



experience, trust, service

Operator's Manual
 Part # 1090050
 Revision: April 8, 2008

2.0 Cubic Foot L-Series Blast Machine



⚠ WARNING

Before using this equipment, read, understand and follow all instructions in the Operator's Manual. If the user or assistants cannot read or understand the warnings and instructions, the employer of the user and assistants must provide adequate and necessary training to ensure proper operation and compliance with all safety procedures pertaining to this equipment. If Operator's Manuals have been lost, contact your distributor or call (563) 324-2519 for replacements. Failure to comply with the above warning could result in death or serious injury.

For more information call:

800-BLAST-IT

Phone: (800) 252-7848
 Fax: (563) 324-6258
 e-mail: sales@marcouisa.com
 www.marcouisa.com

Vision Statement

To be the World’s First Choice for Abrasives, Blasting, Painting, and Safety Equipment & Supplies.

Mission Statement

To provide leadership and innovation to the surface preparation industry. We will dedicate our efforts to the continuous improvement of our products, services, processes, people and most importantly the quality of our Customer’s experience.

Quality Statement

Marco is committed to providing superior quality in the design, manufacturing, distribution and service of our products. As an ISO 9001:2000 registered company, Marco’s quality systems assure our products will meet or exceed our Customer’s expectations. Continuous Improvement in our processes and Supply Chain Integration comprise the core of our Business Strategy for delivering exceptional quality and value in every Marco product and service.

Management Philosophy

We are a Company dedicated to the success of every Customer and Associate. We will discuss, debate, challenge, measure and test our ideas. We will be boundless and limitless in our passion to improve. Through sound leadership and dedicated associates, we will ensure a long term, profitable future for Marco, our Associates, Customers and Suppliers.

Table of Contents

- ▶ **DEFINITION of TERMS** 1
- ▶ **Hazard Identifications** 2-3
- ▶ **Air Consumption Chart** 4

- ▶ **2.0 Cubic FootL-Series Blast Machine**
- Blast Machine** 5-17
- Description & Features 5
- Operational Requirements 5
- Operating Instructions 5-8
- Troubleshooting 9-10
- Assembly/Disassembly 11-12
- Schematic 13-15
- Nozzle Orifice and Media Sizing Chart 16
- Maintenance Notes..... 16-17
- ▶ **Warranty** 18
- Disclaimer of Warranty 18
- Exclusive Remedy for Warranty Claims 18
- Limitation of Remedy 18
- ▶ **Daily Checklist** 19

Definition of Terms

⚠ DANGER

This is an example of danger. This indicates an imminently hazardous situation which, if not avoided, will result in death or serious injury.

⚠ WARNING

This is an example of a warning. This indicates a potentially hazardous situation which, if not avoided, could result in death or serious injury.

⚠ CAUTION

This is an example of a caution. This indicates a potentially hazardous situation which, if not avoided, may result in minor or moderate injury. It can also be used to alert against unsafe practices.

NOTICE

This is an example of a notice. This indicates policy or practice directly related to safety of personnel or protection of property.

⚠ WARNING

Failure to comply with ANY WARNING listed below could result in death or serious injury.

- ▶ Breathing dust containing silica could cause silicosis, a fatal lung disease. Breathing dust during blasting operations, post-blast cleaning operations, and/or servicing equipment within the blasting area may expose an individual to conditions that could cause asbestosis, lead poisoning and/or other serious or fatal diseases. Harmful dust containing toxic material from medias or surfaces being blasted can remain suspended in the air for long periods of time after blasting has ceased. A NIOSH-approved, well-maintained, respirator designed for the specific operation being performed must be used by anyone blasting, handling or using the media, and anyone in the area of the dust.
- ▶ Contact NIOSH and OSHA offices to determine the proper respirator for your specific application. The air supplied to the respirator must be at least Grade D quality as described in Compressed Gas Association Commodity Specification G-7.1 and as specified by OSHA Regulation 1910.134. Ensure air filter and respirator system hoses are not connected to non-air sources or in-plant lines that may contain nitrogen, oxygen, acetylene or other non-breathable gases. Before removing respirator, use an air monitoring instrument to determine if the atmosphere is safe to breathe.
- ▶ You must comply with all OSHA, local, City, State, Province, Country and jurisdiction regulations, ordinances and standards, related to your particular work area and environment. Keep unprotected individuals out of the work area.
- ▶ Blast operators must receive thorough training on the use of media resistant attire which includes: supplied-air respirator, blastsuit, safety shoes, gloves, ear protection and eye protection. Protect the operator and bystanders by complying with NIOSH and OSHA Safety Standards.
- ▶ Inspect all equipment for wear or damage before and after each use. Failure to use Original Equipment Manufacturer repair parts and failure to immediately replace worn or damaged components could void warranties and cause malfunctions.
- ▶ Always depressurize the entire blasting system, disconnect all electrical power sources and lockout/tagout all components before any maintenance or troubleshooting is attempted. Failure to comply with the above warning could cause electrical shock and inadvertent activation of equipment resulting in death or serious injury.
- ▶ OSHA requires blast-cleaning nozzles be equipped with an operating valve, which shall be designed to be held open only by continuous hand pressure and shall close immediately upon release of hand pressure (i.e., a "deadman" control). The valve shall not be modified in any manner that would allow it to remain open without the application of continuous hand pressure by the operator. Failure to comply with the above warning could result in release of high speed media and compressed air resulting in death or serious injury. (OSHA 29 CFR 1910.244(b))
- ▶ Point the blast nozzle only at the surface being blasted. Never point the blast nozzle or media stream at yourself or others.
- ▶ Unless otherwise specified, maximum working pressure of blast machines and related components must not exceed 125 psi. Exceeding maximum working pressure of 125 psi could cause the blast machine and components to burst.
- ▶ Never weld, grind or drill on the blast machine (or any pressure vessel). Doing so will void ASME certification and manufacturer's warranty. Welding, grinding or drilling on the blast machine (or any pressure vessel) could weaken the vessel causing it to burst. (ASME Pressure Vessel Code, Section VIII, Division 1)
- ▶ This equipment is not intended for use in any area that might be considered a hazardous location, as described in the National Electric Code NFPA 70, Article 500. Use of this equipment in a hazardous location could cause an explosion or electrocution.
- ▶ This product is not for use in wet environments. Always use a Ground Fault Interrupter Circuit (GFI) for all electrical power source connections. Use of this product in wet environments could create a shock hazard.
- ▶ Frozen moisture could cause restrictions and obstructions in pneumatic control lines. Any restriction or obstruction in the pneumatic control lines could prevent the proper activation and deactivation of the remote control system, resulting in the release of high speed media and compressed air. In conditions where moisture may freeze in the control lines an antifreeze injection system approved for this application can be installed.
- ▶ Do not cut, obstruct, restrict or pinch pneumatic control lines. Doing so could prevent the proper activation and deactivation of the remote control system, resulting in the release of high speed media and compressed air.
- ▶ Never hang objects from the blast machine handle. Doing so may cause the blast machine to become unstable and tip over.

⚠ WARNING

Failure to comply with ANY WARNING listed below could result in death or serious injury.

- ▶ Never attempt to move a blast machine containing media. Never attempt to manually move blast machines greater than 6.5 cubic foot capacity. Always use at least two capable people to manually move a blast machine on flat, smooth surfaces. A mechanical lifting device must be used if a blast machine is moved in any other manner.
- ▶ Use of Marco remote control switches with other manufacturer's remote control systems could cause unintended activation of remote control systems resulting in the release of high speed media and compressed air. Only Marco remote control switches should be used with Marco remote control systems.
- ▶ Always be certain to have secure footing when blasting. There is a recoil hazard when blasting starts that may cause user to fall and misdirect the media stream at operator or bystander.
- ▶ Never use a blast machine or attachments as a climbing device. The person could slip and fall. The blast machine could become unstable and tip over.
- ▶ The use of this product for any purpose other than originally intended or altered from its original design is prohibited.
- ▶ For equipment manufactured by entities other than Marco, you must consult the Original Equipment Manufacturer operator's manuals, information, training, instructions and warnings, for the proper and intended use of all equipment.

⚠ CAUTION

Failure to comply with ANY CAUTION listed below may result in minor or moderate injury.

- ▶ Static electricity can be generated by media moving through the blast hose causing a shock hazard. Prior to use, ground the blast machine and blast nozzle to dissipate static electricity.
- ▶ High decibel noise levels are generated during the blasting process which may cause loss of hearing. Ensure appropriate Personal Protective Equipment and hearing protection is in use.

NOTICE

- ▶ Always use media that is dry and properly screened. This will reduce the potential for obstructions to enter the remote control system, metering valve and blast nozzle.
- ▶ Moisture build-up occurs when air is compressed. Any moisture within the blast system will cause medias to clump, clogging metering valves, hoses and nozzles. Install an appropriately sized moisture separator at the inlet of the blast machine. Leave the moisture separator petcock slightly open to allow for constant release of water. If insufficient volume of air exists and petcock is unable to be left open (*at all times*) petcock should be opened frequently to release water.
- ▶ To reduce media intrusion in the air supply hose, depressurize the Blast Machine before shutting off air supply from compressor.
- ▶ Inspect nozzle before placing in service. Damage to nozzle liner or jacket may occur during shipping. If you receive a damaged nozzle, contact your distributor immediately for replacement. Nozzles placed in to service may not be returned. Nozzle liners are made of fragile materials and can be damaged by rough handling and striking against hard surfaces. Never use a damaged blast nozzle.
- ▶ Blasting at optimal pressure for the media used is critical to productivity. Example: For a media with an optimal blasting pressure of 100 psi at the nozzle, one pound per square inch of pressure loss will reduce blast efficiency by 1.5%. A 10 psi reduction in air pressure will cause a 15% loss of efficiency. Use a Needle Pressure Gauge to identify pressure drops in your system. Consult with your media supplier for the requirements of your media.
- ▶ Replace Blast Nozzle if liner or jacket is cracked or damaged. Replace nozzle if original orifice size has worn 1/16" or more. Determine nozzle wear by inserting a drill bit 1/16" larger than original size of nozzle orifice. If drill bit passes through nozzle, replacement is needed.
- ▶ When it comes to media & air mixtures, more is not necessarily better. Optimum blasting efficiency takes place when a lean media & air mixture is used. To correctly set the metering valve, begin with the valve fully closed and slowly increase the amount of media entering the airstream. As you increase the media flow, watch for a "blue flame" (*Figure 1*) at the exit of the nozzle. Faster cutting, reduced media consumption and lower clean up costs, are benefits of the "blue flame".
- ▶ See Media Consumption Chart for consumption rates and required air flow (cubic feet per minute). The system must meet these minimum requirements to ensure proper function and performance.

NOTICE

Inspect nozzle before placing in service. Damage to nozzle liner or jacket may occur during shipping. If you receive a damaged nozzle, contact your distributor immediately for replacement. Nozzles placed in to service may not be returned. Nozzle liners are made of fragile materials and can be damaged by rough handling and striking against hard surfaces. Never use a damaged blast nozzle.

NOTICE

► When it comes to media & air mixtures, more is not necessarily better. Optimum blasting efficiency takes place when a lean media & air mixture is used. To correctly set the metering valve, begin with the valve fully closed and slowly increase the amount of media entering the airstream. As you increase the media flow, watch for a "blue flame" (Figure 1) at the exit of the nozzle. Faster cutting, reduced media consumption and lower clean up costs, are benefits of the "blue flame".



Figure 1

NOTICE

See Media Consumption Chart for consumption rates and required air flow (cubic feet per minute). The system must meet these minimum requirements to ensure proper function and performance.

NOTICE

Blasting at optimal pressure for the media used is critical to productivity. Example: For a media with an optimal blasting pressure of 100 psi at the nozzle, one pound per square inch of pressure loss will reduce blast efficiency by 1.5%. A 10 psi reduction in air pressure will cause a 15% loss of efficiency. Use a Needle Pressure Gauge to identify pressure drops in your system. Consult with your media supplier for the requirements of your media.

NOTICE

Replace Blast Nozzle if liner or jacket is cracked or damaged. Replace nozzle if original orifice size has worn 1/16" or more. Determine nozzle wear by inserting a drill bit 1/16" larger than original size of nozzle orifice. If drill bit passes through nozzle, replacement is needed.

Media Consumption Chart*

Nozzle Orifice	Pressure at the Nozzle (psi)								Air (in cfm), Media & Compressor Requirements
	50	60	70	80	90	100	125	140	
No. 2 (1/8")	11	13	15	17	18	20	25	28	Air (cfm)
	67	77	88	101	112	123	152	170	Media (lbs/hr)
	2.5	3	3.5	4	4.5	5	5.5	6.2	Compressor Horsepower
No. 3 (3/16")	26	30	33	38	41	45	55	62	Air (cfm)
	150	171	196	216	238	264	319	357	Media (lbs/hr)
	6	7	8	9	10	10	12	13	Compressor Horsepower
No. 4 (1/4")	47	54	61	68	74	81	98	110	Air (cfm)
	268	312	354	408	448	494	608	681	Media (lbs/hr)
	11	12	14	16	17	18	22	25	Compressor Horsepower
No. 5 (5/16")	77	89	101	113	126	137	168	188	Air (cfm)
	468	534	604	672	740	812	982	1100	Media (lbs/hr)
	18	20	23	26	28	31	37	41	Compressor Horsepower
No. 6 (3/8")	108	126	143	161	173	196	237	265	Air (cfm)
	668	764	864	960	1052	1152	1393	1560	Media (lbs/hr)
	24	28	32	36	39	44	52	58	Compressor Horsepower
No. 7 (7/16")	147	170	194	217	240	254	314	352	Air (cfm)
	896	1032	1176	1312	1448	1584	1931	2163	Media (lbs/hr)
	33	38	44	49	54	57	69	77	Compressor Horsepower
No. 8 (1/2")	195	224	252	280	309	338	409	458	Air (cfm)
	1160	1336	1512	1680	1856	2024	2459	2754	Media (lbs/hr)
	44	50	56	63	69	75	90	101	Compressor Horsepower
No. 10 (5/8")	308	356	404	452	504	548	663	742	Air (cfm)
	1875	2140	2422	2690	2973	3250	3932	4405	Media (lbs/hr)
	68.5	79.5	90	100.5	112	122	146	165	Compressor Horsepower
No. 12 (3/4")	432	504	572	644	692	784	948	1062	Air (cfm)
	2672	3056	3456	3840	4208	4608	5570	6238	Media (lbs/hr)
	96	112	127	143	154	174.5	209	236	Compressor Horsepower

*Media consumption is based on media with a bulk density of 100 lbs per Cu. Ft..

2.0 Cubic Foot L-Series Blast Machine

Description

Rugged, relentless and reliable is what you get with a Marco 2.0 Cubic Foot L-Series Blast Machine. From quick touch-ups to complete jobs, the 2.0 Cubic Foot L-Series Blast Machine is up to the task. Compact design, welded handle, and rugged solid core tires makes this machine highly mobile and easy to move around your job site. The industry proven Two Hole Junior Metering Valve provides the operator with precise metering capabilities, reliable flow, reduced media usage and increased productivity. Equipped with the KwikFire 153 Remote Control Handle, you gain "instant on, instant off" control over your media flow and improved performance. An optional moisture separator will provide dryer air; reducing clogs in the abrasive flow.

Features:

- Built in accordance with ASME Pressure Vessel Code - proven industrial grade durability
- 125 psi operating pressure - allows for a wider range of media and surface profile options
- Durable powder-coated finish - better protection against the elements
- KwikFire 153 Remote Control Handle - gives "instant on, instant off" control over your media
- Bantam Metering Valve - virtually infinite control over abrasive for precise mixture ratio
- Triangular Filler Plug Handle - provides an easy grip during pressurization
- Concave head - makes filling easier with less media spilled on the ground
- Stable tripod design - three point design resists tipping on irregular surfaces
- Solid rubber tires - puncture proof and durable for reliable performance
- Welded handle - makes for easy transport to, from, and around your work site
- Dimensions - 21"W x 24"L x 39"H / Weight - 126 lbs

Operational Requirements

The following may cause safety hazards or reduced performance:

- Improper installation and/or maintenance of components
- Failure to place blast machine on a secure, flat surface
- Improper air supply pressure (minimum 30 psi, maximum 125 psi)
- Incorrect lifting / transporting of blast machine or incorrect or worn lifting devices
- Use of media too coarse for nozzle orifice
- Use of media coarser than 20 mesh may cause clogging in the Bantam Metering Valve

Operating Instructions (Figure 2)

Before using:

- Inspect Blast Machine for damage. Replace any damaged components before use.
- Inspect Filler Plug O-ring (2) and Filler Plug (1) for damage
- Test all Ball Valves (3, 8) for binding by turning to the fully open position and back to the fully closed position. Replace immediately if damaged.
- Test Petcock (5) for binding by turning the handle 180 degrees (from the 9 o'clock to 3 o'clock position). Set Petcock (5) handle to a closed (9 or 3 o'clock) position.
- Test Bantam Metering Valve (6) by twisting Control Knob (7) one full turn clockwise then counter-clockwise. Close Bantam Meter Valve by turning control knob clockwise until the valve seats .
- Attach Blast Hose to Bantam Metering Valve (a).
- Attach KwikFire 153 to Blast Hose and install Blast Nozzle on KwikFire 153 (fig.7).
- Test KwikFire 153 Remote Control System by rotating Control Lever to the operating position and release. If the Control Lever does not return to the closed position, remove system from service and inspect KwikFire 153 for damage before returning system to service.
- Fill Blast Machine with media.
- Attach Air Hose to 2-Lug Hose Fitting (4).

WARNING

Inspect all equipment for wear or damage before and after each use. Failure to use Original Equipment Manufacturer repair parts and failure to immediately replace worn or damaged components could void warranties and cause malfunctions. Failure to comply with the above warning could result in death or serious injury.

WARNING

Never weld, grind or drill on the blast machine (or any pressure vessel). Doing so will void ASME certification and manufacturer's warranty. Welding, grinding or drilling on the blast machine (or any pressure vessel) could weaken the vessel causing it to burst. Failure to comply with the above warning could result in death or serious injury. (ASME Pressure Vessel Code, Section VIII, Division 1)

WARNING

Ensure the surface is stable and is sufficient to support the weight of a Blast Machine full of media. Unstable surfaces and surfaces that cannot support the gross weight of a full blast machine could cause the blast machine to tip over. Failure to comply with the above warning could result in death or serious injury.

NOTICE

Never use the filler plug to lift or move the blast machine.

2.0 Cubic Foot L-Series Blast Machine

Figure 2

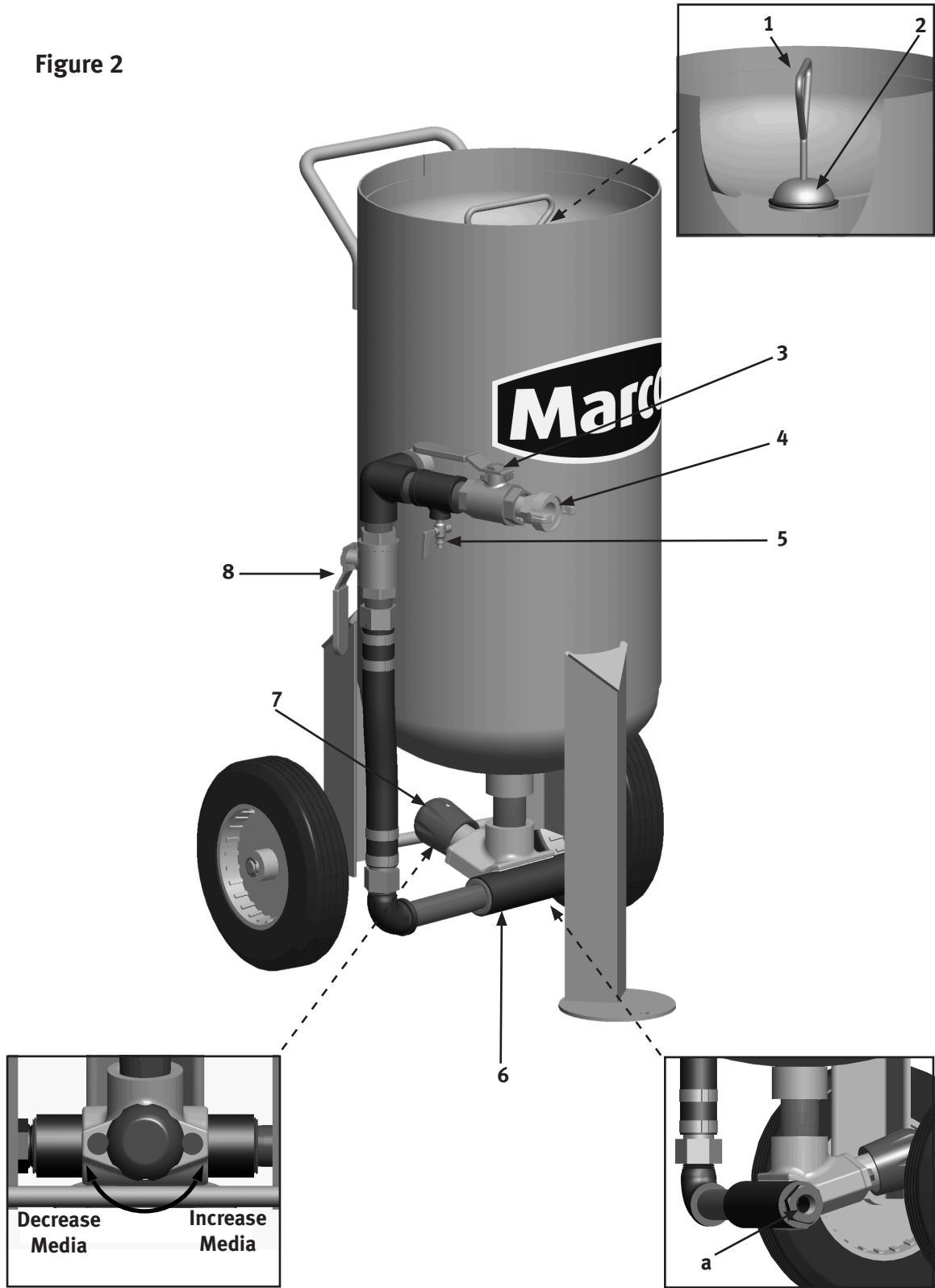

⚠ WARNING

Crushing and pinching are normal functions of this component. Do not place body parts or foreign objects in any area where there are moving parts. Failure to comply with the above warning could result in death or serious injury.

⚠ WARNING

Point the blast nozzle only at the surface being blasted. Never point the blast nozzle or abrasive media stream at yourself or others. Failure to comply with the above warning could result in death or serious injury.

⚠ WARNING

Always be certain to have secure footing when blasting. There is a recoil hazard when blasting starts that may cause user to fall and misdirect the abrasive stream at operator or bystander. Failure to comply with the above warning could result in death or serious injury.

⚠ WARNING

Never hang objects from the blast machine handle. Doing so may cause the blast machine to become unstable and tip over. Failure to comply with the above warning could result in death or serious injury.

2.0 Cubic Foot L-Series Blast Machine

Operating Instructions (Figure 3)

To Start Blasting:

- Ensure Inlet Ball Valve (3) and Choke Valve (8) are in the closed position.
- Attach air hose to 2-Lug Air Hose Fitting (4).
- Grasp Filler Plug Handle (1) and pull up. Turn Inlet Ball Valve (3) to the open position. Wait for the air from the compressor to pressurize the vessel.
- Release the Filler Plug Handle (1).
- Turn the Choke Valve (8) to the open position.
- To begin blasting, rotate Control Lever (a) on KwikFire 153 (6) to the full open operating position .
- To stop media flow, release Control Lever (a) on KwikFire 153 (6).
- Adjust abrasive flow as needed to achieve maximum performance (see fig. 1).

To Stop Blasting Operation:

- To cease blasting release Control Lever (a) on KwikFire 153 (6).
- Close Bantam Metering Valve (7) by rotating Control Knob (b) clockwise until valve seats.
- Close Choke Valve (8).
- Close Inlet Valve (3).
- Turn Petcock (5) to the open (6 o'clock) position to release air from the Blast Machine.
- Once air ceases to release from Petcock (5), move Filler Plug handle (1) back and forth to release Filler Plug (2).

After Use:

- Empty media from Blast Machine when blasting is concluded for the day. To remove media from Blast Machine :
 - ◆ Remove Kwikfire 153 assembly (6) from Blast Hose.
 - ◆ Turn Bantam Metering Valve (7) to a full open position.
 - ◆ Close Petcock (5) by rotating to the 3 o'clock or 9 o'clock position.
 - ◆ Securely hold Blast Hose, place hose end in a container suitable for catching the media. Ensure Operator is prepared for strong recoil, the blast hose will provide strong recoil as the media exits the blast hose.
 - ◆ Slowly open Inlet Valve (3).
 - ◆ After Blast Machine is empty of media, follow the procedure outlined in "To Stop Blasting".
- Inspect Blast Machine components for damage. Replace damaged components before use.
- Cover Blast Machine when not in use to reduce debris and water intrusion.

2.0 Cubic Foot L-Series Blast Machine

Figure 3

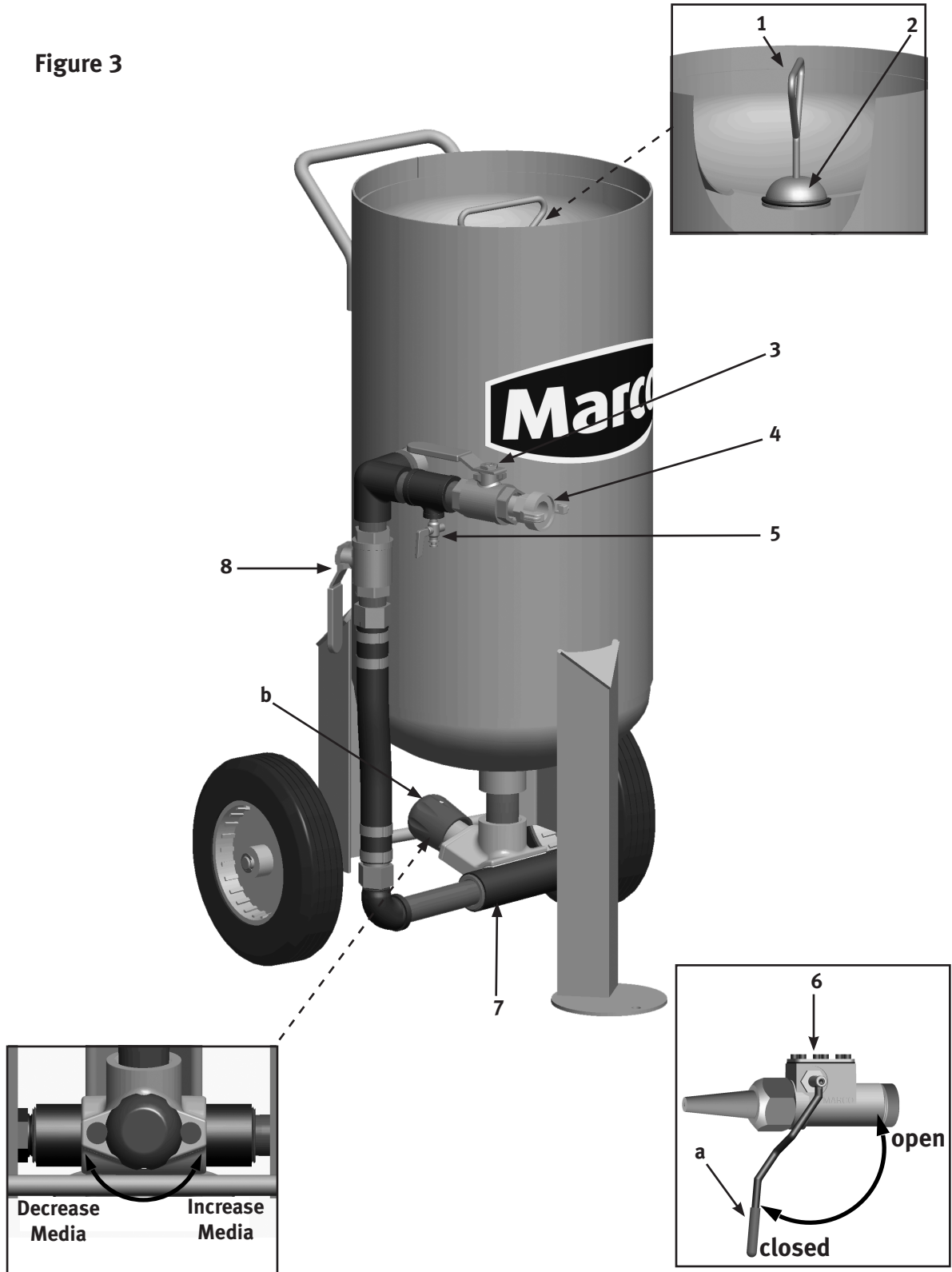

⚠ WARNING

Always depressurize the entire blasting system, disconnect all electrical power sources and lockout/tagout all components before any maintenance or troubleshooting is attempted. Failure to comply with the above warning could cause electrical shock and inadvertent activation of equipment resulting in death or serious injury.

⚠ WARNING

Crushing and pinching are normal functions of this component. Do not place body parts or foreign objects in any area where there are moving parts. Failure to comply with the above caution may result in minor or moderate injury.

⚠ CAUTION

Release of high speed media and compressed air occurs during depressurization of the blast machine. Ensure appropriate Personal Protective Equipment is in use. Failure to comply with the above caution may result in minor or moderate injury.

NOTICE

Moisture build-up occurs when air is compressed. Any moisture within the blast system will cause media to clump, clogging metering valves, hoses and nozzles. Install an appropriately sized moisture separator at the inlet of the blast machine. Leave the moisture separator petcock slightly open to allow for constant release of water. If insufficient volume of air exists and petcock is unable to be left open (at all times) petcock should be opened frequently to release water.

2.0 Cubic Foot L-Series Blast Machine

Troubleshooting

If the Blast Machine does not function properly, check the following:

SYMPTOM (Cause) ACTION

Blast Machine will not pressurize
(Improper Air Supply, Damaged Components)

Insufficient air supply. Ensure air compressor provides sufficient air volume to operate Blast Machine and the Air Hose is of sufficient size to provide adequate air volume.

Filler Plug or Filler Plug O-ring damaged. Inspect Filler Plug and Filler Plug O-ring for wear or damage. Replace damaged Filler Plug O-ring. If Filler Plug is damaged remove blast machine from service.

Filler Plug not seated. Ensure Filler Plug is in proper position and a proper seal has been achieved.

External Piping is damaged or loose. Inspect external piping for damage. Confirm all fittings are tight and free from damage.

Neither air nor media exits the blast nozzle
(Obstructions, Wet Media, Metering Valve, Improperly Sized Media, optional KwikFire 153)

With Blast Machine pressurized, close Choke Valve to "Purge" and clear minor obstruction in Bantam Metering Valve, Blast Hose or Nozzle.

Depressurize Blast Machine. Inspect Blast Nozzle, optional KwikFire 153, and Blast Hose for obstruction. Never look directly down the exit port of the Blast Nozzle. Remove obstruction.

Damp or wet media. Remove all media from Blast Machine and Metering Valve. Ensure dry media is used.

Slightly open optional Moisture Separator Petcock to allow collected moisture to escape while Blast Machine is in use.

Consult Ceramic Nozzles Chart (Fig. 8) for compatible media and nozzle selection.

Refer to Bantam Metering Valve and/or KwikFire 153 Operator's Manual for proper instructions.

⚠ WARNING

Always depressurize the entire blasting system, disconnect all electrical power sources and lockout/tagout all components before any maintenance or troubleshooting is attempted. Failure to comply with the above warning could cause electrical shock and inadvertent activation of equipment resulting in death or serious injury.

⚠ WARNING

Crushing and pinching are normal functions of this component. Do not place body parts or foreign objects in any area where there are moving parts. Failure to comply with the above caution may result in minor or moderate injury.

⚠ CAUTION

Release of high speed media and compressed air occurs during depressurization of the blast machine. Ensure appropriate Personal Protective Equipment is in use. Failure to comply with the above caution may result in minor or moderate injury.

NOTICE

Moisture build-up occurs when air is compressed. Any moisture within the blast system will cause media to clump, clogging metering valves, hoses and nozzles. Install an appropriately sized moisture separator at the inlet of the blast machine. Leave the moisture separator petcock slightly open to allow for constant release of water. If insufficient volume of air exists and petcock is unable to be left open (at all times) petcock should be opened frequently to release water.

2.0 Cubic Foot L-Series Blast Machine

Troubleshooting

If the Blast Machine does not function properly, check the following:

SYMPTOM (Cause)

ACTION

Only air exits Blast Nozzle

(Obstructions, Wet Media, Metering Valve, Improperly Sized Media)

With Blast Machine pressurized, close Choke Valve to "Purge" and clear minor obstruction in Bantam Metering Valve, Blast Hose or Nozzle.

Depressurize Blast Machine. Inspect Blast Nozzle, optional KwikFire 153, and Blast Hose for obstruction. Never look directly down the exit port of the Blast Nozzle. Remove obstruction.

Damp or wet media. Remove all media from Blast Machine and Metering Valve. Ensure dry media is used.

Slightly open optional Moisture Separator Petcock to allow collected moisture to escape while Blast Machine is in use.

Consult Ceramic Nozzles Chart (Fig. 8) for compatible media and nozzle selection.

Refer to Bantam Metering Valve and/or KwikFire 153 Operator's Manual for proper instructions.

Inconsistent media flow

(Improper Air Supply, Damaged Components, Wet Media, Improperly Sized Media)

Insufficient air supply. Ensure air compressor provides sufficient air volume to operate Blast Machine and the Air Hose is of sufficient size to provide adequate air volume.

Filler Plug or Filler Plug O-ring damaged. Inspect Filler Plug and Filler Plug O-ring for wear or damage. Replace damaged Filler Plug O-ring. If Filler Plug is damaged remove blast machine from service.

External Piping Damaged or Loose. Inspect external piping for damage. Confirm all fittings are tight and free from damage.

Damp or wet media. Remove all media from Blast Machine and Metering Valve. Ensure dry media is used.

Slightly open optional Moisture Separator Petcock to allow collected moisture to escape while Blast Machine is in use.

Consult Ceramic Nozzles Chart (Fig. 8) for compatible media and nozzle selection.

Refer to Bantam Metering Valve and/or KwikFire 153 Operator's Manual for proper instructions.

⚠ WARNING

Always depressurize the entire blasting system, disconnect all electrical power sources and lockout/tagout all components before any maintenance or troubleshooting is attempted. Failure to comply with the above warning could cause electrical shock and inadvertent activation of equipment resulting in death or serious injury.

⚠ WARNING

Never weld, grind or drill on the blast machine (or any pressure vessel). Doing so will void ASME certification and manufacturer's warranty. Welding, grinding or drilling on the blast machine (or any pressure vessel) could weaken the vessel causing it to burst. Failure to comply with the above warning could result in death or serious injury. (ASME Pressure Vessel Code, Section VIII, Division 1)

NOTICE

Piping may loosen during transit. Ensure all piping is aligned and tightened before use.

NOTICE

Apply pipe thread sealant to all pipe threads to ensure an airtight seal.

2.0 Cubic Foot L-Series Blast Machine

Maintenance

Maintenance of the Blast Machine is limited to the daily cleaning and the immediate replacement of damaged or worn parts.

2.0 Cubic Foot Industrial Blast Machine

Filler Plug O-ring: (Figure 4)

Disassembly:

- 1) Lift Filler Plug (1) close to Filler Plug Opening (a), leaning to one side for access to Filler Plug O-Ring (2).
- 2) Pull Filler Plug O-Ring (2) from recessed area on Filler Plug (1).
- 3) Pull Filler Plug O-Ring (2) over Filler Plug (1) handle one side at a time.

Assembly:

- 1) Slip Filler Plug O-ring (2) over Filler Plug (1) handle one side at a time, taking care to not over stretch or otherwise damage Filler Plug O-ring (2).
- 2) Lift Filler Plug (1) close to the opening, leaning to one side to access recessed area that receives the Filler Plug O-Ring (2).
- 3) Starting on exposed face, roll Filler Plug O-ring (2) into recessed area on Filler Plug (1), rotating Filler Plug handle until Filler Plug O-ring (2) is completely seated.
- 4) Pull Filler Plug (1) in to place to test Filler Plug O-ring (2) seating.

Nozzle Assembly and KwikFire 153 Installation: (Fig.4)

Disassembly:

- 1) Unthread Nozzle Cap (11) from KwikFire 153 (8).
- 2) Remove Nozzle (10) from KwikFire 153 (8).
- 3) Remove Nozzle Washer (9) from KwikFire 153 (8).
- 4) Remove KwikFire 153 (8) from Nozzle Holder Base (6).
- 5) Remove Liner (7) from Nozzle Holder Base (6).
- 6) Remove Nozzle Holder Base (6) from Blast Hose Assembly (5).

Assembly:

- 1) Attach Nozzle Holder Base (6) to Blast Hose Assembly (5).
- 2) Insert Liner (7) into Nozzle Holder Base (6).
- 3) Attach KwikFire 153 (8) to Nozzle Holder Base (6).
- 4) Insert Nozzle Washer (9) into KwikFire 153 (8).
- 5) Insert Nozzle (10) into KwikFire 153 (8).
- 6) Attach Nozzle Cap (11) onto KwikFire 153 (8).

Hose End Assembly: (Fig. 4)

Disassembly:

- 1) Remove Nozzle Assembly and Kwikfire 153 (6-11) from Hose End Assembly (5).
- 2) Remove Hose Clamp (4) from Blast Hose (5).
- 3) Remove Blast Hose End (3) from Blast Hose (5).

Assembly:

- 1) Cut the Blast Hose (5) square, leaving a smooth and even end.
- 2) Wet barb of Blast Hose End (3) with a small amount of liquid detergent.
- 3) Insert Blast Hose End (3) into Blast Hose (5).
- 4) Place Hose Clamp (4) 1/4" from end of Blast Hose (5) and tighten.
- 5) Attach Nozzle Assembly and Kwikfire 153 (6-11) to Hose End Assembly (5).

2.0 Cubic Foot L-Series Blast Machine

Figure 4

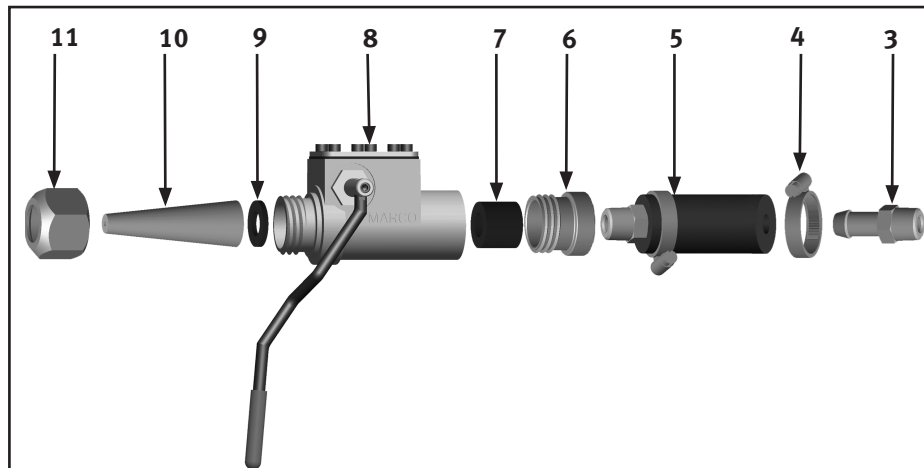
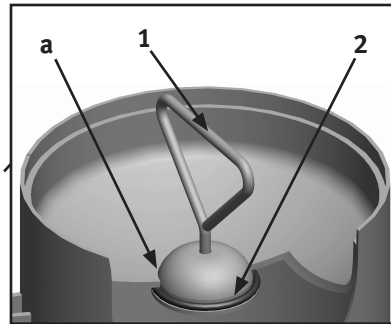
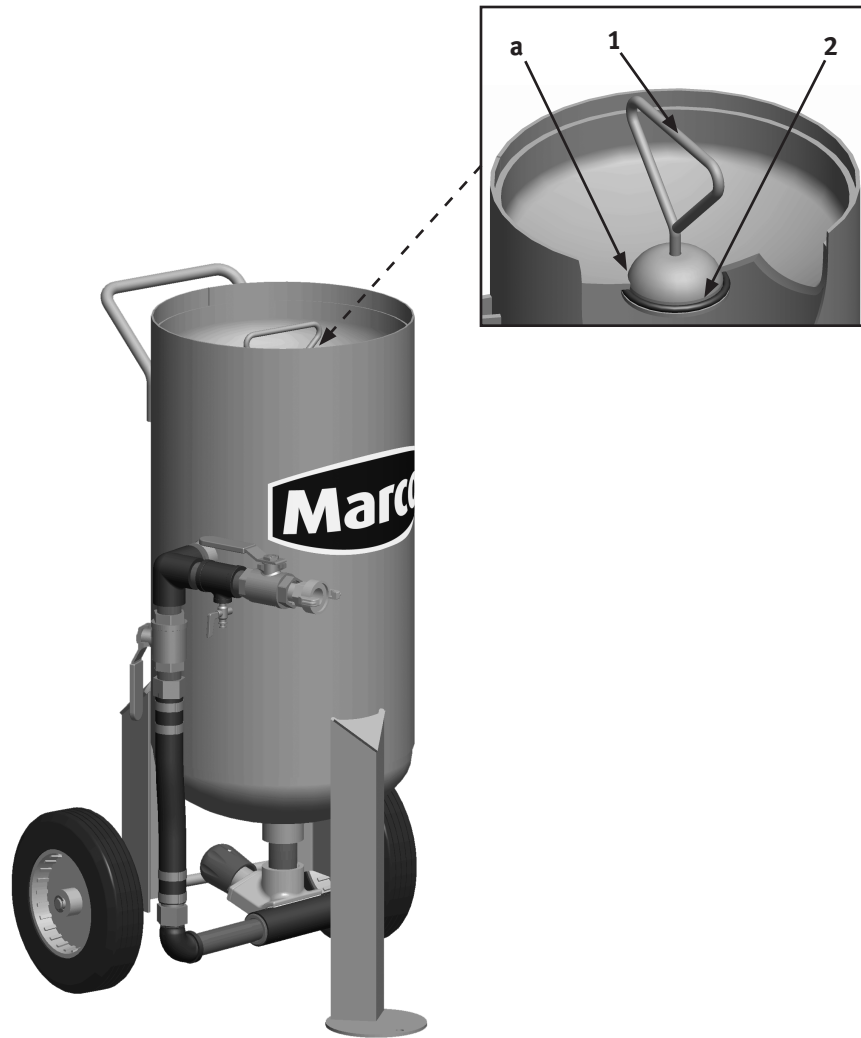

2.0 Cubic Foot L-Series Blast Machine Schematic

Figure 5

Item #	Part #	Description
Fig. 5	1002001	2.0 Cubic Foot L-Series Blast Machine with 25 feet of 1/2" i.d. Blast Hose with Fittings installed and KwikFire 153 Remote Control Handle
	1002001PKB	2.0 Cubic Foot L-Series Blast Machine with Extractor Junior Moisture Separator, 25 feet of 1/2" i.d. Blast Hose with Fittings and KwikFire 153 Remote Control Handle
1	10L650R	Filler Plug O-Ring
2	1011601	1" Full Port Brass Ball Valve (2 required)
3	10ME2	2-lug Air Hose Coupling - 1" NPT Male Threads
4	1012151	1" NPT Close Nipple (5 required)
5	1012101	1/4" NPT Petcock
6	1011813	1-1/4" NPT x 2" Pipe Nipple
7	1011812	1" NPT (Male) x 1/2" (Female) Bushing
8	1014103	Bantam Metering Valve with 1" (F) x 1" (F) Nipple
9	1011815	1" NPT x 5" long Pipe Nipple
10	1011801	1" 90 Degree Street Elbow
11	1006066	10 X 2.75 Solid Wheel (2 required)
12	1011807	5/8" E-Clip (4 required)
13	1006308	1" NPT Air Hose Pusher Line Assembly
14	1011808	1" NPT Pipe Elbow with Side-out
15	1011814	1" x 1" x 1/4" NPT Pipe Tee
16	10L66EVD	KwikFire 153 Remote Control Handle
17	1011750	Extractor Junior Moisture Separator (optional)
-	1002101	14" Cover for 2.0 Industrial Series Blast Machine (optional)
-	1002102	14" Recessed Screen for 2.0 Industrial series Blast Machine (optional)
-	1091045	Hazard Identification Tag
-	1090050	2.0 Cubic Foot Industrial Series Blast Machine Operator's Manual
-	1090034	KwikFire 153 Operator's Manual

2.0 Cubic Foot L-Series Blast Machine Schematic

Figure 5

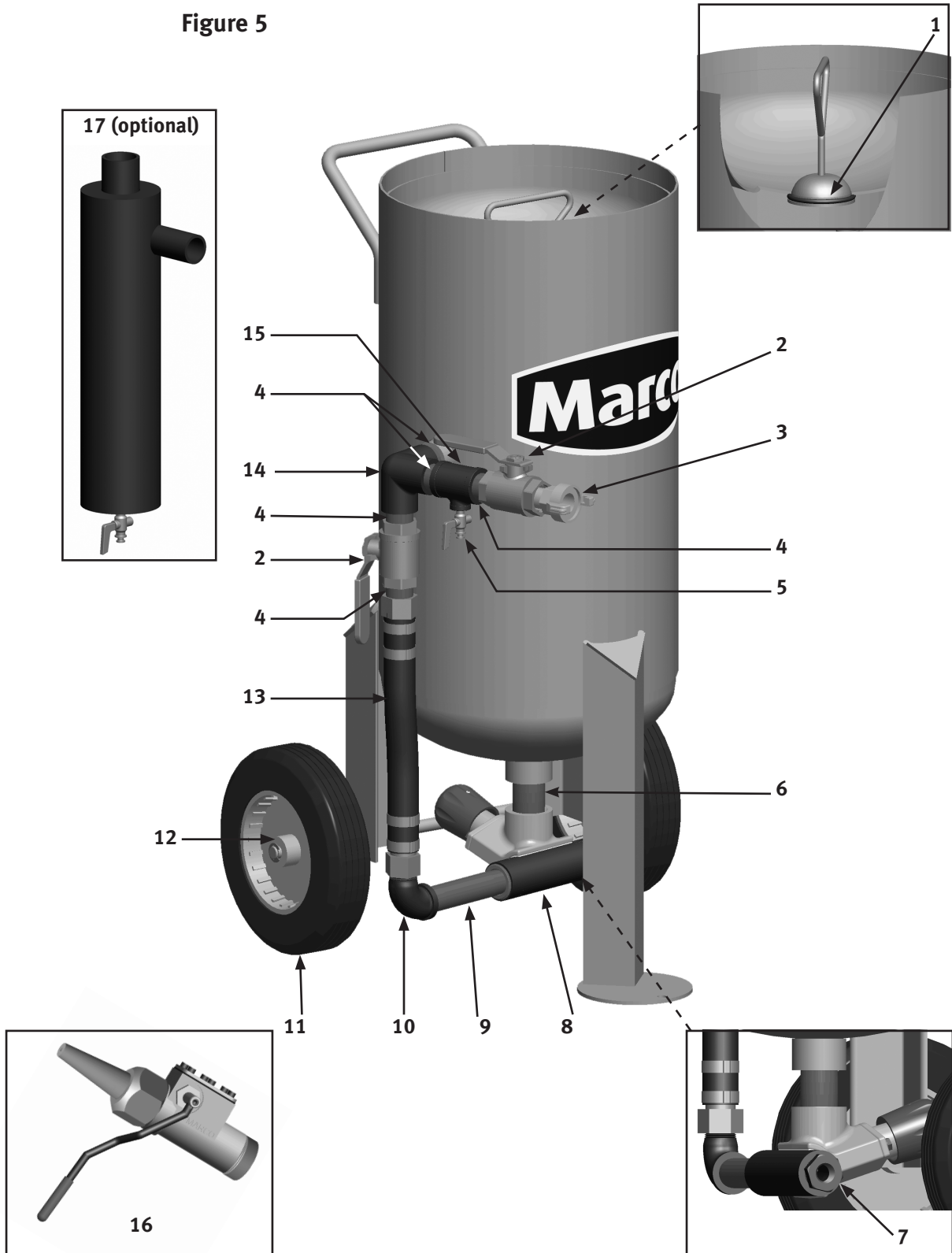

1 / 2 " H o s e E n d A s s e m b l y

Figure. 6

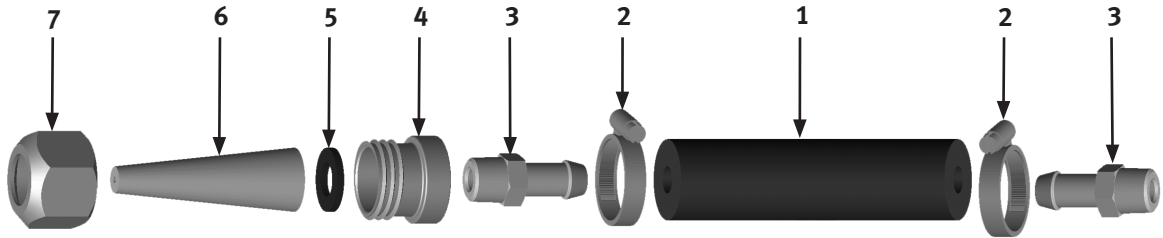

Item #	Part #	Description
1a	10L850119	10' of 1/2" ID/1-3/16" OD Blast Hose with 2 each of items 2 & 3 installed
1b	10L850120	25' of 1/2" ID/1-3/16" OD Blast Hose with 2 each of items 2 & 3 installed
1c	10L850125	50' of 1/2" ID/1-3/16" OD Blast Hose with 2 each of items 2 & 3 installed
1d	10BH01210C	1/2" ID/1-3/16" Blast Hose - 10'
1e	10BH012125C	1/2" ID/1-3/16" Blast Hose - 12.5'
1f	10BH01225C	1/2" ID/1-3/16" Blast Hose - 25'
1g	10BH012C	1/2" ID/1-3/16" Blast Hose - 50'
2	10L800034	Hose Clamp for 1/2" ID Hose (2 Required)
3	10L174	1/2" I.D. Blast Hose End with 1/2" NPT threads (2 Required)
4	10L66B	Nozzle Holder Base (Type 1)
5	10L66CHW	Rubber Washer for Type 1 Nozzle
6		Type 1 Nozzle (See Fig. 8 for size options)
7	10L100164	Nozzle Cap (Fits 10L366HE, 10L466HE and 10L66B)

K w i k F i r e 1 5 3 A s s e m b l y

Figure. 7

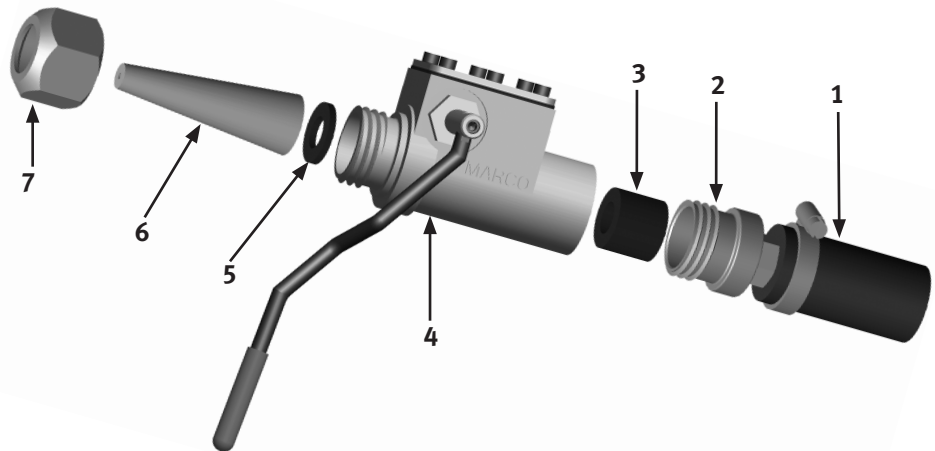

Item #	Part #	Description
1	-	Blast Hose (See Fig. 6 for length options)
2	10L66B	Nozzle Holder Base (Type 1)
3	10L800236	Rubber Liner
4	10L66EVD	KwikFire 153 Remote control Handle - Complete
5	10L66CHW	Rubber Washer for Type 1 Nozzle
6		Type 1 Nozzle (See Fig. 8 for size options)
7	10L100164	Nozzle Cap (Fits 10L366HE, 10L466HE and 10L66B)

ADDITIONAL TECHNICAL DATA

The associations listed below offer information, materials and videos pertaining to media blasting and safe operating practices.

- **American Society for Testing and Materials (ASTM)**
 100 Barr Harbor Drive
 West Conshohocken, PA 19428-2959
 Phone: (610) 832-9585
 FAX: (610) 832-9555
 www.astm.org
- **Occupational Safety & Health Administration (OSHA)**
 United States
 Department of Labor
 200 Constitution Avenue
 Washington, DC 20210
 Phone: (800) 321-OSHA
 (800) 321-6742
 www.osha.gov
- **The National Board of Boiler & Pressure Vessel Inspectors**
 1055 Crupper Avenue
 Columbus, Ohio 43229
 Phone: (614) 888-8320
 FAX: (614) 888-0750
 www.nationalboard.org
- **National Association of Corrosion Engineers (NACE)**
 1440 South Creek Drive
 Houston, TX 77084-4906
 Phone: (281) 228-6200
 FAX: (281) 228-6300
 www.nace.org
- **The Society for Protective Coatings (SSPC)**
 40-24th Street, 6th Floor
 Pittsburgh, PA 15222-4656
 Phone: (412) 281-2331
 FAX: (412) 281-9992
 www.sspc.org

WARRANTY

Seller warrants to the original purchaser that the Product covered by this Warranty will remain free from defects in workmanship or material under normal commercial use and service for a period of one year from the date of shipment to the original Purchaser. This Warranty shall not apply to defects arising, in whole or in part, from any accident, negligence, alteration, misuse or abuse of the Product, operation not in accordance with applicable instructions or manuals or under conditions more severe than, or otherwise exceeding, those set forth in the written specifications for the Product, nor shall this Warranty extend to repairs or alterations of the Product by persons other than Seller or Seller's authorized representatives, or to maintenance parts.

DISCLAIMER OF WARRANTY

The foregoing Warranty is exclusive and is in lieu of all other warranties of quality, whether oral or written and whether express or implied. All warranties of merchantability or fitness for a particular purpose are hereby excluded and are inapplicable to the Product. Seller makes no warranties or representations concerning respirators, or equipment made by other manufacturers.

EXCLUSIVE REMEDIES FOR WARRANTY CLAIMS

THE SOLE AND EXCLUSIVE REMEDIES OF PURCHASER FOR UNDER THE FOREGOING WARRANTY COVERING THIS PRODUCT SHALL BE REPAIR OR REPLACEMENT, FREE OF CHARGE, F.O.B. POINT OF MANUFACTURE, OF ANY DEFECTIVE PART OR PARTS OF THE PRODUCT THAT WERE MANUFACTURED BY SELLER, AND WHICH ARE RETURNED TO SELLER AT SELLER'S PRINCIPAL PLACE OF BUSINESS, POSTAGE PREPAID. THIS SOLE AND EXCLUSIVE REMEDY IS CONDITIONED UPON PURCHASER'S PROMPT WRITTEN NOTICE TO SELLER AT SELLER'S PLACE OF BUSINESS THAT A DEFECT HAS BEEN DISCOVERED, TOGETHER WITH A REASONABLY DETAILED DESCRIPTION OF THE DEFECT IN THE PRODUCT, WITHIN THIRTY (30) DAYS AFTER DISCOVERY OF THE DEFECT, OTHERWISE SUCH CLAIMS SHALL BE DEEMED WAIVED. NO ALLOWANCE WILL BE GRANTED FOR ANY REPAIRS OR ALTERATIONS MADE BY PURCHASER OR OTHERS WITHOUT SELLERS PRIOR WRITTEN CONSENT. IF SUCH NOTICE IS TIMELY GIVEN, SELLER WILL HAVE THE OPTION TO EITHER MODIFY THE PRODUCT OR COMPONENT PART THEREOF TO CORRECT THE DEFECT, REPLACE THE PRODUCT OR PART WITH COMPLYING PRODUCTS OR PARTS, OR REFUND THE AMOUNT PAID FOR THE DEFECTIVE PRODUCT, ANY ONE OF WHICH WILL CONSTITUTE THE SOLE LIABILITY OF SELLER AND FULL SETTLEMENT OF ALL CLAIMS. PURCHASER SHALL AFFORD SELLER PROMPT AND REASONABLE OPPORTUNITY TO INSPECT THE PRODUCT FOR WHICH CLAIM IS MADE. THE SOLE PURPOSE OF THE FOREGOING STIPULATED EXCLUSIVE REMEDY SHALL BE TO REPAIR OR REPLACE DEFECTIVE PRODUCTS OR COMPONENTS THEREOF, OR TO REFUND PURCHASER THE PURCHASE PRICE THEREOF. THIS STIPULATED EXCLUSIVE REMEDY SHALL NOT BE DEEMED TO HAVE FAILED OF ITS ESSENTIAL PURPOSE SO LONG AS SELLER IS WILLING AND ABLE TO REPAIR OR REPLACE THE DEFECTIVE PARTS OR REFUND THE PURCHASE PRICE IN ACCORDANCE WITH THE TERMS HEREOF.

LIMITATION OF REMEDIES

The foregoing stipulated exclusive remedies is in lieu of all other remedies for breach of contract, warranty and/or tort. Seller shall not be liable for the Purchaser's expenses for downtime or for making up downtime, damages for which the Purchaser may be liable to other persons and/or entities, damages to property, and injury to or death of any persons and/or any claims for incidental or consequential damages, including but not limited to loss of profits, regardless of whether Seller has been informed of the possibility of such damages. Seller neither assumes nor authorizes any person to assume for it any other liability in connection with the sale or use of any Products covered by the foregoing Warranty and Disclaimers, and there are no oral agreements relating to remedies which are collateral to or which affect this limitation.

Marco Blast Machine – Hose Configuration

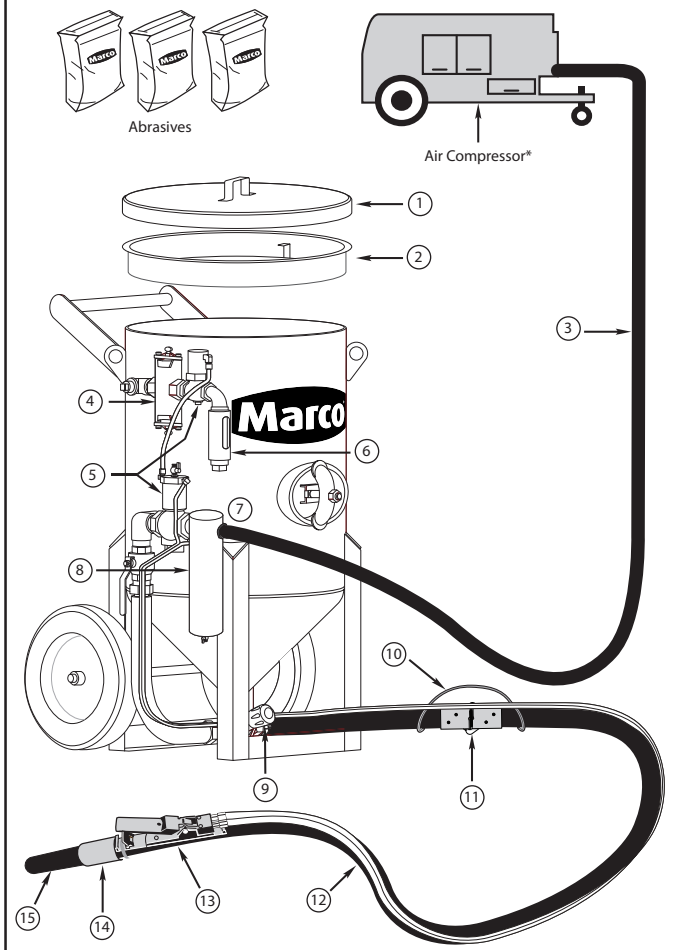

* Grade D quality air in an atmosphere free of contaminants

Ambient Air Pump Configuration

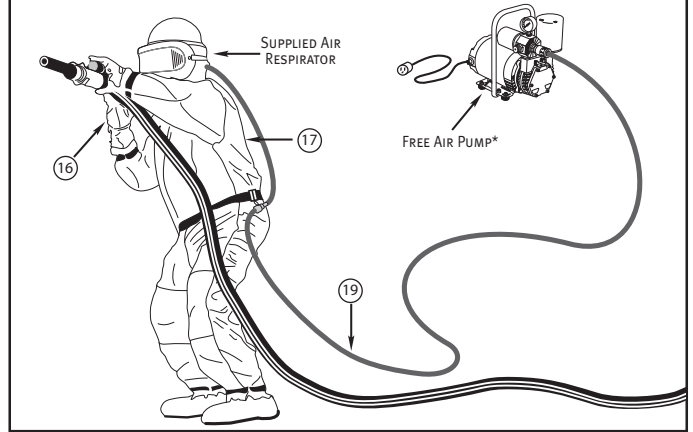

* Grade D quality air in an atmosphere free of contaminants

Air Compressor Breathing Air Configuration

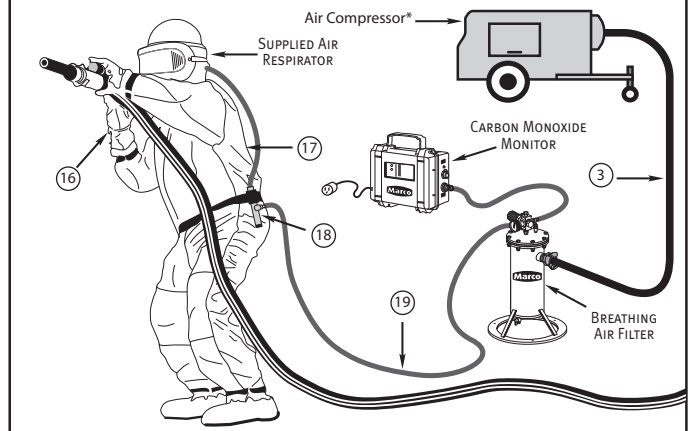

* Grade D quality air in an atmosphere free of contaminants

DAILY PRE-OPERATION CHECKLIST

Additional Components

- ① blast machine lid
- ② blast machine screen
- ③ air hose
- ④ abrasive trap
- ⑤ remote control system
- ⑥ exhaust muffler
- ⑦ air hose couplings & gaskets
- ⑧ moisture separator
- ⑨ metering valve
- ⑩ whip check cable
- ⑪ blast hose couplings & gaskets
- ⑫ remote control line
- ⑬ remote control handle
- ⑭ blasting nozzle holder
- ⑮ blasting nozzle
- ⑯ blasting gloves
- ⑰ media resistant blastersuit
- ⑱ breathing line
- ⑲ climate control device



Phone: (800) 252-7848
 Fax: (563) 324-6258
 e-mail: sales@marcouusa.com
 www.marcouusa.com

MEDIAS:

- Review the Media MSDS (*Material Safety Data Sheet*) to ensure the material is free of toxic or harmful substances such as lead, silica, cyanide or arsenic. Use properly sized media to ensure required surface finish.

BLAST MACHINE:

- Inspect the Blast Machine for internal and external wear, abrasions and leaks.
- Ground the Blast Machine to dissipate static electricity created by the Media moving through the Blast Hose.
- Install a Moisture Separator at the Inlet Port of the Blast Machine. Removing moisture from the Air Supply will allow Media to flow smoothly from the Blast Machine to the work surface.
- Inspect abrasive trap filter and empty trap frequently
- Inspect exhaust muffler and filter element before starting blasting operations. Replace filter element if exhaust air flow is restricted by residue dust

AIR SUPPLY: Respirator

- Inspect Respirator Assemblies for worn components and replace as needed.
- You MUST consult the Operator's Manual supplied with your Respirator for ALL applicable Warnings and Hazards.

BLAST NOZZLES:

- Replace Blast Nozzles if liner or jacket is cracked, damaged or an orifice size 1/16" larger than the original size.
 – Determine Nozzle wear by inserting a drill bit 1/16" larger than original size of the Nozzle orifice. If the drill bit passes, replacement is needed.
- Blast Nozzles with 1/2" I.D. or 1" I.D. Entry require use of a Nozzle Washer. Wide Entry (1-1/4" I.D.) Blast nozzles do not require a Nozzle Washer. Inspect and replace damaged Nozzle Holder or Nozzle Washer before use.

AIR SUPPLY: Blast Machine

- Use an Air Compressor that will provide sufficient CFM (*Cubic Feet Per Minute*) volume of air to the Blast Nozzle and all other pneumatic tools, with an additional 50% to allow for Nozzle wear.

AIR & BLAST HOSE:

- Inspect all Hoses for internal and external wear, abrasions and leaks.
- Lay out Air Hose and Blast Hose as straight as possible to remove restrictions which cause reduced performance and premature wear.
- Blast Hose I.D. should be 3-4 times the size of Nozzle orifice.
- Blast Hose and Air Hose Couplings are to mate securely using Gaskets to provide a positive seal without leaks. Inspect and replace any worn or damaged component before use.
- Install Safety Clips and Safety Cables at each connection.

PROTECTIVE CLOTHING:

- Wear appropriate Protective Clothing and Equipment (*supplied-air respirator, blastersuit, safety shoes, leather gloves, ear protection and eye protection*) appropriate for the work environment.