



US010356243B2

(12) **United States Patent**
Sanghavi et al.

(10) **Patent No.:** **US 10,356,243 B2**
(45) **Date of Patent:** ***Jul. 16, 2019**

(54) **VIRTUAL ASSISTANT AIDED COMMUNICATION WITH 3RD PARTY SERVICE IN A COMMUNICATION SESSION**

(71) Applicant: **Apple Inc.**, Cupertino, CA (US)

(72) Inventors: **Mehul K. Sanghavi**, Sunnyvale, CA (US); **Jeffrey P. Schwerdtfeger**, Santa Cruz, CA (US)

(73) Assignee: **Apple Inc.**, Cupertino, CA (US)

(*) Notice: Subject to any disclaimer, the term of this patent is extended or adjusted under 35 U.S.C. 154(b) by 0 days.

This patent is subject to a terminal disclaimer.

(21) Appl. No.: **15/403,906**

(22) Filed: **Jan. 11, 2017**

(65) **Prior Publication Data**

US 2017/0346949 A1 Nov. 30, 2017

Related U.S. Application Data

(63) Continuation of application No. 14/732,625, filed on Jun. 5, 2015, now Pat. No. 9,578,173.

(51) **Int. Cl.**
H04M 3/00 (2006.01)
H04M 5/00 (2006.01)
(Continued)

(52) **U.S. Cl.**
CPC **H04M 3/5183** (2013.01); **H04L 51/02** (2013.01); **H04L 51/046** (2013.01); **H04L 51/18** (2013.01);
(Continued)

(58) **Field of Classification Search**
CPC H04L 51/02; H04L 51/046; H04L 51/18; H04L 65/1069; H04M 1/72552;
(Continued)

(56) **References Cited**

U.S. PATENT DOCUMENTS

6,011,585 A 1/2000 Anderson
6,014,428 A 1/2000 Wolf
(Continued)

FOREIGN PATENT DOCUMENTS

CA 2631796 A1 7/2007
CA 2694314 A1 8/2010
(Continued)

OTHER PUBLICATIONS

Dobrisek et al., "Evolution of the Information-Retrieval System for Blind and Visually-Impaired People", International Journal of Speech Technology, Kluwer Academic Publishers, Bo, vol. 6, No. 3, pp. 301-309.

(Continued)

Primary Examiner — Khai N. Nguyen

(74) *Attorney, Agent, or Firm* — Dentons US LLP

(57) **ABSTRACT**

Disclosed are systems, methods, and non-transitory computer-readable storage media for utilizing a virtual assistant to assist a user with a communication session between the user and a third party service. A user can use a communication application to enter a message directed to the virtual assistant and request assistance to communicate with a 3rd party service. In response, the virtual assistant can access a set of communication instructions associated with the 3rd party service. The set of communication instructions can include a set of commands for communicating with the 3rd party service, services provided by the 3rd party service and data needed by the 3rd party service to facilitate communication. The virtual assistant can use the communication instructions to gather data needed by the 3rd party service, communicate with the 3rd party service and present the user with data received from the 3rd party service.

39 Claims, 24 Drawing Sheets

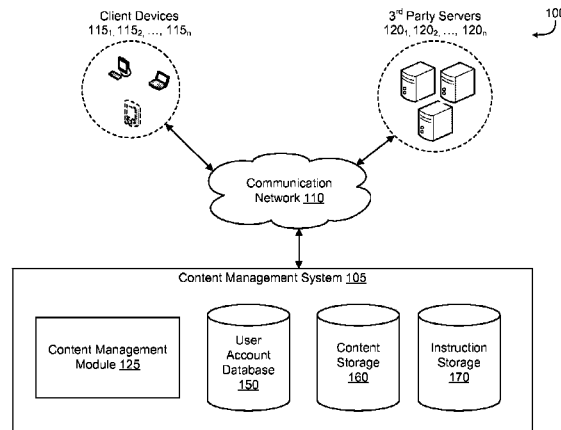

- (51) **Int. Cl.**
H04M 3/51 (2006.01)
H04L 12/58 (2006.01)
H04M 1/725 (2006.01)
H04L 29/06 (2006.01)
H04M 3/42 (2006.01)
- (52) **U.S. Cl.**
CPC **H04L 65/1069** (2013.01); **H04M 1/72552**
(2013.01); **H04M 3/42382** (2013.01); **H04M**
3/5166 (2013.01); **H04M 2203/256** (2013.01);
H04M 2250/74 (2013.01)
- (58) **Field of Classification Search**
CPC H04M 2203/256; H04M 2250/74; H04M
3/42382; H04M 3/5166; H04M 3/5183
USPC 379/210.01, 265.01, 265.02, 265.03,
379/265.04, 265.05, 265.06, 265.07,
379/265.08, 265.09, 265.1, 265.11,
379/265.12, 265.13, 265.14, 266.01,
379/266.02, 266.03, 266.04, 266.05,
379/266.06, 266.07, 266.08, 266.09,
379/266.1
See application file for complete search history.
- (56) **References Cited**
U.S. PATENT DOCUMENTS
- | | | | | | | | |
|-----------|---|--------|--------------------------|-----------|----|---------|--------------------|
| 6,016,471 | A | 1/2000 | Kuhn et al. | 6,076,088 | A | 6/2000 | Paik et al. |
| 6,017,219 | A | 1/2000 | Adams, Jr. et al. | 6,078,885 | A | 6/2000 | Beutnagel |
| 6,018,705 | A | 1/2000 | Gaudet | 6,078,914 | A | 6/2000 | Redfern |
| 6,018,711 | A | 1/2000 | French-St. George et al. | 6,081,750 | A | 6/2000 | Hoffberg et al. |
| 6,020,881 | A | 2/2000 | Naughton et al. | 6,081,774 | A | 6/2000 | de Hita et al. |
| 6,023,536 | A | 2/2000 | Visser | 6,081,780 | A | 6/2000 | Lumelsky |
| 6,023,676 | A | 2/2000 | Erell | 6,081,782 | A | 6/2000 | Rabin |
| 6,023,684 | A | 2/2000 | Pearson | 6,085,204 | A | 7/2000 | Chijiwa et al. |
| 6,024,288 | A | 2/2000 | Gottlich et al. | 6,088,671 | A | 7/2000 | Gould et al. |
| 6,026,345 | A | 2/2000 | Shah et al. | 6,088,731 | A | 7/2000 | Kiraly et al. |
| 6,026,375 | A | 2/2000 | Hall et al. | 6,092,036 | A | 7/2000 | Hamann et al. |
| 6,026,388 | A | 2/2000 | Liddy et al. | 6,092,038 | A | 7/2000 | Kanevsky et al. |
| 6,026,393 | A | 2/2000 | Gupta et al. | 6,092,043 | A | 7/2000 | Squires et al. |
| 6,029,132 | A | 2/2000 | Kuhn et al. | 6,094,649 | A | 7/2000 | Bowen et al. |
| 6,029,135 | A | 2/2000 | Krasle | 6,097,391 | A | 8/2000 | Wilcox |
| 6,035,267 | A | 3/2000 | Watanabe et al. | 6,101,468 | A | 8/2000 | Gould et al. |
| 6,035,303 | A | 3/2000 | Baer et al. | 6,101,470 | A | 8/2000 | Eide et al. |
| 6,035,336 | A | 3/2000 | Lu et al. | 6,105,865 | A | 8/2000 | Hardesty |
| 6,038,533 | A | 3/2000 | Buchsbaum et al. | 6,108,627 | A | 8/2000 | Sabourin |
| 6,040,824 | A | 3/2000 | Maekawa et al. | 6,108,640 | A | 8/2000 | Slotznick |
| 6,041,023 | A | 3/2000 | Lakhansingh | 6,111,562 | A | 8/2000 | Downs et al. |
| 6,047,255 | A | 4/2000 | Williamson | 6,111,572 | A | 8/2000 | Blair et al. |
| 6,047,300 | A | 4/2000 | Walfish et al. | 6,115,686 | A | 9/2000 | Chung et al. |
| 6,052,654 | A | 4/2000 | Gaudet et al. | 6,116,907 | A | 9/2000 | Baker et al. |
| 6,052,656 | A | 4/2000 | Suda et al. | 6,119,101 | A | 9/2000 | Peckover |
| 6,054,990 | A | 4/2000 | Tran | 6,121,960 | A | 9/2000 | Carroll et al. |
| 6,055,514 | A | 4/2000 | Wren | 6,122,340 | A | 9/2000 | Darley et al. |
| 6,055,531 | A | 4/2000 | Bennett et al. | 6,122,614 | A | 9/2000 | Kahn et al. |
| 6,061,646 | A | 5/2000 | Martino et al. | 6,122,616 | A | 9/2000 | Henton |
| 6,064,767 | A | 5/2000 | Muir et al. | 6,122,647 | A | 9/2000 | Horowitz et al. |
| 6,064,951 | A | 5/2000 | Park et al. | 6,125,284 | A | 9/2000 | Moore et al. |
| 6,064,959 | A | 5/2000 | Young et al. | 6,125,346 | A | 9/2000 | Nishimura et al. |
| 6,064,960 | A | 5/2000 | Bellegarda et al. | 6,125,356 | A | 9/2000 | Brockman et al. |
| 6,064,963 | A | 5/2000 | Gainsboro | 6,129,582 | A | 10/2000 | Wilhite et al. |
| 6,067,519 | A | 5/2000 | Lowry | 6,138,098 | A | 10/2000 | Shieber et al. |
| 6,067,520 | A | 5/2000 | Lee | 6,138,158 | A | 10/2000 | Boyle et al. |
| 6,069,648 | A | 5/2000 | Suso et al. | 6,141,642 | A | 10/2000 | Oh |
| 6,070,138 | A | 5/2000 | Iwata | 6,141,644 | A | 10/2000 | Kuhn et al. |
| 6,070,139 | A | 5/2000 | Miyazawa et al. | 6,144,377 | A | 11/2000 | Oppermann et al. |
| 6,070,140 | A | 5/2000 | Tran | 6,144,380 | A | 11/2000 | Shwartz et al. |
| 6,070,147 | A | 5/2000 | Harms et al. | 6,144,938 | A | 11/2000 | Surace et al. |
| 6,073,033 | A | 6/2000 | Campo | 6,144,939 | A | 11/2000 | Pearson et al. |
| 6,073,036 | A | 6/2000 | Heikkinen et al. | 6,151,401 | A | 11/2000 | Annaratone |
| 6,073,091 | A | 6/2000 | Kanevsky et al. | 6,151,574 | A | 11/2000 | Lee et al. |
| 6,073,097 | A | 6/2000 | Gould et al. | 6,154,551 | A | 11/2000 | Frenkel |
| 6,076,051 | A | 6/2000 | Messerly et al. | 6,154,720 | A | 11/2000 | Onishi et al. |
| 6,076,060 | A | 6/2000 | Lin et al. | 6,157,935 | A | 12/2000 | Tran et al. |
| | | | | 6,161,084 | A | 12/2000 | Messerly et al. |
| | | | | 6,161,087 | A | 12/2000 | Wightman et al. |
| | | | | 6,161,944 | A | 12/2000 | Leman |
| | | | | 6,163,769 | A | 12/2000 | Acerro et al. |
| | | | | 6,163,809 | A | 12/2000 | Buckley |
| | | | | 6,167,369 | A | 12/2000 | Schulze |
| | | | | 6,169,538 | B1 | 1/2001 | Nowlan et al. |
| | | | | 6,172,948 | B1 | 1/2001 | Keller et al. |
| | | | | 6,173,194 | B1 | 1/2001 | Vanttila |
| | | | | 6,173,251 | B1 | 1/2001 | Ito et al. |
| | | | | 6,173,261 | B1 | 1/2001 | Arai et al. |
| | | | | 6,173,263 | B1 | 1/2001 | Conkie |
| | | | | 6,173,279 | B1 | 1/2001 | Levin et al. |
| | | | | 6,177,905 | B1 | 1/2001 | Welch |
| | | | | 6,177,931 | B1 | 1/2001 | Alexander et al. |
| | | | | 6,179,432 | B1 | 1/2001 | Zhang et al. |
| | | | | 6,182,028 | B1 | 1/2001 | Karaali et al. |
| | | | | 6,182,099 | B1 | 1/2001 | Nakasato |
| | | | | 6,185,533 | B1 | 2/2001 | Holm et al. |
| | | | | 6,188,391 | B1 | 2/2001 | Seely et al. |
| | | | | 6,188,967 | B1 | 2/2001 | Kurtzberg et al. |
| | | | | 6,188,999 | B1 | 2/2001 | Moody |
| | | | | 6,191,939 | B1 | 2/2001 | Burnett |
| | | | | 6,192,253 | B1 | 2/2001 | Charlier et al. |
| | | | | 6,192,340 | B1 | 2/2001 | Abecassis |
| | | | | 6,195,641 | B1 | 2/2001 | Loring et al. |
| | | | | 6,199,076 | B1 | 3/2001 | Logan et al. |
| | | | | 6,205,456 | B1 | 3/2001 | Nakao |
| | | | | 6,208,044 | B1 | 3/2001 | Viswanadham et al. |
| | | | | 6,208,932 | B1 | 3/2001 | Ohmura et al. |
| | | | | 6,208,956 | B1 | 3/2001 | Motoyama |
| | | | | 6,208,964 | B1 | 3/2001 | Sabourin |

(56)

References Cited

U.S. PATENT DOCUMENTS

6,208,967	B1	3/2001	Pauws et al.	6,323,846	B1	11/2001	Westerman et al.
6,208,971	B1	3/2001	Bellegarda et al.	6,324,499	B1	11/2001	Lewis et al.
6,212,564	B1	4/2001	Harter et al.	6,324,502	B1	11/2001	Handel et al.
6,216,102	B1	4/2001	Martino et al.	6,324,512	B1	11/2001	Junqua et al.
6,216,131	B1	4/2001	Liu et al.	6,324,514	B2	11/2001	Matulich et al.
6,217,183	B1	4/2001	Shipman	6,330,538	B1	12/2001	Breen
6,219,641	B1	4/2001	Socaciu	6,330,539	B1	12/2001	Takayama et al.
6,222,347	B1	4/2001	Gong	6,331,867	B1	12/2001	Eberhard et al.
6,226,403	B1	5/2001	Parthasarathy	6,332,175	B1	12/2001	Birrell et al.
6,226,533	B1	5/2001	Akahane	6,334,103	B1	12/2001	Surace et al.
6,226,614	B1	5/2001	Mizuno et al.	6,335,722	B1	1/2002	Tani et al.
6,226,655	B1	5/2001	Borman et al.	6,336,365	B1	1/2002	Blackadar et al.
6,230,322	B1	5/2001	Saib et al.	6,336,727	B1	1/2002	Kim
6,232,539	B1	5/2001	Looney et al.	6,340,937	B1	1/2002	Stepita-Klauco
6,232,966	B1	5/2001	Kurlander	6,341,316	B1	1/2002	Kloba et al.
6,233,545	B1	5/2001	Datig	6,343,267	B1	1/2002	Kuhn et al.
6,233,547	B1	5/2001	Denber et al.	6,345,240	B1	2/2002	Havens
6,233,559	B1	5/2001	Balakrishnan, Sr.	6,345,250	B1	2/2002	Martin
6,233,578	B1	5/2001	Machihara et al.	6,347,296	B1	2/2002	Friedland
6,237,025	B1	5/2001	Ludwig et al.	6,347,315	B1	2/2002	Kiyoki et al.
6,240,303	B1	5/2001	Katzur	6,351,522	B1	2/2002	Vitikainen
6,243,681	B1	6/2001	Guji et al.	6,351,762	B1	2/2002	Ludwig et al.
6,246,981	B1	6/2001	Papineni et al.	6,353,442	B1	3/2002	Masui
6,248,946	B1	6/2001	Dwek	6,353,794	B1	3/2002	Davis et al.
6,249,606	B1	6/2001	Kiraly et al.	6,356,287	B1	3/2002	Ruberry et al.
6,259,436	B1	7/2001	Moon et al.	6,356,854	B1	3/2002	Schubert et al.
6,259,826	B1	7/2001	Pollard et al.	6,356,864	B1	3/2002	Foltz et al.
6,260,011	B1	7/2001	Heckerman et al.	6,356,905	B1	3/2002	Gershman et al.
6,260,013	B1	7/2001	Sejnoha	6,357,147	B1	3/2002	Darley et al.
6,260,016	B1	7/2001	Holm et al.	6,359,572	B1	3/2002	Vale
6,260,024	B1	7/2001	Shkedy	6,359,970	B1	3/2002	Burgess
6,266,098	B1	7/2001	Cove et al.	6,360,227	B1	3/2002	Aggarwal et al.
6,266,637	B1	7/2001	Donovan et al.	6,360,237	B1	3/2002	Schulz et al.
6,268,859	B1	7/2001	Andresen et al.	6,363,347	B1	3/2002	Rozak
6,269,712	B1	8/2001	Zentmyer	6,363,348	B1	3/2002	Besling et al.
6,271,835	B1	8/2001	Hoeksma	6,366,883	B1	4/2002	Campbell et al.
6,272,456	B1	8/2001	De Campos	6,366,884	B1	4/2002	Bellegarda et al.
6,272,464	B1	8/2001	Kiraz et al.	6,374,217	B1	4/2002	Bellegarda
6,275,795	B1	8/2001	Tzirkel-Hancock	6,374,226	B1	4/2002	Hunt et al.
6,275,824	B1	8/2001	O'Flaherty et al.	6,377,530	B1	4/2002	Burrows
6,278,443	B1	8/2001	Amro et al.	6,377,925	B1	4/2002	Greene, Jr. et al.
6,278,970	B1	8/2001	Milner	6,377,928	B1	4/2002	Saxena et al.
6,282,507	B1	8/2001	Horiguchi et al.	6,381,593	B1	4/2002	Yano et al.
6,282,511	B1	8/2001	Mayer	6,385,586	B1	5/2002	Dietz
6,285,785	B1	9/2001	Bellegarda et al.	6,385,662	B1	5/2002	Moon et al.
6,285,786	B1	9/2001	Seni et al.	6,389,114	B1	5/2002	Dowens et al.
6,289,085	B1	9/2001	Miyashita et al.	6,397,183	B1	5/2002	Baba et al.
6,289,124	B1	9/2001	Okamoto	6,397,186	B1	5/2002	Bush et al.
6,289,301	B1	9/2001	Higginbotham et al.	6,400,806	B1	6/2002	Uppaluru
6,289,353	B1	9/2001	Hazlehurst et al.	6,400,996	B1	6/2002	Hoffberg et al.
6,292,772	B1	9/2001	Kantrowitz	6,401,065	B1	6/2002	Kanevsky et al.
6,292,778	B1	9/2001	Sukkar	6,401,085	B1	6/2002	Gershman et al.
6,295,390	B1	9/2001	Kobayashi et al.	6,405,169	B1	6/2002	Kondo et al.
6,295,391	B1	9/2001	Rudd et al.	6,405,238	B1	6/2002	Votipka
6,295,541	B1	9/2001	Bodnar et al.	6,408,272	B1	6/2002	White et al.
6,297,818	B1	10/2001	Ulrich et al.	6,411,924	B1	6/2002	De Hita et al.
6,298,314	B1	10/2001	Blackadar et al.	6,411,932	B1	6/2002	Molnar et al.
6,298,321	B1	10/2001	Karlov et al.	6,415,250	B1	7/2002	Van Den Akker
6,300,947	B1	10/2001	Kanevsky	6,417,873	B1	7/2002	Fletcher et al.
6,304,844	B1	10/2001	Pan et al.	6,418,431	B1	7/2002	Mahajan et al.
6,304,846	B1	10/2001	George et al.	6,421,305	B1	7/2002	Gioscia et al.
6,307,548	B1	10/2001	Flinchem et al.	6,421,672	B1	7/2002	McAllister et al.
6,308,149	B1	10/2001	Gaussier et al.	6,421,707	B1	7/2002	Miller et al.
6,310,610	B1	10/2001	Beaton et al.	6,424,944	B1	7/2002	Hikawa
6,311,152	B1	10/2001	Bai et al.	6,430,531	B1	8/2002	Polish
6,311,157	B1	10/2001	Strong	6,430,551	B1	8/2002	Thelen et al.
6,311,189	B1	10/2001	deVries et al.	6,434,522	B1	8/2002	Tsuboka
6,314,397	B1	11/2001	Lewis et al.	6,434,524	B1	8/2002	Weber
6,317,237	B1	11/2001	Nakao et al.	6,434,529	B1	8/2002	Walker et al.
6,317,594	B1	11/2001	Gossman et al.	6,434,604	B1	8/2002	Harada et al.
6,317,707	B1	11/2001	Bangalore et al.	6,437,818	B1	8/2002	Ludwig et al.
6,317,831	B1	11/2001	King	6,438,523	B1	8/2002	Oberteuffer et al.
6,321,092	B1	11/2001	Fitch et al.	6,442,518	B1	8/2002	Van Thong et al.
6,321,179	B1	11/2001	Glance et al.	6,442,523	B1	8/2002	Siegel
6,321,196	B1	11/2001	Franceschi	6,446,076	B1	9/2002	Burkey et al.
				6,448,485	B1	9/2002	Barile
				6,448,986	B1	9/2002	Smith
				6,449,620	B1	9/2002	Draper et al.
				6,453,281	B1	9/2002	Walters et al.

(56)

References Cited

U.S. PATENT DOCUMENTS

6,453,292 B2	9/2002	Ramaswamy et al.	6,556,971 B1	4/2003	Rigsby et al.
6,453,312 B1	9/2002	Goiffon et al.	6,556,983 B1	4/2003	Altschuler et al.
6,453,315 B1	9/2002	Weissman et al.	6,560,903 B1	5/2003	Darley
6,456,616 B1	9/2002	Rantanen	6,563,769 B1	5/2003	Van Der Meulen
6,456,972 B1	9/2002	Gladstein et al.	6,564,186 B1	5/2003	Kiraly et al.
6,460,015 B1	10/2002	Hetherington et al.	6,567,549 B1	5/2003	Marianetti et al.
6,460,029 B1	10/2002	Fries et al.	6,570,557 B1	5/2003	Westerman et al.
6,462,778 B1	10/2002	Abram et al.	6,570,596 B2	5/2003	Frederiksen
6,463,128 B1	10/2002	Elwin	6,582,342 B2	6/2003	Kaufman
6,463,413 B1	10/2002	Applebaum et al.	6,583,806 B2	6/2003	Ludwig et al.
6,466,654 B1*	10/2002	Cooper	6,584,464 B1	6/2003	Warthen
			6,587,403 B1	7/2003	Keller et al.
			6,587,404 B1	7/2003	Keller et al.
			6,590,303 B1	7/2003	Austin et al.
			6,591,379 B1	7/2003	LeVine et al.
			6,594,673 B1	7/2003	Smith et al.
			6,594,688 B2	7/2003	Ludwig et al.
6,467,924 B2	10/2002	Shipman	6,597,345 B2	7/2003	Hirshberg
6,469,712 B1	10/2002	Hilpert, Jr. et al.	6,598,021 B1	7/2003	Shambaugh et al.
6,469,722 B1	10/2002	Kinoe et al.	6,598,022 B2	7/2003	Yuschik
6,469,732 B1	10/2002	Chang et al.	6,598,039 B1	7/2003	Livowsky
6,470,347 B1	10/2002	Gillam	6,598,054 B2	7/2003	Schuetze et al.
6,473,630 B1	10/2002	Baranowski et al.	6,601,026 B2	7/2003	Appelt et al.
6,473,754 B1	10/2002	Matsubayashi et al.	6,601,234 B1	7/2003	Bowman-Amuah
6,477,488 B1	11/2002	Bellegarda	6,603,837 B1	8/2003	Kesanupalli et al.
6,477,494 B2	11/2002	Hyde-Thomson et al.	6,604,059 B2	8/2003	Strubbe et al.
6,487,533 B2	11/2002	Hyde-Thomson et al.	6,606,101 B1	8/2003	Malamud et al.
6,487,534 B1	11/2002	Thelen et al.	6,606,388 B1	8/2003	Townsend et al.
6,487,663 B1	11/2002	Jaisimha et al.	6,606,632 B1	8/2003	Saulpaugh et al.
6,489,951 B1	12/2002	Wong et al.	6,611,789 B1	8/2003	Darley
6,490,547 B1	12/2002	Atkin et al.	6,615,172 B1	9/2003	Bennett et al.
6,490,560 B1	12/2002	Ramaswamy et al.	6,615,175 B1	9/2003	Gazdzinski
6,493,006 B1	12/2002	Gourdol et al.	6,615,176 B2	9/2003	Lewis et al.
6,493,428 B1	12/2002	Hillier	6,615,220 B1	9/2003	Austin et al.
6,493,652 B1	12/2002	Ohlenbusch et al.	6,621,768 B1	9/2003	Keller et al.
6,493,667 B1	12/2002	De Souza et al.	6,621,892 B1	9/2003	Banister et al.
6,499,013 B1	12/2002	Weber	6,622,121 B1	9/2003	Crepuy et al.
6,499,014 B1	12/2002	Chihara	6,622,136 B2	9/2003	Russell
6,499,016 B1	12/2002	Anderson et al.	6,622,148 B1	9/2003	Noble et al.
6,501,937 B1	12/2002	Ho et al.	6,623,529 B1	9/2003	Lakritz
6,502,022 B1	12/2002	Chastain et al.	6,625,583 B1	9/2003	Silverman et al.
6,502,194 B1	12/2002	Berman et al.	6,628,808 B1	9/2003	Bach et al.
6,504,990 B1	1/2003	Abecassis	6,631,186 B1	10/2003	Adams et al.
6,505,155 B1	1/2003	Vanbuskirk et al.	6,631,346 B1	10/2003	Karaorman et al.
6,505,158 B1	1/2003	Conkie	6,633,741 B1	10/2003	Posa et al.
6,505,175 B1	1/2003	Silverman et al.	6,633,846 B1	10/2003	Bennett et al.
6,505,183 B1	1/2003	Loofbourrow et al.	6,633,932 B1	10/2003	Bork et al.
6,507,829 B1	1/2003	Richards et al.	6,640,098 B1	10/2003	Roundtree
6,510,406 B1	1/2003	Marchisio	6,642,940 B1	11/2003	Dakss et al.
6,510,412 B1	1/2003	Sasai et al.	6,643,401 B1	11/2003	Kashioka et al.
6,510,417 B1	1/2003	Woods et al.	6,643,824 B1	11/2003	Bates et al.
6,513,006 B2	1/2003	Howard et al.	6,647,260 B2	11/2003	Dusse et al.
6,513,008 B2	1/2003	Pearson et al.	6,650,735 B2	11/2003	Burton et al.
6,513,063 B1	1/2003	Julia et al.	6,651,042 B1	11/2003	Field et al.
6,519,565 B1	2/2003	Clements et al.	6,651,218 B1	11/2003	Adler et al.
6,519,566 B1	2/2003	Boyer et al.	6,654,740 B2	11/2003	Tokuda et al.
6,523,026 B1	2/2003	Gillis	6,658,389 B1	12/2003	Alpdemir
6,523,061 B1	2/2003	Halverson et al.	6,658,408 B2	12/2003	Yano et al.
6,523,172 B1	2/2003	Martinez-Guerra et al.	6,658,577 B2	12/2003	Huppi et al.
6,526,351 B2	2/2003	Whitham	6,661,438 B1	12/2003	Shiraishi et al.
6,526,382 B1	2/2003	Yuschik	6,662,023 B1	12/2003	Helle
6,526,395 B1	2/2003	Morris	6,665,639 B2	12/2003	Mozer et al.
6,529,592 B1	3/2003	Khan	6,665,640 B1	12/2003	Bennett et al.
6,529,608 B2	3/2003	Gersabeck et al.	6,665,641 B1	12/2003	Coorman et al.
6,532,444 B1	3/2003	Weber	6,671,672 B1	12/2003	Heck
6,532,446 B1	3/2003	King	6,671,683 B2	12/2003	Kanno
6,535,610 B1	3/2003	Stewart	6,671,856 B1	12/2003	Gillam
6,535,852 B2	3/2003	Eide	6,675,169 B1	1/2004	Bennett et al.
6,535,983 B1	3/2003	McCormack et al.	6,675,233 B1	1/2004	Du et al.
6,536,139 B2	3/2003	Darley et al.	6,677,932 B1	1/2004	Westerman
6,538,665 B2	3/2003	Crow et al.	6,680,675 B1	1/2004	Suzuki
6,542,171 B1	4/2003	Satou et al.	6,684,187 B1	1/2004	Conkie
6,542,584 B1	4/2003	Sherwood et al.	6,684,376 B1	1/2004	Kerzman et al.
6,542,868 B1	4/2003	Badt et al.	6,690,387 B2	2/2004	Zimmerman et al.
6,546,262 B1	4/2003	Freadman	6,690,800 B2	2/2004	Resnick
6,546,367 B2	4/2003	Otsuka	6,690,828 B2	2/2004	Meyers
6,546,388 B1	4/2003	Edlund et al.	6,690,956 B2	2/2004	Chua et al.
6,549,497 B2	4/2003	Miyamoto et al.	6,691,064 B2	2/2004	Vroman
6,553,343 B1	4/2003	Kagoshima et al.	6,691,090 B1	2/2004	Laurila et al.
6,553,344 B2	4/2003	Bellegarda et al.			

G10L 13/00
379/88.01

(56)

References Cited

U.S. PATENT DOCUMENTS

6,691,111	B2	2/2004	Lazaridis et al.	6,792,083	B2	9/2004	Dams et al.
6,691,151	B1	2/2004	Cheyser et al.	6,792,086	B1	9/2004	Saylor et al.
6,694,295	B2	2/2004	Lindholm et al.	6,792,407	B2	9/2004	Kibre et al.
6,694,297	B2	2/2004	Sato	6,794,566	B2	9/2004	Pachet
6,697,780	B1	2/2004	Beutnagel et al.	6,795,059	B2	9/2004	Endo
6,697,824	B1	2/2004	Bowman-Amuah	6,795,808	B1	9/2004	Strubbe et al.
6,701,294	B1	3/2004	Ball et al.	6,799,162	B1	9/2004	Goronzy et al.
6,701,305	B1	3/2004	Holt et al.	6,799,226	B1	9/2004	Robbin et al.
6,701,318	B2	3/2004	Fox et al.	6,801,604	B2	10/2004	Maes et al.
6,704,015	B1	3/2004	Bovarnick et al.	6,801,964	B1	10/2004	Mahdavi
6,704,034	B1	3/2004	Rodriguez et al.	6,803,905	B1	10/2004	Capps et al.
6,704,698	B1	3/2004	Paulsen, Jr. et al.	6,804,649	B2	10/2004	Miranda
6,704,710	B2	3/2004	Strong	6,804,677	B2	10/2004	Shadmon et al.
6,708,153	B2	3/2004	Brittan et al.	6,807,536	B2	10/2004	Achlioptas et al.
6,711,585	B1	3/2004	Copperman et al.	6,807,574	B1	10/2004	Partovi et al.
6,714,221	B1	3/2004	Christie et al.	6,809,724	B1	10/2004	Shiraishi et al.
6,716,139	B1	4/2004	Hosseinzadeh-Dolkhani et al.	6,810,379	B1	10/2004	Vermeulen et al.
6,718,324	B2	4/2004	Edlund et al.	6,813,218	B1	11/2004	Antonelli et al.
6,718,331	B2	4/2004	Davis et al.	6,813,491	B1	11/2004	McKinney
6,720,980	B1	4/2004	Lui et al.	6,813,607	B1	11/2004	Faruque et al.
6,721,706	B1	4/2004	Strubbe et al.	6,816,578	B1	11/2004	Kredo et al.
6,721,728	B2	4/2004	McGreevy	6,820,055	B2	11/2004	Saindon et al.
6,721,734	B1	4/2004	Subasic et al.	6,829,018	B2	12/2004	Lin et al.
6,724,370	B2	4/2004	Dutta et al.	6,829,603	B1	12/2004	Chai et al.
6,725,197	B1	4/2004	Wuppermann et al.	6,832,194	B1	12/2004	Mozer et al.
6,728,675	B1	4/2004	Maddalozzo, Jr. et al.	6,832,381	B1	12/2004	Mathur et al.
6,728,679	B1	4/2004	Strubbe et al.	6,836,537	B1	12/2004	Zirngibl et al.
6,728,681	B2	4/2004	Whitham	6,836,651	B2	12/2004	Segal et al.
6,728,729	B1	4/2004	Jawa et al.	6,836,760	B1	12/2004	Bellegarda et al.
6,731,307	B1	5/2004	Strubbe et al.	6,839,464	B2	1/2005	Hawkins et al.
6,731,312	B2	5/2004	Robbin	6,839,667	B2	1/2005	Reich
6,732,142	B1	5/2004	Bates et al.	6,839,669	B1	1/2005	Gould et al.
6,735,562	B1	5/2004	Zhang et al.	6,839,670	B1	1/2005	Stammler et al.
6,735,632	B1	5/2004	Kiraly et al.	6,839,742	B1	1/2005	Dyer et al.
6,738,738	B2	5/2004	Henton	6,842,767	B1	1/2005	Partovi et al.
6,738,742	B2	5/2004	Badt et al.	6,847,966	B1	1/2005	Sommer et al.
6,741,264	B1	5/2004	Lesser	6,847,979	B2	1/2005	Allemang et al.
6,742,021	B1	5/2004	Halverson et al.	6,850,775	B1	2/2005	Berg
6,751,592	B1	6/2004	Shiga	6,850,887	B2	2/2005	Epstein et al.
6,751,595	B2	6/2004	Busayapongchai et al.	6,851,115	B1	2/2005	Cheyser et al.
6,751,621	B1	6/2004	Calistri-Yeh et al.	6,856,259	B1	2/2005	Sharp
6,754,504	B1	6/2004	Reed	6,857,800	B2	2/2005	Zhang et al.
6,757,362	B1	6/2004	Cooper et al.	6,859,931	B1	2/2005	Cheyser et al.
6,757,365	B1	6/2004	Bogard	6,862,568	B2	3/2005	Case
6,757,646	B2	6/2004	Marchisio	6,862,710	B1	3/2005	Marchisio
6,757,653	B2	6/2004	Buth et al.	6,862,713	B1	3/2005	Kraft et al.
6,757,718	B1	6/2004	Halverson et al.	6,865,533	B2	3/2005	Addison et al.
6,760,412	B1	7/2004	Loucks	6,868,045	B1	3/2005	Schroder
6,760,700	B2	7/2004	Lewis et al.	6,868,385	B1	3/2005	Gerson
6,760,754	B1	7/2004	Isaacs et al.	6,870,529	B1	3/2005	Davis
6,762,741	B2	7/2004	Weindorf	6,871,346	B1	3/2005	Kumbalimutt et al.
6,762,777	B2	7/2004	Carroll	6,873,953	B1	3/2005	Lennig
6,763,089	B2	7/2004	Feigenbaum	6,873,986	B2	3/2005	McConnell et al.
6,766,294	B2	7/2004	MacGinite et al.	6,876,947	B1	4/2005	Darley et al.
6,766,295	B1	7/2004	Murveit et al.	6,877,003	B2	4/2005	Ho et al.
6,766,320	B1	7/2004	Wang et al.	6,879,957	B1	4/2005	Pechter et al.
6,766,324	B2	7/2004	Carlson et al.	6,882,335	B2	4/2005	Saarin
6,768,979	B1	7/2004	Menendez-Pidal et al.	6,882,337	B2	4/2005	Shetter
6,771,982	B1	8/2004	Toupin	6,882,747	B2	4/2005	Thawonmas et al.
6,772,123	B2	8/2004	Cooklev et al.	6,882,955	B1	4/2005	Ohlenbusch et al.
6,772,195	B1	8/2004	Hatlelid et al.	6,882,971	B2	4/2005	Craner
6,772,394	B1	8/2004	Kamada	6,885,734	B1	4/2005	Eberle et al.
6,775,358	B1	8/2004	Breitenbach et al.	6,889,361	B1	5/2005	Bates et al.
6,778,951	B1	8/2004	Contractor	6,895,084	B1	5/2005	Saylor et al.
6,778,952	B2	8/2004	Bellegarda	6,895,257	B2	5/2005	Boman et al.
6,778,962	B1	8/2004	Kasai et al.	6,895,380	B2	5/2005	Sepe, Jr.
6,778,970	B2	8/2004	Au	6,895,558	B1	5/2005	Loveland
6,778,979	B2	8/2004	Grefenstette et al.	6,898,550	B1	5/2005	Blackadar et al.
6,782,510	B1	8/2004	Gross et al.	6,901,364	B2	5/2005	Nguyen et al.
6,784,901	B1	8/2004	Harvey et al.	6,901,399	B1	5/2005	Corston et al.
6,785,869	B1	8/2004	Berstis	6,904,405	B2	6/2005	Suominen
6,789,094	B2	9/2004	Rudoff et al.	6,907,112	B1	6/2005	Guedalia et al.
6,789,231	B1	9/2004	Reynar et al.	6,907,140	B2	6/2005	Matsugu et al.
6,790,704	B2	9/2004	Doyle et al.	6,910,004	B2	6/2005	Tarbouriech et al.
6,792,082	B1	9/2004	Levine	6,910,007	B2	6/2005	Stylianou et al.
				6,910,012	B2	6/2005	Hartley et al.
				6,910,186	B2	6/2005	Kim
				6,911,971	B2	6/2005	Suzuki et al.
				6,912,407	B1	6/2005	Clarke et al.

(56)

References Cited

U.S. PATENT DOCUMENTS

6,912,498	B2	6/2005	Stevens et al.	7,007,026	B2	2/2006	Wilkinson et al.
6,912,499	B1	6/2005	Sabourin et al.	7,007,239	B1	2/2006	Hawkins et al.
6,915,138	B2	7/2005	Kraft	7,010,581	B2	3/2006	Brown et al.
6,915,246	B2	7/2005	Gusler et al.	7,013,289	B2	3/2006	Horn et al.
6,915,294	B1	7/2005	Singh et al.	7,013,308	B1	3/2006	Tunstall-Pedoe
6,917,373	B2	7/2005	Vong et al.	7,013,429	B2	3/2006	Fujimoto et al.
6,918,677	B2	7/2005	Shipman	7,015,894	B2	3/2006	Morohoshi
6,924,828	B1	8/2005	Hirsch	7,020,685	B1	3/2006	Chen et al.
6,925,438	B2	8/2005	Mohamed et al.	7,023,979	B1	4/2006	Wu et al.
6,928,149	B1	8/2005	Panjwani et al.	7,024,363	B1	4/2006	Comerford et al.
6,928,614	B1	8/2005	Everhart	7,024,364	B2	4/2006	Guerra et al.
6,931,255	B2	8/2005	Mekuria	7,024,366	B1	4/2006	Deyoe et al.
6,931,384	B1	8/2005	Horvitz et al.	7,024,460	B2	4/2006	Koopmas et al.
6,932,708	B2	8/2005	Yamashita et al.	7,027,568	B1	4/2006	Simpson et al.
6,933,928	B1	8/2005	Lilienthal et al.	7,027,974	B1	4/2006	Busch et al.
6,934,394	B1	8/2005	Anderson	7,027,990	B2	4/2006	Sussman
6,934,684	B2	8/2005	Alpdemir et al.	7,028,252	B1	4/2006	Baru et al.
6,934,756	B2	8/2005	Maes	7,030,861	B1	4/2006	Westerman et al.
6,934,812	B1	8/2005	Robbin et al.	7,031,530	B2	4/2006	Driggs et al.
6,937,975	B1	8/2005	Elworthy	7,031,909	B2	4/2006	Mao et al.
6,937,986	B2	8/2005	Denenberg et al.	7,035,794	B2	4/2006	Sirivara
6,944,593	B2	9/2005	Kuzunuki et al.	7,035,801	B2	4/2006	Jimenez-Feltstrom
6,944,846	B2	9/2005	Ryzhov	7,035,807	B1	4/2006	Brittain et al.
6,948,094	B2	9/2005	Schultz et al.	7,036,128	B1	4/2006	Julia et al.
6,950,087	B2	9/2005	Knox et al.	7,036,681	B2	5/2006	Suda et al.
6,950,502	B1	9/2005	Jenkins	7,038,659	B2	5/2006	Rajkowski
6,952,799	B2	10/2005	Edwards et al.	7,039,588	B2	5/2006	Okutani et al.
6,954,755	B2	10/2005	Reisman	7,043,420	B2	5/2006	Ratnaparkhi
6,954,899	B1	10/2005	Anderson	7,043,422	B2	5/2006	Gao et al.
6,956,845	B2	10/2005	Baker et al.	7,046,230	B2	5/2006	Zadesky et al.
6,957,076	B2	10/2005	Hunzinger	7,046,850	B2	5/2006	Braspenning et al.
6,957,183	B2	10/2005	Malayath et al.	7,047,193	B1	5/2006	Bellegarda
6,960,734	B1	11/2005	Park	7,050,550	B2	5/2006	Steinbiss et al.
6,961,699	B1	11/2005	Kahn et al.	7,050,796	B2	5/2006	Humphrey et al.
6,961,704	B1	11/2005	Phillips et al.	7,050,976	B1	5/2006	Packingham
6,961,912	B2	11/2005	Aoki et al.	7,050,977	B1	5/2006	Bennett
6,963,759	B1	11/2005	Gerson	7,051,096	B1	5/2006	Krawiec et al.
6,963,841	B2	11/2005	Handal et al.	7,054,419	B2	5/2006	Culliss
6,964,023	B2	11/2005	Maes et al.	7,054,888	B2	5/2006	LaChapelle et al.
6,965,376	B2	11/2005	Tani et al.	7,057,607	B2	6/2006	Mayoraz et al.
6,965,863	B1	11/2005	Zuberec et al.	7,058,569	B2	6/2006	Coorman et al.
6,968,311	B2	11/2005	Knockeart et al.	7,058,888	B1	6/2006	Gjerstad et al.
6,970,820	B2	11/2005	Junqua et al.	7,058,889	B2	6/2006	Trovato et al.
6,970,881	B1	11/2005	Mohan et al.	7,062,223	B2	6/2006	Gerber et al.
6,970,915	B1	11/2005	Partovi et al.	7,062,225	B2	6/2006	White
6,970,935	B1	11/2005	Maes	7,062,428	B2	6/2006	Hogenhout et al.
6,975,986	B2	12/2005	Hartley et al.	7,062,438	B2	6/2006	Kobayashi et al.
6,976,090	B2	12/2005	Ben-Shaul et al.	7,065,185	B1	6/2006	Koch
6,978,127	B1	12/2005	Bulthuis et al.	7,065,485	B1	6/2006	Chong-White et al.
6,978,239	B2	12/2005	Chu et al.	7,069,213	B2	6/2006	Thompson
6,980,949	B2	12/2005	Ford	7,069,220	B2	6/2006	Coffman et al.
6,980,953	B1	12/2005	Kanevsky et al.	7,069,560	B1	6/2006	Cheyet et al.
6,980,955	B2	12/2005	Okutani et al.	7,072,686	B1	7/2006	Schrager
6,983,251	B1	1/2006	Umemoto et al.	7,072,941	B2	7/2006	Griffin et al.
6,985,858	B2	1/2006	Frey et al.	7,076,527	B2	7/2006	Bellegarda et al.
6,985,865	B1	1/2006	Packingham et al.	7,079,713	B2	7/2006	Simmons
6,985,958	B2	1/2006	Zwiegincew et al.	7,082,322	B2	7/2006	Harano
6,988,063	B2	1/2006	Tokuda et al.	7,084,758	B1	8/2006	Cole
6,988,071	B1	1/2006	Gazdzinski	7,084,856	B2	8/2006	Huppi
6,990,450	B2	1/2006	Case et al.	7,085,716	B1	8/2006	Even et al.
6,996,520	B2	2/2006	Levin	7,085,723	B2	8/2006	Ross et al.
6,996,531	B2	2/2006	Korall et al.	7,085,960	B2	8/2006	Bouat et al.
6,996,575	B2	2/2006	Cox et al.	7,088,345	B2	8/2006	Robinson et al.
6,999,066	B2	2/2006	Litwiller	7,088,853	B2	8/2006	Hiroe et al.
6,999,914	B1	2/2006	Boerner et al.	7,089,292	B1	8/2006	Roderick et al.
6,999,925	B2	2/2006	Fischer et al.	7,092,370	B2	8/2006	Jiang et al.
6,999,927	B2	2/2006	Mozer et al.	7,092,887	B2	8/2006	Mozer et al.
7,000,189	B2	2/2006	Dutta et al.	7,092,928	B1	8/2006	Elad et al.
7,002,556	B2	2/2006	Tsukada et al.	7,092,950	B2	8/2006	Wong et al.
7,003,099	B1	2/2006	Zhang et al.	7,093,693	B1	8/2006	Gazdzinski
7,003,457	B2	2/2006	Halonon et al.	7,095,733	B1	8/2006	Yarlagadda et al.
7,003,463	B1	2/2006	Maes et al.	7,096,183	B2	8/2006	Junqua
7,003,522	B1	2/2006	Reynar et al.	7,100,117	B1	8/2006	Chwa et al.
7,006,969	B2	2/2006	Atal	7,103,548	B2	9/2006	Squibbs et al.
7,006,973	B1	2/2006	Genly et al.	7,107,204	B1	9/2006	Liu et al.
				7,110,938	B1	9/2006	Cheng et al.
				7,110,998	B1	9/2006	Bhandari et al.
				7,111,248	B2	9/2006	Mulvey et al.
				7,111,774	B2	9/2006	Song

(56)

References Cited

U.S. PATENT DOCUMENTS

7,112,827	B2	9/2006	Hayakawa et al.	7,212,827	B1	5/2007	Veschi
7,113,803	B2	9/2006	Dehlin	7,216,008	B2	5/2007	Sakata
7,113,943	B2	9/2006	Bradford et al.	7,216,066	B2	5/2007	Di et al.
7,115,035	B2	10/2006	Tanaka	7,216,073	B2	5/2007	Lavi et al.
7,117,231	B2	10/2006	Fischer et al.	7,216,079	B1	5/2007	Barnard et al.
7,120,586	B2	10/2006	Loui et al.	7,216,080	B2	5/2007	Tsiao et al.
7,120,865	B1	10/2006	Horvitz et al.	7,218,920	B2	5/2007	Hyon
7,123,696	B2	10/2006	Lowe	7,218,943	B2	5/2007	Klassen et al.
7,124,081	B1	10/2006	Bellegarda	7,219,063	B2	5/2007	Schalk et al.
7,124,082	B2	10/2006	Freedman	7,219,123	B1	5/2007	Fiechter et al.
7,124,164	B1	10/2006	Chemtob	7,225,125	B2	5/2007	Bennett et al.
7,124,300	B1	10/2006	Lemke	7,228,278	B2	6/2007	Nguyen et al.
7,127,046	B1	10/2006	Smith et al.	7,231,343	B1	6/2007	Treadgold et al.
7,127,394	B2	10/2006	Strong et al.	7,231,597	B1	6/2007	Braun et al.
7,127,396	B2	10/2006	Chu et al.	7,233,790	B2	6/2007	Kjellberg et al.
7,127,403	B1	10/2006	Saylor et al.	7,233,904	B2	6/2007	Luisi
7,129,932	B1	10/2006	Klarlund et al.	7,234,026	B2	6/2007	Robbin et al.
7,133,900	B1	11/2006	Szeto	7,236,932	B1	6/2007	Grajski
7,136,710	B1	11/2006	Hoffberg et al.	7,240,002	B2	7/2007	Minamino et al.
7,136,818	B1	11/2006	Cosatto et al.	7,243,130	B2	7/2007	Horvitz et al.
7,137,126	B1	11/2006	Coffman et al.	7,243,305	B2	7/2007	Schabes et al.
7,139,697	B2	11/2006	Häkkinen et al.	7,246,118	B2	7/2007	Chastain et al.
7,139,714	B2	11/2006	Bennett et al.	7,246,151	B2	7/2007	Isaacs et al.
7,139,722	B2	11/2006	Perrella et al.	7,248,900	B2	7/2007	Deeds et al.
7,143,028	B2	11/2006	Hillis et al.	7,251,313	B1	7/2007	Miller et al.
7,143,037	B1	11/2006	Chestnut	7,251,454	B2	7/2007	White
7,143,038	B2	11/2006	Katae	7,254,773	B2	8/2007	Bates et al.
7,143,040	B2	11/2006	Durston et al.	7,257,537	B2	8/2007	Ross et al.
7,146,319	B2	12/2006	Hunt	7,259,752	B1	8/2007	Simmons
7,146,437	B2	12/2006	Robbin et al.	7,260,529	B1	8/2007	Lengen
7,149,319	B2	12/2006	Roeck	7,260,567	B2	8/2007	Parikh et al.
7,149,695	B1	12/2006	Bellegarda	7,263,373	B2	8/2007	Mattisson
7,149,964	B1	12/2006	Cottrille et al.	7,266,189	B1	9/2007	Day
7,152,070	B1	12/2006	Musick et al.	7,266,495	B1	9/2007	Beaufays et al.
7,152,093	B2	12/2006	Ludwig et al.	7,266,496	B2	9/2007	Wang et al.
7,154,526	B2	12/2006	Foote et al.	7,266,499	B2	9/2007	Surace et al.
7,155,668	B2	12/2006	Holland et al.	7,269,544	B2	9/2007	Simske
7,158,647	B2	1/2007	Azima et al.	7,269,556	B2	9/2007	Kiss et al.
7,159,174	B2	1/2007	Johnson et al.	7,272,224	B1	9/2007	Normile et al.
7,162,412	B2	1/2007	Yamada et al.	7,275,063	B2	9/2007	Horn
7,162,482	B1	1/2007	Dunning	7,277,088	B2	10/2007	Robinson et al.
7,165,073	B2	1/2007	Vandersluis	7,277,854	B2	10/2007	Bennett et al.
7,166,791	B2	1/2007	Robbin et al.	7,277,855	B1	10/2007	Acker et al.
7,171,350	B2	1/2007	Lin et al.	7,280,958	B2	10/2007	Pavlov et al.
7,171,360	B2	1/2007	Huang et al.	7,283,072	B1	10/2007	Plachta et al.
7,174,042	B1	2/2007	Simmons et al.	7,283,992	B2	10/2007	Liu et al.
7,174,295	B1	2/2007	Kivimaki	7,289,102	B2	10/2007	Hinckley et al.
7,174,297	B2	2/2007	Guerra et al.	7,290,039	B1	10/2007	Lisitsa et al.
7,174,298	B2	2/2007	Sharma	7,292,579	B2	11/2007	Morris
7,177,794	B2	2/2007	Mani et al.	7,292,979	B2	11/2007	Karas et al.
7,177,798	B2	2/2007	Hsu et al.	7,292,980	B1	11/2007	August et al.
7,177,817	B1	2/2007	Khosla et al.	7,296,019	B1	11/2007	Chandrasekar et al.
7,181,386	B2	2/2007	Mohri et al.	7,296,230	B2	11/2007	Fukatsu et al.
7,181,388	B2	2/2007	Tian	7,299,033	B2	11/2007	Kjellberg et al.
7,184,064	B2	2/2007	Zimmerman et al.	7,302,392	B1	11/2007	Thenthiruperai et al.
7,185,276	B2	2/2007	Keswa	7,302,394	B1	11/2007	Baray et al.
7,188,085	B2	3/2007	Pelletier	7,302,686	B2	11/2007	Togawa
7,190,351	B1	3/2007	Goren	7,308,404	B2	12/2007	Venkataraman et al.
7,190,794	B2	3/2007	Hinde	7,308,408	B1	12/2007	Stifelman et al.
7,191,118	B2	3/2007	Bellegarda	7,310,329	B2	12/2007	Vieri et al.
7,191,131	B1	3/2007	Nagao	7,310,600	B1	12/2007	Garner et al.
7,193,615	B2	3/2007	Kim et al.	7,310,605	B2	12/2007	Janakiraman et al.
7,194,186	B1	3/2007	Strub et al.	7,313,514	B2	12/2007	Rose et al.
7,194,413	B2	3/2007	Mahoney et al.	7,313,523	B1	12/2007	Bellegarda et al.
7,194,471	B1	3/2007	Nagatsuka et al.	7,315,809	B2	1/2008	Xun
7,194,611	B2	3/2007	Bear et al.	7,315,818	B2	1/2008	Stevens et al.
7,194,699	B2	3/2007	Thomson et al.	7,318,020	B1	1/2008	Kim
7,197,120	B2	3/2007	Luehrig et al.	7,319,957	B2	1/2008	Robinson et al.
7,197,460	B1	3/2007	Gupta et al.	7,321,783	B2	1/2008	Kim
7,200,550	B2	4/2007	Menezes et al.	7,322,023	B2	1/2008	Shulman et al.
7,200,558	B2	4/2007	Kato et al.	7,324,833	B2	1/2008	White et al.
7,200,559	B2	4/2007	Wang	7,324,947	B2	1/2008	Jordan et al.
7,203,297	B2	4/2007	Vitikainen et al.	7,328,155	B2	2/2008	Endo et al.
7,203,646	B2	4/2007	Bennett	7,328,250	B2	2/2008	Wang et al.
7,206,809	B2	4/2007	Ludwig et al.	7,333,998	B2	2/2008	Heckerman et al.
				7,345,670	B2	3/2008	Armstrong
				7,345,671	B2	3/2008	Robbin et al.
				7,349,953	B2	3/2008	Lisitsa et al.
				7,353,139	B1	4/2008	Burrell et al.

(56)

References Cited

U.S. PATENT DOCUMENTS

7,359,493	B1	4/2008	Wang et al.	7,487,089	B2	2/2009	Mozer
7,359,671	B2	4/2008	Richenstein et al.	7,487,093	B2	2/2009	Mutsuno et al.
7,359,851	B2	4/2008	Tong et al.	7,490,034	B2	2/2009	Finnigan et al.
7,360,158	B1	4/2008	Beeman	7,490,039	B1	2/2009	Shaffer et al.
7,362,738	B2	4/2008	Taube et al.	7,493,251	B2	2/2009	Gao et al.
7,363,227	B2	4/2008	Mapes-Riordan et al.	7,493,560	B1	2/2009	Kipnes et al.
7,363,586	B1	4/2008	Briggs et al.	7,496,498	B2	2/2009	Chu et al.
7,365,260	B2	4/2008	Kawashima	7,496,512	B2	2/2009	Zhao et al.
7,366,461	B1	4/2008	Brown	7,499,923	B2	3/2009	Kawatani
7,369,984	B2	5/2008	Fairweather	7,502,738	B2	3/2009	Kennewick et al.
7,373,291	B2	5/2008	Garst	7,505,795	B1	3/2009	Lim et al.
7,373,612	B2	5/2008	Risch et al.	7,508,324	B2	3/2009	Suraqui
7,376,556	B2	5/2008	Bennett	7,508,373	B2	3/2009	Lin et al.
7,376,632	B1	5/2008	Sadek et al.	7,516,123	B2	4/2009	Betz et al.
7,376,645	B2	5/2008	Bernard	7,519,327	B2	4/2009	White
7,378,963	B1	5/2008	Begault et al.	7,519,398	B2	4/2009	Hirose
7,379,874	B2	5/2008	Schmid et al.	7,522,927	B2	4/2009	Fitch et al.
7,380,203	B2	5/2008	Keely et al.	7,523,036	B2	4/2009	Akabane et al.
7,383,170	B2	6/2008	Mills et al.	7,523,108	B2	4/2009	Cao
7,386,438	B1	6/2008	Franz et al.	7,526,466	B2	4/2009	Au
7,386,449	B2	6/2008	Sun et al.	7,526,738	B2	4/2009	Ording et al.
7,386,799	B1	6/2008	Clanton et al.	7,528,713	B2	5/2009	Singh et al.
7,389,224	B1	6/2008	Elworthy	7,529,671	B2	5/2009	Rockenbeck et al.
7,389,225	B1	6/2008	Jensen et al.	7,529,676	B2	5/2009	Koyama
7,392,185	B2	6/2008	Bennett	7,535,997	B1	5/2009	McQuaide, Jr. et al.
7,394,947	B2	7/2008	Li et al.	7,536,029	B2	5/2009	Choi et al.
7,398,209	B2	7/2008	Kennewick et al.	7,536,565	B2	5/2009	Girish et al.
7,401,300	B2	7/2008	Nurmi	7,538,685	B1	5/2009	Cooper et al.
7,403,938	B2	7/2008	Harrison et al.	7,539,619	B1	5/2009	Seligman et al.
7,403,941	B2	7/2008	Bedworth et al.	7,539,656	B2	5/2009	Fratkina et al.
7,404,143	B2	7/2008	Freelander et al.	7,541,940	B2	6/2009	Upton
7,409,337	B1	8/2008	Potter et al.	7,542,967	B2	6/2009	Hurst-Hiller et al.
7,409,347	B1	8/2008	Bellegarda	7,542,971	B2	6/2009	Thione et al.
7,412,389	B2	8/2008	Yang	7,543,232	B2	6/2009	Easton, Jr. et al.
7,412,470	B2	8/2008	Masuno et al.	7,546,382	B2	6/2009	Healey et al.
7,415,100	B2	8/2008	Cooper et al.	7,546,529	B2	6/2009	Reynar et al.
7,415,469	B2	8/2008	Singh et al.	7,548,895	B2	6/2009	Pulsipher
7,418,382	B1	8/2008	Maes	7,552,045	B2	6/2009	Barliga et al.
7,418,389	B2	8/2008	Chu et al.	7,552,055	B2	6/2009	Lecoeuche
7,418,392	B1	8/2008	Mozer et al.	7,555,431	B2	6/2009	Bennett
7,426,467	B2	9/2008	Nashida et al.	7,555,496	B1	6/2009	Lantrip et al.
7,426,468	B2	9/2008	Coifman et al.	7,558,381	B1	7/2009	Ali et al.
7,427,024	B1	9/2008	Gazdzinski et al.	7,558,730	B2	7/2009	Davis et al.
7,428,541	B2	9/2008	Houle	7,559,026	B2	7/2009	Girish et al.
7,430,508	B2	9/2008	Williamson et al.	7,561,069	B2	7/2009	Horstemeyer
7,433,869	B2	10/2008	Gollapudi	7,562,007	B2	7/2009	Hwang
7,433,921	B2	10/2008	Ludwig et al.	7,562,032	B2	7/2009	Abbosh et al.
7,436,947	B2	10/2008	Wadler et al.	7,565,104	B1	7/2009	Brown et al.
7,441,184	B2	10/2008	Frerebeau et al.	7,565,380	B1	7/2009	Venkatachary
7,443,316	B2	10/2008	Lim	7,568,151	B2	7/2009	Bargeron et al.
7,444,589	B2	10/2008	Zellner	7,571,092	B1	8/2009	Nieh
7,447,360	B2	11/2008	Li et al.	7,571,106	B2	8/2009	Cao et al.
7,447,624	B2	11/2008	Fuhrmann et al.	7,577,522	B2	8/2009	Rosenberg
7,447,635	B1	11/2008	Konopka et al.	7,580,551	B1	8/2009	Srihari et al.
7,447,637	B1	11/2008	Grant et al.	7,580,576	B2	8/2009	Wang et al.
7,451,081	B1	11/2008	Gajic et al.	7,580,839	B2	8/2009	Tamura et al.
7,454,351	B2	11/2008	Jeschke et al.	7,584,093	B2	9/2009	Potter et al.
7,460,652	B2	12/2008	Chang	7,584,278	B2	9/2009	Rajarajan et al.
7,461,043	B2	12/2008	Hess	7,584,429	B2	9/2009	Fabritius
7,467,087	B1	12/2008	Gillick et al.	7,593,868	B2	9/2009	Margiloff et al.
7,467,164	B2	12/2008	Marsh	7,596,269	B2	9/2009	King et al.
7,472,061	B1	12/2008	Alewine et al.	7,596,499	B2	9/2009	Anguera et al.
7,472,065	B2	12/2008	Aaron et al.	7,596,606	B2	9/2009	Codignotto
7,475,010	B2	1/2009	Chao	7,596,765	B2	9/2009	Almas
7,475,015	B2	1/2009	Epstein et al.	7,599,918	B2	10/2009	Shen et al.
7,475,063	B2	1/2009	Datta et al.	7,603,349	B1	10/2009	Kraft et al.
7,477,238	B2	1/2009	Fux et al.	7,603,381	B2	10/2009	Burke et al.
7,477,240	B2	1/2009	Yanagisawa	7,606,444	B1	10/2009	Erol et al.
7,478,037	B2	1/2009	Strong	7,609,179	B2	10/2009	Diaz-Gutierrez et al.
7,478,091	B2	1/2009	Mojsilovic et al.	7,610,258	B2	10/2009	Yuknewicz et al.
7,478,129	B1	1/2009	Chemtob	7,613,264	B2	11/2009	Wells et al.
7,479,948	B2	1/2009	Kim et al.	7,614,008	B2	11/2009	Ording
7,479,949	B2	1/2009	Jobs et al.	7,617,094	B2	11/2009	Aoki et al.
7,483,832	B2	1/2009	Tischer	7,620,407	B1	11/2009	Donald et al.
7,483,894	B2	1/2009	Cao	7,620,549	B2	11/2009	Di Cristo et al.
				7,620,894	B1	11/2009	Kahn
				7,623,119	B2	11/2009	Autio et al.
				7,624,007	B2	11/2009	Bennett
				7,627,481	B1	12/2009	Kuo et al.

(56)

References Cited

U.S. PATENT DOCUMENTS

7,630,900	B1	12/2009	Strom	7,724,696	B1	5/2010	Parekh
7,630,901	B2	12/2009	Omi	7,725,307	B2	5/2010	Bennett
7,633,076	B2	12/2009	Huppi et al.	7,725,318	B2	5/2010	Gavalda et al.
7,634,409	B2	12/2009	Kennewick et al.	7,725,320	B2	5/2010	Bennett
7,634,413	B1	12/2009	Kuo et al.	7,725,321	B2	5/2010	Bennett
7,634,718	B2	12/2009	Nakajima	7,725,838	B2	5/2010	Williams
7,634,732	B1	12/2009	Blagsvedt et al.	7,729,904	B2	6/2010	Bennett
7,636,657	B2	12/2009	Ju et al.	7,729,916	B2	6/2010	Coffman et al.
7,640,158	B2	12/2009	Detlef et al.	7,734,461	B2	6/2010	Kwak et al.
7,640,160	B2	12/2009	Di Cristo et al.	7,735,012	B2	6/2010	Naik
7,643,990	B1	1/2010	Bellegarda	7,739,588	B2	6/2010	Reynar et al.
7,647,225	B2	1/2010	Bennett et al.	7,742,953	B2	6/2010	King et al.
7,649,454	B2	1/2010	Singh et al.	7,743,188	B2	6/2010	Haitani et al.
7,649,877	B2	1/2010	Vieri et al.	7,747,616	B2	6/2010	Yamada et al.
7,653,883	B2	1/2010	Hotelling et al.	7,752,152	B2	7/2010	Paek et al.
7,656,393	B2	2/2010	King et al.	7,756,708	B2	7/2010	Cohen et al.
7,657,424	B2	2/2010	Bennett	7,756,868	B2	7/2010	Lee
7,657,828	B2	2/2010	Lucas et al.	7,756,871	B2	7/2010	Yacoub et al.
7,657,844	B2	2/2010	Gibson et al.	7,757,173	B2	7/2010	Beaman
7,657,849	B2	2/2010	Chaudhri et al.	7,757,182	B2	7/2010	Elliott et al.
7,660,715	B1	2/2010	Thambiratnam	7,761,296	B1	7/2010	Bakis et al.
7,663,607	B2	2/2010	Hotelling et al.	7,763,842	B2	7/2010	Hsu et al.
7,664,558	B2	2/2010	Lindahl et al.	7,774,202	B2	8/2010	Spengler et al.
7,664,638	B2	2/2010	Cooper et al.	7,774,204	B2	8/2010	Mozer et al.
7,668,710	B2	2/2010	Doyle	7,774,388	B1	8/2010	Runchey
7,669,134	B1	2/2010	Christie et al.	7,777,717	B2	8/2010	Fux et al.
7,672,841	B2	3/2010	Bennett	7,778,432	B2	8/2010	Larsen
7,672,952	B2	3/2010	Isaacson et al.	7,778,595	B2	8/2010	White et al.
7,673,238	B2	3/2010	Girish et al.	7,778,632	B2	8/2010	Kurlander et al.
7,673,251	B1	3/2010	Wibisono	7,778,830	B2	8/2010	Davis et al.
7,673,340	B1	3/2010	Cohen et al.	7,779,353	B2	8/2010	Grigoriu et al.
7,676,026	B1	3/2010	Baxter, Jr.	7,779,356	B2	8/2010	Griesmer
7,676,365	B2	3/2010	Hwang et al.	7,779,357	B2	8/2010	Naik
7,676,463	B2	3/2010	Thompson et al.	7,783,283	B2	8/2010	Kuusinen et al.
7,679,534	B2	3/2010	Kay et al.	7,783,486	B2	8/2010	Rosser et al.
7,680,649	B2	3/2010	Park	7,788,590	B2	8/2010	Taboada et al.
7,681,126	B2	3/2010	Roose	7,788,663	B2	8/2010	Illowsky et al.
7,683,886	B2	3/2010	Willey	7,796,980	B1	9/2010	McKinney et al.
7,683,893	B2	3/2010	Kim	7,797,265	B2	9/2010	Brinker et al.
7,684,985	B2	3/2010	Dominach et al.	7,797,269	B2	9/2010	Rieman et al.
7,684,990	B2	3/2010	Caskey et al.	7,797,331	B2	9/2010	Theimer et al.
7,684,991	B2	3/2010	Stohr et al.	7,797,629	B2	9/2010	Fux et al.
7,689,245	B2	3/2010	Cox et al.	7,801,721	B2	9/2010	Rosart et al.
7,689,408	B2	3/2010	Chen et al.	7,801,728	B2	9/2010	Ben-David et al.
7,689,409	B2	3/2010	Heinecke	7,801,729	B2	9/2010	Mozer
7,689,412	B2	3/2010	Wu et al.	7,805,299	B2	9/2010	Coifman
7,689,421	B2	3/2010	Li et al.	7,809,550	B1	10/2010	Barrows
7,693,715	B2	4/2010	Hwang et al.	7,809,565	B2	10/2010	Coifman
7,693,717	B2	4/2010	Kahn et al.	7,809,569	B2	10/2010	Attwater et al.
7,693,719	B2	4/2010	Chu et al.	7,809,570	B2	10/2010	Kennewick et al.
7,693,720	B2	4/2010	Kennewick et al.	7,809,610	B2	10/2010	Cao
7,698,131	B2	4/2010	Bennett	7,809,744	B2	10/2010	Nevidomski et al.
7,702,500	B2	4/2010	Blaedow	7,818,165	B2	10/2010	Carlgren et al.
7,702,508	B2	4/2010	Bennett	7,818,176	B2	10/2010	Freeman et al.
7,703,091	B1	4/2010	Martin et al.	7,818,215	B2	10/2010	King et al.
7,706,510	B2	4/2010	Ng	7,818,291	B2	10/2010	Ferguson et al.
7,707,026	B2	4/2010	Liu	7,818,672	B2	10/2010	Mccormack et al.
7,707,027	B2	4/2010	Balchandran et al.	7,822,608	B2	10/2010	Cross, Jr. et al.
7,707,032	B2	4/2010	Wang et al.	7,823,123	B2	10/2010	Sabbouh
7,707,221	B1	4/2010	Dunning et al.	7,826,945	B2	11/2010	Zhang et al.
7,707,226	B1	4/2010	Tonse	7,827,047	B2	11/2010	Anderson et al.
7,707,267	B2	4/2010	Lisitsa et al.	7,831,246	B1 *	11/2010	Smith G06Q 20/40 455/408
7,710,262	B2	5/2010	Ruha	7,831,423	B2	11/2010	Schubert
7,711,129	B2	5/2010	Lindahl et al.	7,831,426	B2	11/2010	Bennett
7,711,550	B1	5/2010	Feinberg et al.	7,831,432	B2	11/2010	Bodin et al.
7,711,565	B1	5/2010	Gazdzinski	7,835,504	B1	11/2010	Donald et al.
7,711,672	B2	5/2010	Au	7,836,437	B2	11/2010	Kacmarcik et al.
7,712,053	B2	5/2010	Bradford et al.	7,840,348	B2	11/2010	Kim et al.
7,716,056	B2	5/2010	Weng et al.	7,840,400	B2	11/2010	Lavi et al.
7,716,216	B1	5/2010	Harik et al.	7,840,447	B2	11/2010	Kleinrock et al.
7,720,674	B2	5/2010	Kaiser et al.	7,840,581	B2	11/2010	Ross et al.
7,720,683	B1	5/2010	Vermeulen et al.	7,840,912	B2	11/2010	Elias et al.
7,721,226	B2	5/2010	Barabe et al.	7,844,394	B2	11/2010	Kim
7,721,301	B2	5/2010	Wong et al.	7,848,924	B2	12/2010	Nurminen et al.
7,724,242	B2	5/2010	Hillis et al.	7,848,926	B2	12/2010	Goto et al.
				7,853,444	B2	12/2010	Wang et al.
				7,853,445	B2	12/2010	Bachenko et al.
				7,853,574	B2	12/2010	Kraenzel et al.

(56)

References Cited

U.S. PATENT DOCUMENTS

7,853,577	B2	12/2010	Sundaresan et al.	7,996,589	B2	8/2011	Schultz et al.
7,853,664	B1	12/2010	Wang et al.	7,996,769	B2	8/2011	Fux et al.
7,853,900	B2	12/2010	Nguyen et al.	7,996,792	B2	8/2011	Anzures et al.
7,865,817	B2	1/2011	Ryan et al.	7,999,669	B2	8/2011	Singh et al.
7,869,999	B2	1/2011	Amato et al.	8,000,453	B2	8/2011	Cooper et al.
7,870,118	B2	1/2011	Jiang et al.	8,005,664	B2	8/2011	Hanumanthappa
7,870,133	B2	1/2011	Krishnamoorthy et al.	8,005,679	B2	8/2011	Jordan et al.
7,873,149	B2	1/2011	Schultz et al.	8,006,180	B2	8/2011	Tunning et al.
7,873,519	B2	1/2011	Bennett	8,014,308	B2	9/2011	Gates et al.
7,873,654	B2	1/2011	Bernard	8,015,006	B2	9/2011	Kennewick et al.
7,877,705	B2	1/2011	Chambers et al.	8,015,011	B2	9/2011	Nagano et al.
7,880,730	B2	2/2011	Robinson et al.	8,015,144	B2	9/2011	Zheng et al.
7,881,283	B2	2/2011	Cormier et al.	8,018,431	B1	9/2011	Zehr et al.
7,881,936	B2	2/2011	Longe et al.	8,019,271	B1	9/2011	Izdepski
7,885,390	B2	2/2011	Chaudhuri et al.	8,020,104	B2	9/2011	Robarts et al.
7,885,844	B1	2/2011	Cohen et al.	8,024,195	B2	9/2011	Mozer et al.
7,886,233	B2	2/2011	Rainisto et al.	8,024,415	B2	9/2011	Horvitz et al.
7,889,101	B2	2/2011	Yokota	8,027,836	B2	9/2011	Baker et al.
7,889,184	B2	2/2011	Blumenberg et al.	8,031,943	B2	10/2011	Chen et al.
7,889,185	B2	2/2011	Blumenberg et al.	8,032,383	B1	10/2011	Bhardwaj et al.
7,890,330	B2	2/2011	Ozkaragoz et al.	8,036,901	B2	10/2011	Mozer
7,890,652	B2	2/2011	Bull et al.	8,037,034	B2	10/2011	Plachta et al.
7,895,039	B2	2/2011	Braho et al.	8,041,557	B2	10/2011	Liu
7,895,531	B2	2/2011	Radtke et al.	8,041,570	B2	10/2011	Mirkovic et al.
7,899,666	B2	3/2011	Varone	8,041,611	B2	10/2011	Kleinrock et al.
7,904,297	B2	3/2011	Mirkovic et al.	8,042,053	B2	10/2011	Darwish et al.
7,908,287	B1	3/2011	Katragadda	8,046,363	B2	10/2011	Cha et al.
7,912,289	B2	3/2011	Kansal et al.	8,046,374	B1	10/2011	Bromwich et al.
7,912,699	B1	3/2011	Saraclar et al.	8,050,500	B1	11/2011	Batty et al.
7,912,702	B2	3/2011	Bennett	8,054,180	B1	11/2011	Scofield et al.
7,912,720	B1	3/2011	Hakkani-Tur et al.	8,055,502	B2	11/2011	Clark et al.
7,912,828	B2	3/2011	Bonnet et al.	8,055,708	B2	11/2011	Chitsaz et al.
7,913,185	B1	3/2011	Benson et al.	8,056,070	B2	11/2011	Goller et al.
7,916,979	B2	3/2011	Simmons	8,060,824	B2	11/2011	Brownrigg, Jr. et al.
7,917,367	B2	3/2011	Di Cristo et al.	8,064,753	B2	11/2011	Freeman
7,917,497	B2	3/2011	Harrison et al.	8,065,143	B2	11/2011	Yanagihara
7,920,678	B2	4/2011	Cooper et al.	8,065,155	B1	11/2011	Gazdzinski
7,920,682	B2	4/2011	Byrne et al.	8,065,156	B2	11/2011	Gazdzinski
7,920,857	B2	4/2011	Lau et al.	8,068,604	B2	11/2011	Leeds et al.
7,925,525	B2	4/2011	Chin	8,069,046	B2	11/2011	Kennewick et al.
7,925,610	B2	4/2011	Elbaz et al.	8,069,422	B2	11/2011	Sheshagiri et al.
7,929,805	B2	4/2011	Wang et al.	8,073,681	B2	12/2011	Baldwin et al.
7,930,168	B2	4/2011	Weng et al.	8,073,695	B1	12/2011	Hendricks et al.
7,930,183	B2	4/2011	Odell et al.	8,077,153	B2	12/2011	Benko et al.
7,930,197	B2	4/2011	Ozzie et al.	8,078,473	B1	12/2011	Gazdzinski
7,936,339	B2	5/2011	Marggraff et al.	8,082,153	B2	12/2011	Coffman et al.
7,936,861	B2	5/2011	Martin et al.	8,082,498	B2	12/2011	Salamon et al.
7,936,863	B2	5/2011	John et al.	8,090,571	B2	1/2012	Elshishiny et al.
7,937,075	B2	5/2011	Zellner	8,095,364	B2	1/2012	Longe et al.
7,941,009	B2	5/2011	Li et al.	8,099,289	B2	1/2012	Mozer et al.
7,945,294	B2	5/2011	Zhang et al.	8,099,395	B2	1/2012	Pabla et al.
7,945,470	B1	5/2011	Cohen et al.	8,099,418	B2	1/2012	Inoue et al.
7,949,529	B2	5/2011	Weider et al.	8,103,510	B2	1/2012	Sato
7,949,534	B2	5/2011	Davis et al.	8,107,401	B2	1/2012	John et al.
7,949,752	B2	5/2011	Lange et al.	8,112,275	B2	2/2012	Kennewick et al.
7,953,679	B2	5/2011	Chidlovskii et al.	8,112,280	B2	2/2012	Lu
7,957,975	B2	6/2011	Burns et al.	8,117,037	B2	2/2012	Gazdzinski
7,958,136	B1	6/2011	Curtis et al.	8,117,542	B2	2/2012	Radtke et al.
7,962,179	B2	6/2011	Huang	8,121,413	B2	2/2012	Hwang et al.
7,974,835	B2	7/2011	Balchandran et al.	8,121,837	B2	2/2012	Agapi et al.
7,974,844	B2	7/2011	Sumita	8,122,094	B1	2/2012	Kotab
7,974,972	B2	7/2011	Cao	8,122,353	B2	2/2012	Bouta
7,975,216	B2	7/2011	Woolf et al.	8,131,557	B2	3/2012	Davis et al.
7,983,478	B2	7/2011	Liu et al.	8,135,115	B1	3/2012	Hogg, Jr. et al.
7,983,915	B2	7/2011	Knight et al.	8,138,912	B2	3/2012	Singh et al.
7,983,917	B2	7/2011	Kennewick et al.	8,140,335	B2	3/2012	Kennewick et al.
7,983,919	B2	7/2011	Conkie	8,140,567	B2	3/2012	Padovitz et al.
7,983,997	B2	7/2011	Allen et al.	8,145,489	B2	3/2012	Freeman et al.
7,984,062	B2	7/2011	Dunning et al.	8,150,694	B2	4/2012	Kennewick et al.
7,986,431	B2	7/2011	Emori et al.	8,150,700	B2	4/2012	Shin et al.
7,987,151	B2	7/2011	Schott et al.	8,155,956	B2	4/2012	Cho et al.
7,987,244	B1	7/2011	Lewis et al.	8,156,005	B2	4/2012	Vieri
7,991,614	B2	8/2011	Washio et al.	8,160,877	B1	4/2012	Nucci et al.
7,992,085	B2	8/2011	Wang-Aryattanwanich et al.	8,160,883	B2	4/2012	Lecoeuche
7,996,228	B2	8/2011	Miller et al.	8,165,321	B2	4/2012	Paquier et al.
				8,165,886	B1	4/2012	Gagnon et al.
				8,166,019	B1	4/2012	Lee et al.
				8,166,032	B2	4/2012	Sommer et al.
				8,170,790	B2	5/2012	Lee et al.

(56)

References Cited

U.S. PATENT DOCUMENTS

8,175,872	B2	5/2012	Kristjansson et al.	8,391,844	B2	3/2013	Lamiroux et al.
8,179,370	B1	5/2012	Yamasani et al.	8,396,714	B2	3/2013	Rogers et al.
8,188,856	B2	5/2012	Singh et al.	8,406,745	B1	3/2013	Upadhyay et al.
8,190,359	B2	5/2012	Bourne	8,423,288	B2	4/2013	Stahl et al.
8,195,467	B2	6/2012	Mozer et al.	8,428,758	B2	4/2013	Naik et al.
8,195,468	B2	6/2012	Kennewick et al.	8,433,778	B1	4/2013	Shreesha et al.
8,200,495	B2	6/2012	Braho et al.	8,442,821	B1	5/2013	Vanhoucke
8,201,109	B2	6/2012	Van Os et al.	8,447,612	B2	5/2013	Gazdzinski
8,204,238	B2	6/2012	Mozer	8,452,597	B2	5/2013	Bringert et al.
8,205,788	B1	6/2012	Gazdzinski et al.	8,457,959	B2	6/2013	Kaiser
8,209,183	B1	6/2012	Patel et al.	8,458,115	B2	6/2013	Cai et al.
8,213,911	B2	7/2012	Williams et al.	8,458,278	B2	6/2013	Christie et al.
8,219,115	B1	7/2012	Nelissen	8,464,150	B2	6/2013	Davidson et al.
8,219,406	B2	7/2012	Yu et al.	8,473,289	B2	6/2013	Jitkoff et al.
8,219,407	B1	7/2012	Roy et al.	8,479,122	B2	7/2013	Hotelling et al.
8,219,608	B2	7/2012	alSafadi et al.	8,484,027	B1	7/2013	Murphy
8,224,649	B2	7/2012	Chaudhari et al.	8,489,599	B2	7/2013	Bellotti
8,228,299	B1	7/2012	Maloney et al.	8,498,857	B2	7/2013	Kopparapu et al.
8,233,919	B2	7/2012	Haag et al.	8,514,197	B2	8/2013	Shahraray et al.
8,234,111	B2	7/2012	Lloyd et al.	8,515,750	B1	8/2013	Lei et al.
8,239,206	B1	8/2012	LeBeau et al.	8,521,513	B2	8/2013	Millett et al.
8,239,207	B2	8/2012	Seligman et al.	8,527,276	B1	9/2013	Senior et al.
8,244,712	B2	8/2012	Serlet et al.	8,543,398	B1	9/2013	Strope et al.
8,250,071	B1	8/2012	Killalea et al.	8,560,229	B1	10/2013	Park et al.
8,254,829	B1	8/2012	Kindred et al.	8,571,851	B1	10/2013	Tickner et al.
8,255,216	B2	8/2012	White	8,583,416	B2	11/2013	Huang et al.
8,255,217	B2	8/2012	Stent et al.	8,583,511	B2	11/2013	Hendrickson
8,260,247	B2	9/2012	Lazaridis et al.	8,589,869	B2	11/2013	Wolfram
8,260,617	B2	9/2012	Dhanakshirur et al.	8,589,911	B1	11/2013	Sharkey et al.
8,270,933	B2	9/2012	Riemer et al.	8,595,004	B2	11/2013	Koshinaka
8,275,621	B2	9/2012	Alewine et al.	8,600,743	B2	12/2013	Lindahl et al.
8,279,171	B2	10/2012	Hirai et al.	8,600,930	B2	12/2013	Sata et al.
8,280,438	B2	10/2012	Barbera	8,606,568	B1	12/2013	Tickner et al.
8,285,546	B2	10/2012	Reich	8,620,659	B2	12/2013	Di Cristo et al.
8,285,551	B2	10/2012	Gazdzinski	8,620,662	B2	12/2013	Bellegarda
8,285,553	B2	10/2012	Gazdzinski	8,626,681	B1	1/2014	Jurca et al.
8,290,777	B1	10/2012	Nguyen et al.	8,639,516	B2	1/2014	Lindahl et al.
8,290,778	B2	10/2012	Gazdzinski	8,645,137	B2	2/2014	Bellegarda et al.
8,290,781	B2	10/2012	Gazdzinski	8,645,138	B1	2/2014	Weinstein et al.
8,296,124	B1	10/2012	Holsztynska et al.	8,654,936	B1	2/2014	Tofighbakhsh et al.
8,296,145	B2	10/2012	Clark et al.	8,655,646	B2	2/2014	Lee et al.
8,296,146	B2	10/2012	Gazdzinski	8,655,901	B1	2/2014	Li et al.
8,296,153	B2	10/2012	Gazdzinski	8,660,843	B2	2/2014	Falcon et al.
8,296,380	B1	10/2012	Kelly et al.	8,660,849	B2	2/2014	Gruber et al.
8,296,383	B2	10/2012	Lindahl	8,660,970	B1	2/2014	Fiedorowicz
8,300,801	B2	10/2012	Sweeney et al.	8,661,112	B2	2/2014	Creamer et al.
8,301,456	B2	10/2012	Gazdzinski	8,661,340	B2	2/2014	Goldsmith et al.
8,311,834	B1	11/2012	Gazdzinski	8,670,979	B2	3/2014	Gruber et al.
8,311,835	B2	11/2012	Lecoeuche	8,675,084	B2	3/2014	Bolton et al.
8,311,838	B2	11/2012	Lindahl et al.	8,676,904	B2	3/2014	Lindahl et al.
8,312,017	B2	11/2012	Martin et al.	8,677,377	B2	3/2014	Cheyser et al.
8,321,786	B2	11/2012	Lunati et al.	8,681,950	B2	3/2014	Vlack et al.
8,326,627	B2	12/2012	Kennewick et al.	8,682,667	B2	3/2014	Haughay et al.
8,332,205	B2	12/2012	Krishnan et al.	8,687,777	B1	4/2014	Lavian et al.
8,332,218	B2	12/2012	Cross et al.	8,688,446	B2	4/2014	Yanagihara et al.
8,332,224	B2	12/2012	Di Cristo et al.	8,688,453	B1	4/2014	Joshi et al.
8,332,748	B1	12/2012	Karam	8,695,074	B2	4/2014	Saraf et al.
8,340,975	B1	12/2012	Rosenberger	8,696,364	B2	4/2014	Cohen
8,345,665	B2	1/2013	Vieri et al.	8,706,472	B2	4/2014	Ramerth et al.
8,352,183	B2	1/2013	Thota et al.	8,706,474	B2	4/2014	Blume et al.
8,352,268	B2	1/2013	Naik et al.	8,706,503	B2	4/2014	Cheyser et al.
8,352,272	B2	1/2013	Rogers et al.	8,713,119	B2	4/2014	Lindahl et al.
8,355,919	B2	1/2013	Silverman et al.	8,713,418	B2	4/2014	King et al.
8,359,234	B2	1/2013	Vieri	8,719,006	B2	5/2014	Bellegarda et al.
8,370,145	B2	2/2013	Endo et al.	8,719,014	B2	5/2014	Wagner et al.
8,370,158	B2	2/2013	Gazdzinski	8,731,610	B2	5/2014	Appaji
8,371,503	B2	2/2013	Gazdzinski	8,731,912	B1	5/2014	Tickner et al.
8,374,871	B2	2/2013	Ehsani et al.	8,731,942	B2	5/2014	Cheyser et al.
8,375,320	B2	2/2013	Kotler et al.	8,739,208	B2	5/2014	Rodriguez et al.
8,380,504	B1	2/2013	Peden et al.	8,744,852	B1	6/2014	Seymour et al.
8,380,507	B2	2/2013	Herman et al.	8,760,537	B2	6/2014	Johnson et al.
8,381,107	B2	2/2013	Rottler et al.	8,762,145	B2	6/2014	Ouchi et al.
8,381,135	B2	2/2013	Hotelling et al.	8,762,156	B2	6/2014	Chen et al.
8,386,485	B2	2/2013	Kerschberg et al.	8,762,469	B2	6/2014	Lindahl et al.
8,386,926	B1	2/2013	Matsuoka	8,768,693	B2	7/2014	Lempel et al.
				8,768,702	B2	7/2014	Boettcher et al.
				8,775,154	B2	7/2014	Clinchant et al.
				8,775,931	B2	7/2014	Fux et al.
				8,781,841	B1	7/2014	Wang

(56)

References Cited

U.S. PATENT DOCUMENTS

8,798,255	B2	8/2014	Lubowich et al.	9,361,084	B1	6/2016	Costa	
8,798,995	B1	8/2014	Edara et al.	9,367,541	B1	6/2016	Servan et al.	
8,799,000	B2	8/2014	Guzzoni et al.	9,377,871	B2	6/2016	Waddell et al.	
8,805,690	B1	8/2014	LeBeau et al.	9,378,740	B1	6/2016	Rosen et al.	
8,812,302	B2	8/2014	Xiao et al.	9,380,155	B1	6/2016	Reding et al.	
8,838,457	B2	9/2014	Cerra et al.	9,390,726	B1	7/2016	Smus et al.	
8,855,915	B2	10/2014	Furuhata et al.	9,401,147	B2	7/2016	Jitkoff et al.	
8,861,925	B1	10/2014	Ohme	9,412,392	B2	8/2016	Lindahl	
8,862,252	B2	10/2014	Rottler et al.	9,423,266	B2	8/2016	Clark et al.	
8,868,409	B1	10/2014	Mengibar et al.	9,436,918	B2	9/2016	Pantel et al.	
8,880,405	B2	11/2014	Cerra et al.	9,437,186	B1	9/2016	Liu et al.	
8,886,534	B2	11/2014	Nakano et al.	9,437,189	B2	9/2016	Epstein et al.	
8,886,540	B2	11/2014	Cerra et al.	9,454,957	B1	9/2016	Mathias et al.	
8,886,541	B2	11/2014	Friedlander	9,484,021	B1	11/2016	Mairesse et al.	
8,892,446	B2	11/2014	Cheyser et al.	9,495,129	B2	11/2016	Fleizach et al.	
8,898,568	B2	11/2014	Bull et al.	9,502,025	B2	11/2016	Kennewick et al.	
8,903,716	B2	12/2014	Chen et al.	9,510,044	B1	11/2016	Pereira et al.	
8,909,693	B2	12/2014	Frissora et al.	9,536,527	B1	1/2017	Carlson	
8,930,176	B2	1/2015	Li et al.	9,547,647	B2	1/2017	Badaskar	
8,930,191	B2	1/2015	Gruber et al.	9,548,050	B2	1/2017	Gruber et al.	
8,938,394	B1	1/2015	Faaborg et al.	9,578,173	B2*	2/2017	Sanghavi	H04M 3/5183
8,942,986	B2	1/2015	Cheyser et al.	9,607,612	B2	3/2017	Deleeuw	
8,943,423	B2	1/2015	Merrill et al.	9,620,113	B2	4/2017	Kennewick et al.	
8,972,240	B2	3/2015	Brockett et al.	9,620,126	B2	4/2017	Chiba	
8,972,432	B2	3/2015	Shaw et al.	9,626,955	B2	4/2017	Fleizach et al.	
8,972,878	B2	3/2015	Mohler et al.	9,633,660	B2	4/2017	Haughay	
8,983,383	B1	3/2015	Haskin	9,652,453	B2	5/2017	Mathur et al.	
8,989,713	B2	3/2015	Doulton	2001/0000534	A1	4/2001	Matulich et al.	
8,990,235	B2	3/2015	King et al.	2001/0005859	A1	6/2001	Okuyama et al.	
8,994,660	B2	3/2015	Neels et al.	2001/0020259	A1	9/2001	Sekiguchi et al.	
8,996,350	B1	3/2015	Dub et al.	2001/0023397	A1	9/2001	Tajjima et al.	
8,996,376	B2	3/2015	Fleizach et al.	2001/0027394	A1	10/2001	Theimer	
8,996,381	B2	3/2015	Mozer et al.	2001/0027396	A1	10/2001	Sato	
9,009,046	B1	4/2015	Stewart	2001/0029455	A1	10/2001	Chin et al.	
9,020,804	B2	4/2015	Barbaiani et al.	2001/0030660	A1	10/2001	Zainouline	
9,026,425	B2	5/2015	Nikoulina et al.	2001/0032080	A1	10/2001	Fukada	
9,031,834	B2	5/2015	Coorman et al.	2001/0041021	A1	11/2001	Boyle et al.	
9,037,967	B1	5/2015	Al-Jefri et al.	2001/0042107	A1	11/2001	Palm	
9,043,208	B2	5/2015	Koch et al.	2001/0044724	A1	11/2001	Hon et al.	
9,049,255	B2	6/2015	MacFarlane et al.	2001/0047264	A1	11/2001	Roundtree	
9,053,706	B2	6/2015	Jitkoff et al.	2001/0049275	A1	12/2001	Piery et al.	
9,058,811	B2	6/2015	Wang et al.	2001/0049277	A1	12/2001	Meyer et al.	
9,063,979	B2	6/2015	Chiu et al.	2001/0055963	A1	12/2001	Cloutier	
9,070,366	B1	6/2015	Mathias et al.	2001/0056342	A1	12/2001	Piehn et al.	
9,071,701	B2	6/2015	Donaldson et al.	2001/0056347	A1	12/2001	Chazan et al.	
9,081,411	B2	7/2015	Kalns et al.	2002/0001395	A1	1/2002	Davis et al.	
9,081,482	B1	7/2015	Zhai et al.	2002/0002039	A1	1/2002	Qureshey et al.	
9,098,467	B1	8/2015	Blanksteen et al.	2002/0002413	A1	1/2002	Tokue	
9,101,279	B2	8/2015	Ritchey et al.	2002/0002461	A1	1/2002	Tetsumoto	
9,112,984	B2	8/2015	Sejnoha et al.	2002/0002465	A1	1/2002	Maes	
9,117,447	B2	8/2015	Gruber et al.	2002/0002548	A1	1/2002	Roundtree et al.	
9,123,338	B1	9/2015	Sanders et al.	2002/0002575	A1	1/2002	Eisler et al.	
9,171,541	B2	10/2015	Kennewick et al.	2002/0002594	A1	1/2002	Roundtree et al.	
9,171,546	B1	10/2015	Pike	2002/0004703	A1	1/2002	Gaspard, II	
9,190,062	B2	11/2015	Haughay	2002/0004736	A1	1/2002	Roundtree et al.	
9,208,153	B1	12/2015	Zaveri et al.	2002/0010581	A1	1/2002	Euler et al.	
9,218,809	B2	12/2015	Bellegarda	2002/0010584	A1	1/2002	Schultz et al.	
9,218,819	B1	12/2015	Stekkelpak et al.	2002/0010589	A1	1/2002	Nashida et al.	
9,223,537	B2	12/2015	Brown et al.	2002/0010726	A1	1/2002	Rogson	
9,255,812	B2	2/2016	Maeoka et al.	2002/0010798	A1	1/2002	Ben-Shaul et al.	
9,258,604	B1	2/2016	Bilobrov et al.	2002/0013707	A1	1/2002	Shaw et al.	
9,262,612	B2	2/2016	Cheyser	2002/0013784	A1	1/2002	Swanson	
9,292,487	B1	3/2016	Weber	2002/0013852	A1	1/2002	Janik	
9,292,489	B1	3/2016	Sak et al.	2002/0015024	A1	2/2002	Westerman et al.	
9,299,344	B2	3/2016	Braho et al.	2002/0015064	A1	2/2002	Robotham et al.	
9,305,543	B2	4/2016	Fleizach et al.	2002/0021278	A1	2/2002	Hinckley et al.	
9,305,548	B2	4/2016	Kennewick et al.	2002/0026315	A1	2/2002	Miranda	
9,311,912	B1	4/2016	Swietlinski et al.	2002/0026456	A1	2/2002	Bradford	
9,313,317	B1	4/2016	LeBeau et al.	2002/0031254	A1	3/2002	Lantrip et al.	
9,318,108	B2	4/2016	Gruber et al.	2002/0031262	A1	3/2002	Imagawa et al.	
9,325,809	B1	4/2016	Barros et al.	2002/0032048	A1	3/2002	Kitao et al.	
9,325,842	B1*	4/2016	Siddiqi	2002/0032564	A1	3/2002	Ehsani et al.	
9,330,659	B2	5/2016	Ju et al.	2002/0032591	A1	3/2002	Mahaffy et al.	
9,338,493	B2	5/2016	Van Os et al.	2002/0032751	A1	3/2002	Bharadwaj	
9,349,368	B1	5/2016	LeBeau et al.	2002/0035467	A1	3/2002	Morimoto et al.	
				2002/0035469	A1	3/2002	Holzapfel	
				2002/0035474	A1	3/2002	Alpdemir	
				2002/0040297	A1	4/2002	Tsiao et al.	
				2002/0040359	A1	4/2002	Green et al.	

(56)

References Cited

U.S. PATENT DOCUMENTS

2002/0042707	A1	4/2002	Zhao et al.	2002/0133341	A1	9/2002	Gillick et al.
2002/0045438	A1	4/2002	Tagawa et al.	2002/0133347	A1	9/2002	Schoneburg et al.
2002/0045961	A1	4/2002	Gibbs et al.	2002/0133348	A1	9/2002	Pearson et al.
2002/0046025	A1	4/2002	Hain	2002/0135565	A1	9/2002	Gordon et al.
2002/0046032	A1	4/2002	Wutte	2002/0135618	A1	9/2002	Maes et al.
2002/0046315	A1	4/2002	Miller et al.	2002/0137505	A1	9/2002	Eiche et al.
2002/0049587	A1	4/2002	Miyazawa	2002/0138254	A1	9/2002	Isaka et al.
2002/0052730	A1	5/2002	Nakao	2002/0138265	A1	9/2002	Stevens et al.
2002/0052740	A1	5/2002	Charlesworth et al.	2002/0138270	A1	9/2002	Bellegarda et al.
2002/0052746	A1	5/2002	Handelman	2002/0138274	A1	9/2002	Sharma et al.
2002/0052747	A1	5/2002	Sarukkai	2002/0138616	A1	9/2002	Basson et al.
2002/0052913	A1	5/2002	Yamada et al.	2002/0140679	A1	10/2002	Wen
2002/0054094	A1	5/2002	Matsuda	2002/0143523	A1	10/2002	Balaj et al.
2002/0055844	A1	5/2002	L'Esperance et al.	2002/0143532	A1	10/2002	Mclean et al.
2002/0055934	A1	5/2002	Lipscomb et al.	2002/0143533	A1	10/2002	Lucas et al.
2002/0057293	A1	5/2002	Liao	2002/0143542	A1	10/2002	Eide
2002/0059066	A1	5/2002	O'hagan	2002/0143551	A1	10/2002	Sharma et al.
2002/0059068	A1	5/2002	Rose et al.	2002/0143826	A1	10/2002	Day et al.
2002/0065659	A1	5/2002	Isono et al.	2002/0151297	A1	10/2002	Remboski et al.
2002/0065797	A1	5/2002	Meidan et al.	2002/0152045	A1	10/2002	Dowling et al.
2002/0067308	A1	6/2002	Robertson	2002/0152255	A1	10/2002	Smith et al.
2002/0069063	A1	6/2002	Buchner et al.	2002/0154160	A1	10/2002	Hosokawa
2002/0069071	A1	6/2002	Knockeart et al.	2002/0156771	A1	10/2002	Frieder et al.
2002/0069220	A1	6/2002	Tran	2002/0161865	A1	10/2002	Nguyen
2002/0072816	A1	6/2002	Shdema et al.	2002/0163544	A1	11/2002	Baker et al.
2002/0072908	A1	6/2002	Case et al.	2002/0164000	A1	11/2002	Cohen et al.
2002/0072914	A1	6/2002	Alshawi et al.	2002/0165717	A1	11/2002	Solmer et al.
2002/0072915	A1	6/2002	Bower	2002/0165918	A1	11/2002	Bettis
2002/0073177	A1	6/2002	Clark et al.	2002/0166123	A1	11/2002	Schrader et al.
2002/0077082	A1	6/2002	Cruikshank	2002/0167534	A1	11/2002	Burke
2002/0077817	A1	6/2002	Atal	2002/0169592	A1	11/2002	Aityan
2002/0078041	A1	6/2002	Wu	2002/0169605	A1	11/2002	Damiba et al.
2002/0080163	A1	6/2002	Morey	2002/0173273	A1	11/2002	Spurgat et al.
2002/0082831	A1	6/2002	Hwang et al.	2002/0173889	A1	11/2002	Odinak et al.
2002/0083068	A1	6/2002	Quass et al.	2002/0173955	A1	11/2002	Reich
2002/0085037	A1	7/2002	Leavitt et al.	2002/0173961	A1	11/2002	Guerra
2002/0086268	A1	7/2002	Shpiro	2002/0173962	A1	11/2002	Tang et al.
2002/0086680	A1	7/2002	Hunzinger	2002/0173966	A1	11/2002	Henton
2002/0087306	A1	7/2002	Lee et al.	2002/0177993	A1	11/2002	Veditz et al.
2002/0087508	A1	7/2002	Hull et al.	2002/0184003	A1	12/2002	Hakkinen et al.
2002/0087974	A1	7/2002	Sprague et al.	2002/0184015	A1	12/2002	Li et al.
2002/0091511	A1	7/2002	Hellwig et al.	2002/0184027	A1	12/2002	Brittan et al.
2002/0091529	A1	7/2002	Whitham	2002/0184189	A1	12/2002	Hay et al.
2002/0095286	A1	7/2002	Ross et al.	2002/0188454	A1	12/2002	Sauber
2002/0095290	A1	7/2002	Kahn et al.	2002/0188847	A1	12/2002	Valeria
2002/0099547	A1	7/2002	Chu et al.	2002/0189426	A1	12/2002	Hirade et al.
2002/0099552	A1	7/2002	Rubin et al.	2002/0191029	A1	12/2002	Gillespie et al.
2002/0101447	A1	8/2002	Carro	2002/0193996	A1	12/2002	Squibbs et al.
2002/0103641	A1	8/2002	Kuo et al.	2002/0196911	A1	12/2002	Gao et al.
2002/0103644	A1	8/2002	Brocious et al.	2002/0198714	A1	12/2002	Zhou
2002/0103646	A1	8/2002	Kochanski et al.	2002/0198715	A1	12/2002	Belrose
2002/0107684	A1	8/2002	Gao	2003/0001881	A1	1/2003	Mannheimer et al.
2002/0109709	A1	8/2002	Sagar	2003/0002632	A1	1/2003	Bhagal et al.
2002/0110248	A1	8/2002	Kovales et al.	2003/0003609	A1	1/2003	Sauer et al.
2002/0111198	A1	8/2002	Heie et al.	2003/0003897	A1	1/2003	Seung-Taek
2002/0111806	A1	8/2002	Franz et al.	2003/0004703	A1	1/2003	Prabhakar et al.
2002/0111810	A1	8/2002	Khan et al.	2003/0004968	A1	1/2003	Romer et al.
2002/0116082	A1	8/2002	Gudorf	2003/0005174	A1	1/2003	Coffman et al.
2002/0116171	A1	8/2002	Russell	2003/0009459	A1	1/2003	Chastain et al.
2002/0116185	A1	8/2002	Cooper et al.	2003/0013483	A1	1/2003	Ausems et al.
2002/0116189	A1	8/2002	Yeh et al.	2003/0016770	A1	1/2003	Trans et al.
2002/0116420	A1	8/2002	Allam et al.	2003/0018475	A1	1/2003	Basu et al.
2002/0117384	A1	8/2002	Marchant	2003/0020760	A1	1/2003	Takatsu et al.
2002/0120697	A1	8/2002	Generous et al.	2003/0023420	A1	1/2003	Goodman et al.
2002/0120925	A1	8/2002	Logan	2003/0023426	A1	1/2003	Pun et al.
2002/0122053	A1	9/2002	Dutta et al.	2003/0025676	A1	2/2003	Cappendijk
2002/0123804	A1	9/2002	Gwon et al.	2003/0026392	A1	2/2003	Brown et al.
2002/0123891	A1	9/2002	Epstein et al.	2003/0026402	A1	2/2003	Clapper
2002/0123892	A1	9/2002	Woodward	2003/0028380	A1	2/2003	Freeland et al.
2002/0123894	A1	9/2002	Woodward	2003/0030645	A1	2/2003	Ribak et al.
2002/0126097	A1	9/2002	Savolainen	2003/0033148	A1	2/2003	Silverman et al.
2002/0128821	A1	9/2002	Ehsani et al.	2003/0033152	A1	2/2003	Cameron
2002/0128827	A1	9/2002	Bu et al.	2003/0033153	A1	2/2003	Olson et al.
2002/0128840	A1	9/2002	Hinde et al.	2003/0033214	A1	2/2003	Mikkelsen et al.
2002/0129057	A1	9/2002	Spielberg	2003/0036909	A1	2/2003	Kato
				2003/0037073	A1	2/2003	Tokuda et al.
				2003/0037077	A1	2/2003	Brill et al.
				2003/0037254	A1	2/2003	Fischer et al.
				2003/0038786	A1	2/2003	Nguyen et al.

(56)

References Cited

U.S. PATENT DOCUMENTS

2003/0040908	A1	2/2003	Yang et al.	2003/0152261	A1	8/2003	Hiroe et al.
2003/0046075	A1	3/2003	Stone	2003/0152894	A1	8/2003	Townshend
2003/0046401	A1	3/2003	Abbott et al.	2003/0154079	A1	8/2003	Ota et al.
2003/0046434	A1	3/2003	Flanagin et al.	2003/0154081	A1	8/2003	Chu et al.
2003/0048881	A1	3/2003	Trajkovic et al.	2003/0154116	A1	8/2003	Lofton
2003/0050781	A1	3/2003	Tamura et al.	2003/0157968	A1	8/2003	Boman et al.
2003/0051136	A1	3/2003	Curtis et al.	2003/0158732	A1	8/2003	Pi et al.
2003/0055537	A1	3/2003	Odinak et al.	2003/0158735	A1	8/2003	Yamada et al.
2003/0055623	A1	3/2003	Epstein et al.	2003/0158737	A1	8/2003	Csicsatka
2003/0055641	A1	3/2003	Yi et al.	2003/0160702	A1	8/2003	Tanaka
2003/0061317	A1	3/2003	Brown et al.	2003/0160830	A1	8/2003	Degross
2003/0061570	A1	3/2003	Hatori et al.	2003/0163316	A1	8/2003	Addison et al.
2003/0063073	A1	4/2003	Geaghan et al.	2003/0164848	A1	9/2003	Dutta et al.
2003/0065805	A1	4/2003	Barnes, Jr.	2003/0167167	A1	9/2003	Gong
2003/0069893	A1	4/2003	Kanai et al.	2003/0167318	A1	9/2003	Robbin et al.
2003/0074195	A1	4/2003	Bartosik et al.	2003/0167335	A1	9/2003	Alexander
2003/0074198	A1	4/2003	Sussman	2003/0171911	A1	9/2003	Fairweather
2003/0074457	A1	4/2003	Kluth	2003/0171928	A1	9/2003	Falcon et al.
2003/0076301	A1	4/2003	Tsuk et al.	2003/0171936	A1	9/2003	Sall et al.
2003/0078766	A1	4/2003	Appelt et al.	2003/0174830	A1	9/2003	Boyer et al.
2003/0078778	A1	4/2003	Emam et al.	2003/0177046	A1	9/2003	Socha-Leialoha et al.
2003/0078779	A1	4/2003	Desai et al.	2003/0179222	A1	9/2003	Noma et al.
2003/0078780	A1	4/2003	Kochanski et al.	2003/0182115	A1	9/2003	Malayath et al.
2003/0078969	A1	4/2003	Sprague et al.	2003/0182119	A1	9/2003	Junqua et al.
2003/0079024	A1	4/2003	Hough et al.	2003/0182131	A1	9/2003	Arnold et al.
2003/0079038	A1	4/2003	Robbin et al.	2003/0182394	A1	9/2003	Ryngle et al.
2003/0080991	A1	5/2003	Crow et al.	2003/0187655	A1	10/2003	Dunsmuir
2003/0083113	A1	5/2003	Chua et al.	2003/0187659	A1	10/2003	Cho et al.
2003/0083878	A1	5/2003	Lee et al.	2003/0187775	A1	10/2003	Du et al.
2003/0083884	A1	5/2003	Odinak et al.	2003/0187844	A1	10/2003	Li et al.
2003/0084350	A1	5/2003	Eibach et al.	2003/0187925	A1	10/2003	Inala et al.
2003/0085870	A1	5/2003	Hinckley	2003/0188005	A1	10/2003	Yoneda et al.
2003/0086699	A1	5/2003	Benyamin et al.	2003/0188192	A1	10/2003	Tang et al.
2003/0088414	A1	5/2003	Huang et al.	2003/0190074	A1	10/2003	Loudon et al.
2003/0088421	A1	5/2003	Maes et al.	2003/0191625	A1	10/2003	Gorin et al.
2003/0090467	A1	5/2003	Hohl et al.	2003/0191645	A1	10/2003	Zhou
2003/0090474	A1	5/2003	Schaefer	2003/0193481	A1	10/2003	Sokolsky
2003/0095096	A1	5/2003	Robbin et al.	2003/0194080	A1	10/2003	Michaelis et al.
2003/0097210	A1	5/2003	Horst et al.	2003/0195741	A1	10/2003	Mani et al.
2003/0097379	A1	5/2003	Ireton	2003/0197736	A1	10/2003	Murphy
2003/0097407	A1	5/2003	Litwin et al.	2003/0197744	A1	10/2003	Irvine
2003/0097408	A1	5/2003	Kageyama et al.	2003/0200085	A1	10/2003	Nguyen et al.
2003/0098892	A1	5/2003	Hiipakka	2003/0200452	A1	10/2003	Tagawa et al.
2003/0099335	A1	5/2003	Tanaka et al.	2003/0200858	A1	10/2003	Xie
2003/0101045	A1	5/2003	Moffatt et al.	2003/0202697	A1	10/2003	Simard et al.
2003/0101054	A1	5/2003	Davis et al.	2003/0204392	A1	10/2003	Finnigan et al.
2003/0115060	A1	6/2003	Junqua et al.	2003/0204492	A1	10/2003	Wolf et al.
2003/0115064	A1	6/2003	Gusler et al.	2003/0206199	A1	11/2003	Pusa et al.
2003/0115186	A1	6/2003	Wilkinson et al.	2003/0208756	A1	11/2003	Macrae et al.
2003/0115289	A1	6/2003	Chinn et al.	2003/0210266	A1	11/2003	Cragun et al.
2003/0115552	A1	6/2003	Jahnke et al.	2003/0212543	A1	11/2003	Epstein et al.
2003/0117365	A1	6/2003	Shteyn	2003/0212961	A1	11/2003	Soin et al.
2003/0120494	A1	6/2003	Jost et al.	2003/0214519	A1	11/2003	Smith et al.
2003/0122652	A1	7/2003	Himmelstein et al.	2003/0216919	A1	11/2003	Roushar
2003/0122787	A1	7/2003	Zimmerman et al.	2003/0221198	A1	11/2003	Sloo et al.
2003/0125927	A1	7/2003	Seme	2003/0224760	A1	12/2003	Day
2003/0125945	A1	7/2003	Doyle	2003/0228863	A1	12/2003	Vander Veen et al.
2003/0125955	A1	7/2003	Arnold et al.	2003/0228909	A1	12/2003	Tanaka et al.
2003/0126559	A1	7/2003	Fuhrmann	2003/0229490	A1	12/2003	Etter
2003/0128819	A1	7/2003	Lee et al.	2003/0229616	A1	12/2003	Wong
2003/0130847	A1	7/2003	Case et al.	2003/0233230	A1	12/2003	Ammicht et al.
2003/0131320	A1	7/2003	Kumhyr et al.	2003/0233237	A1	12/2003	Garside et al.
2003/0133694	A1	7/2003	Yeo	2003/0233240	A1	12/2003	Kaatrasalo
2003/0134678	A1	7/2003	Tanaka	2003/0234824	A1	12/2003	Litwiller
2003/0135501	A1	7/2003	Frerebeau et al.	2003/0236663	A1	12/2003	Dimitrova et al.
2003/0135740	A1	7/2003	Talmor et al.	2003/0237055	A1	12/2003	Lange et al.
2003/0139925	A1	7/2003	Anderson et al.	2004/0001396	A1	1/2004	Keller et al.
2003/0140088	A1	7/2003	Robinson et al.	2004/0006467	A1	1/2004	Anisimovich et al.
2003/0144846	A1	7/2003	Denenberg et al.	2004/0008277	A1	1/2004	Nagaishi et al.
2003/0145285	A1	7/2003	Miyahira et al.	2004/0010484	A1	1/2004	Foulger et al.
2003/0147512	A1	8/2003	Abhuri	2004/0012556	A1	1/2004	Yong et al.
2003/0149557	A1	8/2003	Cox et al.	2004/0013252	A1	1/2004	Craner
2003/0149567	A1	8/2003	Schmitz et al.	2004/0015342	A1	1/2004	Garst et al.
2003/0149978	A1	8/2003	Plotnick	2004/0021676	A1	2/2004	Chen et al.
2003/0152203	A1	8/2003	Berger et al.	2004/0022369	A1	2/2004	Vitikainen et al.
				2004/0022373	A1	2/2004	Suder et al.
				2004/0023643	A1	2/2004	Vander Veen et al.
				2004/0024834	A1	2/2004	Alegria et al.
				2004/0030551	A1	2/2004	Marcu et al.

(56)

References Cited

U.S. PATENT DOCUMENTS

2004/0030554	A1	2/2004	Boxberger-Oberoi et al.	2004/0172249	A1	9/2004	Taylor et al.
2004/0030556	A1	2/2004	Bennett	2004/0174399	A1	9/2004	Wu et al.
2004/0030559	A1	2/2004	Payne et al.	2004/0174434	A1	9/2004	Walker et al.
2004/0030996	A1	2/2004	Van Liempd et al.	2004/0176958	A1	9/2004	Salmenkaita et al.
2004/0036715	A1	2/2004	Warren	2004/0177319	A1	9/2004	Horn
2004/0044516	A1	3/2004	Kennewick et al.	2004/0178994	A1	9/2004	Kairls, Jr.
2004/0048627	A1	3/2004	Olvera-Hernandez	2004/0181392	A1	9/2004	Parikh et al.
2004/0049388	A1	3/2004	Roth et al.	2004/0183833	A1	9/2004	Chua
2004/0049391	A1	3/2004	Polanyi et al.	2004/0186713	A1	9/2004	Gomas et al.
2004/0051729	A1	3/2004	Borden, IV	2004/0186714	A1	9/2004	Baker
2004/0052338	A1	3/2004	Celi, Jr. et al.	2004/0186777	A1	9/2004	Margiloff et al.
2004/0054530	A1	3/2004	Davis et al.	2004/0186857	A1	9/2004	Serlet et al.
2004/0054533	A1	3/2004	Bellegarda	2004/0193398	A1	9/2004	Chu et al.
2004/0054534	A1	3/2004	Junqua	2004/0193420	A1	9/2004	Kennewick et al.
2004/0054535	A1	3/2004	Mackie et al.	2004/0193421	A1	9/2004	Blass
2004/0054541	A1	3/2004	Kryze et al.	2004/0193426	A1	9/2004	Maddux et al.
2004/0054690	A1	3/2004	Hillerbrand et al.	2004/0196256	A1	10/2004	Wobbrock et al.
2004/0055446	A1	3/2004	Robbin et al.	2004/0198436	A1	10/2004	Alden
2004/0056899	A1	3/2004	Sinclair, II et al.	2004/0199375	A1	10/2004	Ehsani et al.
2004/0059574	A1	3/2004	Ma et al.	2004/0199387	A1	10/2004	Wang et al.
2004/0059576	A1	3/2004	Lucke	2004/0199663	A1	10/2004	Horvitz et al.
2004/0059577	A1	3/2004	Pickering	2004/0203520	A1	10/2004	Schirtzinger et al.
2004/0059790	A1	3/2004	Austin-Lane et al.	2004/0205151	A1	10/2004	Sprigg et al.
2004/0061717	A1	4/2004	Menon et al.	2004/0205671	A1	10/2004	Sukehiro et al.
2004/0062367	A1	4/2004	Fellenstein et al.	2004/0208302	A1	10/2004	Urban et al.
2004/0064593	A1	4/2004	Sinclair et al.	2004/0210438	A1	10/2004	Gillick et al.
2004/0069122	A1	4/2004	Wilson	2004/0210442	A1	10/2004	Glynn et al.
2004/0070567	A1	4/2004	Longe et al.	2004/0210634	A1	10/2004	Ferrer et al.
2004/0070612	A1	4/2004	Sinclair et al.	2004/0213419	A1	10/2004	Varma et al.
2004/0073427	A1	4/2004	Moore	2004/0215449	A1	10/2004	Roy
2004/0073428	A1	4/2004	Zlokarnik et al.	2004/0215731	A1	10/2004	Tzann-en Szeto
2004/0076086	A1	4/2004	Keller et al.	2004/0216049	A1	10/2004	Lewis et al.
2004/0078382	A1	4/2004	Mercer et al.	2004/0218451	A1	11/2004	Said et al.
2004/0085162	A1	5/2004	Agarwal et al.	2004/0220798	A1	11/2004	Chi et al.
2004/0085368	A1	5/2004	Johnson, Jr. et al.	2004/0220809	A1	11/2004	Wang et al.
2004/0086120	A1	5/2004	Akins, III et al.	2004/0221235	A1	11/2004	Marchisio et al.
2004/0093213	A1	5/2004	Conkie	2004/0223485	A1	11/2004	Arellano et al.
2004/0093215	A1	5/2004	Gupta et al.	2004/0223599	A1	11/2004	Bear et al.
2004/0093328	A1	5/2004	Damle	2004/0224638	A1	11/2004	Fadell et al.
2004/0094018	A1	5/2004	Ueshima et al.	2004/0225501	A1	11/2004	Cutaia et al.
2004/0096105	A1	5/2004	Holtsberg	2004/0225504	A1	11/2004	Junqua et al.
2004/0098250	A1	5/2004	Kimchi et al.	2004/0225650	A1	11/2004	Cooper et al.
2004/0100479	A1	5/2004	Nakano et al.	2004/0225746	A1	11/2004	Niell et al.
2004/0106432	A1	6/2004	Kanamori et al.	2004/0226042	A1	11/2004	Ellis
2004/0107169	A1	6/2004	Lowe	2004/0230420	A1	11/2004	Kadambe et al.
2004/0111266	A1	6/2004	Coorman et al.	2004/0230637	A1	11/2004	Lecouche et al.
2004/0111332	A1	6/2004	Baar et al.	2004/0236778	A1	11/2004	Junqua et al.
2004/0114731	A1	6/2004	Gillett et al.	2004/0242286	A1	12/2004	Benco et al.
2004/0120476	A1	6/2004	Harrison et al.	2004/0243412	A1	12/2004	Gupta et al.
2004/0122656	A1	6/2004	Abir	2004/0243415	A1	12/2004	Commarford et al.
2004/0122664	A1	6/2004	Lorenzo et al.	2004/0243419	A1	12/2004	Wang
2004/0122673	A1	6/2004	Park et al.	2004/0249629	A1	12/2004	Webster
2004/0124583	A1	7/2004	Landis	2004/0249637	A1	12/2004	Baker et al.
2004/0125088	A1	7/2004	Zimmerman et al.	2004/0249667	A1	12/2004	Oon
2004/0125922	A1	7/2004	Specht	2004/0252119	A1	12/2004	Hunleth et al.
2004/0127198	A1	7/2004	Roskind et al.	2004/0252604	A1	12/2004	Johnson et al.
2004/0127241	A1	7/2004	Shostak	2004/0252966	A1	12/2004	Holloway et al.
2004/0128137	A1	7/2004	Bush et al.	2004/0254791	A1	12/2004	Coifman et al.
2004/0128614	A1	7/2004	Andrews et al.	2004/0254792	A1	12/2004	Busayapongchai et al.
2004/0133817	A1	7/2004	Choi	2004/0257432	A1	12/2004	Girish et al.
2004/0135701	A1	7/2004	Yasuda et al.	2004/0259536	A1	12/2004	Keskar et al.
2004/0135774	A1	7/2004	La Monica	2004/0260438	A1	12/2004	Chernetsky et al.
2004/0136510	A1	7/2004	Vander Veen	2004/0260547	A1	12/2004	Cohen et al.
2004/0138869	A1	7/2004	Heinecke	2004/0260718	A1	12/2004	Fedorov et al.
2004/0138881	A1	7/2004	Divay et al.	2004/0261023	A1	12/2004	Bier
2004/0145607	A1	7/2004	Alderson	2004/0262051	A1	12/2004	Carro
2004/0148154	A1	7/2004	Acero et al.	2004/0263636	A1	12/2004	Cutler et al.
2004/0152054	A1	8/2004	Gleissner et al.	2004/0267825	A1	12/2004	Novak et al.
2004/0153306	A1	8/2004	Tanner et al.	2004/0268253	A1	12/2004	Demello et al.
2004/0155869	A1	8/2004	Robinson et al.	2004/0268262	A1	12/2004	Gupta et al.
2004/0160419	A1	8/2004	Padgitt	2005/0002507	A1	1/2005	Timmins et al.
2004/0162741	A1	8/2004	Flaxer et al.	2005/0010409	A1	1/2005	Hull et al.
2004/0167778	A1	8/2004	Valsan et al.	2005/0012723	A1	1/2005	Pallakoff
2004/0168120	A1	8/2004	Scopes	2005/0015254	A1	1/2005	Beaman
2004/0170379	A1	9/2004	Yao et al.	2005/0015751	A1	1/2005	Grassens
				2005/0015772	A1	1/2005	Saare et al.
				2005/0021330	A1	1/2005	Mano et al.
				2005/0021424	A1	1/2005	Lewis et al.
				2005/0022114	A1	1/2005	Shanahan et al.

(56)	References Cited						
	U.S. PATENT DOCUMENTS						
2005/0024341	A1	2/2005	Gillespie et al.	2005/0148356	A1	7/2005	Ferguson et al.
2005/0024345	A1	2/2005	Eastty et al.	2005/0149214	A1	7/2005	Yoo et al.
2005/0027385	A1	2/2005	Yueh	2005/0149326	A1	7/2005	Hogengout et al.
2005/0030175	A1	2/2005	Wolfe	2005/0149328	A1	7/2005	Huang et al.
2005/0031106	A1	2/2005	Henderson	2005/0149330	A1	7/2005	Katae
2005/0033582	A1	2/2005	Gadd et al.	2005/0149332	A1	7/2005	Kuzunuki et al.
2005/0033771	A1	2/2005	Schmitter et al.	2005/0149510	A1	7/2005	Shafir
2005/0034164	A1	2/2005	Sano et al.	2005/0152558	A1	7/2005	Van Tassel
2005/0038657	A1	2/2005	Roth et al.	2005/0152602	A1	7/2005	Chen et al.
2005/0039141	A1	2/2005	Burke et al.	2005/0154578	A1	7/2005	Tong et al.
2005/0042591	A1	2/2005	Bloom et al.	2005/0154580	A1	7/2005	Horowitz et al.
2005/0043946	A1	2/2005	Ueyama et al.	2005/0154591	A1	7/2005	Lecoeuche
2005/0043949	A1	2/2005	Roth et al.	2005/0159939	A1	7/2005	Mohler et al.
2005/0043974	A1	2/2005	Vassilev et al.	2005/0159957	A1	7/2005	Roth et al.
2005/0044569	A1	2/2005	Marcus	2005/0162395	A1	7/2005	Unruh
2005/0045373	A1	3/2005	Born	2005/0165015	A1	7/2005	Neube et al.
2005/0049862	A1	3/2005	Choi et al.	2005/0165607	A1	7/2005	Di Fabbriozio et al.
2005/0049870	A1	3/2005	Zhang et al.	2005/0166153	A1	7/2005	Eytchison et al.
2005/0049880	A1	3/2005	Roth et al.	2005/0171766	A1	8/2005	Albesano et al.
2005/0050526	A1	3/2005	Dahne-Steuber et al.	2005/0171779	A1	8/2005	Joublin
2005/0055212	A1	3/2005	Nagao	2005/0177445	A1	8/2005	Church
2005/0055403	A1	3/2005	Brittan	2005/0181770	A1	8/2005	Helferich
2005/0058438	A1	3/2005	Hayashi	2005/0182616	A1	8/2005	Kotipalli
2005/0060151	A1	3/2005	Kuo et al.	2005/0182627	A1	8/2005	Tanaka et al.
2005/0060155	A1	3/2005	Chu et al.	2005/0182628	A1	8/2005	Choi
2005/0071165	A1	3/2005	Hofstader et al.	2005/0182629	A1	8/2005	Coorman et al.
2005/0071332	A1	3/2005	Ortega et al.	2005/0182630	A1	8/2005	Miro et al.
2005/0071437	A1	3/2005	Bear et al.	2005/0182765	A1	8/2005	Liddy
2005/0074113	A1	4/2005	Mathew et al.	2005/0184958	A1	8/2005	Gnanamgari et al.
2005/0075874	A1	4/2005	Balchandran et al.	2005/0185779	A1	8/2005	Toms
2005/0075875	A1	4/2005	Shozakai et al.	2005/0187767	A1	8/2005	Godden
2005/0075881	A1	4/2005	Rigazio et al.	2005/0187770	A1	8/2005	Kompe et al.
2005/0080613	A1	4/2005	Colledge et al.	2005/0187773	A1	8/2005	Filochen et al.
2005/0080620	A1	4/2005	Rao et al.	2005/0190059	A1	9/2005	Wehrenberg
2005/0080625	A1	4/2005	Bennett et al.	2005/0190970	A1	9/2005	Griffin
2005/0080632	A1	4/2005	Endo et al.	2005/0190973	A1	9/2005	Kristensson et al.
2005/0080780	A1	4/2005	Colledge et al.	2005/0191159	A1	9/2005	Benko
2005/0086059	A1	4/2005	Bennett	2005/0192795	A1	9/2005	Lam et al.
2005/0086255	A1	4/2005	Schran et al.	2005/0192801	A1	9/2005	Lewis et al.
2005/0086605	A1	4/2005	Ferrer et al.	2005/0192807	A1	9/2005	Emam et al.
2005/0091118	A1	4/2005	Fano	2005/0192812	A1	9/2005	Buchholz et al.
2005/0094475	A1	5/2005	Naoi	2005/0195077	A1	9/2005	Mcculloch et al.
2005/0099398	A1	5/2005	Garside et al.	2005/0195429	A1	9/2005	Archbold
2005/0100214	A1	5/2005	Zhang et al.	2005/0196733	A1	9/2005	Budra et al.
2005/0102144	A1	5/2005	Rapoport	2005/0201572	A1	9/2005	Lindahl et al.
2005/0102614	A1	5/2005	Brockett et al.	2005/0202854	A1	9/2005	Kortum et al.
2005/0102625	A1	5/2005	Lee et al.	2005/0203738	A1	9/2005	Hwang
2005/0105712	A1	5/2005	Williams et al.	2005/0203747	A1	9/2005	Lecoeuche
2005/0108001	A1	5/2005	Aarskog	2005/0203782	A1	9/2005	Smith
2005/0108017	A1	5/2005	Esser et al.	2005/0203991	A1	9/2005	Kawamura et al.
2005/0108074	A1	5/2005	Bloechl et al.	2005/0209848	A1	9/2005	Ishii
2005/0108338	A1	5/2005	Simske et al.	2005/0210394	A1	9/2005	Crandall et al.
2005/0108344	A1	5/2005	Tafoya et al.	2005/0216271	A1	9/2005	Konig
2005/0108642	A1	5/2005	Sinclair et al.	2005/0216331	A1	9/2005	Ahrens et al.
2005/0114124	A1	5/2005	Liu et al.	2005/0222843	A1	10/2005	Kahn et al.
2005/0114140	A1	5/2005	Brackett et al.	2005/0222973	A1	10/2005	Kaiser
2005/0114306	A1	5/2005	Shu et al.	2005/0228665	A1	10/2005	Kobayashi et al.
2005/0114791	A1	5/2005	Bollenbacher et al.	2005/0245243	A1	11/2005	Zuniga
2005/0119890	A1	6/2005	Hirose	2005/0246350	A1	11/2005	Canaran
2005/0119897	A1	6/2005	Bennett et al.	2005/0246365	A1	11/2005	Lowles et al.
2005/0125215	A1	6/2005	Wu et al.	2005/0246686	A1	11/2005	Seshadri et al.
2005/0125216	A1	6/2005	Chitrapura et al.	2005/0246726	A1	11/2005	Labrou et al.
2005/0125218	A1	6/2005	Rajput et al.	2005/0251572	A1	11/2005	McMahan et al.
2005/0125226	A1	6/2005	Magee	2005/0254481	A1	11/2005	Vishik et al.
2005/0125235	A1	6/2005	Lazay et al.	2005/0255874	A1	11/2005	Stewart-Baxter et al.
2005/0131951	A1	6/2005	Zhang et al.	2005/0261901	A1	11/2005	Davis et al.
2005/0132301	A1	6/2005	Ikeda	2005/0261903	A1	11/2005	Kawazoe et al.
2005/0136949	A1	6/2005	Barnes, Jr.	2005/0262440	A1	11/2005	Stanciu et al.
2005/0138305	A1	6/2005	Zellner	2005/0267738	A1	12/2005	Wilkinson et al.
2005/0140504	A1	6/2005	Marshall et al.	2005/0267757	A1	12/2005	Iso-Sipila et al.
2005/0143970	A1	6/2005	Roth et al.	2005/0268247	A1	12/2005	Baneth
2005/0143972	A1	6/2005	Gopalakrishnan et al.	2005/0271216	A1	12/2005	Lashkari
2005/0144003	A1	6/2005	Iso-Sipila	2005/0273332	A1	12/2005	Scott et al.
2005/0144070	A1	6/2005	Cheshire	2005/0273337	A1	12/2005	Erell et al.
2005/0144568	A1	6/2005	Gruen et al.	2005/0273626	A1	12/2005	Pearson et al.
				2005/0275505	A1	12/2005	Himmelstein
				2005/0278297	A1	12/2005	Nelson
				2005/0278643	A1	12/2005	Ukai et al.
				2005/0278647	A1	12/2005	Leavitt et al.

(56)

References Cited

U.S. PATENT DOCUMENTS

2005/0283363	A1	12/2005	Weng et al.	2006/0097991	A1	5/2006	Hotelling et al.
2005/0283364	A1	12/2005	Longe et al.	2006/0100848	A1	5/2006	Cozzi et al.
2005/0283726	A1	12/2005	Lunati	2006/0100849	A1	5/2006	Chan
2005/0283729	A1	12/2005	Morris et al.	2006/0101354	A1	5/2006	Hashimoto et al.
2005/0288934	A1	12/2005	Omi	2006/0103633	A1	5/2006	Gioeli
2005/0288936	A1	12/2005	Busayapongchai et al.	2006/0106592	A1	5/2006	Brockett et al.
2005/0289458	A1	12/2005	Kylmanen	2006/0106594	A1	5/2006	Brockett et al.
2005/0289463	A1	12/2005	Wu et al.	2006/0106595	A1	5/2006	Brockett et al.
2006/0001652	A1	1/2006	Chiu et al.	2006/0111906	A1	5/2006	Cross et al.
2006/0004570	A1	1/2006	Ju et al.	2006/0111909	A1	5/2006	Maes et al.
2006/0004640	A1	1/2006	Swierczek	2006/0112810	A1	6/2006	Eves et al.
2006/0004744	A1	1/2006	Nevidomski et al.	2006/0116874	A1	6/2006	Samuelsson et al.
2006/0007174	A1	1/2006	Shen	2006/0116877	A1	6/2006	Pickering et al.
2006/0009973	A1	1/2006	Nguyen et al.	2006/0117002	A1	6/2006	Swen
2006/0013414	A1	1/2006	Shih	2006/0119582	A1	6/2006	Ng et al.
2006/0013446	A1	1/2006	Stephens	2006/0122834	A1	6/2006	Bennett
2006/0015317	A1	1/2006	Nakagawa	2006/0122836	A1	6/2006	Cross et al.
2006/0015326	A1	1/2006	Mori et al.	2006/0129379	A1	6/2006	Ramsey et al.
2006/0015341	A1	1/2006	Baker	2006/0129929	A1	6/2006	Weber et al.
2006/0015484	A1	1/2006	Weng et al.	2006/0130006	A1	6/2006	Chitale
2006/0015819	A1	1/2006	Hawkins et al.	2006/0132812	A1	6/2006	Barnes et al.
2006/0018446	A1	1/2006	Schmandt et al.	2006/0135214	A1	6/2006	Zhang et al.
2006/0018492	A1	1/2006	Chiu et al.	2006/0136213	A1	6/2006	Hirose et al.
2006/0020890	A1	1/2006	Kroll et al.	2006/0136280	A1	6/2006	Cho et al.
2006/0025999	A1	2/2006	Feng et al.	2006/0136352	A1	6/2006	Brun et al.
2006/0026233	A1	2/2006	Tenembaum et al.	2006/0141990	A1	6/2006	Zak et al.
2006/0026521	A1	2/2006	Hotelling et al.	2006/0142576	A1	6/2006	Meng et al.
2006/0026535	A1	2/2006	Hotelling et al.	2006/0142993	A1	6/2006	Menendez-Pidal et al.
2006/0026536	A1	2/2006	Hotelling et al.	2006/0143007	A1	6/2006	Koh et al.
2006/0033724	A1	2/2006	Chaudhri et al.	2006/0143559	A1	6/2006	Spielberg et al.
2006/0035632	A1	2/2006	Sorvari et al.	2006/0143576	A1	6/2006	Gupta et al.
2006/0036946	A1	2/2006	Radtke et al.	2006/0148520	A1	7/2006	Baker et al.
2006/0041424	A1	2/2006	Todhunter et al.	2006/0149544	A1	7/2006	Hakkani-Tur et al.
2006/0041431	A1	2/2006	Maes	2006/0149557	A1	7/2006	Kaneko et al.
2006/0041549	A1	2/2006	Gundersen et al.	2006/0149558	A1	7/2006	Kahn et al.
2006/0041590	A1	2/2006	King et al.	2006/0150087	A1	7/2006	Cronenberger et al.
2006/0041926	A1	2/2006	Istvan et al.	2006/0152496	A1	7/2006	Knaven
2006/0047632	A1	3/2006	Zhang	2006/0153040	A1	7/2006	Girish et al.
2006/0050865	A1	3/2006	Kortum et al.	2006/0156252	A1	7/2006	Sheshagiri et al.
2006/0052141	A1	3/2006	Suzuki	2006/0156307	A1	7/2006	Kunjithapatham et al.
2006/0053007	A1	3/2006	Niemisto et al.	2006/0161870	A1	7/2006	Hotelling et al.
2006/0053014	A1	3/2006	Yoshizawa	2006/0161871	A1	7/2006	Hotelling et al.
2006/0053365	A1	3/2006	Hollander et al.	2006/0161872	A1	7/2006	Rytivaara et al.
2006/0053379	A1	3/2006	Henderson et al.	2006/0165105	A1	7/2006	Shenfield et al.
2006/0053387	A1	3/2006	Ording	2006/0167676	A1	7/2006	Plumb
2006/0058999	A1	3/2006	Barker et al.	2006/0168150	A1	7/2006	Naik et al.
2006/0059424	A1	3/2006	Petri et al.	2006/0168507	A1	7/2006	Hansen
2006/0059437	A1	3/2006	Conklin	2006/0168539	A1	7/2006	Hawkins et al.
2006/0060762	A1	3/2006	Chan et al.	2006/0172720	A1	8/2006	Islam et al.
2006/0061488	A1	3/2006	Dunton	2006/0173683	A1	8/2006	Roth et al.
2006/0064693	A1	3/2006	Messer et al.	2006/0173684	A1	8/2006	Fischer et al.
2006/0067535	A1	3/2006	Culbert et al.	2006/0174207	A1	8/2006	Deshpande
2006/0067536	A1	3/2006	Culbert et al.	2006/0178868	A1	8/2006	Billerey-Mosier
2006/0069567	A1	3/2006	Tischer et al.	2006/0181519	A1	8/2006	Vernier et al.
2006/0069664	A1	3/2006	Ling et al.	2006/0183466	A1	8/2006	Lee et al.
2006/0072248	A1	4/2006	Watanabe et al.	2006/0184370	A1	8/2006	Kwak et al.
2006/0072716	A1	4/2006	Pham	2006/0184886	A1	8/2006	Chung et al.
2006/0074628	A1	4/2006	Elbaz et al.	2006/0187073	A1	8/2006	Lin et al.
2006/0074651	A1	4/2006	Arun et al.	2006/0190169	A1	8/2006	Kawai
2006/0074660	A1	4/2006	Waters et al.	2006/0190255	A1	8/2006	Fukada
2006/0074674	A1	4/2006	Zhang et al.	2006/0190269	A1	8/2006	Tessel et al.
2006/0074750	A1	4/2006	Clark et al.	2006/0190436	A1	8/2006	Richardson et al.
2006/0074898	A1	4/2006	Gavalda et al.	2006/0190577	A1	8/2006	Yamada
2006/0075429	A1	4/2006	Istvan et al.	2006/0193518	A1	8/2006	Dong
2006/0077055	A1	4/2006	Basir	2006/0194181	A1	8/2006	Rosenberg
2006/0080098	A1	4/2006	Campbell	2006/0195206	A1	8/2006	Moon et al.
2006/0085183	A1	4/2006	Jain	2006/0195323	A1	8/2006	Monne et al.
2006/0085187	A1	4/2006	Barquilla	2006/0195516	A1	8/2006	Beaupre
2006/0085465	A1	4/2006	Nori et al.	2006/0197753	A1	9/2006	Hotelling
2006/0085757	A1	4/2006	Andre et al.	2006/0197755	A1	9/2006	Bawany
2006/0093998	A1	5/2006	Vertegaal	2006/0200253	A1	9/2006	Hoffberg et al.
2006/0095265	A1	5/2006	Chu et al.	2006/0200342	A1	9/2006	Corston-Oliver et al.
2006/0095790	A1	5/2006	Nguyen et al.	2006/0200347	A1	9/2006	Kim et al.
2006/0095846	A1	5/2006	Nurmi	2006/0205432	A1	9/2006	Hawkins et al.
2006/0095848	A1	5/2006	Naik	2006/0206313	A1	9/2006	Xu et al.
				2006/0206454	A1	9/2006	Forstall et al.
				2006/0206724	A1	9/2006	Schaufele et al.
				2006/0212415	A1	9/2006	Backer et al.
				2006/0217967	A1	9/2006	Goertzen et al.

(56)		References Cited				
		U.S. PATENT DOCUMENTS				
2006/0218244	A1	9/2006	Rasmussen et al.	2007/0038460	A1	2/2007 Navratil et al.
2006/0221738	A1	10/2006	Park et al.	2007/0038609	A1	2/2007 Wu
2006/0221788	A1	10/2006	Lindahl et al.	2007/0040813	A1	2/2007 Kushler et al.
2006/0224570	A1	10/2006	Quiroga et al.	2007/0041361	A1	2/2007 Iso-Sipila
2006/0229802	A1	10/2006	Vertelney et al.	2007/0042812	A1	2/2007 Basir et al.
2006/0229870	A1	10/2006	Kobal	2007/0043568	A1	2/2007 Dhanakshirur et al.
2006/0229876	A1	10/2006	Aaron et al.	2007/0043574	A1	2/2007 Coffman et al.
2006/0230350	A1	10/2006	Baluja	2007/0043687	A1	2/2007 Bodart et al.
2006/0230410	A1	10/2006	Kurganov et al.	2007/0043820	A1	2/2007 George et al.
2006/0234680	A1	10/2006	Doulton	2007/0044038	A1	2/2007 Horentrup et al.
2006/0235550	A1	10/2006	Csicsatka et al.	2007/0046641	A1	3/2007 Lim
2006/0235690	A1	10/2006	Tomasic et al.	2007/0047719	A1	3/2007 Dhawan et al.
2006/0235700	A1	10/2006	Wong et al.	2007/0050184	A1	3/2007 Drucker et al.
2006/0235841	A1	10/2006	Betz et al.	2007/0050191	A1	3/2007 Weider et al.
2006/0236262	A1	10/2006	Bathiche et al.	2007/0050393	A1	3/2007 Vogel et al.
2006/0239419	A1	10/2006	Joseph et al.	2007/0050712	A1	3/2007 Hull et al.
2006/0239471	A1	10/2006	Mao et al.	2007/0052586	A1	3/2007 Horstemeyer
2006/0240866	A1	10/2006	Eilts et al.	2007/0055493	A1	3/2007 Lee
2006/0241948	A1	10/2006	Abrash et al.	2007/0055508	A1	3/2007 Zhao et al.
2006/0242190	A1	10/2006	Wnek	2007/0055514	A1	3/2007 Beattie et al.
2006/0246955	A1	11/2006	Nirhamo et al.	2007/0055525	A1	3/2007 Kennewick et al.
2006/0247931	A1	11/2006	Caskey et al.	2007/0055529	A1	3/2007 Kanevsky et al.
2006/0252457	A1	11/2006	Schrager	2007/0058832	A1	3/2007 Hug et al.
2006/0253210	A1	11/2006	Rosenberg	2007/0060107	A1	3/2007 Day
2006/0253787	A1	11/2006	Fogg	2007/0060114	A1	3/2007 Ramer et al.
2006/0256934	A1	11/2006	Mazor	2007/0060118	A1	3/2007 Guyette
2006/0258376	A1	11/2006	Ewell et al.	2007/0061152	A1	3/2007 Doi
2006/0262876	A1	11/2006	LaDue	2007/0061487	A1	3/2007 Moore et al.
2006/0265208	A1	11/2006	Assadollahi	2007/0061712	A1	3/2007 Bodin et al.
2006/0265503	A1	11/2006	Jones et al.	2007/0061754	A1	3/2007 Ardhanari et al.
2006/0265648	A1	11/2006	Rainisto et al.	2007/0067173	A1	3/2007 Bellegarda
2006/0271364	A1	11/2006	Mirkovic et al.	2007/0067272	A1	3/2007 Flynt et al.
2006/0271627	A1	11/2006	Szczepanek	2007/0072553	A1	3/2007 Barbera
2006/0274051	A1	12/2006	Longe et al.	2007/0073540	A1	3/2007 Hirakawa et al.
2006/0274905	A1	12/2006	Lindahl et al.	2007/0073541	A1	3/2007 Tian
2006/0277031	A1	12/2006	Ramsey et al.	2007/0073745	A1	3/2007 Scott et al.
2006/0277058	A1	12/2006	J'maev et al.	2007/0074131	A1	3/2007 Assadollahi et al.
2006/0282264	A1	12/2006	Denny et al.	2007/0074617	A1	4/2007 Vergo
2006/0282415	A1	12/2006	Shibata et al.	2007/0075965	A1	4/2007 Huppi et al.
2006/0282455	A1	12/2006	Lee et al.	2007/0079027	A1	4/2007 Marriott et al.
2006/0286527	A1	12/2006	Morel	2007/0080936	A1	4/2007 Tsuk et al.
2006/0287864	A1	12/2006	Pusa et al.	2007/0083366	A1	4/2007 Peters
2006/0288024	A1	12/2006	Braica	2007/0083467	A1	4/2007 Lindahl et al.
2006/0291666	A1	12/2006	Ball et al.	2007/0083623	A1	4/2007 Nishimura et al.
2006/0293876	A1	12/2006	Kamatani et al.	2007/0088556	A1	4/2007 Andrew
2006/0293880	A1	12/2006	Elshishiny et al.	2007/0088952	A1*	4/2007 Hewitt H04L 9/3271 713/171
2006/0293886	A1	12/2006	Odell et al.	2007/0089132	A1	4/2007 Qureshey et al.
2006/0293889	A1	12/2006	Kiss et al.	2007/0089135	A1	4/2007 Qureshey et al.
2006/0293890	A1	12/2006	Blair et al.	2007/0093277	A1	4/2007 Cavacuiti et al.
2007/0003026	A1	1/2007	Hodge et al.	2007/0094026	A1	4/2007 Ativanichayaphong et al.
2007/0004451	A1	1/2007	C. Anderson	2007/0098195	A1	5/2007 Holmes
2007/0005206	A1	1/2007	Zhang et al.	2007/0100206	A1	5/2007 Lin et al.
2007/0005849	A1	1/2007	Oliver	2007/0100602	A1	5/2007 Kim
2007/0006098	A1	1/2007	Krumm et al.	2007/0100619	A1	5/2007 Purho et al.
2007/0011154	A1	1/2007	Musgrove et al.	2007/0100624	A1	5/2007 Weng et al.
2007/0014280	A1	1/2007	Cormier et al.	2007/0100635	A1	5/2007 Mahajan et al.
2007/0016563	A1	1/2007	Omoigui	2007/0100709	A1	5/2007 Lee et al.
2007/0016865	A1	1/2007	Johnson et al.	2007/0100790	A1	5/2007 Cheyer et al.
2007/0021956	A1	1/2007	Qu et al.	2007/0100814	A1	5/2007 Lee et al.
2007/0022380	A1	1/2007	Swartz et al.	2007/0100883	A1	5/2007 Rose et al.
2007/0025704	A1	2/2007	Tsukazaki et al.	2007/0106491	A1	5/2007 Carter et al.
2007/0026852	A1	2/2007	Logan et al.	2007/0106497	A1	5/2007 Ramsey et al.
2007/0027732	A1	2/2007	Hudgens	2007/0106512	A1	5/2007 Acero et al.
2007/0028009	A1	2/2007	Robbin et al.	2007/0106513	A1	5/2007 Boillot et al.
2007/0030824	A1	2/2007	Ribaudo et al.	2007/0106657	A1	5/2007 Brzeski et al.
2007/0032247	A1	2/2007	Shaffer et al.	2007/0106674	A1	5/2007 Agrawal et al.
2007/0033003	A1	2/2007	Morris	2007/0106685	A1	5/2007 Houh et al.
2007/0033005	A1	2/2007	Cristo et al.	2007/0112562	A1	5/2007 Vainio et al.
2007/0033026	A1	2/2007	Bartosik et al.	2007/0112568	A1	5/2007 Fingscheidt et al.
2007/0033054	A1	2/2007	Snitkovskiy et al.	2007/0116195	A1	5/2007 Thompson et al.
2007/0036117	A1	2/2007	Taube et al.	2007/0118351	A1	5/2007 Sumita
2007/0036286	A1	2/2007	Champlin et al.	2007/0118377	A1	5/2007 Badino et al.
2007/0036294	A1	2/2007	Chaudhuri et al.	2007/0118378	A1	5/2007 Skuratovsky
2007/0038436	A1	2/2007	Cristo et al.	2007/0121846	A1	5/2007 Altberg et al.
2007/0038452	A1	2/2007	Blair et al.	2007/0124131	A1	5/2007 Chino et al.
				2007/0124132	A1	5/2007 Takeuchi et al.
				2007/0124149	A1	5/2007 Shen et al.
				2007/0124289	A1	5/2007 Imielinski

(56)

References Cited

U.S. PATENT DOCUMENTS

- | | | | | | | | |
|--------------|----|--------|--------------------------|--------------|----|---------|----------------------------|
| 2007/0124291 | A1 | 5/2007 | Hassan et al. | 2007/0219645 | A1 | 9/2007 | Thomas et al. |
| 2007/0124675 | A1 | 5/2007 | Ban et al. | 2007/0219777 | A1 | 9/2007 | Chu et al. |
| 2007/0124676 | A1 | 5/2007 | Amundsen et al. | 2007/0219786 | A1 | 9/2007 | Isaac et al. |
| 2007/0127888 | A1 | 6/2007 | Hayashi et al. | 2007/0219801 | A1 | 9/2007 | Sundaram et al. |
| 2007/0128777 | A1 | 6/2007 | Yin et al. | 2007/0219803 | A1 | 9/2007 | Chiu et al. |
| 2007/0129059 | A1 | 6/2007 | Nadarajah et al. | 2007/0219983 | A1 | 9/2007 | Fish |
| 2007/0129098 | A1 | 6/2007 | Cheng et al. | 2007/0225980 | A1 | 9/2007 | Sumita |
| 2007/0130014 | A1 | 6/2007 | Altberg et al. | 2007/0225984 | A1 | 9/2007 | Milstein et al. |
| 2007/0130128 | A1 | 6/2007 | Garg et al. | 2007/0226652 | A1 | 9/2007 | Kikuchi et al. |
| 2007/0132738 | A1 | 6/2007 | Lowles et al. | 2007/0229323 | A1 | 10/2007 | Plachta et al. |
| 2007/0133771 | A1 | 6/2007 | Stifelman et al. | 2007/0230729 | A1 | 10/2007 | Naylor et al. |
| 2007/0135187 | A1 | 6/2007 | Kreiner et al. | 2007/0233484 | A1 | 10/2007 | Coelho et al. |
| 2007/0135949 | A1 | 6/2007 | Snover et al. | 2007/0233487 | A1 | 10/2007 | Cohen et al. |
| 2007/0136064 | A1 | 6/2007 | Carroll | 2007/0233490 | A1 | 10/2007 | Yao |
| 2007/0136071 | A1 | 6/2007 | Lee et al. | 2007/0233497 | A1 | 10/2007 | Paek et al. |
| 2007/0136778 | A1 | 6/2007 | Birger et al. | 2007/0233692 | A1 | 10/2007 | Lisa et al. |
| 2007/0143163 | A1 | 6/2007 | Weiss et al. | 2007/0233725 | A1 | 10/2007 | Michmerhuizen et al. |
| 2007/0143376 | A1 | 6/2007 | McIntosh | 2007/0238488 | A1 | 10/2007 | Scott |
| 2007/0149252 | A1 | 6/2007 | Jobs et al. | 2007/0238489 | A1 | 10/2007 | Scott |
| 2007/0150403 | A1 | 6/2007 | Mock et al. | 2007/0238520 | A1 | 10/2007 | Kacmarcik |
| 2007/0150444 | A1 | 6/2007 | Chesnais et al. | 2007/0239429 | A1 | 10/2007 | Johnson et al. |
| 2007/0150842 | A1 | 6/2007 | Chaudhri et al. | 2007/0239453 | A1 | 10/2007 | Paek et al. |
| 2007/0152978 | A1 | 7/2007 | Kocienda et al. | 2007/0240043 | A1 | 10/2007 | Fux et al. |
| 2007/0152980 | A1 | 7/2007 | Kocienda et al. | 2007/0240044 | A1 | 10/2007 | Fux et al. |
| 2007/0155346 | A1 | 7/2007 | Mijatovic et al. | 2007/0240045 | A1 | 10/2007 | Fux et al. |
| 2007/0156410 | A1 | 7/2007 | Stohr et al. | 2007/0240172 | A1 | 10/2007 | Banker et al. |
| 2007/0156627 | A1 | 7/2007 | D'Alicandro | 2007/0241885 | A1 | 10/2007 | Clipsham et al. |
| 2007/0157089 | A1 | 7/2007 | Van Os et al. | 2007/0244702 | A1 | 10/2007 | Kahn et al. |
| 2007/0157268 | A1 | 7/2007 | Girish et al. | 2007/0244976 | A1 | 10/2007 | Carroll et al. |
| 2007/0162274 | A1 | 7/2007 | Ruiz et al. | 2007/0247441 | A1 | 10/2007 | Kim et al. |
| 2007/0162296 | A1 | 7/2007 | Altberg et al. | 2007/0255435 | A1 | 11/2007 | Cohen et al. |
| 2007/0162414 | A1 | 7/2007 | Horowitz et al. | 2007/0255979 | A1 | 11/2007 | Deily et al. |
| 2007/0165003 | A1 | 7/2007 | Fux et al. | 2007/0257890 | A1 | 11/2007 | Hotelling et al. |
| 2007/0167136 | A1 | 7/2007 | Groth | 2007/0258642 | A1 | 11/2007 | Thota |
| 2007/0168922 | A1 | 7/2007 | Kaiser et al. | 2007/0260460 | A1 | 11/2007 | Hyatt |
| 2007/0173233 | A1 | 7/2007 | Vander Veen et al. | 2007/0260595 | A1 | 11/2007 | Beatty et al. |
| 2007/0173267 | A1 | 7/2007 | Klassen et al. | 2007/0260822 | A1 | 11/2007 | Adams |
| 2007/0174057 | A1 | 7/2007 | Genly | 2007/0261080 | A1 | 11/2007 | Saetti |
| 2007/0174188 | A1 | 7/2007 | Fish | 2007/0265831 | A1 | 11/2007 | Dinur et al. |
| 2007/0174350 | A1 | 7/2007 | Pell et al. | 2007/0265850 | A1 | 11/2007 | Kennewick et al. |
| 2007/0174396 | A1 | 7/2007 | Kumar et al. | 2007/0271104 | A1 | 11/2007 | McKay |
| 2007/0179776 | A1 | 8/2007 | Segond et al. | 2007/0271510 | A1 | 11/2007 | Grigoriu et al. |
| 2007/0179778 | A1 | 8/2007 | Gong et al. | 2007/0274468 | A1 | 11/2007 | Cai |
| 2007/0180383 | A1 | 8/2007 | Naik | 2007/0276651 | A1 | 11/2007 | Bliss et al. |
| 2007/0182595 | A1 | 8/2007 | Ghasabian | 2007/0276714 | A1 | 11/2007 | Beringer |
| 2007/0185551 | A1 | 8/2007 | Meadows et al. | 2007/0276810 | A1 | 11/2007 | Rosen |
| 2007/0185754 | A1 | 8/2007 | Schmidt | 2007/0277088 | A1 | 11/2007 | Bodin et al. |
| 2007/0185831 | A1 | 8/2007 | Churcher | 2007/0281603 | A1 | 12/2007 | Nath et al. |
| 2007/0185917 | A1 | 8/2007 | Prahlad et al. | 2007/0282595 | A1 | 12/2007 | Tunning et al. |
| 2007/0188901 | A1 | 8/2007 | Heckerman et al. | 2007/0285958 | A1 | 12/2007 | Platchta et al. |
| 2007/0192026 | A1 | 8/2007 | Lee et al. | 2007/0286363 | A1 | 12/2007 | Burg et al. |
| 2007/0192027 | A1 | 8/2007 | Lee et al. | 2007/0286399 | A1 | 12/2007 | Ramamoorthy et al. |
| 2007/0192095 | A1 | 8/2007 | Braho et al. | 2007/0288238 | A1 | 12/2007 | Hetherington et al. |
| 2007/0192105 | A1 | 8/2007 | Neeracher et al. | 2007/0288241 | A1 | 12/2007 | Cross et al. |
| 2007/0192179 | A1 | 8/2007 | Van et al. | 2007/0288449 | A1 | 12/2007 | Datta et al. |
| 2007/0192293 | A1 | 8/2007 | Swen | 2007/0291108 | A1 | 12/2007 | Huber et al. |
| 2007/0192403 | A1 | 8/2007 | Heine et al. | 2007/0294077 | A1 | 12/2007 | Narayanan et al. |
| 2007/0192744 | A1 | 8/2007 | Reponen | 2007/0294078 | A1 | 12/2007 | Kim et al. |
| 2007/0198267 | A1 | 8/2007 | Jones et al. | 2007/0294083 | A1 | 12/2007 | Bellegarda et al. |
| 2007/0198269 | A1 | 8/2007 | Braho et al. | 2007/0294199 | A1 | 12/2007 | Nelken et al. |
| 2007/0198273 | A1 | 8/2007 | Hennecke | 2007/0294263 | A1 | 12/2007 | Punj et al. |
| 2007/0198566 | A1 | 8/2007 | Sustik | 2007/0299664 | A1 | 12/2007 | Peters et al. |
| 2007/0203869 | A1 | 8/2007 | Ramsey et al. | 2007/0299831 | A1 | 12/2007 | Williams et al. |
| 2007/0203955 | A1 | 8/2007 | Pomerantz | 2007/0300140 | A1 | 12/2007 | Makela et al. |
| 2007/0207785 | A1 | 9/2007 | Chatterjee et al. | 2007/0300185 | A1 | 12/2007 | Macbeth et al. |
| 2007/0208555 | A1 | 9/2007 | Blass et al. | 2008/0001785 | A1 | 1/2008 | Elizarov et al. |
| 2007/0208569 | A1 | 9/2007 | Subramanian et al. | 2008/0010355 | A1 | 1/2008 | Vieri et al. |
| 2007/0208579 | A1 | 9/2007 | Peterson | 2008/0010605 | A1 | 1/2008 | Frank et al. |
| 2007/0208726 | A1 | 9/2007 | Krishnaprasad et al. | 2008/0012950 | A1 | 1/2008 | Lee et al. |
| 2007/0211071 | A1 | 9/2007 | Slotznick et al. | 2008/0013751 | A1 | 1/2008 | Hiselius |
| 2007/0213099 | A1 | 9/2007 | Bast | 2008/0015863 | A1 | 1/2008 | Agapi et al. |
| 2007/0213857 | A1 | 9/2007 | Bodin et al. | 2008/0015864 | A1 | 1/2008 | Ross et al. |
| 2007/0213984 | A1 | 9/2007 | Ativanichayaphong et al. | 2008/0016575 | A1 | 1/2008 | Vincent et al. |
| 2007/0213986 | A1 | 9/2007 | Bodin et al. | 2008/0021708 | A1 | 1/2008 | Bennett et al. |
| 2007/0217693 | A1 | 9/2007 | Kretzschmar, Jr. | 2008/0021886 | A1 | 1/2008 | Wang-Aryattanwanich et al. |
| | | | | 2008/0022208 | A1 | 1/2008 | Morse |
| | | | | 2008/0027726 | A1 | 1/2008 | Hansen et al. |
| | | | | 2008/0031475 | A1 | 2/2008 | Goldstein |
| | | | | 2008/0033719 | A1 | 2/2008 | Hall et al. |

(56)

References Cited

U.S. PATENT DOCUMENTS

2008/0034032	A1	2/2008	Healey et al.	2008/0120196	A1	5/2008	Reed et al.
2008/0034044	A1	2/2008	Bhakta et al.	2008/0120311	A1	5/2008	Reed
2008/0036743	A1	2/2008	Westerman et al.	2008/0120312	A1	5/2008	Reed
2008/0040339	A1	2/2008	Zhou et al.	2008/0120330	A1	5/2008	Reed
2008/0042970	A1	2/2008	Liang et al.	2008/0120342	A1	5/2008	Reed et al.
2008/0043936	A1	2/2008	Liebermann	2008/0122796	A1	5/2008	Jobs et al.
2008/0043943	A1	2/2008	Sipher et al.	2008/0124695	A1	5/2008	Myers et al.
2008/0046239	A1	2/2008	Boo	2008/0126075	A1	5/2008	Thorn et al.
2008/0046250	A1	2/2008	Agapi et al.	2008/0126077	A1	5/2008	Thorn
2008/0046422	A1	2/2008	Lee et al.	2008/0126091	A1	5/2008	Clark et al.
2008/0046820	A1	2/2008	Lee et al.	2008/0126093	A1	5/2008	Sivadas
2008/0046948	A1	2/2008	Verosub	2008/0126100	A1	5/2008	Grost et al.
2008/0048908	A1	2/2008	Sato	2008/0126491	A1	5/2008	Portele et al.
2008/0050027	A1	2/2008	Bashyam et al.	2008/0129520	A1	6/2008	Lee
2008/0052063	A1	2/2008	Bennett et al.	2008/0130867	A1	6/2008	Bowen
2008/0052073	A1	2/2008	Goto et al.	2008/0131006	A1	6/2008	Oliver
2008/0052077	A1	2/2008	Bennett et al.	2008/0132221	A1	6/2008	Willey et al.
2008/0052080	A1	2/2008	Narayanan et al.	2008/0132295	A1	6/2008	Horowitz
2008/0052262	A1	2/2008	Kosinov et al.	2008/0133215	A1	6/2008	Sarukkai
2008/0055194	A1	3/2008	Baudino et al.	2008/0133228	A1	6/2008	Rao
2008/0056459	A1	3/2008	Vallier et al.	2008/0133230	A1	6/2008	Herforth et al.
2008/0056579	A1	3/2008	Guha	2008/0133241	A1	6/2008	Baker et al.
2008/0057922	A1	3/2008	Kokes et al.	2008/0133956	A1	6/2008	Fadell
2008/0059190	A1	3/2008	Chu et al.	2008/0140413	A1	6/2008	Millman et al.
2008/0059200	A1	3/2008	Puli	2008/0140416	A1	6/2008	Shostak
2008/0059876	A1	3/2008	Hantler et al.	2008/0140652	A1	6/2008	Millman et al.
2008/0062141	A1	3/2008	Chaudhri	2008/0140657	A1	6/2008	Azvine et al.
2008/0065382	A1	3/2008	Gerl et al.	2008/0140702	A1	6/2008	Reed et al.
2008/0065387	A1	3/2008	Cross et al.	2008/0141125	A1	6/2008	Ghassabian et al.
2008/0071529	A1	3/2008	Silverman et al.	2008/0141180	A1	6/2008	Reed et al.
2008/0071544	A1	3/2008	Beaufays et al.	2008/0141182	A1	6/2008	Barsness et al.
2008/0071742	A1	3/2008	Yang et al.	2008/0146245	A1	6/2008	Appaji
2008/0072143	A1	3/2008	Assadollahi	2008/0146290	A1	6/2008	Sreeram et al.
2008/0075296	A1	3/2008	Lindahl et al.	2008/0147408	A1	6/2008	Da Palma et al.
2008/0076972	A1	3/2008	Dorogusker et al.	2008/0147411	A1	6/2008	Dames et al.
2008/0077310	A1	3/2008	Murlidar et al.	2008/0147874	A1	6/2008	Yoneda et al.
2008/0077384	A1	3/2008	Agapi et al.	2008/0150900	A1	6/2008	Han
2008/0077386	A1	3/2008	Gao et al.	2008/0154577	A1	6/2008	Kim et al.
2008/0077391	A1	3/2008	Chino et al.	2008/0154599	A1	6/2008	Muschett et al.
2008/0077393	A1	3/2008	Gao et al.	2008/0154600	A1	6/2008	Tian et al.
2008/0077406	A1	3/2008	Ganong, III	2008/0154603	A1	6/2008	Oddo
2008/0077859	A1	3/2008	Schabes et al.	2008/0154612	A1	6/2008	Evermann et al.
2008/0079566	A1	4/2008	Singh et al.	2008/0154828	A1	6/2008	Antebi et al.
2008/0080411	A1	4/2008	Cole	2008/0157867	A1	7/2008	Krah
2008/0082332	A1	4/2008	Mallett et al.	2008/0161113	A1	7/2008	Hansen et al.
2008/0082338	A1	4/2008	O'Neil et al.	2008/0162120	A1	7/2008	Mactavish et al.
2008/0082390	A1	4/2008	Hawkins et al.	2008/0162137	A1	7/2008	Saitoh et al.
2008/0082576	A1	4/2008	Bodin et al.	2008/0162471	A1	7/2008	Bernard
2008/0082651	A1	4/2008	Singh et al.	2008/0163119	A1	7/2008	Kim et al.
2008/0084974	A1	4/2008	Dhanakshirur	2008/0163131	A1	7/2008	Hirai et al.
2008/0085689	A1	4/2008	Zellner	2008/0165144	A1	7/2008	Forstall et al.
2008/0091406	A1	4/2008	Baldwin et al.	2008/0165980	A1	7/2008	Pavlovic et al.
2008/0091426	A1	4/2008	Rempel et al.	2008/0165994	A1	7/2008	Caren et al.
2008/0091428	A1	4/2008	Bellegarda	2008/0167013	A1	7/2008	Novick et al.
2008/0091443	A1	4/2008	Strope et al.	2008/0167858	A1	7/2008	Christie et al.
2008/0096531	A1	4/2008	Mcquaide et al.	2008/0167876	A1	7/2008	Bakis et al.
2008/0096533	A1	4/2008	Manfredi et al.	2008/0168052	A1	7/2008	Ott et al.
2008/0096726	A1	4/2008	Riley et al.	2008/0168366	A1	7/2008	Kocienda et al.
2008/0097937	A1	4/2008	Hadjarian	2008/0183473	A1	7/2008	Nagano et al.
2008/0098302	A1	4/2008	Roose	2008/0186960	A1	8/2008	Kocheisen et al.
2008/0098480	A1	4/2008	Henry et al.	2008/0189099	A1	8/2008	Friedman et al.
2008/0100579	A1	5/2008	Robinson et al.	2008/0189106	A1	8/2008	Low et al.
2008/0101584	A1	5/2008	Gray et al.	2008/0189110	A1	8/2008	Freeman et al.
2008/0103774	A1	5/2008	White	2008/0189114	A1	8/2008	Fail et al.
2008/0109222	A1	5/2008	Liu	2008/0189606	A1	8/2008	Rybak
2008/0109402	A1	5/2008	Wang et al.	2008/0195312	A1	8/2008	Aaron et al.
2008/0114480	A1	5/2008	Harb	2008/0195388	A1	8/2008	Bower et al.
2008/0114598	A1	5/2008	Prieto et al.	2008/0195391	A1	8/2008	Marple et al.
2008/0114604	A1	5/2008	Wei et al.	2008/0195601	A1	8/2008	Ntoulas et al.
2008/0114841	A1	5/2008	Lambert	2008/0195630	A1	8/2008	Exartier et al.
2008/0115084	A1	5/2008	Scott et al.	2008/0195940	A1	8/2008	Gail et al.
2008/0118143	A1	5/2008	Gordon et al.	2008/0200142	A1	8/2008	Abdel-Kader et al.
2008/0119953	A1	5/2008	Reed	2008/0201000	A1	8/2008	Heikkila et al.
2008/0120102	A1	5/2008	Rao	2008/0201306	A1	8/2008	Cooper et al.
2008/0120112	A1	5/2008	Jordan et al.	2008/0201375	A1	8/2008	Khedouri et al.
				2008/0201434	A1	8/2008	Holmes et al.
				2008/0204379	A1	8/2008	Perez-Noguera
				2008/0207176	A1	8/2008	Brackbill et al.
				2008/0208585	A1	8/2008	Ativanichayaphong et al.

(56)		References Cited					
		U.S. PATENT DOCUMENTS					
2008/0208587	A1	8/2008	Ben-David et al.	2008/0313335	A1	12/2008	Jung et al.
2008/0208864	A1	8/2008	Cucerzan et al.	2008/0316183	A1	12/2008	Westerman et al.
2008/0212796	A1	9/2008	Denda	2008/0319735	A1	12/2008	Kambhatla et al.
2008/0219641	A1	9/2008	Sandrew et al.	2008/0319738	A1	12/2008	Liu et al.
2008/0221866	A1	9/2008	Katragadda et al.	2008/0319753	A1	12/2008	Hancock
2008/0221879	A1	9/2008	Cerra et al.	2008/0319763	A1	12/2008	Di Fabbriozio et al.
2008/0221880	A1	9/2008	Cerra et al.	2008/0319783	A1	12/2008	Yao et al.
2008/0221887	A1	9/2008	Rose et al.	2009/0003115	A1	1/2009	Lindahl et al.
2008/0221889	A1	9/2008	Cerra et al.	2009/0005012	A1	1/2009	Van Heugten
2008/0221903	A1	9/2008	Kanevsky et al.	2009/0005891	A1	1/2009	Batson et al.
2008/0222118	A1	9/2008	Scian et al.	2009/0006096	A1	1/2009	Li et al.
2008/0226130	A1	9/2008	Kansai et al.	2009/0006097	A1	1/2009	Etezadi et al.
2008/0228463	A1	9/2008	Mori et al.	2009/0006099	A1	1/2009	Sharpe et al.
2008/0228485	A1	9/2008	Owen	2009/0006100	A1	1/2009	Badger et al.
2008/0228490	A1	9/2008	Fischer et al.	2009/0006343	A1	1/2009	Platt et al.
2008/0228495	A1	9/2008	Cross et al.	2009/0006345	A1	1/2009	Platt et al.
2008/0228496	A1	9/2008	Yu et al.	2009/0006488	A1	1/2009	Lindahl et al.
2008/0228928	A1	9/2008	Donelli et al.	2009/0006671	A1	1/2009	Batson et al.
2008/0229185	A1	9/2008	Lynch	2009/0007001	A1	1/2009	Morin et al.
2008/0229218	A1	9/2008	Maeng	2009/0011709	A1	1/2009	Akasaka et al.
2008/0235017	A1	9/2008	Satomura et al.	2009/0012748	A1	1/2009	Beish et al.
2008/0235024	A1	9/2008	Goldberg et al.	2009/0012775	A1	1/2009	El Hady et al.
2008/0235027	A1	9/2008	Cross	2009/0018828	A1	1/2009	Nakadai et al.
2008/0240569	A1	10/2008	Tonouchi	2009/0018829	A1	1/2009	Kuperstein
2008/0242280	A1	10/2008	Shapiro et al.	2009/0018834	A1*	1/2009	Cooper H04M 3/527 704/527
2008/0242322	A1	10/2008	Scott et al.	2009/0018835	A1	1/2009	Cooper et al.
2008/0242363	A1	10/2008	Onda et al.	2009/0018839	A1	1/2009	Cooper et al.
2008/0243834	A1	10/2008	Rieman et al.	2009/0018840	A1	1/2009	Lutz et al.
2008/0244390	A1	10/2008	Fux et al.	2009/0022329	A1	1/2009	Mahowald
2008/0244446	A1	10/2008	Lefevre et al.	2009/0024595	A1	1/2009	Chen
2008/0247519	A1	10/2008	Abella et al.	2009/0028435	A1	1/2009	Wu et al.
2008/0247529	A1	10/2008	Barton et al.	2009/0030800	A1	1/2009	Grois
2008/0248797	A1	10/2008	Freeman et al.	2009/0030978	A1	1/2009	Johnson et al.
2008/0249770	A1	10/2008	Kim et al.	2009/0043580	A1	2/2009	Mozer et al.
2008/0249778	A1	10/2008	Barton et al.	2009/0043583	A1	2/2009	Agapi et al.
2008/0253577	A1	10/2008	Eppolito	2009/0043763	A1	2/2009	Peng
2008/0254425	A1	10/2008	Cohen et al.	2009/0044094	A1	2/2009	Rapp et al.
2008/0255837	A1	10/2008	Kahn et al.	2009/0048821	A1	2/2009	Yam et al.
2008/0255842	A1	10/2008	Simhi et al.	2009/0048841	A1	2/2009	Pollet et al.
2008/0255845	A1	10/2008	Bennett	2009/0048845	A1	2/2009	Burckart et al.
2008/0256613	A1	10/2008	Grover	2009/0049067	A1	2/2009	Murray
2008/0259022	A1	10/2008	Mansfield et al.	2009/0055168	A1	2/2009	Wu et al.
2008/0262828	A1	10/2008	Och et al.	2009/0055175	A1	2/2009	Terrell et al.
2008/0262838	A1	10/2008	Nurminen et al.	2009/0055179	A1	2/2009	Cho et al.
2008/0262846	A1	10/2008	Burns et al.	2009/0055186	A1	2/2009	Lance et al.
2008/0263139	A1	10/2008	Martin	2009/0055380	A1	2/2009	Peng et al.
2008/0267416	A1	10/2008	Goldstein et al.	2009/0055381	A1	2/2009	Wu et al.
2008/0270118	A1	10/2008	Kuo et al.	2009/0055648	A1	2/2009	Kim et al.
2008/0270138	A1	10/2008	Knight et al.	2009/0058823	A1	3/2009	Kocienda
2008/0270139	A1	10/2008	Shi et al.	2009/0058860	A1	3/2009	Fong et al.
2008/0270140	A1	10/2008	Hertz et al.	2009/0060351	A1	3/2009	Li et al.
2008/0270151	A1	10/2008	Mahoney et al.	2009/0060472	A1	3/2009	Bull et al.
2008/0270344	A1	10/2008	Yurick et al.	2009/0063974	A1	3/2009	Bull et al.
2008/0273672	A1	11/2008	Didcock et al.	2009/0064031	A1	3/2009	Bull et al.
2008/0277473	A1	11/2008	Kotlarsky et al.	2009/0070097	A1	3/2009	Wu et al.
2008/0281510	A1	11/2008	Shahine	2009/0070102	A1	3/2009	Maegawa
2008/0281582	A1	11/2008	Hsu et al.	2009/0070109	A1	3/2009	Didcock et al.
2008/0288259	A1	11/2008	Chambers et al.	2009/0070114	A1	3/2009	Staszak
2008/0288460	A1	11/2008	Poniatowski et al.	2009/0074214	A1	3/2009	Bradford et al.
2008/0292112	A1	11/2008	Valenzuela et al.	2009/0076792	A1	3/2009	Lawson-Tancred
2008/0294418	A1	11/2008	Cleary et al.	2009/0076796	A1	3/2009	Daraselina
2008/0294517	A1	11/2008	Hill	2009/0076798	A1	3/2009	Oh et al.
2008/0294651	A1	11/2008	Masuyama et al.	2009/0076819	A1	3/2009	Wouters et al.
2008/0294981	A1	11/2008	Balzano et al.	2009/0076821	A1	3/2009	Brenner et al.
2008/0298563	A1	12/2008	Rondeau et al.	2009/0076825	A1	3/2009	Bradford et al.
2008/0298766	A1	12/2008	Wen et al.	2009/0077165	A1	3/2009	Rhodes et al.
2008/0299523	A1	12/2008	Chai et al.	2009/0079622	A1	3/2009	Seshadri et al.
2008/0300871	A1	12/2008	Gilbert	2009/0083034	A1	3/2009	Hernandez et al.
2008/0300877	A1	12/2008	Gilbert et al.	2009/0083035	A1	3/2009	Huang et al.
2008/0300878	A1	12/2008	Bennett	2009/0083036	A1	3/2009	Zhao et al.
2008/0301567	A1	12/2008	Martin et al.	2009/0083037	A1	3/2009	Gleason et al.
2008/0303645	A1	12/2008	Seymour et al.	2009/0083047	A1	3/2009	Lindahl et al.
2008/0306727	A1	12/2008	Thurmair et al.	2009/0089058	A1	4/2009	Bellegarda
2008/0312909	A1	12/2008	Hermansen et al.	2009/0092239	A1	4/2009	Macwan et al.
2008/0312928	A1	12/2008	Goebel et al.	2009/0092260	A1	4/2009	Powers
				2009/0092261	A1	4/2009	Bard
				2009/0092262	A1	4/2009	Costa et al.
				2009/0094029	A1	4/2009	Koch et al.

(56)

References Cited

U.S. PATENT DOCUMENTS

2009/0094033	A1	4/2009	Mozer et al.	2009/0204596	A1	8/2009	Brun et al.
2009/0097634	A1	4/2009	Nambiar et al.	2009/0204601	A1	8/2009	Grasset
2009/0097637	A1	4/2009	Boscher et al.	2009/0204620	A1	8/2009	Thione et al.
2009/0098903	A1	4/2009	Donaldson et al.	2009/0210230	A1	8/2009	Schwarz et al.
2009/0100049	A1	4/2009	Cao	2009/0210232	A1	8/2009	Sanchez et al.
2009/0100454	A1	4/2009	Weber	2009/0213134	A1	8/2009	Stephanick et al.
2009/0104898	A1	4/2009	Harris	2009/0215466	A1	8/2009	Ahl et al.
2009/0106026	A1	4/2009	Ferrieux	2009/0215503	A1	8/2009	Zhang et al.
2009/0106376	A1	4/2009	Tom et al.	2009/0216396	A1	8/2009	Yamagata
2009/0106397	A1	4/2009	O'Keefe	2009/0216528	A1	8/2009	Gemello et al.
2009/0112572	A1	4/2009	Thorn	2009/0216540	A1	8/2009	Tessel et al.
2009/0112576	A1	4/2009	Jackson et al.	2009/0216704	A1	8/2009	Zheng et al.
2009/0112592	A1	4/2009	Candelore et al.	2009/0219166	A1	9/2009	MacFarlane et al.
2009/0112677	A1	4/2009	Rhett	2009/0221274	A1	9/2009	Venkatakrisshnan et al.
2009/0112892	A1	4/2009	Cardie et al.	2009/0222257	A1	9/2009	Sumita et al.
2009/0119587	A1	5/2009	Allen et al.	2009/0222270	A2	9/2009	Likens et al.
2009/0123021	A1	5/2009	Jung et al.	2009/0222488	A1	9/2009	Boerries et al.
2009/0123071	A1	5/2009	Iwasaki	2009/0228126	A1	9/2009	Spielberg et al.
2009/0125477	A1	5/2009	Lu et al.	2009/0228273	A1	9/2009	Wang et al.
2009/0125602	A1	5/2009	Bhatia et al.	2009/0228277	A1	9/2009	Bonforte et al.
2009/0125947	A1	5/2009	Ibaraki	2009/0228281	A1	9/2009	Singleton et al.
2009/0128505	A1	5/2009	Partridge et al.	2009/0228439	A1	9/2009	Manolescu et al.
2009/0132253	A1	5/2009	Bellegarda	2009/0228792	A1	9/2009	Van Os et al.
2009/0132255	A1	5/2009	Lu	2009/0228842	A1	9/2009	Westerman et al.
2009/0137286	A1	5/2009	Luke et al.	2009/0234638	A1	9/2009	Ranjan et al.
2009/0138263	A1	5/2009	Shozakai et al.	2009/0234651	A1	9/2009	Basir et al.
2009/0138736	A1	5/2009	Chin	2009/0234655	A1	9/2009	Kwon
2009/0138828	A1	5/2009	Schultz et al.	2009/0235280	A1	9/2009	Tannier et al.
2009/0144049	A1	6/2009	Haddad et al.	2009/0239202	A1	9/2009	Stone
2009/0144428	A1	6/2009	Bowater et al.	2009/0239552	A1	9/2009	Churchill et al.
2009/0144609	A1	6/2009	Liang et al.	2009/0240485	A1	9/2009	Dalal et al.
2009/0146848	A1	6/2009	Ghassabian	2009/0241054	A1	9/2009	Hendricks
2009/0150147	A1	6/2009	Jacoby et al.	2009/0241760	A1	10/2009	Georges
2009/0150156	A1	6/2009	Kennewick et al.	2009/0247237	A1	10/2009	Mittleman et al.
2009/0152349	A1	6/2009	Bonev et al.	2009/0248182	A1	10/2009	Logan et al.
2009/0153288	A1	6/2009	Hope et al.	2009/0248395	A1	10/2009	Alewine et al.
2009/0154669	A1	6/2009	Wood et al.	2009/0248402	A1	10/2009	Ito et al.
2009/0157382	A1	6/2009	Bar	2009/0248420	A1	10/2009	Basir et al.
2009/0157384	A1	6/2009	Toutanova et al.	2009/0248422	A1	10/2009	Li et al.
2009/0157401	A1	6/2009	Bennett	2009/0248456	A1	10/2009	Fahmy et al.
2009/0158200	A1	6/2009	Palahnuk et al.	2009/0249198	A1	10/2009	Davis et al.
2009/0158323	A1	6/2009	Bober et al.	2009/0249247	A1	10/2009	Tseng et al.
2009/0158423	A1	6/2009	Orlassino et al.	2009/0252350	A1	10/2009	Seguin
2009/0160803	A1	6/2009	Hashimoto	2009/0253457	A1	10/2009	Seguin
2009/0163243	A1	6/2009	Barbera	2009/0253463	A1	10/2009	Shin et al.
2009/0164301	A1	6/2009	O'Sullivan et al.	2009/0254339	A1	10/2009	Seguin
2009/0164441	A1	6/2009	Cheyre	2009/0254345	A1	10/2009	Fleizach et al.
2009/0164655	A1	6/2009	Pettersson et al.	2009/0254819	A1	10/2009	Song et al.
2009/0164937	A1	6/2009	Alviar et al.	2009/0254823	A1	10/2009	Barrett
2009/0167508	A1	7/2009	Fadell et al.	2009/0259475	A1	10/2009	Yamagami et al.
2009/0167509	A1	7/2009	Fadell et al.	2009/0259969	A1	10/2009	Pallakoff
2009/0171578	A1	7/2009	Kim et al.	2009/0265171	A1	10/2009	Davis
2009/0171662	A1	7/2009	Huang et al.	2009/0265368	A1	10/2009	Crider et al.
2009/0171664	A1	7/2009	Kennewick et al.	2009/0271109	A1	10/2009	Lee et al.
2009/0172108	A1	7/2009	Singh	2009/0271175	A1	10/2009	Bodin et al.
2009/0172542	A1	7/2009	Girish et al.	2009/0271176	A1	10/2009	Bodin et al.
2009/0174667	A1	7/2009	Kocienda et al.	2009/0271178	A1	10/2009	Bodin et al.
2009/0174677	A1	7/2009	Gehani et al.	2009/0271188	A1	10/2009	Agapi et al.
2009/0177300	A1	7/2009	Lee	2009/0271189	A1	10/2009	Agapi et al.
2009/0177461	A1	7/2009	Ehsani et al.	2009/0274315	A1	11/2009	Carnes et al.
2009/0177966	A1	7/2009	Chaudhri	2009/0281789	A1	11/2009	Waibel et al.
2009/0182445	A1	7/2009	Girish et al.	2009/0284482	A1	11/2009	Chin
2009/0182549	A1	7/2009	Anisimovich et al.	2009/0286514	A1	11/2009	Lichorowic et al.
2009/0182702	A1	7/2009	Miller	2009/0287583	A1	11/2009	Holmes
2009/0183070	A1	7/2009	Robbins	2009/0290718	A1	11/2009	Kahn et al.
2009/0187402	A1	7/2009	Scholl	2009/0292987	A1	11/2009	Sorenson
2009/0187577	A1	7/2009	Reznik et al.	2009/0296552	A1	12/2009	Hicks et al.
2009/0187950	A1	7/2009	Nicas et al.	2009/0298474	A1	12/2009	George
2009/0191895	A1	7/2009	Singh et al.	2009/0298529	A1	12/2009	Mahajan
2009/0192782	A1	7/2009	Drewes	2009/0299745	A1	12/2009	Kennewick et al.
2009/0192787	A1	7/2009	Roon	2009/0299849	A1	12/2009	Cao et al.
2009/0192798	A1	7/2009	Basson et al.	2009/0300391	A1	12/2009	Jessup et al.
2009/0198497	A1	8/2009	Kwon	2009/0300488	A1	12/2009	Salamon et al.
2009/0204409	A1	8/2009	Mozer et al.	2009/0304198	A1	12/2009	Herre et al.
2009/0204478	A1	8/2009	Kaib et al.	2009/0305203	A1	12/2009	Okumura et al.
				2009/0306967	A1	12/2009	Nicolov et al.
				2009/0306969	A1	12/2009	Goud et al.
				2009/0306979	A1	12/2009	Jaiswal et al.
				2009/0306980	A1	12/2009	Shin

(56)		References Cited					
		U.S. PATENT DOCUMENTS					
2009/0306981	A1	12/2009	Cromack et al.	2010/0080398	A1	4/2010	Waldmann
2009/0306985	A1	12/2009	Roberts et al.	2010/0080470	A1	4/2010	Deluca et al.
2009/0306988	A1	12/2009	Chen et al.	2010/0081456	A1	4/2010	Singh et al.
2009/0306989	A1	12/2009	Kaji	2010/0081487	A1	4/2010	Chen et al.
2009/0307162	A1	12/2009	Bui et al.	2010/0082286	A1	4/2010	Leung
2009/0307201	A1	12/2009	Dunning et al.	2010/0082327	A1	4/2010	Rogers et al.
2009/0307584	A1	12/2009	Davidson et al.	2010/0082328	A1	4/2010	Rogers et al.
2009/0307594	A1	12/2009	Kosonen et al.	2010/0082329	A1	4/2010	Silverman et al.
2009/0313014	A1	12/2009	Shin et al.	2010/0082333	A1	4/2010	Al-Shammari
2009/0313020	A1	12/2009	Koivunen	2010/0082346	A1	4/2010	Rogers et al.
2009/0313023	A1	12/2009	Jones	2010/0082347	A1	4/2010	Rogers et al.
2009/0313026	A1	12/2009	Coffman et al.	2010/0082348	A1	4/2010	Silverman et al.
2009/0313544	A1	12/2009	Wood et al.	2010/0082349	A1	4/2010	Bellegarda et al.
2009/0313564	A1	12/2009	Rottler et al.	2010/0082567	A1	4/2010	Rosenblatt et al.
2009/0316943	A1	12/2009	Frigola Munoz et al.	2010/0082970	A1	4/2010	Lindahl et al.
2009/0318119	A1	12/2009	Basir et al.	2010/0086152	A1	4/2010	Rank et al.
2009/0318198	A1	12/2009	Carroll	2010/0086153	A1	4/2010	Hagen et al.
2009/0319257	A1	12/2009	Blume et al.	2010/0086156	A1	4/2010	Rank et al.
2009/0319266	A1	12/2009	Brown et al.	2010/0088020	A1	4/2010	Sano et al.
2009/0326923	A1	12/2009	Yan et al.	2010/0088093	A1	4/2010	Lee et al.
2009/0326936	A1	12/2009	Nagashima	2010/0088100	A1	4/2010	Lindahl
2009/0326938	A1	12/2009	Marila et al.	2010/0094632	A1	4/2010	Davis et al.
2009/0326949	A1	12/2009	Douthitt et al.	2010/0098231	A1	4/2010	Wohlert et al.
2009/0327977	A1	12/2009	Bachfischer et al.	2010/0100212	A1	4/2010	Lindahl et al.
2010/0004918	A1	1/2010	Lee et al.	2010/0100384	A1	4/2010	Ju et al.
2010/0004931	A1	1/2010	Ma et al.	2010/0100385	A1	4/2010	Davis et al.
2010/0005081	A1	1/2010	Bennett	2010/0100816	A1	4/2010	McCloskey et al.
2010/0010803	A1	1/2010	Ishikawa et al.	2010/0103776	A1	4/2010	Chan
2010/0010814	A1	1/2010	Patel	2010/0106486	A1	4/2010	Hua et al.
2010/0013760	A1	1/2010	Hirai et al.	2010/0106498	A1	4/2010	Morrison et al.
2010/0013796	A1	1/2010	Abileah et al.	2010/0106500	A1	4/2010	McKee et al.
2010/0017212	A1	1/2010	Attwater et al.	2010/0106503	A1	4/2010	Farrell et al.
2010/0017382	A1	1/2010	Katragadda et al.	2010/0114856	A1	5/2010	Kuboyama
2010/0019834	A1	1/2010	Zerbe et al.	2010/0114887	A1	5/2010	Conway et al.
2010/0023318	A1	1/2010	Lemoine	2010/0121637	A1	5/2010	Roy et al.
2010/0023320	A1	1/2010	Di Cristo et al.	2010/0125456	A1	5/2010	Weng et al.
2010/0023331	A1	1/2010	Duta et al.	2010/0125458	A1	5/2010	Franco et al.
2010/0026526	A1	2/2010	Yokota	2010/0125460	A1	5/2010	Mellott et al.
2010/0030549	A1	2/2010	Lee et al.	2010/0125811	A1	5/2010	Moore et al.
2010/0030928	A1	2/2010	Conroy et al.	2010/0131269	A1	5/2010	Park et al.
2010/0031143	A1	2/2010	Rao et al.	2010/0131273	A1	5/2010	Aley-Raz et al.
2010/0036653	A1	2/2010	Kim et al.	2010/0131498	A1	5/2010	Linthicum et al.
2010/0036655	A1	2/2010	Cecil et al.	2010/0131899	A1	5/2010	Hubert
2010/0036660	A1	2/2010	Bennett	2010/0138215	A1	6/2010	Williams
2010/0037183	A1	2/2010	Miyashita et al.	2010/0138224	A1	6/2010	Bedingfield, Sr.
2010/0042400	A1	2/2010	Block et al.	2010/0138416	A1	6/2010	Bellotti
2010/0042576	A1	2/2010	Roettger et al.	2010/0138680	A1	6/2010	Brisebois et al.
2010/0046842	A1	2/2010	Conwell et al.	2010/0138759	A1	6/2010	Roy
2010/0049498	A1	2/2010	Cao et al.	2010/0138798	A1	6/2010	Wilson et al.
2010/0049514	A1	2/2010	Kennewick et al.	2010/0142740	A1	6/2010	Roerup
2010/0050064	A1	2/2010	Liu et al.	2010/0145694	A1	6/2010	Ju et al.
2010/0054512	A1	3/2010	Solum	2010/0145700	A1	6/2010	Kennewick et al.
2010/0057435	A1	3/2010	Kent et al.	2010/0145707	A1	6/2010	Ljolje et al.
2010/0057443	A1	3/2010	Di Cristo et al.	2010/0146442	A1	6/2010	Nagasaka et al.
2010/0057457	A1	3/2010	Ogata et al.	2010/0150321	A1	6/2010	Harris et al.
2010/0057461	A1	3/2010	Neubacher et al.	2010/0153114	A1	6/2010	Shih et al.
2010/0057643	A1	3/2010	Yang	2010/0153115	A1	6/2010	Klee et al.
2010/0060646	A1	3/2010	Unsal et al.	2010/0153448	A1	6/2010	Harpur et al.
2010/0063804	A1	3/2010	Sato et al.	2010/0161311	A1	6/2010	Massuh
2010/0063825	A1	3/2010	Williams et al.	2010/0161313	A1	6/2010	Karttunen
2010/0063961	A1	3/2010	Guiheneuf et al.	2010/0161337	A1	6/2010	Pulz et al.
2010/0064113	A1	3/2010	Lindahl et al.	2010/0161554	A1	6/2010	Datuashvili et al.
2010/0064218	A1	3/2010	Bull et al.	2010/0164897	A1	7/2010	Morin et al.
2010/0064226	A1	3/2010	Stefaniak et al.	2010/0169075	A1	7/2010	Raffa et al.
2010/0066684	A1	3/2010	Shahraray et al.	2010/0169093	A1	7/2010	Washio
2010/0067723	A1	3/2010	Bergmann et al.	2010/0169097	A1	7/2010	Nachman et al.
2010/0067867	A1	3/2010	Lin et al.	2010/0169098	A1	7/2010	Patch
2010/0070281	A1	3/2010	Conkie et al.	2010/0171713	A1	7/2010	Kwok et al.
2010/0070521	A1	3/2010	Clinchant et al.	2010/0174544	A1	7/2010	Heifets
2010/0070899	A1	3/2010	Hunt et al.	2010/0175066	A1	7/2010	Paik
2010/0071003	A1	3/2010	Bychkov et al.	2010/0179932	A1	7/2010	Yoon et al.
2010/0076760	A1	3/2010	Kraenzel et al.	2010/0179991	A1	7/2010	Lorch et al.
2010/0076993	A1	3/2010	Klawitter et al.	2010/0180218	A1	7/2010	Boston et al.
2010/0077350	A1	3/2010	Lim et al.	2010/0185448	A1	7/2010	Meisel
2010/0079501	A1	4/2010	Ikeda et al.	2010/0185949	A1	7/2010	Jaeger
				2010/0191520	A1	7/2010	Gruhn et al.
				2010/0197359	A1	8/2010	Harris
				2010/0199180	A1	8/2010	Brichter et al.
				2010/0199215	A1	8/2010	Seymour et al.

(56)

References Cited

U.S. PATENT DOCUMENTS

2010/0204986	A1	8/2010	Kennewick et al.	2010/0332976	A1	12/2010	Fux et al.
2010/0211199	A1	8/2010	Naik et al.	2010/0333030	A1	12/2010	Johns
2010/0211379	A1	8/2010	Gorman et al.	2010/0333163	A1	12/2010	Daly
2010/0216509	A1	8/2010	Riemer et al.	2011/0002487	A1	1/2011	Panther et al.
2010/0217604	A1	8/2010	Baldwin et al.	2011/0004475	A1	1/2011	Bellegarda
2010/0222033	A1	9/2010	Scott et al.	2011/0009107	A1	1/2011	Guba et al.
2010/0222098	A1	9/2010	Garg	2011/0010178	A1	1/2011	Lee et al.
2010/0223055	A1	9/2010	Mclean	2011/0010644	A1	1/2011	Merrill et al.
2010/0223056	A1	9/2010	Kadiramanathan et al.	2011/0015928	A1	1/2011	Odell et al.
2010/0223131	A1	9/2010	Scott et al.	2011/0016150	A1	1/2011	Engstrom et al.
2010/0225599	A1	9/2010	Danielsson et al.	2011/0018695	A1	1/2011	Bells et al.
2010/0225809	A1	9/2010	Connors et al.	2011/0021213	A1	1/2011	Carr
2010/0227642	A1	9/2010	Kim et al.	2011/0022292	A1	1/2011	Shen et al.
2010/0228540	A1	9/2010	Bennett	2011/0022388	A1	1/2011	Wu et al.
2010/0228549	A1	9/2010	Herman et al.	2011/0022393	A1	1/2011	Waller et al.
2010/0228691	A1	9/2010	Yang et al.	2011/0022394	A1	1/2011	Wide et al.
2010/0229082	A1	9/2010	Karmarkar et al.	2011/0022472	A1	1/2011	Zon et al.
2010/0229100	A1	9/2010	Miller et al.	2011/0022952	A1	1/2011	Wu et al.
2010/0231474	A1	9/2010	Yamagajo et al.	2011/0029616	A1	2/2011	Wang et al.
2010/0235167	A1	9/2010	Bourdon	2011/0030067	A1	2/2011	Wilson
2010/0235341	A1	9/2010	Bennett	2011/0033064	A1	2/2011	Johnson et al.
2010/0235729	A1	9/2010	Kocienda et al.	2011/0034183	A1	2/2011	Haag et al.
2010/0235732	A1	9/2010	Bergman	2011/0035144	A1	2/2011	Okamoto et al.
2010/0235770	A1	9/2010	Ordning et al.	2011/0035434	A1	2/2011	Lockwood
2010/0241418	A1	9/2010	Maeda et al.	2011/0038489	A1	2/2011	Visser et al.
2010/0250542	A1	9/2010	Fujimaki	2011/0040707	A1	2/2011	Theisen et al.
2010/0250599	A1	9/2010	Schmidt et al.	2011/0045841	A1	2/2011	Kuhlke et al.
2010/0255858	A1	10/2010	Juhasz	2011/0047072	A1	2/2011	Ciurea
2010/0257160	A1	10/2010	Cao	2011/0047149	A1	2/2011	Vaananen
2010/0257478	A1	10/2010	Longe et al.	2011/0047161	A1	2/2011	Myaeng et al.
2010/0262599	A1	10/2010	Nitz	2011/0047246	A1	2/2011	Frissora et al.
2010/0268537	A1	10/2010	Al-Telmissani	2011/0050591	A1	3/2011	Kim et al.
2010/0268539	A1	10/2010	Xu et al.	2011/0050592	A1	3/2011	Kim et al.
2010/0269040	A1	10/2010	Lee	2011/0054647	A1	3/2011	Chipchase
2010/0274753	A1	10/2010	Liberty et al.	2011/0054894	A1	3/2011	Phillips et al.
2010/0277579	A1	11/2010	Cho et al.	2011/0054901	A1	3/2011	Qin et al.
2010/0278320	A1	11/2010	Arsenault et al.	2011/0055256	A1	3/2011	Phillips et al.
2010/0278453	A1	11/2010	King	2011/0060584	A1	3/2011	Ferrucci et al.
2010/0280983	A1	11/2010	Cho et al.	2011/0060587	A1	3/2011	Phillips et al.
2010/0281034	A1	11/2010	Petrou et al.	2011/0060589	A1	3/2011	Weinberg et al.
2010/0286984	A1	11/2010	Wandinger et al.	2011/0060807	A1	3/2011	Martin et al.
2010/0286985	A1	11/2010	Kennewick et al.	2011/0064387	A1	3/2011	Mendeloff et al.
2010/0287514	A1	11/2010	Cragun et al.	2011/0065456	A1	3/2011	Brennan et al.
2010/0290632	A1	11/2010	Lin	2011/0066366	A1	3/2011	Ellanti et al.
2010/0293460	A1	11/2010	Budelli	2011/0066468	A1	3/2011	Huang et al.
2010/0295645	A1	11/2010	Falldin et al.	2011/0066634	A1	3/2011	Phillips et al.
2010/0299133	A1	11/2010	Kopparapu et al.	2011/0072492	A1	3/2011	Mohler et al.
2010/0299138	A1	11/2010	Kim	2011/0076994	A1	3/2011	Kim et al.
2010/0299142	A1	11/2010	Freeman et al.	2011/0077943	A1	3/2011	Miki et al.
2010/0302056	A1	12/2010	Dutton et al.	2011/0080260	A1	4/2011	Wang et al.
2010/0304342	A1	12/2010	Zilber	2011/0081889	A1	4/2011	Gao et al.
2010/0304705	A1	12/2010	Hursey et al.	2011/0082688	A1	4/2011	Kim et al.
2010/0305807	A1	12/2010	Basir et al.	2011/0083079	A1	4/2011	Farrell et al.
2010/0305947	A1	12/2010	Schwarz et al.	2011/0087491	A1	4/2011	Wittenstein et al.
2010/0312547	A1	12/2010	Van Os et al.	2011/0090078	A1	4/2011	Kim et al.
2010/0312566	A1	12/2010	Odinak et al.	2011/0093261	A1	4/2011	Angott
2010/0318366	A1	12/2010	Sullivan et al.	2011/0093265	A1	4/2011	Stent et al.
2010/0318576	A1	12/2010	Kim	2011/0093271	A1	4/2011	Bernard et al.
2010/0322438	A1	12/2010	Siotis	2011/0099000	A1	4/2011	Rai et al.
2010/0324709	A1	12/2010	Starmen	2011/0103682	A1	5/2011	Chidlovskii et al.
2010/0324895	A1	12/2010	Kurzweil et al.	2011/0105097	A1	5/2011	Tadayon et al.
2010/0324896	A1	12/2010	Attwater et al.	2011/0106736	A1	5/2011	Aharonson et al.
2010/0324905	A1	12/2010	Kurzweil et al.	2011/0106892	A1	5/2011	Nelson et al.
2010/0325131	A1	12/2010	Dumais et al.	2011/0110502	A1	5/2011	Daye et al.
2010/0325158	A1	12/2010	Oral et al.	2011/0111724	A1	5/2011	Baptiste
2010/0325573	A1	12/2010	Estrada et al.	2011/0112827	A1	5/2011	Kennewick et al.
2010/0325588	A1	12/2010	Reddy et al.	2011/0112837	A1	5/2011	Kurki-Suonio et al.
2010/0330908	A1	12/2010	Maddern et al.	2011/0112838	A1	5/2011	Adibi
2010/0332220	A1	12/2010	Hursey et al.	2011/0112921	A1	5/2011	Kennewick et al.
2010/0332224	A1	12/2010	Mäkelä et al.	2011/0116610	A1	5/2011	Shaw et al.
2010/0332235	A1	12/2010	David	2011/0119049	A1	5/2011	Ylonen
2010/0332236	A1	12/2010	Tan	2011/0119051	A1	5/2011	Li et al.
2010/0332280	A1	12/2010	Bradley et al.	2011/0119623	A1	5/2011	Kim
2010/0332348	A1	12/2010	Cao	2011/0119715	A1	5/2011	Chang et al.
2010/0332428	A1	12/2010	Mchenry et al.	2011/0123004	A1	5/2011	Chang et al.
				2011/0125498	A1	5/2011	Pickering et al.
				2011/0125540	A1	5/2011	Jang et al.
				2011/0125701	A1	5/2011	Nair et al.
				2011/0130958	A1	6/2011	Stahl et al.

(56)

References Cited

U.S. PATENT DOCUMENTS

2011/0131036	A1	6/2011	DiCristo et al.	2011/0264999	A1	10/2011	Bells et al.
2011/0131038	A1	6/2011	Oyaizu et al.	2011/0274303	A1	11/2011	Filson et al.
2011/0131045	A1	6/2011	Cristo et al.	2011/0276595	A1	11/2011	Kirkland et al.
2011/0137636	A1	6/2011	Srihari et al.	2011/0276598	A1	11/2011	Kozempel
2011/0141141	A1	6/2011	Kankainen	2011/0276944	A1	11/2011	Bergman et al.
2011/0143726	A1	6/2011	de Silva	2011/0279368	A1	11/2011	Klein et al.
2011/0143811	A1	6/2011	Rodriguez	2011/0282663	A1	11/2011	Talwar et al.
2011/0144857	A1	6/2011	Wingrove et al.	2011/0282888	A1	11/2011	Koperski et al.
2011/0144901	A1	6/2011	Wang	2011/0282906	A1	11/2011	Wong
2011/0144973	A1	6/2011	Bocchieri et al.	2011/0283189	A1	11/2011	McCarty
2011/0144999	A1	6/2011	Jang et al.	2011/0288852	A1	11/2011	Dymetman et al.
2011/0145718	A1	6/2011	Ketola et al.	2011/0288855	A1	11/2011	Roy
2011/0151830	A1	6/2011	Blanda et al.	2011/0288861	A1	11/2011	Kurzweil et al.
2011/0153209	A1	6/2011	Geelen	2011/0288863	A1	11/2011	Rasmussen
2011/0153322	A1	6/2011	Kwak et al.	2011/0288866	A1	11/2011	Rasmussen
2011/0153324	A1	6/2011	Ballinger et al.	2011/0298585	A1	12/2011	Barry
2011/0153329	A1	6/2011	Moorer	2011/0301943	A1	12/2011	Patch
2011/0153330	A1	6/2011	Yazdani et al.	2011/0302162	A1	12/2011	Xiao et al.
2011/0153373	A1	6/2011	Dantzig et al.	2011/0306426	A1	12/2011	Novak et al.
2011/0154193	A1	6/2011	Creutz et al.	2011/0307241	A1	12/2011	Waibel et al.
2011/0157029	A1	6/2011	Tseng	2011/0307491	A1	12/2011	Fisk et al.
2011/0161072	A1	6/2011	Terao et al.	2011/0307810	A1	12/2011	Hilerio et al.
2011/0161076	A1	6/2011	Davis et al.	2011/0313775	A1	12/2011	Laligand et al.
2011/0161079	A1	6/2011	Gruhn et al.	2011/0314003	A1	12/2011	Ju et al.
2011/0161309	A1	6/2011	Lung et al.	2011/0314032	A1	12/2011	Bennett et al.
2011/0161852	A1	6/2011	Vainio et al.	2011/0314404	A1	12/2011	Kotler et al.
2011/0166851	A1	7/2011	LeBeau et al.	2011/0320187	A1	12/2011	Motik et al.
2011/0167350	A1	7/2011	Hoellwarth	2012/0002820	A1	1/2012	Leichter
2011/0175810	A1	7/2011	Markovic et al.	2012/0005602	A1	1/2012	Anttila et al.
2011/0179002	A1	7/2011	Dumitru et al.	2012/0008754	A1	1/2012	Mukherjee et al.
2011/0179372	A1	7/2011	Moore et al.	2012/0010886	A1	1/2012	Razavilar
2011/0183650	A1	7/2011	Mckee et al.	2012/0011138	A1	1/2012	Dunning et al.
2011/0184721	A1	7/2011	Subramanian et al.	2012/0013609	A1	1/2012	Reponen et al.
2011/0184730	A1	7/2011	LeBeau et al.	2012/0015629	A1	1/2012	Olsen et al.
2011/0184736	A1	7/2011	Slotznick	2012/0016658	A1	1/2012	Wu et al.
2011/0184737	A1	7/2011	Nakano et al.	2012/0016678	A1	1/2012	Gruber et al.
2011/0184768	A1	7/2011	Norton et al.	2012/0019400	A1	1/2012	Patel et al.
2011/0185288	A1	7/2011	Gupta et al.	2012/0020490	A1	1/2012	Leichter
2011/0191108	A1	8/2011	Friedlander	2012/0022787	A1	1/2012	LeBeau et al.
2011/0191271	A1	8/2011	Baker et al.	2012/0022857	A1	1/2012	Baldwin et al.
2011/0191344	A1	8/2011	Jin et al.	2012/0022860	A1	1/2012	Lloyd et al.
2011/0195758	A1	8/2011	Damale et al.	2012/0022868	A1	1/2012	LeBeau et al.
2011/0196670	A1	8/2011	Dang et al.	2012/0022869	A1	1/2012	Lloyd et al.
2011/0197128	A1	8/2011	Assadollahi et al.	2012/0022870	A1	1/2012	Kristjansson et al.
2011/0201385	A1	8/2011	Higginbotham et al.	2012/0022872	A1	1/2012	Gruber et al.
2011/0201387	A1	8/2011	Paek et al.	2012/0022874	A1	1/2012	Lloyd et al.
2011/0202526	A1	8/2011	Lee et al.	2012/0022876	A1	1/2012	LeBeau et al.
2011/0205149	A1	8/2011	Tom et al.	2012/0022967	A1	1/2012	Bachman et al.
2011/0208511	A1	8/2011	Sikstrom et al.	2012/0023088	A1	1/2012	Cheng et al.
2011/0208524	A1	8/2011	Haughay	2012/0023095	A1	1/2012	Wadycki et al.
2011/0209088	A1	8/2011	Hinckley et al.	2012/0023462	A1	1/2012	Rosing et al.
2011/0212717	A1	9/2011	Rhoads et al.	2012/0029661	A1	2/2012	Jones et al.
2011/0218806	A1	9/2011	Alewine et al.	2012/0029910	A1	2/2012	Medlock et al.
2011/0218855	A1	9/2011	Cao et al.	2012/0034904	A1	2/2012	LeBeau et al.
2011/0219018	A1	9/2011	Bailey et al.	2012/0035907	A1	2/2012	Lebeau et al.
2011/0223893	A1	9/2011	Lau et al.	2012/0035908	A1	2/2012	Lebeau et al.
2011/0224972	A1	9/2011	Millett et al.	2012/0035924	A1	2/2012	Jitkoff et al.
2011/0228913	A1	9/2011	Cochinwala et al.	2012/0035925	A1	2/2012	Friend et al.
2011/0231182	A1	9/2011	Weider et al.	2012/0035926	A1	2/2012	Ambler
2011/0231184	A1	9/2011	Kerr	2012/0035931	A1	2/2012	LeBeau et al.
2011/0231188	A1	9/2011	Kennewick et al.	2012/0035932	A1	2/2012	Jitkoff et al.
2011/0231432	A1	9/2011	Sata et al.	2012/0036556	A1	2/2012	LeBeau et al.
2011/0231474	A1	9/2011	Locker et al.	2012/0039539	A1	2/2012	Boiman et al.
2011/0238407	A1	9/2011	Kent	2012/0041752	A1	2/2012	Wang et al.
2011/0238408	A1	9/2011	Larcheveque et al.	2012/0042014	A1	2/2012	Desai et al.
2011/0238676	A1	9/2011	Liu et al.	2012/0042343	A1	2/2012	Laligand et al.
2011/0239111	A1	9/2011	Grover	2012/0053815	A1	3/2012	Montanari et al.
2011/0242007	A1	10/2011	Gray et al.	2012/0053829	A1	3/2012	Agarwal et al.
2011/0246471	A1	10/2011	Rakib et al.	2012/0053945	A1	3/2012	Gupta et al.
2011/0249144	A1	10/2011	Chang	2012/0056815	A1	3/2012	Mehra
2011/0250570	A1	10/2011	Mack et al.	2012/0059655	A1	3/2012	Cartales
2011/0258188	A1	10/2011	Abdalmageed et al.	2012/0062473	A1	3/2012	Xiao et al.
2011/0260829	A1	10/2011	Lee	2012/0066212	A1	3/2012	Jennings
2011/0260861	A1	10/2011	Singh et al.	2012/0066581	A1	3/2012	Spalink
2011/0264643	A1	10/2011	Cao	2012/0075054	A1	3/2012	Ge et al.
				2012/0078611	A1	3/2012	Soltani et al.
				2012/0078624	A1	3/2012	Yook et al.
				2012/0078627	A1	3/2012	Wagner
				2012/0082317	A1	4/2012	Pance et al.

(56)		References Cited					
		U.S. PATENT DOCUMENTS					
2012/0083286	A1	4/2012	Kim et al.	2012/0275377	A1	11/2012	Lehane et al.
2012/0084086	A1	4/2012	Gilbert et al.	2012/0284015	A1	11/2012	Drewes
2012/0084634	A1	4/2012	Wong et al.	2012/0284027	A1	11/2012	Mallett et al.
2012/0088219	A1	4/2012	Briscoe et al.	2012/0290291	A1	11/2012	Shelley et al.
2012/0089331	A1	4/2012	Schmidt et al.	2012/0290300	A1	11/2012	Lee et al.
2012/0108166	A1	5/2012	Hymel	2012/0295708	A1	11/2012	Hernandez-Abrego et al.
2012/0108221	A1	5/2012	Thomas et al.	2012/0296649	A1	11/2012	Bansal et al.
2012/0116770	A1	5/2012	Chen et al.	2012/0296654	A1	11/2012	Hendrickson et al.
2012/0117499	A1	5/2012	Mori et al.	2012/0296891	A1	11/2012	Rangan
2012/0124126	A1	5/2012	Alcazar et al.	2012/0297348	A1	11/2012	Santoro
2012/0128322	A1	5/2012	Shaffer et al.	2012/0303369	A1	11/2012	Brush et al.
2012/0130709	A1	5/2012	Bocchieri et al.	2012/0303371	A1	11/2012	Labsky et al.
2012/0136572	A1	5/2012	Norton	2012/0304124	A1	11/2012	Chen et al.
2012/0136985	A1	5/2012	Popescu et al.	2012/0309363	A1	12/2012	Gruber et al.
2012/0137367	A1	5/2012	Dupont et al.	2012/0310642	A1	12/2012	Cao et al.
2012/0149342	A1	6/2012	Cohen et al.	2012/0310649	A1	12/2012	Cannistraro et al.
2012/0149394	A1	6/2012	Singh et al.	2012/0310652	A1	12/2012	O'Sullivan
2012/0150544	A1	6/2012	McLoughlin et al.	2012/0310922	A1	12/2012	Johnson et al.
2012/0150580	A1	6/2012	Norton	2012/0311478	A1	12/2012	Van Os et al.
2012/0158293	A1	6/2012	Burnham	2012/0311583	A1	12/2012	Gruber et al.
2012/0158399	A1	6/2012	Tremblay et al.	2012/0311584	A1	12/2012	Gruber et al.
2012/0158422	A1	6/2012	Burnham et al.	2012/0311585	A1	12/2012	Gruber et al.
2012/0159380	A1	6/2012	Kocienda et al.	2012/0316862	A1	12/2012	Sultan et al.
2012/0163710	A1	6/2012	Skaff et al.	2012/0316878	A1	12/2012	Singleton et al.
2012/0166196	A1	6/2012	Ju et al.	2012/0317194	A1	12/2012	Tian
2012/0173222	A1	7/2012	Wang et al.	2012/0317498	A1	12/2012	Logan et al.
2012/0173244	A1	7/2012	Kwak et al.	2012/0321112	A1	12/2012	Schubert et al.
2012/0173464	A1	7/2012	Tur et al.	2012/0324391	A1	12/2012	Tocci et al.
2012/0174121	A1	7/2012	Treat et al.	2012/0327009	A1	12/2012	Fleizach
2012/0179457	A1	7/2012	Newman et al.	2012/0329529	A1	12/2012	van der Raadt
2012/0179467	A1	7/2012	Williams	2012/0330660	A1	12/2012	Jaiswal
2012/0185237	A1	7/2012	Gajic et al.	2012/0330661	A1	12/2012	Lindahl
2012/0185480	A1	7/2012	Ni et al.	2012/0330990	A1	12/2012	Chen et al.
2012/0185781	A1	7/2012	Guzman et al.	2013/0005405	A1	1/2013	Prociw
2012/0191461	A1	7/2012	Lin et al.	2013/0006633	A1	1/2013	Grokop et al.
2012/0192096	A1	7/2012	Bowman et al.	2013/0006637	A1	1/2013	Kanevsky et al.
2012/0197743	A1	8/2012	Grigg et al.	2013/0006638	A1	1/2013	Lindahl
2012/0197995	A1	8/2012	Caruso	2013/0007648	A1	1/2013	Gamon et al.
2012/0197998	A1	8/2012	Kessel et al.	2013/0010575	A1	1/2013	He et al.
2012/0201362	A1	8/2012	Crossan et al.	2013/0013313	A1	1/2013	Shechtman et al.
2012/0209853	A1	8/2012	Desai et al.	2013/0013319	A1	1/2013	Grant et al.
2012/0209874	A1	8/2012	Wong et al.	2013/0018659	A1	1/2013	Chi
2012/0214141	A1	8/2012	Raya et al.	2013/0027875	A1	1/2013	Zhu et al.
2012/0214517	A1	8/2012	Singh et al.	2013/0030787	A1	1/2013	Cancedda et al.
2012/0215762	A1	8/2012	Hall et al.	2013/0030789	A1	1/2013	Dalce
2012/0221339	A1	8/2012	Wang et al.	2013/0030804	A1	1/2013	Zavaliagko et al.
2012/0221552	A1	8/2012	Reponen et al.	2013/0030815	A1	1/2013	Madhvanath et al.
2012/0223889	A1	9/2012	Medlock et al.	2013/0030955	A1	1/2013	David
2012/0223936	A1	9/2012	Aughey et al.	2013/0031162	A1	1/2013	Willis et al.
2012/0232885	A1	9/2012	Barbosa et al.	2013/0031476	A1	1/2013	Coin et al.
2012/0232886	A1	9/2012	Capuozzo et al.	2013/0035086	A1	2/2013	Chardon et al.
2012/0232906	A1	9/2012	Lindahl et al.	2013/0035942	A1	2/2013	Kim et al.
2012/0239661	A1	9/2012	Giblin	2013/0035961	A1	2/2013	Yegnanarayanan
2012/0239761	A1	9/2012	Linner et al.	2013/0041647	A1	2/2013	Ramerth et al.
2012/0242482	A1	9/2012	Elumalai et al.	2013/0041654	A1	2/2013	Walker et al.
2012/0245719	A1	9/2012	Story, Jr. et al.	2013/0041661	A1	2/2013	Lee et al.
2012/0245941	A1	9/2012	Cheyen	2013/0041665	A1	2/2013	Jang et al.
2012/0245944	A1	9/2012	Gruber et al.	2013/0041968	A1	2/2013	Cohen et al.
2012/0246064	A1	9/2012	Balkow	2013/0046544	A1	2/2013	Kay et al.
2012/0250858	A1	10/2012	Iqbal et al.	2013/0050089	A1	2/2013	Neels et al.
2012/0252367	A1	10/2012	Gaglio et al.	2013/0054550	A1	2/2013	Bolohan
2012/0252540	A1	10/2012	Kirigaya	2013/0054609	A1	2/2013	Rajput et al.
2012/0253785	A1	10/2012	Hamid et al.	2013/0054613	A1	2/2013	Bishop
2012/0254143	A1	10/2012	Varma et al.	2013/0054675	A1	2/2013	Jenkins et al.
2012/0254152	A1	10/2012	Park et al.	2013/0054706	A1	2/2013	Graham et al.
2012/0254290	A1	10/2012	Naaman	2013/0055099	A1	2/2013	Yao et al.
2012/0259615	A1	10/2012	Morin et al.	2013/0055147	A1	2/2013	Vasudev et al.
2012/0265528	A1	10/2012	Gruber et al.	2013/0063611	A1	3/2013	Papakipos et al.
2012/0265535	A1	10/2012	Bryant-Rich et al.	2013/0066832	A1	3/2013	Sheehan et al.
2012/0265806	A1	10/2012	Blanchflower et al.	2013/0067307	A1	3/2013	Tian et al.
2012/0271625	A1	10/2012	Bernard	2013/0073286	A1	3/2013	Bastea-Forte et al.
2012/0271634	A1	10/2012	Lenke	2013/0080152	A1	3/2013	Brun et al.
2012/0271635	A1	10/2012	Ljolje	2013/0080162	A1	3/2013	Chang et al.
2012/0271640	A1	10/2012	Basir	2013/0080167	A1	3/2013	Mozer
2012/0271676	A1	10/2012	Aravamudan et al.	2013/0080177	A1	3/2013	Chen
				2013/0080251	A1	3/2013	Dempski
				2013/0085755	A1	4/2013	Bringert et al.
				2013/0085761	A1	4/2013	Bringert et al.
				2013/0090921	A1	4/2013	Liu et al.

(56)

References Cited

U.S. PATENT DOCUMENTS

2013/0091090	A1	4/2013	Spivack et al.	2013/0275899	A1	10/2013	Schubert et al.
2013/0095805	A1	4/2013	Lebeau et al.	2013/0283168	A1	10/2013	Brown et al.
2013/0096909	A1	4/2013	Brun et al.	2013/0289991	A1	10/2013	Eshwar et al.
2013/0096917	A1	4/2013	Edgar et al.	2013/0289993	A1	10/2013	Rao et al.
2013/0097566	A1	4/2013	Berglund	2013/0289994	A1	10/2013	Newman et al.
2013/0097682	A1*	4/2013	Zeljkoivic H04L 9/3231 726/7	2013/0291015	A1	10/2013	Pan
2013/0100268	A1	4/2013	Mihailidis et al.	2013/0297317	A1	11/2013	Lee et al.
2013/0103391	A1	4/2013	Millmore et al.	2013/0297319	A1	11/2013	Kim
2013/0106742	A1	5/2013	Lee et al.	2013/0297348	A1	11/2013	Cardoza et al.
2013/0110505	A1	5/2013	Gruber et al.	2013/0304479	A1	11/2013	Teller et al.
2013/0110515	A1	5/2013	Guzzoni et al.	2013/0304758	A1	11/2013	Gruber et al.
2013/0110518	A1	5/2013	Gruber et al.	2013/0304815	A1	11/2013	Puente et al.
2013/0110519	A1	5/2013	Cheyser et al.	2013/0305119	A1	11/2013	Kern et al.
2013/0110520	A1	5/2013	Cheyser et al.	2013/0307855	A1	11/2013	Lamb et al.
2013/0110943	A1	5/2013	Menon et al.	2013/0307997	A1	11/2013	O'Keefe et al.
2013/0111330	A1	5/2013	Staikos et al.	2013/0308922	A1	11/2013	Sano et al.
2013/0111348	A1	5/2013	Gruber et al.	2013/0311997	A1	11/2013	Gruber et al.
2013/0111487	A1	5/2013	Cheyser et al.	2013/0316746	A1	11/2013	Miller et al.
2013/0115927	A1	5/2013	Gruber et al.	2013/0322634	A1	12/2013	Bennett et al.
2013/0117022	A1	5/2013	Chen et al.	2013/0325436	A1	12/2013	Wang et al.
2013/0124189	A1	5/2013	Baldwin et al.	2013/0325443	A1	12/2013	Begeja et al.
2013/0132084	A1	5/2013	Stonehocker et al.	2013/0325447	A1	12/2013	Levien et al.
2013/0132089	A1	5/2013	Fanty et al.	2013/0325448	A1	12/2013	Levien et al.
2013/0132871	A1	5/2013	Zeng et al.	2013/0325481	A1	12/2013	Van Os et al.
2013/0141551	A1	6/2013	Kim	2013/0325484	A1	12/2013	Chakladar et al.
2013/0142317	A1	6/2013	Reynolds	2013/0325979	A1	12/2013	Mansfield et al.
2013/0142345	A1	6/2013	Waldmann	2013/0329023	A1	12/2013	Suplee, III et al.
2013/0144594	A1	6/2013	Bangalore et al.	2013/0332159	A1	12/2013	Federighi et al.
2013/0144616	A1	6/2013	Bangalore et al.	2013/0332162	A1	12/2013	Keen
2013/0151339	A1	6/2013	Kim et al.	2013/0332164	A1	12/2013	Nalk
2013/0152092	A1	6/2013	Yadgar et al.	2013/0332168	A1	12/2013	Kim et al.
2013/0154811	A1	6/2013	Ferren et al.	2013/0332400	A1	12/2013	González
2013/0158977	A1	6/2013	Senior	2013/0339256	A1	12/2013	Shroff
2013/0165232	A1	6/2013	Nelson et al.	2013/0346068	A1	12/2013	Solem et al.
2013/0166303	A1	6/2013	Chang et al.	2013/0346347	A1	12/2013	Patterson et al.
2013/0166442	A1	6/2013	Nakajima et al.	2014/0006012	A1	1/2014	Zhou et al.
2013/0170738	A1	7/2013	Capuozzo et al.	2014/0006025	A1	1/2014	Krishnan et al.
2013/0172022	A1	7/2013	Seymour et al.	2014/0006027	A1	1/2014	Kim et al.
2013/0176244	A1	7/2013	Yamamoto et al.	2014/0006153	A1	1/2014	Thangam et al.
2013/0176592	A1	7/2013	Sasaki	2014/0012580	A1	1/2014	Ganong et al.
2013/0179440	A1	7/2013	Gordon	2014/0012586	A1	1/2014	Rubin et al.
2013/0183944	A1	7/2013	Mozer et al.	2014/0019116	A1	1/2014	Lundberg et al.
2013/0185059	A1	7/2013	Riccardi et al.	2014/0019133	A1	1/2014	Bao et al.
2013/0185074	A1	7/2013	Gruber et al.	2014/0028735	A1	1/2014	Williams et al.
2013/0185081	A1	7/2013	Cheyser et al.	2014/0032453	A1	1/2014	Eustice et al.
2013/0185336	A1	7/2013	Singh et al.	2014/0033071	A1	1/2014	Gruber et al.
2013/0187850	A1	7/2013	Schulz et al.	2014/0035823	A1	2/2014	Khoe et al.
2013/0191117	A1	7/2013	Atti et al.	2014/0039894	A1	2/2014	Shostak
2013/0197911	A1	8/2013	Wei et al.	2014/0040274	A1	2/2014	Aravamudan et al.
2013/0204813	A1	8/2013	Master et al.	2014/0040748	A1	2/2014	Lemay et al.
2013/0207898	A1	8/2013	Sullivan et al.	2014/0040801	A1	2/2014	Patel et al.
2013/0218553	A1	8/2013	Fujii et al.	2014/0040918	A1	2/2014	Li et al.
2013/0218560	A1	8/2013	Hsiao et al.	2014/0046934	A1	2/2014	Zhou et al.
2013/0222249	A1	8/2013	Pasquero et al.	2014/0047001	A1	2/2014	Phillips et al.
2013/0225128	A1*	8/2013	Gomar H04W 12/06 455/411	2014/0052680	A1	2/2014	Nitz et al.
2013/0231917	A1	9/2013	Naik	2014/0052791	A1	2/2014	Chakra et al.
2013/0234947	A1	9/2013	Kristensson et al.	2014/0053082	A1	2/2014	Park et al.
2013/0235987	A1	9/2013	Arroniz-Escobar et al.	2014/0057610	A1	2/2014	Olincy et al.
2013/0238647	A1	9/2013	Thompson	2014/0059030	A1	2/2014	Hakkani-Tur et al.
2013/0238729	A1	9/2013	Holzman et al.	2014/0067361	A1	3/2014	Nikoulina et al.
2013/0244615	A1	9/2013	Miller et al.	2014/0067371	A1	3/2014	Liensberger
2013/0246048	A1	9/2013	Nagase et al.	2014/0067402	A1	3/2014	Kim
2013/0246050	A1	9/2013	Yu et al.	2014/0068751	A1	3/2014	Last et al.
2013/0253911	A1	9/2013	Petri et al.	2014/0074470	A1	3/2014	Jansche et al.
2013/0253912	A1	9/2013	Medlock et al.	2014/0074472	A1	3/2014	Lin et al.
2013/0262168	A1*	10/2013	Makanawala H04L 51/32 705/7.14	2014/0074589	A1	3/2014	Nielsen et al.
2013/0275117	A1	10/2013	Winer	2014/0074815	A1	3/2014	Plimton
2013/0275138	A1	10/2013	Gruber et al.	2014/0078065	A1	3/2014	Akkok et al.
2013/0275164	A1	10/2013	Gruber et al.	2014/0080428	A1	3/2014	Rhoads et al.
2013/0275199	A1	10/2013	Proctor, Jr. et al.	2014/0081633	A1	3/2014	Badaskar et al.
2013/0275625	A1	10/2013	Taivalsaari et al.	2014/0082501	A1	3/2014	Bae et al.
2013/0275875	A1	10/2013	Gruber et al.	2014/0086458	A1	3/2014	Rogers et al.
				2014/0087711	A1	3/2014	Geyer et al.
				2014/0088961	A1	3/2014	Woodward et al.
				2014/0095171	A1	4/2014	Lynch et al.
				2014/0095172	A1	4/2014	Cabaco et al.
				2014/0095173	A1	4/2014	Lynch et al.
				2014/0096209	A1	4/2014	Saraf et al.
				2014/0098247	A1	4/2014	Rao et al.

(56)	References Cited						
	U.S. PATENT DOCUMENTS						
2014/0108017	A1	4/2014	Mason et al.	2014/0278435	A1	9/2014	Ganong et al.
2014/0114554	A1	4/2014	Lagassey	2014/0278443	A1	9/2014	Gunn et al.
2014/0118155	A1	5/2014	Bowers et al.	2014/0278513	A1	9/2014	Prakash et al.
2014/0122059	A1	5/2014	Patel et al.	2014/0280138	A1	9/2014	Li et al.
2014/0122086	A1	5/2014	Kapur et al.	2014/0280292	A1	9/2014	Skinder
2014/0122136	A1	5/2014	Jayanthi	2014/0280353	A1	9/2014	Delaney et al.
2014/0122153	A1	5/2014	Truitt	2014/0280450	A1	9/2014	Luna
2014/0135036	A1	5/2014	Bonanni et al.	2014/0281983	A1	9/2014	Xian et al.
2014/0136187	A1	5/2014	Wolverton et al.	2014/0282003	A1	9/2014	Gruber et al.
2014/0136195	A1	5/2014	Abdossalami et al.	2014/0282007	A1	9/2014	Fleizach
2014/0136212	A1	5/2014	Kwon et al.	2014/0282045	A1	9/2014	Ayanam et al.
2014/0136946	A1	5/2014	Matas	2014/0282201	A1	9/2014	Pasquero et al.
2014/0142923	A1	5/2014	Jones et al.	2014/0282586	A1	9/2014	Shear et al.
2014/0142935	A1	5/2014	Lindahl et al.	2014/0282743	A1	9/2014	Howard et al.
2014/0143550	A1	5/2014	Ganong, III et al.	2014/0288990	A1	9/2014	Moore et al.
2014/0143721	A1	5/2014	Suzuki et al.	2014/0289508	A1*	9/2014	Wang H04L 63/0853
2014/0146200	A1	5/2014	Scott et al.				713/155
2014/0152577	A1	6/2014	Yuen et al.	2014/0297267	A1	10/2014	Spencer et al.
2014/0155031	A1	6/2014	Lee et al.	2014/0297281	A1	10/2014	Togawa et al.
2014/0157422	A1	6/2014	Livshits et al.	2014/0297284	A1	10/2014	Gruber et al.
2014/0163951	A1	6/2014	Nikoulina et al.	2014/0297288	A1	10/2014	Yu et al.
2014/0163953	A1	6/2014	Parikh	2014/0304605	A1	10/2014	Ohmura et al.
2014/0163981	A1	6/2014	Cook et al.	2014/0310001	A1	10/2014	Kalns et al.
2014/0164532	A1	6/2014	Lynch et al.	2014/0310365	A1*	10/2014	Sample H04L 51/16
2014/0173460	A1	6/2014	Kim				709/206
2014/0180499	A1	6/2014	Cooper et al.	2014/0316585	A1	10/2014	Boesveld et al.
2014/0180689	A1	6/2014	Kim et al.	2014/0317502	A1	10/2014	Brown et al.
2014/0188477	A1	7/2014	Zhang	2014/0324884	A1	10/2014	Lindahl et al.
2014/0195233	A1	7/2014	Bapat	2014/0337048	A1	11/2014	Brown et al.
2014/0195244	A1	7/2014	Cha et al.	2014/0337266	A1	11/2014	Wolverton et al.
2014/0195251	A1	7/2014	Zeinstra et al.	2014/0337751	A1	11/2014	Lim et al.
2014/0195252	A1	7/2014	Gruber et al.	2014/0337814	A1	11/2014	Kalns et al.
2014/0203939	A1	7/2014	Harrington et al.	2014/0344627	A1	11/2014	Schaub et al.
2014/0207439	A1	7/2014	Venkatapathy et al.	2014/0344687	A1	11/2014	Durham et al.
2014/0207582	A1	7/2014	Flinn et al.	2014/0350924	A1	11/2014	Zurek et al.
2014/0211944	A1*	7/2014	Hayward H04L 9/0866	2014/0350933	A1	11/2014	Bak et al.
			380/281	2014/0351741	A1	11/2014	Medlock et al.
2014/0214429	A1	7/2014	Pantel	2014/0351760	A1	11/2014	Skory et al.
2014/0214537	A1	7/2014	Yoo et al.	2014/0358519	A1	12/2014	Mirkin et al.
2014/0218372	A1	8/2014	Missig et al.	2014/0358523	A1	12/2014	Sheth et al.
2014/0222436	A1	8/2014	Binder et al.	2014/0365209	A1	12/2014	Evermann
2014/0222678	A1	8/2014	Sheets et al.	2014/0365214	A1	12/2014	Bayley
2014/0223377	A1	8/2014	Shaw et al.	2014/0365216	A1	12/2014	Gruber et al.
2014/0223481	A1	8/2014	Fundament	2014/0365226	A1	12/2014	Sinha
2014/0230055	A1	8/2014	Boehl	2014/0365227	A1	12/2014	Cash et al.
2014/0232656	A1	8/2014	Pasquero et al.	2014/0365407	A1	12/2014	Brown et al.
2014/0236595	A1	8/2014	Gray	2014/0365880	A1	12/2014	Bellegarda
2014/0236986	A1	8/2014	Guzman	2014/0365885	A1	12/2014	Carson et al.
2014/0237042	A1	8/2014	Ahmed et al.	2014/0365895	A1	12/2014	Paulson et al.
2014/0244254	A1	8/2014	Ju et al.	2014/0370817	A1	12/2014	Luna
2014/0244257	A1	8/2014	Colibro et al.	2014/0372112	A1	12/2014	Xue et al.
2014/0244258	A1	8/2014	Song et al.	2014/0372931	A1	12/2014	Zhai et al.
2014/0244263	A1	8/2014	Pontual et al.	2014/0379334	A1	12/2014	Fry
2014/0244268	A1	8/2014	Abdelsamie et al.	2015/0003797	A1	1/2015	Schmidt
2014/0244271	A1	8/2014	Lindahl	2015/0006148	A1	1/2015	Goldszmit et al.
2014/0244712	A1	8/2014	Walters et al.	2015/0006157	A1	1/2015	Andrade Silva et al.
2014/0247383	A1	9/2014	Dave et al.	2015/0006178	A1	1/2015	Peng et al.
2014/0247926	A1	9/2014	Gainsboro et al.	2015/0006199	A1	1/2015	Snider et al.
2014/0249817	A1	9/2014	Hart et al.	2015/0012271	A1	1/2015	Peng et al.
2014/0249821	A1	9/2014	Kennewick et al.	2015/0019219	A1	1/2015	Tzirkel-hancock et al.
2014/0250046	A1	9/2014	Winn et al.	2015/0019221	A1	1/2015	Lee et al.
2014/0257815	A1	9/2014	Zhao et al.	2015/0019944	A1*	1/2015	Kalgi G06Q 20/227
2014/0258857	A1	9/2014	Dykstra-Erickson et al.				715/205
2014/0267022	A1	9/2014	Kim	2015/0031416	A1	1/2015	Wells et al.
2014/0267599	A1	9/2014	Drouin et al.	2015/0033219	A1	1/2015	Breiner et al.
2014/0272821	A1	9/2014	Pitschel et al.	2015/0039292	A1	2/2015	Suleman et al.
2014/0274203	A1	9/2014	Ganong et al.	2015/0039299	A1	2/2015	Weinstein et al.
2014/0274211	A1	9/2014	Sejnoha et al.	2015/0039305	A1	2/2015	Huang
2014/0278343	A1	9/2014	Tran	2015/0040012	A1	2/2015	Faaborg et al.
2014/0278349	A1	9/2014	Grieves et al.	2015/0045003	A1	2/2015	Vora et al.
2014/0278379	A1	9/2014	Coccaro et al.	2015/0045068	A1	2/2015	Soffer et al.
2014/0278391	A1	9/2014	Braho et al.	2015/0046537	A1	2/2015	Rakib
2014/0278406	A1	9/2014	Tsumura et al.	2015/0050633	A1	2/2015	Christmas et al.
2014/0278413	A1	9/2014	Pitschel et al.	2015/0058013	A1	2/2015	Pakhomov et al.
2014/0278429	A1	9/2014	Ganong, III	2015/0058018	A1	2/2015	Georges et al.
				2015/0058785	A1	2/2015	Ookawara
				2015/0065200	A1	3/2015	Namgung et al.
				2015/0066494	A1	3/2015	Salvador et al.
				2015/0066496	A1	3/2015	Deoras et al.

(56)		References Cited					
		U.S. PATENT DOCUMENTS					
2015/0066506	A1	3/2015	Romano et al.	2015/0245154	A1	8/2015	Dadu et al.
2015/0066516	A1	3/2015	Nishikawa et al.	2015/0248651	A1	9/2015	Akutagawa et al.
2015/0067485	A1	3/2015	Kim et al.	2015/0254057	A1	9/2015	Klein et al.
2015/0067822	A1	3/2015	Randall	2015/0254058	A1	9/2015	Klein et al.
2015/0073788	A1	3/2015	Allauzen et al.	2015/0254333	A1	9/2015	Fife et al.
2015/0073804	A1	3/2015	Senior et al.	2015/0255071	A1	9/2015	Chiba
2015/0074524	A1	3/2015	Nicholson et al.	2015/0256873	A1	9/2015	Klein et al.
2015/0082229	A1	3/2015	Ouyang et al.	2015/0261496	A1	9/2015	Faaborg et al.
2015/0088511	A1	3/2015	Bharadwaj et al.	2015/0269139	A1	9/2015	McAteer et al.
2015/0088514	A1	3/2015	Typrin	2015/0278370	A1	10/2015	Stratvert et al.
2015/0088523	A1	3/2015	Schuster	2015/0279360	A1	10/2015	Mengibar et al.
2015/0088998	A1*	3/2015	Isensee H04L 51/02 709/206	2015/0281380	A1	10/2015	Wang et al.
2015/0095031	A1	4/2015	Conkie et al.	2015/0286627	A1	10/2015	Chang et al.
2015/0095278	A1	4/2015	Flinn et al.	2015/0287401	A1	10/2015	Lee et al.
2015/0100316	A1	4/2015	Williams et al.	2015/0287409	A1	10/2015	Jang
2015/0100983	A1	4/2015	Pan	2015/0288629	A1	10/2015	Choi et al.
2015/0106093	A1	4/2015	Weeks et al.	2015/0294516	A1	10/2015	Chiang
2015/0113407	A1	4/2015	Hoffert et al.	2015/0295915	A1*	10/2015	Xiu H04L 67/2814 726/7
2015/0120723	A1	4/2015	Deshmukh et al.	2015/0302855	A1	10/2015	Kim et al.
2015/0121216	A1*	4/2015	Brown G06N 3/006 715/707	2015/0309997	A1	10/2015	Lee et al.
2015/0127350	A1	5/2015	Agiomyrgiannakis	2015/0310858	A1	10/2015	Li et al.
2015/0133109	A1	5/2015	Freeman et al.	2015/0310862	A1	10/2015	Dauphin et al.
2015/0134334	A1	5/2015	Sachidanandam et al.	2015/0310879	A1	10/2015	Buchanan et al.
2015/0135085	A1	5/2015	Shoham et al.	2015/0312182	A1	10/2015	Langholz
2015/0135123	A1	5/2015	Carr et al.	2015/0317069	A1	11/2015	Clements et al.
2015/0142420	A1	5/2015	Sarikaya et al.	2015/0317310	A1	11/2015	Eiche et al.
2015/0142438	A1	5/2015	Dai et al.	2015/0324041	A1	11/2015	Varley et al.
2015/0142447	A1	5/2015	Kennewick et al.	2015/0324334	A1	11/2015	Lee et al.
2015/0142851	A1	5/2015	Gupta et al.	2015/0331664	A1	11/2015	Osawa et al.
2015/0148013	A1	5/2015	Baldwin et al.	2015/0331711	A1	11/2015	Huang et al.
2015/0149177	A1	5/2015	Kalns et al.	2015/0332667	A1	11/2015	Mason
2015/0149182	A1	5/2015	Kalns et al.	2015/0339049	A1	11/2015	Kasemset et al.
2015/0149354	A1	5/2015	Meccoy	2015/0339391	A1	11/2015	Kang et al.
2015/0149469	A1	5/2015	Xu et al.	2015/0340040	A1	11/2015	Mun et al.
2015/0154185	A1	6/2015	Waibel	2015/0340042	A1	11/2015	Sejnoha et al.
2015/0161370	A1	6/2015	North et al.	2015/0341717	A1	11/2015	Song et al.
2015/0161989	A1	6/2015	Hsu et al.	2015/0347086	A1	12/2015	Liedholm et al.
2015/0170073	A1*	6/2015	Baker G06F 3/167 705/348	2015/0347382	A1	12/2015	Dolfing et al.
2015/0170664	A1	6/2015	Doherty et al.	2015/0347385	A1	12/2015	Flor et al.
2015/0172463	A1	6/2015	Quast et al.	2015/0347393	A1	12/2015	Futrell et al.
2015/0178388	A1	6/2015	Winnemoeller et al.	2015/0347733	A1	12/2015	Tsou et al.
2015/0178785	A1*	6/2015	Salonen G06Q 30/0267 705/14.64	2015/0347985	A1	12/2015	Gross et al.
2015/0179176	A1	6/2015	Ryu et al.	2015/0348547	A1	12/2015	Paulik et al.
2015/0185964	A1	7/2015	Stout	2015/0348548	A1	12/2015	Piernot et al.
2015/0186012	A1	7/2015	Coleman et al.	2015/0348549	A1	12/2015	Giuli et al.
2015/0186110	A1	7/2015	Kannan	2015/0348551	A1	12/2015	Gruber et al.
2015/0186155	A1	7/2015	Brown et al.	2015/0348554	A1	12/2015	Orr et al.
2015/0186351	A1	7/2015	Hicks et al.	2015/0350031	A1	12/2015	Burks et al.
2015/0187355	A1	7/2015	Parkinson et al.	2015/0355879	A1	12/2015	Beckhardt et al.
2015/0189362	A1	7/2015	Lee et al.	2015/0370531	A1	12/2015	Faaborg
2015/0193379	A1	7/2015	Mehta	2015/0370780	A1	12/2015	Wang et al.
2015/0193391	A1	7/2015	Khvostichenko et al.	2015/0371639	A1	12/2015	Foerster et al.
2015/0193392	A1	7/2015	Greenblatt et al.	2015/0371665	A1	12/2015	Naik et al.
2015/0194152	A1	7/2015	Katuri et al.	2015/0373183	A1	12/2015	Woolsey et al.
2015/0195379	A1	7/2015	Zhang et al.	2015/0382047	A1	12/2015	Napolitano et al.
2015/0195606	A1	7/2015	McDevitt	2015/0382079	A1	12/2015	Lister et al.
2015/0199077	A1	7/2015	Zuger et al.	2016/0014476	A1	1/2016	Caliendo, Jr. et al.
2015/0199960	A1	7/2015	Huo et al.	2016/0019886	A1	1/2016	Hong
2015/0199965	A1	7/2015	Leak et al.	2016/0026258	A1	1/2016	Ou et al.
2015/0201064	A1	7/2015	Bells et al.	2016/0027431	A1	1/2016	Kurzweil et al.
2015/0205858	A1	7/2015	Xie et al.	2016/0028666	A1	1/2016	Li
2015/0212791	A1	7/2015	Kumar et al.	2016/0034811	A1	2/2016	Paulik et al.
2015/0220507	A1	8/2015	Mohajer et al.	2016/0042735	A1	2/2016	Vibbert et al.
2015/0221304	A1	8/2015	Stewart	2016/0042748	A1	2/2016	Jain et al.
2015/0221307	A1	8/2015	Shah et al.	2016/0055422	A1	2/2016	Li
2015/0227633	A1	8/2015	Shapira	2016/0063998	A1	3/2016	Krishnamoorthy et al.
2015/0228281	A1	8/2015	Raniere	2016/0071521	A1	3/2016	Haughay
2015/0234636	A1	8/2015	Barnes, Jr.	2016/0077794	A1	3/2016	Kim et al.
2015/0234800	A1	8/2015	Patrick et al.	2016/0080165	A1	3/2016	Ehsani et al.
2015/0242091	A1	8/2015	Lu et al.	2016/0086116	A1	3/2016	Rao et al.
2015/0243278	A1	8/2015	Kibre et al.	2016/0091967	A1	3/2016	Prokofieva et al.
				2016/0092447	A1	3/2016	Venkataraman et al.
				2016/0093291	A1	3/2016	Kim
				2016/0093298	A1	3/2016	Naik et al.
				2016/0093301	A1	3/2016	Bellegarda et al.
				2016/0093304	A1	3/2016	Kim et al.
				2016/0094979	A1	3/2016	Naik et al.

(56) References Cited				CN			
U.S. PATENT DOCUMENTS				CN	1407795	A	4/2003
				CN	1125436	C	10/2003
				CN	1471098	A	1/2004
				CN	1494695	A	5/2004
2016/0099892	A1*	4/2016	Palakovich H04L 51/04	CN	1524218	A	8/2004
				CN	1535519	A	10/2004
				CN	1640191	A	7/2005
2016/0117386	A1	4/2016	Ajmera et al.	CN	1673939	A	9/2005
2016/0119338	A1	4/2016	Cheyser	CN	1757027	A	4/2006
2016/0125048	A1	5/2016	Hamada	CN	1864204	A	11/2006
2016/0139662	A1	5/2016	Dabhade	CN	1898721	A	1/2007
2016/0147725	A1	5/2016	Patten et al.	CN	2865153	Y	1/2007
2016/0148610	A1	5/2016	Kennewick, Jr. et al.	CN	1912994	A	2/2007
2016/0155442	A1	6/2016	Kannan et al.	CN	1959628	A	5/2007
2016/0155443	A1	6/2016	Khan et al.	CN	1975715	A	6/2007
2016/0162456	A1	6/2016	Munro et al.	CN	1995917	A	7/2007
2016/0163312	A1	6/2016	Naik et al.	CN	101008942	A	8/2007
2016/0170966	A1	6/2016	Kolo	CN	101162153	A	4/2008
2016/0173960	A1	6/2016	Snibbe et al.	CN	101179754	A	5/2008
2016/0180844	A1	6/2016	Vanblon et al.	CN	101183525	A	5/2008
2016/0188181	A1	6/2016	Smith	CN	101188644	A	5/2008
2016/0189717	A1	6/2016	Kannan et al.	CN	101228503	A	7/2008
2016/0212488	A1	7/2016	Os et al.	CN	101233741	A	7/2008
2016/0217784	A1	7/2016	Gelfenbeyn et al.	CN	101246020	A	8/2008
2016/0224774	A1*	8/2016	Pender G06F 21/32	CN	101271689	A	9/2008
2016/0225372	A1	8/2016	Cheung et al.	CN	101277501	A	10/2008
2016/0240187	A1	8/2016	Fleizach et al.	CN	101297541	A	10/2008
2016/0260431	A1	9/2016	Newendorp et al.	CN	101325756	A	12/2008
2016/0260433	A1	9/2016	Sumner et al.	CN	101416471	A	4/2009
2016/0260436	A1	9/2016	Lemay et al.	CN	101427244	A	5/2009
2016/0266871	A1	9/2016	Schmid et al.	CN	101448340	A	6/2009
2016/0267904	A1	9/2016	Biadysy et al.	CN	101453498	A	6/2009
2016/0275941	A1	9/2016	Bellegarda et al.	CN	101499156	A	8/2009
2016/0275947	A1	9/2016	Li et al.	CN	101535983	A	9/2009
2016/0282956	A1	9/2016	Ouyang et al.	CN	101557432	A	10/2009
2016/0299685	A1	10/2016	Zhai et al.	CN	101632316	A	1/2010
2016/0299882	A1	10/2016	Hegerty et al.	CN	101636736	A	1/2010
2016/0299883	A1	10/2016	Zhu et al.	CN	101673544	A	3/2010
2016/0307566	A1	10/2016	Bellegarda	CN	101751387	A	6/2010
2016/0308799	A1*	10/2016	Schubert H04L 51/046	CN	101847405	A	9/2010
2016/0314788	A1	10/2016	Jitkoff et al.	CN	101894547	A	11/2010
2016/0314792	A1	10/2016	Alvarez et al.	CN	101939740	A	1/2011
2016/0321261	A1	11/2016	Spasojevic et al.	CN	101951553	A	1/2011
2016/0322050	A1	11/2016	Wang et al.	CN	102137193	A	7/2011
2016/0336007	A1	11/2016	Hanazawa	CN	102160043	A	8/2011
2016/0336010	A1	11/2016	Lindahl	CN	102246136	A	11/2011
2016/0337299	A1	11/2016	Lane et al.	CN	202035047	U	11/2011
2016/0351190	A1	12/2016	Binder et al.	CN	202092650	U	12/2011
2016/0357304	A1	12/2016	Hatori et al.	CN	102368256	A	3/2012
2016/0357728	A1	12/2016	Bellegarda et al.	CN	102682771	A	9/2012
2016/0357861	A1	12/2016	Carlhian et al.	CN	102685295	A	9/2012
2016/0358598	A1	12/2016	Williams et al.	CN	102693725	A	9/2012
2016/0358600	A1	12/2016	Nallasamy et al.	CN	102792320	A	11/2012
2016/0360039	A1*	12/2016	Sanghavi H04M 3/5183	CN	102917004	A	2/2013
2016/0378747	A1	12/2016	Orr et al.	CN	103035240	A	4/2013
2016/0379641	A1	12/2016	Liu et al.	CN	104423625	A	3/2015
2017/0004824	A1	1/2017	Yoo et al.	DE	102004029203	A1	12/2005
2017/0031576	A1	2/2017	Saoji et al.	DE	19841541	B4	12/2007
2017/0068423	A1	3/2017	Napolitano et al.	DE	102008024258	A1	11/2009
2017/0068513	A1	3/2017	Stasior et al.	EP	981236	A1	2/2000
2017/0068670	A1	3/2017	Orr et al.	EP	982732	A1	3/2000
2017/0083179	A1	3/2017	Gruber et al.	EP	984430	A2	3/2000
2017/0091168	A1	3/2017	Bellegarda et al.	EP	1001588	A2	5/2000
2017/0092278	A1	3/2017	Evermann et al.	EP	1014277	A1	6/2000
2017/0161018	A1	6/2017	Lemay et al.	EP	1028425	A2	8/2000
2017/0178626	A1	6/2017	Gruber et al.	EP	1028426	A2	8/2000
2017/0180499	A1	6/2017	Gelfenbeyn et al.	EP	1047251	A2	10/2000
2017/0230709	A1	8/2017	Van Os et al.	EP	1052566	A1	11/2000
FOREIGN PATENT DOCUMENTS				EP	1076302	A1	2/2001
				EP	1091615	A1	4/2001
				EP	1094406	A2	4/2001
				EP	1107229	A2	6/2001
CA	2792412	A1	7/2011	EP	634042	B1	7/2001
CA	2666438	C	6/2013	EP	1229496	A2	8/2002
CN	1263385	A	8/2000	EP	1233600	A2	8/2002
CN	1274440	A	11/2000	EP	1245023	A1	10/2002
CN	1321295	A	11/2001	EP	1246075	A2	10/2002
CN	1369858	A	9/2002	EP	1280326	A1	1/2003
CN	1378156	A	11/2002	EP	1291848	A2	3/2003
CN	1383109	A	12/2002	EP			

(56)

References Cited

FOREIGN PATENT DOCUMENTS

EP	1311102	A1	5/2003	JP	2001-14319	A	1/2001
EP	1315084	A1	5/2003	JP	2001-22498	A	1/2001
EP	1315086	A1	5/2003	JP	2001-34289	A	2/2001
EP	1320848	A1	6/2003	JP	2001-34290	A	2/2001
EP	1345360	A2	9/2003	JP	2001-045553	A	2/2001
EP	1347361	A1	9/2003	JP	2001-56233	A	2/2001
EP	1368961	A2	12/2003	JP	2001-109493	A	4/2001
EP	1379061	A2	1/2004	JP	2001-125896	A	5/2001
EP	1432219	A1	6/2004	JP	2001-148899	A	5/2001
EP	1435620	A1	7/2004	JP	2001-273283	A	10/2001
EP	1480421	A1	11/2004	JP	2001-282813	A	10/2001
EP	1517228	A2	3/2005	JP	2001-296880	A	10/2001
EP	1536612	A1	6/2005	JP	2001-297174	A	10/2001
EP	1566948	A1	8/2005	JP	2001-325052	A	11/2001
EP	1650938	A1	4/2006	JP	2002-14954	A	1/2002
EP	1675025	A2	6/2006	JP	2002-24212	A	1/2002
EP	1693829	A1	8/2006	JP	2002-30676	A	1/2002
EP	1699042	A1	9/2006	JP	2002-33794	A	1/2002
EP	1739546	A2	1/2007	JP	2002-41276	A	2/2002
EP	1181802	B1	2/2007	JP	2002-41624	A	2/2002
EP	1818786	A1	8/2007	JP	2002-82748	A	3/2002
EP	1892700	A1	2/2008	JP	2002-82893	A	3/2002
EP	1912205	A2	4/2008	JP	2002-123295	A	4/2002
EP	1939860	A1	7/2008	JP	2002-132804	A	5/2002
EP	1944997	A2	7/2008	JP	2002-169588	A	6/2002
EP	651543	B1	9/2008	JP	2002-182679	A	6/2002
EP	1909263	B1	1/2009	JP	2002-182680	A	6/2002
EP	1335620	B1	3/2009	JP	2002-516549	A	6/2002
EP	2069895	A1	6/2009	JP	2002-230021	A	8/2002
EP	2094032	A1	8/2009	JP	2002-236029	A	8/2002
EP	2096840	A1	9/2009	JP	2002-524806	A	8/2002
EP	2107553	A1	10/2009	JP	2002-281562	A	9/2002
EP	2109295	A1	10/2009	JP	2002-304410	A	10/2002
EP	1720375	B1	7/2010	JP	2002-534716	A	10/2002
EP	2205010	A1	7/2010	JP	2002-341892	A	11/2002
EP	2309491	A1	4/2011	JP	2002-342033	A	11/2002
EP	2329348		6/2011	JP	2002-342212	A	11/2002
EP	2400373	A1	12/2011	JP	2002-344880	A	11/2002
EP	2431842	A2	3/2012	JP	2002-542501	A	12/2002
EP	2551784	A1	1/2013	JP	2003-15682	A	1/2003
EP	2555536	A1	2/2013	JP	2003-022087	A	1/2003
EP	2575128	A2	4/2013	JP	2003-44091	A	2/2003
EP	2733598	A2	5/2014	JP	2003-84877	A	3/2003
EP	2801890	A1	11/2014	JP	2003-517158	A	5/2003
EP	2801972	A1	11/2014	JP	2003-202897	A	7/2003
EP	2930715	A1	10/2015	JP	2003-233568	A	8/2003
EP	2938022	A1	10/2015	JP	2003-244317	A	8/2003
EP	2940556	A1	11/2015	JP	2003-255991	A	9/2003
FI	20010199	A1	4/2003	JP	2003-527656	A	9/2003
FR	2911201	A1	7/2008	JP	2003-288356	A	10/2003
GB	2342802	A	4/2000	JP	2003-308079	A	10/2003
GB	2343285	A	5/2000	JP	2003-308079	A	10/2003
GB	2346500	A	8/2000	JP	2003-533909	A	11/2003
GB	2352377	A	1/2001	JP	2004-48804	A	2/2004
GB	2367399	A	4/2002	JP	2004-54080	A	2/2004
GB	2384399	A	7/2003	JP	2004-056226	A	2/2004
GB	2402855	A	12/2004	JP	2004-505322	A	2/2004
GB	2445436	A	7/2008	JP	2004-505525	A	2/2004
GB	2445667	A	7/2008	JP	2004-86356	A	3/2004
JP	2000-32140	A	1/2000	JP	2004-94936	A	3/2004
JP	2000-59497	A	2/2000	JP	2004-101901	A	4/2004
JP	2000-90119	A	3/2000	JP	2004-117905	A	4/2004
JP	2000-99225	A	4/2000	JP	2004-152063	A	5/2004
JP	2000-134407	A	5/2000	JP	2004-153306	A	5/2004
JP	2000-163031	A	6/2000	JP	2004-523004	A	7/2004
JP	2000-207167	A	7/2000	JP	2004-289266	A	10/2004
JP	2000-216910	A	8/2000	JP	2004-295837	A	10/2004
JP	2000-224663	A	8/2000	JP	2004-310034	A	11/2004
JP	2000-272349	A	10/2000	JP	2004-333870	A	11/2004
JP	2000-276471	A	10/2000	JP	2004-534268	A	11/2004
JP	2000-331004	A	11/2000	JP	2004-347786	A	12/2004
JP	2000-339137	A	12/2000	JP	2005-55782	A	3/2005
JP	2000-352988	A	12/2000	JP	2005-63257	A	3/2005
JP	2000-352989	A	12/2000	JP	2005-70645	A	3/2005
JP	2001-13978	A	1/2001	JP	2005-80094	A	3/2005
				JP	2005-86624	A	3/2005
				JP	2005-506602	A	3/2005
				JP	2005-92441	A	4/2005
				JP	2005-149481	A	6/2005
				JP	2005-157965	A	6/2005

(56)		References Cited					
			FOREIGN PATENT DOCUMENTS				
JP	2005-181386	A	7/2005	JP	2009-47920	A	3/2009
JP	2005-189454	A	7/2005	JP	2009-069062	A	4/2009
JP	2005-210362	A	8/2005	JP	2009-98490	A	5/2009
JP	2005-221678	A	8/2005	JP	2009-140444	A	6/2009
JP	2005-228075	A	8/2005	JP	2009-186989	A	8/2009
JP	2005-275925	A	10/2005	JP	2009-193448	A	8/2009
JP	2005-283843	A	10/2005	JP	2009-193457	A	8/2009
JP	2005-311864	A	11/2005	JP	2009-193532	A	8/2009
JP	2005-332212	A	12/2005	JP	2009-205367	A	9/2009
JP	2005-334363	A	12/2005	JP	2009-294913	A	12/2009
JP	2006-003142	A	1/2006	JP	2009-294946	A	12/2009
JP	2006-4274	A	1/2006	JP	2010-66519	A	3/2010
JP	2006-5655	A	1/2006	JP	2010-78979	A	4/2010
JP	2006-23860	A	1/2006	JP	2010-108378	A	5/2010
JP	2006-30447	A	2/2006	JP	2010-518526	A	5/2010
JP	2006-31092	A	2/2006	JP	2010-157207	A	7/2010
JP	2006-59094	A	3/2006	JP	2010-224236	A	10/2010
JP	2006-079427	A	3/2006	JP	4563106	B2	10/2010
JP	2006-80617	A	3/2006	JP	2010-535377	A	11/2010
JP	2006-107438	A	4/2006	JP	2010-287063	A	12/2010
JP	2006-146008	A	6/2006	JP	2011-41026	A	2/2011
JP	2006-146182	A	6/2006	JP	2011-45005	A	3/2011
JP	2006-155368	A	6/2006	JP	2011-59659	A	3/2011
JP	2006-189394	A	7/2006	JP	2011-81541	A	4/2011
JP	2006-195637	A	7/2006	JP	2011-525045	A	9/2011
JP	2006-201870	A	8/2006	JP	2011-238022	A	11/2011
JP	2006-208696	A	8/2006	JP	2012-014394	A	1/2012
JP	2006-229730	A	8/2006	JP	2012-089020	A	5/2012
JP	2006-237735	A	9/2006	JP	2012-116442	A	6/2012
JP	2006-244296	A	9/2006	JP	2012-147063	A	8/2012
JP	2006-522549	A	9/2006	JP	2012-518847	A	8/2012
JP	2006-267328	A1	10/2006	JP	2013-511214	A	3/2013
JP	2006-302091	A	11/2006	JP	2013-73240	A	4/2013
JP	2006-318373	A	11/2006	JP	2013-080476	A	5/2013
JP	2006-526185	A	11/2006	JP	2013-517566	A	5/2013
JP	2007-4633	A	1/2007	JP	2013-134430	A	7/2013
JP	2007-17990	A	1/2007	JP	2013-527947	A	7/2013
JP	2007-500903	A	1/2007	JP	2013-156349	A	8/2013
JP	2007-53796	A	3/2007	JP	2013-205999	A	10/2013
JP	2007-79690	A	3/2007	JP	2013-238936	A	11/2013
JP	2007-171534	A	7/2007	JP	2014-10688	A	1/2014
JP	2007-193794	A	8/2007	JP	2014-026629	A	2/2014
JP	2007-206317	A	8/2007	JP	2014-72586	A	4/2014
JP	2007-264471	A	10/2007	JP	2014-077969	A	5/2014
JP	2007-264792	A	10/2007	JP	2014-145842	A	8/2014
JP	2007-264892	A	10/2007	JP	2014-150323	A	8/2014
JP	2007-272773	A	10/2007	JP	2015-41845	A	3/2015
JP	2007-299352	A	11/2007	KR	10-2001-0092415	A	10/2001
JP	2007-23612	A	12/2007	KR	2001-0093654	A	10/2001
JP	2007-322647	A	12/2007	KR	10-2001-0102132	A	11/2001
JP	2007-325089	A	12/2007	KR	2002-0013984	A	2/2002
JP	2007-333603	A	12/2007	KR	2002-0057262	A	7/2002
JP	2008-009120	A	1/2008	KR	2002-0064149	A	8/2002
JP	2008-21002	A	1/2008	KR	2002-0069952	A	9/2002
JP	2008-26381	A	2/2008	KR	2003-0016993	A	3/2003
JP	2008-39928	A	2/2008	KR	10-2004-0014835	A	2/2004
JP	2008-58813	A	3/2008	KR	10-2004-0044632	A	5/2004
JP	2008-064687	A	3/2008	KR	10-2005-0083561	A	8/2005
JP	2008-90545	A	4/2008	KR	10-2005-0090568	A	9/2005
JP	2008-97003	A	4/2008	KR	10-2006-0011603	A	2/2006
JP	2008-134949	A	6/2008	KR	10-2006-0012730	A	2/2006
JP	2008-526101	A	7/2008	KR	10-2006-0055313	A	5/2006
JP	2008-185693	A	8/2008	KR	10-2006-0073574	A	6/2006
JP	2008-198022	A	8/2008	KR	10-2006-0091469	A	8/2006
JP	2008-217468	A	9/2008	KR	10-2006-0127647	A	12/2006
JP	2008-228129	A	9/2008	KR	10-2007-0024262	A	3/2007
JP	2008-233678	A	10/2008	KR	10-2007-0071675	A	7/2007
JP	2008-236448	A	10/2008	KR	10-2007-0094767	A	9/2007
JP	2008-252161	A	10/2008	KR	10-0757496	B1	9/2007
JP	2008-268684	A	11/2008	KR	10-2007-0100837	A	10/2007
JP	2008-269480	A	11/2008	KR	10-0776800	B1	11/2007
JP	2008-271481	A	11/2008	KR	10-0801227	B1	2/2008
JP	2008-299221	A	12/2008	KR	10-0810500	B1	3/2008
JP	2009-503623	A	1/2009	KR	10-2008-0033070	A	4/2008
JP	2009-36999	A	2/2009	KR	10-0819928	B1	4/2008
				KR	10-2008-0049647	A	6/2008
				KR	10-2008-0059332	A	6/2008
				KR	10-2008-0109322	A	12/2008
				KR	10-2009-0001716	A	1/2009

(56) References Cited			WO	2001/067753 A1	9/2001
FOREIGN PATENT DOCUMENTS			WO	2001/071480 A2	9/2001
KR	10-2009-0028464 A	3/2009	WO	2002/010900 A2	2/2002
KR	10-2009-0030117 A	3/2009	WO	2002/025610 A1	3/2002
KR	10-2009-0086805 A	8/2009	WO	2002/031814 A1	4/2002
KR	10-0920267 B1	10/2009	WO	2002/037469 A2	5/2002
KR	10-2009-0122944 A	12/2009	WO	2002/049253 A2	6/2002
KR	10-2009-0127961 A	12/2009	WO	2002/071259 A1	9/2002
KR	10-2009-0129192 A	12/2009	WO	2002/073603 A1	9/2002
KR	10-2010-0015958 A	2/2010	WO	2002/080142 A2	10/2002
KR	10-2010-0048571 A	5/2010	WO	2003/003152 A2	1/2003
KR	10-2010-0053149 A	5/2010	WO	2003/003765 A1	1/2003
KR	10-2010-0119519 A	11/2010	WO	2003/023786 A2	3/2003
KR	10-2011-0043644 A	4/2011	WO	2003/036457 A2	5/2003
KR	10-1032792 B1	5/2011	WO	2003/041364 A2	5/2003
KR	10-2011-0068490 A	6/2011	WO	2003/049494 A1	6/2003
KR	10-2011-0072847 A	6/2011	WO	2003/056789 A1	7/2003
KR	10-2011-0086492 A	7/2011	WO	2003/067202 A2	8/2003
KR	10-2011-0100620 A	9/2011	WO	2003/084196 A1	10/2003
KR	10-2011-0113414 A	10/2011	WO	2003/094489 A1	11/2003
KR	10-2011-0115134 A	10/2011	WO	2003/105125 A1	12/2003
KR	10-2012-0020164 A	3/2012	WO	2003/107179 A1	12/2003
KR	10-2012-0031722 A	4/2012	WO	2004/008801 A1	1/2004
KR	10-1178310 B1	8/2012	WO	2004/025938 A1	3/2004
KR	10-2012-0120316 A	11/2012	WO	2004/047415 A1	6/2004
KR	10-2012-0137435 A	12/2012	WO	2004/055637 A2	7/2004
KR	10-2012-0137440 A	12/2012	WO	2004/057486 A1	7/2004
KR	10-2012-0138826 A	12/2012	WO	2004/061850 A1	7/2004
KR	10-2012-0139827 A	12/2012	WO	2004/072846 A2	8/2004
KR	10-1193668 B1	12/2012	WO	2004/084413 A2	9/2004
KR	10-2013-0035983 A	4/2013	WO	2005/003920 A2	1/2005
KR	10-1334342 B1	11/2013	WO	2005/008505 A1	1/2005
KR	10-2013-0131252 A	12/2013	WO	2005/008899 A1	1/2005
NL	1014847 C	10/2001	WO	2005/010725 A2	2/2005
RU	2273106 C2	3/2006	WO	2005/027472 A2	3/2005
RU	2349970 C2	3/2009	WO	2005/027485 A1	3/2005
RU	2353068 C2	4/2009	WO	2005/031737 A1	4/2005
RU	2364917 C2	8/2009	WO	2005/034082 A1	4/2005
TW	468323 B	12/2001	WO	2005/034085 A1	4/2005
TW	200601264 A	1/2006	WO	2005/041455 A1	5/2005
TW	200638337 A	11/2006	WO	2005/049895 A1	6/2005
TW	200643744 A	12/2006	WO	2005/064592 A1	7/2005
TW	200801988 A	1/2008	WO	2005/069171 A1	7/2005
TW	1301373 B	9/2008	WO	2005/101176 A2	10/2005
TW	M348993 U	1/2009	WO	2006/020305 A2	2/2006
TW	200943903 A	10/2009	WO	2006/037545 A2	4/2006
TW	201018258 A	5/2010	WO	2006/054724 A1	5/2006
TW	201027515 A1	7/2010	WO	2006/056822 A1	6/2006
TW	201028996 A1	8/2010	WO	2006/078246 A1	7/2006
TW	201110108 A1	3/2011	WO	2006/084144 A2	8/2006
TW	2011-42823 A1	12/2011	WO	2006/101649 A2	9/2006
TW	201227715 A1	7/2012	WO	2006/129967 A1	12/2006
TW	201245989 A1	11/2012	WO	2006/133571 A1	12/2006
TW	201312548 A1	3/2013	WO	2007/002753 A2	1/2007
WO	2000/014727 A1	3/2000	WO	2007/036762 A1	4/2007
WO	2000/014728 A1	3/2000	WO	2007/080559 A2	7/2007
WO	2000/019697 A1	4/2000	WO	2007/083894 A1	7/2007
WO	2000/022820 A1	4/2000	WO	2007/125151 A1	11/2007
WO	2000/029964 A1	5/2000	WO	2008/030970 A2	3/2008
WO	2000/030070 A2	5/2000	WO	2008/071231 A1	6/2008
WO	2000/038041 A1	6/2000	WO	2008/085742 A2	7/2008
WO	2000/041065 A1	7/2000	WO	2008/098900 A2	8/2008
WO	2000/044173 A1	7/2000	WO	2008/109835 A2	8/2008
WO	2000/060435 A2	10/2000	WO	2008/120036 A1	10/2008
WO	2000/060435 A3	10/2000	WO	2008/130095 A1	10/2008
WO	2000/063766 A1	10/2000	WO	2008/140236 A1	11/2008
WO	2000/068936 A1	11/2000	WO	2008/142472 A1	11/2008
WO	2001/006489 A1	1/2001	WO	2008/153639 A1	12/2008
WO	2001/26093 A1	4/2001	WO	2009/009240 A2	1/2009
WO	2001/030046 A2	4/2001	WO	2009/016631 A2	2/2009
WO	2001/030047 A2	4/2001	WO	2009/017280 A1	2/2009
WO	2012/8187 A1	4/2001	WO	2009/075912 A1	6/2009
WO	2001/033569 A1	5/2001	WO	2009/104126 A1	8/2009
WO	2001/035391 A1	5/2001	WO	2009/156438 A1	12/2009
WO	2001/044912 A2	6/2001	WO	2009/156978 A1	12/2009
WO	2001/046946 A1	6/2001	WO	2010/054373 A2	5/2010
WO	2001/065413 A1	9/2001	WO	2010/075623 A1	7/2010
			WO	2010/141802 A1	12/2010
			WO	2011/057346 A1	5/2011

(56)

References Cited

FOREIGN PATENT DOCUMENTS

WO	2011/060106	A1	5/2011
WO	2011/088053	A2	7/2011
WO	2011/093025	A1	8/2011
WO	2011/116309	A1	9/2011
WO	2011/133543	A1	10/2011
WO	2011/150730	A1	12/2011
WO	2011/163350	A1	12/2011
WO	2011/088053	A3	1/2012
WO	2012/019637	A1	2/2012
WO	2012/129231	A1	9/2012
WO	2012/135157	A2	10/2012
WO	2012/154317	A1	11/2012
WO	2012/155079	A2	11/2012
WO	2012/167168	A2	12/2012
WO	2013/009578	A2	1/2013
WO	2013/022135	A1	2/2013
WO	2013/048880	A1	4/2013
WO	2013/049358	A1	4/2013
WO	2013/169842	A2	11/2013
WO	2013/173511	A2	11/2013
WO	2013/184953	A1	12/2013
WO	2013/184990	A1	12/2013
WO	2014/003138	A1	1/2014
WO	2014/022148	A1	2/2014
WO	2014/028797	A1	2/2014
WO	2014/031505	A1	2/2014
WO	2014/066352	A1	5/2014
WO	2014/078965	A1	5/2014
WO	2014/096506	A1	6/2014
WO	2014/138604	A1	9/2014
WO	2014/143959	A2	9/2014
WO	2014/144579	A1	9/2014
WO	2014/159581	A1	10/2014
WO	2014/197336	A1	12/2014
WO	2014/200728	A1	12/2014
WO	2014/204659	A2	12/2014
WO	2015/030796	A1	3/2015
WO	2015/041892	A1	3/2015
WO	2015/084659	A1	6/2015
WO	2015/094169	A1	6/2015
WO	2015/094369	A1	6/2015
WO	2015/099939	A1	7/2015
WO	2015/116151	A1	8/2015
WO	2015/151133	A1	10/2015
WO	2015/183401	A1	12/2015
WO	2015/200207	A1	12/2015
WO	2016/057268	A1	4/2016
WO	2016/075081	A1	5/2016
WO	2017/044629	A1	3/2017
WO	2017/053311	A1	3/2017

OTHER PUBLICATIONS

Domingue et al., "Web Service Modeling Ontology (WSMO)—An Ontology for Semantic Web Services", Position Paper at the W3C Workshop on Frameworks for Semantics in Web Services, Innsbruck, Austria, Jun. 2005, 6 pages.

Donovan, R. E., "A New Distance Measure for Costing Spectral Discontinuities in Concatenative Speech Synthesizers", available at <<http://citeseerx.ist.osu.edu/viewdoc/summary?doi=10.1.1.21.6398>>, 2001, 4 pages.

Dragon Naturally Speaking Version 11 Users Guide, Nuance Communications, Inc., Copyright ©2002-2010, 132 pages.

Dusan et al., "Multimodal Interaction on PDA's Integrating Speech and Pen Inputs", Eurospeech Geneva, 2003, 4 pages.

dyslexic.com, "AlphaSmart 3000 with CoWriter SmartApplet: Don Johnston Special Needs", available at <<http://www.dyslexic.com/procuts.php?catid=2&pid=465&PHPSESSID=2511b800000f7da>>, retrieved on Dec. 6, 2005, 13 pages.

Eagle et al., "Social Serendipity: Proximity Sensing and Cueing", MIT Media Laboratory Technical Note 580, May 2004, 18 pages.

Elliott et al., "Annotation Suggestion and Search for Personal Multimedia Objects on the Web", CIVR, Jul. 7-9, 2008, pp. 75-84.

Eluminx, "Illuminated Keyboard", available at <<http://www.eluminx.com/>>, retrieved on Dec. 19, 2002, 1 page.

Engst, Adam C., "SoundJam Keeps on Jammin'", available at <<http://db.tidbits.com/getbits.acgi?tbart=05988>>, Jun. 19, 2000, 3 pages.

Ericsson et al., "Software Illustrating a Unified Approach to Multimodality and Multilinguality in the In-Home Domain", Talk and Look: Tools for Ambient Linguistic Knowledge, Dec. 2006, 127 pages.

Erol et al., "Multimedia Clip Generation From Documents for Browsing on Mobile Devices", IEEE Transactions on Multimedia, vol. 10, No. 5, Aug. 2008, 13 pages.

Eslambolchilar et al., "Making Sense of Fisheye Views", Second Dynamics and Interaction Workshop at University of Glasgow, Aug. 2005, 6 pages.

Eslambolchilar et al., "Multimodal Feedback for Tilt Controlled Speed Dependent Automatic Zooming", UIST'04, Oct. 24-27, 2004, 2 pages.

European Search Report received for European Patent Application No. 01201774.5, dated Sep. 14, 2001, 3 pages.

Evermann et al., "Posterior Probability Decoding, Confidence Estimation and System Combination", Proceedings Speech Transcription Workshop, 2000, 4 pages.

Evi, "Meet Evi: The One Mobile Application that Provides Solutions for your Everyday Problems", Feb. 2012, 3 pages.

Exhibit 1, "Natural Language Interface Using Constrained Intermediate Dictionary of Results", List of Publications Manually Reviewed for the Search of U.S. Pat. No. 7,177,798, Mar. 22, 2013, 1 page.

Extended European Search Report (includes European Search Report and European Search Opinion) received for European Patent Application No. 06256215.2, dated Feb. 20, 2007, 6 pages.

Extended European Search Report (includes European Search Report and European Search Opinion) received for European Patent Application No. 12186113.2, dated Apr. 28, 2014, 14 pages.

Combined Search Report and Examination Report under Sections 17 and 18(3) received for GB Patent Application No. 1009318.5, dated Oct. 8, 2010, 5 pages.

Combined Search Report and Examination Report under Sections 17 and 18(3) received for GB Patent Application No. 1217449.6, dated Jan. 17, 2013, 6 pages.

Compaq Inspiration Technology, "Personal Jukebox (PJB)—Systems Research Center and PAAD", Oct. 13, 2000, 25 pages.

Compaq, "Personal Jukebox", available at <<http://research.compaq.com/SRC/pjb/>>, 3 pages.

Conkie et al., "Preselection of Candidate Units in a Unit Selection-Based Text-to-Speech Synthesis System", ISCA, 2000, 4 pages.

Cox et al., "Speech and Language Processing for Next-Millennium Communications Services", Proceedings of the IEEE, vol. 88, No. 8, Aug. 2000, 24 pages.

Creative Technology Ltd., "Creative NOMAD® II: Getting Started—User Guide (on Line Version)", available at <<http://ecl.images-amazon.com/media/i3d/01/A/man-migrate/MANUAL000026434.pdf>>, Apr. 2000, 46 pages.

Creative Technology Ltd., "Nomad Jukebox", User Guide, Version 1.0, Aug. 2000, 52 pages.

Creative, "Creative NOMAD MuVo TX", available at <<http://web.archive.org/web/20041024175952/www.creative.com/products/pfriendly.asp?product=9672>>, retrieved on Jun. 6, 2006, 1 page.

Creative, "Creative NOMAD MuVo", available at <<http://web.archive.org/web/20041024075901/www.creative.com/products/product.asp?category=213&subcategory=216&product=4983>>, retrieved on Jun. 7, 2006, 1 page.

Creative, "Digital MP3 Player", available at <<http://web.archive.org/web/20041024074823/www.creative.com/products/product.asp?category=213&subcategory=216&product=4983>>, 2004, 1 page.

Cucerzan et al., "Bootstrapping a Multilingual Part-of-Speech Tagger in One Person-Day", In Proceedings of the 6th Conference on Natural Language Learning, vol. 20, 2002, pp. 1-7.

Davis et al., "A Personal Handheld Multi-Modal Shopping Assistant", International Conference on Networking and Services, IEEE, 2006, 9 pages.

Davis et al., "Stone Soup Translation", Department of Linguistics, Ohio State University, 2001, 11 pages.

(56)

References Cited

OTHER PUBLICATIONS

- De Herrera, Chris, "Microsoft ActiveSync 3.1", Version 1.02, available at <<http://www.cewindows.net/wce/activesync3.1.htm>>, Oct. 13, 2000, 8 pages.
- Deedeevuu, "Amazon Echo Alarm Feature", Available online at <https://www.youtube.com/watch?v=fjU8eRLk7c>, Feb. 16, 2015, 1 page.
- Del Strother, Jonathan, "Coverflow", available at <<http://www.steelskies.com/coverflow>>, retrieved on Jun. 15, 2006, 14 pages.
- Digital Audio in the New Era, Electronic Design and Application, No. 6, Jun. 30, 2003, 3 pages.
- "DIRECTV™ Voice", Now Part of the DIRECTV Mobile App for Phones, Sep. 18, 2013, 5 pages.
- Dittenbach et al., "A Natural Language Query Interface for Tourism Information", In: Information and Communication Technologies in Tourism 2003, XP055114393, Feb. 14, 2003, pp. 152-162.
- Feigenbaum et al., "Computer-Assisted Semantic Annotation of Scientific Life Works", Oct. 15, 2007, 22 pages.
- Findlater et al., "Beyond QWERTY: Augmenting Touch-Screen Keyboards with Multi-Touch Gestures for Non-Alphanumeric Input", CHI '12, Austin, Texas, USA, May 5-10, 2012, 4 pages.
- Finkel et al., "Joint Parsing and Named Entity Recognition", Human Language Technologies: The 2009 Annual Conference of the North American Chapter of the ACL, Jun. 2009, pp. 326-334.
- Gannes, Liz, "Alfred App Gives Personalized Restaurant Recommendations", AllThingsD, Jul. 18, 2011, pp. 1-3.
- Gervasio et al., "Active Preference Learning for Personalized Calendar Scheduling Assistance", CiteSeerx, Proceedings of IUT'05, Jan. 2005, pp. 90-97.
- Gilloire et al., "Innovative Speech Processing for Mobile Terminals: An Annotated Bibliography", Signal Processing, vol. 80, No. 7, Jul. 2000, pp. 1149-1166.
- Glass, Alyssa, "Explaining Preference Learning", CiteSeerx, 2006, pp. 1-5.
- Glossary of Adaptive Technologies: Word Prediction, available at <<http://www.utoronto.ca/atrc/reference/techwordpred.html>>, retrieved on Dec. 6, 2005, 5 pages.
- Gmail, "About Group Chat", available at <<http://mail.google.com/support/bin/answer.py?answer=81090>>, Nov. 26, 2007, 2 pages.
- Gomez et al., "Mouth Gesture and Voice Command Based Robot Command Interface", IEEE International Conference on Robotics and Automation, May 12-17, 2009, pp. 333-338.
- Gong et al., "Guidelines for Handheld Mobile Device Interface Design", Proceedings of DSI 2004 Annual Meeting, 2004, pp. 3751-3756.
- Gruber et al., "Siri, a Virtual Personal Assistant Bringing Intelligence to the Interface", Available at URL:<https://web.archive.org/web/20090824055846/http://tomgruber.org/writing/Siri-SemTech09.pdf>, Aug. 24, 2009, 21 pages.
- Gruber, Thomas R., et al., U.S. Appl. No. 61/186,414, filed Jun. 12, 2009 titled "System and Method for Semantic Auto-Completion" 13 pages.
- Gruber, Thomas R., et al., U.S. Appl. No. 61/493,201, filed Jun. 3, 2011 titled "Generating and Processing Data Items That Represent Tasks to Perform", 68 pages.
- Gruber, Thomas R., et al., Unpublished U.S. Appl. No. 61/657,744, filed Jun. 9, 2012 titled "Automatically Adapting User Interfaces for Hands-Free Interaction", 40 pages.
- Gruber, Tom, "(Avoiding) The Travesty of the Commons", Presentation at NPUC, New Paradigms for User Computing, IBM Almaden Research Center, Jul. 24, 2006, 52 pages.
- Gruber, Tom, "2021: Mass Collaboration and the Really New Economy", TNTY Futures, vol. 1, No. 6, Available online at <<http://tomgruber.org/writing/tnty2001.htm>>, Aug. 2001, 5 pages.
- Gruber, Tom, "Big Think Small Screen: How Semantic Computing in the Cloud will Revolutionize the Consumer Experience on the Phone", Keynote Presentation at Web 3.0 Conference, Jan. 2010, 41 pages.
- Gruber, Tom, "Collective Knowledge Systems: Where the Social Web Meets the Semantic Web", Web Semantics: Science, Services and Agents on the World Wide Web, 2007, pp. 1-19.
- Gruber, Tom, "Despite Our Best Efforts, Ontologies are not the Problem", AAAI Spring Symposium, Available online at <<http://tomgruber.org/writing/aaai-ss08.htm>>, Mar. 2008, pp. 1-40.
- Extended European Search Report (includes Partial European Search Report and European Search Opinion) received for European Patent Application No. 13169672.6, dated Aug. 14, 2013, 11 pages.
- Extended European Search Report (includes Partial European Search Report and European Search Opinion) received for European Patent Application No. 15169349.6, dated Jul. 28, 2015, 8 pages.
- Extended European Search Report (includes Partial European Search Report and European Search Opinion) received for European Patent Application No. 15196748.6, dated Apr. 4, 2016.
- Extended European Search Report (includes Partial European Search Report and European Search Opinion) received for European Patent Application No. 16150079.8, dated Feb. 18, 2016, 7 pages.
- Extended European Search Report (includes Supplementary European Search Report and Search Opinion) received for European Patent Application No. 07863218.9, dated Dec. 9, 2010, 7 pages.
- Extended European Search Report (includes Supplementary European Search Report and Search Opinion) received for European Patent Application No. 12727027.0, dated Sep. 26, 2014, 7 pages.
- Extended European Search Report (inclusive of the Partial European Search Report and European Search Opinion) received for European Patent Application No. 12729332.2, dated Oct. 31, 2014, 6 pages.
- Extended European Search Report and Search Opinion received for European Patent Application No. 12185276.8, dated Dec. 18, 2012, 4 pages.
- Extended European Search Report received for European Patent Application No. 11159884.3, dated May 20, 2011, 8 pages.
- Extended European Search Report received for European Patent Application No. 11707939.2, dated Nov. 18, 2016, 13 pages.
- Extended European Search Report received for European Patent Application No. 12186663.6, dated Jul. 16, 2013, 6 pages.
- Extended European Search Report received for European Patent Application No. 13726938.7, dated Dec. 14, 2015, 8 pages.
- Extended European Search Report received for European Patent Application No. 13770552.1, dated Jan. 7, 2016, 5 pages.
- Extended European Search Report received for European Patent Application No. 14719914.5, dated Oct. 10, 2016, 7 pages.
- Extended European Search Report received for European Patent Application No. 14737370.8, dated May 19, 2016, 12 pages.
- Extended European Search Report received for European Patent Application No. 16186308.9, dated Jan. 16, 2017, 9 pages.
- Extended European Search Report received for European Patent Application No. 16188272.5, dated Nov. 18, 2016, 12 pages.
- Extended European Search Report received for European Patent Application No. 16195814.5, dated Jul. 5, 2017, 13 pages.
- Extended European Search Report received for European Patent Application No. 16198245.9, dated Feb. 22, 2017, 13 pages.
- Extended European Search Report received for European Patent Application No. 17173710.9, dated Oct. 4, 2017, 8 pages.
- Extended Search Report received for European Patent Application No. 16188055.4, dated Dec. 22, 2016, 8 pages.
- Apple Computer, Inc., "Apple Introduces iTunes—World's Best and Easiest to Use Jukebox Software", Macworld Expo, Jan. 9, 2001, 2 pages.
- Apple Computer, Inc., "Apple's iPod Available in Stores Tomorrow", Press Release, Nov. 9, 2001, 1 page.
- Apple Computer, Inc., "iTunes 2, Playlist Related Help Screens", iTunes v2.0, 2000-2001, 8 pages.
- Apple Computer, Inc., "iTunes 2: Specification Sheet", 2001, 2 pages.
- Apple Computer, Inc., "iTunes, Playlist Related Help Screens", iTunes v1.0, 2000-2001, 8 pages.
- Apple Computer, Inc., "QuickTime Movie Playback Programming Guide", Aug. 11, 2005, pp. 1-58.
- Apple Computer, Inc., "QuickTime Overview", Aug. 11, 2005, pp. 1-34.

(56)

References Cited

OTHER PUBLICATIONS

- Apple Computer, Inc., "Welcome to Tiger", available at <http://www.maths.dundee.ac.uk/software/Welcome_to_Mac_OS_X_v10.4_Tiger.pdf>, 2005, pp. 1-32.
- Apple, "iPhone User's Guide", Available at <<http://mesnotices.20minutes.fr/manuel-notice-mode-emploi/APPLE/IPHONE%2D%5FE#>>, Retrieved on Mar. 27, 2008, Jun. 2007, 137 pages.
- Apple, "VoiceOver", available at <<http://www.apple.com/accessibility/voiceover/>>, Feb. 2009, 5 pages.
- "Ask Alexa—Things That Are Smart Wiki", Available online at <[URL:http://thingsthataresmart.wiki/index.php?title=Ask_Alexa&oldid=4283](http://thingsthataresmart.wiki/index.php?title=Ask_Alexa&oldid=4283)>, [retrieved from internet on Aug. 2, 2017], Jun. 8, 2016, pp. 1-31.
- Badino et al., "Language Independent Phoneme Mapping for Foreign TTS", 5th ISCA Speech Synthesis Workshop, Pittsburgh, PA, Jun. 14-16, 2004, 2 pages.
- Bederson et al., "The Craft of Information Visualization", Elsevier Science, Inc., 2003, 435 pages.
- Bellegarda, Jerome R., "Latent Semantic Mapping", IEEE Signal Processing Magazine, vol. 22, No. 5, Sep. 2005, pp. 70-80.
- Bellegarda, Jerome R., "Exploiting Latent Semantic Information in Statistical Language Modeling", Proceedings of the IEEE, vol. 88, No. 8, Aug. 2000, 18 pages.
- Bellegarda, Jerome R., "Large Vocabulary Speech Recognition with Multispan Statistical Language Models", IEEE Transactions on Speech and Audio Processing, vol. 8, No. 1, Jan. 2000, 9 pages.
- Belvin et al., "Development of the HRL Route Navigation Dialogue System", Proceedings of the First International Conference on Human Language Technology Research, Paper, 2001, 5 pages.
- Berry et al., "PTIME: Personalized Assistance for Calendaring", ACM Transactions on Intelligent Systems and Technology, vol. 2, No. 4, Article 40, Jul. 2011, pp. 1-22.
- Berry et al., "Task Management under Change and Uncertainty Constraint Solving Experience with the CALO Project", Proceedings of CP'05 Workshop on Constraint Solving under Change, 2005, 5 pages.
- Bertulucci, Jeff, "Google Adds Voice Search to Chrome Browser", PC World, Jun. 14, 2011, 5 pages.
- 2004 Chrysler Pacifica: U-Connect Hands-Free Communication System, The Best and Brightest of 2004, Brief Article, Automotive Industries, Sep. 2003, 1 page.
- 2007 Lexus GS 450h 4dr Sedan (3.5L 6cyl Gas/Electric Hybrid CVT), available at <http://review.cnet.com/4505-10865_16-31833144.html>, retrieved on Aug. 3, 2006, 10 pages.
- Abcom Pty. Ltd. "12.1 925 Candela Mobile PC", LCDHardware.com, available at <http://www.lcdhardware.com/panel/12_1_panel/default.asp>, retrieved on Dec. 19, 2002, 2 pages.
- Adium, "AboutAdium—Adium X-Trac", available at <<http://web.archive.org/web/20070819113247/http://trac.adiumx.com/wiki/AboutAdium>>, retrieved on Nov. 25, 2011, 2 pages.
- adobe.com, "Reading PDF Documents with Adobe Reader 6.0—A Guide for People with Disabilities", Available online at <https://www.adobe.com/enterprise/accessibility/pdfs/acro6_cg_ue.pdf>, Jan. 2004, 76 pages.
- Aikawa et al., "Generation for Multilingual MT", available at <<http://mtarchive.info/MTS-2001-Aikawa.pdf>>, retrieved on Sep. 18, 2001, 6 pages.
- "Alexa, Turn Up the Heat!", Smartthings Samsung [online], Available online at <<https://web.archive.org/web/20160329142041/https://blog.smartthings.com/news/smartthingsupdates/alexa-turn-up-the-heat/>>, Mar. 3, 2016, 3 pages.
- Alfred App, "Alfred", available at <<http://www.alfredapp.com/>>, retrieved on Feb. 8, 2012, 5 pages.
- All Music Website, available at <<http://www.allmusic.com/>>, retrieved on Mar. 19, 2007, 2 pages.
- Allen et al., "Automated Natural Spoken Dialog", Computer, vol. 35, No. 4, Apr. 2002, pp. 51-56.
- Ambite et al., "Design and Implementation of the CALO Query Manager", American Association for Artificial Intelligence, 2006, 8 pages.
- Ambite et al., "Integration of Heterogeneous Knowledge Sources in the CALO Query Manager", The 4th International Conference on Ontologies, Databases and Applications of Semantics (ODBASE), 2005, 18 pages.
- Amrel Corporation, "Rocky Matrix BackLit Keyboard", available at <http://www.amrel.com/asi_matrixkeyboard.html>, retrieved on Dec. 19, 2002, 1 page.
- Anania, Peter, "Amazon Echo with Home Automation (Smart-things)", Available online at <<https://www.youtube.com/watch?v=LMW6aXmsWNE>>, Dec. 20, 2015, 1 page.
- Anhui USTC IFL Ytek Co. Ltd., "Flytek Research Center Information Datasheet", available at <<http://www.ifltek.com/english/Research.htm>>, retrieved on Oct. 15, 2004, 3 pages.
- Api.Ai, "Android App Review—Speaktoit Assistant", Available at <<https://www.youtube.com/watch?v=myE498nyfGw>>, Mar. 30, 2011, 3 pages.
- Apple Computer, "Knowledge Navigator", published by Apple Computer no later than 2008, as depicted in Exemplary Screenshots from video entitled 'Knowledge Navigator', 2008, 7 pages.
- Apple Computer, Inc., "Apple—iPod—Technical Specifications, iPod 20GB and 60GB Mac + PC", available at <<http://www.apple.com/ipod/color/specs.html>>, 2005, 3 pages.
- Apple Computer, Inc., "Apple Announces iTunes 2", Press Release, Oct. 23, 2001, 2 pages.
- Caraballo et al., "Language Identification Based on a Discriminative Text Categorization Technique", Iberspeech 2012—VII Jornadas En Tecnologia Del Habla and Iii Iberiansl Tech Workshop, Nov. 21, 2012, pp. 1-10.
- Castleos, "Whole House Voice Control Demonstration", available online at <https://www.youtube.com/watch?v=9SRCoxrZ_W4>, Jun. 2, 2012, 26 pages.
- Chai et al., "Comparative Evaluation of a Natural Language Dialog Based System and a Menu Driven System for Information Access: A Case Study", Proceedings of the International Conference on Multimedia Information Retrieval (RIAO), Paris, Apr. 2000, 11 pages.
- Chakarova et al., "Digital Still Cameras—Downloading Images to a Computer", Multimedia Reporting and Convergence, available at <<http://journalism.berkeley.edu/multimedia/tutorials/stillcams/downloading.html>>, retrieved on May 9, 2005, 2 pages.
- Chamberlain, Kim, "Quick Start Guide Natural Reader", available online at <http://atrc.colostate.edu/files/quickstarts/Natural_Reader_Quick_Start_Guide>, Apr. 2008, 5 pages.
- Chartier, David, "Using Multi-Network Meebo Chat Service on Your iPhone", available at <<http://www.tuaw.com/2007/07/04/using-multi-network-meebo-chat-service-on-your-iphone/>>, Jul. 4, 2007, 5 pages.
- Chelba et al., "Structured Language Modeling for Speech Recognition", Available online at : <<http://arxiv.org/pdf/cs/0001023.pdf>>, Jan. 25, 2000, 7 pages.
- Chen et al., "An Improved Method for Image Retrieval Using Speech Annotation", The 9th International Conference on Multimedia Modeling, Jan. 2003, pp. 1-17.
- Chen, Yi, "Multimedia Siri Finds and Plays Whatever You Ask for", PSFK Report, Feb. 9, 2012, 9 pages.
- Cheyner et al., "The Open Agent Architecture", Autonomous Agents and Multi-Agent Systems, vol. 4, Mar. 1, 2001, 6 pages.
- Cheyner, A., "Demonstration Video of Vanguard Mobile Portal", published by SRI International no later than 2004, as depicted in 'Exemplary Screenshots from video entitled Demonstration Video of Vanguard Mobile Portal', 2004, 10 pages.
- Cheyner, Adam, "A Perspective on AI & Agent Technologies for SCM", VerticalNet Presentation, 2001, 22 pages.
- Cheyner, Adam, "About Adam Cheyner", available at <<http://www.adam.cheyner.com/about.html>>, retrieved on Sep. 17, 2012, 2 pages.
- Choi et al., "Acoustic and Visual Signal based Context Awareness System for Mobile Application", IEEE Transactions on Consumer Electronics, vol. 57, No. 2, May 2011, pp. 738-746.
- Choularton et al., "User Responses to Speech Recognition Errors: Consistency of Behaviour Across Domains", Proceedings of the 10th Australian International Conference on Speech Science & Technology, Dec. 8-10, 2004, pp. 457-462.

(56)

References Cited

OTHER PUBLICATIONS

- Cisco Systems, Inc., "Cisco Unity Unified Messaging User Guide", Release 4.0(5), Apr. 14, 2005, 152 pages.
- Cisco Systems, Inc., "Installation Guide for Cisco Unity Unified Messaging with Microsoft Exchange 2003/2000 (With Failover Configured)", Release 4.0(5), Apr. 14, 2005, 152 pages.
- Cisco Systems, Inc., "Operations Manager Tutorial, Cisco's IPC Management Solution", 2006, 256 pages.
- Cohen et al., "Voice User Interface Design.", Excerpts from Chapter 1 and Chapter 10, 2004, 36 pages.
- Colt, Sam, "Here's One Way Apple's Smartwatch Could Be Better Than Anything Else", Business Insider, Aug. 21, 2014, pp. 1-4.
- Best Buy, "When it Comes to Selecting a Projection TV, Toshiba Makes Everything Perfectly Clear", Previews of New Releases, available at <<http://www.bestbuy.com/HomeAudioVideo/Specials/ToshibaTVFeatures.asp>>, retrieved on Jan. 23, 2003, 5 pages.
- Biemann et al., "Disentangling from Babylonian Confusion—Unsupervised Language Identification", CICLing'05 Proceedings of the 6th international conference on Computational Linguistics and Intelligent Text Processing, vol. 3406, Feb. 2005, pp. 773-784.
- Biemann, Chris, "Unsupervised Part-of-Speech Tagging Employing Efficient Graph Clustering", Proceeding Coling ACL '06 Proceedings of the 21st International Conference on computational Linguistics and 44th Annual Meeting of the Association for Computational Linguistics: Student Research Workshop, 2006, pp. 7-12.
- Birrell, Andrew, "Personal Jukebox (PJB)", available at <<http://birrell.org/andrew/talks/pjb-overview.ppt>>, Oct. 13, 2000, 6 pages.
- Black et al., "Multilingual Text-to-Speech Synthesis", Acoustics, Speech and Signal Processing (ICASSP'04), Proceedings of the IEEE International Conference, vol. 3, May 17-21, 2004, pp. 761-764.
- BluePhoneElite: About, available at <<http://www.reelintelligence.com/BluePhoneElite>>, retrieved on Sep. 25, 2006, 2 pages.
- BluePhoneElite: Features, available at <<http://www.reelintelligence.com/BluePhoneElite/features.shtml>>, retrieved on Sep. 25, 2006, 2 pages.
- Bluetooth PC Headsets, "'Connecting' Your Bluetooth Headset with Your Computer", Enjoy Wireless VoIP Conversations, available at <<http://www.bluetoothpcheadsets.com/connect.htm>>, retrieved on Apr. 29, 2006, 4 pages.
- Bocchieri et al., "Use of Geographical Meta-Data in ASR Language and Acoustic Models", IEEE International Conference on Acoustics Speech and Signal Processing, 2010, pp. 5118-5121.
- Bociurkiw, Michael, "Product Guide: Vanessa Matz", available at <http://www.forbes.com/asap/2000/1127/vmartz_print.html>, retrieved on Jan. 23, 2003, 2 pages.
- Borden IV, G.R., "An Aural User Interface for Ubiquitous Computing", Proceedings of the 6th International Symposium on Wearable Computers, IEEE, 2002, 2 pages.
- Brain, Marshall, "How MP3 Files Work", available at <<http://www.howstuffworks.com>>, retrieved on Mar. 19, 2007, 4 pages.
- Bulyko et al., "Error-Correction Detection and Response Generation in a Spoken Dialogue System", Speech Communication, vol. 45, 2005, pp. 271-288.
- Bulyko et al., "Joint Prosody Prediction and Unit Selection for Concatenative Speech Synthesis", Electrical Engineering Department, University of Washington, Seattle, 2001, 4 pages.
- Bussler et al., "Web Service Execution Environment (WSMX)", retrieved from Internet on Sep. 17, 2012, available at <<http://www.w3.org/Submission/WSMX>>, Jun. 3, 2005, 29 pages.
- Butcher, Mike, "EVI Arrives in Town to go Toe-to-Toe with Siri", TechCrunch, Jan. 23, 2012, 2 pages.
- Butler, Travis, "Archos Jukebox 6000 Challenges Nomad Jukebox", available at <<http://tidbits.com/article/6521>>, Aug. 13, 2001, 5 pages.
- Butler, Travis, "Portable MP3: The Nomad Jukebox", available at <<http://tidbits.com/article/6261>>, Jan. 8, 2001, 4 pages.
- Cao et al., "Adapting Ranking SVM to Document Retrieval", SIGIR '06, Seattle, WA, Aug. 6-11, 2006, 8 pages.
- Car Working Group, "Hands-Free Profile 1.5 HF1.5_SPEC", Bluetooth Doc, available at <www.bluetooth.org>, Nov. 25, 2005, 93 pages.
- International Search Report and Written Opinion received for PCT Patent Application No. PCT/US2012/040931, dated Feb. 1, 2013, 4 pages (International Search Report only).
- International Search Report and Written Opinion received for PCT Patent Application No. PCT/US2012/043098, dated Nov. 14, 2012, 9 pages.
- International Search Report and Written Opinion received for PCT Patent Application No. PCT/US2012/043100, dated Nov. 15, 2012, 8 pages.
- International Search Report and Written Opinion received for PCT Patent Application No. PCT/US2012/056382, dated Dec. 20, 2012, 11 pages.
- International Search Report and Written Opinion received for PCT Patent Application No. PCT/US2013/028412, dated Sep. 26, 2013, 17 pages.
- International Search Report and Written Opinion received for PCT Patent Application No. PCT/US2013/028920, dated Jun. 27, 2013, 14 pages.
- International Search Report and Written Opinion received for PCT Patent Application No. PCT/US2013/029156, dated Jul. 15, 2013, 9 pages.
- International Search Report and Written Opinion received for PCT Patent Application No. PCT/US2013/040971, dated Nov. 12, 2013, 11 pages.
- International Search Report and Written Opinion received for PCT Patent Application No. PCT/US2013/041225, dated Aug. 23, 2013, 3 pages (International Search Report only).
- International Search Report and Written Opinion received for PCT Patent Application No. PCT/US2013/044574, dated Sep. 27, 2013, 12 pages.
- International Search Report and Written Opinion received for PCT Patent Application No. PCT/US2013/044834, dated Dec. 20, 2013, 13 pages.
- International Search Report and Written Opinion received for PCT Patent Application No. PCT/US2008/000061, dated Jul. 1, 2008, 13 pages.
- International Search Report and Written Opinion received for PCT Patent Application No. PCT/US2009/051954, dated Oct. 30, 2009, 10 pages.
- International Search Report and Written Opinion received for PCT Patent Application No. PCT/US2009/055577, dated Jan. 26, 2010, 9 pages.
- International Search Report and Written Opinion received for PCT Patent Application No. PCT/US2010/037378, dated Aug. 25, 2010, 14 pages.
- International Search Report and Written Opinion received for PCT Patent Application No. PCT/US2011/020350, dated Jun. 30, 2011, 17 pages.
- International Search Report and Written Opinion received for PCT Patent Application No. PCT/US2011/020825, dated Mar. 18, 2011, 9 pages.
- International Search Report and Written Opinion received for PCT Patent Application No. PCT/US2011/020861, dated Nov. 29, 2011, 12 pages.
- International Search Report and Written Opinion received for PCT Patent Application No. PCT/US2012/029810, dated Aug. 17, 2012, 11 pages.
- International Search Report and Written Opinion received for PCT Patent Application No. PCT/US2012/034028, dated Jun. 11, 2012, 9 pages.
- International Search Report and Written Opinion received for PCT Patent Application No. PCT/US2012/040571, dated Nov. 16, 2012, 14 pages.
- International Search Report and Written Opinion received for PCT Patent Application No. PCT/US2012/040801, dated Oct. 22, 2012, 20 pages.
- International Search Report and Written Opinion received for PCT Patent Application No. PCT/US2014/028785, dated Oct. 17, 2014, 23 pages.

(56)

References Cited

OTHER PUBLICATIONS

International Search Report and Written Opinion received for PCT Patent Application No. PCT/US2014/028950, dated Nov. 25, 2014, 10 pages.

International Search Report and Written Opinion received for PCT Patent Application No. PCT/US2014/029050, dated Jul. 31, 2014, 9 pages.

International Search Report and Written Opinion received for PCT Patent Application No. PCT/US2014/029562, dated Sep. 18, 2014, 21 pages.

International Search Report and Written Opinion received for PCT Patent Application No. PCT/US2014/040393, dated Dec. 8, 2014, 23 pages.

International Search Report and Written Opinion received for PCT Patent Application No. PCT/US2014/040394, dated Aug. 8, 2014, 11 pages.

International Search Report and Written Opinion received for PCT Patent Application No. PCT/US2014/040397, dated Aug. 27, 2014, 12 pages.

International Search Report and Written Opinion received for PCT Patent Application No. PCT/US2014/040401, dated Sep. 4, 2014, 10 pages.

International Search Report and Written Opinion received for PCT Patent Application No. PCT/US2014/040403, dated Sep. 23, 2014, 9 pages.

International Search Report and Written Opinion received for PCT Patent Application No. PCT/US2014/040961, dated Mar. 10, 2015, 5 pages.

International Search Report and Written Opinion received for PCT Patent Application No. PCT/US2014/041159, dated Sep. 26, 2014, 10 pages.

International Search Report and Written Opinion received for PCT Patent Application No. PCT/US2013/047659, dated Jul. 7, 2014, 25 pages.

International Search Report and Written Opinion received for PCT Patent Application No. PCT/US2013/047668, dated Feb. 13, 2014, 17 pages.

International Search Report and Written Opinion received for PCT Patent Application No. PCT/US2013/052558, dated Jan. 30, 2014, 15 pages.

International Search Report and Written Opinion received for PCT Patent Application No. PCT/US2013/058916, dated Sep. 8, 2014, 10 pages.

International Search Report and Written Opinion received for PCT Patent Application No. PCT/US2013/060121, dated Dec. 6, 2013, 8 pages.

International Search Report and Written Opinion received for PCT Patent Application No. PCT/US2014/015418, dated Aug. 26, 2014, 17 pages.

International Search Report and Written Opinion received for PCT Patent Application No. PCT/US2014/016988, dated Apr. 29, 2014, 10 pages.

International Search Report and Written Opinion received for PCT Patent Application No. PCT/US2014/023822, dated Sep. 25, 2014, 14 pages.

International Search Report and Written Opinion received for PCT Patent Application No. PCT/US2014/023826, dated Oct. 9, 2014, 13 pages.

International Search Report and Written Opinion received for PCT Patent Application No. PCT/US2014/026871, dated Jul. 23, 2014, 9 pages.

International Search Report and Written Opinion received for PCT Patent Application No. PCT/US2014/026873, dated Jan. 5, 2015, 11 pages.

International Preliminary Report on Patentability received for PCT Patent Application No. PCT/US2015/029554, dated Dec. 29, 2016, 8 pages.

International Preliminary Report on Patentability Received for PCT Patent Application No. PCT/US2015/032470, dated Dec. 15, 2016, 9 pages.

International Preliminary Report on Patentability received for PCT Patent Application No. PCT/US2015/032724, dated Dec. 15, 2016, 8 pages.

International Preliminary Report on Patentability received for PCT Patent Application No. PCT/US2015/033051, dated Dec. 15, 2016, 10 pages.

International Preliminary Report on Patentability received for PCT Patent Application No. PCT/US2015/047062, dated Mar. 9, 2017, 18 pages.

International Preliminary Report on Patentability received for PCT Patent Application No. PCT/US2015/047064, dated Mar. 23, 2017, 9 pages.

International Preliminary Report on Patentability received for PCT Patent Application No. PCT/US2015/047281, dated Apr. 13, 2017, 13 pages.

International Preliminary Report on Patentability received for PCT Patent Application No. PCT/US2015/047553, dated Apr. 13, 2017, 7 pages.

International Preliminary Report on Patentability received for PCT Patent Application No. PCT/US2015/047583, dated Apr. 13, 2017, 7 pages.

International Preliminary Report on Patentability received for PCT Patent Application No. PCT/US2015/047584, dated Apr. 13, 2017, 7 pages.

International Preliminary Report on Patentability received for PCT Patent Application No. PCT/US2016/021103, dated Sep. 21, 2017, 11 pages.

International Preliminary Report on Patentability received for PCT Patent Application No. PCT/US2014/040394, dated Dec. 23, 2015, 7 pages.

International Preliminary Report on Patentability received for PCT Patent Application No. PCT/US2014/040397, dated Dec. 17, 2015, 8 pages.

International Preliminary Report on Patentability received for PCT Patent Application No. PCT/US2014/040401, dated Dec. 8, 2015, 6 pages.

International Preliminary Report on Patentability received for PCT Patent Application No. PCT/US2014/040403, dated Dec. 23, 2015, 7 pages.

International Preliminary Report on Patentability received for PCT Patent Application No. PCT/US2014/040961, dated Dec. 17, 2015, 20 pages.

International Preliminary Report on Patentability received for PCT Patent Application No. PCT/US2014/041159, dated Dec. 17, 2015, 8 pages.

International Preliminary Report on Patentability received for PCT Patent Application No. PCT/US2014/041173, dated Dec. 17, 2015, 9 pages.

International Preliminary Report on Patentability received for PCT Patent Application No. PCT/US2014/049568, dated Feb. 18, 2016, 10 pages.

International Preliminary Report on Patentability received for PCT Patent Application No. PCT/US2015/023089, dated Jan. 12, 2017, 12 pages.

International Preliminary Report on Patentability received for PCT Patent Application No. PCT/US2015/023097, dated Jan. 12, 2017, 11 pages.

International Preliminary Report on Patentability received for PCT Patent Application No. PCT/US2015/023593, dated Dec. 15, 2016, 12 pages.

International Search Report and Written Opinion received for PCT Patent Application No. PCT/US2006/048670, dated May 21, 2007, 11 pages.

International Search Report and Written Opinion received for PCT Patent Application No. PCT/US2006/048753, dated Jun. 19, 2007, 15 pages.

International Search Report and Written Opinion received for PCT Patent Application No. PCT/US2007/026243, dated Mar. 31, 2008, 10 pages.

International Search Report and Written Opinion received for PCT Patent Application No. PCT/US2007/088872, dated May 8, 2008, 8 pages.

(56)

References Cited

OTHER PUBLICATIONS

International Search Report and Written Opinion received for PCT Patent Application No. PCT/US2007/088873, dated May 8, 2008, 7 pages.

International Search Report and Written Opinion received for PCT Patent Application No. PCT/US2008/000032, dated Jun. 12, 2008, 7 pages.

International Search Report and Written Opinion received for PCT Patent Application No. PCT/US2008/000042, dated May 21, 2008, 7 pages.

International Search Report and Written Opinion received for PCT Patent Application No. PCT/US2008/000043, dated Oct. 10, 2008, 12 pages.

International Search Report and Written Opinion received for PCT Patent Application No. PCT/US2008/000045, dated Jun. 12, 2008, 7 pages.

International Search Report and Written Opinion received for PCT Patent Application No. PCT/US2008/000047, dated Sep. 11, 2008, 12 pages.

International Search Report and Written Opinion received for PCT Patent Application No. PCT/US2008/000059, dated Sep. 19, 2008, 18 pages.

International Preliminary Report on Patentability received for PCT Patent Application No. PCT/US2016/021104, dated Sep. 21, 2017, 11 pages.

International Preliminary Report on Patentability received for PCT Patent Application No. PCT/US2016/021409, dated Sep. 21, 2017, 16 pages.

International Preliminary Report on Patentability received for PCT Patent Application No. PCT/US2016/021410, dated Sep. 21, 2017, 12 pages.

International Preliminary Report on Patentability received for PCT Patent Application No. PCT/US2016/23312, dated Sep. 28, 2017, 5 pages.

International Search Report & Written Opinion received for PCT Patent Application No. PCT/US2016/021410, dated Jul. 26, 2016, 19 pages.

International Search Report and Written Opinion received for PCT Patent Application No. PCT/US16/23312, dated Jun. 27, 2016, 7 pages.

International Search Report and Written Opinion received for PCT Patent Application No. PCT/US2004/002873, dated Oct. 13, 2005, 7 pages.

International Search Report and Written Opinion received for PCT Patent Application No. PCT/US2004/016519, dated Nov. 3, 2005, 6 pages.

International Search Report and Written Opinion received for PCT Patent Application No. PCT/US2005/030234, dated Mar. 17, 2006, 11 pages.

International Search Report and Written Opinion received for PCT Patent Application No. PCT/US2005/038819, dated Apr. 5, 2006, 12 pages.

International Search Report and Written Opinion received for PCT Patent Application No. PCT/US2006/048669, dated Jul. 2, 2007, 12 pages.

International Preliminary Report on Patentability received for PCT Patent Application No. PCT/US2011/020861, dated Aug. 2, 2012, 11 pages.

International Preliminary Report on Patentability received for PCT Patent Application No. PCT/US2011/037014, dated Dec. 13, 2012, 10 pages.

International Preliminary Report on Patentability received for PCT Patent Application No. PCT/US2012/029810, dated Oct. 3, 2013, 9 pages.

International Preliminary Report on Patentability received for PCT Patent Application No. PCT/US2012/034028, dated Oct. 31, 2013, 7 pages.

International Preliminary Report on Patentability received for PCT Patent Application No. PCT/US2012/040571, dated Dec. 19, 2013, 10 pages.

International Preliminary Report on Patentability received for PCT Patent Application No. PCT/US2012/040801, dated Dec. 19, 2013, 16 pages.

International Preliminary Report on Patentability received for PCT Patent Application No. PCT/US2012/040931, dated Dec. 18, 2014, 9 pages.

International Preliminary Report on Patentability received for PCT Patent Application No. PCT/US2012/043098, dated Jan. 9, 2014, 8 pages.

International Preliminary Report on Patentability received for PCT Patent Application No. PCT/US2012/043100, dated Jan. 9, 2014, 7 pages.

International Preliminary Report on Patentability received for PCT Patent Application No. PCT/US2012/056382, dated Apr. 10, 2014, 9 pages.

International Preliminary Report on Patentability received for PCT Patent Application No. PCT/US2013/028412, dated Sep. 12, 2014, 12 pages.

International Preliminary Report on Patentability received for PCT Patent Application No. PCT/US2004/002873, dated Feb. 1, 2006, 5 pages.

International Preliminary report on Patentability received for PCT Patent Application No. PCT/US2004/016519, dated Jan. 23, 2006, 12 pages.

International Preliminary Report on Patentability received for PCT Patent Application No. PCT/US2005/030234, dated Mar. 20, 2007, 9 pages.

International Preliminary Report on Patentability received for PCT Patent Application No. PCT/US2008/000042, dated Jul. 7, 2009, 6 pages.

International Preliminary Report on Patentability received for PCT Patent Application No. PCT/US2008/000043, dated Jul. 7, 2009, 8 pages.

International Preliminary Report on Patentability received for PCT Patent Application No. PCT/US2008/000047, dated Jul. 7, 2009, 8 pages.

International Preliminary Report on Patentability received for PCT Patent Application No. PCT/US2009/051954, dated Mar. 24, 2011, 8 pages.

International Preliminary Report on Patentability received for PCT Patent Application No. PCT/US2009/055577, completed on Aug. 6, 2010, 12 pages.

International Preliminary Report on Patentability received for PCT Patent Application No. PCT/US2010/037378, dated Dec. 6, 2011, 9 pages.

International Preliminary Report on Patentability received for PCT Patent Application No. PCT/US2011/020350, dated Jul. 17, 2012, 12 pages.

International Preliminary Report on Patentability received for PCT Patent Application No. PCT/US2011/020825, dated Jan. 13, 2012, 17 pages.

International Preliminary Report on Patentability received for PCT Patent Application No. PCT/US2014/015418, dated Aug. 20, 2015, 12 pages.

International Preliminary Report on Patentability received for PCT Patent Application No. PCT/US2014/016988, dated Sep. 3, 2015, 8 pages.

International Preliminary Report on Patentability received for PCT Patent Application No. PCT/US2014/023822, dated Sep. 24, 2015, 12 pages.

International Preliminary Report on Patentability received for PCT Patent Application No. PCT/US2014/023826, dated Sep. 24, 2015, 9 pages.

International Preliminary Report on Patentability received for PCT Patent Application No. PCT/US2014/026871, dated Sep. 24, 2015, 7 pages.

International Preliminary Report on Patentability received for PCT Patent Application No. PCT/US2014/026873, dated Sep. 24, 2015, 9 pages.

International Preliminary Report on Patentability received for PCT Patent Application No. PCT/US2014/028785, dated Sep. 24, 2015, 10 pages.

(56)

References Cited

OTHER PUBLICATIONS

- International Preliminary Report on Patentability received for PCT Patent Application No. PCT/US2014/028950, dated Sep. 24, 2015, 8 pages.
- International Preliminary Report on Patentability received for PCT Patent Application No. PCT/US2014/029050, dated Sep. 24, 2015, 7 pages.
- International Preliminary Report on Patentability received for PCT Patent Application No. PCT/US2014/029562, dated Sep. 24, 2015, 16 pages.
- International Preliminary Report on Patentability received for PCT Patent Application No. PCT/US2014/040393, dated Dec. 8, 2015, 15 pages.
- International Preliminary Report on Patentability received for PCT Patent Application No. PCT/US2013/028920, dated Sep. 18, 2014, 11 pages.
- International Preliminary Report on Patentability received for PCT Patent Application No. PCT/US2013/029156, dated Sep. 18, 2014, 7 pages.
- International Preliminary Report on Patentability received for PCT Patent Application No. PCT/US2013/041225, dated Nov. 27, 2014, 9 pages.
- International Preliminary Report on Patentability received for PCT Patent Application No. PCT/US2013/041233, dated Nov. 18, 2014, 8 pages.
- International Preliminary Report on Patentability received for PCT Patent Application No. PCT/US2013/044574, dated Dec. 9, 2014, 8 pages.
- International Preliminary Report on Patentability received for PCT Patent Application No. PCT/US2013/044834, dated Dec. 9, 2014, 9 pages.
- International Preliminary Report on Patentability received for PCT Patent Application No. PCT/US2013/047659, dated Dec. 31, 2014, 15 pages.
- International Preliminary Report on Patentability received for PCT Patent Application No. PCT/US2013/047668, dated Jan. 8, 2015, 13 pages.
- International Preliminary Report on Patentability received for PCT Patent Application No. PCT/US2013/052558, dated Feb. 12, 2015, 12 pages.
- International Preliminary Report on Patentability received for PCT Patent Application No. PCT/US2013/058916, dated Mar. 19, 2015, 8 pages.
- International Preliminary Report on Patentability received for PCT Patent Application No. PCT/US2013/060121, dated Apr. 2, 2015, 6 pages.
- Gruber, Tom, "Where the Social Web Meets the Semantic Web", Presentation at the 5th International Semantic Web Conference, Nov. 2006, 38 pages.
- Guay, Matthew, "Location-Driven Productivity with Task Ave", available at <<http://iphone.appstorm.net/reviews/productivity/location-driven-productivity-with-task-ave/>>, Feb. 19, 2011, 7 pages.
- Guim, Mark, "How to Set a Person-Based Reminder with Cortana", available at <<http://www.wpcentral.com/how-to-person-based-reminder-cortana>>, Apr. 26, 2014, 15 pages.
- Gurevych et al., "Semantic Coherence Scoring Using an Ontology", North American Chapter of the Association for Computational Linguistics Archive, Proceedings of the 2003 Conference of the North American Chapter of the Association for Computational Linguistics on Human Language Technology, May 27, 2003, 8 pages.
- Guzzoni et al., "A Unified Platform for Building Intelligent Web Interaction Assistants", Proceedings of the 2006 IEEE/WIC/ACM International Conference on Web Intelligence and Intelligent Agent Technology, Computer Society, 2006, 4 pages.
- Guzzoni et al., "Active, A Platform for Building Intelligent Operating Rooms", Surgetica 2007 Computer-Aided Medical Interventions: Tools and Applications, 2007, pp. 191-198.
- Guzzoni et al., "Active, A platform for Building Intelligent Software", Computational Intelligence, available at <<http://www.informatik.uni-trier.de/~pers/hd/g/Guzzoni:Didier>>, 2006, 5 pages.
- Guzzoni et al., "Active, A Tool for Building Intelligent User Interfaces", ASC 2007, Palma de Mallorca, Aug. 2007, 6 pages.
- Guzzoni et al., "Modeling Human-Agent Interaction with Active Ontologies", AAAI Spring Symposium, Interaction Challenges for Intelligent Assistants, Stanford University, Palo Alto, California, 2007, 8 pages.
- Gruber, Tom, "Enterprise Collaboration Management with Intraspect", Intraspect Technical White Paper, Jul. 2001, pp. 1-24.
- Gruber, Tom, "Every Ontology is a Treaty—A Social Agreement—Among People with Some Common Motive in Sharing", Official Quarterly Bulletin of AIS Special Interest Group on Semantic Web and Information Systems, vol. 1, No. 3, 2004, pp. 1-5.
- Gruber, Tom, "Helping Organizations Collaborate, Communicate, and Learn", Presentation to NASA Ames Research, Available online at <<http://tomgruber.org/writing/organizational-intelligence-talk.htm>>, Mar.-Oct. 2003, 30 pages.
- Gruber, Tom, "Intelligence at the Interface: Semantic Technology and the Consumer Internet Experience", Presentation at Semantic Technologies Conference, Available online at <<http://tomgruber.org/writing/semtech08.htm>>, May 20, 2008, pp. 1-40.
- Gruber, Tom, "It Is What It Does: The Pragmatics of Ontology for Knowledge Sharing", Proceedings of the International CIDOC CRM Symposium, Available online at <<http://tomgruber.org/writing/cidoc-ontology.htm>>, Mar. 26, 2003, 21 pages.
- Gruber, Tom, "Ontologies, Web 2.0 and Beyond", Ontology Summit, Available online at <<http://tomgruber.org/writing/ontolog-social-web-keynote.htm>>, Apr. 2007, 17 pages.
- Gruber, Tom, "Ontology of Folksonomy: A Mash-Up of Apples and Oranges", Int'l Journal on Semantic Web & Information Systems, vol. 3, No. 2, 2007, 7 pages.
- Gruber, Tom, "Siri, A Virtual Personal Assistant-Bringing Intelligence to the Interface", Semantic Technologies Conference, Jun. 16, 2009, 21 pages.
- Gruber, Tom, "TagOntology", Presentation to Tag Camp, Oct. 29, 2005, 20 pages.
- Hendrickson, Bruce, "Latent Semantic Analysis and Fiedler Retrieval", Linear Algebra and its Applications, vol. 421, 2007, pp. 345-355.
- Hodjat et al., "Iterative Statistical Language Model Generation for use with an Agent-Oriented Natural Language Interface", Proceedings of HCI International, vol. 4, 2003, pp. 1422-1426.
- Huang et al., "A Novel Approach to Robust Speech Endpoint Detection in Car Environments", Acoustics, Speech, and Signal Processing 2000, ICASSP '00, Proceeding S. 2000 IEEE International Conference on Jun. 5-9, 2000, vol. 3, Jun. 5, 2000, pp. 1751-1754.
- iAP Sports Lingo 0x09 Protocol V1.00, May 1, 2006, 17 pages.
- IBM, "Why Buy: ThinkPad", available at <<http://www.pc.ibm.com/us/thinkpad/easeofuse.html>>, retrieved on Dec. 19, 2002, 2 pages.
- iChat AV, "Video Conferencing for the Rest of Us", Apple—Mac OS X—iChat AV, available at <<http://www.apple.com/macos/features/ichat/>>, retrieved on Apr. 13, 2006, 3 pages.
- id3.org, "id3v2.4.0-Frames", available at <<http://id3.org/id3v2.4.0-frames?action=print>>, retrieved on Jan. 22, 2015, 41 pages.
- IEEE 1394 (Redirected from Firewire, Wikipedia, The Free Encyclopedia, available at <<http://www.wikipedia.org/wiki/Firewire>>, retrieved on Jun. 8, 2003, 2 pages.
- Interactive Voice, available at <<http://www.helloivee.com/company/>>, retrieved on Feb. 10, 2014, 2 pages.
- International Preliminary Report on Patentability received for PCT Patent Application No. PCT/GB2009/051684, dated Jun. 23, 2011, 10 pages.
- Guzzoni, D., "Active: A Unified Platform for Building Intelligent Assistant Applications", Oct. 25, 2007, 262 pages.
- Haga et al., "A Usability Survey of a Contents-Based Video Retrieval System by Combining Digital Video and an Electronic Bulletin Board", The Internet and Higher Education, vol. 8, No. 3, 2005, pp. 251-262.
- Hain et al., "The Papageno TTS System", Siemens AG, Corporate Technology, Munich, Germany TC-STAR Workshop, 2006, 6 pages.

(56)

References Cited

OTHER PUBLICATIONS

- Haitsma et al., "A Highly Robust Audio Fingerprinting System", In Proceedings of the International Symposium on Music Information Retrieval (ISMIR), 2002, 9 pages.
- Hardwar, Devindra, "Driving App Waze Builds its own Siri for Hands-Free Voice Control", Available online at <<http://venturebeat.com/2012/02/09/driving-app-waze-builds-its-own-siri-for-hands-free-voice-control/>>, retrieved on Feb. 9, 2012, 4 pages.
- Hashimoto, Yoshiyuki, "Simple Guide for iPhone Siri, Which Can Be Operated with Your Voice", Shuwa System Co., Ltd., vol. 1, Jul. 5, 2012, pp. 8, 130, 131.
- Hawkins et al., "Hierarchical Temporal Memory: Concepts, Theory and Terminology", Numenta, Inc., Mar. 27, 2007, 20 pages.
- He et al., "A data-driven spoken language understanding system", 2003 IEEE Workshop on Automatic Speech Recognition and Understanding, 2003, pp. 583-588.
- Headset Button Controller v7.3 APK Full App Download for Android, Blackberry, iPhone, 11 pages.
- Hear voice from Google translate, Available on URL:<https://www.youtube.com/watch?v=18AvMhFqD28>, Jan. 28, 2011, 1 page.
- Mel Scale, Wikipedia the Free Encyclopedia, Last modified on Oct. 13, 2009 and retrieved on Jul. 28, 2010, available at <http://en.wikipedia.org/wiki/Mel_scale>, 2 pages.
- Meng et al., "Generating Phonetic Cognates to Handle Named Entities in English-Chinese Cross-Language Spoken Document Retrieval", Automatic Speech Recognition and Understanding, Dec. 2001, pp. 311-314.
- Menta, Richard, "1200 Song MP3 Portable is a Milestone Player", available at <<http://www.mp3newswire.net/stories/personaljuke.html>>, Jan. 11, 2000, 4 pages.
- Microsoft Corporation, Microsoft Office Word 2003 (SP2), Microsoft Corporation, SP3 as of 2005, pages MSWord 2003 Figures 1-5, 1983-2003.
- Microsoft/Ford, "Basic Sync Commands", www.SyncMyRide.com, Sep. 14, 2007, 1 page.
- Miller, Chance, "Google Keyboard Updated with New Personalized Suggestions Feature", available at <<http://9to5google.com/2014/03/19/google-keyboard-updated-with-new-personalized-suggestions-feature/>>, Mar. 19, 2014, 4 pages.
- Milward et al., "D2.2: Dynamic Multimodal Interface Reconfiguration, Talk and Look: Tools for Ambient Linguistic Knowledge", available at <<http://www.ihmc.us/users/nblaylock!Pubs/Files/talk.d2.2.pdf>>, Aug. 8, 2006, 69 pages.
- Miniman, Jared, "Applian Software's Replay Radio and Player v1.02", pocketnow.com—Review, available at <<http://www.pocketnow.com/reviews/replay/replay.htm>>, Jul. 31, 2001, 16 pages.
- Minimum Phase, Wikipedia the free Encyclopedia, Last modified on Jan. 12, 2010 and retrieved on Jul. 28, 2010, available at <http://en.wikipedia.org/wiki/Minimum_phase>, 8 pages.
- Mitra et al., "A Graph-Oriented Model for Articulation of Ontology Interdependencies", Advances in Database Technology, Lecture Notes in Computer Science, vol. 1777, 2000, pp. 1-15.
- Moberg et al., "Cross-Lingual Phoneme Mapping for Multilingual Synthesis Systems", Proceedings of the 8th International Conference on Spoken Language Processing, Jeju Island, Korea, INTERSPEECH 2004, Oct. 4-8, 2004, 4 pages.
- Moberg, M., "Contributions to Multilingual Low-Footprint TTS System for Hand-Held Devices", Doctoral Thesis, Tampere University of Technology, Aug. 17, 2007, 82 pages.
- Mobile Speech Solutions, Mobile Accessibility, SVOX AG Product Information Sheet, available at <<http://www.svox.com/site/bra840604/con782768/mob965831936.aSQ?osLang=1>>, Sep. 27, 2012, 1 page.
- Mobile Tech News, "T9 Text Input Software Updated", available at <<http://www.mobiletechnews.com/info/2004/11/23/122155.html>>, Nov. 23, 2004, 4 pages.
- Modi et al., "CMRadar: A Personal Assistant Agent for Calendar Management", AAAI, Intelligent Systems Demonstrations, 2004, pp. 1020-1021.
- Mok et al., "Media Searching on Mobile Devices", IEEE EIT 2007 Proceedings, 2007, pp. 126-129.
- Morrison, Jonathan, "iPhone 5 Siri Demo", Online Available at <https://www.youtube.com/watch?v=_wHwWg5IhWc>, Sep. 21, 2012, 3 pages.
- Morton, Philip, "Checking If an Element Is Hidden", StackOverflow, Available at <<http://stackoverflow.com/questions/178325/checking-if-an-element-is-hidden>>, Oct. 7, 2008, 12 pages.
- Murty et al., "Combining Evidence from Residual Phase and MFCC Features for Speaker Recognition", IEEE Signal Processing Letters, vol. 13, No. 1, Jan. 2006, 4 pages.
- My Cool Aids, "What's New", available at <<http://www.mycoolaids.com/>>, 2012, 1 page.
- Myers, Brad A., "Shortcutter for Palm", available at <<http://www.cs.cmu.edu/~pebbles/v5/shortcutter/palm/index.html>>, retrieved on Jun. 18, 2014, 10 pages.
- N200 Hands-Free Bluetooth Car Kit, available at <www.wirelessground.com>, retrieved on Mar. 19, 2007, 3 pages.
- Nakagawa et al., "Speaker Recognition by Combining MFCC and Phase Information", IEEE International Conference on Acoustics, Speech and Signal Processing (ICASSP), 2007, pp. 2005-2008.
- Nakagawa et al., "Unknown Word Guessing and Part-of-Speech Tagging Using Support Vector Machines", Proceedings of the 6th NLPSP, 2001, pp. 325-331.
- Naone, Erica, "TR10: Intelligent Software Assistant", Technology Review, Mar.-Apr. 2009, 2 pages.
- Nardi et al., Collaborative, programmable intelligent agents, Communications of the Acm, Association for computing machinery, Inc., United States, vol. 41, No. 3, Mar. 1998, Mar. 1998, pp. 96-104.
- Navigli, Roberto, "Word Sense Disambiguation: A Survey", ACM Computing Surveys, vol. 41, No. 2, Feb. 2009, 70 pages.
- NCIP, "NCIP Library: Word Prediction Collection", available at <<http://www2.edc.org/ncip/library/wp/toc.htm>>, 1998, 4 pages.
- NDTV, "Sony SmartWatch 2 Launched in India for Rs. 14,990", available at <<http://gadgets.ndtv.com/others/news/sony-smartwatch-2-launched-in-india-for-rs-14990-420319>>, Sep. 18, 2013, 4 pages.
- Ng, Simon, "Google's Task List Now Comes to iPhone", SimonBlog, Available at <<http://www.simonblog.com/2009/02/04/googles-task-list-now-comes-to-iphone/>>, Feb. 4, 2009, 3 pages.
- Nguyen et al., "Generic Manager for Spoken Dialogue Systems", In DiaBruck: 7th Workshop on the Semantics and Pragmatics of Dialogue, Proceedings, 2003, 2 pages.
- Nonhoff-Arps et al., "StraBenmusik: Portable MP3-Spieler mit USB Anschluss", CT Magazin Fuer Computer Technik, Verlag Heinz Heise GMBH, Hannover DE, No. 25, 2000, pp. 166-175.
- Notenboom, Leo A., "Can I Retrieve Old MSN Messenger Conversations?", available at <http://ask-leo.com/can_i_retrieve_old_msn_messenger_conversations.html>, Mar. 11, 2004, 23 pages.
- Noth et al., "Verbmobil: The Use of Prosody in the Linguistic Components of a Speech Understanding System", IEEE Transactions on Speech and Audio Processing, vol. 8, No. 5, Sep. 2000, pp. 519-532.
- Nozawa, Naoki et al., "iPhone 4S Perfect Manual", vol. 1, First Edition, Nov. 11, 2011, 5 pages.
- Oregon Scientific, "512MB Waterproof MP3 Player with FM Radio & Built-in Pedometer", available at <<http://www2.oregonscientific.com/shop/product.asp?cid=4&scid=11&pid=581>>, retrieved on Jul. 31, 2006, 2 pages.
- Oregon Scientific, "Waterproof Music Player with FM Radio and Pedometer (MP121)—User Manual", 2005, 24 pages.
- Jawaid et al., "Machine Translation with Significant Word Reordering and Rich Target-Side Morphology", WDS'11 Proceedings of Contributed Papers, Part I, 2011, pp. 161-166.
- Jaybird, "Everything Wrong with AIM: Because We've All Thought About It", available at <<http://www.psychonoble.com/archives/articles/82.html>>, May 24, 2006, 3 pages.
- Jensvoll, Maja Henriette, "The Acquisition of Past Tense in English/Norwegian Bilingual Children Single versus Dual Mechanisms", Proceedings of the 19th Scandinavian Conference of Linguistics, vol. 31, No. 3, 2003, pp. 545-557.
- Jiang et al., "A Syllable-based Name Transliteration System", Proc. of the 2009 Named Entities Workshop, Aug. 7, 2009, pp. 96-99.
- Jonsson et al., "Proximity-based Reminders Using Bluetooth", 2014 IEEE International Conference on Pervasive Computing and Communications Demonstrations, 2014, pp. 151-153.

(56)

References Cited

OTHER PUBLICATIONS

- Jouvet et al., "Evaluating Grapheme-to-phoneme Converters in Automatic Speech Recognition Context", IEEE, 2012., pp. 4821-4824.
- Kahn et al., "CoABS Grid Scalability Experiments", Autonomous Agents and Multi-Agent Systems, vol. 7, 2003, pp. 171-178.
- Kanda et al., "Robust Domain Selection Using Dialogue History in Multi-domain Spoken Dialogue Systems", Journal of Information Processing Society, vol. 48, No. 5, May 15, 2007, pp. 1980-1989. (English Abstract Submitted).
- Kanda et al., "Spoken Language Understanding Using Dialogue Context in Database Search Task", Journal of Information Processing Society of Japan, vol. 47, No. 6, Jun. 15, 2016, pp. 1802-1811. (English Abstract Submitted).
- Kane et al., "Slide Rule: Making Mobile Touch Screens Accessible to Blind People Using Multi-Touch Interaction Techniques", ASSETS, Oct. 13-15, 2008, pp. 73-80.
- Katz et al., "REXTOR: A System for Generating Relations from Natural Language", Proceedings of the ACL Workshop on Natural Language Processing and Information Retrieval (NLP&IR), Oct. 2000, 11 pages.
- Katzenmaier et al., "Identifying the Addressee in Human-Human-Robot Interactions based on Head Pose and Speech", Proc. ICMI'04, ACM, 2004, pp. 144-151.
- Kazemzadeh et al., "Acoustic Correlates of User Response to Error in Human-Computer Dialogues", Automatic Speech Recognition and Understanding, 2003, pp. 215-220.
- Kazmucha, Allyson, "How to Send Map Locations Using iMessage", iMore.com, Available at <<http://www.imore.com/how-use-imessage-share-your-location-your-iphone>>, Aug. 2, 2012, 6 pages.
- Kickstarter, "Ivee Sleek: Wi-Fi Voice-Activated Assistant", available at <<https://www.kickstarter.com/projects/ivee/ivee-sleek-wi-fi-voice-activated-assistant>>, retrieved on Feb. 10, 2014, 13 pages.
- Kitaoka et al., "Detection and Recognition of Correction Utterances on Misrecognition of Spoken Dialog System", Systems and Computers in Japan, vol. 36, No. 11 Oct. 2005, pp. 24-33.
- Klabbers et al., "Reducing Audible Spectral Discontinuities", IEEE Transactions on Speech and Audio Processing, vol. 9, No. 1, Jan. 2001, 13 pages.
- Knownav, "Knowledge Navigator", YouTube Video available at <http://www.youtube.com/watch?v=QRH8eimU_20>, Apr. 29, 2008, 1 page.
- Kohler, Joachim, "Multilingual Phone Models for Vocabulary-Independent Speech Recognition Tasks", Speech Communication, vol. 35, No. 1-2, Aug. 2001, pp. 21-30.
- Komatani et al., "Multi-domain Spoken Dialogue System with Extensibility and Robustness Against Speech Recognition Errors", Proceedings of the 7th SIGdial Workshop on Discourse and Dialogue, Association for Computational Linguistics, Jul. 2006, pp. 9-17.
- Kominek et al., "Impact of Durational Outlier Removal from Unit Selection Catalogs", 5th ISCA Speech Synthesis Workshop, Jun. 14-16, 2004, 6 pages.
- Küleki et al., "Turkish Word Segmentation Using Morphological Analyzer", 7th European Conference on Speech Communication and Technology, 2nd INTERSPEECH Event, 2001, 4 pages.
- Lafferty et al., "Conditional Random Fields: Probabilistic Models for Segmenting and Labeling Sequence Data", Proceedings of the 18th International Conference on Machine Learning, 2001, 9 pages.
- Larks, "Intelligent Software Agents", available at <<http://www.cs.cmu.edu/~softagents/larks.html>> retrieved on Mar. 15, 2013, 2 pages.
- Lee et al., "On URL Normalization", Proceedings of the International Conference on Computational Science and its Applications, ICCSA 2005, pp. 1076-1085.
- Lemon et al., "Multithreaded Context for Robust Conversational Interfaces: Context-Sensitive Speech Recognition and Interpretation of Corrective Fragments", ACM Transactions on Computer-Human Interaction, vol. 11, No. 3, Sep. 2004, pp. 241-267.
- Leong et al., "CASIS: A Context-Aware Speech Interface System", Proceedings of the 10th International Conference on Intelligent User Interfaces, Jan. 2005, pp. 231-238.
- Lewis, Cameron, "Task Ave for iPhone Review", Mac Life, Available at <http://www.maclife.com/article/reviews/task_ave_iphone_review>, Mar. 3, 2011, 5 pages.
- Lewis, Peter, "Two New Ways to Buy Your Bits", CNN Money, available at <<http://money.cnn.com/2003/12/30/commentary/ontechnology/download/>>, Dec. 31, 2003, 4 pages.
- Li et al., "A Phonotactic Language model for Spoken Language Identification", Proceedings of the 43rd Annual Meeting of the ACL, Jun. 25, 2005, pp. 515-522.
- Lieberman et al., "Out of Context: Computer Systems that Adapt to, and Learn from, Context", IBM Systems Journal, vol. 39, No. 3 & 4, 2000, pp. 617-632.
- Logan et al., "Mel Frequency Cepstral Co-efficients for Music Modeling", International Symposium on Music Information Retrieval, 2000, 2 pages.
- Lyons et al., "Augmenting Conversations Using Dual-Purpose Speech", Proceedings of the 17th Annual ACM Symposium on User Interface Software and Technology, 2004, 10 pages.
- Macsimum News, "Apple Files Patent for an Audio Interface for the iPod", available at <http://www.macsimumnews.com/index.php/archive/apple_files_patent_for_an_audio_interface_for_the_ipod>, retrieved on Jul. 13, 2006, 8 pages.
- Mactech, "KeyStrokes 3.5 for Mac OS X Boosts Word Prediction", available at <<http://www.mactech.com/news/?p=1007129>>, retrieved on Jan. 7, 2008, 3 pages.
- Mahedero et al., "Natural Language Processing of Lyrics", In Proceedings of the 13th Annual ACM International Conference on Multimedia, ACM, Nov. 6-11, 2005, 4 pages.
- Majeras, Wesley, Cell phone accessibility for your blind child, Retrieved from the Internet <[URL:https://web.archive.org/web/20100210001100/https://nfb.org/images/nfb/publications/fr/fr28/3/fr280314.htm](https://web.archive.org/web/20100210001100/https://nfb.org/images/nfb/publications/fr/fr28/3/fr280314.htm)>, 2010, pp. 1-5.
- Mangu et al., "Finding Consensus in Speech Recognition: Word Error Minimization and Other Applications of Confusion Networks", Computer Speech and Language, vol. 14, No. 4, 2000, pp. 373-400.
- Martins et al., "Extracting and Exploring the Geo-Temporal Semantics of Textual Resources", Semantic Computing, IEEE International Conference, 2008, pp. 1-9.
- Meet Ivee, Your Wi-Fi Voice Activated Assistant, available at <<http://www.helloivee.com/>>, retrieved on Feb. 10, 2014, 8 pages.
- International Search Report and Written Opinion Received for PCT Patent Application No. PCT/US2016/054459, dated Dec. 29, 2016, 8 pages.
- International Search Report and Written Opinion received for PCT Patent Application No. PCT/US2016/055914, dated Jan. 17, 2017, 10 pages.
- International Search Report and Written Opinion received for PCT Patent Application No. PCT/US2016/056510, dated Jan. 9, 2017, 9 pages.
- International Search Report and Written Opinion received for PCT Patent Application No. PCT/US2016/064452, dated Feb. 16, 2017, 23 pages.
- International Search Report and Written Opinion received for PCT Patent Application No. PCT/US2017/019332, dated May 18, 2017, 9 pages.
- International Search Report received for PCT Patent Application No. PCT/GB2009/051684, dated Mar. 12, 2010, 4 pages.
- International Search Report received for PCT Patent Application No. PCT/US2002/024669, dated Nov. 5, 2002, 3 pages.
- International Search Report received for PCT Patent Application No. PCT/US2002/024670, dated Sep. 26, 2002, 3 pages.
- International Search Report received for PCT Patent Application No. PCT/US2002/033330, dated Feb. 4, 2003, 6 pages.
- International Search Report received for PCT Patent Application No. PCT/US2005/046797, dated Nov. 24, 2006, 6 pages.
- International Search Report received for PCT Patent Application No. PCT/US2011/037014, dated Oct. 4, 2011, 6 pages.
- International Search Report received for PCT Patent Application No. PCT/US2013/041233, dated Nov. 22, 2013, 3 pages.

(56)

References Cited

OTHER PUBLICATIONS

- Invitation to Pay Additional Fee Received for PCT Patent Application No. PCT/US2016/047184, dated Dec. 6, 2016, 9 pages.
- Invitation to Pay Additional Fee Received for PCT Patent Application No. PCT/US2016/051927, dated Nov. 15, 2016, 2 pages.
- Invitation to Pay Additional Fee Received for PCT Patent Application No. PCT/US2016/052440, dated Nov. 15, 2016, 2 pages.
- Invitation to Pay Additional Fees and Partial International Search Report received for PCT Patent Application No. PCT/US2004/016519, dated Aug. 4, 2005, 6 pages.
- Invitation to Pay Additional Fees and Partial International Search Report received for PCT Patent Application No. PCT/US2005/046797, dated Jul. 3, 2006, 6 pages.
- Invitation to Pay Additional Fees and Partial International Search Report received for PCT Patent Application No. PCT/US2006/048738, dated Jul. 10, 2007, 4 pages.
- Invitation to Pay Additional Fees and Partial International Search Report received for PCT Patent Application No. PCT/US2011/020350, dated Apr. 14, 2011, 5 pages.
- Invitation to Pay Additional Fees and Partial International Search Report received for PCT Patent Application No. PCT/US2015/023089, dated Jun. 17, 2015, 7 pages.
- Invitation to Pay Additional Fees received for PCT Application No. PCT/US2016/021410, dated Apr. 28, 2016, 2 pages.
- Invitation to Pay Additional Fees received for PCT Patent Application No. PCT/US2008/000043, dated Jun. 27, 2008, 4 pages.
- Invitation to Pay Additional Fees received for PCT Patent Application No. PCT/US2008/000047, dated Jul. 4, 2008, 4 pages.
- Invitation to Pay Additional Fees received for PCT Patent Application No. PCT/US2011/037014, dated Aug. 2, 2011, 6 pages.
- Invitation to Pay Additional Fees received for PCT Patent Application No. PCT/US2012/040801, dated Aug. 8, 2012, 2 pages.
- Invitation to Pay Additional Fees received for PCT Patent Application No. PCT/US2013/047659, dated Feb. 27, 2014, 7 pages.
- Invitation to Pay Additional Fees received for PCT Patent Application No. PCT/US2013/052558, dated Nov. 7, 2013, 6 pages.
- Invitation to pay additional fees received for PCT Patent Application No. PCT/US2014/029562, dated Jul. 4, 2014, 7 pages.
- Invitation to Pay Additional Fees received for PCT Patent Application No. PCT/US2012/040393, dated Sep. 17, 2014, 7 pages.
- Invitation to Pay Additional Fees received for PCT Patent Application No. PCT/US2014/040961, dated Jan. 14, 2015, 3 pages.
- Invitation to Pay Additional Fees received for PCT Patent Application No. PCT/US2015/047281, dated Oct. 8, 2015, 6 pages.
- Invitation to Pay Additional Fees received for PCT Patent Application No. PCT/US2015/053366, dated Feb. 19, 2016, 8 pages.
- Invitation to Pay Additional Fees received for PCT Patent Application No. PCT/US2016/025408, dated May 13, 2016, 2 pages.
- Invitation to Pay Additional Fees received for PCT Patent Application No. PCT/US2014/028785, dated Jul. 4, 2014, 7 pages.
- Invitation to pay additional fees received for the PCT Patent Application No. PCT/US2014/015418, dated May 26, 2014, 5 pages.
- Iowegian International, "FIR Filter Properties, DSPGuru, Digital Signal Processing Central", available at <<http://www.dspguru.com/dsp/faq/fir/properties>> retrieved on Jul. 28, 2010, 6 pages.
- iPhone Hacks, "Native iPhone MMS Application Released", available at <<http://www.iphonhacks.com/2007/12/iphone-mms-app.html>>, retrieved on Dec. 25, 2007, 5 pages.
- iPhoneChat, "iChat for iPhone in JavaScript", available at <<http://www.publicity.com/iPhoneChat/>>, retrieved on Dec. 25, 2007, 2 pages.
- Iso-Sipila et al., "Multi-Lingual Speaker-Independent Voice User Interface for Mobile Devices", ICASSP 2006 Proceedings, IEEE International Conference on Acoustics, Speech and Signal Processing May 14, 2006, pp. 1-1081.
- JABRA Corporation, "FreeSpeak: BT200 User Manual", 2002, 42 pages.
- JABRA, "Bluetooth Headset: User Manual", 2005, 17 pages.
- JABRA, "Bluetooth Introduction", 2004, 15 pages.
- International Search Report and Written Opinion received for PCT Patent Application No. PCT/US2014/041173, dated Sep. 10, 2014, 11 pages.
- International Search Report and Written Opinion received for PCT Patent Application No. PCT/US2014/049568, dated Nov. 14, 2014, 12 pages.
- International Search Report and Written Opinion received for PCT Patent Application No. PCT/US2014/053951, dated Dec. 8, 2014, 11 pages.
- International Search Report and Written Opinion received for PCT Patent Application No. PCT/US2014/053957, dated Feb. 19, 2015, 11 pages.
- International Search Report and Written Opinion received for PCT Patent Application No. PCT/US2014/053958, dated Feb. 19, 2015, 10 pages.
- International Search Report and Written Opinion received for PCT Patent Application No. PCT/US2015/019320, dated Jul. 2, 2015, 14 pages.
- International Search Report and Written Opinion received for PCT Patent Application No. PCT/US2015/019321, dated Jun. 3, 2015, 11 pages.
- International Search Report and Written Opinion received for PCT Patent Application No. PCT/US2015/019322, dated Jun. 18, 2015, 16 pages.
- International Search Report and Written Opinion received for PCT Patent Application No. PCT/US2015/023089, dated Aug. 20, 2015, 16 pages.
- International Search Report and Written Opinion received for PCT Patent Application No. PCT/US2015/023097, dated Jul. 7, 2015, 15 pages.
- International Search Report and Written Opinion received for PCT Patent Application No. PCT/US2015/023593, dated Aug. 14, 2015, 16 pages.
- International Search Report and Written Opinion received for PCT Patent Application No. PCT/US2015/025188, dated Jun. 23, 2015, 11 pages.
- International Search Report and Written Opinion received for PCT Patent Application No. PCT/US2015/029554, dated Jul. 16, 2015, 11 pages.
- International Search Report and Written Opinion received for PCT Patent Application No. PCT/US2015/032470, dated Oct. 1, 2015, 13 pages.
- International Search Report and Written Opinion received for PCT Patent Application No. PCT/US2015/032724, dated Jul. 27, 2015, 11 pages.
- International Search Report and Written Opinion received for PCT Patent Application No. PCT/US2015/033051, dated Aug. 5, 2015, 14 pages.
- International Search Report and Written Opinion received for PCT Patent Application No. PCT/US2015/047062, dated Jan. 13, 2016, 25 pages.
- International Search Report and Written Opinion received for PCT Patent Application No. PCT/US2015/047064, dated Nov. 13, 2015, 13 pages.
- International Search Report and Written Opinion received for PCT Patent Application No. PCT/US2015/047281, dated Dec. 17, 2015, 19 pages.
- International Search Report and Written Opinion received for PCT Patent Application No. PCT/US2015/047553, dated Jan. 5, 2016, 10 pages.
- International Search Report and Written opinion received for PCT Patent Application No. PCT/US2015/047583, dated Feb. 3, 2016, 11 pages.
- International Search Report and Written Opinion received for PCT Patent Application No. PCT/US2015/047584, dated Nov. 9, 2015, 10 pages.
- International Search Report and Written Opinion received for PCT Patent Application No. PCT/US2015/053365, dated Mar. 10, 2016, 20 pages.
- International Search Report and Written Opinion received for PCT Patent Application No. PCT/US2015/053366, dated Apr. 26, 2016, 16 pages.

(56)

References Cited

OTHER PUBLICATIONS

- International Search Report and Written Opinion received for PCT Patent Application No. PCT/US2016/021103, dated Jun. 8, 2016, 15 pages.
- International Search Report and Written Opinion received for PCT Patent Application No. PCT/US2016/021104, dated Jun. 8, 2016, 15 pages.
- International Search Report and Written opinion received for PCT Patent Application No. PCT/US2016/021409, dated May 26, 2016, 22 pages.
- International Search report and Written Opinion received for PCT Patent Application No. PCT/US2016/024666, dated Jun. 10, 2016, 13 pages.
- International Search Report and Written Opinion received for PCT Patent Application No. PCT/US2016/025404, dated Jun. 24, 2016, 21 pages.
- International Search Report and Written Opinion received for PCT Patent Application No. PCT/US2016/025407, dated Jun. 23, 2016, 18 pages.
- International Search Report and Written Opinion received for PCT Patent Application No. PCT/US2016/025408, dated Aug. 11, 2016, 19 pages.
- International Search Report and Written Opinion received for PCT Patent Application No. PCT/US2016/031059, dated Aug. 8, 2016, 11 pages.
- International Search Report and Written Opinion received for PCT Patent Application No. PCT/US2016/031549, dated Aug. 5, 2016, 35 pages.
- International Search Report and Written Opinion received for PCT Patent Application No. PCT/US2016/031550, dated Aug. 4, 2016, 13 pages.
- International Search Report and Written Opinion received for PCT Patent Application No. PCT/US2016/035105, dated Aug. 29, 2016, 25 pages.
- International Search Report and Written Opinion received for PCT Patent Application No. PCT/US2016/035107, dated Aug. 31, 2016, 26 pages.
- International Search Report and Written Opinion received for PCT Patent Application No. PCT/US2016/035112, dated Aug. 22, 2016, 21 pages.
- International Search Report and Written Opinion received for PCT Patent Application No. PCT/US2016/043005, dated Oct. 7, 2016, 17 pages.
- International Search Report and Written Opinion Received for PCT Patent Application No. PCT/US2016/047184, dated Jan. 17, 2017, 22 pages.
- International Search Report and Written Opinion received for PCT Patent Application No. PCT/US2016/047215, dated Oct. 24, 2016, 18 pages.
- International Search Report and Written Opinion Received for PCT Patent Application No. PCT/US2016/051151, dated Nov. 22, 2016, 10 pages.
- International Search Report and Written Opinion received for PCT Patent Application No. PCT/US2016/051927, dated Feb. 6, 2017, 17 pages.
- International Search Report and Written Opinion received for PCT Patent Application No. PCT/US2016/052440, dated Jan. 19, 2017, 28 pages.
- International Search Report and Written Opinion received for PCT Patent Application No. PCT/US2016/053445, dated Dec. 6, 2016, 11 pages.
- Zhang et al., "Research of Text Classification Model Based on Latent Semantic Analysis and Improved HS-SVM", Intelligent Systems and Applications (ISA), 2010 2nd International Workshop, May 22-23, 2010, 5 pages.
- Zhong et al., "JustSpeak: Enabling Universal Voice Control on Android", W4A'14, Proceedings of the 11th Web for All Conference, No. 36, Apr. 7-9, 2014, 8 pages.
- Zipnick et al., "U.S. Appl. No. 10/859,661, filed Jun. 2, 2004".
- Zovato et al., "Towards Emotional Speech Synthesis: A Rule based Approach", Proceedings of 5th ISCA Speech Synthesis Workshop—Pittsburgh, 2004, pp. 219-220.
- Zue et al., "Jupiter: A Telephone-Based Conversational Interface for Weather Information", IEEE Transactions on Speech and Audio Processing, Jan. 2000, 13 pages.
- Xu et al., "Speech-Based Interactive Games for Language Learning: Reading, Translation, and Question-Answering", Computational Linguistics and Chinese Language Processing, vol. 14, No. 2, Jun. 2009, pp. 133-160.
- Yan et al., "A Scalable Approach to Using DNN-Derived Features in GMM-HMM Based Acoustic Modeling for LVCSR", InInterspeech, 2013, pp. 104-108.
- Yoon et al., "Letter-to-Sound Rules for Korean", Department of Linguistics, The Ohio State University, 2002, 4 pages.
- Young et al., "The HTK Book", Version 3.4, Dec. 2006, 368 pages.
- Young et al., "The Hidden Information State model: A practical framework for POMDP-based spoken dialogue management", Computer Speech & Language, vol. 24, Issue 2, 2010, pp. 150-174.
- Youtube, "New bar search for Facebook", Available at "https://www.youtube.com/watch?v=vwgN1WbvCas", 2 pages.
- Yunker, John, "Beyond Borders: Web Globalization Strategies", New Riders, Aug. 22, 2002, 11 pages.
- Zainab, "Google Input Tools Shows Onscreen Keyboard in Multiple Languages [Chrome]", available at <http://www.addictivetips.com/internet-tips/google-input-tools-shows-multiple-language-onscreen-keyboards-chrome/>, Jan. 3, 2012, 3 pages.
- Zangerle et al., "Recommending #-Tag in Twitter", Proceedings of the Workshop on Semantic Adaptive Social Web, 2011, pp. 1-12.
- Zelig, "A Review of the Palm Treo 750v", available at <http://www.mtekk.com.au/Articles/tabid/54/articleType/ArticleView/articleId/769/A-Review-of-the-Palm-Treo-750v.aspx>, Feb. 5, 2007, 3 pages.
- Wikipedia, "Speech Recognition", available at <http://en.wikipedia.org/wiki/Speech_recognition>, retrieved on Sep. 14, 2011, 12 pages.
- Wilson, Mark, "New iPod Shuffle Moves Buttons to Headphones, Adds Text to Speech", available at <http://gizmodo.com/5167946/new-ipod-shuffle-moves-buttons-to-headphones-adds-text-to-speech>, Mar. 11, 2009, 12 pages.
- Windows XP: A Big Surprise!—Experiencing Amazement from Windows XP, New Computer, No. 2, Feb. 28, 2002, 8 pages.
- Wirelessinfo, "SMS/MMS Ease of Use (8.0)", available at <http://www.wirelessinfo.com/content/palm-treo-750-cell-phone-review/Messaging.htm>, Mar. 2007, 3 pages.
- Wolf, Jonathan, "The Next Step in Routing Configuration: Auto-Configuration Management Will Speed Service Rollout", vol. 15.3, Mar. 2001, pp. 44-48.
- Written Opinion received for PCT Patent Application No. PCT/US2005/046797, dated Nov. 24, 2006, 9 pages.
- Wu et al., "Automatic Generation of Synthesis Units and Prosodic Information for Chinese Concatenative Synthesis", Speech Communication, vol. 35, No. 3-4, Oct. 2001, pp. 219-237.
- Wu, M., "Digital Speech Processing and Coding", Multimedia Signal Processing, Lecture-2 Course Presentation, University of Maryland, College Park, 2003, 8 pages.
- Wu, M., "Speech Recognition, Synthesis, and H.C.I.", Multimedia Signal Processing, Lecture-3 Course Presentation, University of Maryland, College Park, 2003, 11 pages.
- Xiang et al., "Correcting Phoneme Recognition Errors in Learning Word Pronunciation through Speech Interaction", Speech Communication, vol. 55, No. 1, Jan. 1, 2013, pp. 190-203.
- Vodafone Deutschland, "Samsung Galaxy S3 Tastatur Spracheingabe", Available online at—"https://www.youtube.com/watch?v=6kOd6Gr8uFE", Aug. 22, 2012, 1 page.
- Vogel et al., "Shift: A Technique for Operating Pen-Based Interfaces Using Touch", CHI '07 Proceedings, Mobile Interaction Techniques I, Apr. 28-May 3, 2007, pp. 657-666.
- Voiceassist, "Send Text, Listen to and Send E-Mail by Voice", YouTube Video, Available online at <http://www.youtube.com/watch?v=0tEU61nHHA4>, Jul. 30, 2009, 1 page.
- Voiceonthego, "Voice on the Go (BlackBerry)", YouTube Video, available online at <http://www.youtube.com/watch?v=pJqWgQS98w>, Jul. 27, 2009, 1 page.

(56)

References Cited

OTHER PUBLICATIONS

- W3C Working Draft, "Speech Synthesis Markup Language Specification for the Speech Interface Framework", available at <<http://www.w3.org/TR/speech-synthesis>>, retrieved on Dec. 14, 2000, 42 pages.
- Wahlster et al., "Smartkom: Multimodal Communication with a Life-Like Character", Eurospeech-Scandinavia, 7th European Conference on Speech Communication and Technology, 2001, 5 pages.
- Waldinger et al., "Deductive Question Answering from Multiple Resources", New Directions in Question Answering, Published by AAAI, Menlo Park, 2003, 22 pages.
- Wang et al., "An Industrial-Strength Audio Search Algorithm", In Proceedings of the International Conference on Music Information Retrieval (ISMIR), 2003, 7 pages.
- Wikipedia, "Acoustic Model", available at <<http://en.wikipedia.org/wiki/AcousticModel>>, retrieved on Sep. 14, 2011, 2 pages.
- Wikipedia, "Language Model", available at <http://en.wikipedia.org/wiki/Language_model>, retrieved on Sep. 14, 2011, 4 pages.
- Tucker, Joshua, "Too Lazy to Grab Your TV Remote? Use Siri Instead", Engadget, Nov. 30, 2011, 8 pages.
- Tur et al., "The CALO Meeting Assistant System", IEEE Transactions on Audio, Speech and Language Processing, vol. 18, No. 6, Aug. 2010, pp. 1601-1611.
- Tur et al., "The CALO Meeting Speech Recognition and Understanding System", Proc. IEEE Spoken Language Technology Workshop, 2008, 4 pages.
- Ushida et al., "Spoken Dialogue Engine based on Autonomous Behavior Decision Model", Omron Technics, vol. 40, No. 1, 2000, pp. 16-21. (Official Copy only) {See Communication under 37 CFR § 1.98(a) (3)}.
- Veiga, Alex, "AT&T Wireless Launching Music Service", available at <http://biz.yahoo.com/ap/041005/at_t_mobile_music_5.html?printer=1>, Oct. 5, 2004, 2 pages.
- Vepa et al., "New Objective Distance Measures for Spectral Discontinuities in Concatenative Speech Synthesis", Proceedings of the IEEE 2002 Workshop on Speech Synthesis, 2002, 4 pages.
- Vershelde, Jan, "MATLAB Lecture 8. Special Matrices in MATLAB", UIC, Dept. of Math, Stat. & CS, MCS 320, Introduction to Symbolic Computation, Nov. 23, 2005, 4 pages.
- Viiikki et al., "Speaker- and Language-Independent Speech Recognition in Mobile Communication Systems", IEEE, vol. 1, 2001, pp. 5-8.
- Vlingo Incar, "Distracted Driving Solution with Vlingo InCar", YouTube Video, Available online at <<http://www.youtube.com/watch?v=Vqs8XIXgz4>>, Oct. 2010, 2 pages.
- Vlingo, "Vlingo Launches Voice Enablement Application on Apple App Store", Press Release, Dec. 3, 2008, 2 pages.
- TG3 Electronics, Inc., "BL82 Series Backlit Keyboards", available at <<http://www.tg3electronics.com/products/backlit/backlit.htm>>, retrieved on Dec. 19, 2002, 2 pages.
- "The world of Virtual Assistants—more SemTech.", End of Business as Usual—Glenn's External blog, Online Available at <<https://web.archive.org/web/20091101840940/http://glennas.wordpress.com/2009/10/17/the-world-of-virtual-assistants-more-semtech/>>, Oct. 17, 2009, 5 pages.
- Tidwell, Jenifer, "Animated Transition", Designing Interfaces, Patterns for effective Interaction Design, Nov. 2005, First Edition, 4 pages.
- Timothy et al., "Speech-Based Annotation and Retrieval of Digital Photographs", Interspeech. 8th Annual Conference of the International Speech Communication Association, Aug. 27, 2007, pp. 2165-2168.
- Tofel, Kevin C., "SpeakTolt: A Personal Assistant for Older iPhones, iPads", Apple News, Tips and Reviews, Feb. 9, 2012, 7 pages.
- Tombros et al., "Users' Perception of Relevance of Spoken Documents", Journal of the American Society for Information Science, New York, Aug. 2000, pp. 929-939.
- Tomita et al., Multi-database Searching System Based on WWW: WebSENA, NTT Technology Journal, JPN, vol. 10, No. 5 (serial No. 100), May 15, 2007, pp. 55-58 (Official Copy only) {See Communication under 37 CFR § 1.98(a) (3)}.
- Top 10 Best Practices for Voice User Interface Design available at <<http://www.developer.com/voice/article.php/1567051TTop-10-Best-Practices-for-Voice-User-Interface-Design.htm>>, Nov. 1, 2002, 4 pages.
- Toutanova et al., "Feature-Rich Part-of-Speech Tagging with a Cyclic Dependency Network", Computer Science Dept., Stanford University, Stanford CA 94305-9040, 2003, 8 pages.
- Steinberg, Gene, "Sonicblue Rio Car (10 GB, Reviewed: 6 GB)", available at <<http://electronics.cnet.com/electronics/0-6342420-1304-4098389.html>>, Dec. 12, 2000, 2 pages.
- Stent et al., "Geo-Centric Language Models for Local Business Voice Search", AT&T Labs—Research, 2009, pp. 389-396.
- Strom et al., "Intelligent Barge-In in Conversational Systems", MIT laboratory for Computer Science, 2000, 4 pages.
- Stuker et al., "Cross-System Adaptation and Combination for Continuous Speech Recognition: The Influence of Phoneme Set and Acoustic Front-End", Influence of Phoneme Set and Acoustic Front-End, Interspeech, Sep. 17-21, 2006, pp. 521-524.
- Sullivan, Danny, "How Google Instant's Autocomplete Suggestions Work", available at <<http://searchengineland.com/how-google-instant-autocomplete-suggestions-work-62592>>, Apr. 6, 2011, 12 pages.
- Sundaram et al., "Latent Perceptual Mapping with Data-Driven Variable-Length Acoustic Units for Template-Based Speech Recognition", ICASSP 2012, Mar. 2012, pp. 4125-4128.
- Sycara et al., "The RETSINA MAS Infrastructure", Autonomous Agents and Multi-Agent Systems, vol. 7, 2003, 20 pages.
- T3 Magazine, "Creative MuVo TX 256MB", available at <http://www.t3.co.uk/reviews/entertainment/mp3_player/creative_muvo_tx_256mb>, Aug. 17, 2004, 1 page.
- Taos, "Taos, Inc. Announces Industry's First Ambient Light Sensor to Convert Light Intensity to Digital Signals", News Release, available at <http://www.taosinc.com/pressrelease_090902.htm>, Sep. 16, 2002, 3 pages.
- TextnDrive, "Text'nDrive App Demo—Listen and Reply to your Messages by Voice while Driving!", YouTube Video available at <<http://www.youtube.com/watch?v=WaGfzoHsAMw>>, Apr. 27, 2010, 1 page.
- Sinityn, Alexander, "A Synchronization Framework for Personal Mobile Servers", Proceedings of the Second IEEE Annual Conference on Pervasive Computing and Communications Workshops, Piscataway, 2004, pp. 1, 3 and 5.
- "SmartThings +Amazon Echo", Smartthings Samsung [online], Available online at <<https://web.archive.org/web/20160509231428/https://blog.smartthings.com/featured/alexa-turn-on-my-smarthings/>>, Aug. 21, 2015, 3 pages.
- Sony Eiicsson Corporate, "Sony Ericsson to introduce Auto pairing. TM. to Improve Bluetooth.TM. Connectivity Between Headsets and Phones", Press Release, available at <http://www.sonyericsson.com/spg.jsp?cc=global&lc=en&ver=4001&template=pc3_1_1&z...>, Sep. 28, 2005, 2 pages.
- Speaker Recognition, Wikipedia, The Free Encyclopedia, Nov. 2, 2010, 4 pages.
- Spiller, Karen, "Low-Decibel Earbuds Keep Noise at a Reasonable Level", available at <<http://www.nashuatelegraph.com/apps/pbcs.dll/article?Date=20060813&Cate...>>, Aug. 13, 2006, 3 pages.
- Spivack, Nova, "Sneak Preview of Siri—Part Two—Technical Foundations—Interview with Tom Gruber, CTO of Siri", Online Available at <<https://web.archive.org/web/20100114234454/http://www.twine.com/item/12vhy39k4-22m/interview-with-tom-gruber-of-siri>>, Jan. 14, 2010, 5 pages.
- SRI, "SRI Speech: Products: Software Development Kits: EduSpeak", available at <<http://web.archive.org/web/20090828084033/http://www.speechsri.com/products/eduspeak>html>>, retrieved on Jun. 20, 2013, 2 pages.
- Stealth Computer Corporation, "Peripherals for Industrial Keyboards & Pointing Devices", available at <http://www.stealthcomputer.com/peripherals_oem.htm>, retrieved on Dec. 19, 2002, 6 pages.
- Schnelle, Dirk, "Context Aware Voice User Interfaces for Workflow Support", Dissertation paper, Aug. 27, 2007, 254 pages.
- Schone et al., "Knowledge-Free Induction of Morphology Using Latent Semantic Analysis", Proceedings of the 2nd Workshop on

(56)

References Cited

OTHER PUBLICATIONS

- Learning Language in Logic and the 4th Conference on Computational Natural Language Learning, vol. 7, 2000, pp. 67-72.
- Schultz, Tanja, "Speaker Characteristics", In: Speaker Classification I, retrieved from <<http://ccc.inaoep.mx/~villasen/bib/Speaker%20Characteristics.pdf>>, 2007, pp. 47-74.
- Sen et al., "Indian Accent Text-to-Speech System for Web Browsing", Sadhana, vol. 27, No. 1, Feb. 2002, pp. 113-126.
- Sethy et al., "A Syllable Based Approach for Improved Recognition of Spoken Names", ITRW on Pronunciation Modeling and Lexicon Adaptation for Spoken language Technology (PMLA2002), Sep. 14-15, 2002, pp. 30-35.
- Sheth et al., "Relationships at the Heart of Semantic Web: Modeling, Discovering, and Exploiting Complex Semantic Relationships", Enhancing the Power of the Internet: Studies in Fuzziness and Soft Computing, Oct. 13, 2002, pp. 1-38.
- Sigurdsson et al., "Mel Frequency Cepstral Co-efficients: An Evaluation of Robustness of MP3 Encoded Music", Proceedings of the 7th International Conference on Music Information Retrieval, 2006, 4 pages.
- Simonite, Tom, "One Easy Way to Make Siri Smarter", Technology Review, Oct. 18, 2011, 2 pages.
- Singh et al., "Automatic Generation of Phone Sets and Lexical Transcriptions", Acoustics, Speech and Signal Processing (ICASSP'00), 2000, pp. 1691-1694.
- Roseberry, Catherine, "How to Pair a Bluetooth Headset & Cell Phone", available at <http://mobileoffice.about.com/od/usingyourphone/ht/blueheadset_p.htm>, retrieved on Apr. 29, 2006, 2 pages.
- Routines, "SmartThings Support", Available online at <<https://web.archive.org/web/20151207165701/https://support.smartthings.com/hc/en-us/articles/205380034-Routines>>, 2015, 2 pages.
- Ruch et al., "Using Lexical Disambiguation and Named-Entity Recognition to Improve Spelling Correction in the Electronic Patient Record", Artificial Intelligence in Medicine, Sep. 2003, pp. 169-184.
- Russo et al., "Urgency is a Non-Monotonic Function of Pulse Rate", Journal of the Acoustical Society of America, vol. 122, No. 5, 2007, 6 pages.
- Sankar, Ananth, "Bayesian Model Combination (BAYCOM) for Improved Recognition", IEEE International Conference on Acoustics, Speech, and Signal Processing (ICASSP), Mar. 18-23, 2005, pp. 845-848.
- San-Segundo et al., "Confidence Measures for Dialogue Management in the CU Communicator System", Proceedings of Acoustics, Speech and Signal Processing (ICASSP'00), Jun. 2000, 4 pages.
- Santaholma, Marianne E., "Grammar Sharing Techniques for Rule-based Multilingual NLP Systems", Proceedings of the 16th Nordic Conference of Computational Linguistics, NODALIDA 2007, May 25, 2007, 9 pages.
- Sarawagi, Sunita, "CRF Package Page", available at <<http://crf.sourceforge.net/>>, retrieved on Apr. 6, 2011, 2 pages.
- Sarvas et al., "Metadata Creation System for Mobile Images", Conference Proceedings, The Second International Conference on Mobile Systems, Applications and Services, Jun. 6, 2004, pp. 36-48.
- Schluter et al., "Using Phase Spectrum Information for Improved Speech Recognition Performance", IEEE International Conference on Acoustics, Speech, and Signal Processing, 2001, pp. 133-136.
- Poly-Optical Products, Inc., "Poly-Optical Fiber Optic Membrane Switch Backlighting", available at <http://www.poly-optical.com/membrane_switches.html>, retrieved on Dec. 19, 2002, 3 pages.
- Powell, Josh, "Now You See Me . . . Show/Hide Performance", available at <http://www.learningjquery.com/2010/05/now-you-see-me-showhide-performance>, May 4, 2010, 3 pages.
- Public Safety Technologies, "Tracer 2000 Computer", available at <<http://www.pst911.com/tracer.html>>, retrieved on Dec. 19, 2002, 3 pages.
- Quazza et al., "Actor: A Multilingual Unit-Selection Speech Synthesis System", Proceedings of 4th ISCA Tutorial and Research Workshop on Speech Synthesis, Jan. 1, 2001, 6 pages.
- Ren et al., "Improving Selection Performance on Pen-Based Systems: A Study of Pen-Based Interaction for Selection Tasks", ACM Transactions on Computer-Human Interaction, vol. 7, No. 3, Sep. 2000, pp. 384-416.
- Research in Motion Limited, BlackBerry 5810, BlackBerry Wireless Handheld, Handheld User Guide, Internet Citation, Retrieved from the Internet: URL:<http://www.comparecellular.com/userguidesmanufacturer.asp?I=&ManufacturerID=52>, 2003, pp. 1-77.
- Ricker, Thomas, "Apple Patents Audio User Interface", Engadget, available at <<http://www.engadget.com/2006/05/04/apple-patents-audio-user-interface/>>, May 4, 2006, 6 pages.
- Robbin et al., "MP3 Player and Encoder for Macintosh!", SoundJam MP Plus, Version 2.0, 2000, 76 pages.
- Roddy et al., "Communication and Collaboration in a Landscape of B2B eMarketplaces", VerticalNet Solutions, White Paper, Jun. 15, 2000, 23 pages.
- Oxsdaily, "Get a List of Siri Commands Directly from Siri", Available at <<http://osxdaily.com/2013/02/05/list-siri-commands/>>, Feb. 5, 2013, 15 pages.
- Padilla, Alfredo, "Palm Treo 750 Cell Phone Review—Messaging", available at <<http://www.wirelessinfo.com/content/palm-Treo-750-Cell-Phone-Review/Messaging.htm>>, Mar. 17, 2007, 6 pages.
- Palm, Inc., "User Guide: Your Palm® Treo.TM. 755p Smartphone", 2005-2007, 304 pages.
- Pan et al., "Natural Language Aided Visual Query Building for Complex Data Access", In proceeding of: Proceedings of the Twenty-Second Conference on Innovative Applications of Artificial Intelligence, XP055114607, 2010, pp. 1821-1826.
- Panasonic, "Toughbook 28: Powerful, Rugged and Wireless", Panasonic: Toughbook Models, available at <http://www.panasonic.com/computer/notebook/html/01a_s8.htm>, retrieved on Dec. 19, 2002, 3 pages.
- Pathak et al., "Privacy-preserving Speech Processing: Cryptographic and String-matching Frameworks Show Promise", In: IEEE signal processing magazine, retrieved from <<http://www.merl.com/publications/docs/TR2013-063.pdf>>, Feb. 13, 2013, 16 pages.
- Patra et al., "A Kernel-Based Approach for Biomedical Named Entity Recognition", Scientific World Journal, vol. 2013, 2013, pp. 1-7.
- PhatNoise, Voice Index on Tap, Kenwood Music Keg, available at <<http://www.phatnoise.com/kenwood/kenwoodssmail.html>>, retrieved on Jul. 13, 2006, 1 page.
- Phoenix Solutions, Inc., "Declaration of Christopher Schmandt Regarding the MIT Galaxy System", West Interactive Corp., A Delaware Corporation, Document 40, Jul. 2, 2010, 162 pages.
- Non-Final Office Action received for U.S. Appl. No. 14/732,625, dated May 20, 2016, 14 pages.
- Notice of Allowance received for U.S. Appl. No. 14/732,625, dated Oct. 13, 2016, 14 pages.

* cited by examiner

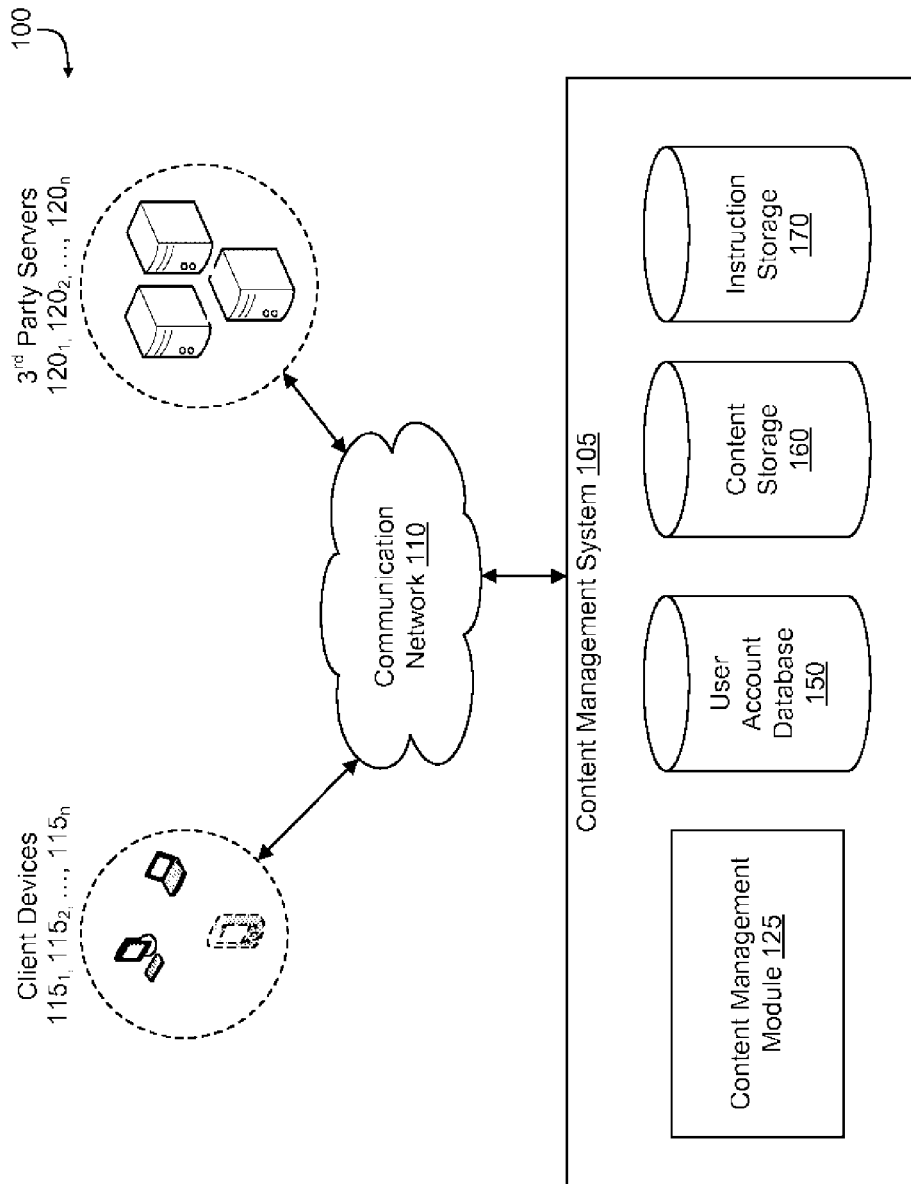

FIG. 1

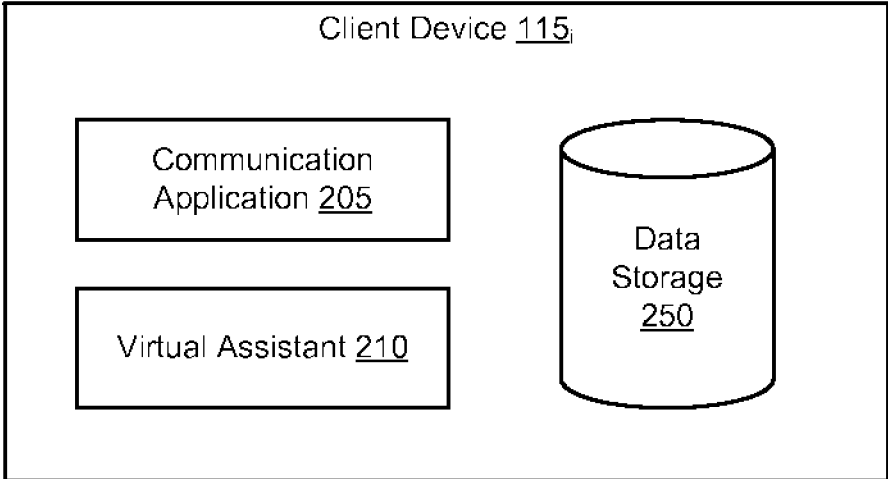

FIG. 2

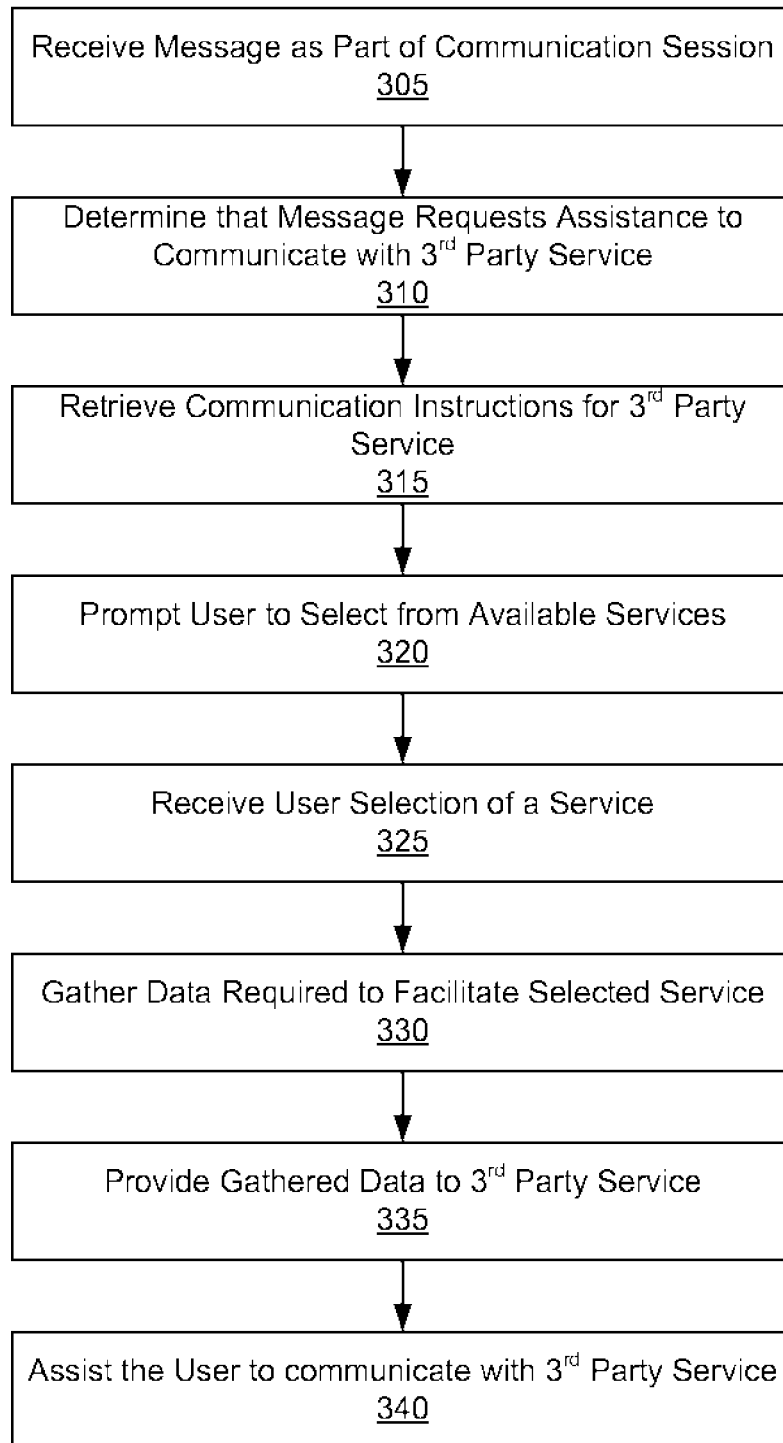

FIG. 3

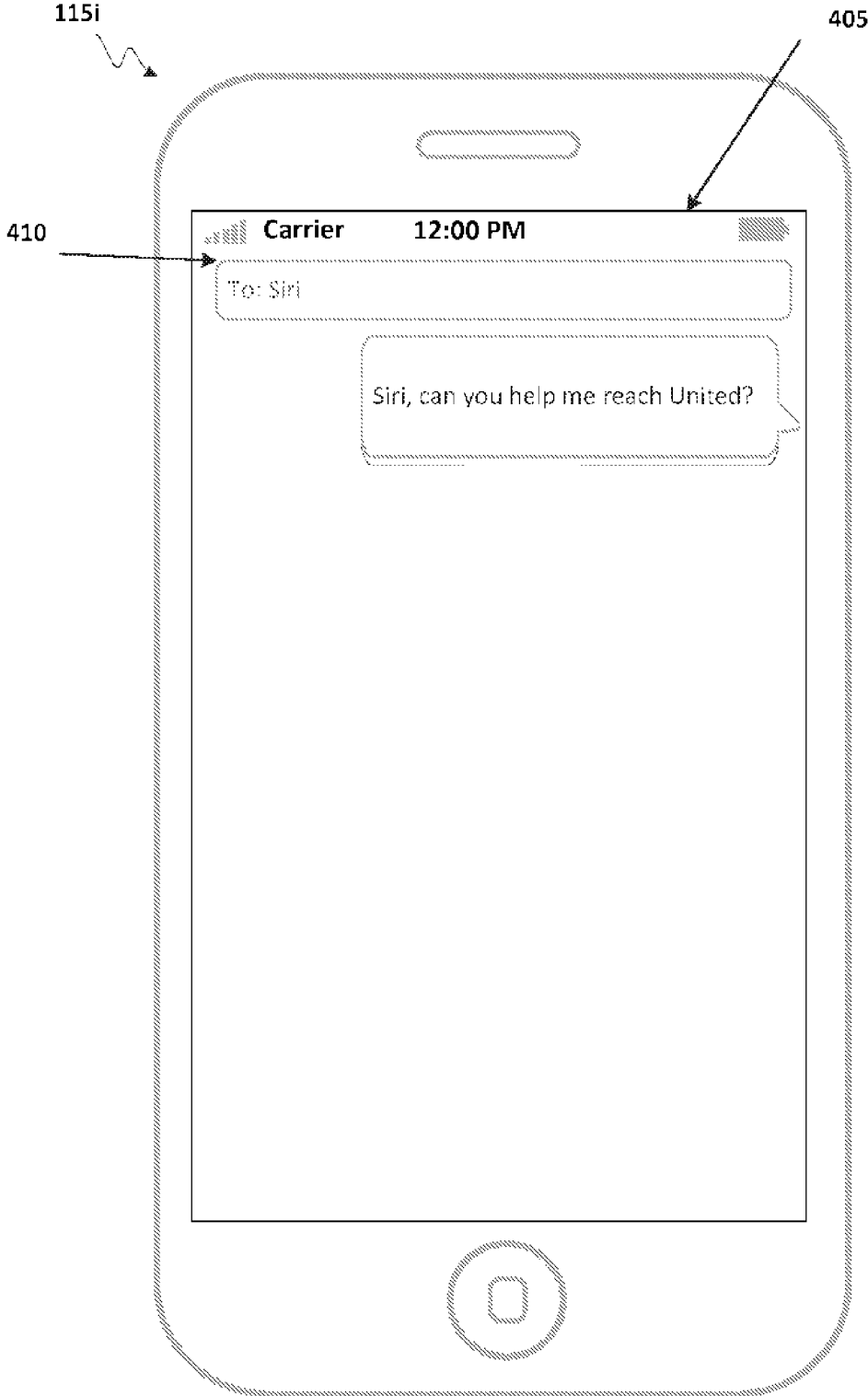

FIG. 4A

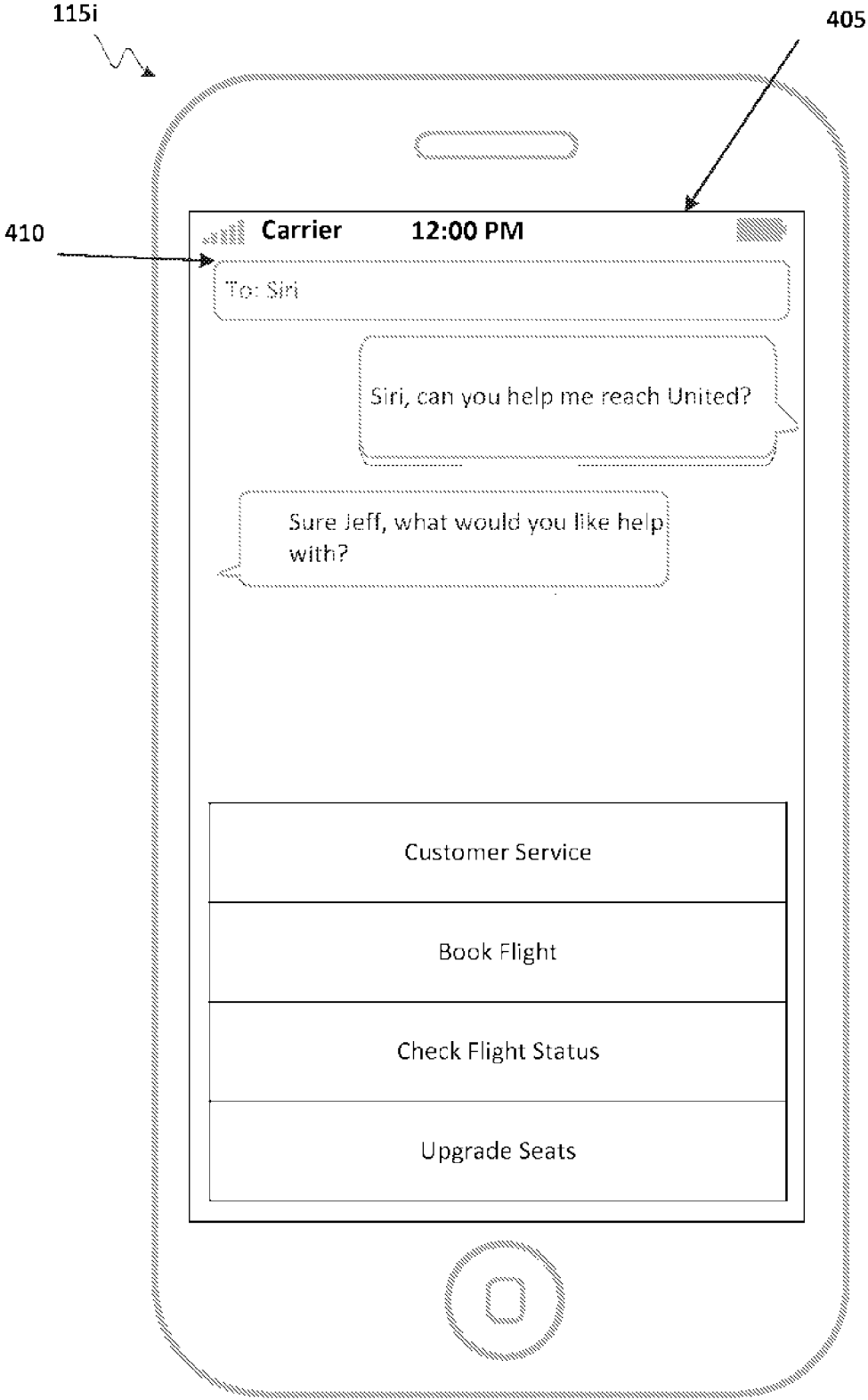

FIG. 4B

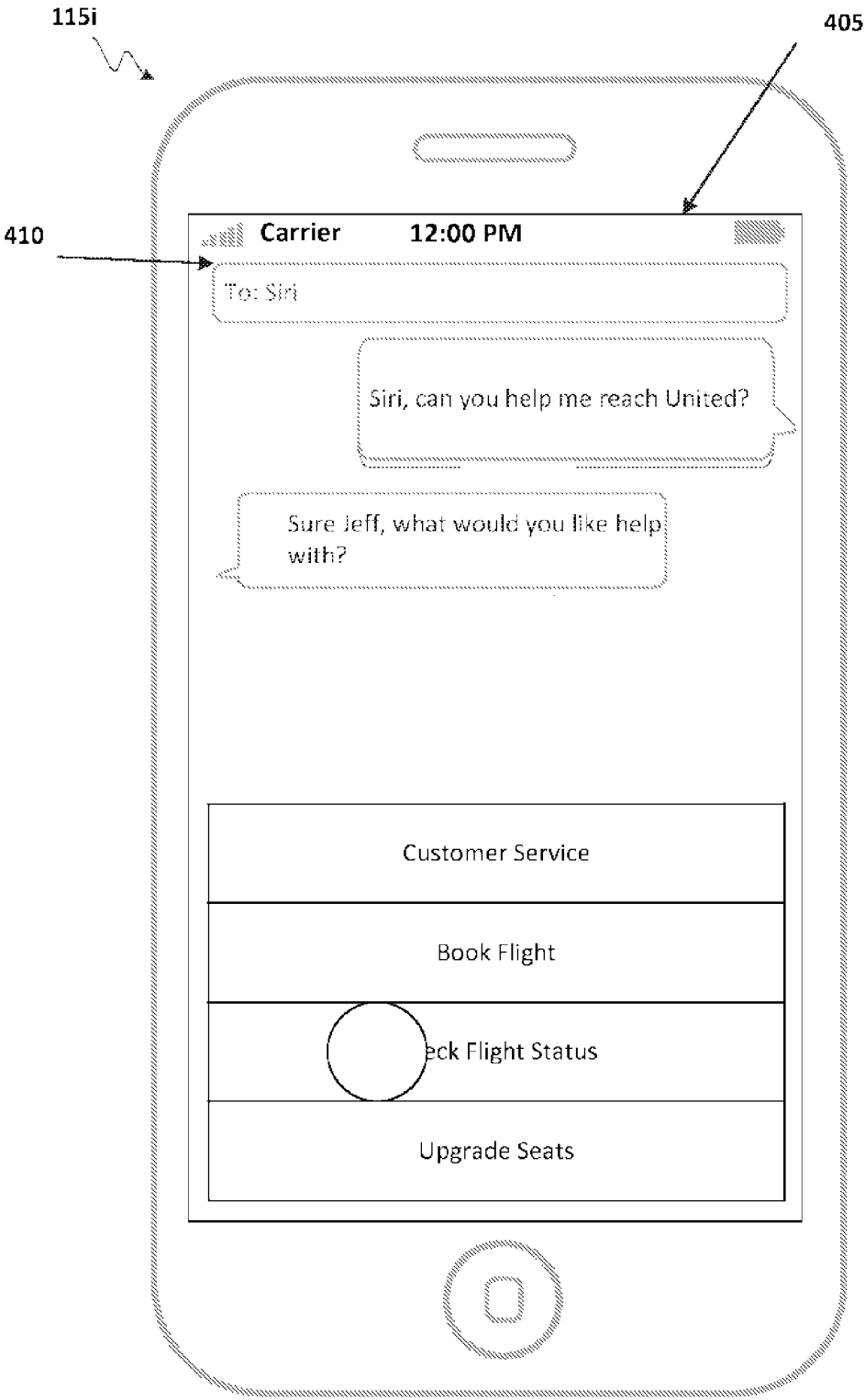

FIG. 4C

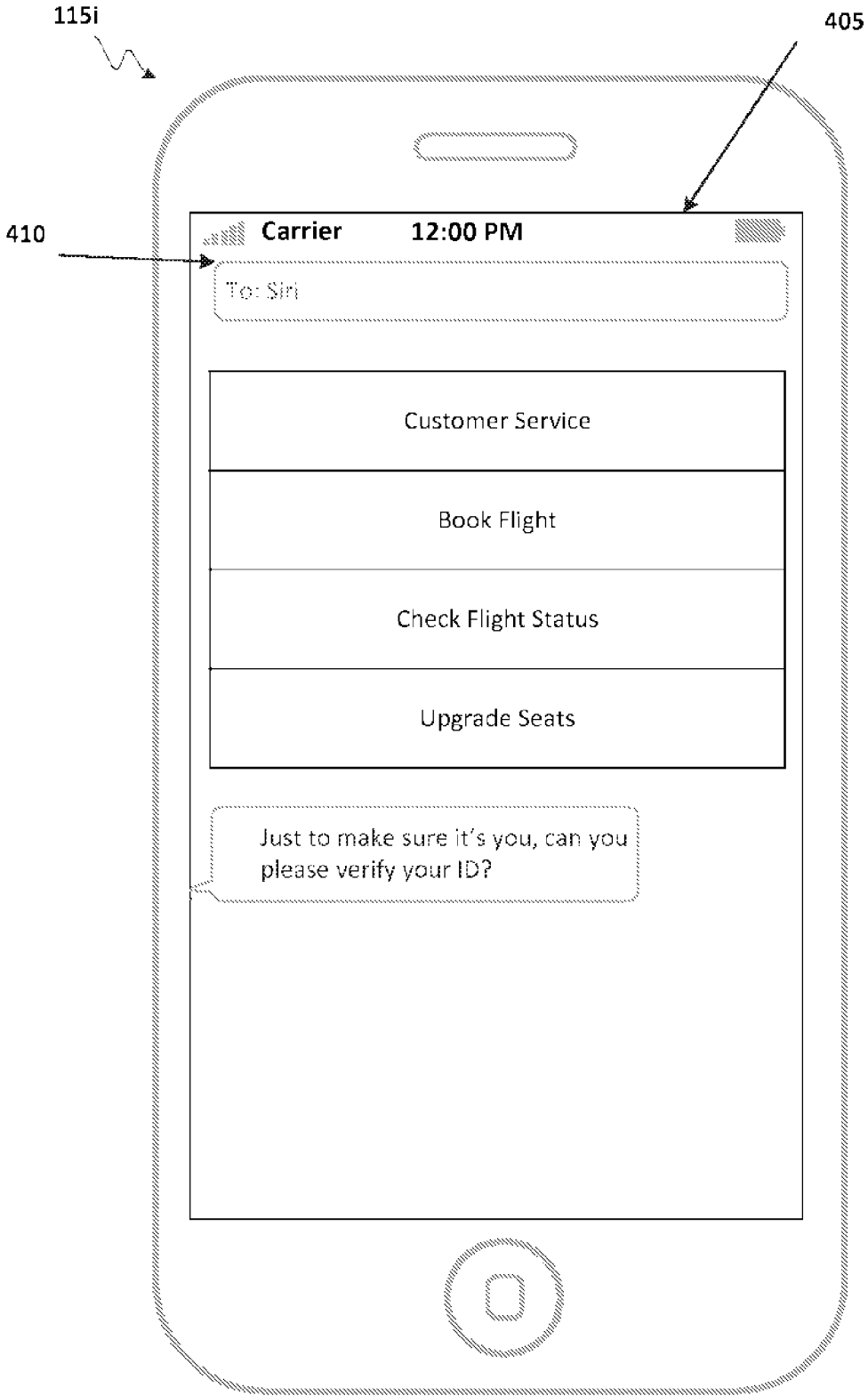

FIG. 4D

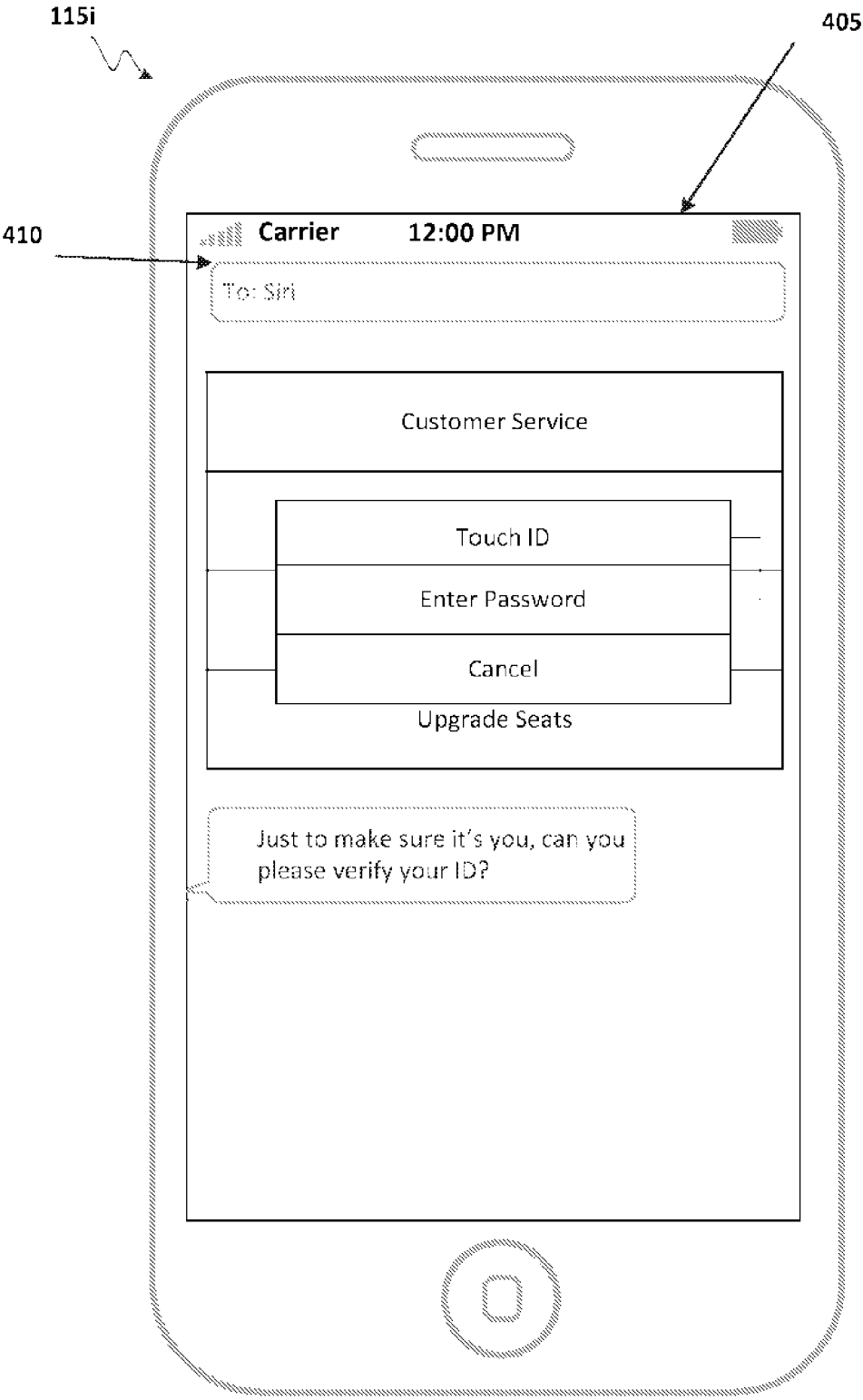

FIG. 4E

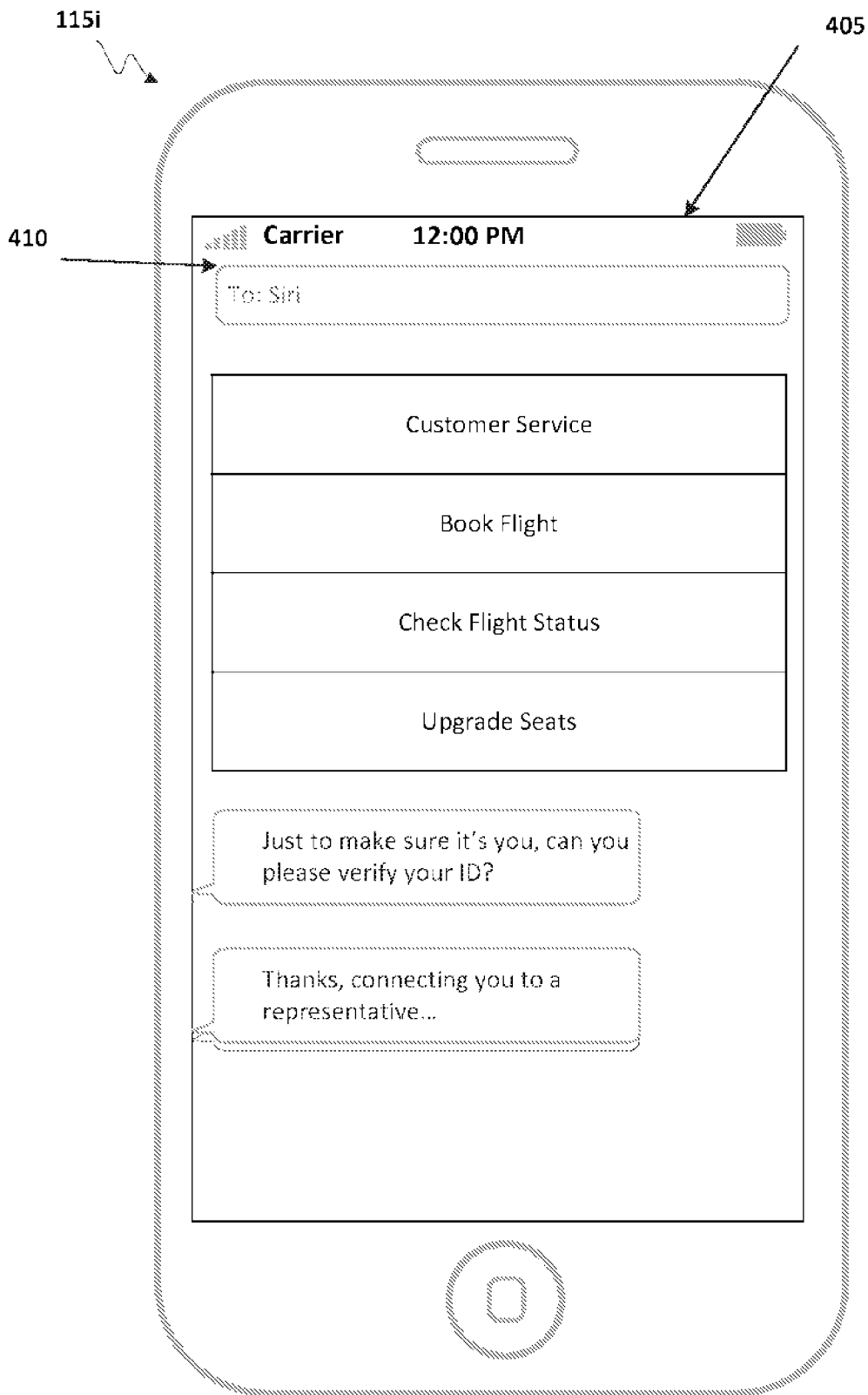

FIG. 4F

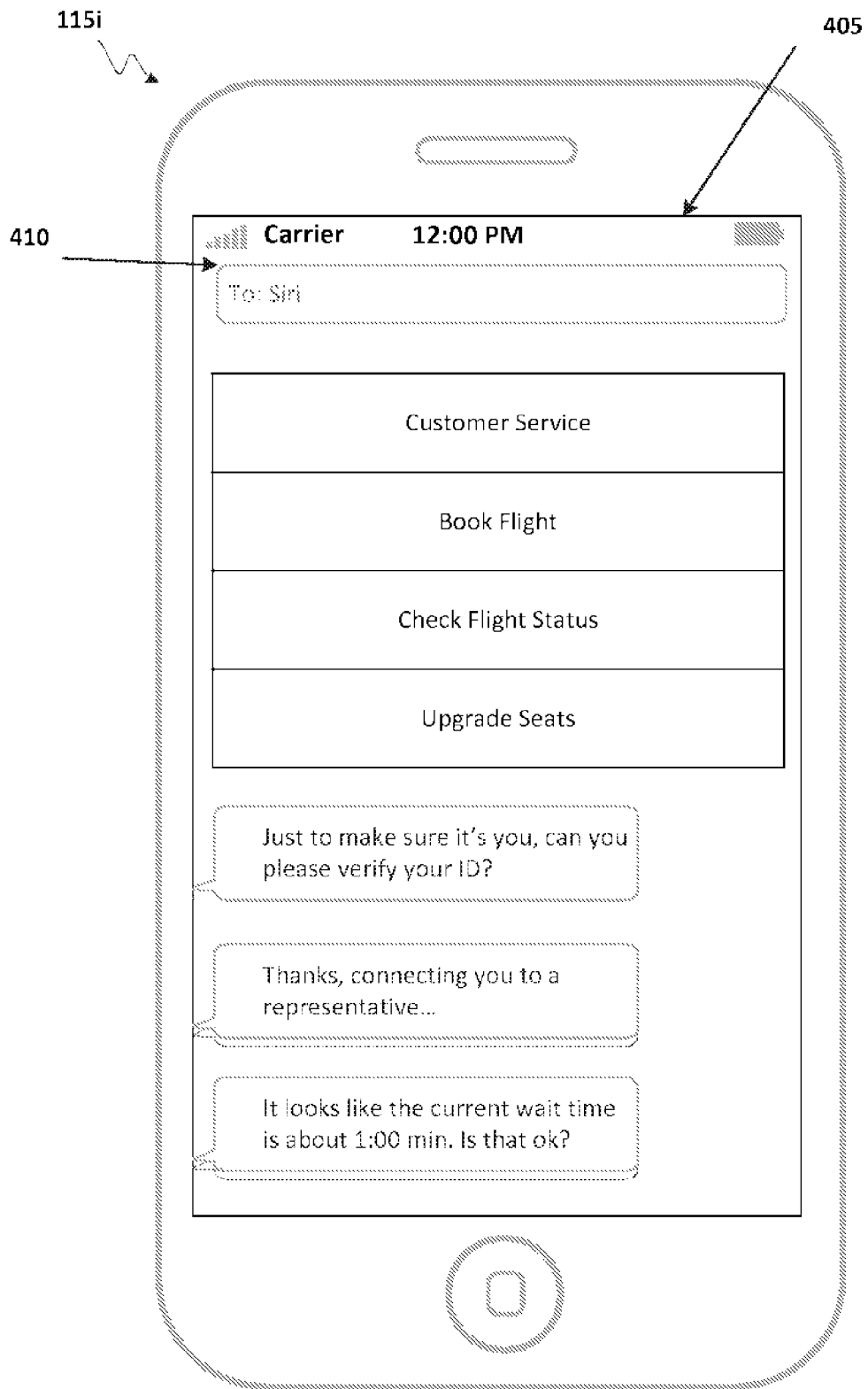

FIG. 4G

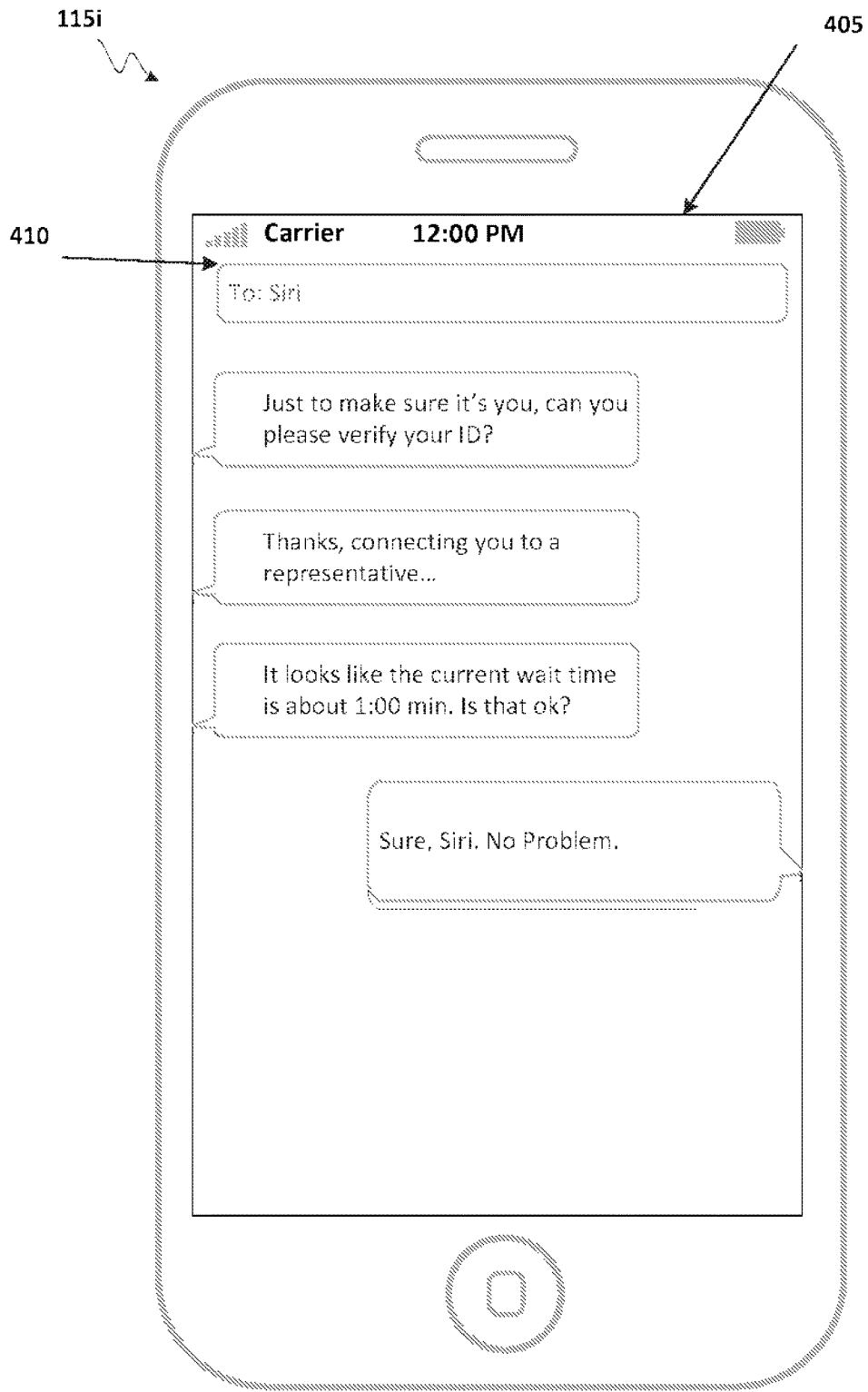

FIG. 4H

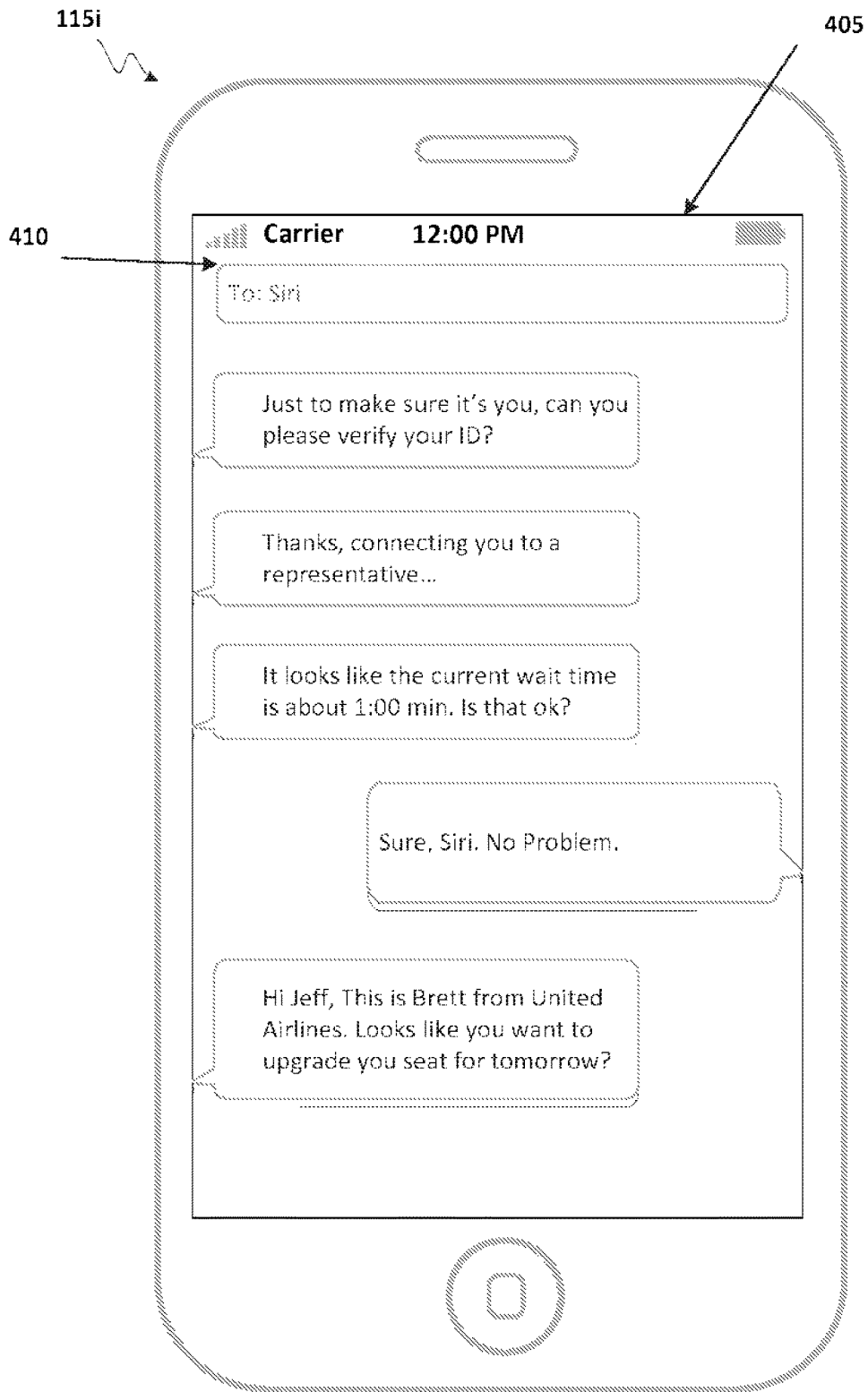

FIG. 4I

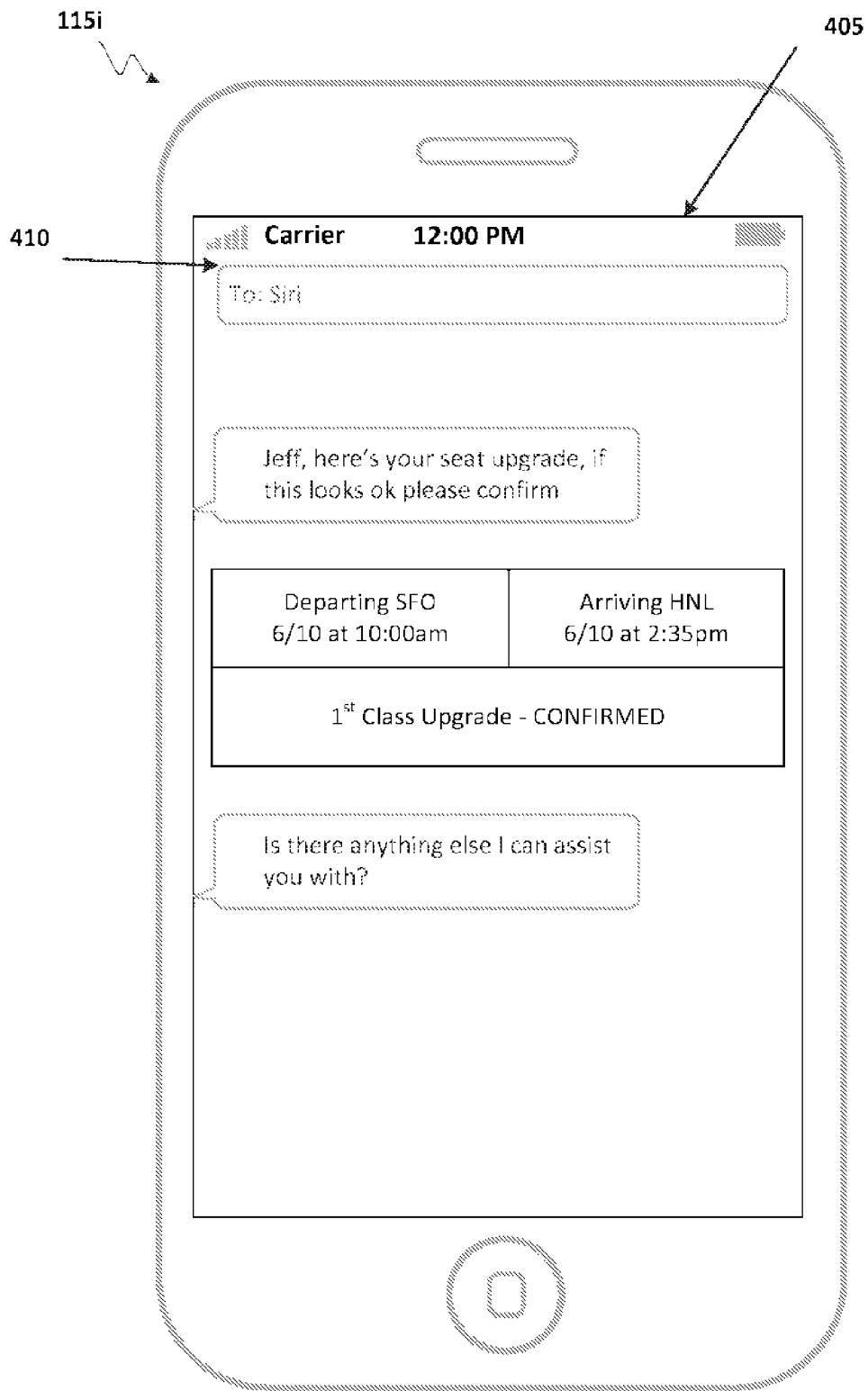

FIG. 4J

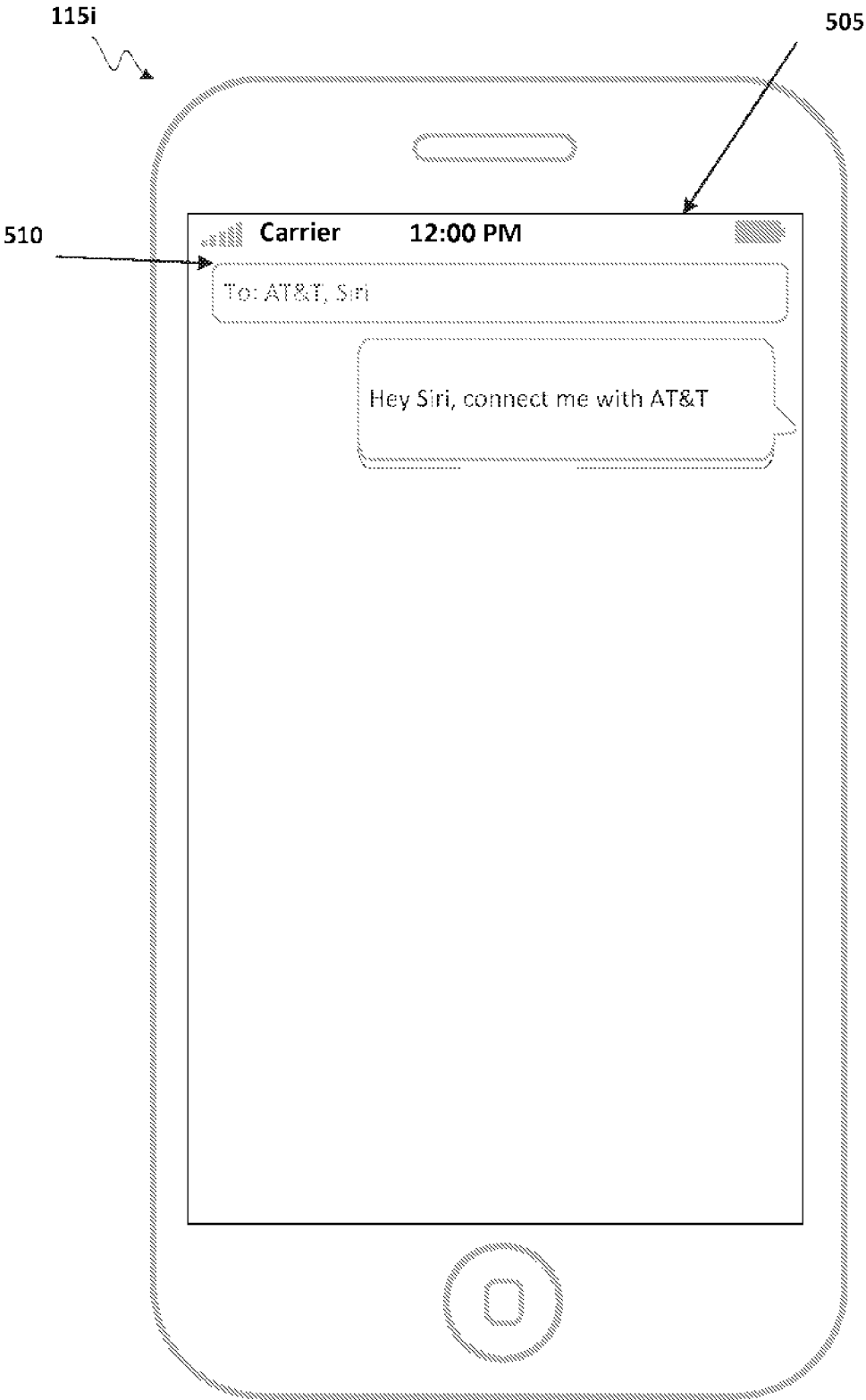

FIG. 5A

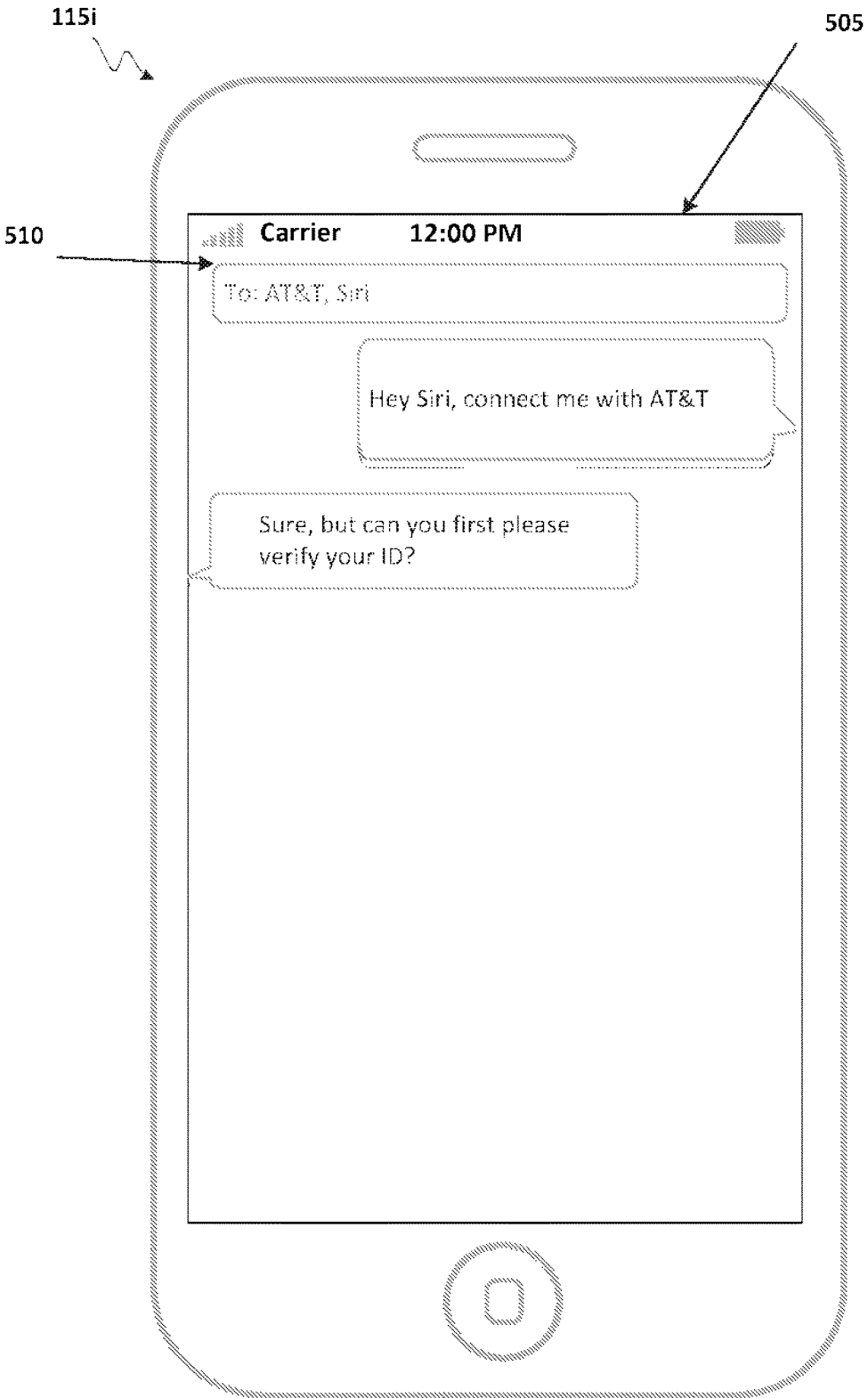

FIG. 5B

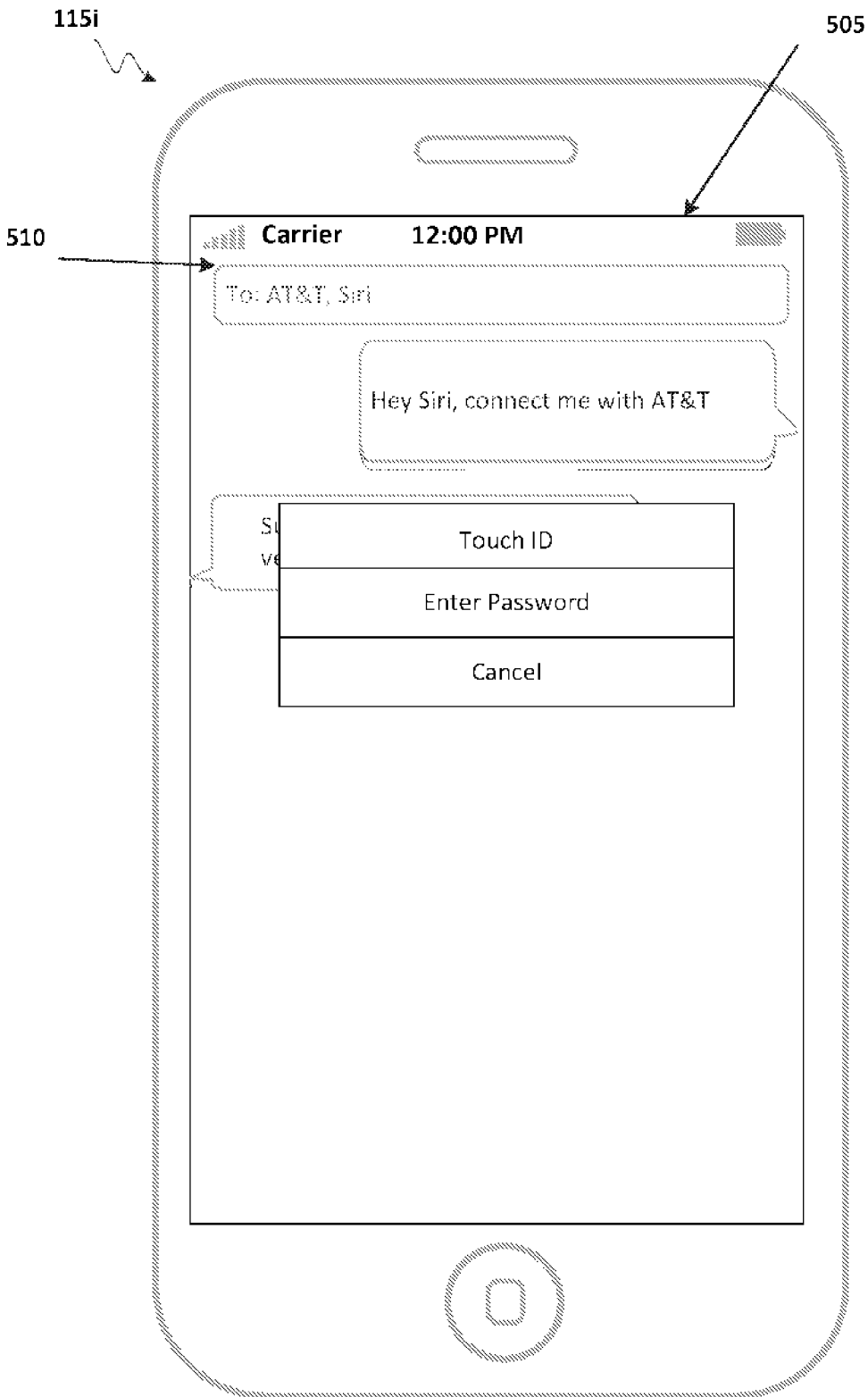

FIG. 5C

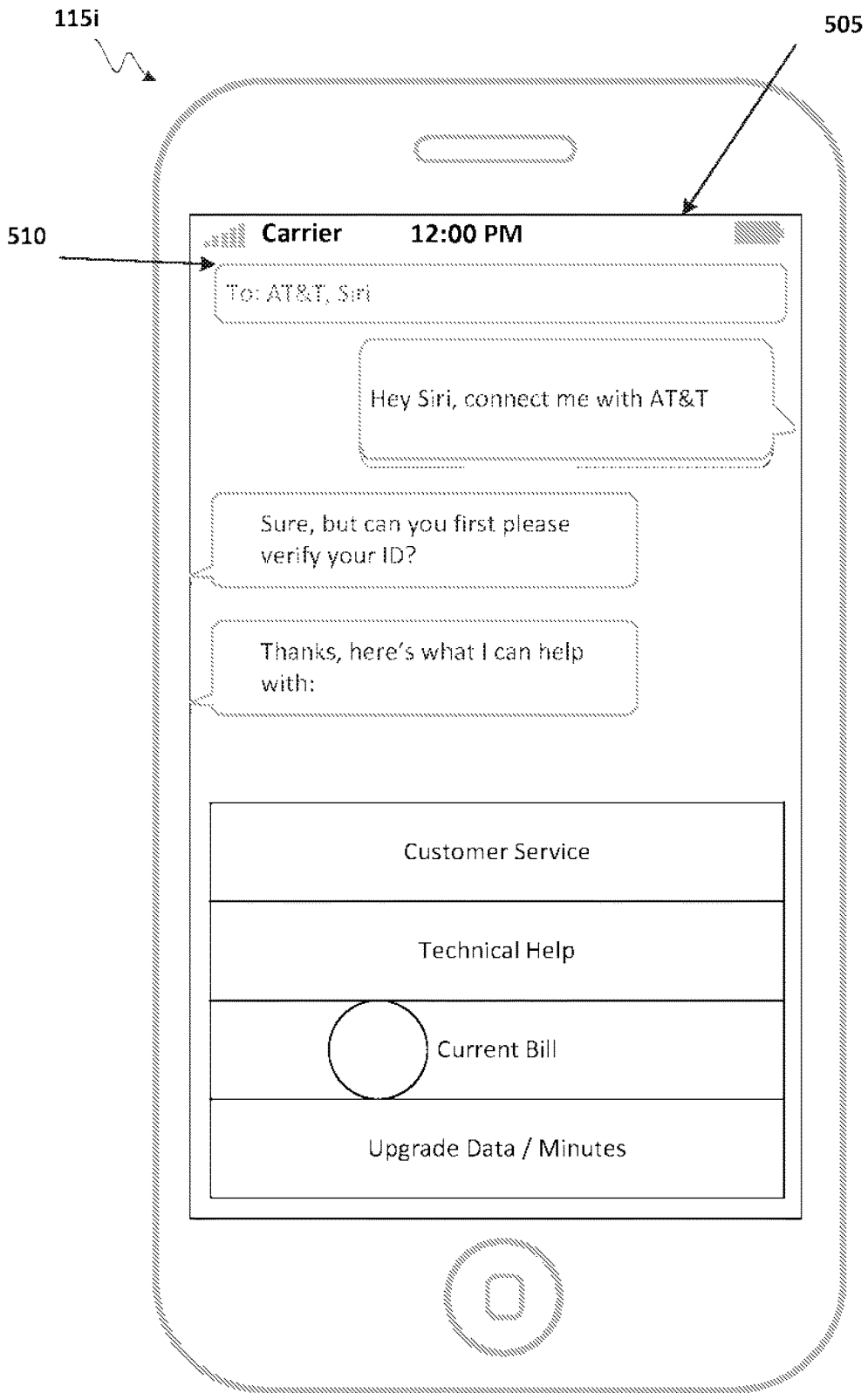

FIG. 5D

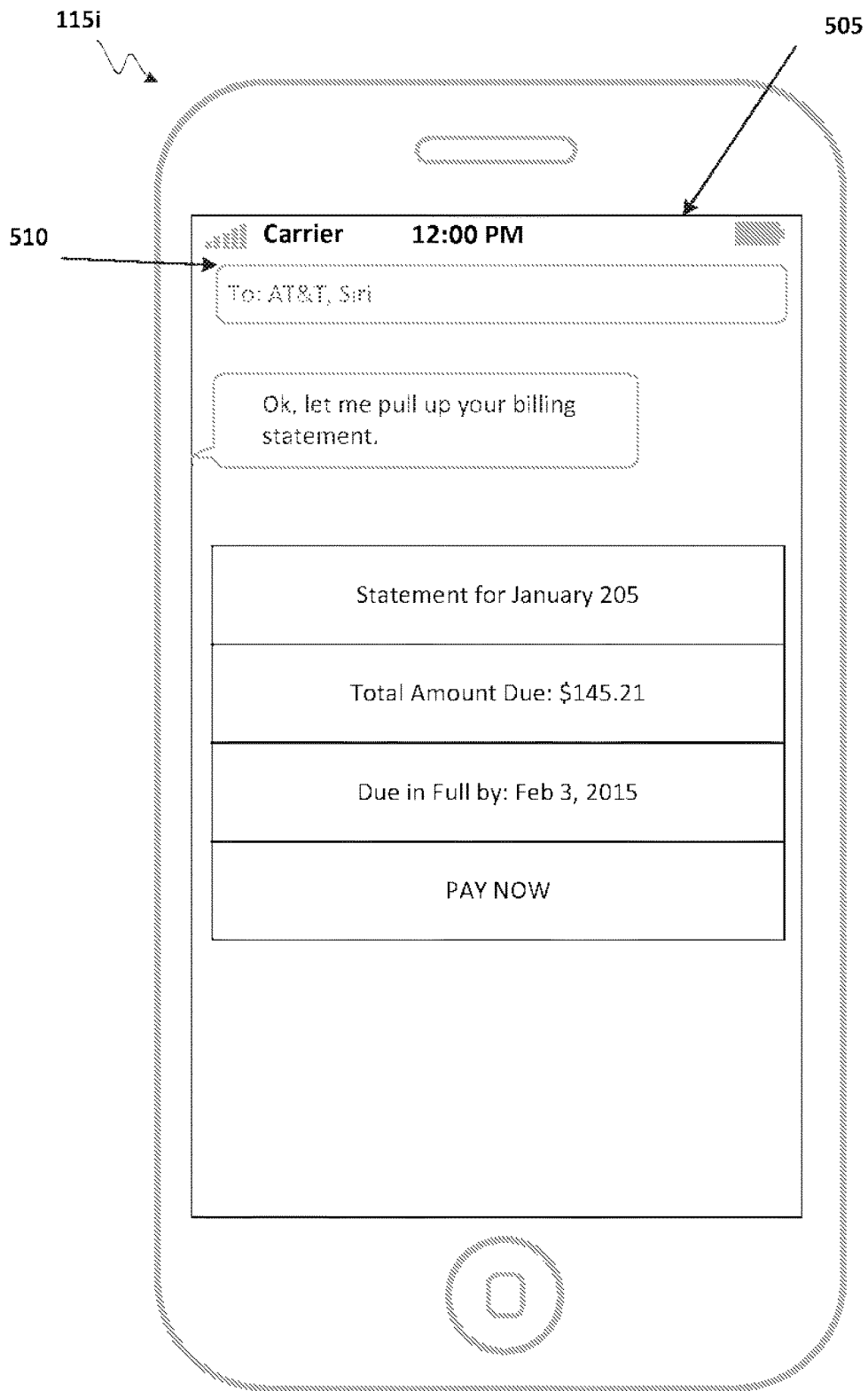

FIG. 5E

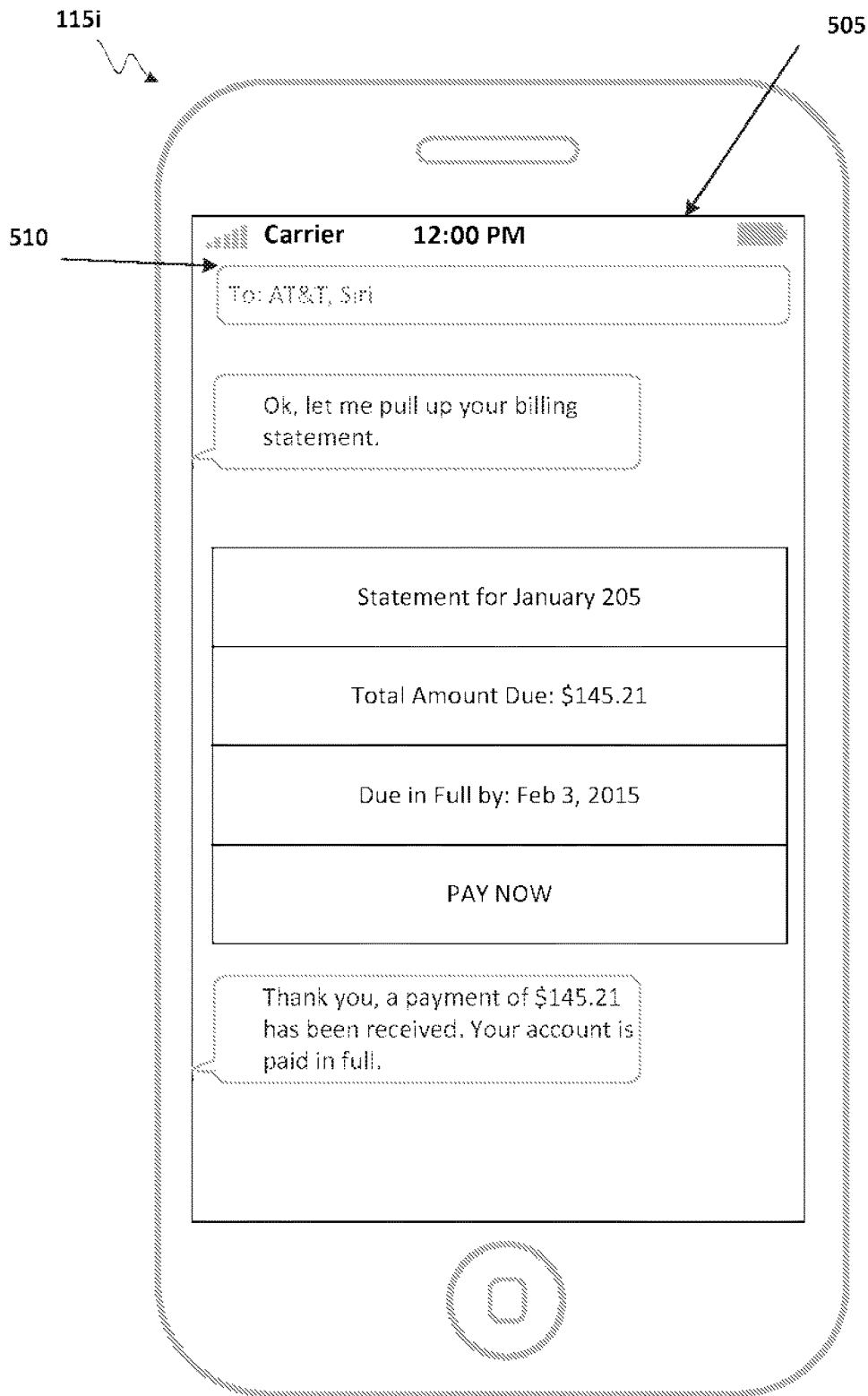

FIG. 5F

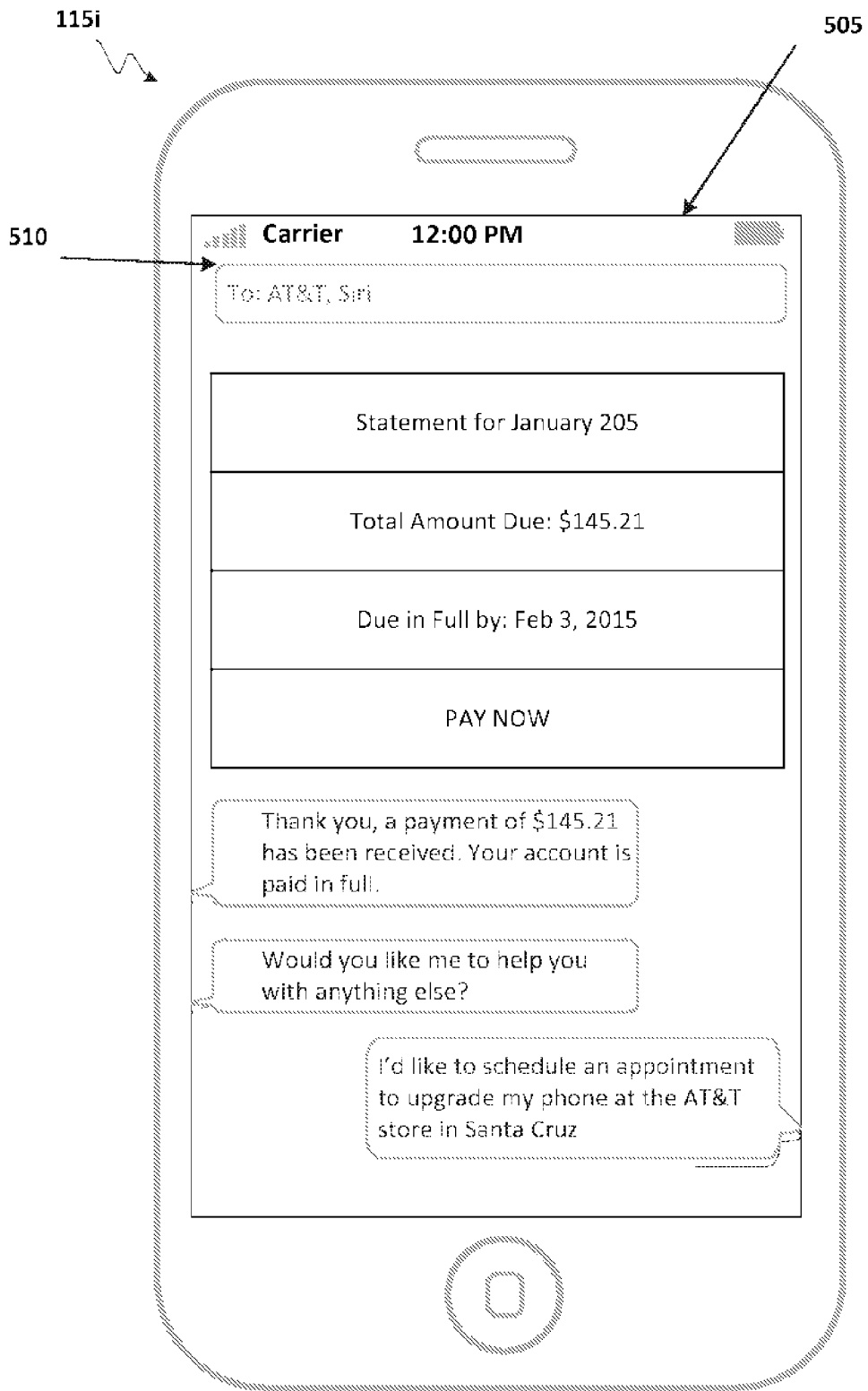

FIG. 5G

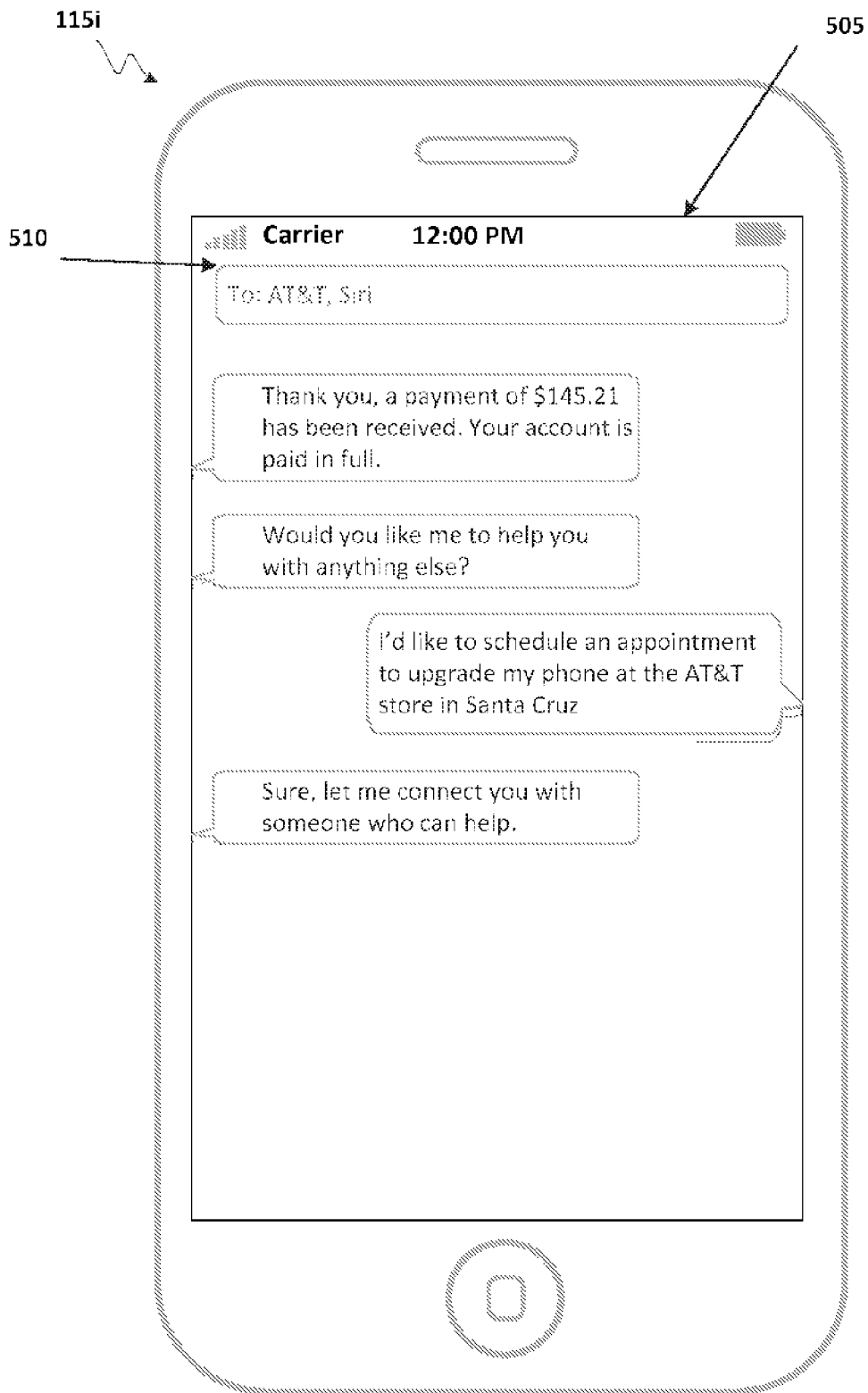

FIG. 5H

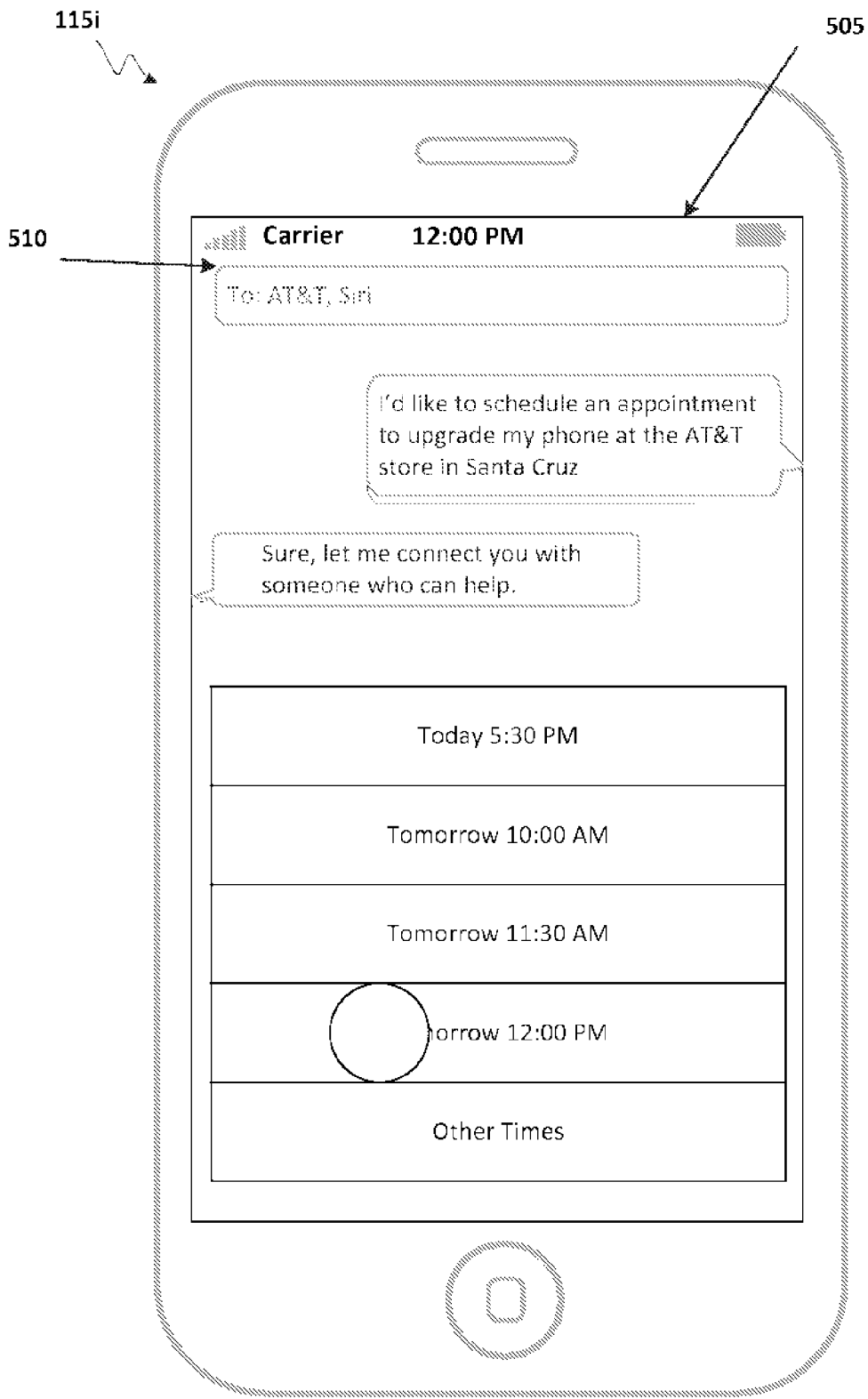

FIG. 5I

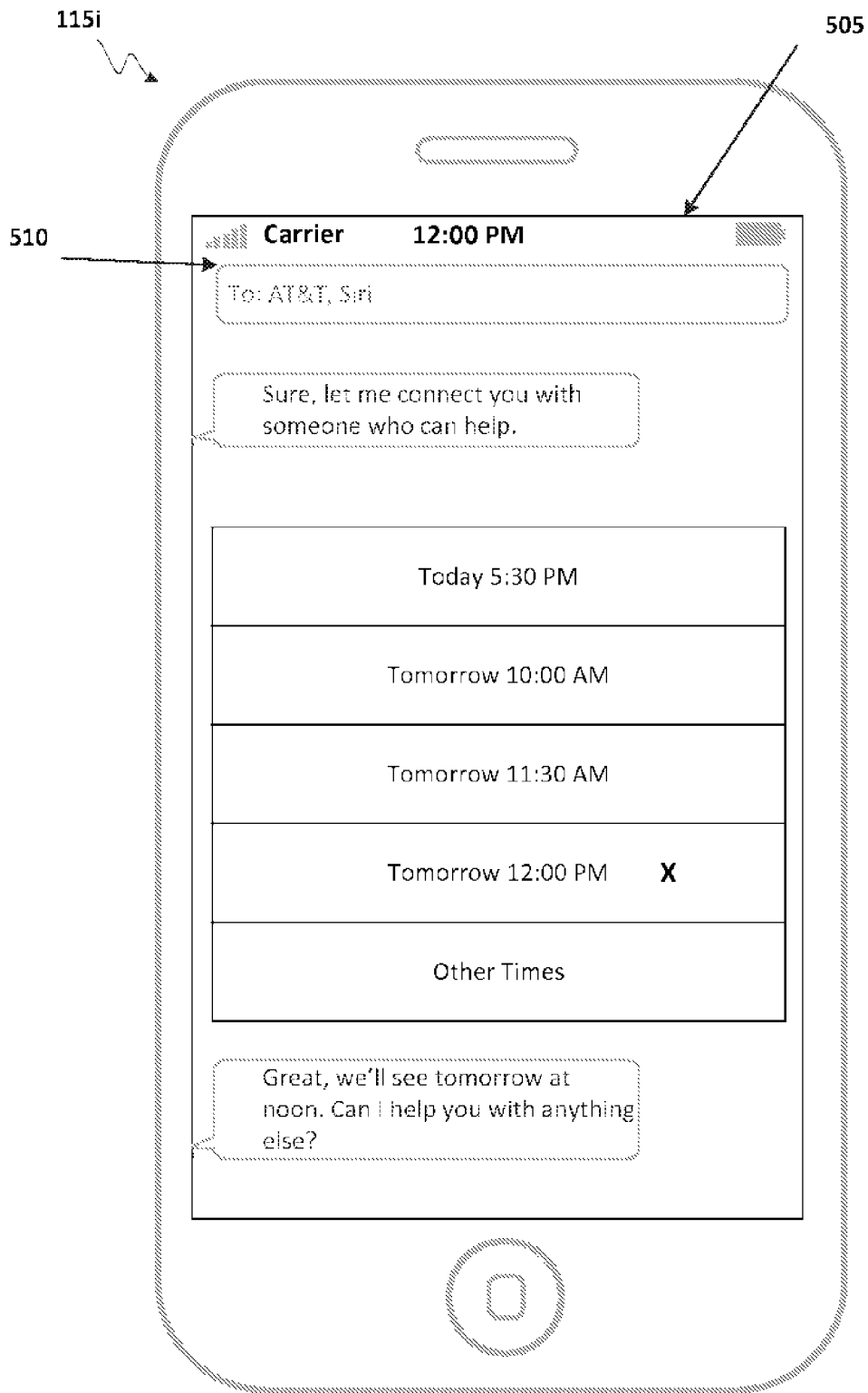

FIG. 5J

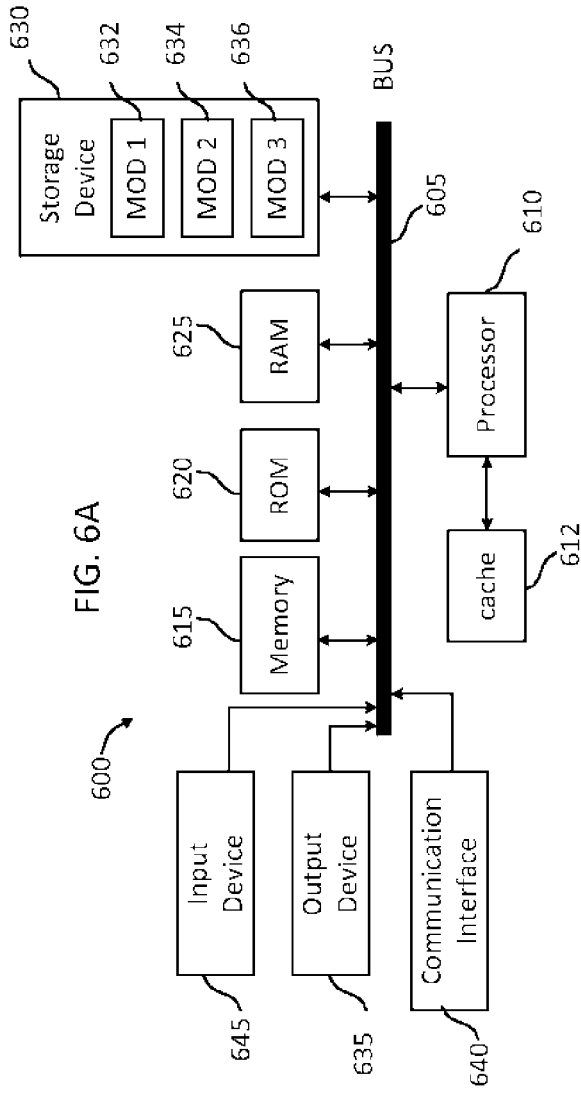

FIG. 6A

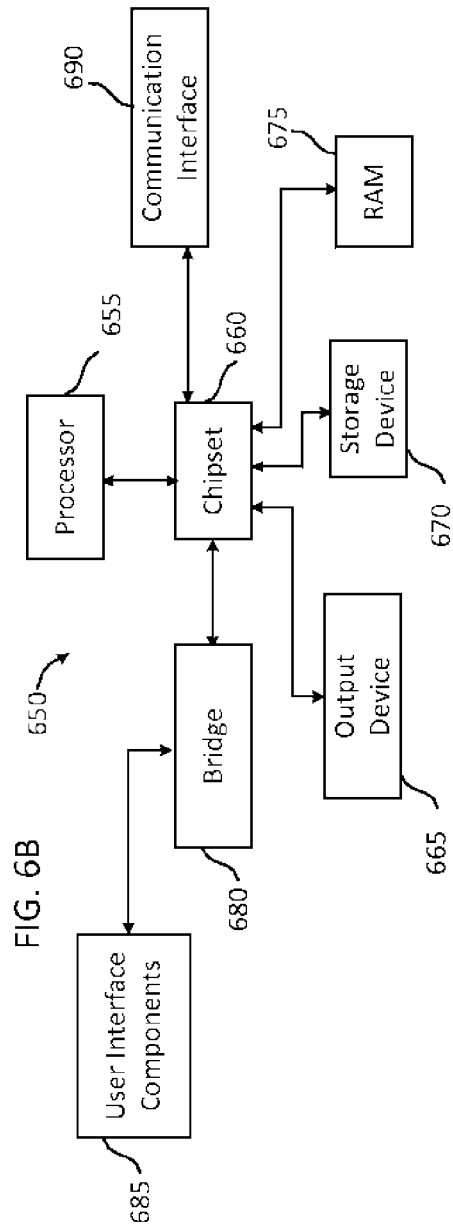

FIG. 6B

1

**VIRTUAL ASSISTANT AIDED
COMMUNICATION WITH 3RD PARTY
SERVICE IN A COMMUNICATION SESSION**

CROSS REFERENCE TO RELATED
APPLICATIONS

This application is a Continuation application of U.S. patent application Ser. No. 14/732,625, filed on Jun. 5, 2015, now U.S. Pat. No. 9,578,173, issued Feb. 21, 2017, entitled VIRTUAL ASSISTANT AIDED COMMUNICATION WITH 3RD PARTY SERVICE IN A COMMUNICATION SESSION, which is hereby incorporated by reference in its entirety for all purposes.

TECHNICAL FIELD

The present technology pertains to communication sessions between a user and a third party service, and more specifically pertains to utilizing a virtual assistant to assist the user with a communication session between the user and the third party service.

BACKGROUND

Current computing devices can include functionality that enables users to communicate with each other by transmitting and receiving messages. For example, many computing devices include text and/or instant messaging functionality that enable users of the computing devices to transmit text, images, sounds, etc., to the client devices of one or more other users. Users can use this functionality to have conversations, make plans and/or perform any other number of tasks.

In addition to communicating with friends, family, etc., users can also utilize communication sessions to communicate with 3rd party services, such as airlines, banks, customer service departments, etc. For example, some 3rd party services provide users with an application and/or website that includes functionality to communicate with a representative of the 3rd party service. While this allows users to communicate with a representative, it also requires the user to access the 3rd party website and/or download the 3rd party service's application. Further, many 3rd party services require a user to navigate a series of selections and/or provide a set of information prior to connecting the user to a representative. Accordingly, improvements are needed.

SUMMARY

Additional features and advantages of the disclosure will be set forth in the description which follows, and in part will be obvious from the description, or can be learned by practice of the herein disclosed principles. The features and advantages of the disclosure can be realized and obtained by means of the instruments and combinations particularly pointed out in the appended claims. These and other features of the disclosure will become more fully apparent from the following description and appended claims, or can be learned by the practice of the principles set forth herein.

Disclosed are systems, methods, and non-transitory computer-readable storage media for utilizing a virtual assistant to assist a user with a communication session between the user and a third party service. A communication session can be a conversation between one or more participants using a communication application such as a text and/or instant messaging application. For example, a communication

2

application can be an application such as iMessage® available by Apple Inc., of Cupertino, Calif.

A virtual assistant can be an application, module, software, etc., capable of analyzing messages included in the communication session to identify tasks and provide assistance with completing the identified tasks. For example, a virtual assistant can be an application such as Siri® available by Apple Inc., of Cupertino, Calif., that uses semantic analysis to analyze text, recognize terms and interpret the intended meaning.

A task can be any type of action that a virtual assistant can provide assistance with. For example, a task can include facilitating communication between the user and a 3rd party service, performing specified actions with the 3rd party service, gathering and providing information to the 3rd party service, receiving information from the 3rd party service, etc. A 3rd party service can be any type of service, business, etc. For example, a 3rd party service can be an airline, bank, insurance company, store, etc.

In some embodiments, a user can communicate with the virtual assistant as part of the communication session. For example, a user can use the communication application to enter a message directed to the virtual assistant. The virtual assistant can analyze the entered message and determine that the message was directed to the virtual assistant and, in response, assist the user. For example, the virtual assistant can identify a task from the message and assist the user with completing the task.

In some embodiments, the virtual assistant can assist the user to communicate with a 3rd party service. For example, a user can use the communication application to enter a message directed to the virtual assistant that requests that the virtual assistant connect the user with a 3rd party service. In response, the virtual assistant can access a set of communication instructions associated with the 3rd party service. The set of communication instructions can include a set of commands for communicating with the 3rd party service, services provided by the 3rd party service as well as data needed by the 3rd party service to facilitate communication with the 3rd party service. The virtual assistant can use the communication instructions to gather data needed by the 3rd party service, communicate with the 3rd party service and present the user with data received from the 3rd party service.

Communication with the 3rd party service can be presented to the user as part of the communication session. For example, the virtual assistant can present messages prompting the user to provide data and make selections, as well as present the user with any data received from the 3rd party service. Further, the virtual assistant can connect the user to a representative of the 3rd party service as part of the communication session. The user can then use the communication session to communicate with the representative.

BRIEF DESCRIPTION OF THE DRAWINGS

The above-recited and other advantages and features of the disclosure will become apparent by reference to specific embodiments thereof which are illustrated in the appended drawings. Understanding that these drawings depict only exemplary embodiments of the disclosure and are not therefore to be considered to be limiting of its scope, the principles herein are described and explained with additional specificity and detail through the use of the accompanying drawings in which:

FIG. 1 shows an exemplary configuration of devices and a network in accordance with the invention;

3

FIG. 2 shows an embodiment of a client device configured to enable a user to utilize a virtual assistant to perform tasks during a communication session;

FIG. 3 shows a method of a client device utilizing a virtual assistant to assist a user communicate with a 3rd party service;

FIGS. 4A-4J show an example of a virtual assistant assisting a participant of a communication session to communicate with a 3rd party service;

FIGS. 5A-5J shown another example of a virtual assistant assisting a participant of a communication session to communicate with a 3rd party service;

FIGS. 6A and 6B illustrate exemplary possible system embodiments.

DESCRIPTION

Various embodiments of the disclosure are discussed in detail below. While specific implementations are discussed, it should be understood that this is done for illustration purposes only. A person skilled in the relevant art will recognize that other components and configurations may be used without parting from the spirit and scope of the disclosure.

The disclosed technology addresses the need in the art for utilizing a virtual assistant to assist a user with a communication session between the user and a third party service. A communication session can be a conversation between one or more participants using a communication application such as a text and/or instant messaging application. For example, a communication application can be an application such as iMessage® available by Apple Inc., of Cupertino, Calif.

A virtual assistant can be an application, module, software, etc., capable of analyzing messages included in the communication session to identify tasks and provide assistance with completing the identified tasks. For example, a virtual assistant can be an application such as Siri® available by Apple Inc., of Cupertino, Calif., that uses semantic analysis to analyze text, recognize terms and interpret the intended meaning.

A task can be any type of action that a virtual assistant can provide assistance with. For example, a task can include facilitating communication between the user and a 3rd party service, performing specified actions with the 3rd party service, gathering and providing information to the 3rd party service, receiving information from the 3rd party service, etc. A 3rd party service can be any type of service, business, etc. For example, a 3rd party service can be an airline, bank, insurance company, store, etc.

In some embodiments, a user can communicate with the virtual assistant as part of the communication session. For example, a user can use the communication application to enter a message directed to the virtual assistant. The virtual assistant can analyze the entered message and determine that the message was directed to the virtual assistant and, in response, assist the user. For example, the virtual assistant can identify a task from the message and assist the user with completing the task.

In some embodiments, the virtual assistant can assist the user to communicate with a 3rd party service. For example, a user can use the communication application to enter a message directed to the virtual assistant that requests that the virtual assistant connect the user with a 3rd party service. In response, the virtual assistant can access a set of communication instructions associated with the 3rd party service. The set of communication instructions can include a set of

4

commands for communicating with the 3rd party service, services provided by the 3rd party service as well as data needed by the 3rd party service to facilitate communication with the 3rd party service. The virtual assistant can use the communication instructions to gather data needed by the 3rd party service, communicate with the 3rd party service and present the user with data received from the 3rd party service.

Communication with the 3rd party service can be presented to the user as part of the communication session. For example, the virtual assistant can present messages prompting the user to provide data and make selections, as well as present the user with any data received from the 3rd party service. Further, the virtual assistant can connect the user to a representative of the 3rd party service as part of the communication session. The user can then use the communication session to communicate with the representative.

FIG. 1 illustrates an exemplary system configuration 100, wherein electronic devices communicate via a network for purposes of exchanging content and other data. As illustrated, multiple computing devices can be connected to communication network 110 and be configured to communicate with each other through use of communication network 110. Communication network 110 can be any type of network, including a local area network (“LAN”), such as an intranet, a wide area network (“WAN”), such as the internet, or any combination thereof. Further, communication network 110 can be a public network, a private network, or a combination thereof. Communication network 110 can also be implemented using any number of communication links associated with one or more service providers, including one or more wired communication links, one or more wireless communication links, or any combination thereof. Additionally, communication network 110 can be configured to support the transmission of data formatted using any number of protocols.

Multiple computing devices can be connected to communication network 110. A computing device can be any type of general computing device capable of network communication with other computing devices. For example, a computing device can be a personal computing device such as a desktop or workstation, a business server, or a portable computing device, such as a laptop, smart phone, or a tablet PC. A computing device can include some or all of the features, components, and peripherals of computing device 500 of FIGS. 5A and 5B.

To facilitate communication with other computing devices, a computing device can also include a communication interface configured to receive a communication, such as a request, data, etc., from another computing device in network communication with the computing device and pass the communication along to an appropriate module running on the computing device. The communication interface can also be configured to send a communication to another computing device in network communication with the computing device.

In system 100, a user can communicate with other users through use of client devices 115₁, 115₂, . . . , 115_n, (collectively “115”) connected to communication network 110. Client devices 115 can be any type of computing device, such as a smart phone, tablet, personal computer, etc. Client devices 115 can include a communication application that enables a user of a client device 115₁ to transmit and receive messages to and from other client devices 115. For example, a communication application can be a text and/or instant messaging application such as iMessage® available by Apple Inc., of Cupertino, Calif.

A user can also use client devices **115** to interact with 3rd party servers **120**₁, **120**₂, . . . , **120**_{*n*}, (collectively “**120**”) connected to communication network **110**. 3rd party servers **120** can be one or more of any type of computing devices and be configured to maintain and provide data to requesting client devices **115**. For example, a 3rd party server **120**₁ can be affiliated with and managed by a 3rd party service to store and provide data for the 3rd party service. For example, a 3rd party server **120**_{*i*} can store and provide web data that can be rendered by client devices **115** to present a webpage, website, etc., to a requesting user.

3rd party servers **120** can also provide one or more services that can be accessed by client devices **115** using specified commands, such as commands defined by an application program interface (API). A service can be any type of action or transaction, such as providing specified data, performing a financial transaction, completing a purchase, etc.

3rd party servers **120** can support connections from a variety of different types of client devices **115**, such as desktop computers; mobile computers; mobile communications devices (e.g. mobile phones, smart phones, tablets, etc.); smart televisions; set-top boxes; and/or any other network enabled computing devices.

System **100** can also include content management system **105**. Content management system **105** can include one or more computing devices configured to manage content items for multiple user accounts. A content item can include any type of digital asset such as an application, audio file, text file, video file, etc.

Content management system **105** can support connections from a variety of different types of client devices **115**, such as desktop computers; mobile computers; mobile communications devices (e.g. mobile phones, smart phones, tablets, etc.); smart televisions; set-top boxes; and/or any other network enabled computing devices. Client devices **115** can be of varying type, capabilities, operating systems, etc. Furthermore, content management system **105** can concurrently accept connections from and interact with multiple client devices **115**.

A user can interact with content management system **105** via a client-side application installed on client device **115**_{*i*}. In some embodiments, the client-side application can include a content management system specific component. For example, the component can be a stand-alone application, one or more application plug-ins, and/or a browser extension. However, the user can also interact with content management system **105** via a third-party application, such as a web browser, that resides on client device **115**_{*i*} and is configured to communicate with content management system **105**. In either case, the client-side application can present a user interface (UI) for the user to interact with content management system **105**. For example, the user can interact with content management system **105** via a client-side application integrated with the file system or via a webpage displayed using a web browser application.

Content management system **105** can be configured to manage content items and data for multiple user accounts. For example, content management system **105** can allow users to purchase, store and access content items, calendar data, contact data, etc. Furthermore, content management system **105** can make it possible for a user to access the stored data, such as content items, calendar data, contact data, etc., from multiple client devices **115**. Accessing a content item can include receiving metadata describing the

content item, streaming the content item from content management system **105** and/or downloading the content item to one of client devices **115**.

To facilitate the various content management services, a user can create a user account with content management system **105**. The account information for each created user account can be maintained in user account database **150**. User account database **150** can store profile information for each user account, including a unique account identifier identifying the user account, personal information, username, password, email address, home address, credit card information, banking information, calendar data, contact data, etc. User account database **150** can also include account management information, such as content storage locations, security settings, personal configuration settings, client devices authorized to access the user account, etc.

A user account can be used to purchase, manage and store content items, such as digital data, documents, text files, audio files, video files, etc. For example, content management system **105** can provide an online content retailer where users can purchase a variety of content items. Further, in some embodiments, a user can upload content items from one of client devices **115** to content management system **105**. The purchased and uploaded content items can be assigned to the user’s account and then accessed by the user from any of client devices **115**. For example, a content item identifier identifying each content item assigned to a user account can be stored in user account database **150** and associated with the corresponding user account. The content item identifier can be used to identify the content item as well as the location of the content item.

The content items can be stored in content storage **160**. Content storage **160** can be a storage device, multiple storage devices, or a server. Alternatively, content storage **160** can be a cloud storage provider or network storage accessible via one or more communications networks. Content management system **105** can hide the complexity and details regarding storage of the content items from client devices **115** such that the location of the content items stored by content management system **105** is not known by client devices **115**. Content management system **105** can store the content items in a network accessible storage (SAN) device, in a redundant array of inexpensive disks (RAID), etc. Content storage **160** can store content items using one or more partition types, such as FAT, FAT32, NTFS, EXT2, EXT3, EXT4, ReiserFS, BTRFS, and so forth.

Content storage **160** can also store metadata describing content items, content item types, and the relationship of content items to various user accounts. The metadata for a content item can be stored as part of the content item or can be stored separately. In one variation, each content item stored in content storage **160** can be assigned a system-wide unique identifier.

Content management system **105** can include content management module **125** configured to manage and access each user account and the content items assigned to the user accounts. For example, content management module **125** can be configured to communicate with user account database **150** and content storage **160** to adjust privileges with respect to content items and otherwise manage content items.

Upon a user logging into their user account from one of client devices **115**, content management module **125** can access the account information associated with the user account to identify the content items assigned to the user account, as well as account configuration data dictating presentation of the content items. Content management

module **125** can then present and/or provide the content items to the user according to the account configuration data. For example, content management module **125** can access a user account to identify the content item identifiers assigned to the user account. The content item identifier can then be used to identify and locate the content items assigned to the user account, which can be presented according to the account configuration data.

Presenting the content items can include transmitting metadata describing the content items to client device **115**, that was used to access the user account. Client device **115**, can then use the received metadata to present the content items that the user account can access. For example, client device **115**, can present information identifying the content items available to the user account in a content item library. This can include presenting the title of the content items, images such as an album or book cover, description of the content item, etc.

Content management system **105** can also maintain a set of communication instructions for one or more 3rd party services. For example, content management system **105** can include instruction storage **170** that is configured to maintain multiple sets of communication instructions.

A set of communication instructions can include data that can be used to communicate with a 3rd party service. For example, a set of communication instructions for a 3rd party service can include a listing of services provided by the 3rd party service. As an example, services provided by a 3rd party service such as a bank can include providing an account balance, transferring money amongst accounts, depositing a check, speaking to a representative, etc. As another example, services provided by a 3rd party service such as an airline can include purchasing an airline ticket, checking a flight arrival time, changing a schedule flight, canceling a flight, speaking to a representative, etc.

A set of communication instruction can also include a listing of data needed by the 3rd party service to facilitate communication. For example, a 3rd party service may require a user name, account number, etc. The listing of data can also include data needed by the 3rd party based on service provided by the 3rd party service. For example, to provide a service such as changing a flight, a 3rd party service such as an airline may require an existing flight number, customer name, etc. As another example, to provide a service such as booking a flight, the airline may require data such as a departing city, destination city, desired departure and return date, etc.

A set of communication instructions can also include one or more commands for communicating with the 3rd party service. The commands can be defined by an application program interface (API) and be used to perform the various services provided by the 3rd party service. The commands can be labeled or identified based on the corresponding service.

Each set of communication instructions stored in instruction storage **170** can be tagged, labeled and/or otherwise identified based on the 3rd party service associated with the set of communication instructions. For example, a set of communications instructions can be tagged with a unique 3rd party identifier for the corresponding 3rd party service.

Content management system **105** can provide one or more sets of communication instructions to any requesting client device **115**. For example, content management system **105** can receive an instruction request from a client device **115**, and, in response, provide the client device **115**, with the set of communication instructions. An instruction request can include an identifier identifying a 3rd party service. Content

management system **105** can use the received identifier to identify the corresponding set of communication instructions from instruction storage **170**.

FIG. 2 shows an embodiment of a client device **115**, configured to enable a user to utilize a virtual assistant to communicate with a 3rd party service during a communication session. FIG. 2 is described in view of the system shown in FIG. 1. As shown, client device **115**, includes communication application **205**. Communication application **205** can be any type of application configured to enable a user to send and receive data messages with one or more other client devices **115**. A data message can be any type of data that can be transmitted from one computing device to another, such as text data, image data, sound data, etc. In some embodiments, communication application **205** can be a text and/or instant messaging application such as iMessage® available by Apple Inc., of Cupertino, Calif.

A user of client device **115**, can use communication application **205** to conduct communication sessions with one or more groups of users and/or entities. A communication session can be a group of messages transmitted between a group of users and/or entities. For example, a communication session can be an instant messaging conversation between a group of two or more users. Alternatively, a communication session can be an instant messaging conversation between one or more users and a third party service, such as with a representative of the 3rd party service and/or an automated computer system maintained by the 3rd party service. As another example, a communication session can be an instant messaging conversation between one or more users and a virtual assistant.

Communication application **205** can provide a user with a messaging interface that enables the user to conduct a communication session. For example, the messaging interface can enable a user to create a new communication session by selecting one or more participant users and entering a message to be transmitted to the participant users. Further, the messaging interface can enable a user to view existing communication session and enter and transmit new messages as part of the existing communication sessions.

Client device **115**, can also include virtual assistant **210** configured to assist the user with tasks during a communication session. Virtual assistant **210** can be an application, module, software, etc., capable of analyzing messages included in a communication session to identify tasks and provide the user with assistance completing the identified tasks. For example, virtual assistant **210** can be an application such as Siri® available by Apple Inc., of Cupertino, Calif., that uses semantic analysis to analyze text, recognize terms and interpret the intended meaning.

A task can be any type of function, actions, etc., with which virtual assistant **210** can assist a user. For example, a task can be retrieving information, such as retrieving the current time, retrieving directions to a specified destination, retrieving sports scores, retrieving weather information, retrieving movie times, etc. Further a task can be coordinating and executing a transaction and/or communication with a 3rd party service, such as scheduling a meeting, performing a financial transaction, purchasing tickets, initiating communication with a representative, etc.

Client device **115**, can enable a user to select to utilize virtual assistant **210** in relation to one or more communication sessions. In some embodiments, communication application **205** can be configured to enable a user to select to utilize virtual assistant **210** by adding virtual assistant **210** as a participant of the communication session. For example, the user can add a nickname associated with virtual assistant

210 as a participant to a communication session. In response, communication application 205 can communicate with virtual assistant 210 to utilize virtual assistant 210 to assist with the communication session.

Further, in some embodiments, communication application 205 can transmit a notification message to the other participants of the communication session indicating that the user of client device 115, has selected to utilize virtual assistant 210. For example, communication application 205 can transmit a message as part of the communication session indicating that the user of client device 115, is utilizing virtual assistant 210. As another example, the nickname associated with virtual assistant 210 can be presented as a member of the communication session, thereby indicating that at least one participant of the communication session is utilizing the virtual assistant. In some embodiments, the other participants can be prompted regarding whether they would like to utilize the virtual assistant in regards to the communication session.

To assist a user with a communication session, virtual assistant 210 can analyze messages included in the communication session to identify tasks. For example, virtual assistant 210 can use semantic analysis to recognize terms, sets of terms, etc., and interpret the intended meaning of the terms to identify one or more tasks that the user may need assistance with.

Virtual assistant 210 can use any type or techniques of semantic analysis known in the art to identify tasks with which virtual assistant 210 can assist the user. For example, in some embodiments, the semantic analysis can include the use of natural language processing (e.g., speech tagging, noun-phrase chunking, dependency and constituent parsing, etc.) to translate text into parsed text. Virtual assistant 210 can then analyze the parsed text to identify tasks. For example, virtual assistant 210 can use question and intent analysis, to detect user commands and/or actions from the text (e.g., schedule a meeting, set my alarm, purchase tickets, connect me with a representative, etc.). Virtual assistant 210 can then analyze the resulting commands and/or actions to determine whether they are commands and/or actions with which virtual assistant can assist the user. For example, virtual assistant 210 can compare the tasks and/or actions to a list of known commands and/or actions with which virtual assistant 210 can assist the user. Any commands and/or actions identified by virtual assistant as being a command and/or action with which virtual assistant 210 can assist the user can be identified as a task by virtual assistant 210.

Further, virtual assistant 210 can identify a 3rd party service with which the user would like to communicate and/or perform a task. For example, a message may identify a specific 3rd party service, such as a specified airline, bank, etc., and virtual assistant 210 can identify the 3rd party service from the message. Alternatively, a message may identify a type of service and virtual assistant can determine the appropriate 3rd party service. For example, messages such as “book a flight,” “check my account balance” and “make a reservation” can infer a type of service such as airline, bank and restaurant respectively.

Virtual assistant 210 can select a 3rd party service based on the type of service determined from the message. For example, virtual assistant 210 can select a 3rd party service of the specified type based on user history and/or user preferences. Alternatively, virtual assistant 210 can query the user regarding which 3rd party service the user would like to use. For example, virtual assistant 210 can identify

candidate 3rd party services and prompt the user as part of the communication to select from one of the candidate 3rd party services.

Virtual assistant 210 can analyze messages transmitted amongst the participant users of the communication session to identify tasks. This can include messages entered by a user of client device 115, to be transmitted to the other participants as part of the communication session, as well as messages received from other users as part of the communication session.

Further, virtual assistant 210 can determine whether a message provided by the user of client device 115, was intended for the other participants of the communication session or intended for the virtual assistant. A user can use communication application 205 to enter a message intended for virtual assistant 210, such as a request or command that the virtual assistant assist the user with a specified task. For example, a user can enter requests such as “help us schedule a meeting,” “help me book a flight” “connect me to a representative,” etc., and virtual assistant can determine that the message was intended for virtual assistant 210. In some embodiments, a user can address messages intended for the virtual assistant by using a nickname for the personal assistant. For example, the user can enter a messages such as “Assistant, connect me to a representative.” Virtual assistant 210 can determine that the message was intended for the virtual assistant based on the use of the nickname addressing the virtual assistant 210.

In some embodiments, messages determined by virtual assistant 210 to be intended for virtual assistant 210 will not be transmitted to the other participant users of the communication session. Likewise, responses provided by virtual assistant 210 can be presented as part of the communication session on client device 115, while not being presented to the other participant users of the communication session. In this way, a user of client device 115, can have a separate conversation with virtual assistant 210 to perform a specified task.

To assist a user with a task, virtual assistant 210 can communicate with one or more computing devices to gather data and perform requested operations. For example, virtual assistant 210 can gather data maintained by client device 115, in memory and/or from other applications on client device 115, such as calendar data, contact data, financial information, flight information, bank account numbers, etc. Further, virtual assistant 210 can gather data from one or more components of client device 115, such as geographic coordinate data from Global positioning system (GPS) component, temperature data, sound data, etc. Virtual assistant 210 can further edit, modify or delete data, such as creating new calendar entries, modifying contact information, etc.

Virtual assistant 210 can also gather data from one or more computing devices in network communication with client device 115. For example, virtual assistant 210 can communicate with one or more of 3rd party servers 120 to request and receive data. For example, virtual assistant 210 can communicate with 3rd party servers 120 to gather sports scores, movie show times, driving directions, etc. Further, virtual assistant 210 can perform requested operations, such as purchase movie tickets, login to a user account, provide payment information, etc.

Further, virtual assistant 210 can also gather data from client devices 115. For example, to assist a user in determining the estimated time of arrival of a participant of the communication session, virtual assistant 210 can communicate with a client device 115, of the participant user to gather geographic location data of the user, which can then be used

to calculate the estimated time of arrival. In some embodiments, virtual assistant **210** can be required to receive approval from the participant of the communication session prior to receiving data from the participants client device **115**. For example, virtual assistant **210** can transmit a message as part of the communication session to the client device **115**, requesting the specified data and the receiving participant can select to either approve or deny the request.

In some embodiments, virtual assistant **210** can gather data from content management system **105**. For example, virtual assistant **210** can gather data from user accounts maintained by content managements system **105**. This can include demographic data for one or more participants of the communication session, contact information, content items assigned to each user, such as applications utilized by each user, etc. In some embodiments, virtual assistant **210** can be required to receive approval from the participant of the communication session prior to being able to access data from the participant's user account. For example, virtual assistant **210** can transmit a message as part of the communication session to the client device **115** requesting approval to access the participant's user account and the receiving participant can select to either approve or deny the request. As another example, virtual assistant **210** can present a user with a message as part of the communication session requesting that the user provide the user credentials associated with the user account (e.g., user name and password).

Alternatively, a participant can authorize virtual assistant **210** to access their user account by selecting to utilize the virtual assistant with respect to the communication session. Thus, virtual assistant **210** can be automatically authorized to access the user account of each participant of the communication session that has selected to utilize the virtual assistant **210**. Virtual assistant **210** can transmit messages requesting approval to access the user account of any participant that has not selected to utilize the personal assistant **210**.

In some embodiments, virtual assistant **210** can gather data directly from the participants of a communication session. For example, virtual assistant **210** can present a poll as part of the communication session to gather feedback from the users. This can include presenting the users with multiple options, such as potential restaurants, meeting times, available services, etc. The poll can enable each participant to enter their selection and virtual assistant **210** can select a time, restaurant, service, etc., based on the provided selections.

In some embodiments, the options presented to the users as part of a poll can be based on data gathered by virtual assistant **210** from the users. For example, to help with the task of selecting a restaurant, the virtual assistant can gather location information from each participant and select restaurants that are nearby or equidistance from the participants. The selected restaurants can then be presented to the users in a poll.

As another example, to assist users schedule a meeting, virtual assistant **210** can gather calendar information from each user to identify a set of candidate times that works best for the participants. Virtual assistant **210** can then present the candidate times to the users as part of the communication session and allow the users to provide feedback.

As another example, to assist a user to perform a financial transaction with one or more other users, virtual assistant **210** can gather data indicating payment methods available to each user and select a set of candidate payment methods that are available to each user. For example, a payment method can be an application that enables a user to transfer money

from one party to another. Virtual assistant **210** can determine which payment methods are installed on each user's client device **115** and then present a set of candidate payments methods from which the user can select.

In some embodiments, virtual assistant **210** can gather communication instructions for a specified 3rd party service and use the communication instructions to facilitate communication with the respective 3rd party service. For example, upon determining that a user has requested that virtual assistant **210** assist the user to communicate with a 3rd party service, virtual assistant **210** can transmit an instruction request to content management system **105** that request the set of communication instructions for the 3rd party service. The instruction request can identify the specified 3rd party service, for example, by including the name of the 3rd party service, an identifier identifying the 3rd party service, etc.

In some embodiments, client device **115**₁ can maintain the set of communication instructions locally, for example, in data storage **250**. Virtual assistant **210** can gather the appropriate set of communication instruction from data storage **250**.

Virtual assistant **210** can use the communication instructions to identify services that are offered by the 3rd party service and with which virtual assistant **210** can assist the user. For example, virtual assistant **210** can present the user with a poll within a communication session that lists the services and prompts the user to select a service with which the user would like help.

Virtual assistant **210** can use the set of communication instructions to identify data required by the 3rd party service to facilitate communication between the user and the 3rd party service to perform a specified service. For example, a 3rd party service may require a user's name, flight number and departure date to perform a service such as change a user's flight. As another example, a 3rd party service may require a user's account number and password to perform a service such as providing the user with an account balance. Virtual assistant **210** can gather the required data and provide it to the 3rd party service.

Virtual assistant **210** can utilize the commands included in the set of communication instructions to communicate with a 3rd party service **120**₁ to transmit data, receive data, present interface elements, etc. This can enable the user to communicate and interact with the 3rd party service completely through use of communication application **205**. For example, to perform a service such as booking a flight, virtual assistant **210** can enable a user to select a departure and destination city, provide dates, select flights, present flights to the user, etc.

Virtual assistant **210** can also connect a user to a representative of a 3rd party service so that a user can communicate directly with the representative as part of the communication session. In some embodiments, virtual assistant **210** can determine an expected wait time to be connected to a representative and notify the user of the expected wait. A communication session with a representative can remain active (e.g., messages entered will be received by the other party) until terminated by either the user or the representative or, alternatively, after a specified period of time with no activity. The communication session record will remain available to the user and the user may request that virtual assistant again reconnect the user to the representative. This further allows each party to have a record of all previous communication between the parties available within the communication session.

FIG. 3 shows a method of a client device **115**, utilizing a virtual assistant **210** to assist a user communicate with a 3rd party service. The method shown in FIG. 3 is described in view of the systems shown in FIG. 1 and FIG. 2. Although specific steps are shown in FIG. 3, in other embodiments the method may have more or less steps. Further, the order in which the steps are performed is just one possible embodiment and is not meant to be limiting. The method may be performed in a variety of differing orders, including one or more steps being performed simultaneously, and/or including more or less steps than those shown in FIG. 3.

At block **305**, a client device **115_i** can receive a message as part of a communication session. For example, a user of the client device **115**, may have entered the message using communication application **205**.

At block **310**, the virtual assistant **210** can determine that the message requests that the virtual assistant **210** assist the user to communicate with a 3rd party service. For example, virtual assistant **210** can use semantic analysis to analyze the text of the message, recognize terms and interpret the intended meaning. The message may identify a specified 3rd party service and the virtual assistant **210** can determine that the user would like to communicate with the specified 3rd party service. Alternatively, the message may identify a 3rd party service type and the virtual assistant **210** can either select a 3rd party service of the specified type or query the user regarding which 3rd party service the user would like to communicate with.

In some embodiments, the user may use a name that is common to two or more 3rd party services. In this type of situation, the virtual assistant **210** can prompt the user to clarify the desired 3rd party service. For example, the virtual assistant can present the user with a poll including the 3rd party services associated with the name and ask the user to select the desired 3rd party service.

At block **315**, the virtual assistant **210** can retrieve communication instruction for the 3rd party service. For example, the virtual assistant **210** can transmit an instruction request to a content management system **105** that maintains communication instructions for one or more 3rd party services. Alternatively, the virtual assistant **210** can retrieve the communication instructions from a data storage **250** of the client device **115_i**.

At block **320**, the virtual assistant **210** can prompt the user to select from one or more available services offered by the 3rd party service. For example, a 3rd party service such as a bank may offer multiple services such as transferring funds, retrieving an account balance, etc. As another example, a 3rd party service such as an airline may offer services such as booking a flight, changing a flight, checking an arrival time, etc.

The virtual assistant **210** can determine the available services from the set of communication instructions for the 3rd party service. For example, the set of communication instructions may include a listing of services provided by the 3rd party service and the virtual assistant may prompt the user to select from one or more of the available services. The virtual assistant **210** can prompt the user by presenting the user with a message as part of the communication session that prompts the user to enter the service. Alternatively, the virtual assistant **210** can present the user with one or more services to choose from, for example, in the form of a poll presented in the communication session, and the user can select from one of the presented options.

In some embodiments, the message provided by the user in block **305** may identify a specified service that the user would like help with. For example, a user may enter a

message such as “please help me book a flight,” in which case the virtual assistant does not need to prompt the user regarding which service the user would like help with.

At block **330**, the virtual assistant **210** can gather data required to facilitate the selected service. A 3rd party service may require specified data to provide or facilitate a selected service. For example, to provide a service such as accessing a bank account, a 3rd party service may require a user’s account number and user account credentials. As another example, to provide a service such as booking a flight, a 3rd party service may require the user’s name, address, desired destination and travel dates.

The virtual assistant **210** can determine the data required from the set of communication instructions for the 3rd party service. The set of communication instructions can identify data required by the 3rd party service based on a selected service and the virtual assistant **210** can identify the specified data based on the service selected by the user.

The virtual assistant **210** can automatically gather the required data. For example, the virtual assistant **210** can gather data from the user’s account maintained by a content management system **105**, from a data storage **250** on the client device **115**, etc.

In some embodiments, the virtual assistant **210** can prompt the user to provide their user credentials prior to accessing the user’s account to gather data. For example, the virtual assistant **210** can request that the user enter a user name and password, provide fingerprint verification, etc.

In some embodiments, the virtual assistant **210** can query the user for specified data. For example, the virtual assistant **210** can present the user with messages as part of the communication session that prompt the user to provide the specified data. Alternatively, the virtual assistant **210** can present the user with one or more options to select from, for example, as a poll within the communication session. The user can select from the provided options to provide the virtual assistant **210** with the specified data.

At block **335**, the virtual assistant **210** can provide the gathered data to the 3rd party service. For example, the virtual assistant **210** can use the appropriate command from the set of communication instructions to initiate contact with a 3rd party server **120_i**, associated with the 3rd party service and provide the gathered data to the 3rd party service.

At block **340**, the virtual assistant **210** can assist the user communicate with the 3rd party service. This can include using the appropriate commands to communicate with the 3rd party server **120_i** to assist the user perform the requested service. For example, the virtual assistant **210** can transmit data to the 3rd party server **120_i**, receive data from the 3rd party server **120_i**, present data to the user as part of the communication session, gather data needed by the 3rd party service, connect the user to a representative of the 3rd party service, etc.

Further, in some embodiments, the virtual assistant **210** can add other users to the communication session and facilitate communication between each user and the 3rd party service. For example, a user may wish to change their flight to correspond to a friend flight. The virtual assistant **210** can add the friend to the communication session so that the user and the friend can both communicate with a representative and each other to schedule the appropriate flight.

FIGS. 4A-4J show an example of a virtual assistant assisting a participant of a communication session to communicate with a 3rd party service. FIGS. 4A-4J will be discussed in view of the systems shown in FIG. 1 and FIG. 2. FIG. 4A shows a client device **115_i**, used to conduct a

communication session **405**. The communication session **405** can be facilitated by communication application **205**.

The communication session **405** can include a recipient list **410** identifying the other participants of the communication session **405**. As shown, the only other participant of the communication session **405** is virtual assistant **210**. Accordingly, messages provided by the user of the client device **115_i**, as part of the communication session **405** will only be presented on the client device **115_i**, and will not be transmitted to another client device **115**. As shown, the user has entered a message directed to the virtual assistant **210** and requesting that the virtual assistant **210** assist the user communicate with an airline.

The virtual assistant **210** can analyze the message to identify the specified 3rd party service. Virtual assistant **210** can then communicate with the content management system **105** to transmit an instruction request for the set of communication instructions associated with the 3rd party service. The set of communication instructions can include a listing of services provided by the 3rd party service, listing of data needed by the 3rd party service to facilitate communication and commands for communicating with the 3rd party service.

FIG. 4B shows the next step in communication session **405**. As shown, virtual assistant **210** has presented the user with a reply message as part of communication session **405** and presented the user with a poll regarding what specified service the user would like help with. Virtual assistant **210** can gather the listing of for the 3rd part service from the set of communication instructions. The user can then select the specified service with which the user would like help.

FIG. 4C shows that the user has selected to upgrade seats. Based on the user selection and the set of communication instructions, virtual assistant **210** can determine data required by the 3rd party to perform the specified service. For example, the 3rd party service may require the user's name, flight number, confirmation number, etc. to assist with upgrading the user's seats. Virtual assistant **210** can gather this data and provide it to the 3rd party service. For example, virtual assistant **210** can gather data from data storage **250** and/or from the user's profile on content management system **105**.

FIG. 4D shows that the virtual assistant **210** has entered a message into the communication session **405** that requests the user to provide user credentials for the user's account. This verification can be required prior to virtual assistant **210** being granted to access the user's data and provide it to a 3rd party service.

FIG. 4E shows the user being prompted to enter their user credentials. As shown, the user can select to either enter a password or provide their fingerprint.

FIG. 4F shows that the virtual assistant **210** has presented the user with a message as part of the communication session **405** indicating that the virtual assistant **210** is initiating communication with the 3rd party service. This can include the virtual assistant **210** using a command from the set of communication instructions to communicate with an appropriate 3rd party server **120_i**, to initiate communication for the selected service, as well as provide any necessary data to facilitate the communication.

FIG. 4G shows that the virtual assistant **210** has presented the user with a message as part of the communication session **405** that notifies the user of an estimated wait time to be connected to a representative. The 3rd party server **120_i**, associated with the 3rd party service can provide the virtual assistant **210** with the estimated wait time, which can then be presented to the user. Further, the virtual assistant **210** can

prompt the user regarding whether the user would like to wait to speak with the representative.

In some embodiments, the virtual assistant **210** can notify a user that a representative is not currently available. For example, some 3rd party services may only offer live representatives during specified hours. The virtual assistant **210** can notify the user that the representative is not available as well as when the user can connect to a live representative.

FIG. 4H shows that the user has entered a message into the communication session **405** indicating that the user is alright waiting for the estimated wait time to speak to the representative. Alternatively, if the user had indicated that the user would not like to wait, the virtual assistant **210** could terminate the attempted connection with the representative.

FIG. 4I shows that the user has been connected with a representative of the 3rd party service and that the representative has presented the user with a message as part of the communication session **405** requesting specific information regarding the service specified by the user. The representative already has the users information, such as name, flight, requested service, etc., that was provided by the virtual assistant. As a result, the representative is ready to discuss the specifics of the service with the user when they are connected.

FIG. 4J shows that the representative has completed the user's request to upgrade seats. Further, the user is presented with a confirmation within the communication session **405**.

FIGS. 5A-5J show another example of a virtual assistant assisting a participant of a communication session to communicate with a 3rd party service. FIGS. 5A-5J will be discussed in view of the systems shown in FIG. 1 and FIG. 2. FIG. 5A shows a client device **115_i**, used to conduct a communication session **505**. The communication session **505** can be facilitated by communication application **205**.

The communication session **505** can include a recipient list **410** identifying the other participants of the communication session **505**. As shown, the only other participant of the communication session **505** is virtual assistant **210**. Accordingly, messages provided by the user of the client device **115_i**, as part of the communication session **505** will only be presented on the client device **115_i**, and will not be transmitted to another client device **115**. As shown, the user has entered a message directed to the virtual assistant **210** and requesting that the virtual assistant **210** assist the user communicate with a specified telephone provider.

FIG. 5B shows that the virtual assistant **210** presented a follow up message responding to the users request and prompting the user to present authentication information. FIG. 5C shows that the user is prompted to either enter their password or, alternatively, authorize using their fingerprint.

FIG. 5D shows that the virtual assistant **210** has presented the user with a poll to select from the services provided by the 3rd party service. The virtual assistant **210** can identify the services from the set of communication instructions for the 3rd party service.

FIG. 5E shows that the virtual assistant **210** has presented the user with the user's current billing statement. The virtual assistant can use the set of communication instructions to gather the required data and commands to request the user's current billing statement, which can be presented as part of the communication session **505**. Further, the user can select to pay the current bill through the communication session **505**.

FIG. 5F shows that the user has been presented with confirmation that the user's payment has been received by the 3rd party service.

FIG. 5G shows that the virtual assistant **210** has prompted the user regarding whether the user needs further assistance. As shown, the user has responded that the user would like assistance scheduling an in-store appointment.

FIG. 5H shows that the virtual assistant **210** has responded to the user indicating that the virtual assistant will assist the user connect to a representative of the 3rd party service.

FIG. 5I shows that the user has been connected with a representative of the 3rd party service and that the virtual assistant **210** is assisting the parties schedule a time to meet. As shown, the virtual assistant **210** has presented the user with a poll that lists multiple candidate times for the meeting. The virtual assistant **210** can gather data from a calendar of the user and the 3rd party service to identify the set of candidate times during which both parties are free. A user can select one of the presented time to schedule the meeting.

FIG. 5J shows that after the user has selected a time for the meeting, the representative of the 3rd party service has presented the user with a message confirming the meeting.

FIG. 6A, and FIG. 6B illustrate exemplary possible system embodiments. The more appropriate embodiment will be apparent to those of ordinary skill in the art when practicing the present technology. Persons of ordinary skill in the art will also readily appreciate that other system embodiments are possible.

FIG. 6A illustrates a conventional system bus computing system architecture **600** wherein the components of the system are in electrical communication with each other using a bus **605**. Exemplary system **600** includes a processing unit (CPU or processor) **610** and a system bus **605** that couples various system components including the system memory **615**, such as read only memory (ROM) **520** and random access memory (RAM) **625**, to the processor **610**. The system **600** can include a cache of high-speed memory connected directly with, in close proximity to, or integrated as part of the processor **610**. The system **600** can copy data from the memory **615** and/or the storage device **630** to the cache **612** for quick access by the processor **610**. In this way, the cache can provide a performance boost that avoids processor **610** delays while waiting for data. These and other modules can control or be configured to control the processor **610** to perform various actions. Other system memory **615** may be available for use as well. The memory **615** can include multiple different types of memory with different performance characteristics. The processor **610** can include any general purpose processor and a hardware module or software module, such as module **1 632**, module **2 634**, and module **3 636** stored in storage device **630**, configured to control the processor **610** as well as a special-purpose processor where software instructions are incorporated into the actual processor design. The processor **610** may essentially be a completely self-contained computing system, containing multiple cores or processors, a bus, memory controller, cache, etc. A multi-core processor may be symmetric or asymmetric.

To enable user interaction with the computing device **600**, an input device **645** can represent any number of input mechanisms, such as a microphone for speech, a touch-sensitive screen for gesture or graphical input, keyboard, mouse, motion input, speech and so forth. An output device **635** can also be one or more of a number of output mechanisms known to those of skill in the art. In some instances, multimodal systems can enable a user to provide multiple types of input to communicate with the computing device **600**. The communications interface **640** can generally govern and manage the user input and system output.

There is no restriction on operating on any particular hardware arrangement and therefore the basic features here may easily be substituted for improved hardware or firmware arrangements as they are developed.

Storage device **630** is a non-volatile memory and can be a hard disk or other types of computer readable media which can store data that are accessible by a computer, such as magnetic cassettes, flash memory cards, solid state memory devices, digital versatile disks, cartridges, random access memories (RAMs) **625**, read only memory (ROM) **620**, and hybrids thereof.

The storage device **630** can include software modules **632**, **634**, **636** for controlling the processor **610**. Other hardware or software modules are contemplated. The storage device **630** can be connected to the system bus **605**. In one aspect, a hardware module that performs a particular function can include the software component stored in a computer-readable medium in connection with the necessary hardware components, such as the processor **610**, bus **605**, display **635**, and so forth, to carry out the function.

FIG. 6B illustrates a computer system **650** having a chipset architecture that can be used in executing the described method and generating and displaying a graphical user interface (GUI). Computer system **650** is an example of computer hardware, software, and firmware that can be used to implement the disclosed technology. System **650** can include a processor **655**, representative of any number of physically and/or logically distinct resources capable of executing software, firmware, and hardware configured to perform identified computations. Processor **655** can communicate with a chipset **660** that can control input to and output from processor **655**. In this example, chipset **660** outputs information to output **665**, such as a display, and can read and write information to storage device **670**, which can include magnetic media, and solid state media, for example. Chipset **660** can also read data from and write data to RAM **675**. A bridge **680** for interfacing with a variety of user interface components **685** can be provided for interfacing with chipset **660**. Such user interface components **685** can include a keyboard, a microphone, touch detection and processing circuitry, a pointing device, such as a mouse, and so on. In general, inputs to system **650** can come from any of a variety of sources, machine generated and/or human generated.

Chipset **660** can also interface with one or more communication interfaces **590** that can have different physical interfaces. Such communication interfaces can include interfaces for wired and wireless local area networks, for broadband wireless networks, as well as personal area networks. Some applications of the methods for generating, displaying, and using the GUI disclosed herein can include receiving ordered datasets over the physical interface or be generated by the machine itself by processor **655** analyzing data stored in storage **670** or **675**. Further, the machine can receive inputs from a user via user interface components **685** and execute appropriate functions, such as browsing functions by interpreting these inputs using processor **655**.

It can be appreciated that exemplary systems **600** and **650** can have more than one processor **610** or be part of a group or cluster of computing devices networked together to provide greater processing capability.

For clarity of explanation, in some instances the present technology may be presented as including individual functional blocks including functional blocks comprising devices, device components, steps or routines in a method embodied in software, or combinations of hardware and software.

In some embodiments the computer-readable storage devices, mediums, and memories can include a cable or wireless signal containing a bit stream and the like. However, when mentioned, non-transitory computer-readable storage media expressly exclude media such as energy, carrier signals, electromagnetic waves, and signals per se.

Methods according to the above-described examples can be implemented using computer-executable instructions that are stored or otherwise available from computer readable media. Such instructions can comprise, for example, instructions and data which cause or otherwise configure a general purpose computer, special purpose computer, or special purpose processing device to perform a certain function or group of functions. Portions of computer resources used can be accessible over a network. The computer executable instructions may be, for example, binaries, intermediate format instructions such as assembly language, firmware, or source code. Examples of computer-readable media that may be used to store instructions, information used, and/or information created during methods according to described examples include magnetic or optical disks, flash memory, USB devices provided with non-volatile memory, networked storage devices, and so on.

Devices implementing methods according to these disclosures can comprise hardware, firmware and/or software, and can take any of a variety of form factors. Typical examples of such form factors include laptops, smart phones, small form factor personal computers, personal digital assistants, and so on. Functionality described herein also can be embodied in peripherals or add-in cards. Such functionality can also be implemented on a circuit board among different chips or different processes executing in a single device, by way of further example.

The instructions, media for conveying such instructions, computing resources for executing them, and other structures for supporting such computing resources are means for providing the functions described in these disclosures.

Although a variety of examples and other information was used to explain aspects within the scope of the appended claims, no limitation of the claims should be implied based on particular features or arrangements in such examples, as one of ordinary skill would be able to use these examples to derive a wide variety of implementations. Further and although some subject matter may have been described in language specific to examples of structural features and/or method steps, it is to be understood that the subject matter defined in the appended claims is not necessarily limited to these described features or acts. For example, such functionality can be distributed differently or performed in components other than those identified herein. Rather, the described features and steps are disclosed as examples of components of systems and methods within the scope of the appended claims.

The invention claimed is:

1. A method comprising: at a client device:

receiving a message of a communication session from a first user of a plurality of users, wherein the message is transmitted during a conversation between the plurality of users;

determining whether a virtual assistant is capable of facilitating a third party service associated with content of the message;

in accordance with a determination that the virtual assistant is capable of facilitating the third party service associated with content of the message:

displaying, in the communication session, a prompt associated with a user authentication procedure;

receiving, from a second user of the plurality of users, user credentials;

identifying data needed by a third party to provide the third party service;

transmitting the data and user credentials to the third party;

receiving a response message from the third party regarding the third party service; and

displaying, in the communication session, information corresponding to the response message received from the third party regarding the third party service.

2. The method of claim 1, wherein determining whether a virtual assistant is capable of facilitating a third party service associated with content of the message further comprises:

analyzing the message; and

identifying at least one task associated with the message.

3. The method of claim 2, wherein analyzing the message further comprises performing semantic analysis on text within the message.

4. The method of claim 3, wherein performing semantic analysis further comprises utilizing natural language processing.

5. The method of claim 1, further comprising:

displaying the virtual assistant as a participant of the communication session.

6. The method of claim 1, wherein the third party service is associated with at least one of an airline, a bank, a restaurant, an insurance company, and/or a store.

7. The method of claim 1, further comprising:

prompting at least one user of the plurality of users regarding whether the at least one user prefers to utilize the virtual assistant in the communication session.

8. The method of claim 1, wherein the conversation is an instant messaging conversation.

9. The method of claim 1, wherein determining whether a virtual assistant is capable of facilitating a third party service associated with content of the message further comprises identifying the third party service based on at least user history information and/or user preference information.

10. The method of claim 1, wherein determining whether a virtual assistant is capable of facilitating a third party service associated with content of the message further comprises analyzing at least one of message entered by a user of the plurality of users.

11. The method of claim 1, wherein determining whether a virtual assistant is capable of facilitating a third party service associated with content of the message further comprises analyzing the message.

12. The method of claim 1, further comprising:

connecting the client device to the third party;

determining that a predetermined amount of time has elapsed during which messages have not been entered as part of the communication session; and

in accordance with a determination that the predetermined amount of time has elapsed during which messages have not been entered as part of the communication session, disconnecting the client device from the third party.

13. The method of claim 1, wherein determining whether a virtual assistant is capable of facilitating a third party service associated with content of the message further comprises determining at least one service associated with the third party.

14. The method of claim 13, wherein determining at least one service associated with the third party further comprises:

21

displaying, in the communication session, at least one service;

receiving, from the second user of the plurality of users, a selection of a displayed service.

15. The method of claim 1, further comprising:
5 prompting the second user of the plurality of users to provide the data needed by the third party to provide the third party service.

16. The method of claim 1, further comprising:
10 adding, by the virtual assistant, at least one additional user to the communication session.

17. The method of claim 1, further comprising:
establishing, by the virtual assistant, communication
15 between at least one user of the communication session and at least one representative of the third party service.

18. The method of claim 1, wherein the communication session is a conversation using a messaging application.

19. The method of claim 1, further comprising:
20 displaying a plurality of options within the communication session;
receiving a selection of at least one option of the plurality of options from at least one user of the plurality of users;
25 determining the data needed by the third party to provide the third party service based on the received selection;
and

transmitting the data to the third party.

20. A system comprising:
30 one or more processors; and
memory having instructions stored thereon, the instructions, when executed by the one or more processors, cause the one or more processors to:

35 receive a message of a communication session from a first user of a plurality of users, wherein the message is transmitted during a conversation between the plurality of users;

determine whether a virtual assistant is capable of facilitating a third party service associated with
40 content of the message;

in accordance with a determination that the virtual assistant is capable of facilitating the third party service associated with content of the message:

45 display, in the communication session, a prompt associated with a user authentication procedure;
receive, from a second user of the plurality of users, user credentials;

identify data needed by a third party to provide the
50 third party service;

transmit the data and user credentials to the third party;

receive a response message from the third party regarding the third party service; and

55 display, in the communication session, information corresponding to the response message received from the third party regarding the third party service.

21. The system of claim 20, wherein determining whether a virtual assistant is capable of facilitating a third party
60 service associated with content of the message further comprises:

analyzing the message; and

identifying at least one task associated with the message.

22. The system of claim 21, wherein analyzing the message further comprises performing semantic analysis on text
65 within the message.

22

23. The system of claim 20, wherein the instructions, which when executed by the one or more processors, further cause the one or more processors to:

display the virtual assistant as a participant of the communication session.

24. The system of claim 20, wherein the instructions, which when executed by the one or more processors, further cause the one or more processors to:

prompt at least one user of the plurality of users regarding whether the at least one user prefers to utilize the virtual assistant in the communication session.

25. The system of claim 20, wherein determining whether a virtual assistant is capable of facilitating a third party service associated with content of the message further
15 comprises identifying the third party service based on at least user history information and/or user preference information.

26. The system of claim 20, wherein the instructions, which when executed by the one or more processors, further cause the one or more processors to:

connect the client device to the third party;
determine that a predetermined amount of time has elapsed during which messages have not been entered as part of the communication session; and

in accordance with a determination that the predetermined amount of time has elapsed during which messages have not been entered as part of the communication session, disconnect the client device from the third party.

27. The system of claim 20, wherein determining whether a virtual assistant is capable of facilitating a third party service associated with content of the message further
30 comprises determining at least one service associated with the third party.

28. The system of claim 20, wherein the instructions, which when executed by the one or more processors, further cause the one or more processors to:

display, in the communication session, at least one service;

40 receive, from the second user of the plurality of users, a selection of a displayed service.

29. The system of claim 20, wherein the instructions, which when executed by the one or more processors, further cause the one or more processors to:

45 prompt the second user of the plurality of users to provide the data needed by the third party to provide the third party service.

30. A non-transitory computer-readable medium having instructions stored thereon, the instructions, when executed
50 by one or more processors, cause the one or more processors to:

receive a message of a communication session from a first user of a plurality of users, wherein the message is transmitted during a conversation between the plurality of users;

determine whether a virtual assistant is capable of facilitating a third party service associated with content of the message;

in accordance with a determination that the virtual assistant is capable of facilitating the third party service associated with content of the message:

55 display, in the communication session, a prompt associated with a user authentication procedure;

receive, from a second user of the plurality of users, user credentials;

identify data needed by a third party to provide the third party service;

23

transmit the data and user credentials to the third party;
 receive a response message from the third party regarding
 the third party service; and
 display, in the communication session, information
 corresponding to the response message received
 from the third party regarding the third party service.

31. The non-transitory computer-readable medium of
 claim 30, wherein determining whether a virtual assistant is
 capable of facilitating a third party service associated with
 content of the message further comprises:
 analyzing the message; and
 identifying at least one task associated with the message.

32. The non-transitory computer-readable medium of
 claim 31, wherein analyzing the message further comprises
 performing semantic analysis on text within the message.

33. The non-transitory computer-readable medium of
 claim 30, wherein the instructions, which when executed by
 the one or more processors, further cause the one or more
 processors to:
 display the virtual assistant as a participant of the com-
 munication session.

34. The non-transitory computer-readable medium of
 claim 30, wherein the instructions, which when executed by
 the one or more processors, further cause the one or more
 processors to:
 prompt at least one user of the plurality of users regarding
 whether the at least one user prefers to utilize the virtual
 assistant in the communication session.

35. The non-transitory computer-readable medium of
 claim 30, wherein determining whether a virtual assistant is
 capable of facilitating a third party service associated with
 content of the message further comprises identifying the
 third party service based on at least user history information
 and/or user preference information.

24

36. The non-transitory computer-readable medium of
 claim 30, wherein the instructions, which when executed by
 the one or more processors, further cause the one or more
 processors to:
 connect the client device to the third party;
 determine that a predetermined amount of time has
 elapsed during which messages have not been entered
 as part of the communication session; and
 in accordance with a determination that the predetermined
 amount of time has elapsed during which messages
 have not been entered as part of the communication
 session, disconnect the client device from the third
 party.

37. The non-transitory computer-readable medium of
 claim 30, wherein determining whether a virtual assistant is
 capable of facilitating a third party service associated with
 content of the message further comprises determining at
 least one service associated with the third party.

38. The non-transitory computer-readable medium of
 claim 30, wherein the instructions, which when executed by
 the one or more processors, further cause the one or more
 processors to:
 display, in the communication session, at least one ser-
 vice;
 receive, from the second user of the plurality of users, a
 selection of a displayed service.

39. The non-transitory computer-readable medium of
 claim 30, wherein the instructions, which when executed by
 the one or more processors, further cause the one or more
 processors to:
 prompt the second user of the plurality of users to provide
 the data needed by the third party to provide the third
 party service.

* * * * *