

---

GUIDE

# **EMERGI-LITE**

An authoritative guide to emergency lighting  
& central power systems



---

**Emergency lighting is a vital and effective life safety tool, providing reassurance and guidance to people at critical times when they need to escape quickly and safely from a building.**

---

# Table of contents

<b>005</b>	<b>Introduction</b>
<b>006–023</b>	<b>Regulations &amp; standards</b>
<b>024–037</b>	<b>Luminaire &amp; system types</b>
<b>038–057</b>	<b>System design &amp; assessment</b>
<b>058–069</b>	<b>Installation, testing &amp; maintenance</b>
<b>070–093</b>	<b>Appendices</b>



# Emergi-Lite

## Introduction

Emergency lighting is a vital and effective life safety tool, providing reassurance and guidance to people at critical times when they need to escape quickly and safely from a building.

This authoritative guide has been prepared to provide a key reference point for all these parties, and is designed to give the reader a thorough appreciation of emergency lighting requirements.

This guide will assist the reader to:

- Understand the principles of emergency lighting
- Assess the requirements for emergency lighting
- Choose the appropriate type and category of emergency luminaire
- Define the appropriate positioning of emergency luminaires and exit signs as required
- Initiate continued safety and maintenance procedures

This guide acts solely as a supplement to the regulations and standards already in place.

Parties involved in or responsible for emergency lighting should therefore ensure familiarity with, and understanding of, the relevant regulations and standards.

Since emergency lighting safeguards life, its requirement is clearly established by law, which in turn is supported by numerous British, European and International standards.

Within these documents, specific locations for emergency lighting, minimum lighting levels, installation and testing requirements, and product quality are all determined.

These regulations and standards impact on all parties involved in the provision of emergency lighting.

From the manufacturer designing suitable products or the specifier preparing emergency lighting schemes to the employer conducting risk assessments for life safety, all need to be aware of their respective obligations pertaining to emergency lighting.

Throughout this guide, reference is made to the most up-to-date information available, however, as standards are regularly reviewed and updated, it is recommended that all parties should keep abreast of any new developments in the sector.

### **Who might benefit from this guide?**

This informative guide is intended for responsible people concerned with providing safety in an emergency situation. It has been designed for those who need to know why emergency lighting is required and whether to provide it.

The guide is intended for:

- Safety officers
- Building designers
- Specifiers
- Consultants
- Employers
- Facilities managers, and
- Any responsible person needing to help people evacuate a building safely, quickly, without stumbling and without panic

Examples of people who will benefit from reading all or part of this guide include:

- A building owner/occupier, or the appointed responsible person for life safety, needing to undertake risk assessment for emergency lighting within an existing premises
- A consultant specifying the emergency lighting system for a new building
- A maintenance engineer involved with the testing of an emergency lighting system
- An electrician responsible for the installation of an emergency lighting system



# Regulations and standards

## Introduction

Emergency lighting is an essential life safety system within buildings and as such its implementation, maintenance and management is required by law.

### Introduction

In addition to core legislation, a number of standards have been developed for emergency lighting which define the particular requirements for emergency lighting systems, their siting, installation, testing, and the quality of product to be considered.

In so far as legislation drives and determines the requirement for emergency lighting, it is adherence to these specific standards which proves compliance.

This section therefore aims to brief the reader on both the key regulations and the standards which need to be reviewed when designing, implementing and managing an emergency lighting system.

### Years of experience

Supporting emergency lighting projects on all scales, backed by friendly service, technical expertise and our continual drive towards new product innovation makes Emergi-Lite the number one choice for emergency lighting.

Our products and services are specifically designed to provide the most effective protection and safety, in line with customer needs, relevant standards and industry regulations. These solutions start at the planning stage for emergency lighting systems, with advice on product selection and system requirements, through to delivery of certified technical drawings.

With project time-lines tight and budgets constrained, choosing the right partner for emergency lighting system design is imperative. By choosing Emergi-Lite, you'll be making the right start.

Emergi-Lite works at the heart of this complex process, assisting designers, specifiers, and final customers with all manner of emergency lighting needs, ensuring schemes are designed to conform to all relevant/necessary standards.



# Regulations and standards

## Regulatory Reform (Fire Safety) Order 2005

The key legislation driving implementation of life safety systems within workplaces and other non-domestic premises is the Regulatory Reform (Fire Safety) Order 2005.

This became law on 1st October 2006 and replaced all previous Laws on fire safety in England and Wales, with similar Laws introduced in Scotland and Northern Ireland. For the remainder of this guide, these Laws are referred to as the “Fire Regulations”.

The introduction of the Fire Regulations creates one simple fire safety legislative control for all workplaces/non-domestic premises.

The Fire Regulations revoke the Fire Precautions Act 1971, and the Fire Precautions (Workplace) Regulations 1997 (as amended 1999), and are retrospective. Therefore all premises specified must adhere to the new requirements.

Fire certificates, as issued by the Fire Authorities under the terms of the Fire Precautions Act 1971 have been withdrawn.

The Fire Regulations require employers or building owners/occupiers to ensure premises have defined escape routes, which are adequately identified and are available for use at all times.

Escape routes must be provided with emergency lighting, and the premises must be equipped with an appropriate fire detection and alarm system. These fire protection products must be ‘fit for purpose’, correctly installed and maintained in accordance with the relevant British & European standards and the instructions of the manufacturer.

To define the emergency lighting requirement, and the specific path of escape routes within a premises, owner/occupiers must undertake a fire safety risk assessment.

### **Risk assessment**

The risk assessment to determine the emergency lighting requirement must be undertaken by a Responsible Person at the premises or by a Competent Person appointed by the Responsible Person.

The Responsible Person is usually either the employer, manager, owner or occupier of the premises. A Competent Person would be someone who has the necessary knowledge, training, experience and abilities to make proper assessment of buildings for fire safety.





Risk assessment is a multi-stage process, which guides the Responsible or Competent Person in identifying and reducing the risks down to acceptable levels. It is through this process that the need for fire precautions and emergency lighting is established within the premises.

Where a set of premises has five or more employees, the risk assessment must be documented. It should be regularly reviewed and revised to ensure it continues to meet requirements.

An example risk assessment check sheet is provided in Appendix D.

When a decision is made to install emergency lighting after completion of a risk assessment, the guidance in the British Standard Code of Practice for the emergency lighting of premises (BS 5266-1) should be followed.

### Implications of legislation

Protection must be provided to all persons in a building and to those who might be affected by a fire.

The Fire Regulations now affirm that not only are smaller premises required to provide adequate fire precautions, but as per the Fire Precautions Act (and hence Fire Certificates) existing premises have to meet current safety standards.

Additionally, Government has published a series of guidance documents to support the Fire Regulations with regard to life safety within particular building types and business sectors.

These guidance documents have been published to set the general fire safety requirement for particular applications or building types and include guidance for:

- Educational establishments
- Factories and warehouses
- Healthcare premises
- Larger places of assembly
- Offices & shops (including superstores)
- Open air activities
- Places providing sleeping accommodation
- Residential care
- Small & medium places of assembly
- Theatres, cinemas (and larger clubs), and transport interchanges

Within these documents reference is made to the standards for emergency lighting which apply in such premises, and therefore they should be reviewed when designing and implementing emergency lighting systems within the types of building specified.

### Other risks apart from fire

The fire safety guides state that fire is only one of many safety issues that management must take into consideration to minimise the risk of injury or fatality to staff or the public. Many of the measures needed impact upon other safety issues and vice versa.

For emergency lighting this is particularly true of the risks that can occur when occupants are suddenly plunged into darkness in the event of a supply failure, so this consideration should be taken into account in the design of the system installed. Further advice on this matter is provided in British Standard BS 5266-1.



# Regulations and standards

## Additional regulations affecting emergency lighting

In addition to the Fire Regulations, many other regulations and European directives define general requirements for fire safety, provision of emergency lighting and the use of safety signage as the means for identifying hazards and escape routes.

These include:

- The Building Regulations 2006 (Approved Document B)
- The Workplace Directive (89/654/EEC)
- The Construction Products Regulation (305/2011/EU) - replacing the Construction Products Directive (89/106/EEC)
- The Safety Signs Directive (92/98/EEC)

Each is considered in brief over the following pages.

### **The Building Regulations 2006 (Approved Document B)**

The Building Regulations 2006 establish within Approved Document B the general requirements for fire safety within buildings, including:

- The materials to be used in construction of fire compartments, in that these should inhibit the spread of fire throughout the building
- The number and size of the escape routes provided within the building, in so far as these should be appropriate to the size and intended use of the building

- The provision of sufficient emergency lighting, in line with the guidelines in BS 5266-1, to enable occupants to use escape routes safely
- The marking of all escape routes with emergency exit sign The Building Regulations 2006 control safety within the building structure, and establish those parts of the building which are required to conform to BS 5266-1.

Along with the Fire Regulations, these regulations implement the recommendations set out in The Workplace Directive and The Construction Products Regulation within the UK.

### **The Workplace Directive (89/654/EEC)**

The Workplace Directive covers most premises where people are employed, and is retrospective, requiring all specified premises to be brought up to standard, setting out the minimum requirements for safety and health within a workplace. It provides specific guidance for escape routes:

- The number and size of escape routes and emergency exits should be appropriate to the size and use of the premises, and the maximum potential number of occupants
- Designated escape routes must be as direct as possible to a place of safety
- Escape routes and emergency exits must be kept clear, free of obstructions and accessible for use at all times
- Emergency escape routes, their exit doors and any doors along the route must be indicated by a sign, in line with the requirements of The Signs Directive
- Sufficient emergency lighting (of adequate intensity) must be provided along escape routes and at emergency exits to protect occupants from danger in the event of a failure of the mains lighting



The Workplace Directive also establishes that safety equipment including emergency lighting should be maintained in efficient working order ready for use as required.

Within the UK, compliance with this directive is audited by the Fire Authority.

#### **Risks from explosive atmospheres 99/92/EC**

Risks from explosive atmospheres harmonises the minimum requirements for the improvements of safety and health of workers potentially at risk from explosive atmospheres.

ATEX is a derivation from the French title "Appareils destinés à être utilisés en Atmosphères explosives". This is known as ATEX 137, the ATEX work directive, which refers to the ATEX equipment directive (ATEX 95), directive 94/95/EC. This was re-aligned under a new legislation framework as ATEX directive 2014/34/EC (The substantive parts of 94/95/EC remain).

Here we will simply limit the overview to note that emergency lighting equipment with a potential source of ignition, must conform to the ATEX regulations, with 3rd party accreditation by an approved test house required.

#### **The Construction Products Regulation (305/2011/EU)**

The Construction Products Regulation (CPR) has replaced the Construction Products Directive in the UK, and came into force on 1st July 2013.

The CPR covers construction works, including most new and refurbished buildings (except private dwellings), and civil engineering works. It will ensure products incorporated into these works are suitable for their intended purpose, controlled by CE marking and Declarations of Performance (DoP).

The CPR requires construction products to meet seven basic requirements for construction works, including safety in case of fire.

The CPR is implemented in the UK by the Building Regulations 2006, Approved Document B, which establishes the need for emergency lighting complying with BS 5266-1.

Compliance with the CPR is audited by Building Control Officers.

#### **Construction products regulation (305/2011/EU)**

A further update was made to this version in October 2014, which included new rules on declaration of performance (DoP) revisions were made to product assessment and certification and the use of CE marking.

#### **The Signs Directive (92/98/EEC)**

The Signs Directive is implemented in England, Wales and Scotland by The Health and Safety (Safety Signs and Signals) Regulations 1996, with comparable regulations introduced in Northern Ireland.

The directive is retrospective, requiring all workplaces to be brought up to specification.

It requires the provision of safety signs within workplaces wherever there is deemed to be a risk or hazard to occupants, which can neither be controlled by other means nor avoided.

The directive further stipulates the need for signs to identify the full extent of emergency escape routes, exit doors, fire fighting equipment and first aid facilities. Specific rules are set to cover the type of sign to be used along emergency escape routes:

- Signs should be rectangular or square in shape
- Signs should be green in colour with a white pictogram
- Escape route signage should be as described in BS 5266-1:2016 section 5.2.9 Section 5.4 (Safety Signs).
- This specifies signs in accordance with BS ISO 7010 as being applicable (see Figure 1). Additionally, signs in accordance with Statutory Instrument SI 341 are still legal and can be used (please refer to the emergency exit clear signs technical statement from ICEL for further information). Note, although numerous sign formats are acceptable, standards clearly dictate that one format only should be used within a given premises
- Signs should be positioned at an appropriate height and contrast their background environment without producing glare
- Signs should be regularly cleaned and maintained, for optimum visibility
- Signs requiring power should have a guaranteed emergency power supply in the event of a failure to the mains supply

Compliance with this directive in the UK is audited by the Fire Authority.

#### **89/391/EEC**

This is an introduction of measures to encourage improvements in the safety and health of employees at work. The provisions within this framework directive apply with 89/654/EEC

# Regulations and standards

## British Standard BS 5266

BS 5266 comprises a suite of standards which is of major importance to all parties involved in the design, installation and management of emergency lighting.

### **BS5266-1:2016 has replaced the 2011 version from 1st June 2016.**

For many aspects of emergency lighting, compliance with the standard is viewed by the appropriate authorities as proof that an emergency lighting system conforms to relevant legislation.

There are now 6 parts to the BS 5266 code of practice.

- BS 5266-1:2016 is the base standard for emergency lighting of premises, including cinemas and places of entertainment. It is a Code of Practice giving guidance and recommendations and also refers to relevant clauses in part 8 and BS EN 1838 (lighting applications).
- BS 5266-2: low location electrical way guidance systems
- BS 5266-4: Use of optical fibre systems
- BS 5266-5: Optical fibre systems – Component specification
- BS 5266-6: Low location photo-luminescent non-electrical guidance systems
- BS 5266-8:2004 (BS EN 50172 – Emergency escape lighting systems) covers system types, design of and consultation regarding emergency lighting systems, and plans and records for emergency lighting. This part also relates to the testing and maintenance of emergency lighting systems.

**BS EN 1838 (Lighting applications – Emergency lighting)** stipulates the illuminance requirements for escape routes, open areas, high risk task areas and exit signs (also previously described in BS 5266-7[withdrawn]).

This guide will focus on parts 1& 8, since they refer to the application of powered emergency lighting positioned at high level (the other parts are listed above for reference).

### **BS 5266-1: 2016**

BS 5266-1 provides the link between all the parts of the standard and drives their implementation. It now establishes three categories of emergency lighting - emergency escape lighting, emergency safety lighting and standby lighting.

### **Emergency escape lighting**

Lighting which provides illumination in escape routes and open areas, to enable immediate and safe evacuation of the premises, and also permits termination of potentially hazardous equipment/processes in high risk task areas.

The new edition of BS 5266-1 stresses the need for risk assessment and the provision of safe escape means, especially for those with disabilities including visual impairment. It also makes a closer alignment with EN 1838:2013.



This category is broken down into the three relevant parts - escape route lighting, open area lighting and high risk task area lighting - since each has particular requirements.

#### Emergency safety 'stay put' lighting

This heading defines the allowable circumstances where people might remain in the building, i.e.:

- In an area of minimal risk having sufficient 'borrowed light' (note: adjacent light source, which is available at all material times, daylight perhaps or another emergency luminaire)
- Having a safe haven place of low risk, where people can be located

Further guidance is provided for its design and implementation. If full activities are to continue then Standby lighting is required.

#### Standby lighting

- Standby lighting refers to emergency lighting which permits continued operational activity when the mains power supply fails.
- For the purpose of this guide, focus is on emergency escape lighting, referenced under the generic term 'emergency lighting'.

#### BS 5266-1:2016 includes guidance on:

- Design and installation of emergency lighting within different premises
- Minimum duration of emergency lighting
- Response times for emergency lighting

- Requirements for maximum to minimum ratio of illuminance, disability glare & colour
  - Installation & wiring of emergency lighting
  - Commissioning and testing requirements
- Additionally, BS 5266-1 incorporates the guidance within the standard and its annexes, to cover light levels, response and duration times for specific locations and circumstances, including:
- Kitchens
  - First aid rooms
  - Examination and treatment rooms
  - Refuge areas for the mobility impaired
  - Plant rooms, switch rooms and emergency winding facilities for lifts
  - Inspection of the condition of fire control and indicating equipment
  - Toilet areas over 8m<sup>2</sup> in area
  - Reception areas
  - Crash bars or security devices at exit doors
  - External areas near final exits

A table showing the illuminance recommendation for these specific locations is provided in BS 5266-1 (see also Section 4.4).

### Summary of standards & code of practice governing emergency lighting in UK

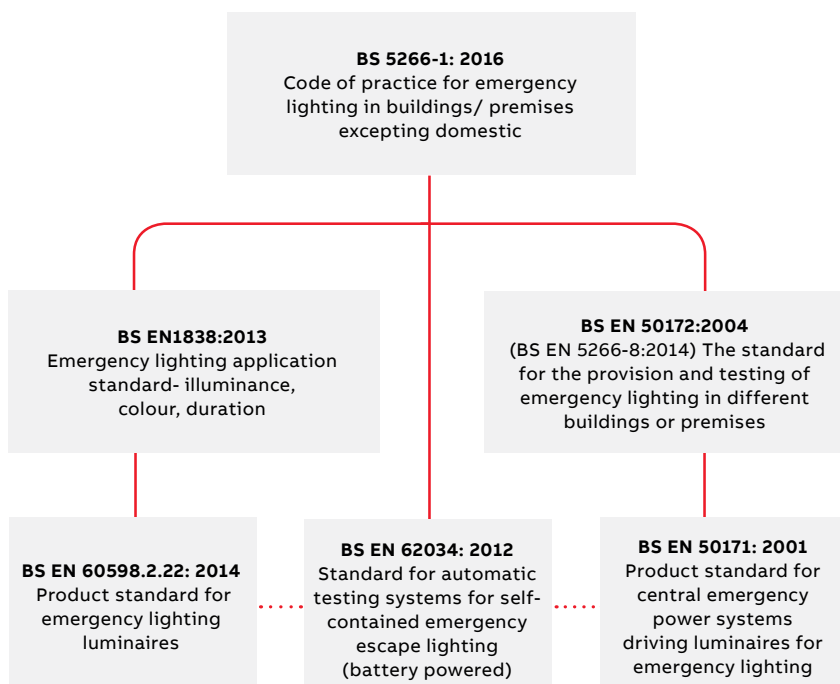

### Sign types



BS ISO 7010 format signs are acceptable and comply with the requirements of BS 5266-1.



European pictogram format signs, compliant with BS 5499-1, remain acceptable.



Text only signs are no longer acceptable and should have been withdrawn.

# Regulations and standards

## British Standard BS 5266

### BS EN 1838:2013

This expands on the conditions set out in BS 5266-1 for the application of emergency lighting, and covers escape routes, open areas and high risk task areas. For escape routes, specific locations for positioning of emergency lighting are defined, i.e.:

- Within 2m (horizontally) of emergency exit doors
- At directional changes along the escape route (to illuminate in each direction)
- At intersections of corridors (to illuminate in all directions)
- Within 2m of changes of level, to avoid tripping
- Within 2m of flights of stairs (direct illumination to each flight)
- Within 2m of each piece of fire fighting equipment and/or manual call point
- Within 2m of first aid points
- Within 2m of exit signs, and other safety signs which identify a hazard
- Within 2m of the last exit to the external escape route away from the structure
- Immediately outside the building to a place of safety
- Externally illuminated signs to do with the escape route or safety that need illumination under emergency lighting conditions
- Within 2m of refuge positions and call/two way telephone points for the less able
- Within 2m of escape equipment in place for the less able
- Within 2m of a disabled toilet alarm position
- First aid equipment, fire fighting and detection equipment listed above will require a minimum 5 lux of vertical illumination

Minimum standards of illumination are set for escape routes, open areas and high risk task areas, with uniformity, disability glare, colour levels and maximum viewing distances also detailed (see Table 1).

Historically, previous BS 5266-7 guidelines have included an “A” deviation permitting illumination of a 2m wide defined escape route to 0.2 lux minimum along the centre line, provided the defined escape route was permanently unobstructed. This was removed in BS 5266-1:2016. A 1 lux minimum now applies.

Note that use of the 1 lux requirement does not imply that permanent obstructions which may impede evacuation, such as photocopiers, vending machines etc. can be installed in escape routes.

### BS 5266-8:2004

BS 5266-8 further controls application of emergency lighting and provides additional guidance on design of emergency lighting systems, location of emergency luminaires, testing and record keeping requirements. BS 5266-8 includes:

- Locating additional exit signs on escape routes where there is a risk that planned signs are not in direct line of sight
- Ensuring all escape route compartments/open areas have a minimum of 2 luminaires
- That emergency lighting circuits should operate on local supply failure
- Defining a standard size of open area (larger than 60m<sup>2</sup>) with exceptions
- Developing controls for record keeping on site, with log books and testing schedules
- Setting standards for luminaire and power supply quality & performance

**Table 1: Summary of requirements in BS EN 1838:2013**

<b>ESCAPE ROUTE</b>	<b>To be completely unobstructed</b>
Size reference	Up to 2m width
Centre line horizontal illuminance	1 lux min
Minimum illumination up to 0.5m from centre line	0.5 lux min
Wider escape route paths	Consider as a number of swaths 2m in width, or as an open area, where practicable
Uniformity - Max: min illuminance	40:1 or better, along the centre line
<b>OPEN AREA (Anti-panic lighting)</b>	0.5 lux min in core area (excluding 0.5m surrounding border)
Uniformity - Max : min illuminance	40:1 or better
<b>ESCAPE ROUTE &amp; OPEN AREA</b>	
Disability glare (anti-dazzle) - horizontal escape routes	In the field of view 60° up from the vertical to the ceiling, the luminous intensity must not exceed the figures given in table 6 on page 53
Disability glare - routes with changes of height	Luminous intensity must kept below the figures in table 6 on page 53
Response time	Required illumination levels within 5 seconds (50%) and 60 seconds (to 100%)
Colour	For clarity of safety colour the colour rendering index must be Ra40 or better
Minimum duration time	Dependent on use of premises. In UK - normally 3h
<b>HIGH RISK TASK AREA</b>	
Uniformity - Max: min illuminance	10:1 or better
Disability glare	Luminous intensity must kept below the figures in table 6
Colour	Ra40 or better
Response time	Required illumination levels to be met at all times or to be reached within 0.5 seconds depending on task application
<b>STANDBY LIGHTING</b>	If used for emergency escape lighting, it will conform to the stated standards
<b>SAFETY EXIT SIGNS</b>	
Conformance	Safety signs will conform to ISO 3864-1 & 4 (photometric). Design will be to EN ISO 7010 [in UK signs format under Statutory Instrument SI341 are allowed]
Luminance of green safety colour	To be a minimum of 2 cd/m <sup>2</sup>
Sign mounting orientation	At least 2m above the floor. Preferably, not more than 20° above the line of sight horizontally from the viewer (taking into account the sign viewing distance)
Response time	60 seconds to end duration, full illuminance, 5 seconds to 60 seconds, 50% minimum of the above
Max : min luminance ratio within white or green	10:01
Ratio (White : green)	Dependent on use of premises. In UK - normally 3h
Minimum & maximum ratios	Not less than 5 : 1 & not greater than 15 : 1
Viewing distance	Differ for internally & externally illuminated signs (see section x)
<b>TESTING</b>	To test and maintain in accord with EN 50172. Automatic testing to comply with EN 62034

1- See Appendix A7 for a graph of light output showing F5, F60 and Fend



# Regulations and standards

## British Standard BS 5266

BS EN 60598-2-22 is the product standard for emergency luminaires, required by BS EN1838:2013. When designing a system for emergency lighting, the luminaires specified should conform to this harmonised British and European standard.

### BS EN1838:2013

The standard (previously listed as BS 5266 7:1999) ensures products are safe to use, and have been designed and manufactured for correct performance under emergency conditions.

Products certified and marked to this standard therefore provide assurance to specifiers and users that good quality safety products are being installed.

Luminaires and internally illuminated exit signs in both self-contained and slave formats (for use with central power supply systems) are covered. The format of exit sign legends should comply with BS 5266-1:2016, or BS 5499, as shown in the Signs Directive (see Section 2.2).

The essential requirements stated directly in this standard or specified from BS EN 60598-1 and other parts in the 60598 series are:

1. Earthing - All exposed metal parts must be earthed, unless the equipment is double insulated (Class II).
2. Flash test - All luminaires must be 100% tested in production to withstand without fault a voltage of 1500 V from line and neutral to earth for 3 seconds when manually tested.
3. Clearances - Creepage and clearance distances between live parts of different polarity and between live parts and accessible metal parts must be adequate.
4. Instructions - Installation instructions and instructions for renewing replaceable parts must be provided.
5. Fire retardancy - External parts of the enclosure must be fire retardant conforming to the 850°C hot wire test.
6. F-marked - Luminaires must be suitable for mounting on a flammable surface and marked accordingly (F-marking does not indicate fire retardancy).
7. Light output - The instructions must show the rated lumen output of the luminaire taking into account all correction and ageing factors.
8. Photometric performance - Spacing details for luminaires calculated at various mounting heights to provide the illuminances required in BS 5266, should be made available, taking into account all correction/ageing factors.
9. Response time - Following a mains failure the light output must be 50% of rated output within 5 seconds and 100% rated output within 60 seconds. For high risk task areas the





response time must be 100% of rated output within 0.5 seconds.

- 10. Brown out operation - The luminaire must changeover from normal to emergency mode and return within the band 60% to 85% of rated supply voltage.
- 11. Battery life - For self-contained luminaires the battery must be designed for a minimum 4 year life with the luminaire operating normally, and maintained lamp on (if applicable), at 1.06 x rated supply voltage.
- 12. Marking - Luminaires must be marked appropriately, following the guidelines in Table 2. Furthermore, luminaires should be labelled and marked using the classification shown in Figure 2.

**Additional considerations for luminaire selection**

Using products certified to the product standard and marked with the approval of a national test house simplifies the job of the Competent Person or installer, because an element of risk or doubt is removed.

If, however, uncertified products are used, the Competent Person or installer takes the responsibility of approving those safety products for use in protecting life.

This is an important responsibility because a safety product such as emergency lighting must not only be safe in use, but it must also operate as intended in an emergency. "If it does not work the premises may not be safe to occupy". CE marking alone on a product does not necessarily imply that it will work in an emergency situation.

Certified and approved emergency lighting therefore has an enhanced level of safety compared to general lighting which is only required to be safe in use.

"Safe in use" means that it is neither a shock hazard nor a fire hazard, non-operation being an inconvenience rather than a safety hazard in the emergency sense.

Third party certification schemes are available to manufacturers to provide assurance that their emergency luminaires meet the requirements of British and European standards.

These schemes involve regular, independent product testing and approval to standards, along with assessment of manufacturing practices.

An example of a third party certification scheme in the UK would be the Kitemark®1 scheme provided by the British Standards Institution (BSI), although other third party testing schemes are available.

ENEC is the comparable Quality Mark within the EU. This Mark demonstrates that emergency luminaires meet the relevant European safety standards.

The Industry Committee for Emergency Lighting (ICEL) has a registration scheme for luminaires and conversion modules, which provides independent testing and performance data for the luminaire, battery life, component life and fire retardancy.

Through selection of an emergency luminaire carrying a mark from an independent test house (e.g. Kitemark® or ENEC), the Competent Person or installer can be further assured that the product is suitable for the application. (See Section 2.7 for more). The majority of Emergi-Lite luminaires have been tested and approved to either ENEC or the Kitemark® scheme, including our premium specification products, Serenga, Horizon and Aqualux.

**Table 2: Luminaire marking requirements to comply with BS EN 60598-2-22**

Marking	Example
Supply voltage range	220 - 240 V, 50/60 Hz
Mark of origin	Supplier company name
Details of replacement parts	Battery: nickel cadmium 2.4 V, 4 Ah
Duration	1h or 3h
Category	NM or M with code designation
Type	Self contained, slave etc.

**Figure 2: Labelling requirements for BS EN 60598-2-22**

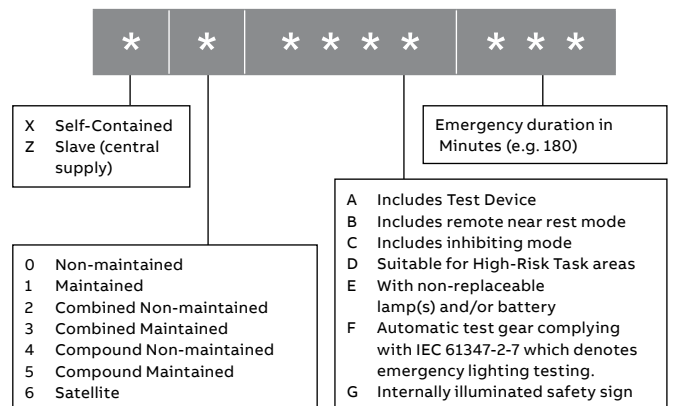

---

# Regulations and standards

## British and European Standard BS EN 50171

BS EN 50171 is the standard relevant to central power supply (CPS) units and systems, controlling their design, construction and performance requirements.

The principle considerations in this standard include:

- Components used in the manufacture of CPS units should conform to the safety and performance requirements of their appropriate standards. For example, battery safety is covered by BS EN 50272
- CPS units should be compatible with luminaires which conform to the Product Standard BS EN 60598-2-22
- The design brief for CPS systems should detail the system operation and full output requirements, including the starting load
- CPS inverters should be able to start the full load without the mains supply present, and be able to overcome any fault protection on the circuit
- Systems operating both AC and DC must be capable of switching both supplies

- CPS systems should be capable of operating at overload for the rated duration, and recharge within 24 hours
- System condition should be clearly indicated on the CPS unit
- Enclosures for CPS units and remote devices should be fire resistant
- Fire resistant cable should be used in CPS installations, with wiring in accordance with BS 7671

BSI operate a Kitemark® certification scheme to mark high quality CPS systems. The Emergi-Lite EMEX AC/AC range of static inverter systems has been certified to this scheme.

Additionally, ICEL have drawn up a standard for CPS systems - ICEL 1009 - which is covered later in this section (see Section 2.7).



# Regulations and standards

## Additional standards relevant to emergency lighting

The standards BS 5266, BS EN 60598-2-22, and BS EN 50171 control many of the requirements of emergency lighting.

—  
01 Automatic test systems facilitate testing of emergency lighting, though need to be compliant with IEC 62034

In addition, these standards reference others which apply to wider aspects of emergency lighting provision, such as installation practice and ongoing testing. These standards include:

- BS EN 62034:2012 (IEC 62034) Automatic test systems for emergency lighting
- IET Wiring Regulations, BS 7671

### **BS EN 62034:2012 (IEC 62034) Automatic test systems for emergency lighting**

Periodic testing is a requirement to ensure continued satisfactory operation of emergency lighting systems post installation and commissioning.

The major standards provide guidance on the testing requirement, and this detail is supported here by specific guidance for automatic test systems available in the marketplace.

IEC 62034 defines that:

- Testing should be undertaken during periods of low risk
- Tests should be performed at the appropriate times for the correct duration

- Testing should prove the emergency circuit operates correctly, and that the battery powers the luminaire for the duration of the test
- Results of the test should be reliably indicated

Test systems for both self-contained and centrally powered emergency lighting systems are covered.

### **IET Wiring Regulations, BS 7671**

Within BS 7671, requirements for satisfactory wiring of emergency luminaires are detailed:

- For self-contained emergency luminaires, the wiring installation should follow the requirements for standard luminaires.
- This applies as the key components in emergency condition, the control gear and battery are sited within the luminaire unit or within close proximity (less than 1m away)
- For central power supply systems and slave luminaires, connecting cables need to be manufactured from a suitable fire resistant material, to ensure continuity of the power supply

Further information on installation and testing of emergency lighting is provided in Section 5.

—  
01

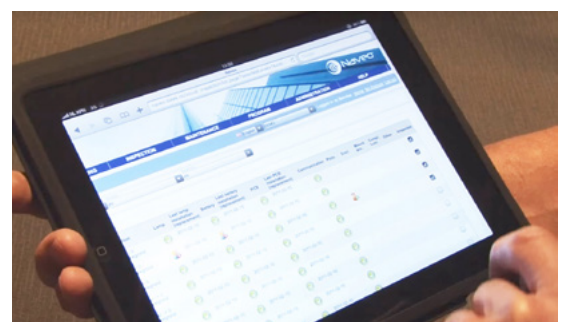
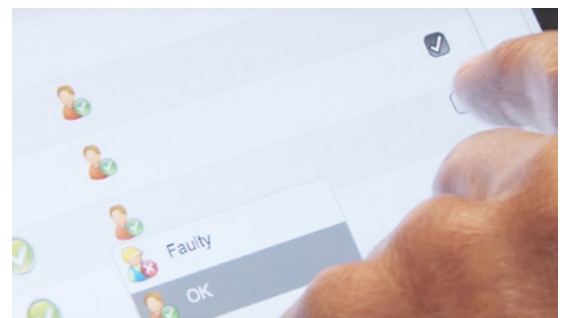
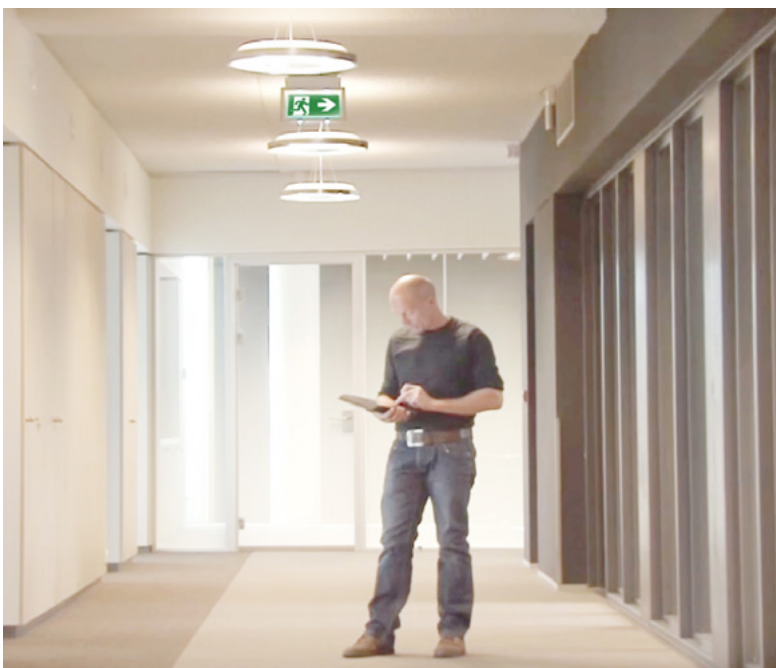

# Regulations and standards

## ICEL guides and registration schemes

ICEL guides and registration schemes establish key guidelines for the quality. Reliability and performance of emergency luminaires and conversion equipment, and are underpinned by an adherence to independent testing.

ICEL is the Industry Committee for Emergency Lighting, which develops guides and registration schemes for emergency lighting.

These guides and registration schemes interact with, and in many cases have formed the basis of current European standards on emergency lighting.

Furthermore, ICEL operates a membership for emergency lighting manufacturers and provides a registration scheme for luminaires which meet the appropriate test criteria.

As an introduction to ICEL, in this section focus is on ICEL 1001 for emergency lighting luminaires, ICEL 1004 for conversion modules and ICEL 1009 for CPS systems.

### ICEL 1001 enhanced requirements for emergency lighting luminaires

Where requirements in BS EN 60598-2-22 are neither explicit nor obligatory, or are omitted, then the ICEL 1001 registration scheme provides additional data for emergency luminaires.

The major points in ICEL 1001 are:

#### 1. Photometric performance

BS EN 60598-2-22 requires data to be “made available”. ICEL 1001 requires the photometric data to be originated by a national test house, and the spacing tables to be 3rd party authenticated. The method of presenting and measuring the photometric data with the correction factors is clarified.

#### 2. Fire retardancy

ICEL 1001 requires a test report from a national test house to verify compliance to the 850°C hot wire test. This does not affect products newly approved to the present version of BS EN 60598-2-22 because the 850°C hot wire test is specified, but the ICEL 1001 mark shows that earlier luminaires and exit signs are also fire retardant<sup>2</sup>.

#### 3. Battery life

ICEL 1001 qualifies the 4-year battery design life specified in BS EN 60598-2-22 (appendix A7) by requiring an initial test, including an



accelerated life test, and regular audit tests to prove cells are suitable for emergency use. ICEL 1010 is the relevant registration scheme for batteries for self-contained emergency luminaires. It is applicable to both nickel cadmium and nickel metal hydride cells and compliance shows that the battery should last a minimum of 4 years use and still provide the rated duration. Cell manufacturers submit cells for type testing and for regular audit testing and if acceptable cells can be marked ICEL 1010.

#### 4. Component life

The battery design life is 4 years, but BS EN 60598-2-22 does not include a requirement for the life of components in the luminaire or conversion module. Electrolytic capacitors wear out in exactly the same way as rechargeable cells, so ICEL have selected these components to be tested. ICEL 1001 requires that electrolytic capacitors are thermally tested and have a design life of 8 years. This is twice the life of the battery. The requirement applies to luminaires at an ambient temperature of 25°C and to conversion modules at a minimum case temperature of 50°C, both measured at 240 Vac.

#### 5. Product compliance

ICEL 1001 requires products to comply with BS EN 60598-2-22 and provides a system of assessed capability according to the ISO 9000 suite of standards.

#### ICEL 1004 requirement for emergency lighting conversions

There is a large number of mains luminaires available for conversion to emergency use, so it is impractical to have all these tested in accordance with the BS EN 60598-2-22 Product Standard.

ICEL 1004 is a registration scheme for organisations showing acceptable capability, competence and procedures in converting luminaires.

The essential points in ICEL 1004 are:

#### 1. Emergency driver

The emergency driver should be compliant with the relevant Product Standards, EN 61347-2-7 and EN 60925.

#### 2. Conversion procedure & record keeping

The procedure and individual luminaire conversion information should be recorded in a technical file.

#### 3. Technical documentation

Technical documentation should include light output, photometric data, emergency driver temperature, battery temperature, ambient temperature, fire retardancy of external parts to the 850°C hot wire test, relevant marking to show connections and installation instructions.

#### 4. Product compliance

Conversion products must comply with the relevant parts of BS EN 60598-2-22. The modification and conversion work should be carried out within a system of assessed capability to the ISO 9000 series of standards. All conversions must comply with Electro-Magnetic Compatibility (EMC) requirements. Further information on the technical requirements for emergency lighting, photometric performance and luminaire conversions is provided in Appendix A.



# Regulations and standards

## ICEL guides and registration schemes

—  
01 An example of an ICEL compliant CPS system with optional testing function

### ICEL 1009 Emergency lighting central power supply systems

ICEL 1009 defines the requirements for central power supply (CPS) systems providing emergency power to emergency lighting.

Systems up to 1000 V with connection to AC power are covered, excluding power supplies 100 W and above, and UPS systems up to 100 Amps, as these are covered by a separate standard.

The major points in ICEL 1009 are:

#### 1. Modes of power supply and response time

Two separate modes of power supply are defined - changeover mode and parallel standby mode. The stipulated response time differs between these two modes. For changeover mode, the response time should not be greater than 5 seconds. For parallel standby mode, it should be immediate.

#### 2. Operation and performance

Systems should be designed for input voltages of 230 V or 400 V (with 10% variance), with frequency 50 Hz (2% variance), as standard unless otherwise agreed between specifier and manufacturer. The central unit should be designed to operate at a nominal ambient temperature of 20°C, within relative humidity

of 85% (non-condensing), up to a height above sea level of 1000m. Required capacity should be initially derated by 20%. The unit and batteries should then meet their declared performance level for their full life-time, with expected battery design life in excess of 10 years at the 20°C ambient temperature. Battery chargers should automatically recharge the battery to at least 80% of the full rated charge within 12 hours of a full discharge. The system should include facilities for testing and monitoring function and performance.

#### 3. Central unit construction

The unit should be ingress rated to at least IP20 and be heat and fire resistant. Preferably, the central unit should be constructed from a minimum 1.6mm zinc plated mild steel with etch primer and epoxy based paint. Where non-metallic construction is used, the material used should be tested to the 850°C hot wire test specified in IEC 695-2-1.

#### 4. Technical documentation

Technical documentation should include reference to harmonised standards, description of electrical equipment, design drawings with all necessary supplementary explanatory material, test reports and statements on quality control procedures.

#### 5. Product compliance

CPS systems should comply with EU Directives for Low Voltage, EMC and Construction Products. Battery enclosures should comply with EN 50272-2. Chargers should comply with BS EN 60335-2-29, EN 60146 and EN 50272-2.

#### Conclusion

Together, the regulations and standards in this section define and drive the requirement for emergency lighting within the built environment.

Whilst this section provides an introduction to these key requirements, the following sections in this guide serve to reinforce and add greater detail to the information provided here.









# Luminaire & system types

## Introduction

Though the need for emergency lighting is clearly defined by the various regulations and standards, the final decision as to the overall format of the system installed remains in the hands of the key stakeholders - the specifier, building designer and, where known, the building owner/occupier.

### Introduction

There is much to consider, and key decisions including luminaire category and duration, system type and testing solution need to be made before planning of the emergency lighting system can begin.

For both newbuild and refurbishment projects, it is recommended that these important considerations are reviewed early in the process, to avoid the risk of possible incorrect specification and potential rework during construction.

With this in mind, this section concentrates on the various system types available and the differences between them, to help guide the reader to making an informed decision on the best emergency lighting for their premises and projects.

Test facilities are introduced here, and are fully defined later in Section 5.



# Luminaire & system types

## Categories (modes) of emergency lighting

Four categories (modes) of emergency lighting apply - non-maintained, maintained, combined non-maintained and combined maintained - to cover the scope of emergency lighting requirements for differing applications and installations.

These categories are usually stated for self-contained emergency luminaires, but are also applicable to the ways a slave luminaire might be powered (see Sections 3.5 - 3.7 for more information on self-contained and slave luminaire types).

### **Non-maintained (NM)**

A non-maintained luminaire operates only when the mains power fails.

### **Maintained (M)**

A maintained luminaire operates at all material times, from the battery when the mains fails. It will have a permanent supply and a switched supply which can be used to turn the lamp on or off in normal mains operation.

### **Combined non-maintained (CNM)**

A combined non-maintained luminaire, (historically referred to as sustained) contains more than one lamp, one of which is mains operated, the other is for emergency use. When mains is healthy, one or more lamps operate, but when mains fails the emergency lamp operates.

### **Combined maintained**

A combined maintained luminaire is similar to a combined non-maintained luminaire but the emergency lamp is maintained, so that when mains is healthy all lamps operate, but when the mains fails only one lamp operates.

Compound self contained emergency luminaires  
Self contained luminaires providing maintained or non-maintained emergency lighting plus also providing an emergency supply for operating a satellite luminaire.

### **Satellite emergency luminaire**

Unit or units comprising a supply changeover system, a battery charging device and, where appropriate, a means for testing.

### **Requirement for maintained emergency lighting**

Non-maintained luminaires may prove sufficient where the emergency lighting system only needs to provide illumination on mains failure. However, maintained exit signs should be installed, in line with BS 5266-1, to cover the specific risk that occupants in the premises might be “unfamiliar” with the escape routes.

This requirement also extends to premises used for recreation where the lighting may be dimmed or turned off (e.g. theatres, cinemas, restaurants, etc.)

Additionally maintained emergency lighting systems should be installed in the following premises:

- Premises providing sleeping accommodation (e.g. hotels, nursing homes, hospitals, boarding schools)
- Recreational establishments (e.g. theatres, cinemas, public houses, restaurants, etc.), and
- Non-residential public premises (e.g. town halls, libraries, shops, shopping malls, museums, art galleries, covered car parks, etc.)

In all premises where regulations apply it is important to consult the appropriate enforcing authority, which may require more stringent emergency lighting than the minimum stated in BS 5266.

# Luminaire & system types

## Control & test facility

In addition to the standard categories of luminaire, features for improved functionality and management can be specified.

—  
01 Manual testing of luminaires would prove difficult in many locations, therefore an automated testing system, such as Emergi-Lite IR2 or Naveo, is recommended

These features include test facilities, inhibit or rest modes, and high risk task area functionality.

Emergency luminaires are marked with the relevant feature, coded as a letter. Where an emergency luminaire includes more than one type of control mode, all are marked on the luminaire.

### Test facility

Test facilities are marked on the luminaire with an 'A'. This applies whether a manual or automatic testing system is incorporated into the luminaire. An example automatic testing solution would be Emergi-Lite IR2 infra-red testing or Naveo addressable testing systems (see Section 5.4).

### Rest mode

Rest mode is marked on the luminaire with a 'B'. During a mains failure and when all people are evacuated, the emergency lighting may be switched off or put into rest mode. If people are evacuated quickly this may mean that the building can be reoccupied immediately the mains is restored, because the batteries have not been fully discharged.

### Inhibit mode

Inhibit mode is marked on the luminaire with a 'C'.

This function allows the discharge of the emergency lighting batteries to be inhibited when the building is unoccupied. Even if there is a mains failure during this period, the batteries remain fully charged, and the building can be occupied when required.

The inhibit switch must be interlocked with an essential building service such as the main lighting, so that the building cannot be inadvertently occupied without the emergency lighting being ready for operation.

### High risk task area function

High risk task area functionality is marked on the luminaire with a 'D', and refers to the luminaire's capability to provide the higher illumination levels required in these areas.

—  
01

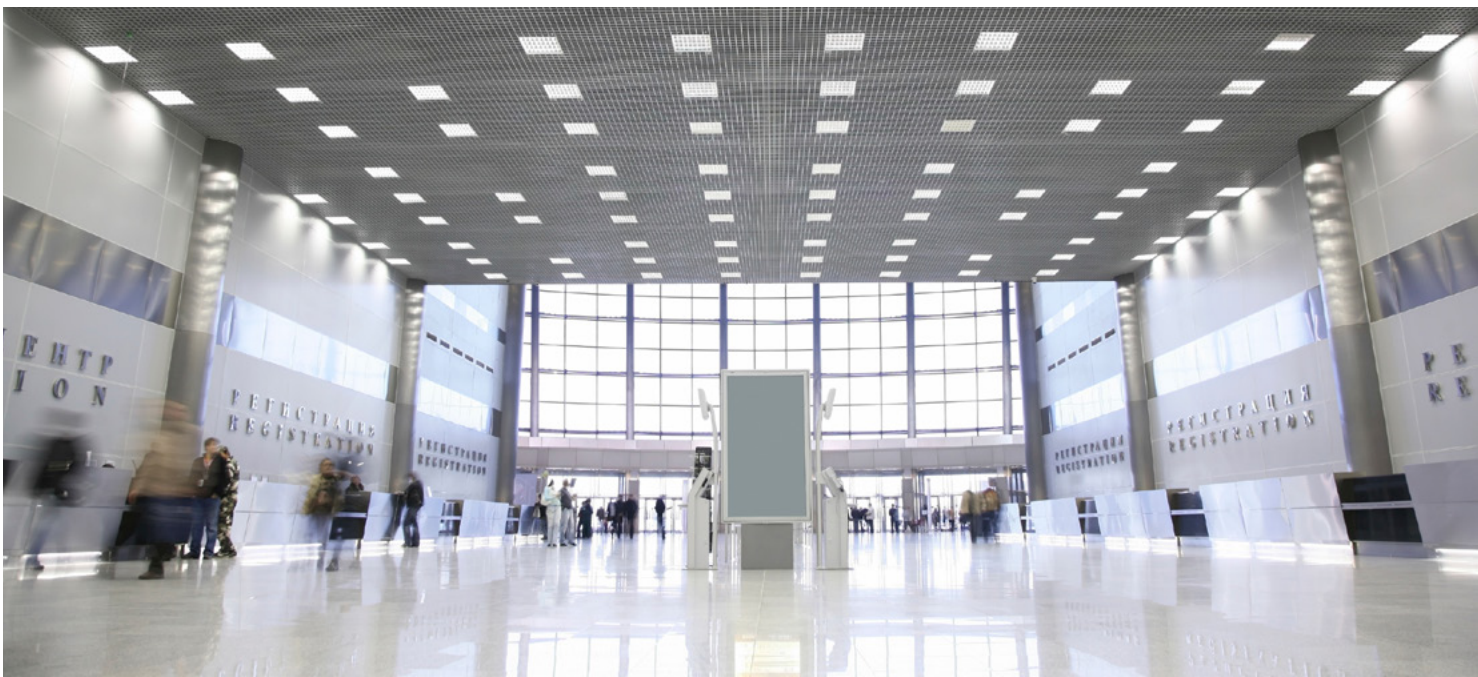

# Luminaire & system types

## Duration

The minimum emergency duration (or autonomy) stipulated by BS 5266 is one hour, though most applications in the UK require a longer duration (see Table 3).

Therefore, in the UK, 3 hours is considered the acceptable duration for an emergency lighting system.

3 Hour duration provides additional safety to locations considered higher risk, and also

enables reoccupation of premises within a shorter period of time, specifically where the battery retains sufficient power to achieve over the minimum 1 hour duration if reactivated before the system has fully recharged.

**Table 3: Required locations for installation of 3 hour duration emergency luminaires**

Required duration	Application
3 hour	Places of entertainment, such as theatres, cinemas, public houses, restaurants, leisure centres etc. These locations are considered higher risk due to the number of occupants likely to be unfamiliar with the premises and the designated escape routes. For these locations, maintained emergency lighting should be installed to ensure maximum visibility of escape routes during times of occupation.
3 hour	Locations with sleeping risk, such as hotels, nursing homes, hospitals, boarding schools, or where evacuation is not immediate. For example, in a hotel, guests could sleep on for up to 2 hours if the mains failed.
3 hour	Locations requiring early reoccupation following a short mains failure, including shops, museums, libraries etc. For example, if a shop was subjected to a mains failure that lasted 1 hour 15 minutes, then, with a 3 hour duration capability, there would be 1 hour 45 minutes remaining capacity. The shop could reopen, because more than 1 hour capability remains. If the emergency lighting had been only 1 hour, then the shop would not have been able to reopen until the battery was recharged. The recharge time could be up to 24 hours for a fully drained battery, but a partially discharged battery would be recharged earlier.

For all these reasons, most emergency lighting systems in the UK are specified as 3 hour duration.



# Luminaire & system types

## Luminaire marking

BS EN 60598-2-22 requires all emergency luminaires to be marked with information relevant to type, performance and manufacture.



01

01 Manual testing of luminaires would prove difficult in many locations, therefore an automated testing system, such as Emergi-Lite IR2 or Naveo, is recommended

Luminaire marking includes:

- Supply voltage range: e.g. 220 - 240 V, 50/60 Hz
- Mark of origin: i.e. the manufacturer's name and address
- Luminaire type: self-contained, slave etc
- Luminaire category:
  - 0 - non-maintained
  - 1 - maintained
  - 2 - combined non-maintained
  - 3 - combined maintained
- Luminaire features:
  - A - test device
  - B - rest mode
  - C - inhibit mode
  - D - high risk task area luminaire
- Luminaire duration, in minutes:
  - 60 - 1 hour
  - 180 - 3 hour
- F-mark if suitable for mounting on a flammable surface

- CE mark
- Product code
- Marking for other Standards (e.g. Kitemark®/ ICEL registration scheme) as applicable

Figure 3 provides an example of the label information displayed on an emergency luminaire.

Figure 3: Product labelling example

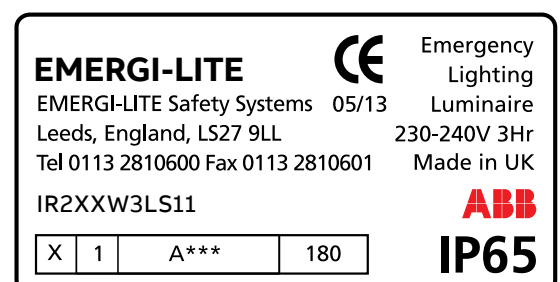

# Luminaire & system types

## Self-contained emergency lighting systems

There are three types of emergency lighting:

- Self-contained
- Slave, or
- Mains lighting conversions

The emergency lighting requirement can be achieved using any of these approaches, though there are considerable differences between them.

Self-contained emergency lighting products should be designed and manufactured to meet the requirements of BS EN 60598-2-22.

Within the self-contained emergency lighting system, each luminaire is self-reliant and operates independently of all other luminaires.

Essentially, the self-contained emergency luminaire operates as a micro-system in itself, and incorporates all the relevant components for starting and maintaining the lamp in an emergency situation, including battery, charger and control unit (see Figure 4).

These components are either built into the unit or are connected via a remote enclosure in close proximity to the luminaire (less than 1m distant).

In a local or general power failure, the emergency luminaire operates from the internal battery.

### Installation

Since each unit operates independently, installation is relatively straightforward.

With the emergency components in-built or within 1m distance, there are no special cable requirements for self-contained emergency lighting, over and above those for installation of standard mains lighting, in line with BS 7671.

However, self-contained emergency lighting must be connected to the unswitched mains supply.

Figure 4: Schematic of a self-contained emergency luminaire

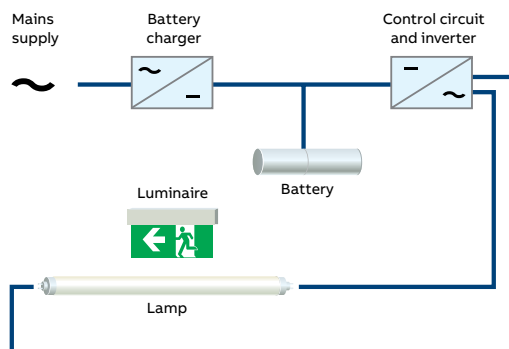

### Maintenance & testing

Self-contained emergency luminaires require regular testing and maintenance checks to ensure proper functioning, as stipulated by the Fire Regulations.

Manual testing of emergency lighting can be highly disruptive and labour intensive, especially over large sites. Therefore, specifying a test facility with the emergency lighting system is recommended.

See Section 5.4 for further information on semi-automatic and automatic test systems.

### Battery performance

Self-contained emergency luminaires are carefully designed to keep the temperature and electrical stress within the limits imposed by the cell manufacturer to achieve a 4 year battery design life.

ICEL 1001 registered luminaires are independently checked for operation within these limits and have regular cell audits to substantiate their life expectations (to Testing Standard ICEL 1010).

Battery replacement should be expected after expiry of the initial 4 year design life of the cells, and at similar regular intervals thereafter.

The battery is usually a cylindrical sealed battery comprising two or more cells. The battery is under charger control, with the luminaire ready to provide full rated duration at any time.

Nickel cadmium (NiCad, or NiCd) or nickel metal hydride (NiMH) sealed cells are most common, though sealed lead acid (SLA) cells may be used,

which have lower temperature limits than NiCad or NiMH batteries.

SLA batteries are available in many amp-hour and voltage ratings however, and their use in self-contained emergency luminaires is therefore limited to those running at moderate temperature, such as twin beam units.

### Cost of ownership

Self-contained systems are considered economic for smaller to medium sized premises. In the first 4 years, few faults would be anticipated. Afterwards, regular battery replacement and maintenance of the system may add substantial cost to the installation.

For larger scale installations, a central power supply solution may prove preferable and be more cost efficient. (See Figure 5 for comparative cost analysis).

**Figure 5: Comparative cost of purchasing and running self-contained and central power supply systems (typical case)**

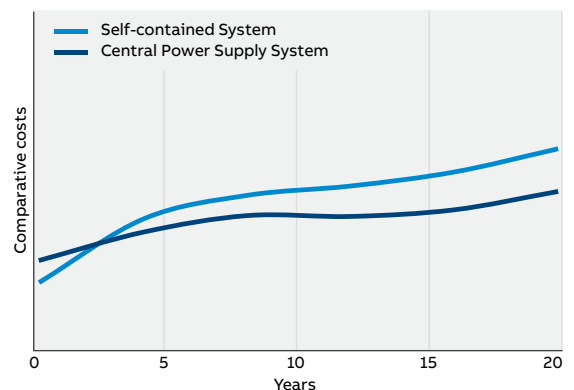

# Luminaire & system types

## Emergency lighting central power supply systems

A central power supply (CPS) system is essentially a large set of batteries with control at a single central location, containing sufficient power to start and maintain all luminaires in the emergency lighting system, should the mains supply fail.

The CPS unit comprises the battery set, battery charger, control circuitry, alarms and instrumentation to ensure reliable provision of emergency power when required.

The emergency lighting throughout the site is provided by 'slave' emergency luminaires, which contain no battery (see Figure 6).

The system can be enhanced with sub-circuit monitoring relays to operate the emergency lighting if the local final mains supply circuit fails.

The CPS system is rated to achieve the load required, with battery duration typically set at 1, 2 or 3 hours, as established by the requirements of BS 5266 and the risk assessment.

### Installation & maintenance

Within CPS systems the power source is remote from the luminaire, so connection between the two must be protected in case of fire.

BS 7671 requires fire resistant cable to be used. This ensures that if fire affects part of the wiring, the luminaires on that circuit will continue to operate.

The central unit houses all the battery power for the emergency lighting system and should be sited within a dedicated room with safety and ventilation requirements complying with EN 50272.

Additionally, this room should be in an area of low fire risk, away from hazards such as electrical switchgear and distribution boards.

### Battery performance

Typically, a CPS system has an operational design life of 20 years or more, with battery replacement required after 8 - 10 years (depending on battery type).

Table 4 below highlights the differing battery types available and the expected design life.

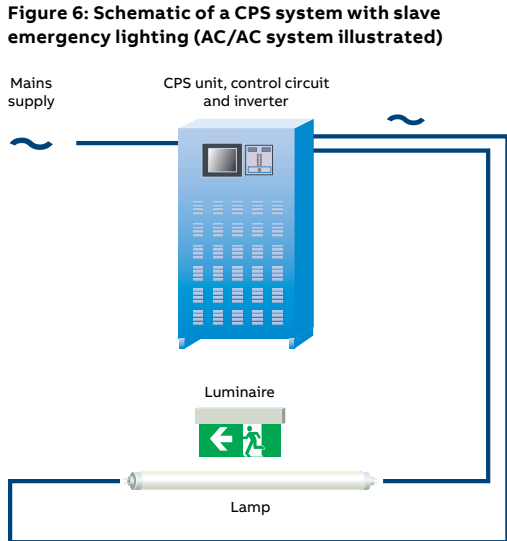

Table 4: Rechargeable battery types for CPS systems

Type	Description	Standard	Design life
Sealed lead acid	High performance valve regulated electrolyte recombination	BS EN 60896-22	10 years
Sealed lead acid	Valve regulated gel electrolyte	BS EN 61056	4 years
Vented lead acid	High performance Plante	BS 6290-2	25 years
Vented lead acid	Pasted plate	BS 6290-3	10 years
Vented nickel cadmium	Prismatic (i.e. not cylindrical)	BS EN 60623	25 years



Lead acid batteries give optimum capacity at room temperature, so if the temperature is likely to fall below 15°C, the battery capacity may have to be increased to compensate.

Battery charging is based on constant voltage techniques, but the charging voltage falls as temperature increases.

Battery chargers must therefore have temperature compensation included, to maximise battery life and ensure a full charge at all temperatures.

Vented cells need maintenance and should be checked monthly or according to instructions and topped up with distilled water if necessary.

Sealed cells do not require maintenance but should be checked for general condition or corrosion of connectors.

All maintenance checks of CPS systems should be undertaken by a competent engineer.

Where uncertain, it is recommended that system owners seek the advice of the system manufacturer.

### System types

Central systems fall into two categories - AC/DC power supply systems and AC/AC static inverter systems.

Both types of central system operate on the same principle; that the luminaire is fed, via emergency sub-distribution, from a single supply source (the CPS unit).

The term 'static inverter' is derived from the lack of moving parts within the equipment, as opposed to rotary motor/generator converter designs.

### DC central power supplies

Central power supplies can be based on direct use of a battery, so that in the emergency condition the battery is connected directly to the emergency lighting load.

The battery is usually 24 V, 48/50 V or 108/110 V.

If the battery is constructed from blocks of multiple cells, then the 48 V and 108 V alternatives are used.

The following categories apply:

- Non-maintained
- Maintained
- DC systems with sub-circuit monitoring

#### Non-Maintained

When the mains fails the contactor CN 1 is de-energised and connects the battery to the load (Figure 7).

#### Maintained

At the output, the load is AC powered through the maintained transformer (T1), and controlled by switch S1.

When the mains fails the contactor CN 1 is de-energised and connects the battery to the load (Figure 8).

DC Systems with sub-circuit monitoring  
Figures 7 & 8 imply that the emergency lighting operates if the normal mains to the CPS fails.

There is a risk in this case that if a local final circuit (usually referred to as a sub-circuit) fails, the mains supply to the system will still be present and the emergency lighting system will not operate.

Figure 7: Non-Maintained DC system

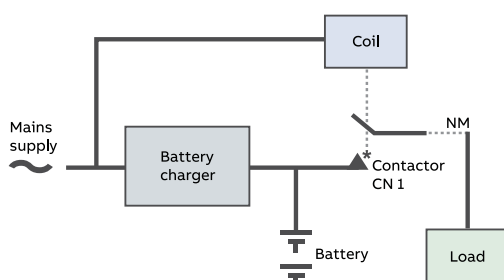

\*two pole contactors are normally used.

Figure 8: Maintained DC system

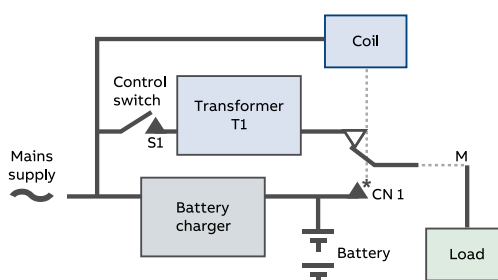

\*Two pole contactors are normally used.

# Luminaire & system types

## Emergency lighting central power supply systems

This can be resolved by using one of the following alternatives:

- A maintained system which operates the emergency slave luminaires at all times
- A maintained system with hold-off devices in each luminaire
- A non-maintained system with sub-circuit relays monitoring each final circuit (Figure 9).
- The monitoring relays are shown with contacts in the energised state. If any relay is de-energised the contact opens, de-energising CN 1 and supplying power to the NM output
- A maintained system with relays sensing each final circuit (Figure 10)

In Figure 10, the output is split with sub-circuit monitoring relays on each output, (A to N) so that if a final circuit fails, only the relevant relay contact closes and the emergency lighting in that area operates. Lamps or luminaires designed for emergency use must conform to BS EN 60598.2.22:2014

### Central power supplies with inverters - AC system

With the use of an inverter the battery voltage is transformed from DC to AC (mains voltage).

The slave luminaires can therefore be mains luminaires without modification or conversion. This can be useful where a uniform decor and luminaire style are required through an area, or where a special luminaire such as a chandelier needs to operate in an emergency.

The categories apply as follows:

### Non-Maintained AC system

When the mains fails the control circuit causes the inverter to operate and power the load (Figure 11).

### Maintained AC System

The load is normally powered using the mains supply connected through the changeover device (which could be a contactor).

Figure 9: DC system with sub-circuit monitoring

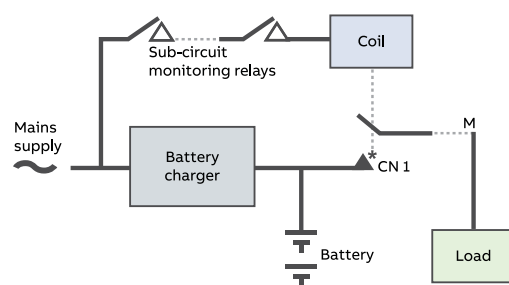

\* Two pole contactors are normally used.

Figure 11: Non-maintained AC system

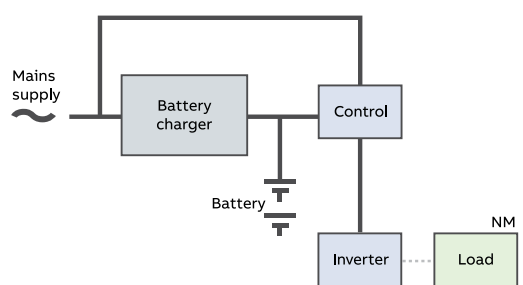

Figure 10: Maintained DC system with relays sensing each final circuit

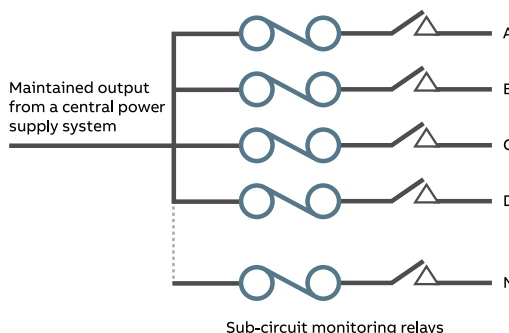
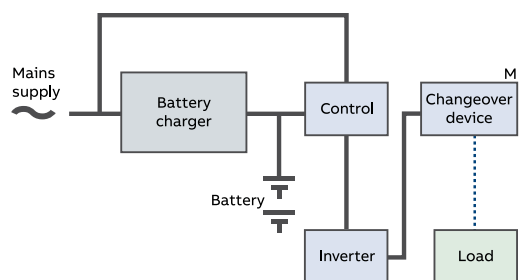

Figure 12: Maintained AC system



When the mains fails the control circuit operates the inverter and the changeover device connects the load to the inverter (Figure 12).

Note :

There are many ways of controlling and connecting active electronic parts such as inverters, and the methods shown are examples.

#### **Changeover contactors for central power supplies**

In the past, contactors complying with BS 764 (specification for automatic changeover contactors for emergency lighting) were specified for use in central power supplies.

This requirement is not included in BS 5266-1 and reference is made to EN 50171 (Central Power Supply Systems), which requires changeover contactors conforming to EN 60947-4-1 and EN 50272-2, with switching thresholds conforming to BS EN 60598-2-22.



# Luminaire & system types

## Mains luminaire conversions

Almost any general lighting can be converted for emergency use.

01 Remote conversion kit for converting mains luminaires for self-contained emergency use

The conversion work is normally undertaken by the emergency lighting manufacturer, who installs a conversion kit into the luminaire.

The emergency lighting manufacturer needs to ensure all work complies with the relevant standards and EU directives.

Emergi-Lite conversions are certified to ICEL 1004, providing this reassurance.

Luminaire conversion kits are available to convert mains luminaires for both self-contained and slave use, providing massive scope to the emergency lighting system designer.

The conversion kit comprises an emergency driver or module, and for self-contained conversions a rechargeable battery.

In instances where the mains luminaire contains more than one lamp, it is usual to convert just one of the lamps for emergency use.

Figure 13 provides an outline of a mains luminaire converted for emergency use.

When converting, care should be taken to ensure that the temperature limits of the battery and control gear are not exceeded and that the control gear is compatible with the lamp to be used.

In cases where the luminaire has insufficient internal room for the conversion kit, or if the luminaire internal temperatures are too high, a remote conversion kit can be used (see Figure 14).

The remote kit is a housing containing the module and battery (for self-contained systems) and wired to the luminaire by a connecting cable.

BS EN 60598-2-22 clause 3.8 limits the length of the connecting cable to 1m, but Emergi-Lite branded conversions include an exposed length of cable not exceeding 0.5m, to comply with EMC and operational requirements.

Figure 13: Schematic of a converted mains luminaire system (before and after conversion)

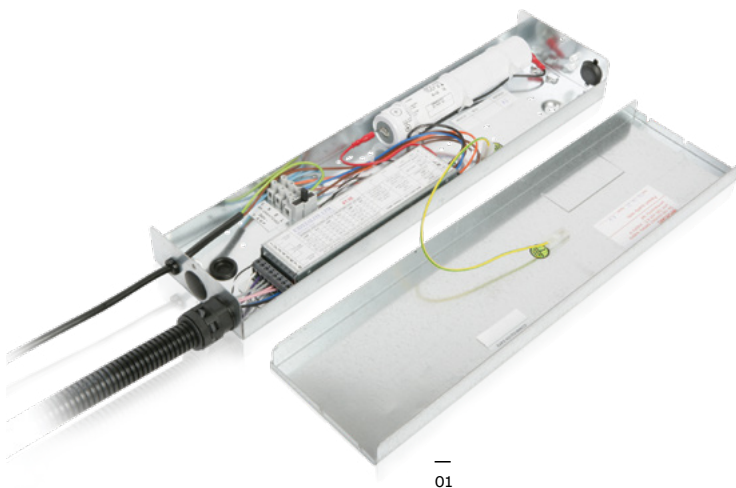
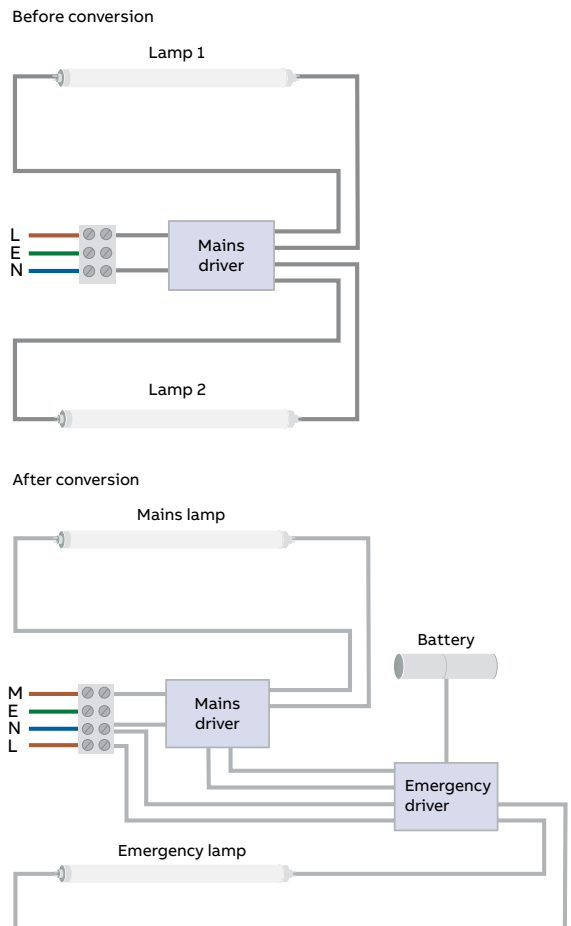

### Considerations when converting mains luminaires

For those considering a mains conversion solution, it is recommended to check the following before commencing conversion work on a luminaire:

- There is sufficient room in the luminaire for the conversion kit
- The internal temperatures in the luminaire at the maximum rated mains voltage are compatible with the module and battery (for self-contained). Modules are usually rated at a maximum case temperature of 70°C and the battery is rated at up to 55°C for the best cells, but more usually 50°C (55°C for higher rated cells)
- The life expectancy required for self-contained emergency luminaires is 4 years for the battery life and at least twice this (ref. ICEL 1001:1999) for the module. To achieve this, measurements should be made to show that battery temperatures are less than 50°C and module temperatures are less than 50°C or as otherwise declared by the manufacturer
- The compatibility of the lamp with the emergency lighting driver. Light output data for the lamp and driver combination should be obtained from the manufacturer, taking into account correction factors, K and BLF (see Appendix A)
- The emergency lighting spacing table (if available) to enable the designer to position the luminaires according to the transverse or axial orientation and height above the floor
- The charge indicator LED for self-contained conversions is visible. If the LED is not visible, an LED mounting flange may be required to fit into the ceiling adjacent to the luminaire
- The lamp(s) to be converted is not 2 pin with integral glow starter. This type of lamp is not permitted for emergency use (ref BS EN 60598-2-22 clause 22.6.1).

Luminaires converted under the ICEL 1004 scheme will provide all the above with certification. This is an excellent quality certificate from which the user can be assured of a product fit for purpose for years of safety in service.

### Other conversion tips and pitfalls

- Tungsten filament and tungsten halogen lamps are power hungry compared to LED
- Many tungsten halogen downlighters have a narrow beam angle. It can therefore be difficult to achieve the 40 : 1 maximum to minimum ratio required, without a large number of downlighters over-lighting the area
- Amalgam fluorescent lamps have a slow warm up and unless special steps are taken, they may not be suitable for emergency lighting. Check lamp/driver compatibility

### Supplementary emergency lighting

A key aspect of mains lighting conversion is the difficulty in realising the emergency light output accurately, since the optics for a mains luminaire are set up for normal illumination.

With the availability of recessed emergency LED downlighters, an alternative is to fit a dedicated emergency LED luminaire in the vicinity to provide reliable emergency illumination, as the spacing for these products is already determined.

Unobtrusive point source emergency LED downlighter products (such as Emergi-Lite Serenga) can therefore provide a suitable supplement to the existing scheme.

Figure 14: Internal versus remote conversion

All parts are housed in the luminaire, all temperatures within limits

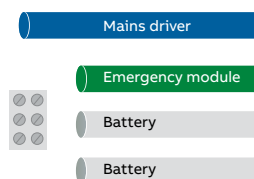

Remote unit required - luminaire too small or internal temperature too high for emergency components

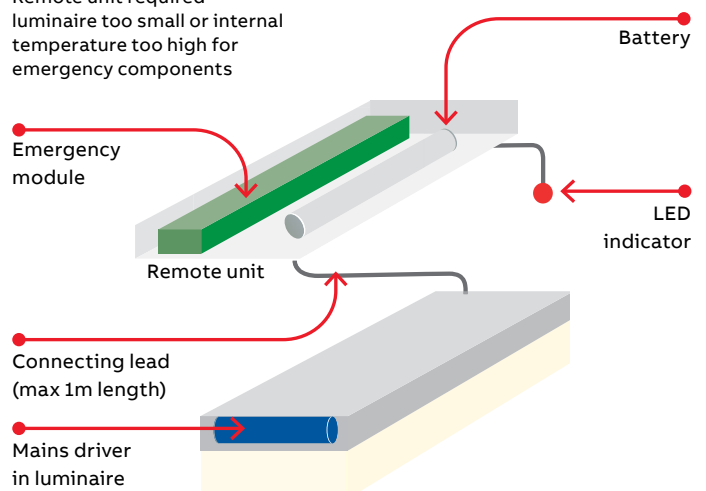

---

# System design & assessment

## Introduction

The Fire Regulations have firmly established the requirement for emergency lighting. In support of these regulations, British Standard, BS 5266, has been drawn up as the Code of Practice controlling the application of emergency lighting within non-domestic premises.

### Introduction

In principle, BS 5266 defines where emergency lighting is required. The standard ensures that:

- Escape routes are clearly indicated with exit signs so there is no doubt as to the way out
- Open areas used as an escape route are appropriately illuminated so that obstructions such as equipment or furniture can be avoided
- Fire alarm call points and fire fighting equipment can be readily located
- High risk task areas have sufficient illumination to allow potentially dangerous processes to be shut down safely

BS 5266 clarifies the type, location and number of emergency luminaires required, and by following

the recommendations, specifiers or designers can ensure building occupants have opportunity to cease operational activities as necessary and navigate safely to an exit in an emergency.

Since the Fire Regulations are retrospective, the requirement for emergency lighting does not extend solely to specifiers and designers planning new systems. All UK premises, both newbuilds and existing, must meet the regulatory requirement and therefore follow the guidance in BS 5266.

This section therefore focuses on the key requirements for the application of emergency lighting, in line with BS 5266.



# System design & assessment

## Directional guidance along escape routes

Any point on an escape route, or leading to it must have an exit sign so that the direction of travel is not in doubt.

Exit signs should clearly identify the full extent of the escape route, including any changes of direction.

If there is doubt at any point, additional signs should be fitted, but directional arrows alone are insufficient. Within BS 5266, mandatory points of emphasis along the escape route are clearly defined (see Section 4.3).

The style of exit sign should follow guidance set out in BS 5266, the Signs Directive and the UK Signs and Signals Regulations.

Historically these documents have identified European, BS 5499 and ISO 3864 format pictograms as acceptable for use in emergency lighting systems, whereas text only exit signs were not permissible.

For the most part, this led the UK market towards provision of illuminated exit signs in European pictogram format. However, the defined format for exit signs now follows BS ISO 7010 (the exit sign format is comparable in style to those established previously by BS 5499 and ISO 3864). The standard makes clear that only one exit sign format should be used within an emergency lighting system, to avoid risk of confusion.

European pictogram format exit signs therefore remain acceptable, as these form the majority of existing installations and are likely to be required for partial retrofit or refurbishment activity.

For new construction projects the BS ISO 7010 sign format should be used.



# System design & assessment

## Directional guidance along escape routes

In addition to format, specific requirements for illuminance and colour contrast have been set in BS ISO 3864-4 for exit signs to ensure these are clearly visible (see Figure 16). Exit signs which have been designed to meet BS EN 60598-2-22 will meet these criteria.

Two options for providing directional guidance are available - exit signboards or internally illuminated exit signs.

### Exit signboards

Following BS 5266-1:2016, exit signboards (including photo-luminescent signs) need to be illuminated to a minimum of 5 lux whenever premises are occupied.

Historically, illumination has been provided by an emergency luminaire sited adjacent to the exit signboard, i.e. within 2m horizontally (see Figure 15), to ensure it is sufficiently lit.

This approach however makes the minimum 5 lux requirement difficult to achieve or calculate. Therefore the use of internally illuminated signs, instead of exit signboards, is the effective approach.

### Minimum illuminance/colour contrast requirements for exit signs

Minimum illuminance levels have been set for exit signs to ensure these are clearly visible at all times the premises are occupied (see Figure 16).

At the specified viewing distance for the exit sign, the minimum level of illuminance at any point on the signboard is stated as 2 cd/m<sup>2</sup>.

The ratio of minimum to maximum illuminance in any part of the pictogram should not be greater than 10 : 1, with contrast between white and green to be between 5 : 1 and 15 : 1.

Emergency luminaires designed to comply with BS EN 60598-2-22 meet this requirement.

Figure 15: Exit signboard externally lit by a emergency luminaire

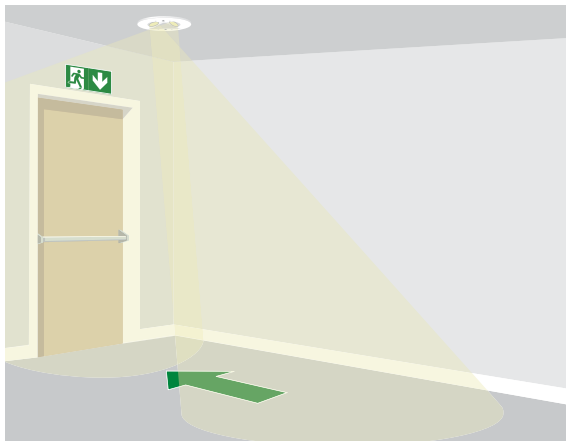
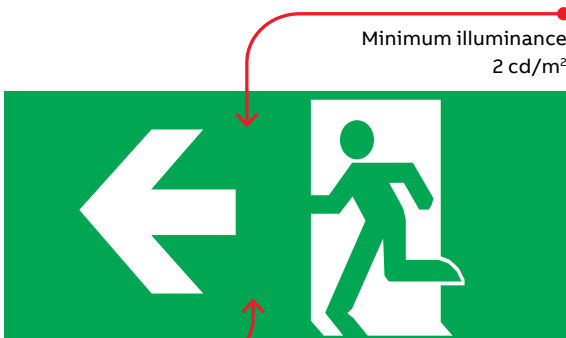

Figure 16: Exit sign formats and minimum illuminance/contrast ratios for emergency exit signs



Contrast between white and green colour to be between 5 : 1 and 15 : 1



BS ISO 7010 format pictograms are the recommended format in BS 5266 and acceptable within the UK Signs and Signals Regulations.



European format pictograms remain acceptable in BS 5266, the Signs Directive and the UK Signs and Signals Regulations.



Text only exit signs are obsolete and must be replaced.



### Internally illuminated exit signs

Internally illuminated exit signs provide a more effective approach of emphasising the way out. This sign type offers twice the viewing distance of exit signboards (see maximum viewing distances and Figures 17 & 19 below).

For internally illuminated signs, the green exit pictogram absorbs most of the light, so for practical purposes when designing a lighting scheme, the small amount of light emitted cannot be considered as part of the overall illuminance of the scheme.

However, some exit signs are specially designed with an effective downlight, which illuminates the doorway, threshold and a certain distance around the sign on the floor, such as Emergi-Lite Serenga 4 LED exit signs (see Figure 18).

Where such signs are approved by a national test house and the light output authenticated, then the published spacing data can be used in a lighting scheme.

Many emergency luminaires can be converted into exit signs using self-adhesive or clip-on pictogram legends.

These types are acceptable as exit signs, but as with dedicated internally illuminated signs, the emergency light output should be ignored unless authenticated otherwise.

### Maximum viewing distances

Internally illuminated exit signs offer twice the viewing distance of exit signboards.

Exit signboards must be illuminated to a minimum of 5 lux on the face of the board. To calculate the maximum viewing distance for exit signboards, the height of the pictogram legend is multiplied by a factor of 100 (see Figure 17).

Therefore the maximum distance (d) at which a sign of 125mm legend height is effective and easily seen would be as follows:

$$d = 100 \times h$$

Where  $h = 125\text{mm}$ , then

$$d = 100 \times 0.125 = 12.5\text{m}$$

For longer corridors or larger open areas where the maximum viewing distance is exceeded, additional signage would be required.

Internally illuminated signs have a maximum viewing distance of  $200 \times$  the height of the pictogram legend in metres, as shown in Figure 19. [Reference: BS 5499-10:2014]

Hence, for a sign with 125mm legend height the maximum viewing distance would be:

$$d = 200 \times h$$

Where  $h = 125\text{mm}$ , then  $d = 200 \times 0.125 = 25\text{m}$

### Exit sign mounting height

Exit signs should be wall mounted at a height of 2 to 2.5m above floor level. This is the height at which the eye is accustomed to look for a sign.

Signs mounted lower may be obscured by other people on the escape route and signs mounted higher may be outside the field of view. If wall mounting is impossible (e.g. because of a glass panel above the doorway) then edge illuminated signs or back illuminated with top fixings can be used.

Alternatively an exit signboard on the wall with an adjacent emergency luminaire could be considered, as long as it is illuminated to a minimum of 5 lux.

Signs mounted on the ceiling with the legend panel parallel to the ceiling are definitely not recommended because the oblique angle will affect legibility and the mounting height recommendation may not be met.

For certain way-finding uses, low mounted signs can be used, but these should be in addition to exit signs mounted at 2 to 2.5m.

Figure 17: Viewing distance calculations for exit signboards (100 x pictogram height 'h')

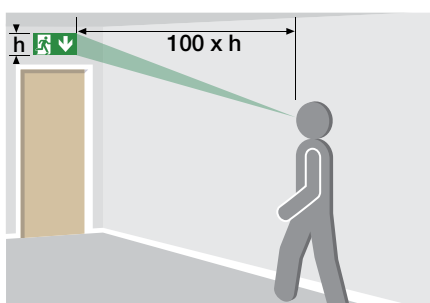

Figure 18: Internally illuminated exit sign with downlight emergency lighting provision

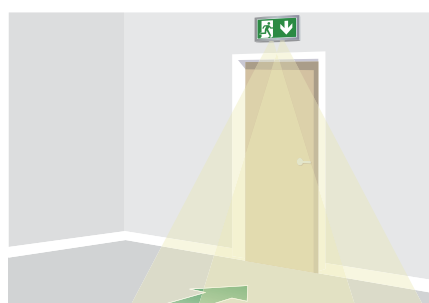
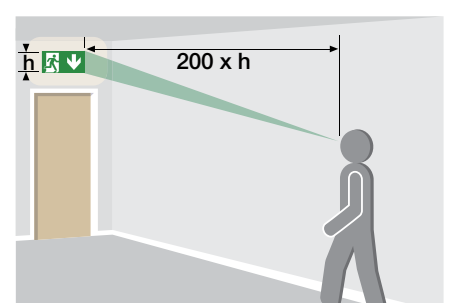

Figure 19: Viewing distance calculations for internally illuminated signs (200 x pictogram height 'h')



# System design & assessment

## Escape route and open area illumination

Emergency lighting must be provided along escape routes, and in the open areas leading to them, to enable people to move quickly and safely to an exit.

Within BS 5266, specific levels of illumination for escape routes, open areas, and for points of emphasis such as fire fighting equipment have been established to ensure building occupants can see clearly and avoid obstacles whilst evacuating.

BS 5266 requires that:

- Mandatory points of emphasis, such as stairs, or fire extinguishers are sufficiently illuminated (see Section 4.3, mandatory points of emphasis)
- A sufficient number of emergency luminaires are installed to provide the minimum illuminance levels in escape routes and open areas
- Escape route compartments should contain a minimum of two emergency luminaires, for system integrity

Additionally, BS 5266 makes clear that escape routes need to be maintained free of obstructions, e.g. photocopiers or temporarily stored items.

Since, in an emergency, objects may be abandoned along the escape route, the emergency lighting installation must also be sufficient for people to see these and avoid them.

### Luminaire mounting height

Emergency luminaires should be mounted at least 2m above the floor.

There is no definite upper limit for mounting height of emergency luminaires, but if there is a significant risk of smoke affecting the illuminance on the floor, luminaires should be fitted below the smoke level.

If there is a special situation with a high risk of smoke, then low level way-finding to BS 5266-2 can be considered in addition to the overhead emergency lighting.

### System integrity

All escape route compartments should contain a minimum of two luminaires. In the event that one luminaire fails, the other maintains a level of illumination within the compartment so as not to hinder people exiting the premises.

For small lobbies where two emergency luminaires would not be viable, glass [vision] panels should be installed to allow light from neighbouring compartments to show through.

No compartment of the escape route should be totally dependent on the light from one emergency luminaire.

The same risk holds true for open areas. Theoretically, a large open area could be illuminated by a single, powerful emergency luminaire.

However, this would not be considered acceptable because if the luminaire were to fail (perhaps due to lamp wear out), the whole area would be plunged into darkness and people may not be able to evacuate.

For this reason, using a larger number of low power luminaires for illuminating open areas is recommended.

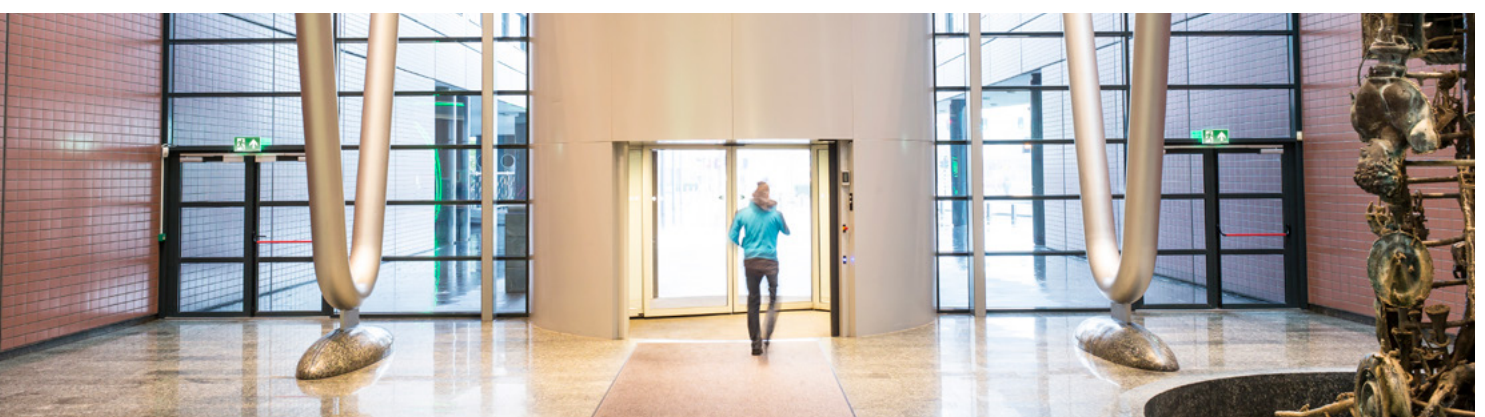

—  
01 Designated escape routes wider than 2m should be calculated as separate strips of 2m or considered as open areas

### Luminaire response times

A designer may choose to use dedicated emergency luminaires, or opt for converted mains luminaires, when planning an emergency lighting system.

In either event, the luminaires must provide their illumination within a specific length of time, as defined by BS 5266.

The requirement for escape routes and open areas is that the emergency lighting should operate within 5 seconds at an output of more than 50%, and within 60 seconds at full output, through to the end of rated duration (see table 5 on page 57 for specific area cover. See Appendix A7 for a graph of light output showing F5, F60 and Fend for further reference).

Dedicated emergency luminaires, designed and manufactured in line with BS EN 60598-2-22, will respond within this time frame.

Many conversion units, used as maintained emergency lighting, will operate within this time and because the lamp is already warm, full power may well be achieved within 0.5 seconds.

Luminaire response time may also be important when mains is restored. Some conversion units compatible with electronic drivers have delay units built in, so the manufacturers should be consulted

to determine response times and photometric output at mains failure and mains restoration transitions. Most types of high-pressure discharge lighting have a slow ignition and gradual warm up phase, so they are not generally recommended for emergency lighting.

If it is essential to use this type of lighting for emergency purposes, a no-break supply may be suitable. However, for simplicity, it is recommended that dedicated emergency lighting, separate from the discharge lighting is used (see also Section 4.9).

### Illuminance levels

Following positioning at mandatory points of emphasis, emergency luminaires should be spaced within escape routes and open areas accordingly to achieve the illumination requirements set out in BS 5266.

### Manufacturers

of emergency lighting can provide relevant spacing data to enable the correct planning of the emergency lighting system.

Using authenticated spacing data provides a more effective way of planning the emergency lighting system to the correct lux levels, rather than having to measure the lux levels following installation to prove compliance (see Appendix A.2 for more information on spacing data).

—  
01



# System design & assessment

## Escape route and open area illumination

### Escape route illumination

The illuminance required on the floor of a corridor-like escape route up to 2m wide should be a minimum of 1 lux along the centre line and a minimum of 0.5 lux in the 1m wide central band.

Escape routes wider than 2m should be treated as multiple strips of 2m or as open areas.

Luminaires placed transversely across the escape route provide wider spacing than luminaires placed axially (see Figures 20 and 21)

Figure 20: Transverse spacing between emergency luminaires, within a 2m wide corridor

Escape route with transverse luminaires

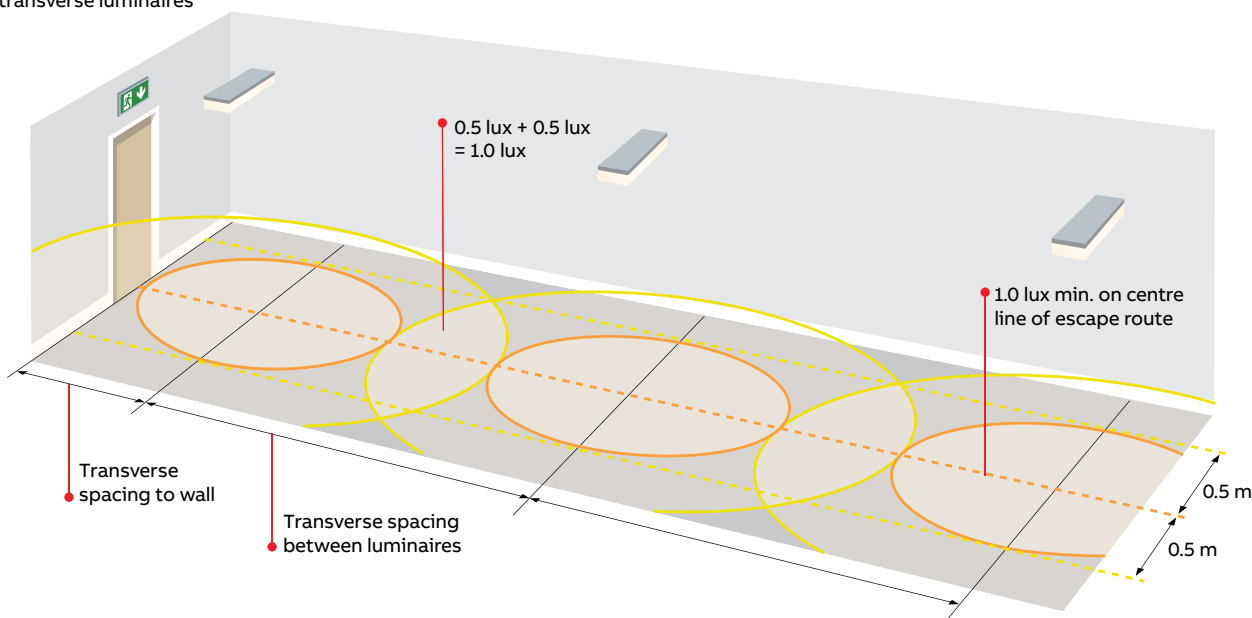
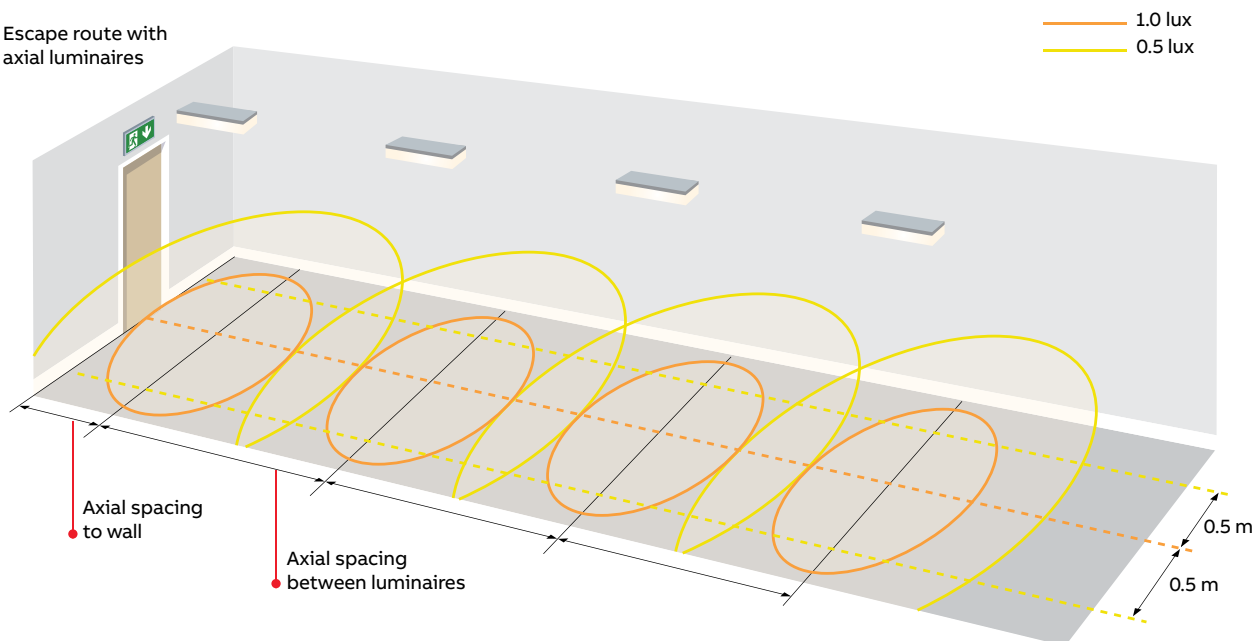

Figure 21: Axial spacing between emergency luminaires, within a 2m wide corridor

Escape route with axial luminaires



### Open area illumination

BS 5266 defines any area larger than  $60\text{m}^2$  where people could find themselves in an emergency as an open area requiring emergency lighting.

In open areas, illumination of 0.5 lux minimum should be provided.

Since people are considered to move through a 'core area' to an exit, the requirement for emergency lighting excludes the outer rim of 0.5m from the walls or fixed partitions, and the floor area under furniture (see Figure 22).

Open areas under  $60\text{m}^2$  may require emergency lighting, especially if they are considered to contain additional hazards.

These hazards should be determined in the risk assessment.

### Ratio of uniformity

To help visibility when moving through escape routes and open areas, brightly illuminated parts should not contrast overly with dimly lit ones.

A ratio for uniformity has been established. For escape routes and open areas, a maximum to minimum 40 : 1 ratio is required. If the minimum is 1 lux, then the maximum should not exceed 40 lux (see Figure 23).

If for some reason the maximum is higher than this, then the minimum should be increased proportionally.

In practice emergency luminaires do not emit sufficient downward light to produce 40 lux on the floor, but if more powerful general lighting luminaires are used for emergency lighting, the maximum should be checked.

Figure 22: Open area illuminance requirements

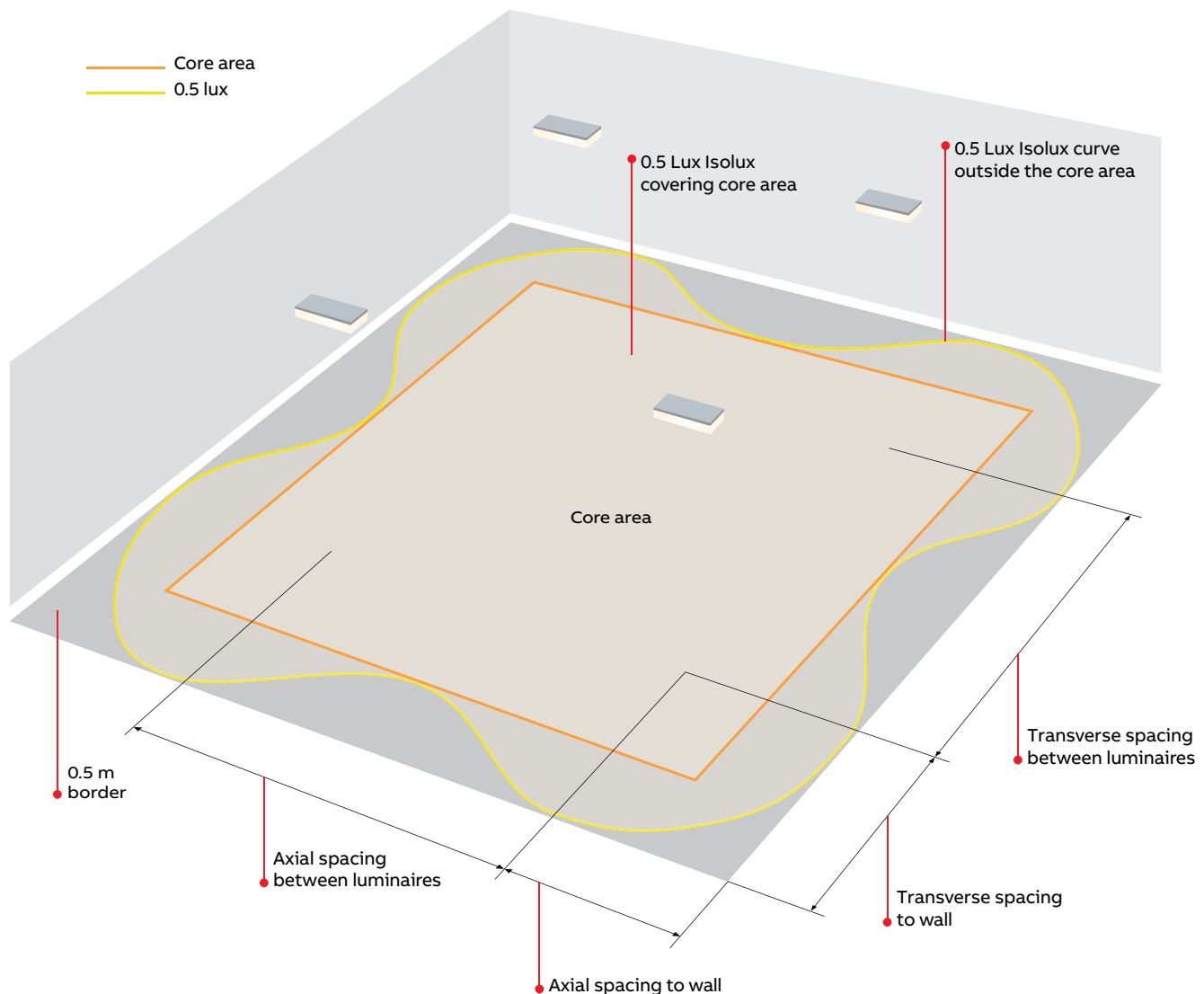

# System design & assessment

## Escape route and open area illumination

01 Whilst emergency lighting is in operation, building occupants should be able to distinguish colours, such as red fire fighting equipment

### Colour referencing (Ra)

For all emergency lighting, the illuminance provided should enable people to distinguish different colours, such as red fire alarm equipment or extinguishers and green safety signs.

As a datum, the CIE colour rendering index, Ra, has been chosen. Emergency lighting should be better than Ra40.

Ra40 is not an onerous limit.

For example, the figure for tungsten filament and tungsten halogen lamps is Ra100, for fluorescent multi-phosphor it is Ra95 and fluorescent tri-phosphor it is Ra85.

Lamps used in emergency lighting and general lighting are well in conformance with Ra40.

Monochromatic lamps such as standard high-pressure sodium (HPS) and low-pressure sodium

(SOX and SOX-E) have a colour rendering index substantially less than Ra40.

However, some colour corrected HPS lamps have acceptable Ra greater than 40.

Figure 23: Uniformity requirement along escape routes

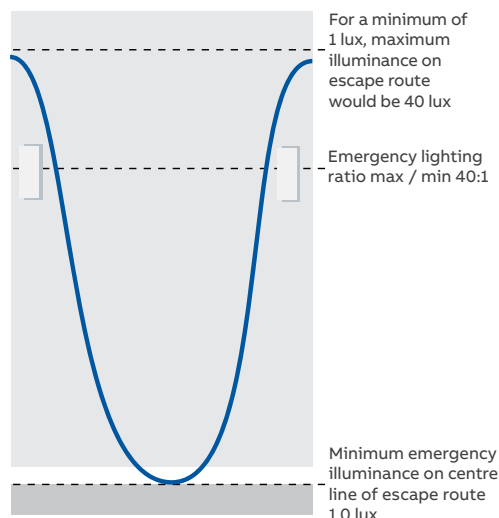

# System design & assessment

## Mandatory points of emphasis

Hazards on the escape route or in open areas need to be highlighted to ensure people do not trip or fall during evacuation. These points on the escape route require extra care.

For this reason the following places have been identified at which an emergency luminaire should be positioned close by (within 2m measured horizontally).

### Near stairs and other changes of level

Potential tripping hazards such as stairs, steps, ramps and other changes of level on the escape route need to be highlighted (see Figure 24).

Each tread should receive direct light from the emergency lighting.

In practice, this often means that stairs require at least two emergency luminaires to ensure the minimum lux level is achieved over the differing tread height levels.

### Near each exit door Inside the premises

Emergency lighting should be positioned near the exit to show the door, the escape sign (if it is not internally illuminated), any safety sign (e.g. 'push bar to open' sign) and the threshold (see Figure 25).

### Sign boards requiring external illumination

Escape route/directional sign or other safety sign boards or stickers require external illumination in emergency lighting condition.



### At changes of direction

Changes of direction need to be highlighted so as to avoid potential confusion and to provide directional guidance to occupants along the escape route, where the final exit is not clearly visible.

Emergency lighting should highlight the wall corner and the facing wall in the direction of travel (see Figure 26).

Figure 24: Illuminating stairs

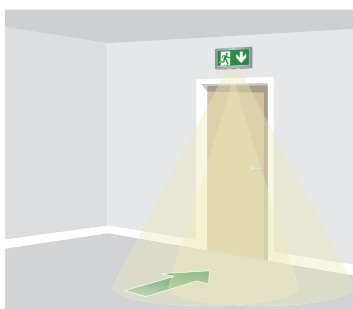

Figure 25: Providing guidance at exits

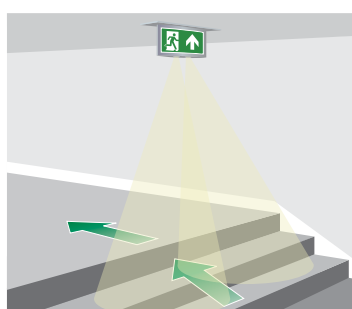
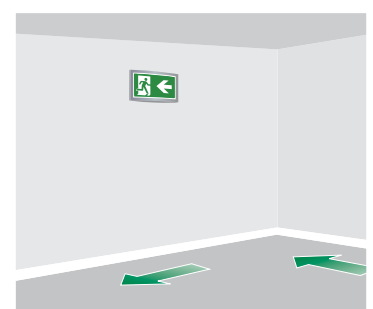

Figure 26: Providing guidance at changes of direction



# System design & assessment

## Mandatory points of emphasis

### At each intersection of a corridor, each T-junction, cross or staggered junction

Corridor intersections and junctions need to be highlighted to show the various walls and corners and to provide directional guidance at potential points of confusion (see Figure 27).

In these areas it is likely that streams of evacuees will converge so the illumination permits those joining the escape route to see others in their path, and also to be seen.

At staggered junctions, two exit signs would be required where the distance to the next section of the escape route is greater than 4m, to ensure an emergency luminaire within 2m of each change of direction.

### Near each piece of fire fighting equipment and call point

Emergency lighting is required to direct attention towards fire fighting equipment and call points, and to make any fire safety related instructions clearly legible (see Figure 28).

For this specific application a minimum light level of 5 lux, directed at the equipment, has been set.

### Near each first aid point

Where the fire risk is not immediate, access to first aid equipment should be available.

Emergency lighting should therefore show any first aid boxes, and be sited within first aid rooms (see Figure 29).

First aid points should be illuminated to a minimum of 5 lux, with first aid rooms being illuminated to a minimum of 15 lux.

### Outside close to exit doors

Outside, emergency lighting should be positioned near to and outside each final exit to guide people away from the building to safety.

Where street lighting is considered for provision of emergency illumination outside the premises, the local Fire Authority needs to be consulted to ensure this application is acceptable.

### Near escape equipment for the disabled

### Near refuges and call points

### Near manual release controls that operate electronically controlled doors

Figure 27: Providing guidance at intersections of corridors and T-junctions

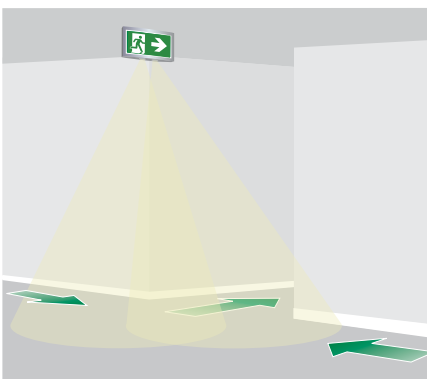

Figure 28: Highlighting fire safety equipment

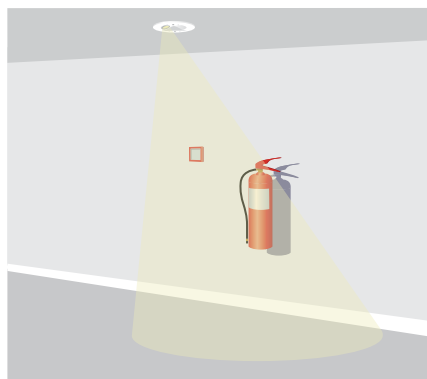
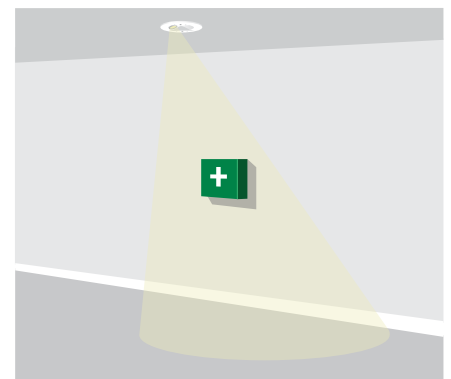

Figure 29: Highlighting first aid equipment





# System design & assessment

## Additional areas requiring emergency lighting

BS 5266 further establishes a number of additional areas requiring emergency lighting within premises.

\*Note: An example of 'borrowed light' would be a glass vision panel in a door allowing an emergency luminaire in a corridor to give some light in a small lobby.

Although not part of a designated escape route, people may be located in these areas at the time of mains failure, and therefore may be at risk and need to move quickly and safely from these areas on to an escape route. These requirements were originally defined within BS 5266-10, but form part of BS 5266-1:2016. The additional areas specified are:

- Lift cars: Lift cars present a risk since occupants may be trapped in these locations during mains supply failures
- Escalators and moving walkways: Escalators should not form part of a planned escape route, however it is feasible that people will be using these at the time of mains failure. Occupants will therefore need to move safely from the escalator or walkway to the escape route. Escalators present a significant tripping hazard since the first and final step are likely to be uneven. Therefore, these locations should be treated as open areas
- Toilets and tiled areas: Toilets, changing rooms etc., larger than 8m<sup>2</sup> require emergency lighting as if they were open areas. Toilets smaller than 8m<sup>2</sup> unless illuminated by borrowed\* emergency light from another area should have at least one emergency luminaire.
- All toilets for disabled use should have at least one luminaire
- Small lobbies with no borrowed\* emergency lighting

- Safety signs
- Motor and plant rooms
- External areas adjacent to final exits: The area needs to be lit if people move to reach a place of safety. If street lighting nearby is unreliable, alternative lighting must be provided as this is part of the escape route
- Pedestrian routes within covered car parks: These need to be treated as escape routes

Additionally, specific recommendations of light levels, response and duration times for particular locations that are at risk in a supply failure are described.

These specific locations include:

- Kitchens
- First aid rooms
- Examination and treatment rooms
- Refuge areas for the mobility impaired
- Plant rooms, switch rooms and emergency winding facilities for lifts
- Fire control and indicating equipment, to enable inspection of their condition
- Reception areas
- Crash bars or security devices at exit doors
- Swimming pool surrounding areas

The illuminance level, response and duration time recommended is shown below in Table 5.

**Table 5: Recommended illuminance level, response and duration time**

Location	Response time(s)	Light level (lux)	Duration	Working plane
Kitchen	0.5	15	30min	Horizontal so switches / openings readily visible
First aid room	5	15	30min	Horizontal
Treatment room	0.5	50	30min	Horizontal
Refuges	5	5	Full rated	Horizontal on floor; vertical on call points / other wall mounted devices
Plant rooms, switch rooms, lift emergency controls	5	15	Full rated	In plane of visual task
Fire panels	5	15	Full rated	In plane of visual task
Reception areas	5	15	Full rated	In plane of visual task (e.g.: desk top)
Crash bars/exit security	5	5	Full rated	Horizontal on level of panic bar; vertical on wall mounted security devices
Swimming & diving pool areas & surrounds	0.5	5	Full rated	Horizontal on floor/walkway/treads

# System design & assessment

## High risk task areas

Areas where additional hazards exist or where processes are being undertaken which would present an increased risk to life safety in the event of an emergency are defined as high risk task areas.

—  
01 Emergi-Lite Cordona high output luminaires can provide illumination to meet the requirement for high risk task areas

In these areas, provided the lives of operators are not in immediate danger, dangerous processes or equipment may need to be shut down for safety before the area is evacuated. Examples include:

- A machine workshop where the equipment/ moving parts could injure occupants
- A control room for an industrial or dangerous process, which needs to be shut down, or
- An industrial process involving dangerous substances which needs to be covered

Emergency lighting should be installed which has sufficient duration to allow occupants to safely remove the hazard.

### Illuminance levels

High risk task areas should be illuminated to 10% of the normal illuminance (lux), or a minimum of 15 lux (whichever is the greater), with a uniformity of 0.1 minimum to the average, at the plane of the task area.

In practice the 15 lux minimum is unlikely to be relevant because the mains lighting for a high risk task is likely to be in excess of 500 lux. 10% of 500 is 50 lux, which is more than the 15 lux minimum.

High risk task area lighting need only provide this higher illuminance in the vicinity of the task. Adjacent areas can be considered as open areas requiring emergency lighting.

### Response times

The requirement for high risk task areas is more critical because a disruption may endanger life while someone is working on a hazardous machine or process.

Full emergency illuminance should therefore be provided within 0.5 seconds through to the end of the required duration.

For highly critical areas a no-break system should be considered.

### Design method for high risk task area lighting

Designers have a choice available to achieve the increased lux requirement for high risk task areas:

- High output LED luminaires, such as the Emergi-Lite Aqualux range, provided their light output from the fixing height meets the percentage emergency lighting requirement for the space under consideration
- Twin beam units with tungsten halogen lamps, such as Emergi-Lite Range-Lites
- A CPS system capable of powering luminaires at much higher lux levels than their self-contained equivalents, such as the Emergi-Lite EMEX range.

AC/AC Static inverter systems have the in-built capacity to power all luminaires at full light output, thereby achieving the minimum lux requirement without issue.

Since these CPS systems also offer the opportunity to power almost any type of mains luminaire, they offer a highly flexible solution

- Mains luminaire conversions using emergency conversion kits to provide 10% of the mains illuminance

—  
01



—  
01 Control rooms  
require high risk  
task area lighting to  
allow shutdown of  
dangerous processes in  
emergency situations

For emergency lighting conversions, the correction factors shown in Appendix A.7 should be included, but the service factor will already be accounted for in the mains lighting design.

Where twin lamp luminaires are used, only one lamp is normally converted, provided the conversion kit can achieve an emergency output of 20% of mains illuminance from one tube. This method will automatically achieve the uniformity required because the mains lighting

design will have achieved a uniformity of 0.8, and the emergency lighting scaled down from that to 10% illuminance, will also have a uniformity approaching 0.8. This is substantially better than the 0.1 uniformity required.

The duration required may be quite short and should provide the necessary illuminance while the hazard exists or until it can be made safe.

—  
01



# System design & assessment

## Places of entertainment

Cinemas, theatres and other places of entertainment may have special requirements, particularly in the auditorium. For example, the illuminance from exit signs in normal conditions should not distract from the entertainment.

The requirements of the specifier and the relevant local authority should be carefully followed.

BS 5266-1 now provides guidance on emergency lighting in cinemas, theatres and other places of entertainment (the previous Code of Practice, CP 1007:1955 is withdrawn). An important clause in BS 5266-1 refers to areas with seating fixed to the floor in cinema and theatre auditoria. In these fixed seating areas, a minimum of 0.1 lux is recommended on a plane 1m above the floor, with aisles or gangways treated as escape routes as described in Section 4.2 above (see also Appendix B4).

### Standby lighting

Standby lighting may be required in areas where work needs to continue uninterrupted, and up to 100% illuminance may be required during the standby time. Standby lighting is not necessarily part of the emergency lighting scheme.

If standby lighting is used as emergency lighting, it should conform to all the requirements of emergency lighting. If this is not possible, for example where the response time is too slow, then additionally either transitional emergency lighting or a full emergency lighting system should be installed.

### Delay units for discharge lighting

Even a short break of a few cycles may extinguish a discharge lamp and a re-strike will be delayed.

The emergency lighting should cover this contingency and have a delay circuit added to hold the emergency lighting on after restoration of the mains, until the discharge lighting is operational (see Figure 30).

A 15-minute delay is normally sufficient.

Figure 30: Delay time of the emergency lamp to provide covering light output during discharge lamp outage.

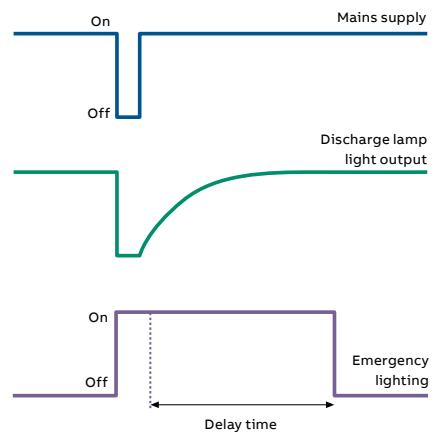

# System design & assessment

## Disability glare

Bright glaring light in the line of vision will dazzle and impair the ability to see. If people have a bright light directed into their line of vision, they will be dazzled and they will not be able to see.

This is disability glare and, in the emergency situation, it may cause them to stumble on a hazard. Disability glare should therefore be avoided. It should not be confused with discomfort glare which is a term used in general lighting related to eyestrain.

Disability glare limits are imposed within certain angles. In an area with a flat floor, the glare zone is regarded as angles above 60° from the vertical (see Figure 31).

This zone is subject to a limit of light intensity, but as the mounting height above the floor increases, the limit also increases.

This is because people would have to look up further to be affected by glare. In an area with hazards such as steps, where the angle of vision is variable, the glare zone is regarded as all angles (see Figure 32).

The glare limits are shown in the Table 6. The glare zone limits for high risk task areas are higher because the emergency lighting illuminance is higher in these areas and the eye will be more tolerant of glare. The maximum luminous intensity from a 1500mm 58 W fluorescent batten luminaire without diffuser or controller is about 650 cd.

The 8 W lamps used traditionally in emergency lighting are therefore unlikely to approach the glare limits.

Projector lamps or spot lamp units, may have a peak intensity exceeding 2000 cd and could exceed the glare limits.

Care should therefore be taken when using these units to avoid the glare zone, by mounting as high as possible and directing downwards at less than 60°.

Figure 31: Disability glare at floor level

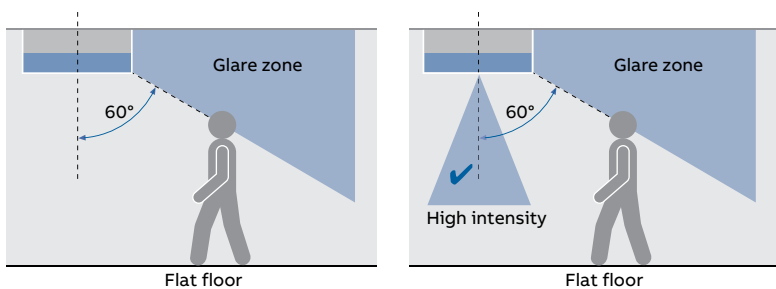
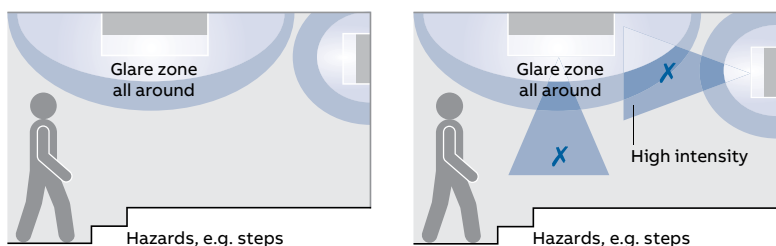

Table 6: Disability glare (anti-dazzle) limits

Mounting height (m)	Max. luminous intensity (cd)		
	Escape route	Open area	High risk task area
Up to 2.5	500	500	1,000
2.5 to 3	900	900	1,800
3 to 3.5	1,800	1,800	3,200
3.5 to 4	2,500	2,500	5,000
4 to 4.5	3,500	3,500	7,000
Above 4.5	00:00	5000	10,000

Figure 32: Disability glare at point of hazard



# System design & assessment

## Guidance for new premises

Planning the emergency lighting system forms a fundamental part of any new building design process and presents many challenges to all stakeholders in the project.

A number of key factors need to be discussed and determined, including:

- The category (mode) of operation of the emergency luminaires (i.e. whether the design requires maintained emergency lighting)
- The emergency luminaire duration
- The type of emergency lighting system to be installed (e.g. self-contained, slave or converted mains luminaires)
- The level of testing solution to be included, and
- The special requirements for the project (for example, any hazardous or high risk task areas)

Therefore the importance of effective consultation between all stakeholders cannot be underestimated, to ensure all aspects of the emergency lighting system can be agreed and specified before commencement of works.

This approach helps to ensure that the installed system will meet the necessary standards and regulations, and to avoid any budget overruns or rework during the installation phase.

For new construction projects, the designer will be working to the Building Regulations and planning the emergency lighting system in line with BS 5266.

Since the building plans are available, escape routes, storey exits, stairways and final exits can all be identified in advance.

The building plans should also identify the location of fire detection, fire fighting and safety equipment.

If a fire safety risk assessment is available, this should also be consulted to identify any particular requirements based on the intended use of the premises and the expected occupants.

As a general guide for emergency lighting planning, an 'Establish/Action' chart is provided below (Figure 33), along with guidelines in Table 7 on page 47.

**Figure 33: Establish/Action chart for emergency lighting design**

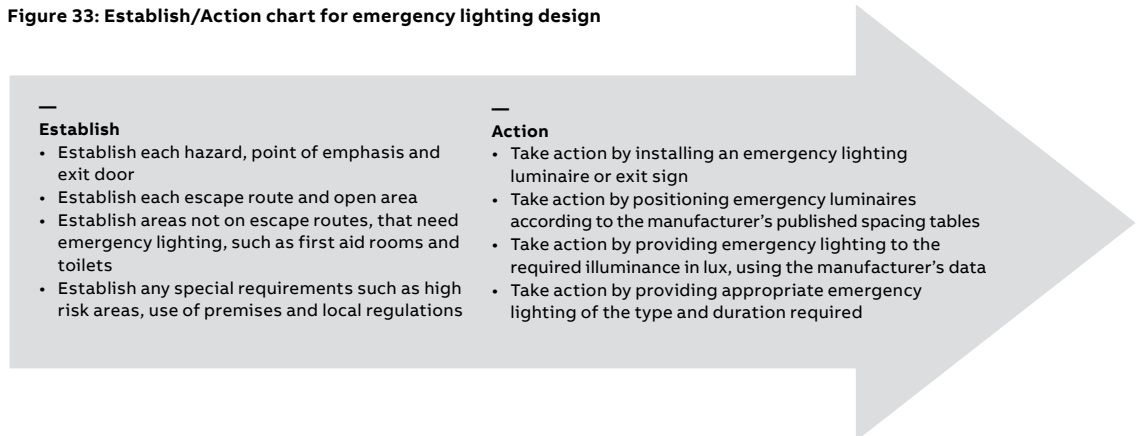

**Table 7: Guidance notes for emergency lighting design in new buildings**

Point	Establish	Actions
1	Establish position of fire equipment, position of hazards such as steps, changes of direction, stairs, first aid points etc. (See Section 4.3).	Provide an emergency luminaire near (within 2m horizontally) of each of these points of emphasis.
2	Establish designated exit doors, points on escape routes or open areas where a sign is required to make the exit obvious.	Provide exit signs with arrows if necessary, observing the viewing distances in Section 4.1.
3	Establish the need for external escape lighting.	Provide emergency luminaires so that people can proceed outside to a place of safety.
4	Establish the escape routes and establish mounting heights of emergency luminaires above the floor.	Position emergency luminaires along parts of the escape route not already illuminated near the above points to provide 1 lux minimum along the centre line and 0.5 lux minimum in the 1m central band. Use published data in the form of spacing tables for the luminaires to determine the positions taking into account the mounting height.
5	Establish the open areas used as escape routes and other open areas larger than 60m <sup>2</sup> and establish mounting heights of emergency luminaires above the floor.	Provide 0.5 lux minimum in the core area. Use published data (as above) to determine the positions.
6	Establish the position of lifts, escalators, toilets, control/plant rooms, pedestrian walkways in covered car parks (see Section 4.4).	Provide emergency luminaires in all of these areas. Treat pedestrian walkways as escape routes.
7	Establish the location of any first aid point or fire equipment not on an escape route or open area.	Provide 5 lux emergency illuminance on the floor in the vicinity of the point. For first aid rooms provide 15 lux illuminance.
8	Establish the toilet areas.	Provide emergency lighting for toilets larger than 8m <sup>2</sup> , as if they were open areas. For toilets smaller than 8m <sup>2</sup> , unless illuminated by borrowed emergency light from another area, provide at least one emergency luminaire. Provide emergency lighting in all disabled toilets (see Section 4.4).
9	Establish any small lobbies with no borrowed light.	Provide emergency lighting.
10	Establish any central power supply (if used) is in an area of low risk.	Position the central power supply in its own room in fire proof construction away from other switchgear or plant.
11	Establish any need for standby lighting.	Provide generators as required. If the response time is longer than 5 seconds, then transitional or alternative or additional emergency lighting must be provided.
12	Establish any special needs for the occupants such as impaired mobility or impaired sight.	Provide additional emergency lighting to reduce the risk to those people to help them evacuate the premises. This applies to designated refuge areas (which may require the provision of emergency voice communication).
13	Establish the location of any high risk task areas and the normal lighting illuminance (lux) in these areas.	Provide 10% of the normal illuminance (lux) or 15 lux minimum (see Section 4.5).
14	Establish if there are any dust or dirt problems.	Allow a service factor as appropriate. 0.8 is allowed for normal areas, but for dusty environments 0.5 may be required (see Appendix A7), or alternatively a regular cleaning procedure instigated.
15	Establish any local regulations.	Provide emergency lighting to comply with the regulations.
16	Establish if there is any dimmable lighting and shopping malls.	Provide maintained emergency lighting.
17	Establish whether people would be "unfamiliar" with the escape routes.	Provide maintained exit signs (see Section 4.1).
18	Establish the use of the premises:	Recommended minimum duration:
	• entertainment (including temporary such as licensed evening dance at a school)	3h
	• sleeping risk	3h
	• residential special care	3h
	• non-residential care	1h
	• public access non-residential	1h
	• industrial	1h
	• multi-storey dwelling over 10 storeys	3h

**Note:** for points 5 and 6 emergency luminaires positioned near points of emphasis can be moved slightly within the 2m horizontal tolerance to fit in with the spacing or array of emergency luminaires in the escape route or open area. This guidance checklist is for guidance purposes only and does not form an exhaustive list of all requirements to standards and legislation, which should be reviewed when undertaking emergency lighting system design.

# System design & assessment

## Guidance for existing premises

Determining the emergency lighting requirement within existing premises is slightly different to new construction projects, as the key factor is the risk assessment which owners/occupiers are legally required to undertake.

Risk assessment as a process is now used extensively in many aspects of health and safety, to identify the potential risks in the building.

For emergency lighting, the aim of undertaking a risk assessment is to help ensure people can evacuate a building safely and quickly, without stumbling and without panic in the event of a fire or a mains failure.

The Fire Regulations require the owner, employer or occupier of the premises to undertake a fire safety risk assessment, or arrange for one to be done, so that employees and occupiers are not placed at unacceptable risk in the event of fire or emergency.

The typical procedure would be for a Responsible Person to be appointed for fire safety and they would then ask a Competent Person to design and install appropriate safety equipment, for example emergency lighting.

### Legal responsibilities

A risk assessment is essential in all workplaces and, where five or more people in total are employed, written records should be made showing the results and the actions taken.

Failure to do this could lead to the prosecution of the person responsible (primarily the employer).

The Fire Authorities are empowered under the Fire Regulations to inspect any premises to check the fire safety, risk assessment records, actions and the emergency measures in place.

If they are found to be unacceptable, an Enforcement notice or Prohibition notice may ensue.

### Risk assessment method

For existing buildings or where there may be a change of use, risk assessment is a straightforward step-by-step routine. The British Standard Code of Practice, BS 5266 can then be followed to design the emergency lighting system.

This design process is best done by a Competent Person who has received training in emergency lighting design and understands the illuminance and spacing requirements.

A risk assessment may be required for a new building, especially if changes have been made to the original design.

### Steps in risk assessment

The risk assessment process for existing buildings and buildings subject to a change of use, can be divided into a 9 step process.

Note that step 8 requires written records, so it is advisable to make records at each step.

1. Identify the use of the building, the times it is used and whether artificial lighting is installed.
2. Identify the escape routes, open areas used as escape routes and open areas larger than 60m<sup>2</sup>.
3. Identify and locate anyone who is in danger in a fire or during a mains failure.
4. Identify possible hazards on the escape route and in other safety critical areas.
5. Identify and evaluate the risks arising from the hazards.
6. Decide if the existing emergency lighting and exit signage is sufficient.
7. Take action as appropriate.
8. Record the findings in the previous steps and record the action taken.
9. Review and revise the risk assessment on a regular basis or when building changes have occurred.

The most important word in this process is "Identify". When the escape routes, the people in danger and the hazards have been identified, action can be taken to reduce the risks. Government Guides have been issued for fire safety risk assessment (see Appendix B1) and these guides list just 5 steps, but in the list above the "Identify" steps have been expanded for greater clarity.



**IMPORTANT:**

The objective of emergency lighting is to save lives and this risk assessment should be carried out in conjunction with any risk check for fire precautions in the same building.

It is worth noting that premises needing a life protection fire alarm system will almost certainly

need emergency lighting. However, some premises that do not require a fire alarm system may need emergency lighting.

Table 8 on page 49 describes the steps in risk assessment and gives examples. Also, see Appendix D for a Risk Assessment Check Sheet.

**Table 8: Steps in risk assessment for existing premises**

Step	Instructions	Examples
1. Identify the use of the building, the times it is used and whether artificial lighting is installed.	All uses of the building should be identified; particularly those which increase the risk.	A building only used in daylight hours with natural light in all parts would not need emergency lighting. If artificial lighting is installed, emergency lighting will be required.
2. Identify the escape routes, open areas used as escape routes and open areas larger than 60m <sup>2</sup> .	Escape routes from all work areas must be identified, for example: through an open area to a storey exit, through fire doors to an escape route in fire resistant construction, then downstairs, leading to a place of safety and into the open air.	Escape routes are usually corridors, or marked aisles through factories. An escape route may lead into an open office and through to another escape route. There may be two or more designated ways.
3. Identify and locate who is in danger in a fire event or during a mains failure.	If there are large numbers of people or people with impaired mobility or sight, they need to be identified and their location noted. If the premises are used for entertainment or if people are sleeping at any time, a longer duration may be required.	Some people may be in a basement from which there is only one escape route. There may be areas where large numbers of people work, or where visitors or members of the public are present but not familiar with the layout of the building.
4. Identify possible hazards on the escape route and in other safety critical areas.	On the escape routes identify: stairs, steps, changes of direction, intersections, and each exit door and final exit door. Identify all fire fighting equipment and manual call points. Identify first aid points or first aid rooms. Identify areas where people may be trapped in an emergency such as lift cars, escalators, toilets, or motor and plant rooms. Identify any high risk task areas, which need to be shut down to make the area safe.	
5. Identify and evaluate the risks arising from the hazards.	Each hazard contributes to the risk. The more people that pass through a hazard, the greater the resultant risk. The more hazards there are, especially if they are close together, the greater the resultant risk.	A step on an escape route where only a few people familiar with the layout will pass, is less of a risk than similar step on another route where 50 people, some of them visitors, and not familiar with the layout will pass.
6. Decide if the existing emergency lighting and exit signage is sufficient.	After the risks have been identified and evaluated, any existing emergency lighting needs to be checked for effectiveness: <ul style="list-style-type: none"> <li>– Clean body and diffuser</li> <li>– It operates for the required duration</li> <li>– It operates when the local final circuit supply fails</li> <li>– Verify the light output</li> </ul> If any risks are high, decide if the existing emergency lighting adequately reduces those risks.	For a long escape route, extra exit signs may remove doubt about which way to go to the emergency exit. The illuminance on the floor along the centre line of escape routes must be a minimum of 1 lux and in open areas a minimum of 0.5 lux. Higher lux levels may be required, for example: if the risk assessment identifies that people with impaired sight will use the escape route. Obsolete (text only) exit signs should be replaced with pictograms. Internally illuminated exit signs have a viewing distance of 200 x the height of the pictogram and signboards have a viewing distance of half that. If signboards are used, check that a nearby emergency luminaire illuminates the sign to a minimum of 5 lux so that it can be seen and understood from all relevant places. Dark conditions may be required for this.
7. Take action as appropriate.	If there are significant risks and there is no emergency lighting, the operation is doubtful, the performance unknown, or if it is considered to be insufficient, then a Competent Person should be asked to design an acceptable emergency lighting scheme. A testing and cleaning maintenance procedure should be set up with a log book to record all test results and action.	A 20-year-old building with the original self-contained emergency luminaires, with no log books or testing records is unlikely to be considered acceptable. Apart from the age of the luminaires, the building use or layout may have changed. The maintenance arrangements should take into account any special site requirements, for example: a dusty environment is likely to reduce the effectiveness of the luminaires, so a frequent cleaning regime is needed, or more luminaires installed to compensate.
8. Record the findings in the previous steps and record the action taken.	There is a legal obligation to do a risk assessment of the fire precautions of which emergency lighting is a part. Failure to do so may result in prosecution.	The Fire Authorities could ask to see the records of risk assessment for the fire precautions, and if none are forthcoming they have the power, particularly where regulations have been seriously infringed, to close the premises until the situation is rectified.
9. Review and revise the risk assessment on a regular basis or when necessary.	The risk assessment should be reviewed at least yearly. If the layout or use of the building has changed the review should be more frequent as necessary.	If a building extension blocks an escape route, another may be opened to retain the same safety. The emergency lighting and signage in that area must be re-assessed to verify safety is not significantly reduced.



---

# Installation, testing & maintenance

## Introduction

Building owners/occupiers have a legal obligation to ensure that their emergency lighting systems are maintained in good working order over the system lifetime.

### Introduction

Regulations and standards direct the requirements for installation, testing and maintenance of both self-contained and slave emergency lighting systems.

Installation depends on system choice and needs to follow the designed emergency lighting scheme to ensure the requisite minimum illuminance levels are achieved.

Following installation, a thorough inspection of the emergency lighting system (commissioning) is required as the formal pre-operational check that the system is in good working order and functions properly. The commissioning process includes a duration test to prove the system.

Once commissioned and in operation, periodic testing of the system is required to warrant against potential failures and to safeguard people against risk.

Building owners/occupiers therefore need to establish a test facility, either manual or automatic, for the system and instigate a regular test regime.

Written records need to be retained, for the system, the commissioning, and all testing undertaken.

An automated testing solution may be specified as part of the emergency lighting system, to assist with this ongoing testing requirement. Options include stand-alone emergency luminaires with in-built testing through to central addressable test solutions.

This section provides guidance on those systems, as well as requirements for installation, commissioning, testing and disposal of emergency luminaires.



# Installation, testing & maintenance

## Wiring and installation

The IET Wiring Regulations, BS 7671, establish statutory requirements and best practice for electrical wiring installation.

The wiring of emergency lighting installations falls within the scope of this standard.

Additionally, BS 5266-1 provides specific guidance for emergency lighting systems.

Both documents should be consulted when installing emergency lighting to ensure compliance.

### Self-contained systems

Since the power supply for self-contained luminaires is installed in the unit, or sited close by (within 1m), there are no special requirements for this luminaire type.

Wiring should follow BS 7671 as per installation of normal mains lighting.

The same holds true for self-contained converted LED luminaires.

The conversion unit is placed within the luminaire frame or installed in a remote box adjacent (within 1m) to the luminaire.

### Wiring self-contained luminaires

All self-contained emergency lighting needs to have a connection to a permanent mains supply.

This supply should be unswitched and on the same final circuit as the local mains lighting, so that if the fuse to that circuit ruptures, then the emergency lighting will operate.

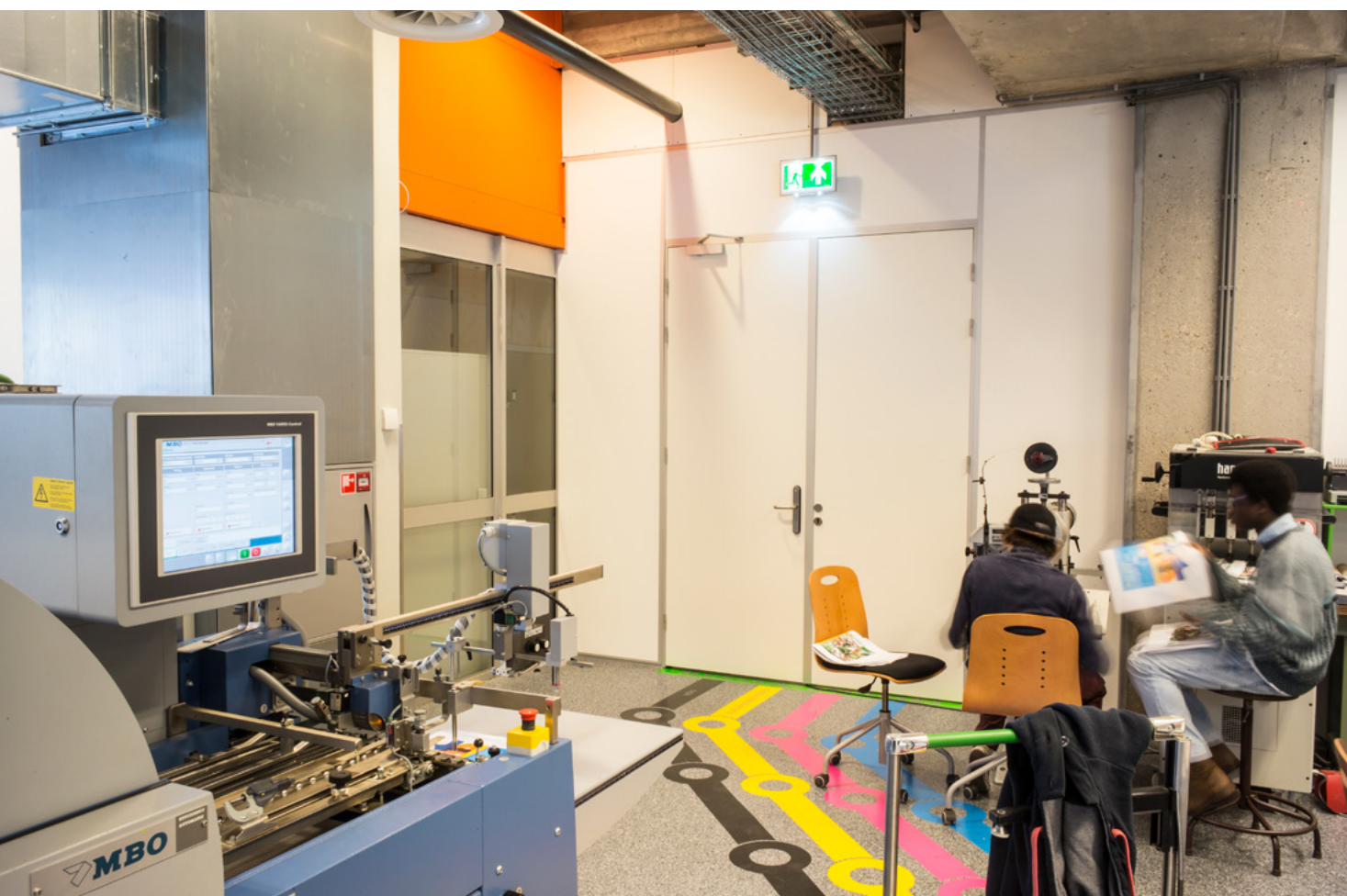

Non-maintained luminaires activate only on failure of the local mains supply and require connection to permanent live, earth and neutral (see Figure 34).

Maintained luminaires are illuminated at all times that the premises are occupied.

Since it is more economical to switch off these luminaires when the property is empty, a separate switched live should be connected to the system (see Figure 35).

**Central power supply systems**

Within CPS systems, connection between the central unit and the slave luminaires should be made using fire resistant cable to ensure continued system operation in the event of a fire.

The central power supply unit should be connected directly to the incoming mains supply to avoid any potential risk to supply.

**Wiring slave luminaires**

Slave luminaires are operated directly from the central power supply.

The central power supply can be non-maintained, or maintained, both using only 2 wires and a protective earth (see Figure 36).

**Wiring slave conversion luminaires**

Slave conversion luminaires are presented in many forms, including:

- Luminaires with one lamp, powered normally from the mains, then from the central power supply in a mains failure
- Luminaires with more than one lamp, one of which is operated by the central power supply or maintained as previous page, and the other from the normal mains supply

In both cases mains and the central power supply need to be connected (see Figure 37).

**Figure 34: Non-maintained self-contained wiring**

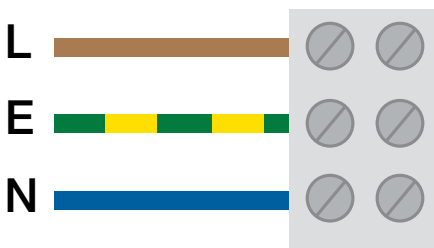

Non-maintained, 3 wires: Permanent live (L), Earth (E), Neutral (N)

**Figure 35: Maintained self-contained wiring**

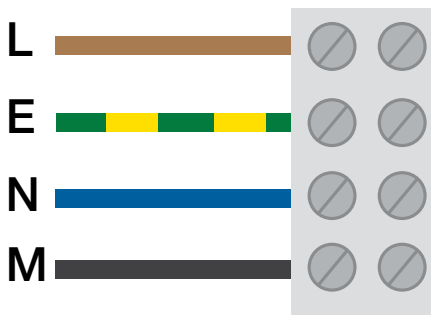

Maintained, 4 wires: Permanent live (L), Earth (E), Neutral (N), Switched live (M)

**Figure 36: Central power supply wiring**

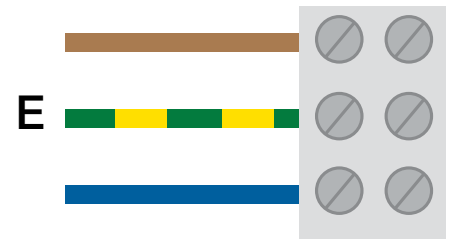

Direct slave, 3 wires +/- or AC supply: (usually AC/DC 24 V, 50 V, 110 V or 220 - 240 Vac, see Section 3.6)

**Figure 37: Wiring to slave conversion unit and central power supply**

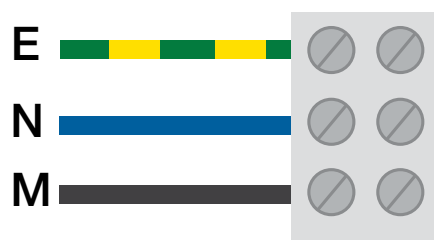

Slave conversion wiring: Switched live (L), Neutral (N), Earth (E)

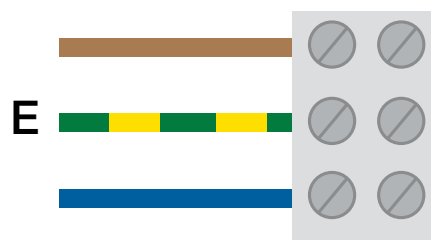

Central power supply: (Usually AC/DC 24 V, 50 V, 110 V or 220 - 240 Vac, see Section 3.6)

# Installation, testing & maintenance

## Wiring and installation

### Wiring slave luminaires with hold-off device

A slave luminaire with a hold-off device can be a purpose-designed luminaire or a conversion, but the permanent mains supply should be connected to the same final circuit as the local mains lighting.

The power from the central power supply unit is present at all times, and held off from operating the emergency lighting until the permanent mains supply fails (see Figure 38).

This hold-off device is used to operate the emergency lighting in the particular area where it is required.

Figure 38: Wiring to slave unit with hold-off device and central power supply

Note: Some luminaires are Class II insulated and therefore do not require an earth connection.

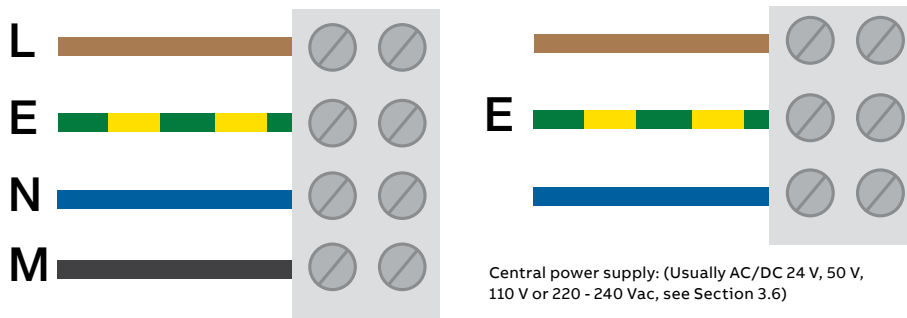

Slave with hold-off device wiring: Permanent live (hold-off) (L), Switched live (M), Earth (E), Neutral (N)



# Installation, testing & maintenance

## Commissioning emergency lighting systems

Following installation, the emergency lighting system must be commissioned prior to use. Commissioning verifies that the emergency lighting system complies with the relevant regulations and standards, and is fit for purpose.

During the commissioning process, the emergency lighting system is fully tested to ensure satisfactory working performance.

Following commissioning, BS 5266-1:2016 requires a written declaration of compliance (a Completion Certificate) to be retained on site for future reference.

This certificate comprises four sections, as outlined in Table 9. A commissioning check sheet is provided in Appendix D.

**Table 9: Requirements for commissioning of emergency lighting systems**

Section	Requirement
Installation quality	Wiring conforms to IET (the Institution of Engineering & Technology) Regulations BS 7671. Non-maintained luminaires connected to the final circuit.
Photometric performance	The installation complies with the original design as regards spacing of luminaires/ photometric performance. Spacing data to be held in writing for reference.
Declaration of satisfactory	Confirmation that the emergency lighting scheme design has been correctly installed. System tested and compliant to BS 5266.
Log book	Log book prepared ready for inspection. Log book records date & details of alterations to the system, inspections, test certificates, maintenance, tests completed with all faults and remedial work noted (see Section 5.5).

Note: Formerly, the IET was recognised as the IEE (Institution of Electrical Engineers).

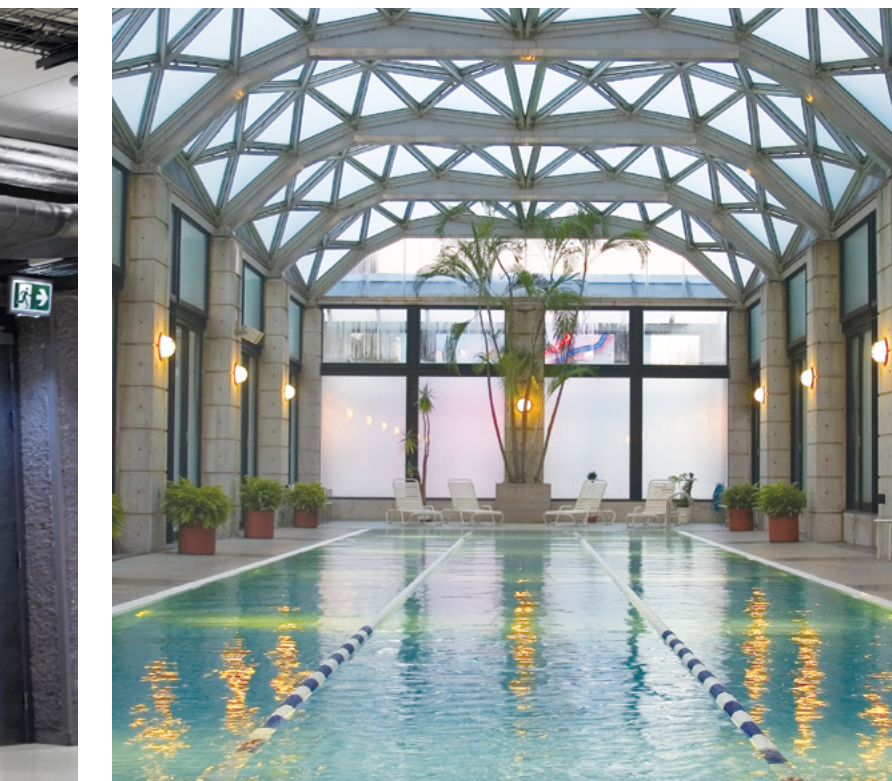

# Installation, testing & maintenance

## Luminaire testing requirement

The party responsible for the building is required by law to ensure the emergency lighting system is tested and maintained, since the Fire Regulations state that safety equipment (including the emergency lighting) must be in good efficient working order.

BS 5266-1 stresses that a suitable test facility should be provided for simulating failure of the mains supply to emergency luminaires and exit signs.

A responsible person must appoint a 'competent person' to run the test schedules.

This test facility should be appropriate for the system in place, and may be either manual or automatic. Results for each luminaire must be recorded in the log book and retained for inspection.

Manual testing requires a Competent Person to walk through the premises, disconnect the local supply and manually check the operation of each emergency luminaire.

In the modern commercial environment, manual testing is less convenient, being both labour intensive and time consuming. Therefore more automated methods are recommended.

These automatic test solutions facilitate the testing requirement. The options for, and scope of, these systems are covered in detail in Section 5.4.

Whichever test facility is chosen, it should meet the testing requirement as established by BS 5266-8:2004 (shown below in Table 10).

A key requirement is that testing should be undertaken when 'safe and convenient' to do so.

In practice, testing should be undertaken at times of low risk, to allow the emergency lighting system sufficient time to recharge, and to cover any potential risks arising if an emergency occurred during the testing period.

Ideally, the annual full duration test should be conducted at a time the building is unoccupied.

Where this is not possible, alternate self-contained luminaires within each compartment can be tested and allowed to recharge, prior to instigating testing on the remainder.

This enables testing of an entire system where the building is continually occupied.

CPS systems provide an additional safety benefit since these only need to be discharged to two-thirds capacity at a higher than normal voltage to prove the battery.

With one third capacity available to the CPS system, a 3 hour duration CPS system would still have sufficient power to meet the minimum 1 hour duration requirement.

**Table 10: Emergency lighting system testing requirement**

Test period	Requirement
Daily	The Competent Person should check central power supplies and check that indicators are healthy (this requirement is not applicable to self-contained emergency lighting).
Monthly	The Competent Person should perform a function test of each emergency luminaire and exit sign by simulating a mains failure for a period sufficient to check each lamp operates from the battery and that they are all clean, in good condition and the LED lamps are bright (not blackened or flickering). Simulate a mains failure for a time sufficient only to verify emergency operation: (a) for self-contained luminaires and slave luminaires with hold-off devices, use the local test facility (b) for central power supplies use the control switch to test the emergency lighting system, ensuring it is safe and convenient to do so
Annually	Testing as monthly but for the full duration (e.g. 3 hours), when it is convenient and safe to do so, and at a time of least risk. Batteries will take up to 24 hours to recharge so the test should take place when the building is not occupied or during daylight hours.
For all tests	Record the test date and results in the emergency lighting log book. Any faults should be repaired and the date of completion recorded. Records should be kept for inspection by the Fire Authorities.



# Installation, testing & maintenance

## Automatic test systems

Automatic test systems can provide testing to the requirements in BS 5266 and make it simpler to find a convenient time of low risk to do the full duration discharge test, bearing in mind that during the recharge time emergency lighting cover is reduced.

A Standard, IEC 62034 Automatic test systems for emergency lighting, has been drawn up to establish the base requirements for these systems.

These include:

- Testing should be undertaken at periods of low risk
- Testing should be conducted at the correct time for the stipulated duration
- Test results should be reliably indicated

Automatic test systems are available for both self-contained and CPS systems, including:

- Automatic stand-alone Self-Test systems (such as Emergi-Lite Self-Test)
- Semi-automatic testing (such as Emergi-Lite IR2 infra-red testing), or
- Central addressable testing (such as Emergi-Lite Naveo system with remote monitoring, or EMEX Test for use with EMEX CPS systems)

### Automatic stand-alone Self-Test systems (Self-Test)

To comply with the Fire Regulations and the BS 5266-8 test regime, the Responsible Person needs to be thorough and to keep records to show the emergency lighting is in good working order.

Automatic test systems can help the Responsible Person in this respect and reduce inspection costs. Stand-alone automatic Self-Test systems follow the schedule in BS 5266 and display the status of the emergency luminaire or exit sign using different coloured LED indicators (see below).

Each emergency luminaire also includes the necessary timing and test functions to conduct the test at the scheduled time.

If a fault occurs (for example in the lamp or the battery) the appropriate indicator shows the type of fault and the maintenance engineer can be contacted to make repairs.

Automatic stand-alone Self-Test systems prove a reasonable option for small to medium sized

premises, since the Responsible Person still has to walk through the premises to inspect the emergency luminaires after the test, and to record the test results for each luminaire in the log book.

### EMEX Test

The complete emergency lighting central system testing solution. Emergency lighting regulations state that periodic, mandatory tests must be carried out to verify the correct operation of any emergency lighting system.

Increasingly, changes in safety legislation, risk assessment, and the requirements of public liability insurance are placing responsibility for the testing of emergency lighting systems firmly with the owner or occupier of the building. Additionally, legislation states that records of this testing must be kept.

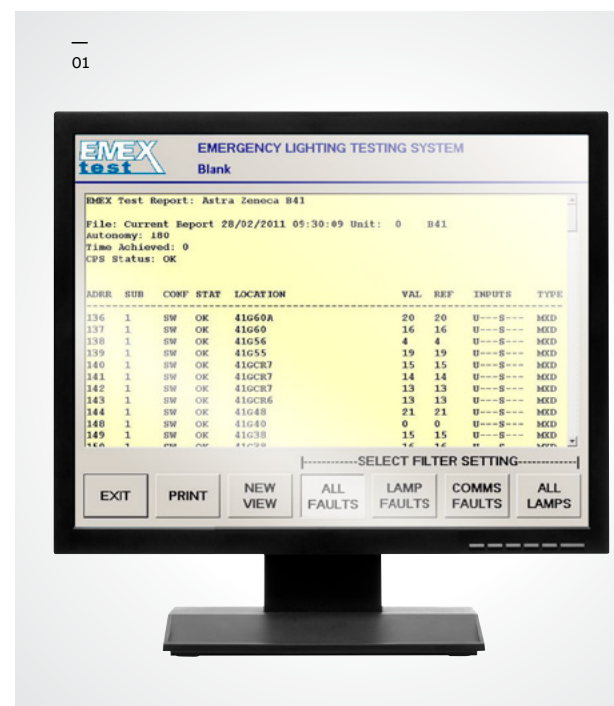

# Installation, testing & maintenance

## Automatic test systems

### Automated testing solution

Manual testing (and record keeping) of emergency lighting systems can prove to be expensive, time consuming and disruptive (even dangerous) exacerbated by access problems caused by physical and commercial reasons. The EMEX Test Central Testing System ensures peace of mind by automating the normal, periodic testing of emergency lighting lamps and control gear.

EMEX Test is simple to operate, being controlled by a dedicated touch screen control panel or a standards desktop PC and is featured packed.

- Multiple static inverter Central Power Supply Systems (CPS) can be networked to a single control PC
- Utilising EMEX TS, Remote access via a Local Area Network (LAN) or internet connection is straightforward

Building Management System communication

### Scheduled testing

System tests are scheduled for periods of minimum disruption using EMEX Test.

Live luminaire data is compared against pre-programmed threshold data to identify any discrepancies. These are then duly highlighted in the test report which is generated and stored automatically.

The user has full control to access test reports locally or remotely at any time. Service personnel can then arrange a convenient time to access any faulty luminaires – ready prepared with any necessary spares in order to further reduce the amount of time required to effect a repair.

In addition, EMEX Test can conduct discharge tests and monitor and record the status of the CPS and end battery voltage. Since discharge tests cannot be performed until visual condition checks have been undertaken by an engineer on site, these annual tests are initiated manually.

—

### DALI emergency lighting

#### Testing & monitoring

ABB DALI emergency lighting offers automatic test functions from either a central controller or from the luminaire itself. This ensures you will always know the status of your emergency fitting. Effective monitoring helps to ensure the safety of

building occupants and give building owners the peace of mind they require.

### Automatic testing & monitoring

Automatic monitoring includes the status of battery charging and the status of the main power supply. Central testing includes the current battery charge condition, functional tests and duration tests. Test frequencies can be adjusted to meet the requirements of the building or the local regulations. Testing periods can vary from weekly to monthly in the case of function tests, or annually for duration tests.

### Function test

A function test that simulates a mains failure and checks the operation of the emergency light from the battery supply. If there is a failure during a function test, the local indicator LED changes its status on the luminaire.

### Duration test

A duration test simulates a power failure and checks the operation of the emergency light from the battery supply for the rated duration of the product. Duration tests can be one, three hours or more depending on the local regulations. If there is a failure during a duration test, the local indicator LED alerts you to a problem or, in the case of a system monitored from a central location, the emergency lighting DALI control unit (DCU) will alert by showing an error message. As with all central test systems that require annual duration testing, this is only started after the battery has had an initial uninterrupted 24 hour+ charge period.

### Local testing

Function and duration tests are initiated by the emergency light fitting. It performs automatic testing according to the locally stored settings.

### Central testing

Function and duration tests are initiated by the DALI control unit and displays results on the screen.

### Switching

Maintained luminaires can be switched and grouped.



## Emergency lighting and control unit



01



02

01 DALI emergency lighting and control system - Normal

02 DALI emergency lighting and control system - Error detected

03 Green LED indicates normal operation

04 Amber LED indicates a fault Self-test indicator colours may vary

### Semi-automatic testing (IR2)

Semi-automatic testing systems are available that can initiate a test to verify the correct operation required in the monthly test and, for the annual test, to continue timing to the end of rated duration and display a healthy or fault light as appropriate.

For example, the Emergi-Lite IR2 testing system uses a hand-held infra-red (IR) transmitter to set up tests. Emergi-Lite IR2 is a bi-directional self-testing system offering additional features for control using the hand-held programmer for set-up test, interrogation and fault display (see below). Test times and functions can be programmed to suit customer requirements and test results can be downloaded to a PC for analysis.

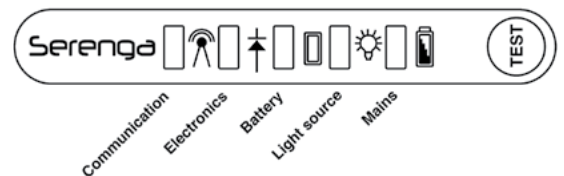

03

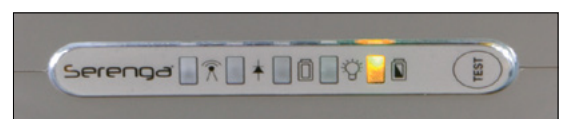

04

# Installation, testing & maintenance

## Automatic test systems

- 01 IR2-TESTWARE™
- 02 IR2-TX

A major advantage of the IR2 remote control system is that it is relatively low cost and does not require any additional wiring, making it ideal for buildings where the fabric or decorations must not be disturbed.

If tests initiated with the IR2 transmitter are satisfactory, indicators will show healthy.

If the test is not acceptable, the indicator will be extinguished or show a fault, along the lines below in Figure 39, identifying that the luminaire needs attention by a service engineer.

### Fully automatic central testing (Naveo)

Fully automatic central testing can be used to test all the emergency luminaires in a building at a set time or sequence, for the lowest risk during the recharge period.

The emergency luminaires are addressable and respond to instructions automatically or manually sent by the central testing system.

Solutions, such as Emergi-Lite Naveo, are now available which permit test programmes to be set up either from a central panel or remote PC, smartphone or tablet via the internet.

Complete records of test data are retained which can be viewed or printed locally in a format which complies with BS 5266-8 (EN 50172).

This printout is an acceptable record of test data for inspection by the Fire Authorities.

Fully automatic central testing systems are the ideal consideration for medium to large scale emergency lighting installations due to the number of luminaires involved, the level of record keeping required and the time needed to manually inspect the site.



Figure 39: Luminaire operation or fault status highlighted by LED indicators

● ○	Normal operation - OK
● ●	24 hour recharge needed
○ ○	Mains failure mode
○ ●	Fault: battery not charging
○ ●	Battery not charging & in 24 hr charge period after mains re-connection
● ●	Charging OK, but other fault present [emergency lamp or battery capacity/voltage]
● ○	Luminaire in test
● ○	Key: ● Flashing LED

Display and fault indications may vary.

Emergi-Lite Naveo is a prime example of the system functionality currently available from fully automatic central testing systems.

This addressable testing system can control a specified number of luminaires via a Data Collection Panel (DCP) with system interaction achieved remotely via a computer, laptop, smartphone or other mobile device (see Figure 40).

The solution provides full testing and reporting facilities, with all test and fault information held securely in an external server for reference from any point and at any convenient time.

Test reports from the system include fault diagnosis and can form the basis of an effective maintenance planning schedule.

The Naveo system communicates with field luminaires via a dedicated twisted pair bus cable.

The circuit can be wired according to design specifications and can be used with self-contained emergency luminaires which include a test and data module.

Tests can be programmed at times to avoid interference with the daily running of the premises and at times of least risk during the charging period.

Luminaires requiring attention are identified on the system by address number and text, and at the emergency luminaire by a flashing indicator, with maintenance requirements automatically flagged to the maintenance engineer by email or SMS, thereby saving repair time.

Figure 40: Emergi-Lite Naveo addressable test system with remote monitoring and management

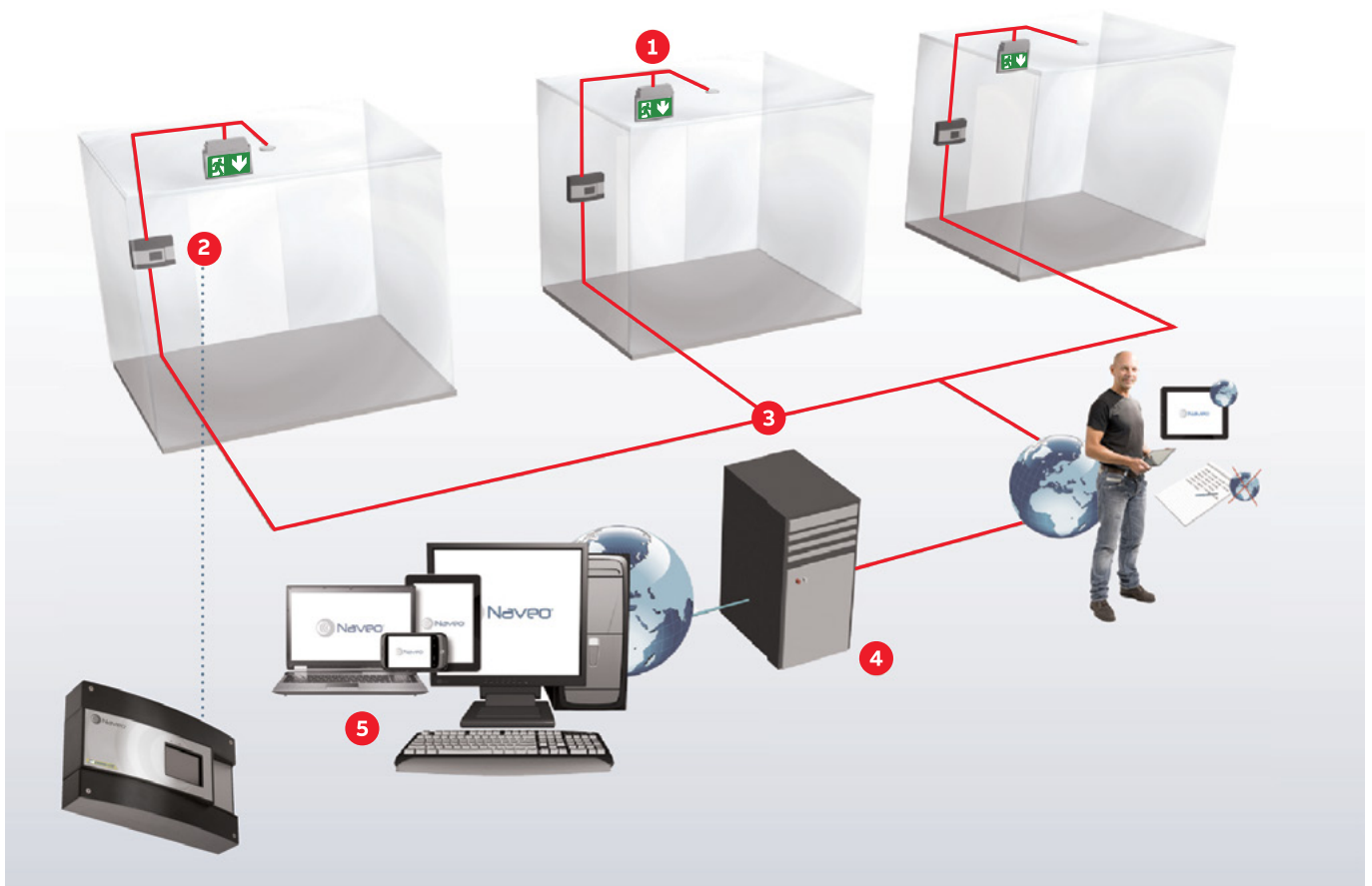

---

# Installation, testing & maintenance

## Emergency lighting system records

Plans of the emergency lighting system, together with a record of test results and maintenance should be retained on site for inspection.

The plans for the emergency lighting installation should have been signed by the Competent Person appointed to commission the emergency lighting system, to show compliance with the relevant regulations and standards.

Any further alterations or upgrades to the emergency lighting system should also be noted on the drawings to ensure the information held is current and accurate.

Additionally, the Responsible Person should retain a log book on site detailing the testing and servicing of all luminaires in the emergency lighting system.

A record for each luminaire needs to be kept.

Failure to provide these records for inspection by the local authorities may result in prosecution or closure of the premises until such time as the system can be proven to be operating effectively.



# Installation, testing & maintenance

## Renovation, recycling & replacement

A servicing regime should be put in place to ensure continuity of the emergency lighting system throughout its lifetime.

Servicing would normally be scheduled alongside testing since this is the most likely point when issues with the system will come to light.

Wherever possible, spares such as replacement lamps etc, should be retained on site to enable rapid refit of the system.

Where new emergency luminaire units are required, a Competent Person would need to be appointed for their installation.

Failed or faulty self-contained emergency luminaires offer straightforward replacement, since the entire unit is removed and replaced.

The replacement emergency luminaire should be tested on installation.

### **Luminaire recycling scheme**

In the EU, disposal of emergency luminaires falls within the scope of the WEEE (Waste Electrical and Electronic Equipment) Regulations.

These regulations place specific responsibilities on the producer or the end user regarding safe disposal of electrical equipment.

A number of compliance schemes have been established in the UK for the recycling of emergency lighting (and general lighting), which ensure luminaires are disposed of in an environmentally sound manner, in line with the requirements of the WEEE Regulations.

One such compliance scheme has been established by Lumicom.

ABB is a member of this compliance scheme. Emergency luminaires being replaced by Emergi-Lite products may be disposed of through Lumicom.

For further details on the scheme and its operation, please see the Lumicom website - [www.lumicom.co.uk](http://www.lumicom.co.uk).

### **Battery recycling**

The Battery Directive requires companies to be licensed for the collection and disposal of emergency luminaire batteries. Within the EU, disposal is regulated by the WEEE Regulations.

ABB is licensed for battery recycling under the Battery Producer recycling scheme (BPRN00373). Batteries being replaced by Emergi-Lite products may be disposed of through this scheme.

### **Central power supply systems**

Due to the complexity inherent in these systems, it is recommended that end users contact the manufacturer regarding replacement of cells, luminaires etc to ensure the system continues to operate effectively following refit.

Owners should make no attempt to repair cells, and these should be treated as hazardous waste when they have outlived their use.

They should be disposed of correctly through a certified waste company.

Do not incinerate or pass to land fill.







# Appendix A

## Emergency lighting technical information - Lux and lumens

The unit of illuminance is lux and this relates directly to the lumens per square metre reaching the floor.

### Introduction

lux = lumens/m<sup>2</sup>

e.g. if the illuminance on the floor is 10 lux, then there are 10 lumens/m<sup>2</sup>

For emergency lighting, escape routes and open areas, the floor is the plane of interest but for normal interior lighting the working plane is usually considered to be 0.85m above the floor. For high risk task areas the working plane is the plane of the task.

### Intensity data

No luminaire is perfect and no room is fully reflecting, so for emergency lighting, photometric distribution of the emergency luminaire is a requirement.

A graph of intensity distribution for a particular luminaire is shown in Figure 41.

Sometimes known as the polar diagram it shows the intensity at various angles to the vertical.

For luminaires intended for ceiling mounting, most light is directed downward, and for the purposes of the polar diagram the axial and transverse intensities are shown.

Absolute intensity is measured in candelas. This is also related to the lumen. A lamp radiating 1 cd in all directions will have a lamp lumen output of 4π lm (pi)

The luminaire relative intensity is usually expressed as cd/1000 lm. This is because certain luminaires will accept lamps of different lumen outputs, e.g.

Figure 41: Luminaire relative intensity (cd/1000 lm)

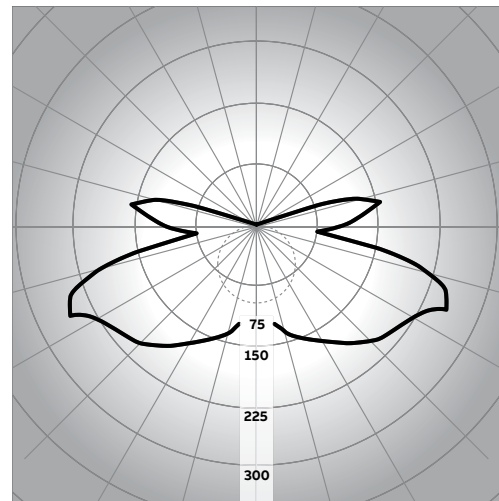

# Appendix A

## Spacing tables for emergency luminaires

Dedicated emergency luminaires are specially designed to provide sufficient illuminance to meet the requirements of 1 lux minimum in escape routes and 0.5 lux minimum in open areas and also the 40 : 1 maximum : minimum ratio.

Manufacturers therefore provide specific data in the form of spacing tables to enable emergency luminaires to be positioned correctly at various mounting heights.

These tables are calculated assuming the worst possible reflectance with black walls, ceiling and floor. Table 12 provides an example for for an LED Bulkhead.

To blend with architectural designs, normal lighting mains luminaires are often converted with emergency gear to provide emergency lighting.

Normal lighting luminaires are designed in many different styles. Luminaires with opal diffusers have a uniform distribution, but other types have definite cut off angles of 55°, 65° and 75° respectively to prevent discomfort glare with computer screens.

If, for example, a luminaire with a 65° cut off is spaced such that the cut off angles do not intersect at or above the floor, then there will be a dark patch at that point, such that the minimum requirement may not be achieved and the 40 : 1 (maximum : minimum) ratio may be exceeded.

Manufacturers who provide conversion facilities in accordance with ICEL 1004 will supply spacing details for converted luminaires.

—

**Weather force opal LED 207 Lm**

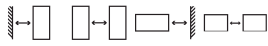

h (m)	□	□	□	□
<b>Escape</b>				
2.0	2.9	7.5	2.7	6.9
2.5	3.0	8.0	2.9	7.5
3.0	3.0	8.3	2.9	7.8
4.0	2.8	8.6	2.7	8.2
<b>Open</b>				
2.0	3.7	9.4	3.5	8.7
2.5	4.0	10.2	3.8	9.4
3.0	4.2	10.8	3.9	10.0
4.0	4.3	1.6	4.1	10.9

# Appendix A

## Spacing to height ratio (SHR)

Most mains luminaires have a figure in their published data, for spacing to height ratio. This shows how far apart the luminaires can be spaced in relation to the height above the working plane and still achieve the uniformity required.

For interior lighting, uniformity is expressed as a minimum/average ratio. In this case at the working plane of 0.85m a figure of 0.8 is usually required.

This is more onerous than the 40 : 1 maximum to minimum ratio on the floor, required in emergency lighting escape routes and open areas. For typical opal luminaires the SHR = 1.5, but for “batwing” luminaires it may be 2 (as shown in Figure 42).

### Example:

For a height of 2m above the working plane, the spacing is:

batwing luminaire spacing =  $2 \times 2 = 4\text{m}$

opal luminaire spacing =  $1.5 \times 2 = 3\text{m}$

When designing for emergency lighting using luminaires positioned according to the SHR, care should be taken that if, for example, every second or third luminaire is converted, that the minimum illuminance requirement is achieved.

**Figure 42: Spacing to height ratios for luminaires with batwing and opal light distribution**

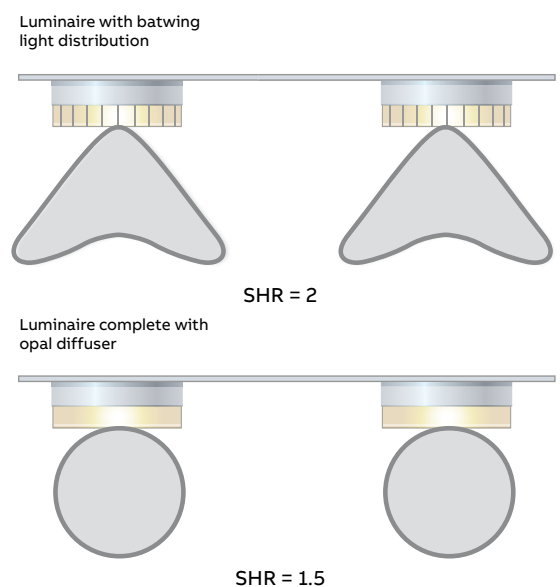

# Appendix A

## Lumen method calculations

This is a technique for calculating the number of luminaires in a room to achieve a certain average illuminance in lux, allowing for various corrections.

The technique is no longer used in emergency lighting calculations for escape routes and open areas, but an understanding of it is useful, particularly for high risk task areas.

**Room index (RI):**

This can be likened to a “goodness factor” for a room shape. The RI for a tall narrow room is not as good as for a lower wider room because most of the light would be absorbed by the walls before it reached the working plane.

$$RI = \frac{L \times W}{H(L + W)}$$

Where L = length of room (m)  
 W = width of room (m)  
 H = height of luminaire above the working plane (m)

**Examples:**

- a) For a room 3m high, 13m wide, 13m long, working plane 0.85m

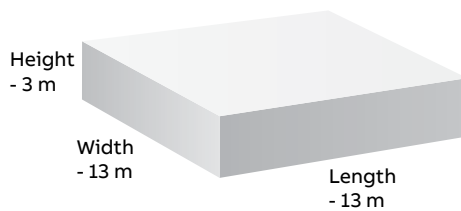

$$RI = \frac{13 \times 13}{(3 - 0.85) \times (13 + 13)} = \frac{169}{2.15 \times 26} = 3.02$$

- b) For a room 5m high, 3m wide, 15m long

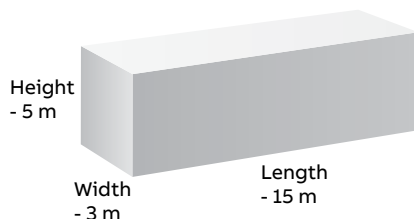

$$RI = \frac{15 \times 3}{(5 - 0.85) \times (15 + 3)} = \frac{45}{4.15 \times 18} = 0.6$$

**Utilisation Factor (UF):**

Manufacturers publish a table of utilisation factors for each style of luminaire (for example, Table 13).

The table uses the RI already calculated and it also uses the room reflectance characteristics for ceiling, walls and floor.

It is often assumed that these reflectances are 70% for the ceiling, 50% for the walls and 20% for the floor, sometimes expressed simply as 70, 50, 20.

In emergency lighting, reflectances are always assumed to be black (non-reflecting), i.e. 0, 0, 0.

Knowing the RI and the reflectances, the UF can be looked up in the table applying for the luminaire.

The UF table includes corrections for the efficiency (ratio of light output to lamp lumens) and photometric performance of the luminaire.

**Example:**

For a room 20m long, 10m wide, 2.5m high with a working plane of 0.85m:

$$RI = \frac{20 \times 10}{(2.5 - 0.85) \times 30} = \frac{200}{1.65 \times 30} = 4.04$$

For reflectances of 70, 30, 20 and using the RI of 4 as above the UF can be determined from Table 13 as 0.78.

**Lumen calculation:**

It is usual to know the design illuminance in lux required for a given room, so knowing this, the room dimensions and the UF, the lumens required are:

$$\text{Total Lumens} = \frac{L \times W \times \text{Design Illuminance}}{UF \times SF \text{ (Service Factor)}}$$

# Appendix A

## Lumen method calculations

**Example:**

For a room 20m long, 10m wide, a Utilisation Factor (UF) of 0.78 and a Service Factor (SF) of 0.8:

Design illuminance required = 200 lux  
 Total lumens =  $\frac{20(L) \times 10(W) \times 200 \text{ lux}}{0.78 \times 0.8} = 64,102 \text{ lm}$

This figure can now be divided by the lumens per lamp.

If 4700 lumen lamps (1500mm size) are used, the number of luminaires is:

$\frac{64102}{4700} = 13.6$

This would be rounded up to a convenient, even number (14) to fit symmetrically into the room.

Within the design scheme, luminaires would then be arranged in the room, taking into account the limit of spacing imposed by the SHR (see Figure 43).

**Table 13: Utilisation Factor (UF)**

Reflectances			Room Index, RI										Reflectances			Room Index, RI									
C	W	F	0.75	1.00	1.25	1.50	2.00	2.50	3.00	4.00	5.00	C	W	F	0.75	1.00	1.25	1.50	2.00	2.50	3.00	4.00	5.00		
70	50	20	0.45	0.52	0.58	0.63	0.70	0.74	0.78	0.82	0.86	50	10	20	0.31	0.37	0.43	0.47	0.54	0.59	0.62	0.68	0.72		
70	30	20	0.38	0.45	0.51	0.56	0.63	0.69	0.73	0.78	0.81	30	50	20	0.39	0.45	0.50	0.54	0.59	0.63	0.65	0.69	0.71		
70	10	20	0.33	0.39	0.45	0.50	0.58	0.63	0.67	0.73	0.77	30	30	20	0.34	0.39	0.45	0.48	0.54	0.58	0.61	0.66	0.68		
50	50	20	0.43	0.49	0.54	0.59	0.65	0.69	0.72	0.76	0.78	30	10	20	0.29	0.35	0.4	0.44	0.50	0.55	0.58	0.63	0.65		
50	30	20	0.36	0.42	0.48	0.52	0.59	0.63	0.67	0.72	0.74	0	0	0	0.26	0.30	0.35	0.38	0.43	0.47	0.50	0.54	0.56		



# Appendix A

## Point calculations

In certain circumstances the illuminance needs to be calculated at a certain point if emergency lighting spacing tables (see Section A.3) are not available.

In this case the following method can be used, but is laborious if a number of points need to be calculated, and the reader is advised to use a suitable computer program.

Light obeys the inverse square law, becoming less intense with the square of the distance from the source, so that:

$$E \text{ (lux)} = I \text{ (cd)} / d^2$$

where d is the distance from source to a point on the working plane.

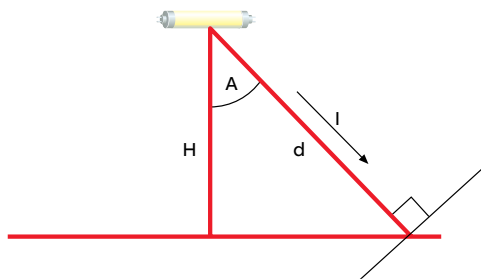

In lighting the height H from the source to the working plane is known, rather than d.

Converting d to H, where A is the angle to the vertical of a line drawn from the source to the point of interest:

$$d = \frac{H}{\cos A} \quad d^2 = \frac{H^2}{\cos^2 A}$$

The working plane is not a right angle to the light so a further cosine correction has to be included. The formula now becomes:

$$E \text{ (lux)} = \frac{I \cos^3 A}{H^2}$$

**Example:**

To determine E for a particular luminaire at 2.5m above the floor (the floor is the working plane for emergency lighting), first look up the luminaire relative intensity at the angle of interest.

For the purposes of this example this could be at 45° on the transverse axis, giving a relative intensity of 200 cd/1000 lm (see Figure 44).

Using an 8 Watt miniature lamp with a full power (mains) output of 420 lm:

$$E(\text{lux}) = \frac{200 \text{ cd} \times 420 \text{ lm}}{1000 \text{ lm} \times 2.5^2 \text{ (m)}^2} \times \cos^3 45^\circ = 4.75 \text{ lux}$$

Figure 43: SHR spacing

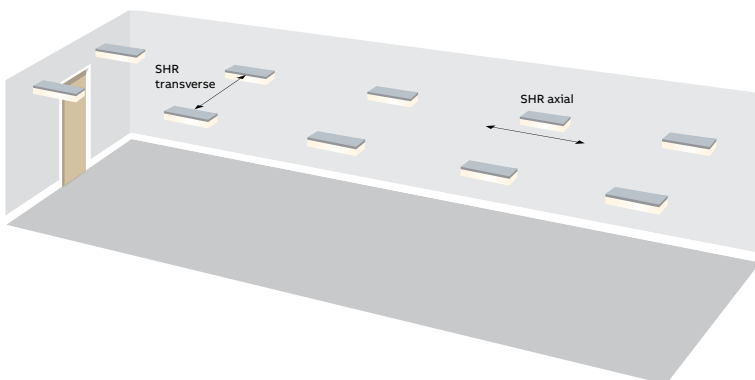
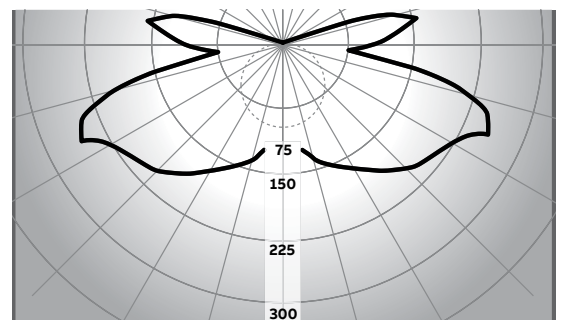

Figure 44: Luminaire relative intensity at 45 degrees



# Appendix A

## Correction factors

For emergency lighting several correction factors have to be included.

These are summarised in the following example and dealt with in detail later. For the purposes of this example, assume the lamp output, operated at full power is rated at 100 lm.

In the following example, the correction factor figures are illustrative only. In the example, for emergency operation, the lamp output works out at  $100 \text{ lm} \times 0.20 = 20 \text{ lm}$ .

### Establish:

Full power lamp output	= 100 lm
Service correction factor, SF	= 0.8
Lamp warm-up, initially F60	= 0.75
Battery voltage falls at end of discharge Fend	= 0.71
Take the least of F5 and Fend for factor, K	= 0.71
For maintained luminaires, lamp degradation E-life	= 0.85
Lamp under-run by emergency driver, BLF	= 0.42

### Overall correction factor:

$$= 0.8 \text{ (SF)} \times 0.71 \text{ (K)}, \times 0.85 \text{ (E-life)} \times 0.42 \text{ (BLF)}$$

$$= 0.20$$

Using the same correction factors for an 8 Watt lamp (full output 420 lm):

### The emergency lamp light output is:

$$420 \text{ lm} \times 0.2 = 84 \text{ lm}$$

### Service Correction Factor (SF)

This is the same factor used in (mains) general lighting and is usually assumed to be 0.8.

However in a dusty environment it may be necessary to reduce this to, for example, 0.5.

### Lamp Warm-Up (F5 and F60)

Fluorescent lamps have an initial warm up period. The emergency lighting illuminance (lux) requirement should be achieved within 60 seconds, so the correction factor is the 60 seconds output divided by the output at 1 hour.

This figure could be quite low for certain lamps, but for tungsten filament or tungsten halogen lamps the output is instantaneous so the factor is 1.0.

Typically for most fluorescent lamps F60 is between 0.6 and 0.8 (see Figure 45).

### End of Discharge (Fend)

The battery voltage falls towards the end of the rated duration, and the lamp output also falls.

A fluorescent lamp operated from a battery falls approximately in proportion to the fall in battery voltage, the output from a tungsten lamp falls with the square of battery voltage.

Each battery emergency driver/lamp combination has a different characteristic and so this must be measured, not predicted from voltages.

### K Factor (K)

This is the least of the F60 and Fend factors. If F60 was 0.79, and Fend was 0.75, the K factor would be taken as 0.75.

### Maintained Factor (E-life)

All lamps degrade and reduce lumen output with age. This factor is usually assumed to be 0.85 and this is the reduction in lamp output after 8000 hours (see Figure 46).

Special lamps have better factor (e.g. 0.9), but for general purposes, the 0.85 factor is acceptable. The maintained factor needs to be included only if the luminaire is maintained.

For non-maintained luminaires, it is omitted.

Figure 45: Service correction factors

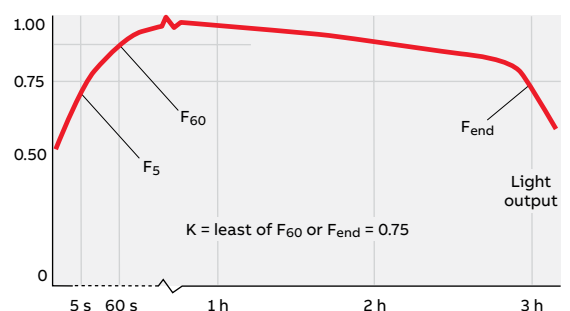

# Appendix A

## Correction factors (continued)

**Ballast Lumen Factor (BLF)**

Emergency drivers usually under-run the lamp.

For example a 3 cell nickel cadmium battery voltage is 3.6 V and the current is usually 1.1 A.

The battery power is therefore 3.6 V x 1.1 A = 3.96 W.

Assuming a driver conversion efficiency of 0.85, the resultant power is 3.96 x 0.85 = 3.37 W.

The BLF with an 8 Watt tube would therefore be approximately:

$$BLF \text{ (approx)} = \frac{3.37}{8} = 0.42$$

This calculation is included for background only and serves as a check for BLF claims.

It is important that the BLF is derived accurately by measuring the light output using the emergency gear and comparing with the light output at full power.

$$BLF = \frac{\text{Emergency light output}}{\text{Full power light output}}$$

Figure 46: Maintained Factor (E-Life)

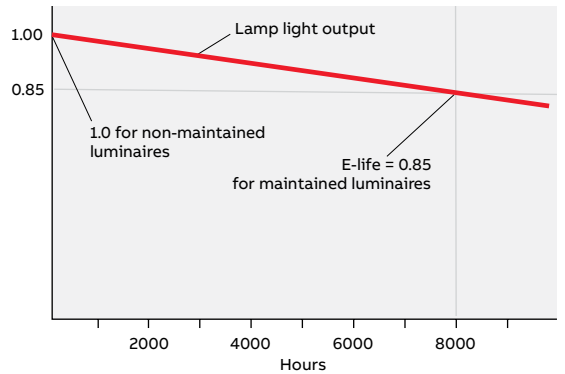



---

# Appendix B: Bibliography

## Regulations relevant to emergency lighting

The Regulatory Reform (Fire Safety) Order 2005 [for England and Wales]

Associated guides available from HM  
Government, [www.firesafetyguides.gov.uk](http://www.firesafetyguides.gov.uk).

Health and Safety (Safety Signs and Signals)  
Regulations 1996

Similar Laws and guides apply for Scotland and  
N. Ireland.

Building Regulations 2006, Approved Document B



# Appendix B: Bibliography

## Standards relevant to emergency lighting

### BS 5266-1 Code of practice for the emergency lighting of premises

This is the base standard for emergency lighting and includes places of entertainment such as cinemas and refers to the relevant clauses in BS EN 1838 and BS EN 5266-8 and in other standards.

BS 5266-2 Code of practice for electrical low mounted way guidance systems for emergency use

BS EN 1838 lighting applications - emergency lighting

This standard includes the illumination lux level requirements.

BS 5266-8 (BS EN 50172) Emergency escape lighting systems

This standard includes the requirements for illumination lux levels for additional areas and the requirements for servicing and maintenance.

BS EN 60598-2-22 Particular requirements - luminaires for emergency lighting (product standard)

BS 5499 Specification for exit signs, including pictograms

The Health and Safety (Safety Signs and Signals) Regulations 1996

This Law includes and accepts the pictogram exit signs as shown in BS 5499 and also as shown in the European Signs Directive.



# Appendix B: Bibliography

## List of ICEL guides and registration schemes

The Regulatory Reform (Fire Safety) Order 2005 [for England and Wales]

**ICEL 1001:1999**

Scheme of product and authenticated photometric data registration for emergency luminaires and conversion modules.

**ICEL 1004:1996**

The use of emergency lighting modifications units.

**ICEL 1006:1997**

Emergency lighting guide.

**ICEL 1008:1998**

Guide to risk assessment.

**ICEL 1009:2000**

Emergency lighting central power supply system registration scheme.

**ICEL 1010:2006**

Scheme of registration of battery cell(s) and batteries for emergency lighting use.



---

# Appendix B: Bibliography

## Other guidance

Technical standards for places of entertainment, published by the District Surveyors Association/Association of British Theatre Technicians.

This document covers emergency lighting and many more relevant subjects.



# Appendix C

## Glossary of terms related to emergency lighting

### Application standard

Standard specifying the emergency lighting design requirements

### Automatic testing

A programmable central test system for emergency lighting

### Axis

Light intensity distributed from a plane projecting from: a) the longer side of the luminaire (transverse axis). b) the shorter side of the luminaire (axial axis)

### Capacity of battery

The product of current (A) and time (h) over a rated time e.g. 35 Ah, at the 20 h rate. A de-rating factor may be required if the duration is less than the rated time

### Category

Maintained, non maintained etc., and duration e.g. NM3

### Central power supply

Central battery, charger etc., supplying power to slave luminaires

### Code of Practice

Standard recommending good practice in emergency lighting design

### Competent Person

Someone who has the sufficient training and experience or knowledge and other qualities that allows them to carry out tasks in the discipline. The level of competency required will depend on the complexity of the situation and the particular discipline involved

### Conversion

A mains luminaire converted for emergency use

### Correction factor

A factor introduced to allow for light reduction due to ageing, dirt, end of duration, etc.

### Designation

A code for summarising type, category, mode and duration, see Annex B in BS EN 60598-2-22

### Disability glare

Intense light that prevents people from seeing the route ahead

### Duration

Autonomy when the mains has failed, e.g. 3 hour  
Emergency driver

Unit or module that operates the lamp in emergency mode

### Escape route

A corridor or delineated route designated for escape in the event of an emergency

### Fire certificate

Issued by the Fire Authorities in compliance with the Fire Precaution Act 1971

### F-mark

Signifies that the luminaire will not ignite a flammable mounting surface

### Harmonised standard

A standard implemented throughout Europe

### Hazard

Something that could cause harm, used in risk assessment

### High risk task area

Area with a potentially dangerous process

### ICEL

Industry Committee for Emergency Lighting

### IEE

Institution of Electrical Engineers

### IET

Institution of Engineering & Technology

### Illuminance

Luminous flux, lux

### Illumination

General term for light

### Internally illuminated sign

Sign with an internal light source

# Appendix C

## Glossary of terms related to emergency lighting (continued)

### Legend

The image, arrow and any supplementary information for a sign

### Lumicom

A not for profit producer compliance scheme which helps producers, selling into the non-household market, meet their obligations under the WEEE Regulations

### Luminaire

Fitting containing a light source and distributing light  
Lux Illuminance, lumens per m<sup>2</sup>

### Mode

Operating status, normal mode, emergency mode, rest mode, non-maintained mode, maintained mode

### Open area

An area leading to an escape route

### Pictogram

A part of a sign or legend giving a message in graphic form

### Point calculation

The exact method using mathematics and trigonometry to calculate light at a particular point and distance from a source

### Polar diagram

Graph of light intensity distribution from a luminaire

### Product standard

Standard applying to the luminaire, the conversion module or the central power supply

### Risk

The chance, high or low, of harm resulting from a hazard

### Risk assessment

The process of assessing the hazards and resultant risks

### Self-contained luminaire

A luminaire containing its own power source or battery

### Semi-automatic testing

A locally initiated test arrangement for emergency luminaires

### (A) sign externally illuminated

Signboard used for emergency applications

### Slave luminaire

A centrally supplied luminaire

### Storey exit

A doorway giving access to a protected stairway in fire resistant construction

### Transitional emergency lighting

Emergency lighting provided to operate, for example, during the startup time of a standby generator

### Type of emergency lighting

Self-contained, slave, conversion

### Uniformity

Ratio minimum divided average illuminance, e.g. 0.8

### Viewing distance

Distance at which an exit or safety sign can be understood

### WEEE Regulations

Waste Electrical and Electronic Equipment Regulations 2006

### Working plane

The plane of task, normally 0.85m, but for emergency lighting, the floor

# Appendix D

## Risk assessment & commissioning check sheets

This check sheet may be used by people checking the provision of emergency lighting. However, a Competent Person trained in emergency lighting

should design, install and verify the complete installation according to the requirements of BS 5266.

### Emergency Lighting Risk Assessment Check Sheet

Identify hazard	Requirement For compliance	Compliance check	
		No	Yes
1. Identify the position of fire equipment and position of hazards such as steps, changes of direction, stairs, first aid points etc.	Emergency luminaire should be provided near (within 2m horizontally) of each of these points of emphasis.		
2. Identify the exit doors, points on escape routes or open areas where a sign is required to make the exit obvious.	Exit signs should be provided observing the maximum viewing distances of 100 x legend height for externally illuminated sign boards (illuminated to 5 lux) and 200 x legend height for internally illuminated signs. Check the sign is a pictogram complying with BS 5266-1:2016, the Signs Directive or BS ISO 7010 (one sign type throughout the installation only).		
3. Identify the need for external escape lighting.	Emergency luminaires should be provided so that people can proceed outside to a place of safety.		
4. Identify the escape routes and establish mounting heights of luminaires above the floor.	Check emergency luminaires are positioned along near the above points to provide 1 lux minimum along the centre line and 0.5 lux minimum in the 1m central band. Use published data in the form of spacing tables for the luminaires at various mounting heights to determine the positions.		
5. Identify the open areas used as escape routes and other open areas larger than 60m <sup>2</sup> and establish mounting heights of luminaires above the floor.	Check that 0.5 lux minimum is provided in the core area. Use published data (as above) to determine the positions.		
6. Identify the position of lifts, escalators, toilets, control/plant rooms, pedestrian walkways in covered car parks (see Section 4.4).	Emergency luminaires should be provided in all of these areas. Treat pedestrian walkways as escape routes.		
7. Identify the location of any first aid point or fire equipment not on an escape route or open area. Identify the location of first aid rooms.	Check that 5 lux emergency illuminance is achieved on the floor in the vicinity of the first aid point or fire equipment. For first aid rooms, 15 lux must be achieved.		
8. Identify toilet areas.	If the toilets are larger than 8m <sup>2</sup> , check that emergency lighting is provided as for escape routes or open areas according to the size of the area. Emergency lighting should also be provided for all disabled toilets.		
9. Identify small lobbies and toilets with no borrowed light.	Check that emergency lighting is adequate. An example of "borrowed light" would be a glass vision panel in a door allowing an emergency luminaire in a corridor to give some light into a small lobby.		
10. Identify whether a central power supply is used.	Emergency luminaire should be provided near (within 2m horizontally) of each of these points of emphasis.		

# Appendix D

## Risk assessment & commissioning check sheets (continued)

### Emergency Lighting Risk Assessment Check Sheet (continued)

Identify hazard	Requirement For compliance	Compliance check	
		No	Yes
11. Identify the type of slave luminaire.	Check that the luminaires are compatible with the central power supply, and do not use glow starters in their emergency circuits.		
12. Identify any special needs for the occupants such as impaired mobility or impaired sight.	Provide additional emergency lighting to reduce the risk to those people to help them evacuate the premises. This applies to designated refuge areas, which may require the provision of emergency voice communication.		
13. Identify high risk task areas and the normal lighting illuminance (lux) in these areas.	Provide 10% of the normal illuminance (lux) or 15 lux minimum. (See Section 4.5).		
14. Identify any dust or dirt problems.	Allow a service factor as appropriate. 0.8 is allowed for normal areas, but for dusty environments 0.5 may be required, or alternatively a regular cleaning procedure should be instigated.		
15. Identify any local regulations.	Check that emergency lighting is provided to comply with the regulations.		
16. Identify any dimmable lighting and shopping malls.	Maintained emergency lighting should be provided.		
17. Identify the use of premises:	Check that the recommended duration is adequate:		
• entertainment (including temporary such as licensed evening dance at a school)			3 h
• sleeping risk			3 h
• residential special care			3 h
• public access non-residential			1 h
• industrial			1 h
• multi-storey dwelling over 10 storeys			3h



# Appendix D

## Risk assessment & commissioning check sheets

Emergency Lighting Installation - BS 5266-1:2016  
Compliance Check Sheet for Inspection Engineers

---

**Site Address**

---



---

**Responsible Person**

---

**Date**

---

**Compliance Check Sheet for Inspection Engineers**

Initial checks and those conducted during work in progress	Y	N	N/A
<b>1. Check that the appropriate system has been installed and documented</b>			
1.1 Are the correct areas of the premises covered?			
1.2 Are all hazards identified by the risk assessment covered?			
1.3 Is the system documentation correct and available?			
1.4 Has the system been designed for the correct mode of operation category?			
1.5 Has the system been designed for the correct emergency duration period?			
1.6 Is a completion certificate available with photometric design data?			
1.7 Is a test log available and are the entries up to date?			
<b>2. Check of the system installed</b>			
2.1 Are the luminaires installed those documented in the design?			
2.2 Are the exit signs and arrow directions correct?			
2.3 Are there luminaires sited at the 'points of emphasis'?			
2.4 Is the spacing between luminaires compliant to spacing tables or drawing?			
2.5 Is there illumination from at least two luminaires in each compartment?			
2.6 Are the luminaire housings suitable for their location?			
2.7 Are non-maintained luminaires monitoring the local lighting circuit?			
<b>3. Check of the quality of the system</b>			
3.1 Do the luminaires conform to BS EN 60598-2-22?			
3.2 If a central power supply unit is used does it conform to BS EN 50171?			
3.3 For centrally powered systems is the wiring fire resistant?			
3.4 Do any converted luminaires conform to BS EN 60598-2-22?			
<b>4. Test facilities</b>			
4.1 Do the test facilities simulate a supply failure?			
4.2 Are the test facilities safe to operate and do not isolate a required service?			
4.3 Are the test facilities clearly marked with their function?			
4.4 Are the user's staff trained and able to operate them and record correctly?			
4.5 If an automatic test system is installed does it comply with IEC 62034?			

# Appendix D

## Risk assessment & commissioning check sheets (continued)

—  
**Compliance Check Sheet for Inspection Engineers (continued)**

Initial checks and those conducted during work in progress	Y	N	N/A
<b>5. Central powered systems</b>			
5.1 Are escape lighting components and cables installed correctly?			
5.2 Can any AC systems start the lamps from the battery in an emergency?			
5.3 Can any AC systems overcome all distribution MCB's/fuses in an emergency?			
<b>Final acceptance to be conducted at completion</b>			
6.1 Are the areas of coverage in accordance with the requirements imposed under the Building Regulations and the risk assessment?			
6.2 For central systems - has the correct cable type been installed?			
6.3 Does the number and distribution of fittings appear to be reasonable?			
6.4 Have escape lighting cables been segregated from all other cables?			
6.5 Is the standard of cable installation satisfactory?			
6.6 Are all isolators, switches and protective devices minimised and marked?			
6.7 Have suitable test facilities been installed and marked?			
6.8 Have all escape lighting cable penetrations been fire stopped?			
6.9 Does the system operate correctly when tested?			
6.10 Has adequate documentation been provided to the user?			

**Site Address**

**Comments**

**Signed**

**Date**

# Appendix E

## Luminaires

Guideway is a high specification, practical and contemporary LED based emergency lighting system, comprising a full range of exit signs with recessed and surface mounted downlighters, called Serenga 2.



Guideway delivers the optimal LED solution, with extended lamp and battery life, for an overall cost of ownership much lower than that of traditional 8 Watt T5 fluorescents.

Additionally, Guideway Escape exit signs can be specified with four LEDs, for downlighting, and are provided as standard with automatic Self-Test.

Guideway Escape exit signs benefit from true modular construction, for maximum flexibility in installation, whether surface, suspended, recessed or wall mounting is required.



Serenga 2 recessed and surface mounted downlighters fully complement Serenga 2 Escape exit signs and deliver optimised spacings via high power, high efficiency LEDs. Escape route and open area versions are available, with an additional 5 Lux spotlight in recessed format.

# Appendix E

## Luminaires

Horizon delivers both sophistication and value to high profile commercial projects, combining great aesthetics with easy installation via its first fix base.

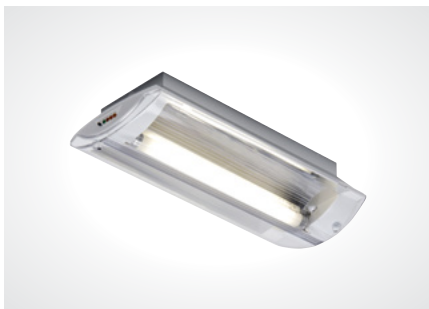

Horizon emergency luminaires include enhanced optics for market-leading spacings when installed as emergency lighting, or can be adjusted simply to exit sign use through addition of a clip-on or slotted legend panel.

All Horizon emergency luminaires include automatic Self-Test as standard.



Aqualux emergency luminaires offer immense durability with high performance, and are ideal for installations requiring a more heavy duty solution, such as warehousing, storage facilities, car parks, sports halls and stadia etc.

and excellent spacings, even when sited in high bays.

LED based exit signs combine with high power LED emergency luminaires for a project-wide application which delivers both energy efficiency

Aqualux emergency luminaires are rated to IP65 & IP67, and include automatic Self-Test as standard.

---

# Appendix E

## Luminaires

Escape Line emergency lighting is ideal for general purpose, mid-range installations, offering IP20 rated luminaires and exit signs for interior commercial use, up to IP65 variants for outdoor or industrial applications.



# Appendix E

## Luminaires

Hy-Lite luminaires provide a high quality, high wattage solution for both emergency lighting and standard mains use.



Hy-Lite luminaires are chosen for aesthetic appeal and their ability to deliver excellent illumination across a number of environments.

Whilst Camarque luminaires provide decorative and stylish interior lighting, Cordona offers the practicality and robustness expected from an IP65 rated luminaire.

Emergi-Lite testing systems deliver the effective solution to the periodic need to test emergency lighting in accordance with the Fire Regulations and BS 5266.

The range extends from simple Self-Test integrated into self-contained emergency lighting and IR2 infra-red testing, through to the comprehensive Naveo testing solution with cloud-based remote monitoring and management.



# Appendix E

## Luminaires

EMEX AC/AC Central Power Supply Systems provide a low maintenance and extremely reliable solution to powering emergency lighting systems.

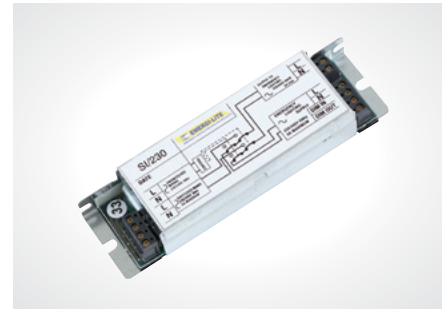

AC/AC static inverters offer the opportunity to power slave emergency luminaires without conversion at full output, promoting the use of fewer emergency luminaires in the system, and easily achieving the higher lux requirements of high risk task areas.

All EMEX AC/AC systems are compatible with EMEX Test automated testing, with EMEX TS systems including a touch screen for monitoring purposes.



EMEX Mini is a compact, space saving AC/AC Central Power Supply system, designed to power emergency lighting systems up to 1.5 kVA in size.

This solution to powering emergency lighting proves ideal where a fragmented system is preferred, with multiple units installed, or as a complement to a self-contained system to achieve appropriate light levels in high risk task areas and high bays.

EMEX Mini is fully compatible with EMEX Test automated testing, and is designed to a modular format comparable to EMEX Power units, making maintenance and inspection a simple task.







**Additional information**

We reserve the right to make technical changes or modify the contents of this document without prior notice. With regard to purchase orders, the agreed particulars shall prevail. ABB AG does not accept any responsibility whatsoever for potential errors or possible lack of information in this document.

We reserve all rights in this document and in the subject matter and illustrations contained therein. Any reproduction, disclosure to third parties or utilisation of its contents – in whole or in parts – is forbidden without prior written consent of ABB AG.





—

**ABB UK Ltd.**

Tower Court  
Foleshill Enterprise Park  
Courtaulds Way  
Coventry  
CV6 5NX

UK Sales Support Tel: Tel: +44 (0)333 999 3300  
Service Enquiry Tel: +44 (0)2476 368 511  
Customer Services E-Mail: [lv.customerservice@gb.abb.com](mailto:lv.customerservice@gb.abb.com)  
Technical Support E-Mail: [LV.enquiries@gb.abb.com](mailto:LV.enquiries@gb.abb.com)

**[emergi-lite.co.uk](http://emergi-lite.co.uk)**