

IBM TS4300 Tape Library
Machine Type 3555

User's Guide



Before using this information and the product it supports, read the information in “Notices” on page 200. To ensure you have the latest publications, visit the web at <http://www.ibm.com/storage/lto>.

This edition applies to the *IBM TS4300 Tape Library User's Guide*, SC27-4629-07, and to the subsequent releases and modifications until otherwise indicated in new editions.

© **Copyright IBM Corporation 2017, 2020.**

US Government Users Restricted Rights – Use, duplication or disclosure restricted by GSA ADP Schedule Contract with IBM Corp.

Read this FIRST

This product might not be certified in your country for connection by any means whatsoever to interfaces of public telecommunications networks. Further certification might be required by law before any such connection is made. Contact IBM® for information.

Regulatory information

- The IBM TS4300 library must be installed in a restricted area.
- Only personnel with technical and product safety training should have access to the library.
- The library must be properly installed in an office or industrial environment with shielded cables and adequate grounding of SAS interface and input power to comply with regulations and standards.

The system complies to all applicable safety standards to allow for shipments worldwide including the America's, European Union Member States, Middle East, and Asia.

Minimum firmware levels for common library features

Feature	Minimum Firmware Levels Required
LTO8 (HH/FH) Tape Drives	Library Firmware must be at 1.1.1.0-A00 or greater to support the LTO8 tape drives. Ensure that any host applications and device drivers are at the minimum level that is required to support LTO8 tape drives. Certain non-IBM LTO8 media requires minimum drive firmware J4D4. Contact your media supplier for details.
LTO6 (HH/FH) and LTO7 (HH/FH) Tape Drives	Library Firmware must be at 1.1.0.1-A00 or greater to support the LTO6 and LTO7 tape drives. Ensure that any host applications and device drivers are at the minimum level that is required to support LTO6 and LTO7 tape drives.
Library-Managed Encryption	Library Firmware must be at 1.1.1.0-A00 or greater to support the Library-Managed Encryption feature. Ensure that any key manager applications are at the minimum level that is required to support the 3U library. SKLM for z/OS encryption requires minimum library firmware 1.2.0.0-B00.
Path Failover (Control Path and Data Path)	Library Firmware must be at 1.1.1.0-A00 or greater to support the Path Failover feature. Ensure that any IBM device drivers are at the minimum level that is required to support the 3U library.
Remote Logging (rsyslog)	Library Firmware must be at 1.1.1.0-A00 or greater to support the Remote Logging feature. Ensure that any IBM device drivers are at the minimum level that is required to support the 3U library.

<i>Table 1. Minimum firmware levels for common library features (continued)</i>	
Feature	Minimum Firmware Levels Required
LTO M8 media	Library Firmware must be at 1.1.1.1-B00 or greater to support the M8 media feature. Drive firmware must be at HB82 or greater to support the M8 media feature. Ensure that any IBM device drivers are at the minimum level that is required to support the 3U library.
Sequential Mode	Library Firmware must be at 1.1.1.2-A00 or greater to support Sequential Mode. Ensure that any host applications are at the minimum level that is required to support the 3U library in this mode.
Library Serial Number 7800K0K or greater	Library firmware must be at 1.2.1.0-A00 or greater to support newer library serial numbers.
Key Path Diagnostics (KPD)	Library Firmware must be at 1.3.0.0-A00 or greater to support KPD.

Accessing online technical support

It is the customer's responsibility to set up this tape drive or library and to ensure that the drive and library have the latest firmware (unless a service contract is purchased).

For online Technical Support, visit <http://www.ibm.com/support/>.

For the latest firmware and diagnostic procedures, visit <http://www.ibm.com/support/>.

Contacting IBM technical support

In the US: Call 1-800-IBM_SERV (1-800-426-7378).

Note: Before you call, complete all the steps in “Contacting IBM technical support” on page 82.

All other Countries or Regions: See <http://www.ibm.com/planetwide/>.

Select your country, then under **Technical Support**, click **Open Service Request**.

Registering for My Notification

My Notification registration provides email notification when new firmware levels are updated and available for download and installation. To register for My Notification:

1. Visit the web at <http://www-01.ibm.com/software/support/einfo.html>.
2. Click **My Notifications**.

Note: Library firmware and tape drive firmware are verified and released together. When you are updating to the latest firmware, verify that all installed components such as tape drives and library firmware are at the latest levels noted on the Support website. Mixing different levels of library and tape drive firmware is not supported and might cause unpredictable results.

Sending comments

Your feedback is important in helping to provide the most accurate and highest quality information.

To submit any comments about this publication or any other IBM storage product documentation:

- Send your comments by email to ibmkc@us.ibm.com. Be sure to include the following information:
 - Exact publication title and version
 - Page, table, or illustration numbers that you are commenting on
 - A detailed description of any information that should be changed

Summary of changes

Summary of changes

This document contains terminology, maintenance, and editorial changes for the seventh edition (SC27-4629-07) of the IBM TS4300 Tape Library User's Guide. Technical changes or additions to the text and illustrations are indicated by a vertical line to the left of the change.

New information

The following section contains new information for the seventh edition (SC27-4629-07).

- Updated Safety information and icons.

The following section contains information for the sixth edition (SC27-4629-06).

- Key Path Diagnostics
- Updated information about KMIP Encryption
- Updated cartridge information in the Cleaning Drives section

The following section contains information for the fifth edition (SC27-4629-05).

- Library serial number updates.

The following section contains information for the fourth edition (SC27-4629-04).

- Information on the Security Key Lifecycle Manager (SKLM) library-managed encryption.

Contents

- **ii**
- Read this FIRST..... iii**
 - Minimum firmware levels for common library features..... iii
 - Accessing online technical support..... iv
 - Contacting IBM technical support..... iv
 - Registering for My Notification..... iv
 - Feedback..... v
- Summary of changes.....vi**

- Figures..... xi**

- Tables..... xvi**

- Safety and environmental noticesxix**
 - Danger and Caution notices..... xix
 - Possible safety hazards..... xxiv
 - Class I laser product..... xxiv
 - Acclimation..... xxv
 - Performing the safety inspection procedure..... xxv
 - Rack safety.....xxv
 - Power Cords..... xxix

- Preface..... XXX**

- Chapter 1. Overview..... 1**
 - Introduction..... 1
 - Structure and supported library configurations..... 2
 - Components.....6
 - User interfaces..... 11
 - Supported tape drives..... 11
 - Control path drives..... 12
 - Mixed drives..... 12
 - Drive sled back panels..... 13
 - Physical and logical addresses of drives..... 15
 - Supported tape cartridges..... 16
 - Library functions..... 16
 - Random and Sequential Logical Library modes..... 16
 - Encryption..... 17
 - Library sharing..... 17
 - Control path failover, Data path failover, and load balancing..... 18
 - Alerts and logging..... 19
 - Host connectivity..... 20
 - Network connectivity..... 21

- Chapter 2. Planning..... 23**
 - Library Layout and Location requirements..... 23
 - Power cords..... 28
 - Network requirements..... 33

Host requirements.....	33
Optional features.....	34
Chapter 3. Installing.....	36
Unpacking the Base Module and Expansion Modules.....	38
Identifying Library Module components.....	42
Preparing top and bottom modules.....	42
Installing modules in a rack.....	45
Installing a tabletop module.....	49
Aligning and connecting modules.....	49
Validating tape drive installation.....	52
Connecting cables.....	53
Powering on the library.....	54
The Initial Setup process.....	55
Initial configuration and customization.....	56
Labeling and loading tape cartridges.....	56
Verifying the installation.....	58
Advanced library configuration.....	58
Overview.....	58
Library partitioning.....	59
Verifying the host connection.....	60
Chapter 4. Managing.....	61
The Management GUI.....	61
The Operator Panel.....	64
Locating Management functions.....	65
Default settings.....	69
Methods of cleaning drives.....	72
Accessing cartridges.....	73
Configuring Library Managed Encryption.....	73
Chapter 5. Troubleshooting.....	77
Finding event information.....	77
Identifying a failed component.....	77
Running library tests.....	77
Troubleshooting Guide.....	77
Pre-call checklist.....	82
Contacting IBM technical support.....	82
Diagnostic information.....	83
IBM Tape Diagnostic tool (ITDT).....	83
Event codes.....	84
TapeAlert Flags.....	108
Sense data.....	114
Drive Error Codes: Single-character display (SCD).....	114
Chapter 6. Upgrading and servicing.....	118
Internal view of library.....	118
Adding, removing, or replacing a tape drive.....	119
Adding or replacing a Base or Expansion Module.....	123
Adding, removing, or replacing a power supply.....	129
Replacing a Base or Expansion controller card.....	132
Installing, removing, or replacing an accessor and spooling mechanism.....	135
Returning the accessor to the Base Module.....	141
Removing or replacing a spooling mechanism.....	143
Removing or replacing a magazine.....	147
Moving the library modules.....	148

Appendix A. Library Configuration Forms.....	151
Library information.....	151
Module and drive information.....	153
Logical Library information.....	154
Users account information.....	155
Appendix B. LTO media.....	156
Data cartridges.....	156
Cartridge Read/Write compatibility.....	157
LTO Type M Cartridge (M8).....	157
Capacity scaling.....	158
WORM (Write Once, Read Many) cartridges.....	158
WORM media.....	159
Data security on WORM media.....	159
WORM media errors.....	159
WORM requirements.....	159
Cleaning cartridge.....	159
Cartridge memory chip (LTO-CM).....	160
Labeling tape cartridges.....	160
Guidelines for bar code labels.....	162
Write-Protect switch.....	162
Handling the cartridges.....	163
Providing training.....	163
Ensuring proper packaging.....	163
Proper acclimation and environmental conditions.....	164
Completing a thorough inspection.....	165
Handling the cartridge carefully.....	166
Examples of cartridge problems.....	166
Repositioning or reattaching a leader pin.....	166
Repositioning a leader pin.....	166
Reattaching a leader pin.....	168
Environmental and shipping specifications for tape cartridges.....	171
Disposing of tape cartridges.....	172
Ordering media supplies.....	172
Ordering bar code labels.....	174
Appendix C. Replacement parts.....	176
Appendix D. Manual cartridge removal procedure.....	178
Recommended tools.....	178
Before you begin.....	178
Beginning procedure.....	179
Removing the drive brick from the sled.....	179
Removing the drive cover.....	180
Full height drive: Tape spooled off supply reel.....	181
Half height drive: Tape spooled off supply reel.....	182
Full height drive: Tape pulled from or broken near leader pin.....	184
Half height drive: Tape pulled from or broken near leader pin.....	185
Full height drive: Tape broken in mid-tape.....	186
Half height drive: Tape broken in mid-tape.....	187
Full height drive: Tape tangled along tape path.....	188
Half height drive: Tape tangled along tape path.....	191
Full height drive: No apparent failure or damage to tape.....	192
Half height drive: No apparent failure or damage to tape.....	195
Ending procedure.....	197

Appendix E. Accessibility.....	199
Notices.....	200
Trademarks.....	201
Electromagnetic compatibility notices.....	202
Canada Notice.....	202
European Community and Morocco Notice.....	202
Germany Notice.....	202
Japan Electronics and Information Technology Industries Association (JEITA) Notice.....	203
Japan Voluntary Control Council for Interference (VCCI) Notice	204
Korea Notice.....	204
People's Republic of China Notice.....	204
Russia Notice.....	204
Taiwan Notice.....	205
United States Federal Communications Commission (FCC) Notice.....	205
Glossary.....	206
Index.....	227

Figures

- 1. Two module tape library..... 1
- 2. Base Module 2
- 3. Expansion Module..... 3
- 4. Base Module..... 3
- 5. 2 module library..... 3
- 6. 3 module library..... 3
- 7. 4 module library..... 4
- 8. 5 module library..... 4
- 9. 6 Module library.....5
- 10. 7 module library..... 6
- 11. Front panel7
- 12. Rear panel.....8
- 13. Physical numbering of modules 9
- 14. Left magazine..... 9
- 15. Right magazine.....10
- 16. Power supply rear panel LEDs..... 11
- 17. Mixed drives in a logical library.....13
- 18. Drive sled indicators.....13
- 19. Half-height SAS dual port..... 14
- 20. Half-height FC single port..... 14
- 21. Full-height FC dual port..... 14
- 22. Physical numbering of drives.....15

23. Psychrometric chart showing recommended and allowable operating environments for the tape library.....	26
24. Types of receptacles.....	32
25. Removing the module from the box.....	39
26. The module after removal from the box.....	39
27. Unlatching the top of the module.....	40
28. Removing the top of the module.....	40
29. The module is opened to show the foam packing.....	41
30. The foam packing is removed, and the internal components are shown - Base Module.....	41
31. Lowering the front of the top cover.....	43
32. Unlocking the spring loaded lock.....	44
33. Removing the cover.....	44
34. Lifting the cover and locking it.....	45
35. Universal rack connector.....	45
36. Incorrect connector locations	46
37. Correct connector locations	46
38. Mounting the rails to the connectors.....	47
39. Side rails installed.....	48
40. Sliding the library into the rack.....	48
41. Library in the rack.....	49
42. Hole for alignment pin.....	50
43. Alignment lever lock.....	50
44. Alignment lever locked or engaged to lower module.....	51
45. Alignment lever unlocked or disengaged.....	51
46. Two modules in rack, seen from the rear.....	52
47. Connected modules.....	52

48. Full-height FC dual port.....	53
49. Half-height FC single port.....	53
50. Half-height SAS dual port.....	54
51. IP address selection.....	55
52. Open I/O station seen from the left.....	57
53. Magazine pulled out.....	57
54. Management GUI main screen.....	62
55. Operator Panel main screen.....	64
56. Front panel LEDs.....	65
57. Internal view of the library.....	118
58. Drive bay covers.....	120
59. Alignment rails.....	120
60. Installing a tape drive.....	121
61. Unlocking the drive.....	121
62. Interconnect cables.....	125
63. Unlocking or disengaging the alignment lever.....	126
64. Loosening the thumbscrews.....	127
65. Sliding the module out of the rack.....	127
66. Placement of the RID tag (Base Module shown).....	129
67. Power supplies.....	130
68. Sliding in the new power supply.....	131
69. Controller card components.....	133
70. Installing a Controller card.....	134
71. Magazine release levers.....	136
72. Unlocking the robot.....	137

73. Finger holes.....	137
74. Unlocking the spooling cable and placing it in its cradle.....	138
75. Spooling cable in park position.....	138
76. Pins are aligned horizontally.....	139
77. Installing the spooling cable.....	140
78. Inserting the screwdriver to manually operate the accessor.....	141
79. Left magazine opening.....	142
80. Unlocking the spooling mechanism.....	144
81. Unlocked spooling mechanism - enlarged view.....	145
82. Locked spooling mechanism - enlarged view.....	146
83. Removing the spooling mechanism.....	147
84. Manually releasing the right magazine.....	148
85. Manually releasing the left magazine.....	148
86. The IBM LTO data cartridge.....	156
87. LTO Data and WORM tape cartridges.....	159
88. Sample bar code label on the LTO8 Tape Cartridge.....	161
89. Setting the write-protect switch.....	163
90. Tape cartridges in a Turtlecase.....	164
91. Double-boxing tape cartridges for shipping.....	164
92. Checking for gaps in the seams of a cartridge.....	165
93. Leader pin in the incorrect and correct positions.....	167
94. Placing the dislodged leader pin into the correct position.....	167
95. Rewinding the tape into the cartridge.....	168
96. Leader Pin Reattachment Kit.....	169
97. Attaching the leader pin attach tool to the cartridge.....	169

98. Winding the tape out of the cartridge.....	170
99. Removing the C-clip from the leader pin.....	170
100. Attaching the leader pin to the tape.....	171
101. Connection screws and plastic cover.....	179
102. The drive brick, showing the cables to be unplugged.....	180
103. Removing the cover from the full height drive.....	180
104. Removing the cover from the half height drive.....	181
105. The hex wrench rewinds tape into cartridge.....	182
106. Rewinding tape into cartridge.....	183
107. Drive with cover removed to reveal gear train.....	184
108. Leader Block Assembly (LBA).....	185
109. Drive with cover removed to reveal gear train.....	185
110. Leader Block Assembly (LBA).....	186
111. The hex wrench rewinds tape into cartridge.....	187
112. Rewinding tape into cartridge.....	188
113. The hex wrench rewinds tape into cartridge.....	189
114. Drive with cover removed to reveal gear train.....	190
115. Leader Block Assembly (LBA).....	191
116. Rewinding tape into cartridge.....	192
117. The hex wrench rewinds tape into cartridge.....	193
118. Drive with cover removed to reveal gear train.....	194
119. Leader Block Assembly (LBA).....	195
120. Rewinding tape into cartridge.....	196
121. Drive with cover removed to reveal gear train.....	197
122. Leader Block Assembly (LBA).....	197

Tables

- 1. Minimum firmware levels for common library features.....iii
- 2. Module designations..... 1
- 3. Minimum and maximum storage configurations..... 2
- 4. Library configurations.....3
- 5. Front panel descriptions..... 7
- 6. Rear panel descriptions.....8
- 7. Physical numbering of storage slots - bottom module..... 10
- 8. Power supply LEDs..... 11
- 9. Supported tape drives..... 12
- 10. Drive sled indicators.....13
- 11. Half-height SAS dual port..... 14
- 12. Half-height FC single port..... 14
- 13. Full-height FC dual port..... 15
- 14. Differences between CPF and DPF..... 18
- 15. Location requirements..... 23
- 16. Physical specifications..... 24
- 17. Electrical specifications for one module (base or expansion)..... 24
- 18. Equipment environment specifications for the tape library..... 25
- 19. Gas and particulate exposure..... 27
- 20. Power cords.....28
- 21. Optional features..... 34
- 22. Installation Precautions.....37
- 23. Full-height FC dual port..... 53

24. Half-height FC single port.....	53
25. Half-height SAS dual port.....	54
26. Main screen elements.....	62
27. Navigation Dock.....	63
28. Status icons.....	63
29. Operator Panel menu tree.....	64
30. Front panel LEDs	65
31. Locating Management functions.....	65
32. Default settings.....	69
33. Magazine state.....	73
34. Resolving errors.....	78
35. Main error events.....	85
36. Warning events.....	95
37. Configuration Change events.....	105
38. Informational Events.....	106
39. Error codes on the single-character display.....	115
40. Meaning of Status light and single-character display (SCD).....	116
41. Internal view description.....	118
42. Pinch hazard.....	119
43. Power supply components.....	130
44. Controller card components.....	133
45. Cartridge data capacity and recording formats.....	156
46. Nominal cartridge life: Load/unload cycles.....	157
47. Data cartridge compatibility with LTO tape drive.....	157
48. LTO Cartridge Types.....	158

49. Cartridges and VOLSERs compatible with the LTO Tape Drives.....	161
50. Location of the write-protect switch.....	163
51. Environment for storage and shipping the LTO tape cartridges.....	172
52. Media supplies.....	173
53. Authorized suppliers of custom bar code labels.....	174
54. Replacement parts.....	176

Safety and environmental notices

When this product is used, observe the danger, caution, and attention notices that are contained in this guide. The notices are accompanied by symbols that represent the severity of the safety condition.

Most danger or caution notices contain a reference number (Dxxxx or Cxxxx). Use the reference number to check the translation in the *IBM Systems Safety Information* (G229-9054) publication included in your ship group.

The sections that follow define each type of safety notice and give examples.

Danger and Caution notices

Danger notices

A danger notice calls attention to a situation that is potentially lethal or extremely hazardous to people. A lightning bolt symbol always accompanies a danger notice to represent a dangerous electrical condition.



<p>To prevent a possible shock from touching two surfaces with different protective ground(earth), use one hand, when possible, to connect or disconnect signal cables. (D001)</p>
<p>Overloading a branch circuit is potentially a fire hazard and a shock hazard under certain conditions. To avoid these hazards, ensure that your system electrical requirements do not exceed branch circuit protection requirements. Refer to the information that is provided with your device or the power rating label for electrical specifications. (D002)</p>
<p>If the receptacle has a metal shell, do not touch the shell until you have completed the voltage and grounding checks. Improper wiring or grounding could place dangerous voltage on the metal shell. If any of the conditions are not as described, STOP. Ensure the improper voltage or impedance conditions are corrected before proceeding.(D003)</p>
<p>An electrical outlet that is not correctly wired could place hazardous voltage on the metal parts of the system or the devices that attach to the system. It is the responsibility of the customer to ensure that the outlet is correctly wired and grounded to prevent an electrical shock.(D004)</p>
<p>When working on or around the system, observe the following precautions:</p> <p>Electrical voltage and current from power, telephone, and communication cables are hazardous. To avoid a shock hazard:</p> <ul style="list-style-type: none">• If IBM supplied a power cord(s), connect power to this unit only with the IBM provided power cord. Do not use the IBM provided power cord for any other product.• Do not open or service any power supply assembly.• Do not connect or disconnect any cables or perform installation, maintenance, or reconfiguration of this product during an electrical storm.• The product might be equipped with multiple power cords. To remove all hazardous voltages, disconnect all power cords.<ul style="list-style-type: none">– For AC power, disconnect all power cords from their AC power source.– For racks with a DC power distribution panel (PDP), disconnect the customer’s DC powersource to the PDP.• When connecting power to the product ensure all power cables are properly connected.<ul style="list-style-type: none">– For racks with AC power, connect all power cords to a properly wired and grounded electrical outlet. Ensure that the outlet supplies proper voltage and phase rotation according to the system rating plate.– For racks with a DC power distribution panel (PDP), connect the customer’s DC power source to the PDP. Ensure that the proper polarity is used when attaching the DC power and DC power return wiring.• Connect any equipment that will be attached to this product to properly wired outlets.



- When possible, use one hand only to connect or disconnect signal cables.
- Never turn on any equipment when there is evidence of fire, water, or structural damage.
- Do not attempt to switch on power to the machine until all possible unsafe conditions are corrected.
- Assume that an electrical safety hazard is present. Perform all continuity, grounding, and power checks specified during the subsystem installation procedures to ensure that the machine meets safety requirements.
- Do not continue with the inspection if any unsafe conditions are present.

- Before you open the device covers, unless instructed otherwise in the installation and configuration procedures: Disconnect the attached AC power cords, turn off the applicable circuit breakers located in the rack power distribution panel (PDP), and disconnect any telecommunications systems, networks, and modems.
- Connect and disconnect cables as described in the following procedures when installing, moving, or opening covers on this product or attached devices.

To disconnect:



1. Turn off everything (unless instructed otherwise).
2. For AC power, remove the power cords from the outlets.
3. For racks with a DC power distribution panel (PDP), turn off the circuit breakers located in the PDP and remove the power from the Customer's DC power source.
4. Remove the signal cables from the connectors.
5. Remove all cables from the devices.

To connect:

1. Turn off everything (unless instructed otherwise).
2. Attach all cables to the devices.
3. Attach the signal cables to the connectors.
4. For AC power, attach the power cords to the outlets.
5. For racks with a DC power distribution panel (PDP), restore the power from the Customer's DC power source and turn on the circuit breakers located in the PDP.
6. Turn on the devices.

- Sharp edges, corners and joints may be present in and around the system. Use care when handling equipment to avoid cuts, scrapes and pinching. (D005)

Heavy equipment - personal injury or equipment damage might result if mishandled. (D006)









	<p>Uninterruptible power supply (UPS) units contain specific hazardous materials. Observe the following precautions if your product contains a UPS:</p> <ul style="list-style-type: none"> • The UPS contains lethal voltages. All repairs and service must be performed only by an authorized service support representative. There are no user serviceable parts inside the UPS. • The UPS contains its own energy source (batteries). The output receptacles might carry live voltage even when the UPS is not connected to an AC supply. • Do not remove or unplug the input cord when the UPS is turned on. This removes the safety ground from the UPS and the equipment connected to the UPS. • The UPS is heavy because of the electronics and batteries that are required. To avoid injury, observe the following precautions: <ul style="list-style-type: none"> – Do not attempt to lift the UPS by yourself. Ask another service representative for assistance. – Remove the battery, electronics assembly, or both from the UPS before removing the UPS from the shipping carton or installing or removing the UPS in the rack. <p>(D007)</p> <p>Professional movers are to be used for all relocation activities. Serious injury or death might occur if systems are handled and moved incorrectly. (D008)</p> <p>Ensure that your DC mains supply is earthed at the point of generation per IEC 60950-1 and ITU-T Recommendation K.27. (D009)</p> <p>Serious injury or death can occur if loaded lift tool falls over or if a heavy load falls off the lift tool. Always completely lower the lift tool load plate and properly secure the load on the lift tool before moving or using the lift tool to lift or move an object. (D010)</p>
	<p> DANGER: Multiple power cords. The product might be equipped with multiple AC power cords or multiple DC power cables. To remove all hazardous voltages, disconnect all power cords and power cables. (L003)</p>





Caution notices

A caution notice calls attention to a situation that is potentially hazardous to people because of some existing condition, or to a potentially dangerous situation that might develop because of some unsafe practice.

	<p>The doors and covers to the product are to be closed at all times except for service by trained service personnel. All covers must be replaced and doors closed at the conclusion of the service operation. (C013)</p> <p>This product is equipped with a 3-wire (two conductors and ground) power cable and plug. Use this power cable with a properly grounded electrical outlet to avoid electrical shock. (C018)</p> <p>This assembly contains mechanical moving parts. Use care when servicing this assembly. (C025)</p>
---	--

A caution notice can be accompanied by one of several symbols:

If the symbol is...	It means...
	<p>A generally hazardous condition not represented by other safety symbols.</p>
 <p>Class I</p>	<p>A hazardous condition due to the use of a laser in the product. Laser symbols are always accompanied by the classification of the laser as defined by the U. S. Department of Health and Human Services (for example, Class I, Class II, and so forth).</p>
 	<p>Risk of hand pinching, can trap hands, fingers and cause serious injury. Keep hands clear during operation (L012).</p>
	<p>Caution: moving parts. (L037)</p>
<p>CAUTION:</p>  <p>18-32 kg (39.7-70.5 lbs)</p>  <p>or</p>  <p>>18 kg (39.7 lbs)</p> <p>or</p>  <p>>18 kg (39.7 lbs)</p>	<p>The weight of this part or unit is between 18 and 32 kg (39.7 and 70.5 lb). It takes two persons to safely lift this part or unit. (C009)</p>

If the symbol is...	It means...
<p>CAUTION:</p>  <p>32-55 kg (70.5-121.2 lbs)</p>  <p>OR</p>  <p>>32 kg (70.5 lb)</p> <p>OR</p>  <p>>32 kg (70.5 lb)</p>	<p>The weight of this part or unit is between 32 and 55 kg (70.5 and 121.2 lb). It takes three persons to safely lift this part or unit. (C010)</p>
	<p>A hazardous condition due to the unit's susceptibility to electrostatic discharge.</p>

Possible safety hazards

Possible safety hazards to the operation of this product are:

Electrical

An electrically charged frame can cause serious electrical shock.

Mechanical

Hazards (for example, a safety cover missing) are potentially harmful to people.

Chemical

Do not use solvents, cleaners, or other chemicals that are not approved for use on this product.

Before the library is used, repair any of the preceding problems.

Class I laser product

Before the library is used, review the following laser safety information.

The product might contain a laser assembly that complies with the performance standards set by the US Food and Drug Administration for a Class I laser product. Class I laser products do not emit hazardous laser radiation. The product has the necessary protective housing and scanning safeguards to ensure that laser radiation is inaccessible during operation or is within Class I limits. External safety agencies reviewed the product and obtained approvals to the latest standards as they apply.

Acclimation

Server and storage equipment (racks and frames) must be gradually acclimated to the surrounding environment to prevent condensation.

When server and storage equipment (racks and frames) is shipped in a climate where the outside temperature is below the dew point of the destination (indoor location), there's a possibility that water condensation can form on the cooler inside and outside surfaces of the equipment when the equipment is brought indoors.

Sufficient time must be allowed for the shipped equipment to gradually reach thermal equilibrium with the indoor environment before you remove the shipping bag and energize the equipment. Follow these guidelines to properly acclimate your equipment:

- Leave the system in the shipping bag. If the installation or staging environment allows it, leave the product in the full package to minimize condensation on or within the equipment.
- Allow the packaged product to acclimate for 24 hours.¹ If there are visible signs of condensation (either external or internal to the product) after 24 hours, acclimate the system without the shipping bag for an extra 12 - 24 hours or until no visible condensation remains.
- Acclimate the product away from perforated tiles or other direct sources of forced air convection to minimize excessive condensation on or within the equipment.

¹ Unless otherwise stated by product-specific installation instructions.

Note: Condensation is a normal occurrence, especially when you ship equipment in cold-weather climates. All IBM® products are tested and verified to withstand condensation that is produced under these circumstances. When sufficient time is provided to allow the hardware to gradually acclimate to the indoor environment, there should be no issues with long-term reliability of the product.

Performing the safety inspection procedure

Before you service the unit, complete the following safety inspection procedure.

1. Stop all activities between the host and the library's tape drives.
2. Turn off the power to the library by pushing in the **Power** button on the front of the tape library for 4 seconds.
3. Unplug the library's power cord from the electrical outlet and the library's power supply unit.
4. Check the library's power cords for damage, such as a pinched, cut, or frayed cord.
5. If drives are FC/SAS attached, check the tape drive's FC/SAS cable for damage.
6. Check the top and bottom covers of the library for sharp edges, damage, or alterations that expose its internal parts.
7. Check the top and bottom covers of the library for proper fit. They must be in place and secure.
8. Check the product label at the rear of the library to make sure that it matches the voltage at your outlet.

Rack safety

The following general safety information must be used for all rack-mounted devices.

DANGER





Observe the following precautions when working on or around your IT rack system.

- Heavy equipment - personal injury or equipment damage might result if mishandled.
- Always lower the leveling pads on the rack cabinet.
- Always install stabilizer brackets on the rack cabinet.
- To avoid hazardous conditions due to uneven mechanical loading, always install the heaviest devices in the bottom of the rack cabinet. Always install servers and optional devices starting from the bottom of the rack cabinet.
- Rack-mounted devices are not to be used as shelves or work spaces. Do not place objects on top of rack-mounted devices. In addition, do not lean on rack mounted devices and do not use them to stabilize your body position (for example, when working from a ladder).



- Each rack cabinet might have more than one power cord.
 - For AC powered racks, be sure to disconnect all power cords in the rack cabinet when directed to disconnect power during servicing.
 - For racks with a DC power distribution panel (PDP), turn off the circuit breaker that controls the power to the system unit(s), or disconnect the customer's DC power source, when directed to disconnect power during servicing.
- Connect all devices installed in a rack cabinet to power devices installed in the same rack cabinet. Do not plug a power cord from a device installed in one rack cabinet into a power device installed in a different rack cabinet.
- An electrical outlet that is not correctly wired could place hazardous voltage on the metal parts of the system or the devices that attach to the system. It is the responsibility of the customer to ensure that the outlet is correctly wired and grounded to prevent an electrical shock. (R001 part 1 of 2)

Caution



- Do not install a unit in a rack where the internal rack ambient temperatures might exceed the manufacturer's recommended ambient temperature for all your rack-mounted devices.
- Do not install a unit in a rack where the air flow is compromised. Ensure that air flow is not blocked or reduced on any side, front, or back of a unit that is used for air flow through the unit.
- Consideration must be given to the connection of the equipment to the supply circuit so that overloading of the circuits does not compromise the supply wiring or overcurrent protection. To provide the correct power connection to a rack, refer to the rating labels on the equipment in the rack to determine the total power requirement of the supply circuit.
- (For sliding drawers) Do not pull out or install any drawer or feature if the rack stabilizer brackets are not attached to the rack. Do not pull out more than one drawer at a time. The rack might become unstable if you pull out more than one drawer at a time.



- (For fixed drawers) This drawer is a fixed drawer and must not be moved for servicing unless specified by the manufacturer. Attempting to move the drawer partially or out of the rack might cause the rack to become unstable or cause the drawer to fall out of the rack. (R001 part 2 of 2)

Caution



Removing components from the upper positions in the rack cabinet improves rack stability during relocation. Follow these general guidelines whenever you relocate a populated rack cabinet within a room or building:

- Reduce the weight of the rack cabinet by removing equipment, starting at the top of the rack cabinet. When possible, restore the rack cabinet to the configuration of the rack cabinet as you received it. If this configuration is not known, you must do the following:
 - Remove all devices in the 32U position (compliance ID RACK-001) or 22U (compliance ID RR001) and above.
 - Ensure that the heaviest devices are installed in the bottom of the rack cabinet.
 - Ensure that there are little-to-no empty U-levels between devices installed in the rack-cabinet below the 32U (compliance ID RACK-001) or 22U (compliance ID RR001) level, unless the received configuration specifically allowed it.
- If the rack cabinet you are relocating is part of a suite of rack cabinets, detach the rack cabinet from the suite.
- If the rack cabinet you are relocating was supplied with removable outriggers, they must be reinstalled before the cabinet is relocated.
- Inspect the route that you plan to take to eliminate potential hazards.
- Verify that the route that you choose can support the weight of the loaded rack cabinet. Refer to the documentation that comes with your rack cabinet for the weight of a loaded rack cabinet.
- Verify that all door openings are at least 760 x 2032 mm (30 x 80 in.).
- Ensure that all devices, shelves, drawers, doors, and cables are secure.
- Ensure that the four leveling pads are raised to their highest position.
- Ensure that no stabilizer bracket is installed on the rack cabinet during movement.
- Do not use a ramp that is inclined at more than 10 degrees.
- When the rack cabinet is in the new location, complete these steps.
 - Lower the four leveling pads.
 - Install stabilizer brackets on the rack cabinet or in an earthquake environment bolt the rack to the floor.
 - If you removed any devices from the rack cabinet, repopulate the rack cabinet from the lowest position to the highest position.

- If a long-distance relocation is required, restore the rack cabinet to the configuration of the rack cabinet as you received it. Pack the rack cabinet in the original packaging material, or equivalent. Also, lower the leveling pads to raise the casters off the pallet and bolt the rack cabinet to the pallet. (R002)
-  **DANGER:** Racks with a total weight of > 227 kg (500 lb.), Use Only Professional Movers! (R003)

Caution



- Rack is not intended to serve as an enclosure and does not provide any degrees of protection required of enclosures.
- It is intended that equipment installed within this rack will have its own enclosure. (R005)
- Tighten the stabilizer brackets until they are flush against the rack. (R006)
- Use safe practices when lifting. (R007)
- Do not place any object on top of a rack-mounted device unless that rack-mounted device is intended for use as a shelf. (R008)
- If the rack is designed to be coupled to another rack only the same model rack should be coupled together with another same model rack. (R009)

Danger

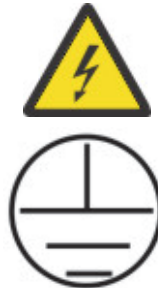

Main Protective Earth (Ground): This symbol is marked on the frame of the rack. The PROTECTIVE EARTHING CONDUCTORS must be terminated at that point. A recognized or certified closed loop connector (ring terminal) must be used and secured to the frame with a lock washer using a bolt or stud. The connector must be properly sized to be suitable for the bolt or stud, the locking washer, the rating for the conducting wire used, and the considered rating of the breaker. The intent is to ensure the frame is electrically bonded to the PROTECTIVE EARTHING CONDUCTORS. The hole that the bolt or stud goes into where the terminal connector and the lock washer contact must be free of any non-conductive material to allow for metal to metal contact. All PROTECTIVE BONDING CONDUCTORS must terminate at this main

protective earthing terminal or at points marked with  . (R010)



Always ensure that a load of 95 kg (210 lb) is inside the bottom of the rack (compliance ID RR001), especially before relocating or servicing units with their Center of Gravity (CoG) higher than 22U. (R011)

Power Cords

For your safety, IBM provides a power cord with a grounded attachment plug to use with this IBM product. To avoid electrical shock, always use the power cord and plug with a properly grounded outlet.

IBM power cords used in the United States and Canada are listed by Underwriter's Laboratories (UL) and certified by the Canadian Standards Association (CSA).

For units intended to be operated at 115 volts: Use a UL-listed and CSA-certified cord set consisting of a minimum 18 AWG, Type SVT or SJT, three-conductor cord, a maximum of 15 feet in length and a parallel blade, grounding-type attachment plug rated 15 amperes, 125 volts.

For units intended to be operated at 230 volts (U.S. use): Use a UL-listed and CSA-certified cord set consisting of a minimum 18 AWG, Type SVT or SJT, three-conductor cord, a maximum of 15 feet in length and a tandem blade, grounding-type attachment plug rated 15 amperes, 250 volts.

For units intended to be operated at 230 volts (outside the U.S.): Use a cord set with a grounding-type attachment plug. The cord set should have the appropriate safety approvals for the country in which the equipment will be installed.

IBM power cords for a specific country or region are usually available only in that country or region.

Preface

This manual contains information and instructions necessary for the installation, operation, and service of the IBM TS4300 Tape Library.

Note: The IBM TS4300 Tape Library is a customer installed unit. The customer is responsible for the setup and maintenance of the tape library. The customer is charged for service if a service contract is not in place.

Related Publications

Refer to the following publications for more information. To ensure that you have the latest publications, visit the web at <http://www.ibm.com/storage/>.

- *IBM TS4300 Tape Library Getting Started Guide* (SC27-4630) provides unpacking and initial setup information.
- *IBM TS4300 Tape Library Knowledge Center* at <https://www.ibm.com/support/knowledgecenter/STAKKZ/> provides online information about the TS4300 tape library.
- *IBM TS4300 Tape Library SCSI Reference* (SC27-4641) provides SCSI information.
- *IBM Safety Notices, (G229-9054)* at <https://www-01.ibm.com/support/docview.wss?uid=isg27d40fbeb5e10ceb985256e31007281fa>.
- *IBM Tape Device Driver Installation and User's Guide* (GC27-2130) provides instructions for attaching IBM-supported hardware to open-systems operating systems. It indicates what devices and levels of operating systems are supported. It also gives requirements for adapter cards, and tells how to configure hosts to use the device driver. All of the above are with the Ultrium family of devices.
- *IBM Tape Device Driver Programming Reference* (GA32-0566) supplies information to application owners who want to integrate their open-systems applications with IBM-supported Ultrium hardware. The reference contains information about the application programming interfaces (APIs) for each of the various supported operating-system environments.
- *IBM Environmental Notices and User Guide (ENUG)* (z125-5823), which is located at ftp://public.dhe.ibm.com/systems/support/warranty/envnotices/environmental_notices_and_user_guide.pdf.
- *IBM Security Key Lifecycle Manager Knowledge Center*, which is located at <http://www-01.ibm.com/support/knowledgecenter/SSWPVP/welcome?lang=en>, contains information to help you install, configure, and use the IBM Security Key Lifecycle Manager.
- The IBM Publications Center: <http://www.ibm.com/shop/publications/order>. The Publications Center is a worldwide central repository for IBM product publications and marketing material with a catalog of 70,000 items. Extensive search facilities are provided. Payment options for orders are with credit card (in the US) or customer number for 20 countries. Many publications are available online in various file formats, and they can all be downloaded by all countries, free of charge.

Chapter 1. Overview

The overview of the features and functions of the IBM® TS4300 tape library is useful for high-level evaluation of the product and planning for the implementation of the product.

Introduction

The IBM TS4300 tape library provides compact, high-capacity, low-cost solutions for simple, unattended data backup. The installation begins with the 3U high Base Module, with capacity for up to 40 tape cartridges and 3 half-height LTO tape drives, or one full-height and one half-height tape drive.

Each module type has its special designation.

MTM	Description
3555-L3A	Base Module
3555-E3A	Expansion Module

Figure 1 on page 1 shows a two-module version of the tape library. The library on the left shows the base module above the expansion module. The library on the right shows the base module below the expansion module. An individual library can consist of one base module and up to six expansion modules. See “Structure and supported library configurations” on page 2 for supported configurations.



Figure 1. Two module tape library

The library provides the following capabilities:

- New user interface for improved usability
- Updated library communication system
- I/O magazines to allow individual cartridge handling to be done independent of the library.
- Mixed media types
- Integrated management tools
- Scalability to seven modules
- Remote management with the management GUI
- Remote monitoring with Simple Network Management Protocol (SNMP)
- Multipath architecture
- Host-based path failover
- Sequential Mode option

Table 3. Minimum and maximum storage configurations

Configuration	Capacity	
Minimum 1 Module Library Base Module only	Cartridges	40 ³ 35 with 5-slot I/O ¹
	HH ² Tape Drives	3
	FH ² Tape Drives	1
	HH/FH Tape Drive Mix	1/1
Maximum 7 Module Library Base Module 6 Expansion Modules	Cartridges	280 ³ 275 with 5-slot I/O ¹
	HH Tape Drives	21
	FH Tape Drives	7
	HH/FH Tape Drive Mix	Nineteen half-height drives to one full-height drive, or Seven half-height drives to seven full-height drives

Notes:

- ¹Every module can contain a 5-slot I/O station. If a seven module library has an I/O station for each module, the maximum number of slots that can be configured as I/O slots are 35.
- ²HH = Half height. FH = Full height.
- ³For libraries with serial numbers before 7800K0K, capacity in lowest module is 32 slots, 28 with 4-slot I/O station.

Structure and supported library configurations

The TS4300 library supports a single base module tabletop configuration or a scalable rackmount configuration.

Supported library configurations

All libraries start with a Base Module. Up to six Expansion Modules can be added as needed to support customer requirements. The architecture is designed to support a maximum of three Expansion Modules above the Base Module and three Expansion Modules below the Base Module. [Table 4 on page 3](#) shows the supported configurations for libraries, ranging 1 - 7 total modules.

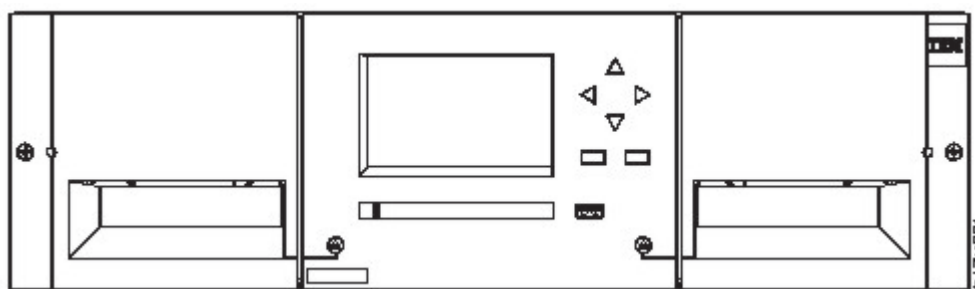

Figure 2. Base Module

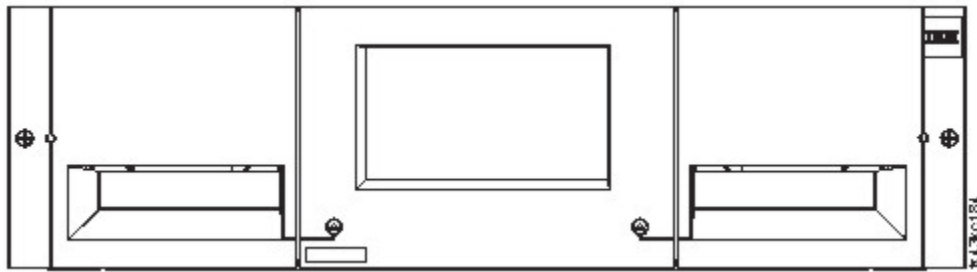

Figure 3. Expansion Module



Table 4. Library configurations. Base module displays are yellow.	
Module quantity	Supported library configuration
1 module library Base Module only	 <p>Figure 4. Base Module</p>
2 module library Base Module, and 1 Expansion Module	 <p>Figure 5. 2 module library</p>
3 module library Base Module, and 2 Expansion Modules	 <p>Figure 6. 3 module library</p>

Table 4. Library configurations. Base module displays are yellow. (continued)

Module quantity	Supported library configuration
<p>4 module library Base Module, and 3 Expansion Modules</p>	 <p>Figure 7. 4 module library</p>
<p>5 module library Base Module, and 4 Expansion Modules</p>	 <p>Figure 8. 5 module library</p>

Table 4. Library configurations. Base module displays are yellow. (continued)

Module quantity	Supported library configuration
<p>6 module library Base Module, and 5 Expansion Modules</p>	 <p>The figure shows two configurations of a 6-module library. In the left configuration, a central yellow base module is surrounded by five expansion modules. In the right configuration, a yellow base module is in the center of a 2x3 grid of expansion modules. A vertical label '03130E14' is visible on the right side of the right diagram.</p>

Figure 9. 6 Module library

Table 4. Library configurations. Base module displays are yellow. (continued)

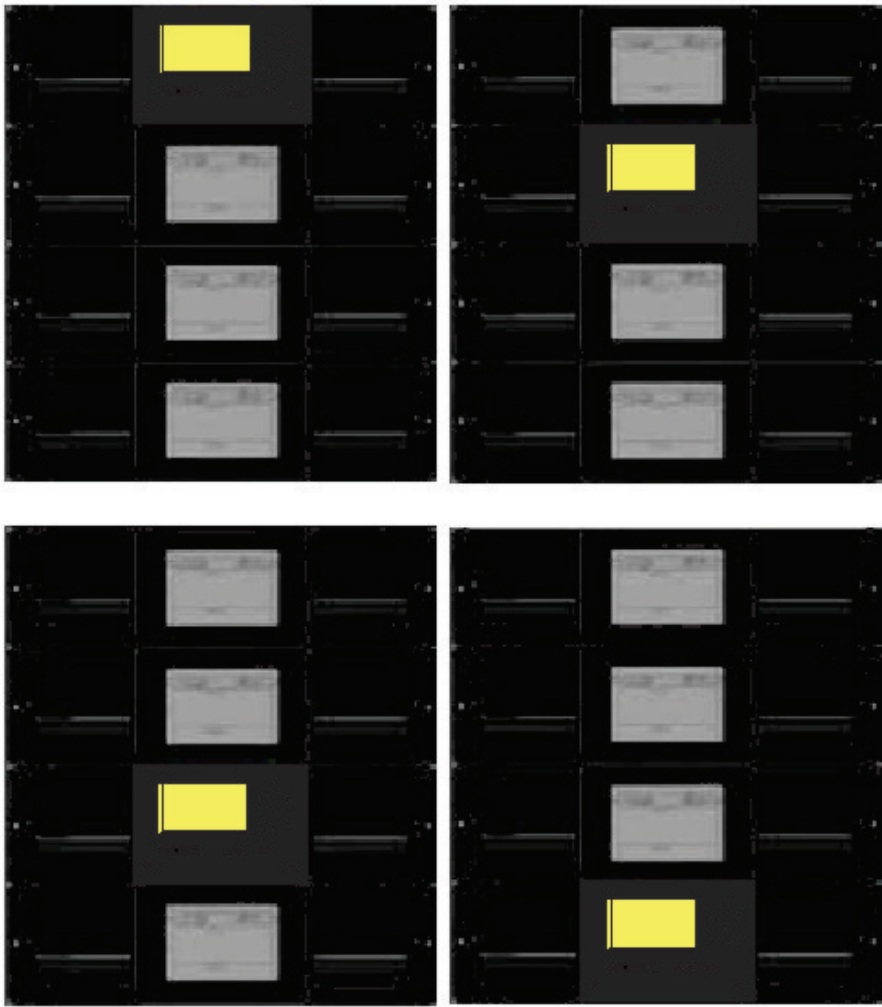
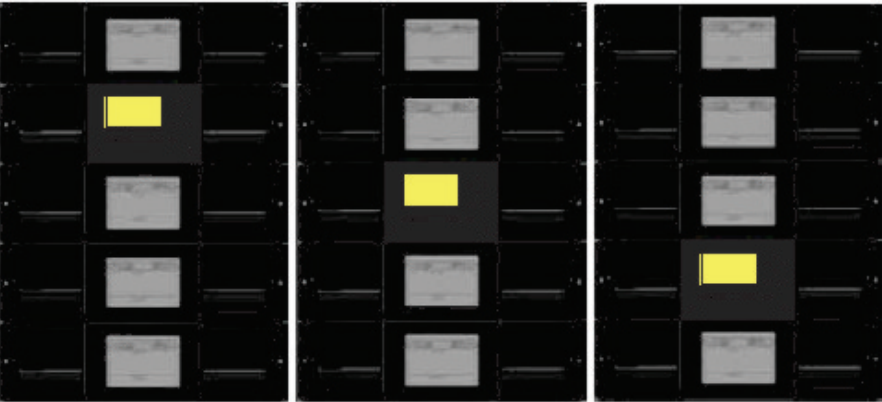
Module quantity	Supported library configuration
7 module library Base Module, and 6 Expansion Modules	 <p data-bbox="555 1381 878 1415">Figure 10. 7 module library</p>

Components

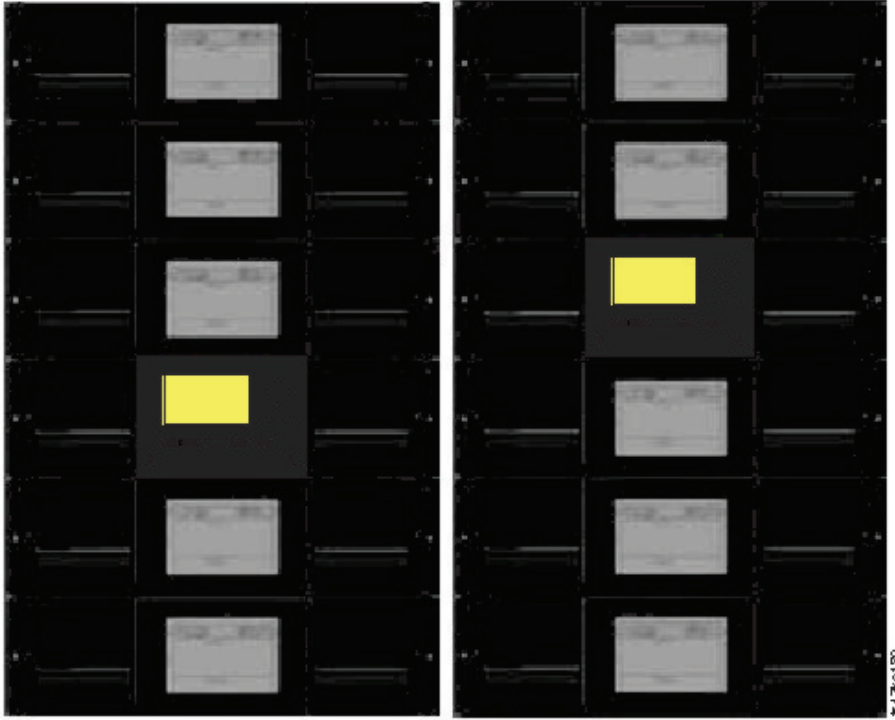
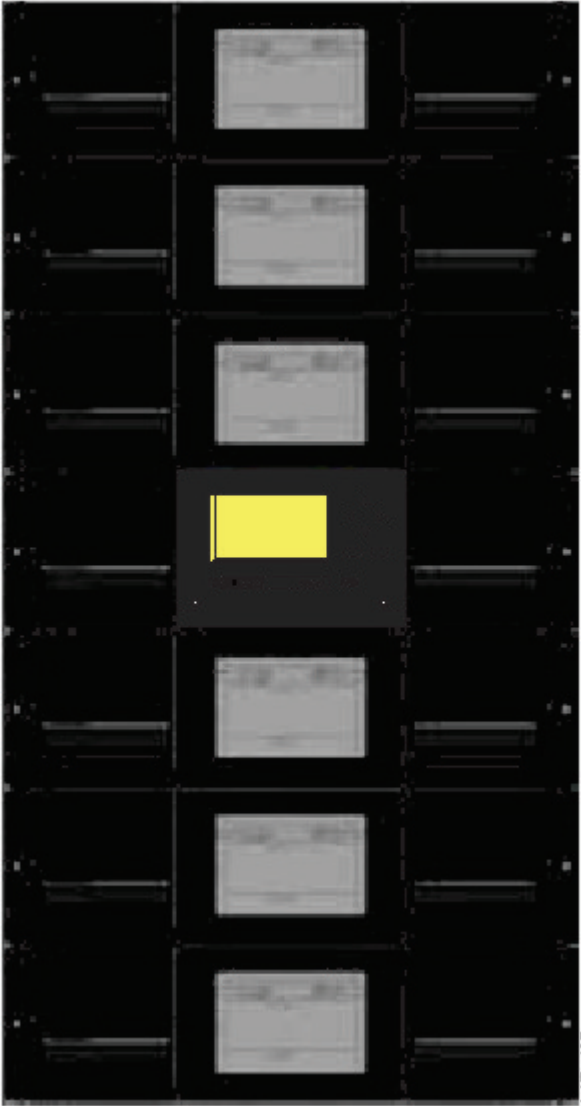
Front panel

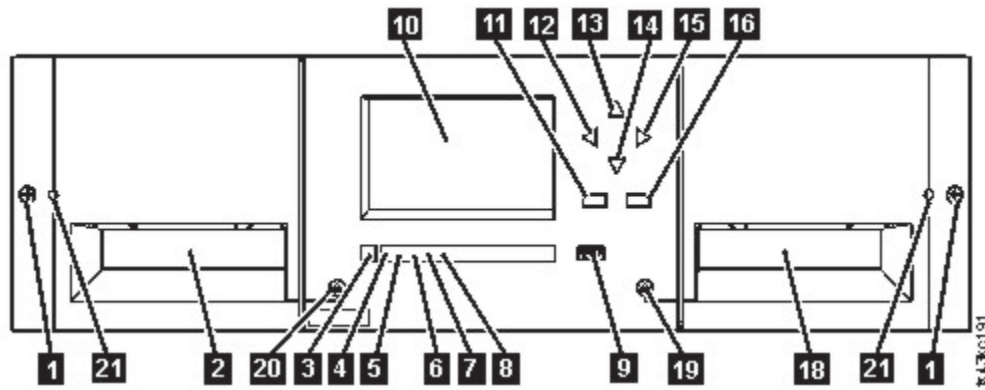

Figure 11. Front panel

Number	Item	Comments
1	Screw holes for attachment to a rack	
2	Left magazine access handle	
3	Power	Base Module only
4	Ready LED, Green	Base Module only
5	Unit Identification LED, Blue	Base Module only
6	Clean LED, Amber	Base Module only
7	Attention LED, Amber	Base Module only
8	Error LED, Amber	Base Module only
9	USB port	Base Module only
10	Operator Panel display	Base Module only
11	Back/Return button	Base Module only
12	Navigation button - Left	Base Module only
13	Navigation button - Up	Base Module only
14	Navigation button - Down	Base Module only
15	Navigation button - Right	Base Module only
16	Enter button	Base Module only
18	I/O station/Right magazine access handle	
19	Right magazine button	
20	Left magazine button	
21	Manual magazine release hole	

Rear panel

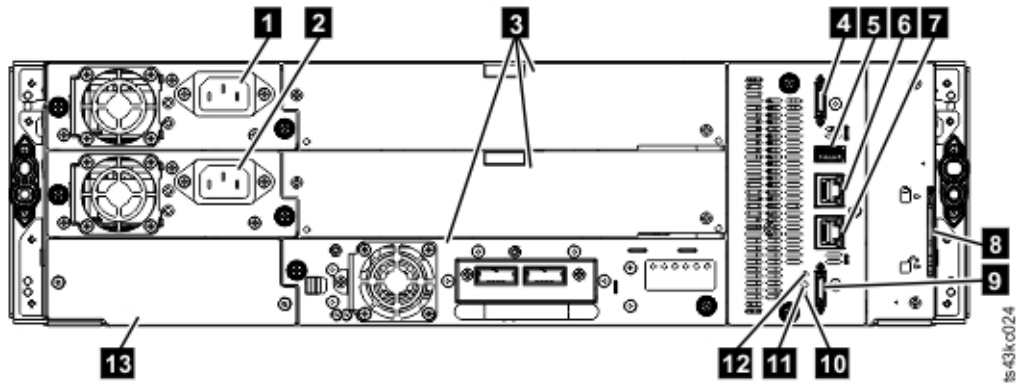

Figure 12. Rear panel

Number	Item	Comments
1	Power supply 1	Standard on Base Module Optional on Expansion Module (required if drives are present)
2	Power supply 2	Optional on Base Module and Expansion Modules
3	Tape drive bays	
4	Upper Expansion Module connection port	
5	USB port	Base Module only
6	Ethernet port B	Base Module only (secondary port for service usage)
7	Ethernet port A	Base Module only
8	Module alignment mechanism	
9	Lower Expansion Module connection port	
10	Unit Identifier LED, Blue	
11	Controller Error LED, Yellow	
12	Controller Health Status LED, Green	
13	Product Serial Number, Tag location	

Physical and logical addresses of modules

The library assigns each module a unique address to indicate its physical location, shown in [Figure 13](#) on [page 9](#). The physical numbering is bottom up on all modules.

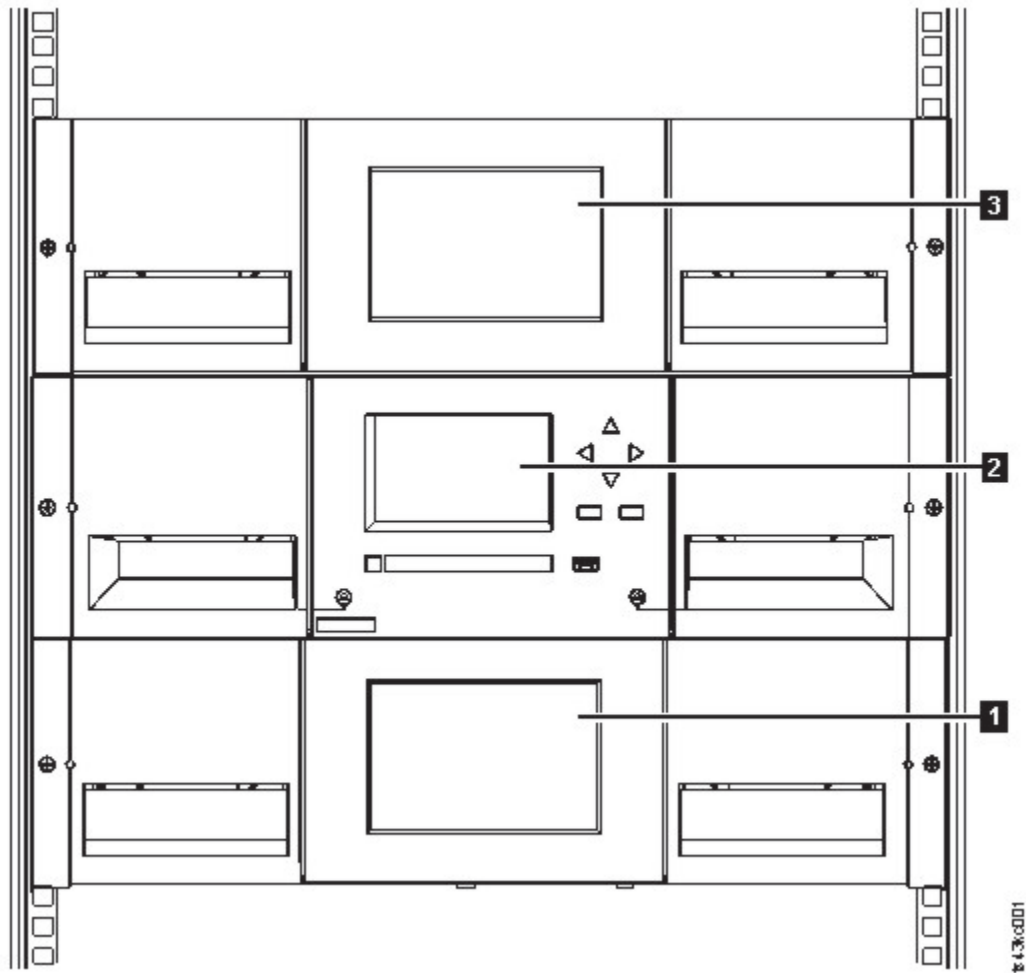

Figure 13. Physical numbering of modules

Magazines

Each module contains two magazines, holding up to 40 cartridges.

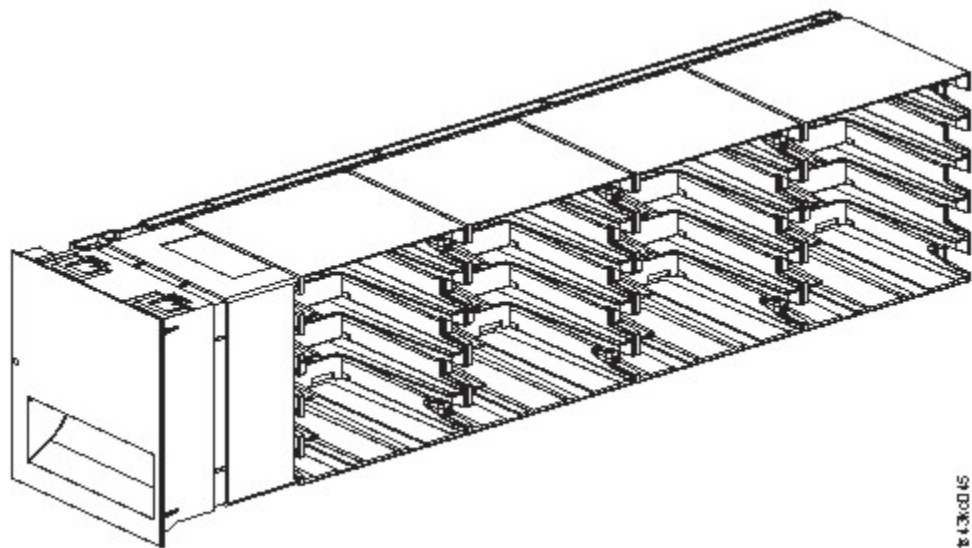

Figure 14. Left magazine

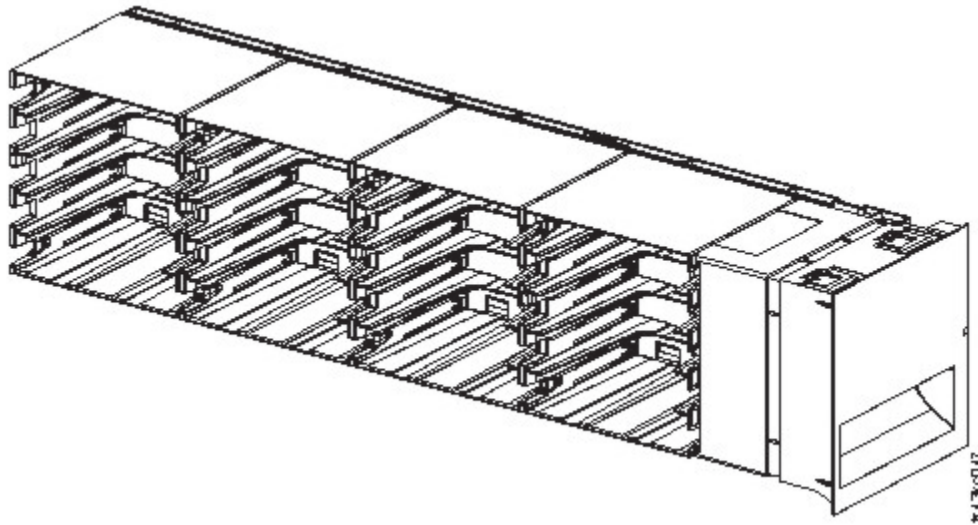

Figure 15. Right magazine

The library assigns each slot in a magazine a unique number to indicate its physical location. This numbering is shown on the **Cartridges** page of the Management GUI.

Table 7. Physical numbering of storage slots - bottom module

Front of the Left Magazine	5	10	15	20	Drives	25	30	35	40	Front of the Right Magazine
	4	9	14	19		24	29	34	39	
	3	8	13	18		23	28	33	38	
	2	7	12	17		22	27	32	37	
	1	6	11	16		21	26	31	36	

Physical numbering of storage slots starts with the left magazine of the lowest module of your library. As modules are added above this module, the numbering continues, starting with the lower left slot of the left magazine, and adding 40 storage slots for each additional module.

Note: For libraries with serial numbers before 7800K0K, the slots in the lowest row (1, 6, 11, 16, 21, 26, 31, 36) of the bottom module are inaccessible, and can contain a 4-slot I/O station only.

Each module can be configured to contain an I/O Station, or one I/O Station can be accessed by several modules. I/O Stations consist of five slots in the front column of the right magazine of each module, except for the lowest module. To enable or disable I/O Stations, go to **Library > Modules and Magazines > Actions > Enable or Disable I/O Station** in the Management GUI.

Important: Ensure that no tapes are in the slots before the I/O Station is enabled or disabled.

Accessor

The accessor is composed of several components: robotic assembly, spooling mechanism, and bar code reader.

- The robotic assembly has fingers that enable it to grab tape cartridges and move them to and from the I/O station, storage slots, and drives.
- The spooling mechanism has a cable that extracts and retracts based on movement of the robotic assembly. This cable provides communication between the robotic assembly and the library main board.
- The high-speed bar code reader is a part of the Base Module. The bar code reader provides inventory feedback to the host application, Operator Panel display, and Management GUI by reading cartridge bar code labels. The library stores the customized inventory data in memory. Library firmware supports a 6

or 8 character volume serial number (VOLSER) on the bar code label on the tape cartridge. It is highly recommended to use bar code labeled cartridges. See “Labeling tape cartridges” on page 160.

Note: For libraries with S/N 7800K0K and higher, review the “Minimum firmware levels for common library features” on page iii.

Power supply

The library provides a single power supply with each library. However, a secondary redundant power supply for the base module can be added. In addition, each expansion module with drives installed requires a power supply. See “Optional features” on page 34.

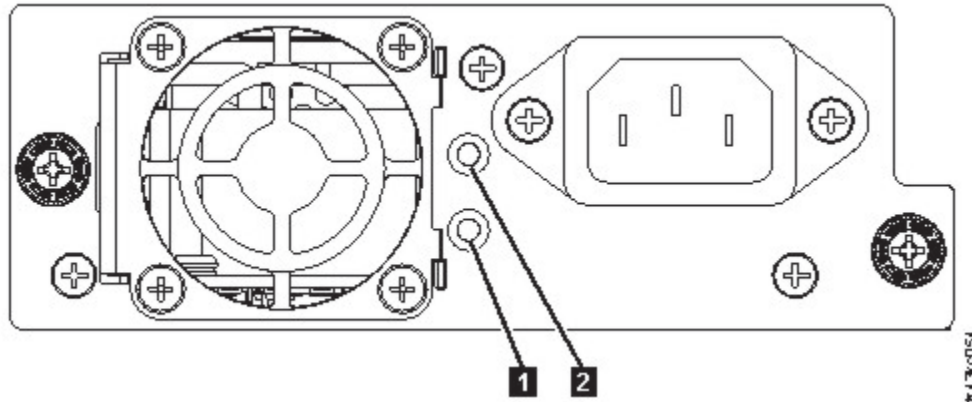

Figure 16. Power supply rear panel LEDs

Number	Color	Description
1	Green	Module powered ON.
2	White	AC power is connected.

User interfaces

This library has two user interfaces: the Management GUI and the Operator Panel.

- “The Management GUI” on page 61 - With the Management GUI, you can monitor, configure, and control the library from a web browser. The Management GUI hosts a dedicated, protected Internet site that displays a graphical representation of the library. For information on network connectivity, see “Network connectivity” on page 21.
- “The Operator Panel” on page 64 - With the Operator Panel, you can monitor, configure, and control the library from the front panel. Functions are limited to those applicable to being in front of the library.

Supported tape drives

The library supports LTO6 and later tape drives.

For minimum and maximum storage configurations, see Table 3 on page 2. For minimum firmware levels, see “Minimum firmware levels for common library features” on page iii.

Listed are the tape drives that are implemented and qualified for use in this library.

Table 9. Supported tape drives

Type	Form factor (height)	Interface	Number of Ports	Speeds of connectivity	Native data rate
LTO6	1U (Half-height)	Serial Attached SCSI (SAS)	2	6 Gbps SAS	160 MB/s
LTO6	1U (Half-height)	Fibre Channel (FC)	1	8 Gbps FC	160 MB/s
LTO6	2U (Full-height)	Fibre Channel (FC)	2	8 Gbps FC	160 MB/s
LTO7	1U (Half-height)	Serial Attached SCSI (SAS)	2	6 Gbps SAS	300 MB/s
LTO7	1U (Half-height)	Fibre Channel (FC)	1	8 Gbps FC	300 MB/s
LTO7	2U (Full-height)	Fibre Channel (FC)	2	8 Gbps FC	300 MB/s
LTO8	1U (Half-height)	Serial Attached SCSI (SAS)	2	6 Gbps SAS	300 MB/s
LTO8	1U (Half-height)	Fibre Channel (FC)	1	8 Gbps FC	300 MB/s
LTO8	2U (Full-height)	Fibre Channel (FC)	2	8 Gbps FC	360 MB/s

The LTO tape drives communicate with the library through an internal Ethernet interface. For enhanced performance, the LTO tape drives include speed matching, channel calibration, and power management. Speed matching dynamically adjusts the drive's normal native (uncompressed) data rate to the slower data rate of a server. Channel calibration customizes each read/write data channel for optimum performance. The customization enables compensation for variations in the recording channel transfer function, media characteristics, and read/write head characteristics. Power management reduces the drive's power consumption during idle power periods.

Control path drives

A control path is a logical path to the library.

A control path is the path for **SCSI Medium Changer** commands that are sent by a server to control a specific logical library. The library has no direct SCSI connection to a host server. When a software host server communicates with the library, it sends the communication by way of a tape drive. The tape drive is designated as a control path drive.

Mixed drives

All supported generations of LTO tape drives and cartridges can be in the same physical library and within a single module.

This library supports a mixture of LTO drive types in a logical library. Some independent software vendors (ISVs) support mixed drive types within a logical library and other do not. Some ISVs that support mixed drive types might have restrictions. For details, contact your ISV.

Figure 17 on page 13 shows examples of methods for mixing LTO drive types in a logical library.

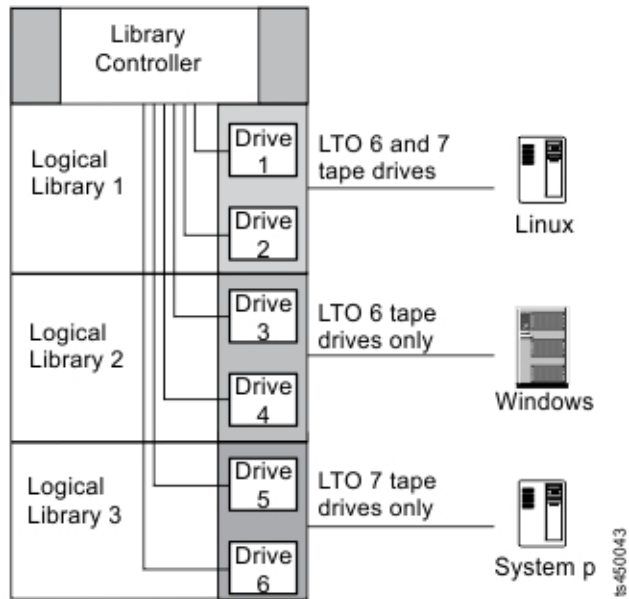

Figure 17. Mixed drives in a logical library

Drive sled back panels

Indicator LEDs are included on all drive sled back panels.

Six indicator LEDs are included on all drive sleds as shown in Figure 18 on page 13.

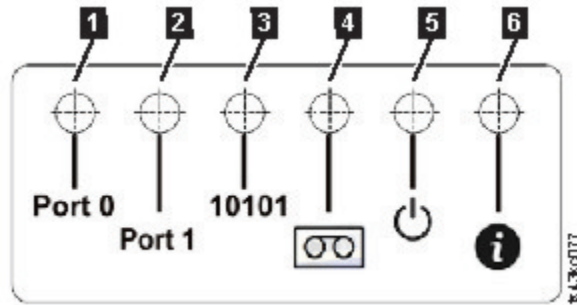

Figure 18. Drive sled indicators

Number	Description
1	Port 0 activity
2	Port 1 activity
3	Library communication
4	Cartridge present
5	Power
6	Beacon /UID

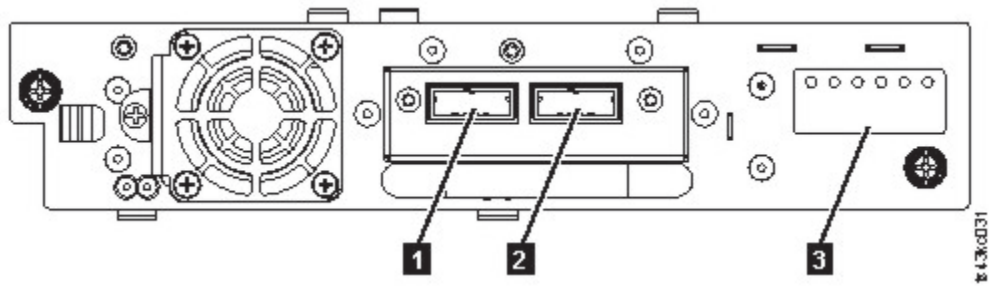

Figure 19. Half-height SAS dual port

Table 11. Half-height SAS dual port	
Number	Description
1	SAS port 0
2	SAS port 1
3	Drive sled indicators (see Figure 18 on page 13)

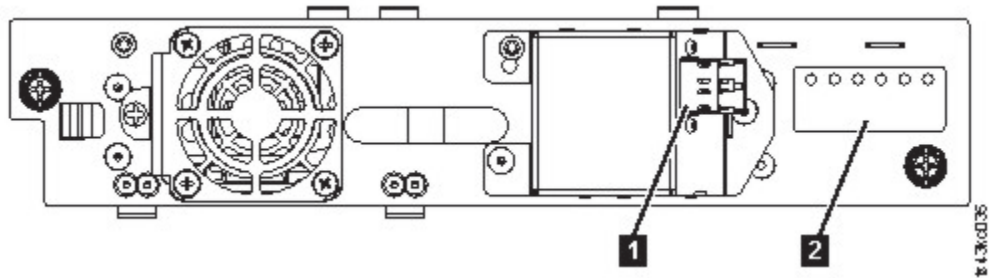

Figure 20. Half-height FC single port

Table 12. Half-height FC single port	
Number	Description
1	FC port 0
2	Drive sled indicators (see Figure 18 on page 13)

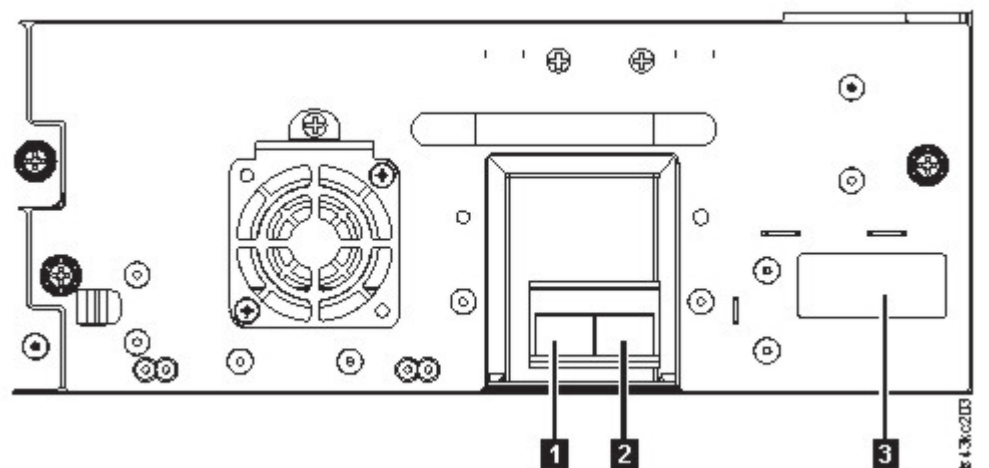

Figure 21. Full-height FC dual port

Table 13. Full-height FC dual port

Number	Description
1	FC port 0
2	FC port 1
3	Drive sled indicators (see Figure 18 on page 13)

Physical and logical addresses of drives

The library assigns each tape drive a unique address to indicate its physical and logical location.

The library assigns each tape drive a unique address to indicate its physical location, which is shown in Figure 22 on page 15. The physical numbering is bottom up on all drives. This information is shown on the **Drives** page of the Management GUI.

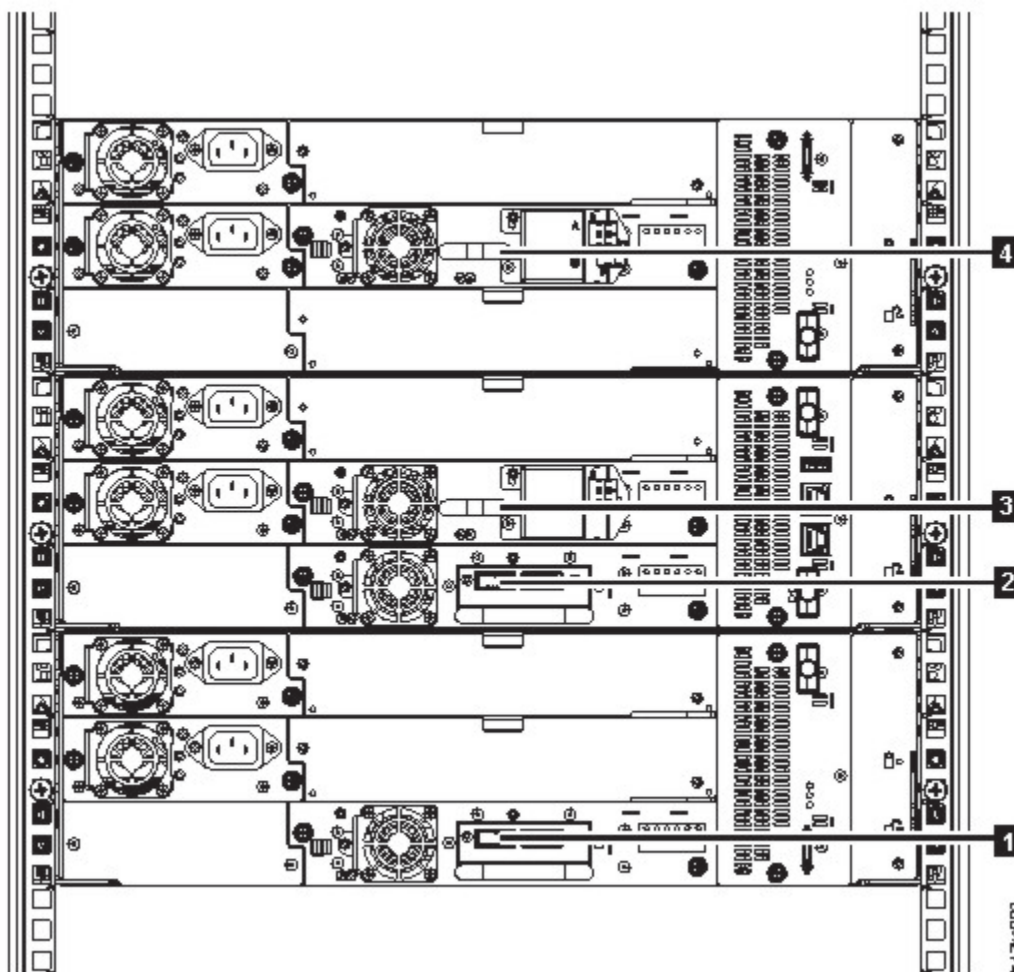

Figure 22. Physical numbering of drives

The library assigns each tape drive a SCSI element address that consists of a value that defines a logical location in the library to the SCSI interface. It is assigned and used by the application when the host server processes SCSI commands. The SCSI element address for a drive is unique to the location of the drive. It does not vary based on other drives in the library. See “Library partitioning” on page 59.

Supported tape cartridges

This library supports LTO tape cartridges.

Within the library, the supported LTO tape drives use the following cartridge types:

- IBM LTO8 Data Cartridge
- IBM LTO8 WORM Data Cartridge
- IBM LTO M8 Data Cartridge
- IBM LTO7 Data Cartridge
- IBM LTO7 WORM Data Cartridge
- IBM LTO6 Data Cartridge
- IBM LTO6 WORM Data Cartridge
- IBM LTO5 Data Cartridge
- IBM LTO5 WORM Data Cartridge
- IBM LTO4 Data Cartridge
- IBM LTO4 WORM Data Cartridge
- IBM Universal LTO Cleaning Cartridge

For information, see [Appendix B, “LTO media,” on page 156](#).

Library functions

The library provides many specific functions, such as random or sequential operating mode, encryption, library sharing, path failover, and alerts and logging.

Random and Sequential Logical Library modes

A Logical Library can be configured in one of two modes: Random and Sequential.

Random Mode

Random Mode is intended to be used by host applications that support SCSI media changer devices. Random Mode is the default.

In Random mode,

- The host application chooses the cartridges that are moved to the drive.
- I/O slots provide the flexibility for the user to add and remove cartridges and the host application is automatically notified of these changes.
- Multiple drives can be assigned to provide parallel processing data operations and redundancy in case of failure.

Sequential Mode

Sequential Mode is intended to be used by host applications that aren't supporting SCSI media changer devices but need to get another cartridge loaded if the current cartridge is full.

In Sequential Mode,

- The library predefines the sequential order that the cartridges are moved to the drive.
- I/O slots are hidden as they aren't assignable to a logical library with sequential mode enabled.
- Only one drive can be assigned to a logical library with sequential mode enabled.
- There's no control path drive and no media changer device is configured to the host server.

Options to consider when Sequential Mode is chosen:

- **Basic Function** - To initiate use of cartridges, the user issues a **Move Cartridge** command to the drive through the Management GUI. After the load, the host application can begin data I/O activity. When the host application unloads the drive, the library moves the next cartridge into the drive. This behavior is implicit, unless otherwise defined by selection of another option.
- **Loop Option** - If a move sequence ends because no more cartridges are available in the current logical library, the sequence starts again by loading the first cartridge of the logical library. This option can be chosen with or without the Autoload function.
- **Autoload Option** - If enabled, the library loads the first cartridge of the logical library to the Sequential Mode tape drive during library startup after inventory scan is finished. This option changes the implicit behavior of the Basic function. This option can be chosen with or without the Loop option.

If storage slots are configured to I/O slots after assignment to a Sequential Mode logical library, they are still considered valid available slots and are used for movements. This option stays until you run the expert wizard again, and then these I/O slots no longer appear in the list of available slots. Finishing the expert wizard then sets the new slot assignment and these I/O slots can no longer be used for movements.

To enable sequential mode, click the **Enable Sequential Mode** check box in the **Basic Logical Library Wizard** or **Expert Logical Library Wizard**.

Encryption

All supported tape drives in this library support encryption.

The encryption enabled drive contains the necessary hardware and firmware to encrypt and decrypt host tape application data. Encryption policy and encryption keys are provided by the host application or host server. A drive digital certificate is installed at manufacturing time. Each drive receives a unique serial number and certificate. The T10 application might validate each drive instance by checking the drive's digital certificate.

The library provides these options.

1. **Encryption disabled**
2. **Application Managed Encryption (AME)**
3. **Library Managed Encryption (LME)**. LME is a built-in feature that is enabled by using a purchased license. The LME feature can be ordered from the factory, or you can order it as a field upgrade. To order a feature, contact your IBM Sales Representative or Business Partner. See [Optional Features](#). For configuration details, see [“Configuring Library Managed Encryption”](#) on page 73.

The default is **Application Managed Encryption**.

Note: All encryption settings must be configured or reverified in the drive after any library or drive reset. A new drive might be added or an existing drive might be swapped with another drive.

Library sharing

The library can be configured into one or more logical libraries that can be shared by multiple applications.

It is advantageous to be able to share a single physical library between heterogeneous or homogeneous applications. However, some applications (and some servers) do not allow for sharing a library between systems.

The library Management GUI provides two methods for logical library configuration.

1. A quick configuration for a simple one logical library configuration
2. An advanced configuration action for a multiple logical library configuration

The second method gives the ability to create configurations that enable the library to process commands from multiple heterogeneous applications (such as an IBM System p application and a Windows application) and multiple homogeneous applications (for example, the same application run by several System p servers). See [“Advanced library configuration”](#) on page 58.

Control path failover, Data path failover, and load balancing

The path failover feature ensures the use of a redundant communication path when the primary path fails.

Command failures and time outs are costly. You want your library to run smoothly and efficiently. Path failover capabilities allow the IBM® device driver to resend a command to an alternate path. The alternate path can include another host bus adapter (HBA), Storage Area Network (SAN), or library control path drive. The device driver initiates error recovery and continues the operation on the alternate path without interrupting the application.

Path failover and load balancing are built-in features that are enabled by using a purchased license. The path failover feature can be ordered from the factory, or you can order it as a field upgrade. The path failover feature (FC 1682) is activated on the Management GUI. To order features, contact your IBM® Sales Representative or Business Partner. See [“Optional features”](#) on page 34.

Two types of path failover capabilities exist: *control path failover (CPF)* and *data path failover (DPF)*. *Control* refers to the command set that controls the library (the **SCSI Medium Changer** command set on LUN 1 of the tape drives). *Data* refers to the command set that carries the customer data to and from the tape drives (the SCSI-3 Stream Commands (SSC) device on LUN 0 of the tape drives). Path failover means the same thing in both. Path failover is where redundancy is in the path from the application to the intended target (the library accessor or the drive mechanism), the device driver transparently fails over to another path in response to a break in the active path.

Both types of failover include host-side failover when configured with multiple HBA ports into a switch. But CPF includes target-side failover through the control paths that are enabled on more than one tape drive. DPF includes target-side failover for the dual-ported tape drives that are supported by the library.

DPF includes load balancing of the HBAs because the channel is a data-intensive path (the control path carries little data, so load balancing is not an issue). The dynamic load balancing support optimizes resources for devices that have physical connections to multiple HBAs in the same machine. When an application opens a device where multiple HBA paths are configured, the device driver determines which path has the HBA with the lowest usage and assigns that path to the application. When another application opens a different device with multiple HBA paths, the device driver again determines the path with the lowest HBA usage and assigns that path to the second application. The device driver updates the usage on the HBA assigned to the application when the device is closed. Dynamic load balancing uses all HBAs whenever possible and balances the load between them to optimize the resources in the machine.

Both CPF and DPF require the use of the IBM device driver. They are supported exclusively with products that bear the IBM logo on the operating systems that is indicated in [Table 14](#) on page 18.

[Table 14](#) on page 18 summarizes the differences between CPF, DPF, and load balancing.

Characteristic	CPF	DPF and Load Balancing
Device type	SMC ¹	SSC ²
LUN ³	LUN 1	LUN 0
Host-side failover	Yes	Yes ⁶
Target-side failover	Yes	Yes ⁶
IBM Device driver required	Yes	Yes
Supported operating systems ⁴	AIX®, SuSE Linux, Red Hat Enterprise Linux, Solaris, Windows	AIX, SuSE Linux, Red Hat Enterprise Linux, Solaris, Windows ⁵ (DPF only)
Order feature to obtain license	Yes	Yes

Table 14. Differences between CPF and DPF (continued)

Characteristic	CPF	DPF and Load Balancing
<p>Notes:</p> <ol style="list-style-type: none"> 1. SMC = SCSI-3 Medium Changer Specification (library) 2. SSC = SCSI-3 Stream Commands (drive) 3. LUN = logical unit number 4. See “Host connectivity” on page 20 for details. 5. Load balancing is not supported on Windows 6. Full-height tape drives only 		

For information about using these features, see the *IBM Tape Device Drivers Installation and User's Guide* (GA32-0565).

Alerts and logging

The library sends alerts about the library and attached tape drives, and offers audit-logging to track user actions.

- **TapeAlert Support:** The tape library is compatible with TapeAlert technology, which provides error and diagnostic information about the drives and the library to the host application. The library provides this error and diagnostic information as TapeAlert flags that are reported to the application by the **SCSI LOG SENSE** command. See [“TapeAlert flags”](#) on page 108.
- **Email (SMTP - Simple Mail Transfer Protocol) Notifications:** The library can configure email notification of library events. The library must have network access to an SMTP server. See [“Locating Management functions”](#) on page 65.
- **Remote Logging (rsyslog):** The library can send syslog (system log) notifications to a configured remote (rsyslog) server. When system events occur, the TS4300 tape library creates a log of these events. With this notification feature configured, the library sends a notification of the event to the syslog server. The syslog server keeps its own log of system events. (The syslog server is a customer-provided server.) See [“Locating Management functions”](#) on page 65.
- **SNMP Support:** The Simple Network Management Protocol (SNMP) allows the library to send alerts over a LAN network to a monitoring server.

Occasionally, the library might encounter situations that you want to know about. These situations can be conditions that affect the library performance, such as an open door that causes the library to stop. You might also want to log user actions, such as a cartridge move or export that is initiated from the Management GUI. SNMP messages can alert you of these conditions.

The library provides a standard TCP/IP protocol that is called SNMP to send alerts about conditions over a TCP/IP LAN network to an SNMP monitoring server. These alerts are called SNMP traps. Using the information that is supplied in each SNMP trap, the monitoring server (together with customer-supplied software) can alert operations staff of possible problems or operator interventions that occur. Many monitoring servers can be used to send email or pager notifications when they receive an SNMP alert. See the manual for your network management application.

The monitoring server must be loaded with systems management software that can receive and process the trap. SNMP supports a get and get-response mechanism for an operator to gather more information about a problem or query the library about its status. Through a monitoring server, the operator enters a "get" using SNMP to request information about the library. A get-response is the information that is provided in response to the get. This type of support generally requires an up-to-date library Management Information Base (MIB). The SNMP server's MIB contains units of information that specifically describe an aspect of a system, such as the system name, hardware number, or communications configuration.

IBM provides the MIBs that are supported by the library. They include

- IBM TS4300 MIB

Type of information:

- The status of each drive in the library
- A list of all cartridges in the library
- The last trap or TapeAlert message that was sent by the library.

- IBM AUTOMATION QUERY MIB

Type of information:

- Library configuration

The library MIBs can be obtained through the **SNMP Notifications Settings** page on the Management GUI. See “[Locating Management functions](#)” on page 65. An operator cannot change library settings by using SNMP. Settings are changed by using the Management GUI.

SNMP Notification Levels

SNMP provides various levels of notification about specific library events and user actions.

- **Inactive** – No events are sent.
- **Critical** – Only critical events are sent.
- **+ Warnings** – Only critical and warning events are sent.
- **+ Configuration** – Only critical, warning, and configuration events are sent.
- **+ Information** – All events are sent.

Simple Network Management Protocol (SNMP) audit logging provides logging information about specific tape library user actions. To configure SNMP, see “[Locating Management functions](#)” on page 65.

Host connectivity

The library is supported by a wide variety of servers, operating systems, and adapters. There are many ways to determine the servers and software that support this library.

Compatible servers and software

These attachments can change throughout the lifecycle of the product. To determine the newest attachments, or to get a comprehensive list of compatible software, do one of the following actions.

- For a list of compatible software, operating systems, and servers for LTO tape drives, see <https://www.ibm.com/us-en/marketplace/ts4300>.

Notes:

1. IBM does not provide application software with this library. To order software, contact your IBM sales representative, IBM Business Partner, or an independent software provider.
 2. If you attach your library to a server with non-IBM software, contact your software vendor for a matrix of compatible hardware, software, firmware revisions, and adapter cards.
- For complete IBM storage interoperability information for the tape library in a storage area network (SAN) configuration, see the IBM® Interoperation Center (SSIC) at <http://www-03.ibm.com/systems/support/storage/ssic/interoperability.wss>. The SSIC has details on supported operating systems, servers, switches, and adapters.

Note: Dependent on the use of Random or Sequential Mode, the library might require an HBA with multiple LUN supports. Also, multiple LUN supports must be enabled on the host computer. When multiple LUN supports are not enabled, the host computer can see the tape drive, but not the library. See “[Random and Sequential Logical Library modes](#)” on page 16.

Supported device drivers

IBM provides device driver support for the LTO tape drives, and the robotics in this library.

IBM maintains the current levels of device drivers and driver documentation on the web. Go to <http://www.ibm.com/support/fixcentral> and follow the steps to access this material.

1. From the **Fix Central** web page, choose the **Select Product** tab, select **System Storage** from the **Product Group** list.
2. Select **Tape Systems** from the **System Storage** list.
3. Select **Tape drivers and software** from the **Tape systems** list.
4. Select **Tape device drivers** from the **Tape drivers and software** list.
5. Select the appropriate operating system from the **Platform** list and click **Continue**.
6. Select the appropriate driver from the list.

The *IBM® Tape Device Drivers Installation and User's Guide* can be found on the web at <http://www-01.ibm.com/support/docview.wss?rs=577&uid=ssg1S7002972>.

Network connectivity

This library supports various browsers and interfaces.

Supported browsers

IBM supports higher versions of the browsers if the vendors don't remove or disable functions that the product relies upon. For browser levels higher than the versions that are certified with the product, customer support accepts usage-related and defect-related service requests. As with operating system and virtualization environments, if IBM support can't re-create the issue in the lab, the client might be asked to re-create the problem on a certified browser version to determine whether a product defect exists. Defects aren't accepted for cosmetic differences between browsers or browser versions that don't affect the functional behavior of the product. If a problem is identified in the product, defects are accepted. If a problem is identified with the browser, IBM might investigate potential solutions or workarounds that the client can implement until a permanent solution becomes available.

Supported interfaces

This tape library supports the Gigabit Ethernet interface in either auto negotiation or fixed modes of 10 Mbps, 100 Mbps, and 1 Gbps by using half or full duplex. The library supports the following TCP/IP protocols:

IPv4 and IPv6 support

This tape library supports Internet Protocol (IP) addresses in both IPv4 and IPv6 format. Both the integrated management console (IMC) and the management GUI allow the definition of IPv4 and IPv6 addresses. The key proxy determines the IP version that is used and presents the correct IP address and parameters to the IP Stack.

Simple Network Management Protocol (SNMP)

SNMP traps are supported for drive and library events. SNMP management query functions are supported by using a standard Management Information Block (MIB).

Hyper Text Transfer Protocol (HTTP)

An embedded web server provides a management GUI for library management and query capabilities.

Secure Socket Layer (SSL)

The tape library supports SSL, a protocol for transmitting private documents through the internet.

Key Management Interoperability Protocol (KMIP)

Used for communicating with the IBM® Security Lifecycle Key Manager and other security key management software.

Simple Mail Transfer Protocol (SMTP)

The tape library supports SMTP for sending email alerts.

Network Time Protocol (NTP)

The tape library supports NTP for external time-and-date synchronization.

Lightweight Directory Access Protocol (LDAP)

The tape library supports LDAP for centralized authentication.

Domain Name System (DNS)

The tape library supports DNS for flexible IP addressing.

Dynamic Host Configuration Protocol (DHCP)

The library supports DHCP for automatically providing an Internet Protocol (IP) host with its IP address and other related configuration information, such as the subnet mask and default gateway.

Chapter 2. Planning

The library requires an environment able to accommodate the appropriate space, power, location, and other technical specifications. Use this section as a reference for onsite requirements to allow for optimum operation of the library.

Save your settings in the [Appendix A, “Library Configuration Forms,”](#) on page 151.

Library Layout and Location requirements

Information for planning the installation and layout of your library, including various specifications for optimal performance.

For tabletop installation - Tabletop installations (one Base Module) require no additional hardware.

For rackmount installation - If possible, install the Base Module in the middle of the rack to provide space for the allowed three Expansion Modules above it and three Expansion Modules below it. See [“Structure and supported library configurations”](#) on page 2 for details.

Security

The equipment must be located so that access to the equipment can be controlled and monitored. Consider all of these recommended security measures when you’re determining where to locate your tape library.

Library location

You’re responsible for the security of this library, the cartridges that are contained within the library, and shelf-resident cartridges. To prevent unauthorized access to data, IBM recommends locating the library and all shelf-resident cartridges in an area where access is controlled.

Onsite security measures

You’re also responsible for evaluating, selecting, and implementing security features, administrative procedures, and appropriate controls in application systems and communication facilities.

Data security

Data security is accomplished through the Management GUI. See [“Locating Management functions”](#) on page 65.

Location requirements

Choose a location that meets the criteria in [Table 15](#) on page 23.

Criteria	Definition
Rack requirements	Standard 19-inch rack (minimum depth of 1 meter) with an appropriate # of Us (Rack Units) of clearance for the planned module quantity (See Table 16 on page 24 for details.)
Rack space requirements	3U for the Base Module and 3U for each Expansion Module
Power source	<ul style="list-style-type: none">AC Power Voltage: 100 - 240 VACLine Frequency: 50 - 60 HzLibrary is located near AC outlet. The AC power cord must be always easily accessible.

Table 15. Location requirements (continued)

Criteria	Definition
Air quality	<ul style="list-style-type: none"> Place the library in an area with minimal sources of particulate contamination. Avoid areas near frequently used doors and walkways, stacks of supplies that collect dust, printers, and smoke-filled rooms. Excessive dust and debris can damage tapes and tape drive.

Technical specifications for this library can be referenced in the following tables.

Physical specifications

Table 16. Physical specifications

Characteristic	Product alone	Packaged
Height	133 mm	330 mm
Width	480 mm ¹	635 mm
Depth	885 mm ²	1168 mm
Weight	Base module: 20 Kg Expansion module: 13 Kg	Base module: 25 Kg Expansion module: 19 Kg

¹Includes front covering of rack rails, allowing for magazine opening clearance.

²From the front of the bezel to the back of the fan on an inserted drive sled.

Electrical specifications for one module (base or expansion)

Table 17. Electrical specifications for one module (base or expansion)

Characteristic	Specification
Current	max. 12.5 A
Voltage	100 - 240 V 50/60 Hz
Power	300 W

Equipment environmental specifications

Table 18. Equipment environment specifications for the tape library

Product operation (equipment is powered on)							Product power off ¹			
Dry-bulb temperature			Humidity range, non-condensing			Maximum wet-bulb temperature	Maximum elevation	Dry-bulb temperature	Relative humidity	Maximum wet-bulb temperature
Allowable ²	Recommended ³	Maximum rate of change	Allowable	Recommended	Maximum rate of change					
16°C to 32°C (60°F to 90°F)	16°C to 25°C (60°F to 77°F)	5°C/hour (9°F/hour)	20 to 80% RH	20 to 50% RH	5% RH/hour with no condensation	26°C (79°F)	3050 m (10,000 feet)	5°C to 45°C (40°F to 113°F)	8 to 80% RH	26°C (79°F)

Notes:

1. Product equipment is removed from the original shipping container and installed but not in use - for example, during repair, maintenance, or upgrade.
2. Derate maximum dry-bulb temperature 1°C/300 m above 900 m (1.8°F/1,000 feet above 3,000 feet).
3. Derate maximum recommended dry-bulb temperature 1°C/300 m above 1,800 m (1.8°F/1,000 feet above 6,000 feet).

Psychrometric chart

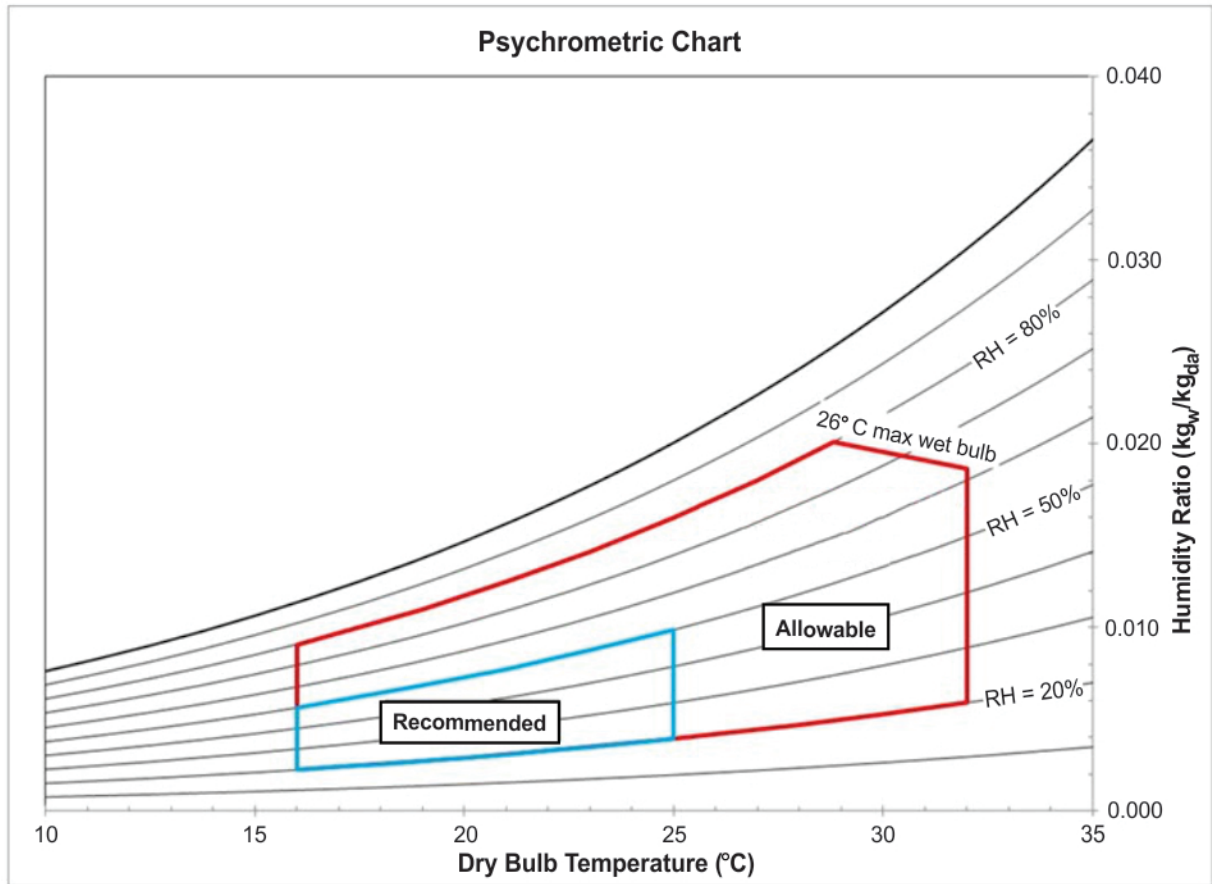

Figure 23. Psychrometric chart showing recommended and allowable operating environments for the tape library

Notes:

- The chart is shown in SI (metric) units and a barometric pressure of 101.325 kPa (sea level).
- The recommended operating environment specifies a long-term operating environment that can result in the greatest reliability and energy efficiency.
- The allowable operating environment represents where the equipment was tested to verify functions. Due to the stresses that operating in the allowable envelope can place on the equipment, these envelopes should be used for short-term operation, not continuous operation (for example, in the case of a cooling failure).

Gas and particulate exposure

Table 19. Gas and particulate exposure	
Contamination	Requirement
Gaseous contamination	Severity level G1 as per ANSI/ISA 71.04-1985 ¹ , which states that the reactivity rate of copper coupons shall be fewer than 300 Angstroms per month ($\text{\AA}/\text{month}$, $\approx 0.0039 \mu\text{g}/\text{cm}^2$ - hour weight gain) ² . In addition, the reactivity rate of silver coupons shall be less than 300 $\text{\AA}/\text{month}$ ($\approx 0.0035 \mu\text{g}/\text{cm}^2$ - hour weight gain) ³ . The reactive monitoring of gaseous corrosivity should be conducted approximately 5 cm (2 in.) in front of the rack on the air inlet side at one-quarter and three-quarter frame height off the floor or where the air velocity is much higher.
Particulate contamination	Data centers must meet the cleanliness level of ISO 14644-1 class 8. For data centers without airside economizer, the ISO 14644-1 class 8 cleanliness might be met by the choice of the following filtration: <ul style="list-style-type: none"> • The room air might be continuously filtered with MERV 8 filters. • Air entering a data center might be filtered with MERV 11 or preferably MERV 13 filters. For data centers with airside economizers, the choice of filters to achieve ISO class 8 cleanliness depends on the specific conditions present at that data center. The deliquescent relative humidity of the particulate contamination should be more than 60% RH. ³⁴ Data centers must be free of zinc whiskers ⁵ .
<p>Notes:</p> <ol style="list-style-type: none"> 1. ANSI/ISA-S71.04. 1985. <i>Environmental conditions for process measurement and control systems: Airborne contaminants</i>, Instrument Society of America, Research Triangle Park, NC, 1985. 2. The derivation of the equivalence between the rate of copper corrosion product thickness growth in $\text{\AA}/\text{month}$ and the rate of weight gain assumes that Cu_2S and Cu_2O grow in equal proportions. 3. The derivation of the equivalence between the rate of silver corrosion product thickness growth in $\text{\AA}/\text{month}$ and the rate of weight gain assumes that Ag_2S is the only corrosion product. 4. The deliquescent relative humidity of particulate contamination is the relative humidity at which the dust absorbs enough water to become wet and promote ionic conduction. 5. Surface debris is randomly collected from 10 areas of the data center on a 1.5-cm diameter disk of sticky electrically conductive tape on a metal stub. If examination of the sticky tape in a scanning electron microscope reveals no zinc whiskers, the data center is considered free of zinc whiskers. 	

Power cords

Electrical and safety information, and feature codes for purchasing power cords.



To avoid electrical shock, a power cord with a grounded attachment plug is provided. Use only properly grounded outlets.

Table 20 on page 28 lists the power cord part number, feature code, the country, or region where the power cord is used, and the plug's standard reference. The last column in the table contains an index number that you can match to a specific receptacle type in Figure 24 on page 32.

All power cords use an appliance coupler that complies with the International Electrotechnical Commission (IEC) Standard 320, Sheet C13.

If the power cord that you receive does not match your receptacle, contact your local dealer.

Power cords that are used in the United States and Canada are listed by Underwriter's Laboratories (UL), are certified by the Canadian Standards Association (CSA), and comply with the plug standards of the National Electrical Manufacturers Association (NEMA). For other worldwide geographies, plug standards are listed in Table 20 on page 28.

Description, Feature Code (FC), and Part Number (P/N)	Plug Standard Reference	Country or Region	Index Number in Figure 24 on page 32
US/Canada <ul style="list-style-type: none"> • 2.8 m, 125 V • FC 9800 • P/N 95P2344 	NEMA 5-15P	Aruba, Bahamas, Barbados, Bermuda, Bolivia, Brazil, Canada, Cayman Islands, Colombia, Costa Rica, Curacao, Dominican Republic, Ecuador, El Salvador, Guatemala, Guyana, Haiti, Honduras, Jamaica, Japan, Liberia, Mexico, Netherlands Antilles, Nicaragua, Panama, Peru, Philippines, Saudi Arabia, South Korea, Suriname, Taiwan, Trinidad Tobago, Venezuela, US	1
Chicago <ul style="list-style-type: none"> • 1.8 m, 125 V • FC 9986 • P/N 39M5080 	NEMA 5-15P	Chicago, U.S.A.	1

Table 20. Power cords (continued)

Description, Feature Code (FC), and Part Number (P/N)	Plug Standard Reference	Country or Region	Index Number in Figure 24 on page 32
<p>US/Canada</p> <ul style="list-style-type: none"> • 2.8 m, 250 V • FC 9833 • P/N 95P2353 	<p>NEMA 6-15P</p>	<p>Aruba, Bahamas, Barbados, Bermuda, Bolivia, Brazil, Canada, Cayman Islands, Costa Rica, Curacao, Dominican Republic, Ecuador, El Salvador, Guatemala, Guyana, Haiti, Honduras, Jamaica, Japan, Liberia, Netherlands Antilles, Nicaragua, Panama, Peru, Philippines, Suriname, Taiwan, Thailand, Trinidad Tobago, Venezuela, US</p>	<p>2</p>
<p>Australia</p> <ul style="list-style-type: none"> • 2.8 m, 250 V • FC 9831 • P/N 95P2352 	<p>AS 3112 NZN 198</p>	<p>Australia, China, Colombia, New Zealand, Papua New Guinea, Paraguay, Uruguay, Western Samoa</p>	<p>3</p>
<p>France, Germany</p> <ul style="list-style-type: none"> • 2.8 m, 250 V • FC 9820 • P/N 95P2345 	<p>CEE 7 - VII</p>	<p>Afghanistan, Algeria, Andorra, Angola, Aruba, Austria, Belgium, Benin, Brazil, Bulgaria, Burkina Faso, Burundi, Cameroon, Central African Republic, Chad, Congo-Brazzaville, Curacao, Czech Republic, Democratic Republic of Congo, Denmark, Egypt, Finland, France, French Guiana, Germany, Greece, Guinea, Hungary, Iceland, Indonesia, Iran, Ivory Coast, Jordan, Kenya, Korea, Lebanon, Luxembourg, Macau, Malagasy, Mali, Martinique, Mauritania, Mauritius, Monaco, Morocco, Mozambique, Netherlands, Netherlands Antilles, New Caledonia, Niger, Norway, Poland, Portugal, Romania, Russia, Saudi Arabia, Senegal, Spain, Sweden, Sudan, Syria, Togo, Tunisia, Turkey, Yugoslavia, Zaire, Zimbabwe, Vietnam</p>	<p>4</p>

Table 20. Power cords (continued)

Description, Feature Code (FC), and Part Number (P/N)	Plug Standard Reference	Country or Region	Index Number in Figure 24 on page 32
Denmark <ul style="list-style-type: none"> • 2.8 m, 250 V • FC 9821 • P/N 95P2346 	DK2-5A	Denmark	5
South Africa <ul style="list-style-type: none"> • 2.8 m, 250 V • FC 9829 • P/N 95P2350 	SABS 164	Bangladesh, Burma, Pakistan, South Africa, Sri Lanka	6
United Kingdom <ul style="list-style-type: none"> • 2.8 m, 250 V • FC 9825 • P/N 95P2347 	BS 1363	Antigua, Bahrain, Bermuda, Brunei, Channel Islands, China (Hong Kong S.A.R.), Cyprus, Fiji, Ghana, Guyana, India, Iraq, Ireland, Jordan, Kenya, Kuwait, Malaysia, Malawi, Malta, Nepal, Nigeria, Oman, Polynesia, Qatar, Sierra Leone, Singapore, Tanzania, Uganda, UK, United Arab Emirate (Dubai), Yemen, Zambia	7
Switzerland <ul style="list-style-type: none"> • 2.8 m, 250 V • FC 9828 • P/N 95P2349 	SEV S/N 416534	Liechtenstein, Switzerland	8
Italy <ul style="list-style-type: none"> • 2.8 m, 250 V • FC 9830 • P/N 95P2351 	CEI 23- 16	Chile, Ethiopia, Italy, Libya, Somalia	9
Israel <ul style="list-style-type: none"> • 2.8 m, 250 V • FC 9827 • P/N 95P2348 	S11-32-1971	Israel	10
Argentina <ul style="list-style-type: none"> • 2.8 m, 250 V • FC 9834 • P/N 95P2354 	IEC 83-A5	Argentina, Brazil, Colombia, Paraguay, Trinidad Tobago, Uruguay	11

Table 20. Power cords (continued)

Description, Feature Code (FC), and Part Number (P/N)	Plug Standard Reference	Country or Region	Index Number in Figure 24 on page 32
China <ul style="list-style-type: none"> • 2.8 m, 250 V • FC 9840 • P/N 95P2355 	CCEE	People's Republic of China	12
Taiwan LV* <ul style="list-style-type: none"> • 2.8 m, 125 V • FC 9835 • P/N 23R3263 	CNS 10917-3	Taiwan	13
Taiwan HV** <ul style="list-style-type: none"> • 2.8 m, 250 V • FC 9841 • P/N 23R6120 	CNS 10917-3	Taiwan	14
Japan LV* <ul style="list-style-type: none"> • 2.8 m, 125 V • FC 9842 • P/N 23R6121 	JIS C8303, C8306	Japan	15
Japan HV** <ul style="list-style-type: none"> • 2.8 m, 250 V • FC 9843 • P/N 39M5186 	JIS C8303, C8306	Japan	16
Korea HV** <ul style="list-style-type: none"> • 2.8 m, 250 V • FC 9844 • P/N 23R6123 	KS C8305, K60884-1	Korea	17
India HV** <ul style="list-style-type: none"> • 2.8 m, 250 V • FC 9845 • P/N 23R6124 	IS 6538	India	18
Brazil LV* <ul style="list-style-type: none"> • 2.8 m, 125 V • FC 9846 • P/N 39M5233 	InMetro NBR 6147	Brazil	19

Table 20. Power cords (continued)

Description, Feature Code (FC), and Part Number (P/N)	Plug Standard Reference	Country or Region	Index Number in Figure 24 on page 32
Brazil HV** <ul style="list-style-type: none"> • 2.8 m, 250 V • FC 9847 • P/N 23R6126 	InMetro NBR 14136	Brazil	20
Rack PDU <ul style="list-style-type: none"> • FC 9848 • P/N 23R6328 			

* Low Voltage

** High Voltage

Figure 24 on page 32 shows the plugs that are used by the power cords in Table 20 on page 28. Match the index number that is beside each plug to the index number in the table.

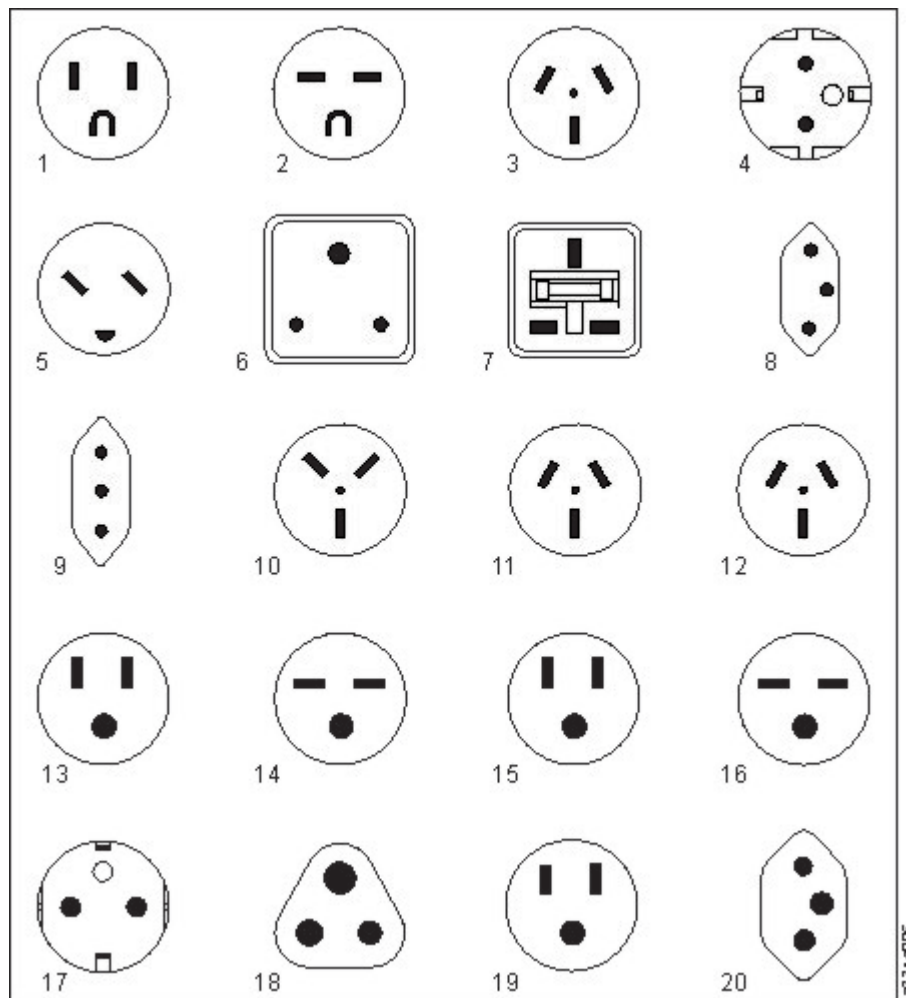

Figure 24. Types of receptacles

Network requirements

The library supports an independent customer network.

It is the customer's responsibility to provide the proper length Ethernet cable for this connectivity.

The base module controller card has two Ethernet ports, which offer primary and redundant customer network connectivity. See [“Rear panel” on page 8](#).

These connections allow remote viewing and management of the library with the Management GUI.

Note: Have your network settings handy to use for entering on the Operator Panel. Your network settings can also be stored as hardcopy on [Appendix A, “Library Configuration Forms,” on page 151](#).

The secondary Ethernet port might be used for service. Three models are available for connection:

- No Ethernet port - Service personnel can connect a laptop to the customer network to use the Management GUI.
- Dedicated secondary Ethernet port - The secondary network port that is dedicated only for service personnel to connect a laptop directly to the library.
- Secondary Ethernet port - The secondary network port can be disconnected and service personnel can use it to connect a laptop directly to the library.

IP range selection

For internal communication between modules, the tape library uses an Ethernet connection with an internal IP address range. To prevent any conflict between the internal IP address range and the external IP addresses, you must select the internal IP range. Choosing the Internal IP address range, and also entering the external IP address information is part of the initial setup of the library.

Host requirements

The library requires attachment to supported SAS or FC HBAs.

The library requires attachment to supported SAS or FC HBAs. See [“Host connectivity” on page 20](#).

	<p>Static Sensitive</p> <p>Risk of damage to devices</p> <ul style="list-style-type: none">• A discharge of static electricity damages static-sensitive devices or micro circuitry.• Proper packaging and grounding techniques are necessary precautions to prevent damage.
---	---

Follow these general guidelines.

- Check with a system administrator before the host computer is powered off.
- For a SAS library, confirm availability or install a SAS HBA that supports multiple LUNs.
- For a direct-attach Fibre Channel library, confirm availability of installation of an FC HBA.
- For connection of a Fibre Channel library through a compatible switch, verify that sufficient ports are available.

Persistent binding to ensure SCSI ID assignment

When a server is booted, devices are discovered and assigned SCSI target and LUN IDs. It is possible for these SCSI assignments to change between boots. Some operating systems do not guarantee that devices are always allocated the same SCSI target ID after rebooting. Also, some software depends on

this association, so you do not want it to change. The issue of SCSI ID assignment is addressed by persistent binding.

Persistent binding is an HBA function that allows a subset of discovered targets to be bound between a server and device. Implemented by a worldwide node name (WWNN) or worldwide port name (WWPN), persistent binding causes a tape drive's WWNN to be bound to a specific SCSI target ID. After a configuration is set, it survives restarts and any hardware configuration changes because the information is preserved. If a drive must be replaced, the new drive assumes the WWNN of the old drive because the WWNN for the drive is location-dependent within the library. Because the WWNN does not change, persistent binding does not need changing, thus preventing a potential outage.

Optional features

More features that are available for your library.

To order extra features, contact your IBM sales representative or Business Partner.

Feature Code	Description
1411	Fibre wrap tool
1412	SAS wrap tool
1682	Path Failover
1899	First Power Supply
1900	Extra Power Supply
7002	Rack Mount Kit
8106	Right Side Magazine
8109	Left Side Magazine
5500	Mini-SAS/Mini-SAS 4x Interposer
5502	2 m Mini-SAS/Mini-SAS 1x Cable
5507	4 m Mini-SAS HD/Mini-SAS 1x Cable Enables attachment of a single tape drive to a host with HD applications (from HD HBA with SFF-8644 to Drive with SFF-8088 connector).
5509	3 m Mini-SAS HD/Mini-SAS 2x Cable Enables attachment of one or two tape drives to a host with HD applications, from HD HBA with SFF-8644 to Drives with SFF-8088 connectors. This cable fans out to enable connection of two devices to one HBA port.
5900	Encryption Configuration
AGK1	10-meter OM3 fiber Cable (LC)
AGK2	25-meter OM3 fiber Cable (LC)
AGKF	LTO 6 HH Fibre Channel Drive
AGKG	LTO 6 HH SAS Drive
AGKH	LTO 6 FH Fibre Channel Drive
AGKJ	LTO 7 HH Fibre Channel Drive
AGKK	LTO 7 HH SAS Drive

Table 21. Optional features (continued)

Feature Code	Description
AGKL	LTO 7 FH Fibre Channel Drive
AGKM	LTO 8 HH Fibre Channel Drive
AGKN	LTO 8 HH SAS Drive
AGKP	LTO 8 FH Fibre Channel Drive
8002	Cleaning Cartridge L1 UCC
8806	LTO 8 Data Cartridges (5-pack)
5521	LTO M8 Data Cartridges (20-pack)
8706	LTO 7 Data Cartridges (5-pack)
8605	LTO 6 Data Cartridges (5-pack)
9800 - 9847	Power cords
9848	Rack Power Distribution Unit (PDU) power cord

Chapter 3. Installing

Use this section to follow the procedures to install and configure your library.

Table 22. Installation Precautions









<p>CAUTION:</p>  <p>18-32 kg (39.7-70.5 lbs)</p>  <p>or</p>  <p>>18 kg (39.7 lbs)</p> <p>or</p>  <p>>18 kg (39.7 lbs)</p> <p>CAUTION:</p>  <p>32-55 kg (70.5-121.2 lbs)</p>  <p>or</p>  <p>>32 kg (70.5 lb)</p> <p>or</p>  <p>>32 kg (70.5 lb)</p>	<p>Product Weight</p> <p>Caution: The weight of this part or unit is between 18.1 and 33.6 kg (40 and 74 lb). It takes two persons to safely lift this part or unit. (C009)</p> <p>Caution: The weight of this part or unit is between 33.6 and 46.3 kg (74 and 102 lb). It takes three persons to safely lift this part or unit. (C010)</p> <p>Risk of personal injury</p> <p>Before a module is lifted or moved</p> <ul style="list-style-type: none">• Observe local health and safety requirements and guidelines for manual material handling.• Remove all tapes to reduce the weight and to prevent cartridges from falling into the robotics path and damaging the library.• Remove all tape drives to reduce the weight.• Obtain adequate assistance to lift and stabilize the module during installation or removal. <p>Risk of damage to devices</p> <p>When a module is placed into or the module is removed from a rack</p> <ul style="list-style-type: none">• Extend the rack's leveling jacks to the floor.• Ensure that the full weight of the rack rests on the leveling jacks.• Install stabilizing feet on the rack.• Extend only one rack component at a time.
---	---

Table 22. Installation Precautions (continued)

	<ul style="list-style-type: none">• Do not expose the library to moisture.• Do not place a module on either the ends or sides as this action might cause damage.
---	---

Complete these procedures to install your library hardware.

1. [“Unpacking the Base Module and Expansion Modules” on page 38](#)
2. [“Identifying Library Module components” on page 42.](#)
3. [“Preparing top and bottom modules” on page 42.](#)
4. [“Installing modules in a rack” on page 45.](#)
5. [“Installing a tabletop module” on page 49.](#)
6. [“Aligning and connecting modules” on page 49](#)
7. [“Validating tape drive installation” on page 52.](#)
8. [“Connecting cables” on page 53.](#)
9. [“Powering on the library” on page 54](#)

Complete these procedures to configure your library.

1. [“The Initial Setup process” on page 55](#)
2. [“Initial configuration and customization” on page 56](#)
3. [“Labeling and loading tape cartridges” on page 56](#)
4. [“Verifying the installation” on page 58](#)
5. [“Advanced library configuration” on page 58](#)
6. [“Verifying the host connection” on page 60](#)

Unpacking the Base Module and Expansion Modules

Procedure for safely unpacking the Base and Expansion Modules.

Before any modules are unpacked, clear a work surface near the targeted rack or table for installation.



Attention: If the temperature in the room where the library operates varies by 15° C (30° F) from where the module was stored, allow it to acclimate for at least 12 hours before it is unpacked.

Unpacking a Base Module or Expansion Module

1. Before a module is opened or removed from the box, inspect the container for shipping damage.
2. If you notice any damage, report it to the shipping company immediately.
3. Remove the module from the box.

Important: Lift the module out of the box by the long sides, not by the display.

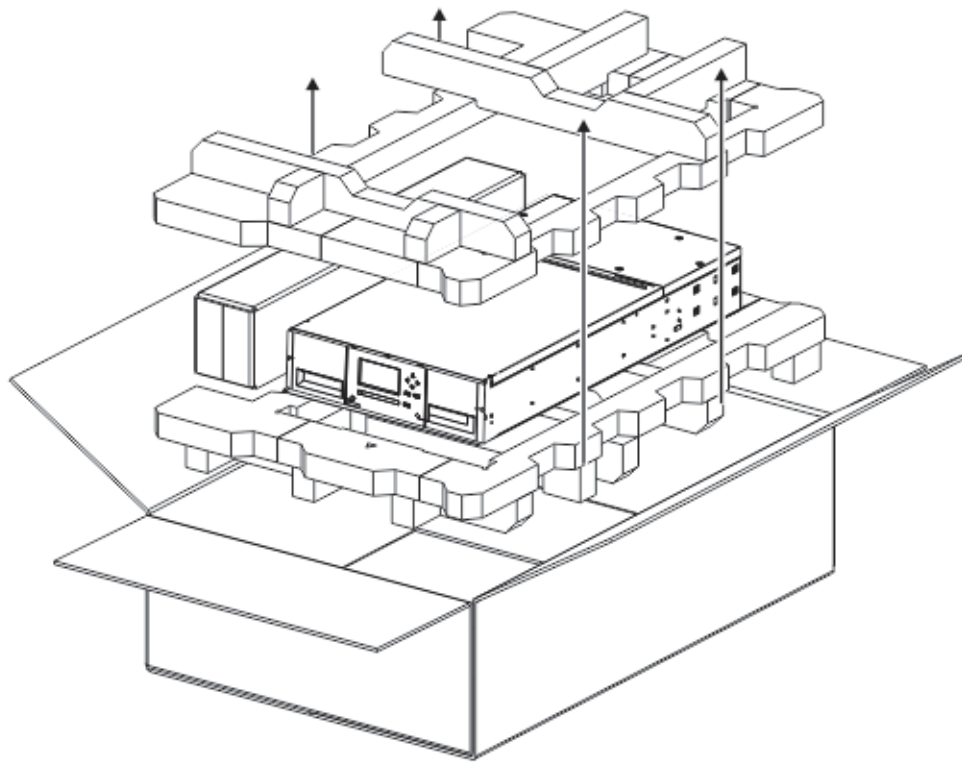

ts43rc009

Figure 25. Removing the module from the box

4. Check that all components for assembling the module are in the box. See [“Identifying Library Module components”](#) on page 42.

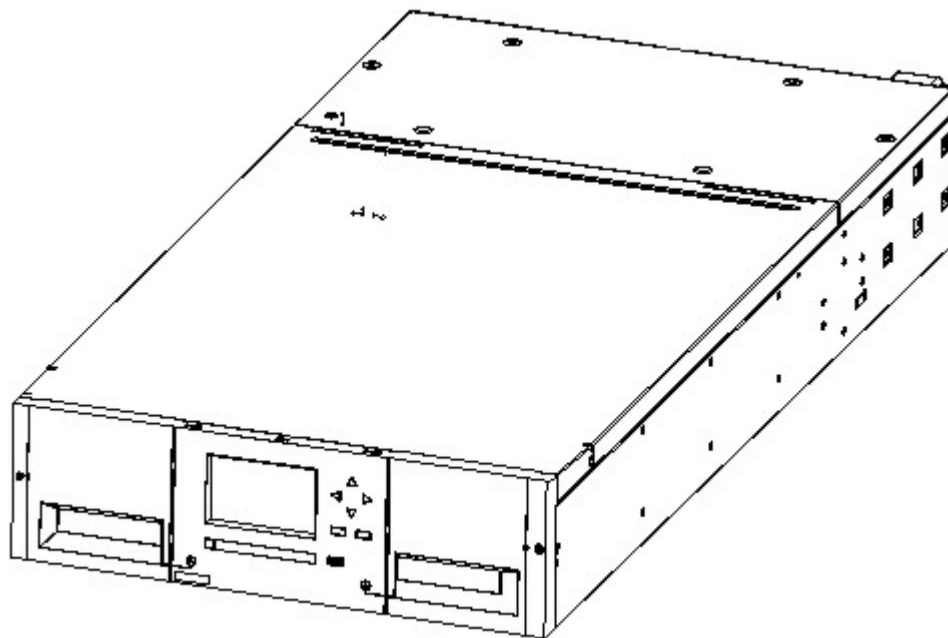

ts43rc011

Figure 26. The module after removal from the box



Attention: Do not place a module on either the ends or sides as this action can damage the module.

5. Unlatch the top of the module by using your fingers or a small tool, one on each side of the lid, and press inward. When the lid is opened, remove it by pulling it forward. See [Figure 27](#) on page 40.

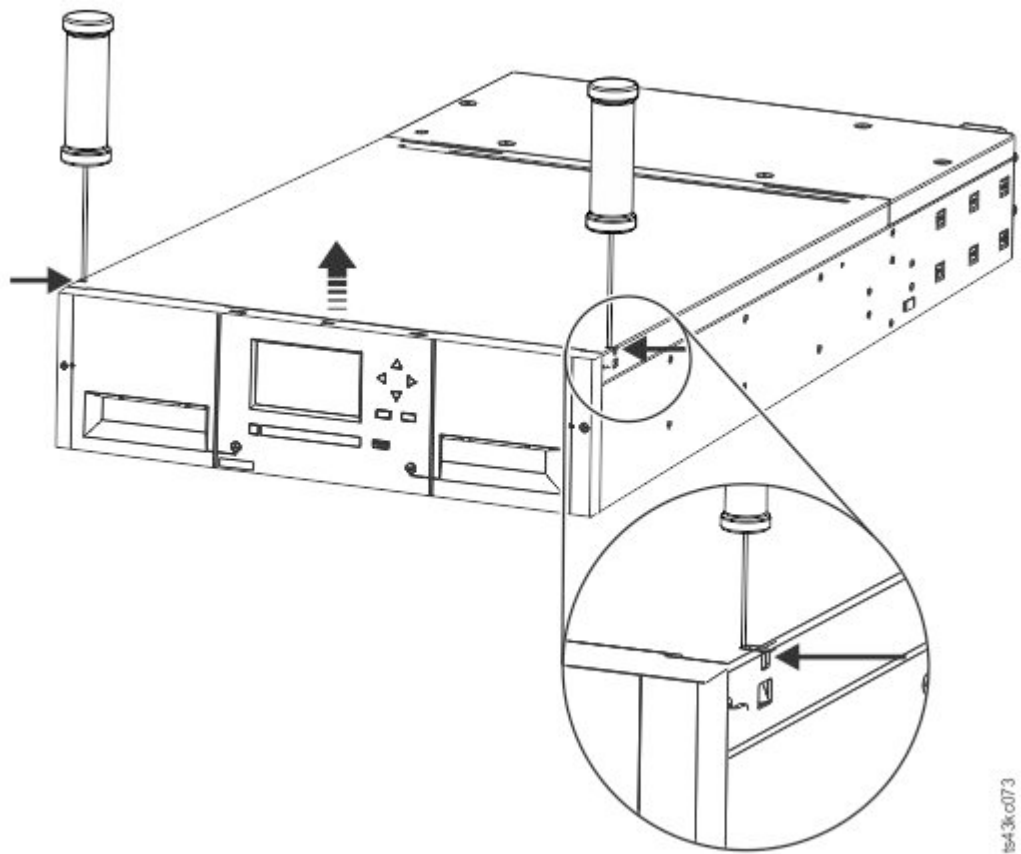

ts43k.c0173

Figure 27. Unlatching the top of the module

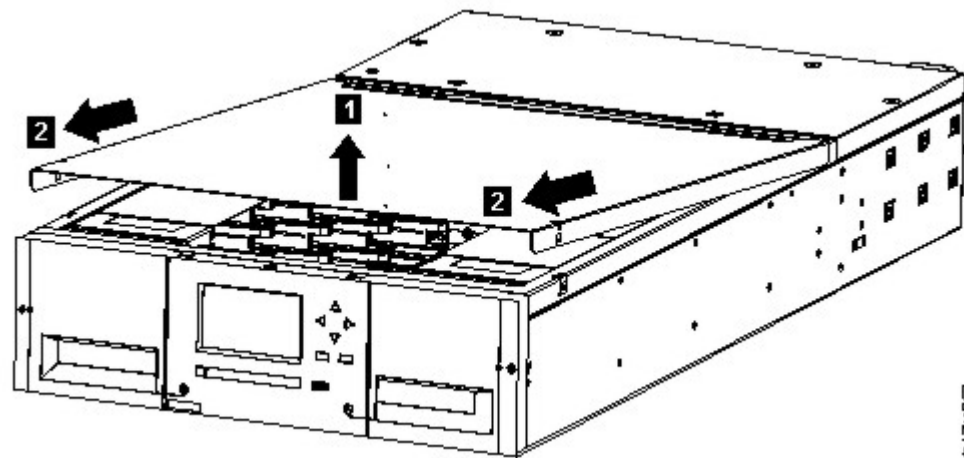

ts43k.c0183

Figure 28. Removing the top of the module

6. Remove the foam packing from the inside of the module.

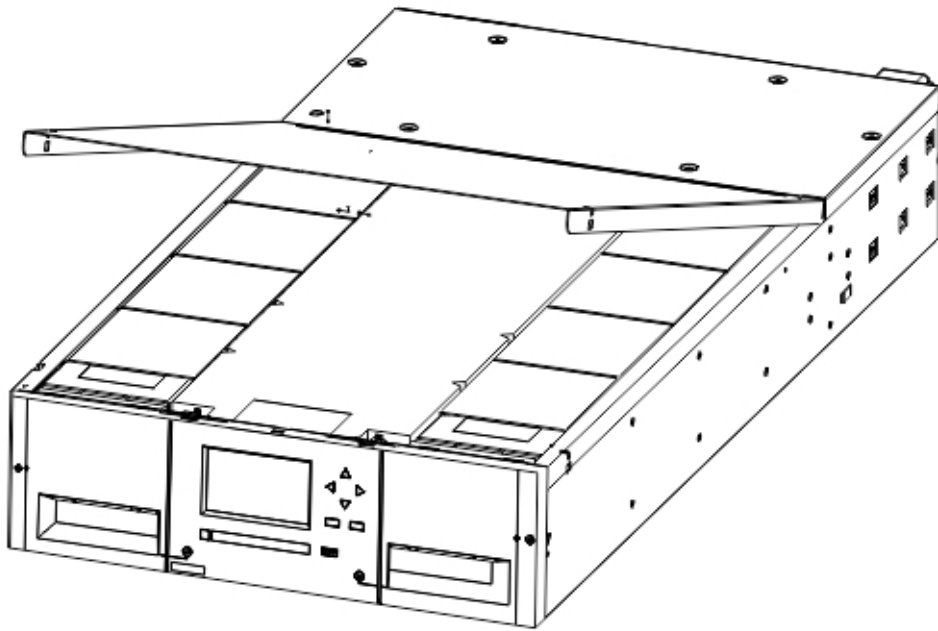

ts-43kr-c012

Figure 29. The module is opened to show the foam packing.
7. After the packing is removed, the internal components are shown.

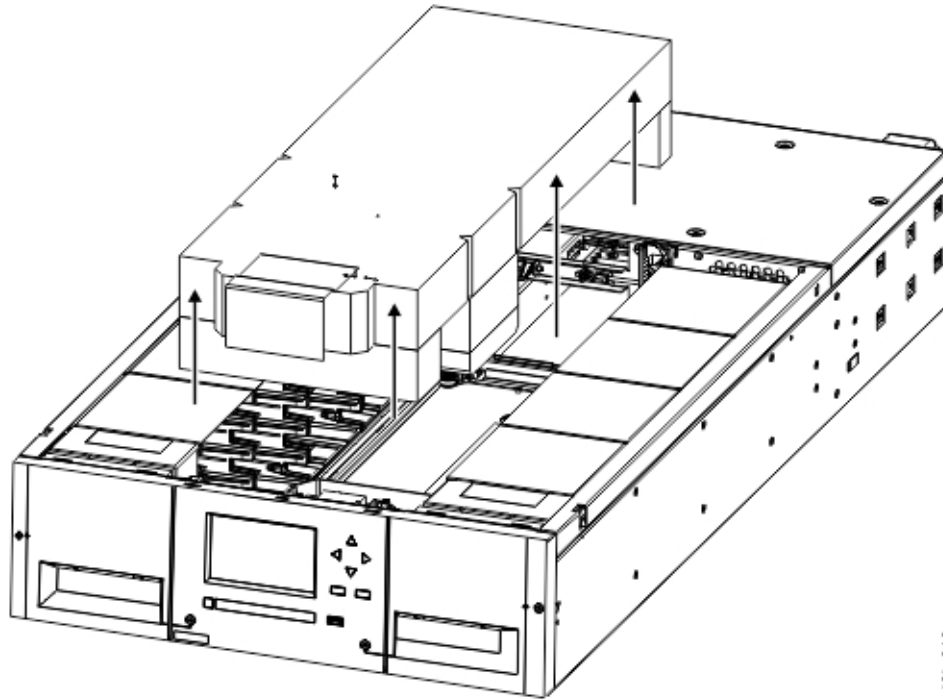

ts-43kr-c013

Figure 30. The foam packing is removed, and the internal components are shown - Base Module.
8. Install the top cover if you do not plan to add modules above this module.
9. Save the packaging materials for future use.
10. If you are adding extra modules, go to [“Preparing top and bottom modules”](#) on page 42.

Identifying Library Module components

Use the packing slip that is included with your module to identify the module components.

The TS4300 model 3555 is not shipped with a rack mount kit (IBM FC: 7002) and/or power cord (IBM FC: 9800-9848) unless it is ordered.

1. Locate one or more packing slips for your module.
2. Verify that you received each item that is listed on the packing slips.

Note: Order the power cord that matches the electrical requirements of the country or area. Power cord FC 9848 must be ordered with the rack mount kit if a rack-based power supply is used.

For SAS libraries, you must provide SAS cabling with the correct configuration for your HBA. For Fibre Channel libraries, you must provide one Fibre Channel cable for each tape drive. See [“Optional features” on page 34](#).

Preparing top and bottom modules

Use these steps to prepare the top and bottom modules for installation.

Skip this step if you are installing a Base Module only without an Expansion Module.

The Base Module has a removable top and bottom covers.

Installing Expansion Modules above the Base Module

If you are installing one or more Expansion Modules above the Base Module, move the top cover from the Base Module to the Expansion Module that is installed at the top of the library.

To move the library top cover plate from the Base Module to an Expansion Module

1. Remove the library top cover plate from the Base Module. See Step 5 in [“Unpacking the Base Module and Expansion Modules” on page 38](#).
2. Install the top cover on the Expansion Module that is installed on the top of the library.
 - a. Place the Expansion Module on a work table.
 - b. With the front of the top cover raised approximately 12 cm, engage the rear of the cover at the Expansion Module pivot point at the back of the opening.
 - c. Lower the front of the top cover until the latches engage on both sides.

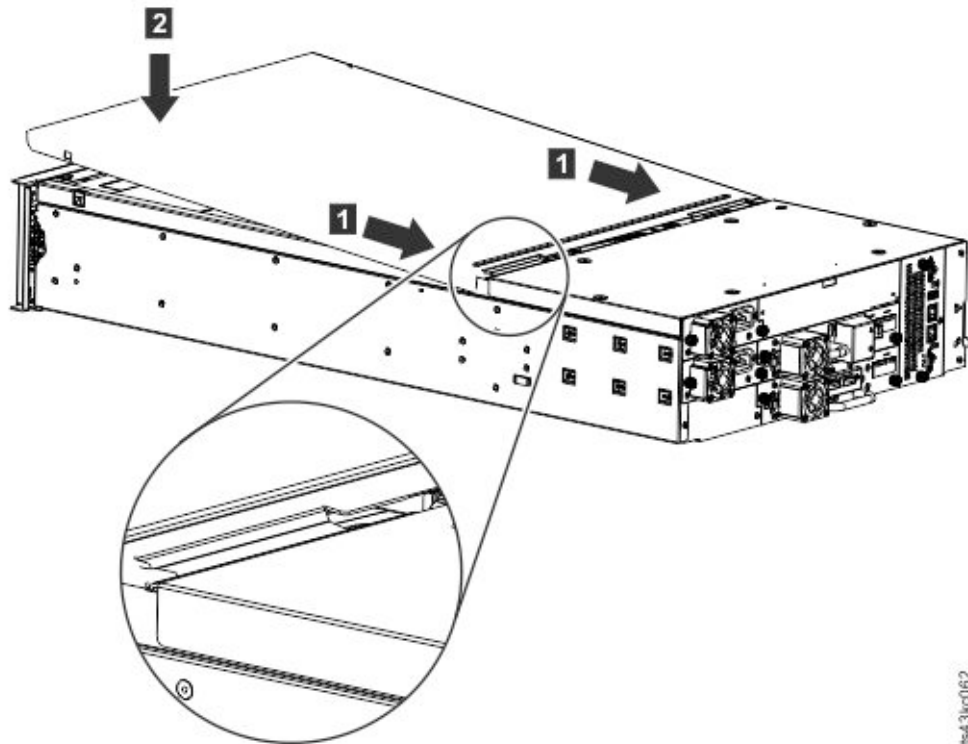

Figure 31. Lowering the front of the top cover

Installing Expansion Modules below the Base Module

If you are installing one or more Expansion Modules below the Base Module, move the bottom cover from the Base Module to the Expansion Module that is installed at the bottom of the library

To move the library bottom cover plate from the Base Module to an Expansion Module

1. Remove the library bottom cover plate from the Base Module.
 - a. Place the Base Module on a work table.
 - b. Lift the unit front end by about 16 cm (use unit rear as a pivot edge).
 - c. Support the bottom cover with one hand. Insert a small flathead screwdriver or Torx screwdriver into the hole and slide about 4 mm sideways to the left to unlock the spring loaded lock. See [Figure 32 on page 44](#).

Important: Do NOT turn the module upside-down to complete this step.

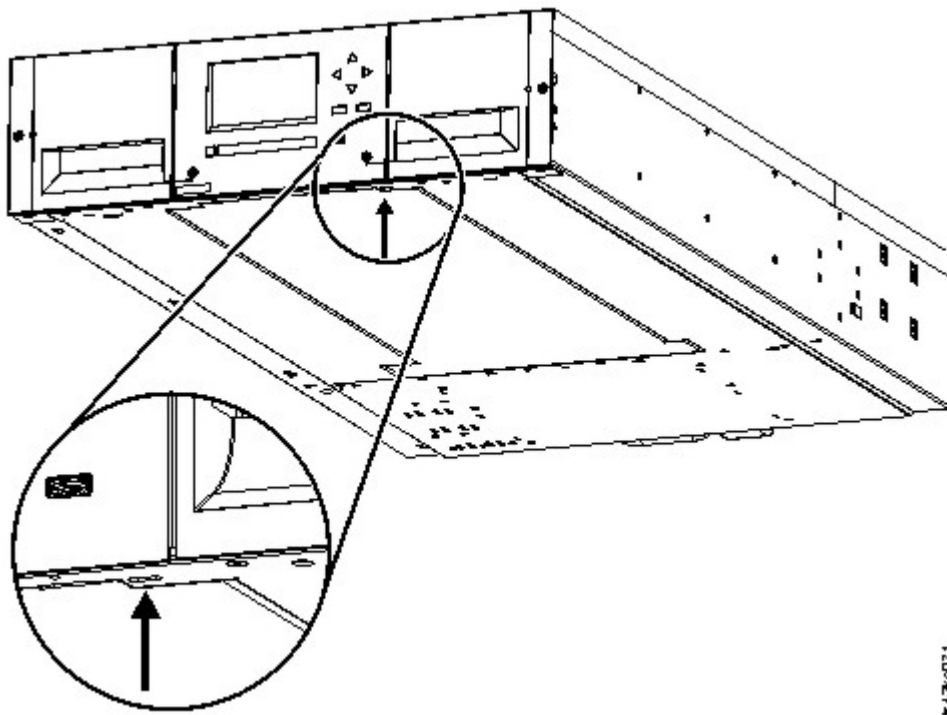

Figure 32. Unlocking the spring loaded lock

- d. Lower the cover front end by about 10 cm (1) and pull gently forward (2) to disengage from the pivot point at the unit center.

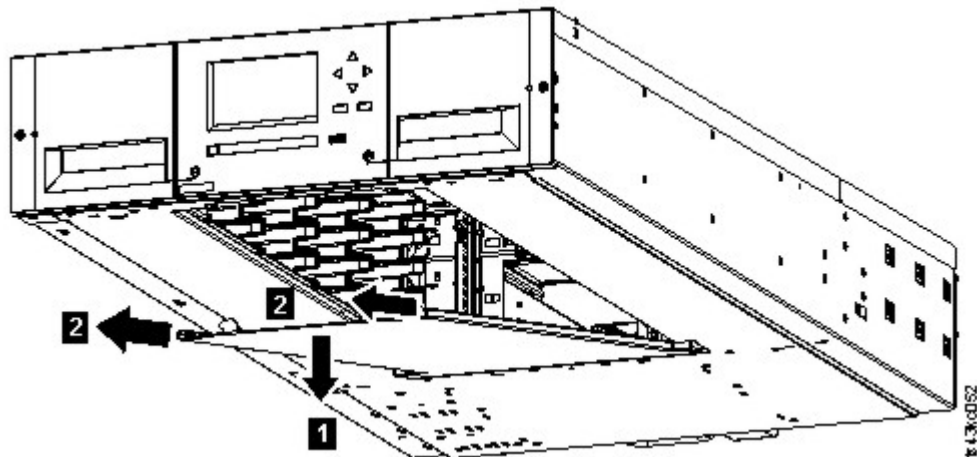

Figure 33. Removing the cover

2. Install the library bottom cover plate to an Expansion Module.
 - a. Place the Expansion Module on a work table.
 - b. Lift the unit front end by about 16 cm (use unit rear as a pivot edge).
 - c. Insert the bottom cover at the center
 - d. Lift the cover front edge until hard stop and it locks in at the unit front. The bottom cover fits only one way.

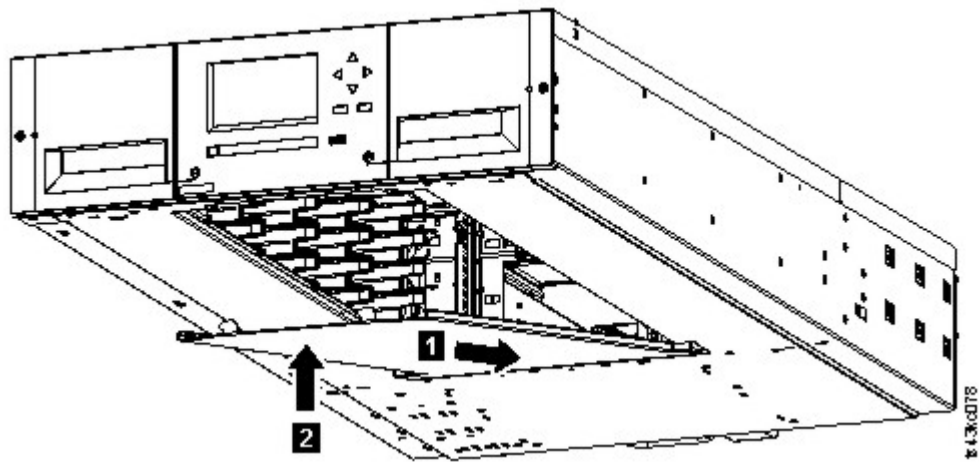

Figure 34. Lifting the cover and locking it

Installing modules in a rack

Rackmount installation procedure.

Modules are easy to install in racks that are compliant to the EIA 310A Standard, when at least 1 meter deep. You need a #2 Phillips screwdriver for this process.

Note: Install modules from the bottom to the top. Refer to [“Structure and supported library configurations”](#) on page 2 for the correct configuration of Base and Expansion Modules.

To locate the rail locations when multiple modules are installed.

1. Locate the bottom of the lowest full U where the lowest module is installed.
2. Continue identifying the locations for any additional module 3U higher.

To install the rails into the rack, starting from the lowest rack location.

- a. Locate the four universal rack connectors, four Philips screws, and two rackmount rails (LH and RH).

Note: The universal rack connectors have two sides, for round hole and square hole racks. The square-hole side might be painted.

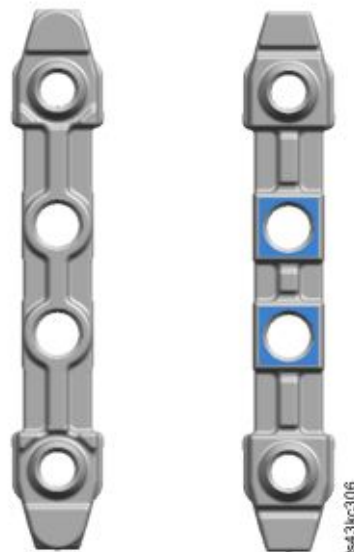

Figure 35. Universal rack connector

- b. On the inside of the racks, facing out, mount the connectors at the appropriate height to the right and left rack posts. Mount them in the middle hole of the height unit (the middle of a height unit is the hole between two wide and neighboring division bars) in both front and back. The four screw holes must align with the holes on your rack. If they do not, the blocks are not in the correct location. See [Figure 36 on page 46](#) and [Figure 37 on page 46](#).

Note: If the connectors are installed incorrectly, the screws on the connectors do not match the holes on the frames. The circles in the graphics highlight the mismatch.



Figure 36. Incorrect connector locations

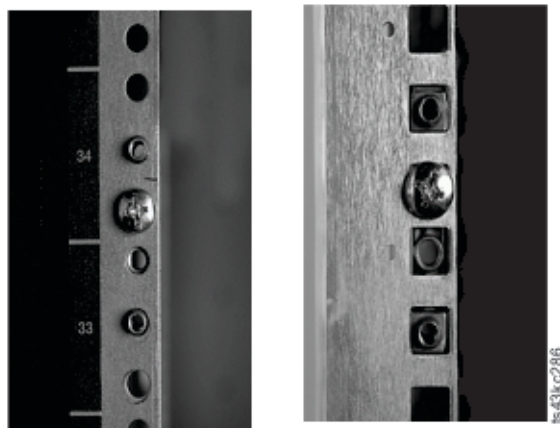

Figure 37. Correct connector locations

- c. Repeat step **b** on the right and left rack posts in the rear of the rack.
d. Mount the LH Rackmount rail to the connectors. See [Figure 38 on page 47](#).
e. Repeat step **d** with the RH Rackmount Rail.

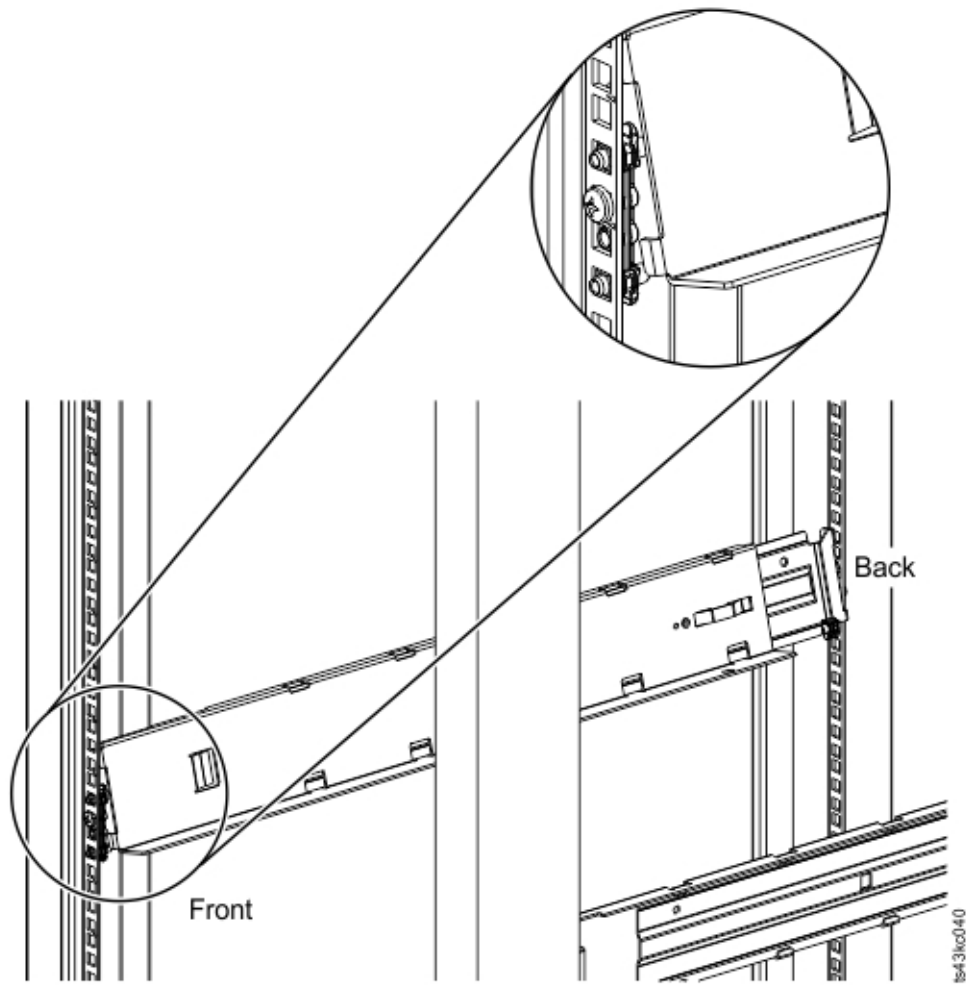

Figure 38. Mounting the rails to the connectors

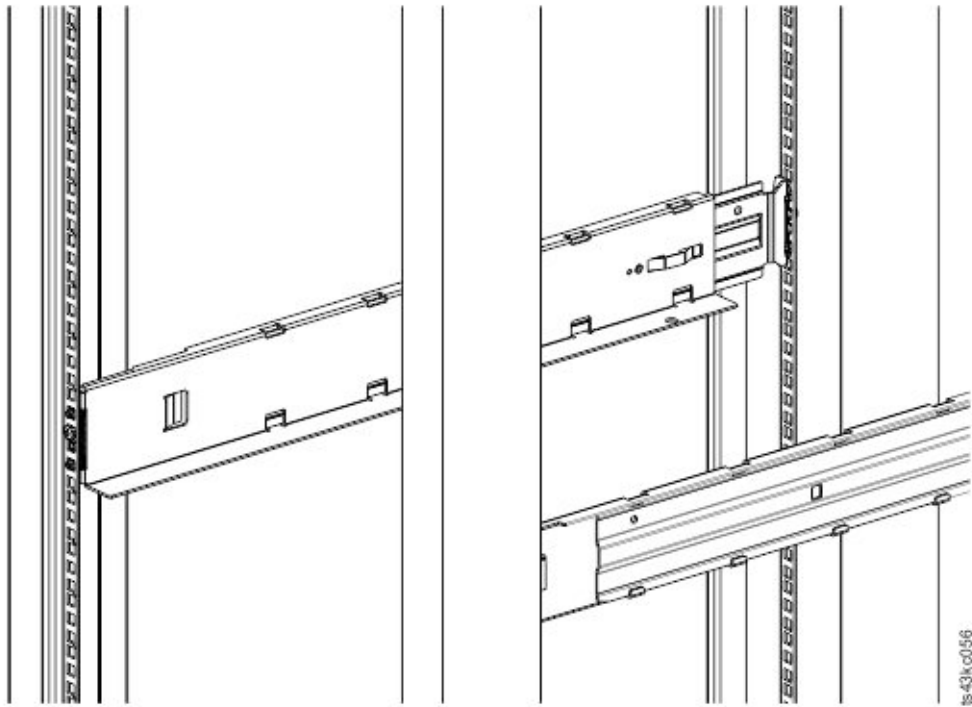

Figure 39. Side rails installed

3. Place the library at the front of the rack on the support angles of the rails and push it into the rack to the back stop.

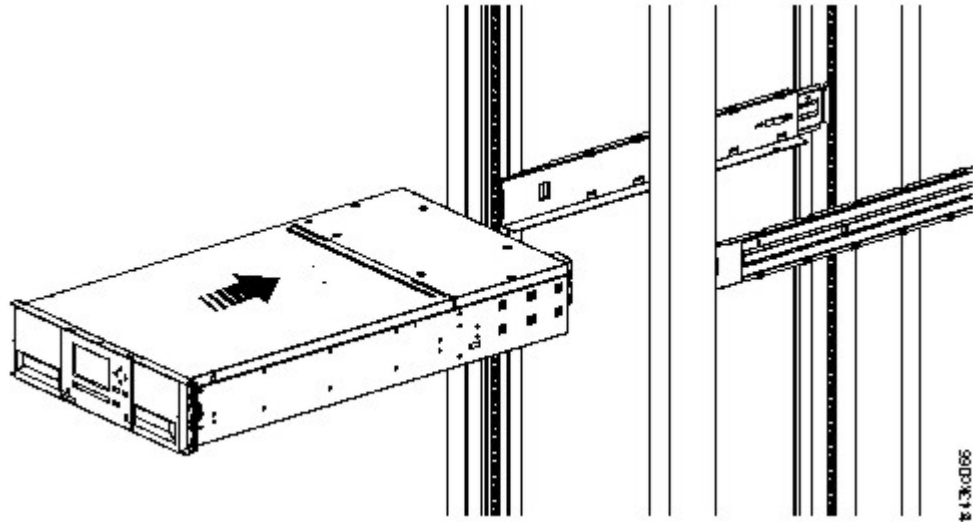

Figure 40. Sliding the library into the rack

4. If you are installing multiple modules, verify that this module is installed directly above or below its adjacent module and is contained within the correct 3U volume. Remove the tape that is covering the alignment pin lock/unlock lever on the rear of each module. The gap between modules must be less than 4 mm.

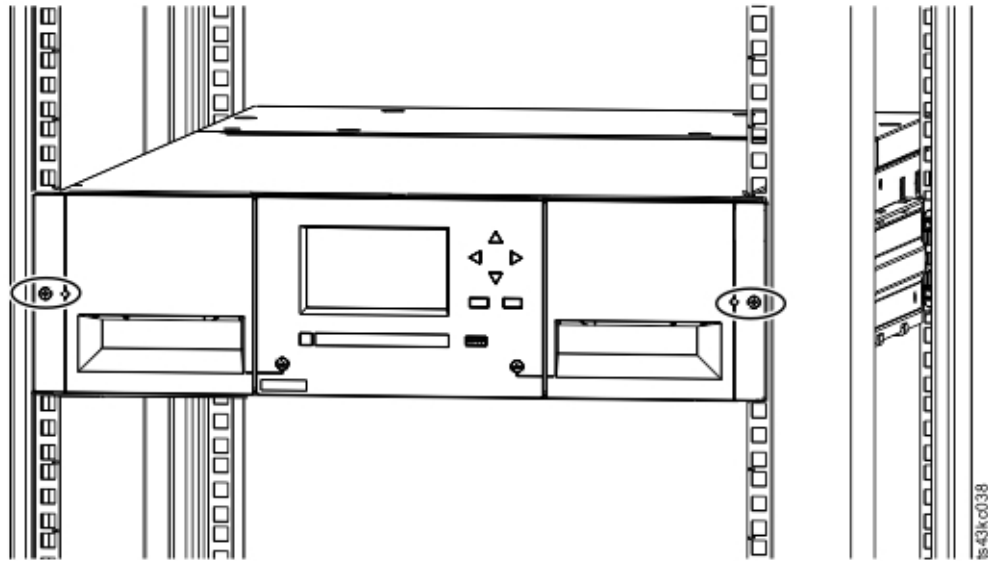

Figure 41. Library in the rack

Important: Each module must be on its own rails.

5. With a Phillips screwdriver, loosely screw the module to the front of the rack, one screw on each side. See the circled areas in [Figure 41 on page 49](#).
6. Align the module as needed. Then, tighten the screws on each side of the module. See [“Aligning and connecting modules” on page 49](#).
7. Repeat steps 2 - 6 to install the rest of the modules into the rack.

Installing a tabletop module

Installation of a one module library (Base Module only) can be completed without special hardware.

If you unpacked a Table Top Module, confirm that you received the following components:

1. Base Module
2. Accessory Kit
 - One North American power cord
 - One European power cord
1. Remove the Base Module from the box.
2. Open the cover and remove the foam packing from inside the enclosure. See [“Unpacking the Base Module and Expansion Modules” on page 38](#).
3. Replace the cover.
4. Set the Base Module in the wanted location. Ensure that it is level.
5. Plug in the power cord and the connecting cables.

Aligning and connecting modules

Aligning the modules ensures that the accessor can move freely between the modules.

Skip this step if the library does not have Expansion Modules.

Aligning the modules ensures that the accessor can move freely between the modules. The library cannot operate unless the alignment mechanisms of the upper modules are in the locked position, and the alignment mechanism of the lowest module is unlocked.

1. From the front of the library, loosen the screws on each of the modules where they are attached to the rails two full turns.
2. From the back of the library, starting with the bottom pair of modules, align each module with the module below it. Repeat for each pair of modules. Refer to [Figure 44](#) on page 51.
 - a. Move the alignment lever of the upper of the pair of modules to the locked or engaged position. If you encounter resistance, adjust the position of the upper module so the pin in the alignment mechanism moves into the mating hole in the lower module. If you still encounter resistance, check to see if the rack rails are installed correctly. Check that the hole for the alignment pin is on the left rail (looking from the front) toward the back of the rack. See **1** in [Figure 42](#) on page 50.

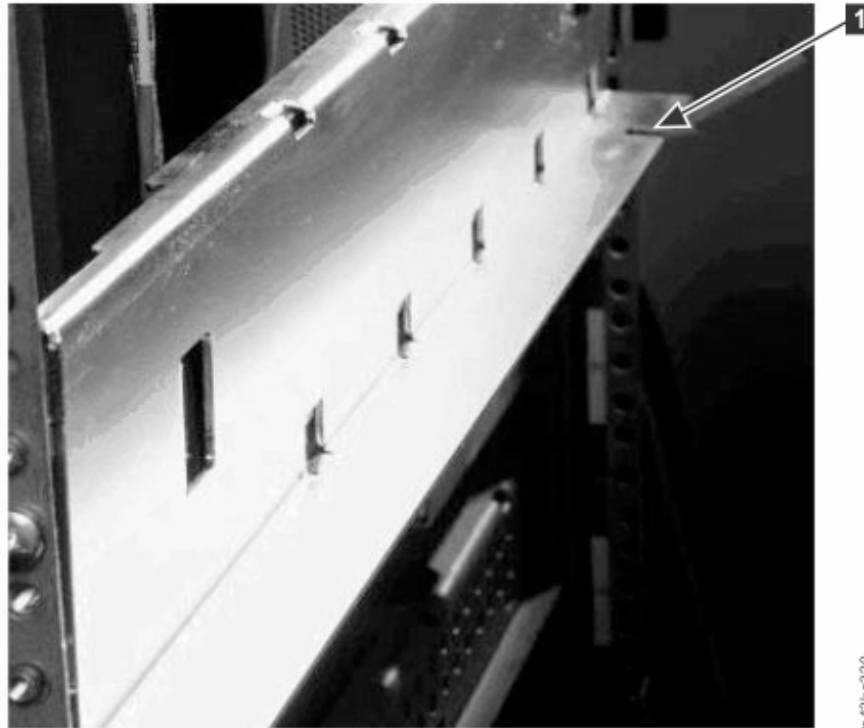

Figure 42. Hole for alignment pin

Note: If a blue alignment lever lock is attached to the rear of the module, slide it to the left, then move the alignment lever. The lever lock has an internal spring, so hold it while the alignment lever is moved, and it automatically springs back into place after the lever is moved. See [Figure 43](#) on page 50.

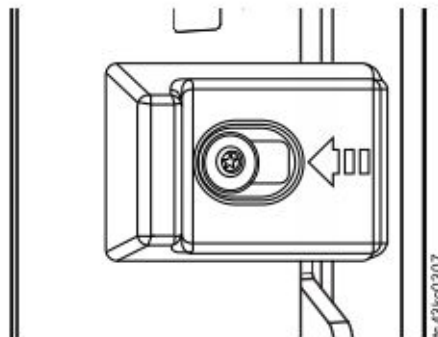
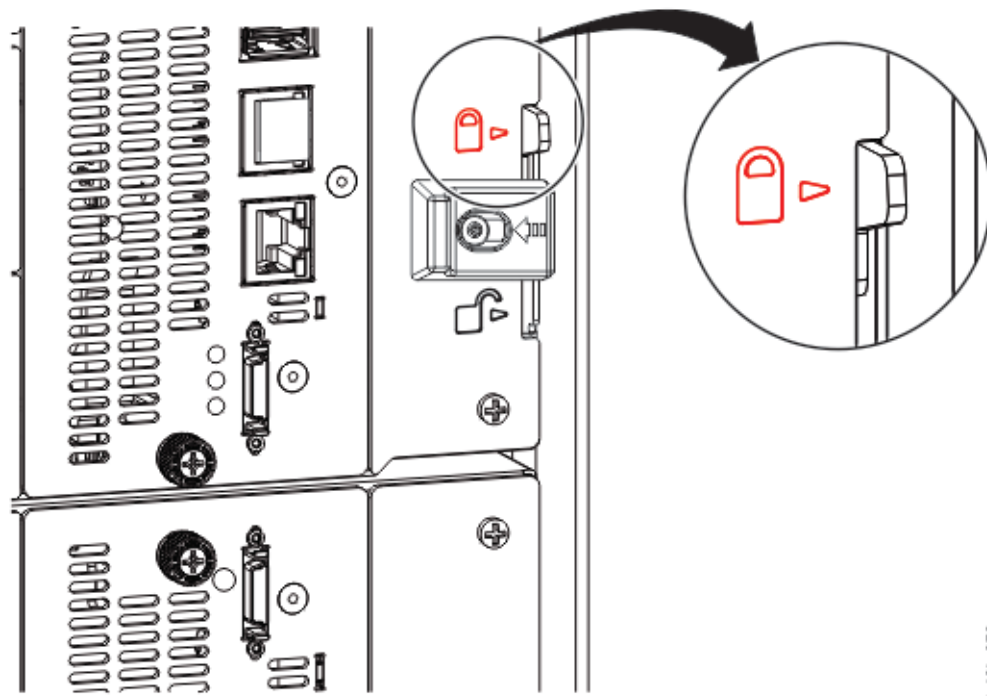
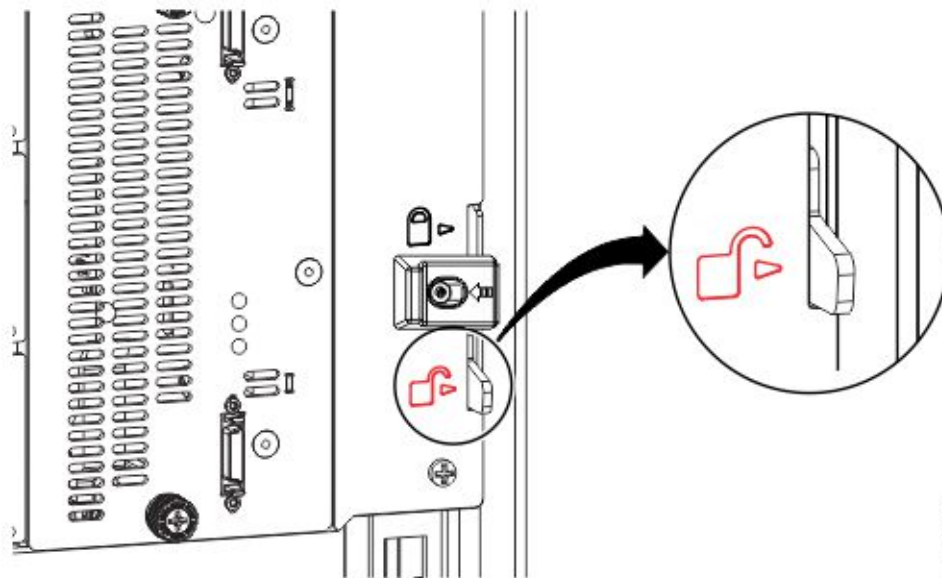

Figure 43. Alignment lever lock



ts4-3kcd079

Figure 44. Alignment lever locked or engaged to lower module



ts4-3kcd080

Figure 45. Alignment lever unlocked or disengaged

3. Verify that the lowest module in the library has its alignment lever is in the unlocked or disengaged position.

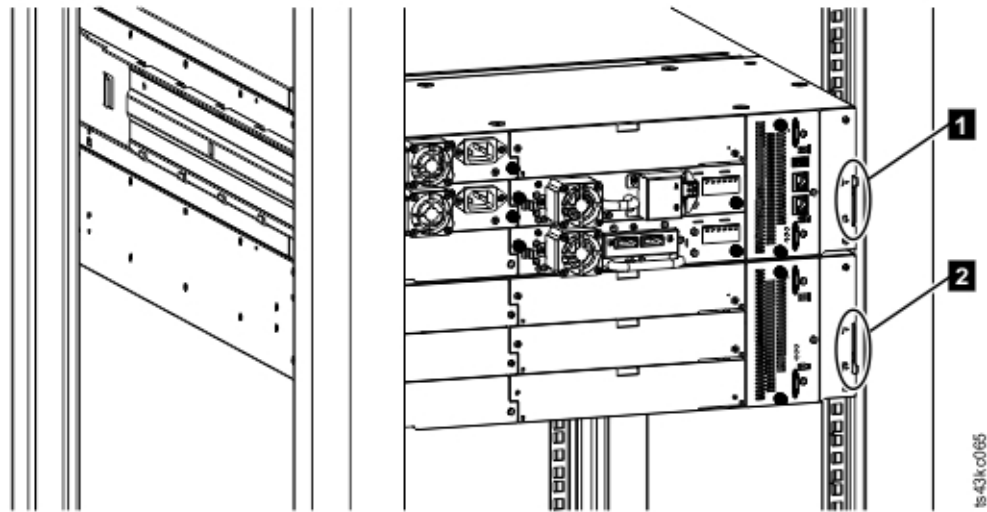

Figure 46. Two modules in rack, seen from the rear

- 1** Locked
- 2** Unlocked

4. From the front of the library, tighten the Philips screws on each of the modules to secure the modules to the rack.
5. From the back of the library, connect the modules of each pair to its adjacent module by using the expansion interconnect cables (**1**) as shown in Figure 47 on page 52.

Note: The top module's top connector and the bottom module's bottom connector has nothing plugged into them.

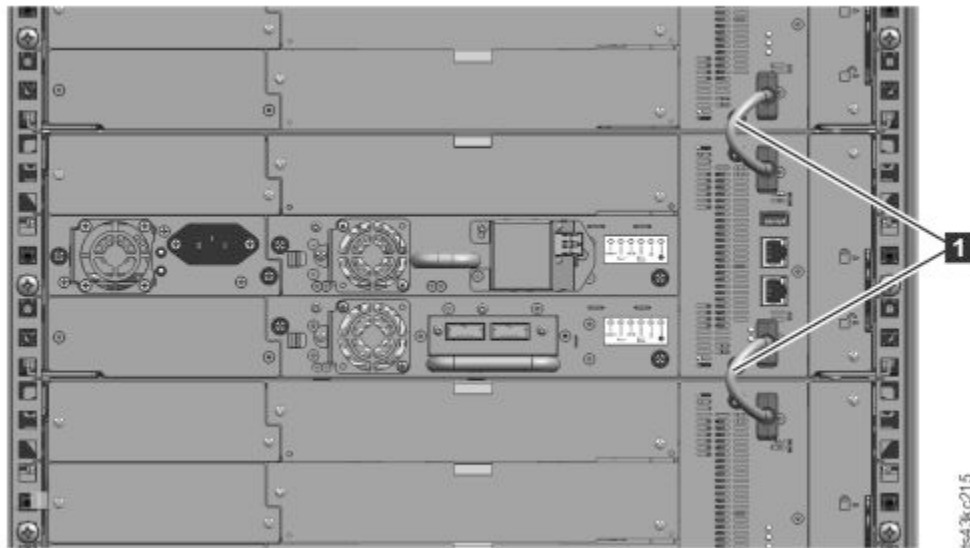

Figure 47. Connected modules

Validating tape drive installation

Tape drives come already installed in the library modules.

- Half-height tape drives can be installed in any drive bay in a module.

- Full-height tape drives must be installed in the lowest two bays of a module. Installing a full-height drive in the top two bays of a module is not supported.

Connecting cables

Procedures to connect Fibre Channel, SAS, USB, and Ethernet cables.

Connecting Fibre Channel cables

1. Remove the FC port caps if necessary. Attach one end of the FC cable to port 0 on the tape drive.

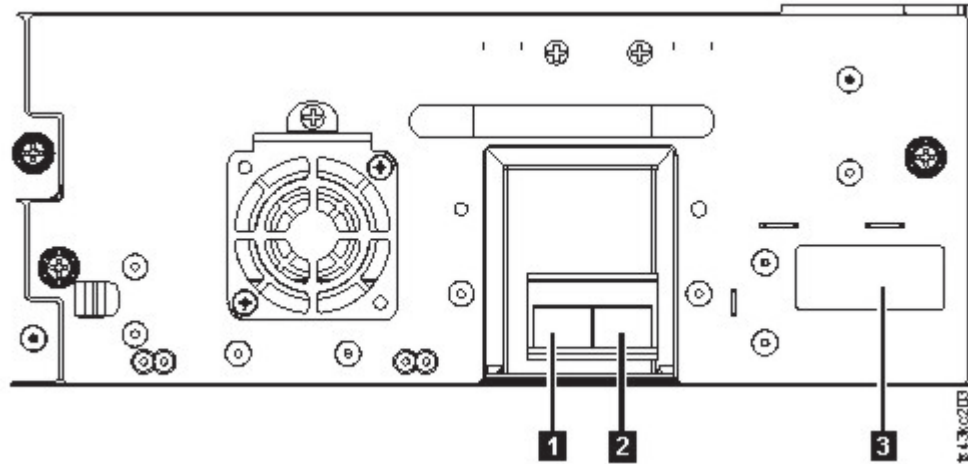

Figure 48. Full-height FC dual port

Number	Description
1	FC port 0
2	FC port 1
3	Drive sled indicators (see Figure 18 on page 13)

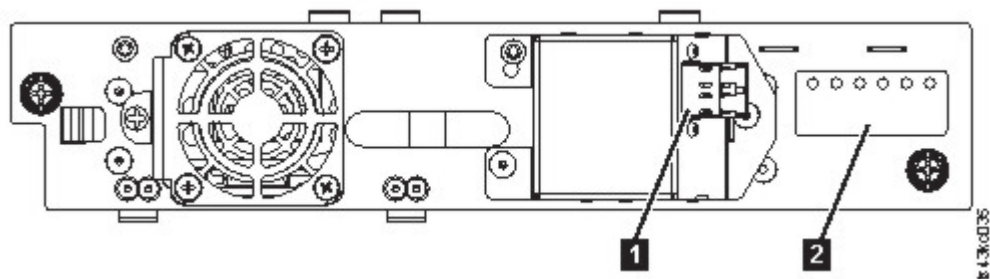

Figure 49. Half-height FC single port

Number	Description
1	FC port 0
2	Drive sled indicators (see Figure 18 on page 13)

2. Attach the other end of the FC cable to a switch or HBA.
3. Repeat the same process with port 1 if you have a dual port drive.

Connecting SAS cables

1. Attach the end of the SAS cable into the connector on the HBA. If you are using a SAS fanout/ Interposer cable, the end of the cable with only one connector must be plugged into the HBA.
2. Connect the drive end of the cable.
 - If you are using a cable with a single connector on each end, attach the other end into the connector on the tape drive.
 - If you are using a SAS fanout/Interposer cable, attach one mini-SAS connector into the connector on each tape drive. The unused ends of the SAS fanout/Interposer cable are single channel and not suitable for use with disk arrays. Use the other ends to connect tape drives, or coil and secure them to the rack to minimize stress on the connectors.

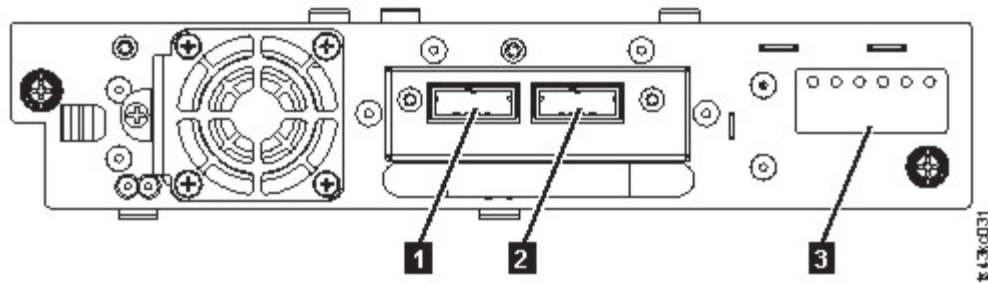

Figure 50. Half-height SAS dual port

Number	Description
1	SAS port 0
2	SAS port 1
3	Drive sled indicators (see Figure 18 on page 13)

Note: SAS signal rates require clean connections between the HBA and tape drive. Do not use adapters or converters between the HBA and the tape drive. For reliable operation, use a maximum SAS cable length of 6 meters.

Connecting USB cables

Two USB ports are on the library, one in the front and one in the rear. USB connections are used by service personnel for diagnostic and service procedures. Attach one end of the USB cable to your notebook or other device and the other end to the front or rear USB port of the library.

Important: USB cable lengths of more than 3 meters are NOT supported for the front or rear USB ports.

Connecting Ethernet cables

To use the Management GUI, connect an Ethernet cable from the bottom Ethernet port on the Base Module controller to your network. See [“Rear panel”](#) on page 8 for the location of the Ethernet ports.

Note: Ethernet port A (bottom Ethernet port) is the primary port. The second Ethernet port, Port B, is for redundancy.

Powering on the library

Steps to power on the library.

1. Plug the power cables into the power connectors on each module and into power outlets.

Notes:

- The library has dual redundant power supplies. To increase redundancy, plug each power cord into a different AC power circuit.
 - A power supply is required in expansion modules if drives are installed.
2. Power on the library by pressing **Power** on the Base Module just below the Operator Panel and hold for 5 seconds. See [“Front panel” on page 7](#) for the location of the **Power** button. When the library is powered on, it
 - a. Inventories the tape cartridges in the magazines,
 - b. Checks the firmware version on all modules,
 - c. Configures the tape drives.
 - d. Confirms the presence of the existing modules,
 - e. Searches for any new modules.
 - f. When the library is powered on for the first time, the Initial Setup starts. See [“The Initial Setup process” on page 55](#).

The Initial Setup process

When you turn on the library for the first time, the **Initial Setup** process starts automatically. Click **Next** to start the process.

The wizard guides you through setting the Internal IP range, setting library network configuration, configuring date and time, and setting the administrator PIN. You can skip items and stop the wizard at any time. After you configure the network settings, you can start the wizard from the Management GUI to complete more configuration items.

Notes on navigation and entering data into the Operator Panel

- The arrow keys on the front panel are used to select numeric and alphanumeric characters and symbols. Capital and lowercase letters, numbers, and punctuation are available to use.
- The right button under the arrows is **Enter**, which is pressed before you enter text.
- The left button under the arrows is **Back/Return**, which is used to delete entries.

See [Figure 55 on page 64](#).

When the library starts up for the first time, the initial setup automatically begins.

1. Enter the IP address for your library. See [“IP range selection” on page 33](#).

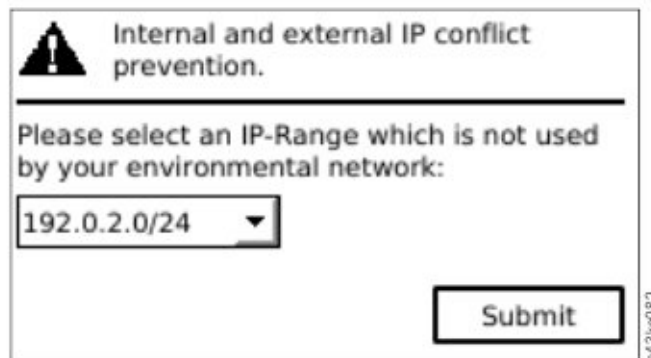

Figure 51. IP address selection

2. Press **Enter** to unlock the Operator Panel.

Note: If you wait too long to make your selection, the unit auto calibrates. The auto calibration finishes, then returns you to the login screen.

3. When you are logged in, the initial configuration process begins with **Network Settings**.

4. Follow the prompts to set date and time, and administrator PIN.
5. When the initial setup is complete, the display returns to the Operator Panel main screen.

To check your configuration at any time, go to **Configuration > Initial System Setup** on the Operator Panel. On the Management GUI, go to **Library**.

Initial configuration and customization

After the physical installation and initial setup by using the Operator Panel is completed, an administrator can log on to the Management GUI to complete the library configuration and configuration of any additional features.

Upon the first login with the user role: `administrator` and password: `adm001`, the **Initial Configuration Wizard** guides you through basic configuration settings.

The library has many features to customize it for your organization. Go to [“Locating Management functions” on page 65](#) to customize your library with these features.

- Enabling or disabling the I/O station.
- Naming the library with the **Manage Logical Library** function.
- Creating or managing Logical Libraries. See [“Library sharing” on page 17](#) for information.
- Selecting Random or Sequential Mode. See [“Random and Sequential Logical Library modes” on page 16](#) for information.
- Enabling and configuring SNMP network management.
- Setting up email event notification.
- Setting up encryption.
- Configuring date and time.
- Enabling or disabling Library Auto Clean. See [“Methods of cleaning drives” on page 72](#).

Labeling and loading tape cartridges

The library can power on without cartridges, but needs cartridges before it can complete data read and write operations, or any tests or operations that transfer cartridges.

Bar code labels are highly recommended in production environments to improve inventory time in the library and ease cartridge-handling processes outside the library. See [“Labeling tape cartridges” on page 160](#).

The I/O station

If the I/O station is enabled, you can use it to load cartridges into the library. Press the magazine button for less than 3 seconds and after the button LED is flashing fast, pull out the I/O station.

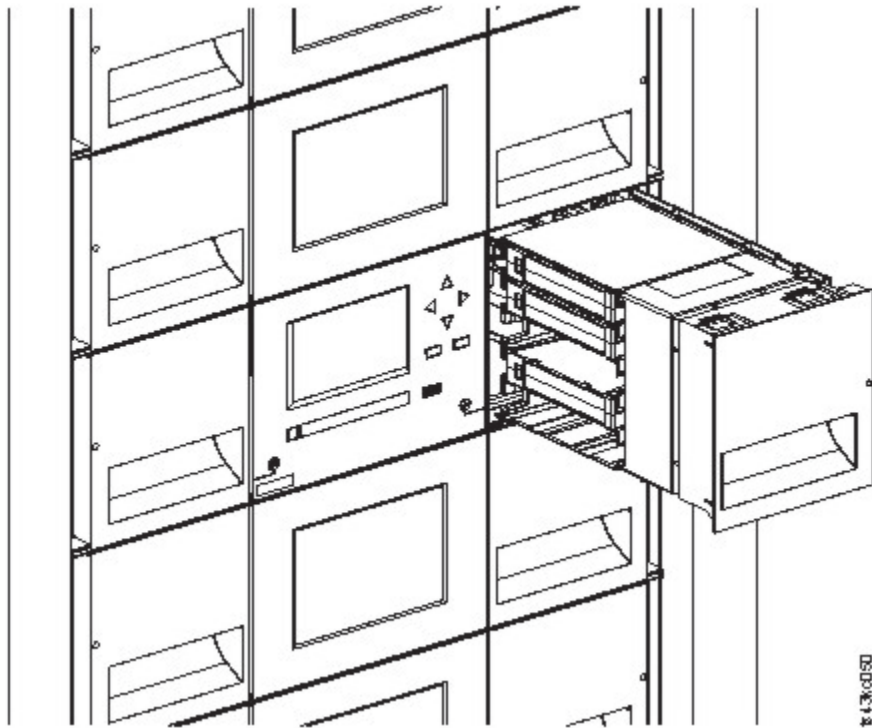

Figure 52. Open I/O station seen from the left

Bulk loading magazines

1. Unlock the magazine by pressing the magazine button for more than 3 seconds, wait for the button to flash fast and then pull out the magazine.
 - a. From the Operator Panel or Management GUI, select the module and then select **Open Magazine**. You can also press the release button on the front panel of the module to release the magazine.
 - b. Wait until the magazine is unlocked, and then pull out the magazine.

Note: Wait for the Operator Panel/Management GUI message to say the magazine is unlocked before the magazine is pulled out.

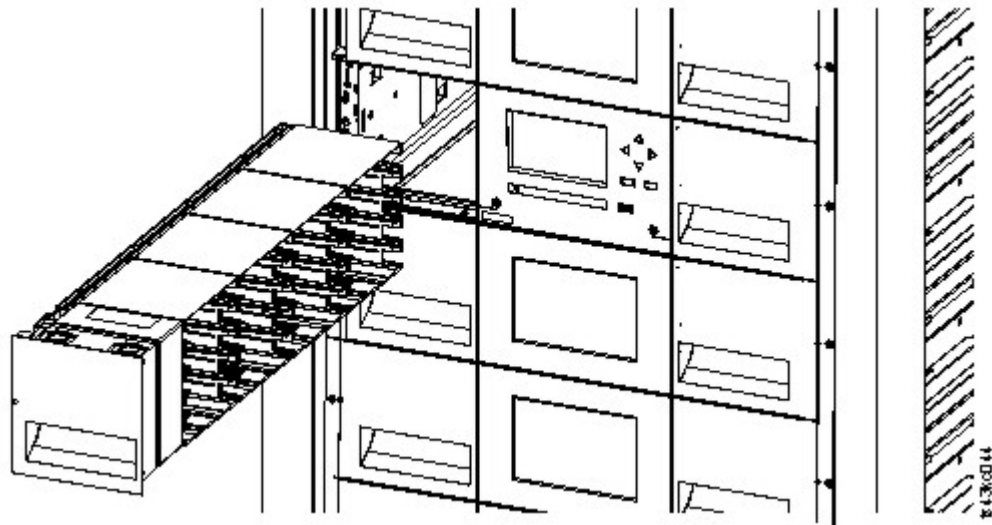

Figure 53. Magazine pulled out

2. Load the tape cartridges into the magazine.

Important: For libraries with serial numbers before 7800K0K, the slots of the lowest row of the bottom module are inaccessible and can contain a 4-slot I/O station only, so do not load cartridges into these slots.

3. Insert the magazine into the unit.
4. Push the magazine handle slowly until the magazine release latch snaps into place. The magazine locks into place.

Important: Push the magazine fully into place until the latch snaps into place.

5. Repeat steps 1 - 3 for each of the other magazines.

See [“Accessing cartridges”](#) on page 73.

Verifying the installation

Verify that the library has the current firmware revision, and save the configuration settings. This action can be helpful if the library requires service.

Verify that the library has the current firmware revision. The library firmware revision is displayed at **Library > Actions > Properties**.

1. Verify library firmware and update if needed: **Library > Actions > Update Library Firmware**
2. Run **Library Verify**.
3. Save the configuration settings to a file on your computer from the Management GUI: **Settings > Library > Advanced > Save Configuration File**.

Having a backup of the library configuration is helpful when the library is recovering from a configuration error or needs service.

Advanced library configuration

To create and manage multiple logical libraries, utilize the advanced logical library function.

Overview

Overview of advanced features such as multipath architecture, multiple logical libraries, and multiple control paths.

Multipath architecture

The multipath architecture feature of this tape library allows Open Systems applications to share the robotics of the library. See [“Library sharing”](#) on page 17.

The library features storage area network (SAN) ready multipath architecture. This architecture allows homogeneous or heterogeneous Open Systems applications to share the library's robotics without middleware or a dedicated server (host) acting as a library manager. The SAN-ready multipath architecture makes sharing possible by partitioning the library's storage slots and tape drives into logical libraries. Servers can then run separate applications for each logical library. This partitioning capability extends the potential centralization of storage that the SAN enables. Partitioning also provides investment protection if your application does not support the mixing of drive generations and media in the same logical library.

The multipath architecture of this library is designed to provide the capability to share the library robotics. The sharing is accomplished first by partitioning the library into multiple logical libraries (up to the number of drives installed). Then, each logical library is assigned its own separate and distinct drives, storage slots, and control paths. Input/output (I/O) slots are shared on a first-come-first-serve basis. This type of partitioning is designed to allow heterogeneous applications to share the library robotics independent of each other. Cartridges under library control are not shared between logical libraries, nor are they allowed to be moved between logical libraries. An example of heterogeneous sharing is a

Microsoft Windows application that is using the drive and storage slots of one logical library, while a UNIX application uses the drive and slots of another logical library. See [“Mixed drives” on page 12](#).

Multiple logical libraries

A library can be partitioned into multiple logical libraries to enable simultaneous data backup and restore tasks from different applications. For example, you can create multiple logical libraries so that is processes

- Commands from Application 1 (about Department A) in Logical Library 1
- Commands from Application 2 (about Department B) in Logical Library 2
- Commands from Application 3 (about Department C) using Sequential Mode in Logical Library 3

In this configuration, the tape drives and cartridges of each logical library are dedicated to that library and are not shared among other libraries and applications. Commands that are issued by the applications travel to the library through unique control paths or sequential mode processing by the library. So, the data processing for Department A is confined to the tape drives and cartridges of Logical Library 1. Processing for Department B is confined to the tape drives and cartridges of Logical Library 2, and so forth.

For applications that do not support mixed drive types and media within the same logical library, partitioning the library into multiple logical libraries provides the capability to keep them separate. For example, you can partition the following tape drives and their media into multiple and separate logical libraries:

- LTO 8
- LTO 7
- LTO 6

Multiple control paths

With this tape library's multipath architecture, in addition to creating multiple logical libraries, you can configure any logical library to have more than one control path. A control path is a logical path into the library through which the library receives standard **SCSI Medium Changer** commands to control the library operations.

Note: No SCSI Medium Changer is configured when the logical library is enabled as Sequential Mode

Multiple control paths reduce the possibility of a failure in one control path to cause the entire library to become unavailable. Also, when you configure more control paths, more library-sharing configurations and options are possible. Access to the library is on a first-come, first-served basis. Each control path for a logical library can accept commands while the library is in use by another control path.

Multiple control paths for control path failover

This tape library offers an optional control path failover feature. See [“Library sharing” on page 17](#) and [“Control path failover, Data path failover, and load balancing” on page 18](#).

Use of the control path failover feature further reduces the possibility of a failure in one control path to cause the entire library to become unavailable.

The control path failover feature (feature code 1682) enables the host device driver to resend a command to a different control path for the same logical library.

Library partitioning

Libraries that contain at least two drives can configure two logical libraries. It is possible to configure up to 21 logical libraries in the library (up to the number of drives installed).

Partitioning of libraries

With full-height or half-height physical drives, physical numbering is bottom up for all drives. For example, if you replace a half-height drive in [Figure 22 on page 15](#), the drives are still numbered 1-4. If you add a

drive in any of the slots in between drives numbered 1 and 4, the physical numbering changes and is still numbered bottom up.

Important: A full-height drive can be installed in a module in the lower two slots only.

Configuration of a 1-logical library system

A one logical library system contains all drives present in any drive positions, and it contains all the slots.

Configuration of multiple logical libraries

A library with multiple logical libraries must have a drive for each logical library and at least five slots. Drives can be in any location in the library. It is best to have drives that are located near the slots that are assigned to the same logical library to minimize accessor movement and maximize performance.

SCSI element-addressing

A logical library assigns SCSI element addresses to drives, storage slots, I/O slots, and the accessor. For each element type (drive, storage, I/O), the SCSI element address can be viewed on the Management GUI.

While SCSI addressing follows the same method as physical location-numbering, this action depends on the **Advanced Logical Library** configuration.

Drive numbering is from bottom to top. Storage slot-numbering is from left magazine (front to back, bottom to top) to right magazine (back to front, bottom to top). IO slot-numbering is from bottom to top. Accessor is single number.

Note: When the number of drives in your library are reduced, update the logical library configuration. This action removes all event notifications that indicate a drive is missing.

Updating the logical library configuration might change the SCSI element addressing.

Verifying the host connection

Procedure to verify the connection between the host computer and the library.

To verify the connections between the host computer and the library

1. Install the application software and drivers that are compatible with the library. Backup software packages might require extra software or licensing to communicate with the robotics.
2. Verify the connection between the library and the host by using the host server's operating system utilities. Or, use the IBM Tape Diagnostic Tool (ITDT) to verify the communication between library and host. See "[IBM Tape Diagnostic tool \(ITDT\)](#)" on page 83.

See "[Host connectivity](#)" on page 20 for compatible servers and software.

Chapter 4. Managing

Four user roles are described, and each user role has its specific functions.

- **Administrator** - This role provides access to the administrator functions on the Management GUI. There is a default administrator password `adm001` for the first login. The administrator password can be changed on the **Users** page
- **Monitor** - This role allows access to library status information and does not allow access to configuration, maintenance, or operation features. Setting a user password restricts access to status information to only those users who know the user password. The user password can be set or changed by the Administrator.
- **Superuser** - This role has same access rights as the Administrator role, except the ability to access the **Users** and **Remote Authentication** pages. In addition, it is possible to do cartridge moves and open magazines and I/O Stations. The Superuser password can be set or changed by the Administrator.
- **Service** - This role provides access to the service functions on the Management GUI. The service password can be changed by the Administrator on the **Users** page.

Note: Monitor, Superuser, and Service user IDs must be enabled by the library administrator. These accounts are disabled by default.

The Management GUI

With the Management graphical user interface (GUI), you can monitor, configure, and operate most library functions from a web browser.

When possible, it is recommended that the Management GUI be used as the primary library interface. The web interface provides access to more features, includes online help, and is easier to use.

Before the Management GUI can be used, you must log in and configure the library network settings with the Operator Panel. This action can be done during Initial Setup. See [“The Initial Setup process”](#) on page 55.

Logging in with the Management GUI

1. Open a supported web browser and enter the IP address of the library in the browser’s address bar.
2. Type in the user name (`administrator` or other administrator-created user) and the password. Click **Login**.

Note: For initial login, type `administrator` and the password: `adm001`. You **must** change the password after the initial login.

Note: Only one person (on Operator Panel or Management GUI) can be logged in to the library at a time. Any time that you try to log in and another person is already logged in, a dialog box appears, asking if you want to log off the other user.

The Library main screen on the Management GUI

The library main screen is organized into the following regions:

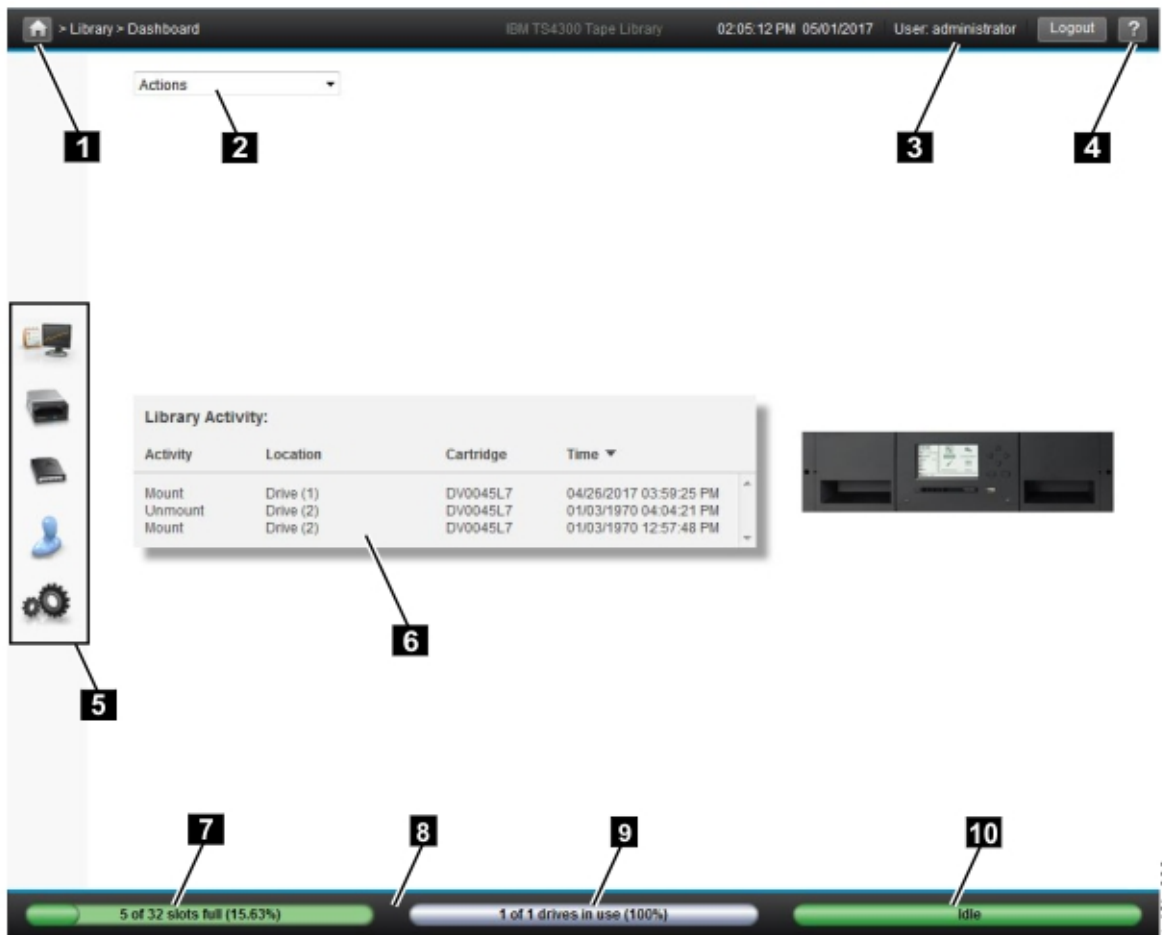

Figure 54. Management GUI main screen





	Element
1	Home icon > Current Navigation
2	Actions > dependent on current navigation
3	User logged in
4	Help
5	Navigation Dock
6	Overview - dependent on current navigation
7	Physical Capacity
8	Status Bar
9	Drive Activity
10	Library Status

Tips:

1. For specific management function navigation, see [“Locating Management functions”](#) on page 65.
2. Check the online help in the Management GUI for additional information. The help pages are updated with firmware updates and often contain up-to-date technical details that might not be contained in



this document. To access Management GUI help, click the ? icon on the right side of the Management GUI top banner.

Navigation Dock

<i>Table 27. Navigation Dock</i>		
Navigation Dock Icons	Element	Extra menus
	Library	<ul style="list-style-type: none"> • Dashboard • Modules and Magazines • Logical Libraries • Events
	Drive	Drives and Ports
	Cartridges	Cartridges and Slots
	Access	Users
	Settings	<ul style="list-style-type: none"> • Library • Network • Notifications • Security

Status icons

Status icons indicate the following conditions.

<i>Table 28. Status icons</i>	
Icon	Description
	The green OK icon indicates that the library is fully operational and that no user interaction is required.
	The yellow exclamation point Warning icon indicates that user attention is necessary, but that the device can still complete most operations.
	The red X Error icon indicates that user intervention is required and that the device is not capable of completing some operations.

The Operator Panel

With the Operator Panel, you can monitor, configure, and operate library functions from the library front panel.

The Operator Panel has a **Power** button, an LCD display, six navigation buttons, and five LEDs. To use the Operator Panel, you must use the six navigation buttons (up/down, left/right, Enter, Back). The Operator Panel is **not** a touchscreen. See “Front panel” on page 7 for the location of the navigation buttons.

Operator Panel screens

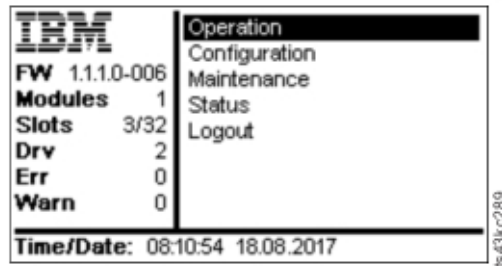

Figure 55. Operator Panel main screen

Operator Panel main screen layout

- Left Pane - Displays the library status (firmware revision, number of modules, number of slots, number of drives, number of errors, number of warnings).
- Center Pane - Provides access to operate, configure, and log out of the library and to view more status information (Operation, Configuration, Maintenance, Status).
- Bottom Pane - Displays more status information (library status, time/date, IPv4, or IPv6 address). The status pane displays one status information for 10 seconds and then switches to the next status item.

Operation	Configuration	Maintenance	Status	Logout
Move Cartridge from Drive to Home Slot Move Cartridge	Initial System Setup Date & Time Network Settings User Accounts Reset	Library Tests View Events Drive Service Logs Download Library Logs Download Drive Firmware Upgrade Library Firmware Upgrade LCD Adjustment	Network Settings Library Drive	Logout

The Operator Panel provides a subset of menu items that are compared to the full capability of the Management GUI. For the operations that are available on the Operator Panel, see “Locating Management functions” on page 65.

Accessing the library with the Operator Panel

The Operator Panel can be accessed in two ways, with a PIN or without one.

1. If the Operator Panel screen saver is on, press **Enter**.
2. If no PIN is configured, press **Enter**.

3. If a PIN is configured, enter the **PIN**, then select **Login** and press **Enter**.

Status icons



Figure 56. Front panel LEDs

LEDs	Color	Descriptions
Ready	Green	Steady when power is on, flashing with tape Ready drive or library robotic activity.
Unit ID	Blue when activated	The unit identification (UID) LEDs are controlled by the user through the Maintenance > UID LED Control screen. The UIDs on the Operator Panel and base module back panel are activated and deactivated together. In addition, UIDs on drives and expansion module back panels can be activated separately. The UIDs are helpful for locating components of the library in a data center.
Clean	Amber	On, when a tape drive-cleaning operation is recommended.
Attention	Amber	Flashing if the library detected a condition for which user attention is necessary, but the library can still complete most operations.
Error	Amber	On, if an unrecoverable tape drive or library error occurs. A corresponding error message is displayed on the LCD screen. User intervention is required as the library is not capable of completing some operations.

Locating Management functions

This table provides the menu navigation to assist with library setup and configuration.

Task	Menu Navigation	
	Operator Panel	Management GUI
Advanced settings	Not available with this interface	Settings > Library > Advanced
Auto Calibration	Not available with this interface	Settings > Library > Auto Calibration
Auto Clean	Not available with this interface	Library > Logical Libraries > Actions > Manage Logical Library (Expert Mode) See “Methods of cleaning drives” on page 72.
Cartridge, eject from a drive	Operation > Move Cartridge from Drive to Home Slot	Drives > Actions > Eject Cartridge from Drive

Table 31. Locating Management functions (continued)

Task	Menu Navigation	
	Operator Panel	Management GUI
Cartridge Inventory, rescan	Not available with this interface	Cartridges > Actions > Inventory Library
Cartridges, list	Not available with this interface	Cartridges
Cartridges, move	Operation > Move Cartridge	Cartridges > Actions > Move Cartridges
Cartridges, graphical view	Not available with this interface	Cartridges > Actions > Graphical View
Certificates, create, backup, restore	Not available with this interface	Settings > Security > GUI
Cleaning, tape drive	Not available with this interface	Drives > Actions > Clean Drive See “Methods of cleaning drives” on page 72.
Configuration, save and restore	Not available with this interface	Settings > Library > Advanced
Configuration, reset	Not available with this interface	Settings > Library > Advanced
Configuration file, restore	Not available with this interface	Settings > Library > Advanced
Configuration file, save	Not available with this interface	Settings > Library > Advanced
Date and time, configure	Configuration > Date & Time	Settings > Library > Date and Time
Diagnostics, run Demo Mode	Maintenance > Library Tests	Library > Actions > Tests
Diagnostics, run Library Verify	Not available with this interface	Library > Actions > Tests
Diagnostics, run Drive test	Maintenance > Library Tests	Library > Actions > Tests
Diagnostics, run Slot to Slot exerciser	Not available with this interface	Library > Actions > Tests
Drive firmware, update	Maintenance > Drive Firmware Upgrade (requires FAT32 format USB drive)	Drive > Actions > Update Drive Firmware
Drives and Modules, reset the list	Not available with this interface	Settings > Library > Advanced
Drive status	Status > Drive	Drives
Drive service logs, download	Maintenance > Drive Service Logs Download (requires FAT32 format USB drive)	Drives > Actions
Drive, modify port settings	Not available with this interface	Drives > Actions
Email Notification	Not available with this interface	Settings > Notifications
Encryption, configure	Not available with this interface	Settings > Security > Encryption See “Configuring Library Managed Encryption” on page 73.
Encryption Connectivity Check	Not available with this interface	Settings > Security > Encryption
Encryption (LME) license key, add or delete	Not available with this interface	Settings > Library > Licensed Features

Table 31. Locating Management functions (continued)

Task	Menu Navigation	
	Operator Panel	Management GUI
Encryption, reset	Not available with this interface	Settings > Security > Encryption
Factory/Manufacturing reset	Configuration > Reset > Full Factory Reset	Settings > Library > Advanced
Identifier light, turn On or Off	Not available with this interface	Library > Actions > Turn Identifier Light On or Off
Initial Setup	Configuration > Initial System Setup	Settings > Library > Initial Configuration Wizard
Inventory List	Not available with this interface	Cartridges
I/O Station, enable or disable	Not available with this interface	Library > Modules and Magazines > Actions > Enable or Disable I/O Station
I/O Station, open	See “Accessing cartridges” on page 73.	Library > Modules and Magazines > Actions > Unlock I/O Station
Kerberos Authentication, configure	Not available with this interface	Settings > Security > Kerberos Authentication
Key Path Diagnostic	Not available with this interface	Settings > Security > Encryption See “Key Path Diagnostics” on page 75.
LCD Adjustment	Maintenance > LCD Adjustment	Not available with this interface
LDAP Authentication, configure	Not available with this interface	Settings > Security > LDAP Authentication
Library firmware, update	Maintenance > Library Firmware Upgrade (requires FAT32 format USB drive)	Library > Actions > Update Library Firmware
Library logs, download	Maintenance > Library Logs Download (requires FAT32 format USB drive)	Library > Actions > Export Library Logs
Library logs, view or clear	Maintenance > View Event Ticket Logs	Library > Events > Actions
Library Information	Status	Library > Actions
Library Managed Encryption, configure	Not available with this interface	Settings > Security > Encryption See “Configuring Library Managed Encryption” on page 73.
Library Verify, run	Maintenance > Library Tests	Library > Actions > Tests > Library Verify
List of Known Drives and Modules, reset	Not available with this interface	Settings > Library > Advanced
Logical Libraries, graphical view	Not available with this interface	Library > Logical Libraries > Actions > Graphical View
Logical Libraries, Manage (Basic Mode)	Not available with this interface	Library > Logical Libraries > Actions > Manage Logical Library (Basic Mode)

Table 31. Locating Management functions (continued)

Task	Menu Navigation	
	Operator Panel	Management GUI
Logical Libraries, Manage (Expert Mode)	Not available with this interface	Library > Logical Libraries > Actions > Manage Logical Library (Expert Mode)
Logical Libraries, Mode configure	Not available with this interface	Library > Logical Libraries > Actions > Manage Logical Library (Basic Mode) or Manage Logical Library (Expert Mode) See “Random and Sequential Logical Library modes” on page 16.
Logical Libraries, Mode status	Not available with this interface	Library > Logical Libraries
Magazines, open	See “Accessing cartridges” on page 73.	Library > Modules and Magazine > Actions > Unlock Magazine
Network settings	Configuration > Network Settings	Settings > Network > Ethernet
Notifications, configure	Not available with this interface	Settings > Notifications
Operator Panel, session lock timeout	Not available with this interface	Settings > Security > GUI
Password Policy	Not available with this interface	Settings > Security > Password Policy
Path Failover license key, add or delete	Not available with this interface	Settings > Library > Licensed Features
Port Settings, modify	Not available with this interface	Drives > Actions > Modify Port Settings
Remote Logging (rsyslog), configure	Not available with this interface	Settings > Notifications > Remote Logging (rsyslog)
Reset, rediscover devices	Not available with this interface	Settings > Library > Advanced
Reset Internal IP Range	Configuration > Reset > Reset Internal IP Range	Not available with this interface
Reset Library	Not available with this interface	Library > Actions > Reset Library
Reset Drive	Not available with this interface	Drives > Actions > Reset Drive
Sequential mode, configure	Not available with this interface	Library > Logical Libraries > Actions > Manage Logical Library (Basic Mode) or Manage Logical Library (Expert Mode) See “Random and Sequential Logical Library modes” on page 16.
SNMP, configure	Not available with this interface	Settings > Notifications > SNMP
SNTP (Simple Network Time Protocol) Synchronization, configure	Not available with this interface	Settings > Library > Date and Time > SNTP (Simple Network Time Protocol) Synchronization
SSL, enable or disable	Not available with this interface	Settings > Security > GUI > Secure Communication

Table 31. Locating Management functions (continued)

Task	Menu Navigation	
	Operator Panel	Management GUI
Session Timeout	Not available with this Interface	Settings > Security > GUI > Session Timeout
Time Zone, set	Not available with this interface	Settings > Library > Date and Time > Time Zone
Unlabeled Media, allow	Not available with this interface	Settings > Library > Advanced
Users, Access recovery	Configuration > User Accounts	Not available with this interface
Users, Modify User Passwords	Not available with this interface	Access > Actions > Modify User Passwords
Users, Modify Role Permissions	Not available with this interface	Access > Actions > Modify Role Permissions
Users, Modify Operator Panel PIN	Configuration > User Accounts	Access > Actions > Modify Operator Panel PIN
Users, Add	Not available with this interface	Access > Add User For information about different roles, see Chapter 4, “Managing,” on page 61.
Users, Remove	Not available with this interface	Access > Actions

Default settings

The library is set to default settings when first purchased. Many of these settings can be customized.

Table 32. Default settings

Parameter	Default	Configuration Reset Default Settings
User Accounts		
Administrator login	User = administrator Management GUI Password = adm001	NOT reset
Local user accounts	Local Default Users = administrator Number of Custom User = 0	x
User Account Settings		
Password rules	Min. number of characters	8
	Min. number of uppercase alphabetic characters	1
	Min. number of lowercase alphabetic characters	1
	Min. number of numeric characters	1
	Min. number of special characters	0
	Max. number of identical consecutive characters	2
	Max. number of failed logins	3
	Max. number of days before PW must be changed	90
	Number of PW changes before it can be used again	3
Management GUI Restricted Login	Disabled	x

Table 32. Default settings (continued)

Parameter	Default	Configuration Reset Default Settings
Allow I/O Station/Magazine access by monitor role	Disabled	x
Session Locking	Disabled	x
Remote Authentication (LDAP) Configuration	Disabled	NOT reset
Network configuration (eth0)		
Host name	Blank	NOT reset
IP address	(dhcp)	NOT reset
Subnet mask	(dhcp)	NOT reset
Default gateway	(dhcp)	NOT reset
Auto Negotiate	Enabled	NOT reset
Speed	Auto	NOT reset
IPv4	Enabled	NOT reset
DHCPv4	Enabled	NOT reset
IPv6		NOT reset
IPv6 Prefix	Enabled	NOT reset
Static v6	Disabled	NOT reset
IPv6 Method	Disabled	NOT reset
DHCPv6	Disabled	NOT reset
DNS1 and DNS2 Configuration for IPv4	(dhcp)	NOT reset
DNS1 and DNS2 Configuration for IPv6	Disabled	NOT reset
Network Access Services		
Primary Network Interface (eth0)	Enabled	NOT reset
Secondary Network Interface (eth1)	Disabled	NOT reset
HTTPS	Disabled	NOT reset
Self Signed SSL Certificate	No file	NOT reset
Internal IP (eth2)		
Internal network IP	IP Range defined with Operator Panel	NOT reset
I/O Station/Magazine		
I/O Station	Enabled	x

Table 32. Default settings (continued)

Parameter	Default	Configuration Reset Default Settings
I/O Station/Magazines Allow Access by monitor role	Disabled	x
Logical Libraries	Disabled	All Logical libraries are deleted
NTP/SNTP Setting	Disabled	NOT reset
Date	Blank or existing	NOT reset
Time	Blank or existing	NOT reset
Time Zone	GMT	NOT reset
Sequential Mode	Disabled	x
Email Notifications (SMTP)	Disabled	x
SNMP		
SNMP v1, v2	Disabled	x
Licensed Features (need license key for enablement)		
Encryption	Disabled	NOT reset
Path Failover	Disabled	NOT reset
SCSI Defaults		
Product Name - Marketing Name	TS4300	x
Library Product ID - INQUIRY Product ID String	3573-TL	x
Library Vendor ID - INQUIRY Vendor ID String	IBM	x
SCSI element addressing	Starting element addresses: Drives = 1 I/E Elements = 101 Storage Slots = 1001	x
Miscellaneous settings		
Barcode format returned to host	Align left	x
Barcode length returned to host	Eight leftmost characters	x
Language settings	English	NOT reset
Auto Clean	Disabled	x
Media Barcode Compatibility Check	Enabled	x

Table 32. Default settings (continued)

Parameter	Default	Configuration Reset Default Settings
Empty Slot/Unlabeled Cartridge Detection	Enabled	x
Management GUI Timeout	30 minutes	x
Drive Defaults		
Drive speed and topology settings	Automatic/Automatic	x
Odometer	Enabled	NOT reset

Methods of cleaning drives

Automatic cleaning of tape drives is disabled by default in the library. However, automatic cleaning of tape drives is recommended for this library. It is also possible to initiate manual or host cleaning methods.

The head of every tape drive in the tape library must be kept clean to prevent errors that are caused by contamination. To help you keep the drives clean, IBM provides a cleaning cartridge with the library. The library uses the cleaning cartridge to clean the drive with whatever cleaning method that you choose. In all methods, cleaning is done after the data cartridge is unloaded from the drive and before the next load.

If you put the cleaning cartridge into a storage slot that is assigned to a logical library, it is visible to any hosts that are associated with that logical library. If you don't want the cleaning cartridge visible to any hosts, put it into a storage slot that is not assigned to any logical libraries.

It is the operator's responsibility to monitor cleaning cartridge usage and replace cleaning cartridges as necessary. This tape library provides multiple ways to monitor and manage cleaning cartridges. If SNMP traps are enabled, a trap is generated when a cleaning cartridge expires. It is also possible to use the Management GUI to monitor the cleaning cycles that remain on a cleaning cartridge.

Three methods of cleaning are available.

Automatic cleaning

Automatic cleaning enables the library to automatically respond to any tape drive's request for cleaning and to begin the cleaning process. The cleaning process is transparent to any host application that uses the library.

Select **Auto Clean** to enable the auto cleaning feature. When enabled, the library automatically initiates a cleaning operation when media is unloaded from a drive that requires cleaning instead of creating a warning event when a drive requires cleaning. For reliable operation, enable Auto Clean for each logical library and ensure that the library has a valid cleaning cartridge.

It is preferred to put the cleaning cartridge into a storage slot that is not assigned to a logical library. If you put the cleaning cartridge into a storage slot that is assigned to a logical library, it is visible to any hosts that are associated with that logical library. If you don't want the cleaning cartridge to be visible to any hosts, put it into a storage slot that is not assigned to any logical libraries.

When a cleaning operation is initiated, the library first attempts to use an unexpired cleaning cartridge from the same logical library as the tape drive. If the logical library does not contain an unexpired cleaning cartridge, the library attempts to use an unexpired cleaning cartridge from a storage slot that is not assigned to a logical library. The library does not use a cleaning cartridge from a different logical library. When auto cleaning is enabled, ensure that each logical library has an unexpired cleaning cartridge. Or, place at least one unexpired cleaning cartridge into a storage slot that is not assigned to a logical library.

After the initial configuration, Auto Clean can be turned on or off by accessing the Logical Library Wizard Expert Mode.

1. Go to **Library > Logical Libraries > Actions > Manage Logical Library (Expert Mode)**.
2. Select the logical library, then click **Edit**.
3. Click **Next** to go to the **General Settings** screen.
4. Check or clear **Auto Clean**, then click **Next** on the subsequent screens.
5. If a change was made, click **Finish** and the Logical Libraries are reconfigured. If no changes were made, click **Cancel**.

Note: IBM recommends enabling the Auto Clean function on the library. With the Auto Clean function enabled, drive cleaning occurs automatically. The only time Auto Cleaning must be disabled is when your backup application requires that it has control.

Manual cleaning

Manual cleaning requires that you select a menu option from the Management GUI to clean one or more of the tape drives. Manual cleaning is always supported.

Host cleaning

Host cleaning enables the backup application to define and control the cleaning process. Automatic and manual cleaning use the CLNxxx VOLSER. It is mandatory to put the cleaning cartridge into a storage slot that is assigned to a logical library. The host needs to "recognize" that the cleaning cartridge is available for use.

Note: For tape cartridge information, see [“Supported tape cartridges” on page 16](#).

Accessing cartridges

Each magazine has a button that provides an easy way to open a magazine.

See [“Front panel” on page 7](#).

Each module can be configured to have a portion of the right magazine that is designated as an I/O station or this option can be disabled.

- To open the I/O station, press the magazine button for less than 3 seconds.
- To open the entire magazine, press the magazine button for more than 3 seconds.

Notes:

1. If a magazine is opened, no other magazines or I/O stations can be opened.
2. If during the magazine open process the magazine is not opened within 30 seconds, the magazine locks.
3. The user must pull out the magazine, as the magazine does not eject.

The LED also provides an indicator of the current state of that magazine.

Magazine state	LED state	Description
Closed	Steady ON	I/O station is enabled.
Closed	Slow Flash	Magazine open is in process.
Closed	Fast Flash	Magazine is opened.
Closed	OFF	I/O station is not enabled.
Opened	OFF	Magazine is opened.

Configuring Library Managed Encryption

Library-Managed Encryption (LME) is a built-in feature that is enabled by using a purchased license.

The LME feature can be ordered from the factory, or you can order it as a field upgrade. To order a feature, contact your IBM Sales Representative or Business Partner. See [Optional Features](#).

Two versions of Library-Managed Encryption are available for configuration.

- [Key Management Interoperability Protocol \(KMIP\) Encryption](#)
- [Security Key Lifecycle Manager \(SKLM\) for z/OS® Encryption](#)

Access the wizard from the **Actions** menu with the **Manage Encryption** option.

Notes: Before you run the Encryption wizard.

- Confirm that the Library-Managed Encryption license is activated on the **Settings > Library > Licensed Features** page.
- Verify that the server is available on the network and is configured for use with this library. For information on configuring servers for use with the library, see the server documentation.

Note: If you plan to use the IBM Security Key Lifecycle Manager (SKLM), go to [“Related Publications” on page xxx](#) for information on setup and configuration.

- If Library Encryption settings are cleared and reconfigured, you're required to accept the new certificate on the server when the Library Self-Signed Certificate is used.

Key Management Interoperability Protocol (KMIP) Encryption

1. In the **Actions** menu, click **Manage KMIP Encryption** to start the wizard.
2. The **Logical Library Selection** screen displays the KMIP configuration options that can be set as the default for all logical libraries, or on a per logical library basis. The second section provides the option to copy the KMIP configuration settings to all logical libraries (default) or to specified logical libraries.
3. The **Wizard Information** screen displays information about the wizard. On this screen, it's also possible to **Reset Encryption Settings**. If the library configuration is complete and the KMIP server is available on the network, click **Next**.
4. The **Certificate Option** screen displays the different certificate options that can be used to establish a secure communication to the KMIP server. You can select from the following options:
 - **Library Self-Signed Certificate** (default option) - A self-signed certificate that is generated by the library is used.
 - **Uploaded Certificate** - Upload a **PKCS #12** file that includes a certificate and corresponding key.
 - **Generate Certificate Request (CSR)** - A CSR is generated by the library that must be signed by a CA server. This method requires a CA certificate that must be provided during the wizard steps.

a. Certification Configuration

- **Library Self-Signed Certificate** – skip to the next step.
- **Uploaded Certificate**
 - 1) Upload the **PKCS #12** file in the certificate area on the **Certificate Option** screen.
 - 2) If this file requires a password, it must be provided in the **Certificate Password** input field. If no password, the field can be left empty.
 - 3) After successfully upload of the certificate, click **Next**.
- **Generate Certificate Request (CSR)**
 - 1) The **Certificate Authority Information** screen displays prerequisites for using the KMIP certificate. When the prerequisites are met, click **Next**.
 - 2) The **Certificate Authority Certificate Entry** screen displays instructions for obtaining the CA certificate for the KMIP server. Follow the instructions to copy the CA certificate from the Management Console. Paste the CA certificate into the wizard and then click **Next**.
 - 3) The **Library Certificate Information** screen displays information about the next wizard steps. Click **Next**.

- b. The **KMIP Client Configuration** screen provides options for two types of server authentication.

- If your KMIP server uses a client username and password for authentication, enter the username and password that were specified on the KMIP Management Console for the library.
- If your KMIP server uses certificate validation for authentication, select **Enable KMIP Certificate only** authentication. Select this option if you use a KMIP server that doesn't support a client username and password. This default method is used when KMIP is used with the IBM Security Key Lifecycle Manager.
 - 1) In the **KMIP Server Configuration** screen, enter the IP address or fully qualified hostname and port number for up to ten KMIP servers. Also, choose which key server type services the encryption keys. You can select from the following options:
 - **IBM SKLM** - IBM Security Lifecycle Manager 2.6.0 or higher KMIP server.
 - **KMIP Compatible** - Key server that is supporting the OASIS standard key management interoperability protocol (KMIP).
 - 2) To verify access to the KMIP servers, click **Connectivity Check**.
 - 3) Check at the KMIP server side that the server accepts the certificate of the library.
 - 4) The **Setup Summary** screen displays the settings that are collected by the wizard. Verify that the settings are correct and that no errors are in the **Done** column.
 - If you need to modify any settings or fix any issues, either click **Back** to reach the applicable screen or **Cancel** to leave the wizard to fix the issues and return later.
 - If the settings are correct and no errors are reported, click **Finish**.

When the wizard finishes, the **Library Managed Encryption (KMIP)** encryption mode is selectable in the **Logical Library Wizard (Expert Mode)** on the **Library > Logical Libraries** page.

Security Key Lifecycle Manager (SKLM) for z/OS Encryption

1. Go to the **Library** menu. Then, go to **Logical Libraries**. Select **Actions**, then select **Manage SKLM for z/OS Encryption**.
2. Enter the IP address and the port of the SKLM z/OS server, then click **Modify**.
3. Go back to **Actions** and select **Manage Logical Library (Expert Mode)**.
4. On the **Expert Logical Library Wizard** screen, click **General Settings**.
5. Next to **Encryption Mode**, choose **Library Managed Encryption (SKLM for z/OS) (Licensed)**.
6. Click **Next**, and then click **Finish Configuration**.
7. A message appears when the Logical Library was successfully enabled for SKLM for z/OS.
8. Go to **Settings > Security > Encryption**. The **Security Encryption Status** and the **Logical Library Encryption Status** shows **Library Managed Encryption (SKLM for z/OS)** as **Enabled**.

Key Path Diagnostics

The Key Path Diagnostic test checks all communication paths to ensure that a key can be transmitted from the encryption key servers to the drive to properly encrypt and decrypt the tape cartridges.

The test consists of two parts. The first part, the **drive** test, verifies whether the communication between library and drive is working properly. This test is run only on the drives that are configured to library-managed encryption (LME).

The second part verifies the communication between the library and the encryption key servers. If the secondary ethernet port is enabled and configured, the tests are run on both ports separately.

The test consists of four subtests:

- **Ping**

This test checks if the key server can be reached. If ICMP requests are blocked on the server side, this test fails as well. Therefore, the following tests are run regardless the result of the ping test.

- **SSL/TLS**

This test tries to establish a SSL/TLS connection with the key server. If this test fails, the following tests are skipped because they would also fail. This test is skipped if SSL/TLS is not enabled.

- **Key Server Login**

This test is run only in combination with a KMIP encryption server since SKLM currently does not support login. If this test fails, the following Key Retrieval test is skipped because it would also fail.

- **Key Retrieval**

This test requests a key from the encryption server. For SKLM servers, a key from the key pool is requested. On other servers, the library acquires a specific diagnostic key.

Chapter 5. Troubleshooting

Use the information in this section to troubleshoot any issues with your library setup and configuration.



Attention: This library is designed to operate when installed in a rack with the rack rail kit or on a tabletop. Operating the library without installing it correctly in the rails might cause errors. Placing any weight on top of the library might also cause errors. Expanded library configurations on tabletops are not supported.

Finding event information

You can find event information by viewing the library log files and downloading support tickets.

You can find event information by viewing log files from the **Library > Events** screen or downloading support tickets from the **Drives > Actions > Export Drive Logs** screen.

See [“Locating Management functions”](#) on page 65.

Identifying a failed component

Follow the procedures to identify a failing component.

1. Management GUI: Activate the UID LEDs from the **Library > Actions > Turn Identifier Light On or Off** screen. This action illuminates the blue LED on the front and rear of the Base Module to identify the library that contains the failed module or component.
2. Identify the module within the library that contains the failed component.
 - a. In the upper left of the **Home** screen, locate the module that indicates an error.
 - b. Click or tap the module for information on the failed component.

Running library tests

The library provides tests to verify library operations.

- On the Management GUI, go to **Library > Actions > Tests** and choose the library test that you want to run.
 - Library Verify
 - Demo Mode
 - Drive Test
 - Slot to Slot Exerciser
- On the Operator Panel, go to **Maintenance > Library Tests** to run tests from the Operator Panel.
 - Demo Mode
 - Drive Diagnostics

Troubleshooting Guide

Refer to this table of symptoms or errors that might occur with the tape library and the installed tape drives.

The table provides actions to correct the problems. If replacement parts are needed, go to [Appendix C, “Replacement parts,”](#) on page 176. See [“Contacting IBM technical support”](#) on page 82.

Table 34. Resolving errors

Problem	Solution
Event code/Attention information on Management GUI or Library	
Event code that is shown on Event Ticket on the Management GUI. See “Finding event information” on page 77.	<ul style="list-style-type: none"> • Look up the error code. See Event Codes. • Try to resolve the failure. • If necessary, power cycle the library.
Failure/Attention Indication on Operator Panel display.	Review tickets on the Check Event Ticket Log on Management GUI.
Attention LED is lit on the front or the rear of the Base Module.	Review tickets on the Check Event Ticket Log on Management GUI.
Failure/Attention Indication on Management GUI Library Dashboard	Tap the icon to see information about the event.
Attention LED and Cleaning LED are lit.	<p>This problem is likely caused by a drive that requires cleaning.</p> <ul style="list-style-type: none"> • Check Event Ticket Log on Management GUI.
Single Character Display (SCD) is shown on drive.	<ol style="list-style-type: none"> 1. Review tickets on the Check Event Ticket Log on Management GUI. 2. Use SCD. See Drive Single Character Display.
The Attention LED is lit but the Cleaning LED isn't lit after a cartridge load.	<p>The library was unable to complete the requested operation with the selected tape cartridge.</p> <ul style="list-style-type: none"> • Use cartridges that are compatible with the drive type. • Use the correct type of cartridges for the operation. For example, use a cleaning cartridge for cleaning. • Make sure that you're using a Universal cleaning cartridge.
The Cleaning LED is lit after a cleaning cartridge was used.	<p>The cleaning cartridge is expired. (A cleaning cartridge expires after 50 cleaning cycles).</p> <ul style="list-style-type: none"> • Replace the cleaning cartridge.
A particular cartridge sets off the Attention LED and possibly the Cleaning LED.	<p>Retry the operation with a different cartridge.</p> <p>If the Attention LED is cleared, and then immediately redisplay each time that a particular cartridge is reloaded, that cartridge must be suspected as defective.</p> <ul style="list-style-type: none"> • Export the cartridge and load a known good cartridge. In some cases, a cartridge can be worn out, the memory is defective, or was formatted as a Firmware Upgrade cartridge. • Any cartridge that is suspected of being defective or contaminated must NOT be reused in any drive. • If the bad cartridge is a cleaning cartridge, it might be expired.
Event Notification on Host, SNMP, or Email	
Host receives error message.	<ul style="list-style-type: none"> • Use ITDT. See “IBM Tape Diagnostic tool (ITDT)” on page 83. • Use Sense Data. See “Sense data” on page 114.

<i>Table 34. Resolving errors (continued)</i>	
Problem	Solution
SNMP Monitoring system receives trap.	Check Event Ticket Log on Management GUI.
Event is received by email notification.	Check Event Ticket Log on Management GUI.
Cartridge Movement Problems	
Tape is stuck in drive.	<p>Try the following steps, in this order, to remove the stuck tape.</p> <p>Note: The tape drive must rewind the tape before it's ejected. This procedure can take up to ten minutes or more, depending on how much tape must be rewound. When the tape is rewound, the eject cycle takes fewer than 16 seconds.</p> <p>The Ready light flashes while the tape rewinds. Wait for the tape to finish rewinding before another operation is attempted.</p> <ol style="list-style-type: none"> 1. Stop all Host Activity. 2. Attempt to unload or move the cartridge to a slot. 3. Power down the library, disconnect the cable from the drive, power on the library, and wait until the tape drive is idle or ready. Attempt to Move Cartridge to Slot. 4. Attempt a Eject Cartridge from Drive as an emergency unload operation. <p>Important: Inspect the tape cartridge that was stuck. Damage or misplaced labels on the cartridge might cause the load/unload failure. Discard any tape cartridge that is found to have issues.</p>
Cartridge can't be removed from storage slot.	<ol style="list-style-type: none"> 1. Unlock the magazine and extend it to access the storage slot. 2. Grasp the cartridge and remove it from the storage slot. Some tapes need to be inserted and removed several times to condition them for free movement in and out of the magazine. 3. Check the bar code label and verify that it's secure to the cartridge. 4. Check the cartridge for damage.
Other Library Problems	
Device doesn't power on.	<ul style="list-style-type: none"> • Check all power cord connections. • Check the LEDs on the power supplies. • Make sure that Power on the front panel was pressed, and the green Ready LED is lit. • Make sure that the outlet has power. Try another working outlet. • Replace the power cord.
No message appears on the Operator Panel display.	<ul style="list-style-type: none"> • Check all power cord connections. • Check the LEDs on the power supplies. • Make sure that Power on the front panel was pressed, and the green Ready LED is lit. • Make sure that the outlet has power. Try another working outlet.

Table 34. Resolving errors (continued)

Problem	Solution
Can't load the cleaning cartridge.	<ul style="list-style-type: none"> • Make sure that you're using an LTO cleaning cartridge. • Make sure that the cleaning cartridge isn't expired. A cleaning cartridge expires after 50 cleaning cycles.
User account locked.	From the Configuration > User Accounts > Access Recovery page, you can receive a temporary administrator password for login to the Management GUI that is valid for two hours.
Tape Drive or Media Problems	
Can't write to or read from tape.	<ul style="list-style-type: none"> • Make sure that the cartridge isn't a WORM cartridge that was already used. • Make sure that the cartridge is write enabled (move the write-protect switch to the enabled position). • Make sure that the data cartridge is compatible with the drive model. See "Supported tape cartridges" on page 16. • Make sure that you're using an LTO cartridge that isn't degaussed. <p> CAUTION: Don't degauss LTO cartridges!</p> <ul style="list-style-type: none"> • Make sure that the cartridge wasn't exposed to harsh environmental or electrical conditions and isn't physically damaged in any way. • Many backup applications don't read or write to cartridges that were created with a different backup application. In this case, you might need to run an erase, format, or label operation on the cartridge. • Make sure that you understand any data protection or overwrite protection schemes that your backup application might be using, which might prevent you from writing to a specific cartridge. • Retry the operation with a different, known good tape. • Clean the tape drive.
A cartridge that is recently imported from a different environment is causing issues.	Media that is moved from one environment to another can cause issues until it acclimates to the new conditions. A cartridge must be acclimated for at least 24 hours before it's used, particularly if it was stored at a substantially different temperature or level of humidity than the device.
The library displays incorrect bar codes.	<ul style="list-style-type: none"> • Verify that the label is properly applied. • Verify that the label isn't soiled.
Cleaning or data cartridge incompatible with drive.	<ul style="list-style-type: none"> • Check the event log to see which cartridge is incompatible. • Make sure that you're using data and cleaning cartridges that are compatible with the drive and model of your device. • Make sure that you're using the correct cartridge type for the operation. The device automatically unloads incompatible cartridges, and the Attention LED flashes. • Export the media.
Connection Problems	

Table 34. Resolving errors (continued)

Problem	Solution
Fibre Channel connection problems	<p>Check Drive Status screen to check the link connection for your tape drive.</p> <ul style="list-style-type: none"> • For each available port, run a drive Wrap Test. <ol style="list-style-type: none"> 1. Unplug the Fibre Channel cable, then plug in the Fibre Channel wrap tool. 2. Go to Library > Actions > Tests > Drive test and run the Fibre Channel wrap test. 3. If the drive test fails, follow the “Pre-call checklist” on page 82. 4. If the FC Wrap Test passes, continue with the next steps. • Check that the Fibre Channel speed is set to either match the HBA/switch speed or set to Automatic • Verify that cables aren’t damaged. • Verify that cables are securely connected on both ends. • Verify Host Connectivity. • Use ITDT to debug the problem.
SAS connection problems	<p>Check Drive Status screen to check the connection for your tape drive.</p> <ul style="list-style-type: none"> • For each available port, run a drive Wrap Test. <ol style="list-style-type: none"> 1. Unplug the SAS cable, then plug in the SAS wrap tool. 2. Go to Library > Actions > Tests > Drive test and run the SAS wrap test. 3. If the drive test fails, follow the “Pre-call checklist” on page 82. 4. If the SAS Wrap Test passes, continue with the next steps. • Verify that cables aren’t damaged. • Verify that cables are securely connected on both ends. • Verify Host Connectivity. • Use ITDT to debug the problem.
Can’t connect to the Management GUI.	<ul style="list-style-type: none"> • Verify that the Ethernet cable is connected to the Base Module’s controller card and to the LAN. • Verify that the link LED on the RJ45 (LAN) connector is lit when the device is turned on. If the LED isn’t lit, the device isn’t communicating with the LAN. See your network administrator for help. • Verify that the device is configured with a valid static network address or DHCP is enabled so the device can obtain a network address. If DHCP is used, write down the device's network address from the Operator Panel login screen. If a valid DHCP address isn’t available, the library isn’t communicating with the DHCP server. See your network administrator for help. • Enter the library’s IP address into the address bar of a web browser that is connected to the same LAN as the device. If the Management GUI page doesn’t display, ping the device's IP address. If the ping fails, check that no firewalls or other obstructions to network traffic exist between the computer with the web browser and the device. See your network administrator for help.

Table 34. Resolving errors (continued)

Problem	Solution
Can't connect to Key Management Server for LME.	<ul style="list-style-type: none"> • Run the Encryption Connectivity Check or Key Path Diagnostics and review the results message. See “Locating Management functions” on page 65. • Validate that the server configuration properties file includes support for TLS 1.2. See the encryption server documentation. • If SKLM v2.7 or higher is used and you're using the Library Self-Signed Certificate. For one time only, you might need to reset your encryption settings to clear out old versions of the self-signed certificate, reconfigure encryption, then accept the new self-signed certificate on the encryption server. See “Configuring Library Managed Encryption” on page 73. • Check that your certificate algorithm is supported by your version of the server.

Pre-call checklist

If you have questions or problems with the library, complete these steps before a call to IBM technical support is placed.

Note: Where instructions refer you to the web, go to <http://www.ibm.com/storage/support/lto>.

1. Verify that you exhausted all troubleshooting options. See [“Troubleshooting Guide”](#) on page 77.
2. Collect library and drive logs. See [“Locating Management functions”](#) on page 65.
3. Verify that the library and drive firmware is at the most recent level. See [“Locating Management functions”](#) on page 65.
4. Verify that your device drivers are at the most recent level.
 - For the current release of IBM device drivers, see [Supported Device Drivers](#).
 - For the current release of device drivers by independent software vendors (ISVs), go to the appropriate third-party website.
5. Verify whether your hardware and software configuration is supported. See [“Host connectivity”](#) on page 20.
6. Check the hardware and connections:
 - Ensure that the host interface cable connector does not contain bent or recessed pins.
 - Ensure that all retention screws for the host interface cable and terminator are securely tightened.
 - Verify the host connection. See [“Verifying the host connection”](#) on page 60.

If you still have a problem after these steps are completed, see [“Contacting IBM technical support”](#) on page 82.

Contacting IBM technical support

Follow the procedures to contact IBM technical support.

Important: This tape library is a customer installed unit. The customer is responsible for the setup and maintenance of the tape library. The customer is charged for service if a service contract is not in place.

- Complete the steps in [Pre-call checklist](#) before a call is placed to IBM technical support.
- Before IBM technical support is called, the customer is responsible for following published LTO diagnostic procedures, including any needed update to the current level of firmware.
- The IBM Support Center assists with problem determination and can initiate shipment of a replacement part, if needed, to the customer's location. Transportation costs, both ways, are paid by IBM. The

replacement part becomes the property of the customer in exchange for the failed part, which becomes the property of IBM. The customer is responsible for packing the failed part into the shipping carton that contained the replacement part. Failure to return the failed part to IBM within 30 days results in a bill sent to the customer for the new list price. The customer is responsible for installing and setting up all replacement parts.

- Failure to use the carton in which the replacement part was received, or failure to properly pack the returned part, can result in charges that are incurred for damage to the failed part during shipment.
- Before you call technical support, follow these steps that help you take full advantage of your call.
 1. Be prepared to provide
 - Machine type and Model name
 - Serial number of the library
 - Hardware configuration, including firmware versions, drive types, modules
 - Type of host, operating system version, device driver information, software application, and version, clock speed, RAM, network type, network version
 - A brief description of the problem, including **Event Ticket** information. See [“Finding event information”](#) on page 77.
 2. Review all documentation carefully. (Experience demonstrates that most questions are answered in your documentation).
 3. Be prepared to explain whether the software or hardware worked properly anytime in the past. Have you changed anything recently?
 4. Pinpoint the exact location of your problem, if possible. Note the steps that led to the problem. Can you duplicate the problem or is it a one-time occurrence?
 5. Note any host error messages displayed. Write down the exact error message.
 6. If possible, call while at your computer, with the library installed and turned on.
- The IBM Support Center assists with problem determination and initiates shipment of a replacement part, if needed, to your location. To contact IBM technical support:
 - In the US: 1-800-IBM_SERV (1-800-426-7378).
 - All other Countries or Regions: <http://www.ibm.com/planetwide/>.
 - Select your country, then under **Technical Support**, click **Open Service Request**.

Diagnostic information

This section provides various diagnostic tools and information.

IBM Tape Diagnostic tool (ITDT)

ITDT has multiple functional capabilities and is a quick, convenient, and efficient method for drive firmware updates. As a note, drive memory dump retrievals are completed by the tool as well.

The IBM Tape Diagnostic tool (ITDT):

- Runs quick or extended diagnostic tests on tape drives. If the library is online to the server/host where the tool resides, ITDT communicates with the drive through the library to load and unload a test cartridge, exercising some library functions.
- Retrieves firmware memory dumps from tape drives and libraries.
- Completes a firmware update on tape drives or libraries. See note about library firmware update.
- Tests the performance of the environment by completely writing a cartridge and measuring performance.
- Retrieves and displays cartridge information.
- Verifies the encryption environment.

- Does not require special device drivers.
- Is available for most major platforms.
- Scans the host interface and finds and displays for selection all IBM LTO devices. The tool does not display non-IBM devices.

The IBM Tape Diagnostic tool (ITDT) is available as a command line utility and a graphical user interface (GUI) version.

- The **IBM Tape Diagnostic Tool (ITDT)** is started by entering the executable file from the directory where the tool is located. The Help feature gives a brief explanation of each function and shows the syntax.

Note: Be sure that you have the most current version of ITDT if you are updating firmware on a recent drive type. Before ITDT is used, verify that your library host operating system is at the current released level. This action ensures optimum read/write operations for diagnostic tests.

IBM maintains the current levels of ITDT on the web. Go to <http://www.ibm.com/support/fixcentral> and follow these steps to access this material.

1. From the **Fix Central** web page, choose the **Select Product** tab, select **System Storage** from the **Product Group** list.
2. Select **Tape Systems** from the **System Storage** list.
3. Select **Tape drivers and software** from the **Tape systems** list.
4. Select **IBM Tape Diagnostic Tool ITDT** from the **Tape drivers and software** list.
5. Select the appropriate operating system from the **Platform** list and click **Continue**.
6. Select the appropriate version from the list.

Additional information about the IBM Tape Diagnostic Tool (ITDT) is included in the *IBM® Tape Device Drivers Installation and User's Guide*, and can be found on the web at <http://www-01.ibm.com/support/docview.wss?rs=577&uid=ssg1S7002972>.

Event codes

Events are used in the library Ticket and Event system to store all types of events with a unique event code and event description.

Event Reporting System

These event codes are shown on the user interfaces as the resulting code for any type of event at the highest level of information. No internal error code is shown at this level.

Events are sent by the library to different recipients like SNMP targets or email notification. These events have a common structure and unique codes for every type of event.

The event code system is used for the following events:

- Error event (2XXX)
- Warning event (4XXX)
- Configuration event (8XXX)
- Informational event (9XXX)

Event code structure

Example event code

```
Event: 2057 - Robotics shipping lock in incorrect position
```

The event log with the library also includes a date and time stamp for each event. Press the associated time stamp to see the event code and a description of the event. The date and time format can be changed in the **Date/Time Format** section in the Management GUI.

- mm.dd.yyyy
- dd.mm.yyyy
- yyyy.mm.dd

The time format can be set for 12 hours or 24 hours.

- 12 hour: hh.mm.ss am/pm
- 24 hour: hh.mm.ss

Where

- yyyy is the year.
- mm is the month.
- dd is the current day.
- hh is hours.
- mm is minutes.
- ss is seconds.

Resolving an error code

1. Record the error information that is displayed on the Operator Panel display or Management GUI screen.
2. If possible, cycle library power and retry the operation.
 - If the error does not recur, run **Library Verify** before normal library operation is continued.
3. If the error recurs, click the event to see its details. If available, click **Troubleshooting** on the **Event Ticket Details** screen to get suggestions on how to fix the error. Click **OK** to close the **Event Ticket Details** screen.
4. When the proposed solution is applied, run **Library Verify** before normal library operation is continued.

Complete the steps in “Resolving an error code” on page 85 before you complete the User Action that is listed in the various **Event Codes**.

Main error events

<i>Table 35. Main error events</i>		
Event Code	Message Text and Description	Details and Solution
2000	Move Cartridge failed.	Verify the source and destination elements and retry the move operation.
2002	The initial module discovery (detection of expansion modules) failed.	Ensure that all modules are powered and have the interconnection cables properly attached. Also, ensure that the module alignment locks (at the rear of module) are in the correct positions.
2003	The library’s temperature exceeded the critical temperature threshold.	Check to ensure that <ol style="list-style-type: none"> 1. The drive cover plates are installed where no drive exists. 2. All power supplies are installed. 3. The ambient room temperature is within limits.

Table 35. Main error events (continued)

Event Code	Message Text and Description	Details and Solution
2004	The Library Startup process failed.	<ul style="list-style-type: none"> • Verify that magazines are closed, cartridges are fully seated, and that no accessor obstructions exist. • Verify that all modules are powered and any expansion modules are cabled correctly with the interconnect cable. • Verify that a top and bottom cover is properly installed on the library. • Verify that the module alignment locks (at rear of module) are in the proper position. • If the accessor moves front to back, but not vertically, the accessor shipping lock might be positioned incorrectly and must be moved to either the fully locked or fully unlocked position. • If the error persists, review library events for information or restart the library.
2005	Cable to accessor is broken.	Ensure that the spooling cable is fully seated in the base module and connected correctly to the accessor assembly.
2009	Library test failed due to accessor problem.	<ul style="list-style-type: none"> • Review test requirements and retry the test. • If the test continues to fail, check for accessor obstructions or other accessor problems. • For proper operation, the accessor must be able to reach the bottom of the library. Verify that no obstructions are at the bottom of the library or on the bottom cover of the library in the path of the accessor. <ol style="list-style-type: none"> 1. To check for obstructions at the bottom of the library, first power off the library by pressing Power for 5 seconds and select the Default Park location. 2. When the library is powered off, remove the left magazine of the lowest library module, and verify that the entire area of the bottom cover is free of any objects that might obstruct the accessor's path. 3. After any obstructions are cleared, replace the magazine, power the library on, and after the library finishes initialization and inventory, verify that no further critical events were generated.
2010	Library test failed due to spooling mechanism defect.	Ensure that the spooling mechanism is fully seated in the base module and installed correctly to the accessor assembly.
2012	Multiple bottom covers detected.	Remove all bottom covers except for the bottom module in the library.
2013	Multiple top covers detected.	Remove all top covers except for the top module in the library.
2014	Bottom cover is missing.	Install the bottom cover on the bottom module of the library, also check the module interconnect cabling and module power cabling. If the base module can't detect both a top and bottom cover, the accessor doesn't move.

Table 35. Main error events (continued)

Event Code	Message Text and Description	Details and Solution
2015	Top cover is missing.	Install the top cover on the top module of the library. Also, check the module interconnect cabling and module power cabling. If the base module can't detect both a top and bottom cover, the accessor doesn't move.
2016	Unit to unit not locked.	Ensure that the alignment mechanism is engaged in every module that is above another module in the library.
2017	Communication errors during stack discover process.	<ul style="list-style-type: none"> • Ensure that all modules are powered and have the interconnect cable properly attached. • Ensure that the module alignment locks (at the rear of module) are in the correct positions.
2021	Database access error.	Restore a configuration backup and run a power cycle.
2022	Drive was hot-removed.	Reinsert the removed drive at the same position as it was removed.
2023	Internal Software error.	Check for a new system Software version for upgrade.
2024	Unhandled Exception	Check for a new system Software version for upgrade.
2027	Move failed pulling cartridge from slot.	<ul style="list-style-type: none"> • Check for labels or cartridge misalignments that can prevent the cartridge from coming out of the slot or drive. • For proper operation, the accessor must be able to reach the bottom of the library. Verify that no obstructions exist at the bottom of the library or on the bottom cover of the library in the path of the accessor. <ol style="list-style-type: none"> 1. To check for obstructions at the bottom of the library, first power off the library by pressing Power for 5 seconds and select the Default Park location. 2. When the library is powered off, remove the left magazine of the lowest library module, and verify that the entire area of the bottom cover is free of any objects that might obstruct the accessor's path. 3. After obstructions are cleared, replace the magazine, power the library on, and after the library finishes initialization and inventory, verify that no further critical events were generated.

Table 35. Main error events (continued)

Event Code	Message Text and Description	Details and Solution
2028	Move failed inserting cartridge to slot.	<ul style="list-style-type: none"> • Check for labels or cartridge misalignments that can prevent the cartridge from coming out of the slot or drive. • For proper operation, the accessor must be able to reach the bottom of the library. Verify that no obstructions exist at the bottom of the library or on the bottom cover of the library in the path of the accessor. <ol style="list-style-type: none"> 1. To check for obstructions at the bottom of the library, first power off the library by pressing Power for 5 seconds and select the Default Park location. 2. When the library is powered off, remove the left magazine of the lowest library module, and verify that the entire area of the bottom cover is free of any objects that might obstruct the accessor's path. 3. After obstructions are cleared, replace the magazine, power the library on, and after the library finishes initialization and inventory, verify that no further critical events were generated.
2029	Initialization failure due to accessor front to back positioning error.	<ol style="list-style-type: none"> 1. Check for obstructions in the pathway of the accessor such as a cartridge that is sticking out. 2. Verify the module alignment and frame alignment. Check whether the accessor is stuck in lock mechanism. 3. Move the accessor apart from lock mechanism and enable lock mechanism correctly.
2032	Initialization failure due to accessor rotation positioning error.	Check for obstructions in the vertical pathway of the accessor, such as a cartridge that is sitting in the shuttle of the accessor or any other impedance to accessor movement.
2033	Initialization failure due to accessor vertical positioning error.	<ul style="list-style-type: none"> • Check for obstructions in the vertical pathway of the accessor such as a cartridge that is sticking out. • For proper operation, the accessor must be able to reach the bottom of the library. Verify that no obstructions exist at the bottom of the library or on the bottom cover of the library in the path of the accessor. <ol style="list-style-type: none"> 1. To check for obstructions at the bottom of the library, first power off the library by pressing Power for 5 seconds and select the Default Park location. 2. When the library is powered off, remove the left magazine of the lowest library module, and verify that the entire area of the bottom cover is free of any objects that might obstruct the accessor's path. 3. After obstructions are cleared, replace the magazine, power the library on, and after the library finishes initialization and inventory, verify that no further critical events were generated.
2034	Cable to spooling mechanism is broken during initialization.	Ensure that the spooling mechanism is fully seated in the base module and connected correctly to the accessor.

Table 35. Main error events (continued)

Event Code	Message Text and Description	Details and Solution
2035	Initialization failure due to accessor gripper positioning error.	Check for obstructions in the vertical pathway of the accessor, such as a cartridge that is sitting in the shuttle of the accessor or any other impedance to accessor movement.
2036	Unintended process termination.	Restart or power cycle system.
2037	Accessor firmware version upgrade failed.	Restart or power cycle system.
2038	Lost connection to Module.	<ul style="list-style-type: none"> • Ensure that all modules are powered and have the interconnect cable properly attached. • Restart or power cycle the system.
2039	Cartridge was left in accessor gripper, unable to be moved to any open location.	<ul style="list-style-type: none"> • Enable I/O station and ensure that empty slots are available in the I/O station. • Power-cycle the library. • If still failing, open covers and remove the cartridge manually from gripper.
2040	Library Verify test failed with critical error.	An unidentified failure occurred. Contact your IBM service representative.
2041	Library Verify test failed because of unit lock failed.	Ensure that the alignment mechanism is engaged in every module that is above another module in the library.
2042	Library Verify test failed because top cover is missing.	<ul style="list-style-type: none"> • Install the top cover on the top module of the library. • Check the module interconnect cabling and module power cabling. • If the base module can't detect both a top and bottom cover, the accessor doesn't move.
2043	Library Verify test failed because bottom cover is missing.	<ul style="list-style-type: none"> • Install the bottom cover on the bottom module of the library. • Check the module interconnect cabling and module power cabling. • If the base module can't detect both a top and bottom cover, the accessor doesn't move.

Table 35. Main error events (continued)

Event Code	Message Text and Description	Details and Solution
2045	Library Verify test failed because move media test failed.	<p>The minimum requirements for the Library Verify are at least one unloaded drive and one data cartridge that is compatible with that unloaded drive that is installed in the library. If no drives are unloaded or no compatible media is found, the test fails and an error event is generated.</p> <ul style="list-style-type: none"> • To view event details from Management GUI, click the event, and then view all of the event details to see what elements were involved in the move failure. • Check for obstructions in the pathway of the accessor such as a cartridge that is sticking out. • Verify module alignment and frame alignment. • Check if accessor is stuck in lock mechanism, move the accessor apart from lock mechanism and enable lock mechanism correctly.
2046	Library Verify test failed because drive communication test failed.	<ul style="list-style-type: none"> • Remove and reseat the drive canister to ensure that the drive is fully seated. • If the issue persists, reset the drive. • Use the library Management GUI to pull a drive support ticket and check the device analysis section for help (HPE Library and Tape Tools must be installed to view support ticket).
2047	Library Verify test failed because the bar code scanning test failed.	<ul style="list-style-type: none"> • Verify that no obstruction is in front of the bar code scanning module on the cartridge table on the accessor. • If the error persists replace the accessor. • For proper operation, the accessor must be able to reach the bottom of the library. Verify that no obstructions are at the bottom of the library or on the bottom cover of the library in the path of the accessor. <ol style="list-style-type: none"> 1. To check for obstructions at the bottom of the library, first power off the library by pressing Power for 5 seconds and select the Default Park location. 2. When the library is powered off, remove the left magazine of the lowest library module, and verify that the entire area of the bottom cover is free of any objects that might obstruct the accessor's path. 3. After obstructions are cleared, replace the magazine, power the library on, and after the library finishes initialization and inventory, verify that no further critical events were generated.
2052	An open magazine was detected in one or more modules.	Ensure that all magazines are inserted and properly locked. Don't open magazines by using the emergency release while the library is operating and the accessor is moving.
2053	An open top cover was detected.	Ensure that the top cover is inserted and properly locked. Don't open top cover by using the emergency release while the library is operating and the accessor is moving.

Table 35. Main error events (continued)

Event Code	Message Text and Description	Details and Solution
2054	An open bottom cover was detected.	Ensure that the bottom cover is inserted and properly locked. Don't open bottom cover by using the emergency release while the library is operating and the accessor is moving.
2055	An open unit lock was detected.	Ensure that all unit locks are properly locked. Don't open unit locks by using the emergency release while the library is operating and the accessor is moving.
2056	Initialization failure due to picker push pull positioning error.	Check for obstructions in the horizontal pathway of the accessor such as a cartridge that is sticking out or a cable that is impeding progress.
2057	Startup failure due to shipping lock in incorrect position.	<ol style="list-style-type: none"> 1. Get access to the picker assembly and manually move the shipping lock lever to either locked or unlocked position. 2. After the shipping lock is moved to the one of the correct positions, restart the library.
2061	Move failed pulling cartridge from drive.	Check for labels or cartridge misalignments that would prevent the cartridge from coming out of the drive.
2062	Move failed inserting cartridge to drive.	Check for labels or cartridge misalignments that would prevent the cartridge from moving into the drive.
2063	Move failed positioning picker in front of drive.	Check for obstructions in the vertical or horizontal pathway of the accessor. Examples might include a cartridge that isn't seated completely in a slot, an accessor isn't sitting horizontally level, or a problem with the accessor spooling cable that is impeding progress.
2064	Library test failed with critical error.	An unidentified failure occurred. Contact your IBM service representative.
2065	Library startup process failed because of accessor initialization issue.	<ul style="list-style-type: none"> • Verify that magazines are closed, cartridges are fully seated, and that no accessor obstructions exist. • Verify that all modules are powered and any expansion modules are cabled correctly with the interconnect cable. • Verify that a top and bottom cover is properly installed on the library. • Verify that the module alignment locks (at rear of module) are in the proper position. • If the accessor moves front to back, but not vertically, the accessor shipping lock might be positioned incorrectly and must be moved to either the fully locked or fully unlocked position. • If the error persists, review library events for information or restart the library.

Table 35. Main error events (continued)

Event Code	Message Text and Description	Details and Solution
2066	Library startup process failed during inventory scan.	<ul style="list-style-type: none"> • Verify that magazines are closed, cartridges are fully seated, and that no accessor obstructions exist. • Verify that all modules are powered and any expansion modules are cabled correctly with the interconnect cable. • Verify that a top and bottom cover is properly installed on the library. • Verify that the module alignment locks (at rear of module) are in the proper position. • If the accessor moves front to back, but not vertically, the accessor shipping lock might be positioned incorrectly and must be moved to either the fully locked or fully unlocked position. • If the error persists, review library events for information or restart the library.
2067	For safety reason, the accessor movement was halted in place.	<ul style="list-style-type: none"> • Ensure that all magazines, top or bottom covers and unit locks are inserted and properly locked. • Don't open magazines by using the emergency release or remove covers or unit locks while the library is operating and the accessor is moving. • Ensure that all modules are powered and have the interconnect cable properly attached.
2068	An emergency stop condition was detected in one or more modules and prevented the accessor from initialization.	<ul style="list-style-type: none"> • Ensure that all magazines, top or bottom covers and unit locks are inserted and properly locked. • Insert all open magazines and install all necessary covers and unit locks before the library is powered on. • Ensure that all modules are powered and have the interconnect cable properly attached.
2069	Initialization failure due to bar code reader error.	Restart the library and if the error persists, replace the accessor assembly.

Table 35. Main error events (continued)

Event Code	Message Text and Description	Details and Solution
2070	Inventory scan failed because of Elevator axis problem.	<ul style="list-style-type: none"> • Check for obstructions in the vertical pathway of the accessor such as a cartridge that is sticking out. • Verify module alignment and frame alignment. • For proper operation, the accessor must be able to reach the bottom of the library. Verify that no obstructions are at the bottom of the library or on the bottom cover of the library in the path of the accessor. <ol style="list-style-type: none"> 1. To check for obstructions at the bottom of the library, first power off the library by pressing Power for 5 seconds and select the Default Park location. 2. When the library is powered off, remove the left magazine of the lowest library module, and verify that the entire area of the bottom cover is free of any objects that might obstruct the accessor's path. 3. After obstructions are cleared, replace the magazine, power the library on, and after the library finishes initialization and inventory, verify that no further critical events were generated.
2071	Cartridge on picker when trying to scan.	<ul style="list-style-type: none"> • Verify that no obstruction is in front of the bar code scanning module on the cartridge table that is on the accessor. • If the error persists, replace the accessor.
2072	Bottom cover was detected at an incorrect position.	Review the stack assembly and place the covers to the proper position.
2073	Top cover was detected at an incorrect position.	Review the stack assembly and place the covers to the proper position.
2074	The library startup failed due to a GPIO error.	Restart or power cycle system.
2075	The library startup failed due to an error when trying to open the accessor serial port.	Restart or power cycle system.
2076	I2C bus signals invalid.	<ul style="list-style-type: none"> • Remove all drive canisters of the affected chassis and restart the library. • If the problem persists, replace the chassis. If not, add one drive after the other until the problem comes back. • Replace the last drive that was added before it failed again.
2077	Failed to store Calibration Data to Chassis.	Restart or power cycle system. Note: This is a singular ticket and must be resolved manually.
2079	Couldn't upgrade bar code reader firmware.	Restart the library and if the error persists, replace the accessor.
2080	Cartridge lost while inserting it into slot/drive.	Check the source/destination element and ensure that no obstructions are in the pathway of the accessor.

Table 35. Main error events (continued)

Event Code	Message Text and Description	Details and Solution
2087	Error accessing the backplane flash memory.	<ul style="list-style-type: none"> • Restart the library and if the error persists, replace the chassis. • Before the chassis is replaced, ensure that you remove all of your tape cartridges. • If magazines need to be removed to get access to the tape cartridges, first power down the device and then manually release each magazine. Only one magazine must be opened at a time.
2089	Incompatible Robotics Assembly Detected	An incompatible robotics assembly is detected. The robotics assembly was not powered on to avoid damage to the library. Power off the library and replace the robotics assembly with a compatible version.
2092	Locking the accessor assembly failed during Power Down process	Power up the library. In case of accessor failure, error events are reported at power-up. Look for the proposed solution for these new errors. If no new errors are reported, the 2092 event can be ignored.
2093	Communication to accessor controller couldn't be established.	Restart the library and if the error persists, replace the accessor assembly.
2094	An emergency stop condition was detected in one or more modules and prevented the accessor from running the inventory scan.	<ul style="list-style-type: none"> • Ensure that all magazines, top or bottom covers and unit locks are inserted and properly locked. • Insert all open magazines and install all necessary covers and unit locks before powering on the library. • Ensure that all modules are powered and have the interconnect cable properly attached.
2095	Inventory scan failed because of accessor positioning problem.	Check for obstructions in the horizontal pathway of the accessor such as a cartridge that is sticking out or lying on the accessor table.
2096	Initializing a communication interface on the library controller failed.	Restart the library, and if the error persists, replace the library controller.
2097	Accessor reinitialization failed.	Restart the library and if the error persists, replace the accessor assembly.
2100	Robotic move to requested position failed.	<ul style="list-style-type: none"> • Check for obstructions in the pathway of the accessor such as a cartridge that is sticking out. • Verify module alignment and frame alignment. • Check if the accessor is stuck in the lock mechanism. Move the accessor away from the lock mechanism and enable the lock mechanism correctly.
2103	Incorrect stack assembly, too many expansion modules below main library.	Ensure that no more than three expansion modules are mounted and connected below or above main library.

Table 35. Main error events (continued)

Event Code	Message Text and Description	Details and Solution
2104	Incorrect stack assembly, too many expansion modules above main library.	Ensure that no more than three expansion modules are mounted and connected below or above main library.

Warning error events

An appropriate message is posted on the Operator Control Panel and the Management GUI.

Table 36. Warning events

Event Code	Message Text and Description	Details and Solution
4000	Drive Sled Fan Speed too low.	Ensure that no obstructions are in the fan.
4002	Drive clean request.	Clean the drive with an approved cleaning cartridge.
4003	The drive configuration failed.	Remove and reseat the drive canister and retry the operation.
4004	The drive status request failed.	Remove and reseat the drive canister to ensure that the drive is fully seated. If the issue persists, reset the drive.
4005	Drive is reporting a critical TapeAlert.	Power-cycle the drive, and verify whether the drive reports the same TapeAlert.
4006	A drive reported temperature is above the threshold.	<ul style="list-style-type: none"> • Verify that the drive fan is spinning, isn't obstructed, and that the ambient temperature is within specification. • Ensure that drive bay cover plates are in place in each location where no drive is installed. The drive cover plates are required for proper airflow.
4008	Cleaning tape expired.	Discard the cleaning cartridge and retry the cleaning operation with a new cleaning cartridge.
4009	Firmware upgrade of one or multiple expansion modules failed.	<p>The Base Module must be able to communicate with a powered on and connected expansion module to complete the upgrade.</p> <ul style="list-style-type: none"> • Reseat the expansion controller and check the interconnect cable and power connections. • Retry the firmware upgrade.
4010	Incompatible drive.	Remove the incompatible drive. Install only drives that are supported by the library.

Table 36. Warning events (continued)

Event Code	Message Text and Description	Details and Solution
4012	Move Cartridge failed due to cartridge issue.	<ul style="list-style-type: none"> • View the event details to determine which cartridge was involved. • Verify surrounding events that might point to problems with this media in other move operations. • Remove the media from the library, and physically inspect the media to ensure that no physical damage exists. • If the media appears to be undamaged, put the media back into the library and retry the move operation. If the problem persists, retry the operation with a different cartridge in the same drive. • If the problem follows the media, remove the media from use. • If the problem follows the drive, use the library Management GUI to pull a drive support ticket and check the device analysis section for help.
4014	Library test failed due to a Drive issue.	<ul style="list-style-type: none"> • Verify the test parameters, and retry the test. • If the test fails, check the library event log for specific events that are associated with this drive. • Use the Management GUI to pull a drive support ticket and check the device analysis section for help.
4015	Power supply failed. Redundancy isn't available.	Ensure that all power supplies are installed properly (two per module), and that each power supply is connected to a valid power source.
4016	Back up configuration data to base module failed.	Attempt to save the library configuration, power cycle the library, and retry the operation.
4017	Restore configuration data from Chassis failed.	Attempt to save the library configuration, power cycle the library, and retry the operation.
4019	Drive Firmware bundle upgrade failed.	<ol style="list-style-type: none"> 1. Verify that the firmware file is correct for the drives. 2. Ensure that the drives are in a healthy state with no cartridge in the drive. 3. Retry the operation.
4020	Database was reset due to a problem that prevented the library from powering up.	<ul style="list-style-type: none"> • If the library was restored to default settings, restore a saved configuration by using a previously saved config file. • If no config file exists, then proceed in configuring the library.

Table 36. Warning events (continued)

Event Code	Message Text and Description	Details and Solution
4021	Drive was hot-removed while in active status as data transfer device.	<ul style="list-style-type: none"> Put the drive back into the library. Follow the “Removing a tape drive” on page 121 procedure to remove the tape drive.
4025	Library test failed due to a cartridge error.	Remove the cartridge and inspect it for damage. Retry operation with another cartridge.
4028	Library Test failed due to incompatible cartridge.	Check LTO generation for cartridge and drives. Remove cartridges that aren’t compatible to your tape drives.
4029	Library Test failed - Cartridge bar code indicates incompatibility with drive.	Check if Media bar code label is matching LTO generation. Replace the label or remove incompatible media from your system.
4030	Move cartridge operation failed due to cartridge error.	Remove the cartridge and inspect it for damage. Retry operation with another cartridge.
4041	Library Verify failed because the power supply redundancy test failed.	Ensure that all power supplies are installed properly (two per module), and that each power supply is connected to a valid power source.
4044	One of the Library tests failed because a source element or destination element isn’t accessible.	Verify the source and destination elements and retry the move operation.
4060	Connection to the KMIP server failed.	<ul style="list-style-type: none"> Verify the user name and password and all needed SSL certificates that are needed for connecting to the KMIP server. Verify that the KMIP server is reachable within the network. Verify the IP addresses and host names of the KMIP servers that are entered into the wizard. <p>If this error happens during the connectivity check, the additional information parameter includes further error information received from the Cryptsoft KMIP library. It also includes the information if the server wasn't able to ping.</p>
4061	Key isn’t found on KMIP server.	Verify that the requested key is available on the KMIP server. Check the KMIP server logs for details.
4062	Key creation on KMIP server failed.	Check the KMIP server logs for details about why key creation failed.
4063	KMIP configuration invalid.	Use the KMIP configuration wizard to verify the KMIP configuration.
4064	KMIP feature not licensed.	Disable KMIP or install appropriate license for KMIP feature.

Table 36. Warning events (continued)

Event Code	Message Text and Description	Details and Solution
4065	A tape alert flag was reported by a drive.	Look for logged TapeAlert flags and see its description in the “TapeAlert flags” on page 108 section.
4067	Cleaning cartridge will soon expire and must be replaced.	Replace the cartridge.
4072	No cleaning cartridge in logical library available for auto cleaning.	<ul style="list-style-type: none"> • Auto cleaning is enabled, but the logical library contains no labeled cleaning cartridge. The library was unable to complete the auto clean function for one or more drives in this logical library. • Install a valid and labeled cleaning cartridge into the logical library and then complete a load and unload on the drive that needs cleaning to start the auto cleaning.
4073	Medium source element empty.	Check the source slot visually and rescan the inventory. Additionally, check for valid and readable bar code label.
4074	Medium source element empty.	Check the source slot visually and rescan the inventory. Additionally, check for valid and readable bar code label.
4075	Cartridge lost while it was extracted from slot/drive.	Check the source/destination element and ensure that no obstructions are in the pathway of the accessor.
4077	Unlocking the right magazine failed.	<ul style="list-style-type: none"> • Restart the library and retry the operation. • If the error persists, replace the chassis. • If the magazine needs to be removed to get access to the tape cartridges, first power down the device, and then release the magazine manually. Only one magazine can be open at a time.
4078	Unlocking the left magazine failed.	<ul style="list-style-type: none"> • Restart the library and retry the operation. • If the error persists, replace the chassis. • If the magazine needs to be removed to get access to the tape cartridges, first power down the device, and then release the magazine manually. Only one magazine can be open at a time.
4079	Unlocking the I/O station failed.	<ul style="list-style-type: none"> • Restart the library and retry the operation. • If the error persists, replace the chassis. • If the I/O station needs to be removed to get access to the tape cartridges, first power down the device, and then release the magazine manually. Only one magazine can be open at a time.

Table 36. Warning events (continued)

Event Code	Message Text and Description	Details and Solution
4080	Library Verify test failed with warning.	An unidentified failure occurred. Contact your IBM service representative.
4085	Drive command retries expired.	<ul style="list-style-type: none"> • Run a drive read/write test (Library > Actions > Tests > Drive test) with a known working cartridge. • If the drive test is successful, check in the host for errors that are related with the retries. • If the drive test failed, replace the drive.
4086	Move operation failed.	<ul style="list-style-type: none"> • Ensure that the network the library is connected to is operating normally. • Ensure that the library is running the current firmware. • Restart the library.
4089	Auto calibration of one or more modules failed. Adjustment to calibration target failed.	<ul style="list-style-type: none"> • The library must be recalibrated. • Ensure that the library firmware is up-to-date. • This event indicates that one or more of the gray calibration targets on the library magazines couldn't be used in calibration. • Inspect the calibration targets in each module and then repeat the auto-calibration routine with the Management GUI.
4090	Auto calibration of one or more modules failed. Calibration target not found	<ul style="list-style-type: none"> • The library must be recalibrated. • Ensure that the library firmware is up-to-date. • This event indicates that one or more of the gray calibration targets on the library magazines couldn't be used in calibration. • Inspect the calibration targets in each module and then repeat the auto-calibration routine with the Management GUI.
4091	Auto calibration of one or more modules failed. Adjustment out of range	<ul style="list-style-type: none"> • The library must be recalibrated. • Ensure that the library firmware is up-to-date. • This event indicates that one or more of the gray calibration targets on the library magazines couldn't be used in calibration. • Inspect the calibration targets in each module and then repeat the auto-calibration routine with the Management GUI.

Table 36. Warning events (continued)

Event Code	Message Text and Description	Details and Solution
4093	Couldn't obtain an IP address from DHCP server.	<ul style="list-style-type: none"> • Check the network configuration settings and check if the DHCP server is reachable. • Use the network configuration menu or unplug the network cable and plug it in after a few seconds to trigger an automatic reconfiguration of the network interface.
4095	Library test failed. Not enough valid cartridges available for testing.	Load the cartridges into the library.
4098	System time synchronization with SNTP failed.	Check for valid SNTP server address in Time configuration. If correct, ensure that the server is reachable from your network and not blocked by a firewall.
4099	An unexpected reset of accessor was detected.	Ensure that the spooling cable is fully seated in the base module and connected correctly to the accessor assembly. If the error recurs, replace the accessor assembly.
4113	Move from drive failed.	Check for labels or cartridge misalignments that prevents the cartridge from coming out of the slot or drive.
4117	Drive disabled because no power supply available.	Remove all affected drives, insert, and power up at least one power supply to the failing module. Wait 10 seconds and put the drives back into the module.
4119	Drive disabled because internal IP address unknown.	<ul style="list-style-type: none"> • Remove affected drive, wait 10 seconds, and put it back into the module. • Restart Library stack.
4120	No empty drive available for system test.	Make sure that at least one empty drive and one compatible cartridge are available.
4121	No compatible media available for system test.	Make sure that at least one empty drive and one compatible cartridge are in the drive.
4122	No cartridge available for slot to slot exerciser test.	Make sure that at least one cartridge and one empty slot are in the library.
4123	No empty slot available for slot to slot exerciser test.	Make sure that at least one cartridge and one empty slot are in the library.
4124	Drive or media statistics couldn't be retrieved when the tape was unloaded.	Check for more warning tickets. Replace media if media-related tape alert flags reported.
4126	Cartridge was found in inaccessible slot of lowermost unit.	Bottom slots from the lowermost unit are inaccessible to the accessor. Place the cartridge in an upper slot.
4127	Drive was restarted because of canister reset.	Verify that the drive is installed properly in its slot and thumb screws are tightened. If the error persists, replace the drive.

Table 36. Warning events (continued)

Event Code	Message Text and Description	Details and Solution
4128	An installed power supply is detected but doesn't provide power.	Ensure that the power supply has a power cord plugged in and is connected to a valid power source. Although the power source isn't available, this expansion module can still be used for tape storage. Operation of tape drives isn't possible.
4129	Move from drive failed.	Check backup application how to allow media removal from drive. If unsuccessful, try the Force Drive Media Eject option in the Operations menu.
4133	Protection Foam not removed from Base Module	<ul style="list-style-type: none"> • Power down the library. • Remove top cover and then remove the protection foam. • Install the top cover again and restart the library.
4135	Drive diagnostic failed	Use another diagnostic tape and run test once more. If still failing, download drive dumps and contact service.
4136	The base module detected an installed power supply but this power supply doesn't provide power.	Ensure that the power supply has a power cord plugged in and is connected to a valid power source.
4137	Diagnostic Tape not removed.	Open Magazine or I/O station to remove the diagnostic tape with the OP or Management GUI.
4139	Magazine or I/O Station operation failed.	<ul style="list-style-type: none"> • Check whether any obstacle is preventing the accessor from movement. • Restart the library and retry the operation. If the error persists, replace the accessor assembly. • If the magazine needs to be removed to get access to the tape cartridges, first power down the device and then release the magazine manually. Only one magazine can be open at a time.
4140	Personality mismatch detected.	Replace either chassis or library controller to ensure that all parts in the stack are matching the personality of the main library controller.
4142	Medium destination element full.	Ensure that your destination slot or drive is empty and try again.
4144	Unit to unit lock of lowermost module is engaged.	Ensure that the alignment mechanism isn't engaged in the lowermost module.
4148	Download of of one or multiple drive dumps failed	Check status of selected drives and ensure that they are present and finally initialized before downloading dumps.
4150	Sequential Mode move operation failed.	Check event details for further information.

Table 36. Warning events (continued)

Event Code	Message Text and Description	Details and Solution
4151	Download of drive firmware image completed, but firmware revision didn't change after restart.	<ul style="list-style-type: none"> • Check if the uploaded firmware image is matching your drive type and generation. • Ensure that the image file isn't corrupted. • Download a new image from the drive vendor's website if you aren't sure about file integrity.
4152	KMIP Connection refused	The selected port on the target machine isn't open. The connection is refused. Check that the server application is running on the target machine and the firewall isn't blocking the selected port. Contact IT Personnel to verify the port settings.
4153	KMIP Server doesn't trust the client certificate.	Use a client certificate that is signed by a trusted certificate authority (CA) or manually select the untrusted certificate on the server side and trust it (not available on all servers).
4154	KMIP Ping to server failed	<p>The target machine couldn't be reached, so no network connection possible.</p> <ul style="list-style-type: none"> • Verify that the IP address in the settings is correct. • Check that the target machine is powered and connected to the network. • Check the network cable. • Verify that the Firewall setting on the target machine allows ping requests and responses.
4155	KMIP No route to host	<p>The target machine couldn't be reached. The network route to the machine isn't available.</p> <ul style="list-style-type: none"> • Check your IP settings (IP address, Gateway and Netmask) and verify it with your IT personnel. • Check that the Firewall settings on the target machine are correct.
4156	KMIP Handshake failure	<p>The TLS connection couldn't be established because of Handshake errors during certificate exchange.</p> <ul style="list-style-type: none"> • Check the certificates on server and client side for valid entries and that they are still valid and not expired. • Verify that TLS1.2 is enabled on the server. • Check the client and server date/time for current time. • Ask your IT personnel for new and valid certificates.

Table 36. Warning events (continued)

Event Code	Message Text and Description	Details and Solution
4157	KMIP Certificate unknown	<p>The server certificate is unknown, because its root certificate is missing or not trusted. Run a new certificate request with your server or certificate authority and import the resulting certificate chain.</p>
4158	KMIP host name lookup failed.	<p>The host name on the network couldn't be found. It doesn't exist or is misspelled.</p> <ul style="list-style-type: none"> • Verify that the entered host name is correct. • Check your DNS address in the network settings. • Contact your IT personnel to verify the entered data.
4159	KMIP certificate verify failed.	<p>The TLS server certificate couldn't be verified as a valid and trusted certificate.</p> <ul style="list-style-type: none"> • Check if your server root certificate changed. • Create a certificate request against your server to generate a new client certificate based on the changed server certificates.
4160	Connection to SKLM server failed.	<p>Retrieving IPP encryption key failed because connection to SKLM server could not be established.</p> <p>Check for availability of server and verify your server settings. Add a secondary fallback server if possible.</p>
4161	Internal encryption key handshake failed.	<p>Retrieving IPP encryption key failed because of internal data transfer failure between drive and library.</p> <p>Verify if the latest drive software is installed. If the failure reoccurs, check the library event log for specific events associated with this drive.</p>
4162	SKLM for z/OS encryption not licensed.	<p>Disable SKLM for z/OS encryption or install appropriate license for Library Managed Encryption.</p>

Table 36. Warning events (continued)

Event Code	Message Text and Description	Details and Solution
4163	Drive sled discovery timeout.	<p>Drive sled discovery timeout, status of Drive sleds not available in time.</p> <ul style="list-style-type: none"> • Ensure that all modules are powered and have the interconnect cable properly attached. • If this event is seen on multiple modules or after ensuring all interconnect cables are properly attached, ensure that the network that the base module is connected to is not experiencing broadcast storms or other abnormal activity. • Reboot or power cycle the system to rediscover the modules.
4164	Inventory has been updated due to an unexpected empty or full slot.	<p>If a move fails due to an unexpected empty or full slot, the slot is rescanned and the inventory is corrected.</p>
4165	Bottom magazine slots in the lowermost unit are not accessible.	<p>The installed robotics does not support access to all 40 slots in the lowermost unit. The bottom slots in the lowermost unit are not accessible, so only 32 slots are available.</p> <p>Install a robotics that supports access to all 40 slots in the lowermost unit.</p>
4166	Drive self-test diagnostic failed.	<p>Reset Drive and run the test again. If still failing, download drive dumps and contact service.</p>
4167	Drive primary port diagnostic failed.	<ul style="list-style-type: none"> • Check whether the wrap test connector is correctly connected to the selected port. • Reset drive and run test again. • If the diagnostic still fails, download drive dumps and contact service.
4168	Drive encryption key path diagnostic failed.	<ul style="list-style-type: none"> • Check the SKLM server configuration and your network settings. • If the diagnostic still fails, download the library logs and contact service.
4173	Encryption Key Path diagnostics failed.	<ul style="list-style-type: none"> • Check the Key server configuration and your network settings. • If the diagnostic still fails, download the library logs and contact service.
4174	KMIP CA certificate failure	<p>Check whether you provided the correct CA certificate or the CA certificate on the encryption server was changed.</p>

Configuration Change events

Table 37. Configuration Change events

Event Code	Message Text and Description
8000	The configuration of a drive changed.
8001	The drive was added or removed from the system.
8002	A logical library was added/removed or changed.
8003	I/O station was enabled/disabled.
8004	Drive firmware changed due to firmware upgrade.
8005	Hostname/domain name changed.
8006	Email configuration settings changed.
8007	Date/time format changed.
8009	Time zone configuration changed.
8011	Network configuration changed.
8012	Expansion Module upgraded.
8013	NTP time server settings changed.
8014	The SSH Access was enabled/disabled.
8016	Library reset default settings started by user.
8017	Library Firmware changed.
8018	The Unlabeled Cartridge Support configuration changed.
8019	Accessor firmware version upgraded.
8022	Management GUI/Operator Panel Timeout configuration changed.
8024	I/O station/Magazine access control configuration changed.
8026	Accessor change detected.
8029	The SNMP configuration changed.
8030	An SNMP target was added.
8031	An SNMP target was deleted.
8033	The Operator Panel module was changed.
8034	Manual Drive reset executed.
8036	New chassis detected.
8037	Chassis was removed.
8040	LDAP Server was added.
8041	LDAP Server was modified.
8042	LDAP Server was deleted.
8043	LDAP User was added.
8044	LDAP User was modified.
8045	LDAP User was deleted.

Table 37. Configuration Change events (continued)

Event Code	Message Text and Description
8046	Logout prevention configuration changed.
8057	Hardware component added.
8058	Hardware component removed.
8059	Hardware component of Library replaced.
8060	New Expansion Controller detected.
8061	New Base Library Controller detected.
8062	Auto calibration successfully finished.
8064	Password rules configuration changed.
8065	User was added.
8066	User was deleted.
8068	Remote Logging configuration changed.
8069	User password changed.
8072	Kerberos Realm was added.
8073	Kerberos Realm was modified.
8074	Kerberos Realm was deleted.
8075	Kerberos User was added.
8076	Kerberos User was modified.
8077	Kerberos User was deleted.
8079	SKLM for z/OS Encryption settings modified.

Informational events

Table 38. Informational Events

Event Code	Message Text and Description
9000	A tape alert flag was reported by a drive.
9001	A drive is present but currently disabled.
9002	The library was powered on.
9003	Move Cartridge command was run.
9004	Inventory scan was completed.
9005	The library was powered down from Front Panel.
9006	The network interface was turned on.
9007	The network interface was turned off.
9008	The System Time was synchronized with an NTP server.
9009	A magazine was unlocked and opened.
9010	A magazine was closed and locked.
9011	An I/O station was unlocked and opened.

Table 38. Informational Events (continued)

Event Code	Message Text and Description
9012	An I/O station was closed and locked.
9013	A user logged in at the Management GUI.
9014	A user logged out at the Management GUI.
9015	A user logged in at the Operator Panel interface.
9016	A user logged out at the Operator Panel interface.
9024	Drive support ticket created.
9025	Library test started.
9026	Library test successfully finished.
9027	Library test was stopped by user.
9028	Configuration back up to chassis was successful.
9029	Configuration restore from chassis was successful.
9031	Library health Status was changed to status "OK".
9032	Library health status was changed to status "Warning".
9033	Library health status was changed to status "Critical".
9035	New library chassis detected.
9038	The library was rebooted through user interface.
9041	Key on KMIP server created.
9043	Drive cleaning was started.
9045	Library configuration data failed to duplicate on to the Base Module.
9060	One or multiple configured DNS servers aren't responding.
9061	User account was locked due to too many invalid login attempts on Management GUI.
9062	Invalid password used for login.
9063	The network port used to contact the encryption server was changed.
9064	Backup of certificate created.
9065	Certificate is restored.
9066	Temporary password generated.
9067	LTO7 formatted cartridge with a Type M bar code detected.
9068	Type M cartridge without a Type M bar code detected.
9069	Sequential Mode load sequence ended because last storage cartridge of logical library was unloaded.
9070	Sequential Mode load sequence restarted (Loop Mode) because last storage cartridge of logical library was unloaded.

TapeAlert flags

This section is intended to provide information to the reader about the tape drive by using TapeAlert technology.

All error code and diagnostic information can be accessed from the Management GUI of the library. The drive portion of the Management GUI contains drive error codes. Therefore, it is not necessary to open the Library to access the buttons on the drive. See [“Locating Management functions”](#) on page 65 for a complete description of the Management GUI functions and displays.

TapeAlert is a standard that defines status conditions and problems that are experienced by devices such as tape drives, autoloaders, and libraries. The standard enables a server to read TapeAlert messages (called flags) from a tape drive with the SCSI bus. The server reads the flags from Log Sense Page 0x2E. Refer to the *IBM TS4300 Tape Library SCSI Reference* for library and drive TapeAlert Flag information.

This library is compatible with TapeAlert technology, which provides error and diagnostic information about the drives and the library to the server. Because library and drive firmware might change periodically, the SNMP interface in the library does not require code changes if devices add more TapeAlerts that are not supported today. However, if this issue occurs the Management Information Block (MIB) is written to minimize impact to the SNMP monitoring station. At the time of this writing, the TapeAlert flags correctly represent TapeAlerts that are sent. The MIB file must not be taken to mean that all traps that are defined in the MIB are sent by the library or that they will be sent in the future.

TapeAlert flags supported by the library

Parameter Code	Flag name	Type	Description
01d	Library Hardware A	C	The media changer mechanism is having difficulty communicating with the drive: <ul style="list-style-type: none">• Turn the media changer OFF, then ON• Restart the operation.• If problem persists, contact Technical Support.
02d	Library Hardware B	W	There is a problem with the media changer mechanism. If the problem persists, contact Technical Support.
04d	Library Hardware D	C	The library has a hardware fault that is not mechanically related or requires a power cycle to recover. <ul style="list-style-type: none">• Turn the media changer OFF, then ON.• Restart the operation.• If the problem persists, contact Technical Support.
05d	Library Diagnostics Required	W	The library mechanism might have a hardware fault. Run extended diagnostics to verify and diagnose the problem. Check the library user's manual for device-specific instructions on running extended diagnostic tests.
13d	Library Pick Retry	W	There is a potential problem with the drive ejecting cartridges or with the library picking cartridges from a slot. <ul style="list-style-type: none">• No action needs to be taken at this time.• If the problem persists, contact Technical Support.

Parameter Code	Flag name	Type	Description
14d	Library Place Retry	W	There is a potential problem with the library mechanism placing a cartridge into a slot. <ul style="list-style-type: none"> • No action needs to be taken at this time. • If the problem persists, contact Technical Support.
15d	Library Load Retry	W	There is a potential problem with the drive or the library mechanism loading cartridges, or an incompatible cartridge. This flag is cleared when the next move command is received.
16d	Library Door	C	The operation failed because the library door is open. <ul style="list-style-type: none"> • Clear any obstructions from the library door. • Close the library door. • If the problem persists, call the library supplier help line.
17d	Library I/O Station	C	There is a mechanical problem with the library media I/O Station.
19d	Library Security	W	Library security is compromised. The door was opened then closed during operation.
20d	Library Security Mode	I	The library security mode was changed. The library was either put into secure mode, or the library exited the secure mode. This is for information purposes only. No action is required.
21d	Library Offline	I	The library was manually turned offline and is unavailable for use.
22d	Library Drive Offline	I	A drive inside the library was taken offline. This is for information purposes only. No action is required.
24d	Library Inventory	C	The library detected an inconsistency in its inventory. <ul style="list-style-type: none"> • Redo the library inventory to correct inconsistency. • Restart the operation.
28d	Power Supply	W	A redundant power supply failed inside the library. Check the library users manual for instructions on replacing the failed power supply.
33d	Library Capacity Exceeded	C	The total number of volumes exceeds the available number of storage elements. Remove a cartridge from the inventory to recover.
<ul style="list-style-type: none"> • I = Informational suggestion to user • W = Warning. Remedial action is advised. Performance of data might be at risk. • C = Critical immediate remedial action is required. 			

TapeAlert flags supported by the drive

Flag Number	Flag Name	Hex Code	Description	Action Required	Event
1	Read warning	01h	Set when the tape drive is having problems reading data. No data is lost, but there is a reduction in the performance of the tape.	<p>Isolate the fault between drive and tape by following these steps:</p> <ul style="list-style-type: none"> • Use a known good tape cartridge in the suspect drive. If the drive fails, contact your IBM® Service Representative. • Use the suspect tape cartridge in a known good drive. If the test fails, discard the cartridge. 	Warning Event
2	Write warning	02h	Set when the tape drive is having problems writing data. No data is lost, but there is a reduction in the performance of the tape.	<p>Isolate the fault between drive and tape by following these steps:</p> <ul style="list-style-type: none"> • Use a known good tape cartridge in the suspect drive. If the drive fails, contact your IBM® service representative. • Use the suspect tape cartridge in a known good drive. If the test fails, discard the cartridge. 	Warning Event
3	Hard error	03h	Set for any unrecoverable read, write, or positioning error. (This flag is set with flags 4, 5, or 6).	<p>See the Action Required column for Flag Number 4, 5, or 6 in this table.</p> <p>Ensure that tape drive firmware is at the latest version. See “Minimum firmware levels for common library features” on page iii.</p>	Warning Event
4	Media	04h	Set for any unrecoverable read, write, or positioning error that is due to a faulty tape cartridge.	Replace the tape cartridge.	Warning Event
5	Read failure	05h	Set for any unrecoverable read error where isolation is uncertain and failure might be due to a faulty tape cartridge or to faulty drive hardware.	If Flag Number 4 is also set, the cartridge is defective. Replace the tape cartridge. If Flag Number 4 is not set, see Error Code 6 in “Drive Error Codes: Single-character display (SCD)” on page 114.	Warning Event

Flag Number	Flag Name	Hex Code	Description	Action Required	Event
6	Write failure	06h	Set for any unrecoverable write or positioning error where isolation is uncertain and failure might be due to a faulty tape cartridge or to faulty drive hardware.	If Flag Number 9 is also set, make sure that the write-protect switch is set so that data can be written to the tape. If Flag Number 4 is also set, the cartridge is defective. Replace the tape cartridge. If Flag Number 4 is not set, see Error Code 6 in “Drive Error Codes: Single-character display (SCD)” on page 114.	Warning Event
7	Media life	07h	Set when the tape cartridge reaches its end of life (EOL).	<ol style="list-style-type: none"> 1. Copy the data to another tape cartridge. 2. Discard the old (EOL) tape. 	Warning Event
8	Not data grade	08h	Set when the cartridge is not data-grade. Any data that you write to the tape is at risk.	Replace the tape with a data-grade tape.	Warning Event
9	Write protect	09h	Set when the tape drive detects that the tape cartridge is write-protected.	Make sure that the cartridge's write-protect switch is set so that the tape drive can write data to the tape.	Warning Event
10	No removal	0Ah	Set when the tape drive receives an UNLOAD command after the server prevented the tape cartridge from being removed.	Refer to the documentation for your server's operating system.	Info Event
11	Cleaning media	0Bh	Set when you load a cleaning cartridge into the drive.	No action is required. Informational message only.	Info Event
12	Unsupported format	0Ch	Set when you load an unsupported cartridge type into the drive or when the cartridge format is corrupted.	Use a supported tape cartridge.	Info Event
14	Unrecoverable snapped tape	0Eh	Set when the tape is snapped/cut or has a mechanical failure.	Do not attempt to extract the old tape cartridge. Call the tape drive supplier's help line.	Warning Event
15	Cartridge memory chip failure	0Fh	Set when a cartridge memory (CM) failure is detected on the loaded tape cartridge.	Replace the tape cartridge. If this error occurs on multiple cartridges, see Error Code 6 in “Drive Error Codes: Single-character display (SCD)” on page 114.	Warning Event
16	Forced eject	10h	Set when you manually unload the tape cartridge while the drive was reading or writing.	No action is required. Informational message only.	Warning Event

Flag Number	Flag Name	Hex Code	Description	Action Required	Event
17	Loaded media is Read-only format	11h	Set when a write attempt is made on a read-only cartridge. The flag is cleared when the cartridge is ejected (this flag is not supported for Ultrium 1 or Ultrium 2).	No action is required. Informational message only.	Warning Event
18	Tape directory is corrupted in the cartridge memory	12h	Set when the drive detects that the tape directory in the cartridge memory is corrupted.	Reread all data from the tape to rebuild the tape directory.	Warning Event
19	Nearing media life	13h	Set when the tape cartridge is nearing its specified end of life.	1. Copy the data to another tape cartridge. 2. Replace the tape cartridge.	Info Event
20	Clean now	14h	Set when the tape drive detects that it needs cleaning.	Clean the tape drive.	Warning Event
21	Clean periodic	15h	Set when the drive detects that it needs routine cleaning.	Clean the tape drive as soon as possible. The drive can continue to operate, but you must clean the drive soon.	Warning Event
22	Expired clean	16h	Set when the tape drive detects an expired cleaning cartridge.	Replace the cleaning cartridge.	Warning Event
23	Invalid cleaning tape	17h	Set when the drive expects a cleaning cartridge and the loaded cartridge is not a cleaning cartridge.	Use a valid cleaning cartridge.	Warning Event
25	Interface	19h	Set when the tape drive detects a problem with the SCSI, Fibre Channel, or RS-422 interface.	Locate Error Code 8 or 9 in " Drive Error Codes: Single-character display (SCD) " on page 114.	Warning Event
26	Cooling Fan Failure	1Ah	A tape drive cooling fan failed.	Fan failure inside tape drive mechanism or tape drive enclosure.	Warning Event
27	Power Supply	1Bh	A redundant power supply failed inside the tape drive enclosure. Check the enclosure users manual for instructions on replacing the failed power supply.	A redundant power supply failed inside the tape drive enclosure. Check the enclosure users manual for instructions on replacing the failed power supply.	Warning Event
30	Hardware A	1Eh	Set when a hardware failure occurs that requires that you reset the tape drive to recover.	A redundant power supply failed inside the tape drive enclosure. Check the enclosure users manual for instructions on replacing the failed power supply.	Warning Event

Flag Number	Flag Name	Hex Code	Description	Action Required	Event
31	Hardware B	1Fh	Set when the tape drive fails its internal Power-On Self-Tests.	Note the error code on the single-character display and see in “Drive Error Codes: Single-character display (SCD)” on page 114 for the appropriate instructions.	Warning Event
32	Interface	20h	Set when the tape drive detects a problem with the SCSI, Fibre Channel, or RS-422 interface.	Set when the tape drive detects a problem with the SCSI, Fibre Channel, or RS-422 interface.	Warning Event
33	Eject media	21h	Set when a failure occurs that requires you to unload the cartridge from the drive.	Unload the tape cartridge, then reinsert it and restart the operation.	Warning Event
34	Download fail	22h	Set when the tape drive detects a problem with the SCSI, Fibre Channel, or RS-422 interface.	Ensure that it is the correct FMR image. Download the FMR image again.	Warning Event
36	Drive temperature	24h	Set when the drive's temperature sensor indicates that the drive's temperature is exceeding the recommended temperature of the library.	See Error Code 1 in “Drive Error Codes: Single-character display (SCD)” on page 114.	Warning Event
37	Drive voltage	25h	Set when the drive detects that the externally supplied voltages are either approaching the specified voltage limits or are outside the voltage limits.	See Error Code 2 in “Drive Error Codes: Single-character display (SCD)” on page 114.	Warning Event
38	Predictive failure	26h	A hardware failure of the tape drive is predicted. Call the tape drive supplier helpline.	Predictive failure of drive hardware	Warning Event
39	Failure	27h	The tape drive might have a fault. Check for availability of diagnostic information and run extended diagnostics if applicable. Check the tape drive user's manual for instructions on running extended diagnostic tests and retrieving diagnostic data.	The drive might have a failure that can be identified by stored diagnostic information or by running extended diagnostics (Send Diagnostics).	Warning Event
49	Diminished Native Capacity	31h	Set when Native Capacity is diminished.	No action is required. Informational message only.	Info Event
51	Tape directory invalid at unload	33h	Set when the tape directory on the tape cartridge that was previously unloaded is corrupted. The file-search performance is degraded.	Use your backup software to rebuild the tape directory by reading all the data.	Warning Event
52	Tape system area write failure	34h	Set when the tape cartridge that was previously unloaded cannot write its system area successfully.	Copy the data to another tape cartridge, and discard the old cartridge.	Warning Event

Flag Number	Flag Name	Hex Code	Description	Action Required	Event
53	Tape system area read failure	35h	Set when the tape system area cannot be read successfully at load time.	Copy the data to another tape cartridge, and discard the old cartridge.	Warning Event
55	Load Failure	37h	The operation failed because the media cannot be loaded and threaded.	Remove the tape and try another. If the problem persists, contact your IBM® service representative. Ensure that tape drive firmware is at the latest version. See “Minimum firmware levels for common library features” on page iii.	Warning Event
56	Unrecoverable unload failure	38h	The operation failed because the media cannot be unloaded.	Contact your IBM® service representative.	Warning Event
59	WORM Medium – integrity check failed	3Bh	Set when the drive determines that the data on tape is suspect from a WORM point of view.	1. Copy the data to another WORM tape cartridge. 2. Discard the faulty WORM tape.	Warning Event
60	WORM Medium – Overwrite attempted	3Ch	Set when the drive rejects a write operation because the rules for allowing WORM writes are not met. Data can be appended only to WORM media. Overwrites to WORM media are not allowed.	Write the data to a WORM tape cartridge or write the data to a non-WORM tape cartridge.	Warning Event

Sense data

When a drive encounters an error, it provides sense data as a response to the host.

Refer to the *IBM TS4300 Tape Library SCSI Reference* for library sense data information. Refer to the *IBM LTO Ultrium Tape Drive SCSI Reference* for tape drive sense data information.

In addition, you can use the IBM Tape Diagnostic Tool (ITDT) to further examine data and determine errors. See [“IBM Tape Diagnostic tool \(ITDT\)”](#) on page 83.

Drive Error Codes: Single-character display (SCD)

SCD drive error codes give descriptions of the errors and messages that pertain to the drive.

If you encounter problems while the tape drive is running, refer to [“Finding event information”](#) on page 77.

The SCD display appears on the inside back of an installed library and can be seen through the front window of an expansion unit. It is seen on the lower center of a full-height drive. Each drive has a status light and single-character display, that when visible provides drive informational and error conditions. The single-character display shows either a single character, a dot (in the lower right of the display), or both.

Note: The SCD can be seen through the windows of expansion units, and for full-height drives only. If you have a base unit without expansion units, or if you have half-height drives, the SCD cannot be seen.

[“Single-character display \(SCD\) codes”](#) on page 115 lists the codes for error conditions and informational messages. If multiple errors occur, the code with the highest priority (represented by the lowest number) displays first. When the error is corrected, the code with the next highest priority displays until no errors remain.

The SCD is blank during normal operation.

Single-character display (SCD) codes

Table 39 on page 115 gives descriptions of the errors and messages that pertain to the drive. For troubleshooting tips, see [“Troubleshooting Guide”](#) on page 77.

- Make note of the SCD error code before a cartridge is removed or the SCD error code is cleared.
- If an error occurred with a cartridge in the drive, eject the cartridge from the drive with the library Management GUI (see [“Locating Management functions”](#) on page 65).



Attention: If the drive detects a permanent error and displays an error code other than SCD , it automatically runs a drive dump. If you force a drive dump, the existing dump is overwritten and data can be lost. After you force a drive dump, do not turn OFF the power to the drive or you might lose the dump data.









Error code	Meaning
	No error occurred and no action is required. This code displays when diagnostics finish running and no error occurred. Note: The single-character display is blank during normal operation of the tape drive.
	Temperature problem. The tape drive detected that the recommended operating temperature was exceeded.
	Power problem. The tape drive detected that the externally supplied power is outside the specified voltage limits (the tape drive is not operating).
	Firmware problem. The tape drive determined that a firmware error occurred Note: Do not force a new dump; the tape drive already created one.
	Firmware or hardware problem. The tape drive determined that a firmware or tape drive hardware failure occurred. Note: Do not force a new dump; the tape drive already created one.
	Tape drive hardware problem. The drive determined that a tape path or read/write error occurred. Notes: <ul style="list-style-type: none"> • To prevent damage to the drive or tape, the tape drive does not allow a cartridge to be inserted if the current cartridge was successfully ejected. • Do not force a new dump; the tape drive already created one.
	Tape drive or media error. The tape drive determined that an error occurred, but it cannot isolate the error to faulty hardware or to the tape cartridge. Ensure that the tape cartridge is the correct media type. See Appendix B, “LTO media,” on page 156. Ensure tape drive is at the latest firmware version. See “Minimum firmware levels for common library features” on page iii.
	Tape drive or media error. The tape drive determined that an error occurred, but it cannot isolate the error to faulty hardware or to the tape cartridge. Ensure that the tape cartridge is the correct media type. See Appendix B, “LTO media,” on page 156.
	Interface problem. The tape drive determined that a failure occurred in the tape drive hardware or in the host bus. Note: The error code clears 10 seconds after the drive detected the error.

Table 39. Error codes on the single-character display (continued)

Error code	Meaning
G	Tape drive or library-drive communication error. The tape drive determined that a failure occurred in the tape drive's hardware or in the library-drive connection.
A	Degraded operation. The tape drive determined that a problem occurred which degraded the operation of the tape drive, but it did not restrict continued use. If the problem persists, determine whether the problem is with the drive or the media. Note: The drive is usable, though the single-character display continues to indicate an error and the status light flashes amber.
C	The tape drive needs to be cleaned. See “Locating Management functions” on page 65.
D	Fiber AL_PA conflict. Two drives on fiber loop have the same AL_PA.
E	Encryption error. Displayed when the drive detects an error that is associated with an encryption operation.
F	Fiber Port offline. Displayed when the drive fiber port received a port bypass command from another port on the Fibre Channel network.
F	Fibre Channel error. No light is displayed if the drive fiber port does not detect light.
P	Write operation to a write protected cartridge was attempted. This action includes any attempt to overwrite a WORM protected tape. Ensure that the tape cartridge is the correct media type. See Appendix B, “LTO media,” on page 156.

SCD dot

If a drive dump is present while the drive is in maintenance mode, a single red dot illuminates in the lower right corner of the SCD. To download the drive dump, see [“Locating Management functions”](#) on page 65 or [“IBM Tape Diagnostic tool \(ITDT\)”](#) on page 83.

The SCD dot turns OFF when you obtain a dump or update the drive firmware.

Note: If the drive dump is stored in ROM memory (SCD dot ON solid), the dump is lost when you turn OFF the power or reset the drive.





Status light

The Status light is a light-emitting diode (LED) that provides information about the state of the drive. The light can be green or amber, and (when lit) solid or flashing. Table 40 on page 116 lists the conditions of the Status light and single-character display (SCD) and provides an explanation of what each condition means.

Table 40. Meaning of Status light and single-character display (SCD)

If the Status light is...	And the SCD is...	Meaning
OFF	OFF	The drive has no power or is powered OFF.
Green	OFF	The drive is powered ON and in an idle state.
Flashing green	OFF	The drive is reading from the tape, writing to the tape, rewinding the tape, locating data on the tape, loading the tape, or unloading the tape.

Table 40. Meaning of Status light and single-character display (SCD) (continued)

If the Status light is...	And the SCD is...	Meaning
Flashing green	OFF	The drive contains a cartridge during the power-ON cycle. In this case, the drive completes POST and slowly rewinds the tape (the process can take up to ten minutes). The light stops flashing and becomes solid when the drive completes the recovery and is ready for a read or write operation.
Flashing amber	Displaying error code	The drive is displaying error codes from the error code log on the SCD.
Amber	Red numbers, letters, or segments	During the power-on/initialization and POST (power-on self-test), the SCD briefly displays  , then becomes blank (not lit) when POST is complete and no POST errors occur. If a POST error is detected, an error code is displayed in the SCD and the Status light flashes amber.
Amber	Flashing 	The drive is exiting from maintenance mode.
Amber	Flashing function	The drive is running the maintenance function.
Flashing amber once per second	Displaying error code	An error occurred and the drive or media might require service, or it might require cleaning.
Flashing amber once per second	Displaying 	The drive needs cleaning.
Flashing amber twice per second	OFF	The drive is updating firmware.
Flashing amber twice per second	OFF	The drive detected an error and is running a firmware recovery. It resets automatically.
Flashing amber twice per second	Flashing 	The drive is requesting a cartridge to be loaded.
Flashing amber twice per second	OFF	A drive dump is in flash memory.
Power must not be removed from the drive until the microcode update is complete. The drive indicates that the update is complete by resetting and running POST.		

Chapter 6. Upgrading and servicing

In this section, you can follow the procedures to add, remove, and replace library components.

Recommended tools

- #2 Phillips screwdriver
- Small Flat Head or Torx screwdriver

Identifying a failed component

Check which module contains the failed component. See “Identifying a failed component” on page 77. If replacement parts are needed, go to [Appendix C, “Replacement parts,”](#) on page 176.

Internal view of library

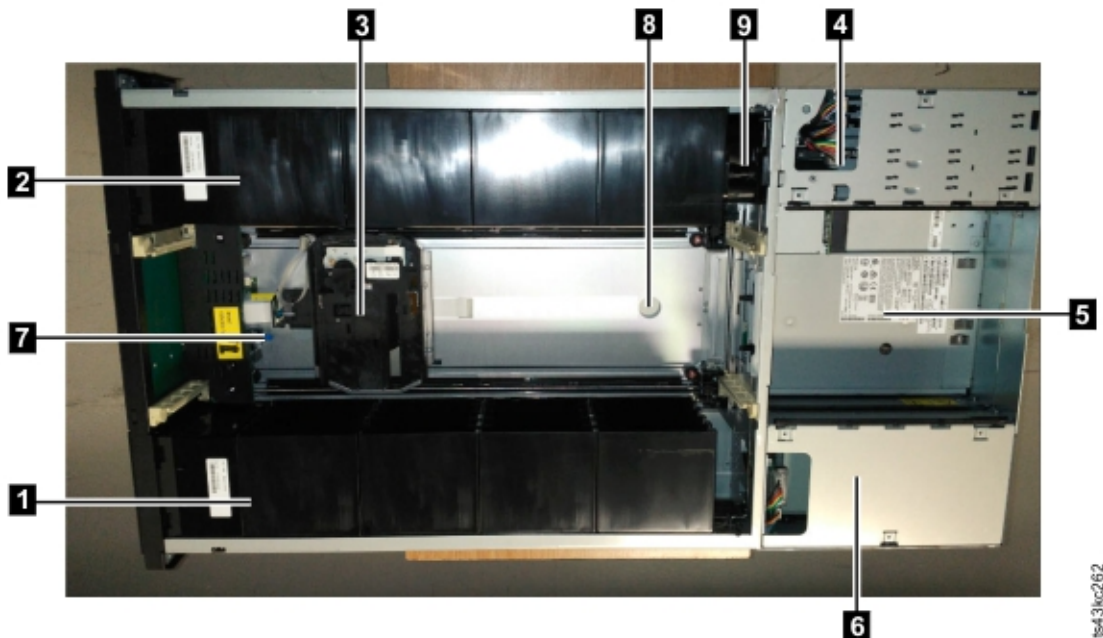

Figure 57. Internal view of the library



Number	Item	Description
1	Right cartridge magazine	If the module is on the bottom, the right cartridge magazine holds 16 cartridges; if anywhere else in the library, it can hold 20 cartridges.
2	Left cartridge magazine	If the module is on the bottom, the left cartridge magazine holds 16 cartridges; if anywhere else in the library, it can hold 20 cartridges.

Table 41. Internal view description (continued)

Number	Item	Description
3	Accessor	This component contains the library accessor and bar code reader. The accessor moves cartridges to and from the <ul style="list-style-type: none"> • I/O station • Storage slots • Tape drive
4	Controller Card	This component is a customer replaceable unit (CRU) and stores the user configuration information or vital product data (VPD).
5	Tape drive	The module can contain a half-height or a full-height tape drive. The drive is a customer replaceable unit (CRU), and is designed for easy removal and replacement.
6	Power supply	The power supply is a customer replaceable unit (CRU) and the sole source of power for the module. The module is shipped with one power supply, but can contain an optional second power supply for redundancy.
7	Robotic lock lever	This component is used to lock down the accessor so it cannot move. This action is done when the module is moved or when the robotic assembly is removed.
8	Finger hole	One of two finger holes that are used to lift out the accessor assembly. The other is under the accessor in the photograph.
9	Spooling mechanism	This component moves the accessor.

Adding, removing, or replacing a tape drive

Table 42. Pinch hazard

	 <p>CAUTION: Risk of pinching hands or fingers. Can trap hands, fingers, and cause serious injury. Keep hands clear during operation. (L012)</p>
---	--

 **Warning:** Only individuals who are informed about the procedures and risks can replace or upgrade this tape drive assembly. Read all troubleshooting documentation and procedures before you proceed with repair or upgrade procedures. Hazardous moving parts exist inside this product. Do not insert tools or any portion of your body into the drive bay openings.

Adding a tape drive

1. If you are adding a tape drive, remove a drive bay cover. With a Philips screwdriver, remove one half-height drive bay cover to install one half-height drive, or remove two drive bays covers to install a full-height tape drive.

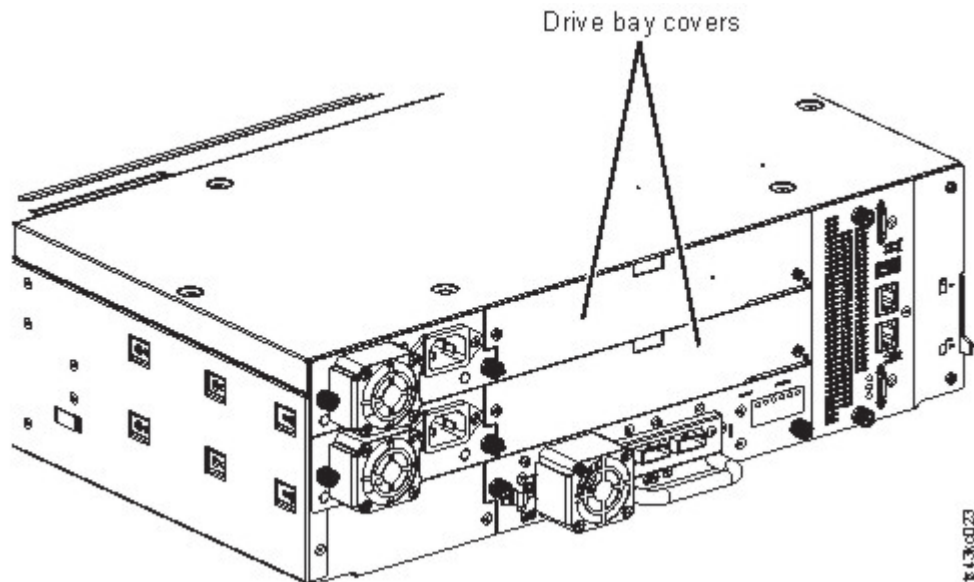

Figure 58. Drive bay covers

Note: A full-height tape drive must be installed in the lowest bay of the module.

2. Align and slowly insert the new tape drive into the drive bay along the alignment rails (1 in Figure 59 on page 120) while the drive assembly is supported. The tape drive must be flush with the back panel of the library.

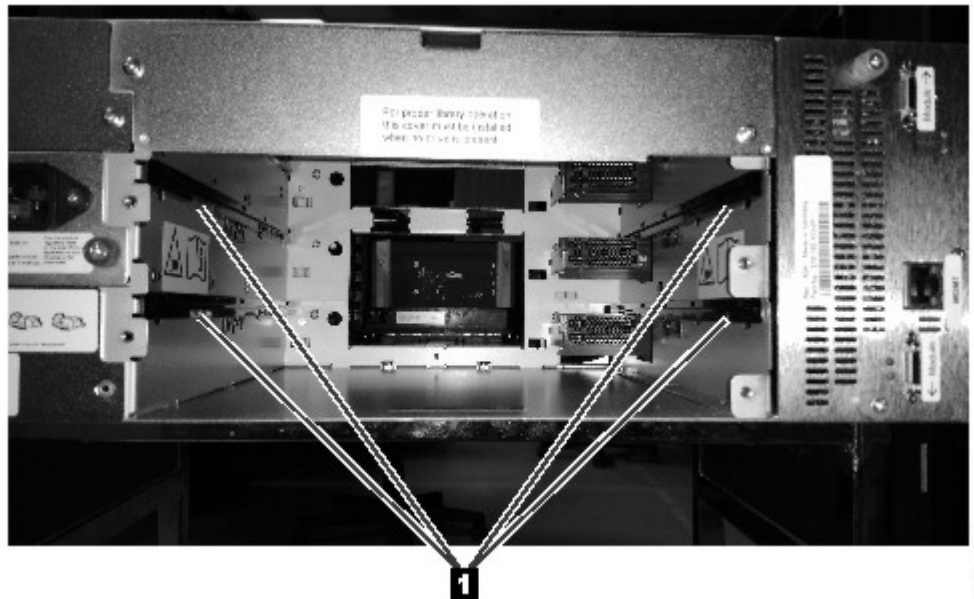

Figure 59. Alignment rails

3. Tighten the captive thumbscrews (1 in Figure 60 on page 121) with your fingers until the tape drive is secure.

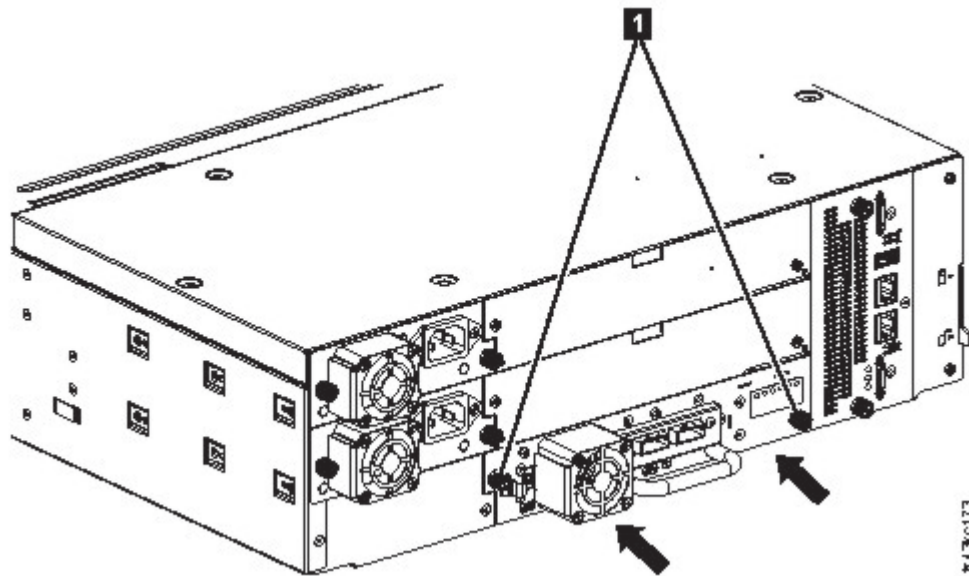

Figure 60. Installing a tape drive

4. Verify the drive operation.

Removing a tape drive

- Ensure that all host activity, including library operations are stopped to the drive being removed.
- Ensure that the tape cartridge is removed from the tape drive. Use the Management GUI to move the cartridge to a storage slot or I/O station.
- Remove the FC or SAS cables from the tape drive.
- Loosen the blue captive thumbscrews (1 in Figure 61 on page 121) on the tape drive. Press the lock lever (2 Figure 61 on page 121) to the right and pull straight back on the tape drive handle while the bottom of the drive is supported to remove it from the unit.

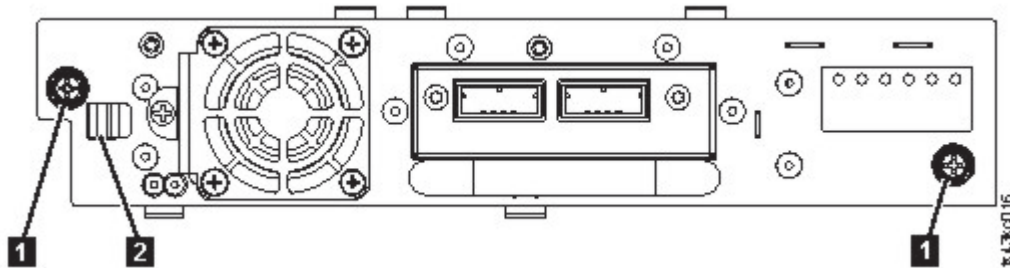

Figure 61. Unlocking the drive



Attention: Support the bottom of the tape drive when it is removed to avoid damaging any of the internal connections.

- Reset the list of known drives and modules. See [“Locating Management functions”](#) on page 65.
- Confirm that the drive is logically removed by checking the Operator Panel or Management GUI.
- If there is no replacement drive, install the drive bay cover.
- If you are replacing the drive, see [“Adding a tape drive”](#) on page 120.









Verifying Drive installation and operation

Using the Operator Panel or the Management GUI:

1. Confirm that the library recognizes the new tape drive by checking the Operator Panel or Management GUI. The new drive appears in the module status overview area on the left side of the screen.

2. Use the Management GUI or Operator Panel to verify that the tape drive has the current firmware. Update the firmware if necessary.
3. Use the Management GUI or Operator Panel to test the drive. See [“Locating Management functions” on page 65](#).

Adding or replacing a Base or Expansion Module

<p>CAUTION:</p>  <p>18-32 kg (39.7-70.5 lbs)</p>  <p>OR</p>  <p>>18 kg (39.7 lbs)</p> <p>OR</p>  <p>>18 kg (39.7 lbs)</p> <p>CAUTION:</p>  <p>32-55 kg (70.5-121.2 lbs)</p>  <p>OR</p>  <p>>32 kg (70.5 lb)</p> <p>OR</p>  <p>>32 kg (70.5 lb)</p>	<p> Warning:</p> <p>Product Weight</p> <p>Caution: The weight of this part or unit is between 18.1 and 33.6 kg (40 and 74 lb). It takes two persons to safely lift this part or unit. (C009)</p> <p>Caution: The weight of this part or unit is between 33.6 and 46.3 kg (74 and 102 lb). It takes three persons to safely lift this part or unit. (C010)</p> <p>Risk of personal injury</p> <p>Before a module is moved or lifted</p> <ul style="list-style-type: none">• Observe local health and safety requirements and guidelines for manual material handling.• Remove all tapes to reduce the weight and to prevent cartridges from falling into the robotics path and damaging the library.• Remove all tape drives to reduce the weight.• Obtain adequate assistance to lift and stabilize the module during installation or removal. <p>Risk of damage to devices</p> <p>When a module is placed into or removed from a rack</p> <ul style="list-style-type: none">• Extend the rack's leveling jacks to the floor.• Ensure that the full weight of the rack rests on the leveling jacks.• Install stabilizing feet on the rack.• Extend only one rack component at a time.
---	--



CAUTION: Parts can be damaged by electrostatic discharge. Keep parts in electrostatic containers until needed. Ensure that you are properly grounded when static sensitive components are touched.

Adding a module: Overview

To add a module to an existing configuration, you will

1. Power down the library.
2. Remove the top or bottom plate of the module. See [“Preparing top and bottom modules”](#) on page 42.
3. Install the module into the rack. See [“Installing modules in a rack”](#) on page 45.
4. Align and connect the modules. See [“Aligning and connecting modules”](#) on page 49.
5. Connect the components and cables. See [“Replacing the Module components and cables”](#) on page 128.
6. Connect the power cords, power on the library, and complete [“Verifying Library Module installation and configuration”](#) on page 128.
7. Add tape cartridges to the new module.

Replacing a module: Overview

To replace the module, you will

1. Update the library firmware to the minimum code level of 1.2.1.0-A00 or higher.
2. Save the library configuration. See [“Saving the configuration”](#) on page 124.
3. Remove tape cartridges and power off the library. See [“Removing the magazines and cartridges”](#) on page 125 and [“Powering off the library”](#) on page 125.
4. Remove all the components from the module and disconnect the power cords and cables. See [“Removing the Module cables”](#) on page 125.
5. Remove the module from the rack. See [“Removing the Module from a rack”](#) on page 126.
6. Install the replacement module into the rack. See [“Installing the Module into a rack”](#) on page 128.
7. Replace the components and cables. See [“Replacing the Module components and cables”](#) on page 128.
8. Connect the power cords, power on the library, and complete [“Verifying Library Module installation and configuration”](#) on page 128.
9. Replace the tape cartridges.

You need a T-10 Torx screwdriver to remove the drive bay covers and a small flat head screwdriver. Have several static safe bags available for the boards that are moved to the replacement chassis.

Before the replacement procedure is begun

- Ensure that the rack is level side to side and front to back.
- Verify that any applications that are using the library are idle.



Attention: If the temperature in the room where the replacement module is installed varies by 15 C (59 F) from the room where it was stored, allow it to acclimate to the surrounding environment for at least 12 hours before it is unpacked from the shipping container.

Saving the configuration

See [“Locating Management functions”](#) on page 65 for instructions on saving configuration settings to a file or an FAT32 formatted USB flash drive with the Management GUI or with the Operator Panel. This action is needed only for the Base chassis module and only as an extra safety precaution for both chassis and controller card replacement.

Note: Do not do a **Save Configuration** on a library that is in a failed state. Save the configuration on a working library only.

Removing the magazines and cartridges

For detailed instructions, see [“Locating Management functions”](#) on page 65 to open the magazines.

Note: As a best practice, complete this procedure while applications are idle. While the magazine is pulled or removed, the library robotic assembly cannot move media.

Powering off the library

Power off the library from the front panel. Depress **Power** and hold it for 5 seconds. If the library does not complete a soft shutdown, depress and hold **Power** for 10 seconds.

Important: Under normal circumstances, when the library is powered off by using the front **Power**, the robot automatically parks and locks into the Base Module behind the Operator Panel. If you are given a choice during the power down procedure, choose the default park position. To protect the spooling cable or other sensitive parts, the accessor **must** be in the Base Module before any modules are removed from the library. If it is not, follow the procedure for returning the accessor to the base module. See [“Returning the accessor to the Base Module”](#) on page 141.

Verify that all host processes are idle.

Removing the Module cables

1. Remove the power cords from the module that is replaced.
2. Remove the expansion interconnect cables (1) from the module that is replaced and from the modules that are connected to it.

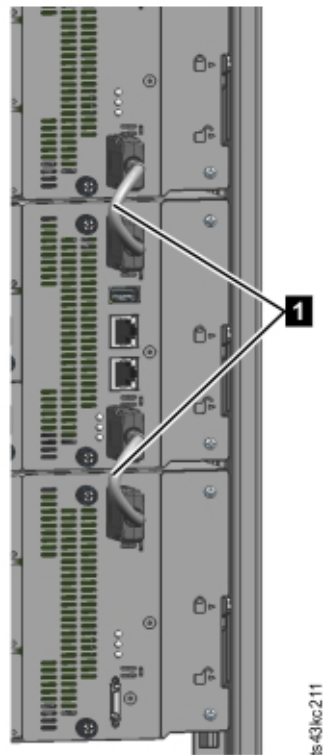

Figure 62. Interconnect cables

Note: Completely removing the cables from both ends prevents damaging the expansion interconnect cables during module removal and replacement.

3. Remove any SAS, FC, or Ethernet cables from the module that is replaced.

4. Remove the USB device, if present.

Removing the tape drives

Remove any tape drives from the module that is replaced. The library tracks the drive locations and issues events if the drives aren't in the expected locations. Note the drive locations so they can be replaced in the same order and drive bays.

1. Use your fingers to loosen the blue captive thumbscrews on the tape drive.
2. Pull straight back on the tape drive handle while the bottom of the drive is supported to remove it from the module.



Attention: Support the bottom of the tape drive when it is removed to avoid damaging any of the internal connections.

Removing the power supplies

While the power supplies are removed, be sure to support the bottom. For detailed instructions, see [“Adding, removing, or replacing a power supply”](#) on page 129.

Removing the Base or Expansion controller card

For detailed instructions, see [“Replacing a Base or Expansion controller card”](#) on page 132.

Removing the Module from a rack

Obtain assistance to lift and stabilize the module during removal and replacement.

- If you are removing a module that has a module immediately above or below it,
 1. From the front of the library, use a #2 Phillips screwdriver to loosen the screws two full turns on the module and its adjacent modules.
 2. From the back of the library, unlock the alignment mechanisms that connect the module with the adjacent modules.

Note: If a blue alignment lever lock is attached to the rear of the module, slide it to the left, then move the alignment lever. The lever lock has an internal spring, so hold it while the alignment lever is moved, and it automatically springs back into place after the lever is moved. See [Figure 43](#) on page 50.

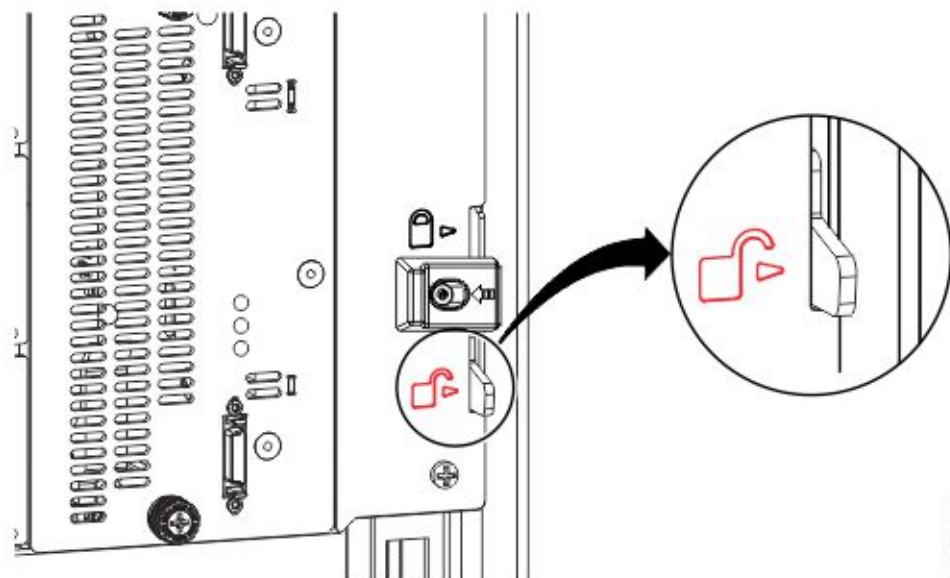

Figure 63. Unlocking or disengaging the alignment lever

ts43hc080

From the front of the library, use a #2 Phillips screwdriver and your fingers to loosen the captive thumbscrews screws two full turns on the module to be removed (circled in [Figure 64](#) on page 127). Then, slide the module out of the rack.

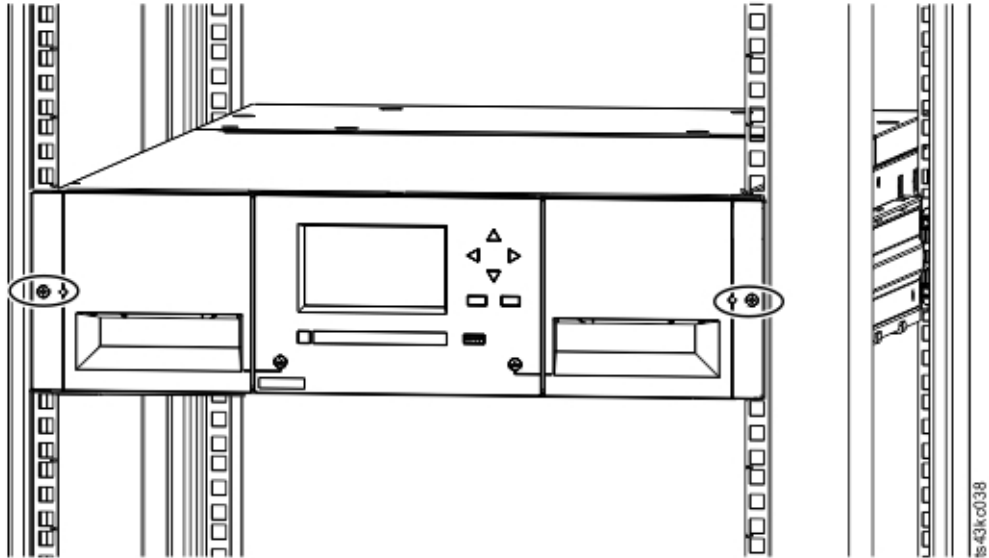

Figure 64. Loosening the thumbscrews

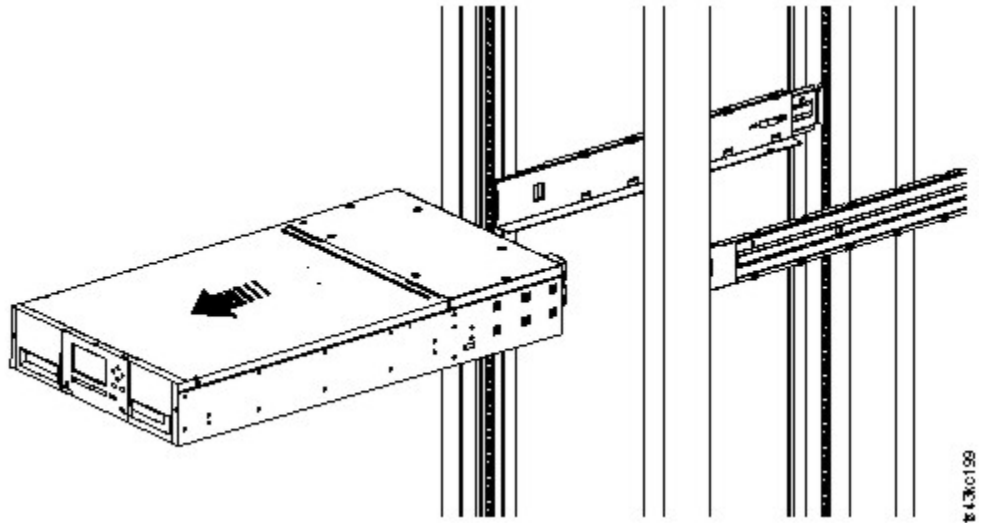

Figure 65. Sliding the module out of the rack

Moving the library cover plates

Unpack the replacement module and place it on a sturdy work surface. Save the packaging materials to return the empty module.

The Base Module has removable top and bottom cover plates. The two covers are identical and the process for removing and installing them is the same for the top and bottom of the module. See “Preparing top and bottom modules” on page 42 for details. While this procedure refers to moving a cover from the Base Module, the information is the same for moving a cover from an Expansion Module. The covers must be removed only if the failed unit does not have the covers (the cover is on another module).

The replacement module is shipped with a bottom cover plate but not a top cover plate. Move the cover plates as necessary so the replacement module has the cover plates in the same location as the empty module and the empty module has a bottom cover plate.

Installing the Module into a rack

See [“Installing modules in a rack”](#) on page 45 for details.

Replacing the Module components and cables

Replace the module components by reversing the removal procedures. Align the components carefully in the guide slots and tighten thumbscrews only with your fingers. If the thumbscrews cannot be tightened easily, verify that the component is aligned properly.

1. Replace the controller card. See [“Replacing a Base or Expansion controller card”](#) on page 132.
2. Replace the tape drives in the same locations.

Tip: To help align the drive, remove the drive bay covers for one drive at a time.

See [“Adding, removing, or replacing a tape drive”](#) on page 119.

3. Replace the magazines in the same locations.
4. Replace the power supplies. See [“Adding, removing, or replacing a power supply”](#) on page 129.
5. Reattach any SAS, FC, expansion interconnect, and Ethernet cables that was removed earlier.
6. Reinsert the USB device if you removed it earlier.
7. Reattach the power cords.

Verifying Library Module installation and configuration

- Power on the library.
- Verify that the library initializes correctly and that the status is **Ready**.
- Run **Library Verify** to verify that the replacement module is visible in the Operator Panel or Management GUI.
- If a module was replaced, validate the library configuration in the Management GUI at **Library > Logical Libraries**.
- Properly complete the Repair Identification (RID) tag that was included with the replacement module.

Note: A RID (Repair Identification) tag maintains the original serial number record of the module to ensure your warranty coverage, if applicable, is not interrupted. The tag is important for customer inventory accuracy. Follow the instructions on the RID tag precisely.

- Copy the serial number of the defective module onto the RID tag.
- Apply the tag to the front of the new replacement module.

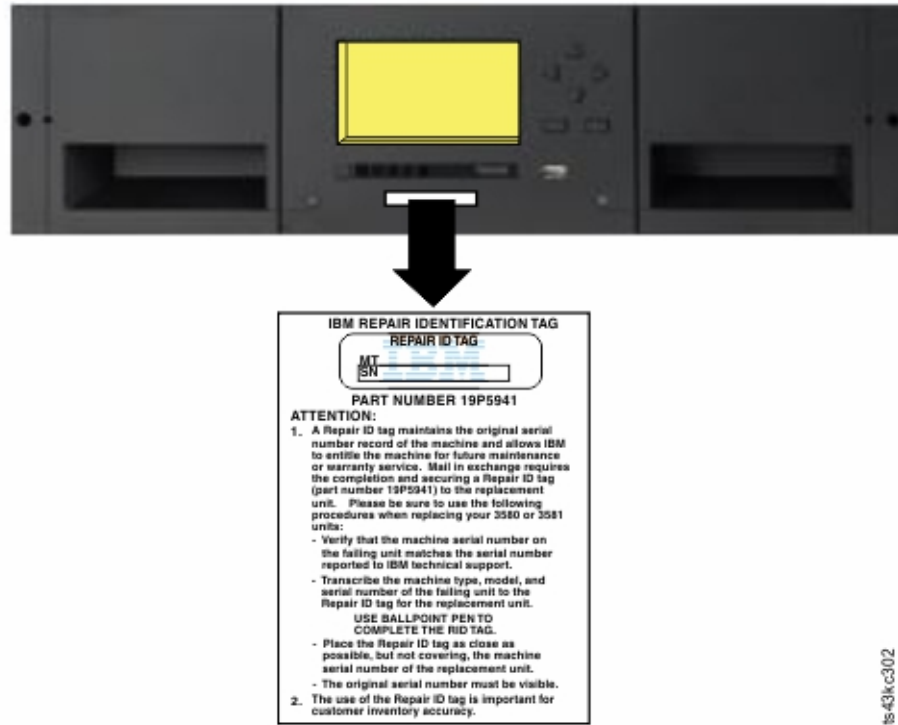



Figure 66. Placement of the RID tag (Base Module shown)

- If a module was added, you must reset your logical libraries by using the basic logical library wizard. See [“Locating Management functions”](#) on page 65 to find and run the basic logical library wizard.

Adding, removing, or replacing a power supply

	<p>CAUTION:</p> <p>Static Sensitive Risk of damage to devices</p> <ul style="list-style-type: none"> • A discharge of static electricity damages static-sensitive devices or micro circuitry. • Proper packaging and grounding techniques are necessary precautions to prevent damage.
---	--

Removing the power supply

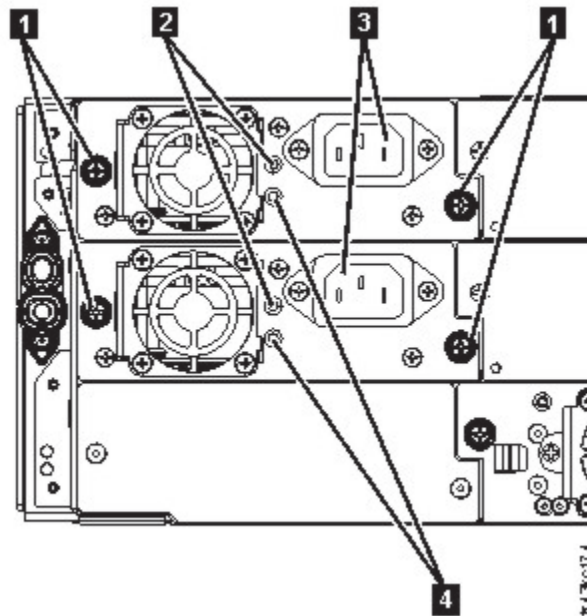

Figure 67. Power supplies

Table 43. Power supply components

1	Blue captive thumbscrews
2	White, lit if the AC power is connected.
3	AC power outlet
4	Green, lit if the module in turned on.

1. Locate the failed power supply on the rear of the library by the UID LEDs notification, and also by the power supply LEDs. Either the green LED (**4**) is lit or both LEDs are unlit.
2. Unplug the AC power cord (**3**) from the power supply you are replacing.
3. Loosen the two blue captive thumbscrews (**1**) with your fingers on the power supply.
4. Using the thumbscrews (one on each side), slowly pull the power supply approximately 10 cm (4 inches) from the back of the module.
5. Use one hand to completely remove the power supply from the module, while the other hand is used to support the bottom.

Adding or replacing the power supply

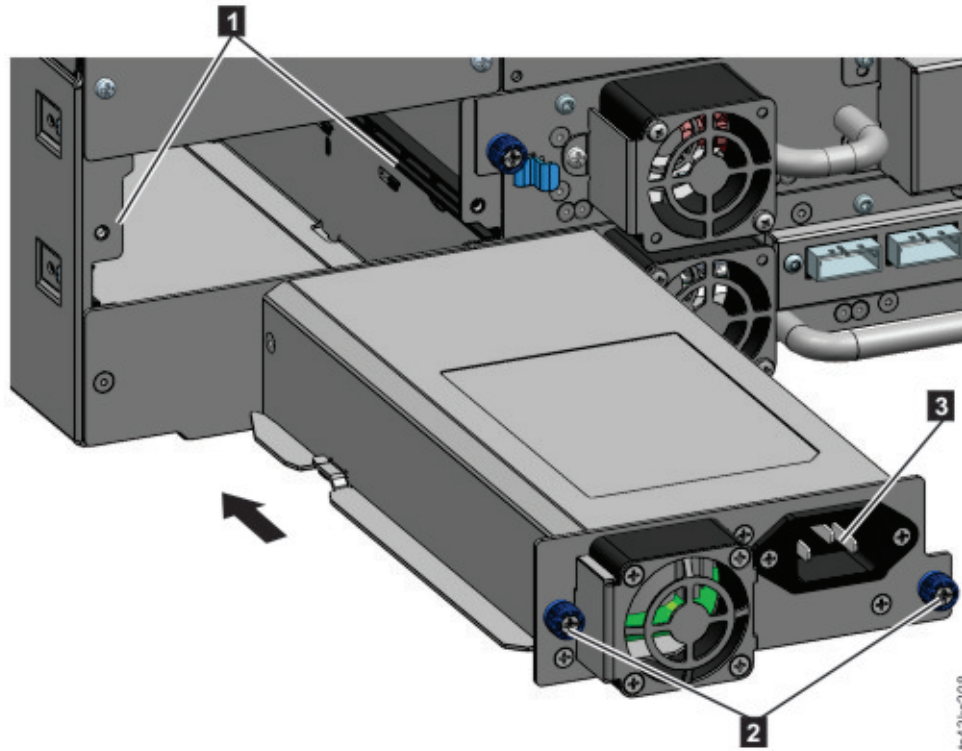

Figure 68. Sliding in the new power supply

1. Position the new power supply onto the alignment rails (1).
2. Slide the power supply into the module until it is flush with the back panel of the module.
3. Tighten the blue captive thumbscrews (2) with your fingers to secure it to the module.
4. Attach the AC power cord to the new power supply (3) and plug the power cord into an outlet.

Installing a secondary power supply

1. Position the secondary power supply onto the alignment rails. Note the positions of the primary versus the secondary power supplies - top versus middle bay.
2. Slide the power supply into the module until it is flush with the back panel of the module.
3. Tighten the blue captive thumbscrews with your fingers to secure it to the module.
4. Attach the AC power cord to the new secondary power supply.

Verifying the power supply installation and operation

1. Verify that the new power supply is operating properly by checking the power supply LEDs.
 - The white (2 in Figure 67 on page 130) LED is lit.
 - The green (4 in Figure 67 on page 130) LED is unlit.

Note: If a second power supply is installed when the TS4300 is powered on (concurrent MES), the green LED is lit.

With the Operator Panel or Management GUI, confirm that the power supply is operating correctly. The event that indicated that the power supply was faulty is cleared.

2. If the UID LEDs are still illuminated, deactivate them by using the Operator Panel or Management GUI.

Replacing a Base or Expansion controller card



CAUTION:

- Parts can be damaged by electrostatic discharge. Keep parts in electrostatic containers until needed. Ensure that you are properly grounded when static sensitive components are touched.
- You must power off the library to install or replace this part or damage can occur.

Important: Do not replace both the base chassis and the Base Module controller card with repair components in the same procedure. The firmware does not allow the library to operate if both components are replaced at the same time. Critical library information is saved in the controller card and within the chassis. When one is replaced, the data from the original component is transferred to the repair component. If both the base chassis and Base Module controller are replaced, you must power cycle the library between component replacements.

Saving the configuration

See [“Locating Management functions”](#) on page 65 for instructions on saving configuration settings to a file with the Management GUI or with the Operator Panel. This procedure is done when a Base Module controller card is replaced, or as an extra precaution when both the controller card and the module are replaced.

Note: Do not do a **Save Configuration** on a library that is in a failed state. Save the configuration on a working library only.

Powering off the library

Verify that all host processes are idle, then power off the library from the front panel. Depress **Power** and hold it for 5 seconds. If the library does not complete a soft shutdown, depress and hold **Power** for 10 seconds.

Important: Under normal circumstances, when the library is powered off by using the front **Power**, the robot automatically parks and locks into the Base Module behind the Operator Panel. If you are given a choice during the power down procedure, choose the default park position. To protect the spooling cable or other sensitive parts, the accessor **must** be in the Base Module before any modules or drives are removed from the library. If it is not, follow the procedure for returning the accessor to the base module. See [“Returning the accessor to the Base Module”](#) on page 141.

Removing the controller card

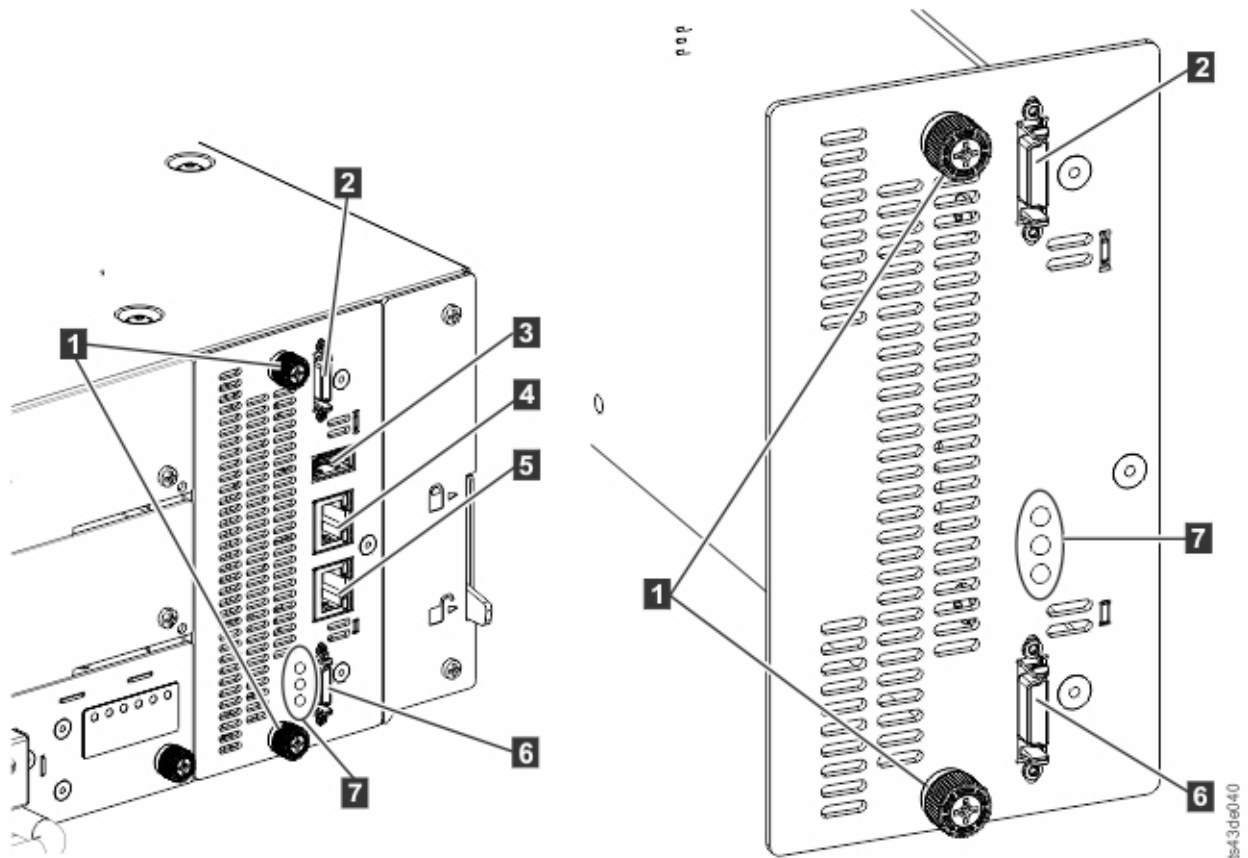

Figure 69. Controller card components

Note: The base controller card is on the left, and the expansion controller card is on the right.

1	Blue captive thumbscrews
2	Upper Expansion Module connection port
3	USB Port
4	Ethernet Port A
5	Ethernet Port B
6	Lower Expansion Module connection port
7	Controller card LEDs, top to bottom <ul style="list-style-type: none"> • Green Controller Health Status. The flashing LED indicates that the controller is in good health status and properly working. • Yellow Controller Error. This LED turns on if the controller has a hardware issue. In this case, the green LED stops flashing. • Blue Unit Identifier. This LED is a beacon that can be turned on or off through the Management GUI. The LED gives the user an indication that the controller needs attention. See “Identifying a failed component” on page 77.

1. Unplug the AC power cables from the module that contains the failed controller card.
2. On the module that contains the failed controller card, remove the expansion interconnect cables (**2** and **6**) that connect to other modules, if present.

3. Remove the Ethernet cables (4) and (5) and the USB cable (3), if present. (An Expansion Module does not have Ethernet or USB ports. See Figure 69 on page 133).
4. Loosen the two blue captive thumbscrews (1) on the controller.
5. Using the thumbscrews, slowly remove the controller from the module.

Installing the Base or Expansion controller card

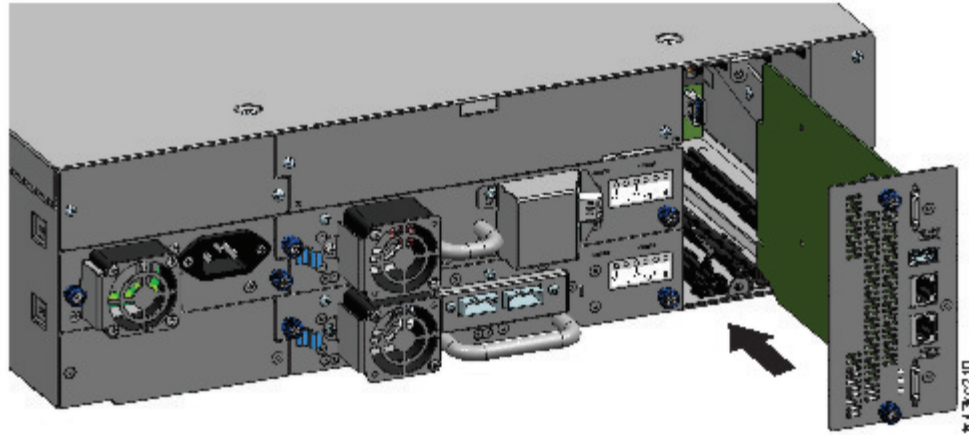

Figure 70. Installing a Controller card

Important: Base and Expansion Module controller cards are keyed to fit in their respective modules only. A Base Module controller card **does not fit** into an Expansion Module, and vice versa. If you encounter resistance when the controller card is installed, make sure that you are installing the controller card into the appropriate module.

1. Position the new controller card on the alignment rails.
2. Slide the controller card slowly into the module until it is flush with the back panel of the module.
3. Tighten the blue captive thumbscrews (1) with your fingers to secure it to the module.
4. Replace the expansion interconnect cables (2) and (6), the Ethernet cable or cables (4) and (5), and the USB cable (3) that were removed previously. (An Expansion Module does not have Ethernet or USB ports. See Figure 69 on page 133).
5. Plug in the AC power cables.

Powering on the library

Power on the library by pressing **Power** on the Base Module just below the Operator Panel. The green light illuminates. When the library is powered on, it inventories the tape cartridges in the magazines, checks the firmware version on all modules, and configures the tape drives. Then, the library confirms the presence of the existing modules, and searches for any new modules.

Verifying the Base or Expansion controller card



1. Verify that the library has the most up-to-date firmware revision. To find the version of firmware that is installed on the library, check the **Library Properties** page of the Management GUI or the **Status > Library** page of the Operator Panel.
2. If the Base Module controller is replaced, upgrade the firmware if necessary. Update the firmware from the Management GUI at **Library > Actions > Update Library Firmware**.

Important: If you are asked whether to retain the serial number, always select **Yes**.

3. Check the **Attention** light on the front panel and login to web interface and check the dashboard for any alerts.
4. With the Operator Panel or the Management GUI, check for any events. The event that indicated that the controller was faulty is cleared.

5. If the base module controller is replaced, the library configuration is automatically restored. Validate the library configuration, and complete a **Restore** if the library configuration was not restored.
6. If the UID LEDs are still illuminated, deactivate them by using the Operator Panel or Management GUI.
7. Resume the host applications.

Installing, removing, or replacing an accessor and spooling mechanism



	 <p>CAUTION: Parts can be damaged by electrostatic discharge. Keep parts in electrostatic containers until needed. Ensure that you are properly grounded when static sensitive components are touched.</p>
---	--

Powering off the library

Verify that all host processes are idle, then power off the library from the front panel. Depress **Power** and hold it for 5 seconds. If the library does not complete a soft shutdown, depress and hold **Power** for 10 seconds.

Important: Under normal circumstances, when the library is powered off by using the front **Power**, the robot automatically parks and locks into the Base Module behind the Operator Panel. If you are given a choice during the power down procedure, choose the default park position. To protect the spooling cable or other sensitive parts, the accessor **must** be in the Base Module before any components are removed from the library. If it is not, follow the procedure for returning the accessor to the base module. See [“Returning the accessor to the Base Module”](#) on page 141.

Preparing to remove the accessor and spooling mechanism from the Base Module

	 <p>Warning:</p> <p>When a module is extended from the library - to reduce the risk of personal injury or damage to equipment</p> <ul style="list-style-type: none"> • Extend the rack-leveling jacks to the floor. • Ensure that the full weight of the rack rests on the leveling jacks. • Verify that the rack is level side to side and front to back. • Install the rack stabilizer kit on the rack. • Extend only one rack component at a time. Racks can become unstable if more than one component is extended.
---	--

1. Loosen the front captive screws that connect the Base Module to the rack two full turns.
2. If adjacent Expansion Modules exist
 - a. Loosen the front captive screws two full turns on the adjacent expansion modules.
 - b. Unlock the alignment lever.
 - c. Disconnect and completely remove the expansion interconnect cables from the Base Module and from the adjacent modules. Removing the expansion interconnect cables completely prevents damaging the cables when the module is moved in and out of the rack.
3. Disconnect the power supply cables on the Base Module.
4. Disconnect the Ethernet, SAS, and Fibre Channel cables from the Base Module.
5. Completely loosen the front captive screws of the Base Module.
6. Slowly extend the Base Module from the front of the rack and remove it from the rack.

7. Place the Base Module on a flat, level surface, such as a table.
8. Remove the top library cover plate, if present.
 - a. Unlock the top cover with two small screwdrivers.
 - b. Remove the cover from the module.

Removing the accessor and spooling mechanism from the Base Module

1. Remove the left and right magazines by using the magazine release levers (circled in [Figure 71](#) on [page 136](#)). Push up on the lever, then pull the magazine out.

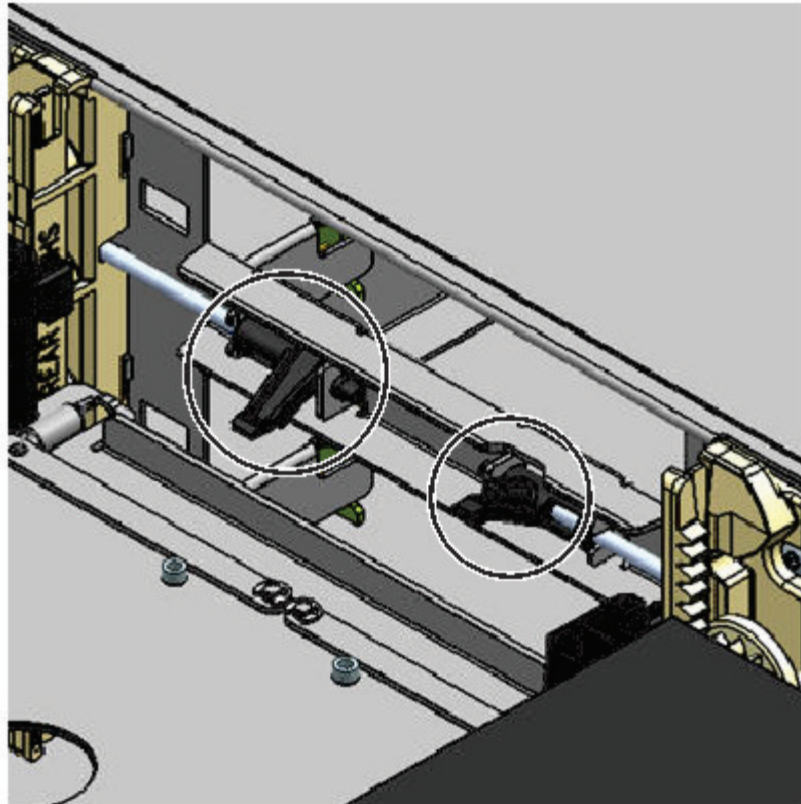

Figure 71. Magazine release levers

2. Slide the cartridge carrier toward the center of the accessor to access the robot-locking lever.
3. Standing at the front of the module, unlock the robot by moving the blue lever to the left, then toward you, then to the right.

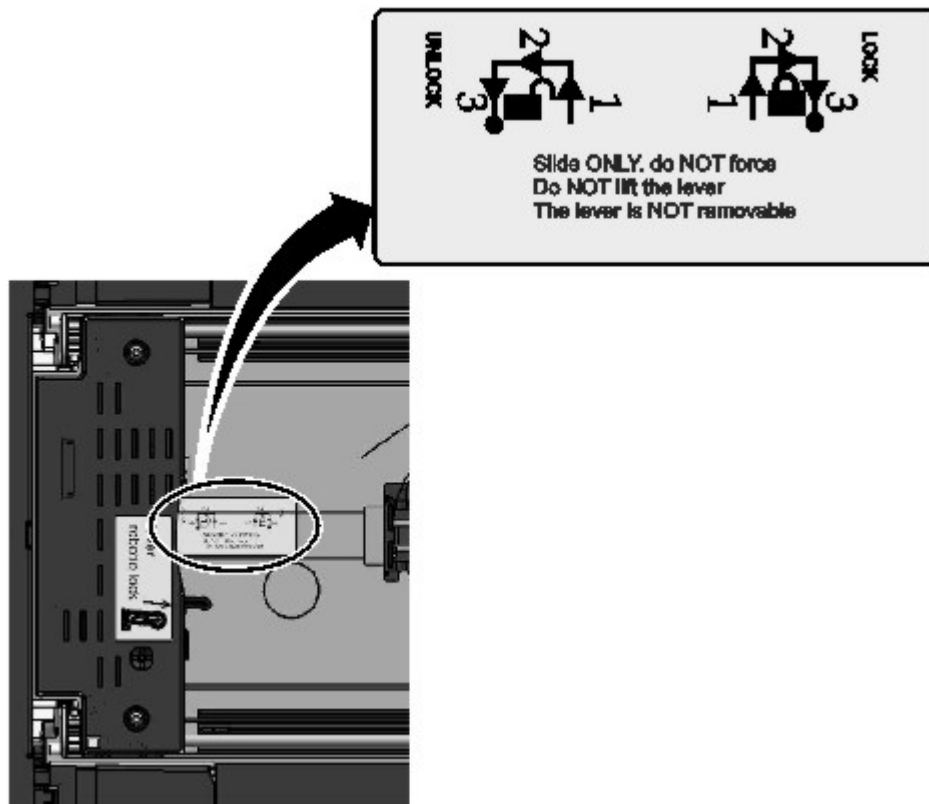

Figure 72. Unlocking the robot

4. Place your fingers into the large holes on the accessor and pull up slowly.

Note: The accessor offers resistance. Lift the accessor no faster than 12 mm (0.5 inches) per second.

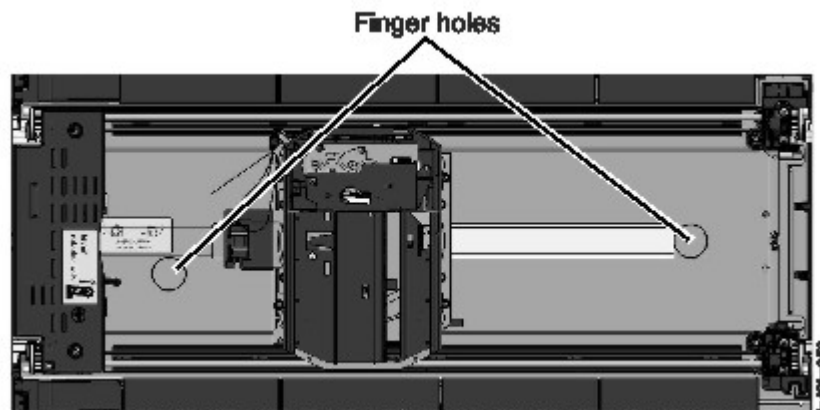

Figure 73. Finger holes

5. Lift the accessor gently from the module and place it on top of the gear mechanism. Take care not to damage the spooling cable.
6. Lock the robot to keep it from lowering
7. On the top of the accessor where the spooling cable is attached, press down on the latch (1 in Figure 74 on page 138), then tilt out the piece that holds the spooling cable (2).

Note: Note where the end of the spooling cable pivots in the accessor. It is important to know when you attach the new spooling cable to the accessor. See 2 in Figure 75 on page 138.

8. Lift the spooling cable from the accessor and place it in its cradle at the top of the spooling mechanism (3 in Figure 74 on page 138).

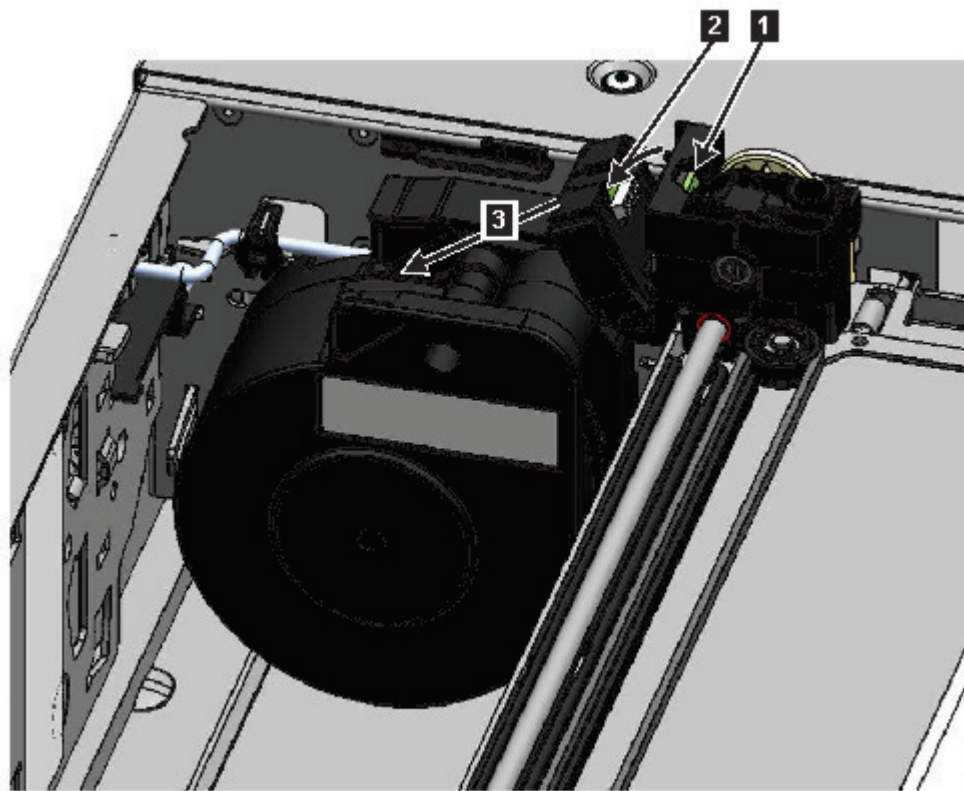

Figure 74. Unlocking the spooling cable and placing it in its cradle

9. Place the spooling connector (1 in Figure 75 on page 138) to the park position.

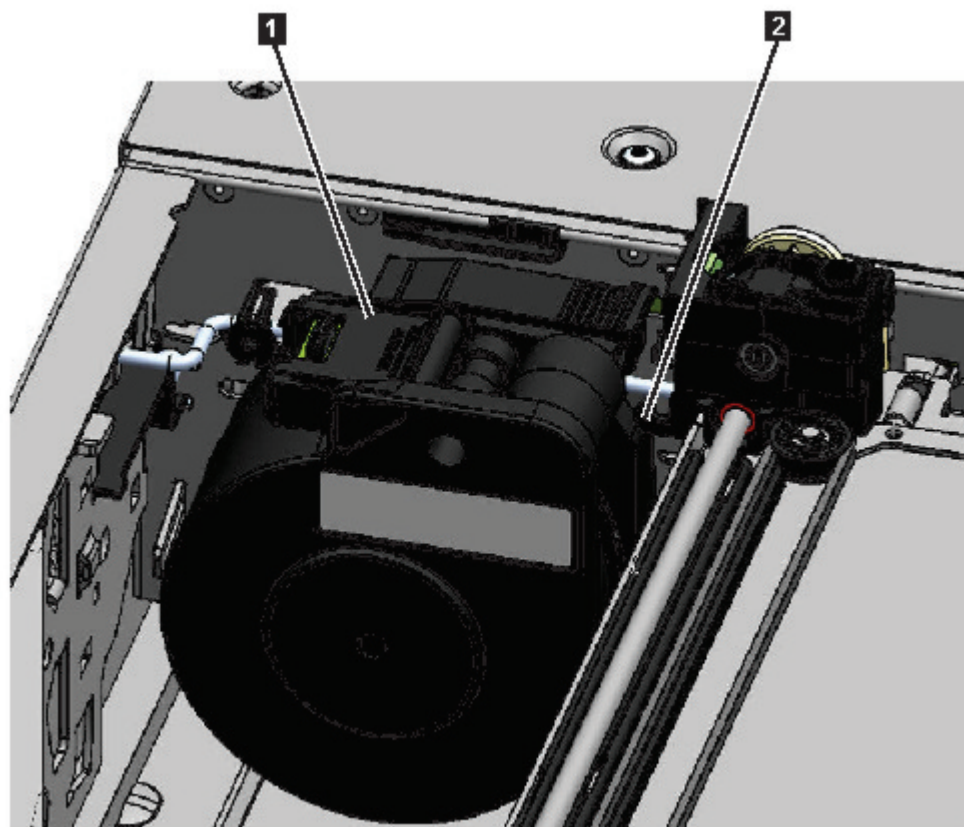

Figure 75. Spooling cable in park position

10. Unlock the lever and set aside the accessor. See [Figure 72 on page 137](#).

Important: If a tape cartridge is still in the cartridge carrier, remove the cartridge by lifting it straight up. You might need to move the cartridge slightly from side to side.

11. Replace the spooling mechanism. Refer to [“Removing or replacing a spooling mechanism” on page 143](#).

Installing the accessor into the Base Module

Important: If an accessor assembly is replaced, the minimum library firmware must be 1.2.1.0-A00. Go to **Library > Actions > Update Library Firmware** to update the library firmware.

1. Each corner of the accessor has a gear with two protruding pins. Rotate one of the gears on the accessor so that the two pins are aligned horizontally. See [Figure 76 on page 139](#)

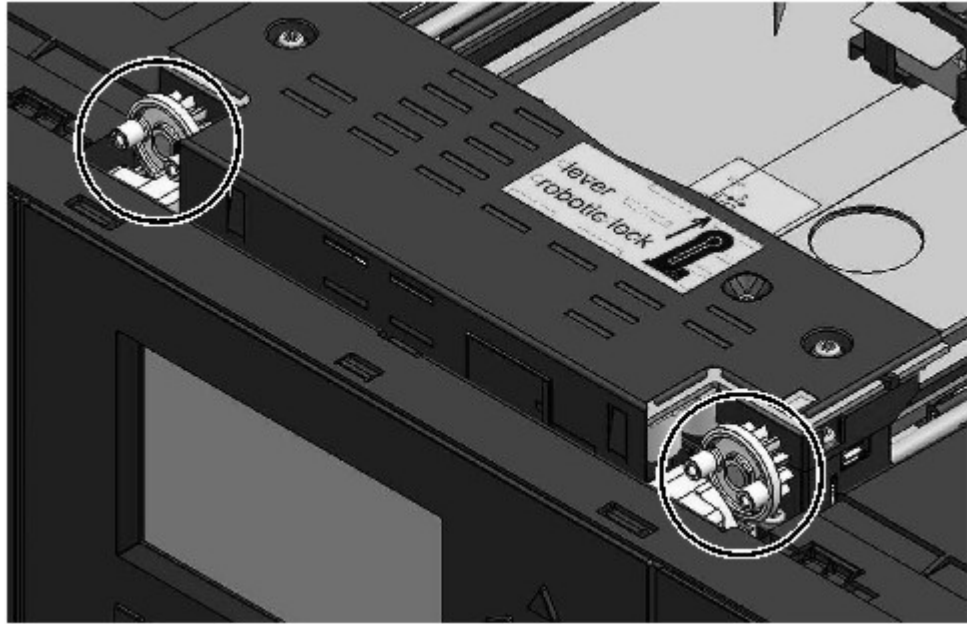

Figure 76. Pins are aligned horizontally

2. The accessor is shipped with the robot in the unlocked position. Verify that the replacement unit is **locked**, then set it on top of the gears.
3. Place the gears of the accessor into the grooves on the inside corners of the module. **Confirm that all four of the pins are touching the outside of the grooves.**
4. Standing at the right side of the module, remove the end of the spooling cable from the park position.
5. Place the spooling cable into the grooves where it attaches to the accessor and rotate it until it snaps into place. See [Figure 77 on page 140](#).

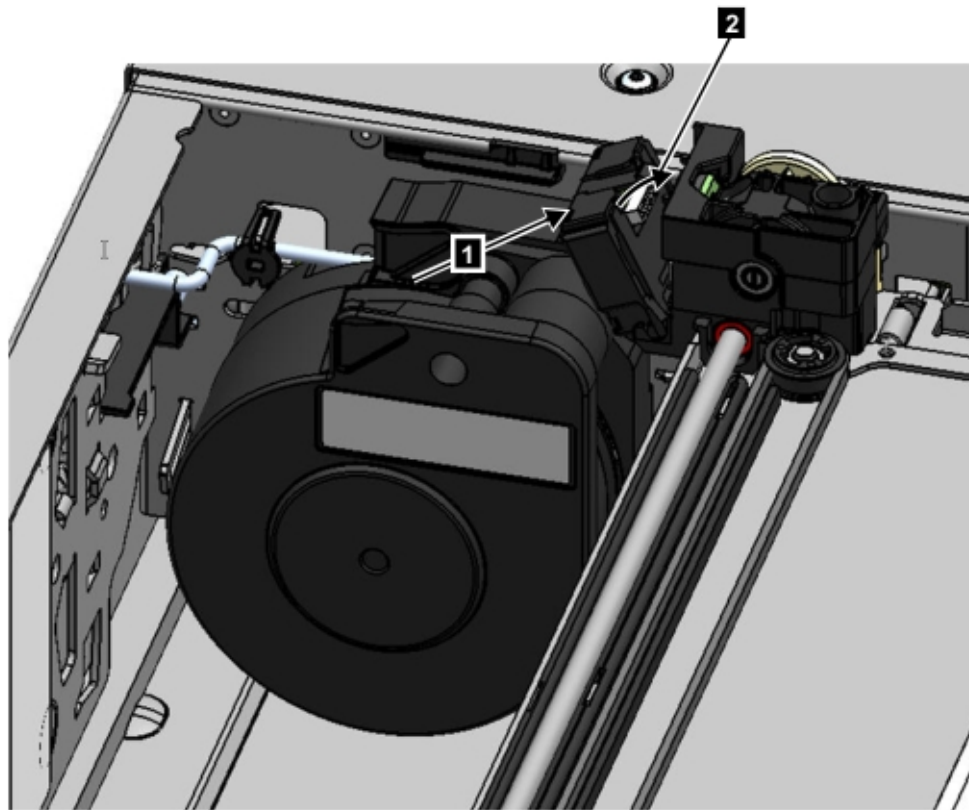

Figure 77. Installing the spooling cable

6. Unlock the accessor. The accessor drops smoothly. If it does not, check the alignment of the gears.
7. Before the accessor gets to the bottom, lock the robot. Standing at the front of the module, move the blue lever to the left, then away from you, then to the right.

Tip: If the end of the spooling cable drops into the module, unlock the accessor, remove it from the module, return the end of the spooling cable to its cradle, return the accessor to its previous position in the module, relock the accessor, and repeat the procedure.

After the accessor and spooling mechanism installation

1. Push the magazines back into the module until they lock into place.
2. Replace the top cover on the Base Module if you removed one.
3. Slide the module into the rack.
4. If no adjacent modules exist, tighten the front screws.
5. If adjacent modules exist
 - a. Set the alignment mechanisms to the lock position. If you encounter resistance, adjust the upper module so the pin in the alignment mechanism moves into the hole in the lower module.
 - b. When the alignment mechanism is in the locked position, tighten the front screws on the module
 - c. Reconnect the expansion interconnect cables.
6. Reconnect the Ethernet, SAS, and Fibre Channel cables to the Base Module.
7. Reconnect the power supply cables to the Base Module.
8. Pack the failed accessor and spooling mechanism to return to your service.

Powering on the library

1. Power on the library by pressing **Power** on the Base Module just below the Operator Panel for 5 seconds.

2. The green light illuminates.
3. When the library is powered on, it inventories the tape cartridges in the magazines, checks the firmware version on all modules, configures the tape drives, confirms the presence of the existing modules, and searches for any new modules.

Verifying the installation

1. Verify that the library powers on and initializes correctly, and that the status is **Ready**.
2. If the UID LEDs are still illuminated, deactivate them by using the Operator Panel or Management GUI.
3. Run **Library Verify** to ensure that the library is working correctly.

Returning the accessor to the Base Module

If you powered off the library and the accessor did not return to its park position in the Base Module behind the Operator Panel.

1. Power on the library by pressing **Power** on the Base Module just below the Operator Panel.
2. Return the accessor to its park position.
3. Power off the library by pressing **Power** on the Base Module and holding for 5 seconds.

If the accessor is still not in the Base Module, use one of the procedures in the following two sections.

If the accessor is stopped in an Expansion Module that is near the Base Module or is stopped directly between two modules.

1. Remove the front bezel from the Base Module, the Expansion Module containing the accessor, and modules in between as needed.
2. Insert a small flat head screwdriver into the screwdriver relief on the right rear bearing block of the accessor.

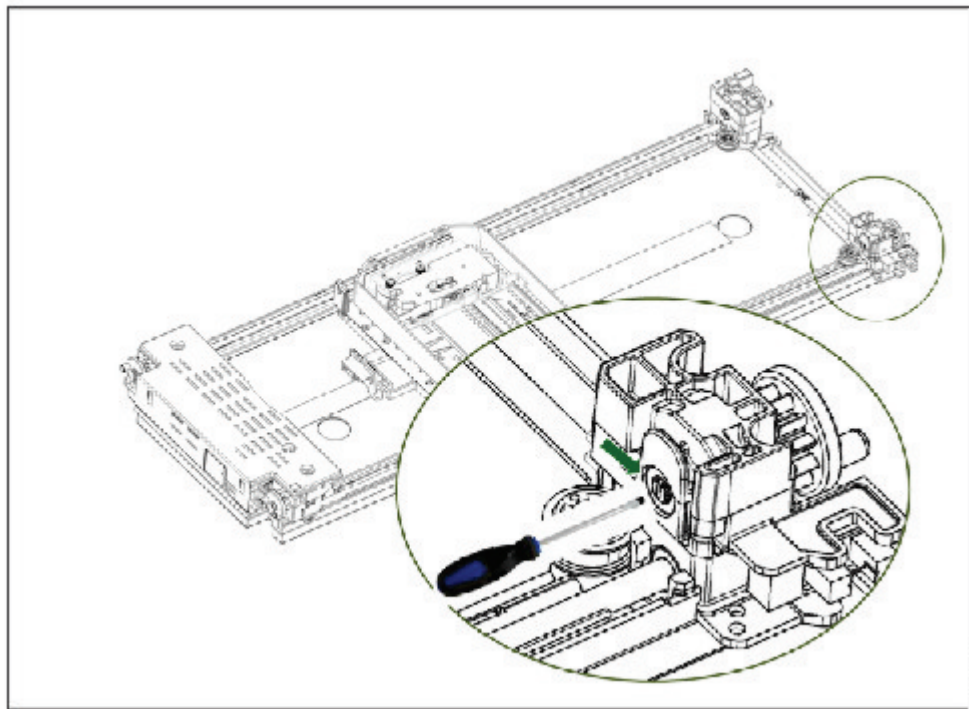

Figure 78. Inserting the screwdriver to manually operate the accessor

3. Turn the screwdriver to manually operate the accessor gear train and move the accessor into the Base Module.

4. Lock the accessor. Standing at the front of the module, move the blue lever to the left, then away from you, then to the right.
5. Reinstall the bezels that were previously removed.
6. Remove the accessor and spooling mechanism. See [“Preparing to remove the accessor and spooling mechanism from the Base Module”](#) on page 135.
7. Install the new accessor and spooling mechanism. See [“Installing the accessor into the Base Module”](#) on page 139.
8. Slide the Base Module back into the rack. See [“After the accessor and spooling mechanism installation”](#) on page 140.

If the accessor is stopped in an Expansion Module that is not near the Base Module or it cannot move vertically.

1. Remove the left magazine of the Base Module. See [“Removing or replacing a magazine”](#) on page 147. The library must already be powered off. Therefore, you must unlock the magazine by using the manual release.
2. Disconnect the power supply cables from all of the modules.
3. Using plastic-handled scissors, reach through the left magazine opening of the Base Module and carefully cut the spooling cable.

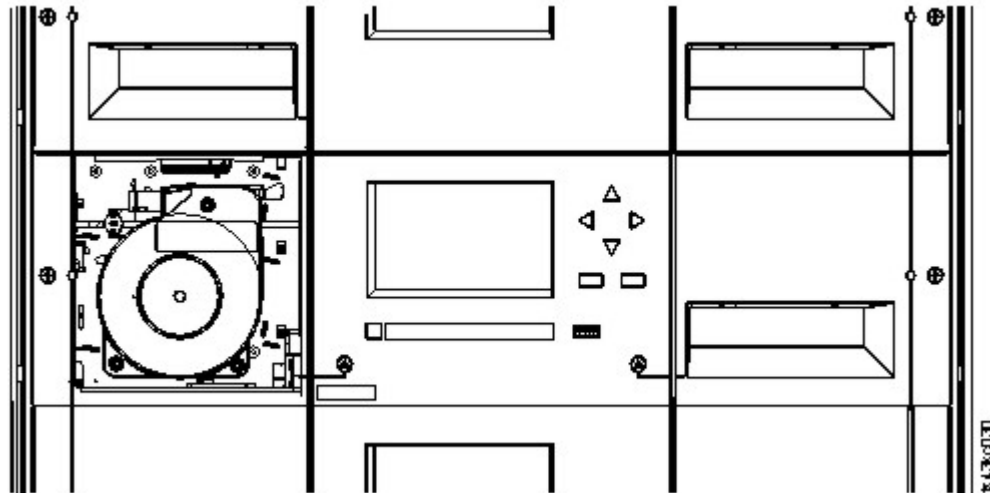

Figure 79. Left magazine opening

4. Extend the expansion module that contains the accessor while carefully guiding the free spooling cable. See [“Preparing to remove the accessor and spooling mechanism from the Base Module”](#) on page 135. While minor differences might occur, these instructions for a Base Module also apply to an Expansion Module.
5. Remove the accessor from the Expansion Module by using Step 1 through Step 7 in [“Removing the accessor and spooling mechanism from the Base Module”](#) on page 136.
6. Slide the Expansion Module back into the rack. See [“After the accessor and spooling mechanism installation”](#) on page 140. While minor differences might occur, these instructions for a Base Module also apply to an Expansion Module.
7. Extend the Base Module. See [“Preparing to remove the accessor and spooling mechanism from the Base Module”](#) on page 135.
8. Remove the spooling mechanism from the Base Module by using Step 8 through Step 10 in [“Removing the accessor and spooling mechanism from the Base Module”](#) on page 136.
9. Install the new accessor and spooling mechanism. See [“Installing the accessor into the Base Module”](#) on page 139.
10. Slide the Base Module back into the rack. See [“After the accessor and spooling mechanism installation”](#) on page 140.

Removing or replacing a spooling mechanism

Occasionally, only the robotic spooling cable must be removed and replaced. See [“Identifying a failed component”](#) on page 77.

1. Power down the library.

Important: Under normal circumstances, when the library is powered off by using the front **Power**, the robot automatically parks and locks into the Base Module behind the Operator Panel. If you are given a choice during the power down procedure, choose the default park position. To protect the spooling cable or other sensitive parts, the accessor **must** be in the Base Module before any components are removed from the library. If it is not, follow the procedure for returning the accessor to the base module. See [“Returning the accessor to the Base Module”](#) on page 141.

2. Refer to [“Preparing to remove the accessor and spooling mechanism from the Base Module”](#) on page 135 for the steps in preparing your library.
3. Remove the left magazine to provide clear access to the spooling mechanism.
4. Follow the steps in [“Removing the accessor and spooling mechanism from the Base Module”](#) on page 136 to remove the accessor, disconnect the spooling cable, and place it in the park position.
5. Push down on the lever on the top of the spooling mechanism (1) and slide about 10 mm towards the center (2) to unlock the mechanism.

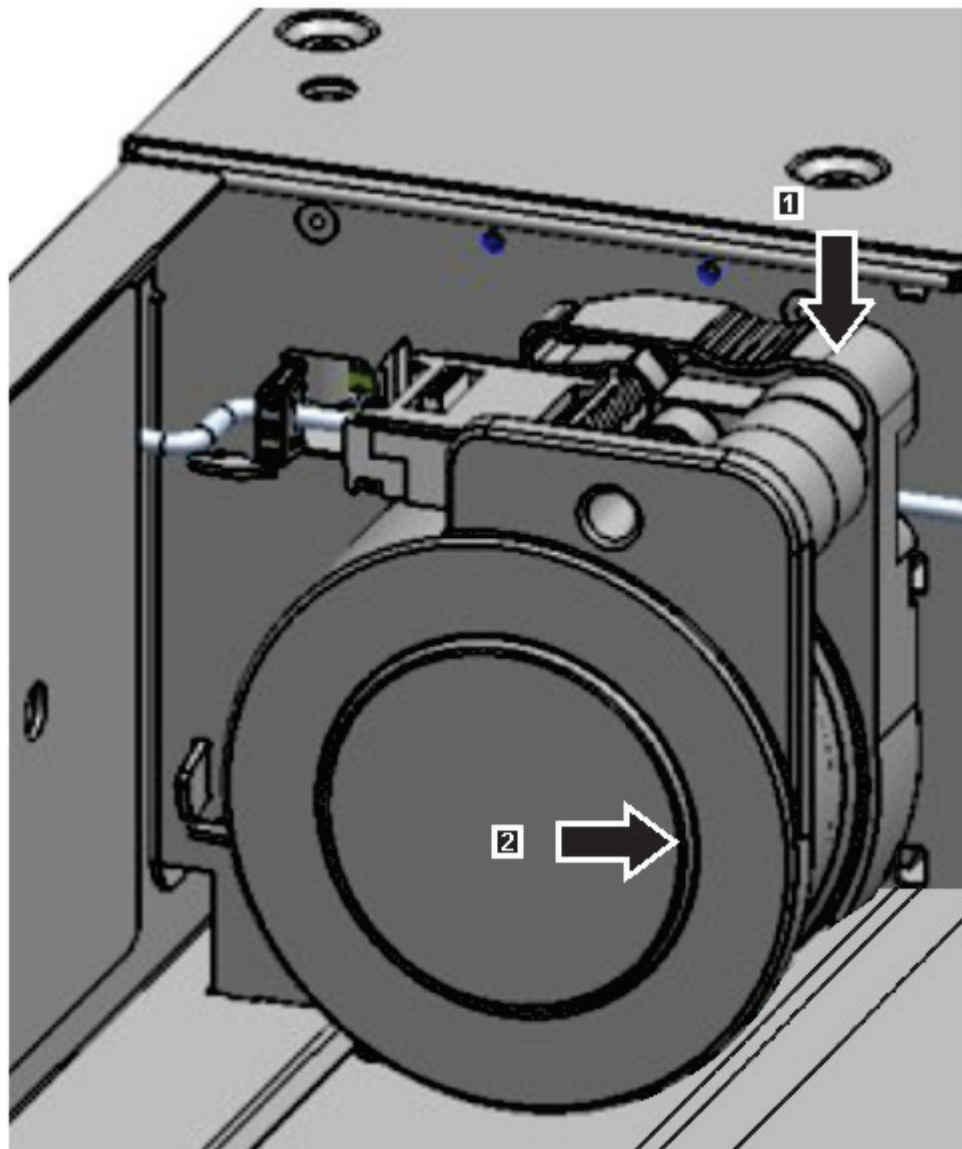

Figure 80. Unlocking the spooling mechanism

Note: Make sure that the spooling mechanism is unlocked before you try to pull it out. When the mechanism is unlocked, the cutout behind the mechanism is covered, and the mechanism cannot slide any further to the center.

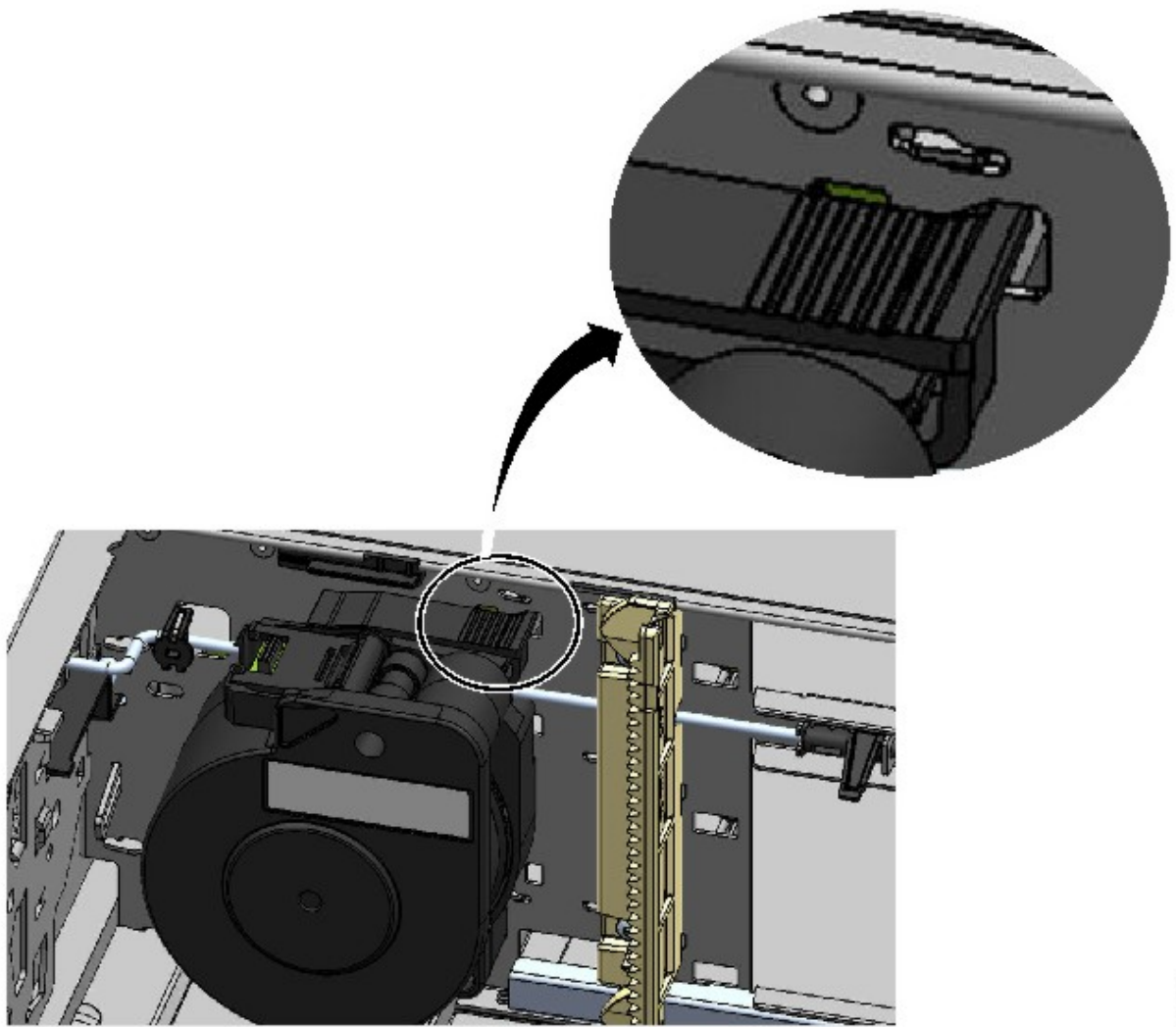
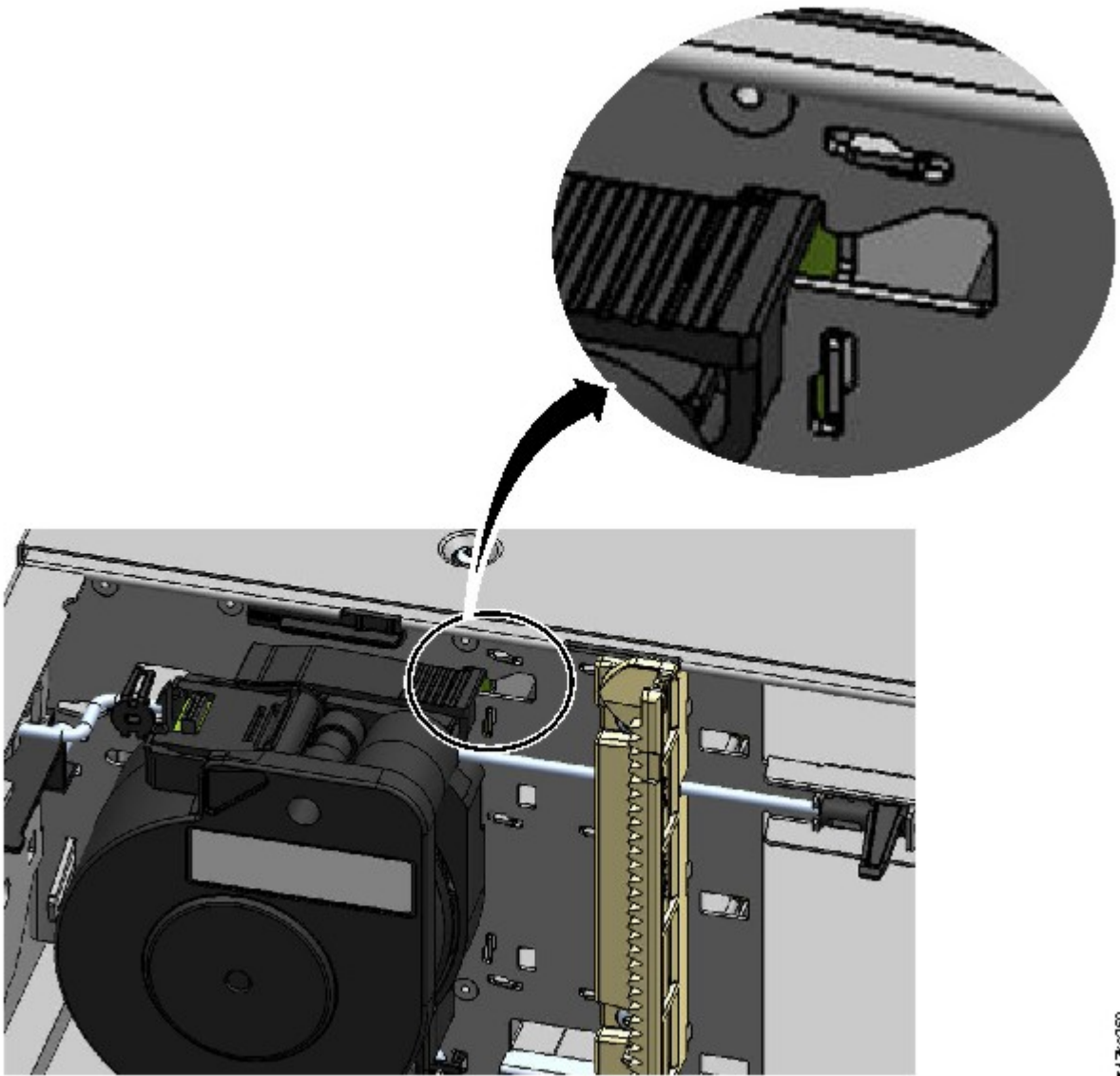

Figure 81. Unlocked spooling mechanism - enlarged view

18-43362-005



43K0269

Figure 82. Locked spooling mechanism - enlarged view

6. Pull the spooling mechanism towards the front of the module to remove it.

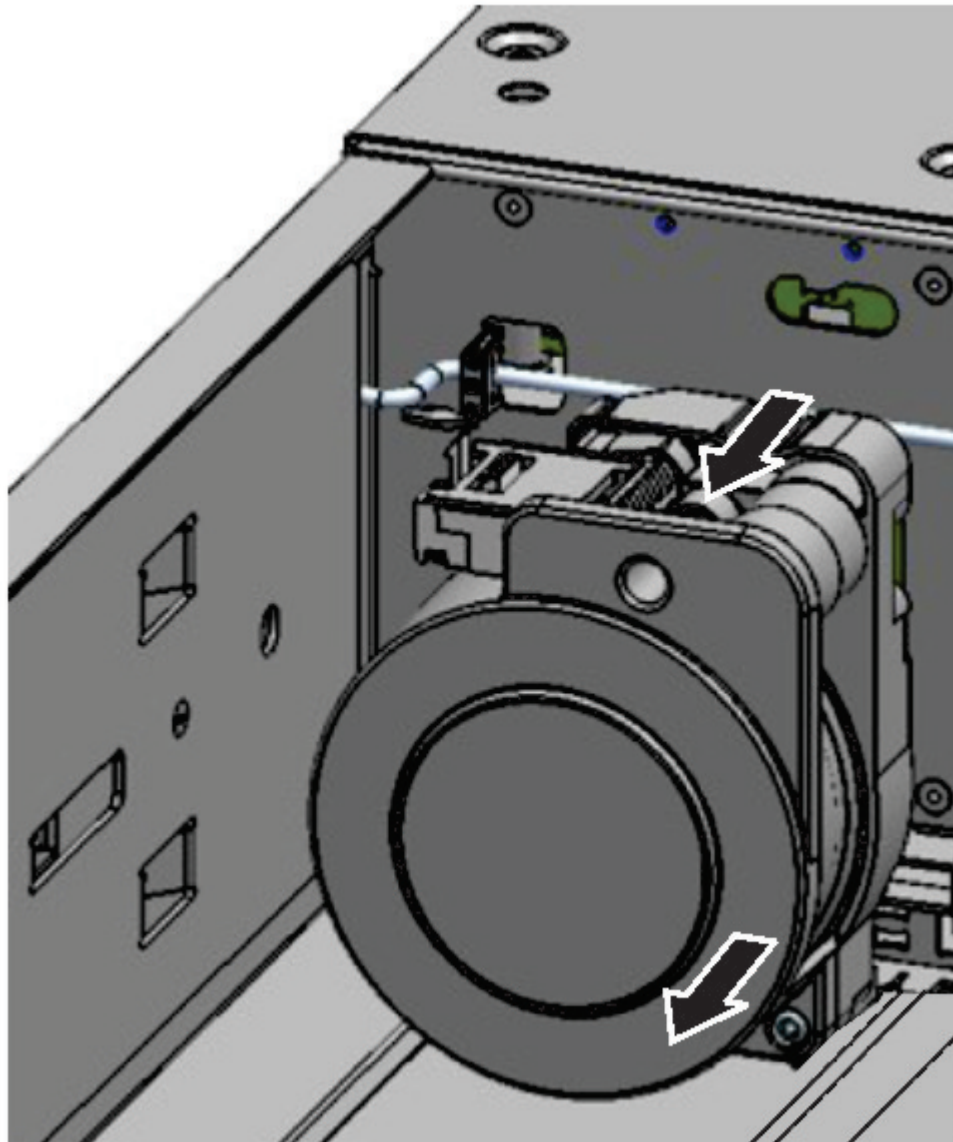

Figure 83. Removing the spooling mechanism

7. Reverse the steps to replace the failed spooling mechanism with the new unit.
8. Follow the steps in [“Installing the accessor into the Base Module”](#) on page 139 and [“After the accessor and spooling mechanism installation”](#) on page 140 to put the library back into service.

Removing or replacing a magazine

It is recommended that you unlock the magazine with the Operator Panel, Management GUI, or the release button on the front panel. If these methods fail, or if a magazine needs to be removed when the power to the device is off, you can release the magazine manually. Only one magazine or I/O station can be open at a time.

Note: This procedure is completed more effectively while applications are idle. While the magazine is extended, the library robotic assembly cannot move media.

1. Log in as an administrator.
2. Go to **Library > Modules and Magazines**.
3. On the **Actions** menu, click **Unlock Magazine**.

4. Click **Open** in the left or right magazine column within the module that contains the magazine to be opened.
5. A message box indicates when the magazine is unlocked.
6. **Unlock Magazine** screen shows that the magazine is now unlocked.

Note: If not removed, the magazine and the I/O station relock after 30 seconds.

To manually eject the magazine, insert a paper clip or a small flat head screwdriver into the appropriate magazine release hole and gently push the tab in. See [Figure 84 on page 148](#) and [Figure 85 on page 148](#).

1. Open the magazine access door.
2. Insert a paper clip or a small flat head screwdriver into the appropriate magazine release hole and gently push the tab in.



Figure 84. Manually releasing the right magazine











Figure 85. Manually releasing the left magazine

3. Pull the magazines out of the module.

Moving the library modules

When a library module is moved within the rack, to a different rack, or in a rack to a different physical location, care must be taken to avoid personal injury and damage to the module.

<p>CAUTION:</p>   <p>OR</p>  <p>OR</p>  <p>CAUTION:</p>   <p>OR</p>  <p>OR</p> 	<p> Warning:</p> <p>Product Weight</p> <p>Caution: The weight of this part or unit is between 18.1 and 33.6 kg (40 and 74 lb). It takes two persons to safely lift this part or unit. (C009)</p> <p>Caution: The weight of this part or unit is between 33.6 and 46.3 kg (74 and 102 lb). It takes three persons to safely lift this part or unit. (C010)</p> <p>Risk of personal injury</p> <p>Before a module is moved or lifted:</p> <ul style="list-style-type: none"> • Observe local health and safety requirements and guidelines for manual material handling. • Remove all tapes to reduce the weight and to prevent cartridges from falling into the robotics path and damaging the library. • Remove all tape drives to reduce the weight. • Obtain adequate assistance to lift and stabilize the module during installation or removal. <p>Risk of damage to devices</p> <p>When a module is placed into or removed from a rack:</p> <ul style="list-style-type: none"> • Extend the rack's leveling jacks to the floor. • Ensure that the full weight of the rack rests on the leveling jacks. • Install stabilizing feet on the rack. • Extend only one rack component at a time.
---	--

Important: Under normal circumstances, when the library is powered off by using the front **Power**, the robot automatically parks and locks into the Base Module behind the Operator Panel. If you are given a choice during the power down procedure, choose the default park position. To protect the spooling cable or other sensitive parts, the accessor must be in the Base Module before any drives are removed from the library.

To move a module within a rack or into a different rack:

1. Save the library configuration.
2. Remove the tape cartridges from the tape drives and magazines, and power off the library.
3. Disconnect the power cords and cables, and unlock the alignment mechanisms.



Attention: Failure to disconnect all cables can result to damage to the cable or the mating electronic assembly in the library.

4. Remove the modules from the rack.
5. Remove the rack rails from the rack.
6. Verify that the destination rack is level side to side and front to back.
7. Install the rack rails in the destination rack.
8. Install the modules in the rack.
9. Replace the cables and lock the alignment mechanisms.
10. Connect the power cords, power on the library, and verify the operation.
11. Replace the tape cartridges.

For instructions for these steps, see [“Adding or replacing a Base or Expansion Module” on page 123](#) and [Chapter 3, “Installing,” on page 36](#).

Appendix A. Library Configuration Forms

Make a copy of these forms, and fill them out as you are installing and configuring your library.

Update the forms each time that changes are made to the library configuration and store these forms in a secure location. Having the information on these forms are helpful if a call to IBM® service is necessary.

You can also save library configuration data from the Management GUI. See [“Locating Management functions”](#) on page 65.

Library information

General Information	
Library type	TS4300 (MT 3555)
Serial Number	
Host name	
SNTP server	
Encryption License Key	
Path Failover License Key	
Network Settings	
Domain Name	
Network Protocol	IPv4/IPv6
Max. Link Speed	
Method	
IP Address	
Gateway	
DNS1	
DNS2	
Security Settings	
Password Policy	
SSL	
Certificates	
LDAP Server (See also User Accounts)	
LDAP Domain	
Encryption Settings	
Encryption Key Manager Server 1/Port	
Encryption Key Manager Server 2/Port	
Notification Settings	
SMTP Notification Level	

General Information	
SMTP Server/Port	
SMTP Security	
SMTP Email Address	
SNMP Community Name	
SNMP Notification Level	
SNMP Server/Port 1	
SNMP Server/Port 2	

Module and drive information

Make a copy of this page, for more than 2 modules.

Number	
Number of Power Supplies	
I/O Station Enabled	
Drive 1 (bottom slot) Type	
-- Serial Number	
-- Logical Library Number/Control Path	
-- Port Settings (FC only)	
Drive 2 (middle slot) Type	
-- Serial Number	
-- Logical Library Number/Control Path	
-- Port Settings (FC only)	
Drive 3 (top slot) Type	
-- Serial Number	
-- Logical Library Number/Control Path	
-- Port Settings (FC only)	

Number	
Number of Power Supplies	
I/O Station Enabled	
Drive 1 (bottom slot) Type	
-- Serial Number	
-- Logical Library Number/Control Path	
-- Port Settings (FC only)	
Drive 2 (middle slot) Type	
-- Serial Number	
-- Logical Library Number/Control Path	
-- Port Settings (FC only)	
Drive 3 (top slot) Type	
-- Serial Number	
-- Logical Library Number/Control Path	
-- Port Settings (FC only)	

Logical Library information

Make a copy of this page, for more than 2 logical libraries.

Number	
Name	
Number of Drives	
Number of Slots	
Number of I/O Slots	
Barcode Label Length Rep to Host	
Barcode Label Alignment Rep to Host	
Auto Clean	
Key Manager Type	
LTO7+ Multi-Initiator SCSI Conflict Detection	
Sequential Mode	

Number	
Name	
Number of Drives	
Number of Slots	
Number of I/O Slots	
Barcode Label Length Rep to Host	
Barcode Label Alignment Rep to Host	
Auto Clean	
Key Manager Type	
LTO7+ Multi-Initiator SCSI Conflict Detection	
Sequential Mode	

Appendix B. LTO media

This section provides an overview of LTO media, which is recommended for use with this library.

To ensure that your IBM tape drive conforms to IBM's specifications for reliability, use only IBM LTO tape cartridges. You might use other LTO-certified data cartridges, but they might not meet the standards of reliability that are established by IBM. The IBM LTO data cartridge cannot be interchanged with the media used in other IBM non-LTO tape products.

Figure 86 on page 156 shows the IBM LTO data cartridge and its components.

- | | | | |
|----------|----------------------|----------|----------------------|
| 1 | LTO cartridge memory | 4 | Write-protect Switch |
| 2 | Cartridge door | 5 | Label area |
| 3 | Leader pin | 6 | Insertion guide |

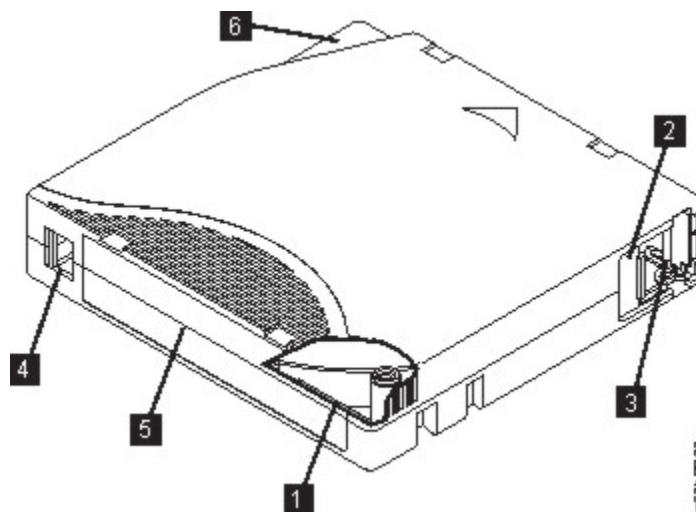

Figure 86. The IBM LTO data cartridge

Note: The same components are on all the IBM LTO data cartridges.

Data cartridges

Use the LTO data and cleaning tape cartridges that are designed for your model of library.

You can order tape cartridges with the bar code labels included, or you can order custom labels. To obtain tape cartridges and bar code labels, see “Ordering media supplies” on page 172.

When tape is processed in the cartridges, LTO Tape Drives use a linear, serpentine recording format. The native data capacity and recording format of LTO data cartridges is as follows:

Type	Native Data Capacity	Recording Format
LTO8	12 TB (30 TB at 2.5:1 compression)	Reads and writes data on 6656 tracks, 32 tracks at a time.
LTO M8	9 TB (22.5 TB at 2.5:1 compression)	Reads and writes data on 3584 tracks, 32 tracks at a time.
LTO7	6 TB (15 TB at 2.5:1 compression)	Reads and writes data on 3584 tracks, 32 tracks at a time.

Table 45. Cartridge data capacity and recording formats (continued)

Type	Native Data Capacity	Recording Format
LTO6	2.5 TB (6.25 TB at 2.5:1 compression)	Reads and writes data on 2176 tracks, 16 tracks at a time.
See “Minimum firmware levels for common library features” on page iii for minimum firmware levels for LTO 8 drives and media.		

The first set of tracks is written from near the beginning of the tape to near the end of the tape. The head then repositions to the next set of tracks for the return pass. This process continues until all tracks are written and the cartridge is full, or until all data is written.

The cartridge door (2 in Figure 86 on page 156) protects the tape from contamination when the cartridge is out of the drive. The tape is attached to a leader pin (3 in Figure 86 on page 156) behind the door. When the cartridge is inserted into the drive, a threading mechanism pulls the pin (and tape) out of the cartridge, across the drive head, and onto a non-removable take-up reel. The head can then read or write data from or to the tape.

The write-protect switch (4 in Figure 86 on page 156) prevents data from being written to the tape cartridge. For more information, see “Write-Protect switch” on page 162.

The label area (5 in Figure 86 on page 156) provides a location to place a label. See “Labeling tape cartridges” on page 160.

The insertion guide (6 in Figure 86 on page 156) is a large, notched area that prevents the cartridge from being inserted incorrectly.

Table 46. Nominal cartridge life: Load/unload cycles

Type	Load/Unload Cycles
LTO8	20,000 (20k)
LTO M8	20,000 (20k)
LTO7	20,000 (20k)
LTO6	20,000 (20k)

Cartridge Read/Write compatibility

Table 47. Data cartridge compatibility with LTO tape drive

IBM LTO Tape Drive	IBM LTO Data Cartridges					
	LTO 8	LTO M8	LTO 7	LTO 6	LTO 5	LTO 4
LTO8 tape drive	Read/Write	Read/Write	Read/Write			
LTO7 tape drive			Read/Write	Read/Write	Read only	
LTO6 tape drive				Read/Write	Read/Write	Read only
See “Minimum firmware levels for common library features” on page iii for minimum firmware levels for LTO 8 drives and media.						

LTO Type M Cartridge (M8)

The LTO Program introduced a new capability with LTO8 tape drives: the ability to write 9 TB (native) on a brand new LTO Ultrium 7 cartridge instead of 6 TB (native) as specified by the LTO 7 format. Such a

cartridge is called an LTO 7 initialized LTO Type M cartridge. These LTO Type M cartridges are identifiable by using an automation bar code label that ends with the last 2 characters “M8”.

<i>Table 48. LTO Cartridge Types</i>				
Cartridge/Density type	Bar code label	Cartridge Packaging/ Silkscreen labeling	Native capacity	Tape Drive compatibility
L8	xxxxxxL8	LTO Ultrium 8	12 TB	LTO 8
M8	xxxxxxM8	LTO Ultrium 7	9 TB	LTO 8
L7	xxxxxxL7	LTO Ultrium 7	6 TB	LTO 7, LTO 8

From now on, these cartridges are referred to as L8, M8, and L7.

Only new, unused LTO Ultrium 7 cartridges can be initialized as M8 cartridges. When a cartridge is initialized as M8, it cannot be changed back to L7. Initialized M8 cartridges can be written and read only in an LTO 8 tape drive; LTO7 tape drives cannot read initialized M8 cartridges.

M8 cartridges can be purchased as either preinitialized (also referred to as “labeled and initialized”) M8 data cartridges or uninitialized M8 data cartridges (M8 WORM cartridges are not supported). For either option, the bar code label is included. However, the uninitialized M8 data cartridge must first be initialized in tape libraries that support the automatic initialization of uninitialized M8 cartridges while under the control of ISV applications that recognize the “M8” bar code label.

A tape cartridge is initialized when it is first loaded into a compatible tape drive and data is written by the ISV application at the beginning of tape (sometimes referred to as "labeling a tape" or "writing from BOT"). The tape drive then establishes the density of the media.

If an uninitialized M8 cartridge is not initialized in a tape library that supports uninitialized M8 cartridges, then the cartridge might inadvertently and silently be initialized at the L7 density (that is, at a 6 TB native capacity) even if the bar code label states “M8”. This action might occur with the usage of non-TS4300 tape libraries, stand-alone LTO7 tape drives, stand-alone LTO8 tape drives, earlier LTO8 tape drive firmware, earlier TS4300 library firmware, or earlier ISV software that does not recognize that M8 cartridges must be mounted only in LTO8 tape drives. M8 cartridges that are inadvertently initialized at the L7 density can continue to be read and written in LTO7 and LTO8 tape drives. However, they remain limited to the 6 TB native capacity.

TS4300 Tape Library firmware version 1.1.1.1-B00 added support for uninitialized M8 cartridges, in addition to support for preinitialized M8 cartridges. In any tape product with M8 cartridges, the minimum LTO8 tape drive firmware version is HB82.

Note: See “Minimum firmware levels for common library features” on page iii for minimum firmware levels for LTO M8 media.

Capacity scaling

To control the capacity of the cartridge (for example, to obtain a faster seek time) issue the SCSI command **SET CAPACITY**. For information about this command, see the *IBM Ultrium Tape Drive SCSI Reference*.

WORM (Write Once, Read Many) cartridges

Certain records retention and data security applications require a Write Once, Read Many (WORM) method for storing data on tape. LTO drives that are supported by the library enable WORM support when a WORM tape cartridge is loaded into the drive.

WORM media

Because standard read/write media are incompatible with the WORM feature, a specially formatted WORM tape cartridge (see Figure 87 on page 159) is required. Each WORM cartridge has a unique, worldwide cartridge identifier (WWCID), which comprises the unique CM chip serial number and the unique tape media serial number. Ultrium 8 WORM media are two-tone burgundy and silvery gray. See “Ordering media supplies” on page 172 for information about how to choose and purchase the appropriate WORM tape cartridges for your tape drive.

Note: All IBM drive firmware allows the use of WORM media.

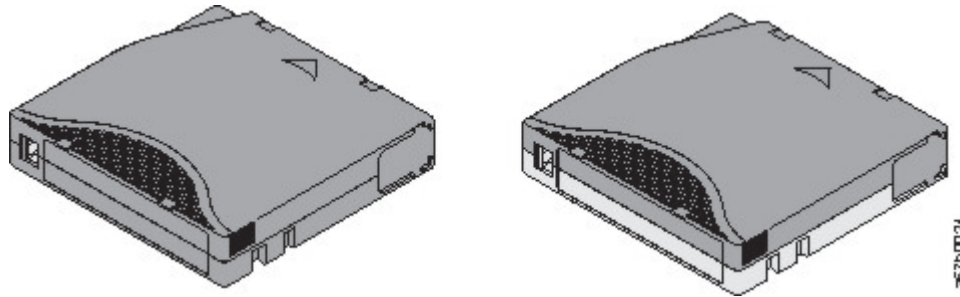

Figure 87. LTO Data and WORM tape cartridges

Data security on WORM media

Certain built-in security measures help ensure that the data that is written on a WORM cartridge do not become compromised. For example

- The format of a WORM Tape Cartridge is unlike that of standard read/write media. This unique format prevents a drive that lacks WORM-capable firmware from writing on a WORM tape cartridge. For LTO 8, native data capacity is 12000 GB and compressed data capacity is 30000 GB.
- When the drive senses a WORM cartridge, the firmware prohibits the changing or altering of user data that is already written on the tape. The firmware tracks the last appendable point on the tape.

WORM media errors

The following conditions cause WORM media errors to occur.

- Information in the servo manufacturer's word (SMW) on the tape must match information from the cartridge memory (CM) module in the cartridge. If it does not match, a media Error Code 7 posts on the drive's single-character display (SCD).
- Inserting a WORM tape cartridge into a drive that is not compatible with WORM causes the cartridge to be treated as an unsupported medium. The drive reports a media Error Code 7.

WORM requirements

To add WORM capability to your IBM LTO drives, you must use either IBM LTO 8 12000 GB WORM tape cartridges, IBM LTO 7 6000 GB WORM tape cartridges, or IBM LTO 6 2500 GB WORM tape cartridges. See “Ordering media supplies” on page 172.

Cleaning cartridge

With each library, a specially labeled IBM Cleaning Cartridge is required to clean the drive head. The drive itself determines when a head must be cleaned. It alerts you by lighting the **Clean Drive** (amber LED) on the Operator Panel. IBM recommends the use of the Auto Clean function on this library. When enabled, the library retrieves the cleaning cartridge, inserts it in the drive that needs cleaning, cleans the drive, then returns the cleaning cartridge to its home slot. To clean the head manually, insert a cleaning cartridge into the tape load compartment. The drive completes the cleaning automatically. When the

cleaning is finished, the drive ejects the cartridge, and the library turns off the **Clean Drive** LED. See “Methods of cleaning drives” on page 72.

Note: The drive automatically ejects an expired cleaning cartridge.

The IBM Cleaning Cartridges are valid for 50 uses. The cartridge's LTO-CM chip tracks the number of times that the cartridge is used.

Cartridge memory chip (LTO-CM)

All generations of the IBM LTO Data Cartridges include a Linear Tape-Open Cartridge Memory (LTO-CM) chip (1) in Figure 86 on page 156). This chip contains information about the cartridge and the tape (such as the name of the manufacturer that created the tape), and also statistical information about the cartridge's use. The LTO-CM enhances the efficiency of the cartridge. For example, the LTO-CM stores the end-of-data location. The next time that this cartridge is inserted and the **Write** command is issued, enables the drive to quickly locate the recording area and begin recording. The LTO-CM also aids in determining the reliability of the cartridge by storing data about its age, how many times it was loaded, and how many errors it accumulated. When a tape cartridge is unloaded, the tape drive writes any pertinent information to the cartridge memory.

The storage capacity of the LTO Generation 6, 7, M8, and 8 LTO-CM is 16320 bytes.

Labeling tape cartridges

The bar code reader is a part of the library accessor. The bar code reader reads each cartridge bar code label that identifies the types of cartridge magazines and tape drive that is installed in the library. It also provides inventory feedback to the host application, Operator Panel, and Management GUI. The library stores the customized inventory data in memory. Library firmware supports a 6 or 8-character volume serial number (VOLSER) on the bar code label on the tape cartridge. Having a bar code label on each tape cartridge enables the bar code reader to identify the cartridge quickly, thus speeding up inventory time. Make it a practice to use bar code labels on your tape cartridges.

A bar code label contains:

- A volume serial number (VOLSER) that is human-readable.
- A bar code that the library can read.

Note: In a library environment, it is highly recommended to use bar code labels for performance and easily identifiable reasons. This library requires bar code labels.

Your host software might need to track the following information by using the associated bar code.

- Date of format or initialization
- Tape's media pool
- Data residing on the tape
- Age of the backup
- Errors that are encountered while the tape is used (to determine whether the tape is faulty).

Important: Misusing and misunderstanding bar code technology can result in backup and restore failures. Use only high-quality labels. Self-printed labels are not recommended as they are often a source of bar code reading issues.

When read by a library's bar code reader, the bar code identifies the cartridge's VOLSER to the library. The bar code also tells the library whether the cartridge is a data cartridge or cleaning cartridge. The bar code includes the two-character media-type identifier:

- L or M identifies the cartridge as an LTO cartridge.
- 6, 7, or 8 indicates that the cartridge is the sixth, seventh, or eighth generation of its type. Only LTO 6 or later cartridges are supported by the TS4300 tape library.

- W indicates that the cartridge is a generation 6 WORM cartridge. X indicates that the cartridge is a generation 7 WORM cartridge, and Y indicates that the cartridge is a generation 8 WORM cartridge.

Figure 88 on page 161 shows a sample bar code label for the LTO Tape Cartridge.

Tape cartridges are ordered with the labels included or with custom labels. To order tape cartridges and bar code labels, see “Ordering media supplies” on page 172. The bar code usage for IBM tape libraries must meet predefined specifications. They include (but are not limited to)

- Six or eight (the default) uppercase alphanumeric characters, where the last 2 characters must be L6, L7, M8, or L8 (LW, LX, or LY for WORM cartridges).
- Label and printing to be non-glossy.
- Nominal narrow line or space width of 0.423 mm (0.017 in.)
- Wide to narrow ratio of 2.75:1.
- Minimum bar length of 11.1 mm (0.44 in.)

Cartridges	VOLSER
LTO8 Data Cartridge	xxxxxxL8
LTO8 WORM Cartridge	xxxxxxLY
LTO M8 Cartridge	xxxxxxM8
LTO7 Data Cartridge	xxxxxxL7
LTO7 WORM Cartridge	xxxxxxLX
LTO6 Data Cartridge	xxxxxxL6
LTO6 WORM Cartridge	xxxxxxLW
LTO Cleaning Cartridge	CLNxxxLx

To determine the complete specifications of the bar code and the bar code label, go to the web at <http://www.ibm.com/> and enter IBM LTO Cartridge Label Specification in the search box. Or, contact your IBM sales representative.

LTO tape cartridges have a recessed area on the face of the cartridge next to the write-protect switch. Use this area for attaching the adhesive-backed bar code label. Place the label only in the recessed label area (see 5 in Figure 86 on page 156). A label that extends outside of the recessed area can cause loading problems in the drive.

 **Attention:** Do not place any type of mark on the white space at either end of the bar code. A mark in this area might prevent the library from reading the label.

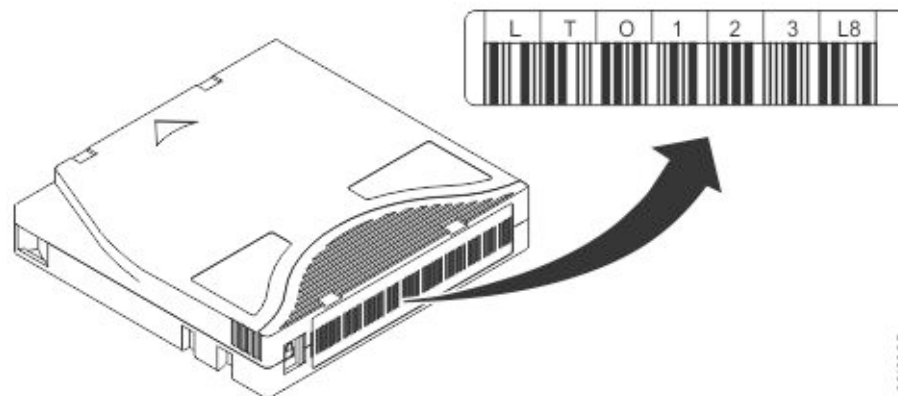

Figure 88. Sample bar code label on the LTO8 Tape Cartridge

Important: The bar code label must be applied as shown, with the alphanumeric characters on top and the bar codes on the hub side (bottom). Never apply multiple labels onto a cartridge because extra labels can cause the cartridge to jam in a tape drive.

Guidelines for bar code labels

Apply the following guidelines whenever bar code labels are used.

- Use only IBM-approved bar code labels on cartridges to be used in an IBM tape library.
- Do not reuse a label or reapply a used label over an existing label.
- Before you apply a new label, remove the old label by slowly pulling it at a right angle to the cartridge case.
- Use peel-clean labels that do not leave a residue after it is removed. If glue residue is on the cartridge, remove it by gently rubbing it with your finger. Do not use a sharp object, water, or a chemical to clean the label area.
- Examine the label before it is applied to the cartridge. Do not use the label if it has voids or smears in the printed characters or bar code. A library's inventory operation takes much longer if the bar code label is not readable.
- Remove the label from the label sheet carefully. Do not stretch the label or cause the edges to curl.
- Position the label within the recessed label area (see **5** in [Figure 86 on page 156](#)).
- With light finger pressure, smooth the label so that no wrinkles or bubbles exist on its surface.
- Verify that the label is smooth and parallel, and has no roll-up or roll-over. The label must be flat to within 0.5 mm (0.02 in.) over the length of the label and have no folds, missing pieces, or smudges.
- Do not place other machine-readable labels on other surfaces of the cartridge. They might interfere with the ability of the drive to load the cartridge.

Write-Protect switch

All rewriteable data cartridges have a write-protect switch to prevent accidental erasure or overwriting of data. Before a cartridge is loaded into the device, make sure the write-protect switch on the front of the cartridge is in the wanted position.

The position of the write-protect switch on the tape cartridge (see **1**) determines whether you can write to the tape. If the switch is set to:

- Slide the switch to the right to write-protect the cartridge. An indicator, such as a red mark or small padlock, is visible showing that the cartridge is write-protected. 
- Slide the switch to the left to allow the device to write data to the cartridge.

If possible, use your server's application Software to write-protect your cartridges (rather than manually setting the write-protect switch). This setting allows the server's Software to identify a cartridge that no longer contains current data and is eligible to become a scratch (blank) data cartridge. Do not write-protect scratch (blank) cartridges; the tape drive is not able to write new data to them.

If you must manually set the write-protect switch, slide it left or right to the wanted position.

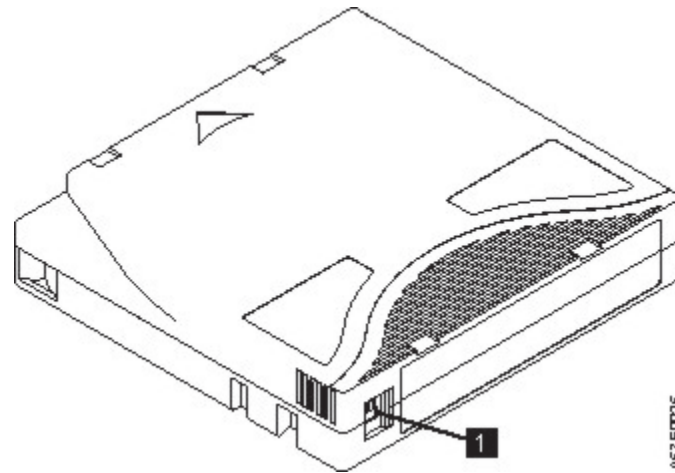

Figure 89. Setting the write-protect switch

Table 50. Location of the write-protect switch

1	Write-protect switch
---	----------------------

Handling the cartridges



Attention: Do not insert a damaged tape cartridge into the drive. A damaged cartridge can interfere with the reliability of a drive and might void the warranties of the drive and the cartridge. Before a tape cartridge is inserted, inspect the cartridge case, cartridge door, and write-protect switch for breaks.

Incorrect handling or an incorrect environment can damage cartridges or their magnetic tape. To avoid damage to your tape cartridges and to ensure the continued high reliability of your IBM LTO Ultrium Tape Drives, use the following guidelines.

Providing training

- Post procedures that describe appropriate media handling in places where people gather.
- Ensure that anyone who handles tape is properly trained in handling and shipping procedures. This training includes operators, users, programmers, archival services, and shipping personnel.
- Ensure that any service or contract personnel who complete archiving procedures are properly trained in media-handling procedures.
- Include media-handling procedures as part of any services contract.
- Define and make personnel aware of data recovery procedures.

Ensuring proper packaging

- When a cartridge is shipped, use the original or better packaging.
- Always ship or store a cartridge in a jewel case.
- Use only a recommended shipping container that securely holds the cartridge in its jewel case during transportation. Ultrium Turtlecases (by Perm-A-Store) are tested and found to be satisfactory (see Figure 90 on page 164). They are available at <http://www.turtlecase.com>.



Figure 90. Tape cartridges in a Turtlecase

- Never ship a cartridge in a commercial shipping envelope. Always place it in a box or package.
- If you ship the cartridge in a cardboard box or a box of a sturdy material, ensure that you
 - Place the cartridge in polyethylene plastic wrap or bags to protect it from dust, moisture, and other contaminants.
 - Pack the cartridge snugly; do not allow it to move around.
 - Double-box the cartridge (place it inside a box, then place that box inside the shipping box) and add padding between the two boxes (see [Figure 91](#) on [page 164](#)).



Figure 91. Double-boxing tape cartridges for shipping

Proper acclimation and environmental conditions

To ensure the longest possible life for your data cartridges, follow these guidelines.

- Before you use a tape cartridge, acclimate it to the operating environment for 24 hours or the time necessary to prevent condensation in the drive. The time varies, depending on the environmental extremes to which the cartridge was exposed. If the data cartridge was exposed to temperatures outside the specified ranges, stabilize the cartridge at room temperature for the same length of time it was exposed to extreme temperatures or 24 hours, whichever is less.

- Ensure that all surfaces of a cartridge are dry before it is inserted.
- Do not expose data cartridges to direct sunlight or sources of heat, including portable heaters and heating ducts.
- Do not place data cartridges near sources of electromagnetic energy or strong magnetic fields such as computer monitors, electric motors, speakers, or X-ray equipment. Exposure to electromagnetic energy or magnetic fields can destroy data and the embedded servo code that is written on the media by the cartridge manufacturer, which can render the cartridge unusable.
- Use only the data cartridges that are designated for your device.
- Clean the tape drive when the Clean drive LED is illuminated.
- Do not drop a cartridge. Excessive shock can damage the internal contents of the cartridge or the cartridge case itself, making the cartridge unusable.
- Place identification labels only in the designated area on the cartridge.
- Maintain the conditions that are described in [“Environmental and shipping specifications for tape cartridges”](#) on page 171.



Attention: Do not degauss LTO data cartridges! These data cartridges are pre-recorded with a magnetic servo signal. This signal is required to use the cartridge with the LTO tape drive. Keep magnetically charged objects away from the cartridge.

Completing a thorough inspection

After a cartridge is purchased and before it is used, complete the following steps.

- Inspect the cartridge's packaging to determine potential rough handling.
- When a cartridge is inspected, open only the cartridge door. Do not open any other part of the cartridge case. The upper and lower parts of the case are held together with screws; separating them impairs the usefulness of the cartridge.
- Inspect the cartridge for damage before it is used or stored.
- Inspect the rear of the cartridge (the part that loads first into the tape load compartment) and ensure that no gaps appear in the seam of the cartridge case. See **1** in Figure 92 on page 165 and **4** in Figure 94 on page 167. If gaps appear in the seam (see Figure 92 on page 165), the leader pin might be dislodged. Go to [“Repositioning or reattaching a leader pin”](#) on page 166.

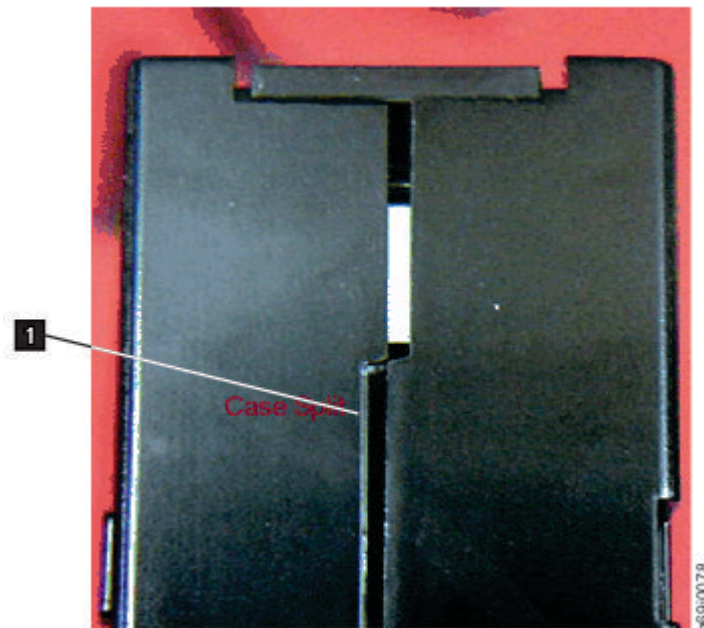

Figure 92. Checking for gaps in the seams of a cartridge

- Check that the leader pin is properly seated. See **2** in Figure 93 on page 167.

- If you suspect that the cartridge was mishandled but it appears usable, copy any data onto a good cartridge immediately for possible data recovery. Discard the mishandled cartridge.
- Review handling and shipping procedures.

Handling the cartridge carefully

- Do not drop the cartridge. If the cartridge drops, slide the cartridge door back and ensure that the leader pin is properly seated in the pin-retaining spring clips. See **2** in Figure 93 on page 167. If the leader pin becomes dislodged, go to “Repositioning or reattaching a leader pin” on page 166.
- Do not handle tape that is outside the cartridge. Handling the tape can damage the tape's surface or edges, which might interfere with read or write reliability. Pulling on tape that is outside the cartridge can damage the tape and the brake mechanism in the cartridge.
- Do not stack more than six cartridges.
- Do not degauss a cartridge that you intend to reuse. Degaussing makes the tape unusable.

Examples of cartridge problems

Split cartridge case. See [Figure 92 on page 165](#).

The cartridge's case is damaged. There is a high possibility of media damage and potential loss.

1. Look for cartridge mishandling.
2. Use the IBM Leader Pin Reattachment Kit (part number 08L9129) to correctly seat the pin (see “Repositioning or reattaching a leader pin” on page 166). Then, immediately use data recovery procedures to minimize chances of data loss.
3. Review media-handling procedures.

Improper placement of leader pin. See [Figure 93 on page 167](#).

The leader pin is misaligned.

1. Look for cartridge damage.
2. Use the IBM Leader Pin Reattachment Kit (part number 08L9129) to correctly seat the pin (see “Repositioning or reattaching a leader pin” on page 166). Then, immediately use data recovery procedures to minimize chances of data loss.

Repositioning or reattaching a leader pin



Attention: Use a repaired tape cartridge only to recover data and move it to another cartridge. Continued use of a repaired cartridge might void the warranties of the drive and the cartridge.

If the leader pin in your cartridge becomes dislodged from its pin-retaining spring clips or detaches from the tape, you must use the IBM Leader Pin Reattachment Kit (part number 08L9129) to reposition or reattach it. (Do not reattach the pin if you must remove more than 7 meters (23 feet) of leader tape.) The sections that follow describe each procedure.

Repositioning a leader pin

A leader pin that is improperly seated inside a cartridge interferes with the operation of the drive. [Figure 93 on page 167](#) shows a leader pin in the incorrect **1** and correct **2** positions.

To place the leader pin in its proper position, you need the following tools:

- Plastic or blunt-end tweezers
- Cartridge manual rewind tool (from Leader Pin Reattachment Kit, part number 08L9129)

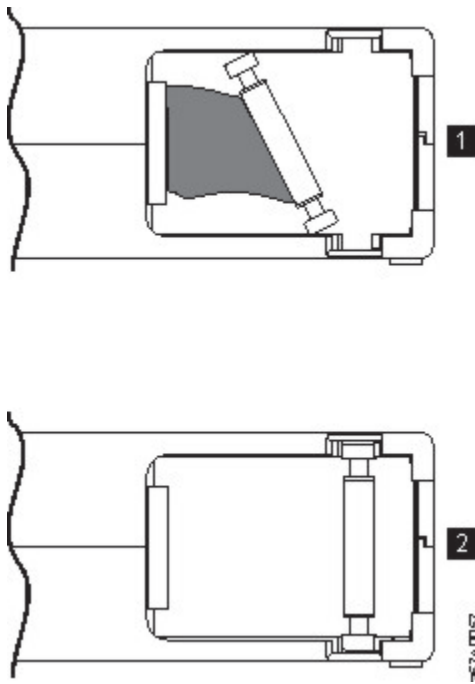

Figure 93. Leader pin in the incorrect and correct positions

To reposition the leader pin:

1. Slide open the cartridge door (1 in Figure 94 on page 167) and locate the leader pin (2) (you might need to shake the cartridge gently to roll the pin toward the door).
2. With plastic or blunt-end tweezers, grasp the leader pin and position it in the pin-retaining spring clips (3).
3. Press the leader pin gently into the clips until it snaps into place and is firmly seated.
4. Close the cartridge door.

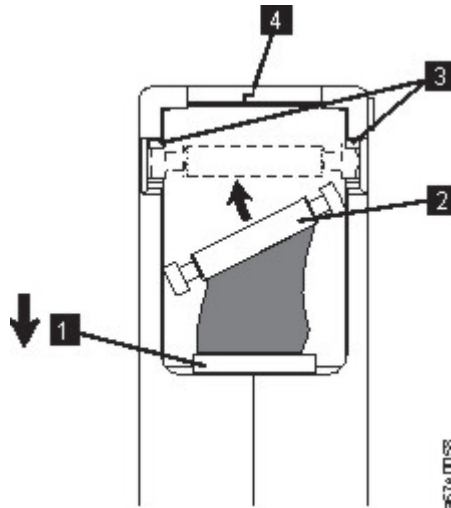

Figure 94. Placing the dislodged leader pin into the correct position

5. To rewind the tape, insert the cartridge manual rewind tool (1 in Figure 95 on page 168) into the cartridge's hub (2) and turn it clockwise until the tape becomes taut.

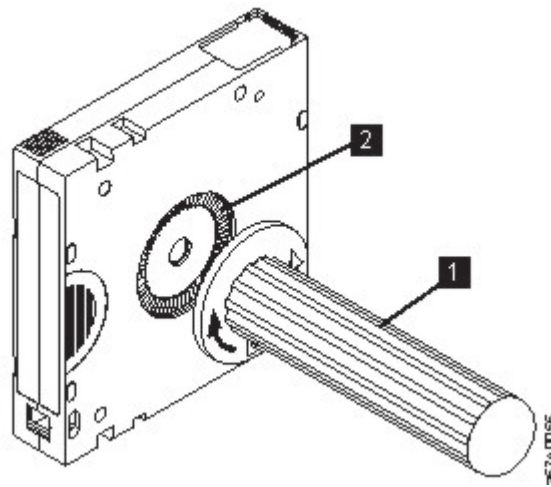

Figure 95. Rewinding the tape into the cartridge

6. Remove the rewind tool by pulling it away from the cartridge.
7. If you suspect that the cartridge was mishandled but it appears usable, copy any data onto a good cartridge immediately for possible data recovery. Discard the mishandled cartridge.

Reattaching a leader pin

The first meter of tape in a cartridge is leader tape. Once the leader tape is removed, tape breakage might occur. After the leader pin is reattached, transfer data from the defective tape cartridge. **Do not reuse the defective tape cartridge.**

The Leader Pin Reattachment Kit contains three parts.

- **Leader pin attach tool** (see **1** in [Figure 96 on page 169](#)). A plastic brace that holds the cartridge door open.
- **Cartridge manual rewind tool** (see **2** in [Figure 96 on page 169](#)). A device that fits into the cartridge's hub and winds the tape into and out of the cartridge.
- **Pin supplies** (see **3** in [Figure 96 on page 169](#)). Leader pins and C-clips.



Attention:

- Use only the IBM Leader Pin Reattachment Kit to reattach the leader pin to the tape. Other methods of reattaching the pin damages the tape, the drive, or both.
- Use this procedure on your tape cartridge only when the leader pin detaches from the magnetic tape and you must copy the cartridge's data onto another cartridge. Destroy the damaged cartridge after you copy the data. This procedure might affect the performance of the leader pin during threading and unloading operations.
- Touch only the end of the tape. Touching the tape in an area other than the end can damage the tape's surface or edges, which might interfere with read or write reliability.

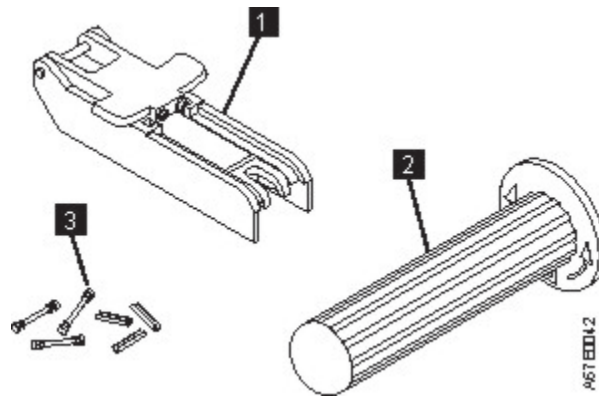

Figure 96. Leader Pin Reattachment Kit

The following procedure describes how to reattach a leader pin.

To reattach a leader pin by using the IBM Leader Pin Reattachment Kit:

1. Attach the leader pin attach tool (1 in Figure 97 on page 169) to the cartridge (2) so that the tool's hook (3) latches into the cartridge's door (4). Pull the tool back to hold the door open, then slide the tool onto the cartridge. Open the tool's pivot arm (5).

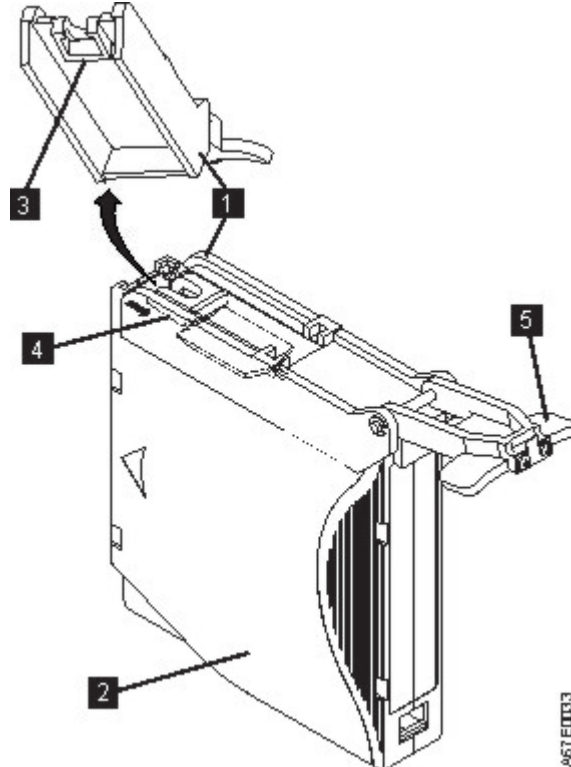

Figure 97. Attaching the leader pin attach tool to the cartridge

2. To find the end of the tape inside the cartridge, attach the cartridge manual rewind tool (1 in Figure 98 on page 170) to the cartridge's hub (2) by fitting the tool's teeth between the teeth of the hub. Turn the tool clockwise until you see the end of the tape inside the cartridge. Then, slowly turn the rewind tool counterclockwise to bring the tape edge toward the cartridge door (3).
3. Continue to turn the rewind tool counterclockwise until approximately 13 cm (5 in.) of tape hangs from the cartridge door. If necessary, grasp the tape and pull gently to unwind it from the cartridge.
4. Remove the rewind tool by pulling it away from the cartridge. Set the tool and the cartridge aside.

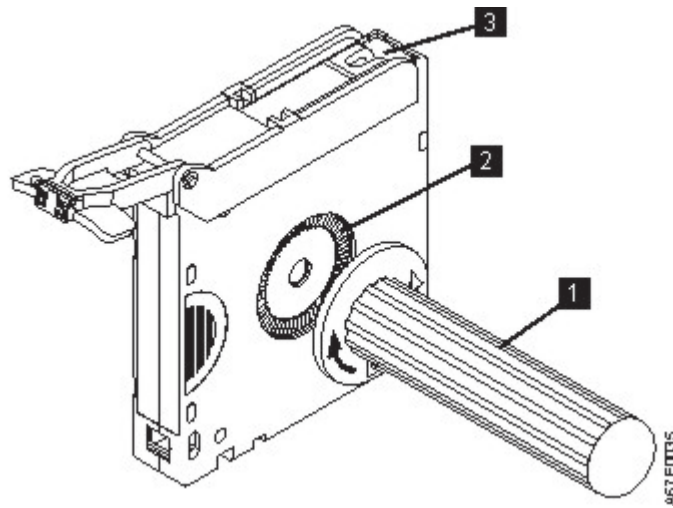

Figure 98. Winding the tape out of the cartridge

5. On the leader pin (1 in Figure 99 on page 170), locate the open side of the C-clip (2). The C-clip is a small black part that secures the tape (3) to the pin.
6. Remove the C-clip from the leader pin by using your fingers to push the clip away from the pin. Set the pin aside and discard the clip.

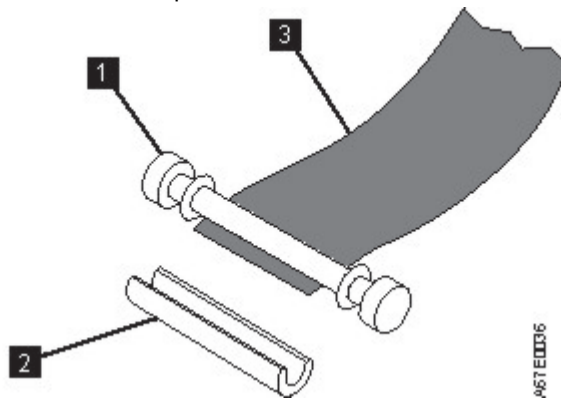

Figure 99. Removing the C-clip from the leader pin

7. Position the tape in the alignment groove of the leader pin attach tool (see 1 in Figure 100 on page 171).
8. Place a new C-clip into the retention groove (2 (Figure 100 on page 171) on the leader pin attachment tool and make sure that the clip's open side faces up.
9. Place the leader pin (from step 6) into the cavity (3 (Figure 100 on page 171) of the leader pin attach tool.



Attention: To prevent the leader pin from rolling into the cartridge, in the following step use care when the tape is folded over the pin.

10. Fold the tape over the leader pin and hold it with your fingers (see Figure 100 on page 171).

Note: Use care to ensure that the tape is centered over the leader pin. Failure to properly center the tape on the pin causes the repaired cartridge to fail. When the tape is properly centered, a 0.25 mm (0.01-in.) gap exists on both sides of the pin.

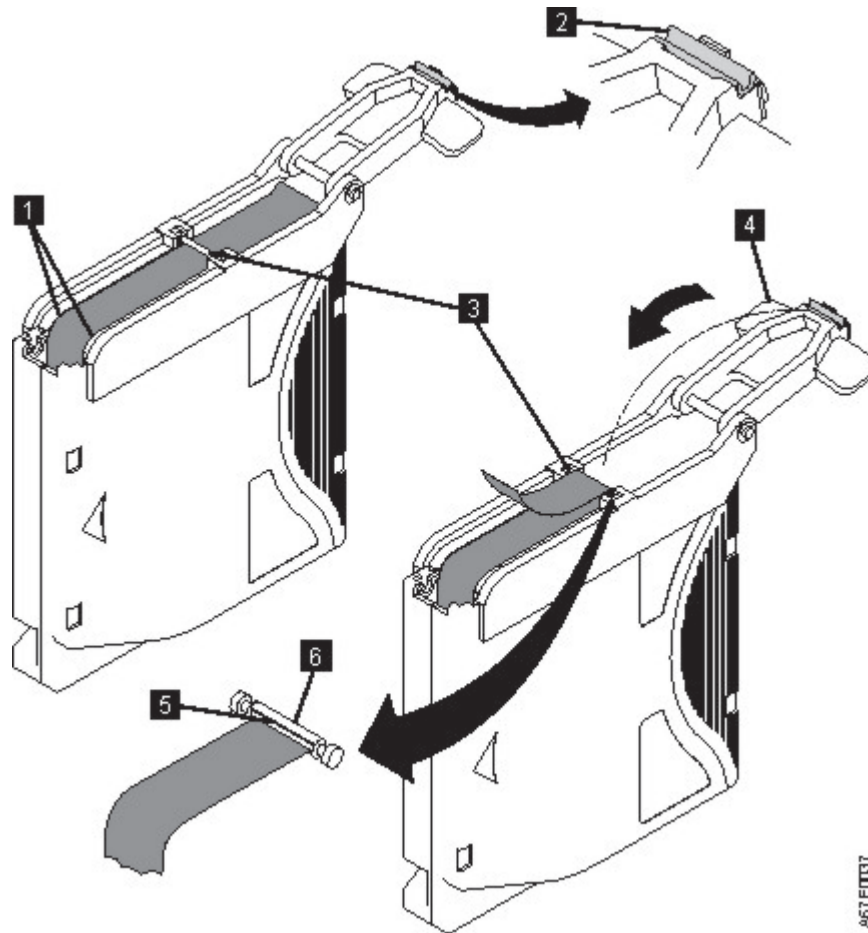

Figure 100. Attaching the leader pin to the tape

11. Close the pivot arm **4** of the leader pin attach tool by swinging it over the leader pin so that the C-clip snaps onto the pin and the tape.
12. Swing the pivot arm open and trim the excess tape **5** so that it is flush with the reattached leader pin **6**.
13. Use your fingers to remove the leader pin from the cavity **3** in the leader pin attach tool.
14. Use the cartridge manual rewind tool to wind the tape back into the cartridge (wind the tape clockwise). Ensure that the leader pin is latched by the pin-retaining spring clips on each end of the leader pin.
15. Remove the rewind tool.
16. Remove the leader pin attach tool by lifting its end up and away from the cartridge.

Environmental and shipping specifications for tape cartridges

Before you use a tape cartridge, acclimate it to the operating environment for 24 hours or the time necessary to prevent condensation in the drive. The time varies, depending on the environmental extremes to which the cartridge was exposed. If the data cartridge was exposed to temperatures outside the specified ranges, stabilize the cartridge at room temperature for the same length of time it was exposed to extreme temperatures or 24 hours, whichever is less.

The best storage container for the cartridges (until they are opened) is the original shipping container. The plastic wrapping prevents dirt from accumulating on the cartridges and partially protects them from humidity changes.

When you ship a cartridge, place it in its jewel case or in a sealed, moisture-proof bag to protect it from moisture, contaminants, and physical damage. Ship the cartridge in a shipping container that has enough packing material to cushion the cartridge and prevent it from moving within the container.

Table 51 on page 172 gives the environment for operating, storing, and shipping LTO Ultrium Tape Cartridges.

<i>Table 51. Environment for storage and shipping the LTO tape cartridges</i>			
Environmental Specifications			
Environmental Factor	Allowable Storage	Recommended Storage	Shipping
Temperature	16 to 32°C (61 to 90°F)	16 to 25°C (61 to 77°F)	-23 to 49°C (-9 to 120°F)
Relative humidity (noncondensing)	20 to 80%	20 to 50%	5 to 80%
Maximum wet bulb temperature	26°C (79°F)	26°C (79°F)	26°C (79°F)
Magnetic field	Stray magnetic field at any point on tape not to exceed 50 oersteds (4000 ampere/meter).		

Disposing of tape cartridges

Under the current rules of the US Environmental Protection Agency (EPA), regulation 40CFR261, the LTO Ultrium Tape Cartridge is classified as non-hazardous waste. As such, it might be disposed of in the same way as normal office trash. These regulations are amended from time to time, and you must review them at the time of disposal.

If your local, state, country (non-US), or regional regulations are more restrictive than EPA 40CFR261, you must review them before you dispose of a cartridge. Contact your account representative for information about the materials that are in the cartridge.

If a tape cartridge must be disposed of in a secure manner, you can erase the data on the cartridge with a high-energy ac degausser. Use a minimum of 4000 oersted peak field over the entire space that the cartridge occupies. The tape must make two passes through the field at 90-degree orientation change for each pass to achieve complete erasure. Some commercial degaussers have two magnetic field regions offset 90 degrees from each other to accomplish complete erasure in one pass for higher throughput. Degaussing makes the cartridge unusable.

If you burn the cartridge and tape, ensure that the incineration complies with all applicable regulations.

Ordering media supplies

Table 52 on page 173 lists the cartridges and media supplies that you can order for the drive.

Table 52. Media supplies

Supply Item	Methods of Ordering	Feature codes for Radio Frequency Identification (RFID) labels
<p>12 TB Ultrium 8 Data Cartridge 20Pk</p> <p>Bar code labels are preapplied to cartridges.</p>	<p>Specify Machine Type 3589 Model 552 and the VOLSER characters that you want.</p>	<p>Available from media resellers.</p>
<p>12 TB Ultrium 8 Data Cartridge 20Pk</p> <p>Order VOLSER labels separately.</p>	<p>Specify Machine Type 3589 Model 652.</p>	<p>N/A</p>
<p>12 TB Ultrium 8 Data Cartridge 5Pk (black and white labels unattached)</p>	<p>Specify Part Number 01PL340 through an IBM-authorized distributor.</p>	<p>N/A</p>
<p>12 TB Ultrium 8 WORM Data Cartridges</p>	<p>Available from media resellers.</p>	<p>Available from media resellers.</p>
<p>9 TB Ultrium 7 Uninitialized Data Cartridge 20Pk M8 Labeled</p>	<p>Specify Machine Type 3589 Model 452 and the VOLSER characters that you want.</p>	<p>N/A</p>
<p>6 TB Ultrium 7 Data Cartridge 20Pk</p> <p>Bar code labels are preapplied to cartridges.</p>	<p>Specify Machine Type 3589 Model 551 and the VOLSER characters that you want.</p> <p>You can also order through an IBM-authorized distributor.</p>	<p>FC 5511</p>
<p>6 TB Ultrium 7 Data Cartridge 20Pk</p> <p>Order VOLSER labels separately.</p>	<p>Specify Machine Type 3589 Model 651.</p> <p>You can also order through an IBM-authorized distributor.</p>	<p>N/A</p>
<p>6 TB Ultrium 7 Data Cartridge 5Pk</p> <p>No labels.</p>	<p>Specify Part Number 38L7189 through an IBM-authorized distributor.</p>	<p>N/A</p>
<p>6 TB Ultrium 7 WORM Tape Cartridge 20Pk</p> <p>Bar code labels are preapplied to cartridges.</p>	<p>Specify Machine Type 3589 Model 571 and the VOLSER characters that you want.</p> <p>If you would like RFID labels, also specify the feature code provided.</p>	<p>FC 5711</p>
<p>6 TB Ultrium 7 WORM Tape Cartridge 20Pk</p> <p>Order VOLSER labels separately.</p>	<p>Specify Machine Type 3589 Model 671.</p>	<p>N/A</p>
<p>2.5 TB Ultrium 6 Data Cartridge 20Pk</p> <p>Bar code labels are preapplied to cartridges.</p>	<p>Specify Machine Type 3589 Model 550 and the VOLSER characters that you want.</p> <p>If you would like RFID labels, also specify the feature code provided.</p>	<p>FC 5510</p>

<i>Table 52. Media supplies (continued)</i>		
Supply Item	Methods of Ordering	Feature codes for Radio Frequency Identification (RFID) labels
2.5 TB Ultrium 6 Data Cartridge 20Pk Order VOLSER labels separately.	Specify Machine Type 3589 Model 650.	N/A
2.5 TB Ultrium 6 Data Cartridge 5Pk (black and white labels unattached)	Specify Part Number 35P1902 through an IBM-authorized distributor	N/A
2.5 TB Ultrium 6 WORM Tape Cartridge 20Pk Bar code labels are preapplied to cartridges.	Specify Machine Type 3589 Model 570 and the VOLSER characters that you want.. If you would like RFID labels, also specify the feature code provided.	FC 5710
2.5 TB Ultrium 6 WORM Tape Cartridge 20Pk Order VOLSER labels separately.	Specify Machine Type 3589 Model 670.	N/A
Leader Pin Reattachment Kit	Order Part Number 08L9129 through an IBM-authorized distributor.	N/A
Manual Rewind Tool	Order Part Number 08L9130 through an IBM-authorized distributor.	N/A

To find the closest IBM-authorized distributor, visit the web at <http://www.ibm.com/storage/media> or call 1-888-IBM-MEDIA.

Ordering bar code labels

LTO drives don't require cartridges to have bar code labels. However, in a library environment it's highly recommended to use bar code labels for performance and easily identifiable reasons. You can order these labels separately from the IBM data cartridges and cleaning cartridges.

You can order bar code labels directly from the authorized suppliers of bar code labels.

<i>Table 53. Authorized suppliers of custom bar code labels</i>	
In the Americas	In Europe and Asia
EDP/Tri-Optic 6800 West 117th Avenue Broomfield, CO 80020 US Telephone: 888-438-8362 or 303-464-3547 Fax: 888-438-8363 or 303-666-2166 http://www.tri-optic.com	

Table 53. Authorized suppliers of custom bar code labels (continued)

In the Americas	In Europe and Asia
<p>Netc, L.L.C.¹ 100 Corporate Drive Trumbull, CT 06611 US Telephone: 203-372-6382 Fax: 203-372-0676 http://www.netclabels.com</p>	<p>Netc Europe¹ Telephone.: +49-2151-970-900 Fax: +49-2151-970-908 Email: Vertrieb@netclabels.de http://www.netclabels.de</p> <hr/> <p>Netc Asia Pacific Pty. Ltd.¹ 7 Cordwood Drive Cooroy QLD 4563 Australia Telephone: +61 (0)7 5442 6263 Fax: +61 (0)7 5442 6522 http://www.netclabels.com.au</p>

¹Netc is the only authorized supplier of radio frequency identification (RFID) labels. Orders for RFID labels must be placed through the U.S. office. Orders are shipped worldwide.

Appendix C. Replacement parts

This library has Tier 1 and Tier 2 CRUs (customer replaceable units). (Tier 1: No tools needed Tier 2: Tools needed) These CRUs are parts of the library that must be added, removed, and replaced by the customer.

To order parts, contact IBM Service. See “Contacting IBM technical support” on page 82.

Part Number	Description
00VJ943	3555 Base Chassis - Includes operator panel, accessor, spooling mechanism, 1 power supply
00VJ944	3555 Expansion Chassis
00VJ955 02JE722	3555 Accessor - Includes Spooling Mechanism
00VJ956	3555 Spooling Mechanism
02XV763	3555 Base Controller
00VJ962	3555 Expansion Controller
00GH772	3555 Expansion Cable
00GH763	3555 LTO6 FH FC Drive Assembly
00GH761	3555 LTO6 HH FC Drive Assembly
00GH759	3555 LTO6 HH SAS Drive Assembly
00GH768	3555 LTO7 FH FC Drive Assembly
00GH766	3555 LTO7 HH FC Drive Assembly
00GH764	3555 LTO7 HH SAS Drive Assembly
00GH814	3555 LTO8 FH FC Drive Assembly
00GH812	3555 LTO8 HH FC Drive Assembly
00GH810	3555 LTO8 HH SAS Drive Assembly
00GH724	3555 Left Magazine Asm
00GH726	3555 Right Magazine Asm
00VJ940	3555 Power supply
12R9314	Fibre Channel Wrap Tool
95P6566	SAS Wrap Tool
00VJ139	2 M Mini-SAS/Mini-SAS 1x Cable
15R8848	Fiber Cable HBW LC/LC 25 M
41V2120	Fiber Cable HBW LC/LC 10 M
46C2900	4 M AE1 MINI-SAS TO MINI-SAS
46C2902	3 M Y MINI-SAS HD TO MINI-SAS
46X9904	SAS 1X to 4X INTERPOSER

Table 54. Replacement parts (continued)

Part Number	Description
39M5068	Power Cable 10 AMP / 250 VAC - 2.8M
39M5081	Power Cable 10 AMP / 125 VAC - 2.8M
39M5095	Power Cable 10 AMP / 250 VAC - 2.8M
39M5102	Power Cable 10 AMP / 250 VAC - 2.8M
39M5123	Power Cable 10 AMP / 250 VAC - 2.8M
39M5130	Power Cable 10 AMP / 250 VAC - 2.8M
39M5144	Power Cable 10 AMP / 250 VAC - 2.8M
39M5151	Power Cable 10 AMP / 250 VAC - 2.8M
39M5158	Power Cable 10 AMP / 250 VAC - 2.8M
39M5165	Power Cable 10 AMP / 250 VAC - 2.8M
39M5172	Power Cable 10 AMP / 250 VAC - 2.8M
39M5199	Power Cable 10 AMP / 250 VAC - 2.8M
39M5206	Power Cable 10 AMP / 250 VAC - 2.8M
39M5219	Power Cable 10 AMP / 250 VAC - 2.8M
39M5226	Power Cable 10 AMP / 250 VAC - 2.8M
39M5240	Power Cable 10 AMP / 250 VAC - 2.8M
39M5247	Power Cable 10 AMP / 250 VAC - 2.8M
39M5254	Power Cable 10 AMP / 250 VAC - 2.8M
39M5378	Power Cable 10 AMP / 250 VAC - 4.3M

Appendix D. Manual cartridge removal procedure

Follow this procedure if a cartridge must be manually removed and repaired.



Attention:

- It is recommended that the drive and tape be returned to IBM for removal and recovery.
- If the cartridge in the drive is an INPUT tape that contains ACTIVE or 'ONLY COPY' data (no backup), eject commands that are issued at the host fail to unload the tape, and power-cycling the drive fails to eject the cartridge, make no further attempts to unload this tape. Call Technical Support and open a PMR if one is not already open, to initiate the process of sending the drive with the loaded cartridge in for recovery.
- These procedures must be completed only by a trained IBM service provider. SSRs claim their time against service code 33 ECA 013 when they complete this procedure.
- Inform the customer that the following procedure has high risk of damaging the drive and high risk of not being able to recover the data.
- A drive brick transfer to another drive sled is NOT POSSIBLE with this library.

Recommended tools

- #1 Phillips screwdriver
- ESD Kit
- Flashlight (optional)
- #1 Flathead screwdriver (optional)

Before you begin

When a tape drive error is reported by the library, the drive produces a memory dump and saves it in Random Access Memory (RAM). If the library or drive is powered OFF, this information is lost. To preserve this information for analysis by IBM Technical Support, the drive memory dump must be copied to the drive's flash memory. Complete the following steps to write a drive memory dump to flash memory.

1. Log in to the Management GUI.
2. Attempt to remove the cartridge with the device power ON and with library manager, a host application, or the **Unload** button. Press and hold **Unload** for 12 seconds. This action causes the drive to eject the cartridge when it completes the midtape recovery
3. Ensure that the operator issued the appropriate application commands to complete a rewind and unload of the cartridge. This procedure is to ensure that the stuck cartridge is not because of a hang condition in the application
4. Attempt to remove the cartridge by power-cycling the drive. Look for the drive to attempt a midtape recovery.

Note: It can take 5 minutes to 1 hour (depending on cartridge type (LTO 5, and so on) and how much of the tape is spooled out of the cartridge) for the cartridge to rewind and unload.

5. If the cartridge unloads, inform the operator that the cartridge is unloaded. If the cartridge does not unload, repeat steps 2 and 3 before this procedure is continued.

Note: If the cartridge in the drive is an INPUT tape that contains ACTIVE or 'ONLY COPY' data (there is no backup), eject commands that are issued at the host fail to unload the tape, and power-cycling the drive fails to eject the cartridge, make **no further attempts** to unload this tape. Call Technical Support and open a PMR if one is not already open, to initiate the process of sending the drive with the loaded cartridge in for recovery.

Beginning procedure

Note: If the cartridge in the drive is an INPUT tape that contains ACTIVE or 'ONLY COPY' data (there is no backup), eject commands that are issued at the host fail to unload the tape, and power-cycling the drive fails to eject the cartridge, make **no further attempts** to unload this tape. Call Technical Support and open a PMR if one is not already open, to initiate the process of sending the drive with the loaded cartridge in for recovery.

Removing the drive brick from the sled

1. Remove the tape drive sled from the library.
2. Place the sled on a clean, sturdy work surface.

It is not necessary to remove the plastic cover or connection card.

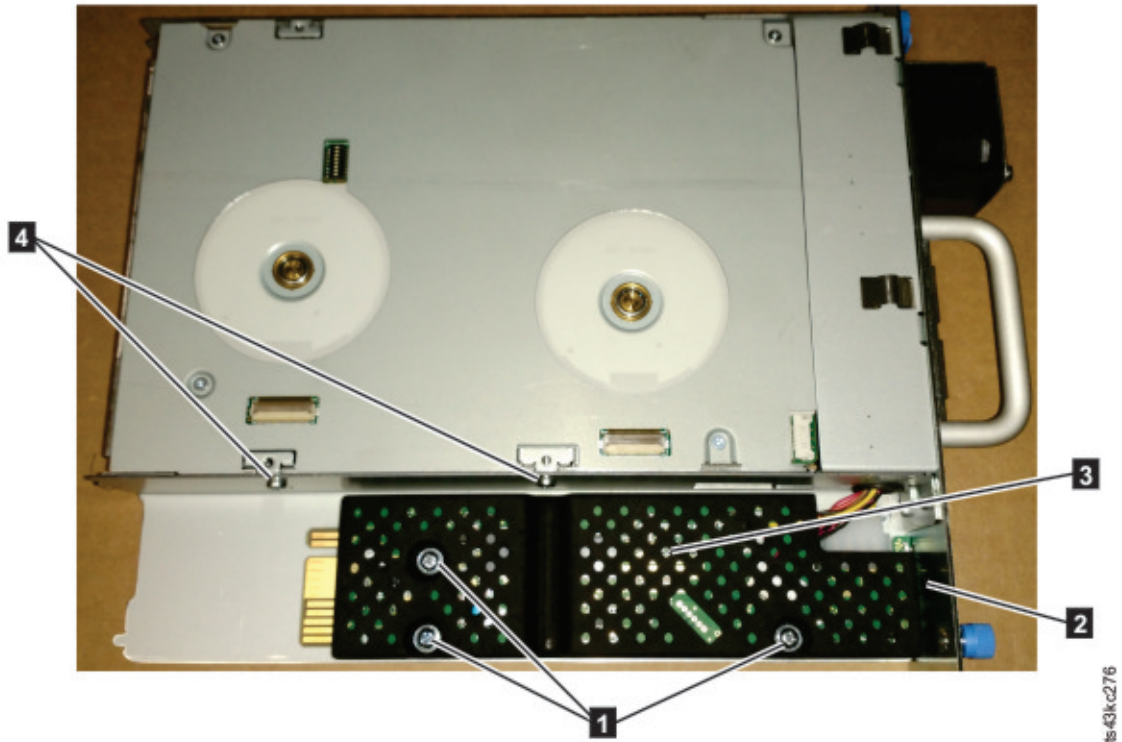

Figure 101. Connection screws and plastic cover

1	Connection card screws
2	Plastic cover
3	Connection card (under the plastic cover)
4	Screws that hold the drive brick to the sled (2 on each side).

3. Remove the drive brick from the sled by completing these steps:
 - a. Remove the four screws (two on each side of the sled 4) that secure the sled to the drive brick.
 - b. Pull the drive brick out of the front of the sled far enough to unplug the cables (5). Some of the cables and connectors are small and can be delicate, so be careful when you are unplugging them.

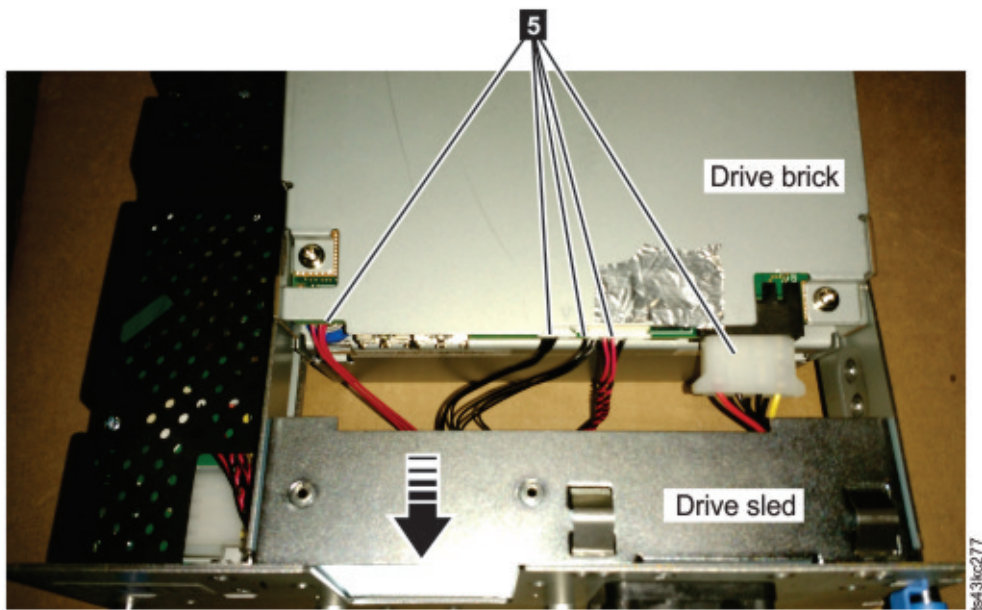

Figure 102. The drive brick, showing the cables to be unplugged.

Note: Make sure to note where each cable is connected, so they can be connected correctly later.

c. Remove the drive brick from the sled.

Removing the drive cover

1. Ground yourself to the drive by using an ESD Kit.
2. Remove the cover of the full height drive by completing these steps:
 - a. Remove the four cover-mounting screws and washers **1**.
 - b. Remove the cover by lifting it up.

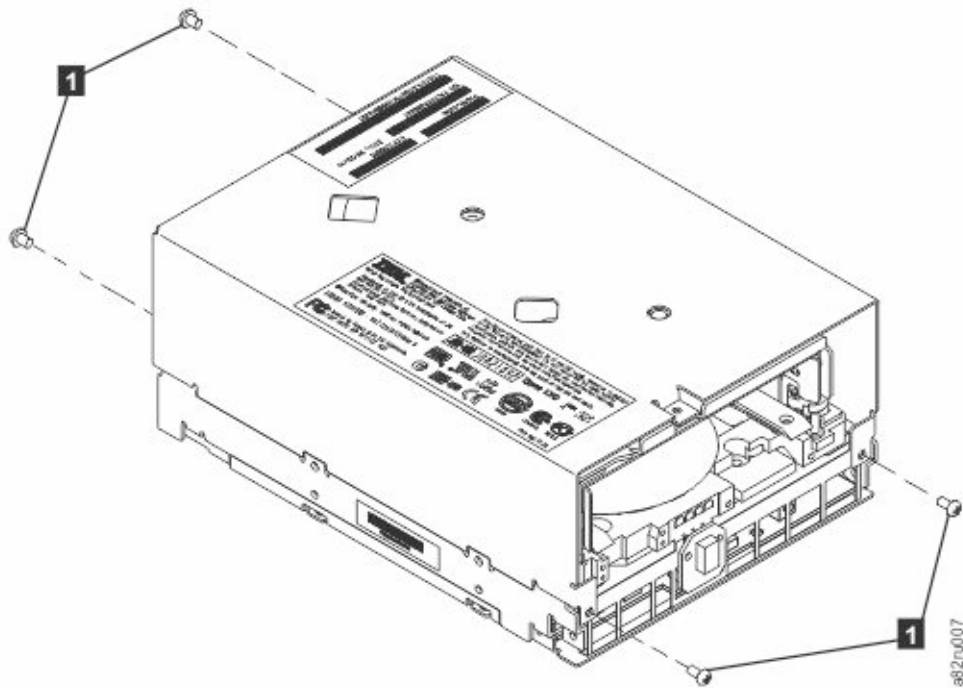

Figure 103. Removing the cover from the full height drive

3. Remove the cover of the half height drive by completing these steps:

- a. Remove the four cover-mounting screws (1). Two screws are on each side of the drive.
- b. Remove the cover by lifting it up.

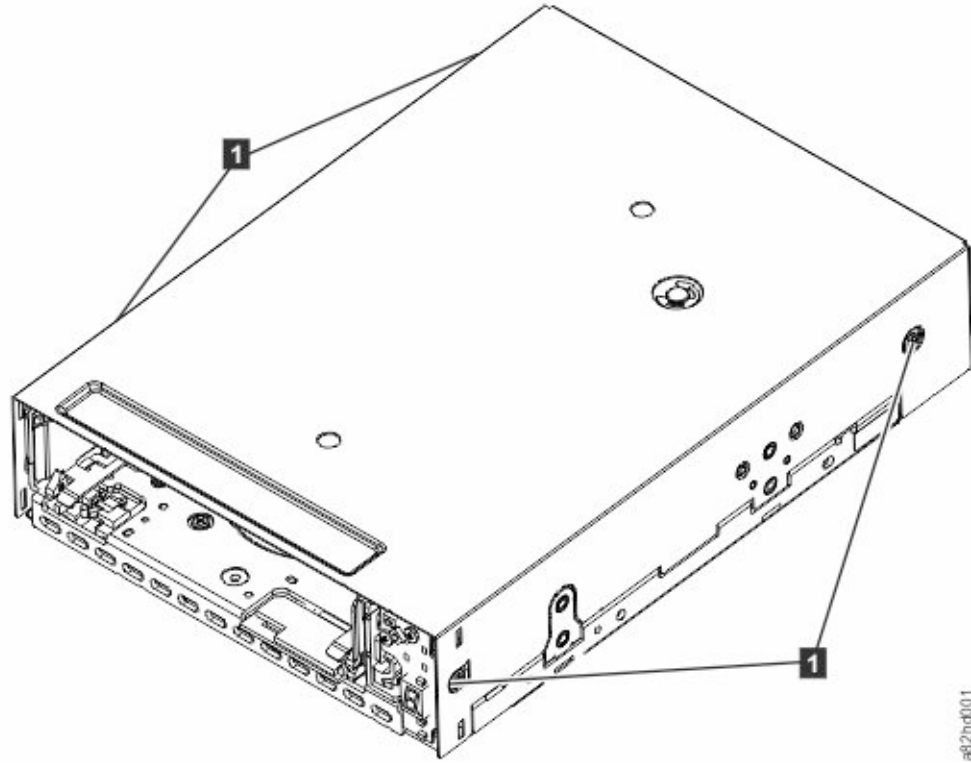

Figure 104. Removing the cover from the half height drive

4. Inspect the drive to decide which of the following conditions most closely matches the symptom on the drive:

- **Tape spooled off the supply reel** - All the tape appears to be on the take up reel and no tape is on the supply reel (inside the cartridge). Test the drive after the procedure is completed.
 - **Tape pulled from leader pin (or broken at the front end)** - All the tape appears to be on the supply reel (inside the cartridge) and little or no tape appears to be on the take up reel. The leader block is positioned in the take up reel. Return the drive after the procedure is completed.
 - **Tape broken in mid-tape** - Tape appears to be on both the supply reel (inside the cartridge) and take up reel. Test the drive after the procedure is completed.
 - **Tape tangled along tape path** - Tape appears to be tangled and damaged but intact. Return the drive after the procedure is completed.
- OR --
- **No damage to tape (or no apparent failure)** - There appears to be no damage or slack to the tape. Return the drive after the procedure is completed.

Full height drive: Tape spooled off supply reel

Note: If the cartridge in the drive is an INPUT tape that contains ACTIVE or 'ONLY COPY' data (there is no backup), eject commands that are issued at the host fail to unload the tape, and power-cycling the drive fails to eject the cartridge, make **no further attempts** to unload this tape. Call Technical Support and open a PMR if one is not already open, to initiate the process of sending the drive with the loaded cartridge in for recovery.

1. With the front of the drive facing you, pull an arm's length of tape out of the take up reel from the left side of the drive.

2. From the take up reel, thread tape around the rear of the tape path and over the head and rollers on the left side of the drive.
3. Set the drive on its left side with the head and tape path facing up.
4. Moisten a cotton swab with water and wet approximately 13 mm (0.5 in.) of the tape end and feed it onto the supply reel (inside the cartridge).
5. From the bottom of the drive, insert a 2.5 mm offset hex wrench through the bottom cover access hole and into the reel motor axle.

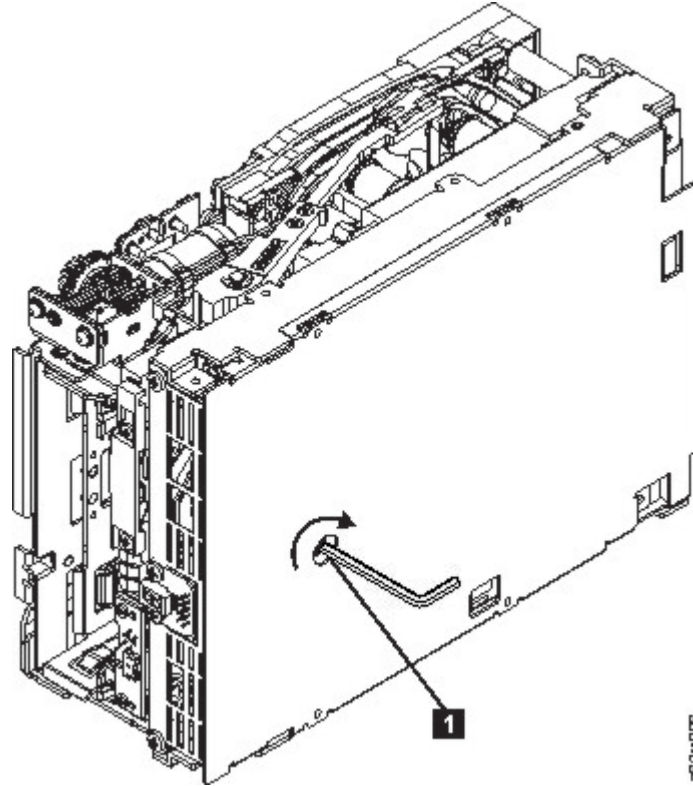

Figure 105. The hex wrench rewinds tape into cartridge

6. Turn the supply reel clockwise, allowing the moistened tape to adhere to the hub as it winds around the supply reel (inside the cartridge).
7. Continue spooling into the cartridge until the tape is taut and remains within the flanges of the tape guiding rollers. Ensure that you do not stretch the tape.
8. Go to [“Ending procedure”](#) on page 197.

Half height drive: Tape spooled off supply reel



Attention: DO NOT TOUCH THE OUTER GUIDE RAIL (2). THIS RAIL IS DELICATE AND EASILY DAMAGED.

Note: If the cartridge in the drive is an INPUT tape that contains ACTIVE or 'ONLY COPY' data (there is no backup), eject commands that are issued at the host fail to unload the tape, and power-cycling the drive fails to eject the cartridge, make **no further attempts** to unload this tape. Call Technical Support and open a PMR if one is not already open, to initiate the process of sending the drive with the loaded cartridge in for recovery.

1. From the takeup reel, pull an arm's length of tape around the rear of the tape path and over the head and rollers on the left side of the drive.
2. Set the drive on its left side with the head and tape path facing up.
3. Ensure that the tape is not twisted. Untwist the tape if required.
4. Moisten a cotton swab with water and wet approximately 13 mm (0.5 in.) of the tape end and feed it onto the supply reel (inside the cartridge).

- Turn the supply reel (4) clockwise, allowing the moistened tape to adhere to the hub as it winds around the supply reel (inside the cartridge).

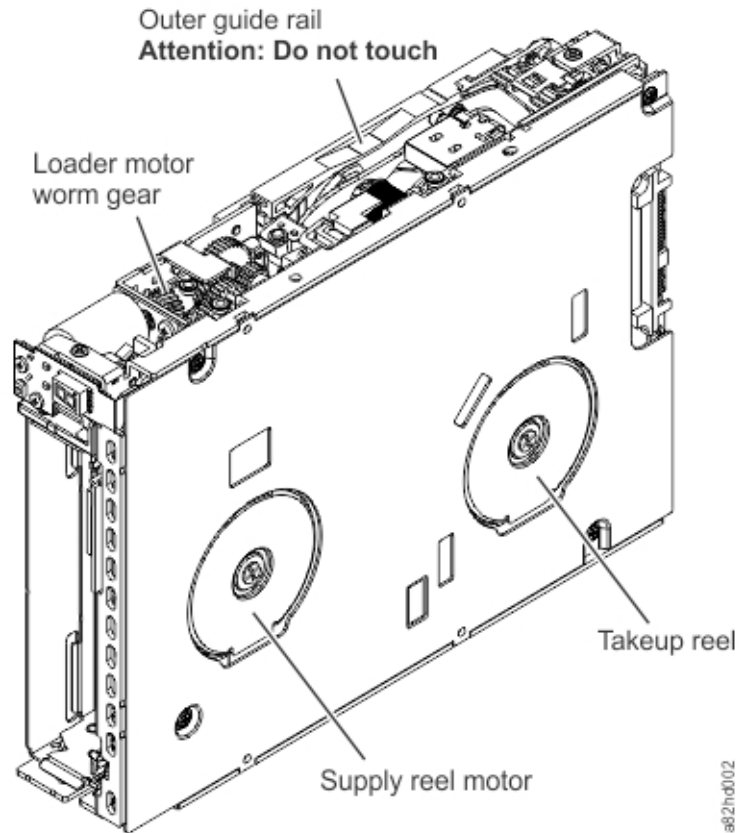

Figure 106. Rewinding tape into cartridge

- | | | | |
|----------|---|----------|-------------------|
| 1 | Loader motor worm gear | 3 | Takeup reel motor |
| 2 | Outer guide rail (WARNING: Do Not Touch) | 4 | Supply reel motor |

- Continue spooling into the cartridge until the tape is taut and remains within the flanges of the tape guiding rollers. Turn the supply reel (4) 10 more turns. Ensure that you do not stretch the tape.
- Go to [“Ending procedure”](#) on page 197.

Full height drive: Tape pulled from or broken near leader pin

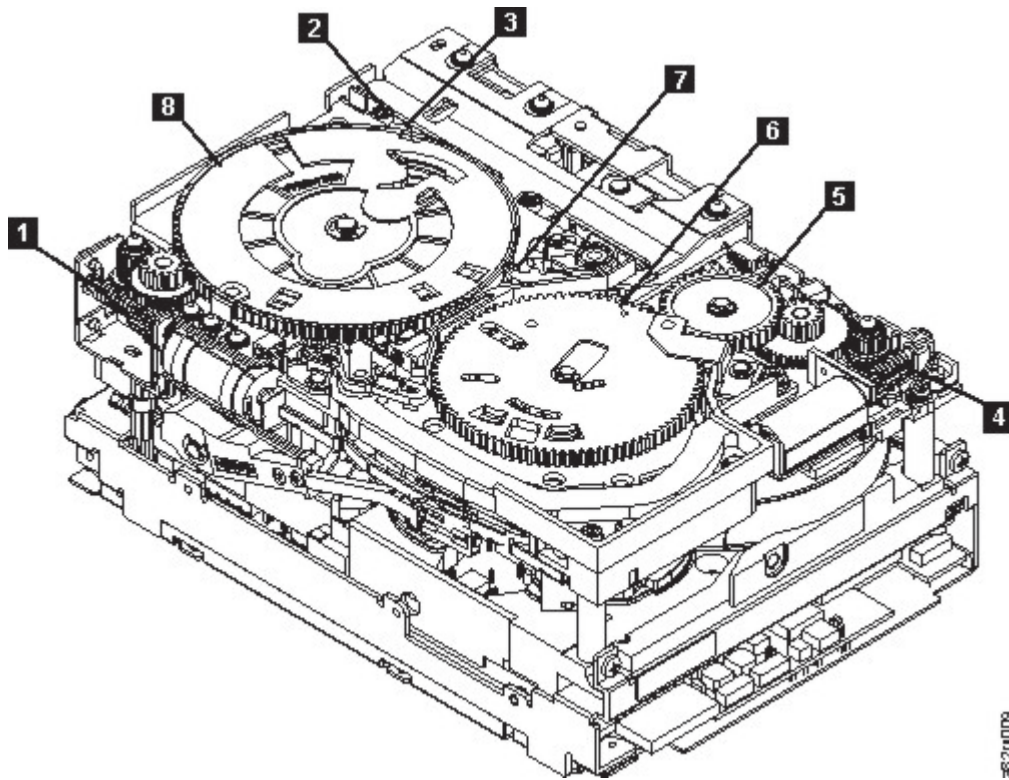

Figure 107. Drive with cover removed to reveal gear train.

1	Loader motor worm gear	6	Threader mechanism gear
2	Cartridge loader tray guide bearing	7	Lever
3	Rotator stub	8	Loader mechanism gear
4	Threader motor worm gear		
5	Threader intermediate gear		

1. From the left side of the drive, pull out tape from the take up reel.

Note: If there is more than approximately 0.6 m (2 ft.) of tape on the take up reel, go to [“Full height drive: Tape broken in mid-tape”](#) on page 186.

2. If there is less than approximately 0.6 m (2 ft.) of tape on the take up reel, cut off the excess tape as close to the leader pin, as possible.
3. Locate the threader motor worm gear (4) the rear of the drive. Use your finger to rotate the threader motor worm gear and slowly rotate the threader mechanism gear (6) clockwise. This action rotates the threader motor worm gear (4) clockwise, drawing the tape leader block assembly (LBA) into the cartridge.
4. As the LBA is secured in the cartridge, you hear the LBA retention spring clips click into place. If you do not hear the click, continue rolling until the threader motor worm gear (4) stops. The LBA is in the correct position.

Note: Be sure to keep tension on the tape as the LBA is drawn into the cartridge by using a hex wrench as shown in [Figure 105](#) on page 182.

5. Notice the following mechanisms:
 - a. Loader mechanism gear (8) nearest the front of the drive that actuates the cartridge loader mechanism

- b. Position of the rotator stub (3).
 - c. Front loader motor worm gear (1). Rotating this gear allows the loader mechanism gear (8) to turn.
6. Rotate the loader motor worm gear (1) to turn the loader mechanism gear (6) counterclockwise. Continue turning until the rotator stub (3) loses contact with the lever (7). This action releases the LBA leader pin.
 7. Rotate the threader motor worm gear (4) to turn the threader mechanism gear (6) counterclockwise. This action moves the LBA out of the cartridge and past the read/write head. Stop this rotation when the LBA is near the tape guide roller nearest the rear of the drive (1).

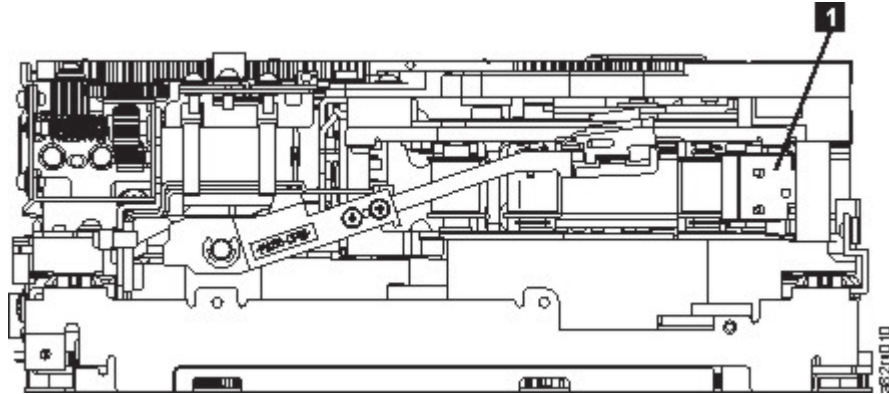

Figure 108. Leader Block Assembly (LBA)

8. Continue rotating the loader motor worm gear (1) until the rotator stub (3) is positioned as shown. Notice that the rotator stub (3) is nearly aligned with the cartridge loader tray guide bearing (2).
9. Remove the cartridge from the cartridge loader tray.
10. Go to “Ending procedure” on page 197.

Half height drive: Tape pulled from or broken near leader pin

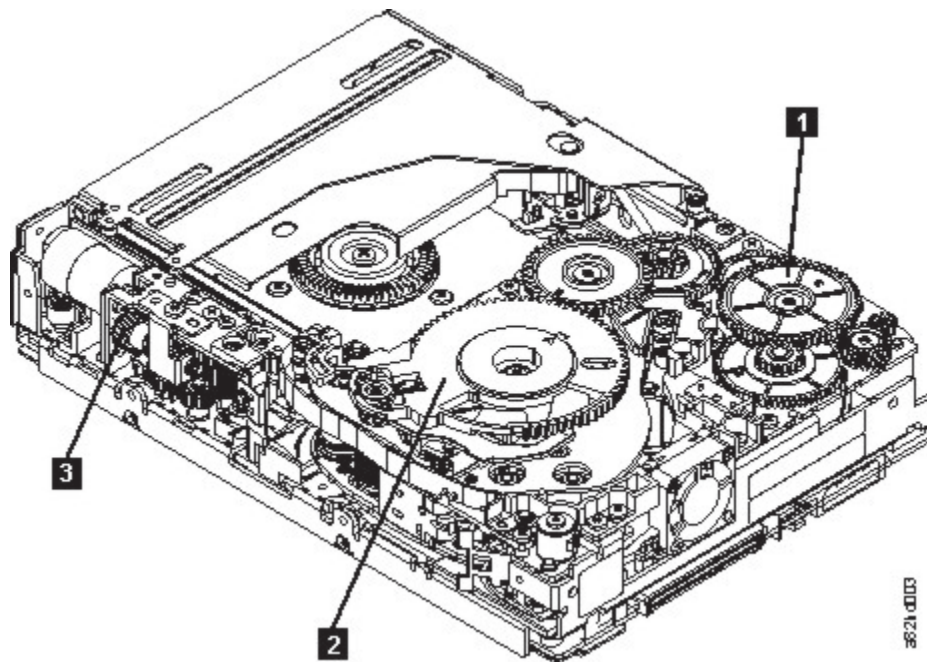

Figure 109. Drive with cover removed to reveal gear train.

- | | | | | | |
|----------|----------------------------|----------|-------------------------|----------|------------------------|
| 1 | Threader intermediate gear | 2 | Threader mechanism gear | 3 | Loader motor worm gear |
|----------|----------------------------|----------|-------------------------|----------|------------------------|

1. Pull out tape from the takeup reel.

Note: If there is more than approximately 0.6 m (2 ft.) of tape on the takeup reel, go to [“Half height drive: Tape broken in mid-tape”](#) on page 187
2. If there is less than approximately 0.6 m (2 ft.) of tape on the takeup reel, cut off the excess tape as close to the leader pin, as possible.
3. Reattach the leader pin to the remaining tape.
4. Locate the threader intermediate gear (1) near the rear of the drive. You can use your finger to rotate the threader intermediate gear (1) and slowly rotate the threader mechanism gear (2) clockwise. This action draws the tape leader block assembly (LBA) into the cartridge.
5. As the leader pin is secured in the cartridge, you hear the leader pin retention spring clips click into place. If you do not hear the click, continue rolling until the threader intermediate gear (1) stops. The LBA is in the correct position.
6. Rotate the loader motor worm gear (3) clockwise as viewed from the front of the drive until it stops. This action releases the LBA leader pin.
7. Rotate the threader intermediate gear (1) counterclockwise until the leader block is in front of the read/write head. This action moves the LBA out of the cartridge.

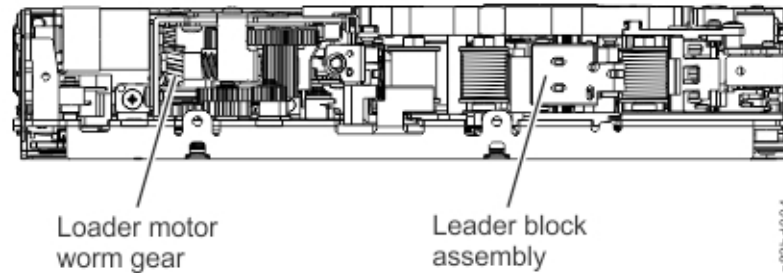

Figure 110. Leader Block Assembly (LBA)

1 Loader motor worm gear 2 Leader block assembly (LBA)

8. Rotate the loader motor worm gear (3) counterclockwise as viewed from the front of the drive until it stops.
9. Remove the cartridge from the cartridge loader tray.
10. Go to [“Ending procedure”](#) on page 197.

Full height drive: Tape broken in mid-tape

1. With the front of the drive facing you, pull an arm's length of tape out of the take up reel from the left side of the drive.

Note: If there is less than approximately 5 cm (2 in.) of tape on the take up reel, go to [“Full height drive: Tape pulled from or broken near leader pin”](#) on page 184.
2. From the supply reel inside the cartridge, pull approximately 0.3 m (1 ft.) of tape.
3. From the take up reel, thread tape around the rear of the tape path and over the head rollers on the left side of the drive.
4. Moisten a cotton swab with water, and wet approximately 13 mm (0.5 in.) of the tape end. Overlap the tape ends, loosely mending them together.
5. Set the drive on its left side with the head and tape path facing up.
6. From the bottom of the drive, locate the access hole (1 in Figure 111 on page 187) in the bottom cover. Insert a 2.5 mm offset hex wrench through the bottom cover access hole and into the reel motor axle. Begin spooling tape back into the cartridge by turning the hex wrench clockwise.

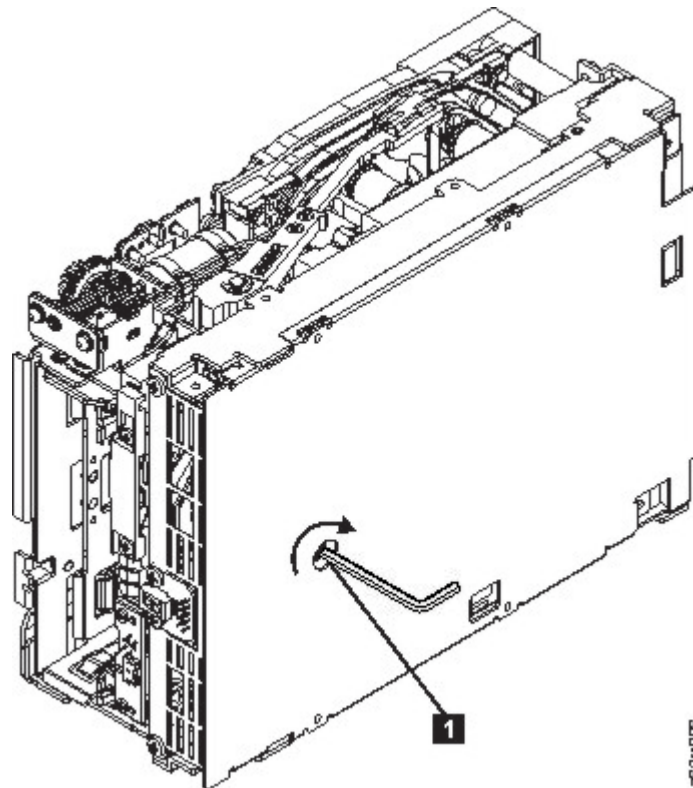

Figure 111. The hex wrench rewinds tape into cartridge

7. Turn the supply reel clockwise, carefully guiding the mended portion of the tape to wind around the hub of the supply reel that is located inside the cartridge. Continue spooling into the cartridge until the tape is taut. The tape must remain within the flanges of the tape guiding rollers. Ensure that you do not stretch the tape.
8. Go to [“Ending procedure”](#) on page 197.

Half height drive: Tape broken in mid-tape

1. With the front of the drive facing you, pull an arm's length of tape out of the takeup reel. From the takeup reel, thread tape around the rear of the tape path and over the head rollers on the left side of the drive.

Note: If there is less than approximately 5 cm (2 in.) of tape on the takeup reel, go to [“Half height drive: Tape pulled from or broken near leader pin”](#) on page 185.
2. From the supply reel inside the cartridge, pull approximately 0.3 m (1 ft.) of tape.
3. Ensure that the tape is not twisted. Untwist the tape if required
4. Moisten a cotton swab with water, and wet approximately 13 mm (0.5 in.) of the tape end. Overlap the tape ends, loosely mending them together.
5. Set the drive on its left side with the head and tape path facing up
6. Turn the supply reel (4) clockwise, carefully guiding the mended portion of the tape to wind around the hub of the supply reel that is located inside the cartridge. Continue spooling into the cartridge until the tape is taut. The tape must remain within the flanges of the tape guiding rollers. Turn the supply reel (4) 10 more turns. Ensure that you do not stretch the tape.

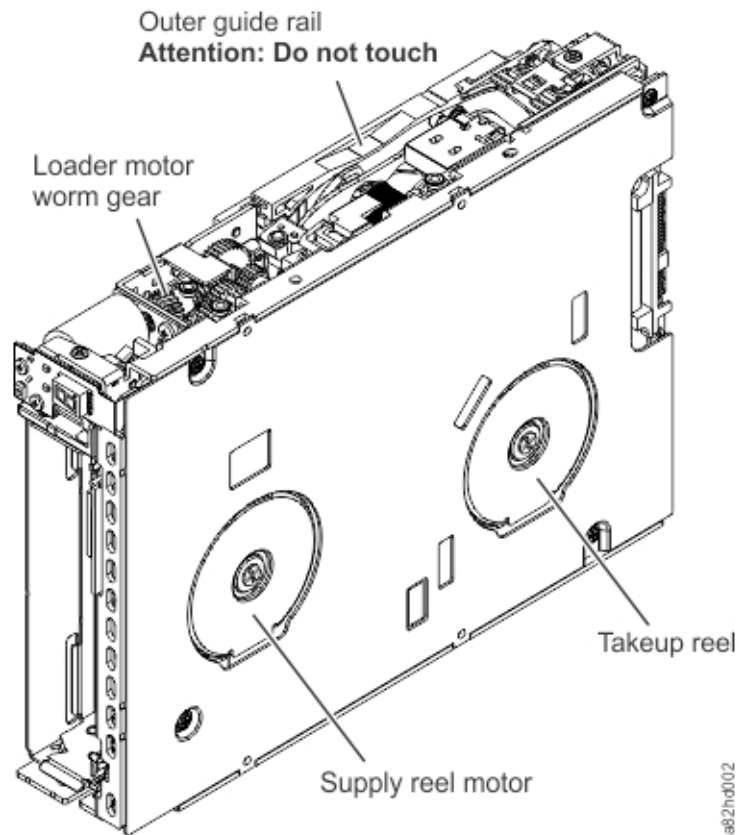

Figure 112. Rewinding tape into cartridge

- | | | | |
|---------------------------------|--|---------------------------------|---|
| <p>1</p> <p>2</p> | <p>Loader motor worm gear</p> <p>Outer guide rail (WARNING: Do Not Touch)</p> | <p>3</p> <p>4</p> | <p>Takeup reel motor</p> <p>Supply reel motor</p> |
|---------------------------------|--|---------------------------------|---|

7. Go to [“Ending procedure”](#) on page 197.

Full height drive: Tape tangled along tape path

Note: If the cartridge in the drive is an INPUT tape that contains ACTIVE or 'ONLY COPY' data (there is no backup), eject commands that are issued at the host fail to unload the tape, and power-cycling the drive fails to eject the cartridge, make **no further attempts** to unload this tape. Call Technical Support and open a PMR if one is not already open, to initiate the process of sending the drive with the loaded cartridge in for recovery.

1. Carefully pull out excess tape and untangle.

Note: If you find the tape to be broken, go to one of the following appropriate procedures:

- [“Full height drive: Tape spooled off supply reel”](#) on page 181
- [“Full height drive: Tape pulled from or broken near leader pin”](#) on page 184

--OR--

[“Full height drive: Tape broken in mid-tape”](#) on page 186

2. Set the drive on its left side with the head and tape path facing up.

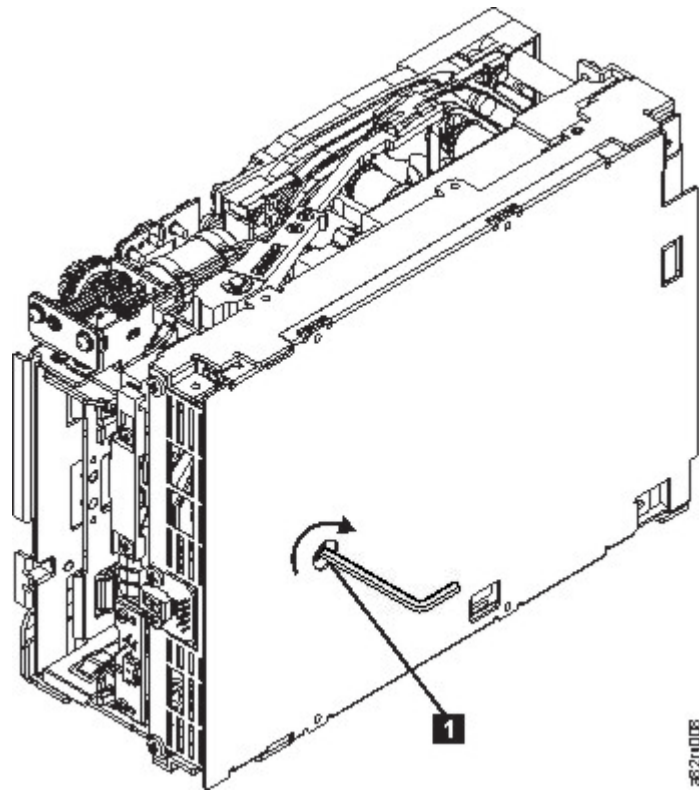

Figure 113. The hex wrench rewinds tape into cartridge

3. From the bottom of the drive, locate the access hole (1 in Figure 113 on page 189).
4. Insert a 2.5 mm offset hex wrench through the bottom cover access hole and into the reel motor axle. Begin spooling the tape back into the cartridge by turning the hex wrench clockwise.
5. Continue spooling into the cartridge until the tape is taut and remains within the flanges of the tape guiding rollers. Ensure that you do not stretch the tape.
6. Locate the threader motor worm gear (4 in Figure 114 on page 190) on the rear of the drive. Use your finger to rotate the threader motor worm gear and slowly rotate the threader mechanism gear (6 in Figure 114 on page 190) clockwise.
This action rotates the threader motor worm gear (4 in Figure 114 on page 190) clockwise, drawing the LBA into the cartridge.

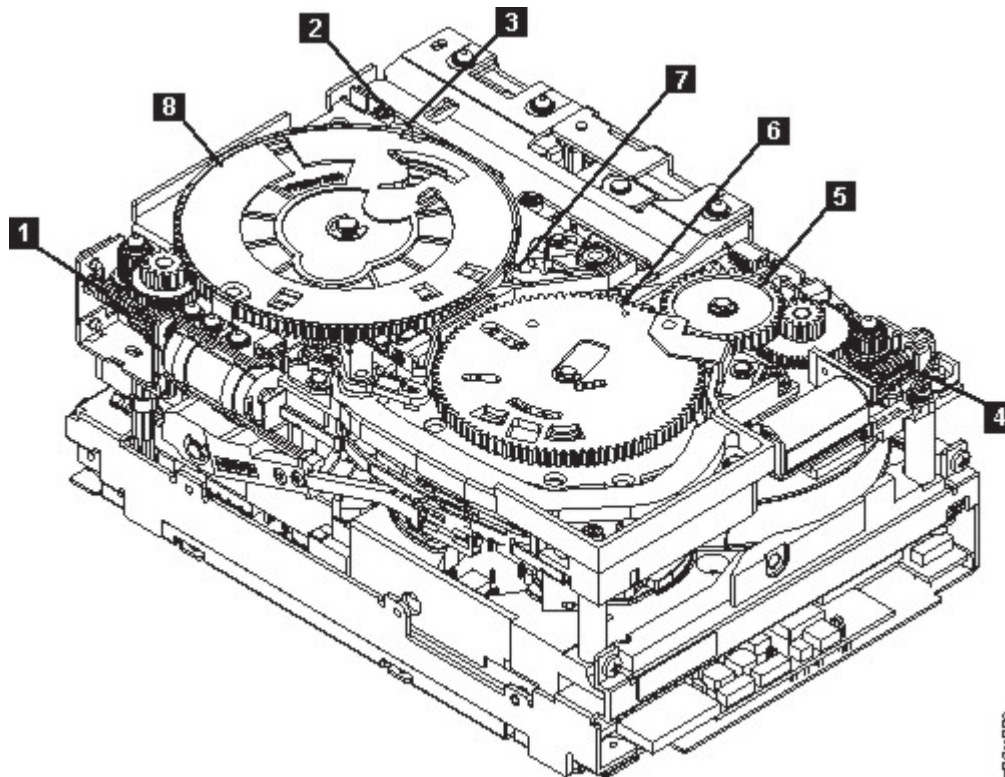

Figure 114. Drive with cover removed to reveal gear train.

1	Loader motor worm gear	6	Threader mechanism gear
2	Cartridge loader tray guide bearing	7	Lever
3	Rotator stub	8	Loader mechanism gear
4	Threader motor worm gear		
5	Threader intermediate gear		

7. As the tape leader block assembly (LBA) is secured in the cartridge, you hear the LBA retention spring clips click into place. If you do not hear the click, continue rolling until the threader motor worm gear (**4** in Figure 114 on page 190) stops. The LBA is in the correct position.

Note: Be sure to keep tension on the tape as the LBA is drawn into the cartridge by using a hex wrench as shown in Figure 113 on page 189.

8. Notice these mechanisms:

- a) Loader mechanism gear (**6** in Figure 114 on page 190) nearest the front of the drive that actuates the cartridge loader mechanism.
 - b) Position of the rotate stub (**3** in Figure 114 on page 190).
 - c) Front loader motor worm gear (**1** in Figure 114 on page 190). Rotating this gear allows the loader mechanism gear (**8** in Figure 114 on page 190) to turn.
9. Rotate the loader motor worm gear (**1** in Figure 114 on page 190) to turn the threader mechanism gear (**6** in Figure 114 on page 190) counterclockwise. Continue turning until the rotator stub (**3** in Figure 114 on page 190) loses contact with the lever (**7** in Figure 114 on page 190). This action releases the LBA leader pin.
10. Rotate the threader motor worm gear (**4** in Figure 114 on page 190) to turn the threader mechanism gear (**6** in Figure 114 on page 190) counterclockwise. This action moves the LBA out of the cartridge and past the read/write head. Stop this rotation when the LBA is near the tape guide roller nearest the rear of the drive that is shown as **1** Figure 115 on page 191.

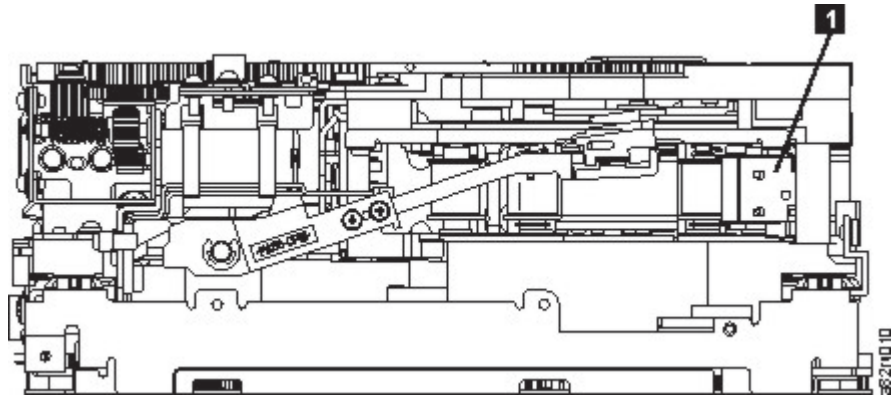

Figure 115. Leader Block Assembly (LBA)

11. Continue rotating the loader motor worm gear (1 in Figure 114 on page 190) until the rotator stub (3 in Figure 114 on page 190) is positioned as shown. Notice that the rotator stub (3 in Figure 114 on page 190) is nearly aligned with the cartridge loader tray guide bearing (2 in Figure 114 on page 190).
12. Remove the cartridge from the cartridge loader tray.
13. Go to [“Ending procedure” on page 197.](#)

Half height drive: Tape tangled along tape path

Note: If the cartridge in the drive is an INPUT tape that contains ACTIVE or 'ONLY COPY' data (there is no backup), eject commands that are issued at the host fail to unload the tape, and power-cycling the drive fails to eject the cartridge, make **no further attempts** to unload this tape. Call Technical Support and open a PMR if one is not already open, to initiate the process of sending the drive with the loaded cartridge in for recovery.

1. Carefully pull out excess tape and untangle.

Note: If you find the tape to be broken, go to one of the following appropriate procedures:

- [“Half height drive: Tape spooled off supply reel” on page 182](#)
- [“Half height drive: Tape pulled from or broken near leader pin” on page 185](#)

–OR–

- [“Half height drive: Tape broken in mid-tape” on page 187](#)

2. Set the drive on its left side with the head and tape path facing up.

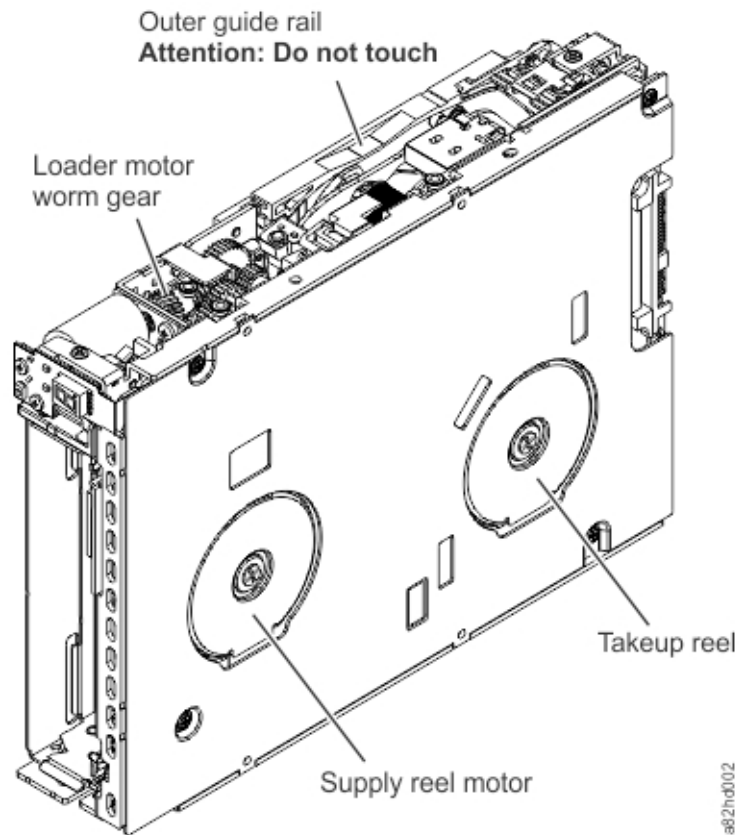

Figure 116. Rewinding tape into cartridge

- | | | | |
|---------------------------------|--|---------------------------------|---|
| <p>1</p> <p>2</p> | <p>Loader motor worm gear</p> <p>Outer guide rail (WARNING: Do Not Touch)</p> | <p>3</p> <p>4</p> | <p>Takeup reel motor</p> <p>Supply reel motor</p> |
|---------------------------------|--|---------------------------------|---|

3. Turn the supply reel (**4**) clockwise.
4. Continue spooling into the cartridge until the tape is taut and remains within the flanges of the tape guiding rollers. Turn the supply reel (**4**) 10 turns. Ensure that you do not stretch the tape.
5. Go to [“Ending procedure”](#) on page 197.

Full height drive: No apparent failure or damage to tape

Note: If the cartridge in the drive is an INPUT tape that contains ACTIVE or 'ONLY COPY' data (there is no backup), eject commands that are issued at the host fail to unload the tape, and power-cycling the drive fails to eject the cartridge, make **no further attempts** to unload this tape. Call Technical Support and open a PMR if one is not already open, to initiate the process of sending the drive with the loaded cartridge in for recovery.

1. Set the drive on its left side with the head and tape path facing up.

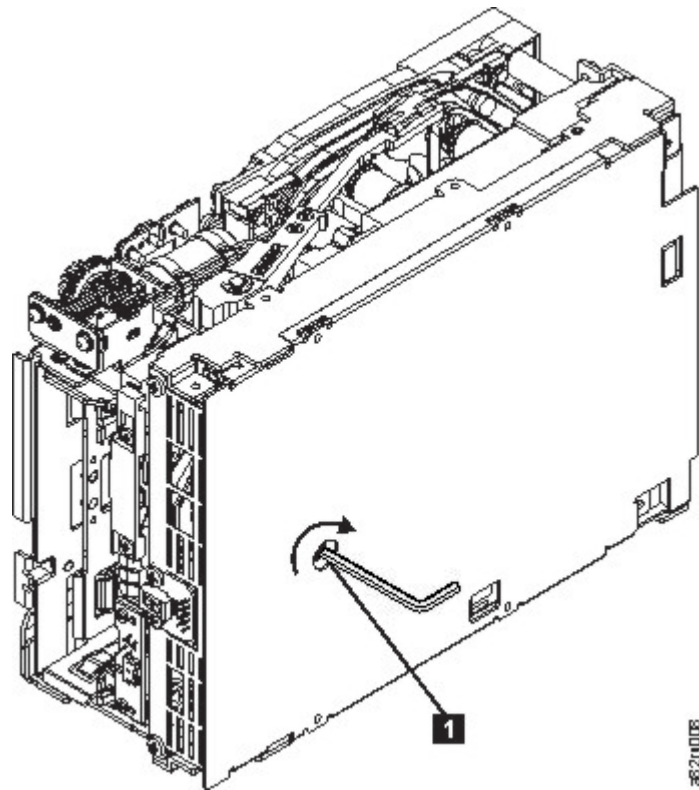

Figure 117. The hex wrench rewinds tape into cartridge

2. From the bottom of the drive, locate the access hole (1 in Figure 117 on page 193).
 3. Insert a 2.5 mm offset hex wrench through the bottom cover access hole and into the reel motor axle. Begin spooling the tape back into the cartridge by turning the hex wrench clockwise.
 4. Continue spooling into the cartridge until the tape is taut and remains within the flanges of the tape guiding rollers. Ensure that you do not stretch the tape.
 5. Locate the threader motor worm gear (4 in Figure 118 on page 194) on the rear of the drive. Use your finger to rotate the threader motor worm gear and slowly rotate the threader mechanism gear (6 in Figure 118 on page 194) clockwise.
- This action rotates the threader motor worm gear (4 in Figure 118 on page 194) clockwise, drawing the LBA into the cartridge.

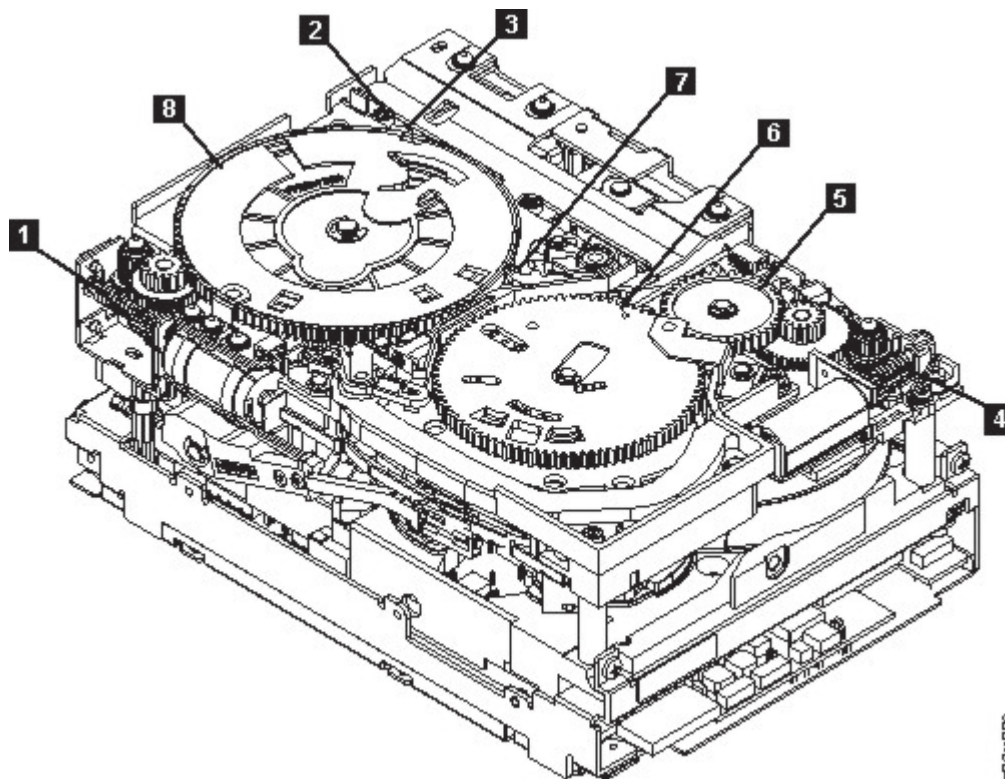

Figure 118. Drive with cover removed to reveal gear train.

1	Loader motor worm gear	6	Threader mechanism gear
2	Cartridge loader tray guide bearing	7	Lever
3	Rotator stub	8	Loader mechanism gear
4	Threader motor worm gear		
5	Threader intermediate gear		

6. As the tape leader block assembly (LBA) is secured in the cartridge, you hear the LBA retention spring clips click into place. If you do not hear the click, continue rolling until the threader motor worm gear (**4** in [Figure 118 on page 194](#)) stops. The LBA is in the correct position.

Note: Be sure to keep tension on the tape as the LBA is drawn into the cartridge by using a hex wrench as shown in [Figure 117 on page 193](#).

7. Notice these mechanisms:
- Loader mechanism gear (**6** in [Figure 118 on page 194](#)) nearest the front of the drive that actuates the cartridge loader mechanism.
 - Position of the rotate stub (**3** in [Figure 118 on page 194](#)).
 - Front loader motor worm gear (**1** in [Figure 118 on page 194](#)). Rotating this gear allows the loader mechanism gear (**8** in [Figure 118 on page 194](#)) to turn.
8. Rotate the loader motor worm gear (**1** in [Figure 118 on page 194](#)) to turn the loader mechanism gear (**6** in [Figure 118 on page 194](#)) counterclockwise. Continue turning until the rotator stub (**3** in [Figure 118 on page 194](#)) loses contact with the lever (**7** in [Figure 118 on page 194](#)). This action releases the LBA leader pin.
9. Rotate the threader motor worm gear (**4** in [Figure 118 on page 194](#)) to turn the threader mechanism gear (**6** in [Figure 118 on page 194](#)) counterclockwise. This action moves the LBA out of the cartridge and past the read/write head. Stop this rotation when the LBA is near the tape guide roller nearest the rear of the drive that is shown as **1** [Figure 119 on page 195](#).

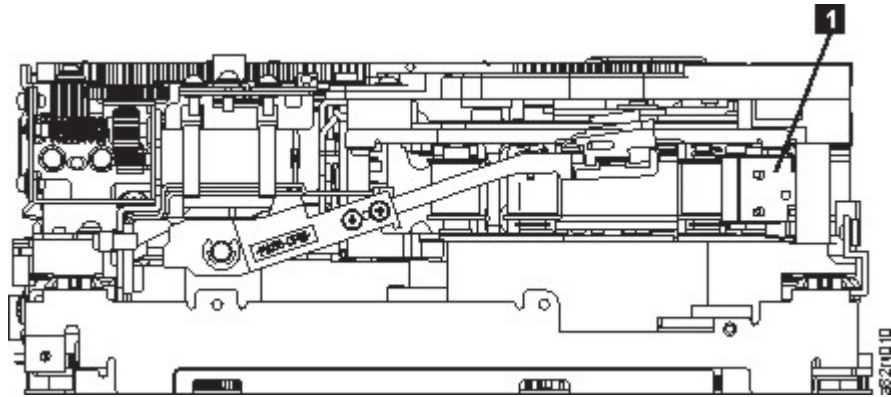

Figure 119. Leader Block Assembly (LBA)

10. Continue rotating the loader motor worm gear (1 in Figure 118 on page 194) until the rotator stub (3 in Figure 118 on page 194) is positioned as shown. Notice that the rotator stub (3 in Figure 118 on page 194) is nearly aligned with the cartridge loader tray guide bearing (2 in Figure 118 on page 194).
11. Remove the cartridge from the cartridge loader tray.
12. Go to [“Ending procedure” on page 197.](#)

Half height drive: No apparent failure or damage to tape

Note: If the cartridge in the drive is an INPUT tape that contains ACTIVE or 'ONLY COPY' data (there is no backup), eject commands that are issued at the host fail to unload the tape, and power-cycling the drive fails to eject the cartridge, make **no further attempts** to unload this tape. Call Technical Support and open a PMR if one is not already open, to initiate the process of sending the drive with the loaded cartridge in for recovery.

1. Set the drive on its left side with the head and tape path facing up.

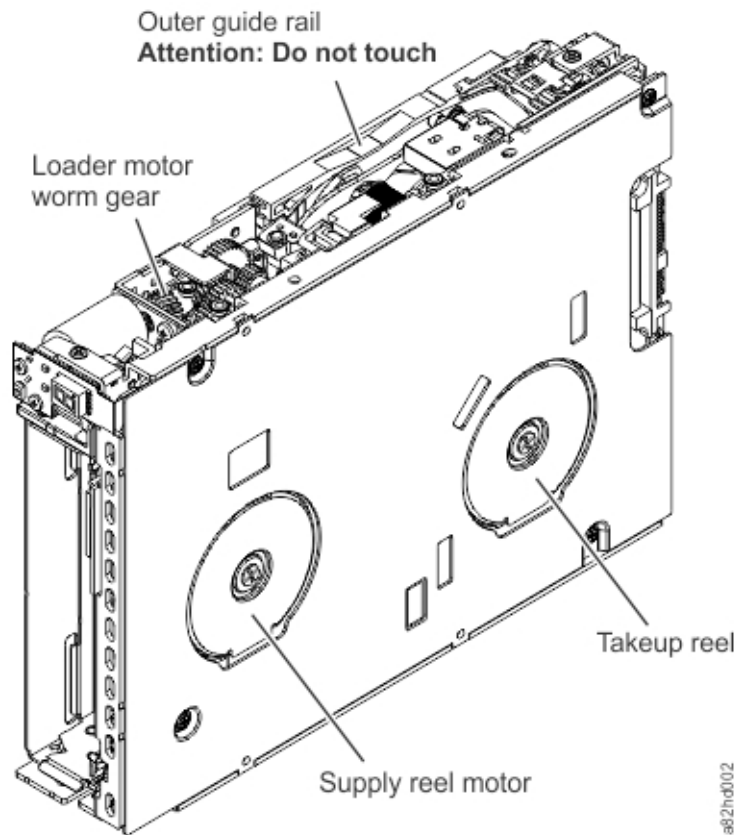

Figure 120. Rewinding tape into cartridge

- | | | | |
|----------|---|----------|-------------------|
| 1 | Loader motor worm gear | 3 | Takeup reel motor |
| 2 | Outer guide rail (WARNING: Do Not Touch) | 4 | Supply reel motor |

2. Begin spooling the tape back into the cartridge by turning the supply reel motor **(4)** clockwise.
3. Continue spooling into the cartridge until the tape is taut and remains within the flanges of the tape guiding rollers. Ensure that you do not stretch the tape. Continue spooling until all tape is removed from the takeup reel **(3)**.
4. Locate the threader intermediate gear **(1)** near the rear of the drive. You can use your finger to rotate the threader intermediate gear **(1)** and slowly rotate the threader mechanism gear **(2)** clockwise. This action draws the tape leader block assembly (LBA) into the cartridge.

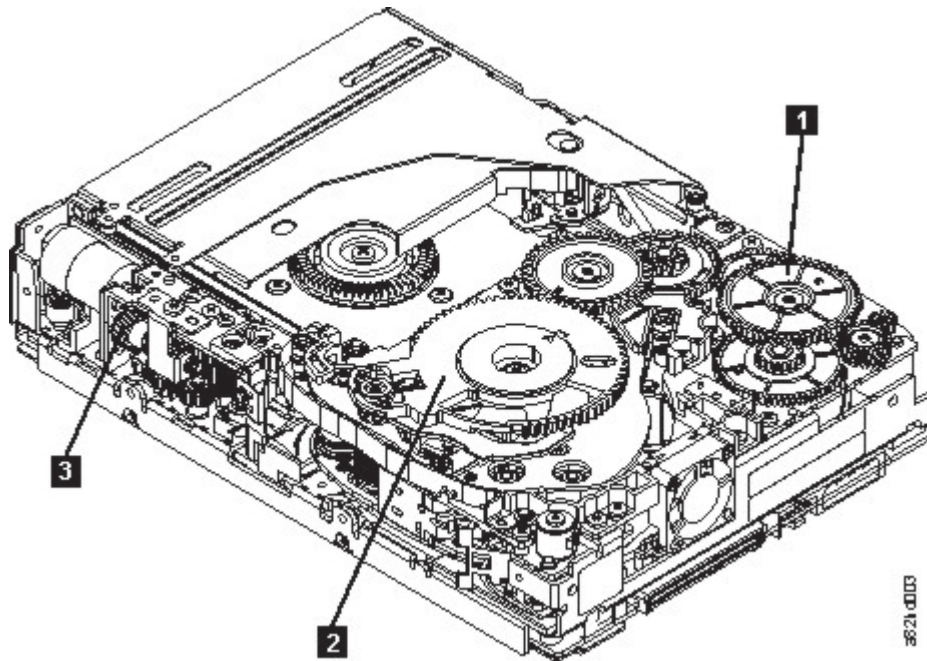

Figure 121. Drive with cover removed to reveal gear train.

- 1** Threader intermediate gear **2** Threader mechanism gear **3** Loader motor worm gear

5. As the leader pin is secured in the cartridge, you hear the leader pin retention spring clips click into place. If you do not hear the click, continue rolling until the threader intermediate gear (**1**) stops. The LBA is in the correct position.

Note: Be sure to keep tension on the tape as the LBA is drawn into the cartridge.

6. Rotate the loader intermediate gear (**1**) clockwise as viewed from the front of the drive until it stops. This action releases the LBA leader pin.
 7. Rotate the threader motor worm gear (**3**) counterclockwise until the leader block is in front of the read/write head. This action moves the LBA out of the cartridge.

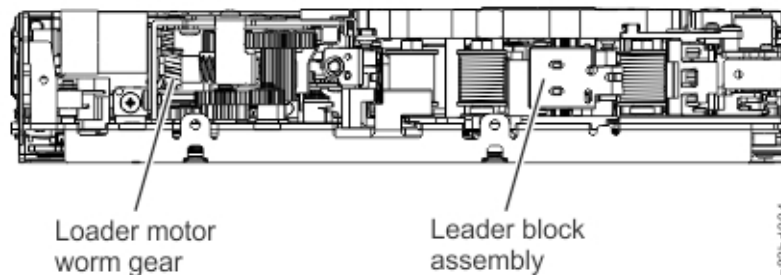

Figure 122. Leader Block Assembly (LBA)

- 1** Loader motor worm gear **2** Leader block assembly (LBA)

8. Rotate the loader motor worm gear (**3**) counterclockwise as viewed from the front of the drive until it stops.
 9. Remove the cartridge from the cartridge loader tray.
 10. Go to [“Ending procedure”](#) on page 197.

Ending procedure

1. Reassemble the drive brick by reversing the steps in [“Removing the drive cover”](#) on page 180.

2. Reassemble the drive sled and reinstall the drive brick by completing these steps:
 - Plug in the RS-422 cable, the power cable (if applicable), and the signal cable.
 - Push the drive brick fully into the sled.
 - Align the two screws holes on each side of the sled with the screw holes on each side of the drive brick. **DO NOT TIGHTEN THE SCREWS COMPLETELY.**
 - When the drive and sled are properly aligned, fully tighten the screws.
3. Install the tape drive sled in the library.
4. Power ON the library and wait for the library to finish POST (power on self test), inventory, and mid-tape recovery. This step can take up to 1 hour.
5. If the cartridge does not eject from the drive, move the cartridge from the drive to the I/O station, then discard the cartridge.
 - Operator Panel: **Operation > Move Cartridge from Drive to Home Slot**
 - Management GUI: **Drives > Actions > Eject Cartridge from Drive**
6. Run **Library Verify** before normal library operations resume.
7. If necessary, return the failed drive sled to IBM.

Appendix E. Accessibility

Accessibility features help a user who has a physical disability, such as restricted mobility or limited vision, to use the HTML version of the customer documentation successfully.

Features

The major accessibility features for the HTML version of this document are:

- You can use screen-reader software and a digital speech synthesizer to hear what is displayed on the screen. The following screen readers are tested: WebKing and Window-Eyes.
- You can operate all features with the keyboard instead of the mouse.

Navigating by keyboard

You can use keys or key combinations to complete operations and initiate many menu actions that are also done through mouse actions. You can navigate the HTML version of the *IBM TS4300 Tape Library User's Guide* help system from the keyboard with the following key combinations:

- To traverse to the next link, button, or topic, press **Tab** inside a frame (page).
- To move to the previous topic, press **^** or **Shift+Tab**.
- To scroll all the way up or down, press **Home** or **End**.
- To print the current page or active frame, press **Ctrl+P**.
- To select, press **Enter**.

Accessing the publications

You can view the publications for this library in Adobe Portable Document Format (PDF) with the Adobe Acrobat Reader. The PDFs are provided at the following website: <http://www.ibm.com/storage/support/> .

Notices

This information was developed for products and services that are offered in the US. This material might be available from IBM in other languages. However, you might be required to own a copy of the product or product version in that language in order to access it.

IBM may not offer the products, services, or features discussed in this document in other countries. Consult your local IBM representative for information on the products and services currently available in your area. Any reference to an IBM product, program, or service is not intended to state or imply that only that IBM product, program, or service may be used. Any functionally equivalent product, program, or service that does not infringe any IBM intellectual property right may be used instead. However, it is the user's responsibility to evaluate and verify the operation of any non-IBM product, program, or service.

IBM may have patents or pending patent applications covering subject matter described in this document. The furnishing of this document does not grant you any license to these patents. You can send license inquiries, in writing, to:

*IBM Director of Licensing
IBM Corporation
North Castle Drive, MD-NC119
Armonk, NY 10504-1785
US*

For license inquiries regarding double-byte character set (DBCS) information, contact the IBM Intellectual Property Department in your country or send inquiries, in writing, to:

*Intellectual Property Licensing
Legal and Intellectual Property Law
IBM Japan Ltd.
19-21, Nihonbashi-Hakozakicho, Chuo-ku
Tokyo 103-8510, Japan*

INTERNATIONAL BUSINESS MACHINES CORPORATION PROVIDES THIS PUBLICATION "AS IS" WITHOUT WARRANTY OF ANY KIND, EITHER EXPRESS OR IMPLIED, INCLUDING, BUT NOT LIMITED TO, THE IMPLIED WARRANTIES OF NON-INFRINGEMENT, MERCHANTABILITY OR FITNESS FOR A PARTICULAR PURPOSE. Some jurisdictions do not allow disclaimer of express or implied warranties in certain transactions, therefore, this statement may not apply to you.

This information could include technical inaccuracies or typographical errors. Changes are periodically made to the information herein; these changes will be incorporated in new editions of the publication. IBM may make improvements and/or changes in the product(s) and/or the program(s) described in this publication at any time without notice.

Any references in this information to non-IBM websites are provided for convenience only and do not in any manner serve as an endorsement of those websites. The materials at those websites are not part of the materials for this IBM product and use of those websites is at your own risk.

IBM may use or distribute any of the information you provide in any way it believes appropriate without incurring any obligation to you.

Licenseses of this program who wish to have information about it for the purpose of enabling: (i) the exchange of information between independently created programs and other programs (including this one) and (ii) the mutual use of the information which has been exchanged, should contact:

*IBM Director of Licensing
IBM Corporation
North Castle Drive, MD-NC119
Armonk, NY 10504-1785
US*

Such information may be available, subject to appropriate terms and conditions, including in some cases, payment of a fee.

The licensed program described in this document and all licensed material available for it are provided by IBM under terms of the IBM Customer Agreement, IBM International Program License Agreement or any equivalent agreement between us.

The performance data discussed herein is presented as derived under specific operating conditions. Actual results may vary.

The client examples cited are presented for illustrative purposes only. Actual performance results may vary depending on specific configurations and operating conditions.

The performance data and client examples cited are presented for illustrative purposes only. Actual performance results may vary depending on specific configurations and operating conditions.

Information concerning non-IBM products was obtained from the suppliers of those products, their published announcements or other publicly available sources. IBM has not tested those products and cannot confirm the accuracy of performance, compatibility or any other claims related to non-IBM products. Questions on the capabilities of non-IBM products should be addressed to the suppliers of those products.

Statements regarding IBM's future direction or intent are subject to change or withdrawal without notice, and represent goals and objectives only.

All IBM prices shown are IBM's suggested retail prices, are current and are subject to change without notice. Dealer prices may vary.

This information is for planning purposes only. The information herein is subject to change before the products described become available.

This information contains examples of data and reports used in daily business operations. To illustrate them as completely as possible, the examples include the names of individuals, companies, brands, and products. All of these names are fictitious and any similarity to actual people or business enterprises is entirely coincidental.

COPYRIGHT LICENSE:

This information contains sample application programs in source language, which illustrate programming techniques on various operating platforms. You may copy, modify, and distribute these sample programs in any form without payment to IBM, for the purposes of developing, using, marketing or distributing application programs conforming to the application programming interface for the operating platform for which the sample programs are written. These examples have not been thoroughly tested under all conditions. IBM, therefore, cannot guarantee or imply reliability, serviceability, or function of these programs. The sample programs are provided "AS IS", without warranty of any kind. IBM shall not be liable for any damages arising out of your use of the sample programs.

Each copy or any portion of these sample programs or any derivative work must include a copyright notice as follows:

© (your company name) (year).

Portions of this code are derived from IBM Corp. Sample Programs.

© Copyright IBM Corp. _enter the year or years_.

If you are viewing this information softcopy, the photographs and color illustrations may not appear.

Trademarks

A list of trademarks for IBM and other companies.

IBM, the IBM logo, and ibm.com[®] are trademarks or registered trademarks of International Business Machines Corp., registered in many jurisdictions worldwide. Other product and service names might be trademarks of IBM or other companies. A current list of IBM trademarks is available on the web at Copyright and trademark information at www.ibm.com/legal/copytrade.shtml.

Adobe, the Adobe logo, PostScript, and the PostScript logo are either registered trademarks or trademarks of Adobe Systems Incorporated in the United States, and/or other countries.

IT Infrastructure Library is a registered trademark of the Central Computer and Telecommunications Agency which is now part of the Office of Government Commerce.

Intel, Intel logo, Intel Inside, Intel Inside logo, Intel Centrino, Intel Centrino logo, Celeron, Intel Xeon, Intel SpeedStep, Itanium, and Pentium are trademarks or registered trademarks of Intel Corporation or its subsidiaries in the United States and other countries.

Linux is a registered trademark of Linus Torvalds in the United States, other countries, or both.

Microsoft, Windows, Windows NT, and the Windows logo are trademarks of Microsoft Corporation in the United States, other countries, or both.

ITIL is a registered trademark, and a registered community trademark of The Minister for the Cabinet Office, and is registered in the U.S. Patent and Trademark Office.

UNIX is a registered trademark of The Open Group in the United States and other countries.

Java and all Java-based trademarks and logos are trademarks or registered trademarks of Oracle and/or its affiliates.

Cell Broadband Engine is a trademark of Sony Computer Entertainment, Inc. in the United States, other countries, or both and is used under license therefrom.

Linear Tape-Open, LTO, the LTO Logo, Ultrium, and the Ultrium logo are trademarks of HP, IBM Corp. and Quantum in the U.S. and other countries.

Electromagnetic compatibility notices

The following Class A statements apply to IBM products and their features unless designated as electromagnetic compatibility (EMC) Class B in the feature information.

When attaching a monitor to the equipment, you must use the designated monitor cable and any interference suppression devices that are supplied with the monitor.

Canada Notice

CAN ICES-3 (A)/NMB-3(A)

European Community and Morocco Notice

This product is in conformity with the protection requirements of Directive 2014/30/EU of the European Parliament and of the Council on the harmonization of the laws of the Member States relating to electromagnetic compatibility. IBM cannot accept responsibility for any failure to satisfy the protection requirements resulting from a non-recommended modification of the product, including the fitting of non-IBM option cards.

This product may cause interference if used in residential areas. Such use must be avoided unless the user takes special measures to reduce electromagnetic emissions to prevent interference to the reception of radio and television broadcasts.

Warning: This equipment is compliant with Class A of CISPR 32. In a residential environment this equipment may cause radio interference.

Germany Notice

Deutschsprachiger EU Hinweis: Hinweis für Geräte der Klasse A EU-Richtlinie zur Elektromagnetischen Verträglichkeit

Dieses Produkt entspricht den Schutzanforderungen der EU-Richtlinie 2014/30/EU zur Angleichung der Rechtsvorschriften über die elektromagnetische Verträglichkeit in den EU-Mitgliedsstaaten und hält die Grenzwerte der EN 55032 Klasse A ein.

Um dieses sicherzustellen, sind die Geräte wie in den Handbüchern beschrieben zu installieren und zu betreiben. Des Weiteren dürfen auch nur von der IBM empfohlene Kabel angeschlossen werden. IBM übernimmt keine Verantwortung für die Einhaltung der Schutzanforderungen, wenn das Produkt ohne Zustimmung von IBM verändert bzw. wenn Erweiterungskomponenten von Fremdherstellern ohne Empfehlung von IBM gesteckt/eingebaut werden.

EN 55032 Klasse A Geräte müssen mit folgendem Warnhinweis versehen werden:

"Warnung: Dieses ist eine Einrichtung der Klasse A. Diese Einrichtung kann im Wohnbereich Funk-Störungen verursachen; in diesem Fall kann vom Betreiber verlangt werden, angemessene Maßnahmen zu ergreifen und dafür aufzukommen."

Deutschland: Einhaltung des Gesetzes über die elektromagnetische Verträglichkeit von Geräten

Dieses Produkt entspricht dem "Gesetz über die elektromagnetische Verträglichkeit von Geräten (EMVG)." Dies ist die Umsetzung der EU-Richtlinie 2014/30/EU in der Bundesrepublik Deutschland.

Zulassungsbescheinigung laut dem Deutschen Gesetz über die elektromagnetische Verträglichkeit von Geräten (EMVG) (bzw. der EMC Richtlinie 2014/30/EU) für Geräte der Klasse A

Dieses Gerät ist berechtigt, in Übereinstimmung mit dem Deutschen EMVG das EG-Konformitätszeichen - CE - zu führen.

Verantwortlich für die Einhaltung der EMV-Vorschriften ist der Hersteller:

International Business Machines Corp.
New Orchard Road
Armonk, New York 10504
Tel: 914-499-1900

Der verantwortliche Ansprechpartner des Herstellers in der EU ist:

IBM Deutschland GmbH
Technical Relations Europe, Abteilung M456
IBM-Allee 1, 71139 Ehningen, Germany
Tel: +49 800 225 5426
e-mail: Halloibm@de.ibm.com

Generelle Informationen:

Das Gerät erfüllt die Schutzanforderungen nach EN 55024 und EN 55032 Klasse A.

Japan Electronics and Information Technology Industries Association (JEITA) Notice

(一社) 電子情報技術産業協会 高調波電流抑制対策実施
要領に基づく定格入力電力値 : Knowledge Centerの各製品の
仕様ページ参照

This statement applies to products less than or equal to 20 A per phase.

高調波電流規格 JIS C 61000-3-2 適合品

This statement applies to products greater than 20 A, single phase.

高調波電流規格 JIS C 61000-3-2 準用品

本装置は、「高圧又は特別高圧で受電する需要家の高調波抑制対策ガイドライン」対象機器（高調波発生機器）です。

- 回路分類：6（単相、PFC回路付）
- 換算係数：0

This statement applies to products greater than 20 A per phase, three-phase.

高調波電流規格 JIS C 61000-3-2 準用品

本装置は、「高圧又は特別高圧で受電する需要家の高調波抑制対策ガイドライン」対象機器（高調波発生機器）です。

- 回路分類：5（3相、PFC回路付）
- 換算係数：0

Japan Voluntary Control Council for Interference (VCCI) Notice

この装置は、クラス A 情報技術装置です。この装置を家庭環境で使用すると電波妨害を引き起こすことがあります。この場合には使用者が適切な対策を講ずるよう要求されることがあります。 VCCI-A

Korea Notice

이 기기는 업무용 환경에서 사용할 목적으로 적합성평가를 받은 기기로서 가정용 환경에서 사용하는 경우 전파간섭의 우려가 있습니다.

People's Republic of China Notice

声 明

此为 A 级产品,在生活环境
中,该产品可能会造成无线电干
扰,在这种情况下,可能需要用户
对其干扰采取切实可行的措施。

Russia Notice

ВНИМАНИЕ! Настоящее изделие относится к классу А.
В жилых помещениях оно может создавать радиопомехи, для снижения которых необходимы дополнительные меры

rusemi

Taiwan Notice

警告使用者：
這是甲類的資訊產品，在
居住的環境中使用時，可
能會造成射頻干擾，在這
種情況下，使用者會被要
求採取某些適當的對策。

IBM Taiwan Contact Information:

台灣IBM 產品服務聯絡方式：
台灣國際商業機器股份有限公司
台北市松仁路7號3樓
電話：0800-016-888

12c00790

United States Federal Communications Commission (FCC) Notice

This equipment has been tested and found to comply with the limits for a Class A digital device, pursuant to Part 15 of the FCC Rules. These limits are designed to provide reasonable protection against harmful interference when the equipment is operated in a commercial environment. This equipment generates, uses, and can radiate radio frequency energy and, if not installed and used in accordance with the instruction manual, may cause harmful interference to radio communications. Operation of this equipment in a residential area is likely to cause harmful interference, in which case the user will be required to correct the interference at his own expense.

Properly shielded and grounded cables and connectors must be used in order to meet FCC emission limits. Proper cables and connectors are available from IBM-authorized dealers. IBM is not responsible for any radio or television interference caused by using other than recommended cables and connectors or by unauthorized changes or modifications to this equipment. Unauthorized changes or modifications could void the user's authority to operate the equipment.

This device complies with Part 15 of the FCC rules. Operation is subject to the following two conditions: (1) this device might not cause harmful interference, and (2) this device must accept any interference received, including interference that might cause undesired operation.

Responsible Party:

International Business Machines Corporation
New Orchard Road
Armonk, NY 10504
Contact for FCC compliance information only: fccinfo@us.ibm.com

Glossary

This glossary defines the special terms, abbreviations, and acronyms that are used in this publication. If you do not find the term that you are looking for, refer to the index or to the *Dictionary of Computing*, 1994.

Numbers

2:1 compression

The relationship between the quantity of data that can be stored with compression as compared to the quantity of data that can be stored without compression. In 2:1 compression, twice as much data can be stored with compression as can be stored without compression.

2.5:1 compression

The relationship between the quantity of data that can be stored with compression as compared to the quantity of data that can be stored without compression. In 2.5:1 compression, two-and-a-half times as much data can be stored with compression as can be stored without compression.

3U

This library requires 3 units (3U) of rack space.

A

A

Ampere.

AC

Alternating current.

Access method

A technique for moving data between main storage and input or output devices.

Accessor

This component contains the library robot and bar code reader. The accessor moves cartridges to and from the I/O Station, storage slots, and tape drives.

Adapter card

A circuit board that adds function to a computer.

Adj

Adjustment.

Administrator (Admin)

The Admin role has access to all menus. The default password is adm001, and the default PIN is 0000.

AH

Authentication Header. An Internet Protocol intended to guarantee connectionless integrity and data origin authentication of IP datagrams. Further, it can optionally protect against replay attacks by using the sliding window technique and discarding old packets.

AIX®

Advanced Interactive Executive. IBM's implementation of the UNIX operating system. The System p system, among others, uses AIX as its operating system.

Alphanumeric

Pertaining to a character set that contains letters, numerals, and other characters, such as punctuation marks.

Alter

To change.

Ambient temperature

The temperature of air or other media in a designated area, particularly the area that is surrounding equipment.

AME

Application Managed Encryption.

ampere (A)

A unit of measure for electric current that is equivalent to a flow of 1 coulomb per second, or to the current produced by 1 volt applied across a resistance of 1 ohm.

ANSI

American National Standards Institute.

API

Application planning interface. A set of clearly defined methods of communication between various software components.

Application-managed encryption

Tape encryption that is controlled by an application.

Archive

To collect and store files in a designated place.

ASCII

American National Standard Code for Information Interchange. A 7 bit coded character set (8 bits including parity check) that consists of control characters and graphic characters.

Assigning a device

The establishing of the relationship of a device to a running task, process, job, or program.

Assignment

The naming of a specific device to complete a function.

Asynchronous

Pertaining to two or more processes that do not depend upon the occurrence of specific events such as common timing signals.

Attention (notice)

A word for calling attention to the possibility of danger to a program, device, or system, or to data. Contrast with *caution* and *danger*.

ATTN

Attention.

Authentication Header (AH)

A member of the IPSec protocol suite. AH guarantees connectionless integrity and data origin authentication of IP packets.

B**Backup**

To make extra copies of documents or software for safekeeping.

Bar code

A code that represents characters by sets of parallel bars of varying thickness and separation, which are read optically by transverse scanning.

Bar code label

Paper bearing a bar code and having an adhesive backing. The bar code label must be affixed to a tape cartridge to enable the library to identify the cartridge and its volume serial number.

Bar code reader

A laser device that is specialized for scanning and reading bar codes and converting them into either the ASCII or EBCDIC digital character code.

Bezel

Decorative and safety cover.

Bicolored

Having two colors.

bit

Either of the digits 0 or 1 when used in the binary numbering system.

BOM or bill of materials

A list of specific types and amounts of direct materials that are expected to be used to produce a specific job or quantity of output.

Border Gateway Protocol (BGP)

BGP is the core routing protocol of the Internet. It works by maintaining a table of IP networks or 'prefixes' that designate network reachability among autonomous systems (AS).

BRMS

Backup Recovery and Media Services.

Browser

A client program that initiates requests to a web server and displays the information that the server returns.

Buffer

A routine or storage that is used to compensate for a difference in rate of flow of data or time of occurrence of events, when data is transferred from one device to another.

Bus

A facility for transferring data between several devices that are located between two end points, only one device able to transmit at a specified moment.

byte

A string that consists of some bits (usually 8) that are treated as a unit and represent a character. A fundamental data unit.

C**CA**

Certificate Authority.

CA certification

In cryptography, a certificate from a certificate authority (CA).

Capacity

The amount of data that can be contained on storage media and expressed in bytes of data.

Cartridge manual rewind tool

A device that can be fitted into the reel of a cartridge and used to rewind tape into or out of the cartridge.

Cartridge memory (CM)

Within each data cartridge, an embedded electronics and interface module that can store and retrieve a cartridge's historical usage and other information.

Cartridge storage slot

Individual slot that is located within a magazine that is used to house tape cartridges.

Caution (notice)

A word to call attention to possible personal harm to people. Contrast with *attention* and *danger*.

CD

Compact Disc. A disc, usually 4.75 inches in diameter, from which data is read optically by using a laser.

CE

Customer engineer, field engineer, service representative.

Centimeter (cm)

One one-hundredth of a meter (0.01 m). Approximately 0.39 inches.

Channel command

An instruction that directs a data channel, control unit, or device to run an operation or set of operations.

Char

Character.

CHK

Check.

Cleaning cartridge

A tape cartridge that is used to clean the heads of a tape drive. Contrast with *data cartridge*.

CM

Cartridge Memory. Within each data cartridge, an embedded electronics and interface module that can store and retrieve a cartridge's historical usage and other information.

CoD

Capacity on-demand.

Command

A control signal that initiates an action or the start of a sequence of actions.

Compact disc (CD)

A disk, usually 4.75 inches in diameter, from which data is read optically by using a laser.

Compression

The process of eliminating gaps, empty fields, redundancies, and unnecessary data to shorten the length of records or blocks.

Concurrent

Refers to diagnostic procedures that can be run on one control unit while the rest of the subsystem remains available for customer applications.

Contingent connection

A connection between a channel path and a drive that is caused when a unit check occurs during an I/O operation.

Controller

A device that provides the interface between a system and one or more tape drives.

Control path drive

Controller A device that provides the interface between a system and one or more tape drives. *Control path drive* A drive that communicates messages from the host computer to the library in which the drive is installed.

Cookie

A packet of data that is exchanged between the library and a web browser to track configuration.

CP

Circuit protector.

CPF

Control Path Failover.

CRU

Customer Replaceable Unit.

CSA

Canadian Standards Association.

Ctrl

Control.

CU

Control unit.

D**Danger (notice)**

A word to call attention to possible lethal harm to people. Contrast with *attention* and *caution*.

Data

Any representations such as characters or analog quantities to which meaning is or might be assigned.

Data buffer

The storage buffer in the control unit. This buffer is used to increase the data transfer rate between the control unit and the channel.

Data cartridge

A tape cartridge that is dedicated to storing data. Contrast with *cleaning cartridge*.

Data check

A synchronous or asynchronous indication of a condition that is caused by invalid data or incorrect positioning of data.

DC

Direct current.

DCS

Designated Cleaning Slot.

Degauss

Makes a magnetic tape nonmagnetic by using electrical coils that carry currents that neutralize the magnetism of the tape.

Degausser

A device that makes magnetic tape nonmagnetic.

Degradation

A decrease in quality of output or throughput or an increase in machine error rate.

Degraded

Decreased in quality of output or throughput or increased machine error rate.

Deserialize

To change from serial-by-bit to parallel-by-byte.

Detented

A part that is held in position with a catch or lever.

Device

Any hardware component or peripheral device, such as a tape drive or tape library, that can receive and send data.

Device driver

A file that contains the code that is needed to use an attached device.

DHCPv6

The Dynamic Host Configuration Protocol for IPv6. Although IPv6's stateless address autoconfiguration removes the primary motivation for DHCP in IPv4, DHCPv6 can still be used to statefully assign addresses if the network administrator wants more control over addressing.

DH group

Diffie-Hellman group.

DIAG

Diagnostic section of maintenance information manual.

Differential

See *High Voltage Differential (HVD)*.

Direct-access storage

A storage device in which the access time is independent of the location of the data.

Display contrast

The brightness of the display on the Operator Panel.

DLL

Dynamic Link Library. The Microsoft implementation of the shared library concept. These libraries usually have the file extension `dll`, `ocs` (for libraries that contain activeX controls, or `drv` (for legacy system drivers).

DNS

Directory Name System. This system allows the library to recognize text-based addresses instead of numeric IP addresses.

Download

To transfer programs or data from a computer to a connected device, typically a personal computer.

To transfer data from a computer to a connected device, such as a workstation or personal computer.

DPF

Data Path Failover.

DRAM

Dynamic random-access memory.

Drive, magnetic tape

A mechanism for moving magnetic tape and controlling its movement.

Drive Not Configured

This message occurs during the first boot after a factory settings restore is run. This message is not a real issue since it takes time for the library to configure.

DRV

Drive.

DSA key

Encryption key type.

DSE

Data security erase.

DSP

Digital signal processor.

E**EBCDIC**

Extended binary-coded decimal interchange code.

EC

Edge connector. Engineering change.

ECC

Error correction code.

EEB

Ethernet Expansion Blade.

EEPROM

Electrically erasable programmable read-only memory.

EIA

Electronics Industries Association.

EIA unit

A unit of measure, which is established by the Electronic Industries Association, equal to 44.45 millimeters (1.75 inches).

Eject

To remove or force out from within.

EKM

Encryption Key Manager.

Electronic mail

Correspondence in the form of messages that are transmitted between user terminals over a computer network.

Email

See *electronic mail*.

Encryption

A method of storing data in a format that helps protect data from inadvertent or deliberate compromise. An encryption-enabled drive contains the necessary hardware and firmware to encrypt and decrypt host tape application data. Encryption policy and encryption keys are provided by the host application or host server.

Encryption key manager (EKM)

A software program that assists IBM-encrypting tape drives in generating, protecting, storing, and maintaining encryption keys that encrypt information that is written to and decrypt information that is read from tape media.

Entitlement

IBM Entitlement is the official right to receive service and support for your tape library.

EPO

Emergency power off.

EPRM

Erasable programmable read only memory.

EQC

Equipment check.

Equipment check

An asynchronous indication of a malfunction.

Error log

A data set or file in a product or system where error information is stored for later access.

ESD

Electrostatic discharge.

ESP

Encapsulating Security Payload. An Internet Protocol that provides origin authenticity, integrity, and confidentiality protection of a packet. ESP also supports encryption-only and authentication-only configurations, but encryption without authentication is discouraged because it is insecure.

F**FAT32**

FAT stands for File Allocation Table. FAT32 is an extension which means that data is stored in chunks of 32 bits. Any USB flash drive that is used for updating firmware or exporting logs for the TS4300 library must be in this format.

Fault symptom code (FSC)

A hexadecimal code that is generated by the drive or the control unit microcode in response to a detected subsystem error.

FC

Fibre Channel, Feature code.

FCC

Federal communications commission.

FE

Field engineer, customer engineer, or service representative.

FH

Full Height.

Fibre Channel

A high-speed method to connect data storage to a server. The British spelling of "Fibre" is used because the technology can be used with either fiber optic or copper cables. Thus, the name does not imply that it can be used only with a fiber optic cable.

Fiducial

A target that is used for teaching a physical location to a robot.

Field replaceable unit (FRU)

An assembly that is replaced in its entirety when any one of its components fails.

File

A named set of records that are stored or processed as a unit. Also referred to as a data set.

File protection

The processes and procedures that are established in an information system that are designed to inhibit unauthorized access to, contamination of, or deletion of a file.

File transfer protocol (FTP)

In the Internet suite of protocols, an application layer protocol that uses TCP and Telnet services to transfer bulk-data files between machines or hosts.

Firmware

Proprietary code that is delivered as microcode as part of an operating system. Firmware is more efficient than software loaded from an alterable medium and more adaptable to change than pure hardware circuitry. An example of firmware is the Basic input/output system (BIOS) in read-only memory (ROM) on a PC system board.

FLASH EEPROM

An electrically erasable programmable read-only memory (EEPROM) that can be updated.

FMR

Field microcode replacement.

Format

The arrangement or layout of data on a data medium.

Formatter

Part of a magnetic tape subsystem that runs data conversion, speed matching, encoding, first-level error recovery, and interfaces to one or more tape drives.

FP

File protect.

Frayed

Damaged as if by an abrasive substance.

FRU

Field replaceable unit.

FSC

Fault symptom code.

FSI

Fault symptom index.

FTSS

Field Technical Sales Support.

Functional microcode

Microcode that is resident in the machine during normal customer operation.

G**g**

Gram.

GB

gigabyte.

GBIC

Gigabit Interface Converter.

Gb/s

gigabits/second

Gbit

gigabit

gigabit (Gbit)

1 000 000 000 bits.

gigabyte (GB)

1 000 000 000 bytes.

Gigabit Interface Converter (GBIC)

Converts copper interface to optic interface.

Gnd

Ground.

GUI

Graphical User Interface

H**HBA**

Host Bus Adapter.

HD Slot Technology

High-density (HD) slot technology. Allows multiple cartridges to be stored in a tiered architecture.

hertz (Hz)

Unit of frequency. 1 hertz equals one cycle per second.

hex

Hexadecimal.

HH

Half Height.

High Voltage Differential (HVD)

A logic-signaling system that enables data communication between a supported host and the library. HVD signaling uses a paired plus and minus signal level to reduce the effects of noise on the SCSI bus. Any noise that is injected into the signal is present in both a plus and minus state, and is canceled. Synonymous with *differential*.

HVD

SCSI Bus High-Voltage Differential.

Hz

Hertz (cycles per second).

I**IBM Security Key Lifecycle Manager (SKLM)**

IBM's EKM application that assists encrypting tape drives in generating, protecting, storing, and maintaining encryption keys that encrypt information that is written to and decrypt information that is read from tape media.

IBM Spectrum Archive

Formerly known as Linear Tape File System (LTFS). A file system that works with LTO Generation tape technology to access data stored on an IBM tape cartridge.

IBM Ultrium Tape Drive

Located within the library, a data-storage device that controls the movement of the magnetic tape in an IBM LTO Ultrium Tape Cartridge. The drive houses the mechanism (drive head) that reads and writes data to the tape.

ID

Identifier.

Identifier (ID)

(1) In programming languages, a lexical unit that names a language object. For example, the names of variables, arrays, records, labels, or procedures. An identifier usually consists of a letter optionally followed by letters, digits, or other characters. (2) One or more characters that are used to identify or

name data element and possibly to indicate certain properties of that data element. (3) A sequence of bits or characters that identifies a program, device, or system to another program, device, or system.

IEC

International Electrotechnical Commission.

IKE

Internet Key Exchange that is used in the IPsec protocol.

IML

Initial microprogram load.

Incompatible magazine

This message might display on the Operator Panel during library initialization. It occurs during factory restore or VPD. This message is not a real issue since it takes time for the library to configure.

Initial microprogram load (IML)

The action of loading a microprogram from external storage to writable control storage.

Initiator

The component that runs a command. The initiator can be the host system or the tape control unit.

INST

Installation.

Interface

A shared boundary. An interface might be a hardware component to link two devices or it might be a portion of storage or registers accessed by two or more computer programs.

Internet Key Exchange (IKE)

The protocol that is used to set up a security association (SA) in the IPsec protocol suite. See also *Security Association (SA)*.

Internet Protocol Version 4 (IPv4)

See *IPv4*.

Internet Protocol Version 6 (IPv6)

See *IPv6*.

Interposer

The part that is used to convert a 68-pin connector to a 50-pin D-shell connector.

Intervention required

Manual action is needed.

INTRO

Introduction.

I/O

Input/output.

I/O Station

Cartridge location that is dedicated for the insertion of cartridges into and the removal of cartridges from the library.

IOP

Input/output processor.

IP

Internet Protocol.

IP address

An identifier for a computer or device on an Internet Protocol (TCP/IP) network. Networks that use the TCP/IP protocol route messages that are based on the IP address of the destination. See *IPv4* and *IPv6*.

IPL

Initial program load.

IPsec (IP Security)

A set of protocols for securing IPv6 network communications by authentication and encryption.

IP Stack

A TCP/IP protocol stack that manages static IP addresses.

IPv4

A network layer protocol for packet-switched networks. IPv4 supports 2^{32} (about 4.3 billion) addresses.

IPv6

A network layer protocol for packet-switched networks. It is the designated successor of IPv4 for general use on the Internet. The main improvement of IPv6 is the increase in the number of addresses available for networked devices, allowing, for example, each mobile phone and mobile electronic device to have its own unique address.

ISV

Independent software vendor.

ITDT

IBM Tape Diagnostic tool.

ITST

Idle-time self-test.

K**Kerberos**

Kerberos Authentication is a standard (RFC 1510) third-party authentication protocol that provides end-to-end security for distributed computing environments.

Key Path Diagnostics (KPD)

Key Path Diagnostics is a test tool that provides details to troubleshoot Encryption communication issues.

kilogram (kg)

1000 grams (approximately 2.2 pounds).

km

kilometer. 1000 Meters, Approximately 5/8 mile.

KMIP

Key Management Interoperability Protocol.

L**LAN**

Local area network. A computer network within a limited area.

LCB

Library Control Blade.

LCD

See *liquid crystal display*.

LDAP

Lightweight Directory Access Protocol. This protocol allows the library to use login and password information that is stored on a server to grant access to the library functions.

LDAPS

Secure LDAP over SSL.

LDI

Library Drive Interface.

LED

Light-emitting diode.

Library certification

In cryptography, a certificate that is provided by the library.

Library-managed encryption

Tape encryption that is controlled by the tape library.

Linear Tape-Open (LTO)

A type of tape storage technology that is developed by the IBM Corporation, Hewlett-Packard, and Quantum. LTO technology is an "open format" technology, which means that its users have multiple sources of product and media. The "open" nature of LTO technology enables compatibility between different vendors' offerings by ensuring that vendors comply with verification standards. The LTO technology is implemented in two formats: the Accelis format focuses on fast access; the Ultrium format focuses on high capacity. The Ultrium format is the preferred format when capacity (rather than fast access) is the key storage consideration. An Ultrium cartridge has a compressed data capacity of up to 30 TB (2.5:1 compression) and a native data capacity of up to 12 TB.

Liquid crystal display (LCD)

A low-power display technology that is used in computers and other I/O devices.

Loadable

The ability to be loaded.

LME

Library Managed Encryption.

LTO

See *Linear Tape-Open*.

LTO cartridge memory (LTO-CM)

Within each LTO Ultrium data cartridge, an embedded electronics and interface module that can store and retrieve a cartridge's historical usage and other information.

LUN

Logical Unit Number.

LVD

SCSI Bus Low Voltage Differential.

M**M8**

LTO 8 Type M Cartridge.

MAC address

The Media Access Control address of a computer networking device.

Magnetic tape

A tape with a magnetic surface layer on which data can be stored by magnetic recording.

Management GUI

Web User Interface, Web UI, Web GUI.

MAP

Maintenance analysis procedure.

Mask

A pattern of characters that controls the retention or elimination of portions of another pattern of characters. To use a pattern of characters to control the retention or elimination of portions of another pattern of characters.

Master file

A file that is used as an authority in a job and that is relatively permanent, even though its contents might change. Synonymous with main file.

Maximum Transmission Unit (MTU)

The size of the largest packet that a network protocol can transmit.

MB

Megabyte (expressed as data rate in MB/s or MB/second).

Media capacity

The amount of data that can be contained on a storage medium, expressed in bytes of data.

Media-type identifier

Pertaining to the bar code on the bar code label of the IBM Ultrium tape cartridge, a two-character code, L1, that represents information about the cartridge. L identifies the cartridge as one that can be read by devices that incorporate LTO technology; 1 indicates that it is the first generation of its type.

Mega

One million of.

meter

In the Metric System, the basic unit of length equal to approximately 39.37 inches.

MIB

Management Information Base. Information repository that is used by SNMP.

Micro

One millionth of.

Microcode

(1) One or more micro instructions. (2) A code, representing the instructions of an instruction set, which is implemented in a part of storage that is not program-addressable. (3) To design, write, and test one or more micro instructions. (4) See also *microprogram*.

Microdiagnostic routine

A program that runs under the control of a supervisor, usually to identify field replaceable units.

Microdiagnostic utility

A program that is run by the customer engineer to test the machine.

Microinstruction

A basic or elementary machine instruction.

Microprogram

A group of micro instructions that when run completes a planned function.

The term microprogram represents a dynamic arrangement or selection of one or more groups of micro instructions for execution to complete a particular function. The term microcode represents microinstructions that are used in a product as an alternative to hard-wired circuitry to implement certain functions of a processor or other system component.

MIM

Media information message.

mm

Millimeter.

Modifier

That which changes the meaning.

Monitor

The Monitor role is an interchangeable term corresponding to the User role. The Monitor role has viewing privileges to the unit, but is not able to make configuration changes.

Mount a device

To assign an I/O device with a request to the operator.

MP

Microprocessor.

ms

Millisecond.

MSG

Message.

Multipath

Pertaining to using more than one path.

N

N/A

Not applicable.

Network Address Translation (NAT)

NAT involves rewriting the source or destination addresses of IP packets as they pass through a router or firewall. Most systems that use NAT do so to enable multiple hosts on a private network to access the Internet over a single public IP address.

NEMA

National Electrical Manufacturers Association.

Node

In a network, a point at which one or more functional units connect channels or data circuits.

NTFS

New Technology File System. The primary file system that is used in Windows.

NTP

Network Time Protocol. This protocol allows the library to set its internal date and time that is based on the date and time of a server.

NVS

Nonvolatile storage. A storage device whose contents are not lost when power is cut off.

O

OCP

Operator Panel (Operator Control Panel).

Oersted

The unit of magnetic field strength in the unrationalized centimeter-gram-second (cgs) electromagnetic system. The oersted is the magnetic field strength in the interior of an elongated, uniformly wound solenoid that is excited with a linear current density in its winding of 1 ampere per 4π centimeters of axial length.

Offline

Pertaining to the operation of a functional unit without the continual control of a computer. Contrast with *online*.

Online

Pertaining to the operation of a functional unit that is under the continual control of a computer. Contrast with *offline*.

OPER

Operation.

OV

Over voltage.

Overrun

Loss of data because a receiving device is unable to accept data at the rate it is transmitted.

Overtightening

To tighten too much.

P

Parameter

A variable that is given a constant value for a specified application and that might denote the application.

p bit

Parity bit.

PC

Parity check.

PCC

Power® control compartment.

PDF

Portable Document Format.

PE

Parity error. Product engineer.

PFS

Perfect forward secrecy.

Pick

Pertaining to the library to remove, by using a robotic device, a tape cartridge from a storage slot or drive.

Picker

A robotic mechanism that is located inside the library that moves cartridges between the cartridge storage slots and the drive.

PM

Preventive maintenance.

POR

Power-on reset.

Port

A physical connection for communication between the 3590 and the host processor. The 3590 has 2 SCSI ports.

Portable Document Format (PDF)

A standard that is specified by Adobe Systems, Incorporated, for the electronic distribution of documents. PDF files are compact, can be distributed globally (by way of email, the web, intranets, or CD-ROM), and can be viewed with the Acrobat Reader. Acrobat Reader is software from Adobe Systems that can be downloaded at no cost from the Adobe Systems home page.

Private key

A cryptographic key that is used to decrypt a message.

PROM

Programmable read only memory.

PS

Power supply.

PTF

Program temporary fix. A single bugfix or group of bugfixes that are distributed in a form ready to install for customers.

PWR

Power.

R**Rack**

A unit that houses the components of a storage subsystem, such as the library.

Rackmount kit

A packaged collection of articles that are used to install the rack-mounted version of the library.

RAM

Random access memory.

Random access memory

A storage device into which data is entered and from which data is retrieved in a nonsequential manner.

Random Mode

In Random mode, the library allows the server's (host's) application software to select any data cartridge in any order.

RAS

Reliability, availability, and serviceability.

Record

A collection of related data or words, which are treated as a unit.

Recording density

The number of bits in a single linear track measured per unit of length of the recording medium.

Recoverable error

An error condition that allows continued execution of a program.

Ref

Reference.

Reg

Register.

Reinventory

To inventory again.

REST

Representational state transfer. Part of an API. REST systems aim for fast performance, reliability, and the ability to grow, by reusing components that can be managed and updated without affecting the system as a whole, even while it is running.

Retension

The process or function of tightening the tape onto the cartridge, if it is sensed that the tape has a loose wrap on the cartridge.

RFC (Request for Comments)

Request for Comments (RFC) documents are a series of memoranda, which encompasses new research, innovations, and methodologies applicable to Internet technologies.

RH

Relative humidity.

RID tag

Repair identification tag.

RML

Rack Mount Line.

Robot

Picker.

Robotic Assembly

The picker, picker assembly.

Robotics

Picker assembly.

Root CA certification

In cryptography, a root certificate from a certificate authority (CA).

RPQ

Request for price quotation.

RSA key

Encryption key type.

R/W

read/write.

S**s**

Seconds of time.

SAC

Service Action Code. Code that is developed to indicate possible FRU or FRUs to replace to repair the hardware.

SAN

Storage area network.

SAS

Serial Attached SCSI. A computer bus technology and serial communication protocol for direct attached storage devices. SAS is a replacement for parallel SCSI with higher speeds, but still uses SCSI commands.

Scratch cartridge

A data cartridge that contains no useful data, but can be written to with new data.

SCD

Single Character Display.

SCSI

Small computer system interface.

SE

Single-ended.

Sequential Mode

Sequential Mode is intended to be used by host applications that aren't supporting SCSI media changer devices but need to get another cartridge loaded if the current cartridge is full.

Segment

A part.

Sel

Select.

Serial Attached SCSI (SAS)

A drive with a SAS interface can be linked directly to controllers. SAS is a performance improvement over traditional SCSI because SAS enables multiple devices (up to 128) of different sizes and types to be connected simultaneously with thinner and longer cables. It supports full-duplex signal transmission up to 3 Gb/s. In addition, SAS drives can be hot-plugged.

Serialize

To change from parallel-by-byte to serial-by-bit.

Serializer

A device that converts a space distribution of simultaneous states, which represents data into a corresponding time sequence of states.

Service

Access to this level is for Service personnel only - Service personnel have access to all menus.

Servo, servos

An adjective for use in qualifying some part or aspect of a servomechanism.

Servomechanism

A feedback control system in which at least one of the system signals represents mechanical motion.

Signature

A digital signature that is used in cryptography to identify one party to ensure authenticity.

SKLM (IBM Security Key Lifecycle Manager)

IBM EKM application that assists encrypting tape drives in generating, protecting, storing, and maintaining encryption keys that encrypt information that is written to and decrypt information that is read from tape media.

SKLM for z/OS

Security Key Lifecycle Manager for IBM System z® mainframes.

Slot blocker

A slot blocker is used to restrict/close off a data cell so a data cartridge cannot be inserted.

Small Computer Systems Interface (SCSI)

A standard that is used by computer manufacturers for attaching peripheral devices (such as tape drives, hard disks, CD-ROM players, printers, and scanners) to computers (servers). Pronounced "scuzzy". Variations of the SCSI interface provide for faster data transmission rates than standard serial and parallel ports (up to 320 megabytes per second). The variations include

- Fast/Wide SCSI - Uses a 16-bit bus, and supports data rates of up to 20 MBps.
- SCSI-1 - Uses an 8-bit bus, and supports data rates of 4 MBps.
- SCSI-2 - Same as SCSI-1, but uses a 50-pin connector instead of a 25-pin connector, and supports multiple devices.
- Ultra-SCSI - Uses an 8- or 16-bit bus, and supports data rates of 20 or 40 MBps.
- Ultra2 SCSI - Uses an 8- or 16-bit bus and supports data rates of 40 or 80 MBps.
- Ultra3 SCSI - Uses a 16-bit bus and supports data rates of 80 or 160 MBps.
- Ultra160 SCSI - Uses a 16-bit bus and supports data rates of 80 or 160 MBps.
- Ultra320 SCSI - Uses a 16-bit bus and supports data rates of 320 MBps.

SMI-S

See *Storage Management Initiative Specification (SMI-S)*.

SMTP

Simple Mail Transfer Protocol. SMTP is a standard for email transmissions across the internet.

SNMP

Simple Network Management Protocol. SNMP is used by network management systems to monitor network-attached devices for conditions that warrant administrative attention.

SNTP

Simple Network Time Protocol. Used to synchronize the clocks of network-attached devices.

SMW

Servo Manufacturer's Word.

SNS

Sense.

Special feature

A feature that can be ordered to enhance the capability, storage capacity, or performance of a product, but is not essential for its basic work.

SPI

Security Parameters Index.

SR

Service representative, see also *CE*.

SRAM

Static random access memory.

SS

Status store.

SSH

Secure Shell.

SSL (Secure Sockets Layer)

A set of cryptographic protocols for secure communications on the Internet for such things as web browsing, email, Internet faxing, instant messaging, and other data transfer. SSL allows applications to communicate across a network in a way that is designed to prevent eavesdropping, tampering, and message forgery.

SSP

Serial SCSI Protocol.

ST

Store.

Standard feature

The significant design elements of a product that are included as part of the fundamental product.

START

Start maintenance.

StartTLS

Secure LDAP communication that uses TLS.

Storage Management Initiative Specification (SMI-S)

A storage standard that is developed and maintained by the Storage Networking Industry Association (SNIA). It is also ratified as an ISO standard. The main objective of SMI-S is to enable broad interoperable management of heterogeneous storage vendor systems.

Subsystem

A secondary or subordinate system, capable of operating independently of, or asynchronously with, a controlling system.

Superuser

The Superuser role has access to most sections of the library menus.

SUPP

Support.

Sync

Synchronous, synchronize. Occurring with a regular or predictable time relationship.

T**Tachometer, tach**

A device that emits pulses that are used to measure/check speed or distance.

Tape cartridge

A container that holds magnetic tape that can be processed without separating it from the container.

Tape void

An area in the tape in which no signal can be detected.

TB

Terabyte.

TCP/IP

Transmission Control Protocol/Internet Protocol.

TCU

Tape control unit.

Terabyte

One terabyte = 1,000,000,000,000 bytes, or 1000 gigabytes (GBs).

TH

Thermal.

TKLM (IBM Tivoli® Key Lifecycle Manager)

IBM's EKM application that assists encrypting tape drives in generating, protecting, storing, and maintaining encryption keys that encrypt information that is written to and decrypt information that is read from tape media.

thread/load operation

A procedure that places tape along the tape path.

TLS

Transport Layer Security.

TM

Tapemark, Trademark.

Transport mode

End-to-end communications security in which the end-point computers do the security processing.

Trusted certification

In cryptography, a trustworthy certificate that is not registered with a certificate authority.

Tunnel mode

Port-to-port communications security in which security is provided to several machines by a single node.

U**UART**

Universal asynchronous receiver/transmitter.

UID

Unit Identification.

UL

Underwriter's Laboratories.

Universal rack connector

A rackmount kit has four universal rack connectors as part of the kit. Each connector has two sides - one side is for round-hole racks, and the other side is for square-hole racks. The square-hole side might be painted. The connectors are installed from the inside of the rack out, and the rails are hooked onto them. See [Figure 35 on page 45](#).

Unload

Prepare the tape cartridge for removal from the drive.

User

The User role is an interchangeable term corresponding to the Monitor role. The User role has viewing privileges to the unit, but is not able to make configuration changes.

Utilities

Utility programs.

Utility programs

A computer program in general support of the processes of a computer. For instance, a diagnostic program.

UV

Under voltage.

V**VOLSER**

Volume serial number.

Volume

A certain portion of data, together with its data carrier, that can be handled conveniently as a unit.

VPD

Vital product data. The information that is contained within the tape drive that requires nonvolatile storage that is used by functional areas of the drive, and information that is required for manufacturing, RAS, and engineering.

W**Web UI, Web GUI, Web User Interface**

Management GUI

Word

A character string that is convenient for some purpose to consider as an entity.

Worldwide Node Name (WWNN)

A unique character string that identifies Fibre Channel Host Bus adapters (HBA).

WORM

Write Once, Read Many.

Write

Write command.

WT

World trade.

WWCID

Worldwide Cartridge Identifier.

WWN

Worldwide Name.

WWNN

Worldwide Node Name.

WWPN

Worldwide port name.

X**XR**

External register.

XRA

External register address register.

Index

A

- accessibility
 - keyboard [199](#)
 - repeat rate of up and down buttons [199](#)
 - shortcut keys [199](#)
- accessor [10](#)
- Accessor [118](#)
- accessor designs [10](#)
- Accessor, return to Base Module [141](#)
- accessoric system [10](#)
- accessory kit [42](#)
- acclimation [xxv](#)
- Adding components [118](#)
- Advanced configuration [58](#)
- Advanced settings [65](#)
- air vents, front panel [7](#)
- Alerts and logging [19](#)
- Application managed encryption [17](#)
- Auto Calibration [65](#)
- Auto Clean [65](#)
- Auto Clean, configure [72](#)
- Auto Clean, initial configuration [72](#)

B

- Back panel
 - Drive [13](#)
- bar code labels [160](#)
- Bar code labels
 - guidelines for using [162](#)
 - ordering [174](#)
- Base Module components [23](#), [42](#)
- Base Module, installing [42](#)

C

- Cartridge
 - capacity scaling [156](#), [158](#)
 - cleaning [159](#)
 - compatibility [157](#)
 - data [156](#)
 - disposal of [172](#)
 - leader pin [166](#)
 - M8 [157](#)
 - memory chip [160](#)
 - ordering [172](#)
 - proper handling [163](#)
 - specifications [171](#)
 - Type M [157](#)
 - write-protect switch [162](#)
- Cartridge Inventory
 - rescan [65](#)
- cartridge magazines [7](#), [118](#)
- Cartridge, acclimation [164](#)
- Cartridge, environment [164](#)
- Cartridges

- Cartridges (*continued*)
 - accessing [73](#)
 - eject [65](#)
 - graphical view [65](#)
 - list [65](#)
 - move [65](#)
- Cartridges, labeling [160](#)
- Cartridges, repairing [178](#)
- Certificates
 - backup [65](#)
 - create [65](#)
 - restore [65](#)
- checking components [42](#)
- Cleaning
 - tape drive [65](#)
- Cleaning drives [72](#)
- cold weather procedures [xxv](#)
- comments, sending [v](#)
- components
 - interior
 - accessoric system [10](#)
 - picker assembly [10](#)
- Components
 - adding, removing, replacing [118](#)
- Configuration
 - Reset [65](#)
 - Restore [65](#)
 - Save [65](#)
- Configuration file
 - Restore [65](#)
 - Save [65](#)
- Configuration, saving [123](#)
- ConfigurationAdvanced [58](#)
- configure host connection [60](#)
- Configuring logical libraries [16](#)
- Connecting Fibre Channel cables [53](#)
- Connecting SAS cables [53](#)
- ConnectivityHost [20](#)
- ConnectivityNetwork [21](#)
- Control path failover [18](#)
- control path, drives [12](#)
- Control paths
 - multiple [56](#)
- CPF [18](#)
- Customized features [58](#)
- Customizing library features [56](#)

D

- Data path failover [18](#)
- Date and Time
 - configure [65](#)
- default settings [69](#)
- description [1](#)
- Diagnostics
 - Demo Mode [65](#)
 - Drive test [65](#)

- Diagnostics (*continued*)
 - Library Verify [65](#)
 - Slot to Slot [65](#)
- display
 - SCD dot [116](#)
 - single-character [114](#)
- DNS [21](#)
- DPF [18](#)
- Drive
 - modify port settings [65](#)
- Drive firmware
 - update [65](#)
- Drive service logs
 - download [65](#)
- drive sled
 - description [6](#), [11](#)
- Drive sled [13](#)
- Drive status [65](#)
- Drive, logical addresses [15](#)
- Drive, physical addresses [15](#)
- Drives and Modules
 - reset list [65](#)

E

- element addresses [59](#)
- Email Notification
 - configure [65](#)
- Encryption
 - enable or disable [65](#)
 - KMIP [65](#)
 - Library Managed Encryption [65](#)
 - reset [65](#)
 - SKLM for z/OS [65](#)
- Encryption Key Manager
 - EKM [73](#)
- Encryption license
 - enable [65](#)
- Environmental specifications [23](#)
- Error codes [84](#)
- Error log [84](#)
- Ethernet Port [8](#)
- event codes [84](#)
- Event information [77](#)
- Events [77](#)
- Expansion Module components [42](#)
- Expansion Module, installing [42](#)
- Export drive logs [77](#)

F

- Factory Reset [65](#)
- Failed components, identifying [77](#), [141](#)
- features
 - optional
 - drives [6](#), [11](#)
- Features, configuring [56](#)
- feedback, sending [v](#)
- Fibre Channel cabling [53](#)
- Firmware
 - updating
 - using ITDT Tool [83](#)
- firmware revision, verify [58](#)

- front panel components [7](#)

G

- Gas and particulate exposure [23](#)
- glossary [206](#)

H

- hazards, possible [xxiv](#)
- Host connectivity [20](#)
- host interface connectors [8](#)
- HTTP [21](#)

I

- I/O station [7](#)
- I/O Station
 - enable and disable [65](#)
 - open [65](#)
- Identifier Light
 - on and off [65](#)
- identify cables [42](#)
- identify library components [42](#)
- Identifying failed components [77](#), [118](#), [141](#)
- Initial Setup [65](#)
- installation
 - rack
 - safety [xxv](#)
 - installation, verify [58](#)
- interfaces, supported [6](#)
- interior components
 - accessoric system [10](#)
 - picker assembly [10](#)
- internal view of library [118](#)
- Inventory List [65](#)
- IPv4/IPv6 [21](#)
- ITDT Tool [83](#)

K

- Key Management Interoperability Protocol [73](#)
- Key Path Diagnostics [65](#), [73](#)
- keyboard [199](#)
- KMIP [73](#)
- KMIP encryption [17](#)
- KMIP wizard [73](#)
- KPD [65](#), [73](#)

L

- Labels
 - bar code
 - guidelines for using [162](#)
 - ordering [174](#)
- laser
 - compliance [xxiv](#)
 - safety [xxiv](#)
- LCD Adjustment [65](#)
- LDAP [21](#)
- LEDs, front panel [7](#)
- Library
 - adding, removing, replacing components [118](#)

- Library (*continued*)
 - Tools needed [118](#)
- library configuration forms [151](#)
- Library Controller Board [118](#)
- Library firmware
 - update [65](#)
- Library information [65](#)
- library layout [23](#)
- Library logs
 - download [65](#)
 - view or clear [65](#)
- Library Managed Encryption
 - configure [73](#)
- Library sharing [17](#)
- Library tests, running [77](#)
- Library troubleshooting [77](#)
- Library Verify [65](#)
- library, table top installation [49](#), [54](#)
- library, verify host connection [60](#)
- License Key management [65](#)
- List of Drives and Modules
 - reset [65](#)
- Load balancing [18](#)
- location requirements [23](#)
- Log files
 - download [65](#)
- logical libraries [59](#)
- Logical libraries
 - multiple [56](#)
- Logical Libraries
 - graphical view [65](#)
 - Manage (Basic mode) [65](#)
 - Manage (Expert mode) [65](#)
- Logical libraries, configuration [16](#)
- Logical library modes [16](#)
- LTO Tape Drives [6](#), [11](#)
- LTO Type M data cartridge [157](#)

M

- M8 data cartridge [157](#)
- Magazine, unlocking [147](#)
- magazines [7](#), [118](#)
- Magazines
 - open [65](#)
- Magazines lock
 - enable or disable [65](#)
- Main screen, Management GUI [61](#)
- Main screen, Operator Panel [64](#)
- Management function
 - locating [65](#)
- Management Graphical User Interface [61](#)
- Management GUI
 - operating [61](#)
- Management GUI menu items [61](#)
- Managing
 - Operator Panel [64](#)
- Manually unlock magazines [147](#)
- media [16](#)
- Media [156](#)
- media capacity [1](#)
- menu shortcuts [65](#)
- Methods
 - cleaning drives [72](#)

- MIB [108](#)
- MIBs [19](#)
- Minimum firmware levels
 - Library Managed Encryption [iii](#)
 - LTO M8 [iii](#)
 - LTO6 [iii](#)
 - LTO7 [iii](#)
 - LTO8 [iii](#)
 - Path Failover [iii](#)
- Mixed drives [11](#), [12](#)
- module components [118](#)
- Modules, adding [123](#)
- Modules, replacing [123](#)
- Multipath architecture [56](#)

N

- Network connectivity [21](#)
- Network settings [65](#)

O

- Operation problems [77](#)
- Operations
 - Management GUI [61](#)
- Operator Panel
 - control keys on front panel [7](#)
 - display [7](#)
 - managing [64](#)
 - session lock timeout [65](#)
- Operator Panel menu items [64](#)
- Optional features [34](#)
- Ordering Media
 - Ordering WORM cartridges [159](#)
- Overview [1](#)

P

- packaging materials [38](#)
- partitioning [59](#)
- Password Policy [65](#)
- Path Failover license
 - enable [65](#)
- Physical specifications [23](#)
- picker assembly [10](#)
- power button [7](#)
- power connector [8](#)
- Power cords [28](#)
- Power specifications [23](#)
- power supply [118](#)
- Power supply [11](#)
- power supply LEDs [8](#)
- Pre-call checklist [82](#)

R

- rack installation
 - safety [xxv](#)
- rack mounting the library [45](#), [49](#)
- Random mode [16](#)
- Read/Write capability [157](#)
- Rear panel [8](#)
- rear panel of library [8](#)

- regulatory information [iii](#)
- Regulatory specifications [23](#)
- Remote Authentication (LDAP)
 - configure [65](#)
- Remote Logging (rsyslog)
 - configure [65](#)
- Removing components [118](#)
- Replacing components [118](#)
- Reset
 - drive [65](#)
 - library [65](#)
 - rediscover devices [65](#)
- RID tag [123](#)
- robotic lock lever [118](#)
- Robotic spooling cable [143](#)
- rsyslog [19](#)

S

- safety information
 - laser compliance [xxiv](#)
 - laser safety [xxiv](#)
 - possible hazards [xxiv](#)
- SAS cabling [53](#)
- Saving the configuration [123](#)
- SCSI address
 - Drive [15](#)
- Security [23](#)
- Security Key Lifecycle Manager (SKLM) [73](#)
- sending your comments [iii](#)
- Sense data
 - using [114](#)
- Sequential mode [16](#)
- Sequential Mode, configure [65](#)
- Sequential Mode, status [65](#)
- Serial Port [8](#)
- Session Timeout [65](#)
- shipping container [38](#)
- shortcut keys [199](#)
- SKLM (Security Key Lifecycle Manager) [17](#)
- SKLM for z/OS Encryption [73](#)
- sled, description of tape drive [6](#), [11](#)
- SMTP [21](#)
- SNMP
 - configure [65](#)
- SNMP Audit Logging [19](#)
- SNMP support [19](#)
- SNTP
 - configure [65](#)
 - specifications [69](#)
- Specifications
 - cartridges [171](#)
- Spooling mechanism
 - removing [143](#)
 - replacing [143](#)
- SSL
 - enable or disable [65](#)
- Status light [116](#)
- support notification [iii](#)

T

- table top installation [49](#), [54](#)

- tape cartridge [16](#)
- tape cartridges, labeling [56](#)
- tape cartridges, loading [56](#)
- tape drive [118](#)
- tape drive sled [8](#)
- Tape drives
 - description [11](#)
 - quantity in library [6](#), [11](#)
- tape drives, install [52](#)
- TapeAlert Flags
 - for drives [110](#)
- TapeAlert Flags, library [108](#)
- TapeAlert support [19](#)
- technical support [iii](#), [82](#)
- Technical Support
 - accessing online [iv](#)
- Time Zone
 - set [65](#)
- trademarks [201](#)
- troubleshooting [77](#)
- Troubleshooting, library [77](#)

U

- Universal rack connectors [45](#)
- Unlabeled Media
 - allow [65](#)
- Unlock magazines with Management GUI [147](#)
- Unlock magazines with Operator Panel [147](#)
- unpacking the library [38](#)
- Updating firmware
 - using ITDT Tool [83](#)
- USB cabling [53](#)
- USB port [8](#)
- Users
 - Access Recovery [65](#)
 - Add [65](#)
 - Modify Operator Panel PIN [65](#)
 - Modify Role Permissions [65](#)
 - Modify User Passwords [65](#)
 - Remove [65](#)

V

- validate, tape drive installation [52](#)

W

- WORM [159](#)
- WORM (Write Once, Read Many) [158](#)
- WORM cartridges [160](#)
- WORM requirements [159](#)
- Write Once, Read Many (see WORM) [158](#)
- Write Once, Read Many cartridges [160](#)
- Write-Protect switch
 - setting [162](#)
- WWNN
 - Worldwide node name [59](#)
- WWPN
 - Worldwide port name [59](#)



SC27-4629-07

