

# E5080B Method of Implementation (MOI) for USB Type-C to Type-C Cable Assembly Compliance Test

Using Keysight Network Analyzer with Enhanced TDR App  
for Type-C to Type-C Passive Cable Assemblies



## Table of Contents

1. Revision History.....	4
2. Configuration Requirements.....	5
3. Test Procedure.....	6
3.1 Test Flow Chart.....	6
3.2 Test Port Cable and Fixture Connection.....	7
3.3 Description of Measurement Window.....	7
4. Measurement Setups.....	10
4.1 Recalling a State File.....	10
4.2 Common Parameters Setup for Frequency Domain Measurements.....	12
4.2.1 Setup for High-Speed Signal Measurement.....	12
4.2.2 Setup for Low-Speed Signal Measurement.....	13
4.3 Calibration Setup.....	13
4.3.1. ECal Calibration on Time Domain.....	13
4.3.2 De-embedding on Time Domain.....	14
4.3.3. ECal Calibration on Frequency Domain.....	15
4.3.4. De-embedding on Frequency Domain.....	15
4.3.5. Adjustment of effective rise time.....	16
5. Measurement and Data Analysis.....	17
5.1 D+/D- Differential Impedance.....	18
5.2 D+/D- Intra-Pair Skew.....	18
5.3. D+/D- Propagation Delay.....	19
5.4 D+/D- Pair Attenuation.....	19
5.5 Channel Metrics (ILfitatNq, IMR, IXT, IRL, Differential-to-Common-Mode Conversion) - For USB4 Gen2 and USB3.2 Gen2.....	20
5.6 Channel Operating Margin, COM (Normative – For USB4 Gen3 only).....	23
5.7 Differential-to-Common-Mode Conversion.....	26
5.8 Cable Shielding Effectiveness.....	27
5.9 [Raw Cable] Differential Impedance (Informative).....	30
5.10 [Raw Cable] Intra-Pair Skew (Informative).....	31
5.11 [Raw Cable] Differential Insertion Loss (Informative).....	31
5.12 [Mated Connector] Differential Impedance (Informative).....	33
5.13 [Mated Connector] Channel Metrics (ILfitatNq, IMR, IXT, IRL, Differential-to-Common-Mode Conversion) - Normative for USB4 Gen3.....	33
5.14 [Mated Connector] Differential Insertion Loss (Informative).....	36

5.15 [Mated Connector] Differential Return Loss (Informative).....	37
5.16 [Mated Connector] Differential NEXT & FEXT between SS Signal Pairs (Informative) .....	37
5.17 [Mated Connector] Differential NEXT and FEXT between D+/D- Pair and SS Signal Pairs (Normative for USB4 Gen3).....	38
5.18 [Mated Connector] Differential to Common-Mode Conversion (Normative for USB4 Gen3).....	39
5.19 Differential Insertion Loss (Informative).....	40
5.20 Differential Return Loss (Informative).....	40
5.21 Differential NEXT & FEXT between SS Signal Pairs (Informative).....	41
5.22 Differential NEXT and FEXT between D+/D- Pair and SS Signal Pairs (Informative) .....	42
5.23 [Low Speed Signal] Characteristic Impedance on CC Wire and SBU .....	43
5.24 [Low Speed Signal] Crosstalk, VBUS Loop L/C, Coupling Factor .....	44
5.25 [Low Speed Signal] Coupling between CC and Differential D+/D- .....	47
5.26 [Low Speed Signal] Single-Ended Coupling between CC and D+/D- .....	47
5.27 [Low Speed Signal] Coupling between VBUS and Differential D+/D-.....	48
5.28 [Low Speed Signal] Single-ended Coupling between SBU_A and SBU_B.....	48
5.29 [Low Speed Signal] Single-ended Coupling between SBU_A/SBU_B and CC.....	49
5.30 [Low Speed Signal] Coupling between SBU_A/SBU_B and Differential D+/D-.....	50
6. Manual Setup .....	50
6.1. Channel & Trace Setup .....	50
6.2. D+/D- Intra-Pair Skew.....	51
6.3 Crosstalk Compensation.....	52
6.4 D+/D- Pair Propagation Delay.....	53
6.5 Differential Impedance.....	53
6.6 [Low-Speed Signal] Single-ended Impedance.....	54
6.7 Common Parameters Setup for Frequency-domain Measurements.....	54
6.7.1 Setup for High-Speed Signal Measurement.....	54
6.7.2 Setup for Low-Speed Signal Measurement .....	55
6.8 Defining Limit Line Tables .....	56
Web Resources.....	57

## 1. Revision History

Revision	Comments	Date
1.0	First draft for E5080B series	30-Nov-2020
1.1	- Added Channel Metrics test for Mated Connector - Updated new release of USB-IF compliance tool	12-Jan-2021

### Reference documents

1. Universal Serial Bus Type-C Connectors and Cable Assemblies Compliance Document; Revision 2.0 (Apr 29, 2020).
2. Universal Serial Bus Type-C Cable and Connector Specification; Release 2.0 (August 2019).

## 2. Configuration Requirements

Description	Test Equipment	Qty
Network Analyzer	<p>Keysight Network Analyzer: (20 GHz is recommended as USB4/Type-C cable/connector requires measurements up to 20 GHz)</p> <ul style="list-style-type: none"> <li>• E5080B-4K0: 4-port test set, 9 kHz to 20 GHz or</li> <li>• P5024/25A Streamline USB Series VNA or</li> <li>• M9804/05A PXI Multiport VNA</li> </ul> <p>Note: Ensure that E5080B firmware revision is at least version A.14.10 or above (Windows 10)</p>	1 ea.
Software	<p>S9x011A/B Enhanced time-domain analysis with TDR * Selection is based on the VNA platforms. x=6 for ENA, x=7 for Streamline USB, x=5 for PXI</p>	1 ea.
Compliance Tool	<p>Compliance Tool provided by USB-IF: <a href="https://compliance.usb.org/files/Ger_iPar_v0p91a_release.zip">https://compliance.usb.org/files/Ger_iPar_v0p91a_release.zip</a> (Released 7-Dec-2020) <a href="https://compliance.usb.org/files/IntePar_1p6.zip">https://compliance.usb.org/files/IntePar_1p6.zip</a> (Released 3-Jan-2021)</p>	2 ea.
E-Cal or Mechanical Cal Kit	<p>N4433D-010/0DC 4-Ports Electronic Calibration (E-Cal) Module or 85052D Economy Mechanical Calibration Kit</p>	1 ea.
Test Fixture	<p>USB Type-C official test fixture and calibration standards, or an equivalent set of fixtures and standards. Note: Fixtures for testing USB Type-C connectors and cable assemblies are available for purchase through <a href="#">LUXSHARE-ICT</a>.</p>	1 ea.
Adapter (for E5080B only)	<p>Coaxial straight Female-SMA Female-SMA 50-Ohm adapters (Keysight 1250-1666).</p>	4 ea.
RF Cable	<p>3.5 mm or SMA cables of 4 GHz bandwidth or more (EG: 5062-6691) * Y1740A-100 (3.5-mm m-m, 36 inch) cable is recommended for Streamline USB and PXI VNA.</p>	4 ea.
Terminator	<p>50-ohm terminations to terminate unused channels.</p>	16 ea.

## 3. Test Procedure

### 3.1 Test Flow Chart

Steps	Procedure
Step 1	<p>The VNA should be powered on and allowed to warm up - recommendation is for 24 hours prior to measurement.</p> <ul style="list-style-type: none"><li>• Recommended to set the frequency sweep range 20 GHz for the USB Type-C SuperSpeed pairs as required by the spec.</li><li>• The IF Bandwidth should be low enough to help reduce noise effects (e.g. &lt; 300 Hz).</li></ul>
Step 2	<p>Set measurement conditions by recalling a state file or manual setup. There are <u>3 type of USB Type-C Cable-Connector tests state files and MOIs</u>. Choose the right one base on your DUT type.</p> <ol style="list-style-type: none"><li>1. Type-C to Type-C Passive Cable Assemblies (for High Speed Signal and Low Speed Signals)</li><li>2. Type-C to Legacy USB Cable Assemblies</li><li>3. Type-C to Legacy USB Adapter Assemblies</li></ol>
Step 3	<p>Connect USB Type-C Test fixture to test ports of the VNA.</p>
Step 4	<p>For Time Domain Measurements, perform Electronic Calibration (ECal) and de-embedding.</p>
Step 5	<p>For Frequency Domain Measurements, perform Electronic Calibration (ECal) and de-embedding.</p>
Step 6	<p><b>Perform Time Domain Measurements</b></p> <ul style="list-style-type: none"><li>- D+/D- Differential Impedance (Normative)</li><li>- D+/D- Intra-Pair Skew (Normative)</li><li>- D+/D- Propagation Delay (Normative)</li><li>- [Raw Cable] Differential Impedance (Informative)</li><li>- [Raw Cable] Intra-Pair Skew (Informative)</li><li>- [Mated Connector] Differential Impedance (Normative for USB4 Gen3, Informative for USB 3.2 Gen2, USB4 Gen2)</li><li>- [Low Speed Signal] Characteristic Impedance (Informative)</li></ul>
Step 7	<p><b>Perform Frequency Domain Measurements</b></p> <ul style="list-style-type: none"><li>- D+/D- Pair Attenuation (Normative)</li><li>- Channel Metrics (ILfitatNq, IMR, IXT, IRL) (Normative)</li><li>- Channel Operating Margin, COM (Normative – USB4 Gen3)</li><li>- Differential-to-Common Mode conversion) (Normative)</li><li>- Cable Shielding Effectiveness (Normative)</li><li>- [Raw Cable] Differential Insertion Loss (Informative)</li><li>- [Mated Connector] - Channel Metrics (ILfitatNq, IMR, IXT, IRL) (Normative for USB4 Gen3)</li><li>- [Mated Connector] Differential Insertion Loss (Informative)</li><li>- [Mated Connector] Differential Return Loss (Informative)</li><li>- [Mated Connector] Differential NEXT &amp; FEXT between SS Signal Pairs (Informative)</li></ul>

- [Mated Connector] Differential NEXT & FEXT between D+/D- Pair and SS Signal Pairs (Normative for USB4 Gen3, Informative for USB 3.2 Gen2, USB4 Gen2)
- [Mated Connector] Differential to Common Mode Conversion (Normative for USB4 Gen3, Informative for USB 3.2 Gen2, USB4 Gen2)
- Differential Insertion Loss (Informative)
- Differential Return Loss (Informative)
- Differential NEXT & FEXT between SS Signal Pairs (Informative)
- Differential NEXT & FEXT between D+/D- Pair and SS Signal Pairs (Informative)
- [Low Speed Signal] Crosstalk, VBUS Loop L/C, Coupling Factor
- [Low Speed Signal] Coupling between CC and Differential D+/D-
- [Low Speed Signal] Coupling between CC and D+/D-
- [Low Speed Signal] Coupling between VBUS and Differential D+/D-
- [Low Speed Signal] Single-ended Coupling between SBU\_A and SBU\_B
- [Low Speed Signal] Single-ended Coupling between SBU\_A/SBU\_B and CC
- [Low Speed Signal] Coupling between SBU\_A/SBU\_B and Differential D+/D-

### 3.2 Test Port Cable and Fixture Connection

Cable under test will be tested in the following manner



Example: USB4 Type-C to Type-C Cable Assembly Test

### 3.3 Description of Measurement Window

The following figure is the description of the measurement window.

Channel 1- Time Domain	Channel 2- Frequency Domain
<ul style="list-style-type: none"> <li>5.1. D+/D- Diff. Impedance (Tr 1 &amp; Tr 5)</li> <li>5.2. D+/D- Intra-pair Skew (Tr 3)</li> <li>5.3. D+/D Propagation Delay (Tr 4)</li> <li>5.9.[Raw Cable] Differential Impedance (Tr 2 &amp; Tr 6)</li> <li>5.10.[Raw Cable] Intra-Pair Skew (Tr 3)</li> <li>5.12.[Mated Connector] Diff. Impedance (Tr 15 &amp; Tr 16)</li> </ul>	<ul style="list-style-type: none"> <li>5.4. D+/D Pair Attenuation (Tr 11)</li> <li>5.5 Channel Metrics (ILfitatNq, IMR, IXT, IRL)</li> <li>5.6 Channel Operating Margin, COM (Normative – USB4 Gen3)</li> <li>5.7. Differential to Common Mode Conversion (Tr 10)</li> <li>5.8.Cable Shielding Effectiveness (Tr 13 &amp; Tr 14)</li> <li>5.11. [Raw Cable] Differential Insertion Loss (Tr 9)</li> <li>5.13. [Mated Connector] Channel Metrics (ILfitatNq, IMR, IXT, IRL) (Normative – USB4 Gen3)</li> <li>5.14. [Mated Connector] Diff. Insertion Loss (ILfitatNq) (Tr 12)</li> <li>5.15. [Mated Connector] Diff. Return Loss. (Tr 17)</li> <li>5.16. [Mated Connector] Diff. NEXT &amp; FEXT between SS Signal Pairs (Tr 18)</li> <li>5.17. [Mated Connector] Diff. NEXT &amp; FEXT between D+/D Pair and SS Signal Pairs (Tr 19)</li> <li>5.18. [Mated Connector] Differential to Common Mode Conversion (Tr 20)</li> <li>5.19. Diff Insertion Loss (Tr 21)</li> <li>5.20. Diff Return Loss (Tr 22)</li> <li>5.21. Diff. NEXT &amp; FEXT between SS Signal Pairs (Tr 23)</li> <li>5.22. Diff. NEXT &amp; FEXT between D+/D Pair and SS Signal Pairs (Tr 24)</li> </ul>



### Normative and Informative Parameters (High Speed Signal)

Channel 1- Time Domain	Channel 2- Frequency Domain
<p>5.23. [Low Speed Signal] Characteristic Impedance (Tr 25 &amp; Tr 26 / Tr 27 &amp; Tr 28)</p>	<p>5.24. [Low Speed Signal] Crosstalk, VBUS Loop L/C, Coupling Factor (Tr 29)            5.25. [Low Speed Signal] Coupling between CC and Differential D+/D- (Tr 30)            5.26. [Low Speed Signal] Single-ended Coupling between CC and D+/D- (Tr 31 &amp; Tr 32)            5.27. [Low Speed Signal] Coupling between VBUS and Differential D+/D- (Tr 33)            5.28. [Low Speed Signal] Single-ended Coupling between SBU_A and SBU_B (Tr 34)            5.29. [Low Speed Signal] Single-ended Coupling between SBU_A/SBU_B and CC (Tr 35)            5.30. [Low Speed Signal] Coupling between SBU_A/SBU_B and Differential D+/D- (Tr 36)</p>

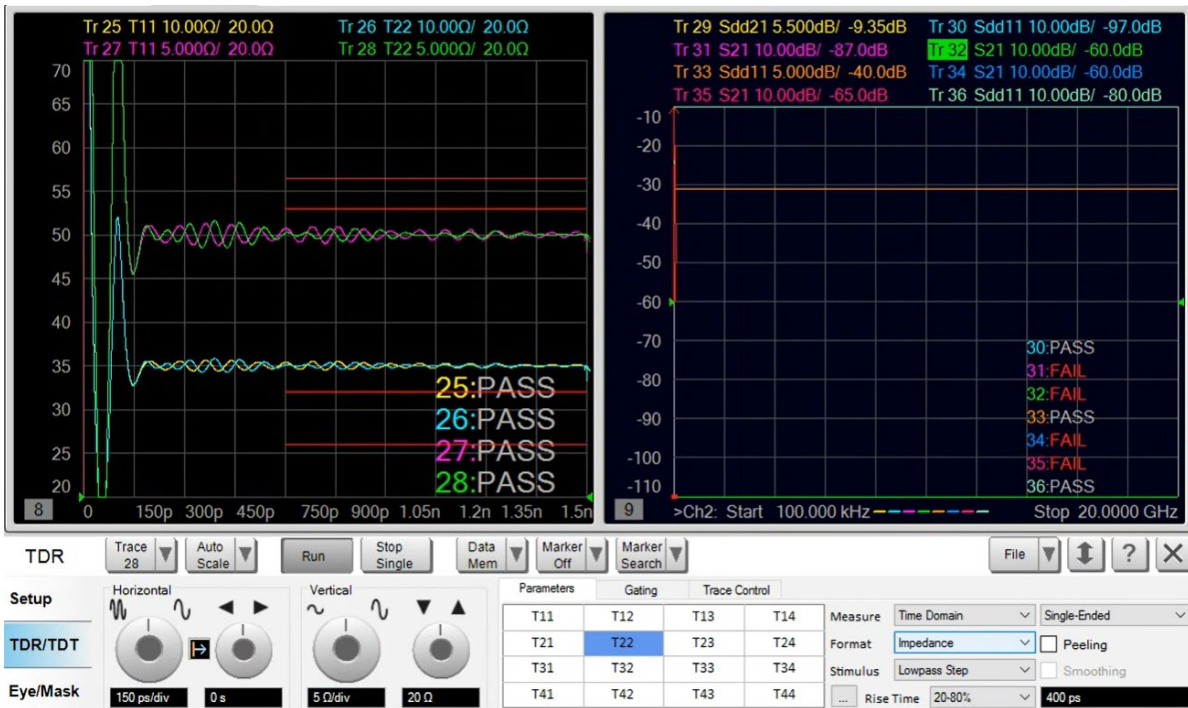

### Normative and Informative Parameters (Low Speed Signal)

Note:

1. Hard Keys are displayed in **Blue color** and **Bold**. (Example: **Avg, Analysis**)
2. Soft keys (Keys on the screen) are displayed in **Bold**. (Example: **S11, Real, Transform**)
3. Buttons (in the TDR) are displayed in **Green color** and **Bold**. (Example: **Trace, Rise Time**)
4. Tabs (in the TDR) are displayed in **Brown color** and **Bold**. (Example: **Setup, Trace Control**)

## 4. Measurement Setups

### 4.1 Recalling a State File

This section describes how to recall a state file for Time Domain and Frequency Domain settings.

A state file can be downloaded from Keysight.com at the following URL.

[www.keysight.com/find/ena-tdr\\_compliance](http://www.keysight.com/find/ena-tdr_compliance)

If you use your local PC to download, save the state file to a USB mass storage device in order to move it to the VNA unit. Connect the USB mass storage device into the front USB port of the VNA unit.

For manual measurement settings, refer to Chapter 6.0 Appendix for manual setup procedure.

Note: For USB Type-C to Type-C passive cable assemblies compliance tests, there are two state files. One for high speed signal tests and the other for low speed signal tests respectively. Recall one of two state files then follow the procedure below.

1. Click **Setup** > **Main** > **Meas Class...** to launch measurement class setup dialog box
2. Select **TDR** and click OK.

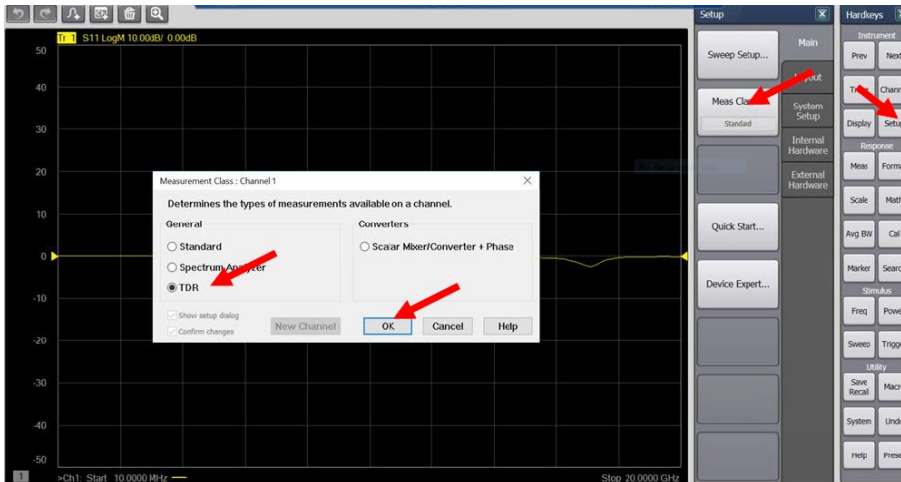

3. Select Close and confirm with Yes to close the setup wizard.

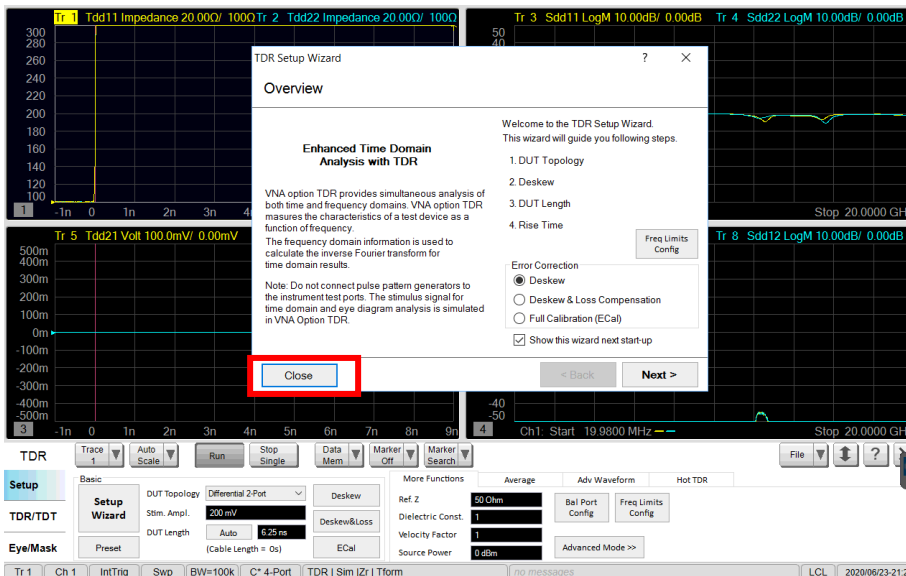

- Select Click **Advanced Mode** of TDR software and Click Yes to enter the advanced mode.

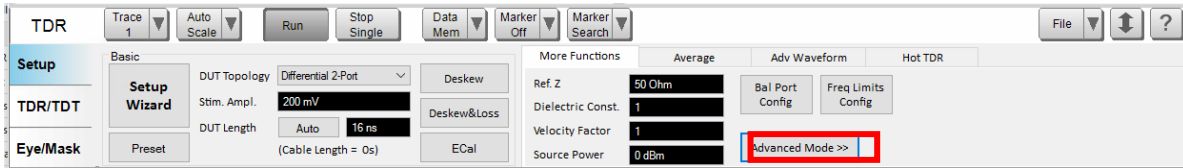

- Click **File > Recall State**. Select the state file (\*.tdr) and click Open to recall.

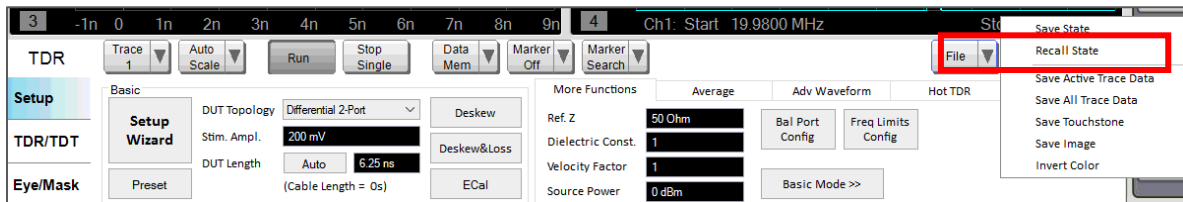

- The windows will launch pre-define state file configuration for USB Type-C compliance testing.

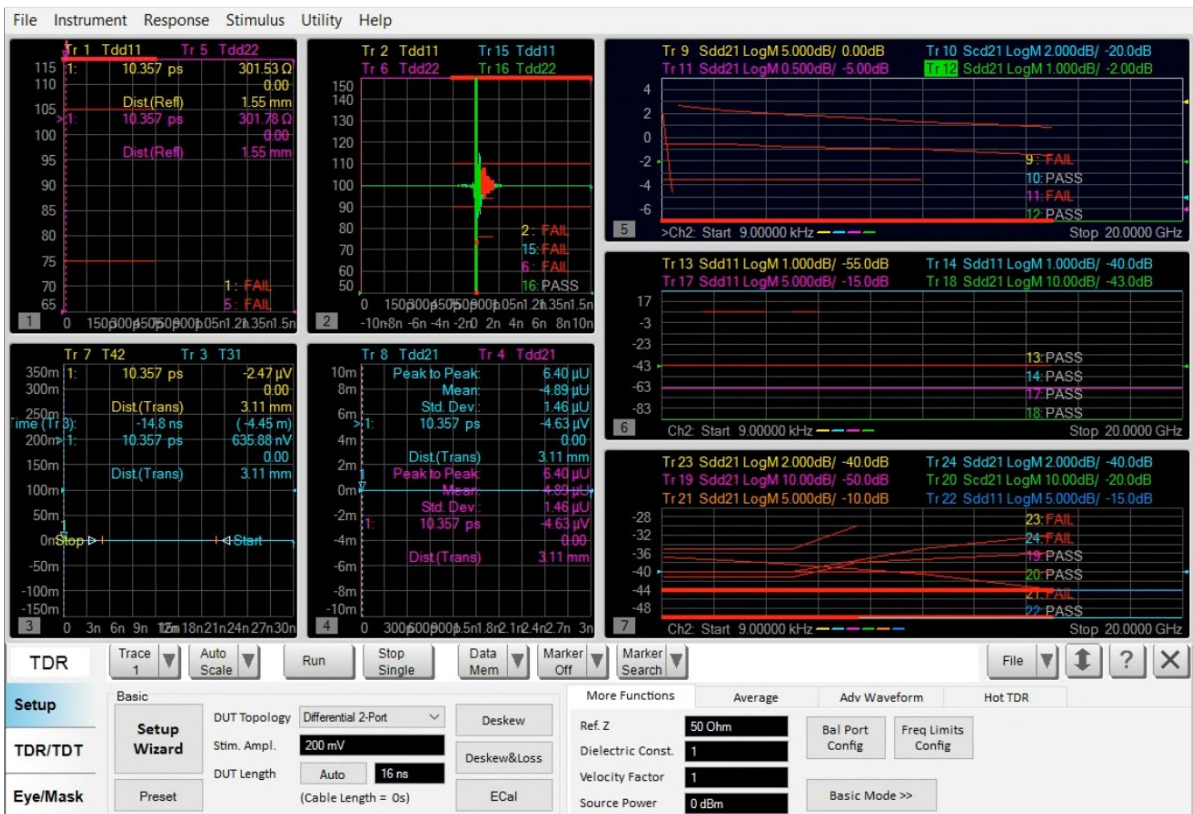

- All the measurement settings including calibration information can be saved. Select **File > Save State As... > State and Cal Set Date (\*.csa)** to save the settings.

## 4.2 Common Parameters Setup for Frequency Domain Measurements

### 4.2.1 Setup for High-Speed Signal Measurement

1. Press **Channel Next** to select Channel 2.
2. Select **Sweep** > Sweep Setup and key-in sweep properties as below:
  - Set **Start** value to “10 MHz”.
  - Set **Stop** value to “20 GHz”.
  - Set **Points** and set to “2000”.
  - Set **IF Bandwidth** to “1 kHz”.

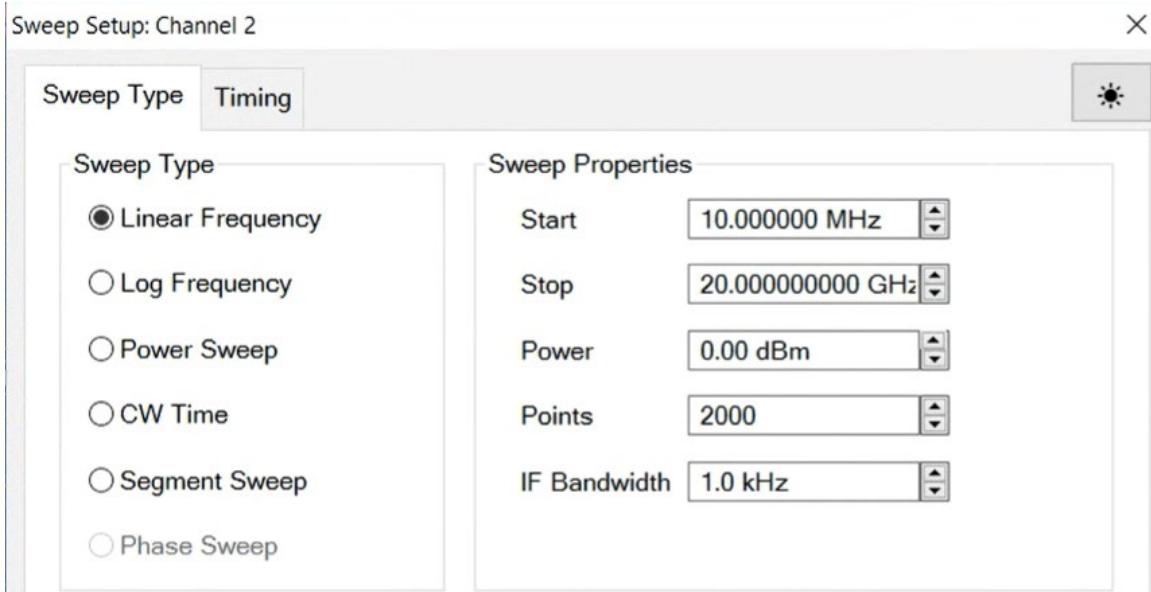

3. Select **Cal** > **Fixtures** > **Fixture Setup** > **Port Z...** Select and check “**Enable Port Z Conversion (all ports)**” to turn ON Port Z conversion.
4. Select **Meas** > **Balanced** > **Topology...** > **BAL-BAL**
5. Select **Balanced Port** > **1 BAL** > **Port 1- Port 3**
6. Select **Balanced Port** > **2 BAL** > **Port 2- Port 4**

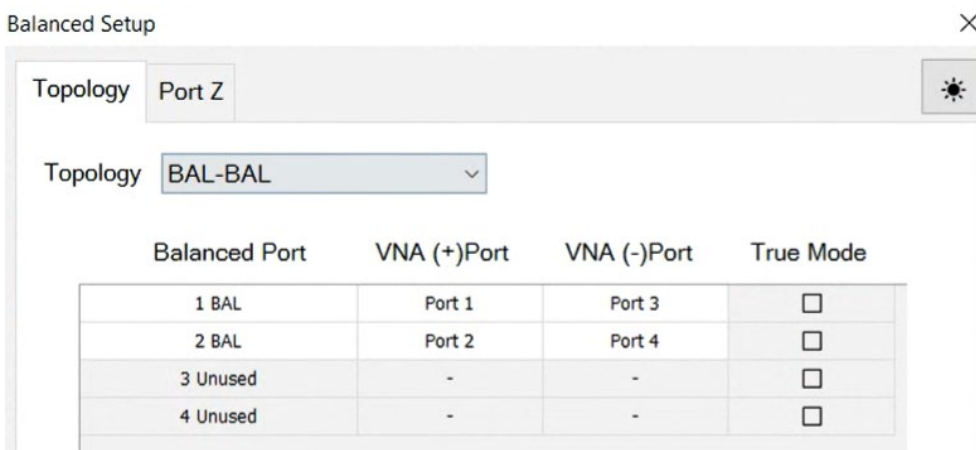

## 4.2.2 Setup for Low-Speed Signal Measurement

1. Press **Channel Next** to select Channel 2.
2. Select **Sweep** > Sweep Setup and key-in sweep properties as below:
  - Select Sweep Type as “Log Frequency”.
  - Set **Start** value to “300 kHz”.
  - Set **Stop** value to “100 MHz”.
  - Set **Power** value to “10 dBm”
  - Set **Points** and set to “1601”.
  - Set **IF Bandwidth** to “1 kHz”.

The screenshot shows a software interface for setting sweep parameters. It has two tabs: 'Sweep Type' and 'Timing'. The 'Sweep Type' tab is active, showing a list of radio buttons: 'Linear Frequency', 'Log Frequency' (which is selected), 'Power Sweep', 'CW Time', 'Segment Sweep', and 'Phase Sweep'. To the right, the 'Sweep Properties' section contains five input fields with up/down arrows: 'Start' (300.000 kHz), 'Stop' (100.000000 MHz), 'Power' (10.00 dBm), 'Points' (1601), and 'IF Bandwidth' (1.0 kHz).

## 4.3 Calibration Setup

The purpose of this step is to calibrate the RF effects such as delay, loss or mismatch of RF cables and test fixture traces before measurements. In order to remove the fixture trace effect, two calibration methods (ECal calibration & de-embedding or TRL calibration) are available with the VNA firmware.

### 4.3.1. ECal Calibration on Time Domain

Full calibration is performed by using the 4-port ECal Module (i.e. N4433A) at the end of RF cables connected to the VNA's test ports. The effect of the fixture is removed by de-embedding the fixture traces with S-parameter Touchstone files.

ECal calibration and de-embedding for time-domain measurements are performed by the TDR software.

1. Press **Channel Next** to select Channel 1.
2. Click **Setup** tab.
3. Click **ECal** to launch the TDR Setup Wizard.

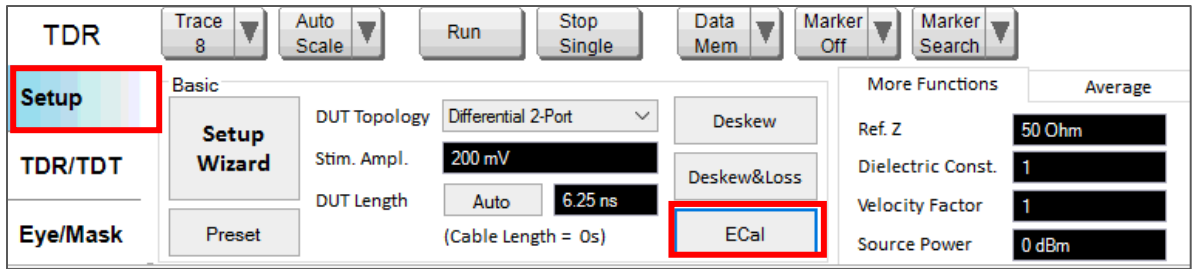

4. Connect the VNA ports (port 1 to 4) to the ECal module with RF cables.
5. Click **Calibrate** to perform ECal Calibration.

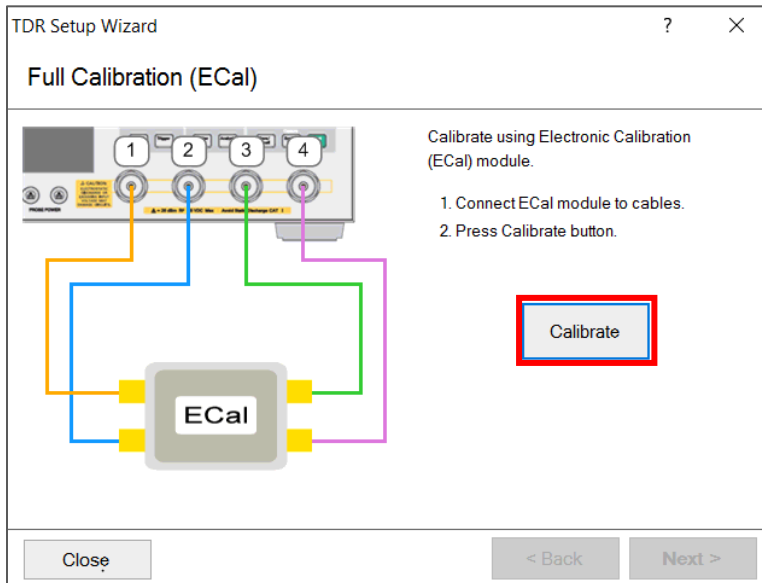

6. Click **Next >** to proceed
7. Click **Finish** to complete the ECal.

#### 4.3.2 De-embedding on Time Domain

1. Click **Adv Waveform** tab > **De-embedding** to launch Advanced Waveform wizard.

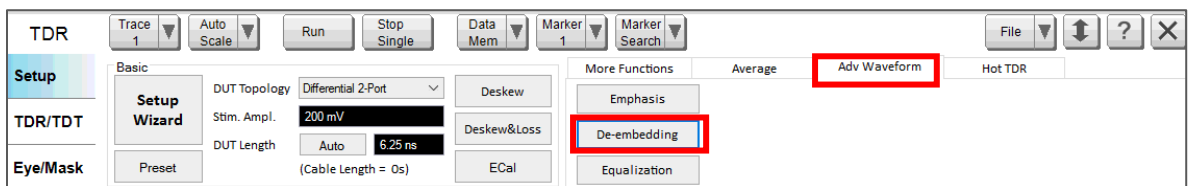

2. Click De-embedding box to set the Touchstone file. 2 port files (\*.s2p) for single ended lines or 4 port files (\*.s4p) for differential lines can be selected for the de embedding function.
3. Load the USB Type-C 2X THRU Touchstone file for as below (files are available in state file zip):  
 Select **Port1** > Load “2x\_AFR\_Top\_L\_Port1.s2p” file.  
 Select **Port3** > Load “2x\_AFR\_Top\_R\_Port3.s2p” file.  
 Select **Port2** > Load “2x\_AFR\_Bot\_L\_Port2.s2p” file.  
 Select **Port4** > Load “2x\_AFR\_Bot\_R\_Port4.s2p” file.
4. Enable the de-embedding function and Click OK.

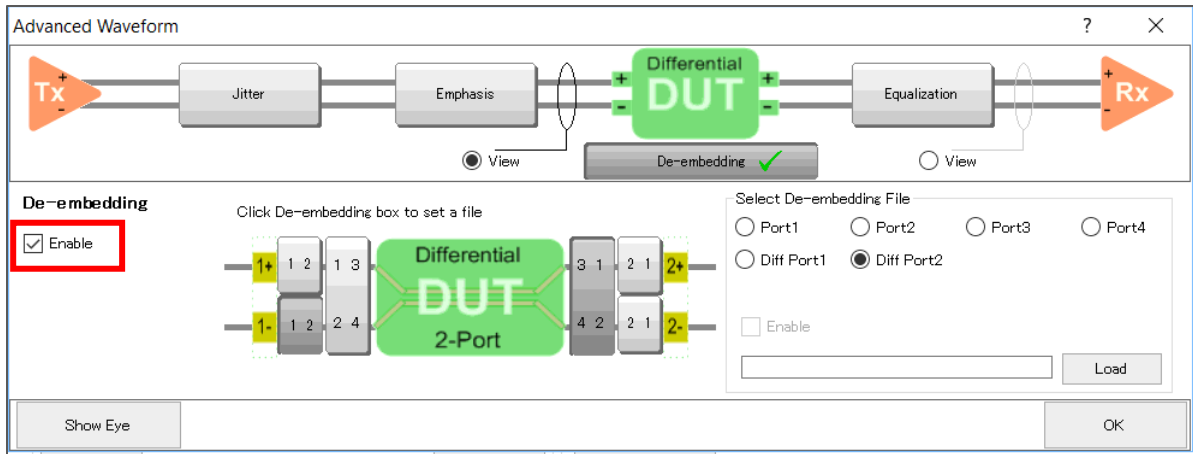

Note: For more details about the de-embedding function, refer to the VNA help below.

[http://ena.support.keysight.com/e5080/manuals/webhelp/eng/index.htm#S3\\_Cals/Fixturing.htm#deembed](http://ena.support.keysight.com/e5080/manuals/webhelp/eng/index.htm#S3_Cals/Fixturing.htm#deembed)

### 4.3.3. ECal Calibration on Frequency Domain

ECal calibration and de-embedding for frequency-domain measurements are performed by the VNA firmware.

1. Press **Channel Next** to select Channel 2.
2. Connect the VNA ports (Port 1 to 4) to the ECal module with RF cables.
3. Press **Cal > Main > Other ECal > Ecal...** > select **4-Port ECal** and click **Next** to proceed Ecal.

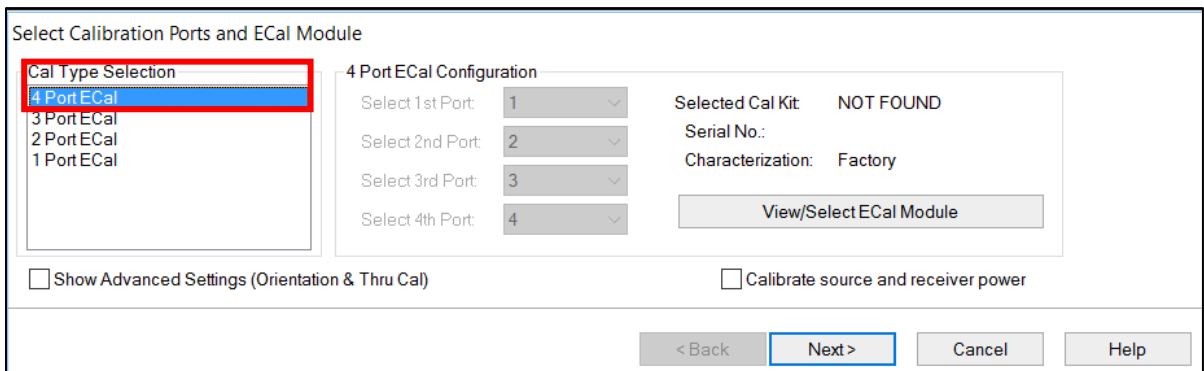

### 4.3.4. De-embedding on Frequency Domain

1. Press **Cal > Fixtures > Fixture Setup > 2-port DeEmbed...** and check on **Enable De-embedding (all ports)** to de-embed fixture trace.
2. Select **User S2P File** and specify a 2-port de-embedding file (\*.s2p).  
 Select **Port-1** > User Defined (S2P File) > Load **"2x\_AFR\_Top\_L\_Port1.s2p"** file.  
 Select **Port-3** > User Defined (S2P File) > Load **"2x\_AFR\_Top\_R\_Port3.s2p"** file.  
 Select **Port-2** > User Defined (S2P File) > Load **"2x\_AFR\_Bot\_L\_Port2.s2p"** file.  
 Select **Port-4** > User Defined (S2P File) > Load **"2x\_AFR\_Bot\_R\_Port4.s2p"** file.

3. Close and proceed.

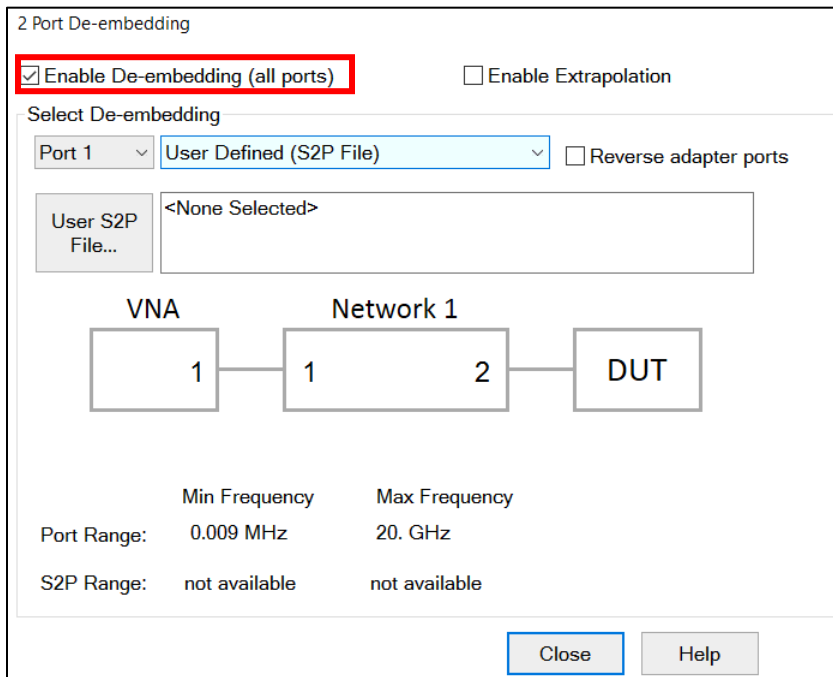

Note: For more details about the de-embedding function, refer to the VNA help below.

#### 2-port de-embedding -

[http://ena.support.keysight.com/e5080/manuals/webhelp/eng/index.htm#S3\\_Cals/Fixturing.htm#deembed](http://ena.support.keysight.com/e5080/manuals/webhelp/eng/index.htm#S3_Cals/Fixturing.htm#deembed)

#### 4.3.5. Adjustment of effective rise time

After performing the calibration, the effective rise time entering the USB connector pins should adjusted for the specification in time domain measurements.

1. Press **Channel Next** to select Channel 1.
2. Double click to maximize the selected trace in the screen.
3. Open **TDR/TDT** tab. Select the trace of interest.
4. Confirm effective rise time for each trace.

Trace	Test Parameters	Rise Time %	Target Rise Time
Tr 1 & 5	D+/D- Differential Impedance	20 - 80 %	400 ps
Tr 4	D+/D- Propagation Delay	20 - 80 %	400 ps
Tr 3 & 7	D+/D- Intra-Pair Skew	20 - 80 %	400 ps
Tr 2 & 6	[Raw Cable] Differential Impedance	10 - 90 %	200 ps
Tr 15 & 16	[Mated Connector] Differential Impedance	20 - 80 %	40 ps
Tr 25,26, 27,28	[Low Speed Signal] Characteristic Impedance on CC Wire and SBU	20 - 80 %	400 ps

## 5. Measurement and Data Analysis

The connections for Type-C to Type-C cable assembly, raw cable and mated connector are assumed as follows (Note: TF stands for Test Fixture). For cable assembly frequency domain measurements, the standard compliance tool is used for the pass/fail judgment. The manual measurement procedures for raw cable, mated connector, and several test items of cable assembly using the Enhanced Option TDR are also supported with the limit lines.

1. Connect USB Type-C test fixtures to the test port cables according to tables below. Unused terminals should be terminated with 50-ohm terminators.
2. Press **Channel Next** key on the instrument front panel to select Channel 1/Channel 2.
3. Click **Stop Single** for Time Domain measurements.
4. Press **Trigger > Single** for Frequency Domain measurements.

### Type-C to Type-C Cable Assembly Connection (High Speed Signal)

TF L Side	Cable Assembly		TF R Side
Type-C (Receptacle)	Type-C (Plug)	Type-C (Plug)	Type-C (Receptacle)
D+/D-		↔	D+/D-
Tx1+/Tx1-		↔	Rx1+/Rx1-
Rx1+/Rx1-		↔	Tx1+/Tx1-
Tx2+/Tx2-		↔	Rx2+/Rx2-
Rx2+/Rx2-		↔	Tx2+/Tx2-

### Raw Cable Connection

A Side	Raw Cable	B Side
D+/D-	↔	D+/D-
Tx1+/Tx1-	↔	Tx1+/Tx1-
Rx1+/Rx1-	↔	Rx1+/Rx1-
Tx2+/Tx2-	n/a	Tx2+/Tx2-
Rx2+/Rx2-	n/a	Rx2+/Rx2-

### Mated Connector Connection

TF 1	Mated Connector	TF 2
Type-C (Receptacle)		Type-C (Plug)
D+/D-	↔	D+/D-
Tx1+/Tx1-	↔	Tx1+/Tx1-
Rx1+/Rx1-	↔	Rx1+/Rx1-
Tx2+/Tx2-	↔	Tx2+/Tx2-
Rx2+/Rx2-	↔	Rx2+/Rx2-

## 5.1 D+/D- Differential Impedance

Multiple reflections from impedance mismatches cause noise at the receiver. Therefore, the impedance profile provides an indication of multiple reflection induced noise. This test ensures that the signal conductors of the USB Type-C connectors have the proper impedance.

1. Connect the VNA ports (port 1 to 4) to the test fixture ports with RF cables.

VNA Port#	Port 1	Port 2	Port 3	Port 4
Test Fixtures	L Side D+	R Side D+	L Side D-	R Side D-

Note: Unused fixture pots should be terminated with 50-ohm terminators.

2. Press **Channel Max** to maximize Channel 1 on the screen.
3. Select **Trace 1 (Tdd11)**.
4. Double-click the Trace to maximize the selected trace on the screen.
5. Click Stop Single.
6. Confirm the measured impedance is within the limit shown below. Otherwise, it will show Fail.
7. Select **Trace 5 (Tdd22)** and repeat Step 5-6 for the far end of the DUT.

DUT Type	Max Limit	Min Limit
Type-C to Type-C passive cable assembly	105 $\Omega$	75 $\Omega$
Type-C to legacy cable assembly	105 $\Omega$	75 $\Omega$
Type-C to legacy adapter assembly	105 $\Omega$	75 $\Omega$

Note: The measurement should be evaluated using a 400ps (20%-80%) rise time.

## 5.2 D+/D- Intra-Pair Skew

The propagation delay skew measurement ensures that the signal on both the D+ and D- lines of cable assembly arrive at the receiver at the same time.

1. Connect the VNA ports (port 1 to port 4) to the test fixture ports with RF cables.

VNA Port#	Port 1	Port 2	Port 3	Port 4
Test Fixtures	L Side D+	R Side D+	L Side D-	R Side D-

2. Press Double-click on the instrument front panel to enlarge the trace.
3. Press **Channel Next** to select Channel 1.
4. Select **Trace 3 (T31)**.
5. Click **Stop Single**
6. Read the Delta Time and confirm the measured value is within the limit shown below. Otherwise, Fail.

DUT Type	Test Limit
Type-C to Type-C passive cable assembly Type-C to legacy cable assembly	If Delta Time < 100 psec: Pass, else: Fail
Type-C to legacy adapter assembly	If Delta Time < 20 psec: Pass, else: Fail

Note: The measurement should be evaluated using a 400ps (20%-80%) rise time.

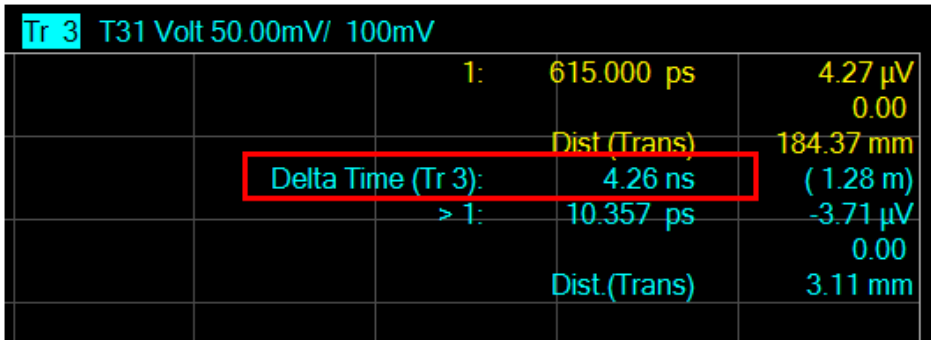

### 5.3. D+/D- Propagation Delay

The propagation delay measurement is to verify the end to end propagation of the D+/D- lines of the cable assembly.

1. Connect VNA ports (port 1 to port 4) to the test fixture ports with RF cables.

VNA Port#	Port 1	Port 2	Port 3	Port 4
Test Fixtures	L Side D+	R Side D+	L Side D-	R Side D-

2. Press Double-click on the instrument front panel to enlarge the trace.
3. Select **Trace 4 (Tdd21)**.
4. Click **Stop Single**.
5. Read Marker Value 1 on **Trace 4** and confirm the measured value is within the limit shown below.

DUT Type	Test Limit
Type-C to Type-C passive cable assembly	If the time at the rising edge < 26 nsec: Pass, else: Fail
Type-C to legacy cable assembly	Type-C to Micro-B: If the time at the rising edge < 10 nsec: Pass, else: Fail
	Type-C to legacy: If the time at the rising edge < 20 nsec: Pass, else: Fail

Note: The measurement should be evaluated using a 400ps (20%-80%) rise time.

### 5.4 D+/D- Pair Attenuation

This test ensures the D+/D- pair of a cable assembly can provide adequate signal strength to the receiver in order to maintain a low error rate.

1. Connect VNA ports (port 1 to port 4) to the test fixture ports with RF cables.

VNA Port#	Port 1	Port 2	Port 3	Port 4
Test Fixtures	L Side D+	R Side D+	L Side D-	R Side D-

2. Press **Channel Next** to select Channel 2.
3. Select **Trace 11 (Sdd21)**.
4. Press Double-click on the instrument front panel to enlarge the trace.
5. Press **Trigger** > Single.
6. Run and confirm the measured values is within the limit shown below. Otherwise, it will show Fail.

DUT Type	Start Frequency	End Frequency	Start Limit	End Limit
Type-C to Type-C passive cable assembly	50 MHz	100 MHz	-1.02 dB	-1.43 dB
	100 MHz	200 MHz	-1.43 dB	-2.40 dB
Type-C to legacy cable assembly	200 MHz	400 MHz	-2.40 dB	-4.35 dB
Type-C to legacy adapter assembly	50 MHz	400 MHz	-0.70 dB	-0.70 dB

## 5.5 Channel Metrics (ILfitatNq, IMR, IXT, IRL, Differential-to-Common-Mode Conversion) - For USB4 Gen2 and USB3.2 Gen2

The **USB4 Gen2 and USB3.2 Gen2** test results of channel metrics will check with a standard tool (InterPar.exe) provided by USB-IF. The USB Type-C compliance tool may be down-loaded from the following link: [http://compliance.usb.org/files/IntePar\\_1p6.zip](http://compliance.usb.org/files/IntePar_1p6.zip) (Released 3-Jan-2021)

Fifteen 4-port Touchstone files (\*.s4p) will measure and save by the VNA firmware, and then imported by the compliance tool to conduct cable assembly compliance test.

**Note: USB4 Gen3 Cable assembly will use Ger\_iPar compliance tool to run the COM and Channel Metrics. Refer to Section 5.6: Channel Operating Margin (COM)**

Note: Trace 11 is allocated for the measurements though, other traces can be used to check the measurement results with the limit line and the pass/fail judgment as described in Note below

Note: Turn off the Port Z conversion in order to perform the measurements based on 50-ohm port impedance setting which required by the standard compliance tool.

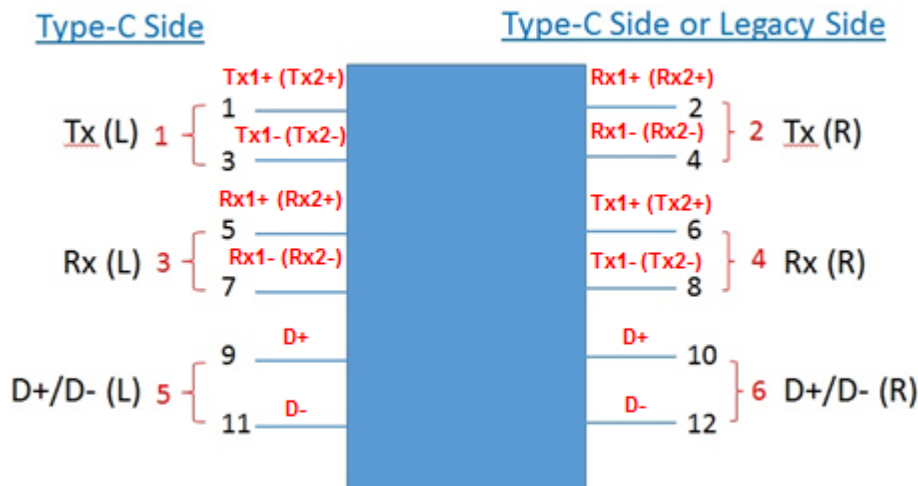

1. Connect the VNA ports (port 1 to 4) to the test fixture ports with RF cables.
2. Select **Cal** > **Fixtures** > **Fixture Setup** > **Port Z...** uncheck "Enable Port Z Conversion (all ports)" to turn OFF Port Z conversion.

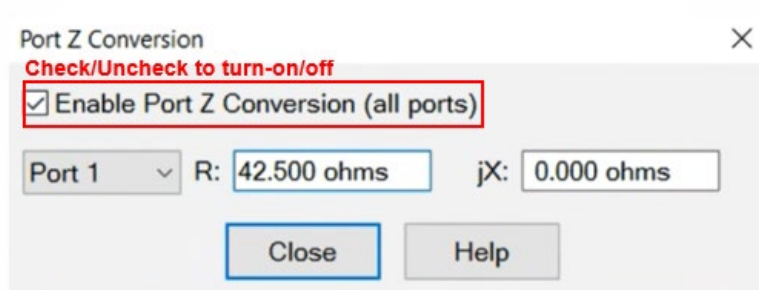

3. Press **Channel Next** to select Channel 2.
4. The same connection can use for below measurement for Pass/Fail testing. Select the desired trace as described to check the limit line and the pass/fail judgment. Press Double-click on the instrument front panel to enlarge the trace.
  - 5.4 D+/D- Pair Attenuation (**Trace 11**)
  - 5.7: Differential-to-Common-Mode Conversion (**Trace 10**)
  - 5.17: Differential Insertion Loss (**Trace 21**)
  - 5.18: Differential Return Loss (**Trace 22**)
  - 5.19: Differential NEXT and FEXT between SS Signal Pair (**Trace 23**)
  - 5.20: Differential NEXT and FEXT between D+/D- Pair and SS Signal Pairs (**Trace 24**)
5. Press **Trigger** > Single.
6. Press **Save Recall** > **Save Other** > **Save Data...** > **Filename.s4p** to save the measured Touchstone file (\*.s4p). Select format "Real/Imaginary" and "Normal" mode > then OK.
7. Connect the VNA ports with test fixture ports shown below and repeat step 3 to step 6 to save all 15-sets Touchstone files (\*.s4p) for Tx1/Rx1 pairs.

Test Path Name	Trace	Port 1	Port 2	Port 3	Port4
Tx(L), Tx(R) [1,2,3,4]	<b>Tr-10/ 21/22</b>	L Side Tx1+	R Side Rx1+	L Side Tx1-	R Side Rx1-
Rx(L), Rx(R) [5,6,7,8]	<b>Tr-10/ 21/22</b>	L Side Rx1+	R Side Tx1+	L Side Rx1-	R Side Tx1-
D+/D-(L), D+/D-(R) [9,10,11,12]	<b>Tr-11</b>	L Side D+	R Side D+	L Side D-	R Side D-
Tx(L), Rx(L) [1,3,5,7]	<b>Tr-23</b>	L Side Tx1+	L Side Rx1+	L Side Tx1-	L Side Rx1-
Tx(R), Rx(R) [2,4,6,8]	<b>Tr-23</b>	R Side Rx1+	R Side Tx1+	R Side Rx1-	R Side Tx1-
Tx(L), D+/D-(L) [1,3,9,11]	<b>Tr-24</b>	L Side Tx1+	L Side D+	L Side Tx1-	L Side D-
Rx(L), D+/D-(L) [5,7,9,11]	<b>Tr-24</b>	L Side Rx1+	L Side D+	L Side Rx1-	L Side D-
Tx(R), D+/D-(R) [2,4,10,12]	<b>Tr-24</b>	R Side Rx1+	R Side D+	R Side Rx1-	R Side D-
Rx(R), D+/D-(R) [6,8,10,12]	<b>Tr-24</b>	R Side Tx1+	R Side D+	R Side Tx1-	R Side D-
Tx(L), Rx(R) [1,3,6,8]	<b>Tr-23</b>	L Side Tx1+	R Side Tx1+	L Side Tx1-	R Side Tx1-
Tx(R), Rx(L) [2,4,5,7]	<b>Tr-23</b>	R Side Rx1+	L Side Rx1+	R Side Rx1-	L Side Rx1-
Tx(R), D+/D-(L) [2,4,9,11]	<b>Tr-24</b>	R Side Rx1+	L Side D+	R Side Rx1-	L Side D-
Rx(R), D+/D-(L) [6,8,9,11]	<b>Tr-24</b>	R Side Tx1+	L Side D+	R Side Tx1-	L Side D-
Tx(L), D+/D-(R) [1,3,10,12]	<b>Tr-24</b>	L Side Tx1+	R Side D+	L Side Tx1-	R Side D-
Rx(L), D+/D-(R) [5,7,10,12]	<b>Tr-24</b>	L Side Rx1+	R Side D+	L Side Rx1-	R Side D-

8. Open the Excel spreadsheet [High\_Config\_4ports.xlsx and modify “Cable Type” to 1 (C2C- Gen2 or C2C-Gen1) and S-parameter Path and Name to match them with fifteen 4 port Touchstone files (\*.s4p) you measured. Do not change “Number of VNA Ports” and “Port Arrangement”.
9. Launch the USB.org compliance test tool and load the excel spreadsheet “[High\_Speed]\_Config\_4ports.xlsx” by clicking “**Load Config Spreadsheet**”. Click **Import** to import fifteen 4 port Touchstone files (\*.s4p), then click **Check Compliance** for pass/fail judgment.

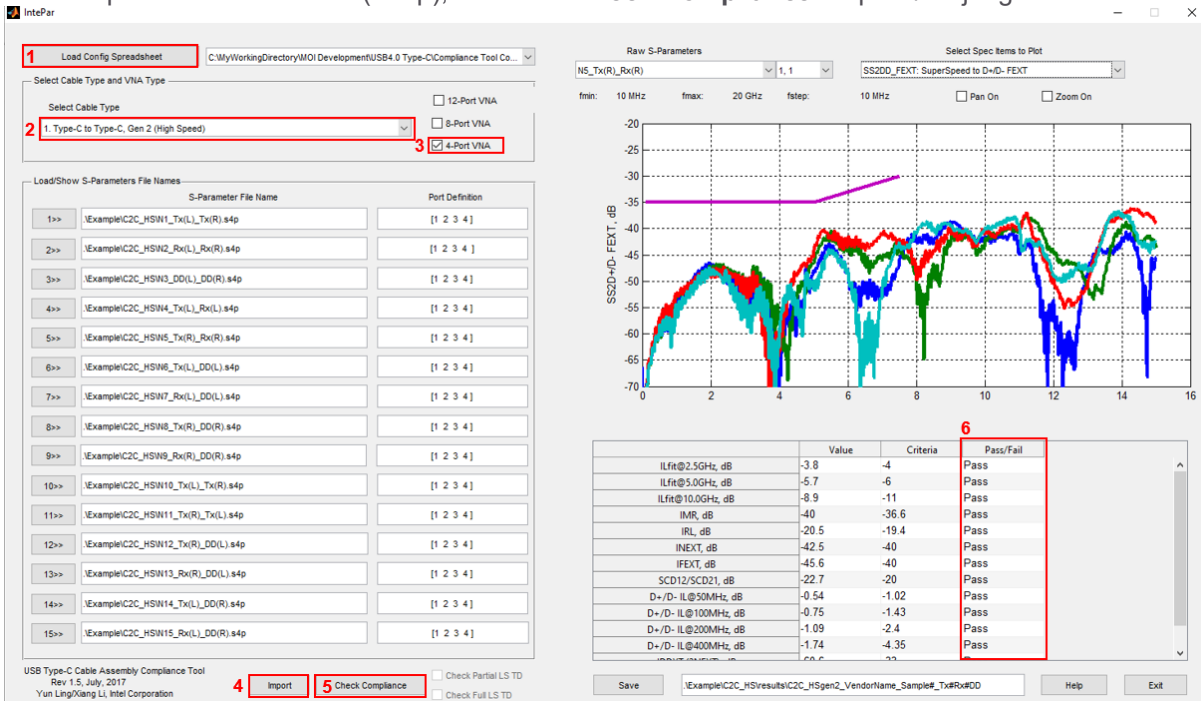

10. Connect the VNA ports with test fixture ports shown below and repeat step 3 to step 6 to save all necessary Touchstone files (\*.s4p) in the VNA, then repeat step 8 to step 9 for Tx2/Rx2 pairs.

Test Path Name	Trace	Port 1	Port 2	Port 3	Port4
Tx(L), Tx(R) [1,2,3,4]	Tr-23	L Side Tx2+	R Side Rx2+	L Side Tx2-	R Side Rx2-
Rx(L), Rx(R) [5,6,7,8]	Tr-23	L Side Rx2+	R Side Tx2+	L Side Rx2-	R Side Tx2-
D+/D-(L), D+/D-(R) [9,10,11,12]	Tr-11	L Side D+	R Side D+	L Side D-	R Side D-
Tx(L), Rx(L) [1,3,5,7]	Tr-23	L Side Tx2+	L Side Rx2+	L Side Tx2-	L Side Rx2-
Tx(R), Rx(R) [2,4,6,8]	Tr-23	R Side Rx2+	R Side Tx2+	R Side Rx2-	R Side Tx2-
Tx(L), D+/D-(L) [1,3,9,11]	Tr-24	L Side Tx2+	L Side D+	L Side Tx2-	L Side D-
Rx(L), D+/D-(L) [5,7,9,11]	Tr-24	L Side Rx2+	L Side D+	L Side Rx2-	L Side D-
Tx(R), D+/D-(R) [2,4,10,12]	Tr-24	R Side Rx2+	R Side D+	R Side Rx2-	R Side D-
Rx(R), D+/D-(R) [6,8,10,12]	Tr-24	R Side Tx2+	R Side D+	R Side Tx2-	R Side D-
Tx(L), Rx(R) [1,6,3,8]	Tr-10/ 21/22	L Side Tx2+	R Side Tx2+	L Side Tx2-	R Side Tx2-
Tx(R), Rx(L) [5,2,7,4]	Tr-10/ 21/22	R Side Rx2+	L Side Rx2+	R Side Rx2-	L Side Rx2-

Tx(R), D+/D-(L) [2,4,9,11]	Tr-24	R Side Rx2+	L Side D+	R Side Rx2-	L Side D-
Rx(R), D+/D-(L) [6,8,9,11]	Tr-24	R Side Tx2+	L Side D+	R Side Tx2-	L Side D-
Tx(L), D+/D-(R) [1,3,10,12]	Tr-24	L Side Tx2+	R Side D+	L Side Tx2-	R Side D-
Rx(L), D+/D-(R) [5,7,10,12]	Tr-24	L Side Rx2+	R Side D+	L Side Rx2-	R Side D-

11. After completed the measurement, Press **Cal** > **Fixtures** > **Fixture Setup** > **Port Z...** check “**Enable Port Z Conversion (all ports)**” to turn ON Port Z conversion as default setting.

## 5.6 Channel Operating Margin, COM (Normative – For USB4 Gen3 only)

Channel Operating Margin (COM) is checked with a standard compliance tool (**Ger\_iPar.exe**) provided by USB IF after the measurements have made. Download the tool from USB-IF link: [https://compliance.usb.org/files/Ger\\_iPar\\_v0p91a\\_release.zip](https://compliance.usb.org/files/Ger_iPar_v0p91a_release.zip) (Released 7-Dec-2020)

4-port Touchstone files (\*.s4p) is measured and saved by the VNA firmware, and then imported by the compliance tool to conduct cable assembly compliance tests. Recommended to run full S-parameters for High-speed TX/RX pairs (28-sets) + Optional for D+/D- Pairs (16-sets) to run the COM tool.

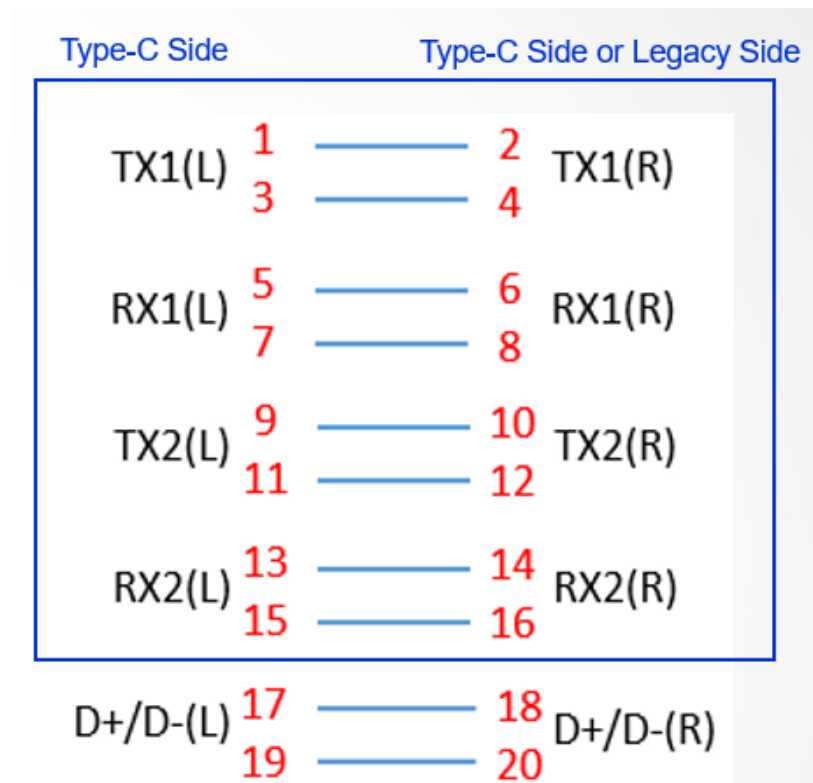

Note: The Port Z conversion is turned off, so the measurements are performed based on 50-ohm port impedance setting required by the standard tool. Select **Cal** > **Fixtures** > **Fixture Setup** > **Port Z...** uncheck “**Enable Port Z Conversion (all ports)**” to turn OFF Port Z conversion.

1. Connect the VNA ports (port 1 to 4) to the test fixture ports with RF cables.
2. Select **Cal** > **Fixtures** > **Fixture Setup** > **Port Z...** uncheck “**Enable Port Z Conversion (all ports)**” to turn OFF Port Z conversion.

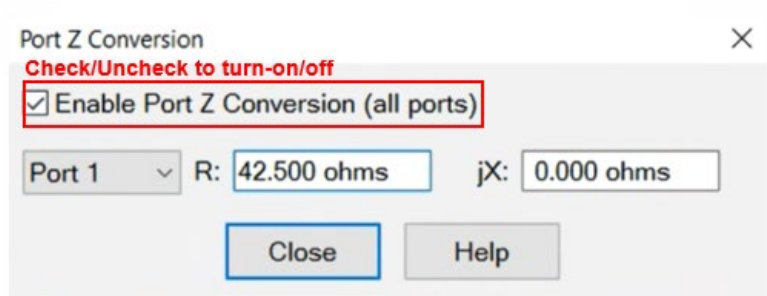

3. Press **Channel Next** to select Channel 2.
4. The same connection can use for below measurement for Pass/Fail testing. Select the desired trace as described to check the limit line and the pass/fail judgment. Press Double-click on the instrument front panel to enlarge the trace.
  - 5.4 D+/D- Pair Attenuation (**Trace 11**)
  - 5.7: Differential-to-Common-Mode Conversion (**Trace 10**)
  - 5.17: Differential Insertion Loss (**Trace 21**)
  - 5.18: Differential Return Loss (**Trace 22**)
  - 5.19: Differential NEXT and FEXT between SS Signal Pair (**Trace 23**)
  - 5.20: Differential NEXT and FEXT between D+/D- Pair and SS Signal Pairs (**Trace 24**)
5. Press **Trigger** > Single.
6. Press **Save Recall** > **Save Other** > **Save Data...** > **Filename.s4p** to save the measured Touchstone file (\*.s4p). Select format "Real/Imaginary" and "Normal" mode > then OK.
7. Connect the VNA ports with test fixture ports shown below and repeat step 3 to step 6 to save all necessary Touchstone files (\*.s4p) for VNA.

High-Speed TX/RX (SS Signal) Pair					
Test Path Name	Trace	Port 1	Port 2	Port 3	Port 4
Tx1(L), Tx1(R) [1,2,3,4]	<b>Tr-10/21/22</b>	L Side Tx1+	R Side Rx1+	L Side Tx1-	R Side Rx1-
Tx1(L), Rx1(R) [1,6,3,8]	<b>Tr-23</b>	L Side Tx1+	R Side Tx1+	L Side Tx1-	R Side Tx1-
Tx1(L), Tx2(R) [1,10,3,12]	<b>Tr-23</b>	L Side Tx1+	R Side Rx2+	L Side Tx1-	R Side Rx2-
Tx1(L), Rx2(R) [1,14,3,16]	<b>Tr-23</b>	L Side Tx1+	R Side Tx2+	L Side Tx1-	R Side Tx2-
Tx1(L), Rx1(L) [1,5,3,7]	<b>Tr-23</b>	L Side Tx1+	L Side Rx1+	L Side Tx1-	L Side Rx1-
Tx1(L), Tx2(L) [1,9,3,11]	<b>Tr-23</b>	L Side Tx1+	L Side Tx2+	L Side Tx1-	L Side Tx2-
Tx1(L), Rx2(L) [1,13,3,15]	<b>Tr-23</b>	L Side Tx1+	L Side Rx2+	L Side Tx1-	L Side Rx2-
Tx1(R), Rx1(L) [2,5,4,7]	<b>Tr-23</b>	R Side Tx1+	L Side Tx1+	R Side Tx1-	L Side Tx1-
Tx1(R), Tx2(L) [2,9,4,11]	<b>Tr-23</b>	R Side Tx1+	L Side Rx2+	R Side Tx1-	L Side Rx2-
Tx1(R), Rx2(L) [2,13,4,15]	<b>Tr-23</b>	R Side Tx1+	L Side Tx2+	R Side Tx1-	L Side Tx2-
Tx1(R), Rx1(R) [2,6,4,8]	<b>Tr-23</b>	R Side Tx1+	R Side Rx1+	R Side Tx1-	R Side Rx1-
Tx1(R), Tx2(R) [2,10,4,12]	<b>Tr-23</b>	R Side Tx1+	R Side Tx2+	R Side Tx1-	R Side Tx2-
Tx1(R), Rx2(R) [2,14,4,16]	<b>Tr-23</b>	R Side Tx1+	R Side Rx2+	R Side Tx1-	R Side Rx2-
Rx1(L), Rx1(R) [5,6,7,8]	<b>Tr-10/21/22</b>	L Side Rx1+	R Side Tx1+	L Side Rx1-	R Side Tx1-
Rx1(L), Tx2(R) [5,10,7,12]	<b>Tr-23</b>	L Side Rx1+	R Side Rx2+	L Side Rx1-	R Side Rx2-
Rx1(L), Rx2(R) [5,14,7,16]	<b>Tr-23</b>	L Side Rx1+	R Side Tx2+	L Side Rx1-	R Side Tx2-

Rx1(L), Tx2(L) [5,9,7,11]	Tr-23	L Side Rx1+	L Side Tx2+	L Side Rx1-	L Side Tx2-
Rx1(L), Rx2(L) [5,13,7,15]	Tr-23	L Side Rx1+	L Side Rx2+	L Side Rx1-	L Side Rx2-
Rx1(R), Tx2(L) [6,9,8,11]	Tr-23	R Side Rx1+	L Side Rx2+	R Side Rx1-	L Side Rx2-
Rx1(R), Rx2(L) [6,13,8,15]	Tr-23	R Side Rx1+	L Side Tx2+	R Side Rx1-	L Side Tx2-
Rx1(R), Tx2(R) [6,10,8,12]	Tr-23	R Side Rx1+	R Side Tx2+	R Side Rx1-	R Side Tx2-
Rx1(R), Rx2(R) [6,14,8,16]	Tr-23	R Side Rx1+	R Side Rx2+	R Side Rx1-	R Side Rx2-
Tx2(L), Tx2(R) [9,10,11,12]	Tr-10/ 21/22	L Side Tx2+	R Side Rx2+	L Side Tx2-	R Side Rx2-
Tx2(L), Rx2(R) [9,14,11,16]	Tr-23	L Side Tx2+	R Side Tx2+	L Side Tx2-	R Side Tx2-
Tx2(L), Rx2(L) [9,13,11,15]	Tr-23	L Side Tx2+	L Side Rx2+	L Side Tx2-	L Side Rx2-
Tx2(R), Rx2(L) [10,13,12,15]	Tr-23	R Side Tx2+	L Side Tx2+	R Side Tx2-	L Side Tx2-
Tx2(R), Rx2(R) [10,14,12,16]	Tr-23	R Side Tx2+	R Side Rx2+	R Side Tx2-	R Side Rx2-
Rx2(L), Rx2(R) [13,14,15,16]	Tr-10/ 21/22	L Side Rx2+	R Side Tx2+	L Side Rx2-	R Side Tx2-

Optional

D+/D- Pair and SS Signal Pairs					
Test Path Name	Trace	Port 1	Port 2	Port 3	Port 4
D+/D-(L), Tx1(L) [17,1,19,3]	Tr-24	L Side D+	L Side Tx1+	L Side D-	L Side Tx1-
D+/D-(L), Tx1(R) [17 2 19 4]	Tr-24	L Side D+	R Side Tx1+	L Side D-	R Side Tx1-
D+/D-(L), Rx1(L) [17 5 19 7]	Tr-24	L Side D+	L Side Rx1+	L Side D-	L Side Rx1-
D+/D-(L), Rx1(R) [17 6 19 8]	Tr-24	L Side D+	R Side Rx1+	L Side D-	R Side Rx1-
D+/D-(L), Tx2(L) [17 9 19 11]	Tr-24	L Side D+	L Side Tx2+	L Side D-	L Side Tx2-
D+/D-(L), Tx2(R) [17 10 19 12]	Tr-24	L Side D+	R Side Tx2+	L Side D-	R Side Tx2-
D+/D-(L), Rx2(L) [17 13 19 15]	Tr-24	L Side D+	L Side Rx2+	L Side D-	L Side Rx2-
D+/D-(L), Rx2(R) [17 14 19 16]	Tr-24	L Side D+	R Side Rx2+	L Side D-	R Side Rx2-
D+/D-(R), Tx1(L) [18 1 20 3]	Tr-24	R Side D+	L Side Rx1+	R Side D-	L Side Rx1-
D+/D-(R), Tx1(R) [18 2 20 4]	Tr-24	R Side D+	R Side Tx1+	R Side D-	R Side Tx1-
D+/D-(R), Rx1(L) [18 5 20 7]	Tr-24	R Side D+	L Side Tx1+	R Side D-	L Side Tx1-
D+/D-(R), Rx1(R) [18 6 20 8]	Tr-24	R Side D+	L Side Rx1+	R Side D-	L Side Rx1-
D+/D-(R), Tx2(L) [18 9 20 11]	Tr-24	R Side D+	L Side Rx2+	R Side D-	L Side Rx2-
D+/D-(R), Tx2(R) [18 10 20 12]	Tr-24	R Side D+	R Side Tx2+	R Side D-	R Side Tx2-
D+/D-(R), Rx2(L) [18 13 20 15]	Tr-24	R Side D+	L Side Tx2+	R Side D-	L Side Tx2-
D+/D-(R), Rx2(R) [18 14 20 16]	Tr-24	R Side D+	R Side Rx2+	R Side D-	R Side Rx2-

- After completed the measurement, Press **Cal** > **Fixtures** > **Fixture Setup** > **Port Z...** check “**Enable Port Z Conversion (all ports)**” to turn ON Port Z conversion as default setting.
- Open the Excel spreadsheet “**s4p\_example\_0p91a.xlsx**” and update “file location path” (sp\_file\_1 until sp\_file\_28) with 28-sets 4-port Touchstone files (\*.s4p) you measured.
- Modify the excel spreadsheet “**USB4\_Gen3\_CableCom\_Config\_Example1.xlsx**”. Use “**comp\_check\_type**” = 1, “**case\_number**” = [1] for 4-ports measurements and “**Cable\_Type**” = 0 for passive cable.

USB4 Gen3 Cable Compliance Check Configuration File Example	
comp_check_type	1
result_folder	.\Templates\Results
cable_type	0
eta_0	5.67E-08
save_assembled_cable_sp	0
plot_cable_sp	1
case_number	[1]
case_1	.\Templates\[Touchstone file folder]\s4p_example_1.xlsx
case_2	.\Templates\s8p_example_0p91a.xlsx
case_3	.\Templates\s16p_example_0p91a.xlsx
case_4	.\Templates\s20p_example_0p91a.xlsx

- Launch the USB.org compliance test tool (*Ger\_iPar.exe*) load the excel spreadsheet “**USB4\_Gen3\_CableCom\_Config\_Example1.xlsx**” to execute the COM tool to check compliance for COM pass/fail judgment. The result is show in “**COM\_report.xlsx**” for COM and “**\*cable\_iPar\_report.xlsx**” for Channel metrics result in the results folder.

	A	B	C	D	E	F	G	H	I	J	K	L	M	N
1	Host#	Device#	Cable#	Victim	ILfitatNq	Signal_mV	ISI_mV	Crosstalk	FFE	CTEL Gain	DFE	COM	COM Limit	Pass/Fail
2	3	1	1	s4p_examTx1	-20.8772	61.87996	25.31	6.33	-0.17	0	-8	0.30832	3.989687	3 Pass
3	4	1	1	s4p_examRx1	-21.4691	60.0826	26.54	4.82	-0.17	0	-8	0.33649	3.645231	3 Pass
4	5	1	1	s4p_examTx2	-21.4689	59.94919	27.2	6.42	-0.17	0	-8	0.33765	3.359511	3 Pass
5	6	1	1	s4p_examRx2	-20.9257	61.70371	25.53	5.31	-0.17	0	-8	0.31026	4.07448	3 Pass
6	7	1	2	s4p_examTx1	-16.6616	88.80515	30.77	8.79	-0.17	0	-5	0.2229	5.200366	3 Pass
7	8	1	2	s4p_examRx1	-17.1408	84.14337	28.47	7.41	-0.17	0	-6	0.20325	5.323006	3 Pass
8	9	1	2	s4p_examTx2	-17.2178	83.75694	28.08	8.39	-0.17	0	-6	0.21316	5.267796	3 Pass
9	10	1	2	s4p_examRx2	-16.6715	86.20519	28.65	8.48	-0.17	0	-6	0.18083	5.487671	3 Pass
10	11	2	1	s4p_examTx1	-16.6571	89.13483	29.21	6.41	-0.17	0	-5	0.22868	5.594176	3 Pass
11	12	2	1	s4p_examRx1	-17.244	83.9963	27.46	5.28	-0.17	0	-6	0.21207	5.606285	3 Pass
12	13	2	1	s4p_examTx2	-17.2499	83.74507	27.92	6.83	-0.17	0	-6	0.21779	5.414258	3 Pass
13	14	2	1	s4p_examRx2	-16.6945	86.45531	27.66	5.83	-0.17	0	-6	0.18621	5.799919	3 Pass
14	15	2	2	s4p_examTx1	-12.3989	126.4545	43.83	8.89	-0.17	0	-3	0.12076	5.335026	3 Pass
15	16	2	2	s4p_examRx1	-12.8874	118.9768	33.9	8.33	-0.17	0	-4	0.078314	6.382613	3 Pass
16	17	2	2	s4p_examTx2	-12.9804	118.3529	35.13	9.08	-0.17	0	-4	0.092491	6.07603	3 Pass
17	18	2	2	s4p_examRx2	-12.4028	126.3285	40.69	9.8	-0.17	0	-3	0.11863	5.76909	3 Pass

## 5.7 Differential-to-Common-Mode Conversion

The main purpose of this requirement is to limit the cable assembly EMI emission.

- Connect the VNA ports (port 1 to 4) to the test fixture ports with RF cables.

VNA Port#	Port 1	Port 2	Port 3	Port 4
Test Fixtures	L Side Tx1+	R Side Rx1+	L Side Tx1-	R Side Rx1-

- Select **Trace 10 (Scd21)**.
- Press **Trigger** > Single. Press Double-click on the instrument front panel to enlarge the trace.
- Confirm the measured differential to common mode conversion is less than or equal to -20 dB across the frequency range from 100 MHz to 10 GHz.

Note: The conversion does not require embedding the reference host and the reference device with the mated cable assembly; it is for the mated cable assembly only.

DUT Type	Start Frequency	End Frequency	Start Limit	End Limit
Type-C to Type-C passive cable assembly (USB4 Gen3)	100 MHz	10 GHz	-17.00 dB	-17.00 dB
Type-C to Type-C passive cable assembly (USB3.2 Gen 2 and USB4 Gen 2)	100 MHz	10 GHz	-20.00 dB	-20.00 dB
Type-C to legacy cable assembly	100 MHz	10 GHz	-20.00 dB	-20.00 dB

Type-C to legacy adapter assembly	100 MHz	7.5 GHz	-15.00 dB	-15.00 dB
-----------------------------------	---------	---------	-----------	-----------

- Repeat the same operation of step 3 to step 4 for all the combinations below to confirm the measured differential-to-common-mode conversion is within the specification.

VNA Port#	Port 1	Port 2	Port 3	Port 4
Test Fixtures	L Side Rx1+	R Side Tx1+	L Side Rx1-	R Side Tx1-
	L Side Tx2+	R Side Rx2+	L Side Tx2-	R Side Rx2-
	L Side Rx2+	R Side Tx2+	L Side Rx2-	R Side Tx2-

## 5.8 Cable Shielding Effectiveness

Shielding Effectiveness is checked with a standard compliance tool (IntePar.exe) provided by USB IF after the measurements have made using a shielding effectiveness test fixture. Download the tool from USB-IF link: [http://compliance.usb.org/files/IntePar\\_1p6.zip](http://compliance.usb.org/files/IntePar_1p6.zip) (Released 3-Jan-2021).

4 port Touchstone files (\*.s4p) is measured and saved by the VNA firmware, and then imported by the compliance tool to conduct cable assembly compliance tests. The manual measurement procedure using the ENA Option TDR is also supported with the limit lines.

Note: The Port Z conversion is turned off, so the measurements are performed based on 50-ohm port impedance setting required by the standard tool.

- Connect the VNA ports (port 1 to 3) to the test fixture ports with RF cables.

VNA Port#	Port 1 (SE)	Port 2 (Bal+)	Port 3 (Bal-)
Test Fixtures	SE	Tx1+	Tx1-

- Press **Meas** > Balanced > Topology > SE-BAL
- In the setup table, select Balanced Port > 1 SE = Port 1 (VNA+)
- In the setup table, select Balanced port > 2 BAL = Port 2 (VNA+) & Port 3 (VNA-) as shown below.

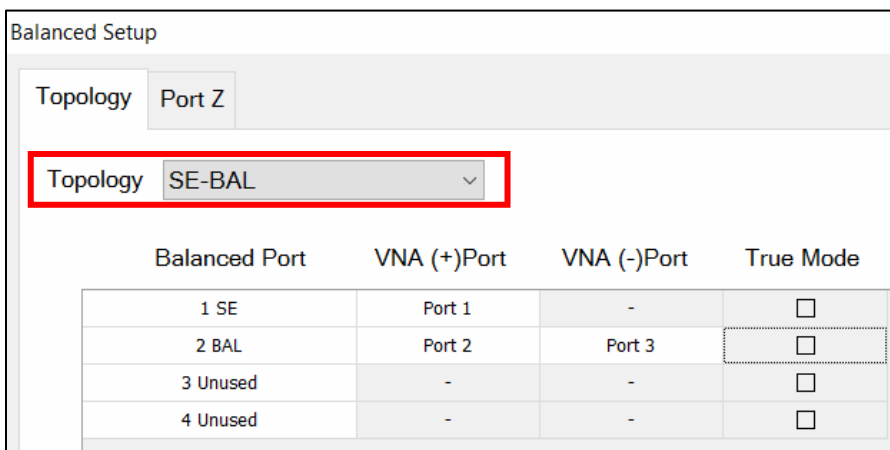

- Select **Cal** > **Fixtures** > **Fixture Setup** > **Port Z...** uncheck “Enable Port Z Conversion (all ports)” to turn OFF Port Z conversion.

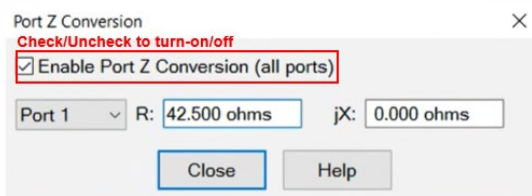

6. Click Adv Waveform tab > De-embedding and turn off De Embedding.

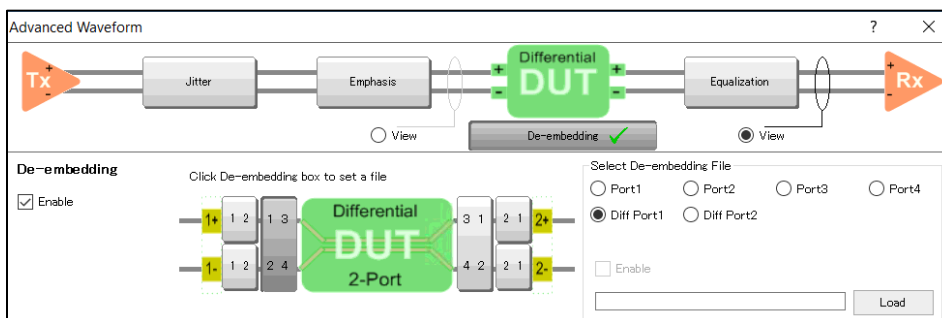

7. Press **Trace Next** to select **Trace 13 (Sds21)**
8. Press **Trigger** > Single.
9. Press **Trace Next** to select **Trace 14 (Scs21)**
10. Press **Meas** > Balanced > Other > Scs21
11. Press **Trigger** > Single
12. Confirm the measured Sds21/Scs21 is within the limits shown below.

#### Differential Model (Sds21)

DUT Type	Start Frequency	End Frequency	Start Limit	End Limit
Type-C to Type-C passive cable assembly	10.0 MHz	1.6 GHz	-55.0 dB	-55.0 dB
	1.6 GHz	4.0 GHz	-50.0 dB	-50.0 dB
	5.0 GHz	6.0 GHz	-50.0 dB	-50.0 dB
Type-C to legacy cable assembly	10.0 MHz	1.6 GHz	-49.0 dB	-49.0 dB
	1.6 GHz	4.0 GHz	-44.0 dB	-44.0 dB
	5.0 GHz	6.0 GHz	-44.0 dB	-44.0 dB
Type-C to legacy adapter assembly	10.0 MHz	1.6 GHz	-44.0 dB	-44.0 dB
	1.6 GHz	4.0 GHz	-39.0 dB	-39.0 dB
	5.0 GHz	6.0 GHz	-39.0 dB	-39.0 dB

#### Common Model (Scs21)

DUT Type	Start Frequency	End Frequency	Start Limit	End Limit
Type-C to Type-C passive cable assembly	10.0 MHz	1.6 GHz	-40.0 dB	-40.0 dB
	1.6 GHz	4.0 GHz	-35.0 dB	-35.0 dB
	5.0 GHz	6.0 GHz	-35.0 dB	-35.0 dB
Type-C to legacy cable assembly	10.0 MHz	1.6 GHz	-34.0 dB	-34.0 dB
	1.6 GHz	4.0 GHz	-29.0 dB	-29.0 dB
	5.0 GHz	6.0 GHz	-29.0 dB	-29.0 dB

Type-C to legacy adapter assembly	10.0 MHz	1.6 GHz	-24.0 dB	-24.0 dB
	1.6 GHz	4.0 GHz	-24.0 dB	-24.0 dB
	5.0 GHz	6.0 GHz	-24.0 dB	-24.0 dB

- Press **Save Recall** > **Save Other** > **Save Data...** > **Filename.s4p** to save the measured Touchstone file (\*.s4p). Select format “Real/Imaginary” and “Normal” mode > then OK.
- Repeat the same operation of step 10 to step 11 for all the following combinations to confirm the measured Sds21/Scs21 is within the specification.

VNA Port#	Port 1 (SE)	Port 2 (Bal+)	Port 3 (Bal-)
Test Fixtures	SE	Rx1+	Rx1-
	SE	Tx2+	Tx2-
	SE	Rx2+	Rx2-

- Launch compliance tool and select “**8. Shielding Effectiveness (Type-C to Type-C)**” for “Select Cable Type”, check “4-Port VNA”. Load 4 port Touchstone file (\*.s4p) by clicking “1>>”, click “Import” to import 4-port Touchstone file (\*.s4p), then click “Check Compliance” for pass/fail judgment.

The screenshot displays the IntePar compliance tool interface. On the left, the configuration panel includes a 'Load Config Spreadsheet' field (1), a 'Select Cable Type' dropdown set to '8. Shielding Effectiveness (Type-C to Type-C)' (2), and '4-Port VNA' checked under 'Select Cable Type and VNA Type' (3). Below this is a table for loading S-Parameter files. At the bottom, the 'Import' (4) and 'Check Compliance' (5) buttons are highlighted. On the right, the 'Raw S-Parameters' plot shows 'Differential mode Coupling, dB' on the y-axis (ranging from -90 to -20) and frequency on the x-axis (ranging from 0.5 to 6 x 10^9 Hz). A red line indicates the specification, and a blue line shows the measured data. Below the plot, a table (6) shows the results: Differential Coupling (3.4dB margin, Pass) and Common Mode Coupling (5.7dB margin, Pass). The 'Pass/Fail' column is highlighted in red.

- Press **Meas** > **Balanced** > **Topology** > **BAL-BAL** to reset the setting.
- In the setup table, select **Balanced Port** > 1 **BAL** = Port 1 (VNA+) & Port 3 (VNA-)
- In the setup table, select **Balanced port** > 2 **BAL** = Port 2 (VNA+) & Port 4 (VNA-) as shown below
- Press **Analysis** > **Fixture Simulator** > **De Embedding** to turn on De Embedding.

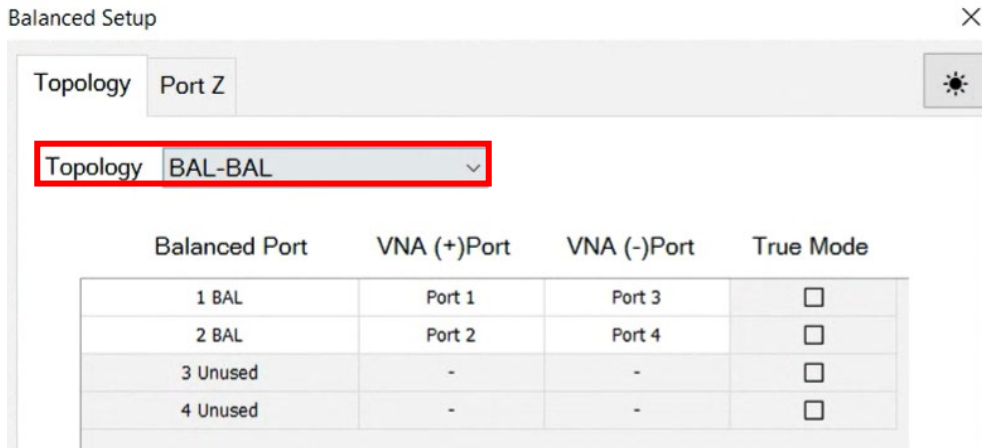

20. After completed the measurement, Press **Cal** > **Fixtures** > **Fixture Setup** > **Port Z...** check “**Enable Port Z Conversion (all ports)**” to turn ON Port Z conversion as default setting.

### Informative Measurements

Informative electrical performance targets are provided for raw cables, mated connectors and mated cable assemblies. These targets are not part of the USB Type-C compliance requirements but provided for the purpose of design guidelines and manufacturing control. For [Raw Cable] and [Mated Connector] measurements, apply the appropriate calibration depending on the test fixture and also set the appropriate port-Z conversion by pressing Channel Next to select Channel 2 frequency domain measurements , then **Cal** > **Fixtures** > **Fixture Setup** > **Port Z...** Set Port Z Conversion (45-ohm for all Port1 /2/3/4 Z0 Real for [Raw Cable] and 42.5-ohm for all Port1/2/3/4 Z0 Real for [Mated Connector]).

### 5.9 [Raw Cable] Differential Impedance (Informative)

1. Connect the VNA ports (port 1 to 4) to the test fixture ports with RF cables.

VNA Port#	Port 1	Port 2	Port 3	Port 4
Test Fixtures	A Side Tx1+	B Side Tx1+	A Side Tx1-	B Side Tx1-

- Press **Channel Next** to select Channel 1
- Select **Trace 2 (Tdd11)**.
- Double-click the Trace to maximize the selected trace on the screen.
- Click Stop Single.
- Confirm the measured impedance is within the limit shown below. Otherwise, it will show Fail.
- Select **Trace 6 (Tdd22)** and repeat Step 4-5 for far-end of the DUT.

DUT Type	Max Limit	Min Limit
Shielded Differential Pair (SDP)	95 $\Omega$	85 $\Omega$
Single-ended coaxial SS+ signal wires	48 $\Omega$	42 $\Omega$

Note: The impedance should be evaluated using a 200ps (10%-90%) rise time.

8. Connect the VNA ports (port 1 to 4) to the test fixture ports with RF cables.

VNA Port#	Port 1	Port 2	Port 3	Port 4
Test Fixtures	A Side Rx1+	B Side Rx1+	A Side Rx1-	B Side Rx1-

- Repeat the same operation of step 3 to step 7 to confirm the measured impedance for Rx pair is within the specification.

### 5.10 [Raw Cable] Intra-Pair Skew (Informative)

- Connect the VNA ports (port 1 to 4) to the test fixture ports with RF cables.

VNA Port#	Port 1	Port 2	Port 3	Port 4
Test Fixtures	A Side Tx1+	B Side Tx1+	A Side Tx1-	B Side Tx1-

- Press Double-click on the instrument front panel to enlarge the trace.
- Select **Trace 3 (T31)**.
- Click **Stop Single**.
- Read the Delta Time and confirm the measured value is within the limit shown below. Otherwise, Fail.

Test Limit
If Delta Time < 10 psec: Pass, else: Fail

Note: The measurement should be evaluated using a 200ps (10%-90%) rise time.

- Connect the VNA ports (port 1 to 4) to the test fixture ports with RF cables.

VNA Port#	Port 1	Port 2	Port 3	Port 4
Test Fixtures	A Side Rx1+	B Side Rx1+	A Side Rx1-	B Side Rx1-

- Repeat the same operation of step 3 to step 5 to confirm the measured skew for Rx pair is within the specification.

### 5.11 [Raw Cable] Differential Insertion Loss (Informative)

- Connect the VNA ports (port 1 to 4) to the test fixture ports with RF cables.

VNA Port#	Port 1	Port 2	Port 3	Port 4
RF Connection	A Side Tx1+	B Side Tx1+	A Side Tx1-	B Side Tx1-

- Press **Channel Next** to select Channel 2.
- Select **Trace 9 (Sdd21)**.
- Press **Trigger** > Single
- Run and confirm the measured value is within the limit shown below. Otherwise, it will show Fail. Change and set the limit according to DUT type. (Refer Manual setup section on Defining limit line).

DUT Type	Start Frequency	End Frequency	Start Limit	End Limit
Twisted Pair Construction (34AWG)	625 MHz	1.25 GHz	-1.8 dB	-2.5 dB
	1.25 GHz	2.50 GHz	-2.5 dB	-3.7 dB
	2.50 GHz	5.00 GHz	-3.7 dB	-5.5 dB
	5.00 GHz	7.50 GHz	-5.5 dB	-7.0 dB
	7.50 GHz	10.00 GHz	-7.0 dB	-8.4 dB
	10.00 GHz	12.50 GHz	-8.4 dB	-9.5 dB
	12.50 GHz	15.00 GHz	-9.5 dB	-11.0 dB
Coaxial Construction (34 AWG)	625 MHz	1.25 GHz	-1.8 dB	-2.8 dB

	1.25 GHz	2.50 GHz	-2.8 dB	-4.2 dB
	2.50 GHz	5.00 GHz	-4.2 dB	-6.1 dB
	5.00 GHz	7.50 GHz	-6.1 dB	-7.6 dB
	7.50 GHz	10.00 GHz	-7.6 dB	-8.8 dB
	10.00 GHz	12.50 GHz	-8.8 dB	-9.9 dB
	12.50 GHz	15.00 GHz	-9.9 dB	-12.1 dB

Note: The limit is based on 34 AWG conductor size. Change and set the test limit based on DUT type limit below (34AWG/32AWG/30AWG/28AWG) as stated in USB Type-C CTS.

**Table 3-21 Differential Insertion Loss Examples for TX/RX with Twisted Pair Construction**

Frequency	34AWG	32AWG	30AWG	28AWG
0.625 GHz	-1.8 dB/m	-1.4 dB/m	-1.2 dB/m	-1.0 dB/m
1.25 GHz	-2.5 dB/m	-2.0 dB/m	-1.7 dB/m	-1.4 dB/m
2.50 GHz	-3.7 dB/m	-2.9 dB/m	-2.5 dB/m	-2.1 dB/m
5.00 GHz	-5.5 dB/m	-4.5 dB/m	-3.9 dB/m	-3.1 dB/m
7.50 GHz	-7.0 dB/m	-5.9 dB/m	-5.0 dB/m	-4.1 dB/m
10.00 GHz	-8.4 dB/m	-7.2 dB/m	-6.1 dB/m	-4.8 dB/m
12.50 GHz	-9.5 dB/m	-8.2 dB/m	-7.3 dB/m	-5.5 dB/m
15.00 GHz	-11.0 dB/m	-9.5 dB/m	-8.7 dB/m	-6.5 dB/m

**Table 3-22 Differential Insertion Loss Examples for USB TX/RX with Coaxial Construction**

Frequency	34AWG	32AWG	30AWG	28AWG
0.625 GHz	-1.8 dB/m	-1.5 dB/m	-1.2 dB/m	-1.0 dB/m
1.25 GHz	-2.8 dB/m	-2.2 dB/m	-1.8 dB/m	-1.3 dB/m
2.50 GHz	-4.2 dB/m	-3.4 dB/m	-2.7 dB/m	-1.9 dB/m
5.00 GHz	-6.1 dB/m	-4.9 dB/m	-4.0 dB/m	-3.1 dB/m
7.50 GHz	-7.6 dB/m	-6.5 dB/m	-5.2 dB/m	-4.2 dB/m
10.0 GHz	-8.8 dB/m	-7.6 dB/m	-6.1 dB/m	-4.9 dB/m
12.5 GHz	-9.9 dB/m	-8.6 dB/m	-7.1 dB/m	-5.7 dB/m
15.0 GHz	-12.1 dB/m	-10.9 dB/m	-9.0 dB/m	-6.5 dB/m

6. Connect the VNA ports (port 1 to 4) to the test fixture ports with RF cables.

VNA Port#	Port 1	Port 2	Port 3	Port 4
RF Connection	A Side Rx1+	B Side Rx1+	A Side Rx1-	B Side Rx1-

7. Repeat the same operation of step 3 to step 5 to confirm the measured insertion loss is within the specification.

## 5.12 [Mated Connector] Differential Impedance (Informative)

1. Connect the VNA ports (port 1 to 4) to the test fixture ports with RF cables.

VNA Port#	Port 1	Port 2	Port 3	Port 4
Test Fixtures	TF1 Tx1+	TF2 Tx1+	TF1 Tx1-	TF2 Tx1-

2. Press **Channel Next** to select Channel 1
3. Select **Trace 15 (Tdd11)**. Change and set the limit according to table below (Refer Manual setup section on Defining limit line).
4. Double-click the Trace to maximize the selected trace on the screen.
5. Click Stop Single.
6. Confirm the measured impedance is within the limit shown below. Otherwise, it will show Fail.
7. Select **Trace 16 (Tdd22)**. Repeat Step 4-5 for far-end of the DUT.

DUT Type	Max Limit	Min Limit
Mated connector – USB 3.2 Gen2 and USB4 Gen2	94 $\Omega$	76 $\Omega$

Note: The impedance should be evaluated using a 40ps (20%-80%) rise time.

8. Repeat the same operation of step 3 to step 7 to confirm the measured impedance for following combinations are within the specification.

VNA Port#	Port 1	Port 2	Port 3	Port 4
Test Fixtures	TF1 Rx1+	TF2 Rx1+	TF1 Rx1-	TF2 Rx1-
	TF1 Tx2+	TF2 Tx2+	TF1 Tx2-	TF2 Tx2-
	TF1 Rx2+	TF2 Rx2+	TF1 Rx2-	TF2 Rx2-

## 5.13 [Mated Connector] Channel Metrics (ILfitatNq, IMR, IXT, IRL, Differential-to-Common-Mode Conversion) - Normative for USB4 Gen3 only

Channel metrics or Signal Integrity Characteristic - ILfitatNq, IMR, IXT, IRL, Differential-to-Common-Mode Conversion is checked with a standard compliance tool (**Ger\_iPar.exe**) provided by USB IF after the measurements have made. The same tool is use for USB4 Gen3 COM test. Download the tool from USB-IF link: [https://compliance.usb.org/files/Ger\\_iPar\\_v0p91a\\_release.zip](https://compliance.usb.org/files/Ger_iPar_v0p91a_release.zip) (Released 7-Dec-2020).

4-port Touchstone files (\*.s4p) is measured and saved by the VNA firmware, and then imported by the compliance tool to conduct cable assembly compliance tests. It required full S-parameters for High-speed TX/RX pairs (28-sets) + D+/D- Pairs (16-sets) to run the compliance tool.

Note: The Port Z conversion is turned off, so the measurements are performed based on 50-ohm port impedance setting required by the standard tool. Select **Cal > Fixtures > Fixture Setup > Port Z...** uncheck **“Enable Port Z Conversion (all ports)”** to turn OFF Port Z conversion.

1. Connect the VNA ports (port 1 to 4) to the test fixture ports with RF cables.
2. Select **Cal > Fixtures > Fixture Setup > Port Z...** uncheck **“Enable Port Z Conversion (all ports)”** to turn OFF Port Z conversion.

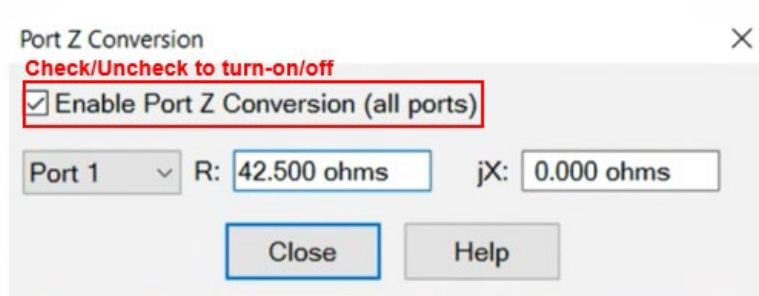

3. Press **Channel Next** to select Channel 2.
4. The same connection can use for below measurement for Pass/Fail testing. Select the desired trace as described to check the limit line and the pass/fail judgment. Press Double-click on the instrument front panel to enlarge the trace.
  - 5.14: [Mated Connector] Differential Insertion Loss (**Trace 12**)
  - 5.15: [Mated Connector] Differential Return Loss (**Trace 17**)
  - 5.16: [Mated Connector] Differential NEXT and FEXT between SS Signal Pair (**Trace 18**)
  - 5.17: [Mated Connector] Differential NEXT and FEXT between D+/D- Pair and SS Signal Pairs (**Trace 19**)
  - 5.18: [Mated Connector] Differential to Common Mode Conversion (**Trace 20**)
5. Press **Trigger** > Single.
6. Press **Save Recall** > **Save Other** > **Save Data...** > **Filename.s4p** to save the measured Touchstone file (\*.s4p). Select format "Real/Imaginary" and "Normal" mode > then OK.
7. Connect the VNA ports with test fixture ports shown below and repeat step 3 to step 6 to save all necessary Touchstone files (\*.s4p) for VNA.

High-Speed TX/RX (SS Signal) Pair					
Test Path Name	Trace	Port 1	Port 2	Port 3	Port 4
Tx1(L), Tx1(R) [1,2,3,4]	<b>Tr-12/17/20</b>	TF1 Tx1+	TF2 Tx1+	TF1 Tx1-	TF2 Tx1-
Tx1(L), Rx1(R) [1,6,3,8]	<b>Tr-18</b>	TF1 Tx1+	TF2 Rx1+	TF1 Tx1-	TF2 Rx1-
Tx1(L), Tx2(R) [1,10,3,12]	<b>Tr-18</b>	TF1 Tx1+	TF2 Tx2+	TF1 Tx1-	TF2 Tx2-
Tx1(L), Rx2(R) [1,14,3,16]	<b>Tr-18</b>	TF1 Tx1+	TF2 Rx2+	TF1 Tx1-	TF2 Rx2-
Tx1(L), Rx1(L) [1,5,3,7]	<b>Tr-18</b>	TF1 Tx1+	TF1 Rx1+	TF1 Tx1-	TF1 Rx1-
Tx1(L), Tx2(L) [1,9,3,11]	<b>Tr-18</b>	TF1 Tx1+	TF1 Tx2+	TF1 Tx1-	TF1 Tx2-
Tx1(L), Rx2(L) [1,13,3,15]	<b>Tr-18</b>	TF1 Tx1+	TF1 Rx2+	TF1Tx1-	TF1Rx2-
Tx1(R), Rx1(L) [2,5,4,7]	<b>Tr-18</b>	TF2 Tx1+	TF1 Tx1+	TF2 Tx1-	TF1Tx1-
Tx1(R), Tx2(L) [2,9,4,11]	<b>Tr-18</b>	TF2 Tx1+	TF1 Rx2+	TF2 Tx1-	TF1 Rx2-
Tx1(R), Rx2(L) [2,13,4,15]	<b>Tr-18</b>	TF2 Tx1+	TF1 Tx2+	TF2 Tx1-	TF1 Tx2-
Tx1(R), Rx1(R) [2,6,4,8]	<b>Tr-18</b>	TF2 Tx1+	TF2 Rx1+	TF2 Tx1-	TF2 Rx1-
Tx1(R), Tx2(R) [2,10,4,12]	<b>Tr-18</b>	TF2 Tx1+	TF2 Tx2+	TF2 Tx1-	TF2 Tx2-
Tx1(R), Rx2(R) [2,14,4,16]	<b>Tr-18</b>	TF2 Tx1+	TF2 Rx2+	TF2 Tx1-	TF2 Rx2-
Rx1(L), Rx1(R) [5,6,7,8]	<b>Tr-12/17/20</b>	TF1 Rx1+	TF2 Rx1+	TF1 Rx1-	TF2 Rx1-
Rx1(L), Tx2(R) [5,10,7,12]	<b>Tr-18</b>	TF1 Rx1+	TF2 Tx2+	TF1 Rx1-	TF2 Tx2-

Rx1(L), Rx2(R) [5,14,7,16]	Tr-18	TF1 Rx1+	TF2 Rx2+	TF1 Rx1-	TF2 Rx2-
Rx1(L), Tx2(L) [5,9,7,11]	Tr-18	TF1 Rx1+	TF1 Tx2+	TF1 Rx1-	TF1 Tx2-
Rx1(L), Rx2(L) [5,13,7,15]	Tr-18	TF1 Rx1+	TF1Rx2+	TF1 Rx1-	TF1 Rx2-
Rx1(R), Tx2(L) [6,9,8,11]	Tr-18	TF2 Rx1+	TF1 Tx2+	TF2 Rx1-	TF1 Tx2-
Rx1(R), Rx2(L) [6,13,8,15]	Tr-18	TF2 Rx1+	TF1 Rx2+	TF2 Rx1-	TF1 Rx2-
Rx1(R), Tx2(R) [6,10,8,12]	Tr-18	TF2 Rx1+	TF2 Tx2+	TF2 Rx1-	TF2 Tx2-
Rx1(R), Rx2(R) [6,14,8,16]	Tr-18	TF2 Rx1+	TF2 Rx2+	TF2 Rx1-	TF2 Rx2-
Tx2(L), Tx2(R) [9,10,11,12]	Tr-12/ 17/20	TF1 Tx2+	TF2 Tx2+	TF1 Tx2-	TF2 Tx2-
Tx2(L), Rx2(R) [9,14,11,16]	Tr-18	TF1 Tx2+	TF2 Rx2+	TF1 Tx2-	TF2 Rx2-
Tx2(L), Rx2(L) [9,13,11,15]	Tr-18	TF1 Tx2+	TF1 Rx2+	TF1 Tx2-	TF1 Rx2-
Tx2(R), Rx2(L) [10,13,12,15]	Tr-18	TF2 Tx2+	TF1 Rx2+	TF2 Tx2-	TF1 Rx2-
Tx2(R), Rx2(R) [10,14,12,16]	Tr-18	TF2 Tx2+	TF2 Rx2+	TF2 Tx2-	TF2 Rx2-
Rx2(L), Rx2(R) [13,14,15,16]	Tr-12/ 17/20	TF1 Rx2+	TF2 Rx2+	TF1 Rx2-	TF2 Rx2-

D+/D- Pair and SS Signal Pairs					
Test Path Name	Trace	Port 1	Port 2	Port 3	Port 4
D+/D-(L), Tx1(L) [17,1,19,3]	Tr-19	TF1 D+	TF1 Tx1+	TF1 D-	TF1 Tx1-
D+/D-(L), Tx1(R) [17 2 19 4]	Tr-19	TF1 D+	TF2 Tx1+	TF1 D-	TF2 Tx1-
D+/D-(L), Rx1(L) [17 5 19 7]	Tr-19	TF1 D+	TF1 Rx1+	TF1 D-	TF1 Rx1-
D+/D-(L), Rx1(R) [17 6 19 8]	Tr-19	TF1 D+	TF2 Rx1+	TF1 D-	TF2 Rx1-
D+/D-(L), Tx2(L) [17 9 19 11]	Tr-19	TF1 D+	TF1 Tx2+	TF1 D-	TF1 Tx2-
D+/D-(L), Tx2(R) [17 10 19 12]	Tr-19	TF1 D+	TF2 Tx2+	TF1 D-	TF2 Tx2-
D+/D-(L), Rx2(L) [17 13 19 15]	Tr-19	TF1 D+	TF1 Rx2+	TF1 D-	TF1 Rx2-
D+/D-(L), Rx2(R) [17 14 19 16]	Tr-19	TF1 D+	TF2 Rx2+	TF1 D-	TF2 Rx2-
D+/D-(R), Tx1(L) [18 1 20 3]	Tr-19	TF2 D+	TF1 Rx1+	TF2 D-	TF1 Rx1-
D+/D-(R), Tx1(R) [18 2 20 4]	Tr-19	TF2 D+	TF2 Tx1+	TF2 D-	TF2 Tx1-
D+/D-(R), Rx1(L) [18 5 20 7]	Tr-19	TF2 D+	TF1 Tx1+	TF2 D-	TF1 Tx1-
D+/D-(R), Rx1(R) [18 6 20 8]	Tr-19	TF2 D+	TF1 Rx1+	TF2 D-	TF1 Rx1-
D+/D-(R), Tx2(L) [18 9 20 11]	Tr-19	TF2 D+	TF1 Rx2+	TF2 D-	TF1 Rx2-
D+/D-(R), Tx2(R) [18 10 20 12]	Tr-19	TF2 D+	TF2 Tx2+	TF2 D-	TF2 Tx2-
D+/D-(R), Rx2(L) [18 13 20 15]	Tr-19	TF2 D+	TF1 Tx2+	TF2 D-	TF1 Tx2-
D+/D-(R), Rx2(R) [18 14 20 16]	Tr-19	TF2 D+	TF2 Rx2+	TF2 D-	TF2 Rx2-

- After completed the measurement, Press **Cal** > **Fixtures** > **Fixture Setup** > **Port Z...** check **“Enable Port Z Conversion (all ports)”** to turn ON Port Z conversion as default setting.
- Open the Excel spreadsheet **“s4p\_example\_0p91a.xlsx”** and update “file location path” (sp\_file\_1 until sp\_file\_28) with 28-sets 4-port Touchstone files (\*.s4p) you measured.
- Modify the excel spreadsheet **“USB4\_Gen3\_CableCom\_Config\_Example1.xlsx”**. Use **“Comp\_check\_type”** = 4 for connector, **“Cable\_Type”** = 0 for passive cable and **“case\_number”** = [1] for 4-ports measurements.

USB4 Gen3 Cable Compliance Check Configuration File Example	
comp_check_type	4
result_folder	.\Templates\Results
cable_type	0
eta_0	5.67E-08
save_assembled_cable_sp	0
plot_cable_sp	1
case_number	[1]
case_1	.\Templates\[Touchstone File Folder]\s4p_example_1.xlsx
case_2	.\Templates\s8p_example_0p91a.xlsx
case_3	.\Templates\s16p_example_0p91a.xlsx
case_4	.\Templates\s20p_example_0p91a.xlsx

- Launch the USB.org compliance test tool (*Ger\_iPar.exe*), load the excel spreadsheet “**USB4\_Gen3\_CableCom\_Config\_Example1.xlsx**” to execute the compliance tool to check compliance for pass/fail judgment. The result is show in “**\*cable\_iPar\_report.xlsx**” for Channel metrics result in the results folder.

Active cable	TX1(L)	TX1(R)	RX1(L)	RX1(R)	TX2(L)	TX2(R)	RX2(L)	RX2(R)	Limit	Pass/Fail
ILfit@0.1GHz, dB	-0.51	-0.51	-0.5	-0.5	-0.5	-0.5	-0.53	-0.53	-1	Pass
ILfit@2.5GHz, dB	-2.84	-2.84	-2.81	-2.81	-2.83	-2.83	-2.88	-2.88	-4.2	Pass
ILfit@5GHz, dB	-3.96	-3.96	-3.99	-3.99	-3.98	-3.98	-4.09	-4.09	-6	Pass
ILfit@10GHz, dB	-5.94	-5.94	-6.11	-6.11	-5.88	-5.88	-6.09	-6.09	-7.5	Pass
ILfit@12.5GHz, dB	-7.15	-7.15	-7.34	-7.34	-6.96	-6.96	-7.24	-7.24	-9.3	Pass
ILfit@15GHz, dB	-8.62	-8.62	-8.76	-8.76	-8.23	-8.23	-8.58	-8.58	-11	Pass
IMR, dB	-43.59	-43.59	-41.93	-41.93	-40.99	-40.99	-41.76	-41.76	-32.38	Pass
IRL, dB	-20.03	-20.03	-19.97	-19.97	-19.15	-19.15	-19.39	-19.39	-14.88	Pass
C2D, dB	-33.3	-33.25	-24.56	-24	-28.88	-27.9	-22.97	-21.9	-17	Pass
D2C, dB	-32.82	-33.24	-23.05	-24.32	-28.99	-28.09	-22.85	-22.08	-17	Pass
I <sub>XT</sub> _DP, dB	-49.39	-49.03	-49.25	-49.29	-49.6	-49.85	-49.62	-49.73	-40.11	Pass
I <sub>XT</sub> _USB, dB	-50.7	-48.85	-49.74	-48.93	-49.77	-49.27	-50.76	-49.2	-40.21	Pass
Detailed crosstalk between each pair in dB										
Vic/Agg Port	TX1(L)	TX1(R)	RX1(L)	RX1(R)	TX2(L)	TX2(R)	RX2(L)	RX2(R)		
TX1(L)			-52.3	-50.44	-58.46	-59.12	-58.55	-59.01		
TX1(R)			-50.49	-50.56	-58.38	-57.33	-56.75	-55.55		
RX1(L)	-52.3	-50.49			-54.75	-58.03	-56.73	-58.57		
RX1(R)	-50.44	-50.56			-58.21	-55.59	-59.07	-55.39		
TX2(L)	-58.46	-58.38	-54.75	-58.21			-52.4	-50.97		
TX2(R)	-59.12	-57.33	-58.03	-55.59			-51.22	-51.05		
RX2(L)	-58.55	-56.75	-56.73	-59.07	-52.4	-51.22				
RX2(R)	-59.01	-55.55	-58.57	-55.39	-50.97	-51.05				

## 5.14 [Mated Connector] Differential Insertion Loss (Informative)

- Connect the VNA ports (port 1 to 4) to the test fixture ports with RF cables.

VNA Port#	Port 1	Port 2	Port 3	Port 4
Test Fixtures	TF1 Tx1+	TF2 Tx1+	TF1 Tx1-	TF2 Tx1-

- 6 Press Channel Next to select Channel 2.
- 7 Select **Trace 12 (Sdd21)**.
- 8 Press **Trigger** > Single
- 9 Run and confirm the measured value is within the limit shown below. Otherwise, it will show Fail.

Start Frequency	End Frequency	Start Limit	End Limit
100 MHz	2.50 GHz	-0.6 dB	-0.6 dB
2.50 GHz	5.00 GHz	-0.6 dB	-0.8 dB
5.00 GHz	10.00 GHz	-0.8 dB	-1.0 dB
10.00 GHz	12.50 GHz	-1.0 dB	-1.25 dB
12.50 GHz	15.00 GHz	-1.25 dB	-1.50 dB

- 10 Connect the VNA ports (port 1 to 4) to the test fixture ports with RF cables. Repeat the same operation of step 3 to step 5 to confirm the measured values are within the specification.

VNA Port#	Port 1	Port 2	Port 3	Port 4
Test Fixtures	TF1 Rx1+	TF2 Rx1+	TF1 Rx1-	TF2 Rx1-
	TF1 Tx2+	TF2 Tx2+	TF1 Tx2-	TF2 Tx2-
	TF1 Rx2+	TF2 Rx2+	TF1 Rx2-	TF2 Rx2-

### 5.15 [Mated Connector] Differential Return Loss (Informative)

1. Connect the VNA ports (port 1 to 4) to the test fixture ports with RF cables.

VNA Port#	Port 1	Port 2	Port 3	Port 4
Test Fixtures	TF1 Tx1+	TF2 Tx1+	TF1 Tx1-	TF2 Tx1-

2. Press Channel Next to select Channel 2.
3. Select **Trace 17 (Sdd11)**.
4. Press **Trigger** > Single
5. Run and confirm the measured value is within the limit shown below. Otherwise, it will show Fail.

Start Frequency	End Frequency	Start Limit	End Limit
100 MHz	5 GHz	-20 dB	-20 dB
5 GHz	10 GHz	-20 dB	-13 dB
10 GHz	15 GHz	-13 dB	-6 dB

6. Connect the VNA ports (port 1 to 4) to the test fixture ports with RF cables. Repeat the same operation of step 3 to step 5 to confirm the measured values are within the specification.

VNA Port#	Port 1	Port 2	Port 3	Port 4
Test Fixtures	TF1 Rx1+	TF2 Rx1+	TF1 Rx1-	TF2 Rx1-
	TF1 Tx2+	TF2 Tx2+	TF1 Tx2-	TF2 Tx2-
	TF1 Rx2+	TF2 Rx2+	TF1 Rx2-	TF2 Rx2-

### 5.16 [Mated Connector] Differential NEXT & FEXT between SS Signal Pairs (Informative)

1. Connect the VNA ports (port 1 to 4) to the test fixture ports with RF cables.

VNA Port#	Port 1	Port 2	Port 3	Port 4
Test Fixtures	TF1 Tx1+	TF1 Rx1+	TF1 Tx1-	TF1 Rx1-

2. Press **Channel Next** to select Channel 2.

3. Select **Trace 18 (Sdd21)**.
4. Press **Trigger** > Single
5. Run and confirm the measured differential crosstalk is within limit below. Otherwise, it will show Fail.

Start Frequency	End Frequency	Start Limit	End Limit
100 MHz	5 GHz	-40 dB	-40 dB
5 GHz	10 GHz	-40 dB	-36 dB
10 GHz	15 GHz	-36 dB	-30 dB

6. Connect the VNA ports (port 1 to 4) to the test fixture ports with RF cables. Repeat the same operation of step 3 to step 5 to confirm the measured value is within the specification.

VNA Port#	Port 1	Port 2	Port 3	Port 4
Test Fixtures	TF1 Tx1+	TF2 Tx2+	TF1 Tx1-	TF2 Tx2-
	TF1 Tx1+	TF2 Rx2+	TF1 Tx1-	TF2 Rx2-
	TF1 Tx1+	TF1 Rx1+	TF1 Tx1-	TF1 Rx1-
	TF1 Tx1+	TF1 Tx2+	TF1 Tx1-	TF1 Tx2-
	TF1 Tx1+	TF1 Rx2+	TF1Tx1-	TF1Rx2-
	TF2 Tx1+	TF1 Tx1+	TF2 Tx1-	TF1Tx1-
	TF2 Tx1+	TF1 Rx2+	TF2 Tx1-	TF1 Rx2-
	TF2 Tx1+	TF1 Tx2+	TF2 Tx1-	TF1 Tx2-
	TF2 Tx1+	TF2 Rx1+	TF2 Tx1-	TF2 Rx1-
	TF2 Tx1+	TF2 Tx2+	TF2 Tx1-	TF2 Tx2-
	TF2 Tx1+	TF2 Rx2+	TF2 Tx1-	TF2 Rx2-
	TF1 Rx1+	TF2 Tx2+	TF1 Rx1-	TF2 Tx2-
	TF1 Rx1+	TF2 Rx2+	TF1 Rx1-	TF2 Rx2-
	TF1 Rx1+	TF1 Tx2+	TF1 Rx1-	TF1 Tx2-
	TF1 Rx1+	TF1Rx2+	TF1 Rx1-	TF1 Rx2-
	TF2 Rx1+	TF1 Tx2+	TF2 Rx1-	TF1 Tx2-
	TF2 Rx1+	TF1 Rx2+	TF2 Rx1-	TF1 Rx2-
	TF2 Rx1+	TF2 Tx2+	TF2 Rx1-	TF2 Tx2-
	TF2 Rx1+	TF2 Rx2+	TF2 Rx1-	TF2 Rx2-
	TF1 Tx2+	TF2 Rx2+	TF1 Tx2-	TF2 Rx2-
	TF1 Tx2+	TF1 Rx2+	TF1 Tx2-	TF1 Rx2-
	TF2 Tx2+	TF1 Rx2+	TF2 Tx2-	TF1 Rx2-
	TF2 Tx2+	TF2 Rx2+	TF2 Tx2-	TF2 Rx2-

### 5.17 [Mated Connector] Differential NEXT and FEXT between D+/D- Pair and SS Signal Pairs (Normative for USB4 Gen3)

(Informative for USB4 Gen2 and USB3.2 Gen2)

1. Connect the VNA ports (port 1 to 4) to the test fixture ports with RF cables.

VNA Port#	Port 1	Port 2	Port 3	Port 4
Test Fixture	TF1 D+	TF1 Tx1+	TF1 D-	TF1 Tx1-

2. Press **Channel Next** to select Channel 2.
3. Select **Trace 19 (Sdd21)**.
4. Press **Trigger** > Single
5. Run and confirm the measured differential crosstalk is less than or equal to -30dB up to 5GHz. Otherwise, it will show Fail.

DUT Type	Start Frequency	End Frequency	Start Limit	End Limit
USB4 Gen 3	100 MHz	5 GHz	-50 dB	-50 dB
	5 GHz	7.5 GHz	-50 dB	-50 dB
USB3.2 Gen 2 and USB4 Gen 2	100 MHz	5 GHz	-40 dB	-40 dB
	5 GHz	7.5 GHz	-40 dB	-36 dB

6. Repeat the same operation of step 3 to step 5 for all the following combinations to confirm the measured crosstalk is within the specification.

VNA Port#	Port 1	Port 2	Port 3	Port 4
Test Fixtures	TF1 D+	TF2 Tx1+	TF1 D-	TF2 Tx1-
	TF1 D+	TF1 Rx1+	TF1 D-	TF1 Rx1-
	TF1 D+	TF2 Rx1+	TF1 D-	TF2 Rx1-
	TF1 D+	TF1 Tx2+	TF1 D-	TF1 Tx2-
	TF1 D+	TF2 Tx2+	TF1 D-	TF2 Tx2-
	TF1 D+	TF1 Rx2+	TF1 D-	TF1 Rx2-
	TF1 D+	TF2 Rx2+	TF1 D-	TF2 Rx2-
	TF2 D+	TF1 Rx1+	TF2 D-	TF1 Rx1-
	TF2 D+	TF2 Tx1+	TF2 D-	TF2 Tx1-
	TF2 D+	TF1 Tx1+	TF2 D-	TF1 Tx1-
	TF2 D+	TF1 Rx1+	TF2 D-	TF1 Rx1-
	TF2 D+	TF1 Rx2+	TF2 D-	TF1 Rx2-
	TF2 D+	TF2 Tx2+	TF2 D-	TF2 Tx2-
	TF2 D+	TF1 Tx2+	TF2 D-	TF1 Tx2-
	TF2 D+	TF2 Rx2+	TF2 D-	TF2 Rx2-

### 5.18 [Mated Connector] Differential to Common-Mode Conversion (Normative for USB4 Gen3)

(Informative for USB4 Gen2 and USB3.2 Gen2)

1. Connect the VNA ports (port 1 to 4) to the test fixture ports with RF cables.

VNA Port#	Port 1	Port 2	Port 3	Port 4
Test Fixtures	TF1 Tx1+	TF2 Tx1+	TF1 Tx1-	TF2 Tx1-

7. Press Channel Next to select Channel 2.  
8. Select **Trace 20 (Scd21)**.  
9. Press **Trigger** > Single.  
10. Run and confirm the measured value is within the limit shown below. Otherwise, it will show Fail.

DUT Type	Start Frequency	End Frequency	Start Limit	End Limit
USB4 Gen 3	100 MHz	10 GHz	-20 dB	-20 dB
USB3.2 Gen 2 and USB4 Gen 2	100 MHz	2.5 GHz	-30 dB	-30 dB
	2.5 GHz	7.5 GHz	-25 dB	-25 dB
	7.5 GHz	10 GHz	-20 dB	-20 dB

11. Repeat the same operation of step 3 to step 5 to confirm the measured values are within the specification.

VNA Port#	Port 1	Port 2	Port 3	Port 4
Test Fixtures	TF1 Rx1+	TF2 Rx1+	TF1 Rx1-	TF2 Rx1-
	TF1 Tx2+	TF2 Tx2+	TF1 Tx2-	TF2 Tx2-
	TF1 Rx2+	TF2 Rx2+	TF1 Rx2-	TF2 Rx2-

## 5.19 Differential Insertion Loss (Informative)

1. Connect the VNA ports (port 1 to 4) to the test fixture ports with RF cables.

VNA Port#	Port 1	Port 2	Port 3	Port 4
Test Fixtures	L Side Tx1+	R Side Rx1+	L Side Tx1-	R Side Rx1-

2. Press Channel Next to select Channel 2.
3. Select **Trace 21 (Sdd21)**.
4. Press **Trigger** > Single
5. Run and confirm the measured value is within the limit shown below. Otherwise, it will show Fail.

**Note:** The limit setting in state file is based on USB3.2 Gen 2 and USB4 Gen 2 Pairs. Change and set the test limit based on your DUT type in Table below. Refer Manual setup procedure on how to change the limit line. Go to Math> Analysis > Limit Table > to edit the limit table.

DUT Type	Start Frequency	End Frequency	Start Limit	End Limit
USB4 Gen 3	100 MHz	2.5 GHz	-1.0 dB	-4.2 dB
	2.5 GHz	5.0 GHz	-4.2 dB	-6.0 dB
	5.0 GHz	10.0 GHz	-6.0 dB	-7.5 dB
	10.0 GHz	12.0 GHz	-7.5 dB	-9.3 dB
	12.0 GHz	15.0 GHz	-9.3 dB	-11.0 dB
USB3.2 Gen 2 and USB4 Gen 2	100 MHz	2.5 GHz	-2.0 dB	-4.0 dB
	2.5 GHz	5.0 GHz	-4.0 dB	-6.0 dB
	5.0 GHz	10.0 GHz	-6.0 dB	-11.0 dB
	10.0 GHz	15.0 GHz	-11.0 dB	-20.0 dB

6. Connect the VNA ports (port 1 to 4) to the test fixture ports with RF cables. Repeat the same operation of step 3 to step 5 to confirm the measured values are within the specification.

VNA Port#	Port 1	Port 2	Port 3	Port 4
Test Fixtures	L Side Rx1+	R Side Tx1+	L Side Rx1-	R Side Tx1-
	L Side Tx2+	R Side Rx2+	L Side Tx2-	R Side Rx2-
	L Side Rx2+	R Side Tx2+	L Side Rx2-	R Side Tx2-

## 5.20 Differential Return Loss (Informative)

1. Connect the VNA ports (port 1 to 4) to the test fixture ports with RF cables.

VNA Port#	Port 1	Port 2	Port 3	Port 4
Test Fixtures	L Side Tx1+	R Side Rx1+	L Side Tx1-	R Side Rx1-

2. Press Channel Next to select Channel 2.
3. Select **Trace 22 (Sdd11)**.
4. Press **Trigger** > Single
5. Run and confirm the measured value is within the limit shown below. Otherwise, it will show Fail.

DUT Type	Start Frequency	End Frequency	Start Limit	End Limit
All Type (USB4 Gen 3, USB4 Gen 2 and USB3.2 Gen 2)	100 MHz	5.0 GHz	-18.0 dB	-18.0 dB
	5.0 GHz	7.5 GHz	-18.0 dB	-10.0 dB
	7.5 GHz	10.0 GHz	-10.0 dB	-8.0 dB
	10.0 GHz	15.0 GHz	-8.0 dB	-5.0 dB

- Connect the VNA ports (port 1 to 4) to the test fixture ports with RF cables. Repeat the same operation of step 3 to step 5 to confirm the measured values are within the specification.

VNA Port#	Port 1	Port 2	Port 3	Port 4
Test Fixtures	L Side Rx1+	R Side Tx1+	L Side Rx1-	R Side Tx1-
	L Side Tx2+	R Side Rx2+	L Side Tx2-	R Side Rx2-
	L Side Rx2+	R Side Tx2+	L Side Rx2-	R Side Tx2-

## 5.21 Differential NEXT & FEXT between SS Signal Pairs (Informative)

- Connect the VNA ports (port 1 to 4) to the test fixture ports with RF cables.

VNA Port#	Port 1	Port 2	Port 3	Port 4
Test Fixtures	L Side Tx1+	R Side Tx1+	L Side Tx1-	R Side Tx1-

- Press **Channel Next** to select Channel 2.
- Select **Trace 23 (Sdd21)**.
- Press **Trigger** > Single
- Run and confirm the measured differential crosstalk is within limit below. Otherwise, it will show Fail.

DUT Type	Start Frequency	End Frequency	Start Limit	End Limit
All Type (USB4 Gen 3, USB4 Gen 2 and USB3.2 Gen 2)	100 MHz	5 GHz	-40 dB	-40 dB
	5 GHz	10 GHz	-40 dB	-35 dB
	10 GHz	15 GHz	-35 dB	-32 dB

- Connect the VNA ports (port 1 to 4) to the test fixture ports with RF cables. Repeat the same operation of step 3 to step 5 to confirm the measured value is within the specification.

VNA Port#	Port 1	Port 2	Port 3	Port 4
Test Fixtures	L Side Tx1+	R Side Rx2+	L Side Tx1-	R Side Rx2-
	L Side Tx1+	R Side Tx2+	L Side Tx1-	R Side Tx2-
	L Side Tx1+	L Side Rx1+	L Side Tx1-	L Side Rx1-
	L Side Tx1+	L Side Tx2+	L Side Tx1-	L Side Tx2-
	L Side Tx1+	L Side Rx2+	L Side Tx1-	L Side Rx2-
	R Side Tx1+	L Side Tx1+	R Side Tx1-	L Side Tx1-
	R Side Tx1+	L Side Rx2+	R Side Tx1-	L Side Rx2-
	R Side Tx1+	L Side Tx2+	R Side Tx1-	L Side Tx2-
	R Side Tx1+	R Side Rx1+	R Side Tx1-	R Side Rx1-
	R Side Tx1+	R Side Tx2+	R Side Tx1-	R Side Tx2-
	R Side Tx1+	R Side Rx2+	R Side Tx1-	R Side Rx2-
	L Side Rx1+	R Side Rx2+	L Side Rx1-	R Side Rx2-
	L Side Rx1+	R Side Tx2+	L Side Rx1-	R Side Tx2-
	L Side Rx1+	L Side Tx2+	L Side Rx1-	L Side Tx2-

	L Side Rx1+	L Side Rx2+	L Side Rx1-	L Side Rx2-
	R Side Rx1+	L Side Rx2+	R Side Rx1-	L Side Rx2-
	R Side Rx1+	L Side Tx2+	R Side Rx1-	L Side Tx2-
	R Side Rx1+	R Side Tx2+	R Side Rx1-	R Side Tx2-
	R Side Rx1+	R Side Rx2+	R Side Rx1-	R Side Rx2-
	L Side Tx2+	R Side Tx2+	L Side Tx2-	R Side Tx2-
	L Side Tx2+	L Side Rx2+	L Side Tx2-	L Side Rx2-
	R Side Tx2+	L Side Tx2+	R Side Tx2-	L Side Tx2-
	R Side Tx2+	R Side Rx2+	R Side Tx2-	R Side Rx2-

## 5.22 Differential NEXT and FEXT between D+/D- Pair and SS Signal Pairs (Informative)

1. Connect the VNA ports (port 1 to 4) to the test fixture ports with RF cables.

VNA Port#	Port 1	Port 2	Port 3	Port 4
Test Fixture	L Side D+	L Side Tx1+	L Side D-	L Side Tx1-

2. Press **Channel Next** to select Channel 2.
3. Select **Trace 24 (Sdd21)**.
4. Press **Trigger** > Single
5. Run and confirm the measured differential crosstalk is within limit below. Otherwise, it will show Fail.

DUT Type	Start Frequency	End Frequency	Start Limit	End Limit
All Type (USB4 Gen 3, USB4 Gen 2 and USB3.2 Gen 2)	100 MHz	5 GHz	-35 dB	-35 dB
	5 GHz	7.5 GHz	-35 dB	-30 dB

6. Repeat the same operation of step 3 to step 5 for all the following combinations to confirm the measured crosstalk is within the specification.

VNA Port#	Port 1	Port 2	Port 3	Port 4
Test Fixtures	L Side D+	R Side Tx1+	L Side D-	R Side Tx1-
	L Side D+	L Side Rx1+	L Side D-	L Side Rx1-
	L Side D+	R Side Rx1+	L Side D-	R Side Rx1-
	L Side D+	L Side Tx2+	L Side D-	L Side Tx2-
	L Side D+	R Side Tx2+	L Side D-	R Side Tx2-
	L Side D+	L Side Rx2+	L Side D-	L Side Rx2-
	L Side D+	R Side Rx2+	L Side D-	R Side Rx2-
	R Side D+	L Side Rx1+	R Side D-	L Side Rx1-
	R Side D+	R Side Tx1+	R Side D-	R Side Tx1-
	R Side D+	L Side Tx1+	R Side D-	L Side Tx1-
	R Side D+	L Side Rx1+	R Side D-	L Side Rx1-
	R Side D+	L Side Rx2+	R Side D-	L Side Rx2-
	R Side D+	R Side Tx2+	R Side D-	R Side Tx2-
	R Side D+	L Side Tx2+	R Side D-	L Side Tx2-
R Side D+	R Side Rx2+	R Side D-	R Side Rx2-	

## Low Speed Signal Measurement

The connections for Type-C to Type-C cable assembly (low speed signal) is assumed as follows (Note: TF stands for Test Fixture). For frequency domain measurements, the standard compliance tool is used for the pass/fail judgment. The manual measurement procedures for several test items using the ENA Option TDR are also supported with the limit lines. Use “**Low-Speed**” sheet in the state file for Low-Speed signal measurement.

### Type-C to Type-C Cable Assembly Connection (Low Speed Signal)

TF A Side	Cable Assembly		TF B Side
Type-C (Receptacle)	Type-C (Plug)	Type-C (Plug)	Type-C (Receptacle)
D+/D-	↔		D+/D-
VBUS	↔		VBUS
CC1	↔		CC1
SBU1	↔		SBU1
SBU2	↔		SBU2

### 5.23 [Low Speed Signal] Characteristic Impedance on CC Wire and SBU

1. Select “Low-Speed” sheet in the state file tab. Connect the VNA ports (port 1 to 2) to the test fixture ports with RF cables.

VNA Port#	Port 1	Port 2
Test Fixtures	A Side CC1	B Side CC1

Note: Unused fixture pots should be terminated with 50-ohm terminators.

2. Press **Channel Max** to maximize Channel 1 on the screen.
3. Select **Trace 25 (T11)**.
4. Double-click the Trace to maximize the selected trace on the screen.
5. Click Stop Single.
6. Confirm the measured impedance is within the limit shown below. Otherwise, it will show Fail.
7. Select **Trace 26 (T22)** and repeat Step 5-6 for the far end of the DUT.

DUT Type	Max Limit	Min Limit
Cable characteristic impedance on the CC wire	93 $\Omega$	32 $\Omega$
Cable characteristic impedance on the SBU wires	53 $\Omega$	32 $\Omega$

Note: The measurement should be evaluated using a 400ps (20%-80%) rise time.

8. Select **Trace 27 (T11)** and **Trace 28 (T22)** and repeat the same operation of step 3 to step 7 for all the following SBU wire combinations.

VNA Port#	Port 1	Port 2
Test Fixtures	A Side SBU1	B Side SBU2
	A Side SBU2	B Side SBU1

## 5.24 [Low Speed Signal] Crosstalk, VBUS Loop L/C, Coupling Factor

The test results of low speed signal measurement will check with a standard tool (InterPar.exe) provided by USB-IF. The USB Type-C compliance tool may be down-loaded from the following link:

[http://compliance.usb.org/files/IntePar\\_1p6.zip](http://compliance.usb.org/files/IntePar_1p6.zip) (Released 3-Jan-2021).

Fifteen (15-sets) 4-port Touchstone files (\*.s4p) will measure and save by the VNA firmware, and then imported by the compliance tool to conduct cable assembly compliance test.

Note: Trace 29 is allocated for the measurements though.

Note: Turn off the Port Z conversion in order to perform the measurements based on 50-ohm port impedance setting which required by the standard compliance tool.

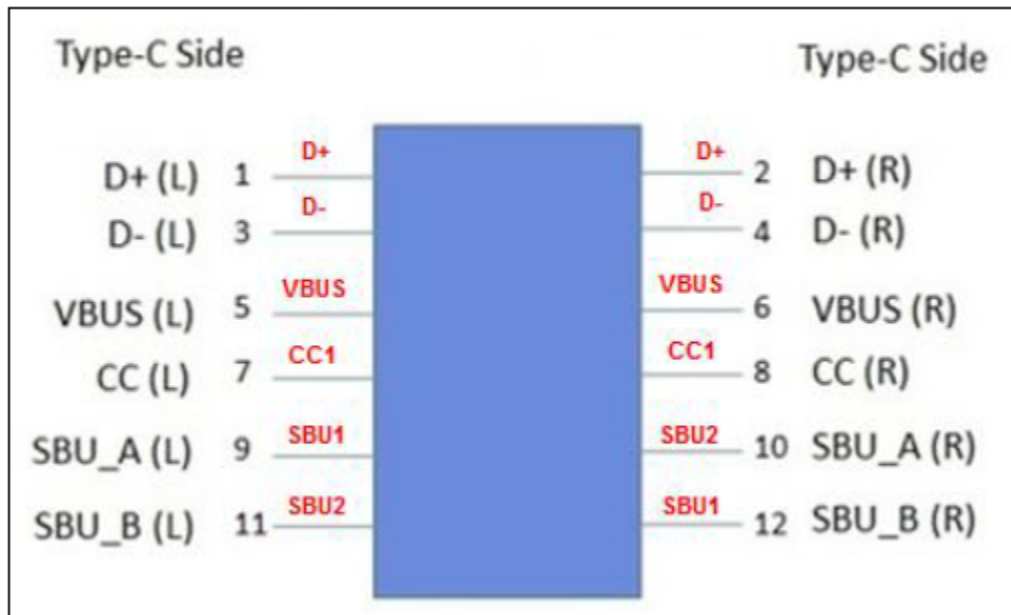

1. Connect the VNA ports (port 1 to 4) to the test fixture ports with RF cables.

Test Path Name	Port 1	Port 2	Port 3	Port 4
D+(L),D+(R),D-(L),D-(R) [1,2,3,4]	A Side D+	B Side D+	A Side D-	B Side D-

2. Select **Cal** > **Fixtures** > **Fixture Setup** > **Port Z...** uncheck “**Enable Port Z Conversion (all ports)**” to turn OFF Port Z conversion.

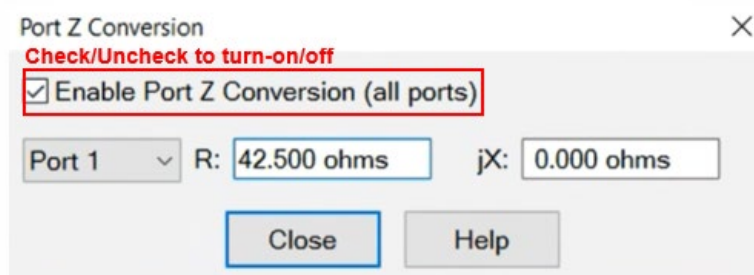

3. Press **Meas** > **Balanced** > **Topology** > **Port Z** > uncheck to disable all Port Z conversion.
4. Press **Channel Next** to select Channel 2.
5. Select **Trace 29 (Sdd21)**. Press Double-click on the instrument front panel to enlarge the trace.
6. Press **Trigger** > Single.

7. Press **Save Recall** > **Save Other** > **Save Data...** > **Filename.s4p** to save the measured Touchstone file (\*.s4p). Select format “Real/Imaginary”.
8. Connect the VNA ports with test fixture ports shown below and repeat step 3 to step 6 to save all necessary Touchstone files (\*.s4p) for VNA.

Test Path Name	Port 1	Port 2	Port 3	Port 4
D+(L),D+(R),VBUS(L),VBUS(R) [1,2,5,6]	A Side D+	B Side D+	A Side VBUS	B Side VBUS
D+(L),D+(R),CC(L),CC(R) [1,2,7,8]	A Side D+	B Side D+	A Side CC1	B Side CC1
D+(L),D+(R),SBU_A(L),SBU_A(R) [1,2,9,10]	A Side D+	B Side D+	A Side SBU1	B Side SBU2
D+(L),D+(R),SBU_B(L),SBU_B(R) [1,2,11,12]	A Side D+	B Side D+	A Side SBU2	B Side SBU1
D-(L),D-(R),VBUS(L),VBUS(R), [3,4,5,6]	A Side D-	B Side D-	A Side VBUS	B Side VBUS
D-(L),D-(R),CC(L),CC(R) [3,4,7,8]	A Side D-	B Side D-	A Side CC1	B Side CC1
D-(L),D-(R),SBU_A(L),SBU_A(R) [3,4,9,10]	A Side D-	B Side D-	A Side SBU1	B Side SBU2
D-(L),D-(R),SBU_B(L),SBU_B(R) [3,4,11,12]	A Side D-	B Side D-	A Side SBU2	B Side SBU1
VBUS(L),VBUS(R),CC(L),CC(R) [5,6,7,8]	A Side VBUS	B Side VBUS	A Side CC1	B Side CC1
VBUS(L),VBUS(R),SBU_A(L),SBU_A(R) [5,6,9,10]	A Side VBUS	B Side VBUS	A Side SBU1	B Side SBU2
VBUS(L),VBUS(R),SBU_B(L),SBU_B(R) [5,6,11,12]	A Side VBUS	B Side VBUS	A Side SBU2	B Side SBU1
CC(L),CC(R),SBU_A(L),SBU_A(R) [7,8,9,10]	A Side CC1	B Side CC1	A Side SBU1	B Side SBU2
CC(L),CC(R),SBU_B(L),SBU_B(R) [7,8,11,12]	A Side CC1	B Side CC1	A Side SBU2	B Side SBU1
SBU_A(L),SBU_A(R),SBU_B(L),SBU_B(R) [9,10,11,12]	A Side SBU1	B Side SBU2	A Side SBU2	B Side SBU1

9. Open the Excel spreadsheet [Low\_Speed\_Full-Featured]\_Config\_4ports.xlsx and modify “Cable Type” to 4 (C2C Low Speed – FF), and S-parameter Path and Name to match them with fifteen 4 port Touchstone files (\*.s4p) you measured . Do not change “Number of VNA Ports” and “Port Arrangement”.
10. Launch the USB.org compliance test tool and load the excel spreadsheet “[Low\_Speed\_Full-Featured]\_Config\_4ports.xlsx” by clicking “**Load Config Spreadsheet**”. Click **Import** to import fifteen 4 port Touchstone files (\*.s4p), then click **Check Compliance** for pass/fail judgment.
11. After completed the measurement, Press **Cal** > **Fixtures** > **Fixture Setup** > **Port Z...** check “**Enable Port Z Conversion (all ports)**” to turn ON Port Z conversion as default setting.

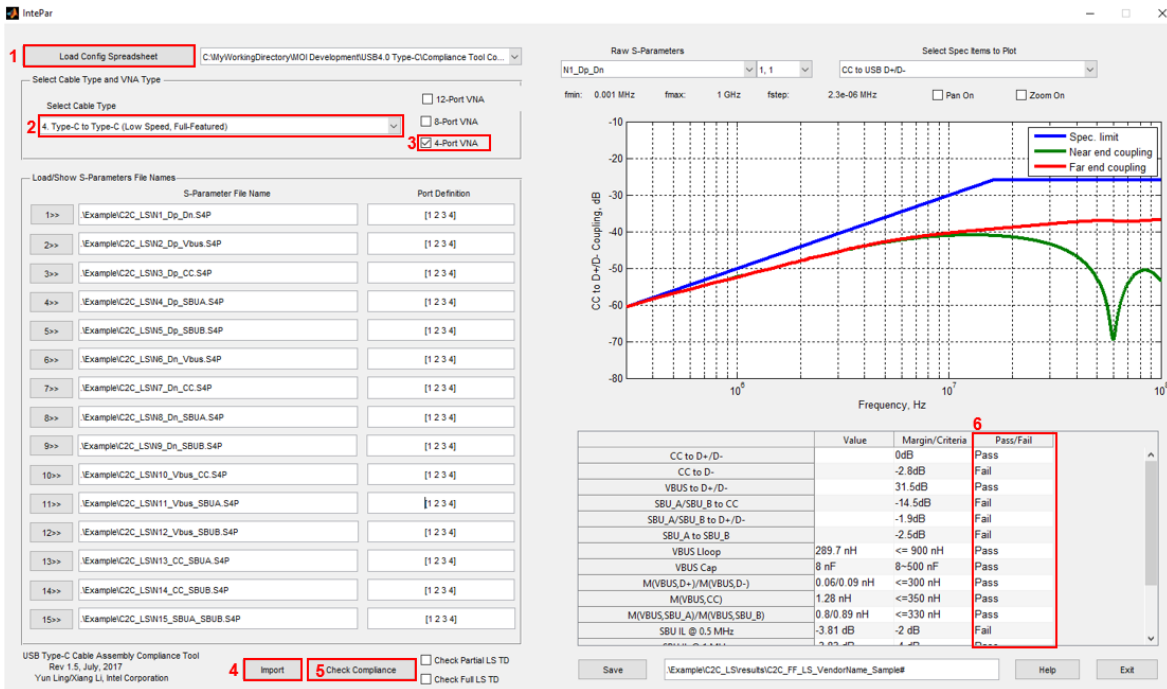

For charged-thru cable, perform the measurements for the following connections. Six (6-sets) 4-port Touchstone files (\*.s4p) will measure and save to run the compliance. Use the Excel spreadsheet [Low\_Speed\_Charged\_Through]\_Config\_4ports.xlsx for pass/fail judgment.

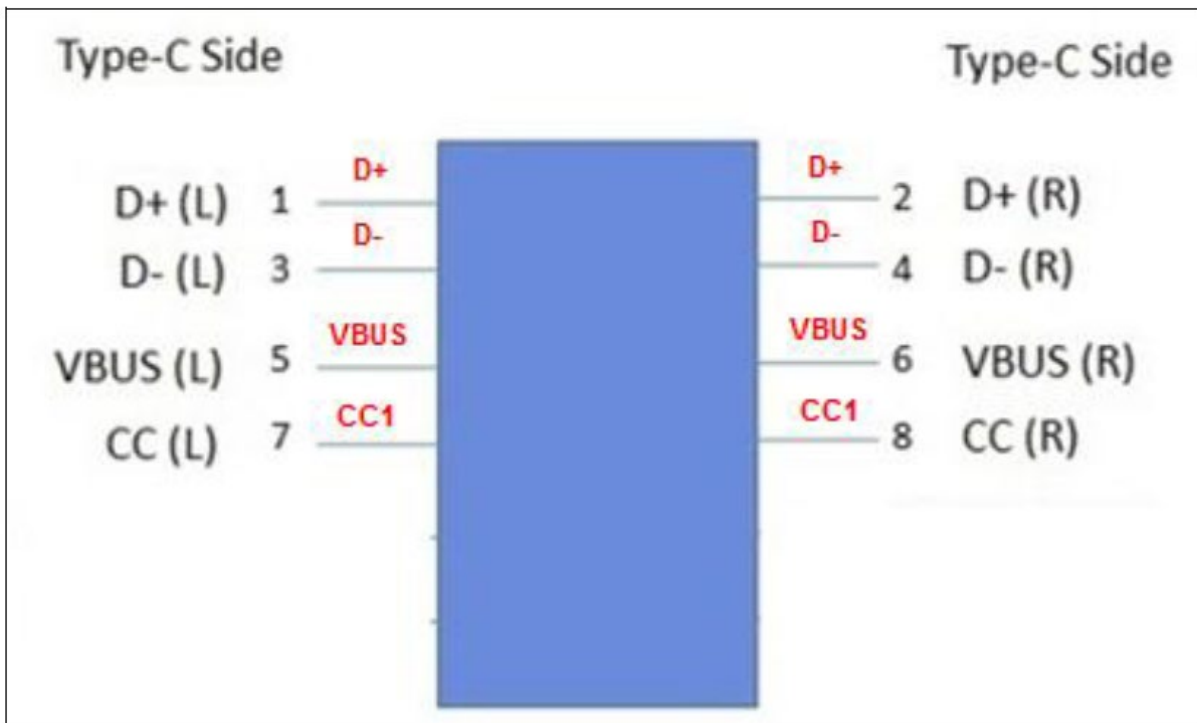

Test Path Name	Port 1	Port 2	Port 3	Port 4
D+(L),D+(R),D-(L),D-(R) [1,2,3,4]	A Side D+	B Side D+	A Side D-	B Side D-
D+(L),D+(R),VBUS(L),VBUS(R) [1,2,5,6]	A Side D+	B Side D+	A Side VBUS	B Side VBUS

D+(L),D+(R),CC(L),CC(R) [1,2,7,8]	A Side D+	B Side D+	A Side CC1	B Side CC1
D-(L),D-(R),VBUS(L),VBUS(R), [3,4,5,6]	A Side D-	B Side D-	A Side VBUS	B Side VBUS
D-(L),D-(R),CC(L),CC(R) [3,4,7,8]	A Side D-	B Side D-	A Side CC1	B Side CC1
VBUS(L),VBUS(R),CC(L),CC(R) [5,6,7,8]	A Side VBUS	B Side VBUS	A Side CC1	B Side CC1

## 5.25 [Low Speed Signal] Coupling between CC and Differential D+/D-

1. Connect the VNA ports (port 1 to 3) to the test fixture ports with RF cables.

VNA Port#	Port 1	Port 2	Port 3
Test Fixtures	A Side CC1	A Side D+	A Side D-

2. Press **Channel Next** to select Channel 2.
3. Press **Meas** > Balanced > Topology > SE-BAL.
4. Select **Trace 30 (Sds21)**.
5. Press **Trigger** > Single
6. Run and confirm the measured coupling is within limit below. Otherwise, it will show Fail.

DUT Type	Start Frequency	End Frequency	Start Limit	End Limit
All Type	0.3 MHz	1.0 MHz	-60.5 dB	-50 dB
	1.0 MHz	10 MHz	-50 dB	-30 dB
	10 MHz	16 MHz	-30 dB	-26 dB
	16 MHz	100 MHz	-26 dB	-26 dB

7. Connect the VNA ports (port 1 to 4) to the test fixture ports with RF cables. Repeat the same operation of step 3 to step 5 to confirm the measured value is within the specification.
8. Press **Meas** > Balanced > Topology > BAL-BAL to reset the setting.

VNA Port#	Port 1	Port 2	Port 3
Test Fixtures	A Side CC1	B Side D+	B Side D-
	B Side CC1	B Side D+	B Side D-
	B Side CC1	A Side D+	A Side D-

## 5.26 [Low Speed Signal] Single-Ended Coupling between CC and D+/D-

1. Connect the VNA ports (port 1 to 2) to the test fixture ports with RF cables.

VNA Port#	Port 1	Port 2
Test Fixtures	A Side CC1	A Side D-

2. Press **Channel Next** to select Channel 2.
3. Select **Trace 31 (S21)** for USB2.0 Type-C cable assembly **or Trace 32 (S21)** for full-featured Type-C.
4. Press **Trigger** > Single
5. Run and confirm the measured coupling is within limit below. Otherwise, it will show Fail.

DUT Type	Start Frequency	End Frequency	Start Limit	End Limit
USB 2.0 Type-C Cable Assembly	0.3 MHz	1.0 MHz	-48.5 dB	-38 dB
	1.0 MHz	10 MHz	-38 dB	-18 dB

	10 MHz	100 MHz	-18 dB	-18 dB
Full-featured Type-C Cable Assembly	0.3 MHz	10 MHz	-58 dB	-27.5 dB
	10 MHz	11.8 MHz	-27.5 dB	-26 dB
	11.8 MHz	100 MHz	-26 dB	-26 dB

- Repeat the same operation of step 3 to step 5 to confirm the measured value is within the specification.

VNA Port#	Port 1	Port 2
Test Fixtures	A Side CC1	B Side D-
	B Side CC1	B Side D-
	B Side CC1	A Side D-

### 5.27 [Low Speed Signal] Coupling between VBUS and Differential D+/D-

- Connect the VNA ports (port 1 to 3) to the test fixture ports with RF cables.

VNA Port#	Port 1	Port 2	Port 3
Test Fixtures	A Side VBUS	A Side D+	A Side D-

- Press **Channel Next** to select Channel 2.
- Press **Meas** > Balanced > Topology > SE-BAL.
- Select **Trace 33 (Sds21)**.
- Press **Trigger** > Single
- Run and confirm the measured coupling is within limit below. Otherwise, it will show Fail.

DUT Type	Start Frequency	End Frequency	Start Limit	End Limit
All Type	0.3 MHz	1.0 MHz	-40 dB	-40 dB
	1.0 MHz	30 MHz	-40 dB	-40 dB
	30 MHz	100 MHz	-40 dB	-30 dB

- Connect the VNA ports (port 1 to 3) to the test fixture ports with RF cables. Repeat the same operation of step 3 to step 5 to confirm the measured value is within the specification.
- Press **Meas** > Balanced > Topology > BAL-BAL to reset the setting.

VNA Port#	Port 1	Port 2	Port 3
Test Fixtures	A Side VBUS	B Side D+	B Side D-
	B Side VBUS	B Side D+	B Side D-
	B Side VBUS	A Side D+	A Side D-

### 5.28 [Low Speed Signal] Single-ended Coupling between SBU\_A and SBU\_B

- Connect the VNA ports (port 1 to 2) to the test fixture ports with RF cables.

VNA Port#	Port 1	Port 2
Test Fixtures	A Side SBU1	A Side SBU2

- Press **Channel Next** to select Channel 2.
- Select **Trace 34 (S21)**.
- Press **Trigger** > Single

- Run and confirm the measured coupling is within limit below. Otherwise, it will show Fail.

DUT Type	Start Frequency	End Frequency	Start Limit	End Limit
All Type	0.3 MHz	1.0 MHz	-56.5 dB	-46 dB
	1.0 MHz	10 MHz	-46 dB	-26 dB
	10 MHz	11.2 MHz	-26 dB	-26 dB
	11.2 MHz	100 MHz	-25 dB	-25 dB

- Repeat the same operation of step 3 to step 5 to confirm the measured value is within the specification.

VNA Port#	Port 1	Port 2
Test Fixtures	A Side SBU1	B Side SBU1
	B Side SBU2	B Side SBU1
	B Side SBU2	A Side SBU2

### 5.29 [Low Speed Signal] Single-ended Coupling between SBU\_A/SBU\_B and CC

- Connect the VNA ports (port 1 to 2) to the test fixture ports with RF cables.

VNA Port#	Port 1	Port 2
Test Fixtures	A Side SBU1	A Side CC1

- Press **Channel Next** to select Channel 2.
- Select **Trace 35 (S21)**.
- Press **Trigger** > Single
- Run and confirm the measured coupling is within limit below. Otherwise, it will show Fail.

DUT Type	Start Frequency	End Frequency	Start Limit	End Limit
All Type	0.3 MHz	1 MHz	-65 dB	-55 dB
	1 MHz	18 MHz	-55 dB	-30 dB
	18 MHz	100 MHz	-30 dB	-30 dB

- Repeat the same operation of step 3 to step 5 to confirm the measured value is within the specification.

VNA Port#	Port 1	Port 2
Test Fixtures	A Side SBU1	B Side CC1
	A Side SBU2	A Side CC1
	A Side SBU2	B Side CC1
	B Side SBU1	B Side CC1
	B Side SBU1	A Side CC1
	B Side SBU2	B Side CC1
	B Side SBU2	A Side CC1

### 5.30 [Low Speed Signal] Coupling between SBU\_A/SBU\_B and Differential D+/D-

1. Connect the VNA ports (port 1 to 3) to the test fixture ports with RF cables.

VNA Port#	Port 1	Port 2	Port 3
Test Fixtures	A Side SBU1	A Side D+	A Side D-

2. Press **Channel Next** to select Channel 2.
3. Press **Meas** > Balanced > Topology > SE-BAL.
4. Select **Trace 36 (Sds21)**.
5. Press **Trigger** > Single
6. Run and confirm the measured coupling is within limit below. Otherwise, it will show Fail.

DUT Type	Start Frequency	End Frequency	Start Limit	End Limit
All Type	0.3 MHz	30 MHz	-80 dB	-40 dB
	30 MHz	100 MHz	-40 dB	-40 dB

7. Repeat the same operation of step 3 to step 5 to confirm the measured value is within the specification.
8. Press **Meas** > Balanced > Topology > BAL-BAL to reset the setting.

VNA Port#	Port 1	Port 2	Port 3
Test Fixtures	A Side SBU1	B Side D+	B Side D-
	A Side SBU2	A Side D+	A Side D-
	A Side SBU2	B Side D+	B Side D-
	B Side SBU1	B Side D+	B Side D-
	B Side SBU1	A Side D+	A Side D-
	B Side SBU2	B Side D+	B Side D-
	B Side SBU2	A Side D+	A Side D-

## 6.Manual Setup

The procedures of manual setup for time domain and frequency domain measurements are introduced in this section for reference. All the required testing parameters have been properly set and saved in the respective standards testing state file (\*.tdr).

### 6.1. Channel & Trace Setup

If TDR setup wizard is shown when launching the TDR software, click **Close** button in the TDR setup wizard main window.

1. Open **Setup** tab in the TDR software
2. Click **Preset** to preset the instrument Click OK in a dialog box to continue.
3. Set **DUT Topology** to “**Differential 2 Port**” Click OK in a dialog box.
4. Click **Advanced Mode>>** and click Yes to enter to Advanced mode.

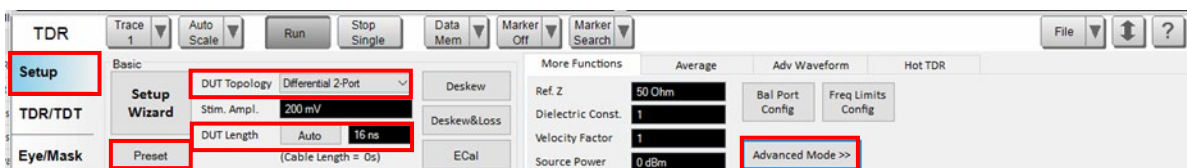

- Click **Stop Single**.
- Set DUT Length to “16 ns”.
- Open **TDR/TDT** tab.
- Click **Trace Control** tab.
- Clear **Time, Marker, Rise Time & Scale** check box under Coupling.

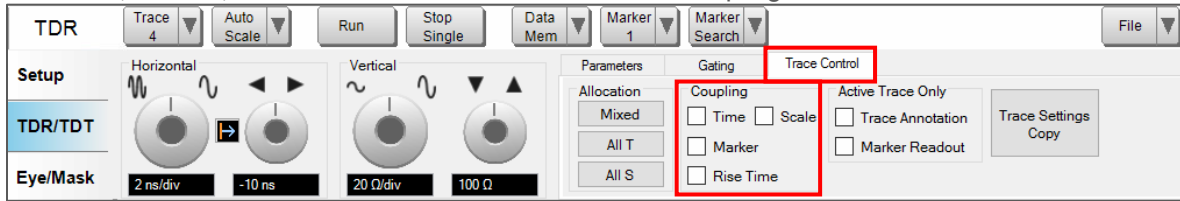

Note:

- Selecting **Marker** under **Coupling** will enable all the marker on other traces to be moved in same alignment.
- Selecting **Time** under **Coupling** will enable all other traces using the same X axis (Time).
- Selecting **Rise Time** under **Coupling** will enable all other traces using the same rise time.
- Selecting **Scale** under **Coupling** will enable all other traces using the same scale.

## 6.2. D+/D- Intra-Pair Skew

- Select **Trace 3**.
- Open **Parameters** tab.
- Select “**Time Domain**” and “**Single-Ended**” for Measure.
- Select Formant to “**Volt**”.
- Select **Rise Time** to “**20-80%**” and input value to 400 ps (follow rise time setting in Table 4.1).
- Click **T31**.

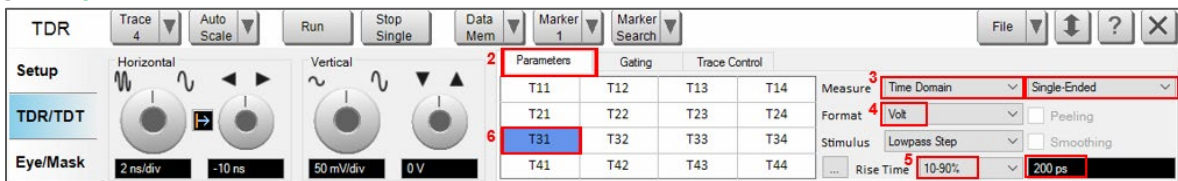

- Open **Trace Control** tab.
- Click **Trace Settings Copy** to launch trace copy dialog box.

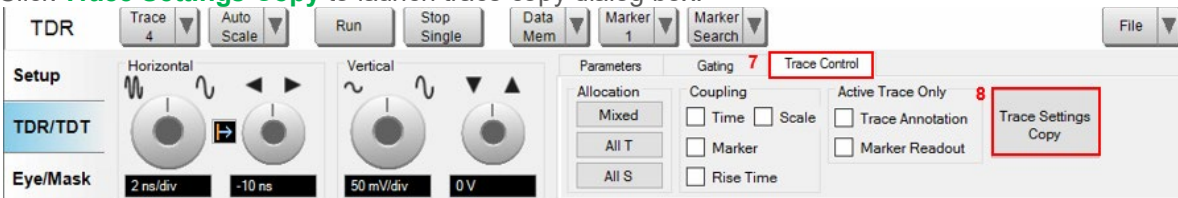

- Select **Trace 3** in the From list.
- Select **Trace 7** in the To list.
- Click **Copy**.

12. Click **Close**.

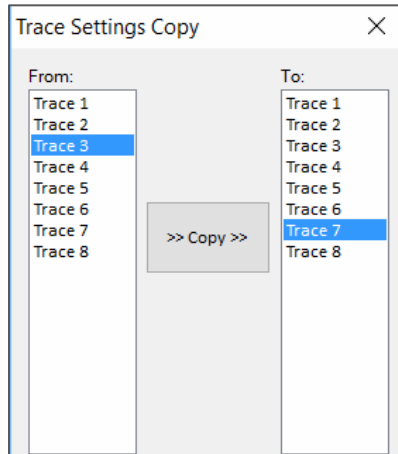

13. Select **Trace 7**.

14. Open **Parameters** tab.

15. Click **T42**

16. Select **Trace 3 (T31)**

17. Click Marker Search and select  $\Delta$  Time

18. Check  $\Delta$  Time

19. Select Target (Stop) to **Trace 7** and click OK

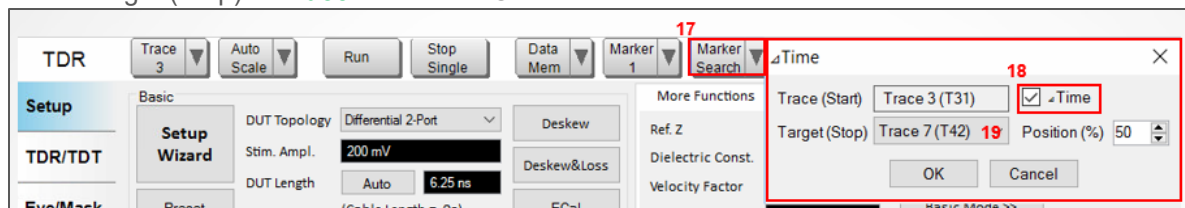

## 6.3 Crosstalk Compensation

1. Select **Trace 3**.

2. Press **Math > Analysis > Equation Editor...** Enter an equation "**S31-S32**".

3. Check **Enabled** to enable the equation on trace.

4. Click **Apply**.

5. Click **Close**.

6. Select **Trace 7**.

7. Press **Math > Analysis > Equation Editor...** Enter an equation "**S42-S41**".

8. Check **Enabled** to enable the equation on trace.

9. Click **Apply**.

10. Click **Close**.

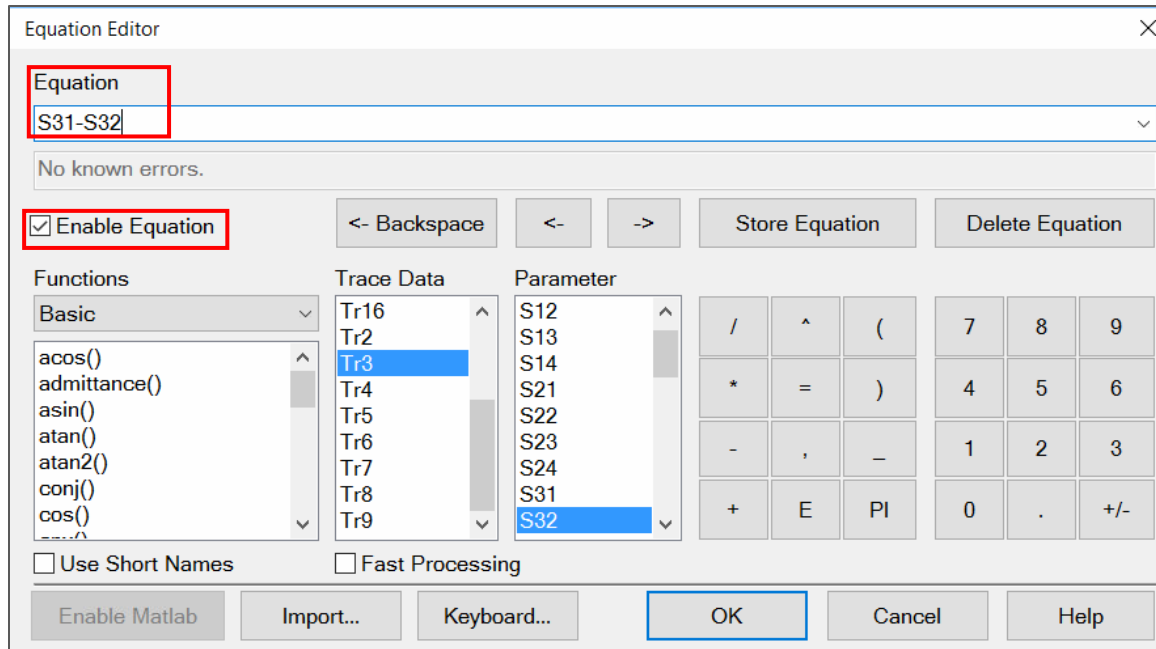

## 6.4 D+/D- Pair Propagation Delay

1. Select **Trace 4**.
2. Open **Parameters** tab.
3. Select "**Time Domain**" and "**Differential**" for Measure.
4. Select Formant to "**Volt**".
5. Select **Rise Time** to "**20-80%**" and input value "**400 ps**" (follow raise time requirement by USB.org).
6. Click **Tdd21**.
7. Input vertical scale (100 mV/div) and vertical position (200 mV).
8. Press **Search**> **Target**> **Target Value** and enter 200 mV.
9. Press **Search**> **Target**> **Tracking**> **Target** to turn on **Tracking**.

## 6.5 Differential Impedance

1. Select **Trace 1 (Trace 2/Trace 15)**.
2. Open **Parameters** tab.
3. Select "**Time Domain**" and "**Differential**" for Measure.
4. Select Formant to "**Impedance**".
5. Select **Rise Time** to "**20-80%**" and input value "**400 ps**" (follow raise time requirement by USB.org).
6. Click **Tdd11**.
7. Input vertical scale (10 Ohm/div) and vertical position (50 Ohm).
8. Open **Trace Control** tab.

9. Click **Trace Settings Copy** to launch trace copy dialog box.

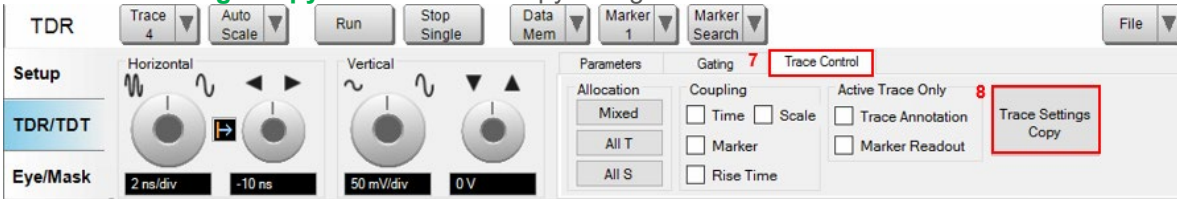

10. Select **Trace 1 (Trace 2/Trace 15)** in the From list.

11. Select **Trace 5 (Trace 6/Trace 16)** in the To list.

12. Click **Copy**.

13. Click **Close**.

14. Select **Trace 5 (Trace 6/Trace 16)**.

15. Open **Parameter** tab.

16. Click **Tdd22**.

## 6.6 [Low-Speed Signal] Single-ended Impedance

1. Select **Trace 25 (Trace 27)**.

2. Open **Parameters** tab.

3. Select "**Time Domain**" and "**Single-Ended**" for Measure.

4. Select Formant to "**Impedance**".

5. Select **Rise Time** to "**20-80%**" and input value "**400 ps**" (follow raise time requirement by USB.org).

6. Click **T11**.

7. Input vertical scale (10 Ohm/div) and vertical position (50 Ohm).

8. Open **Trace Control** tab.

9. Click **Trace Settings Copy** to launch trace copy dialog box.

10. Select **Trace 25 (Trace 27)** in the From list.

11. Select **Trace 26 (Trace 28)** in the To list.

12. Click **Copy**.

13. Click **Close**.

14. Select **Trace 6 (Trace 28)**.

15. Open **Parameter** tab.

16. Click **T22**.

## 6.7 Common Parameters Setup for Frequency-domain Measurements

### 6.7.1 Setup for High-Speed Signal Measurement

1. Press **Channel Next** to select Channel 2.

2. Select **Sweep** > Sweep Setup and key-in sweep properties as below:

- Set **Start** value to "10 MHz".
- Set **Stop** value to "20 GHz".
- Set **Points** and set to "2000".
- Set **IF Bandwidth** to "1 kHz".

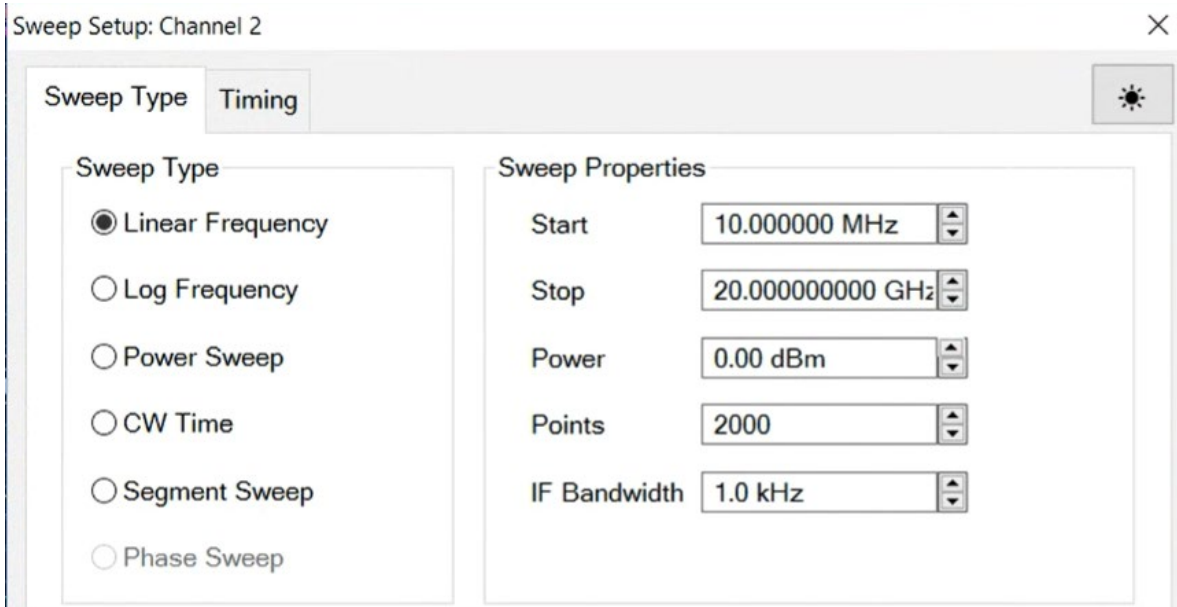

7. Select **Cal** > **Fixtures** > **Fixture Setup** > **Port Z...** Select and check “**Enable Port Z Conversion (all ports)**” to turn ON Port Z conversion.
8. Set **Port impedance** to “42.5-ohm” for all Port1/2/3/4 Z0 Real.  
*Note: 45-ohm for [Raw Cable] and 42.5-ohm for [Mated Connector].*

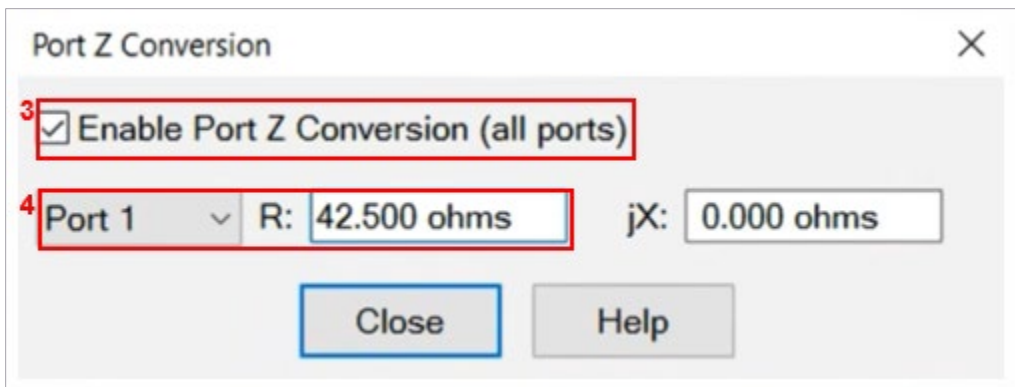

### 6.7.2 Setup for Low-Speed Signal Measurement

1. Press **Channel Next** to select Channel 2.
2. Select **Sweep** > Sweep Setup and key-in sweep properties as below:
  - Select Sweep Type as “Log Frequency”.
  - Set **Start** value to “300 kHz”.
  - Set **Stop** value to “100 MHz”.
  - Set **Power** value to “10 dBm”
  - Set **Points** and set to “1601”.
  - Set **IF Bandwidth** to “1 kHz”.

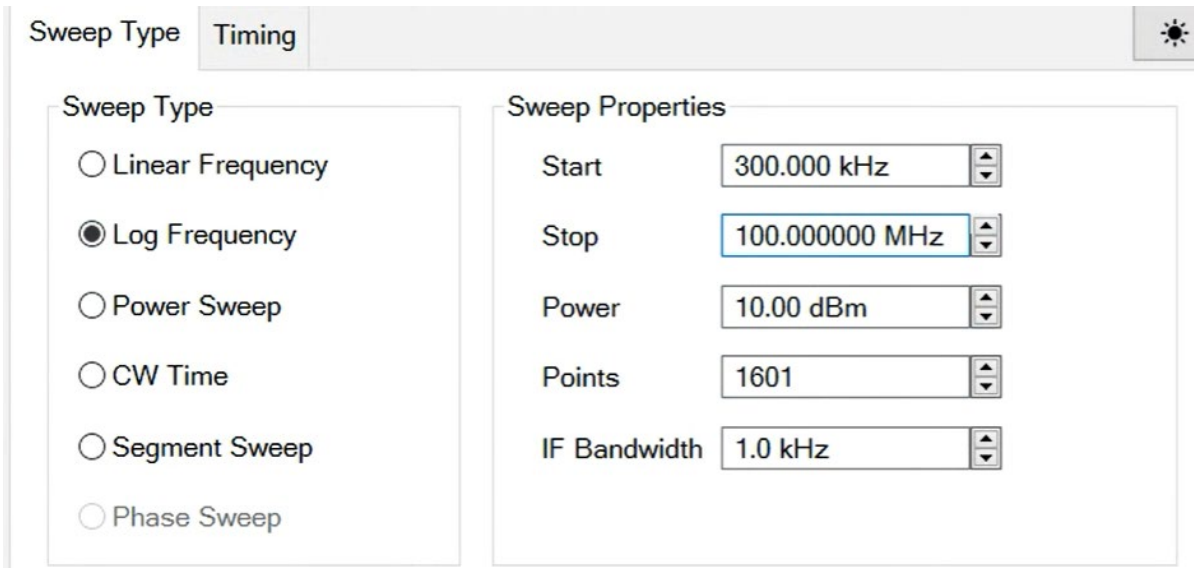

3. Select **Cal** > **Fixtures** > **Fixture Setup** > **Port Z...** Select and check “**Enable Port Z Conversion (all ports)**” to turn ON Port Z conversion.
4. Set **Port Z impedance** “42.5-ohm” for all Port1/2/3/4 Z0 Real.

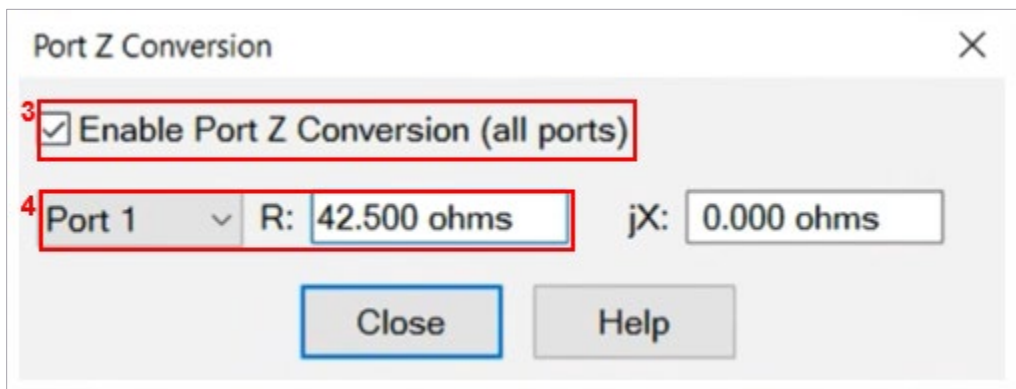

## 6.8 Defining Limit Line Tables

1. Press **Trace Next** to select trace to set the limit line table.
2. Press **Math**> **Analysis** > **Limit Table** > to edit the limit table.

	Type	Begin Stimulus	End Stimulus	Begin Response	End Response
1	Min	100.0000 MHz	5.00000 GHz	-35.0000 dB	-35.0000 dB
2	Min	5.00000 GHz	7.50000 GHz	-35.0000 dB	-30.0000 dB
3	Off	0.000000 Hz	0.000000 Hz	0.000000 dB	0.000000 dB

3. Press **Math**> **Analysis** > **Limit...** > to launch Limit Test Setup window.
4. Select to turn on “Limit Test ON” and “Limit Line ON”, optional to turn on “Sound ON Fail”.

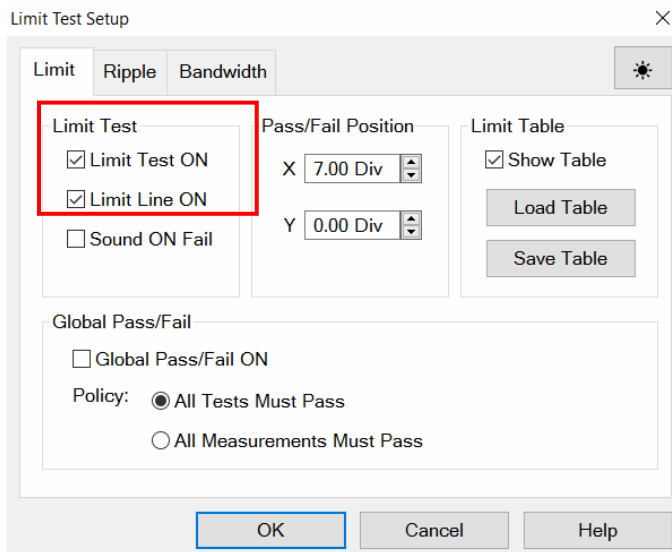

## Web Resources

[www.keysight.com/find/ena-tdr\\_compliance](http://www.keysight.com/find/ena-tdr_compliance)

[www.keysight.com/find/usb-vna](http://www.keysight.com/find/usb-vna)

[www.keysight.com/find/na](http://www.keysight.com/find/na)

[www.keysight.com/find/vnasoftware](http://www.keysight.com/find/vnasoftware)

[www.keysight.com/find/ecal](http://www.keysight.com/find/ecal)

Learn more at: [www.keysight.com](http://www.keysight.com)

For more information on Keysight Technologies' products, applications or services, please contact your local Keysight office. The complete list is available at: [www.keysight.com/find/contactus](http://www.keysight.com/find/contactus)

