

Bulletin 1694 Electronic circuit protection for 24V DC



WARNING: Electrostatically sensitive sub-assemblies can be destroyed by voltages far below the human perception threshold. These voltages already occur if you touch a component or electrical terminals of a sub-assembly without being electrostatically discharged. The damage of a sub-assembly caused by an overvoltage is often not immediately recognised, but will be noticed only after a longer operating time.



Mounting or actuation of the 1694 connector arm must only be effected at dead-voltage. For start-up the 1694 connector arm must be closed.



Device to be installed, operated and maintained by trained personnel only.

To secure device properly against unintended access, product shall be mounted in locked cabinet.

The device can't be serviced or repaired.

Do not open device's enclosure.

Bulletin 1694 Electronic circuit protection for 24V DC

Bulletin 1694 Electronic Circuit Protection is a modular solution with a max. system capacity of 40A. The protection modules come in a fix current rating in a range from 1A...10A. Designed for 24V DC circuits, the 1694 provides comprehensive protection against short circuit and overcurrent conditions while allowing for inrush current.

Basic trip curve and schematic diagram 1694-PM

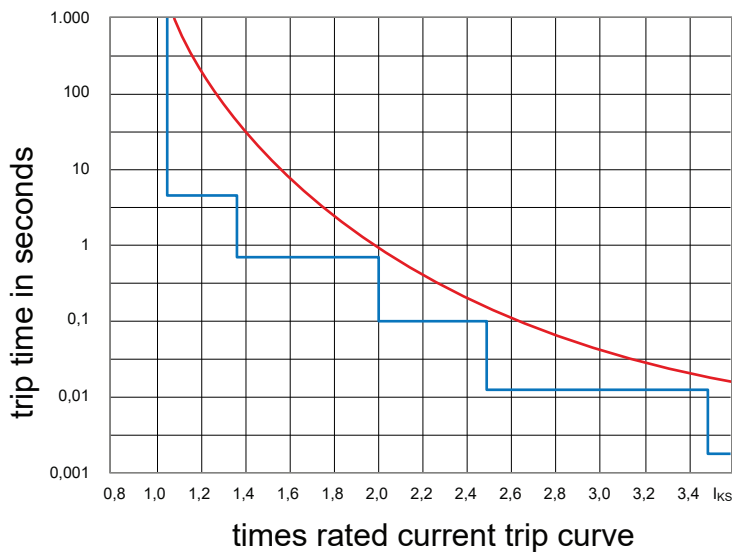

Schematic diagram

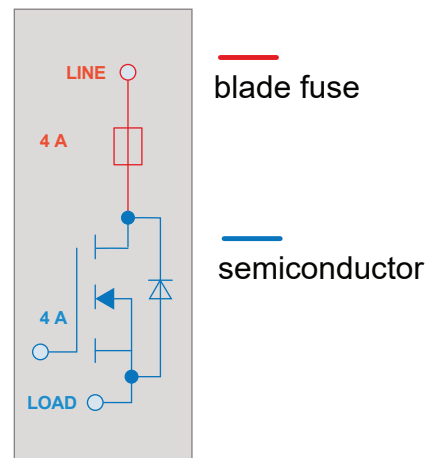

Features

- Combination of supply modules, circuit protection and power distribution
- Selective load protection by means of electronic trip curve
- No accessories required for connecting the components
- Width per channel only 12.5 mm (1-channel) or 6.25mm (2-channel)
- Integral fail-safe element, adjusted to current rating
- Switching capacitive loads up to 20,000 µF (at I_N > 6A)
- Manual ON/OFF/reset momentary switch
- Clear status indication by means of LED and auxiliary contact (1694-PF supply module)
- Connection via push-in terminals
- 1694-PMx available in Class 2 version with nominal currents: 1A, 2A, 3A, 4A

Notes

- Connection to a higher or not reliably disconnected voltage can cause hazardous conditions or damages
- Only the intended circuit protectors must be used
- The technical data of the circuit protectors used have to be observed
- The entire power distribution system must only be installed by qualified personnel
- Only after expert installation must the device be supplied with power
- After tripping of the circuit protector and before reset, the cause of the failure (short circuit or overload) must be remedied
- The national standards have to be observed for installation and selection of feed and return cables.

Technical data ($T_{amb} = +23\text{ °C}$, $U_B = \text{DC } 24\text{ V}$)

1694-PM Circuit Protection Module

Operating voltage U_B DC 24 V (min. 18 V, max. 30 V)
(no battery-buffered applications)

Closed current I_0
1694-PM1 (1-channel) in ON condition:
typically 5 mA
1694-PM2 (2-channel) typically 8 mA

Reverse polarity protection Yes, without load

Rated current I_N current ratings:
1694-PM1 (1-channel) 1 A, 2 A, 3 A, 4 A, 6 A, 8 A, 10 A
1694-PM2 (2-channel) 1A/1A, 2A/2A, 3A/3A, 4A/4A, 6A/6A

Visual status indication by means of LED:

- Green: ● Load circuit connected
- flashing orange ● ● Load current warning limit reached
- green: ●
- orange: ● Overload or short circuit until disconnection
- red: ● After disconnection (trip condition) due to overload or short circuit after undervoltage release of operating voltage in ON condition with autoreset
- OFF: ● Device switched off by means of ON/OFF momentary switch or no operating voltage
- Non Illuminated ●

Load circuit
Load current warning limit (I_{WLimit}) typically $0.9 \times I_N$
1694-PM
Hysteresis typically 5%

Status of auxiliary contact is not affected by 90% load current warning

Overload disconnection (I_{OL}) with trip times (t_{OL})	typically $I_{OL}: I_N \times 1.05$	$t_{OL}: 3\text{ s}$
	typically $I_{OL}: I_N \times 1.35$	$t_{OL}: 0.5\text{ s}$
	typically $I_{OL}: I_N \times 2.00$	$t_{OL}: 0.1\text{ s}$
	typically $I_{OL}: I_N \times 2.50$	$t_{OL}: 0.012\text{ s}$
short circuit trip time (t_{KS})	typically at (I_{KS}) see time/current characteristics	$t_{KS}: 0.002\text{ s}^1$

¹ depending on power source

Influence of ambient temperature on overload trip and load current warning limit see temperature factor table

Leakage current in load circuit in OFF condition typically <1 mA

Voltage drop in load circuit at I_N for 1694-PM between LINE+ and LOAD+	• $I_N: 1\text{ A (CL2)}$	typically 180 mV
	• $I_N: 2\text{ A (CL2)}$	typically 110 mV
	• $I_N: 3\text{ A}$	typically 120 mV
	• $I_N: 3\text{ A- CL2}$	typically 130 mV
	• $I_N: 4\text{ A}$	typically 115 mV
	• $I_N: 4\text{ A- CL2}$	typically 180 mV
	• $I_N: 6\text{ A}$	typically 170 mV
	• $I_N: 8\text{ A}$	typically 160 mV
	• $I_N: 10\text{ A}$	typically 180 mV

3 Installation Instructions: Bulletin 1694 Electronic circuit protection for 24V DC

Fail-safe element integrated fuse	Adjusted to the corresponding rated current I_N																
	<ul style="list-style-type: none"> • I_N: 1A (CL2) fail-safe I_N: 1A • I_N: 2A (CL2) fail-safe I_N: 2A • I_N: 3A fail-safe I_N: 3.15A • I_N: 3A-CL2 fail-safe I_N: 4A • I_N: 4A fail-safe I_N: 4A • I_N: 4A-CL2 fail-safe I_N: 4A • I_N: 6A fail-safe I_N: 6.3A • I_N: 8A fail-safe I_N: 8A • I_N: 10A fail-safe I_N: 10A 																
Low voltage monitoring of operating voltage	OFF at typically $U_B < 16.0\text{ V}$ ON at typically $U_B > 19.0\text{ V}$ Hysteresis typically 2 V with automatic OFF and ON operation																
ON delay																	
- with power ON	channel 1: typically 100ms (1694-PM) channel 2: typically 200ms (1694-PM)																
- when switching on via ON/OFF momentary switch	channel 1: typically 5 ms channel 2: typically 100 ms																
- after an undervoltage	channel 1: typically 5 ms channel 2: typically 5 ms																
Disconnection of the load circuit	<ul style="list-style-type: none"> • manually on the device with the ON/OFF momentary switch • after an overload / short circuit disconnection with storage (no automatic reset) • temporarily at undervoltage • at no operating voltage 																
Switching on the load circuit	Unit can only be switched on when operating voltage was applied The device re-starts with the last stored condition.																
- Momentary switch ON/OFF																	
- Apply operating voltage																	
Reset function	A blocked load output (blocked by overload / short circuit) can be reset or switched on manually by the momentary ON/OFF switch (LED button).																
Capacitive loads (Depending on: cable attenuation, power supply used, load current and current rating)	<table border="0"> <tr> <td>at I_N:</td> <td>1A</td> <td>DC24V</td> <td>up to 5,000μF</td> </tr> <tr> <td>at I_N:</td> <td>2A, 3A</td> <td>DC24V</td> <td>up to 10,000μF</td> </tr> <tr> <td>at I_N:</td> <td>4A</td> <td>DC24V</td> <td>up to 12,000μF</td> </tr> <tr> <td>at I_N:</td> <td>> 6A</td> <td>DC24V</td> <td>up to 20,000μF</td> </tr> </table>	at I_N :	1A	DC24V	up to 5,000 μ F	at I_N :	2A, 3A	DC24V	up to 10,000 μ F	at I_N :	4A	DC24V	up to 12,000 μ F	at I_N :	> 6A	DC24V	up to 20,000 μ F
at I_N :	1A	DC24V	up to 5,000 μ F														
at I_N :	2A, 3A	DC24V	up to 10,000 μ F														
at I_N :	4A	DC24V	up to 12,000 μ F														
at I_N :	> 6A	DC24V	up to 20,000 μ F														
Free-wheeling circuit	external free-wheeling circuit at inductive load (rating according to load) is recommended.																
Parallel connection of several load outputs	not permitted																

4 Installation Instructions: Bulletin 1694 Electronic circuit protection for 24V DC

General Data

Ambient temperature (T _{amb})	-25°...+60 °C (without condensation, cf. EN 60204-1)		
Storage temperature	-30°...+70 °C		
Mounting temperature	+5°... +60°C		
Humidity:	96 hrs / 95% RH RH/40 °C to IEC 60068-2-78-Cab climate class 3K3 to EN 60721		
Corrosion Only 1694-DM and 1694-PF accessories	96hrs. in 5% salt mist to IEC 60068-2-11 test Ka		
Vibration resistance	3 g, test to IEC 60068-2-6 test Fc		
Degree of protection Operating area 1694-PM:	IEC 60529, DIN VDE 0470 IP30		
EMC requirements (EMC Directive, CE Logo)	Emitted interference:	EN 61000-6-3	
	Noise immunity:	EN 61000-6-2	
Insulation co-ordination (IEC 60934)	0.5 kV / pollution degree 2		
Dielectric strength	max. DC 30 V (load circuit)		
Insulation resistance (OFF condition)	n/a, only electronic disconnection		
Modules mountable side by side	max. 36 channels allowed. Total current value shall be below 40 Amps. (sample case: 36 channels refer to 1 Amp nominal current channels)		
Terminals Push-in terminal PT 2.5	LOAD+ 0.14mm ² to 2.5mm ² , flexible AWG24 – AWG14 str. ²		
wire stripping length	8mm to 10mm		
² Rockwell Automation recommends to use ferrules for smaller diameter cables.			
Dimensions (h x w x d)	12.5 x 80 x 98.5 mm		
Weight	approx. 60 g		

Conformity and approvals for 1694-PM with 1694-PF

Conformity	CE Marking RoHS compliant China RoHS WEEE Morocco EMC		
Approvals	UL 2367 RA	File # E350272	current rating range:1A... 10A
	UL 1310 RA NEC Class2 ³	File # E350272	current rating range: 1A, 2A, 3A, 4A
	cULus508RA listed	File # E56639	current rating range:1A... 10A

³ Class 2 only for Protection Modules



At the End of its life, this equipment should be collected separately from any unsorted municipal waste.

Typical time/current characteristic ($T_{amb} = +23\text{ }^{\circ}\text{C}$, UB = DC 24 V)

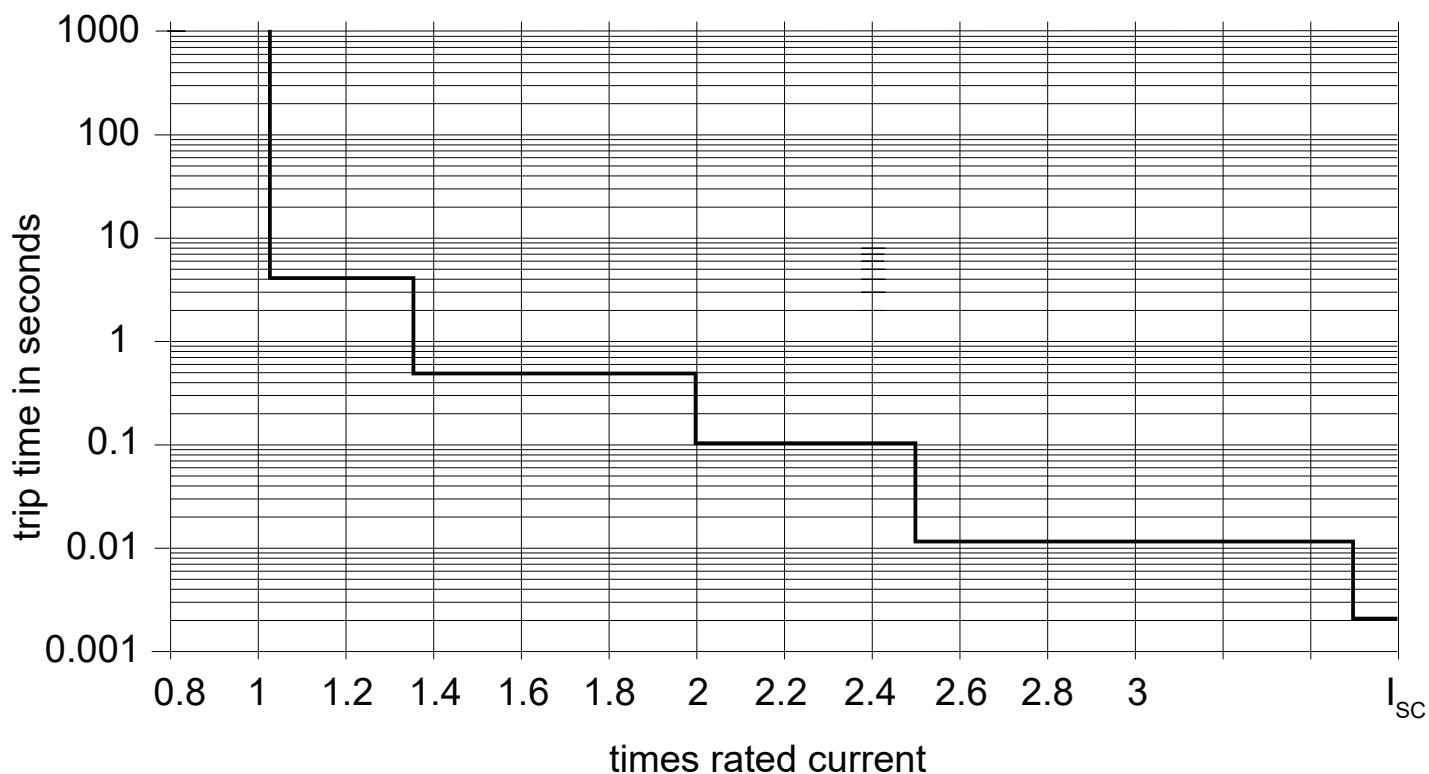

I_{sc} - short circuit current

Temperature factor / continuous duty

The time/current characteristic depends on the ambient temperature. In order to determine the max. load current, please multiply the current rating with the temperature factor and consider the factor for side-by-side mounting.

Temperature factor table:

ambient temperature [$^{\circ}\text{C}$]	0	10	23	40	50	60
temperature factor	1	1	1	0.95	0.90	0.85

Please note

- When mounted side-by-side, the devices can carry max. 80 % of their rated load or a different rating has to be selected.
- With high temperatures, the load current warning threshold "warn limit typically $0.9 \times I_N$ " will be reduced in accordance with the temperature factor.
- Selection of current rating of the circuit protector \leq rating of power supply.

Dimensions 1694-...

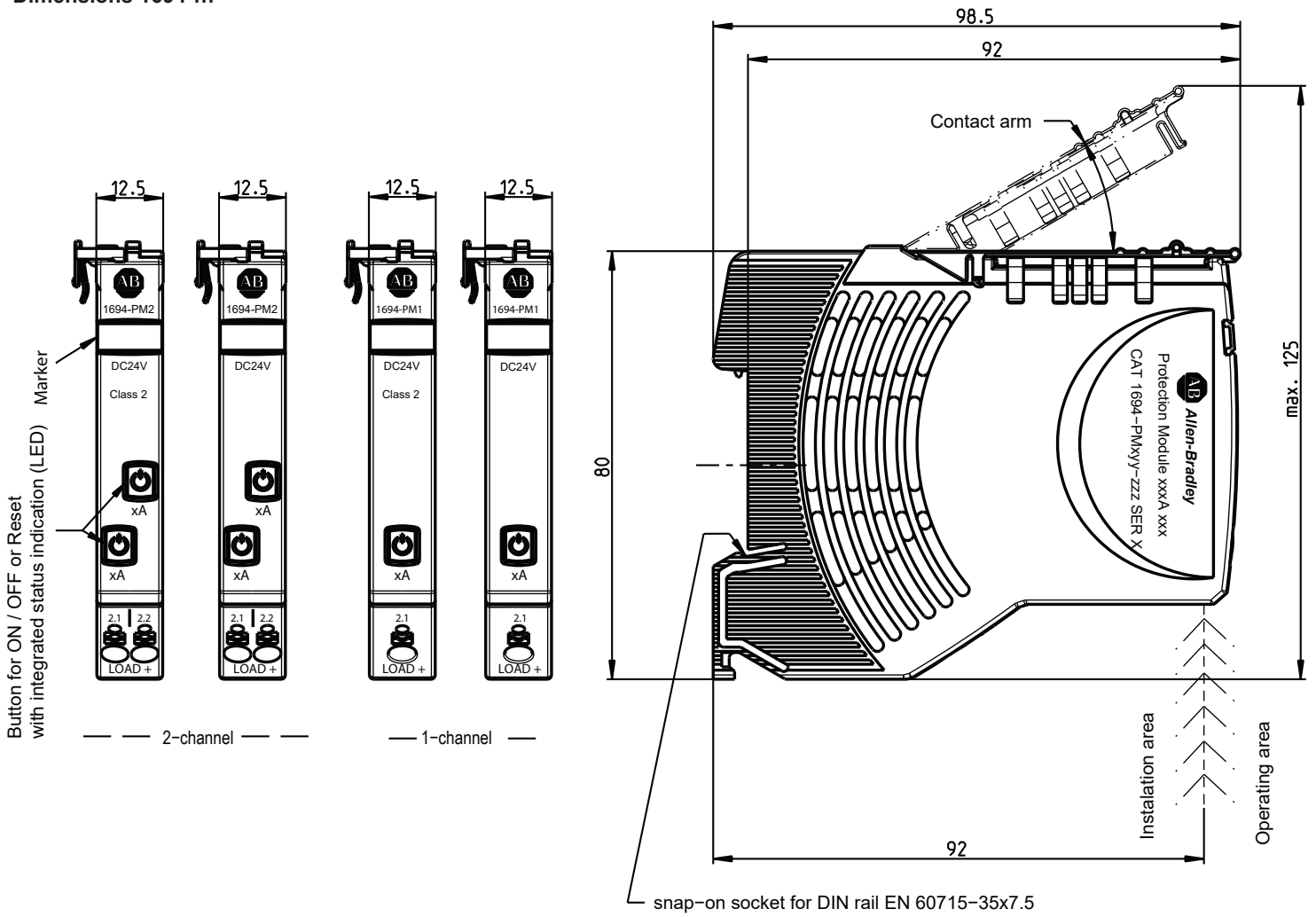

Small opening above the screwdriver insert (marked as 2.1 and 2.2) = voltage measuring point.
 Larger opening under the screwdriver insert (marked as LOAD +) = wire connection area.

General recommendation for all 1694 modules installation.

Screwdriver for installation: blade-style screwdriver size 1 for smaller Push-in terminal (PT 2.5) inserts.

Mounting position: horizontal mounting position is preferred.

Product selection list - 1694-PMx

Catalog Code	Description
1694-PM110	Electronic Circuit Protection, Protection Module, 1-Channel, Fix Current, In 10A
1694-PM11	Electronic Circuit Protection, Protection Module, 1-Channel, Fix Current, In 1A
1694-PM11-CL2	Electronic Circuit Protection, Protection Module, 1-Channel, Fix Current, In 1A, Class 2
1694-PM12	Electronic Circuit Protection, Protection Module, 1-Channel, Fix Current, In 2A
1694-PM12-CL2	Electronic Circuit Protection, Protection Module, 1-Channel, Fix Current, In 2A, Class 2
1694-PM13	Electronic Circuit Protection, Protection Module, 1-Channel, Fix Current, In 3A
1694-PM13-CL2	Electronic Circuit Protection, Protection Module, 1-Channel, Fix Current, In 3A, Class 2
1694-PM14	Electronic Circuit Protection, Protection Module, 1-Channel, Fix Current, In 4A
1694-PM14-CL2	Electronic Circuit Protection, Protection Module, 1-Channel, Fix Current, In 4A, Class 2
1694-PM16	Electronic Circuit Protection, Protection Module, 1-Channel, Fix Current, In 6A
1694-PM18	Electronic Circuit Protection, Protection Module, 1-Channel, Fix Current, In 8A
1694-PM211	Electronic Circuit Protection, Protection Module, 2-Channels, Fix Current, 1A, 1A
1694-PM211-CL2	Electronic Circuit Protection, Protection Module, 2-Channels, Fix Current, 1A, 1A, Class 2
1694-PM222	Electronic Circuit Protection, Protection Module, 2-Channels, Fix Current, 2A, 2A
1694-PM222-CL2	Electronic Circuit Protection, Protection Module, 2-Channels, Fix Current, 2A, 2A, Class 2
1694-PM233	Electronic Circuit Protection, Protection Module, 2-Channels, Fix Current, 3A, 3A
1694-PM233-CL2	Electronic Circuit Protection, Protection Module, 2-Channels, Fix Current, 3A, 3A, Class 2
1694-PM244	Electronic Circuit Protection, Protection Module, 2-Channels, Fix Current, 4A, 4A
1694-PM244-CL2	Electronic Circuit Protection, Protection Module, 2-Channels, Fix Current, 4A, 4A, Class 2
1694-PM266	Electronic Circuit Protection, Protection Module, 2-Channels, Fix Current, 6A, 6A

Bulletin 1694. Power Feed 1694-PFx and Distribution Modules 1694-DMx

Power Feed 1694-PFx: Power Feed Module receives the DC 24 V supply voltage, e.g. from a switched mode power supply, and distributes it to the mounted circuit protectors via the integral connector arm of the 1694-PM.

(The potential-free auxiliary contact in the 1694-PFA1244 indicates any detected failures through the circuit protector, e.g. to the superordinate control unit (CPU).)

Distribution Modules 1694-DMx: For terminal multiplication to add multiple wires for + and – 24VDC

Notes

Please refer to notes section for Electronic circuit protection for 24V DC

Technical data ($T_{amb} = +23\text{ °C}$, $U_B = \text{DC } 24\text{ V}$)**General data - common for 1694-PFx / 1694-DMx**

Mounting method	symmetrical rail to EN 60715-35x7.5
Ambient temperature (T_{amb})	-25°...+60 °C (without condensation, cf. EN 60204-1)
Storage temperature	-30°...+70 °C
Mounting temperature	+5°... +60°C
Humidity:	96 hrs / 95% RH RH/40 °C to IEC 60068-2-78-Cab climate class 3K3 to EN 60721
Corrosion Only 1694-DM and 1694-PF accessories	96hrs. in 5% salt mist to IEC 60068-2-11 test Ka

8 Installation Instructions: Bulletin 1694 Electronic circuit protection for 24V DC

Vibration resistance	3 g, test to IEC 60068-2-6 test Fc	
Degree of protection terminal area 1694-PF, 1694-DM:	IEC 60529, DIN VDE 0470 IP20	
EMC requirements (EMC Directive, CE Logo)	Emitted interference: Noise immunity:	EN 61000-6-3 EN 61000-6-2
Insulation co-ordination (IEC 60934)	0.5 kV / pollution degree 2	
Dielectric strength	max. DC 30 V (load circuit)	
Dimensions	12.5 x 80 x 98 mm	

Data for Distribution Module 1694-DMx

Operational Current	Max. 20 A in total. Max. 10 A per terminal	
Operating voltage U_b	0V - DC 24V (0 ... 30 V)	
Dimensions (h x w x d)	12.5 x 80 x 98.5 mm	
Weight approx.	60 g	
Insulation coordination	0.5 kV / pollution degree 2 For 1694-DM1L2, 1694-DM2L2: 0.8 kV / pollution degree 2	

Data for Power Feed Module 1694-PFx

Operating voltage U_b	DC 24 V (min. 18 V, max. 30 V) (no battery-buffered applications)	
Operating current I_b	1694-PFx: Max. 40 A	
Dimensions (h x w x d)	12.5 x 80 x 98 mm	
Reverse polarity protection	Yes, without load	
Closed current I_o	normal condition: typically 10 mA	(min. 6,5 mA; max. 11,8 mA)
Auxiliary contact potential-free	only in 1694-PFA1244 max. DC 30 V/0.5 A, min. 10 V/1 mA	
Group signalling Si terminal: Si (13) / Si (14)	Auxiliary contact N/O	
Normal condition:	Auxiliary contact closed	
Trip condition:	coming from all protection modules - when ON, load output ON - when OFF, load output OFF auxiliary contact open Coming from one or more protection modules - after disconnection due to overload or short circuit - after undervoltage release of operating voltage in ON condition with auto reset - at no operating voltage U_b in supply module	
Insulation coordination	0.5 kV / pollution degree 2 For 1694-PF3L4C, 1694-PF2L4S: 0.8 kV / pollution degree 2	

Terminals 1694-PFx: LINE+1, 1694-PF3G4: 0V

Push-in terminal PT 10	0.5mm ² to 10mm ² , flexible
	AWG20 – AWG8 str. ⁴
wire stripping length	18mm

⁴ Rockwell Automation recommends to use ferrules for smaller diameter cables

Terminals 1694-PFx: 0 V / Si 13 / Si 14

Push-in terminal PT 2.5	0.14mm ² to 2.5mm ² , flexible
	AWG24 – AWG14 str. ⁵
wire stripping length	8mm to 10mm

⁵ Rockwell Automation recommends to use ferrules for smaller diameter cables

Terminals 1694-DMx: LOAD+, 1694-DM3G2: 0V

Push-in terminal PT 2.5	0.14mm ² to 2.5mm ² , flexible
	AWG24 – AWG14 str. ⁵
wire stripping length	8mm to 10mm

⁵ Rockwell Automation recommends to use ferrules for smaller diameter cables

Dimensions (h x w x d) 12.5 x 80 x 98.5 mm

Weight approx. 60 g

Terminals 1694-DM and 1694-PF

Conformity	1694-DM*	CE Marking RoHS compliant China RoHS WEEE
	1694-PF1G4, 1694-PF3L4C	CE Marking RoHS compliant China RoHS WEEE
	1694-PF1244, 1694-PF2L4S, 1694-PFA1244	CE Marking RoHS compliant China RoHS WEEE Morocco EMC

Approvals: **1694-PF3L4C, 1694-PF1G4, 1694-PF3G4:**
 UL 1059, RA File # E40735
1694-PF2L4S:
 UL 2367, RA File # E350272
 cULus508listed, RA File # E56639
1694-DM1L2, 1694-DM2L2, 1694-DM3G2:
 UL 1059, RA File # E40735



At the End of its life, this equipment should be collected separately from any unsorted municipal waste.

Dimensions: 1694-PF1244 Power Feed Left Mount

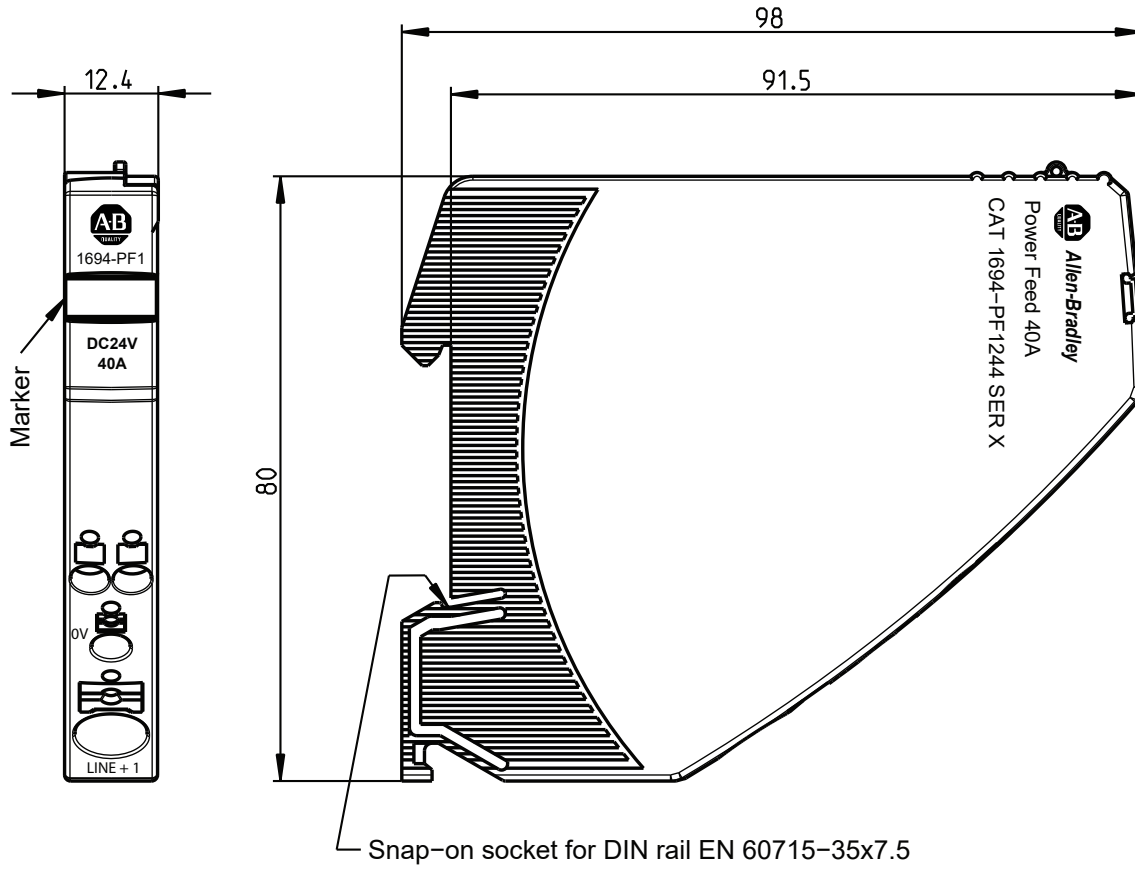

Schematic diagram: 1694-PF1244 (with 1694-PM). Left Mount

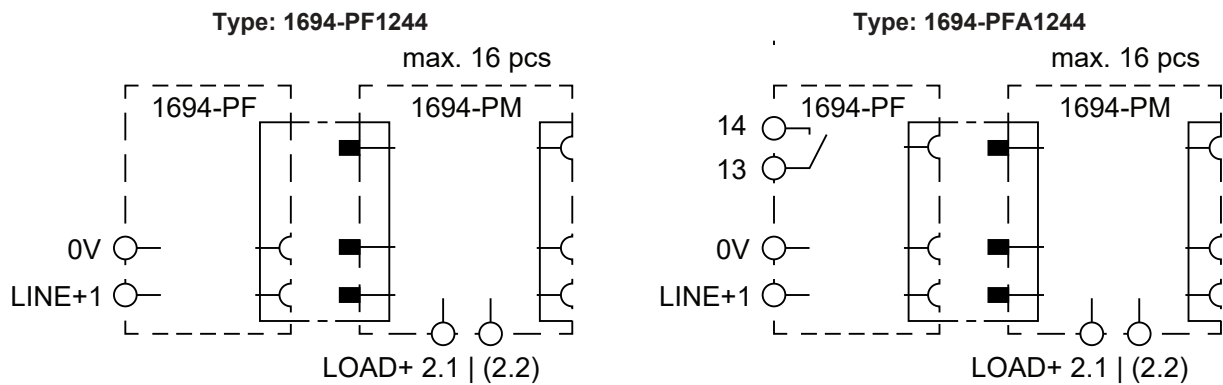

The meaning of diagram is symbolic (there is electrical connection between output and input connections for Line +1 and 0V done by semiconductor element).

Dimensions: 1694-PF3L4C Power Feed. Centre/Right Mount, LINE Connected

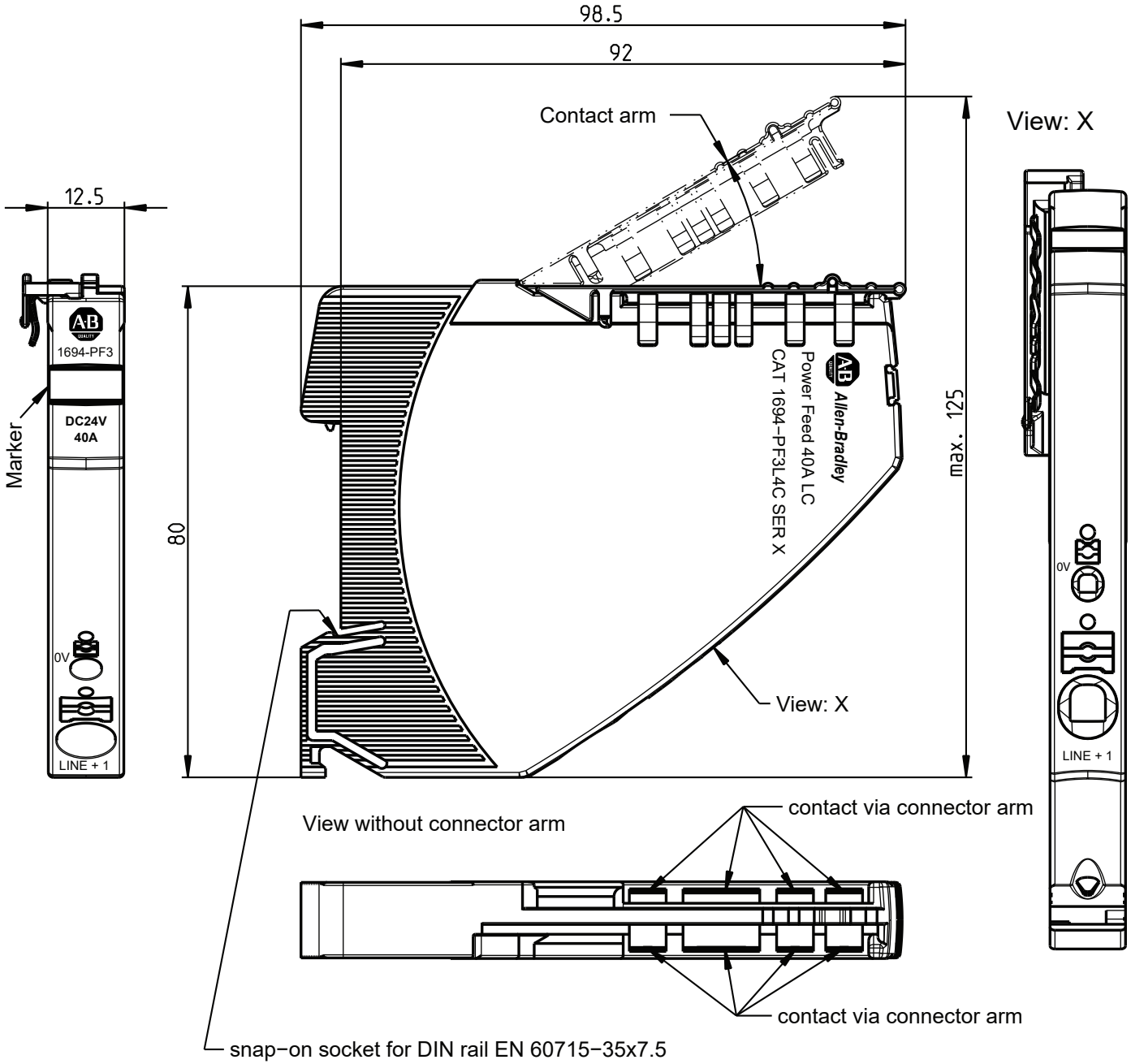

Schematic diagram: 1694-PF3L4C. Centre/Right Mount, LINE Connected

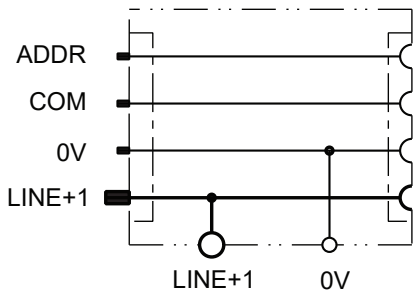

Dimensions: 1694-PF2L4S Power Feed Center Mount, LINE Separated

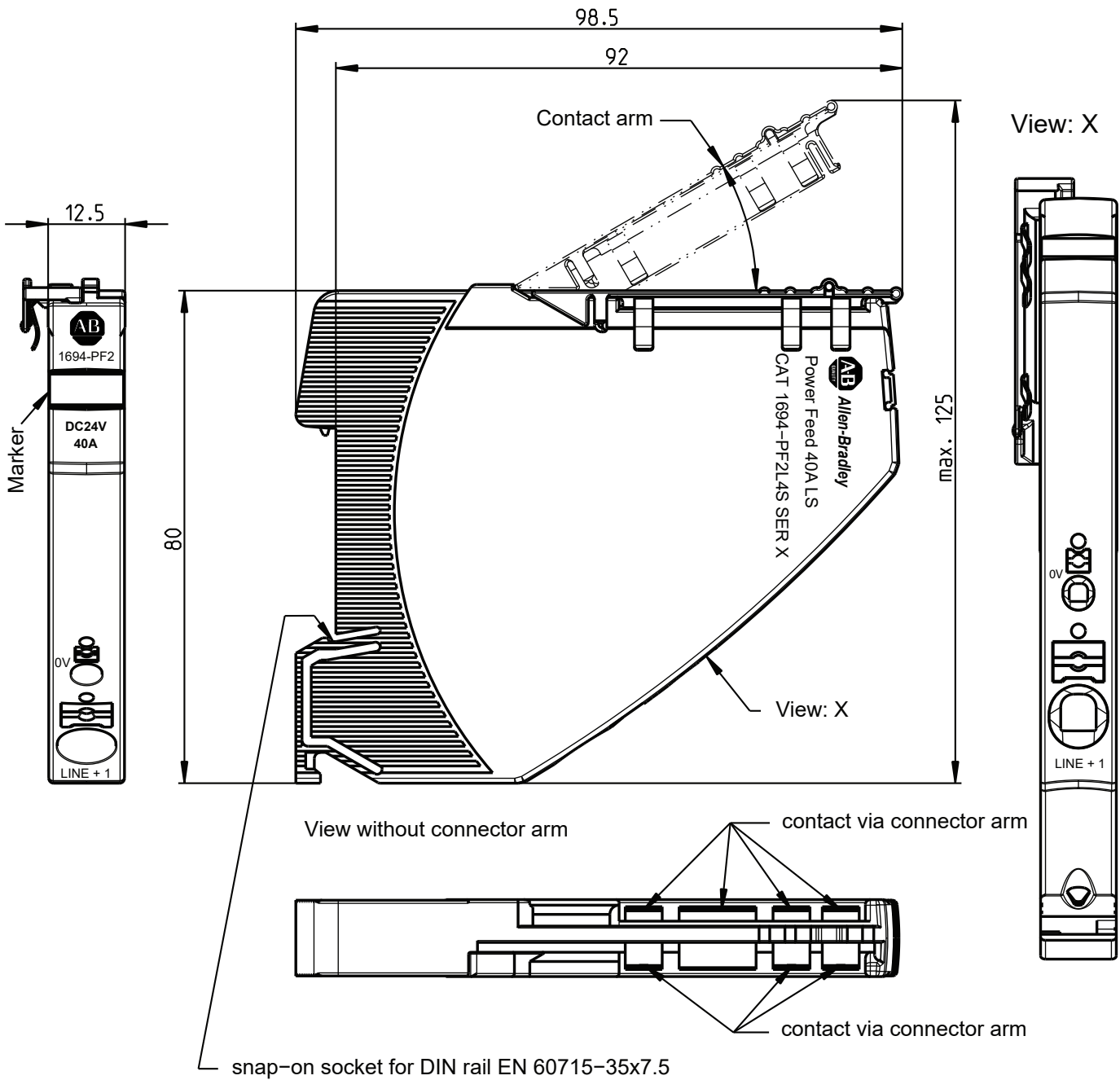

Schematic diagram: 1694-PF2L4S Power Feed Center Mount, LINE Separated

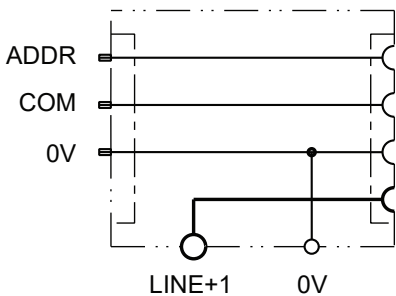

Dimensions: 1694-DM1L2 Distribution Load 10 Terminals, 1xLINE, 9xLOAD, I_{max} 20A

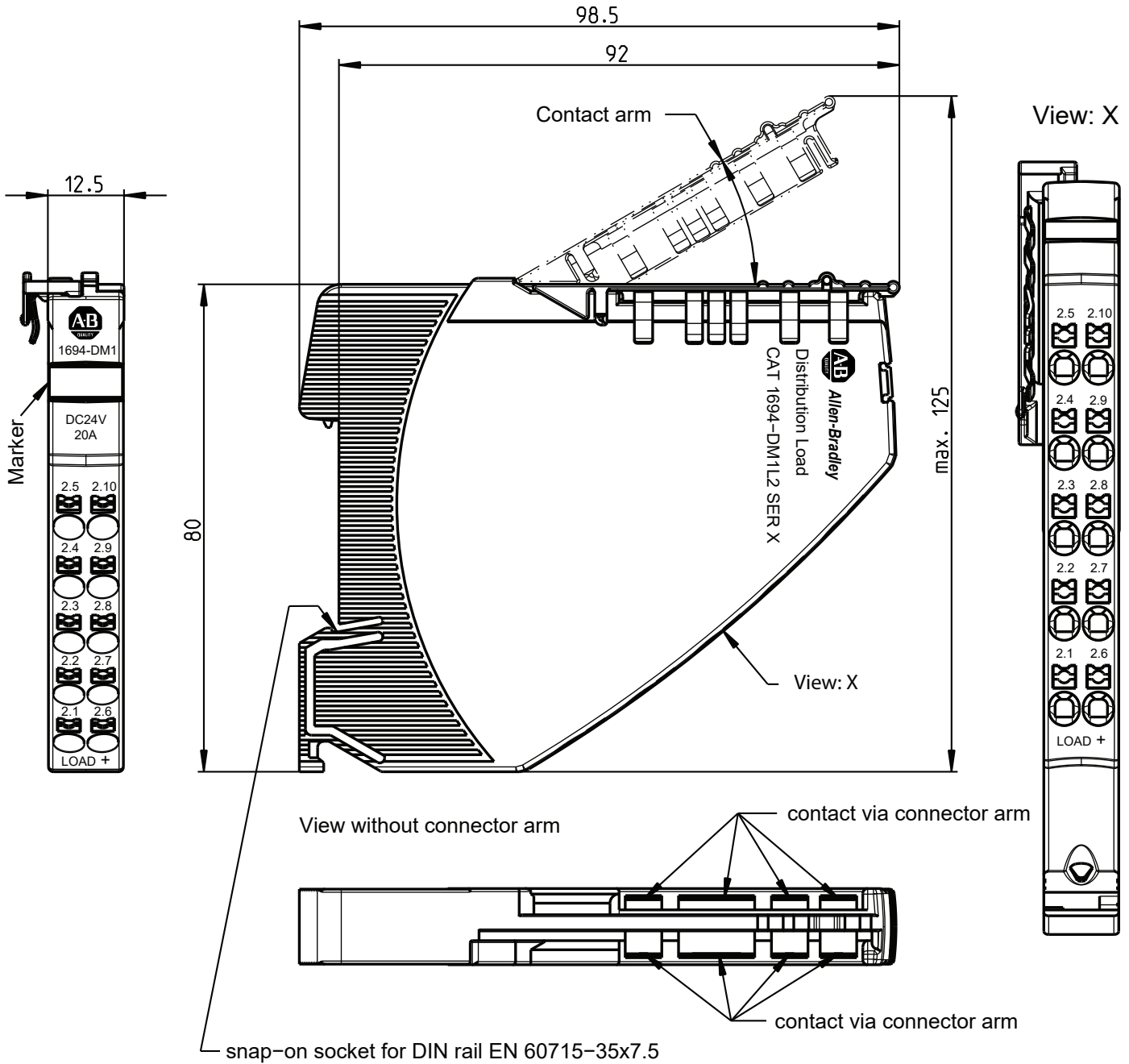

Schematic diagram: 1694-DM1L2 Distribution Load, 10 Terminals, 1xLINE, 9xLOAD, I_{max} 20A

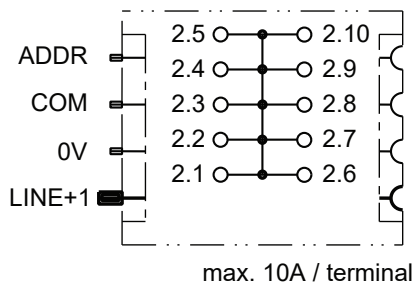

Dimensions: 1694-DM2L2 Distribution Load, 10 Terminals, 2xLINE separated, 4xLOAD each, I_{max} 20A

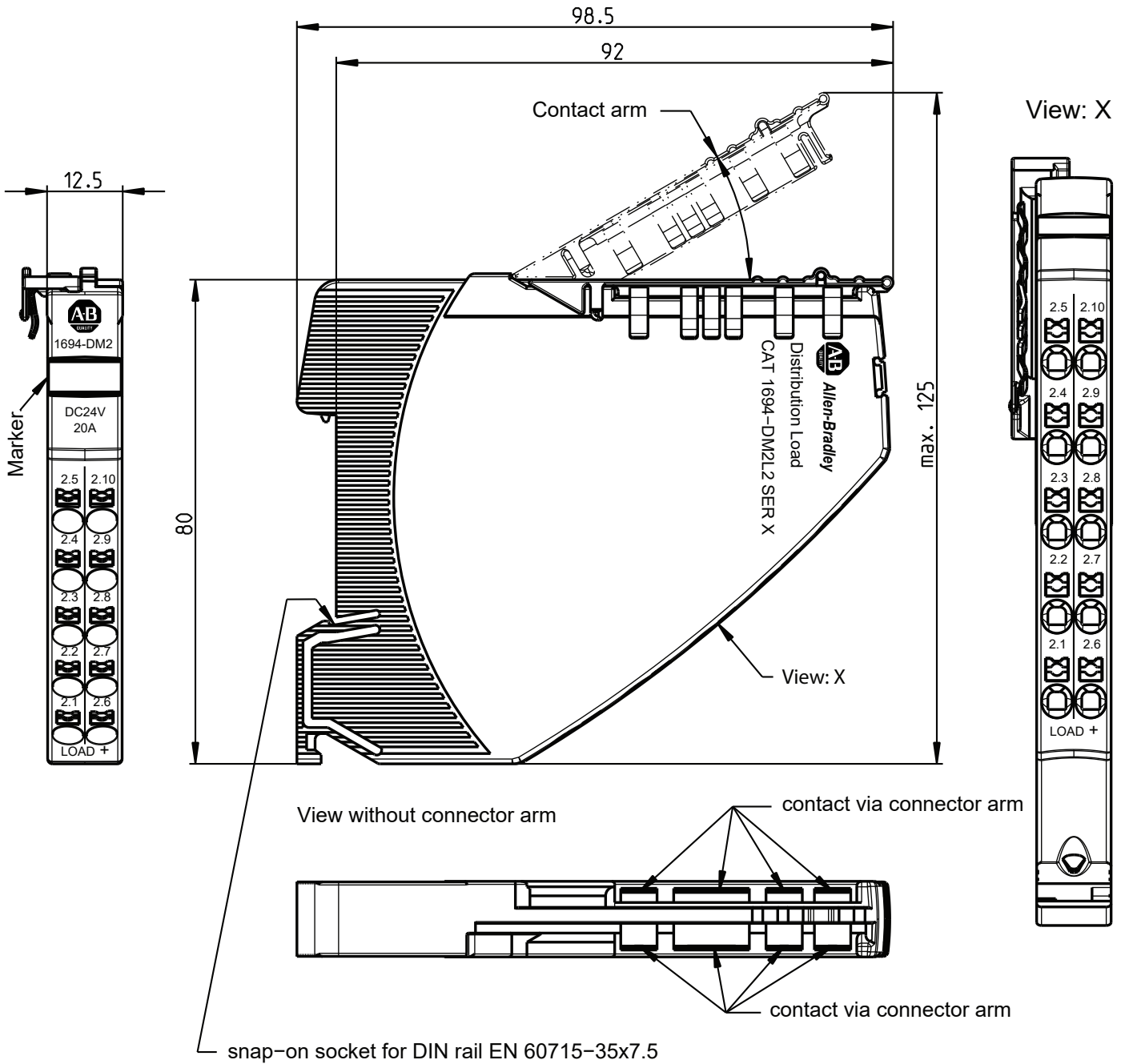

Schematic diagram: 1694-DM2L2 Distribution Load, 10 Terminals, 2xLINE separated, 4xLOAD each, I_{max} 20A

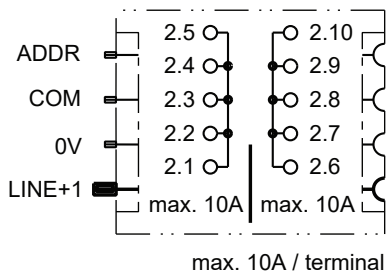

Dimensions: 1694-PF1G4 Power Feed GND, 0V Ground, I_{max} 40A

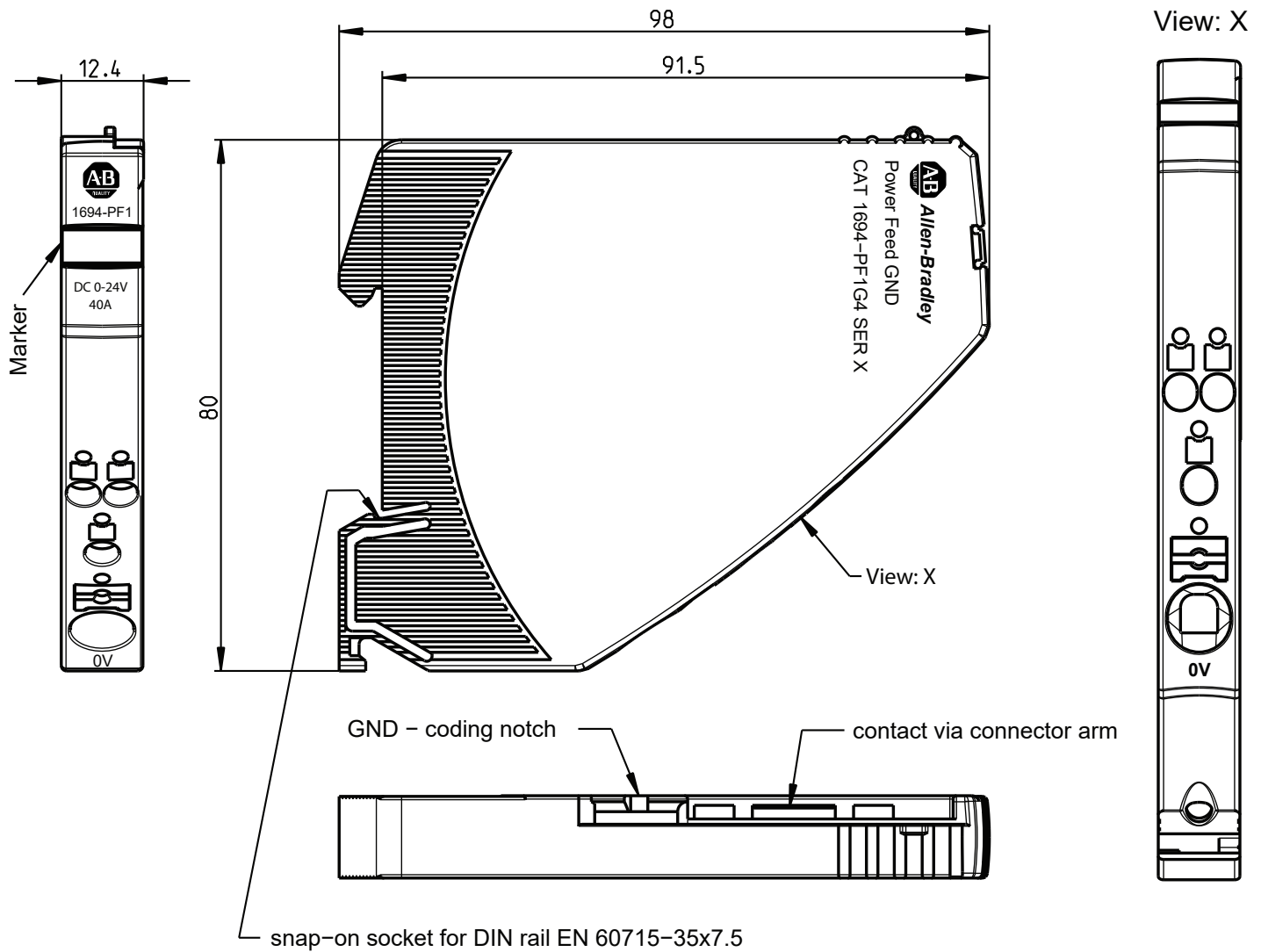

Schematic diagram: 1694-PF1G4 Power Feed GND, 0V Groud, I_{max} 40A

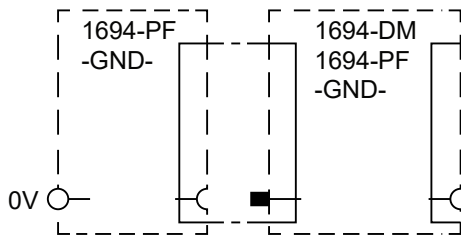

The meaning of diagram is symbolic (there is electrical connection between output and input connections for Line +1 and 0V done by semiconductor element).

Dimensions: 1694-DM3G2 Distribution GND, 10 Terminals, Ground, I_{max} 20A

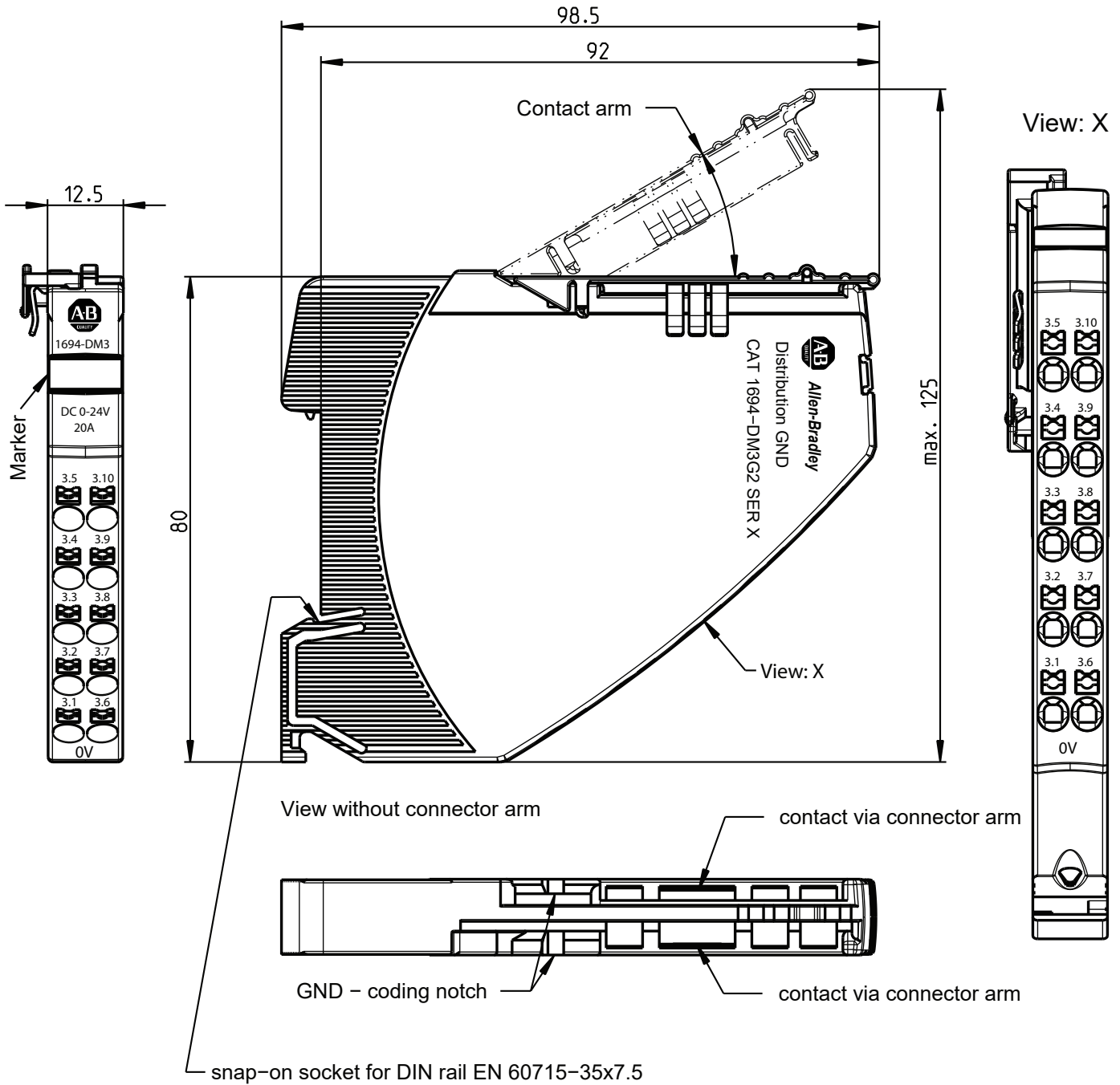

Schematic diagram: 1694-DM3G2 Distribution GND, 10 Terminals, Ground, I_{max} 20A

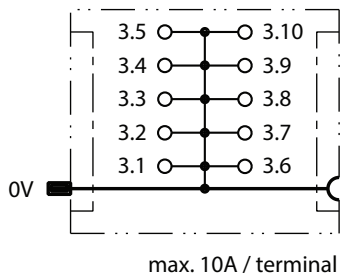

Dimensions: 1694-PF3G4 Power Feed GND Middle or Right Mount, 0V Ground, I_{max} 40A

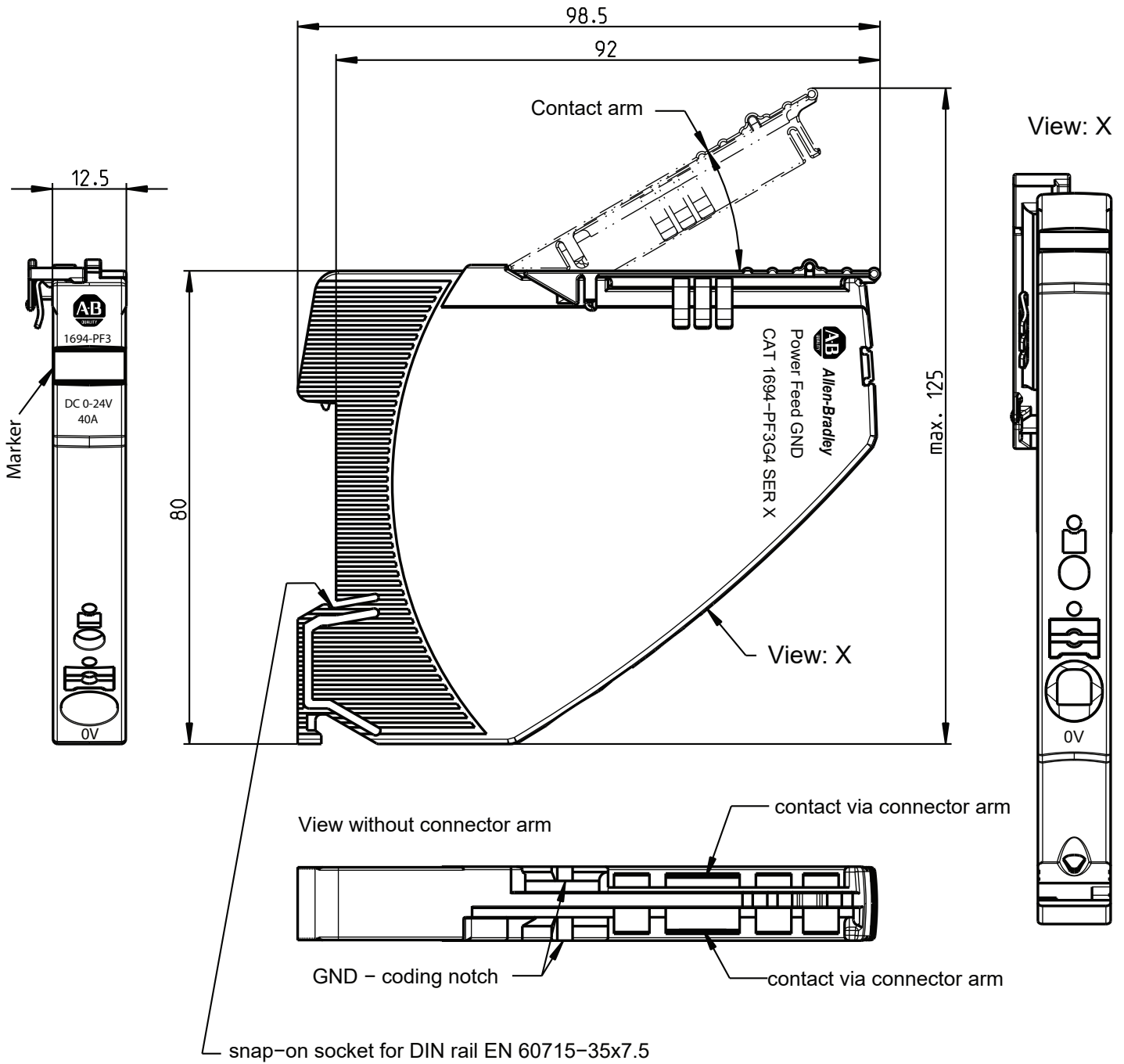

Schematic diagram: 1694-PF3G4 Power Feed GND Middle or Right Mount, 0V Ground, I_{max} 40A

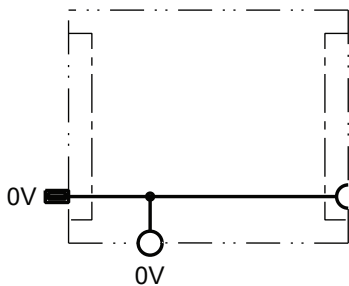

Product selection list - 1694-PFx / 1694-DMx

Catalog Code	Description
1694-PF1244	Power Feed, Left Mount, Supply Voltage 24V DC, I _{max} 40A, No AUX Contact
1694-PFA1244	Power Feed, Left Mount, Supply Voltage 24V DC, I _{max} 40A, with AUX Contact
1694-PF3L4C	Power Feed, Middle or Right Mount, Supply Voltage 24V DC, I _{max} 40A, LINE connected
1694-PF2L4S	Power Feed, Middle Mount, Supply Voltage 24V DC, I _{max} 40A, LINE separated
1694-DM1L2	Distribution Module, 10 Terminals, 1xLINE, 9xLOAD, I _{max} 20A
1694-DM2L2	Distribution Module, 10 Terminals, 2xLINE separate, 4xLOAD each, I _{max} 20A
1694-PF1G4	Power Feed, 0V Ground, I _{max} 40A
1694-DM3G2	Distribution Module, 10 Terminals, Ground, I _{max} 20A
1694-PF3G4	Power Feed, Middle or Right Position, 0V Ground, I _{max} 40A

Sample configuration

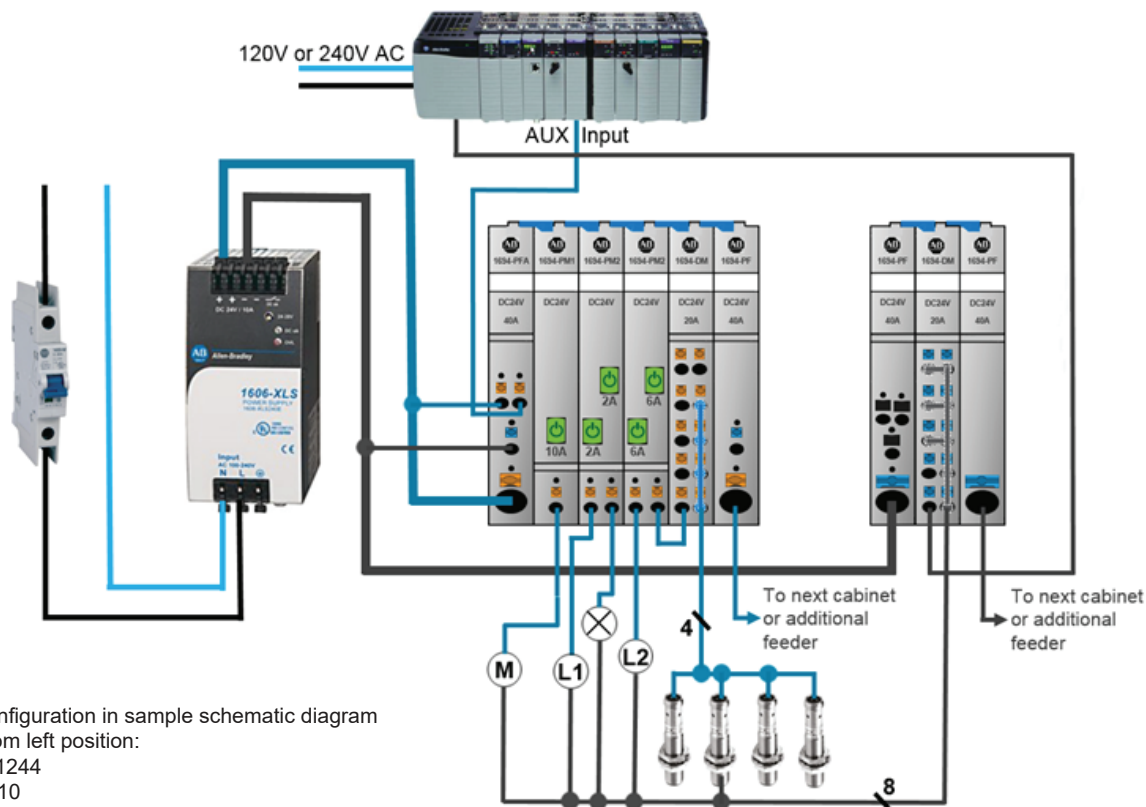

Module configuration in sample schematic diagram
 Starting from left position:
 1694-PFA1244
 1694-PM110
 1694-PM222
 1694-PM266
 1694-DM1L2
 1694-PF3L4C
 1694-PF1G4
 1694-DM3G2
 1694-PF3G4

Mounting on or removing of 1694-... from symmetrical rail

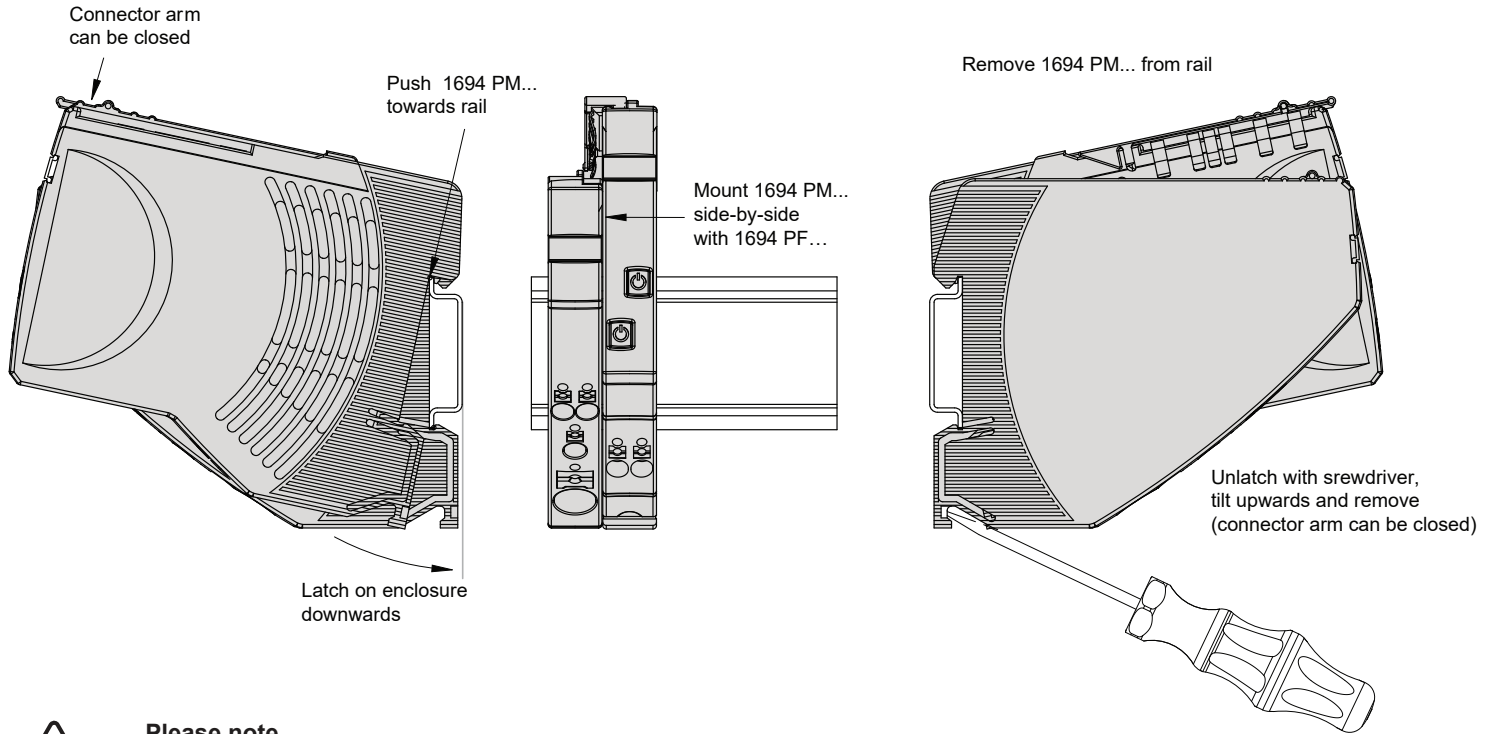

Please note

- Sliding on DIN rail is not permitted.
- Open connector arm carefully to avoid damage

General recommendation for all 1694 modules installation.

Screwdriver for installation:

- blade-style screwdriver size 1 for smaller Push-in terminal (PT 2.5) inserts
- blade-style screwdriver size 4 for larger Push-in terminal (PT 10) inserts

Mounting position:

- horizontal mounting position is preferred

Application example: Latch on housing Replacement or disassembly

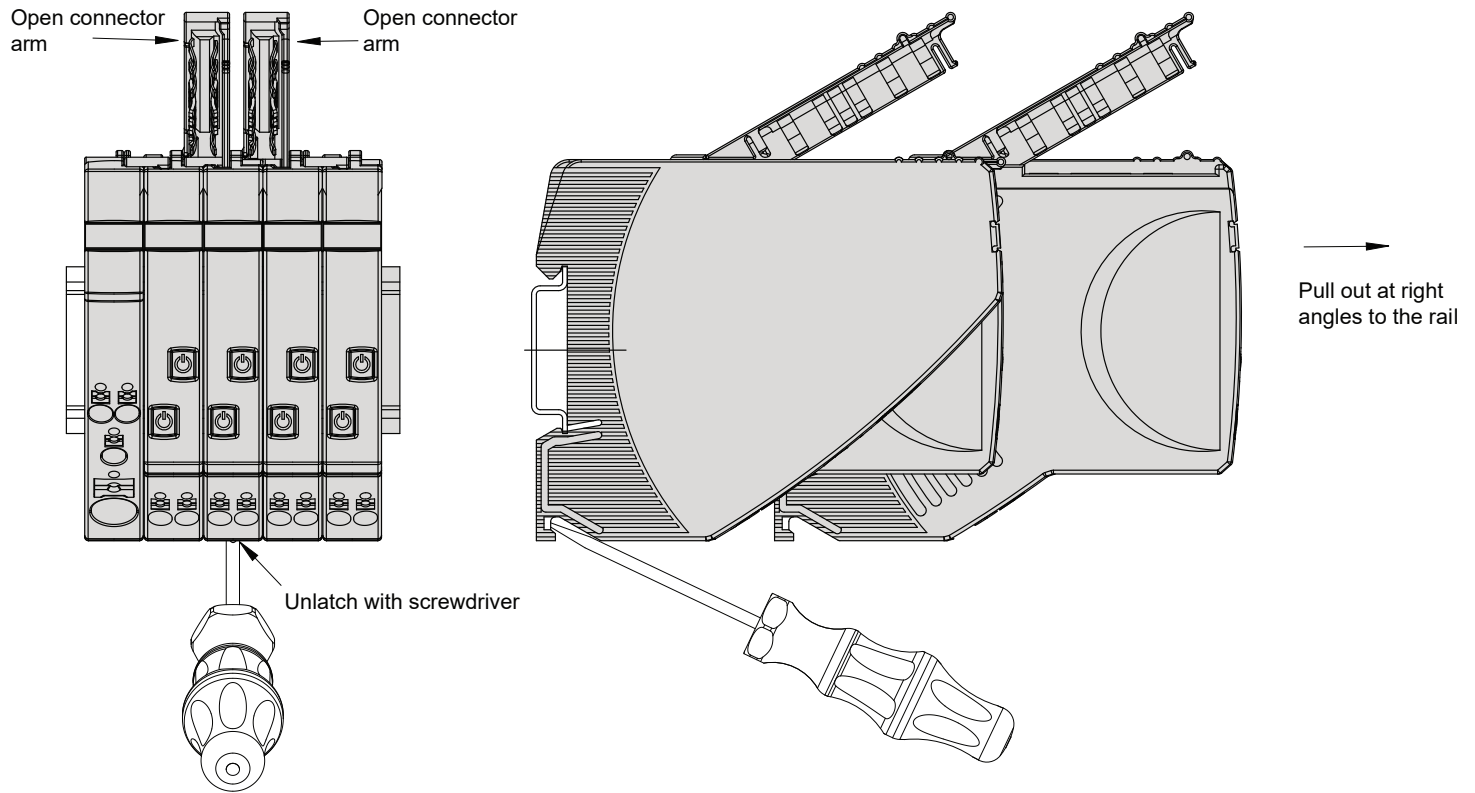

Caution: Exchange/disassembly only in dead-voltage condition! Potentials will be interrupted.

Locked connector arms of 1694-PM...

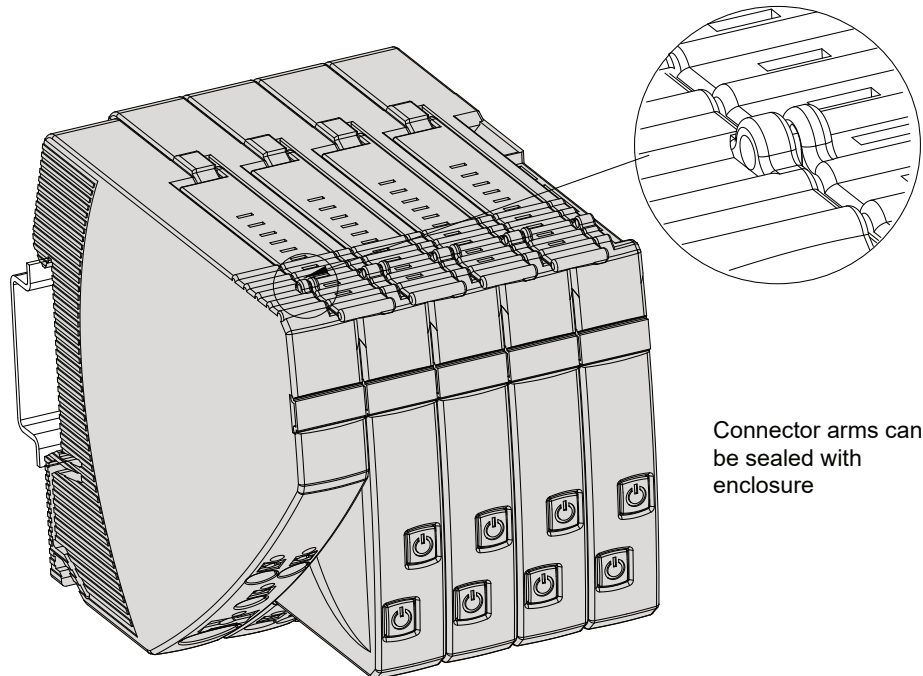

Distance between cable duct and connector arm of 1694-...

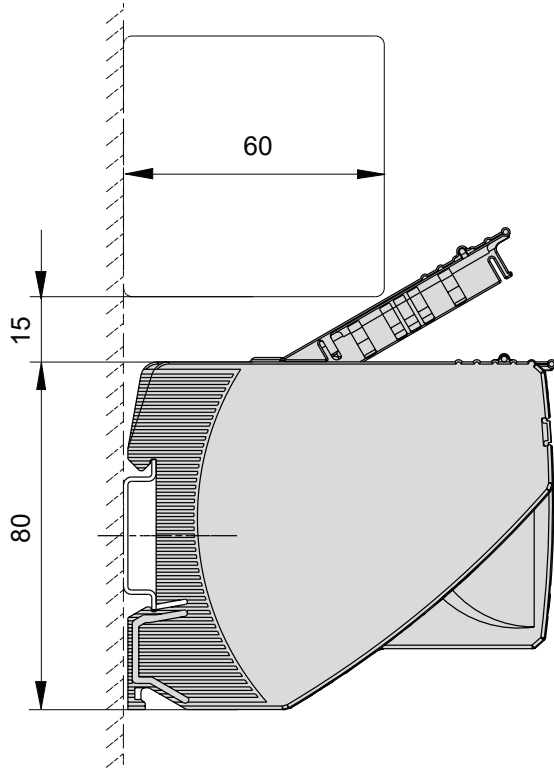

Application example: 1694-... installation area – operating area

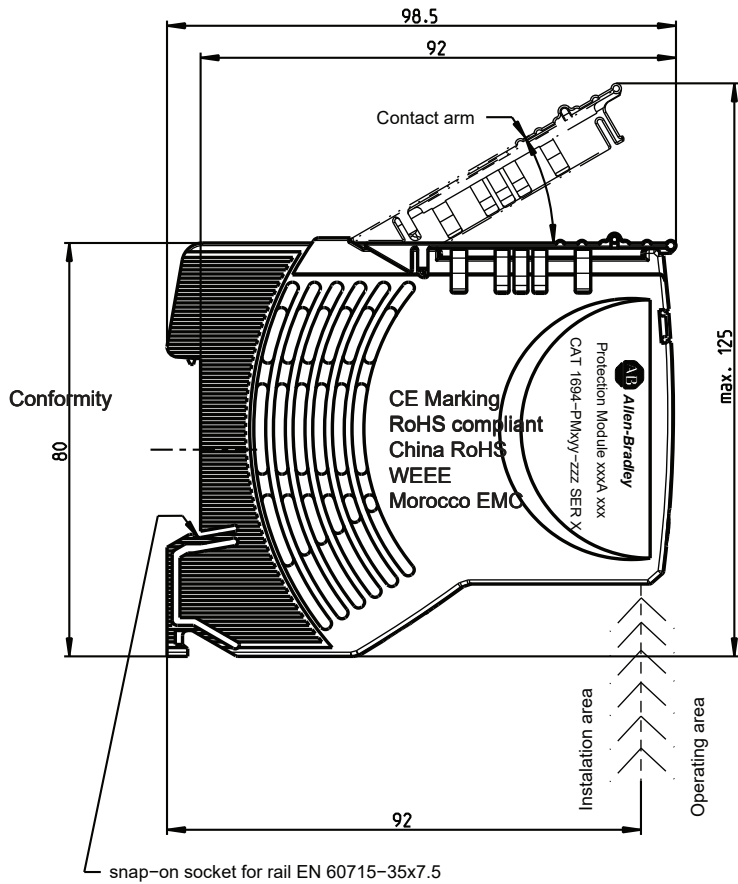

Rockwell Automation Support

Rockwell Automation maintains current product environmental information on its website at:

<http://www.rockwellautomation.com/rockwellautomation/about-us/sustainability-ethics/product-environmental-compliance.page>





Installation Instructions, Manuals, Brochures, and Technical Data:

<https://www.rockwellautomation.com/global/literature-library/overview.page>

Bulletin 1694 web page:

<https://rok.auto/1694-ECP>

For the latest product information updates please check above links or www.rockwellautomation.com

Connect with us.    

For Technical Support, visit ROK.AUTO/SUPPORT.

Rockwell Automation maintains current product environmental compliance information on its website at rok.auto/pec.

Rockwell Otomasyon Ticaret A.Ş. Kar Plaza İş Merkezi E Blok Kat:6 34752 İçerenköy, İstanbul, Tel: +90 (216) 5698400
EEE Yönetmeliğine Uygundur

rockwellautomation.com ————— expanding **human possibility™**

AMERICAS: Rockwell Automation, 1201 South Second Street, Milwaukee, WI 53204-2496 USA, Tel: (1) 414.382.2000, Fax: (1) 414.382.4444

EUROPE/MIDDLE EAST/AFRICA: Rockwell Automation NV, Pegasus Park, De Kleetlaan 12a, 1831 Diegem, Belgium, Tel: (32) 2 663 0600, Fax: (32) 2 663 0640

ASIA PACIFIC: Rockwell Automation, Level 14, Core F, Cyberport 3, 100 Cyberport Road, Hong Kong, Tel: (852) 2887 4788, Fax: (852) 2508 1846

Allen-Bradley, Rockwell Automation, and Rockwell Software are trademarks of Rockwell Automation.
Trademarks not belonging to Rockwell Automation are property of their respective companies.

Publication 1694-IN002E-EN-E - June2020

Copyright ©2020 Rockwell Automation, Inc. All Rights Reserved. Printed in USA.



DIR 10005220601 (Version 03)