

Installation, Operation and Maintenance Manual

Please read and save these instructions for future reference. Read carefully before attempting to assemble, install, operate or maintain the product described. Protect yourself and others by observing all safety information. Failure to comply with these instructions will result in voiding of the product warranty and may result in personal injury and/or property damage.

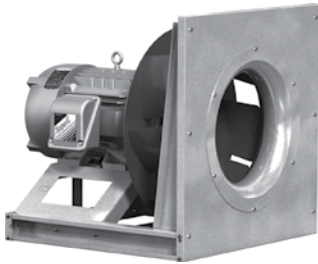

Model APD - Advanced Plenum Direct

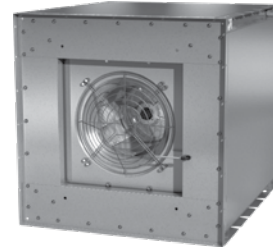

Model HPA - Housed Plenum Array

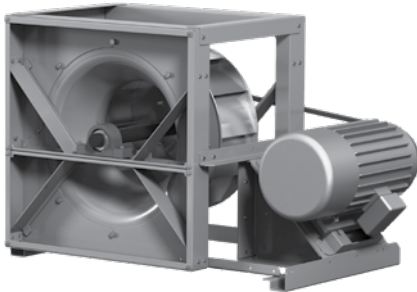

Model APM - Advanced Plenum Medium Pressure

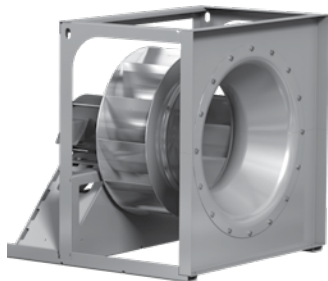

Model APH - Advanced Plenum High Pressure

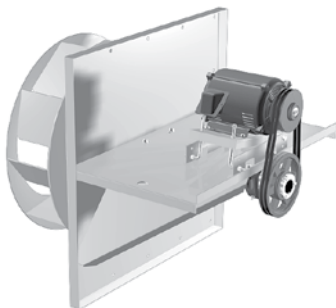

Model PLG - Plug

DANGER

Always disconnect, lock and tag power source before installing or servicing. Failure to disconnect power source can result in fire, shock or serious injury.

CAUTION

When servicing the fan, motor may be hot enough to cause pain or injury. Allow motor to cool before servicing.

CAUTION

Precaution should be taken in explosive atmospheres.

DANGER

Pour écarter les risques d'incendie, de choc électrique ou de blessure grave, veiller à toujours débrancher, verrouiller et étiqueter la source de courant avant l'installation ou l'entretien.

ATTENTION

Lors de toute intervention sur la soufflante, le moteur peut être suffisamment chaud pour provoquer une douleur voire une blessure. Laisser le moteur refroidir avant toute maintenance.

ATTENTION

Faire preuve de précaution dans les atmosphères explosives.

Table of Contents

General Safety Information	2
General Information	4
Fans – Rigging and Lifting	5
Installation - Housed Plenum Array	6
Installation - Plenum and Plug Fans	6
Installation - Plenum and Plug Fans (continued)	7
V-Belt Drives	8
Radial Gap, Overlap and Wheel Alignment	9
Radial Gap, Overlap and Wheel Alignment (continued)	10
Field Coating Touch-Up Procedure for Scratched Areas	10
Electrical Connections	10
Unit Start-Up	11
Variable Frequency Drive (VFD) Operation.	11
Vibration	12
Routine Maintenance	12
Parts List	14
Parts List (continued)	15
Troubleshooting	15
Maintenance Log.	16

General Safety Information

Only qualified personnel should install this fan. Personnel should have a clear understanding of these instructions and should be aware of general safety precautions. Improper installation can result in electric shock, possible injury due to coming in contact with moving parts, as well as other potential hazards. Other considerations may be required if high winds or seismic activity are present. If more information is needed, contact a licensed professional engineer before moving forward.

1. Follow all local electrical and safety codes, as well as the National Electrical Code (NEC), the National Fire Protection Agency (NFPA), where applicable. Follow the Canadian Electric Code (CEC) in Canada.
2. The rotation of the wheel is critical. It must be free to rotate without striking or rubbing any stationary objects.
3. Motor must be securely and adequately grounded.
4. Do not spin fan wheel faster than max cataloged fan rpm. Adjustments to fan speed significantly effects motor load. If the fan RPM is changed, the motor current should be checked to make sure it is not exceeding the motor nameplate amps.
5. Do not allow the power cable to kink or come in contact with oil, grease, hot surfaces or chemicals. Replace cord immediately if damaged.
6. Verify that the power source is compatible with the equipment.
7. Never open access doors to a duct while the fan is running.

Receiving

Upon receiving the product check to ensure all items are accounted for by referencing the delivery receipt or packing list. Inspect each crate or carton for shipping damage before accepting delivery. Alert the carrier of any damage detected. The customer will make a notation of damage (or shortage of items) on the delivery receipt and all copies of the bill of lading which is countersigned by the delivering carrier. If damaged, immediately contact your Greenheck representative. Any physical damage to the unit after acceptance is not the responsibility of Greenheck Fan Corporation.

Unpacking

Verify that all required parts and the correct quantity of each item have been received. If any items are missing report shortages to your local representative to arrange for obtaining missing parts. Sometimes it is not possible that all items for the unit be shipped together due to availability of transportation and truck space. Confirmation of shipment(s) must be limited to only items on the bill of lading.



Handling

Fans are to be rigged and moved by the lifting brackets provided or by the skid when a forklift is used. Location of brackets varies by model and size. Handle in such a manner as to keep from scratching or chipping the coating. Damaged finish may reduce the ability of the fan to resist corrosion. Fans should never be lifted by the shaft, fan housing, motor, belt guard, windband or accessories.

Storage

- Rotate fan wheel monthly and purge bearings once every three months
- Energize fan motor once every three months
- Store belts flat to keep them from warping & stretching
- Store unit in location which does not have vibration
- After storage period, purge grease before putting fan into service

If storage of fan is in a humid, dusty or corrosive atmosphere, rotate the fan and purge the bearings once a month. Improper storage which results in damage to the fan will void the warranty.

Fans are protected against damage during shipment. If the unit cannot be installed and operated immediately, precautions need to be taken to prevent deterioration of the unit during storage. The user assumes responsibility of the fan and accessories while in storage. The manufacturer will not be responsible for damage during storage. These suggestions are provided solely as a convenience to the user.

The ideal environment for the storage of fans and accessories is indoors, above grade, in a low humidity atmosphere which is sealed to prevent the entry of blowing dust, rain, or snow. Temperatures should be evenly maintained between 30°F (-1°C) and 110°F (43°C) (wide temperature swings may cause condensation and “sweating” of metal parts). All accessories must be stored indoors in a clean, dry atmosphere.

Remove any accumulations of dirt, water, ice or snow and wipe dry before moving to indoor storage. To avoid “sweating” of metal parts allow cold parts to reach room temperature. To dry parts and packages use a portable electric heater to get rid of any moisture build up. Leave coverings loose to permit air circulation and to allow for periodic inspection.

The unit should be stored at least 3½ in. (89 mm) off the floor on wooden blocks covered with moisture proof paper or polyethylene sheathing. Aisles between parts and along all walls should be provided to permit air circulation and space for inspection.

Inspection & Maintenance during Storage

While in storage, inspect fans once per month. Keep a record of inspection and maintenance performed.

If moisture or dirt accumulations are found on parts, the source should be located and eliminated. At each inspection, rotate the wheel by hand ten to fifteen revolutions to distribute lubricant on motor. If paint deterioration begins, consideration should be given to touch-up or repainting. Fans with special coatings may require special techniques for touch-up or repair.

Machined parts coated with rust preventive should be restored to good condition promptly if signs of rust occur. Immediately remove the original rust preventive coating with petroleum solvent and clean with lint-free cloths. Polish any remaining rust from surface with crocus cloth or fine emery paper and oil. Do not destroy the continuity of the surfaces. Wipe clean thoroughly with Tectyl® 506 (Ashland Inc.) or the equivalent. For hard to reach internal surfaces or for occasional use, consider using Tectyl® 511M Rust Preventive or WD-40® or the equivalent.

Removing from Storage

As fans are removed from storage to be installed in their final location, they should be protected and maintained in a similar fashion, until the fan equipment goes into operation.

Prior to fully assembling and installing the fan and system components, inspect the fan assembly to make sure it is in working order.

1. Check all fasteners, set screws, wheel, bearings, drive, motor base and accessories for tightness.
2. Rotate the fan wheel by hand and assure not parts are rubbing. Access to the wheel is obtained through an access panel located on the side of the fan housing.
3. Ensure proper wheel settings for radial gap and alignment. See pages 9-10.

General Information

To ensure a successful installation, the instructions in this manual should be read and adhered to. Failure to comply with proper installation procedures may void the warranty.

Unit and System Identification Tags

Each fan has a permanently affixed manufacturer's engraved metal nameplate containing the model number and individual serial number.

The tag shown is an example of an identification nameplate on the fan. The information provides general details about the fan, as well as containing specific information unique to the unit. When contacting your Greenheck representative with future needs or questions, please have the information on this label available. Tags are mounted in an area which is clearly visible, usually on the side of the fan cabinet.

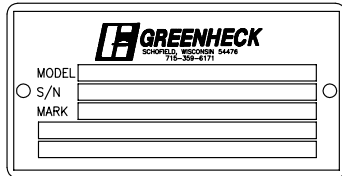

Air Pressure and Suction

In addition to the usual hazards associated with rotating machinery, fans also create a dangerous suction at the inlet. Special caution needs to be used when moving around a fan, whether it is in operation or not. Before start-up, make sure the inlet area is clear of personnel and loose objects.

Pre-Installation Information

Before installation, it is important to be certain the mounting surface will bear the operating weight of the unit. For proper unit operation, it is also important that it be operated in a completely level position.

For further details on safety practices involving industrial and commercial fans, please refer to AMCA Publication 410.

Electrical Disconnects

All fan motors should have disconnects located in close visual proximity to turn off electrical service. Service disconnects shall be locked-out when maintenance is being performed.

Moving Parts

All moving parts must have guards to protect personnel. Refer to local codes for requirements as to the number, type and design. Fully secure fan wheel before performing any maintenance. The fan wheel may start "free wheeling" even if all electrical power has been disconnected. Before the initial start-up or any restart, check the following items to make sure that they are installed and secure.

- Do not spin fan wheel faster than the maximum cataloged fan rpm.
- Adjustments to fan speed significantly affects motor load. If the fan RPM is changed, the motor current should be checked to make sure it is not exceeding the motor nameplate amps.

Belt Guards

Do not operate fans without proper protective devices in place. Failure to do so may result in serious bodily injury and property damage. Check local codes to ensure compliance for all protective devices.

Fans – Rigging and Lifting

CAUTION

Fans should never be lifted by the shaft, motor, motor cover or accessories.

Fans are to be rigged and moved by the lifting brackets and/or lifting points provided or by the skid when a forklift is used. Location of brackets varies by model and size. Handle in such a manner as to keep from scratching or chipping the coating. Damaged finish may reduce ability of fan to resist corrosion. See coating repair section of this manual for details involving touch-up of damaged surfaces.

- Use standard lifting and rigging practices including the use of spreader bars.
- **ALL** lifting brackets on each component must be utilized at the same time.
- Fan to be kept level during lifting and installation.

APD

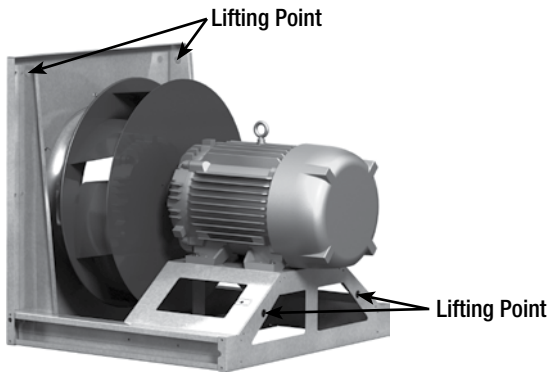

APM

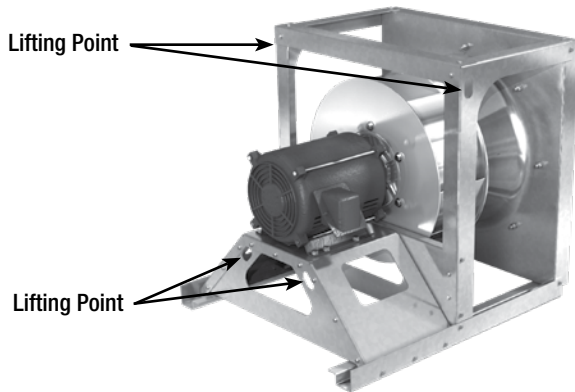

APH

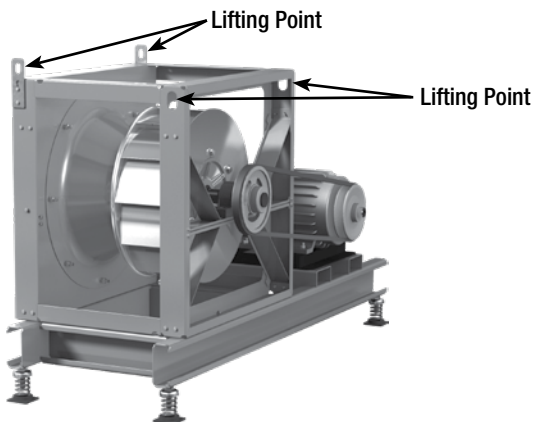

Installation - Housed Plenum Array

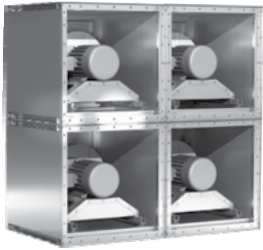

- Carefully remove any crate and packing materials.
- Place the fan onto the mounting structure using the recommended lifting points and hooking method as shown. Lift each fan individually into its proper position.

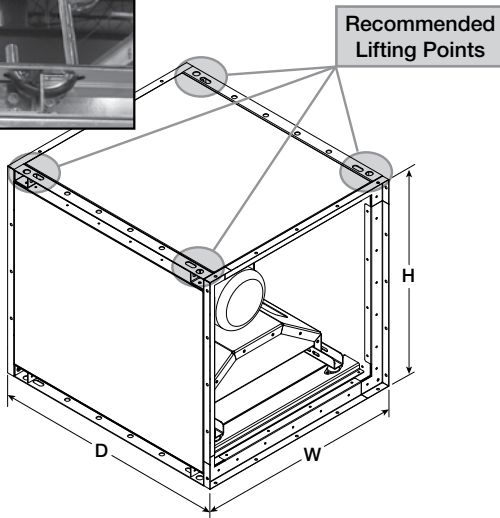

- Bolt the fan to the floor and adjacent fans using the inlet and outlet mounting flanges. The first layer of fans should be securely installed before installing the second layer of fans.
- Thin gasket material or caulk between fans is recommended to prevent unwanted noise of air.
- Do not exceed the maximum number of stacked modules (refer to table).

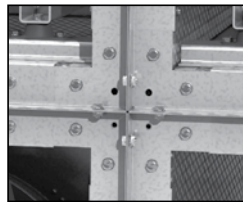

Installation - Plenum and Plug Fans

Unhoused Wheels

Adjacent Walls - The distance between the fan and walls or ceilings will effect the performance of the fan. The recommended distance between the fan wheel and any wall is a minimum of one-half wheel diameter. Multiple walls reduce the performance even more.

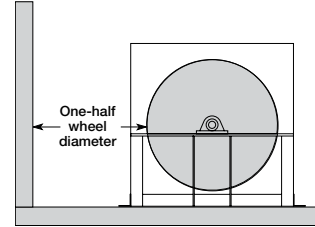

Side by Side - When two or more plenum fans are in parallel, there should be at least one fan diameter spacing between the wheels. Applications with less spacing will experience performance losses.

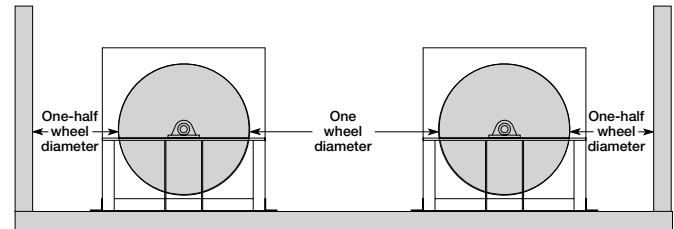

CAUTION

When installing a fan, ensure the proper protective devices are used to protect personnel from moving parts and other hazards. A complete line of protective accessories are available from Greenheck including inlet guards, outlet guards, belt guards, shaft guards, protective cages, and electrical disconnects.

Wheel Size	Standard Housing			Maximum Stacked Modules	Maximum Motor Frame	Weight* (lbs.)
	W	H	D [^]			
15	29.00	29.00	32.06	4	215T	215
16	31.50	31.50	37.00		256T	250
18	34.38	34.38	38.19	3	256T	290
20	37.25	37.25	39.56		256T	340
22	41.00	41.00	42.19		286T	380
24	44.75	44.75	43.75	2	286T	425
27	48.94	48.94	47.56		286T	680
30	53.81	53.81	48.94		326T	820
33	58.81	58.81	51.06		326T	960
36	64.56	64.56	51.06		326T	1100

Dimensions are in inches.

[^]Does not account for motors or accessories.

*Weight is less motor and drives.

Installation - Plenum and Plug Fans (continued)

Belt Guards

Greenheck offers various types of customized belt guards dependent upon fan model, arrangement and motor position. Motor position is determined from the drive side.

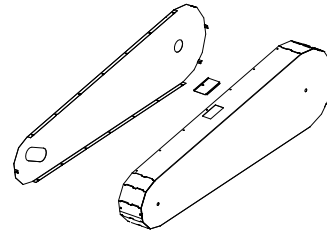
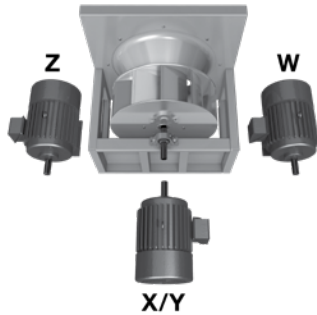

APH, Arr 1, 3
Motor Position (W/Z)

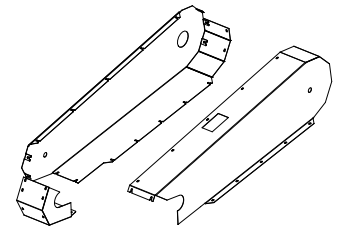

APH Arr 1, 3
Motor Position (X/Y)

APM, PLG Arr 9

The various types of belt guards are shown in these illustrations. If the guard is not purchased from Greenheck, they must be supplied by the installer or owner.

If the belt guard is not factory mounted or was not supplied by Greenheck, then it must be field mounted. **Brackets and mounting hardware are the responsibility of the installer.**

This figure illustrates the suggested attachment point for belt guard mounting bracket locations. These locations vary with motor mounting position, arrangement, and fan type. The bearing supports and fan structure are used in most instances and when the motor is not mounted to the fan itself, a bracket should also be located near it.

This information is intended as only a guide and actual field conditions may dictate another mounting location for the guard brackets. Refer to local codes for securing guarding.

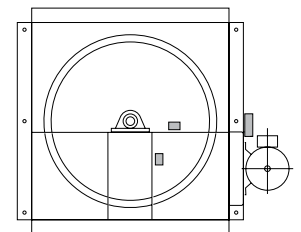

Motor Position: Side

Suggested Attachment Points
(shaded gray)

Bases (Foundation and Isolation)

Critical to every fan installation is a strong, level foundation. A reinforced poured concrete pad with a structural steel base or inertia base provides an excellent foundation. Structural bases must be sturdy enough, with welded construction, to prevent flexing and vibration.

To eliminate vibration and noise from being transferred to the building, vibration isolators should be used. The fan is mounted directly on the isolation base and must be supported for the entire length of the fan base angle (Refer to the installation manual for structural bases if the base was supplied by Greenheck). Isolators are installed between the isolation base and the foundation.

After the fan, isolation base, and isolators are installed, the entire assembly must be leveled. Position the level on the isolation base, not the fan shaft, for proper leveling. Additionally, the motor and fan shafts must be level and parallel relative to each other for proper alignment.



Typical Fan on Isolation Base with Isolators

V-Belt Drives

V-Belt Drive Installation

The V-belt drive components, when supplied by Greenheck, have been carefully selected for this unit's specific operating condition.

IMPORTANT

Changing V-belt drive components could result in unsafe operating conditions which may cause personal injury or failure of the following components:

- Fan shaft
- Fan wheel
- Bearings
- V-belt
- Motor

1. Remove the protective coating from the end of the fan shaft and assure that it is free of nicks and burrs.
2. Check fan and motor shafts for parallel and angular alignment.
3. Slide sheaves on shafts, Do not drive sheaves on as this may result in bearing damage.
4. Align fan and motor sheaves with a straight edge or string, and tighten.
5. Place belts over sheaves. Do not pry or force belts, as this could result in damage to the cords in the belts.
6. Adjust the tension until the belts appear snug. Run the unit for a few minutes (see section on Unit Start-Up) and allow the belts to seat properly. Refer to Greenheck's Product Application Guide "Measuring Belt Tension" for additional information.
7. With the fan off, adjust the belt tension by moving the motor base. (See belt tensioning procedures in the maintenance section of this manual). When in operation, the tight side of the belts should be in a straight line from sheave to sheave with a slight bow on the slack side.

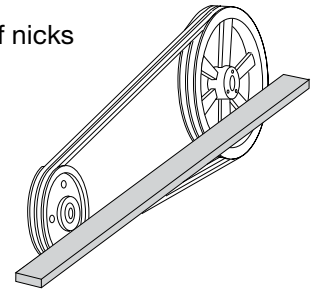

Aligning Sheaves with a Straight Edge

Alignment of Pulleys and Belts

Check pulleys and belts for proper alignment to avoid unnecessary belt wear, noise, vibration and power loss. Motor and drive shafts must be parallel and pulleys in line as shown.

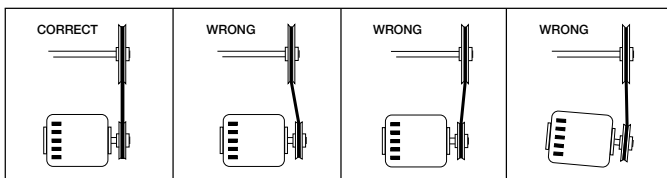

The adjustable motor pulley is set at the factory for the fan RPM specified by the customer. Fan RPM can be increased by closing or decreased by opening the adjustable motor pulley. Multi-groove variable pitch pulleys must be adjusted an equal number of turns open or closed. Any increase in fan speed represents a substantial increase in load on the motor.

To avoid motor overheating and possible burnout, motor load amperes should always be checked and compared to nameplate rating when fan speed is increased.

Radial Gap, Overlap and Wheel Alignment

Efficient fan performance can be maintained by having the correct radial gap, overlap and wheel alignment. These items should be checked after the fan has been in operation for 24 hours and before start-up after the unit has been serviced.

Unit Size	PLG Inlet Cone to Backplate				APM, APH Wheel Cone to Inlet Cone				HPA Wheel Cone to Inlet Cone			
	A Dimension* ± Tolerance (in.)		A Dimension* ± Tolerance (mm)		Offset ± Tolerance (in.)		Offset ± Tolerance (mm)		Offset ± Tolerance (in.)		Offset ± Tolerance (mm)	
7	1 ³ / ₁₆	± 1/8	30	± 3								
8	2 ³ / ₁₆	± 1/8	36	± 3								
9	3 ³ / ₁₆	± 1/8	81	± 3								
10	3 ⁷ / ₁₆	± 1/8	87	± 3								
12	4	± 1/8	102	± 3	1/8	± 1/16	3	± 1.5	7/16	± 1/16	11	± 1.5
13	4 ⁷ / ₁₆	± 1/8	113	± 3								
15	5	± 1/8	127	± 3	1/8	± 1/16	3	± 1.5	7/16	± 1/16	11	± 1.5
16	5 ⁷ / ₁₆	± 1/8	138	± 3	3/16	± 1/16	5	± 1.5	7/16	± 1/16	11	± 1.5
18	6 ³ / ₈	± 1/8	162	± 3	3/16	± 1/16	5	± 1.5	7/16	± 1/16	11	± 1.5
20	7	± 3/16	178	± 5	1/4	± 1/16	6	± 1.5	7/16	± 1/16	11	± 1.5
22	7 ¹³ / ₁₆	± 3/16	198	± 5	1/4	± 1/16	6	± 1.5	7/16	± 1/16	11	± 1.5
24	8 ⁵ / ₈	± 1/4	219	± 6	5/16	± 1/16	8	± 1.5	7/16	± 1/16	11	± 1.5
27	9 ⁷ / ₁₆	± 1/4	240	± 6	3/8	± 1/16	9.5	± 1.5	9/16	± 1/8	14	± 1.5
30	10 ⁹ / ₁₆	± 3/8	268	± 10	3/8	± 1/16	9.5	± 1.5	9/16	± 1/8	14	± 1.5
33	11 ⁷ / ₁₆	± 3/8	291	± 10	7/16	± 1/16	11	± 1.5	9/16	± 1/8	14	± 1.5
36	12 ³ / ₄	± 3/8	324	± 10	7/16	± 1/8	11	± 3	9/16	± 1/8	14	± 3
40	14 ³ / ₁₆	± 3/8	360	± 10	1/2	± 1/8	13	± 3				
44	15 ⁹ / ₁₆	± 3/8	395	± 10	9/16	± 1/8	14	± 3				
49	17 ¹ / ₈	± 1/2	435	± 13	5/8	± 1/8	16	± 3				
54	18 ¹³ / ₁₆	± 1/2	478	± 13	5/8	± 1/8	16	± 3				
60	20 ¹⁵ / ₁₆	± 1/2	532	± 13	3/4	± 1/8	19	± 3				
66	22 ⁷ / ₈	± 1/2	581	± 13	7/8	± 1/8	22	± 3				
73	25 ¹ / ₂	± 1/2	648	± 13	1	± 1/8	25	± 3				

*A dimension does not apply to partial width wheels.

Radial Gap, Overlap and Wheel Alignment (continued)

Unit Size	APD Wheel Back to Inlet Cone			
	Overlap		Overall Assembly	
	in.	mm	in.	mm
315	0.12	3.15	7.26	184
355	0.14	3.55	8.17	208
400	0.16	4.0	9.01	231
450	0.18	4.5	10.15	259
500	0.20	5.0	11.32	288
560	0.22	5.6	12.8	325
630	0.25	6.3	14.49	368

Radial Gap (model PLG) is adjusted by loosening the inlet cone bolts and centering the cone/ring on the wheel. If additional adjustment is required to maintain a constant radial gap, loosening the bearing bolts and centering the wheel is acceptable as a secondary option.

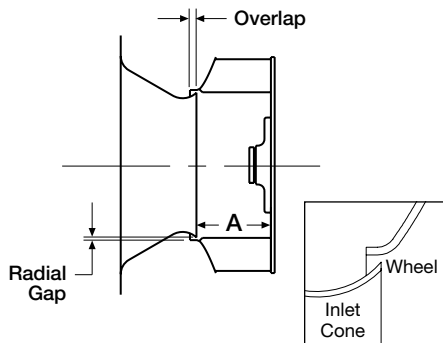

PLG

Overlap, or offset, (model APD, APM, APH, HPA) is adjusted by loosening the wheel hub from the shaft and moving the wheel to the desired position along the motor shaft. The transition between the inlet cone and wheel should be as shown; there is a smooth feel to the profile when moving from one component to the other.

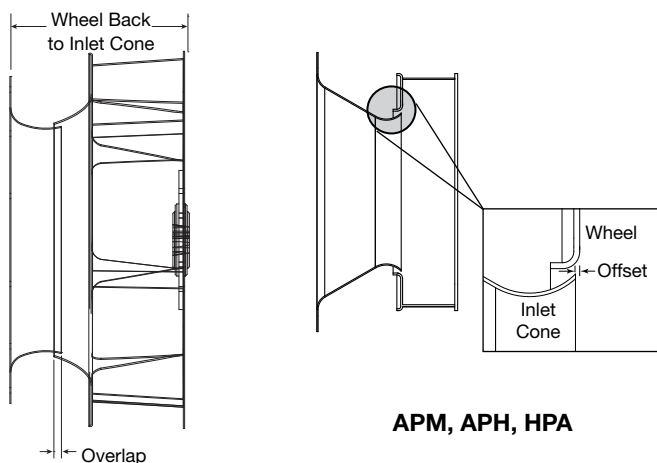

APM, APH, HPA

APD

Field Coating Touch-Up Procedure for Scratched Areas

Standard coating is Greenheck's Concrete Grey, RAL 7023. The procedure below details the correct method for repairing minor scratches in the coating.

TOUCH-UP PAINT REPAIR KIT CONTENTS

- One pint of Kem Kromik primer
 - including a technical data sheet
- One pint of industrial enamel
 - including a technical data sheet
- Four disposable foam brushes
- One sheet sandpaper
- Repair procedure details

1. Scuff affected area to be repaired using medium sandpaper (provided) or medium scotch brite pad. Feather the edges.
2. Clean affected area to be touched up using an alkaline based cleaner and rinse.
3. Apply Kem Kromik primer using 1 inch foam brush (provided). Follow technical data sheet instructions.
4. Allow primer to dry a minimum of 2-1/2 hours before top coating.
5. Apply topcoat with industrial enamel using 1 inch foam brush (provided). Follow technical data sheets instructions. Allow painted units to air-dry and cure before putting into service. See enclosed Technical Data sheets for detailed drying and cure schedules at different temperatures.

To order additional coating repair kits please reference Greenheck's part number HAZ2597, PNT FIELD REPAIR KIT, RAL 7023 CONCRETE GREY kit. Please contact factory with your fan's serial number for colors other than our standard.

Electrical Connections

Before electrical connections are made, the supply voltage, phase and ampere capacity must be checked for compatibility with the fan motor. In addition, the supply wiring must be properly fused and conform to local and national electrical codes. If the unit is supplied with a safety disconnect switch, ensure proper wiring to the fan motor. Be sure the disconnect is switched to the "OFF" position before connecting supply wires. If no disconnect is supplied, ensure the supply wire is not live before connection. Supply wires are then connected to the optional safety disconnect switch (if supplied) or motor.

Unit Start-Up

WARNING

Disconnect and secure to the “Off” position all electrical power to the fan prior to inspection or servicing. Failure to comply with this safety precaution could result in serious injury or death.

Visual Inspection of Equipment

The equipment type and arrangement should be verified as ordered at once when it arrives at the jobsite. When a discrepancy is found, the local Greenheck sales representative must be notified immediately so that corrective action may be investigated, also verify electrical conformance to specifications. Unauthorized alterations and unauthorized backcharges will not be recognized by Greenheck Fan Corporation.

After the unit has been assembled, installed and all utilities have been hooked up, the unit is now ready for operation.

Check

Before starting the unit, check the following:

1. Confirm that building supply voltage matches the voltage for which the unit is wired.
2. Disconnect and lock-out all power switches to fan. See warning below.
3. Check all piping and wiring penetrations made by contractors for water tightness. All penetrations must be made watertight to prevent water damage to the unit and building.
4. Check all fasteners, set screws and locking collars on the fan, bearings, drive, motor base and accessories for tightness.
5. Rotate the fan wheel by hand and assure no parts are rubbing. Remove any dirt or debris that may have accumulated during installation.
6. Check for bearing alignment and lubrication.
7. Check the V-belt drive for proper alignment and tension.
8. Check all guarding (if supplied) for being securely attached and not interfering with rotating parts.
9. Check all electrical connections for proper attachment.
10. Check for obstructions and foreign material that may damage the fan wheel.

Additional Steps for Initial Start-Up

1. Check for proper wheel rotation by momentarily energizing the fan. Rotation is always determined by viewing the wheel from the drive side and should correspond to the rotation decal affixed to the unit.

Note: One of the most frequently encountered problems with centrifugal fans is motors which are wired to run in the wrong direction. This is especially true with 3-phase installations where the motor will run in either direction, depending on how it has been wired. To reverse rotation of a 3-phase motor, interchange any two of the three electrical leads. Single phase motors can be reversed by changing internal connections as described on the motor label or wiring diagram.

2. Fans with multi-speed motors should be checked on low speed during initial start-up.
3. Check for unusual noise, vibration or overheating of bearings. Refer to the “Troubleshooting” section of this manual if a problem develops.
4. Grease may be forced out of the bearing seals during initial start-up. This is a normal self-purging feature of this type of bearing.

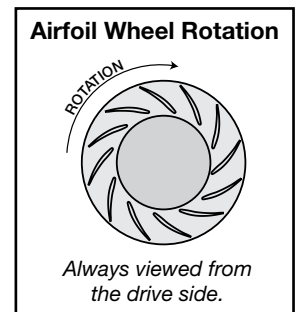

Variable Frequency Drive (VFD) Operation

Fan vibration levels differ with the method of installation. Operating a fan on a variable frequency drive (VFD) may experience certain speed ranges with excessively high vibration levels and possible resonant frequencies. Problem speed ranges or resonant frequencies can be determined during the commissioning process. Either run through this resonant range as quickly as possible, program out operation at determined Hz to skip over these speeds, or find alternative remedy.

It is the responsibility of the installing body to perform coast-down tests and identify any resonant frequencies after the equipment is fully installed. These resonant frequencies are to be removed from the operating range of the fan by using the “skip frequency” function in the VFD programming. Failure to remove resonant frequencies from the operating range will decrease the operating life of the fan and void the warranty.



Vibration

Excessive vibration is the most frequent problem experienced during initial start-up.

Left unchecked, excessive vibration can cause a multitude of problems, including structural and/or component failure.

Common Sources of Vibration

1. Wheel Unbalance
2. Drive Pulley Misalignment
3. Incorrect Belt Tension
4. Bearing
5. Mechanical Looseness
6. Faulty Belts
7. Drive Component Unbalance
8. Poor Inlet/Outlet Conditions
9. Foundation Stiffness

Many of these conditions can be discovered by careful observation. Refer to the troubleshooting section of this manual for corrective actions. If observation cannot locate the source of vibration, a qualified

technician using vibration analysis equipment should be consulted. If the problem is wheel unbalance, in-place balancing can be done providing there is access to the fan wheel. Any correction weights added to the wheel should be attached securely.

Greenheck performs a vibration test on all centrifugal fans before shipping. Three vibration readings are taken on each bearing in the horizontal, vertical, and axial directions.

The maximum allowable vibration for models PLG and APM (belt and direct drive) and APH (belt drive) is 0.15 in/sec. peak velocity filter-in at the fan rpm per AMCA Standard 204.

The maximum allowable vibration for models APD and HPA (direct drive) is 0.10 in/sec. and for model APH (direct drive) is 0.08 in.sec. peak velocity filter-in at the fan rpm per AMCA Standard 204.

These vibration signatures are a permanent record of how the fan left the factory and are available upon request.

Generally, fan vibration and noise is transmitted to other parts of the building by the ductwork. To eliminate this undesirable effect, the use of heavy canvas connectors is recommended. If fireproof material is required, Flexweave™ 1000, Type FN-30 can be used.

Routine Maintenance

CAUTION

When performing any service to the fan, disconnect the electrical supply and secure fan impeller.

Once the unit has been put into operation, a routine maintenance schedule should be set up to accomplish the following:

1. Lubrication of bearings and motor (see below).
2. Wheel, housing, bolts and set screws on the entire fan should be checked for tightness.
3. Any dirt accumulation on the wheel or in the housing should be removed to prevent unbalance and possible damage.
4. Isolation bases should be checked for freedom of movement and the bolts for tightness. Springs should be checked for breaks and fatigue. Rubber isolators should be checked for deterioration.
5. Inspect fan impeller and housing looking for fatigue, corrosion, or wear.

When performing any service to the fan, disconnect the electrical supply and secure fan impeller.

Fan Operation

All fans should be run every thirty (30) days, or at least “bumped” every thirty days. It is preferred that each fan is run as this causes all electrical and mechanical components to get up to temperature, displacing any formed condensation, redistributes load on bearings, and redistributes grease in the bearings (motor and shaft bearings).

CAUTION

- Always check the fan RPM when adjusting the operating frequency. Do not exceed maximum class fan RPM of the wheel.
- When operating conditions of the fan are to be changed (speed, pressure, temperature, etc.), consult Greenheck to determine if the unit can operate safely at the new conditions.

Motors

Motor maintenance is generally limited to cleaning and lubrication. Cleaning should be limited to exterior surfaces only. Removing dust and grease build up on the motor housing assists proper motor cooling. Never wash-down motor with high pressure spray. Many fractional motors are permanently lubricated for life and require no further lubrication. Motors supplied with grease fittings should be greased in accordance with the manufacturer’s recommendations.

Belt Drive Maintenance

V-belt drives must be checked on a regular basis for wear, tension, alignment and dirt accumulation. Premature or frequent belt failures can be caused by improper belt tension, (either too loose or too tight) or misaligned sheaves. Abnormally high belt tension or drive misalignment will cause excessive bearing loads and may result in failure of the fan and/or motor bearings. Conversely, loose belts will cause squealing on start-up, excessive belt flutter, slippage, and overheated sheaves. Either excessively loose or tight belts may cause fan vibration.

When replacing V-belts on multiple groove drives all belts should be changed to provide uniform drive loading. Do not pry belts on or off the sheave. Loosen belt tension until belts can be removed by simply lifting the belts off the sheaves. After replacing belts, insure that slack in each belt is on the same side of the drive. Belt dressing should never be used.

Do not install new belts on worn sheaves. If the sheaves have grooves worn in them, they must be replaced before new belts are installed.

The proper tension for operating a V-belt drive is the lowest tension at which the belts will not slip at peak load conditions. Belts are adjusted by raising or lowering the motor pivot plate. For initial tensioning, the proper belt deflection halfway between sheave centers is 1/64-inch per each inch of belt span.

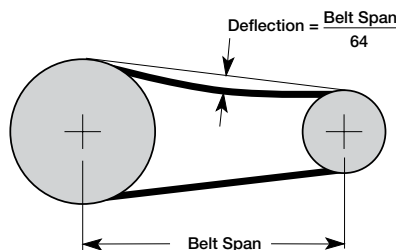

For more information about measuring belt tension, refer to Greenheck's Product Application Guide, FA/127-11, Measuring Belt Tension, found online at www.greenheck.com in the library section.

Check belt tension before start up and after the first 24 hours of operation. The belt tension should also be checked periodically thereafter.

Variable Frequency Drive Operation

For operation with Variable Frequency Drive (VFD), always check motor amps when adjusting the operating frequency. Motor may be sized for the original selected operating speed under 60 Hz. Bypassing the VFD or increasing the speed from this original selection, even if less than 60 Hz, may cause motor overload or failure. Consult factory—with fan serial number—before increasing the upper limiting frequency.

Always check the fan rpm when adjusting the operating frequency. Do not exceed maximum class fan rpm of the wheel.

Shaft Bearings

The bearings for Greenheck fans are carefully selected to match the maximum load and operating conditions of the specific class, arrangement, and fan size. The instructions provided in this manual and those provided by the bearing manufacturer, will minimize any bearing problems. Bearings are the most critical moving part of the fan, therefore special care is required when mounting them on the unit and maintaining them.

Refer to the following chart and the manufacturer's instructions for grease types and intervals for various operating conditions. Never mix greases made with different bases. This will cause a breakdown of the grease and possible failure of the bearing.

Recommended Bearing Lubrication Schedule Relubrication Schedule in Months*								
Fan RPM	Bearing Bore (inches)							
	1/2 - 1	1 1/8 - 1 1/2	1 5/8 - 1 7/8	1 15/16 - 2 1/16	2 1/16 - 2 3/16	2 3/8 - 2 1/2	2 5/8 - 3 1/8	3 1/4 - 3 7/8
To 250	12	12	12	12	12	12	10	8
500	12	12	11	10	8	7	5	4
750	12	9	8	7	6	4	3	2
1000	12	7	6	5	4	3	2	1
1250	12	6	5	4	3	2	1	.5
1500	12	5	4	3	2	1	.75	
2000	12	3	3	2	1	.5	.25	
2500	12	2	2	1	.5	.25		
3000	12	2	1	.5	.25			
3500	12	1	.5	.25				
4000	12	.5	.25					
5000	12	.25						
Number of shots**	4	8	8	10	16	25	41	57

* Lubrication interval is based on 12 hour day operation and maximum 160°F housing temperature.

For 24 hour per day operation, the interval should be cut in half.

** Lubricant should be added with the shaft rotating and until clean grease is seen purging from the bearing. The lubrication interval may be modified based on the condition of the purged grease. If bearing is not visible to observe purged grease, lubricate with number of shots indicated for bore size.

- For conditions including high temperatures, moisture, dirt or excessive vibration, consult the factory for a specific lubrication interval for your application.
- Lubricant should be a high quality lithium complex grease conforming to NLGI Grade 2. Factory recommends Mobilux EP-2 or synthetic Mobilith SHC100.
- The use of synthetic lubricants will increase lubrication intervals by approximately three times.
- Storage periods of three months or longer require monthly rotation of the shaft and purging grease prior to storage and start-up.

Parts List

Model HPA - Housed Plenum Array

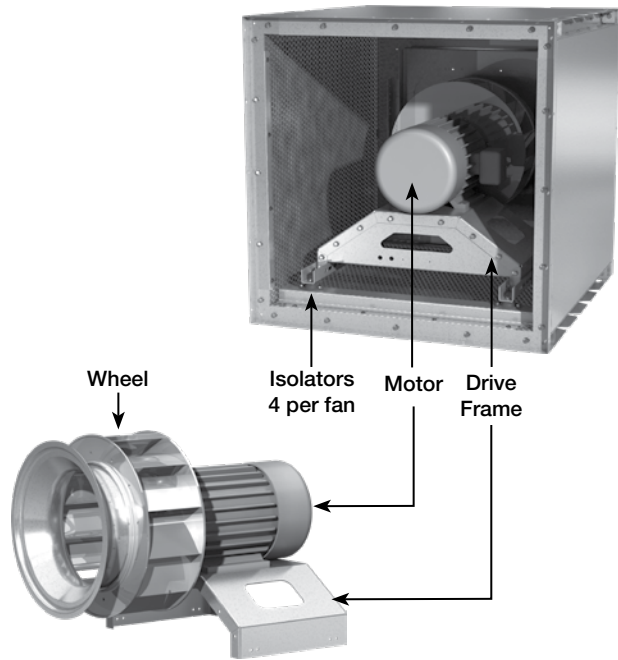

Model PLG - Plug

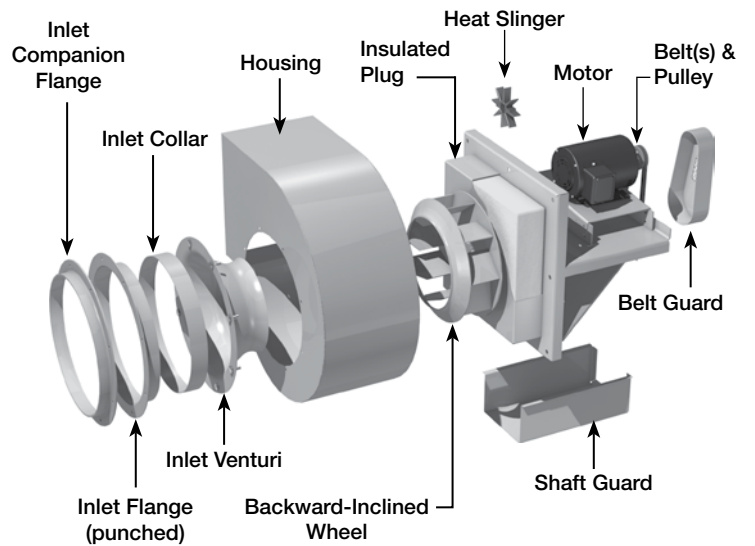

Model APD - Advanced Plenum Direct Drive Arr. 4

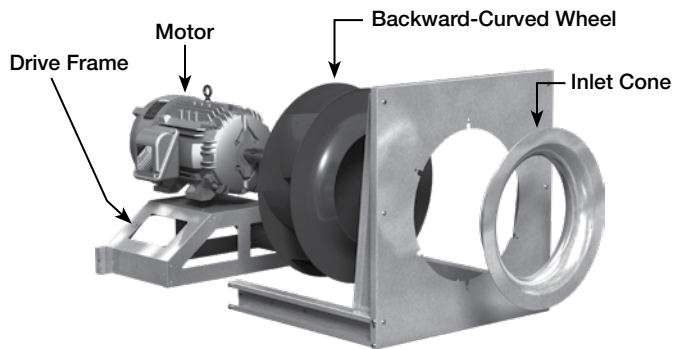

Model APM - Advance Plenum Medium Pressure Arr. 3

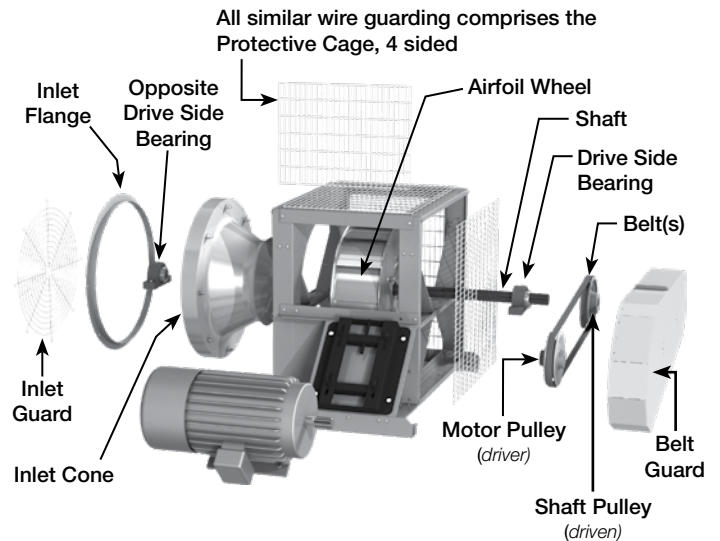

Other arrangements will have variations in motor mounting positions.

Parts List (continued)

Model APH - Advanced Plenum High Pressure Arr. 4

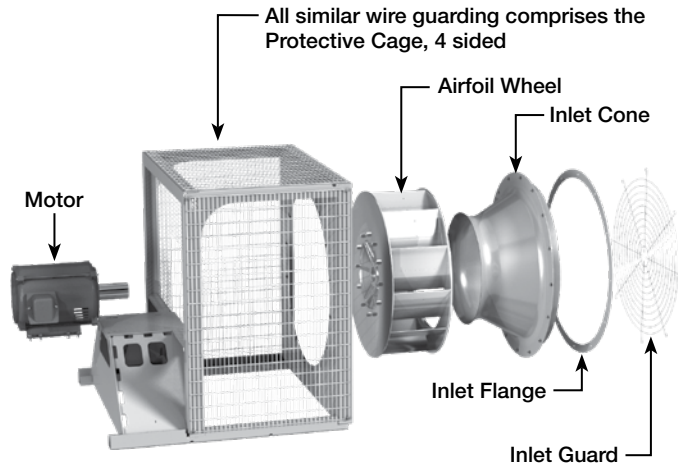

Troubleshooting

Problem	Cause	Corrective Action
Excessive Noise	Wheel rubbing (inlet)	Adjust wheel and/or inlet cone. Tighten wheel hub or bearing collars on shaft.
	V-belt drive	Tighten Sheaves on motor/fan shaft. Adjust belt tension. Align sheaves properly (see V-Belt Drive section). Replace worn belts or sheaves.
	Bearings	Replace defective bearing(s). Lubricate bearings. Tighten collars and fasteners.
	Wheel unbalance	Clean all dirt off wheel. Check wheel balance, rebalance in place if necessary.
Low CFM	Fan	Check wheel for correct rotation. Increase fan speed.*
	Duct system	Check duct installations with poor inlet or discharge configurations.
High CFM	Fan	Decrease fan speed.
High Horsepower	Fan	Check rotation of wheel. Reduce fan speed.
Fan Doesn't Operate	Electrical supply	Check fuses/circuit breakers. Check for switches turned off or disconnected. Check for correct supply voltage.
	Drive	Check for broken belts. Tighten loose pulleys.
	Motor	Assure motor is correct horsepower and not tripping overload protector.
Overheated Shaft Bearing	Lubrication	Check for excessive or insufficient grease in the bearings.
	Mechanical	Replace damaged bearing. Relieve excessive belt tension. Align bearings. Check for bent shaft.
Excessive Vibration	Belts	Adjust tightness of belts. Replacement belts should be a matched set.
	System unbalance	Check alignment of shaft, motor and pulleys. Adjustable pitch pulleys with motors over 15 hp are especially prone to unbalance. Check wheel balance, rebalance if necessary.

*Always check motor amps and compare to nameplate rating. Excessive fan speed may overload the motor and result in motor failure. Do not exceed the maximum cataloged RPM of the fan.

NOTE: Always provide the unit model and serial numbers when requesting parts or service information.

Maintenance Log

Date _____ Time _____ AM/PM

Notes: _____

Date _____ Time _____ AM/PM

Notes: _____

Date _____ Time _____ AM/PM

Notes: _____

Date _____ Time _____ AM/PM

Notes: _____

Date _____ Time _____ AM/PM

Notes: _____

Date _____ Time _____ AM/PM

Notes: _____

Date _____ Time _____ AM/PM

Notes: _____

Date _____ Time _____ AM/PM

Notes: _____

Our Commitment

As a result of our commitment to continuous improvement, Greenheck reserves the right to change specifications without notice.

Product warranties can be found online at Greenheck.com, either on the specific product page or in the literature section of the website at Greenheck.com/Resources/Library/Literature.

Greenheck's Plenum Fans or Plug Fans catalogs provides additional information describing the equipment, fan performance, available accessories, and specification data.

AMCA Publication 410-96, Safety Practices for Users and Installers of Industrial and Commercial Fans, provides additional safety information. This publication can be obtained from AMCA International, Inc. at www.amca.org.

