WHITE PAPER

How to select an Automatic Transfer Switch class

A guide for IEC markets



Table of contents

1. Introduction	5
2. Automatic transfer switch classes	6
3. Automatic transfer switch location on the single-line diagram	8
3.1. Where can ATS equipment be found?	8
3.2. ATS in the main distribution board (MDB)	8
3.3. ATS in the sub-distribution board (SDB)	9
3.4. ATS in the fire-fighting panels	10
4. Technical performance	11
4.1. Rated current	11
4.2. Performance under short-circuit conditions	11
4.3. Number of operations	12
4.4. Rated operational voltage	12
4.5. Embedded protections	12
4.6. Summary of ATS technical parameters	12
5. Safety and simplicity	13
5.1. Class CC	13
5.2. Class PC	14
5.3. Class CB	15
6. Transition types	16
7. Power supply configurations	19
8. Summary	20
9. References	21

1. Introduction

In most cases, a power outage can lead to economic losses associated with downtime and failure of process equipment, loss of information and in some cases, it can threaten people's safety and lives.

Despite investments of utilities in grid resilience, the number of power outages is growing every year: according to the research by the University of Minnesota, the number of power outages has increased by 124% in the last two decades. A survey was conducted in the US among facility and energy managers of commercial and industrial businesses [1], where 84% of respondents confirmed that their facilities had experienced power outages in 2017, and, for 50% of respondents, the power outage had lasted for more than one hour.

An Automatic Transfer Switch (ATS) is needed to switch the power supply from the main line to an emergency line to reduce problems caused by faulty conditions in the public network to the minimum level. ATS are used in segments like commercial, academic, residential and institutional buildings, data centers, telecommunication, healthcare, power utilities, transportation, industrial plants, motor control centers, etc.

There are various classes and types of ATS solutions available on the market, based on low voltage circuit breakers, switch technology and contactors. Some manufacturers focus on the development, production and delivery of one type of solution, based on either circuit breakers, switches or contactors. ABB proposes more than one type of solution to provide continuous operation, easy installation, data and connectivity and safety according to specific needs and characteristics of the application.

ABB offers a wide variety of transfer switch solutions — from well-established technologies to the latest digital innovations — with all the advantages to empower you.

The purpose of this document is to explain the main differences between ATS types, and since in many applications at least two types of ATS can be applied, this document also explains which parameters should be considered when choosing a specific solution.

Abbreviations:

TSE – Transfer Switch Equipment
ATS – Automatic Transfer Switch
CB – Circuit Breaker
ACB – Air Circuit Breaker
MCCB – Molded Case Circuit Breaker
MDB – Main Distribution Board
SDB – Sub-Distribution Board

NOTE: The content of this document is provided for guidance only and does not substitute any official standards and directives. ABB is not responsible for the final selection of the transfer switch equipment.

2. Automatic transfer switch classes



TruONE™ ATS

IEC 60947-6-1 “Low-voltage switchgear and controlgear – Part 6-1: Multiple function equipment – Transfer switching equipment” defines the following classification of transfer switching equipment according to the short-circuit capability:

1. **Class PC:** transfer switch equipment (TSE) that is capable of making and withstanding but is not intended for breaking short-circuit currents. This concerns TSE based on switch technology (also known as change-over switches) such as TruONE™ ATS, or switch-disconnectors derived from circuit breakers (without protection trip units), such as ABB Tmax XT and Emax 2.
2. **Class CB:** TSE that is capable of making, withstanding and is intended for breaking short-circuit currents, and is provided with overcurrent releases. This concerns TSE based on circuit breakers such as ABB Tmax XT and Emax 2 or switch-disconnectors derived from circuit breakers when used in combination with external protection trip unit, for example, ABB Ekip UP.
3. **Class CC:** TSE that is capable of making and withstanding but is not intended for breaking short-circuit currents, and is based on devices fulfilling the requirements of IEC 60947-4-1 “Low-voltage switchgear and controlgear - Part 4-1: Contactors and motor-starters - Electromechanical contactors and motor-starters”. This concerns TSE based on 3- or 4-pole contactors such as ABB’s AF contactors range.



Emax 2



AF contactors pair

In this document only automatic type TSE (hereinafter "ATS") will be considered. ATS can be defined as transfer switch equipment equipped with an ATS controller (either inbuilt or external), or with embedded ATS software. The controller or software will define the behavior of the ATS in the event of a monitored supply deviation. The ATS controller or embedded software is usually able to monitor voltage and frequency and to detect source abnormalities such as undervoltage, voltage imbalance and phase loss. In addition, the ATS controller/software controls the switching device(s), starts/stops the generator, and provides human-machine-interface.

In this paper, we will discuss the main aspects to consider when selecting an ATS class, including:

- ATS location on the single-line diagram
- Technical performance (voltage, current, performance under short-circuit conditions, number of operations...)
- Safety and simplicity
- Transition types
- Power supply configuration



—
ABB Transfer switch
solutions website

ABB offers all possible ATS classes, but how to select the most suitable ATS class for your application or project? Which factors should be considered when making the decision?



3. Automatic transfer switch location on the single-line diagram

3.1. Where can ATS equipment be found?

The most important aspect that should be defined during the single-line diagram design phase is which ATS class to use in a certain application.

ATS equipment can be located in:

- Main Distribution Board (MDB) – ATS for backing up the power supply for most of facility loads with Main-Main (or Utility-Utility or Transformer-Transformer), Main-Tie-Main, etc. power supply configurations.
- Sub-Distribution Board (SDB) – ATS for backing up the power supply for selected critical facility loads with Main-Main or Main-Gen power supply configurations.
- Fire Fighting Panel (or Emergency Distribution Board) - ATS for backing up the power supply for loads belonging to the firefighting extinguishing system.

The following electrical equipment might also require an ATS, but are not the subject of this document: fire-fighting pump control panel, cooling equipment control panel (chiller, air-handling unit, computer room air conditioner, etc.), ATS panels for Generator sets, ATS for microgrid and renewable applications, etc.

3.2. ATS in the main distribution board (MDB)

According to the standard IEC 60364-4-43 “Low-voltage electrical installations – Part 4-43: Protection for safety - Protection against overcurrent” the first protection device after the MV/LV transformer should be placed no more than 3 meters from the transformer. Therefore, in most of cases, low voltage circuit breakers or

switch-fuses must be used in the MDB as main switch devices (also known as incomers), dedicated for the protection of a main busbar system against short-circuit currents.

Air circuit breakers (ACBs) are common MDB incomers from transformers with the rated power approximately over 800 kVA, as ACBs allow total selectivity thanks to the B utilization category that gives the possibility to set a time delay for overcurrent protection (S function, ANSI 51 & 50TD).

The most common class of ATS for this scenario is Class CB, so this means that incoming ACBs are used for ATS purpose. Class PC and Class CC transfer switch solutions may increase the number of components and overall dimensions of the MDB, because:

1. All necessary accessories of ACBs (spring charger, shunt opening/closing, etc.) are installed inside the circuit breaker, so they do not require additional space.
2. ACBs can be mechanically interlocked with cables, allowing flexible location of the ACBs in the MDB.
3. Application of ATS Classes CC or PC will require additional space in the MDB, because as it was explained earlier, a short-circuit protection devices as incomers are required in most of the cases.

In case the transformer or facility rated power is below 800 kVA, all ATS classes can be applied. Despite the requirements of having short-circuit protection devices as incomers, these protection devices are not used as ATS in all the cases. It is common to separate protection and ATS functions for MDB below 800 kVA. For example, molded case circuit breakers like ABB Tmax XT might be used for protection, while switch based solutions such as TruONE™ ATS can be used for ATS purposes. In this case, it is necessary to evaluate each single-line diagram separately, conduct a financial analysis and consider other aspects described in this document, such as technical performance, transition types or power supply configuration.

3.3. ATS in the sub-distribution board (SDB)

The most common example of ATS Class PC application is shown in the Figure 1, where the ATS is used as an incomer in the SDB.

Why is there no need for incoming circuit breakers or fuse protection in the SDB? Is it more effective to use the ATS Class PC?

According to the standard IEC 60364-4-43 “Low-voltage electrical installations – Part 4-43: Protection for safety – Protection against overcurrent”, the protection device against short-circuit and overload shall be placed where there is a reduction in the cross-sectional area of the conductors or any other variation that causes a change to the current-carrying capacity of the conductors. As shown in the Figure 1, there is no reduction in the current-carrying capacity, therefore protection of the lines by an outgoing circuit breaker in the MDB and circuit breaker in the genset is enough.



—
ABB Selectivity
portal

—
Figure 1. Location
of ATS on the single
line diagram.

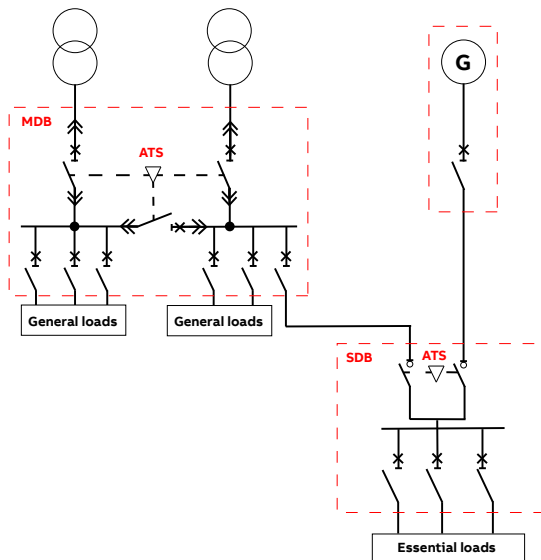

An ATS Class CB can also be placed in the SDB instead of Class PC. However, a selectivity study must be made, and due to the same current-carrying capacity of the outgoing CB in the MDB and incoming CB in the SDB, usually full selectivity can be achieved by only using two techniques:

- To oversize the outgoing CB in the MDB, compared to the incoming CB in the SDB to achieve energy selectivity among devices.
- To apply zone or digital selectivity among the outgoing CB in the MDB and the incoming CB in the SDB to achieve selectivity among CBs with the same frame sizes.

For more details about energy and zone selectivity, visit ABB's Selectivity portal: <https://new.abb.com/low-voltage/solutions/selectivity>

ATS Class CC can also be used in SDBs instead of Class PC. However, in order to perform the maintenance of outgoing feeders in the SDB, the incoming devices should be suitable for isolation. Contactors as per IEC 60947-4-1 “Low-voltage switchgear and controlgear – Part 4-1: Contactors and motor-starters – Electromechanical contactors and motor-starters” do not provide isolation, therefore switch-disconnectors should be placed upstream of ATS to guarantee isolation for outgoing feeders and ATS equipment.

In conclusion, ATS Class PC is the effective solution for incoming ATS in the SDB compared to Classes CC and CB ATS, especially at the rated power installation 400kVA and below. Of course, there are exceptions where the presence of CBs as incomers will be needed; for example, if the utility requires the usage of CBs, or selectivity should be arranged between two switchboards.

3.4. ATS in the fire-fighting panels

According to the standard IEC 60364-5-56 “Low-voltage electrical installations – Part 5-56: Selection and erection of electrical equipment – Safety services”, the circuit of safety services, such as fire-fighting equipment must be independent from non-critical lines, and one or more electrical sources for safety services shall be provided to maintain a supply in case of failure of the main supply. Usually, the fire-fighting equipment is connected above the incoming circuit breakers to guarantee the separation of critical and non-critical loads.

There are two options of emergency circuit design that are quite often applied by designers:

1. ATS Class CB is implemented both for the protection of busbars and ATS functions (see Figure 2). Usually, this might be required due to the low value of rated current in conjunction with the high prospective short-circuit current at the point of ATS installation.
2. Circuit breakers are used only for protection when the ATS is PC class (see Figure 3). This solution grants higher reliability compared to the one shown before, because a failure of circuit breakers based ATS will not lead to the failure of ATS equipment in general. Failure of CB class ATS might be associated with incorrect equipment assembly; for example, an installation of mechanical interlock, external motor operator and other accessories.

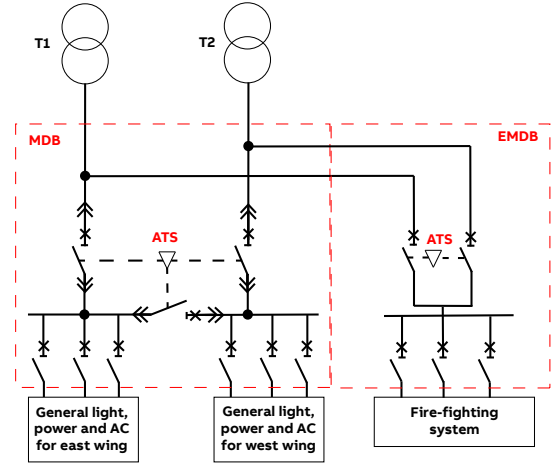

Figure 2. ATS class CB implemented for protection of busbars and ATS functions.

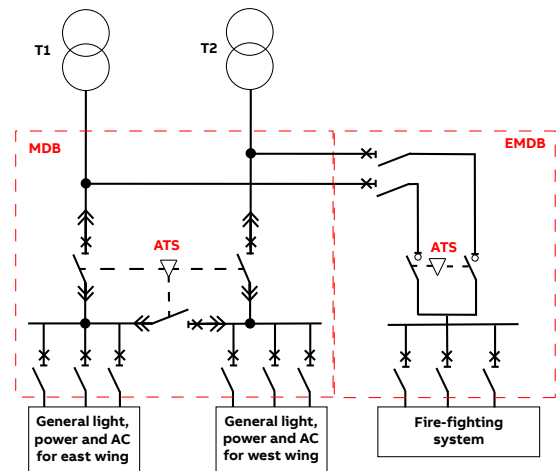

Figure 3. Circuit breakers used for protection when the ATS is the PC class.

4. Technical performance

4.1. Rated current

The most obvious parameter for the selection of an ATS class is the rated current of the equipment. ABB offers a wide variety of solutions for different current ratings, based on the following technologies:

1. **Circuit breakers and their switch disconnecter versions:** Tmax XT and Emax 2 up to 6300 Amperes, which can be equipped for automatic operation with:
 - a. External controllers ATS021 or ATS022
 - b. Embedded ATS software function

2. **Switch technology:** OTM_C, TruONE™ ATS and Compact ATS from 40 to 3200 Amperes. TruONE™ ATS and Compact ATS are solutions with integrated controllers while OTM_C should be equipped with an external controller for automatic operation.

3. **Contactors:** 3-, 4-poles AF range from 25 to 2850 Amperes (AC-1 utilization category). For automatic operation, contactors should be equipped with an external controller or use the control logic based on electronic relays.

For more details on rated currents, please refer to the overview brochure for ABB transfer switch solutions.



Transfer switch solutions brochure

4.2. Performance under short-circuit conditions

There are three main parameters that describe performance of ATS under short-circuit conditions, but they are not limited to these:

1. **Icu – Rated ultimate short-circuit breaking capacity (applies to Class CB ATS)** is the value assigned to a circuit-breakers by the manufacturer for the corresponding rated operational voltage. It is expressed as the value of the prospective breaking current, in kA.

2. **Iq – Rated conditional short-circuit current (applies to Class PC and CC ATS)** is the value of prospective current, stated by the manufacturer, which the TSE, protected by a specified short-circuit protective device (SCPD), can satisfactorily withstand for the operating time of this device under the test conditions.

3. **Icw - Rated short-time withstand current (applies to Class CB and Class PC)** is the value of short-time current, assigned to the equipment by the manufacturer, that the equipment can carry without damage, under the test condition specified in the relevant standard. Usually the manufacturer provides Icw value and the time in seconds during which the equipment should withstand this current.

Usually, ATS Class CB can withstand higher values of a prospective short-circuit current: up to 150kA (Icu) for Emax 2 and up to 200kA (Icu) for Tmax XT, which allows them to be used closer to power sources, e.g., MV/LV transformers.

ATS Class PC might have a conditional short-circuit current (Iq) up to 100 kA, when it is protected by manufacturer specified fuses, while for circuit breakers protected ATS Class PC, designers have to refer to the rated conditional short-circuit current values, generally up to 65 kA. The exact value normally depends on the TSE frame size.

The minimum rated conditional short-circuit current of contactor is usually defined by the test current value "r" in Table 13 or Table 14 of the IEC 60947-4-1 standard. This value may vary from 1 up to 42 kA depends on the contractor rated operational current according to utilization category AC-3. If the contactor is specified according to utilization category AC-1, the prospective current "r" shall be subject of agreement between manufacturer and user. The manufacturer may also state another value of Iq, as long as it is higher than the current value "r".



—
ABB Transfer Switch
Solutions

4.3. Number of operations

ATS class CC, in comparison to PC or CB classes, can perform a much higher number of operations, measured in millions of operations. Circuit breakers- or switch-based solutions can usually perform operations from several thousand up to 10 000 operating cycles (O - I - O - II - O).

Thanks to the high number of operations, ATS class CC can be used for very unstable grids that require frequent switching to the back-up power source.

4.4. Rated operational voltage

The next parameter, which should also be carefully considered, is the rated operational voltage. When choosing an ATS, make sure that the rated operation voltage of the switching device (circuit breakers, switch or contactors) and controller (if not integrated) meet the requirements of the application.

4.5. Embedded protections

As mentioned earlier, overload and short-circuit protections are always embedded in low voltage circuit breakers. Some variants of circuit breakers have an extended list of protection functions, which include protections based on voltage, power, frequency, etc. Therefore, ATS class CB is a self-protected solution that does not require any additional protection devices. ATS class PC and CC must always be protected by circuit breakers or fuses.

4.6. Summary of ATS technical parameters

The table 1 below summarizes technical parameters for selected products. To find out more about the complete portfolio of ABB Transfer Switch Solutions, visit the webpage <http://solutions.abb/transferswitches>.

Table 1. ATS technical parameters

	Contactors (AF range)	Switch (TruONE™ ATS)	Circuit breakers (Tmax XT or Emax 2)
Rated current	up to 2850 A (AC-1)	up to 1600 A	up to 6300 A
Voltage	Depends on selected controller/relay (up to 1000 V AC)	200...480 V AC	Depends on selected controller/relay (up to 1150 V AC)
Performance under short-circuit conditions	up to 42 kA or higher according to the agreement between manufacturer and user.	up to 100 kA (Iq)	up to 150 kA (Icu, Emax 2) up to 200 kA (Icu, Tmax XT)
Number of operation cycles	Millions	From 3.000 up to 6.000	From 2.000 up to 10.000
Embedded protections	NO	NO	YES
Suitable for isolation	NO	YES	YES

5. Safety and simplicity

Class CC, CB and PC transfer switches differ from each other significantly due to differences in the mechanical construction of current carrying components. Therefore, ATS solutions have different advantages and limitations among various TSE classes.

Contactors have in-built electromagnetic coil and it requires only one signal to operate - voltage applied to the coil. Therefore, the automatic transfer switching solution can easily be built with a simple control diagram based on electronic relays logic or with an external controller.

5.1. Class CC

An ATS class CC is usually based on 3- or 4-pole low voltage contactors. In order to prevent simultaneous closing of several contactors connected to unsynchronized power sources, the electrical and mechanical interlock shall always be used.

ABB offers AF contactors with the latest technology of electronically controlled coils. It offers multiple benefits over conventional alternatives, such as AC/DC operation and a wide control voltage range. The 3-pole AF contactors allow assembly of an ATS from 25 up to 2850A (AC-1), with 4-pole AF contactors the ATS can be from 25 up to 525 A (AC-1) and with EK contactors up to 1000 A (AC-1).

AF contactors and accessories

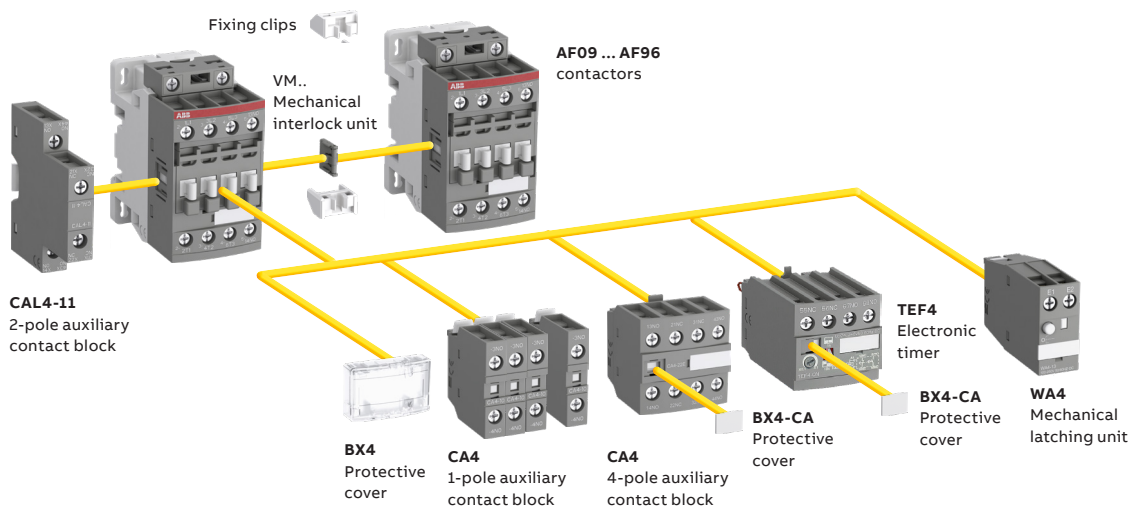

5.2. Class PC

In the past, many ATS Class PC were built by connecting two switch-disconnectors together, one after another or side by side. The mechanical switching procedure was usually executed with a common shaft or electromechanical motor acting on both switches. This approach brought several benefits, such as standardized accessories with switch-disconnectors, production optimization, compact design or inbuilt mechanical interlock to prevent simultaneous closing of two power sources.

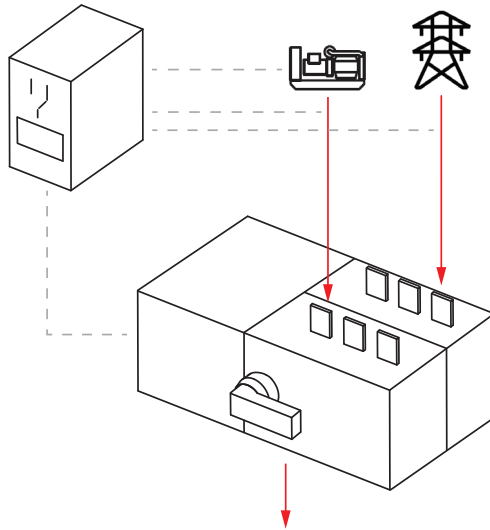

Conventional ATS class PC

However, this approach has limitations like low switching speed, the need for copper bridging bars on the load side and the need for external controller for automatic operation that usually has basic functionality. For example, it has limited measuring capability, diagnostic data, configuration and communication capabilities.

Nowadays, the most modern automatic transfer switching solutions are purpose built. This means that the ATS does not consist of several switch-disconnectors, combined with an external controller and a motor operator. The device is designed to be the automatic transfer switch.

The modern Class PC ATSs are designed to be used for transfer switching purposes:

- Power poles are mechanically designed to carry the current from the first or second power source, without the need to make a copper bridging bar on the load side
- Solenoid operation instead of an electromechanical motor to reach a higher speed of switching
- Solenoid driven actuator (mechanism) and controller in one module with the possibility to be field-replaced
- Integrated voltage and current sensors with no need for wiring

Modern integrated controllers have the following features:

- provide current, power, energy, THD measurements via communication protocols and locally on display
- equipped with enhanced commissioning features and configuration tools
- provide extensive diagnostic data, like generator start time/date, start up time, internal temperature etc.

TruONE™ ATS, up to 1600 A, is a purpose-built, integrated class PC ATS solution from ABB. TruONE™ ATS is also available as an enclosed version.



TruONE™ ATS

As a conclusion, the modern Class PC ATSS reduce significantly the installation time of the device in the panel, while reaching a high level of reliability due to the limited number of components to be assembled and mounted.

Table 2. Comparison table PC type ATS - conventional vs. latest designs

	ABB's latest PC type ATS	Conventional PC type ATS
Power poles are designed for ATS application to simplify installation	Yes	No
Controller is integrated to increase reliability	Yes	No
Solenoid operation to increase switching speed and number of operations	Yes	No
Integrated voltage and current sensors for power monitoring	Yes	No
Extensive diagnostic and maintenance data to simplify service	Yes	No

5.3. Class CB

A Class CB ATS is usually assembled by an installer using several MCCBs or ACBs that must be accessorized:

- to be suitable for remote operation – motor operator / spring charger, shunt opening, shunt closing releases, etc.
- to share CB status information with external ATS controller – auxiliary contacts or communication protocols.
- to avoid accidental closing of two or more CBs – mechanical and electrical interlock
- to make automatic logic – external ATS controller, such as ABB's ATS021 or ATS022.

The external ATS controller is usually responsible for sensing voltage and frequency and is able to detect source abnormalities like undervoltage, voltage imbalance and phase loss. In addition, the ATS controller controls the switching devices, starts/stops the generator, and provides a human-machine-interface. Same as for ATS Class PC, the external controllers usually feature basic functionality.

Nowadays, the approach in building ATS with circuit breakers is also changing. Modern circuit breakers, such as ABB's Emax 2, do not require an external ATS controller, because:

- Voltage and frequency sensing can be done by circuit breakers thanks to integrated measurement modules
- CB is able to identify its own status and share the information with other CBs via ABB's proprietary protocol Ekip Link
- Modern CB electronic trip units may perform logic operations like PLC, based on voltage measurements, status of another CB, etc.

This new approach increases reliability of ATS solutions with CBs thanks to the reduced number of connection points, since the external controller is no longer needed. In addition, the communication channel between CBs is monitored along with the internal chains of CBs.

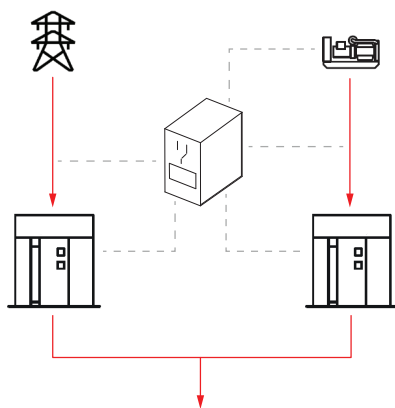

Conventional ATS class CB



Embedded ATS

6. Transition types

There are three main transition types available nowadays: delayed, open and closed transitions.

Delayed transition (also known as open transition with stable "OFF" position or 3-position transfer switch)

The ATS breaks the load current from one source prior to making it to the other source, so there is a period of OFF-time when the load is neither connected to the main nor to the backup power sources.

During the transfer, the ATS can be paused at the "0" / "OFF" position. These ATSs typically have a programmable timer to define how long the ATS sits in the "0" / "OFF" position during transfer. The typical delayed transition transfer sequence for Main-Gen power supply configuration with reverse switching procedure is shown below:

Typical delayed transition transfer sequence for Main-Gen power supply configuration

Sequence when main power source fails

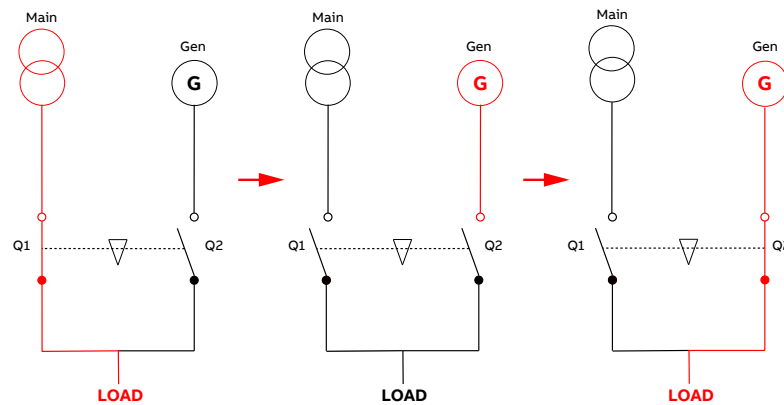

Re-transfer to main power source when it recovers

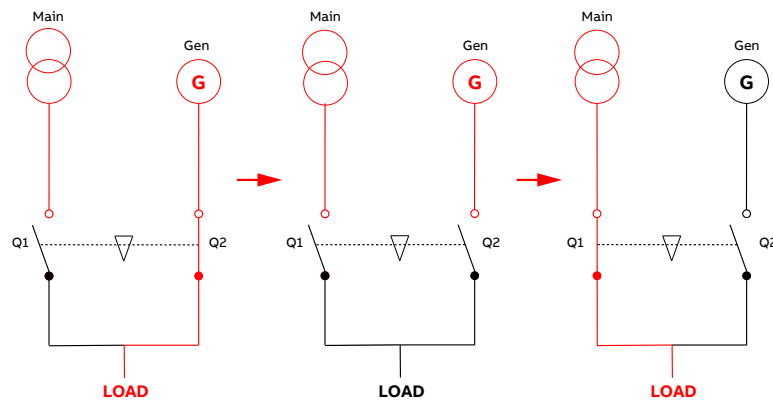

Note: Q1 and Q2 demonstrate whether the load is connected or disconnected from the power sources. Q1 and Q2 can be ATS class CB, CC or PC.

Open transition (also known as open transition without stable "OFF" position or 2-position transfer switch):

Like Delayed transition, the open transition ATS breaks the load current from one source prior to making it to the other source. However, the open transition ATS does not have the "0" / "OFF" position. Thanks to this feature, the transfer between two sources is accomplished in a very rapid time, < 50 ms.

The open transition TSE can be equipped with an in-phase monitor, which permits the transfer when the sources are in near-synchronism and aims to complete the transfer within a zero degrees phase shift. The typical open transition transfer sequence for the Main-Gen power supply configuration is shown below.

Typical open transition transfer sequence for Main-Gen power supply configuration

Sequence when main power source fails

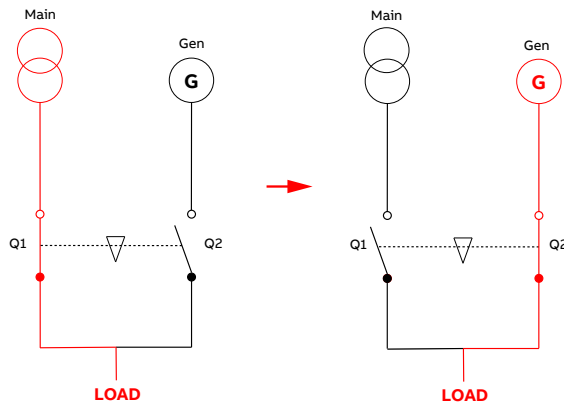

Re-transfer to main power source when it recovers

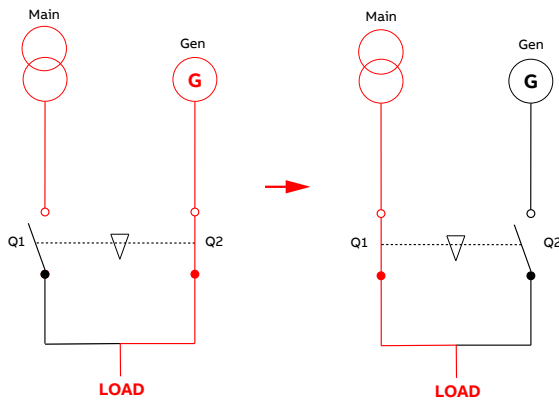

Note: Q1 and Q2 demonstrate whether the load is connected or disconnected from the power sources. Q1 and Q2 can be ATS class CB, CC or PC.

Closed transition:

When two power sources are available (re-transfer or test sequence), the transfer switch makes the load current of a second synchronized source before breaking it from the first source, so that both power sources supply the load in a parallel fashion for a short period of time. The closed transition transfer switch must be able to check the synchronization conditions between two power sources, such as voltage, frequency and phase angle differences.

The closed transition transfer switch allows the power interruption to be completely eliminated during the transfer between the two available power sources. However, if one power source fails, the closed transition will behave as a delayed transition transfer switch. The closed transition is used for loaded generator engine testing, transformer maintenance, microgrid applications and, of course, for eliminating the second power interruption during the re-transfer phase.

Typical closed transition transfer sequence for Main-Gen power supply configuration

Sequence when main power source fails

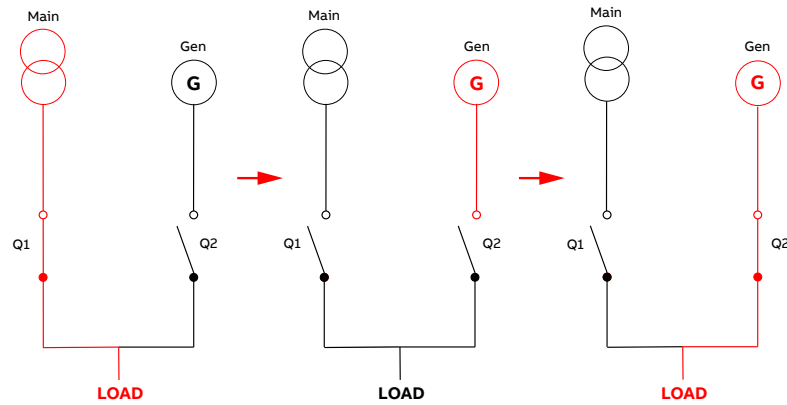

Re-transfer to main power source when it recovers

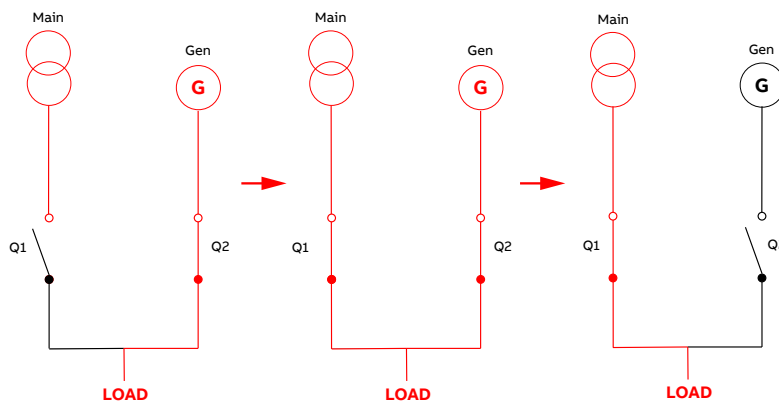

Note: Q1 and Q2 demonstrate whether the load is connected or disconnected from the power sources. Q1 and Q2 can be the ATS Class CB, CC or PC.

7. Power supply configurations

The selected ATS equipment should also be suitable for a designed power supply configuration. The table below summarizes ABB's ATS offering according to the power supply configuration and transition type.

Table 3. ABB's ATS offering according to the power supply configuration and transition type.

Power supply configuration / Transition type	Contactors	Switch technology			Circuit breakers		
	Relays	Compact ATS (20D)	Compact ATS (21D)	TruONE™ ATS	ATS021	ATS022	Embedded ATS
Main – Main	Open, Delayed	Delayed	Delayed	Open, Delayed	Delayed	Delayed	Delayed
Main – Gen	Open, Delayed	-	Delayed	Open, Delayed	Delayed	Delayed	Delayed
Main – Tie – Main	-	-	-	-	-	Delayed	Closed
Main – Tie – Gen	-	-	-	-	-	Delayed	-
Main – Main – Main	-	-	-	-	RTSE*	RTSE*	RTSE*
Main – Main – Gen	-	-	-	-	RTSE*	RTSE*	RTSE*

* Remote (motorized) transfer switch equipment, mechanical interlock available. ABB does not provide controllers for three power source configurations.

8. Summary

How to select the ATS class for the installation? As outlined in this document, there is no single answer to this question. There is a set of parameters and design aspects that should be taken into account when selecting the ATS class, such as power supply configuration, transition type, rated current, voltage and location of ATS in the system.

The decision should always be made towards the most modern ATS solutions to increase the availability of your critical loads, and optimize installation and the commissioning process.

Whether you need to ensure the steady delivery of critical power or simply keep the lights on, ABB is your one stop for transfer switch solutions.

9. References

-
- | | |
|-----|--|
| [1] | S&C/Frost and Sullivan, State of Commercial & Industrial Power Reliability Report 2018 |
| [2] | IEC 60947-1 "Low-voltage switchgear and controlgear - Part 1: General rules" |
| [3] | IEC 60947-4-1 "Low-voltage switchgear and controlgear - Part 4-1: Contactors and motor-starters - Electromechanical contactors and motor-starters" |
| [4] | IEC 60947-6-1 "Low-voltage switchgear and controlgear - Part 6-1: Multiple function equipment - Transfer switching equipment" |
| [5] | IEC 60364-4-43 "Low-voltage electrical installations - Part 4-43: Protection for safety - Protection against overcurrent" |
| [6] | IEC 60364-5-56 "Low-voltage electrical installations – Part 5-56: Selection and erection of electrical equipment – Safety services" |
-

Additional information

We reserve the right to make technical changes or modify the contents of this document without prior notice. With regard to purchase orders, the agreed particulars shall prevail. ABB AG does not accept any responsibility whatsoever for potential errors or possible lack of information in this document.

We reserve all rights in this document and in the subject matter and illustrations contained therein. Any reproduction, disclosure to third parties or utilization of its contents – in whole or in parts – is forbidden without prior written consent of ABB.



—
ABB S.p.A.
Electrification business
5, Via Pescaria I-24123 Bergamo - Italy
Phone: +39 035 395.111

solutions.abb/transferswitches