

WPT15-2

Operation Manual

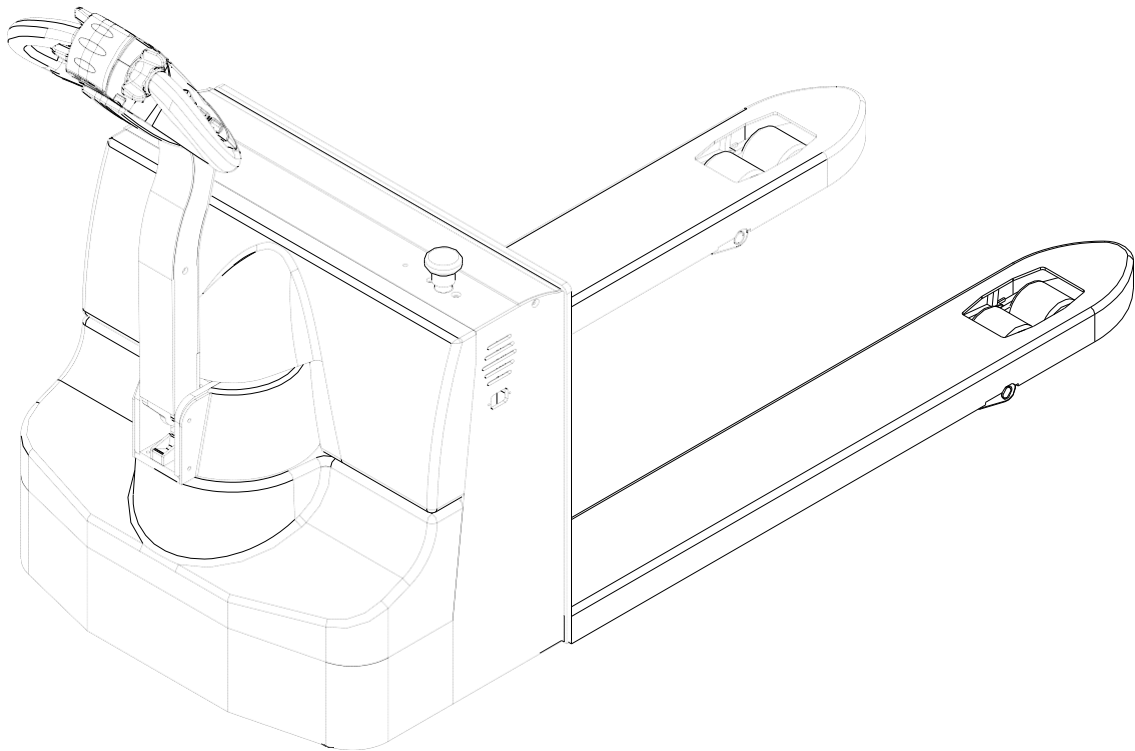

Foreword

Thanks for your purchasing our Pallet truck.

This manual is about how to use, operation and maintenance WPT15-2. Please operator and whom in charge of the truck must read the manual carefully before operate the truck.

We have the right to improve the truck, maybe there are some difference between your product and the description in this manual.

If you have any questions please keep in touch with the sales department or let the dealer know.

NINGBO LIFTSTAR IMPORT&EXPORT CO., LTD

Address: No.688, JINGDA Rd, NINGBO, CHINA 315105

Tel: 86-574-89217230

Fax: 86-574-89217240

Net: www.lift-star.com

Email: info@liftstar.cn

ALL RIGHT RESERVED COPYRIGHT

2016.8 1st EDITION

WARNING!

TO PREVENT SETIOUS RISK OF INJURY TO YOUORSELF AND OTHERS OBSERVE THE FOLLOWING SAFETY INSTRUCTIONS.

These truck may become hazardous if adequate maintenance is neglected. Therefore, adequate maintenance facilities, trained personnel and procedures should be provided.

Maintenance and inspection shall be performed in conformance with the following practices:

1. A scheduled planned maintenance,lubrication and inspection system should be followed.
2. Only qualified and authorized personnel shall be permitted to maintain, repair, adjust, and inspect truck.
3. Before leaving the truck:
 - Do not park the truck on an incline.
 - Fully lower the load forks.
 - Set the key switch to the "OFF" position and remove the key.
4. Before starting to operate truck:
 - Be in operating position
 - Place directional control in neutral
 - Before operating truck, check functions of lift systems, directional control,speed control,steering, warning devices and brakes.
5. Avoid fire hazards and have fire protection equipment present. Do not use open flame to check lever, or for leakage of electrolyte and fluids or oil. Do not use open pans of fuel or flammable cleaning fluids for cleaning parts.
6. Brakes,steering mechanisms, control mechanisms,guards and safety devices shall be inspected regularly and maintained in legible condition.
7. Capacity, operation and maintenance instruction plates or decals shall be maintained in legible condition.
8. All parts of lift mechanisms shall be inspected to maintain them in safe operating condition.

9. All hydraulic systems shall be regularly inspected and maintained in conformance with good practice. Cylinders, valves and other similar parts shall be checked to assure that "drift" has not developed to the extent that it would create a hazard.

10. Truck shall be kept in a clean condition to minimize fire hazards facilitate detection of loose or detective parts.

11. Modifications and additions which affect capacity and safe truck operation shall not be performed by the customer or user without manufacturers prior written approval. Capacity, operation and maintenance plates or decals shall be changed accordingly.

Catalog

Correct use and application.....	1
1. Truck Description.....	2
1.1 Application	2
1.2 Assemblies	3
1.2.1 Control Handle.....	4
1.2.2 Key switch.....	4
1.2.3 Battery discharge indicator.....	5
1.3 Identification points and data plates.....	5
1.3.1 Truck data plate.....	7
1.4 Standard Version Specifications.....	8
1.4.1 Performance data for standard trucks	8
1.4.2 Dimensions.....	9
2.Transport and Commissioning	11
2.1 Using the Truck for the First Time.....	11
2.2 During brake-in.....	11
3.Operation.....	12
3.1 Safety Regulations for the Operation of Pallet Trucks.....	12
3.2 Operate and run the truck	13
3.2.1 Preparing	13
3.2.2 Travel ,Steering,Braking	13
3.2.3Lifting, transporting and depositing loads	14
3.2.4Parking the truck securely	15
4.Battery Maintenance & Charging.....	16
4.1 Safety regulations for handling acid batteries.....	16
4.2 Battery type & dimension	16
4.3Charging the battery.....	16
4.4 Battery removal and installation.....	17
4.5Battery maintenance	18
4.6 Battery Disposal.....	18
5.Pallet Truck Maintenance.....	19
5.1Operational safety and environmental protection	19
5.2Maintenance Safety Regulations	19
5.3Servicing and inspection	20
5.3.1Maintenance Checklist	21
5.3.2 Lubrication Schedule	22
5.3.3 Maintenance Instructions	23

5.4 Decommissioning the industrial truck	25
5.4.1 Prior to decommissioning	25
5.4.2 Restoring the truck to operation after decommissioning	25
5.5 Safety checks to be performed at regular intervals and following any unusual incidents	26
5.6 Final de-commissioning, disposal	26
6. Troubleshooting	27

Correct use and application

The “Guidelines for the Correct Use and Application of Industrial Trucks” (VDMA) are supplied with the truck. The guidelines form part of these operating instructions and must be observed. National regulations apply in full.

The truck described in the present operator manual is an industrial truck designed for lifting and transporting load units.

It must be used, operated and serviced in accordance with the present instructions. Any other type of use is beyond the scope of application and can result in damage to personnel, the truck or property. In particular, avoid overloading the truck with loads which are too heavy or placed on one side. The data plate attached to the truck or the load diagram are binding for the maximum load capacity. The industrial truck must not be used in fire or explosion endangered areas, or areas threatened by corrosion or excessive dust.

Proprietor responsibilities

For the purposes of the present operator manual the “proprietor” is defined as any natural or legal person who either uses the industrial truck himself, or on whose behalf it is used. In special cases (e.g. leasing or renting) the proprietor is considered the person who, in accordance with existing contractual agreements between the owner and user of the industrial truck, is charged with operational duties.

The proprietor must ensure that the truck is used only for the purpose it is intended for and that danger to life and limb of the user and third parties are excluded.

Furthermore, accident prevention regulations, safety regulations and operating, servicing and repair guidelines must be followed. The proprietor must ensure that all truck users have read and understood this operator manual.

Failure to comply with the operator manual shall invalidate the warranty. The same applies if improper work is carried out on the truck by the customer or third parties without the permission of the manufacturer’s customer service department.

Attaching accessories

The mounting or installation of additional equipment which affects or supplements the performance of the industrial truck requires the written permission of the manufacturer. In some cases, local authority approval shall be required.

Approval of the local authorities however does not constitute the manufacturer’s Approval.

1. Truck Description

1.1 Application

The truck is designed to transport goods on level surfaces. It can lift open bottom or diagonal board pallets as well as roll cages beyond the area of the load wheels.

Suitable environment temperature is 5°C to 40 °C.

If a long time in less than 5 ° C environment, cold storage or in the extreme conditions of temperature and humidity changes in the use of Pallet, you must install additional special equipment, and obtain permission from the manufacturer.

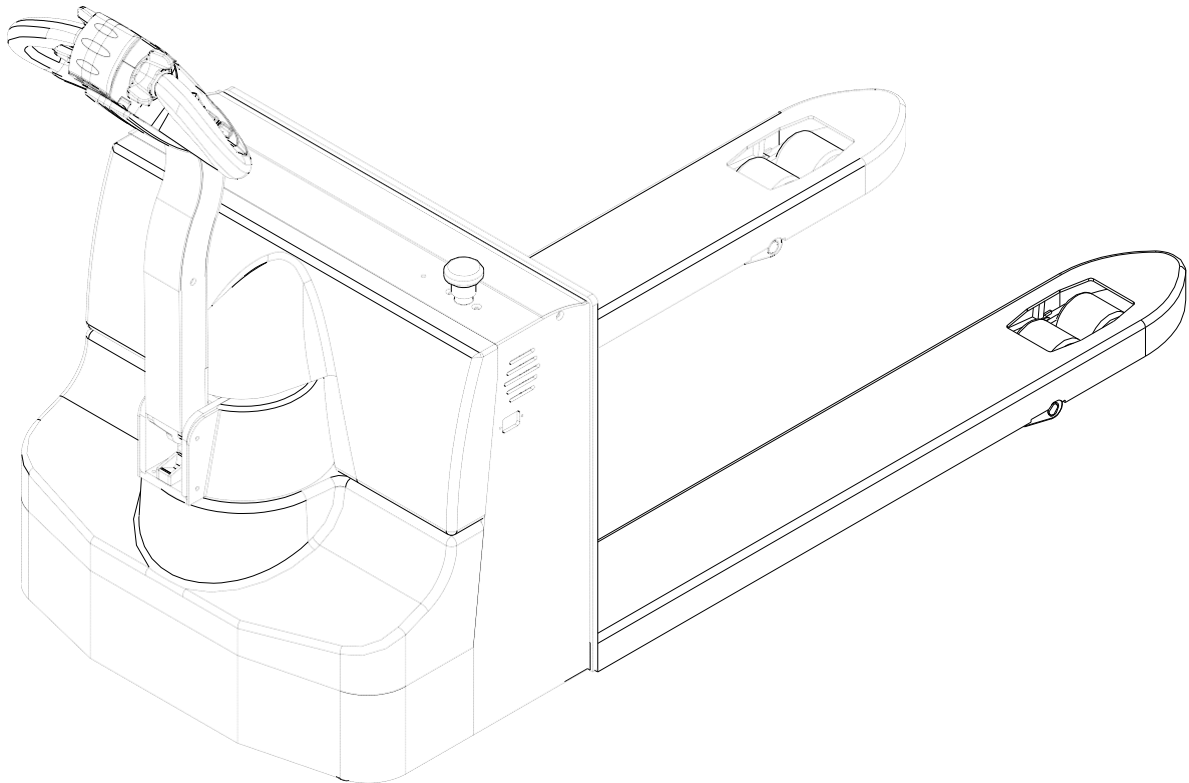

1.2 Assemblies

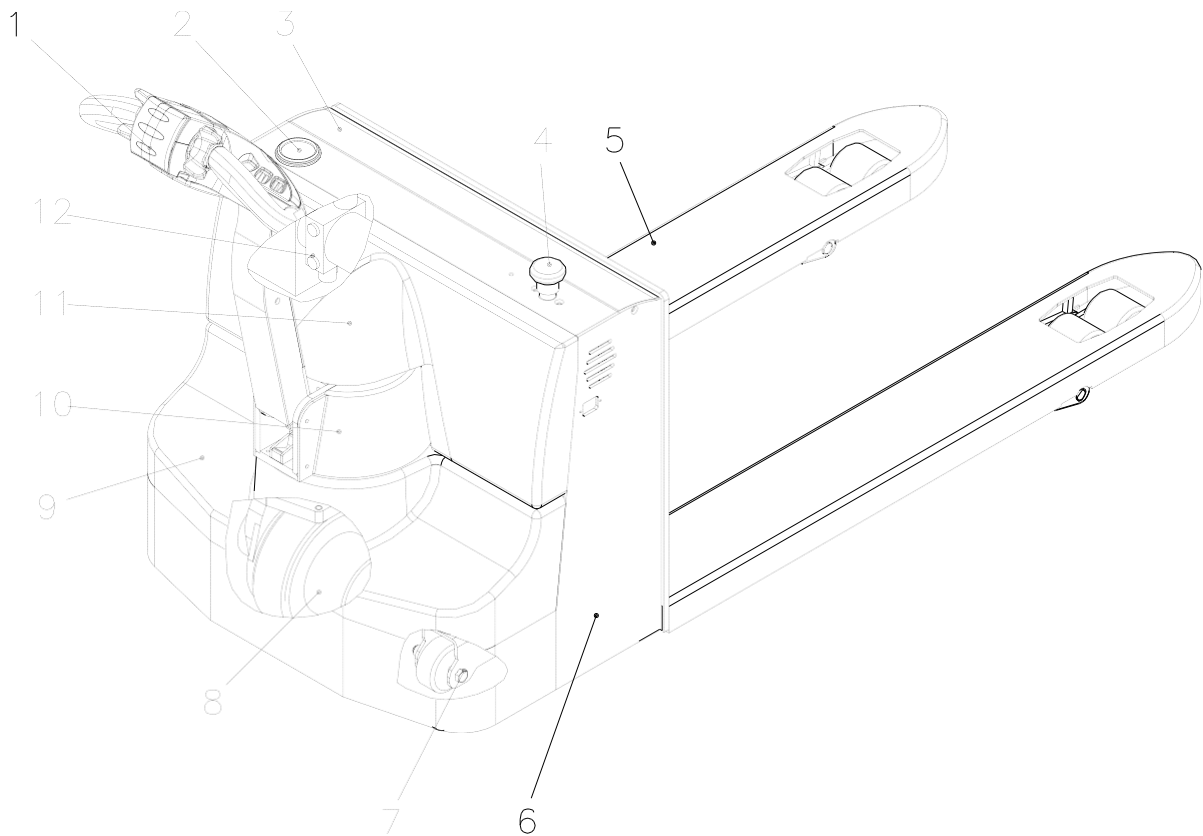

Item	Component	Item	Component
1	Control handle	6	Chassis
2	Battery indicator	7	Balance wheel
3	Upper cover	8	Driving wheel
4	Emergency stop button	9	Down rear cover
5	Fork	10	Protection cover
11	Up rear cover	12	Pump

1.2.1 Control Handle

Item	Control / Display	Function
13	Key switch	Switches control current on and off.
14	Speed module	Fast/slow travel speed
15	Collision safety switch	Safety function which, when activated, forces the truck to reverse until the switch restored to neutral.
16	Travel switch	Controls the driving speed and direction
17/19	"Lift/Lower" button	Raises/Lower load forks
18	Warning signal button	Triggers a warning signal.

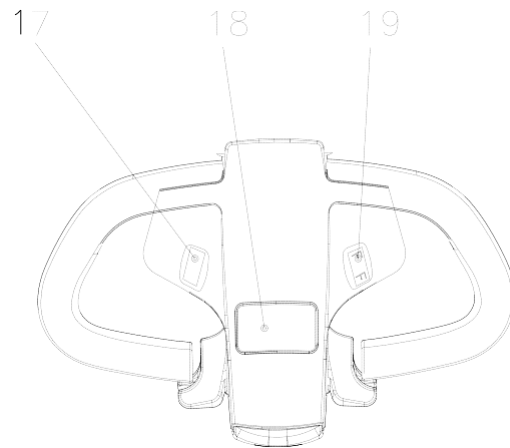
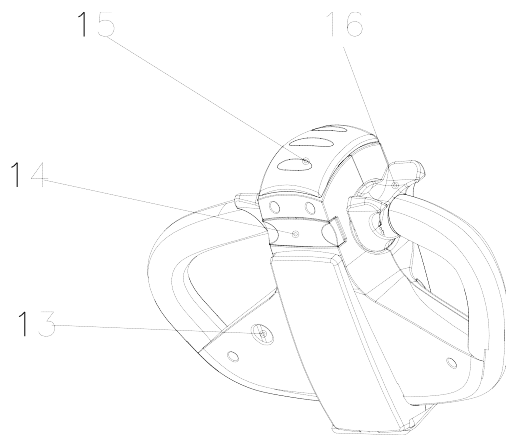

1.2.2 Key switch

Switches control current on and off.

Truck power supply is break off when the key turn "OFF".

Truck power supply is turn on when the key turn "ON".

Removing the key prevents the truck from being switched on by unauthorised personnel.

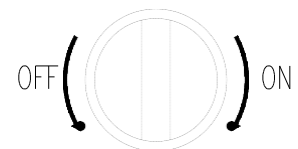

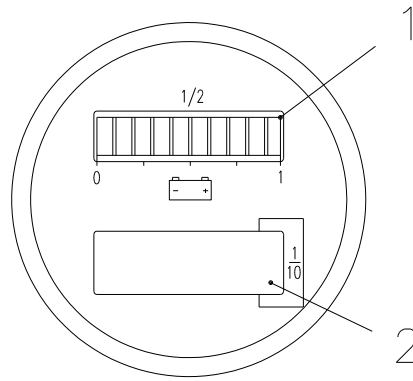

1.2.3 Battery discharge indicator

The LEDs (1) represent battery residual capacity, The LCD (2) displays the operating hours.

Battery Discharge Indicator(1)

When the truck has been released via the key switch, the battery charge status is displayed.

The colours of the LEDs (1) represent the following conditions:

Component	LED colour	value
Standard battery residual capacity	Green	70-100%
	Orange	30-60%
	Flashing Red	0-20%

Battery Discharge for 70%, A flashing red show on storage battery charge warning.

Battery Discharge for 80%, Two flashing reds show on battery charge used up warning, Lifting is now inhibited. The battery must be charged.

Operating hours display(2)

Display range between 0.0 and 99,999.0 hours. Travel and lifting are logged. This is a backlit display.

Power up test

On power up the display shows:

- the operating hours
- the charge status

The battery discharge indicator has a memory function, it can remember the battery power after the power turn off, and next time the power has be turned on it will show the power in it memory . If you want reset battery discharge indicator, please turn on the key after properly charging .

Low Voltage Protection

This vehicle has a low-voltage protection function.

When the battery voltage is less than, the vehicle will appear that the driving speed is slow ,but the fork can be lifted.And now the battery needs to be charged.

1.3 Identification points and data plates

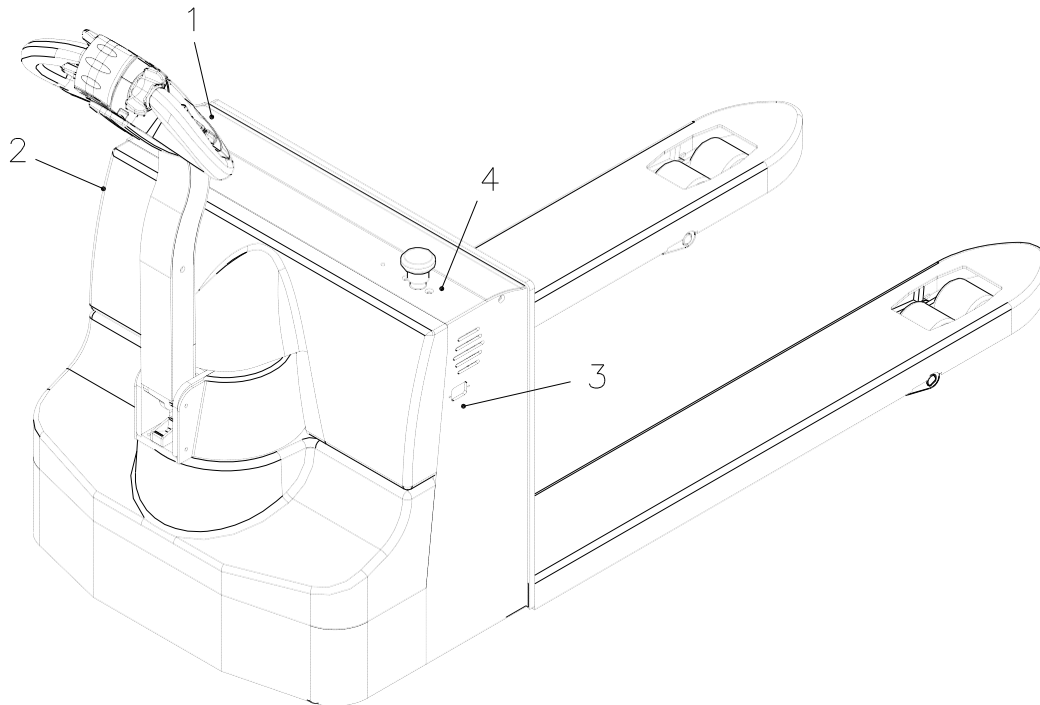

<p>1</p>		<p>3</p>	
<p>2</p>		<p>4</p>	

1.3.1 Truck data plate

Item	Description	Item	Description
1	Truck type	5	Fork length (mm)
2	Model No.	6	Battery capacity (Ah)
3	Capacity	7	Selfweight without battery (kg)
4	Fork width (mm)	8	Serial number

For queries regarding the truck or ordering spare parts please quote the truck serial number(8).

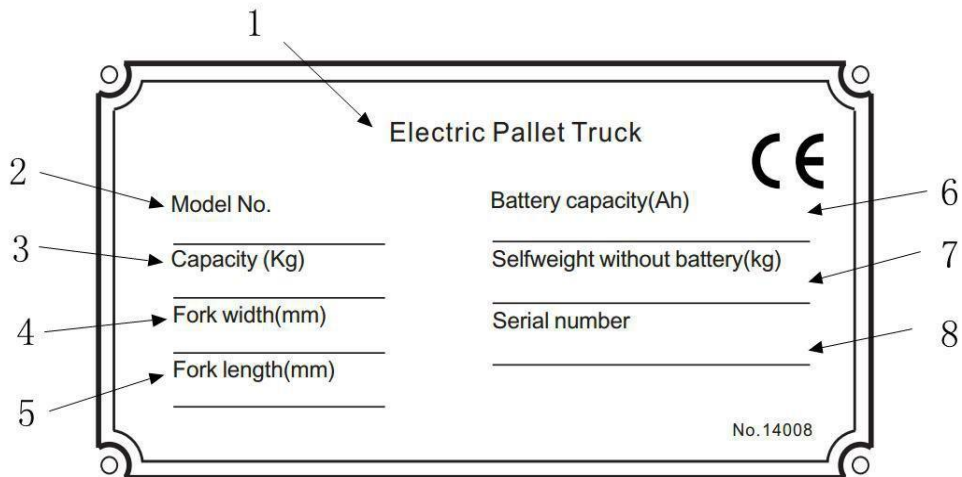

MODEL NUMBER EXAMPLE

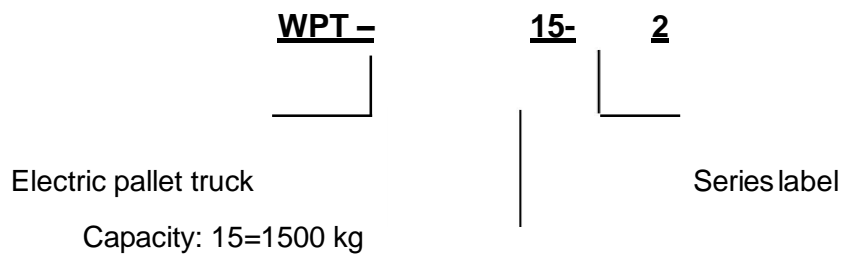

1.4 Standard Version Specifications

Technical specification details in accordance with VDI 2198. Technical modifications and additions reserved.

1.4.1 Performance data for standard trucks

Item	Description		WPT15-2	Unit
Q	Load capacity		1500	kg
C	Load center		600	mm
	Travel speed	laden	2.5	km/h
		unladen	3	km/h
	Lifting speed	laden	0.035	m/s
		unladen	0.045	m/s
	Lowering speed	laden	0.05	m/s
		unladen	0.04	m/s
	Maximum gradeability, S ₂ 5 min.	laden	5	%
		unladen	7	%
	Service brake		Electromagnetic	
	Service weight	Incl. battery	260	kg
	Motor	Drive	0.75	Kw
		Lift	0.8	Kw
	Tyre type, operator/load side		PU/ PU	
	Tyre size, operator side		Φ220	
	Tyre size, load side		2-Φ78×60	
	Battery	type	Maintenance free battery	
		voltage/ rated capacity (5h)	2×12/ 65	V/Ah
		weight	15×2	kg
	Sound level at operator's ear		74	dB(A)

1.4.2 Dimensions

Item	Description		WPT15-2	Unit
X	Load distance		1018	mm
Y	Wheelbase		1255	mm
h3	Lift height		200	mm
b11	Tread	load side	378 (398)	mm
h13	Fork height	lowered	85	mm
h14	Height of tiller arm in operating position	min	720	mm
		max	1175	mm
L1	Overall length		1610	mm
L2	Length to face of forks		460	mm
b1	Overall width		680	mm
s	Fork dimensions	Thickness	54	mm
e		Width	162	mm
L		Length	1150	mm
b5	Fork spread		680	mm
m2	Ground clearance		20	mm
Wa	Outer turning radius		1430	mm
Ast	Aisle width ¹⁾	1000x1200 pallet crossways	2400	mm
		800x1200 pallet lengthways	2300	mm

¹⁾ Including safety distance a = 200 mm

WPT15-2

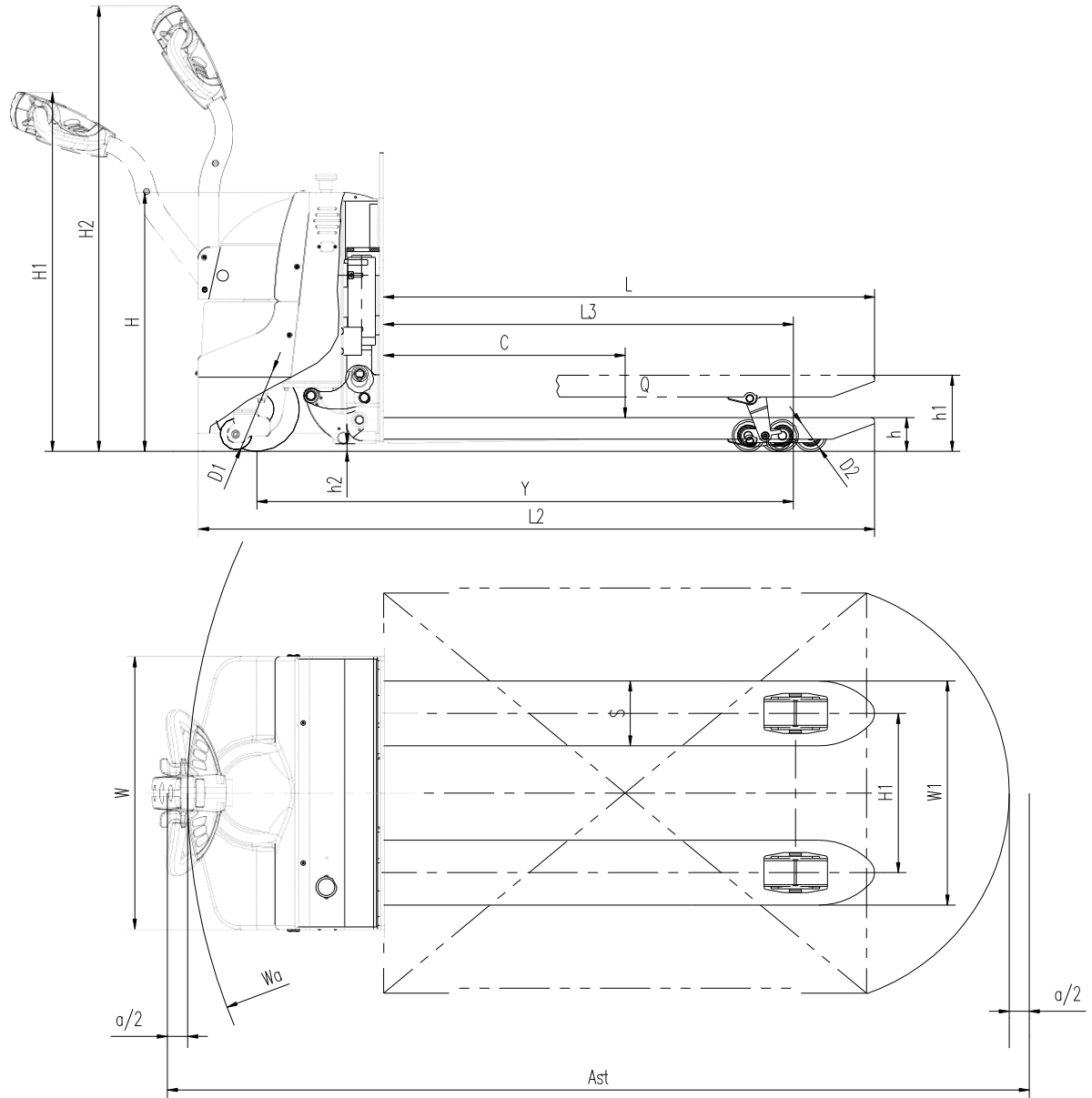

2.Transport and Commissioning

2.1 Using the Truck for the First Time

Only operate the truck with battery current. Rectified current will damage the electronic components. Cable connections to the battery (tow leads) must be less than 6 m .

Preparing the truck for operation after delivery or transport Procedure

- Check the equipment is complete.
- Check the hydraulic oil level.
- Install the battery if necessary (where required), (see "4.4 Battery removal and installation" on page 17) do not damage battery cable.
- Charge the battery, (see "4.3 Charging the battery" on page 16).

When the truck is parked the surface of the tyres will flatten. The flattening will disappear after a short period of operation.

2.2 During brake-in

We recommended operating the machine under light load conditions for the first stage of operation to get the most from it. Especially the requirements given below should be observed while the machine is in a stage of 100 hours of operation.

- Must prevent the new battery from over discharging when early used. Please charging when remain power less than 20%.
- Perform specified preventive maintenance services carefully and completely.
- Avoid sudden stop, starts or turns.
- Oil changes and lubrication are recommended to do earlier than specified.
- Limited load is 70~80% of the rated load.

3.Operation

3.1 Safety Regulations for the Operation of Pallet Trucks

Driver authorisation: The Pallet truck may only be used by suitably trained personnel, who have demonstrated to the proprietor or his representative that they can drive and handle loads and have been authorised to operate the truck by the proprietor or his representative.

Driver's rights, obligations and responsibilities: The driver must be informed of his duties and responsibilities and be instructed in the operation of the truck and shall be familiar with the operator manual . The driver shall be afforded all due rights . Safety shoes must be worn with pedestrian operated trucks.

Unauthorised Use of Truck: The driver is responsible for the truck during the time it is in use. He shall prevent unauthorised persons from driving or operating the truck. It is forbidden to carry passengers or lift personnel.

Damage and Faults: The supervisor must be immediately informed of any damage or faults to the Pallet truck. Trucks not safe for operation (e.g. wheel or brake problems) must not be used until they have been rectified.

Repairs: The driver must not carry out any repairs or alterations to the Pallet truck without the necessary training and authorisation to do so. The driver must never disable or adjust safety mechanisms or switches.

Hazardous area: A hazardous area is defined as the area in which a person is at risk due to truck movement, lifting operations, the load handler (e.g. forks or attachments) or the load itself. This also includes areas which can be reached by falling loads or lowering operating equipment.

Unauthorised persons must be kept away from the hazardous area. Where there is danger to personnel, a warning must be sounded with sufficient notice. If unauthorised personnel are still within the hazardous area the truck shall be brought to a halt immediately.

Safety Devices and Warning Signs: Safety devices, warning signs and warning instructions shall be strictly observed.

3.2 Operate and run the truck

3.2.1 Preparing

Before the truck can be commissioned, operated or a load unit lifted, the driver must ensure that there is nobody within the hazardous area.

Checks and operations to be performed before starting daily work

- Visually inspect the entire truck (in particular wheels and load handler) for obvious damage.

Switching on the truck

- Insert the key in the key switch and turn it as far right as it will go.

3.2.2 Travel ,Steering,Braking

Do not drive the truck unless the panels are closed and properly locked.

1.Traction

Set the control handle to the travel zone (M).Set the travel switch (16) (see Page 4) to control the driving speed and direction.

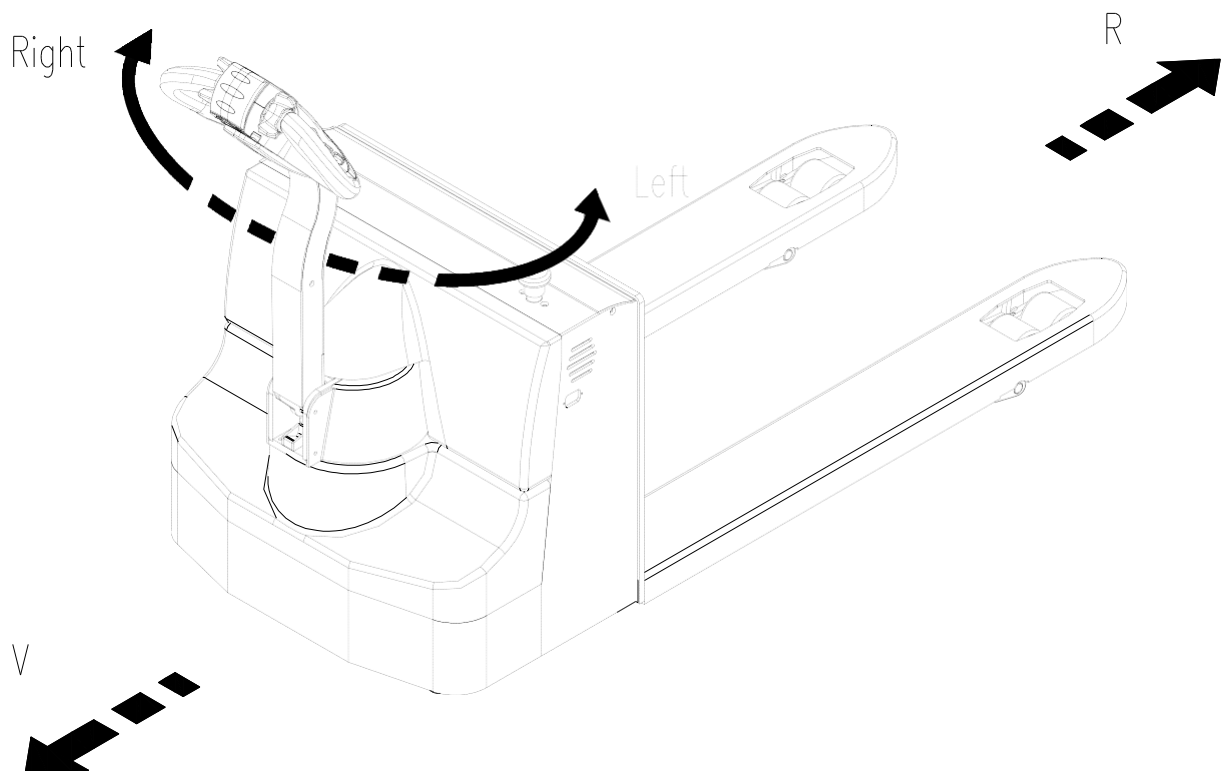

2.Steering

- Apply the control handle (1) to the left or right.

3.Braking

Emergency stop

Pull out the Emergency stop button(4), all electrical functions are cut out and the truck automatically brakes.

Automatic braking

When the control handle is released it automatically sets itself to the upper brake zone (B) and automatic braking ensues.

Regenerative braking

If the travel switch is released, the truck automatically brakes regeneratively. When the speed below 1Km/h, the brake then applies and motor brake stop.

Inversion braking

You can set the travel switch to the opposite direction when traveling. The truck brakes regeneratively until it starts to move in the opposite direction.

Warning : When driving on a hill or uneven roads, please lift fork leg to stop the bottom of fork leg and the ground being rubbed.

3.2.3Lifting, transporting and depositing loads

Unsecured and incorrectly positioned loads can cause accidents

- Instruct other people to move out of the hazardous area of the truck. Stop working with the truck if people do not leave the hazardous.
- Only carry loads that have been correctly secured and positioned. Use suitable precautions to prevent parts of the load from tipping or falling down.
- Do not transport with bad handbarrow (as truck and stock) .
- Never stand underneath a raised load handler.
- Do not stand on the load handler.
- Do not lift other people on the load handler.
- Insert the forks as far as possible underneath the load.

Warning!

Before lifting a load unit the driver must make sure that it has been correctly stowed and does not exceed the truck's capacity.

Do not lift long loads at an angle.

Lift

Press "Lift" button(3) until the height you need.

Warning!

Don't lift to tiptop, to avoid shorted life of oil cylinder.

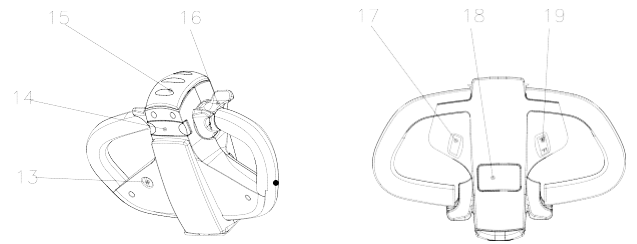

Lower

Press "Lower" button(3) until the lowest position.

3.2.4 Parking the truck securely

When you leave the truck it must be securely parked even if you only intend to leave it for a short time.

- Press "Lower" button(3), fully lower the load handler.
- Press the emergency brake switch(1).
- Turn off the key switch and remove the key(2).

Warning!

Parking the truck securely.
Forbid parking on an incline.
Always fully lower the forks.

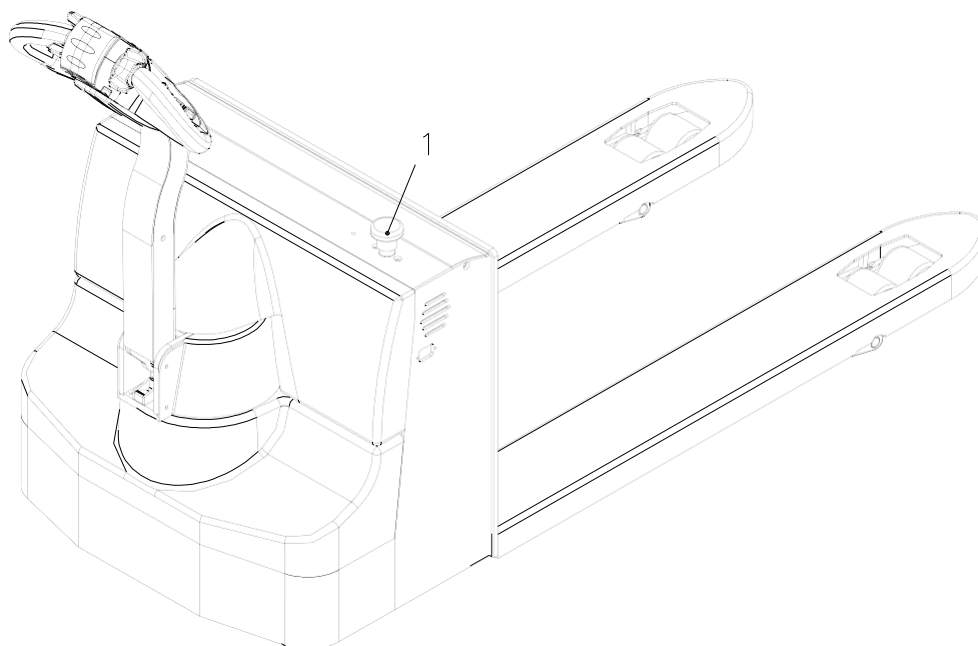
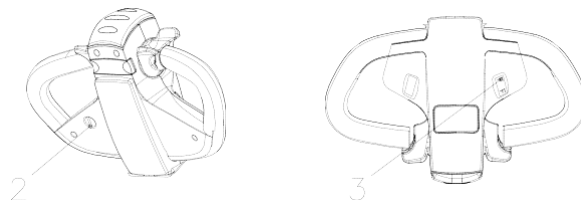

4. Battery Maintenance & Charging

4.1 Safety regulations for handling acid batteries

Park the truck securely before carrying out any work on the batteries.

Maintenance personnel : Batteries may only be charged, serviced or replaced by trained personnel .The present operator manual and the manufacturer 's instructions concerning batteries and charging stations must be observed when carrying out the work.

Fire protection :

- Smoking and naked flames must be avoided when working with batteries.
- Wherever a truck is parked for charging there shall be no inflammable material or operating fluids capable of creating sparks within 2 meters around the truck.
- The area must be well ventilated.
- Fire protection equipment must be provided.



Protection against electric shock:

- Battery has high voltage and energy.
- Do not bring short circuit.
- Do not approach tools to the two poles of the battery, which can cause the sparkle.

4.2 Battery type & dimension

Battery type & dimension as follow :

Tuck type	Battery type	voltage/ rated capacity	Battery height (mm)	Battery length (mm)	Battery width (mm)
WPT15-2	Maintenance free battery	2x12/65	178	224	135

When replacing or installing batteries, ensure that the battery is correctly secured in the battery compartment of the truck.

4.3 Charging the battery

Safety regulations for Charging the battery

- To charge the battery, the truck must be parked in a closed and properly ventilated room. When charging, the tops of the battery cells must be exposed to provide sufficient ventilation.
- Do not place any metal objects on the battery.

- Before charging, check all cables and plug connections for visible signs of damage.
- Before start and finish charging to make sure power is turn OFF.
- It is essential to follow the safety regulations of the battery and charging station manufacturers.

Charging step

- Check whether the condition is according with "Safety regulations for Charging the battery".
- Park the truck securely(See 3.2.4 Parking the truck securely Page15).
- Remove the battery plug (1).
- Connect the battery plug (1) with the charging lead of the stationary charger and turn on the charger.

LED lamp :

- Red ligh : the battery is charging
- Green light : the battery is fully charged
- Yellow light : Check the charging circuit.

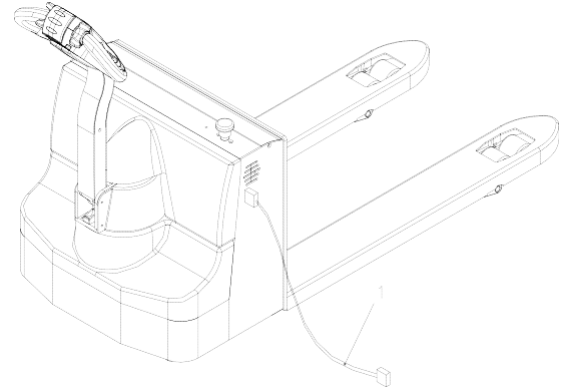

4.4 Battery removal and installation

Park the truck securely(See 3.2.4 Parking the truck securely Page 15) and turn off the power before removal and installation battery.

Battery removal and installation steps:

- Remove four screws(1), take out the cover(3)(4)
- Remove wire harness、 battery cable . Take out the battery.

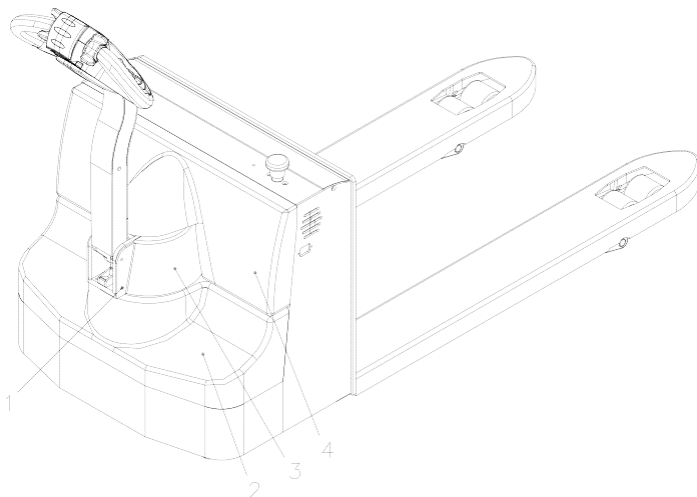

Warning!

Well place cables to avoid be damaged when you removal and installation battery.

- Installation is in the reverse order of operations, pay attention on battery install position and cable connection. Make sure the well place cables to avoid be damaged when you removal and installation battery.

4.5 Battery maintenance

Do not overuse battery:

- If you use up the energy of battery till the Pallet immovability, you will shorten its working hours.
- Shower for battery appears need for charge, please charge it quickly.

Battery maintenance:

The battery cell covers must be kept dry and clean. The terminals and cable shoes must be clean, secure and have a light coating of dielectric grease. Batteries with non insulated terminals must be covered with a non slip insulation mat.

Warning!

1. Do not use dry cloth or fibre cloth to clean the battery, avoiding static to bring the explosion.
2. Unfixing battery plug.
3. Cleaning with wet cloth.
4. Wearing glasses for protecting eyes rubber overshoes and rubber glove.

4.6 Battery Disposal

Batteries may only be disposed of in accordance with national environmental protection regulations or disposal laws. The manufacturer's disposal instructions must be followed.

Batteries contain an acid solution which is poisonous and corrosive . Therefore , always wear protective clothing and eye protection when carrying out work on batteries . Above all avoid any contact with battery acid.

Nevertheless, should clothing, skin or eyes come in contact with acid the affected parts should be rinsed with plenty of clean water-where the skin or eyes are affected call a doctor immediately. Immediately neutralise any spilled battery acid.

Only batteries with a sealed battery container may be used.

The weight and dimensions of the battery have considerable affect on the operational safety of the truck. Battery equipment may only be replaced with the agreement of the manufacturer.

5.Pallet Truck Maintenance

5.1Operational safety and environmental protection

- The servicing and inspection operations contained in this chapter must be performed in accordance with the intervals indicated in the servicing checklists.
- Any modification to the Pallet truck assemblies, in particular the safety mechanisms, is prohibited. The operational speeds of the truck must not be changed under any circumstances.
- Only original spare parts have been certified by our quality assurance department. To ensure safe and reliable operation of the Pallet truck, use only the manufacturer's spare parts. Used parts, oils and fuels must be disposed of in accordance with the relevant environmental protection regulations. For oil changes, contact the manufacturer's specialist department.
- Upon completion of inspection and servicing, carry out the activities listed in the "Recommissioning (on page 24)" section.

5.2Maintenance Safety Regulations

Maintenance personnel

Industrial trucks must only be serviced and maintained by the manufacturer's trained personnel.

The manufacturer's service department has field technicians specially trained for these tasks. We therefore recommend a maintenance contract with the manufacturer's local service center.

Lifting and jacking up

When an industrial truck is to be lifted, the lifting gear must only be secured to the points specially provided for this purpose.

When jacking up the truck, take appropriate measures to prevent the truck from slipping or tipping over (e.g. wedges, wooden blocks).

You may only work underneath a raised load handler if it is supported by a sufficiently strong chain.

Cleaning

Do not use flammable liquids to clean the industrial truck.

Prior to cleaning, all safety measures required to prevent sparking (e.g. through short circuits) must be taken. For battery-operated trucks, the battery connect cable must be removed.

Only weak suction or compressed air and non-conductive antistatic brushes may be used for cleaning electric or electronic assemblies.

If the truck is to be cleaned with a water jet or a high-pressure cleaner, all electrical and electronic components must be carefully covered beforehand as moisture can cause malfunctions.

Do not clean with pressurised water.

After cleaning the truck, carry out the activities detailed in the “Recommissioning (on page 24)” section.

Electrical System

Only suitably trained personnel may operate on the truck’s electrical system.

Before working on the electrical system, take all precautionary measures to avoid – electric shocks.

For battery-operated trucks, also de-energise the truck by removing the key.

Settings

When repairing or replacing hydraulic, electric or electronic components or assemblies, always note the truck-specific settings.

Tyres

The quality of tyres affects the stability and performance of the truck. When replacing factory fitted tyres only used original manufacturer’s spare parts, as otherwise the data plate specifications will not be kept.

When changing wheels and tyres, ensure that the truck does not slew (e.g. when replacing wheels always left and right simultaneously).

5.3 Servicing and inspection

Thorough and expert servicing is one of the most important requirements for the safe operation of the industrial truck. Failure to perform regular servicing can lead to truck failure and poses a potential hazard to personnel and equipment.

The service intervals stated are based on single shift operation under normal operating conditions. They must be reduced accordingly if the truck is to be used in conditions of extreme dust, temperature fluctuations or multiple shifts.

The following maintenance checklist states the tasks and intervals after which they should be carried out. Maintenance intervals are defined as:

W = Every 50 service hours, at least

weekly A = Every 500 operating hours

B = Every 1000 operating hours, or at least annually

C = Every 2000 operating hours, or at least annually

W service intervals are to be performed by the customer.

In the run-in period - after approx. 100 service hours - or after repair work, the owner must check the wheel nuts/bolts and re-tighten if necessary.

5.3.1 Maintenance Checklist

		Maintenance interval ●			
		W	A	B	C
Brake	Check magnetic brake air gap.			●	
Electrics	Test instruments, displays and control switches.	●			
	Test warning and safety device.		●		
	Make sure wire connections are secure and check for damage.			●	
	Test micro switch setting.	●			
	Check relays.			●	
	Fix the motor and cable			●	
Power supply	Visually inspect battery		●		
	Check battery cable connections are secure, grease terminals if necessary.			●	
Travel	Check the transmission for noise and leakage.			●	
	Check travel mechanism, adjust and lubricate if necessary. Check control handle recuperating function.		●		
	Check wheels for wear and damage.			●	
	Check wheel bearings and attachments.			●	
Truck frame	Check truck frame for damage.			●	
Hydraulic operation	Test hydraulic system.		●		
	Check cylinders and piston rods for damage and leaks, and make sure they are secure.		●		
	Check cylinders and piston rods for damage and leaks, and make sure they are secure.			●	
	Check load chain setting and tension if necessary.			●	
	Visually inspect mast rollers and check contact surface wear level			●	
	Check forks, load handler for wear and damage			●	
	Check hydraulic oil level.			●	
	Replace hydraulic oil.				●
	Check and clean hydraulic oil filter. Replace it if necessary.				●

5.3.2 Lubrication Schedule

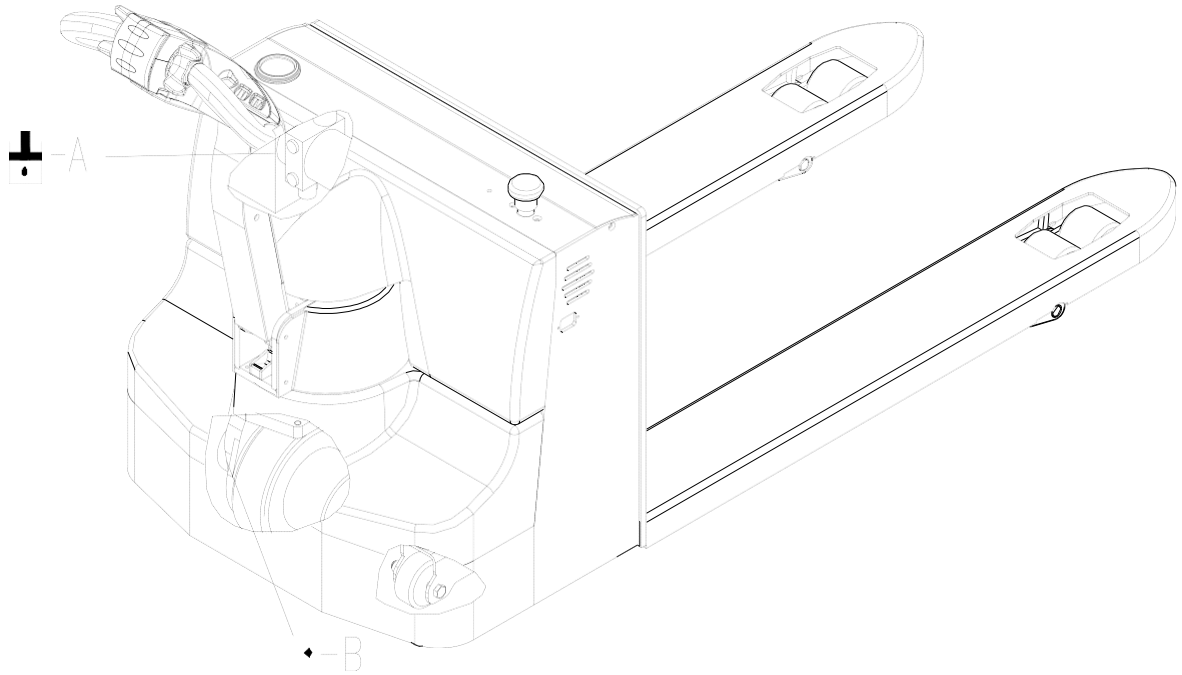

⊥ Hydraulic oil filler neck

◆ Transmission oil filler neck

Fuels, coolants and lubricants

Handling consumables: Consumables must always be handled correctly. Follow the manufacturer's instructions.

Improper handling is hazardous to health, life and the environment. Consumables must only be stored in appropriate containers. They may be flammable and must therefore not come into contact with hot components or naked flames.

Only use clean containers when filling up with consumables. Do not mix consumables of different grades. The only exception to this is when mixing is expressly stipulated in the Operating Instructions.

Avoid spillage. Spilled liquids must be removed immediately with suitable bonding agents and the bonding agent/consumable mixture must be disposed of in accordance with regulations.

Code	Description	Used for
A	HM46#	Hydraulic system
B	Grease(contain MUS ₂)	Lubrication and gear case

5.3.3 Maintenance Instructions

Prepare the truck for maintenance and repairs

All necessary safety measures must be taken to avoid accidents when carrying out maintenance and repairs. The following preparations must be made:

- Park the truck securely (See 3.2.4 Parking the truck securely Page 15).
- Remove the key to prevent the truck from accidentally starting.
- When working under a raised lift truck, secure it to prevent it from tipping or sliding away.

Removing the cover

- Remove upper cover(5).
- Remove the four screws(1).Lift off protection Cover(3).
- Remove the screws on (4).Carefully open the down cover (2).

Replacing the drive wheel

The drive wheel must only be replaced by authorised service personnel.

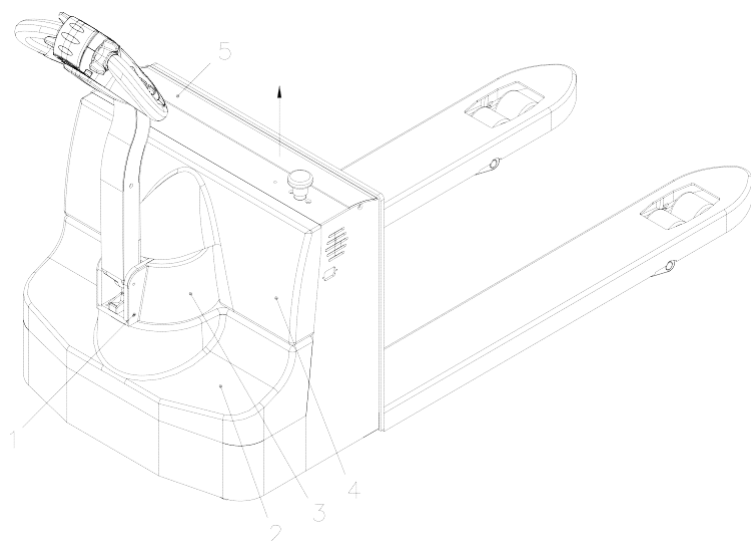

Check the hydraulic oil level

It is going to add hydraulic oil when you heard explosion sound from pipe during lifting.

Warning!

Forbid adding hydraulic oil within impurity.

- Prepare the truck for maintenance and repairs (See 5.3.3 Maintenance Instructions Page23).
 - Opening the upper cover.
 - Add hydraulic oil of the correct grade (See 5.3.2 Lubrication Schedule P22) .
- Add hydraulic oil till you cant hear explosion sound during lifting.
Installation is the reverse order.

Check transmission oil level

- Prepare the truck for maintenance and repairs (See 5.3.3 Maintenance Instructions Page23).
 - Add transmission oil of the correct grade to oil cup(See 5.3.2 Lubrication Schedule Page22).
 - add transmission oil every 1000 operating hours or at least annually.
- Installation is the reverse order.

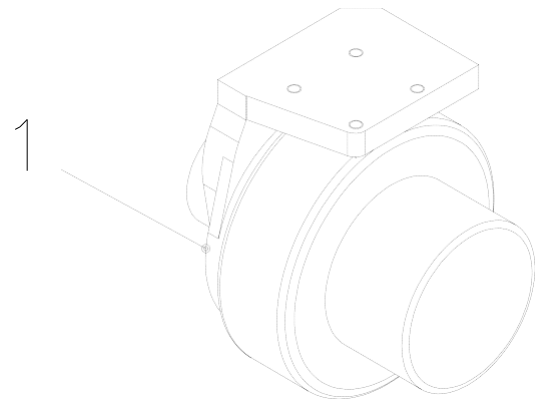

Warning!

Forbid adding transmission oil within impurity.

Recommissioning

The truck may only be recommissioned after cleaning or repair work, once the following operations have been performed.

- Test horn.
- Test brake.
- Lubricate the truck in accordance with the maintenance schedule.

5.4 Decommissioning the industrial truck

If the industrial truck is to be decommissioned for more than two months , e.g. For operational reasons,it must be parked in a frost-free and dry location and all necessary measures must be taken before, during and after decommissioning as described.

On decommissioning the truck must be jacked up so that all the wheels are clear of the ground. This is the only way of ensuring that the wheels and wheel bearings are not damaged.

If the truck is to be out of service for more than 6 months , further measures must be taken in consultation with the manufacturer's service department.

5.4.1 Prior to decommissioning

- Thoroughly clean the truck.
- Check the brakes.
- Check the hydraulic oil level and replenish as necessary (See 5.3.3 Maintenance Instructions Page23).
- Apply a thin layer of oil or grease to any non-painted mechanical components.
- Lubricate the truck in accordance with the maintenance schedule (See 5.3.2 Lubrication Schedule P22).
- Charge the battery (See 4.3Charging the battery P18).
- Disconnect the battery, clean it and apply grease to the terminals.
In addition, follow the battery manufacturer's instructions.
- Spay all exposed electrical contacts with a suitable contact spray.

Warning !

Charge every months:

– Charge the battery.

Battery powered trucks:

The battery must be charged at regular intervals to avoid depletion of the battery through self-discharge.

The sulfatisation would destroy the battery.

5.4.2 Restoring the truck to operation after decommissioning

- Thoroughly clean the truck.
- Lubricate the truck in accordance with the maintenance schedule (See 5.3.2 Lubrication Schedule P22).
- Clean the battery, grease the terminals and connect the battery.
- Charge the battery (See 4.3Charging the battery P16).
- Check hydraulic oil for condensed water and replace if necessary.
- Start up the truck (see 3.2 Operate and run the truck P13).

If there are switching problems in the electrical system, apply contact spray to the exposed contacts and remove any oxide layers on the contacts of the operating controls by applying them repeatedly.

Perform several brake tests immediately after re-commissioning the truck.

5.5 Safety checks to be performed at regular intervals and following any unusual incidents

Carry out a safety check in accordance with national regulations. EP has a special safety department with trained personnel to carry out such checks. The truck must be inspected at least annually (refer to national regulations) or after any unusual event by a qualified inspector. The inspector shall assess the condition of the truck from purely a safety viewpoint, without regard to operational or economic circumstances. The inspector shall be sufficiently instructed and experienced to be able to assess the condition of the truck and the effectiveness of the safety mechanisms based on the technical regulations and principles governing the inspection of Pallet trucks.

A thorough test of the truck must be undertaken with regard to its technical condition from a safety aspect. The truck must also be examined for damage caused by possible improper use. A test report shall be provided. The test results must be kept for at least the next 2 inspections.

The owner is responsible for ensuring that faults are immediately rectified.

A test plate is attached to the truck as proof that it has passed the safety inspection.

This plate indicates the due date for the next inspection.

5.6 Final de-commissioning, disposal

Final, proper decommissioning or disposal of the truck must be performed in accordance with the regulations of the country of application. In particular, regulations governing the disposal of batteries, fuels and electronic and electrical systems must be observed.

6.Troubleshooting

This chapter is designed to help the user identify and rectify basic faults or the results of incorrect operation. When locating a fault, proceed in the order shown in the table.

Fault	Possible cause	Action
Truck does not start.	<ul style="list-style-type: none">• Key switch in “OFF” position• Battery charge too low• Truck in charge mode• Faulty fuse	<ul style="list-style-type: none">• Set key switch to “ON”• Check battery charge, charge battery if Necessary• Interrupt charging• Test fuses
Load can not be lifted	<ul style="list-style-type: none">• Hydraulic oil level too low• Excessive load	<ul style="list-style-type: none">• Check the hydraulic oil level• Note maximum capacity (see data plate)

If the fault cannot be rectified after carrying out the remedial procedure, notify the manufacturer’s service department ,as any further troubleshooting can only be performed by specially trained and qualified service personnel.

Error Message

The error message can be obtained in this way: by reading the appropriate display on the hand set display

HAND SET DISPLAY DIAGNOSTICS

Faults are displayed in the Faults menu.

:

1212P MOTOR CONTROLLER

Number	Error Message	EXPLANATION	Possible cause
	Error text		
1	THERMAL FAULT	over-/under-temperature cutback	1. Temperature >80°C or <-10°C. 2. Excessive load on vehicle. 3. Operation in extreme environments. 4. Electromagnetic brake not releasing.
2	THROTTLE FAULT	PotLow and/or PotWiper out of range	1. Throttle input wire open or shorted. 2. Throttle pot defective. 3. Wrong throttle type selected.
3	SPEED POT FAULT	speed limit pot wiper out of range	1. Speed limit pot wire(s) broken or shorted. 2. Broken speed limit pot.
4	UNDERVOLTAGE FAULT	battery voltage too low	1. Battery voltage <17 volts. 2. Bad connection at battery or controller.
5	OVERVOLTAGE FAULT	battery voltage too high	1. Battery voltage >31 volts. 2. Vehicle operating with charger attached. 3. Intermittent battery connection.
1	MAIN OFF FAULT	main contactor driver Off fault	1. Main contactor driver failed open.
3	MAIN FAULT	main contactor fault	1. Main contactor welded or stuck open. 2. Main contactor driver fault.
4	MAIN ON FAULT	main contactor driver On fault	1. Main contactor driver failed closed.

3	1	WIRING FAULT	HPD fault present >10 sec.	1.Misadjusted throttle. 2.Broken throttle pot or throttle mechanism.
3	2	BRAKE ON FAULT	brake On fault	1.Electromagnetic brake driver shorted. 2.Electromagnetic brake coil open.
3	3	PRECHARGE FAULT	precharge fault	1. Brake driver shorted. 2. Precharge circuit damaged. 3. MOSFET failure.
3	4	BRAKE OFF FAULT	brake Off fault	1.Electromagnetic brake driver open. 2.Electromagnetic brake coil shorted.
3	5	HPD FAULT	HPD (High Pedal Disable)	1. Improper sequence of throttle and KSI,push, or inhibit inputs. 2. Misadjusted throttle pot.
4	1	CURRENT SENSE FAULT	current sense out of range	1.Short in motor or in motor wiring. 2. Controller failure. ★
4	2	HARDWARE FAILSAFE	motor voltage out of range	1.Motor voltage does not correspond to throttle request. 2.Short in motor or in motor wiring. 3. Controller failure. ★
4	3	EE CHECKSUM FAULT	EEPROM fault	1. EEPROM failure or fault.
4	5	BATTERY DISCONNECT FAULT	battery disconnected	1. Battery not connected. 2.Poor connection to battery terminals.

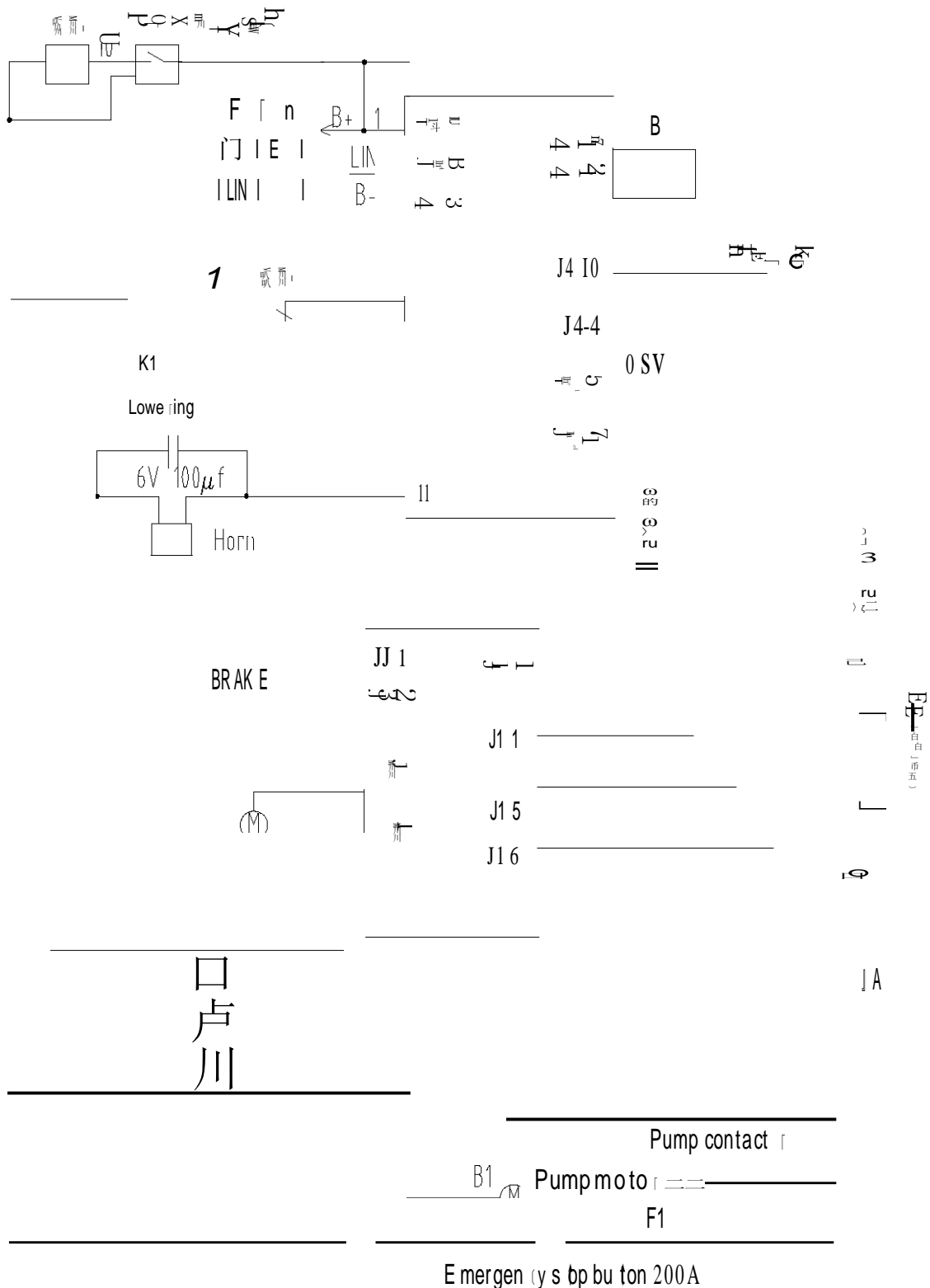

山;