

Air Handling Unit Topvex SC, TC

Operation and Maintenance Instructions

GB

Document in original language | 214959 · A002



© Copyright Systemair AB
All rights reserved
E&OE

Systemair AB reserves the rights to alter their products without notice.
This also applies to products already ordered, as long as it does not affect the previously agreed specifications.

Contents

1	Overview	1	7.12	How to reset the manual overheat protection (EL units).....	23
1.1	Intended use	1	7.13	How to replace the fan module.....	24
1.2	Disclaimer	1	7.14	How to replace the heat exchanger	24
1.3	Warranty.....	1	7.15	Change the internal battery in control unit CU27-C	29
2	Warnings.....	1	8	Troubleshooting.....	30
3	Warnings signs on product	2	9	Alarms.....	31
4	Product description.....	3	9.1	Alarm list.....	31
4.1	Supply and extract air fans	3	10	Service	32
4.2	Pressure transmitter fans/filters	3	11	EU Declaration of Conformity	33
4.3	Supply and extract air filters.....	3	12	General conditions.....	34
4.4	Heat exchanger	3	12.1	Standard tools	34
4.5	Temperature sensor.....	3	12.2	Reference documentation.....	34
4.6	Water heating coil	3	13	Spare parts	34
4.7	Electric heating coil.....	3			
4.8	Internal components position.....	4			
4.9	Access control cabinet.....	6			
5	Start up.....	7			
5.1	NaviPad	7			
6	Operation	11			
6.1	Controller settings	11			
6.2	Advanced HMI (Human Machine Interface) Settings.....	17			
6.3	No communication	18			
7	Maintenance	19			
7.1	Maintenance intervals	19			
7.2	How to replace supply/extract air filter	20			
7.3	How to clean NaviPad	20			
7.4	How to clean the heat exchanger.....	20			
7.5	How to clean the fans	21			
7.6	How to clean hot water heating coil.....	21			
7.7	How to clean the electric heating coil.....	22			
7.8	How to clean the extract air louvres and inlet diffusers	22			
7.9	Clean the outdoor air intake.....	22			
7.10	How to clean the duct system	22			
7.11	Where to reset tripped fuses.....	23			

1 Overview

This manual includes the information required. If other accessories not included at delivery are in use, read their separate instructions. The key to proper and safe operating is to read this manual thoroughly, use the air handling unit according to given guidelines and follow all safety requirements.

1.1 Intended use

The heat recovery units are intended to provide ventilation and depending on settings, heat recovery, air heating or free cooling. Topvex SC, TC are meant for indoor installation.

Sound levels exceeding 70 dB(A) may occur depending on model and size (see online catalogue at www.systemair.com for detailed information).

1.2 Disclaimer

The manufacturer may not be held liable for any damage to people or property caused by improper installation, start-up and/or improper use of the unit and/or failure to implement the procedures and instructions included in this manual.

1.3 Warranty

General conditions are applied if purchase contract not state otherwise.

These units are delivered complete, tested and ready for being operated. Any form of warranty will become null and void in the event that the unit is modified without manufacturer's authorisation. Carry out all the planned maintenance according to this manual in a timely and proper way.

Wear parts are not covered by the warranty.

2 Warnings

The following admonitions will be presented in the different sections of the document:



Danger

- Indicates a potentially or imminently hazardous situation which, if not avoided, could result in death or serious injury.



Warning

- Indicates a potentially hazardous situation that may result in minor or moderate injuries.



Caution

- Indicates a risk of damaging the product or prevent optimal operation.

Important

- This appliance can be used by children aged from 8 years and above and persons with reduced physical, sensory or mental capabilities or lack of experience and knowledge if they have been given supervision or instruction concerning use of the appliance in a safe way and understand the hazards involved.
- Children shall not play with the appliance. Cleaning and user maintenance shall not be made by children without supervision.

3 Warnings signs on product

Warning signs located on the air handling units.



Fig. 1 Disconnect all supply circuits before access to terminals

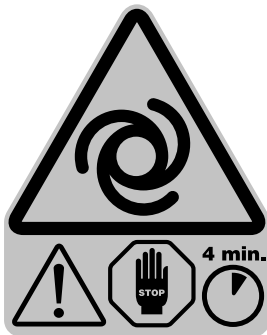

Fig. 2 Rotating fan during 4 minutes rundown period

4 Product description

4.1 Supply and extract air fans

The fans have external rotor motors of EC type which are steplessly controlled individually by setting the control signal to a fixed value. It is possible to program the speed in 3 steps (high/normal/low) depending on the programming of the week schedule. The motor bearings are life time lubricated and maintenance free. It is possible to remove the fans for cleaning, see chapter 7 for more information.

4.2 Pressure transmitter fans/filters

Two pressure transmitters are installed, each of the sensors has two functions. One function is to measure the differential pressure over the inlet cone of the fan impellers to maintain the airflow at constant level (CAV function as standard). The other function, is to measure the differential pressure over the supply and extract air filters. When the pressure drop reaches the set value, an alarm is triggered in the main regulator, which indicates that the filter needs to be replaced.

4.3 Supply and extract air filters

The filters are of bag filter type with filter quality ePM1 60% (F7) for the supply air filter and ePM10 60% (M5) for the extract air filter. The filters need to be replaced when polluted. We recommend ordering original filters from Systemair.

4.4 Heat exchanger

Topvex SC, TC models are equipped with a counter flow heat exchanger and a by-pass damper. The operation of the by-pass damper is automatic and depends on the set temperature or if defrosting is in operation.

For defrosting a pressure transmitter is installed which measure the differential pressure over the heat exchanger.

4.5 Temperature sensor

4 temperature sensors (PT1000) are included in the unit from factory. The sensors are as follows:

- Supply air sensor
- Extract air temperature sensor
- Outdoor air temperature sensor
- Exhaust air temperature sensor
- Efficiency temperature sensor

The supply air sensor is loosely delivered with the unit and needs to be installed in the supply air duct externally from the unit. See Installation instructions for more information.

4.6 Water heating coil

In units with built in water heating coil the hot water coil is located next to the supply air connection. The hot water coil can be either HWL (hot water coil, low power) or HWH (hot water coil, high power). The coil material is copper piping with a frame of galvanized sheet steel and aluminium fins. The coil is equipped with venting and immersion sensor for frost protection.

4.7 Electric heating coil

In units with built in electrical heater the heating rods are located after the supply air fan in the airflow direction. The material is stainless steel. The electrical heating coil has both automatic and manual overheating protection. The manual overheat protection is reset by pushing the red button on top of the electrical heater frame (figure 9). The electrical heater is mechanically interlocked by an air flow sensor in the supply air. The power demand of the electric heating coil is controlled by the main regulator, which controls the heat steplessly by a TTC triac control according to the selected control function that is set in the control panel.

4.8 Internal components position

4.8.1 Topvex SC

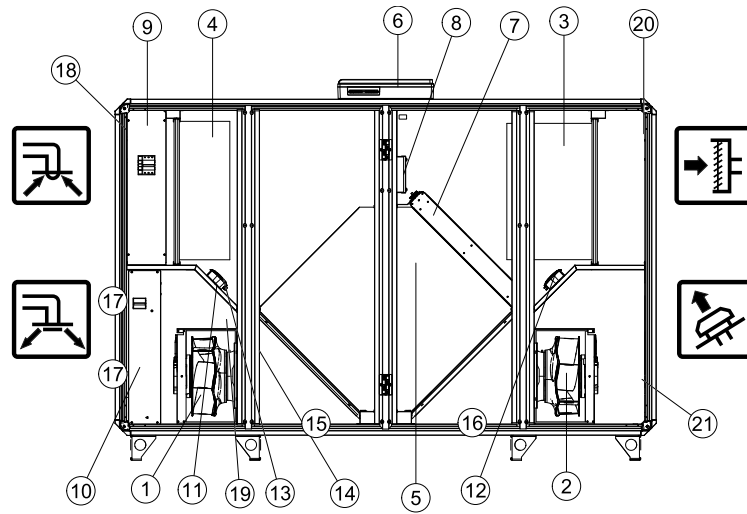

Fig. 3 Left hand unit



Supply air



Exhaust air



Outdoor air



Extract air

Position	Description
1	Fan supply air
2	Fan extract air
3	Filter supply air
4	Filter extract air
5	Heat exchanger
6	Access control cabinet
7	Damper by-pass outdoor air/Section defrosting (only units with section defrosting)
8	Control box for section defrosting (only for unit with section defrosting)
9	Internal electrical cabinet
10	Heating coil (EL or HWH/HWL)
11	Pressure transmitter supply air fan/extract air filter
12	Pressure transmitter extract air fan/supply air filter
13	Pressure transmitter defrosting exchanger
14	Air flow sensor (only for units with electric heating coil)
15	Condensation drain, outdoor air
16	Condensation drain, extract air
17	Water battery connection
18	Extract air temperature sensor (ETS)
19	Efficiency temperature sensor (EFS)
20	Outdoor air temperature sensor (OS)
21	Exhaust air temperature sensor (EHS)

4.8.2 Topvex TC

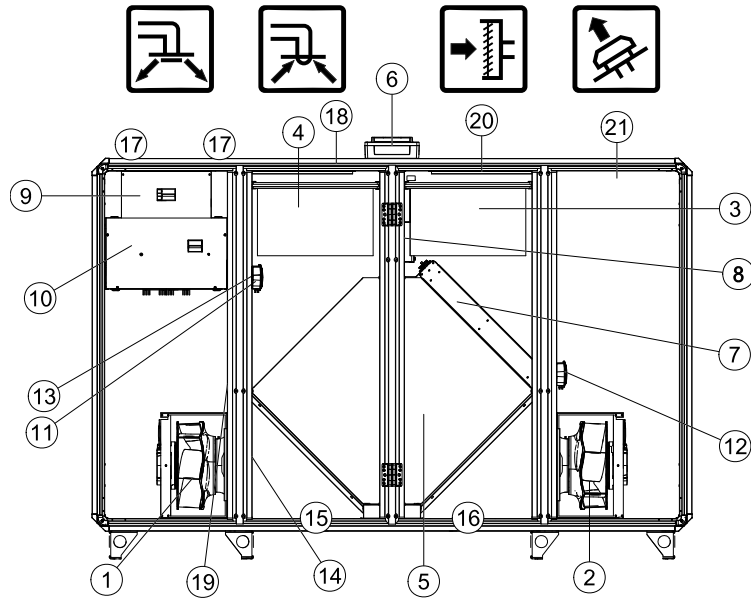

Fig. 4 Left hand unit



Supply air



Exhaust air



Outdoor air



Extract air

Position	Description
1	Fan supply air
2	Fan extract air
3	Filter supply air
4	Filter extract air
5	Heat exchanger
6	Access control cabinet
7	Damper by-pass outdoor air/Section defrosting (only units with section defrosting)
8	Control box for section defrosting (only for unit with section defrosting)
9	Internal electrical cabinet
10	Heating coil (EL or HWH/HWL)
11	Pressure transmitter supply air fan/extract air filter
12	Pressure transmitter extract air fan/supply air filter
13	Pressure transmitter defrosting exchanger
14	Air flow sensor (only for units with electric heating coil)
15	Condensation drain, outdoor air
16	Condensation drain, extract air
17	Water battery connection
18	Extract air temperature sensor (ETS)
19	Efficiency temperature sensor (EFS)
20	Outdoor air temperature sensor (OS)
21	Exhaust air temperature sensor (EHS)

4.9 Access control cabinet



Danger

Disconnect the mains power supply to the unit before moving the Access control cabinet or opening the lid.



Warning

Before obtaining access to terminals, all supply circuits must be disconnected.

Access control cabinet is mounted on top of the unit. It is possible to remove the cabinet and mount it in a suitable location, a control cabinet kit is available as an accessory.

The enclosure class for Access control cabinet is IP44. The dimensions are; length 450 mm, width 230 mm, height 92,5 mm.

Use one of the three flanges on the control cabinet to install accessories. If there is a need to change the type of flange on one position, it's possible to order additional flanges from Systemair. If Access control cabinet is mounted in an exposed environment and a higher enclosure class is required, order a flange suitable for cable glands and replace the existing one (3).

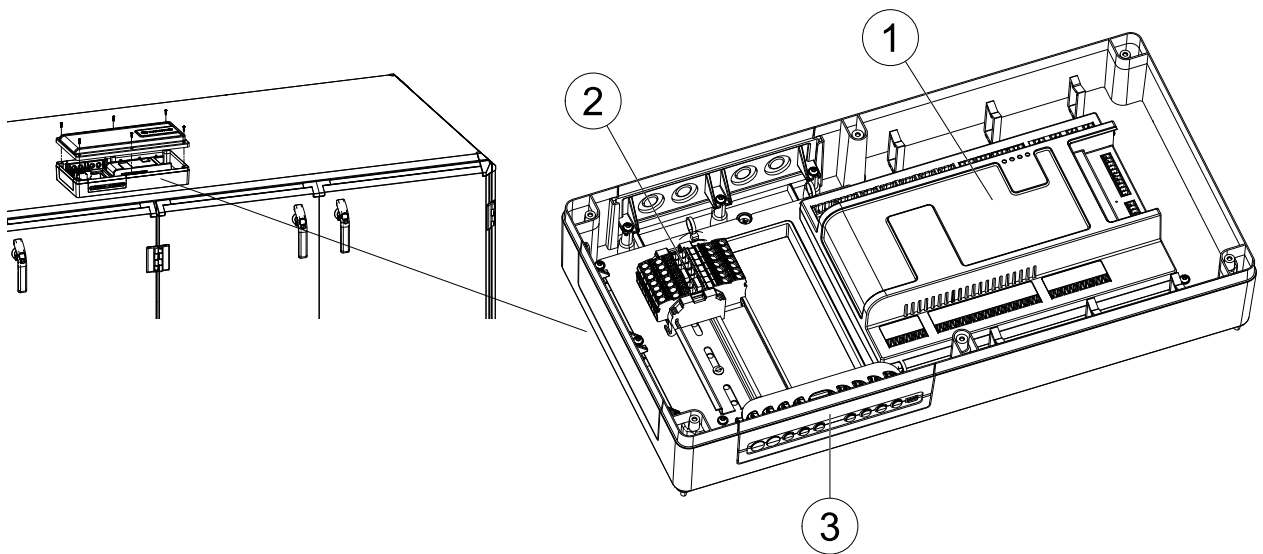

Fig. 5

Position	Description
1	Control unit CU27-C
2	Terminals
3	Flange

5 Start up

Read and follow carefully the installations instruction before start up.

Before stating up the unit check following points with power supply off.

- Check so the unit is placed horizontally
- Check inside the unit and secure that the unit is clean
- Check that all transport protection is removed
- Turn on the power supply

5.1 NaviPad

NaviPad is Systemair's user interface with a 7" capacitive touch screen. The user interface provides operation information about the connected air handling units and allows you to control all functions. You navigate by pressing the touchscreen, to activate a function, change setting or by reading values in real time.

After 5 min inactivity the screen activate sleep mode, you return to the screen you left by pressing the touchscreen. After additional 10 min. inactivity you return to the system overview dashboard (figure 3) and have to log in again.

Editable text and values are shown in blue and differs depending on user level.

Since the user interface of the air handling unit consists of a web server with web pages it is possible to use a computer to browse the user interface. Identify the IP address of the air handling unit with NaviPad, see Example 4 and then write it in the address field of an internet browser.

Important

- The air handling unit and the NaviPad as well as any computer has to be connected on a local network with the same IP subnet.
- Chrome browser for computer is supported to navigate the web pages of the air handling unit.

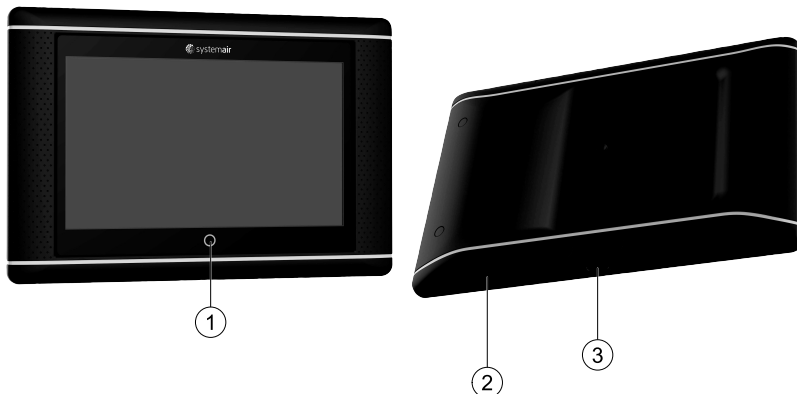

Fig. 6 (1) Home button, (2) USB connection, reboot button, (3) power supply and communication

5.1.1 Start-up wizard

At the first start up of NaviPad you need to calibrate the screen by pressing lightly on the cross marks.

Then you will be requested to fill in following information:

- Language
- Time & Date

Available air handling units will be shown in the device list. Choose the air handling unit you want to pair with your NaviPad. Use the controller’s serial number in the air handling unit to be sure to pair the correct air handling unit with NaviPad.

If the start-up wizard is cancelled it will start again during next power up of the NaviPad, this will continue until start-up wizard is successfully finished.

Version: PR1.2 (1.1.0.128) and later

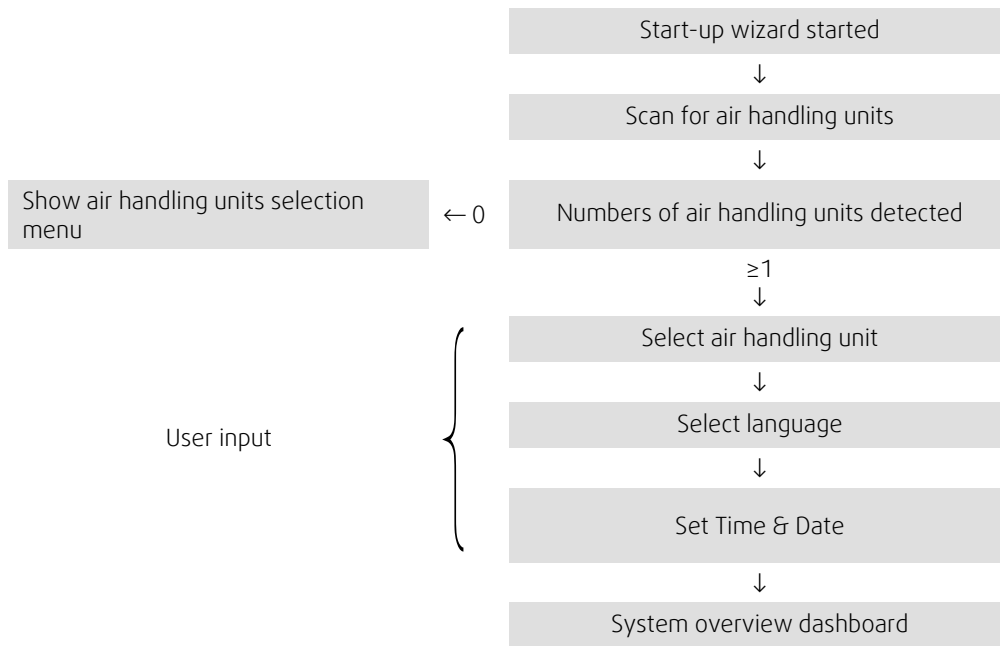

After the start-up wizard is completed the system overview dashboard is shown. Press on the symbol of the air handling unit to access the unit’s home page.

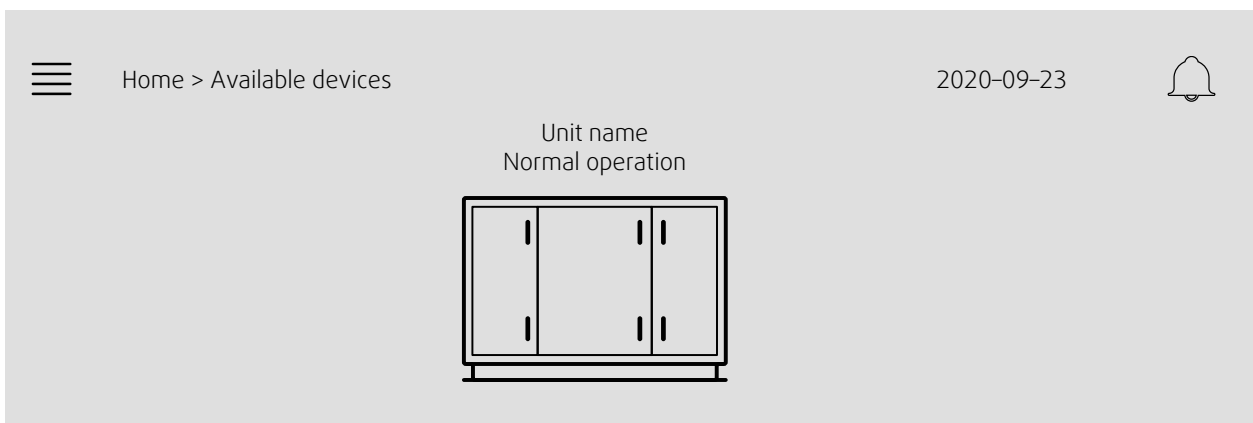

Figure 3: System dashboard



Note:

You can always return to system overview dashboard by pressing the home button, figure 6, (1).

5.1.2 Home page

Menus and functions may differ depending on actual configuration and/or application version running in the air handling unit.

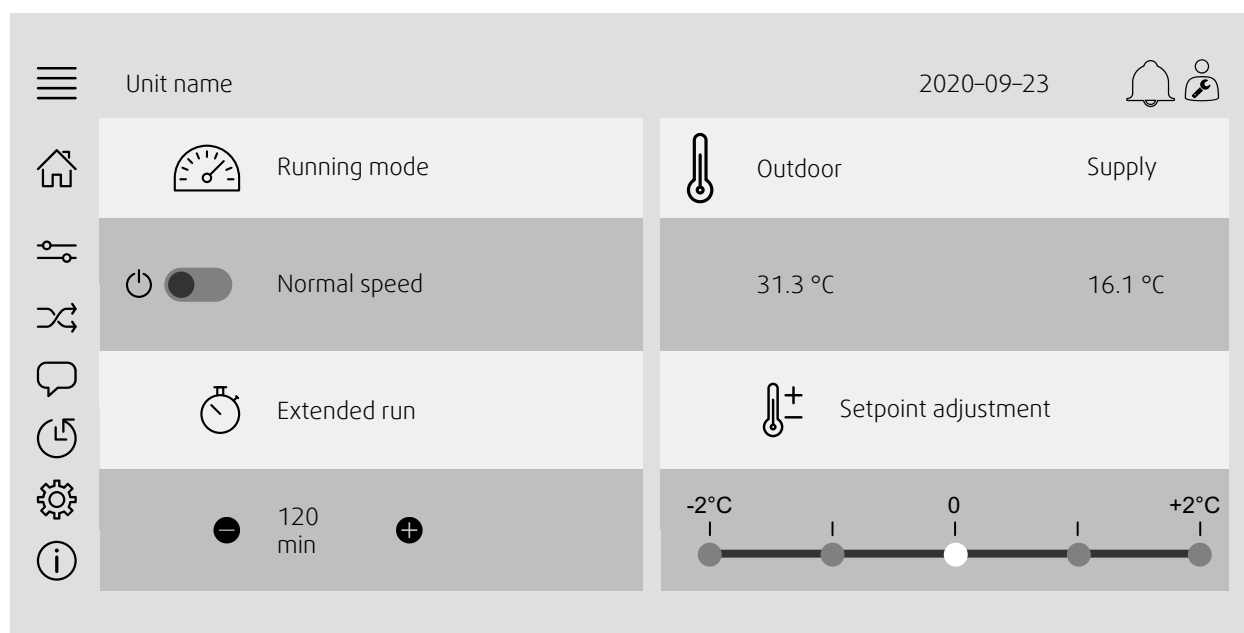









Figure 4: The home page shows an overview of the air handling unit operation status.

5.1.3 Key board

When a name, value or password need to be changed/written a key board will appear at the bottom of the touchscreen.

5.1.4 Symbol description

-  Home (home page)
-  Data and settings
Shows operating information and settings
-  Flow diagram
A schematic overview of the air handling unit and its components
-  Language
Change language
-  Time and date
Weekly schedule
-  Configuration
Alarm and functions configurations, I/O allocation settings
-  System information
Shows information about the air handling unit, installation site, control unit, communication and the Systemair product.
-  Alarm symbol, indicates if there are active alarms. One press on the symbol will direct you to the alarm list.

5.1.5 User levels



End user
When logged out

Read /write – Home page
Possible actions in end user mode are to stop the air handling unit for maintenance (e.g. filter exchange), change the time for extended run and change the temperature setpoint.
Flow diagram and active alarms in alarm list are visible.



Operator mode – log in with 1111
Logged in

Read and write privileges (except Configuration).
Acknowledge/block/unblock alarms and view the alarm history.



Service mode – log in with 0612
Logged in

Full read and write privileges.



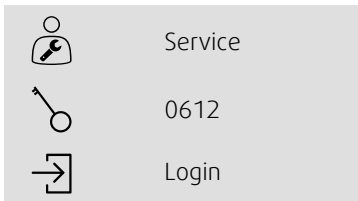

5.1.6 Log in

Log in with service mode using password 0612.

Overview:



Step by step:

1.  Open the log in window
2.  Select service from drop down list
3.  Type in password 0612
4.  Press Login.

5.1.7 Configuration wizard

A configuration wizard is available in the configuration menu . This could be used for the most common configurations.

See enclosed Quick Configuration guide for more information.

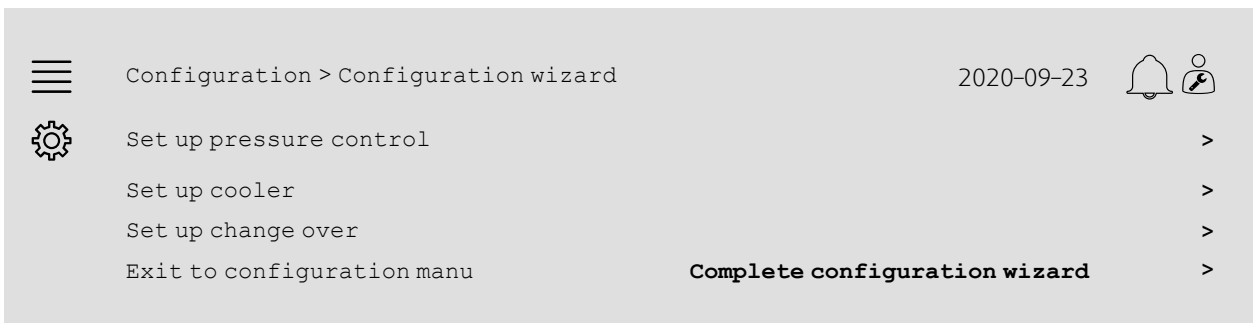





6 Operation

6.1 Controller settings

Menus and functions may differ depending on actual configuration and/or application version running in the air handling unit.

6.1.1 Data & Settings



	Data & Settings	2020-09-23	 
	Operation overview		>
	In-/Output status		>
	Temperature control		>
	Fan control		>
	Demand control		>
	Fire/Smoke		>
	Alarm list		>

6.1.1.1 Operation overview



Value of active signals
I/O signals and operation mode.

- Temperature
- Air flow/pressure
- CO2
- RH
- Heating
- Exchanger
- Cooler
- Recirculation

6.1.1.2 In- and output status



I/O status
Total overview of:

- Sensors
 - I/O
 - Fan control
 - Temperature sequencing
 - Running mode
- All can be controlled in manual mode.
- Manual setting of temperature sensor
 - Locking of fans at adjustment
 - Manually I/O testing of external functions
 - Raw values

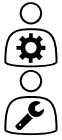

6.1.1.3 Temperature control



Settings for temperature.

- Limit values
- *Setpoint for current control type (Example 1)*
- Min/max limitation
- Outdoor temperature values

Example 1: Setpoint for current control type

☰	Data & Settings > Temperature control > Supply air controller	2020-09-23	 
🔧	Supply air temperature	10.4 °C	
	Setpoint adjustment	0 °C	
	Setpoint adjustment low speed	0 °C	
	Setpoint adjustment high speed	0 °C	
	Setpoint Supply air	18 °C	

Example show temperature control type set to supply air. To change the setpoint, press on the current value and change to desired setting in the following pop-up menu. Confirm with ok. (Editable text and values are shown in blue on NaviPad.)

6.1.1.4 Fan control

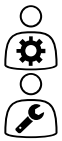

Settings for fan control.

- Setpoint for different fan speed
- Fan compensation e.g. outdoor compensated fan curves
- Start delay of fans, shut of dampers etc.
- SFP menu
- External fans

6.1.1.5 Demand control



Settings for:

- CO2
- Recirculation
- Support control
- Free cooling

6.1.1.6 Fire/Smoke



Settings for:

- Fire dampers
- Smoke detector status
- Fire damper test

6.1.1.7 Humidity control

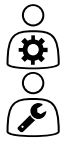

Setpoints and settings for dehumidification and humidification

6.1.2 Flow chart

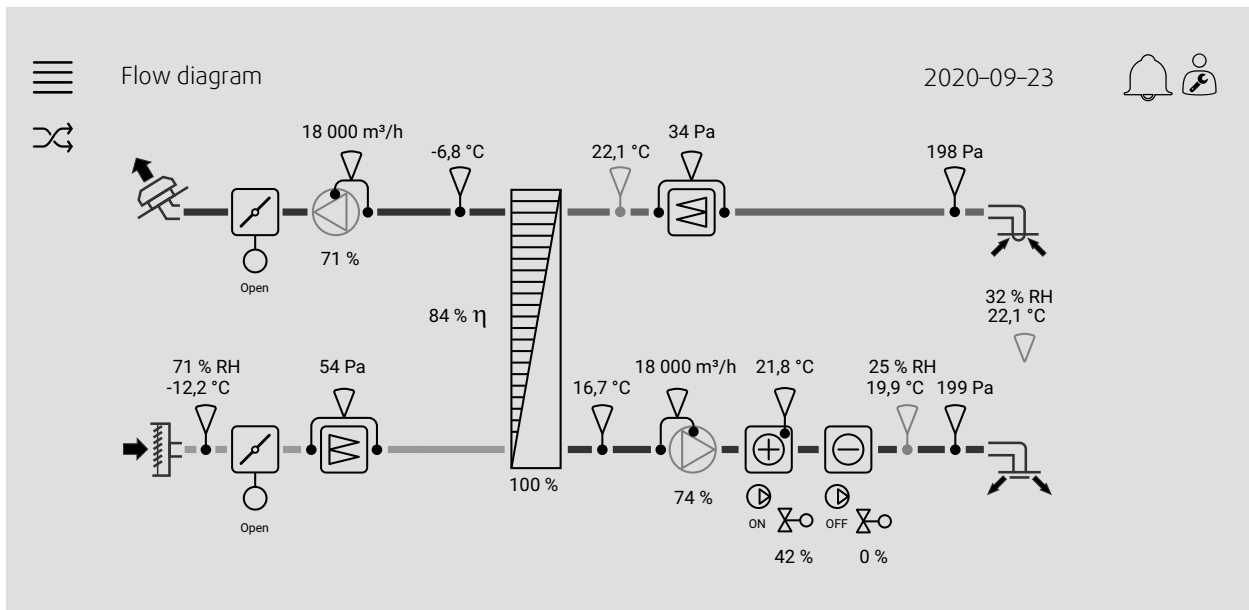

Dynamic flow chart of current configured air handling unit. Active sensors and components are visible with values shown in real time. When pressing on values or items marked in blue you will be forwarded to related settings and/or overview page.

6.1.3 Language



Settings of language.

- To synchronize NaviPad with all connected air handling units, go to system dashboard by pressing the home button figure 6, (1). Press and , choose language.
- Using in selected air handling units homepage via NaviPad or computer will only change language in the selected air handling unit.

6.1.4 Time Settings



In this menu date and time can be changed as well as other system settings.
Settings for:



- Date and time
- *Schedule for operating time (Example 2 & 3)*
- Schedule for holiday
- Schedule for extra time groups

Each day has up to two individual running periods, set desired start and stop time.
For holidays, set the dates in *Time settings > Schedule > Holiday calendar* and the time in *Time settings > Schedule > Fan Low Speed/Fan Normal Speed/High Speed*.

Example 2: Schedule for normal fan speed

Time settings > Schedule > Fan Normal Speed		2020-09-23			
	Start	Stop	Start	Stop	
Monday (12-hour clock system)	5:00 AM	6:00 PM	12:00 AM	12:00 AM	
Monday (24-hour clock system)	05:00	18:00	00:00	00:00	

In above example, the air handling unit starts at a normal fan speed at 5:00 AM (05:00) and stops at 6:00 PM (18:00). The second running period is deactivated.

Example 3: Schedule for low fan speed

Time settings > Schedule > Fan Low Speed		2020-09-23			
	Start	Stop	Start	Stop	
Monday (12-hour clock system)	6:00 PM	24:00 AM	12:00 AM	5:00 AM	
Monday (24-hour clock system)	18:00	24:00	00:00	05:00	

In above example, the air handling unit starts at a low fan speed at 6:00 AM (18:00) and stops at 24:00 AM (24:00). The second running period on low fan speed is between 12:00 AM (00:00) and 5:00 AM (05:00).

6.1.5 Configuration



- System settings
- *Configuration wizard (Example 4)*
- *Function configuration (Example 5)*
- I/O allocation settings
- *Alarm configuration (Example 6)*
- PID controllers

The configuration wizard is a menu that simplify the procedure to **Activate** and **Configure** common accessories and functions and **Allocate** it's in- and outputs. The wizard makes necessary configurations automatically and guide the user through limited options.

Example 4: Configuration wizard

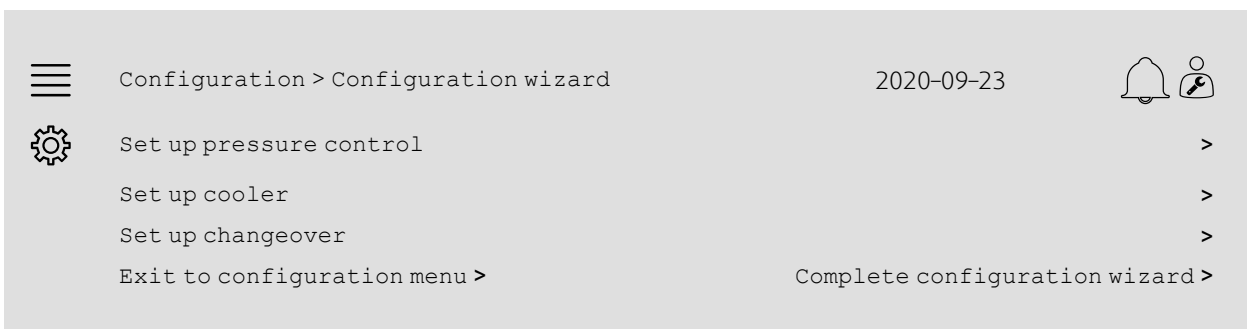

If the configuration wizard does not cover the desired accessory or function it can still be configured via the configuration menu.

Example 5: Function configuration

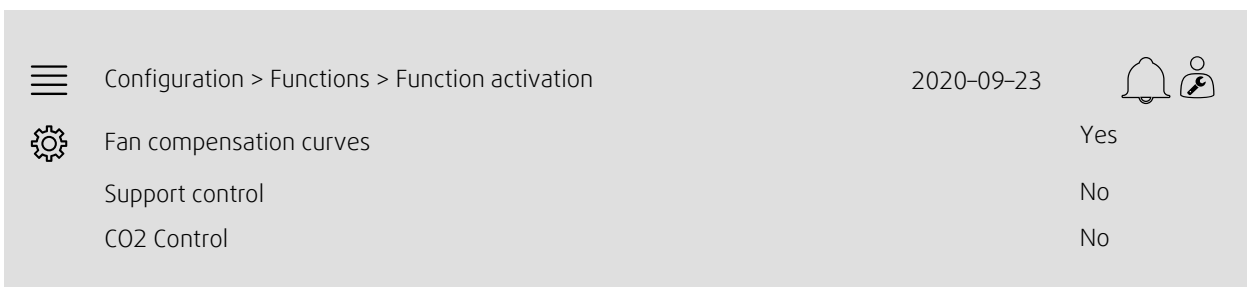

To activate a function go to **Function activation**. Choose function to activate and set **Yes** in the following pop-up menu. Values for the activated function are now visible and can be adjusted in **Data Settings**.

If required, allocate in- and outputs in **I/O allocation settings**.

Example 6: Alarm configuration

☰ Configuration > Alarms
2020-09-23
🔔 👤

⚙️ Alarm delay at start up
60 s

Search alarm no: **53** Filter alarm supply air >

Air and temperature control >

Extra functions >

Extra sensors and alarms >

Fire/Smoke >

Component malfunction >

Manual operation and warnings >

☰ Configuration > ... > Filter alarm supply air
2020-09-23
🔔 👤

⚙️

Action: **No action**

Level: **Class B**

Delay: **300 s** Limit X1: **0 m³/h** Limit Y1: **10 Pa**

No: 53 Limit X2: **2000 m³/h** Limit Y2: **150 Pa**

Name: **Filter alarm supply air**

Original name: Filter alarm supply air

6.1.6 System information



Shows information about the air handling unit, installation site, control unit, communication and the Systemair product. To enter information, such as site specific unit name or server partner's contact information, go to `System information setup` with user level `Service`.

Example 7: System information

☰ System information
2020-09-23
🔔 👤

ⓘ Unit information

Installation address

Service partner

Communication

Access Control Unit

Systemair product

System information setup >

6.2 Advanced HMI (Human Machine Interface) Settings

Return to system overview dashboard by pressing on the home button, figure 6, (1). Go to  and choose *Advanced HMI settings*. Login required – 1111

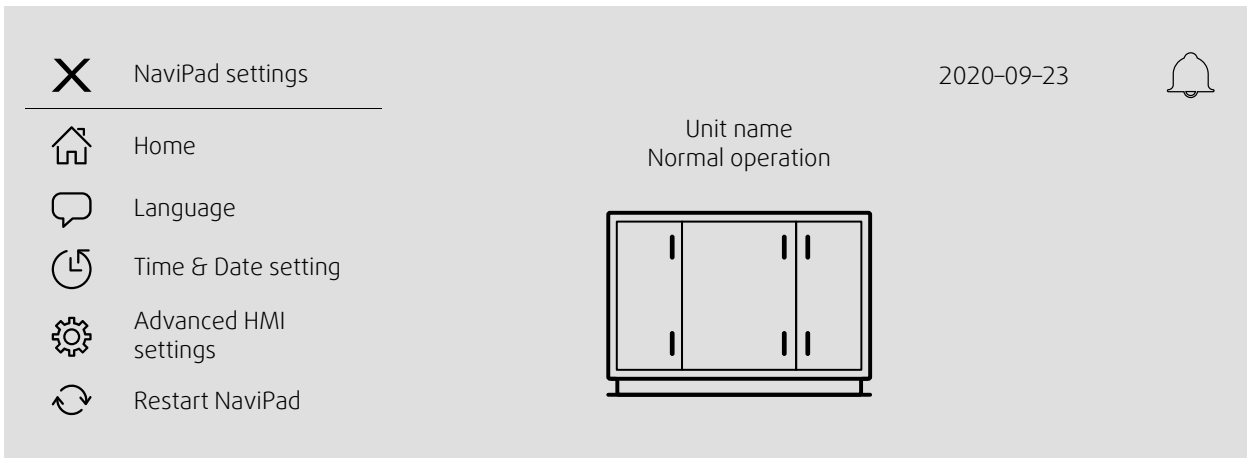

- Available devices (air handling units) (Example 8)
- Change Password
- Ethernet setting: IP address can be configured to either obtain an IP address from a DHCP server (dynamic) or set manually as a static IP address¹
- Restore NaviPad Factory Settings (Example 9)
- Software Update

¹ For further support setting a static IP address, see “Access Manual Communication”

Example 8: Available devices (air handling units)



The air handling unit will appear, press the button to select the air handling unit to pair it with the NaviPad. If there are several air handling units at the same IP subnet, a list of available air handling units will be presented.

The IP address of NaviPad itself is presented above the Select device header

Example 9: Restore NaviPad factory settings

You will be requested to confirm your action.

All settings including password will be reset and Start-Up wizard will run again.

6.3 No communication

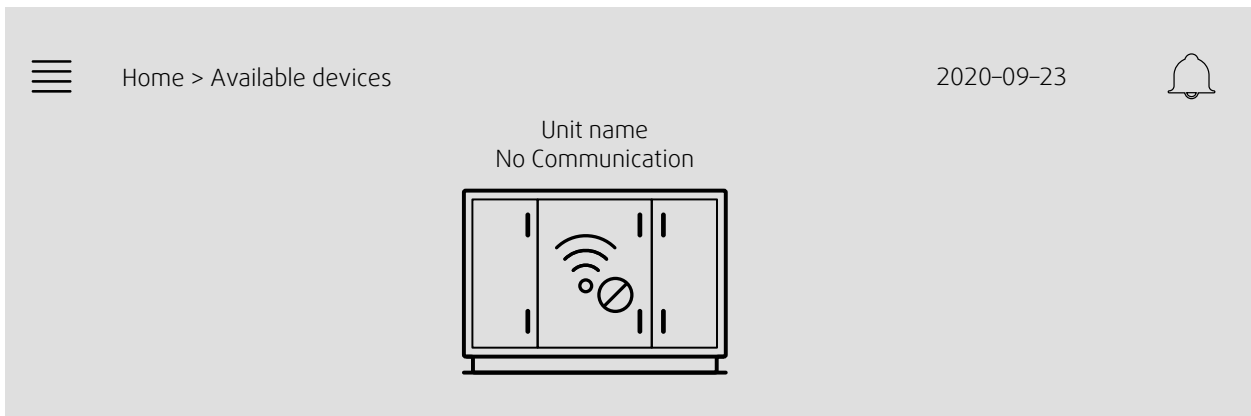

If the above symbols are shown, the communication to the selected air handling unit is lost. One reason could be that the IP number has changed. Go back to available devices (air handling units), figure 4, and first deactivate all the air handling units and then activate them again.

7 Maintenance



Danger

- Disconnect the mains power supply to the unit is before performing any maintenance or electrical work!
- Carry out all electrical connections in accordance with local rules and regulation. Electrical connections must be carried out by an authorized installer.



Warning

- Be aware of rotating parts even if the mains power supply is disconnected
- Beware of sharp edges during mounting and maintenance. Use protective clothing.
- Beware of hot surface on the heating coil during maintenance and service.

7.1 Maintenance intervals

Perform maintenance according to the operation and maintenance instructions to ensure a long operation lifetime for the unit.

A thorough and recurrent maintenance is a must for a valid guarantee.

Type of maintenance	Once a year	When necessary
Cleaning the heat exchanger.	X	
Cleaning the fans.	X	
Cleaning extract louvres and supply air diffusers.		X
Cleaning the outdoor air intake.	X	
Cleaning the duct system.		X ¹

¹ Or in accordance with local rules and regulations

7.2 How to replace supply/extract air filter

The bag filter must be changed when necessary, they cannot be cleaned. We recommend ordering original filters from Systemair. Operation time between filter changes depends on the air quality. A differential pressure transmitter indicates when it is time to change the filters, which will trigger an alarm in NaviPad.

1. Pull out the old filters and replace with new ones.
2. In NaviPad, log in as operator; 1111 (min. level).
3. Press on the alarm symbol  on the control panel.
4. Choose `Filter alarm` and press acknowledge.

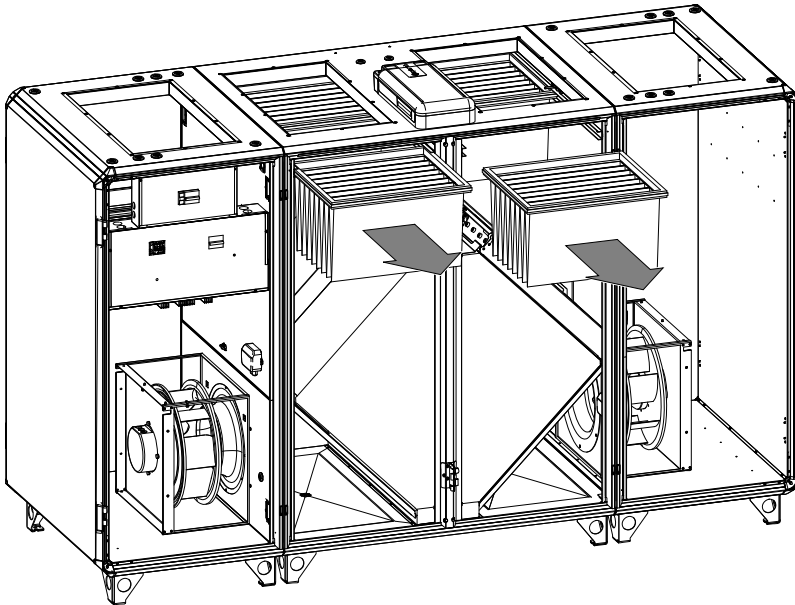

7.3 How to clean NaviPad

Disconnect the NaviPad power cord. Wipe the NaviPad gently with a soft cloth. Remove resistant marks with mild detergent (intended for touch screens) on the cloth, gently wipe the screen. Do not use other cleaning agents (they may contain ammonia or other additives).

7.4 How to clean the heat exchanger



Caution

- Do not use detergent containing ammonia
- The heat exchanger is sensitive for impacts. Handle with care

Clean the heat exchanger with hot soapy water. It is also possible to use pressure air, but not with too high pressure.

7.5 How to clean the fans



Caution

- Do not use water!

Clean the fans with a cloth or a soft brush. Use white spirit to remove obstinate settlements. Allow drying properly. It is possible to remove the fan for cleaning, figure 7.

1. Disconnect the fast coupling to the electric wire and the blue and red tubes from the supply air fan (standard units with CAV)
2. Loosen the two bolts on the rail to remove the fan.

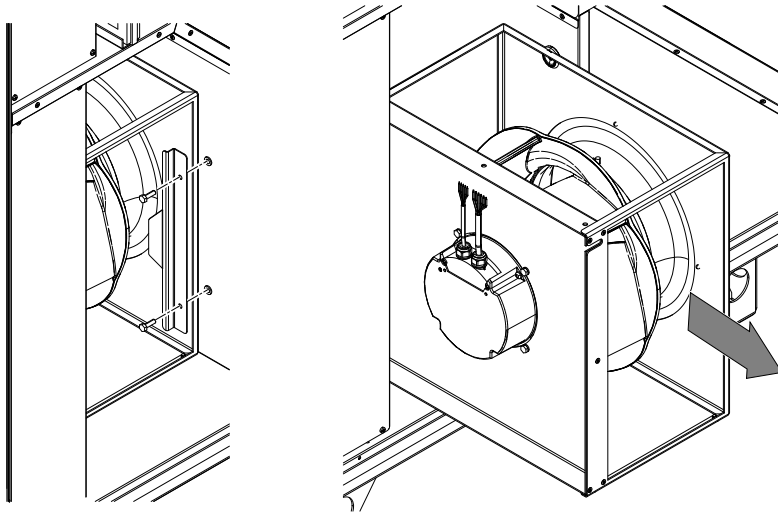

Fig. 7

3. Replace the motor and connect the electric wire and tubes.
4. Fastening the motor with the rail and bolts.

7.6 How to clean hot water heating coil



Caution

- Clean carefully to not damage the batteries aluminium fins.

Clean the battery with pressure washer with misting jets or with compressed air. Remove the fan for access, see chapter 7.5.



Note:

- Vent the battery's water circuit once a year to maintain the batteries capacity.

7.7 How to clean the electric heating coil

Clean the heating rods with compressed air, vacuum or a brush. Remove the fan for access, see chapter 7.5.

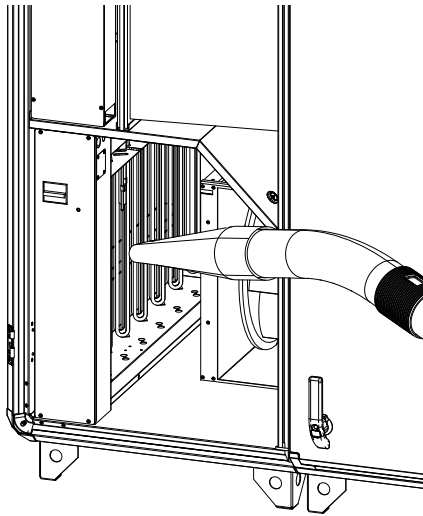

7.8 How to clean the extract air louvres and inlet diffusers

Remove diffusers and louvres and wash in hot soapy water when necessary. Remount them with their original settings and positions in order not to unbalance the system.

7.9 Clean the outdoor air intake

Clean the air intake grille at least twice a year.

7.10 How to clean the duct system

Clean steel ducts by pulling a brush through the duct via diffuser, louver openings or special inspection hatches in the duct system (if fitted). Use hot soapy water.

7.11 Where to reset tripped fuses

Possible to reset the fuses without opening the hatch to the compartment.

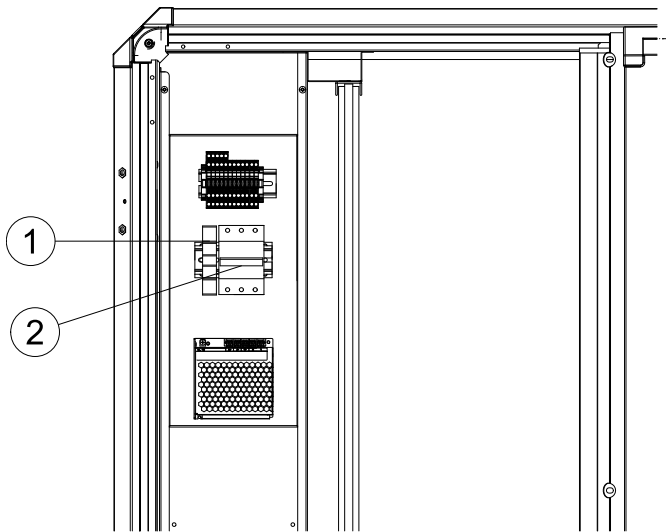

Fig. 8

Position	Description
1	Automatic fuse 1~ (Controls only)
2	Automatic fuse 3~ (Fans only)

7.12 How to reset the manual overheat protection (EL units)

Push the red button on the electrical heater, figure 9, (1).

Possible to reset overheat protection for electric heating coil without opening the hatch to the compartment.

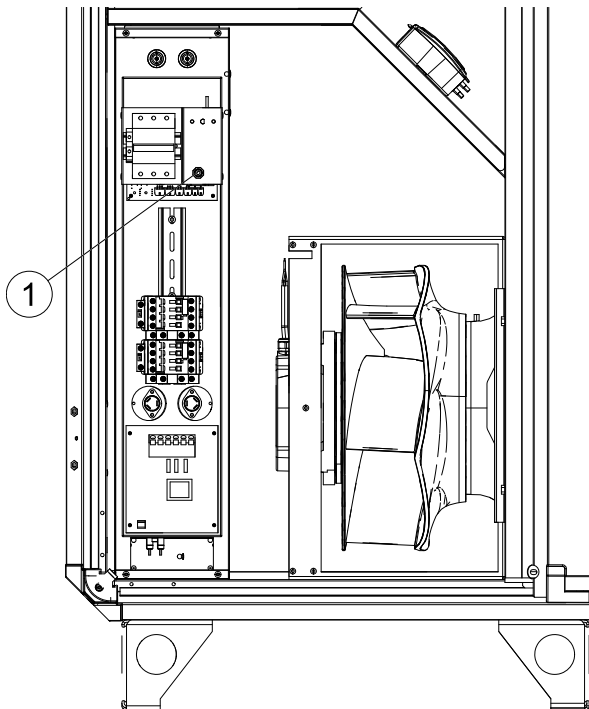
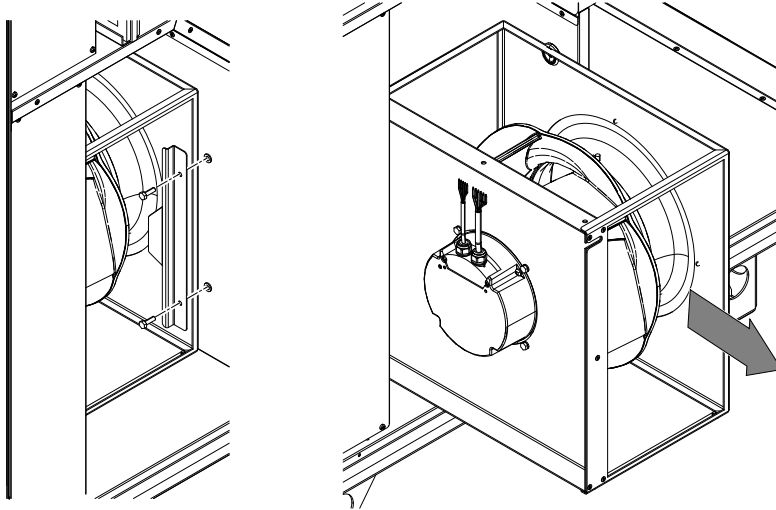

Fig. 9

7.13 How to replace the fan module

When ordering a replacement fan module, note if it is supply or extract fan. This is important for the fan to get the correct Modbus address.

1. Disconnect the fast coupling to the electric wire and the blue and red tubes from the supply air fan (standard units with CAV).
2. Loosen the two bolts on the rail to remove the fan.



3. Replace the motor and connect the electric wire and tubes.
4. Fastening the motor with the rail and bolts.

7.14 How to replace the heat exchanger

Remove the doors

1. Remove the cover over the hinges with a screwdriver.
2. Remove the hinge pins
3. Remove the doors on front and back side.

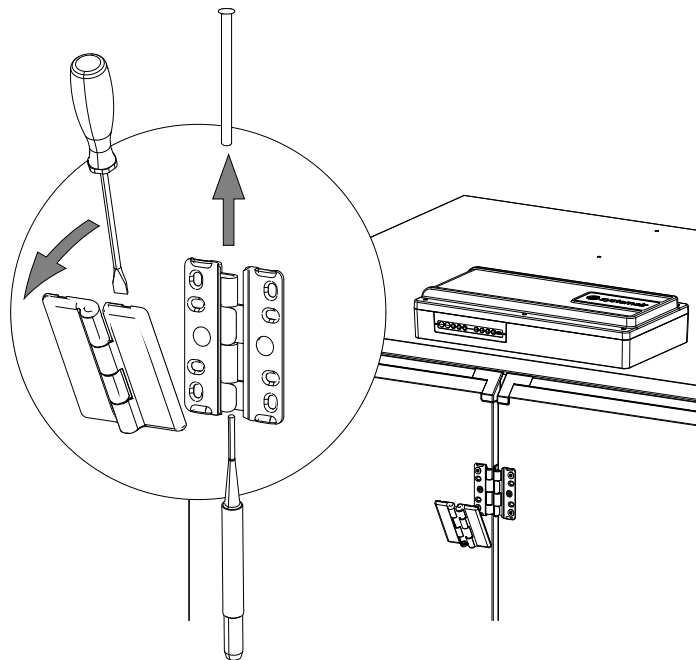

Remove damper



Warning

Beware of sharp edges. Use gloves and protective clothing.

4. Loosen the bolts holding the damper rails. Remove the damper rails.
5. Rotate the damper and lift in the direction away from the exchanger.
6. Lift the damper out from the middle section.



Caution

Do not drag the damper on the exchanger.

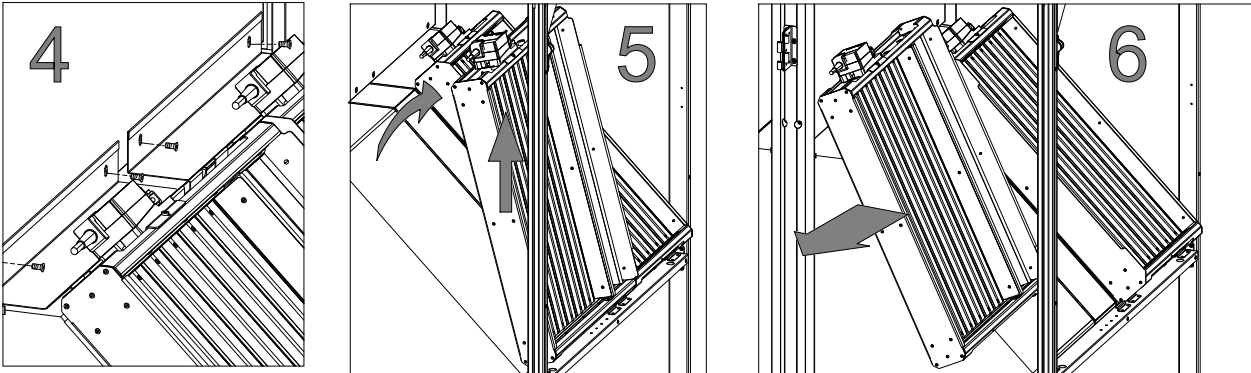
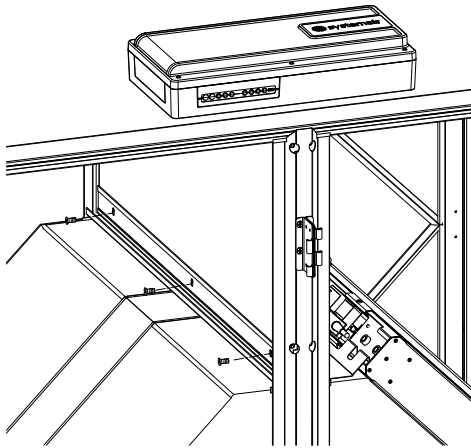

Fig. 10 Image shows Topvex SC60

Remove rail holding the exchanger

7. Loosen the bolts holding the rail on the opposite side of the partition wall.



Remove the door beam

8. Loosen the screw on the front door beam (6 screws) and remove the beam.

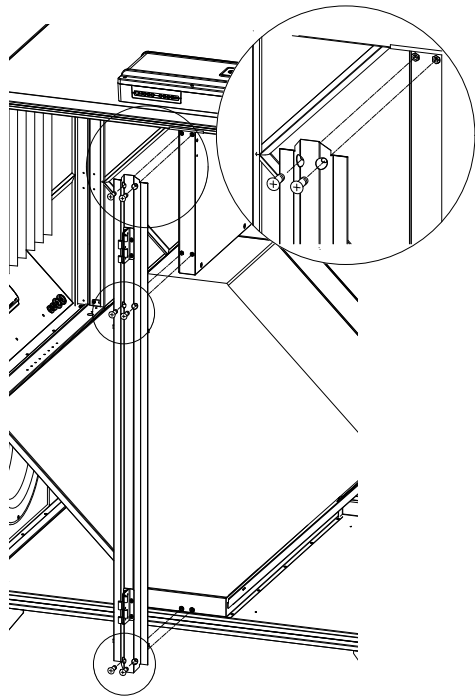

Replace the exchanger



Caution

- Handle the heat exchanger with care.
- The heat exchanger is heavy.

9. Push the exchanger out.

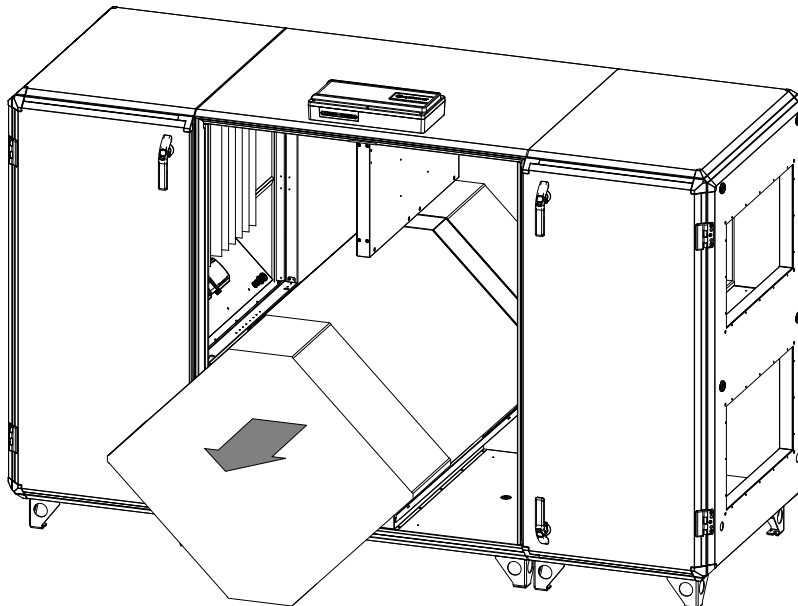

10. Remove the old exchanger.

11. Place the new exchanger carefully in the opening and push gently in place.

Fasten the door beam

12. Fasten the door beams (6 screws on front and 6 screws on the back).

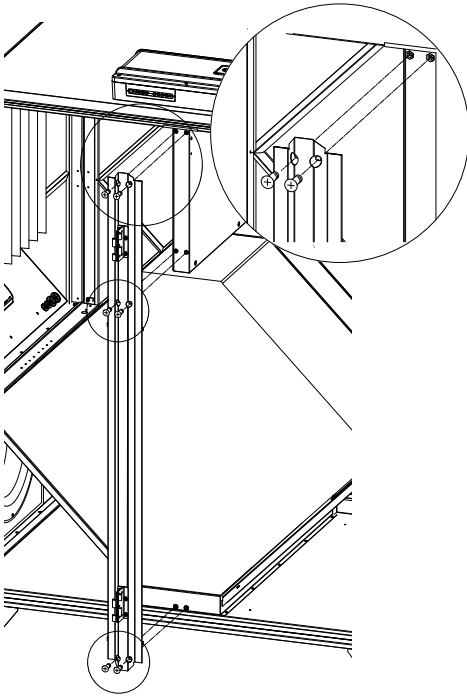
**Fasten the rail holding the exchanger**

13. Fasten the bolts holding the rail on the opposite side of the partition wall.

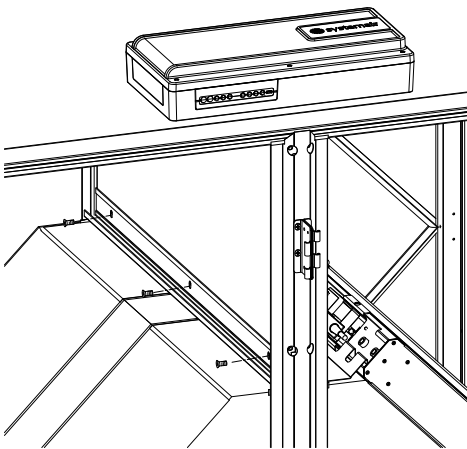

Fasten the damper

14. Insert the damper in the area above the exchanger.



Caution
Do not drag the damper on the exchanger.

15. Lift the damper with the short end on the rail at the outer beams. Observe the small hooks to secure the damper.

16. Fasten the damper by fastening the damper rails with the bolts.

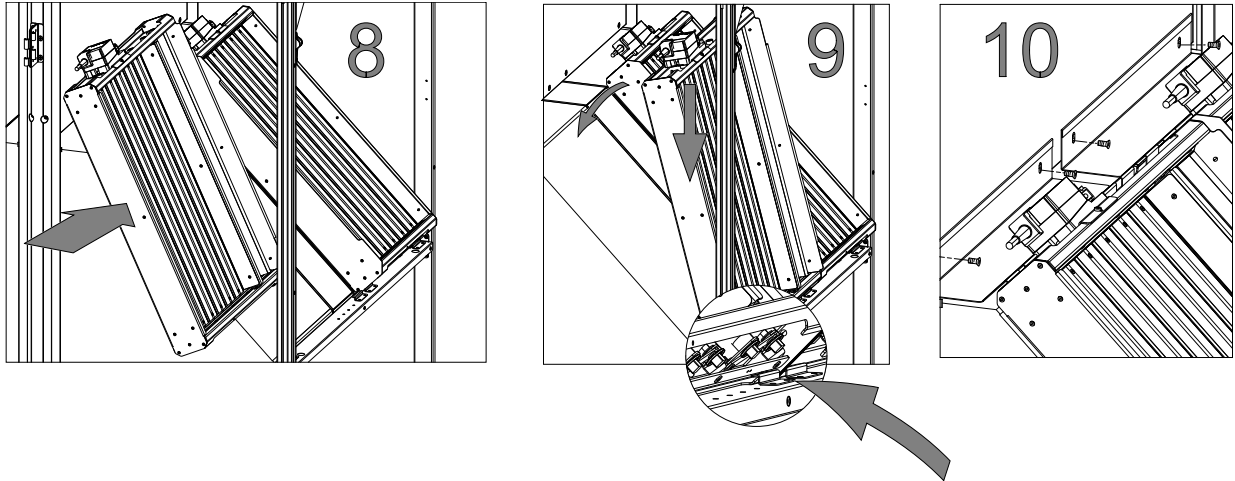

Mount the doors

17. Place the doors in position.

18. Unite the hinges and replace the pin.

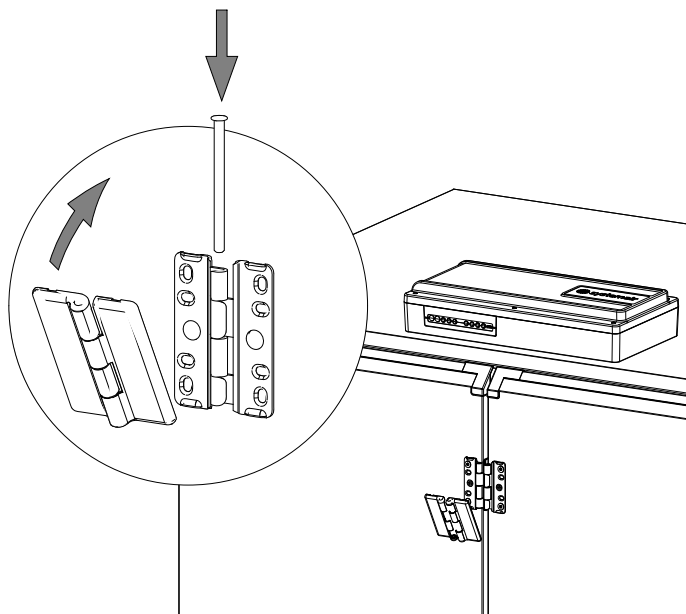

7.15 Change the internal battery in control unit CU27-C

The alarm text `Internal battery error` is shown in NaviPad when it is time to change the battery. Expected life time of battery is 5 years.



Caution

ESD protection; i.e. an earthed wristband must be used!

Disconnect all the wired cable connectors (1) from control unit CU27-C. Push CU27-C slightly in the direction of the arrow (2), lift the opposite side up (3), figure 11.

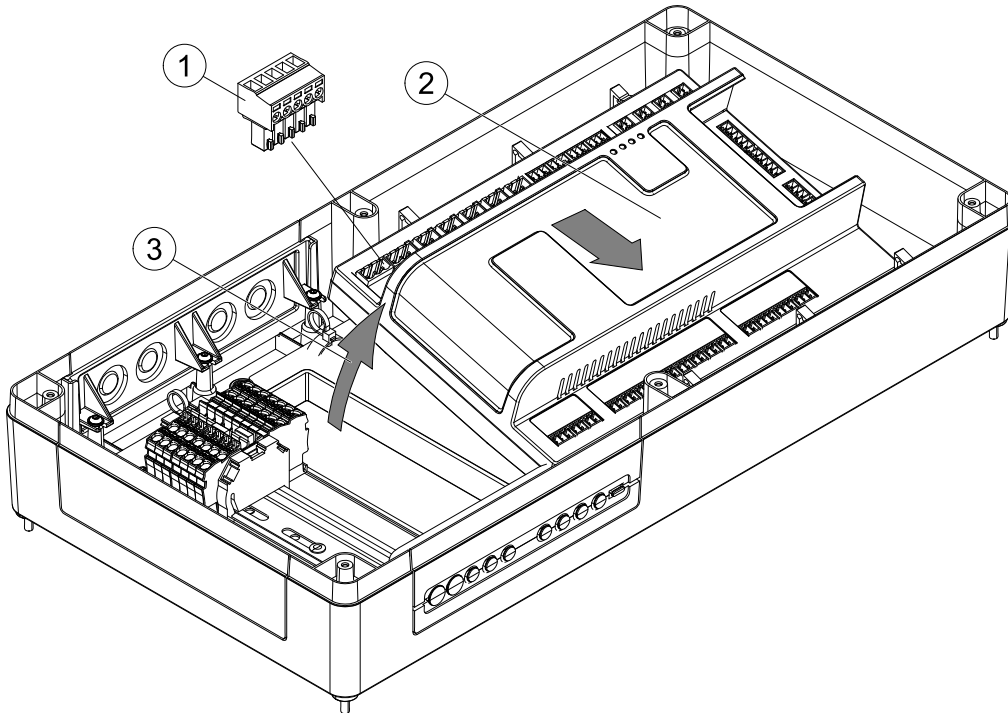

Fig. 11

Release each of the 6 locking clips (1), figure 12 to open CU27-C.

Replacement battery is of type CR2032, observe the correct polarity.

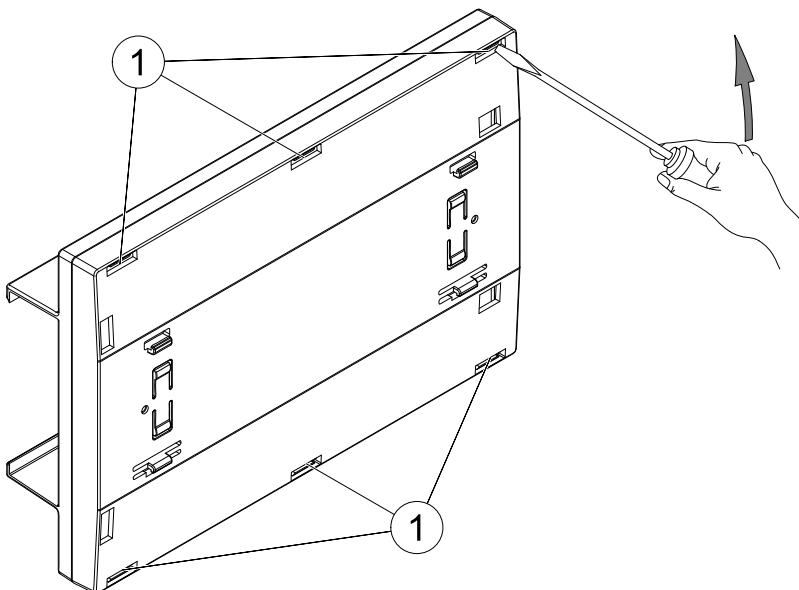

Fig. 12

8 Troubleshooting

Check or correct the following before contacting your service representative. Always check if there are any alarms active in the control panel (chapter 9).

1. Fan(s) do not start

- Check if there are any alarm messages.
- Check the settings in the control panel (times, week schedule, auto/manual operation etc.).
- Check if the fuses has tripped.

2. Reduced airflow

- Check the settings for normal and low fan speed.
- Check if filters need changing.
- Check that the outdoor/exhaust air damper (if used) opens.
- Check if diffusers and louvres need cleaning.
- Check diffuser/louvre openings.
- Check if fans and exchanger block need cleaning.
- Check if the roof unit or air intake is clogged.
- Check ducts for visible damage and/or build up of dust/pollution.

3. Cold supply air

- Check if the fans have stopped. If so the alarm relay might have tripped (shown as fan alarm in the control panel).
- Check the temperature settings in the control panel.
- Check if the extract filter must be changed.
- Check if the overheating thermostat has tripped. After the heater has cooled down, press the red button on the electrical heater.

4. Noise/vibrations

- Check that the unit is completely levelled.
- Clean the fan impellers.
- Check that the screws holding the fans are tightened properly.

9 Alarms

A LED-light in the home button indicate the status of the air handling unit.

- Fixed green – Status ok (no active alarms).
- Flashing red – Active/returned alarms in one or several air handling units.
- Fixed red – Acknowledged/blocked alarms in one or several air handling units, alarms not reset.

Different alarm levels



Class A alarm
Needs to be acknowledged





Class B alarm
Needs to be acknowledged



Class C alarm
Returns when the cause of the alarm disappear

9.1 Alarm list



☰	Data & Settings > Alarm list	2020-09-23	 
🔑	Acknowledge all		No
	Name:	Level:	Status:
	Filter guard 1		Alarmed
	Show all alarms		>
	Alarm history		>



Alarm status:

- Alarmed
- Acknowledged
- Blocked
- Returned

Accessible when pressing the alarm symbol. 

Enter the current alarm and choose action; acknowledge, block or unblock.

10 Service

Before calling your service representative, make a note of the specification and production number from the type label (figure 13)

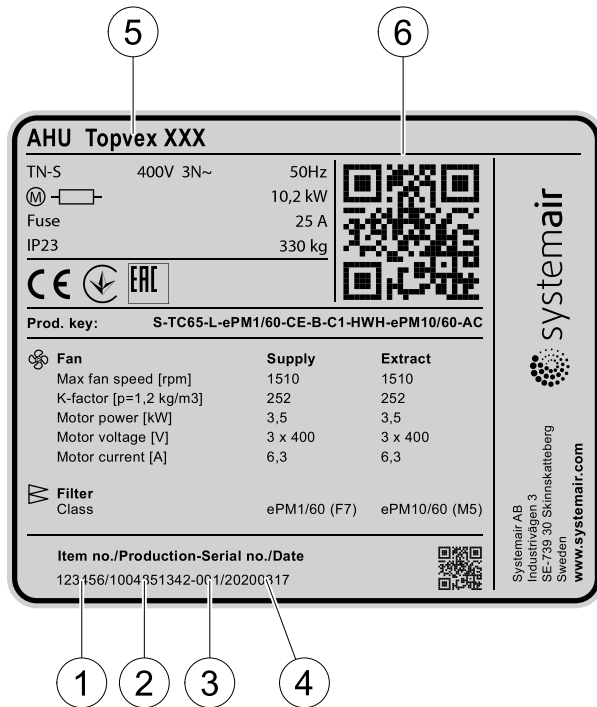

Fig. 13 Type label

Position	Description
1	Item number
2	Production order number
3	Consecutive number
4	Production date
5	Product code (product specification)
6	QR code (spare parts)

11 EU Declaration of Conformity



Manufacturer
Systemair Sverige AB
Industrivägen 3
SE-739 30 Skinnskatteberg Sweden
Phone: +46 222 440 00
www.systemair.com

The manufacturer hereby confirms that Topvex SC, TC comply with all applicable requirements in the following directives and regulations.

Machinery Directive 2006/42/EC

Ecodesign Directive 2009/125/EC

327/2011 Requirements for fans
1253/2014 Requirements for ventilation units

Low Voltage Directive 2014/35/EU

EMC Directive 2014/30/EU

RoHS Directive 2011/65/EU, 2015/863/EU

The following harmonized standards are applied in applicable parts:

EN ISO 12100

Safety of machinery - General principles for design - Risk assessment and risk reduction.

EN 13857

Safety of machinery – Safety distances to prevent hazard zones being reached by upper or lower limbs.

EN 60204-1

Safety of machinery – Electrical equipment of machines – Part 1: General requirements.

EN 60335-1

Household and similar electrical appliances – Safety Part 1: General requirements.

EN 60335-2-40

Safety of household and similar electrical appliances - Part 2-40: Particular requirements for electrical heat pumps, air-conditioners and dehumidifiers.

EN 50106

Safety of household and similar appliances – Particular rules for routine tests referring to appliances under the scope of EN 60 335-1.

EN 60529

Degrees of protection provided by enclosures (IP Code).

EN 62233

Measurement methods for electromagnetic fields of household appliances and similar apparatus with regard to human exposure.

EN 61000-6-2

Electromagnetic compatibility (EMC) – Part 6-2: Generic standards – Immunity for industrial environments.

EN 61000-6-3

Electromagnetic compatibility (EMC) – Part 6-3: Generic standards – Emission standards for residential, commercial and light-industrial environments.

EN 13053

Ventilation for buildings – Air handling units – Rating and performance for units, components and sections.

The declaration applies only to product in the condition it was delivered in and installed in the facility in accordance with the included installation instructions. The insurance does not cover components that are added or actions carried out subsequently on the product.

The complete technical documentation is available.

Skinnskatteberg, 2020-09-23

Sofia Rask
Managing Director

12 General conditions

12.1 Standard tools

If handles are misplaced; open the doors with a 16 mm wrench.

12.2 Reference documentation

If other accessories not included at delivery are in use, read their separate instructions.

Commissioning record form is available on www.systemair.com.

13 Spare parts

See spare parts at <https://portal.systemair.com>, or use the QR code on the type label, figure 13.



Systemair Sverige AB
Industrivägen 3
SE-739 30 Skinnskatteberg, Sweden

Phone +46 222 440 00

www.systemair.com