



Agilent 1290 Infinity Binary Pump

User Manual



Agilent Technologies

Notices

© Agilent Technologies, Inc. 2010-2018

No part of this manual may be reproduced in any form or by any means (including electronic storage and retrieval or translation into a foreign language) without prior agreement and written consent from Agilent Technologies, Inc. as governed by United States and international copyright laws.

Manual Part Number

G4220-90007 Rev. B

Edition

10/2018

Printed in Germany

Agilent Technologies
Hewlett-Packard-Strasse 8
76337 Waldbronn

Warranty

The material contained in this document is provided “as is,” and is subject to being changed, without notice, in future editions. Further, to the maximum extent permitted by applicable law, Agilent disclaims all warranties, either express or implied, with regard to this manual and any information contained herein, including but not limited to the implied warranties of merchantability and fitness for a particular purpose. Agilent shall not be liable for errors or for incidental or consequential damages in connection with the furnishing, use, or performance of this document or of any information contained herein. Should Agilent and the user have a separate written agreement with warranty terms covering the material in this document that conflict with these terms, the warranty terms in the separate agreement shall control.

Technology Licenses

The hardware and/or software described in this document are furnished under a license and may be used or copied only in accordance with the terms of such license.

Restricted Rights Legend

If software is for use in the performance of a U.S. Government prime contract or subcontract, Software is delivered and licensed as “Commercial computer software” as defined in DFAR 252.227-7014 (June 1995), or as a “commercial item” as defined in FAR 2.101(a) or as “Restricted computer software” as defined in FAR 52.227-19 (June 1987) or any equivalent agency regulation or contract clause. Use, duplication or disclosure of Software is subject to Agilent Technologies’ standard commercial license terms, and non-DOD Departments and Agencies of the U.S. Government will

receive no greater than Restricted Rights as defined in FAR 52.227-19(c)(1-2) (June 1987). U.S. Government users will receive no greater than Limited Rights as defined in FAR 52.227-14 (June 1987) or DFAR 252.227-7015 (b)(2) (November 1995), as applicable in any technical data.

Safety Notices

CAUTION

A **CAUTION** notice denotes a hazard. It calls attention to an operating procedure, practice, or the like that, if not correctly performed or adhered to, could result in damage to the product or loss of important data. Do not proceed beyond a **CAUTION** notice until the indicated conditions are fully understood and met.

WARNING

A **WARNING** notice denotes a hazard. It calls attention to an operating procedure, practice, or the like that, if not correctly performed or adhered to, could result in personal injury or death. Do not proceed beyond a **WARNING** notice until the indicated conditions are fully understood and met.

In This Guide...

This manual covers the Agilent 1290 Infinity Binary Pump (G4220A).

1 Introduction

This chapter gives an introduction to the pump, instrument overview and internal connectors.

2 Site Requirements and Specifications

This chapter provides information on environmental requirements, physical and performance specifications.

3 Installing the Module

This chapter gives information about the preferred stack setup for your system and the installation of your Agilent 1290 Infinity Binary Pump.

4 Using the Pump

This chapter explains the operational parameters of the Agilent 1290 Infinity Binary Pump.

5 Optimizing Performance

This chapter gives hints on how to optimize the performance or use additional devices.

6 Troubleshooting and Diagnostics

Overview about the troubleshooting and diagnostic features.

7 Error Information

This chapter describes the meaning of error messages, and provides information on probable causes and suggested actions how to recover from error conditions.

In This Guide...

8 Test Functions and Calibrations

This chapter describes the tests for the module.

9 Maintenance

This chapter describes the maintenance of the Agilent 1290 Infinity Binary Pump.

10 Parts and Materials for Maintenance

This chapter provides information on parts for maintenance.

11 Identifying Cables

This chapter provides information on cables used with the Agilent 1200 Infinity Series modules.

12 Hardware Information

This chapter describes the pump in more detail on hardware and electronics.

13 LAN Configuration

This chapter provides information on connecting the detector to the Agilent ChemStation PC.

14 Appendix

This chapter provides addition information on safety, legal and web.

Contents

1	Introduction	9
	Features	10
	Overview of the Binary Pump	11
	Pump Principle	12
	System Overview	15
2	Site Requirements and Specifications	17
	Site Requirements	18
	Physical Specifications	21
	Specifications	22
3	Installing the Module	25
	Unpacking the Module	26
	Optimizing the Stack Configuration	27
	Installation Information on Leak and Waste Handling	32
	Removing the Transport Foam	36
	Installing the Pump	37
	Flow Connections to the Pump	41
	Installation of Seal Wash Function	45
4	Using the Pump	47
	Magnets	48
	Turn on/off	49
	Status Indicators	51
	Leak and Waste Handling	52
	Best Practices	53
	Preparing the Binary Pump	58
	Algae Growth in HPLC Systems	59
	Setting up the Pump with the Instrument Control Interface	60
	Purging the Pump	69
	Solvent Information	71
	Solvent Recommendation for Agilent 1290 Infinity and 1290 Infinity II and 1260 Infinity II Flexible Pumps	78

5	Optimizing Performance	83
	Delay Volume and Extra-Column Volume	84
	How to Configure the Optimum Delay Volume	85
	How to Achieve Higher Resolution	87
	Using Solvent Calibration Tables	90
6	Troubleshooting and Diagnostics	91
	Available Tests vs User Interfaces	92
	Agilent Lab Advisor Software	93
7	Error Information	95
	What Are Error Messages	97
	General Error Messages	98
	Pump Error Messages	107
8	Test Functions and Calibrations	123
	Introduction	124
	Pump Leak Rate Test	125
	System Pressure Test	130
9	Maintenance	133
	Introduction to Maintenance	135
	Warnings and Cautions	137
	Overview of Maintenance	138
	Cleaning the Module	139
	Installing Fittings and Capillaries	140
	Replacing the Shutoff Valve Panel	141
	Replacing the Pressure Sensor	143
	Replacing the Inlet valve	146
	Replacing the Outlet Valve	148
	Replacing the Solvent Selection Valve (SSV)	151
	Changing configuration or replacing the Jet Weaver	153
	Replacing the Seal Wash Pump	156
	Releasing a Stuck Inlet Valve	157
	Remove the Pump Head Assembly	160
	Pump Head Maintenance (Tool Free)	163

Install the Pump Head Assembly	178
Replacing the Purge Valve Head	180
Replacing Parts of the High Pressure Filter Assembly	183
Installing the Valve Rail Kit	185
Replacing the Main Power Fuses	186
Replacing Module Firmware	188
Preparing the Pump Module for Transport	189
10 Parts and Materials for Maintenance	195
Overview of Maintenance Parts	196
Flow Connections	198
Solvent Cabinet Kit	200
Seal Wash Option	201
Pump Heads	202
Purge Valve	206
Cover Parts	208
Leak Parts	210
Fuses	211
Accessory Kit	212
Tools	213
HPLC System Tool Kit	215
11 Identifying Cables	217
Cable Overview	218
Analog cables	220
Remote Cables	222
BCD Cables	225
CAN/LAN Cable	227
RS-232 Cable Kit	228
Agilent 1200 Module to Printer	229

12 Hardware Information	231
Firmware Description	232
Electrical Connections	235
Interfaces	237
Setting the 8-bit Configuration Switch	244
Instrument Layout	248
Early Maintenance Feedback	249
13 LAN Configuration	251
What You Have to Do First	252
TCP/IP parameter configuration	253
Configuration Switch	254
Initialization mode selection	255
Dynamic Host Configuration Protocol (DHCP)	257
Link configuration selection	260
Manual Configuration	261
PC and User Interface Software Setup	267
14 Appendix	269
General Safety Information	270
The Waste Electrical and Electronic Equipment (WEEE) Directive (2002-96-EC)	273
Radio Interference	274
Sound Emission	275
Agilent Technologies on Internet	276

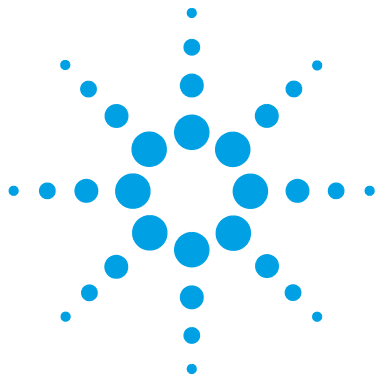

1 Introduction

Features	10
Overview of the Binary Pump	11
Pump Principle	12
System Overview	15
Leak and Waste Handling	15

This chapter gives an introduction to the pump, instrument overview and internal connectors.



Features

The Binary pump is designed for highest performance, GLP compliance and easy maintenance. It includes the following features:

- Seal wash for continued high lifetime of pump seals for buffer applications.
- Solvent selection valve for method flexibility.
- Jet Weaver for optimum mixing performance with a minimum of delay volume.
- Automatic purge function for ease of use and unattended preparation of the system.
- Auto tuning of the delivery cycle for compensation of elasticity and solvent volume change effects (compressibility, thermal expansion, mixing contraction).
- Solvent selection for optimum flow and composition accuracy.
- Fast defill function for improved intake and delivery performance.
- Two pistons in series design for increased reliability.
- High resolution piston movement control for smooth and reliable motion.

For specifications, see [Table 2](#) on page 22.

NOTE

This Binary pump has been introduced together with the Agilent 1290 Infinity Liquid Chromatograph.

Overview of the Binary Pump

The Agilent 1290 Infinity Binary Pump comprises two identical pumps integrated into one housing. Binary gradients are created by high-pressure mixing. A degassing unit is included for applications that require best flow stability, especially at low flow rates, for maximum detector sensitivity. The flow path of the pump has been optimized for minimal delay of gradients. Typical applications are high throughput methods with fast gradients on high resolution 2.1 mm columns. The pump is capable of delivering flow in the range of 0.05-5 mL/min against up to 1200 bar. A solvent selection valve allows forming binary mixtures (isocratic or gradient) from one of two solvents per channel. Active seal wash is available for use with concentrated buffer solutions.

Pump Principle

The Binary Pump is based on a two-channel, dual-piston in-series design which comprises all essential functions that a solvent delivery system has to fulfill. Metering of solvent and delivery to the high-pressure side are performed by two pump assemblies which can generate pressure up to 1200 bar.

Each channel comprises a pump assembly including independent pump drive for each piston, pump head, inlet valve, outlet valve, solvent heat exchanger and an outlet filter. The two channels are fed into a low-volume mixing groove in an automatic purge valve and a Jet Weaver mixer, with 35 or 100 µl volume can be added downstream for optimum mixing performance.

A system pressure sensor, for monitoring the pump pressure, is attached to the purge valve, normally connected in the B-channel of the pump, before the mixing groove, in order to minimize delay volumes.

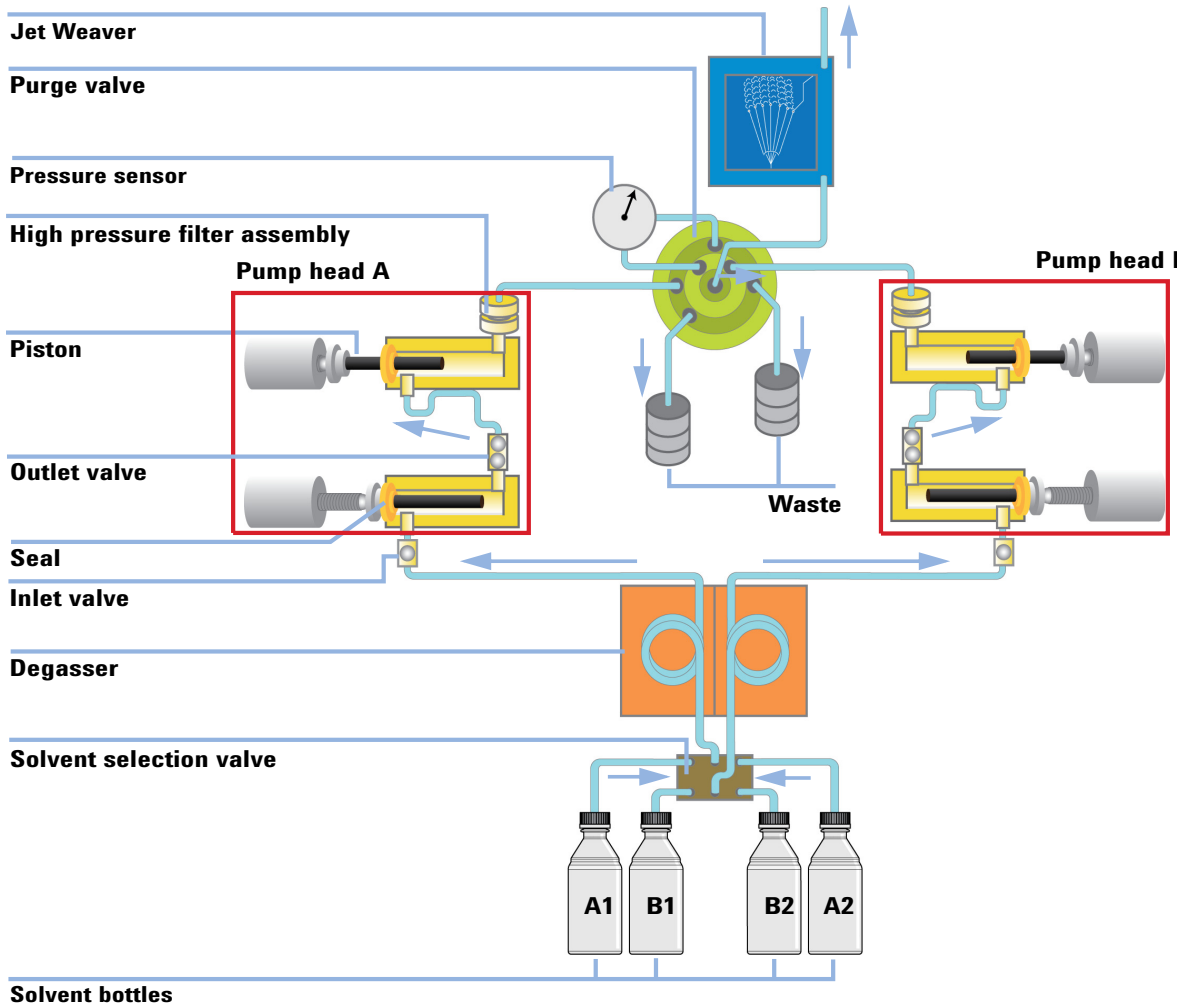

Figure 1 The hydraulic path

In the user interface the solvent in use for each channel can be selected in order to get optimum flow and composition accuracy. Although selecting the right solvent is not required for low ripple, especially for composition accuracy across pressure it is vital for the compensation algorithm to use the right solvent properties. The density of the solvents is increased under the influence of pressure and a certain displaced solvent will expand again when the pressure is released, for example across the column. In order to achieve the correct volumetric flow while sample passes through the detector it is necessary to correct for density related flow inaccuracies in the pump module.

In order to always deliver the best possible pressure stability, the pump constantly tunes the delivery cycle for elasticity and dead volume effects. With this feature the pump is able to deliver a stable and accurate flow without requiring individual calibration settings. A further feature of the control and compensation algorithm is leak correction. With this it is even possible to compensate for minor leaks in primary pump chamber (inlet valve and seal), without the performance of the pump being affected.

To increase the robustness of the pump it uses a fast defill function which reduces the delivery time of the primary piston, thereby reducing the net effects of leaks considerably. Furthermore each pump channel has only two valves on its two pump heads which also reduce the potential of failures. In order to reduce stresses on the pump hardware, it uses a smooth motion control, which slowly increases or decreases the speed of the pistons to prevent shock movements. In order to be able to control these movements a high resolution encoder unit is attached to the pump drives which resolves a revolution into 65000 steps, and each step translates to a volume of about 300 pl.

System Overview

Leak and Waste Handling

The 1200 Infinity Series has been designed for safe leak and waste handling. It is important that all security concepts are understood and instructions are carefully followed.

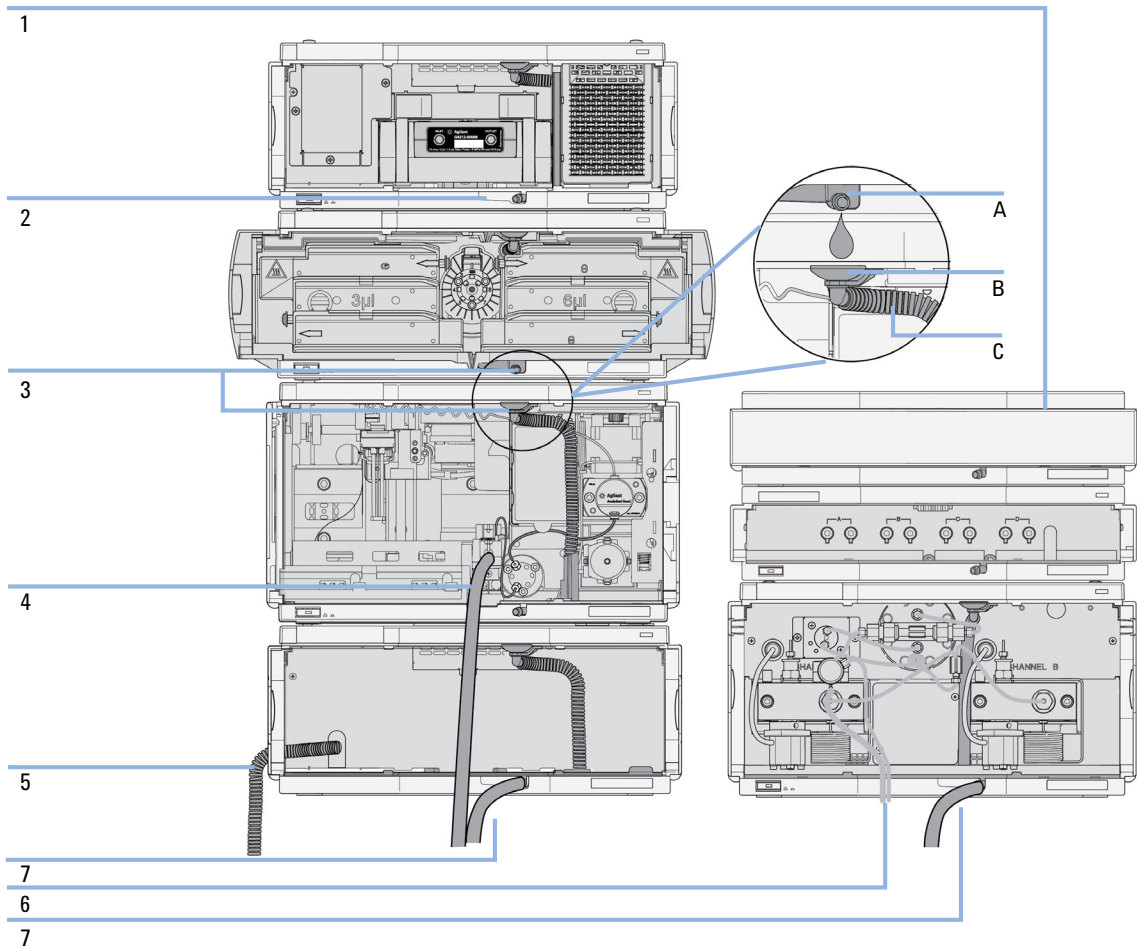

Figure 2 Leak and waste handling concept (overview - typical stack configuration as an example)

1 Introduction

System Overview

The solvent cabinet (1) is designed to store a maximum volume of 6 L solvent. The maximum volume for an individual bottle stored in the solvent cabinet should not exceed 2.5 L. For details, see the usage guideline for the Agilent 1200 Infinity Series Solvent Cabinets (a printed copy of the guideline has been shipped with the solvent cabinet, electronic copies are available on the Internet).

The leak pan (2) (individually designed in each module) guides solvents to the front of the module. The concept covers also leakages on internal parts (e.g. the detector's flow cell). The leak sensor in the leak pan stops the running system as soon as the leak detection level is reached.

The leak pan's outlet port (3, A) guides excessive overflow from one module to the next, as the solvent flows into the next module's leak funnel (3, B) and the connected corrugated waste tube (3, C). The corrugated waste tube guides the solvent to the next lower positioned module's leak tray and sensor.

The waste tube of the sampler's needle wash port (4) guides solvents to waste.

The condense drain outlet of the autosampler cooler (5) guides condensate to waste.

The waste tube of the purge valve (6) guides solvents to waste.

The waste tube connected to the leak pan outlet on each of the bottom instruments (7) guides the solvent to a suitable waste container.

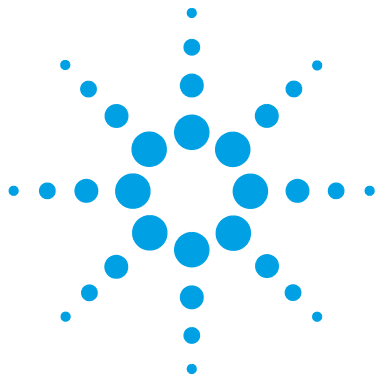

2 Site Requirements and Specifications

Site Requirements	18
Physical Specifications	21
Specifications	22

This chapter provides information on environmental requirements, physical and performance specifications.



Site Requirements

A suitable environment is important to ensure optimal performance of the instrument.

Power Consideration

The module power supply has wide ranging capabilities and accepts any line voltage in the range mentioned in [Table 1](#) on page 21. Consequently, there is no voltage selector in the rear of the module. There are also no externally accessible fuses, because automatic electronic fuses are implemented in the power supply.

WARNING

Module is partially energized when switched off, as long as the power cord is plugged in.

Repair work at the module can lead to personal injuries, e.g. shock hazard, when the cover is opened and the module is connected to power.

- Make sure that it is always possible to access the power plug.
- Remove the power cable from the instrument before opening the cover.
- Do not connect the power cable to the Instrument while the covers are removed.

WARNING

Incorrect line voltage at the module

Shock hazard or damage of your instrument can result if the devices are connected to line voltage higher than specified.

- Connect your module to the specified line voltage.

WARNING

Inaccessible power plug.

In case of emergency it must be possible to disconnect the instrument from the power line at any time.

- Make sure the power connector of the instrument can be easily reached and unplugged.
- Provide sufficient space behind the power socket of the instrument to unplug the cable.

Power Cords

Country-specific power cords are available for the module. The female end of all power cords is identical. It plugs into the power-input socket at the rear. The male end of each power cord is different and designed to match the wall socket of a particular country or region.

Agilent makes sure that your instrument is shipped with the power cord that is suitable for your particular country or region.

WARNING

Unintended use of power cords

Using power cords for unintended purposes can lead to personal injury or damage of electronic equipment.

- Never use a power cord other than the one that Agilent shipped with this instrument.
 - Never use the power cords that Agilent Technologies supplies with this instrument for any other equipment.
 - Never use cables other than the ones supplied by Agilent Technologies to ensure proper functionality and compliance with safety or EMC regulations.
-

WARNING

Absence of ground connection

The absence of ground connection can lead to electric shock or short circuit.

- Never operate your instrumentation from a power outlet that has no ground connection.
-

WARNING

Electrical shock hazard

Solvents may damage electrical cables.

- Prevent electrical cables from getting in contact with solvents.
 - Exchange electrical cables after contact with solvents.
-

Bench Space

The module dimensions and weight (see [Table 1](#) on page 21) allow you to place the module on almost any desk or laboratory bench. It needs an additional 2.5 cm (1.0 inches) of space on either side and approximately 8 cm (3.1 inches) in the rear for air circulation and electric connections.

If the bench shall carry a complete HPLC system, make sure that the bench is designed to bear the weight of all modules.

The module should be operated in a horizontal position.

NOTE

Agilent recommends that you install the HPLC instrument in the InfinityLab Flex Bench rack. This option helps to save bench space as all modules can be placed into one single stack. It also allows to easily relocate the instrument to another Lab.

Condensation

CAUTION

Condensation within the module

Condensation can damage the system electronics.

- Do not store, ship or use your module under conditions where temperature fluctuations could cause condensation within the module.
 - If your module was shipped in cold weather, leave it in its box and allow it to warm slowly to room temperature to avoid condensation.
-

Physical Specifications

Table 1 Physical Specifications

Type	Specification	Comments
Weight	21.8 kg (48 lbs)	
Dimensions (height × width × depth)	240 x 345 x 435 mm (9.3 x 13.5 x 17 inches)	
Line voltage	100 – 240 V~, ± 10 %	Wide-ranging capability
Line frequency	50 or 60 Hz, ± 5 %	
Power consumption	350 VA / 270 W / 922 BTU	Maximum
Ambient operating temperature	4–55 °C (39–131 °F)	
Ambient non-operating temperature	-40 – 70 °C (-40 – 158 °F)	
Humidity	< 95 % r.h. at 40 °C (104 °F)	Non-condensing
Operating altitude	Up to 2000 m (6562 ft)	
Non-operating altitude	Up to 4600 m (15092 ft)	For storing the module
Safety standards: IEC, CSA, UL	Installation category II, Pollution degree 2	For indoor use only.

Specifications

Table 2 Performance specifications

Type	Specification	Comments
Hydraulic system	Two dual pistons in series pumps with proprietary servo-controlled variable stroke design, power transmission by ball screws, smooth motion control of pistons for active damping.	
Settable flow range	Setpoints 0.001—5 ml/min, in 0.001 ml/min increments.	Executed in 300 pl/step increments
Flow precision	≤0.07 % RSD or 0.005 min SD, whatever is greater (0.2—5.0 ml/min).	Based on retention time at constant room temperature.
Flow accuracy	±1 % or 10 µl/min, whatever is greater.	Pumping degassed H ₂ O at 10 MPa (100 bar)
Pressure operating range	Operating range up to 120 MPa (1200 bar), up to 2 ml/min, 80 MPa (800 bar) at 5 ml/min.	
Pressure pulsation	<1 % amplitude or < 0.5 MPa (5 bar), whatever is greater.	At 1 ml/min water
Compressibility compensation	Automatic, pre-defined, based on mobile phase selection.	
Gradient formation	High pressure binary mixing.	
Delay volume	Jet Weaver V35: <45 µl Jet Weaver V100: <75 µl	JetWeaver generally recommended. For applications requiring lowest delay volumes, JetWeaver can be removed out of the flow path. Delay volume is then solely determined by the volume of the connection capillary.
Composition range	Settable range: 0 – 100 %	Recommended range: 1 – 99 % or 5 µl/min per channel, whatever is greater.

Table 2 Performance specifications

Type	Specification	Comments
Composition precision	<0.15 % RSD, or 0.01 min SD, whatever is greater.	0.2 —5.0 ml/min; based on retention time at constant room temperature
Composition accuracy	±0.35 % absolute (5 – 95 %, 0.2 – 5.0 ml/min)	Water/caffeine tracer
Solvent selection valve	Default	Standard part of the pump
Integrated degassing unit	Number of channels: 2 Internal volume per channel: 1.5 mL	
Control	Agilent ChemStation for LC (B.04.02 or above) EZChrom Elite (3.3.2 SP1 or above) OpenLAB (3.3.2 SP3) Masshunter (B.02.01 SP1 or above)	
Local control	Agilent Instant Pilot (G4208A) (B.02.08 or above)	
Communications	Controller-area network (CAN), RS232C, APG remote: ready, start, stop and shutdown signals, LAN	
Safety and maintenance	Extensive diagnostics, error detection and display (through Agilent Lab Advisor), leak detection, safe leak handling, leak output signal for shutdown of the pumping system. Low voltage in major maintenance areas.	
GLP features	Early maintenance feedback (EMF) for continuous tracking of instrument usage in terms of purge valve switches and volume of pumped mobile phase with pre-defined and user settable limits and feedback messages. Electronic records of maintenance and errors.	
Housing	All materials recyclable.	

2 Site Requirements and Specifications

Specifications

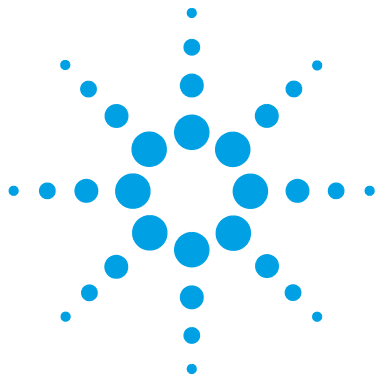

3 Installing the Module

Unpacking the Module	26
Optimizing the Stack Configuration	27
One Stack Configuration	27
Two Stack Configuration	30
Installation Information on Leak and Waste Handling	32
Removing the Transport Foam	36
Installing the Pump	37
Flow Connections to the Pump	41
Installation of Seal Wash Function	45

This chapter gives information about the preferred stack setup for your system and the installation of your Agilent 1290 Infinity Binary Pump.



Unpacking the Module

Damaged Packaging

If the delivery packaging shows signs of external damage, please call your Agilent Technologies sales and service office immediately. Inform your service representative that the instrument may have been damaged during shipment.

CAUTION

"Defective on arrival" problems

If there are signs of damage, please do not attempt to install the module. Inspection by Agilent is required to evaluate if the instrument is in good condition or damaged.

- Notify your Agilent sales and service office about the damage.
 - An Agilent service representative will inspect the instrument at your site and initiate appropriate actions.
-

Delivery Checklist

Ensure all parts and materials have been delivered with your module. The delivery checklist is included to your shipment. For parts identification please check the illustrated parts breakdown in [“Parts and Materials for Maintenance”](#) on page 195. Please report any missing or damaged parts to your local Agilent Technologies sales and service office.

Optimizing the Stack Configuration

If your module is part of a complete Agilent 1290 Infinity Liquid Chromatograph, you can ensure optimum performance by installing the following configurations. These configurations optimize the system flow path, ensuring minimum delay volume.

For other possible configurations, please refer to the Agilent 1290 Infinity System Manual.

One Stack Configuration

Ensure optimum performance by installing the modules of the Agilent 1290 Infinity Binary LC System in the following configuration (See [Figure 3](#) on page 28 and [Figure 4](#) on page 29). This configuration optimizes the flow path for minimum delay volume and minimizes the bench space required.

The Agilent 1290 Infinity Binary Pump should always be installed at the bottom of the stack.

3 Installing the Module

Optimizing the Stack Configuration

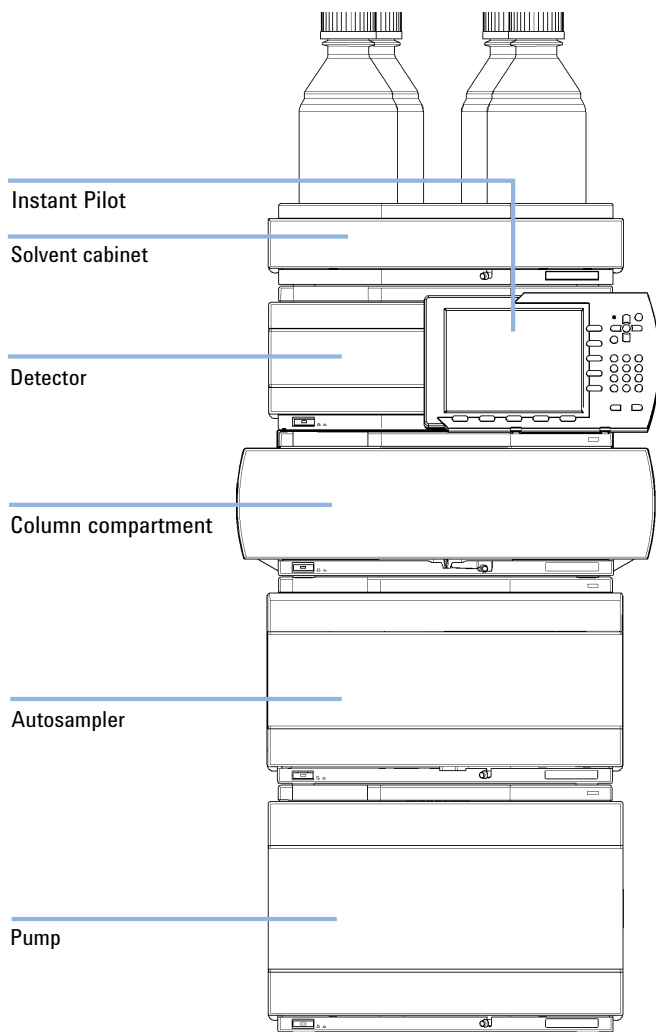

Figure 3 Recommended stack configuration for 1290 Infinity (front view)

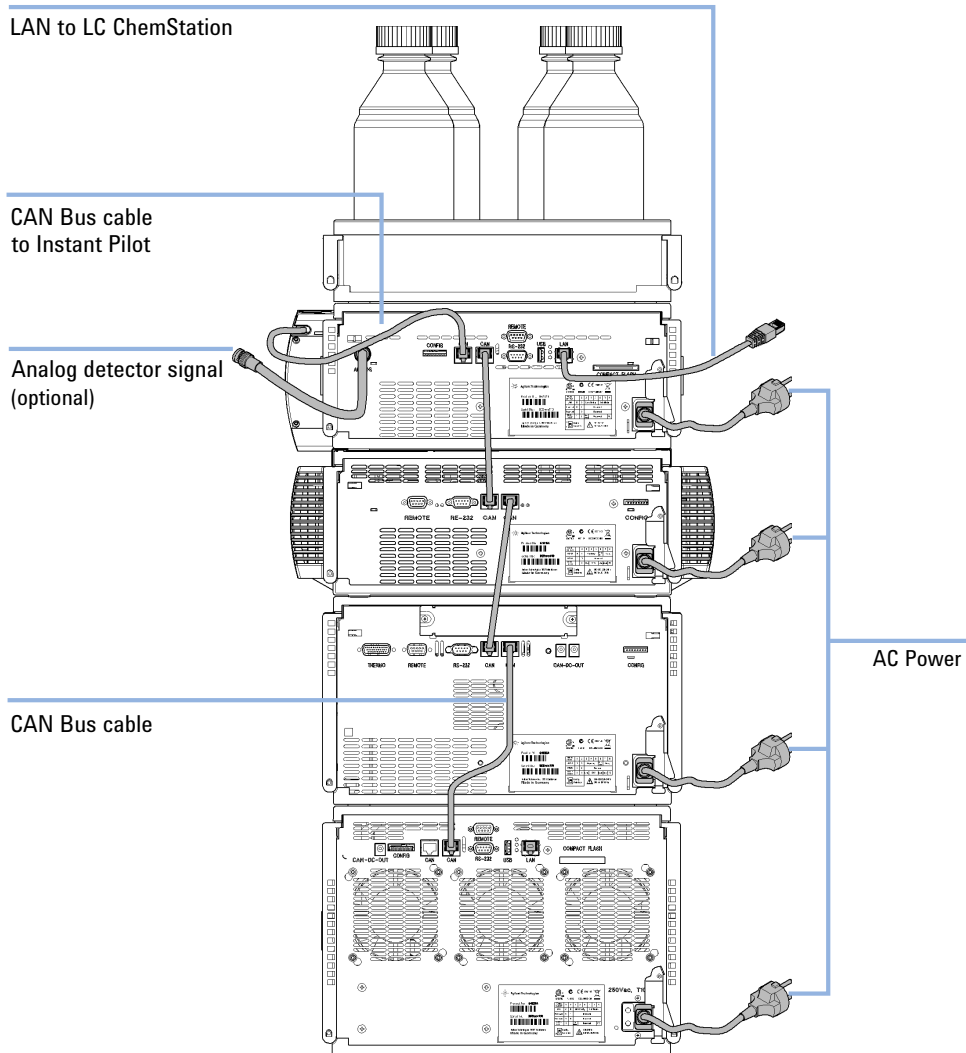

Figure 4 Recommended stack configuration 1290 Infinity (rear view)

Two Stack Configuration

In case the autosampler thermostat is added to the system, a two-stack configuration is recommended, which places both heavy modules (1290 Infinity pump and thermostat) at the bottom of each stack and avoids high stacks. Some users prefer the lower height of this arrangement even without the autosampler thermostat. A slightly longer capillary is required between the pump and autosampler. (See [Figure 5](#) on page 30 and [Figure 6](#) on page 31).

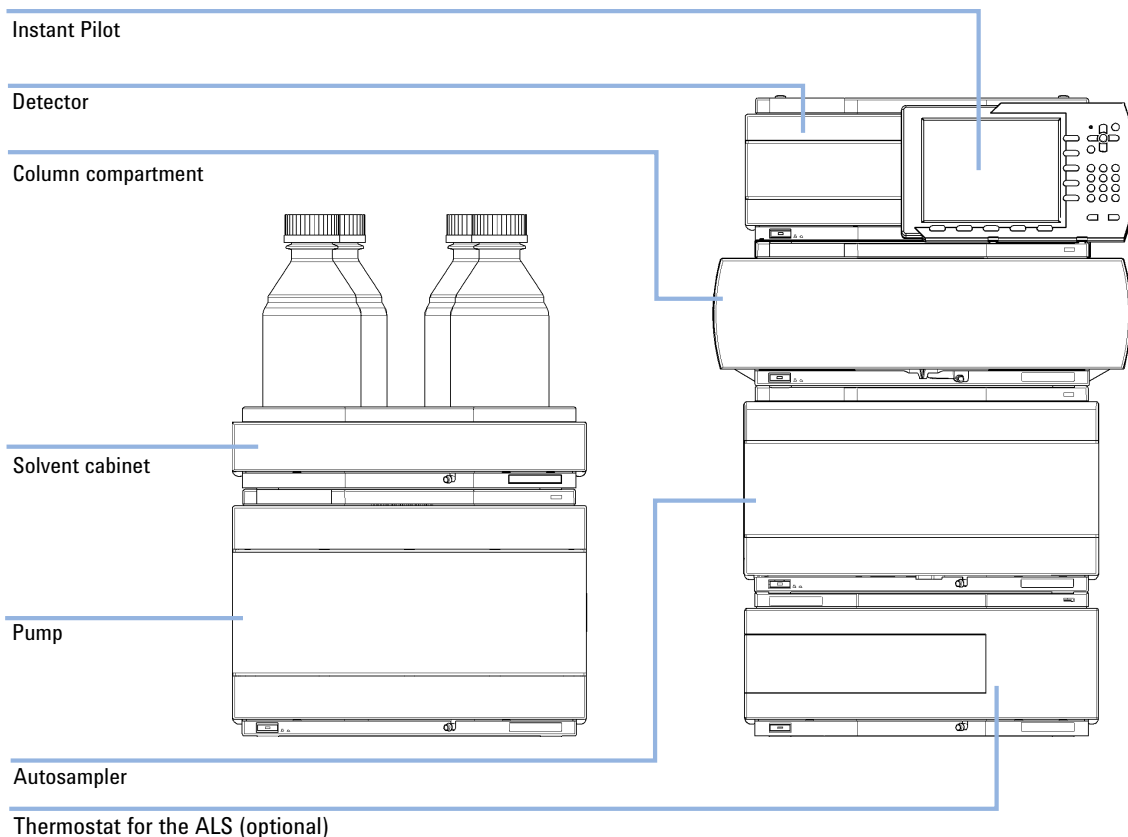

Figure 5 Recommended two stack configuration for 1290 Infinity (front view)

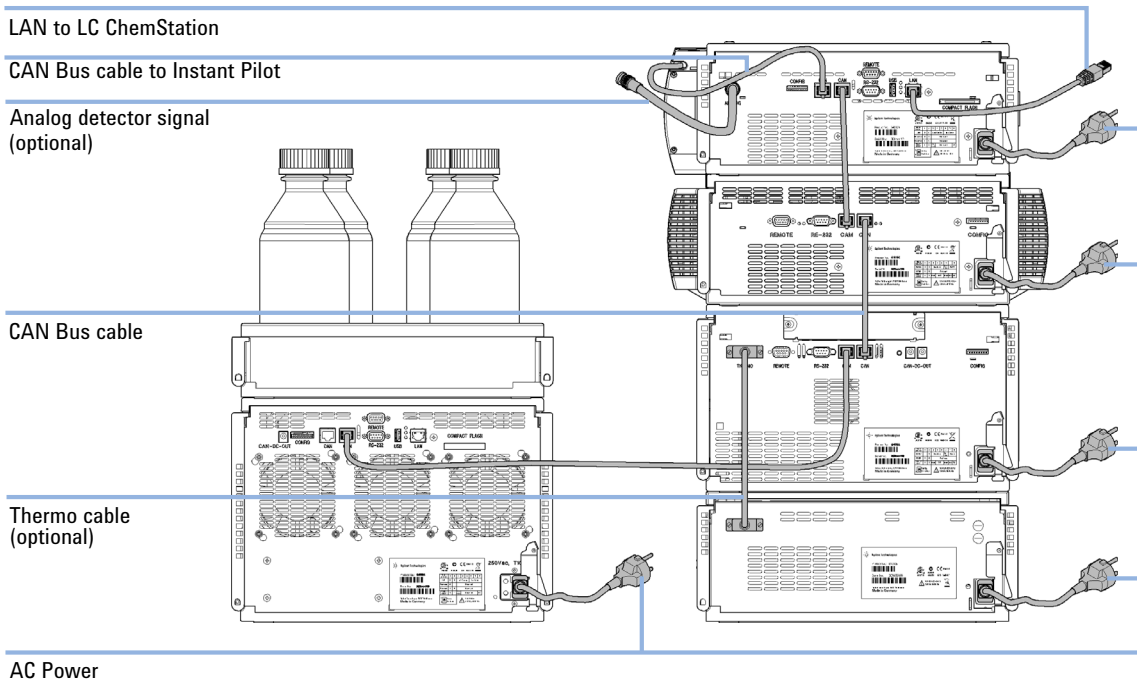

Figure 6 Recommended two stack configuration for 1290 Infinity (rear view)

Installation Information on Leak and Waste Handling

The Agilent 1200 Infinity Series has been designed for safe leak and waste handling. It is important that all security concepts are understood and instructions are carefully followed.

WARNING

Toxic, flammable and hazardous solvents, samples and reagents

The handling of solvents, samples and reagents can hold health and safety risks.

- When working with these substances observe appropriate safety procedures (for example by wearing goggles, safety gloves and protective clothing) as described in the material handling and safety data sheet supplied by the vendor, and follow good laboratory practice.
- The volume of substances should be reduced to the minimum required for the analysis.
- Never exceed the maximal permissible volume of solvents (6 L) in the solvent cabinet.
- Do not use bottles that exceed the maximum permissible volume as specified in the usage guideline for the Agilent 1200 Infinity Series Solvent Cabinets.
- Arrange the bottles as specified in the usage guideline for the solvent cabinet.
- A printed copy of the guideline has been shipped with the solvent cabinet, electronic copies are available on the Internet.

NOTE

Recommendations for Solvent Cabinet

For details, see the usage guideline for the Agilent 1200 Infinity Series Solvent Cabinets.

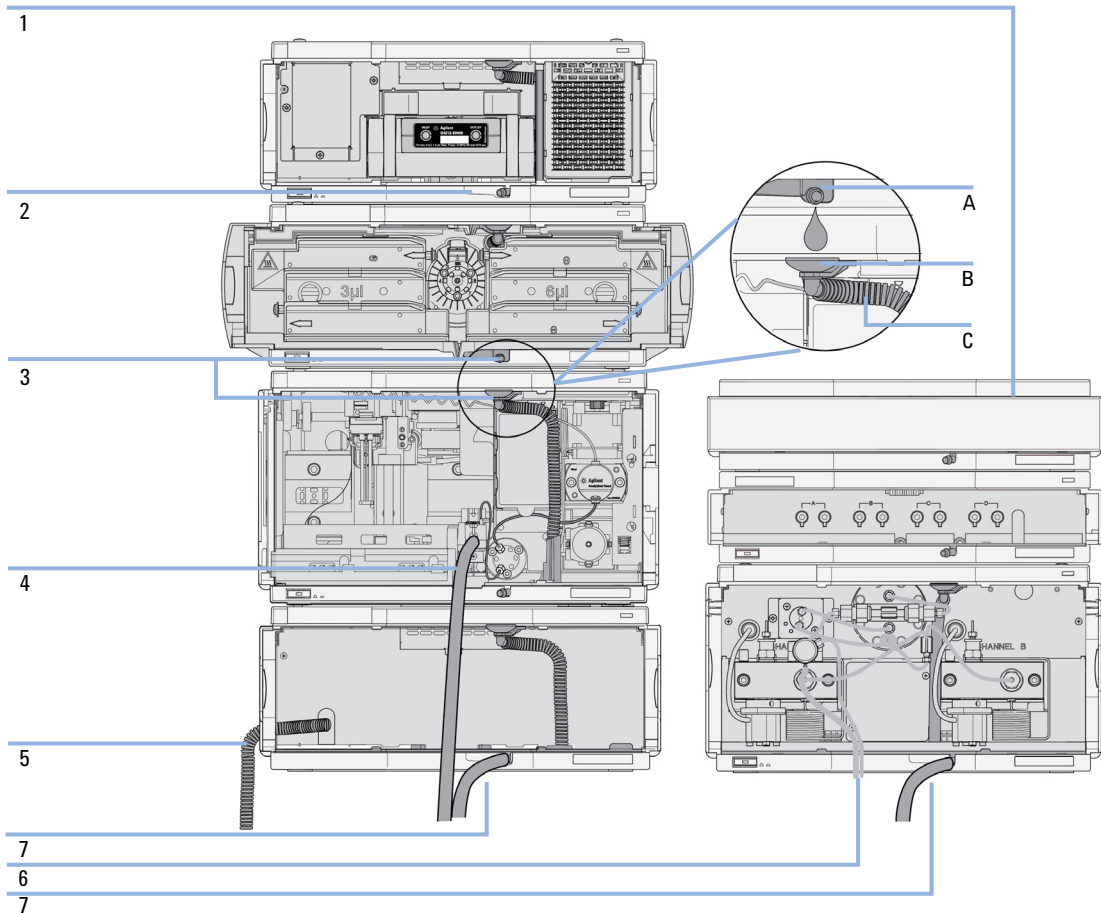

Figure 7 Leak and waste handling (overview - typical stack configuration as an example)

1	Solvent cabinet
2	Leak pan
3	Leak pan's outlet port (A), leak funnel (B) and corrugated waste tube (C)
4	Waste tube of the sampler's needle wash
5	Condense drain outlet of the autosampler cooler
6	Waste tube of the purge valve
7	Waste tube

3 Installing the Module

Installation Information on Leak and Waste Handling

- 1 Stack the modules according to the adequate stack configuration.
The leak pan outlet of the upper module must be vertically positioned above the leak tray of the lower module, see [Figure 7](#) on page 33.
- 2 Connect data and power cables to the modules, see section *Installing the Module* below.
- 3 Connect capillaries and tubes to the modules, see section *Flow Connections to the module* below or the relevant system manual.

WARNING

Toxic, flammable and hazardous solvents, samples and reagents

- Keep solvent path free from blockages.
 - Keep the flow path closed (in case the pump in the system is equipped with a passive inlet valve, solvent may leak out due to hydrostatic pressure, even if your instrument is off).
 - Avoid loops.
 - Tubes must not sag.
 - Do not bend tubes.
 - Do not immerse tube end in waste liquid.
 - Do not intubate tubes in other tubes.
 - For correct tubing follow instructions on label attached to the module.
-

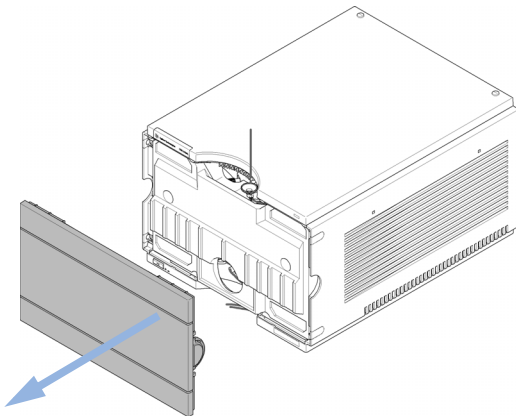

Figure 8 Warning label (illustration for correct waste tubing)

3 Installing the Module
Removing the Transport Foam

Removing the Transport Foam

1 Open the front cover of the module.



2 Carefully remove the protective foam.

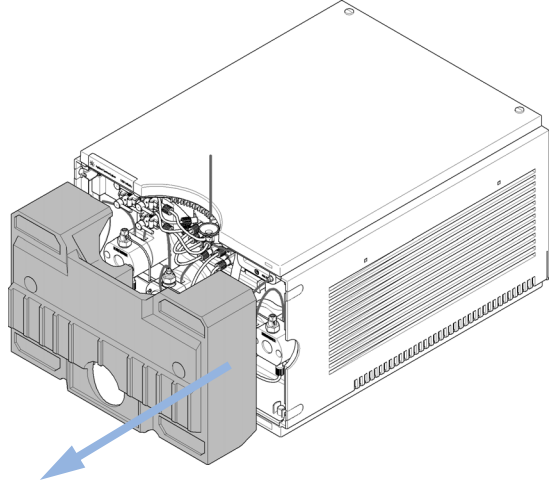

3 Close the front cover.

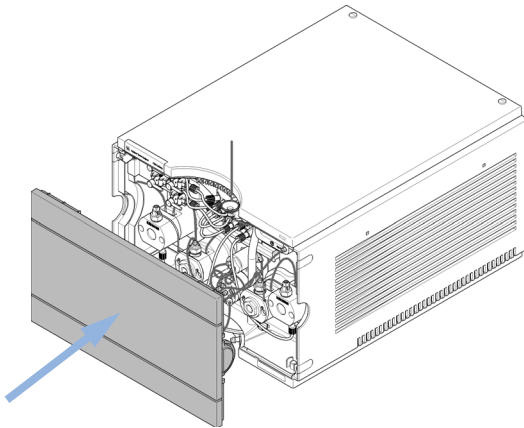

Installing the Pump

Parts required	#	Description
	1	Pump
	1	Power cord
	1	Agilent Control Software and/or Instant Pilot G4208

Preparations

- Locate bench space
- Provide power connections
- Unpack the pump

- 1 Place the module on the bench in a horizontal position.

3 Installing the Module

Installing the Pump

- 2 Ensure the power switch on the front of the module is OFF (switch stands out).

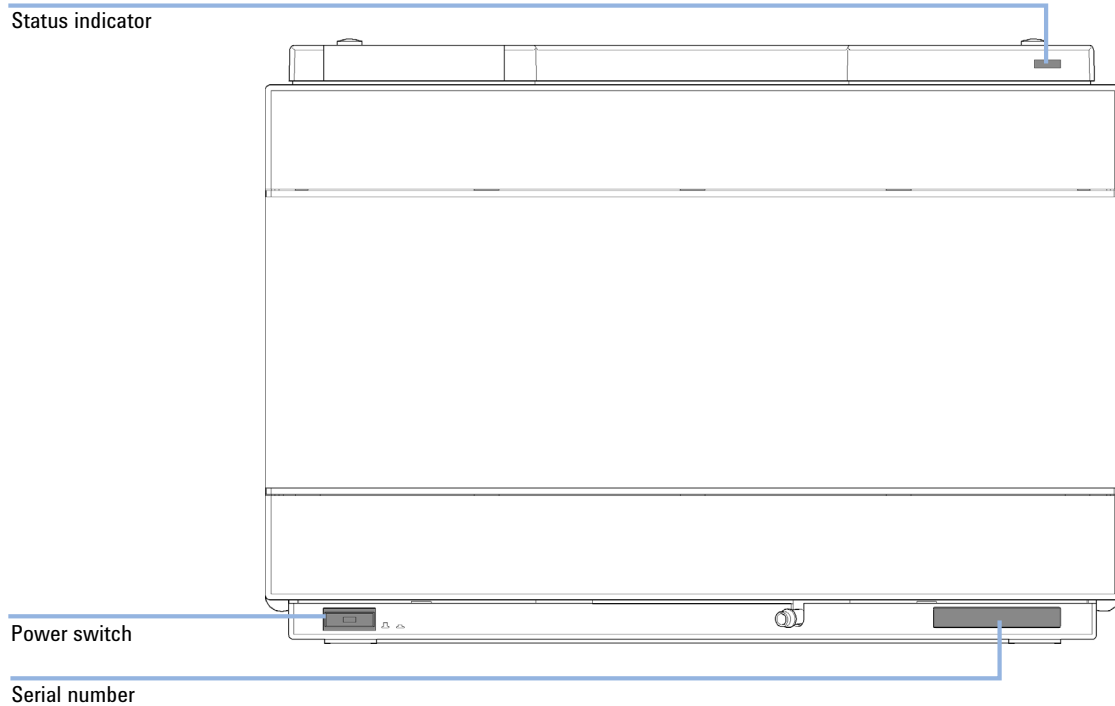

Figure 9 Front of Binary Pump

- 3 Connect the power cable to the power connector at the back of the 1290 Infinity Binary Pump.

- 4 Connect the required interface cables to the rear of the 1290 Infinity Binary Pump.

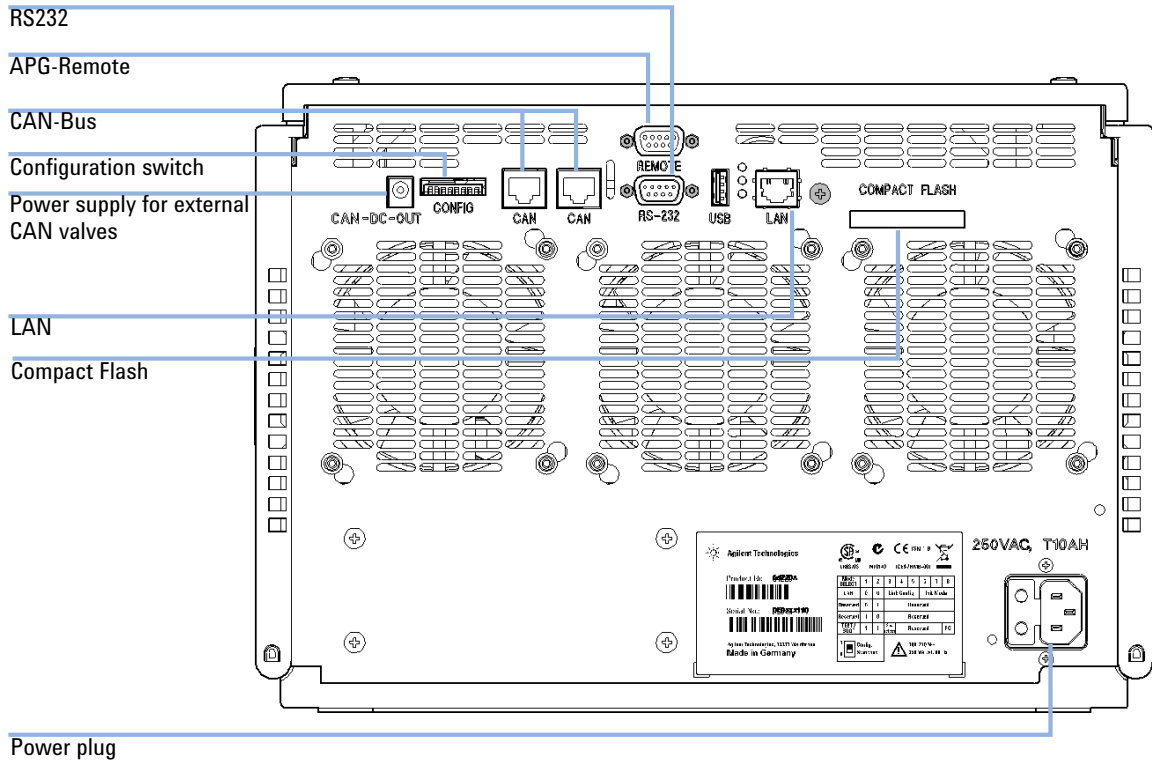

Figure 10 Rear of Binary Pump

NOTE

In an Agilent 1290 Infinity System, the individual modules are connected by CAN cables. An Agilent 1200 Series Instant Pilot can be connected to the CAN bus of any module. Connection to an Agilent data system is established through the built-in LAN port of the detector. The LAN port of the detector must be used as the detector generates the highest data rate of all modules. For more information about connecting the Instant Pilot or Agilent Data System, please refer to the respective user manual. For setting up the LAN access, see “LAN Configuration” on page 251.

3 Installing the Module

Installing the Pump

- 5 Turn on the power by pushing the button at the lower left hand side of the module.

The power button stays pressed in and the status LED should be green.

NOTE

When the line power button stands out and the green light is off, the module is turned off.

NOTE

The module was shipped with default configuration settings. For changing these settings, refer to section *Setting the 8-bit configuration switch*.

Flow Connections to the Pump

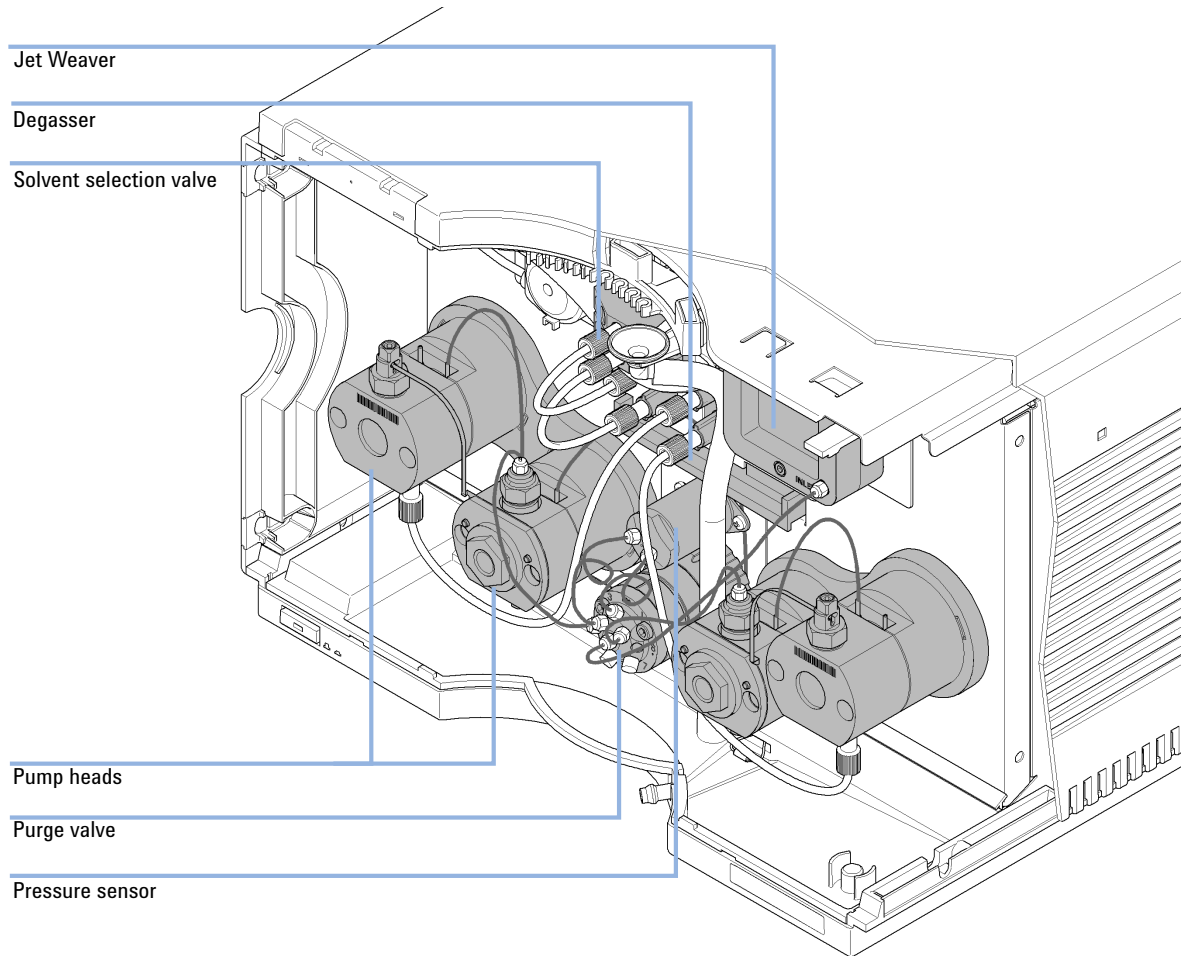

The pump is shipped with tubing and capillary connections installed between solvent selection valve, degassing unit, pump heads, pressure sensor, purge valve, Jet Weaver, and seal wash pump. This section describes the installation of additional flow connections.

3 Installing the Module

Flow Connections to the Pump

Parts required	#	p/n	Description
	1		Other modules
	1	G4220-68705	Accessory kit
	1	G5067-1531	Solvent Cabinet Kit

Preparations Pump is installed in the LC system.

WARNING

Toxic, flammable and hazardous solvents, samples and reagents

The handling of solvents, samples and reagents can hold health and safety risks.

- When working with these substances observe appropriate safety procedures (for example by wearing goggles, safety gloves and protective clothing) as described in the material handling and safety data sheet supplied by the vendor, and follow good laboratory practice.
- The volume of substances should be reduced to the minimum required for the analysis.
- Do not operate the instrument in an explosive atmosphere.

- 1 Remove the front cover by pressing the snap fasteners on both sides.

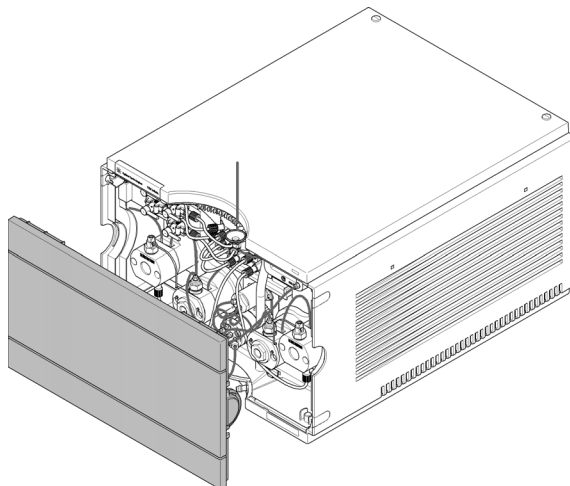
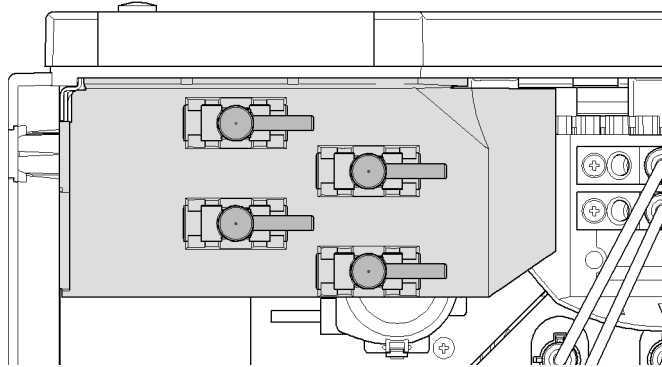

Figure 11 Removing the Front Cover

- 2 Place the solvent cabinet on top of the module stack that includes the 1290 Infinity Binary Pump.
- 3 Put the four bottles into the solvent cabinet and screw a bottle head assembly onto each bottle.
- 4 Install the shutoff valve panel at the top left corner of the instrument.



3 Installing the Module

Flow Connections to the Pump

- 5 Connect the solvent tubes from the bottle head assemblies to the inlet connectors A1, A2, B1 and B2 of the solvent selection valves. Use the brown bottle for the aqueous solvent (usually channel A1).

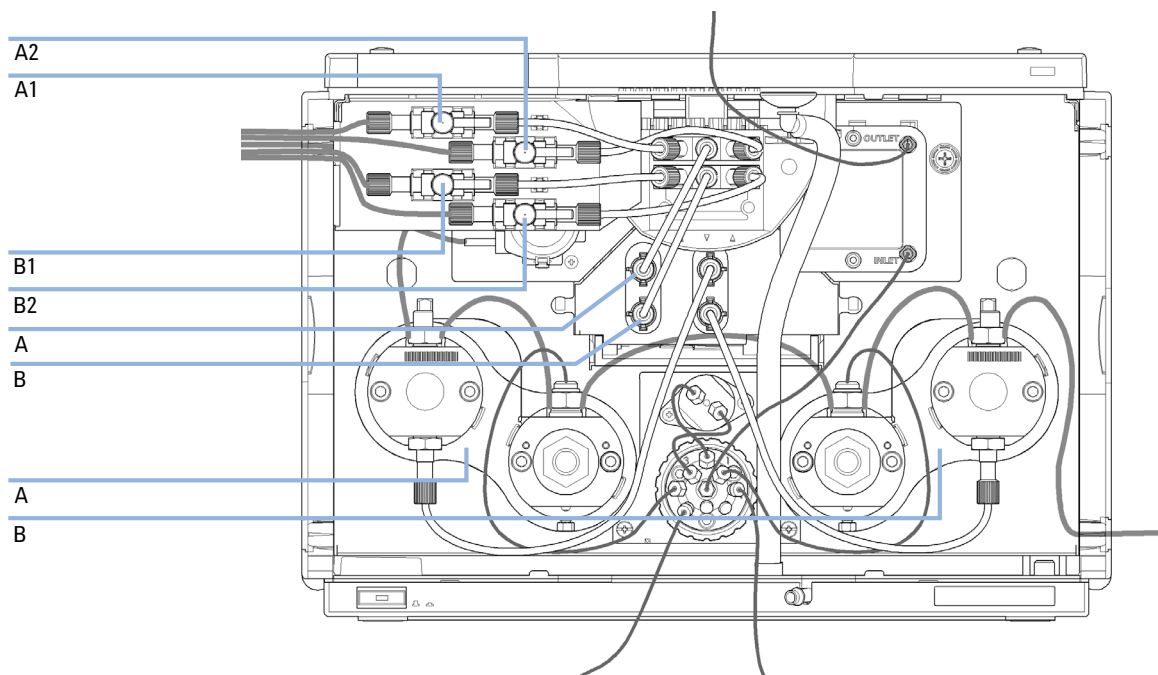

- 6 Label the tubes accordingly using the supplied stickers and fix the tubes in the clips of solvent cabinet and 1290 Infinity Binary Pump.
- 7 Connect the outlet of the Jet Weaver to the autosampler.
- 8 Connect Waste tubes (G4220-67000) to the purge valve outlets at ports 5 and 6.
- 9 Connect the corrugated waste tube to the outlet of the leak panel.
- 10 Route the corrugated waste tube to a waste container.
- 11 Route drain tubes coming from modules on top of the pump through the pump.
- 12 Purge your system prior to the first use (see “Purging the Pump” on page 69).

Installation of Seal Wash Function

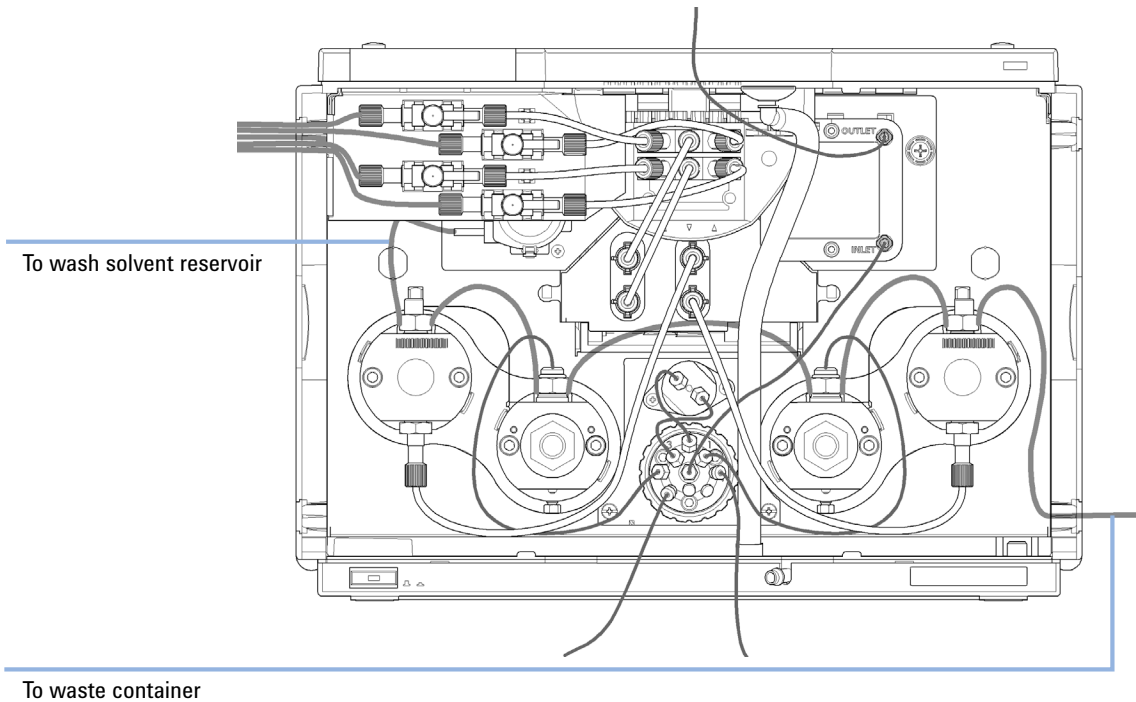

Figure 12 Binary Pump with Seal Wash Function

The 1290 Infinity Binary Pump has a built-in seal wash function, which is recommended when using buffers or other non-volatile solvents or additives that could deposit on pistons and seals. It is used for regularly cleaning these parts automatically.

- 1 Place a wash solvent reservoir into the solvent cabinet. A mixture of distilled water and isopropanol (90/10) is a good choice for many applications.
- 2 Put the solvent inlet tube into the solvent reservoir, close it and connect the tube to the seal wash pump.
- 3 Route the outlet of the wash tube into a waste container.

3 Installing the Module

Installation of Seal Wash Function

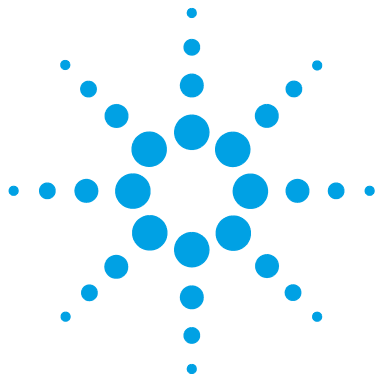

4 Using the Pump

Magnets	48
Turn on/off	49
Status Indicators	51
Leak and Waste Handling	52
Best Practices	53
Daily / Weekly tasks	53
Power up / Shut-down the pump	54
Prepare the pump	54
How to deal with solvents	56
Select channels for Multi-Channel Gradient Valve (MCGV)	56
Optional Inline Filter	56
Preparing the Binary Pump	58
Algae Growth in HPLC Systems	59
How to Prevent and-or Reduce the Algae Problem	59
Setting up the Pump with the Instrument Control Interface	60
Overview	60
Instrument Configuration	60
The Pump User Interface (Dashboard Panel)	62
Control Settings	64
Method Parameter Settings	65
Purging the Pump	69
Solvent Information	71
Solvent Recommendation for Agilent 1290 Infinity and 1290 Infinity II and 1260 Infinity II Flexible Pumps	78
Normal Phase Applications	79
Solvent Handling	80

This chapter explains the operational parameters of the Agilent 1290 Infinity Binary Pump.



Magnets

- 1 This stack exemplarily shows the magnets' positions in the modules.

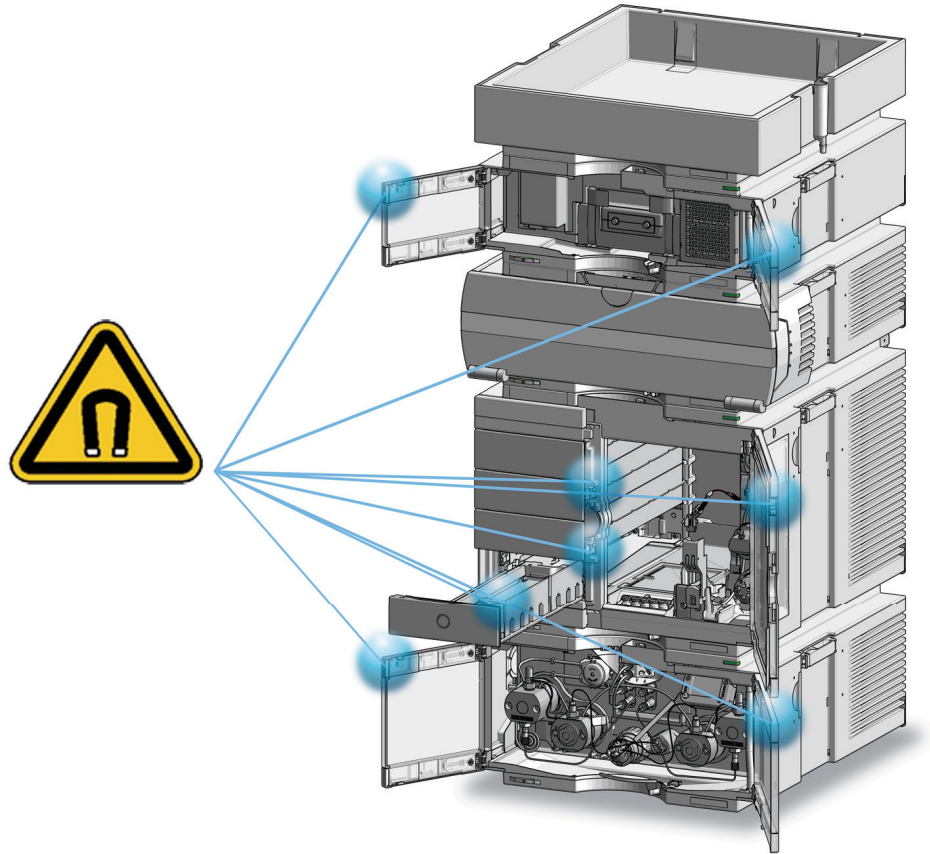

Turn on/off

1

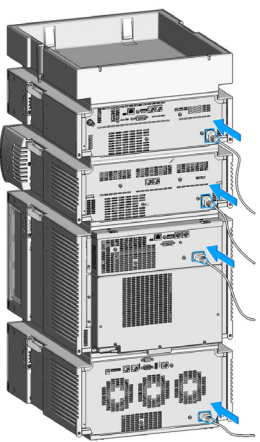

2

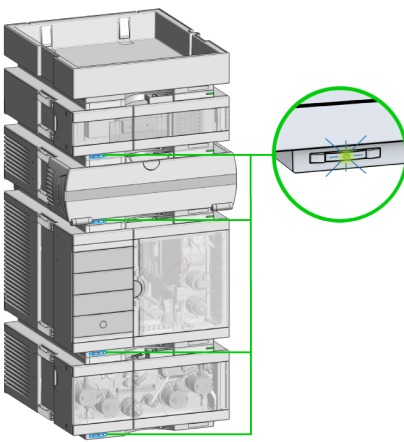

Power switch: On

3 Turn instrument **On/Off** with the control software.

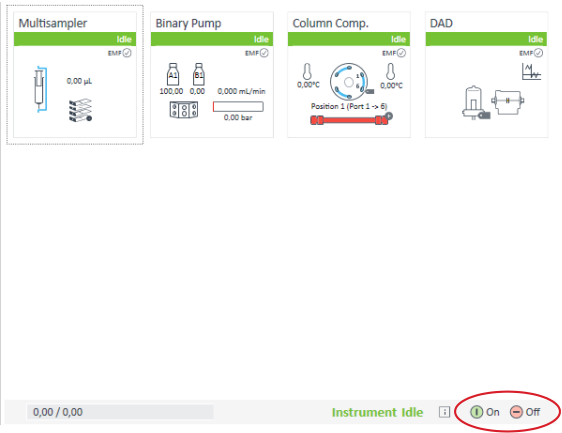

4

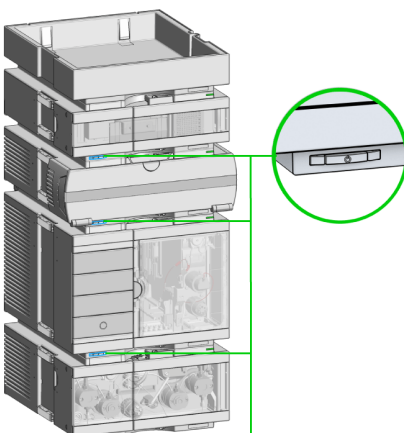

Power switch: Off

4 Using the Pump

Turn on/off

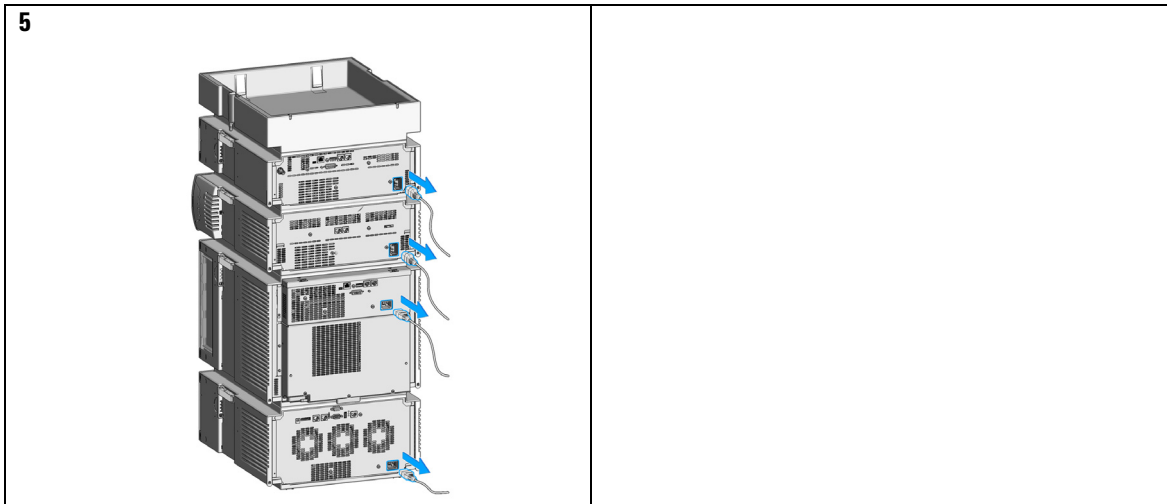

Status Indicators

- 1 The module status indicator indicates one of six possible module conditions:

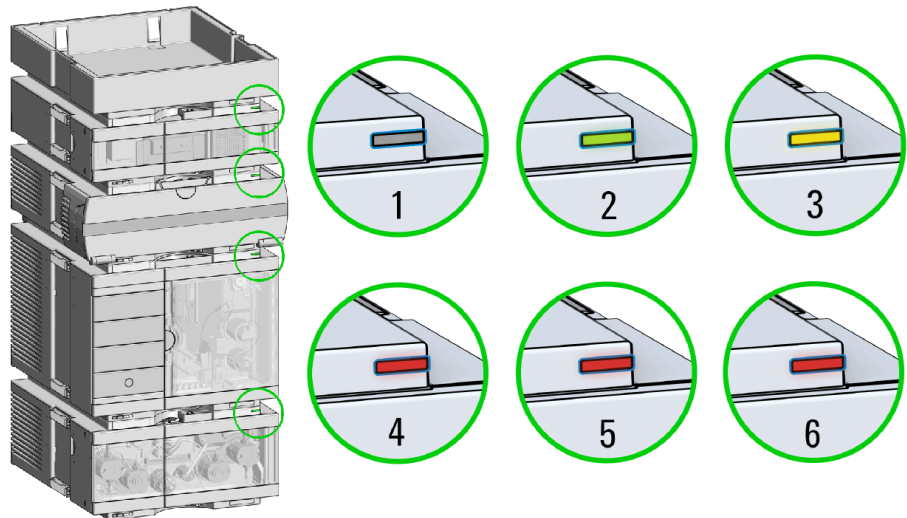

Status indicators

1. Idle
2. Run mode
3. Not-ready. Waiting for a specific pre-run condition to be reached or completed.
4. Error mode - interrupts the analysis and requires attention (for example a leak or defective internal components).
5. Resident mode (blinking) - for example during update of main firmware.
6. Bootloader mode (fast blinking). Try to re-boot the module or try a cold-start. Then try a firmware update.

Leak and Waste Handling

WARNING

Toxic, flammable and hazardous solvents, samples and reagents

The handling of solvents, samples and reagents can hold health and safety risks.

- When working with these substances, observe appropriate safety procedures (for example by wearing goggles, safety gloves and protective clothing) as described in the material handling and safety data sheet supplied by the vendor, and follow good laboratory practice.
- The volume of substances should be reduced to the minimum required for the analysis.
- Do not operate the instrument in an explosive atmosphere.
- Never exceed the maximal permissible volume of solvents (6 L) in the solvent cabinet.
- Do not use bottles that exceed the maximum permissible volume as specified in the usage guideline for the Agilent 1200 Infinity Series Solvent Cabinets.
- Arrange the bottles as specified in the usage guideline for the solvent cabinet.
- A printed copy of the guideline has been shipped with the solvent cabinet, electronic copies are available on the Internet.
- Ground the waste container.
- The residual free volume in the appropriate waste container must be large enough to collect the waste liquid.
- Check the filling level of the waste container regularly.
- To achieve maximal safety, check regularly for correct installation.
- Do not use solvents with an auto-ignition temperature below 200 °C (392 °F).

NOTE

Recommendations for Solvent Cabinet

For details, see the usage guideline for the Agilent 1200 Infinity Series Solvent Cabinets.

For details on correct installation, see section *Installation Information on Leak and Waste Handling* in the service manual.

Best Practices

Daily / Weekly tasks

Daily tasks

- Replace solvents and solvent bottles for mobile phases based on water/buffer.
- Replace solvents and solvent bottles for organic mobile phase latest every second day.
- Check presence of seal wash solvent.
- Purge each channel with fresh solvent at 2.5 – 3 mL/min for 5 min.
- Equilibrate your system with composition of your application for 15 min. Use conditioning for 1290 Infinity II Pumps and G7104C.

Weekly tasks

- Change seal wash solvent (10 % / 90 % isopropanol/water) and bottle.
- Flush all channels with water at 2.5 – 3 mL/min for 5 min to remove salt deposits if buffer applications were used.
- Inspect solvent filters for dirt or blockages. Clean or exchange if no flow is coming out of the solvent line when removed from the degasser inlet.

Power up / Shut-down the pump

Power up the pump

- Use new or different mobile phase (as required).
- Purge each channel with 2.5 – 3 mL/min for 5 min. Open the manual purge valve or use the purge command.
- Equilibrate your system with composition of your application for 15 min. Use conditioning for 1290 Infinity II Pumps and G7104C.

Long-term shut-down of the system

- Flush system with water to remove buffer.
- Remove all samples from the sampler and store according to good laboratory practice.
- Use recommended solvents to store the system.
- Power off the system.

Prepare the pump

Purge

Use the Purge function to:

- fill the pump,
- exchange a solvent,
- remove air bubbles in tubes and pump heads.

Condition

Use the Conditioning function:

- daily when starting the pump,
- to minimize pressure ripple by dissolving air bubbles in pump heads.

NOTE

Condition your complete system with solvents and composition of your application (for example 50 %/50 % A/B at 0.5 mL/min).

Seal wash

Using the seal wash function is recommended when using buffers or other non-volatile solvents or additives that could deposit on pistons and seals. The seal wash function regularly cleans these parts automatically.

Seal Wash Dialog in OpenLAB Software (1290 Infinity Pumps only):

- Seal Wash settings are NO method parameters
- Find dialog under **Control**
- On ERROR – seal wash is switched off
- At Power Off – seal wash is switched off



Figure 13 Seal wash dialog

CAUTION

Contaminated seal wash solvent

- Do not recycle seal wash solvent to avoid contamination.
 - Weekly exchange seal wash solvent.
-

How to deal with solvents

- Use clean bottles only.
- Exchange water-based solvents daily.
- Select solvent volume to be used up within 1 – 2 days.
- Use only HPLC-grade solvents and water filtered through 0.2 µm filters.
- Label bottles correctly with bottle content, and filling date / expiry date.
- Use solvent inlet filters.
- Reduce risk of algae growth: use brown bottles for aqueous solvents, avoid direct sunlight.

Select channels for Multi-Channel Gradient Valve (MCGV)

- Use lower channels (A and/or D) for buffer solutions.
- Regularly flush all MCGV channels with water to remove possible salt deposits.
- Check compatibility of buffers and organic solvents to avoid precipitation.

Optional Inline Filter

The pump can be equipped with an additional inline filter (Inline Filter Assembly (5067-5407)) with a nominal filter pore size of 0.3 µL.

Advantages of the inline filter:

- Very small internal volume
- Specified for working at high pressures
- Possibility of back-flushing the filter

Using the inline filter is recommended:

- to protect the downstream system from blockages,
- for solvent combinations that can form precipitation after mixing,
- for applications running with buffers.

General hints for effective usage of the inline filter:

- filter solvents before usage,
- follow best practices,
- back-flush the filter weekly,
- exchange the filter frit on a regular basis.

CAUTION

Damage to the valve

→ Use the filter flush mode only if the optional inline filter is installed.

See Technote G7167-90130 for further reference.

Preparing the Binary Pump

For best performance of the pump:

- Place solvent cabinet with the solvent bottles always on top (or at a higher level) of the pump.
- For optimum performance, use the built-in degasser. This is mandatory for flow rates below 0.5 mL/min and for configurations without Jet Weaver.
- When using the pump with vacuum degassing unit, flush the degassing unit with at least 5 mL per channel before operating the pump, especially when the pumping system had been turned off for a certain length of time (for example, overnight) and volatile solvent mixtures are used in the channels.
- Prevent blocking of solvent inlet filters (never use the pump without solvent inlet filters). Growth of algae should be avoided, see “[Algae Growth in HPLC Systems](#)” on page 59.
- Check pump outlet filters and column frit in regular time intervals. A blocked pump outlet filter can be identified by black, yellow or greenish layers on its surface.
- Whenever possible use a minimum flow rate of 5 μ L/min per solvent channel to avoid crossflow of solvent into the unused pump channel.
- When using buffer solutions, flush the system with water before switching it off.
- The seal wash function should be used when buffer solutions with concentrations of 0.1 M or higher are being pumped for long periods of time.
- Never leave an unused pump with water in a channel for an extended period of time (2-3 days). Always flush with organic solvent or add 10 % isopropanol to water.

Algae Growth in HPLC Systems

The presence of algae in HPLC systems can cause a variety of problems that may be incorrectly diagnosed as instrument or application problems. Algae grow in aqueous media, preferably in a pH range of 4-8. Their growth is accelerated by buffers, for example phosphate or acetate. Since algae grow through photosynthesis, light will also stimulate their growth. Even in distilled water small-sized algae grow after some time.

Instrumental Problems Associated With Algae

Algae deposit and grow everywhere within the HPLC system, causing the following problems:

- Blocked solvent filters, or deposits on inlet or outlet valves, resulting in unstable flow, composition or gradient problems, or a complete failure of the pump.
- Plugging of small-pore, high-pressure solvent filters, usually placed before the injector, resulting in high system pressure.
- Blockage of PTFE frits, leading to increased system pressure.
- Plugging of column filters, giving high system pressure.
- Dirty flow cell windows of detectors, resulting in higher noise levels (since the detector is the last module in the flow path, this problem is less common).

How to Prevent and-or Reduce the Algae Problem

- Always use freshly prepared solvents, especially use demineralized water which was filtered through 0.2 μm filters.
- Never leave mobile phase in the instrument for several days without flow.
- Always discard old mobile phase.
- Use the amber solvent bottle (Solvent bottle, amber, 1000 mL (9301-6526)) supplied with the instrument for your aqueous mobile phase.
- If possible add a few mg/L sodium azide or a few percent organic solvent to the aqueous mobile phase.

Setting up the Pump with the Instrument Control Interface

Overview

Parameters described in following sections are offered by the instrument control interface and can usually be accessed through Agilent instrument control software. For details, please refer to manuals and online help of respective user interfaces.

Instrument Configuration

Use the **Instrument Configuration** dialog box to examine and, if necessary, modify your instrument configuration. The **Configurable Modules** panel contains a list of all modules available for configuration. The **Selected Modules** panel contains the list of configured modules.

Auto Configuration: Under **Communication settings**, select either the **Host Name** option or the **IP address** option and enter the appropriate value for the host computer to enable automatic detection of the hardware configuration. The system configures the instrument automatically with no further manual configuration necessary.

The Binary Pump configuration parameters are in two sections:

- **Communication**
- **Options**

Communication: The parameters in this dialog box are detected automatically during autoconfiguration.

- **Device name,**
- **Type ID,**
- **Serial number,**
- **Firmware revision,**
- Button **Connection settings**

Options:• **Pressure Unit:**

select the pressure units from the drop-down list (bar, psi or MPa).

• **Seal wash installed:**

This check box is marked to indicate that an optional seal wash has been detected during autoconfiguration.

• **ISET installed:**

This check box is marked to indicate that ISET is installed. Click **ISET Configurations** to open the **ISET Configuration** dialog box, which allows you to configure a sampler for the ISET emulation.

Configure Solvent Type Catalogs: Displays the **Solvent Type Catalogs** dialog box, which allows you to import and export solvent calibration data. See [“Importing Solvent Calibration Tables”](#) on page 90.

Please refer to the online help of your user interface for more detailed information.

The Pump User Interface (Dashboard Panel)

Module Graphic

The items in the pump graphic have the following meaning and function:



Indicates that an External Contacts board is installed.



The level of solvent in the bottle is denoted by the green area; when the solvent level falls below the specified volume, the area turns yellow; when the bottle is empty, the area turns red. Clicking on the solvent bottle displays the **Bottle Fillings** dialog box. The tooltip for the bottle shows the solvent name.



Indicates that the ISET option is installed but with no active method (gray) or installed and active (orange). (G4220A only)



Indicates the presence of a solvent selection valve. Click the graphic to switch the valve; the animation shows when the valve is switched.



The pressure setpoints. The red line shows the current maximum pressure limit; the green area shows the current pressure (also shown as text).

The current solvent flow rate (in mL/min) is displayed above the pressure display.

Instrument Signals

The following pump signals are displayed:

Flow	The current solvent flow rate (in mL/min).
Pressure	The current pump pressure (in bar, psi or MPa, see “ Instrument Configuration ” on page 60).
Pressure Limit	The current maximum pressure limit.
Composition A:B	The current solvent composition. When a solvent selection valve is fitted, the channels are shown in the graphic.
Tuning	The signal represents the current effort the pumpdrives have to take to maintain the current system status.

Context Menu

The context menu of the dashboard panel contains the following commands:



Control Displays the pump's **Control** dialog box.



Method Displays the pump's **Method Setup** dialog box.

Set Error Method Sets the method that is loaded if an error occurs to the method that is currently available in the hardware.

Identify Device Causes the LED on the front of the module to blink for a few seconds.



Switch Pump On/Off Toggles the status of the pump, on or off.

Switch solvent selection Valve A allows you to switch the solvent inlet line for channel A from inlet line 1 to 2

Bottle Fillings Displays the **Bottle Fillings** dialog box.

Prepare Pump Allows you to control the Purge, Condition or the Prime function.

Seal Wash Purge Allows you to refill the Seal Wash lines once the Seal Wash solvent has been changed

Control Settings

The Binary Pump control parameters are in six sections:

- **Pump**
- **Seal Wash**
- **Automatic Turn On**
- **Purge**
- **Prime**
- **Conditioning**

Table 3 Pump control parameters

Parameter	Limits	Description
Pump		Enables you to switch the pump On , Off or to a Standby condition. In the Standby condition, the pump motor is still active, and when the pump is switched on again, does not need to be re-initialized.
Automatic Turn On		Module can be turned on at a specified date/time. This feature can only be used if the module power switch is turned on.
Purge	Time: 0 – 100.00 min in steps of 0.01. Flow: 0.000 – 5.000 mL/min for each channel, in steps of 0.001 (10.000 mL/min maximum).	Setup and activation of Purge parameters. The automatic purge valve can be used for purging the system. The process has been automated for ease of use. <ul style="list-style-type: none"> • Off: Turns off the purge. • On: The device is purged. • Purge Flow, Time and Composition during purge have to be defined. As soon as the duration time of the purge ends, the module automatically switches to analytical conditions again.
Prime		Select On to start priming, Off to turn priming off. The Prime function is helpful for filling empty solvent lines or if air has entered the pump heads. The module draws solvent, at high speed with all four pump drives simultaneously, and dispenses it against the waste position of the automatic purge valve. This is done 20 times, before the process comes to an end.
Conditioning	at least 200 bar (> 500 bar is better).	Use this function if you see excessive pressure or composition ripple, and you are sure that the solvent type (aqueous/organic or specific solvent/solvent mix) is correctly set, and there is no evidence of leakage in the pump. Conditioning may be necessary if the pump may contain air, for example after running out of solvent, after a long period of standby or after service or repair.

Method Parameter Settings

The Binary Pump method setup parameters are in eight sections:

- **Flow**
- **Solvents A and B**
- **Stoptime**
- **Posttime**
- **Pressure Limits**
- **Timetable**
- **Advanced**
- **External Contacts**

Table 4 Method parameters

Parameter	Limits	Description
Flow	0.00 – 5.00 mL/min in steps of 0.001. Recommended flow range: 0.05 – 5.00 mL/min .	The flow is the rate of movement of eluent along the column. It is important that the flow rate is kept constant to ensure precise retention time, and peak measurements. Variations in flow rate can occur as a result of the partial failure of the pumping system, air in the pumping system, a change in the mobile phase viscosity or a temperature change.
Solvents A and B		For each channel, you can select which of the two solvents to deliver. You can set the percentage of solvent B to any value from 0 through 100 % . Solvent A always delivers the remaining volume: 100 - %B. The solvent B check boxes allow you to turn the solvent B channels on (checked) or off (cleared). When the Use solvent types check box in the Compressibility section is checked (see “ Advanced Settings ” on page 67), you click the down arrow and select either a Generic solvent or a calibrated Solvent .
Stoptime	0.01 – 99999 min or As Injector/No Limit (an infinite run time).	The stoptime sets a time limit for your analysis. After the stoptime, all gradients are stopped and the pump parameters return to their initial values. The pump can be used as a stoptime master for the complete analytical system. The pump also stops the detectors if they have a No Limit stoptime setting. If no limit is given, a method will have to be stopped manually.
Posttime	0.01 – 99999 min or Off (0.0 min).	Your instrument remains in a not ready state during the posttime to delay the start of the next analysis. You can use the Posttime to allow your column to equilibrate after changes in solvent composition (for example after gradient elution).

4 Using the Pump

Setting up the Pump with the Instrument Control Interface

Table 4 Method parameters

Parameter	Limits	Description
Pressure Limits	Max: 1200 bar (17400 psi) for flow rates up to 2 mL/min. For flow rates between 2 mL/min and 5 mL/min, the maximum pressure ramps down to 800 bar (11600 psi). Min: any value between 0 and the upper pressure limit setting.	Sets the maximum and minimum pressure limits for the pump. <ul style="list-style-type: none">• Max is the maximum pressure limit at which the pump will switch itself off, protecting the analytical system against over-pressure.• Min is the minimum limit at which the pump will switch itself off, for example, if any solvent reservoir is empty, this prevents system damage by pumping air.
Timetable		See " Timetable Settings " on page 68
Advanced		See " Advanced Settings " on page 67
External Contacts		The External Contacts section enables you to set up the switching of the external contacts.
		<div style="background-color: #cccccc; padding: 5px; text-align: center;">NOTE</div> The External Contacts section is present only when a BCD/external contacts board is installed.

Advanced Settings

The Binary Pump advanced method setup parameters are in three sections:

- **Minimum Stroke**
- **Compressibility**
- **Maximum Flow Gradient**

Table 5 Advanced method parameters

Parameter	Limits	Description
Minimum Stroke	20 – 100 μ L	<p>The Stroke Volume is used for optimizing between performance of the module and seal life time. For performance a low stroke volume is beneficial, as it divides disturbances into smaller packages, but a larger volume is extending the life time of the pump seals.</p> <p>If Automatic is activated, the pump tries to achieve an optimized stroke volume for the Jet Weaver geometry.</p> <p>Synchronized: Select this option to synchronize the strokes for both channels; the values for Channel B are set to the same as those for Channel A. This is done to avoid floating disturbances affecting instrument performance.</p>
Compressibility		<p>The compressibility of the mobile phase has an effect on the performance of the pump. For best flow accuracy and mixing performance, you can set the parameter according to the mobile phase being used.</p> <p>Use solvent types:</p> <ul style="list-style-type: none"> • Clear this check box to display the compressibility fields, which allow you to enter compressibility values. • When the check box is selected, the compressibility fields are not displayed, and the enhanced compressibility calibration is enabled. Select the required calibrated solvents from the drop-down lists using the combo boxes in the Solvents section.
Maximum Flow Gradient	1.000 – 1000.000 mL/min/min in steps of 0.001 mL/min/min Default value: 100.000 mL/min/min	<p>You can set a limit on the rate of change of the solvent flow to protect your analytical column. You can set individual values for Flow ramp up and Flow ramp down.</p>

4 Using the Pump

Setting up the Pump with the Instrument Control Interface

Timetable Settings

Use the **Timetable** to program changes in the pump parameters during the analysis by entering a time in the **Time** field and appropriate values in the following fields of the timetable. Changes in flow rate occur linearly from either time zero or the time of the last defined change; other parameters change instantaneously at the time defined in the timetable.

Show **Advanced Timetable** toggles the timetable display between standard mode and advanced mode.

The following parameters can be changed:

- **Change Contacts**
- **Change Flow**
- **Change Max. Pressure Limit**
- **Change Solvent Composition** - You can only use solvents, which have been enabled in the solvents section.
- **Function centric view** - This checkbox allows you displaying parameter changes instead of a time table.

Purging the Pump

When the solvents have been exchanged or the pumping system has been turned off for a certain time (for example, overnight) oxygen will re-diffuse into the solvent channel between the solvent reservoir, vacuum degassing unit (when available in the system) and the pump. Solvents containing volatile ingredients will slightly lose these. Therefore purging of the pumping system is required before starting an application.

- 1 Initiate a purge in the controlling software with a Purge flow set to 3 – 5 ml/min per channel.
- 2 Flush all tubes with at least 30 ml of solvent.

Table 6 Choice of Priming Solvents for Different Purposes

Activity	Solvent	Comments
After an installation	Isopropanol	Best solvent to flush air out of the system
When switching between reverse phase and normal phase (both times)	Isopropanol	Isopropanol is miscible with both normal phase and reverse phase solvents.
After an installation	Ethanol or Methanol	Alternative to Isopropanol (second choice) if no Isopropanol is available
To clean the system when using buffers	Bidistilled water	Best solvent to re-dissolve buffer crystals
After a solvent change	Bidistilled water	Best solvent to re-dissolve buffer crystals
Before turning off system for an extended period of time	Organic or 10 % isopropanol in water	

NOTE

The pump should never be used for priming/purging empty tubings (never let the pump run dry). Use a syringe to draw enough solvent for completely filling the tubings to the pump inlet before continuing to prime with the pump.

4 Using the Pump

Purging the Pump

If the system has been run dry or air has diffused into the pump it might require additional steps to get rid of the air again. Following the procedure below will give the best and fastest results.

- 1 Change solvent to isopropanol.
- 2 Turn on the Prime function.
- 3 Purge the system with 10 ml, composition 50/50 and for 10 min.
- 4 Attach a column suitable for isopropanol and set the Max. pressure limit to the limit of the column.
- 5 Run the system at composition 50/50 and a flow rate that gives a pressure close to the limit of the column. Turn on the **Conditioning** function.
- 6 Observe the pressure fluctuations. The system is air free as soon as the pressure is stable.
- 7 Change solvents and column according to the analytical conditions and purge the system to change solvents.

Solvent Information

Introduction

Observe the following recommendations on the use of solvents.

- Follow recommendations for avoiding the growth of algae, see [“Algae Growth in HPLC Systems”](#) on page 59.
- Small particles can permanently block capillaries and valves. Therefore, always filter solvents through 0.22 µm filters.
- Avoid or minimize the use of solvents that may corrode parts in the flow path. Consider specifications for the pH range given for different materials like flow cells, valve materials etc. and recommendations in subsequent sections.

Materials in Flow Path

Following materials are used in the flow path of this module:

Part	Materials
Degasser chamber	TFE/PDD copolymer, PFA (internal tubings); PEEK (inlets); FEP (tubings); ETFE (fittings)
Ultra clean tubings ¹	PFA (tubings), PEEK (fittings)
Microfluidic structures ²	SST
SSV	PEEK, FEP, PFA, Al ₂ O ₃ -based ceramic, ruby, sapphire, SST
Passive inlet valve	SST, gold, ruby, ZrO ₂ -based ceramic, tantalum
Outlet valve	SST, gold, ruby, ZrO ₂ -based ceramic, tantalum
Pump head	SST
Pistons	ZrO ₂ -based ceramic
Piston/wash seals	UHMW-PE, SST
Pressure sensor	SST
Automatic purge valve	Polyimide, SST, DLC

¹ Ultra clean tubings are available for the use with high-end MS detectors. They are also compatible to THF.

² Jet Weaver, Heat Exchanger

Material Information

Materials in the flow path are carefully selected based on Agilent's experiences in developing highest quality instruments for HPLC analysis over several decades. These materials exhibit excellent robustness under typical HPLC conditions. For any special condition, please consult the material information section or contact Agilent.

Disclaimer

Subsequent data was collected from external resources and is meant as a reference. Agilent cannot guarantee the correctness and completeness of such information. Data is based on compatibility libraries, which are not specific for estimating the long-term life time under specific but highly variable conditions of UHPLC systems, solvents, solvent mixtures and samples. Information can also not be generalized due to catalytic effects of impurities like metal ions, complexing agents, oxygen etc. Apart from pure chemical corrosion, other effects like electro corrosion, electrostatic charging (especially for non-conductive organic solvents), swelling of polymer parts etc. need to be considered. Most data available refers to room temperature (typically 20 – 25 °C, 68 – 77 °F). If corrosion is possible, it usually accelerates at higher temperatures. If in doubt, please consult technical literature on chemical compatibility of materials.

PEEK

PEEK (Polyether-Ether Ketones) combines excellent properties regarding biocompatibility, chemical resistance, mechanical and thermal stability. PEEK is therefore the material of choice for UHPLC and biochemical instrumentation.

It is stable in the specified pH range (for the Bio-inert LC system: pH 1 – 13, see bio-inert module manuals for details), and inert to many common solvents.

There is still a number of known incompatibilities with chemicals such as chloroform, methylene chloride, THF, DMSO, strong acids (nitric acid > 10 %, sulphuric acid > 10 %, sulfonic acids, trichloroacetic acid), halogenes or aqueous halogene solutions, phenol and derivatives (cresols, salicylic acid etc.).

When used above room temperature, PEEK is sensitive to bases and various organic solvents, which can cause it to swell. Under such conditions normal

PEEK capillaries are very sensitive to high pressure. Therefore Agilent uses stainless steel clad PEEK capillaries in bio-inert systems. The use of stainless steel clad PEEK capillaries keeps the flow path free of steel and ensures pressure stability to at least 600 bar. If in doubt, consult the available literature about the chemical compatibility of PEEK.

Polyimide

Agilent uses semi-crystalline polyimide for rotor seals in valves and needle seats in autosamplers. One supplier of polyimide is DuPont, which brands polyimide as Vespel, which is also used by Agilent.

Polyimide is stable in a pH range between 1 and 10 and in most organic solvents. It is incompatible with concentrated mineral acids (e.g. sulphuric acid), glacial acetic acid, DMSO and THF. It is also degraded by nucleophilic substances like ammonia (e.g. ammonium salts in basic conditions) or acetates.

Polyethylene (PE)

Agilent uses UHMW (ultra-high molecular weight)-PE/PTFE blends for yellow piston and wash seals, which are used in 1290 Infinity pumps, 1290 Infinity II pumps, the G7104C and for normal phase applications in 1260 Infinity pumps.

Polyethylene has a good stability for most common inorganic solvents including acids and bases in a pH range of 1 to 12.5. It is compatible with many organic solvents used in chromatographic systems like methanol, acetonitrile and isopropanol. It has limited stability with aliphatic, aromatic and halogenated hydrocarbons, THF, phenol and derivatives, concentrated acids and bases. For normal phase applications, the maximum pressure should be limited to 200 bar.

Tantalum (Ta)

Tantalum is inert to most common HPLC solvents and almost all acids except fluoric acid and acids with free sulfur trioxide. It can be corroded by strong bases (e.g. hydroxide solutions > 10 %, diethylamine). It is not recommended for the use with fluoric acid and fluorides.

Stainless Steel (ST)

Stainless steel is inert against many common solvents. It is stable in the presence of acids and bases in a pH range of 1 to 12.5. It can be corroded by acids below pH 2.3. It can also corrode in following solvents:

- Solutions of alkali halides, their respective acids (for example, lithium iodide, potassium chloride, and so on) and aqueous solutions of halogens.
- High concentrations of inorganic acids like nitric acid, sulfuric acid and organic solvents especially at higher temperatures (replace, if your chromatography method allows, by phosphoric acid or phosphate buffer which are less corrosive against stainless steel).
- Halogenated solvents or mixtures which form radicals and/or acids, for example:

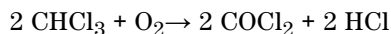

This reaction, in which stainless steel probably acts as a catalyst, occurs quickly with dried chloroform if the drying process removes the stabilizing alcohol.

- Chromatographic grade ethers, which can contain peroxides (for example, THF, dioxane, diisopropylether). Such ethers should be filtered through dry aluminium oxide which adsorbs the peroxides.
- Solutions of organic acids (acetic acid, formic acid, and so on) in organic solvents. For example, a 1 % solution of acetic acid in methanol will attack steel.
- Solutions containing strong complexing agents (for example, EDTA, ethylene diamine tetra-acetic acid).
- Mixtures of carbon tetrachloride with 2-propanol or THF.

Titanium (Ti)

Titanium is highly resistant to oxidizing acids (for example, nitric, perchloric and hypochlorous acid) over a wide range of concentrations and temperatures. This is due to a thin oxide layer on the surface, which is stabilized by oxidizing compounds. Non-oxidizing acids (for example, hydrochloric, sulfuric and phosphoric acid) can cause slight corrosion, which increases with acid concentration and temperature. For example, the corrosion rate with 3 % HCl (about pH 0.1) at room temperature is about 13 $\mu\text{m}/\text{year}$. At room temperature, titanium is resistant to concentrations of about 5 % sulfuric acid (about pH 0.3). Addition of nitric acid to hydrochloric or sulfuric acids

significantly reduces corrosion rates. Titanium is sensitive to acidic metal chlorides like FeCl_3 or CuCl_2 . Titanium is subject to corrosion in anhydrous methanol, which can be avoided by adding a small amount of water (about 3 %). Slight corrosion is possible with ammonia > 10 %.

Diamond-Like Carbon (DLC)

Diamond-Like Carbon is inert to almost all common acids, bases and solvents. There are no documented incompatibilities for HPLC applications.

Fused silica and Quartz (SiO_2)

Fused silica is used in Max Light Cartridges. Quartz is used for classical flow cell windows. It is inert against all common solvents and acids except hydrofluoric acid and acidic solvents containing fluorides. It is corroded by strong bases and should not be used above pH 12 at room temperature. The corrosion of flow cell windows can negatively affect measurement results. For a pH greater than 12, the use of flow cells with sapphire windows is recommended.

Gold

Gold is inert to all common HPLC solvents, acids and bases within the specified pH range. It can be corroded by complexing cyanides and concentrated acids like aqua regia.

Zirconium Oxide (ZrO_2)

Zirconium Oxide is inert to almost all common acids, bases and solvents. There are no documented incompatibilities for HPLC applications.

Platinum/Iridium

Platinum/Iridium is inert to almost all common acids, bases and solvents. There are no documented incompatibilities for HPLC applications.

Fluorinated polymers (PTFE, PFA, FEP, FFKM, PVDF)

Fluorinated polymers like PTFE (polytetrafluorethylene), PFA (perfluoroalkoxy) and FEP (fluorinated ethylene propylene) are inert to almost all common acids, bases, and solvents. FFKM is perfluorinated rubber, which is also resistant to most chemicals. As an elastomer, it may swell in some organic solvents like halogenated hydrocarbons.

TFE/PDD copolymer tubings, which are used in all Agilent degassers except G1322A, are not compatible with fluorinated solvents like Freon, Fluorinert, or Vertrel. They have limited life time in the presence of Hexafluoroisopropanol (HFIP). To ensure the longest possible life with HFIP, it is best to dedicate a particular chamber to this solvent, not to switch solvents, and not to let dry out the chamber. For optimizing the life of the pressure sensor, do not leave HFIP in the chamber when the unit is off.

The tubing of the leak sensor is made of PVDF (polyvinylidene fluoride), which is incompatible with the solvent DMF (dimethyl formamide).

Sapphire, Ruby and Al₂O₃-based ceramics

Sapphire, ruby and ceramics based on aluminum oxide Al₂O₃ are inert to almost all common acids, bases and solvents. There are no documented incompatibilities for HPLC applications.

Solvent Recommendation for Agilent 1290 Infinity and 1290 Infinity II and 1260 Infinity II Flexible Pumps

While the Agilent 1290 Infinity, 1290 Infinity II, and 1260 Infinity II Flexible Pumps guarantee a high performance with a wide variety of solvents, other solvents may cause harm to the pump or to the (U)HPLC system. No modifications are necessary when using standard reversed phase applications with water and other polar protic solvents in combination with most polar aprotic solvents. Normal phase applications work well with the modifications detailed in the section “[Normal Phase Applications](#)” on page 79.

Corrosion can occur in stainless steel systems if free halides, hydroperoxides, free radicals or strong, oxidizing acids are present. There are several solvents where, under nonideal conditions, reactions can occur and these harmful compounds are generated. Prevent formation of reactive substances when using the following solvents:

- Solutions of alkali halides and their respective acids (for example, lithium iodide, potassium chloride, and so on)
- High concentrations of inorganic acids like sulfuric acid and nitric acid, especially at higher temperatures
- Halogenated organic solvents or mixtures which form radicals and/or acids (for example, chloroform, methylene chloride)
- Chromatographic grade ethers, which can contain peroxides (for example, THF, dioxane, di-isopropylether)
- Solvents containing strong complexing agents (for example, EDTA).

All these solvents can be used in Agilent (U)HPLC systems. Refer to the Technical Note *Best Practices for Addressing Problems Associated With Unstable Solvents in an (U)HPLC Environment* (01200-90092), for recommendations on how to avoid damage to the instrument or separation column when working with these solvents.

Normal Phase Applications

Valves for Normal Phase Applications

Current passive inlet valves and outlet ball valves used with Agilent Infinity and Infinity II pumps do not work well while running nonpolar solvents for normal phase applications (for example, hexane and heptane). With such applications, pressure drops could be observed. They are the result of particles in insulating solvents, electrostatically charging up, and sticking to the nonconductive ruby balls inside the standard valves, such that the valves no longer close properly (could take just hours). For normal phase applications, a second type of valve is available. These valves use a new material for valve balls, which is a conductive ceramic. The ceramic balls do not charge up electrostatically and show good performance in normal phase applications. The valves are marked with "N" to stand for normal phase. Agilent recommends using these valves for (and only for) normal phase applications.

To avoid changing to the Type N valves when running critical solvents, it is possible to increase the conductivity of the mobile phase, by adding 5 % of a miscible, polar solvent. In general, isopropanol is a good choice.

No design change has been done for active inlet valves, which have already been used successfully for normal phase applications in 1260 Infinity I/II pumps.

Seals for Normal Phase Applications

For running normal phase applications on Agilent Infinity and Infinity II pumps, yellow PE seals are required as piston seals. By default, 1290 Infinity, 1290 Infinity II, and 1260 Infinity II Flexible Pumps use ceramic pistons and yellow PE seals as piston seals. 1260 Infinity I/II pumps use sapphire pistons and black PTFE piston seals in a standard configuration. If using black PTFE seals with normal phase applications, the black PTFE seals wear and generate small particles. Such particles can clog valves and other parts in the flow path. When running normal phase applications on 1260 Infinity I/II pumps, the piston seals have to be changed to yellow PE seals. For optimum performance, PE seals should be replaced during preventive maintenance.

4 Using the Pump

Solvent Recommendation for Agilent 1290 Infinity and 1290 Infinity II and 1260 Infinity II Flexible Pumps

Table 7 Recommended valves for normal phase applications

	Binary or High Speed Pumps	Quaternary or Flexible Pumps
Inlet valves	1290 Infinity Inlet Valve Type N (G4220-60122)	1290 Infinity Quat Inlet Valve Type N (G4204-60122)
Outlet valves	1290 Infinity Outlet Valve Type N (G4220-60128)	1290 Infinity Outlet Valve Type N (G4220-60128)

CAUTION

Corrosion of valves

Normal phase balls/valves corrode quickly in aqueous solutions and acids (at or below pH 7).

→ Do not use normal phase valves in applications running with aqueous solutions.

Solvent Handling

Handling of Normal Phase Solvents

Observe the following recommendations when using normal phase solvents:

- Always use fresh, filtered solvents. Exchange solvents every second day.
- Prevent reactions caused by heat, light and oxygen. Use brown, firmly closed bottles.
- Whenever possible, use stabilizers, e.g. butylated hydroxytoluene (BHT) for ethyl ether.
- Use isopropanol (IPA) to flush out the previous solvent when converting a system from normal phase to reverse phase, or vice versa.
- Store all unused channels in IPA.
- Don't turn off the pump while it is filled with low boiling solvents. Generate a small flow throughout the used channels when the pump is not in use.

Handling of Buffers

The following recommendations should be observed when using buffer solutions:

- Buffers and aqueous solutions are possible sources of algae contamination, for avoiding related problems, please read “[Algae Growth in HPLC Systems](#)” on page 59.
- For buffer concentrations of 0.1 M or higher using the seal wash function periodically with a runtime of 0.3 min every 3 min is strongly recommended.
- Filter buffer solutions to avoid increased wear or blockages that are caused by undissolved crystals. Always use solvent inlet filters.
- Avoid conditions where mixing of buffers and organic solvents may cause precipitation, as this impairs the reproducibility of chromatographic experiments and may also reduce the system life time. For example in reversed phase chromatography, avoid buffers (especially phosphate buffers) with a concentration higher than 20 mmol/L. For phosphate buffers, avoid compositions containing more than 65 % acetonitrile or other organic solvents.
- Consider using an inline filter, for example Inline filter (G1311-60006).
- Never leave buffers in a system without flow. Before shutting down a system, flush it extensively with warm water to avoid clogging of valves, capillaries, or flow cells or reducing the life time of your column. If the system is not used for some time, for example more than a day depending on lab temperature, fill all solvent lines with organic solvent or water with at least 10 % isopropanol.
- Regularly maintain the LC system.

Handling of Acetonitrile

Acetonitrile is a solvent that is frequently used in reversed-phase chromatography. Despite of its common use, it can be a source of issues if not handled correctly.

As Acetonitrile ages, some residue can get stuck on internal pump surfaces which can cause issues with valve performance and therefore affect retention time precision.

When using acetonitrile:

- Use high-quality solvents from renowned suppliers.
- Use fresh solvents and filter them.
- Minimize exposure to light and air/oxygen.
- Choose a bottle size which fits to your application and usage.
- Acids accelerate solvent aging. If possible avoid such additives or refresh solvents more frequently.
- Pure acetonitrile ages faster. If your application allows, add about 5 % water and adjust gradient compositions.
- Do not leave acetonitrile in unused systems to avoid aging. If not in use, flush all solvent lines with a mixture of water and 10 % isopropanol.
- In case of blocked valves, flush the system with hot water. Knock at valves, flush them (see “[Releasing a Stuck Inlet Valve](#)” on page 157) or ultrasonicate them, for example in methanol.

Handling of Acids

Acids can corrode stainless steel and other materials in the flow path of LC systems. For stainless steel, the minimum pH is 2.3 for corrosive acids and pH 1 for non-corrosive acids.

Please note that for non-volatile acids like phosphoric acid or perchloric acid concentrations increase after evaporation of water. This means that originally diluted acids can damage parts over time, e.g. because of liquid, which has left the solvent path through micro leaks. Such systems should be flushed regularly with pure water and may require shorter maintenance cycles. Using the seal wash function should be considered for protecting pump heads.

Please also refer to *TechNote 01200-90090*, which can be downloaded from our website www.agilent.com.

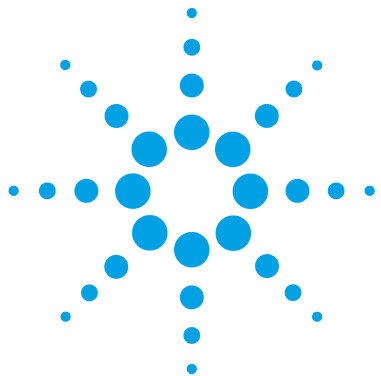

5 Optimizing Performance

Delay Volume and Extra-Column Volume	84
Delay Volume	84
How to Configure the Optimum Delay Volume	85
How to Achieve Higher Resolution	87
Using Solvent Calibration Tables	90

This chapter gives hints on how to optimize the performance or use additional devices.



Delay Volume and Extra-Column Volume

The *delay volume* is defined as the system volume between the point of mixing in the pump and the top of the column.

The *extra-column volume* is defined as the volume between the injection point and the detection point, excluding the volume in the column.

Delay Volume

In gradient separations, this volume causes a delay between the mixture changing in the pump and that change reaching the column. The delay depends on the flow rate and the delay volume of the system. In effect, this means that in every HPLC system there is an additional isocratic segment in the gradient profile at the start of every run. Usually the gradient profile is reported in terms of the mixture settings at the pump and the delay volume is not quoted even though this will have an effect on the chromatography. This effect becomes more significant at low flow rates and small column volumes and can have a large impact on the transferability of gradient methods. It is important, therefore, for fast gradient separations to have small delay volumes, especially with narrow bore columns (e.g., 2.1 mm i.d.) as often used with mass spectrometric detection.

The delay volume in a system includes the volume in the pump from the point of mixing, connections between pump and autosampler, volume of the flow path through the autosampler and connections between autosampler and column.

How to Configure the Optimum Delay Volume

The physical delay volume of the pump depends primarily on the use of the Jet Weaver mixer. For UV detection the Jet Weaver should always be used but for mass spectrometric detection the user can decide to bypass the Jet Weaver in order to reduce the delay volume. This only makes sense for ultra-fast gradient operation (less than 0.5 min) or for use with very small volume columns. If the Jet Weaver is bypassed the connection tubing to the autosampler is routed directly from the purge valve.

NOTE

Before disconnecting a Jet Weaver from the flow path, flush it with organic solvent. Avoid leaving water or buffers inside the Jet Weaver, which may cause the growth of microorganisms like algae or bacteria.

Sometimes it may be advisable to increase the delay volume in the pump. Specifically this can be the case when UV detection is employed and a strongly UV-absorbing compound has been added to the mobile phase. This can have the effect of emphasizing any pump noise and the most common example is the use of trifluoroacetic acid (TFA) in the analysis of proteins and peptides. The effect can be mitigated by increasing the mixer volume.

The following different Jet Weaver configurations are available:

- The Jet Weaver 35 μL / 100 μL (G4220-60006) has two alternative volumes in the same unit.

The switch from the lower volume, 35 μL , to the higher volume, 100 μL , is done by uninstalling it, turning it around from front to back and re-installing it, see [“Changing configuration or replacing the Jet Weaver”](#) on page 153. The delay volume is increased by approximately 31 μL and the baseline performance with additives like TFA will be improved. The configuration of the Jet Weaver is logged automatically by an attached RFID tag.

- The 380 μL Jet Weaver high performance mixer is optionally available for demanding applications, which use solvents in different channels (for example A versus B), that differ strongly in their UV/Vis absorption, for example by using trifluoroacetic acid (TFA) as a modifier, which has a high absorbance.

5 Optimizing Performance

How to Configure the Optimum Delay Volume

Solvent packages created by the pump may persist until the solvent reaches the detector flow cell. Absorption fluctuations can then show up as baseline noise, also referred to as mixing noise. Applications like impurity quantitation or lowest level compound detection require minimizing this noise. The 380 μL Jet Weaver strongly improves mixing and therefore reduces baseline noise and improves sensitivity in detection. Patented Agilent microfluidic technology offers high mixing performance at a low internal volume of 380 μL .

How to Achieve Higher Resolution

Increased resolution in a separation will improve the qualitative and quantitative data analysis, allow more peaks to be separated or offer further scope for speeding up the separation. This section explains how resolution can be increased by examining the following points:

- Optimize selectivity
- Smaller particle-size packing
- Longer Columns
- Shallower gradients, faster flow

Resolution between two peaks is described by the resolution equation:

$$R_s = \frac{1}{4} \sqrt{N} \frac{(\alpha - 1)}{\alpha} \frac{(k_2 + 1)}{k_2}$$

where

- R_s =resolution,
- N =plate count (measure of column efficiency),
- α =selectivity (between two peaks),
- k_2 =retention factor of second peak (formerly called capacity factor).

The term that has the most significant effect on resolution is the selectivity, α , and practically varying this term involves changing the type of stationary phase (C18, C8, phenyl, nitrile etc.), the mobile phase and temperature to maximize the selectivity differences between the solutes to be separated. This is a substantial piece of work which is best done with an automated method development system which allows a wide range of conditions on different columns and mobile phases to be assessed in an ordered scouting protocol. This section considers how to get higher resolution with any chosen stationary and mobile phases. If an automated method development system was used in the decision on phases it is likely that short columns were used for fast analysis in each step of the scouting.

The resolution equation shows that the next most significant term is the plate count or efficiency, N , and this can be optimized in a number of ways. N is inversely proportional to the particle size and directly proportional to the

5 Optimizing Performance

How to Achieve Higher Resolution

length of a column and so smaller particle size and a longer column will give a higher plate number. The pressure rises with the inverse square of the particle size and proportionally with the length of the column. Resolution increases with the square root of N so doubling the length of the column will increase resolution by a factor of 1.4. What is achievable depends on the viscosity of the mobile phase as this relates directly to the pressure. Methanol mixtures will generate more back pressure than acetonitrile mixtures. Acetonitrile is often preferred because peak shapes are better and narrower in addition to the lower viscosity but methanol generally yields better selectivity (certainly for small molecules less than about 500 Da). The viscosity can be reduced by increasing the temperature but it should be remembered that this can change the selectivity of the separation. Experiment will show if this leads to increase or decrease in selectivity. As flow and pressure are increased it should be remembered that frictional heating inside the column will increase and that can lead to slightly increased dispersion and possibly a small selectivity change both of which could be seen as a reduction in resolution. The latter case might be offset by reducing the temperature of the thermostat by a few degrees and again experiment will reveal the answer.

The van Deemter curve shows that the optimum flow rate through an STM column is higher than for larger particles and is fairly flat as the flow rate increases. Typical, close to optimum, flow rates for STM columns are: 2 ml/min for 4.6 mm i.d.; and 0.4 ml/min for 2.1 mm i.d. columns.

In isocratic separations, increasing the retention factor, k , results in better resolution because the solute is retained longer. In gradient separations the retention is described by k^* in the following equation:

$$k^* = \frac{t_G}{\Delta\%B} \cdot \frac{F}{V_m} \cdot \frac{100}{S}$$

where:

- k^* = mean k value,
- t_G = time length of gradient (or segment of gradient) (min),
- F = flow (ml/min),
- V_m = column delay volume,
- $\Delta\%B$ = change in fraction of solvent B during the gradient,
- S = constant (ca. 4-5 for small molecules).

This shows that k and hence resolution can be increased by having a shallower gradient (2 to 5 %/min change is a guideline), higher flow rate and a smaller volume column. This equation also shows how to speed up an existing gradient – if the flow is doubled but the gradient time is halved, k^* remains constant and the separation looks the same but happens in half the time. Recently published research has shown how a shorter STM column (at temperatures above 40 °C) can generate higher peak capacity than a longer STM column by virtue of running it faster. (Refer to *Petersson et al., J.Sep.Sci, 31, 2346-2357, 2008, Maximizing peak capacity and separation speed in liquid chromatography*).

Using Solvent Calibration Tables

Importing Solvent Calibration Tables

RC.NET based Agilent graphical user interfaces (ChemStation, EZChrom Elite, OpenLAB etc.) include data for most commonly used solvents in HPLC. This data contains solvent properties and is used for optimum pump control in order to ensure best flow and composition accuracy.

If your solvent is not included to the software, please check the Agilent web site <http://www.agilent.com/en-us/firmwareDownload?whid=69761> for additional libraries (registration required), which also provides updates and optimized data.

If your solvent is neither available in the user interface nor in the library, please use generic solvents. "Generic aqueous" gives good results for most solvent mixtures with at least 50 % water, which have similar properties as pure water. For other solvents with high organic percentage, "Generic organic" gives a good approximation.

Importing Solvent Calibration in ChemStation

- 1 Go to menu **Instrument > Instrument configuration**.
- 2 In the **Instrument Configuration** screen choose your module and click **Configure**.
- 3 Click **Configure Solvent Type Catalogs**.
- 4 In **Solvent Type Catalogs** click **Import**.
- 5 Navigate to the location of the solvent calibration table and click **Open**.

The new solvent will now appear in the **Solvent Type Catalogs**.

The imported solvent is now available for selection as a solvent type in the pump's method parameters.

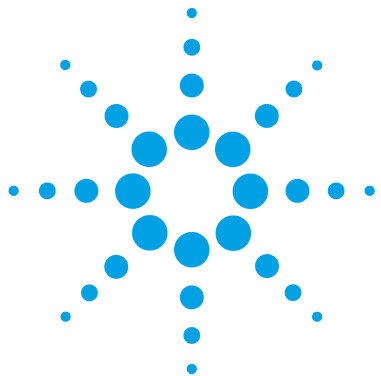

6 Troubleshooting and Diagnostics

Available Tests vs User Interfaces [92](#)

Agilent Lab Advisor Software [93](#)

Overview about the troubleshooting and diagnostic features.



Available Tests vs User Interfaces

- Depending on the user interface, the available tests and the screens/reports may vary (see chapter "*Test Functions and Calibrations*").
- Preferred tool should be the Agilent Lab Advisor software, see "[Agilent Lab Advisor Software](#)" on page 93.
- The Agilent ChemStation may not include any maintenance/test functions.
- Screenshots used within these procedures are based on the Agilent Lab Advisor software.

Agilent Lab Advisor Software

The Agilent Lab Advisor Software is a standalone product that can be used with or without a chromatographic data system. Agilent Lab Advisor helps to manage the lab for high-quality chromatographic results by providing a detailed system overview of all connected analytical instruments with instrument status, Early Maintenance Feedback counters (EMF), instrument configuration information, and diagnostic tests. By the push of a button, a detailed diagnostic report can be generated. Upon request, the user can send this report to Agilent for a significantly improved troubleshooting and repair process.

The Agilent Lab Advisor software is available in two versions:

- Lab Advisor Basic
- Lab Advisor Advanced

Lab Advisor Basic is included with every Agilent 1200 Infinity Series and Agilent InfinityLab LC Series instrument.

The Lab Advisor Advanced features can be unlocked by purchasing a license key, and include real-time monitoring of instrument actuals, all various instrument signals, and state machines. In addition, all diagnostic test results, calibration results, and acquired signal data can be uploaded to a shared network folder. The Review Client included in Lab Advisor Advanced allows to load and examine the uploaded data no matter on which instrument it was generated. This makes Data Sharing an ideal tool for internal support groups and users who want to track the instrument history of their analytical systems.

The optional Agilent Maintenance Wizard Add-on provides an easy-to-use, step-by-step multimedia guide for performing preventive maintenance on Agilent 1200 Infinity and Agilent InfinityLab LC Series instrument.

The tests and diagnostic features that are provided by the Agilent Lab Advisor software may differ from the descriptions in this manual. For details, refer to the Agilent Lab Advisor software help files.

6 Troubleshooting and Diagnostics
Agilent Lab Advisor Software



7 Error Information

What Are Error Messages	97
General Error Messages	98
Timeout	98
Shutdown	99
Remote Timeout	100
Lost CAN Partner	100
Leak Sensor Short	101
Leak Sensor Open	101
Compensation Sensor Open	102
Compensation Sensor Short	103
Fan Failed	104
Leak	105
Open Cover	105
Cover Violation	106
Pump Error Messages	107
Pressure of binary pump above upper limit	107
Pressure below lower limit	107
Target pressure not reached for binary pump degasser	108
Degasser's pressure limit violation	108
Solvent counter exceeded limit	109
Waste counter limit exceeded	109
Flow rate limit exceeded	110
Binary pump shutdown during analysis	110
Reading the pump encoder tag failed	111
Writing the pump encoder tag failed	111
Pump drive blocked or encoder failed	112
Drive current too low	112
Drive Encoder failed	112



Drive current too high	113
Drive timeout	113
Overcurrent of pump drive	113
Overcurrent of solvent selection valve (SSV)	114
Deliver underrun	114
Defect connection between main board and pump drive encoder	114
Pump drive encoder defect	115
Purge valve failed	115
Reading of purge valve tag failed	115
Pump drive encoder rollover	116
Drive position limit	116
Insufficient power of drive encoder LED	116
Drive encoder error	117
Writing the purge valve tag failed	117
Current of primary pump drive too high	117
Current of secondary pump drive too high	118
Unknown purge valve type	118
Pump drive encoder error	118
Pump drive error	119
Pump drive stroke blocked	119
Pump drive stop not found	120
Pressure sensor calibration wrong or missing	120
Seal wash pump was missing when tried to turn on	121

This chapter describes the meaning of error messages, and provides information on probable causes and suggested actions how to recover from error conditions.

What Are Error Messages

Error messages are displayed in the user interface when an electronic, mechanical, or hydraulic (flow path) failure occurs which requires attention before the analysis can be continued (for example, repair, or exchange of consumables is necessary). In the event of such a failure, the red status indicator at the front of the module is switched on, and an entry is written into the module logbook.

If an error occurs outside a method run, other modules will not be informed about this error. If it occurs within a method run, all connected modules will get a notification, all LEDs get red and the run will be stopped. Depending on the module type, this stop is implemented differently. For example, for a pump the flow will be stopped for safety reasons. For a detector, the lamp will stay on in order to avoid equilibration time. Depending on the error type, the next run can only be started, if the error has been resolved, for example liquid from a leak has been dried. Errors for presumably single time events can be recovered by switching on the system in the user interface.

Special handling is done in case of a leak. As a leak is a potential safety issue and may have occurred at a different module from where it has been observed, a leak always causes a shutdown of all modules, even outside a method run.

In all cases, error propagation is done via the CAN bus or via an APG/ERI remote cable (see documentation for the APG/ERI interface).

General Error Messages

General error messages are generic to all Agilent series HPLC modules and may show up on other modules as well.

Timeout

Error ID: 0062

The timeout threshold was exceeded.

Probable cause

- 1** The analysis was completed successfully, and the timeout function switched off the module as requested.
- 2** A not-ready condition was present during a sequence or multiple-injection run for a period longer than the timeout threshold.

Suggested actions

- Check the logbook for the occurrence and source of a not-ready condition. Restart the analysis where required.
- Check the logbook for the occurrence and source of a not-ready condition. Restart the analysis where required.

Shutdown

Error ID: 0063

An external instrument has generated a shutdown signal on the remote line.

The module continually monitors the remote input connectors for status signals. A LOW signal input on pin 4 of the remote connector generates the error message.

Probable cause

Suggested actions

- | | |
|---|---|
| <p>1 Leak detected in another module with a CAN connection to the system.</p> | Fix the leak in the external instrument before restarting the module. |
| <p>2 Leak detected in an external instrument with a remote connection to the system.</p> | Fix the leak in the external instrument before restarting the module. |
| <p>3 Shut-down in an external instrument with a remote connection to the system.</p> | Check external instruments for a shut-down condition. |
| <p>4 The degasser failed to generate sufficient vacuum for solvent degassing.</p> | Check the vacuum degasser for an error condition. Refer to the <i>Service Manual</i> for the degasser or the pump that has the degasser built-in. |

Remote Timeout

Error ID: 0070

A not-ready condition is still present on the remote input. When an analysis is started, the system expects all not-ready conditions (for example, a not-ready condition during detector balance) to switch to run conditions within one minute of starting the analysis. If a not-ready condition is still present on the remote line after one minute the error message is generated.

Probable cause

- 1 Not-ready condition in one of the instruments connected to the remote line.
- 2 Defective remote cable.
- 3 Defective components in the instrument showing the not-ready condition.

Suggested actions

- Ensure the instrument showing the not-ready condition is installed correctly, and is set up correctly for analysis.
- Exchange the remote cable.
- Check the instrument for defects (refer to the instrument's documentation).

Lost CAN Partner

Error ID: 0071

During an analysis, the internal synchronization or communication between one or more of the modules in the system has failed.

The system processors continually monitor the system configuration. If one or more of the modules is no longer recognized as being connected to the system, the error message is generated.

Probable cause

- 1 CAN cable disconnected.
- 2 Defective CAN cable.
- 3 Defective main board in another module.

Suggested actions

- Ensure all the CAN cables are connected correctly.
 - Ensure all CAN cables are installed correctly.
- Exchange the CAN cable.
- Switch off the system. Restart the system, and determine which module or modules are not recognized by the system.

Leak Sensor Short

Error ID: 0082

The leak sensor in the module has failed (short circuit).

The current through the leak sensor is dependent on temperature. A leak is detected when solvent cools the leak sensor, causing the leak sensor current to change within defined limits. If the current increases above the upper limit, the error message is generated.

Probable cause	Suggested actions
1 Defective leak sensor.	Please contact your Agilent service representative.
2 Leak sensor incorrectly routed, being pinched by a metal component.	Please contact your Agilent service representative.

Leak Sensor Open

Error ID: 0083

The leak sensor in the module has failed (open circuit).

The current through the leak sensor is dependent on temperature. A leak is detected when solvent cools the leak sensor, causing the leak-sensor current to change within defined limits. If the current falls outside the lower limit, the error message is generated.

Probable cause	Suggested actions
1 Leak sensor not connected to the main board.	Please contact your Agilent service representative.
2 Defective leak sensor.	Please contact your Agilent service representative.
3 Leak sensor incorrectly routed, being pinched by a metal component.	Please contact your Agilent service representative.

Compensation Sensor Open

Error ID: 0081

The ambient-compensation sensor (NTC) on the power switch board in the module has failed (open circuit).

The resistance across the temperature compensation sensor (NTC) on the power switch board is dependent on ambient temperature. The change in resistance is used by the leak circuit to compensate for ambient temperature changes. If the resistance across the sensor increases above the upper limit, the error message is generated.

Probable cause

- 1** Loose connection between the power switch board and the main board
- 2** Defective power switch assembly
- 3** Defective main board.

Suggested actions

- Please contact your Agilent service representative.
- Please contact your Agilent service representative.
- Please contact your Agilent service representative.

Compensation Sensor Short

Error ID: 0080

The ambient-compensation sensor (NTC) on the power switch board in the module has failed (open circuit).

The resistance across the temperature compensation sensor (NTC) on the power switch board is dependent on ambient temperature. The change in resistance is used by the leak circuit to compensate for ambient temperature changes. If the resistance across the sensor falls below the lower limit, the error message is generated.

Probable cause

- 1 Defective power switch assembly
- 2 Loose connection between the power switch board and the main board
- 3 Defective main board.

Suggested actions

- Please contact your Agilent service representative.
- Please contact your Agilent service representative.
- Please contact your Agilent service representative.

Fan Failed

Error ID: 0068

The cooling fan in the module has failed.

The hall sensor on the fan shaft is used by the main board to monitor the fan speed. If the fan speed falls below a certain limit for a certain length of time, the error message is generated.

Depending on the module, assemblies (e.g. the lamp in the detector) are turned off to assure that the module does not overheat inside.

Probable cause

- 1** Fan cable disconnected.
- 2** Defective fan.
- 3** Defective main board.

Suggested actions

- Please contact your Agilent service representative.
- Please contact your Agilent service representative.
- Please contact your Agilent service representative.

Leak

Error ID: 0064

A leak was detected in the module.

The signals from the two temperature sensors (leak sensor and board-mounted temperature-compensation sensor) are used by the leak algorithm to determine whether a leak is present. When a leak occurs, the leak sensor is cooled by the solvent. This changes the resistance of the leak sensor which is sensed by the leak-sensor circuit on the main board.

Probable cause	Suggested actions
1 Loose fittings.	Ensure all fittings are tight.
2 Broken capillary.	Exchange defective capillaries.
3 Loose or leaking purge valve, inlet valve, or outlet valve.	Ensure pump components are seated correctly. If there are still signs of a leak, exchange the appropriate seal (purge valve, inlet valve, outlet valve).
4 Defective pump seals.	Exchange the pump seals.

Open Cover

Error ID: 0205

The top foam has been removed.

Probable cause	Suggested actions
1 Foam not activating the sensor.	Please contact your Agilent service representative.
2 Defective sensor or main board.	Please contact your Agilent service representative.

Cover Violation

Error ID: 7461

The top foam has been removed.

The sensor on the main board detects when the top foam is in place. If the foam is removed while the lamps are on (or if an attempt is made to switch on for example the lamps with the foam removed), the lamps are switched off, and the error message is generated.

Probable cause

- 1** The top foam was removed during operation.
- 2** Foam not activating the sensor.

Suggested actions

- Please contact your Agilent service representative.
- Please contact your Agilent service representative.

Pump Error Messages

These errors are pump specific.

Pressure of binary pump above upper limit

Error ID: 22014

The pressure has exceeded the upper pressure limit.

- Parameter: Measured pressure

Probable cause

- 1 Blockage in flow path after the pressure sensor.
- 2 Inappropriate settings (pressure limit, flow rate).

Suggested actions

- Check for blockages in the LC system, e.g. purge valve, Jet Weaver, degraded column, column frits, needle, needle seat, capillaries etc.
- Check for particles in the solvent.
- Decrease flow rate.
- Increase pressure limit.

Pressure below lower limit

Error ID: 22015

The pressure has dropped below the lower limit.

- Parameter: None

Probable cause

- 1 Leak
- 2 Bottle empty
- 3 Wrong solvent (viscosity)
- 4 Inappropriate setting
- 5 Column degradation

Suggested actions

- Check for leaks.
- Check bottle filling.
- Check solvent.
- Check flow rate and lower pressure limit.
- Replace column.

Target pressure not reached for binary pump degasser

Error ID: 22031

The target pressure of the binary pump degasser has not been reached within the expected time.

- Parameter: Pressure in mbar

Probable cause

- 1 Condensation in degasser chamber due to temperature fluctuation.
- 2 Degasser is defect.

Suggested actions

- Equilibrate and restart module.
- Please contact your Agilent service representative.

Degasser's pressure limit violation

Error ID: 22032

Pressure too far above the limit.

Probable cause

- 1 Leak in degasser chamber or degasser tubing.
- 2 Defect vacuum pump.
- 3 Degasser chamber empty or connected to air.

Suggested actions

- Please contact your Agilent service representative.
- Please contact your Agilent service representative.
- Block unused degasser channels.

Solvent counter exceeded limit

Error ID: 22055

The counter for the solvent volume has exceeded the limit, which has been set in the user interface.

Parameter:

- Without Solvent Selection Valve:
0 for channel A, 1 for channel B
- With Solvent Selection Valve:
2 for channel A1, 3 for channel B1, 4 for channel A2, 5 for channel B2

Probable cause

- 1 No solvent present.
- 2 Inappropriate setting.

Suggested actions

- Refill solvent bottle.
- Check solvent counter setting in user interface.

Waste counter limit exceeded

Error ID: 22056

The counter for the waste volume has exceeded the limit, which has been set in the user interface.

- Parameter: None

Probable cause

- 1 The waste container is full.
- 2 Inappropriate setting for waste counter.

Suggested actions

- Empty waste container.
- Reset waste counter.
- Adjust waste counter limit.

Flow rate limit exceeded

Error ID: 22064

The flow rate of the binary pump has exceeded the limit, while the pump runs in pressure controlled mode, e.g. during a pressure test.

- Parameter: None

Probable cause

- 1** Leak
- 2** Bottle empty.
- 3** Shutoff valve closed.
- 4** Drift of pressure sensor (unlikely for short tests taking some minutes).

Suggested actions

- Check for leaks in the pump and flow path.
- Fill solvent bottle.
- Open shutoff valve.
- Replace pressure sensor.

Binary pump shutdown during analysis

Error ID: 22065

The binary pump has been shut down by the control software or control module during an analysis.

- Parameter: 0 for off, 1 for standby.

Probable cause

- 1** Pump has been shut down.

Suggested actions

- Restart pump.

Reading the pump encoder tag failed

Error ID: 22402

Reading the pump encoder tag has failed.

- Parameter: 1 – 4 referring to pump drive

Probable cause

- 1** Defect connection between encoder and main board.
- 2** Missing or defect tag Defect connection between tag and encoder.

Suggested actions

- Please contact your Agilent service representative.
- Please contact your Agilent service representative.

Writing the pump encoder tag failed

Error ID: 22405

Writing the pump encoder tag has failed.

- Parameter: 1 – 4 referring to pump drive

Probable cause

- 1** Defect connection between encoder and main board.
- 2** Defect tag Defect connection between tag and encoder.

Suggested actions

- Please contact your Agilent service representative.
- Please contact your Agilent service representative.

Pump drive blocked or encoder failed

Error ID: 22406

Pump drive blocked or encoder failed.

- Parameter: None

Probable cause

- 1 Blockage of the pump drive Drive encoder failed.

Suggested actions

Please contact your Agilent service representative.

Drive current too low

Error ID: 22407

The current consumption of the pump drive is too low.

- Parameter: 1 – 4 referring to pump drive

Probable cause

- 1 Drive motor defect.
- 2 Wrong/missing connection of pump drive to main board.

Suggested actions

Please contact your Agilent service representative.

Please contact your Agilent service representative.

Drive Encoder failed

Error ID: 22408

Drive encoder failed during pump drive calibration.

Probable cause

- 1 Internal error.

Suggested actions

Contact Agilent support.

Drive current too high

Error ID: 22409

The current consumption of the pump drive is too high.

- Parameter: 1 – 4 referring to pump drive

Probable cause

- 1 Blockage of system before pressure sensor.
- 2 Drive motor defect.

Suggested actions

- Check for blockage of e.g. outlet valve filter frit, purge valve, heat exchanger.
- Please contact your Agilent service representative.

Drive timeout

Error ID: 22410

Drive is blocked mechanically, fails during initialization.

- Parameter: 1 – 4 referring to pump drive

Probable cause

- 1 Blockage of pump drive Drive motor defect.

Suggested actions

- Please contact your Agilent service representative.

Overcurrent of pump drive

Error ID: 22411

The current consumption of the pump drive is too high.

- Parameter: 1 – 4 referring to pump drive

Probable cause

- 1 Blockage of system before pressure sensor.
- 2 Drive motor defect.

Suggested actions

- Check for blockage of e.g. outlet valve filter frit, purge valve, heat exchanger.
- Please contact your Agilent service representative.

Overcurrent of solvent selection valve (SSV)

Error ID: 22412

Overcurrent of solvent selection valve (SSV).

- Parameter: None

Probable cause

- 1 Valve defect.

Suggested actions

Replace the solvent selection valve.

Deliver underrun

Error ID: 22413

Internal error.

- Parameter: None

Probable cause

- 1 Internal error.

Suggested actions

Please contact your Agilent service representative.

Defect connection between main board and pump drive encoder

Error ID: 22414

Defect connection between main board and pump drive encoder.

- Parameter: 1 – 4 referring to pump drive

Probable cause

- 1 Defect connection between main board and pump drive encoder.
- 2 Defect encoder.

Suggested actions

Please contact your Agilent service representative.

Please contact your Agilent service representative.

Pump drive encoder defect

Error ID: 22415

Defect pump drive encoder.

- Parameter: 1 – 4 referring to pump drive

Probable cause

- 1 Defect encoder.

Suggested actions

Please contact your Agilent service representative.

Purge valve failed

Error ID: 22417

Lost steps of the purge valve encoder.

- Parameter: None

Probable cause

- 1 Purge valve drive mechanically blocked or defect.

Suggested actions

- Check installation of purge valve head.
- Please contact your Agilent service representative.

Reading of purge valve tag failed

Error ID: 22420

Reading the purge valve tag failed.

- Parameter: None

Probable cause

- 1 Reading of purge valve tag failed.
- 2 Purge valve head tag defect or empty.
- 3 Purge valve tag reader is defect.

Suggested actions

Check cable connection.
Replace purge valve head.
Please contact your Agilent service representative.

Pump drive encoder rollover

Error ID: 22424

Invalid pump drive encoder signals have been detected.

- Parameter: 1 – 4 referring to pump drive

Probable cause

- 1 Pump drive encoder is defect.

Suggested actions

Please contact your Agilent service representative.

Drive position limit

Error ID: 22425

Internal error.

- Parameter: 1 – 4 referring to pump drive

Probable cause

- 1 Internal error.

Suggested actions

Please contact your Agilent service representative.

Insufficient power of drive encoder LED

Error ID: 22426

Insufficient power of drive encoder LED.

- Parameter: 1 – 4 referring to pump drive

Probable cause

- 1 Pump drive encoder is defect.

Suggested actions

Please contact your Agilent service representative.

Drive encoder error

Error ID: 22427- 22430

An error has occurred for the pump drive encoder.

- Parameter: 1 – 4 referring to pump drive

Probable cause

- 1 Pump drive encoder is defect.

Suggested actions

Please contact your Agilent service representative.

Writing the purge valve tag failed

Error ID: 22431

Writing the purge valve tag failed.

- Parameter: None

Probable cause

- 1 Purge valve head tag defect.
- 2 Purge valve tag reader is defect.

Suggested actions

Replace purge valve head.
Please contact your Agilent service representative.

Current of primary pump drive too high

Error ID: 22433

The current of the primary pump drive is too high.

- Parameter: 1 or 4 referring to pump drive.

Probable cause

- 1 Blockage of flow path between primary pump head and pressure sensor, e.g. of the heat exchanger.
- 2 Primary pump drive is defect.

Suggested actions

- Check for blockages in flow path.
- Please contact your Agilent service representative.

Please contact your Agilent service representative.

Current of secondary pump drive too high

Error ID: 22434

The current of the secondary pump drive is too high.

- Parameter: 2 or 3 referring to pump drive

Probable cause

- 1 Blockage of flow path between secondary pump head and pressure sensor, e.g. of the heat exchanger.
- 2 Secondary pump drive is defect.

Suggested actions

- Check for blockages in the flow path.
- Please contact your Agilent service representative.

Please contact your Agilent service representative.

Unknown purge valve type

Error ID: 22435

The type information of the purge valve is invalid.

- Parameter: None

Probable cause

- 1 Wrong valve head installed.
- 2 Valve head has invalid RFID tag content.

Suggested actions

- Check or replace purge valve head.
- Check or replace purge valve head.

Pump drive encoder error

Error ID: 22437

The pump drive encoder has generated no signal.

- Parameter: 1 – 4 referring to pump drive

Probable cause

- 1 Pump drive encoder is defect.

Suggested actions

Please contact your Agilent service representative.

Pump drive error

Error ID: 22438, 22439

The pump drive failed during calibration.

- Parameter: 1 – 4 referring to pump drive

Probable cause

- 1 Pump drive motor defect or mechanically blocked.

Suggested actions

Please contact your Agilent service representative.

Pump drive stroke blocked

Error ID: 22441

During initialization the pump defines the operation position of the pump drives and therefore the pistons. First the pump drive moves backwards to find a mechanical stop within the ball screw. Afterwards, pistons move forwards for finding the maximum available stroke volume. These values are expected within a pre-defined range. "Maximum stroke too short" means that the outer drive position is too close. This can be caused by a drive initialization without pump head or if the pump head has not been installed properly (screws are loose).

- Parameter: 1 – 4 referring to pump drive

Probable cause

- 1 Wiper shifted
- 2 Pump head blocks piston movement
- 3 Pump drive motor is mechanically blocked.

Suggested actions

Please contact your Agilent service representative.

Replace, clean or repair pump head.

Please contact your Agilent service representative.

Pump drive stop not found

Error ID: 22442

The maximum stroke is too long.

- Parameter: 1 – 4 referring to pump drive

Probable cause

- 1 Wiper shifted
- 2 Pump drive spindle is defect.

Suggested actions

- Please contact your Agilent service representative.
- Please contact your Agilent service representative.

Pressure sensor calibration wrong or missing

Error ID: 22443

Pressure sensor calibration wrong or missing.

- Parameter: None

Probable cause

- 1 Pressure sensor calibration wrong or missing.

Suggested actions

- Replace pressure sensor.
- Please contact your Agilent service representative.

Seal wash pump was missing when tried to turn on

Error ID: 22499

The seal wash pump has not been detected (while being configured or detected before).

Probable cause

- 1 Defect cable connection to seal wash pump.
- 2 Defect seal wash pump motor.
- 3 Defective main board.

Suggested actions

- Check cable connection.
- Please contact your Agilent service representative.
- Please contact your Agilent service representative.

7 Error Information

Pump Error Messages

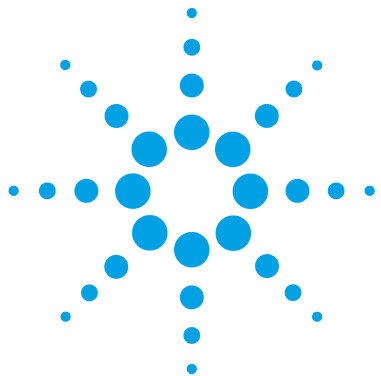

8 Test Functions and Calibrations

Introduction	124
Pump Leak Rate Test	125
Troubleshooting the Pump Leak Rate Test	128
System Pressure Test	130

This chapter describes the tests for the module.



Introduction

All tests are described based on the Agilent Lab Advisor Software B.01.04. Other user interfaces may not provide any test or just a few.

Table 8 Interfaces and available test functions

Interface	Comment	Available Function
Agilent Instrument Utilities	Maintenance tests available	<ul style="list-style-type: none"> • System pressure test
Agilent Lab Advisor	All tests are available	<ul style="list-style-type: none"> • System pressure test • Pump head leak test
Agilent ChemStation	No tests available Adding of pressure to chromatographic signals possible	<ul style="list-style-type: none"> • Pressure • Pressure ripple • Temperature main board
Agilent Instant Pilot	Some tests are available	<ul style="list-style-type: none"> • System pressure test • Monitoring of values <ul style="list-style-type: none"> • Pressure • Pressure ripple • Flow (in case of operating pressure)

For details on the use of the interface refer to the interface documentation.

Pump Leak Rate Test

The Pump Leak Rate Tests is a diagnostic test to check the integrity and tightness of the pump components. The test is started from the Services & Diagnostics section in the Agilent Lab Advisor Software. The test is first evaluating the tightness from the outlet valve downstream to the purge valve. The pistons are positioned; afterwards the purge valve is switched to the closed position. By moving the secondary piston into the pump chamber the system is pressurized to 1000 bar (or 800 bar for G7104C). The flow rate to keep the pressure stable is the corresponding leak rate.

The second part of the test is designed to verify the tightness along the piston. Any irregularity on the piston surface (for example, scratches or deposits) will be detected. During this test all components from the inlet valve downstream to the blocked purge valve are included tested.

Now the primary piston is moving to deliver and generate pressure but the secondary piston is retracting. The pressure is kept constant at 800 bar. The process is repeated for the second pump head, if applicable.

Preparations:

- 1 Flush the system with HPLC grade water for several minutes from any solvent channel.
- 2 Start the **Pump Leak Rate Test** from Lab Advisor.
- 3 Choose the channel with HPLC grade water and if you want to include or skip an additional purging step.
- 4 Click **OK** and follow the instructions.

The test runs automatically without any further user interaction.

Evaluation:

The result as well as the applied limits are displayed after the automatic evaluation. The limits are:

- The allowed leak limit for the secondary piston is $\leq 3 \mu\text{L}/\text{min}$
- The allowed leak limit for the primary piston is $\leq 30 \mu\text{L}/\text{min}$

A report can be displayed, saved or printed by opening it with the **Print Result** button at the lower right of the screen.

8 Test Functions and Calibrations

Pump Leak Rate Test

If the test does not pass, check the system for leaks or call a local Agilent representative.

Figure 14 on page 126 and Figure 15 on page 127 show a typical test run.

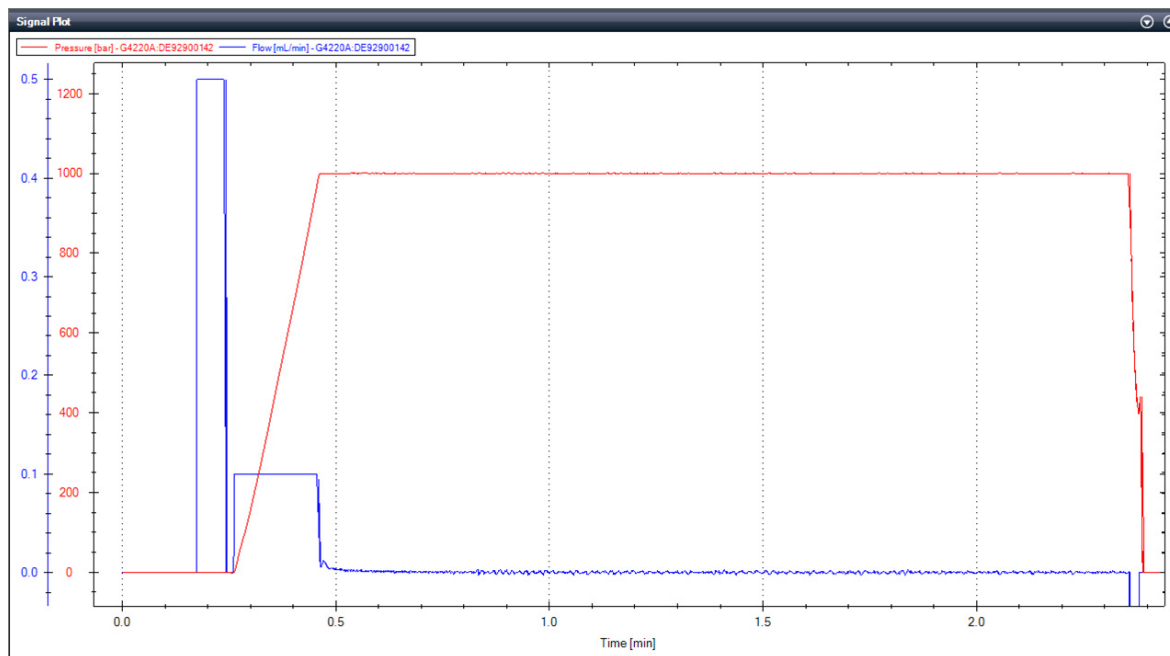

Figure 14 Static (secondary) Leak Test

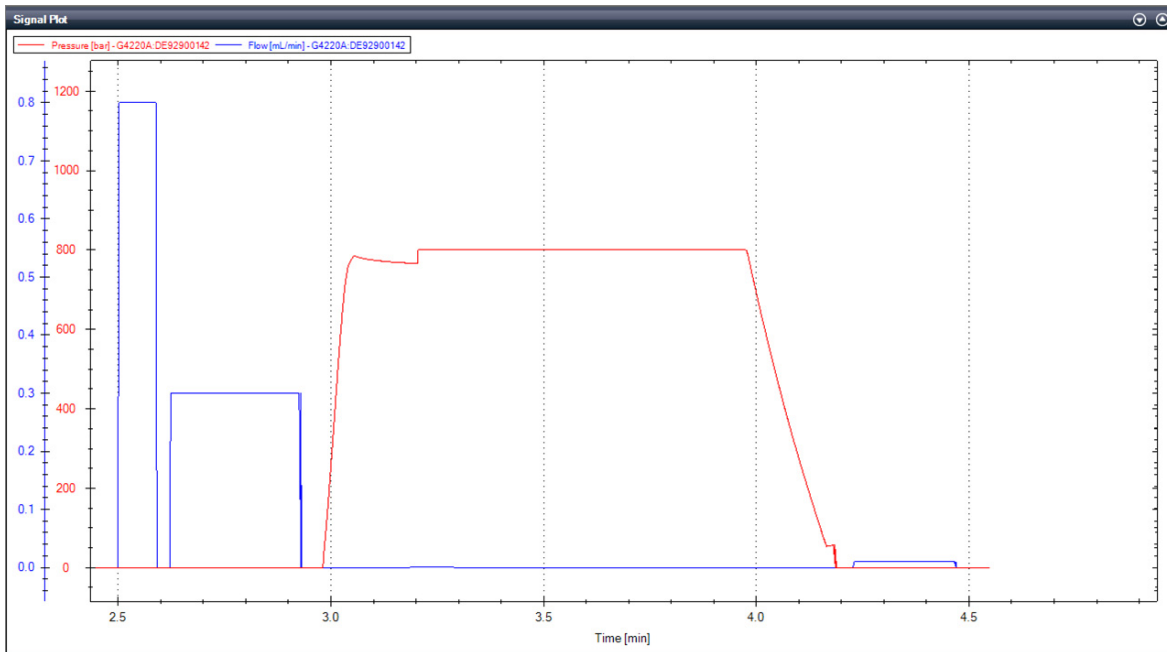

Figure 15 Dynamic (primary) Leak Test

Troubleshooting the Pump Leak Rate Test

Secondary Leak > 3 $\mu\text{L}/\text{min}$

- Leak between the OBV and automatic purge valve
 - Check for visible leaks on fittings and connectors
 - Connector not fixed / tight enough
 - Connector damaged
 - Leaky filter frit assembly
 - Remove the seal wash tubes from the support ring and check for leak into the seal wash path
 - Main seal leaking/damaged
 - Piston damaged
 - Remove waste lines from the automatic purge valve
 - Damage to rotor seal and/or stator head
- Outlet valve not properly assembled
 - Re-tighten the outlet valve
 - Check the position of the gold seal

Dynamic Leak > 30 $\mu\text{L}/\text{min}$ or Dynamic Leak Rate Test fails

- Air in the primary pump chamber
 - Check for air in the solvent inlet lines and the Tuning signal
 - Purge the lines, Prime and Condition the pump head
- Abort due to over pressure
 - Check solvent and solvent settings
 - Purge and condition the pump head with water
- Leak in Inlet Valve
 - Check for moving air bubbles in tubing directly to the Inlet Valve
 - Purge the lines with water to remove dirt
 - Knock at the valve, clean or replace it

- Outlet valve not properly assembled
 - Re-tighten the outlet valve
 - Check the position of the gold seal
- Leaky piston seals and/or position dependent leaks on the piston
 - Remove the SW tubes from the support ring and check for leaks
 - Replace the piston seals and clean the pistons
 - Ensure that seals are lubricated when pushed in
 - Use abrasive mesh >5000 grit

System Pressure Test

The System Pressure Test is performed to evaluate the leak tightness of the system up to the point where the system is capped off. The test is started from the Services & Diagnostics section in the Agilent Lab Advisor Software or in the Local Controller. Modules like pump, sampler, column compartments as well as accessories like valves or columns can be included into the flow path for this test.

Preparations:

- 1 Flush the system with HPLC grade water for several minutes from any solvent channel.
- 2 Start the **System Pressure Test** and choose the pressure you want to test the system with. Consider pressure limits of modules or accessories included into the flow path.
- 3 Choose the channel with HPLC grade water and if you want to include or skip an additional purging step.
- 4 Click **OK** and follow the instructions: Place a blank nut into the port up to which you want to test the leak tightness of the system.

The test runs automatically without any further user interaction.

Evaluation:

The result as well as the applied limits are displayed after the automatic evaluation. The limits are:

- For a pressure setting ≤ 1000 bar, the allowed leak limit is ≤ 5 $\mu\text{L}/\text{min}$
- For a pressure setting > 1000 bar, the allowed leak limit is ≤ 15 $\mu\text{L}/\text{min}$

A report can be displayed, saved or printed by opening it with the **Print Result** button at the lower right of the screen.

If the test does not pass, check the system for leaks or call a local Agilent representative.

Figure 16 on page 131 shows a typical test run.

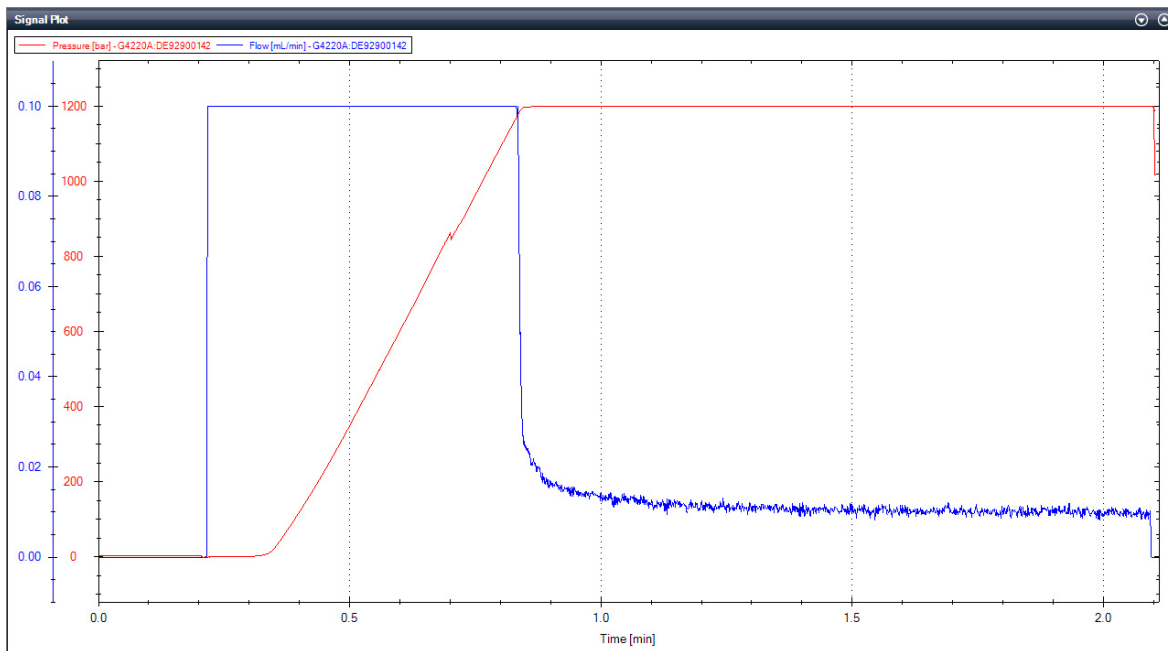
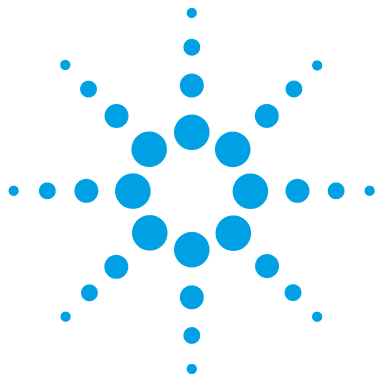

Figure 16 System Pressure Test

8 Test Functions and Calibrations

System Pressure Test



9 Maintenance

Introduction to Maintenance	135
Warnings and Cautions	137
Overview of Maintenance	138
Cleaning the Module	139
Installing Fittings and Capillaries	140
Replacing the Shutoff Valve Panel	141
Replacing the Pressure Sensor	143
Replacing the Inlet valve	146
Replacing the Outlet Valve	148
Replacing the Solvent Selection Valve (SSV)	151
Changing configuration or replacing the Jet Weaver	153
Replacing the Seal Wash Pump	156
Releasing a Stuck Inlet Valve	157
Remove the Pump Head Assembly	160
Pump Head Maintenance (Tool Free)	163
Disassemble Pump Heads	164
Replace the Heat Exchanger	169
Assemble Pump Heads	171
Install the Pump Head Assembly	178
Replacing the Purge Valve Head	180
Replacing Parts of the High Pressure Filter Assembly	183
Installing the Valve Rail Kit	185
Replacing the Main Power Fuses	186



9 Maintenance

System Pressure Test

Replacing Module Firmware [188](#)

Preparing the Pump Module for Transport [189](#)

This chapter describes the maintenance of the Agilent 1290 Infinity Binary Pump.

Introduction to Maintenance

Figure 17 on page 135 shows the main user accessible assemblies of the Agilent 1290 Infinity Binary Pump. These parts can be accessed from the front (simple repairs) and don't require to remove the pump from the system stack.

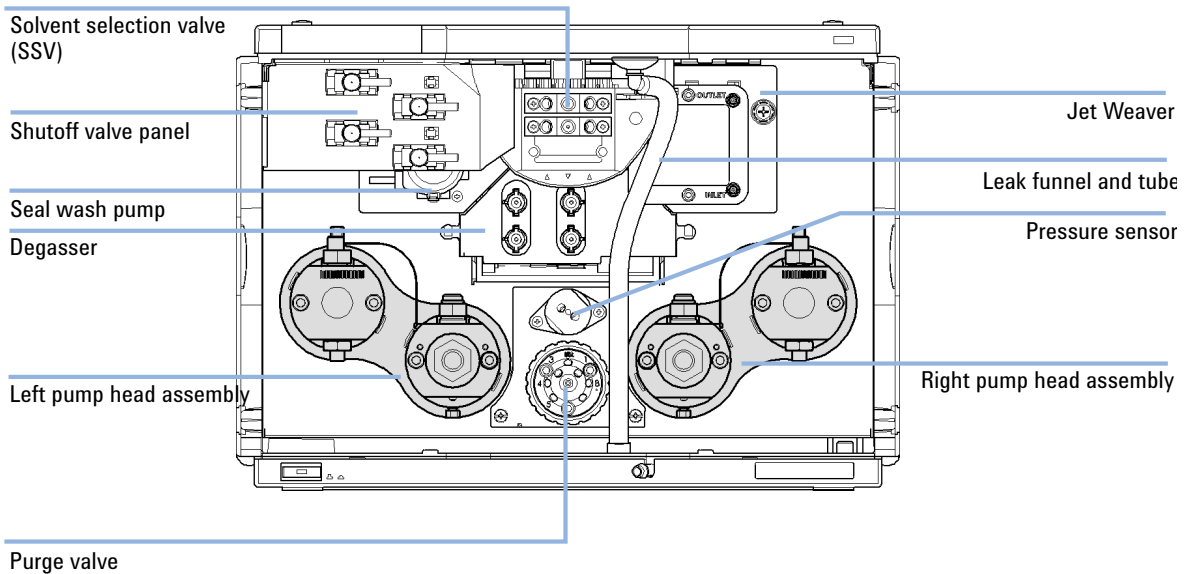

Figure 17 Maintenance Parts

Figure 18 on page 136 shows the flow connections between these main assemblies.

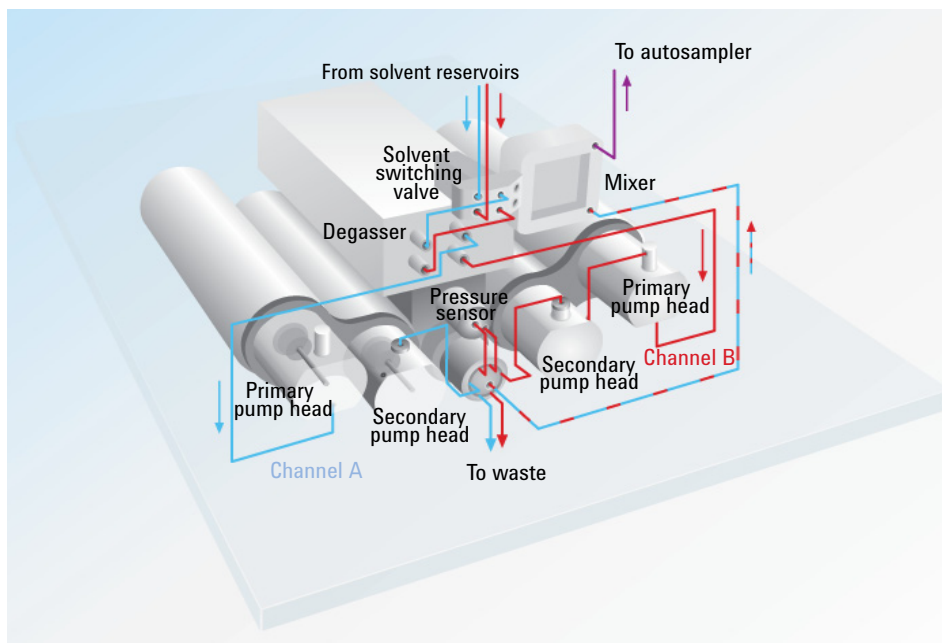

Figure 18 Flow Connections

Recommended Interval for Preventive Maintenance

The recommended interval for preventive maintenance is:

- 100 L (150 L for Long Life Technology) or 1 year (whichever comes first).

This recommendation is valid for LC instruments on which “typical” applications are running.

A “typical” application can be characterized as follows:

- pressure range 100 – 800 bar,
- flow rates 0.5 – 3.5 mL/min,
- typical solvents used in reversed phase LC.

Warnings and Cautions

WARNING

Toxic, flammable and hazardous solvents, samples and reagents

The handling of solvents, samples and reagents can hold health and safety risks.

- When working with these substances observe appropriate safety procedures (for example by wearing goggles, safety gloves and protective clothing) as described in the material handling and safety data sheet supplied by the vendor, and follow good laboratory practice.
 - The volume of substances should be reduced to the minimum required for the analysis.
 - Do not operate the instrument in an explosive atmosphere.
-

WARNING

Electrical shock

Repair work at the module can lead to personal injuries, e.g. shock hazard, when the cover is opened.

- Do not remove the cover of the module.
 - Only certified persons are authorized to carry out repairs inside the module.
-

WARNING

Personal injury or damage to the product

Agilent is not responsible for any damages caused, in whole or in part, by improper use of the products, unauthorized alterations, adjustments or modifications to the products, failure to comply with procedures in Agilent product user guides, or use of the products in violation of applicable laws, rules or regulations.

- Use your Agilent products only in the manner described in the Agilent product user guides.
-

CAUTION

Safety standards for external equipment

- If you connect external equipment to the instrument, make sure that you only use accessory units tested and approved according to the safety standards appropriate for the type of external equipment.
-

Overview of Maintenance

The following pages describe maintenance (simple repairs) of the module that can be carried out without opening the main cover.

Cleaning the Module

To keep the module case clean, use a soft cloth slightly dampened with water, or a solution of water and mild detergent.

WARNING

Liquid dripping into the electronic compartment of your module can cause shock hazard and damage the module

- Do not use an excessively damp cloth during cleaning.
 - Drain all solvent lines before opening any connections in the flow path.
-

Installing Fittings and Capillaries

WARNING

Solvent can spray under high pressure.

→ Observe appropriate safety procedures (for example, goggles, safety gloves and protective clothing), when opening flow path.

CAUTION

Deformation of fittings and seals

Liquid drops under high pressure act like solid parts. Tightening connections under high pressure can deform or destroy fittings and seals.

→ Never tighten flow connections under pressure.

NOTE

The lifetime of a fitting depends on how firmly it has been tightened; firm tightening reduces the lifetime.

If fitting has been overtightened, replace it.

- 1 Install fittings and capillaries.
- 2 Tighten fittings and capillaries.

Replacing the Shutoff Valve Panel

When If a shutoff valve is damaged or the panel needs to be removed for other repair procedures.

Parts required	#	p/n	Description
	1	5067-4124	Shutoff valve
	1	G4220-40004	Shutoff valve panel
	2	G4220-60035	Tubing kit 140 mm, 2/pk SSV to shutoff valve or degassing unit

Preparations In order to avoid leaks, remove tubings from the solvent bottles.

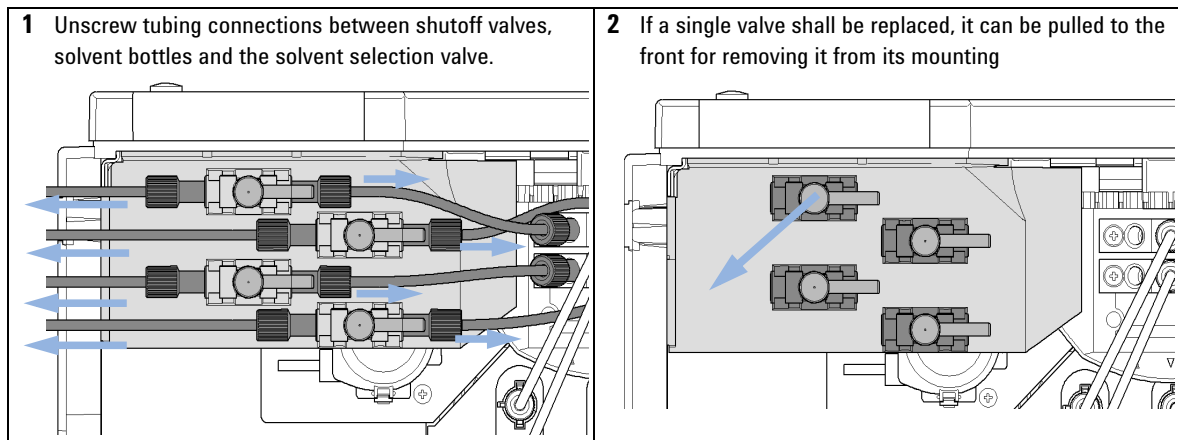

9 Maintenance

Replacing the Shutoff Valve Panel

3 Remove the shutoff valve panel by pulling it downwards

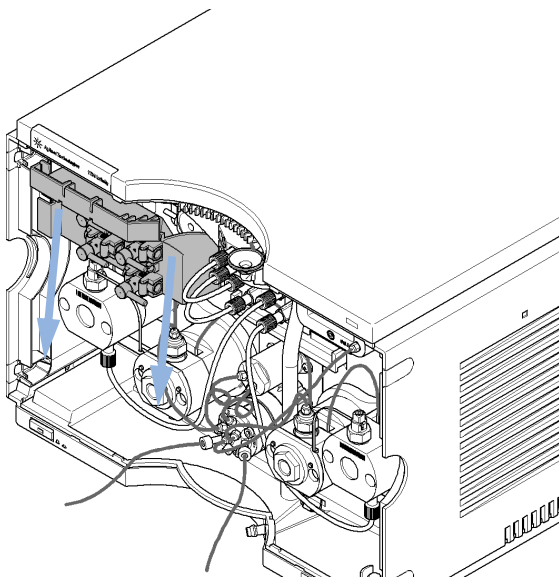

4 After replacing the panel or after completion of other maintenance, re-install the panel and all flow connections.

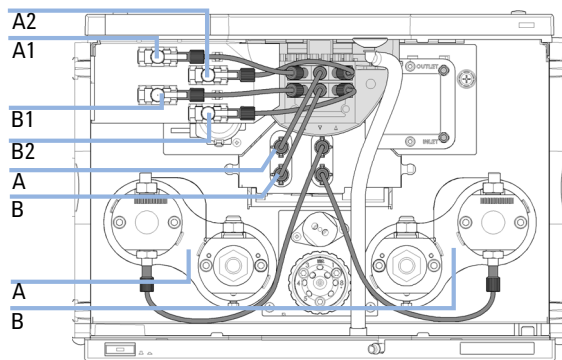

Replacing the Pressure Sensor

When No or invalid pressure signal

Tools required	p/n	Description
	8710-2412	Hex key 2.5 mm, 15 cm long, straight handle
	8710-0510	Open-end wrench 1/4 — 5/16 inch
		Screwdriver

Parts required	#	p/n	Description
	1	G4220-60001	Pressure sensor 1200 bar

Preparations Turn off pump flow, switch off pump

NOTE

This procedure describes how to replace the pressure sensor.

In case the cable to the sensor shall be replaced as well, please contact your Agilent service representative.

9 Maintenance

Replacing the Pressure Sensor

- 1** Remove capillary connections between the pressure sensor and purge valve.

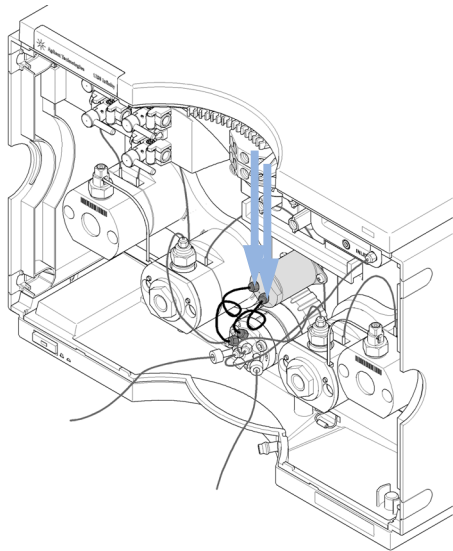

- 2** Remove the screws that fix the pressure sensor to the chassis.

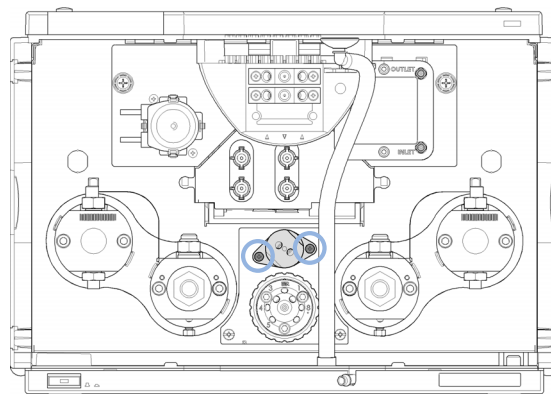

- 3** Carefully pull out the pressure sensor for about 2 cm. Then unscrew the cable from the pressure sensor.

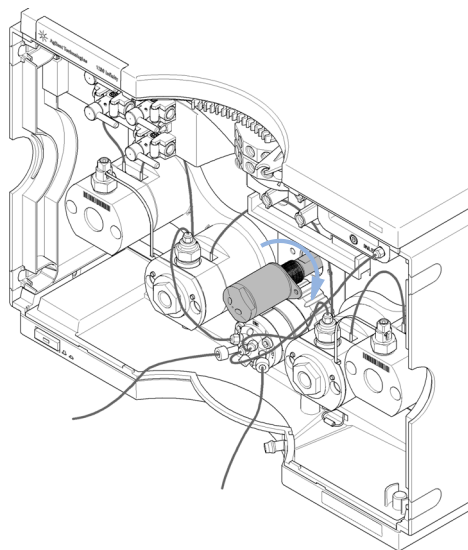

- 4** Connect the new pressure sensor to the pressure sensor connector.

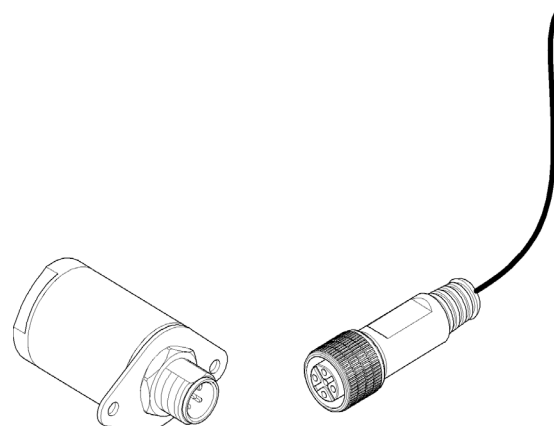

5 Fix the pressure sensor to the instrument chassis.

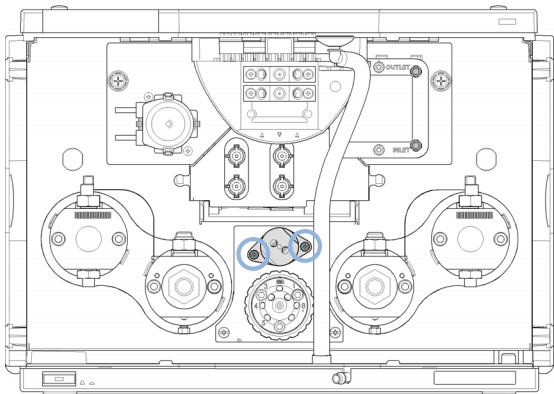

6 Connect the capillaries from the valve to the pressure sensor: connect port 3 to the pressure sensor inlet and port 2 to the outlet.

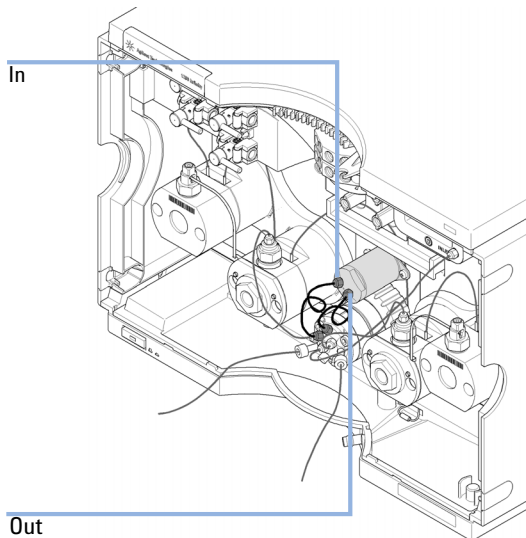

9 Maintenance

Replacing the Inlet valve

Replacing the Inlet valve

When If Inlet valve is defective.

Tools required	p/n	Description
		Wrench, 14 mm
	5067-5688	Torque wrench 1 – 25 Nm with 14 mm wrench

Parts required	p/n	Description
	G4220-60022	Inlet valve (primary pump head)

NOTE

For best performance and life time and for avoiding leaks, use a torque wrench set to 10 Nm for fixing the inlet valve.

1 Close the shut off valves to avoid solvent leaks.

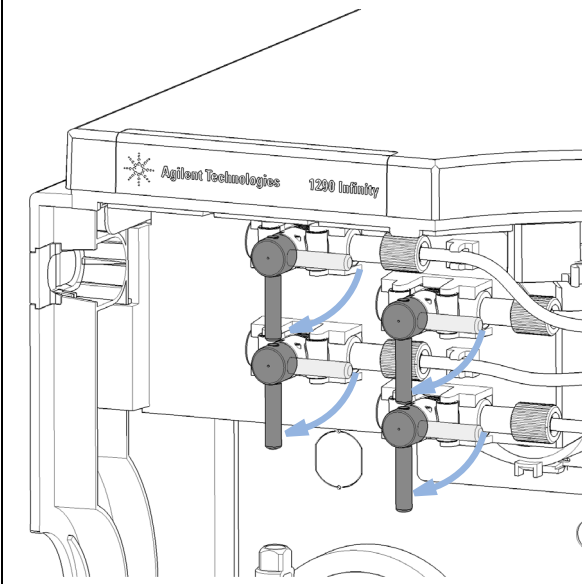

2 Unscrew the tubing at the inlet valve.

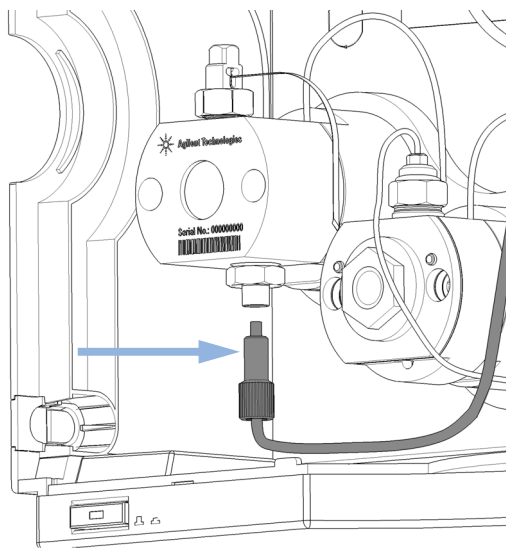

- 3 With a 14 mm wrench, unscrew the inlet valve and remove it.

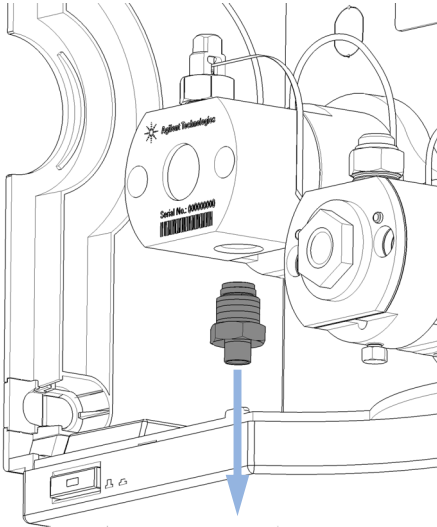

- 4 Install inlet valve and tighten it at 10 Nm with a torque wrench (14 mm).

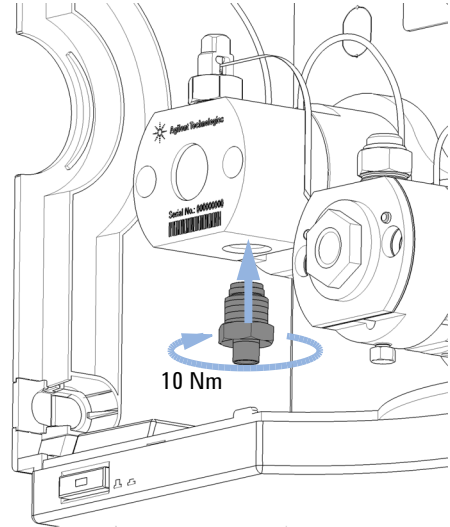

- 5 Attach the inlet tubing at the inlet valve.

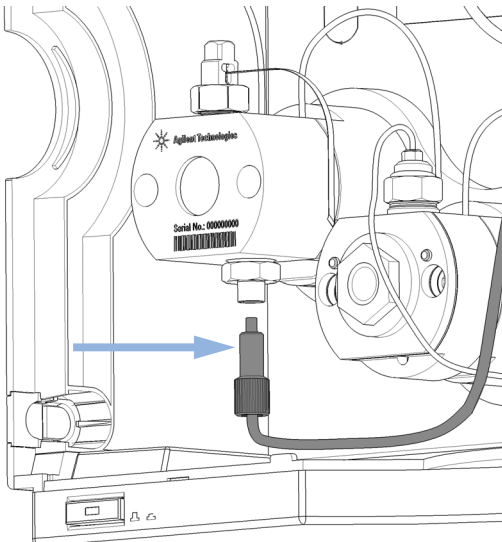

- 6 Open the shut off valves and purge the system to remove air.

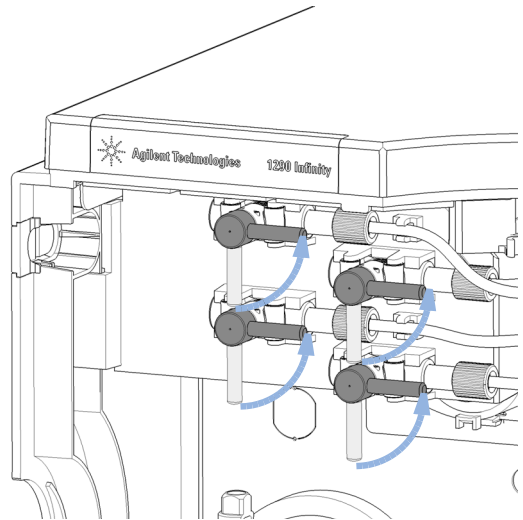

Replacing the Outlet Valve

When If Outlet valve is defective.

Tools required	p/n	Description
	8710-0510	Wrench open 1/4 — 5/16 inch
	8710-2603	Spanner-double open ended 12X14 mm Chrome
	G4220-20012	Torque wrench 2 – 25 Nm
	G4220-20041	Bit Torx 10x25 mm

Parts required	p/n	Description
	G4220-60028	Outlet valve (primary pump head)
	G4220-20020	Internal gold seal for Outlet Valve

1 Close the shut off valves to avoid solvent leaks.

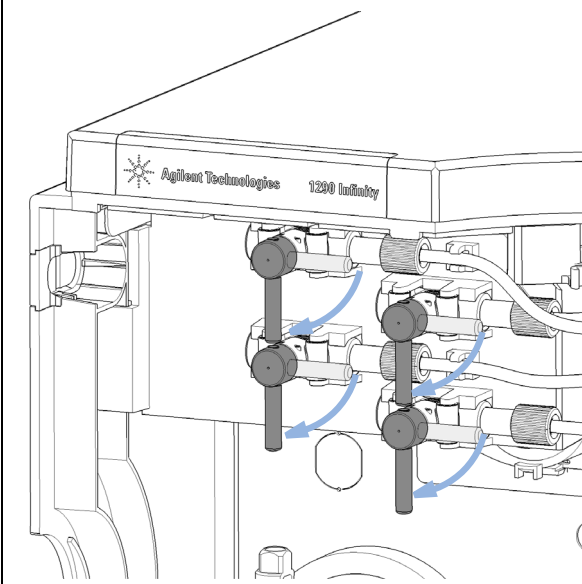

2 Lift up the capillary and remove it from the primary pump head.

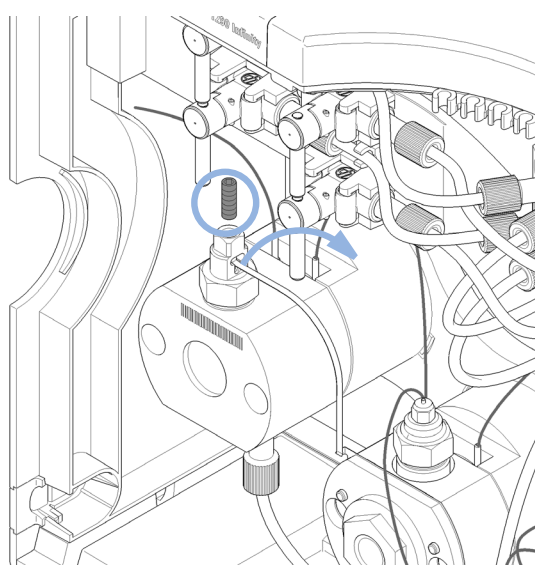

3 A gold seal between outlet valve and heat exchanger capillary is used for a tight connection. The seal can be replaced separately as needed.

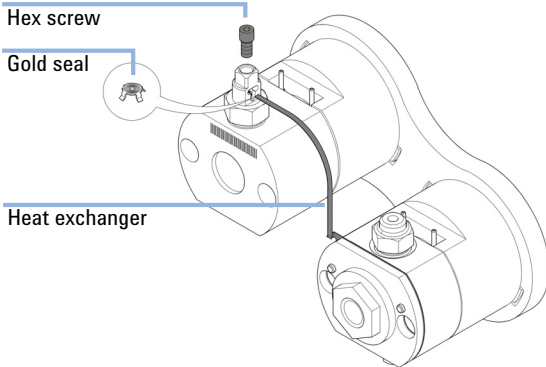

4 Unscrew the outlet valve with a 14 mm wrench.

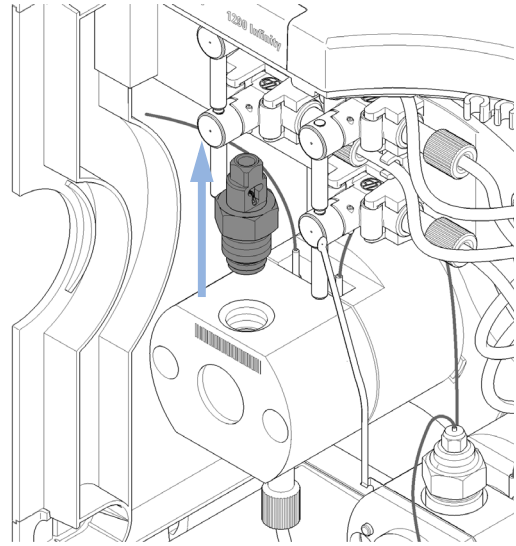

5 Insert the outlet valve into the pump head. Using a torque wrench, set 10 Nm and close the outlet valve.

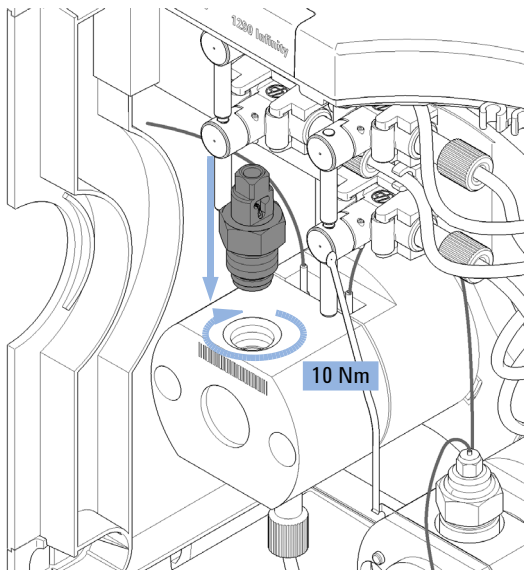

6 Insert the heat exchanger capillary into the outlet of the outlet valve. Using a torque wrench with a 2.5 mm hex bit, set 3 Nm and close the hex screw at the top of the outlet.

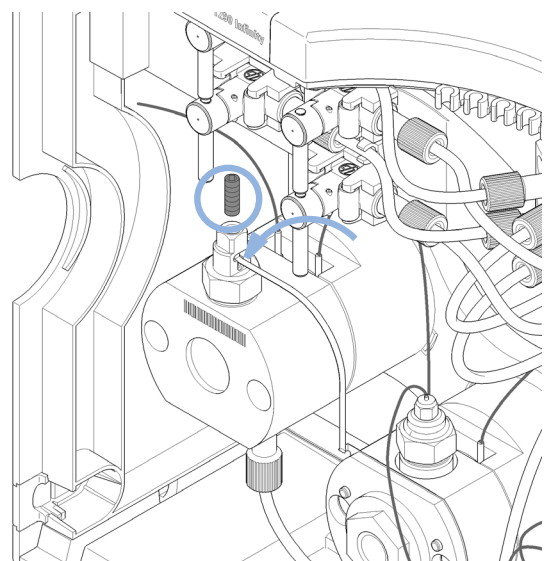

9 Maintenance

Replacing the Outlet Valve

- 7 Open the shut off valves and purge the system to remove air.

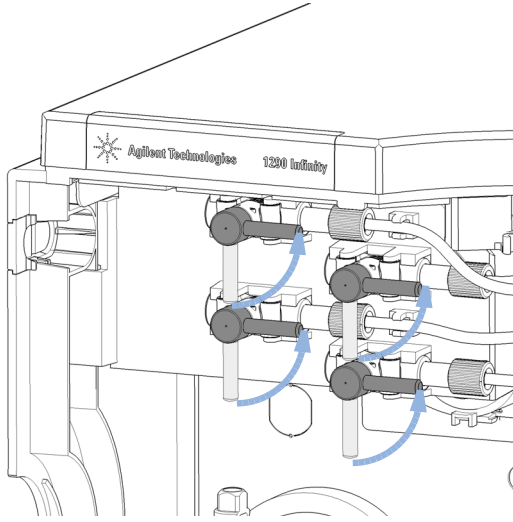

Replacing the Solvent Selection Valve (SSV)

When In case of problems with the solvent selection valve

Parts required	#	p/n	Description
	1	G4280-60029	Solvent selection valve
	4	G4220-60035	Tubing kit 140 mm, 2/pk SSV to shutoff valve or degassing unit

1 Close shut-off valve. Remove tubing connections between the SSV and the solvent shut-off valves and the SSV and the degassing unit inlets.

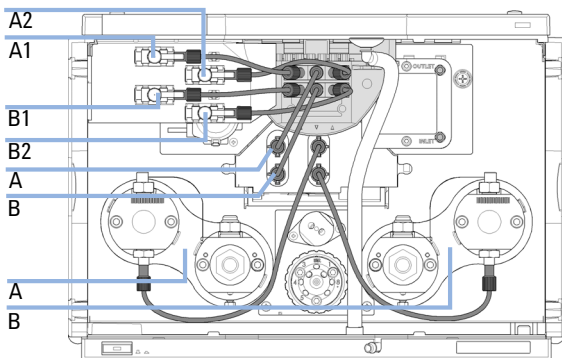

2 Push down the SSV panel for removing it.

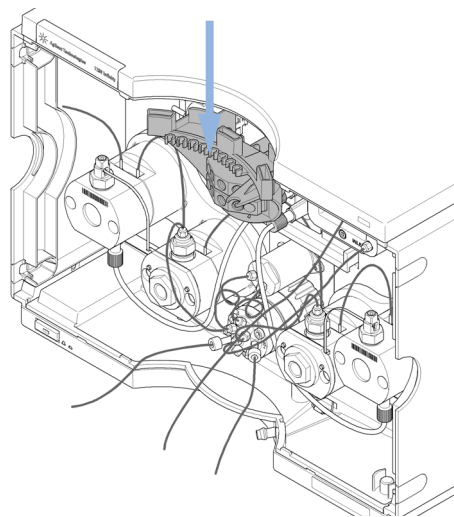

9 Maintenance

Replacing the Solvent Selection Valve (SSV)

- 3** Remove the connector by pushing up the small clip at the bottom of the connector.

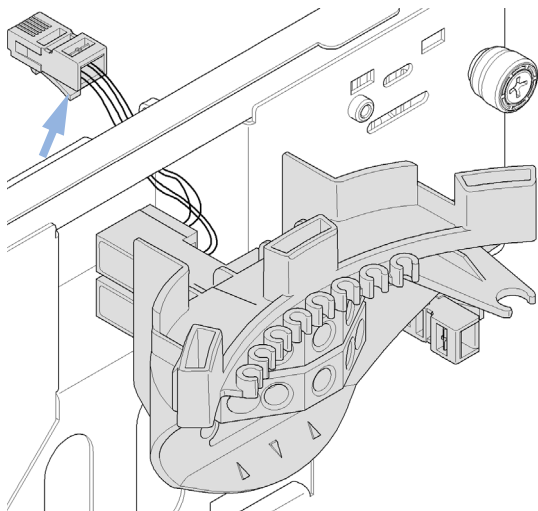

- 4** Install a new SSV by inserting the connector and clipping the SSV panel to the module top panel. Then re-install all tubing connections, open shut-off valve and purge valve.

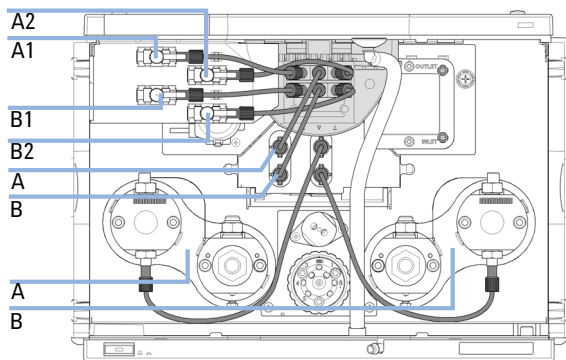

Changing configuration or replacing the Jet Weaver

When For optimizing the pump configuration to mixing performance or low delay volumes/fast gradients, see chapter *Optimizing Performance*.

Tools required	p/n	Description
	8710-0510	¼ inch wrench 3 mm hex key

Parts required	#	p/n	Description
	1	G4220-60006	Jet Weaver 35 µL/100 µL
	1	G4220-60012	Jet Weaver 380 µL (OPTIONAL)
	1	G4220-87000	Capillary ST 0.17 mm x 300 mm Valve to Jet Weaver

9 Maintenance

Changing configuration or replacing the Jet Weaver

- 1 Remove capillary connections from the Jet Weaver.

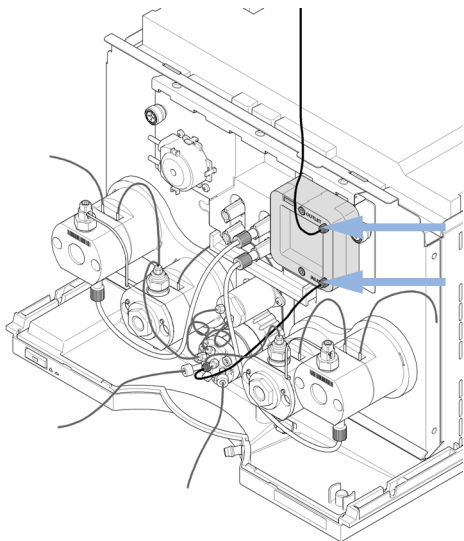

- 2 Remove the hex screws that fix the Jet Weaver to the pump housing.

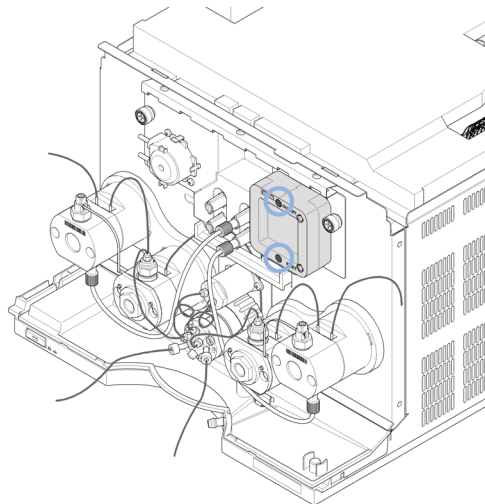

NOTE

The standard Jet Weaver (Jet Weaver 35 μ L/ 100 μ L (G4220-60006)) has a front and a rear side with different internal volumes (35 / 100 μ L) that are optimized for a low delay volume or best mixing performance. Please refer to recommendations in the *Agilent 1290 Infinity System Manual*.

The optional Jet Weaver (Jet Weaver 380 μ L (G4220-60012)) is recommended for applications which are challenging with respect to mixing noise (e.g. TFA applications) and has just one side.

Changing configuration or replacing the Jet Weaver

- 3** Install new Jet Weaver or flip the Jet Weaver for backside.

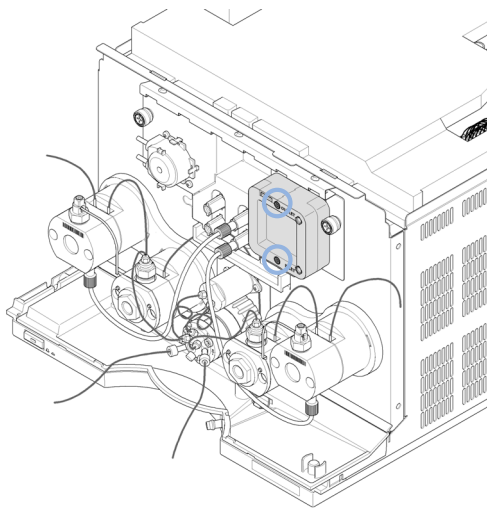

- 4** Reinstall the capillary connections.

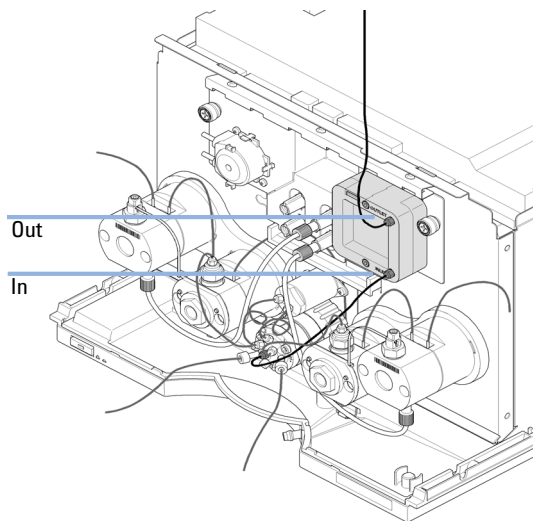

The inlet at the bottom of the Jet Weaver is connected to the central port of the pump valve by a capillary (length 300 mm, 0.17 mm i.d.). The outlet at the top is connected to the autosampler.

9 Maintenance
Replacing the Seal Wash Pump

Replacing the Seal Wash Pump

When In case of wear of the seal wash pump

Parts required	p/n	Description
	5065-4445	Peristaltic pump with Pharmed tubing

Preparations Remove the shutoff valve panel (“Replacing the Shutoff Valve Panel” on page 141) and flow connections from and to the seal wash pump

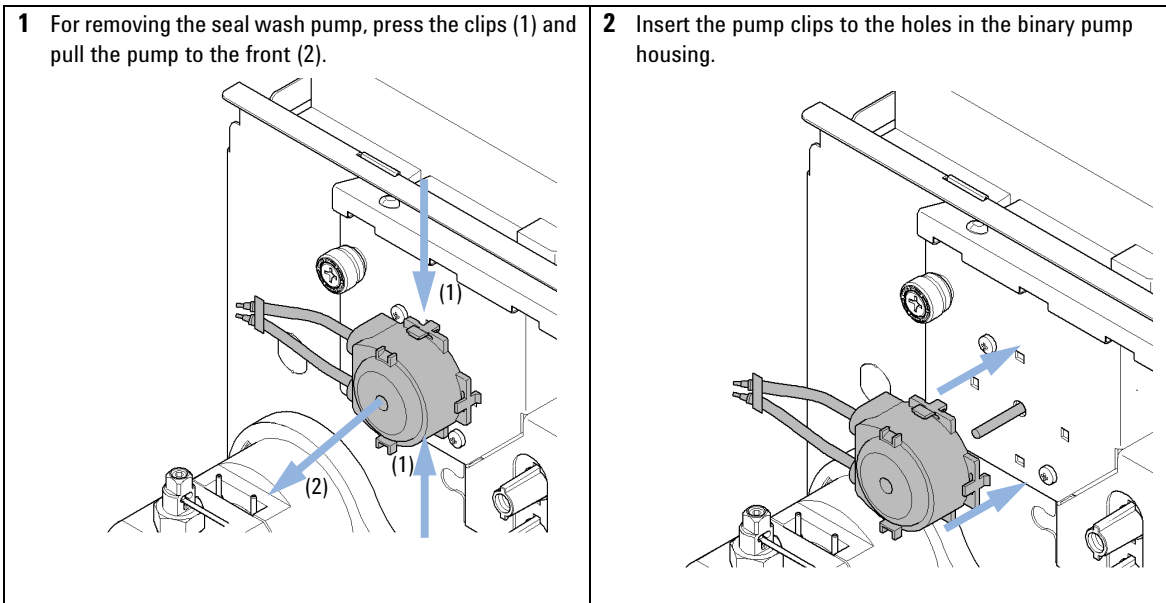

Releasing a Stuck Inlet Valve

When If inlet valve is stuck, or if pump is not generating pressure after being turned off for an extended period of time.

NOTE

Before the system is turned off for an extended period of time, it should be flushed with at least 10 % IPA to prevent inlet valves from getting stuck.

1 Remove the capillary connection from the outlet of the secondary pump head.

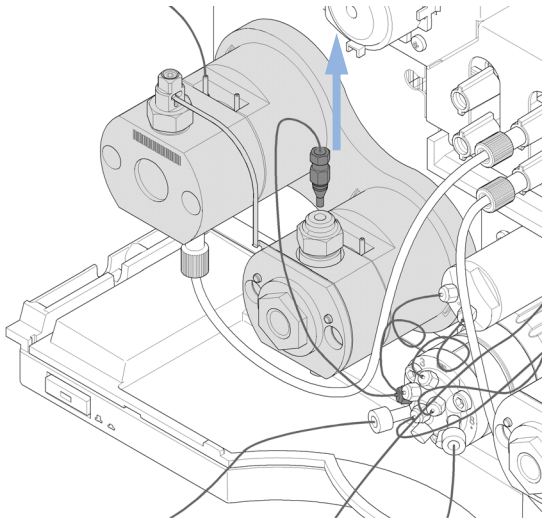

2 Unscrew the tubing at the inlet valve.

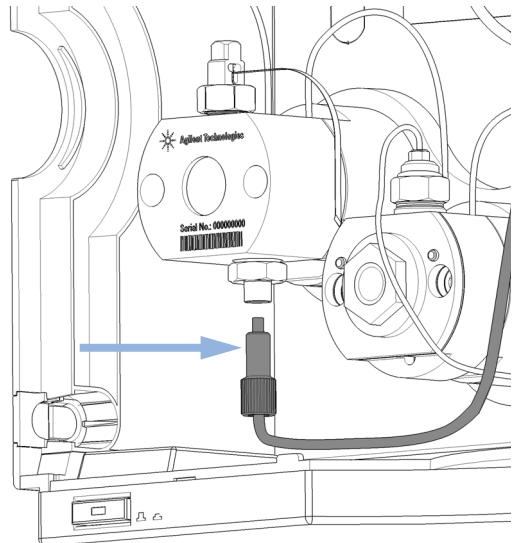

9 Maintenance

Releasing a Stuck Inlet Valve

- 3** Attach a Luer lock syringe with adapter to the tubing and fill it with solvent.

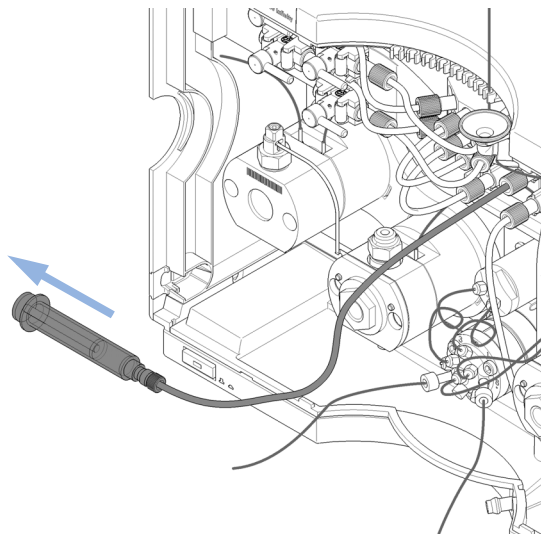

- 4** Reconnect tubing to inlet valve.

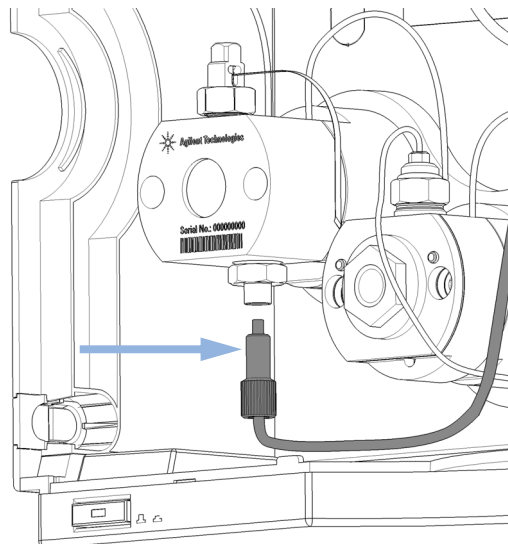

- 5** Unscrew tubing at degassing unit and attach the syringe to it.

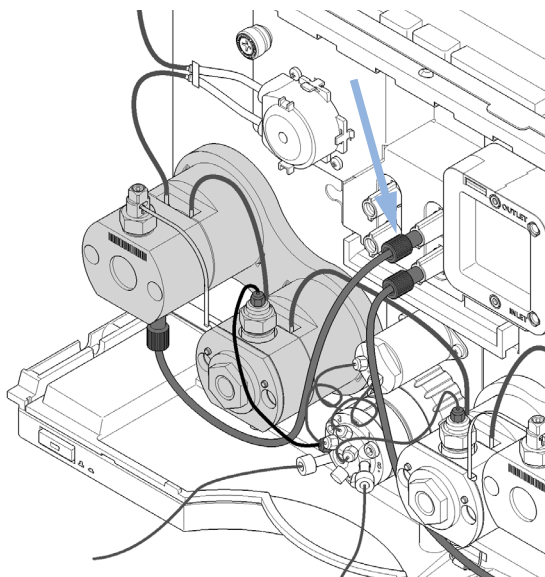

- 6** Push solvent with syringe until it comes out at the top of the High Pressure Filter Assembly.

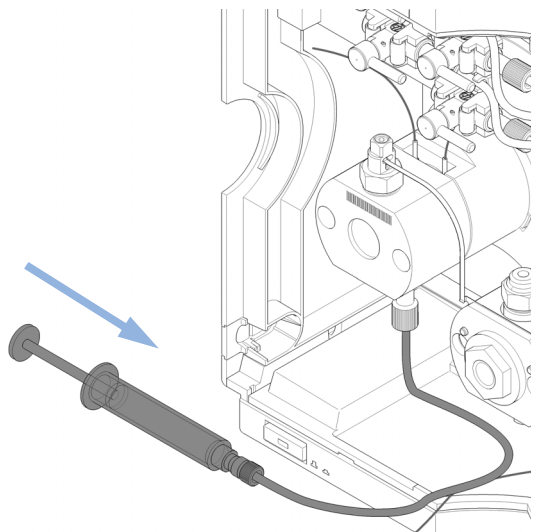

- 7** Detach the syringe and reconnect the tubing into the degassing unit.

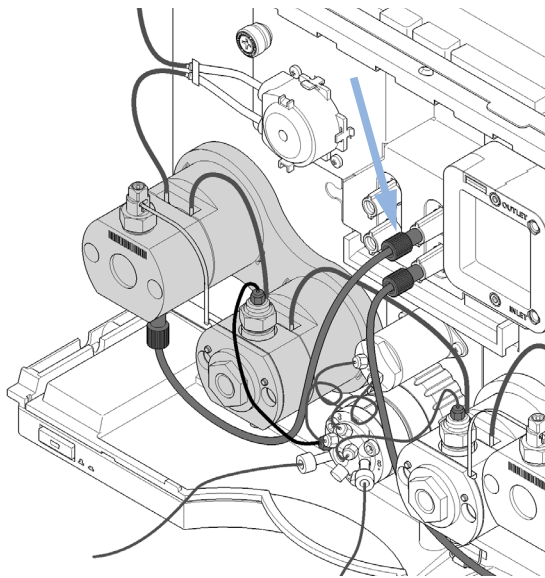

- 8** Reinstall the capillary connection to the High Pressure Filter Assembly.

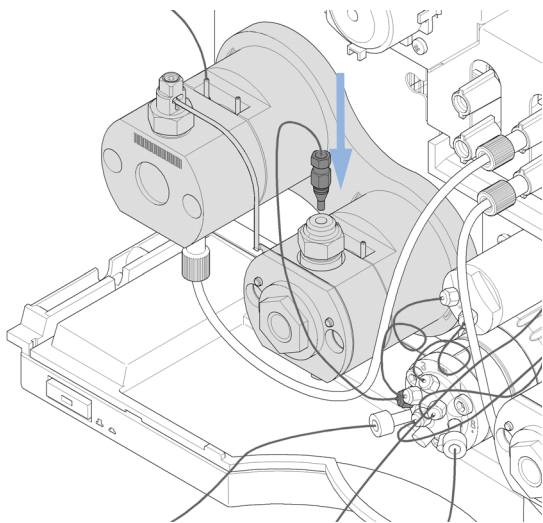

- 9** Purge the system to remove air.

Remove the Pump Head Assembly

Tools required	p/n	Description
	G7120-68708	HPLC System Tool Kit-Infinity-II

NOTE

This procedure describes the replacement of the left pump head assembly (channel A). Similarly, the right pump head assembly (channel B) can be replaced.

One pump head assembly consists of two pump heads, which are both removed at the same time.

1 In Lab Advisor go to **Service & Diagnostics > Remove/Install Pump Head** and follow instructions given on the screen.

2 Close the shut-off valve of the respective pump channel.

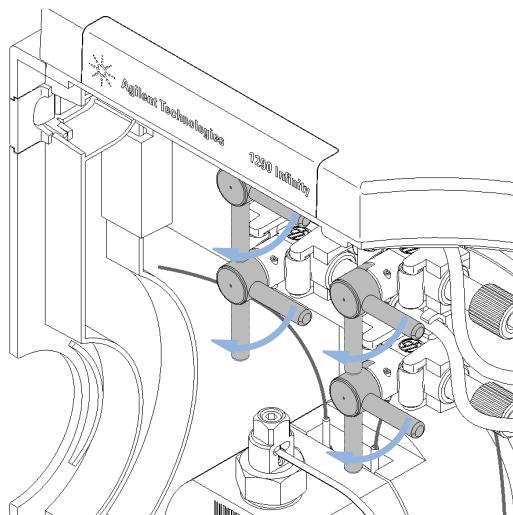

Remove the Pump Head Assembly

- 3** Remove the flow connection between the degassing unit and the primary pump head inlet. Remove the capillary connection at the top of the secondary pump head to the pump valve. Remove the seal wash tubings.

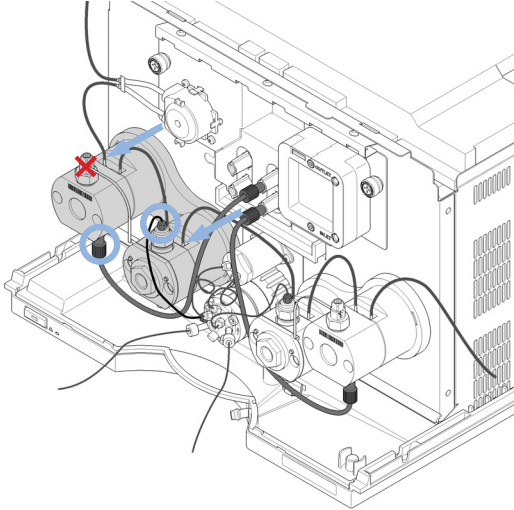

DO NOT REMOVE the capillary connection between the pump heads marked by the red X.

- 4** Loosen the inlet valve. Keep the inlet valve installed to the pump head assembly.

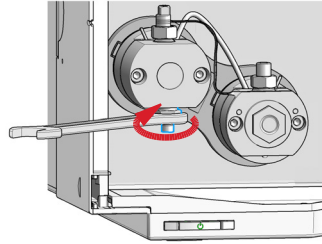

- 5** Counter the lock screw of the heat exchanger capillary while loosening the outlet valve. Keep the outlet valve installed to the pump head assembly.

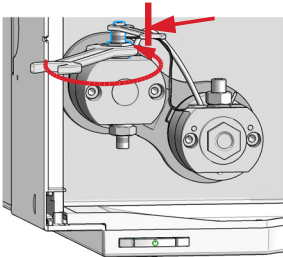

- 6** Loosen the high pressure filter. Keep the filter installed to the pump head assembly.

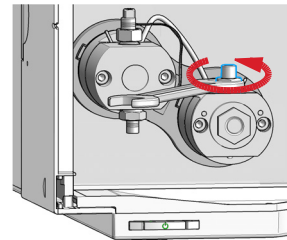

9 Maintenance

Remove the Pump Head Assembly

- 7 Open the 4 screws holding the pump heads.

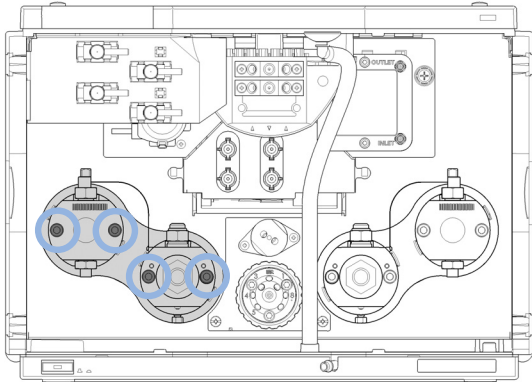

NOTE

Open all screws step by step, not screw by screw.

- 8 Remove the complete pump head assembly by holding it with both hands and pulling it to the front.

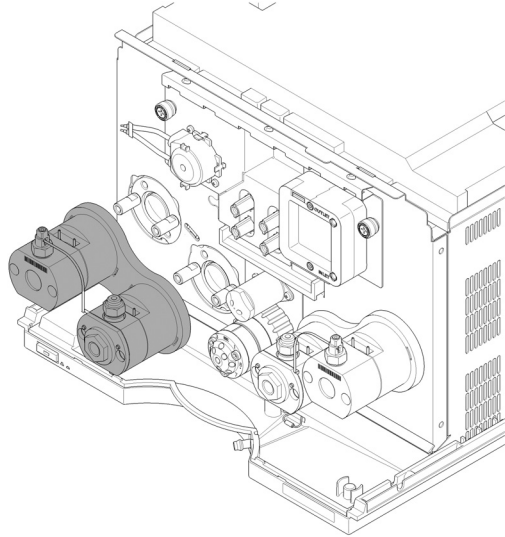

- 9 Remove the seal wash tubing interconnecting the two pump heads.

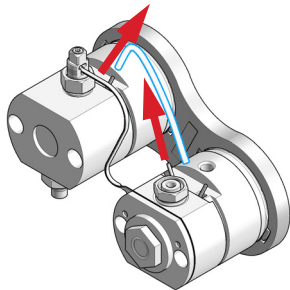

Pump Head Maintenance (Tool Free)

Infinity II Flexible Pumps (G7104A/C) and 1290 Infinity II High Speed Pumps (G7120A) are equipped with Long Life Pump Heads.

Long Life Pump Heads offer a significantly increased lifetime of pistons and seals compared to other pump heads.

Maintenance of Long Life Pump Heads requires no special tool.

The following procedures explain the maintenance of Long Life Pump Heads.

Please refer to Agilent 1290 Infinity II Easy Maintenance Pump Head Technical Note (01200-90120) for instructions on maintenance of Easy Maintenance Pump Heads, or to Agilent 1290 Infinity Pump Head Maintenance Technical Note (G4220-90122) for instructions on maintenance of classical pump heads.

Disassemble Pump Heads

This procedure shows how to open the pump head assembly, exchange seals, and clean pistons.

Exchanging seals and cleaning pistons is exemplarily shown for the primary pump head, but works in the same way for the secondary pump head.

Tools required	p/n	Description
	G7120-68708	HPLC System Tool Kit-Infinity-II
	5043-1400	Pump Head Holder
	5067-6197	Seal Handling Device
	8660-0852	Abrasive mesh Isopropanol

NOTE

Seals must be exchanged and pistons must be cleaned in both primary and secondary pump heads.

- 1 Counter the outlet valve while opening the lock screw of the heat exchanger capillary.

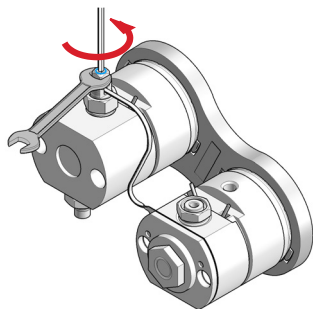

- 2 Remove the heat exchanger capillary by pushing the connector up and pulling it out of the valve.

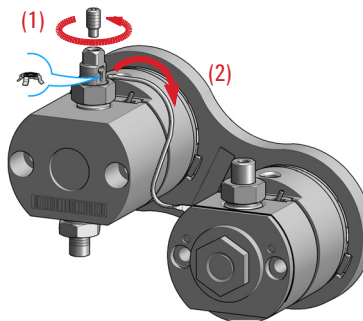

NOTE

A gold seal between outlet valve and heat exchanger capillary is used for a tight connection.

Pump Head Maintenance (Tool Free)

3 Turn the pump head assembly upside down.

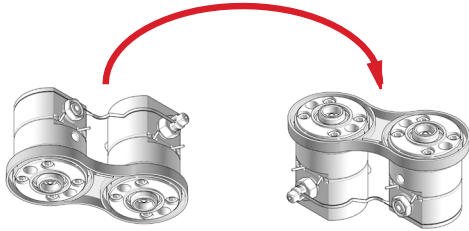

4 Remove the link plate by gently pulling it off the pump head assembly.

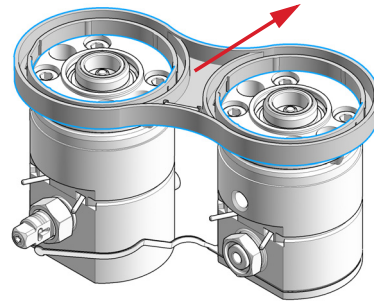

The two pump chambers are now isolated.

5 Remove the inlet valve and the outlet valve from the primary pump head.

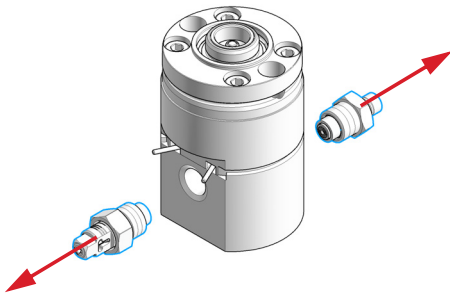

NOTE

Clean the valves by sonication, if appropriate. A good cleaning solution is 50 % isopropanol in water.

6 Binary/High Speed Pumps only: Remove the high pressure filter from the secondary pump head.

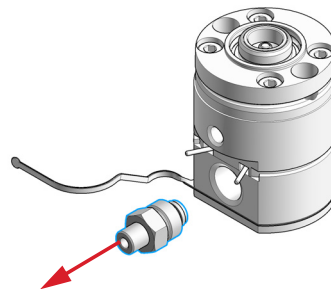

9 Maintenance
Pump Head Maintenance (Tool Free)

7 Place the two pump heads in the Pump Head Holder.

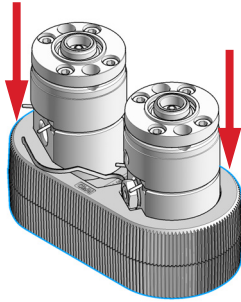

8 Remove the pump head screws from the back of the pump heads.

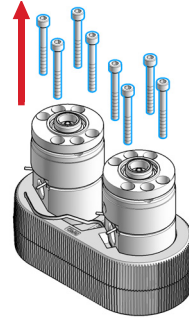

9 Open the pump heads and remove the piston housings from the pump chambers.

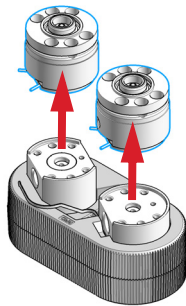

10 Remove the piston by pressing it out of the seal holder with a finger.

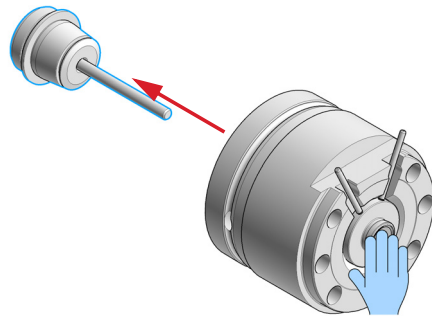

11 Remove the seal holder from the spring housing.

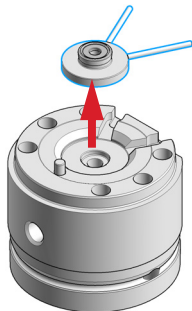

12 Screw the pin of the seal handling device into the piston seal.

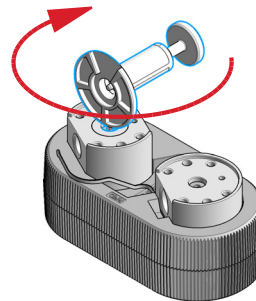

- 13** Pull out the Seal Handling Device with the piston seal in a straight movement with only gentle force.

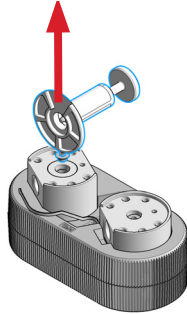

- 14** Repeat for the other pump chamber.

- 15** Screw the pin of the seal handling device into the wash seal.

NOTE

The seal holder has two different sides. The black backup ring is supporting the piston seal and must not be removed. The side with the backup ring has a bigger diameter and a sharp edge to hold the piston seal. The other side has no sharp edge and holds the smaller wash seal.

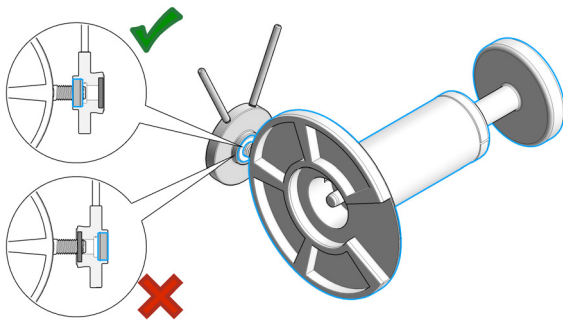

- 16** Pull out the Seal Handling Device with the wash seal in a straight movement with only gentle force.

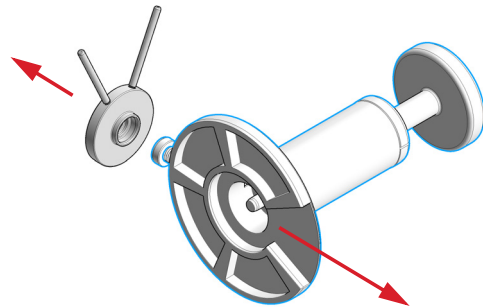

9 Maintenance
Pump Head Maintenance (Tool Free)

17 Repeat for the other seal holder.

18 Clean the piston with abrasive paper.

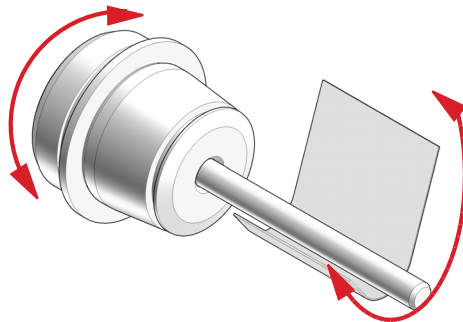

19 Rinse pump heads and pistons with isopropanol.

Replace the Heat Exchanger

Tools required	p/n	Description
		Wrench, 19 mm
	5023-2501	Screwdriver Torx-T10
	5067-5688	Torque wrench 1 – 25 Nm with 14 mm wrench
	G4220-20013	4 mm hex bit
	G4220-20015	Adapter ¼ in square to hex
	G4220-20041	Bit Torx 10x25 mm

Parts required	#	p/n	Description
	1	G4220-81013	Heat Exchanger Channel A (secondary pump head only)
OR	1	G4220-81012	Heat Exchanger Channel B (secondary pump head only)

- Preparations**
- Remove the pump head assembly from the pump
 - Remove the secondary pump head from the link plate

CAUTION

Loss of small spacer fitting

Inside the secondary pump head is a small spacer fitting, which can be dropped easily when removing the heat exchanger.

→ The heat exchanger does not need to be removed for pump head maintenance.

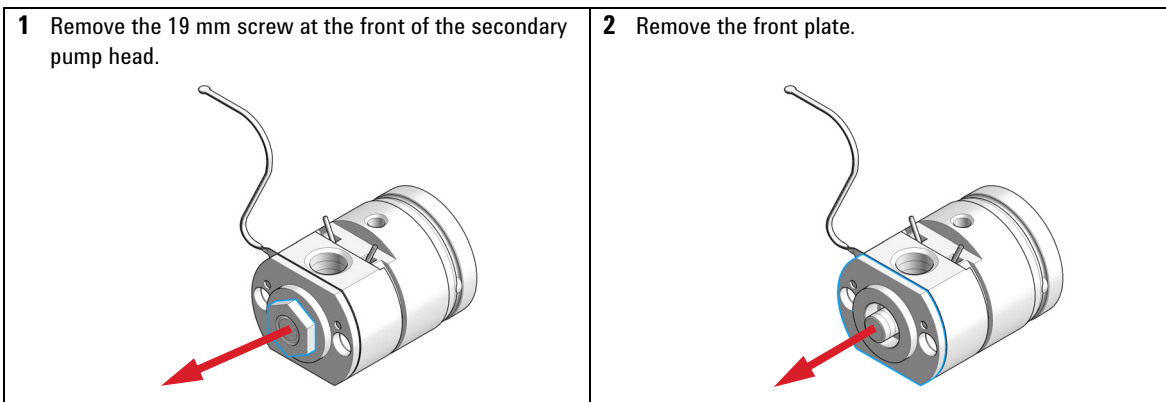

9 Maintenance

Pump Head Maintenance (Tool Free)

3 Remove the screw at the bottom of the pump head. Do not drop the golden spacer fitting.

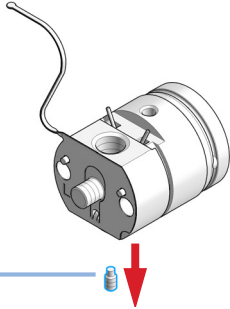

4 Lift out the heat exchanger.

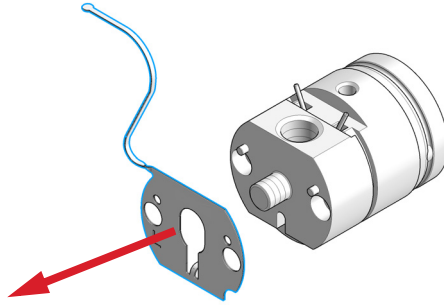

5 If removed, first insert the spacer fitting. Then insert the new heat exchanger to the opening in the pump head and lift it over the pins.

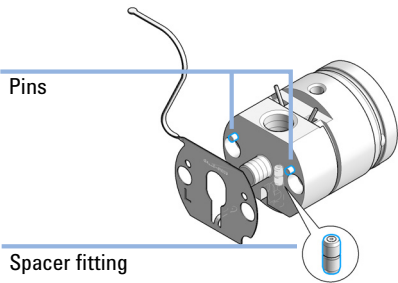

6 Use the 19 mm screw for fixing the front plate.

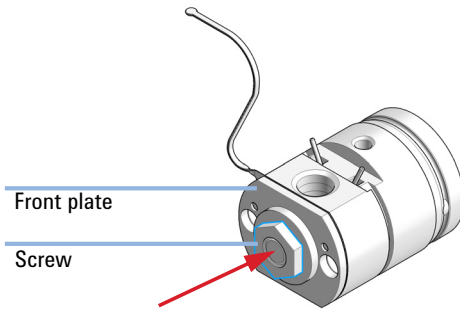

7 Insert and fix the screw.

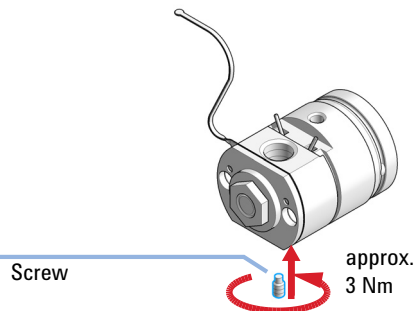

Assemble Pump Heads

This procedure shows how to exchange seals, and reassemble the pump head assembly.

Exchanging seals is exemplarily shown for the primary pump head, but works in the same way for the secondary pump head.

Tools required	p/n	Description
	G7120-68708	HPLC System Tool Kit-Infinity-II
	5067-5688	Torque wrench 1 – 25 Nm with 14 mm wrench
	G4220-20013	4 mm hex bit
	G4220-20015	Adapter ¼ in square to hex
	G4220-20041	Bit Torx 10x25 mm
	5043-1400	Pump Head Holder
	5067-6197	Seal Handling Device
		Isopropanol

Parts required	#	p/n	Description
	2	0905-1719	PE Seal
	2	0905-1175	Wash seal (PTFE)

NOTE

Seals must be exchanged in both primary and secondary pump heads.

9 Maintenance

Pump Head Maintenance (Tool Free)

1 Lubricate the seals, the seal holder, and the pump chambers with isopropanol.

2 Place the piston seal onto the designated nose of the Seal Handling Device. The metal spring of the piston seal must be visible.

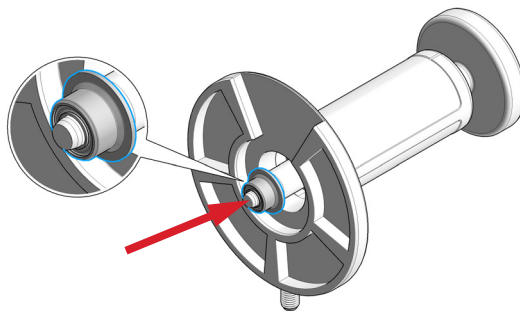

3 Take care that the Seal Handling Device is seating flush and press the seal into the pump chamber.

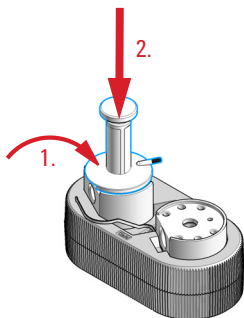

4 Repeat for the other pump chamber.

5 Place the seal holder onto the pump chamber.

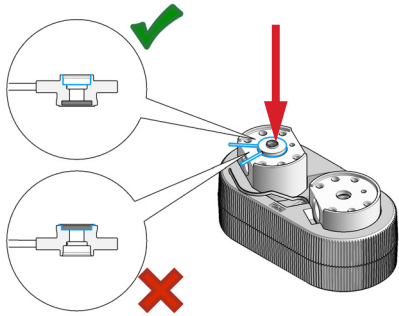

NOTE

Mind the correct orientation of the seal holder. The backup ring must face down.

6 Place the wash seal onto the designated nose of the Seal Handling Device. The metal spring of the wash seal must be visible.

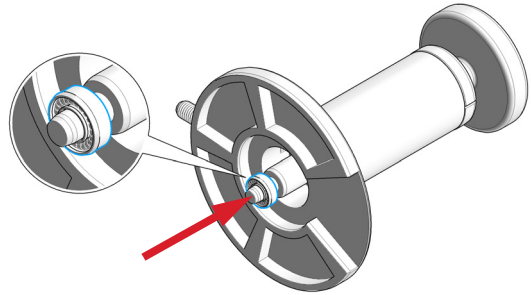

7 Take care that the Seal Handling Device is seating flush and press the wash seal into the seal holder.

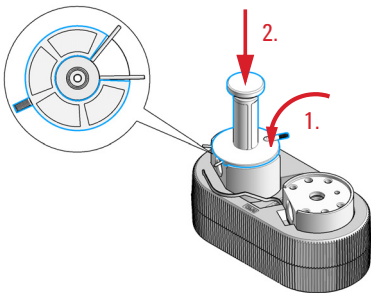

NOTE

The Seal Handling Device has a cavity to fit over the pins of the seal wash tubings.

8 Repeat for the other seal holder.

9 Maintenance

Pump Head Maintenance (Tool Free)

9 Remove the seal holders from the pump chambers.

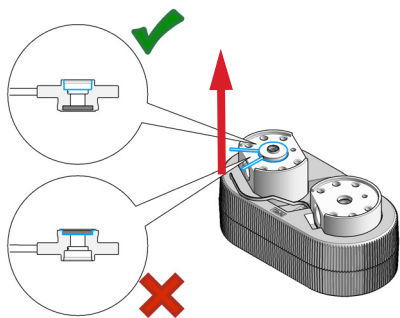

10 Lubricate the piston with isopropanol and place it into the spring housing.

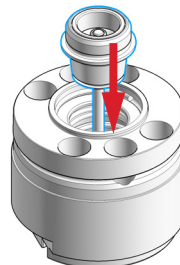

11 Place the seal holder onto the spring housing.

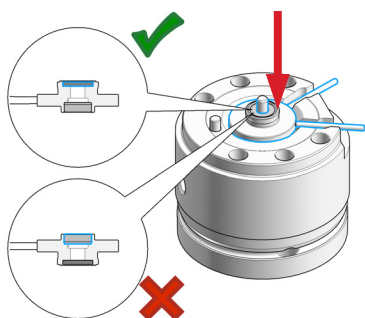

NOTE

Mind the correct orientation: The backup ring must face upwards and the seal holder must sit correctly.

12 Place the assembled spring housings on top of the pump chambers.

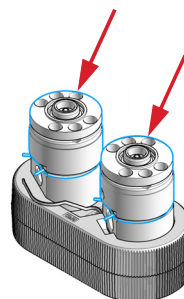

NOTE

Both spring housings are identical, there is no risk when mixing them, but make sure that the seal holder is oriented correctly.

- 13** Place the screws into the pump heads and loosely tighten them in a crosswise manner.

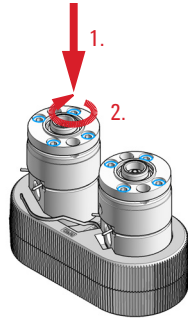

NOTE

The spring housing will tilt slightly when the first screw is hand tightened. Stop at this point and continue to tighten the three other screws in a crosswise manner.

- 14** Mind the correct orientation of the link plate and click it into place.

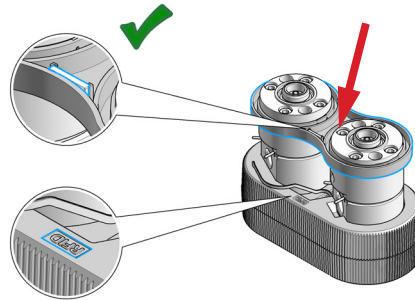

NOTE

The Pump Head Holder has a marker to illustrate the correct placement of the link plate. The link plate holds an identification tag; this has to be placed onto the correct position to be readable by the pump.

- 15** Tighten the pump head screws with a torque wrench set to approx. 5 Nm in a crosswise manner.

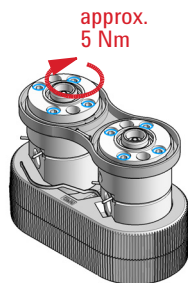

NOTE

When the wrench clicks, the set torque is reached. Do not overtighten the screws.

- 16** Mount the pump head to the module. Do not fix the screws at this stage!

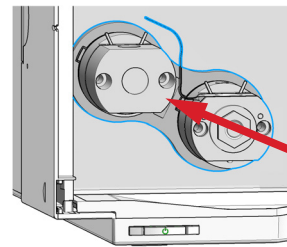

9 Maintenance
Pump Head Maintenance (Tool Free)

17 Screw in the inlet valve and the outlet valve and fix them with a torque wrench set to approx. 10 Nm.

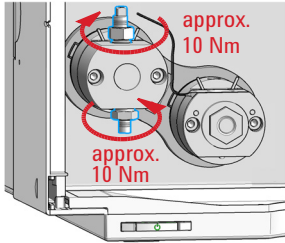

18 Binary/High Speed Pumps only: Screw in the high pressure filter and fix it with a torque wrench set to approx. 16 Nm.

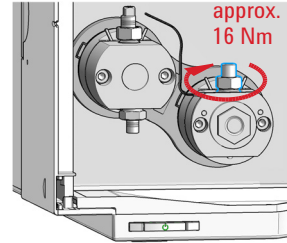

19 Remove the pump head from the module again.

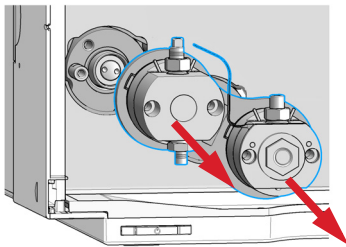

20 Position the entrance slit for the heat exchanger capillary to face exactly to it, and then seat the heat exchanger capillary back into the outlet valve by moving it into the valve and pressing it down.

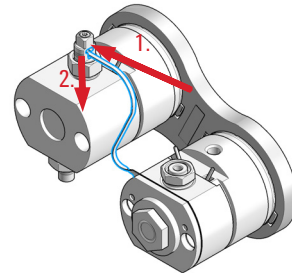

21 Counter the outlet valve and tighten the lock screw of the heat exchanger capillary with a torque wrench set to approx. 3 Nm.

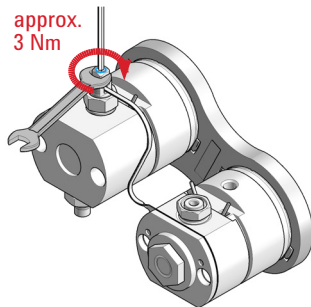

22 Attach the seal wash tubing interconnecting the two pump heads.

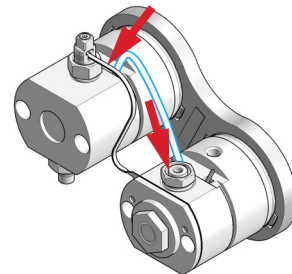

23 Insert the screws that later fix the pump head assembly to the module housing.

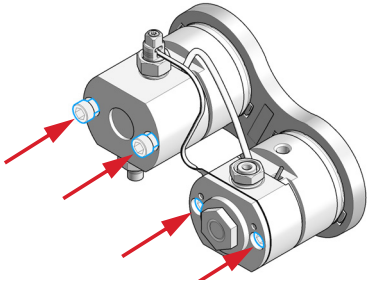

9 Maintenance

Install the Pump Head Assembly

Install the Pump Head Assembly

Tools required	p/n	Description
	G7120-68708	HPLC System Tool Kit-Infinity-II
	5067-5688	Torque wrench 1 – 25 Nm with 14 mm wrench
	G4220-20013	4 mm hex bit
	G4220-20015	Adapter ¼ in square to hex

- 1 Bring the pump drive to the maintenance position using the Lab Advisor user interface: Go to **Service & Diagnostics > Remove/Install Pump Head** and follow instructions given on the screen. Both pump drives must be retracted.

CAUTION

Damage to the pump head
Using a wrong torque will damage the pump head.

→ For handling the torque wrench, setting and applying the right torque, consult the manual of your torque wrench.

- 2 Install the pump head assembly by fixing the 4 screws using a 4 mm hex key and a torque wrench, which are included to the 1290 Infinity Service Kit p/n 5067-4699 set to 5 Nm. Install screws step by step, not screw by screw.

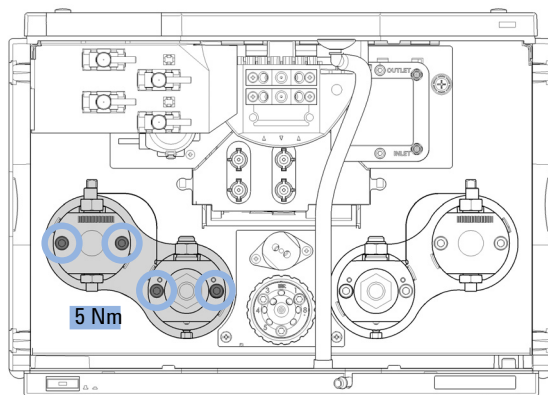

3 Install flow connections.

- Connect the degassing unit outlet to the inlet of the primary pump head and the outlet of the secondary pump head to the inlet of the purge valve.
- Channel A (left pump head assembly) is connected to port 4, channel B (right pump head assembly) to port 1.

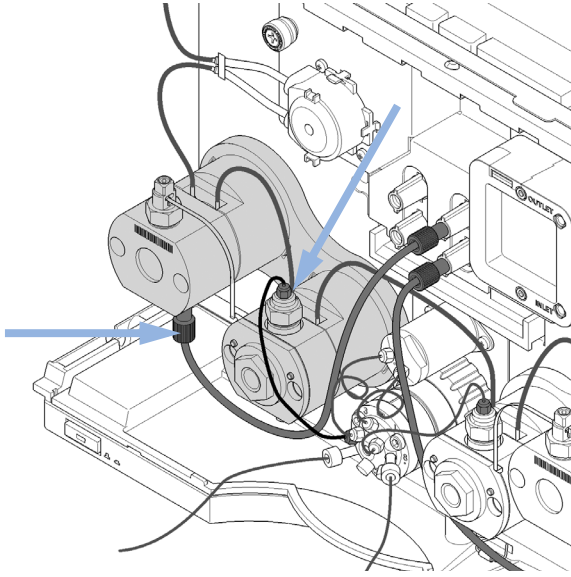
**Next Steps:**

- 4** Replace the seal wash tubes.
- 5** Open the shut-off valves.
- 6** Perform a Pump Leak Rate Test.

Replacing the Purge Valve Head

When In case of problems with the purge valve

Parts required	#	p/n	Description
	1	5067-4119	Purge valve head
	2	5067-4655	Capillary ST, 0.25 mm x 250 mm to pump head assemblies channel A and B (2x)
	1	G4220-87000	Capillary ST 0.17 mm x 300 mm Valve to Jet Weaver
	2	5067-4656	Capillary ST, 0.25 mm x 80 mm to pressure sensor (2x)

Preparations Remove all capillary connections to the purge valve

CAUTION

Potential damage of valve head or malfunction of valve

When the pump is switched on, the valve tag is accessed (read/write) and used for correctly positioning the valve.

If the valve head is replaced while the pump is on, invalid information may be written to the valve head making it unusable, or positioning may be wrong resulting in wrong flow connections inside the valve potentially damaging parts.

→ Switch off the pump before working on the purge valve.

CAUTION

Bias measurement results

The valve drive contains sensitive optical parts. Pollution of these parts can impair the accurate selection of valve ports and therefore bias measurement results.

→ Protect the optical parts from dust and other pollutions.

Replacing the Purge Valve Head

- 1** Remove all capillary connections. Then unscrew the black union nut and remove the head of the purge valve by pulling it to the front.

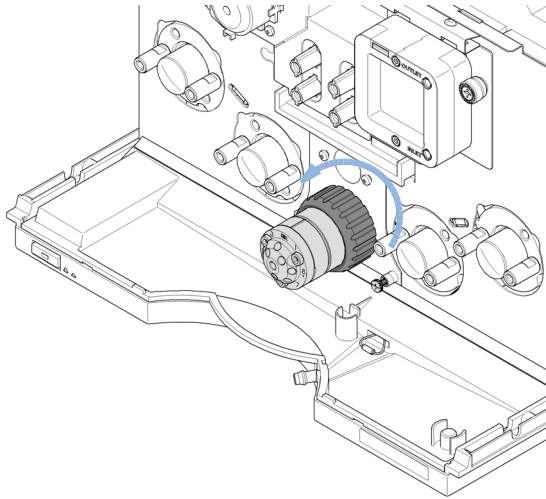

- 2** Put the new valve head onto the valve drive such that the lobe fits to the groove. Screw the valve head onto the valve drive using the union nut.

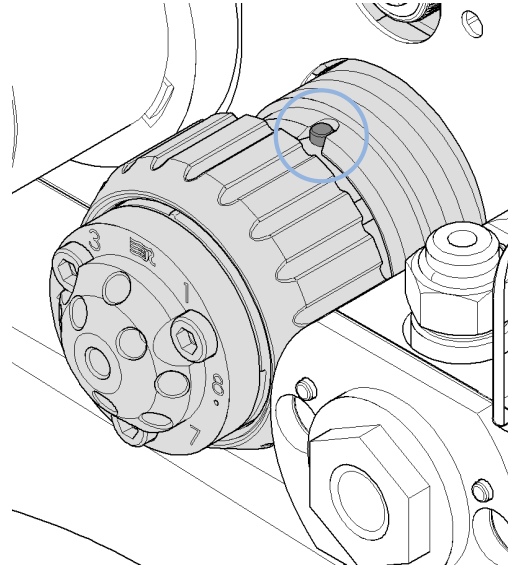

9 Maintenance

Replacing the Purge Valve Head

3 Install all flow connections:

- Port 1 is connected to the outlet of the secondary pump head of channel B
- Port 2 is connected to the outlet of the pressure sensor
- Port 3 is connected to the inlet of the pressure sensor
- Port 4 is connected the outlet of the secondary pump head of channel A
- Ports 5 and 6 are connected to waste capillaries
- The central port is connected to the Jet Weaver inlet

To pressure sensor

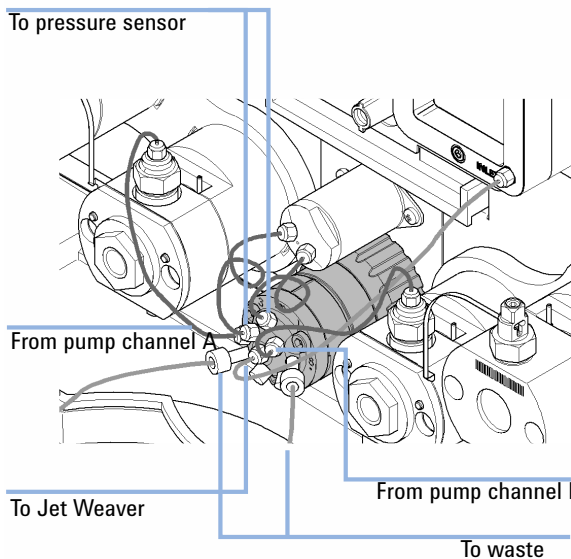

Replacing Parts of the High Pressure Filter Assembly

When For removing blockages and leaks in the high pressure filter assembly. The filter frit in the outlet valve should be replaced regularly depending on the system usage.

Tools required	p/n	Description
	5067-5688	Torque wrench 1 – 25 Nm with 14 mm wrench
	8710-0510	Open-end wrench 1/4 — 5/16 inch

Parts required	p/n	Description
	5067-4728	Seal cap
	01018-22707	PTFE frits (pack of 5)

CAUTION

Leakage or damaged connection

Opening the outlet of the primary pump head may cause leaks or damage the connection between the pump heads.

→ Do not open the outlet of the primary pump head.

NOTE

This procedure describes replacements for channel A (left pump head assembly) and can be applied accordingly to channel B. In both cases, maintenance is done only at the secondary pump head outlet, which hosts the filter frit.

NOTE

When replacing a PTFE frit, consider replacing the seal cap as well in order to prevent leaks.

9 Maintenance

Replacing Parts of the High Pressure Filter Assembly

- 1** Remove the capillary connection from the outlet of the secondary pump head.

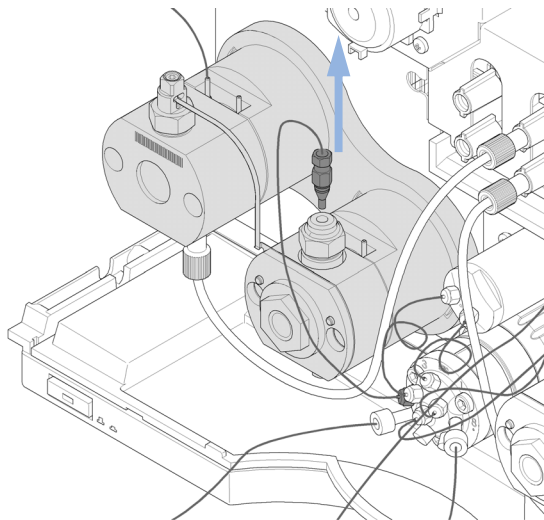

- 2** Use a 14 mm hex wrench for opening the filter assembly of the secondary pump head

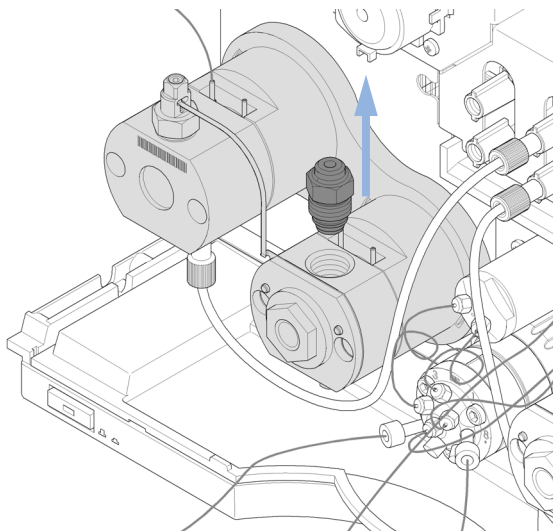

- 3** Replace the filter frit and seal cap as desired. Please note the correct orientation of the filter frit.

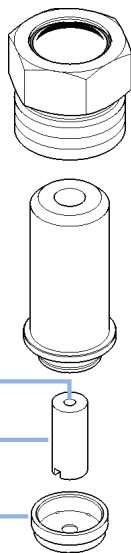

Hole

Filter frit

Seal cap

- 4** Re-install the filter assembly using the torque wrench (14 mm hex bit) set to 16 Nm.

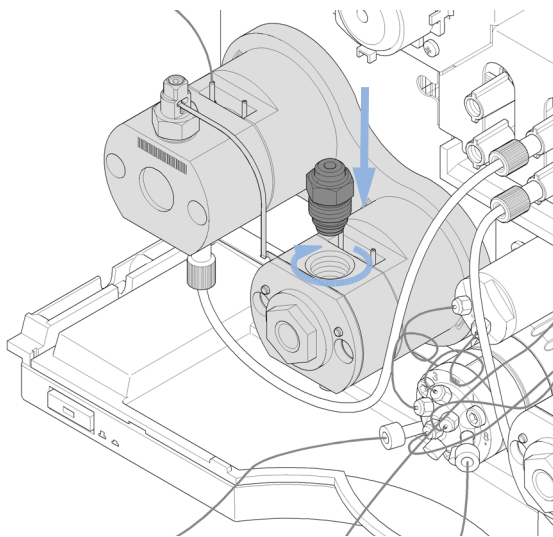

Installing the Valve Rail Kit

When This rail is needed for the installation of external valves

Tools required **Description**
Pozidrive screwdriver #1

Parts required	#	p/n	Description
	1	5067-4634	Valve Rail Kit

NOTE

The rail can be installed on the left or right side of the pump. This procedure describes the installation on the left side and applies similarly to the right side.

- 1 The valve rail is fixed to the pump cover by 4 screws. The position of the lower screws is marked on the module cover. First tighten these screws, and then tighten the upper screws.

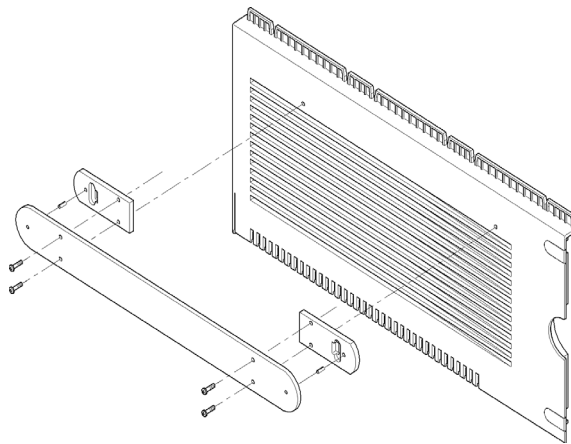

Replacing the Main Power Fuses

When If the main power LED is off while the main power button is pressed.

Tools required **Description**
Flat head screwdriver

Parts required	#	p/n	Description
	1	2110-1004	Fuse 10 A t

Preparations Switch off the instrument and unplug the main power cable.

WARNING

Fire hazard

Using wrong fuses can result in fire hazard.

- For continued protection against fire hazard, replace line fuses only with the same type and ratings.
- Only use the fuses specified for this instrument. The use of other fuses or materials is prohibited.

NOTE

There are more fuses inside the instrument.

If replacing the main power fuse does not resolve the issue, please contact your Agilent service representative.

Replacing the Main Power Fuses

- 1 Use a screwdriver for removing the main fuse carrier from the compartment next to the main power plug. Remove the fuse from the carrier.

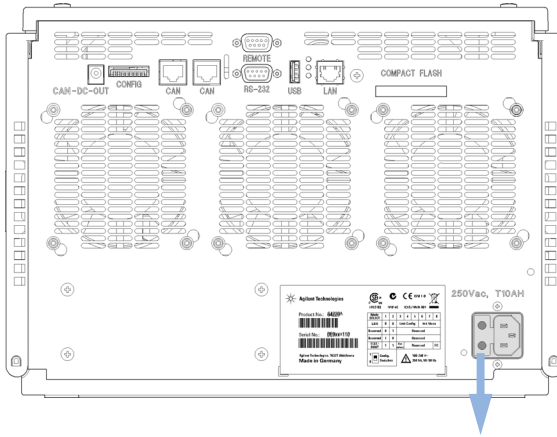

- 2 Install the new fuse 10A to the carrier and insert the carrier to the fuse compartment.

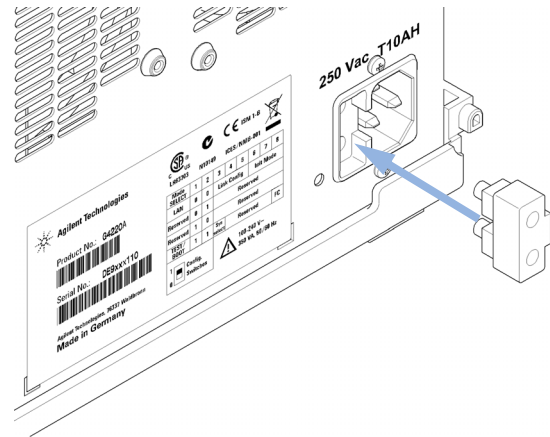

Replacing Module Firmware

When	The installation of newer firmware might be necessary <ul style="list-style-type: none">• if a newer version solves problems of older versions or• to keep all systems on the same (validated) revision. The installation of older firmware might be necessary <ul style="list-style-type: none">• to keep all systems on the same (validated) revision or• if a new module with newer firmware is added to a system or• if third party control software requires a special version.
-------------	---

Tools required	Description
	LAN/RS-232 Firmware Update Tool
OR	Agilent Lab Advisor software
OR	Instant Pilot G4208A (only if supported by module)

Parts required	#	Description
	1	Firmware, tools and documentation from Agilent web site

Preparations Read update documentation provided with the Firmware Update Tool.

To upgrade/downgrade the module's firmware carry out the following steps:

- 1 Download the required module firmware, the latest LAN/RS-232 FW Update Tool and the documentation from the Agilent web.
 - <http://www.agilent.com/en-us/firmwareDownload?whid=69761>
- 2 For loading the firmware into the module follow the instructions in the documentation.

Module Specific Information

There is no specific information for this module.

Preparing the Pump Module for Transport

When If the module shall be transported or shipped.

Parts required	#	p/n	Description
	1	9301-0411	Syringe; Plastic
	1	9301-1337	Syringe adapter
	1	G4220-44000	Protective Foam

Preparations Flush both solvent channels with isopropanol.

CAUTION

Mechanical damage

- For shipping the module, insert the Protective Foam to protected the module from mechanical damage.
 - Be careful not to damage tubing or capillary connections while inserting the module in the Protective Foam.
-

9 Maintenance

Preparing the Pump Module for Transport

- 1 Remove solvent inlets from solvent reservoirs. Disconnect the solvent tubing from the inlet of primary pump heads for both solvent channels. Use a syringe for removing liquid from the solvent tubings between solvent reservoir, shutoff valve panel, solvent selection valve, degassing unit and pump inlets. Switch the solvent selection valve if applicable.

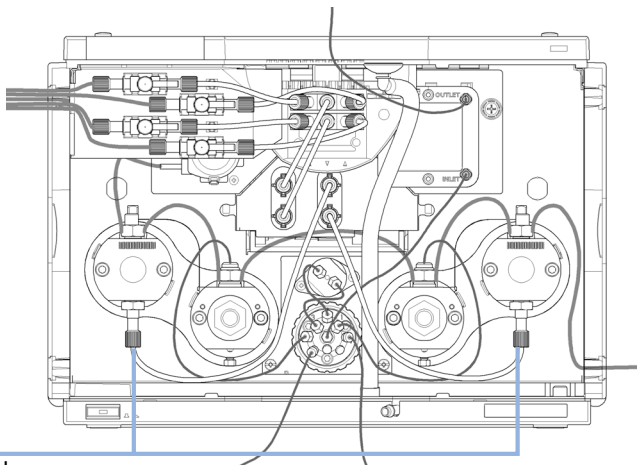

Inlet primary pump head

- 2 Remove tubing and capillary connections to other modules and the solvent cabinet. Remove tubing plugs.

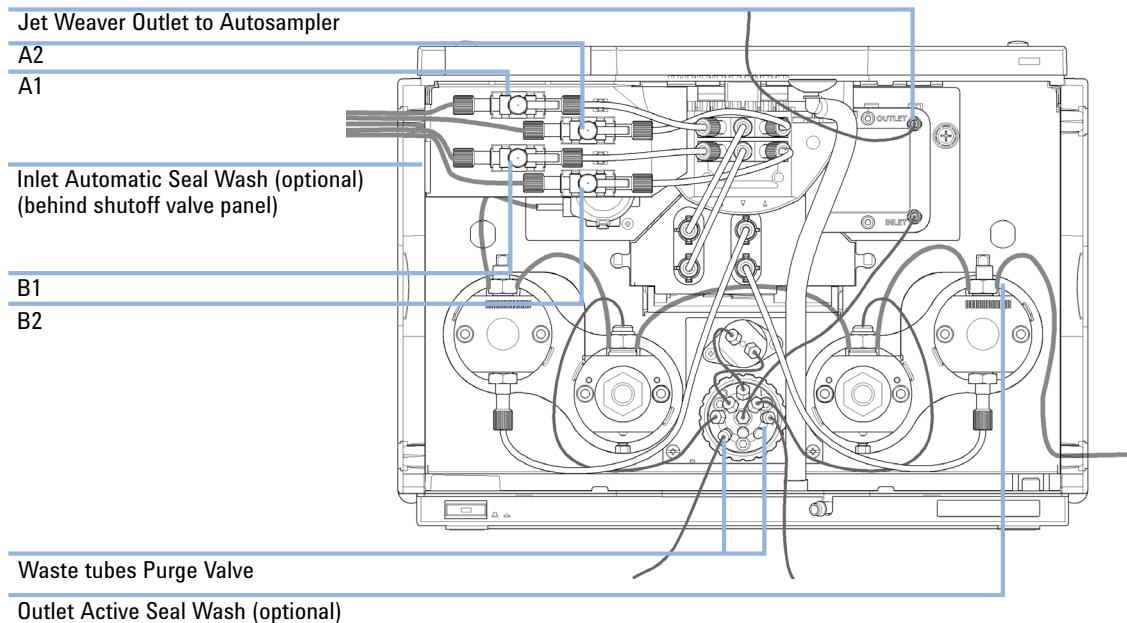

9 Maintenance

Preparing the Pump Module for Transport

- 3 Remove the shutoff valve panel by pulling it downwards

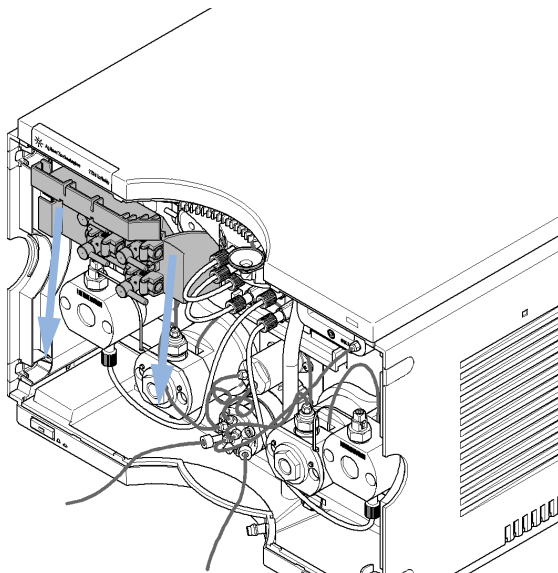

- 4 You may keep internal tubing and capillary connections.

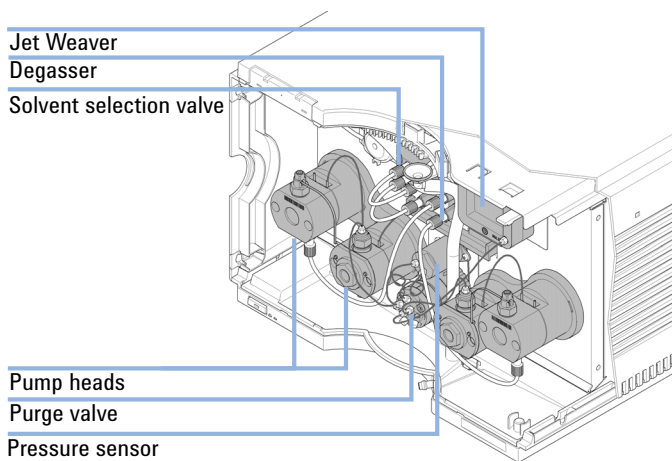

- 5 Remove cable connections to other modules. Remove the module from the stack.

- 6 Carefully insert the Protective Foam to the front part of the instrument. Do not damage any tubing or capillary connections.

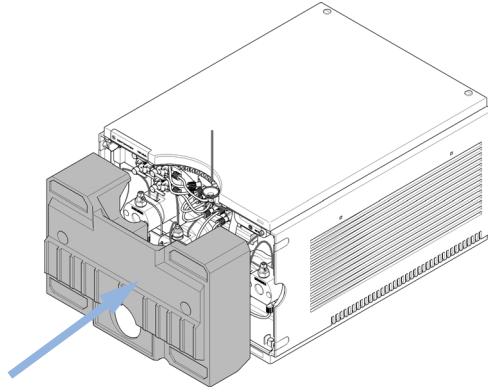

- 7 Close the front cover.

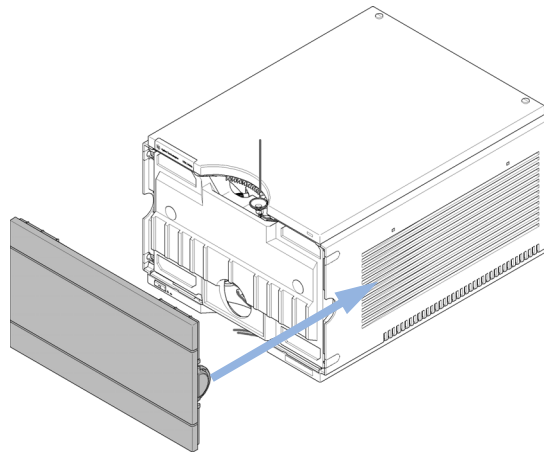

- 8 For transport or shipment, put the module and accessory kit to the original shipment box.

9 Maintenance

Preparing the Pump Module for Transport

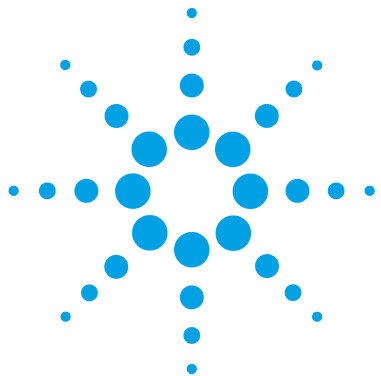

10 Parts and Materials for Maintenance

Overview of Maintenance Parts	196
Flow Connections	198
Solvent Cabinet Kit	200
Seal Wash Option	201
Pump Heads	202
Pump Head Assembly Parts	203
Primary Pump Head Parts	204
Secondary Pump Head Parts	205
Purge Valve	206
Cover Parts	208
Leak Parts	210
Fuses	211
Accessory Kit	212
Tools	213
HPLC System Tool Kit	215

This chapter provides information on parts for maintenance.



Overview of Maintenance Parts

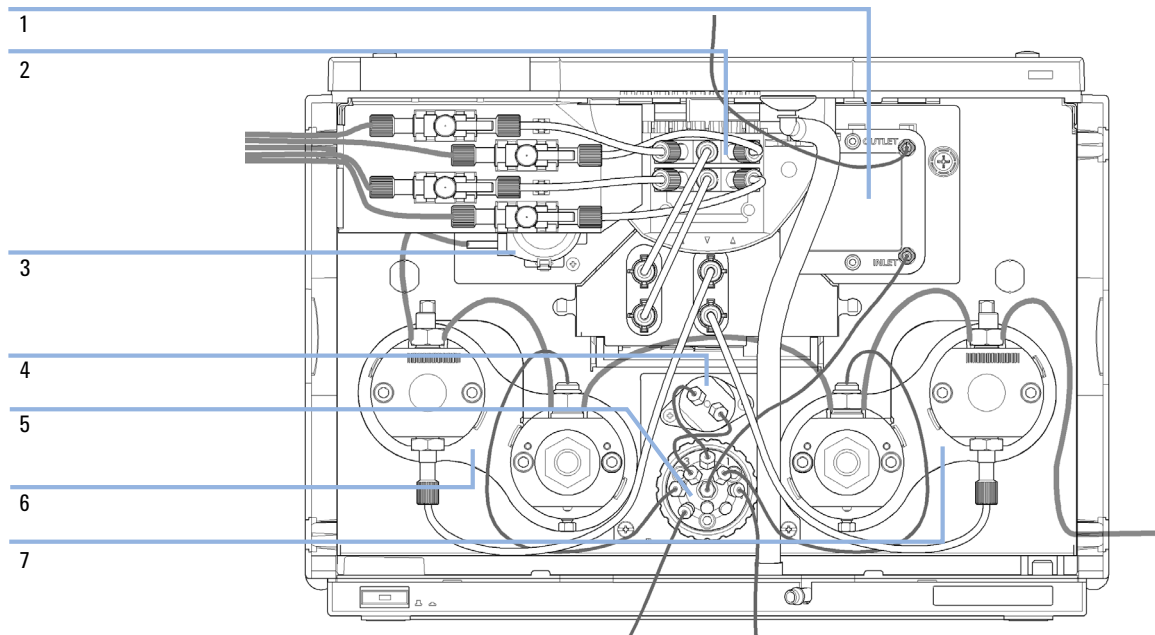

Figure 19 Overview of main assemblies

Item	p/n	Description
1	G4220-60006	Jet Weaver 35 µL/100 µL
	G4220-60012	Jet Weaver 380 µL (OPTIONAL)
2	G4280-60029	Solvent selection valve
3	5065-4445	Peristaltic pump with Pharmed tubing
4	G4220-60001	Pressure sensor 1200 bar
5	5067-4119	Purge valve head
6	G4220-60350	Long Life Pump Head Channel A
7	G4220-60360	Long Life Pump Head Channel B

Flow Connections

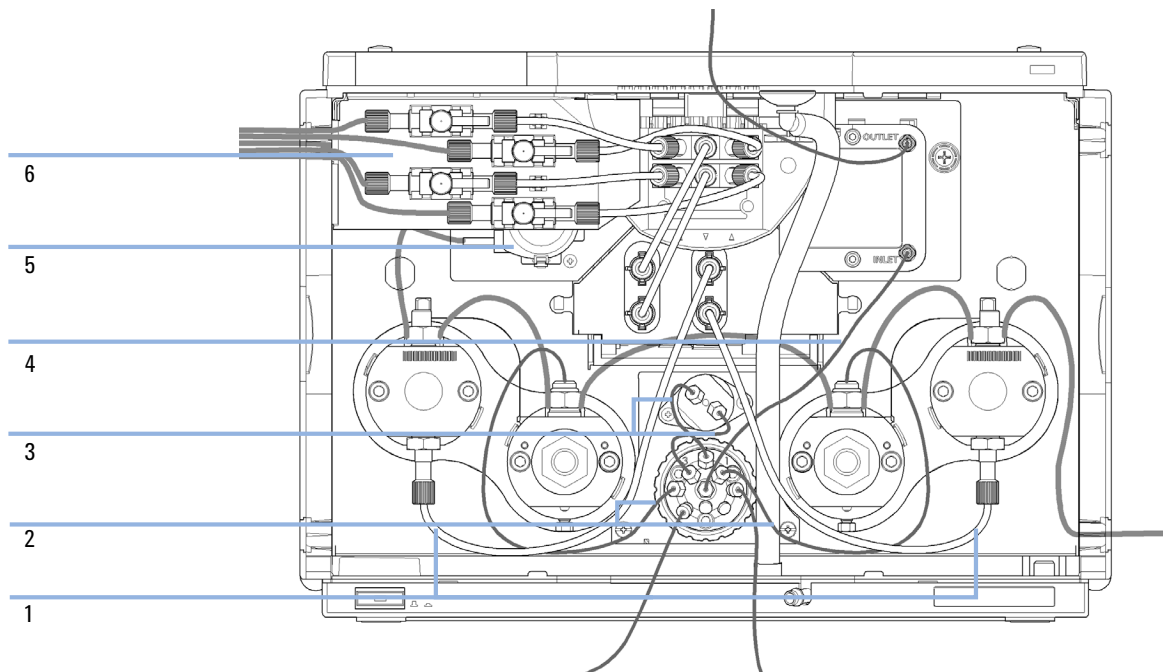

Figure 20 Flow connections of the pump

Item	#	p/n	Description
1	1	5067-4661	Tubing kit 270 mm for connection of degassing unit to inlet valve (set of 2 tubes)
2	2	5067-4655	Capillary ST, 0.25 mm x 250 mm purge valve to pump head assemblies channel A and B, 2x
3	2	5067-4656	Capillary ST, 0.25 mm x 80 mm purge valve to pressure sensor, 2x
4	1	G4220-87000	Capillary ST 0.17 mm x 300 mm Valve to Jet Weaver
5	1	5065-4445	Peristaltic pump with Pharmed tubing
	1	5065-9978	Tubing, 1 mm i.d., 3 mm o.d., silicone, 5 m
6	1	G4220-40004	Shutoff valve panel
	1	5067-4124	Shutoff valve
	1	G4220-60035	Tubing kit 140 mm, 2/pk SSV to shutoff valve or degassing unit
	1	G4220-60007	Bottle Head Assembly
	1	G4220-68070	Ultra Clean Tubing Kit (includes bottle head assemblies and tubing connections within the pump)
	1	G4220-60070	Tubing Kit 140 mm - Ultra Clean Tubing (tubes from SSV to shutoff valve or degassing unit to MCGV)
	1	G4220-60017	Bottle Head Assembly Ultra Clean Tubing (bottle heads and tubing to shutoff panel/degasser)

Solvent Cabinet Kit

Item	#	p/n	Description
1	1	5067-4644	Solvent Cabinet Kit 1290 Infinity Pump includes the following parts:
2	1	5065-9981	Solvent cabinet 1200 Infinity, including all plastic parts
3	3	9301-1420	Solvent bottle, transparent
4	1	9301-1450	Solvent bottle, amber
5	4	5067-4124	Shutoff valve
6	4	G4220-60007	Bottle Head Assembly
7	4	G4220-60035	Tubing kit 140 mm, 2/pk SSV to shutoff valve or degassing unit
8	1	G4220-40004	Shutoff valve panel
9	1	5042-9967	Tubing clip (set of 5 clips)

Seal Wash Option

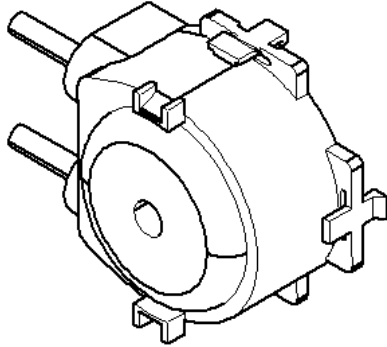

Figure 21 Seal wash pump

p/n	Description
5065-4445	Peristaltic pump with Pharmed tubing
5065-9978	Tubing, 1 mm i.d., 3 mm o.d., silicone, 5 m

Pump Heads

The following pages contain parts information for LongLife Pump Heads.

For parts information on other pump head types, please refer to Agilent 1290 Infinity II Easy Maintenance Pump Head Technical Note (01200-90120) and to Agilent 1290 Infinity Pump Head Maintenance Technical Note (G4220-90122).

Pump Head Assembly Parts

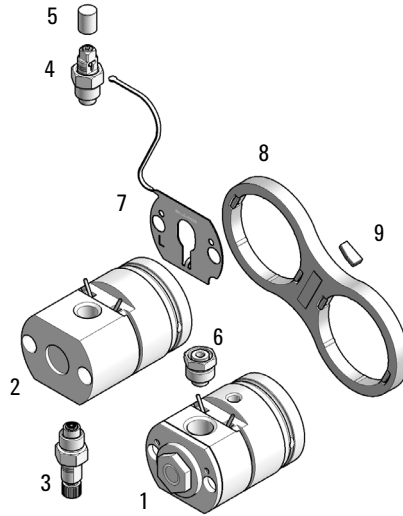
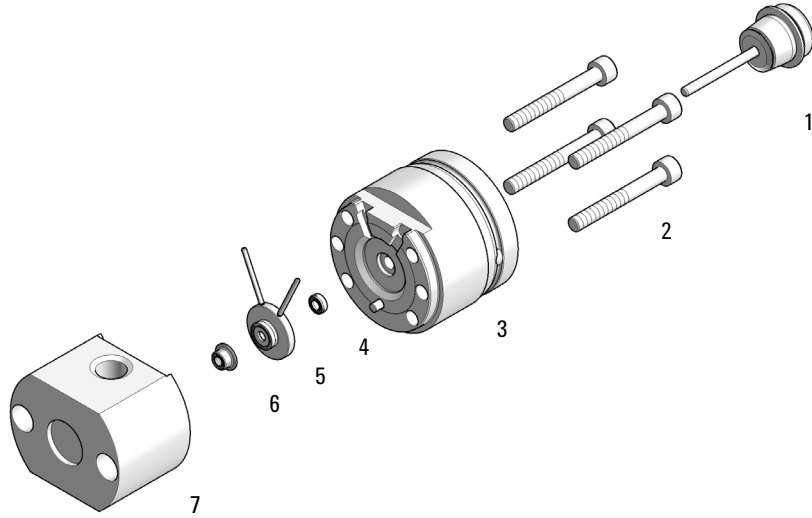

Figure 22 Pump head assembly parts

Long Life Pump Head Quat (G4204-60350)

Item	p/n	Description
1	G4220-60660	Secondary Pump Head Assembly Pendulum
2	G4220-60661	Primary Pump Head Assembly Pendulum
3	G4204-60022	Inlet Valve Quaternary Pump/Flexible Pump
4	G4220-60028	Outlet valve (primary pump head)
	G4220-20020	Internal gold seal for Outlet Valve (not shown)
5	5042-9966	Cap Outlet Valve
6	G1312-60001	Adapter
7	G4220-81013	Heat Exchanger
8	G4220-40001	Link Plate
9	0960-2971	RF Transponder

Primary Pump Head Parts



Primary Pump Head Assembly Pendulum (G4220-60661)

Item	p/n	Description
1	5067-5975	Plunger Assy ZrO ₂ LL
2	0515-6154	Screw-Socket-HD-Cap Hex-Recess M5X0.8 40
3	G4220-60046	Preload-Support Assembly LL
4	0905-1175	Wash seal (PTFE)
5	G4220-60616	Seal Holder Integrated Assembly EM/LL
6	0905-1719	PE Seal
7	G4220-60533	Body Head Primary EM/LL

Secondary Pump Head Parts

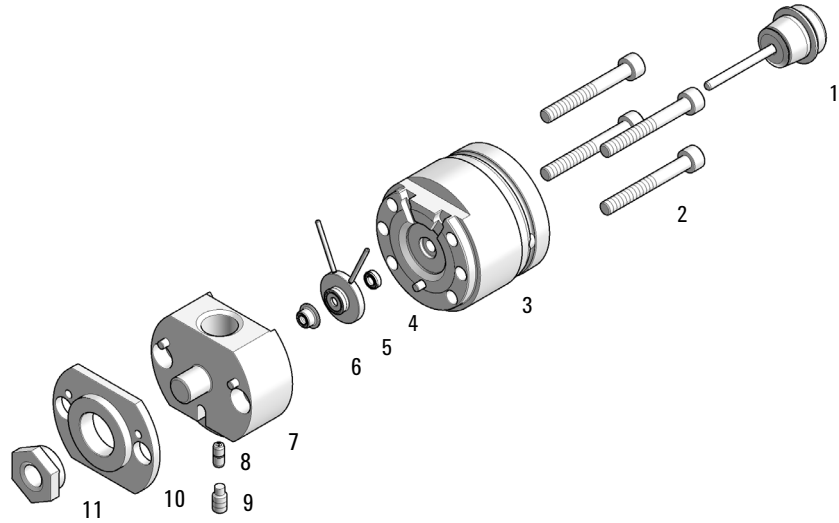

Secondary Pump Head Assembly Pendulum (G4220-60660)

Item	p/n	Description
1	5067-5975	Plunger Assy ZrO ₂ LL
2	0515-6154	Screw-Socket-HD-Cap Hex-Recess M5X0.8 40
3	G4220-60046	Preload-Support Assembly LL
4	0905-1175	Wash seal (PTFE)
5	G4220-60616	Seal Holder Integrated Assembly EM/LL
6	0905-1719	PE Seal
7	G4220-25513	Body Head Secondary EM/LL
8	G4220-20001	Spacer Fitting
9	G4220-20028	Headless screw for 1290 Infinity pump heads
10	G4220-20000	LID
11	G4220-20003	Pump Head Screw

Purge Valve

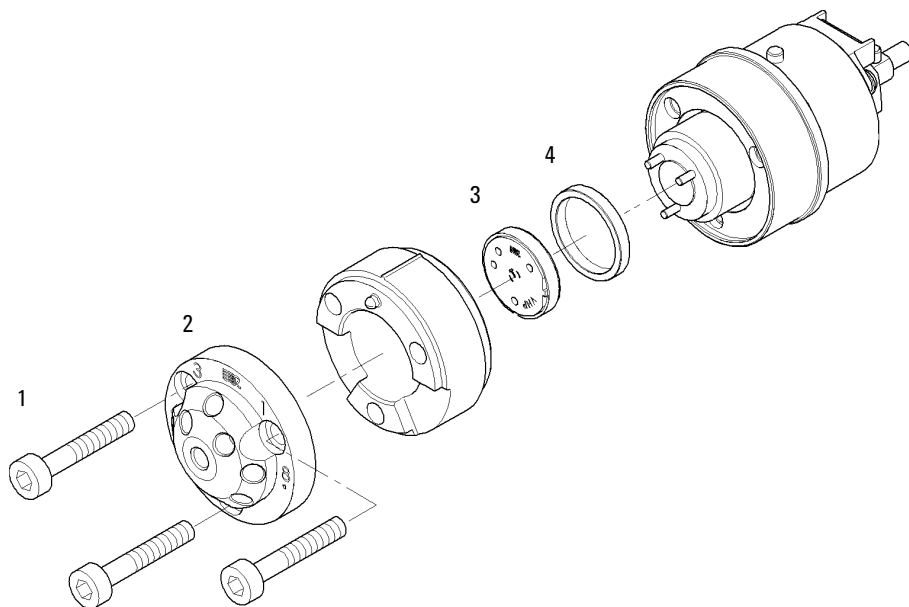

Figure 23 Purge valve parts

Item	p/n	Description
	5067-4119	Purge valve head
1	1535-4857	Stator screws
2	5068-0004	Purge Valve Stator
3	5068-0005	Purge Valve Rotor Seal, polyimide, 1200 bar
4	1535-4045	Bearing ring

Cover Parts

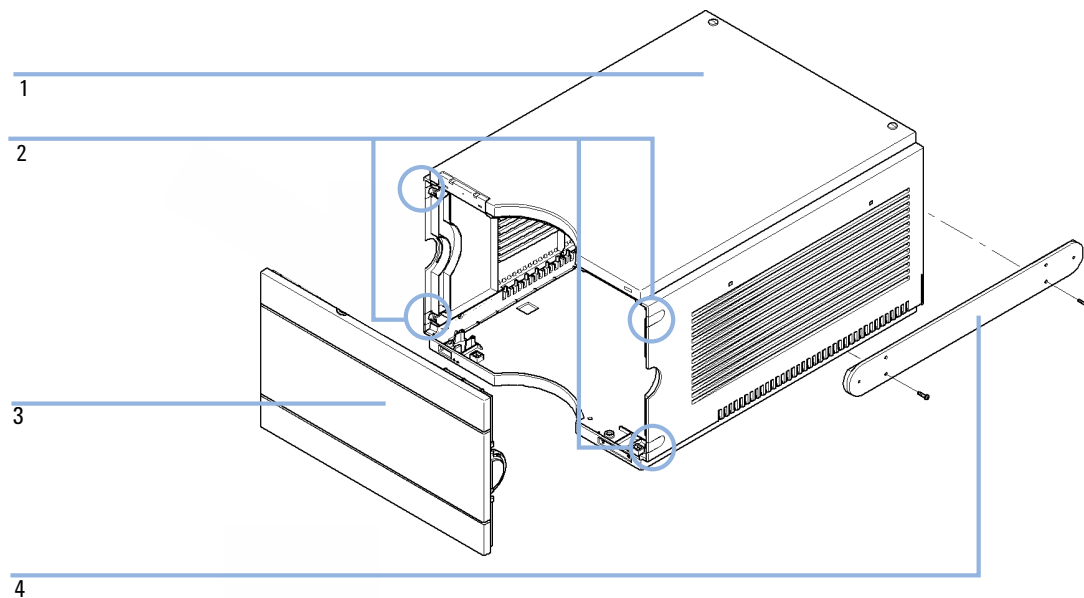

Figure 24 Cover Parts

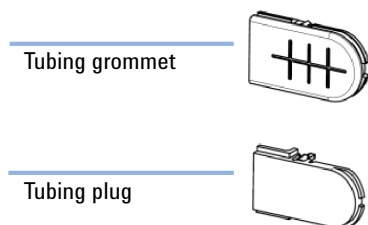

Figure 25 Tubing plug and tubing grommet

Item	p/n	Description
1	5067-4613	Cabinet Kit (Side Covers left/right, Top Cover, Tubing Plug, Base Cover and Leak Seal)
2	5042-9949	Tubing Plug, Plastic
	5042-9972	Tubing grommet
3	5067-4612	Front Cover 1290 Infinity Binary Pump
4	5067-4634	Valve Rail Kit

10 Parts and Materials for Maintenance

Leak Parts

Leak Parts



Figure 26 Leak funnel

p/n	Description
5041-8388	Leak funnel

Fuses

Item	#	p/n	Description
1	2	2110-1004	Fuse 10 A t

Accessory Kit

The Accessory Kit (G4220-68755) contains:

#	p/n	Description
2	0100-1816	Fitting Waste Tube to Purge Valve
1	5181-1519	CAN cable, Agilent module to module, 1 m
1	0890-2207	Tubing/Sleeving-Flex
1	5042-9967	Tubing clip (set of 5 clips)
4	5042-9972	Tubing grommet
1	9301-6476	Syringe with luerlock 5 mL Polypropylene
1	G1311-90107	Algae note
1	5063-6527	Tubing assembly, i.d. 6 mm, o.d. 9 mm, 1.2 m (to waste)
1	5500-1245	Capillary ST 0.17 mm x 400 mm SI/SI
1	5500-1217	Capillary ST 0.17 mm x 900 mm SI/SX ps-ps
1	9301-1337	Syringe adapter
1	01200-90091	1290 Infinity Pump Quick Reference Sheet
1	01200-90131	RFID Tag Assembly Version TechNote ENG
1	5067-6197	Seal Handling Device
1	5043-1400	Pump Head Holder

Tools

Item	p/n	Description
	5067-4699	1290 Infinity pump service kit
1	5067-5688	Torque wrench 1 – 25 Nm with 14 mm wrench
2	G4220-20013	4 mm hex bit
3	G4220-20014	2.5 mm Hex Bit
4	G4220-20015	Adapter ¼ in square to hex
	5023-0285	Replacement kit for 1290 Infinity pump head alignment tool (piston/handle)
	G4220-44000	Protective Foam
	G6500-88888	Hexalobular Key Set
	8710-0803	Wrench 9/16 inch, 7/16 inch

The 1290 Infinity pump service kit (5067-4699) includes pump head alignment tool and items 1 – 4.

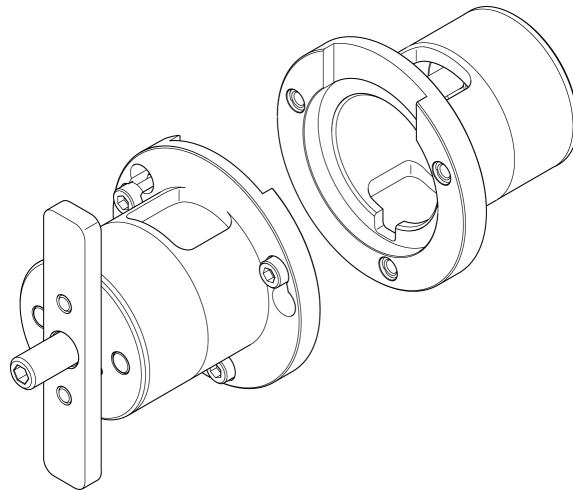

Figure 27 Pump head alignment tool

10 Parts and Materials for Maintenance

Tools

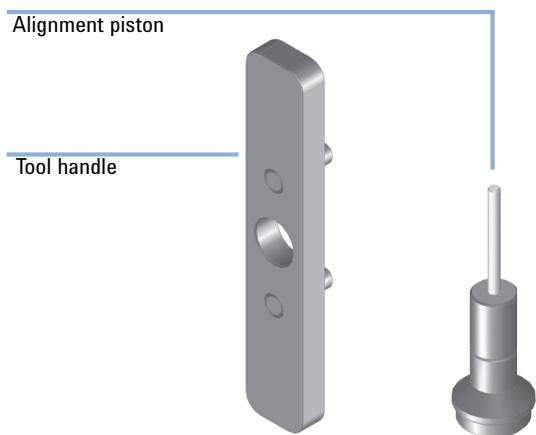
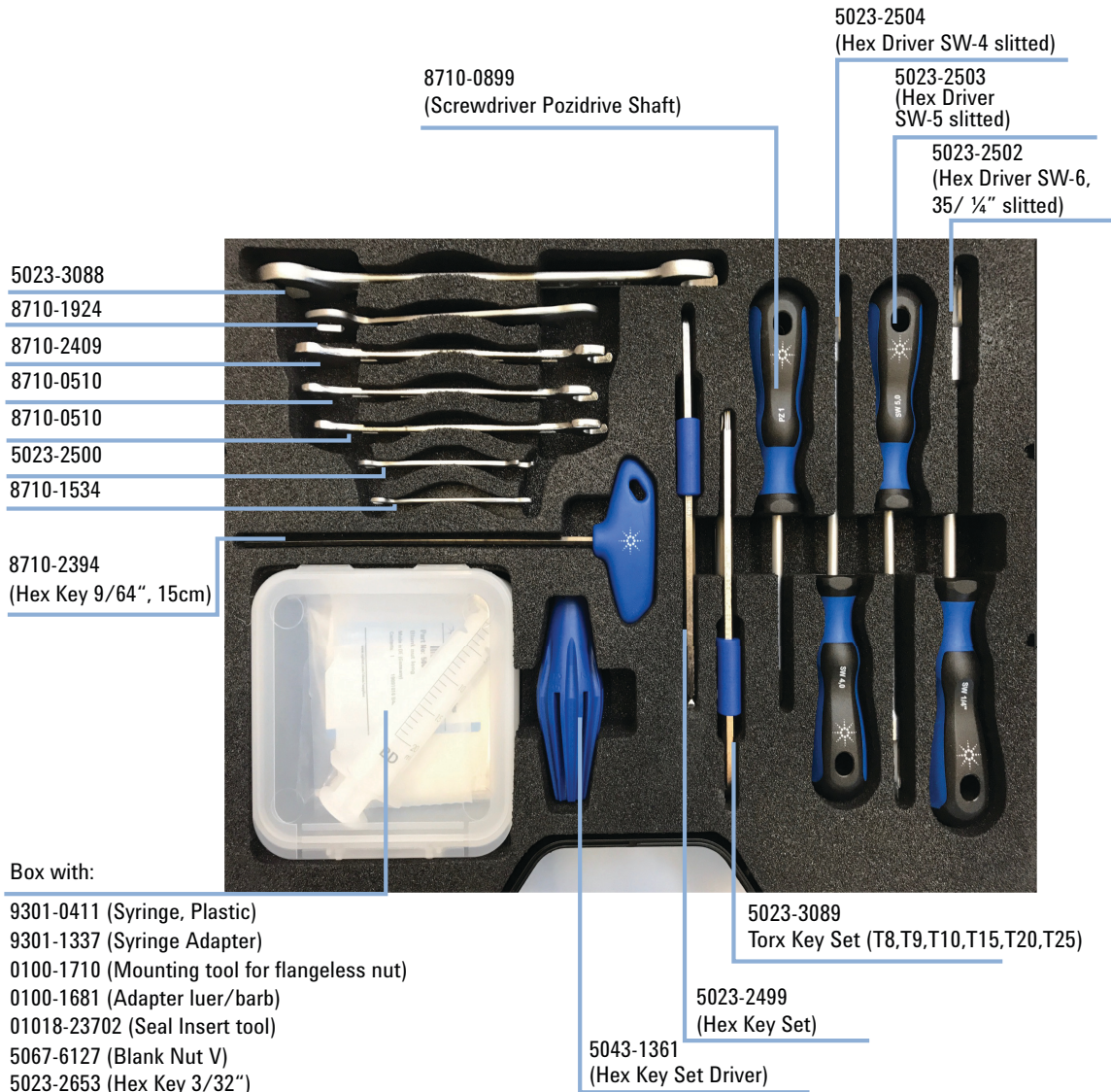

Figure 28 Replacement kit for 1290 Infinity pump head alignment tool (piston/handle)



Figure 29 HPLC System Tool Kit

HPLC System Tool Kit



10 Parts and Materials for Maintenance

HPLC System Tool Kit

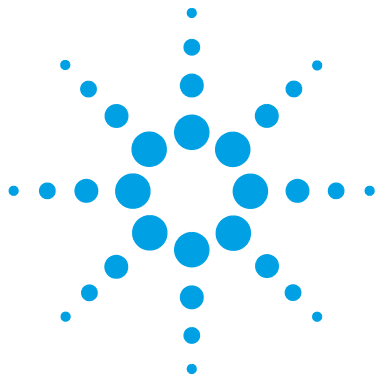

11 Identifying Cables

Cable Overview	218
Analog cables	220
Remote Cables	222
BCD Cables	225
CAN/LAN Cable	227
RS-232 Cable Kit	228
Agilent 1200 Module to Printer	229

This chapter provides information on cables used with the Agilent 1200 Infinity Series modules.



Cable Overview

NOTE

Never use cables other than the ones supplied by Agilent Technologies to ensure proper functionality and compliance with safety or EMC regulations.

Analog cables

p/n	Description
35900-60750	Agilent module to 3394/6 integrators
35900-60750	Agilent 35900A A/D converter
01046-60105	Analog cable (BNC to general purpose, spade lugs)

Remote cables

p/n	Description
03394-60600	Agilent module to 3396A Series I integrators 3396 Series II / 3395A integrator, see details in section " Remote Cables " on page 222
03396-61010	Agilent module to 3396 Series III / 3395B integrators
5061-3378	Remote Cable
01046-60201	Agilent module to general purpose

BCD cables

p/n	Description
03396-60560	Agilent module to 3396 integrators
G1351-81600	Agilent module to general purpose

CAN cables

p/n	Description
5181-1516	CAN cable, Agilent module to module, 0.5 m
5181-1519	CAN cable, Agilent module to module, 1 m

LAN cables

p/n	Description
5023-0203	Cross-over network cable, shielded, 3 m (for point to point connection)
5023-0202	Twisted pair network cable, shielded, 7 m (for point to point connection)

RS-232 cables

p/n	Description
RS232-61601	RS-232 cable, 2.5 m Instrument to PC, 9-to-9 pin (female). This cable has special pin-out, and is not compatible with connecting printers and plotters. It is also called "Null Modem Cable" with full handshaking where the wiring is made between pins 1-1, 2-3, 3-2, 4-6, 5-5, 6-4, 7-8, 8-7, 9-9.
5181-1561	RS-232 cable, 8 m

11 Identifying Cables
Analog cables

Analog cables

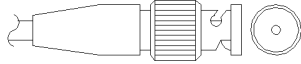

One end of these cables provides a BNC connector to be connected to Agilent modules. The other end depends on the instrument to which connection is being made.

Agilent Module to 3394/6 Integrators

p/n 35900-60750	Pin 3394/6	Pin Agilent module	Signal Name
	1		Not connected
	2	Shield	Analog -
	3	Center	Analog +

Agilent Module to BNC Connector

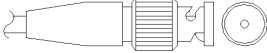
p/n 8120-1840	Pin BNC	Pin Agilent module	Signal Name
	Shield	Shield	Analog -
	Center	Center	Analog +

Agilent Module to General Purpose

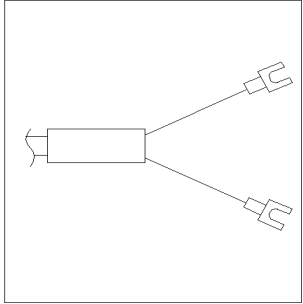
p/n 01046-60105	Pin	Pin Agilent module	Signal Name
	1		Not connected
	2	Black	Analog -
	3	Red	Analog +

Remote Cables

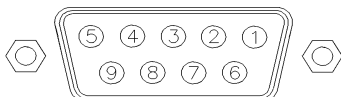

One end of these cables provides a Agilent Technologies APG (Analytical Products Group) remote connector to be connected to Agilent modules. The other end depends on the instrument to be connected to.

Agilent Module to 3396A Integrators

p/n 03394-60600	Pin 3396A	Pin Agilent module	Signal Name	Active (TTL)
<p>A diagram of the Agilent module connector, a vertical rectangular component with a central row of pins. Pins 1, 3, 5, 7, and 9 are labeled on the left side, and pins 13 and 15 are labeled on the right side.</p>	9	1 - White	Digital ground	
	NC	2 - Brown	Prepare run	Low
	3	3 - Gray	Start	Low
	NC	4 - Blue	Shut down	Low
	NC	5 - Pink	Not connected	
	NC	6 - Yellow	Power on	High
	5,14	7 - Red	Ready	High
	1	8 - Green	Stop	Low
	NC	9 - Black	Start request	Low
	13, 15		Not connected	

Agilent Module to 3396 Series II / 3395A Integrators

Use the cable Agilent module to 3396A Series I integrators (03394-60600) and cut pin #5 on the integrator side. Otherwise the integrator prints START; not ready.

Agilent Module to 3396 Series III / 3395B Integrators

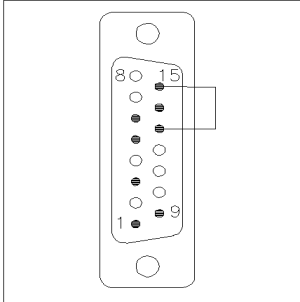
p/n 03396-61010	Pin 33XX	Pin Agilent module	Signal Name	Active (TTL)
	9	1 - White	Digital ground	
	NC	2 - Brown	Prepare run	Low
	3	3 - Gray	Start	Low
	NC	4 - Blue	Shut down	Low
	NC	5 - Pink	Not connected	
	NC	6 - Yellow	Power on	High
	14	7 - Red	Ready	High
	4	8 - Green	Stop	Low
	NC	9 - Black	Start request	Low
	13, 15		Not connected	

Agilent Module to Agilent 35900 A/D Converters

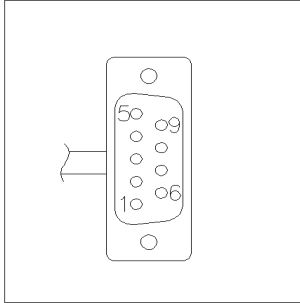
p/n 5061-3378	Pin 35900 A/D	Pin Agilent module	Signal Name	Active (TTL)
	1 - White	1 - White	Digital ground	
	2 - Brown	2 - Brown	Prepare run	Low
	3 - Gray	3 - Gray	Start	Low
	4 - Blue	4 - Blue	Shut down	Low
	5 - Pink	5 - Pink	Not connected	
	6 - Yellow	6 - Yellow	Power on	High
	7 - Red	7 - Red	Ready	High
	8 - Green	8 - Green	Stop	Low
	9 - Black	9 - Black	Start request	Low

Agilent Module to General Purpose

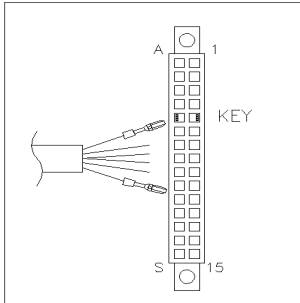
p/n 01046-60201	Wire Color	Pin Agilent module	Signal Name	Active (TTL)
	White	1	Digital ground	
	Brown	2	Prepare run	Low
	Gray	3	Start	Low
	Blue	4	Shut down	Low
	Pink	5	Not connected	
	Yellow	6	Power on	High
	Red	7	Ready	High
	Green	8	Stop	Low
	Black	9	Start request	Low

BCD Cables



One end of these cables provides a 15-pin BCD connector to be connected to the Agilent modules. The other end depends on the instrument to be connected to

Agilent Module to General Purpose

p/n G1351-81600	Wire Color	Pin Agilent module	Signal Name	BCD Digit
	Green	1	BCD 5	20
	Violet	2	BCD 7	80
	Blue	3	BCD 6	40
	Yellow	4	BCD 4	10
	Black	5	BCD 0	1
	Orange	6	BCD 3	8
	Red	7	BCD 2	4
	Brown	8	BCD 1	2
	Gray	9	Digital ground	Gray
	Gray/pink	10	BCD 11	800
	Red/blue	11	BCD 10	400
	White/green	12	BCD 9	200
	Brown/green	13	BCD 8	100
	not connected	14		
	not connected	15	+ 5 V	Low

11 Identifying Cables

BCD Cables

Agilent Module to 3396 Integrators

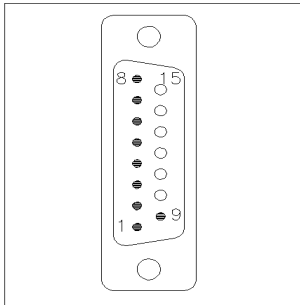
p/n 03396-60560	Pin 3396	Pin Agilent module	Signal Name	BCD Digit
	1	1	BCD 5	20
	2	2	BCD 7	80
	3	3	BCD 6	40
	4	4	BCD 4	10
	5	5	BCD0	1
	6	6	BCD 3	8
	7	7	BCD 2	4
	8	8	BCD 1	2
	9	9	Digital ground	
	NC	15	+ 5 V	Low

CAN/LAN Cable

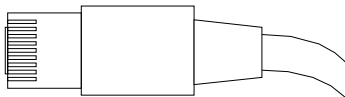

Both ends of this cable provide a modular plug to be connected to Agilent modules CAN or LAN connectors.

CAN Cables

p/n	Description
5181-1516	CAN cable, Agilent module to module, 0.5 m
5181-1519	CAN cable, Agilent module to module, 1 m

LAN Cables

p/n	Description
5023-0203	Cross-over network cable, shielded, 3 m (for point to point connection)
5023-0202	Twisted pair network cable, shielded, 7 m (for point to point connection)

RS-232 Cable Kit

p/n	Description
RS232-61601	RS-232 cable, 2.5 m Instrument to PC, 9-to-9 pin (female). This cable has special pin-out, and is not compatible with connecting printers and plotters. It is also called "Null Modem Cable" with full handshaking where the wiring is made between pins 1-1, 2-3, 3-2, 4-6, 5-5, 6-4, 7-8, 8-7, 9-9.
5181-1561	RS-232 cable, 8 m

Agilent 1200 Module to Printer

p/n	Description
5181-1529	Cable Printer Serial & Parallel, is a SUB-D 9 pin female vs. Centronics connector on the other end (NOT FOR FW UPDATE). For use with G1323 Control Module.

11 Identifying Cables

Agilent 1200 Module to Printer



12 Hardware Information

Firmware Description	232
Electrical Connections	235
Rear View of the Module	236
Interfaces	237
Overview Interfaces	240
Setting the 8-bit Configuration Switch	244
Special Settings	246
Instrument Layout	248
Early Maintenance Feedback	249

This chapter describes the pump in more detail on hardware and electronics.



Firmware Description

The firmware of the instrument consists of two independent sections:

- a non-instrument specific section, called *resident system*
- an instrument specific section, called *main system*

Resident System

This resident section of the firmware is identical for all Agilent 1100/1200/1220/1260/1290 series modules. Its properties are:

- the complete communication capabilities (CAN, LAN and RS-232C)
- memory management
- ability to update the firmware of the 'main system'

Main System

Its properties are:

- the complete communication capabilities (CAN, LAN and RS-232C)
- memory management
- ability to update the firmware of the 'resident system'

In addition the main system comprises the instrument functions that are divided into common functions like

- run synchronization through APG remote,
- error handling,
- diagnostic functions,
- or module specific functions like
 - internal events such as lamp control, filter movements,
 - raw data collection and conversion to absorbance.

Firmware Updates

Firmware updates can be done with the Agilent Lab Advisor software with files on the hard disk (latest version should be used).

Required tools, firmware and documentation are available from the Agilent web: <http://www.agilent.com/en-us/firmwareDownload?whid=69761>

The file naming conventions are:

PPPP_RVVV_XXX.dlb, where

- PPPP is the product number, for example, 1315B for the G1315B DAD,
- R the firmware revision, for example, A for G1315B or B for the G1315C DAD,
- VVV is the revision number, for example 650 is revision 6.50,
- XXX is the build number of the firmware.

For instructions on firmware updates refer to section *Replacing Firmware* in chapter "Maintenance" or use the documentation provided with the *Firmware Update Tools*.

NOTE

Update of main system can be done in the resident system only. Update of the resident system can be done in the main system only.

Main and resident firmware must be from the same set.

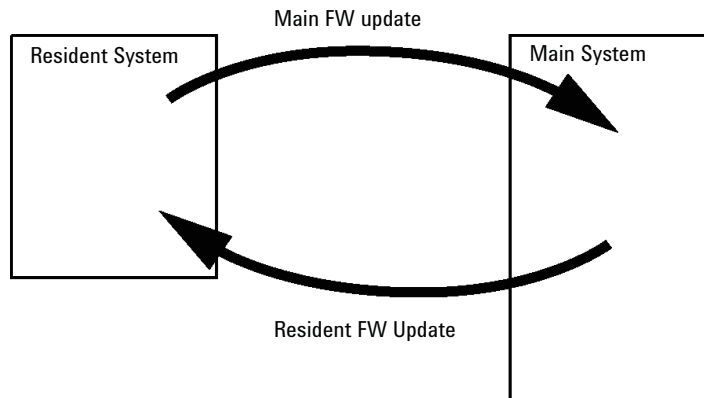

Figure 30 Firmware Update Mechanism

12 Hardware Information

Firmware Description

NOTE

Some modules are limited in downgrading due to their main board version or their initial firmware revision. For example, a G1315C DAD SL cannot be downgraded below firmware revision B.01.02 or to a A.xx.xx.

Some modules can be re-branded (e.g. G1314C to G1314B) to allow operation in specific control software environments. In this case, the feature set of the target type is used and the feature set of the original one is lost. After re-branding (e.g. from G1314B to G1314C), the original feature set is available again.

All this specific information is described in the documentation provided with the firmware update tools.

The firmware update tools, firmware and documentation are available from the Agilent web.

- <http://www.agilent.com/en-us/firmwareDownload?whid=69761>

Electrical Connections

- The CAN bus is a serial bus with high speed data transfer. The two connectors for the CAN bus are used for internal module data transfer and synchronization.
- The REMOTE connector may be used in combination with other analytical instruments from Agilent Technologies if you want to use features such as start, stop, common shut down, prepare, and so on.
- With the appropriate software, the RS-232C connector may be used to control the module from a computer through a RS-232C connection. This connector is activated and can be configured with the configuration switch.
- The power input socket accepts a line voltage of 100 – 240 VAC \pm 10 % with a line frequency of 50 or 60 Hz. Maximum power consumption varies by module. There is no voltage selector on your module because the power supply has wide-ranging capability. There are no externally accessible fuses, because automatic electronic fuses are implemented in the power supply.

NOTE

Never use cables other than the ones supplied by Agilent Technologies to ensure proper functionality and compliance with safety or EMC regulations.

Rear View of the Module

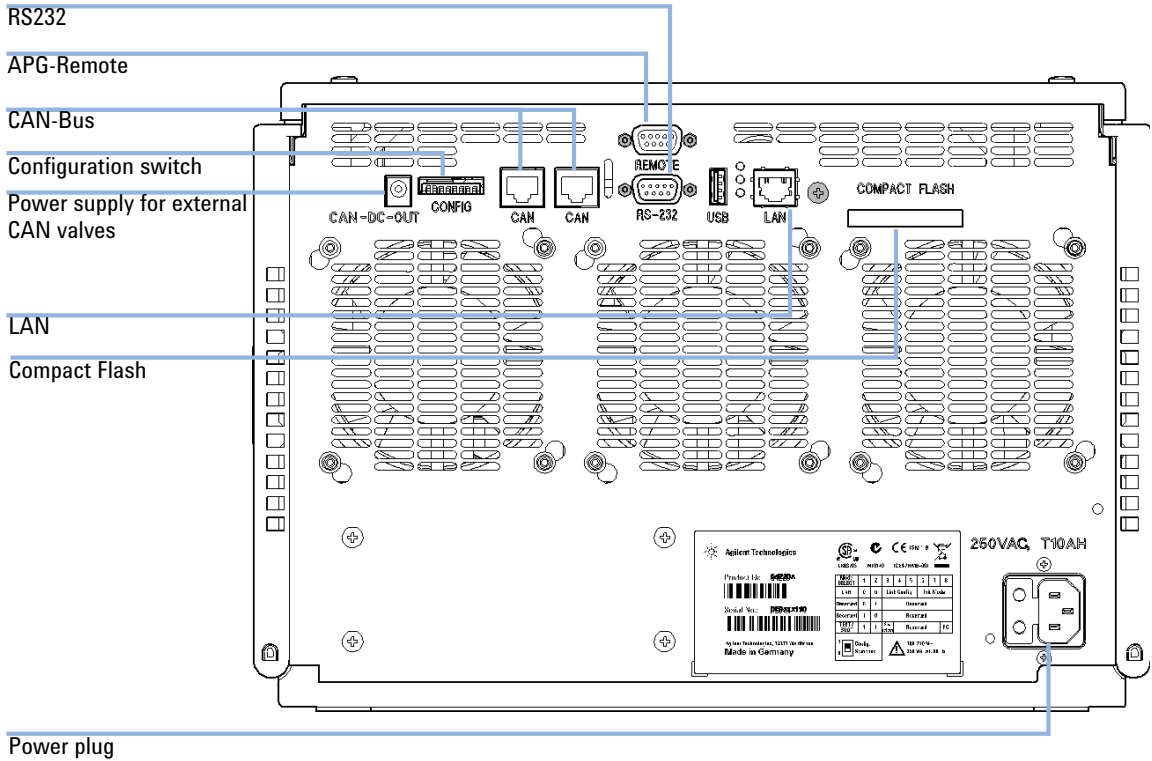

Figure 31 Rear of Binary Pump

Interfaces

The Agilent 1200 Infinity Series modules provide the following interfaces:

Table 9 Agilent 1200 Infinity Series Interfaces

Module	CAN	LAN/BCD (optional)	LAN (on-board)	RS-232	Analog	APG Remote	Special
Pumps							
G1310B Iso Pump G1311B Quat Pump G1311C Quat Pump VL G1312B Bin Pump K1312B Bin Pump Clinical Ed. G1312C Bin Pump VL 1376A Cap Pump G2226A Nano Pump G5611A Bio-inert Quat Pump	2	Yes	No	Yes	1	Yes	
G4220A/B Bin Pump G4204A Quat Pump	2	No	Yes	Yes	No	Yes	CAN-DC- OUT for CAN slaves
G1361A Prep Pump	2	Yes	No	Yes	No	Yes	CAN-DC- OUT for CAN slaves
Samplers							
G1329B ALS G2260A Prep ALS	2	Yes	No	Yes	No	Yes	THERMOSTAT for G1330B/K1330B
G1364B FC-PS G1364C FC-AS G1364D FC- μ S G1367E HiP ALS K1367E HiP ALS Clinical Ed. G1377A HiP micro ALS G2258A DL ALS G5664A Bio-inert FC-AS G5667A Bio-inert Autosampler	2	Yes	No	Yes	No	Yes	THERMOSTAT for G1330B/K1330B CAN-DC- OUT for CAN slaves
G4226A ALS	2	Yes	No	Yes	No	Yes	

12 Hardware Information

Interfaces

Table 9 Agilent 1200 Infinity Series Interfaces

Module	CAN	LAN/BCD (optional)	LAN (on-board)	RS-232	Analog	APG Remote	Special
Detectors							
G1314B VWD VL G1314C VWD VL+	2	Yes	No	Yes	1	Yes	
G1314E/F VWD K1314F Clinical Ed.	2	No	Yes	Yes	1	Yes	
G4212A/B DAD K4212B DAD Clinical Ed.	2	No	Yes	Yes	1	Yes	
G1315C DAD VL+ G1365C MWD G1315D DAD VL G1365D MWD VL	2	No	Yes	Yes	2	Yes	
G1321B FLD K1321B FLD Clinical Ed. G1321C FLD	2	Yes	No	Yes	2	Yes	
G1362A RID	2	Yes	No	Yes	1	Yes	
G4280A ELSD	No	No	No	Yes	Yes	Yes	EXT Contact AUTOZERO
Others							
G1170A Valve Drive	2	No	No	No	No	No	1
G1316A/C TCC K1316C TCC Clinical Ed.	2	No	No	Yes	No	Yes	
G1322A DEG K1322A DEG Clinical Ed.	No	No	No	No	No	Yes	AUX
G1379B DEG	No	No	No	Yes	No	Yes	
G4225A DEG K4225A DEG Clinical Ed.	No	No	No	Yes	No	Yes	

Table 9 Agilent 1200 Infinity Series Interfaces

Module	CAN	LAN/BCD (optional)	LAN (on-board)	RS-232	Analog	APG Remote	Special
G4227A Flex Cube	2	No	No	No	No	No	CAN-DC- OUT for CAN slaves ²
G4240A CHIP CUBE	2	Yes	No	Yes	No	Yes	CAN-DC- OUT for CAN slaves THERMOSTAT for G1330A/B (NOT USED), K1330B

¹ Requires a HOST module with on-board LAN (e.g. G4212A or G4220A with minimum firmware B.06.40 or C.06.40) or with additional G1369C LAN Card

NOTE

The detector (DAD/MWD/FLD/VWD/RID) is the preferred access point for control via LAN. The inter-module communication is done via CAN.

- CAN connectors as interface to other modules
- LAN connector as interface to the control software
- RS-232C as interface to a computer
- REMOTE connector as interface to other Agilent products
- Analog output connector(s) for signal output

Overview Interfaces

CAN

The CAN is inter-module communication interface. It is a 2-wire serial bus system supporting high speed data communication and real-time requirement.

LAN

The modules have either an interface slot for a LAN card (e.g. Agilent G1369B/C LAN Interface) or they have an on-board LAN interface (e.g. detectors G1315C/D DAD and G1365C/D MWD). This interface allows the control of the module/system via a PC with the appropriate control software. Some modules have neither on-board LAN nor an interface slot for a LAN card (e.g. G1170A Valve Drive or G4227A Flexible Cube). These are hosted modules and require a Host module with firmware B.06.40 or later or with additional G1369C LAN Card.

NOTE

If an Agilent detector (DAD/MWD/FLD/VWD/RID) is in the system, the LAN should be connected to the DAD/MWD/FLD/VWD/RID (due to higher data load). If no Agilent detector is part of the system, the LAN interface should be installed in the pump or autosampler.

RS-232C (Serial)

The RS-232C connector is used to control the module from a computer through RS-232C connection, using the appropriate software. This connector can be configured with the configuration switch module at the rear of the module. Refer to *Communication Settings for RS-232C*.

NOTE

There is no configuration possible on main boards with on-board LAN. These are pre-configured for

- 19200 baud,
- 8 data bit with no parity and
- one start bit and one stop bit are always used (not selectable).

The RS-232C is designed as DCE (data communication equipment) with a 9-pin male SUB-D type connector. The pins are defined as:

Table 10 RS-232C Connection Table

Pin	Direction	Function
1	In	DCD
2	In	RxD
3	Out	TxD
4	Out	DTR
5		Ground
6	In	DSR
7	Out	RTS
8	In	CTS
9	In	RI

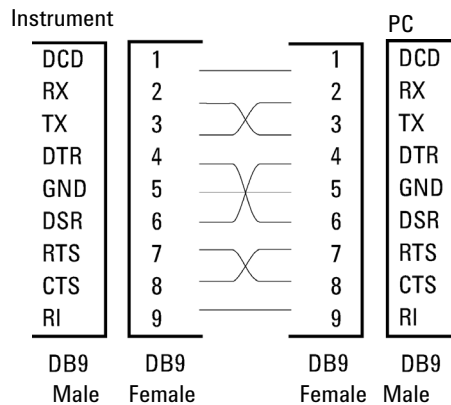

Figure 32 RS-232 Cable

Analog Signal Output

The analog signal output can be distributed to a recording device. For details refer to the description of the module's main board.

APG Remote

The APG Remote connector may be used in combination with other analytical instruments from Agilent Technologies if you want to use features as common shut down, prepare, and so on.

Remote control allows easy connection between single instruments or systems to ensure coordinated analysis with simple coupling requirements.

The subminiature D connector is used. The module provides one remote connector which is inputs/outputs (wired- or technique).

To provide maximum safety within a distributed analysis system, one line is dedicated to **SHUT DOWN** the system's critical parts in case any module detects a serious problem. To detect whether all participating modules are switched on or properly powered, one line is defined to summarize the **POWER ON** state of all connected modules. Control of analysis is maintained by signal readiness **READY** for next analysis, followed by **START** of run and optional **STOP** of run triggered on the respective lines. In addition **PREPARE** and **START REQUEST** may be issued. The signal levels are defined as:

- standard TTL levels (0 V is logic true, + 5.0 V is false),
- fan-out is 10,
- input load is 2.2 kOhm against + 5.0 V, and
- output are open collector type, inputs/outputs (wired- or technique).

NOTE

All common TTL circuits operate with a 5 V power supply. A TTL signal is defined as "low" or L when between 0 V and 0.8 V and "high" or H when between 2.0 V and 5.0 V (with respect to the ground terminal).

Table 11 Remote Signal Distribution

Pin	Signal	Description
1	DGND	Digital ground
2	PREPARE	(L) Request to prepare for analysis (for example, calibration, detector lamp on). Receiver is any module performing pre-analysis activities.
3	START	(L) Request to start run / timetable. Receiver is any module performing run-time controlled activities.
4	SHUT DOWN	(L) System has serious problem (for example, leak: stops pump). Receiver is any module capable to reduce safety risk.
5		Not used
6	POWER ON	(H) All modules connected to system are switched on. Receiver is any module relying on operation of others.
7	READY	(H) System is ready for next analysis. Receiver is any sequence controller.
8	STOP	(L) Request to reach system ready state as soon as possible (for example, stop run, abort or finish and stop injection). Receiver is any module performing run-time controlled activities.
9	START REQUEST	(L) Request to start injection cycle (for example, by start key on any module). Receiver is the autosampler.

Special Interfaces

The module includes a DC-Out (24 VDC) power line that is intended to be used with certain modules that operate as CAN slaves, for example external valves. The line has a limited output of 0.5 A (1.7 A as of August 2011) and is self resetting.

Setting the 8-bit Configuration Switch

The 8-bit configuration switch is located at the rear of the module. Switch settings provide configuration parameters for LAN, serial communication protocol and instrument specific initialization procedures.

All modules with on-board LAN:

- Default is ALL switches DOWN (best settings).
 - 19200 baud, 8 data bit / 1 stop bit with no parity for RS-232
- For specific LAN modes switches 3-8 must be set as required.
- For boot/test modes switches 1+2 must be UP plus required mode.

NOTE

For normal operation use the default (best) settings.

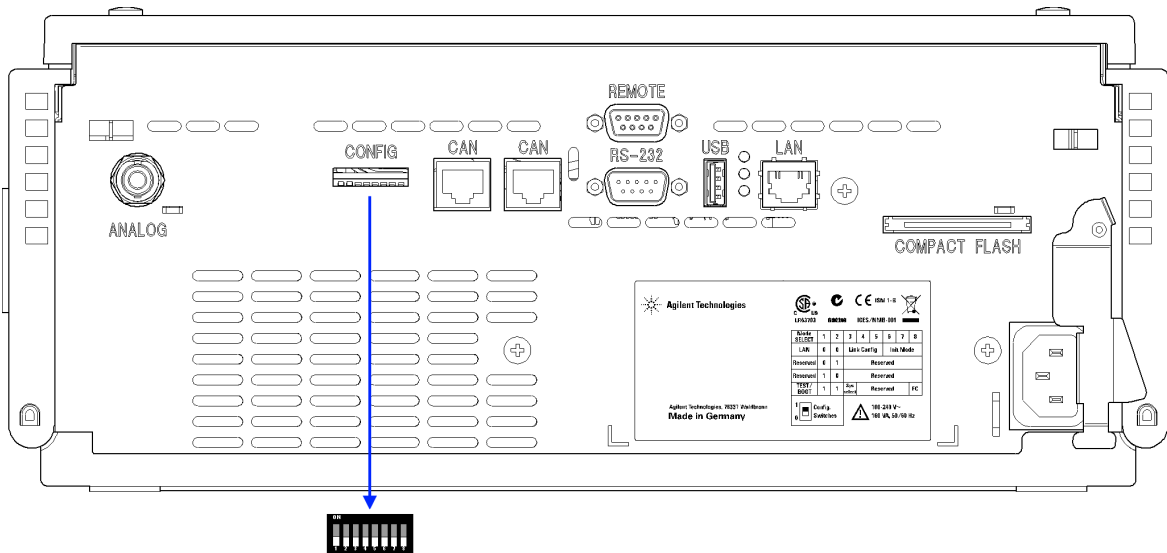

Figure 33 Location of Configuration Switch (example shows a G4212A DAD)

NOTE

To perform any LAN configuration, SW1 and SW2 must be set to OFF. For details on the LAN settings/configuration refer to chapter LAN Configuration.

Table 12 8-bit Configuration Switch (with on-board LAN)

	Mode		Function					
	SW 1	SW 2	SW 3	SW 4	SW 5	SW 6	SW 7	SW 8
LAN	0	0	Link Configuration			Init Mode Selection		
Auto-negotiation			0	x	x	x	x	x
10 MBit, half-duplex			1	0	0	x	x	x
10 MBit, full-duplex			1	0	1	x	x	x
100 MBit, half-duplex			1	1	0	x	x	x
100 MBit, full-duplex			1	1	1	x	x	x
Using Stored			x	x	x	0	1	0
DHCP			x	x	x	1	0	0
Using Default			x	x	x	0	1	1
TEST	1	1	System					NVRAM
Boot Resident System			1					x
Revert to Default Data (Coldstart)			x	x	x			1

Legend:

0 (switch down), 1 (switch up), x (any position)

NOTE

When selecting the mode TEST, the LAN settings are: Auto-Negotiation & Using Stored.

NOTE

For explanation of "Boot Resident System" and "Revert to Default Data (Coldstart)" refer to "Special Settings" on page 246.

Special Settings

The special settings are required for specific actions (normally in a service case).

NOTE

The tables include both settings for modules – with on-board LAN and without on-board LAN. They are identified as LAN and no LAN.

Boot-Resident

Firmware update procedures may require this mode in case of firmware loading errors (main firmware part).

If you use the following switch settings and power the instrument up again, the instrument firmware stays in the resident mode. It is not operable as a module. It only uses basic functions of the operating system for example, for communication. In this mode the main firmware can be loaded (using update utilities).

Table 13 Boot Resident Settings (On-board LAN)

Mode Select	SW1	SW2	SW3	SW4	SW5	SW6	SW7	SW8
TEST/BOOT	1	1	1	0	0	0	0	0

Forced Cold Start

A forced cold start can be used to bring the module into a defined mode with default parameter settings.

CAUTION

Loss of data

Forced cold start erases all methods and data stored in the non-volatile memory. Exceptions are calibration settings, diagnosis and repair log books which will not be erased.

→ Save your methods and data before executing a forced cold start.

If you use the following switch settings and power the instrument up again, a forced cold start has been completed.

Table 14 Forced Cold Start Settings (On-board LAN)

Mode Select	SW1	SW2	SW3	SW4	SW5	SW6	SW7	SW8
TEST/BOOT	1	1	0	0	0	0	0	1

Instrument Layout

The industrial design of the module incorporates several innovative features. It uses Agilent's E-PAC concept for the packaging of electronics and mechanical assemblies. This concept is based upon the use of expanded polypropylene (EPP) layers of foam plastic spacers in which the mechanical and electronic boards components of the module are placed. This pack is then housed in a metal inner cabinet which is enclosed by a plastic external cabinet. The advantages of this packaging technology are:

- virtual elimination of fixing screws, bolts or ties, reducing the number of components and increasing the speed of assembly/disassembly,
- the plastic layers have air channels molded into them so that cooling air can be guided exactly to the required locations,
- the plastic layers help cushion the electronic and mechanical parts from physical shock, and
- the metal inner cabinet shields the internal electronics from electromagnetic interference and also helps to reduce or eliminate radio frequency emissions from the instrument itself.

Early Maintenance Feedback

Maintenance requires the exchange of components which are subject to wear or stress. Ideally, the frequency at which components are exchanged should be based on the intensity of usage of the module and the analytical conditions, and not on a predefined time interval. The early maintenance feedback (**EMF**) feature monitors the usage of specific components in the instrument, and provides feedback when the user-selectable limits have been exceeded. The visual feedback in the user interface provides an indication that maintenance procedures should be scheduled.

EMF Counters

EMF counters increment with use and can be assigned a maximum limit which provides visual feedback in the user interface when the limit is exceeded. Some counters can be reset to zero after the required maintenance procedure.

Using the EMF Counters

The user-settable **EMF** limits for the **EMF Counters** enable the early maintenance feedback to be adapted to specific user requirements. The useful maintenance cycle is dependent on the requirements for use. Therefore, the definition of the maximum limits need to be determined based on the specific operating conditions of the instrument.

Setting the EMF Limits

The setting of the **EMF** limits must be optimized over one or two maintenance cycles. Initially the default **EMF** limits should be set. When instrument performance indicates maintenance is necessary, take note of the values displayed by the **EMF counters**. Enter these values (or values slightly less than the displayed values) as **EMF** limits, and then reset the **EMF counters** to zero. The next time the **EMF counters** exceed the new **EMF** limits, the **EMF** flag will be displayed, providing a reminder that maintenance needs to be scheduled.

12 Hardware Information

Early Maintenance Feedback

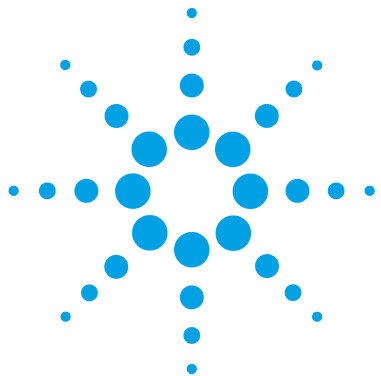

13 LAN Configuration

What You Have to Do First	252
TCP/IP parameter configuration	253
Configuration Switch	254
Initialization mode selection	255
Dynamic Host Configuration Protocol (DHCP)	257
General Information (DHCP)	257
Setup (DHCP)	258
Link configuration selection	260
Manual Configuration	261
With Telnet	262
With the Instant Pilot (G4208A)	266
PC and User Interface Software Setup	267
PC Setup for Local Configuration	267
User Interface Software Setup	268

This chapter provides information on connecting the detector to the Agilent ChemStation PC.



What You Have to Do First

The module has an on-board LAN communication interface.

- 1 Note the MAC (Media Access Control) address for further reference. The MAC or hardware address of the LAN interfaces is a world wide unique identifier. No other network device will have the same hardware address. The MAC address can be found on a label at the rear of the module (see [Figure 35](#) on page 252).

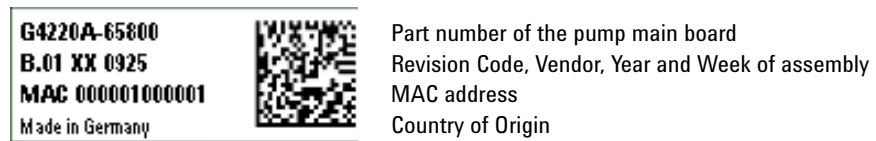

Figure 34 MAC-Label

- 2 Connect the instrument's LAN interface (see [Figure 35](#) on page 252) to
 - the PC network card using a crossover network cable (point-to-point) or
 - a hub or switch using a standard LAN cable.

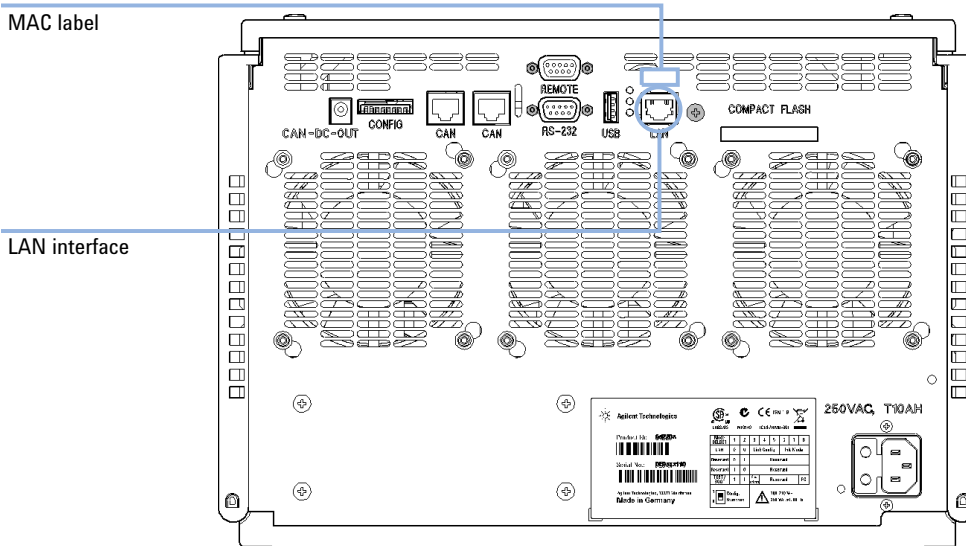

Figure 35 Location of LAN interfaces and MAC label

TCP/IP parameter configuration

To operate properly in a network environment, the LAN interface must be configured with valid TCP/IP network parameters. These parameters are:

- IP address
- Subnet Mask
- Default Gateway

The TCP/IP parameters can be configured by the following methods:

- by automatically requesting the parameters from a network-based DHCP Server (using the so-called Dynamic Host Configuration Protocol). This mode requires a LAN-onboard Module or a G1369C LAN Interface card, see [“Setup \(DHCP\)”](#) on page 258
- by manually setting the parameters using Telnet
- by manually setting the parameters using the Instant Pilot (G4208A)

The LAN interface differentiates between several initialization modes. The initialization mode (short form ‘init mode’) defines how to determine the active TCP/IP parameters after power-on. The parameters may be derived from non-volatile memory or initialized with known default values. The initialization mode is selected by the configuration switch, see [Table 16](#) on page 255.

Configuration Switch

The configuration switch can be accessed at the rear of the module.

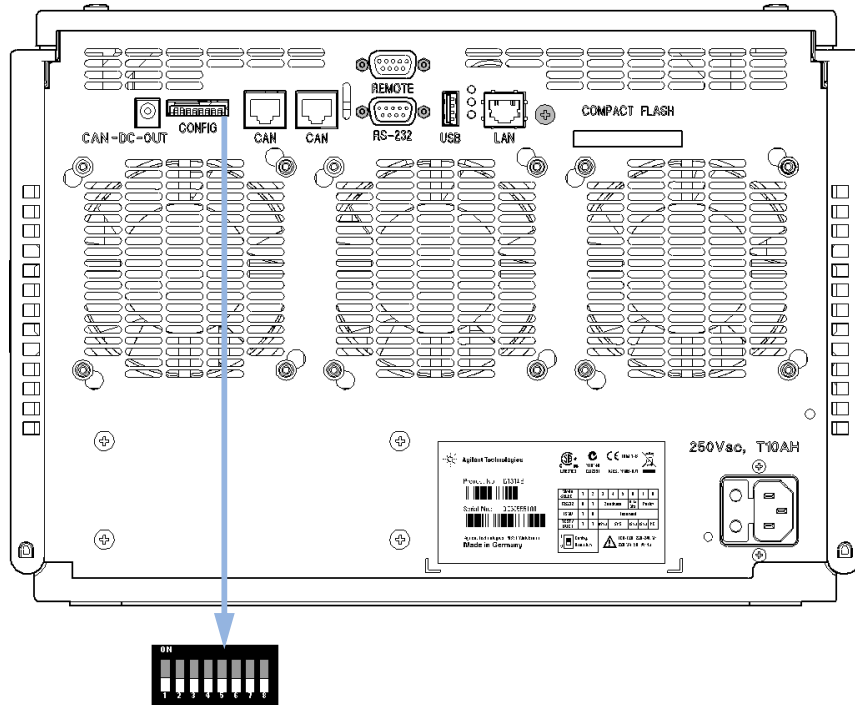

Figure 36 Location of Configuration Switch

The module is shipped with all switches set to OFF, as shown above.

NOTE

To perform any LAN configuration, SW1 and SW2 must be set to OFF.

Table 15 Factory Default Settings

Link Configuration

speed and duplex mode determined by auto-negotiation, for details see “Link configuration selection” on page 260

Initialization mode selection

The following initialization (init) modes are selectable:

Table 16 Initialization Mode Switches

	SW 6	SW 7	SW 8	Init Mode
	OFF	ON	OFF	Using Stored
	OFF	ON	ON	Using Default
	ON	OFF	OFF	DHCP ¹

¹ Requires firmware B.06.40 or above. Modules without LAN on board, see G1369C LAN Interface Card

Using Stored

When initialization mode **Using Stored** is selected, the parameters are taken from the non-volatile memory of the module. The TCP/IP connection will be established using these parameters. The parameters were configured previously by one of the described methods.

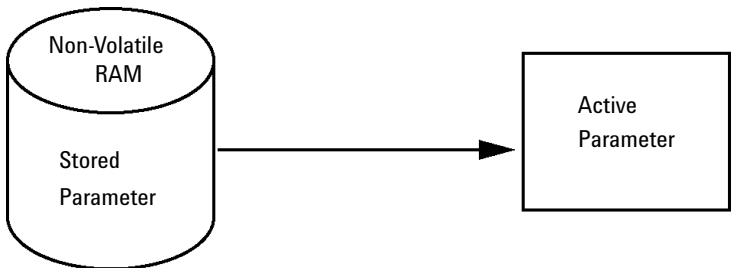

Figure 37 Using Stored (Principle)

Using Default

When **Using Default** is selected, the factory default parameters are taken instead. These parameters enable a TCP/IP connection to the LAN interface without further configuration, see [Table 17](#) on page 256.

13 LAN Configuration

Initialization mode selection

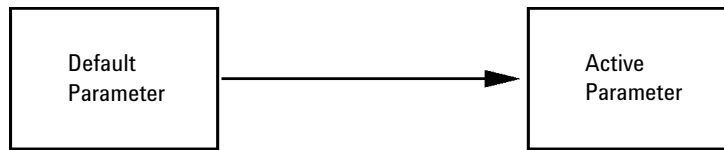

Figure 38 Using Default (Principle)

NOTE

Using the default address in your local area network may result in network problems. Take care and change it to a valid address immediately.

Table 17 Using Default Parameters

IP address:	192.168.254.11
Subnet Mask:	255.255.255.0
Default Gateway	not specified

Since the default IP address is a so-called local address, it will not be routed by any network device. Thus, the PC and the module must reside in the same subnet.

The user may open a Telnet session using the default IP address and change the parameters stored in the non-volatile memory of the module. He may then close the session, select the initialization mode Using Stored, power-on again and establish the TCP/IP connection using the new parameters.

When the module is wired to the PC directly (e.g. using a cross-over cable or a local hub), separated from the local area network, the user may simply keep the default parameters to establish the TCP/IP connection.

NOTE

In the **Using Default** mode, the parameters stored in the memory of the module are not cleared automatically. If not changed by the user, they are still available, when switching back to the mode Using Stored.

Dynamic Host Configuration Protocol (DHCP)

General Information (DHCP)

The Dynamic Host Configuration Protocol (DHCP) is an auto configuration protocol used on IP networks. The DHCP functionality is available on all Agilent HPLC modules with on-board LAN Interface or LAN Interface Card G1369C, and "B"-firmware (B.06.40 or above) or modules with "D"-firmware. All modules should use latest firmware from the same set.

When the initialization mode "DHCP" is selected, the card tries to download the parameters from a DHCP Server. The parameters obtained become the active parameters immediately. They are not stored to the non-volatile memory of the card.

Besides requesting the network parameters, the card also submits its hostname to the DHCP Server. The hostname equals the MAC address of the card, e.g. *0030d3177321*. It is the DHCP server's responsibility to forward the hostname/address information to the Domain Name Server. The card does not offer any services for hostname resolution (e.g. NetBIOS).

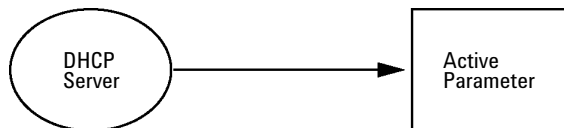

Figure 39 DHCP (Principle)

NOTE

- 1 It may take some time until the DHCP server has updated the DNS server with the hostname information.
- 2 It may be necessary to fully qualify the hostname with the DNS suffix, e.g. *0030d3177321.country.company.com*.
- 3 The DHCP server may reject the hostname proposed by the card and assign a name following local naming conventions.

13 LAN Configuration

Dynamic Host Configuration Protocol (DHCP)

Setup (DHCP)

The DHCP functionality is available on all Agilent HPLC modules with on-board LAN Interface or LAN Interface Card G1369C, and "B"-firmware (B.06.40 or above) or modules with "D"-firmware. All modules should use latest firmware from the same set.

- 1 Note the MAC address of the LAN interface (provided with G1369C LAN Interface Card or Main Board). This MAC address is on a label on the card or at the rear of the main board, e.g. *0030d3177321*.

On the Local Controller the MAC address can be found under **Details** in the LAN section.

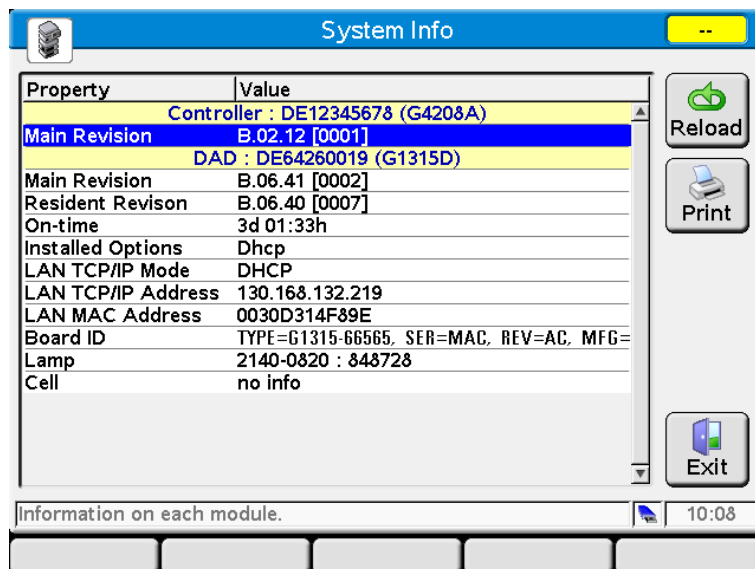

The screenshot shows the 'System Info' window with a table of properties and values. The table includes fields for Controller, Main Revision, Resident Revision, On-time, Installed Options, LAN TCP/IP Mode, LAN TCP/IP Address, LAN MAC Address, Board ID, Lamp, and Cell. The LAN MAC Address is 0030D314F89E. On the right side of the window, there are buttons for Reload, Print, and Exit. At the bottom, there is a status bar with the text 'Information on each module.' and a clock showing 10:08.

Property	Value
Controller : DE12345678 (G4208A)	
Main Revision	B.02.12 [0001]
DAD : DE64260019 (G1315D)	
Main Revision	B.06.41 [0002]
Resident Revision	B.06.40 [0007]
On-time	3d 01:33h
Installed Options	Dhcp
LAN TCP/IP Mode	DHCP
LAN TCP/IP Address	130.168.132.219
LAN MAC Address	0030D314F89E
Board ID	TYPE=G1315-66565, SER=MAC, REV=AC, MFG=
Lamp	2140-0820 : 848728
Cell	no info

Figure 40 LAN Setting on Instant Pilot

- 2 Set the Configuration Switch to DHCP either on the G1369C LAN Interface Card or the main board of above mentioned modules.

Table 18 G1369C LAN Interface Card (configuration switch on the card)

SW 4	SW 5	SW 6	SW 7	SW 8	Initialization Mode
ON	OFF	OFF	OFF	OFF	DHCP

Table 19 LC Modules with 8-bit configuration switch (B-firmware) (configuration switch at rear of the instrument)

SW 6	SW 7	SW 8	Initialization Mode
ON	OFF	OFF	DHCP

- 3 Turn on the module that hosts the LAN interface.
- 4 Configure your Control Software (e.g. OpenLAB CDS ChemStation Edition, Lab Advisor, Firmware Update Tool) and use MAC address as host name, e.g. *0030d3177321*.

The LC system should become visible in the control software (see Note in section “[General Information \(DHCP\)](#)” on page 257).

13 LAN Configuration

Link configuration selection

Link configuration selection

The LAN interface supports 10 or 100 Mbps operation in full- or half-duplex modes. In most cases, full-duplex is supported when the connecting network device - such as a network switch or hub - supports IEEE 802.3u auto-negotiation specifications.

When connecting to network devices that do not support auto-negotiation, the LAN interface will configure itself for 10- or 100-Mbps half-duplex operation.

For example, when connected to a non-negotiating 10-Mbps hub, the LAN interface will be automatically set to operate at 10-Mbps half-duplex.

If the module is not able to connect to the network through auto-negotiation, you can manually set the link operating mode using link configuration switches on the module.

Table 20 Link Configuration Switches

	SW 3	SW 4	SW 5	Link Configuration
	OFF	-	-	speed and duplex mode determined by auto-negotiation
	ON	OFF	OFF	manually set to 10 Mbps, half-duplex
	ON	OFF	ON	manually set to 10 Mbps, full-duplex
	ON	ON	OFF	manually set to 100 Mbps, half-duplex
	ON	ON	ON	manually set to 100 Mbps, full-duplex

Manual Configuration

Manual configuration only alters the set of parameters stored in the non-volatile memory of the module. It never affects the currently active parameters. Therefore, manual configuration can be done at any time. A power cycle is mandatory to make the stored parameters become the active parameters, given that the initialization mode selection switches are allowing it.

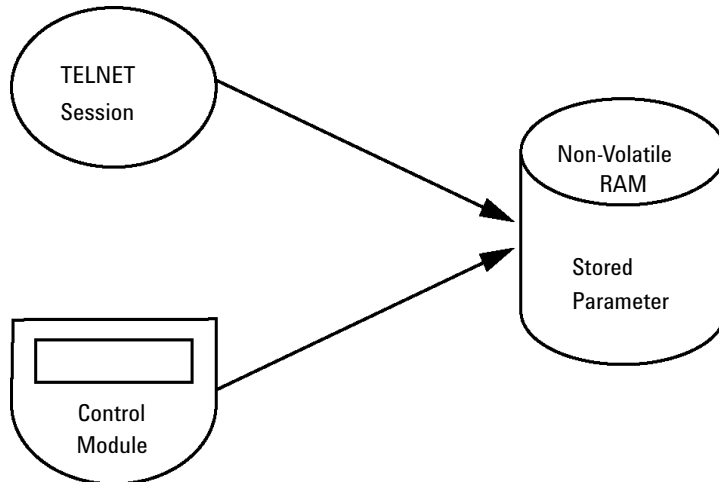
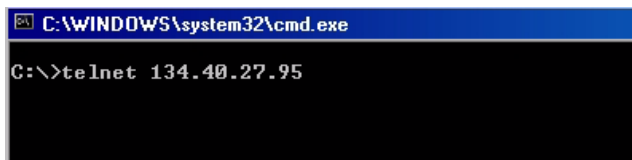

Figure 41 Manual Configuration (Principle)

With Telnet

Whenever a TCP/IP connection to the module is possible (TCP/IP parameters set by any method), the parameters may be altered by opening a Telnet session.

- 1 Open the system (DOS) prompt window by clicking on Windows **START** button and select **"Run..."**. Type **"cmd"** and press OK.
- 2 Type the following at the system (DOS) prompt:
 - `c:\>telnet <IP address>` or
 - `c:\>telnet <host name>`



```
C:\WINDOWS\system32\cmd.exe
C:\>telnet 134.40.27.95
```

Figure 42 Telnet - Starting a session

where `<IP address>` may be the assigned address from a Bootp cycle, a configuration session with the Handheld Controller, or the default IP address (see ["Configuration Switch"](#) on page 254).

When the connection was established successfully, the module responds with the following:

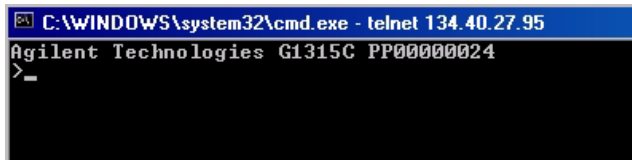

```
C:\WINDOWS\system32\cmd.exe - telnet 134.40.27.95
Agilent Technologies G1315C PP00000024
>_-
```

Figure 43 A connection to the module is made

- 3 Type `?` and press enter to see the available commands.

```

C:\WINDOWS\system32\cmd.exe - telnet 134.40.27.95
Agilent Technologies G1315C PP00000024
>?
command syntax          description
-----
?                        display help info
/                        display current LAN settings
ip <x.x.x.x>             set IP Address
sm <x.x.x.x>             set Subnet Mask
gw <x.x.x.x>             set Default Gateway
exit                    exit shell
>
  
```

Figure 44 Telnet Commands

Table 21 Telnet Commands

Value	Description
<code>?</code>	displays syntax and descriptions of commands
<code>/</code>	displays current LAN settings
<code>ip <x.x.x.x></code>	sets new ip address
<code>sm <x.x.x.x></code>	sets new subnet mask
<code>gw <x.x.x.x></code>	sets new default gateway
<code>exit</code>	exits shell and saves all changes

- 4 To change a parameter follows the style:

- parameter value, for example:
`ip 134.40.27.230`

Then press [Enter], where parameter refers to the configuration parameter you are defining, and value refers to the definitions you are assigning to that parameter. Each parameter entry is followed by a carriage return.

13 LAN Configuration

Manual Configuration

- 5 Use the “/” and press Enter to list the current settings.

```
C:\WINDOWS\system32\cmd.exe - telnet 134.40.27.95
>/
LAN Status Page
-----
MAC Address   : 0030D30A0838
-----
Init Mode    : Using Stored
-----
TCP/IP Properties
- active -
IP Address   : 134.40.27.95
Subnet Mask  : 255.255.248.0
Def. Gateway : 134.40.24.1
-----
TCP/IP Status : Ready
-----
Controllers  : no connections
>_
```

information about the LAN interface
MAC address, initialization mode
Initialization mode is Using Stored
active TCP/IP settings
TCP/IP status - here ready
connected to PC with controller software (e.g. Agilent
ChemStation), here not connected

Figure 45 Telnet - Current settings in "Using Stored" mode

- 6 Change the IP address (in this example 134.40.27.99) and type “/” to list current settings.

```
C:\WINDOWS\system32\cmd.exe - telnet 134.40.27.95
>ip 134.40.27.99
>/
LAN Status Page
-----
MAC Address   : 0030D30A0838
-----
Init Mode    : Using Stored
-----
TCP/IP Properties
- active -
IP Address   : 134.40.27.95
Subnet Mask  : 255.255.248.0
Def. Gateway : 134.40.24.1
- stored -
IP Address   : 134.40.27.99
Subnet Mask  : 255.255.248.0
Def. Gateway : 134.40.24.1
-----
TCP/IP Status : Ready
-----
Controllers  : no connections
>_
```

change of IP setting to
Initialization mode is Using Stored
active TCP/IP settings
stored TCP/IP settings in non-volatile memory

connected to PC with controller software (e.g. Agilent
ChemStation), here not connected

Figure 46 Telnet - Change IP settings

- 7 When you have finished typing the configuration parameters, type **exit** and press **Enter** to exit with storing parameters.

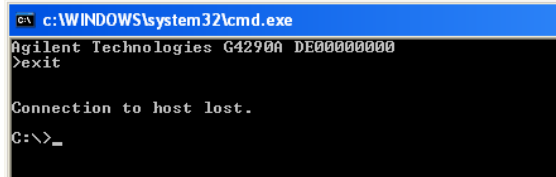

```
CA c:\WINDOWS\system32\cmd.exe
Agilent Technologies G4290A DE00000000
>exit

Connection to host lost.
C:\>_
```

Figure 47 Closing the Telnet Session

NOTE

If the Initialization Mode Switch is changed now to “Using Stored” mode, the instrument will take the stored settings when the module is re-booted. In the example above it would be 134.40.27.99.

With the Instant Pilot (G4208A)

To configure the TCP/IP parameters before connecting the module to the network, the Instant Pilot (G4208A) can be used.

- 1 From the Welcome screen press the **More** button.
- 2 Select **Configure**.
- 3 Press the module button of the module that hosts the LAN interface (usually the detector).
- 4 Scroll down to the LAN settings.

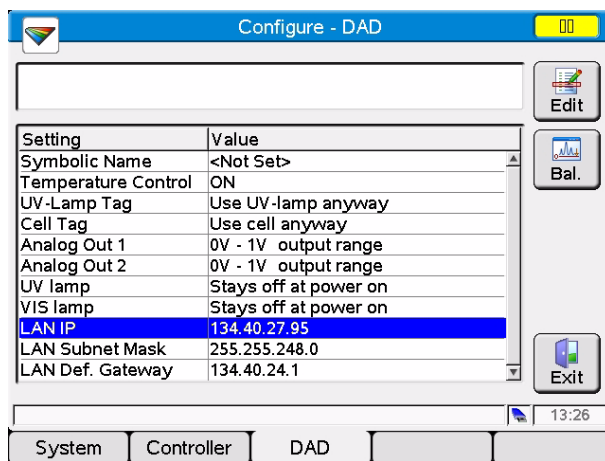

Figure 48 Instant Pilot - LAN Configuration

- 5 Press the **Edit** button (only visible if not in Edit mode), perform the required changes and press the **Done** button.
- 6 Leave the screen by clicking **Exit**.

PC and User Interface Software Setup Setup

PC Setup for Local Configuration

This procedure describes the change of the TCP/IP settings on your PC to match the module's default parameters in a local configuration (see also “Initialization mode selection” on page 255).

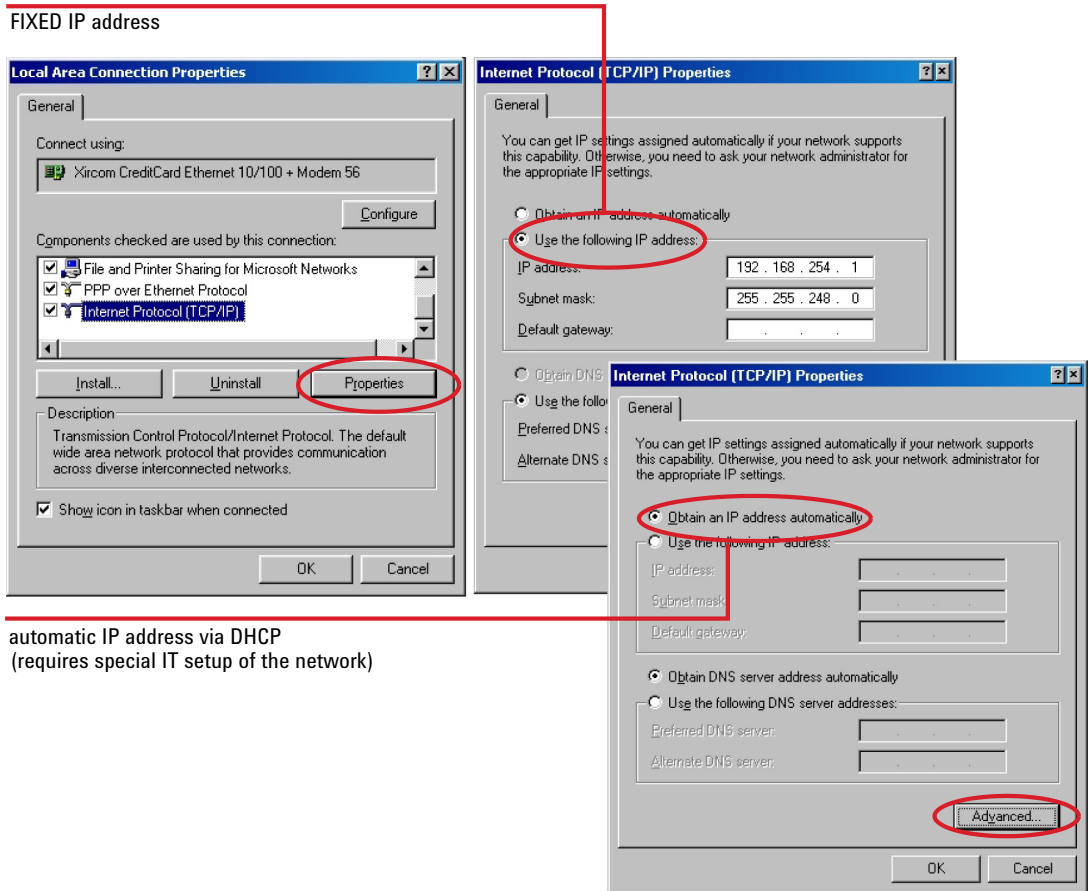

Figure 49 Changing the TCP/IP settings of the PC

13 LAN Configuration

PC and User Interface Software Setup

User Interface Software Setup

Install you user interface software according the provided *User Interface Software Setup Guide*.

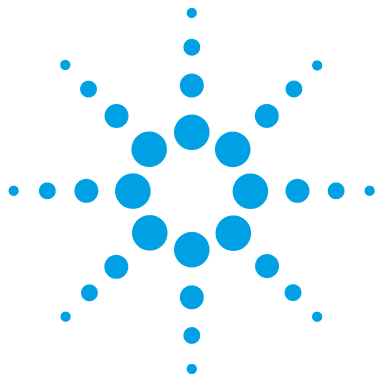

14 Appendix

General Safety Information [270](#)

The Waste Electrical and Electronic Equipment (WEEE) Directive
(2002-96-EC) [273](#)

Radio Interference [274](#)

Sound Emission [275](#)

Agilent Technologies on Internet [276](#)





This chapter provides addition information on safety, legal and web.



General Safety Information

Safety Symbols

Table 22 Safety Symbols

Symbol	Description
	The apparatus is marked with this symbol when the user should refer to the instruction manual in order to protect risk of harm to the operator and to protect the apparatus against damage.
	Indicates dangerous voltages.
	Indicates a protected ground terminal.
	Indicates eye damage may result from directly viewing the light produced by the deuterium lamp used in this product.
	The apparatus is marked with this symbol when hot surfaces are available and the user should not touch it when heated up.

WARNING

A WARNING

alerts you to situations that could cause physical injury or death.

- Do not proceed beyond a warning until you have fully understood and met the indicated conditions.

CAUTION

A CAUTION

alerts you to situations that could cause loss of data, or damage of equipment.

- Do not proceed beyond a caution until you have fully understood and met the indicated conditions.

General Safety Information

The following general safety precautions must be observed during all phases of operation, service, and repair of this instrument. Failure to comply with these precautions or with specific warnings elsewhere in this manual violates safety standards of design, manufacture, and intended use of the instrument. Agilent Technologies assumes no liability for the customer's failure to comply with these requirements.

WARNING

Ensure the proper usage of the equipment.

The protection provided by the equipment may be impaired.

→ The operator of this instrument is advised to use the equipment in a manner as specified in this manual.

Safety Standards

This is a Safety Class I instrument (provided with terminal for protective earthing) and has been manufactured and tested according to international safety standards.

Operation

Before applying power, comply with the installation section. Additionally the following must be observed.

Do not remove instrument covers when operating. Before the instrument is switched on, all protective earth terminals, extension cords, auto-transformers, and devices connected to it must be connected to a protective earth via a ground socket. Any interruption of the protective earth grounding will cause a potential shock hazard that could result in serious personal injury. Whenever it is likely that the protection has been impaired, the instrument must be made inoperative and be secured against any intended operation.

Make sure that only fuses with the required rated current and of the specified type (normal blow, time delay, and so on) are used for replacement. The use of repaired fuses and the short-circuiting of fuse holders must be avoided.

Some adjustments described in the manual, are made with power supplied to the instrument, and protective covers removed. Energy available at many points may, if contacted, result in personal injury.

Any adjustment, maintenance, and repair of the opened instrument under voltage should be avoided whenever possible. When inevitable, this has to be carried out by a skilled person who is aware of the hazard involved. Do not attempt internal service or adjustment unless another person, capable of rendering first aid and resuscitation, is present. Do not replace components with power cable connected.

Do not operate the instrument in the presence of flammable gases or fumes. Operation of any electrical instrument in such an environment constitutes a definite safety hazard.

Do not install substitute parts or make any unauthorized modification to the instrument.

Capacitors inside the instrument may still be charged, even though the instrument has been disconnected from its source of supply. Dangerous voltages, capable of causing serious personal injury, are present in this instrument. Use extreme caution when handling, testing and adjusting.

When working with solvents, observe appropriate safety procedures (for example, goggles, safety gloves and protective clothing) as described in the material handling and safety data sheet by the solvent vendor, especially when toxic or hazardous solvents are used.

The Waste Electrical and Electronic Equipment (WEEE) Directive (2002-96-EC)

This product complies with the European WEEE Directive marking requirements. The affixed label indicates that you must not discard this electrical/electronic product in domestic household waste.

**NOTE**

Do not dispose of in domestic household waste

To return unwanted products, contact your local Agilent office, or see <http://www.agilent.com> for more information.

Radio Interference

Never use cables other than the ones supplied by Agilent Technologies to ensure proper functionality and compliance with safety or EMC regulations.

Test and Measurement

If test and measurement equipment is operated with equipment unshielded cables and/or used for measurements on open set-ups, the user has to assure that under operating conditions the radio interference limits are still met within the premises.

Sound Emission

Manufacturer's Declaration

This statement is provided to comply with the requirements of the German Sound Emission Directive of 18 January 1991.

This product has a sound pressure emission (at the operator position) < 70 dB.

- Sound Pressure $L_p < 70$ dB (A)
- At Operator Position
- Normal Operation
- According to ISO 7779:1988/EN 27779/1991 (Type Test)

Agilent Technologies on Internet

For the latest information on products and services visit our worldwide web site on the Internet at:

<http://www.agilent.com>

Index

8

- 8-bit configuration switch
 - on-board LAN 244

A

- Agilent Lab Advisor software 93
- Agilent Lab Advisor 93
- Agilent
 - on internet 276
 - User Interface Software Setup 267
- algae 58
- ambient non-operating temperature 21
- ambient operating temperature 21
- analog signal 241
- analog
 - cable 220
- apg remote 242
- assembling
 - LongLife pump head 171

B

- BCD
 - cable 225
- bench space 20
- binary pump shutdown during analysis 110
- buffer application 58

C

- cable
 - analog 220
 - BCD 225
 - CAN 227

- LAN 227
 - remote 222
 - RS-232 228

cables

- analog 218
- BCD 218
- CAN 219
- LAN 219
- overview 218
- remote 218
- RS-232 219

CAN

- cable 227
- capillaries 140
- cleaning 139
- compensation sensor open 102
- compensation sensor short 103
- condensation 20
- configuration switches 254
- configuration
 - low flow rates 58
 - one stack 27
 - two stack front 30
 - two stack rear 31
 - two stack 30

- current of primary pump drive too high 117
- current of secondary pump drive too high 118

D

- defect connection between main board and pump drive encoder 114
- defect on arrival 26
- degasser's pressure limit violation 108

delay volume

- configure 85
- description 84
- optimize 85
- deliver underrun 114
- delivery checklist 26
- DHCP
 - general information 257
 - setup 258
- dimensions 21
- disassembling
 - LongLife pump head 164
- drive current too high 113
- drive current too low 112
- drive encoder error 117
- drive Encoder failed 112
- drive position limit 116
- drive timeout 113

E

- electrical connections
 - descriptions of 235
- electronic waste 273
- EMF
 - early maintenance feedback 249
- error messages
 - binary pump shutdown during analysis 110
 - compensation sensor open 102
 - compensation sensor short 103
 - cover violation 106
 - current of primary pump drive too high 117
 - current of secondary pump drive too high 118

Index

defect connection between main board and pump drive encoder 114
degasser's pressure limit violation 108
deliver underrun 114
drive current too high 113
drive current too low 112
drive encoder error 117
drive Encoder failed 112
drive position limit 116
drive timeout 113
fan failed 104
flow rate limit exceeded 110
ignition without cover 105, 105
insufficient power of drive encoder LED 116
leak sensor open 101
leak sensor short 101
leak 105
lost CAN partner 100
overcurrent of pump drive 113
overcurrent of solvent selection valve (SSV) 114
pressure below lower limit 107
pressure exceeded upper pressure limit 107
pressure sensor calibration wrong or missing 120
pump drive blocked or encoder failed 112
pump drive encoder defect 115
pump drive encoder error 118
pump drive encoder rollover 116
pump drive error 119
pump drive stop not found 120
pump drive stroke blocked 119
pump error 107
purge valve failed 115
reading of purge valve tag failed 115
reading the pump encoder tag failed 111

remote timeout 100
seal wash pump was missing when tried to turn on 121
shutdown 99
solvent counter exceeded limit 109
target pressure not reached for binary pump degasser 108
timeout 98
unknown purge valve type 118
waste counter limit exceeded 109
writing the pump encoder tag failed 111
writing the purge valve tag failed 117

extra-column volume 84

F

fan failed 104
filter
 solvent inlet 58
firmware
 description 232
 main system 232
 resident system 232
 update tool 233
 updates 233, 188
 upgrade/downgrade 188
fittings 140
flow connections
 to pump 41
flow rate limit exceeded 110
flow rate
 minimum 58
frequency range 21

G

general error messages 98

H

handling acetonitrile 82

handling acids 82
handling buffers 81
heat exchanger
 replace 169
humidity 21

I

initialization mode selection 255
installation
 bench space 20
 power considerations 18
 seal wash function 45
 site requirements 17
installing pump head assembly 178
instrument layout 248
insufficient power of drive encoder LED 116
interfaces 237
internet 276

J

Jet Weaver 153
 remove capillary connections 154

L

Lab Advisor Software
 tests 124
LAN
 cable 227
 configuration switche 254
 configuration 251
 initialization mode selection 255
 link configuration selection 260
 manual configuration with telnet 262
 manual configuration 261
 PC and User Interface Software Setup 267
 TCP/IP parameter configuration 253

- using default 255
 - using stored 255
 - what you have to do first 252
- leak sensor open 101
- leak sensor short 101
- leak 105
- line frequency 21
- line voltage 21
- link configuration selection 260
- LongLife pump head
 - assembling 171
 - disassembling 164
- lost CAN partner 100

M

- MAC
 - address 252
- maintenance
 - feedback 249
 - introduction 135
 - replacing firmware 188
- manual configuration
 - of LAN 261
- message
 - cover violation 106
 - ignition without cover 105, 105
 - remote timeout 100
- minimum flow rate 58

N

- non-operating altitude 21
- non-operating temperature 21

O

- operating Altitude 21
- operating temperature 21
- optimization
 - achieving higher resolution 87
 - stack configuration 27

- outlet valve 148
- overcurrent of pump drive 113
- overcurrent of solvent selection valve (SSV) 114

P

- packaging
 - damaged 26
- parts
 - accessory kit 212
 - primary pump head 204
 - pump head assembly 203
 - pump heads 202
 - secondary pump head 205
- PC and User Interface Software Setup 267
- performance specifications 22
- performance
 - Optimization 83
- physical specifications 21
- power considerations 18
- power consumption 21
- power cords 19
- power switch 38
- pressure below lower limit 107
- pressure exceeded upper pressure limit 107
- pressure sensor calibration wrong or missing 120
- pressure sensor
 - replace 143
- primary pump head
 - parts 204
- pump drive blocked or encoder failed 112
- pump drive encoder defect 115
- pump drive encoder error 118
- pump drive encoder rollover 116
- pump drive error 119
- pump drive stop not found 120
- pump drive stroke blocked 119
- pump error messages 107
- pump head assembly
 - installing 178
 - parts 203
 - removing 160
- pump head
 - LongLife 171, 164
- pump leak rate test 125
- pump
 - features 10
 - flow connections 41
 - overview 11
 - preparing 58
 - principle 12
- purge valve failed 115
- purging 69

R

- reading of purge valve tag failed 115
- reading the pump encoder tag failed 111
- remote
 - cable 222
- removing pump head assembly 160
- repairs
 - replacing firmware 188
- resolution
 - Optimization 87
- RS-232C
 - cable 228

S

- safety class I 271
- safety
 - general information 271
 - standards 21
 - symbols 270
- seal wash function 45

Index

- installation 45
- seal wash pump was missing when tried to turn on 121
- seal wash pump
 - replacing 156
- secondary pump head
 - parts 205
- shutdown 99
- shutoff valve panel
 - replacing 141
- shutoff valves
 - replacing 141
- site requirements 17
 - power cords 19
- solvent cabinet 43, 58
- solvent counter exceeded limit 109
- solvent handling 80
- solvent inlet filter 58
- special interfaces 243
- special settings
 - boot-resident 246
 - forced cold start 246
- specification
 - physical 21
- specifications 17
 - performance 22
- system pressure test 130
- system setup and installation
 - optimizing stack configuration 27

T

- target pressure not reached for binary pump degasser 108
- TCP/IP parameter configuration 253
- telnet
 - configuration 262
- temperature sensor 105
- tests 124
 - pump leak rate test 125

- system pressure test 130
- timeout 98
- troubleshooting
 - error messages 97

U

- unknown purge valve type 118
- unpacking 26
- user interfaces 92

V

- vacuum degassing unit 58
- voltage range 21

W

- waste counter limit exceeded 109
- waste
 - electrical and electronic equipment 273
- WEEE directive 273
- weight 21
- writing the pump encoder tag failed 111
- writing the purge valve tag failed 117

www.agilent.com

In This Book

This manual contains technical reference information about the Agilent 1290 Infinity Binary Pump G4220A:

- introduction and specifications,
- installation,
- using and optimizing,
- troubleshooting and diagnose,
- maintenance,
- parts identification,
- hardware information,
- safety and related information.

© Agilent Technologies 2010-2018

Printed in Germany
10/2018



G4220-90007
Rev. B