

ELITE

HIGH PERFORMANCE MACHINERY

Operating Instructions and Parts Manual

1800 Series Lathe

Models: EGH-1880 | EGH-2180 | EGH-21120

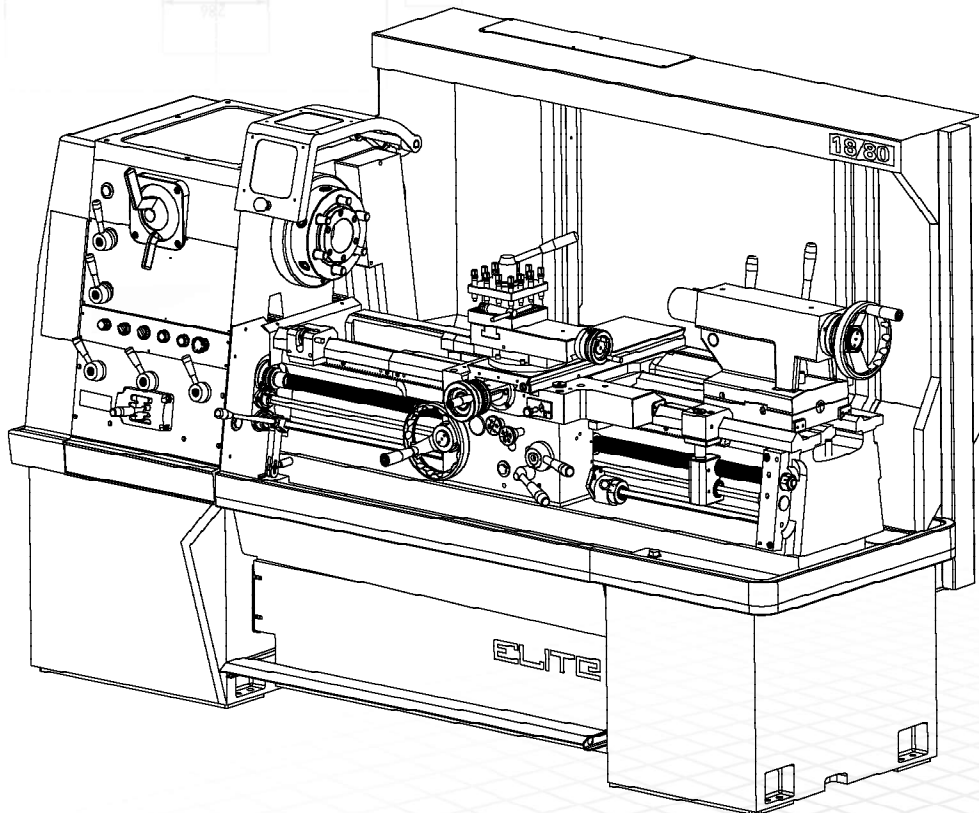

JET[®]

427 New Sanford Road
LaVergne, Tennessee 37086
www.jettools.com
Ph.: 855-336-4032

Part No. M-EGH-1880
REV D2 04/2019
Copyright © 2015 JET



1.0 WARRANTY AND SERVICE

JET® warrants every product it sells against manufacturers' defects. If one of our tools needs service or repair, please contact Technical Service by calling 1-855-336-4032, 8AM to 5PM CST, Monday through Friday.

WARRANTY PERIOD

The general warranty lasts for the time period specified in the literature included with your product or on the official JET branded website, jettools.com.



WHO IS COVERED?

This warranty covers only the initial purchaser of the product from the date of delivery.

WHAT IS COVERED?

This warranty covers any defects in workmanship or materials subject to the limitations stated below. This warranty does not cover failures due directly or indirectly to misuse, abuse, negligence or accidents, normal wear-and-tear, improper repair, alterations or lack of maintenance.

HOW TO GET TECHNICAL SUPPORT

Please contact Technical Service by calling 1-855-336-4032. Please note that you will be asked to provide proof of initial purchase when calling. If a product requires further inspection, the Technical Service representative will explain and assist with any additional action needed. JET has Authorized Service Centers located throughout the United States. For the name of an Authorized Service Center in your area call 1-855-336-4032 or use the Service Center Locator on the JET website.

MORE INFORMATION

JET® is constantly adding new products. For complete, up-to-date product information, check with your local distributor or visit the JET website, jettools.com.

HOW STATE LAW APPLIES

This warranty gives you specific legal rights, subject to applicable state law.

LIMITATIONS ON THIS WARRANTY

JET LIMITS ALL IMPLIED WARRANTIES TO THE PERIOD OF THE LIMITED WARRANTY FOR EACH PRODUCT. EXCEPT AS STATED HEREIN, ANY IMPLIED WARRANTIES OF MERCHANTABILITY AND FITNESS FOR A PARTICULAR PURPOSE ARE EXCLUDED. SOME STATES DO NOT ALLOW LIMITATIONS ON HOW LONG AN IMPLIED WARRANTY LASTS, SO THE ABOVE LIMITATION MAY NOT APPLY TO YOU.

JET SHALL IN NO EVENT BE LIABLE FOR DEATH, INJURIES TO PERSONS OR PROPERTY, OR FOR INCIDENTAL, CONTINGENT, SPECIAL, OR CONSEQUENTIAL DAMAGES ARISING FROM THE USE OF OUR PRODUCTS. SOME STATES DO NOT ALLOW THE EXCLUSION OR LIMITATION OF INCIDENTAL OR CONSEQUENTIAL DAMAGES, SO THE ABOVE LIMITATION OR EXCLUSION MAY NOT APPLY TO YOU.

JET sells through distributors only. The specifications listed in JET printed materials and on official JET website are given as general information and are not binding. JET reserves the right to effect at any time, without prior notice, those alterations to parts, fittings, and accessory equipment which they may deem necessary for any reason whatsoever. JET® branded products are not sold in Canada by JPW Industries, Inc.

NOTE: JET is a division of JPW Industries, Inc. References in this document to JET also apply to JPW Industries, Inc., or any of its successors in interest to the JET brand.



2.0 TABLE OF CONTENTS

1.0 WARRANTY AND SERVICE.....	2
2.0 TABLE OF CONTENTS.....	4
3.0 SAFETY PRECAUTIONS	5
4.0 INTRODUCTION	6
5.0 SPECIFICATIONS.....	7
6.0 GENERAL INSTRUCTION.....	8
6.1 GENERAL LAYOUT OF LATHE	8
6.2 FOUNDATION PLAN.....	9
7.0 INSTALLATION.....	11
7.1 LEVELING THE LATHE.....	11
7.2 CLEANING THE MACHINE.....	12
7.3 LUBRICATION CHECKS.....	12
7.4 CHUCK AND CHUCK MOUNTING (FOR D1-6 SPINDLE).....	13
8.0 ELECTRICAL CONNECTIONS	14
9.0 OPERATION	14
9.1 LATHE CONTROLS	14
9.2 ELECTRICAL CONTROL PANEL	15
9.3 HEADSTOCK SELECTORS.....	15
9.4 THREADS AND FEEDS.....	16
9.5 APRON CONTROLS.....	16
9.6 THREADING DIAL INDICATOR.....	17
9.7 CROSS SLIDE.....	17
9.8 TOP SLIDE.....	18
9.9 TAILSTOCK	19
9.10 END GEAR TRAIN	19
9.11 DRIVING BELTS.....	19
9.12 LEADSCREW SHEAR PIN.....	20
9.13 FEED TRIP ADJUSTMENT	20
9.14 APRON HANDWHEEL.....	21
9.15 LIMIT SWITCHES	21
9.16 LATHE ALIGNMENT	21
9.17 GAP BRIDGE (FOR GAP BED TYPE LATHE).....	22
10.0 TROUBLE SHOOTING.....	23
11.0 LAYOUT OF ELECTRICAL BOX	24
12.0 RECOMMENDED CUTTING SPEED OF LATHE	25
13.0 PARTS LISTS AND DIAGRAMS.....	25
14.0 WIRING DIAGRAM.....	90

3.0 SAFETY PRECAUTIONS

1. Read and understand the entire owner's manual before attempting assembly or operation.
2. Read and understand the warnings posted on the machine and in this manual. Failure to comply with all of these warnings may cause serious injury.
3. Replace the warning labels if they become obscured or removed.
4. This lathe is designed and intended for use by properly trained and experienced personnel only. If you are not familiar with the proper and safe operation of a lathe, do not use until proper training and knowledge have been obtained.
5. Do not use this lathe for other than its intended use. If used for other purposes, JET®, disclaims any real or implied warranty and holds itself harmless from any injury that may result from that use.
6. Always wear approved safety glasses/face shields while using this lathe. Everyday eyeglasses only have impact resistant lenses; they are not safety glasses.
7. Before operating this lathe, remove tie, rings, watches and other jewelry, and roll sleeves up past the elbows. Remove all loose clothing and confine long hair. Non-slip footwear or anti-skid floor strips are recommended. Do not wear gloves.
8. Wear ear protectors (plugs or muffs) during extended periods of operation.
9. Do not operate this machine while tired or under the influence of drugs, alcohol or any medication.
10. Make certain the switch is in the OFF position before connecting the machine to the power supply.
11. Make certain the machine is properly grounded.
12. Make all machine adjustments or maintenance with the machine unplugged from the power source.
13. Remove adjusting keys and wrenches. Form a habit of checking to see that keys and adjusting wrenches are removed from the machine before turning it on.
14. Keep safety guards in place at all times when the machine is in use. If removed for maintenance purposes, use extreme caution and replace the guards immediately after maintenance is complete.
15. Check damaged parts. Before further use of the machine, a guard or other part that is damaged should be carefully checked to determine that it will operate properly and perform its intended function. Check for alignment of moving parts, binding of moving parts, breakage of parts, mounting and any other conditions that may affect its operation. A guard or other part that is damaged should be properly repaired or replaced.
16. Do not use power tools in damp/wet locations or other dangerous environments. Do not expose them to rain. Keep work area well lighted. Provide for adequate space surrounding work area and non-glare, overhead lighting.
17. Keep the floor around the machine clean and free of scrap material, oil and grease.
18. Keep visitors a safe distance from the work area. Keep children away.
19. Make your workshop child proof with padlocks, master switches or by removing starter keys.
20. Give your work undivided attention. Looking around, carrying on a conversation and "horse-play" are careless acts that can result in serious injury.
21. Maintain a balanced stance at all times so that you do not fall or lean against moving parts. Do not overreach or use excessive force to perform any machine operation. Never force the cutting action.
22. Do not operate the lathe in flammable or explosive environments. Do not use in a damp environment or expose to rain.
23. Use the right tool at the correct speed and feed rate. Do not force a tool or attachment to do a job for which it was not designed. The right tool will do the job better and more safely.
24. Use recommended accessories; improper accessories may be hazardous.
25. Maintain tools with care. Keep cutting tools sharp and clean for the best and safest performance. Follow instructions for lubricating and changing accessories.
26. Do not attempt to adjust or remove tools during operation. Disconnect tools before servicing; when changing accessories, such as blades, bits, cutters, and the like.
27. Never stop a rotating chuck or workpiece with your hands.
28. Choose a low spindle speed when working unbalanced workpieces, and for threading and tapping operations.



29. Do not exceed the maximum speed of the workholding device.
30. Do not exceed the clamping capacity of the chuck.
31. Secure Work. For safety and use of both hands, use clamps or a vise to hold work when practical.
32. Workpieces longer than 3 times the chucking diameter must be supported by the tailstock or a steady rest.
33. Avoid small chuck diameters with large turning diameters.
34. Avoid short chucking lengths and small chucking contact.
35. Turn off the machine and disconnect from power before cleaning. Use a brush to remove shavings or debris — do not use your hands.
36. Do not stand on the machine. Serious injury could occur if the machine tips over.
37. Never leave the machine running unattended. Turn the power off and do not leave the machine until moving parts come to a complete stop.
38. Remove loose items and unnecessary work pieces from the area before starting the machine.
39. Direction of feed — feed work into a blade or cutter against the direction of rotation of the blade or cutter only.
40. Installation work and electrical wiring must be done by qualified electrician in accordance with all applicable codes and standards.
41. Tighten all locks before operating.
42. Rotate workpiece by hand before applying power.
43. Rough out workpiece before installing on faceplate.
44. Do not mount split workpiece or one containing knot.
45. Use lowest speed when starting new workpiece.

⚠ WARNING: This product can expose you to chemicals including lead and cadmium which are known to the State of California to cause cancer and birth defects or other reproductive harm. For more information go to <http://www.p65warnings.ca.gov>.

⚠ WARNING: Some dust, fumes and gases created by power sanding, sawing, grinding, drilling, welding and other construction activities contain chemicals known to the State of California to cause cancer and birth defects or other reproductive harm. Some examples of these chemicals are:

- lead from lead based paint
- crystalline silica from bricks, cement and other masonry products
- arsenic and chromium from chemically treated lumber

Your risk of exposure varies, depending on how often you do this type of work. To reduce your exposure to these chemicals, work in a well-ventilated area and work with approved safety equipment, such as dust masks that are specifically designed to filter out microscopic particles. For more information go to <http://www.p65warnings.ca.gov/> and <http://www.p65warnings.ca.gov/wood>.

⚠ CAUTION

This means that if precautions are not heeded, it may result in minor injury and/or possible machine damage.

⚠ WARNING

This means that if precautions are not heeded, it may result in serious injury or possibly even death.

4.0 INTRODUCTION

This manual is provided by JET® covering the safe operation and maintenance procedures for a JET Model EGH-1880/2180 and EGH-21120. This manual contains instructions on installation, safety precautions, general operating procedures, maintenance instructions and parts breakdown. Your machine has been designed and constructed to provide years of trouble-free operation if used in accordance with the instructions as set forth in this document.

If there are questions or comments, please contact your local supplier or JET. JET can also be reached at our web site: www.jettools.com. Retain this manual for future reference. If the machine transfers ownership, the manual should accompany it.

5.0 SPECIFICATIONS

MODEL	EGH-1880	EGH-2180	EGH-21120
STOCK NUMBER	892200	892250	892270
CAPACITY			
Swing over Bed	18-1/9 in.	21 in.	21 in.
Swing over Cross Slide	11 in.	14 in.	14 in.
Distance between Centers	80 in.	80 in.	120 in.
BED			
Width of Bed	13-4/7 in.	13-4/7 in.	13-4/7 in.
Swing Through Gap	28 in.	31 in.	31 in.
Length of Gap	9-5/6 in.	9-5/6 in.	9-5/6 in.
HEADSTOCK			
Spindle Mount	D1-8		
Spindle Bore	3-1/8 in.		
Number of spindle speeds	16		
Range of spindle speeds	20-1,600 R.P.M		
Spindle Taper	MT-7		
CROSS SLIDE			
Cross Slide Travel	10-2/3 in.		
Top Slide Travel	5-2/5 in.		
TAIL STOCK			
Tailstock Spindle Travel	6-1/2 in.		
Tailstock Diameter	3 in.		
Taper in Tailstock Spindle	MT-5		
THREADS AND FEEDS			
Longitudinal feeds (IPR)	0.0015-0.04"		
Cross feeds (IPR)	0.00075-0.02"		
Inch threads Number/Range	(38) 2-72"		
Metric threads Number/Range	(40) 0.4-14mm		
D.P. threads Number/Range	(21) 8-44		
M.P. threads Number/Range	(18) 0.3-3.5		
ELECTRICS			
Motor	10 HP, 230/460V, 3-PH Prewired 230V CSA/CUS Certified	12-1/2 HP, 230/460V, 3-PH Prewired 230V CSA/CUS Certified	12-1/2 HP, 230/460V, 3-PH Prewired 230V CSA/CUS Certified
Coolant Pump Motor	1/8 HP		
Overall Dimensions	139 x 44 x 69 in.	139 x 44 x 69 in.	182 x 44 x 69 in.
Machine Net Weight	5,953 lbs.	6,614 lbs.	8,157 lbs.
Gross Weight	6,835 lbs.	7,496 lbs.	9,920 lbs.
We reserve the right to modify and improve our products.			

6.0 GENERAL INSTRUCTION

6.1 GENERAL LAYOUT OF LATHE

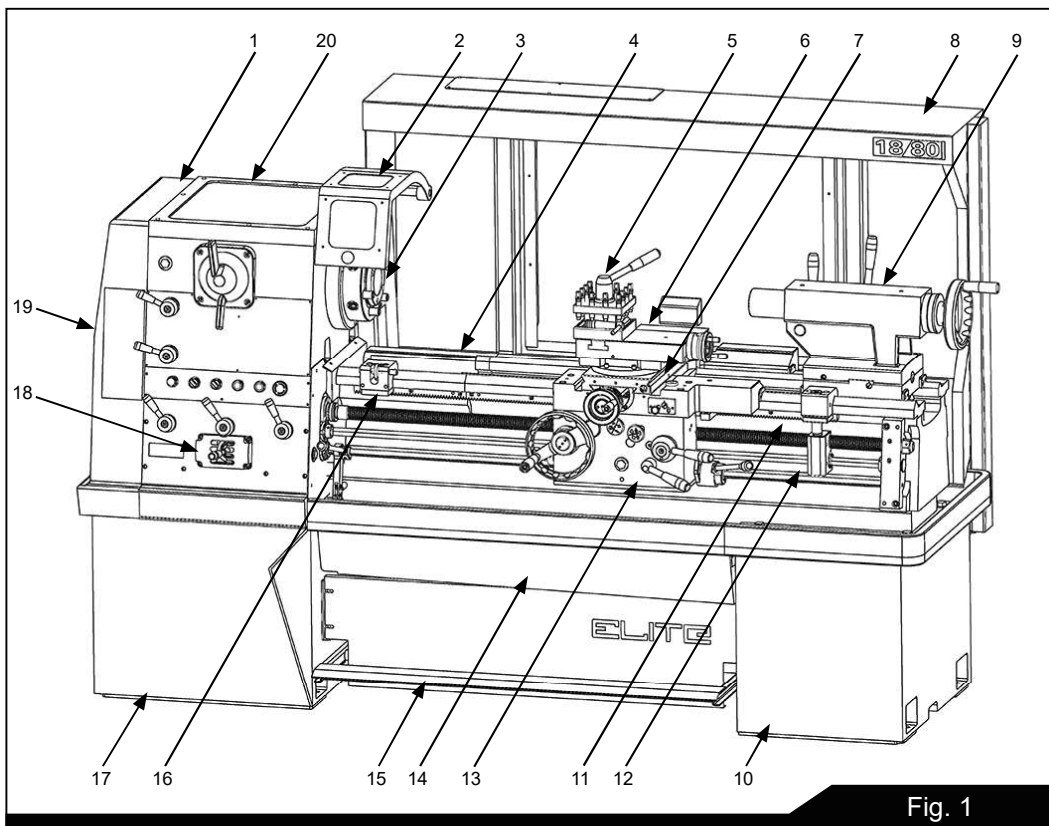
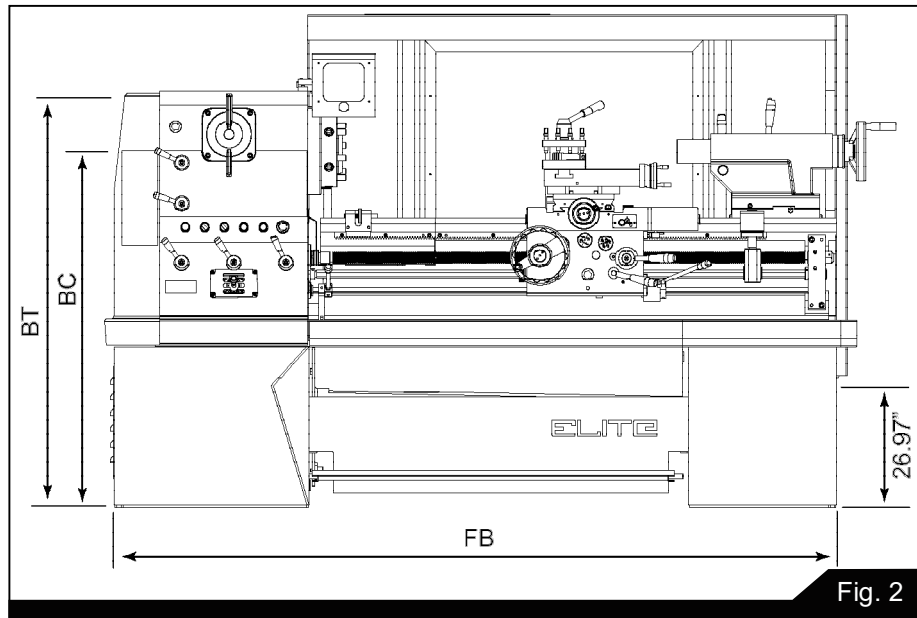

Fig. 1

- | | |
|-------------------------------------|------------------------------|
| 1. Headstock | 12. Feed shaft |
| 2. Chuck guard | 13. Apron |
| 3. Spindle | 14. Front moveable chip tray |
| 4. Bed | 15. Footbrake |
| 5. 4-Way tool post | 16. Carriage micro stop set |
| 6. Top slide | 17. Head-end plinth |
| 7. Saddle and Cross slide | 18. Gearbox |
| 8. Splash guard | 19. End Cover (gear train) |
| 9. Tailstock | 20. Electrical control |
| 10. Tail-end plinth | |
| 11. Protection Cover for lead-screw | |

6.2 FOUNDATION PLAN



Model	LCY	FB	BC	BT	FW
EGH-1880	162.60"	88.58"	45.08"	53.54"	130.12"
EGH-2180	162.60"	88.58"	46.65"	54.72"	130.12"

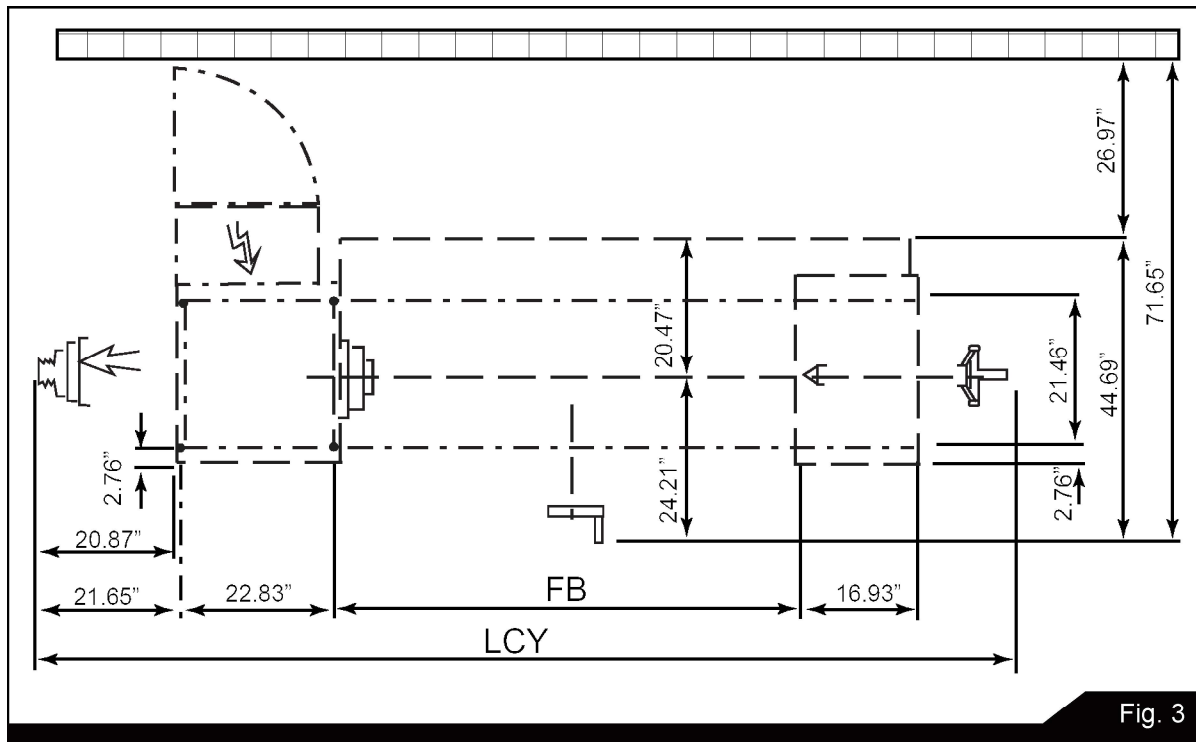

6.2 FOUNDATION PLAN

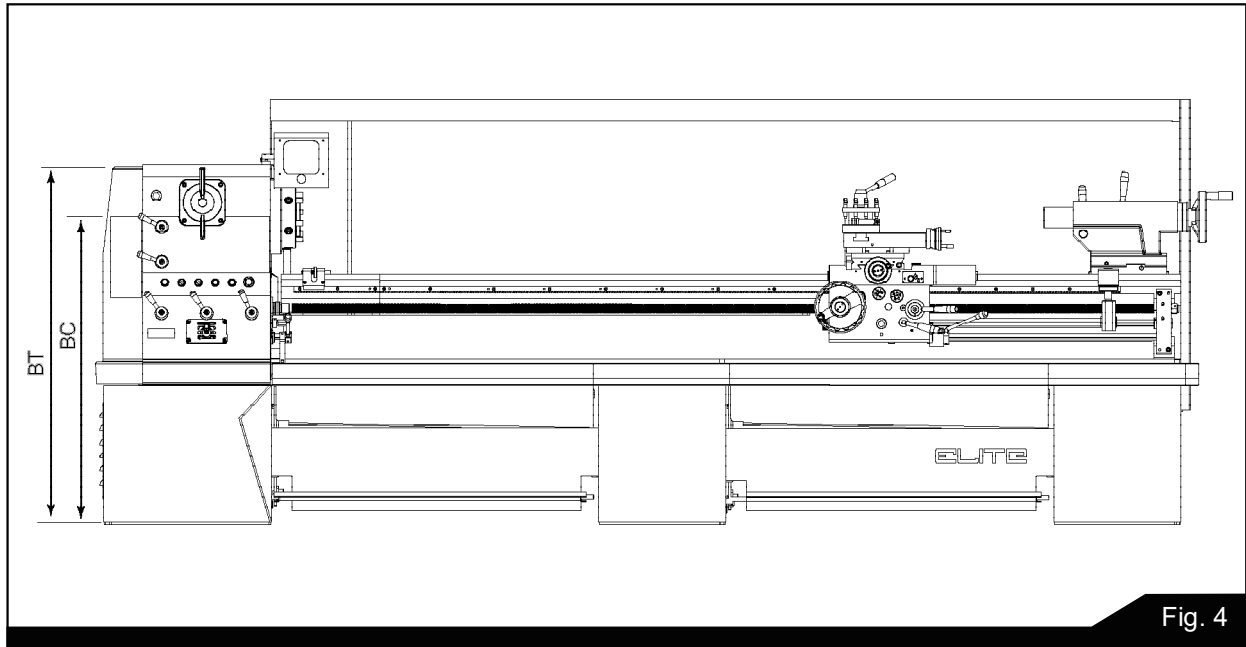

Model	BC	BT
EGH - 21120	46.65"	54.72"

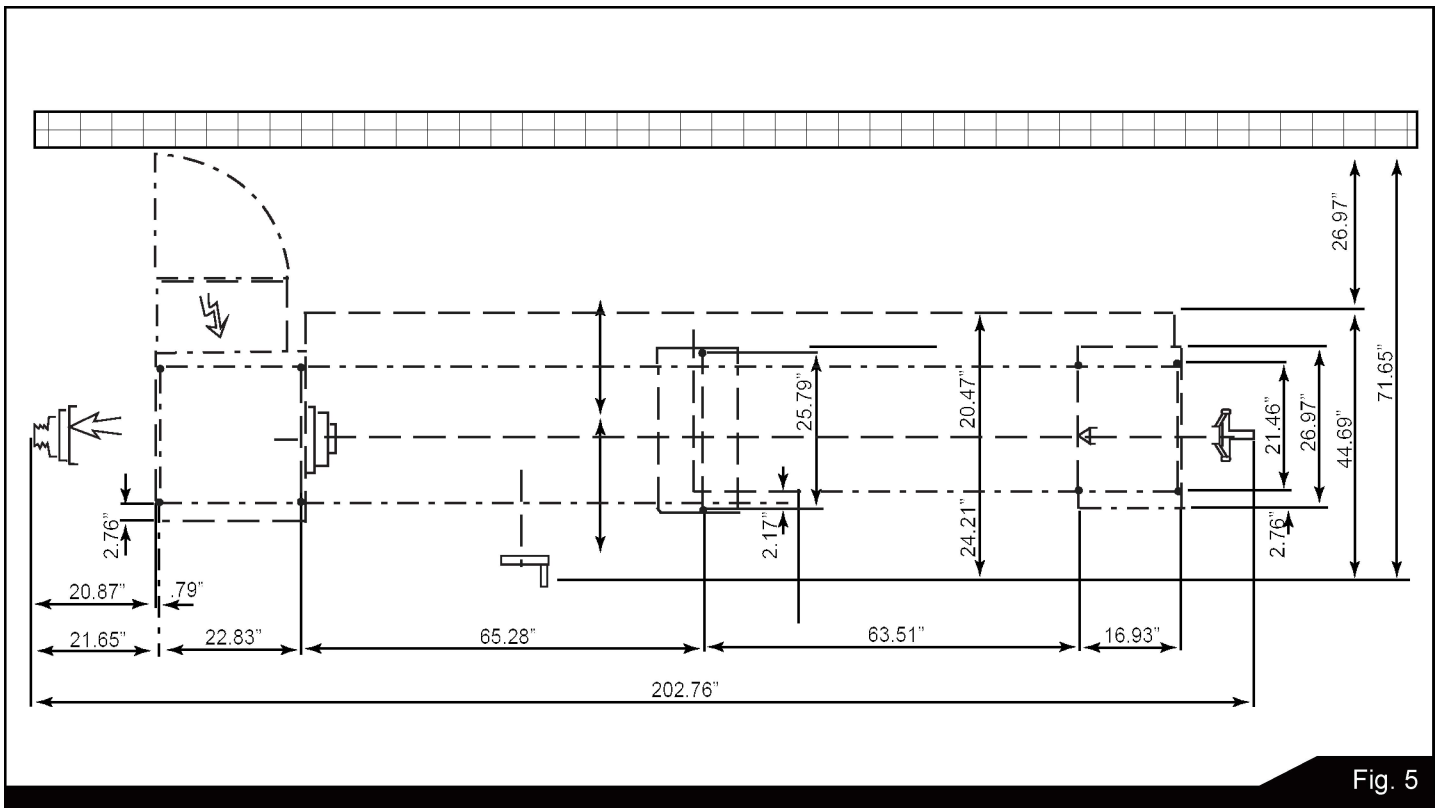

7.0 INSTALLATION

1. Finish removing all crate material from around lathe.
2. Unbolt lathe from shipping pallet.
3. Choose a location for the lathe that is dry and has sufficient illumination (consult OSHA or ANSI standards for recommended lighting levels in workshop environments).
4. Allow enough room to service the lathe on all four sides, and to load and off-load work pieces. In addition, if bar work is to be performed, allow enough space for stock to extend out the headstock end. If used in production operations, leave enough space for stacking unfinished and finished parts.
5. The foundation must be solid to support the weight of the machine and prevent vibration, preferably a solid concrete floor.
6. The lathe's center of weight is near the headstock. Before lifting, move the tailstock and the carriage to the right end of the bed and lock them.
7. With properly rated lifting equipment, slowly raise lathe off shipping pallet. (see Figure 6). Do not lift lathe by the spindle.

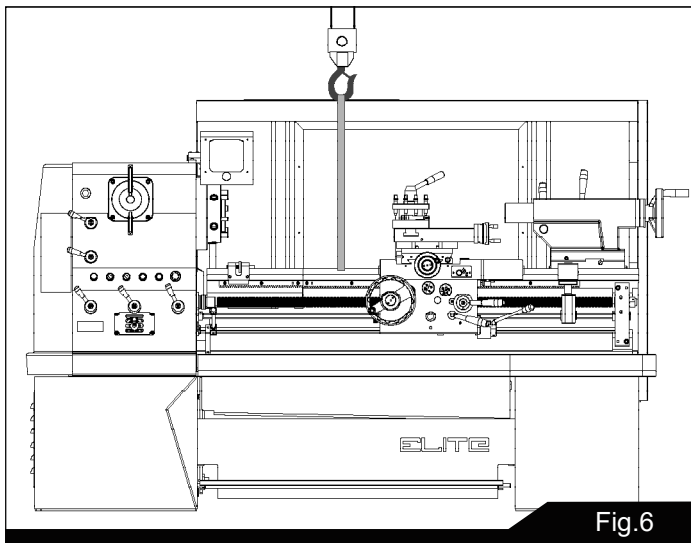

Fig.6

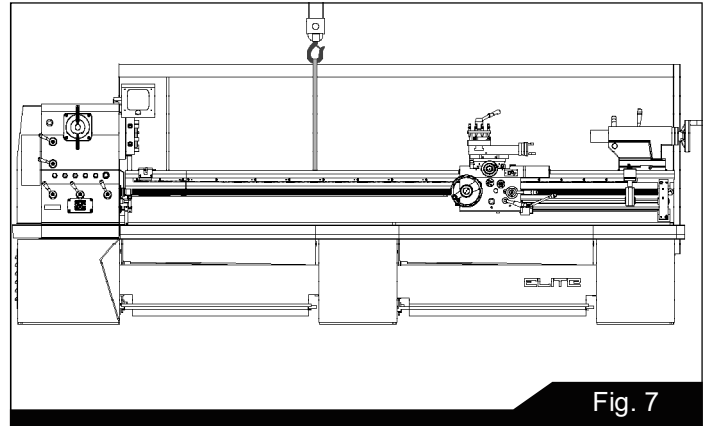

Fig. 7

CAUTION

Confirm that all suspension equipment is properly rated and in good condition for lifting lathe. Do not allow anyone beneath or near load while lifting.

7.1 LEVELING THE LATHE

It is imperative that the lathe be on a level plane; that is, where headstock and tailstock center points remain aligned throughout the tailstock travel, with the bed ways absent of twist and thus parallel to the operational center line.

A lathe which is not properly leveled will be inaccurate, producing tapered cuts. Also, the center point of the tailstock will vary as it is positioned along the bed, thus requiring constant readjustment.

9. Use a machinist's precision level on the bed ways both front to back and side to side, as shown in Figure 7. Take the reading in one direction every ten inches. Make sure the ways are clean and free of any debris before placing a level upon them.
10. Deviation over bed length (see Figure 8):
 - (a) Maximum 0.02/1000mm
 - (b) Maximum 0.04/1000mm

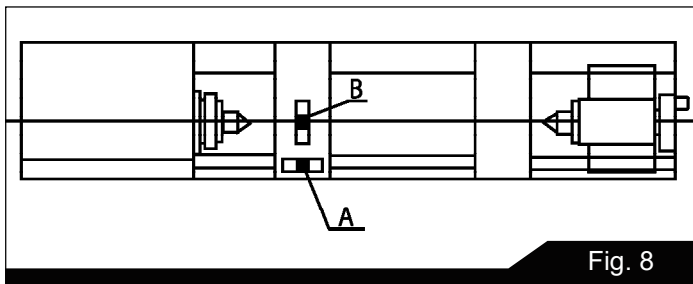

Fig. 8

11. Tighten foot screw nuts evenly to avoid distortion.
12. Leveling should be inspected occasionally, and especially if the accuracy of the lathe begins to diminish.

7.2 CLEANING THE MACHINE

*Notice items:

1. Before operating any controls, remove the anti-rust coating on all slideways and other places.
2. When cleaning, use mineral spirits or kerosene, instead of cellulose solvents, which may damage the paint finish.
3. Oil all brightly machined surfaces immediately after cleaning. Apply machine oil on slideway and heavy oil or grease on the end gears.
4. It is recommended that all slideways, the leadscrew and feedshaft are lightly cleaned (a bristle paint brush is useful for this).

⚠ CAUTION

Do not use compressed air to clean the machine.

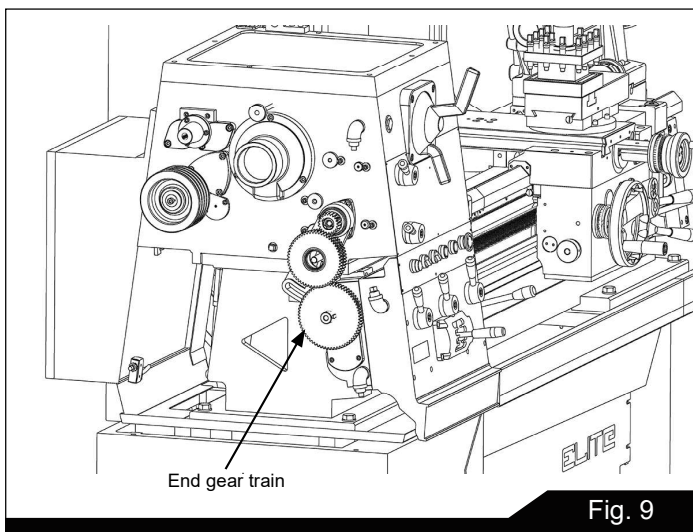

Fig. 9

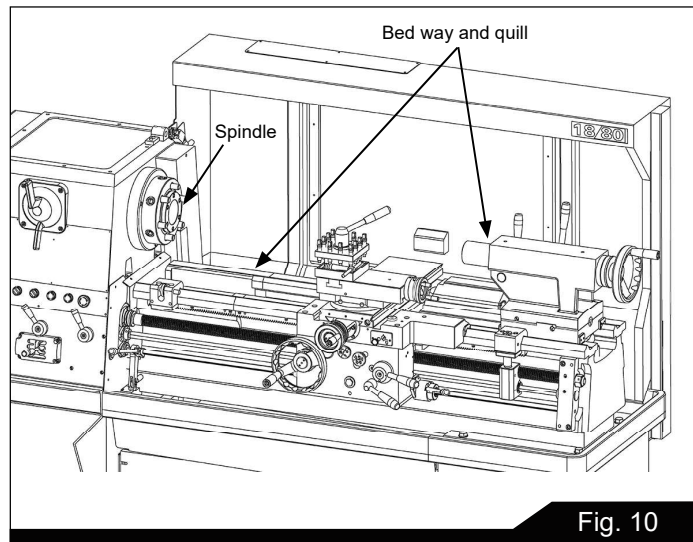

Fig. 10

7.3 LUBRICATION CHECKS

Headstock/Gearbox/Carriage, Apron/Tailstock

Refer to Figure 11.

Before operating the machine, make the following important checks:

- The headstock is filled to correct level marked on oil sight window with Shell Tellus oil 32 or equivalent. Check oil weekly and change the oil every 6 months.
- The gearbox is filled to level marked on oil sight window with Shell Tellus oil 68 or equivalent. Check oil weekly and change the oil every year.
- The carriage apron is filled to level marked on oil sight window with Shell Tellus oil 68 or equivalent. Check oil weekly and change the oil every year.
- There are two oil balls on the tailstock and two oil balls on the bracket.
- Add No.68 oil 3 c.c. to them respectively every day before operating to ensure the smoothness of ways.
- There are three oil balls on the cross slide and top slide.
- Add No.68 oil 10 c.c. to them respectively every day before operating to ensure the smoothness of lead screws.

A manually operated one-shot lubrication pump (A) is incorporated into the apron, and draws oil from the apron reservoir.

It enables the operator to ensure that the slideways are kept adequately lubricated. The pump should be operated before and occasionally during the work period.

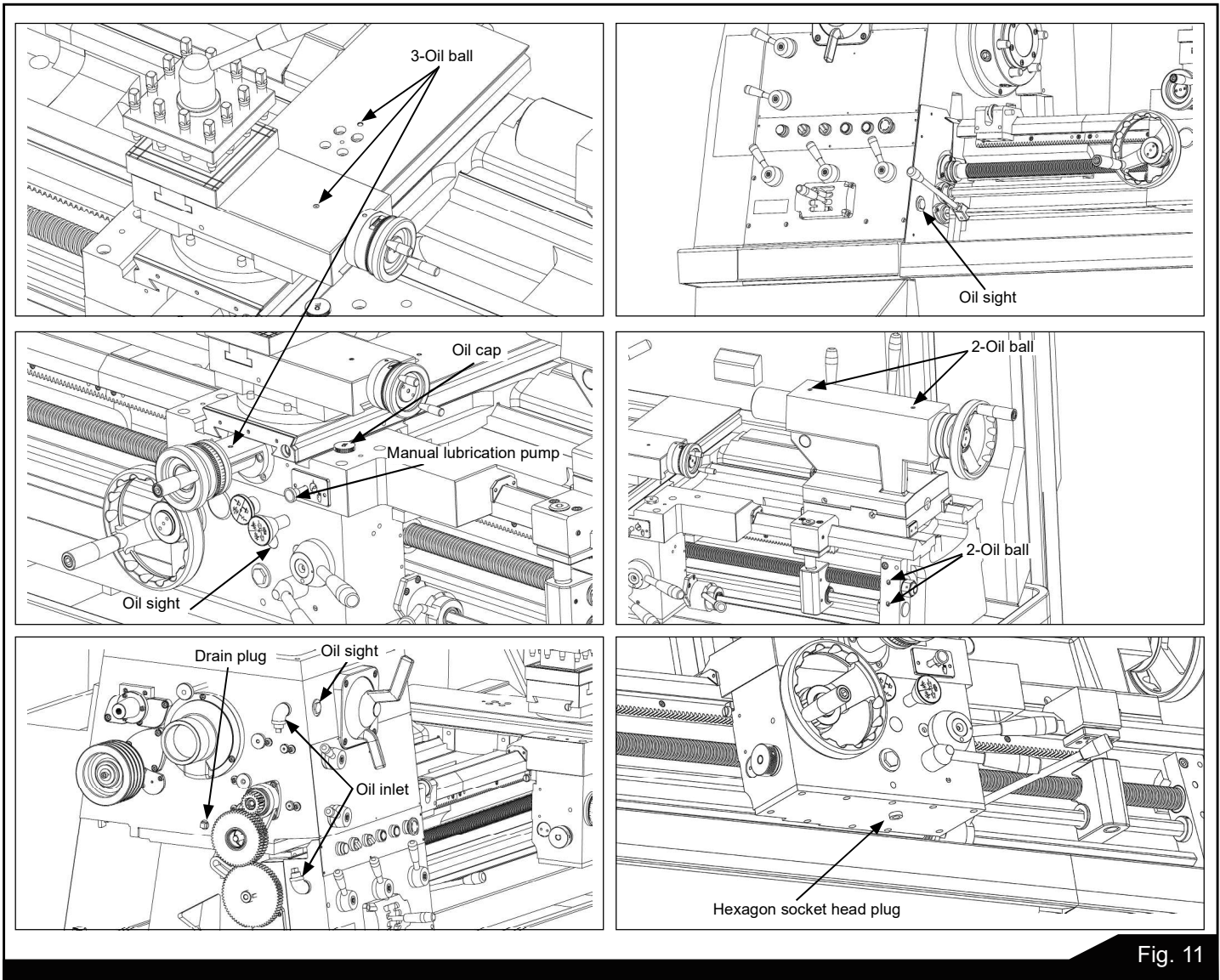

Fig. 11

7.4 CHUCK AND CHUCK MOUNTING (FOR D1-6 SPINDLE)

WARNING

Use only high-speed chucks with these machines.

When fitting chucks or faceplate, ensure that spindle and chuck tapers are thoroughly cleaned and that all cams lock in the correct positions the first.

It may be necessary to re-set the camlock studs (A) when mounting a new chuck. To do this, remove the hexagon socket locking screws (B) and set each stud so that the

scribed ring (C) is flush with the rear face of the chuck - with the slot - lining up with the locking screw hold.

Now mount the chuck or faceplate on the spindle nose and tighten the six cams in turn.

When fully tightened, the cam lock line on each cam should be between the two V marks on the spindle nose.

If any of the cams do not tighten fully within these limit marks, remove the chuck or faceplate and readjust the stud as indicated in the illustration.

Fit and tighten the locking screw (B) at each stud before remounting the chuck for work. A reference mark should be made on each correctly fitted chuck or faceplate to coincide with the reference scribed on the spindle nose. This will assist subsequent remounting.

Note: Do not interchange chucks or faceplates between lathes without checking for correct cam lock.

Note: Take careful note of speed limitations when using faceplates; 12 inch faceplates should not be run at speeds higher than 1000 rev/min. and 14 inch faceplates should not be run at speeds higher than 770 rev/min.

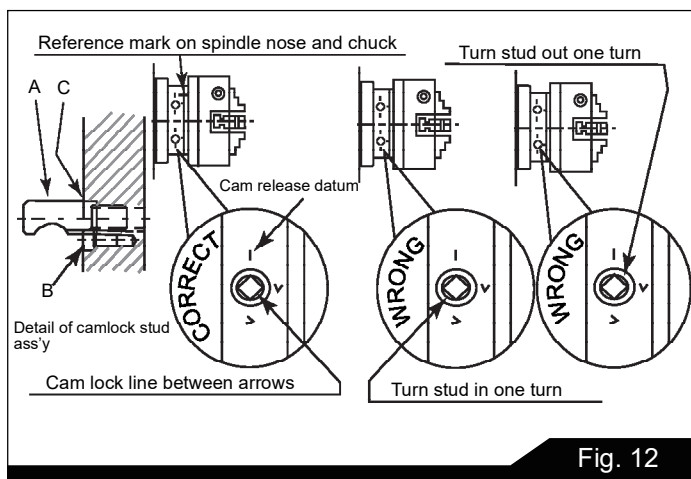

Fig. 12

8.0 ELECTRICAL CONNECTIONS

Confirm that power available at the lathe's location is the same rating as the lathe.

WARNING

Electrical connections must be made by a qualified electrician in compliance with all relevant codes. This machine must be properly grounded while in use to help protect the operator from electrical shock and possible fatal injury.

IMPORTANT: The lathe must be wired properly and phased correctly. The spindle should rotate counterclockwise (as viewed from the tailstock end) while the feed rod rotates clockwise (as viewed from the tailstock end). If the phasing needs correction, disconnect lathe from power source and switch any two of the three power leads (not the green ground wire).

Make sure the lathe is properly grounded.

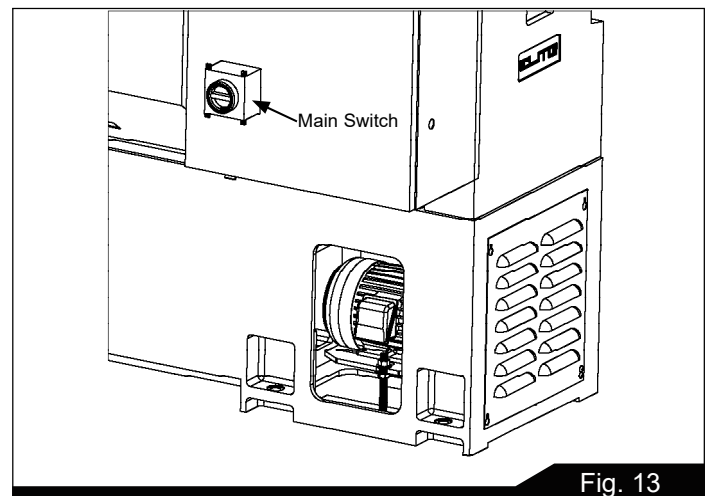

Fig. 13

9.0 OPERATION

9.1 LATHE CONTROLS

- A. Headstock selector
- B. Electrical control
- C. Gearbox (threads and feeds)
- D. Apron control units, for surfacing, sliding and threading controls.
- E. Spindle rotation, forward, stop and reverse.
- F. Footbrake.

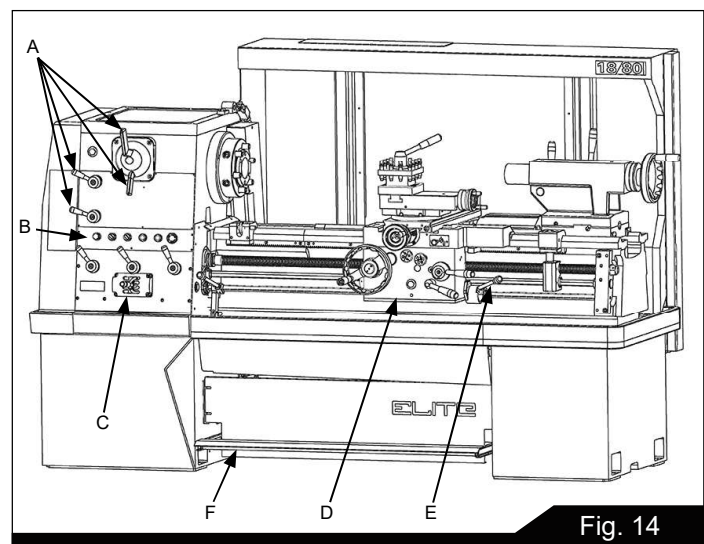

Fig. 14

9.2 ELECTRICAL CONTROL PANEL

With the exception of the lathe isolator, all electrical controls are fitted onto the front face of the headstock.

1. POWER INDICATOR LIGHT: When the power is on, the indicator light glows.
2. WORK LAMP: On/Off switch.
3. COOLANT PUMP: On/Off switch.
4. Press the red mushroom-head button to stop the main motor and also electrical supply to auxiliary services.
5. Press the green button to start the main drive motor. The indicator lamp glows while the motor is running.
6. EMERGENCY STOP SWITCH: press in order to kill all electric power to lathe.

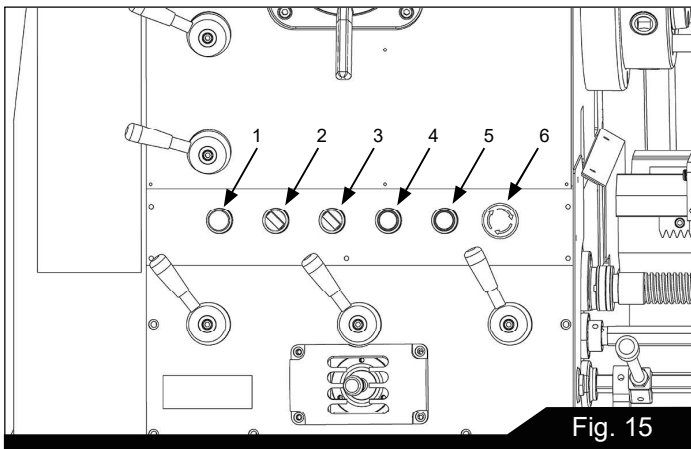

Fig. 15

9.3 HEADSTOCK SELECTORS

Spindle speed selector (H1, H2, H3)

1. The sixteen available speeds are shown on the lever-operated dial (H1) in four groups, each of which is further divided into four displayed spindle speeds. To select your speed, rotate the outer dial until the desired speed aligns with its corresponding color on the plate that is affixed to the machine. Then turn inner dial until the same color of arrow aligns with the desired speed.

Note: Do not select speeds while spindle is rotating or clutch is engaged - apron control must be central (disengaged) to avoid gear damage.

To free the spindle for hand rotation, set any one of the blank spaces on the outer dial to the mid-point of the plate that is affixed to machine (H2).

H-L selector for gearbox (H4)

1. Following each feed rate or thread pitch on gearbox thread and feed chart, there is a prefix of either H or L.
2. Move H-L selector to H or L accordingly for feeding or threading. If this lever is positioned at “-”, the headstock rotation will not be transmitted to gearbox.

WARNING

In High position do not exceed spindle speed of 350 R.P.M.

Apron orientation selector (H5)

1. This selector may affect the rotation orientation of lead screw, feed rod and therefore the movement direction of apron.
2. Forward (left-hand arrow) is used for cutting right-hand threads. Reverse (right-hand arrow) is used for cutting left-hand threads.

Headstock selectors

- H1: Four colors correspond to 16 speeds.
- H2: Four kinds of colors.
- H3: Four kinds of color arrow points.
- H4: Low-High selector for gearbox.
- H5: Apron orientation selector.

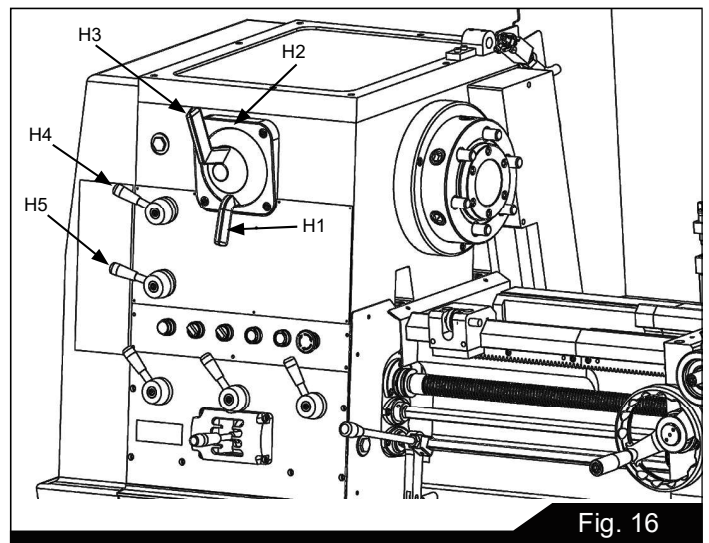

Fig. 16

9.4 THREADS AND FEEDS

Gearbox, thread and feed selectors

All the thread pitches and feeds directly available from the gearbox are shown on the data plate fitted on the front of headstock and the positioning control levers are (G1), (G2), (G3), and (G4).

End gear trains diagram

The end gear train should be arranged as in the diagram shown on the dataplate (G5) to meet threading requirements.

Feeds:

Sliding feeds per spindle revolution range from 0.0015 to 0.04 inch (0.04mm to 1.0mm).

Surfacing feeds per spindle revolution range from 0.00075 to 0.02 inch (0.02 to 0.5mm).

Threads & Feeds	
Imperial threads: Kinds / Range	38 Kinds / 2–72 T.P.I.
Metric threads:	40 Kinds / 0.4–14mm
Diametral pitch (D.P.) worm gear	21 Kinds / 8–44 D.P.
Module pitch (M.P.) worm gear	18 Kinds / 0.3–3.5 M.P.
Longitudinal feeds	0.04–1.0mm (0.0015"–0.04")
Cross feeds	0.02–0.5mm (0.00075"–0.02")

Gearbox Selectors

- (G1) A,B,C three section selector
- (G2) R,S,T three section selector
- (G3) 1–8 eight section selector

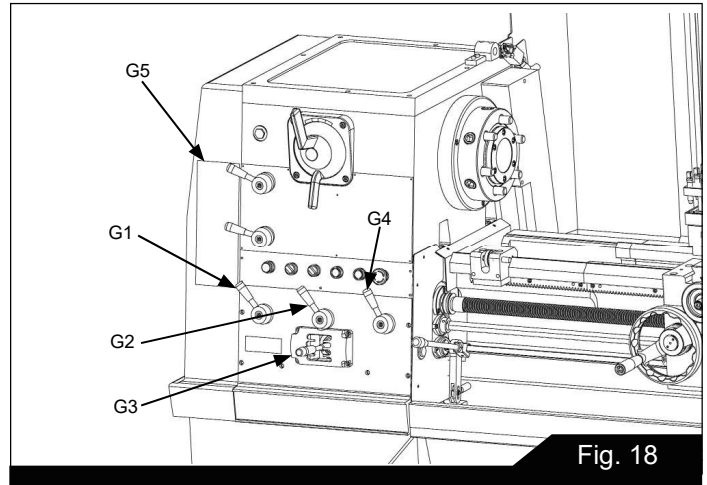

Fig. 18

9.5 APRON CONTROLS

In addition to handwheel traverse the carriage can be power-operated through controls on the front of the apron.

- (OL) Lever is moved down for power operation and up for manual operation.
- (A1) Push-pull knob selects power surfacing (cross feed) when pulled out, sliding feeds are selected when the knob is pushed in.
- (A2) The adjacent push pull knob controls forward or backward feed direction.
- (A3) Lever is pressed downward to engage the lead-screw nut for thread cutting. To avoid undue wear, release the nut except when thread cutting. An interlock within the apron prevents inadvertent engagement of levers OL and A3 at the same time.

Note: Do not use headstock lever for reversing feeds except during left-hand thread cutting; Use instead, the apron handle (A2).

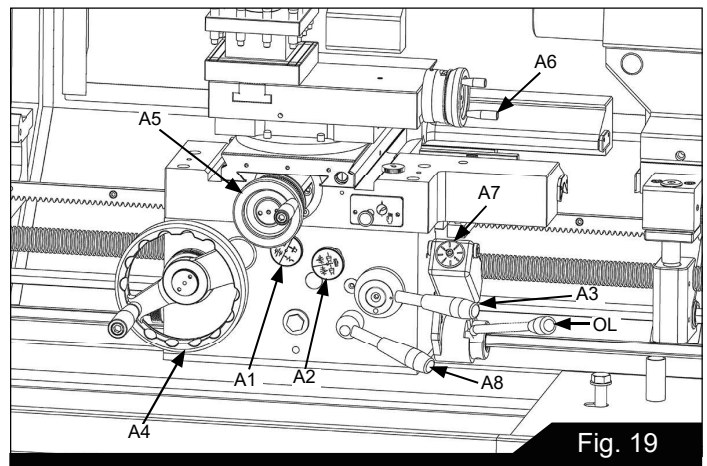

Fig. 19

9.6 THREADING DIAL INDICATOR

For thread cutting:

- Tighten the handnut in order to maintain engagement when engaging the indicator with the leadscrew. When not required, release hand-nut and swing indicator to disengage.
- To cut even number threads per inch, the leadscrew nut can be closed as any line on the dial aligns with the datum mark.
- To cut odd number threads per inch, close the leadscrew nut at any NUMBERED line.
- Fractional threads of 1/2 or 1/4 T.P.I. may be cut by closing the nut at the SAME NUMBERED LINE on each pass of the tool.
- This dial can not be used with an IMPERIAL lead-screw to cut metric threads, D.P., M.P. which are shown on gear box data plate. For the threads being shown, the leadscrew nut must be kept closed. Use apron control lever after each thread cutting when the tool is withdrawn to original start of thread cutting operation.

Multi-start threads can be cut on a lathe in three ways:

1. By repositioning the compound (top) slide one pitch forward for each start. Note that the slide is normally set at 90° to the axis of the machine cross-slide. The accuracy of this method depends upon the skill of the operator.
2. By using an accurately divided driver plate and turning the work-piece one division forward for each start.
3. By advancing the driver gear a calculated number of turns to advance the spindle by one pitch of the thread to be cut. The accuracy of this method is that of the machine.
 - With all series lathes, two ratios exist between the spindle and driver gear shift, i.e. the LOW range where the ratio is 1:2 and the HIGH range where the ratio is 2:1
 - In order to use this method, the number of teeth on the driver gear must be divisible by the number of starts being cut. The driver gear is then advanced by half this number of teeth when in LOW range. And conversely, by twice the number of teeth when in HIGH range.
 - On the standard end gear train for this machine the driver gear has 24 teeth; so that two, three or four start threads, can readily be cut. For other odd numbers of start a choice must be made of methods 1 or 2.

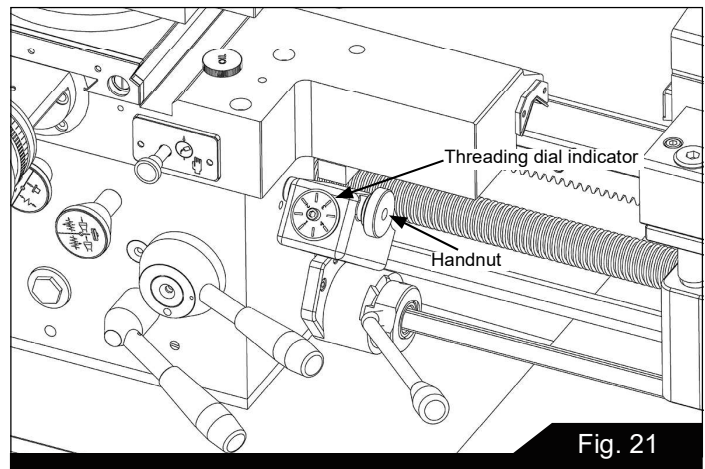
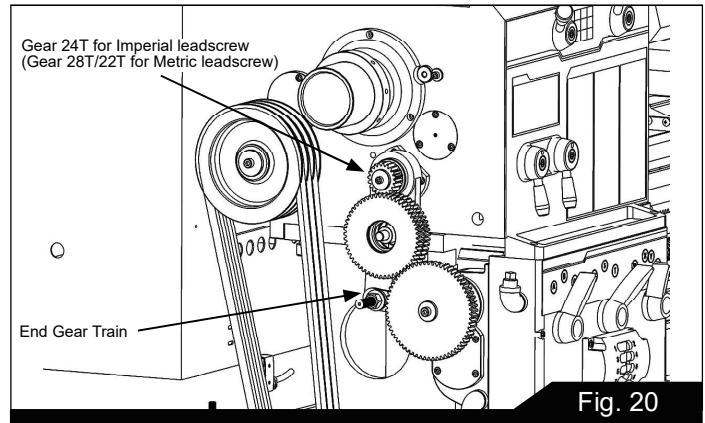

9.7 CROSS SLIDE

Cross slide nut adjusting:

- Reduce backlash by loosening rear hexagon socket head bolt (M6) in top of cross slide, then carefully screw in center set screw (S6) to adjust a wedge within the split nut.
- Make only small adjustments at a time and retighten two bolts (M6) before operating the cross slide several times by hand to be sure of smooth operation throughout full travel.

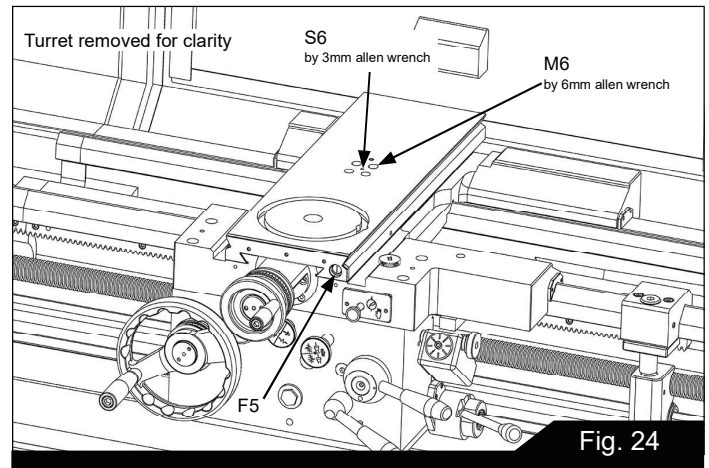
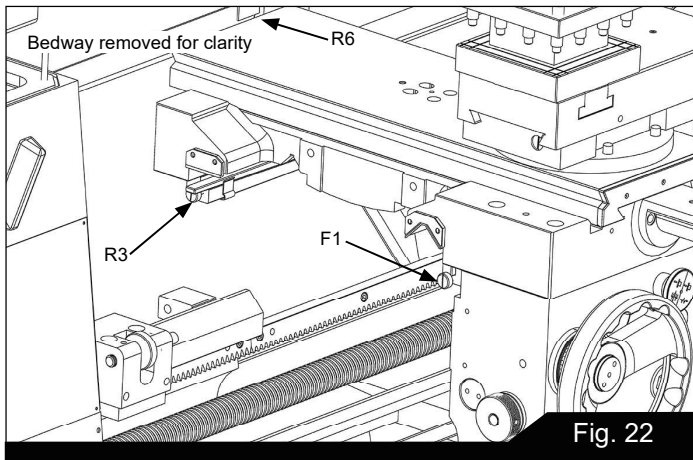

Saddle and Cross slide gibs adjusting:

- Tapered gib strip is fitted to the slideways of saddle cross-slide and top (compound) slides so that any slack which may develop can be diminished. Check and adjust them every six months.
- Ensure that slideways are thoroughly cleaned and lubricated before attempting adjustment.

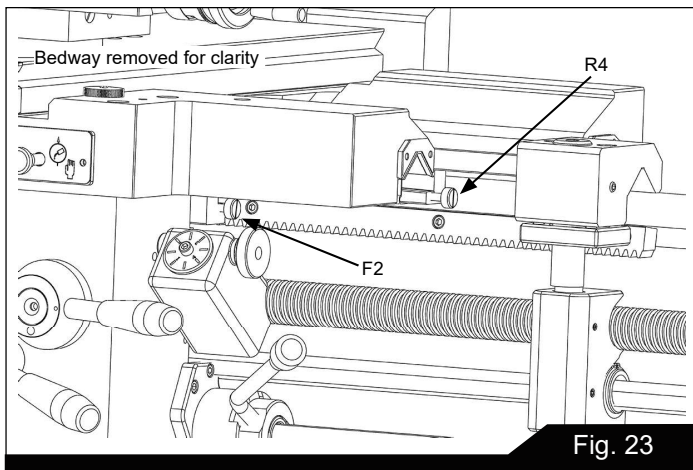

According to the following steps:

1. Use flat head screw driver to loosen the adjust screw (F1) and (R4)/(R6) about 1/2 turn CCW.
2. Appropriately tighten adjust screw (F2) and (R3)/(F5) about 1/2 turn CW.
3. Move saddle left and right to ensure smoothness.
4. Move cross slide forward and backward to ensure smoothness.

9.8 TOP SLIDE

A solid topslide is fitted as standard equipment to the cross-slide mounted on a swivel base which is marked 0-90-0-90° for accurate indexing.

(A5) Cross slide handwheel

(A6) Compound rest handwheel

Handwheel dials are graduated in inch or metric divisions to suit the operation. (Dual dials supply imperial system screw only)

Top slide gibs adjusting:

- You should regularly check and adjust them every six months.
- Ensure that slideways are thoroughly cleaned and lubricated before attempting adjustment.

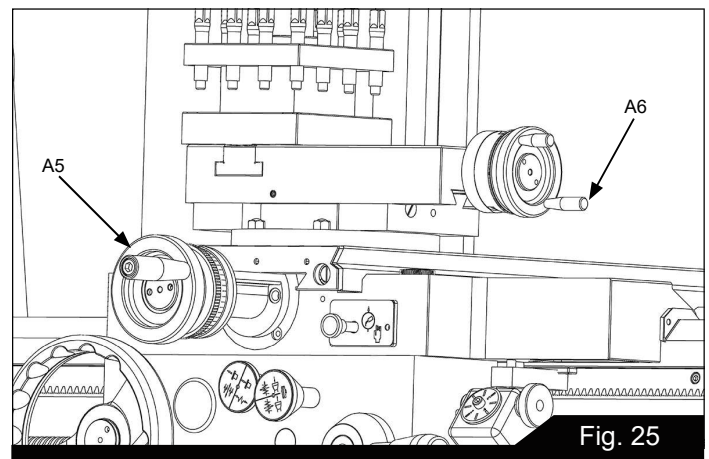

According to the following steps:

1. Use a flat head screw driver to loosen the adjust screw (P1), about 1/2 turn CCW.
2. Appropriately tighten adjust screw (P2), about 1/2 turn CCW.
3. Move top slide left and right to satisfy smoothness.

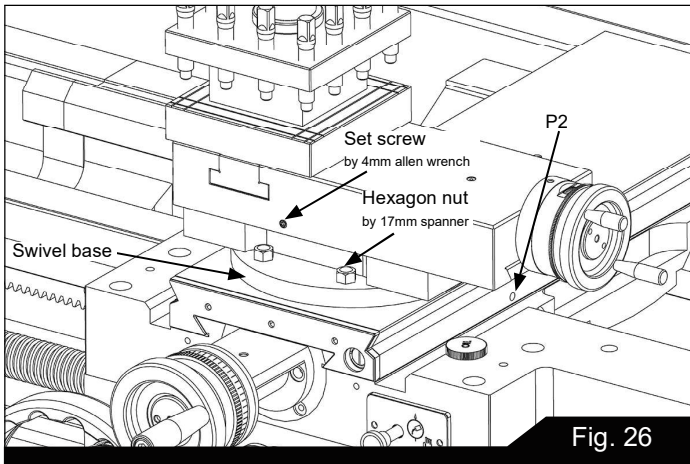

9.9 TAILSTOCK

Operation:

1. The tailstock can be freed for movement along the bed by unlocking the clamp lever (A).
2. Additional clamping may be obtained by tightening the large nut (B) located in a recess below the hand-wheel.
3. Release this clamping lever (A) before attempting to move the tailstock or after there is no longer a need for the additional clamping force.
4. The tailstock quill can be locked by lever (C).

Adjustment/Realignment

- The tailstock also can be offset for turning shallow tapers or for realignment.
- Release the clamping lever (A) and adjust screw (S) at each side of the base to move tailstock laterally across the base.
- An indication of the offset is given by the datum mark (D) at the tailstock end face, as picture shows.
- Tighten clamp lever after adjusting offset.

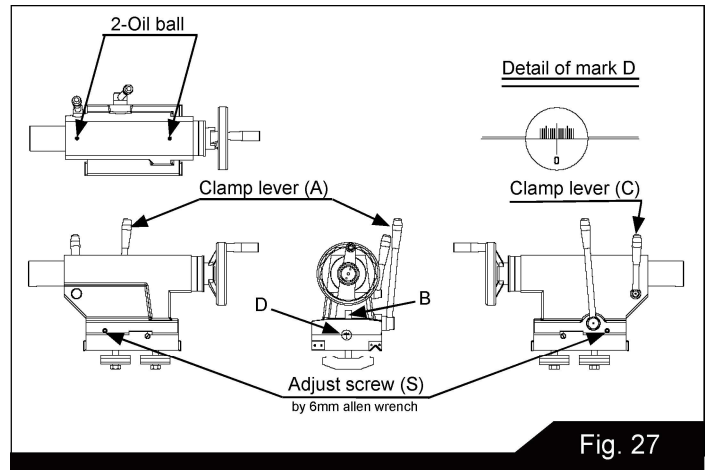

9.10 END GEAR TRAIN

1. Drive from headstock to gear box is transmitted through a gear train enclosed by the headstock end guard. Intermediate gears are carried on an adjustable swing-frame (M).
2. Gears must be thoroughly cleaned before fitting and backlash must be maintained at 0.005" (0.127mm) for correct meshing.
3. Lubricate gear regularly with thick oil or grease.

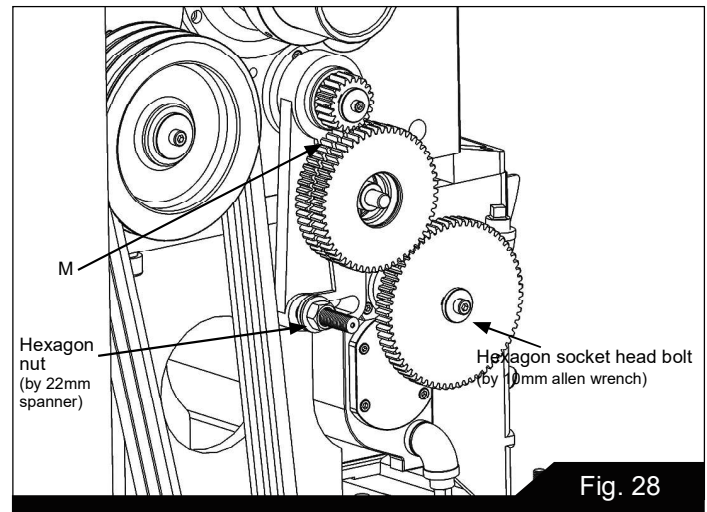

9.11 DRIVING BELTS

1. To modify belt tension, remove the cover plate on back of the headstock and adjust the screws (X) on the hinged motor platform.
2. Ensure that the motor is correctly aligned with the lathe axis.
3. Apply light finger pressure at a point midway between motor and headstock pulleys, the resulting depression will be about 3/4" (19mm) when under tension.

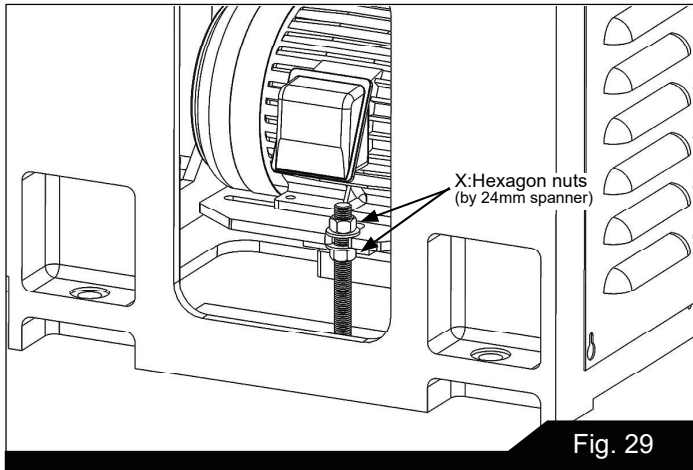

Fig. 29

- Align the holes in flanged-shaft, collar and shroud washer, then insert a new pin and turn the shroud washer half circle towards the left to the collar with snap ring to retain the new shear pin.

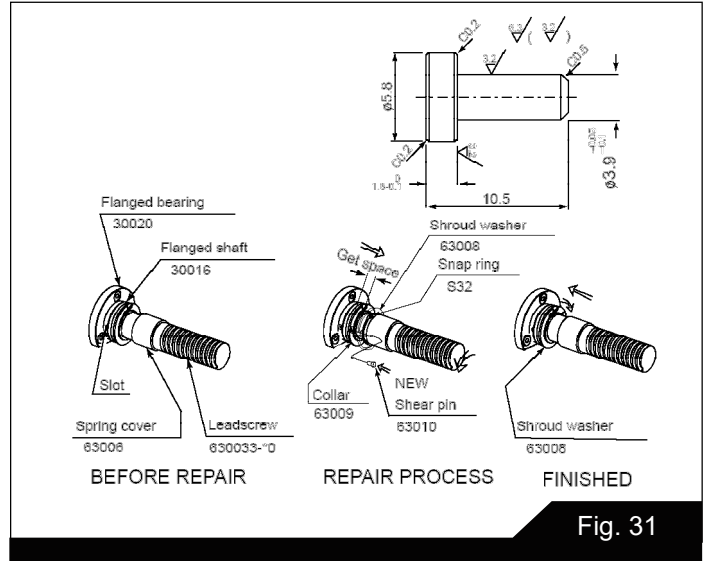

Fig. 31

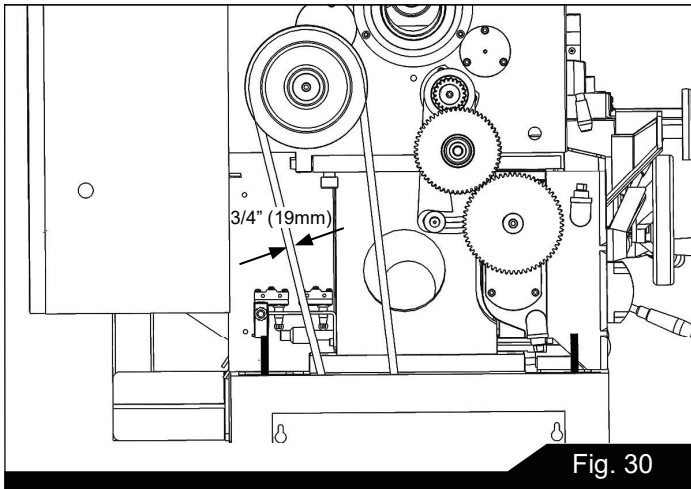

Fig. 30

9.12 LEADSCREW SHEAR PIN

Safety feature:

The transmission is protected against severe overload by a shear pin fitted into the leadscrew drive, just beside the right hand of the gearbox.

To replace a shear pin:

- First disengage drive to the leadscrew by setting the right-hand lever of the gearbox to the position W or X.
- Move the shroud washer with snap ring right-ward to the spring cover.
- Then rotate the leadscrew by hand carrying the broken pin to the frontview, on same level to the slot of flanged bearing.
- With a magnetic screw driver, remove the broken pin head from the collar, and other broken pin from gearbox housing slot hole.

9.13 FEED TRIP ADJUSTMENT

A trip mechanism is incorporated into the apron, enabling saddle and/or cross-slide to be fed up to fixed stops.

Trip loads can be set high (+) or low (-) by adjustment of the knurled handwheel (A9) on the side of the apron.

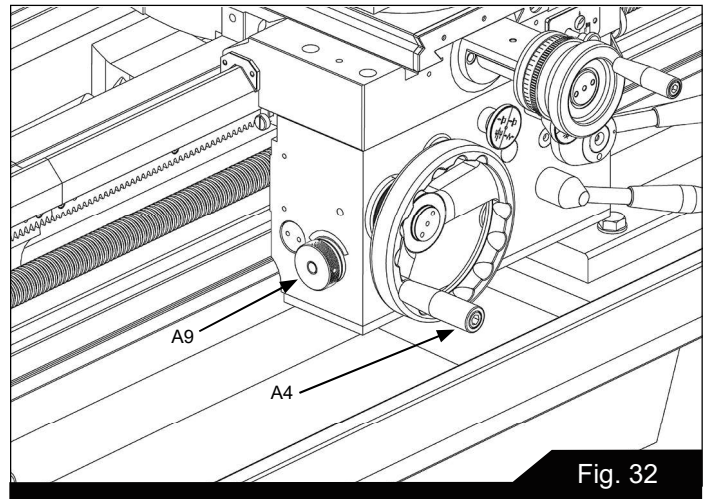
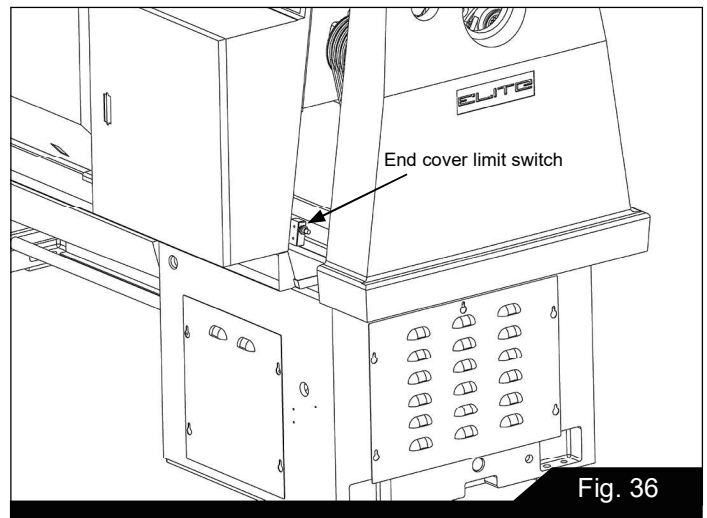
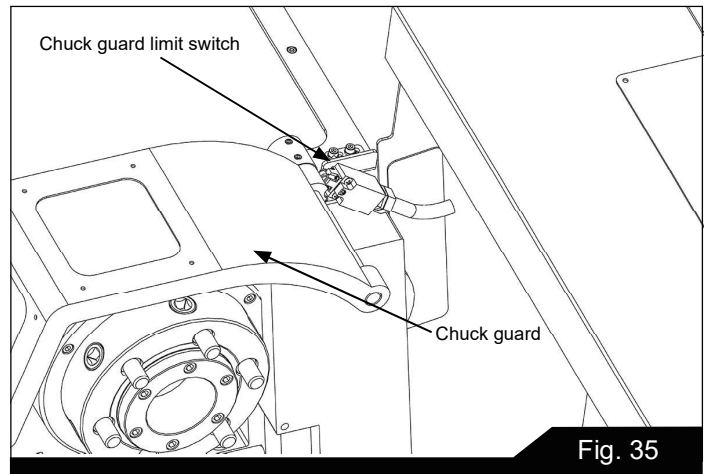
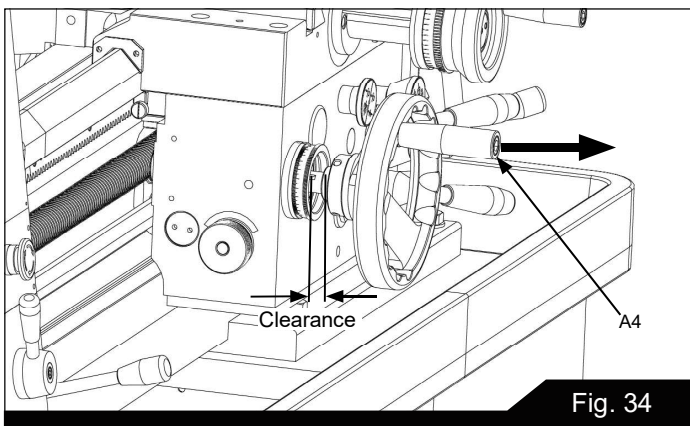
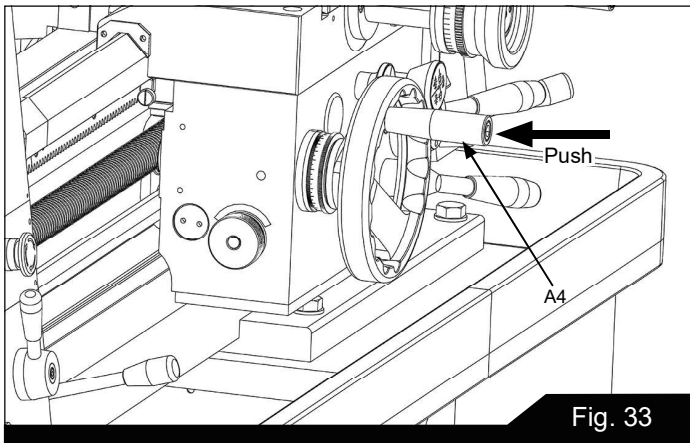

Fig. 32

9.14 APRON HANDWHEEL

The apron handwheel (A4) may be disengaged from its gear train during power operation or when thread cutting, by pulling the handwheel outwards to another spring-ball detent.



9.16 LATHE ALIGNMENT

With the lathe installed and running we recommend verification on machine alignment before beginning work. Check machine level and alignment at regular periods to ensure continued lathe accuracy.

Headstock check:

1. Take a light cut with a cutting tool over a 6" (152mm) length of 2" diameter (50mm) steel bar gripped in the chuck but not supported at the free end.
2. Micrometer readings at each end of the turned length (at A and B) should be the same.
3. To correct a difference in readings, loosen the four headstock hold-down screws (I) behind headstock and (J) under the headstock, then adjust the offset adjusting screws (K).
4. After adjustment, tighten screws (I)/(J) first and then screw (K).

Note: This does not apply when the longitudinal power feed accessory is fitted.

9.15 LIMIT SWITCHES

Safety interlock:

- If the end cover is not closed, then the spindle and coolant pump will not operate.

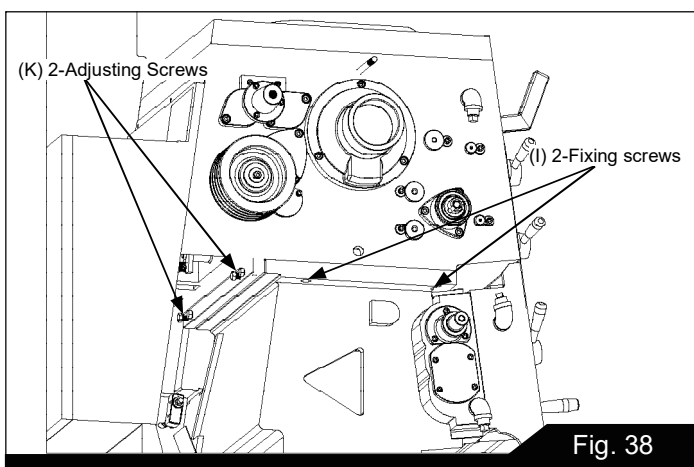
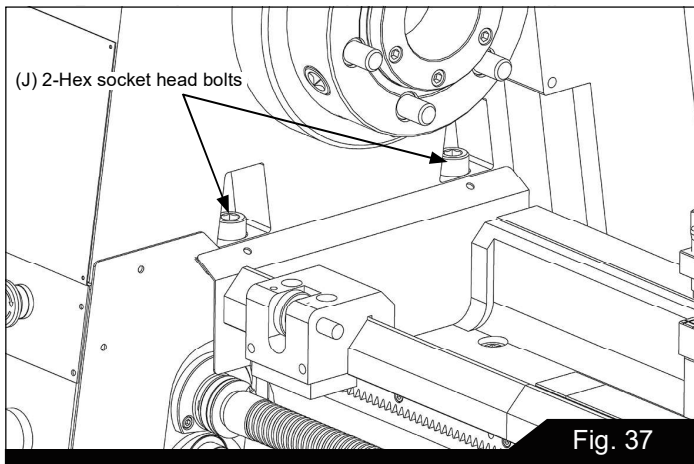

Tailstock check:

1. Using a 12" (305mm) ground steel bar fitted between headstock and tailstock centers, check the alignment by fitting a dial-test indicator to the toolpost and traversing the center line of the bar.
2. To correct error, release the tailstock clamp lever and adjust the offset screws provided.
3. Continue with checking and correction until alignment is perfect.

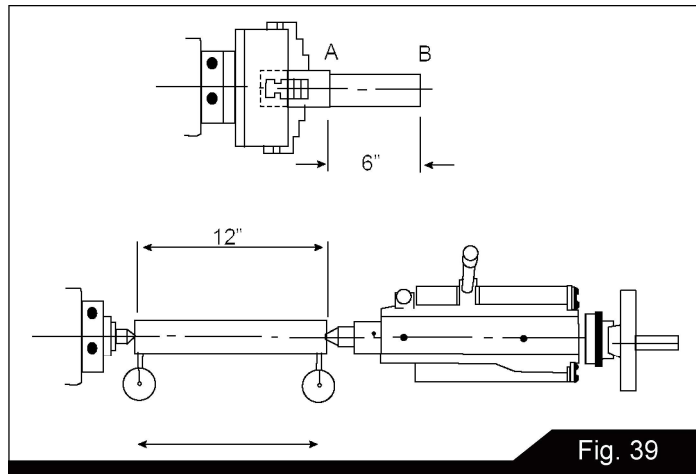

9.17 GAP BRIDGE (FOR GAP BED TYPE LATHE)

- When removing the gap bridge from bedway, be very careful in loosening the four fixing bolts and lift the gap until guiding taper pins separate from bedway completely.
- When loosening the fixing bolts and separating the taper pin, every particular precaution should be made to prevent any damage to fixing bolts and taper pins.
- The taper pins should be left in the gap portion after removal of the gap bridge.
- Removed gap bridge must be stored in a very clean and safe place with every precaution made against damage and rust.
- The taper pins should be greased so as to make it easy to reset the gap bridge with optimum original accuracy.
- Be careful not to have dirt or chips entering into taper pin holes, holes for fixing bolts, or on the surface where gap bridge is to be reset.
- Always keep the gap bridge clean.

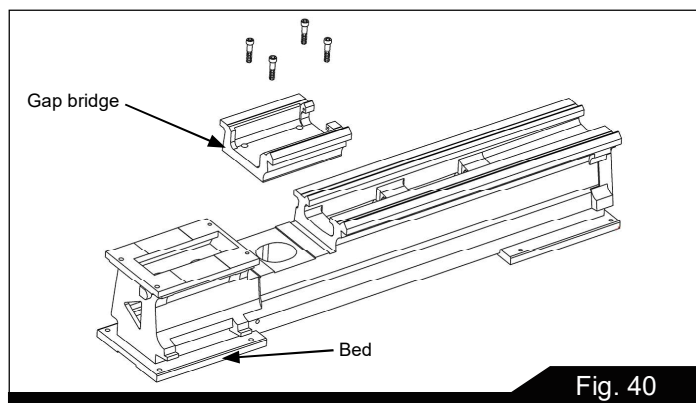

10.0 TROUBLE SHOOTING

Trouble or Failure		Possible Causes	Correction
1	The electricity is on, but the spindle does not run after the starting lever is moved downward or upward	1. Fuse is burned 2. Thermal relay is overloaded	1. Replace fuse 2. Reset thermal relay
2	Outflow of coolant fluid is weak	1. Running orientation of coolant pump is wrong 2. The inside of coolant pipe is rusted or otherwise restricted	1. Interchange any two line of 3 phase line 2. Clear the pipe by compressed air or rigid steel rod
3	No coolant fluid comes out of coolant nozzle	The steel ball inside the coolant pipe is stuck to the "O" ring	Separate the steel ball from "O" ring by compressed air
4	Spindle does not stop instantly even when treadle is fully depressed. Sharp, shriek noise in braking action	Brake lining has been worn out	Replace brake lining
5	Intermittent noise in headstock	Headstock shift levers are not in position	Gearbox shift levers are not in position
6	Headstock and gear train are running and starting lever is moved upward or downward, but the feed rod or leadscrew does not rotate	Gearbox shift levers are not in position	Shift levers to correct positions as specified on data plate
7	When turning long workpiece the right end is smaller than the left end in diameter	Tailstock is not in good alignment to headstock	Offset tailstock until the center line between headstock is parallel to carriage movement
8	Chatter line occurs on turned workpiece	1. Lathe cutter is dull 2. Bearing is too loose	1. Sharpen the cutting angles of lathe cutter 2. Adjust the tightness of nut.
9	No oil comes out of one shot lubrication	Too much air is caught in oil groove	Keep on pushing one shot lubrication pump until all air is driven out
10	Carriage vibrates during heavy cutting	Gib is too loose in fitting	Adjust screw in cross slide to drive the gib slightly inside
11	Oil leaks at right side of gearbox	The lubricant in gearbox is too light	Replace with slightly denser lubricant in gearbox

11.0 LAYOUT OF ELECTRICAL BOX

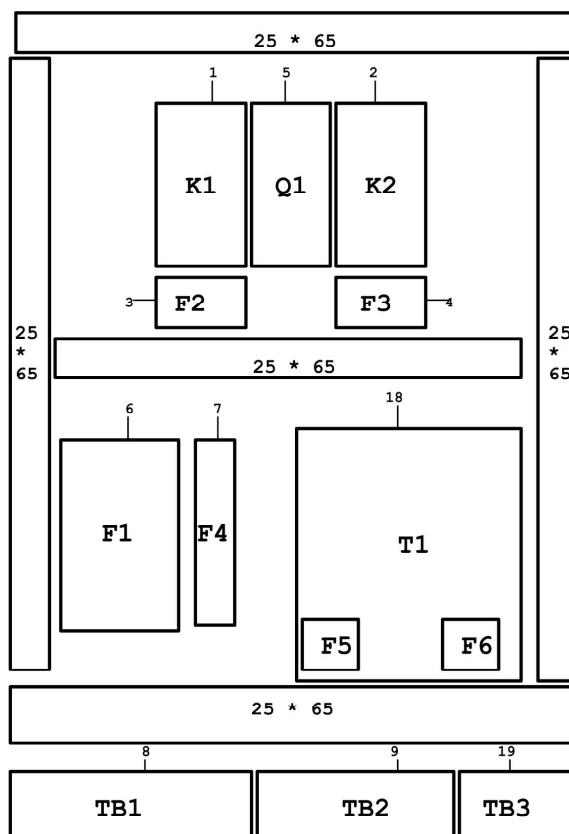

MODEL	DESCRIPTION	SPECIFICATION	QUANTITY	SYMBOL
1880 AC 220V 10HP	AC MAGNETIC SWITCH	TENLC1D326B7	1	K1
	AC MAGNETIC SWITCH	TENLC1D096B7	1	K2
	OVER RELAY	TENLR3D356	1	F2
	OVER RELAY	TENLR3D036	1	F3
	MAIN FUSE BASE	TFU-303 3P50A	1	F1
	FUSE BASE	TFBR-102 2P10A	1	F4, F5
	MICRO SWITCH	TM-1307	1	LS1
	E-STOP	ALEPB-22-1B	1	E-STOP
	SPINDLE MOTOR STOP	APB-22-1B-R	1	SPB1
	SPINDLE MOTOR RUN	NFLPB-1A-30V-G	1	PB1
	COOLANT STOP	APB-22-1B-R	1	SPB2
	COOLANT RUN	NFLPB-1A-30V-G	1	PB2
	POWER LAMP	ALPL-22-30V-W	1	POWER LAMP
	TRANSFORMER	140VA	1	T1
	TERMINAL BOARD	TB-25A-6P	1	TB1
	TERMINAL BOARD	TB-15A-12P	1	TB2

12.0 RECOMMENDED CUTTING SPEED OF LATHE

Workpiece material		Speed (sfm)	Feed (lpr)
Aluminum	2021 to 6061	500	0.002
Brass		75	0.001
Bronze		70	0.001
Cast Iron	Gray	35 to 125	0.0015 to 0.004
	Ductile	15 to 125	0.001 to 0.004
	Malleable	35 to 170	0.0015 to 0.003
Copper	101 to 757	85 to 90	0.002
	834 to 978	340	0.003
Magnesium	AZ, AM, EZ, ZE, HK types	500	0.002
Nickel	Nickel 200 to 230	85	0.002
	Monel	15 to 60	0.001 to 0.0015
	Inconel, Waspaloy	15	0.002
	Hastelloy	10 to 15	0.002
Plastic	TFE, CTFE	250	0.002
	Nylon	350	0.002 to 0.003
	Phenolic	350	0.003
Stainless Steel	201 to 385	65 to 85	0.001 to 0.0015
	405 to 446	90	0.0011
	15-5 PH, 16-6 PH, 14-4 PH	30 to 60	0.0006 to 0.0012
Steel	1005 to 1029	80 to 140	0.001 to 0.002
	1030 to 1055	35 to 115	0.0009 to 0.0015
	1060 to 1095	30 to 80	0.0007 to 0.001
	10L45 to 10L50	40 to 140	0.0009 to 0.0015
	12L13 to 12L15	225 to 280	0.003 to 0.0035
	41L30 to 41L50	20 to 110	0.0007 to 0.0015
	4140 to 4150	20 to 115	0.0007 to 0.0015
	4140 (35 HRC)	70	0.001
	8617 to 8622	40 to 120	0.001 to 0.0016
	M-1 to M-6	60	0.0013
	H-10 to H-19	20 to 80	0.007 to 0.0011
	D-2 to D-7	45 to 60	0.001
	A-2 to A-9, 01 to 07	45 to 60	0.001
	W-1, W-2	110	0.0015
	M-50, 52100	20 to 85	0.0007 to 0.0015
Titanium	TI-6Al-6V	45	0.001

13.0 REPLACEMENT PARTS — EGH-1880, 2180, 21120

Replacement parts are listed on the following pages. To order parts or reach our service department, call 1-855-336-4032, Monday through Friday (see our website for business hours, www.jettools.com). Having the Model Number and Serial Number of your machine available when you call will allow us to serve you quickly and accurately.

JET®

427 New Sanford Road

LaVergne, Tennessee 37086

www.jettools.com

Phone: 855-336-4032

HEADSTOCK ASSEMBLY 1

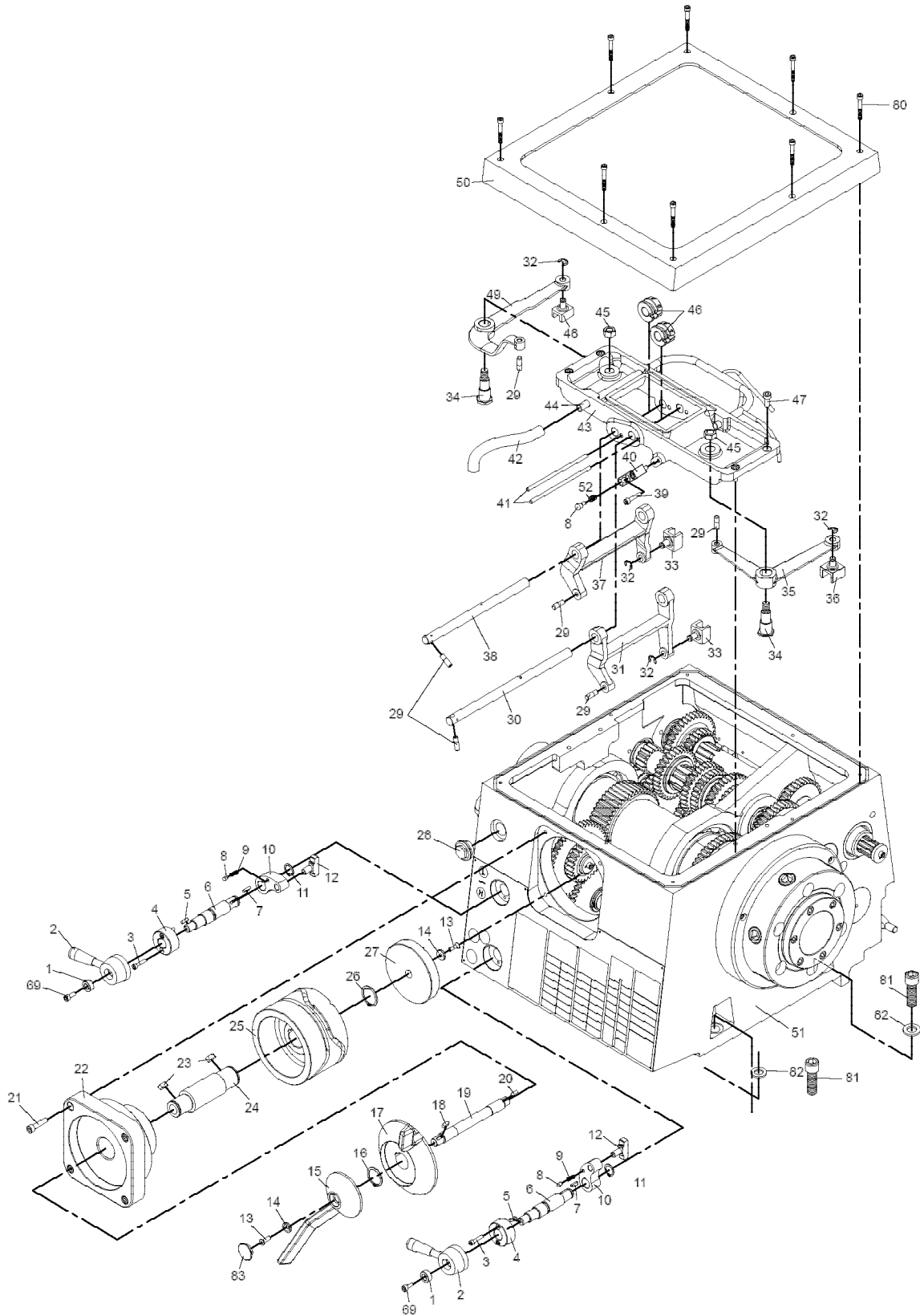

HEADSTOCK ASSEMBLY 1

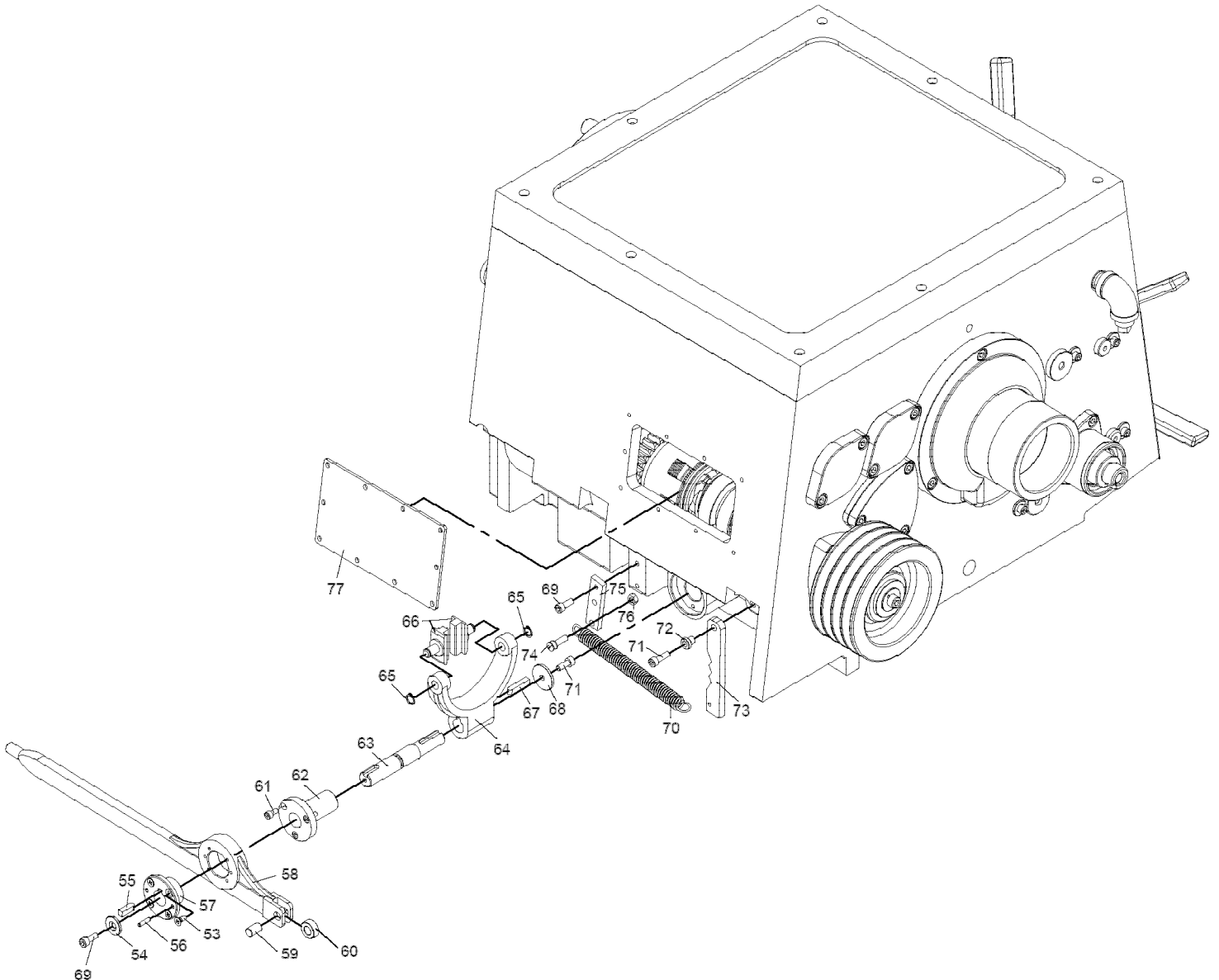



HEADSTOCK ASSEMBLY 1 – PARTS LIST (16 SECTIONS HAVE CLUTCHES)

Index No.	Part No.	Description	Size	Qty.
1	EGH1880-1-A01	Washer		2
2	EGH1880-1-A02	Hub & Handle		2
3	TS-1502061	Hex. Socket Head Bolt	CAP 5x25	4
4	EGH1880-1-A04	Collar		2
5	EGH1880-1-A05	S Key	4x4x15	2
6	EGH1880-1-A06	Shaft		2
7	EGH1880-1-A07	Key	4x4x20	2
8	EGH1880-1-A08	Pin		4
9	EGH1880-1-A09	Spring		2
10	EGH1880-1-A10	Shift Levers		2
11	EGH1880-1-A11	Snap Ring	S18	2
12	EGH1880-1-A12	Change Speed Claw		2
13	EGH1880-1-A13	Flat Cross Screw	6x20	2
14	EGH1880-1-A14	Washer		2
15	EGH1880-1-A15	Speed Selector		1
16	EGH1880-1-A16	Snap Ring	S30	1
17	EGH1880-1-A17	Speed Selector		1
18	EGH1880-1-A18	Key	5x5x14	1
19	EGH1880-1-A19	Cam Shaft		1
20	EGH1880-1-A20	S Key	5x5x14	1
21	TS-1504071	Hex. Socket Head Bolt	CAP 8x35	4
22	EGH1880-1-A22	Cam Cover		1
23	EGH1880-1-A23	Key	7x7x18	2
24	EGH1880-1-A24	Cam Shaft		1
25	EGH1880-1-A25	Cam		1
26	EGH1880-1-A26	Snap Ring	S35	1
27	EGH1880-1-A27	Cam		1
28	EGH1880-1-A28	Oil Sight		1
29	EGH1880-1-A29	Pin		6
30	EGH1880-1-A30	Rod		1
31	EGH1880-1-A31	Lever		1
32	EGH1880-1-A32	Snap Ring	E10	4
33	EGH1880-1-A33	Change Speed Claw		2
34	EGH1880-1-A34	Bolt		2
35	EGH1880-1-A35	Lever		1
36	EGH1880-1-A36	Change Speed Claw		1
37	EGH1880-1-A37	Lever		1
38	EGH1880-1-A38	Rod		1
39	TS-1503071	Hex. Socket Head Bolt	CAP 6x30	2
40	EGH1880-1-A40	Bracket		1
41	EGH1880-1-A41	Rod		2
42	EGH1880-1-A42	Nylon Tube & Spring Assembly		1

Index No.	Part No.	Description	Size	Qty.
43	EGH1880-1-A43	Lever Frame		1
44	EGH1880-1-A44	Oil Pipe		1
45	TS-1540081	Nut	M12	2
46	EGH1880-1-A46	Collars		2
47	TS-1504041	Hex. Socket Head Bolt	CAP 8x20	4
48	EGH1880-1-A48	Change Speed Claw		1
49	EGH1880-1-A49	Lever		1
50	EGH1880-1-A50	Head Cover		1
51	EGH1880-1-A51	Headstock		1
	EGH2180-1-A51	Headstock		1
	EGH21120-1-A52	Headstock		1
52	EGH1880-1-A52	Spring		2
53	TS-2285121	Flat Cross Screw	5x12	4
54	EGH1880-1-A54	Washer		1
55	EGH1880-1-A55	S Key	6x6x20	1
56	EGH1880-1-A56	Spring Pin	Ø4x16	2
57	EGH1880-1-A57	Bush		1
58	EGH1880-1-A58	Lever		1
59	EGH1880-1-A59	Pin		1
60	EGH1880-1-A60	Roller		1
61	TS-1502021	Hex. Socket Head Bolt	CAP 5x10	3
62	EGH1880-1-A62	Sleeve		1
63	EGH1880-1-A63	Shaft		1
64	EGH1880-1-A64	Shift Fork		1
65	EGH1880-1-A65	Snap Ring	S10	2
66	EGH1880-1-A66	Set Aside One		2
67	EGH1880-1-A67	S Key	6x6x30	1
68	EGH1880-1-A68	Washer		1
69	TS-1503041	Hex. Socket Head Bolt	CAP 6x16	4
70	EGH1880-1-A70	Spring		1
71	TS-1503051	Hex. Socket Head Bolt	CAP 6x20	2
72	EGH1880-1-A72	Bush		1
73	EGH1880-1-A73	Pivot Plate		1
74	EGH1880-1-A74	Pin		1
75	EGH1880-1-A75	Bar		1
76	TS-1540041	Nut	M6	1
77	EGH1880-1-A77	Oil Tray		1
80	TS-1503101	Hex. Socket Head Bolt	CAP 6x45	8
81	EGH1880-1-A81	Hex. Socket Head Bolt	CAP 16x50	2
82	EGH1880-1-A82	Washer	Ø16.5xØ25x3t	2
83	EGH1880-1-A83	Plug		1

HEADSTOCK ASSEMBLY 2

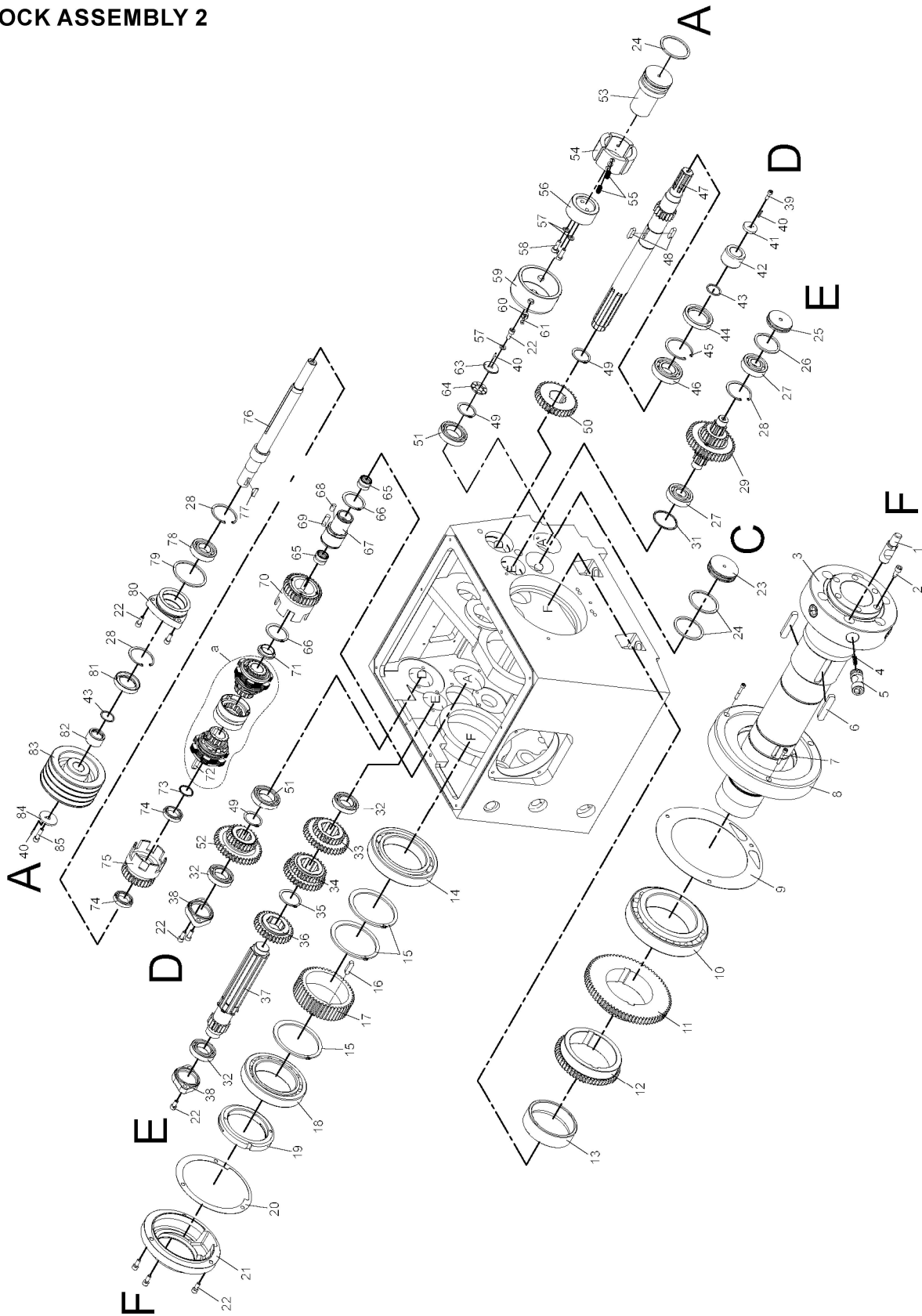

HEADSTOCK ASSEMBLY 2

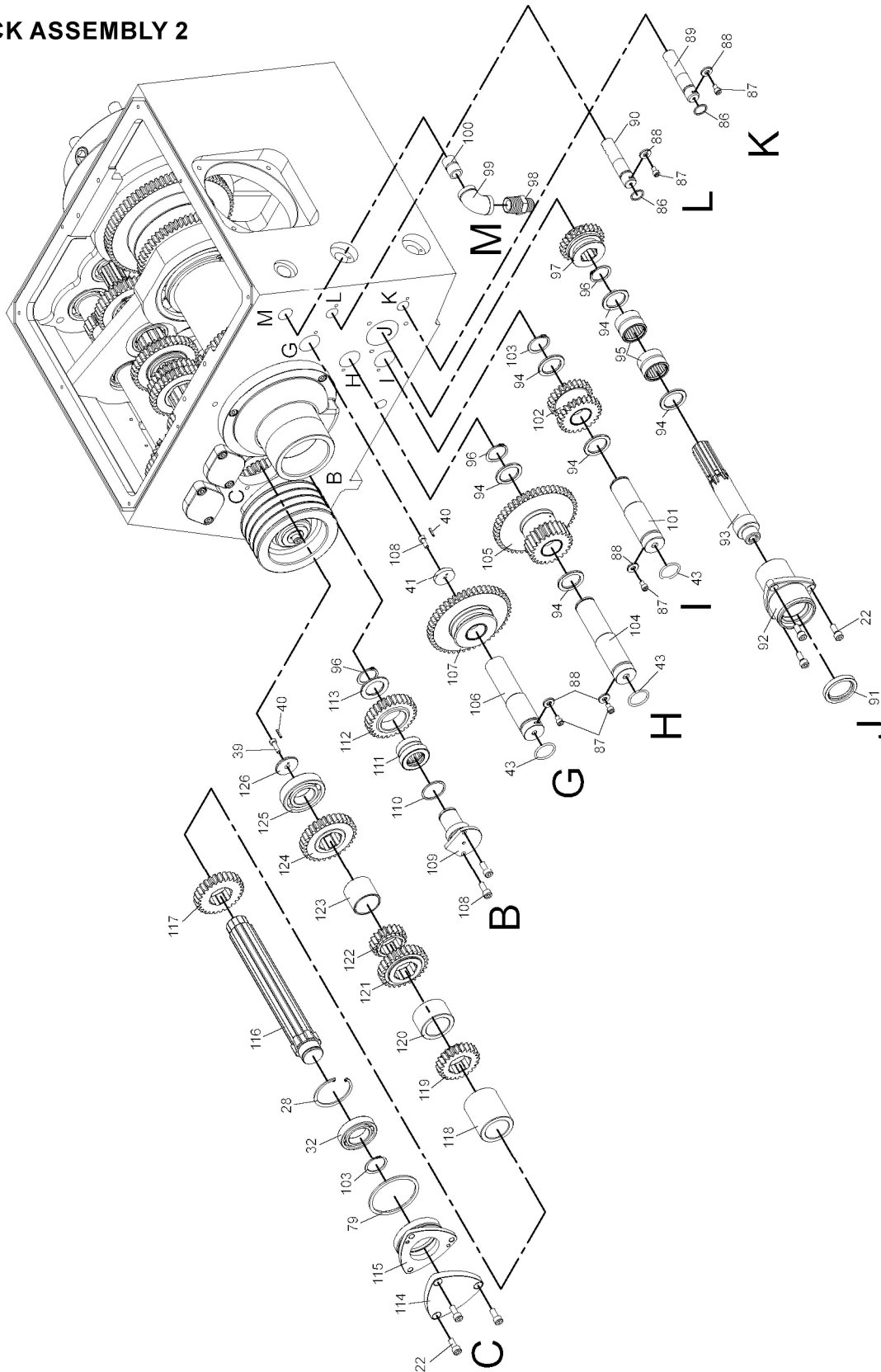



HEADSTOCK ASSEMBLY – 2 PARTS LIST

Index No.	Part No.	Description	Size	Qty.
1	EGH1880-2-A01	Shaft		6
	EGH1880-2-A02A	Bolt Ass'y (includes No. 2-5)		1
2	EGH1880-2-A02	Bolt		6
3	EGH1880-2-A03	Spindle		1
4	EGH1880-2-A04	Spring		6
5	EGH1880-2-A05	Pin		6
6	EGH1880-2-A06	Key	15×10×78	2
7	TS-1503091	Hex. Socket Head Bolt	CAP 6×40	3
8	EGH1880-2-A08	Front Bearing Cover		1
9	EGH1880-2-A09	Asbestos Pad		1
10	EGH1880-2-A10	Taper Roller Bearing	32026	1
11	EGH1880-2-A11	Gear	75T	1
12	EGH1880-2-A12	Gear	56T	1
13	EGH1880-2-A13	Collar		1
14	EGH1880-2-A14	Ball Bearing	6022	1
15	EGH1880-2-A15	Snap Ring	S110	3
16	EGH1880-2-A16	Key	10×8×36	1
17	EGH1880-2-A17	Gear	48T	1
18	EGH1880-2-A18	Taper Roller Bearing	32021	1
19	EGH1880-2-A19	Nut		1
20	EGH1880-2-A20	Asbestos Pad		1
21	EGH1880-2-A21	Outside Cover		1
22	TS-1504041	Hex. Socket Head Bolt	CAP 8×20	17
23	EGH1880-2-A23	Plug		1
24	EGH1880-2-A24	O ring	G65	3
25	EGH1880-2-A25	Plug		1
26	EGH1880-2-A26	O Ring	G55	1
27	BB-6305	Ball Bearing	6305	2
28	EGH1880-2-A28	Snap Ring	R62	4
29	EGH1880-2-A29	Snap Ring(S65), 21T, 40T Assembly		1
30	EGH1880-2-A30	Shaft		1
31	EGH1880-2-A31	Collar		1
32	BB-6007	Ball Bearing	6007	4
33	EGH1880-2-A33	Gear 26T / 38T Assembly		1
34	EGH1880-2-A34	Gear 30T / 34T Assembly		1
35	EGH1880-2-A35	Snap Ring	S48	1
36	EGH1880-2-A36	Gear	32T	1
37	EGH1880-2-A37	Gear Shaft	16T	1
38	EGH1880-2-A38	Cover		2
39	TS-1503051	Hex. Socket Head Bolt	CAP 6×20	2
40	EGH1880-2-A40	Spring Pin	∅3×16	5
41	EGH1880-2-A41	Washer		2
42	EGH1880-2-A42	Collar		1

Index No.	Part No.	Description	Size	Qty.
43	EGH1880-2-A43	O Ring	P30	5
44	EGH1880-2-A44	Oil Seal	507212	1
45	EGH1880-2-A45	Snap Ring	R72	1
46	EGH1880-2-A46	Ball Bearing	6207RS	1
47	EGH1880-2-A47	Gear Shaft	16T	1
48	EGH1880-2-A48	Key	8×8×30	2
49	EGH1880-2-A49	Snap Ring	S40	3
50	EGH1880-2-A50	Gear	35T	1
51	BB-6008	Ball Bearing	6008	2
52	EGH1880-2-A52	Gear 25T / 40T Assembly		1
53	EGH1880-2-A53	Brake Shaft		1
54	EGH1880-2-A54	Brake Strap		4
55	EGH1880-2-A55	Spring		8
56	EGH1880-2-A56	Brake Disc		1
57	TS-1550061	Washer	M8	3
58	TS-1504051	Hex. Socket Head Bolt	CAP 8×25	2
59	EGH1880-2-A59	Brake Cylinder		1
60	EGH1880-2-A60	Brake Bush		4
61	TS-1514021	Flat Cross Screw	6×16	4
63	EGH1880-2-A63	Washer		1
64	EGH1880-2-A64	Collar		1
65	EGH1880-2-A65	Needle Bearing	NK22/20	2
66	EGH1880-2-A66	Snap Ring	S50	2
67	EGH1880-2-A67	Shaft		1
68	EGH1880-2-A68	Key	10×7×18	1
69	EGH1880-2-A69	Key	10×7×30	1
70	EGH1880-2-A70	Clutch & Gear 31T Assembly		1
71	EGH1880-2-A71	Copper Collar		1
72	EGH1880-2-A72	S Key	8×8×135	1
73	EGH1880-2-A73	Copper Collar		1
74	EGH1880-2-A74	Ball Bearing	6906	2
75	EGH1880-2-A75	Clutch & Gear 27T Assembly		1
76	EGH1880-2-A76	Shaft		1
77	EGH1880-2-A77	Woodruff Key	Ø25×7	1
78	BB-6206	Ball Bearing	6206	1
79	EGH1880-2-A79	O Ring	G75	2
80	EGH1880-2-A80	Bearing Seat		1
81	EGH1880-2-A81	Oil Seal	406212	1
82	EGH1880-2-A82	Collar		1
83	EGH1880-2-A83	Pulley		1
84	EGH1880-2-A84	Washer		1
85	TS-1504061	Hex. Socket Head Bolt	CAP 8×30	1
86	EGH1880-2-A86	O Ring	G16	2



Index No.	Part No.	Description	Size	Qty.
87	TS-1503031	Hex. Socket Head Bolt	CAP 6×12	5
88	EGH1880-2-A88	Washer		5
89	EGH1880-2-A89	Shaft		1
90	EGH1880-2-A90	Shaft		1
91	EGH1880-2-A91	Oil Seal	385508	1
92	EGH1880-2-A92	Flanged Bearing		1
93	EGH1880-2-A93	Shaft	J	1
94	EGH1880-2-A94	Collar		6
95	EGH1880-2-A95	Needle Bearing	32×30	2
96	EGH1880-2-A96	Snap Ring	S30	2
97	EGH1880-2-A97	Gear	24T	1
98	EGH1880-2-A98	Fitting	3/4" × 5/8"	1
99	EGH1880-2-A99	Female Elbow	3/4"× 90°	1
100	EGH1880-2-A100	Nipple	3/4"× 1"	1
101	EGH1880-2-A101	Shaft	I	1
102	EGH1880-2-A102	Gear	24T	1
103	EGH1880-2-A103	Snap Ring	S32	3
104	EGH1880-2-A104	Shaft	H	1
105	EGH1880-2-A105	Gear 24T / 48T Assembly		1
106	EGH1880-2-A106	Shaft	G	1
107	EGH1880-2-A107	Gear 48T / 24T Assembly		1
108	TS-1503041	Hex. Socket Head Bolt	CAP 6×16	3
109	EGH1880-2-A109	Shaft	B	1
110	EGH1880-2-A110	O Ring	G35	1
111	EGH1880-2-A111	Bearing	NAX3030	1
112	EGH1880-2-A112	Gear	28T	1
113	EGH1880-2-A113	Washer		1
114	EGH1880-2-A114	Collar		1
115	EGH1880-2-A115	Flanged Bearing	C	1
116	EGH1880-2-A116	Shaft	C	1
117	EGH1880-2-A117	Gear	27T	1
118	EGH1880-2-A118	Collar		1
119	EGH1880-2-A119	Gear	23T	1
120	EGH1880-2-A120	Collar		1
121	EGH1880-2-A121	Gear	27T	1
122	EGH1880-2-A122	Gear	19T	1
123	EGH1880-2-A123	Collar		1
124	EGH1880-2-A124	Gear	31T	1
125	BB-6207	Ball Bearing	6207	1
126	EGH1880-2-A126	Washer		1
a		Clutch	ZC30DGDW	1

GEARBOX ASSEMBLY

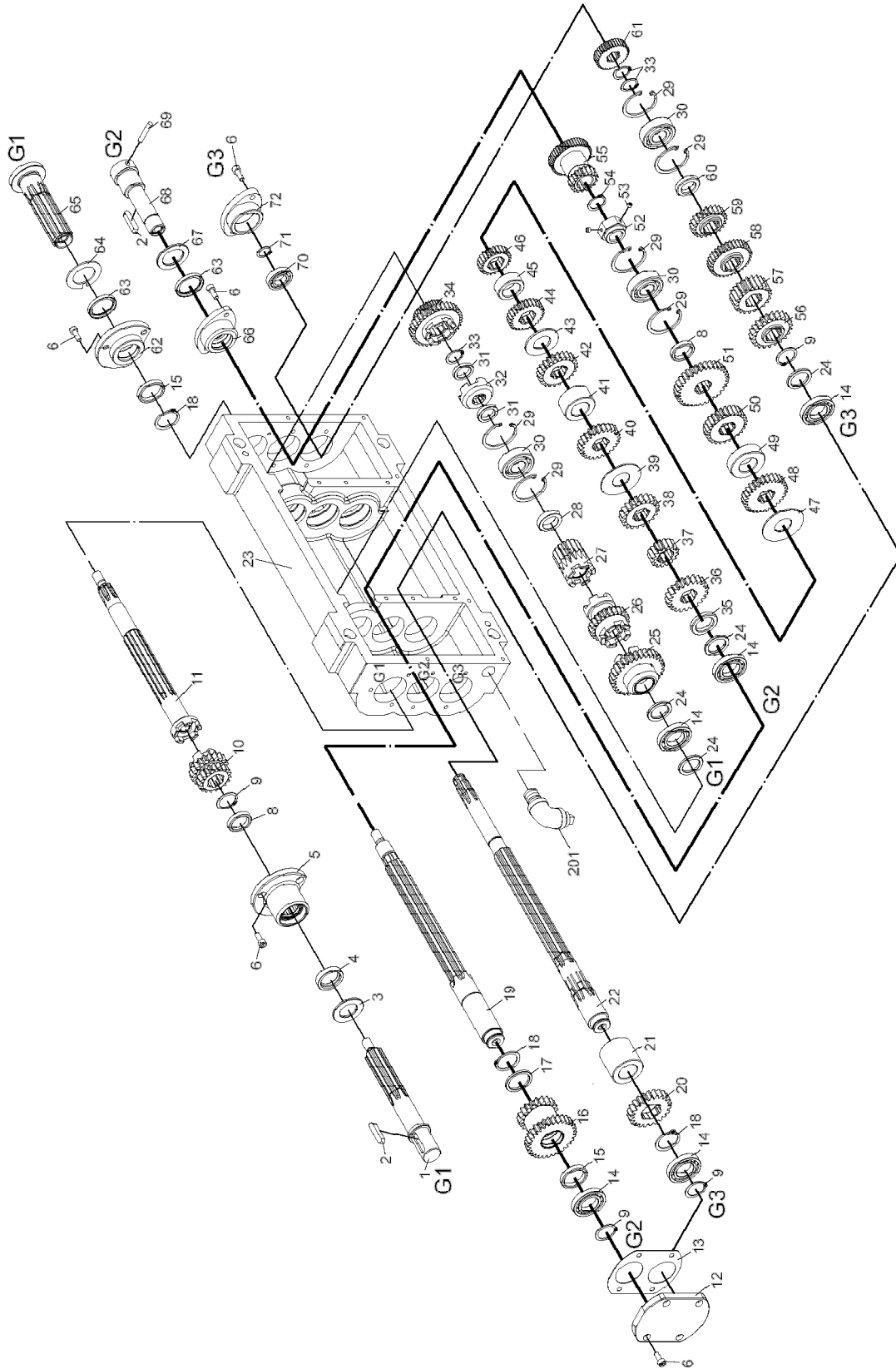

GEARBOX ASSEMBLY

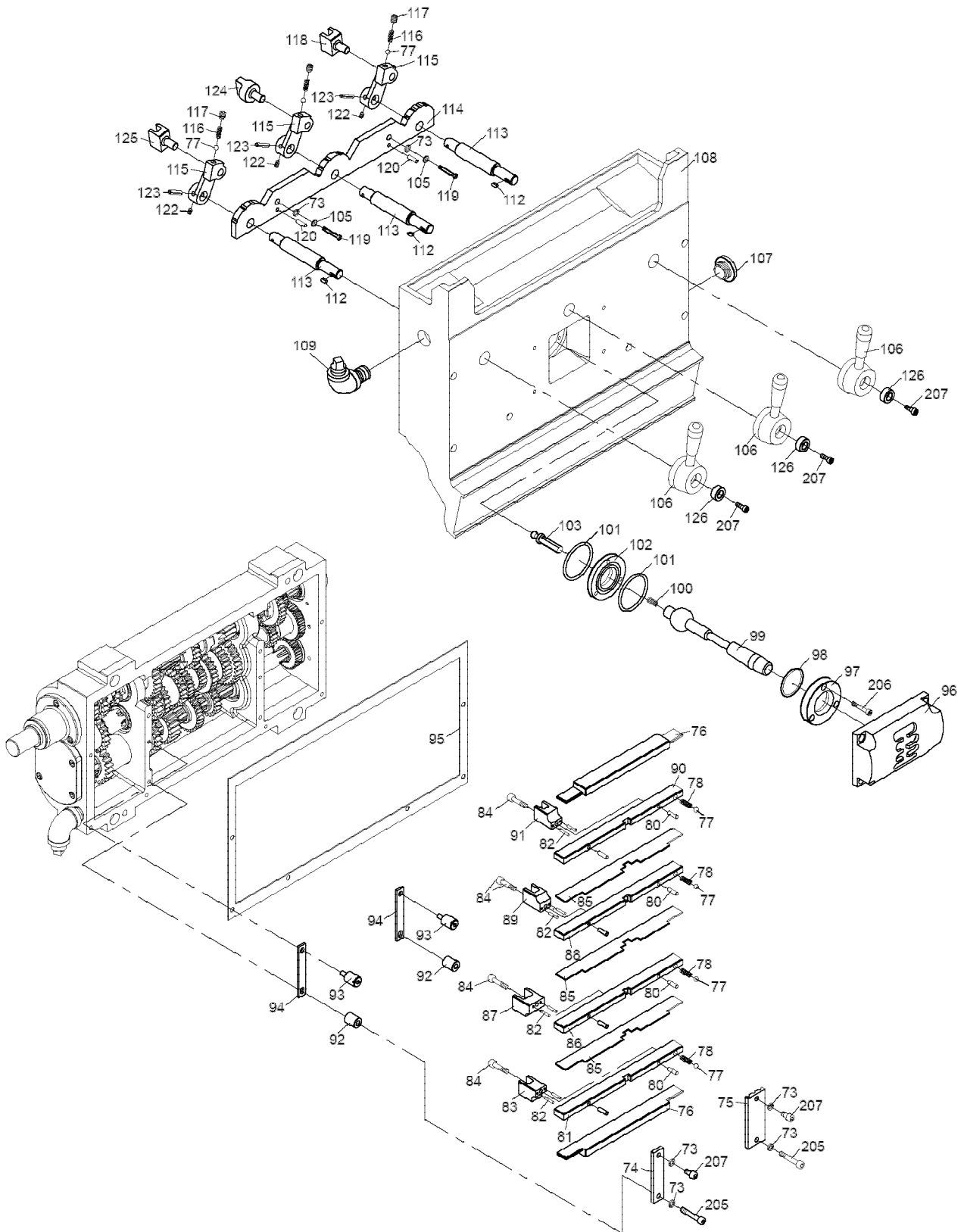

GEARBOX ASSEMBLY PARTS LIST

Index No.	Part No.	Description	Size	Qty.
1	EGH1880-B01	Shaft		1
2	EGH1880-B02	Key	7×7×35	2
3	EGH1880-B03	Washer		1
4	EGH1880-B04	Oil Seal	253708	1
5	EGH1880-B05	Needle Bearing	TAF253320	2
6	TS-1503041	Hex. Socket Head Bolt	CAP 6×16	14
7	EGH1880-B07	Axle Seat	I	1
8	EGH1880-B08	Washer		2
9	EGH1880-B09	Snap Ring	S25	4
10	EGH1880-B10	Gear	19T/19T	1
11	EGH1880-B11	Shaft		1
12	EGH1880-B12	Cover		1
13	EGH1880-B13	Asbestos Pad		1
14	BB-16005	Ball Bearing	16005	5
15	EGH1880-B15	Washer		2
16	EGH1880-B16	Gear	20T/30T	1
17	EGH1880-B17	Washer		1
18	EGH1880-B18	Snap Ring	S30	3
19	EGH1880-B19	Shaft		1
20	EGH1880-B20	Gear	22T	1
21	EGH1880-B21	Washer		1
22	EGH1880-B22	Shaft		1
23	EGH1880-B23	Gear Box		1
24	EGH1880-B24	Washer		4
25	EGH1880-B25	Gear	32T	1
26	EGH1880-B26	Gear	23T	1
27	EGH1880-B27	Gear	16T	1
28	EGH1880-B28	Washer		1
29	EGH1880-B29	Snap Ring	R47	6
30	BB-6204	Ball Bearing	6204	3
31	EGH1880-B31	Washer		2
32	EGH1880-B32	Clutch		1
33	EGH1880-B33	Snap Ring	S20	3
34	EGH1880-B34	Gear	35T/35T	1
35	EGH1880-B35	Washer		1
36	EGH1880-B36	Gear	22T	1
37	EGH1880-B37	Gear	16T	1
38	EGH1880-B38	Gear	20T	1
39	EGH1880-B39	Washer		1
40	EGH1880-B40	Gear	24T	1
41	EGH1880-B41	Washer		1
42	EGH1880-B42	Gear	23T	1
43	EGH1880-B43	Washer		1
44	EGH1880-B44	Gear	27T	1



Index No.	Part No.	Description	Size	Qty.
45	EGH1880-B45	Washer		1
46	EGH1880-B46	Gear	24T	1
47	EGH1880-B47	Washer		1
48	EGH1880-B48	Gear	28T	1
49	EGH1880-B49	Washer		1
50	EGH1880-B50	Gear	26T	1
51	EGH1880-B51	Gear	32T	1
52	EGH1880-B52	Nut		1
53	TS-1523011	Set Screw	SET 6x6	2
54	EGH1880-B54	Snap Ring	S22	1
55	EGH1880-B55	Gear	45T/18T	1
56	EGH1880-B56	Gear	22T	1
57	EGH1880-B57	Gear	22T	1
58	EGH1880-B58	Gear	33T	1
59	EGH1880-B59	Gear	22T	1
60	EGH1880-B60	Washer		1
61	EGH1880-B61	Gear	36T	1
62	EGH1880-B62	Axle Seat		1
63	EGH1880-B63	Oil Seal	304005	2
64	EGH1880-B64	Washer		1
65	EGH1880-B65	Shaft		1
66	EGH1880-B66	Axle Seat		1
67	EGH1880-B67	Washer		1
68	EGH1880-B68	Shaft		1
69	EGH1880-B69	Pin	Ø6x36	1
70	BB-16003	Ball Bearing	16003	1
71	EGH1880-B71	Snap Ring	S17	1
72	EGH1880-B72	Bearing Seat		1
73	TS-2361061	Spring Washer	M6	7
74	EGH1880-B74	Shoulder Plate		1
75	EGH1880-B75	Reverse-Stop		1
76	EGH1880-B76	Upper Plate		2
77	EGH1880-B77	Steel Ball	1/4"	7
78	EGH1880-B78	Spring		4
80	EGH1880-B80	Spring Pin	5x16	8
81	EGH1880-B81	Fort Support		1
82	EGH1880-B82	Spring Pin	Ø5x16	8
83	EGH1880-B83	Fork		1
84	TS-1502051	Hex. Socket Head Bolt	CAP 5x20	4
85	EGH1880-B85	Partition		3
86	EGH1880-B86	Fort Support		1
87	EGH1880-B87	Fork		1
88	EGH1880-B88	Fort Support		1
89	EGH1880-B89	Fork		1
90	EGH1880-B90	Fort Support		1

Index No.	Part No.	Description	Size	Qty.
91	EGH1880-B91	Fork		1
92	EGH1880-B92	Spacer		2
93	EGH1880-B93	Partition Nut		2
94	EGH1880-B94	Fixed Plate		2
95	EGH1880-B95	Seal		1
96	EGH1880-B96	Specifying Base		1
97	EGH1880-B97	Selector Lever Cover		1
98	EGH1880-B98	O-Ring	G35	1
99	EGH1880-B99	Selector Lever		1
100	EGH1880-B100	Spring		1
101	EGH1880-B101	O-Ring	G40	2
102	EGH1880-B102	Selector Lever Support		1
103	EGH1880-B103	Selector Lever		1
104	EGH1880-B104	Plug		3
105	TS-1550041	Washer	M6	2
106	EGH1880-B106	Hub & Handle		3
107	EGH1880-B107	Oil Sight		1
108	EGH1880-B108	Gearbox Cover		1
	EGH2180-B108	Gearbox Cover		1
109	EGH1880-B109	Nipple	3/4"	1
110	EGH1880-B110	Elbow	3/4"	1
111	EGH1880-B111	Square Head Plug	3/4"	1
112	EGH1880-B112	Key	4x4x10	3
113	EGH1880-B113	Shaft		3
	EGH2180-B113	Shaft		3
114	EGH1880-B114	Selector Bar		1
115	EGH1880-B115	Lever		3
116	EGH1880-B116	Spring		3
117	TS-1524011	Set Screw	SET 8x8	3
118	EGH1880-B118	Fork		1
119	TS-1503051	Hex. Socket Head Bolt	CAP6x20	2
120	EGH1880-B120	Spring Pin	5x16	2
122	TS-1523011	Set Screw	SET 6x6	3
123	EGH1880-B123	Spring Pin	Ø4x24	3
124	EGH1880-B124	Fork		1
125	EGH1880-B125	Fork		1
126	EGH1880-B126	Washer		3
201	EGH1880-B201	Square Head Plug	1/2"	1
202	EGH1880-B202	Elbow	1/2"	1
203	EGH1880-B203	Nipple	1/2"	1
204	TS-1503031	Hex. Socket Head Bolt	CAP 6x12	3
205	TS-1503091	Hex. Socket Head Bolt	CAP 6x40	2
206	TS-1502061	Hex. Socket Head Bolt	CAP 5x25	3
207	TS-1503041	Hex. Socket Head Bolt	CAP 6x16	5

APRON (L.H) ASSEMBLY

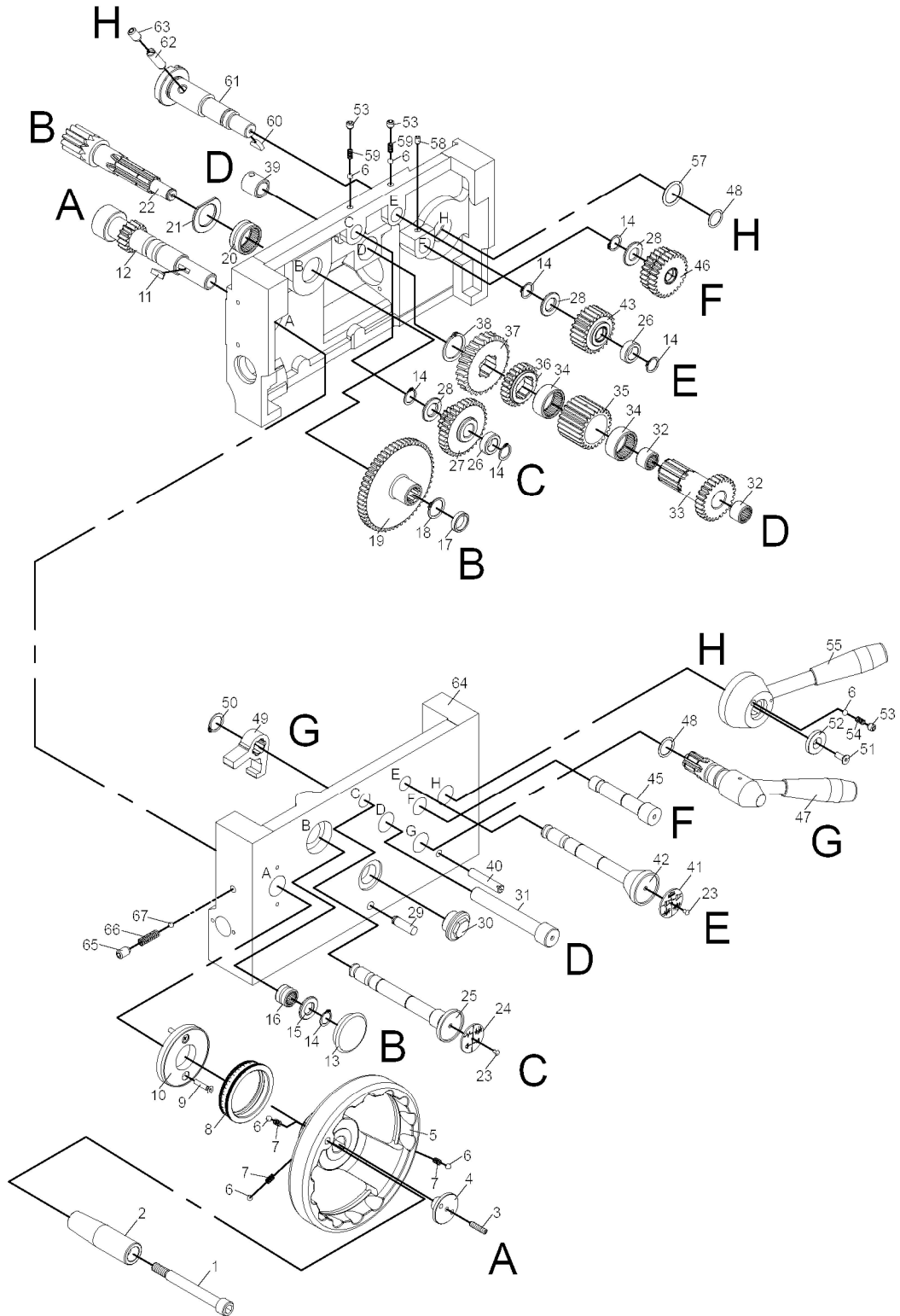

APRON ASSEMBLY

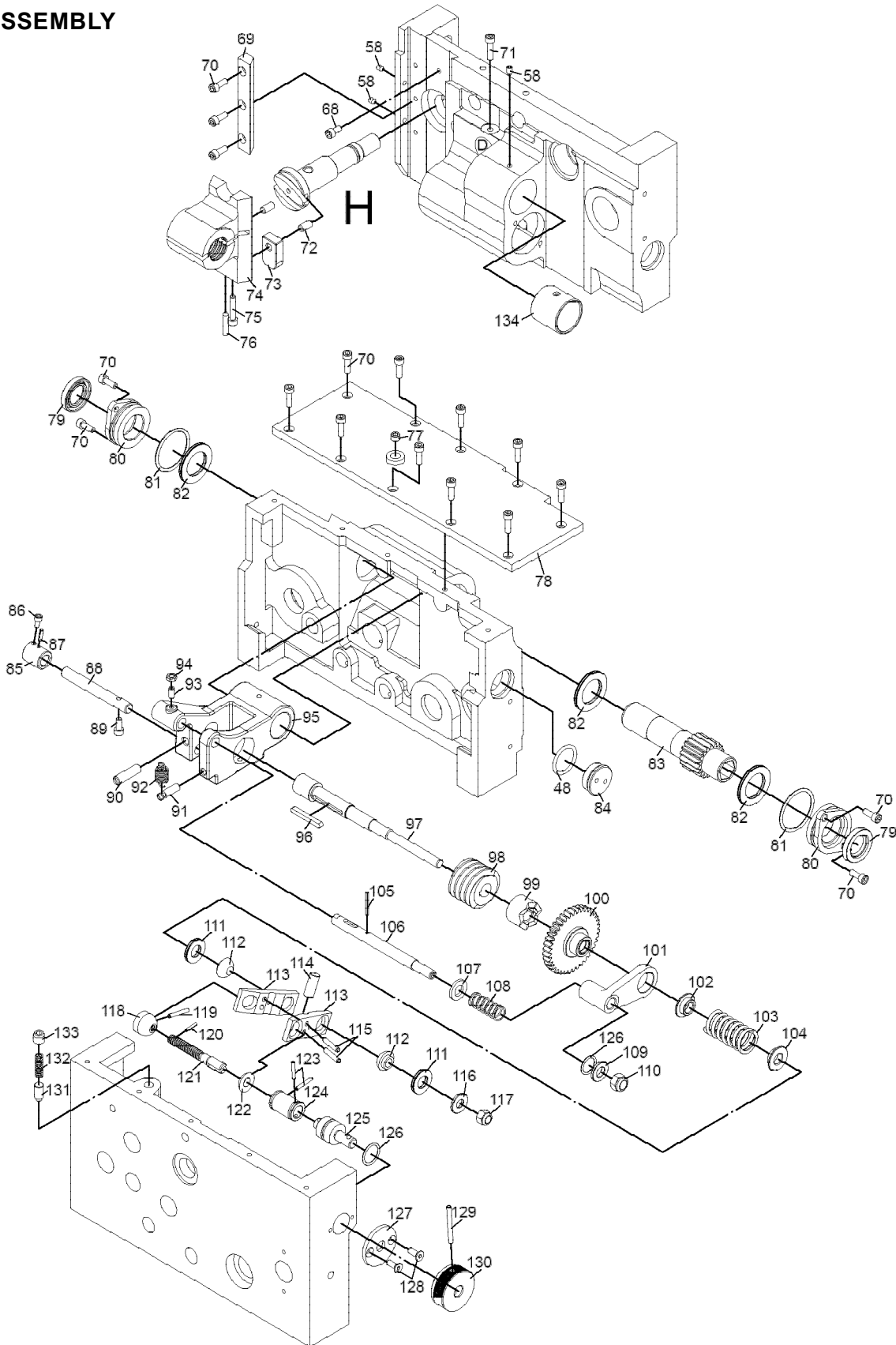



APRON (L.H) ASSEMBLY PARTS LIST

Index No.	Part No.	Description	Size	Qty.
1	EGH1880-C01	Handle		1
2	EGH1880-C02	Handle		1
3	TS-1523071	Set Screw	SET 6×25	1
4	EGH1880-C04	Bolt		1
5	EGH1880-C05	Hand Wheel		1
6	EGH1880-C06	Steel Ball	1/4"	6
7	EGH1880-C07	Spring		3
8	EGH1880-C08	Index Ring		1
9	TS-1513021	Flat Hexagon Screw	5×12	2
10	EGH1880-C10	Shaft Liner		1
11	EGH1880-C11	Woodruff Key	Ø19×5	1
12	EGH1880-C12	Gear Shaft	(A)	1
13	EGH1880-C13	Plug		1
14	EGH1880-C14	Snap Ring	S18	6
15	EGH1880-C15	Collar		1
16	EGH1880-C16	Needle Bearing	18/20	1
17	EGH1880-C17	Washer		1
18	EGH1880-C18	Snap Ring	S25	1
19	EGH1880-C19	Gear	56T	1
20	EGH1880-C20	Needle Bearing	28/20	1
21	EGH1880-C21	Washer		1
22	EGH1880-C22	Gear Shaft	(B)	1
23	EGH1880-C23	Rivet	2.8×10	2
24	EGH1880-C24	Name Plate		1
25	EGH1880-C25	Shaft	C	1
26	EGH1880-C26	Collar		2
27	EGH1880-C27	Gear	15T/33T	1
28	EGH1880-C28	Collar		3
29	EGH1880-C29	Pin		1
30	EGH1880-C30	Oil Sight		1
31	EGH1880-C31	Shaft	D	1
32	EGH1880-C32	Needle Bearing	TLA1616	2
33	EGH1880-C33	Gear Shaft	26T	1
34	EGH1880-C34	Needle Bearing	TLA3016	2
35	EGH1880-C35	Gear	24T	1
36	EGH1880-C36	Gear	24T	1
37	EGH1880-C37	Worm Wheel		1
38	EGH1880-C38	Snap Ring	S30	1
39	EGH1880-C39	Collar	D	1
40	EGH1880-C40	Pin		1
41	EGH1880-C41	Name Plate		1
42	EGH1880-C42	Shaft	E	1
43	EGH1880-C43	Gear	24T	1
45	EGH1880-C45	Shaft	F	1

Index No.	Part No.	Description	Size	Qty.
46	EGH1880-C46	Gear	24T/26T	1
47	EGH1880-C47	Handle, Sleeve & Spring Pin(Φ3×24) Assembly		1
48	EGH1880-C48	O Ring	P21	3
49	EGH1880-C49	Elasticity Pole		1
50	EGH1880-C50	Snap Ring	S21	1
51	TS-1514021	Flat Hexagon Screw	6×16	1
52	EGH1880-C52	Washer		1
53	TS-1524011	Set Screw	SET 8×8	3
54	EGH1880-C54	Spring		1
55	EGH1880-C55	Lead Nut Lever Assembly		1
57	EGH1880-C57	O Ring	G25	1
58	TS-1523021	Set Screw	SET 6×8	4
59	EGH1880-C59	Spring		2
60	EGH1880-C60	Key	Ø16×5	1
61	EGH1880-C61	Cam Shaft		1
62	TS-2279351	Set Screw	SET 10×35	1
63	TS-1525011	Set Screw	SET 10×10	1
64	EGH1880-C64	Apron		1
65	TS-1525031	Set Screw	SET 10×16	1
66	EGH1880-C66	Spring		1
67	EGH1880-C67	Steel Ball	3/8"	1
68	TS-1503031	Hexagon Socket Head Bolt	CAP 6×12	1
69	EGH1880-C69	Adjust Plate		1
70	TS-1503041	Hexagon Socket Head Bolt	CAP 6×16	17
71	TS-1503071	Hexagon Socket Head Bolt	CAP 6×30	1
72	EGH1880-C72	Pin		2
73	EGH1880-C73	Slide Plate		1
74	EGH1880-C74	Half Nut		1
75	TS-1503071	Hexagon Socket Head Bolt	CAP 6×30	1
76	EGH1880-C76	Set Screw	SET 6×30	1
77	EGH1880-C77	Hexagon Socket Head Plug	PT1/4"	1
78	EGH1880-C78	Plate		1
79	EGH1880-C79	Oil Seal	30×40×5	2
80	EGH1880-C80	Sleeve		2
81	EGH1880-C81	O Ring	G45	2
82	EGH1880-C82	Thrust Bearing	NTB3047/AS2	3
83	EGH1880-C83	Pinion		1
84	EGH1880-C84	Nut		1
85	EGH1880-C85	Spacer		1
86	TS-1503031	Hexagon Socket Head Bolt	CAP6×12	1
87	EGH1880-C87	Spring Pin	4×16	1
88	EGH1880-C88	Pin		1
89	TS-1502061	Hexagon Socket Head Bolt	CAP5×25	1
90	EGH1880-C90	Pin		1
91	EGH1880-C91	Pin		1



Index No.	Part No.	Description	Size	Qty.
92	EGH1880-C92	Spring		1
93	EGH1880-C93	Set Screw	SET 6×14	1
94	TS-1541021	Nylon Jam Nut	M6	1
95	EGH1880-C95	Bracket		1
96	EGH1880-C96	Key	5×5×45	1
97	EGH1880-C97	Shaft		1
98	EGH1880-C98	Worm		1
99	EGH1880-C99	Clutch		1
100	EGH1880-C100	Clutch Gear		1
101	EGH1880-C101	Lever Arm		1
102	EGH1880-C102	Washer		1
103	EGH1880-C103	Spring		1
104	EGH1880-C104	Washer		1
105	EGH1880-C105	Spring Pin	4×24	1
106	EGH1880-C106	Trip Rod		1
107	EGH1880-C107	Washer		1
108	EGH1880-C108	Spring		1
109	EGH1880-C109	Washer		1
110	TS-2342121	Nylon Jam Nut	M12	1
111	EGH1880-C111	Thrust Bearing	NTB1528/AS2	2
	EGH1880-C112A	Flanged Bearing Ass'y (No. 112-115)		1
112	EGH1880-C112	Flanged Bearing		2
113	EGH1880-C113	Plate Assembly		1
114	EGH1880-C114	Pin		1
115	EGH1880-C115	Spring Pin	Ø5×30	2
116	EGH1880-C116	Washer		1
117	TS-1541041	Nylon Jam Nut	M10	1
118	EGH1880-C118	Nut		1
119	EGH1880-C119	Spring Pin	4×24	1
120	EGH1880-C120	Spring Pin	3×16	1
121	EGH1880-C121	Rod		1
122	EGH1880-C122	Washer		1
	EGH1880-C123A	Spring Pin Ass'y (No. 120-130)	3x24	1
123	EGH1880-C123	Spring Pin	3×24	2
124	EGH1880-C124	Coupling		1
125	EGH1880-C125	Shaft		1
126	EGH1880-C126	O Ring	P18	2
127	EGH1880-C127	Washer		1
128	TS-1513031	Flat Hexagon Screw	5×16	2
129	EGH1880-C129	Spring Pin	5×36	1
130	EGH1880-C130	Sleeve		1
131	EGH1880-C131	Pin		1
132	EGH1880-C132	Spring		1
133	TS-1526011	Set Screw	SET 12×12	1
134	EGH1880-C134	Spacer		1

DIAL INDICATOR ASSEMBLY

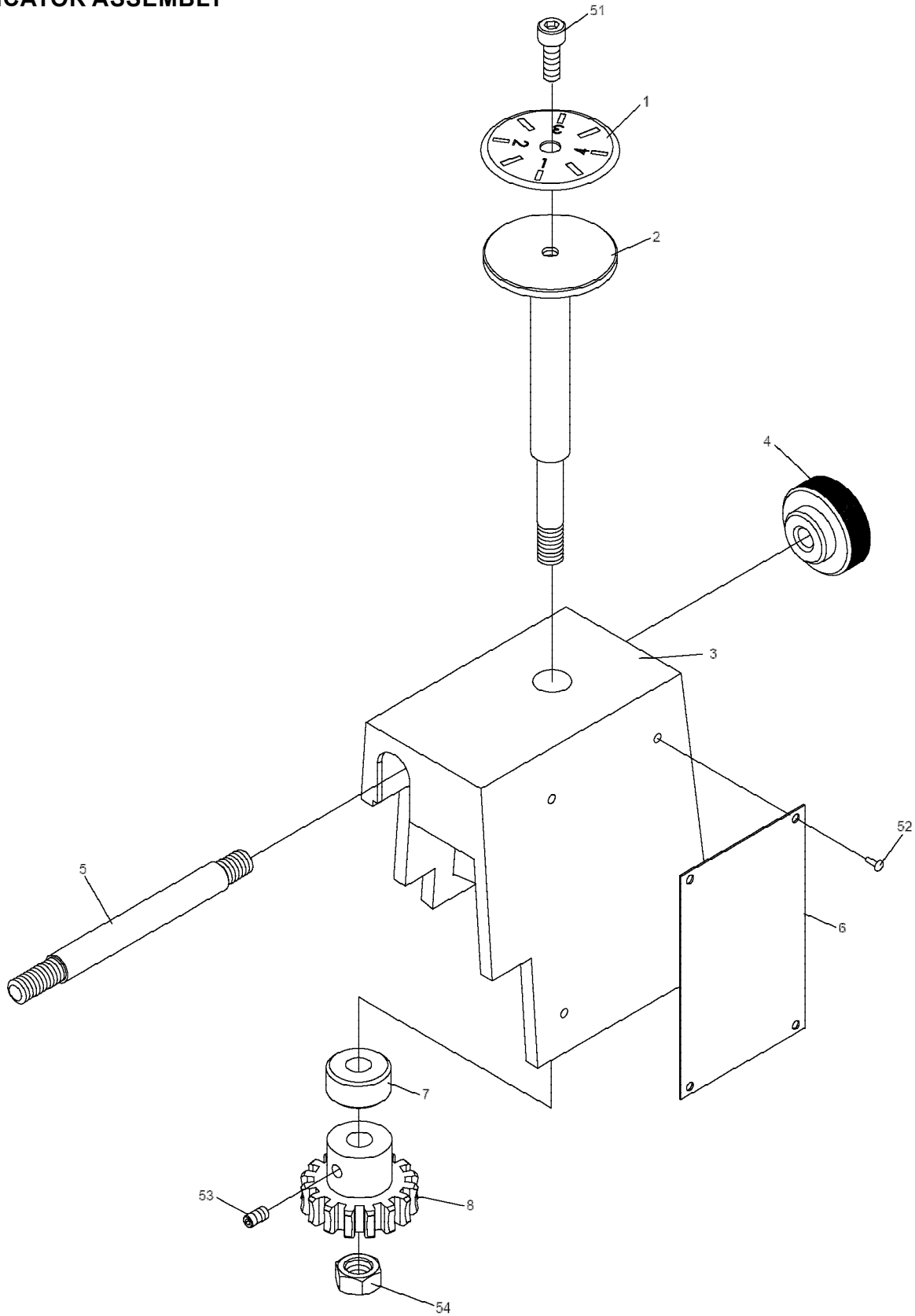



DIAL INDICATOR ASSEMBLY PARTS LIST

Index No.	Part No.	Description	Size	Qty.
1	EGH1880-D01	Pilot Plate		1
2	EGH1880-D02	Gear Pivot		1
3	EGH1880-D03	Body		1
4	EGH1880-D04	Nut		1
5	EGH1880-D05	Stud		1
6	EGH1880-D06	Threading Plate		1
7	EGH1880-D07	Spacer		1
8	EGH1880-D08	Dial Gear	16T	1
51	EGH1880-D51	Hex. Socket Head Bolt		1
52	EGH1880-D52	Rivet	Ø2	4
53	TS-1523011	Set Screw	SET 6x6	1
54	EGH1880-D54	Hexagon Nut		1

4 WAY TOOL POST

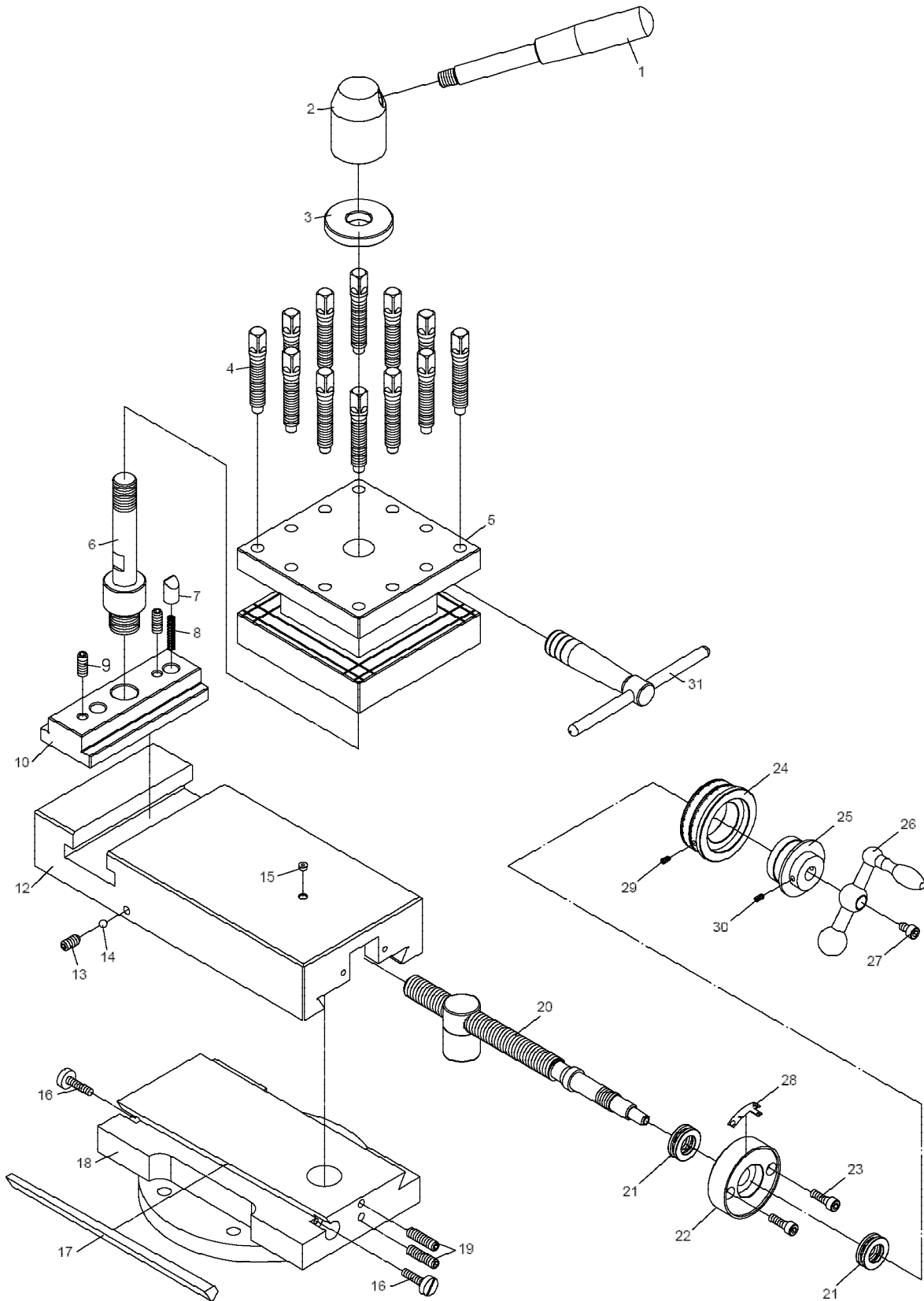



4 WAY TOOL POST PARTS LIST

Index No.	Part No.	Description	Size	Qty.
1	EGH1880-E01	Handle		1
2	EGH1880-E02	Turret nut		1
3	EGH1880-E03	Collar		1
4	EGH1880-E04	Bolt		12
5	EGH1880-E05	Turret body		1
6	EGH1880-E06	Turret shaft		1
7	EGH1880-E07	Pin		1
8	EGH1880-E08	Spring		1
9	EGH1880-E09	Set screw	SET 8x25	2
10	EGH1880-E10	Nut		1
12	EGH1880-E12	Solid topslide		1
13	EGH1880-E13	Set screw	SET 8x12	1
14	EGH1880-E14	Steel ball	1/4"	5
15	EGH1880-E15	Oil ball	1/4"	1
16	EGH1880-E16	Screw		2
17	EGH1880-E17	Gib		1
18	EGH1880-E18	Swivel		1
	EGH2180-E18	Swivel		1
19	EGH1880-E19	Set screw	SET 6x25	2
20	EGH1880-E20	Nut & Screw	Assembly For Replacement	1
21	EGH1880-E21	Thrust bearing	51102	2
22	EGH1880-E22	Keep assy		1
23	EGH1880-E23	Hex. socket head bolt	CAP 6x20	2
24	EGH1880-E24	Dial		1
25	EGH1880-E25	Bush		1
26	EGH1880-E26	Handle		1
27	EGH1880-E27	Hex. socket head bolt	CAP 6x16	1
28	EGH1880-E28	Curve pilot		1
29	EGH1880-E29	Set screw	SET 5x10	1
30	EGH1880-E30	Set screw	SET 5x6	1
31	EGH1880-E31	T wrench		1

SADDLE ASSEMBLY

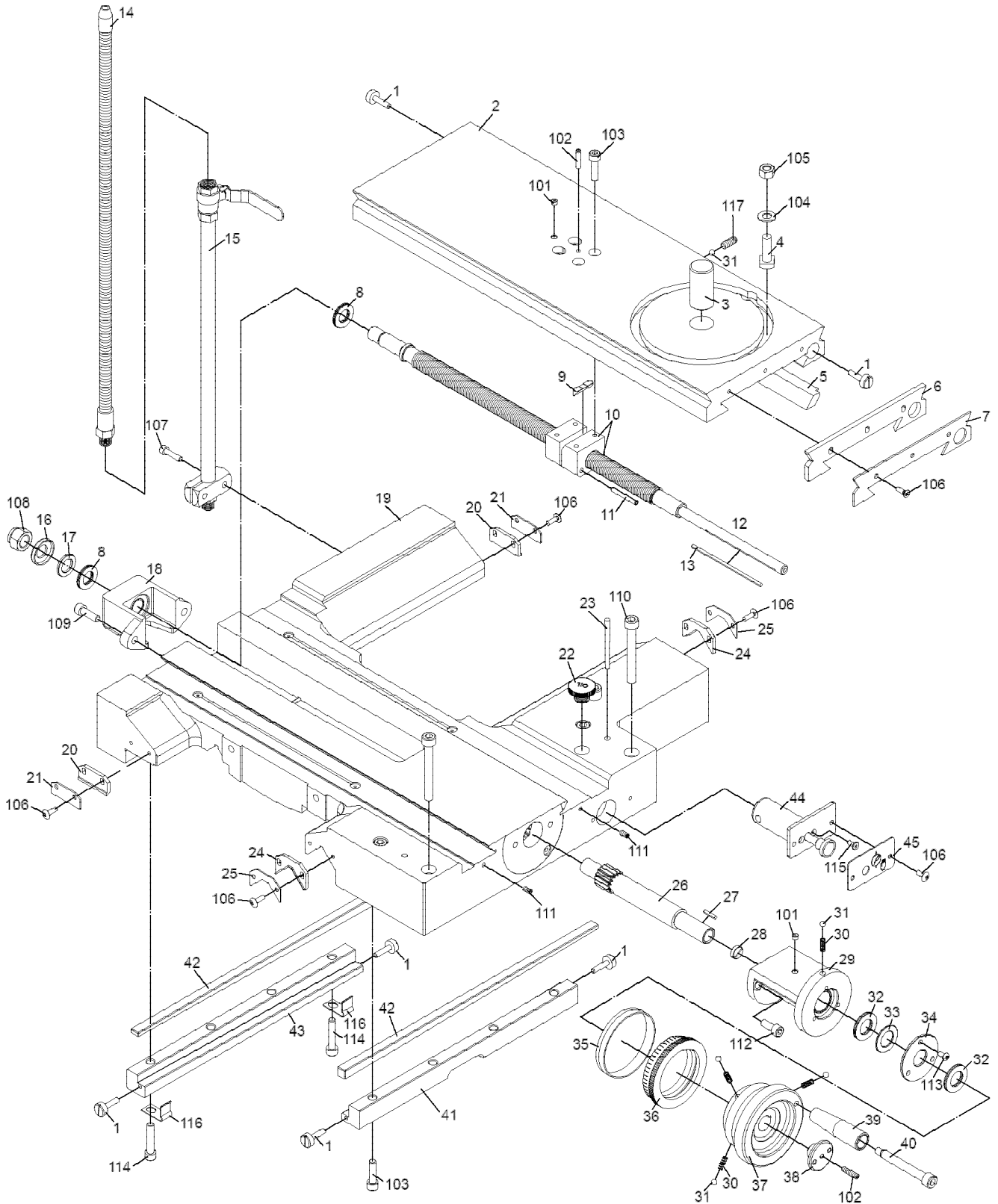

SADDLE ASSEMBLY

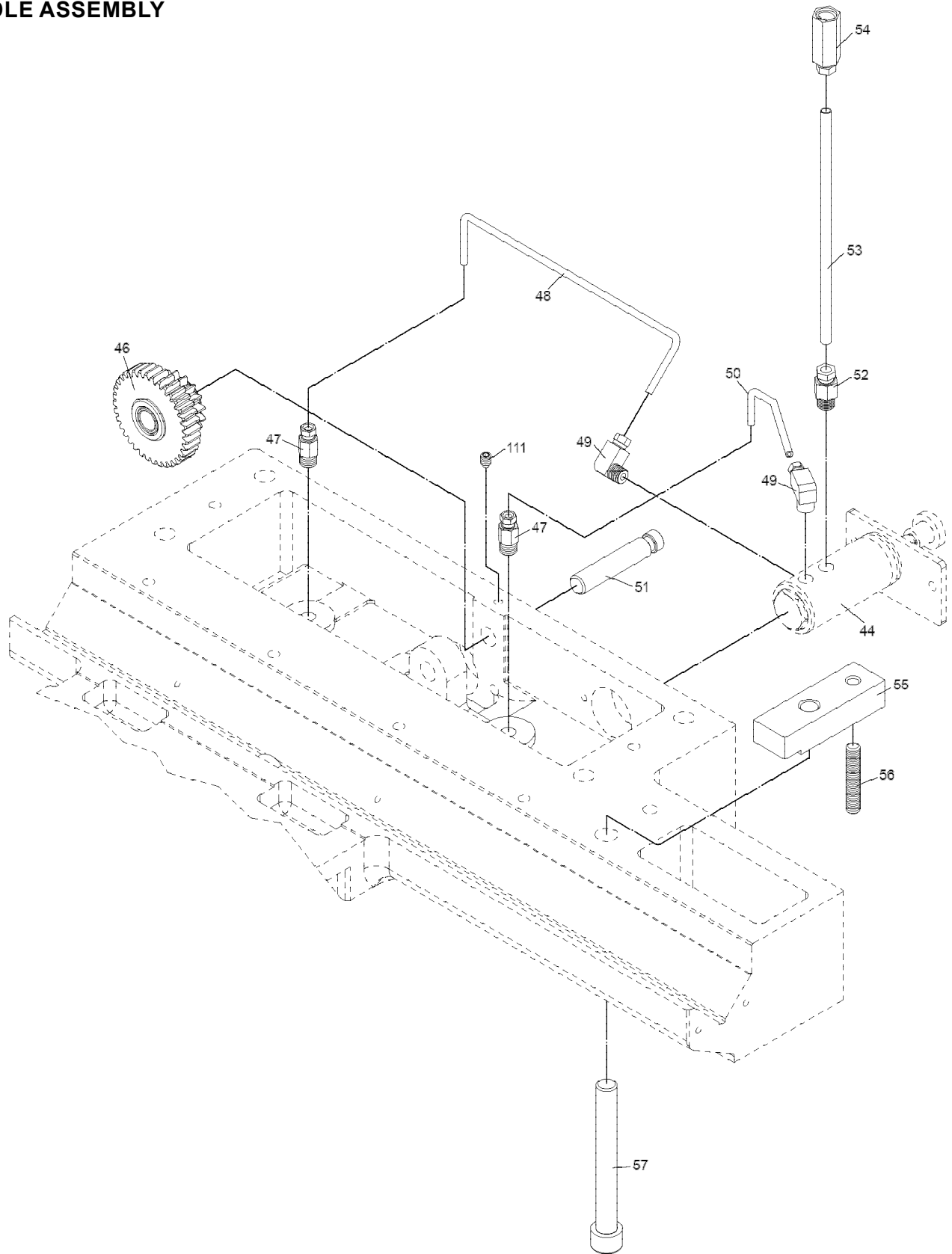

SADDLES ASSEMBLY PARTS LIST

Index No.	Part No.	Description	Size	Qty.
1	EGH1880-F01	Adjust Screw		6
2	EGH1880-F02	Cross Slide		1
3	EGH1880-F03	Pivot		1
4	EGH1880-F04	T Bolt	T	4
5	EGH1880-F05	Gib-X		1
6	EGH1880-F06	Wiper-X		1
7	EGH1880-F07	Plate -X		1
8	EGH1880-F08	Thrust Bearing	NTB/AS2 1730	2
9	EGH1880-F09	Wedge	7x7x30	1
10	EGH1880-F10	Nut & Screw Assembly		1
11	EGH1880-F11	Spring Pin	Ø5x40	2
13	EGH1880-F13	Key	3x3x115	1
14	EGH1880-F14	Spraying Pipe	PT3/8 x 24"	1
15	EGH1880-F15	Valve & Junction Assy.	PT3/8	1
16	EGH1880-F16	Cap Collar		2
17	EGH1880-F17	Washer		1
18	EGH1880-F18	Bracket		1
19	EGH1880-F19	Saddle		1
20	EGH1880-F20	Wiper F		2
21	EGH1880-F21	Plate F		2
22	EGH1880-F22	Oil Cover	NF3/4"	1
23	EGH1880-F23	Taper Pin	#6x90L	2
24	EGH1880-F24	Wiper V		2
25	EGH1880-F25	Plate V		2
26	EGH1880-F26	Pinion	16T	1
27	EGH1880-F27	Key	3x3x20	1
28	EGH1880-F28	Bolt	M16x5L	1
29	EGH1880-F29	Keep Assy.		1
30	EGH1880-F30	Spring		4
31	EGH1880-F31	Steel Ball	1/4"	5
32	EGH1880-F32	Thrust Bearing	NTB/AS2 2035	2
33	EGH1880-F33	Washer		1
34	EGH1880-F34	Washer		1
35	EGH1880-F35	Dial Ring		1
36	EGH1880-F36	Dial		1
37	EGH1880-F37	Hand Wheel		1
38	EGH1880-F38	Fix Screw		1
39	EGH1880-F39	Handle		1
40	EGH1880-F40	Bolt		1



Index No.	Part No.	Description	Size	Qty.
41	EGH1880-F41	Front Anti-Floater		1
42	EGH1880-F42	Gib-Z		2
43	EGH1880-F43	Front Anti-Floater		1
44	EGH1880-F44	Lubricator Assy.		1
45	EGH1880-F45	Plate		1
46	EGH1880-F46	Gear	16T/36T	1
47	EGH1880-F47	Elbow Adapter	1/8xØ4	2
48	EGH1880-F48	Al. Tube	Ø4x258	1
49	EGH1880-F49	Straight Adapter	1/8xØ4	2
50	EGH1880-F50	Al. Tube	Ø4x121	1
51	EGH1880-F51	Short Shaft		1
52	EGH1880-F52	Straight Adapter	1/8xØ6	1
53	EGH1880-F53	Al. Tube	Ø6x175	1
54	EGH1880-F54	Oil Filter	Ø6	1
55	EGH1880-F56	Clamp Plate		1
56	EGH1880-F57	Set Screw	SET 8x40	1
57	EGH1880-F58	Hex. Socket Head Bolt	CAP12x85	1
101	EGH1880-F101	Oil Ball	1/4"	2
102	TS-1523071	Set Screw	SET 6x25	2
103	TS-1504061	Hex. Socket Head Bolt	CAP 8x30	8
104	TS-1550071	Washer	M10	4
105	TS-1541041	Nut	M10	4
106	TS-2285121	Dome Cross Screw	M5x12	13
107	TS-1503061	Hex. Socket Head Bolt	CAP 5x35	2
108	TS-2342161	Nut	M16	1
109	TS-1502061	Hex. Socket Head Bolt	CAP5x25	2
110	TS-1505131	Hex. Socket Head Bolt	CAP10x80	2
111	TS-1523021	Set Screw	SET 6x8	3
112	TS-1504041	Hex. Socket Head Bolt	CAP 8x20	2
113	TS-1534041	Dome Hexagon Screw	M5x10	3
114	TS-1504081	Hex. Socket Head Bolt	CAP8x40	4
115	TS-1513021	Flat Hexagon Screw	M5x12L	2
116	EGH1880-F116	Spring Slice		2
117	TS-1524051	Set Screw	SET 8x20	1
118	EGH1880-F118	Joint Block		1

BED AND SHAFTS ASSEMBLY

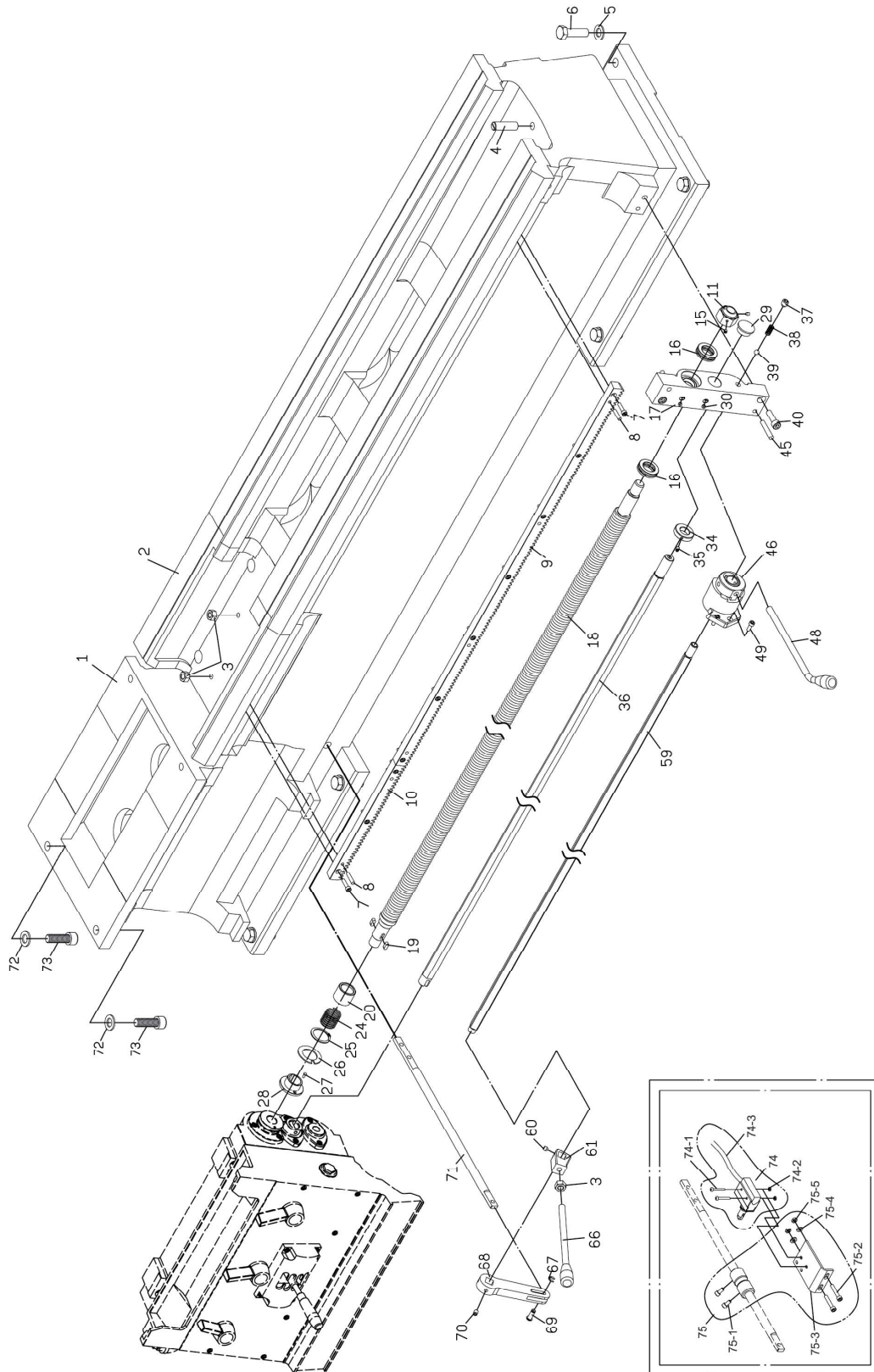

BED AND SHAFTS ASSEMBLY

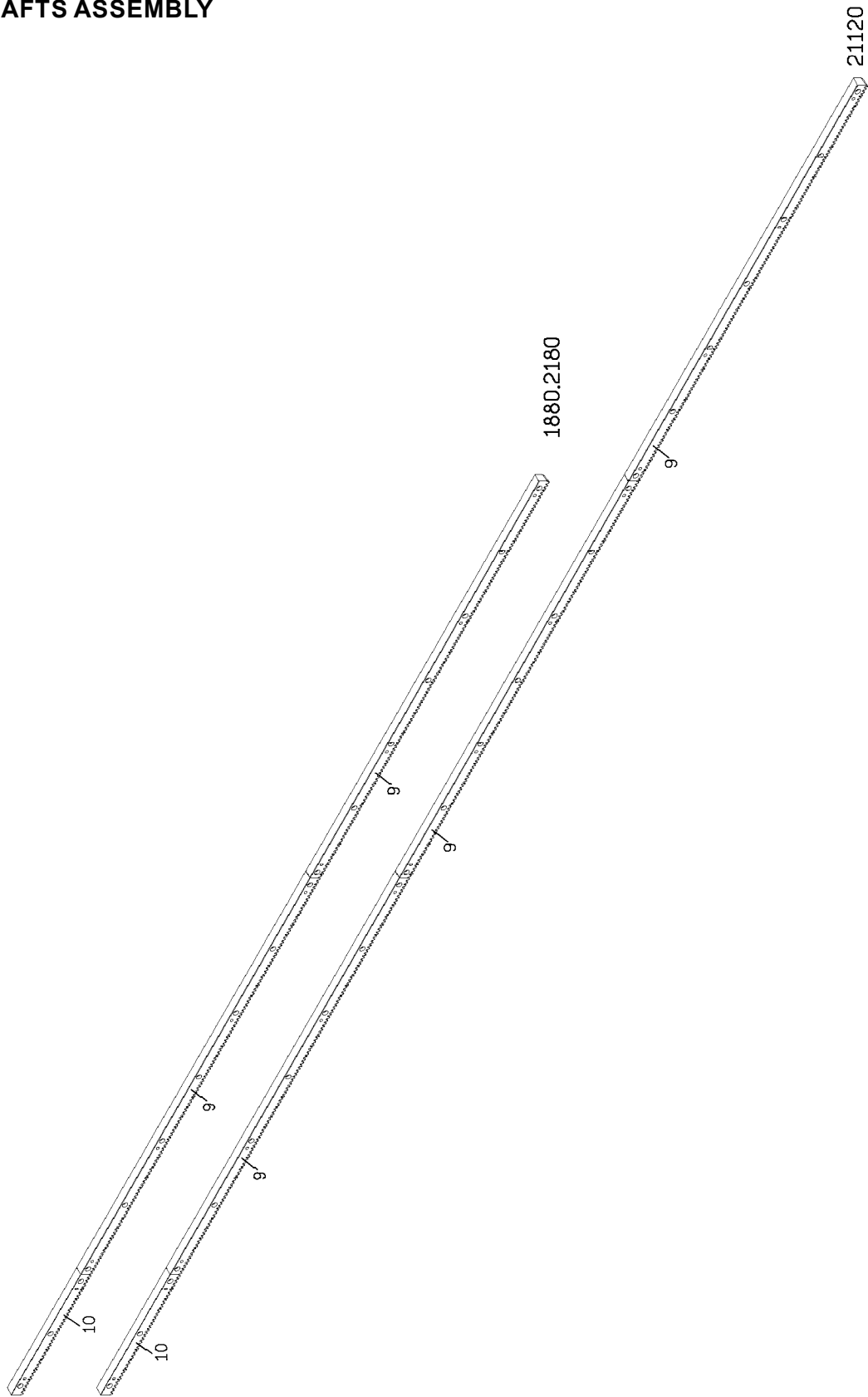

BED AND SHAFTS ASSEMBLY

**ONLY MODEL :
21120**

**LEFT AND RIGHT
SIDES ARE ONE
RESPECTIVELY**

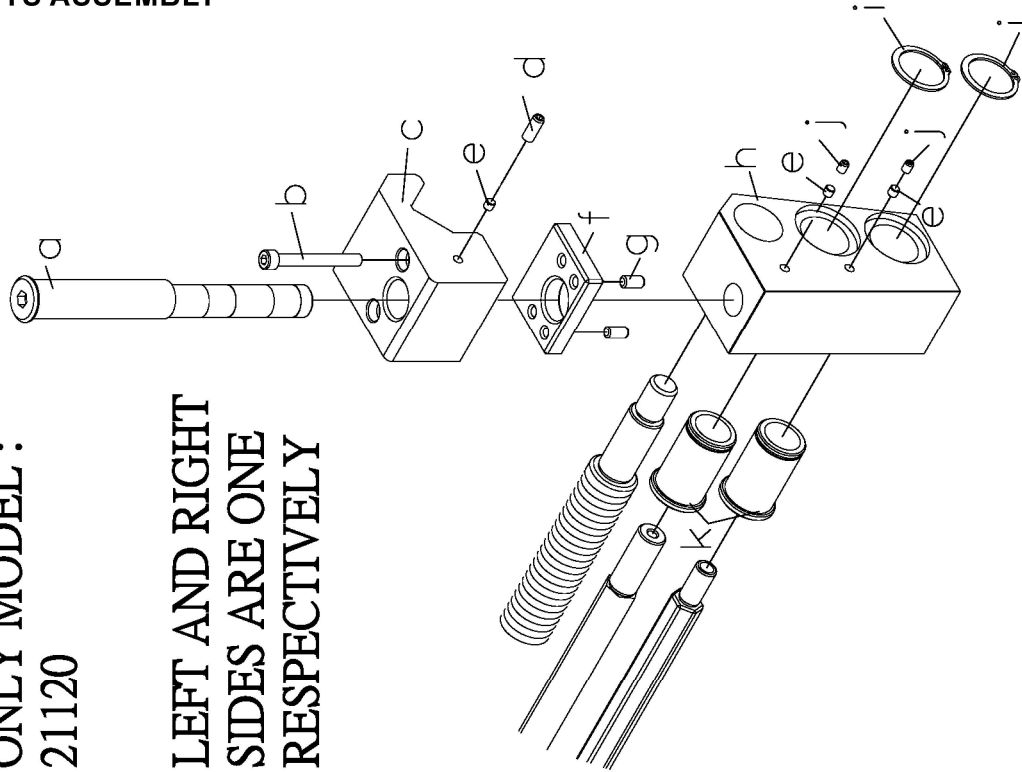

**ONLY MODEL :
1880**

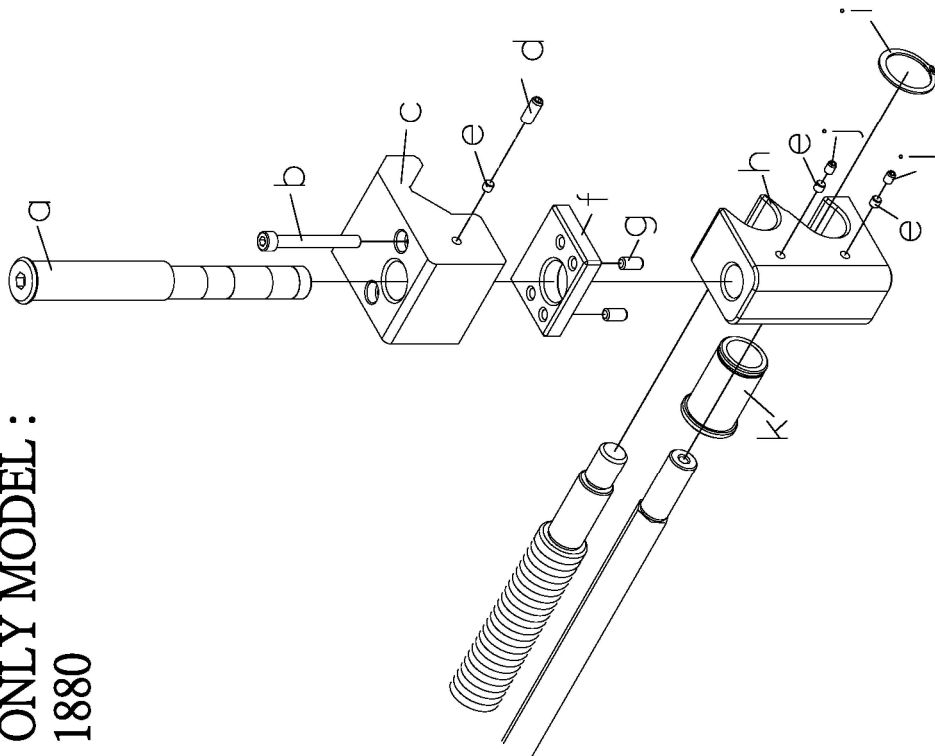



BED & SHAFTS ASSEMBLY PARTS LIST

Index No.	Part No.	Description	Size	Qty.
	EGH1880-G01A	Bed Ass'y (No. 1-2)	The same as EGH2180	1
	EGH21120-G01A	Bed Ass'y (No. 1-2)		1
1	EGH1880-G01	Bed	The same as EGH2180	1
	EGH21120-G01	Bed		1
2	EGH1880-G02	Gap Bridge		1
3	TS-1540081	Nut	M12	1
4	EGH1880-G04	Bolt		1
5	TS-155010	Washer	M16	8
6	EGH1880-G06	Hexagon Head Bolt	M16x55	8
7	TS-1503061	Hex. Socket Head Bolt	CAP 6x25	10
8	EGH1880-G08	Pin	Ø6×30	6
9	EGH1880-G09	Rack	The same as EGH2180	2
	EGH21120-G09	Rack		3
10	EGH1880-G10	Rack		1
11	EGH1880-G11	Nut		1
15	TS-1523021	Set Screw	SET 6x8	2
16	EGH1880-G16	Thrust Bearing	51105	2
17	EGH1880-G17	Bracket		1
18	EGH1880-G18	Lead Screw	The same as EGH2180	1
	EGH21120-G18	Lead Screw		1
19	EGH1880-G19	Key	6x6x15	2
20	EGH1880-G20	Spring Cover		1
24	EGH1880-G24	Spring		1
25	EGH1880-G25	Clip	S32	1
26	EGH1880-G26	Washer		1
27	EGH1880-G27	Shear Pin		1
28	EGH1880-G28	Collar		1
29	EGH1880-G29	Plug		1
30	EGH1880-G30	Oil Ball	1/4"	2
34	EGH1880-G31	Collar		1
35	TS-1523031	Set Screw	SET 6x10	1
36	EGH1880-G36	Feed Rod	The same as EGH2180	1
	EGH21120-G36	Feed Rod		1
37	TS-1526011	Set Screw	SET 12x12	2
38	EGH1880-G38	Spring		1
39	EGH1880-G39	Steel Ball	3/8"	1

Index No.	Part No.	Description	Size	Qty.
40	TS-1505051	Hex. Socket Head Bolt	CAP 10x35	2
45	EGH1880-G45	Pin	#7×50	2
	EGH1880-G46A	Lever Ass'y (No. 46-47, 50-58)		1
46	EGH1880-G46	Lever Ass'y		1
47	EGH1880-G47	Pin		2
48	EGH1880-G48	Knob & Handle Assembly		1
49	TS-1503041	Hex. Socket Head Bolt	CAP 6x16	2
50	EGH1880-G50	Bracket		1
55	EGH1880-G55	Sleeve		1
56	EGH1880-G56	Spring		1
57	EGH1880-G57	Spring Cover		1
58	EGH1880-G58	Clip	S32	1
59	EGH1880-G59	Spindle Control Shaft	Same as EGH2180	1
	EGH21120-G59	Spindle Control Shaft		1
60	TS-1524011	Set Screw	SET 8x8	1
61	EGH1880-G61	Bracket		1
66	EGH1880-G66	Handle & Knob Assembly		1
67	EGH1880-G67	Clip	E8	1
68	EGH1880-G68	Connecting Rod		1
69	EGH1880-G69	Pin		1
70	TS-1524031	Set Screw	SET 8x12	1
71	EGH1880-G71	Connecting Rod		1
72	EGH1880-G72	Washer	Ø16.5xØ25x3t	2
73	EGH1880-G73	Hex. Socket Head Bolt	CAP 16×50	2
74	EGH1880-G74A	Limit Switch Ass'y EGH-1880 serial # after 1308188006 EGH-2180 serial # after 1308218004 EGH-21120 serial # after 1308212002	TZ7311	1
74-1		Dome Cross Screw	M4x30	2
74-2		Nut	M4	2
74-3		Electric Wire	18AWGx2c 1800m	1
75	EGH1880-G75A	Switch Support Block Ass'y EGH-1880 serial # after 1308188006 EGH-2180 serial # after 1308218004 EGH-21120 serial # after 1308212002		1
75-1		Hex. Socket Head Bolt	CAP 6x12	2
75-2		Hex. Socket Head Bolt	M6x35	2
75-3		Bracket		1
75-4		Washer	M6	2
75-5		Nut	M6	2
a	EGH1880-G0a	Shaft	Same as EGH2180	1
	EGH21120-G0a	Shaft		2



Index No.	Part No.	Description	Size	Qty.
b	EGH1880-G0b	Hex. Socket Head Bolt	CAP 8x70	4
c	EGH1880-G0c	Block	Same as EGH2180	1
	EGH21120-G0c	Block		2
d	EGH1880-G0d	Set Screw	SET 8x20	2
e	EGH1880-G0e	Pin		6
f	EGH1880-G0f	Block		2
g	EGH1880-G0g	Set Screw	SET 8x16	4
h	EGH1880-G0h	Bracket	Same as EGH2180	1
	EGH21120-G0h	Bracket		1
i	EGH1880-G0i	Clip	Same as EGH2180	1
	EGH21120G0i	Clip	S35	2
j	EGH1880-G0j	Set Screw	SET 8x8	4
k	EGH1880-G0k	Barrel	Same as EGH2180	1
	EGH21120-G0k	Barrel		2

END GEAR IMPERIAL PHL18

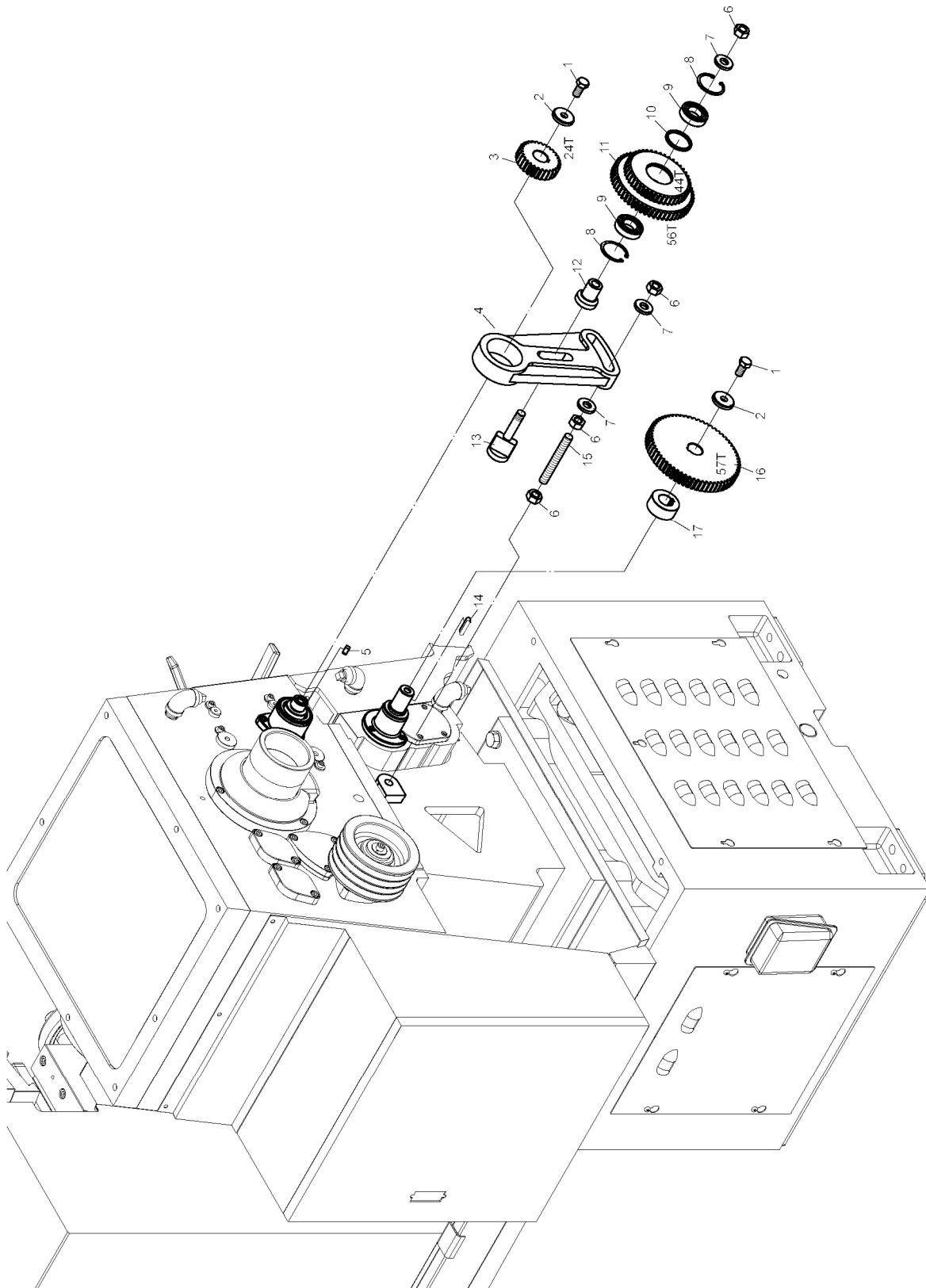



END GEAR IMPERIAL PHL18 PARTS LIST

Index No.	Part No.	Description	Size	Qty.
1	TS-1506021	Hexagon Head Bolt	M12x25	2
2	EGH1880-H02	Washer		2
3	EGH1880-H03	Gear	24T	1
4	EGH1880-H04	Swing Fence		1
5	EGH1880-H05	Key	7x7x15	1
6	TS-231014-2	Nut	M14	4
7	EGH1880-H07	Washer		3
8	EGH1880-H08	Clip	R47	2
9	BB-6005Z	Ball Bearing	6005Z	2
10	EGH1880-H10	Collar		1
11	EGH1880-H11	Gear	44T/56T	1
12	EGH1880-H12	Shaft		1
13	EGH1880-H13	Shaft		1
14	EGH1880-H14	Key	7x7x35	1
15	EGH1880-H15	Bolt	M14x110	1
16	EGH1880-H16	Gear	57T	1
17	EGH1880-H17	Collar		1

END GEAR IMPERIAL PHL21

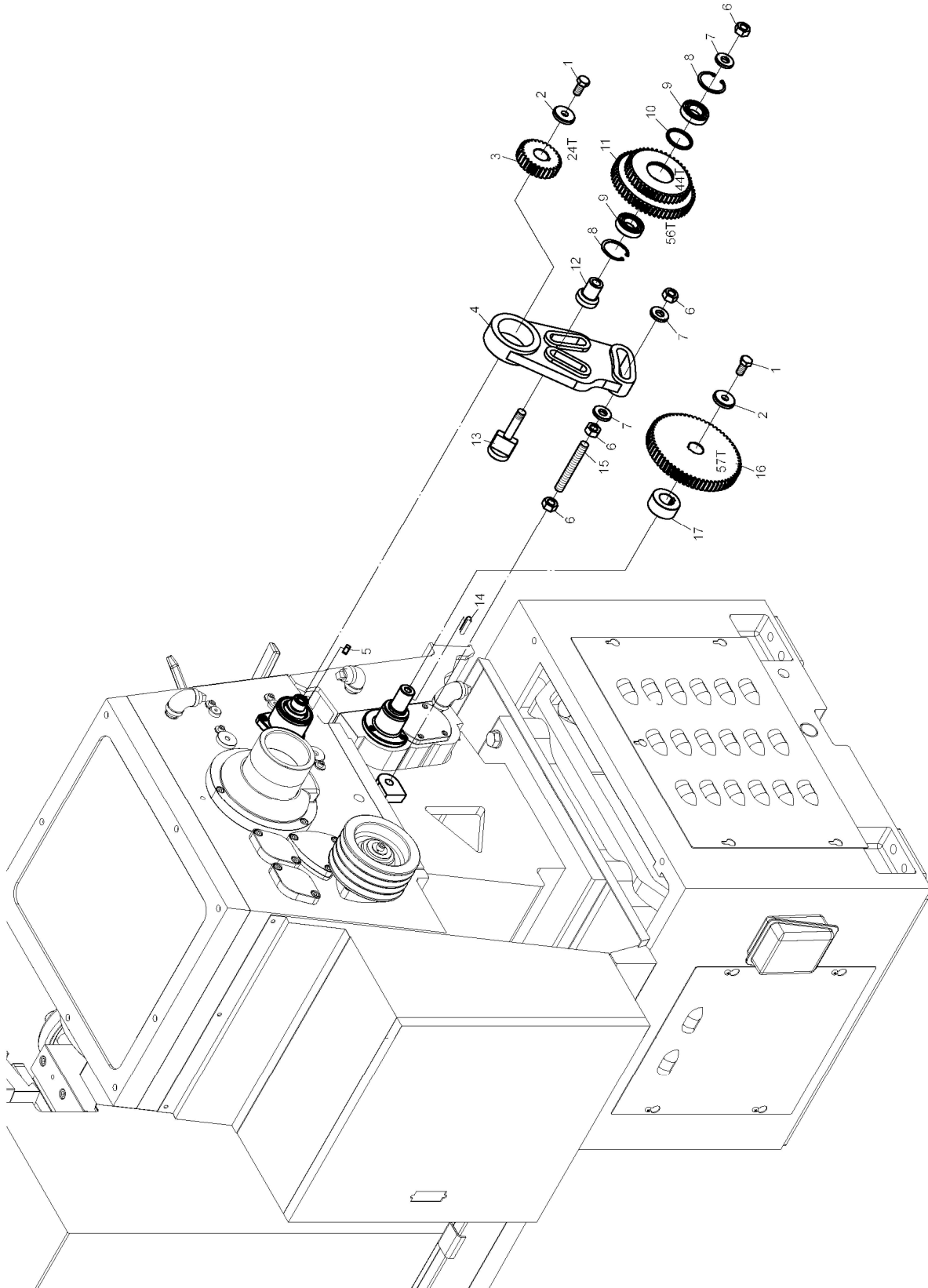



END GEAR IMPERIAL PHL21 PARTS LIST

Index No.	Part No.	Description	Size	Qty.
1	TS-1506021	Hexagon Head Bolt	M12x25	2
2	EGH2180-H02	Washer		2
3	EGH2180-H03	Gear	24T	1
4	EGH2180-H04	Swing Frame		1
5	EGH2180-H05	Key	7x7x15	1
6	TS-154009	Nut	M14	4
7	EGH2180-H07	Washer		3
8	EGH2180-H08	Clip	R47	2
9	EGH2180-H09	Ball Bearing	6005Z	2
10	EGH2180-H10	Collar		1
11	EGH2180-H11	Gear	44T/56T	1
12	EGH2180-H12	Shaft		1
13	EGH2180-H13	Shaft		1
14	EGH2180-H14	Key	7x7x35	1
15	EGH2180-H15	Bolt	M14x110	1
16	EGH2180-H16	Gear	57T	1
17	EGH2180-H17	Collar		1

MAIN MOTOR ASSEMBLY

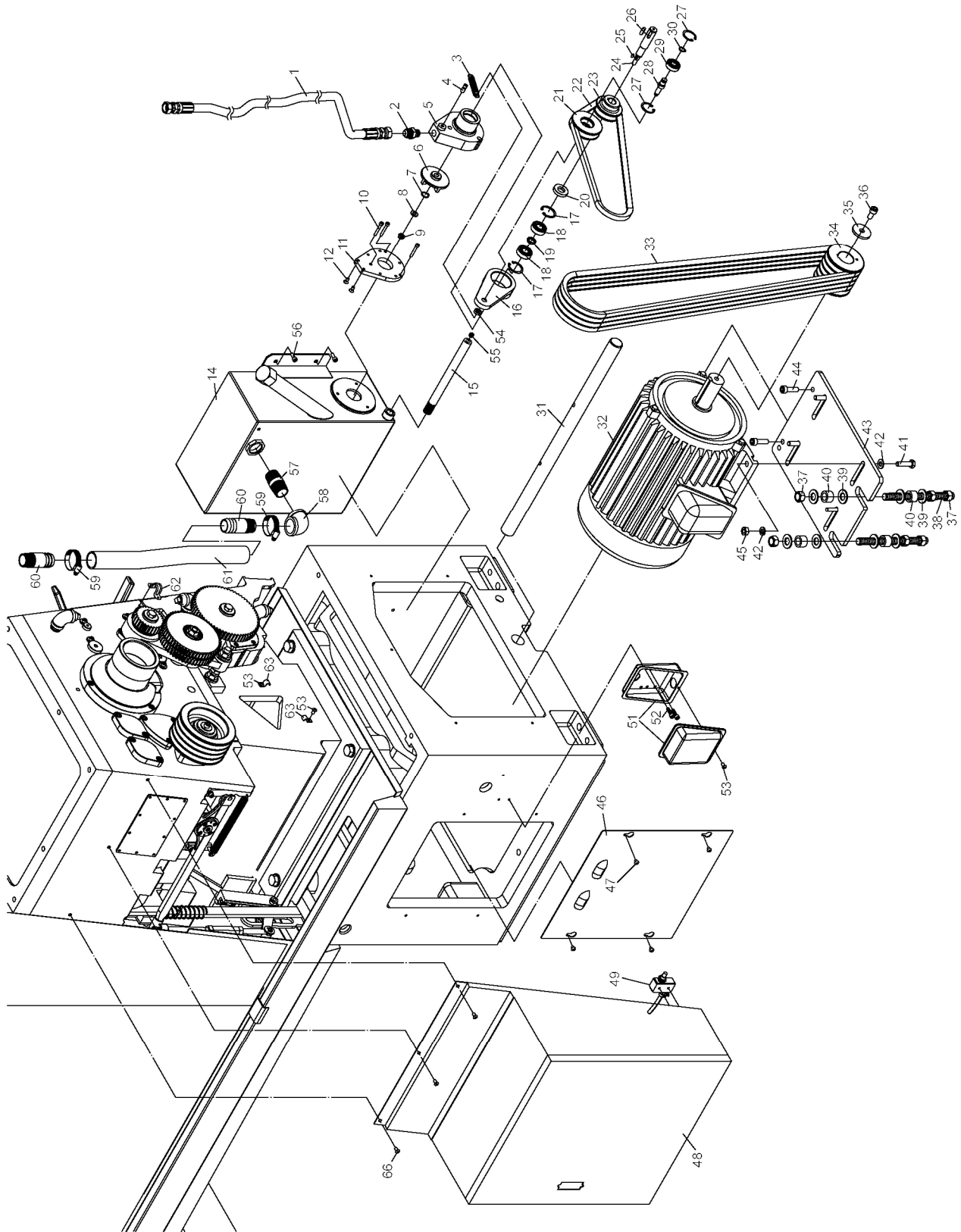



MAIN MOTOR ASSEMBLY PARTS LIST

Index No.	Part No.	Description	Size	Qty.
1	EGH1880-I01	Flexible Tube	5/8× 1/2	1
	EGH2180-I01	Flexible Tube	Same as EGH21120	1
2	EGH1880-I02	Hexagon	5/8× 1/2	1
3	EGH1880-I03	Spring		1
4	EGH1880-I04	Set Screw		1
5	EGH1880-I05	Pump Pu		1
6	EGH1880-I06	Impeller		1
7	EGH1880-I07	Snap Ring	S15	1
8	TS-1550061	Washer	M8	1
9	TS-1541031	Nut	M8	1
10	TS-1502081	Hex. Socket Head Bolt	CAP 5×35	3
11	EGH1880-I11	Back Plate		1
12	TS-2286121	Flat Cross Screw	6× 12	2
14	EGH1880-I14	Tank		1
15	EGH1880-I15	Plug		1
16	EGH1880-I16	Plate		1
17	EGH1880-I17	Snap Ring	R35	1
18	BB-6202	Ball Bearing	6202	2
19	EGH1880-I19	Alternate Ring		1
20	EGH1880-I20	Oil Seal	18×35×7	1
21	EGH1880-I21	Middle Wheel		1
22	EGH1880-I22	V Belt	50HZ-A39,A38	1
23	EGH1880-I23	Pump Wheel		1
24	EGH1880-I24	Shaft		1
25	EGH1880-I25	Key	4×4×8	1
26	EGH1880-I26	Key	6×6×20	1
27	EGH1880-I27	Snap Ring	R32	2
28	EGH1880-I28	Middle Shaft		1
29	BB-6201	Ball Bearing	6201	1
30	EGH1880-I30	Snap Ring	S12	1
31	EGH1880-I31	Shaft	32×625L	1
32	EGH1880-I32	Induction Motor (EGH2180 Same As)	18-60HZ-10HP	1
	EGH21120-I32	Induction Motor	21-60HZ-12.5HP	1
33	EGH1880-I33	V Belt (EGH2180 Same As)	18-60HZ-A76	1
	EGH2180-I33	V Belt	21-60HZ-A76	1
34	EGH1880-I34	Motor Wheel (EGH2180 Same As)	18-60Hz-10HP	1

Index No.	Part No.	Description	Size	Qty.
	EGH21120-I34	Motor Wheel	21-60Hz-12.5HP	1
35	TS-2360121	Washer	Ø12×Ø45×5	1
36	TS-1505031	Hex. Socket Head Bolt	CAP 10×25	1
37	TS-154010	Nut	M16	6
38	EGH1880-I38	Screw		2
39	EGH1880-I39	Washer	Ø16.5×Ø40	8
40	EGH1880-I40	Rubber Ring		4
41	TS-1491061	Hex. Head Bolt	M10×40	4
42	TS-1550071	Washer	M10	8
43	EGH1880-I43	Plate		1
44	TS-1505031	Hex. Socket Head Bolt	CAP 10×25	2
45	TS-2311101	Nut	M10	4
46	EGH1880-I46	Plate		1
47	TS-1534042	Dome Cross Screw	6×12	4
48	EGH1880-I48	Electrical Box		1
49	EGH1880-I49	TM1307		1
51	EGH1880-I51	Terminal Box		1
52	TS-1503061	Hex. Socket Head Bolt	CAP 6×25	2
53	EGH1880-I53	Dome Cross Screw	M5×8	3
54	TS-1540071	Nut	M10	1
55	EGH1880-I55	Hexagon Socket Head Plug	1/4"	1
56	TS-1504031	Hex. Socket Head Bolt	CAP 8×16	2
57	EGH1880-I57	Connect	1"× 60	2
58	EGH1880-I58	Male Elbow	1"× 90°	1
59	EGH1880-I59	Hose Clamp	3/4"	2
60	EGH1880-I60	Connect	1"× 75	2
61	EGH1880-I61	Net Hose		1
	EGH2180-I61	Net Hose	Same as EGH21120	1
62	EGH1880-I62	Pipe clip		1
63	EGH1880-I63	Pipe clip	Ø10	1
66	EGH1880-I66	Dome cross screw	5×8	3

CABINET AND PANEL (EGH – 1880/2180)

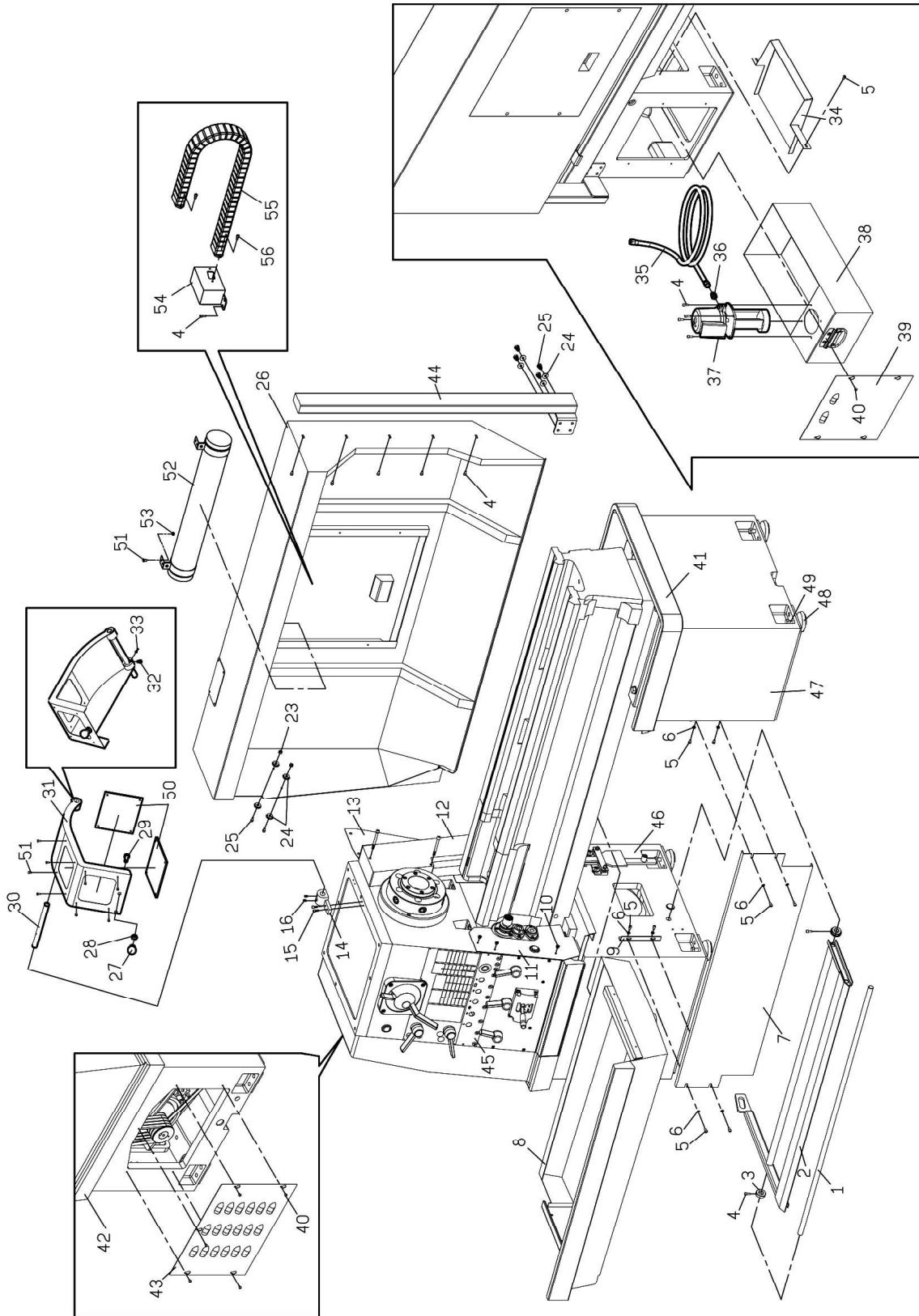

CABINET & PANEL ASSEMBLY PARTS LIST (EGH-1880 & EGH-2180)

Index No.	Part No.	Description	Size	Qty.
1	EGH1880-J01	Shaft		1
2	EGH1880-J02	Saddle		1
3	EGH1880-J03	Collar		2
4	TS-1503041	Hex. Socket Head Bolt	CAP 6x16	11
5	TS-1503021	Hex. Socket Head Bolt	CAP 6x10	10
6	TS-1550041	Washer	M6	8
7	EGH1880-J07	Plate		1
8	EGH1880-J08	Sliding Tray		1
9	EGH1880-J09	Bracket		2
10	EGH1880-J10	Dome Cross Screw	M5x8	3
11	EGH1880-J11	Guard		1
	EGH2180-J11	Guard	Same as EGH21120	1
12	EGH1880-J12	Brake Guard		1
	EGH2180-J12	Brake Guard	Same as EGH21120	1
13	EGH1880-J13	Plate		1
14	EGH1880-J14	Small Bracket		1
15	TS-1505021	Hex. Socket Head Bolt	CAP 10x20	2
16	TS-1524031	Set Screw	SET 8x12	2
23	TS-2311081	Nut	M8xP1.25	2
24	TS-1550061	Washer	M8	8
25	TS-1504041	Hex. Socket Head Bolt	CAP 8x20	6
26	EGH1880-J26	Splash Guard		1
27	EGH1880-J27	Knob		1
28	TS-0561051	Nut	1/2"	1
29	TS-0070011	Hex. Head Bolt	1/2x1"	1
30	EGH1880-J30	Pivot		1
31	EGH1880-J31	Chuck Safety Guard		1
32	TS-1503031	Hex. Socket Head Bolt	CAP 6x12	1
33	TS-1522051	Set Screw	SET 5x16	1
34	EGH1880-J34	Chute		1
35	EGH1880-J35	Coolant Conduit	CT801x3/8"x96"	1
36	EGH1880-J36	Nipple	3/8"PTx3/8"PH	1
37	EGH1880-J37	Coolant Pump	MC-8150'	1
38	EGH1880-J38	Coolant Tank		1
39	EGH1880-J39	Cover		1
40	TS-1534032	Dome Cross Screw	M6x10	9
41	EGH1880-J41	Tray		1
42	EGH1880-J42	Cover		1
43	EGH1880-J43	Cover Plate		1
44	EGH1880-J44	Bracket		1
45	EGH1880-J45	Plate		1
46	EGH1880-J47	Head End Plinth		1
47	EGH1880-J46	Tail End Plinth		1
48	EGH1880-J48	Block		8
49	EGH1880-J49	Hexagon Head Bolt	M16x55	8
50	EGH1880-J50	Plate		2
51	TS-2286121	Dome Hex. Screw	M6x12	8
52	EGH1880-J52	Work Lamp		1
53	TS-2311061	Nut	M6	4
54	EGH1880-J54	Upper Socket Enclosure		1
55	EGH1880-J55	Cable Sheath (Alum.)	KR100No8-1650mm	1
56	TS-1503051	Hex Socket Head Bolt	CAP 6x20	4

CABINET AND PANEL (EGH – 21120)

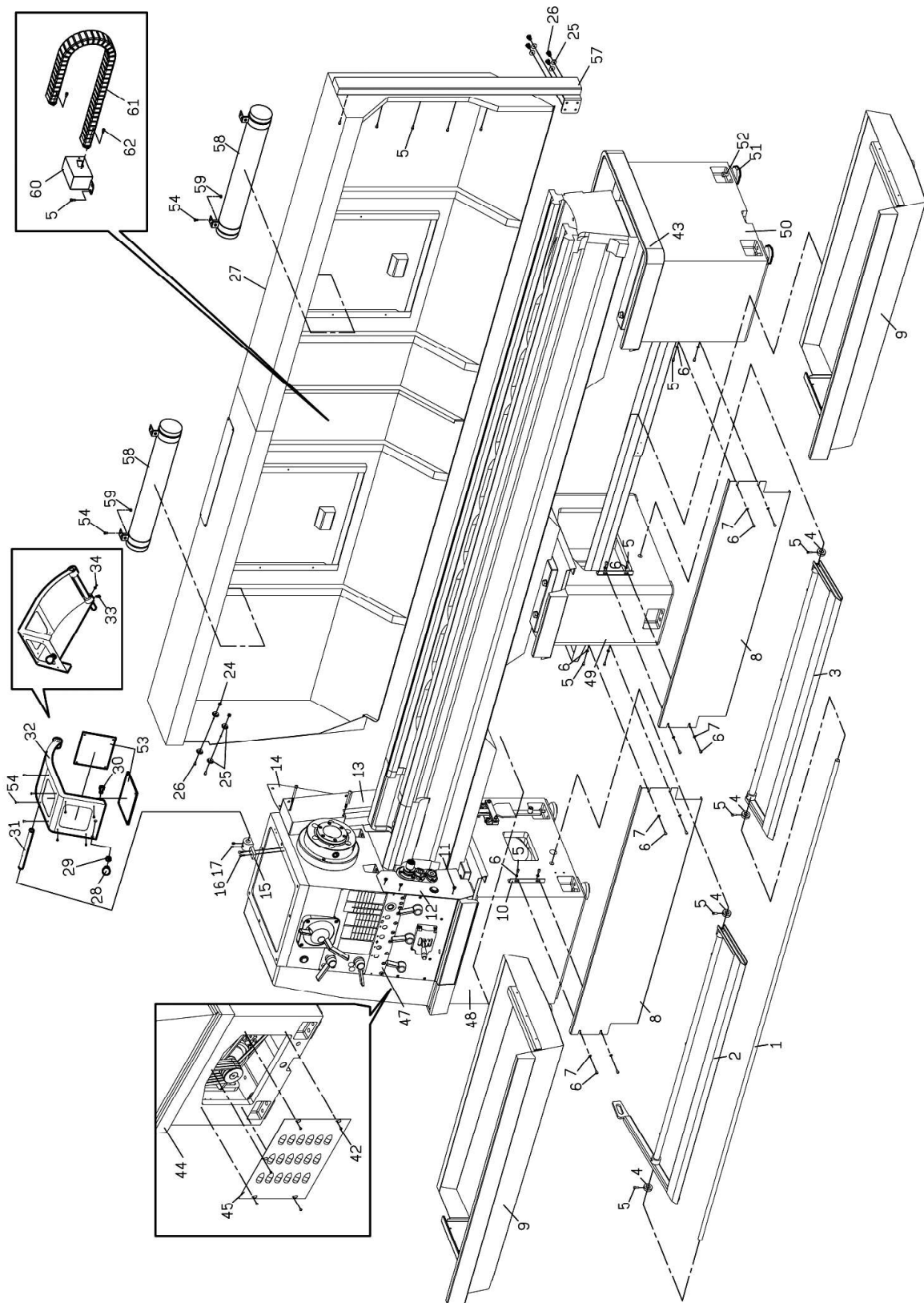

CABINET AND PANEL (EGH – 21120)

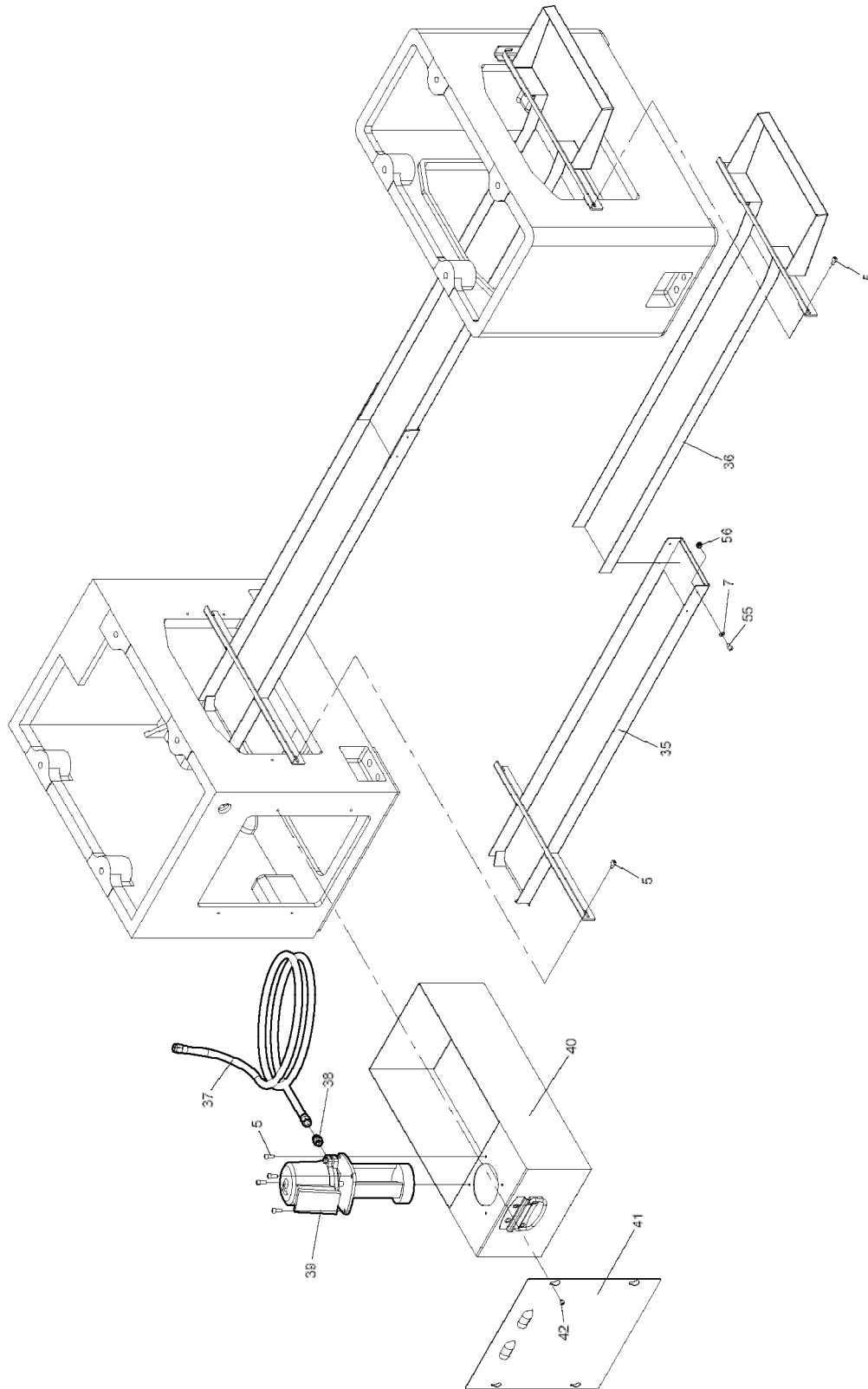



CABINET & PANEL ASSEMBLY PARTS LIST (EGH-21120)

Index No.	Part No.	Description	Size	Qty.
1	EGH21120-U01	Shaft		1
2	EGH21120-U02	Saddle		1
3	EGH21120-U03	Saddle		1
4	EGH21120-U04	Collar		4
5	TS-1534052	Hex. Socket Head Bolt	CAP 6x16	13
6	TS-1534032	Hex. Socket Head Bolt	CAP 6x10	20
7	TS-1550041	Washer	M6	20
8	EGH21120-U08	Plate		2
9	EGH21120-U09	Sliding Tray		2
10	EGH21120-U10	Bracket		4
11	EGH21120-U11	Dome Cross Screw	M5x8	3
12	EGH21120-U12	Plate		1
13	EGH21120-U13	Brake Guard		1
14	EGH21120-U14	Plate		1
15	EGH21120-U15	Small Bracket		1
16	TS-1505021	Hex. Socket Head Bolt	CAP 10x20	2
17	TS-1524031	Set Screw	SET 8x12	2
24	TS-2311081	Nut	M8xP1.25	2
25	TS-1550061	Washer	M8	8
26	TS-1504041	Hex. Socket Head Bolt	CAP 8x20	6
27	EGH21120-U27	Splash Guard		1
28	EGH21120-U28	Knob		1
29	TS-0561051	Nut	1/2"	1
30	TS-0070011	Hex. Head Bolt	1/2x1"	1
31	EGH21120-U31	Pivot		1
32	EGH21120-U32	Chuck Safety Guard		1
33	TS-1503031	Hex. Socket Head Bolt	CAP 6x12	1
34	TS-1522051	Set Screw	SET 5x16	1
35	EGH21120-U35	Chute		1
36	EGH21120-U36	Chute		1
37	EGH21120-U37	Coolant Conduit (Only for EGH21120)	CT801x3/8"x185"	1
38	EGH21120-U38	Nipple	3/8"PTx3/8"PH	1
39	EGH21120-U39	Coolant Pump	MC-8150'	1
40	EGH21120-U40	Coolant Tank		1
41	EGH21120-U41	Cover		1
42	TS-1534032	Dome Cross Screw	M6x10	9
43	EGH21120-U43	Tray		1

Index No.	Part No.	Description	Size	Qty.
44	EGH21120-U44	Cover		1
45	EGH21120-U45	Cover Plate		1
47	EGH21120-U47	Plate		1
48	EGH21120-U50	Head End Plinth		1
49	EGH21120-U49	Middle End Plinth		1
50	EGH21120-U48	Tail End Plinth		1
51	EGH21120-U51	Block		10
52	EGH21120-U52	Hexagon Head Bolt	M16x55	10
53	EGH21120-U53	Plate		2
54	TS-1534042	Dome Hex. Screw	M6x12	8
55	TS-1503041	Hex. Socket Head Bolt	CAP 6x16	4
56	TS-1540041	Nut	M6	4
57	EGH21120-U57	Bracket		1
58	EGH1880-J52	Work Lamp		2
59	TS-2311061	Hex Nut	M6	8
60	EGH21120-U60	Upper Socket Enclosure		1
61	EGH21120-U61	Cable Sheath (Alum.)	KR100No8-2100mm	1
62	TS-1503051	Hex. Socket Head Bolt	CAP 6x20	4

CONVENTIONAL TAILSTOCK ASSEMBLY

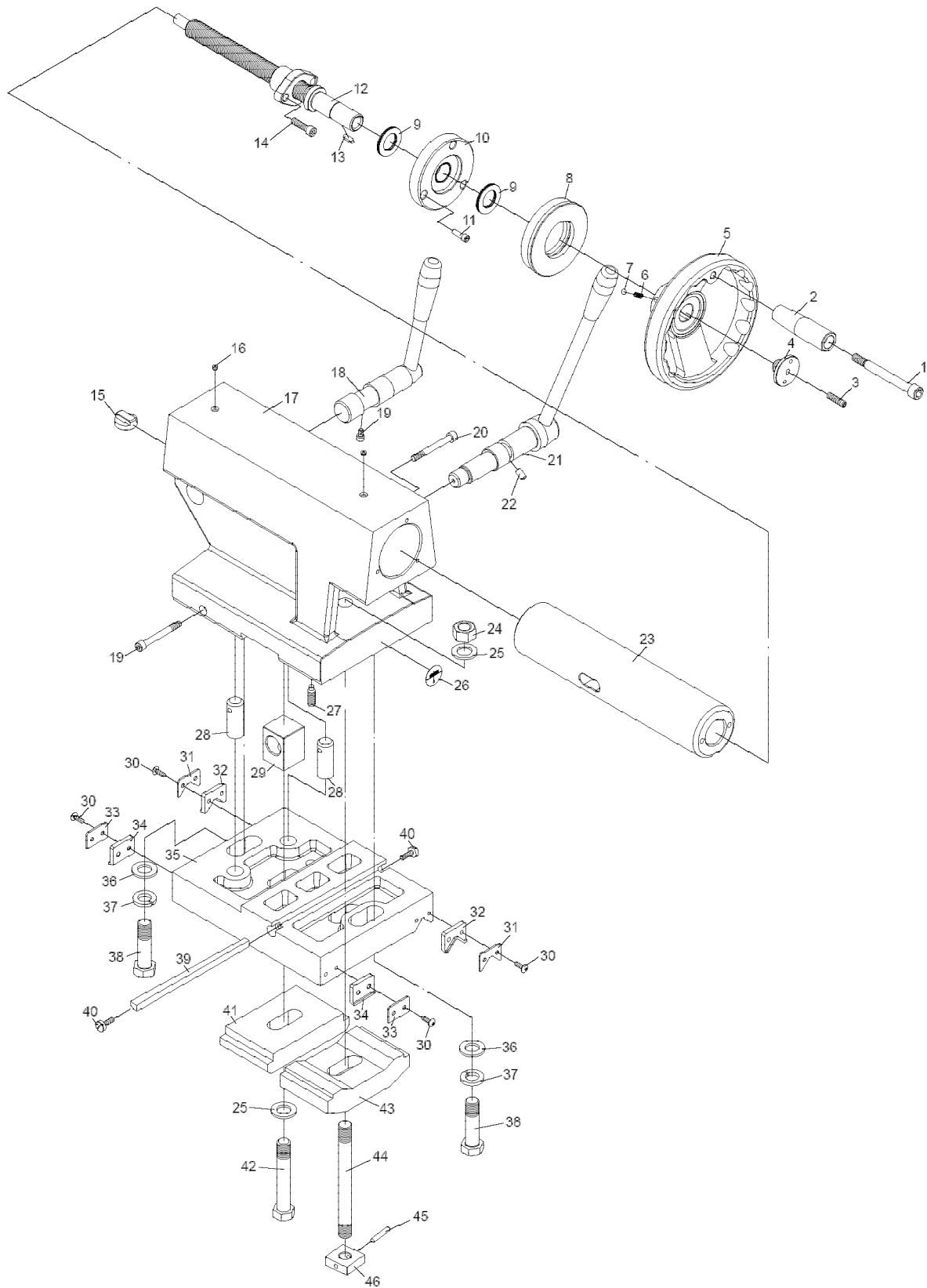

CONVENTIONAL TAILSTOCK ASSEMBLY PARTS LIST

Index No.	Part No.	Description	Size	Qty.
1	EGH1880-K01	Bolt		1
2	EGH1880-K02	Handle		1
3	EGH1880-K03	Set Screw	SET 8×30	1
4	EGH1880-K04	Fixed Screw		1
5	EGH1880-K05	Handle		1
6	EGH1880-K06	Spring		3
7	EGH1880-K07	Steel Ball	1/4"	3
8	EGH1880-K08	Index Ring		1
9	BB-51105	Bearing	51105	2
10	EGH1880-K10	Flange		1
11	TS-1503051	Hexagon Socket Head Bolt	CAP 6×20	3
12	EGH1880-K12	Lead Screw, Nut Assembly		1
13	EGH1880-K13	Key	5×5×12	1
14	TS-1504061	Hexagon Socket Head Bolt	CAP 8×30	2
15	EGH1880-K15	Guide Key		1
16	EGH1880-K16	Oil Ball	1/4"	2
17	EGH1880-K17	Tail Stock		1
18	EGH1880-K18	Clamp Lever L & Cam Shaft L Assembly		1
19	TS-1503021	Hexagon Socket Head Bolt	CAP 6×10	1
20	TS-1504131	Hexagon Socket Head Bolt	CAP 8×70	2
21	EGH1880-K21	Cam Shaft R & Clamp Lever R Assembly		1
22	EGH1880-K22	Pins		1
23	EGH1880-K23	Quill		1
24	TS-2310181	Nut	M18	1
25	TS-2360181	Washer	M18	2
26	EGH1880-K26	Name Plate		1
27	TS-2279301	Set Screw	10×30	1
28	EGH1880-K28	Pin Nut		2
29	EGH1880-K29	Pivot Block		1
30	TS-1533052	Dome Cross Screw	M5×16	8
31	EGH1880-K31	Plate V		2
32	EGH1880-K32	Wiper V		2
33	EGH1880-K33	Plate F		2
34	EGH1880-K34	Wiper F		2
35	EGH1880-K35	Base		1
36	EGH2180-K35	Base	Same as EGH21120	1
37	EGH1880-K36	Washer		2
38	TS-2361181	Spring Washer	M18	2
39	EGH1880-K38	Hexagon Socket Head Bolt		2
40	EGH1880-K39	Gib		1
41	EGH1880-K40	Gib Screw		2
42	EGH1880-K41	Clamp Block		1
43	EGH1880-K42	Hexagon Socket Head Bolt		1
44	EGH1880-K43	Clamp Block		1
45	EGH1880-K44	Stud Bolt		1
46	EGH1880-K45	Pin	Ø6×36	1
47	EGH1880-K46	Nut		1

BED STOP ASSEMBLY

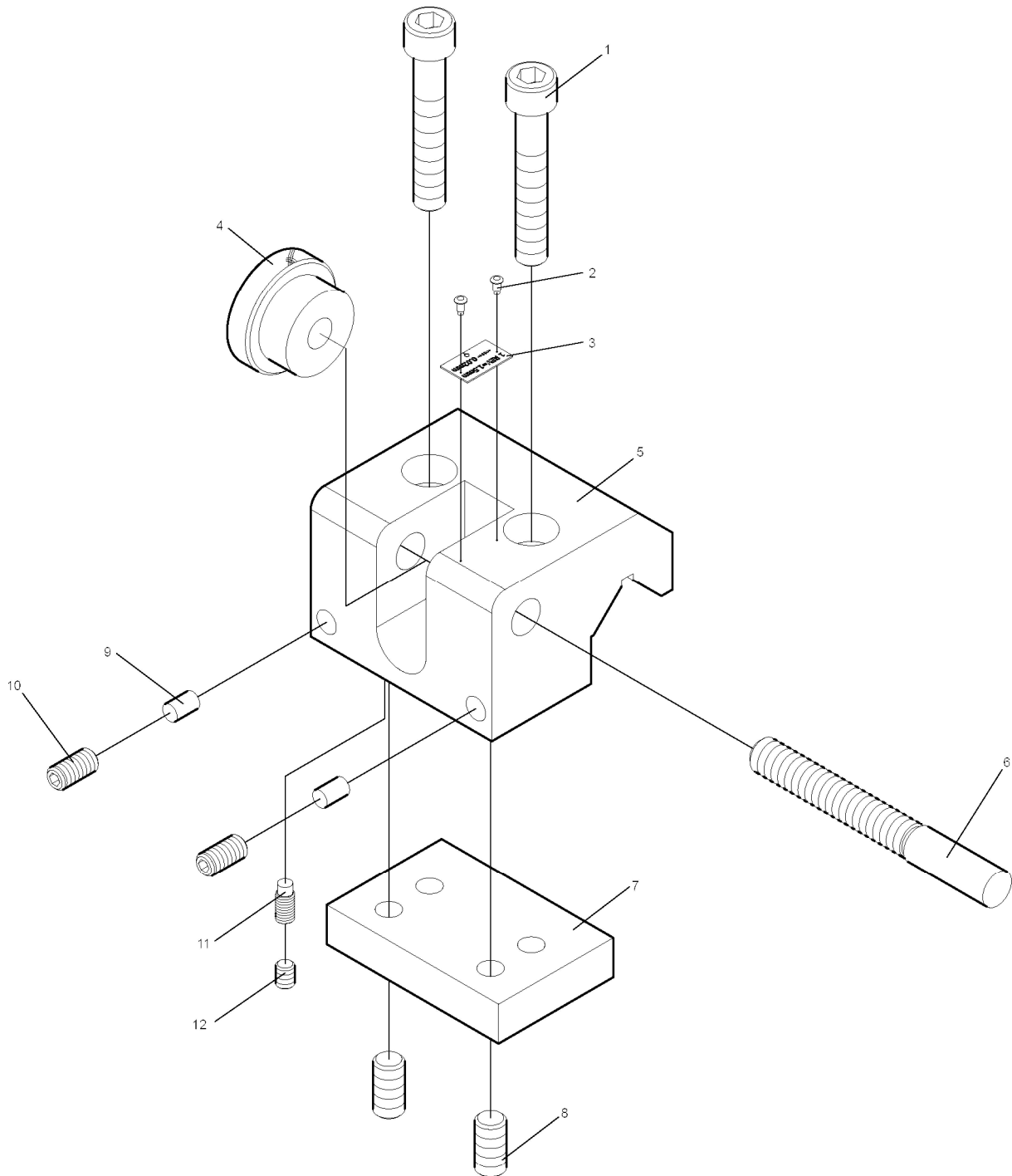

BED STOP ASSEMBLY PARTS LIST

Index No.	Part No.	Description	Size	Qty.
1	TS-1505101	Hex. Socket Head Bolt	M10x60	2
2	EGH1880-P02	Rivet	Ø2	2
3	EGH1880-P03	Name Plate		1
4	EGH1880-P04	Micro Dial		1
5	EGH1880-P05	Body		1
6	EGH1880-P06	Rod		1
7	EGH1880-P07	Clamp Plate		1
8	TS-1525041	Set Screw	M10x20	2
9	EGH1880-P09	Copper Pin		2
10	TS-1524041	Set Screw	M8x16	2
11	TS-1524031	Set Screw	M8x12	1
12	TS-1524031	Set Screw	M8x12	1

STATIONARY STEADY

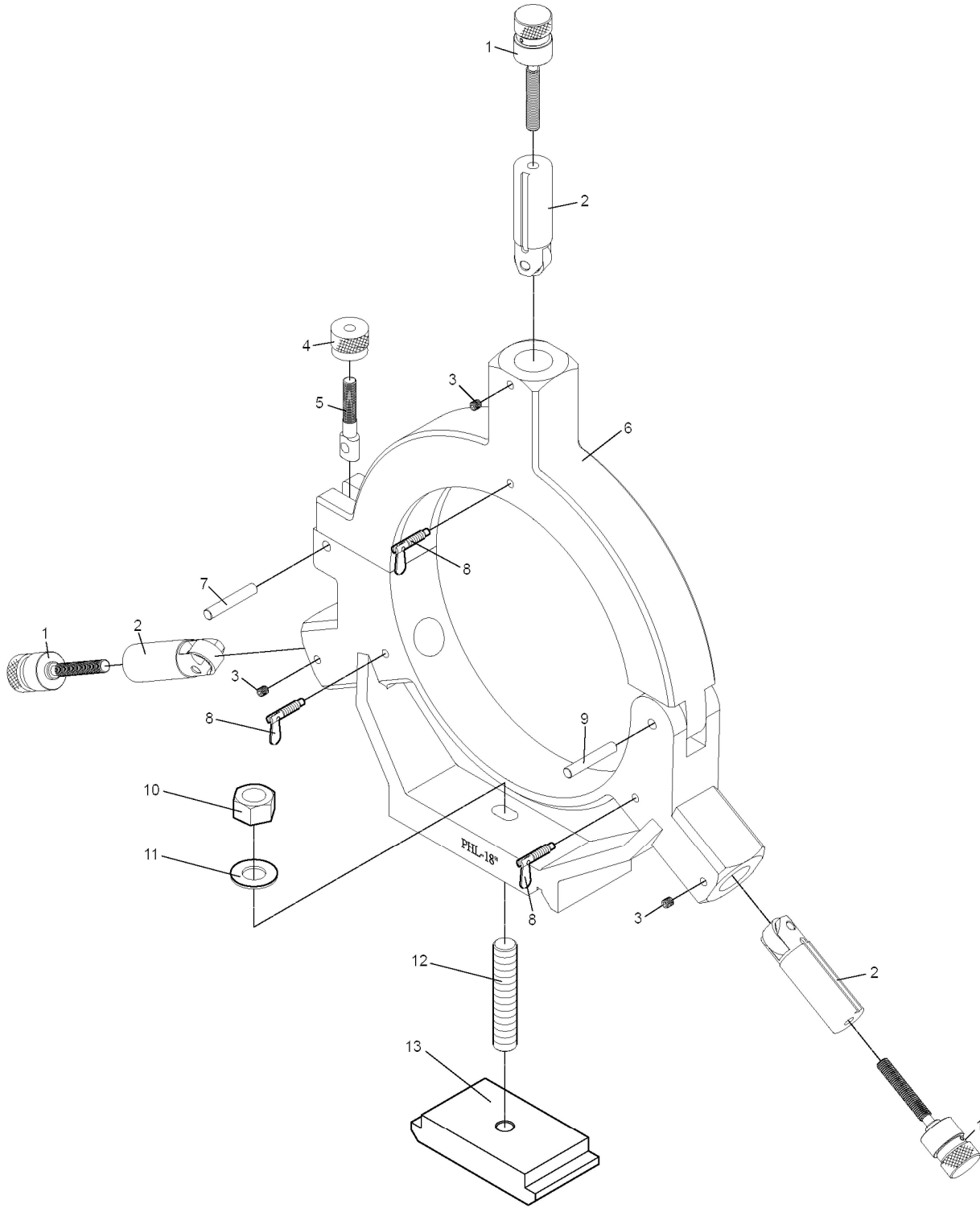

STEADY REST ASSEMBLY PARTS LIST

Index No.	Part No.	Description	Size	Qty.
1	EGH1880-Q01	Adjusting Knob Assembly		3
2	EGH1880-Q02	Finger,Pin,Ball Bearing (627) Assembly		3
3	TS-1524011	Set Screw	M8x8L	3
4	EGH1880-Q04	Knob Nut		1
5	EGH1880-Q05	Clamp Screw		1
6	EGH1880-Q06	Top & Base Casting Assembly		1
	EGH2180-Q06	Top & Base Casting Assembly	Same as EGH21120	1
7	EGH1880-Q07	Pin		1
8	EGH1880-Q08	Single Wing Bolt		3
9	EGH1880-Q09	Hinge Pin		1
10	EGH1880-Q10	Nut	M18xP2.5	1
11	TS-2361181	Spring Washer	M18	1
12	EGH1880-Q12	Hexagon Head Bolt		1
13	EGH1880-Q13	Clamp Plate		1
	EGH-18-SRA	Steady Rest Assembly		1
	EGH-21-SRA	Steady Rest Assembly	Same as EGH21120	1

TRAVELING STEADY ASSEMBLY

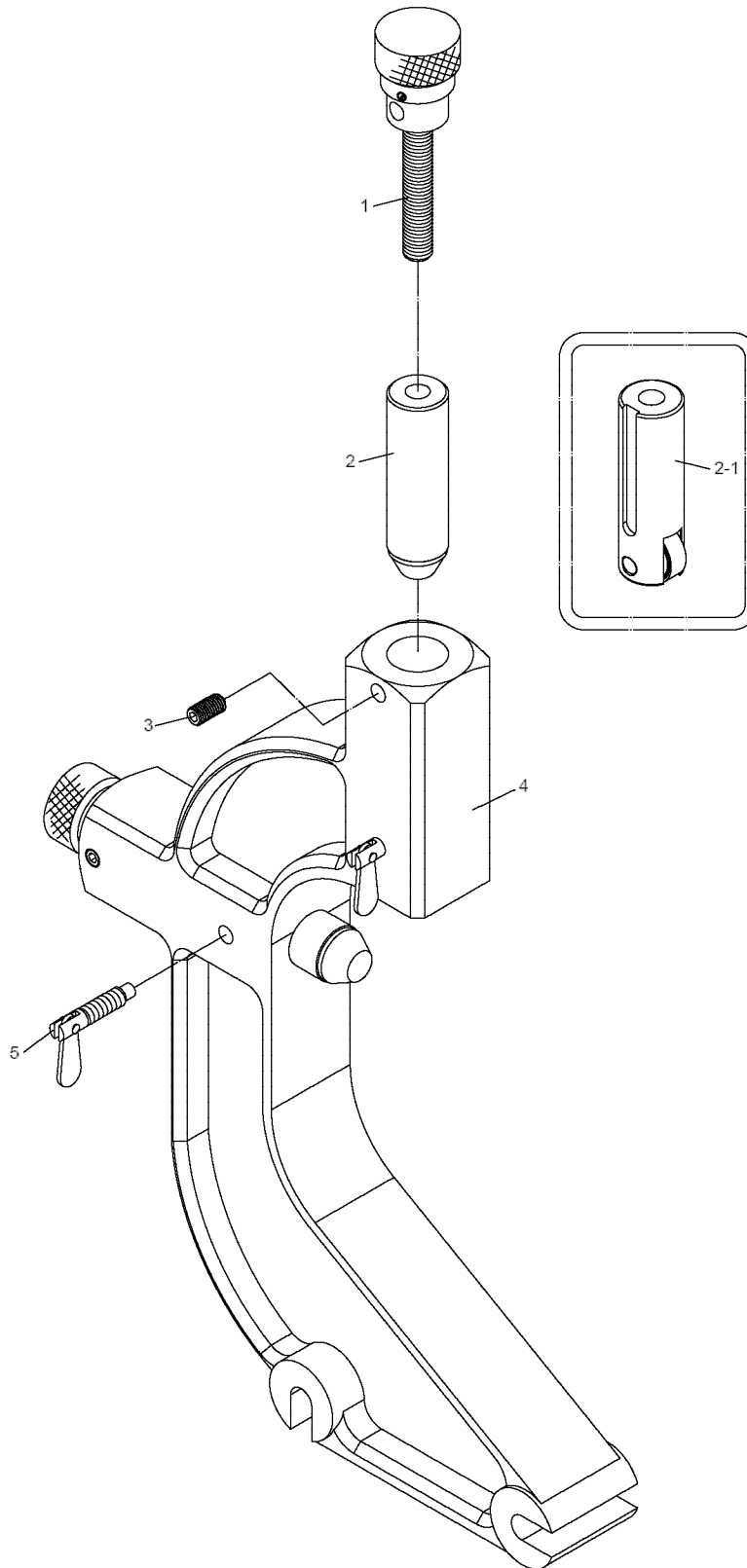

TRAVELING STEADY ASSEMBLY PARTS LIST

Index No.	Part No.	Description	Size	Qty.
1	EGH1880-R01	Adjusting Screw, Spring Pin(Ø4x40L), Collar, Screw	Assembly For Replacement	2
2	EGH1880-R02	Finger & Bracket	Assembly For Replacement	2
2-1	EGH1880-R02BB	Finger, Ball bearing bracket	Assembly For Replacement	2
3	TS-1524041	Set Screw	M8x16	2
4	EGH1880-R04	Casting		1
	EGH2180-R04	Casting	Same as EGH21120	1
5	EGH1880-R05	Single Wing Bolt		3
	EGH18-FCA	Follow Rest Assembly w/ Copper (Key No.2)		1
	EGH21-FCA	Follow Rest Assembly w/ Copper (Key No. 2)		1
	EGH18-FBBA	Follow Rest Assembly w/ Ball Bearing (Key No.2-1)		1
	EGH21-FBBA	Follow Rest Assembly w/ Ball Bearing (Key No. 2-1)		1

BRAKE ASSEMBLY

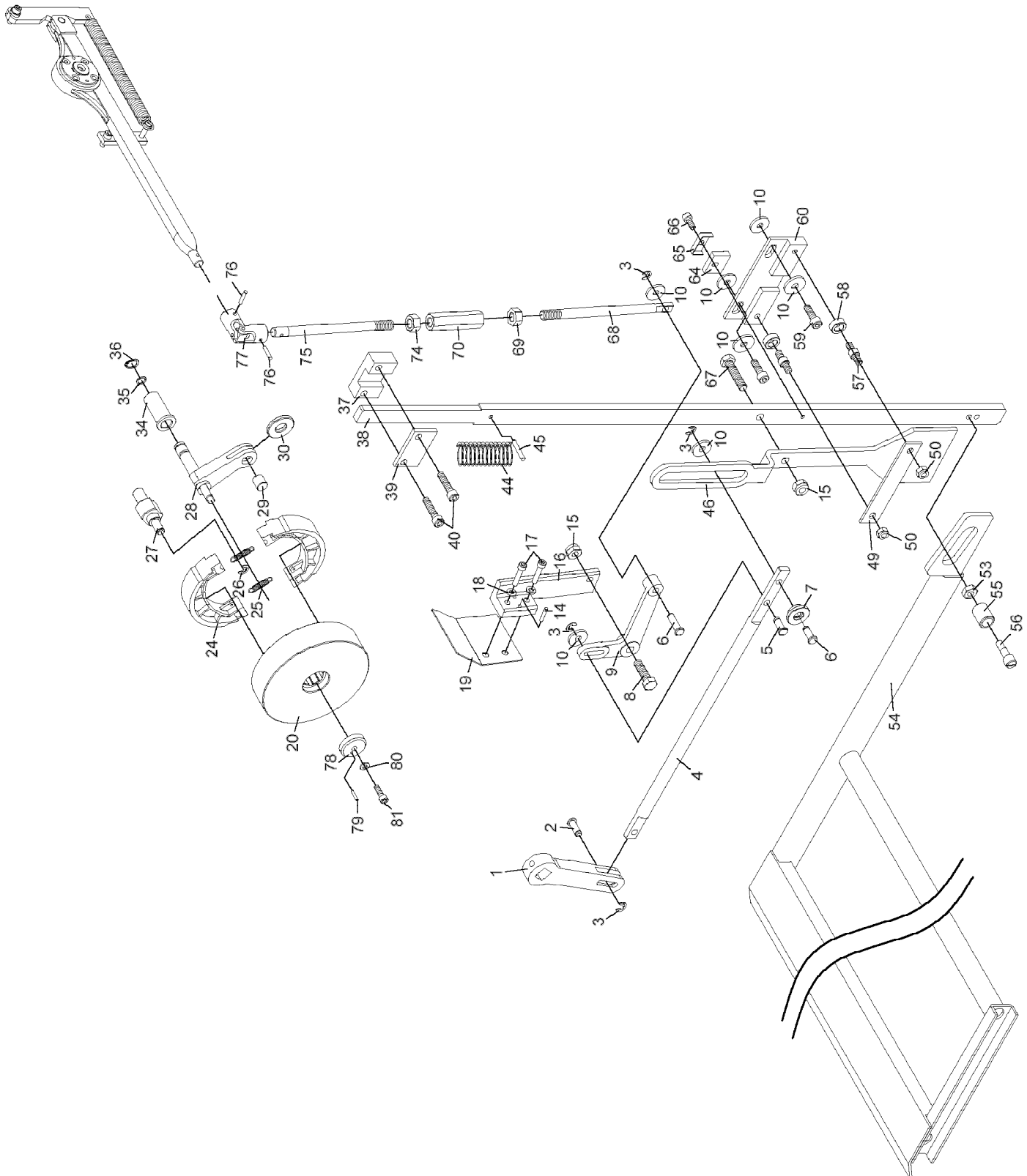

BRAKE ASSEMBLY PARTS LIST

Index No.	Part No.	Description	Size	Qty.
1	EGH1880-T01	Rod		1
2	EGH1880-T02	Pin		1
3	EGH1880-T03	Snap Ring	E6	4
4	EGH1880-T04	Connecting Rod		1
5	EGH1880-T05	Pin		1
6	EGH1880-T06	Pin		2
7	EGH1880-T07	Gyro Wheel		1
8	TS-149105	Hex. Head Bolt	10×35	1
9	EGH1880-T09	Rocker Arm		1
10	EGH1880-T10	Washer	M8	7
14	EGH1880-T14	Pin	Ø4×24	2
15	TS-1541041	Nut	M10	2
16	EGH1880-T16	Bracket		1
17	TS-1503071	Hex. Socket Head Bolt	CAP6x30	2
18	TS-2361061	Spring Washer	M6	2
19	EGH1880-T19	Plate		1
20	EGH1880-T20	Brake Cylinder		1
24	EGH1880-T24	Brake Lining		2
25	EGH1880-T25	Spring		2
26	EGH1880-T26	Snap RING	E8	1
27	EGH1880-T27	Shaft		1
28	EGH1880-T28	Cam		1
29	EGH1880-T29	Shaft		1
30	EGH1880-T30	Washer		1
34	EGH1880-T34	Bush		1
35	EGH1880-T35	O Ring	P10	1
36	EGH1880-T36	Snap Ring	S14	1
37	EGH1880-T37	Chunk		1
38	EGH1880-T38	Board		1
	EGH2180-T38	Board	Same as EGH21120	1
39	EGH1880-T39	Fixed Plate		1
40	TS-1504071	Hex. Socket Head Bolt	CAP 8x35	2
44	EGH1880-T44	Spring		1
45	EGH1880-T45	Pin	Ø5×30	1
46	EGH1880-T46	Control And Put		1
49	EGH1880-T49	Fixed Plate		1
50	TS-1541031	Nut	M8	2
53	TS-1540061	Nut	M8	2
54	EGH1880-T54	Saddle		1



Index No.	Part No.	Description	Size	Qty.
55	EGH1880-T55	Pin		1
56	EGH1880-T56	Bolt		1
57	EGH1880-T57	Bolt		2
58	EGH1880-T58	Gyro Wheel		2
59	TS-1504051	Hex. Socket Head Bolt	CAP 8x25	2
60	EGH1880-T60	Bracket		1
64	EGH1880-T64	Stop		1
65	EGH1880-T65	Guard Shield		1
66	TS-1503021	Hex. Socket Head Bolt	CAP 6x10	1
67	TS-2210451	Hex. Head Bolt	10x45	1
68	EGH1880-T68	Rod		1
	EGH2180-T68	Rod	Same as EGH21120	1
69	EGH1880-T69	Nut		1
70	EGH1880-T70	Nut		1
74	TS-1540081	Nut	M12	1
75	EGH1880-T75	Bolt		1
	EGH218-T75	Bolt	Same as EGH21120	1
76	EGH1880-T76	Pin	Ø4×20	1
77	EGH1880-T77	Joint Ass'Y		2
78	EGH1880-T78	Washer		1
79	EGH1880-T79	Pin	Ø3×16	1
80	TS-2361061	Spring Washer	M6	1
81	TS-1503051	Hex. Socket Head Bolt	CAP 6x20	1

ELECTRICAL BOX ASSEMBLY

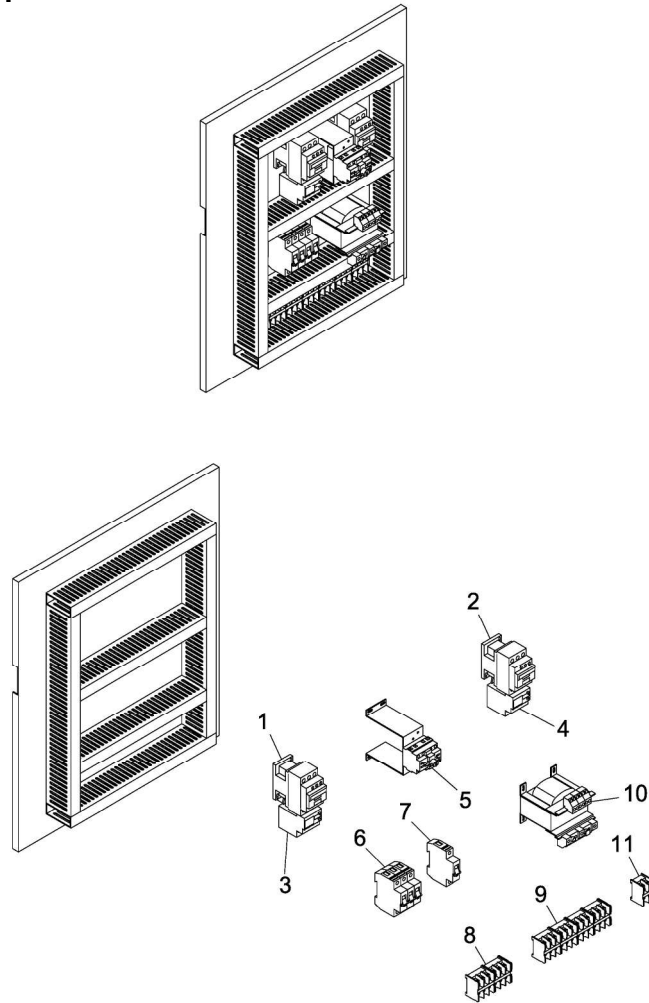

EGH1880/EGH2180/EGH21120 ELECTRICAL BOX ASSEMBLY PARTS LIST

Index No.	Part No.	Description	Size	Qty.
1	EGH1880-EL01	AC Magnetic Switch	D32 AC24V	1
2	EGH1880-EL02	AC Magnetic Switch	D09 AC24V	1
3	EGH1880-EL03	Over Relay	30A~38A	1
4	EGH1880-EL04	Over Relay	0.25A~0.4A	1
5	EGH1880-EL05	Door-Type Main Cam Switch	32A	1
6	EGH1880-EL06	Fuse Base		1
7	EGH1880-EL07	Fuse Base		1
8	EGH1880-EL08	Terminal Board	3P 50A	2
9	EGH1880-EL09	Terminal Board	3P 20A	4
10	EGH1880-EL10	Transformer	155VA	1
	EGH21120-EL10	Transformer	237VA	1
11	EGH1880-EL11	Terminal Board	2P 20A	1
	EGH1880-EL12	Power Relay + Seat (not shown)		1

CONTROL BOX ASSEMBLY

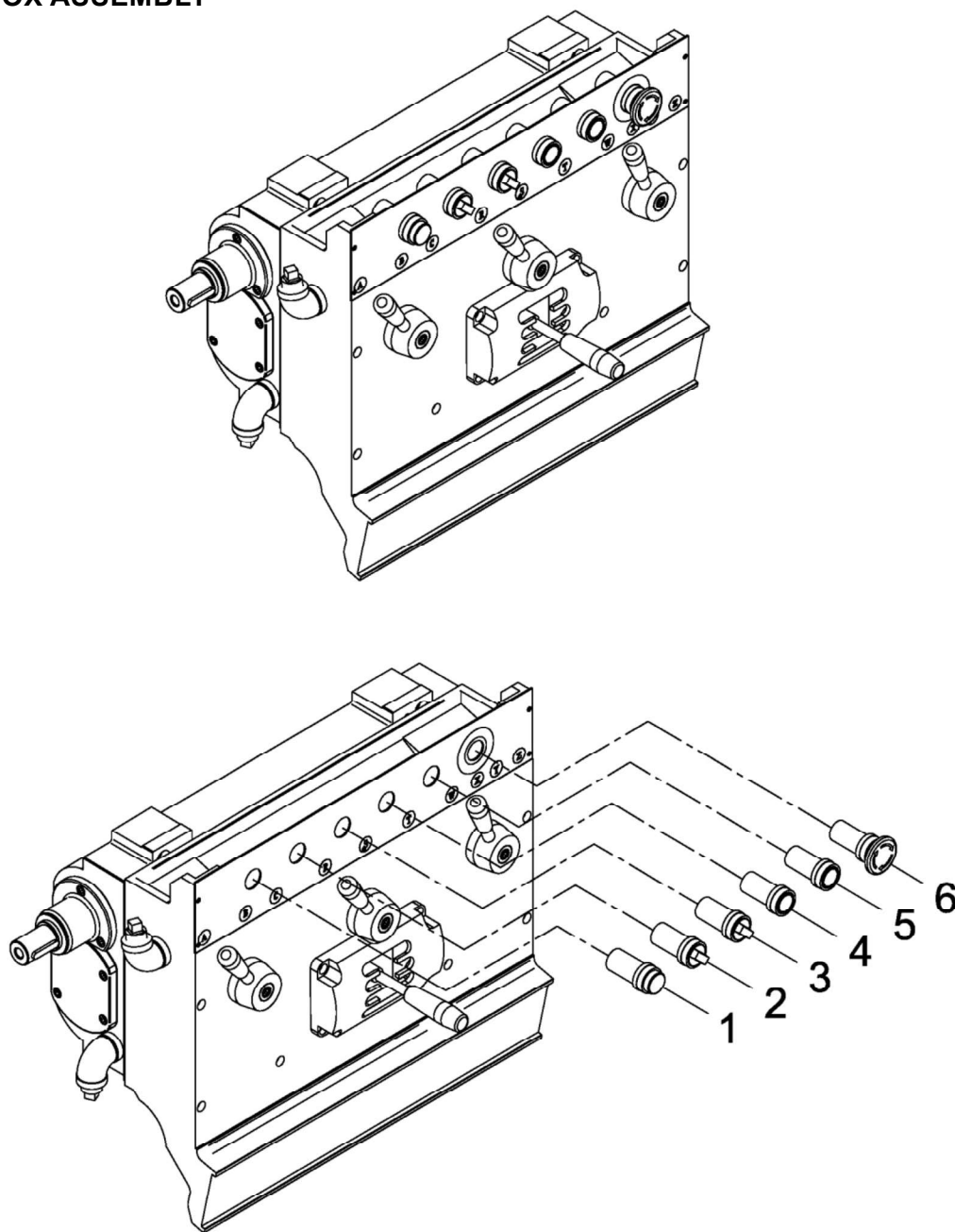

EGH1880/EGH2180/EGH21120 CONTROL BOX ASSEMBLY PARTS LIST

Index No.	Part No.	Description	Size	Qty.
1	EGH1880-CB01	Power Lamp	W1	1
2	EGH1880-CB02	Light Switch	SW2	1
3	EGH1880-CB03	Pump Change Over Switch	SW1	1
4	EGH1880-CB04	Spindle Motor Stop	SPB1	1
5	EGH1880-CB05	Spindle Motor Run	PB1	1
6	EGH1880-CB06	E-Stop	E-Stop	1

892253 5C COLLET CLOSER ASSEMBLY (OPTIONAL)

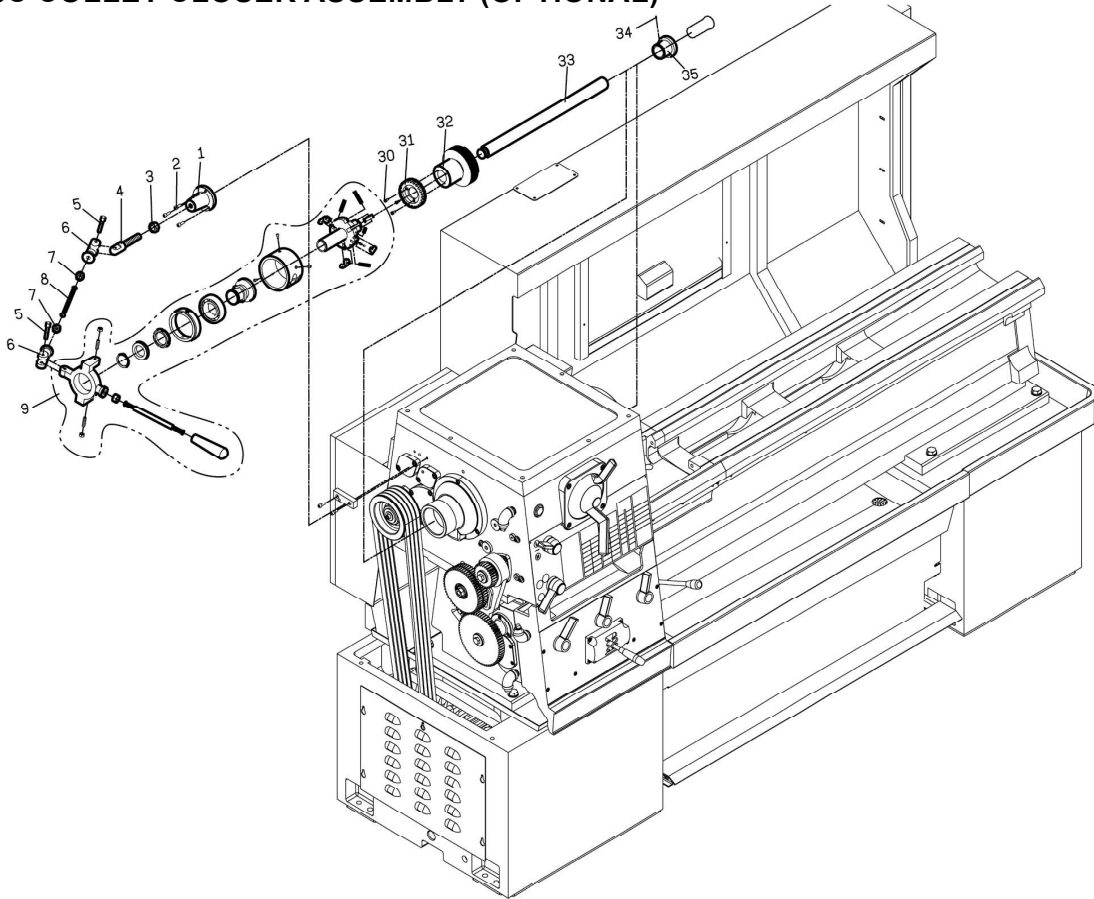

892253 5C COLLET CLOSER ASSEMBLY (OPTIONAL) PARTS LIST

Index No.	Part No.	Description	Size	Qty.
1	EGH1740-O02	Bracket		1
2	TS-1503061	Hex. Socket Head Bolt	M6x25	3
3	TS-154010	Hex Nut	M16	1
4	EGH1740-O04	Bolt		1
5	EGH1740-O05	Bolt		2
6	EGH1740-O06	Connector Casting		2
7	TS-0561051	Nut	1/2"-13	2
8	EGH1740-O08	Screw	W1/2" x 155mm	1
9	EGH-1880-O09	Handle Casting Assembly		1
30	TS-1502031	Hex. Socket Head Bolt	M5x12	3
31	EGH1880-O31	Index Ring		1
32	EGH1880-O32	Hub		1
33	EGH1880-O33	Tube		1
34	EGH1880-O34	Pin		1
35	EGH1880-O35	Bushing		1
	892253	5C Collet Closer Assembly (#1 thru 35)		1

892254 TAPER ATTACHMENT ASSEMBLY (OPTIONAL)

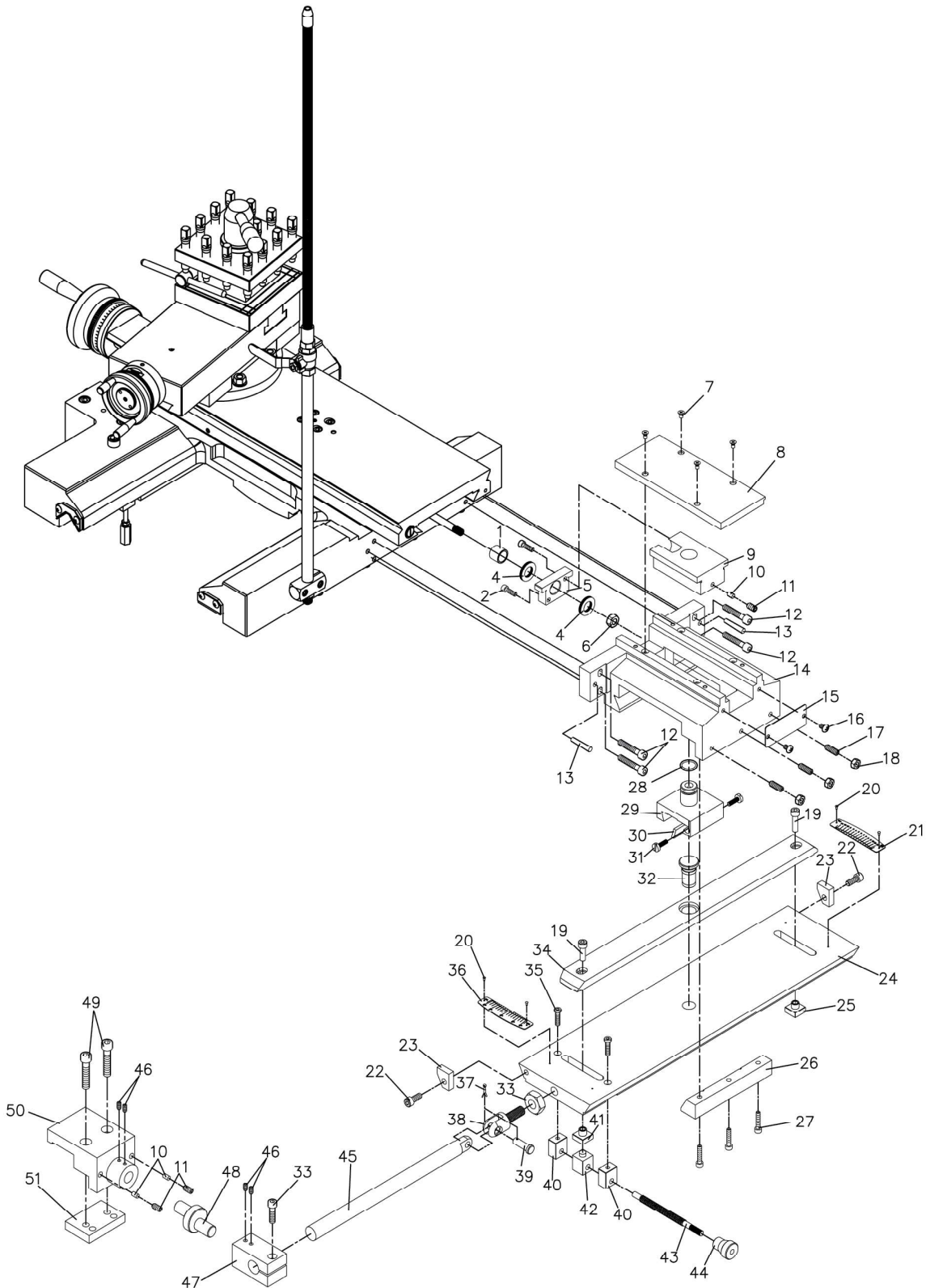

892254 TAPER ATTACHMENT ASSEMBLY (OPTIONAL) PARTS LIST

Index No.	Part No.	Description	Size	Qty.
1	EGH1880-N01	Collar		1
2	TS-1503051	Hex. Socket Head Bolt	CAP 6x20	2
4	EGH1880-N03	Thrust Bearing	NTB/AS2 1730	2
5	EGH1880-N04	Yoke Plate		1
6	TS-154010	Nut	M16	1
7	TS-2246101	Socket Hd Flat Screw	M6x10	4
8	EGH1880-N07	Cover Plate		1
9	EGH1880-N08	Yoke		1
10	EGH1880-N09	Copper Pin		3
11	TS-1524041	Set Screw	SET8x16	3
12	TS-1504091	Hex. Socket Head Bolt	CAP 8x45	4
13	EGH1880-N12	Taper Pin	#6x1 1/2"	2
14	EGH1880-N13	Main Bracket		1
15	EGH1880-N14	Plate		1
16	TS-1534032	Dome Cross Screw	M6x10	2
17	TS-1524061	Set Screw	SET 8x25	3
18	TS-2311081	Hexagon Nut	M8	3
19	TS-1504061	Hex. Socket Head Bolt	CAP 8x30	2
20	EGH1880-N19	Rivet	Ø2	4
21	EGH1880-N20	Angle Scale		1
22	TS-1504041	Hex. Socket Head Bolt	CAP 8x20	2
23	EGH1880-N22	Stop		2
24	EGH1880-N23	Plate		1
25	EGH1880-N24	Nut		1
26	EGH1880-N25	Gib		1
27	TS-1503071	Hex. Socket Head Bolt	CAP 6x30	3
28	EGH1880-N27	O Ring	P21	1
29	EGH1880-N28	Side Block		1
30	EGH1880-N29	Gib		1
31	EGH1880-N30	Screw		2
32	EGH1880-N31	Slide Pivot Pin		1
33	TS-154009	Nut	M14	1
34	EGH1880-N33	Swivel Slide		1
35	TS-1503061	Hex. Socket Head Bolt	CAP6x25	2
36	EGH1880-N35	Angle Scale		1
37	EGH1880-N36	Cotter Pin	Ø2.5x16	1
38	EGH1880-N37	Bolt		1
39	EGH1880-N38	Clevis Pin		1
40	EGH1880-N39	Block		2



892254 TAPER ATTACHMENT ASSEMBLY PARTS LIST (OPTIONAL)

Index No.	Part No.	Description	Size	Qty.
41	EGH1880-N40	Nut		1
42	EGH1880-N41	Nut		1
43	EGH1880-N42	Screw		1
44	EGH1880-N43	Knob		1
45	EGH1880-N44	Clamp Rod		1
46	TS-1523041	Set Screw	SET 6x12	4
47	EGH1880-N46	Bracket		1
48	EGH1880-N47	Eccentric Pin		1
49	TS-1505081	Hex. Socket Head Bolt	CAP 10x50	2
50	EGH1880-N49	Bracket		1
51	EGH1880-N50	Clamp		1
	892254	Taper Attachment Assembly (#1 thru 51)		

14.0 WIRING DIAGRAMS

EGH-1880/EGH-2180 ELECTRICAL DIAGRAM

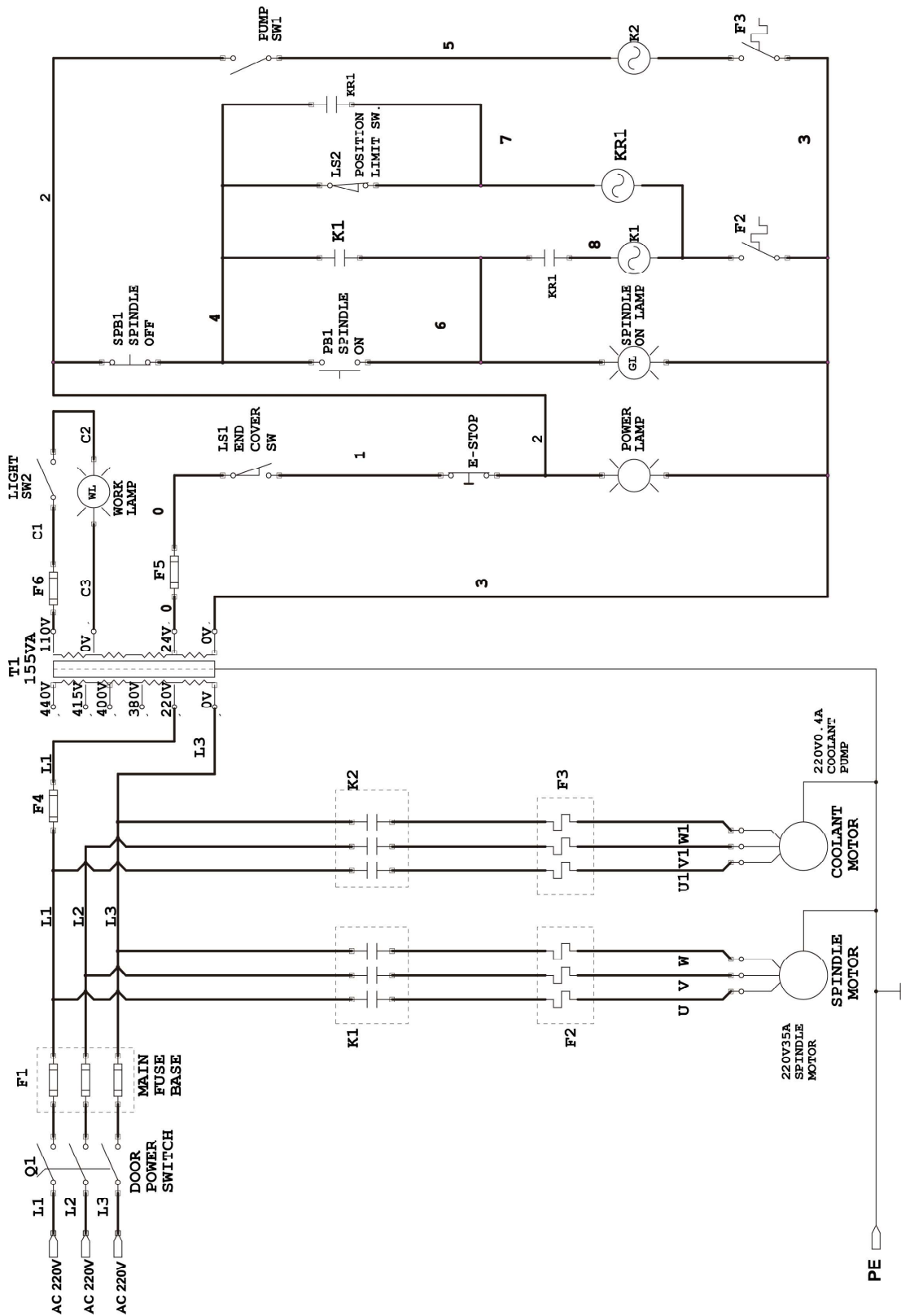

EGH-21120 ELECTRICAL DIAGRAM

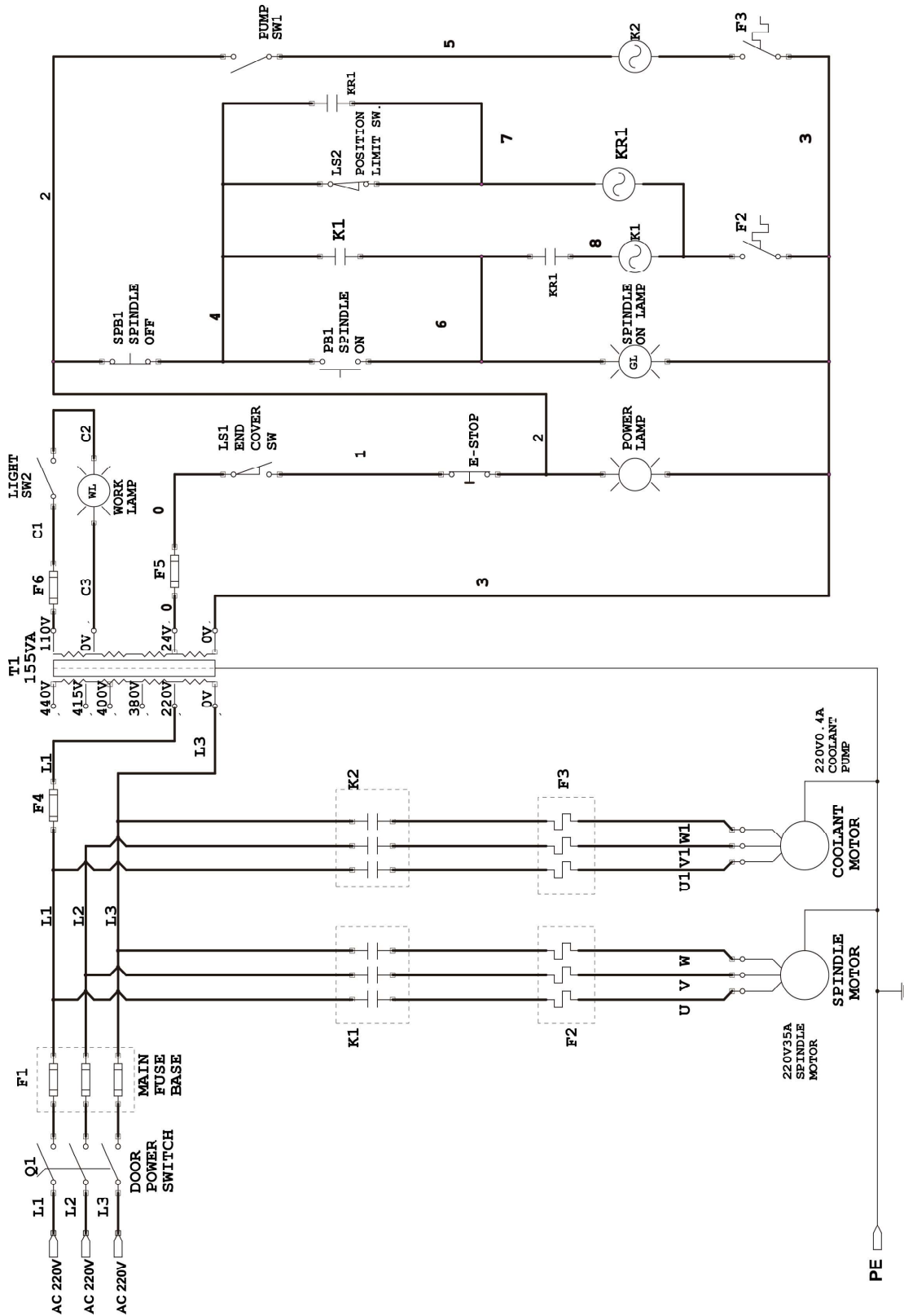

NOTES



NOTES