

GROUND CONTROL

Field Commander's Handbook

Version 1.61

You will soon be a commander of a CLSV-601 Command APC, assigned to active duty on the Crayven heavy cruiser CSS ASTRID attached to 34th Assault Regiment located to the contested colony of Krig-7B. As a field commander in the 34th Assault Regiment you will be required to configure your own strike team as appropriate for missions assigned to you. You and your squads will be transported to designated combat zones on the planet surface in UV/4 Dropships, where you will personally lead them into battle to complete your mission objectives. Between active combat duty you will be accommodated aboard the CSS ASTRID.

The acquisition operation on Krig-7B is under a joint corporate-military jurisdiction and your commanding officer on this campaign will be Director Enrica Hayes. All information regarding this operation is to be viewed as strictly confidential. Breach of confidentiality will lead to summary execution according to directive #9, paragraph 65.

To your aid you have received the Ground Control Direct Command Interface System (GC-DCIS) and the Field Commander's handbook. Remember the Crayven Corporation allows you to be all you can be!

TABLE OF CONTENTS

| | |
|--|-----------|
| Message From Crayven High Command | 2 |
| Table of Contents | 3 |
| 1. Introduction | 5 |
| System Requirements | 6 |
| Installing Ground Control..... | 6 |
| Installing DirectX | 6 |
| 2. Background | 7 |
| The Order of the New Dawn | 7 |
| The Crayven Corporation | 13 |
| 3. Quick Start | 20 |
| 4. Playing the Game | 21 |
| Single Player Game | 23 |
| Multiplayer Game | 25 |
| Options | 26 |
| Credits..... | 26 |
| 5. The Management Interface | 27 |
| Briefing | 27 |
| Configure Dropships..... | 27 |
| Configure Squads | 29 |
| Mission Debriefing | 30 |
| 6. Commanding your Strike Force | 31 |
| The Command Environment | 31 |
| Camera control | 31 |
| The Tactical Map..... | 32 |
| Calling down the Dropships..... | 33 |

| | |
|---|-----------|
| The Squad Buttons | 34 |
| Squad Behavior Menu | 35 |
| Ordering your squads..... | 36 |
| 7. Options | 39 |
| General Options..... | 39 |
| Video Options | 39 |
| 8. Multiplayer | 41 |
| Multiplayer setup..... | 41 |
| Internet Standard game | 45 |
| Internet Drop-in game | 48 |
| Local Area Network (LAN) | 49 |
| 9. Ground Control Tactics | 50 |
| Knowing your battlefield terrain | 50 |
| Line of Sight | 50 |
| Suppressive Fire | 50 |
| Flanking maneuvers | 51 |
| Friendly Fire | 51 |
| Combined Arms | 51 |
| Squads and Experience..... | 52 |
| 10. Technical Manual | 53 |
| Crayven Corporation units..... | 53 |
| The Order of the New Dawn units | 68 |
| 11. Credits | 83 |
| 12. Technical Support..... | 87 |
| 13. Warranty | 88 |
| 14. Default Buttons and Key Settings | 89 |

This Field Commander's Handbook will teach you how to interact with the Ground Control Direct Command Interface System - GC-DCIS - available onboard your CLSV-601 Command APC.

The Field Commander's Handbook also contains a refreshment tactic section intended to refresh the very basics of the tactics taught at the Ney Vesta Academy of Martial Arts.

“Configuration of terrain is an aid to the enemy. Analyzing the enemy, taking control of victory, estimating ravines and defiles, the distant and near, it the Tao of the superior general. One who knows these and employs them in combat will certainly be victorious. One who does not know these or employ them in combat will certainly be defeated.”

-Sun-Tsu

Please note that the keyboard commands mentioned in this manual are referenced to the default settings. If the default settings have been changed, the keyboard commands may no longer be true to your system.

SYSTEM REQUIREMENTS

Minimum System Requirements

The Ground Control Direct Command Interface System (GC-DCIS) requires that your Command APC onboard computer is equipped with:

- Pentium II 233 MHz or Pentium II 200 with 3D Accelerator Card
- 32 MB RAM
- 250 MB HD Space
- CD-ROM: 4x or better
- 640 x 480 SVGA high color (16-bit) 4 MB Video Card
- DirectX 7.0a (included on CD)
- Windows® compatible sound device
- Mouse and Keyboard

Recommended System Requirements

For maximum combat performance Crayven Tactical Military Operations recommend the following:

- Pentium II 333 MHz or better
- 64 MB RAM
- 3D accelerator card (Glide or Direct3D compatible)
- 450 MB HD Space

Installing Ground Control

Crayven High Command recommends that you take the time to run Disk Defragmenter on the current hard drive before you install the game. Disk Defragmenter is activated via the Start button on the Windows taskbar in the [programs/accessories/system tools] group. Follow its instructions.

In order to install the GC-DCIS to your Command APC onboard computer safely, you need to insert the Ground Control CD into your CD-ROM and follow the instructions on the screen.

If no instructions shortly appear, double-click on the "my computer" icon on your desktop. Double-click on the CD-ROM drive icon. In the file window, double-click on the file icon of AUTORUN.EXE. Follow the instructions on screen.

Installing DirectX

The Ground Control Direct Command Interface System requires that you have Microsoft DirectX 7.0a or higher installed. During the installation your onboard system will be checked to see if you have correct drivers installed. Should you require new drivers, you will be asked if you would like to install DirectX 7.0a.

THE ORDER OF THE NEW DAWN

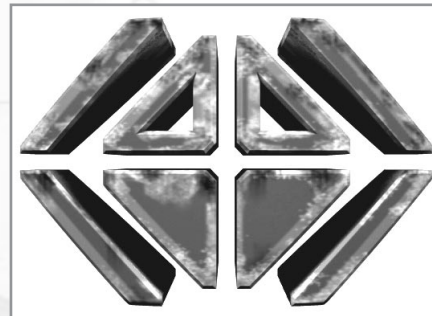

Introduction

The Order of the New Dawn is Earth's largest religious faith, and if its financial strength were rated against the world's corporations, it would be the third largest. The Order counts nearly 700,000,000 Faithful among its ranks, and its holdings range from Mars to the Spinward Reaches.

The Order's ranks are divided into three great branches of service. The first of these is the Manus Dei, "the Hands of God", by far the largest grouping of the Faithful; of the Order's 700 million members, nearly 600 million belong to the Manus Dei. The Hands of God are the workforce of the Order, both Earthside and abroad. They come from every technical and labor discipline, and many are recruited directly from the ranks of other corporations. While there are laws regarding the appropriation of skilled workers between corporations, religious conversion is currently unrestricted, and so the Manus Dei is constantly being refreshed with a steady influx of talent. It is not unusual for the Order to actively try to convert corporate personnel involved in high-tech research projects.



The second branch of the Order is much smaller than the Manus Dei, but without them, no branch of the Order could exist. The Pax Dei, as they are known—the “Peace of God”, in common tongue—is a standing security force of over 90 million men and women. These soldiers form the colonial armies of the New Dawn and see themselves as the Holy Defenders of the Faith, dedicated to protecting the Order and its interests on Earth and throughout the galaxy. Members of the Pax Dei provide policing and security for the Order’s settlements on no fewer than fourteen worlds, and they are also called to provide pilots and crew for any and all vessels belonging to the Church. Given their grounding in the faith of the New Dawn, Pax Dei troops have a very high morale factor under fire and will often fight to the last soldier unless directly ordered to retreat.

The third and final branch of the Order is the Vox Dei, “the Voice of God”, and functions as the spiritual arm of the church. Members of the Vox include Ministers, Astronomers and Inquisitors. The Order only allows men to join the ranks of the Vox Dei, and only after many months of continuous indoctrination. The Ministers effectively rule the Order and make all strategic decisions, both economic and military. The Sacred Astronomers are the priest-scientists of the Order, and guide both the exploration of new worlds and research into new technologies. The Inquisition is the Order’s internal police force and intelligence division, and their task is to examine threats to the spiritual purity of the Order from without and within. A sub-branch of the Inquisition trains the Battle-Priests; these men accompany most military units to observe behavior in combat, and make sure field commanders are issuing orders that are “spiritually correct”. The Vox Dei is the smallest of the 3 Order branches, and numbers slightly over 10 million personnel.

History

Little is known of the earliest days of the Order, which was founded in the troubled years before the Sixteen Minutes’ War. Although it is believed that the great majority of the Order’s pre-war records survived the nuclear exchange on March 27, 2093 intact, they are believed to have been lost in the intervening centuries. Today we know only that The Order of the New Dawn was founded by a small coalition of men and women of Faith, who united in common cause during the dark days of the latter 21st century. Foreseeing the coming cataclysm, these early cultists dedicated themselves to preserving as much technology and knowledge as possible, in order to bring about a New Dawn after the inevitable holocaust. Many analysts have observed that without the Sixteen Minutes’ War, the Order would have been just another apocalyptic cult.

But the End of the Civilized World did indeed come, and the proto-Order was ready for it—and even the corporations, no matter what they may think of the Order in the present day, do not deny the debt all of humanity owes them. The greatest prize saved by the Order was the Liber Aurorae Novae, the Book of the New Dawn: millions of digitally stored books, recordings, and images, which members of the Order chose to save from the coming holocaust. Of course,

critics are quick to point out that this treasure was not saved merely for the benefit of humanity. Since 2177, the works collected in the L.A.N. have been protected under the existing salvage laws of the GCC, and are no longer considered to be “in the Public Domain”. Many irreplaceable classics of human art and literature are thus copyrighted to the Church in perpetuity, and every reader of Charles Dickens, William Butler Yeats and Joseph Conrad must pay royalties to the church.

The ancient Order also preserved the Spicelegium Dei, “God’s Gleaning”, which consists of over 700,000 cryogenically preserved tissue samples of human, plant, and animal life on Earth. The S.D. has been replicated many thousands of times since 2157, and is still archived by scholars of the Order on Earth, Europa (Sol 5B), and Proxima 3. It has yet to be surpassed as a reference library of uncorrupted genetic material from before the Age of Chaos.

Historians estimate that the Order’s underground shelters were opened in the year 2097, just 48 months after the destruction of the Old World. Although radiation levels were still dangerous, the brothers and sisters of the Order quickly realized that the world above them had not been completely destroyed, and that there were many survivors in need of help. Although their shelters were not set to open for another fifteen years, the Order opened its doors and returned to the surface early, hoping to make a difference to the billions of refugees and convert them to the cause in the process. During the last six months of a bitter nuclear winter, the Church set up way stations around the globe to provide shelter to the homeless, and share its remaining supplies with those in need.

Throughout the Age of Chaos, the Order of the New Dawn built and fortified over 130 Sanctuaries world-wide. These facilities served many functions in that dangerous age: to minister to the sick and starving, to provide shelter to the weary and destitute, to educate the young, and to spread the teachings of the New Dawn Bible. The most important function of the Sanctuaries, however, was to keep the peace; it was during these years that the armed forces branch of the Church, the Pax Dei, was established. During this time the Vox Dei and Manus Dei helped to reclaim thousands of hectares of farmland, and began carefully supervised breeding programs to re-create many species of livestock. By luck, faith, or just cold, shrewd sense, the Order came out of the second Dark Age as the pre-eminent political and spiritual power on Earth.

Unfortunately for the long-term plans of the Order, although the 16 Minutes’ War killed hundreds of millions, destroyed dozens of great cities and brought the human race very nearly to its knees, the long twilight of chaos was not enough to kill many major Corporations. By the year 2157, several of these mighty juggernauts had risen from the ashes, and were once again uniting vast sections of the Earth under the terms of peace and profit. When the new Global Central Command was established, the Order of the New Dawn considered it more of a Free Trade organization than an actual powerful ruling body. This changed when the GCC passed the “Religious Constraint Agreement”—a

powerful legal block against the Order's influence in economic matters, and one that was backed with the armed force of corporate security divisions.

Despite their dedication to peace, the Order did not surrender its power easily, and open warfare once more scarred the Earth's surface as the Pax Dei battled corporate troops for control of various power centers. The Order and the Corporations battled off and on for seventeen years, until a unilateral cease-fire was signed in 2177, when the World Court announced that the Order would be allowed to incorporate its holdings. While its power was greatly diminished, and the Order now found itself constrained by most of the same laws that bound the Corporations, the Order was still powerful, and retained many of the lands and cities it had reclaimed during the Dark Years. Since then, The Order of the New Dawn has been a respected member of the Terran Commodities Exchange and a powerful corporation in its own right, holding many valuable copyrights and patents.

Over the past two and a half centuries, the Order has pursued its interests peacefully whenever possible, but the lesson of 2157 has never been forgotten, and the Church defends its interests with force when necessary.

Pax Dei Technology and tactical doctrines

The Order of the New Dawn has possessed a technological advantage over the corporations since the end of the Dark Years and, while that lead has been diminished over the centuries, the Pax Dei still holds the high tech edge over its opponents. While most corporate forces are restricted to high efficiency bore cannons and mass drivers for heavy weapons, the Order has used its mastery of high-energy physics to produce various beam weapons and lightning generators. These energy weapons pack a much heavier punch than their projectile counterparts and are, of course, free of logistical constraints like ammunition.

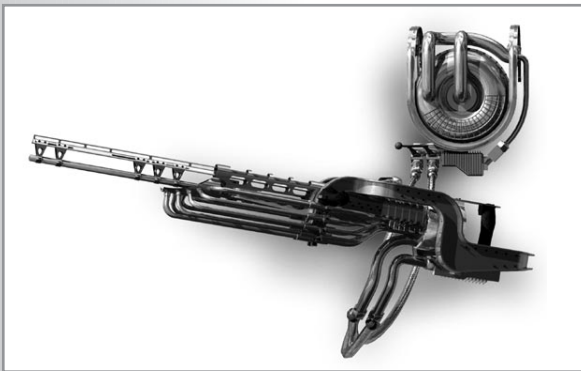

The Order's energy manipulation technology is also displayed in their use of anti-grav generators as the propulsion for their heavy armor units. This generation of hoverdynes being currently used by the Pax Dei in the field are the first of their kind to see combat. A hoverdyne is much faster and more maneuverable than an analogous terradyne, but

it cannot currently pack as much armor. Later generations of hoverdynes may have more powerful grav generators and hence heavier armor, but for the time being, Pax Dei armored units will depend on speed and heavy firepower to

resolve battles as fast as possible. When on the defensive, the Order will use the speed of its armor to make a series of guerilla raids against enemy supply and command centers until the enemy advance is slowed and the Order can regain the initiative.

Despite their dependence on high technology, the backbone of the Pax Dei is still the powered infantryman. Known as Crusaders, Order infantry takes the brunt of any assault or defense mission. When combined with the Order's Heavy Artillery units, Crusaders can overwhelm almost any defense, and many a corporate position has gone down under the human wave attacks of the Pax Dei. While these tactics cost heavily in terms of manpower, the Order training Seminaries produce Crusaders at the rate of over a million every solar year.

Between advanced weaponry and sheer manpower, the Pax Dei can continue a campaign long after it becomes too expensive for even the richest corporation.

Intercepted Personnel File

Name: Brother Jarred Stone

Branch: Pax Dei

Rank: Deacon

Age: 29

Height: 5'11

Weight: 170 lbs

Date of Birth: 142-2390

Place of Birth: Rosario Sanctuary, Buenos Aires District

Education: Light of the Pampas Children's Collective,

Rosario Sanctuary, XXX-2394

Osculum Dei Middle Seminary, 230—2404

Called to the Pax Dei: 015-2410

Basic Training: Dawn Forge Combat Seminary, Brasilia Sanctuary

Advanced training: Sword of Dawn Testing Grounds, Mons Olympus Sanctuary

Assignment: Pax Dei Crusader Corps, 333-2414

Battle of Guderian Prime, 127-2415

Wounded: Received the Heart of Zion

Awards: The Order of Venus for Courage in the Field of Combat

Fleet Action, Battle of King's Cross, 256-2416

Wounded: Received the Heart of Zion

Awards: The Star of Dawn for Heroism in the Field of Combat

Promoted to Deacon: 022-2417

Current Assignment: Defense of Krig-7B



Jarred Stone was born behind the walls of the Rosario Sanctuary, in an Order hospital which had opened its doors to the poor, and was adopted by the Order of the New Dawn. He was given the name Jarred Stone, after the doctor and nurse who delivered him, and taken to the Light of the Pampas Children's Collective, where the sisters of the Manus Dei cared for him until his 14th birthday. At this point, vocational testing revealed he would best serve the Order in the ranks of the Pax Dei, as a soldier. And so he was sent on to the Forge of Dawn combat seminary.

His first combat trainer, the Paladin Valerius, was so impressed with Brother Stone's aptitude for war that he made only one comment on the young man's chart: "Jarred Stone will make a perfect soldier; his body is strong and his Faith is stronger. His one weakness may be that he has no weakness—even when faced with the impossible, he shows no fear, no doubt, no hesitation."

In his first year of active duty, Stone served on the line in no less than six armed conflicts, including the battle of Guderian Prime. There Stone led two squads of Crusaders over the walls of a Benton-Yutan mining fortress, and destroyed the automated turrets which held the rest of his company pinned against the bluffs. The lives of over a hundred of his fellow Crusaders were thus saved, and although Brother Stone was badly injured, he was still able to negotiate a peaceful surrender of the fortress without further bloodshed, once he realized that his commanding officer had been killed in the fighting. Brother Stone's initiative and valor earned him a short rest at the Nova Roma Sanctuary, where he received treatment for the injuries he suffered on Guderian Prime. As soon as he was able, he rejoined his Company in a fleet action at King's Cross, where the Armada of Dawn captured two heavy cruisers belonging to Dai Sheung Heavy Industries.

Brother Stone distinguished himself once more in the boarding action against the DSS Seoul's Champion, when he broke through an enemy barricade and rescued several brothers of the Vox Dei. The brothers, who had been captured by Dai Sheung when their Temple on King's Cross 3 was destroyed, were being held onboard the Lafayette for ransom. As a reward for his extreme heroism, Jarred Stone was promoted to the rank of Deacon and given command of his own Company.

THE CRAYVEN CORPORATION

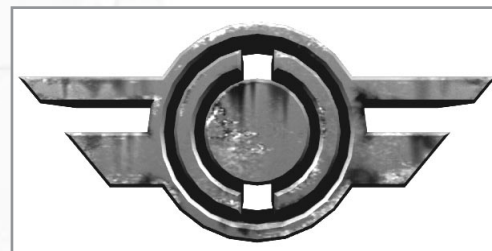

Introduction

The Crayven Corporation is currently the largest incorporated body listed in by the Terran Commodities Exchange. The organization employs over 900,000,000 men, women and children on Earth and abroad, and produces a range of products as well developing vast off-world petrochemical and biological assets.

Crayven Corporation holdings span the known galaxy, from Earth to the furthest reaches of human-explored space. Although the output of Crayven factories, farms and mining facilities offer a wide range of production, they are perhaps best known for their terra-forming projects. Crayven technologies have been crucial in the terra-forming of a variety of marginal worlds including the eight colonies that Crayven has established under its sole ownership.

History

The Crayven Corporation began its life in the year 2162, as a small construction company; its original name was Crayven Construction, and it was based on the Australian continent, jointly owned by the partnership of Crayven, Schindler and Beck. The founder of the company, Reno Crayven, was a talented businessman and a gifted architect; he formed the triune partnership with Schindler and Beck to take advantage of their greater capital and political resources. The services that Crayven Construction provided were very much in demand by various Australian business concerns during the Heresy War, and Crayven backstabbed and hamstrung the competition unmercifully in search of the most lucrative and influential contracts. His company prospered and expanded, and the year before the armistice of 2177 was signed, Reno Crayven bought out his partners in a bitter takeover struggle. Amidst rumors of kidnapping and blackmail, Reno consolidated his new company, the Crayven Corporation, and applied for membership in the GCC in 2178.

The Crayven Corporation grew throughout the Reconstruction era, and many of the structures that Reno Crayven built between 2178-2202 are still celebrated as wonders of post-war architecture. The Kenji Arcology on Okinawa, the Sunrise Cathedral in Monterrey, and the Domed Gardens of Mars are only a few of the many buildings still standing which bear the stamp of Reno Crayven's personal

genius. Most of the profits from these rebuilding projects was funneled into CrayArms, the wholly owned weapons and ammunition subsidiary of the Crayven Corporation.

Reno Crayven was more just than a builder and an artist, however; he was also a visionary. It was his dream not just to indulge his talent for architecture on Earth, but to shape whole new worlds for the future. The discovery of FTL drive in 2207 interested him greatly, and for many years he obsessively battled other members of the GCC for their technological secrets. If his earlier business tactics might be regarded as unscrupulous, the Reno Crayven of this period could be called downright Machiavellian-but as always, he could never be formally charged with any misconduct, since witnesses or claimants against him had a tendency to die before they could testify against him. In the year 2231, when he was diagnosed with a rare and terminal form of bone cancer, many of his enemies rejoiced and began counting his days.

But Reno Crayven was not finished. He was already heavily invested in anti-grav and jump drive technologies. Given the limited time he had left among the living, he decided to risk everything that he had gained from a lifetime of hard work and sound investment to realize his greater dream. His impending death, rather than inspiring cautious consolidation or the need to make amends, made him even more bold in his ambitions; he felt that he had nothing to lose.

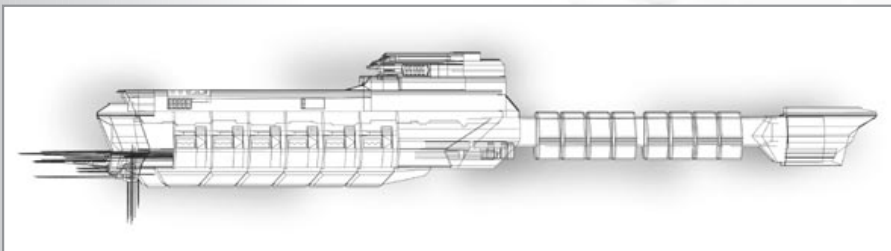

Unfortunately, Crayven's descendants did not agree. While Reno Crayven liquidated billions of dollars of corporate assets, as well as the totality of his personal wealth, to form a new subsidiary known as Crayven Enterprises, his immediate heirs, the children of his half-sister Murielle Crayven, protested this endangerment of their long-awaited inheritance. Reno Crayven responded to their gambit for control of the "family" company by ruthlessly crushing their attempts to have him declared mentally incompetent, and writing them out of his will completely. His eldest nephew, Julian Crayven, was ousted as chairman of the board of the Crayven Corporation, after his Uncle moved to deprive him of his controlling share of the company's stock. Whether Julian Crayven intended to put up more of a fight against his Uncle Reno is unknown; the younger man died in a plane crash within two weeks of the signing of the new will, and thereafter his siblings decided that discretion was the better part of

valor. They did not interfere with the elder Crayven's plans any further, and the old man went ahead with his new initiative unopposed.

Crayven personally took the helm of the new division, Crayven Enterprises, and laid out a bold plan for building a large-scale terra-forming project on Mars. The result was the Domed Gardens, an indoor paradise containing over 50 square miles of ancient Earth-style forest. Filled with sparkling waterfalls and lakes, a self-sustaining weather system, and over 5,000,000 species of plant and animal life, this man-made Eden became the jewel in the Crayven corporate crown-as well as providing a test of Reno Crayven's terra-forming theories on an unprecedented scale. With the passing of the six-month milestone for viability of the Gardens, plans moved forward for the colonization of the planet known as Vesta 3-better known to us today as the jewel world Ney Vesta.

Because Reno Crayven's own body was too frail to survive the rigors of FTL travel, he was never able to see his dream being realized by the planetary engineers, construction crews, and science teams of Crayven Enterprises. Crayven died on Mars in 2237, in a small pavilion in the center of his Domed Gardens. A modest granite obelisk stands in the same spot today, and bears a simple panel of stainless steel with his name, date of birth, and date of death inscribed on it. It was the only monument stipulated in his will.

For nearly two hundred years since the landing of the first terra-forming crews on Ney Vesta, the Crayven Corporation has pursued its goal to be first and foremost among the stars. They have established seventeen colonies on fourteen separate worlds, as well as countless water- and ore-mining facilities on asteroids and nearby moons. Crayven expertise in both terra-forming and genetic engineering has made their consulting services the most valuable investment that any would-be colony can make in its own future. This is why the Crayven Corporation's motto hasn't changed for 182 years: "We Bring New Worlds to Life".

Crayven Security Forces

The Crayven military grew from a small self-defense force in the era following the 16 Minutes' War to a fully-fledged military unit during the Heresy Wars. Crayven technology has always placed reliability at the forefront, and while other Corporations can field equipment with higher performance characteristics, Crayven vehicles and battle-suits are unmatched in their strength and durability under fire.



The Crayven Corporation fields a very balanced military force, centered around their next-generation main battle terradyne. Heavy infantry is usually deployed to screen the terradyne units from enemy anti-armor and artillery attacks. While Crayven Commanders tend to save air assets for breakthroughs and assaulting heavily fortified bases, an aerodyne interceptor wing is almost always attached to a ground division to act as combat air patrol for any operation.

The Crayven Corporation favors slow, methodical offensives, and this is reflected in their unit designs. Overall the Crayven vehicles have much stronger armor in their front panels compared to the rear. The Crayven military motto is "Better safe than sorry", which is apparent in their terradyne designs. Once enemy territory has been penetrated, the Crayven division on point will dig in to secure the objective while a fresh unit moves up to take their place on the spearhead.

This means most Crayven unit Commanders will see themselves in a series of short tactical engagements over specific objectives instead of long strategic advances. When deploying offensively, Crayven dropships will often try and get as close to their objectives as possible before landing and dropping off their troops. Some Crayven commanders prefer using dropships in waves, so that the units from one drop will clear an objective in order for reinforcements to arrive from another dropship. This "leapfrog" method of deployment has become a Crayven Security hallmark, and it keeps enemy commanders from correctly assessing the true objective or Crayven force levels.

Personnel

Major Sarah Parker's Bio

Age: 35
Height: 5'8"
Weight: 155
Date of birth: 045-2384
Place of Birth: Chicago district, Crayven Holdings
Education: Training Crèche 1275DZ, Chicago district, Crayven Holding
 Enlisted Crayven Security Division: 045-2401
Basic Training: Crayven Security Base Alpha, Panama district, Crayven Holdings
Advanced training: Crayven Security Academy, Gamma Dome, Pluto

Assignment: Crayven Security powered infantry corp.

Awards: Bravery Bonus, 231-2404 (Acquisition Op, Wolf 328-2A) Bravery Bonus, 011-2405 (Counter Insurgency op, Wolf 328-2A) Conspicuous Gallantry Bonus, 351-2408 (Acquisition Op, Gamma Hydrea 4) Wounded Bonus, 355-2408 (Acquisition Op, Gamma Hydrea 4)

Fines: None

Assignment: Cross training, Crayven Security commando corp. 002-2409

Awards: Bravery Bonus, 304-2410 (Security Sweep Op, Barnard's Star 2) Wounded Bonus, 304-2410 (Security Sweep Op, Barnard's Star 2) Extreme Heroism Bonus, 115-2412 (Acquisition Defense Op, Sigma Draconis 4-G) Wounded Bonus, 115-2412 (Acquisition Defense Op, Sigma Draconis 4-G) Termination Achievement Bonus, 115-2412 (Acquisition Defense Op, Sigma Draconis 4-G)

Fines: Refusal Penalty, 323-2412 (Security Sweep Op, Wolf 328-2A)

Assignment: Transfer Request, Crayven Security ground control. 089-2413

Awards: None

Fines: Refusal Penalty, 156-2414 (Counter Insurgency Op, Beta Iridani 2) Dereliction Penalty, 200-2414 (Counter Insurgency Op, Beta Iridani 2) Refusal Penalty, 045-2416 (Acquisition Defense Op, Wolf 328-6D) Refusal Penalty, 306-2418 (Acquisition Op, Epsilon Iridani 3)

Current Assignment: Acquisition Op. Krig-7B

Status: Probationary

Analysis



Major Parker had all the signs of becoming a superlative soldier. She applied for a position in the Crayven Security the exact moment she reached the age of consent at 14. After an exemplary training period, marred only by one or two incidences of excessive force during combat exercises, she entered the Powered Infantry Corps. During an acquisition Operation against an illegal TerraTech claim on Wolf 328-2A, Parker, then a Corporal, single-handedly rallied her platoon that had come under heavy fire from TerraTech artillery. Personally destroying 3 Artillery pieces earned her a Bravery Bonus. The first of many.

Sarah Parker quickly rose through the ranks while continuing to receive bonus after bonus for her conduct on the battlefield. She was asked to take training as a Commando and accepted the transfer in 2409. She achieved the rank of Major by the age of 28 and seemed she was bound for the Fast Track until the Battle of Hanson's Rift in 2412.

Major Parker's Commando unit was stationed at firebase Zulu on the main continent of Sigma Draconis when it was attacked by the Order of the New Dawn, who had declared the planet sacred ground and filed Jihad against any corporate holding which did not immediately evacuate. The firebase was cut off and subjected to wave after wave of attack. When relief finally arrived, they found no Crayven survivors except for a badly wounded Major Parker, whose bunker was surrounded by over 800 Crusader bodies. Major Parker underwent extensive psychiatric treatment.

When she returned to combat duty her CO noted that despite the rewards given for her combat valor, she seemed strangely ungrateful, and the quality of her performance became a problem. Things came to a head during a boarding action when she refused a direct order to void the atmosphere of an enemy Drop ship.

After suffering a fine for her misconduct, Major Parker requested a transfer back to standard ground control, where she has remained to this day. Her combat skills are still exemplary, but time and again she has refused to carry out special commands given her regarding efficient termination of Enemy Assets. She has been in front of a performance review board twice in the

past 6 years, but each time her amazing record up to and including the action on Sigma Draconis has won her a stay against dismissal. At this point Major Parker can no longer be considered a promising officer and she receives only low priority combat assignments where her usefulness on the battlefield will not be compromised by her problems with Corporate authority.

This section is for Field Commanders eager to start their Military career as soon as possible. When you start up Ground Control you first have to select a video renderer, and select what video mode in which to play the game. Depending on your system configuration, different options will be displayed. Click OK to continue.

After the movie is played you will see the main menu. Click on the *SINGLE PLAYER* button. If it is the first time you run GC on your computer, you will be asked to select difficulty. Select a difficulty level and then click OK.

The game will start, the three first missions will be the Boot Camp, which will teach you how to play Ground Control and how to quickly master the basics of the game.

When you have played through the Boot Camp missions continue to read the next section in the manual *PLAYING THE GAME*.

Ground Control is a game of tactical action oriented combat. In Ground Control you are the Commander of a special operations task force operating from a starcruiser orbiting the planet Krig-7B. The goal of the game is to archive your mission objectives, which will span from destroying enemy installations to protecting engineer teams while they archive their objective. To aid you in completing your objectives you have your task force. The task force consists of several squads that you control. Before entering a mission you have the option of changing their general outfit, unit type and equipment. Be careful with your task force, as surviving squads will receive experience after each battle.

SQUADS

Your strike team consists of one or more squads. As the campaign progresses you will receive new squads and destroyed squads will be replaced with fresh new ones. The squad box indicates the squad's name, current unit configuration and attributes. A squad belongs to one of the four available branches:

Infantry The lightest and slowest soldier on the battlefield. They can be transported inside the Command APC.

Assault Assault vehicles are the units that excel in offensive maneuvers, and acquiring strategic locations.

Support Support units fill a special niche on the battlefield, be it anti-air or long range artillery fire.

Aerodyne The airborne aerodynes' main advantage is their great speed and unobstructed movement.

A squad can be changed into another unit type of the same branch when that unit type becomes available. For example in later missions a Marine squad can be changed into a Jaeger Special Forces squad. For more information about units see section 9, the Tactical Manual. Killed squads will be replaced with new fresh inexperienced squads between missions but all experience and medals will be lost in the process.



Dropships

Your strike force is brought down to the battlefield in large AV/U4 "Behemoth" dropships. Each dropship is capable of transporting four squads complete with equipment down to the battlefield.

The Ground Control Direct Command Interface System is an advanced piece of software developed solely for the purpose of commanding military elements in combat situations.

As a beginning Crayven Field Commander it is highly recommended that you read through these directives to get familiar with the Ground Control interface.

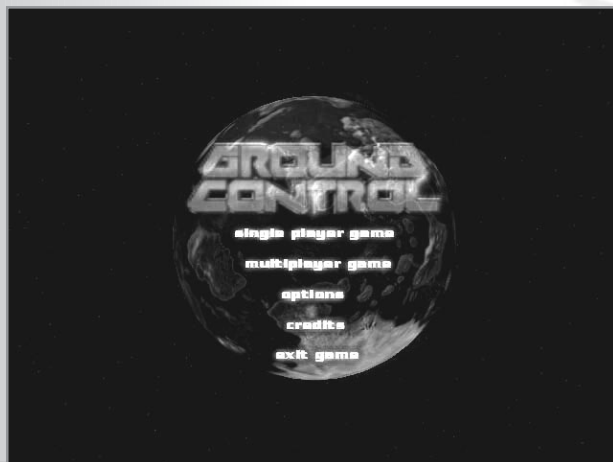

Screenshot of the Main Menu

Single Player Game

Single Player Game allows you to access the single player game. The first time you select Single Player Game on your computer you immediately start a new game. You will be asked to provide a game name (optional) and to select a difficulty level. The next time you access the Single Player Game you will have a few options:



Screenshot of the Single Player Game menu.

Continue Game

Continue Game will allow you to continue on the last game played. A description of the last game played will be displayed to show you the name of the game, the name of the next mission and the difficulty setting. Selecting *CONTINUE GAME* will immediately take you to the current mission's briefing.

New Game

New Game will allow you to start a new game. Note that the previous game will still be available, but through the Change Game selection. When you select *NEW GAME*, a prompt will ask you to name the game (optional) and select difficulty. The difficulty levels are: *Easy*, *Normal* and *Hard*. The *Normal* difficulty setting is recommended for most players. If you are a very experienced player, you should select the *Hard* difficulty setting.



Screenshot of the New Game prompt.

Load Game

Load Game allows you to load another game stored on your computer. Selecting *LOAD GAME* takes you to a new screen.

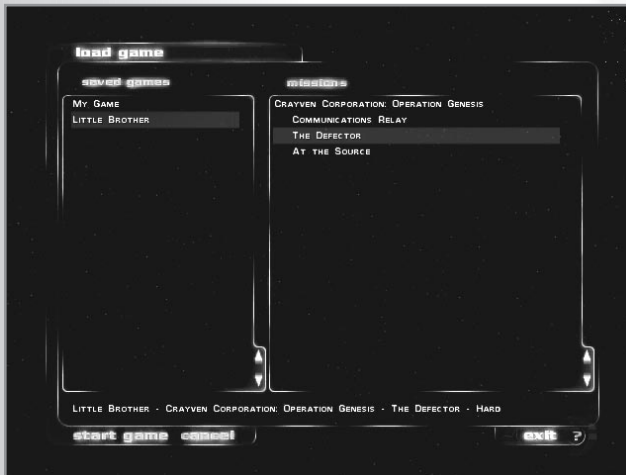

Screenshot of the Change Game screen.

The list to the left contains all the saved games available. The list to the right contains all missions played within a selected game. Choose a game and a mission to start at, and then left click on *START GAME*.

Custom Game

Custom Game allows you to access missions and campaigns that you have created yourself or downloaded from the Internet. Pressing *CANCEL* will take you back to the Single Player Game screen.

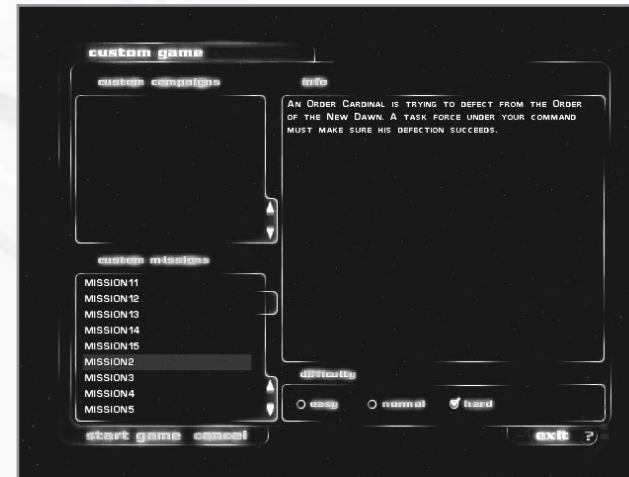

Screenshot of the Custom Game screen.

Custom Campaigns

If you have any custom campaigns on your computer, you can select them in the top left list and then click *START GAME*. A campaign is a series of missions, usually linked together. When playing a custom campaign you will automatically start the next mission after the debriefing as in the usual Single Player Game.

Custom Missions

Custom Missions allows you to play a single custom mission available on your computer. Select a mission from the list and then click *START GAME*.

Multiplayer Game

Multiplayer Game allows you to engage in multiplayer battle over the Internet or on a LAN (Local Area Network). A multiplayer game requires that you have an Internet connection or access to a LAN in order to run. For more information of how to play on the Internet over WON (World Opponent Network) or on a LAN see section 8, Multiplayer.

Options

Options allows you to modify the performance of Ground Control or to configure the controls. Note that all changes only apply to the current commander. For more information about the different options, see section 7, Options.

Credits

Pressing Credits will show you the hard working people involved in the making of Ground Control. Return to the main menu by pressing *ESCAPE* on your keyboard.

As a Field Commander in the Crayven Corporation, it is your duty to configure your strike force before you are dropped into a combat zone. The GC-DCIS software will aid you in this process but it is ultimately your responsibility to make sure your strike force is balanced correctly.

Briefing

Before the mission you will receive a mission briefing stating your objectives. Pay attention to the briefing, as it will give you hints of what to expect in the mission.



Screenshot of the Mission Briefing screen.

During the briefing your objectives and other vital locations are displayed on the tactical map. Move the mouse over the objective for a short description. Use the REPLAY button to replay the briefing or SKIP button to skip it. When you are ready to begin the mission select *START MISSION* or select *CONFIGURE DROPSHIPS* to configure your strike team.

Configure Dropships

Before you go into a mission you have the option to configure the strike force you will be using. Once committed to a strike force, it is not possible to change it during the mission. Changing your strike team is optional, if you don't want to worry about the strike team, ANNIE-1, the artificial intelligence advisor will do it for you.



The Dropship Loadout screen is where you assign your available squads to one of the three available dropships.

1. Squad Tab
2. Dropship 1
3. Dropship 2
4. Dropship 3
5. Configure Squads button
6. Available unassigned squads
7. Autoload checkbox
8. Start Mission button

Here you can decide what squads you want in each dropship. Early missions allow you to put squads in only one dropship. Later missions allow you to add squads to all three dropships and may provide more squad choices than you can fit in all three dropships. Some squads may be left behind and you'll have to choose which ones you take into battle.

The list on the left of the screen contains slots for any unassigned squads. The three areas on the right of the screen contain slots for each of the three dropships. To move a squad from its current location, LEFT-CLICK on a Squad Tab. This will pick up the Squad Tab. To place the Squad in a Dropship or in the unused list, just LEFT-CLICK on an empty squad space in either area. If you put it in a squad space that is occupied, you will switch Squad Tabs and automatically pick up the one that previously occupied the slot.

To configure the details of the squads that are currently assigned to the dropships, enter the CONFIGURE SQUADS screen by clicking on the Configure Squads button in the bottom of the screen.

Autoload

The Artificial Advisor will automatically configure your drop ships if the AUTOLOAD checkbox is checked. You can also manually move squads between drop ships and the unassigned list by clicking on the squad to select it and then click again on the slot you want it in. When the AUTOLOAD is checked, the advisor will also configure your squads, equipping them with special weapons and equipment. Click on CONFIGURE SQUADS to change their setup manually.

Note that only the squads in the drop ships will be available during the mission.

Configure Squads

On this screen you can configure the details for each Squad that you plan to bring with you to the battlefield.



The Configure Squad screen allows you to customize your squads.

1. Dropships
2. Squad Tab
3. Unit Type
4. Unit Edition
5. Special Weapon
6. Equipment

The left area of the screen shows you the Squads that are currently assigned to the Dropship(s). The larger right part of the screen displays the details of the currently selected (or highlighted) Squad.

LEFT-CLICK on a Squad Tab to start configuring it. The right part of the screen shows you information about the chosen Unit Type, the Unit Edition and the currently selected Special Weapon and Special Equipment.

To change Unit Type, click on one of the available unit type icons on the top of the screen. Note that you will not always have access to all unit types. In early missions only one type might be available, in later missions up to four possible types may be available. For more information about unit types, see the Technical Manual, Section 9

To change Unit Edition, click one of the four Edition Tabs below the unit description text. The different editions slightly change Firepower, Speed, Armor and Range. Pick an edition that is appropriate for the way you expect to command your troops in the current mission.

To change Special Weapon and/or Special Equipment, click on one of the icons in the lower part of the screen. Note that you will not always have access to Special Weapons and Special Equipment. As the game progresses you will receive more Weapons and Equipment to select from for each unit.

Mission Debriefing

After a mission, successful or not, you will be presented with a debriefing screen. On this screen you are informed if your last mission was a success or failure. Additionally, the rotating model of Krig-7B shows you the progress of the current campaign.

Click STATISTICS to see detailed mission statistics and the battle performance for each participating squad. Click on one of the SQUAD TABS to see the battle performance for the selected squad. Note that you will receive replacements for squads killed in battle.

If you failed the mission you can click RESTART MISSION to try again. If the mission was a success, click NEXT MISSION to go the briefing of the next available mission.

In order to become a successful Field Commander you need to master how to order your Strike Force and interact with the battlefield.

The Command Environment

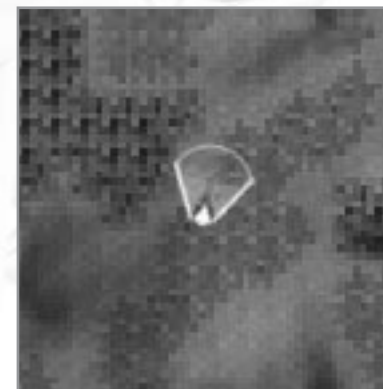

Image of the Command Environment with legend below.

1. Battlefield View
2. The Tactical Map
3. Dropship button
4. Squad buttons
5. Squad Behavior Menu

Camera control

The camera is your point of view and it is free-roaming, meaning that you can position it anywhere on the battlefield and have it face any direction. The camera view position on the battlefield is displayed on the tactical map. Note that even though you can place the camera anywhere does not mean you can see units or buildings. Only enemy units and buildings that your own units or allies can see are visible in your view. For more information about the line of sight, see section 9, Ground Control Tactics.



The Camera View Cone is displayed on the Tactical Map.

Rotate the camera view by moving the mouse cursor to the left or the right edge of the screen. By moving the mouse to the top or the bottom screen

edge, you tilt the camera view upwards or downwards. The camera view is moved forward, backwards or sideways with the **ARROW** keys. Note that you cannot move the camera view outside the boundaries of the map.

The altitude of the camera view can be changed with the **PAGE UP** or **PAGE DOWN** keys. Press **PAGE UP** to go to a higher altitude and **PAGE DOWN** to go to a lower altitude. If your computer mouse is equipped with a mouse wheel, you can use it to change the altitude as well.

You can also move the camera instantly to any location on the battlefield by simply left clicking with the mouse on the small map or on the tactical overview.

You can order the camera view to track a certain squad by double clicking on the squad or its squad button. When the camera view tracks a squad it will follow it around the battlefield. The camera keeps tracking the squad until you press an **ARROW** key or until you double click on another squad.

The Tactical Map

In the bottom left corner is the Tactical Map, the Field Commanders best friend. The tactical map shows you a top-down view of the entire battlefield.

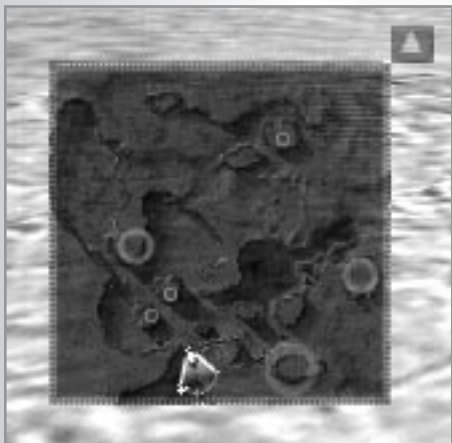

The units you command show up as green dots, with the currently selected squad(s) blinking. Friendly non-controlled units or buildings are displayed by yellow dots while enemy units or buildings appear as red dots. A white cone marks your current camera view position, with your view expanding along the cone. Use the cone to quickly see where your view is on the battlefield.

Blue circles on the tactical map indicate that the position is the location of a mission objective. The blue circle will disappear when you have completed the objective.

Yellow, pulsating circles indicate a possible drop zone. Drop zone circles are only displayed when a dropship is activated and indicate that you can order a dropship to land at that location.

Clicking on the tactical map with the **LEFT** mouse button instantly moves your camera view to that location. It is also possible to issue orders to selected squads on the small map, just like you would do in the camera view.

The small arrow button, up and to the right of the small map toggles the larger tactical overview map on and off. Pressing **M** on the keyboard also toggles the tactical overview on and off.

The larger tactical overview displays your current and completed mission objectives. Objectives are marked on the tactical overview with blue circles and in addition they are represented with boxes to the left of the overview. Moving the cursor over the objective displays more information about the objective.



*The tactical overview is activated by clicking on the small arrow icon next to the small map or by pressing the **M** key on the keyboard.*

Move the mouse over the objective box to see more information about the objective.

The sensors aboard your Command APC are capable of detecting both friendly and enemy weapons fired in the combat zone. Weapons fire is indicated by small white moving dots.

Calling down the Dropships

You and your strike team are still loaded aboard dropships launched from the Crayven battle cruiser orbiting the planet Krig-7B when the mission starts. The dropships will not touch down on the planet surface until you order them down to do so. The available dropships are displayed on the left side of the screen as small icons.



To call down a dropship, simply click on the dropship icon and then on a dropzone on the tactical map. Possible drop zones are displayed on the tactical map as yellow pulsating circles that appear once you have clicked on a dropship.

The dropships will initiate the drop sequence as soon as you have called them down. The squads will be unloaded as soon as the dropship arrives. Your Command APC will always arrive with the first dropship ordered down.

Be advised that you may have more than one possible drop zone in some missions. Drop all your dropships to the same drop zone or spread them out - it is your call and your soldiers' lives may depend on it. You are in no hurry to drop your squads, survey the terrain and your objectives and select the best approach. You must be on the alert once you have committed and called down a dropship

to a drop zone. Note that you do not have to drop all available dropships at once. A dropship can be held back in order to be used as reinforcements later in the mission.

The Squad Buttons

As a Field Commander it is of utmost importance to quickly be able to select and issue orders to your squads. All squads under your command will be represented on the screen with a squad button.



The Squad Buttons allow you to quickly select and give orders to your squads.

A squad is selected by clicking on a squad button with the LEFT mouse button. A double click on a squad button makes the camera view orbit and track the squad.

HINT: The Function keys are preset hotkeys for selecting individual squads. F1 quickly selects squad 1 and F2 selects squad 2 and so on. The Command APC is reached by pressing the <BACKSPACE> key.

The squad button gives you information about your squad's health even to the point of individual units within the squad.

The icon on the squad button identifies the squad's unit type and the vertical bar on the left side of the bar is the squad's overall health. When a squad is taking damage, the bar slowly moves down and changes color from green to red. Green indicates full health while red indicates close to death or destruction. The squad button also displays the health of individual units within the squad by showing green or red dots for each unit that is part of the squad.

The three squares to the far left of the button are the behavior settings. The brightness of the square indicates which setting in a mode is chosen. The position of the boxes indicates which mode.

- Top - Attack Mode
- Middle - Movement Mode
- Bottom - Current Formation

Squad Behavior Menu

The squad behavior menu allows you to change the behavior of your squads. The menu can be shown or hidden with the key on the keyboard. To change behavior on a squad, make sure it is selected, then click on the new behavior button.



The Squad Behavior Menu allows you to change the squad's attack and movement modes and in addition, to select a formation.

There are three different behaviors you can change:

Attack Mode

Affects when the squad will attack the enemy.

- In FREE FIRE mode your squad will automatically engage enemies within their weapon range. With multiple enemies present, it will attack the enemy it fears the most.
- In RETURN FIRE mode your squads will only open fire if fired upon first.
- In HOLD FIRE mode the squads will secure their weapons and not fire until you give them specific orders or change their attack mode.

Movement Mode

Affects how the squads move around.

- DEFENSIVE MOVEMENT - The squad moves cautiously and when it encounters an enemy, the units will immediately halt and turn to face the enemy.
- OFFENSIVE MOVEMENT - The squad always moves to the location you've ordered them to, even if they are fired upon. The squad will return fire if its attack mode allows it.
- HOLD POSITION - The squad will not move an inch from its current position except for making sure their fronts are facing the enemy. *A squad in Hold Position mode will not obey any movement orders until a new mode is selected.*

Formation

Orders the squad to maintain one of three different formations.

- BOX - The squad groups in to a tight box formation.
- LINE - The squad forms up on a line.
- COLUMN - The squad forms up on a column, following the leader.

Ordering your squads

Giving orders to your squads is a simple task mainly handled with the mouse. When you get more proficient commanding your squads you should start experimenting with the shortcut keys described in each section below.

Selecting Squads

To select a squad simply LEFT click on its squad button in the interface or click directly on the unit in the 3D view. The squad button of a selected squad is highlighted and a green circle encompasses all the units in the squad.

Select several squads by holding down <SHIFT> and click on the squad buttons of the squads you want to select. You can also select several units by LEFT clicking, holding down the button, and dragging a box around the units on the battlefield. This is called drag selecting. When selecting your squads this way, the box will be colored green.

Movement

The position of the cursor automatically determines the type of order issued when you click. To move your selected squad, move the mouse cursor to the desired location where you want the squad to move. Then click on empty ground with the LEFT or RIGHT mouse button and you will issue a move command to the desired location. Note that your squads cannot move on all terrain. Some terrain is simply too steep or occupied by trees or other landscape features. When you move the cursor over impassable terrain it will change to a Cannot move there cursor.

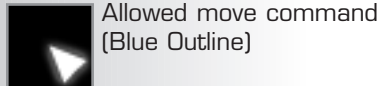

Allowed move command
(Blue Outline)



Set movement waypoint
(Blue Outline)



Squad(s) cannot move there
(Orange Outline)

It is possible to decide what direction your squad should face after a move. Click on the desired location with the RIGHT mouse button, hold down the button and you will see a direction vector appear. Move the mouse to change the direction the squad will face and when you are satisfied release the RIGHT mouse button.

The cursor may change if it is placed over enemy or friendly units. Holding down the <ALT> key on the keyboard while issuing orders will force a move command instead of the command due to the cursor change. In this way you can override the context-sensitive command system.

You can give your squad(s) waypoints by holding down the <SHIFT> key when issuing move orders. Your squad will move to one waypoint at a time until reaching the final waypoint.

Attack orders

If the cursor is over an enemy, it will change to an attack cursor. Click on enemy units with the LEFT or RIGHT mouse button to issue an attack order. Your squads will move towards the target if needed and attack the target when it gets in range.

It is possible to issue multiple attack orders by LEFT clicking, holding down the button and dragging a box around the enemies. When selecting your squads this way, the box will be colored red.

Holding down the <SHIFT> key is another method of stacking attack orders.

HINT: It is possible to stack both move and attack orders. Your squad will execute your orders in the order you gave it.

Holding down the <CTRL> key while issuing orders will force an attack command. Holding down <CTRL> while clicking on the ground will order the squad to suppress the desired location. This is especially useful with Artillery squads. Holding down <CTRL> will override the context-sensitive cursor with an attack command in the same way the <ALT> key does for a move command.



Attack: target in range
(red outline)



Attack: Target out of range
Unit will move to attack
(red and blue outline)



Force fire on location:
target in range
(red outline)



Force fire on location:
target out of range
Unit will move to attack
(blue outline)

Follow/Guard orders

You can order a selected squad to follow another squad by simply RIGHT clicking on the squad you wish to have followed. The originally selected squad will follow that squad until another order is given. A squad following another squad will attack enemies attacking the followed squad.



Guard targeted squad
(blue outline)



Cannot guard targeted squad
(red outline)

Loading/unloading infantry into the Command APC

The Command APC can be used to transport infantry in combat. To order your infantry to board the Command APC, simply select the infantry and then click with the RIGHT mouse button on the Command APC directly or its Squad Button. The infantry will move to the Command APC and board it. An "APC" icon will be displayed on the squad buttons of infantry loaded inside the Command APC.

To unload an infantry squad, simply select the squad button and give it a move order on the terrain. The infantry will disembark and move to the selected location.



Load into Command APC
(blue outline)

Special Weapons and Equipment

Your squads can be equipped with both special weapons and equipment before the mission starts. The Special Weapon and equipment icon is only visible when the actual squad is selected. The spheres next to the icon display the number of remaining charges. As charges are used, the spheres turn red.

Special Weapons are powerful weapons with only a limited number of charges. To use a special weapon click on its icon with either mouse button and then click on the desired target, ground or unit. Your squad will move within weapon range if needed. To cancel the special weapon, simply click on the special weapon icon again.

Pressing the <W> key on the keyboard will also activate a selected squad's special weapon.

Special Equipment is activated as soon as you press on the squad's equipment icon or press the <E> key on the keyboard. For a more detailed description and effects of special weapons or equipment, see section 9, the Technical Manual.



Fire special weapon
(red outline)



Deploy equipment at position
(blue outline)

Grouping Squads

You can form groups among your squads and assign the group to a special shortcut key to be able to quickly select several squads. Select the squads you wish to add to the group and then press <CTRL> and a number key (1,2,3...9). To select the group of squads simply click on the designated number (1-9).

The options menu can be reached either from the MAIN MENU or by pressing ESCAPE on your keyboard and selecting OPTIONS in a mission. Note that certain options such as changing Render API (Graphics Mode) is not available from inside a mission.

General Options

Music Volume - This slider controls how loud the music is played. Note that dragging the slider to the far left disables music all together and might increase performance a little.

Voice Volume - This slider controls how loud the message voices are played during the missions and during the briefings. If you drag the slider to the far left, messages will still be displayed in message boxes.

SFX Volume - This slider controls how loud the sound effects (gun fire, explosions, engines etc.) are in the game. We recommend you keep this slider far to the right for maximum experience.

Team Markers - The options toggles the team markers on and off. Turn the team markers off for a more realistic battlefield. Note that turning off the team markers does not affect performance.

Map projectiles - This option allows you to toggle on/off the projectiles on the tactical overview.

Squad Waypoints - This option allows you to hide the lines between a squad's waypoints. Toggle waypoints off for a more realistic battlefield.

Video Options

Render API - This option allows you to change the currently selected render API. Note that you have to click ACCEPT before the renderer changes.

Resolution - This option allows you to change the game resolution.

View Distance - Moving the slider increases/decreases the distance you can see on the battlefield. Lowering the view distance increases the performance. Software Rendering is especially sensitive to the view distance. Note that changing the view distance does not affect your units, but simply how far you, the player, can see on the battlefield.

Priority Level - This option changes the current priority level. Move the slider to the left to lower the priority level. A lower priority level will reduce the number of special effects and particles. Lower the priority level if you need to increase the performance.

Texel Center - This option allows you to change the texel center. Change this slider ONLY if you experience strange offsets in the art.

Tracks - This toggle turns the tracks after vehicles on or off. Certain Hardware cards cannot handle tracks properly and will be turned off. Turning off tracks has a minimal impact on performance in hardware mode but having tracks on does lower performance in software mode.

Cloud Shadows - Toggle the cloud shadows on/off

Fog - Toggles the fog effect on or off. If you are running GC in software mode you will notice better performance with the fog turned off.

Lensflares - This option toggles the lensflare effects on or off.

Bumpmap - This option toggles the ground bumpmap on or off. There is no real performance gain in turning off the bumpmap.

Specular Light - This option toggles the specular lighting on or off.

Ground Quality - (Software only) This option allows you to improve/reduce the quality of the ground rendering. Lowering the ground quality will increase the performance.

Unit Quality - (Software only) This option toggles High Unit quality on or off. Turning this on will reduce the performance slightly.

Blend - (Software only) This option turns on the blended transparency, mainly used in the interface to make it look better and makes shadows look better.

Additive - (Software only) This turns on additive transparency, which makes explosions and muzzle flames look much better. Turn the additive transparency off if you need to improve the performance.

Ground Control features extensive multiplayer capabilities that are all easily reached from the game. Ground Control multiplayer, to play versus another person, can be played over the Internet or on a LAN.

Ground Control multiplayer can be played in standard game mode or in the drop-in game mode. The drop-in game mode allows people to join existing games that are already in progress.

To play Ground Control over the Internet you create or use an existing WON.net account or register a new account. WON accounts are free of charge and can easily be created through Ground Control. You must already have internet access with your own internet service provider in order to access or create your own free WON.net account.

Multiplayer setup



If you already have a WON account, simply enter your login name and password. You should also select the appropriate connection speed.

If you don't have a WON account, simply click on the CREATE NEW WON ACCOUNT button. You will be asked to enter a login name (max 31 letters) and a password. Unless the login name is taken, your registration is instantaneous and you are ready to prove your worth on the multiplayer battlefield.

Internet Standard game

When you click on the INTERNET STANDARD GAME you will connect to the World Opponent Network (WON.net) where you will see all available games and opponents.

Select Room



Join Room - When you log on to WON you will want to select a CHAT ROOM from the list. Select a room from the list and click JOIN ROOM or simply double click on the room name.

Create Room - You can also create your own room by clicking on the CREATE ROOM button. You will be prompted to give the room a name and if you want, a password.

Refresh List - Gets the latest list of rooms. This can take some time depending on the speed of your connection so it is not done automatically.

Chat Rooms



The chat rooms are stages for finding people to play with. The list on the left side of the screen displays the people in the chat room. To chat simply enter your message in the chat box at the bottom of the right section of the screen.

Additionally, you'll notice web links on these two screens. Web links are designated with a circle-W icon and will launch your web browser to take you to news, strategy, and community pages for Ground Control.

View Games - Allows you to see all games started in the current room.



Both games starting up and games in progress are displayed in the list. To join a game simply double click on the game name or highlight the game name and click the JOIN GAME button.

The icon in front of the game displays its current status:



Game waiting for players - click to join



Password protected game waiting for players



Game in progress - not possible to join

Create Game - This button allows you to create a new game. You will be prompted to enter a name and to supply a password (optional). You can also change the max number of players that will be able to join your game.

Refresh List - Gets the latest list of games. Since this can take some time depending on your connection, it does not happen automatically.

Join an Internet Standard Game

When you join an existing game you will enter the Game Lobby. The player who created the game cannot start the game until all players have checked the ready box. When all players have checked the ready box and the hosting player presses start, all players are brought to a Briefing screen. Press START GAME to drop down to the planet surface or enter the DROPSHIP LOADOUT as usual to configure your squads.

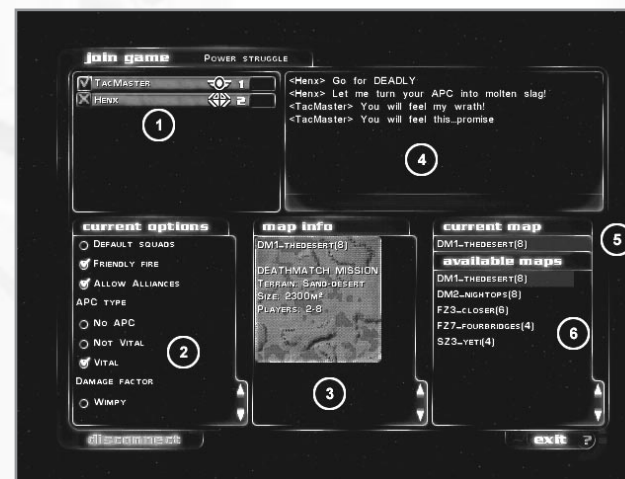

1. Players
2. Current Map Options
3. Map info
4. Chat
5. Currently Selected Map
6. Available Maps

Players

All players currently in the Game Lobby are listed in this box.

Ready Box - The leftmost icon in the players section is the ready box. Check this box to indicate that you are ready to play. Note that the game cannot start until all players have checked their ready box.

Player Color - Click on the Player Name bar to cycle between the available colors. You can not check the ready box if you have the same color as another player.

Force - Click on the force icon to switch between Crayven or Order forces.

Team - Click on the Team Number icon to change team. Note that certain maps only allow a set number of teams.

Current Map Options

Displays the currently selected options for the map. Only the player who created the game can change the options.

Map Info

Displays information about the selected map.

Currently Selected Map

Displays the map that will be played. Click on the map name to view it in the MAP INFO panel.

Available Maps

Displays a list of the maps that are available on the server. Click on the map names to view it in the MAP INFO panel.

Create an Internet Standard Game

As the creator of a game (host) you can change all the options and choose which map to play. In Ground Control you do not host a game on your own machine, the game is hosted on dedicated Ground Control servers. Before you can make any changes or select map you must select a server to host the game.

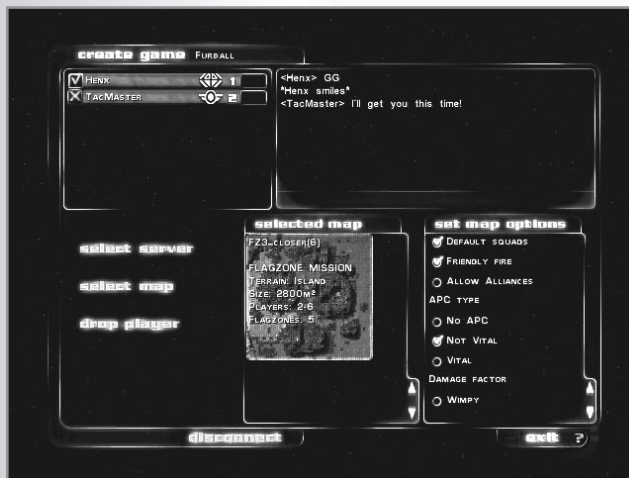

Select Server - Click this button to select a server. Select a server with a low ping for best performance. Click the ACCEPT button when you have selected a server.

Select Map - Click the button to select a map to play. Select the map you wish to play from the list of AVAILABLE MAPS and then click ACCEPT.

Multiplayer Map Options

The host can change the map options for more varied gameplay.

Default Squads - With this option checked players are not allowed to change the default strike force.

Friendly Fire - With this option checked Friendly Fire is turned on.

Allow Alliances - With this option checked players are allowed to be on the same team. Unchecked this option forces "free for all" games.

APC Type (Vital) - A player is defeated if his Command APC is destroyed.

APC Type (Not Vital) - A player is not defeated when his Command APC is destroyed.

APC Type (None) - Players will not have the Command APC on the battlefield.

Damage Factor - Changing the damage factor changes the pacing of the game. The higher damage factor, the more damage weapon inflicts. Higher damage leads to faster games.

Time Limit - The match ends when the time limit is reached. A time limit of zero disables the time limit function.

Score Limit - The match ends when the score limit is reached. Score is achieved by controlling score zones and for killing enemy units. A score limit of zero disables the score limit function.

Reinforcements - If the reinforcement box is checked killed squads will be replaced during the game according to the REINFORCE INTERVAL. Replacement squads will arrive in dropships and must be called down by the player.

Tech Level - Determines the units, special weapons and equipment available. Consult section 9, the Technical Manual, for units and their respective tech level.

Internet Drop-in game

The Internet Drop-in Game allows for near instant action. In a Ground Control Drop-in Game you never meet up in the Game Lobby, action awaits on the planet surface. When the time limit or score limit is reached, a new map is loaded and the battle continues.

When logging on to WON.net you will receive a list of games together with the number of players, network speed and the current map being played. Double click on a game or select the game in the list and then press the JOIN GAME button to enter.

The pre-game screen will display the player names of the people playing the game together with their chosen force and team. You will also be able to see all the maps in the map-cycle and the configured map options.

Choose your forces wisely since you cannot change your dropship loadout once planetside.

Join Game - Click this button to join the selected game. It is also possible to double click on the game you wish to join.

Refresh List - Gets the latest list of available drop-in games.



Drop-in game



Drop-in game, password required

Local Area Network (LAN)

Playing Ground Control on a Local Area Network works the same way as on the Internet with a few exceptions. When you enter the LAN screen you will be presented with a list of the games currently available on the LAN.

Join Game - Click on the button to join the selected game. It is also possible to double click on the game you wish to join.

Create Game - Allows you to create a new game on the LAN. You will be prompted to enter a game name, a password (optional), and maximum number of players. Check the Drop-in checkbox if you want it to be a Drop-in game.

Refresh List - Gets the latest list of available LAN games.

Hosting a LAN Drop-in Game

Hosting a drop-in game allows you to configure the map options as usual but also to set up a map cycle. When the victory conditions have been met, the game switches to the next map in the cycle.

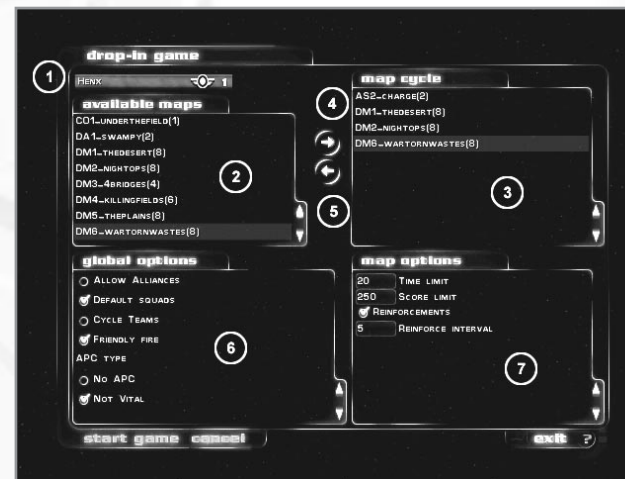

1. Player information
2. Available Maps
3. Map Cycle
4. Add map to cycle
5. Remove map from cycle
6. Global Map Options
7. Specific Map Options

Player information - Change your color, force and team.

Available Maps - A list of the available maps. Add a map to the map cycle by double clicking on a map.

Map Cycle - A list of the maps currently in the map cycle. Remove a map from the map cycle by double clicking on a map.

Global Map Options - All the options in this panel applies to all the missions in the map cycle.

Specific Map Options - Options that only applies to the currently selected map in the map cycle panel. It is recommended that you have the reinforcement box checked in drop-in games.

Knowing your battlefield terrain

Only a foolish Field Commander would send his strike team into a combat zone without surveying the surrounding battlefield. Knowing how the terrain affects your units is a cornerstone on the road to victory.

Elevated positions

Having your squads attack from elevated positions is very advantageous. Their accuracy will increase when firing at targets below themselves. Also note that squads on high ground will usually be blessed with an unobstructed view. Likewise it is important to deny the enemy high ground. You can use your artillery to clear enemy captured hills.

Slopes and impassable terrain

Infantry have much better movement capabilities than Terradynes and Hoverdynes. Most hills and mountains can be climbed by Infantry while only some Terradynes and Hoverdynes can move on steep terrain. Use this knowledge to position your infantry on high ground where they cannot be easily reached by enemy vehicles.

Line of Sight

To detect enemy units they must be within your own units view range and unless your units are equipped with radar they must also have an unobstructed line of sight to the enemy. Hills and other terrain features block the line of sight. Smaller targets such as infantry can easily hide in small furrows, while large terradynes require larger depressions in the ground to stay hidden.

Scout vehicles and other light units have better view range compared to the heavier vehicles. Therefore it is useful to make sure reconnaissance squads support your heavier units. You can bring up a unit's view range by holding the mouse cursor over the unit and press the <r> key. The blue circle indicates the units view range and the red circle indicates the weapon's maximum range.

Note that the enemy can always detect your units' presence if they fire their weapons, as weapon firings are detectable from orbit.

Stealth & Perception

Certain units such as the Crayven Jaeger Special Forces have excellent stealth rating, allowing them to sneak almost up to the enemy. The perception rating indicated how good a unit is to spot a stealthy unit. For more information about unit types' stealth and perception rating, see the Technical Manual in section 9. A stealthy unit can move within an enemy's view range without being detected.

Suppressive Fire

Units under attack will slow down and receive an accuracy penalty as it becomes suppressed. Vehicles will "button up" and infantry will keep their heads down. Light units can even suppress heavy units. Use this knowledge

wisely and try to suppress an enemy unit if you need to slow down their progress. Even if your units don't inflict any major damage it might give you enough time to regroup.

Soldiers of the Pax Dei are notorious for their coolness under fire due their fanatical faith and do not suffer as heavily from suppressive fire as Crayven soldiers.

Flanking maneuvers

Terradynes and Hoverdynes have thicker armor in the front than in the rear. It is important to use this wisely; a controlled attack from the flanks or the rear will hurt the enemy a lot more than an all-out frontal assault. It is equally important to deny the enemy the opportunity to attack your units from the rear or else they will quickly slaughter your units.

When attacking your enemy, have fast units ready to circle around the enemy and attack them from the rear.

Friendly Fire

It is imperative to avoid friendly fire. Units within a Squad will automatically avoid firing at each other. Avoid grouping several Squads in tight locations or your units will become casualties of friendly fire, especially when you take into account that the armor is weaker in the rear.

Certain units such as the Crayven Rocket Terradyne fire their weapons above other units and can be positioned behind other squads in an offensive maneuver.

Note that Friendly Fire is disabled when playing on EASY difficulty setting.

Combined Arms

You have many different unit types at your disposal, learn their strengths and weaknesses to create a powerful strike force. Know that a force consisting entirely of heavy terradynes and artillery vehicles are extremely vulnerable to aerodynes. Similarly an aerodyne force requires ground support to fend off enemy anti-air.

Artillery vehicles have extremely efficient long-range attacks. However, they are very vulnerable to attacks from enemy units. Make sure to have protective units around your Artillery vehicles or you will quickly lose them. Artillery vehicles do not automatically attack when they detect enemy units unless you order them into FREE FIRE MODE which can be very dangerous if the enemy moves near your own troops. You as the Commander should keep artillery units in HOLD FIRE MODE and then give a direct order on what to target. Make sure that you don't have any friendly units near the target point or the effect will be devastating.

Scout vehicles have excellent reconnaissance capabilities and will detect enemy units at long range. An Artillery strike is much more powerful when using forward observers to pinpoint the enemy's location.

Infantry is hard to detect and are capable of climbing steep slopes. Keep them well protected against fast firing enemies and use the Command APC to transport them quickly into battle.

Squads and Experience

Each Squad that survives a mission receives experience depending on its performance in the mission. Experience is accumulated over missions and affects the efficiency of a Squad. A veteran Squad will have increased ACCURACY, STEALTH, PERCEPTION and inflict more DAMAGE than a fresh Squad. Use your Squads wisely and make sure to build a balanced and experienced Battle Group. Note that Squads do not gain any experience in the multiplayer game.

The following section has been authorized for Crayven military personnel of ranking FC-E/9 or higher only.

Crayven Corporation units

Crayven Command APC - CLSV-601 "Rhino"

| | | | |
|-------------------|-----------|-------------------|--------|
| Firepower | Medium | Armor | Medium |
| Health | Very High | Speed | Medium |
| View range | Medium | Stealth | None |
| Perception | Low | Tech level | n/a |



The CLSV-601 Command Armored Personnel Carrier (APC) is the most important unit on the battlefield, it is the vehicle from where the Field Commander controls his strike force and allows the Commander to transport infantry. The four-manned APC is crewed by a driver, gunner, repair-manager and the Field Commander. The extremely well protected inside compartment of the Command APC contains the advanced Ground Control Direct Command Interface System - GC-DCIS, designed to assist the Commander in controlling their

forces. An infantry transport compartment is located in the rear and allows up to 20 marines to cram in for transport.

The Command APC is armed with the Welby-Simms Cor13-1 .50 Autocannon, capable of dealing with all but the heaviest of titanium layered terradyne armors. The APC is armored with heavy B-25 Titanium shockplates also fitted to the Crayven main battle terradyne. The Command APC is not however, an assault terradyne, the armor and autocannon are for pure defensive reasons. With all the equipment fitted to the Command APC, it is one of the heaviest terradynes operational today. A heavily improved Zephrim fusion engine powers the APC.

A SULAC-29 Repair module is fitted on the Command APC that gives it the very important ability to repair other units.

The Field Commander is further protected inside the APC in a hard-shell pod, designed to keep the Commander alive should the APC be destroyed. The pod contains enough life supporting systems to keep the Commander alive for several weeks until a rescue operation can be launched.

Infantry Units

Crayven Rifle Infantry - CCMIB-2 "Marine"

| | | | |
|-------------------|----------|-------------------|-----------|
| Firepower | Very Low | Armor | Very Low |
| Health | Low | Speed | Very slow |
| View range | Medium | Stealth | Medium |
| Perception | Low | Tech level | 1 |

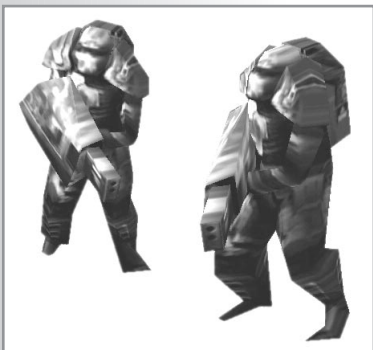

Infantry have always been and will always remain an important role in any army. The Crayven Marines are highly trained infantry soldiers who fight alongside terradynes carrying out special assignments. Infantry can be loaded into the Command APC for protection and transport.

Their primary weapon is the Welby-Simms Dev20011 "Devastator" assault rifle, which is adequate for enemy infantry but underpowered against armored targets such as terradynes or hoverdynes.

Considering the devastating firepower

deployed on the battlefield, personal armor is essential. Marine combat armor is designed for maximum mobility with optimum protection and is the toughest protection available to infantry short of powered armor. The CB39 Battlesuit is composed of a fused amalgam of hardened alloys, ceramic plates and Polysteel-battleplastics formed to allow maximum maneuverability. The armor consists of a rigid exoskeletal armor covering most of the body with an undersuiting of mesh and resilient webbing to protect exposed locations such as joints, neck and the groin.

A marine squad can be equipped with the RMM-9 Mortar, lobbing high-explosive grenades in a high arc towards the target or the CG-89mm Anti-tank rocket launcher. It fires an 89mm rocket capable of defeating most tanks unlucky enough to be in its way.

Special Weapons

- RMM-9 Infantry Mortar Rifle mounted mortar, capable of indirect fire with limited blast radius. 3 charges.
- CG-89mm AT Rocket Disposable Anti-Terradyne rocket capable of defeating heavy terradyne armor. 3 charges.

Equipment

- Personal Medkit Personal medkit capable of extreme healing acceleration repairing damaged tissues, also includes basic tools for armor field repairs. 3 charges.
- Deployable Radar Small portable radar station that once deployed relays all tactical information to the Command APC. 1 charge.

Crayven Special Forces - CCSF-9 "Jaeger"

| | | | |
|-------------------|---------|-------------------|-----------|
| Firepower | Medium | Armor | None |
| Health | Low | Speed | Very Slow |
| View range | Extreme | Stealth | Extreme |
| Perception | Extreme | Tech level | 2 |



The Crayven Corporation special forces also known as the "Jaegers" are the masters of stealth and infiltration. A favorite tactic is to deploy a Jaeger unit on high ground where they have an excellent view over the battlefield. Using their Gauss rifles they are able to deliver a good amount of damage before being detected. Another tactic is to equip the Jaeger squad with demolition charges and have them blow up important enemy structures.

Jaeger units are primarily armed with a K516d High Impact Gauss Rifle. It is a heavy sniper rifle designed to take out heavily armored soldiers and lightly armored vehicles. A Jaeger sniper rifle is powerful enough to punch through the armor of a light to medium terradyne.

The Jaeger's combat suit is designed purely for stealth. The Jaeger armor consists of an environmentally secure bodysuit of flexible cloth covered with lam

inated armor pieces. The armored sections are made of duralloys layered with battleplastics.

Even though they are physically trained they stand no chance in close combat with enemy vehicles or even enemy infantry.

Special Weapons

- GyroJet Ammunition Special HEAT rounds for taking out enemy vehicles. 3 charges.
- 140mm Rifle Attached Warheads, fires an explosive fragmentation grenade designed to take out enemy infantry and light vehicles. 1 charge.

Equipment

- Personal Medkit Personal medkit capable of extreme healing acceleration repairing damaged tissues, also includes basic tools for armor field repairs. 3 charges.
- Demolition Kit A Demolition kit that is triggered by the Field Commander. 3 charges.
- Vision Enhancer Helmet mounted vision enhancer. Increases the possible view range with advanced image intensifier equipment. 3 charges.

Assault Units

Crayven Scout Terradyne - CLSV-112 FSV "Locust"

| | | | |
|-------------------|--------|-------------------|------|
| Firepower | Low | Armor | Low |
| Health | Medium | Speed | Good |
| View range | High | Stealth | Good |
| Perception | High | Tech level | 1 |



The CLSV-112 FSV is mainly used for fast attack or scouting missions. The two-seater Locust is able to outrun most terradynes as it is designed with speed and stealth in mind. With its extremely good view range it is the eyes and the ears of the Crayven military. The Locust's main drawback is its light armor, or so say its drivers. The light polysteel-

15 armor is mainly designed to absorb small arms fire and shrapnel. Direct hits from large caliber guns are not deflected in any way.

The Locust is armed with the Welby-Simms HePeX-932 - Cutter, which is the result of intense field research and according to field Commanders, the best machine gun available today. It features an integral cooling system, advanced recoil absorption padding and the brand new GTI-Targeting computer. The scout terradyne is however not intended to engage enemy terradynes. Its gunmount has two-positions, one for engaging ground targets and a second when firing at aerodynes.

The Scout Terradyne can be equipped with a FinnTech Mine Layer unit, which effectively allows the scout to assume the additional role of a minelayer unit.

Special Weapons

Depleted Uranium Rounds The rounds have a penetrator made of depleted uranium that dramatically increases its ability to penetrate armor. 3 charges.

HE Grenade Launcher Fires High-Explosive grenades in a ballistic trajectory, mainly designed to take out infantry or light vehicles. 3 charges.

Equipment

Repair Module Repair module that allows simple repairs to armor plates and also includes several auxiliary backup systems. 3 charges.

Minelayer unit A minelayer unit allows the Locust to deploy anti-vehicle mines. 3 charges.

Crayven Light Terradyne - CT-917 FST "Jackal"

| | | | |
|-------------------|--------|-------------------|--------|
| Firepower | Medium | Armor | Medium |
| Health | Medium | Speed | Good |
| View range | Medium | Stealth | Low |
| Perception | Low | Tech level | 1 |



The CT-917 FST light terradyne mainly used for fast attack or scouting missions. The Jackal's coaxial weapon mount allows it to target both ground and air units. Its Piranha 4-4 SlugDrive is optimized for maximum maneuverability and speed.

Its turret is fitted with a servo contraption allowing for fast rotation and tilting mounted with a coaxial Welby-Simms Cor 13-1.50 AC, an autocannon capable of tearing infantry to shreds and, given some time,

can pound through heavy terradyne armor. The weapons dual fire system is configured for optimal performance, assuring the crew that a steady stream of hot tungsten rounds will harass the target.

Except for being a fast terradyne, the Jackal can also be equipped with additional firepower in the form of deployable Marduk GS-5 Sentry Guns. The sentry guns can be placed in strategically important places to assist the defense or serve as early warning systems for the creative Field Commander.

Special Weapons

Depleted Uranium Rounds The rounds have a penetrator made of depleted uranium that dramatically increases its ability to penetrate armor. 3 charges.

HE Grenade Launcher Fires High-Explosive grenades in a ballistic trajectory, mainly designed to take out infantry or light vehicles. 3 charges.

Equipment

Repair Module Repair module that allows simple repairs to armor plates and also includes several auxiliary backup systems. 3 charges.

Sentry gun - Autocannon A deployable sentry gun armed with a single Autocannon. Cannot be moved after being placed. 1 charge.

Sentry gun - Rocket A deployable sentry gun armed with an Anti-Tank Launcher rocket launcher. Cannot be moved after being placed. 1 charge.

Sentry gun - Anti-Air A deployable sentry gun armed with an Anti-Air missile system. Cannot be moved after being placed. 1 charge.

Crayven Main Battle Terradyne - SFB-209 AAT "Wolf"

| | | | |
|-------------------|--------|-------------------|--------|
| Firepower | Great | Armor | Good |
| Health | Good | Speed | Medium |
| View range | Medium | Stealth | None |
| Perception | None | Tech level | 2 |

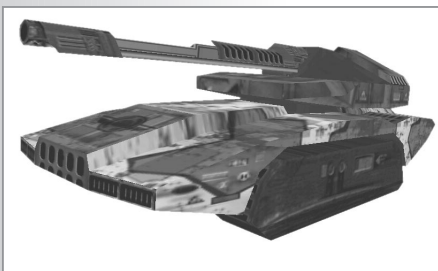

The SFB-209 AAT is the main battle terradyne in the Crayven Army. The terradyne excels at offensive maneuvers but requires the support of other vehicles, such as Anti-Air, and scout terradynes. There have not yet been any official requests for a complete overhaul of the Wolf, even though it is the oldest terradyne model in the Crayven repertoire.

The main armament of the Wolf is a Reinhart LAK4-150mm - Storm. The 150mm large caliber gun is considered to be a most efficient and accurate weapon system, firing fin-stabilized sabot rounds. The barrel is configurable for multiple settings with extended recoil absorbers and specially designed Tak-2 coils that give the gunner full control of the gun. A serious weakness with the Wolf is its inability to target aerodynes, which leaves it heavily relying on other support vehicles.

Since the Wolf is an armored assault terradyne it is expected to withstand direct enemy incoming fire and subsequently only the best armor is sufficient. The Wolf is normally armored with B-25 Titanium shockplates but this armor can be bolstered by attaching additional armor plates.

Wolf tank commanders are generally unpleasant to be around as they consider themselves to be better than any fighting unit. They develop a strange bond with their tanks and it is common practice for them to repair a wolf tank as long as its crew is alive no matter how badly damaged.

Special Weapons

- HE Rounds** A high explosive round set to detonate on impact, it is useful against infantry and other light targets. 3 charges.
- Advanced HE Round** An even more powerful high explosive round set to detonate on impact. 1 charge.

Equipment

- Repair Module** Repair module that allows simple repairs to armor plates and also includes several auxiliary backup systems. 3 charges.
- Improved Targeting Computer** Improves the accuracy of the squad. 3 charges.
- Deployable Repair Station** Deploys a repair station, similar to the one found on the Command APC. The station cannot be moved once placed. 1 charge.

Crayven Annihilator Terradyne - DTT-1203 "Grizzly"

| | | | |
|-------------------|--------|-------------------|-------|
| Firepower | Good | Armor | Great |
| Health | Great | Speed | Low |
| View range | Medium | Stealth | None |
| Perception | None | Tech level | 3 |



Crayven's heaviest tank is the DTT-1203 Annihilator Terradyne. The terradyne is a technological marvel with its twin Zephrim SlugDrive engine capable of generating enough energy to move this 113 ton titanium-alloy hulk. The four-crewed Grizzly is a recent addition to the

Crayven military with only seven years of active service.

The Annihilator terradyne is mainly deployed in siege situations where its devastating firepower really is of maximum use.

The primary armament of the Annihilator is the double-barreled 120mm MT-LCGx2. It is a very powerful gun, easily out-matching any conventional large caliber gun on the market today. The new Welby-Simms ShellLoader2000x is able to feed the gun at maximum speed without any jamming risk whatsoever. The weapon is however unsuitable for stealth missions where its muzzle flames easily reveals its position.

Special Weapons

- HE Rounds** A high explosive round set to detonate on impact, it is useful against infantry and other light targets. 3 charges.
- Advanced HE Round** An even more powerful high explosive round set to detonate on impact. 1 charge.

Equipment

- Repair Module** Repair module that allows simple repairs to armor plates and also includes several auxiliary backup systems. 3 charges.
- Missile Countermeasure** When activated protects the squad against incoming missiles, rockets and grenades. 3 charges.

Support Units

Crayven Rocket Terradyne - DTA-266 AMRLT "Firecracker"

| | | | |
|-------------------|--------|-------------------|--------|
| Firepower | Good | Armor | Medium |
| Health | Medium | Speed | Medium |
| View range | Medium | Stealth | None |
| Perception | None | Tech level | 1 |

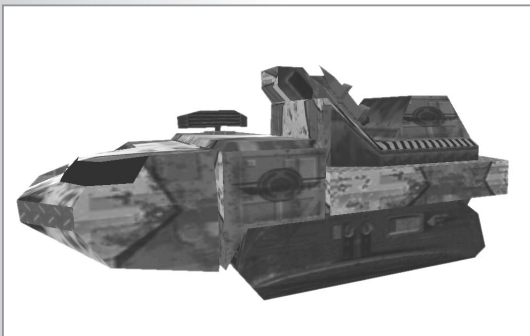

A well balanced battleforce routinely attaches support terradynes to its core units of main battle terradynes. The DTA-266 AMRLT is an excellent support terradyne capable of defeating both terradynes and aerodynes. It is not intended to be deployed in the frontlines but rather behind the protection of more armored terradynes such as the Wolf or the Grizzly.

The Firecracker's primary weapon is the Crayven OSI-L2 - Hurricane Air Defense Anti Tank Missile System. It is equipped with the latest Crayven TrueSight targeting modification that establishes a direct neural link between gunner and missile. The gunner is able to target and fire with minimum response time and with extreme precision. Once the missile is airborne it locks onto the targets alpha emissions. Since humans alone do not generate enough quantities of alpha emissions, the missiles cannot establish a lock-on and are considered harmless against infantry.

The light Meshed H2 armor fitted to the Firecracker does not provide enough protection against enemy anti-tank weapons. The nature of the ADAT missile system allows the Firecracker to use other vehicles for protection as its missiles are launched high into the air before striking down on its target from the above.

Special Weapons

- Hammerhead warhead Missile specially designed to take out aerodynes. 3 charges.
- Hellfire warhead Homing missile warhead designed to take out ground vehicles. 3 charge.

Equipment

- Repair Module Repair module that allows simple repairs to armor plates and also includes several auxiliary backup systems. 3 charges.
- Image intensifier system When activated, improves view range for limited amount of time. 3 charges.

Crayven Anti-Air Terradyne - APF-331 MAAG "Ocelot"

| | | | |
|-------------------|-----------|-------------------|--------|
| Firepower | Great | Armor | Medium |
| Health | Medium | Speed | Good |
| View range | Very good | Stealth | None |
| Perception | Medium | Tech level | 2 |



The APF-331 MAAG (Mobile Anti-Air Gun) manufactured by the Crayven Corporation is a terradyne designed to shoot down enemy aerodynes. The Ocelot depends heavily on computer and radar capabilities in order to target and track enemy aerodynes and is therefore very vulnerable to enemy EW tactics. The Ocelot is a two-manned vehicle requiring only a driver and a gunner. When its onboard radar picks up a potential target it automatically swings the turret and barrel to the correct firing angle, leaving the gunner to press the fire button.

The Ocelot is primarily armed with a Hugh 75mm 2xAC Air Defense Cannon. The four parallel mounted Autocannons sends an extremely deadly hail of rounds in supersonic speed towards the enemy.

An Ocelot depends on battle tanks for protection while it accurately removes aerodynes from the sky since it cannot target ground vehicles. Its light Polysteel-15 armor is not capable of shielding the vehicle from anything more powerful than infantry fire. It relies on speed and maneuverability to survive the battle.

Equipment

- Repair Module Repair module that allows simple repairs to armor plates and also includes several auxiliary backup systems. 3 charges.
- Image intensifier system When activated, improves view range for limited amount of time. 3 charges.

Crayven Artillery Terradyne - APP-671 CAT "HOG"

| | | | |
|-------------------|-----------|-------------------|--------|
| Firepower | Fantastic | Armor | Medium |
| Health | Great | Speed | Slow |
| View range | Low | Stealth | None |
| Perception | None | Tech level | 4 |

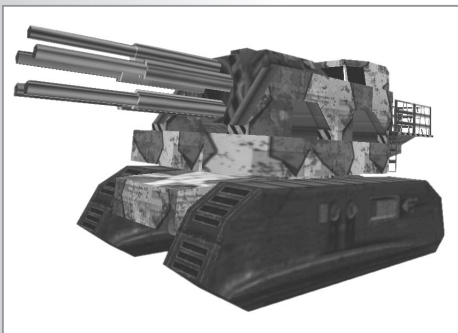

The APP-671 HOG is a mobile artillery terradyne that fires ballistic artillery grenades. The HOG works best when used together with other units acting as forward observers, such as Jaegers or scout terradynes. The artillery unit can target the ground in order to suppress enemies or force them choose another route. Commanders must be careful when ordering an artillery strike as friendly units can be hit which can spell disaster during a combat mission.

A crew of six soldiers mans the Hog, including the terradyne commander, making it the most crew demanding vehicles in the strike force.

“Mobile artillery units cause more casualties to the enemy and have a greater adverse effect on his will to fight than any other weapon.” Crayven Field Commander Illena Mackenzie

The primary weapon of the HOG class artillery is a 155mm howitzer that with its fully automatic breech block and hydro-pneumatic recoil system allows a rate of fire of three rounds per second. It is very adept in taking out enemy buildings with its siege-like weapon. A unique cooling system consisting of five barrels rotate into place in order to avoid overheating problems during extreme combat situations. The heavy turret is extremely slow and it requires a few seconds to align its barrel to the designated target. It is hardly useful to fire the howitzer while moving.

The volatile warheads stored inside the HOG requires its heavy polysteel-20 armor plating to be extremely durable, but even with the powerful Zephrim SlugDrive its speed is limited to a slow crawl.

Note that an artillery unit defaults to hold fire mode, and will never automatically attack another enemy on its own unless the mode is changed. A direct order from the Field Commander is required to fire in this mode.

Special Weapons

- Tactical Nuclear Shell The TacNuke is reserved for extreme conditions as it totally annihilates everything within its blast radius. 1 charge.
- Jannice warhead Extremely accurate computer guided artillery shells. 3 charge.

Equipment

- Repair Module Repair module that allows simple repairs to armor plates and also includes several auxiliary backup systems. 3 charges.
- Image intensifier system When activated, improves view range for limited amount of time.3 charges.

Aerodyne Units

Crayven Light Scout Aerodyne - AV/U-122 LSA "Hawk"

| | | | |
|-------------------|---------|-------------------|---------|
| Firepower | Low | Armor | Low |
| Health | Medium | Speed | Extreme |
| View range | Extreme | Stealth | Good |
| Perception | Good | Tech level | 1 |



The Crayven Corporation often uses the AV/U-122 LSA for deep scout missions as well as low-threat patrols. The Hawk is equipped with advanced sensors, both passive and active, and routinely relays its information to the nearest BattleSat in orbit, which in addition to its high flying altitude makes it the best scout unit in the Crayven military.

The Hawk is lightly armed and lightly armored and is generally not suited for heavy combat. Its high stealth enables it to sneak up on its enemies and deliver a hit-and-run blow, but more importantly, identify targets for the Artillery terradyne or other long range weapons.

The Hawk is armed with a belly mounted Welby-Simms 20mm Chaingun pod capable of penetrating light terradyne armor. The Hawk is highly successful engaging infantry or bomber aerodynes but is no match against attack or fighter aerodynes. The Hawk is only armored with VonTec 45I-3 Stealth plates, relying on its low target profile and evasive combat maneuvers to avoid incoming fire.

Special Weapons

- Depleted Uranium Rounds The rounds have a penetrator made of depleted uranium that dramatically increases its ability to penetrate armor. 3 charges.
- HE Grenade Launcher Fires High-Explosive grenades in a ballistic trajectory, mainly designed to take out infantry or light vehicles. 3 charges.

Equipment

- Image Intensifier Increases the squad's view range when activated. 3 charges.
- Countermeasure system Protects the squad against incoming missiles and rockets when activated. 3 charges.
- Afterburner Boosts the squad's flying speed when activated. 3 charges.

Crayven Attack Aerodyne - AV/U-309 HAA "Vulture"

| | | | |
|-------------------|--------|-------------------|-------|
| Firepower | Good | Armor | Low |
| Health | Medium | Speed | Great |
| View range | Medium | Stealth | None |
| Perception | None | Tech level | 5 |



The Crayven AV/U-309 HAA or Vulture, is one of the most effective terradyne busting units available in the Crayven arsenal. It is primarily designed as a terradyne breaker, capable of quickly approaching the enemy and blowing him to pieces. A favorite tactic amongst Vulture commanders is to circle the enemy and attack from behind where he least expects it and where the armor is weaker.

The Vulture is armed with the W-T SR-II Mosquito, which is a good 84mm aerodyne mounted rocket launcher considering its weight and targeting system. Its primary drawback is its relatively short range. Upon detonation the Mosquito rocket shows superheated fragments over a wide area making it critical for Field Commanders to make sure no friendly forces are close to the target. The Vulture's rocket launcher can also target other aerodynes but with limited success as the rocket's guiding system is designed for slower ground units.

The Vulture can quickly reach a designated location on the battlefield and use its firepower wherever need making it great for surprise support activities. The Vulture is - like all aerodynes - extremely vulnerable to enemy anti-air and enemy fighter aerodynes.

Special Weapons

- ICM-DP TseTse Rocket** The Improved Conventional Munitions, Dual Purpose Rocket contains shaped-charge grenades, which have an improved effectiveness against armored targets. 2 charges.
- HE Firefly Rocket** The High Explosive Firefly Rocket is designed to take out enemy infantry. 3 charges.

Equipment

- Image Intensifier** Increases the squad's view range when activated. 3 charges.
- Countermeasure system** Protects the squad against incoming missiles and rockets when activated. 3 charges.
- Afterburner** Boosts the squad's flying speed when activated. 3 charges.

Crayven Fighter Aerodyne - AV/F-1001 FA "Delta"

| | | | |
|-------------------|--------|-------------------|--------|
| Firepower | Great | Armor | Medium |
| Health | Medium | Speed | Great |
| View range | Medium | Stealth | Low |
| Perception | Low | Tech level | 5 |



The Crayven Corporation manufactured AV/F-1001 FA Delta is the latest advanced fighter aerodyne in the AV/F(Fowler) series. The Delta - powered by two SecAmp fusion engines complemented with standard Lavnoc hover drives - is able to pull off amazing maneuvers at low altitude. The one-manned fighter is equipped with an extremely advanced computer system aiding the pilot, feeding him with topology data and vector plans. The system is intimately hooked into the pilot's combat suit and regulates all pressure and stimulants the pilot needs.

The Delta can fly into low orbit if necessary, but is more often transported in AV/U4's, as its combat capabilities are severely lowered without its maneuver advantage.

The Crayven fighter aerodyne is primarily loaded with N69-PDU GLORY missiles, capable of destroying enemy aerodynes in a heartbeat. The GLORY missiles are Air-to-Air only.

Special Weapons

- Improved AIM Missile** Dramatically more powerful air-to-air missile warhead. 3 charges.

Equipment

- Image Intensifier** Increases the squad's view range when activated. 3 charges.
- Countermeasure system** Protects the squad against incoming missiles and rockets when activated. 3 charges.
- Afterburner** Boots the squad's flying speed when activated. 3 charges.

Crayven Bomber Aerodyne - AV/U-45 SRBA "Condor"

| | | | |
|-------------------|---------|-------------------|------|
| Firepower | Extreme | Armor | Low |
| Health | Good | Speed | Good |
| View range | Medium | Stealth | None |
| Perception | None | Tech level | 5 |



The sight of the Crayven Corporation manufactured AV/U-45 SRBA (Short-Range Bomber Aerodyne) Condor, strikes fear into the enemy as it is loaded with pure destruction in the shape of bombs and guided missiles. The Condor is a short-range bomber aerodyne able to surgically bomb enemies of the Crayven Corporation. It can be loaded with up to 8,000 kilo's worth of bombs without sacrificing its flight qualities.

Typically the Condor is deployed in combat regions together with an escort; relying on the escort for both protection and reconnaissance. Since the Condor lacks the speed and maneuverability of the Delta, it is highly vulnerable to both enemy aerodynes and anti-air guns. Compared to other aerodynes the Condor moves like a snail but packs the firepower of a small sized army.

The Condor is armed with High Explosive bombs, which are dropped over the enemy. Fast moving units such as light terradynes are hard to hit but buildings and other immobile structures are no match for a Condor.

Special Weapons

Tactical Nuclear Bomb

The TacNuke is an extremely powerful weapon and is only used when absolutely no other alternatives remains as it wipes out everything within its radius.
1 charge.

Fragmentation Bomb

The fragmentation bomb sends white-hot metal over an extremely large radius. It is not capable of destroying vehicles but certainly severely damaging them.
1 charge.

Equipment

Image Intensifie

Increases the squad's view range when activated.
3 charges.

Countermeasure system

Protects the squad against incoming missiles and rockets when activated. 3 charges.

Afterburner

Boosts the squad's flying speed when activated.
3 charges.

The Order of the New Dawn units

Order Command APC - 05/DCAPC

| | | | |
|-------------------|-----------|-------------------|--------|
| Firepower | Medium | Armor | Medium |
| Health | Very High | Speed | Good |
| View range | Medium | Stealth | Low |
| Perception | Low | Tech level | n/a |



The 05/DCAPC Command APC is the Order battlefield nerve center. In addition to being able to transport Crusaders and Templars, it houses the Order Deacon - the equivalent of the Crayven Field Commander. The Command APC can carry up to 20 fully armed and armored Crusaders without sacrificing its excellent combat maneuverability. It is equipped with fully hydraulic rear doors to ensure that the infantry can enter and exit the vehicle no matter the circumstances.

The turret located on top of the vehicle mounts a slightly modified 200 kilocycle Electro Discharge Canon that has a very useful armor penetrating capability. The weapon is also capable of limited air defense, even though it is not its primary purpose.

The Order Command APC is extremely robust and can operate under extreme conditions that would wreck many other hoverdynes.

A modified version of the Crayven SULAC-29 Repair system is mounted on the Command APC that enables it to swiftly repair units.

Infantry Units

Order Shock Infantry - OCRU-1001 "Crusaders"

| | | | |
|-------------------|----------|-------------------|-----------|
| Firepower | Very Low | Armor | Very Low |
| Health | Low | Speed | Very Slow |
| View range | Medium | Stealth | Medium |
| Perception | Low | Tech level | 1 |



The Crusaders are the shock infantry of the Pax Dei, the military division of the Order of the New Dawn. Many soldiers view the Crusaders with extreme respect and it is considered to be very prestigious to be a Crusader in the Pax Dei.

The Crusaders primary armament is the Cobra AAG-50 "Soul Cleanser" Storm Carbine. In order to operate the gun properly a heavy combat suit with an enhanced exoskeleton is needed, such as the Crusader armor. It is powerful enough to seriously damage light vehicles but against heavier targets, the Crusaders need to approach from the rear where the armor is weaker.

The powered exoskeleton worn by the Crusaders allows them to go head-to-head against enemy terradynes even though a frontal assault would be futile. Order Field Commanders regularly inject different combat drugs into the Crusaders in order to improve their aggressiveness factor. As a result many Crusaders are burned out at an early age.

The Crusader combat armor is designed for maximum mobility with optimum protection and is the toughest protection available to infantry short of powered armor. Crusaders are classified as infantry and can be loaded into a Command APC for transport.

Special Weapons

Focused Storm Pulse

An energy draining weapon configuration to take out armored vehicles. 3 charges.

SMAUG-12 Flamethrower

The SMAUG-12 is an accessory mounted on the standard Crusader pulse rifle and is extremely effective against enemy infantry. Its main drawback is its short range. 3 charges.

Equipment

Personal Medkit

Personal medkit with drugs for extreme healing acceleration and repairing damaged tissues, also includes basic tools for armor field repairs. 3 charges.

Deployable Radar

Small portable radar station that once deployed relays all tactical information to the Command APC. 1 charge.

Order AT Infantry - ATI-720 "Templar"

| | | | |
|-------------------|----------|-------------------|-----------|
| Firepower | Great | Armor | None |
| Health | Very Low | Speed | Very Slow |
| View range | Medium | Stealth | Medium |
| Perception | Low | Tech level | 2 |



The Order Templars are anti-terradyne infantry armed with the Retribution shoulder Anti-Armor Missile System capable of demolishing most terradynes in a matter of seconds. Only combat-proven female members of the Pax Dei are allowed to join the Templar division because of old dogmatic reasons.

The primary weapon of a Templar is the GrU-6 Retribution Shoulder Anti-Armor Missile System. The weapon system is considered to be the most powerful infantry weapon available today and it is rumored that the Crayven Corporation are currently researching and developing their own version. Retribution missiles are capable of defeating the most powerful terradyne armor with ease and spreading death and chaos on the battlefield. A Crayven Field Commander is urged not to underestimate the small frame of

the Templars as they are certainly one of the Orders most deadliest units. Templars are regularly loaded into Command APC's for quick transport and added protection.

Internal Memorandum: Major Thomas, Crayven Field Commander in the 13th Assault Regiment mentioned in battle report 450/DT-2419 that an entire strike force consisting of three Wolf squads bumped into a single Templar squad on a routine mission on Sigma Draconis-4.

Only two Wolf terradynes managed to survive the encounter.

They executed, according to Major Thomas, an unsanctioned fallback and were charged with showing cowardice in the face of the enemy.

However the Templar does have a severe weakness; they are completely defenseless against enemy infantry as a soldier does not generate a strong enough tracking signal for the powerful Retribution missiles. Templars are seldom encountered alone on the battlefield without a Crusader squad attached or other means of protection.

Special Weapons

- MicroNuke Warhead Retribution missile with a micronuke shape-charged warhead designed to crack open heavy armored vehicles. 3 charges.
- Anti-Air Warheads Multiple homing anti-air Retribution loaded missiles. 3 charges.

Equipment

- Personal Medkit Personal medkit with drugs for extreme healing acceleration and repairing damaged tissues, also includes field repairs. 3 charges.
- Image intensifier Improves view range when activated. 3 charges.
- Personal Cloaker Cloaks squad when activated. 3 charges.

Assault Units

Order Scout Hoverdyne - W/SAH-4 "Apus"

| | | | |
|-------------------|--------|-------------------|-------|
| Firepower | Low | Armor | Low |
| Health | Medium | Speed | Great |
| View range | Good | Stealth | Good |
| Perception | Good | Tech level | 1 |



The one-manned W/SAH-4 hoverbike is mainly used for scouting purposes even though its turret-mounted pulse laser can engage both enemy infantry and terradynes. When used in combat encounters, it is usually deployed for hit-and-run strikes, relying on its speed and maneuverability to remain unscathed. The pilot's modified Crusader armor is wired into the powerful sensors fitted to the hoverbike blessing him with an extremely detailed image of

the surrounding terrain and elements. The hoverbike is armored with light polysteel-15 and is not suitable for frontal assaults against enemy assault terradynes.

The Apus is powered with a Mk.IV Durfire Advanced Grav Engine with four titanium plated outlets, with the back turbines providing momentum and the two front outlets controlling the direction. Advanced targeting and visual enhancing equipment is standard on the Apus, strengthening its scout role.

The hoverbike's primary weapon - the SourKodd 8Bx10 "BerZerk" - is a light pulse laser mounted on a small turret located behind the pilot with full 360 degrees movement. Its targeting system is somewhat limited in targeting fast moving aerodynes. A RamTech minelayer unit can be fitted to the rear chassis at the Field Commanders discretion, giving it a secondary defensive role.

Special Weapons

- Electro Dagger The Electro Dagger sends forth an extremely concentrated electro discharge that is designed to penetrate heavy armor. 3 charges.
- Electro Field Electro Field is an area effect variant of the Electro Dagger designed to wipe out concentrations of enemy infantry. 3 charges.

Equipment

- Repair Module Tools and software for minor field repairs to armor plates and vital systems. 3 charges.
- Minelayer unit Deploys Anti-tank mines. 3 charges.

Order Light Hoverdyne - O1/SAC-34 LAT "Sculptor"

| | | | |
|-------------------|--------|-------------------|--------|
| Firepower | Medium | Armor | Medium |
| Health | Medium | Speed | Good |
| View range | Medium | Stealth | Low |
| Perception | Low | Tech level | 1 |

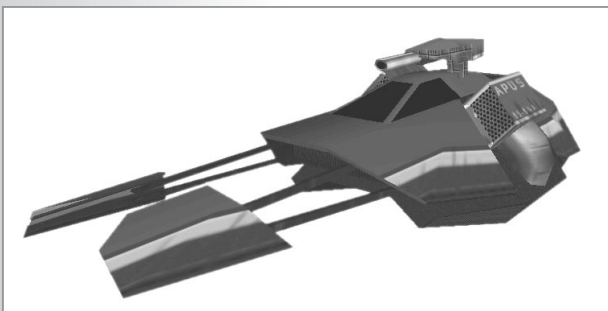

The O1/SAC-34 LAH is a highly advanced hoverdyne used for reconnaissance patrols, fast attack and deep scout missions.

The fitted Rover-8005 battle engine makes it fast and maneuverable.

The primary weapon mounted on the Sculptor is the Order

developed 20KHz Electro Discharge Cannon "Lightning Strike". It is still considered by the Tech Priests in the Pax Dei to be highly experimental and ongoing modifications and tweaking are made on a monthly basis. Even so it has been authorized to be used on the battle field. The rapid firing Electro Discharge Cannon is capable of defeating light titanium alloys with ease. The turret is equipped with both ground targeting sensors and a Hugh G4 aerodyne tracking unit.

Order forces regularly use the Sculptor for fast flanking maneuvers, letting heavier hoverdynes soak up the main enemy fire. The Electro Cannon can be extremely devastating when engaging enemy infantry as it's rapid firing system is better suited for small targets compared to the particle beam accelerators fitted on heavier Order hoverdynes.

The Sculptor is lightly armored with a layer of titanium fused Heavy Polysteel-15 and can definitively hold its own unless cornered by Anti-Tank defeating weapons.

Special Weapons

Electro Dagger The Electro Dagger sends forth an extremely concentrated electro discharge that is designed to penetrate heavy armor. 3 charges.

Electro Field Electro Field is an area effect variant of the Electro Dagger designed to wipe out concentrations of enemy infantry. 3 charges.

Equipment

Repair Module Tools and software for minor field repairs to armor plates and vital systems. 3 charges.

Deployable Defender System The defender system shoots down incoming missiles, rockets and grenades when deployed. Once deployed it cannot be moved. 1 charge.

Deployable Cloaking Unit Cloaks an entire area when deployed. It cannot be moved once deployed. 1 charge.

Order Main Battle Hoverdyne - O1/MAT-3 "Lynx"

| | | | |
|-------------------|--------|-------------------|------|
| Firepower | Great | Armor | Good |
| Health | Medium | Speed | Good |
| View range | Medium | Stealth | None |
| Perception | None | Tech level | 2 |

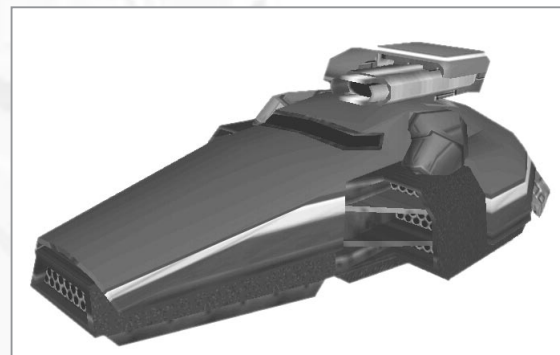

The O1/MAT-3 is the Order Main Battle Hoverdyne, a medium sized hoverdyne with a turret-mounted particle beam accelerator. The Lynx have good speed and maneuverability rating compared to the Crayven equivalent making it an ideal offensive hoverdyne for most combat situations.

The Lynx turret mounts the Shogata-PDX9 "Messenger" which is the latest version

of the first energy based vehicle weapon ever produced. The weapons internal fusion reactor heats particles into plasma, which is accelerated out of the specially designed barrel against the target. The Shogata-PDX9 is incredible expensive and requires enormous resources for upkeep compared to conventional large caliber guns. In order to preserve the secrecy of the plasma accelerators, the Order have installed a remote controlled self-destruct device that overheats the fusion reactor, resulting in a massive and lethal plasma burst.

The turret does not have an adequate targeting computer for aerodyne tracking, making it defenseless against enemy aerodynes. Its electro-treated heavy polysteel-20 shockplates, mainly concentrated to the front and sides, are however capable of withstanding a great deal of punishment before collapsing.

Special Weapons

Plasma Sunburst The Plasma Sunburst explodes on impact, sending molten plasma over a wide area, lethal to infantry. 3 charges.

Plasma Moonburst The Plasma Moonburst is a single charge anti-infantry weapon. 1 charge.

Equipment

Repair Module Tools and software for minor field repairs to armor plates and vital systems. 3 charges.

Protectorshield When activated protects the squad against all weapons. 3 charges.

Speed booster Improves movement speed when activated. 3 charges.

Order Heavy Hoverdyne - O1/WL8 "Volans"

| | | | |
|-------------------|--------|-------------------|--------|
| Firepower | Good | Armor | Great |
| Health | Great | Speed | Medium |
| View range | Medium | Stealth | None |
| Perception | None | Tech level | 3 |

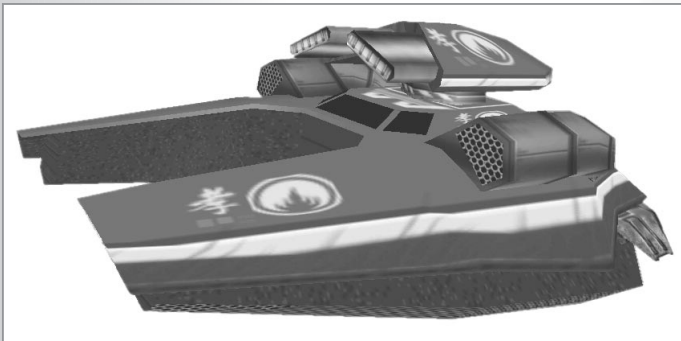

The massive O1/WL8 - Volans is the Order of the New Dawn's largest hoverdyne capable of unsurpassed destruction. The Volans is sometimes called God's Might in inspiring

Order speeches. The hoverdyne is often employed by the Order as stationary guns additionally protected by sandbags or other protection. Some critics claim that the Volans is too slow on the battlefield and that it would be more suitable to call it a mobile cannon instead of a hoverdyne.

It is an incredible honor to command and crew a Volans and the privilege are only given to those soldiers with an impeccable religious background. Volans crews are selected from the children of the priesthood at an early age and are both mentally and physically trained during their entire adolescence.

The fearsome Volans is not only huge on the battlefield; it's turret supports a twin mounted Shogata-PDX9 particle beam accelerator. It was praised during the Atherstone acquisition for its supreme firepower and accuracy but the skilled Pax Dei technicians have not yet been able to improve its relatively slow fire rate. The fusion generator is not able reenergize the particle accelerator any faster without endangering the crew.

The Volans armor consists of a thick titanium-4 layer, reinforced with electro-treated crysteel bars. The heavy armor is responsible for its low acceleration but, according to most Pax Dei officers, is still a good tradeoff.

Internal Memorandum: Field Commander Mackenzie filed in her battle report 23/JM-2419 that during the initial landing engagement she successfully destroyed two Volans units with a single marine squad. The marine squad equipped with CG-89mm AT Rockets managed slip behind the hoverdynes. It should be noted, however, that the marine squad was killed right after their victory by a Sunburst from one of the surviving hoverdynes. The deceased soldiers were postmortem awarded the Crayven Medal of Valor.

An interesting side note is that the number of heavy hoverdyne units so far detected on Krig-7B, far exceeds the number stationed at any other Order conflict zone.

Special Weapons

- Plasma Sunburst The Plasma Sunburst explodes on impact, sending molten plasma over a wide area, lethal to infantry. 3 charges.
- Plasma Moonburst The Plasma Moonburst is a single charge anti-infantry weapon. 1 charge.

Equipment

- Repair Module Tools and software for minor field repairs to armor plates and vital systems. 3 charges.
- Protectorshield When activated protects the squad against all weapons. 3 charges.
- Speed booster Improves movement speed when activated. 3 charges.

Support Units

Order Beam Platform - O12/BT-MV Mk. II "Lacerta"

| | | | |
|-------------------|-----------|-------------------|--------|
| Firepower | Fantastic | Armor | Medium |
| Health | Medium | Speed | Good |
| View range | Good | Stealth | None |
| Perception | None | Tech level | 1 |

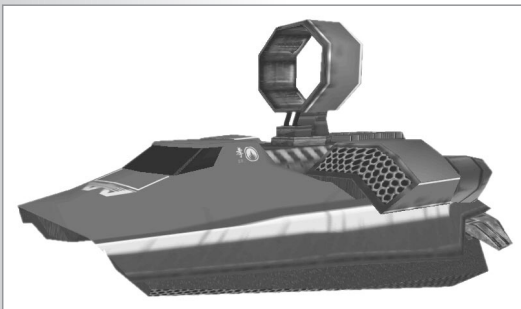

The Order of the New Dawn has adopted BehemoTech's BT-MV Mk.II into their ever-growing military arsenal. The Lacerta is essentially a grav fitted three-crewed platform supporting a heavy beam weapon. It is primarily a long-range support weapon for taking out enemy defensive structures.

The sole armament of the Lacerta is the X9k Purifier weapon system mounted on top of the hoverdyne chassis. The sheer amount of concentrated energy generated by the Purifier beam is powerful enough to blast through any known armor alloy available to ground vehicles today.

The highly advanced Purifier weapon system is linked to an improved version of the Seccom FFI targeting scanner, feeding the targeting computer with extremely detailed and accurate information of targets' movement trajectory, and environmental effects.

Internal Memorandum: Several Field Commanders have reported that they've seen the Purifier beam "bounce" from several targets, effectively hitting more than one target. Crayven Intelligence has not been able to confirm these sightings and no Beam Platform has been captured with its weapon system intact. If these sightings are more than visual glitches, it could prove useful to approach Beam Platforms in scattered formations.

The Beam Platform is armored with relatively light armor, amalgam fused layers of Polysteel-15 and can be destroyed with infantry carried weapons.

Special Weapons

- SCU-Frequency Prism Increases the frequency of the Purifier Beam for a better rate of fire. 3 charges.
- SCU-Focus Prism Focuses the Purifier Beam, making it amazingly powerful. 3 charges.

Equipment

- Repair Module Tools and software for minor field repairs to armor plates and vital systems. 3 charges.
- Protector shield When activated protects the squad against all weapons. 3 charges.
- Image Intensifier Improves view range when activated. 3 charges.

Order Anti-Air Hoverdyne - O1/AAPBT-600 "Pavo"

| | | | |
|-------------------|--------|-------------------|--------|
| Firepower | Good | Armor | Medium |
| Health | Medium | Speed | Good |
| View range | Good | Stealth | None |
| Perception | None | Tech level | 2 |

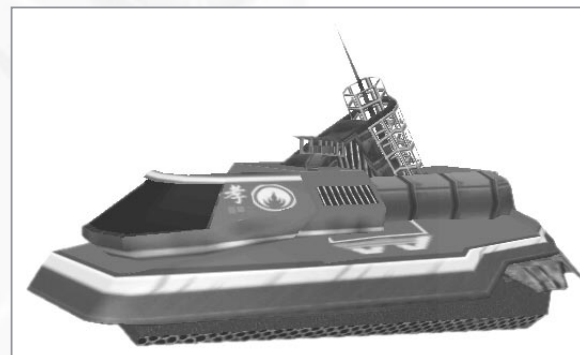

The O1/AAPBT-600 is another example of the latest Order weapon technology that's barely been through a thorough field test. The Pax Dei have recently begun to replace their older Anti-Air Missile System with the new FUR/X9 "Stryke" Lightning Generator. The Pavo uses the same hoverdyne battle-proven O3-chassis

with the top module replaced. The Pavo has one single purpose, and that is to destroy enemy aerodynes. It accomplishes this with an annoying accuracy.

Its aerodyne defeating weapon is a fixed mounted high frequency lightning generator which literally slices incoming aerodynes. The lightning balls generated by the weapon system seemingly homes in on the target aerodyne. However the lightning generator requires enormous amounts of energy to operate and has been fitted with a powerful Zephrim engine. The Lightning Generator system is according to Crayven Intelligence, not yet completely stable and requires an intricate cooling system, which as of this date does not work well in hot and dry regions.

The internal cooling system is its main weakness and prohibits it from being fitted with heavy shock plates. The current design is armored with amalgam fused layers of Polysteel-15. Due its grav engine, the Pavo is much faster and maneuverable than most Crayven terradynes.

Equipment

- Repair Module Tools and software for minor field repairs to armor plates and vital systems. 3 charges.
- Image Intensifier Improves view range when activated. 3 charges.

Order Artillery Hoverdyne - 04/DN9-F0 OAH "Sagitta"

| | | | |
|-------------------|-----------|-------------------|--------|
| Firepower | Fantastic | Armor | Medium |
| Health | Great | Speed | Medium |
| View range | Low | Stealth | None |
| Perception | None | Tech level | 4 |

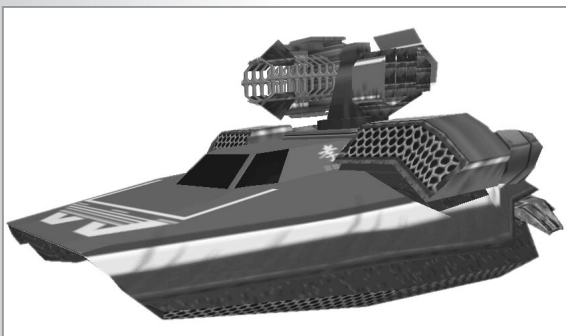

The 04/DN9-F0 OAH or Sagitta is a mobile artillery hoverdyne armed with a ballistic Proton Particle Launcher. The Sagitta is relatively slow compared to other Order hoverdynes, yet it still moves faster than most Crayven terradynes. The Artillery hoverdyne is really fearsome when used in conjunction with stealthy forward observers.

A single gunner operates the weapon system launcher and it actually requires surprisingly little maintenance compared to other Order energy weapons, though greater care must be taken with its ordinance. The primary weapon, a BPPL-12 "Defiance" ejector, lobs overpacked and unstable proton particle clusters in a high ballistic arc towards the target. Upon impact, the Schrödinger repulsor field generators are disabled, creating an enormous energy discharge, resembling a miniature nuclear detonation. While the heat and energy of such an explosion is deadly in its own right, the sub-particle emissions of the blast cause electrons of atmospheric molecules in the surrounding atmosphere to be literally stripped off. This causes a powerful ionization field and wreaks havoc with all surrounding electronic equipment. The dissipation of this ionization field, however presents the most significant problem leading to recombination-independent photogeneration which emits enough energetic photons to literally reduce armor to molten slag. Infantry...does not survive a ground zero blast. The Artillery hoverdyne is fitted with an internal fusion reactor that provides the launcher with the needed energy to maintain the Schrödinger repulsor fields on all ordinances.

The Sagitta requires tight protection from other hoverdynes, even though its Polysteel-20 shock plates keeps the chassis intact for prolonged firefights.

Special Weapons

TankBuster Discharge Improved armor-defeating capabilities. 1 charge.
 LongRange Discharge A setting allowing the launcher to lob the cluster to extreme long ranges. 3 charges.

Equipment

Repair Module Tools and software for minor field repairs to armor plates and vital systems. 3 charges.

Order Drone Carrier - 011/BEHCCA "Orion"

| | | | |
|-------------------|-----------|-------------------|--------|
| Firepower | Medium | Armor | Medium |
| Health | Great | Speed | Medium |
| View range | Good | Stealth | None |
| Perception | Fantastic | Tech level | 3 |

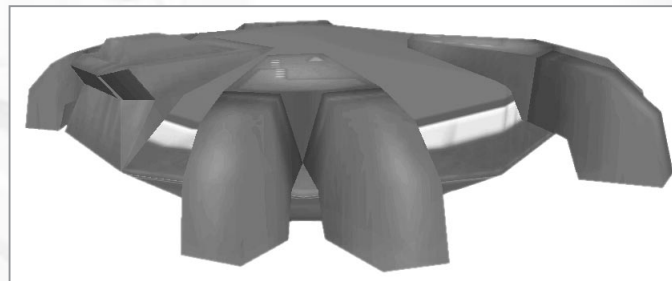

The 03/BEHCCA Drone Carrier is an Order support hoverdyne designed to stay in the background of combat encounters. A single Rover-2000 grav engine, with four side mounted articulating

energy outlets, powers the six-crewed hoverdyne. Inside the heavily armored belly of the Carrier is a large container module where heavy payloads of GHE Spider Drones are stored.

An advanced targeting system identifies enemy ground vehicles and calculates the targets' movement vector and signature. The data is then transferred to a computer inside each of the GHE spider drones. The drones are launched out of the carrier and as soon as they touch ground they home in on their target's signature. The eight-legged spider drone is highly maneuverable and their combat speed tops most terradynes. The advanced computer onboard the drone makes all necessary movement corrections required to successfully strike the target. When the drone comes within a pre-programmed detonation range, optimal range being 5 meters, the drone explodes, sending shrapnel towards the target. To guarantee the destruction of the target, a batch of drones are usually sent out at once.

Special Weapons

Advanced Spider Drone Spider drones with an advanced guidance system and increased explosive payload. 3 charges.

Equipment

Repair Module Tools and software for minor field repairs to armor plates and vital systems. 3 charges.
 Protectorshield When activated protects the squad against all weapons. 3 charges.
 Image Intensifier Improves view range when activated. 3 charges.

Aerodyne Units

Order Recon Aerodyne - OA1/FAS-T12 "Lyra"

| | | | |
|-------------------|--------|-------------------|-----------|
| Firepower | Low | Armor | Low |
| Health | Medium | Speed | Fantastic |
| View range | Great | Stealth | Good |
| Perception | Good | Tech level | 1 |

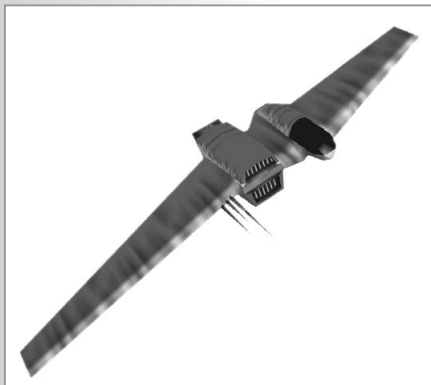

The OA1/FAS-T12 Lyra is a fast, high-altitude, scout aerodyne suitable for reconnaissance patrols and target-identifying missions. The Lyra is unrivaled in speed and maneuverability and easily outruns any Crayven aerodynes. Its main strength is its incredible long-range sensors that bestow an Order Field Commander great insight to the battlefield. The Lyra is not intended to actively participate in combat with its thin armor and relatively weak weapon system.

Its main armament is a fixed belly mounted Veevaert JSM-6 Scatter Laser. The scatter laser main strength

is its extreme high rate of fire, while its main weakness is its low firepower. The Lyra is a one-man craft and the scatter laser is equipped with an improved auto-targeting computer allowing the pilot to concentrate on the flying.

Special Weapons

Electro Dagger

The Electro Dagger sends forth an extremely concentrated electro discharge that is designed to penetrate heavy armor. 3 charges.

Electro Field

Electro Field is an area effect variant of the Electro Dagger designed to wipe out concentrations of enemy infantry. 3 charges.

Equipment

Protector Shield

Protects the aerodyne against all incoming enemy fire when activated. 3 charges.

Perception

Increases the probability of detecting stealthy or cloaked units. 3 charges.

Image Intensifier

Improves view range when activated. 3 charges.

Order Attack Aerodyne - OA2/HAA-309 "Phoenix"

| | | | |
|-------------------|--------|-------------------|--------|
| Firepower | Good | Armor | Medium |
| Health | Medium | Speed | Great |
| View range | Medium | Stealth | None |
| Perception | None | Tech level | 5 |



The Phoenix or OA2/HAA-309 is one of the most feared Order aerodynes as its terradyne breaking ability is legendary or as the Pax Dei uncannily expresses it - divine. The Phoenix relies on its high speed and stealthy maneuvers to get within range of the enemy and then launches a deadly barrage of torpedoes. The aerodyne's single engine outlet and its active VonTec Mk. III electronic countermeasures give the enemy a hard time hitting it. Its aerodyne Polysteel-15 layered armor gives it little or no protection when weapons do hit.

The Phoenix is primarily loaded with Hugh SZX-3000 "Jaguar" SCREAM torpedoes. The SCREAM torpedo warheads contains a shaped-charged director in the nose to provide the warhead with an enhanced armor penetrating capability.

A secondary warhead explodes milliseconds later - inside the armored layers of the target.

The weapon system can with limited success also target other aerodyne targets, however it is no match versus a true aerodyne fighter such as the Crayven Delta.

Special Weapons

Fragmentation Torpedo

The fragmentation torpedo is specifically designed to take out enemy infantry and light vehicles. 3 charges.

Solar Torpedo

The Solar Torpedo's main function is to totally annihilate enemy structures. It is not very useful versus terradynes due the torpedo's extremely slow velocity. 2 charges.

Equipment

Protector Shield

Protects the aerodyne against all incoming enemy fire when activated. 3 charges.

Image Intensifier

Improves view range when activated. 3 charges.

Order Fighter Aerodyne - OA3/AN-9000 "Draco"

| | | | |
|-------------------|--------|-------------------|--------|
| Firepower | Great | Armor | Medium |
| Health | Medium | Speed | Great |
| View range | Medium | Stealth | Low |
| Perception | Low | Tech level | 5 |



The Order's answer to the Delta fighter is the OA3/AN-9000 "Draco" and it is considered to be a worthy opponent.

As a fighter craft its main objective is to eliminate enemy fighter aerodynes and attack aerodynes. The Draco's weapon system cannot engage ground targets and must rely on other units to take out enemy Anti-Air capable units. The Draco is crewed by a pilot and a gunner, both in direct contact with the Field Commander's APC.

The Draco is primarily armed with Air-To-Air Dell-Hugh RV4 Plasma Missiles. When the missiles are launched, a mechanism in the war-head generates a powerful energy field, filling a particle confinement with plasma that is released upon detonation. It takes a second or two

for the missile to generate the plasma, making the weapon system not entirely efficient for extreme close aerial combat. The gunner can however arm the missiles before they are launched but due to the hazards of having armed plasma missiles in the launch tubes, this highly unusual form of attack is only used by truly suicidal pilots.

Most weapons easily penetrate the Draco Light Polysteel-15 armor, which is also considered to be Draco's main weakness.

Special Weapons

Improved Plasma Missile An improved and more powerful Air-to-Air Plasma missile. 3 charges.

Equipment

Protector Shield Protects the aerodyne against all incoming enemy fire when activated. 3 charges.

Image Intensifier Improves view range when activated. 3 charges.

Move Mouse Cursor to the Edges of the Screen to Turn/Tilt Camera.

MOUSE CLICK COMMANDS

| | Left Click | Right Click |
|---|---|---|
| Automatic: no keyboard keys pressed | Select Move Attack Select APC | Guard Unit Move & Point Attack Load Squad into APC |
| While pressing Attack Modifier (<CTRL> key on keyboard) | Attack Location or Box Around Enemy Units to Attack | |
| While pressing Move Modifier (<ALT> key on keyboard) | Move & Point | |
| While pressing Guard Modifier (<G> key on keyboard) | Guard Unit | |

Ground Control automatically determines the action to take when you click a mouse button based on your cursor location. This system is designed to be intuitive and many people enjoy the game without ever looking at this table. It is there for your reference.

For greater control, the automatic system can always be temporarily overridden by using one of the three modifier keys described above. If you desire, you can additionally disable the automatic context feature entirely in the options menu.



**GROUND CONTROL:
DARK CONSPIRACY**

MESSAGE FROM SARAH PARKER

“Jarred and I did manage to stop Enrica and Aegeri from activating those blasted Xenofacts, and in the process, practically destroyed Order influence on Krig. That’s a good thing. However, we also managed to destroy our only way off this backwater planet and we are surrounded on all sides by a very irate Crayven army waiting for their mothership to return. Without a strong Order presence to keep them in check, the Crays are seizing every part of Krig they can get their grubby little hands on. Order troops are scattered all over the place looking for a rock to crawl under and somehow, someway, Jarred and I have to keep our troops from killing each other and find some way to continue our fight. Victory is a temporary state of being. The fight isn’t over...it’s just beginning.”

TABLE OF CONTENTS

Message from Sarah Parker **2**

Table of Contents **3**

Introduction **4**

 System Requirements 4

 Installing Ground Control: Dark Conspiracy 5

 Installing DirectX 5

Background **6**

 The Crayven Corporation 9

 The Order of the New Dawn 11

Quick Start **14**

Playing the Ground Control: Dark Conspiracy **15**

 Single Player Game 16

 Multiplayer Game 17

 Options 17

 Credits 17

 Playing the original Ground Control through the expansion 18

The Management Interface **19**

 Briefing 19

 Configure Dropships and Squads 20

 Mission Debriefing 21

Multiplayer **22**

Technical Manual **24**

 Crayven Corporation Units 24

 The Order of the New Dawn Units 28

 Phoenix Units 32

Credits **62**

Customer Services **68**

Warranty **69**

Technical Support Policy **71**

SYSTEM REQUIREMENTS

The Ground Control Direct Command Interface System (GC-DCIS) requires that your Command APC onboard computer is equipped with:

Pentium II 233MHz or Pentium II 200 with a 3D Accelerator Card
32 MB RAM
350 MB Hard Drive Space (may change)
CD-ROM: 4x or better
640x480 SVGA high color (16-bit) 4 MB Video Card
DirectX 7.0a (included on this CD)
Windows compatible sound device
Mouse and Keyboard

Recommended System Requirements

For Maximum combat performance Sarah Parker recommends the following:
Pentium II 333 MHz or better
64 MB RAM
3D Accelerator Card (Glide or Direct 3D compatible)

INSTALLING GROUND CONTROL: DARK CONSPIRACY

It is recommended that you run Disk Defragmenter on the current hard drive before you install the game. Disk Defragmenter is activated via the Start button on the Windows task bar in the [programs/accessories/system tools] group. Follow its instructions.

Insert the Ground Control: Dark Conspiracy disc into your CD-ROM drive. Note: You must have the Original Ground Control game installed in order to install Ground Control: Dark Conspiracy. Ground Control: Dark Conspiracy will check for the original version and update it if necessary before proceeding with the installation of Ground Control: Dark Conspiracy.

If no instructions appear, double-click the "my computer" icon on your desktop. Double-click on the CD-ROM drive icon. In the file window, double click on the file icon AUTORUN.EXE. Follow the instructions on screen.

Installing DirectX 7.0a

Ground Control: Dark Conspiracy requires Microsoft DirectX 7.0a or higher to run properly. If you have the original game installed, you should have the latest version of DirectX already on your computer. There is also a copy of DirectX on the Ground Control: Dark Conspiracy CD, in case you wish to re-install.

BACKGROUND

Memo

To: Mr. Conner Drake

From: Director Wallace Davidson

Date: 019-2419

Re: Parker/Mercenaries

Mr. Drake,

I will of course take care of Parker. I'll need to acquisition some additional equipment and squads to ensure success, so please authorize under code Aw2-14-b. I have already issued a release about Parker's actions on Krig and the vultures are eating it up. Pretty soon, nice old ladies are going to want that Parker dead. The Order clean up on Krig is going smoothly and I'm sure you will be pleased with my progress. I also need you to authorize payment for the Crim-12 Mercenaries we hired a few months ago. Their leader Cobb isn't happy about the wait, but I told him he's lucky we let them operate at all. I hope that was all right. I had one of our engineers compile a list of their known equipment and have attached it. They have once again requested 30 tons of scrap in this shipment, so if that's all right, I'll need your authorization for that as well. Thank you sir.

Director Wallace Davidson

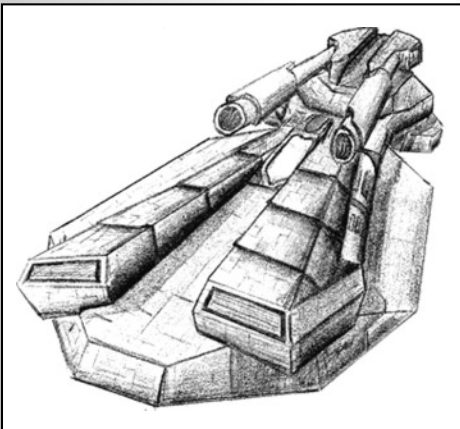



Memo

To: Director Wallace Davidson
From: Connor Drake
Date: 019-2419
Re: Krig 7-b

Davidson,

As you well know, Enrica Hayes' attempt to seize control of the Krig Xenofacts was brought to an immediate and screeching halt by Sarah Parker and Deacon Jarred Stone. Hayes' unauthorized alliance with the Order Commander Aegeri and very public defeat needs to be spun very quickly. The masses may be apathetic, but the last thing we need is them to turn Parker into some sort of Joan of Arc. Continue to expand our control over Krig and wipe out the last of the Order army on the planet. Pin whatever you have to on Parker. Parker's responsible for Krig, the deaths, and the national debt. Is that clear? After you leak all that information to the press, you'll be free to eliminate her and her Order friends. She doesn't have a way off the planet, and I expect this to be taken care of immediately.

Drake

BACKGROUND

Memo

To: Davidson

From: Connor Drake

Date: 19-2419

Re: Backbone!

Davidson, just punch in the code yourself, and stop bothering me with petty details! Do you think I care that a bunch of junk-mongering Mercs wants a pile of scrap? Just pay them off and deal with this problem. I trust you won't be bothering me again until Parker is taken care of.

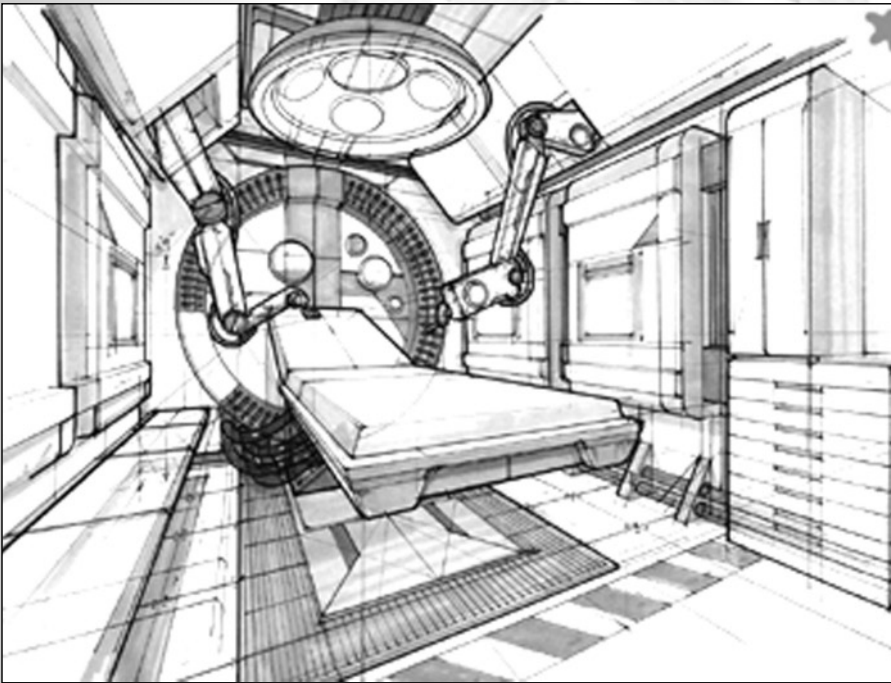

CRAYVEN CORPORATION



Press Release

Major Parker had all the signs of being a problem case. She applied for a position in the Crayven Security the exact moment she reached the age of consent at 14. After her training period, marred by several incidences of excessive force during combat exercises, she entered the Powered Infantry Corps. During an acquisition Operation against an illegal TerraTech claim on Wolf 328-3A, Parker; then a Corporal, almost single-handedly ruined the operation. Luckily, her superior was able to seize victory despite Parker's mistakes.

Sarah Parker quickly rose through the ranks, (research indicates a great deal of questionable field promotions where her field commanders suffered questionable injuries.) She was asked to take training as a Commando and accepted the transfer in 2409. She achieved the rank of Major by the age of 28. She was a competent, if unimaginative officer until the Battle of Hanson's Rift in 2412.

Major Parker's Commando unit was stationed at firebase Zulu on the main continent of Sigma Draconis when it was attacked by the Order of the New Dawn, who had declared the planet sacred ground and filed Jihad against any corporate holding that did not immediately evacuate. The firebase was cut off and subjected to wave after wave of attack. When relief finally arrived, they found no Crayven survivors except for a badly wounded Major Parker, whose bunker was surrounded by over 800 Crusader bodies. No one is certain how Parker was able to survive, while her entire unit perished. Current events show a possible link to the Order, and there is an investigation to determine whether or not Major Parker allowed this atrocity to happen.

BACKGROUND

Unable to substantiate a case, Parker was returned to combat duty. Her CO noted that Parker was acting strangely since her return from Sigma Draconis. (Perhaps feeling guilty about her actions.) The quality of her performance became a problem. And things came to a head during a boarding action when she refused a direct order to void the atmosphere of an Order Drop ship.

After suffering a fine for her misconduct, Major Parker requested a transfer back to standard ground control, where she has remained to this day. Time and time again she has refused to carry out special commands given her regarding efficient termination of Enemy Assets. She has been in front of a performance review board twice in the past 6 years, but each time the lack of substantial evidence has won her a stay against dismissal.

Currently, Sarah Parker has lost her ranking as Major in the Crayven Corporation, and is wanted for criminal terrorist action on Krig 7-b. She is accused of working with Order forces to subvert Crayven holdings on Krig. Sarah Parker is to be considered extremely dangerous and her whereabouts reported immediately.

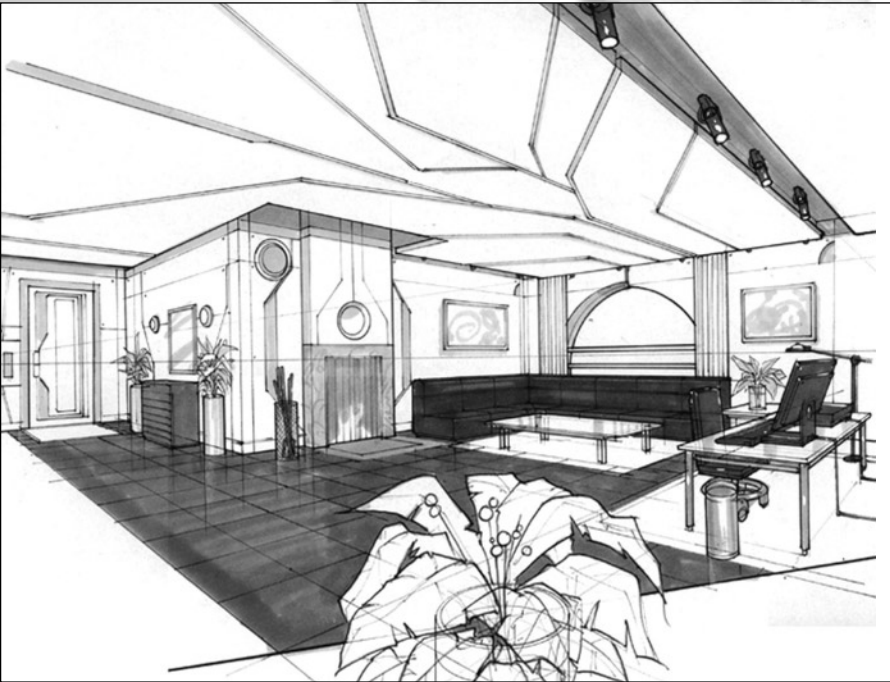

ORDER OF THE NEW DAWN**Personnel Files**

Memorandum

To: Cardinal Balor
From: High Bishop Leoric Hayzer
Re: Jarred Stone

Greetings Lightsister. I have requested your assistance on this particular situation because of your exemplary record, and your reputation for diplomacy. This matter of Deacon Stone must be handled with the utmost care. I have not yet issued a formal statement, but we cannot for one moment admit that he is acting of his own free will with this heathen Parker even if it was against the treachery of Cardinal Aegeri. I would like you to prepare a formal release to be presented to our children this evening on Lightspan. When the show airs, we will paint this Parker woman as the puppeteer, and Stone as a poor helpless victim. Perhaps even a hostage. It is imperative however, that you locate him as soon as possible without implicating the Order, and above all else do not let him fall into the clutches of the Crays. They would gladly do anything they could to capture him alive and use him against us in front of our people. We cannot afford this loss of face. I repeat, Jarred Stone must never return to speak of his actions on Krig 7-b. In addition, I have included an encoded list of suspected accomplices to Cardinal Aegeri. It is possible that these betrayers of the Sun will seek to continue Aegeri's plans. I leave them to your merciful hands Balor. Do what you must. Sacrifices must be made. Walk in the Sun my sister.



Jarred Stone Bio

Jarred Stone was born behind the walls of the Rosario Sanctuary, in an Order hospital which had opened its doors to the poor, and was adopted by the Order of the New Dawn. He was given the name Jarred Stone, after the doctor and nurse who delivered him, and taken to the Light of the Pampas Children's Collective, where the sisters of the Manus Dei cared for him until his 14th birthday. At this point, vocational testing revealed he would best serve the Order in the ranks of the Pax Dei, as a soldier. And so he was sent on to the Forge of Dawn combat seminary.

His first combat trainer, the Paladin Valerius, was so impressed with Brother Stone's aptitude for war that he made only one comment on the young man's chart: "Jarred Stone will make a perfect soldier; his body is strong and his Faith is stronger. His one weakness may be that he has no weakness-even when faced with the impossible, he shows no fear, no doubt, no hesitation.

In the first year of active duty, Stone served on the line in no less than six armed conflicts, including the battle of Guderian Prime. There Stone led two squads of Crusaders over the walls of a Benton-Yutan mining fortress, and destroyed the automated turrets which held the rest of his company pinned against the bluffs. The lives of over a hundred of his fellow Crusaders were thus saved, and although Brother Stone was badly injured, he was still able to negotiate a peaceful surrender of the fortress without further bloodshed, once he realized that his commanding officer had been killed in the fighting.

Brother Stone's initiative and valor earned him a short rest at the Nova Roma Sanctuary, where he received treatment for the injuries he suffered on Guderian Prime. As soon as he was able, he rejoined his Company in a fleet action at King's cross, where the Armada of Dawn captured two heavy cruisers belonging to Dai Sheung Heavy Industries. Brother Stone

distinguished himself once more in the boarding action against the DSS Seoul's Champion, when he broke through an enemy barricade and rescued several brothers of the Vox Dei. The brothers, who had been captured by Dai Sheung when their temple on King's Cross 3 was destroyed, were being held onboard the Lafayette for ransom. As a reward for his extreme heroism, Jarred Stone was promoted to the rank of Deacon and given command of his own Company.

Memorandum

Deacon Stone's current actions on Krig 7-b should not be considered his own. The Order believes that Stone's behavior is a direct result of the treacherous actions of Sarah Parker. She has most likely taken Stone against his will and is forcing him and his personal Company to follow her. Deacon Stone is to be brought immediately to Cardinal Balor's attention. Do not attempt to make personal contact with him. We cannot underestimate the extent of Parker's control over Stone. Pray with us my children, and bring our Brother home.



QUICK START

For those commanders eager to continue their battles, here are some quick start instructions.

The Install process should have created a shortcut on your desktop or task bar. Be sure to click on the Ground Control: Dark Conspiracy icon, not the original Ground Control icon.

Once you arrive at the Main Menu, click on the SINGLE PLAYER button. Click on the NEW GAME button. This will start the first mission for Ground Control Dark Conspiracy.

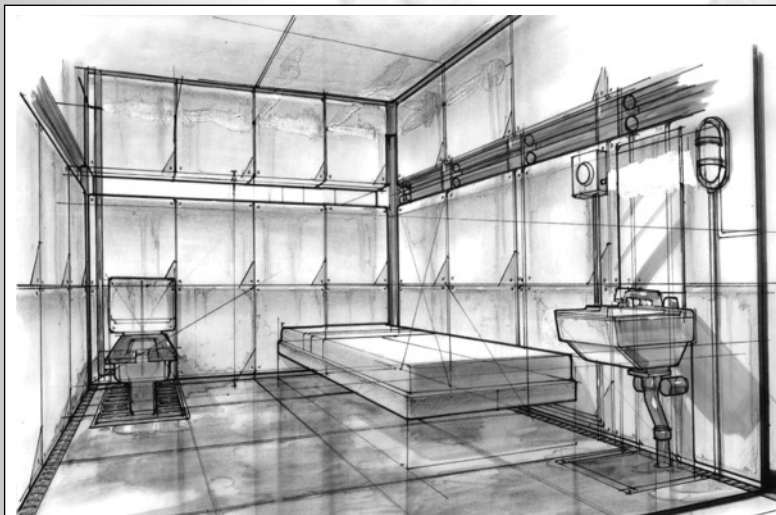

PLAYING GROUND CONTROL: DARK CONSPIRACY

In Ground Control: Dark Conspiracy, you continue playing the role of Major Sarah Parker, Commander of what is left of the special operations task force on Krig-7B. Your first goal is to find a way off Krig-7B. From there, you're on your own.

When starting new missions, make sure you take the time to configure your dropships and squads. This could mean the difference between success and failure.

Squads

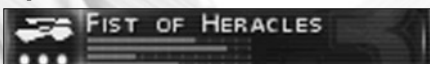

There are 4 types of squads: Infantry, Assault, Support, and Aerodyne. Refer to the original Ground Control manual for details on these squads.

Dropships

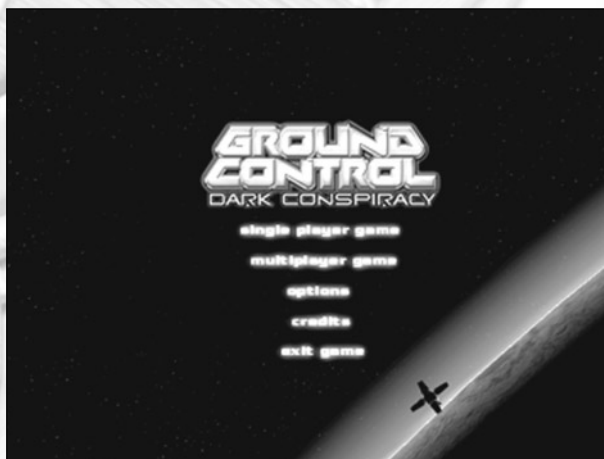

Your force is usually brought down to the battlefield in a large AV/ U4 "Behemoth" dropship. There may be some missions where you will not use a dropship. If this is the case, you will not be able to configure your squads before the missions start (and will thus skip the Dropship and Squad configuration screens).

Single Player Game



Single Player Game allows you to access the single player game options. Select New Game to start a new game in the Ground Control: Dark Conspiracy Campaign. If you have a previously saved game, you can select Continue Game to continue from your last successful mission. You can also continue a previous mission you completed by loading it from the Load Game option. Likewise you can play custom games by selecting the custom Game option.

Multiplayer Game



Multiplayer game allows you to engage in multiplayer battles over the internet or on a LAN (Local Area Network). A multiplayer game requires you have access to the internet or a LAN in order to run.

You can play original multiplayer maps with the new faction (The Phoenix). Keep in mind that you need to run Ground Control: Dark Conspiracy to play with the Phoenix faction. If you run the original Ground Control, the Phoenix faction will not be accessible.

OPTIONS

Options allows you to modify the performance of Ground Control: Dark Conspiracy or to configure the controls. Note that all changes only apply to the current commander.

CREDITS

Credits will show you the hard working people who brought Ground Control: Dark Conspiracy to life. Return to the main menu by pressing ESC on your keyboard.

Playing the Original Ground Control Through the Expansion



Ground Control: Dark Conspiracy is firmly rooted in the Ground Control Universe. For the complete story experience you may wish to play through the first two campaigns and then continue with the expansion. To make this possible, once Ground Control Dark Conspiracy is installed, it unlocks the original campaigns. You can play through the entire Crayven and Order Campaign easily and without exiting Dark Conspiracy. Just click on SINGLE PLAYER, and then click on CUSTOM GAME. In the CUSTOM GAME menu, you should be able to see the original campaigns in their entirety. Select any one you would like to play by simply clicking on it!

THE MANAGEMENT INTERFACE

As a Field Commander, it is your duty to make sure your squads are properly prepared for your mission.

BRIEFING

Mission briefings will be given before each mission. Pay special attention to the briefings as they give important information about mission objectives.



After you hear the mission-briefing, make sure you configure your dropship with the proper troops.

CONFIGURE DROPSHIPS AND SQUADS



The Artificial Advisor will automatically configure your dropships and individual squads, but you should always think about which troops you want in missions, and adjust them accordingly. Remember that there will be different limits on what squads are available based on what mission you are about to take on.

See original Ground Control manual for specific instructions on configuring dropships and squads.

MISSION DEBRIEFING

After a mission you will be presented with a debriefing screen. This will explain the mission, if it succeeded or failed, and show you a progress map (if you are playing a campaign).

You can see statistics of the mission by selecting the Statistics option.

If you failed the mission, you can click Restart Mission to try again. If the mission was successful, click Next Mission to go to the briefing for the next mission. Note that you will receive replacements for squads killed in battle. Your progress is automatically saved in between missions like in the original Ground Control game.



MULTIPLAYER

We have some new maps developed just for Ground Control: Dark Conspiracy. These maps were created by Massive Entertainment, Ground Control's developers. Here are detailed descriptions of these action packed new maps

AS4_Salamander (4 Teams)

-Assault-

Another base defending and attacking mission but this time for four teams. Each team has a beacon; these beacons are the team's key to reinforcements.

When a team moves close to an enemy beacon it is destroyed and the team owning that beacon will not be able to get any more reinforcements.

BF1_GrandMelee (2 Teams)

BF2_Vengeance (2 Teams)

-Battlefield-

This is a deathmatch map where players capture dropzones as they advance towards the enemy. Initially there are nine dropzone locations around the area. When a player moves a squad close to a zone it is "captured" and a dropzone will be available at that zone. The team with the highest score when the time runs out wins.

DM8_Colosseum (8 Teams)

-Deathmatch-

An arena style deathmatch played out on a circular, bumpy metallic map. The gray concrete and white metal sparks set a glum tone for this 8-team deathmatch free-for-all map. The map is best played without reinforcements. Last man standing, survives.

ES2_Riverbed (2 Teams)

-Escape-

Team one must proceed from their dropzone and make it to their escape zone while team two has to prevent them from succeeding to reach their goal. Alarms have been placed around the middle of the area giving team two hints of where the escapers are trying to pass.

ES3_NoneShallPass (2 Teams)**ES4_Pincer (2 Teams)*****-Escape-***

Team one must get away from their dropzone while preventing team two from reaching their escape zone. The second team must also get away from their dropzone and flee while preventing the first team from reaching their escape zone. The two teams will have to cross each other lines to be able to get to their respective escape zones.

FZ10_Islands (4 Teams)***-Flagzone-***

This standard flagzone mission is a huge map with zones placed on strategic locations. The player controlling all five will win the game.

SK2_FieldOfDestruction (1 Team)***-Skirmish-***

This map is another skirmish mission where the single player team is dropped at the center of the map and enemy attacks can come from anywhere. A lonesome player can play the mission, to do this you should select LAN, choose the map and just start the game alone. The human players win if they reach the score limit before the time limit runs out. They lose if the time limit runs out, unless of course time limit is 0.

SO1_TheAtoll (2 Teams)**SO2_RedRocks (2 Teams)****SO3_Dunes (2 Teams)*****-Shoot Out-***

Yet another type of multiplayer maps where two teams battle over three different areas on each map. The team that wins at least two of the battles is the winner. A battle is won when only one team is left on an arena. Only one area is played at a time, when the battle is won but either side the battle is moved on to the next area.

TN3_CaptureTheTruck (2 Teams)***-Truckers Nightmare-***

A modified Truckers Nightmare mission where you have to capture the enemy truck and bring it to your own base while you will have to protect your own truck from being captured. A sort of capture the flag type of game but slightly modified. When the squad capturing a truck is destroyed the truck is returned.

TECHNICAL MANUAL

This section contains unconfirmed information about new squad types, their statistics, equipment, and special weapons.

CRAYVEN CORPORATION UNITS



Support Unit

CRAYVEN RADAR TERRADYNE

CCRTR-11 The Bat

| | | | |
|-------------------|----------------|-------------------|-----------------|
| Firepower | <i>Low</i> | Armor | <i>Good</i> |
| Health | <i>Low</i> | Speed | <i>Good</i> |
| View Range | <i>Extreme</i> | Stealth | <i>Very Low</i> |
| Perception | <i>Good</i> | Tech Level | <i>7</i> |

The newest addition to the Crayven Support team is the Radar Terradyne. Heavily armored and lightly armed, it is designed to safely get near enemy encampments and relay this information back to the ground units for accurate deployment.

The Radar terradyne is equipped with the prototype Oracle-164 triangulation device. With this system the radar terradyne can pinpoint within 5 meters the location of enemy targets from well out of firing range. The visibility of this unit is so powerful, it circumvents intervening barriers and allows for full targeting through almost anything. If the radar-dyne does come under enemy fire, it is

armed with the Welby-simms Cutter like the Scout vehicle. It is capable of holding off some troops, but cannot withstand continued attacks.

The radar-dyne is best used with protective tank units or aerodynes to make sure it safely reaches enemy range and gets an accurate reading.

Special Weapons

Atmospheric Ionizer: Targets air units with wide blast radius.

Charged particle Burst: focused attack that targets ground troops.

Equipment

Image Intensifier: When activated, improves view range for limited amount of time.

Repair Module: Repair module that allows simple repairs to armor plates and also includes several auxiliary backup systems.

Anti-Missile System: Protects the unit from incoming missiles.

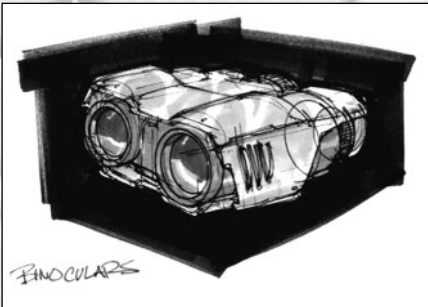

CRAYVEN POWER ARMOR

CCPWR-7 "Badger"



| | | | |
|-------------------|-----------------|-------------------|------------------|
| Firepower | <i>Good</i> | Armor | <i>Very Good</i> |
| Health | <i>Great</i> | Speed | <i>Very Low</i> |
| View Range | <i>Very Low</i> | Stealth | <i>None</i> |
| Perception | <i>None</i> | Tech Level | <i>7</i> |

The Crayven Power Armor is designed to supplement the infantry. Only the best infantry soldiers are chosen to pilot these destructive suits. Crayven Power armor is protective enough to take on tanks head-to-head, while remaining mobile enough to maneuver difficult terrain and even load into the APC. This is extremely important due to the slow ground speed of the power armor. Powered Armor is not right for all missions however; the suits are heavy and uncomfortable. On planets with increased gravity, the suits become unbearable.

The primary weapon of the Crayven Power Armor are the twin Welby-Simms Penetrators. These chain-guns are designed to punch through most tank armor plating. Crayven Power Armor is an exoskeleton personally fitted to its pilot. The interface helmet allows the pilot to make complicated movements quickly and easily and is able to stand against infantry and vehicles with confidence.

Special Weapons

AG-72 Short Range Perforator: A close ranged attack that does large amounts of damage to a small area. The perforator is very effective against infantry. 3 Charges.

RMM-13 Heavy Infantry Mortar: A mortar weapon similar to the standard Marine special weapon that is capable of penetrating heavy terradyne armor. 3 Charges

Special Equipment

Medkit: Personal medkit capable of extreme healing acceleration, repairing damaged tissues, also includes basic tools for armor field repairs. 3 charges.

Entrench: This is a special modification the Powerarmor may choose that allows it to “plant” itself and raise it’s defensive abilities. This lowers its movement rate to O. 1 Charge.

THE ORDER OF THE NEW DAWN UNITS**ORDER FAITHFUL**

| | | | |
|-------------------|-----------------|-------------------|-----------------|
| Firepower | <i>Low</i> | Armor | <i>Very Low</i> |
| Health | <i>Very Low</i> | Speed | <i>Low</i> |
| View Range | <i>Good</i> | Stealth | <i>Good</i> |
| Perception | <i>None</i> | Tech Level | <i>7</i> |

Not all the followers of the Light who wish to become members of the Pax Dei are able to withstand the rigors of training. The Order, in its infinite wisdom, has found a place for these “soldiers” of the light. The Order Faithful are in technical terms, “fodder”. The Faithful as a group wish only to serve the Order, and if the only way to accomplish this is by blocking gunfire with their body...so be it.

As individuals, Faithful are poorly trained and equipped for combat. They wear the lowest grade armor available to the Order, which is basically a robe laced with mesh. Faithful are armed with archaic pulse-bolt throwers with surprising function reliability. As a group however the Faithful are a sight to behold. Their units are quite large and they have absolutely no fear. Even more frightening is the tendency of the Faithful to rush a larger target, (such as a tank) and to detonate massive amounts of explosive. Thus destroying the tank, and themselves. This disregard for their own lives is what makes the Faithful so fearsome on the battlefield.

Faithful may also be armed with flechette guns, which launches a spray of foot-long metal needles at their target. These will tear through the armor of infantry and some lighter tanks.

Special Weapons

Needle Spray: A Flechette barrage of long metal projectiles that tears through infantry, but is fast enough to hit air units. 3 charges.

Fires of the Damned: A gout of flame erupts from the faithfuls rifle. The range is short with limited blast radius. 3 Charges.

Equipment Medkit: Personal medkit capable of extreme healing acceleration, repairing damaged tissues, also includes basic tools for armor field repairs. 3 charges.

Holy Martyrdom: The faithful use a detonator to destroy themselves to do a massive attack. The attack does the damage over a large area, centered on the current location.

Deployable Defender System: The defender system shoots down incoming missiles rockets and grenades when deployed. Once deployed it cannot be moved. 1 Charge

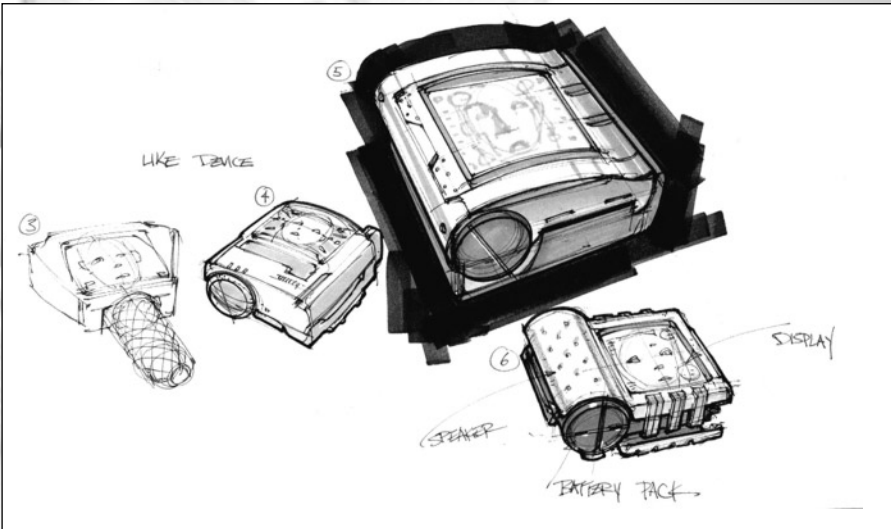

ORDER POWER ARMOR

CCRTR - "The Gibbon"



| | | | |
|-------------------|--------------|----------------|-----------------|
| Firepower | <i>Good</i> | Armor | <i>Great</i> |
| Health | <i>Great</i> | Speed | <i>Very Low</i> |
| View Range | <i>Low</i> | Stealth | <i>None</i> |
| Perception | <i>None</i> | Tech | <i>Level 7</i> |

The Gibbon, so named because of the Armors resemblance to a simian, is the Orders first foray into Powered Armor production.

Thus far, the Armor has proven very useful and powerful in combat. The armor, which boasts a retrofitted Rover 8005 battle engine, moves quite quickly for such a large suit. The armor is extremely flexible, using Plasteel plates and an experimental Flex-skeleton. The pilot does not fit directly inside the suit. He is seated in a gyro-stabilized seat in the "hump" of the suit allowing him to see out the visor. Just above the pilot is the Plasma accelerator cannon, which is powered from the mini-reactor housed in the armors stomach. The Gibbon is able to entrench itself thus protecting it greatly from incoming attacks, however it cannot move at all when entrenched.

The Gibbon is able to traverse difficult terrain far easier than most tanks and add the protective benefit to the infantry troops. Gibbon armor is proving cheaper to produce than Main Battle Hoverdynes, and with their protection and freedom of terrain, the armor is quickly becoming popular with many field Commanders.

Special Weapons

Close Range Energy Perforator: A close ranged attack that does large amounts of damage to a small area. The perforator is very effective against infantry. 3 Charges.

GrU-9 RSAAMS Missiles Mk.7: Similar to the Templar, the Gibbon launches high arcing rockets that target ground units. This attack has more range than the standard Powerarmor attack. 3 Charges

Equipment

Medkit: Personal medkit capable of extreme healing acceleration, repairing damaged tissues, also includes basic tools for armor field repairs. 3 charges.

Entrench: This is a special modification the Powerarmor may choose that allows it to "plant" itself and raise it's defensive abilities. This lowers its movement rate to 0. 1 Charge.

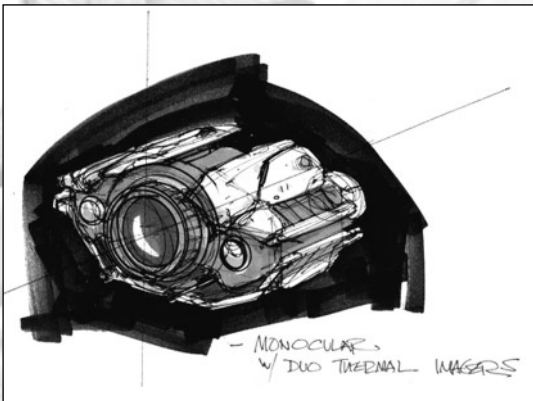

PHOENIX UNITS



The Phoenix Mercenary Faction makes its home on the Planet Crim-12. Every society has its outcasts and Crayven is no exception. Many people found themselves suffocated under the corporate structure and unable to function. Some of these people even spear-headed groups that proposed changes to alleviate some of these problems. The Crayven Corporation discovered that it was more economically sound and less public to simply relocate these people to another planet. The original refugees were left on the planet with little equipment and supplies. Crim-12 had long ago been mined for its resources and was considered without value.

Left to their own devices, this group scavenged what they could from the area and old bases, and battlegrounds. The refugees refitted old vehicles and bases and began to rebuild their own society from the scraps of the Order and Crayven. Engineers and ex-soldiers and people tired of the Crayven Corporation eventually found their way to the independent planet of Crim-12. One man, Patrick Spanning a former Corporate Executive, predicted that if they continued to grow, Crayven would start noticing them, and he was right. In order to avoid repercussions and the loss of their hard-won society, Patrick worked out a solution. The refugees would agree to handle tasks and missions that Crayven could not; any missions where Crayven had to remain anonymous or just couldn't be bothered. In exchange, the refugees were allowed to stay on the planet and were paid in scrap.



The Phoenix Mercenaries were able to build an effective army under the guidance of former Crayven Soldier Kristoff Cobb. Phoenix soldiers weren't the hard-nosed marines of Crayven, but they got the job done. Their vehicles were built from existing vehicles and re-fitted with Pyro-tech engines, which combined hover technology and fossil fuel

burning for their own unique propulsion system. The powerful propulsion system's main drawback is its slow and deliberate acceleration.

Phoenix Command APC

10496-DJ- "Charon"

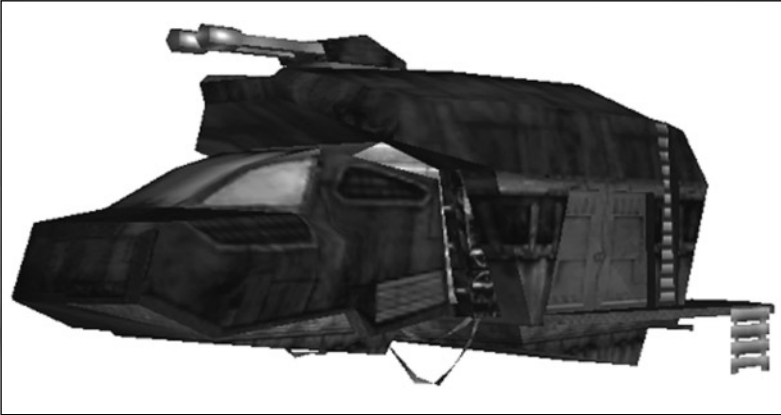

| | | | |
|-------------------|------------------|-------------------|---------------|
| Firepower | <i>Medium</i> | Armor | <i>Medium</i> |
| Health | <i>Excellent</i> | Speed | <i>Good</i> |
| View Range | <i>Medium</i> | Stealth | <i>None</i> |
| Perception | <i>Low</i> | Tech Level | <i>n/a</i> |

The Phoenix Command Apc is designed to be the heart of the Phoenix Army. From this vehicle the Commander issues orders and examines the data transmitted from scout vehicles in order to plot the best course of action. The Charon is designed to carry up to 20 Phoenix infantry units for swift transport into battle. Infantry are able to load and unload quickly through the hydraulic lift gates.

The APC is layered with sheets of reinforced Plasteel and laced with a titanium mesh, making it one of the sturdiest vehicles on the battlefield. The APC is not meant for extended heavy combat and is armed with a modified plasma-shell ejector that is able to dissuade most attackers. A HERA-432 particle agitator repair module is loaded onto the APC to repair friendly units quickly and efficiently. It is also outfitted with a twin retro-fitted Pyro-tech engine that efficiently carries the heavily armored vehicle across the battlefield.

The Charon carries a team of four, the Commander, two engineers and a pilot. The pilot doubles as a gunner, leaving the two engineers to handle any problems with the Pyro-tech engines.

Phoenix Infantry

PXWR 5113 "Warriors"



| | | | |
|-------------------|-----------------|-------------------|-----------------|
| Firepower | <i>Low</i> | Armor | <i>Good</i> |
| Health | <i>Very Low</i> | Speed | <i>Very Low</i> |
| View Range | <i>Good</i> | Stealth | <i>Good</i> |
| Perception | <i>Great</i> | Tech Level | <i>1</i> |

Phoenix Warrior's are the backbone of the Phoenix mercenary army. Body armor is not easily come by on Crim-12, and Phoenix warriors are not heavily armored. Phoenix warriors come from all walks of life and their abilities are varied. Their primary weapon is a rebuilt Carbine rifle that is light enough to be operated without an exoskeleton. Their jumpsuits are layered with protective inlaid mesh that provides some protection against ballistic and energy attacks; but it's minimal at best.

Phoenix Warriors are also able to deploy special Hyper-Accelerated Plasma Charges that are able to destroy almost any single unit with one shot. This ammo is extremely unstable and they only carry a few rounds at a time. A tactic is to use this ammo to strafe the area, thus spreading the damage to more units.

The Phoenix warriors can be loaded into the Command APC for swift transport.

Special Weapons

Hyper Accelerated Plasma Charges: A burst of plasma that is capable of destroying almost any unit with a single blast.

Plasma Grenade: Similar to what the Furies use, the Warrior launches a fiery grenade at its target damaging more targets.

Equipment

Medkit: Personal medkit capable of extreme healing acceleration, repairing damaged tissues, also includes basic tools for armor field repairs.

Booster Station: This is a special Phoenix item that raises selected stats of friendly nearby units.

Deployable Radar: Small portable radar station that once deployed, relays all tactical information to the Command APC.

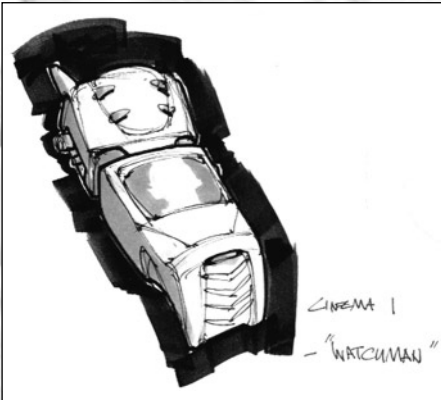

Phoenix Special Forces Troops

PXSNP-1113 "Snipers/Lynceus"



| | | | |
|-------------------|-----------------|-------------------|----------------|
| Firepower | <i>Great</i> | Armor | <i>Low</i> |
| Health | <i>Very Low</i> | Speed | <i>Low</i> |
| View Range | <i>Extreme</i> | Stealth | <i>Extreme</i> |
| Perception | <i>Great</i> | Tech Level | <i>2</i> |

Most Phoenix tech is experimental and the Sniper units are fitted with the newest equipment. Snipers are the swiftest and snekiest of all the Phoenix ground troops. Snipers are outfitted with very thin micro-fiber suits, which are designed to refract ambient light. This makes the Snipers extremely difficult to see. The lightweight suits enable them to cover ground quickly and handle stealth missions perfectly.

All Snipers are armed with high-powered long-range rifles. These rifles are deadly when employed against infantry; the rounds are designed specifically to penetrate the protective outer layer of Crayven and Order troops without losing velocity. They may also use special anti-tank rounds that are housed in unstable energy sheathes and designed to puncture tank armor and explode.

Snipers are also equipped with light enhancing visors. The visors can penetrate even the blackest night, and are able to magnify the objects in the distance for more precise shots, giving them vast line of sight. Snipers are meant to be used from a distance and cannot hope to withstand close

combat with even normal infantry. Snipers can be loaded into the APC for swift transport.

"I've seen Phoenix Snipers pick a spot and settle in and become stone for hours at time. They just wait, and wait, and hold that rifle in place; and the minute their target shows...boom. One shot and it's over. The guy never heard the shot that took him out. "

Special Weapons

"Ares" Armor piercing rounds: Anti-tank rounds that will usually obliterate a tank with one clean shot.

"Hermes Rounds": Similar to the anti-tank rounds but usable against both land and air targets.

Equipment

Medkit: Personal medkit capable of extreme healing acceleration, repairing damaged tissues, also includes basic tools for armor field repairs.

Vision: Increases view range of all friendly units for a short time.

Disruptor: Affects targets weapons and slows their rate of fire.

Phoenix Power Armor

PXPAR/3676 "Talus"



| | | | |
|-------------------|-------------|-------------------|-----------------|
| Firepower | <i>Good</i> | Armor | <i>Great</i> |
| Health | <i>Good</i> | Speed | <i>Very Low</i> |
| View Range | <i>Good</i> | Stealth | <i>None</i> |
| Perception | <i>None</i> | Tech Level | <i>7</i> |

The Phoenix power armor is basically a walking tank. It lacks the streamlined appearance and speed of most power armor. But its lumbering power is still evident. Designed to traverse the difficult terrain of Crim-12, the Phoenix power armor has the back bent legs of swift ground fowl. This design steadies the armor and makes it difficult to tip over.

The suit is protected by sheets of tank and hoverdyne armor, shaped and welded into place. Its heavy armor allows it to close range and use its perforator Mk3 to greatest effect. The suit may also target air or ground units with its super-heated plasma burst, powerful enough to destroy a target with one shot.

Special Weapons

MK3 Short Range Perforator: A close ranged attack that does large amounts of damage to a small area. The perforator is very effective against infantry.

Super Heated Plasma-Burst: Can target both air and ground units and will damage individual units.

Equipment

Medkit: Personal medkit capable of extreme healing acceleration, repairing damaged tissues, also includes basic tools for armor field repairs.

Entrench: This is a special modification the Powerarmor may choose that allows it to “plant” itself and raise it’s defensive abilities. This lowers its movement rate to 0.

Mirage Cloaking Field: Cloaks squad when activated.

Phoenix Plasma-Grenadier

PXPGA-1025 "Furies"



| | | | |
|-------------------|------------------|-------------------|-------------|
| Firepower | <i>Good</i> | Armor | <i>Good</i> |
| Health | <i>Low</i> | Speed | <i>Low</i> |
| View Range | <i>Very Good</i> | Stealth | <i>Good</i> |
| Perception | <i>None</i> | Tech Level | <i>1</i> |

Plasma-Grenadiers are perhaps the bravest, or craziest of the Phoenix units. These ground troops wear backpacks of unstable plasma-molecules, which are accelerated when the soldier hits the trigger. This acceleration deploys bursts of white-hot explosive plasma that can tear down building or tank with swift ease. The backpack unit itself however is extremely unstable and dangerous to wear. The units have had a tendency to spontaneously combust in combat, but the Phoenix are still working out the bugs in the system. Grenadiers wear almost no armor; instead they wear an insulated flame-retardant suit and protective headgear. The deployment unit is heavy enough without the added weight of armor. For this reason, grenadiers are very easy to kill. They tend to stay behind a screen of tanks or power armor and send their waves of white-hot death over the heads of their allies to burn their targets.

Grenadiers may also supercharge their plasma, which creates condensed micro-nukes that deal horrendous amounts of damage to a small area.

Grenadiers may be transported in the APC for swift movement.

“Being burned alive is one of man’s deepest, and most primal fears. The Plasma-Grenadiers bring this fear to the battlefield. The appearance of their emotionless masks and white-plasma emitters is enough to break the sturdiest line of soldiers.”

Special Weapons

“Hades” Micro-nuke grenades: Has the same radius as normal grenades, but does massive amounts of damage within a small blast area.

Expanding Napalm Grenades: Fires a shell which continuously rebuilds itself and expands and burns a wider blast area.

Equipment

Medkit: Personal medkit capable of extreme healing acceleration, repairing damaged tissues, and also includes basic tools for armor field repairs.

Web: Targets enemies in a small range and covers them in a quick-hardening synthetic polymer that slows their movement.

Disruptor: Affects targets weapons and slows their rate of fire.

Vision: A retractable visor that increases the view range of the unit.

Phoenix Scouts

MHKPX 134 "Basilisk"

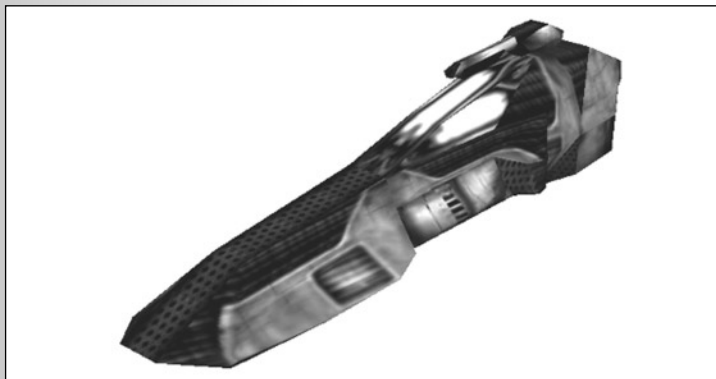

| | | | |
|-------------------|------------------|-------------------|-----------------|
| Firepower | <i>Low</i> | Armor | <i>Very low</i> |
| Health | <i>Low</i> | Speed | <i>Great</i> |
| View Range | <i>Extreme</i> | Stealth | <i>Great</i> |
| Perception | <i>Fantastic</i> | Tech Level | <i>1</i> |

Phoenix Scouts are used primarily for recon purposes. They have excellent viewing range and speed and are able to outrun almost any ground vehicle. It is powered by the Pyro-tech combustion engine and armed with turret-mounted slug-throwers. The scouts' best use in combat is to either hit-and-run, or concentrated rear attacks. The scout is very lightly armored to cut down on drag and cannot withstand combat with tank vehicles.

The Scout uses a modified version of the Orders' visual enhancing equipment to extend its viewing range. To outpace the most dogged opponents, the Scout can use a speed boost, which superheats the engine and gives it a short surge of power. Its versatile targeting system can fire on ground and air troops, but is not quite swift enough to be called reliable.

Special Weapons

Fireball: Flame barrage to wide blast radius.

Hyper Rockets: A triple-missile cluster designed to shatter enemy tank armor. Used against a single target.

Equipment

ADPP Repair Module: Tools and software for minor field repairs to armor plates and vital systems.

Web: Targets enemies in a small range and covers them in a quick-hardening synthetic polymer that slows their movement.

Vision: A retractable visor that increases the view range of the unit.

Rocket: A speed boost that propels the units forward with little actual control. Good for getting somewhere in a hurry.

Phoenix Light Tanks ACDMH 6541 "Chimaera"

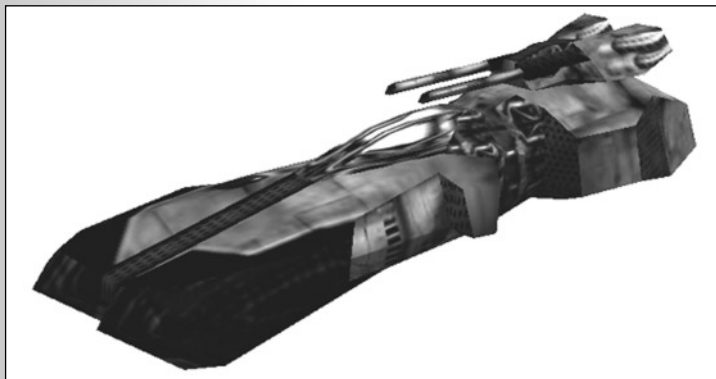

| | | | |
|-------------------|-------------|-------------------|------------------|
| Firepower | <i>Good</i> | Armor | <i>Good</i> |
| Health | <i>Low</i> | Speed | <i>Very Good</i> |
| View Range | <i>Good</i> | Stealth | <i>Low</i> |
| Perception | <i>Good</i> | Tech Level | <i>1</i> |

The Phoenix light tanks are used for swift attack runs at slower enemies and to draw them toward the more powerful units. Because of their Pyro-tech Combustion engines, the Light Tanks have the poor acceleration of most Phoenix units but once it starts rolling, it's practically untouchable. The Phoenix light tanks are more stable than hoverdynes. They are not heavily armored; using the standard riveted scavenged plates of most units. But Light Tanks tend to use the polysteel sheets of armor that are easily pierced by enemy fire.

The Tanks are armed with rotating mounted cannons that fire standard rounds at ground and air targets. The tanks are capable of issuing fireballs into ranks of infantry and tanks to soften up the enemy for their larger allies.

Special Weapons

Fireball: Flame barrage to wide blast radius.

Land/Air Plasma Emulator: Small area of effect that can damage both land and air targets.

Equipment

Rocket: A speed boost that propels the units forward with little actual control. Good for getting somewhere in a hurry.

Booster Station: This is a special Phoenix item that raises selected stats of friendly nearby units.

ADPP Repair Module: Tools and software for minor field repairs to armor plates and vital systems.

Phoenix Main Battle Tank JJDVS/3675 "Manticore"

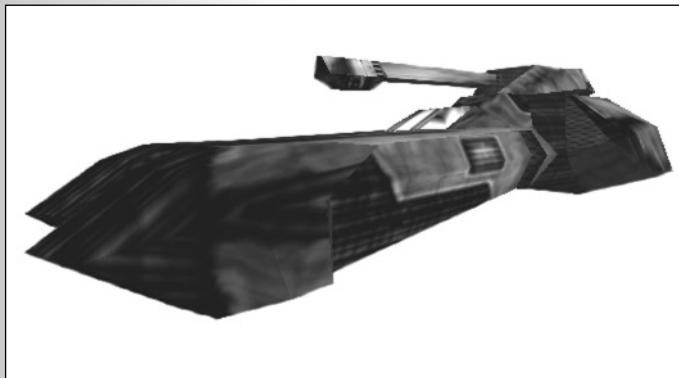

| | | | |
|-------------------|------------------|-------------------|------------------|
| Firepower | <i>Great</i> | Armor | <i>Very Good</i> |
| Health | <i>Very Good</i> | Speed | <i>Good</i> |
| View Range | <i>Good</i> | Stealth | <i>None</i> |
| Perception | <i>None</i> | Tech Level | <i>2</i> |

The medium tank is the offensive leader for the Phoenix army. With its dual heavy plate armor and experimental kinetic discharge field it is the most suited for head on assaults. It is mounted with twin cannons that fire molten shells of metal at their targets able to penetrate absolutely anything, and its powerful cannons can also fire explosive phosphorous rounds at ground and air targets. Its modified Pyro-Tech engine uses a continuous cycle instead of the normal exhaust. This process forces the pilot to be sealed inside the cockpit to avoid suffocation, but propels the armored vehicle forward at a disturbing pace. The Medium tank is slow to accelerate and turn and is not perfect for quick maneuvers. It is best supported with Lighter tanks or support vehicles.

Special Weapons

Hellenback Rockets: A barrage of rockets with a large blast radius.

Land/Air Plasma Emulator: Small area of effect that can damage both land and air targets.

Special Equipment

Rocket: A speed boost that propels the units forward with little actual control. Good for getting somewhere in a hurry.

ADPP Repair Module: Tools and software for minor field repairs to armor plates and vital systems.

Regenerate Units: Instantly repairs all units in a small area. Not as much as a personal repair unit.

Phoenix Heavy Tank LWHS-3-02 "Minotaur"

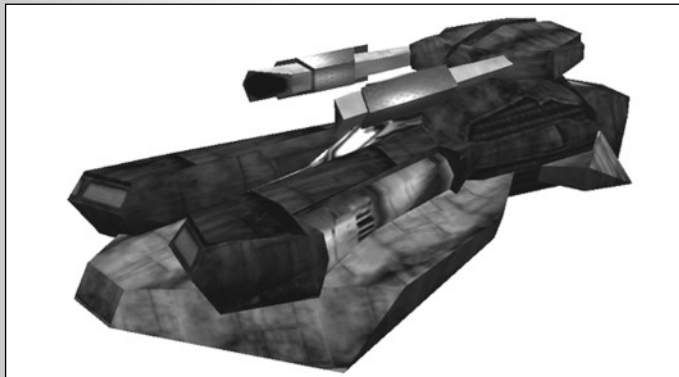

| | | | |
|-------------------|------------------|-------------------|--------------|
| Firepower | <i>Great</i> | Armor | <i>Great</i> |
| Health | <i>Excellent</i> | Speed | <i>Low</i> |
| View Range | <i>Good</i> | Stealth | <i>None</i> |
| Perception | <i>None</i> | Tech Level | <i>3</i> |

The Phoenix Heavy tank is basically a mobile gun. It is a slow moving, juggernaut of destruction. Unable to target air units, the Heavy Tank is usually kept in reserve until their targets are in close range. Once the Minotaur closes in on its target it unleashes a barrage of massive explosive shells that tear it to pieces.

The Phoenix Heavy Tank is a hybrid of Order and Crayven technology with Phoenix ingenuity thrown in. It is far more stable than the order Volans and better armored because of its polysteel/titanium shell. Its experimental cannons are far more effective than the large caliber guns on the Grizzly. However, it is ponderously slow and should only be used in certain circumstances. Like most large tanks, its lightest armor is in the rear and leaves it vulnerable.

Special Weapons

Hellenback Rockets: A barrage of rockets with a large blast radius.

Land/Air Plasma Emulator: Small area of effect that can damage both land and air targets.

Special Equipment

Rocket: A speed boost that propels the units forward with little actual control. Good for getting somewhere in a hurry.

ADPP Repair Module: Tools and software for minor field repairs to armor plates and vital systems.

Phoenix Pyro-Dyne

JMDP 1812 "Prometheus"

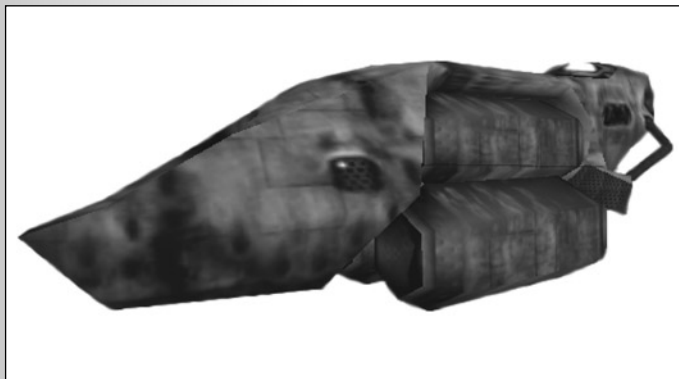

| | | | |
|-------------------|------------------|-------------------|------------------|
| Firepower | <i>Excellent</i> | Armor | <i>Good</i> |
| Health | <i>Good</i> | Speed | <i>Very Good</i> |
| View Range | <i>Very Low</i> | Stealth | <i>None</i> |
| Perception | <i>None</i> | Tech Level | <i>5</i> |

The Phoenix have taken their Pyro-tech to the next level with this fire-breathing monster. This tank's power is devastating to behold and is one of the "secret" weapons of the Phoenix. One that the Crayven Corp. has no idea about.

The Pyro-Dyne is armed with high-powered short ranged flame-jets. The unstable plasma accelerator is similar to the one used by the Grenadiers but to a higher degree. The bursts are ejected inside the craft, and then magnified by the accelerator. The flame jets strike with amazing force and can demolish buildings and tanks in seconds. Its main weakness is its poor range; the design of the Pyro-Dyne requires it to be very close for effective use.

The Pyro-Dyne is also capable of ejecting an explosive round of force called a Helios Flame that will devastate the nearby area, friendly units, and sometimes even the Pyro-Dyne itself.

Special Weapons

Hades Maelstrom: Gouts of flame erupt in the area around the Pyrodyne damaging all units in the radius, including the Pyrodyne itself.

High Radius Fuel: Similar to the Pyrodyne's normal attack, but with much greater intensity.

Equipment

ADPP Repair Module: Tools and software for minor field repairs to armor plates and vital systems.

Web: Targets enemies in a small range and covers them in a quick-hardening synthetic polymer that slows their movement.

Disruptor: Affects targets weapons and slows their rate of fire.

Helios Flame: Does massive amounts of damage to all the units in the area, including friendly units.

Phoenix Anti-air unit

JHCS-8813 "Icarus"



| | | | |
|-------------------|----------------|-------------------|-------------|
| Firepower | <i>Good</i> | Armor | <i>Good</i> |
| Health | <i>Good</i> | Speed | <i>Good</i> |
| View Range | <i>Extreme</i> | Stealth | <i>None</i> |
| Perception | <i>None</i> | Tech Level | <i>4</i> |

Icarus, as the anti-air unit has been named, is one of the newest additions to the support class of Phoenix vehicles. This sleek, maneuverable, craft is capable of tearing enemy aerodynes apart in seconds and bringing them crashing to the surface. The Icarus is designed around its unstable molecule plasma launcher. To lend to it's speed the Icarus is lightly armored and is better kept safe around large tanks.

The Icarus is armed with a first generation Plasma Launcher designed by Marc Herra. The cannon creates a ball of unstable plasma molecules, held together by a shell of energy and a wish. The shell is launched into the air and rapidly cools causing it to shatter. Once this happens the plasma erupts into several individual precalculated bursts. These bursts fly almost unerringly toward aerodynes and shred the light armor of the aerodynes.

The targeting system is based loosely on the Drone Carrier's system of rapidly calculating a pattern and determining the best placement for fire. Thus far the Icarus has proven itself on the battlefield and continues to impress.

Special Weapons

ADPP Repair Module: Tools and software for minor field repairs to armor plates and vital systems.

Deployable Defender System: Deploys a defendergun near this unit to protect it from incoming grenades, missiles and artillery.



Phoenix Artillery

STNK 336-11 "Hydra"



| | | | |
|-------------------|------------------|-------------------|-------------|
| Firepower | <i>Fantastic</i> | Armor | <i>Good</i> |
| Health | <i>Good</i> | Speed | <i>Good</i> |
| View Range | <i>Good</i> | Stealth | <i>None</i> |
| Perception | <i>Great</i> | Tech Level | <i>5</i> |

The Phoenix Artillery unit was one of the first support vehicles designed for the mercenaries. They realized early on the need for long-range support and responded accordingly. The mobile long-range capabilities of the Artillery unit are a powerful combination.

The Phoenix Artillery is fitted with the powerful dual Pyro-tech engine. Utilizing the same continuous cycle process as the main battle tank, the artillery swiftly makes its way across the battlefield. Its large size slows it down a bit but its primary focus is in the rear of the battle.

Choosing accuracy over power the Phoenix artillery is not as damaging as some artillery, however its quadruple barreled swivel cannons are capable of firing multiple rounds of white-phosphorous across vast distances with alarming accuracy. Its barrage will continue without a heartbeat between impacts and pound even the most resilient target into dust. The phoenix artillery is also capable of sending unstable nuclear-napalm shells, which continue to burn the area and targets long after it's shell has exploded. These are particularly nasty, and enemies speak horrifically of the screams caused by this weapon.

Special Weapons

Nuclear Napalm: The artillery focuses on one area and does continuous flame damage over time.

Anti-Plasma Destroyer Shells: Does incredible damage over a wide attack radius.

Equipment

ADPP Repair Module: Tools and software for minor field repairs to armor plates and vital systems.

Deployable Defender System: Deploys a defendergun near this unit to protect it from incoming grenades, missiles and artillery.

Phoenix Scout Aerodyne

DHVS 715-00 "Pegasus"

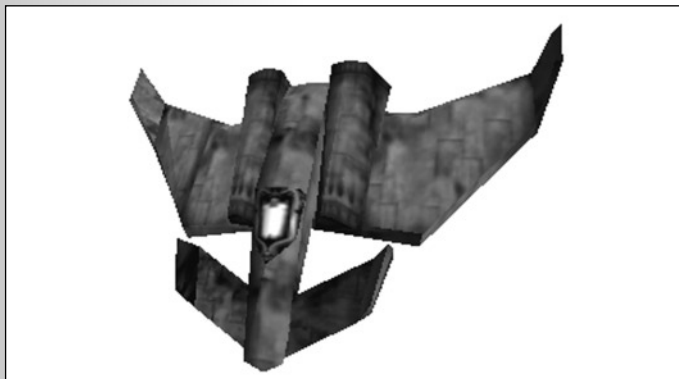

| | | | |
|-------------------|------------------|-------------------|------------------|
| Firepower | <i>Very Low</i> | Armor | <i>Very Low</i> |
| Health | <i>Good</i> | Speed | <i>Extreme</i> |
| View Range | <i>Excellent</i> | Stealth | <i>Excellent</i> |
| Perception | <i>Fantastic</i> | Tech Level | <i>1</i> |

The Phoenix Scout and recon vehicle is a short-range aerodyne. Used primarily to scout forward positions of enemy units, it is sleek and swift, and able to outrun most targets. The scout will then relay these positions to artillery and anti-air to begin targeting enemies early, and leave the remnants for the tank and infantry units.

The scout uses a light, self-loading slug thrower. Its primary use is to discourage pursuit, and is not designed for prolonged dogfights with enemy attack or fighter aerodynes. It's speed makes it difficult to target and it's kinetic discharge shielding protects it, but a single well placed missile will send a scout to the ground in flames.

The scout is well suited for damaging unprotected enemy structures as well. It can use wide area plasma torpedoes to weaken structures and anyone who happens to be inside.

Special Weapons

Death From Above: Does a large amount of damage to a single ground target.

Plasma Bombs: With a larger attack radius, this shell can damage more targets.

Equipment

Aero Defender Gun: A version of the defendergun is centered on this unit to protect it.

Vision: A retractable visor that increases the view range of the unit.

AMH-Air Repair Unit: This aerodyne is able to spot-repair other aerodynes without landing.

Artemis Targeting System: The aerodyne's weapons are almost flawless in their precision for a short duration.

Phoenix Attack Aerodynes

ALRPX 0128 "Gryphon"



| | | | |
|-------------------|------------------|-------------------|--------------|
| Firepower | <i>Very Good</i> | Armor | <i>Low</i> |
| Health | <i>Good</i> | Speed | <i>Great</i> |
| View Range | <i>Low</i> | Stealth | <i>None</i> |
| Perception | <i>None</i> | Tech Level | <i>4</i> |

The Phoenix Attack Aerodynes are the air strength of the Phoenix army. Able to target both air and ground targets with its devastating torpedo barrage, the Attack aerodyne is a feared opponent. The Gryphon's main strength however is in breaking enemy ground troops. It's swift movement and resilient kinetic shielding makes it very difficult to hit from air or ground, but Order Anti-air and fighter aerodynes can tear a Phoenix Attack Aerodyne to shreds.

The attack aerodyne is armed with versatile Merlin 16-90 torpedoes. These torpedoes house a plasma accelerator chamber that detonates upon impact and is able to penetrate most air and land unit armor. The attack aerodyne also uses an advanced targeting system that allows it to pinpoint ground units with ease and make large sweeping passes that quickly break enemy ground forces.

Special Weapons

Anti-Personnel Bombs: Specifically tailored to decimate enemy infantry with a medium blast radius.

Atmospheric Particle Accelerator: Damages all air units within its target area.

Equipment

Aero Defender Gun: A version of the defendergun is centered on this unit to protect it.

Artemis Targeting System: The aerodyne's weapons are almost flawless in their precision for a short duration.

Rocket: Similar to ground units rocket boost, the Aerodyne has incredible speed for a short time with little actual control.

Phoenix Fighter Aerodynes

AIN-2/B1 "Wyvern"



| | | | |
|-------------------|------------------|-------------------|------------------|
| Firepower | <i>Great</i> | Armor | <i>Good</i> |
| Health | <i>Good</i> | Speed | <i>Excellent</i> |
| View Range | <i>Good</i> | Stealth | <i>None</i> |
| Perception | <i>Very Good</i> | Tech Level | <i>4</i> |

Phoenix Fighter Aerodynes are designed specifically for engaging enemy air units. It's sleek design and powerful repulsor fields allows it a radical range of movement and is built to withstand prolonged attacks. The Fighter is meant to protect ground troops from fast-moving attack aerodynes. The Fighter aerodyne is armed with rapid firing incendiary torpedoes that cover ground very quickly and demolish enemy fighters. The fighter is as heavily armored as is possible, with thin sheets of resilient plasteel and a kinetic repulsor field, which redirects enemy fire. The fighter targeting system is without peer and doggedly tracks and predicts vectors for more accurate torpedo fire.

Special Weapons

Atmospheric Particle Accelerator: Damages all air units within its target area.

Equipment

Rocket: Similar to ground units rocket boost, the Aerodyne has incredible speed for a short time with little actual control.

Phoenix Swarm
SMND-1200/A "Imp"

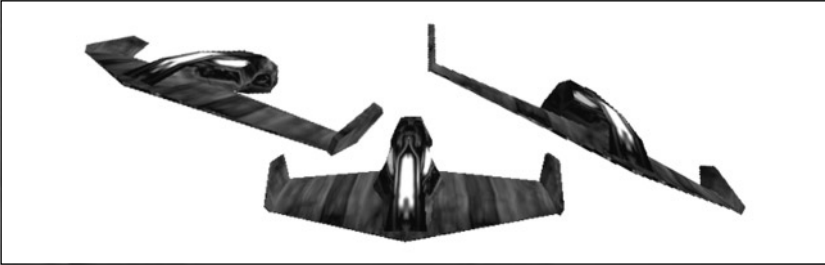

| | | | |
|-------------------|------------------|-------------------|------------------|
| Firepower | <i>Low</i> | Armor | <i>Low</i> |
| Health | <i>Good</i> | Speed | <i>Excellent</i> |
| View Range | <i>Great</i> | Stealth | <i>Extreme</i> |
| Perception | <i>Very Good</i> | Tech Level | <i>7</i> |

The Phoenix Swarm aerodynes are piloted by the most daring Phoenix soldiers on Crim-12. The swarm consists of very small one-man planes with less armor than even the scouts. Because of their speed and maneuverability, the swarm travels in large numbers and weaves a complicated pattern around each other. They carry the lightest possible weapons and count on their combined firepower to take out their targets. Once their numbers dwindle they do become less of an offensive force, but given enough time, they can whittle down large targets.

Special Weapons

Atmospheric Particle Accelerator: Damages all air units within its target area.

Death From Above: Does a large amount of damage to a single ground target.

Equipment

Artemis Targeting System: The aerodyne's weapons are almost flawless in their precision for a short duration.

Rocket: Similar to ground units rocket boost, the Aerodyne has incredible speed for a short time with little actual control.

Aero Defender Gun: A version of the defendergun is centered on this unit to protect it.

High Voltage Software

EXECUTIVE PRODUCER

Keith Morton

LEAD PROGRAMMER

Daniel Chambers

PROGRAMMERS

Matthew Steinke

Carlos Garcia

Dan Goodman

LEAD ARTIST

Joe Hamell

ARTISTS/ANIMATORS

Chris Cobb

Darren Edwards

Cedric Busse

LEAD DESIGNER

Tom Smith

DESIGNERS

Jeff Marks

David A. Rodriguez

Leif Lathrop

STORYBOARD

Pete McLennon

SOUND ENGINEER

D. Chadd Portwine

CEO/FOUNDER

Kerry J. Ganofsky

VP - BUSINESS DEVELOPMENT

John Kopecky

VP - DEVELOPMENT

Dwight Luetscher

VP - CREATIVE CONTENT

Eric Nofsinger

Massive Entertainment

DIRECTOR & LEAD GAME DESIGNER

Martin Walfisz

LEAD SOFTWARE ENGINEER

Dan Andersson

TECHNICAL DIRECTOR

Mats Graham

ART DIRECTOR

Tobias Strömvall

LEAD MISSION DESIGNER

Henrik Sebring

GAME DESIGN

Martin Walfisz

Henrik Sebring

SOFTWARE ENGINEERING

Dan Andersson

Johannes Norneby

Martin Ryststrand

Daniel Ljungberg

3D ENGINE DEVELOPMENT

Mats Graham

Niklas Hansson

ART

Tobias Strömvall

Thomas Bengtsson

Orhan Karagöz

Joakim Månsson

Glenn Kristoffersen

MISSION DESIGN

Henrik Sebring
Per Edman
Niklas Larsson
Anders Olsson
Johan Persson

MANUAL CONTENT

Henrik Sebring
Marcus Skyler

MUSIC & AUDIO EFFECTS

Ola Strandh

**PROJECT MANAGEMENT & QA
LEAD**

Peter Kullgard

QA TEAM

Peter Kullgard
Martin Persson
Richard Hultgren
Carl Fransson
Fredrik Jansson

GAME STORY

Marcus Skyler
Henrik Sebring
Martin Walfisz

ADDITIONAL ART

Magnus Larsson
Jonas Dahlin

PR COORDINATOR

Anne Eckles

FINANCES

Mats Melander

SPECIAL THANKS TO

Christian Pérez
Susan Lewis (ThinkBIG)
Paul Grace
Jeff Lee
Magnus Nilsson
Sven Jansson
Tomas Althén
Arne Borg
Johan "Bepp" Ramestam
Andreas "Diktator" Selling
Christian Franzén
Åsa Wiebe
Stefan Sylvén
Fredrik Nilsson
Patrik Berander
John Tillberg
Cpt. Björn Kullgard
Mathias Malmqvist
Elizabeth Lindau
Ronnie Nilsson
Patrik Nilsson KA2
Chefen KA2
The Swedish Armed Forces