

# Operation Manual

## S7200 Series TV Signal Spectrum Analyzer

Ver 2.00



This manual is applicable to the following product models:

S7200

S7200-ISDB

S7200-ATSC



# Catalog

<b>1. Safety Precautions</b> .....	<b>1</b>
<b>2. Maintenance and Safety Considerations</b> .....	<b>3</b>
2.1. Calibrating the Meter .....	3
2.2. About Battery, Adapter and Firmware upgrade.....	4
<b>3. Safety Symbols</b> .....	<b>6</b>
<b>4. Statement of FCC Compliance</b> .....	<b>7</b>
<b>5. Warranty</b> .....	<b>8</b>
<b>6. General Introduction</b> .....	<b>10</b>
6.1. Basic Information .....	10
6.2. Technical Support & Service .....	12
6.3. Electrostatic Discharge .....	13
6.4. Power Supply .....	13
6.4.1. Battery .....	13
6.4.2. Charging.....	15
<b>7. Terminology</b> .....	<b>16</b>
<b>8. Instrument Overview</b> .....	<b>26</b>
8.1. Recommendations before Using .....	26
8.2. Front Panel Overview .....	27

8.3.	Top Panel .....	29
8.4.	Button introduction .....	31
8.5.	Main Menu Software Function .....	34
8.5.1.	Main Menu .....	34
8.5.2.	Title Bar .....	34
8.5.3.	Function Icon .....	36
8.5.4.	Status Bar .....	36
<b>9.</b>	<b>Quick Start Guide .....</b>	<b>37</b>
9.1.	Spectrum Analysis Navigation Menu .....	37
9.2.	Set Up Your Channel Plan First .....	38
9.3.	Touch screen operation instruction .....	39
9.4.	Optical power meter and optical receiver .....	45
9.5.	Passive Sweep Introduction .....	46
<b>10.</b>	<b>Create and Edit a Channel Plan .....</b>	<b>47</b>
10.1.	Create Cable and Terrestrial Channel Plan .....	47
10.2.	Editing TV Channel Plans .....	50
10.3.	Importing and Exporting TV Channel Plans .....	63
10.4.	Create and Edit Satellite Channel Plan .....	65
<b>11.</b>	<b>Analog TV Measurements .....</b>	<b>70</b>
11.1.	Channel Measurement .....	70

11.2.	Analog FM .....	72
11.3.	FM Demodulation.....	74
11.4.	HUM Modulation.....	76
11.5.	AUTO .....	77
11.6.	Channel Scan .....	78
11.7.	Passive Sweep.....	80
11.8.	Tilt Measurement .....	82
11.9.	Depth of Modulation .....	85
11.10.	Analog Non-linear distortion measurement.....	87
11.10.1.	Carrier to Composite Noise Ratio Measurement.....	87
11.10.2.	CSO and CTB Measurement.....	90
<b>12.</b>	<b>Digital Signal Measurements.....</b>	<b>93</b>
12.1.	DVB-C Measurement .....	94
12.2.	Digital HUM .....	95
12.3.	Constellation Diagram .....	97
12.4.	Error Vector Spectrum (EVS) Function.....	99
12.5.	ATSC (8VSB) measurement .....	101
12.6.	DVB-C2 measurement .....	107
12.7.	DVB-T/H measurement.....	110
12.8.	DVB-T2 measurement .....	119

12.9.	ISDB-TB Measurement .....	126
12.10.	DTMB Measurement .....	129
12.11.	DAB/DAB+ Measurement .....	136
12.12.	DVB-S/S2 Measurement .....	138
12.13.	Antenna Modify.....	143
12.14.	Transport Stream Analysis .....	149
12.14.1.	Transport Stream Realtime Analysis .....	150
12.14.2.	Basic Information.....	154
12.14.3.	TR 101 290Priority 1, 2 and 3 Tests.....	155
12.14.4.	PID Viewer .....	164
12.14.5.	PCR Analysis.....	165
12.14.6.	Program List.....	166
12.14.7.	PSI/SI Table Analysis .....	167
12.14.8.	PSI/PSIP Table Analysis .....	173
12.14.9.	Data Capture.....	179
12.14.10.	EPG(Electroic Program Guide) .....	180
12.14.11.	Record and Replay Transport Stream.....	181
12.14.12.	How to use the CA module .....	185
12.14.13.	BISS Decryption .....	187
12.15.	TS over IP Measurement .....	195
12.16.	Optical Power Measurement and Optical Receiver .....	197
12.16.1.	Fiber Optical Connector and Adapter Introduction .....	197
12.16.2.	Optical to RF Conversion.....	199
12.16.3.	Optical Power Measurement.....	200

12.17.	Forward Spectrum Analysis .....	204
12.17.1.	Frequency Setting .....	207
12.17.2.	Amplitude Settings .....	208
12.17.3.	RBW & VBW Bandwidth/Sweep Setting .....	211
12.17.4.	Markers.....	215
12.17.5.	Trace Setting .....	219
12.17.6.	Display Mode Setting.....	221
12.18.	WiFi Analysis.....	226
<b>13.</b>	<b>Concept .....</b>	<b>228</b>
13.1.	Unit conversion chart .....	228
13.2.	Analog TV Standard and Color Transmission System Basic Knowledge.....	228
13.3.	Analog TV Baseband Signal Basic Knowledge .....	233
13.3.1.	Understanding Composite Video Signal .....	233
13.3.2.	Interlaced Scanning Concept .....	238
13.3.3.	Gated Measurement Basic Concept .....	240
13.3.4.	CCN, C/CSO and C/CTB Gated Measurement .....	243
13.3.5.	Video Parameters Gated Measurement .....	245
13.4.	Satellites and Transponders.....	253
13.4.1.	Sub-Satellites .....	253
13.4.2.	Polarization and LNB.....	255
13.4.3.	SaTCR principle introduction .....	258
13.5.	Resolution and Video Bandwidth .....	260
13.5.1.	Resolution BandWidth filter (RBW) .....	260

13.5.2.	Video BandWidth filter(VBW).....	261
13.6.	Detector Mode .....	262
13.7.	International CATV Standards .....	264
13.7.1.	System and Standards by Country .....	264
13.7.2.	USA CATV and DTTB Channel Plan .....	268
13.7.3.	People's Republic of China CATV and DTTB Channel Plan .....	278
13.7.4.	Europe CATV and DTTB Channel Plan .....	284
13.7.5.	Japan and Brazil Channel Plan .....	289
<b>14.</b>	<b>System Settings.....</b>	<b>301</b>
14.1.	Introduction.....	301
14.2.	System Information .....	302
14.3.	Available Option .....	303
14.4.	General Settings .....	305
14.4.1.	Network Setting.....	305
14.4.2.	Ping.....	309
14.4.3.	Display & Power.....	310
14.4.4.	Date & Time.....	311
14.4.5.	Language .....	313
14.4.6.	User Management.....	314
14.4.7.	GPS .....	316
14.4.8.	Disk Management.....	318
14.4.9.	Restoring Factory Settings .....	320
14.4.10.	S7200 System Upgrade Operation Steps .....	321
14.5.	Measurement Settings .....	325



14.5.1.	Level Unit.....	325
14.5.2.	Test Point Compensation .....	326
14.5.3.	Adaptive Equalizer .....	328
14.5.4.	Transport Stream Setting.....	330
14.5.5.	Transport Stream Limit Setting .....	334
14.6.	Antenna Settings .....	335
14.7.	External Interface Setup .....	340
14.7.1.	LNB Power Setup .....	340
14.7.2.	DisEqC Control Signal.....	344
14.7.3.	SaTCR Control Signal.....	347
14.7.4.	dCSS.....	349
14.7.5.	ASI Input and Output Control .....	353
14.7.6.	Transport Stream Input Control.....	354
14.7.7.	Signal Source .....	358
<b>15.</b>	<b>Reviewing &amp; Exporting Files .....</b>	<b>360</b>
15.1.	File management .....	360
15.2.	Reviewing Files .....	363
<b>16.</b>	<b>Saving DATA.....</b>	<b>364</b>
<b>17.</b>	<b>Specifications.....</b>	<b>366</b>

## 1. Safety Precautions

All rights reserved. Reproduction, adaptation, or translation without prior written permission is prohibited, except as allowed under the copyright laws. The information contained in this document is subject to change without notice.

**Deviser Instruments Inc makes no warranty of any kind with regard to this material, including, but not limited to, the implied warranties of merchantability and fitness for a particular purpose.**

Deviser Instruments Inc shall not be liable for errors contained herein or for incidental or consequential damage in connection with the furnishing, performance, or use of this material.

### Safety Notices

Observe the following safety precautions whenever you operate any Deviser Instruments equipment. Failure to comply with these and other specific warnings and cautions is a violation of Deviser Instruments Inc' safety standards of design, manufacturing, and intended use of the measurement device.

Deviser Instruments Inc assumes no liability for the operator's failure to comply with these precautions.

### Product Damage

**Danger!** Do not use this product if it shows visible damage, fails to perform, has been stored in unfavorable conditions, or has been subject to severe

transportation stresses. Make the product inoperative and secure it against any unintended operation. Contact your Deviser Instruments Inc representative for assistance.

**Explosion Hazard Danger!** Do not operate the instrument in the presence of flammable gases or fumes.

**Electric Shock Hazard Danger!** To avoid the possibility of severe injury or death, observe the following precautions when using any Deviser Instruments

equipment:

Do not remove the system covers, and do not perform electrical tests if there are signs of shipping damage to the outer enclosure.

When connecting test cables to a line, do not touch the cable's metal contact points, or allow the cable leads to touch each other.

Use only the supplied power cords and connect only to a properly grounded wall outlet. Do not use extension cords that do not have a protective ground conductor.

## **2. Maintenance and Safety Considerations**

### **2.1. Calibrating the Meter**

All the instruments have analog circuitry: preamplifiers, filter, etc.-whose performance can change over time. A regular schedule of calibrations will keep your instrument in optimal condition to support you design, troubleshooting, and manufacturing work.

It is recommended to calibrate and verify the instrument at least once a year to ensure that the instrument meets the original designed performance and specifications.

To avoid damaging the default calibration data stored in a non-violated memory, a calibration to the instrument can only be done by an authorized service center and qualified personnel with appropriate equipment.

For detailed information on the calibration procedures, please contact factory or authorized distributor.

Environmental condition: Calibration or verification test should be performed under laboratory condition whereby the ambient temperature or relative humidity can be controlled.

Warm up: Allow up to at least 5- minutes warm- up before performing calibration to the instrument. After exposure or storage in a high humidity (condensing) environment, relative recovery period is required essentially.

## 2.2. About Battery, Adapter and Firmware upgrade

Please charge-discharge the battery in every 3 months to extend battery life!

**Warning:** Danger of explosion if the battery is incorrectly replaced. Replace only with the same type battery recommended. Do NOT dispose of batteries in a fire. Do NOT place batteries in the trash. Batteries must be recycled or disposed of properly.

**CAUTION:** Recharge the battery only in the instrument. If left unused, a fully charged battery will discharge itself over time.

Never use a damaged or worn-out adapter or battery. Charging the batteries internally, even while the analyzer is powered off, the analyzer may keep warm. To avoid overheating, always disconnect the analyzer from the AC adapter before storing the analyzer into the soft carrying case.

**CAUTION:** Connect the automotive adapter to the power output connector for IT equipment, when charging the battery on your automotive.

**CAUTION:** Temperature extremes will affect the ability of the battery to charge. Allow the battery to cool down or warm up as necessary before use or charging. Storing a battery in extreme hot or cold temperatures will reduce the capacity and lifetime of a battery. Battery storage is recommended at a temperature of less than 25°C.

The analyzer cannot be used in the standard soft carrying case for more than 1 hours if the ambient temperature is higher than 35°C.

**CAUTION:** Use only the original AC-DC adapter or originally supplied battery for the power source.

Whether the instrument work or power off, you can charge the battery.

1 Insert the battery in the analyzer.

2 Plug in the AC-DC adapter and switch on the external power.

3 The charge indicator lights color is red, indicating that the battery is charging. When the battery is fully charged, the charging indicator color is green. The charging time for a fully depleted battery, is approximately four hours. If the meter is power on, the charging time is longer.

**CAUTION:** In updating process, there must be a constant power supply to for at least 60% battery power. If power fails during the updating process it can cause damage to the instrument.

### 3. Safety Symbols

The following are general definitions of safety symbols used on equipment and in manuals.



Dangerous voltage.



Protective ground.



Frame or chassis ground.



Alternating current



Direct current



Alternating or direct current



Caution! Read the manual

## **4. Statement of FCC Compliance**

This device complies with Part 15 of the FCC Rules. Operation is subject to the following two conditions: (1) this device may not cause harmful interference, and (2) this device must accept any interference received, including interference that may cause undesired operation.

NOTE: This equipment has been tested and found to comply with the limits for a Class A digital device, pursuant to Part 15 of the FCC Rules. These limits are designed to provide reasonable protection against harmful interference when the equipment is operated in a commercial environment. This equipment generates, uses, and can radiate radio frequency energy and, if not installed and used in accordance with the instruction manual, may cause harmful interference to radio communications. Operation of this equipment in a residential area is likely to cause harmful interference in which case the user will be required to correct the interference at his own expense.



## 5. Warranty

This Deviser Instruments Inc product is warranted against defects in material and workmanship for a period of 36 months from date of shipment. During the warranty period, Deviser Instruments Inc will, at its option, either repair or replace products which prove to be defective.

For warranty service or repair, this product must be returned to an authorized service center designated by Deviser Instruments Inc. The buyer shall prepay shipping charges to Deviser Instruments Inc or to the service center and Deviser Instruments Inc or the service center shall pay the shipping charges to return the product to . However, the buyer is responsible for all shipping charges, duties, and taxes, both ways, for products returned to Deviser Instruments Inc or one of its authorized service center that are out of the warranty period.

Deviser Instruments Inc warrants that its software and firmware is designated by Deviser Instruments Inc for use with Deviser Instrument equipment, and will execute its programming instructions when properly installed on that instrument. Deviser Instruments Inc does not warrant that the operation of the instrument, or software, or firmware will be uninterrupted or error-free but strives to insure the best operating condition as per specifications and datasheets.

### Limitation of Warranty

Unauthorized repair or update, physical damage or improper operational voltage (at the power supply or RF input) will void this warranty. The main lithium battery is covered for a period of 1year.

The foregoing warranty shall not apply to defects resulting from improper or inadequate use or maintenance by Buyer, Buyer-supplied software or interfacing, unauthorized modification or misuse, operation outside of the environmental specifications for the product.

NO OTHER WARRANTY IS EXPRESSED OR IMPLIED. DEVISER INSTRUMENTS INC SPECIFICALLY DISCLAIMS THE IMPLIED WARRANTIES OF MERCHANTABILITY AND FITNESS FOR A PARTICULAR PURPOSE.

**Attention:**

- 1.This instruction is applicable to S7200 Series TV Signal Spectrum Analyzer, including the following product modelS7200, S7200-ISDB,S7200-ATSC. If not specifically specified, the document for the series of products collectively referred to as S7200,The specific product model function difference please refer to the product propaganda material.**
- 2.Due to different software versions, there are differences in content.**

## 6. General Introduction

### 6.1. Basic Information

S7200 is a high performance TV signal spectrum analyzer. S7200 has fast spectrum analysis function, support multi cable, terrestrial and satellite digital TV standards: DVB-C/C2, DVB-S/S2, DVB-T/T2, ATSC, ISDB-T<sub>b</sub>, DTMB, DAB. The TV signal spectrum analyzer also support multi type video encoding format, example MPEG2/4, H.264, H.265, AVS/AVS+, VC-1 and HD and SD image decoding, example 4K, 1080p, 720p or 576i. S7200 provide DVB-CI option, user can use this option decode the encryption program. S7200 support the encryption of mode 1 and mode E modes of BISS. For analog TV, S7200 support NTSC, PAL, SECAM standard.

More and more countries use the 700MHz as LTE service, the LTE signals has effect the same frequency band CATV signals. S7200 provide time domain EVS function, user can use this function check LTE interference without interruption of service.

S7200 support RF and ASI port input signals do transport stream analysis, also support SATA SSD or USB disk transport stream record and playback function.

Many users began using optical LNB, so S7200 provide optical power meter and optical receiver option.

S7200 also provide TS over IP function, WiFi analysis function and GPS dongle. The capacitive touch screen is a major of S7200. User experience is greatly enhance, especially in the function of spectrum analysis.

#### **Key Features:**

- All standards in one: S7200: DVB-C(J.83A/B/C)/C2, DVB-T/H/T2, DVB-S/S2, ATSC, ISDB-T, DTMB, DAB

- Digital/Analog TV and Digital Satellite TV analysis
- MPEG2 Transport stream analyzer and monitoring via TS-ASI input & RF input
- Fast spectrum analysis with 500kHz~2150 MHz frequency, Cable/Terrestrial range: 500kHz-1220MHz, Satellite: 950MHz-2150MHz, Max span 1219.5MHz,
- DSP Technology to support different video decoding: MPEG-2, MPEG-4, H.264, H.265, AVS/AVS+, VC-1 for 4k,1080p, 720p and 576i, support PAL/NTSC/SECAM color system
- Support different audio decoding: MPEG-1,2,4,AAC,AAC+,DRA
- Support SD&HD Video format
- CAM module (Conditional Access) for encrypted channels
- Support BISS Mode 1 and Mode E decrypt
- EVS: Be able to search LTE and other interference signals covered by the QAM signals in service;
- TS-ASI input and output
- TS over IP analysis option
- TS record and TS replay, Very High speed (>95Mbps) Transport Stream record & analysis
- Optical Power measurement and Optical Receiver option
- Double 1000M LAN and USB 3.0 interface
- Inside WiFi option
- Outside GPS Dongle option
- Capacitive Touch Screen, High resolution touch 7" TFT LCD with bright display for indoors and outdoors Easy to use

## **6.2. Technical Support & Service**

This instrument after the sale of two-year warranty, before the two-year warranty expires, users can purchase an extended warranty period of one year; battery warranty for one year. Depending on number of units purchased, customers can receive initial onsite training from our technical support engineers in a “train the trainer” format. Our application engineers can also answer questions and ongoing technical support regarding software or equipment.

For special applications, Deviser instruments offers custom software design at an extremely competitive rate and time to market.

Ongoing development and “maintenance engineering” is provided on all products and yearly maintenance programs are offered to insure customers can fully benefit from the latest upgrades available for their products. Technical documents and applications guides are released and available on an on-going basis.

### 6.3. Electrostatic Discharge

An electrostatic discharge may damage the instrument, so it should be used in electrostatic free environment. These safeguards will provide guidance in reducing and avoiding ESD instances during normal use of the instrument:

- When connecting a coaxial cable to the instrument for the first time every day, the center conductor of the cable and the outer braided shielding layer should connect to the ground instantly.
- While servicing the unit, insure that the technician is grounded before removing inner parts or component, or pulling out connecting cables.
- Make sure the instrument is well grounded so not to store any static charges.
- Electrostatic protection of this instrument is up to standards of 6KV contact and 8KV air-gap.

### 6.4. Power Supply

There are 3 powering methods for the S7200, battery power, DC power adaptor or AC power adaptor.

#### 6.4.1. Battery

The S7200 uses a 7.4V/13Ah lithium batteries for power. The autonomy is estimated at more than 8 hours, in measurement modes, when fully charged. When the voltage gets to or below 6.9V, the instrument will alarm for the first time and pop up a dialog box, indicating low battery status. When the power reaches 6.7V or less, the instrument will alarm for the second time and again pop up the dialog box, indicating low battery status. The battery icon will then

flicker. When the voltage reaches 6.2V or less, the instrument will alarm for the third time and again pop up the dialog box, indicating low battery status, at which time, the instrument will provide a long audible beep, and shut down automatically after that. The unit can then only operate if connected to an external AC or DC power source. If the unit remains powered off, charging time will take about 4 hours for a full charge. Charging time will be longer if the unit is being used in measurement modes while charging.

**Attention:**

**1 Please use only the original power supply of the instrument to charge the battery**

**2 It is suggested to power off the instrument when charging.**

**3 Low temperatures may cause a temporary reduction of the battery capacity. It will not damage the battery. High temperatures however, may cause permanent damage to the battery.**

**4 When the working time decreases below 50% of its initial capacity, it is recommended to replace the battery.**

## 6.4.2. Charging

Please follow the following steps to charge:

1. Place the instrument standing up with screen facing you, then insert the DC connector into the DC power inlet at the top left of the instrument.  
Connect the AC adaptor with the supplied AC 100V-240V power supply. When the charging indicator displays an alternating red and green battery icon in the title bar on the screen, the instrument is charging. The indicator light status: green means fully charged, red means charging in progress, and red and green flickering indicates no battery or battery abnormal.

When the charging indicator changes to green, the battery is full. It is suggested to keep charging for one hour more which will help extend the useful time of the battery. After charging, unplug the DC connector, and then pull out the AC adaptor from the AC wall outlet.

### Attention:

- 1 Please charge the instrument before using it for the first time.
- 2 The internal battery is a lithium battery. It must be charged with the original manufacturer's dedicated adaptor, or it might get damaged. During a charge cycle, for maximum overall battery life, it is recommended that the temperature be between 10°C and 35°C.

Adaptor parameters:

Adaptor model No.: FSP060-DBAE1

AC input: 100-240V~, 1.5A, 50-60Hz

DC output: 12.0V  5A MAX





## 7. Terminology

8VSB	8-level Vestigial Side Band
AAC	Advanced Audio Coding
AC-3	Dolby AC-3 audio coding
ACPR	Adjacent Channel Power Ratio
AES	Audio Engineering Society
AES	Advanced Encryption Standard
APSK	Amplitude and phase-shift keying
ASI	Asynchronous Serial Interface
ATSC	Advanced Television Systems Committee
ATDMA	Advanced Time Division Multiple Access
AVG	Average
AVS	Audio Video coding Standard
BAT	Bouquet Association Table
BB	Baseband
BBC	British Broadcasting Corporation
BCH	Bose Chaudhuri Hocquengham Code
BER	Bit Error Rate
BICM	Bit-Interleaved Coded Modulation
BISS	Basic Interoperable Scrambling System
BPCP	Bidirectional Coded Picture
CAT	Conditional Access Table
CBER	Channel Bit Error Rate
CBR	Constant Bit Rate
CCIR	Consultative Committee on International Radio

CDR	China Digital Radio
COFDM	Coded Orthogonal Frequency Division Multiplexing
C/N	Carrier-to-Noise Ratio
CLDI	Chrominance-Luminance Delay Inequality
CLGI	Chrominance-Luminance Gain Inequality
CRC	Cycling Redundancy Check
CSO	Composite Second Order Beat
CTB	Composite Triple Beat
CVBS	Composite Video Broadcast Signal Color Video Blanking and Sync Composite Video, Blanking, Synchronization Composite Video Bar Signal
CVCT	Cable Virtual Channel Table
CW	Continuous Wave
DAB	Digital Audio Broadcasting
DAVIC	Digital Audio Visual Council
DBS	Direct Broadcasting Satellite
DCT	Discrete Cosine Transform
dCSS	Digital Channel Stacking Switch
DES	Data Encryption Standard
DFT	Discrete Fourier Transform
DHCP	Dynamic Host Configuration Protocol
DisEqC	Digital Satellite Equipment Control
DRA	Digital Rise Audio
DTMB	Digital Terrestrial Multimedia Broadcast
DNS	Domain Name System

DVB	Digital Video Broadcasting
DVB	Digital Video Broadcasting
DVB-C	Digital Video Broadcasting – Cable
DVB-C2	Second generation Digital Video Broadcasting –Cable
DVB-T	Digital Video Broadcasting – Terrestrial
DVB-T/H	Digital Video Broadcasting-Terrestrial/Handheld
DVB-T2	Second generation Digital Video Broadcasting –Terrestrial
DVB-S	Digital Video Broadcasting – Satellite
DVB-S2	Second generation Digital Video Broadcasting – Satellite
DVB-S2X	DVB-S2-Extensions
DG	Differential Gain
DHCP	Dynamic Host Configuration Protocol
DIT	Discontinuity Information Table
DNS	Domain Name System
DOM	Depth of Modulation
DP	Differential Phase
DTH	Direct To Home
DTS	Decoding Time Stamp
DVB	Digital Video Broadcasting
DVB-C	Digital Video Broadcasting-Cable
EAP	Extensible Authentication Protocol
EBU	European Broadcasting Union
ECM	Entitlement Control Message
EIA	Electronic Industries Association
EIT	Event Information Table
EIRP	Equivalent Isotropic Radiated Power

EMM	Entitlement Management Message
eMTA	Embedded multimedia terminal adapter
EPG	Electronic Program Guide
ES	Elementary Stream
ETSI	European Telecommunication Standard Institute
ETT	Extended Text Table
ETM	Extended Text Message
EVM	Error Vector Magnitude
EVS	Error Vector Spectrum
FCC	Federal Communications Commission
FDD	Frequency Division Duplex
FEC	Forward Error Correction
FEF	Future Extension Frame
FFT	Fast Fourier Transformation
FH	Feed Horn
FSK	Frequency-Shift Keying
FM	Frequency Modulation
FSS	Fixed Satellite Service
FTP	File Transport Protocol
GCR	Ghost Cancellation Reference
GOP	Group Of Pictures
GPS	Global Positioning System
HDTV	High Definition (HD) Television
HFC	Hybrid Fiber-Coaxial
IC	Integrated Circuit Card
ICP	Intra Coded Picture

ICMP	Internet Control Message Protocol
ICR	In Channel Frequency Response
IEC	International Electrotechnical Commission
IEEE	Institute of Electrical and Electronics Engineers
IF	Intermediate Frequency
IFFT	Inverse Fast Fourier Transformation
IGMP	Internet Group Management Protocol
IMD	Intermodulation Distortion
IP	Internet Protocol
IPTV	Internet Protocol Television
IRD	Integrated Receiver Decoder
ISDB-T	Integrated Services Digital Broadcasting–Terrestrial
ISO	International Organization for Standardization
ISMA	Internet Streaming Media Alliance
ITU	International Telecommunication Union
ISO	International Organization for Standardization
ISSY	Input Stream Synchronizer
JCTEA	Japan Cable Television Engineering Association
LAN	Local Area Network
LBER	LDPC Bit Error Rate
LDPC	Low Density Parity Check
LHCP	Left Hand Circular Polarization
LNA	Low Noise Amplifier
LNB	Low Noise Block Down Converter
LNC	Low Noise Converter
LM	Link Margin

LSB	Least Significant Bit
LTE	Long term evolution
MAC	Media Access Control layer
MCPC	Multiple Channel Per Carrier
MER	Modulation Error Ratio
MGT	Master Guide Table
MISO	Multiple Input Signal Output
MPE	Multiprotocol Encapsulation
MPEG	Moving Pictures Expert Group
MPTS	Multi Program Transport Stream
MSB	Most Significant Bit
MSD	Minimum Signal Duration
NCTA	National Cable Television Association
NEG	Negative peak
NIT	Network Information Table
NTSC	National Television Standards Committee
NVOD	Near Video On Demand
ODU	Out-door Unit
OFDM	Orthogonal frequency division multiplexing
OFDMA	Orthogonal frequency division multiple access
PAL	Phase Alternate Line
PAT	Program Association Table
PARP	Peak to Average Power Ratio
PCP	Predictive Coded Picture
PCR	Program Clock Reference
PDCCH	Physical downlink control channel

PER	(MPEG TS) Packet Error Rate
PES	Packetized Elementary Stream
PID	Packet Identifier
PLP	Physical Layer Pipe
PMT	Program Map Table
POS	Positive Peak
POI	Probability Of Intercept
PING	Packet Internet Groper
PPPoE	Point to Point Protocol over Ethernet
PSD	Power Spectral Density
PSI	Program Specific Information
PSIP	Program and System Information Protocol
PSK	Phase Shift Keying
PSK	Pre-Shared Key
PTC	Physical Transmission Channel
PTS	Presentation Time Stamp
QAM	Quadrature Amplitude Modulation
QEF	Quasi Error Free
QoE	Quality of Experience
QoS	Quality of Service
QPSK	Quadrature Phase Shift Keyin
RMS	Root Mean Square
RBW	Resolution Band Width
RF	Radio Frequency
RRT	Ratings Text Table
RS	Reed-Solomon

RSSI	Received signal strength indicator
RST	Running Status Table
RF	Radio Frequency
RHCP	Right Hand Circular Polarization
RSVP	Resource Reservation Protocol
RTCP	Real-time Transport Control Protocol
RTSP	Real Time Streaming Protocol
RTP	Real Time Transport Protocol
SAM	Sample detector
SCPC	Single Channel Per Carrier
SC	Smart Card
SCDMA	Synchronous Code Division Multiple Access
SC-FDMA	Single carrier frequency division multiple access
SCR	Satellite Channel Router
SCTE	Society of Cable Telecommunication Engineers
SD	Standard Definition (video)
SDT	Service Description Table
S/N	Signal-to-Noise Ratio
SECAM	Sequential Color and Memory Sequential Couleur avec Memoire
SES	Severely errored second
SDTV	Standard Definition (SD) Television
SFN	Single Frequency Network
SI	Service Information
SIT	Selection Information Table
SISO	Single Input Single Output



SMPTE	Society of Motion Picture and Television Engineers
SPTS	Single Program Transport Stream
SSID	Service Set Identifier
ST	Stuffing Table
STB	Set Top Box
STC	System Time Clock
STD	System Target Decoder
STT	System Time Table
SIP	Session Initiation Protocol
SNG	Satellite News Gathering
TDMA	Time Division Multiple Access
TDD	Time division duplex
TDT	Time and Date Table
TFTP	Trivial File Transfer Protocol
TKIP	Temporal Key Integrity Protocol
T2-MI	T2 Modulator Interface
TCP	Transmission Control Protocol
TI Block	Time Interleaving Block
TFS	Time Frequency Slicing
TOD	Time Of Date
TOT	Time Offset Table
TS	Transport Stream
TSDT	Transport Stream Description Table
TVCT	Terrestrial Virtual Channel Table
UCD	Upstream Channel Descriptor
UE	User equipment

UTC	Coordinated Universal Time
UDP	User Datagram Protocol
USALS	Universal Satellite Automatic Location System
VBER	Viterbi Bit Error Rate
VSAT	Very Small Aperture Terminal
VBW	Video Bandwidth
VCT	Virtual Channel Table
V/A	The Video to Audio carrier power ratio
VITS	Vertical Interval Test Signal
VoIP	Voice over Internet Protocol
WiFi	Wireless Fidelity
WEP	Wired Equivalent Privacy
WPA	Wi-Fi Protected Access

## **8. Instrument Overview**

### **8.1. Recommendations before Using**

When using S7200 for the first time:

(1) Open the package carefully. Check the box and packing material and keep it for future service use.

If the packing material is damaged, the instrument was potentially damaged during shipping so please proceed with caution during the following steps. Keep detailed records and pictures of the physical damage to the box and possibly the equipment inside for the transport company claims efforts. Take out the instrument, and check for physical damage that could have occurred during shipping. Please follow instructions upon initial power up. If repairs are required, please contact your nearest Deviser Instruments Inc representative.

(2) Check that all accessories and materials are accounted for, if not, please contact your nearest Deviser Instruments Inc representative.

(3) Connect the power supply to the instrument for a full charge before using it.

## 8.2. Front Panel Overview



Figure 8-1 Picture: S7200 Front Panel

7 inch color LCD, resolution: 800×480



Indicator light

①  Battery charging indicator light

Front panel buttons







②  Power on & power off, press/hold briefly for power on, press briefly for power off.

③ Shortcut function keys, used for quick access to the corresponding functions as indicated below

-  :Transport stream analysis shortcut key;
-  :Spectrum analysis function shortcut key;
-  : All signals input and output or signals transport path control.



④  Input and output signals' indicator.

⑤ Main function button

- : Channel plan function shortcut key, to enter the channel plan, channel information and editing screens.
- : File management shortcut key, to enter the file management function screen.
- : File saving function shortcut key, used for saving current measurement result or screen snapshot.
- : Auto-test function shortcut key, to enter the auto-test function screen.
- : Setup function shortcut key, to enter system parameters setup function screens.
- : Home screen shortcut key, to get back to home screen from anywhere.



Letter and number key.

- ⑦  arrow keys
- ⑧  Enter button
- ⑨  ESC or return to previous menu or quit one function key

### 8.3. Top Panel

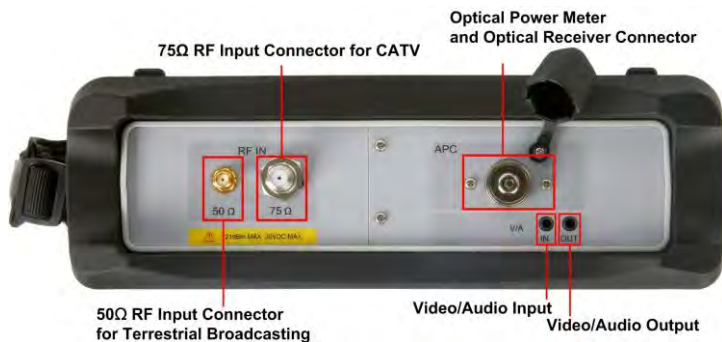

Figure 8-2 Picture: S7200 Top Panel

RF input has two ports, 50Ω is used for Terrestrial broadcasting, and 75Ω is used for CATV.

Attention: RF input: DC~100Hz, max.: 30VDC, 500kHz~2150MHz, max.: +70dBmV。

Video/audio input and output ports are connected by CVBS line.

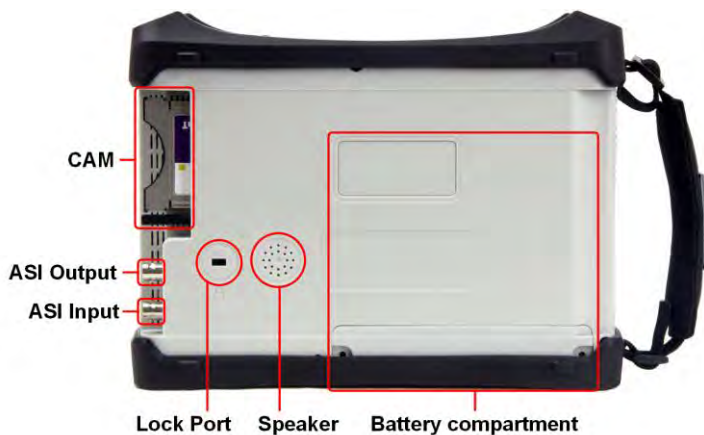



Figure 8-3 Picture: S7200 Back Side



Figure 8-4 Picture: S7200 Left Side and Right Side

## 8.4. Button introduction

 Battery charging indicator light. The indicator light status: The indicator light status: green means fully charged, red means charging in progress, and red and green flickering indicates no battery or battery abnormal.

 Power on or off the instrument. When user power off the instrument, the screen will popup a prompting information: Power off or reboot to avoid user misoperation.

 Output feeding current to satellite antenna active indicator light.

 Output 22kHz control signal to satellite antenna active indicator light.

 ASI input or output active indicator light.

6 functional shortcut buttons:

: press this button to enter the channel list and channel plan, to create a new plan, or edit an existing plan.



: press this button to search for a saved file, including saved images, test results, and auto-test results.

: press this button in any mode to save the screen snapshot or the test results.

: press this button to enter the auto-test function.

: press this button to enter the system setup functions.

: press this button to revert back to the default home screen, no matter which menu or function you are in.

: If you enter any menu or interface and realize you made a wrong selection, and wish to return to the previous menu, press  button.

During any operation, if a dialog box pops up for confirmation and it's not



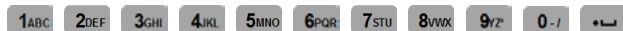

what you wanted, press the  button to cancel the operation.



Character and number buttons: each button includes 2 to 4 characters. Press once to input the first character, press twice to input the second character, three times to input the third character, and four times to input the fourth character or number. If you want to enter different characters with the same button, you must pause briefly before pressing the same button again until the cursor moves to the next character position.

 The back space button in green is used to step back or delete the wrong character.

: press this button to enter the spectrum analyzer function.

: Transport stream analysis function shortcut key. Press this key, user can directly enter the TS analysis function interface, the system default enter TS analysis interface is realtime decode module.

: Input and output setup shortcut key. Press this key, user can enter input and output control interface from anyone interface.

General soft-key system operation explanation:

- when accessing a soft-key menu, if there is an arrow following the soft-key title, for example: **FREQ>**, this means a submenu is available.
- If there are brackets following the soft-key title, for example: **[DATA]**, this means the status will change with every press of the soft-key in a circular manner offering different options for the user.
- Another kind of soft-keys is mutual exclusive. Only one of them works. The one in orange is the chosen one.

Example: you only can choose one type level unit, or you only can choose one

type frequency step in spectrum mode.



Blue means this soft button status is inactive.



Orange means this soft button status is active.



The gray means this soft button status is not available.

## 8.5. Main Menu Software Function

### 8.5.1. Main Menu



Figure 8-5 Snapshot: Main Menu

### 8.5.2. Title Bar

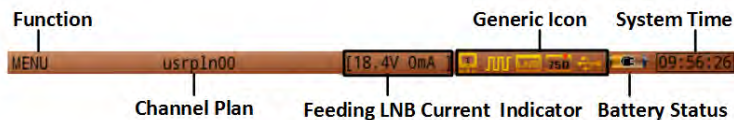

Figure 8-6 Title Bar

The instruction of different devices and service icon in the title bar:



: The instrument has recognized a USB disk.



: LAN cable connected.



: The instrument is in the WiFi function.



: The instrument WiFi function work on the hotspot mode.







: When the three icons cycle display, means the GPS module search

GPS satellite signal.

: LNB feeding current indicator icon.

: 22KHz signal status icon. When user uses the DisEqC protocol, this signal need open.

  : CA(Condition Access) card icon. Icon  means CA module successful recognition, icon  means the smart card successful recognition. The related programs can be decoded.

: TS-ASI input/output status icon, indicator the ASI function is working.

: SSD (Solid State Disk) icon.

: The instrument opens 75Ω input port.

: The instrument opens 50Ω input port.

: SaTCR icon.

: The instrument opens dCSS function.

: Antenna coefficient is enabled

: OPTICAL port is enabled.

Different battery icon instruction:

: Adaptor connected;

: Full battery;

: Low battery;

: Empty battery.

### 8.5.3. Function Icon

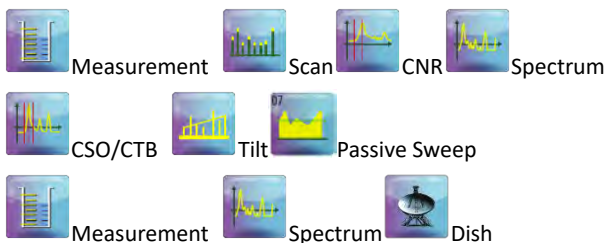

### 8.5.4. Status Bar

On the Home screen, the status bar will display which measurement mode you have chosen based on your selection. When you enter individual measurement screens, it will indicate measurement results or part of the measurement result.

## 9. Quick Start Guide

### 9.1. Spectrum Analysis Navigation Menu

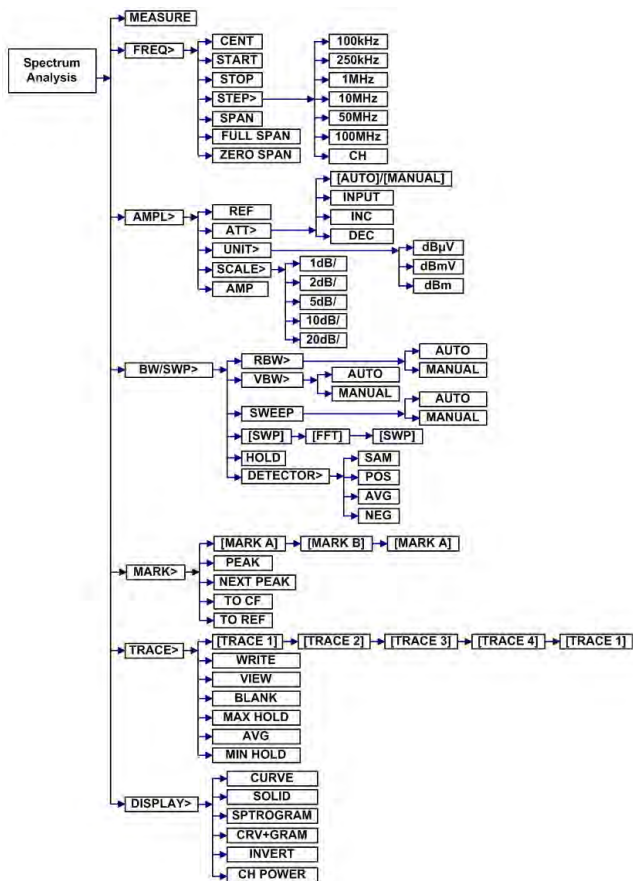

Figure 9-1 Spectrum menu tree

## 9.2. Set Up Your Channel Plan First

Create Cable/Terrestrial Channel Plan

Create Satellite Channel Plan

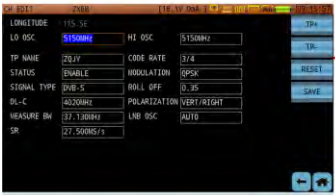
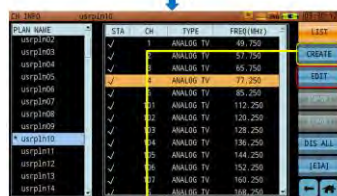

Figure 9-2 Create TV Channel Plan Figure 9-3 Create Satellite Channel Plan



### 9.3. Touch screen operation instruction

S7200 uses the capacitive touch screen. Before many operation must use the button to do, now we can directly use finger on the capacitive touch screen to operate. So many operation steps become very simple, the follow contents will introduction the main touch screen operation.

User wants to open one function, he only need use the finger tap on the icon or menu.



Figure 9-4 Touch Screen Operation-Open Measurement Function

From one function return to pervious menu or quit this function, user can tap the icon  on the touch screen. If user want to return to home page, he can tap the icon , show as the Figure 9-5.



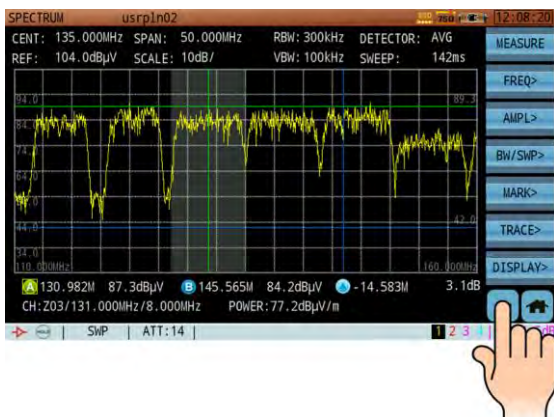

Figure 9-5 Touch Screen Operation-Quit or Return to Previous Menu

We often do input letter and number operation. We can use S7200 hard keyboard and soft keyboard. If user tap the input box, the soft keyboard will popup. S7200 provide two types soft keyboard according the input box requirement. The soft keyboard can provide more symbols than hard keyboard.



Figure 9-6 Touch Screen Input – Soft Keyboard

In spectrum analysis function apply many touch screen operation, support

multitouch operation.

Move marker: User only need put the finger on one marker, then swipe the finger to the left or right. The marker will follow the finger move to different position, till user's finger stop on one position. As show in Figure 9-7.

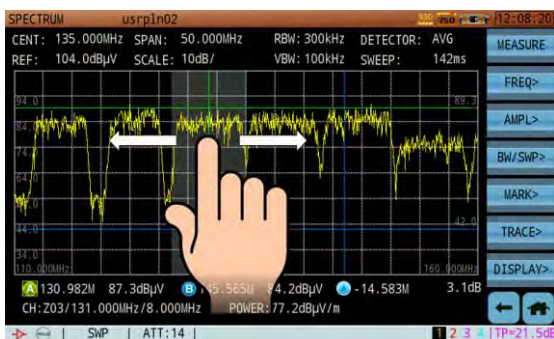

Figure 9-7 Move Vertical Marker

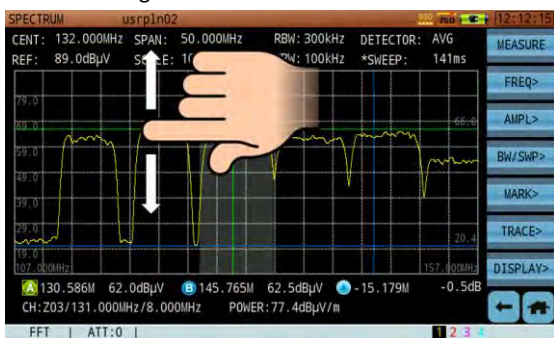

Figure 9-8 Move Horizontal Marker

Decrease the frequency span width: This operation will use multitouch. User need both hands two fingers (every hand use one finger) on the screen and move to the left and right side at the same time, the span will become narrow.

The center frequency has a little change. As show in Figure 9-9. User also can use only one hand two finger two complete this operation, as show in Figure 9-10.

The Figure 9-11 shows the increase span operation.

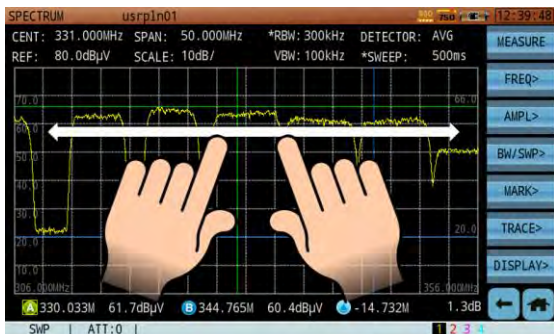

Figure 9-9 Decrease the span frequency range with both hands

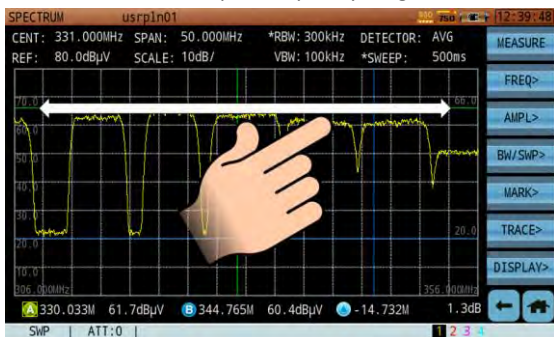

Figure 9-10 Decrease the span frequency range with one hand

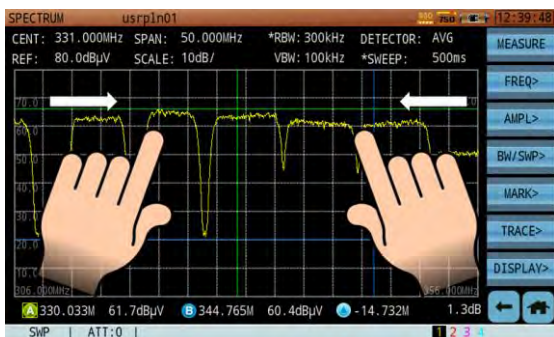

Figure 9-11 Increase the span frequency range with both hands

Modify center frequency: User need put the finger on the blank spectrum analysis measurement zone and swipe the finger to left or right side, the center frequency will change, as show in Figure 9-12.

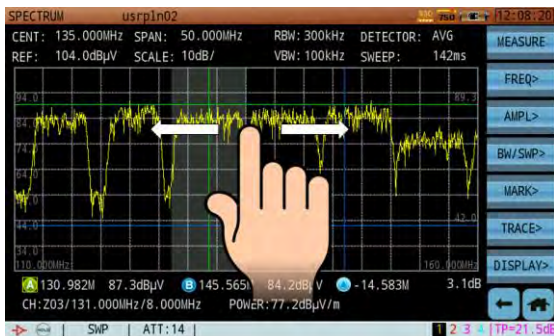

Figure 9-12 Change center frequency

Modify reference level: User need put the finger on the blank spectrum analysis measurement zone and swipe the finger to up and down, the reference level will change, as show in Figure 9-13.

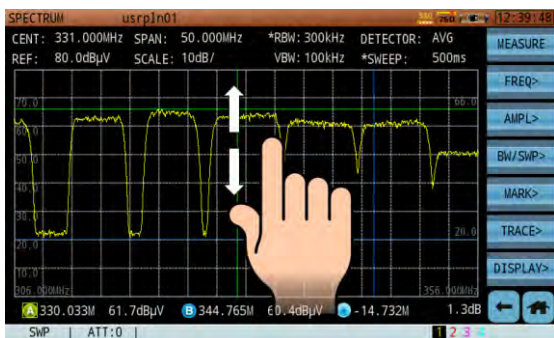

Figure 9-13 Change reference level

## Channel SCAN touch screen operation instruction

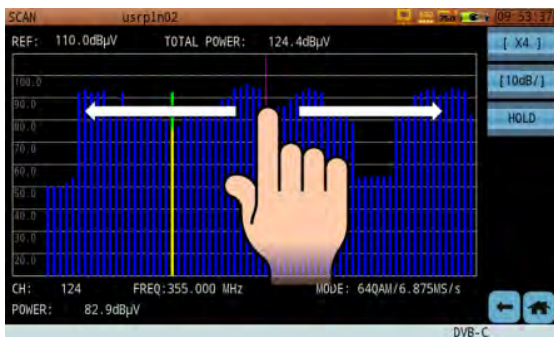

Figure 9-14 Channel SCAN Touch Screen Operation

## 9.4. Optical power meter and optical receiver

Connect the fiber to the APC port. Open the OPM function, the optical power test result will automatic display on the screen according right wavelength.

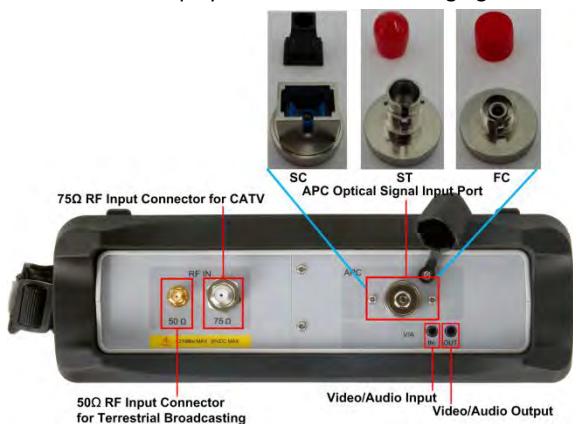

Figure 9-15 Optical Signal Input Port Introduction



Figure 9-16 Optical Power Measurement

## 9.5. Passive Sweep Introduction

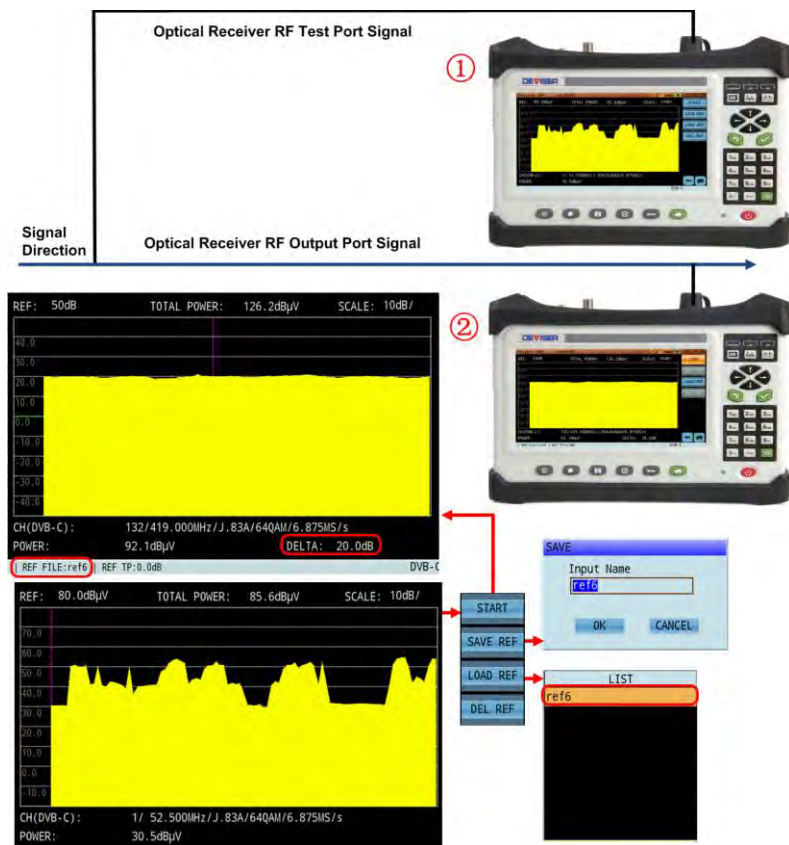



Figure 9-17 Passive Sweep Application Instruction

## 10. Create and Edit a Channel Plan

S7200 support cable, terrestrial and satellite broadcast measurement. The cable and terrestrial broadcast channel plan similar, but the satellite channel plan has many difference with the cable and terrestrial channel plan. S7200 provide two test mode: cable and terrestrial broadcast use one mode, satellite use another mode. In different test mode, press the  button can enter different channel plan create screen.

### 10.1. Create Cable and Terrestrial Channel Plan

Under the cable and terrestrial test mode, press  button on the front panel below the screen, the channel plan menu comes up. The available channel Plans are in the left window and identified by a customizable naming structure. The asterisk (\*) identifies to the active channel plan.

To create a new channel plan, tap the [CREATE] soft-key to open the channel plan creation page. Using you finger, tap on the desired plan template according to your global region, check the appropriate boxed(s) if either or both analog and digital channels will be part of this channel plan. The S7200 features an automatic channel plan builder; it will identify peak levels and frequency of analog carriers available as well as identify digital carriers. Tap the [Start] soft-key to start scanning and create the channel plan automatically.

To edit a channel, highlight the desired channel plan first, then use your finger tap on the desired channel. Press the  button to enable or disable the channel active status.





Figure 10-1 Snapshot: Edit Channel Plan-Choose Channel Plan

If the DAB module option of the instrument is enabled, the instrument will create DAB channel plan automatically when power on the unit, the name is DAB shown as Figure 10-2. DAB channel plan can only include DAB type channels, cannot be modified to other types of channel, and do not support creating DAB type channel plan.



Figure 10-2 DAB Channel Plan

All channels are listed in the middle window.

[ENA ALL] / [DIS ALL] for fast edit of channel status. If only a few select channel need to change active status, hit the edit soft key, the appropriate soft key menu will popup.

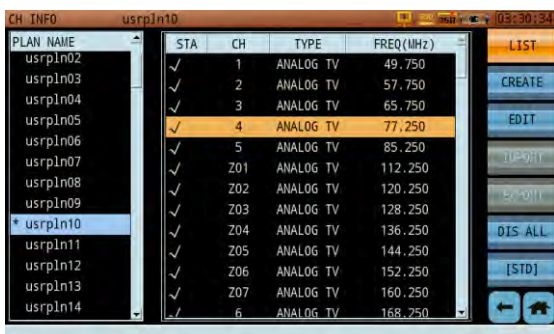

The screenshot shows a software interface for editing channel plans. On the left, a list of plan names is shown, with 'usrp1n10' selected. On the right, a table displays the details for the selected plan. The table has columns for STA, CH, TYPE, and FREQ(MHz). The rows show channel 1 through 6, all of which are ANALOG TV channels with various frequencies. On the far right, there are several soft buttons: LIST, CREATE, EDIT, DIS ALL, and [STD].

PLAN NAME	STA	CH	TYPE	FREQ(MHz)
usrp1n02	✓	1	ANALOG TV	49.750
usrp1n03	✓	2	ANALOG TV	57.750
usrp1n04	✓	3	ANALOG TV	65.750
usrp1n05	✓	4	ANALOG TV	77.250
usrp1n06	✓	5	ANALOG TV	85.250
usrp1n07	✓	201	ANALOG TV	112.250
usrp1n08	✓	202	ANALOG TV	120.250
usrp1n09	✓	203	ANALOG TV	128.250
*usrp1n10	✓	204	ANALOG TV	136.250
usrp1n11	✓	205	ANALOG TV	144.250
usrp1n12	✓	206	ANALOG TV	152.250
usrp1n13	✓	207	ANALOG TV	160.250
usrp1n14	✓	6	ANALOG TV	168.250

Figure 10-3 Snapshot: Edit Channel Plan-Activate or Deactivate

[EIA] / [STD] name is used to choose all channels' name use numbers name or numbers and letters, as show in the Figure 10-1 (numbers name) and Figure 10-3 (numbers and letters name).

Tap the soft button [CREATE] to open the channel plan creation page. Use your finger tap on the desired plan template according to your global region, tap and check the appropriate boxed(s) if either or both analog and digital channels will be part of this channel plan. The S7200 features an automatic channel plan builder; it will identify peak levels and frequency of analog carriers available as well as identify digital carriers. Tap the [Start] soft-key to start scanning and create the channel plan automatically, as show in Figure 10-4.



Figure 10-4 Create Channel Plan

## 10.2. Editing TV Channel Plans

In channel plan screen, tap the [EDIT] button can open the channel edit screen.

Cable and terrestrial broadcast channel type include: ANALOG FM, ANALOG TV, DVB-C, DOCSIS, DVB-T/H, DVB-T2, ATSC, DAB, ISDB-T, DTMB, DVB-C2.

Some parameters can freely edit content, user only need tap on the parameter's position, input the content from the pop up virtual keyboard. Some parameters have data list (as show in Figure 10-5), user must choose one item from the data list.

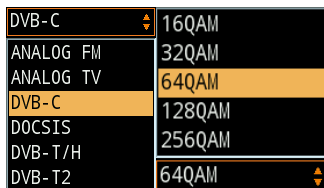

Figure 10-5 Touch Screen Operation: Parameters Drop List

Touch screen input content, only input number, the screen will pop up left side keyboard. If program need input number, letter and symbol, the screen will

pop up the right side keyboard.



Figure 10-6 Touch Screen Input Virtual Keyboard

Many parameters can automatic setup according user choose parameters (example: standard). [CH+] and [CH-] buttons are used to quickly change channel. [RESET] button is used to recall your saved value. After modify the parameters, user want to quit this page, you must press the [SAVE] button, otherwise the change can't be saved.



Figure 10-7 Edit ANALOG FM channel parameters

Analog FM channel parameters:

Channel serial number: channel use number name display

Channel name: no option, editable content

Channel status: ENABLE、DISABLE

Signal type: ANALOG FM

System rate: 50Hz, 60Hz  
 Frequency: editable content

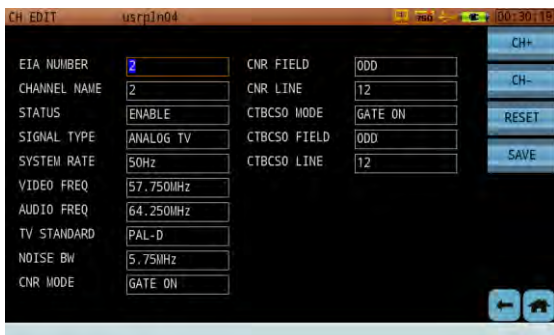

Figure 10-8 Edit Analog TV Channel Parameters

Analog TV channel parameters:

Channel serial number: channel use number name display

Channel name: no option, editable content

Channel status: ENABLE、DISABLE

Signal type: ANALOG TV

System rate: 50Hz, 60Hz

Frequency: editable content

Video frequency: editable content

Audio frequency: editable content

TV standard: NTSC-M、PAL-B、PAL-D、PAL-G、PAL-H、PAL-I、PAL-K、PAL-M、PAL-N

Noise BW: editable content

CNR mode: GATE OFF, GATE ON

CNR field: ODD, EVEN

CNR line: 525 lines system: Field 1 (odd), line 1~263; Field 2

(even), line 2~262

625 lines system: Field 1 (odd), line 1~313; Field 2 (even), line 2~312

CTBCSO mode: GATE OFF, GATE ON

CTBCSO field: ODD, EVEN

CTBCSO line: 525 lines system: Field 1 (odd), line 1~263; Field 2 (even), line 2~262

625 lines system: Field 1 (odd), line 1~313; Field 2 (even), line 2~312

#### Supported analog TV standards

TV standard	Number of lines per frame	Field frequency	Color encoding method
NTSC-M	525	60Hz	NTSC
PAL-M	525	60Hz	NTSC
PAL-B,D,G,H,I,K	625	50Hz	PAL
PAL-N	625	50Hz	PAL



Figure 10-9 Edit Digital TV Channel Parameters

Digital channel parameters option:

Channel serial number: channel use number name display

Channel name: no option, editable content

Channel status: ENABLE、DISABLE

Signal type: DVB-C

System rate: 50Hz, 60Hz

Frequency: editable content

Measure BW: editable content

Modulation: 16QAM、32QAM、64QAM、128QAM、256QAM

SR (System Rate): The symbol rate is auto-configured according to the modulation type and standard. It will set automatically once the modulation type and standard are selected. Users can input values manually, ranging between 4.00MS/s ~ 7.00MS/s

STD (Standard): J.83A、J.83B、J.83C

US and EU Default Symbol Rate for DVB-C:

Standard and Modulation Type	Symbol Rate	Bandwidth
ITU-T J.83 Annex A 64QAM	6.952MS/s	8MHz
ITU-T J.83 Annex A 256QAM	6.952MS/s	8MHz
ITU-T J.83 Annex B 64QAM	5.057MS/s	6MHz
ITU-T J.83 Annex B 256QAM	5.361MS/s	6MHz
ITU-T J.83 Annex C 64QAM	5.274MS/s	6MHz
ITU-T J.83 Annex C256QAM	5.274MS/s	6MHz



Figure 10-10 Edit DOCSIS Channel Parameters

DOCSIS channel parameters option:

Channel serial number: channel use number name display

Channel name: no option, editable content

Channel status: ENABLE、DISABLE

Signal type: DOCSIS

System rate: 50Hz, 60Hz



Frequency:	editable content
Measure BW:	editable content
STD:	DOCSIS、EuroDOCSIS
Modulation:	64QAM、256QAM
SR (System Rate):	The symbol rate is auto-configured according to the modulation type and standard. It will set automatically once the modulation type and standard are selected. Users can input values manually, ranging between 2.00MS/s ~ 7.00MS/s

US and EU Default Symbol Rate for DOCSIS:

Standard and Modulation Type	Symbol Rate	Bandwidth
DOCSIS 64QAM	5.057MS/s	6MHz
DOCSIS 256QAM	5.361MS/s	6MHz
EuroDOCSIS 64QAM	6.952MS/s	8MHz
EuroDOCSIS 256QAM	6.952MS/s	8MHz



Figure 10-11 Edit DVB-T/H Channel Parameters

DVB-T/H channel parameters option:

Channel serial number: channel use number name display

Channel name: no option, editable content

Channel status: ENABLE、DISABLE

Signal type: DVB-T/H

System rate: 50Hz, 60Hz

Frequency: editable content

Measure BW: 6MHz, 7MHz, 8MHz

Modulation: QPSK, 16QAM, 64QAM

GI: 1/4, 1/8, 1/16, 1/32

FFT Mode: 2K, 8K

Code Rate: 1/2, 2/3, 3/4, 5/6, 7/8

Hierarchy: None, 1, 2, 4

Cell ID: no option, editable content

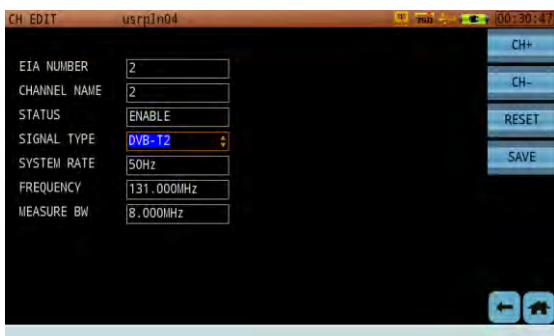

Figure 10-12 Edit DVB-T2 Channel Parameters

DVB-T2 channel parameters option:

Channel serial number: channel use number name display

Channel name: no option, editable content

Channel status: ENABLE、DISABLE

Signal type: DVB-T2

System rate: 50Hz, 60Hz

Frequency: editable content

Measure BW: 1.7MHz,5MHz,6MHz,7MHz,8MHz



Figure 10-13 Edit ATSC Channel Parameters

ATSC channel parameters option:

Channel serial number: channel use number name display

Channel name: no option, editable content

Channel status: ENABLE、DISABLE

Signal type: ATSC

System rate: 50Hz, 60Hz

Frequency: no option, editable content

Measure BW: no option, editable content

STD: ATSC

Modulation: 8VSB

Symbol rate: 10.762MS/s



Figure 10-14 Edit DAB Channel Parameters

DAB channel parameters option:

Channel serial number: channel use number name display

Channel name: no option, editable content

Channel status: ENABLE、DISABLE

Signal type: DAB

System rate: 50Hz, 60Hz

Frequency: editable content



Figure 10-15 Edit DTMB Channel Parameters

DTMB channel parameters option:

Channel serial number: channel use number name display

Channel name: no option, editable content

Channel status: ENABLE、DISABLE

Signal type: DTMB

System rate: 50Hz, 60Hz

Frequency: editable content

Measure BW: 6MHz,7MHz,8MHz

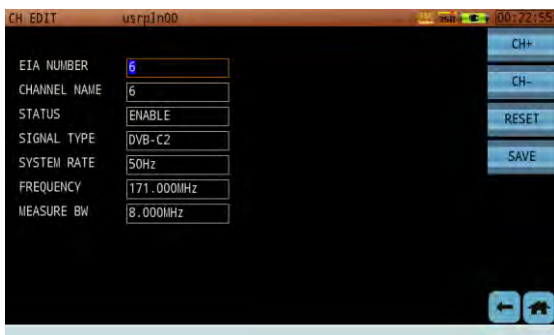

Figure 10-16 Edit DVB-C2 Channel Parameters

DVB-C2 channel parameters option:

Channel serial number: channel use number name display

Channel name: no option, editable content

Channel status: ENABLE、DISABLE

Signal type: DVB-C2

System rate: 50Hz, 60Hz

Frequency: editable content

Measure BW: 6MHz,8MHz

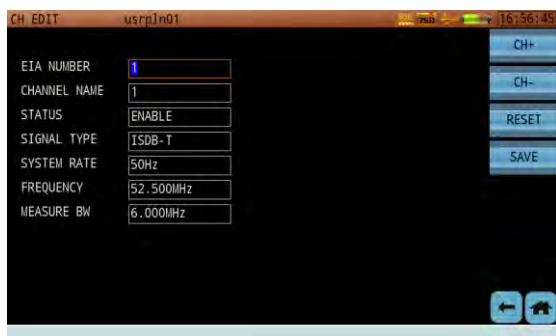

Figure 10-17 Edit ISDB-T Channel Parameters

ISDB-T channel parameters option:

Channel serial number: channel use number name display

Channel name: no option, editable content

Channel status: ENABLE、DISABLE

Signal type: ISDB-T

System rate: 50Hz, 60Hz

Frequency: editable content

Measure BW: 6MHz,8MHz

When moving from one channel to the other using the [CH+] and [CH-] soft keys or quitting from this function, a pop-up window will ask: "Do you want to save the changes? The user must choose OK to save changes or choose CANCEL to quit this function without saving.

More channel plan templates are available in the S7200 Toolbox software. Our company may be able to write customer specific channel plans upon request.

### 10.3. Importing and Exporting TV Channel Plans

Users can insert a USB Disk in the S7200 USB port, the export channel plan softkey will then become active. Tap the soft button [EXPORT], the screen will pop up a EXPORT window, user can choose need exported channel plan from the channel plan list. Tap the button , will prompt a message and let the user confirm "Export plan(s)? OK or Cancel". If user confirms OK, the selected channel plans will export to the USB disk. The folder S7200\_plan will display on the USB disk root directory, as show in Figure 10-18.

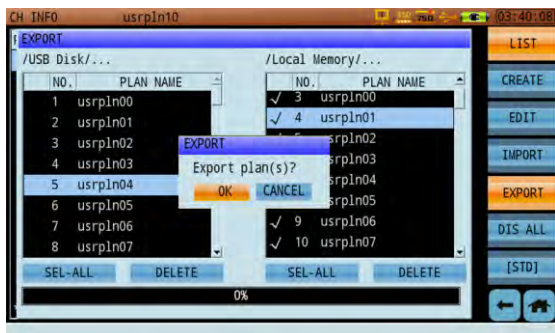

Figure 10-18 Confirm Export Channel Plan

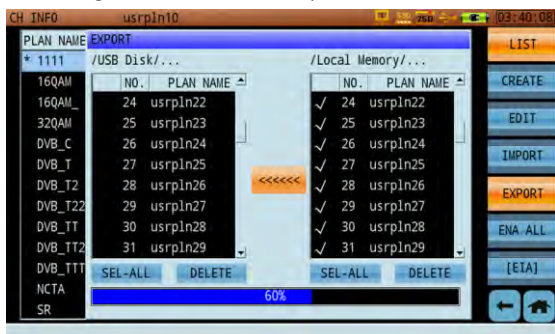

Figure 10-19 Export Channel Plan



Similar operation steps can apply on import channel plan, as show in Figure 10-20. This function can be used to clone channel plan on different units.

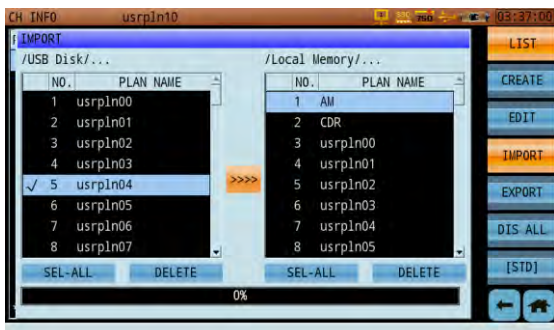





Figure 10-20 Import Channel Plan

## 10.4. Create and Edit Satellite Channel Plan

When system switch to satellite mode, press the  button, S7200 will open satellite channel plan edit interface. Left side column is satellite list (include satellite name and satellite longitude). The asterisk (\*) identifies to the active satellite. The active satellite name display on the title bar. When the symbol “V” is marked on the transponder, it means this transponder is valid. No symbol “V” is marked on the transponder, it means this transponder is invalid. User can directly use finger tap on the STA column to modify the transponder valid and invalid status. User also can use the arrow keys move the cursor to the transponder list position, then use the  and  move the cursor on the different transponder, press the  button to change transponder’s valid or invalid status.

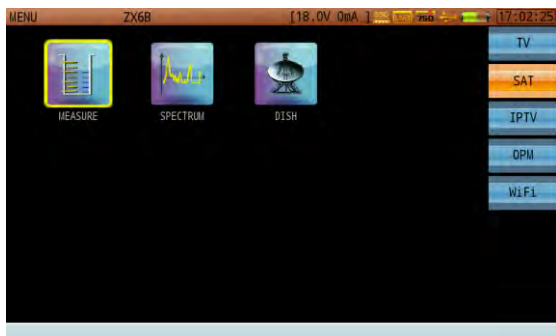

Figure 10-21 System Switch to Satellite Measurement Mode



Figure 10-22 Add New Satellite

Create satellite channel plan, the first step is add new satellite. Open the satellite edit and create interface, tap the [ADD] button, user can see interface as the Figure 10-22 show. Satellite name need user fill content; setup satellite longitude, W means west longitude, E means east longitude; the transponder number need user fill content; the band provide two options: DL-C and DL-Ku. After user complete all parameters setup, tap the [ADD] button below the parameters, the program will open satellite transponder list interface, as the Figure 10-23 show.



Figure 10-23 Edit Satellite Channel Plan Interface



Figure 10-24 Edit Satellite Transponder Parameters

### Satellite transponder parameter

Satellite longitude:	Come from satellite parameter
Low oscillator:	User fill content
High oscillator:	User fill content
Transponder name:	User fill content
Transponder status:	Enable, Disable
Channel type:	ANALOG TV, DVB-S, DVB-S2, DSS
DL-Ku band:	User fill content (According to satellite setup)
DL-C band:	User fill content (According to satellite setup)
Bandwidth:	User fill content
Symbol rate:	User fill content
Code rate:	1/2, 2/3, 3/4, 5/6, 7/8
Modulation type:	QPSK ( DVB-S, DSS ) QPSK,8PSK,16APSK,32APSK ( DVB-S2 )
Roll-off factor:	0.35, 0.25, 0.2
Polarization:	Off, Vertical/RHCP, Horizontal/LHCP
LNB oscillator:	Low, High, Auto

The satellite transponder has many parameters need setup, the follow content

will give some introduction for some important parameters.

LNB (Low Noise Block Down Converter) is composed by microwave LNA (Low Noise Amplifier) and LNC (Low Noise Converter), the LNC is composed by mixer, local oscillator and IF preamplifier.

LNB first amplifier received C band (3.4~4.2GHz) or Ku band (10.7~12.75GHz) signal. The second step use the signal frequency minus the local oscillator frequency in mixer, the different frequency band signals will be converted to uniform frequency band IF signal (950~2150MHz) which can be processed by IRD.

C band satellite transponder frequency allocation table

Transponder Number	polarization	Downlink frequency (MHz)	Bandwidth range (MHz)
1	H	3720	3702~3738
2	V	3740	3722~3758
3	H	3760	3742~3778
4	V	3780	3762~3798
5	H	3800	3782~3818
6	V	3820	3802~3838
7	H	3840	3822~3858
8	V	3860	3842~3878
9	H	3880	3862~3898
10	V	3900	3882~3918
11	H	3920	3902~3938
12	V	3940	3922~3958
13	H	3960	3942~3978
14	V	3980	3962~3998
15	H	4000	3982~4018

## S7200 Series TV Signal Analyzer Operation Manual

Transponder Number	polarization	Downlink frequency (MHz)	Bandwidth range (MHz)
16	V	4020	4002~4038
17	H	4040	4022~4058
18	V	4060	4042~4078
19	H	4080	4062~4098
20	V	4100	4082~4118
21	H	4120	4102~4138
22	V	4140	4122~4158
23	H	4160	4142~4178
24	V	4180	4162~4198

### Ku band satellite channel allocation

Channel	Downlink frequency (MHz)	Channel	Downlink frequency (MHz)	Channel	Downlink frequency (MHz)
1	11727.48	9	11880.92	17	12034.36
2	11746.66	10	11900.10	18	12053.54
3	11765.84	11	11919.28	19	12072.72
4	11785.02	12	11938.46	20	12091.90
5	11804.20	13	11957.64	21	12111.02
6	11823.38	14	11976.82	22	12130.26
7	11842.56	15	11996.00	23	12149.44
8	11861.74	16	12015.18	24	12168.62

## 11. Analog TV Measurements

In this chapter, we discuss the S7200's powerful suite of TV signal measurement applications – including the Channel Measurement, Spectrum, TILT, Scan, Passive Sweep, CNR, and CTB/CSO functions.

### 11.1. Channel Measurement

In this mode, the S7200 measures the basic parameters of a channel. The channel types currently supported all TV standard. For different channel types, the channel measurement screen offers different settings and measurement parameters.

The Analog TV measurement screen, shown below, is used to measure parameters such as video level, audio level, V/A and etc. The green bar graph indicates the level value of the video carrier, the yellow bar graph indicates the level of the audio carrier.



User can directly tap on the channels, video frequency and audio frequency, user can use the popup virtual keyboard input value. User also can use  and  arrow keys to move to the next active channel in the channel list. You can also enter the channel number value with the numerical keypad.



Figure 11-1 Snapshot: Channel Measurement - Analog TV Analysis

#### Parameter Instruction

Channel, can select between all active channels in the active channel plan.

Video Frequency input range: 4MHz-1220MHz;

Audio Frequency input range: 4MHz-1220MHz;

Soft-key buttons in this menu:

VIDEO: Look at the analog TV video. If analog carrier no modulation information, this button status is invalid.

HUM: switch to hum modulation function



DOM: switch to Depth of Modulation function

CNR: switch to CNR measurement function

CSO/CTB: switch to CSO/CTB measurement function

FM DEMOD: switch to FM Demodulation measurement function

AUTO: Search the current frequency automatically.

If user open the analog TV video screen, user need press the  and  arrow keys to adjust the volume.



## 11.2. Analog FM

The Analog FM measurement screen, shown below, is primarily used to measure level. If user tap the soft button [LISTEN], the listen FM function work and modify volume button also is active.



Figure 11-2 Channel Measurement - FM Measurement



Figure 11-3 Channel Measurement –Listen FM

#### Parameter Instruction

Channel: select between all active channels in the active channel plan

Frequency Range: 64MHz-108MHz;

Step: Use arrow key to change the step, range: 1MHz-1000MHz

Test result: LEVEL, Bar graph display; Peak Value; Frequency error FM frequency offset.

#### Button operation:

**【LISTEN】** Activate the demodulation FM voice function.

**【VOL+】** Turn up the demodulation sound volume.

**【VOL-】** Turn down the demodulation sound volume.

**【FM DEMOD】** Go to FM demodulation measurement screen.

**【AUTO】** Search the current frequency automatically.

### 11.3. FM Demodulation

The FM Demodulation function allows to listen FM broadcast and analog TV audio sound. If users use this function, the FM Deviation measurement is disable.



Figure 11-4 Snapshot: FM Listening

#### Parameter Instruction

Channel, can select between all active ANALOG TV and ANALOG FM channels in the active channel plan.

Frequency Range: 4MHz-1220MHz;

Loop Count: Use arrow key to change the Loop Count, range: 1-100

Test Result: LEVEL; Bar graph display; FM frequency offset; FM Maximum frequency offset.

#### Buttons operation

**【LISTEN】** Activate the demodulation FM voice function

**【VOL+】** Turn up the demodulation sound volume.

**【VOL-】** Turn down the demodulation sound volume.

When the user stops listening to audio, the FM Demodulation will

automatically restart. If the user setup loop number > 1 (example 20), the max positive and max negative frequency deviation traces will be recorded on the screen, every 20 loop times, the peak hold trace will refresh once. The FM Deviation max value and the current value uses a bar graph display at the bottom of the screen.



Figure 11-5 Snapshot: FM Frequency Demodulation -Loop Count=1



Figure 11-6 Snapshot: FM Frequency Demodulation -Loop Count>1

## 11.4. HUM Modulation

Hum modulation is a power source frequency interference. It creates a visible distortion in the television picture. The S7200 measures hum modulation interference for analog and digital channels. The analog measurement screen is shown below.

The low frequency interference and interference harmonic will disrupt the analog TV signal, the highest measurable fourth harmonic of the S7200 are :

- 50Hz, 100Hz, 150Hz and 200Hz in 50Hz,
- 60Hz, 120Hz, 180Hz and 240Hz in 60Hz.

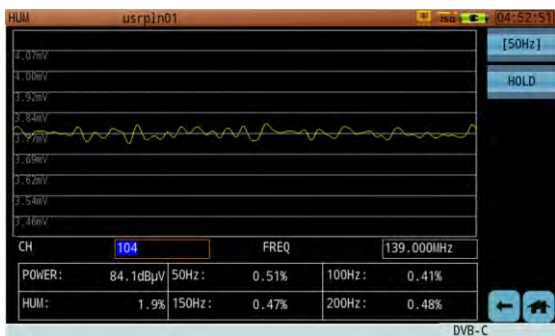

Figure 11-7 Snapshot: Analog TV Hum Measurement

### Parameter Instruction

Channel select active channels in the active channel plan

Frequency Range: 4MHz-1220MHz;

### Button Operations:

[50Hz]/[60Hz]press this button to toggle the power frequency to be measured between 50Hz and 60Hz depending on your region.

[Hold] press this button to pause, and press again to continue

## 11.5. AUTO

AUTO function is to fast search frequency channel type and judge the channel is digital or analog according to the level value . When it is digital, auto search according to DVB-C, DVB-T/H, DVB-T2, DTMB, DOCSIS, DVB-C2, ISDB-T, ATSC sequence one by one. When it is under AUTO, first to judge the options enabled or not, when the option is enabled, auto search one by one. When the option is not enabled, will skip this option, continue to search others, it will stop when the signal is locked. Like Figure 11-8, press **【AUTO】** to judge if the current signal is effective or not, will stop automatically if the signal is invalid. When the signal is effective, will start to search from DVB-T2 channel type, when the signal is locked, will directly end and update the parameters and test result; When the signal is not locked, will continually search others according to the search sequence. If the signal is not locked till ATSC, then start the search loop from DVB-C again. “Effective signal, not locked” will be displayed if the signal is not locked all the time.



Figure 11-8 Auto Search

## 11.6. Channel Scan

The S7200 offers a channel scan function to quickly measure the flatness and amplitude of a CATV system. The interface is shown in Figure 11-9 below. By default, the device will scan all active channels in an active channel plan. Video and audio carrier levels will appear at the same bar graph position with a different color, one superimposed over the other.

The channel scan function is to fast scan the amplitude of all channels in the system. In Figure 11-9below, the bars with yellow (audio carrier level or FM) and green (video carrier level) represent an analog TV channel, and the blue bars represents digital channels. Users can view individual channel information by moving the marker. The detailed information is shown at the bottom of the screen. A zoom feature is offered as X1, X2, X3, X4, X5 and X6.

### Measurement Result:

Total Power shows the total power level measured over a specified bandwidth. Level/Power will show measurement results of a specified channel. The S7200 measures the sync pulse of an analog video carrier for analog channels and channel power over the specified bandwidth for digital channels.

### Buttons Operation

[x1] Changes the zoom level, choosing from  $\times 1$ ,  $\times 2$ ,  $\times 3$ ,  $\times 4$ ,  $\times 5$  and  $\times 6$ . (keep pressing the same button.

[Hold] Holds the scanning process and press again to continue to refresh.

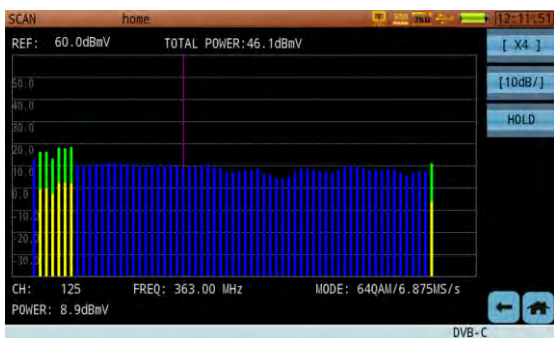

Figure 11-9 Channel SCAN

Frequency SCAN provide a marker, user can use finger directly operation this marker on touch screen.

Move marker: User only need put the finger on one marker, then swipe the finger to the left or right. The marker will follow the finger move to different position, till user's finger stop on one position. As show in Figure 11-10.

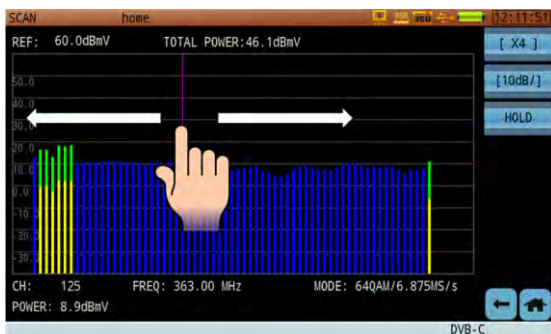

Figure 11-10 Channel SCAN Touch Screen Operation



## 11.7. Passive Sweep

A stored passive sweep trace can be considered as a reference trace, up to 8 trace records can be saved as reference traces at one time in the unit. This feature is primarily used when an active sweep reference generator is not used at the HE or hub. After saving a reference trace, (it will show at the top of the screen) it can be compared to a live trace downstream from the different location where the live trace is being measured.

The Figure 11-11 is a comparison of optical receiver RF output port and test port output signal level. The amplitude read by the marker is the differentials of the two traces.

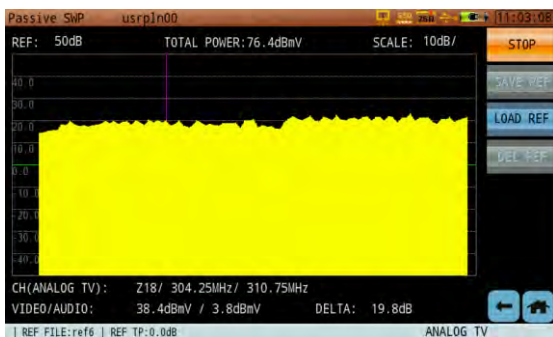

Figure 11-11 Passive Sweep

The Figure 11-12 shows the passive sweep detailed operation steps. First connect the S7200 to initiate a channel sweep measurement at the optical receiver test port, and store the trace measurement result as reference trace. Then connect the S7200 at the RF output port of optical receiver, and initiate a second channel sweep measurement. Compare the measurement signal with the saved signal. We could see that the differential value is 19.6dB, which indicates that the signal attenuated 19.6dB, including attenuation for the test

port, connector attenuation and signal fluctuation.

If the user active the test point compensation function, the saved reference trace value also include compensation value. The passive sweep function display compensation value at the lower left corner of the screen, display applied reference value at the lower right corner of the screen.

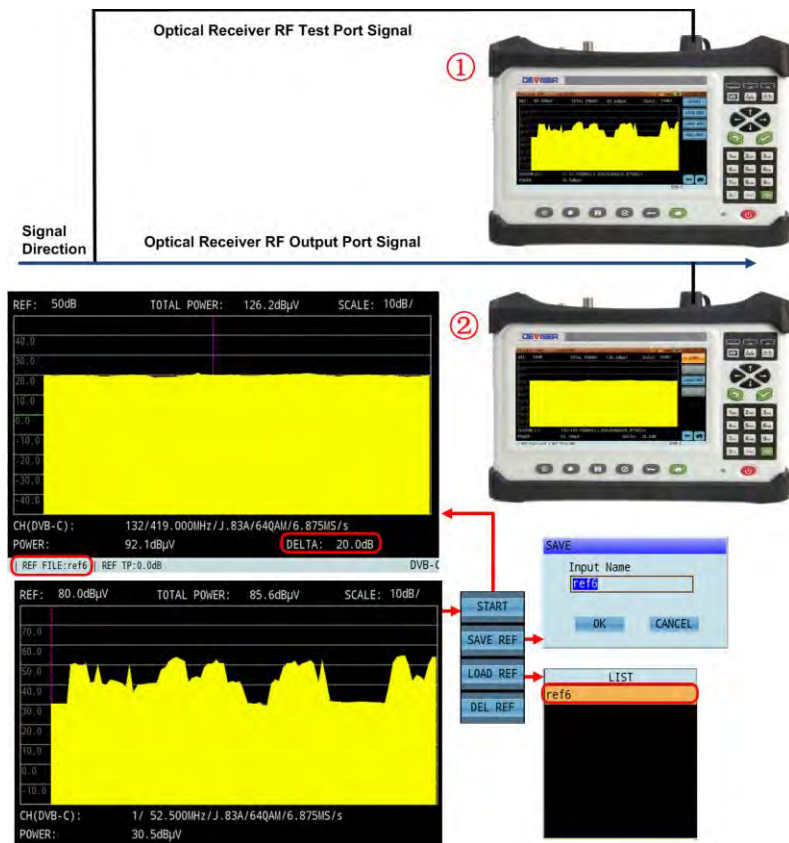

Figure 11-12 Passive Sweep Application Instruction

## 11.8. Tilt Measurement

To quickly measure the flatness of a CATV system and the gain of the splitters/taps, select the tilt measurement. This feature measures quickly the level and power of up to 16 channels.

Enter the Tilt function from the main menu -> Press the edit soft-key to set the tilt channels. 2 channels minimum are required to enable this function.

There are 2 markers in the tilt measurement screen. Only the active marker is being controlled. User can directly use finger operate marker. User need put the finger on one marker, then swipe the finger to the left or right. The marker will follow the finger move to different position, till user's finger stop on one position. The 2 display modes in this function are either the bar graph or list. Tap the soft button [[Graph]] or [[List]] to toggle between these two modes. The [Hold] button is used to stop refreshing measurements. Tap it again to continue to refresh. The [SETUP] button is used to select the channels for tilt measurement.

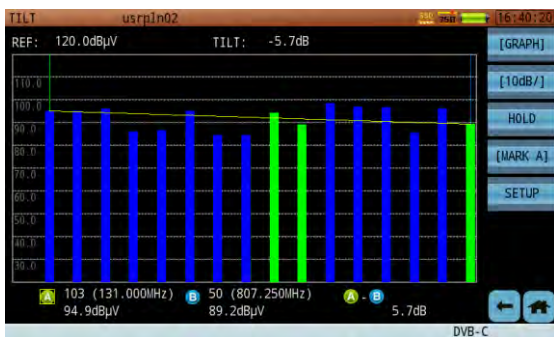

Figure 11-13 Tilt Measurement – Graph Display

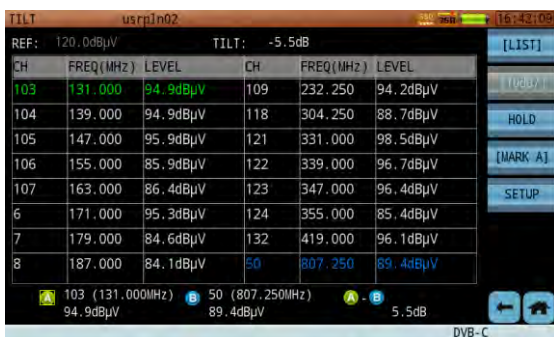

Figure 11-14 Tilt Measurement – Channel Listing Display

The below Figure 11-15 is the tilt editing page. Choose 2-16 channels among all active channels in the active channel plan to perform a tilt measurement. All active channels in the channel plan are listed and available in the edit tilt plan page.



Figure 11-15 Tilt Measurement - Channel Selection

### Measurement Results

Low frequency channels are displayed at the left, high frequency channels are displayed at the right of the graph. No matter what your channel selection is, they will all be placed in order automatically. Tilt results are measured between Marker A & B.

Analog channels measure on the sync pulse peak value of the video carrier, while digital channels show the average power.

'A-B' shows the level difference (tilt) value between Marker A and B.

## 11.9. Depth of Modulation

Analog TV video measurements required by the FCC include: Depth of Modulation. If you want to make those measurements in the gated mode, you must use a VITS inserter to insert the various test signals needed for specific measurements. You may find that those test signals are already part of the video feed provided by the broadcaster, however, it is highly recommended to do your own VITS signal insertion, for better accuracy, AND, to insure your measurement results don't include the low quality feed from the broadcaster.

In analog TV measurement mode, tap the soft button [DOM] to enter Depth of Modulation menu. Depth of modulation is measured as the percentage of the total amplitude change of the carrier, as the signal progresses from sync tip to peak white. You can measure depth of modulation on a TV channel with a vertical interval test signal (VITS). A test signal transmitted on the VITS of program video provides a reference to calibrate the video depth of modulation. Transmission standards require that the DOM ratio be in the range of 87.5%. At horizontal sync position, the carrier reaches maximum amplitude. At the peak white color position, the carrier amplitude is 12.5% less than the maximum amplitude.

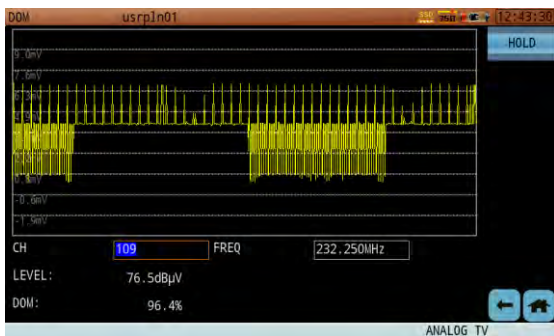

Figure 11-16 Snapshot: Depth of Modulation Measurement

## 11.10. Analog Non-linear distortion measurement

### 11.10.1. Carrier to Composite Noise Ratio Measurement

To measure CCN Ratio with your S7200, you must set-up the video carrier frequency and noise bandwidth correction correctly in the channel plan editor. Noise bandwidth is different depending on the channel bandwidth, which depends on your location. (NA, or EU). NTSC-M system uses 4MHz noise bandwidth correction. PAL-D system uses 5.75MHz noise bandwidth correction.

Noise measurement bandwidth for different TV standard

Standard	I	B, G	K1, L	D, K	M, N
Video bandwidth	6.75	5.75	7.25	6.75	4.95
Noise bandwidth	5.08	4.75	5.58	5.75	4.00

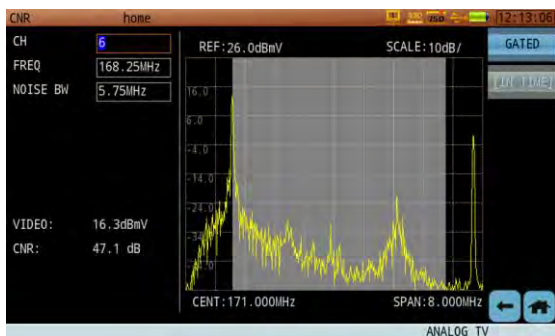

Figure 11-17 CCN measurement

Typically, CCN measurements require that system engineers measure video carrier level (Sync tip of the modulation is the absolute peak level), then remove the video modulation by shutting down the modulator, or simply



remove the modulation from the carrier, so to allow accurate noise measurement. Of course, removing modulation will interrupt the service which is not desirable. A better way to measure CCN accurately, is to perform an in-service “gated” measurement, with the help of gating technology and quiet line insertion in the vertical blanking interval of the video signal that are off the viewable screen. (usually below line 12), if you choose a higher VITS line, you may start encountering video modulation, thus visible interference on the television picture...In the gated mode, the S7200 will first measure peak carrier level, then will trigger on the appropriate VITS line # (preset for each channel to be set in the channel plan editor) to measure system noise. Sometimes, VITS lines are already quiet enough when video signals are delivered by the broadcaster, but some operators prefer to add VITS deletion/insertion to remove any uncertainty of measurement. (and so not to assume lower quality signals coming from the broadcaster) Many other types of test signals may be inserted for gated mode testing, such as in-channel frequency response, diff gain, diff phase. A quiet line is absolutely required when one needs to measure CCN, CSO, CTB, or cross-modulation. The S7200 offers triggering technology that accurately locks on a specific VITS line and provides very accurate measurement results.



Figure 11-18 Gated CCN Measurement – Frequency Domain Waveform

The parameter setup needed for gated measurements are: video carrier frequency, noise bandwidth, TV signal standard, odd/even field & line number. (setup in the channel plan editor)

CNR gated measurement support the fellow TV standard

System and Standard	Line/Frame	Field frequency	Color encoding technique
NTSC-M	525	60Hz	NTSC
PAL-M	525	60Hz	NTSC
PAL-B、D、G、H、I、K	625	50Hz	PAL
PAL-N	625	50Hz	PAL

Per frame 525 lines system: Field 1 (odd field), line 1-263; Field 2 (even field), line2-262

Per frame 625 lines system: Field 1 (odd field), line 1- 313; Field 2 (even field), line2- 312

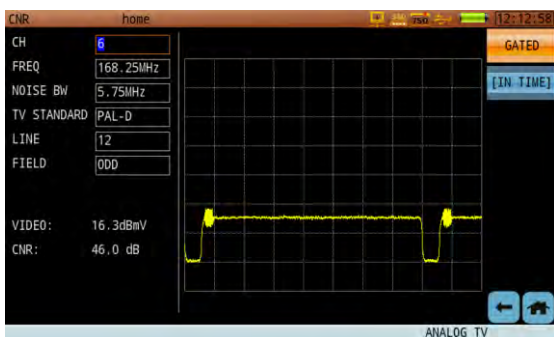

Figure 11-19 Snapshot: Gated CCN Measurement – Time Domain Waveform

### 11.10.2. CSO and CTB Measurement

Typically, CSO & CTB measurements require that system engineers measure video carrier peak level (Sync tip of the modulation is the absolute highest level), then remove the video modulation by shutting down the modulator, or simply remove the modulation from the carrier, so to allow accurate noise measurement. Of course, removing modulation will interrupt the service which is not desirable. A better way to measure CSO/CTB accurately, is to perform an in-service measurement, with the help of gating technology and quiet line deletion/insertion in the vertical blanking interval of the video signal that are off the viewable screen. (usually below line 12), if you choose a higher VITS line, you may start encountering video modulation... (thus visible interference on the television picture) Sometimes, those VITS lines are already quiet enough when video is delivered by the broadcaster, but some operators prefer to add VITS insertion to remove any uncertainty of measurement. (and so not to assume lower quality signals coming from the broadcaster)

The CTB distortion typically falls exactly at the video carrier frequency. The CSO distortion typically falls  $\pm 0.75\text{MHz}$  and  $\pm 1.25\text{MHz}$  from the video carrier.

In a PAL-D system, the CSO production fall  $\pm 0.25\text{MHz}$  and  $\pm 1.25\text{MHz}$  away from the carrier.

When we measure CSO and CTB, the test results are C/CSO and C/CTB, C meaning carrier level. In the gated mode, the S7200 will first measure absolute carrier level, then will trigger on the appropriate VITS line # to measure system noise. (preset for each channel to be set in the channel plan editor) Measuring CTB however, is likely to REQUIRE a line deletion/insertion piece of equipment to remove carrier signal from one of the field of the quiet line to measure the beat interference signal. The CTB interference signal falls exactly under the video carrier frequency and since the video carrier amplitude is more than likely to be higher than the interference, gated CTB measurement **must** use a line removing piece of equipment to remove one line the video carrier signal.

Many other types of test signals may be inserted for gated mode testing, such as in-channel frequency response, diff gain, diff phase. A quiet line is absolutely required when one needs to measure CCN, CSO, CTB, or cross-modulation. The S7200 offers triggering technology that accurately locks on a specific VITS line and provide very accurate measurement results Figure 11-21 is CSO/CTB screen, Press **【Continue Test】** to test CSO/CTB, “Please turn off the carrier! Confirm to cancel” will be prompted and enter CSO/CTB test screen like Figure 11-22.

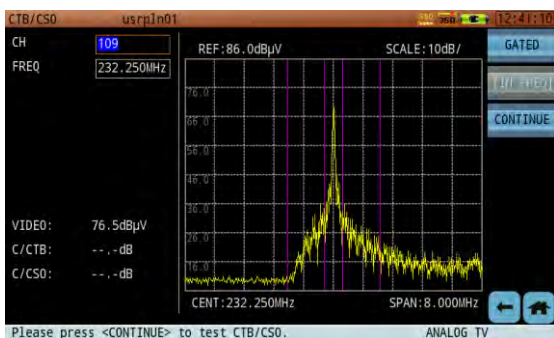

Figure 11-20 CSO/CTB Measurement-1

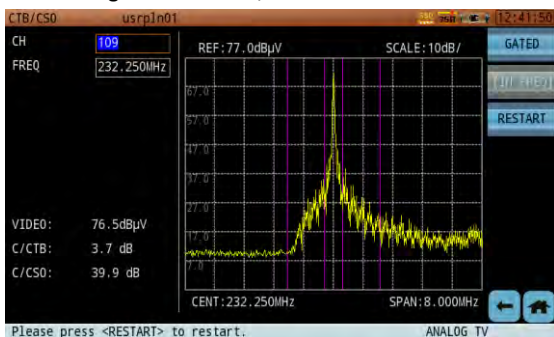

Figure 11-21 CSO/CTB Measurement-2

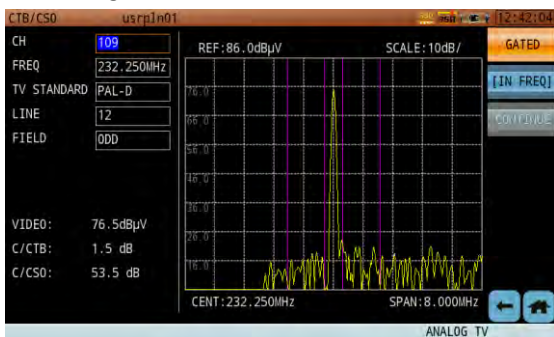

Figure 11-22 Gated CSO/CTB Measurement – Frequency Domain Waveform

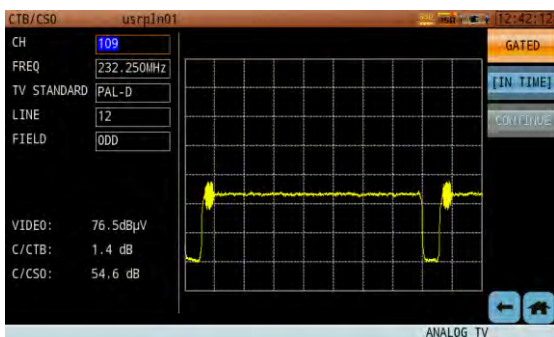

Figure 11-23 Gated CSO/CTB Measurement – Time Domain Waveform

## 12. Digital Signal Measurements

DVB-C QAM analysis functions include the following channel measurements,

- Constellation diagram,
- Channel power
- EVS (Error vector spectrum),
- Digital Hum.

### Parameter Settings

Adjustable parameters and range of the DVB-C function of the S7200 are listed below:

CH-Channel NO.:

—Value Range: all active channels or active digital channels in the active channel plan

FREQ-Centre Frequency:

—Value Range: 4MHz-1220MHz

BW-Channel Bandwidth

—Value Range: 1MHz-50MHz

## MODE-Modulation Mode

—Value Range:

- J.83A & J.83C, the available modulation modes are 16/32/64/128 and 256QAM;

- J.83B, the available modulation modes are 64QAM and 256QAM;

SR-Symbol Rate (MS/s) —Value Range:2MS/s to 7MS/s

Interface Icon description:



QAM signal losing lock,



QAM signal lock

## 12.1. DVB-C Measurement

The digital channel measurement screen shown below in Figure 12-1, displays the basic digital metrics after demodulation.

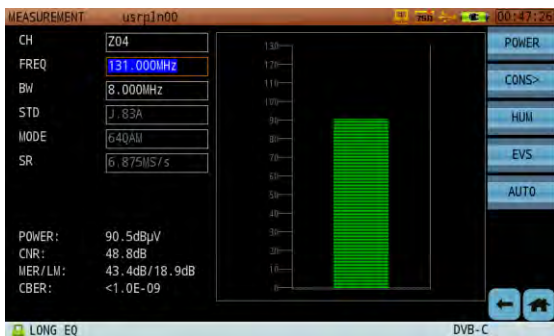

Figure 12-1 Channel Measurement – QAM Signal Analysis

User can use finger directly tap parameter's position use virtual keyboard enter content or from drop list to choose one item.

Buttons Operation:

- [POWER] Average Power Measurement interface shortcut
- [HUM] Digital HUM shortcut
- [CONS>] Constellation diagram shortcut

[EVS]	EVS function shortcut
[AUTO]	Auto search the current frequency

Test result parameters description:

LM (Link Margin) is the difference value between the actual received MER and MER threshold standard. Different type of channel has different MER threshold standard value, and different modulation type and different code rate of each type of channel also have different MER threshold standard value.

## 12.2. Digital HUM

Hum modulation is also called power source frequency modulation distortion and comes from a power source frequency interference. HUM modulation generally degrades MER values of a digital carrier. TheS7200 supports hum modulation measurements for digital channels. The measurement interface is shown below in Figure 12-2.

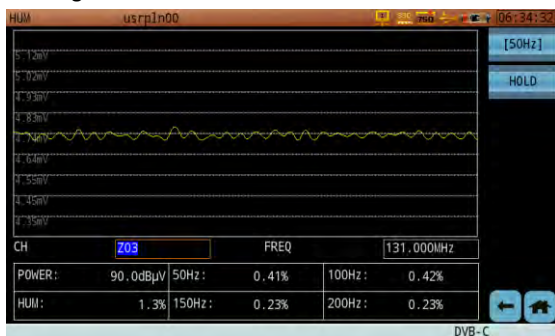

Figure 12-2 Digital Hum Measurement

Parameters setup description:

Channel Can be changed between all active channels in the



active channel plan

Frequency Range: 4MHz-1220MHz;

Measurement Result:

Average Power measured over the occupied bandwidth (Level)

Hum Modulation The % of modulation measured under the QAM carrier.

Frequency Component displays the percentage of HUM for each of the distortion frequencies

Soft key button description:

[50Hz] / [60Hz] press this button to switch the power frequency between 50Hz or 60Hz.

[Hold] press this button to pause, and press again to continue to refresh the interface

You can choose the AC power frequency according to your local region.

The low frequency interference and interference harmonics measurable with the S7200 are;

- 50Hz, 100Hz, 150Hz and 200Hz for 50Hz,
- 60Hz, 120Hz, 180Hz and 240Hz for 60Hz.

## 12.3. Constellation Diagram

The DVB-C constellation diagram function is shown below in Figure.



Figure 12-3 Constellation display



In power measurement function, tap the soft button [CONS>] to open the constellation diagram interface. You can refresh and zoom the constellation. The diagram zoom-in function will only zoom one of the four quadrant of the diagram. The [Select] button is used to select the quadrant. After choosing the quadrant, tap the soft button [Zoom IN], and the selected quadrant will then fully occupy the screen. (as seen in Figure 12-5)



Figure 12-4 Constellation Zoom – select a Quadrant



Figure 12-5 Constellation Zoom – Zoom In &amp; Zoom Out

User can use tap the parameter on touch screen to modify parameter value or use  and  arrow key to modify parameters value, or input the value with the numerical keypad.

#### Buttons Operation:

- [POWER] Average Power Measurement interface shortcut
- [HUM] Digital HUM shortcut
- [CONS>] Constellation diagram shortcut
- [EVS] EVS function shortcut
- [AUTO] Auto search the current frequency
- [Refresh] Clear the current constellation diagram and refresh.
- [Select] Select the desired quadrant
- [Zoom in] Zoom the selected quadrant in, you can only zoom in one level
- [Zoom out] Zoom the selected quadrant out, you can only zoom out one level

## 12.4. Error Vector Spectrum (EVS) Function

The EVS function is a great tool to help find signal interference under the QAM (DV or DOCSIS), but the greatest benefit is that the test can be performed in-service. The traditional methods to find interference signals under QAM signals, was to briefly interrupt the QAM signal allowing to see any distortion products mixed with the noise floor underneath. However, this is an intrusive method which is unacceptable in today's HFC preventive network maintenance practices. The EVS function will help you find interference signal under the QAM signal, without interrupting services. The EVS function works two different ways; one is in the time domain, the other in the frequency domain. The EVS frequency domain function is typically used to find narrower band interference signal, when the interference signal bandwidth is much narrower than the QAM signal bandwidth.

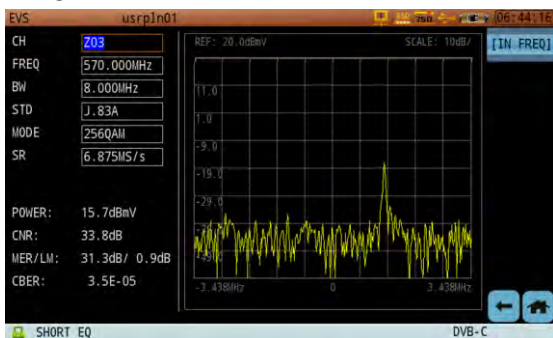

Figure 12-6 Error Vector Spectrum – Frequency Domain

However, when the interference signal is broadband in nature, which means the interference signal bandwidth is close to or wider than the QAM signal bandwidth (6MHz or 8MHz), like an LTE signal for example, the EVS time domain function is recommended to make use of the LTE signal time domain characteristics. In recent years, the most disrupting and increasingly used broadband signals are cellular LTE signals and have been found to creep their way into an HFC network and interfere with the QAM signals being transmitted over Cable at the same frequencies. Frequently used LTE bandwidths are 5MHz, 10MHz and 20MHz. These types of bandwidth are all close or wider than DVB-C signal bandwidth. Both LTE signals and DVB-C signals are digital signals, all of them are similar with noise. The S7200 uses the EVS time domain function to measure the LTE interference results, shown as the below Figure 12-7.

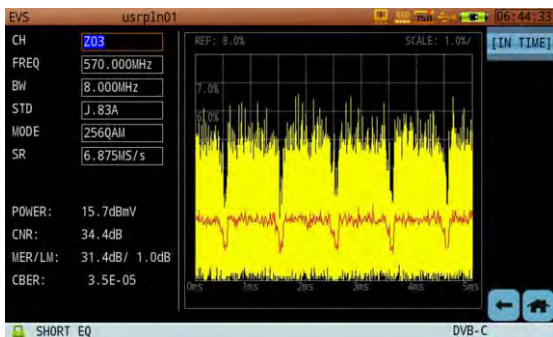

Figure 12-7 Error Vector Spectrum – Time Domain

## 12.5. ATSC (8VSB) measurement

S7200 support ATSC (8VSB) signal measurement option, ATSC (8VSB) option is an hardware option, need install a PCB.

For 8VSB signal, S7200 provide the follow measurement functions : average power, constellation diagram, eye diagram, digital HUM, spectrum mask. The digital hum main focus on cable transmission 8VSB signal.

If S7200 want to demodulate 8VSB signal, must setup the follow parameters :

The pilot position: other measurement instrument maybe setup this parameters, but S7200's program automatic judgement this parameter, don't need user setup this parameters. The pilot position can be set to the left (low) side of the spectrum or be set to the right (high) side of the spectrum.

Center frequency: the carrier center frequency

Modulation type: 8VSB

Symbol rate: 10.762MS/s

If all parameters was setup right and the signal no problem, the S7200 can correctly demodulate 8VSB signal.

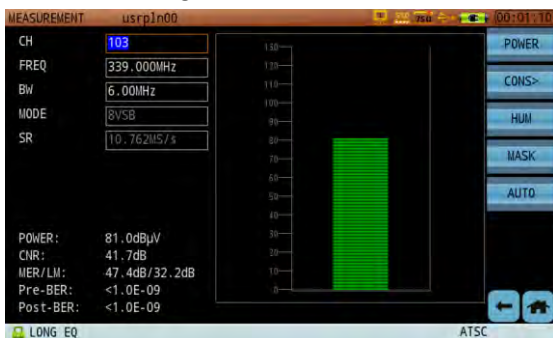

Figure 12-8 8VSB Average Power Measurement

In average power measurement interface, the screen display 8VSB signal average power, MER, Pre-BER and Post-BER. The average power use the histogram display.

8VSB constellation diagram include 8 vertical lines. Every line is composed by many constellation points. Every constellation point's horizontal coordinate (or data real part) carry information, vertical coordinate (or data imaginary part) doesn't carry information. The thinner the vertical line, the better the signal. The thicker the vertical line, the worse the signal. The constellation diagram can be used to quick check the signal quality. Bowed lines indicate amplitude error such as clipping or nonlinear expansion. (AM-AM distortion) S-shaped lines indicate phase error (AM-PM distortion). Lines frayed at edges indicate phase noise problems.

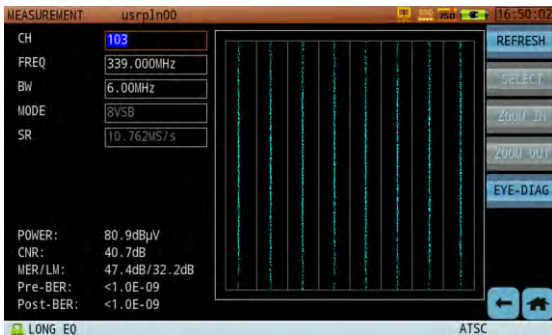

Figure 12-9 8VSB Constellation

Another way to determine the signal quality is with the eye diagram. Look for the seven open eyes in the eye diagram. If some eyes are not fully open indicates that the signal has some error, and the 8 vertical bars are not as compact as they could be. A perfectly compacted signal would have straight vertical line on the 8VSB constellation and open eyes in the eye diagram. The Figure 12-11 shows decreased signal quality, eye diagram gradually closed.

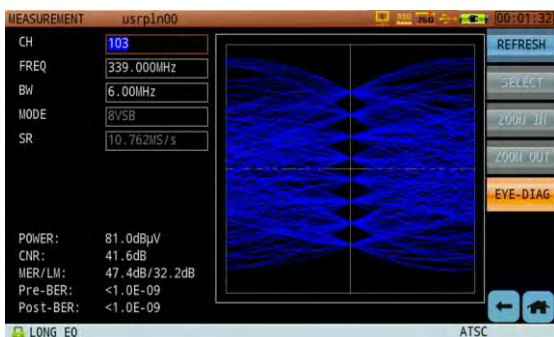

Figure 12-10 8VSB Diagram

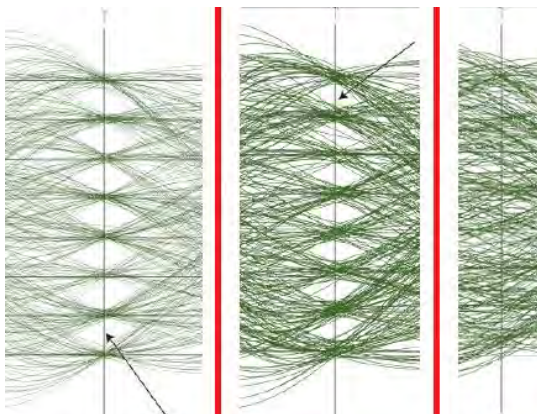

Figure 12-11 Decreased signal quality, eye diagram gradually closed

In the US, the FCC has specified different emission masks for different types of 8-VSB DTV transmitters. One mask is specified for Full Service digital transmitters. Two other masks are specified for digital LPTV (Low-Power Television) transmitters, Class A digital transmitters and digital TV translators; one mask is termed “Simple” and the other “Stringent”. The conditions imposed by the licensing process and the FCC’s regulations should be



consulted to determine which mask is appropriate for a given digital transmitter.

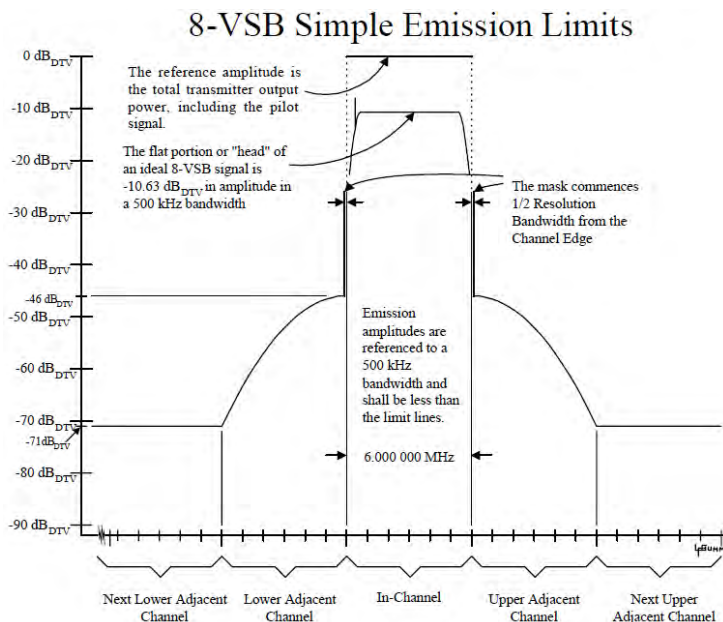

Figure 12-12 Simple Emissions Mask requirements for low power 8-VSB LPTV transmitters and translators

S7200 only support 8-VSB Simple Emission Limits, as the Figure 12-12 show. The Figure 12-13 shows the 8-VSB spectrum mask test PASS status, the screen display a green text "PASS", no alarm sound. If the 8-VSB signal doesn't meet the "Simple Emissions Mask requirements", the instrument will use the speaker alarm and display a red text "FAILED", user can tap the soft button [MUTE] to stop the alarm sound.

If user enter the spectrum mask test function, the system judgment signal

status is “FAILED”, sometimes the failed status is caused by instrument attenuator setting. So user can tap the soft button [ATT>] to open attenuator modify sub-menu. User taps the button [INPUT] can directly input attenuator value, tap the button [INC] or [DEC] to increase or decrease the attenuator value. By modify attenuator, some signal can meet the Simple Emissions Mask requirements.



Figure 12-13 Spectrum Mask Test - Pass

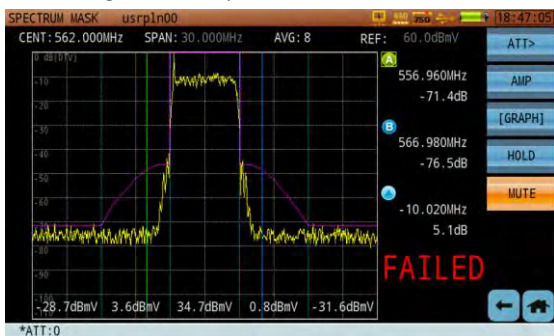

Figure 12-14 Spectrum Mask Test - Failed

The spectrum mask also support list display, the main frequency point display on the list, every frequency point give pass or failed indication and test value, as the Figure 12-15 show.

SPECTRUM MASK usrp1n00

CENT: 562.000MHz SPAN: 30.000MHz AVG: 8 REF: 60.0dBmV

Band	VALUE	MASK	STATUS	Band	VALUE	MASK	STATUS
-12	-74.6dB	-69.0dB	PASS	1	-48.0dB	-46.0dB	PASS
-11	-73.9dB	-65.1dB	PASS	2	-58.4dB	-46.4dB	PASS
-10	-74.5dB	-61.7dB	PASS	3	-73.3dB	-47.1dB	PASS
-9	-73.5dB	-58.5dB	PASS	4	-73.9dB	-48.1dB	PASS
-8	-73.4dB	-55.8dB	PASS	5	-73.6dB	-49.5dB	PASS
-7	-73.8dB	-53.3dB	PASS	6	-73.8dB	-51.3dB	PASS
-6	-73.5dB	-51.3dB	PASS	7	-74.1dB	-53.3dB	PASS
-5	-74.1dB	-49.5dB	PASS	8	-73.8dB	-55.8dB	PASS
-4	-73.3dB	-48.1dB	PASS	9	-74.1dB	-58.5dB	PASS
-3	-72.5dB	-47.1dB	PASS	10	-74.3dB	-61.7dB	PASS
-2	-57.9dB	-46.4dB	PASS	11	-74.4dB	-65.1dB	PASS
-1	-45.5dB	-46.0dB	FAILED	12	-74.3dB	-69.0dB	PASS

\*ATT:0

Figure 12-15 Spectrum Mask Test – List Display

## 12.6. DVB-C2 measurement

S7200 support DVB-C2 signal demodulation, include 1024QAM and 4096QAM signal. User can read L1 and SLICE ID information.

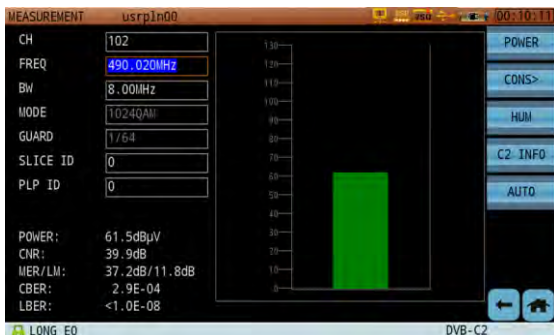

Figure 12-16 DVB-C2 Power Measurement

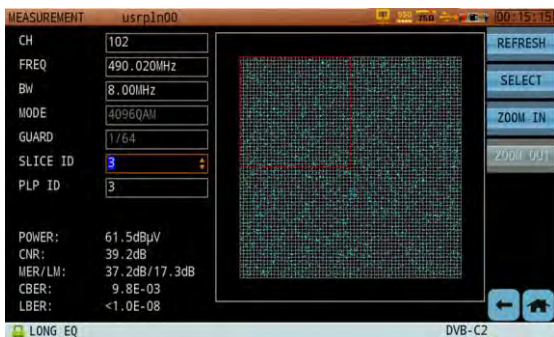

Figure 12-17 DVB-C2 4096QAM Constellation

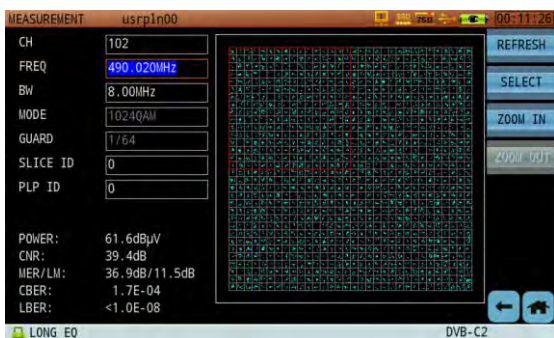

Figure 12-18 DVB-C2 1024QAM Constellation

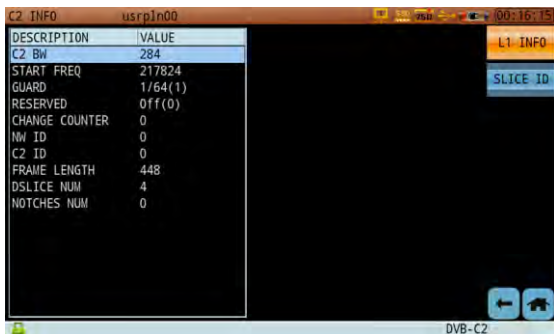

Figure 12-19 DVB-C2 L1 Information

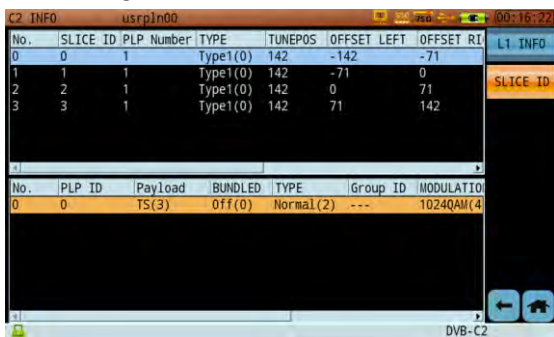

Figure 12-20 DVB-C2 SLICE ID

A DVB-C2 frame begins with preamble symbols which are repeated every 7.61MHz and have a width of 3408 carriers each. These are followed by the data symbols, a total 448 data symbols. The preamble symbols are used both for time and frequency synchronization and for signaling of the Layer-1 (L1) parameters. The preamble symbols are arranged with respect to frequency in such a way that a receiver with a receiver bandwidth of 7.61Mhz will get all the data necessary for finding the Layer-1 parameters.

There are actually no longer any channels in DVB-C2 but only two channel rasters of either 6 or 8 MHz Channels can be bundled together to form a channel with a total width of approx. 450MHz. There are no longer any gaps between the original channels. The lack of any more gaps (guard bands) then enables the frequency spectrum to be used more effectively and allows a higher data rate overall. However, there are very frequently also disturbed frequency bands in the cable or frequency bands which could interfere with other radio services. These can be notched out in DVB-C2 by simply switching off certain OFDM carriers. This is called nothing which produces gaps in the frequency spectrum.

## 12.7. DVB-T/H measurement

S7200 support DVB-T/H signal measurement.

For DVB-T/H signal, S7200 provide the follow functions : average power, constellation diagram, MER and BER measurement ; all carriers constellation or single carrier constellation, single frequency network echo measurement.

If user need S7200 demodulation DVB-T/H signal, user must right setup the follow parameters :

First step need setup the channel type as DVB-T/H in channel plan edit function.

Center Frequency      editable content

For all other parameters, the S7200 auto detect from the pilot and TPS carrier.  
(S7200 not support DVB-H 4k carriers mode)

If all parameters was setup right and the signal no problem, the S7200 can correctly demodulate DVB-T/H signal.

Test results parameters introduction:

CBER and VBER

CBER and VBER give an indication of the quality of the signal provided to the receiver. A TV receiver is able to identify and correct certain amounts of error in the transmission channel. In the TV receiver, error correction takes place in two distinct stages called Viterbi (or 'outer') and Reed Solomon (or 'inner') correction. The bit error rate (BER) before Viterbi correction stage is known as CBER. It is also known as 'pre Viterbi BER', raw BER' or channel BER. CBER indicates errors present before any correction has taken place in the TV, set-top box or test instrument. Therefore, CBER is a very important part in digital TV measurements and it should be better than  $2E-2$  (2 errors in every

100 bits of data) for good quality TV reception.

The bit error rate after the Viterbi correction is known as VBER or post Viterbi. It should be better than  $2E-4$  (2 errors in every 10000 bits of data).

In average power measurement interface, the screen display DVB-T/H signal average power, MER, CBER and VBER. The average power use the histogram display.

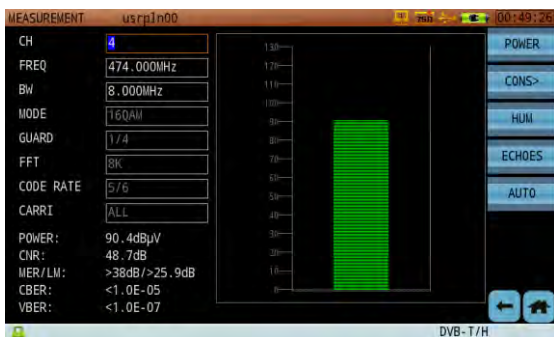

Figure 12-21 DVB-T/H Average Power Measurement

S7200 DVB-T/H constellation function has multi-type display: All carriers constellation, only one carrier constellation, hierarchical modulation constellation. S7200 DVB-T/H function default display all carriers constellation, as the Figure 12-22 show. When user taps the soft button [CARRIER], parameter "CARRIER" can be edit in the parameters list. User taps this parameter position, a drop-down list let user choose carrier number. If a carrier number followed by text "DATA", it means this carrier is used for data transmission. If a carrier number followed by text "TPS", it means this carrier is used for TPS (Transport Parameter Signaling) transmission. The DATA carrier constellation as the Figure 12-23 show. The TPS carrier constellation as the Figure 12-24 show.



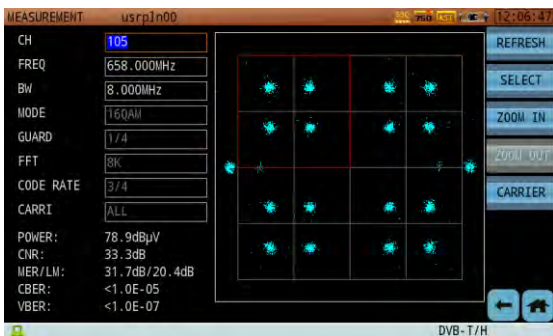

Figure 12-22 DVB-T/H All Carrier Constellation

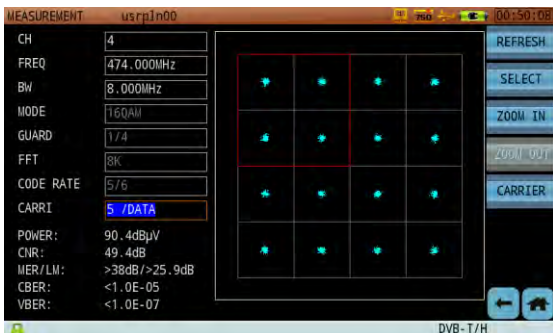

Figure 12-23 DVB-T/H Sub-Carrier Constellation - Data

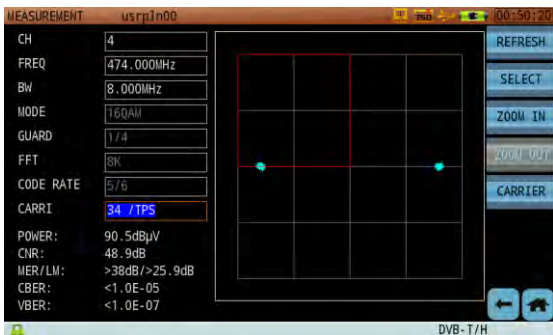

Figure 12-24 DVB-T/H Sub-Carrier Constellation - TPS

DVB-T 8k mode has 6817 sub-carriers and 2k mode has 1705 sub-carriers. All sub-carriers can be classified into three types:

(1) Data carriers are used to transmit digital TV transport stream MPEG-2 signal.

(2) TPS(Tansport Parameter Signaling) carriers are used to transport receiver needed parameter, example: modulation type (QPSK,16QAM,64QAM), FEC coding (1/2,2/3,3/4,5/6,7/8), 2k or 8k mode, guard interval (1/4,1/8,1/16,1/32).

(3) Pilot carriers are used to help receiver calibrate receive signal amplitude and phase.

For 8k mode: total carrier amount 6817 = 6048 (Data) + 68 (TPS) + 701 (Pilot).

For 2k mode: total carrier amount 1705 = 1512 (Data) + 17 (TPS) + 176 (Pilot).

TPS Carrier Number

2K Mode TPS Carrier Position	8K Mode TPS Carrier Position
34, 50, 209, 346, 413, 569, 595, 688, 790, 901, 1073, 1219, 1262, 1286, 1469, 1594, 1687	34, 50, 209, 346, 413, 569, 595, 688, 790, 901, 1073, 1219, 1262, 1286, 1469, 1594, 1687, 1738, 1754, 1913, 2050, 2117, 2273, 2299, 2392, 2494, 2605, 2777, 2923, 2966, 2990, 3173, 3298, 3391, 3442, 3458, 3617, 3754, 3821, 3977, 4003, 4096, 4198, 4309, 4481, 4627, 4670, 4694, 4877, 5002, 5095, 5146, 5162, 5321, 5458, 5525, 5681, 5707, 5800, 5902, 6013, 6185, 6331, 6374, 6398, 6581, 6706, 6799

## DVB-T Hierarchical Modulation

DVB-T introduce the hierarchical modulation conception, the adjacent quadrants symbol use nonuniform mapping. DVB-T define a parameter factor  $\alpha$ ,  $\alpha=1, 2, 4$ . The factor  $\alpha$  means the distance which a symbol is the closest to the axes X and Y. When  $\alpha=1$ , it means no hierarchical modulation. When  $\alpha=2$  or 4, it means hierarchical modulation, the Figure 12-25 and Figure 12-26 show the hierarchical modulation constellation.

In hierarchical modulation, two separate data streams are modulated onto a single DVB-T stream. One stream, call the “High Priority” (HP) stream is embedded within a “Low Priority” (LP) stream.

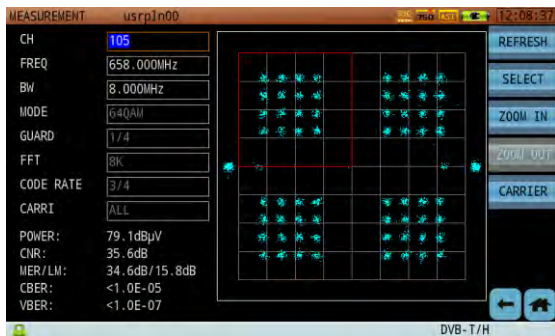

Figure 12-25 Hierarchical Modulation Constellation-1

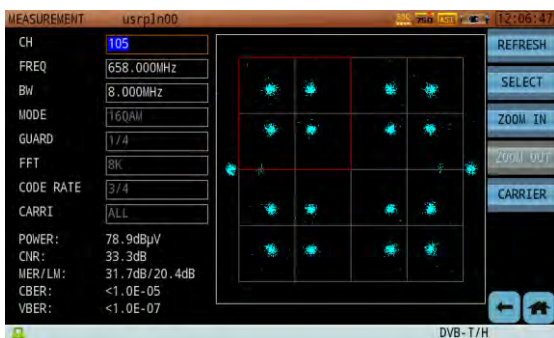

Figure 12-26 Hierarchical Modulation Constellation-2

### DVB-T/H Echo Pattern

Post-echo scenario

The transmission scenario and the channel impulse response for post-echoes are shown in Figure 12-27. In the post-echo scenario, the strongest path (main path) is from the nearest transmitter tower and the other paths are either from transmitters located further away or from reflections which arrive after the main path and have lower power levels. In Figure 12-27, just one echo is shown.

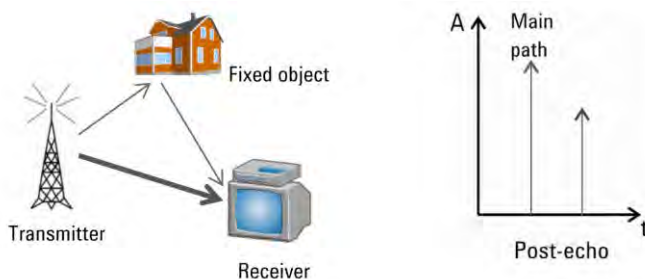

Figure 12-27 Post-echo Scenario and the Associated Channel Impulse Response

### Pre-echo scenario

The transmission scenario and channel impulse response for pre-echoes are given in Figure 12-28. Pre-echoes often occur when there are repeaters nearby. For the pre-echo scenario, the strongest is re-transmitted from the repeater and doesn't arrive first. The LOS (line of sight) path arrives first but has a lower power level.

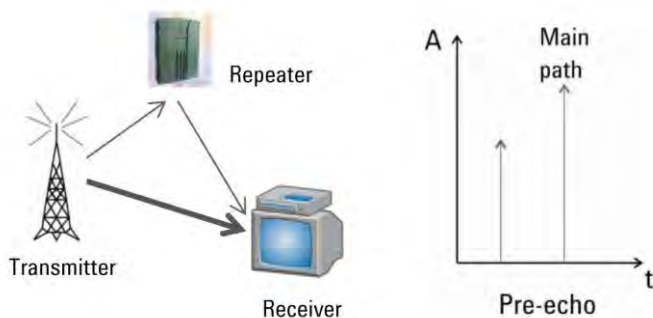

Figure 12-28 Pre-echo Scenario and the Associated Channel Impulse Response

### Pre-echoes and post echoes

A pre-echo and post-echo scenario occurs when both a pre-echo and a post-echo exist in the transmission channel. The transmission scenario and channel impulse response are shown in Figure 12-29. The strongest path is re-transmitted from the repeater. The LOS signal arrives first but it has a lower power level and the paths that arrive later may be from reflections.

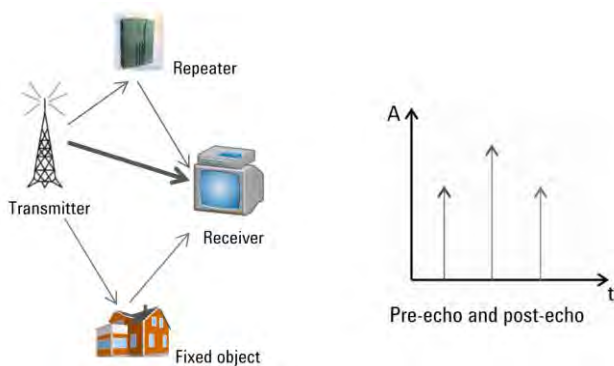

Figure 12-29 Pre-echo and Post-echo Scenario and the Associated Channel

#### Impulse Response.

The Figure 12-30 is echo pattern analysis interface. The main path signal at the center of the pattern. At the left side of the main path is pre-echo, at the right side of the main path is the post-echo. The area of not covered by the shadow is area of guard interval. Different guard interval setting has different shadow display in echo pattern. In echo list, user can tap different echo item, the marker will auto move on the corresponding echo. The echo also provide the distance and delay time from generate echo transmitter to the main transmitter.



Figure 12-30 Echo Pattern

## 12.8. DVB-T2 measurement

DVB-T2 standard EN 302755 provide version 1.1.1, version 1.2.1 and version 1.3.1. The version 1.3.1 added a T2-Lite profile. This profile is intended to all simpler receiver implementations for very low capacity applications such as mobile broadcasting, although it may also be received by conventional stationary receivers. T2-Lite is a “light version” of DVB-T2 that allows for implementation of mobile devices with low complexity and low power consumption. T2-Lite is mainly a subset of the main DVB-T2 standard (T2-Base), where components with high complexity are removed. T2-Lite is specified in an updated version of the DVB-T2 standard –was published by ETSI in 2012 (EN 302 755 v.1.3).

S7200 support EN 302 755 V1.1.1,V1.2.1and V1.3.1DVB-T2 signal test. S7200 provide the follow test functions: average power, MER, CBER, VBER and constellation test, echo Patten, provide L1 and PLP information.

If user want S7200 to demodulate DVB-T2 signal, user must do some setting: First step, user must setup channel type as DVB-T2 in channel plan edit interface.

Center Frequency: carrier center frequency

Other DVB-T2 parameters come from pilot, P1 symbol, L1 presignaling and L1 postsignaling.

If user set all parameters correctly and signal no problem, S7200 can demodulate DVB-T2 signal. User can tap soft button [T2 INFO], read P1 symbol, L1 presignaling and L1 postsignaling information, as the Figure 12-37and the Figure 12-38show.



Test results parameters introduction:

### CBER and VBER

CBER and VBER give an indication of the quality of the signal provided to the receiver. A TV receiver is able to identify and correct certain amounts of error in the transmission channel. In the TV receiver, error correction takes place in two distinct stages called Viterbi (or 'outer') and Reed Solomon (or 'inner') correction. The bit error rate (BER) before Viterbi correction stage is known as CBER. It is also known as 'pre Viterbi BER', raw BER' or channel BER. CBER indicates errors present before any correction has taken place in the TV, set-top box or test instrument. Therefore, CBER is a very important part in digital TV measurements and it should be better than  $2E-2$  (2 errors in every 100 bits of data) for good quality TV reception.

The bit error rate after the Viterbi correction is known as VBER or post Viterbi. It should be better than  $2E-4$  (2 errors in every 10000 bits of data).

In average power measurement interface, the screen display DVB-T/H signal average power, MER, CBER and VBER. The average power use the histogram display.



Figure 12-31 DVB-T2 Average Power Measurement

Rotated constellations were introduced in DVB-T2 for improving the system performance in fading scenarios by means of signal-space diversity. When rotated constellations are used, a rotation is applied to the constellation symbols in such a manner that the two components in the imaginary plane, in-phase I and quadrature Q, carry all the binary information. Then, the real and imaginary parts of each symbol are cyclically delayed and end up being transmitted in different subcarriers. This increases the reception robustness in the presence of deep fades but requires a high demodulation complexity.

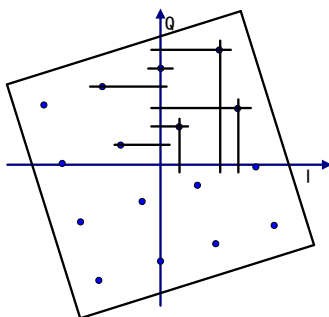

Figure 12-32 Discrete mapping of constellation points on the I and Q axis with a rotated constellation diagram.

In reality, however, the whole process is slightly more complex. With a rotated diagram, the Q component is not transmitted on the same carrier, or more precisely in the same “cell”, but with delay on another carrier (Figure 12-32 and Figure 12-33) or better in another cell. From one QAM, virtually two ASKs (Amplitude Shift Keying modulations) in the I and Q direction are then produced which are then transmitted on independent carriers – “cell” which are disturbed differently in practice and are thus intended to contribute to the reliability of demodulation.

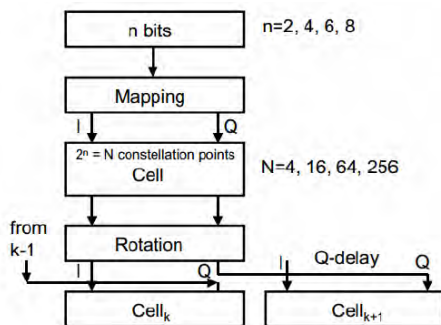

Figure 12-33 Mapping, rotation and Q delay

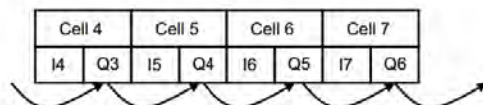

Figure 12-34 Cyclic Q delay between adjacent cells

The S7200 measures DVB-T2 rotated constellation shows in Figure 12-35 错误! 未找到引用源。 . The constellation only for PLP content. If DVB-T2 signal only include one PLP, user cannot change “PLP ID” parameter. If DVB-T2 signal include multi PLP, user can switch parameter “PLP ID”, the constellation also change with different PLP ID (if every PLP has different modulation type).

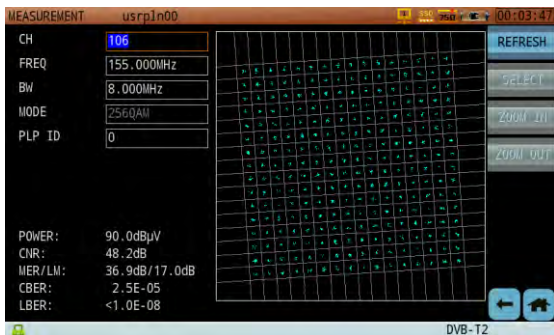

Figure 12-35 DVB-T2 Constellation

The Figure 12-36 shows how to zoom DVB-T2 constellation.



Figure 12-36 DVB-T2 Constellation Zoom

The physical layer signaling in DVB-T2 is transmitted inside preamble symbols known as the P1 and P2 symbols at the beginning of each T2 frame. The P1 symbol is the first OFDM symbol transmitted in the T2 frame and intended for fast identification of available T2 signals. P2 symbols are transmitted right after the P1 symbol and carry the Layer 1 (L1) signaling, divided in L1 presignaling and L1 postsignaling. The L1 presignaling consists of very basic information (200 bits) and is always transmitted with the most robust configuration available (BPSK and code rate 1/5). The L1 postsignaling enables the reception of the actual data and is transmitted with constellations BPSK, QPSK, 16QAM or 64QAM and code rate 1/2. The L1 postsignaling can be divided into the configurable part and the dynamic part. The configurable part signals the configuration of the PLPs and is seldom changed during the transmission of T2 signals. The dynamic part signals the position of the PLPs in each frame and changes from frame to frame.

The S7200 can provide signaling, the Figure 12-37 shows S7200 can provide all singlings information.

L1-pre Signalling		L1-post Signalling	
DESCRIPTION	VALUE	DESCRIPTION	VALUE
Pilot Pattern	PP7(b)	Sub Slices	1
System ID	32769	PLP Number	1
Cell ID	0	Aux Number	0
Network ID	12421	AUX Config Rfu	0
T2 Frames	2	Freq	155.000 MHz
RF Num	1	FEF Type	0
RF Index	0	FEF Length	0
S2	8	FEF Interval	0
L1 Rep	Off(0)		
L1 Post Size	250		

Figure 12-37 DVB-T2 L1 Information

The term PLP (Physical Layer Pipe) was used for the first time in DVB-T2. If only one data stream is fed into the DVB-T2 modulator call Mode A. The Multiple Input Mode is called Mode B and will also be used as such. It is especially the possibility of being able to use this standard for transmitting contents with different robustness and with different data rates which will be made use of and is here called VCM – Variable Coding and Modulation.

The S7200 provides DVB-T2 PLP information show in Figure 12-38.

ID	Group ID	Payload Type	Type	DESCRIPTION	VALUE
0	1	TS(3)	TYPE1(1)	FEC Type	64K(1)
				FEC Block	129
				Mod	256QAM(3)
				Rot	N0
				CR	3/5(1)
				IL Type	0
				IL Length	2
				Frame Interval	1
				InbandA	N0(0)
				InbandB	N0(0)
				FF	N0(0)
				First Rf Idx	0
				First Frm Idx	0
				Rsvd	0

Figure 12-38 DVB-T2 Mode A PLP Information

The echo principle related content please reference DVB-T/H echo test part.

Figure 12-39 shows S7000 does DVB-T2 echo test interface.

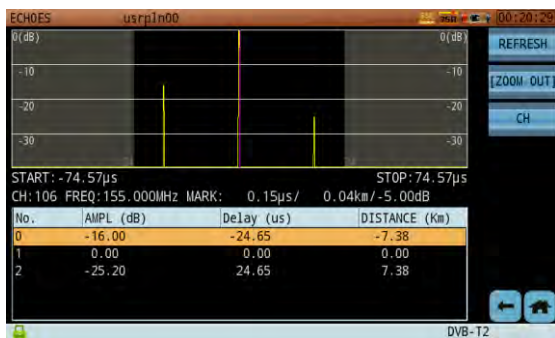

Figure 12-39 DVB-T2 Echoes Measurement

## 12.9. ISDB-T<sub>B</sub> Measurement

The ISDB system was designed for high-quality audio, video, and associated data. Originally, it was developed by and for Japan. In 2006, Brazil adopted a slightly modified version of the standard, known as ISDB-T<sub>B</sub>, which has been the terrestrial broadcast choice in most countries of South America.

In ISDB-T<sub>B</sub>, COFDM is used in 2K, 4K, 8K mode. The 6MHz-wide channel can be subdivided into 13 subbands in which different modulation parameters can be selected and contents transmitted. Time interleaving can be optionally switched on in various stages. With an actual channel bandwidth of 6MHz, the useful band only has a width of 5.57MHz, i.e. there is a guard band of about 200kHz each for the upper and lower adjacent channels. One subband of the ISDB-T channel has a width of 430kHz.

It is possible to select different types of modulation in ISDB-T:

- QPSK with channel correction
- 16QAM with channel correction
- 64QAM with channel correction
- DQPSK without channel correction

There are 3 possible modes (6MHz channel as example):

- Mode I, with

---

1 The main differences of ISDB-T<sub>B</sub> compared to ISDB-T are source code (H.264 for video and MPEG-4 HE AAC for audio); middleware (Ginga); and adoption of VHF/UHF bands for channels 7 – 13 and 14 – 69, respectively. For ISDB-T, the MPEG-2 method was chosen as the source coding for the digital TV signals to be transmitted.

108 carriers per subband

3.986 kHz subcarrier spacing

1404 carriers within the channel

2048-points IFFT

- Mode II, with

216 carriers per subband

1.9841kHz subcarrier spacing

2808 carriers within the channel

4196-points IFFT

- Mode III, with

432 carriers per subband

0.99206kHz subcarrier spacing

5616 carriers within the channel

8192-points IFFT

The individual segments in ISDB-T can be combined to form a total of 3 layers in which different transmission parameters (type of modulation and error protection) can be selected. In the 3 hierarchical layers, different contents can then be error-protected to different degrees and transmitted with modulation of different robustness. The number of segments to be combined in one layer is selectable but the same transmission parameters are used in each segment of a layer. In the case of 3 layers, in principle, 3 associated, mutually independent data streams must then be supplied.



S7200 support ISDB-T<sub>B</sub> measurement.



Figure 12-40 ISDB-T<sub>B</sub> Measurement



Figure 12-41 ISDB-T<sub>B</sub> Constellation

## 12.10. DTMB Measurement

**Note:** To ensure the test signal sensitivity, the distance between the user connected DTMB antenna and instrument should be longer than 80cm.

S7200 supports DTMB signal measurement option.

DTMB channel measurement screens are shown as Figure 12-42 and Figure 12-43. It is used to test DTMB channel parameters, like power level, CNR, MER, LM, BER, Constellation analysis, etc.

Parameters setting description:

- CH: Shows the current channel ID, modify this parameter to switch the channels directly.
- FREQ: 4MHz-1220MHz
- BW: 6MHz、7MHz、8MHz
- MODE: Self-adaptive, cannot be set.
- PN MODE: Self-adaptive, cannot be set.
- CR/TD: Self-adaptive, cannot be set.
- CARRI: Self-adaptive, cannot be set.



Figure 12-42 DTMB Average Power Measurement

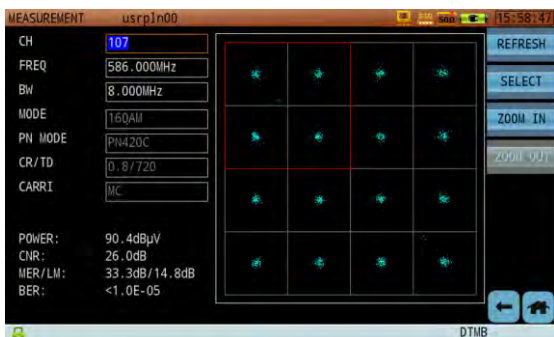

Figure 12-43 DTMB Constellation



When DTMB signal has been demodulated normally, press  key on the panel to watch the video information in DTMB signals, press  key again, then it can be full screen displayed.



Figure 12-44 View image of DTMB signal

## Signal shoulder

After the digital TV signal through the amplifier, the intermodulation output of outside the channel is approximate continuous spectrum. The continuous spectrum outside the channel will generate “shoulder” effect, this is called band shoulder. Shoulder ratio definition is the ratio of power of

center frequency point signal and the power of one point deviating from the center frequency outside the carrier. In China, one TV channel bandwidth is 8MHz, band shoulder ratio is defined as the ration of the power of center frequency point and the power of  $\pm 4.2\text{MHz}$  deviating from the center frequency, the unit is dBc.

In the transmitter of the terrestrial digital broadcasting, power amplifier is the main nonlinear device, its efficiency and linearity are a pair of contradictions. Generally, for increasing the efficiency of power amplifier, it will show a strong nonlinearity. This kind of nonlinearity will cause the signal distortion, it is the signal output spectrum changed, generate in-band, out-band interfere, what this reflected on the spectrum is the shoulder ratio difference. Should ratio is a key technical specification of digital TV RF output, it expresses the linear level of the digital TV transmitter power amplifier.

Terrestrial digital broadcasting transmitter signal band shoulder measurement block diagram is shown as Figure 12-45. The signal shoulder measurement need stream source, the transmitter under the testing and spectrum analyzer. Terrestrial digital broadcasting transmitter shoulder performance specification is  $\leq -36\text{dBc}$ .

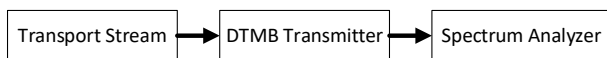

Figure 12-45 Transmitter signal band shoulder measurement block diagram

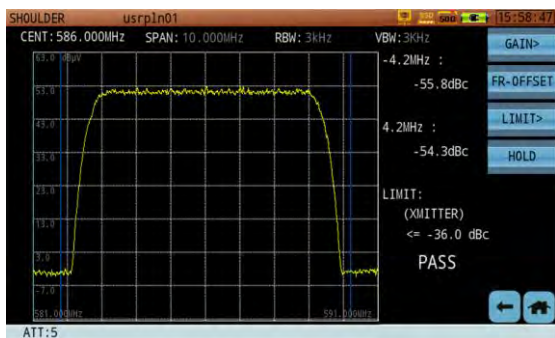

Figure 12-46 Transmitter signal band shoulder test

Terrestrial digital broadcasting actuator signal band shoulder measurement block diagram is shown as Figure 12-47. The signal shoulder measurement need stream source, terrestrial digital TV actuator and spectrum analyzer. Terrestrial digital broadcasting actuator shoulder performance specification is  $\leq -48\text{dBc}$ .

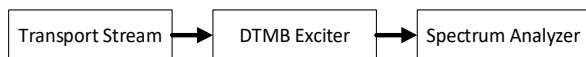

Figure 12-47 Actuator signal band shoulder measurement block diagram

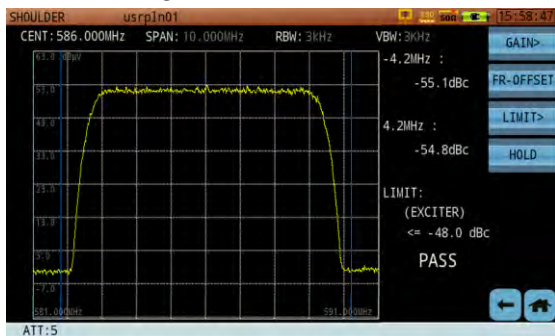

Figure 12-48 Actuator band shoulder test

Gain adjustment is to adjust the spectrum analyzer. Press **[GAIN>]** under

the shoulder test first level menu, enter the next level menu. If the gain is adjusted to auto status, continue to press **[AUTO]**, **[AUTO]** is converted to **[MANUAL]**. If the gain is adjusted to manual status, the status will be converted to **[AUTO]**. Under the manual mode to set the attenuator will also enable the amplifier.



Figure 12-49 Gain adjustment setting

**Spectrum Offset** is the frequency deviating from the center frequency. As show in Figure 12-49, the spectrum offset is 4.2MHz, the setting range is 0~5.0MHz.

**Limit line** is the signal shoulder threshold value. Terrestrial digital broadcasting transmitter shoulder performance specification is  $\leq -36\text{dBc}$ , that means the transmitter limit value is  $\leq -36\text{dBc}$ . Terrestrial digital broadcasting actuator shoulder performance specification is  $\leq -48\text{dBc}$ , that means the actuator limit value is  $\leq -48\text{dBc}$ .

Press **[XMITTER]**, limit line will be transmitter limit, if the signal shoulder value is unqualified limit line standard, the judgment result will be FAIL, Vice versa the result is PASS. As show in Figure 12-50. Press **[EXCITER]**, limit line will be actuator limit. As show in Figure 12-51. You can also define the limit by yourself. As show in Figure 12-52.

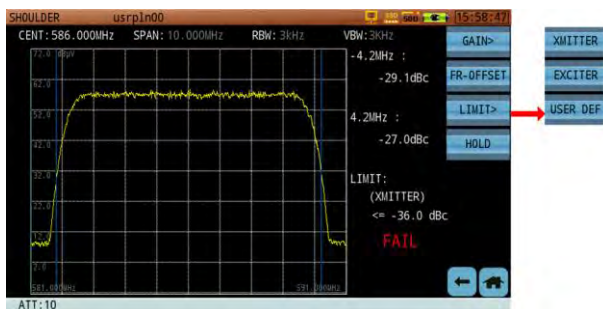

Figure 12-50 Limit Setting



Figure 12-51 Actuator Limit

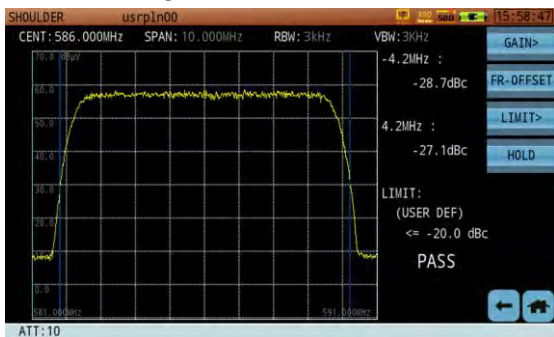

Figure 12-52 Self-defined Limit

**Hold** Mode application: when press hold key, the whole spectrum curve is frozen on the screen. The key color will also be changed to highlight display. When press hold key again, the spectrum will recovery to the scan status and the key color will be changed to normal display again.



## 12.11. DAB/DAB+ Measurement

DAB is the English abbreviations of Digital Audio Broadcasting. DAB system development is sourced from 1980 German Institute of radio technology. Based on Eureka-147 system to research terrestrial digital audio broadcasting technology and define Eureka-147 DAB standard, it has been a good development in Europe. DAB is the third generation broadcasting technology after amplitude modulation (AM) and frequency modulation (FM) broadcasting and it is complete new digital broadcasting system. Digital broadcasting has the advantages of high spectrum utilization, anti-interference and encryption, and can provide high quality audio. Since the DAB standard, DAB has been using the MPEG Audio Layer II coding method. DAB+ uses MPEG-4 High Efficiency AAC v2 coding method.

S7200 supports DAB and DAB+ measurement, the band is 1.536MHz, frequency can be set within 167.392MHz-239.968MHz, the setting accuracy is KHz.



Figure 12-53 DAB measurement

When the signal is locked, the instrument will search all programs,

sub-channel ID, DAB type and encryption sign of setting channel automatically.  
When the audio problem is found, can touch **【LISTEN】** button to open or close audio output, and adjust volume through **【VOL+】** and **【VOL-】** .

## 12.12. DVB-S/S2 Measurement

If user want to measure satellite signals. First step need change system switch to satellite mode, as the Figure 12-54 show. In satellite mode, press  button and connect the satellite antenna RF cable on S7200 RF input port. In Figure 12-55, use choose the right LNB power supply option and receiver right satellite signal.

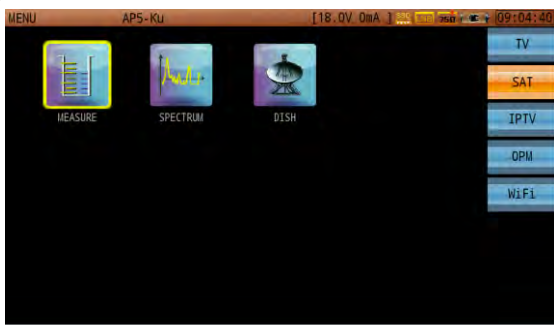

Figure 12-54 Satellite Measurement Home Page

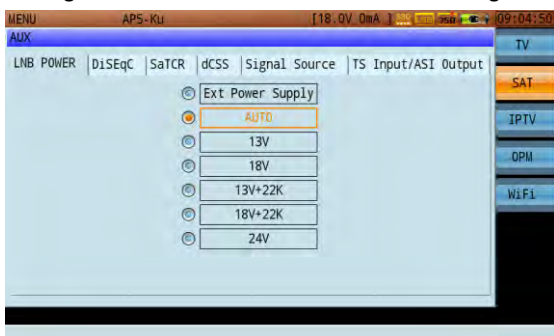

Figure 12-55 LNB Power Supply Control

According to choose satellite channel plan, tap the measure icon, user can look at measurement results for a transponder on current selected satellite.

S7200 support DVB-S and DVB-S2 signal demodulation. For DVB-S2, S7200 only support QPSK ,8PSK,16APSK and 32APSK signal demodulation.

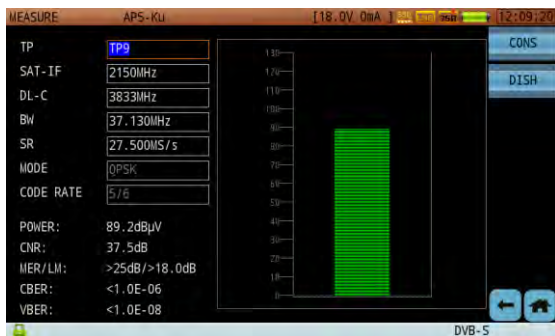

Figure 12-56 DVB-S Average Power Measurement

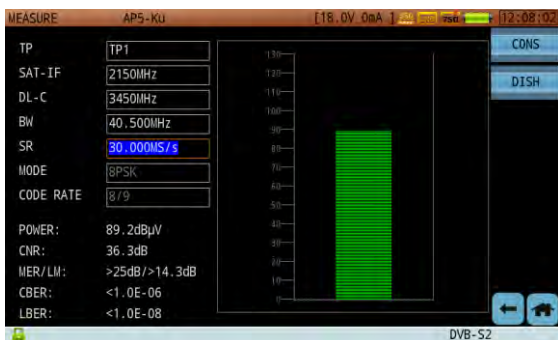



Figure 12-57 DVB-S2 Average Power Measurement

Parameters Introduction:

TP: Transponder name, user can use  and  button switch transponder.

SAT-IF: Satellite IF, LNB output frequency, setup range: 950MHz ~ 2150MHz.

Satellite frequency band setup: DL-Ku band (10.75GHz ~ 12.75GHz), DL-C band (3.4GHz ~ 4.2GHz)

BW and SR: Bandwidth and Symbol Rate(1MS/s~45MS/s),

$BW=(1+\alpha)SR$ , the  $\alpha$  is Roll-off factor, user can transponder setup interface find Roll-off factor value.

Modulation type: transponder parameter setup

Code rate: transponder parameter setup

Tap the soft button [CONS], enter the constellation test interface, as the Figure 12-58 and Figure 12-59 show.

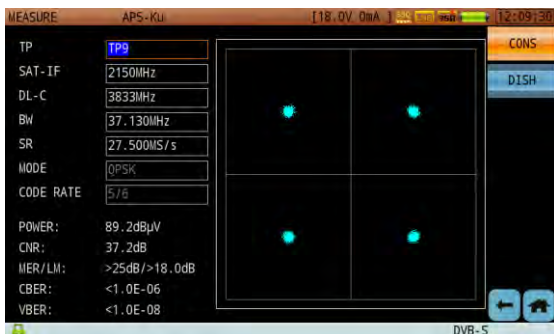

Figure 12-58 DVB-S QPSK Constellation

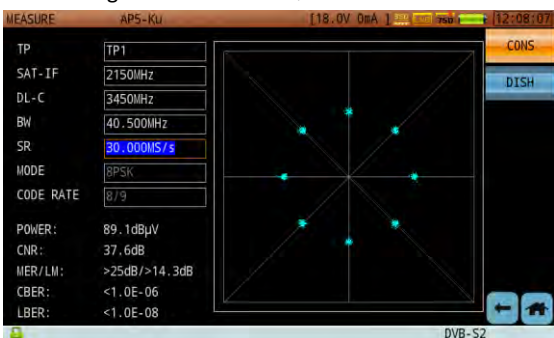

Figure 12-59 DVB-S2 8PSK Constellation

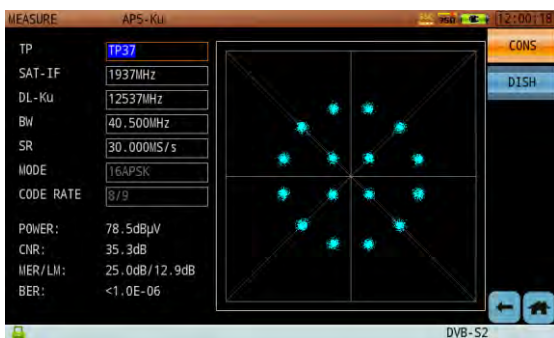

Figure 12-60 DVB-S2 16APSK Constellation

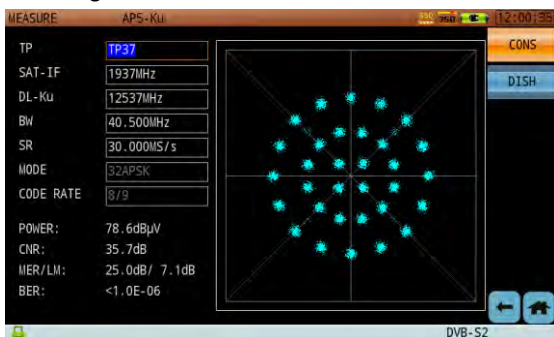

Figure 12-61 DVB-S2 32APSK Constellation

In satellite mode, tap the spectrum icon, user can open satellite IF spectrum analysis function, as the Figure 12-62 show.

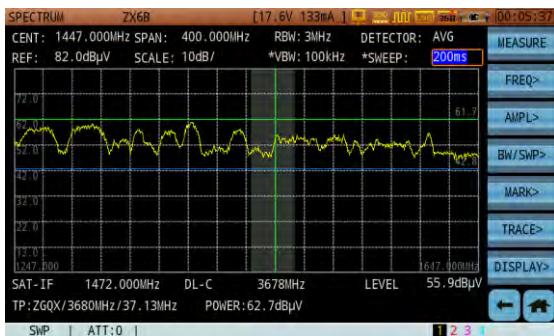

Figure 12-62 Satellite Signal IF Spectrum

## 12.13. Antenna Modify

Antenna modify interface or satellite find interface is use to quick and dynamic display one or multi transponders signal strength and signal quality. This function is convenient for user install or troubleshooting satellite and routine maintenance. Antenna modify interface as the Figure 12-63 show.



Figure 12-63 Antenna Modify Interface

Attention: This function support up to 10 active transponder to be list on the screen. If the satellite's active transponder number more than ten, the program automatic choose the top ten. If the satellite's active transponder number less than ten, the program will display all active transponder.

This function is used to observe the satellite signal overall situation. So user can switch satellite or the transponder on the satellite. Directly enter this function, user first step is to choose one satellite, tap the soft buttons [SAT+] or [SAT-] to switch satellite. Press the  button, tap one transponder from transponder list STA column to edit transponder valid or invalid status.



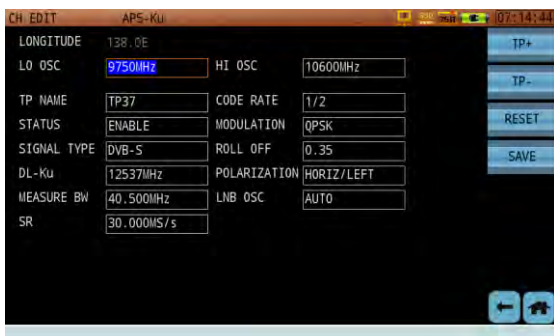

Figure 12-64 Satellite Transponder Setup Interface

If user finish choosing satellite and transponder, user need setup LNB power supply according satellite parameters and local antenna condition.

For antenna installer, he need know the follow parameters:



Antenna position GPS information. S7200 provide GPS module option, user can use the GPS module acquire local longitude and latitude or manually input local longitude and latitude, the GPS information as the Figure 12-65 show.



Figure 12-65 GPS Setup Interface



Azimuth Angle(0~180degree), it indicates the current horizontal deflection angle and direction of the satellite antenna, 'S' means South



Azimuth Angle, 'N' means North



Elevation Angle (0 ~ 90 degree)



LNB polarization angle

If user select one satellite and setup local longitude and latitude, the program auto calculate Azimuth Angle, Elevation Angle and LNB polarization angle.

Every transponder test result use different color display, the color use identification threshold to judgment, user press the [THRESHOLD] button can open the threshold setup screen, as the Figure 12-66 show.

WEAK(S) :	40
STRONG(S) :	80
LOW(Q) :	40
HIGH(Q) :	80

Figure 12-66 Signal Strength and Quality Threshold Setup

The first angle is the angle of elevation to the satellite. From the point of looking at the satellite view with horizontal angle formed is called elevation. (See Figure 12-67). The other angle is the azimuth angle of the antenna. The azimuth angle is the angle between north and the location of the satellite. This is always counted clockwise. Figure 12-68 shows that a satellite located straight to north has an azimuth angle of 0 degrees, to the east has an azimuth angle of 90 degrees, to the south is 180 degrees and west is 270 degrees.

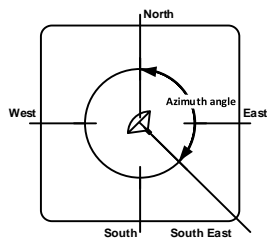
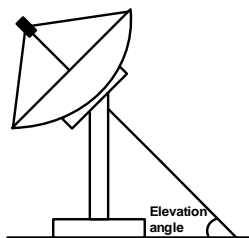

Figure 12-67 Elevation Angle Definition Figure 12-68 Azimuth Angle Definition

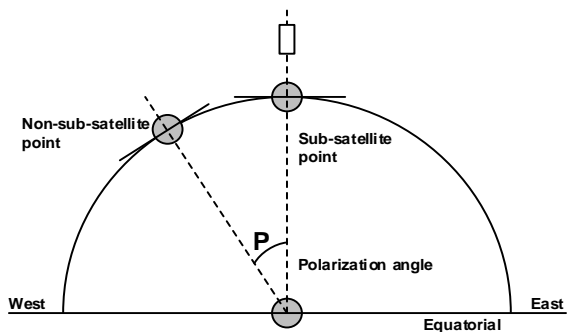

Figure 12-69 How to generate the polarization angle

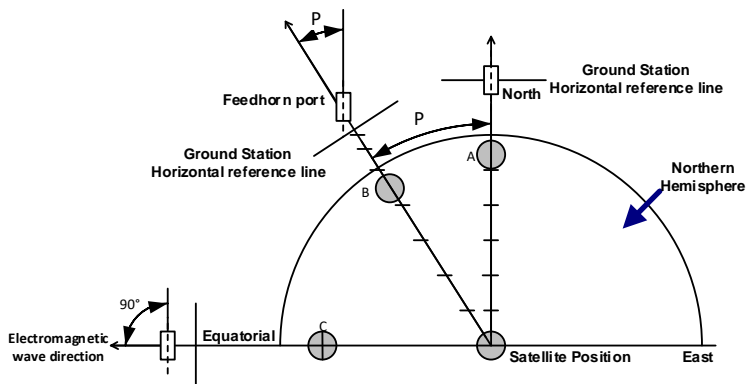

Figure 12-70 See From the Satellite to the Ground

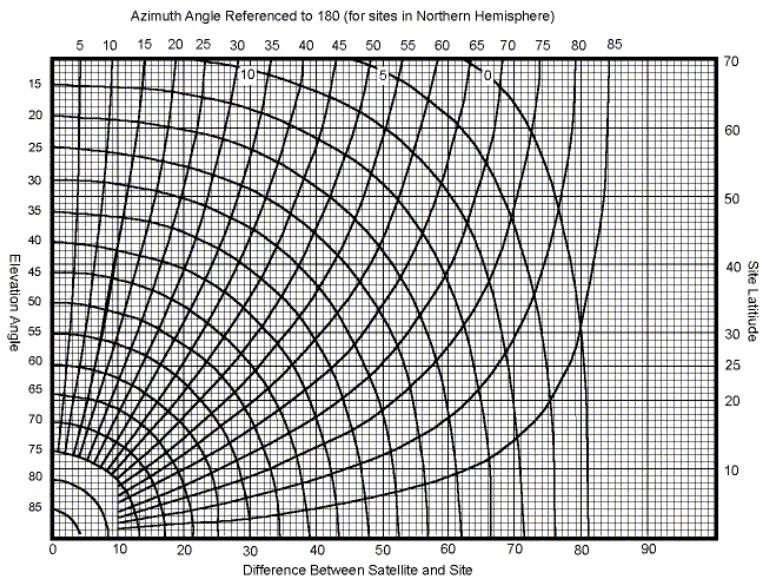

Figure 12-71 Polarization angle compensation curve

Tap the soft button [FIX], program stop doing transponder scan.

Tap the soft button [MEASURE], the program enter the measure interface.

When program doing satellite transponder scan, the test failed transponder will active the speaker alarm, tap the soft button [MUTE] can stop alarm.

Tap the soft button [DRIVE] can open a polar antenna control window. User can input some value, and tap the soft button [SEND] to send the control value to polar antenna.

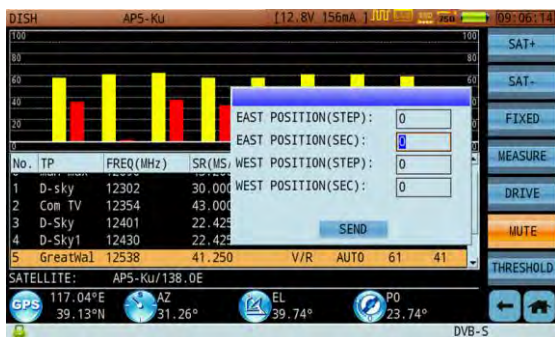

Figure 12-72 Drive Polar Antenna

## 12.14. Transport Stream Analysis

The TS analysis function supports DVB and ATSC standard Realtime TS analysis. Sub functions are: Basic Information, TR 101 290 Priority 1, 2 and 3 Tests, PID Viewer, Program Information, PCR Analysis, Program List, PSI/SI, Data Capture and Parameters Setting.

Supported Standards:

- MPEG-1: 1) ISO-IEC-11172-2(Video)  
2) ISO-IEC-11172-3(Audio)
- MPEG-2: 1) ISO/IEC 13818-1 (System)  
2) ISO/IEC 13818-2 (Video)  
3) ISO/IEC 13818-3 (Audio)  
4) ISO/IEC 13818-6 (DSM-CC)  
5) ISO/IEC 13818-7 (AAC)
- MPEG-4: 1) ISO/IEC 14496-2 (Video)  
2) ISO/IEC 14496-3 (Audio)
- H264: 1) ITU-T H.264  
2) ISO/IEC 14496-10 (AVC)
- H256: 1) ITU-T H.265  
2) ISO/IEC 23008-2 (HEVC)

### 12.14.1. Transport Stream Realtime Analysis



Figure 12-73 TS Analysis-Realtime Analysis

Display parameters description:

SID: the program number in decimal or hexadecimal according to the Setup.

Service Name: the service name of the program, '---' is displayed if the description doesn't exist.

CA: 🟢 stands for not encrypted, and 🔴 stands for encrypted.

Provider: the provider of the program, '---' is displayed if the description doesn't exist.

Service Type: a brief description of the service type of the program.

Video PID: the video PID of the selected program.

Video Type: the video type of the program, '---' is displayed if video information is not included in the program.

Audio PID1: the first audio PID of the selected program.

Audio PID2: the second audio PID of the selected program.

Audio Type: the audio type of the program, example MPEG2 Audio.

There is a program information display area at the bottom of the screen.

This function parses the information from audio and video ES. It supports

MPEG-1/2/4, H.264, H.265,AVS/AVS+,VC-1 video format and MPEG-1/2/4, AAC , AAC+,DRA audio format. At most, two audio information are displayed.

It lists all programs' SID, Service Name, CA, provider, service type, video PID, video type, Audio1 PID, Audio2 PID, Audio type in the upper part of screen.

In the bottom part of the screen, the video/audio information of selected program are displayed. The video information include: resolution, frame rate, bit rate, profile, level, aspect ratio and chroma type. The Audio information include: mode, layer, bit rate, sampling, profile, channel configuration and emphasis.

These parameters may be different according to the audio/video format. Figure 12-73 show the content. If the parameter is not parsed or the program is an encrypted program, the '---' will be displayed. If the program has no video information, a message box with 'No PAT.' will pop up.



S7200 can look at realtime picture, the picture display on the upper left conner of the screen. At the bottom of the picture, a sliding scale is used to modify volume. If the program signal is unencrypted, user can directly use S7200 look at program picture. If the program is encrypted, user must insert the decryption card to look at program. When TS analysis function display picture, user press the  button, the picture will change to full screen display status, as the Figure 12-74 show. User press  button again, screen back to TS interface,





Figure 12-74 Full Screen Display Picture

The realtime analysis option offers four submenus: video/audio information and bandwidth. The V/A information option is the same as the Figure 12-73 content. The bandwidth shows the selected program bandwidth information in the program list which has been highlighted. The yellow curve is the video BW rate curve if the video information is included in the program. The green curve is the first audio BW curve if the audio information is included in the program. The purple curve is the second audio BW curve if the second audio information is included in the program. The horizontal coordinate is description the percentage of the current for a period of time, and the left vertical coordinates description the percentage of the BW percent of the video in the program. The right vertical coordinates description the percentage of the BW percent of the audio in the program. If the program is not a digital TV program, no curve will be displayed.

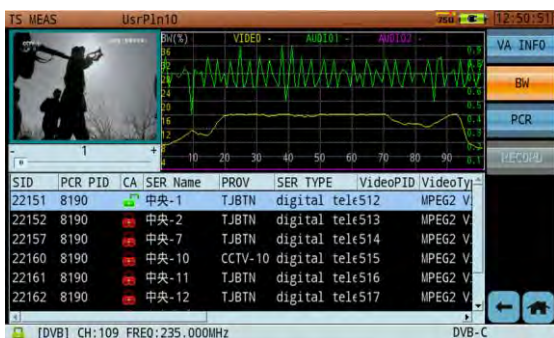

Figure 12-75 Occupy Bandwidth Analysis

## 12.14.2. Basic Information

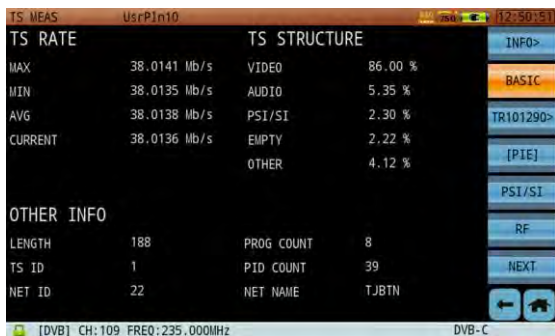

Figure 12-76 Transport Stream Basic Information

This part shows you the basic information of the transport stream.

**TS RATE:** Shows the stream's transport rate in a second (Mb/s). The S7200 displays; Min, Max, Avg and Current TS rate of the last second interval.

**TS STRUCTURE:** Describes the components of the TS and the percentage of each component, including video, audio, PSI/SI, empty packet and other types of information (example: data or encryption information).

**OTHER INFO:** Describes other information of the stream.

**LENGTH:** The length of the packets in bytes, there are 188 bytes and/or 204 bytes type in any given transport stream structure.

**PROG COUNT:** Show the total number of programs.

**TS ID:** Different channels have different TS ID, this indicated how many IDs (or channels).

**PID COUNT:** The sum of PIDs of a stream.

**NET ID:** The PID of NIT indicated by PAT, if not indicated, '---' is displayed.

**NET NAME:** The provider (Operator) name, '---' is displayed if it is not provided in the stream.

### 12.14.3. TR 101 290 Priority 1, 2 and 3 Tests

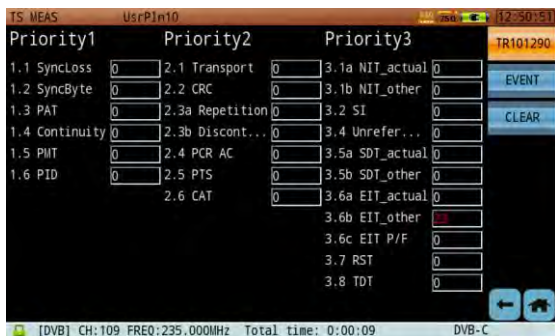

Figure 12-77 TR 101 290 Priority 1, 2 and 3 Tests

The DVB group has defined a set of recommended measurements to be made on transport streams, set in the ETSI TR101290 document. Based on TR 101 290 recommendations, errors to be detected by means of these measurement recommendations are graded into three levels of priority: Priority 1, 2, 3.

Priority 1 - no decidability

Priority 2- partially no decidability

Priority 3- errors in the supplementary information/SI

Because hardware resource limit, S7200 transport stream analysis function not include buffer test related parameters.

Priority 1 parameters include: TS\_sync\_loss, sync\_byte\_error, PAT\_error, PID\_error, continuity\_count\_error.

(1) TS\_sync\_loss: It is suggested that five consecutive correct sync bytes are sufficient for sync acquisition, and two or more consecutive corrupted sync bytes indicate a sync loss. The loss of transport stream synchronization, which

may occur either because of severe interference or simply because of a break in the line, is called "TS\_sync\_loss". "TS\_sync\_loss" occurs when the content of the sync bytes of at least 3 successful transport stream packets is not equal to 0x47.

(2) Sync\_byte\_error: is set as soon as the correct sync byte (0x47) does not appear after 188 or 204 bytes. This is fundamental since this structure is used throughout the channel encoder and decoder chains for synchronization. It is also important for the decoder to check every sync byte for correctness since the encoders may not necessarily check the sync byte. Some encoders may use the sync byte flag signal on a parallel interface to control the randomizer re-sending a byte inversion without checking that the corresponding byte is a valid sync byte. A "sync\_byte\_error" occurs when the content of a sync byte in the transport stream header is not equal to 0x47.

(3) PAT\_error: The Program Association Table (PAT), only appears in PID 0x0000 packets, tells the decoder what programs are in the TS and points to the Program Map Tables (PMT) which in turn point to the component video, audio and data streams that make up the program. If the PAT is missing then the decoder can decode no programs.

A PAT error occurs when: 1.- the PAT is missing, 2.- the repetition rate is greater than 500 ms, 3.- the PAT is scrambled or 4.- the table ID is not equal to zero.

(4) Continuity\_count\_error:

Each transport stream packet contains a 4-byte-long header, a 4-bit counter which counts from 0 to 15 in a loop, and then begins at zero again after an overflow (modulo 16 counter). However, each transport stream packet for

each PID has its own continuity counter, i.e. packets with a PID=100, e.g., have a different counter, as do packets with a PID=200. It's the purpose of this counter to enable one to recognize missing or repeated transport stream packets of the same PID in order to draw attention to any multiplexer problems.

Such problems can also arise as a result of errors in remultiplexing or due to random bit errors in the transmission link. Although MPEG-2 allows discontinuities in the transport stream, they must be indicated in the adaptation field, e.g. after a switch-over (discontinuity indicator=1). In the case of zero packets (PID=0x1FF), discontinuities are allowed and are not verified.

A continuity\_error occurs when

- The same TS packet is transmitted twice without a discontinuity being indicated, or
- If a packet is missing (count incremented by 2) without a discontinuity being indicated, or
- The sequence of packets is wrong.

### (5) PMT\_error

For each program, a Program Map Table (PMT) is transmitted at maximum intervals of 500 ms. The PIDs of the MAPs are listed in the PAT. The PMT contains the respective PIDs of all elementary streams belonging to this program. If a PMT referred to in the PAT is missing, the set top box or decoder will be unable to demultiplex or decode them. If a PMT is listed in the PAT but is either missing, errored or scrambled, will lead to the error message "PMT\_error".

A "PMT error" occurs when

- A PMT listed in the PAT is missing,

- A section of the PMT is not repeated after 500 ms or less,
- A PMT is scrambled,
- The table ID is not 2.

(6) **PID\_error**: The PIDs of all elementary streams of a given program are contained in the associated program map table (PMT). The PIDs are pointers to the elementary streams: they are used to access to the corresponding packets of the elementary stream to be decoded. If a PID is listed in a PMT but not contained in the transport stream, the decoder will be unable to access the corresponding elementary stream.

A “PID\_error” occurs when

- Transport stream packets with a PID referred to in a PMT but not contained in the transport stream or
- Their repetition rate exceeds a user-definable limit which is usually 500 ms or less.

Priority 2 parameters include: **Transport\_error**, **CRC\_error**, **PCR\_repetition\_error**, **PCR\_discontinuity\_indicator\_error**, **PCR\_accuracy\_error**, **PTS\_error**, **CAT error**.

(1) **Transport\_error**

Every MPEG-2 transport stream packet contains a bit called **Transport ErrorIndicator** which is transmitted right after the sync byte. This bit flags any errors in the transport stream packets at the receiver. During the transmission, bit errors may occur for various reasons. If error protection (at least Reed Solomon in DVB and ATSC) is no longer able to repair all errors in a packet, this bit is set indicating this packet can no longer be utilized by the MPEG-2 decoder and must be discarded.

A transport\_error (Fig. 11.5.) occurs when

- The transport error indicator bit in the TS header is set to 1.

### (2) CRC\_error

During the transmission, all tables in the MPEG-2 transport stream, whether they are PSI tables or other private tables according to DVB (SItables) or according to ATSC (PSIP tables), are protected by a CRC checksum. It is 32 bits long and transmitted at the end of each sector. Each sector, which can be composed of many transport stream packets, is thus additionally protected. A CRC error has occurred if these checksums don't match the content of the actual section of the respective table. The MPEG-2 decoder must then discard this table content and wait for this section to be repeated.

A CRC\_error occurs when

- A table (PAT, PMT, CAT, NIT,...) in a section has a wrong checksum which doesn't match its content.

### (3) PCR\_repetition\_error

The PCRs are used to re-generate the local 27 MHz system clock. If the PCRs are not transmitted with sufficient regularity, then this clock may jitter or drift. The receiver/decoder may even go out of lock. In DVB, a repetition period of not more than 100 ms is permitted, previously a maximum of 40ms was recommended.

A PCR\_error occurs when

- The difference between two successive PCR values of a program is greater than 100 ms, and no discontinuity is indicated in the adaptation field or HeaderOptionalAdaptationField, or
- The time interval between two packets with PCR values of a program is more



than 40 ms.

(4) PCR\_discontinuity\_indicator\_error

The PCR\_discontinuity\_indicator\_error is set in the case that a discontinuity of the PCR values occurred and has not been signalled appropriately by the discontinuity indicator.

(5) PCR\_accuracy\_error

If the PCR jitter exceeds  $\pm 500$  ns, a PCR\_accuracy\_error will be set.

(6) PTS\_error

The spacing between two PTS values must not be greater than 700 ms to avoid a PTS error.

(7) CAT\_error

An MPEG-2 transport stream packet can contain scrambled data, but only the payload must be scrambled, never the header or the adaptation field. A scrambled payload is flagged by two special bits in the TS header, the Transport Scrambling Control bits. If both bits are set to zero, there is no scrambling. If one of the two is not zero, the payload part is scrambled and a Conditional Access Table (CAT) is needed to descramble it. If this is missing or only rarely there, a CAT\_error occurs. The CAT has a 1 as PID and also a 1 as table ID. Apart from the EIT in the case of the transmission of a program guide, all DVB tables must be unscrambled.

Priority 3 parameters include: NIT\_actual\_error, NIT\_other\_error, SI\_repetition\_error, Unreferenced\_PID, SDT\_actual\_error, SDT\_other\_error, EIT\_actual\_error, EIT\_other\_error.

(1) NIT\_actual\_error

Network Information Tables (NITs) as defined by DVB contains information on frequency, code rates, modulation, polarization, etc. of various programs which the decoder can use. It is checked whether the NIT related to the respective TS is present in this TS and whether it has the correct PID.

(2) NIT\_other\_error

Further Network Information Tables (NITs) can be present under a separate PID and refer to other TSs to provide more information on programs available on other channels. Their distribution is not mandatory and the checks should only be performed if they are present.

(3) SI\_repetition\_error

For SI tables, a maximum and minimum periodicity are specified in EN 300 468 and TR 101 211 documents. This indicator should be set in addition to other indicators of repetition errors for specific tables.

(4) Unreferenced\_PID

Each non-private program data stream should have its PID listed in the PMTs.

(5) SDT\_actual\_error

The SDT (Service Description Table) describes the services available to the viewer. It is split into sub-tables containing details of the contents of the current TS (mandatory) and other TS (optional). Without the SDT, the

receiver is unable to give the viewer a list of what services are available. It is also possible to transmit a BAT on the same PID, which groups services by type.

(6) SDT\_other\_error

This check is only performed if the presence of a SDT for other TSs has been established.

(7) EIT\_actual\_error

The EIT (Event Information Table) describes what is on now and next on each service, and optionally details the complete programming schedule. The EIT is divided into several sub-tables, with only the "present and following" information for the current TS being mandatory. If there are no 'Present' or 'Following' events, empty EIT sections will be transmitted according to TR 101 211. The EIT schedule information is only accessible if the TS is not scrambled.

(8) EIT\_other\_error

This check is only performed if the presence of an EIT for other TSs has been established.

(9) EIT\_PF\_error

If either section ('0' or '1') of each EIT P/F subtable is present both should exist. Otherwise EIT\_PF\_error should be indicated.

(10) RST\_error

The RST is a quick updating mechanism for the status information carried in the EIT.

## (11) TDT\_error

The TDT carries the current UTC time and date information. In addition to the TDT, a TOT can be transmitted which gives information about a local time offset in a given area.

PSI/SI Table Repetition Time

Service Information	Max. interval (complete table)	Min. interval (single sections)
PAT	0.5s	25ms
CAT	0.5s	25ms
PMT	0.5s	25ms
NIT	10s	25ms
SDT	2s	25ms
BAT	10s	25ms
EIT	2s	25ms
RST	-	25ms
TDT	30s	25ms
TOT	30s	25ms

No.	TIME	DESCRIPTION
1	2000/02/12 07:08:22 3.6b	Interval between sections '1' with ta
2	2000/02/12 07:08:22 3.6b	Interval between sections '1' with ta
3	2000/02/12 07:08:22 3.6b	Interval between sections '1' with ta
4	2000/02/12 07:08:22 3.6b	Interval between sections '0' with ta
5	2000/02/12 07:08:22 3.6b	Interval between sections '0' with ta
6	2000/02/12 07:08:22 3.6b	Interval between sections '0' with ta
7	2000/02/12 07:08:22 3.6b	Interval between sections '0' with ta
8	2000/02/12 07:08:22 3.6b	Interval between sections '0' with ta
9	2000/02/12 07:08:22 3.6b	Interval between sections '0' with ta
10	2000/02/12 07:08:22 3.6b	Interval between sections '0' with ta
11	2000/02/12 07:08:22 3.6b	Interval between sections '0' with ta
12	2000/02/12 07:08:22 3.6b	Interval between sections '0' with ta
13	2000/02/12 07:08:22 3.6b	Interval between sections '0' with ta
14	2000/02/12 07:08:22 3.6b	Interval between sections '0' with ta
15	2000/02/12 07:08:22 3.6b	Interval between sections '0' with ta

Figure 12-78 TR 101 290 Priority 1, 2 and 3 Tests Event List

TR 101 290 Priority 1, 2 and 3 Tests Event List describes the detailed information for every event, including the number, record time and error detailed information.

### 12.14.4. PID Viewer



Figure 12-79 PID View

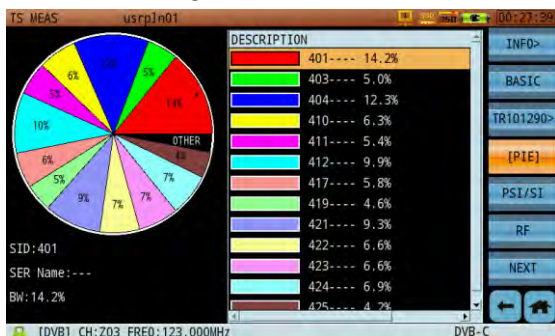

Figure 12-80 Pie Chart View

Describes the information with section, simplified information, value(%), PID and the CR of every PID of the stream.

Section: the PID type, example: PSI/SI, video PID or Audio PID.

PID: the PID value.

CR: the bitrate of the PID.

The Value and CR are calculated in one second increments.

Tap the button [PID VIEW] again, the screen will display pie chart.

### 12.14.5. PCR Analysis

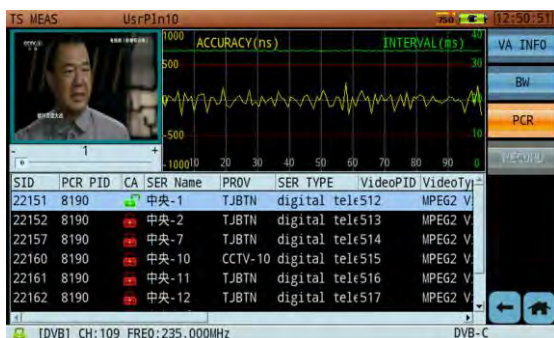

Figure 12-81 PCR Accuracy and PCR Interval Analysis

Function description: To display the PCR accuracy and PCR interval of the selected program.

Figure 12-81 shows the detailed PCR information. The top half of the screen displays PCR detailed information in one transport stream, including PCR PID, minimum accuracy, maximum accuracy, minimum interval, maximum interval. If the PCR doesn't exist, '---' is displayed. Different programs can have the same PCR and/or every program can have its own PCR.

The user can directly tap on one program item in the top half of the screen. PCR accuracy and PCR interval traces display in the same area. The left vertical coordinate shows PCR accuracy coordinates in ns. The right vertical coordinate shows PCR interval coordinates in ms. Two red lines will show the PCR accuracy limit lines. PCR accuracy of the selected program should be within  $\pm 500$  ns and PCR interval of the selected program between 0 ms - 40 ms.

### 12.14.6. Program List

No.	FREQ	SID	CA	SER Name	PROV	SER TYPE
1	658.000	501	0	CCTV-3	中央电视台	digital television
2	658.000	502	1	CCTV-5	中央电视台	digital television
3	658.000	503	1	CCTV-6	中央电视台	digital television
4	658.000	504	1	CCTV-8	中央电视台	digital television
5	658.000	505	0	CCTV-少儿	中央电视台	digital television
6	658.000	506	1	CCTV-新闻	中央电视台	digital television

[DVB] CH: 101 FREQ: 658.000MHz DVB-C

Figure 12-82 Program List

Function description: To list the programs information in the current selected channel or satellite transponder. The program list includes: program number, frequency, SID, service name, CA, provider, service type. Depending on the encoding method, the program information may be displayed differently, so you might see the program information of the selected frequency, or the program information of all frequencies. The CA may be different from Realtime subfunction, PROG INFO subfunction because of the different way of getting the CA value. The CA of this subfunction is retrieved from TS directly. Users can quickly find the corresponding channel frequency program.

### **12.14.7.PSI/SI Table Analysis**

The “Program Specific Information” (PSI) has exactly the same structure. The PAT has a PID of zero and begins with a table ID of zero. The PMT has the PIDs defined in the PAT as PID and has a table ID of 2. The CAT has a PID and a table ID of 1 in each case. The PSI can be composed of one or more transport stream packets for PAT, PMT and CAT depending on content.

Apart from the PSI tables PAT, PMT and CAT, another table, the “network information table” (NIT) is provided in principle but not standardized in detail. It was actually implemented as part of the DVB (Digital Video Broadcasting) project.

All tables are implemented through the mechanism of sections. There are non-private and private sections. Non-private sections are defined in the original MPEG-2 Systems Standard. All others are by default private. The non-private sections include the PSI tables and the private ones include the SI sections of DVB which are used for data broadcasting. The header of a table contains the version number of a table and information about the number of sections of which a table is made of.

Taking advantage of the “private section” and “private table” features, the European DVB Group has introduced numerous additional tables intended to simplify the operation of the set-top boxes or quite generally of the DVB receivers. Called “service information” (SI), they are defined in ETSI Standard ETS300468. They are the following tables:



PAT	Program Association Table	MPEG-2 PSI Program Specific Information
PMT	Program Map Table	
CAT	Conditional Access Table	
(NIT)	Network Information Table Private Sections / Tables	
NIT	Network Information Table	DVB SI Service Information
SDT	Service Descriptor Table	
BAT	Bouquet Association Table	
EIT	Event Information Table	
RST	Running Status Table	
TDT	Time&Date Table	
TOT	Time Offset Table	
ST	Stuffing Table	

Figure 12-83 MPEG-2 PSI and DVB SI

S7200 PSI/SI analysis only include PAT, PMT, CAT, NIT Actual, SDT Actual, EIT Actual, TDT. The following screen snapshots highlight more detailed analysis information. User can directly use finger to choose table and tap the symbol “+” to expansion the multiple level tables.

Service Information Allocation

Table	PID Value	PID Decimalism Value
PAT	0x0000	0
CAT	0x0001	1
TSTD	0x0002	2
NIT	0x0010	16
SDT,BAT,ST	0x0011	17
EIT,ST	0x0012	18
RST,ST	0x0013	19
TDT,TOT,ST	0x0014	20
DIT	0x001E	30
SIT	0x001F	31

PIDs and table IDs of the PSI/SI tables

Table	PID	Table_ID
PAT	0x0000	0x00
PMT	0x0020...0x1FFE	0x02
CAT	0x0001	0x01
NIT	0x0010	0x40...0x41
BAT	0x0011	0x4A
SDT	0x0011	0x42, 0x46
EIT	0x0012	0x4E...0x6F
RST	0x0013	0x71
TDT	0x0014	0x70
TOT	0x0014	0x73
ST	0x0010...0x0014	0x72

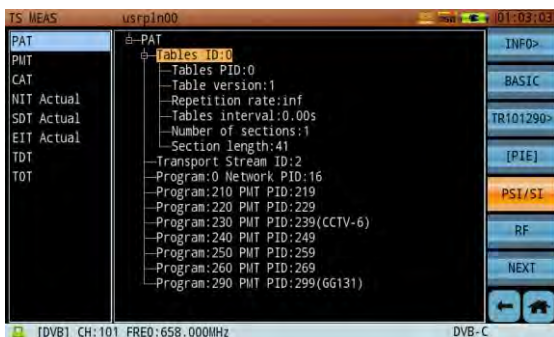

Figure 12-84 PSI/SI Analysis-PAT Table



Figure 12-85 PSI/SI Analysis-PMT Table

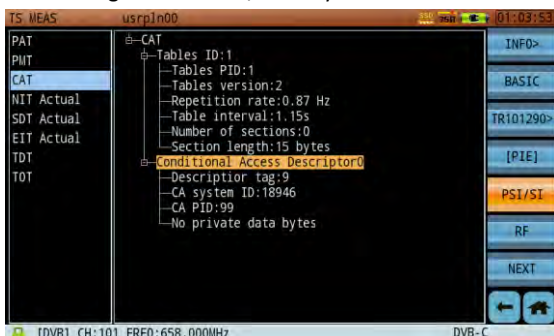

Figure 12-86 PSI/SI Analysis-CAT Table

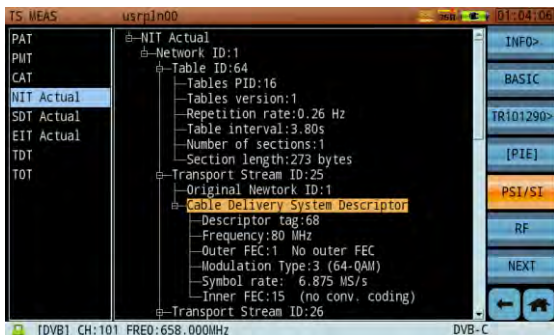

Figure 12-87 PSI/SI Analysis-NIT Table



Figure 12-88 PSI/SI Analysis-SDT Table

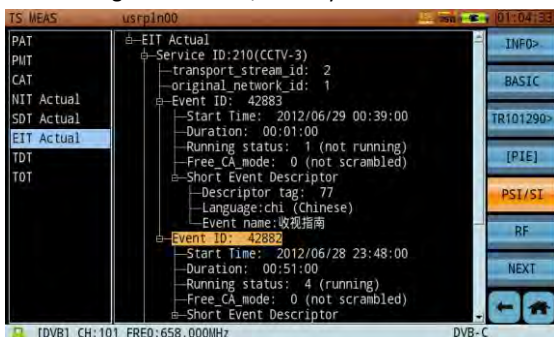

Figure 12-89 PSI/SI Analysis-EIT Table



Figure 12-90 PSI/SI Analysis-TDT Table

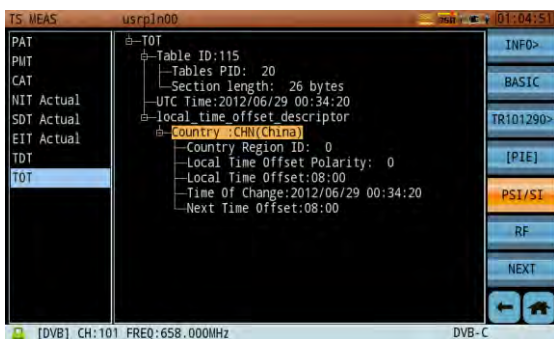

Figure 12-91 PSI/SI Analysis-TOT Table

### 12.14.8. PSI/PSIP Table Analysis

Like the SI tables, DVB& ATSC also provide PSIP tables.

PSIP stands for "program and system information protocol" and represents very similar information that is given on DVB SI. In ATSC, the following tables are used: the Master Guide Table (MGT), the Event Information Table (EIT), the Extended Text Table (ETT), the System Time Table (STT), the Rating Region Table (RRT), and the Cable Virtual Channel Table (CVCT) or the Terrestrial Virtual Channel Table (TVCT).

According to ATSC, the PSI tables defined in MPEG-2 and provided in the MPEG Standard are used for accessing the video and audio streams, i.e. the transport stream carries one PAT and several PMTs. The conditional access information is also referenced via a CAT.

The actual ATSC tables are implemented as "private tables". The MasterGuide Table, contains the PIDs for some of these ATSC tables. The Master Guide Table can be recognized by the packet ID = 0x1FFB and the table ID = 0xC7. The transport stream must contain at least four Event Information Tables (EIT-0, EIT-1, EIT-2, EIT-3) and the PIDs for these EITs are found in the Master Guide Table. Up to 128 further Event Information Tables are possible but also optional. An EIT contains a 3-hour section of an electronic program guide (EPG). Together with the 4 mandatory EITs, it is possible to cover a period of 12 hours. Furthermore, Extended Text Tables may optionally be accessed through the MGT. Each existing Extended Text Table (ETT) is allocated to one EIT. Thus, e.g. ETT-0 contains extended text information for EIT-0. It is possible to have up to a total of 128 ETs.

PSIP Table ID Ranges and Value

Table	PID	Table ID Value (hex)
Program Association Table (PAT)	0x0	0x0
Program Map Table (PMT)	per PAT	0x2
Conditional Access Table (CAT)	0x1	0x1
Master Guide Table (MGT)	0x1FFB	0xC7
Terrestrial Virtual Channel Table (TVCT)	0x1FFB	0xC8
Cable Virtual Channel Table (CVCT)	0x1FFB	0xC9
Rating Region Table (RRT)	0x1FFB	0xCA
Event Information Table (EIT)	per MGT	0xCB
Extended Text Table (ETT)	per MGT	0xCC
System Time Tables (STT)	0x1FFB	0xCD

In the Virtual Channel Table, which can be present either as Terrestrial Virtual Channel Table (TVCT) or as Cable Virtual Channel Table (CVCT) depending on the transmission path, identification information for the virtual channels, i.e. programs, contained in a multiplexed transport stream are transmitted. The VCT contains, among other things, the program names. The VCT is thus comparable to the SDT table in DVB:

In the System Time Table (STT), all the necessary time information is transmitted. The STT can be recognized by the packet ID = 0x1FFB and the table ID = 0xCD. In the STT, the GPS (Global Positioning System) time and the time difference between GPS time and UTC (Universal Time Coordinated (= GMT)) is transmitted. The Rating Region Table (RRT) can be used for restricting the size of the audience in terms of age or region. In addition to the information about region (e.g. a Federal State in the US), information relating

to the minimum age set for the program currently being broadcast is also included. Using the RRT, a type of parental lock can be implemented in the set-top box. The RRT is recognized by the packet ID = 0x1FFB and the table ID = 0xCA.

The PIDs and Table IDs of the PSIP tables are listed in Table: PSIP Table ID Ranges and Value.

PAT	Program Association Table	MPEG-2 PSI Program Specific Information
PMTs	Program Map Table	
CAT	Conditional Access Table	
Private Tables		
MGT	Master Guide Table	ATSC PSIP Program and System Information Protocol
EIT	Event Information Table	
ETT	Extended Text Table	
STT	System Time Table	
RRT	Rating Region Table	
CVCT	Cable Virtual Channel Table	
TVCT	Terrestrial Virtual Channel Table	

Figure 12-92 ATSC PSIP tables

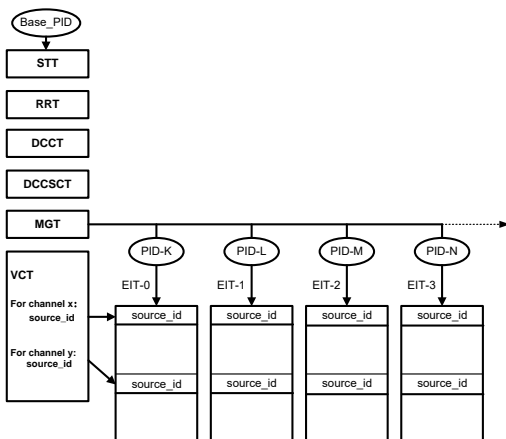

Figure 12-93 Table hierarchy for the Program and System Information Protocol (PSIP)



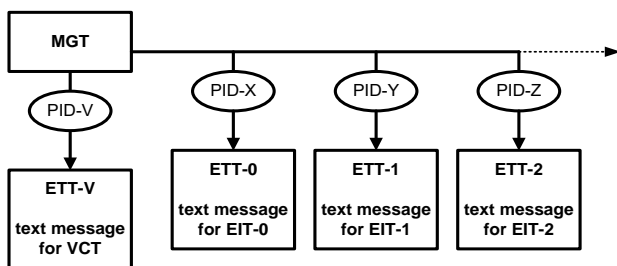

Figure 12-94 Extended Text Tables (ETTs) defined to carry text messages for describing virtual channels and events.



Figure 12-95 PSI/PSIP Analysis-PAT Table

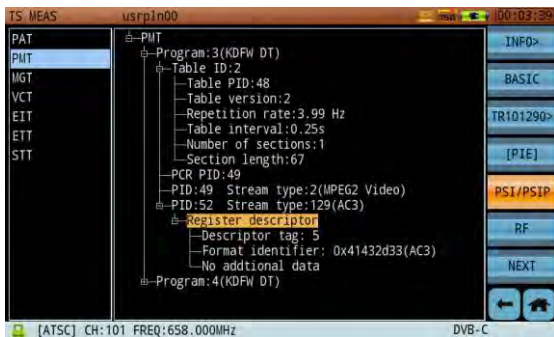

Figure 12-96 PSI/PSIP Analysis-PMT Table

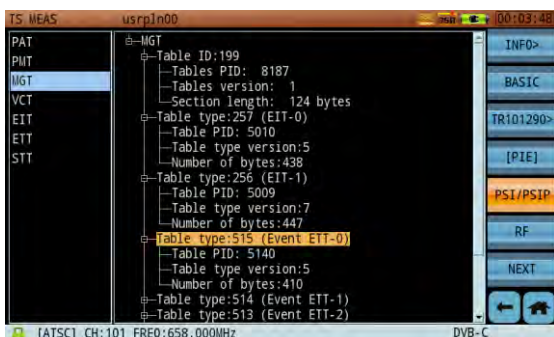

Figure 12-97 PSI/PSIP Analysis-MGT Table

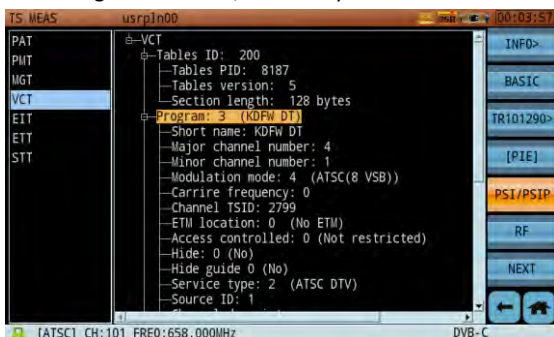

Figure 12-98 PSI/PSIP Analysis-VCT Table

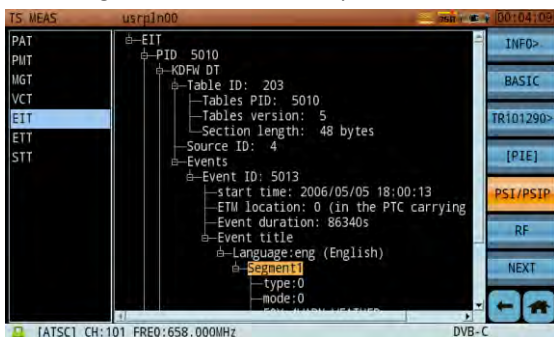

Figure 12-99 PSI/PSIP Analysis-EIT Table

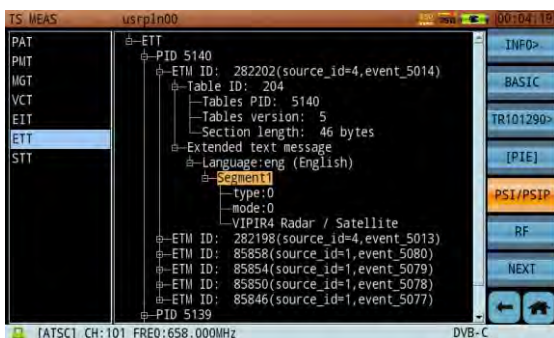

Figure 12-100 PSI/PSIP Analysis-ETT Table

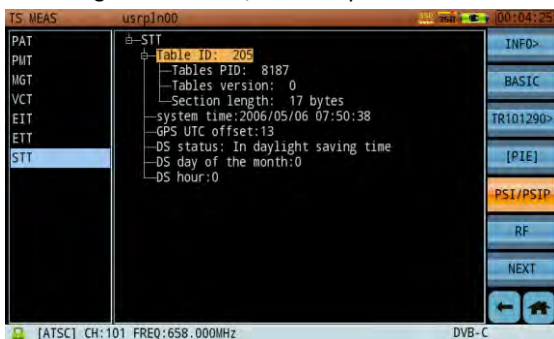

Figure 12-101 PSI/PSIP Analysis-STT Table

### 12.14.9. Data Capture



Figure 12-102 Data Capture

Figure 12-102 shows captured transport package data according to PID value. This function divides the PID into six types: video, audio, PCR, PSI/SI, ECM/EMM, and DATA. If you choose one type, the related PID value will be displayed in the PID position. The next step is to input the capture number, with a maximum of 255. Tap the soft button [START]. The program starts to capture data. This will be very brief as capture is very fast. Tap the soft button [CLEAR] to clear all captured data.

The lower left corner displays captured data. The detailed contents of the captured data are displayed on the right side in hexadecimal format. The data capture function only supports real-time capture. After data capture is complete, tap on the data items that are required. Choose one data item, and the detailed content will be displayed on the right side of the screen.

### 12.14.10. EPG(Electroic Program Guide)

Now, S7200 only support ATSC EPG function. In transport stream analysis function, tap the soft button [NEXT], user can look at the soft button [EPG]. The soft button is unavailable in DVB mode, user must set the standard as ATSC can active EPG function, as the Figure 12-104 show. If the EPG function available, user can tap the soft button [EPG] to open this function. The left column is program list in one channel, the right column is one program corresponding EPG.



Figure 12-103 EPG Function



Figure 12-104 Switch Digital TV Standard

### 12.14.11. Record and Replay Transport Stream

#### Record Transport Stream

S7200 support record transport stream. If user has SATA SSD option, user can directly record the transport stream on SSD. If user no SATA SSD option, user must insert USB disk on USB port and record transport stream on USB disk. Open transport stream record function operation steps:  (or TS measurement) -> [INFO>] -> [RECORD]. When user tap the soft button [RECORD], the screen popup windows, let use select record device (USB disk or SATA SSD) and saved file name, as the Figure 12-105 show. If one device not exist, this device status is unavailable (gray). When the transport stream already started, the record related information display on the status bar at the bottom of the screen, as the Figure 12-106 show.



Figure 12-105 Start to Record Transport Stream Status



Figure 12-106 Transport Stream Record Process

### Playback Recorded Transport Stream

After you finish recording transport stream, you need playback these transport stream files. Press the  button, tap the first soft button multi-times, till the soft button display [TS]. This screen only display SSD saved transport files' list. The USB Disk saved transport files don't be displayed in this interface. Before user start playback saved transport stream files, user must change TS input setup. The TS input should be set to DISK, as the Figure 12-108 show.

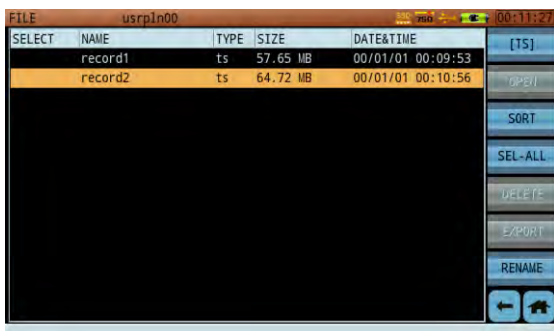

Figure 12-107 SSD Saved TS file list

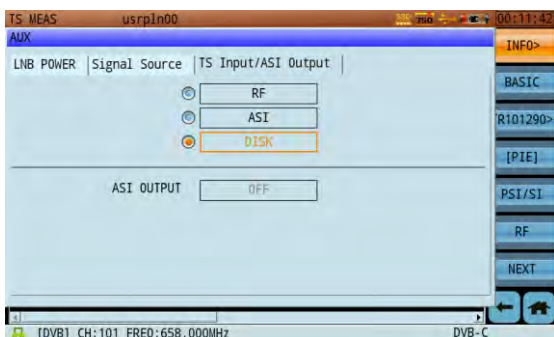



Figure 12-108 Change TS Input Setup

After user finish TS input configuration, press the  button, open transport stream analysis function. Tap the soft button [DISK], the screen popup two TS file lists: SATA SSD TS file list and USB TS file list. If user tap one TS file, the TS analysis program start to analysis this TS file. After the program finish analysis, the screen popup message “Analysis finished!”

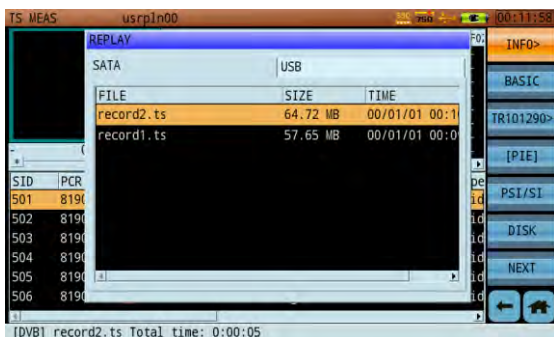

Figure 12-109 Choose Playback TS file from TS File List





Figure 12-110 Playback Saved Transport Stream File

### 12.14.12. How to use the CA module

S7200 support to decode encrypted program, but this function need the program related decryption card. In Figure 12-111, the place circled in red line on the title bar indicates system program detects the CAM module has been inserted in DVB-CI port. In Figure, the system program detects the smart card has been inserted in CAM module. All above only proves the hardware is well, these information don't guarantee the smart card can descrypt one program. The special program need special decryption card.

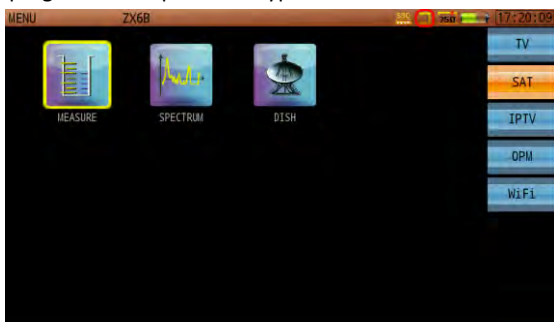

Figure 12-111 System Detected the CAM Module

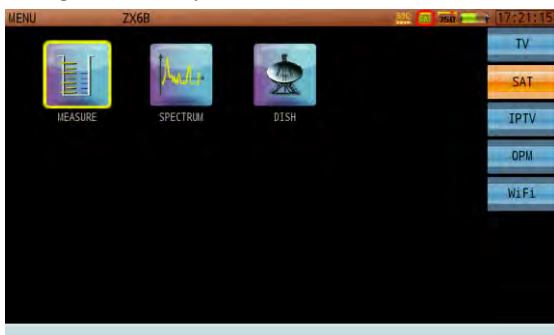

Figure 12-112 System Detected the Smart Card inserted in CAM Module

S7200 DVB-CI interface as the Figure 12-113 show.



Figure 12-113 S7200's DVB-CI Interface

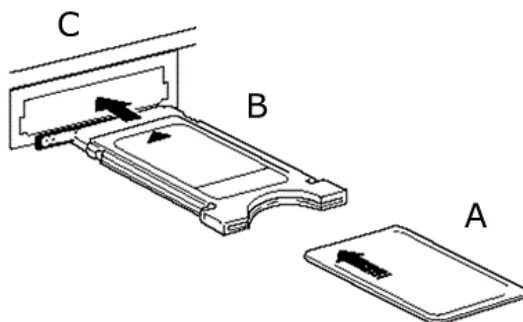

Figure 12-114 Smart Card, CA Module and Common Interface Relationship

The Figure 12-114 describes the Smart Card, CA Module and Common Interface Relationship. (A: Smart Card, B: CA Module, C: Common Interface)

CA	Conditional Access
CAM	CA Module
CI	Common Interface
PCMCIA	Personal Computer Memory Card International Association
SC	Smart Card

### **12.14.13. BISS Decryption**

Basic Interoperable Scrambling System, usually known as BISS, is a satellite signal scrambling system developed by the European Broadcasting Union and a consortium of hardware manufacturers.

Prior to its development, "ad hoc" or "occasional use" satellite news feeds were transmitted either using proprietary encryption methods (e.g. RAS, or PowerVu), or without any encryption. Unencrypted satellite feeds allowed anyone with the correct equipment to view the program material.

Proprietary encryption methods were determined by encoder manufacturers, and placed major compatibility limitations on the type of satellite receiver (IRD) that could be used for each feed. BISS was an attempt to create an "open platform" encryption system, which could be used across a range of manufacturers equipment.

Fields for entering BISS-keys on an Ericsson RX8200 IRD

There are mainly two different types of BISS encryption used:

BISS-1 transmissions are protected by a 12 digit hexadecimal "session key" that is agreed by the transmitting and receiving parties prior to transmission. The key is entered into both the encoder and decoder, this key then forms part of the encryption of the digital TV signal and any receiver with BISS-support with the correct key will decrypt the signal.

BISS-E (E for encrypted) is a variation where the decoder has stored one secret BISS-key entered by for example a rightsholder. This is unknown to the user of the decoder. The user is then sent a 16-digit hexadecimal code, which is entered as a "session key". This session key is then mathematically combined

internally to calculate a BISS-1 key that can decrypt the signal.

Only a decoder with the correct secret BISS-key will be able to decrypt a BISS-E feed. This gives rightsholder control as to exactly which decoder can be used to decrypt/decode a specific feed. Any BISS-E encrypted feed will have a corresponding BISS-1 key that will unlock it.

BISS-E is amongst others used by EBU to protect UEFA Champions League and other high-profile satellite feeds.

S7200 also supports BISS Mode 1 and Mode E modes Decryption. BISS CAM is different with common DVB CA CAM, it does not smart card. It need know the Service id, encryption mode of descramble program and key: BISS 1 or BISS E before descrambling a set to program.

After user inserts the BISS decryption card into the slot,  will be displayed on the title bar, press **【CAMENU】** to view decryption card main menu like Figure 12-115. Press **【Information】** to view BISS information including software version, harder version, Loader version, serial number, Buried ID, software mode and hard mode like Figure 12-116.

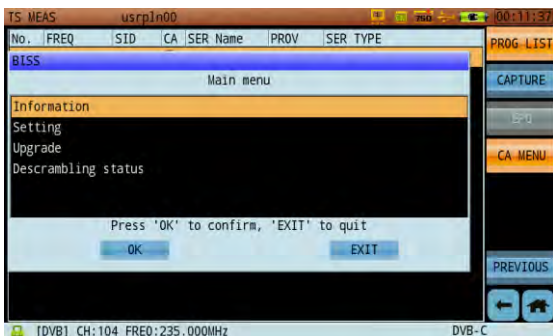

Figure 12-115 BISS Main menu

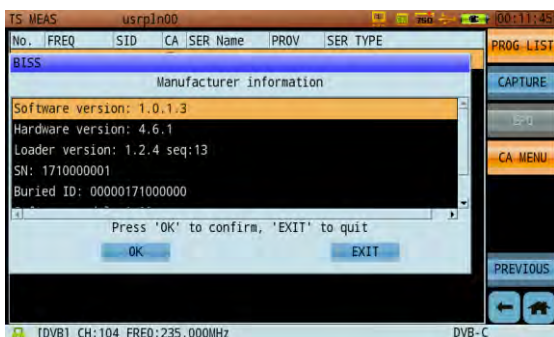

Figure 12-116 BISS Manufacturer information

Press **【Setting】** to set BISS input mode, active ID, edit secret key, BISS language setting and recover the factory setting like Figure 12-117. The input mode includes hexadecimal and decimal. active ID includes Buried ID and Inject ID. Now BISS supports 2 languages translation: English and German. BISS still supports recovery to the factory setting.

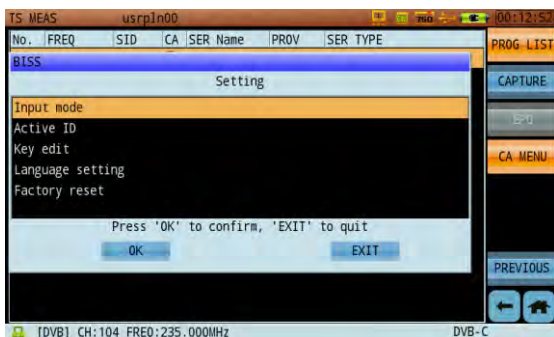

Figure 12-117 Setting

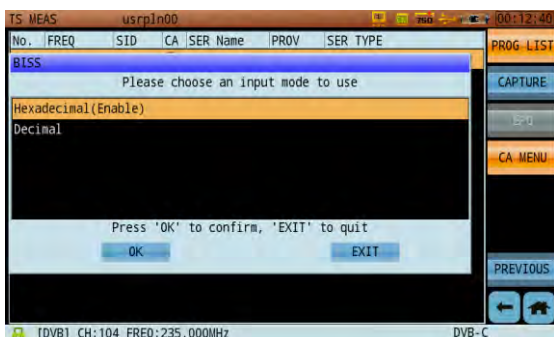

Figure 12-118 input mode

Active ID Setting, Enter Active ID screen and select one kind of active ID, like selecting Inject ID, directly edit Inject ID like Figure 12-120. If Buried ID is selected, because it has been existed, you only need enable it.

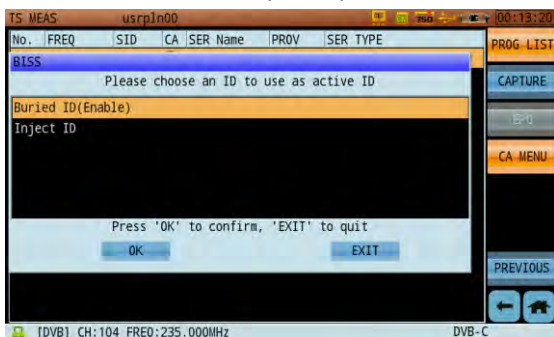

Figure 12-119 active ID

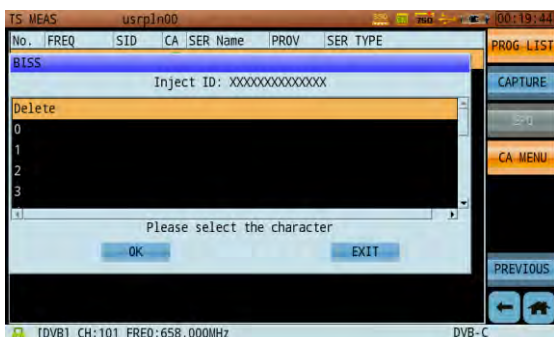

Figure 12-120 Edit Inject ID

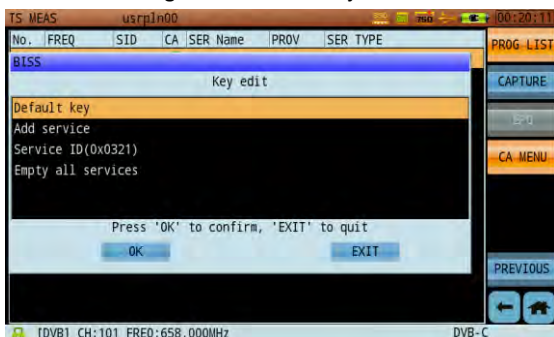

Figure 12-121 Key edit

User enters the secret key edit screen like Figure 12-121 including Default key, Add service, Service ID and Empty all services.

If there is no Service ID under the key edit menu, need add service ID. Press **【Add service】** to add the automatic recognized Service ID. Service ID will be displayed in turn, then select Service that needs to be descrambled and will prompt to modify Service's key or delete Service like Figure 12-122. Press **【Modify key】** to select encryption mode, edit key, enter key edit screen like Figure 12-124. User the UP and DOWN key or manual to select keys, the user inputted keys will be displayed on the top of the menu. When the user done



the input, it will prompt edit key successfully screen and will display the inputted keys.

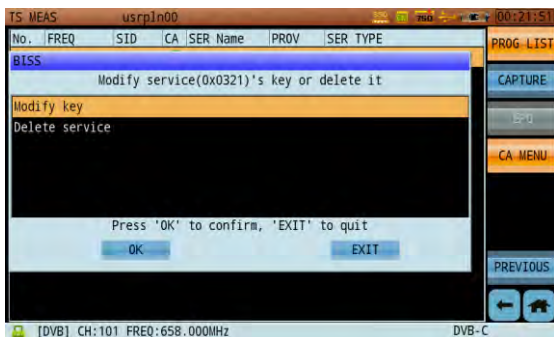

Figure 12-122 Modify service Key

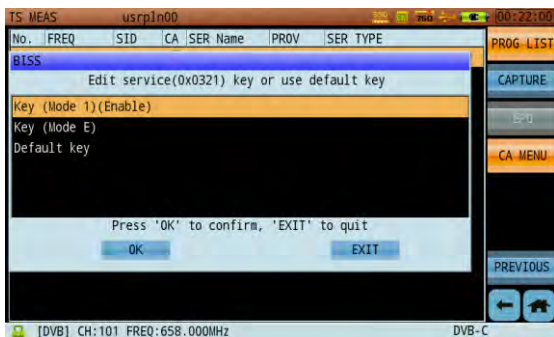

Figure 12-123 key Mode chosen

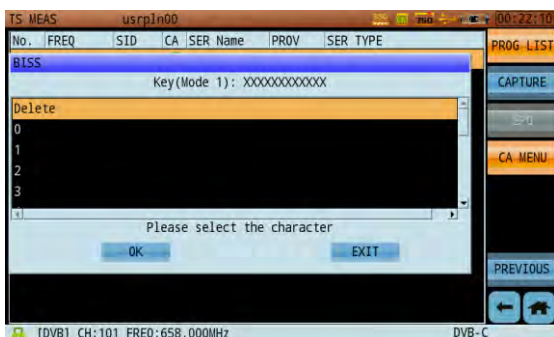

Figure 12-124 Edit key

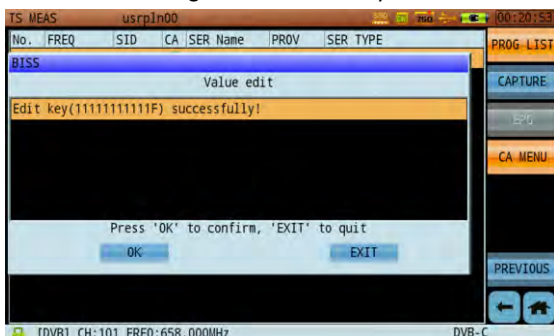

Figure 12-125 Done the key edit

Select Default key edit in Figure 12-123, Default key edit input operation is same as common Service key input, only need select the mode and then input the key. If several sets of program use the same one key, user only need set the default key.

Software upgrade: Upgrade, BISS CAM supports OTA upgrade.

Descrambling status: display the descrambling status, user configured descrambling mode and Active ID of Service that the host sends to CAM.

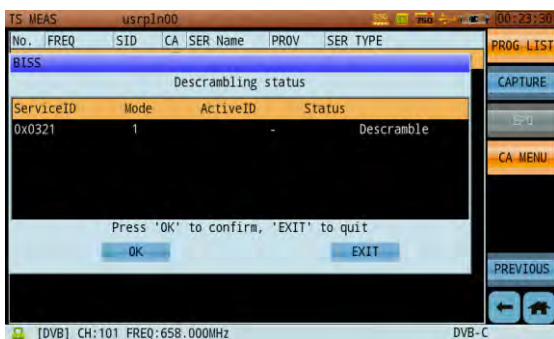

Figure 12-126 Descrambling status

## 12.15. TS over IP Measurement

Now, S7200 TS over IP function only support MPEG-2 TS over IP method.

Connect Ethernet cable on S7200 RJ-45 port. In home page, tap the soft button [TS over IP], open the TS over IP function. The instrument will automatic detect TS over IP stream in network, the detected TS over IP stream will be listed at the bottom of the screen. User can tap one TS over IP stream, the test result will display on the screen. If you want to look at program picture or other video information, you can tap the soft button [TS MEAS] to open transport stream analysis function.

Src IP	Src Port	Des IP	Des Port	Rate	Pack
192.168.63.16	2338	230.0.0.10	5004	3.3052 Mb/s	312

LOCAL IP: 192.168.63.17

Figure 12-127 TS over IP Measurement Function

**TS MEAS:** The shortcut key of entering TS measurement.

**ADD:** Add the favorite TS over IP, input TS over IP protocol, destination IP and port number to add the favorite list successfully.

**FAV LIST:** Select destination IP in the favorite list to switch to the current TS over IP measurement.

Some concepts:

Transport protocol for real-time applications (RTP)

Real-Time Protocol (RTP) is a transport protocol that was developed for

streaming data. RTP includes extra data fields not present in TCP. It provides a timestamp and sequence number to facilitate the data transport timing, and allows control of the media server so that the video stream is served at the correct rate for real-time display. The media player then uses these RTP fields to assemble the received packets into the correct order and playback rate

RTP usually runs on UDP, and uses its multiplexing and checksum features. Note that RTP does not provide any control of the quality of service or reservation of network resources.

### Real-Time Control Protocol (RTCP)

RTCP is used in conjunction with RTP. It gives feedback to each participant in an RTP session that can be used to control the session. The messages include reception reports, including number of packets lost and jitter statistics (early or late arrivals). This information potentially can be used by higher layer applications to modify the transmission. For example, the bit rate of a stream could be changed to counter network congestion. Some RTCP messages relate to control of a video conference with multiple participants.

### Media Delivery Index

Both packet delay and packet loss have been taken into account by IETF RFC 4445. This RFC describes Media Delivery Index (MDI) and it is defined as a single figure of merit used to quantify 2 IP transport impairments, namely Packet Jitter or Delay and Packet Loss. These two test parameters are defined as Media Delay Factor (MDI-DF) and Media Loss Rate (MDI-MLR).

The Delay Factor indicates how long a data stream must be buffered (i.e. delayed) at its nominal bit rate to prevent packet loss.

The Media Loss Rate is the number of packets lost during a period of 1 second.

## 12.16. Optical Power Measurement and Optical Receiver

### 12.16.1. Fiber Optical Connector and Adapter Introduction

Fiber optical connector is the most commonly used passive optical fiber device. It connects two fiber optical end faces, realizing optical signal continuous transmission. You can find optical connectors at many positions: optical fiber end face, passive optical fiber device input and output ports, active optical equipment input and output ports and fiber jumpers.

Optical fiber connectors are composed of pins and connectors, for example FC/PC type connectors. "FC" at the front side of the symbol "/", means outside connection type. Often used outside connection types: FC, SC, ST, LC, MU, MT-RJ, D4, E2000. "PC" at the back of symbol "/", means the shape of the pin end face. Often used shapes of the end face: PC, APC, UPC.

- Straight physical contact (PC)



Figure 12-128 Straight Physical Contact (PC)

The fiber ends are pressed together in the connector. There is no air gap left to cause reflections. The return loss is 30 – 55 dB.

This is the most common connector for single mode fibers (for example FC/PC, ST, SC/PC, DIN, HMS, E 2000 connectors).

- Slanted (angled) physical contact (APC)



Figure 12-129 Slanted (angled) Physical Contact (APC)

In these connectors the ends of the fibers are slanted. Again no air gap is left. This gives the best return loss(60-80 dB).

These connectors are used for high-speed telecom and CATV links (for example FC/APC, SC/APC, E 2000-HRL connectors).

- Straight air gap



Figure 12-130 Straight Air Gap

Inside these connectors there is a small air gap between the two fiber ends. Their return loss is less than 14 dB and the reflection is fairly high.

Straight air gap connectors, for example ST connectors, are used for multimode fibers.

Common connector illustration



Figure 12-131 FC Fiber Optical Connector



Figure 12-132 SC Fiber Optical Connector



Figure 12-133 ST Fiber Optical Connector

S7200 use FC/SC/ST replaceable connector interface, user can replace different appropriate connector interface according to field application environment.

### 12.16.2. Optical to RF Conversion

S7200 provide an optical receive option. User can directly connect fiber to FC/APC port. Before user connect fiber to optical port, user must change OPTICAL. The Figure 12-134 shows the setup interface. Now the optical fiber input the signal into optical receiver in S7200 and user can measure demodulated electric signal.

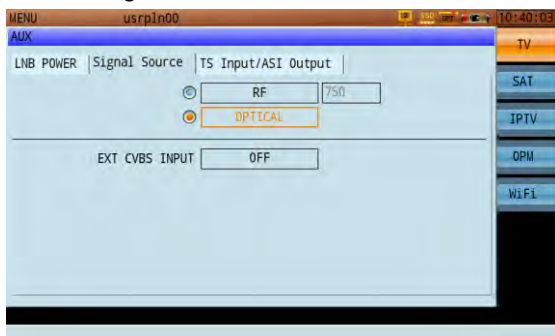

Figure 12-134 Optical to RF Setup Interface



### 12.16.3. Optical Power Measurement

S7200 also provide optical power measurement function. The function also need optical receiver option. Measure optical power doesn't need setup optical to RF switch. User only need connect optical fiber on FC/APC port. S7200 auto judgment optical signal wavelength, the user doesn't need to set.



Figure 12-135 Optical Power Meter Function

The reference value is used to set a limit. If optical signal power higher than the reference value, the “SUCCESS” will display on the top of the screen, otherwise the “FAILED” will display on the top of the screen.



Figure 12-136 Modify Reference Value

Reference. Figure 12-136 is to show and edit three wavelength reference values, 1310nm reference, 1490nm reference and 1550nm reference, input the value into the box after 'Reference' directly, the setting range is -50dBm-27dBm. "SAVE REF" is to save the current measure value as reference, press **【SAVE REF】** to prompt the message "Will you save the measure value as reference? Confirm Cancel".

The Compensation. If user use the optical power meter for a long time. The test results has offset, user need do a little correction for test results. User need plus or minus a value from the display test result. User need input a value in "Compensation" position.

The display test result = True optical power + (Compensation: -1, +1 or any other value)

Example: The display test result = 10 + (-1) = 9dBm.



Figure 12-137 Modify Compensation Value

Threshold. User sets strong and weak threshold value to differentiate the received light strong or weak. When the optical signal measurement value is bigger than "STRONG" threshold, the current bar graph will be changed to be green. When the optical signal measurement value is less than "STRONG" threshold and bigger than "WEAK" threshold, the bar graph will be changed to

be yellow. When the optical signal measurement value is less than “WEAK” threshold, the bar graph will be changed to be red.



Figure 12-138 Modify Threshold Value

When the optical receiver starts to work, the user can plug the fiber into the APC port on the top of the instrument. The user can test the signal of photoelectric conversion under different functions directly like Figure 12-139 and Figure 12-140.

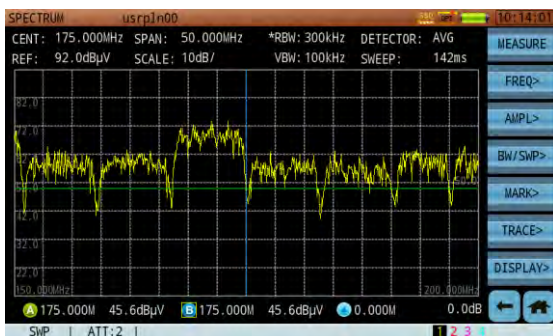

Figure 12-139 SPECTRUM: Test photoelectric conversion signal

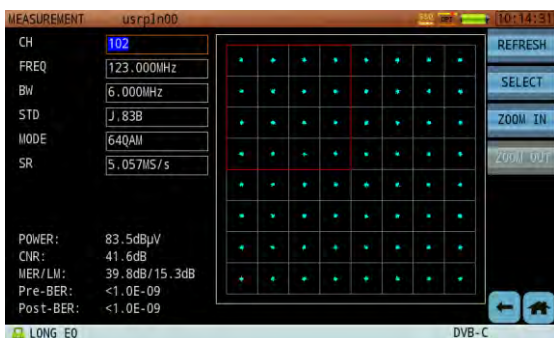

Figure 12-140 Constellation: Test photoelectric conversion signal

Conversion table between common dBm and mW

dBm		mW
30.0	1W	1000
20.0	100mW	100
10.0	10mW	10
7.0	5mW	5
0.0	1mW	1
-3.0	500 $\mu$ W	0.5
-10.0	100 $\mu$ W	0.1
-20.0	10 $\mu$ W	0.01
-30.0	1 $\mu$ W	0.001
-40.0	100nW	0.0001

## 12.17. Forward Spectrum Analysis

The spectrum frequency band of the S7200 covers cable, terrestrial and satellite frequency bands. You will find below settings instructions for the spectrum analysis functions. The spectrum analysis function is one of the primary, basic and most powerful functions of the S7200. In the spectrum analysis mode, user can directly use finger operate the touch screen, user also can use button to operation the spectrum analyzsis function. The detailed touch screen operation steps, user can reference section 9.3 content.

Spectrum analysis menu description

In main menu, tap the spectrum icon to confirm the spectrum analysis function main menu selection, shown in the below Figure 12-141.





Figure 12-141 Snapshot: Spectrum Analysis Screen Elements Instruction

### Screen Elements description

1. Channel plan name.
2. Center frequency.(CENT)
3. Span. (SPAN)
4. Resolution bandwidth filter selection. (RBW)
5. Video bandwidth filter selection. (VBW)
6. Sweep time. (SWEEP)
7. Detector mode. (DETECTOR)
8. Reference level. (REF)
9. Division scale. (SCALE)
10. Reference scale.
11. Markers.
12. Pre-amplifier On-Off: If pre-amp is on, the icon appears, if pre-amp is off, no icon is displayed.
13. Spectrum hold: this icon will show if the spectrum sweep is on hold, if signal is live, no icon shows.
14. Spectrum analysis mode: SWP and FFT.
15. Attenuator. (ATT)
16. Frequency and level of marker A
17. Frequency and level of marker B
18. Delta variation between marker A and B (in frequency and level)
19. Active trace: four traces can be displayed simultaneously by the S7200. Only one trace is controlled at a time.
20. Test Point Compensation. (TP)
21. Multi-function soft-keys: a button followed by an arrow ">" means there is a sub-menu available. A button with a bracket "[ ]" means the button offers multi-functions.

S7200 spectrum operation mode is basically designed in the style of a handheld spectrum analyzer. The following is to introduce how to set up the spectrum measurement. The first level menu totally has 7 buttons, representing Channel measurement, frequency, amplitude, bandwidth/scan, frequency scale, sweep, and display control parameters in spectrum analysis functions separately. Channel measurement in the first level menu, fast enter the channel measurement function.

### 12.17.1. Frequency Setting

Tap the [FREQ>] soft button to enter the frequency menu. Then tap different soft buttons again to access any of the submenu as the Figure 12-142 show. You can input the center frequency through the numerical keypad (available resolution of 1KHz) and adjust the center frequency with the  and  arrow keys or directly tap the parameter's position, directly use the popup virtual keyboard input center frequency value. (selectable frequency between 4-1220MHz) The default frequency step is 10MHz but can be manually changed to any of the following; 100kHz, 250kHz, 1MHz, 50MHz, 100MHz and CH (based on active channels in the active channel plan).

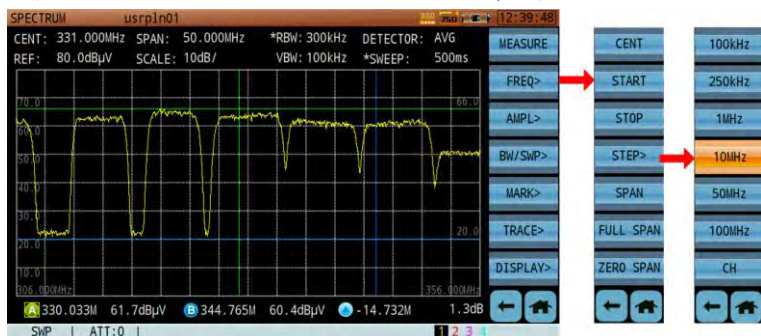



Figure 12-142 Snapshot: Frequency and Span Setting Menu

#### Span Setting

In the same sub menu for Frequency, tapping the soft button [Span] allows you to set the span with the numerical keypad, accuracy = 1KHz. You can also adjust the Span with the  and  arrow keys, (steps of 10MHz) or directly tap the parameter's position and use virtual keyboard input value. (Max span range is 0MHz to 1216MHz). The span can also be set automatically by dialing in the start/stop frequency.





### 12.17.2. Amplitude Settings

Amplitude settings: reference level, attenuator, unit & scale reference and pre-amplifier.

Setting up the reference level

The setting range of the reference level is from -80dBmV to +70dBmV and is displayed at the top left of the display window. (REF)

In the amplitude submenu, tap the soft button [REF], then press the  and  arrow keys to change the reference level value, in steps of 10dB.

Setting up and using the attenuator

There are two ways to set the attenuator, manual or automatic. In manual mode there is a "\*" before the attenuator icon at the bottom of the screen.

In the amplitude submenu, tap the soft button [ATT>] to enter the submenu. If the current status of the attenuator is automatic, (Auto), tap the [Auto] to toggle the attenuator mode to manual, and vice-versa depending on the desired setting. To manually control the attenuator, in the manual attenuator setting, tap the soft button [Input] to input the attenuation value with the numerical keypad, the available resolution is 1dB. Press the  button to confirm your selection. Tap the soft button [INC] or the soft button [DEC] to increase or decrease the attenuation value manually. The adjustable range of the attenuator is from 0 to 45dB. Pressing the [INC] and [DEC] buttons will change the attenuator setting by 5dB. 1dB steps are available only through the numerical keypad.

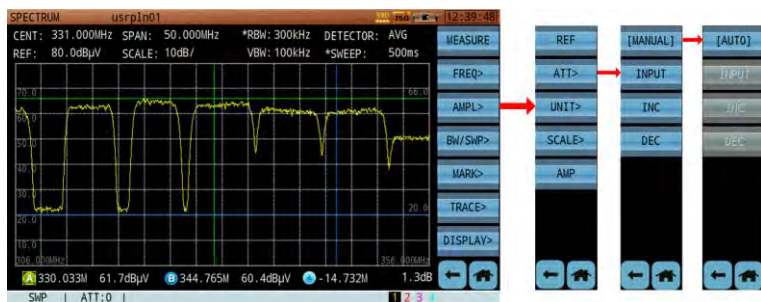



Figure 12-143 Snapshot: Amplitude Setting Menu - Attenuator

Setting up, enabling or disabling the pre-amplifier

Tap the soft button [AMPL>], then tap the soft button [AMP]. If the pre-amplifier is currently off, tap the soft button [AMP] to highlight, turn on the amplifier. When the pre-amplifier is on, an amplifier icon  will appear at the lower left corner of the screen. To turn the pre-amplifier off, tap the soft button [AMP] again, the amplifier will turn off and the icon  will disappear.

Setting up the amplitude scale - dB/division

Tap the soft button [AMPL>] and then tap the soft button [Scale>] to open the scale setting sub-menu. The default is 10dB/division. 1dB/2dB/5dB/10dB & 20dB per division is selectable/available.

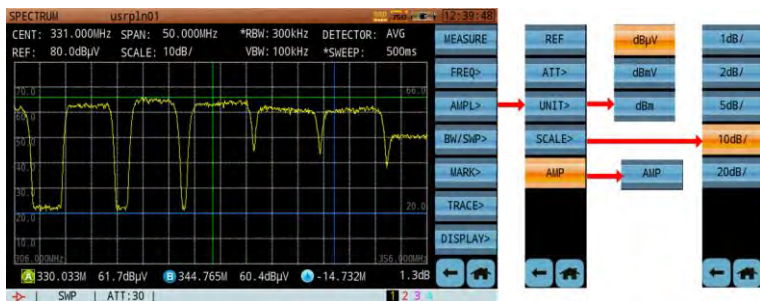

Figure 12-144 Snapshot: Amplitude Setting Menu – Unit, Scale & Amplifier

Tap the soft button [AMPL>] and then tap the soft button [UNIT>] to open the unit setting sub-menu. Available unit selection, dBuV, dBmV, dBm.

RF input port is  $75\Omega$ , The conversion factors: (Automatically calculated for your convenience)

$$\text{dBm} = \text{dBuV} - 108.8$$

$$\text{dBmV} = \text{dBuV} - 60$$

$$\text{dBm} = \text{dBmV} - 48.8$$

$$\text{dBm} = 20 \times \log(\text{mV}) - 48.8$$

RF input port is  $50\Omega$ , The conversion factors: (Automatically calculated for your convenience)

$$\text{dBm} = \text{dB}\mu\text{V} - 107$$

$$\text{dBm} = \text{dBmV} - 47$$



$$\text{dBm} = 20 \times \log(\text{mV}) - 47$$

### 12.17.3. RBW & VBW Bandwidth/Sweep Setting

How to setup or change RBW, VBW and sweep time values, spectrum calculation mode and trace hold features.

RBW (Resolution bandwidth filter)

The RBW filters can be used in manual or automatic mode. In manual mode there is a “\*” before the RBW parameter at the top of the screen.

Tap the soft button [BW/SWP>] to enter the submenu and then tap the soft button [RBW>]. Tap [AUTO] to allow the S7200 to choose a suitable RBW according to sweep speed, span and VBW selections, when manual mode is desired and the cursor on the RBW parameter, use the  and  arrow keys to choose the required RBW. Press the  button to confirm. RBW choices are: 1kHz,3kHz,10kHz,30 kHz, 100 kHz, 300 kHz and 1 MHz

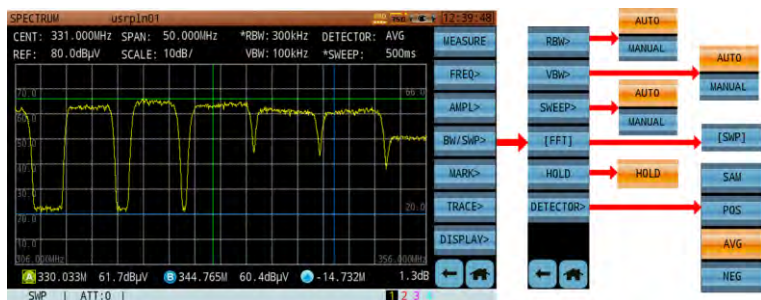





Figure 12-145 Snapshot: Bandwidth/Sweep Menu

VBW (Video Bandwidth Filter)



The VBW can be used in manual and automatic mode. In manual mode, there is a “\*” before the VBW parameter under the RBW parameter at the top of the screen.

Tap the soft button [BW/SWP>] to enter the submenu and then tap the soft

button [VBW>]. Tap[AUTO] to allow the S7200 to choose a suitable VBW according to sweep speed, span and RBW selections, when manual mode is desired and the cursor on the VBW parameter, use the  and  arrow keys to choose the required VBW. Press the  button to confirm. VBW choices are; 10Hz, 30Hz, 100Hz, 300Hz, 1 kHz, 3 kHz, 10 kHz, 30 kHz, 100 kHz, 300 kHz, 1 MHz and 3 MHz

### SWP (Sweep time)

There are two ways to set the sweep time, manual and automatic. In manual mode there is a “\*” before the sweep time parameter.

Tap the soft button [BW/SWP>] to enter the submenu and then tap the soft button [Sweep>]. Tap the[AUTO] to allow the S7200 to choose a suitable sweep time according to the active Span, VBW and RBW settings. However, when manual mode is desired and the cursor on the sweep time parameter, use the  and  arrow keys to choose the desired SWP speed, in steps of 10ms. Press the  button to confirm.

Spectrum analyzers normally couple sweep time, span setting and resolution bandwidth selections automatically. This allows the signal to be measured enough time to achieve full amplitude within the RBW for an accurate & calibrated measurement. If any of the parameters are not in “sync”, an “UNCAL” message will appear in the status bar at the bottom of the screen.

### Control and spectrum calculation mode

The S7200 offers two spectrum calculation modes, FFT and DFT. The DFT is the foundation of FFT, and the FFT is the fast algorithm of DFT. Every result calculated with DFT represents a pixel point of the spectrum trace, while every result calculated with FFT represents a segment of the spectrum trace. If a

faster sweep speed is required, the FFT mode is better suited for the task. In the digital persistence mode introduced later, only the FFT mode can be used.

### Spectrum hold mode

While in the spectrum analysis mode, tapping the soft button [BW/SWP] will expose the Hold button. When the hold button is tapped, the spectrum trace will be frozen on the screen, and the soft key button will highlight. Press the button again to restart the live trace, the soft key button will turn back to normal status.

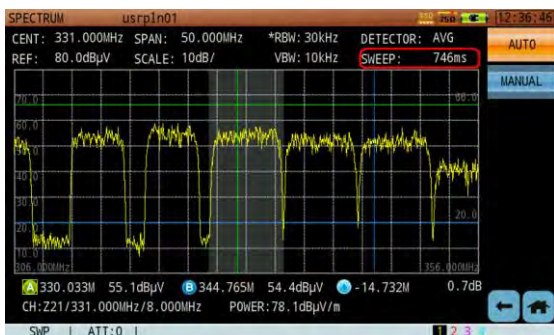

Figure 12-146 Auto Sweep Time

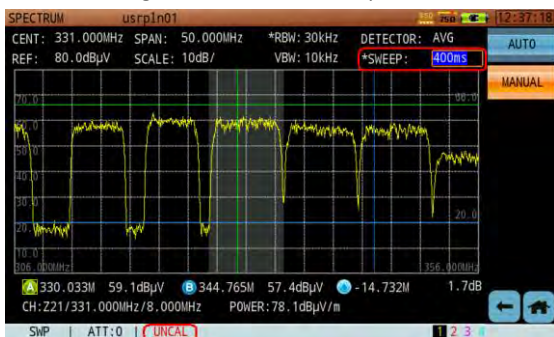

Figure 12-147 Manual Modify Sweep Time Cause UNCAL Information

### Detector Type Setting

Tap the soft button [DETECTOR>] to enter the detector mode submenu. Press any one of five soft buttons to choose the desired detector mode. The available detector modes are SAM (Sample detector), POS (Positive peak detector), AVG (Average detector) and NEG (Negative peak detector) .

### 12.17.4. Markers

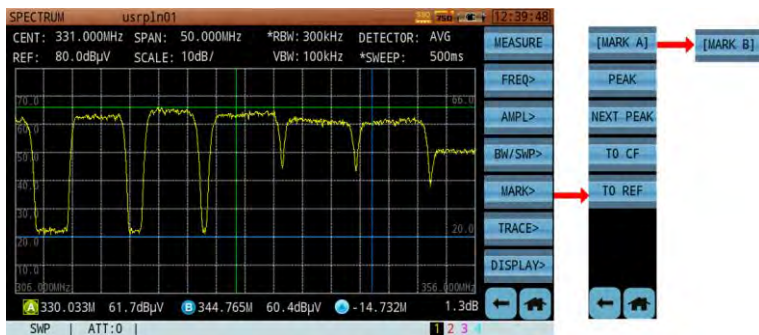

Figure 12-148 Marker Settings Menu

#### Marker function

The S7200 offers two Vertical markers and two horizontal markers in Terrestrial System; A and B. and one Vertical marker and two horizontal markers in Satellite System. User can use finger directly operation marker on the touch screen, please reference the section 9.3 to get the detailed operation steps

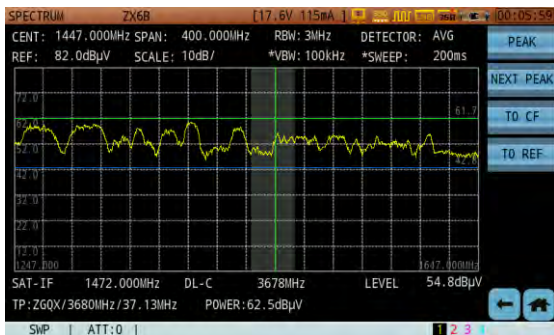

Figure 12-149 Satellite Spectrum Marker Menu



### Peak

To automatically find the highest peak level of the signal of the spectrum analyzer curve on the screen, tap the soft button [Peak], as shown in Figure 12-150 below.

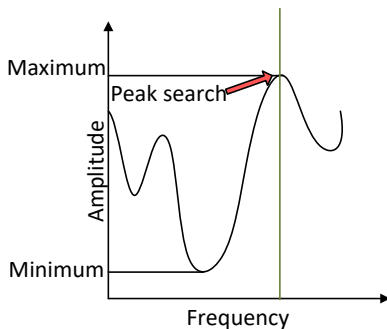

Figure 12-150 Marker - Peak Search

### Next Peak

Tap the soft button [Next Peak], to automatically find the next highest (second highest) peak level of the spectrum analyzer trace on the screen, as shown in Figure 12-151 below.

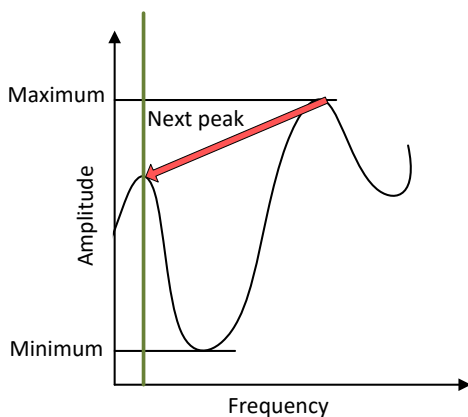

Figure 12-151 Marker –Next Peak

Marker to the center frequency

Tap the soft button [TO CF], and the marker will position itself at the center frequency of the on-screen spectrum curve automatically as shown in Figure 12-152 below.

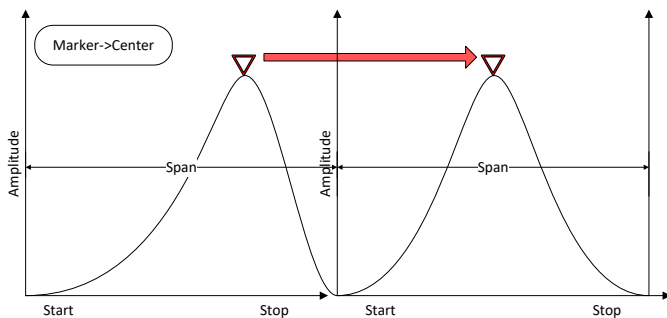

Figure 12-152 Marker -&gt; Center

Marker -> REF

Tap the soft button [TO REF], the position of the active marker will be set as reference level as shown in the Figure 12-153 below.

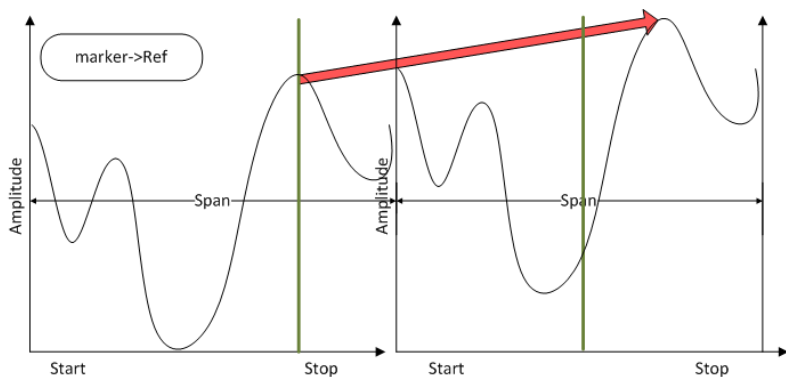

Figure 12-153 Marker ->Ref

### 12.17.5. Trace Setting

The S7200 can display 4 traces simultaneously. The display settings are: max. hold, min. hold, average and normal. Each trace is actively displayed on the screen, individually or simultaneously, each with a different color, 1, 2, 3 or 4 traces at a time. You can toggle in a circular way when tapping the first soft button repeatedly. Tap the soft button [WRITE] to activate the desired trace, Tap the soft button [BLANK] to deactivate and turn off the current trace. Each trace is identified at the bottom right (1-2-3-4) to the left of the TP value. In any of the Spectrum Analysis modes, the number highlighted in black at the bottom right is the active trace which you have control on at that moment.

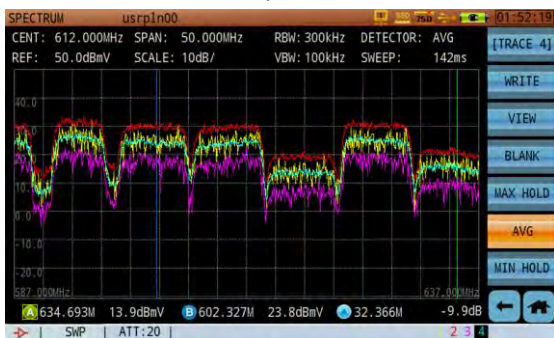

Figure 12-154 Snapshot : Four Traces Display Simultaneously

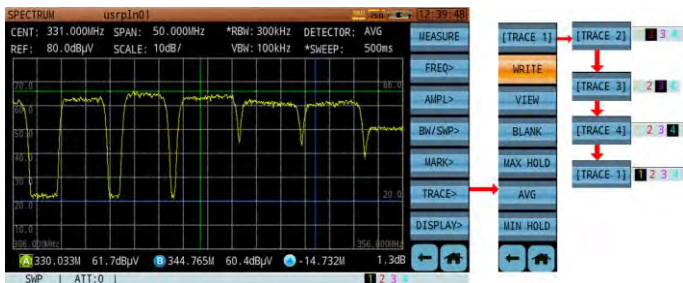

Figure 12-155 Snapshot : Trace Setting Menu

#### Max. hold trace

Tap the soft button [TRACE>] to enter the submenu, then tap the soft button [Max. Hold] to activate the max. hold function.

#### Min. hold trace

Tap the soft button [TRACE>] to enter the submenu, then tap the soft button [Min. Hold] to activate the min. hold function.

#### Average trace

Tap the soft button [TRACE>] to enter the submenu, then tap the soft button [AVG] to activate the average trace function.

### 12.17.6. Display Mode Setting



Figure 12-156 Snapshot: Display mode Setting

The spectrum analysis function offers 5 display modes: curve mode, solid mode, spectrogram, combined Curve/Spectrogram and Channel Power mode. Tap the soft button to enter the submenu, then tap the soft button [CURVE], or soft button [SOLID], or soft button [SPO], or soft button [CRV+SPO], or soft button [CH POWER] to select which display mode is required.

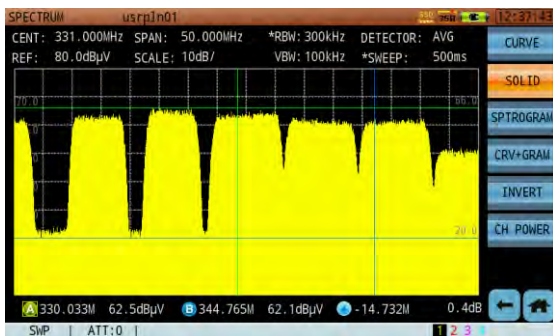

Figure 12-157 Snapshot: Solid Display Mode

### Curve mode

The curve mode is the standard default Spectrum Analysis mode

### Solid mode

The solid mode fills the area below the signal with a solid color. (yellow) as per Figure 12-157 below.

### Spectrogram mode

The scrolling three-dimensional display is useful for its ability to track frequency and power behavior over time, particularly intermittent signals. You can use the spectrogram mode to analyze the stability of a signal over time, or to identify intermittent interference signals. The X-axis (horizontal) represents frequency, amplitude is represented by color, (red for a high level signal and blue for the noise floor). The Y-axis (vertical) represents time, with the most recent trace acquisition displayed at the bottom of the graph to the oldest acquisition at the top of the graph. (upwards movement of acquisitions)

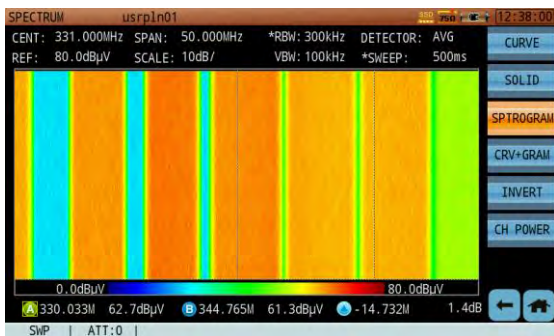

Figure 12-158 Snapshot: Spectrogram display mode

The Curve- Spectrogram mode provides simultaneous display of spectrum trace and spectrogram. There is a definite advantage in using the combined

mode from a visual stand-point. (It will be MUCH easier to visualize signal variations, for example: a hopping frequency signal.)

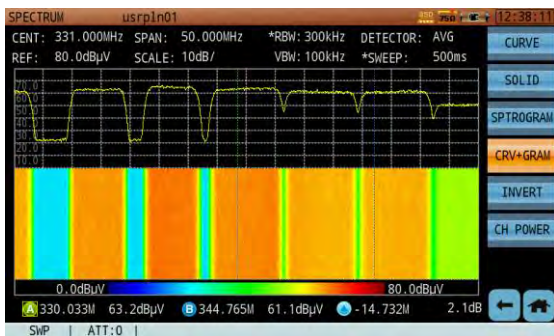

Figure 12-159 Snapshot: Curve - Spectrogram Display Mode

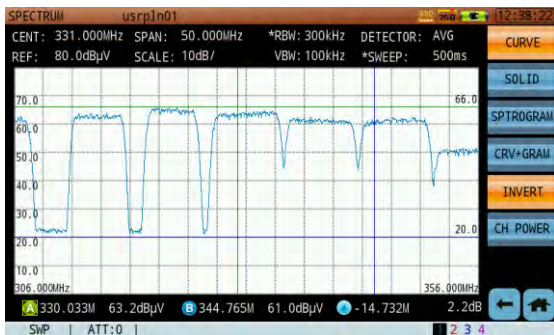

Figure 12-160 Snapshot: Print Mode

We have just introduced a new feature that provides 2 benefits. By inverting the screen colors from dark background and a light trace color to a light background and a dark trace color, this can save a lot of toner when printing saved traces for reporting purposes, AND, when using the instrument in very sunny outdoors conditions, the screen becomes much more easily viewable. The typical dark screen and light trace color is perfect for indoors use and viewability.



## Channel Power Mode

Channel Power is the total power of the signal in a certain sweep frequency band. View the total power of effective digital channel in the current channel plan. When the frequency marker is in the band of effective digital channel in the channel plan, the screen will appear the light green channel automatically. Channel bandwidth value is the bandwidth of the channel, the bar graph part represents the power range that participates in the calculation.

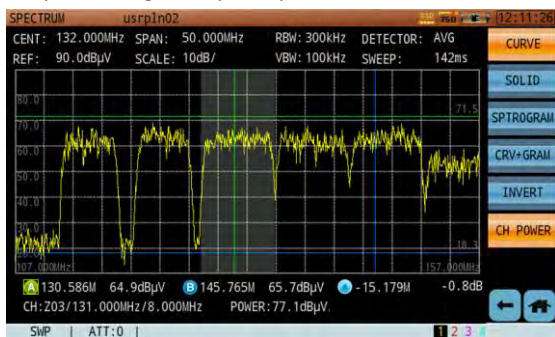

Figure 12-161 Snapshot: Channel Power Mode

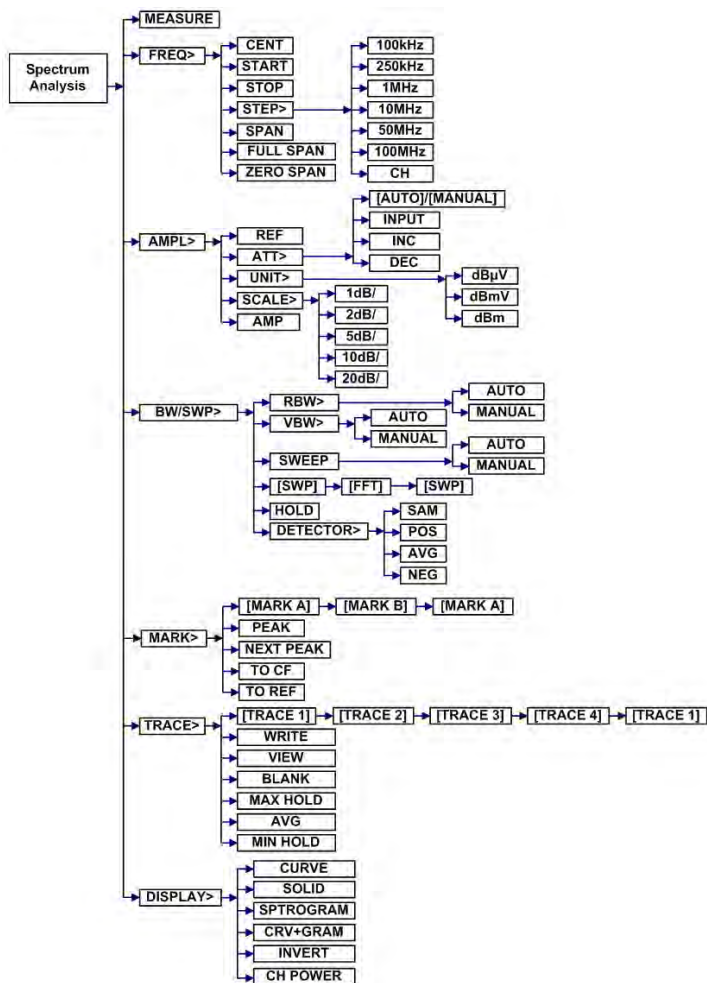

Figure 12-162 Spectrum Analysis Menu Tree

## 12.18. WiFi Analysis

The WiFi analysis mode is primarily used to display the surrounding WiFi channels, their SSID, their designated channel within the WiFi band used, and their relative amplitude level from the S7200 location. (Figure 12-163 below shows the graphical interface)

The two display modes of the WiFi mode are graphical and list. The list mode, (as is Figure 12-165 below) shows the name, status, channel, relative signal strength, MAC address and encryption method of the various SSID carriers detected.

Currently, the WiFi analysis function supports WLAN of 2.4G and 5G.

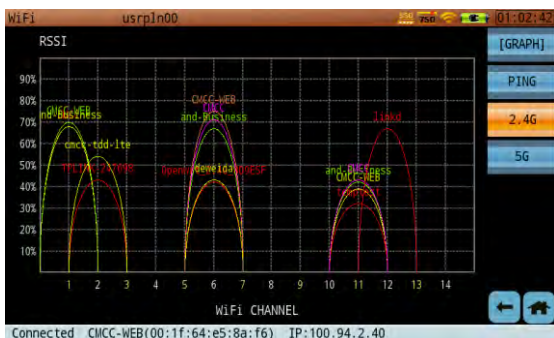

Figure 12-163 Snapshot: 2.4GWiFi Channel - Graphical Display

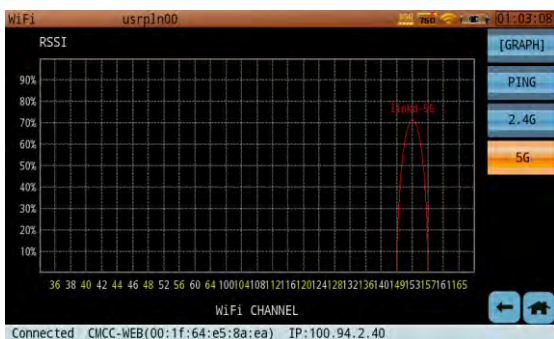

Figure 12-164 Snapshot 5G WiFi Channel - Graphical Display

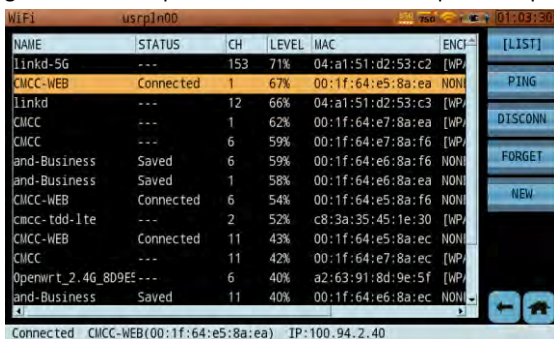

Figure 12-165 Snapshot: WiFi Channel - List Display

## 13. Concept

### 13.1. Unit conversion chart

Unit	Impedance 50Ω	Impedance 75Ω
μV	1μV=10 <sup>-6</sup> V	1μV=10 <sup>-6</sup> V
mV	1mV=1000μV	1mV=1000μV
dBuV	0dBμV=1μV	0dBμV=1μV
dBmV	0dBmV=1mV	0dBmV=1mV
dBm	0dBm=107dBμV	0dBm=108.8dBμV

### 13.2. Analog TV Standard and Color Transmission System

#### Basic Knowledge

There are many different TV standards in use around the world, defining in detail the baseband and RF structure of the signal, but for the broadband engineer and technician, the key parameters are; bandwidth, the dimensions of the lower (vestigial) and upper sidebands, the frequency and amplitude relationships of the vision (luminance), color (chrominance) and audio subcarriers.

In terms of these parameters, the vast majority of TV transmissions fall into just six categories, which are illustrated in the following diagrams.

Note that these diagrams do not define such parameters as field frequency, line frequency, or color encoding technique, which distinguish the NTSC, PAL and SECAM systems.

The letters B, G, M, etc. refer to TV standards, and the encoding techniques (NTSC, PAL, etc.) refer to systems.

The relationship between the TV standard and color transmission system

Standard	Can be used with these Systems:
B	PAL, SECAM
D	SECAM
G	PAL, SECAM
H	PAL, SECAM
I	PAL
K	SECAM
K1	SECAM
L	SECAM
M	NTSC, PAL
N	PAL

Up to now, there are 10 types TV standard in use around the world. These standards are: B, D, G, H, I, K, K1, L, M, N. There are three types of color transmission system: PAL, NTSC, SECAM.

Different Standards and Systems have different field frequencies, line frequencies and color encoding techniques. For example, Europe and China use PAL-D color transmission system and TV standard, North America (USA, Canada & Mexico) use NTSC-M color transmission system and TV standard.

Cs: Audio carrier

Cv: Video carrier

Cc: Color subcarrier

VSB: Vestigial Sideband

USB: Upper Sideband

M, N

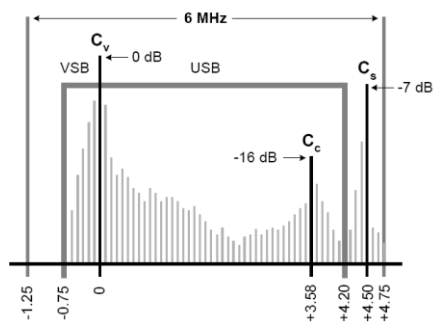

Figure 13-1 TV Standard - M, N

B (7 MHz)  
G (8 MHz)

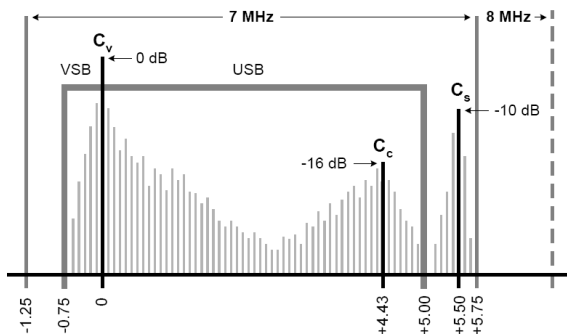

Figure 13-2 TV Standard - B, G

D, K

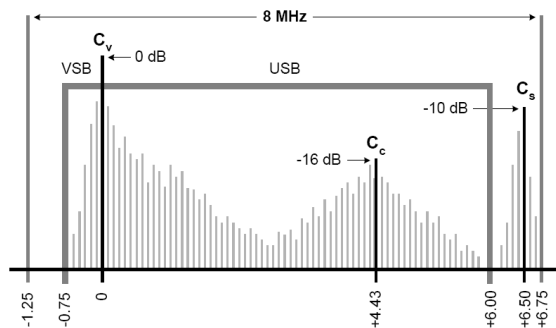

Figure 13-3 TV Standard - D, K

H

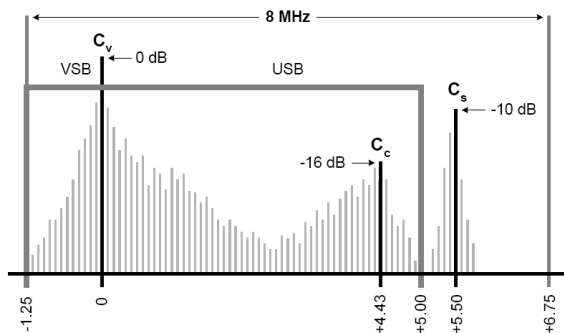

Figure 13-4 TV Standard - H

I

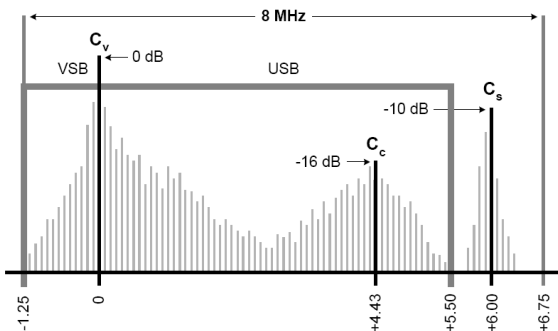

Figure 13-5 TV Standard - I

K1, L

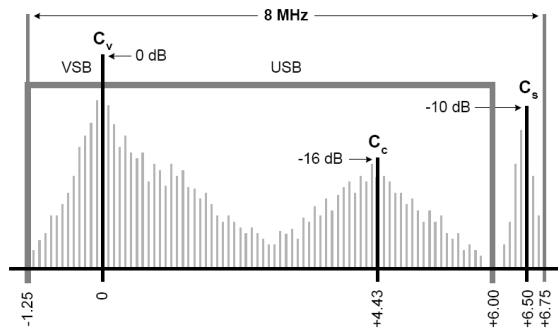

Figure 13-6 TV Standard - K1, L



## TV standard and color system parameters setup

TV Standard	Number of lines per frame	Field frequency	Color encoding	Color subcarrier
NTSC-M	525	60Hz	NTSC	3.58MHz
PAL-M	525	60Hz	NTSC	3.58MHz
PAL-B、D、G、H、I	625	50Hz	PAL	4.43MHz
PAL-N	625	50Hz	PAL	4.43MHz
PAL-N combination	625	50Hz	PAL	3.58MHz
SECAM	625	50Hz	SECAM	4.406MHz 4.250MHz

## Different standard audio frequency and bandwidth

Analog TV standard and system	Audio 1 offset	Audio 2 offset	Channel bandwidth
NTSC-M	4.50 MHz	4.50 MHz	6.00MHz
PAL-B	5.50 MHz	5.85MHz	7.00MHz
PAL-D	6.50 MHz	6.85MHz	8.00MHz
PAL-H	5.50 MHz	5.85MHz	8.00MHz
PAL-I	6.00MHz	6.50MHz	8.00MHz
PAL-K	6.50MHz	6.85MHz	8.00MHz
PAL-M	4.50MHz	4.50MHz	6.00MHz
PAL-N	4.50MHz	4.50MHz	6.00MHz
SECAM-B	5.50MHz	5.85MHz	7.00MHz
SECAM-D	6.50MHz	6.85MHz	8.00MHz
SECAM-G	5.50MHz	5.85MHz	8.00MHz
SECAM-H	5.50MHz	5.85MHz	8.00MHz
SECAM-K1	6.50MHz	6.85MHz	8.00MHz
SECAM-K	6.50MHz	6.85MHz	8.00MHz
SECAM-L	6.50MHz	6.85MHz	8.00MHz

## 13.3. Analog TV Baseband Signal Basic Knowledge

### 13.3.1. Understanding Composite Video Signal

A composite video signal is a signal in which all the components required to generate a video signal are embedded in a single signal. The three main components that together form a composite signal are as follows:

The luminance signal — contains the intensity (brightness or darkness) information of the video image

The chrominance signal — contains the color information of the video image

The synchronization signal — controls the scanning of the signal on a display such as a TV screen

The monochrome composite signal is built of two components: luminance and synchronization. This signal, which is usually called the Y signal, is shown in Figure 13-7 below.

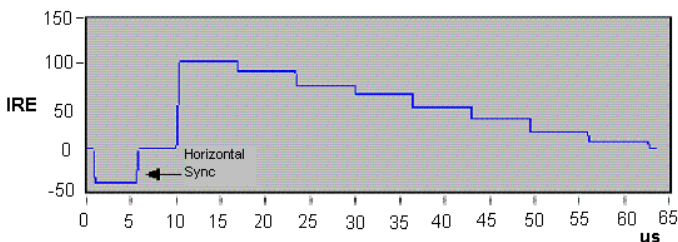

Figure 13-7 Monochrome Composite Video Signal  
(Luminance Steps from White to Black)

The chrominance signal by itself, which is usually called the C signal, is shown in Figure 13-8 below.

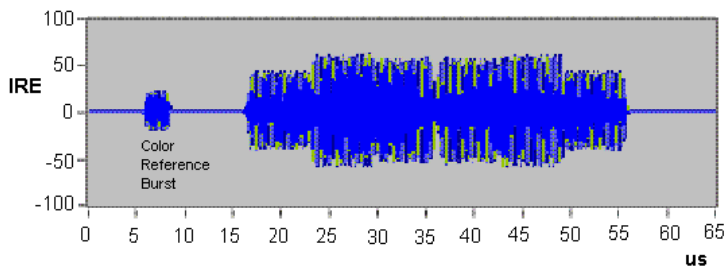

Figure 13-8 Color Information Signal for a Color Bar Line  
(Including the Color Burst)

The composite color video signal, often called the Color Video, Blank, and Sync (CVBS) signal, is the sum of Y and C, is shown in below Figure 13-9.

$$\text{CVBS} = \text{Y} + \text{C}$$

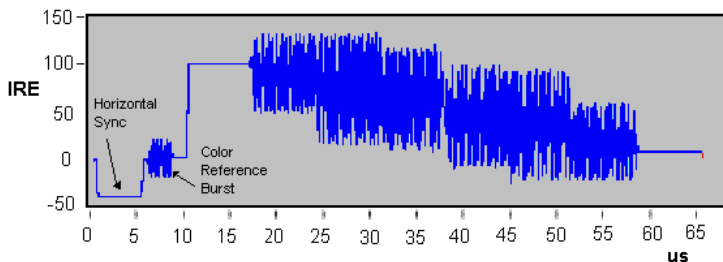

Figure 13-9 Color Composite Video Signal for a Color Bar Line

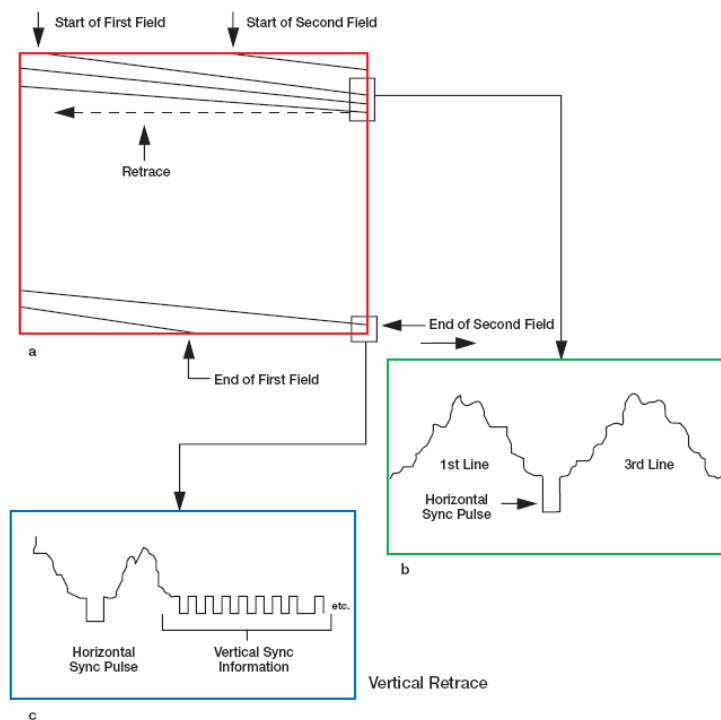

Figure 13-10 The synchronization signals in an analog composite baseband

To reproduce an image, both the camera and the video display are scanned horizontally and vertically (see graph **a** in Figure 13-10 above). The horizontal lines on the screen are scanned alternately – odd numbered lines first, then even numbered lines – as in interlaced scanning systems, or they might be scanned sequentially as in progressive scanning systems.

Both the camera and display must be synchronized to scan the same part of the image at the same time. This synchronization is handled by the horizontal sync

pulse which is part of the baseband video signal. The horizontal sync pulse starts a horizontal trace. During the horizontal blanking interval, the beam returns to the left side of the screen and waits for the horizontal sync pulse before tracing another line. This is called “horizontal retrace” (see graph **b** in Figure 13-10 above).

When the beam reaches the bottom of the screen, it must return to the top to begin the next field or frame. This is called the “vertical retrace” and is signaled by the vertical sync pulse (see graph **c** in Figure 13-10 above). The vertical retrace takes much longer than one horizontal retrace, so a longer synchronizing interval – the “vertical blanking interval” – is employed. No information is written on the video screen during the horizontal or vertical blanking intervals.

Each video standard defines a series of synchronization signals that control how the video signal is displayed. PAL signals display a video frame 25 times a second and a frame contains 625 video lines. NTSC signals display a video frame 30 times a second, but with only 525 lines.

Table: Active Image Value

Video Format	Lines/ Frame	Active Lines	Frame Rate	Line Duration	Active Line Duration
NTSC	525	480/486	29.97 frame/sec	63.55 $\mu$ s	52.2 $\mu$ s
PAL/SECAM	625	576	25.00 frame/sec	64.00 $\mu$ s	52.0 $\mu$ s

The active video image resulting from the scanning always has an aspect ratio (horizontal/vertical) of 4/3 no matter what the video format is. The color composite video signal shows that the scanning process requires some additional room on the left and right sides of each line as well as on the top

and bottom of the active video image region. This additional room includes the synchronization signals, color bursts, and other format-specific information, like the ITS, which are not part of the active video image. Approximately 90 percent of all the lines and 80 percent of each line can transmit the active image information. The exact values depend on the video format, as shown in above table.

"Active Lines" represents the number of lines that are actually used to transmit the image information. For example, only 480 lines out of 525 lines per frame transmit the image information in NTSC. Likewise, on each line, the image information is transmitted only during the active lines sequence, which is shorter than the entire line duration. For example, of  $63.55 \mu\text{s}$ , only  $52.2 \mu\text{s}$  are the active line duration in NTSC. Frame rate is the scanning speed.

### 13.3.2. Interlaced Scanning Concept

All composite video systems display the video image on a TV screen using an interlaced scanning technique. The Figure 13-11 below shows the interlaced scanning concept.

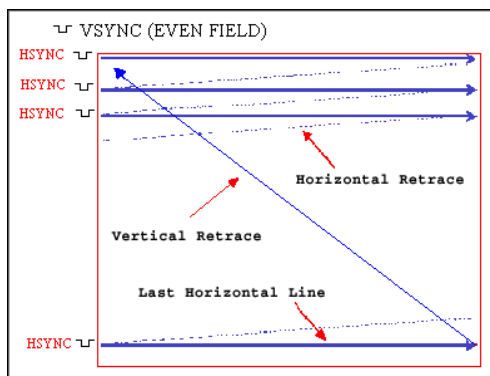

Figure 13-11 Video Scanning

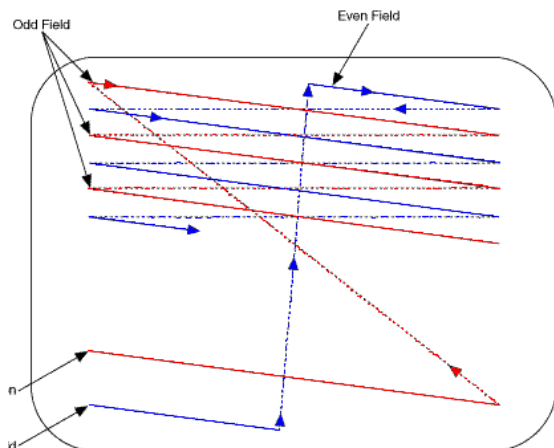

Figure 13-12 Interlaced Scanning on a TV Screen

The analog video signal includes synchronization pulses that control the scanning line by line from left to right and field by field from top to bottom. The pulses that control the line-by-line scanning are called the horizontal synchronization pulses (H-Sync). The pulses that control the vertical scanning are called the vertical synchronization pulses (V-Sync).

Two interlaced fields compose a complete frame. The first field, called the odd field, scans the odd lines of the video image. The second field, called the even field, scans the even lines of the video image. The process repeats for every frame.

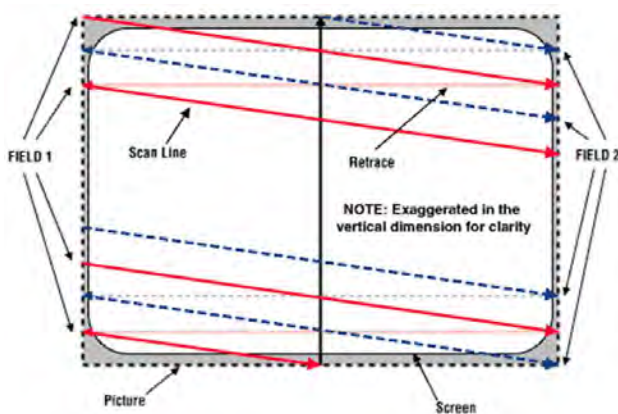

Figure 13-13 The Picture Area larger than Screen Area



### 13.3.3. Gated Measurement Basic Concept

- **Field**

A television image or frame is composed of 525 (or 625 lines) and delivered in two successive fields of 262.5 (or 312.5 lines) interlaced together on a CRT when displayed. When **Field** is set to **Entire Frame**, the line count starts at line one in field one (often referred to as the “odd field”) and ends at 525 (or 625) in field two (often referred to as the “even field”). When **Field** is set to **Field One** or **Field Two**, the line count begins at “1” with the first full line in the selected field and ends at count 263 (or 313) for Field One, and 262 (or 312) for Field Two.

- **Sync**

Analog broadcast or cable television signals are usually amplitude modulated on an RF carrier. For NTSC and PAL broadcasts, typically the RF carrier amplitude is maximized at the sync tips of the baseband video waveform and minimized at the “white” level. This results in a demodulated waveform on the analyzer where the sync pulses are on top, or positive (**Sync (Pos)**). With SECAM broadcasts, typically the RF carrier amplitude is minimized at the sync tips of the video waveform and maximized at the “white” level. This results in a waveform on the analyzer where the sync pulses are at the bottom, or negative (**Sync (Neg)**). A normal baseband video waveform for all TV standards will have the sync tips on the bottom. When **TV Source** is set to **Ext Video In**, **Sync** should be set to **Neg**.

Composite color TV video signal is composed by the modulated chrominance, and is added to the luminance information along with appropriate horizontal and vertical sync signals, blanking signals, and color burst signals. In 625

scanning lines system, there are 25 blanking line, lines 623~22 in odd field and line lines 311~335 in even field. These lines are used to transmit blanking signal for the electron beam at the end of the line scanning and field scanning can come back to the start point of the picture.

In 625 scanning lines system, every field has 25 lines as the flyback line, so every frame only has 575 effective lines.

When engineers test TV system, they often use full field test signal, this operation require engineers to stop TV program broadcast. Obviously, if we want to test the dynamic parameters, we cannot do measurement and broadcast TV program at the same time. With the development of the TV industry, TV program broadcast hours continuously increase. TV program service providers hope to monitor TV system performance parameters and judge whether the broadcast equipment work well or not according to these parameters. They can modify these equipments according to these parameters. The requirement is very important for TV program service providers.

Vertical blanking interval is not used to transmit any information, later the researchers use these free lines to convey auxiliary signals for increasing the bandwidth utilization ratio. Vertical Interval Test Signal (VITS) can give important system dynamic performance parameters without influencing the TV program broadcast. VITS also provides the possibility to automatically monitor, modify and broadcast. Inserting test signals in the vertical blanking interval is used in real time monitoring, helping to modify and improve TV program transmission quality by at least determining which parameter is below acceptable quality or below mandatory thresholds prescribed by the FCC. Now, the VITS signal is an indispensable part of international and domestic TV signals.

Some signals can measure video parameters: in-channel frequency response, luminance nonlinear distortion, Differential Gain, Differential Phase, Chrominance Luminance Gain Inequality and Chrominance Luminance Time Delay Inequality. These test signals are combined into some composite test signals meeting the video transmission line signal and insert vertical blanking interval after the field sync pulse. These composite signals are called VITS signal and these vertical blanking interval line are called insert test line.

### 13.3.4. CCN, C/CSO and C/CTB Gated Measurement

CCN, C/CSO and C/CTB all can do gated measurement, but C/CTB gated measurement is slightly different from C/N and C/CSO gated measurement because the C/CTB interference falls right at the Video carrier frequency. First, let's talk about CCN and C/CSO gated measurement.

CCN gated measurement needs to measure video signal carrier peak level and corrected noise level (over a specified bandwidth) on a quiet line during the vertical blanking interval, and then uses the two results to calculate CCN.

C/CSO gated measurement also needs to measure video signal carrier peak level and second order beat on a quiet line during the vertical blanking interval, and then uses two results to calculate C/CSO.

C/CTB gated measurement is definitely different from CCN and C/CSO measurement, because the third order beat coherent distortion is located directly at the video carrier frequency. By definition, this signal is covered by the video carrier. If you want to measure the third order beat, you must shut off the video signal carrier. In normal measurement method, you would need to shut off the modulator, let the video carrier level disappear, and then measure the third order beat right at the video carrier frequency. In gated measurement mode, it is suggested that you use a quiet line inserter, which gate off at necessary time, (at the specified field). The S7200 first measures the video carrier peak level during the sync pulse, then, while the quiet line inserter removes a specified line at the same time in every frame. The instrument uses the gated function to measure third order beat during that specific quiet line period. The instrument uses two results to calculate the C/CTB. The effects of removing a quiet line during a specific vertical blanking interval are the same as if you would shut off the modulator, but at a very

specific time, and for a very short time. Figure 13-14 below describes how a quiet line inserter should be installed behind each modulator to be tested. The advantage of using a quiet line inserter is that prior to inserting a quiet line, it removes the line to be used for insertion of the quiet line first. Using this method, making C/CTB measurements are “almost” undetectable by the end user customer, where a low level audible sound will be heard, but this is an acceptable trade-off to removing modulation completely, where the TV picture and sound will completely shut down for the duration of the test. When performing a C/CTB measurement with a quiet line inserter, (removing the line first) by removing/inserting only one of the 2 video fields, the audible distortion coming out of the speaker of your television is almost un-distinguishable. (if both fields are used, the pitch of the audible distortion is higher, hence, more easily distinguishable to the human ear).

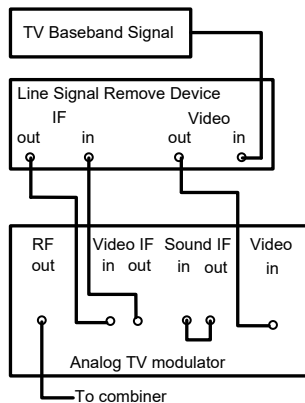

Figure 13-14 CTB quit line removing equipment connection  
Quiet line inserter in this example: TVMS4200.

### **13.3.5. Video Parameters Gated Measurement**

VITS (Vertical Interval Test Signal)

In the past, engineers often uses full field test signal to test TV system. This particular test process then requires the field or HE engineer to interrupt the specific channel broadcast TV program. Obviously, in today's HFC networks and for competitive reasons, it is quite imposible to use full field test signals to measure TV system parameters in a non-intrusive manner. With the continuous development and competitiveness of the CATV industry, the un-interrupted broadcast of an increasing number of TV programs is critical to go without customers services interruptions. It is critical that broadcast TV programs are un-interrupted during testing and monitoring of the CATV system performance parameters. Inserting un-detectable test signals during the vertical blanking interval allows CATV operators to perform system performance testing in-service, without any service interruptions or customers detecting any interruptions or distortions of the service they are paying for.

#### **1. VITS insert position provision.**

The composite test signal are basic and inserted in an empty, un-important or undesired line of the vertical blanking interval behind the sync pulse field, for example from line 16 to line 22 or from line 329 to line 335 in a 625 lines system. (those particular lines will not typically show and/or cannot be visualized on the viewable portion of your television screen)

CCIR recommended usage of international TV program exchange VITS signal for 625 line systems in 1969, the VITS inserted position is as the following recommendation:

Insertion Line	Application
16 (329)	Data and communication signal
17、18 (330、331)	International VITS signal position, for
21 (334)	Teletext broadcast

The following figures are some of the most widely used VITS signals.

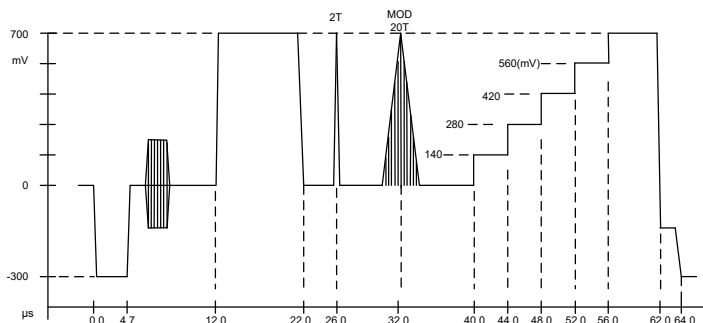

Figure 13-15 CCIR Line 17

### CCIR17 test signal

The first peak from the left is a white flag with peak amplitude of 700mV (relative to blanking level) and a width of 10 $\mu$ s; a zero carrier reference (base white) for measuring video signal amplitude and depth of modulation. The second from the left is 2T pulse with a half-amplitude width of 200ns, it is used to measure K factor. Cable TV systems use K-2T factor to replace echo measurement. The third from the left is a composite sine square pulse with a half-amplitude width of 20T (2 $\mu$ s). The 4.43MHz color subcarrier sine wave is filled in the 20 sine square envelope (standard for luminance signal), 20T modulated chrominance pulse is used to measure Chrominance-Luminance Delay Inequality and Gain Inequality. The fourth from the left is 5-step luminance staircase signal; every staircase step is 140mV, which is used to

measure luminance nonlinear characteristic.

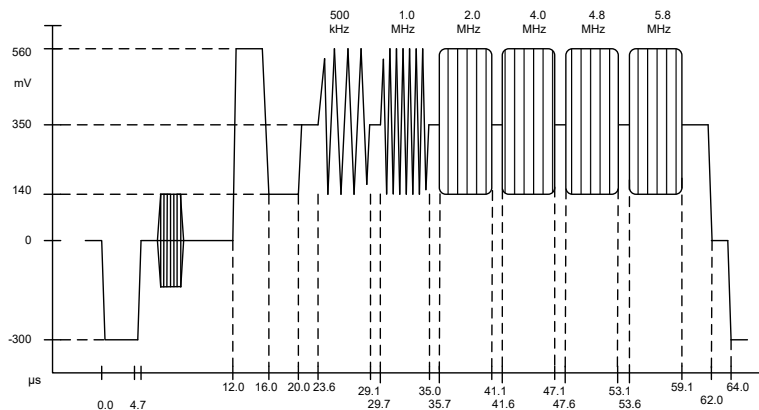

Figure 13-16 CCIR Line 18(Multiburst)

#### CCIR 18 test signal

CCIR 18 is also called a multiburst signal which consists of a set of single frequency sine wave signals with equal amplitude. The left side is a white flag with a peak amplitude 420mVp-p and provide amplitude standard for the following multiburst signals. Followed by six sine wave frequency packets, each frequency packet is: 0.5MHz、1.0MHz、2.0MHz、4.0MHz、4.8MHz and 5.8MHz. The multiburst signal is used to measure transmission system video bandwidth frequency and amplitude response characteristic.



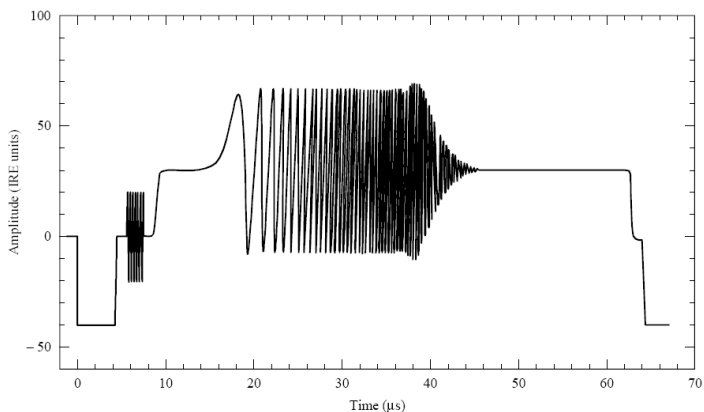

Figure 13-17 GCR signal line A for 525-line systems

## Ghost Cancellation Reference (GCR)

This signal is also often used to measure in-channel frequency response.

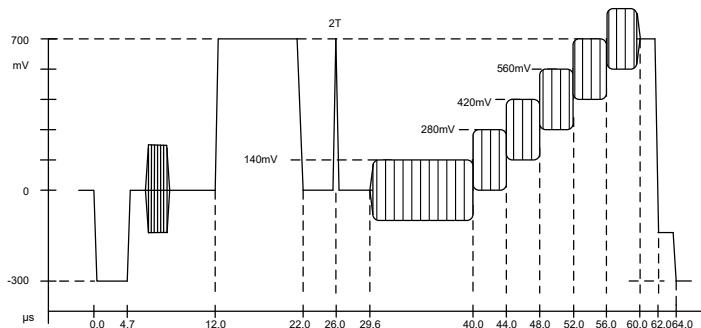

Figure 13-18 CCIR Line 330

## CCIR 330 test signal

The first peak from the left is a white flag with peak amplitude of 700mV (relative to blanking level) and a width of 10 $\mu$ s; a zero carrier reference (base white) for measuring video signal amplitude and depth of modulation. The second from the left is 2T pulse with a half-amplitude width of 200ns, it is used

to measure K factor. Cable TV systems use K-2T factor to replace echo measurement. The third from the left is the blanking level and 5 luminance steps superimposed with a 4.43MHz color subcarrier sine wave; the color burst is 280mV and used to lock color signal phase. The 5-step luminance staircase and blanking is used to represent six different luminance levels. This third part of the signal is used to measure DG and DP.

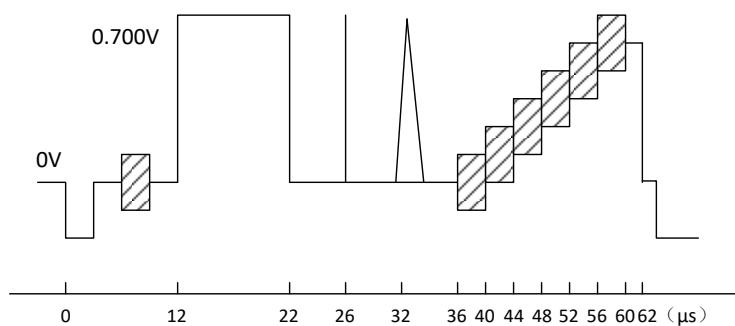

Figure 13-19 GB19

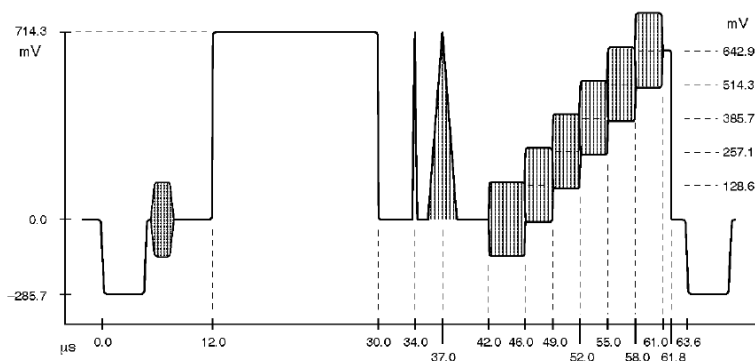

Figure 13-20 NTC-7 Composite

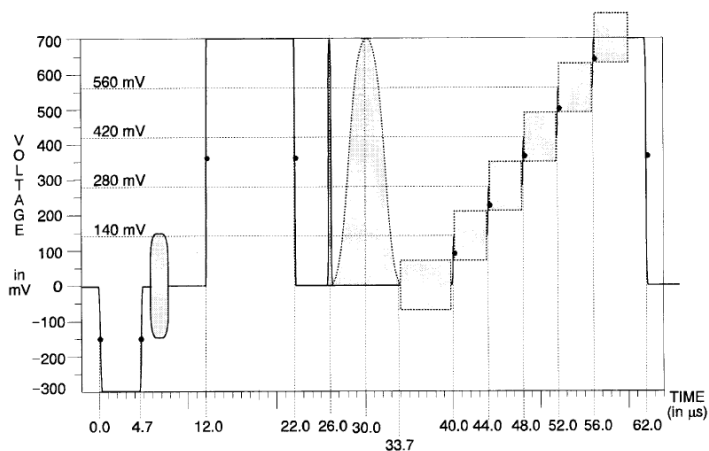

Figure 13-21 UK ITS1

The VITS composite signals are composed of basic types of test signal:

- (1)  $0.7 \pm 7 \text{ mV}$  line bar, as the standard level;
- (2) 2T pulse: used to measure high frequency character of channel;
- (3) 10T or 20T pulse made up of a sine-squared luminance pulse and a chrominance packet with a sine-squared envelope: used to measure Chrominance-Luminance Inequality character of a channel.
- (4) 5-step luminance staircase signal: used to measure Luminance nonlinear distortion of channel.
- (5) Luminance steps superimposed with modulated chrominance: used to measure chrominance amplitude and phase distortion caused by luminance amplitude change of a channel.
- (6) Multiburst: used to measure the flatness of a channel in 6MHz video bandwidth.

## VITS signal application

Measurement parameter	VITS signal
A short period of time waveform distortion	2T pulse (CCIR 17)
CLDI	10T pulse is made up of a sine-squared luminance pulse and a chrominance packet with a sine-squared envelope (CCIR 17)
Chrominance nonlinear distortion	Three -level chrominance bar (CCIR 331)
Overshoot distortion	2T pulse (CCIR 17)
Luminance nonlinear distortion	5-step luminance staircase signal
In Channel Frequency Response	Multiburst (CCIR 18)
Differential Gain and Differential Phase	luminance steps superimposed with modulated chrominance (CCIR 330)
Intermodulation Distortion	Three -level chrominance bar (CCIR 331)

VITS test signal use several types of test signals to compose one composite test signal. This composite test signal is inserted in an empty or unused line of the vertical blanking interval behind the field sync pulse. The line position of these VITS signals are typically off the viewable portion of your television screen. These signals are inserted at the top of every field signal. They are specifically designed to meet non-intrusive measurement practices.

Gated video signal measurements need VITS signal generators and/or test signal inserters. VITS signal generators are used to generate basic test signals. The video test signal inserter is typically used to insert a VITS signal on the

blanking line of a video signal. The following two figures (Figure 13-22 and Figure 13-23) illustrate the signal connection methods of out-of-service testing and/or in-service testing.

### Out-of-Service (Full Field Testing)

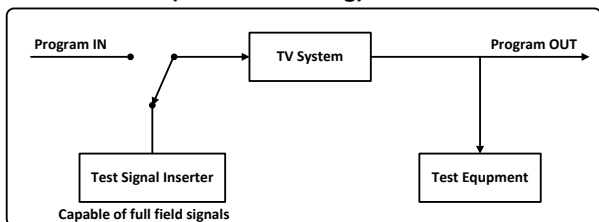

Figure 13-22 Out-of-Service (Full Field Testing)

### In-Service (VITS or ITS Mode Testing)

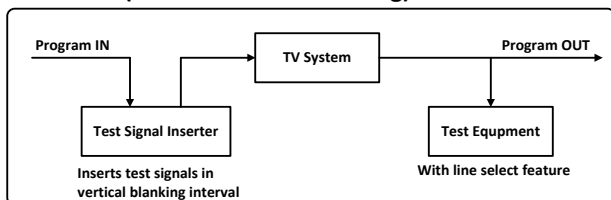

Figure 13-23 In-Service (VITS or ITS Mode Testing)

## **13.4. Satellites and Transponders**

Satellite channel plan is composed of satellite and satellite transponder. Every year many new satellites have been launched and many satellite often midify transponder setting. Not any uniform standards, so user need manually add satellite channel plan parameters and update transponder parameters.

The following content will provide some create satellite channel plan related basic knowledge.

Broadcast satellite is the geostationary orbit satellite. Each satellite in geosynchronous orbit over the equator on a fixed position point, its purpose is to make every broadcast satellite to be able to cover the designated service area. Each country launch broadcast satellites' latitude is  $0^{\circ}$ , the longitude use the point of the intersection of the earth's center and satellite connection with equatorial position (sub-satellite point) as longitude, the longitude range is  $0^{\circ} \sim 360^{\circ}$ . Located at east longitude abbreviated as  $^{\circ}\text{E}$ , located west abbreviated as  $^{\circ}\text{W}$ .

### **13.4.1. Sub-Satellites**

The sub-satellite concept: In order to determine the look angles of a satellite, its precise location should be know. The location of a satellite is very often determined by the position of the sub-satellite point. The sub-satellite point is the location on the surface of the Earth that lies directly between the satellite and the center of the Earth. To an observer on the sub-satellite point, the satellite will appear to be directly overhead, as the show Figure.

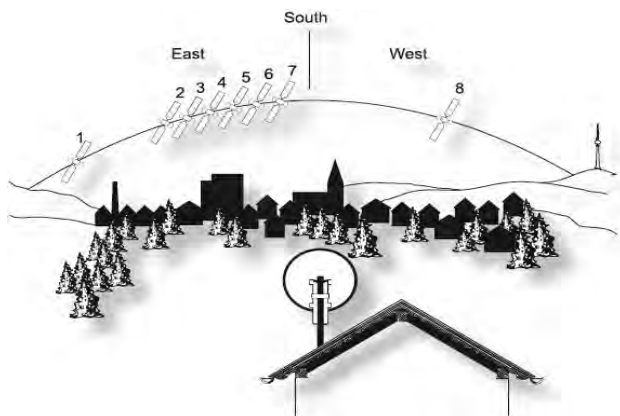

Figure 13-24 How to Describe the Satellite Position

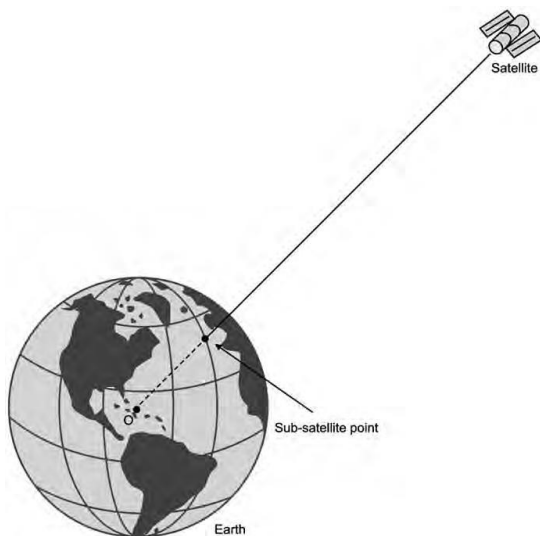

Figure 13-25 Sub-satellite point

Often used satellite broadcast frequency band is C band (3.4 ~ 4.2GHz) and Ku band (10.7 ~ 12.75GHz).

### 13.4.2. Polarization and LNB

The satellite transponder has many parameters need setup, the follow content will give some introduction for some important parameters.

LNB (Low Noise Block Down Converter) is composed by microwave LNA (Low Noise Amplifier) and LNC (Low Noise Converter), the LNC is composed by mixer, local oscillator and IF preamplifier.

LNB first amplifier received C band (3.4~4.2GHz) or Ku band (10.7~12.75GHz) signal. The second step use the signal frequency minus the local oscillator frequency in mixer, the different frequency band signals will be converted to uniform frequency band IF signal (950~2150MHz) which can be processed by IRD.

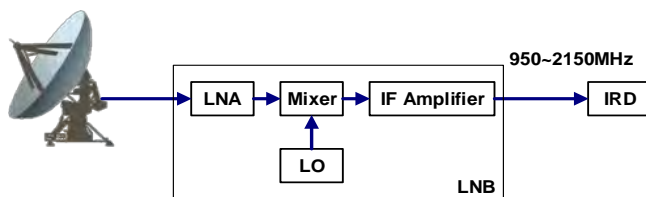

Figure 13-26 LNA Block Diagram

Satellite signals have two types polarization: circular polarization and linear polarization. The circular polarization include right-hand circular and left-hand circular polarizations. The linear polarization include horizontal and vertical polarizations. Most satellite use the horizontal and vertical polarizations transmission signals. Because the IRD need receiver different type polarization satellite signals, the polarization selection and modify function is needed for feed horn. Now, many new productions combine the LNB and Feedhorn into one production-LNBF (LNB with Feedhorn).

The LNBF often provide two mutually perpendicular probes in feedhorn



different position. Two mutually perpendicular probe respectively receive horizontal polarization signal and vertical polarization signal, then couple the signal to microwave LNA. The IRD use the 13V/18V signal to control two polarization paths amplifier power on or off.

Satellite C band downlink frequency range from 3.7GHz to 4.2GHz, and the C band LNB is universal in the world. Because each satellite use different frequency in Ku band, example some satellites use 11.7~12.2GHz, some satellites use 12.25~12.75GHz, the user receives the Ku band signal should choose right frequency band LNB according to satellite downlink frequency range.

#### **About LNB local oscillator**

C band LNB single local oscillator use 5150MHz and 5750MHz. IRD receives signal frequency range is 950~2150MHz, and C band full bandwidth about 500MHz, only about half of the 950~2150MHz. Some new products provide two sets of circuits to respectively handle horizontal polarization and vertical polarization signals. Two local oscillator frequency respectively set up to 5150MHz and 5750MHz. After signal mixing, the horizontal polarization and vertical polarization respectively output 950~1450MHz ( $5150 - 4200 = 950$ ,  $5150 - 3700 = 1450$ ) and 1550~2050MHz ( $5750 - 4200 = 1550$ ,  $5750 - 3700 = 2050$ ), two signals in the IRD receive frequency range.

The Ku band satellite signal downlink frequency range from 10.7GHz to 12.75GHz, the bandwidth about 2.05GHz, about 4 times C band bandwidth. Use one local oscillator frequency to receive full bandwidth signal is difficult on Ku band. So divided the 2.05GHz bandwidth into several frequency bands, and every frequency band use different local oscillator frequency. Often used local oscillator frequency are 9.75GHz, 10.6GHz, 10.75GHz, 11.25GHz, 11.3GHz,

etc. The follow table give the every type local oscillator frequency and corresponding receive frequency and IF range.

Different LO Ku band LNB receive signal and output IF frequency range

LO(GHz)	Receive Signal frequency range (GHz)	LNB output IF Range (GHz)
9.75	10.7~11.9	950~2150
10	10.95~12.15	950~2150
10.6	11.55~12.75	950~2150
10.75	11.7~12.75	950~2000
11.25	12.2~12.75	950~1500
11.3	12.25~12.75	950~1450

Some manufactures provide double local oscillator Ku band LNB, it provide two sets of circuits and local oscillator for different polarization, often used LO are 9.75GHz and 10.6GHz. User can use 0/22kHz impulse signal to control low frequency band LO and high frequency band LO work.

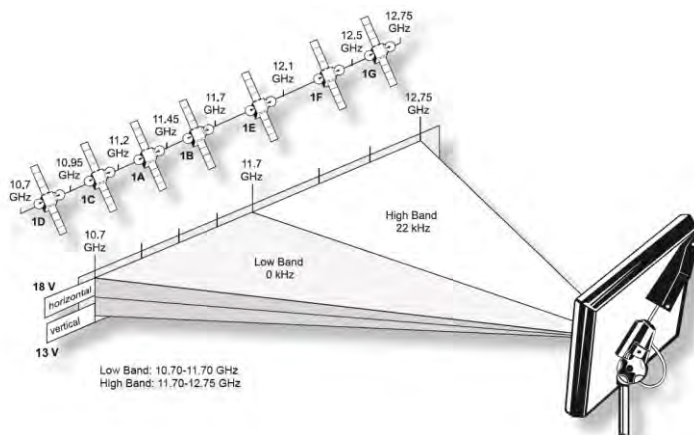

Figure 13-27 The low band and high band in Ku band

### 13.4.3. SaTCR principle introduction

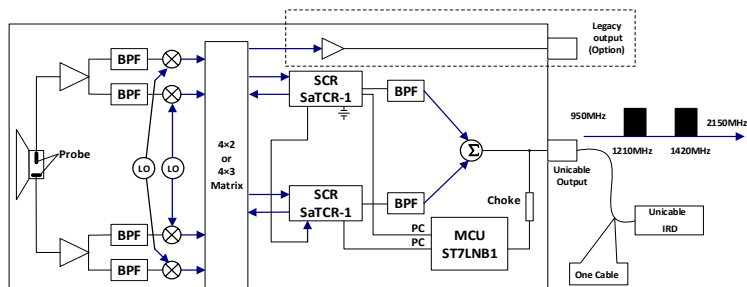

Figure 13-28 Unicable LNB Block Diagram

Unicable LNB receive Ku band satellite signal similar with traditional LNB, the difference is add SCR and MCU chip. These chips are ST provided SaTCR-1 and ST7LLNB1 chip. Unicable LNB principle as the Figure 13-28 show.

Vertical polarization / Low LO (V/L), Vertical polarization / High LO (V/H), Horizontal / Low LO, Horizontal / High LO (H/H), four different frequency bands satellite signal enter low noise amplifier, ensure received signals have high sensitivity. These signals pass the band pass filter to filter the useless signals. Mixing these signals with low LO and high LO, after mixing all the signal is convert to L band. These L band signals input in a circuit matrix switch

ST Microelectronics has introduced a new device that targets the LNB, multi-switch and SMATV market. This device, called SaTCR-1 (Satellite Channel Router), is able to translate a transponder to any location in the satellite bandwidth (950~2150MHz). Multiple SaTCR devices coupled with band-pass filters and RF matrix allow to combine transponders from different polarizations and bands on a single coaxial cable.

To be able to receive all the available channels in the Ku-band using a

conventional LNB, a set top box has to select the polarization and the local oscillator corresponding to the desired transponder. The polarization is selected by changing the voltage of the LNB supply (13 volts for vertical polarization, 18V for horizontal polarization). The local oscillator is selected by adding or not a 22kHz tone on the LNB supply (when 22kHz in on the highest LO is selected). Local oscillator frequency can be 9750MHz or 10600MHz depending on the location of the transponder. If the respective transponder is in the lower part of the spectrum (<11700MHz) the 9750MHz LO is selected, otherwise 10600MHz LO is selected. The tuner has to be set to the correct frequency using the following formula:

$$F_{\text{tuner}} = F_{\text{transponder}} - F_{\text{LO}}$$

With a LNB integrating SaTCR-1 devices, the transponder selection (polarization, LO selection and frequency translation) is done through a single DiSEqC command named **ODU\_ChannelChange**.

First stage of a SaTCR LNB(up to the matrix) is similar to a conventional LNB. As a consequence, the transponder frequency at the input of a SaTCR device is the same as  $F_{\text{tuner}}$  with a classical LNB:

$$F_{\text{satcr\_input}} = F_{\text{transponder}} - F_{\text{LO}}$$

Then, the SaTCR device should translate the transponder inside the bandwidth of its associated band pass filter. To perform that operation, the SaTCR VCO has to be set according to the following formula:

$$F_{\text{satcr\_voc}} = F_{\text{satcr\_input}} + F_{\text{bpf}} = F_{\text{transponder}} - F_{\text{LO}} + F_{\text{bpf}}$$

In addition, SaTCR LNB includes new features that allow auto-detection of its parameters.

## 13.5. Resolution and Video Bandwidth

### 13.5.1. Resolution BandWidth filter (RBW)

The frequency resolution is the ability to clearly distinguish 2 input sine wavesignal responses of a spectrum analyzer. The ability of a spectrum analyzer to distinguish signals is generally described within 3dB of the available bandwidth IF filter.

For analog intermediate frequency:

The bandwidth of the smallest intermediate frequency filter generally determines the resolution bandwidth capability of an instrument.

Switching from one filter to another offers a different resolution of the measurement. Wide resolution bandwidth filters require less time to scan, are more stable when the sweep time is shorter (faster), require less time for the signal to reach full amplitude withing the filter shape as it is scanning through. However, they offer less resolution, dynamic range and lower S/N range. Narrower bandwidth filters requires more time, or slower sweep time setting to allow the full amplitude of the signal to be measured, to be reached withing the filter as it is scanning, but it does offer a much higher resolution, better dynamic range and better S/N.

The S7200 offers automatic or manual RBW selection depending on frequency/span/sweep time selection and/or what the user is looking for. The S7200 uses digital IF and leverages DSP (Digital Signal Processing) techniques of implementation, so the digital filters won't drift as analog filters would in older spectrum analyzers. Digital IF technology provides VERY good measurement stability with a much wider selection of Frequency/Span/Sweep times, and still provide a very stable and accurate measurement.

### **13.5.2. Video BandWidth filter(VBW)**

In order to reduce the influence of noise variations in the display of signal amplitude, Spectrum Analyzers typically smooth or average the trace display. The selectable video bandwidth filter in a spectrum analyzer is used for that purpose. It is a low-pass video filter, which determines the bandwidth of the video signal located behind the envelope detector. The value of this video filter is typically lower than the RBW selected. The intended purpose is to average or smooth the displayed signal.

## 13.6. Detector Mode

When measuring and analyzing different types of signals with a spectrum analyzer, the detector mode should be set correctly. "Pixel point" is an important concept related to the detector mode of a spectrum analyzer. Divide the spectrum curve into "n" pixel points. When the span of the spectrum is large, each pixel point contains a relatively large frequency range of information (acquired data or acquisitions). Screen size and resolution limits the amount of pixels that can be displayed on the screen, and since each pixel point can only show one value, each pixel may represent multiple measurement (or sample or acquisition) points. It is clear that not all data points can be displayed on the screen of a small portable piece of equipment so each displayed pixel on the screen must be processed to reduce the number of displayed pixels.

### Detector modes & applications

Positive peak detection: recommended for CW signal and peak signal level measurements

It is a great tool or setting to detect the maximum value from all sample points of a pixel point to display.

Sample detection: recommended for noise signal measurements

Sample detection selects randomly a sample point from all acquisitions (or sample) points. It represents random noise fluctuations very well.

Negative peak detection: recommended for small resolution signal measurements it is a great tool to detect the minimum value from all sample points of a pixel point to display.

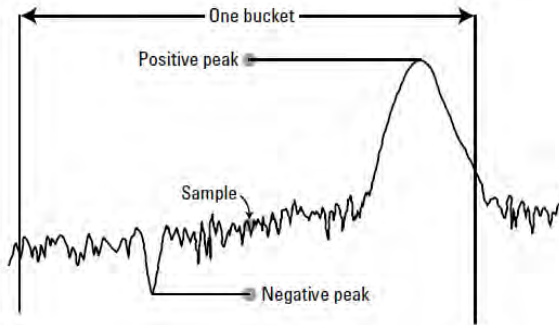

Figure 13-29 the number of trace points saved in memory is based on detector type algorithm

Average detection: recommended for ACPR and channel power measurement  
 Each pixel point of the analyzer represents multiple sample points and amplitude information. The average value of the detector uses each of the sample point's information for each pixel point and averages the linear value of all sample points dedicated to each pixel point.

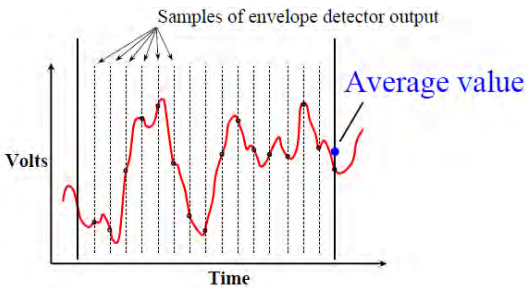

Figure 13-30 Principle of Average Detector



## 13.7. International CATV Standards

### 13.7.1. System and Standards by Country

Country	System	Std.	Country	System	Std.
Afghanistan	PAL	D	El Salvador	NTSC	M
Albania	PAL	B/G	Equatorial Guinea	PAL	B
Algeria	PAL	B	Estonia	PAL	B/G
Argentina	PAL	N	Ethiopia	PAL	B
Angola	PAL	I	Finland	PAL	B/G
Australia	PAL	B	France	SECAM	L
Antigua & Barbuda	NTSC	M	French Guiana	SECAM	K
Austria	PAL	B/G	Gabon	SECAM	K
Azores (Portugal)	PAL	B	Germany	PAL	B/G
Bahamas	NTSC	M	Ghana	PAL	B
Bahrain	PAL	B	Gibraltar	PAL	B
Bangladesh	PAL	B	Greece	SECAM	B/G
Barbados	NTSC	M	Greenland	NTSC	M
Belgium	PAL	B/G	Granada	NTSC	M
Belize	NTSC	M	Guadeloupe	SECAM	K
Bermuda	NTSC	M	Guam	NTSC	M
Bolivia	NTSC	N	Guatemala	NTSC	M
Brazil	PAL	M	Haiti	SECAM	M
Bosnia	PAL	B/H	Honduras	NTSC	M
Brunei	PAL	B	Hong Kong	PAL	I
Bulgaria	SECAM	D	Hungary	PAL	B/G
Burma (Myanmar)	NTSC	N	Iceland	PAL	B

S7200 Series TV Signal Analyzer Operation Manual

Country	System	Std.	Country	System	Std.
Cambodia	SECAM	M	India	PAL	B
Cameroon	PAL	B	Indonesia	PAL	B
Canada	NTSC	M	Iran	SECAM	B
Canary Islands	PAL	B	Iraq	SECAM	B
Central African Rep.	SECAM	K	Ireland (Republic of)	PAL	I
Chad	SECAM	K	Israel	PAL	B/G
Chile	NTSC	M	Italy	PAL	B/G
China	PAL	D	Ivory Coast	SECAM	K
Colombia	NTSC	M	Jamaica	NTSC	M
Congo	SECAM	D	Japan	NTSC	M
Costa Rica	NTSC	M	Jordan	PAL	B
Cuba	NTSC	M	Kenya	PAL	B
Cyprus	PAL	B/G	Korea (P.D.R.)	PAL	D
Czech Republic	SECAM	D/K	Korea (South)	NTSC	M
Denmark	PAL	B/G	Kuwait	PAL	B/G
Dominican Rep.	NTSC	M	Laos	PAL	M
Ecuador	NTSC	M	Latvia	PAL	B/G
Egypt	SECAM	B	Lebanon	PAL	B/G
Eire (Ireland)	PAL	I	Liberia	PAL	B
Libya	PAL	B	Sierra Leone	PAL	B
Lithuania	PAL	B/G	Singapore	PAL	B
Luxembourg	PAL	B/G	Slovakia	SECAM	D/K
Malaysia	PAL	B	Slovenia	PAL	B/G
Mali	SECAM	K	Somalia	PAL	B
Malta	PAL	B/G	South Africa	PAL	I

S7200 Series TV Signal Analyzer Operation Manual

Country	System	Std.	Country	System	Std.
Martinique	SECAM	K	Spain	PAL	B/G
Mauritius	SECAM	B	Sri Lanka	PAL	B
Mexico	NTSC	M	Sudan	PAL	B
Monaco	SECAM	L/G	Surinam	NTSC	M
Mongolia	SECAM	D	Swaziland	PAL	B/G
Montenegro	PAL	B/H	Sweden	PAL	B/G
Morocco	SECAM	B	Switzerland	PAL	B/G
Mozambique	PAL	G	Syria	SECAM	B
Nepal	PAL	B	Tahiti	SECAM	K
Netherlands	PAL	B/G	Taiwan	NTSC	M
New Zealand	PAL	B/G	Tanzania	PAL	I
Nicaragua	NTSC	M	Thailand	PAL	B
Niger	SECAM	K	Tonga	NTSC	M
Nigeria	PAL	B	Trinidad y Tobago	NTSC	M
Norway	PAL	B/G	Tunisia	SECAM	B
Oman	PAL	B/G	Turkey	PAL	B
Pakistan	PAL	B	Uganda	PAL	B
Panama	NTSC	M	Ukraine	SECAM	D
Paraguay	PAL	N	U. A. Emirates	PAL	B/G
Peru	NTSC	M	United Kingdom	PAL	I
Philippines	NTSC	M	U.S.A.	NTSC	M
Poland	PAL	D/K	Uruguay	PAL	N
Portugal	PAL	B/G	Uzbekistan	SECAM	D
Puerto Rico	NTSC	M	Venezuela	NTSC	M
Qatar	PAL	B	Vietnam	PAL	M

S7200 Series TV Signal Analyzer Operation Manual

---

Country	System	Std.	Country	System	Std.
Reunion	SECAM	K	Virgin Islands (U.S.)	NTSC	M
Romania	PAL	G	Yemen (A.R.)	PAL	B
Russian Federation	SECAM	D	Yemen (P.D.R.)	PAL	B
Rwanda	SECAM	K	Yugoslavia	PAL	B/H
St Kitts & Nevis	NTSC	M	Zaire	SECAM	K
St Lucia	NTSC	M	Zambia	PAL	B
St Vincent	NTSC	M	Zimbabwe	PAL	B
Samoa	NTSC	M			
Saudi Arabia	SECAM	B			
Senegal	SECAM	K			

### 13.7.2. USA CATV and DTTB Channel Plan

#### CATV channels North America

EIA channel designation		Standard		Incremental		Harmonic	
new	old	Video	Audio	Video	Audio	Video	Audio
T7	none	7.0000	11.5000	NA	NA	NA	NA
T8	none	13.0000	17.5000	NA	NA	NA	NA
T9	none	19.0000	23.5000	NA	NA	NA	NA
T10	none	25.0000	29.5000	NA	NA	NA	NA
T11	none	31.0000	35.5000	NA	NA	NA	NA
T12	none	37.0000	41.5000	NA	NA	NA	NA
T13	none	43.0000	47.5000	NA	NA	NA	NA
2	2	55.2500	59.7500	55.2625	59.7625	54.0027	58.5027
3	3	61.2500	65.7500	61.2625	65.7625	60.0030	64.5030
4	4	67.2500	71.7500	67.2625	71.7625	66.0033	70.5033
1	A-8	NA	NA	73.2625	77.7625	72.0036	76.5036
5	5	77.2500	81.7500	79.2625	83.7625	78.0039	82.5039
6	6	83.2500	87.7500	85.2625	89.7625	84.0042	88.5042
95	A-5	91.2500	95.7500	91.2625	95.7625	90.0045	94.5045
96	A-4	97.2500	101.7500	97.2625	101.7625	96.0048	100.5048
97	A-3	103.2500	107.7500	103.2625	107.7625	102.0051	106.5051
98	A-2	109.2750	113.7750	109.2750	113.7750	Cannot lock to comb	
99	A-1	115.2750	119.7750	115.2750	119.7750	ref: refer to FCC regs.	
14	A	121.2625	125.7625	121.2625	125.7625	120.0060	124.5060
15	B	127.2625	131.7625	127.2625	131.7625	126.0063	130.5063
16	C	133.2625	137.7625	133.2625	137.7625	132.0066	136.5066

## S7200 Series TV Signal Analyzer Operation Manual

EIA channel designation		Standard		Incremental		Harmonic	
new	old	Video	Audio	Video	Audio	Video	Audio
17	D	139.2500	143.7500	139.2625	143.7625	138.0069	142.5069
18	E	145.2500	149.7500	145.2625	149.7625	144.0072	148.5072
19	F	151.2500	155.7500	151.2625	155.7625	150.0075	154.5075
20	G	157.2500	161.7500	157.2625	161.7625	156.0078	160.5078
21	H	163.2500	167.7500	163.2625	167.7625	162.0081	166.5081
22	I	169.2500	173.7500	169.2625	173.7625	168.0084	172.5084
7	7	175.2500	179.7500	175.2625	179.7625	174.0087	178.5087
8	8	181.2500	185.7500	181.2625	185.7625	180.0090	184.5090
9	9	187.2500	191.7500	187.2625	191.7625	186.0093	190.5093
10	10	193.2500	197.7500	193.2625	197.7625	192.0096	196.5096
11	11	199.2500	203.7500	199.2625	203.7625	198.0099	202.5099
12	12	205.2500	209.7500	205.2625	209.7625	204.0102	208.5102
13	13	211.2500	215.7500	211.2625	215.7625	210.0105	214.5105
23	J	217.2500	221.7500	217.2625	221.7625	216.0108	220.5108
24	K	223.2500	227.7500	223.2625	227.7625	222.0111	226.5111
25	L	229.2625	233.7625	229.2625	233.7625	228.0114	232.5114
26	M	235.2625	239.7625	235.2625	239.7625	234.0117	238.5117
27	N	241.2625	245.7625	241.2625	245.7625	240.0120	244.5120
28	O	247.2625	251.7625	247.2625	251.7625	246.0123	250.5123
29	P	253.2625	257.7625	253.2625	257.7625	252.0126	256.5126
30	Q	259.2625	263.7625	259.2625	263.7625	258.0129	262.5129
31	R	265.2625	269.7625	265.2625	269.7625	264.0132	268.5132
32	S	271.2625	275.7625	271.2625	275.7625	270.0135	274.5135

## S7200 Series TV Signal Analyzer Operation Manual

EIA channel designation		Standard		Incremental		Harmonic	
new	old	Video	Audio	Video	Audio	Video	Audio
33	T	277.2625	281.7625	277.2625	281.7625	276.0138	280.5138
34	U	283.2625	287.7625	283.2625	287.7625	282.0141	286.5141
35	V	289.2625	293.7625	289.2625	293.7625	288.0144	292.5144
36	W	295.2625	299.7625	295.2625	299.7625	294.0147	298.5147
37	AA	301.2625	305.7625	301.2625	305.7625	300.0150	304.5150
38	BB	307.2625	311.7625	307.2625	311.7625	306.0153	310.5153
39	CC	313.2625	317.7625	313.2625	317.7625	312.0156	316.5156
40	DD	319.2625	323.7625	319.2625	323.7625	318.0159	322.5159
41	EE	325.2625	329.7625	325.2625	329.7625	324.0162	328.5162
42	FF	331.2750	335.7750	331.2750	335.7750	330.0165	334.5165
43	GG	337.2625	341.7625	337.2625	341.7625	336.0168	340.5168
44	HH	343.2625	347.7625	343.2625	347.7625	342.0171	346.5171
45	II	349.2625	353.7625	349.2625	353.7625	348.0174	352.5174
46	JJ	355.2625	359.7625	355.2625	359.7625	354.0177	358.5177
47	KK	361.2625	365.7625	361.2625	365.7625	360.0180	364.5180
48	LL	367.2625	371.7625	367.2625	371.7625	366.0183	370.5183
49	MM	373.2625	377.7625	373.2625	377.7625	372.0186	376.5186
50	NN	379.2625	383.7625	379.2625	383.7625	378.0189	382.5189
51	OO	385.2625	389.7625	385.2625	389.7625	384.0192	388.5192
52	PP	391.2625	395.7625	391.2625	395.7625	390.0195	394.5195
53	QQ	397.2625	401.7625	397.2625	401.7625	396.0198	400.5198
54	RR	403.2500	407.7500	403.2625	407.7625	402.0201	406.5201
55	SS	409.2500	413.7500	409.2625	413.7625	408.0204	412.5204

## S7200 Series TV Signal Analyzer Operation Manual

EIA channel designation		Standard		Incremental		Harmonic	
new	old	Video	Audio	Video	Audio	Video	Audio
56	TT	415.2500	419.7500	415.2625	419.7625	414.0207	418.5207
57	UU	421.2500	425.7500	421.2625	425.7625	420.0210	424.5210
58	VV	427.2500	431.7500	427.2625	431.7625	426.0213	430.5213
59	WW	433.2500	437.7500	433.2625	437.7625	432.0216	436.5216
60	XX	439.2500	443.7500	439.2625	443.7625	438.0219	442.5219
61	YY	445.2500	449.7500	445.2625	449.7625	444.0222	448.5222
62	ZZ	451.2500	455.7500	451.2625	455.7625	450.0225	454.5225
63	63	457.2500	461.7500	457.2625	461.7625	456.0228	460.5228
64	64	463.2500	467.7500	463.2625	467.7625	462.0231	466.5231
65	65	469.2500	473.7500	469.2625	473.7625	468.0234	472.5234
66	66	475.2500	479.7500	475.2625	479.7625	474.0237	478.5237
67	67	481.2500	485.7500	481.2625	485.7625	480.0240	484.5240
68	68	487.2500	491.7500	487.2625	491.7625	486.0243	490.5243
69	69	493.2500	497.7500	493.2625	497.7625	492.0246	496.5246
70	70	499.2500	503.7500	499.2625	503.7625	498.0249	502.5249
71	71	505.2500	509.7500	505.2625	509.7625	504.0252	508.5252
72	72	511.2500	515.7500	511.2625	515.7625	510.0255	514.5255
73	73	517.2500	521.7500	517.2625	521.7625	516.0258	520.5258
74	74	523.2500	527.7500	523.2625	527.7625	522.0261	526.5261
75	75	529.2500	533.7500	529.2625	533.7625	528.0264	532.5264
76	76	535.2500	539.7500	535.2625	539.7625	534.0267	538.5267
77	77	541.2500	545.7500	541.2625	545.7625	540.0270	544.5270
78	78	547.2500	551.7500	547.2625	551.7625	546.0273	550.5273



## S7200 Series TV Signal Analyzer Operation Manual

EIA channel designation		Standard		Incremental		Harmonic	
new	old	Video	Audio	Video	Audio	Video	Audio
79	79	553.2500	557.7500	553.2625	557.7625	552.0276	556.5276
80	80	559.2500	563.7500	559.2625	563.7625	558.0279	562.5279
81	81	565.2500	569.7500	565.2625	569.7625	564.0282	568.5282
82	82	571.2500	575.7500	571.2625	575.7625	570.0285	574.5285
83	83	577.2500	581.7500	577.2625	581.7625	576.0288	580.5288
84	84	583.2500	587.7500	583.2625	587.7625	582.0291	586.5291
85	85	589.2500	593.7500	589.2625	593.7625	588.0294	592.5294
86	86	595.2500	599.7500	595.2625	599.7625	594.0297	598.5297
87	87	601.2500	605.7500	601.2625	605.7625	600.0300	604.5300
88	88	607.2500	611.7500	607.2625	611.7625	606.0303	610.5303
89	89	613.2500	617.7500	613.2625	617.7625	612.0306	616.5306
90	90	619.2500	623.7500	619.2625	623.7625	618.0309	622.5309
91	91	625.2500	629.7500	625.2625	629.7625	624.0312	628.5312
92	92	631.2500	635.7500	631.2625	635.7625	630.0315	634.5315
93	93	637.2500	641.7500	637.2625	641.7625	636.0318	640.5318
94	94	643.2500	647.7500	643.2625	647.7625	642.0321	646.5321
100	100	649.2500	653.7500	649.2625	653.7625	648.0324	652.5324
101	101	655.2500	659.7500	655.2625	659.7625	654.0327	658.5327
102	102	661.2500	665.7500	661.2625	665.7625	660.0330	664.5330
103	103	667.2500	671.7500	667.2625	671.7625	666.0333	670.5333
104	104	673.2500	677.7500	673.2625	677.7625	672.0336	676.5336
105	105	679.2500	683.7500	679.2625	683.7625	678.0339	682.5339
106	106	685.2500	689.7500	685.2625	689.7625	684.0342	688.5342

## S7200 Series TV Signal Analyzer Operation Manual

EIA channel designation		Standard		Incremental		Harmonic	
new	old	Video	Audio	Video	Audio	Video	Audio
107	107	691.2500	695.7500	691.2625	695.7625	690.0345	694.5345
108	108	697.2500	701.7500	697.2625	701.7625	696.0348	700.5348
109	109	703.2500	707.7500	703.2625	707.7625	702.0351	706.5351
110	110	709.2500	713.7500	709.2625	713.7625	708.0354	712.5354
111	111	715.2500	719.7500	715.2625	719.7625	714.0357	718.5357
112	112	721.2500	725.7500	721.2625	725.7625	720.0360	724.5360
113	113	727.2500	731.7500	727.2625	731.7625	726.0363	730.5363
114	114	733.2500	737.7500	733.2625	737.7625	732.0366	736.5366
115	115	739.2500	743.7500	739.2625	743.7625	738.0369	742.5369
116	116	745.2500	749.7500	745.2625	749.7625	744.0372	748.5372
117	117	757.2500	761.7500	757.2625	761.7625	756.0378	760.5378
119	119	763.2500	767.7500	763.2625	767.7625	762.0381	766.5381
120	120	769.2500	773.7500	769.2625	773.7625	768.0384	772.5384
121	121	775.2500	779.7500	775.2625	779.7625	774.0387	778.5387
122	122	781.2500	785.7500	781.2625	785.7625	780.0390	784.5390
123	123	787.2500	791.7500	787.2625	791.7625	786.0393	790.5393
124	124	793.2500	797.7500	793.2625	797.7625	792.0396	796.5396
125	125	799.2500	803.7500	799.2625	803.7625	798.0399	802.5399
126	126	805.2500	809.7500	805.2625	809.7625	804.0402	808.5402
127	127	811.2500	815.7500	811.2625	815.7625	810.0405	814.5405
128	128	817.2500	821.7500	817.2625	821.7625	816.0408	820.5408
129	129	823.2500	827.7500	823.2625	827.7625	822.0411	826.5411
130	130	829.2500	833.7500	829.2625	833.7625	828.0414	832.5414

## S7200 Series TV Signal Analyzer Operation Manual

EIA channel designation		Standard		Incremental		Harmonic	
new	old	Video	Audio	Video	Audio	Video	Audio
131	131	835.2500	839.7500	835.2625	839.7625	834.0417	838.5417
132	132	841.2500	845.7500	841.2625	845.7625	840.0420	844.5420
133	133	847.2500	851.7500	847.2625	851.7625	846.0423	850.5423
134	134	853.2500	857.7500	853.2625	857.7625	852.0426	856.5426
135	135	859.2500	863.7500	859.2625	863.7625	858.0429	862.5429
136	136	865.2500	869.7500	865.2625	869.7625	864.0432	868.5432
137	137	871.2500	875.7500	871.2625	875.7625	870.0435	874.5435
138	138	877.2500	881.7500	877.2625	881.7625	876.0438	880.5438
139	139	883.2500	887.7500	883.2625	887.7625	882.0441	886.5441
140	140	889.2500	893.7500	889.2625	893.7625	888.0444	892.5444
141	141	895.2500	899.7500	895.2625	899.7625	894.0447	898.5447
142	142	901.2500	905.7500	901.2625	905.7625	900.0450	904.5450
143	143	907.2500	911.7500	907.2625	911.7625	906.0453	910.5453
144	144	913.2500	917.7500	913.2625	917.7625	912.0456	916.5456
145	145	919.2500	923.7500	919.2625	923.7625	918.0459	922.5459
146	146	925.2500	929.7500	925.2625	929.7625	924.0462	928.5462
147	147	931.2500	935.7500	931.2625	935.7625	930.0465	934.5465
148	148	937.2500	941.7500	937.2625	941.7625	936.0468	940.5468
149	149	943.2500	947.7500	943.2625	947.7625	942.0471	946.5471
150	150	949.2500	953.7500	949.2625	953.7625	948.0474	952.5474
151	151	955.2500	959.7500	955.2625	959.7625	954.0477	958.5477
152	152	961.2500	965.7500	961.2625	965.7625	960.0480	964.5480
153	153	967.2500	971.7500	967.2625	971.7625	966.0483	970.5483

## S7200 Series TV Signal Analyzer Operation Manual

EIA channel designation		Standard		Incremental		Harmonic	
new	old	Video	Audio	Video	Audio	Video	Audio
154	154	973.2500	977.7500	973.2625	977.7625	972.0486	976.5486
155	155	979.2500	983.7500	979.2625	983.7625	978.0489	982.5489
156	156	985.2500	989.7500	985.2625	989.7625	984.0492	988.5492
157	157	991.2500	995.7500	991.2625	995.7625	990.0495	994.5495
158	158	997.2500	1001.7500	997.2625	1001.7625	996.0498	1000.5498

### NTSC Air Channel

Channel	RF(MHz)	Band	Channel	RF(MHz)	Band
2	55.25	1	36	603.25	3
3	61.25	1	37	609.25	3
4	67.25	1	38	615.25	3
1	73.25	1	39	621.25	3
5	77.25	1	40	627.25	3
6	83.25	1	41	633.25	3
7	175.25	2	42	639.25	3
8	181.25	2	43	645.25	3
9	187.25	2	44	651.25	3
10	193.25	2	45	657.25	3
11	199.25	2	46	663.25	3
12	205.25	2	47	669.25	3
13	211.25	2	48	675.25	3
14	471.25	3	49	681.25	3

Channel	RF(MHz)	Band	Channel	RF(MHz)	Band
15	477.25	3	50	687.25	3
16	483.25	3	51	693.25	3
17	489.25	3	52	699.25	3
18	495.25	3	53	705.25	3
19	501.25	3	54	711.25	3
20	507.25	3	55	717.25	3
21	513.25	3	56	723.25	3
22	519.25	3	57	729.25	3
23	525.25	3	58	735.25	3
24	531.25	3	59	741.25	3
25	537.25	3	60	747.25	3
26	543.25	3	61	753.25	3
27	549.25	3	62	759.25	3
28	555.25	3	63	765.25	3
29	561.25	3	64	771.25	3
30	567.25	3	65	777.25	3
31	573.25	3	66	783.25	3
32	579.25	3	67	789.25	3
33	585.25	3	68	795.25	3
34	591.25	3	69	801.25	3
35	597.25	3			

## Digital ATSC Channel

Channel	RF(MHz)	Band	Channel	RF(MHz)	Band
2	57	1	36	605	3
3	63	1	37	611	3
4	69	1	38	617	3
5	79	1	39	623	3
6	85	1	40	629	3
7	177	1	41	635	3
8	183	2	42	641	3
9	189	2	43	647	3
10	195	2	44	653	3
11	201	2	45	659	3
12	207	2	46	665	3
13	213	2	47	671	3
14	473	2	48	677	3
15	479	3	49	683	3
16	485	3	50	689	3
17	491	3	51	695	3
18	497	3	52	701	3
19	503	3	53	707	3
20	509	3	54	713	3
21	515	3	55	719	3
22	521	3	56	725	3
23	527	3	57	731	3
24	533	3	58	737	3
25	539	3	59	743	3

Channel	RF(MHz)	Band	Channel	RF(MHz)	Band
26	545	3	60	749	3
27	551	3	61	755	3
28	557	3	62	761	3
29	563	3	63	767	3
30	569	3	64	773	3
31	575	3	65	779	3
32	581	3	66	785	3
33	587	3	67	791	3
34	593	3	68	797	3
35	599	3	69	803	3

### 13.7.3. People's Republic of China CATV and DTTB Channel Plan

People's Republic of China CATV Channel Plan

Channel Bandwidth: 8MHz (PAL; standard D/K)					
Ch. No.	Video	Audio	Ch. No.	Video	Audio
DS1	49.75	56.25	DS13	471.25	477.75
DS2	57.75	64.25	DS14	479.25	485.75
DS3	65.75	72.25	DS15	487.25	493.75
DS4	77.25	83.75	DS16	495.25	501.75
DS5	85.25	91.75	DS17	503.25	509.75
Z1	112.25	118.75	DS18	511.25	517.75
Z2	120.25	126.75	DS19	519.25	525.75
Z3	128.25	134.75	DS20	527.25	533.75

Channel Bandwidth: 8MHz (PAL; standard D/K)					
Ch. No.	Video	Audio	Ch. No.	Video	Audio
Z4	136.25	142.75	DS21	535.25	541.75
Z5	144.25	150.75	DS22	543.25	549.75
Z6	152.25	158.75	DS23	551.25	557.75
Z7	160.25	166.75	DS24	559.25	565.75
DS6	168.25	174.75	Z38	567.25	573.75
DS7	176.25	182.75	Z39	575.25	581.75
DS8	184.25	190.75	Z40	583.25	589.75
DS9	192.25	198.75	Z41	591.25	597.75
DS10	200.25	206.75	Z42	599.25	605.75
DS11	208.25	214.75	DS25	607.25	613.75
DS12	216.25	222.75	DS26	615.25	621.75
Z8	224.25	230.75	DS27	623.25	629.75
Z9	232.25	238.75	DS28	631.25	637.75
Z10	240.25	246.75	DS29	639.25	645.75
Z11	248.25	254.75	DS30	647.25	653.75
Z12	256.25	262.75	DS31	655.25	661.75
Z13	264.25	270.75	DS32	663.25	669.75
Z14	272.25	278.75	DS33	671.25	677.75
Z15	280.25	286.75	DS34	679.25	685.75
Z16	288.25	294.75	DS35	687.25	693.75
Z17	296.25	302.75	DS36	695.25	701.75
Z18	304.25	310.75	DS37	703.25	709.75
Z19	312.25	318.75	DS38	711.25	717.75
Z20	320.25	326.75	DS39	719.25	725.75



Channel Bandwidth: 8MHz (PAL; standard D/K)					
Ch. No.	Video	Audio	Ch. No.	Video	Audio
Z21	328.25	334.75	DS40	727.25	733.75
Z22	336.25	342.75	DS41	735.25	741.75
Z23	344.25	350.75	DS42	743.25	749.75
Z24	352.25	358.75	DS43	751.25	757.75
Z25	360.25	366.75	DS44	759.25	765.75
Z26	368.25	374.75	DS45	767.25	773.75
Z27	376.25	382.75	DS46	775.25	781.75
Z28	384.25	390.75	DS47	783.25	789.75
Z29	392.25	398.75	DS48	791.25	797.75
Z30	400.25	406.75	DS49	799.25	805.75
Z31	408.25	414.75	DS50	807.25	813.75
Z32	416.25	422.75	DS51	815.25	821.75
Z33	424.25	430.75	DS52	823.25	829.75
Z34	432.25	438.75	DS53	831.25	837.75
Z35	440.25	446.75	DS54	839.25	845.75
Z36	448.25	454.75	DS55	847.25	853.75
Z37	456.25	462.75	DS56	855.25	861.75

## People's Republic of China DTTB Channel Plan

Ch. No.	BW:8MHz Unit: MHz			
Number	Frequency Range	Center Frequency	Video	Audio
DS1	48.5-56.5	52.5	49.75	56.25
DS2	56.5-64.5	60.5	57.75	64.25
DS3	64.5-72.5	68.5	65.75	72.25
DS4	76-84	80	77.25	83.75
DS5	84-92	88	85.25	91.75
DS6	167-175	171	168.25	174.75
DS7	175-183	179	176.25	182.75
DS8	183-191	187	184.25	190.75
DS9	191-199	195	192.25	198.75
DS10	199-207	203	200.25	206.75
DS11	207-215	211	208.25	214.75
DS12	215-223	219	216.25	222.75
DS13	470-478	474	471.25	477.75
DS14	478-486	482	479.25	485.75
DS15	486-494	490	487.25	493.75
DS16	494-502	498	495.25	501.75
DS17	502-510	506	503.25	509.75
DS18	510-518	514	511.25	517.75
DS19	518-526	522	519.25	525.75
DS20	526-534	530	527.25	533.75
DS21	534-542	538	535.25	541.75
DS22	542-550	546	543.25	549.75
DS23	550-558	554	551.25	557.75

## S7200 Series TV Signal Analyzer Operation Manual

Ch. No.	BW:8MHz Unit: MHz			
Number	Frequency Range	Center Frequency	Video	Audio
DS24	558-566	562	559.25	565.75
DS25	606-614	610	607.25	613.75
DS26	614-622	618	615.25	621.75
DS27	622-630	626	623.25	629.75
DS28	630-638	634	631.25	637.75
DS29	638-646	642	639.25	645.75
DS30	646-654	650	647.25	653.75
DS31	654-662	658	655.25	661.75
DS32	662-670	666	663.25	669.75
DS33	670-678	674	671.25	677.75
DS34	678-686	682	679.25	685.75
DS35	686-694	690	687.25	693.75
DS36	694-702	698	695.25	701.75
DS37	702-710	706	703.25	709.75
DS38	710-718	714	711.25	717.75
DS39	718-726	722	719.25	725.75
DS40	726-734	730	727.25	733.75
DS41	734-742	738	735.25	741.75
DS42	742-750	746	743.25	749.75
DS43	750-758	754	751.25	757.75
DS44	758-766	762	759.25	765.75
DS45	766-774	770	767.25	773.75
DS46	774-782	778	775.25	781.75
DS47	782-790	786	783.25	789.75

## S7200 Series TV Signal Analyzer Operation Manual

Ch. No.	BW:8MHz Unit: MHz			
Number	Frequency Range	Center Frequency	Video	Audio
DS48	790-798	794	791.25	797.75
DS49	798-806	802	799.25	805.75
DS50	806-814	810	807.25	813.75
DS51	814-822	818	815.25	821.75
DS52	822-830	826	823.25	829.75
DS53	830-838	834	831.25	837.75
DS54	838-846	842	839.25	845.75
DS55	846-854	850	847.25	853.75
DS56	854-862	858	855.25	861.75
DS57	862-870	866	863.25	869.75
DS58	870-878	874	871.25	877.75
DS59	878-886	882	879.25	885.75
DS60	886-894	890	887.25	893.75
DS61	894-902	898	895.25	910.75
DS62	902-910	906	903.25	909.75
DS63	910-918	914	911.25	917.75
DS64	918-926	922	919.25	925.75
DS65	926-934	930	927.25	933.75
DS66	934-942	938	935.25	941.75
DS67	942-950	946	943.25	949.75
DS68	950-958	954	951.25	957.75

### 13.7.4. Europe CATV and DTTB Channel Plan

CATV channels Europe (PAL; standard B/G)

Channel Bandwidth: 7 and 8 MHz					
Ch.No.	Video	Audio	Ch.No.	Video	Audio
7MHz channel spacing			8MHz channel spacing		
E2	48.25	53.75	S21	303.25	308.75
E3	55.25	60.75	S22	311.25	316.75
E4	62.25	67.75	S23	319.25	324.75
			S24	327.25	332.75
S2	112.25	117.75	S25	335.25	340.75
S3	119.25	124.75	S26	343.25	348.75
S4	126.25	131.75	S27	351.25	356.75
S5	133.25	138.75	S28	359.25	364.75
S6	140.25	145.75	S29	367.25	372.75
S7	147.25	152.75	S30	375.25	380.75
S8	154.25	159.75	S31	383.25	388.75
S9	161.25	166.75	S32	391.25	396.75
S10	168.25	173.75	S33	399.25	404.75
			S34	407.25	412.75
E5	175.25	180.75	S35	415.25	420.75
E6	182.25	187.75	S36	423.25	428.75
E7	189.25	194.75	S37	431.25	436.75
E8	196.25	201.75	S38	439.25	444.75
E9	203.25	208.75	S39	447.25	452.75
E10	210.25	215.75	S40	455.25	460.75
E11	217.25	222.75	S41	463.25	468.75

Channel Bandwidth: 7 and 8 MHz					
Ch.No.	Video	Audio	Ch.No	Video	Audio
7MHz channel spacing			8MHz channel spacing		
E12	224.25	229.75	E21	471.25	476.75
S11	231.25	236.75	E22	479.25	484.75
S12	238.25	243.75	E23	487.25	492.75
S13	245.25	250.75	E24	495.25	500.75
S14	252.25	257.75	E25	503.25	508.75
S15	259.25	264.75	E26	511.25	516.75
S16	266.25	271.75	E27	519.25	524.75
S17	273.25	278.75	E28	527.25	532.75
S18	280.25	285.75	E29	535.25	540.75
S19	287.25	292.75	E30	543.25	548.75
S20	294.25	299.75	E31	551.25	556.75
			E32	559.25	564.75
			E33	567.25	572.75
			E34	575.25	580.75
			E35	583.25	588.75
E36	591.25	596.75	E53	727.25	732.75
E37	599.25	604.75	E54	735.25	740.75
E38	607.25	612.75	E55	743.25	748.75
E39	615.25	620.75	E56	751.25	756.75
E40	623.25	628.75	E67	759.25	764.75
E41	631.25	636.75	E58	767.25	772.75
E42	639.25	644.75	E59	775.25	780.75

Channel Bandwidth: 7 and 8 MHz					
Ch.No.	Video	Audio	Ch.No	Video	Audio
7MHz channel spacing			8MHz channel spacing		
E43	647.25	652.75	E60	783.25	788.75
E44	655.25	660.75	E61	791.25	796.75
E45	663.25	668.75	E62	799.25	804.75
E46	671.25	676.75	E63	807.25	812.75
E47	679.25	684.75	E64	815.25	820.75
E48	687.25	692.75	E65	823.25	828.75
E49	695.25	700.75	E66	831.25	836.75
E50	703.25	708.75	E67	839.25	844.75
E51	711.25	716.75	E68	847.25	852.75
E52	719.25	724.75	E69	855.25	860.75

## CATV channels - United Kingdom (PAL; ITU-R standard I)

Channel Bandwidth: 8 MHz					
Video	Audio	Video	Audio	Video	Audio
8.0	14.0	296.0	302.0	584.0	590.0
16.0	22.0	304.0	310.0	592.0	598.0
24.0	30.0	312.0	318.0	600.0	606.0
32.0	38.0	320.0	326.0	608.0	614.0
40.0	46.0	328.0	334.0	616.0	622.0
48.0	54.0	336.0	342.0	624.0	630.0
56.0	62.0	344.0	350.0	632.0	638.0
64.0	70.0	352.0	358.0	640.0	646.0
72.0	78.0	360.0	366.0	648.0	654.0
80.0	86.0	368.0	374.0	656.0	662.0
88.0	94.0	376.0	382.0	664.0	670.0
96.0	102.0	384.0	390.0	672.0	678.0
104.0	110.0	392.0	398.0	680.0	686.0
112.0	118.0	400.0	406.0	688.0	694.0
120.0	126.0	408.0	414.0	696.0	702.0
128.0	134.0	416.0	422.0	704.0	710.0
136.0	142.0	424.0	430.0	712.0	718.0
144.0	150.0	432.0	438.0	720.0	726.0
152.0	158.0	440.0	446.0	728.0	734.0
160.0	166.0	448.0	454.0	736.0	742.0
168.0	174.0	456.0	462.0	744.0	750.0
176.0	182.0	464.0	470.0	752.0	758.0
184.0	190.0	472.0	478.0	760.0	766.0



Channel Bandwidth: 8 MHz					
Video	Audio	Video	Audio	Video	Audio
192.0	198.0	480.0	486.0	768.0	774.0
200.0	206.0	488.0	494.0	776.0	782.0
208.0	214.0	496.0	502.0	784.0	790.0
216.0	222.0	504.0	510.0	792.0	798.0
224.0	230.0	512.0	518.0	800.0	806.0
232.0	238.0	520.0	526.0	808.0	814.0
240.0	246.0	528.0	534.0	816.0	822.0
248.0	254.0	536.0	542.0	824.0	830.0
256.0	262.0	544.0	550.0	832.0	838.0
264.0	270.0	552.0	558.0	840.0	846.0
272.0	278.0	560.0	566.0	848.0	854.0
280.0	286.0	568.0	574.0	856.0	862.0
288.0	294.0	576.0	582.0	864.0	870.0

### 13.7.5. Japan and Brazil Channel Plan

Japan Cable TV and DTTB Channel Plan

Number	Frequency Ranger (MHz)	Center Frequency (MHz)	Video Frequency (MHz)	Audio Frequency (MHz)
FM	76~90	---	---	---
1	90~96	93	91.25	95.75
2	96~102	99	97.25	101.75
3	102~108	105	103.25	107.75
VHF(Cable TV)				
Number	Frequency Ranger (MHz)	Center Frequency (MHz)	Video Frequency (MHz)	Audio Frequency (MHz)
C13	108~114	111	109.25	113.75
C14	114~120	117	115.25	119.75
C15	120~126	123	121.25	125.75
C16	126~132	129	127.25	131.75
C17	132~138	135	133.25	137.75
C18	138~144	141	139.25	143.75
C19	144~150	147	145.25	149.75
C20	150~156	153	151.25	155.75
C21	156~162	159	157.25	161.75
C22	164~170	167	165.25	169.75

## S7200 Series TV Signal Analyzer Operation Manual

Number	Frequency Ranger (MHz)	Center Frequency (MHz)	Video Frequency (MHz)	Audio Frequency (MHz)
VHF(DTTB)				
4	170~176	173	171.25	175.75
5	176~182	179	177.25	181.75
6	182~188	185	183.25	187.75
7	188~194	191	189.25	193.75
8	192~198	195	193.25	197.75
9	198~204	201	199.25	203.75
10	204~210	207	205.25	209.75
11	210~216	213	211.25	215.75
12	216~222	219	217.25	221.75
VHF and UHF(Cable TV)				
C23	222~228	225	223.25	227.75
C24	230~236	233	※	
C25	236~242	239	※	
C26	242~248	245	※	
C27	248~254	251	※	
C28	252~258	255	253.25	257.75
C29	258~264	261	259.25	263.75
C30	264~270	267	265.25	269.75
C31	270~276	273	271.25	275.75
C32	276~282	279	277.25	281.75
C33	282~288	285	283.25	287.75
C34	288~294	291	289.25	293.75

Number	Frequency Ranger (MHz)	Center Frequency (MHz)	Video Frequency (MHz)	Audio Frequency (MHz)
C35	294~300	297	295.25	299.75
C36	300~306	303	301.25	305.75
C37	306~312	309	307.25	311.75
C38	312~318	315	313.25	317.75
C39	318~324	321	319.25	323.75
C40	324~330	327	325.25	329.75
C41	330~336	333	331.25	335.75
C42	336~342	339	337.25	341.75
C43	342~348	345	343.25	347.75
C44	348~354	351	349.25	353.75
C45	354~360	357	355.25	359.75
C46	360~366	363	361.25	365.75
C47	366~372	369	367.25	371.75
C48	372~378	375	373.25	377.75
C49	378~384	381	379.25	383.75
C50	384~390	387	385.25	389.75
C51	390~396	393	391.25	395.75
C52	396~402	399	397.25	401.75
C53	402~408	405	403.25	407.75
C54	408~414	411	409.25	413.75
C55	414~420	417	415.25	419.75
C56	420~426	423	421.25	425.75
C57	426~432	429	427.25	431.75

## S7200 Series TV Signal Analyzer Operation Manual

Number	Frequency Ranger (MHz)	Center Frequency (MHz)	Video Frequency (MHz)	Audio Frequency (MHz)
C58	432~438	435	433.25	437.75
C59	438~444	441	439.25	443.75
C60	444~450	447	445.25	449.75
C61	450~456	453	451.25	455.75
C62	456~462	459	457.25	461.75
C63	462~468	465	463.25	467.75
UHF(DTTB)				
13	470~476	473	471.25	475.75
14	476~482	479	477.25	481.75
15	482~488	485	483.25	487.75
16	488~494	491	489.25	493.75
17	494~500	497	495.25	499.75
18	500~506	503	501.25	505.75
19	506~512	509	507.25	511.75
20	512~518	515	513.25	517.75
21	518~524	521	519.25	523.75
22	524~530	527	525.25	529.75
23	530~536	533	531.25	535.75
24	536~542	539	537.25	541.75
25	542~548	545	543.25	547.75
26	548~554	551	549.25	553.75
27	554~560	557	555.25	559.75
28	560~566	563	561.25	565.75

Number	Frequency Ranger (MHz)	Center Frequency (MHz)	Video Frequency (MHz)	Audio Frequency (MHz)
29	566~572	569	567.25	571.75
30	572~578	575	573.25	577.75
31	578~584	581	579.25	583.75
32	584~590	587	585.25	589.75
33	590~596	593	591.25	595.75
34	596~602	599	597.25	601.75
35	602~608	605	603.25	607.75
36	608~614	611	609.25	613.75
37	614~620	617	615.25	619.75
38	620~626	623	621.25	625.75
39	626~632	629	627.25	631.75
40	632~638	635	633.25	637.75
41	638~644	641	639.25	643.75
42	644~650	647	645.25	649.75
43	650~656	653	651.25	655.75
44	656~662	659	657.25	661.75
45	662~668	665	663.25	667.75
46	668~674	671	669.25	673.75
47	674~680	677	675.25	679.75
48	680~686	683	681.25	685.75
49	686~692	689	687.25	691.75
50	692~698	695	693.25	697.75
51	698~704	701	699.25	703.75

Number	Frequency Ranger (MHz)	Center Frequency (MHZ)	Video Frequency (MHz)	Audio Frequency (MHz)
52	704~710	707	705.25	709.75
53	710~716	713	711.25	715.75
54	716~722	719	717.25	721.75
55	722~728	725	723.25	727.75
56	728~734	731	729.25	733.75
57	734~740	737	735.25	739.75
58	740~746	743	741.25	745.75
59	746~752	749	747.25	751.75
60	752~758	755	753.25	757.75
61	758~764	761	759.25	763.75
62	764~770	767	765.25	769.75

Brazil DTTB Channel Plan

ReceptionChannel	Center Frequency (MHz)	Remarks	
V H F	7	117.143	
	8	123.143	
	9	129.143	
	10	135.143	
	11	141.143	
	12	147.143	
U H F	13	153.143	
	14	473.143	
	15	479.143	
	16	485.143	
	17	491.143	
	18	497.143	
	19	503.143	
	20	509.143	
	21	515.143	
	22	521.143	
	23	527.143	
	24	533.143	
	25	539.143	
	26	545.143	
27	551.143		
28	557.143		
29	563.143		
30	569.143		



ReceptionChannel	Center Frequency (MHz)	Remarks	
U  H  F	31	575.143	
	32	581.143	
	33	587.143	
	34	593.143	
	35	599.143	
	36	605.143	
	37	611.143	
	38	617.143	
	39	623.143	
	40	629.143	
	41	635.143	
	42	641.143	
	43	647.143	
	44	653.143	
	45	659.143	
	46	665.143	
	47	671.143	
	48	677.143	
	49	683.143	
	50	689.143	
	51	695.143	
	52	701.143	
	53	707.143	
	54	713.143	
	55	719.143	

ReceptionChannel	Center Frequency (MHz)	Remarks	
U	56	725.143	
	57	731.143	
	58	737.143	
H	59	743.143	
	60	749.143	
	61	755.143	
F	62	761.143	
	63	767.143	
	64	773.143	
	65	779.143	
	66	785.143	
	67	791.143	
	68	797.143	
	69	803.143	

Brazil Cable TV Channel Plan

ReceptionChannel	Center Frequency (MHz)	Remarks
C13	111.143	
C14	117.143	
C15	123.143	
C16	129.143	
C17	135.143	
C18	141.143	
C19	147.143	
C20	153.143	
C21	159.143	
C22	167.143	
C23	225.143	
C24	231.143	
C25	237.143	
C26	243.143	
C27	249.143	
C28	255.143	
C29	261.143	
C30	267.143	
C31	273.143	
C32	279.143	
C33	285.143	
C34	291.143	

ReceptionChannel	Center Frequency (MHz)	Remarks
C35	297.143	
C36	303.143	
C37	309.143	
C38	315.143	
C39	321.143	
C40	327.143	
C41	333.143	
C42	339.143	
C43	345.143	
C44	351.143	
C45	357.143	
C46	363.143	
C47	369.143	
C48	375.143	
C49	381.143	
C50	387.143	
C51	393.143	
C52	399.143	
C53	405.143	
C54	411.143	
C55	417.143	
C56	423.143	
C57	429.143	

ReceptionChannel	Center Frequency (MHz)	Remarks
C58	435.143	
C59	441.143	
C60	447.143	
C61	453.143	
C62	459.143	
C63	465.143	

## 14. System Settings

### 14.1. Introduction

Press  to enter the setup interface

The system setup screen offers 3 selections,

- System information,
- General settings
- Measurement settings.
- Antenna settings

## 14.2. System Information

Press  > [About] will display such information as: Hardware and Software version, as shown below.

Press [About] again to turn to the second page, again to toggle back to the first page.

There are 2 pages of system information. The first page shows the information of hardware and software, including the S.N., software version, file system version, kernel version, boot loader version, hardware version, CA module version, MAC address, calibration date.

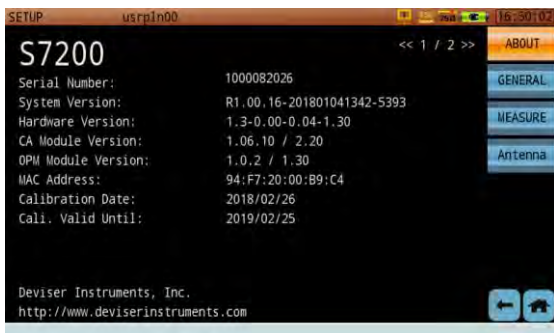

Figure 14-1 System Information - Hardware and Software Version

The second page displays information of the loaded options on your unit. Items with check marks confirm the options that have been installed on your device.

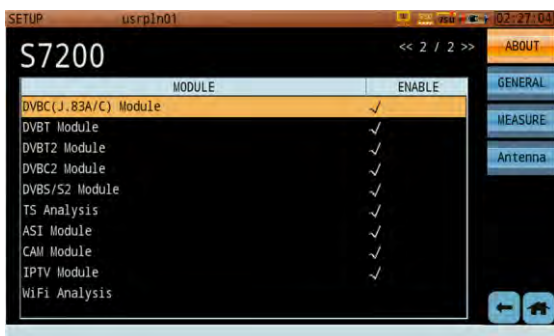



Figure 14-2 Snapshot: System information-Options

### 14.3. Available Option

To activate your options, if they haven't yet been activated following your initial purchase, you need to enter the options listscreen on your S7200. To enter this menu, on the numerical keypad, you need to press 1, 2, 3, 4, 5, 6 one after the other. A popup window will appear, which will require you to input your received option active code from the factory. Once your active options code is entered, press the  button, your desired option has now been activated, and you can open this option on your S7200. If the active code is correct, the instrument will automatic restart. If the active code wrong, the screen will popup a window "Code error."



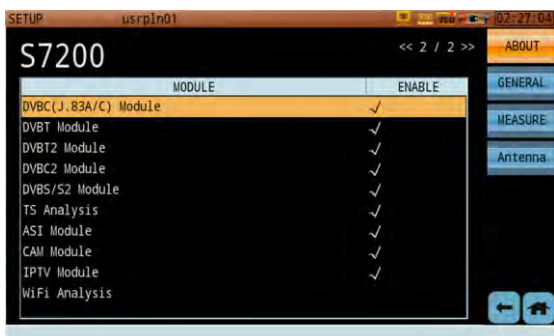

Figure 14-3 Snapshot Option List

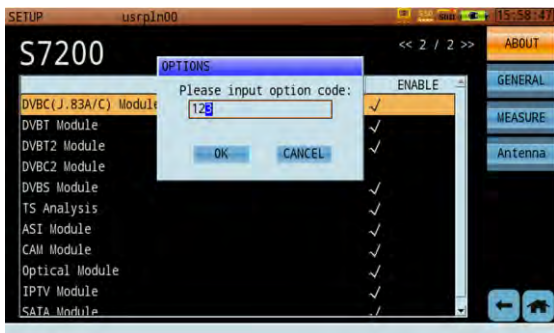

Figure 14-4 Snapshot Input Active Code

## 14.4. General Settings

This section will cover

- Network settings,
- Ping
- Display & battery settings,
- Date & time,
- Language,
- User management,
- Disk management
- GPS
- Factory reset

### 14.4.1. Network Setting

How to turn WiFi on or off, (Battery life will be reduced when WiFi is turned on)

- In the network setup page, if the WiFi box is checked, the WiFi connection is active and you will see the WiFi icon in the title bar beside the battery icon reminding you that WiFi connection is active.

- If both the WiFi box and DHCP box are checked, the S7200 will connect to the WiFi network automatically.

- If the WiFi box is checked, but not the DHCP box, you can setup a static IP address as well as all other network configuration requirements such as MASK, Gateway and DNS.



Figure 14-5 WiFi Icon appears in the title bar



Figure 14-6 Turn on WiFi Module



Figure 14-7 Network Configuration-DHCP

How to set your S7200 with an Ethernet connection; with DHCP or a static IP address,

- In the network setup page, when the WiFi box is un-checked, the WiFi connection is inactive, the default connection is through the Ethernet

connector, and the WiFi icon in the title bar is off.

- If the DHCP box is checked, (WiFi off) the S7200 will acquire a network address and configuration automatically when a CAT5/6 cable is connected to an active network.

- When the DHCP box is un-checked, you can setup your static IP address as well as all other network configuration requirements such as MASK, Gateway and DNS.



Figure 14-8 Network Configuration-Static

The S7200 offers a WiFi hotspot configuration function, this function is used to support an application program which connects to a mobile phone or tablet computer. An engineer can use this App to allow the S7200 onto a public network when he works in the field. If no good network connectivity is present, the field engineer can use this function to complete the measurement task and upload measurement results. We currently only support Android App on your mobile devices, other devices will become compatible in future firmware releases.

Figure 14-10 shows WLAN hotspot setup parameters, which include:

- SSID                    Service Set Identifier, the user selects the correct name
- Password              User defined
- IP Address             This is a fixed IP address, users cannot modify it.



Figure 14-9 Setup S7200 as a WiFi hotspot



Figure 14-10 WiFi AP SSID and password Setup

When S7200 as a WiFi hotspot, the WiFi icon color is blue, Figure 14-11 show the WiFi icons difference.



Figure 14-11 WiFi Icon-S7200 as a WiFi Hotspot

## 14.4.2. Ping

PING is practical to quickly verify your network connectivity status and speed as shown in Figure 14-12 below.



Figure 14-12 Ping Result Display

Input the network address or the desired IP address to be tested in the host address box at the top (for example: [www.bing.com](http://www.bing.com)), then press the [START] soft key button to start the network test. Press the [STOP] soft key button to stop the test. The test information displays in real time in the window.

Parameter Instruction:

“-n” option: means “Packet Count”, the number of data packets sent by the assigned PING order.

“-t”: means “Unlimited”, if this box is checked, the PING function will be continuous until the test is interrupted by pressing the stop button.

“-l”: means “Packet length”, the package length of the PING request

“-I”: means “Interval”, time interval delay between ping packets, in ms.

### 14.4.3. Display & Power

From the general settings page, tap the display & battery option. Users can set the shutdown time-lapse and backlight time-lapse. The internal temperature of the instrument is displayed, both in Farenheit and Celsius.



Figure 14-13 Display and Battery setting

To extend the battery life and usage, the device should be set to auto shutdown (3, 5, 10, 30min or disable).

To extend the battery life and usage, the device backlight should be set to auto turnoff (3, 5, 10, 30min or disable).

Back light brightness adjustment: to save the battery in various working environments, the cursor can be used to modify the brightness adjustment of the LCD, the LCD brightness will change according to cursor position.

#### 14.4.4. Date & Time

Upon initial activation of the unit, the system date & time needs to be set.



Figure 14-14 Snapshot: Data & Time Setting

There are three ways of displaying the date, YYYY/MM/DD, DD/MM/YYYY and MM/DD/YYYY. Tap the display format position [Y/M/D], from the drop list to choose the desired format. Other position need input digital, if user tap the related position, the virtual keyboard will pop up, user also can use the keyboard on the S7200 front panel.

At the bottom of the DATA & TIME setting page is time zone setup option. The time zone used for EPG function. In EPG, time and data table TDT (section 12.14.3 and section 12.14.7 describe the TDT table detailed information) only transmission UTC time and date information. In digital video broadcast, equipment combine the TDT table and EPG can provide many application for user.





Figure 14-15 Division of the world's 24 time zones

Standard time in the world is GMT (Greenwich Mean Time) plus (+) or minus (-) the number of time zones in the subject of the hour time difference. Instruments need to set the time zone corresponding to the location selection, location and time zone relationship such as shown in Figure. For example, China is the East eight districts (+8) in the list of options to choose the time zone GMT + 8: 00; eastern United States is the West Fifth District (-5) in the time zone list to select GMT-5: 00. GMT is the abbreviation for Greenwich Mean Time. UTC is the abbreviation for Universal Time Coordinated.

### 14.4.5. Language

The S7200 supports multiple languages, only Chinese, English, Russian, Spanish and German are currently supported.

To switch between languages, tap the language setting item. Tap on you needed language option. Once your selection is made, a pop up window will indicate “the system needs to restart for the changes to take effect” Press OK to restart.



Figure 14-16 Snapshot: Language Setting

### 14.4.6. User Management

Tap the user management item and tap the multi-user, the screen will popup a drop list let user to choose enable or disable the multi-user feature.



Figure 14-17 Snapshot: Multi-User Function Open/Close

After enabling the multi-user feature, restart the system for the changes to take effect. Figure 14-18 will be the first screen to appear once the unit powers up. It will display username, ID and the company name. Editing the existing users' information, adding/deleting users, changing the system language, can all be done from this page.

Press the[LOGIN] soft button to enter the S7200 home page.

When you choose different users, all users are independent from one another, however, channel lists and limit files are shared and can be selected by any or all users. The channel list used by each user can also be different. The files saved by different users are unique to each user. A file saved by user A cannot be viewed or used by user B and so on.



Figure 14-18 Snapshot: Multi-User Function Edition

In Figure 14-17, user can modify the current login user information. User can edit user name (USER1), user ID (000000001), company name (GROUP). When the user chooses other user's ID, he cannot modify other user information in this account. The current user must press [SWITCH USER] button to the choosed user's space to edit the user information. Figure shows the interface.



Figure 14-19 Snapshot: Switch User Space

### 14.4.7. GPS

S7200 support GPS location function, this function is an option. GPS receiver and GPS antenna integrate in one module. GPS module use USB cable connect with S7200.

If S7200 not install GPS module, user also can manually input GPS information and user can save the manually input GPS information in test results, as the Figure 14-20 show.



Figure 14-20 Manual Input GPS Information

If GPS module connected with S7200, the instrument automatic identify GPS module. User can find GPS icon on the status bar, as the Figure 14-21 show.

 When the three icons cycle display, means the GPS module search GPS satellite signal.

If status bar only display the icon , means GPS module has been successful locked the GPS satellite signal and successful acquire the user local position latitude and longitude information, the information "GpsSTATUS: LOCK(5)" means GPS module find 5 GPS satellites.

After GPS module location successful, use does any measurement operation

and save test results, user local position latitude and longitude information can be saved in test result information, as the Figure show.



Figure 14-21 GPS Location Successful

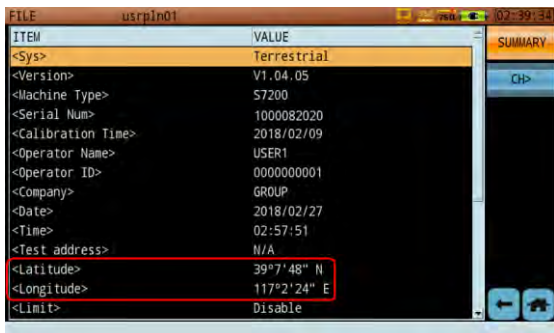

Figure 14-22 The GPS Information Saved in Test Result

### 14.4.8. Disk Management

Disk management is used for user data partition of the internal devices including the devices with SATA solid state hard disk option and can be inserted with USB-Disk. When the user choose Local or SATA, the screen will prompt a “Format” button as Figure 14-23. If the user select USB, then the “Format” button will be not available as Figure 14-24. When SATA is selected, “Format” button will re-format SATA solid hard disk and all the data in the hard disk will be deleted. When Local is selected, all the user data will be deleted such as the saved pictures or data files, and format the Local data partition. When the cursor moves to USB device, “Format” button will be changed to unavailable status.

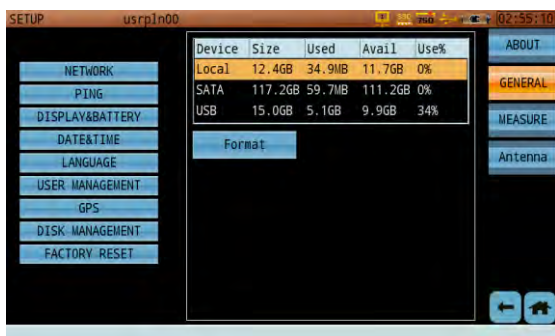

Figure 14-23 Disk Management – Install SATA SSD Option



Figure 14-24 Disk Management



Figure 14-25 Disk Management – No SATA SSD Option



### 14.4.9. Restoring Factory Settings

This feature restores all configuration parameters (only) to the original factory settings, however, all saved files in S7200 remain intact, as saved, for each of the users. After a factory reset, if multiple-users are active, the S7200 will revert to the first user on the list by default.

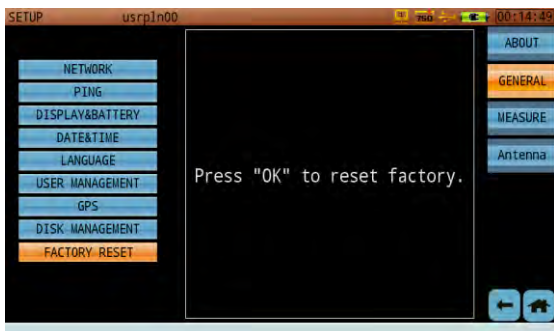

Figure 14-26 Snapshot: Restoring Factory Settings

### 14.4.10.S7200 System Upgrade Operation Steps

S7200 provides simple and easy used system U disk upgrade function and disk partition function.

Upgrade operation steps

1. Prepare a USB-disk.

Ensure the USB-disk is empty and formatted in FAT or FAT32.



2. Loading the upgrade files to your USB-disk

Load the upgrade file `initrd.bin`, `PKG01R1.00.01201709301026.bin` (Note: The file name must remain exactly as provided by the factory, it is **CRITICAL** that the file name, **not be modified**) directly on the root directory of the USB-disk (NOT in a directory). If multiple `PKG01R1.00.01201709301026.bin` files exist simultaneously on the same USB-disk root directory, the program will automatic sort by file name, and the user decides to choose which one upgrade package.

The upgrade file `PKG01R1.00.01201709301026.bin` includes a date and time, for example:

`PKG01R1.00.01201709301026.bin` shows that the program packet time stamp is September 30,2017 and 10 o'clock 26 minutes. The program uses this time stamp to confirm which firmware is the latest version.

Upgrade instructions:

With the instrument powered OFF, insert the USB-disk into the S7200 USB port, then press and hold the  button, simultaneously press down on the power on button, until the instrument powers up and enters the upgrade function interface screen. Once the upgrade interface screen comes up, (as shown below) you can release the  and power buttons. The user can then

choose the upgrade option [in this case, upgrade from USB], and enter the user upgrade mode.

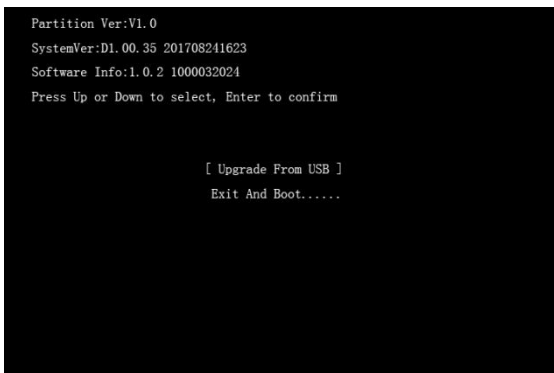

Figure 14-27 Snapshot: Choose Program Upgrade mode

If the new upgrade package need the repartition for the instrument's flash, the software will enter the partition mode to execute partition automatically as Figure 14-28; If the flash partition table is not changed, software will enter the screen of selecting the upgrade file directly as Figure 14-30;

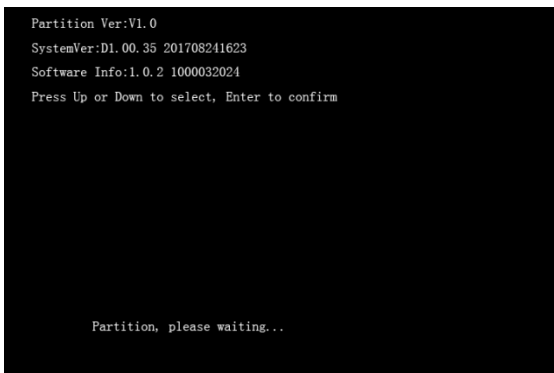

Figure 14-28 In the partition processing

Note: the partition procedure will take around 2 minutes, if the screen of

Figure 14-30 appears, that means the partition is done, shut down; Then repeat the step 1, step 2 will enter the screen of selecting the upgrade file as Figure 14-31.

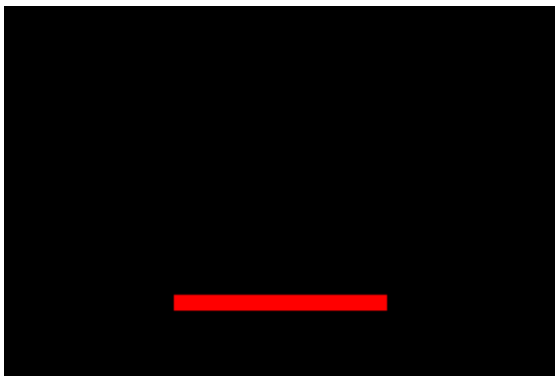

Figure 14-29 The partition is done

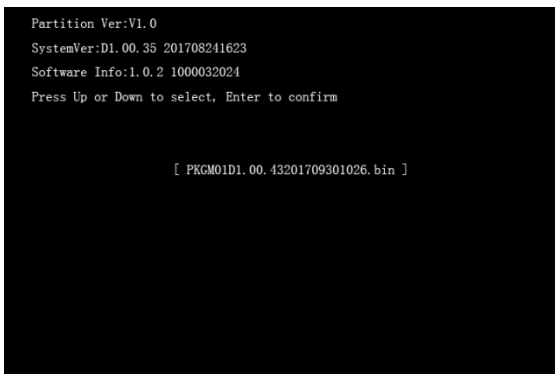



Figure 14-30 The upgrade file list

Select the corresponded file package, press  button again and enter the upgrade screen, the upgrading process is shown as Figure 14-31.

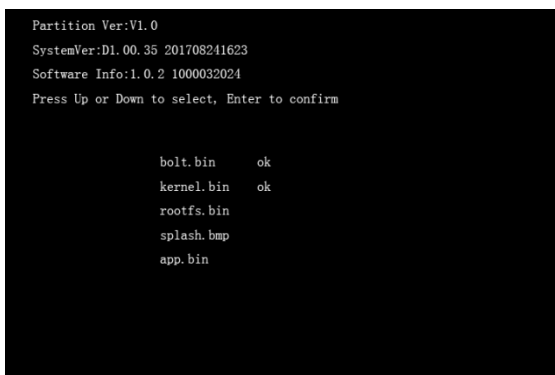

Figure 14-31 In the process of upgrade

Wait for 3 seconds after the upgrade done and will reboot automatically.

Other options description

**【Exit And Boot ...】** Exit and Boot

Exit the upgrade function and system will start up normally.

## 14.5. Measurement Settings

The measurement settings include level unit, Test Point (TP) compensation and limit file editing.

### 14.5.1. Level Unit

There are different units of measure for different countries and industries, the S7200 supports 3 unit formats: dBmV, dBuV and dBm and will automatically convert values for convenience and better user experience.



Figure 14-32 Snapshot: Level Unit Settings

## 14.5.2. Test Point Compensation

Tap the “TP Compensation” item, continue tap the checkbox in the middle window. TP compensation can be edited and applied only if the box is checked.

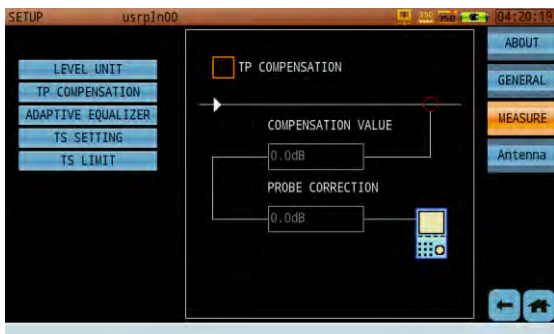

Figure 14-33 Snapshot: Test point compensation screen

The typical optical receiver test port loss is 20dB, older CATV active equipment may have 30dB down test points, if so, the user can input the required compensation. (20dB in this example) Some probes along with specific length of cables may account for 1.5dB loss (in this example), the user can input that loss value in the probe correction box. In this example, the total correction value is 21.5dB. In the measurement interface, the instrument will display TP=21.5dB in the status bar at the lower right corner of the screen. After total compensation, the test result will display the true network measurement values.

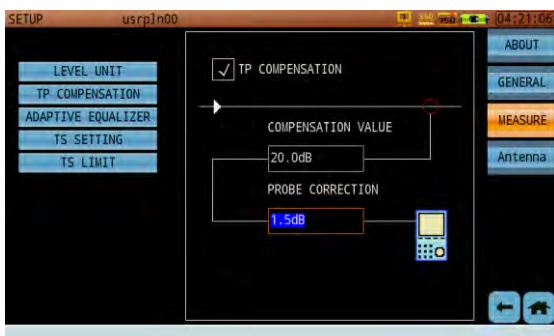

Figure 14-34 Example of Test Point Compensation

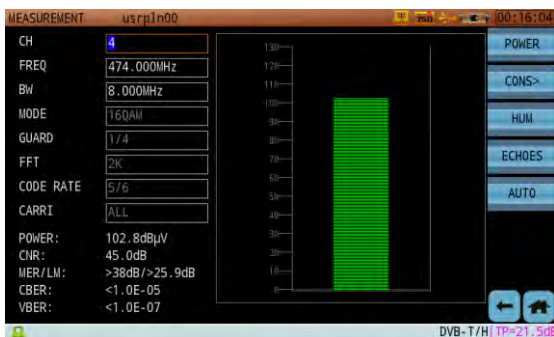

Figure 14-35 Screen location of TP Compensation in the Measurement Screen



### 14.5.3. Adaptive Equalizer

The S7200 offers adaptive equalizer setup : The adaptive equalizer setup only for Cable TV take effect. Long Taps and Short Taps. Long Taps can better suppression ISI (Inter Symbol Interference) and co-frequency interference. Short taps equalizer cooperate with a better selective filter and provide a better performance in full-loaded CATV plant.

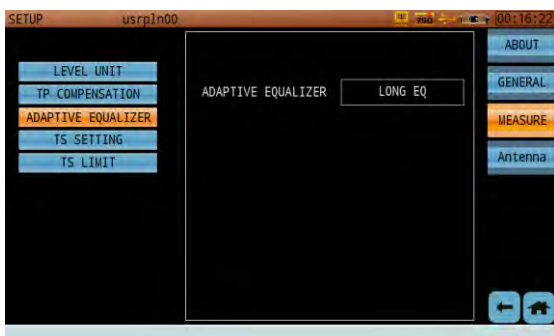

Figure 14-36 Snapshot: QAM Demodulation-Hardware



Figure 14-37 Snapshot: QAM Demodulation-Software

Equalizer setup in measurement screen position.

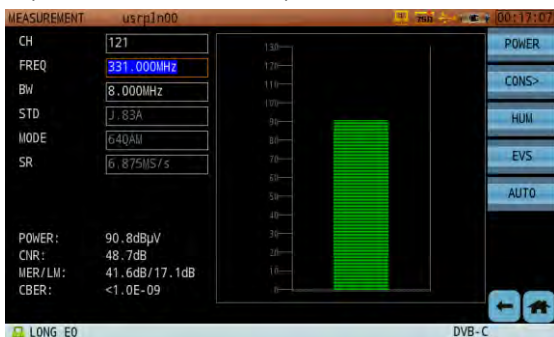

Figure 14-38 Equalizer Setup: Long Tap Measurement

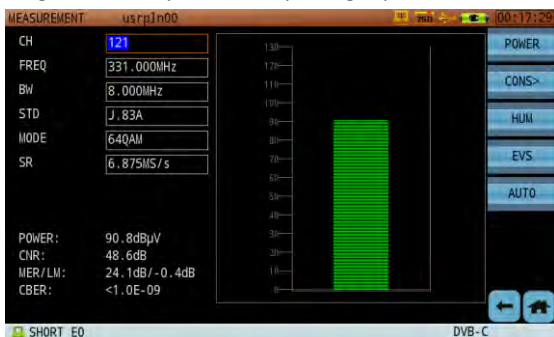

Figure 14-39 Equalizer Setup: Short Tap Measurement

### 14.5.4. Transport Stream Setting

The TS analysis function supports DVB and ATSC standard. For different country or district, user self chooses DVB or ATSC according local standard. DVB option display PSI/SI analysis and ATSC option display PSI/PSIP analysis. Figure 14-41 shows the content.



Figure 14-40 Transport Stream Setup

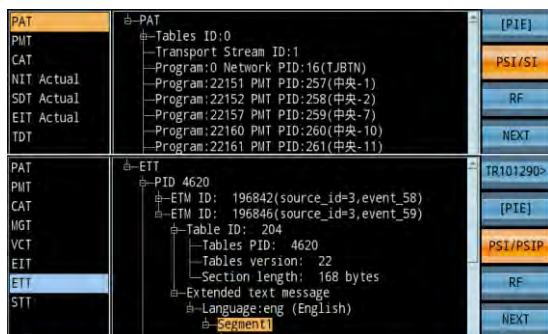

Figure 14-41 PSI/PSIP and PSI/SI Table Contrast

STANDARD	ATSC	STANDARD	DVB
FORMAT	DEC	FORMAT	HEX
Aspect	4:3	Aspect	16:9
AUDIO SELECT	1	AUDIO SELECT	2
CLOSED CAPTION	CLOSE	CLOSED CAPTION	OPEN

Figure 14-42 Transport Stream Parameters Setup Option

Data format has two options: Decimalism and hexadecimal. Figure 14-43 shows Decimalism PID value is 850 and hexadecimal PID value is 0x352.

VIDEO	INFO	AUDIO1	INFO1	AUDIO2	INFO2
PID	0x352	PID	0x353	PID	---
Resolution	720*480I	Mode	stereo	Mode	---
Frames	29.97	Layer	II	Layer	---
BitRate	15000000	BitRate	256 Kbps	BitRate	---
Profile	main	Sampling	48 kHz	Sampling	---
Level	main	Profile	---	Profile	---
Aspect	4:3	CH CONF	---	CH CONF	---
Chroma	4:2:0	Emphasis	none	Emphasis	---

VIDEO	INFO	AUDIO1	INFO1	AUDIO2	INFO2
PID	850	PID	851	PID	---
Resolution	720*480I	Mode	stereo	Mode	---
Frames	29.97	Layer	II	Layer	---
BitRate	15000000	BitRate	256 Kbps	BitRate	---
Profile	main	Sampling	48 kHz	Sampling	---
Level	main	Profile	---	Profile	---
Aspect	4:3	CH CONF	---	CH CONF	---
Chroma	4:2:0	Emphasis	none	Emphasis	---

Figure 14-43 Decimal and hexadecimal PID Value Contrast

### Image aspect ratio:

Image aspect ratio setup can independent of the image, same image can give different aspect ration setting. The display effect is the image is stretched or compressed.

### Audio select:

If one transport stream include mulit audio channel for different language, user can switch with different audio channels.

**Closed captions:** Only ATSC standard uses the closed captions. Close the closed captions, no captions display on the screen. Open the closed captions, the captions display on the screen again. The closed captions effect as show in the Figure 14-44.



Figure 14-44 ATSC Closed Caption

User are required to choose the right character encoding according to your local operator's preferred language, your country and/or district. Please choose very carefully, otherwise, the parser program will show you garbled information. User are encouraged to use "Auto Detect" option, this will let the program automatically recognize the proper character encoding.

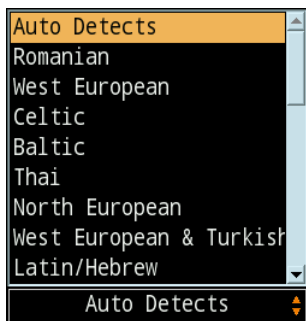

Figure 14-45 Character Encoding Option List

S7200 supports the fellow Character Encoding Options:

Auto Detects	Romanian (ISO 8859-16)
West European (ISO 8859-15)	Celtic (ISO 8859-14)
Baltic (ISO 8859-13)	Thai (ISO 8859-11)
North European (ISO 8859-10)	West European & Turkish (ISO 8859-9)
Latin/Hebrew (ISO 8859-8)	Latin/Greek (ISO 8859-7)
Latin/Arabic (ISO 8859-6)	Latin/Cyrillic (ISO 8859-5)
North (-East) European (ISO 8859-4)	South European (ISO 8859-3)
East European (ISO 8859-2)	West European (ISO 8859-1)
Simplified Chinese (GB-2312-1980)	GBK
GB18030-0	Traditional Chinese (Big5 subset)
EUC-KR	JISX0201-0
JISX0208-0	JISX0201-1
JISX0208-1	UTF-8
UTF-16 LE	UTF-16 BE

### 14.5.5. Transport Stream Limit Setting

TR 101 290 Priority 1, 2 and 3 tests parameters limit value can be modified and applied in the realtime transport stream analysis.



Figure 14-46 TR 101 290 Priority 1, 2 and 3 Tests Parameters Limit

The table give some parameters reference value. More parameters setup information please reference section 12.14.3.



PSI/SI Table Repetition Time

Service Information	Max. interval (complete table)	Min. interval (single sections)
PAT	0.5s	25ms
CAT	0.5s	25ms
PMT	0.5s	25ms
NIT	10s	25ms
SDT	2s	25ms
BAT	10s	25ms
EIT	2s	25ms
RST	-	25ms
TDT	30s	25ms
TOT	30s	25ms

## 14.6. Antenna Settings

Antenna setting provides View, Edit, Import, Export, Delete and On-Off function for FM antenna, DAB antenna and DTMB antenna.

Press the first button on the right side to view different type of antenna and the operation will be illustrated with FM antenna as an example.

The list on the left side lists all saved FM antenna files in the instrument, one file will be selected through  and  or finger touch. When you select one file like fm4, then the list will show “\*fm4”, here “\*” means that this antenna is being used. Meanwhile, The content of fm4 is displayed on the right side list, including ID, Frequency (MHz), Antenna coefficient (dB) as Figure 14-47 and Figure 14-48.



The screenshot shows the 'Antenna' settings screen. On the left, a list of file names is shown: fm1, fm2, fm3, \*fm4 (selected), and fm\_factordef. On the right, a table displays the details for the selected file, fm4. The table has three columns: ID, FREQ(MHz), and Coefficient (dB). The data rows are as follows:

FILE NAME	ID	FREQ(MHz)	Coefficient (dB)
fm1	7	80.700	0.0
fm2	8	80.800	0.0
fm3	9	80.900	0.0
*fm4	10	81.000	0.0
fm_factordef	11	81.100	0.0
	12	81.200	0.0
	13	81.300	0.0
	14	81.400	0.0
	15	81.500	0.0
	16	81.600	0.0
	17	81.700	0.0
	18	81.800	0.0
	19	81.900	0.0

On the right side of the screen, there are buttons for [FM], [OFF], [IMPORT], [EXPORT], [DELETE], and [ON]. At the bottom right, there are navigation arrows and a home button.

Figure 14-47 FM Antenna Settings







Figure 14-48 DAB Antenna Settings

Operation description:

**【EDIT】** The antenna file name is editable, but the antenna data that is shown in the list on the right side is not editable. When it is not editable, **【EDIT】** will be gray.

**【DELETE】** will delete the selected antenna file on the left side list. "fm\_factordef" on the left side is the default antenna file and it cannot be deleted by the user. If the cursor moves to list on the right side **【DELETE】** button will be not available, at this moment, **【DELETE】** button will be gray.

**【ON】** This is the reuse button, continuously press this button to open and close the antenna function. But after the antenna is enabled, it only takes effect for the current type of channel. When the current channel is the enabled antenna type,  icon will appear on the title bar.

For example, after FM antenna is enabled, the title bar will display  icon when the current channel is ANALOG FM in the channel measurement or what the frequency marker signified is ANALOG FM. The measurement unit is the field strength unit and the testing result includes the antenna coefficient shown as Figure 14-49.

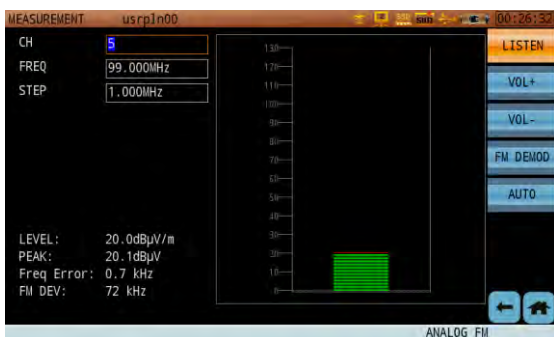

Figure 14-49 Opening Antenna Test

**【Export】**

The user plug the USB-Disk into USB port, the antenna file export function will be enabled. **【Export】** gray unavailable status will be changed to the blue available status. The user press the button **【Export】**, according to the prompt message, press the Enter key to export all selected channel plans in the instrument to USB-Disk. If FM antenna files are exported, the exported antenna files will be in the folder S7200\_Antenna/FmCoff under the USB-Disk root directory. If DAB antenna files are exported, the exported antenna files will be in the folder S7200\_Antenna/DABCoff under the USB-Disk root directory. The antenna file extension name is dat, the user can export all or part of antenna files according to the requirement.



Figure 14-50 Export Antenna Files

### 【Import】

Before importing the files, you can export the local antenna files to USB device first, then modify the antenna files with text editor from PC. Take fm4 antenna file as an example, open fm4.dat file from PC text editor and modify the antenna attribute according to the requirement shown as below figure.

NO.	Antenna
1	80000,0
2	80100,0
3	80200,0
4	80300,0
5	80400,0
6	80500,0
7	80600,0
8	80700,0
9	80800,0
10	80900,0
11	81000,0
12	81100,0
13	81200,0
14	81300,0
15	81400,0

Figure 14-51 Edit Antenna Files

The content of the antenna file are divided into 2 columns by the comma



## 14.7. External Interface Setup

In TV and satellite mode, the external interface setup has different parameters option. In TV mode, include: LNB Power, Signal Source, TS Input/ASI Output.

In satellite mode, include: LNB Power, DiSEqC, SaTCR, Signal Source, TS Input/ASI Output.

### 14.7.1. LNB Power Setup

TV mode power setup provide several options: Ext power supply, 5V, 3V, 15V, 24V. These voltage options can be used to power on LNB or preamplifier, as the Figure 14-53 show.

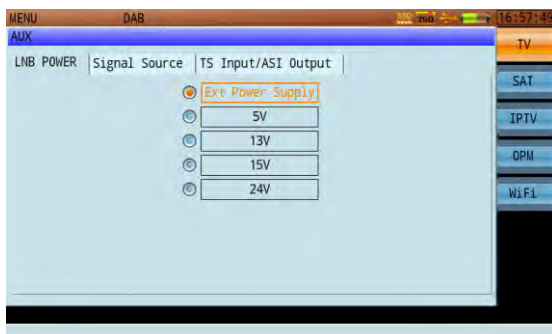

Figure 14-53 TV Mode Power Setup

In satellite mode, power setup provide several options: Ext power supply, Auto, 13V, 18V, 13V+22kHz, 18V+22kHz, 24V. These options mainly used for preamplifier and LNB power supply, or control different type switch in LNB.

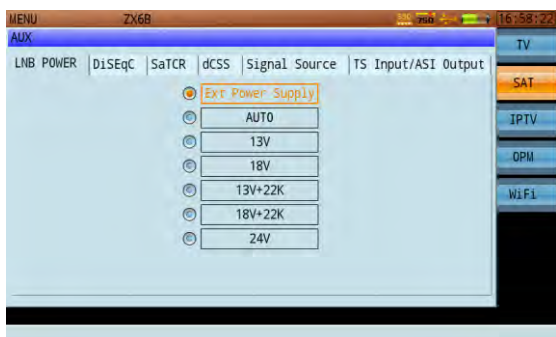

Figure 14-54 Satellite Mode Power Setup

When user have multi satellite receive or multi user receiver requirement, the control signals 13/18V, 0/22kHz and DiSEqC are needed.

We know, 18V is used to control horizontal polarization, 13V is used to control vertical polarization. 0/22kHz signal is used to control Ku band high band and low band switch. A 22kHz square-wave signal with 1V peak-to-peak value is superimposed on 13V or 18V.

If user want to receive C band horizontal polarization signal, only use 18V signal, as the Figure 14-55(A) show. If user want to receive C band vertical polarization signal, only use 13V signal, as the Figure 14-55(B) show.

If user want to receive Ku band high band horizontal polarization signal, the 22kHz square-wave signal is superimposed on 18V signal, the 0/22kHz status is "On", the frequency is 22kHz, as the Figure 14-55(C) show. If user want to receive Ku band high band vertical polarization signal, the 22kHz square-wave signal is superimposed on 13V signal, the 0/22kHz status is "On", the frequency is 22kHz, as the Figure 14-55(D) show.

If user want to receive Ku band low band horizontal polarization signal, the 22kHz square-wave signal is not superimposed on 18V signal, the 0/22kHz

status is "Off", the frequency is 0kHz, as the Figure 14-55(E) show. If user want to receive Ku band low band vertical polarization signal, the 22kHz square-wave signal is not superimposed on 13V signal, the 0/22kHz status is "Off", the frequency is 0kHz, as the Figure 14-55(F) show.

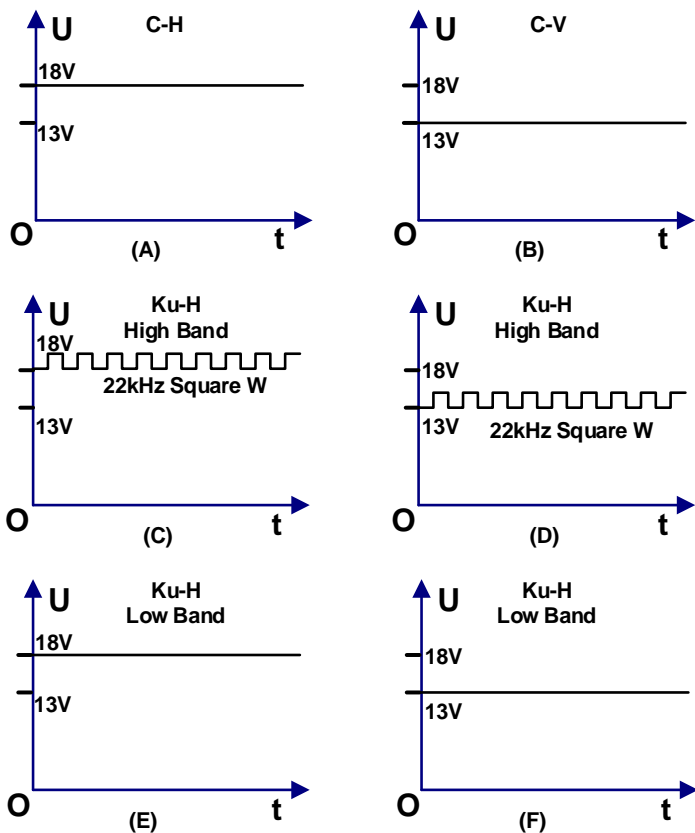

Figure 14-55 Satellite IF signal switch work principle

## Power Supply Operation Guide

Power	Operation Guide
Auto	According satellite setup automatic setup
13V	Vertical polarization and low LO
18V	Horizontal polarization and low LO
13V+22K	Vertical polarization and high LO
18V+22K	Horizontal polarization and high LO
24V	24V



## 14.7.2. DiSEqC Control Signal

EUTELSAT(European Telecommunication Satellite Organization) and Philips jointly developed DiSEqC (Digital Satellite Equipment Control) technology in 1990s. Now DiSEqC has been developed several versions, every version use DiSEqC icon + version to describe. Every new version has backward compatibility.

S7200 support 1.0, 1.1, 1.2, 2.x version DiSEqC protocol.

If LNB power supply status is disable, when user sent DiSEqC command to LNB, the screen will tips “Please enable the LNB power supply!”.



In DiSEqC control interface, user only need tap on one command item, the screen will pop-up tips: “Send command .....”, “Send command OK!”. If the cursor on one command item, and the icon  behind the command, it means user can use  and  button modify the command value, as the Figure 14-57 show.



Figure 14-56 DiSEqC Version Icon

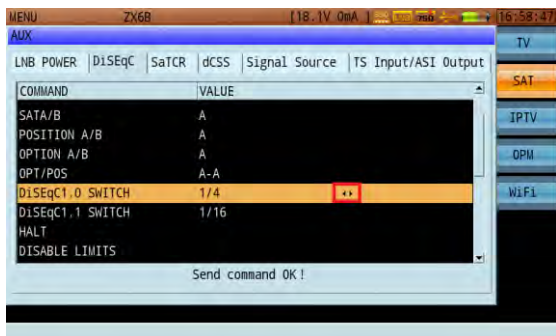

Figure 14-57 DiSEqC Control Signal Configure Interface

## Different DiSEqC Version Difference

DiSEqC Version	Directivity	Characteristic
DiSEqC1.0	Unidirectional	Provide basic DiSEqC instruction set, has Tone Burst function and four LNB control. It can use a series of instructions to send these commands: polarization, high and low bands, antenna position and other control. But it was a unidirectional system, the receiver send instruction to the system corresponding module. The instruction only can by sent one time, cannot repeately sent.
DiSEqC1.1		Base the version 1.0, version 1.1 add C band LNB control function and four Uncommitted functions. In order to ensure the accuracy of transmitted the instruction, which allow multi times send same instruction.
DiSEqC1.2		Version 1.2 is the expansion and extension of the version 1.1. Add polar antenna remote control capability.
DiSEqC2.0	Bidirectional	The function of version 2.0 is same with the function of versin 1.0, the difference is the version 2.0 is a bidirection system. System module received instruction and give response, and the receiver know this instruction is executed or not. The receiver also can use this response to detect which type module exist.
DiSEqC2.1		Combined all version 1.1 and version 2.0 functions
DiSEqC2.2		Base on the version 2.1, add remote control function

## DiSEqC Protocol Command list:

Class	Command	Parameter
General	RESET	----
	STANDBY	----
	POWER ON	----
Switch control	SAT A/B	A/B
	POSITION A/B	A/B
	OPTION A/B	A/B
	OPT/POS	A-A/A-B/B-A/B-B
	DiSEqC1.0 SWITCH	1 to 4
DiSEqC1.1 SWITCH	1 to 16	
Polar base control	HALT	----
	DISABLE LIMITS	----
	SET LIMIT EAST	----
	SET LIMIT WEST	----
	DRIVE EAST SEC	1 to 127
	DRIVE EAST STEPS	1 to 127
	DRIVE WEST SEC	1 to 127
	DRIVE WEST STEPS	1 to 127
	STORE POSITION	1 to 255
	GOTO POSITION	1 to 255
	GOTO X.X°	-80° to 80°
	GOTO 0	----

### 14.7.3. SaTCR Control Signal

SaTCR protocol is DiSEqC protocol extension. The SaTCR allow satellite STB control coaxial cable connected external device. The SaTCR protocol make the STB has the ability to control LNB which based on SaTCR standard.

S7200 supports SatCR/SCR(EN50494) and dCSS/SCR2(EN50607), it provides SatCR and dCSS different equipment control and configure functions.

Under SaTCR control screen, set SatCR as effective status to enable SaTCR function, set as invalid to close SaTCR function; When set as effective status, the title bar will show  picture. The user press one command with the finger, the command running waiting box will appear on the screen as "Please wait...",the waiting box will be closed automatically after the command executed. Touch the frequency, status or position of the selected user channel to modify the parameters, send the commands immediately when the data modification is done. Can also modify the first column to determine whether or not to test this user's channel. If it is not tick selected, this channel will not be used as Figure 14-58.

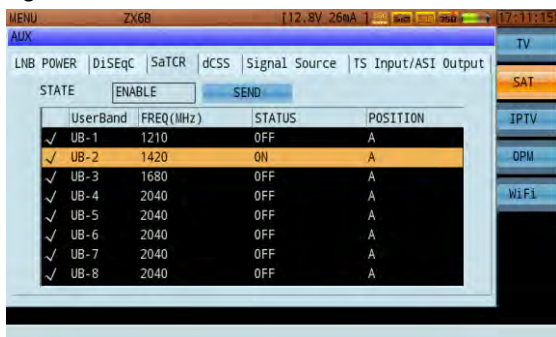

Figure 14-58 SaTCR Control Signal Configure Interface

SaTCR protocol control command transmission need S7200 power supply

status enable. When power supply off or other external device power supply, this function doesn't take effect.

SaTCR setup interface display 8 channel, the frequency range is 950~2150MHz.

S7200max support 8 slots SaTCR LNB.

Command	Parameter	Description
SaTCR Status	Valid/Invalid	Support On/Off SaTCR function
Select	v	Select the current SaTCR channel
Status	On / Off	Set the current channel status
Position	A / B	Move SaTCR LNB

#### 14.7.4. dCSS

Digital Channel Stacking Switch LNB can support several users on a single cable distribution system by allocating specific user bands for each of them. It is not possible to work with this type of LNB unless your field strength meter communicates using EN50494 (SATCR, UNICABLE) and EN50607 (dCSS, JESS, UNICABLE II) standard protocols.

dCSS supports SCR(EN50494) and SCR2(EN50607) standard. S7200 supports maximum 32 user channel control. Under dCSS function, the instrument provides equipment installation and channel setting function. dCSS protocol control command transmit need enable the external feed function. When S7200 external feed status is closed or external other device feed, this function will not take effect.

Set dCSS as effective status to enable dCSS function, set as invalid to close dCSS function; When set as effective, the title bar will show  picture. dCSS user channel information are shown as Figure 14-59 and Figure 14-60. When first time to use through touching “Install” button, the instrument will automatically search dCSS device channel total amount, each channel frequency, use status, protect status and update the channel list; Describe dCSS operation method with UB-2 channel as an example.

Column	Description
First Column	“√”,This channel can be used, otherwise, this channel cannot be used.
UserBand	User channel ID, likeUB-2
Frequency(MHz)	Channel Frequency, depend on device parameter.
Status	“ON” Open UB-2 Channel, “OFF” close UB-2 channel
Position	Set A or B

PINcode	Channel protected PINCODE, need be consistent with the this channel parameter setting; For example, UB-2PIN code is 18; IfUB-2 protected status is “YES”, other users like to use UB-2, need input the same PIN code or close device power to be able to control this device.
USED	“YES” means other user has already used this channel;“NO” means channel is available and can be used.
Protect	“YES” means other user has already protected this channel with PIN code and in used; “NO” means this channel is protected

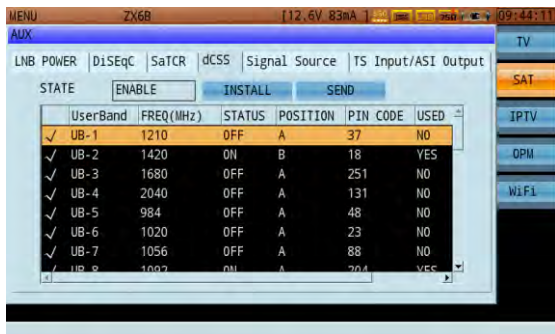

Figure 14-59 dCSS control signal setting screen

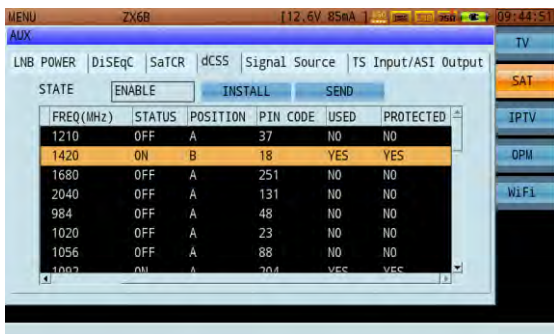

Figure 14-60 dCSS control signal setting screen

The spectrum is like Figure 14-61 and Figure 14-62 when UB-2 channel is opened and closed.

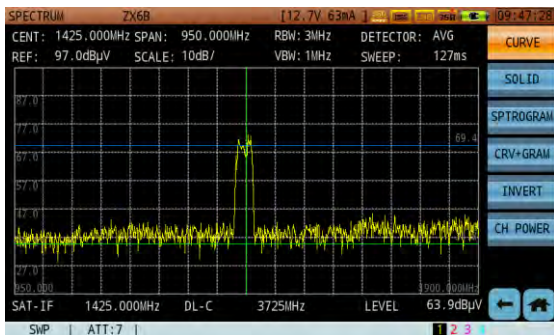

Figure 14-61 UB-2 Channel is Opened



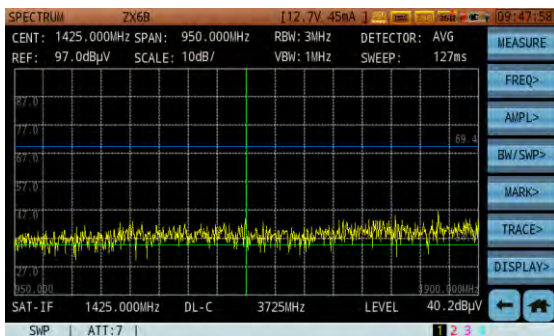



Figure 14-62 UB-2 Channel is Closed

### 14.7.5. ASI Input and Output Control

ASI input and output port on the right side of the instrument. Choose the ASI input status valid, the icon  display on the title bar. ASI input and output introduction as the Figure 14-63 and Figure 14-64 show.

If user choose internal transport stream input type (DISK or TS over IP), the ASI output port status is invalid. If user choose the transport stream input type is ASI, the ASI input port status is valid. The Figure 14-63 shows the relationship. If ASI output port status is invalid, the ASI output port no signal output. If RF or ASI input port signal is unencrypted multiplex stream, ASI output port can output this unencrypted stream. If input signal is encrypted, the system will popup message "No CA Found!". If user doesn't insert the decryption card, the ASI output EncropTS option is forbidden. The Figure 14-64 shows the relationship.

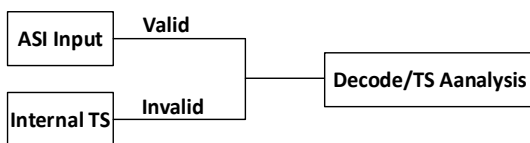

Figure 14-63 ASI valid and invalid introduction

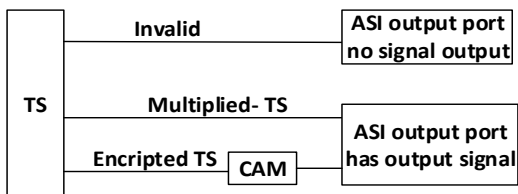

Figure 14-64 ASI output option introduction

## 14.7.6. Transport Stream Input Control

S7200 has four types transport stream input types: RF, ASI, DISK.

RF input : The cable, terrestrial and satellite signal from the RF input port enter instrument. The transport stream is demodulated from the RF signal, then enter TS analysis module. The Figure 14-65 shows the setup interface. When instrument TS analysis function work in RF input mode, the interface give the description, as the Figure 14-66 show.

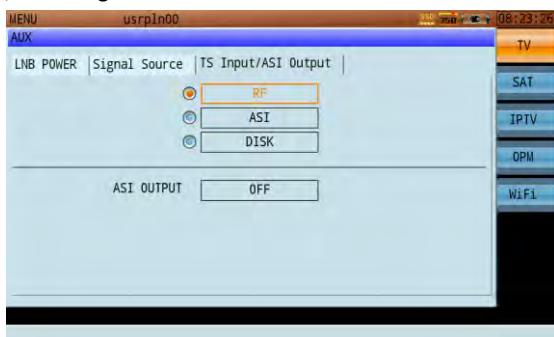

Figure 14-65 Transport Stream Input Control – RF Input



Figure 14-66 RF Input Transport Stream does TS Analysis

ASI input: The ASI input port on the right side of the instrument. The baseband transport stream signal from the ASI input port enter the TS analysis module. The Figure 14-67 shows setup interface. When TS analysis function work in ASI input mode, the test screen give the description, as the Figure 14-68 show. If the TS analysis module work in ASI input mode, the ASI parameter cannot be modified.



Figure 14-67 Transport Stream Input Control – ASI Input



Figure 14-68 ASI Input Transport Stream does TS Analysis

DISK input: This option change the internal SATA SSD (Solid State Disk) or USB disk as the transport stream source. When the title bar display the icon , it means this instrument already install SSD (option) and user can use SSD record

and playback TS file. User SSD or USB disk recorded TS file does TS analysis, operation instruction steps as the Figure 14-69 and Figure 14-70 shows. First step setup TS input port, second step enter TS analysis function press soft button [DISK] open TS file operation interface. User can open the TS file from SSD or USB disk. When TS analysis function work in DISK input mode, the test screen give the description, as the Figure 14-71 show.

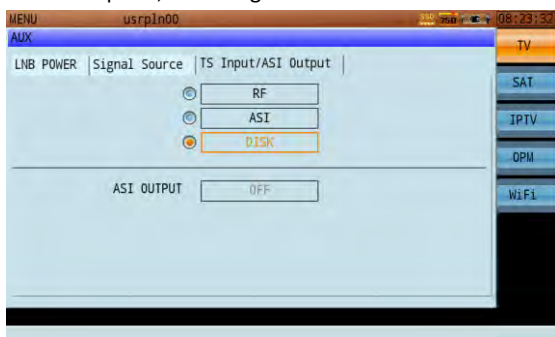

Figure 14-69 Transport Stream Input Control – DISK

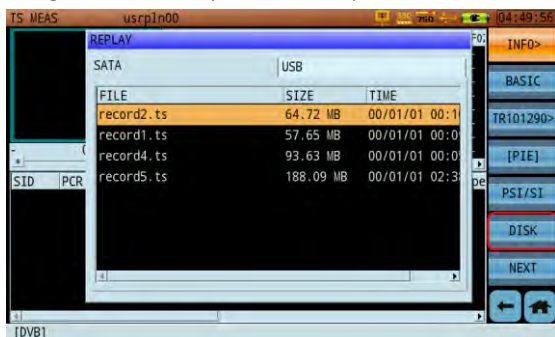

Figure 14-70 Choose TS file form SATA SSD or USB Disk





Figure 14-71 Disk Input Transport Stream does TS Analysis

### 14.7.7. Signal Source

In recent years, fiber LNB is becoming popular. Through the coaxial cable, 13V or 18V control voltage decides LNB received signal is vertical polarization or horizontal polarization. The another one is 22kHz control signal to switch the band low or high. The satellite frequency range that the low band covers is from 10.7 to 11.75GHz, the high band covered range is from 11.8 to 12.75GHz. Finally, there are four possible combining form (low band horizontal or vertical, high band vertical or horizontal) can be converted to different frequency from 0.95 to 5.45GHz range. Then, RF signal is converted to the optical signal, and transmitted through optical fiber, this is called fiber LNB.

On the other end of the fiber, the optical signal enters into photoelectric conversion equipment and converts the light to the recognizable signal according to the satellite receive standard.

S7200 provides the optical signal demodulation function. User can set the optical demodulation on/off switch like Figure 14-72 screen. When OPTICAL is selected, the optical receiver can be used to test the optical power and  icon will be shown at the top of the title bar. Optical receiver starts to work and user can plug the fiber into APC port on the top of the instrument directly. User can test the signal of photoelectric conversion under different function directly.

User can select the signal input way of optical converted to video or video input way. Select 75 ohm or 50 ohm according to the connected cable and  or  icon will appear on the top of the title bar; When the satellite system is selected by the user, the instrument will be inputted with the fixed 75 ohm.

Meanwhile, the external CVBS signal can be inputted to the device

through the earphone hole under this function. When the external CVBS input is open, CVBS will be full screen displayed; Can cancel the external input through pressing  button.

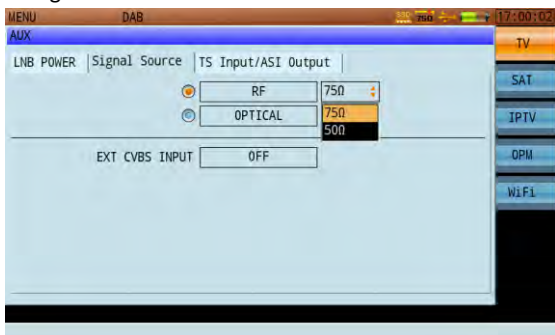

Figure 14-72 Signal Source Control



Figure 14-73 CVBS Line



## 15. Reviewing & Exporting Files

### 15.1. File management

Tap the  button on the front panel below the screen to open the file management menu. The saved files are available in 3 different categories, picture, data and TS.

Tap the first soft button multi-times, the button will cycle between [[Picture]], [[Data]] and [[TS]]. Use your finger tap on the SELECT column to select the desired file. If no file is chosen, the delete and export buttons are not available. To export files, insert a USB memory stick in the USB port. The USB icon will appear in the title bar. Tap the soft button [EXPORT] to export the desired files on the USB stick. Editable self-created directories will appear on the USB stick, measurement data files will appear as “ds7200\_file” and screen snapshot files will appear as “ds7200\_bmp”. Saved TS file can be saved in USB disk root directory. Pressing the soft button [SORT] will pop up a sorting window offering different sorting choices.

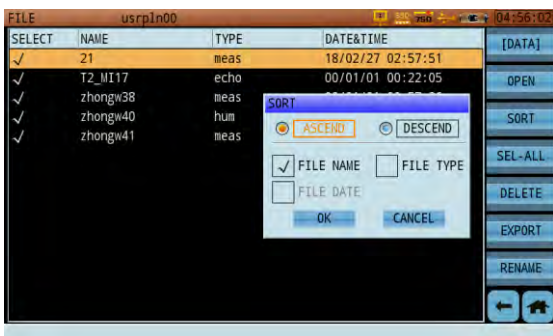

Figure 15-1 File Sorting

When one or more files are selected, the delete button becomes active. When one or more files are chosen, and a USB storage disk is inserted, the export button becomes active.

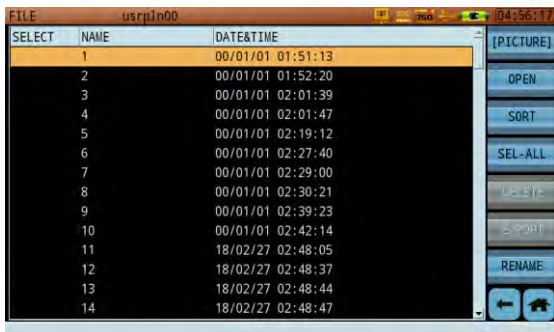

Figure 15-2 Screenshot Delete file

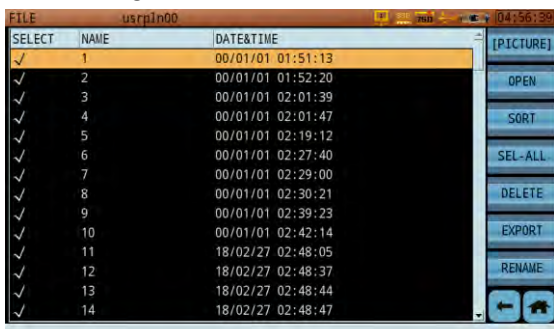
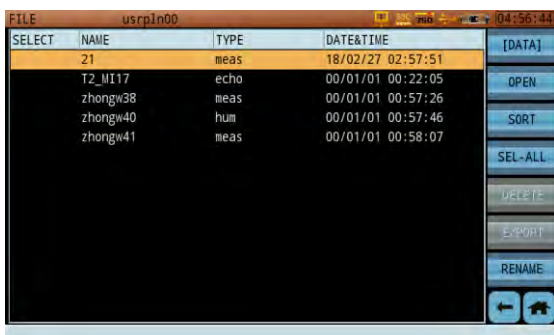

Figure 15-3 Screenshot Export file (USB stick inserted)



The screenshot shows a file management interface with a table of data files. The table has columns for SELECT, NAME, TYPE, and DATE&TIME. The first row is highlighted in orange. To the right of the table is a vertical menu with buttons for [DATA], OPEN, SORT, SEL-ALL, DELETE, EXPORT, and RENAME. At the bottom right are navigation icons for back and home.

SELECT	NAME	TYPE	DATE&TIME
	z1	meas	18/02/27 02:57:51
	T2_MI17	echo	00/01/01 00:22:05
	zhongw38	meas	00/01/01 00:57:26
	zhongw40	hum	00/01/01 00:57:46
	zhongw41	meas	00/01/01 00:58:07

Figure 15-4 Screenshot Data File Operation

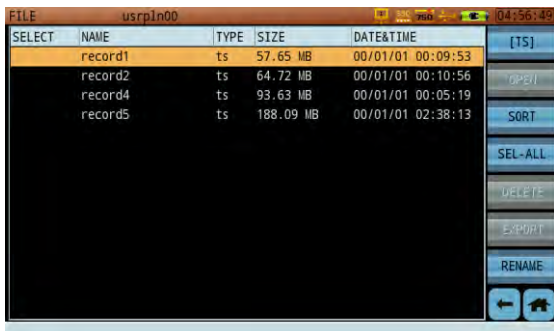

The screenshot shows a file management interface with a table of transport stream files. The table has columns for SELECT, NAME, TYPE, SIZE, and DATE&TIME. The first row is highlighted in orange. To the right of the table is a vertical menu with buttons for [TS], OPEN, SORT, SEL-ALL, DELETE, EXPORT, and RENAME. At the bottom right are navigation icons for back and home.

SELECT	NAME	TYPE	SIZE	DATE&TIME
	record1	ts	57.65 MB	00/01/01 00:09:53
	record2	ts	64.72 MB	00/01/01 00:10:56
	record4	ts	93.63 MB	00/01/01 00:05:19
	record5	ts	188.09 MB	00/01/01 02:38:13

Figure 15-5 Transport Stream File List

## 15.2. Reviewing Files

Picture files can be viewed in this menu. Data files show different information based on type, but all will include the basic information of the instrument; system, software/firmware version, machine type, serial number, calibration time, operator name, operator ID, company name, date & time stamp, test address, latitude, longitude, limit, limit file, channel plan, project, level unit and TP compensation.

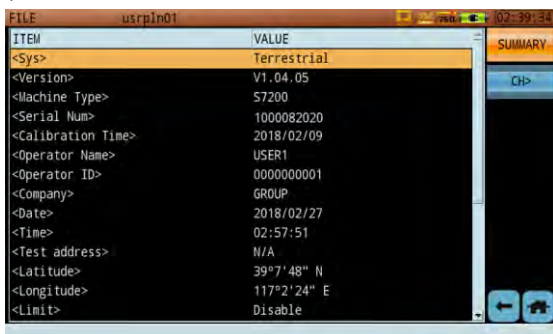



Figure 15-6 File Summary





Figure 15-7 Saved Constellation

The export file format is CSV, use UTF-8 code, which opens with Excel.

## 16. Saving DATA

Tap the  button to store screen snapshots and test results.

If you tap the  button in a non-measurement screen, the instrument will ask “Please enter the file name” and offer a suggested file name. This is your opportunity to enter a custom file name, if you just press “enter”, the file name will be generated automatically, incrementally from the last automated saved file.

If you tap the  button in a measurement screen, the instrument will ask “Please select the file type”: Picture or Data. If you choose “Picture”, the instrument will save the screen snapshot. If you select “data”, the active test result will be saved.

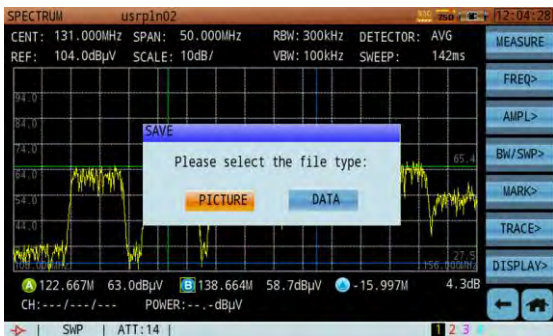

Figure 16-1 Save Screen Snapshot or Test Result

If the user chooses to save the picture, the instrument will ask to confirm the file name and add a watermark on the picture or not. Figure 16-3 shows the watermark effect. (File name on the top toolbar, this allows to easily distinguish a stored trace from any other trace)

Putting a date on the saved picture will increase ease of use when recalling traces for reports or other reasons.



Figure 16-2 Snapshot: Picture Add Watermark Option

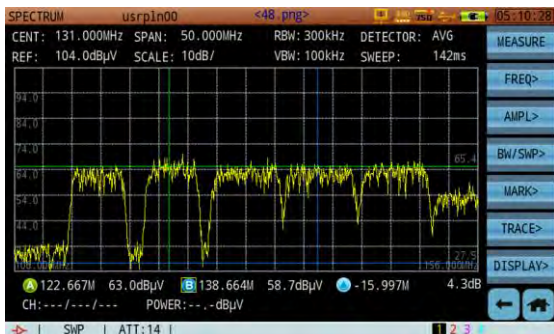

Figure 16-3 Snapshot: Watermark Display Effect

## 17. Specifications

Spectrum Analysis	
Frequency Range	4MHz ~ 1220MHz (TV), 950 MHz ~ 2150 MHz (Satellite)
Frequency Span	0 MHz ~ 1216MHz (TV), 0 ~ 1200MHz (Satellite)
Frequency Step	1 kHz (TV & Satellite)
Resolution Bandwidth (-3dB)	1kHz, 3kHz, 10kHz, 30kHz, 100kHz, 300kHz, 1MHz, 3MHz
Level Measurement Range	-50dBmV ~ +60dBmV (TV), -30dBmV ~ +60dBmV (Satellite)
Accuracy Of Measurements	<1.5 dB
Measurement Detector	Positive Peak, Negative Peak, Sample, Average
Reference Level	-30dBmV ~ +60dBmV
Markers	2 vertical markers and 2 horizontal markers(TV), 1 vertical markers and 2 horizontal markers(Satellite)
Analog TV Measurement	
Standards	B/G, H,I, D/K, L/L', M/N
Color Standards	PAL, SECAM, NTSC
Frequency Step	10 kHz
Hum Measurement	1% ~ 15%
C/N	> 50dB
Level Measurement Range	-30dBmV ~ +60dBmV

Accuracy Of Measurements	< 1.5 dB
Level Resolution	0.1 dB
<b>DVB-C Measurement</b>	
Frequency Range	42~1002MHz
Modulation Type	16/32/64/128/256 QAM ITU-T J.83 ANNEX A/C
Symbol Rate	1.8 MS/s ~ 7.0 MS/s
Power Level Range	-30dBmV ~ +50dBmV
Level Resolution	0.1 dB
Power Level Accuracy	±1.5 dB(C/N > 20 dB)
MER Measurement	~42dB
MER Accuracy	±2.0 dB
BER	1E-3 ~ 1E-9
Constellation	v
<b>DVB-C2 Measurement</b>	
Power Level Range	-30dBmV ~ +50dBmV
Power Level Accuracy	±1.5 dB(C/N > 20 dB)
Guard Interval	1/64, 1/128
Bandwidth	6MHz and 8MHz
Spectrum Inversion	Auto
PLP Code Rates	2/3, 3/4, 4/5, 5/6, 8/9, 9/10
PLP Constellation	16, 64,256, 1024, 4096QAM
Data Slices	Type 1 & 2 supported, width up to 7.61MHz
<b>DTMB Measurement</b>	
Carrier Type	C=1,3780



S7200 Series TV Signal Analyzer Operation Manual

Power Level Range	-35 dBmV ~ +50dBmV
Level Resolution	0.1dB
Level Accuracy	±2.0dB (C/N>20dB)
MER Measurement	>36dB
MER Accuracy	±2.0dB
BER	1E-1~1E-5
Constellation	√
Echo Pattern	-64.02μs~64.02μs(PN420); -87μs~+87μs(PN595); -133.47μs~+133.47(PN945); Scalable. Automatic capture peak function, maximum support 50Markers
<b>DVB-T/H Measurement</b>	
Frequency Range	42~1002MHz
Modulation Type	QPSK, 16 QAM, 64 QAM
Power Level Range	-35dBmV ~ +50dBmV
Level Resolution	0.1 dB
Power Level Accuracy	±1.5 dB (C/N >20 dB)
MER Measurement	> 35 dB
MER Accuracy	±2.0 dB
CBER/VBER	√
Constellation	√
Echo Pattern	√
<b>DVB-T2 Measurement</b>	
Frequency Range	42~1002MHz
Modulation Type	QPSK, 16 QAM, 64 QAM, 256QAM

Power Level Range	-35dBmV ~ +50dBmV
Level Resolution	0.1dB
Power Level Accuracy	$\pm 1.5$ dB(C/N >20 dB)
MER Measurement	>38 dB
MER Accuracy	$\pm 2.0$ dB
CBER/LBER	√
Constellation	√
Echo Pattern	√
<b>ISDB-T/T<sub>B</sub> Measurement</b>	
Modulation Type	DQPSK,QPSK, 16 QAM, 64 QAM
Modulation Bandwidth	6MHz
PowerLevelRange	-35dBmV ~ +50dBmV
Power Resolution	0.1dB
Power Level Accuracy	$\pm 2.0$ dB(C/N>20dB)
MER Measurement	> 40dB
MER Accuracy	$\pm 2.0$ dB
CBER	1E-1~1E-5
VBER	1E-1~1E-7
Constellation	√
<b>ATSC Measurement</b>	
Modulation Type	8 VSB
Power Level Range	-35dBmV ~ 50dBmV
Level Resolution	0.1 dB
Power Level Accuracy	$\pm 1.5$ dB(C/N >20 dB)
MER Measurement	>40 dB
MER Accuracy	$\pm 2.0$ dB

BER	√
Constellation	√
<b>DVB-S/S2 Measurement</b>	
Modulation Type	QPSK, 8PSK,16APSK,32APSK
Symbol Rate	2 - 45 MS/s (DVB-S) 1 - 45 MS/s (QPSK DVB-S2) 1 - 45 MS/s (8PSK DVB-S2) 1 - 45 MS/s (16APSK DVB-S2) 1 - 38 MS/s (32APSK DVB-S2)
Power Level Range	-20 dBmV ~ +50 dBmV
Level Resolution	0.1 dB
Power Level Accuracy	±1.5 dB (C/N>20dB)
MER Measurement	> 25 dB
MER Accuracy	±2.0 dB
BER	DVB-S(CBER/VBER)DVB-S2 (CBER/LBER)
Constellation	√
<b>Video Decoder</b>	
Video	MPEG2/4, H.264, H.256,VC-1, AVS/AVS+
Video Resolution	4k,1080p, 720p and 576i
Decryption Standard	EN50221 (DVB-CI); BISS Mode 1 and Mode E
TS-ASI Input And Output	√
TS Record	√
<b>TS Analyzer</b>	
En 50083-9(DVB SPI, ASI)	
DVB-ASI Interface	75 Ω BNC

DVB-ASI Clock	270 MHz
DVB-ASI Max Data Rate	0 to 120 Mbps
DVB-ASI Output Signal Level	1.0 Vp-p nominal
DVB-ASI Return Loss	> 15dB
DVB-ASI Input Level	800 mV +/- 10%
RealtimeDecoder	Display the real time television pictures (through CA system). Including program numbers, program names, provider information, video & audio PIDs
TR101290 Priority 1, 2 & 3 Monitoring	TR 101 290 Priority 1, 2 & 3 real time monitoring, not include buffer test related parameters
Base Information	Count the PIDs percent according to the type of the streams. Videos, Audios, PSI/SI, Null Packages
PID List	Display all the PIDs in current stream
Program Information	The detail information about a program if it isn't be encrypted. The video resolutions and audio compress rate.
PCR Monitoring	Calculate PCR interval and PCR accuracy
PSI/SI List	Display the PSI/SI infos by tree view. Including PAT,PMT,CAT,(NIT,SDT,RST,TDT,EIT options)

Program Info	EPG
PID Capture	Capture a specified PID by its type: Video, Audio, PSI (PAT, PMT, NIT, TDT, RST, SDT, EIT) etc. And display the data in HEX format
Transport Stream Record and Replay	SSD disk for TS record
TS over IP Analysis	
Support Protocol	UDP,RTP
Supported transport type	MPEG-2 TS over IP
Broadcast type	Unicast, Multicast
WiFi Analysis	
Frequency	2.4G, 5G
Support Standard	802.11 a/b/g/n
Security Mode	WPA/WPA2/WPA-PSK/WPA2-PSK
Encryption	WEP/AES/TKIP
Test Parameters	SSID, Level, Channel
Optical Power Measurement	
Measurement Wavelength	1310nm, 1490nm, 1550nm
Measurement Range	-50dBm ~ 27dBm
Accuracy	$\pm 0.17\text{dB}$ ( $\pm 3\%$ )
Linearity	0.07dB/10dB
Resolution	0.01dBm
OPTICAL Input	FC\SC\ST/APC General Optical Adaptor
Optical to RF Converter	
Dynamic Range of Conversion	-70dBm~10dBm
RF Band Converted (Optical Cable)	From 65MHz ~ 1000MHz

and DTT links)	
RF Band Converted (Optical IF-Satellite Installations)	From 950MHz ~ 2150MHz
<b>Interface</b>	
RF Input	Terrestrial broadcasting: 50ΩSMA; cable TV: 75Ω
Analog Video and audio input/output	3.5mm Multi-pole jack
USB	1 USB 3.0
LAN	2 100/1000 M
CAM	1 PCMCIA
TS-AS Input/output	2 75Ω BNC
DC Supply Input	12V / 5A
GPS Input	USB Dongle
<b>General</b>	
Display	7 inches TFT LCD 800 × 480 pixels, Capacitive Touch Screen
AC/DC Adapter	AC 100 - 240 V/50-60 Hz DC 12 V/5 A
Battery	Li-ion, 7.4 V/13 Ah
Charge Time	around 5 Hours
Working Time	>5 Hours
Remote Feeding	5/13/15/18/24 V, Max. 5 W
22 kHz Control Signals	DiSEqC 1.2 and SaTCR
Dimension (W×H×L)	253 mm × 194 mm × 84mm
Weight	around 2.4 kg
Working Temperature	-10 ~ +50 °C



**Australia**

Address: 38A 8 Herbert Street | St Leonards | Sydney | NSW 2065

Email: [sales@avw.com.au](mailto:sales@avw.com.au)

Syd: 02 8213 0200 Mel: 03 8691 5210 Qld: 07 3607 3785 WA/SA/NT: 08 8120 3203

**New Zealand**

Address: 7 Ra Ora Drive | East Tamaki | Auckland, 2013

Email: [sales@avw.co.nz](mailto:sales@avw.co.nz)

Aki: 09 271 4000 | Wel: 04 499 3888