



Elite Premier

Volume Water Heaters

Installation

Start-Up

Maintenance

Parts

Warranty

EP-220 / 299 / 301 / 399 VWH Models*

* "N" Denotes Natural Gas Operation

"LP" Denotes Propane Gas Operation

"VWH" Denotes Hot Water Supply Boiler

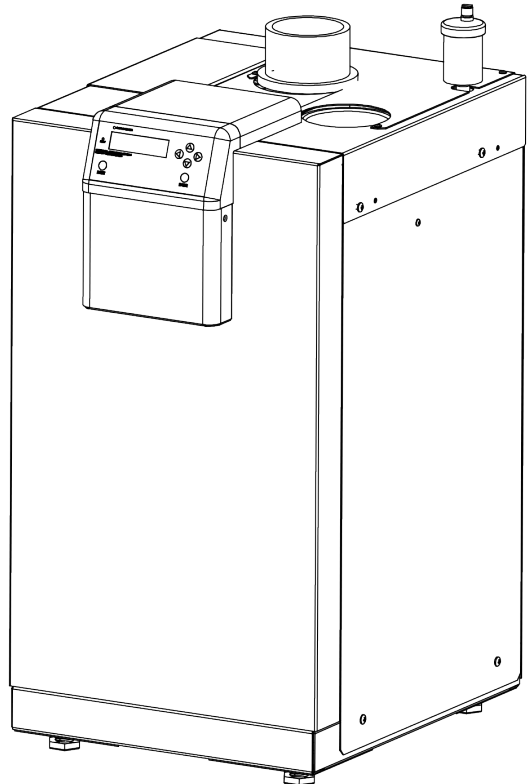

Heat Exchanger Bears the ASME "H" Stamp



! DANGER

This manual must only be used by a qualified installer / service technician. Read all instructions in this manual before installing. Perform steps in the given order. Failure to do so could result in substantial property damage, severe personal injury, or death.

! WARNING

Improper installation, adjustment, alteration, service, or maintenance could void product warranty and cause property damage, severe personal injury, or death.

California Proposition 65 Warning: This product contains chemicals known to the State of California to cause cancer, birth defects, or other reproductive harm.

NOTICE

HTP reserves the right to make product changes or updates without notice and will not be held liable for typographical errors in literature.

The surfaces of these products contacted by potable (consumable) water contain less than 0.25% lead by weight as required by the Safe Drinking Water Act, Section 1417.

NOTE TO CONSUMER: PLEASE KEEP ALL INSTRUCTIONS FOR FUTURE REFERENCE.

! WARNING

WARNING: If the information in these instructions is not followed exactly, a fire or explosion may result causing property damage, personal injury or death.

- Do not store or use gasoline or other flammable vapors and liquids in the vicinity of this or any other appliance.

WHAT TO DO IF YOU SMELL GAS

- Do not try to light any appliance.
- Do not touch any electrical switch; do not use any phone in your building.
- Immediately call your gas supplier from a neighbor's phone. Follow the gas supplier's instructions.
- If you cannot reach your gas supplier, call the fire department.
- Installation and service must be provided by a qualified installer, service agency or the gas supplier.

Improper installation, adjustment, alteration, service, or maintenance can cause injury, property damage, or death. Refer to this manual. Installation and service must be performed by a qualified installer, service agency, or gas supplier.

FOR YOUR SAFETY READ BEFORE OPERATING

WARNING: If you do not follow these instructions exactly, a fire or explosion may result, causing property damage, personal injury or loss of life.

- A.** This appliance does not have a pilot. It is equipped with an ignition device which automatically lights the burner. Do not try to light the burner by hand.
- B.** BEFORE OPERATING smell all around the appliance area for gas. Be sure to smell next to the floor because some gas is heavier than air and will settle on the floor.
- WHAT TO DO IF YOU SMELL GAS**
- Do not try to light any appliance
 - Do not touch any electric switch; do not use any phone in your building
 - Immediately call your gas supplier from a neighbor's phone. Follow the gas suppliers' instructions.
- C.** Use only your hand to turn the gas control knob. Never use tools. If the handle will not turn by hand, don't try to repair it, call a qualified service technician. Force or attempted repair may result in a fire or explosion.
- D.** Do not use this appliance if any part has been under water. Immediately call a qualified service technician to inspect the appliance and to replace any part of the control system and any gas control which has been under water.
- E.** If you cannot reach your gas supplier, call the fire department.

OPERATING INSTRUCTIONS

- STOP! Read the safety information above.
- Set the thermostat to lowest setting.
- Turn off all electric power to the appliance.
- This appliance is equipped with an ignition device which automatically lights the burner. Do not try to light the burner by hand.
- Remove front cover.
- Turn gas shutoff valve to "off". Handle will be across the piping, do not force.
- Wait five (5) minutes to clear out any gas. If you then smell gas, STOP! Follow "B" in the safety information above on this label. If you don't smell gas, go to next step.
- Turn gas shutoff valve to "on". Handle will be in line with piping.
- Install Front Cover.
- Turn on all electric power to appliance.
- Set thermostat to desired setting.
- If the appliance will not operate, follow the instructions "To Turn Off Gas To Appliance" and call your service technician or gas supplier.

**GAS VALVE
ON**

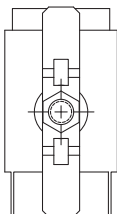

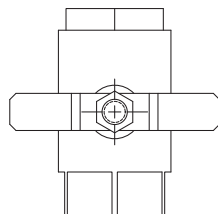

**GAS VALVE
OFF**



TO TURN OFF GAS TO APPLIANCE

- Set the thermostat to lowest setting.
- Turn off all electric power to the appliance if service is to be performed.
- Remove Front Cover.
- Turn gas shutoff valve to "off". Handle will be across the piping. Do not force.
- Install Front Cover.

LP-175 Rev. 4 3-11-08

SPECIAL ATTENTION BOXES	
The following defined terms are used throughout this manual to bring attention to the presence of hazards of various risk levels or to important product information.	
	DANGER
DANGER indicates an imminently hazardous situation which, if not avoided, will result in serious personal injury or death.	
	WARNING
WARNING indicates a potentially hazardous situation which, if not avoided, could result in personal injury or death.	
	CAUTION
CAUTION indicates a potentially hazardous situation which, if not avoided, may result in moderate or minor personal injury.	
CAUTION	
CAUTION used without the safety alert symbol indicates a potentially hazardous situation which, if not avoided, may result in property damage.	
NOTICE	
NOTICE is used to address practices not related to personal injury.	

Foreword

This manual is intended to be used in conjunction with other literature provided with the VWH. This includes all related control information. It is important that this manual, all other documents included in this system, and additional publications including the *National Fuel Gas Code - ANSI Z223.1* (latest versions), be reviewed in their entirety before beginning any work.

Installation should be made in accordance with the regulations of the Authority Having Jurisdiction, local code authorities, and utility companies which pertain to this type of water heating equipment.

Authority Having Jurisdiction (AHJ) – The AHJ may be a federal, state, local government, or individual such as a fire chief, fire marshal, chief of a fire prevention bureau, labor department or health department, building official or electrical inspector, or others having statutory authority. In some circumstances, the property owner or his/her agent assumes the role, and at government installations, the commanding officer or departmental official may be the AHJ.

NOTE: HTP reserves the right to modify product technical specifications and components without prior notice.

For the Installer

This VWH must be installed by qualified and licensed personnel. The installer should be guided by the instructions furnished with the VWH, and by local codes and utility company requirements. In the absence of local codes, preference should be given to the *National Fuel Gas Code - ANSI Z223.1* in the United States and the *Natural Gas and Propane Installation Code - B149.1* in Canada (latest versions).

Installations Must Comply With:

Local, state, provincial, and national codes, laws, regulations, and ordinances.

In the United States - The latest version of the *National Fuel Gas Code, ANSI Z223.1*, from American Gas Association Laboratories, 8501 East Pleasant Valley Road, Cleveland, OH 44131.

The latest version of the *National Electrical Code, NFPA No. 70*.

In Canada - The latest versions of the *Natural Gas and Propane Installation Code, CSA B149.1*, and the *Canadian Electrical Code, C22.1*, from CSA Group, 178 Rexdale Blvd, Toronto, Ontario, Canada M9W 1R3.

NOTE: The gas manifold and controls met safe lighting and other performance criteria when undergoing tests specified in *ANSI Z21.13* - latest edition.

! DANGER



! Vapors from flammable liquids will explode and catch fire causing death or severe burns.
Do not use or store flammable products such as gasoline, solvents or adhesives in the same room or area near the water heater.
Keep flammable products:

1. far away from heater,
2. in approved containers,
3. tightly closed and
4. out of children's reach.

Installation:
Do not install water heater where flammable products will be stored or used unless the main burner and pilot flames

Water heater has a main burner and pilot flame.
The pilot flame:

1. which can come on at any time and
2. will ignite flammable vapors.

Vapors:

1. cannot be seen,
2. are heavier than air,
3. go a long way on the floor and
4. can be carried from other rooms to the pilot flame by air currents.

are at least 18" above the floor. This will reduce, but not eliminate, the risk of vapors being ignited by the main burner or pilot flame.

Read and follow water heater warnings and instructions. If owners manual is missing, contact the retailer or manufacturer.

! DANGER

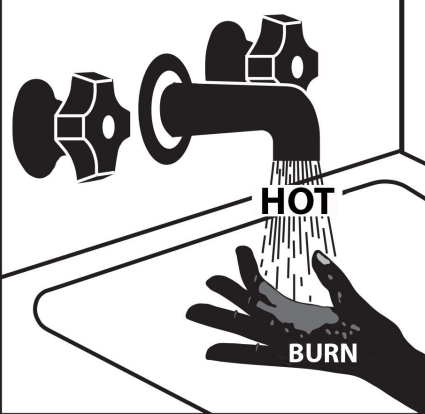

Water temperature over 125°F can cause severe burns instantly or death from scalds. Children, disabled and elderly are at highest risk of being scalded. See instruction manual before setting temperature at water heater. Feel water before bathing or showering. Temperature limiting valves are available, see manual.

NOTICE

The CSD-1 ASME Code, Section CW-400 requires that hot water heating and supply boilers have a) a UL 353 temperature control device, b) at least one (1) temperature-actuated control to shut off the fuel supply when system water reaches a preset operating temperature, c) a high temperature limit control that prevents the water temperature from exceeding the maximum allowable temperature by causing a safety shutdown and lockout, and d) its own sensing element and operating switch.

The temperature control system integrated into the 926 control provided with this heating appliance complies with the requirements of CSD-1 Section CW-400 as a temperature operation control. The control monitors the temperature difference between the inlet and the outlet sensor, which is affected by boiler water flow. If this temperature difference exceeds 55°F (typically because of low water flow or very low heat load), the control will reduce the maximum fan speed. If the temperature difference exceeds 60°F, the control will effectively sense there is little or no water flow or heat load and shut the boiler down. The controller will restart automatically once the temperature difference has dropped below 55°F and the minimum off time (anti-cycle time) has expired. In addition, if the control senses that the outlet water temperature has reached 210°F, the boiler is put into a hard lockout and requires manual reset to restart.

Table of Contents

Part 1 - General Safety Information	5	Part 5 - Venting	25
A. Operation and Installation Warnings	5	A. General	25
B. Improper Combustion	6	B. Approved Materials for Exhaust Vent and Intake Pipe	26
C. Gas	6	C. Additional Requirements for Installation in Canada	26
D. When Servicing the Water Heating System	6	D. Exhaust Vent and Intake Pipe Location	27
E. Water Chemistry Requirements*	6	E. Exhaust Vent and Intake Pipe Sizing	28
F. Freeze Protection	6	F. Longer Vent Runs	28
G. Water Temperature Adjustment	7	G. Exhaust Vent and Intake Pipe Installation	28
H. High Elevation Installations	7	H. Applications	29
Part 2 - Before You Start	8	1. Direct Vent Installation of Exhaust and Intake	29
A. What's in the Box	9	2. Venting Through an Existing System	33
B. How the VWH Operates	9	3. Power Venting, Indoor Combustion Air in Confined or Unconfined Space	34
C. Optional Equipment	10	Part 6 - Condensate Removal	35
Part 3 - Prepare the VWH	10	Part 7 - Wiring	36
A. Locating the VWH	10	A. Installation Must Comply With	36
B. Flooring	11	B. Field Wiring Terminations	36
C. Leveling	11	C. Field Wiring	36
D. Clearances for Service Access	12	D. Line Voltage Wiring for Standard VWH	36
E. Residential Garage and Closet Installations	12	E. Alarm Connections	36
F. Exhaust Vent and Intake Pipe	12	F. Low Voltage Connections for Standard VWH	36
1. Direct Vent of Exhaust and Intake	12	G. Tank Sensor or Mechanical Control	36
2. Power Venting, Indoor Combustion Air in Confined or Unconfined Space	13	H. System / Pipe Sensor	37
G. Carbon Monoxide Detectors	13	I. Optional 0-10 Volt Building Control Signal	37
H. Prevent Combustion Air Contamination	13	J. Optional UL353 Low Water Cut-Off Interface Kit	37
I. Removing a VWH from a Common Vent System	13	K. Wiring of Cascade System Communication Bus	37
K. Technical Specifications	15	L. Cascade Master Pump and Sensor Wiring	38
Part 4 - Piping	18	M. Cascade Follower Pump and Sensor Wiring	38
A. General Plumbing Information	18	N. Variable Speed Pumping	38
B. Backflow Preventer	18	Part 8 - Gas Connections	41
C. Potable Expansion Tank	18	A. Gas Piping	41
D. Circulators	18	B. Gas Table	42
E. Flow Switch Installation	19	C. Additional Precaution for Excess Flow Valve (EFV)	42
F. Relief Valve	19	D. Check Inlet Gas Pressure	42
G. Scalding	20	E. VWH Gas Valve	43
H. High Velocity Circulator Pump	20	Part 9 - Start-Up Preparation	44
I. Check / Control Water Chemistry	22	A. Check / Control Water Chemistry	44
J. Plumbing	22	B. Check for Gas Leaks	44
K. Applications	23	C. Condensate Removal	44
		D. Filling and Testing the VWH System	44
		E. Final Checks Before Starting VWH	44
		F. Setting Up a Single VWH	45
		G. Setting Up a Cascaded System	45
		H. Lockout Condition	45
		I. Cascade System Programming	45
		Part 10 - Start-Up Procedure	47
		A. Control Overview	47
		B. Navigation of the Display	47
		C. Operating Instructions	47
		D. Programming VWH Settings	47
		E. Programming the System Setting	48
		F. System Setting Program Navigation	48
		G. Resetting the Maintenance Schedule	50
		Part 11 - Start-Up Procedures for the Installer	51
		A. VWH Control Status Menu	51
		B. Cascade Menu	53
		C. VWH Test Mode	54
		Part 12 - Troubleshooting	54
		A. VWH Error and Fault Codes	54
		B. VWH Error	54
		C. VWH Fault	54
		D. User Interface Display	55
		Part 13 - Maintenance	60
		A. Procedures	60
		B. Combustion Chamber Coil Cleaning Instructions	60
		C. Cleaning Water Side of Heat Exchanger	61
		D. Maintaining the Condensate System	61

Part 14 - Installation Checklist 63
Part 15 - Maintenance Report 63
Part 16 - Replacement Parts 65
 Limited Warranty 69
 Maintenance Notes 71
 Customer Installation Record Form 72

Part 1 - General Safety Information

This VWH is approved for indoor installations only and is not intended for use as a pool heater. Clearance to combustible materials: 0" top, bottom, sides, and back. Left side has all VWH mechanical connections. VWH must have room for service: 24" front is minimum recommended service clearance. (A combustible door or removable panel is acceptable front clearance.) This VWH has been approved for closet installation and installation on combustible flooring. Do not install directly on carpeting. Install the VWH in a location where temperature and pressure relief valve discharge or a leak will not result in damage to the surrounding area. If such a location is not available install an auxiliary catch pan.

This appliance is rated Category IV (pressurized vent, likely to form condensate in the vent) and requires a special vent system designed for pressurized venting. **Use only Category IV vent systems.**

 WARNING
Installer - Read all instructions in this manual before installing. Perform steps in the given order.
User - This manual is for use only by a qualified heating installer / service technician. Have this VWH serviced / inspected annually by a qualified service technician.
FAILURE TO ADHERE TO THE GUIDELINES ON THIS PAGE CAN RESULT IN SUBSTANTIAL PROPERTY DAMAGE, SEVERE PERSONAL INJURY, OR DEATH.
NOTE: Obey all local codes. Obtain all applicable permits before installing the VWH.
NOTE: Install all system components and piping in such a manner that does not reduce the performance of any fire rated assembly.

A. Operation and Installation Warnings

To avoid serious injury or death, read, understand, and follow all of the precautions listed here.

 DANGER
Vapors from flammable liquids will explode and cause a fire, resulting in personal injury or death. The VWH has a burner that can come on at any time and ignite vapors. DO NOT use or store flammable liquids around the VWH.
Improper venting can cause a build-up of carbon monoxide. Breathing carbon monoxide can result in brain damage or death. DO NOT operate the VWH unless it is properly vented to the outside and has an adequate fresh air supply for safe operation. Inspect the exterior exhaust gas outlet port and fresh air inlet port on a regular basis to ensure they are functioning properly.
A concentration of carbon monoxide as small as .04% (400 parts per million) in the air can be fatal. When making high fire or low fire adjustments, CO levels must be monitored using a calibrated combustion analyzer such that a CO level of no more than 150 ppm is exceeded at any time during operation.
Adjusting the "low fire offset" or the "main flow restrictor" in small increments can result in a significant increase in CO concentration. To avoid serious injury or death, DO NOT make any adjustments to the gas valve without monitoring the exhaust gases with a fully functional and calibrated combustion analyzer.
Failure to follow these instructions will result in property damage, severe personal injury, or death.

 WARNING
This VWH must be installed by a licensed plumber, licensed gas fitter, and/or professional service technician. Improper installation and/or operation can cause a potentially hazardous situation, which, if not avoided, could result in serious injury or death, and will void the warranty.
The manufacturer cannot anticipate every circumstance that might involve a potential hazard. Each installation has its own specialized characteristics, requirements, and possible hazards. Therefore, all possible incidents are not included in these warnings. Proper and safe installation, operation, and service are the responsibility of the qualified service technician.
Proper care of the VWH is the user's responsibility. Ensure the user carefully reads and understands the User's Information Manual before operating the VWH.
Make sure the user knows the location of the gas shut-off valve and how to operate it. Immediately close the gas shut-off valve if the appliance is subjected to fire, overheating, flood, physical damage, or any other damaging condition that might affect the operation of the unit. Have the appliance checked by a qualified service technician before resuming operation.
Do not power up the unit unless the gas and water supply valves are fully opened. Make sure the fresh air intake port and exhaust gas port are open and functional.
No one but a qualified service technician should attempt to install, service, or repair this VWH. There are no serviceable parts which can be changed by the user / owner.
User / Owner: Contact the original qualified service technician if the VWH needs repair / maintenance. If the original technician is unavailable, ask your gas supplier for a list of qualified service providers.
DO NOT store or place newspapers, laundry, or other combustible items near the appliance or the exterior exhaust gas outlet and/or fresh air inlet port.
The owner should inspect the system monthly for damage, water stains, signs of rust, corrosion, and exhaust vent and air intake blockage. If inspection of the unit shows signs of damage, the VWH should be shut off until the problem is repaired by a qualified technician.
After installation, all appliance safety devices should be tested.
Carefully consider installation location and the placement of critical components (circulators, condensate neutralizers, etc.) before installing the VWH.
DO NOT allow children to operate this VWH. DO NOT use this VWH if it does not appear to be operating correctly. A qualified service technician should service and inspect the VWH annually.
NOTE: If the VWH is exposed to fire or water (or is any way damaged), do not operate. Immediately call a qualified service technician. Failure to follow this information could result in property damage, severe personal injury, or death.
DO NOT USE THIS VWH IF ANY PART HAS BEEN SUBMERGED IN WATER. Immediately call a qualified service technician. The VWH MUST BE replaced if it has been submerged. Attempting to operate a VWH that has been submerged could create numerous harmful conditions, such as a potential gas leakage causing a fire and/or explosion, or the release of mold, bacteria, or other harmful particulates into the air. Operating a previously submerged VWH could result in property damage, severe personal injury, or death. NOTE: VWH damage due to flood or submersion is considered an Act of God, and IS NOT covered under product warranty.

▲ WARNING

The appliance is certified for indoor installations only. The appliance consists of gas ignition system components which must be protected from water (dripping, spraying, etc.) during operation and service. Carefully consider installation location and the placement of critical components (circulators, condensate neutralizers, etc.) before installing the appliance.

DO NOT alter or modify the appliance or appliance controls. Altering any HTP VWH with parts not manufactured by HTP WILL INSTANTLY VOID the VWH warranty and could result in property damage, personal injury, or death.

This VWH has been designed to heat potable water ONLY. Using this VWH to heat non-potable fluid WILL VOID product warranty, and could result in property damage, personal injury, or death.

CAUTION

High heat sources (sources generating heat 100°F / 37°C or greater, such as stove pipes, space heaters, etc.) may damage plastic components of the VWH as well as plastic vent pipe materials. Such damages ARE NOT covered by warranty. It is recommended to keep a minimum clearance of 8" from high heat sources. Observe heat source manufacturer instructions, as well as local, state, provincial, and national codes, laws, regulations and ordinances when installing this VWH and related components near high heat sources.

NOTICE

This appliance provides an overheat shutdown limit. In the event the appliance water temperature exceeds the setpoint of the control limit, the cutoff will trip and the appliance will shut down. Certain local codes require additional temperature limits. In addition, certain types of systems may operate at temperatures below the minimum setpoint of the limit provided with the appliance. Contact the manufacturer for additional overheat controls.

B. Improper Combustion

▲ WARNING

Do not obstruct the flow of combustion and ventilating air. Adequate air is necessary for safe operation. Failure to keep the exhaust vent and combustion air intake clear of ice, snow, or other debris could result in property damage, serious personal injury, or death.

C. Gas

Should overheating or gas supply fail to shut off, turn off the manual gas control valve to the VWH.

D. When Servicing the Water Heating System

▲ WARNING

Be sure to disconnect electrical power before opening VWH cabinet or performing service. Label all wires while performing service to ensure proper re-wiring of the VWH. Wiring errors can cause improper or dangerous operation. Failure to do so could result in an electrical shock, improper VWH operation, property damage, serious personal injury, or death.

- To avoid electric shock, disconnect electrical supply before performing maintenance.
- To avoid severe burns, allow VWH and associated equipment to cool before servicing.
- Do not use petroleum-based cleaning or sealing compounds in a water heating system. Gaskets and seals in the system may be damaged. This can result in substantial property damage.

- Do not use "homemade cures" or "patent medicines". Damage to the VWH, substantial property damage, and/or serious personal injury may result.
- Always verify proper operation after servicing the VWH.

NOTE: When inquiring about service or troubleshooting, reference the model and serial numbers from the VWH rating label.

E. Water Chemistry Requirements*

CAUTION

Chemical imbalance of the water supply may affect efficiency and cause severe damage to the appliance and associated equipment. Water quality must be professionally analyzed to determine whether it is necessary to treat the water. Various solutions are available to adjust water quality. Adverse water quality will affect the reliability of the system. In addition, operating temperatures above 135°F will accelerate the build-up of lime scale and possibly shorten appliance service life. Failure of an appliance due to lime scale build-up, low pH, or other chemical imbalance IS NOT covered by the warranty.

The water must be potable, free of corrosive chemicals, sand, dirt, and other contaminants. It is up to the installer to ensure the water does not contain corrosive chemicals or elements that can damage the heat exchanger. Potable water is defined as drinkable water supplied from utility or well water in compliance with EPA secondary maximum contaminant levels (40 CFR Part 143.3) as shown in the table below. If the water contains contaminants higher than outlined by the EPA, water treatment is recommended and additional, more frequent maintenance may be required.

If you suspect that your water is contaminated in any way, discontinue use of the appliance and contact an authorized technician or licensed professional.

Contaminant	Maximum Allowable Level	Contaminant	Maximum Allowable Level
Total Hardness (Commercial Use - 140°F and above water temperature)	120 mg/l (7 grains/gallon)	pH	6.5-8.5
		Sulfate	205 mg/l
		Total Dissolved Solids (TDS)	500 mg/l
Aluminum	0.05 to 0.2 mg/l	Zinc	5 mg/l
Chloride	100 mg/l		
Copper	1 mg/l	Dissolved Carbon Dioxide (CO ₂)	15 mg/l or PPM
Iron	0.3 mg/l		
Manganese	0.05 mg/l		

Table 1 - Water Quality Specifications

***NOTE:** It is recommended to clean heat exchanger at least once a year to prevent lime scale buildup. Follow the maintenance procedure in the Maintenance Section of this manual to clean the heat exchanger.

F. Freeze Protection

NOTE: Consider piping and installation when determining heater location.

CAUTION

Failure of the VWH due to freeze related damage IS NOT covered by product warranty.

⚠ WARNING

NEVER use any toxic chemical, including automotive, standard glycol antifreeze, or ethylene glycol made for hydronic (non-potable) systems. These chemicals can attack gaskets and seals in water systems, are poisonous if consumed, and can cause personal injury or death.

NOTE: HTP DOES NOT WARRANT THE APPLIANCE AGAINST FREEZE-RELATED DAMAGE.

G. Water Temperature Adjustment

This VWH can deliver scalding water. Be careful whenever using hot water to avoid scalding injury. Certain appliances such as dishwashers and automatic clothes washers may require increased water temperatures. By setting the thermostat on this heater to obtain the increased water temperature required by these appliances you may create the potential for scald injury.

To protect against injury, install a mixing valve in the water system. This valve will reduce point of use discharge temperatures by mixing cold and hot water in branch supply lines. Such valves are available from your local plumbing supplier.

Table 2 details the relationship of water temperature and time with regard to scald injury and may be used as a guide in determining the safest water temperature for your applications.

⚠ WARNING

Households with small children, disabled, or elderly persons may require a 120°F or lower temperature setting to prevent severe personal injury or death due to scalding.

Approximate Time / Temperature Relationships in Scalds	
120°F	More than 5 minutes
125°F	1 1/2 to 2 minutes
130°F	About 30 seconds
135°F	About 10 seconds
140°F	Less than 5 seconds
145°F	Less than 3 seconds
150°F	About 1 1/2 seconds
155°F	About 1 second

Table 2 - Approximate Time / Temperature Relationships in Scalds

⚠ WARNING

An ASSE 1017 or ASSE 1070 temperature limiting or mixing valve is recommended in installations servicing disabled or elderly persons, or children. Mixing valves do not eliminate the risk of scalding.

To avoid scalding:

- Set the VWH set point temperature as low as possible.
- Feel water before bathing or showering.
- If thermostatic valves are required, use devices specifically designed for such purpose. Install these devices in accordance with instructions provided by the manufacturer.

Failure to install a temperature limiting or mixing valve and follow these instructions could result in property damage, severe personal injury, or death due to scalds.

Households with small children, disabled, or elderly persons may require a 120°F or lower temperature setting to prevent severe personal injury or death due to scalding.

H. High Elevation Installations

This VWH is designed to operate at its maximum listed capacity in installations located at 0 - 2000 ft above Sea Level. Since the density of air decreases as elevation increases, maximum specified capacity should be de-rated for elevations above 2000 ft (610 m) in accordance with the table below.

Elevations	2001 ft (610 m)	3000 ft (914 m)	4000 ft (1219 m)	4500 ft (1372 m)	5000 ft (1524 m)
In Canada¹, de-rate by:	10%	10%	10%	10%	may vary
In USA², de-rate by:	-	12%	16%	18%	20%

NOTES:
¹Canada: Elevations between 2000 - 4500 ft (610 - 1372 m), de-rate by 10%. Consult local authorities for de-rating for elevations above 4500 ft (1372 m).
²USA: If elevation is above 2000 ft (610 m), de-rate capacity by 4% for every 1000 ft (305 m).

Table 3 - De-Rate % for High Elevations

⚠ WARNING

Combustion - At elevations above 2000 ft, the combustion of the VWH must be checked with a calibrated combustion analyzer to ensure safe and reliable operation. **It is the Installer's responsibility to check and adjust the combustion in accordance with this manual.** Failure to follow these instructions may result in property damage, serious personal injury, or death.

Part 2 - Before You Start

CAUTION

These VWH units must be connected to a storage tank. You must not have a direct connection of the potable water system into the heat exchanger. This could cause flow issues, short cycling, and an increase of mineral build-up in the unit. This system is designed to have incoming potable water flow through the storage tank first, then through the heat exchanger. Failure to connect the VWH to a storage tank of the minimum size requirements (80 gallons for these VWH models) will result in property damage and/or premature VWH failure. Damages resulting from incorrect installation or from use of products not approved by HTP ARE NOT covered by warranty.

ΔT (Delta T) (°F)	220VWH				299VWH / 301VWH				399VWH			
	Gallons Per Hour	First Hour Rating 80 Gallon Tank	First Hour Rating 119 Gallon Tank	First Hour Rating 175 Gallon Tank	Gallons Per Hour	First Hour Rating 80 Gallon Tank	First Hour Rating 119 Gallon Tank	First Hour Rating 175 Gallon Tank	Gallons Per Hour	First Hour Rating 80 Gallon Tank	First Hour Rating 119 Gallon Tank	First Hour Rating 175 Gallon Tank
		Contact HTP for Available Storage Tanks				Contact HTP for Avail- able Storage Tanks				Contact HTP for Available Storage Tanks		
40°	635	397	414	438	866	529	546	570	1152	693	709	733
50°	508	406	427	457	693	538	559	589	922	701	722	752
60°	424	415	440	476	578	547	572	608	768	710	735	771
70°	363	423	452	494	495	555	584	626	658	718	748	790
80°	318	432	465	513	433	564	597	645	576	727	760	808
90°	282	440	478	532	385	572	610	664	512	736	773	827
100°	254	449	491	551	347	581	623	683	461	744	786	846
110°	231	457	503	569	315	589	635	701	419	753	799	865
120°	212	466	516	588	289	598	648	720	384	761	811	883
130°	196	475	529	607	267	607	661	739	355	770	824	902
140°	182	483	542	626	248	615	674	758	329	778	837	921

Table 4 - VWH Ratings with Storage Tanks - NOTE: Gallons Per Hour Does Not Take a Storage Tank into Account

Min Tank Size (Gal.) = Required Flow (GPM) X 10

$$\text{Mixing Factor } (M_f) = \frac{\text{VWH Outlet Temp} - \text{Inlet Temp}}{70}$$

$$\text{First Hour Rating} = \left[\frac{\text{Total VWH Output} \times \text{VWH Efficiency}}{(\text{VWH Outlet Temp} - \text{Inlet Temp}) \times 8.31} + .75 \times \text{Total Storage} \right] \times M_f$$

Example:

2 220VWHs - Total Output = 440,000 BTU @ 96% Efficiency

VWH Outlet Temp = 140°F - Inlet Temp = 40°F

2 Storage Tanks (80 Gallons Each) = Total Storage = 160 Gallons

$$\text{Mixing Factor } (M_f) = \frac{140 - 40}{70} = 1.43$$

$$\text{First Hour Rating} = \left[\frac{440,000 \times .96}{(140 - 40) \times 8.31} + .75 \times 160 \right] \times 1.43$$

$$\text{First Hour Rating} = \left[\frac{422,400}{831} + 120 \right] \times 1.43$$

$$\text{First Hour Rating} = \left[508 + 120 \right] \times 1.43$$

$$\text{First Hour Rating} = 628 \times 1.43$$

$$\text{First Hour Rating} = 898 \text{ Gallons}$$

NOTICE

UNCRATING THE VWH - Any claims for damage or shortage in shipment must be filed immediately against the transportation company by the consignee.

Remove the VWH and accessories from the packaging. Take care to place the VWH and accessories in a safe location prior to installation to prevent damage to the mechanical connections.

The VWH is also equipped with leveling feet that can be used to level the VWH properly on an uneven location surface. If surface flooring is rough, take care when moving the VWH into position, as catching the leveling feet could damage the VWH.

A. What's in the Box

Components (and Part #) included with the VWH:

- Temperature and Pressure Gauge (7250P-499)
- Pressure Relief Valve (7450P-254)
- Intake PVC Tee with Screens
- Exhaust PVC Coupling with Screens
- Outlet Combination Fitting (220 Model - 7450P-235, 299/301 Models - 7450P-236, 399 Model - 7450P-237)
- Flow Switch and Paddles (7250P-517)
- Installation Manual and Warranty
- CSD-1 Form
- H-3 Data Sheet

B. How the VWH Operates

Condensing technology intelligently delivers large amounts of hot water while maximizing efficiency. Outlined below are the features of the system and how they operate:

Stainless Steel Heat Exchanger

The highly efficient stainless steel heat exchanger is designed to extract all available heat from the storage tank cold water return before it is exhausted.

Modulating Combustion System

The combustion system modulates the output of the burner during operation to match system demand and achieve the control set point while in operation. The set point can change by internal or external signals to enhance the overall performance of the system.

Control

The integrated control system monitors the system and regulates fan speed to control VWH output. This allows the VWH to deliver only the amount of heat energy required and nothing more.

The control can regulate the output of multiple VWHs through its cascade system function. The cascade system is capable of connecting up to eight VWHs together in such a way that they function as one VWH system. This allows for greater turn down ratios and provides systematic control of the multiple VWHs in an installation to minimize downtime and maximize efficiency.

The cascade system works by establishing one VWH as the master and the other connected VWHs as followers. The master VWH requires a sensor to provide feedback on set point temperature in order to adjust heating input from the connected VWHs. Each cascaded VWH will have its own pump to provide maximum flow and control heat exchanger flow rate.

Text Display and Operational LED Light Indicators

The display allows the user to change system parameters and monitor system outputs.

Gas Valve

Senses suction from the blower, allowing gas to flow only if powered and combustion air is flowing.

All Metal Integrated Venturi

Controls air and gas flow into the burner.

Burner

The high grade stainless steel burner uses premixed air and gas to provide a wide range of firing rates.

Spark Ignition

The burner is ignited by applying high voltage through the system spark electrode. The spark from the electrode ignites mixed gas off of the burner.

Dual Supply Water Temperature Sensor / High Limit Water ECO

This dual sensor monitors the VWH outlet water temperature (System Supply). The control adjusts VWH firing rate so the supply temperature will match the VWH set point. The dual sensor meets all requirements to function as a safety, eliminating the mechanical ECO and increasing safety and reliability.

Return Water Temperature Sensor

This sensor monitors VWH return water temperature (System Return).

Flue Sensor

Monitors flue temperature and adjusts firing rate.

Temperature and Pressure Gauge

Allows the user to monitor system temperature and pressure.

Electrical field connections with terminal strips

The electrical cover allows easy access to the clearly marked line voltage and low voltage terminal strips to facilitate wiring the VWH.

Condensate Collection System

This VWH is a high efficiency appliance and will produce condensate. The condensate collection system has a float which monitors condensate level and prevents condensate from backing up into the combustion system. Inside the collection system is a built in trap which seals the combustion system from the connected drain. This condensate should be neutralized to avoid damage to the drainage system or piping.

Flow Protection

The supplied flow switch is designed to protect the VWH during low flow conditions. The VWH control also monitors flow through the heat exchanger by monitoring the return and supply sensors and will shut down the burner before overheating occurs.

0-10 Volt Input

Allows the installer to connect a BMS (Building Management System) to control the VWH.

0-10 Volt Output A (Configured through Control System)

0-10 Volt Output A is configured through the VWH's control system. 0-10 Volt Output A is related to one of the following VWH values: VWH power, cascade power, fan speed, alarm status, or temperature setting based on outdoor reset curve.

UL 353 Internal Low Water Cutoff (LWCO)

The supplied internal Low Water Cutoff meets UL 353 requirements to function as a safety, locking out the VWH when water level is inadequate for safe operation. To test LWCO function, press and hold v and RESET simultaneously for five (5) seconds. Press RESET to clear the error code.

Boost Timer Function

This function temporarily overrides the outdoor reset curve in order to satisfy a thermostat setpoint in a short amount of time, especially during a relatively warm day.

Flue Temperature Modulation

As an additional safety feature, if the flue temperature exceeds 200°F, the control will modulate the VWH down based on the vent temperature, rather than the supply temperature. If the flue temperature exceeds 210°F the control will lock out the VWH.

System Sensor (Optional)

This sensor is designed to be used in a cascade system. The system pipe sensor measures the temperature of return water and communicates with the control system to modulate the firing rate of the connected VWHs.

NOTE: When using a system sensor, pipe insulation must be wrapped around it to improve temperature measurement accuracy and increase overall system efficiency.

External Low Water Cutoff (Optional)

Connection points are provided on the Field Connection Board to install an external LWCO if required by local codes.

Condensate Flue Check System

The check system prevents heat exchanger exhaust from backing up into the cabinet.

Pump Service Mode

Allows manual operation of pumps to commission system and check pump operation.

C. Optional Equipment

Optional equipment available from HTP (and Part #):

- Wall Mount Bracket (7450P-211)
- System Sensor (7250P-324)
- Indirect Tank Sensor (7250P-325)
- 3" Stainless Steel Vent Termination Kit (V1000)
- 4" Stainless Steel Vent Termination Kit (V2000)
- 6" Stainless Steel Vent Termination Kit (V3000)
- 2" PVC Concentric Vent Kit (KGAVT0501CVT)
- 3" PVC Concentric Vent Kit (KGAVT0601CVT)
- 3" Polypro Vent Kit (8400P-001)
- 3" Polypro Pipe
 - (33' length # 8400P-002, 49.5' length # 8400P-003)
- Low Water Cut-Off Kit (7450P-904)
- Manual Reset High Limit (7450P-910)
- Alarm System (to monitor any failure) (7350P-602)
- 928 PC Connection Kit with Software (7450P-330)
- Condensate Neutralizer (220/299/301 Models - 7450P-212, 399 Model - 7350P-611)
- Eighty Gallon Glass-Lined Storage Tank (GL-80)
- Eighty Gallon Stainless Steel Storage Tank (SSU-80CB)

VWH Circulator Kits

- 220 Model - Part # 7450P-248
- 299 / 301 Models - Part # 7450P-249
- 399 Model - Part # 7450P-250

NOTE: When using an optional system sensor, pipe insulation must be wrapped around it to improve temperature measurement accuracy and increase overall system efficiency.

Part 3 - Prepare the VWH

CAUTION

COLD WEATHER HANDLING - If the VWH has been stored in a very cold location (BELOW 0°F) before installation, handle with care until the components come to room temperature. Failure to do so could result in damage to the VWH.

Carefully consider installation when determining VWH location. Please read the entire manual before attempting installation. Failure to properly take factors such as VWH venting, piping, condensate removal, and wiring into account before installation could result in wasted time, money, and possible property damage and personal injury.

A. Locating the VWH

WARNING

This VWH is certified for indoor use only. DO NOT INSTALL OUTDOORS. Outdoor installations ARE NOT covered by warranty. Failure to install the VWH indoors could result in property damage, severe personal injury, or death.

Incorrect ambient conditions can lead to damage to the heating system and put safe operation at risk. Ensure that the installation location adheres to the information included in this manual. Failure to do so could result in property damage, serious personal injury, or death. Failure of VWH or components due to incorrect operating conditions IS NOT covered by product warranty.

WARNING

This VWH must be installed upright in the vertical position as described in this manual. DO NOT attempt to install this VWH in any other orientation. Doing so will result in improper VWH operation and property damage, and could result in serious personal injury or death.

This VWH is heavy. Take precautions when moving the VWH into its installation location to avoid tipping, bumping, or dropping it. Failure to take such precautions may result in property damage, severe personal injury, or death.

This VWH has a condensate disposal system that may freeze if exposed to sustained temperatures below 32°F. Precautions should be taken to protect the condensate trap and drain lines from sustained freezing conditions. Failure to take precautions could result in property damage, severe personal injury, or death.

1. Installation Area (Mechanical Room) Operating Conditions

- Ensure ambient temperatures are higher than 33°F / 0.6°C and lower than 104°F / 40°C
- Prevent the air from becoming contaminated by the products, places, and conditions listed in this manual
- Avoid continuously high levels of humidity
- Never close existing ventilation openings
- Ensure a minimum 1" clearance around hot water and exhaust vent pipes
- NOTE: To prevent condensing in the fan, it is recommended to avoid prolonged exposure to temperatures below 45°F

2. Check for nearby connections to:

- System water piping
- Venting connections
- Gas supply piping
- Electrical power
- Condensate drain

3. Check area around VWH. Remove any combustible materials, gasoline, and other flammable liquids.

WARNING

Failure to keep the VWH area clear and free of combustible materials, liquids, and vapors can result in substantial property damage, severe personal injury, or death.

Do not connect the VWH to any heating systems or components that have been previously used for non-potable applications.

Do not introduce toxic chemicals, such as antifreeze or VWH treatments, into the VWH or any piping meant for potable water purposes.

Ensure that all piping and components connected to the VWH are suitable for potable water applications.

Do not use this VWH for space heating applications.

Circulators suitable for DHW applications must be used.

Failure to follow these instructions could result in serious personal injury or death.

CAUTION

Always take future maintenance into consideration when locating the VWH. If the VWH is located in an installation location with limited clearances, it may be necessary to remove the VWH from the space to perform maintenance. Failure to consider maintenance when determining installation location could result in property damage.

The service life of the VWH's exposed metallic surfaces, such as the casing, as well as internal surfaces, such as the heat exchanger, are directly influenced by proximity to damp and salty marine environments. In such areas higher concentration levels of chlorides from sea spray coupled with relative humidity can lead to degradation of VWH components. In these environments, heaters must not be installed using direct vent systems which draw outdoor air for combustion. Such heaters must be installed using room air for combustion. Indoor air will have a much lower relative humidity, and hence potential corrosion will be minimized.

All VWHs eventually leak. Locate the VWH where any leakage from the relief valve, related piping, tank, or connections will not result in damage to surrounding areas or lower floors of the building. Any VWH should be installed in such a manner that if it should leak the resulting flow of water will not cause damage to the area in which it is installed. National Plumbing codes require a drain pan for any VWH installation. This drain pan should be sized with a maximum depth of 2", and a minimum diameter 2" greater than the diameter of the VWH. The drain pan should empty into an open drain line. This drain line should be 3/4" ID minimum, piped to an open drain. Leakage damages ARE NOT covered by warranty. Failure to install a drain pan is the sole responsibility of the owner and/or installer. Reference UPC 2000 (Uniform Plumbing Code) Section 510 - Protection from Damage or IPC 200 (International Plumbing code) Section 504 - Safety Devices. Leakage damages ARE NOT covered by warranty.

In addition, water leak detection devices and automatic water shutoff valves are readily available at plumbing supply houses. IT IS HIGHLY RECOMMENDED BY THE MANUFACTURER TO INSTALL WATER LEAK DETECTION DEVICES AND AUTOMATIC SHUTOFF VALVES IN ANY VWH INSTALLATION WHERE A LEAKAGE OF WATER COULD RESULT IN PROPERTY DAMAGES.

Failure of the VWH or components due to incorrect operating conditions IS NOT covered by product warranty.

4. Gas control system components must be protected from dripping water during operation and service.
5. If the VWH is to replace an existing VWH, check for and correct any existing system problems, such as:
 - System leaks
 - Location that could cause the system and VWH to freeze and leak
 - Incorrectly sized expansion tank
6. Clean and flush system when reinstalling a VWH.

NOTE: When installing in a zero clearance location, it may not be possible to read or view some product labeling. It is recommended to make note of the heater model and serial number.

NOTE: A combustible door or removable panel is acceptable front clearance.

WARNING

Do not mount the VWH to a hollow wall. Mount to the studs only.

Use extreme care not to drop the VWH or cause bodily injury while lifting or mounting the VWH onto the optional wall mount bracket.

Gas conversion should be performed BEFORE the VWH is installed. Carefully follow the gas conversion instructions when performing the conversion.

Failure to follow these instructions could result in property damage, severe personal injury, or death.

B. Flooring

WARNING

Ensure that the floor and structure of the installation location are sufficient to support the full installed weight of the VWH, including water content of the heat exchanger and related piping. Failure to ensure the floor and structure of the installation location are structurally sound before installation of the VWH can result in structural failure, substantial property damage, severe personal injury, or death.

This VWH is approved for installation on combustible flooring, but must never be installed on carpeting. Installing this VWH on carpeting could result in fire, property damage, severe personal injury, or death.

C. Leveling

CAUTION

In order for the condensate to properly flow out of the collection system, the area where you locate the VWH must be level. Location must also fully support the weight of the filled VWH.

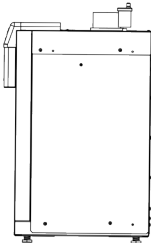

CORRECT

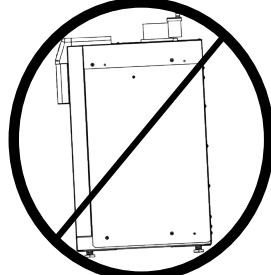

INCORRECT

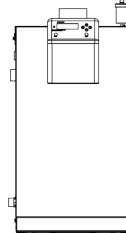

CORRECT



INCORRECT

LP-550-M
07/08/15

Figure 1 - Correct and Incorrect Leveling

D. Clearances for Service Access

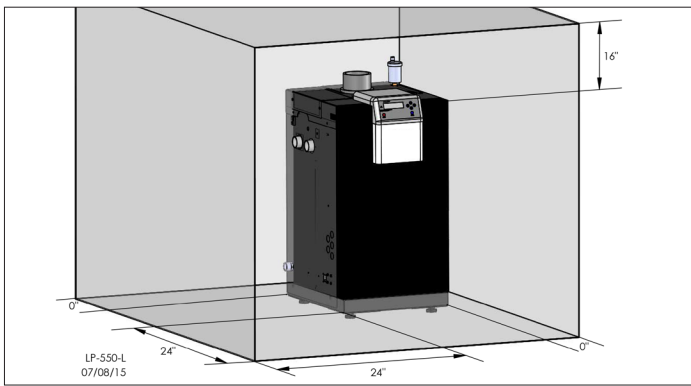

Figure 2 - Recommended Service Clearances

NOTE: If you do not provide the minimum clearances shown in Figure 2 it might not be possible to service the VWH without removing it from the space.

NOTE: A combustible door or removable panel is acceptable front clearance.

Minimum Clearances from Combustible Materials

- Hot water pipes - at least 1" from combustible materials
- Exhaust vent pipe - at least 1" from combustible materials

NOTE: For closet installations, a combustible door or removable panel is acceptable front clearance. A 3" minimum clearance must be provided from the appliance front cover to the removable panel or combustible door.

Appliance Area Ventilation Air Openings - Closet Installations

If the appliance is installed in a closet or alcove the appliance area/room must be ventilated.

EXCEPTION: If the appliance area/room has a volume of 150 ft³ or greater, ventilation of the appliance area/room is not required.

Each ventilation air opening must meet the minimum requirements of 1 in² per 1000 BTU/hr., but not less than 100 in². The lower ventilation opening must be located within 6 in. of the floor, while the upper opening must be located 6 in. from the top of the space.

WARNING

If the appliance area has a volume less than 150 ft³, it is considered a Closet or Alcove. In the US/Canada, PVC vent pipe and fittings SHALL NOT BE USED within the closet or alcove. Only approved CPVC, Polypropylene, or Stainless Steel vent pipe and fittings may be used. See Table 5 for a list of approved materials. Under all circumstances proper ventilation must be provided.

The space must be provided with correctly sized combustion/ventilation air openings for all other appliances located in the space with the appliance. For power venting installations using room air for combustion, refer to the appliance venting section, this manual, for descriptions of confined and unconfined spaces. Do not install the appliance in an attic. The appliance cover must be securely fastened to prevent the appliance from drawing air from the appliance room. This is particularly important if the appliance is in a room with other appliances. Failure to comply with the above warnings could result in substantial property damage, severe personal injury, or death.

Alcove Installations

Alcove installations have the same minimum dimensions as closet installations, except the installation must be completely open to the room at a distance no greater than 18 in. (457 mm) from the front of the appliance and the room must be at least three (3) times the size of the alcove. Provided these conditions are met, the appliance requires no extra ventilation air openings to the space. If these conditions are not met, follow the requirements for Closet Installations.

E. Residential Garage and Closet Installations

CAUTION

Check with your local Authority Having Jurisdiction for requirements when installing the VWH in a garage or closet. Please read the entire manual before attempting installation. Failure to properly take factors such as venting, piping, condensate removal, and wiring into account before installation could result in wasted time, money, and possible property damage and personal injury.

Precautions

If the VWH is located in a residential garage, per ANSI Z223.1:

- Install the VWH burner and ignition devices a minimum of 18" above the floor of the garage. This will ensure the burner and ignition devices are well off the floor.
- When raising the VWH ensure the entire bottom and fully filled weight of the VWH are fully supported.
- Locate or protect the VWH so it cannot be damaged by a moving vehicle.

WARNING

The space must be provided with correctly sized combustion/ventilation air openings for all other appliances located in the space with the VWH. For power venting installations using room air for combustion, refer to the venting section, this manual, for descriptions of confined and unconfined spaces. Do not install the VWH in an attic. Failure to comply with these warnings could result in substantial property damage, severe personal injury, or death.

F. Exhaust Vent and Intake Pipe

The VWH is rated ANSI Z21.13 Category IV (pressurized vent, likely to form condensate in the vent) and requires a special vent system designed for pressurized venting.

NOTE: The venting options described here (and further detailed in the Venting section, this manual) are the lone venting options approved for this VWH. Failure to vent the VWH in accordance with the provided venting instructions will void the warranty.

DANGER

Failure to vent the VWH properly will result in serious personal injury or death.

WARNING

Do not attempt to vent this VWH by any means other than those described in this manual. Doing so will void the warranty and may result in severe personal injury or death.

The exhaust discharged by this VWH may be very hot. Avoid touching or other direct contact with the exhaust gases of the vent termination assembly. Doing so could result in severe personal injury or death.

Vents must be properly supported. VWH exhaust and intake connections are not designed to carry heavy weight. Vent support brackets must be within 1' of the VWH and the balance at 4' intervals. VWH must be readily accessible for visual inspection for first 3' from the VWH. Failure to properly support vents could result in property damage, severe personal injury, or death.

1. Direct Vent of Exhaust and Intake

If installing a direct vent option, combustion air must be drawn from the outdoors directly into the VWH intake and exhaust must terminate outdoors. There are three basic direct vent options detailed in this manual: 1. Side Wall Venting, 2. Roof Venting, and 3. Unbalanced Venting.

Be sure to locate the VWH such that the exhaust vent and intake piping can be routed through the building and properly terminated. Different vent terminals can be used to simplify and eliminate multiple penetrations in the building structure (see Optional Equipment in Venting Section). The exhaust vent and intake piping lengths, routing, and termination methods must all comply with the methods and limits given in the Venting Section, this manual.

When installing a combustion air intake from outdoors, care must be taken to utilize uncontaminated combustion air. **To prevent combustion air contamination, see Table 5.**

2. Power Venting, Indoor Combustion Air in Confined or Unconfined Space

This VWH requires fresh, uncontaminated air for safe operation and must be installed in a mechanical room where there is adequate combustion and ventilating air. **NOTE: To prevent combustion air contamination, see Table 5.**

Combustion air from the indoor space can be used if the space has adequate area or when air is provided through a duct or louver to supply sufficient combustion air based on the VWH input. Never obstruct the supply of combustion air to the VWH. If the VWH is installed in areas where indoor air is contaminated (see Table 5) it is imperative that the VWH be installed as direct vent so that all combustion air is taken directly from the outdoors into the VWH intake connection.

Unconfined space is space with volume greater than 50 cubic feet per 1,000 BTU/hr (4.8 cubic meters per kW) of the total input rating of all fuel-burning appliances installed in that space. Rooms connected directly to this space through openings not furnished with doors are considered part of the space. See Venting Section for details.

Confined space is space with volume less than 50 cubic feet per 1,000 BTU/hr (4.8 cubic meters per kW) of the total input rating of all fuel-burning appliances installed in that space. Rooms connected directly to this space through openings not furnished with doors are considered part of the space.

When drawing combustion air from inside a conventionally constructed building to a confined space, such space should be provided with two permanent openings: one located 6" (15 cm) below the space ceiling, the other 6" (15cm) above the space floor. Each opening should have a free area of one square inch per 1,000 BTU/hr (22cm²/kW) of the total input of all appliances in the space, but not less than 100 square inches (645cm²).

If the confined space is within a building of tight construction, air for combustion must be obtained from the outdoors as outlined in the Venting section of this manual.

CAUTION
When drawing combustion air from the outside into the mechanical room, care must be taken to provide adequate freeze protection.
WARNING
Failure to provide an adequate supply of fresh combustion air can cause poisonous flue gases to enter the living space, resulting in severe personal injury or death. To prevent combustion air contamination, see Table 5.

**G. Carbon Monoxide Detectors
In the Commonwealth of Massachusetts and As Required by State and Local Codes:**

Installation of Carbon Monoxide Detectors: At the time of installation or replacement of the vented gas fueled appliance, the installing plumber or gas fitter shall observe that a hard wired carbon monoxide detector with an alarm and battery back-up is installed on the floor level where the gas appliance is installed, unless the appliance is located in a detached, uninhabitable structure separate from the dwelling, building, or structure used in whole or in part for residential purposes.

In addition, the installing plumber or gas fitter shall observe that a hard wired carbon monoxide detector with an alarm and battery back-up is installed on each additional level of the dwelling, building, or structure served by the vented gas appliance. It shall be the responsibility of the property owner to secure the service of qualified licensed professionals for the installation of hard wired carbon monoxide detectors.

a. In the event that the vented gas fueled appliance is installed in a crawl space or attic, the hard wired carbon monoxide detector with alarm and battery back-up shall be installed on the next adjacent floor level.

b. In the event that these requirements cannot be met at the time of completion of installation, the owner shall have a period of thirty (30) days to comply with the above requirements; provided, however, that during said thirty (30) day period, a battery operated carbon monoxide detector with an alarm shall be installed.

WARNING
Do not attempt to vent this appliance by any means other than those described in this manual. Doing so will void the warranty and may result in severe personal injury or death.

Approved Carbon Monoxide Detectors: Each carbon monoxide detector as required in accordance with the above provisions shall comply with NFPA 70 and be ANSI/UL 2034 listed and IAS certified.

H. Prevent Combustion Air Contamination

Install intake air piping for the VWH as described in the Venting Section, this manual. Do not terminate exhaust in locations that can allow contamination of intake air.

WARNING
Ensure that the intake air will not contain any of the contaminants in Table 5. Contaminated air will damage the VWH, resulting in possible substantial property damage, severe personal injury, or death. For example, do not pipe intake air near a swimming pool or laundry facilities. These areas always contain contaminants.

I. Removing a VWH from a Common Vent System

DANGER
Do not install the VWH into a common vent with any other appliance. This will cause flue gas spillage or appliance malfunction, resulting in possible substantial property damage, severe personal injury, or death.

WARNING
Failure to follow all instructions can result in flue gas spillage and carbon monoxide emissions, causing severe personal injury or death.

When removing an existing VWH, follow the steps below.

1. Seal any unused openings in the common venting system.
2. Visually inspect the venting system for proper size and horizontal pitch to determine if there is blockage, leakage, corrosion, or other deficiencies that could cause an unsafe condition.
3. If practical, close all building doors, windows, and doors between the space in which the VWH remains connected to the common venting system and other spaces in the building. Turn on clothes dryers and any appliances not connected to the common venting system. Turn on any exhaust fans, such as range hoods and bathroom exhausts, at maximum speed. Do not operate a summer exhaust fan. Close all fireplace dampers.
4. Place in operation the appliance being inspected. Follow the lighting instructions. Adjust the thermostat so the appliance will operate continuously.
5. Test for spillage at the draft hood relief opening after 5 minutes of main burner operation. Use the flame of a match or candle or smoke from a cigarette.

6. After it has been determined that each appliance remaining connected to the common venting system properly vents when tested as outlined, return doors, windows, exhaust fans, fireplace dampers, and any other gas burning appliances to their previous condition of use.

7. Any improper operation of the common venting system should be corrected to conform to the National Fuel Gas Code, ANSI Z223.1. When resizing any portion of the common venting system, the system should approach the minimum size as determined using the appropriate tables in Appendix G of ANSI Z223.1.

Products to Avoid	Areas Likely to Have Contaminants
Spray cans containing fluorocarbons	Dry cleaning / laundry areas and establishments
Permanent wave solutions	Swimming pools
Chlorinated waxes / cleaners	Metal fabrication plants
Chlorine-based swimming pool chemicals	Beauty shops
Calcium chloride used for thawing	Refrigeration repair shops
Sodium chloride used for water softening	Photo processing plants
Refrigerant leaks	Auto body shops
Paint or varnish removers	Plastic manufacturing plants
Hydrochloric or Muriatic acid	Furniture refinishing areas and establishments
Cements and glues	New building construction
Antistatic fabric softeners used in clothes dryers	Remodeling areas
Chlorine-type bleaches, laundry detergents, and cleaning solvents	Garages and workshops
Adhesives used to fasten building products	

Table 5 - Products and Areas Likely to Have Contaminants

NOTE: DAMAGE TO THE VWH CAUSED BY EXPOSURE TO CORROSIVE VAPORS IS NOT COVERED BY WARRANTY. (Refer to the limited warranty for complete terms and conditions.)

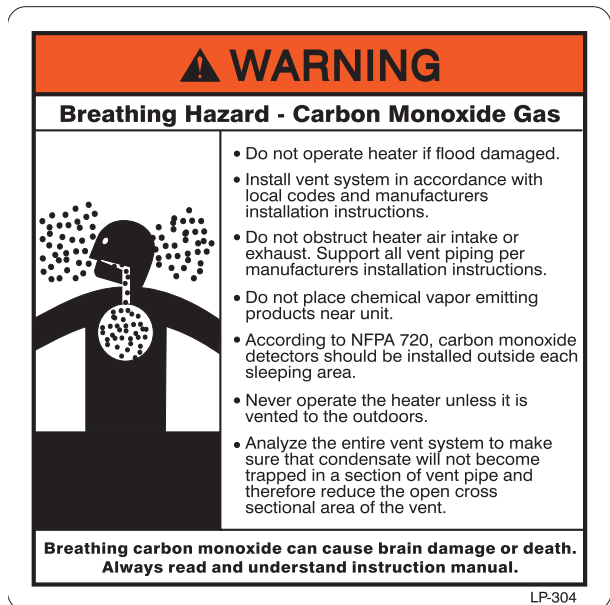

Figure 3 - CO Warning Label

K. Technical Specifications

Model		220	299	301	399
Installation		Indoor, Floor Standing or Wall Mount (with Optional Kit), Fully Condensing			
Minimum / Maximum Input (Btu/Hr)		22,000 / 220,000	30,000 / 299,000	30,000 / 301,000	40,000 / 399,000
Heating Capacity (MBH)		204	277	289	385
Flue System		Category IV, Sealed Combustion Direct Vent, Power Vent			
Minimum Combined Vent Run		16 feet			
Maximum Combined Vent Run		3" (200 feet), 4" (275 feet)	4" (200 feet), 6" (275 feet)		
Approved Exhaust Vent Materials		PVC, CPVC, PP, Stainless Steel			
Shipping Weight (lbs)		164	211	256	
Gas Supply Pressure	NG	3.5" to 14" WC			
	LP				
Manifold Pressure	Min / Max	NG/LP: -0.01" WC			
Power Supply		120V 60 Hz, 6.3A			
General Operating Conditions		Ambient Temperature Range: 33 – 104°F (0.6 – 40°C) Product Approvals and Requirements: ANSI Z21.13 / CSA 4.9			
Ignition System		Direct Electronic Spark Ignition / Flame Rectification			
Burner System		Premixed Fuel Modulation / Stainless Steel Metal Fiber Burner			
Gas Valve System		Air Ratio Valve			
Dimensions (in Inches)	W	14.5			
	H	24.5	36.5	36	
	D	26.5	24.75	31.75	
VWH Water Content (Gallons)		2.6	3.1	3.7	
Minimum Flow Rate @ 30°F ΔT (GPM)		14.6	20	26	
DHW Setpoint Temperature Range		95 – 180°F			
Water Pressure (PSI)	Heat Exchanger MAWP	160			
	Pressure Relief Valve	125			
Control Panel / Main Controller		LCD Display with LED Indicators / 928 SIT Control			
Connection Sizes	Supply / Return	1" NPTF	1 1/4" NPTF	1 1/2" NPTF	
	Gas Inlet	1" NPTF			
Materials	Cabinet	Powder Coated Galvaneal Steel			
	Heat Exchanger	316L Stainless Steel Water Tube			
Safety Devices		Flame Rectifier Probe, Dual Water Supply Temperature Sensor (210°F), Water Pressure High Limit Switch, Freeze Protection, Condensate Pressure Switch, Condensate Trap with Float, Dual Flue Sensor (210°F), Blocked Vent Pressure Switch, Optional External Low Water Cut-Off			

Table 6 - Technical Specifications

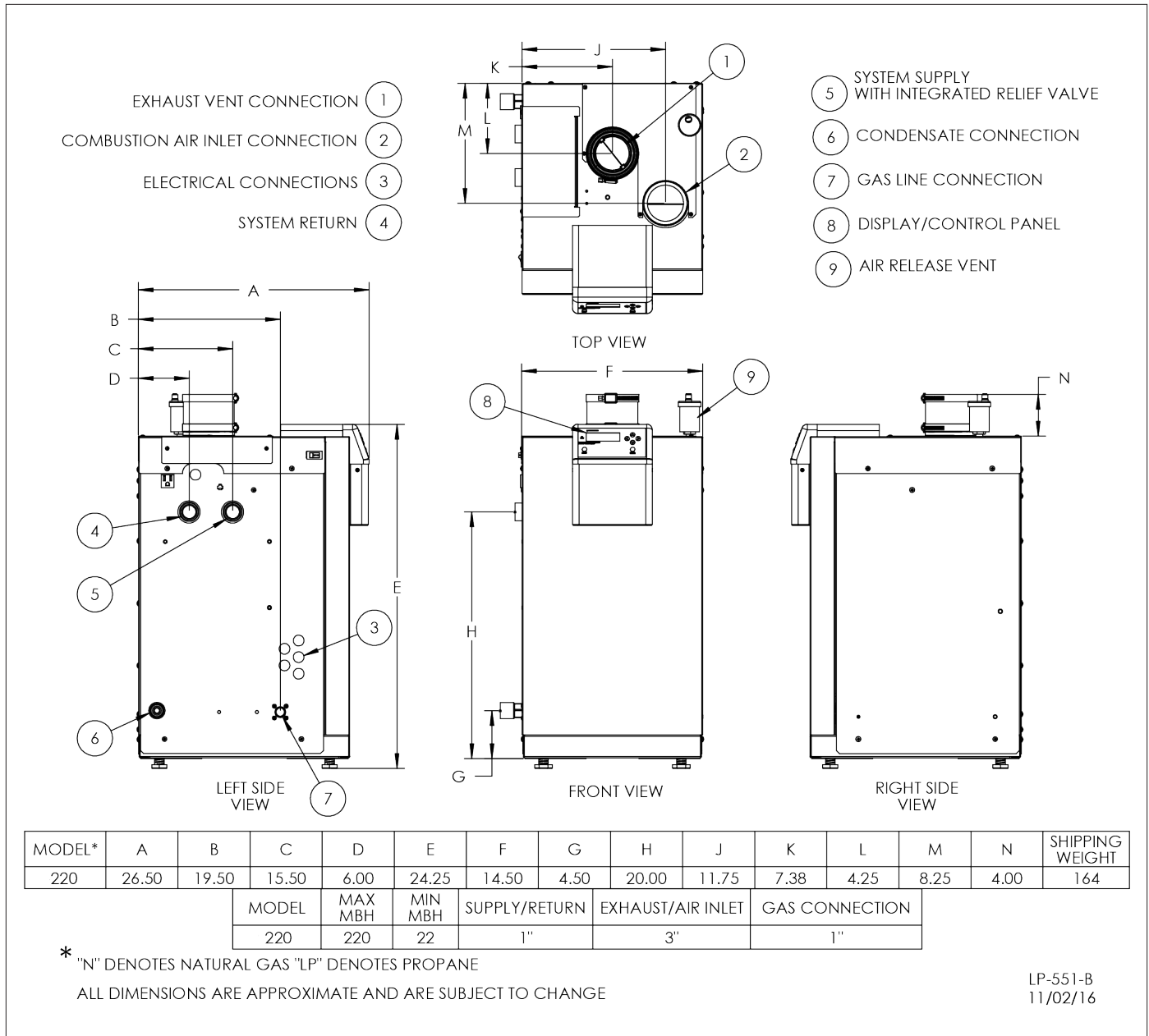

Figure 4 - VWH Dimensions - NOTE: All Dimensions Are Approximate - VWH in Model Number Denotes Volume Water Heater Model

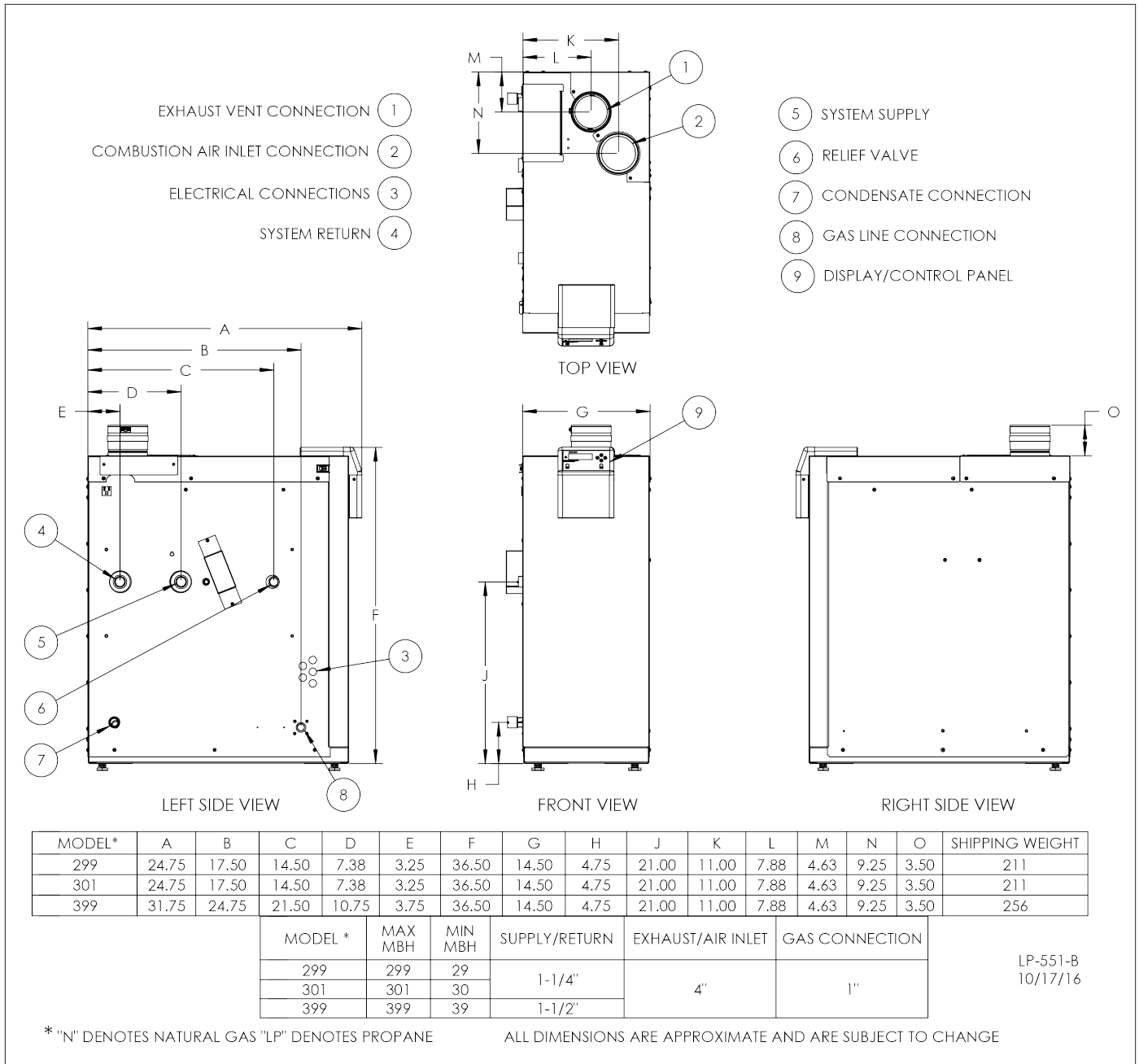

Figure 5 - VVH Dimensions - NOTE: All Dimensions Are Approximate - VVH in Model Number Denotes Volume Water Heater Model

Part 4 - Piping

WARNING

Failure to follow the instructions in this section WILL VOID the warranty and may result in property damage, severe personal injury, or death.

CAUTION

DO NOT pipe this VWH with black iron, galvanized steel, steel, or lead pipe. Doing so will result in premature product failure and property damage, and WILL VOID the warranty.

Do not apply a torch within 12" of the VWH. If sweat connections are used, sweat tubing to the adapter before fitting adapter to the water connections on the heater. Damages due to improper installation practices ARE NOT covered by warranty.

Dielectric unions or galvanized steel fittings must not be used in a system with this VWH. Doing so WILL VOID the warranty. Use only copper, brass, or stainless steel fittings. Teflon thread sealant must be used on all connections.

Plumbing of this product should only be done by a qualified, licensed plumber in accordance with all local plumbing codes. The VWH is designed to be connected to a storage tank to supply domestic hot water. HTP offers 60/80/119/175 gallon size storage tanks in either stainless steel or glass-lined construction. These storage tanks will be directly connected to the VWH supply and return connection.

A. General Plumbing Information

CAUTION

The building piping system must meet or exceed the the piping requirements in this manual.

Use two wrenches when tightening water piping at heater. Use one wrench to prevent the heater return or supply line from turning. Failure to prevent piping connections from turning could cause damage to heater components.

The heater control module uses temperature sensors to provide both high limit protection and modulating temperature control. The control module also provides low water protection by sensing the water level in the tank. Some codes / jurisdictions may require additional external controls.

Pump motors should not be supported by any type of stand due to possible misalignment of pump and motor. Failure to follow this instruction may result in property damage or personal injury.

NOTE: The addition of a high temperature limiting device is important if the VWH is to be connected to a domestic hot water system.

The domestic water connections must be installed in accordance to all local and national plumbing codes, or any applicable standard which prevails.

- Pipe material must be suitable to meet local codes and industry standards.
- The pipe must be cleaned and without blemish before any connections are made.
- All water piping should be insulated.

Connect the cold water supply to both the storage bottom port and the supply side of the VWH (shown in Applications, this manual). It is important that you install a flow check on the supply line of the VWH BEFORE connecting the feed line to the storage tank. This allows the cold feed to flow through the storage tank first. It is recommended that you install shut off valves on the cold feed line for future ease of service.

If there is a back flow preventer or any type of no return valve in the system, then you must install an additional tee for a suitable potable hot water expansion tank. Connect the storage tank return line to the return connection located on the VWH (shown in Applications, this manual). Then connect the storage tank hot water outlet to the hot water plumbing lines.

B. Backflow Preventer

Use a backflow preventer specifically designed for VWH installations. This valve should be installed on the cold water fill supply line per local codes.

C. Potable Expansion Tank

A potable hot water expansion tank is required to offset heated water expansion. In most city plumbing systems, the water meter has a no return or back flow device built into the system to prevent back flowing of water into city mains. Some local codes require back flow preventers on all incoming water supplies. The hot water expansion tank must be listed for potable water use. The expansion tank should be located on the cold inlet piping close to the VWH.

Expansion Tank and Make-Up Water

1. Ensure that the expansion tank is sized to correctly handle VWH and system water volume and temperature.

WARNING

Expansion tanks must be sized according to total system volume. This includes all length of pipe, all fixtures, VWHs, etc. Failure to properly size for system expansion could result in wasted time, money, possible property damage, serious injury, or death.

CAUTION

Undersized expansion tanks cause system water to be lost from the relief valve, causing make-up water to be added. Eventual VWH failure can result due to excessive make-up water addition. **SUCH FAILURE IS NOT COVERED BY WARRANTY.**

DO NOT install automatic air vents on closed type expansion tank systems. Air must remain in the system and return to the tank to provide an air cushion. An automatic air vent would cause air to leave the system, resulting in improper operation of the expansion tank.

The expansion tank must be suitable for hot potable water systems.

Expansion Tank Sizing*

Model	Heat Exchanger Volume (Gallons)
220	2.6
299 / 301	3.1
399	3.7

Table 7 - *Add Required Storage Tank Gallon Size to Heat Exchanger Volume - 60, 80, 119, and 175 Gallon Tanks Available

2. The expansion tank must be located as shown in Applications, this manual, or following recognized design methods. See expansion tank manufacturer's instructions for details.

D. Circulators

Every VWH system requires special attention to circulator size to overcome pressure drop through the VWH and its related piping. All circulators installed on the VWH system must be designed for potable water installations. VWH pressure drop is detailed in this manual.

CAUTION

Water temperature above 140°F requires the circulator to run continuously. Water hardness must be between 5 and 7 grains. Hardness above 7 grains will damage the heat exchanger and shorten the service life of the VWH.

DO NOT use the VWH circulator in any location other than the ones shown in this manual. The VWH circulator location is selected to ensure adequate flow through the VWH. Failure to comply with this caution could result in unreliable performance and nuisance shutdowns from insufficient flow.

E. Flow Switch Installation

1. Choosing the correct flow paddle.

The VWH comes with a flow switch and four flow paddles. Use the table below to determine which paddle to use with the VWH.

Model	Paddle Size
220	H1
299 / 301	H2
399	H3
N/A	H4

Table 8 - Flow Paddle Sizing

2. Use a Phillips Head screwdriver to attach flow paddle as shown below.

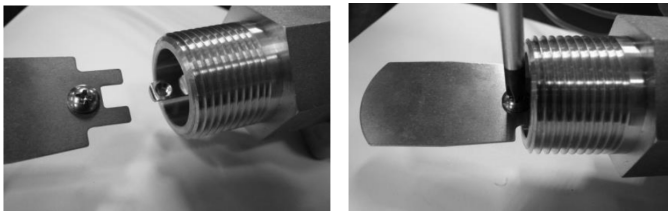

3. Thread outlet combination fitting onto supply outlet of VWH using pipe dope.



4. Thread flow switch into outlet combination fitting using pipe dope, **making certain the FLOW arrow points in the correct direction.**

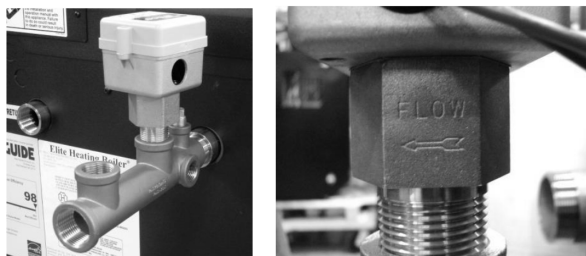

5. Thread relief valve into outlet combination fitting using pipe dope.



6. Thread temperature and pressure gauge into outlet combination fitting using pipe dope.

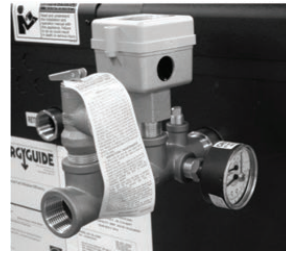

7. Connect red wire from flow switch to VWH wire harness.

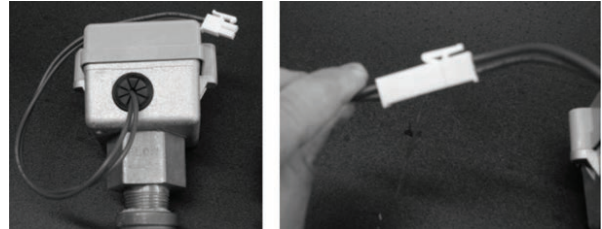

8. When installation is complete, power up the VWH and program set point. ***Please note that these illustrations are meant only to demonstrate installation. The installer is responsible for all equipment and detailing required by local codes.**

F. Relief Valve

Connect discharge piping to a safe disposal location following the guidelines below.

WARNING

To avoid water damage or scalding due to relief valve operation:

- Discharge line must be connected to relief valve outlet and run to a safe place of disposal. Terminate the discharge line in a manner that will prevent possibility of severe burns or property damage should the relief valve discharge.
- Discharge line must be as short as possible and the same size as the valve discharge connection throughout its entire length.
- Discharge line must pitch downward from the valve and terminate at least 6" above the floor drain, making discharge clearly visible.
- The discharge line shall terminate plain, not threaded, with a material serviceable for temperatures of 375°F or greater.
- Do not pipe discharge to any location where freezing could occur.
- No valve may be installed between the relief valve and VWH or in the discharge line. Do not plug or place any obstruction in the discharge line.
- Test the operation of the relief valve after filling and pressurizing the system by lifting the lever. Make sure the valve discharges freely. If the valve fails to operate correctly, immediately replace with a new properly rated relief valve.
- Test T&P valve at least once annually to ensure the waterway is clear. If valve does not operate, turn the VWH "off" and call a plumber immediately.
- Take care whenever operating relief valve to avoid scalding injury or property damage.

FAILURE TO COMPLY WITH THE ABOVE GUIDELINES COULD RESULT IN FAILURE OF RELIEF VALVE OPERATION, RESULTING IN POSSIBILITY OF SUBSTANTIAL PROPERTY DAMAGE, SEVERE PERSONAL INJURY, OR DEATH.

WARNING

Do not thread a cap or plug into the relief valve or relief valve line under any circumstances! Explosion and property damage, serious injury, or death may result.

RE-INSPECTION OF T&P RELIEF VALVES: T&P valves should be inspected AT LEAST ONCE EVERY THREE YEARS, and replaced if necessary, by a licensed plumbing contractor or qualified service technician to ensure that the product has not been affected by corrosive water conditions and to ensure that the valve and discharge line have not been altered or tampered with illegally. Certain naturally occurring conditions may corrode the valve and its components over time, rendering the valve inoperative. Such conditions can only be detected if the valve and its components are physically removed and inspected. **Do not attempt to conduct an inspection on your own.** Contact your plumbing contractor for a re-inspection to assure continued safety.

FAILURE TO RE-INSPECT THE T&P VALVE AS DIRECTED COULD RESULT IN UNSAFE TEMPERATURE AND/OR PRESSURE BUILD-UP WHICH CAN RESULT IN PROPERTY DAMAGE, SERIOUS PERSONAL INJURY, OR DEATH.

G. Scalding

This VWH can deliver scalding water at any faucet in the system. Be careful whenever using hot water to avoid scalding injury. Certain appliances such as dishwashers and automatic clothes washers may require increased water temperatures. By setting the thermostat on this VWH to obtain the increased water temperature required by these appliances you may create the potential for scald injury.

To protect against injury, install a mixing valve in the water system. This valve will reduce point of use discharge temperatures by mixing cold and hot water in branch supply lines. Such valves are available from your local plumbing supplier.

Table 9 details the relationship of water temperature and time with regard to scald injury and may be used as a guide in determining the safest water temperature for your applications.

DANGER



Water temperature over 125°F can cause severe burns instantly or death from scalds. Children, disabled and elderly are at highest risk of being scalded. See instruction manual before setting temperature at water heater. Feel water before bathing or showering. Temperature limiting valves are available, see manual.

WARNING

The risk of scalding increases when raising tank temperature. Use a water tempering or mixing valve when raising tank temperature to lessen the chance of scalds. Consult codes for conformance. Failure to install a temperature limiting or mixing valve and follow these instructions could result in property damage, severe personal injury, or death due to scalds.

Approximate Time / Temperature Relationships in Scalds	
120°F	More than 5 minutes
125°F	1 1/2 to 2 minutes
130°F	About 30 seconds
135°F	About 10 seconds
140°F	Less than 5 seconds
145°F	Less than 3 seconds
150°F	About 1 1/2 seconds
155°F	About 1 second

Table 9 - Approximate Time / Temperature Relationships in Scalds

H. High Velocity Circulator Pump

Every VWH system requires special attention to pump size in order to overcome pressure drop through the VWH and its related piping. All circulators installed on the VWH system must be designed for a potable water system.

In addition, the heat exchanger has a minimum total water volume that must be taken into account when sizing the circulator. Minimum flow rates are listed in the table below.

Minimum VWH Flow Rates	
Model	Minimum Flow (GPM)
220	14.6
299 / 301	20
399	26

Table 10 - Minimum Flow Rates

Heat Exchanger Pressure Drop																	
Flow Rate in GPM and Corresponding Pressure Drop in Feet ($\Delta P'$)																	
Model	6	7	8	9	10	11	12	13	14	15	16	17	18	19	20	21	22
220	*	*	*	*	*	*	*	*	*	8'	10'	11.5'	13'	15'	16.5'	17'	19'
299 / 301	*	*	*	*	*	*	*	*	*	*	*	*	*	*	13'	14'	15'
399	*	*	*	*	*	*	*	*	*	*	*	*	*	*	*	*	*
Model	23	24	25	26	27	28	29	30	31	32	33	34	35	36	37	38	39
220	21'	23'	24'	*	*	*	*	*	*	*	*	*	*	*	*	*	*
299 / 301	16.5'	18'	20'	22'	24'	26'	29'	33'	36'	*	*	*	*	*	*	*	*
399	*	*	*	12.9'	13.6'	14'	15.7'	17'	18'	19.4'	21'	22.5'	26'	28'	31'	34'	39'

Table 11 - *Do not operate the VWH at these flow rates. These low or high flow rates will damage the heat exchanger or related components. Damages due to improper operation ARE NOT covered by warranty.

The chart below represents various system design temperature rise through the VWH along with respective flows and friction loss. This is provided to aid in circulator selection.

System Temperature Rise Chart						
Model	20° Δt		25° Δt		30° Δt	
	Friction Ft	Flow Rate (GPM)	Friction Ft	Flow Rate (GPM)	Friction Ft	Flow Rate (GPM)
220	19'	22	13'	18.3	8'	14.6
299 / 301	29'	29	18'	24.5	13'	20
399	39'	39	19'	32.5		26

Table 12 - Temperature Rise, Friction Ft and Flow Rate

The chart below represents the combined flow rates and pipe sizes when using multiple VWHs to design the manifold system for the primary circuit. To size, simply add up the number of VWHs and the required flow rates for the system design temperature.

Example: (5) 220 model VWHs with a design of 20° Δt degree temperature rise with each VWH having an individual flow rate of 22 GPM. To correctly size the manifold feeding these (5) VWHs you would need a pipe size of 4".

Multiple VWH Manifold Piping																					
Flow Rate (GPM)	16	22	24	30	32	33	40	44	45	48	50	55	60	66	75	80	85	88	90	100	110
Pipe Dia. (In.)	2				2 1/2						3						4				

Table 13 - Multiple VWH Manifold Piping

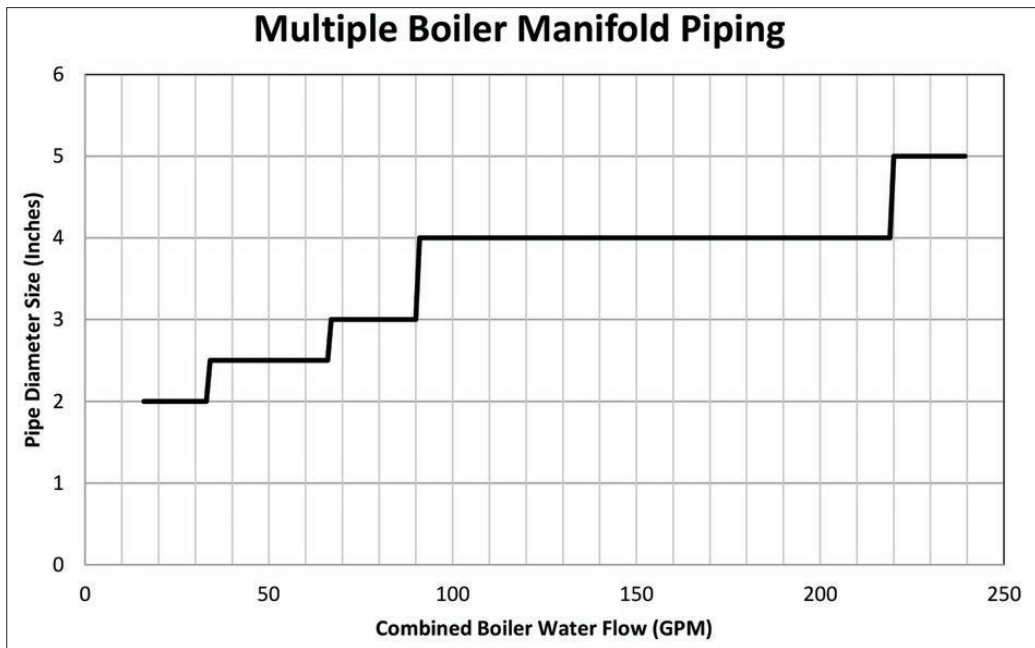

Figure 6 - Multiple VWH Manifold Piping

Multiple VWH Manifold Piping																				
Flow Rate (GPM)	120	132	150	160	170	179	200	210	239	240	250	255	300	340	350	400	425	510	595	680
Pipe Dia. (In.)	4						5						6			8				

Table 14 - Multiple VWH Manifold Piping

I. Check / Control Water Chemistry

CAUTION

Chemical imbalance of the water supply may affect efficiency and cause severe damage to the appliance and associated equipment. Water quality must be professionally analyzed to determine whether it is necessary to treat the water. Various solutions are available to adjust water quality. Adverse water quality will affect the reliability of the system. In addition, operating temperatures above 135°F will accelerate the build-up of lime scale and possibly shorten appliance service life. Failure of an appliance due to lime scale build-up, low pH, or other chemical imbalance IS NOT covered by the warranty.

The water must be potable, free of corrosive chemicals, sand, dirt, and other contaminants. It is up to the installer to ensure the water does not contain corrosive chemicals or elements that can damage the heat exchanger. Potable water is defined as drinkable water supplied from utility or well water in compliance with EPA secondary maximum contaminant levels (40 CFR Part 143.3) as shown in the table below. If the water contains contaminants higher than outlined by the EPA, water treatment is recommended and additional, more frequent maintenance may be required.

If you suspect that your water is contaminated in any way, discontinue use of the appliance and contact an authorized technician or licensed professional.

Contaminant	Maximum Allowable Level	Contaminant	Maximum Allowable Level
Total Hardness (Commercial Use - 140°F and above water temperature)	120 mg/l (7 grains/gallon)	pH	6.5-8.5
		Sulfate	205 mg/l
		Total Dissolved Solids (TDS)	500 mg/l
Aluminum	0.05 to 0.2 mg/l	Zinc	5 mg/l
Chloride	100 mg/l		
Copper	1 mg/l	Dissolved Carbon Dioxide (CO2)	15 mg/l or PPM
Iron	0.3 mg/l		
Manganese	0.05 mg/l		

***NOTE:** It is recommended to clean heat exchanger at least once a year to prevent lime scale buildup. Follow the maintenance procedure in the Maintenance Section of this manual to clean the heat exchanger.

J. Plumbing

Piping Components

Water Heating System Piping

System piping MUST be sized per technical pipe requirements listed in Tables 11 - 14. Reducing pipe size can restrict flow rate through the VWH, causing inadvertent short cycling and poor system performance.

Minimum Pipe Sizes	
220	1" NPT
299 / 301	1 1/4" NPT
399	1 1/2" NPT

Table 15 - Minimum Pipe Sizes

Check Valves

Field supplied. Check valves are recommended for installation as shown in Applications.

Isolation Valves

Field supplied. Full port ball valves are required. Failure to use full port ball valves could result in a restricted flow rate through the VWH.

Anti-Scald Mixing Valve

Field supplied. An anti-scald mixing valve is recommended when storing domestic hot water above 115°F.

Unions

Field supplied. Recommended for unit serviceability. DO NOT USE DIELECTRIC UNIONS! ONLY BRASS, COPPER, OR STAINLESS STEEL.

Pressure Relief Valve

Factory supplied on VWH. The pressure relief valve is sized to ASME specifications. Storage tank may require additional relief valves depending on local codes.

The VWH is designed to function in an open loop hot water supply system. We have included a temperature and pressure gauge that allows the user to monitor the system pressure and outlet temperature from the VWH. It is important to note that the VWH has a minimal amount of pressure drop and must be calculated when sizing the circulators.

Install the VWH so the gas ignition system components are protected from water (dripping, spraying, etc.). Allow clearance for basic service of VWH circulator, valves and other components.

Observe the minimum 1" clearance around all uninsulated hot water pipes when openings around pipes are not protected by non-combustible materials.

Basic steps are listed below, with illustration that will guide you through the installation of the VWH.

1. Connect the system return marked "Boiler Return".
2. Connect the system supply marked "Boiler Supply".
3. Install a circulator as shown in Applications (this manual). Make sure the circulator is properly sized for the system and friction loss.
4. Install an expansion tank on the system supply. Consult the expansion tank manufacturer's instruction manual (see Part 4, Section D for water volume) for specific information relating to expansion tank installation. Size the expansion tank for the required system volume and capacity.
5. Install a drain valve at the lowest point of the system. Note: The VWH cannot be drained completely of water without purging the unit with an air pressure of 15 PSI.
6. The relief valve and temperature and pressure gauge are included in the accessory kit. A discharge line should be installed 6" above the drain in the event of a pressure relief. The pipe size must be the same size as the relief valve outlet. **NEVER BLOCK THE OUTLET OF THE SAFETY RELIEF VALVE.**

K. Applications

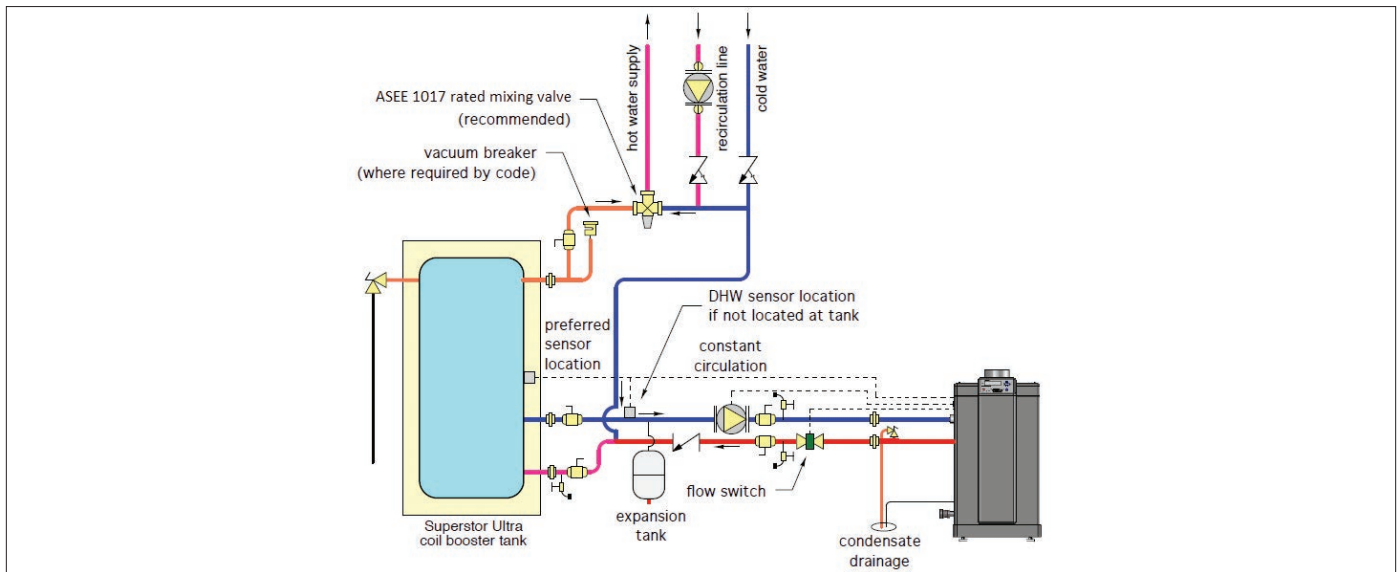

Figure 7 - VWH with Storage Tank

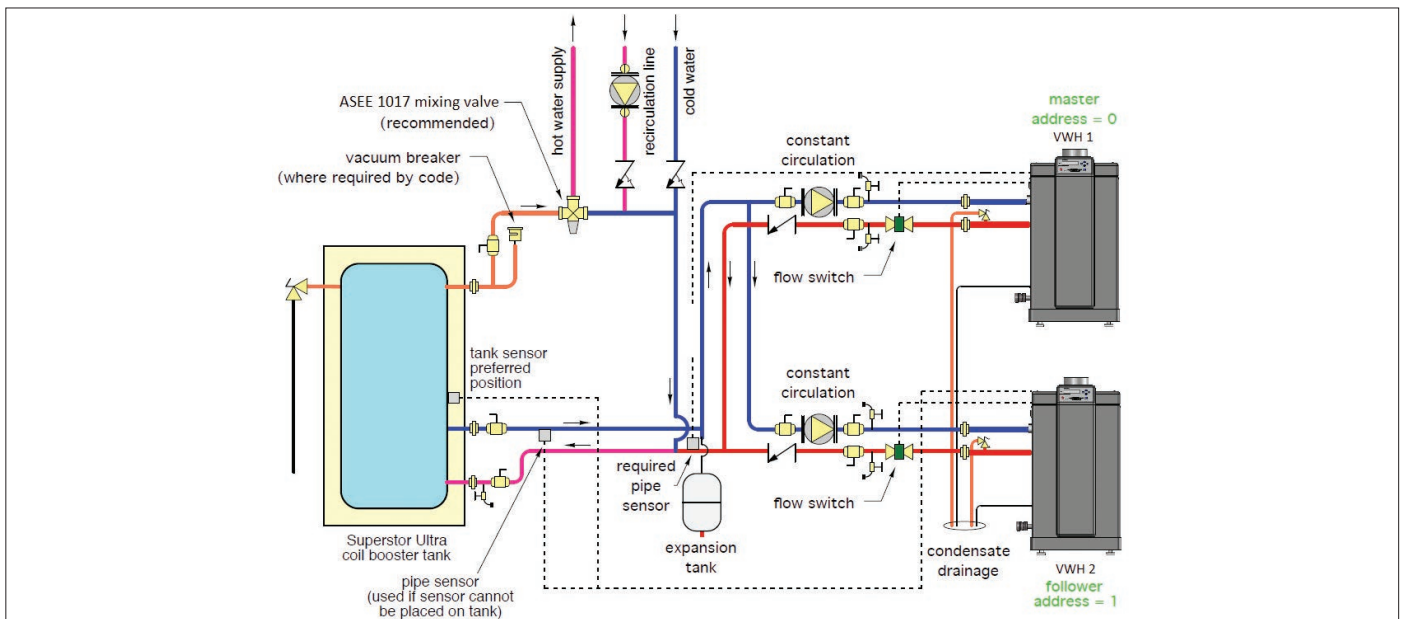

Figure 8 - Two VWHs with Storage Tank

NOTES:

1. This drawing is meant to show system piping concept only. Installer is responsible for all equipment & detailing required by local codes.
2. VWH circulator must be rated for open loop application. Do not use cast-iron circulators.
3. VWH circulator(s) operate continuously.
4. Piping to the water storage tank must be at least the size of the VWH return and supply connections.
5. See this manual for minimum pipe sizing.
6. All pumps are shown with isolation flanges or full port ball valves for isolation. The alternative is standard flanges with full port ball valves and a separate flow check valve.
7. Install a minimum of 12 diameters of straight pipe upstream of all circulators and check valves.
8. Install vacuum relief valve in accordance with local code requirements.
9. All multiple VWHs and multiple storage tanks must be installed with reverse return piping as shown.
10. Expansion tank must be rated for use with potable water.
11. Use either indirect/tank sensor or system/pipe sensor mounted on common return to the VWH.
12. Aquastat or system/pipe sensor connects to DHW sensor input on master VWH.

⚠ WARNING

An ASSE 1017 thermostatic mixing valve is recommended on all tanks if the hot water temperature leaving the tank is above 119°F. Failure to do so could result in substantial property damage, serious injury, or death.

The piping will not support the weight of the circulators. Refer to the circulator manufacturer's instructions to properly support the circulator. Failure to comply with these instructions could result in property damage, severe personal injury, or death.

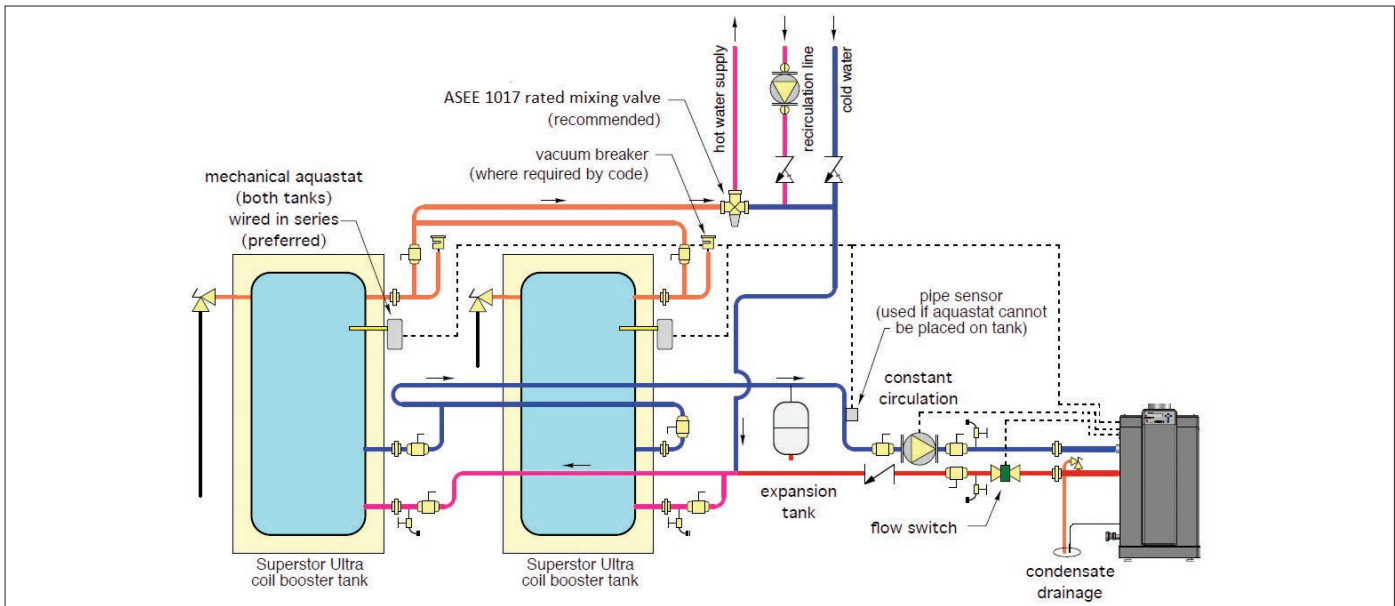

Figure 10 - VWH with Two Storage Tanks

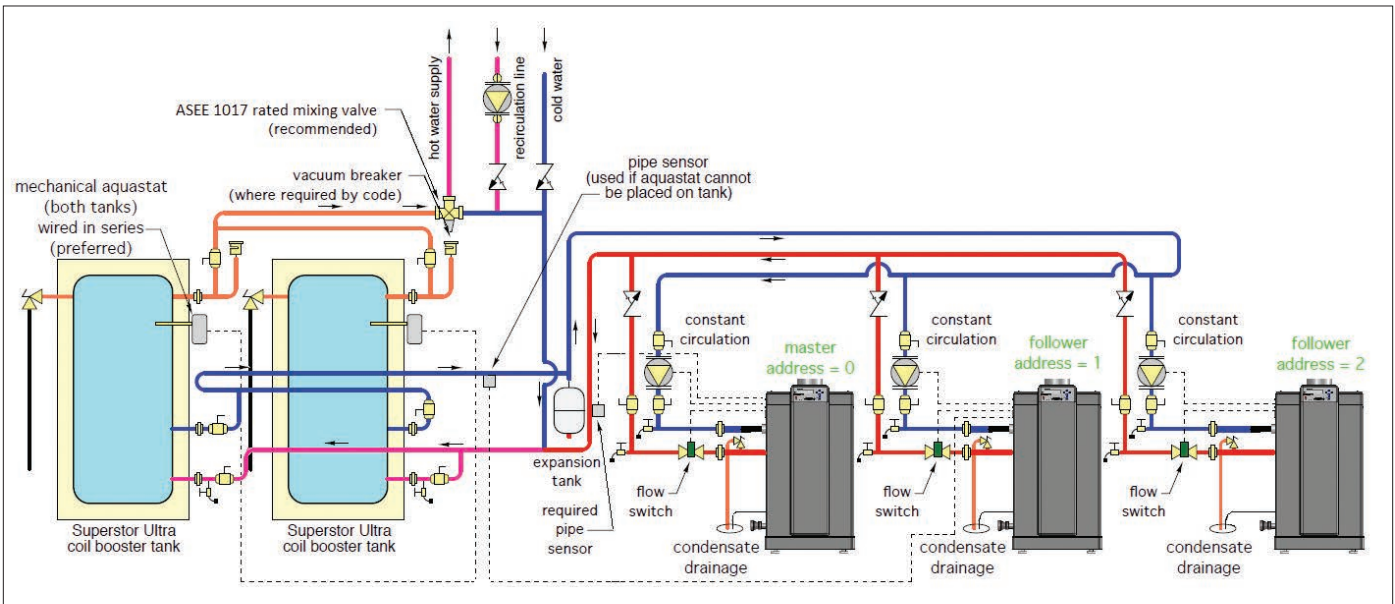

Figure 9 - Three VWHs with Two Storage Tanks

NOTES:

1. This drawing is meant to show system piping concept only. Installer is responsible for all equipment & detailing required by local codes.
2. VWH circulator must be rated for open loop application. Do not use cast-iron circulators.
3. VWH circulator(s) operate continuously.
4. Piping to the water storage tank must be at least the size of the VWH return and supply connections.
5. See this manual for minimum pipe sizing.
6. All pumps are shown with isolation flanges or full port ball valves for isolation. The alternative is standard flanges with full port ball valves and a separate flow check valve.
7. Install a minimum of 12 diameters of straight pipe upstream of all circulators and check valves.
8. Install vacuum relief valve in accordance with local code requirements.
9. All multiple VWHs and multiple storage tanks must be installed with reverse return piping as shown.
10. Expansion tank must be rated for use with potable water.
11. Use either indirect/tank sensor or system/pipe sensor mounted on common return to the VWH.
12. Aquastat or system/pipe sensor connects to DHW sensor input on master VWH.

WARNING

An ASSE 1017 thermostatic mixing valve is recommended on all tanks if the hot water temperature leaving the tank is above 119°F. Failure to do so could result in substantial property damage, serious injury, or death.

The piping will not support the weight of the circulators. Refer to the circulator manufacturer's instructions to properly support the circulator. Failure to comply with these instructions could result in property damage, severe personal injury, or death.

Part 5 - Venting

⚠ DANGER

The heater must be vented as detailed in this section. Ensure exhaust vent and intake piping complies with these instructions regarding vent system. Inspect finished exhaust vent and intake piping thoroughly to ensure all joints are well secured, airtight, and comply with all applicable code requirements, as well as the instructions provided in this manual. Failure to properly install the vent system will result in severe personal injury or death.

A. General

⚠ DANGER

This heater is certified as a "Category IV" appliance and requires a special venting system. The vent system will operate with a positive pressure in the pipe. Exhaust gases must be piped directly outdoors using the vent materials and rules outlined in these instructions. Do not connect vent connectors serving appliances vented by natural draft into any portion of mechanical draft systems operating under positive pressure. Follow the venting instructions carefully. Failure to do so will result in substantial property damage, severe personal injury, or death.

Exhaust and intake are to be piped separately. This heater cannot share a common exhaust or intake with multiple appliances without an approved HTP Backflow Valve (7100P-340) and Condensate Assembly (7100P-341). One (1) Backflow Valve must be installed per each heater installed in the common vent system. One (1) Condensate Assembly must be installed in the common vent system. Failure to follow these instructions will result in substantial property damage, severe personal injury, or death.

1. Installation should be made in accordance with the regulations of the Authority Having Jurisdiction, local code authorities, and utility companies which pertain to this type of water heating equipment.
2. Install the venting system in accordance with these instructions and with the National Fuel Gas Code, ANSI Z223.1/NFPA 54, CAN/CGA B149, and / or applicable provisions of local building codes.
3. This VWH must be vented with materials, components, and systems listed and approved for Category IV appliances.

NOTE: To avoid contamination often contained in indoor air, it is best to pipe all intake combustion air directly to the outdoors.

NOTE: Care must be taken to prevent condensate freezing in the exhaust vent pipe system. See local, state, provincial, and national codes for best practices to prevent condensate freezing in the exhaust vent pipe system.

⚠ WARNING

Improper seating of vent pipe gaskets can cause eventual gasket failure and exhaust gas leakage. Ensure the exhaust vent pipe is properly beveled and seated before insertion into the flue adapter. Failure to do so could result in property damage, severe personal injury, or death.

Exhaust vent adaptors are not designed as load-bearing devices, and must not be used to support exhaust vent piping. All vent pipes must be properly connected, supported, and the exhaust vent must be pitched a minimum of 1/4" per foot back to the heater to allow drainage of condensate. Failure to properly support vent piping and follow the information in this statement could result in product damage, severe personal injury, or death.

It is required to insert the provided exhaust and intake screens into the vent terminations to prevent blockage caused by debris or birds. Failure to keep terminations clear could result in property damage, severe personal injury, or death.

⚠ WARNING

Breathing Hazard - Carbon Monoxide Gas



- Do not operate heater if flood damaged.
- Install vent system in accordance with local codes and manufacturers installation instructions.
- Do not obstruct heater air intake or exhaust. Support all vent piping per manufacturers installation instructions.
- Do not place chemical vapor emitting products near unit.
- According to NFPA 720, carbon monoxide detectors should be installed outside each sleeping area.
- Never operate the heater unless it is vented to the outdoors.
- Analyze the entire vent system to make sure that condensate will not become trapped in a section of vent pipe and therefore reduce the open cross sectional area of the vent.

Breathing carbon monoxide can cause brain damage or death. Always read and understand instruction manual.

⚠ DANGER

Due to the extreme flammability of most glues, cements, solvents, and primers used to join plastic exhaust vent and intake pipes, explosive solvent vapors must be cleared from all vent piping before start-up. Avoid using excess cement or primer, as this may pool in the vent pipes. Vent assemblies should be allowed to cure for a period of at least 8 hours before powering a connected appliance. Failure to follow these instructions will result in substantial property damage, severe personal injury, or death. It is the installers' responsibility to understand the hazards associated with explosive solvents and take the necessary precautions to avoid these risks.

⚠ WARNING

- Only Stainless Steel exhaust vent pipe material may be insulated.
- DO NOT insulate the first three (3) linear feet of the exhaust vent run.
- DO NOT insulate PVC, CPVC, or Polypropylene exhaust vent pipe material. Doing so will cause increased vent wall temperatures, which could result in vent pipe failure.
- CPVC, Polypropylene, or Stainless Steel pipe material MUST be used if the first three (3) linear feet of the exhaust vent run passes through an enclosed space greater than 6" in length, such as a wall or ceiling.*
- If CPVC is used to meet these requirements, the balance may be installed with approved PVC pipe.
- If Polypropylene or Stainless Steel is used to meet these requirements, the balance of the vent run MUST be installed with the same material.
- Failure to comply with these requirements could result in property damage, severe personal injury, or death.

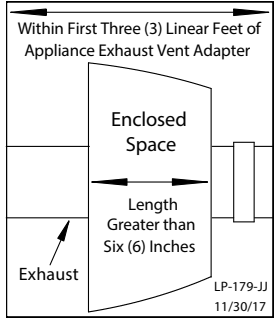

*This rule applies when the exhaust vent passes through the enclosed space into another interior space, i.e. through a floor or wall from the mechanical room into another room. This rule DOES NOT apply when the exhaust vent passes through the enclosed space immediately to the exterior of the building.

B. Approved Materials for Exhaust Vent and Intake Pipe

Item	Material	Standards for Installation In:	
		United States	Canada
Pipe and Fittings Approved for Intake ONLY	ABS*	ANSI/ASTM D2661	ANSI/ASTM D2661
Pipe Approved for Intake OR Exhaust Vent	PVC Schedule 40/80	UL-1738 or ANSI/ASTM D1785	UL-1738 or ULC-S636
	PVC-DWV Schedule 40/80	UL-1738 or ANSI/ASTM D2665	
	CPVC Schedule 40/80	UL-1738 or ANSI/ASTM F441	
	Polypropylene	UL-1738 or ULC-S636	
	Stainless Steel AL29-4C	Certified for Category IV and Direct Vent Appliance Venting	
Pipe Fittings	PVC Schedule 40	UL-1738, ANSI/ASTM D2466 or D2665	UL-1738 or ULC-S636
	PVC Schedule 80	UL-1738, ANSI/ASTM D2467 or D2665	
	CPVC Schedule 40	UL-1738 or ANSI/ASTM F438	
	CPVC Schedule 80	UL-1738 or ANSI/ASTM F439	
Pipe Cement	ABS*	ANSI/ASTM D2235	UL-S636 Approved Cements and Primers
	PVC	ANSI/ASTM D2564	
	CPVC	ANSI/ASTM F493	
Pipe Primer	PVC / CPVC	ASTM F656	

DANGER

- The exhaust and intake components installed with this appliance must be used for near appliance piping BEFORE transitioning to the approved materials listed above. DO NOT REMOVE these installed components. Doing so WILL VOID appliance warranty.
- In the US/Canada, PVC vent pipe and fittings SHALL NOT BE USED within the closet or alcove. Only approved CPVC, Polypropylene, or Stainless Steel vent pipe and fittings may be used.
- PVC / CPVC pipe and fittings of the same diameter are considered interchangeable.
- The use of cellular core PVC (ASTM F891), cellular core CPVC, or Radel® (polyphenolsulfone) in exhaust venting systems is prohibited.
- Covering non-metallic vent pipe and fittings with thermal insulation is prohibited.
- When installing AL29-4C vent piping, DO NOT mix AL29-4C piping from different manufacturers unless using adapters specifically designed for the purpose by the manufacturer.
- DO NOT mix components from different venting systems without proper adapters. The vent system could fail, causing leakage of flue products into the living space. Use only the approved pipe and fitting materials, and primer and cement specifically designed for the material used, as listed in the above table.
- A double wall vent or insulated material may be used when using stainless steel vent material in a freezing climate.
- *ABS may be used for air intake applications ONLY.
- Contact the venting material manufacturer if there is any question about the applicability of the proposed venting material.

Failure to follow these directions will result in substantial property damage, severe personal injury, or death.

Table 16 - Approved Materials for Exhaust Vent and Intake Pipe

CAUTION
High heat sources (generating heat 100°F / 37°C or greater, such as VWH flue pipes, space heaters, etc.) may damage plastic components of the VWH as well as plastic vent pipe materials. Such damages ARE NOT covered by warranty. It is recommended to keep a minimum clearance of 8" from high heat sources. Observe heat source manufacturer instructions, as well as local, state, provincial, and national codes, laws, regulations, and ordinances when installing this VWH and related components near high heat sources.

NOTE: The use of double-wall vent or insulated material for the combustion air intake pipe is recommended in cold climates to prevent the condensation of airborne moisture in the incoming combustion air.

DANGER

You must not use "B" vent in an exhaust application. "B" vent is for intake applications ONLY. Using "B" vent in an exhaust application will result in serious injury or death.

C. Additional Requirements for Installation in Canada

1. Installations must be made with a vent pipe system certified to ULC-S636.
2. The first three (3) feet of vent pipe from the appliance flue outlet must be readily accessible for visual inspection.
3. The components of the certified vent system must not be interchanged with other vent systems or unlisted pipe / fittings.

D. Exhaust Vent and Intake Pipe Location

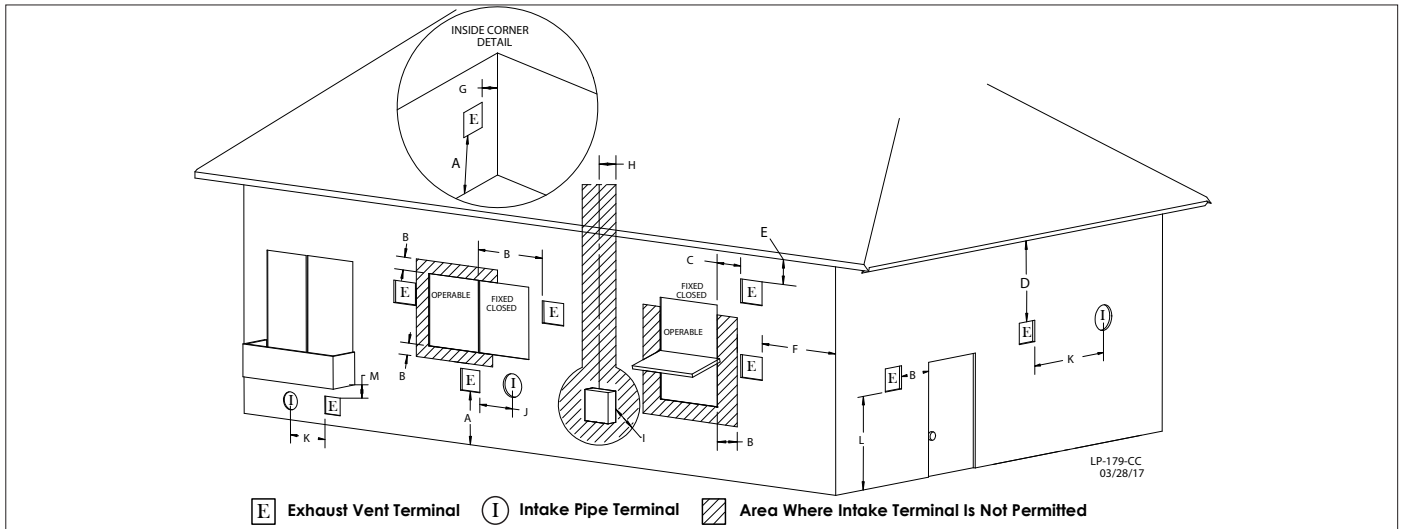

Figure 11 - Exit Terminals for Direct Vent Systems - ANSI Z223.1 / NFPA 54 for US and CAN/CSA B149.1 for Canada

DESCRIPTION		US	CANADA
A	Clearance above grade, veranda, porch, deck, or balcony	1 foot (30 cm)	
B	Clearance to window or door that may be opened	Direct Vent	3 feet (91 cm)
		Power Vent	
C	Clearance to permanently closed window	*	
D	Vertical clearance to ventilated soffit located above the terminal within a horizontal distance 2 feet (61 cm) from the center line of the terminal	*	
E	Clearance to unventilated soffit	*	
F	Clearance to outside corner	*	
G	Clearance to inside corner	*	
H	Clearance to each side of center line extended above meter / regulator assembly	*	
I	Clearance to service regulator vent outlet	*	Above a regulator within 3 feet (91 cm) horizontally of the vertical center line of the regulator vent outlet to a maximum vertical distance of 15 ft (4.5 m)
J	Clearance to nonmechanical air supply inlet to building or the combustion air inlet to any other appliance	Direct Vent	3 feet (91 cm)
		Power Vent	
K	Clearance to mechanical air supply inlet	3 feet above if within 10 feet horizontally	6 feet (1.83 m)
L	Clearance above paved sidewalk or paved driveway located on public property	Direct Vent	7 feet (2.13 m)
		Power Vent	
M	Clearance under veranda, porch deck, or balcony	1 foot (30 cm)	

Table 17 - Vent Termination Clearances - *NOTE: For clearances not specified in ANSI Z223.1 / NFPA 54 for US and CAN/CSA B149.1 for Canada, please use clearances in accordance with local installation codes and the requirements of the gas supplier.

WARNING

The building owner is responsible for keeping the exhaust and intake terminations free of snow, ice, or other potential blockages, as well as scheduling routing maintenance. Failure to keep the vent piping terminations clear and properly maintain the heater could result in property damage, severe personal injury, or death.

WARNING

For each floor containing bedroom(s), a carbon monoxide detector and alarm shall be placed in the living area outside the bedrooms, as well as in the room that houses the heater. Detectors and alarms shall comply with NFPA 720 (latest edition). Failure to comply with these requirements could result in product damage, severe personal injury, or death.

E. Exhaust Vent and Intake Pipe Sizing

1. The exhaust vent and intake pipe size is 3" for 220 models and 4" for 299 - 399 models.
2. The maximum total equivalent length of exhaust vent and intake pipe **should not exceed 200 feet**.
 - a. The equivalent length of elbows, tees, and other fittings are listed in the Friction Loss Table.

Friction Loss Equivalent in Piping and Fittings			
Fittings or Piping	Equivalent Feet		
	3"	4"	6"
90 Degree Elbow*	5'	3'	3'
45 Degree Elbow	3'	3'	2'
Coupling	0'	0'	0'
Air Inlet Tee	0'	0'	0'
Straight Pipe	1'	1'	1'
Concentric Kit	3'	N/A	N/A
V Series Vent Kit	1'	1'	1'
AL20 4c Vent Terminal	1'	1'	1'

Table 18 - *Friction loss for long radius elbow is 1 foot less. NOTE: Consult Polypropylene venting instructions for friction loss and pressure drop equivalents.

- b. For example: If the exhaust vent is 3" in diameter, has two 90° elbows, and 10 feet of PVC pipe we will calculate:
 Exhaust Vent Equivalent Length = (2x5) + 10 = 20 feet.
 Further, if the 3" intake pipe has two 90° elbows, one 45° elbow, and 10 feet of PVC pipe, the following calculation applies:
 Intake Pipe Equivalent Length = (2x5) + 3 + 10 = 23 feet.
 The total equivalent length is 43 feet, well below the maximum of 200 feet.
 - c. Effort should be made to keep a minimum difference in equivalent length between the exhaust vent and intake pipe.
3. The minimum total equivalent length is 16 feet.

! WARNING

Failure to install the appliance within the minimum and maximum vent length requirements could result in improper product operation and property damage, serious personal injury, or death.

F. Longer Vent Runs

The maximum total equivalent length can be extended by increasing the diameter of both the exhaust vent and intake pipes equally. However, the transitions should begin a minimum of 16 equivalent feet from the VWH. Transitions should always be made in vertical sections of pipe to prevent the condensate from pooling in the vent pipe.
 The maximum equivalent length for increased diameter vent pipes is 275 ft, which includes 16 ft from with VWH with a transition total of 259 ft upsized piping for longer vent runs.

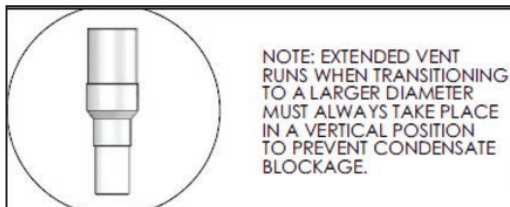

Figure 12 - Extended Vent Runs

Standard Vent Connection and Maximum Total Equivalent Length	Reducing Coupling	Increased Vent Size and Maximum Total Equivalent Length
3" (200')	4" x 3"	4" (275')
4" (200')	6" x 4"	6" (275')
6" (200')	8" x 6"	8" (275')

Table 19 - Vent Run Transition

! DANGER

Total maximum equivalent length of increased diameter exhaust vent and intake pipe must not exceed the lengths defined in this manual. Failure to keep the total equivalent length below the maximum lengths determined in this manual will result in faulty VWH operation, substantial property damage, serious personal injury, or death.

G. Exhaust Vent and Intake Pipe Installation

! WARNING

All joints of positive pressure vent systems must be sealed completely to prevent leakage of flue products into the living space. Failure to do so could result in property damage, serious injury, or death.

1. Use only solid PVC, CPVC, or stainless steel pipe or a Polypropylene vent system approved for use with Category IV appliances. ABS pipe material may be used on air inlet piping **only**.
2. Remove all burrs and debris from joints and fittings.
3. When using PVC or CPVC pipe, all joints must be properly cleaned, primed, and cemented. Use only cement and primer approved for use with the pipe material. Cement must conform to ASTM D2564 for PVC and ASTM F493 for CPVC pipe. **NOTE: DO NOT CEMENT POLYPROPYLENE PIPE.**
4. Ensure the vent is located where it will not be exposed to prevailing winds.
5. In all roof venting applications, exhaust discharge must point away from the pitch of the roof.
6. If the exhaust vent is to be terminated in a walled off area (such as a roof with a parapet wall), ensure the exhaust vent terminates a minimum of 10' from nearest wall and extends level with or above the top of the wall. This will ensure flue gas does not get trapped and possibly recirculated into the intake air pipe, which could contaminate the combustion air.
7. To prevent water leakage, install adequate roof flashing where the pipe enters the roof.
8. If it can be avoided do not locate vent directly over public walkways, driveways, or parking lots in climates where freezing conditions are possible. Condensate could drip and freeze, resulting in a slip hazard or damage to vehicles or machinery.
9. Due to potential moisture build-up, sidewall venting may not be the preferred venting option. To save time and cost, carefully consider venting installation and location.
10. Horizontal lengths of exhaust vent must slope back towards the appliance not less than 1/4" per foot to allow condensate to drain from the vent pipe.
11. Do not terminate vent where vapors can accumulate and harm people or pets.
12. When it can be avoided, do not terminate vent where vapors can damage shrubs or plants. Such damages are not covered by product warranty.
13. Moisture in the exhaust gas will condense as it leaves the vent terminal. In cold weather this condensate can freeze on the exterior wall, under the eaves, and on surrounding objects, including shrubs. Some discoloration to the exterior of the building is to be

expected. However, improper location or installation can result in severe damage to the structure or exterior finish of the building, and increase the opportunity for vent blockages and nuisance shutdowns.

14. In vacant chimney applications, install and seal a rain cap over existing chimney openings.

15. All piping must be fully supported. Use pipe hangers at a minimum of 4 foot intervals to prevent sagging of the pipe where condensate may form.

16. Do not use the heater to support any piping.

17. A screened straight coupling is provided with the heater for use as an outside exhaust termination.

18. A screened inlet air tee is provided with the heater to be used as an outside intake termination.

19. Maximum Snow Level Determination: These installation instructions reference snow levels in establishing a minimum height for the installation of exhaust vent or air intake terminations. Snow levels shall be determined as follows:

- a. The installation location may, by ordinance, designate how snow levels are calculated in that location; or
- b. In the absence of specific ordinances, snow levels shall be calculated from the average monthly maximum depth of snow accumulation as indicated by the National Weather Service’s 10 year statistics for the installation location/geographical area.

In addition:

- Total length of vent piping shall not exceed the limits specified in this manual.
- The vent piping for this direct vented appliance is approved for zero clearance to combustible construction.
- The flue products coming from the exhaust vent will create a large plume when the heater is in operation. Avoid venting in areas that will affect neighboring buildings or be considered objectionable.
- DO NOT locate exhaust vent or intake pipe in a parking area where machinery may damage the pipe.
- DO NOT vent near soffit vents, crawl space vents, or other areas where condensate or vapor could create a nuisance or hazard or cause property damage.
- DO NOT vent where condensate vapor could cause damage or could be detrimental to the operation of regulators, relief valve, or other equipment.

In the Commonwealth of Massachusetts and as Required by State and Local Codes:

The vented gas fueled appliance shall not be installed so its combustion, ventilation, or dilution air is obtained from a bedroom or bathroom.

Signage: Whenever any through-the-wall (horizontal or sidewall) vent is installed less than seven feet above the finished grade, a metal or plastic identification plate shall be permanently mounted to the exterior of the building at a minimum height of eight feet above grade directly in line with the exhaust vent terminal. The sign shall read, in print no less than 0.5 inches in size, "GAS VENT DIRECTLY BELOW. KEEP CLEAR OF ALL OBSTRUCTIONS".

Marking of Exhaust Vent and Intake Pipe: Piping used for ventilation, make-up, or combustion air intake shall be labeled as follows:

- a. Throughout the entire developed length:
 - i. Labels must be placed every ten feet for exposed/visible piping; or
 - ii. Labels must be placed every three feet for concealed piping.
- b. At all changes of direction;
- c. On each side of a penetration through a partition, wall or ceiling; and
- d. The labels shall be black lettering that:

- i. Indicates that the piping is used for ventilation, make-up, or combustion air intake, and
- ii. The letters shall be sized equal to a minimum of the pipe diameter. However, for piping with a diameter exceeding two inches, said lettering does not need to be larger than two inches.

The following table lists optional exhaust/intake terminations available from HTP:

Description	Stock Code
3" PVC Concentric Termination Kit	KGAVT0601CVT
3" Stainless Steel Termination Kit	V1000
4" Stainless Steel Termination Kit	V2000
6" Stainless Steel Termination Kit	V3000
3" Polypro Vent Kit	8400P-001

Table 20 - Optional Vent Kits

H. Applications

1. Direct Vent Installation of Exhaust and Intake

If installing a direct vent option, combustion air must be drawn from the outdoors directly into the VWH intake, and exhaust must terminate outside. There are three basic direct vent options detailed in this manual: 1. Side Wall Venting, 2. Roof Venting, and 3. Unbalanced Venting.

Be sure to locate the VWH such that the exhaust vent and intake pipe can be routed through the building and properly terminated. Different vent terminals can be used to simplify and eliminate multiple penetrations in the building structure (see Optional Equipment in Venting Section). The exhaust vent and intake pipe lengths, routing and termination methods must all comply with the methods and limits given in the Venting section of this manual.

When installing a combustion air intake from outdoors, care must be taken to utilize uncontaminated combustion air. **NOTE:** To prevent combustion air contamination, see Table 5.

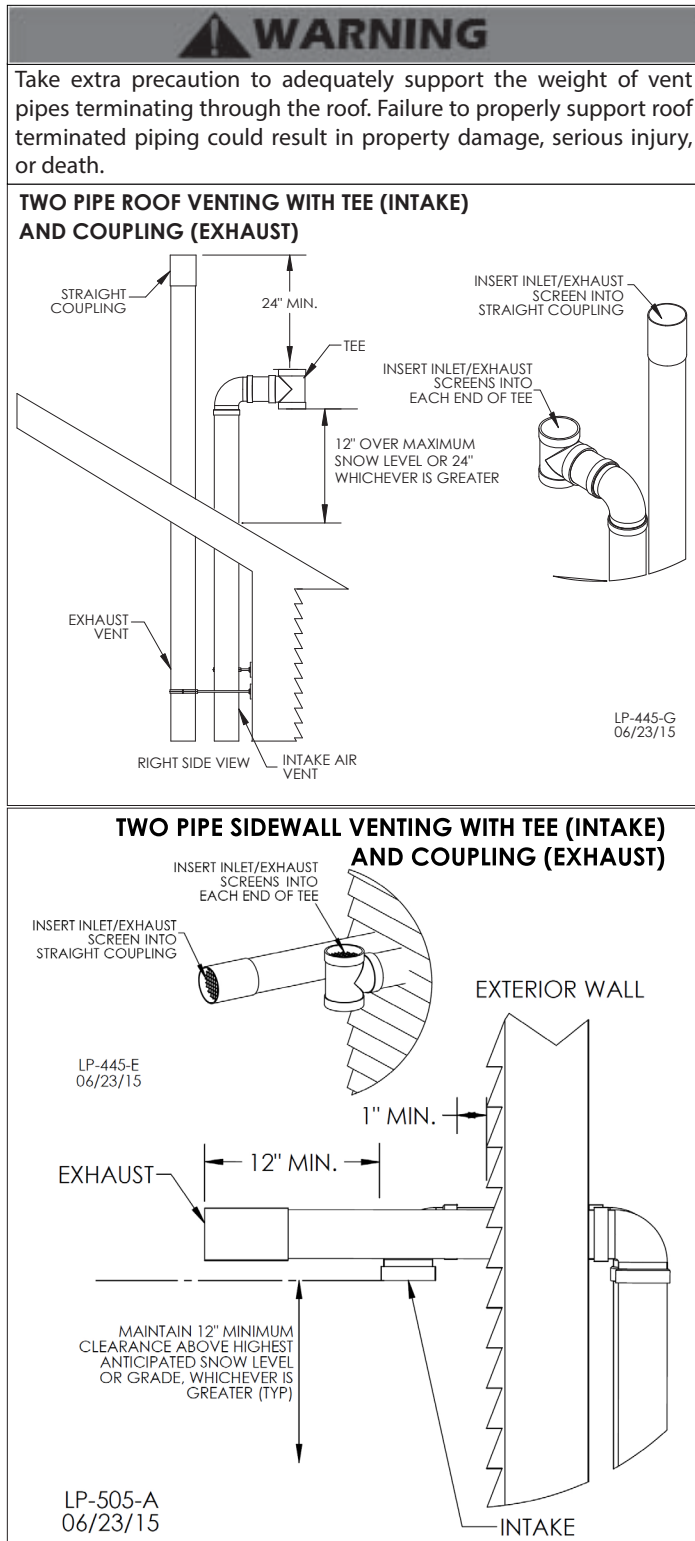

Figure 13 - Two Pipe Roof and Sidewall Venting

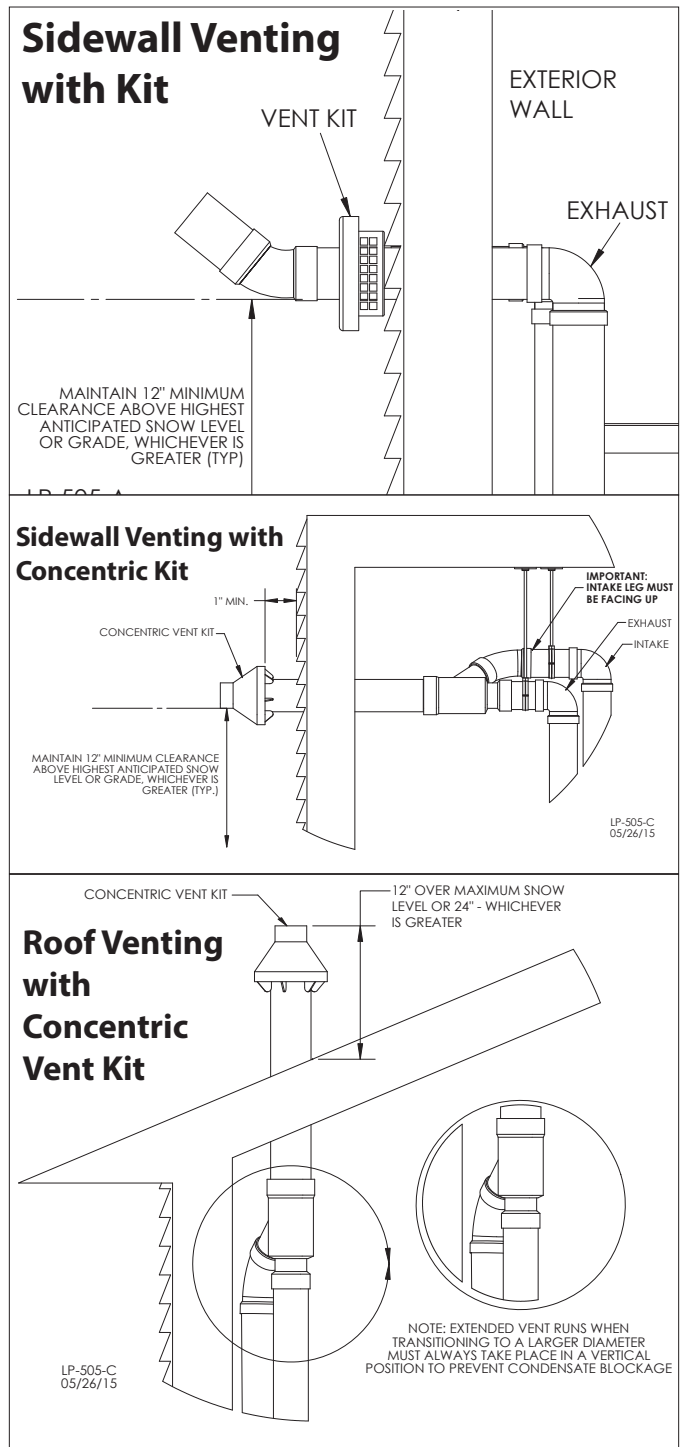
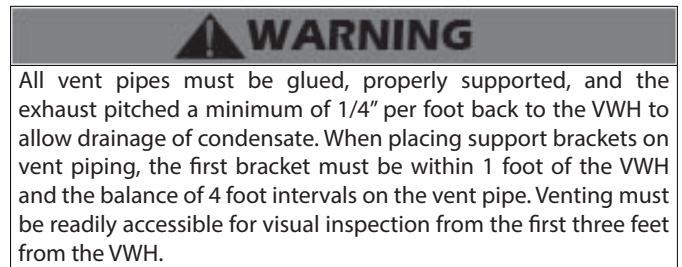

Figure 14 - Venting with Optional Kits (NOT INCLUDED WITH THE VWH)

NOTE: These drawings are meant to demonstrate system venting only. The installer is responsible for all equipment and detailing required by local codes.



Snorkel Venting (Two Pipe Sidewall Venting Terminations Beneath an Overhang)

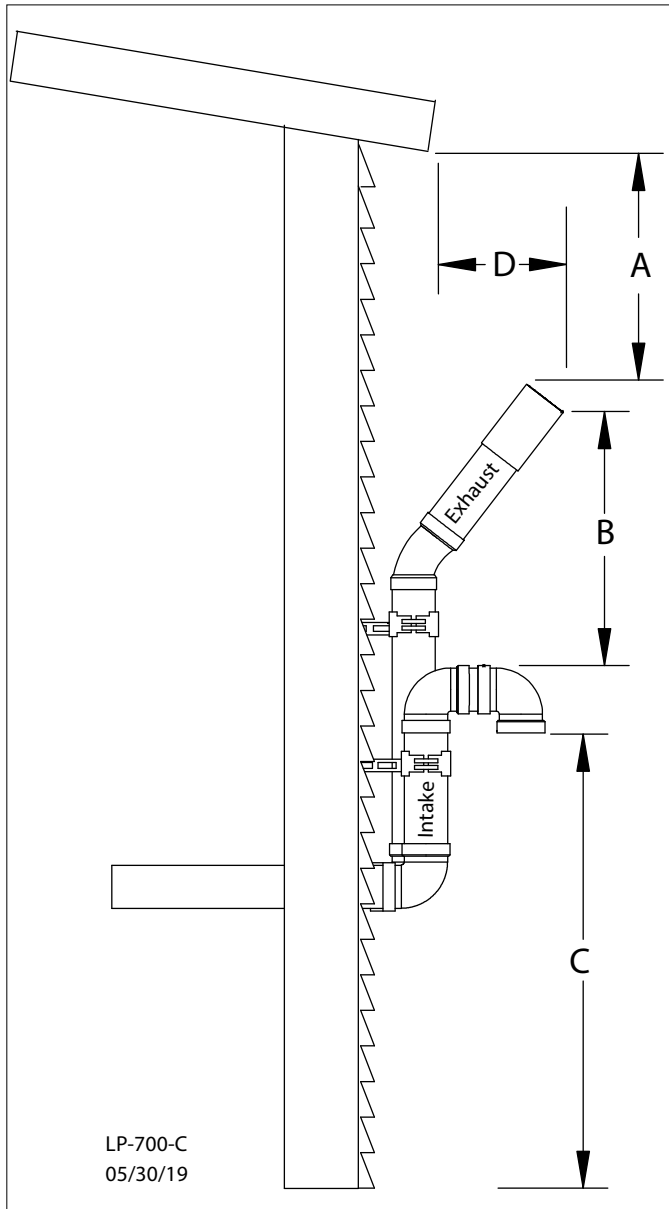

Figure 15 - Two Pipe Sidewall (Horizontal Snorkel) Venting

NOTES:

- A. For every 1" of overhang, the exhaust vent must be located 1" vertical below the overhang (12" minimum). Overhang means top of building structure (roof) and not two adjacent walls (corner of building).
- B. Maintain minimum separation between exhaust vent and air intake sidewall terminations, as required by local codes.
- C. Maintain 12" minimum clearance above highest anticipated snow level or grade (whichever is greater).
- D. The exhaust vent must extend a minimum of 12" to a maximum of 24" beyond the building.

NOTE: These drawings are meant to demonstrate system venting only. The installer is responsible for all equipment and detailing required by local codes.

Venting Below Grade

For installations that exit the wall below grade:

1. Excavate the site to a point where the pipes are to exit as shown in Figure 16.
2. Ensure the wall is fully sealed where the pipes penetrate.
3. The exhaust vent / air intake piping **MUST** be secured to the side of the building above grade, as shown, to provide rigidity.
4. Ensure that the exhaust vent / air intake clearances are maintained.

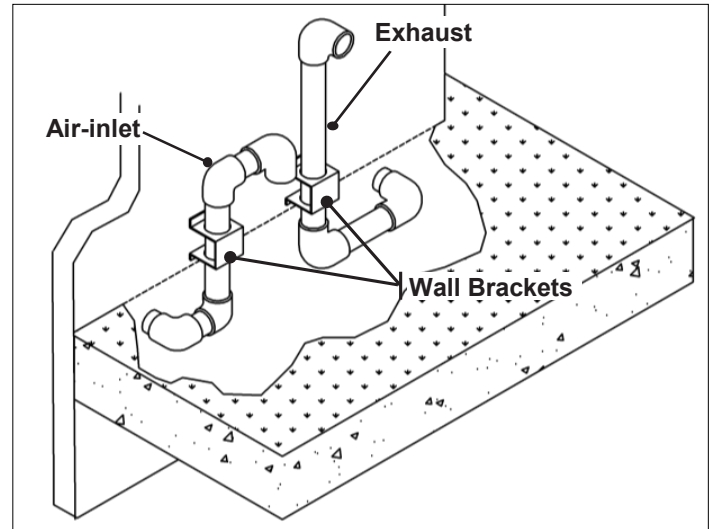

Figure 16 - Venting Below Grade

Outdoor Venting

Vent piping outside the building is permitted under the following conditions:

1. The maximum length outside the building is 20 feet (6.1 m). Note that outdoor length must be included in the overall vent length calculation.
2. All normal termination clearances are maintained.
3. The pipe is supported every 24" (610 mm).
4. The exhaust and air intake are sloped back to the appliance 1/2" elevation for every linear foot (13 mm for every linear 305 mm).

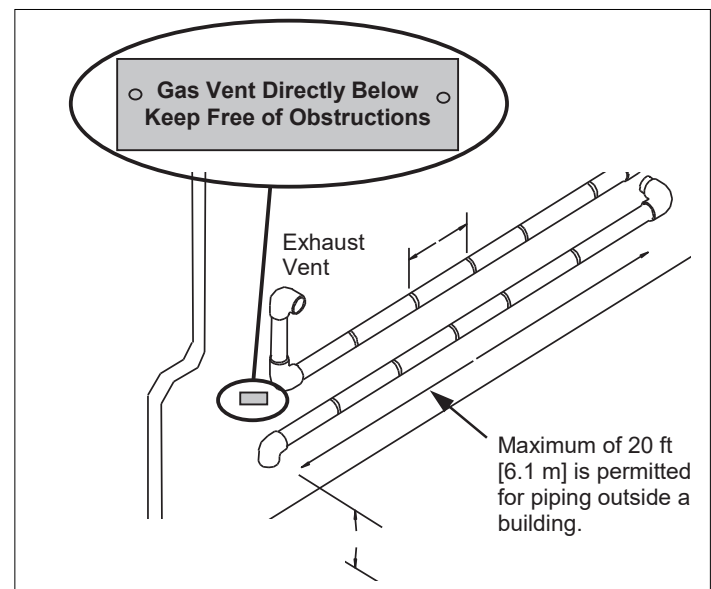

Figure 17 - Outdoor Venting

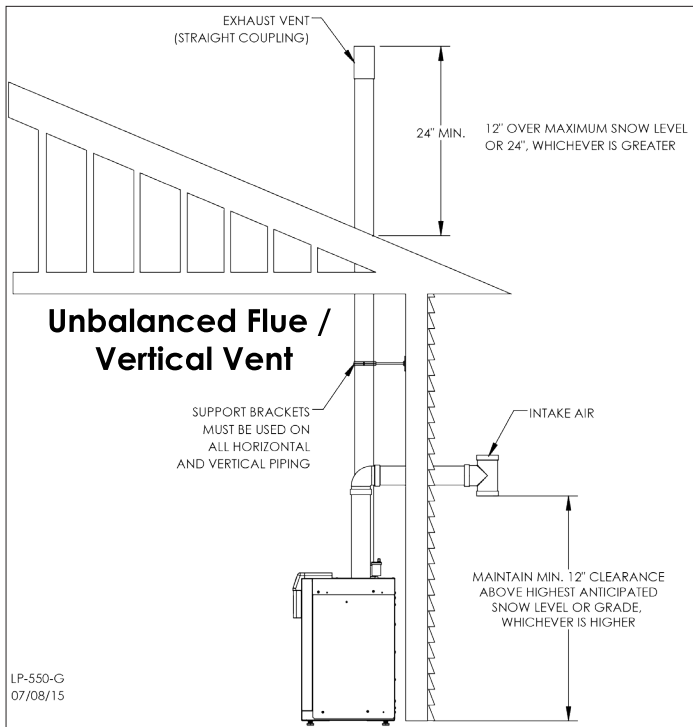

Figure 18 - Unbalanced Venting - Roof Exhaust and Sidewall Intake

NOTE: These drawings are meant to demonstrate system venting only. The installer is responsible for all equipment and detailing required by local codes.

WARNING

All vent pipes must be glued, properly supported, and the exhaust pitched a minimum of 1/4" per foot back to the VWH to allow drainage of condensate. When placing support brackets on vent piping, the first bracket must be within 1 foot of the VWH and the balance of 4 foot intervals on the vent pipe. Venting must be readily accessible for visual inspection from the first three feet from the VWH.

An unbalanced vent system can be installed **ONLY** when the exhaust is in the vertical position. Failure to do so could result in serious personal injury or death.

2. Venting Through an Existing System

This VWH may be vented through an existing unused vent system. The inner diameter of the existing vent system is utilized for the combustion air source. Two methods have been approved for such venting: Concentric Venting Through an Existing System and Venting as a Chase.

Vent / Air Intake Size	Minimum Existing Vent / Chase Size
3"	5"
4"	7"

Table 21 - Minimum Existing Vent / Chase Sizing

DANGER

Do not install the VWH into a common existing vent with any other appliance. This will cause flue gas spillage or VWH malfunction, resulting in substantial property damage, serious personal injury, or death.

CAUTION

Contractors must check state and local codes before installing through an existing vent opening. State and local codes always take precedence over manufacturer's instructions. Failure to check state and local codes before installing through an existing opening could result in property damage and add significantly to installation costs.

If an existing venting system is converted for use with this VWH, the installer must ensure that the existing venting system is clean and free from particulate contamination that could damage the VWH. Failure to do so could result in property damage and VWH failure. Such failure IS NOT covered under warranty.

Concentric Venting Through an Existing System

NOTE: The following instructions refer only to venting through an existing vent system, and not to venting with HTP's optional concentric vent kits. Refer to Concentric Vent Kit installation manual (LP-166) for further information on venting with the optional concentric vent kits. Concentric venting through an existing system must run vertically through the roof. See Table 21 for proper minimum vent sizing. Use only the approved venting materials specified in Table 16 for piping the system. All instructions listed in this Venting section apply. See Figures 19-1 and 19-2 for venting demonstrations.

DANGER

The upper and lower vent terminations as well as all joints in the venting system must be properly sealed to ensure that all combustion air is drawn properly and exhaust does not leak from the system. Failure to properly seal the venting system will result in property damage, serious personal injury, or death.

Chase Venting Through an Existing System

When venting as a chase, follow all instructions included in this Venting section, including those in the previous Concentric Venting Through an Existing System section. See Figure 19-3 for chase venting demonstration.

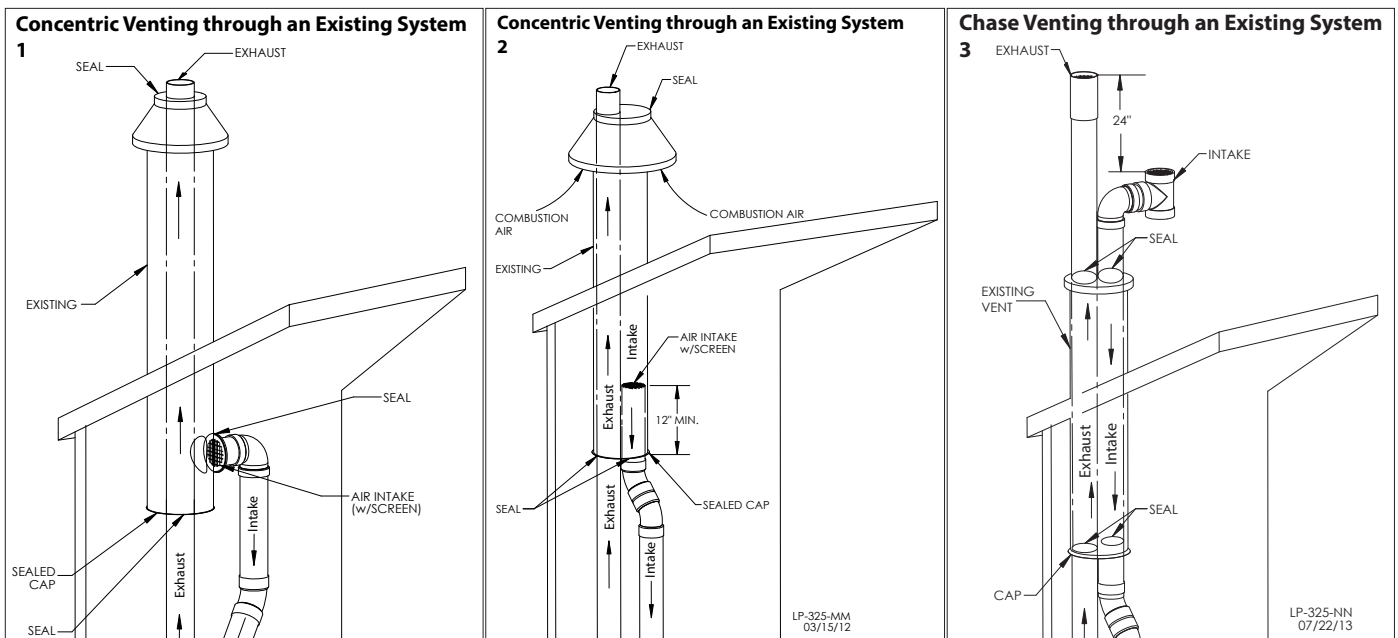

Figure 19 - 1, 2 - Concentric Venting Through an Existing System, 3, Chase Venting Through an Existing System

NOTE: These drawings are meant to demonstrate system venting only. The installer is responsible for all equipment and detailing required by local codes.

3. Power Venting, Indoor Combustion Air in Confined or Unconfined Space

This VWH requires fresh, uncontaminated air for safe operation and must be installed in a mechanical room where there is adequate combustion and ventilating air. **NOTE: To prevent combustion air contamination, see Table 5.**

Combustion air from the indoor space can be used if the space has adequate area or when air is provided through a duct or louver to supply sufficient combustion air based on the VWH input. **Never obstruct the supply of combustion air to the VWH.** If the VWH is installed in areas where indoor air is contaminated (see Figure 20) it is imperative that the VWH be installed as direct vent so that all combustion air is taken directly from the outdoors into the VWH intake connection.

Unconfined space is space with volume greater than 50 cubic feet per 1,000 Btu/hour (4.8 cubic meters per kW) of the total input rating of all fuel-burning appliances installed in that space. Rooms connected directly to this space, through openings not furnished with doors, are considered part of the space.

Confined space is space with volume less than 50 cubic feet per 1,000 Btu/hour (4.8 cubic meters per kW) of the total input rating of all fuel-burning appliances installed in that space. Rooms connected directly to this space, through openings not furnished with doors, are considered part of the space.

When drawing combustion air from inside a conventionally constructed building to a confined space, such space should be provided with two permanent openings: one located 6" (15 cm) below the space ceiling, the other 6" (15cm) above the space floor. Each opening should have a free area of one square inch per 1,000 Btu/hr (22cm²/kW) of the total input of all appliances in the space, but not less than 100 square inches (645cm²).

If the confined space is within a building of tight construction, air for combustion must be obtained from the outdoors as outlined in the Venting section of this manual. See Figure 21.

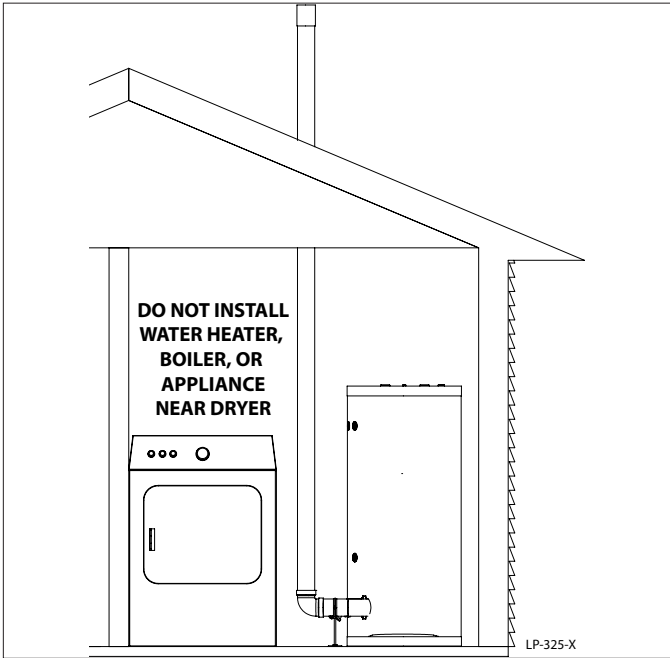

Figure 20 - Do Not Place Appliance Near Dryer

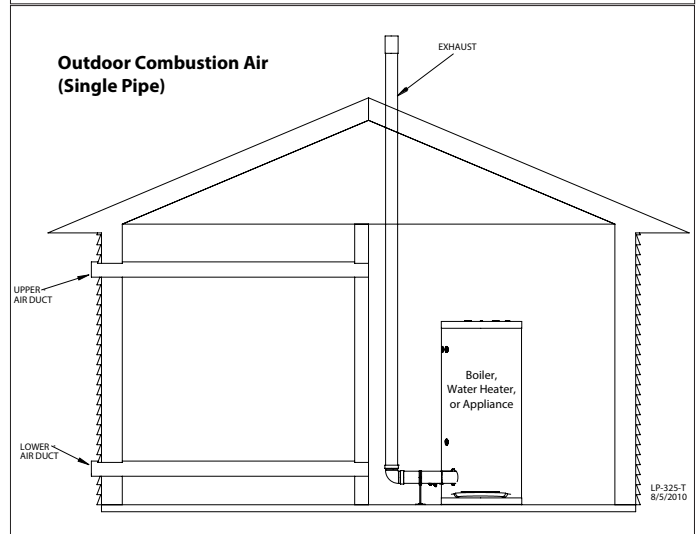
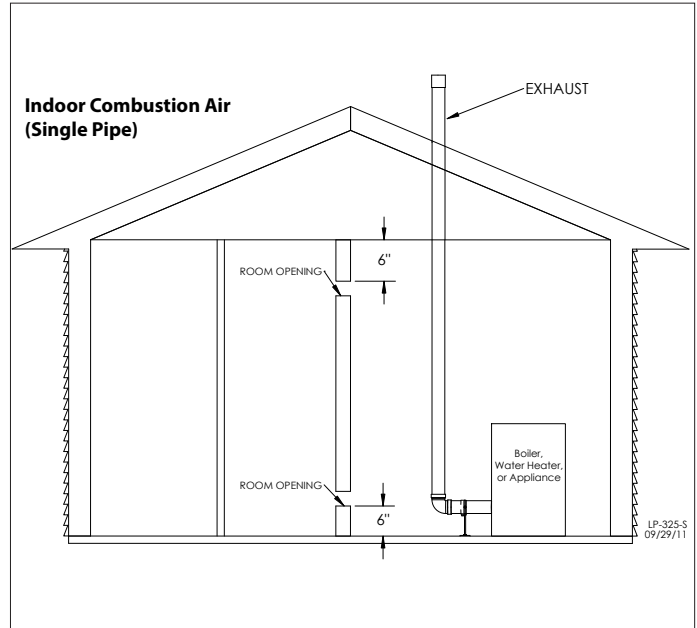

Figure 21 - Indoor and Outdoor Combustion Air - Single Pipe

WARNING

Breathing Hazard - Carbon Monoxide Gas

- Do not operate heater if flood damaged.
- Install vent system in accordance with local codes and manufacturers installation instructions.
- Do not obstruct heater air intake or exhaust. Support all vent piping per manufacturers installation instructions.
- Do not place chemical vapor emitting products near unit.
- According to NFPA 720, carbon monoxide detectors should be installed outside each sleeping area.
- Never operate the heater unless it is vented to the outdoors.
- Analyze the entire vent system to make sure that condensate will not become trapped in a section of vent pipe and therefore reduce the open cross sectional area of the vent.

Breathing carbon monoxide can cause brain damage or death. Always read and understand instruction manual.

LP-304

Part 6 -Condensate Removal

CAUTION

This condensing high efficiency appliance has a condensate removal system. Condensate is water vapor derived from combustion products, similar to that produced by an automobile when it is initially started. It is very important that the condensate line is sloped down away from the appliance and to a suitable drain.

The condensate line must remain unobstructed. If allowed to freeze in the line or obstructed in any other manner, condensate can exit from the appliance tee, resulting in potential water damage to property.

When installing a condensate pump, select one approved for use with condensing boilers and furnaces. The condensate pump should have an overflow switch to prevent property damage from spillage.

Condensate from the appliance will be slightly acidic (pH from 3.2 to 4.5). Check with your local gas company to determine if combustion condensate disposal is permitted in your area. Install a neutralizing filter if required by local codes.

It is very important that condensate piping be no smaller than 1/2". Use a tee at the condensate connection with a branch vertically up and open to the atmosphere to prevent a vacuum that could obstruct the flow of condensate from the VWH. To prevent sagging and maintain pitch, condensate piping should be supported with pipe supports.

WARNING

Power to the optional condensate pump is continuous. When the VWH is powered off the condensate pump will remain on. It is important to remember to turn off the condensate pump when powering down the VWH. Failure to do so could result in property damage, severe personal injury, or death.

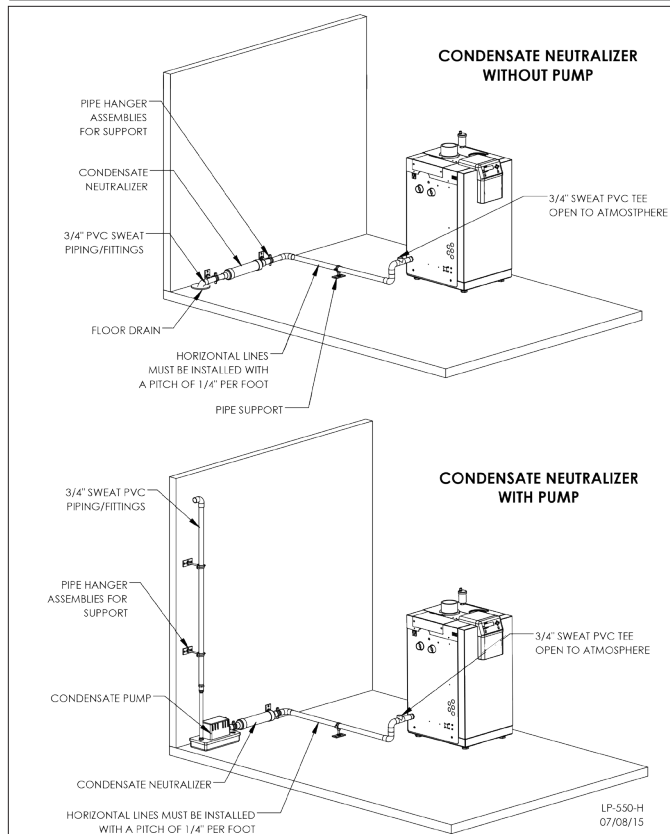

Figure 22 - Condensate Piping

NOTES:

1. Due to its efficient design, the appliance produces condensate (water) as a normal by-product. This condensate is acidic, with a pH level between 2 and 4.5. This condensate must be drained away from the appliance and disposed in accordance with all local regulations.
 2. The condensate line should be as short as possible and must be pitched at least 1/4" per foot to properly drain. If this cannot be done, increase the condensate line and place a tee in the line to properly reduce vacuum lock in the drain line. Tees should be placed after the condensate neutralizer (if used).
 3. Use corrosion-resistant materials to drain condensate. Use flexible plastic hose or tube, PVC, or CPVC pipe. PVC or CPVC pipe must comply with ASTM D1785, F441, or D2665. Cement must comply with ASTM D2564 for PVC pipe or F493 for CPVC pipe. For Canadian applications, use CSA or ULC certified flexible tube, PVC or CPVC pipe, fittings, and cement.
 4. If using flexible tube, place an overflow tee in the tube line to prevent condensate backing up into the appliance if the tube should kink. Ensure the overflow tee is positioned near a drain or in a location that will not damage the surrounding area.
 5. Do not reduce the size of the condensate line. The line must at minimum equal the diameter of the line included with the appliance.
 6. A frozen condensate line could result in a blocked vent condition. It is very important to protect the condensate line from freezing temperatures or any type of blockage. In installations that may encounter sustained freezing conditions, the use of heat tape is recommended to avoid freezing of the condensate line. Longer condensate runs are more prone to freezing.
 7. Support of the condensate line may be necessary to avoid blockage of the condensate flow.
 8. Local building codes may require an in-line neutralizer to be installed (not included) to treat the condensate. See Figure 22. If required by local authorities, a condensate filter of lime crystals, marble, or phosphate chips will neutralize slightly acidic condensate (Part # 7450P-212 for 80/110/150/220/299/301 models, Part # 7350P-611 for the 399 model). Follow all the installation instructions included with the neutralizer. If a neutralizer is installed, periodic replacement of the limestone (or neutralizing agent) will be required. The rate of depletion of the limestone varies with usage of the appliance. During the first year of appliance operation, check the neutralizer every few months for depletion.
 9. Route the drain line to a nearby floor drain, laundry tub, or condensate pump. If the appliance condensate outlet is lower than the drain, you must use a condensate removal pump (kit p/n 554200 available from HTP).
- NOTE:** If a nearby laundry tub is used as a disposal for waste water from the washing machine, draining the condensate into this tub allows the soapy water discharge to neutralize the acidic condensate.
10. An error will appear on the appliance display if condensate line is blocked. The appliance will not operate with a blocked condensate line. It is extremely important to have this condition repaired by a qualified service technician.
 11. Damages due to frozen or blocked condensate lines or leaks ARE NOT covered by warranty.

NOTE: To clean out condensate trap, see Maintenance section.

Part 7 - Wiring

WARNING

Install wiring and electrically ground VWH in accordance with the authority having jurisdiction or, in the absence of such an authority, follow the National Electrical Code, NFPA 70, and/or CSA C22.1 Electrical Code-Part 1 in Canada. Failure to follow all applicable local, state, and national regulations, mandates, and building supply codes for guidelines to install the electrical power supply could result in property damage, serious personal injury, or death.

ELECTRICAL SHOCK HAZARD – To ensure safety, turn off electrical power supply at service entrance panel before making any electrical connections to avoid possible electric shock hazard. Failure to do so could result in property damage, serious personal injury, or death.

Jumping out control circuits or components WILL VOID product warranty and can result in property damage, personal injury, or death.

It is of extreme importance that this unit be properly grounded. It is very important that the building system ground is inspected by a qualified electrician prior to making this connection. Electrical power must only be turned on when the heater is completely filled with cold water. Failure to follow these instructions could result in component or product failure, serious injury, or death.

CAUTION

Label all wires prior to disconnecting them when servicing the heater. Wiring errors can cause improper and dangerous operation. Failure to follow these instructions may result in property damage or personal injury.

CAUTION

Wiring must be NEC Class 1. If original wiring supplied with the VWH must be replaced, use only TEW 105 °C wire or equivalent. VWH must be electrically grounded as required by the National Electrical Code, ANSI/NFPA 70 - Latest Edition.

A. Installation Must Comply With

1. National Electrical Code and any other national, state, provincial, or local codes or regulations.
2. In Canada, CSA C22.1, Canadian Electrical Code Part 1, and any local codes.

B. Field Wiring Terminations

All connections made to the VWH in the field are done inside the electrical junction box located on the left side of the unit. Multiple knockout locations are available to route field wires into and out of the electrical junction box.

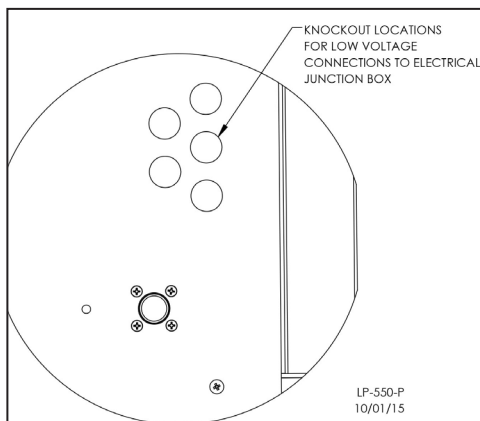

Figure 23 - Knockout Locations

C. Field Wiring

The control used in the VWH is capable of directly controlling 2 pumps in standard mode and 3 pumps when configured as a cascade master VWH. As a standard unit, each pump can provide a maximum of 2 amps at 120 volts. If a pump requires more than this amount of power, an external contactor or motor starter is needed.

The electrical junction box has separate, clearly marked terminal strips for line voltage and low voltage wiring. Special jacks are provided for trouble-free cascade system wiring using standard CAT3 or CAT5 patch cables.

D. Line Voltage Wiring for Standard VWH

NOTE: A termination plug is included in the CAT 3 / CAT 5 Bus Connection Point, labeled J3 in Figure 24. DO NOT REMOVE THIS PLUG! Doing so will affect VWH operation and void warranty.

1. Connect 120V / 60Hz / 15 AMP incoming power wiring to the line voltage terminal strip in the electrical junction box at terminals 120V, Neutral, Ground (shown in Figure 24).
2. A line voltage fused disconnect switch may be required, externally mounted and connected according to local codes that may apply.
3. Connect the VWH pump as shown in Figure 24 to the terminals marked 1 – (HOT), 2 – (NEUT), and 3 – (GND). The connections shown are suitable for a maximum continuous pump draw of 2 amps at 120 volts. If the pump requires more current or voltage than the 120 volts supplied, an external motor starter or contactor will be required.

E. Alarm Connections

The control includes a dry contact alarm output. This is an SPDT circuit, rated at 5 amps at 120 volts. This contact can be used to activate an alarm light or bell or notify a building management system if the VWH goes into a lockout condition. The circuit between the ALARM COM and NC terminals is closed during normal operation and the circuit between ALARM COM and NO is open during normal operation. The connections depicted in Figure 24 show two 120 volt lights connected to the alarm terminals. One light will be on when the VWH is in normal mode and the other light will be on when the VWH is in lockout mode.

F. Low Voltage Connections for Standard VWH

1. All low voltage cables should enter the electrical junction box through the provided knock out holes as shown in Figure 23.
2. Connect all low voltage field devices to the low voltage terminal strip located in the electrical junction box.

G. Tank Sensor or Mechanical Control

Connect the tank sensor or mechanical controls to the TANK SENSOR terminals (10, 11) of the low voltage terminal strip as shown in Figure 24. The control will automatically determine which type of sensor is connected and operate accordingly.

WARNING

Failure to use the correct sensor may result in tank temperature being either above or below set point, and could result in decreased performance, substantial property damage, or heightened risk of injury or death due to scalds.

Caution should be used to ensure neither of these terminals becomes connected to ground.

NOTE: If sensor wires are located in an area with sources of potential electromagnetic interference (EMI), the sensor wires should be shielded, or the wires routed in a grounded metal conduit. If using shielded cable, the shielding should be connected to the common ground of the VWH.

H. System / Pipe Sensor

The system/pipe sensor can be used to control the temperature of the storage tank when a tank sensor or mechanical control cannot be mounted. The system/pipe sensor would be wired into the terminals of the low voltage terminal strip as shown on Figure 24. It is important to note that when a system/pipe sensor is used, the circulating pump must be wired to operate continuously; otherwise the VWH will short cycle.

The system/pipe sensor can also be used in a cascade system when the sensor is placed on the supply line of multiple VWHs that feed the storage tank. This will control the temperature and modulate the firing rate of the connected VWHs. The system/pipe sensor would then be wired into the master VWH terminals on the low voltage strip as shown on Figure 26.

NOTE: If sensor wires are located in an area with sources of potential electromagnetic interference (EMI), the sensor wires should be shielded, or the wires routed in a grounded metal conduit. If using shielded cable, the shielding should be connected to the common ground of the VWH.

I. Optional 0-10 Volt Building Control Signal

1. A signal from a building management system may be connected to the VWH to enable remote control. This signal should be a 0-10 volt positive-going DC signal. When this input is enabled using the installer menu, a building control system can be used to control the set point temperature of the VWH. The control interprets the 0-10 volt signal as follows; when the signal is between 0 and 1.5 volts, the VWH will be in standby mode, not firing. When the signal rises above 1.5 volts, the VWH will ignite. As the signal continues to rise towards its maximum of 10 volts, the VWH will increase in set point temperature. See Part 10 for details on the setting of function 16.

2. Connect a building management system or other auxiliary control signal to the terminals marked 16, 0-10 VOLT + and 17, 0-10 VOLT - in the electrical junction box (shown in Figure 24). Caution should be used to ensure that the 0-10 VOLT + connection does not become connected to ground.

3. See Function 17 this manual to program the 0-10 volt signal.

NOTE: When a 0-10 volt building management system is installed, the return sensor temperature cannot be monitored through the appliance display.

J. Optional UL353 Low Water Cut-Off Interface Kit

If an optional Low Water Cut-Off (LWCO) Kit is used, the LWCO probe should be mounted into the fitting provided in the outlet combination fitting.

Follow the complete instructions included in the kit for proper installation.

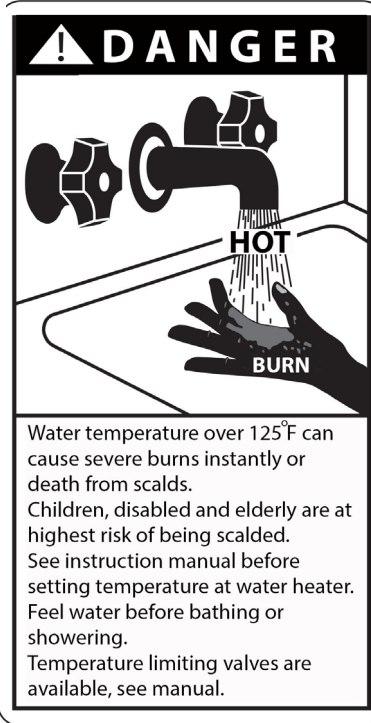

K. Wiring of Cascade System Communication Bus

1. A Cascade Bus Termination Plug has been installed on the customer connection board of this VWH. The purpose of this plug is to stabilize communication between multiple VWHs and reduce electrical "noise". See Figures 25 and 26 for Cascade Bus Termination Plug installation detail.

2. Use standard CAT3 or CAT5 computer network patch cables to connect the communication bus between each of the VWHs. These cables are readily available at any office supply, computer, electronic, department or discount home supply store in varying lengths. If you possess the skills you can also construct custom length cables.

3. It is recommended to use the shortest length cable that will reach between the VWHs and create a neat installation. Do not run unprotected cables across the floor where they may become wet or damaged. Avoid running communication cables parallel and close to or against high voltage (120 volt or greater) wiring. HTP recommends that the maximum length of communication bus cables not exceed 200 feet.

4. Route the communication cables through one of the knockouts in the cabinet.

5. Connect the VWHs in a daisy chain configuration as shown below. It is best to wire the VWHs using the shortest wire runs rather than trying to wire them in the order that they are addressed. The communication bus jacks on the customer connection panel are interchangeable so you can use either one or both in any order to connect the cable.

If you have connected the VWHs to each other properly, there will be no open communication connection ports.

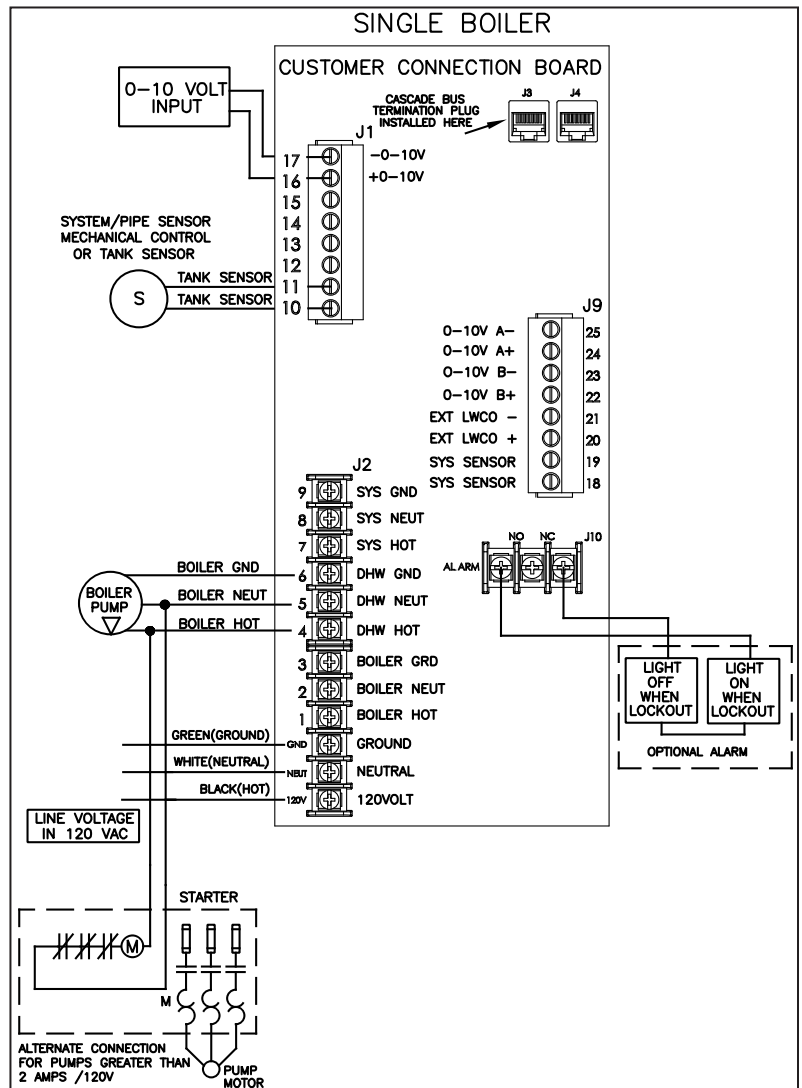

Figure 24 - VWH Control Wiring

L. Cascade Master Pump and Sensor Wiring

1. Connect the system pump hot wire to the terminal marked 7 (SYS PUMP).
2. Connect the system pump neutral to the 8 (SYS NEUT) terminal and the pump ground wire to the 9 (SYS GND) terminal.
3. Connect the VWH pump to the terminals marked 1 (BOILER HOT), 2 (BOILER NEUT), and 3 (BOILER GND).
4. Connect the system pipe sensor to the terminals marked 10 and 11 (TANK SENSOR).

M. Cascade Follower Pump and Sensor Wiring

1. Connect the VWH pump to the terminals labeled 1 (HOT), 2 (NEUT), and 3 (GND).
2. An alarm bell or light can be connected to the alarm contacts of the follower VWH. The normally closed alarm contact may be used to turn a device off if the VWH goes into lockout mode. The alarm contacts are rated 5 amps at 120 VAC.

To connect an alarm device, connect the power for the device to the ALARM COM terminal. Connect the alarm device hot wire to the ALARM NO terminal. Connect the neutral or return of the alarm device to the neutral or return of the power for the alarm device.

To connect a device that should be powered off during a VWH lockout condition, follow the same instructions as above except use the ALARM NC terminal rather than the ALARM NO terminal.

Note that in a cascade system the alarm output of the VWH addressed as #1 will also be active if the master VWH has a lockout condition. The alarm output of VWHs addressed as 2-7 will only activate an alarm if a lockout condition occurs on that specific VWH.

N. Variable Speed Pumping

Variable speed pump support is available on the primary loop of all models manufactured after 11/15/2016. This feature controls pump speed via an analog 0-10VDC signal supplied via the 0-10VA connection on the Customer Connection Board.

When this feature is in use, an installer selected Delta T is maintained with the Supply and Return sensors, increasing efficiency and providing better system temperature control. When the difference between the Supply and Return temperatures is greater than the desired setting, the pump will increase speed and flow to compensate. Conversely, if the Delta T is less than the desired setting, the pump will decrease speed and flow to compensate.

NOTE: This feature may be used in Primary / Secondary piping arrangements ONLY!

Variable Speed Pumping Wiring:

1. Connect the VWH pump as shown in Figure 24 to the terminals marked 1 – (HOT), 2 – (NEUT), and 3 – (GND). The connections shown are suitable for a maximum continuous pump draw of 2 amps at 120 volts. If the pump requires more current or voltage than the 120 volts supplied, an external motor starter or contactor will be required.
2. Connect the 0-10v input wires on the variable speed pump to the 0-10v output on J9 of the customer connection board. Connect the positive pump input wire to J9-24, and the negative wire to J9-25.

NOTE: When making wiring connections, ensure proper polarity or the system will not operate properly.

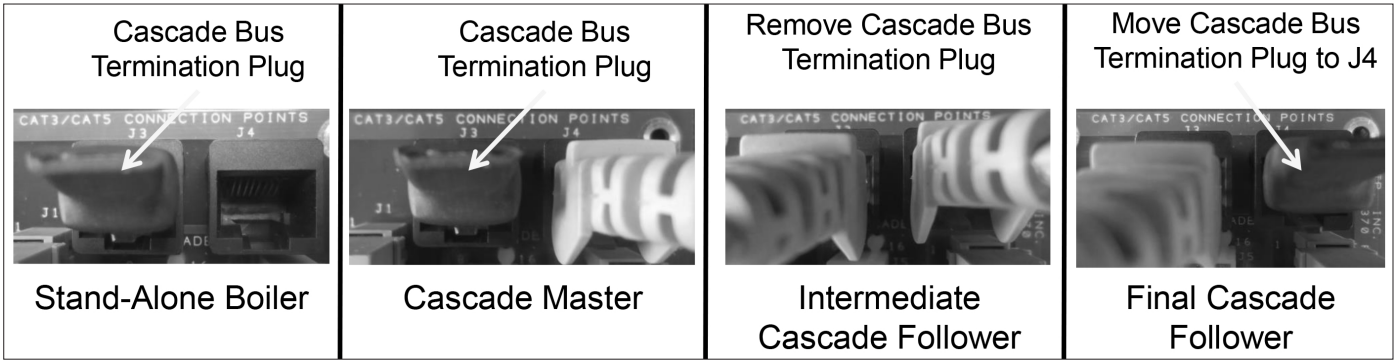

Figure 25 - Cascade Termination Plug Detail

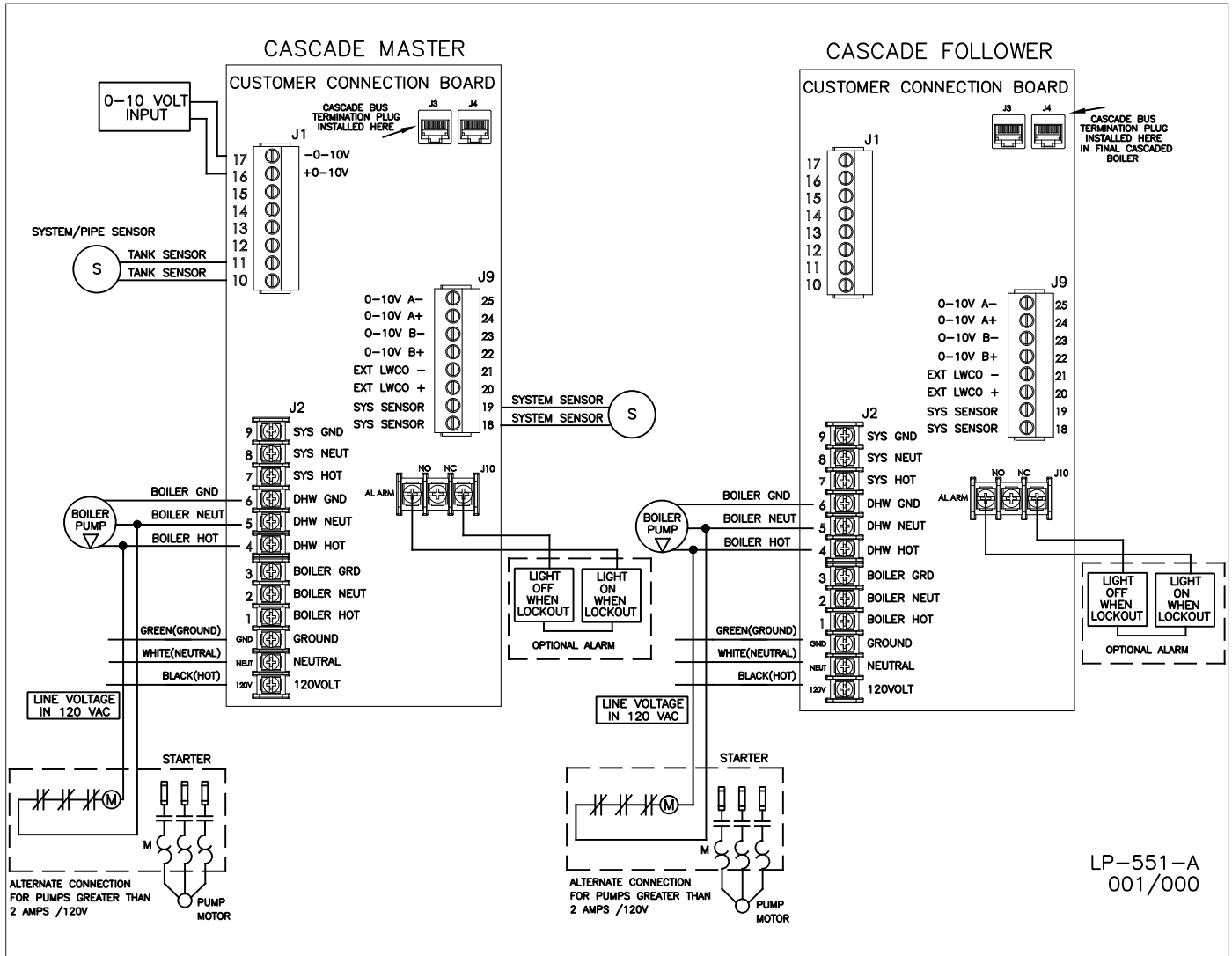
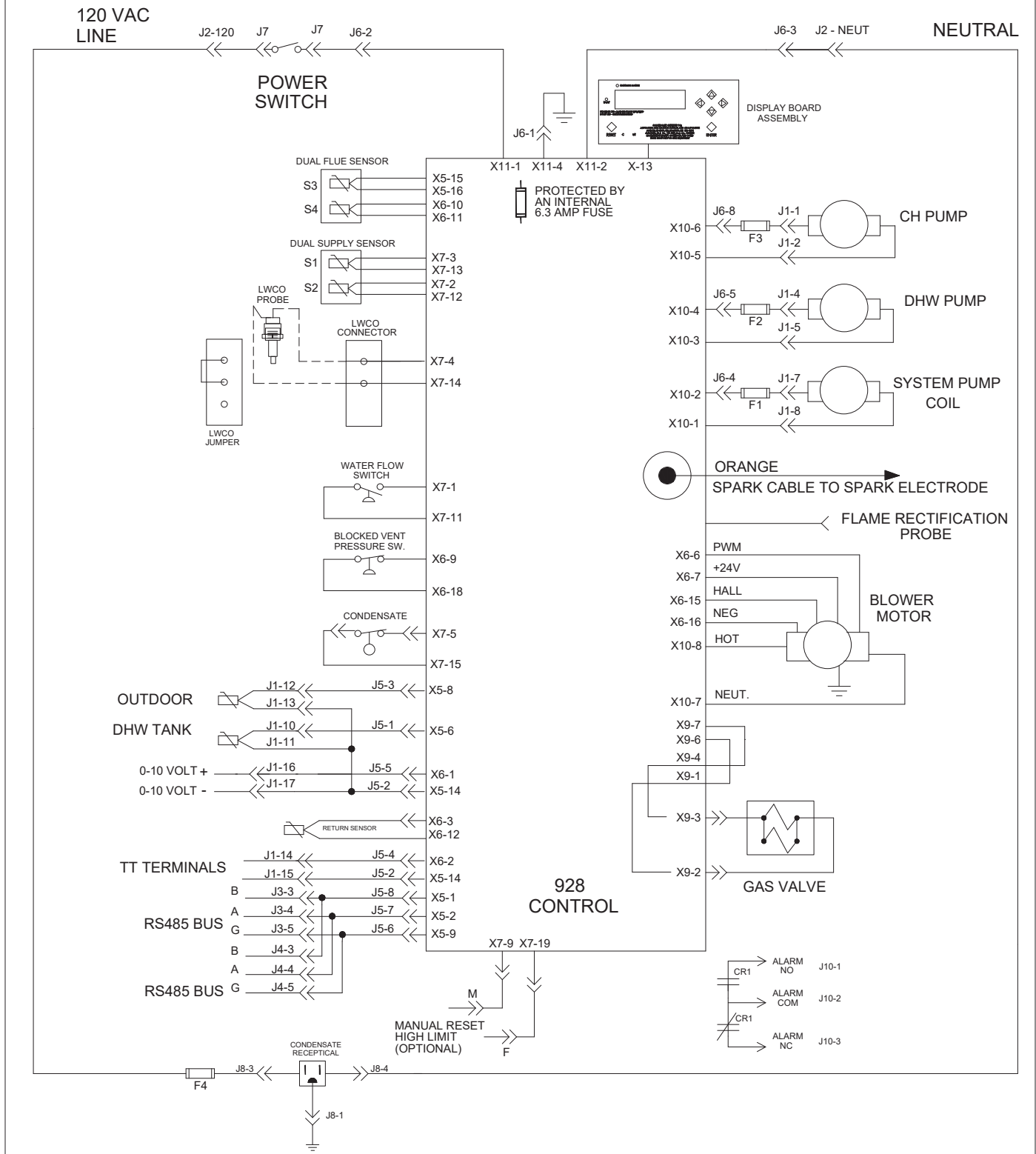

Figure 26 - Cascade Master and Follower Wiring

LP-551-A
001/000

CONTROL BOARD WIRING DIAGRAM VWH MODELS ONLY



* NOTE: "J" REFERENCES FIELD CONNECTION BOARD

LP-551-C
11/09/15

Figure 27 - Internal Connection Diagram

Part 8 - Gas Connections

WARNING

FIRE AND/OR EXPLOSION HAZARD

To avoid serious injury or death, the gas line installation and the gas line inlet pressure test must be done by a licensed professional.

It is very important that the VWH is connected to the type of gas noted on the rating plate. "LP" for liquefied petroleum, propane gas, or "NG" for natural gas. Do not do a gas conversion without an approved gas conversion kit (not included). Prior to turning the gas on, all gas connections must be approved by the local gas supplier or utility, in addition to the governing authority.

Make sure the gas line pressures are within normal limits. Pressures outside normal limits can result in poor performance and hazardous operating conditions, property damage, personal injury, or death.

UL recognized fuel gas detectors are recommended in all enclosed propane and natural gas applications where there is a potential for an explosive mixture of fuel gas to accumulate. The installation of these detectors should be made in accordance with the detector manufacturer's recommendations, and/or local laws. Failure to install fuel gas detectors in these applications could result in fire, explosion, property damage, severe personal injury, or death.

Never use an open flame (match or lighter) to check for gas leaks. Use a soapy solution to test connection.

Do not use Teflon tape on gas line pipe thread. Use a pipe compound rated for use with natural gases. Apply sparingly on male pipe ends, leaving the two end threads bare and flow unobstructed.

Support gas supply piping with hangers, not by the VWH or its accessories. The VWH gas valve and blower will not support the weight of the piping. Make sure the gas piping is protected from physical damage and freezing, where required.

Failure to follow these instructions could result in property damage, gas leakage, fire, explosion, serious personal injury, or death.

The gas supply shall have a maximum inlet pressure of less than 14" w.c. (3.5 kPa), and a minimum of 3.5" w.c. (.87 kPa). The entire piping system, gas meter and regulator must be sized properly to prevent pressure drop greater than 0.5" (.12 kPa) as stated in the National Fuel Gas Code. This information is listed on the rating label.

NOTICE

Do not operate the VWH on Natural Gas or LP gas with average sulfur rates greater than 30 mg/m³. Doing so could result in improper product operation and failure, and WILL VOID the VWH warranty.

The gas connection on the VWH is 3/4" for 80/110/150 models and 1" for 220/299/301/399 models. It is mandatory that this fitting is used for connection to a field fabricated drip leg as shown in the illustration per the National Fuel Gas Code. You must ensure that the entire gas line to the connection at the VWH is no smaller than the unit supplied connection.

Once all inspections have been performed, the piping must be leak tested. If the leak test requirement is a higher test pressure than the maximum inlet pressure, you must isolate the VWH from the gas line. In order to do this, shut the gas off using factory and field-installed gas cocks. This will prevent high pressure. Failure to do so may damage the gas valve. In the event the gas valve is exposed to a pressure greater than 1/2 PSI, 14" w.c. (3.5 kPa), the gas valve must be replaced. Never use an open flame (match, lighter, etc.) to check gas connections.

A. Gas Piping

1. Run the gas supply line in accordance with all applicable codes.
2. Locate and install manual shutoff valves in accordance with state and local requirements.
3. In Canada, the Manual Shutoff must be identified by the installing contractor.
4. It is important to support gas piping as the unit is not designed to structurally support a large amount of weight.
5. Purge all gas lines thoroughly to avoid start up issues with air in the lines.
6. Sealing compound must be approved for gas connections. Care must be taken when applying compound to prevent blockage or obstruction of gas flow which may affect the operation of the unit.

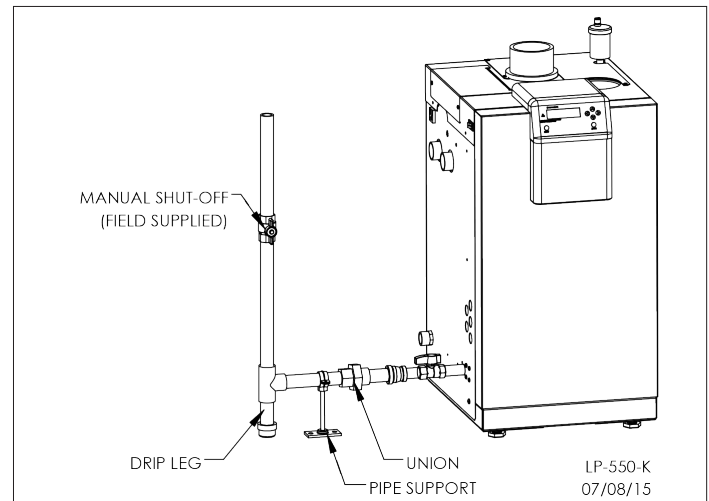

Figure 28 - Gas Connection

CAUTION

Use two wrenches when tightening gas piping at the VWH: One to prevent the VWH gas line from turning. Failure to prevent the VWH gas connection from turning could result in damage to the gas line components, substantial property damage, severe personal injury, or death.

CSA or UL listed flexible gas connections can be used when installing the VWH. Flexible gas connections have different capacities and must be sized correctly for the connected VWH firing rates. Consult with the flex line supplier to assure the line size is adequate for the job. Follow local codes for proper installation and service requirements.

WARNING

Breathing Hazard - Carbon Monoxide Gas



- Do not operate heater if flood damaged.
- Install vent system in accordance with local codes and manufacturers installation instructions.
- Do not obstruct heater air intake or exhaust. Support all vent piping per manufacturers installation instructions.
- Do not place chemical vapor emitting products near unit.
- According to NFPA 720, carbon monoxide detectors should be installed outside each sleeping area.
- Never operate the heater unless it is vented to the outdoors.
- Analyze the entire vent system to make sure that condensate will not become trapped in a section of vent pipe and therefore reduce the open cross sectional area of the vent.

Breathing carbon monoxide can cause brain damage or death. Always read and understand instruction manual.

LP-304

B. Gas Table

Refer to Table 23 to size the supply piping to minimize pressure drop between the meter or regulator and unit. Maximum capacity of pipe in cubic feet of gas per hour cannot have a pressure drop greater than .5 w.c.

NOTE: For greater capacities, see NFPA 54, The National Fuel Gas Code.

Natural Gas Supply Piping Capacity Chart - Schedule 40 metallic pipe size in nominal inches														
(0.6 Specific gravity gas; 0.5" WC pressure drop)														
Pipe Size (Inches)	Capacity in Cubic Ft. Hr. by Length of Pipe in Straight Feet													
	10	20	30	40	50	60	70	80	90	100	125	150	175	200
1	678	466	N/A	N/A	N/A	N/A	N/A	N/A	N/A	N/A	N/A	N/A	N/A	N/A
1 1/4	1390	957	768	657	583	528	486	452	424	400	N/A	N/A	N/A	N/A
1 1/2	2090	1430	1150	985	873	791	728	677	635	600	532	482	443	412
2	4020	2760	2220	1900	1680	1520	1400	1300	1220	1160	1020	928	854	794
2 1/2	6400	4400	3530	3020	2680	2430	2230	2080	1950	1840	1630	1480	1360	1270
3	11300	7780	6250	5350	4740	4290	3950	3670	3450	3260	2890	2610	2410	2240

Table 23 - Gas Supply Piping Size Chart for Boilers - from NFPA 54, The National Fuel Gas Code

C. Additional Precaution for Excess Flow Valve (EFV)

If an excess flow valve (EFV) is in the gas line, check the manufacturer's minimum and maximum flow capacity ratings. An improperly sized EFV will not allow for a full flow of gas to the VWH and will cause the VWH to malfunction. See Figure 29.



Figure 29 - Excess Flow Valve (EFV)

WARNING

When performing a pressure test on the gas line piping, be sure the VWH is disconnected or isolated if the test pressure is expected to exceed 1/2 PSI (14" WC), as damage to the gas valve could occur. Such damage could result in fire, property damage, serious personal injury, or death.

D. Check Inlet Gas Pressure

The gas valve is equipped with an inlet gas pressure tap that can be used to measure the gas pressure to the unit. To check gas pressure, perform the steps listed below:

- IMPORTANT!** Before you connect to the inlet pressure, shut off the gas and electrical power to unit.
- Loosen the pressure tap with a small screwdriver. Refer to Figure 30 for location.
- Each unit is equipped with a needle valve that will accept a 5/16 ID hose to connect to a digital manometer or liquid gauge to measure incoming pressure from 0-35" w.c. See Figure 30.
- Turn on the gas and power up the unit.
- Put the unit into manual test mode (details on test mode are in Part 10). In test mode, monitor pressure to assure it does not drop below 1 inch from its idle reading. If gas pressure is out of range or pressure drop is excessive, contact the gas utility, gas supplier, qualified installer, or service agency to determine correct action that is needed to provide proper gas pressure to the unit. If Gas Pressure is within normal range proceed to Step 6.
- Exit test mode, then turn power off and shut off gas supply at the manual gas valve before disconnecting the hose from the gas monitoring device. Tighten screw on the pressure tap and turn gas on. Check for leaks with soapy solution. Bubbles will appear on the pipe to indicate a leak is present.

WARNING

Ensure the pressure tap screw is properly tightened to prevent gas leaks. Failure to do so could cause substantial property damage, severe personal injury, or death.

The gas piping must be sized for the proper flow and length of pipe to avoid pressure drop. The gas meter and regulator must be properly sized for the total gas load. If you experience a pressure drop greater than 1" w.c. (.87 kPa), the meter, regulator or gas line may be undersized or in need of service. You can attach a manometer to the incoming gas drip leg after removing the cap. The gas pressure must remain between 3.5" (.87 kPa) and 14" (3.5 kPa) during stand-by (static) mode and while in operating (dynamic) mode. If an in-line regulator is used, it must be a minimum of 10 feet from the VWH. It is very important that the gas line is properly purged by the gas supplier or utility. Failure to properly purge the lines, or improper line sizing, will result in ignition failure. This problem is especially noticeable in NEW LP installations and empty tank situations. This situation can also occur when a utility company shuts off service to an area to provide maintenance to their lines. This gas valve must not be replaced with a conventional gas valve under any circumstances.

WARNING

DO NOT adjust or attempt to measure gas valve outlet pressure. The gas valve is factory-set for the correct outlet pressure and requires no field adjustment. Attempts by the installer to adjust or measure the gas valve outlet pressure could result in damage to the valve and cause substantial property damage, severe personal injury, or death.

Ensure that the high gas pressure regulator is as least 6 – 10 feet upstream of the appliance. Failure to do so could result in substantial property damage, severe personal injury, or death.

Natural or LP Gas	
Minimum Pressure	3.5" WC
Maximum Pressure	14" WC

Table 22 - Gas Pressure Requirements

NOTICE

Do not fire (operate) the VWH until all connections have been completed and the heat exchanger is filled with water. Doing so will damage the VWH and void the warranty.

E. VWH Gas Valve

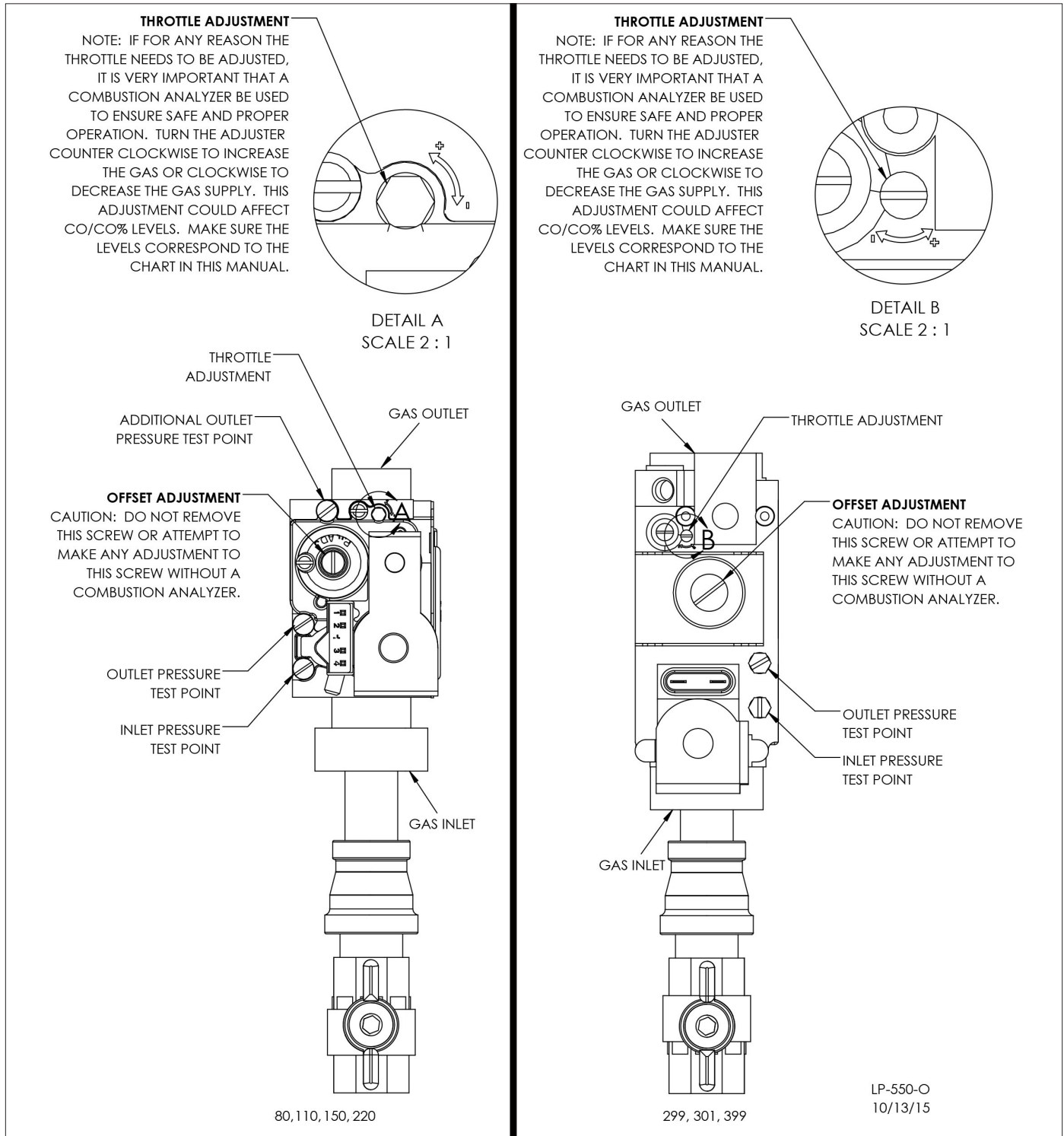

Figure 30 - Gas Valve

⚠ DANGER

Do not do a gas conversion on this VWH without an officially approved conversion kit and instructions supplied by HTP. Failure to use a conversion kit when converting the VWH to fire on Natural or Propane gas will result in extremely dangerous burner operation, leading to fire, explosion, severe personal injury, or death.

⚠ WARNING

Strain on the gas valve and fittings may result in vibration, premature component failure and gas leakage, and result in fire, explosion, property damage, severe personal injury, or death.

Adjustments to the throttle screw or offset may only be made by a qualified gas technician using a calibrated combustion analyzer capable of measuring CO₂ and CO. Failure to follow this instruction could result in fire, explosion, property damage, severe personal injury, or death.

Part 9 - Start-Up Preparation

A. Check / Control Water Chemistry

CAUTION

Chemical imbalance of the water supply may affect efficiency and cause severe damage to the appliance and associated equipment. Water quality must be professionally analyzed to determine whether it is necessary to treat the water. Various solutions are available to adjust water quality. Adverse water quality will affect the reliability of the system. In addition, operating temperatures above 135°F will accelerate the build-up of lime scale and possibly shorten appliance service life. Failure of an appliance due to lime scale build-up, low pH, or other chemical imbalance IS NOT covered by the warranty.

The water must be potable, free of corrosive chemicals, sand, dirt, and other contaminants. It is up to the installer to ensure the water does not contain corrosive chemicals or elements that can damage the heat exchanger. Potable water is defined as drinkable water supplied from utility or well water in compliance with EPA secondary maximum contaminant levels (40 CFR Part 143.3) as shown in the table below. If the water contains contaminants higher than outlined by the EPA, water treatment is recommended and additional, more frequent maintenance may be required.

If you suspect that your water is contaminated in any way, discontinue use of the appliance and contact an authorized technician or licensed professional.

Contaminant	Maximum Allowable Level	Contaminant	Maximum Allowable Level
Total Hardness (Commercial Use - 140°F and above water temperature)	120 mg/l (7 grains/gallon)	pH	6.5-8.5
		Sulfate	205 mg/l
		Total Dissolved Solids (TDS)	500 mg/l
Aluminum	0.05 to 0.2 mg/l	Zinc	5 mg/l
Chloride	100 mg/l		
Copper	1 mg/l	Dissolved Carbon Dioxide (CO2)	15 mg/l or PPM
Iron	0.3 mg/l		
Manganese	0.05 mg/l		

CAUTION

Do not use petroleum-based cleaning or sealing compounds in the appliance system. Damage to elastomer seals and gaskets in the system could occur, resulting in substantial property damage.

B. Check for Gas Leaks

WARNING

Before starting the VWH, and during initial operation, smell near the floor and around the VWH for gas odorant or any unusual odor. Remove VWH front door and smell interior of VWH enclosure. Do not proceed with startup if there is any indication of a gas leak. Repair any leaks at once.

PROPANE VWHs ONLY – The propane supplier mixes an odorant with the propane to make its presence detectable. In some instances the odorant can fade, and the gas may no longer have an odor. Before startup (and periodically thereafter), have the propane supplier verify the correct odorant level in the gas.

C. Condensate Removal

1. The VWH is a high efficiency condensing VWH. Therefore, the unit has a condensate drain. Condensate fluid is nothing more than water vapor, derived from combustion products, similar to that produced by

an automobile when it is initially started.

Condensation is slightly acidic (typically with a pH of 3 to 5) and must be piped with the correct materials. Never pipe the condensate using steel, copper, brass or other materials that will be subject to corrosion. Plastic PVC or CPVC pipe are the only approved materials. A condensate neutralizer, if required by local authorities, can be made up of lime crystals, marble or phosphate chips that will neutralize the condensate. This may be done by the installer or you may purchase a condensate neutralizer from HTP (7450P-212).

2. The VWH is equipped with a ¾ female socket weld fitting connection that must be piped to a local drain. It is very important that the condensate line is sloped downward away from the VWH to a suitable inside drain. If the condensate outlet on the appliance is lower than the drain, you must use a condensate removal pump, available from HTP (554200). This pump is equipped with two leads that can be connected to an alarm or another type of warning device to alert the user of a condensate overflow, which, if not corrected, could cause property damage.

3. If a long horizontal run is used, it may be necessary to create a vent in the horizontal run to prevent a vacuum lock in the condensate line.

4. Do not expose the condensate to freezing temperatures.

5. It is very important you support the condensation line to assure proper drainage.

D. Filling and Testing the VWH System

WARNING

The VWH must be full of water and the system fully purged BEFORE firing the burner. When filling the system, open hot water outlets to release air in the storage tanks and piping. All air has been purged from the system when water runs freely from the outlets. Firing the VWH when it is not full of water will damage the heat exchanger, and could result in property damage, serious personal injury, or death. Such damages ARE NOT covered by VWH warranty.

- Fill the system only after ensuring water chemistry meets the requirements listed in this manual.
- Make certain the drain valves are completely closed.
- Open the shut-off valve in the cold water supply line.
- Open the hot water outlets to allow air to vent from the VWH, storage tanks, and piping.

CAUTION

It is important to purge the system of air to avoid damage to the VWH.

- Allow sufficient time for the system to completely fill with water.
- At initial fill and during VWH startup and testing, check system thoroughly for leaks. Repair all leaks before proceeding further.

E. Final Checks Before Starting VWH

1. Read Startup Procedures within this manual for proper steps to start VWH. (See Startup Report to record steps for future reference.)
2. Verify the VWH and system are full of water and all system components are correctly set for operation.

WARNING

Ensure the VWH is full of water before firing the burner. Failure to do so will damage the VWH. Such damage IS NOT covered by warranty, and could result in property damage, severe personal injury, or death.

3. Fill condensate trap with water.

4. Verify electrical connections are correct and securely attached.

5. Inspect exhaust vent and intake piping for signs of deterioration from corrosion, physical damage or sagging. Verify exhaust vent and intake piping are intact and correctly installed per Venting Section and local codes.

F. Setting Up a Single VWH

When power is applied to the VWH, the control first completes a power-up systems check. During this time the combustion fan may run. The display will initially show the current VWH outlet temperature. If a fault is detected during the power-up test, the control will display the appropriate fault code. Otherwise, the display will continue to show the VWH outlet temperature and stand-by, waiting for a demand for hot water. If the temperature of the tank sensor falls below the tank set point minus the tank differential temperature, a demand for hot water is generated by the control.

When a demand for hot water is received, the control begins the following demand sequence. The VWH first turns on the pump (if it is not wired to run continuously). Once the pump is running, the control will display LOW WATER FLOW and wait for the water flow in the system to increase to an acceptable level determined by the flow switch on the outside of the VWH. (NOTE: This step may happen very rapidly. If flow is adequate, LOW WATER FLOW may never display.)

Once flow through the VWH is adequate, the control will measure the supply temperature. If it is below the set point temperature minus the ignition differential set point, the control will ignite the burner. After the burner is lit, the control modulates the firing rate to control the supply water temperature at the set point temperature plus the supply offset temperature (installer #4) above the tank set point temperature. When the tank temperature is equal to the tank set point temperature, the control will extinguish the burner and run the combustion fan to purge gasses from the combustion chamber. In addition, the pump will run for a pump post purge interval. The control will then be in standby, waiting to process the next demand for heat.

During this process, the control will extinguish the burner if it senses a dangerous or unsafe condition. If the control determines that a dangerous or unsafe condition has occurred, the control may lock out the VWH and prevent it from igniting until a maintenance person diagnoses the problem, repairs it, and resets the control. In the event that the control goes into lockout, it will show a diagnostic code on the display, illuminate the LED fault indicator, and close the alarm relay contacts to aid in recognition of the condition, diagnosis, and repair.

G. Setting Up a Cascaded System

If the VWH is part of a cascaded system the operation is somewhat different. The control of each VWH in a cascaded system completes its own power up system check as described above. One of the VWHs in the cascade system is designated as the master VWH. After the master VWH completes its power up sequence, it checks the communication bus to see if any other VWHs are present. If other VWHs are present, the master control determines these follower VWH addresses. The master VWH control will recheck the bus every few seconds as long as it is powered up to update the status of the connected VWHs. The control in the master VWH processes all heat demands and dictates which of the follower VWHs should light and what firing rate the followers should try to achieve.

When the master VWH receives a demand for heat, it determines which VWH is first in the firing sequence and sends that VWH a command to begin a demand sequence. That VWH will then begin a demand sequence as described above. Once the VWH ignites, the master VWH control will increase the firing rate command to that VWH until the system sensor temperature is at the tank set point temperature plus the supply offset temperature (installer #4), or that VWH is at high firing rate. If the command from the master VWH control gets to the high firing rate of the follower VWH, but the system sensor is below the required temperature, the master VWH

control will then tell the next VWH in the firing sequence to begin its demand sequence. The master VWH control will then begin to ramp up the firing rate command of that VWH. This process will continue while there is a demand until all VWHs in the cascade system are at high fire or the desired temperature of the system sensor is reached. If the system sensor temperature reaches tank set point and installer #4 before all VWHs are at high fire, the master control will modulate the cascade command signal to maintain the system sensor at tank set point and installer #4 until the demand is complete. When the tank temperature is equal to the set point temperature, the demand is complete, and the master VWH control will extinguish all VWHs that may be lit. If the demand decreases, the firing rate command and amount of VWHs lit will decrease exactly opposite as described above.

Whenever the master VWH control needs to fire a follower VWH, it sends a firing rate command to that VWH. The follower VWH will respond to the command until its supply sensor temperature gets to be 5°F above the tank set point temperature plus the supply offset temperature (installer #4), at which point the individual VWH will modulate on its own so as not to overheat. As a result, it is not uncommon to see the cascade output at maximum but individual VWHs firing at less than their maximum firing rate.

H. Lockout Condition

If any boilers, including the master boiler in the cascade system, are in a lockout condition, the master control will recognize the lockout condition and skip over the boiler in the firing sequence. Each boiler in the cascade system is responsible for its own safety functions. So, if any individual boiler control senses an unsafe condition, it will extinguish the burner and, if necessary, go to a lockout condition. In this way, every boiler in the system has its individual safety controls intact and operational, even if the firing of the boiler is under control of the master boiler.

In the event that the system sensor fails, all boilers in the system will ignite simultaneously when there is a demand, and each boiler will individually regulate firing rates to maintain the master set point temperature (supply temperature set point + differential) at the individual supply sensors built into the boiler. If this should happen, the master boiler will display an E03 fault code, indicating that the supply sensor has failed.

I. Cascade System Programming

1. If the VWH is used alone, skip this section.

2. Programming the Master VWH:

- a. Make sure there is no demand for heat being supplied to the VWH.
- b. Apply power to the VWH.
- c. Enter the system setting program navigation following instructions in Part 10 of this manual.
- d. Verify that cascade address function 15 is set to 0. This makes the master VWH address 0. NOTE: The Master VWH MUST be addressed as 0.
- e. Change Cascade Mode Function 23 to 928 Boilers. This makes it the master VWH.
- f. Exit the installer menu.

NOTE: The temperature set point of the master must match the follower VWH set point in order for the system to operate properly.

3. Programming Follower VWHs:

NOTE: READ THE NOTES BELOW BEFORE PROGRAMMING FOLLOWER VWHs

- The VWH addressed as 1 will share its alarm output with the master VWH.
- It is recommended but not necessary to address VWHs in the order that they are wired.
- No two VWHs can have the same address.
- It is not required to use all consecutive address numbers.
 - a. Make sure there is no demand for heat being supplied to the master VWH

- b. Apply power to the follower VWH you are working on.
- c. Enter system settings following instructions in Part 10 of this manual
- d. Set cascade address parameter 15 to 1 for the first follower, 2 for the second follower, etc. depending on which VWH you are programming based on the above notes.
- e. Change "CASCADE MODE" parameter to "926 BOILERS". This makes the VWH a follower VWH and enables all data to be transferred between VWHs as needed for the system to function to full capability.
- f. Exit the installer menu.

NOTE: The temperature set point of the follower must match the master VWH set point in order for the system to operate properly.

Part 10 - Start-Up Procedure



FOR YOUR OWN SAFETY READ BEFORE OPERATING

1. This boiler does not have a pilot. It is equipped with an ignition device which automatically lights the burner. Do not try to light the burner by hand.
2. BEFORE OPERATING: Smell all around the boiler area for gas. Be sure to smell next to the floor because some gas is heavier than air and will settle on the floor.

3. WHAT TO DO IF YOU SMELL GAS

- Do not try to light any boiler.
- Do not touch any electric switch, do not use any phone in your building.
- Immediately call your gas supplier from a neighbor's phone. Follow the gas suppliers' instructions.
- If you cannot reach your gas supplier, call the fire department.
- Turn off the gas shut-off valve (located outside the boiler) so that the handle is crosswise to the gas pipe. If the handle will not turn by hand, don't try to force or repair it, call a qualified service technician. Force or attempted repair may result in a fire or explosion.

4. Do not use this boiler if any part has been under water. Immediately call a qualified service technician to inspect the boiler and to replace any part of the control system and any gas control that has been damaged.

5. The boiler shall be installed so the gas ignition system components are protected from water (dripping, spraying, rain, etc.) during boiler operation and service (circulator replacement, condensate trap, control replacement, etc.)

Failure to follow these instructions could result in property damage, serious personal injury, or death.

If you discover any evidence of a gas leak, shut down the VWH at once. Find the leak source with a bubble test and repair immediately. Do not start the VWH again until the leak is repaired. Failure to comply could result in substantial property damage, severe personal injury, or death.

A. Control Overview

The control is one of the primary safety devices of the VWH. It monitors the safety sensors of the VWH to assure safe and efficient operation. The control has many features associated with system design. This section addresses programming features, including Boiler Settings / System Settings / Maintenance Settings and System Diagnostics, to help in customizing your control. It is important to fully understand control capabilities before customization, as its factory defaults may already fit your system design and not require any adjustment at all.

B. Navigation of the Display

The display includes a two line backlit LCD readout to provide informative messages about the operation of the VWH. Many operating parameters can be viewed and adjusted by using the six buttons on the display. The function of each button is described below.

RESET – The RESET button has two functions.

- Resets any lockout error code
- Returns the user to the default display screen.

ENTER – The ENTER key is used to access parameter programming mode. To access this mode, hold down the ENTER key for more than 4 seconds. The readout will change to:



One of the zeroes will be blinking. Use the ^ v arrow keys to change the blinking digit to the correct value. Use the < > arrow keys to select the next digit to change and again use the ^ v keys to change the

value. Repeat until the correct code is entered. Press the **ENTER** key to accept the code entered. If the code is correct, the readout will change to the appropriate screen. If the programming code is not accepted, the readout will continue to display as shown above.

ENTER is also used to enable a function for editing. After the user navigates to the desired function, the user holds down **ENTER** for one second. When **ENTER** is released, the function value will begin to blink. The function can now be changed using the ^ v keys. After the new value is displayed, the user then presses **ENTER** for 1 second to lock the new value of the function. The value will then stop blinking.

LEFT AND RIGHT ARROW KEYS – < > are used to navigate between the default display, status display, analog and cascade displays if they are enabled. The < > keys are also used in programming modes to change between programmable functions. It is recommended you use the Menu Maps in the back of this manual and the detailed menu instructions printed in this section to help in menu navigation.

UP AND DOWN ARROW KEYS – ^ v are used to navigate between the various functions displayed in the menu. After the function is enabled for editing by pushing the **ENTER** key, the ^ v keys are used to adjust the function upward or downward to the desired value.

C. Operating Instructions

Before operating the unit, it is important to remove the cover and verify that the gas line and water lines are connected to VWH and fully purged. If you smell gas, STOP; Follow the safety instructions listed in the first part of this section. If you do not smell gas, follow the next steps.

1. Turn down the thermostats before applying power to the VWH. If 0–10 volt or other inputs are used, make sure that they are set so there is no call for heat while programming.
2. Turn on the power to the VWH or VWHs if a cascade system used.
3. Next, check the VWH settings. Adjustment and factory defaults are outlined within this section. If a cascade system is used, it is important that all the VWHs have the same VWH settings.
4. Next, check the system settings. Adjustments and factory defaults are outlined within this section. If a cascade system is used, it is important that the Master VWH is programmed with the correct system settings.
5. Create a demand on the VWH or VWHs if a cascade system is used. The user can monitor system functions when the VWHs are operational.
6. If the VWHs fail to start, refer to the troubleshooting section in the back of this manual.

D. Programming VWH Settings

Boiler Setting Program Access

Note: Programming the VWH control is not possible when the VWH is firing. Make sure any input which can create a demand on the VWH, such as the tank thermostat, is turned off, so the VWH will remain idle to allow programming.

Screen	Description
ENTER MENU CODE 000	To access the VWH setting program, press and hold ENTER for 4 seconds until the display shows the screen at left.
ENTER MENU CODE 600	Use the arrow keys to log in the Boiler Menu Access Code - 600 . Press ENTER to confirm the code and access the Boiler Setting Program navigation menu.

Table 24 - Boiler Setting Access

Boiler Setting Program Navigation

Once the code is confirmed, the user can start to set the **Boiler Settings**. Use the arrow keys on the display to navigate through the **Boiler Settings**. A blinking setting indicates the setting can be changed. To change a setting, press **ENTER**. Settings can be increased by pressing ^ and decreased by pressing v on the display.

When done, press **ENTER**. The setting will stop blinking and the user can move on to next setting. Press **RESET** to exit programming and store settings. Listed below are the settings that can be programmed into the control.

Screen	Description
IGNITION DIFF SET 7 °F	Allows the user to adjust the ignition differential set point from 1 to 36°F (Factory Default 7°F). Degrees below set point must be equal to or below tank differentials.
TANK SETPOINT 120 °F	Adjusts the tank set point from 59°F to 180°F (Factory Default 120°F).
TANK DIFF SETPOINT 7 °F	Adjusts the tank differential set point from 1°F to 18°F (Factory Default 7°F). Degrees below set point where demand starts.
TEMP DISPLAY C OR F °F	Adjusts the temperature measurement in F = Fahrenheit to C = Celsius (Default is Fahrenheit).

Table 25 - Boiler Setting Program Navigation

Clock Settings

(NOTE: The clock will reset if the VWH is powered off for more than a week.)

Screen	Description
CLOCK MODE (12/24) 08/28/2009 Fr 9:42A	Changes the clock from 12 hour mode (8:45 PM) to 24 hour mode (20:45). To change to 24 hour mode, press ENTER . The letter (A or P) after the time will blink. Press the up or down arrow key once and the letter will disappear. Press ENTER to save the new setting.
CLOCK HOUR 08/28/2009 Fr 10:01A	Allows the user to adjust the hour setting.
CLOCK MINUTE 08/28/2009 Fr 10:01A	Adjusts the minute setting.
CLOCK DAY OF WEEK 08/28/2009 Fr 10:01A	Adjusts the day of the week.
CLOCK DATE MODE 08/28/2009 Fr 10:01A	Allows the user to switch to European date format (2009/08/28) from US format (08/28/2009).
CLOCK YEAR 08/28/2009 Fr 10:01A	Adjusts the year setting.
CLOCK MONTH 08/28/2009 Fr 10:01A	Adjusts the month setting.
CLOCK DATE 08/28/2009 Fr 10:01A	The clock is set.

Table 26 - Clock Setting Screens

(NOTE: The internal clock does not adjust for daylight savings time and requires manual adjustment.)

E. Programming the System Setting

System Setting Program Access

Note: Programming the VWH control is not possible when the VWH is firing. Make sure any input which can create a demand on the VWH, such as the tank thermostat, is turned off, so the VWH will remain idle to allow programming.

Screen	Description
ENTER MENU CODE 000	To access the VWH setting program, press and hold ENTER for 4 seconds until the display shows the screen at left.
ENTER MENU CODE 925	Use the arrow keys to log in the Boiler Menu Access Code - 925 . Press ENTER to confirm the code and access the Boiler Setting Program navigation menu.

Table 27 - System Setting Access

F. System Setting Program Navigation

Once the **System Menu Access Code** is confirmed, the user can begin to set the system setting menu. Use the < > keys on the display to navigate through the System Settings. To change a setting, press **ENTER**. System settings can be **increased** by pressing **^** and **decreased** by pressing **v** on the display. When done, press **ENTER**. The setting will stop blinking and you can move on to next setting. Press **RESET** to exit programming and store settings. Listed below are the VWH settings that can be programmed into the control.

Screen	Description
Function 1	Factory Program Mode
MODE VWH MODE 1	This indicates that the control is configured correctly for a volume water heater. Do not change this setting.
Function 3	DHW Tank Max Temp
DHW TANK MAX TEMP 180 °F 3	This is the maximum temperature that can be selected in VWH settings for the DHW tank. Factory Default is 180°F. (Range: 95°F to 180°F)
Function 4	Burner Off Differential
BURNER OFF DIFF 20 °F 4	This is the amount of degrees above tank set point that the burner will maintain its outlet water temperature while there is a demand for heat. Factory Default is 20°F. (Range: 1°F to 45°F)
Function 6	VWH Post Pump Time
VWH POST PUMP TIME 0 MINUTES 6	The VWH pump has the ability to post purge energy from the VWH to the tank after the set point has been achieved. Please note that running the pump for a time greater than 5 minutes may cause tank energy to be released back to the heat exchanger. Factory Default of 0 Minutes. (Range: 0 – 10 minutes)
Function 7	Warm Weather Shutoff
WARM WEATHER OFF 68 °F 7	Not applicable on this product.
Function 8	Min Outdoor Temp
MIN OUTDOOR TEMP 5 °F 8	Not applicable on this product.
Function 9	Max Supply Temp
MAX SUPPLY TEMP 190 °F 9	Not applicable on this product.
Function 10	Max Outdoor Temp
MAX OUTDOOR TEMP 68 °F 10	Not applicable on this product.

Screen	Description	Function	Description
Function 11	Min Supply Temp		
MIN SUPPLY TEMP 95 °F	11	Not applicable on this product.	
Function 12	Min Boiler Temp		
MIN BOILER TEMP 68 °F	12	Not applicable on this product.	
Function 13	CH Post Pump Time		
CH POST PUMP TIME 0 MINUTES	13	Not applicable on this product.	
Function 14	DHW Priority		
DHW PRIORITY 30 MINUTES	14	Not applicable on this product.	
Function 15	Cascade Address		
CASCADE ADDRESS 0	15	Bus addressing VWHs (maximum VWHs allowed is eight (8) in a cascade system). Master VWH address is 0 and Follower VWHs are addressed 1 thru 7. Default: 0 (Range: 0 – 15). NOTE: DO NOT USE ADDRESSES 8 - 15.	
Function 16	Optional Inputs		
OPTIONAL INPUT RETURN SEN	16	Allows the user to select optional inputs to control or monitor the system. Default: RETURN (Range: Off / Booster Board / 0-10 Volt / DHW Sensor / Return Sen).	
Function 17	0-10 Volt Function		
0-10 VOLT FUNCTION TEMPERATURE	17	Control VWH modulation through temperature control. Factory Default = Temperature (Temperature only on VWH).	
Function 18	Step Modulation Mode		
STEP MODULATE MODE ON	18	Not applicable on this product.	
Function 19	Boiler DHW Temp		
BOILER SUPPLY DHW 180 °F	19	Not applicable on this product.	
Function 20	Water Safety Input		
WATER SAFETY INPUT FLOW SWITCH	20	The user can select various water safety inputs used in the VWH system. Default: Flow Switch (Range: None / Low Water Cut Off / Flow Switch / Water Pressure).	
Function 21	Error Outdoor Sensor		
ERROR OUTD SENSOR OFF	21	Not applicable on this product.	
Function 22	Adjust Boiler Output %		
ADJ HEATER OUTPUT 100%	22	Adjusts the VWH output down from 100% to 50%. Factory Default: 100%. (Range: 100% – 50%)	
Function 23	Cascade Mode		
CASCADE MODE OFF	23	Allows the user to select cascade mode. Select OFF if VWH is operating alone or with Vision 3 panel. Select 928 BOILRS to establish a cascaded system. Factory Default: OFF (Range: OFF / 928 BOILRS).	
Function 24	Cascade Rotation		
CASCADE ROTATION 48 HOURS	24	Sets the amount of hours before the first VWH in the cascade firing rotation will be changed. NOTE: If this is set to 0, the firing order of the VWHs will not rotate. Default: 48 hours (Range: 0 – 240 hours).	
Function 25	Cascade DHW Mode		
NOT USED NOT USED	25	Not applicable on this product.	
Function 26	System Freeze Protection		
SYS FREEZE PROT PROTECT OFF	26	NOTE: This parameter is only present if the VWH is a cascade master. Allows the user to set the freeze protection when a system pump is used. Factory Default: OFF. Selection of temperature activates freeze protection. (Range: OFF, -40°F – 104°F).	
Function 27	Error System Sensor		
ERROR SYSTEM SENS ON	27	Sets the control to display an error message if the system sensor is open or shorted. NOTE: This error does not stop the VWH (or VWHs) from running. Factory Default: ON (Range: ON / OFF).	
Function 28	Freeze Protection		
FREEZE PROTECTION ON	28	Allows the user to set freeze protection on the VWH. Factory Default: ON (Range: ON / OFF).	
Function 29	DHW Modulation Mode		
DHW MODULATE MODE NORMAL MOD	29	Not applicable on this product.	
Function 30	Extra Boiler Mode		
EXTRA BOILER MODE OFF	30	Allows for a non HTP VWH to be controlled when the cascade output has risen above the percent of the cascade firing rate set in this parameter. Factory Default: Off (Range: 50% - 100%).	
Function 31	System Sensor Mode		
SYSTEM SENSOR MODE OFF	31	Suppresses the 'NO FOLLOWER' display message if the VWH is used as a cascade master VWH with no follower VWHs connected. Factory Default: OFF (Range: ON / OFF).	
Function 32	Service Schedule		
SERVICE SCHEDULE OFF	32	Selects a service date or time based on the VWH run hours to program the VWH maintenance schedule. Factory Default: OFF (Range: Date or Run Hours). NOTE: Without setting this function, Functions 33/34/35/36 will not display.	
Function 37	Modbus Mode		

MODBUS MODE OFF	37	Enables Modbus Mode on the appliance. Factory Default: OFF (Range: OFF, ON, AUTO). NOTE: Turning Modbus Mode "ON" will open a number of additional parameters to customize Modbus installation. See Modbus Instructions (lp-372) for details. NOTE: Turning this Mode "ON" without a connected and powered Modbus communication adapter (p/n 7350P-629) will result in improper appliance operation. Service calls associated with this ARE NOT covered by warranty.
Function 56		OA1 Configuration
O-10V A OUTPUT CONFIG POWER BOIL	56	Controls the operation of the 0-10V A output on the Field Connection Board. Factory Default: BOIL POWER (Range: BOIL POWER / CASC POWER / FAN SPEED / ALARM / TEMPERATUR / FLAME / PUMP dT).

The following information details the 0-10V output parameters described in Function 56 that can be read at a Building Management System.

BOIL POWER - 0-10V output is proportional to VWH firing rate. 0V = Not Firing, 1.5V = Minimum Firing Rate, 10V = Maximum Firing Rate

CASC POWER - When configured on the Cascade Master, 0-10V is proportional to the firing rate of the Cascaded System. 0V = Not Firing, 1.5V = Minimum Firing Rate (One VWH Lit), 10V = Maximum Firing Rate of all Connected VWHs

FAN SPEED - Output is proportional to VWH fan speed. 0V = Fan is Off, 1.5V = Minimum Fan Speed, 10V = Maximum Fan Speed

ALARM - 0V = Alarm is Off, 10V = Alarm is On

TEMPERATUR - Output follows VWH temperature setting based on outdoor reset. 0V = Minimum VWH Temperature for Maximum Outdoor Temperature Setting. 10V = CH (or cascade) temperature setting. This number will vary with the outdoor temperature so that the user can know what setpoint temperature the VWH is trying to achieve.

FLAME - Equals VWH Flame Current. 0V = 0ua, 10V = 10ua.

PUMP dT - This output controls pump speed to maintain the desired Delta T. 0V = OFF, 2V (or output offset value greater than 2) = Minimum Pump Speed, 10V = Maximum Pump Speed.

Function 57		OA1 Offset
O-10V A OUTPUT OFFSET 1.5	57	This value is added to the OFFSTATE VOLT OA1 value, to determine the total voltage output required at the minimum case. Factory Default: 1.5 (Range: 0.0 to 9.9)
Function 58		OA2 Configuration
O-10V B OUTPUT CONFIG POWER BOIL	58	Controls the operation of the 0-10V B output on the Field Connection Board. Factory Default: BOIL POWER (Range: BOIL POWER / CASC POWER / FAN SPEED / ALARM / TEMPERATUR / FLAME).
Function 59		OA2 Offset
O-10V B OUTPUT OFFSET 1.5	59	This value is added to the OFFSTATE VOLT OA2 value, to determine the total voltage output required at the minimum case. Factory Default: 1.5 (Range: 0.0 to 9.9)

Function 60		CH dT Setting
CH dT SETTING 20F	60	This parameter is only available when PUMP dT is selected in Function 56. Determines the desired temperature difference between the SUPPLY And RETURN temperatures. Factory Default: 20F (Range: 0 - 47F)
Function 61		Offstate Voltage OA1
OFFSTATE VOLT 0-10V A 0.0V	61	This parameter is only available when PUMP dT is selected in Function 56. Determines the voltage present in OA1 when the pump is supposed to be OFF. Factory Default: 0.0 (Range: 0.0 to 9.9)

Table 28 - System Setting Program Navigation

NOTE: For the following functions, you must have your maintenance function turned on.

To change these functions, press **ENTER**. The left most digit will begin to blink. Use the **^** or **v** arrows to change the digit. Use the **<** **>** arrow keys to switch between digits. When you've made your selection, press **ENTER** again.

Screen	Description	
Function 33	Year	
SERVICE SCHEDULE YEAR 00/00/2000	33	Allows the user to set the year of the next service reminder.
	Hours	
SERVICE SCHEDULE 10000's 000000	33	Allows the user to set the left two digits of the amount of run hours before next service reminder.
Function 34	Month	
SERVICE SCHEDULE MONTH 00/00/2000	34	If the date function was selected, this function programs the month. If you selected the run hour function, you will need to program 10,000 hours, if required.
	Hours	
SERVICE SCHEDULE 10000's 000000	34	Allows the user to set the middle two digits of the amount of run hours before next service reminder.
Function 35	Day	
SERVICE SCHEDULE DAY 00/00/2000	35	Sets the day of next service reminder.
	Hours	
SERVICE SCHEDULE 10000's 000000	35	Sets the two right digits of the amount of run hours for the next service reminder.
Function 36	Telephone	
TELEPHONE # 000 000 0000	36	Allows the user to input a telephone number that will display when maintenance is required.

Table 29 - Maintenance Reminder Function Screens

G. Resetting the Maintenance Schedule

When the system control flashes MAINTENANCE REQUIRED, it is advisable that you call for service. After the service is performed, reset the schedule for the next required service by using the following steps. Press **ENTER** on the display for 3 seconds. The Menu code will appear as 000. This does not change. Press **ENTER** again. SERVICE SCHEDULE RESET will be displayed. Using the **>** key scroll to the selection of year or hours. Press **ENTER** to reset the selected Service Schedule. To change

a setting, press **ENTER**. Press the **^** and **v** keys to make adjustments. Press **ENTER** when reset is complete.

Part 11 - Start-Up Procedures for the Installer

A. VWH Control Status Menu

The VWH control also has the ability to review system status. To access the status screens, press **>**. Once the first value is displayed, press **^** and **v** to scroll through additional information. At any point press **RESET** to exit the status screens.

Screen	Description
SUPPLY SEN 180°F RETURN SEN 150°F	This is the first screen that appears after pressing > , and shows the actual temperatures measured by the supply and return sensors. NOTE: If the VWH is configured to use a 0 – 10 volt input, the return sensor is disabled and the second line of the display will be blank.
Press v once.	
NA SUPPLY SEN NA 122°F	The actual temperature measured by the supply sensor is displayed on the bottom.
Press v once.	
0-10 * SIGNAL ON	Shows if 0-10 volt is enabled.
Press v once.	This screen appears only when the VWH is set as a Master VWH.
CAS SET SYSTEM 190°F 112°F	This screen displays the cascade set point (maximum 190°F) on the top line. The system sensor reading is on the second line. The control will cascade the VWHs up to this set point depending on demand.
Press v once.	
TANK SET RET /TANK 120°F OFF	Displays the current tank temperature set point on the top line. The actual temperature measured by the tank or return sensor (HTP 7250P-325) is displayed on the bottom line. If a mechanical aquastat is used in place of the recommended sensor, the second line will display 'OFF' in place of the temperature if the aquastat measures close to its set temperature, or 'ON' if the aquastat temperature is too low.
Press v once.	
NA FLUE 11°F 95°F	The second line displays the current VWH flue temperature.
Press v once.	
FLAME FAN SPEED 0.0uA 3497 RPM	This screen displays VWH flame current on the top line. The second line displays VWH fan speed.
Press v once.	
0-10 * V 0.0V	The top line displays the voltage on the optional input. This voltage is only relevant if an external 0-10 volt signal is being used to control the VWH.
Press v once.	

BUS COMM NO CONN	This display shows the status of the communication bus between multiple VWHs. If in a single VWH configuration, the display will show 'NO CONN'. In a multiple VWH configuration, if this is the Master VWH and other VWHs are connected to the communication bus and powered, this screen will show the address of each VWH connected to the bus.
Press v once.	
POWER ON 0H CH ON 0H	The top line indicates the amount of hours the VWH has been powered over its life. The second line is not applicable.
Press v once.	
VWH ON 0H GOOD IGNIT 1X	The top line indicates the hours the burner has been on for hot water demand over the VWH's life. The second line indicates how many times the burner has successfully ignited over the VWH's life.
Press v once.	
SYS CH ON 0H SYS VWH ON 0H	The top line is not applicable. The second line registers system pump hours on the cascade master ONLY.
Press > once at any status screen.	
TEMPERATURE CONTROL ANALOG SIG 0.2 V	Displays 0-10V status when 0-10V is connected.

Table 30 - Boiler Control Status Menu Screens

The next ten screens display the last ten VWH lockout faults. Press **v** to scroll through the faults from most recent to oldest.

Screen	Description
FAULT HISTORY 1 07/27/2009 Mo 5:19A	This screen displays the most recent VWH control lockout fault. The top line will alternate between the words 'FAULT HISTORY' and the fault code encountered. The bottom line displays the date and time the fault occurred.
Press v once.	
FAULT HISTORY 2 08/28/2009 Fr 5:19A	The second oldest VWH control lockout fault. The top line will alternate between the words 'FAULT HISTORY' and the actual fault encountered. The bottom line will display the date and time that the fault occurred.
Press v once.	
FAULT HISTORY 3 08/28/2009 Fr 5:19A	The third oldest VWH control lockout fault. The top line will alternate between the words 'FAULT HISTORY' and the actual fault encountered. The bottom line will display the date and time that the fault occurred.
Press v once.	

FAULT HISTORY 08/28/2009	4 Fr 5:19A	The fourth oldest VWH control lockout fault. The top line will alternate between the words 'FAULT HISTORY' and the actual fault encountered. The bottom line will display the date and time that the fault occurred.
Press v once.		
FAULT HISTORY 08/28/2009	5 Fr 5:19A	The fifth oldest VWH control lockout fault. The top line will alternate between the words 'FAULT HISTORY' and the actual fault encountered. The bottom line will display the date and time that the fault occurred.
Press v once.		
FAULT HISTORY 08/28/2009	6 Fr 5:19A	The sixth oldest VWH control lockout fault. The top line will alternate between the words 'FAULT HISTORY' and the actual fault encountered. The bottom line will display the date and time that the fault occurred.
Press v once.		
FAULT HISTORY 08/28/2009	7 Fr 5:19A	The seventh oldest VWH control lockout fault. The top line will alternate between the words 'FAULT HISTORY' and the actual fault encountered. The bottom line will display the date and time that the fault occurred.
Press v once.		
FAULT HISTORY 08/28/2009	8 Fr 5:19A	The eighth oldest VWH control lockout fault. The top line will alternate between the words 'FAULT HISTORY' and the actual fault encountered. The bottom line will display the date and time that the fault occurred.
Press v once.		
FAULT HISTORY 08/28/2009	9 Fr 5:19A	The ninth oldest VWH control lockout fault. The top line will alternate between the words 'FAULT HISTORY' and the actual fault encountered. The bottom line will display the date and time that the fault occurred.
Press v once.		
FAULT HISTORY 08/28/2009	10 Fr 5:19A	The tenth oldest VWH control lockout fault. The top line will alternate between the words 'FAULT HISTORY' and the actual fault encountered. The bottom line will display the date and time that the fault occurred.

Table 31 - Boiler Fault Screens

Screen	Description
BLOCKING HISTORY 08/28/2009	1 Fr 5:19A This screen displays the most recent VWH control blocking error. The top line will alternate between the words 'BLOCKING HISTORY' and the blocking code encountered.
Press v once.	
BLOCKING HISTORY 08/28/2009	2 Fr 5:19A The second oldest VWH control blocking error. The top line will alternate between the words 'BLOCKING HISTORY' and the actual blocking code encountered.
Press v once.	
BLOCKING HISTORY 08/28/2009	3 Fr 5:19A The third oldest VWH control blocking error. The top line will alternate between the words 'BLOCKING HISTORY' and the actual blocking code encountered.
Press v once.	
BLOCKING HISTORY 08/28/2009	4 Fr 5:19A The fourth oldest VWH control blocking error. The top line will alternate between the words 'BLOCKING HISTORY' and the actual blocking code encountered.
Press v once.	
BLOCKING HISTORY 08/28/2009	5 Fr 5:19A The fifth oldest VWH control blocking error. The top line will alternate between the words 'BLOCKING HISTORY' and the actual blocking code encountered.
Press v once.	
BLOCKING HISTORY 08/28/2009	6 Fr 5:19A The sixth oldest VWH control blocking error. The top line will alternate between the words 'BLOCKING HISTORY' and the actual blocking code encountered.
Press v once.	
BLOCKING HISTORY 08/28/2009	7 Fr 5:19A The seventh oldest VWH control blocking error. The top line will alternate between the words 'BLOCKING HISTORY' and the actual blocking code encountered.
Press v once.	
BLOCKING HISTORY 08/28/2009	8 Fr 5:19A The eighth oldest VWH control blocking error. The top line will alternate between the words 'BLOCKING HISTORY' and the actual blocking code encountered.
Press v once.	
BLOCKING HISTORY 08/28/2009	9 Fr 5:19A The ninth oldest VWH control blocking error. The top line will alternate between the words 'BLOCKING HISTORY' and the actual blocking code encountered.
Press v once.	

BLOCKING HISTORY 10 08/28/2009 Fr 5:19A	The tenth oldest VWH control blocking error. The top line will alternate between the words 'BLOCKING HISTORY' and the blocking code encountered.
Press v once.	
OA1 0.0V OA2 0.0V	Displays the voltage level present on the 0-10VA and 0-10VB inputs.
Press v once.	
ARBA-P 160831 ASBA-P 150806	Displays the Comfort and Safety firmware revisions programmed into the control.

Table 32 - VWH Fault Screens

B. Cascade Menu

This menu is accessed by pressing < at the default menu or > at the status menu.

Screen	Description
CASCADE MASTER READY SYS PUMP OFF	This screen displays when the VWH is configured as a Cascade Master and the system is ready to accept a demand for heat. The second line indicates the cascade system pump output status. This screen alternates with the default screen every 5 seconds or can be accessed by pressing the < key from the default screen.
CASCADE NO FOLLOWER SYS PUMP OFF	This screen displays when the VWH is configured as a Master VWH and there are no connected follower VWHs, or the follower VWHs are not powered. The second line indicates cascade system pump output status. This screen alternates with the default screen every 5 seconds or can be accessed by pressing the < key from the default screen.
CASCADE NO SENSOR SYS PUMP OFF	This screen displays when the VWH is configured as a Master VWH and there is no system temperature sensor connected or the system sensor is defective. The cascade system will still function in this situation with reduced efficiency. All VWHs will run simultaneously rather than in a staged fashion. The second line indicates cascade system pump output status. This screen will alternate with the default screen every 5 seconds or can be accessed by pressing the < key from the default screen.

CASCADE VWH 0123 567 SYS PUMP ON 12:47P	This screen displays information about cascade status. The VWH in the center of the top line shows that cascade demand is coming from the tank sensor or thermostat. You may also see 0-10 if the demand is from a 0-10 volt input. The following numbers show which VWH addresses are currently communicating to the master. If a VWH address is not used or communicating, the number will not display. In the example to the left, VWH address #4 is not communicating. When a VWH in the system is firing, its address number will alternate with a " ' to signify it is firing. The bottom line shows the status of the system pump output contacts.
Press v once.	
CASCADE PWR 100% PRESENT 01234567	This screen displays overall cascade power output. The range of this value is the number of VWHs communicating with the Master x 100. For example, if 8 VWHs are connected and firing, the maximum cascade power is 800%. The second line shows which VWH addresses are communicating with the Master.
Press v once.	
CASCADE SYST 118°F CASCADE SET 190°F	This screen displays current system temperature sensor reading on the top line and the cascade system temperature setting on the bottom.
Press v once.	
BOILER 0 100% BOILER 1 56%	This screen displays the current cascade power demand output on a per connected VWH basis for VWHs addressed as 0 and 1. In the example, VWH 0 is being commanded to fire at 100% and VWH 1 at 56%. If this were a 2 VWH system, the 'CASCADE PWR' screen above would read 156%.
Press v once.	
BOILER 2 0% BOILER 3 0%	This screen displays the current cascade power demand output on a per connected VWH basis for VWHs addressed as 2 and 3.
Press v once.	
BOILER 4 0% BOILER 5 0%	This screen displays the current cascade power demand output on a per connected VWH basis for VWHs addressed as 4 and 5.
Press v once.	
BOILER 6 0% BOILER 7 0%	This screen displays the current cascade power demand output on a per connected VWH basis for VWHs addressed as 6 and 7.

Press v once.		
BOILER 8	N/A	This screen is not applicable.
BOILER 9	N/A	
Press v once.		
BOILER A10	N/A	This screen is not applicable.
BOILER B11	N/A	
Press v once.		
BOILER C12	N/A	This screen is not applicable.
BOILER D13	N/A	
Press v once.		
BOILER E14	N/A	This screen is not applicable.
BOILER F15	N/A	

Table 33 - Cascade Menu

C. VWH Test Mode

This function is intended to simplify gas adjustment. The following tables include recommended combustion settings by fuel type and VWH fan speeds. Automatic modulation does not take place while the controller is in Test Mode. However, the VWHs will modulate down if the program set point is reached while running in Test Mode. It is recommended to enter Test Mode with the largest load possible to create such a heat demand that Test Mode will not be interrupted. To enter Test Mode press \wedge and **ENTER** simultaneously.

NOTE: The VWH will automatically exit Test Mode after 20 minutes of operation.

Press \wedge to increase and v to decrease fan speed ten (10) RPM. Press \wedge and **ENTER** simultaneously to go directly to max fan speed. Press v and **ENTER** simultaneously to go directly to min fan speed.

To leave Test Mode press \wedge and v simultaneously.

SERVICE RUN	3400 RPM
PUMP ON	4:49P

Combustion Settings on All Models						
Fan Speed	Natural Gas (NG)			Propane (LP)		
	Low	Ignition	High	Low	Ignition	High
Carbon Monoxide (CO) PPM	5-50	60-100	≤ 150	5-50	60-100	≤ 150
Carbon Dioxide (CO ₂) %	8-10	8 1/2-10 1/2		9-10 1/2	9 1/2-11	

Table 34 - Combustion Settings - All Models

Fan Speeds			
Model	Ignition	Min	Max
80kBTU NG / LP	3000	1600	5500
110kBTU NG	3800	1500	5150
110kBTU LP		1550	5200
150kBTU NG		1600	5550
150kBTU LP		1525	
220kBTU NG	3000	1320	5200
220kBTU LP		1300	4800
299 / 301kBTU NG		1420	5650
299 / 301kBTU LP		1370	5800
399kBTU NG		1500	6850
399kBTU LP		1525	6625

Table 35 - Fan Speeds

Part 12 - Troubleshooting

A. VWH Error and Fault Codes

If any of the sensors detect an abnormal condition, or an internal component fails during the operation of the VWH, the display may show an error message and error code. This message and code may be the result of a temporary condition, in which case the display will revert to its normal readout when the condition is corrected, or it may be a condition that the controller has evaluated as not safe to restart the VWH. In this case, the VWH control will be locked out, the red **FAULT** light will be lit, and the message "LOCKOUT" will be displayed on the readout in the lower line.

The VWH will not start until a qualified technician has repaired the VWH and pressed the **RESET** button for more than 1 second. If there is an error message displayed on the readout, and the message "LOCKOUT" is not displayed and the **FAULT** light is not lit, then the message is the result of a temporary condition and will disappear when the problem corrects itself.

IMPORTANT NOTE: If you see error messages on your display readout, call a technician immediately, since the message may indicate a more serious problem will occur soon.

B. VWH Error

The controller will display an error code and message when an error condition occurs. These error codes, descriptions, and recommended corrective actions are described in Section D.

C. VWH Fault

1. The controller will illuminate the red "FAULT" indication light and display a fault code and message when a fault condition occurs. The alarm output will also activate. Most fault conditions cause the CH pump to run in an attempt to cool the VWH.
2. Note the displayed fault code and refer to Section D for an explanation of the message along with several suggestions for corrective actions.
3. Press **RESET** to clear the fault and resume operation. Be sure to observe the operation of the unit for a period of time to assure correct operation and no reoccurrence of fault message.

WARNING

When servicing or replacing components that are in direct contact with VWH water, be certain that:

- There is no pressure in the VWH. Pull the release on the relief valve. Do not depend on the pressure gauge reading.
- The VWH water is not hot.
- The electrical power is disconnected.
- The gas is shut off.

Failure to make these checks could result in substantial property damage, serious personal injury, or death.

DO NOT USE THIS APPLIANCE IF ANY PART HAS BEEN SUBMERGED IN WATER. Immediately call a qualified service technician. The appliance **MUST** BE replaced if it has been submerged. Attempting to operate an appliance that has been submerged could create numerous harmful conditions, such as a potential gas leakage causing a fire and/or explosion, or the release of mold, bacteria, or other harmful particulates into the air. Operating a previously submerged appliance could result in property damage, severe personal injury, or death.

NOTE: Appliance damage due to flood or submersion is considered an Act of God, and IS NOT covered under product warranty.

If overheating occurs or the gas supply fails to shut off, do not turn off electrical power to the circulating pump. This may aggravate the problem and increase the likelihood of VWH damage. Instead, shut off the gas supply to the VWH at the gas service valve. Failure to do so may result in property damage, personal injury, or death.

CAUTION

Label all wires prior to disconnecting them when servicing the VWH. Wiring errors can cause improper and dangerous operation. Failure to follow these instructions may result in property damage or personal injury.

NOTE: If system return temperatures are maintained below the dew point, condensation will form on the inside of the VWH cabinet and cause some internal sheet metal components to rust.

D. User Interface Display

Cascade Control Fault Codes

Screen	Description	Possible Remedy
SYS SUPPLY SENSOR E03 PUMP OFF 12:56P	E03 indicates a problem with the system sensor circuit. The circuit could be open or shorted. Possible reasons for this error are: There is no system sensor connected to the Master VWH. The system sensor is faulty. There is a short circuit in the system sensor wiring; possibly from a staple placed through the wire, or damage to the wire causing both conductors to touch. The system sensor wiring is open due to defect or damage.	Disconnect the system sensor from the wiring and measure its resistance. Compare the measured resistance to the table in this manual to see if it corresponds to the temperature of the sensor. If the resistance does not agree with the sensor, replace the sensor. If the sensor is OK, disconnect the sensor wiring from both the VWH and the sensor and check continuity using an ohmmeter. Repair or replace as necessary. If this error is present, the VWHs in the cascaded group will run and ignite simultaneously when there is a heat demand. Each VWH will modulate to maintain set point temperature on its own supply sensor. This code automatically resets when repair is complete. This code will not display if system setting function ERROR SYSTEM SENS is set to OFF.
SUPPLY SENSOR F02 PUMP ON TIME	The dual supply sensor contains two sensing elements within a single body. F02 indicates that one or both halves of the supply temperature sensor has failed OR the difference between the dual sensor readings is greater than 18°F. This is a serious safety issue and the VWH will not restart until the sensor is replaced by a technician and he pushes the RESET button on the display. This situation is indicated by the red light on the display and the flashing word LOCKOUT. During this lockout fault, the pump will be on as indicated on the second line of the display.	<ol style="list-style-type: none"> 1. Check the electrical connections to each half of the sensor on the outlet manifold. Verify 3.3 VDC by checking in Molex connector. If there is not 3.3 VDC, check the harness. If harness and sensors are OK, replace control. NOTE: The VWH will reset automatically. Verify sensor resistance values of each half of the dual sensor by referencing chart in this manual. 2. Replace thermistor if necessary.
RETURN SENSOR F03 PUMP ON TIME	F03 indicates the return temperature sensor of the VWH has failed. The VWH will not restart until a technician replaces the sensor and pushes RESET on the display. This is a serious safety issue as indicated by the illuminated red light and the word LOCKOUT flashing on the display. During this lockout fault, the pump will be on.	<ol style="list-style-type: none"> 1. Check circulator pump operation. 2. Ensure adequate flow through the VWH by accessing the status menu and determining there is less than a 50°F rise from the return thermistor to the supply thermistor. 3. Troubleshoot thermistor by following the steps in F02.
FLUE SENSOR F04 PUMP ON TIME	The dual flue sensor contains two sensing elements within a single body. F04 indicates that one or both halves of the flue temperature sensor has failed OR the difference between the dual sensor readings is greater than 18°F. This is a serious safety issue and the VWH will not restart until the sensor is replaced by a technician and he pushes the RESET button on the display. This situation is indicated by the red light on the display and the flashing word LOCKOUT. During this lockout fault, the pump will be on as indicated on the second line of the display.	<ol style="list-style-type: none"> 1. Inspect the dual flue sensor for physical damage, blockage, or corrosion and replace it if necessary. 2. Check the electrical connection to the dual flue sensor and repair as necessary. Verify 3.3 VDC by checking in Molex connector. If there is not 3.3 VDC, check the harness. If harness and sensors are OK, replace control. NOTE: The VWH will reset automatically. Verify sensor resistance values of each half of the dual sensor by referencing chart in this manual. 3. Replace sensor if necessary.

<p>SUPPLY HIGH PUMP ON</p> <p>F05 TIME</p>	<p>F05 indicates the VWH supply temperature is excessive. When accompanied by the red FAULT light and LOCKOUT flashing on the display, this code indicates the supply sensor temperature has exceeded 210°F and a serious safety issue exists. The VWH will not restart until a technician determines and repairs the cause of excessive temperature and pushes RESET on the display. If the FAULT light is not illuminated and this message is displayed, the supply temperature of the VWH is at or above 199°F. The message will clear automatically when the temperature drops below 194°F. During the time that this fault is displayed, the pump will be on.</p>	<ol style="list-style-type: none"> 1. Check circulator pump operation. 2. Ensure adequate flow through the VWH by accessing the status menu and determining there is less than a 50°F rise from the return thermistor to the supply thermistor. 3. Check the direction of flow off the VWH circulator. (See Piping Details in this manual.) 4. Troubleshoot the dual supply thermistor by following steps in F02.
<p>RETURN TEMP HIGH PUMP ON</p> <p>F06 TIME</p>	<p>This display indicates that the VWH return temperature is excessive. When accompanied by the red FAULT light and LOCKOUT flashing on the display, this code indicates that the return sensor temperature has exceeded 210°F and a serious safety issue exists. The VWH will not restart until a technician determines and repairs the cause of excessive temperature and pushes RESET on the display. If the red FAULT light is not illuminated and this message is displayed, then the return temperature of the VWH is at or above 199°F. The message will clear automatically when the temperature drops below 194°F. During the time that this message or lockout fault is displayed, the pump will be on.</p>	<ol style="list-style-type: none"> 1. Check circulator pump operation. 2. Ensure adequate flow through the VWH by accessing the status menu and determining there is less than a 50°F rise from the return thermistor to the supply thermistor. 3. Check the direction of flow on VWH circulator. (See Piping Details in this manual.) 4. Troubleshoot thermistor by following steps in F02.
<p>NO FLAME ON IGN PUMP ON</p> <p>F09 TIME</p>	<p>The VWH tried to ignite four times during one heat call and failed. This is a serious safety issue as indicated by the illuminated red light and the word LOCKOUT flashing on the display. The VWH will not restart until a technician determines and repairs the cause of ignition failure and pushes RESET on the display. During this lockout fault, the pump will remain on.</p>	<ol style="list-style-type: none"> 1. Watch the igniter through the observation window. 2. If there is no spark, check the spark electrode for the proper 1/4" gap between the burner. 3. Remove any corrosion from the spark electrode. 4. If there is a spark but no flame, check the gas supply to the VWH. 5. If there is a flame, check the flame current. 6. Check any flue blockage or condensate blocks. 7. Replace the ignitor.
<p>FLAME LOSS PUMP ON</p> <p>F10 TIME</p>	<p>The flame was lost 3 times while the VWH was firing during 1 demand call. This is a serious safety issue as indicated by the illuminated red light and the word LOCKOUT flashing on the display. The VWH will not restart until a technician determines and repairs the cause of flame loss and pushes RESET on the display. During this lockout fault, the pump will be on.</p>	<ol style="list-style-type: none"> 1. Monitor gas pressure to the unit while in operation. 2. Assure the flame is stable when lit. 3. Check if the display readout changes from "GAS VALVE ON" to "RUN" within a few seconds of VWH ignition. 4. Check the FLAME signal on the display. It should be above 2.5uA when the VWH is firing. 5. If the signal reads less than 2.5uA, clean the spark probe. 6. If the problem persists and the "FLAME" signal is still less than 2.5uA, replace the spark igniter probe. 7. The flame signal should be steady after the VWH has been firing for 1 minute and is normally at 5.0 to 9.0. If the flame signal is not steady, disassemble the burner door and check the burner and its sealing gaskets.

<p>FALSE FLAME SIG PUMP ON</p> <p>F11 TIME</p>	<p>There is flame when the control is not telling the VWH to run. This is a serious safety issue as indicated by the illuminated red light and the word LOCKOUT flashing on the display. The VWH will not restart until a technician determines and repairs the cause and pushes RESET on the display. During this lockout fault, the pump will be on.</p>	<ol style="list-style-type: none"> 1. Look into window. If there is flame, turn the gas off to the unit at the service valve and replace the gas valve. 2. If the flame signal on the status menu is greater than 2.5uA when the burner is not lit, replace the spark ignitor. 3. If the flame signal is not present after turning off the gas supply, check the gas valve electrical connection. 4. Check for condensate backup. Repair condensate system as necessary. If condensate has partially filled the combustion chamber, the refractory wall may be damaged and should be replaced. 5. Turn the gas on at the service valve after corrective action is taken. 6. If the refractory wall falls against the spark ignitor, it may conduct the signal to ground, giving a false reading.
<p>FAN SPEED ERROR PUMP ON</p> <p>F13 TIME</p>	<p>The fan is not running at the speed determined by the control. Fan speed has been more than 30% faster or slower than the commanded speed for more than 10 seconds. This is a serious safety issue as indicated by the illuminated red light and the word LOCKOUT flashing on the display. This VWH will not restart until a technician determines and repairs the cause and pushes RESET on the display. During this lockout fault, the pump will be on.</p>	<ol style="list-style-type: none"> 1. Check the combustion fan wiring. 2. Measure DC voltage from the red fan wire to ground while it is connected to the fan. It should be between 24 and 40 volts. If it is lower than 24 volts, check for excessive external loads connected to the VWH sensor terminals 3. Disconnect the 5 pin plug from the fan and check the voltage on the red wire again. If it is now between 24-40 volts, replace the fan. If it is still below 24 volts replace the VWH control board.
<p>FLUE LIMIT PUMP ON</p> <p>F17 TIME</p>	<p>F17 indicates the VWH flue temperature is excessive. When accompanied by the red FAULT light and LOCKOUT flashing on the display, this code indicates the flue sensor temperature has exceeded 210°F and a serious safety issue exists. The VWH will not restart until a technician determines and repairs the cause of excessive temperature and pushes RESET on the display.</p>	<ol style="list-style-type: none"> 1. Check the flue for obstructions and any sign of damage, especially signs of excessive heat. Repair as necessary. 2. Run the VWH and check the flue temperature with an external thermometer. If the flue temperature on the thermometer does not agree with the flue temperature displayed in the status menu, inspect the wiring to the flue temperature sensor in the VWH and repair as necessary. If the wiring is intact replace the flue sensor. 3. If the flue temperature is excessive on the status menu and the test thermometer reads the same, check and adjust combustion controls on the VWH.
<p>CONDENSATE FULL PUMP OFF</p> <p>F20 TIME</p>	<p>The condensate trap is full. This is a serious safety issue as indicated by the illuminated red light and the word LOCKOUT flashing on the display. The VWH will not restart until a technician determines and repairs the cause and pushes RESET on the display. During this lockout fault, the pump will be off.</p>	<ol style="list-style-type: none"> 1. Check condensate lines for obstructions. 2. Check float switch in condensate reservoir. 3. Check wiring from condensate reservoir to 928 control and repair as necessary.
<p>LWCO FAULT PUMP OFF</p> <p>F21 TIME</p>	<p>Water level in the VWH is low.</p> <p>To test LWCO function, press and hold v and RESET simultaneously for five (5) seconds. Press RESET to clear the error code.*</p> <p>*This procedure applicable to models with 928 control firmware ARBA-P 170426 or later or ASAA-P 170412 or later ONLY.</p> <p>NOTE: The date code is in YYMMDD format.</p>	<ol style="list-style-type: none"> 1. Check VWH feed water system to be sure it is supplying make-up water to the VWH system. 2. Ensure all air is bled from the system. 3. Check for leaks in the VWH and system piping and repair as necessary. 4. Inspect low water cutoff probe and wiring for damage and repair and replace as necessary.

EXTERNAL LWCO PUMP ON	F22 TIME This error is generated when the External Low Water Cut Off is installed and the water level in the VWH is low. When this code is displayed, the VWH will not respond to a demand for heat. The bottom line of the display indicates the status of the pump. The pump will remain on when this error is displayed.	IF EXT LWCO is installed: 1. Check VWH feed water system. Ensure it is supplying make-up water to the VWH system. 2. Be sure all air is bled from the system. 3. Check for leaks in the VWH and system piping and repair as necessary. 4. Inspect low water cut off wiring for damage and repair as necessary. 5. Ensure EXT LWCO has power applied to the power input terminals. 6. Press Reset button on LWCO. If error reoccurs, replace EXT LWCO. IF EXT LWCO is NOT installed: Inspect the jumper from terminals 20 and 21 on the Field Connection Board for damage or loose connections.
TARGET WALL PUMP OFF	F24 TIME This error is generated when the target wall fuse has been disconnected or tripped on VWHs 299kBTU or larger, or the target wall jumper wires are not installed on all other sizes.	For models 299/301/399: Check to ensure wires are connected to the target wall fuse. If wires are not connected, inspect the target wall in the combustion chamber and replace if damaged. For all other models: Check to ensure the jumper wire for target wall is connected on the control between wire locations X7-8 and X7-18.
GAS PRESSURE PUMP ON	F26 TIME The following switches are optional equipment that may be installed on VWH. These devices have indicator lights that illuminate if tripped. High gas pressure switch – Trips if there is excessive gas pressure on the outlet side of the gas valve and must be manually reset. Low gas pressure switch – Trips if there is low gas pressure on the inlet side of the gas valve and must be manually reset.	1. If an indicator light is illuminated, investigate the source of the error for that particular switch. 2. With VWH in service mode, measure the gas pressure in the supply line with a gas pressure meter. Monitor the gas pressure during both low and high fire conditions for correct pressure range. 3. If there are no optional switches or none of the indicator lights is illuminated on the optional switches, use an ohmmeter to test each of the switches one at a time. Turn the power off to the VWH and disconnect the switch to be tested from the VWH to determine which has tripped. When you find the tripped switch investigate the cause of the fault based on the purpose of the switch.
PROGRAM ERROR F31 PUMP OFF	F31 There was an error while programming the control and the memory is corrupt. The VWH control will not function in this state and the pump will be off as indicated on the bottom line. This error only occurs if a technician is programming the control and the programming function fails. The only way to recover from this error is to reprogram the control. If this error occurs at any time other than when a technician is servicing the VWH, the control has failed and must be replaced by a qualified technician.	The control must be reprogrammed. If programming does not solve the problem, the control must be replaced.
HARD FAULT COND	F41 This error indicates there is an internal fault in the circuit within the control connected to the condensate switch.	1. Inspect the ground wires for damage or loose connections. 2. Inspect the condensate wiring for damage and repair as necessary. 3. Ensure no high voltage wires are routed in parallel with the condensate low voltage wiring. 4. Replace control.
HARD FAULT LWCO	F42 This error indicates there is an internal fault in the LWCO circuit.	1. Inspect the ground wires for damage or loose connections. 2. Inspect the LWCO wiring for damage and repair as necessary. 3. Ensure no high voltage wires are routed in parallel with the LWCO low voltage wiring. 4. Replace control.

AD SAFT FAULT F43	The temperature of either the flue or supply sensors has risen nine degrees in 100 milliseconds and not returned to normal within 1 second.	Ensure the connections to the flue and supply sensors are intact. If wires are intact, check sensor resistance. If the problem persists or the sensors are out of normal resistance range, replace the sensors.
CONTROL PROGRAMED PP	The control has been programmed by a technician or the factory. After programming, the control is left in a locked out mode.	Press RESET for at least 1 second to use the control.
OUTDOOR SENSOR PUMP ON FOU 1:45P	There is an issue with the outdoor sensor. It is shorted, damaged, or disconnected from the VWH.	<ol style="list-style-type: none"> 1. Check outdoor sensor connections and wiring. Ensure the sensor and wiring are intact and that the sensor is connected to the VWH. 2. Check the outdoor sensor resistance with an ohmmeter. See table in this manual for correct outdoor sensor resistance. 3. Replace the outdoor sensor.
The following blocking codes will block operation until the control determines the situation safe for VWH operation.		
LOW WATER FLOW PUMP OFF FL 4:32P	This indicates the flow switch is not activated.	<ol style="list-style-type: none"> 1. Ensure VWH contains water and all valves are open. 2. Check the VWH circulator and ensure it is in good operating condition (operating, wiring intact, etc.). 3. Inspect the wiring to the flow switch for damage and repair as necessary. 4. Disconnect one wire from the flow switch and test for continuity across the switch while flow is confirmed to be present. 5. Remove flow switch and inspect switch paddle for proper operation.
FLUE TEMP HIGH PUMP ON E07 TIME	This display indicates that the flue sensor temperature is above 210°F. When this code is displayed, the VWH will not respond to a demand for heat. When the flue temperature decreases below 194°F, the display will return to normal and allow the VWH to respond to a heat demand. The bottom line indicates the status of the pump. The pump will remain on when this error is displayed.	Check the flue for obstructions or any sign of damage, especially signs of excessive heat. Repair as necessary. Run the VWH and check the flue temperature with an external thermometer. If the flue temperature on the thermometer does not agree with the flue temperature displayed in the status menu, inspect the wiring to the flue temperature sensor in the VWH and repair as necessary. If the wiring is intact, replace the flue sensor. If the flue temperature is excessive on the status menu and the test thermometer reads the same, check and adjust combustion controls on the VWH.
TEMPER BLOCKING PUMP ON TT	TT indicates there is a demand for heat on the VWH, the pump is powered on, and the supply sensor temperature is too high for the VWH to ignite. This occurs because the water temperature measured by the supply sensor is higher than the tank temperature – ignition diff setting.	This message will stay present until the water temperature measured by the supply sensor is less than the tank temperature – ignition diff setting.
HIGH FLUE PRESS PUMP ON FLU	FLU indicates excessive flue pressure. This code resets automatically after the high pressure condition is resolved. The second line indicates pump status.	<ol style="list-style-type: none"> 1. Assure the flue is not blocked. 2. Check the switch wiring by applying a jumper in place of the switch. If the code clears with the jumper in place, REPLACE the flue switch and connect the wires to the new switch BEFORE running VWH.
WARNING: Do not use jumper to remedy an FLU error. Faulty switch MUST be replaced. Failure to follow this instruction could result in serious personal injury or death.		
FLUE TEMP HIGH PUMP OFF E07 TIME	E07 indicates the flue sensor temperature is excessive and above 210°F. When E07 is displayed the VWH will not respond to a demand for heat and begin to modulate down on vent temp rather than supply temp. During reduced modulation, the display will show VENT RED MODULATION, and the second line will alternate between PUMP ON TIME and the actual vent temperature. When the flue temperature decreases below 194°F, the display will return to normal and allow the VWH to respond to a heat demand.	<ol style="list-style-type: none"> 1. Check the flue for obstructions and any sign of damage, especially signs of excessive heat. Repair as necessary. 2. Run the VWH and check the flue temperature with an external thermometer. If the flue temperature on the thermometer does not agree with the flue temperature displayed in the status menu, inspect the wiring to the flue temperature sensor in the VWH and repair as necessary. If the wiring is intact replace the flue sensor. 3. If the flue temperature is excessive on the status menu and the test thermometer reads the same, check and adjust combustion controls on the VWH.

LINE VOLTAGE PUMP OFF	E19	E19 indicates the line voltage frequency is out of range. This could happen if the VWH is being powered from a small gasoline powered generator that is overloaded or not functioning correctly.	Inspect power wiring to the VWH and repair as necessary. If connected to line voltage, notify the power company. If connected to an alternate power source such as a generator or inverter, make sure the line voltage frequency supplied by the device is 47 - 62.5 Hz.
-----------------------	-----	--	--

Table 36 - VWH Error and Fault Codes

Supply Temperature Sensor (7700P-073)	Indirect Sensor (7250P-325)	Return Sensor (7250P-667)	Dual Flue Temperature Sensor (7450P-176)
Temperature (°F)		Resistance (ohms)	
32		32624	
41		25381	
50		19897	
59		15711	
68		12493	
77		10000	
86		8056	
95		6530	
104		5324	
113		4365	
122		3599	
131		2982	
140		2483	
149		2079	
158		1748	
167		1476	
176		1252	
185		1066	
194		912	
203		782	
212		674	

Table 37 - Sensor Temperature Resistance

Part 13 - Maintenance

A. Procedures

Periodic maintenance should be performed once a year by a qualified service technician to assure that all the equipment is operating safely and efficiently. The owner should make necessary arrangements with a qualified heating contractor for periodic maintenance of the VWH. The installer must also inform the owner that a lack of proper care and maintenance of the VWH may result in a hazardous condition.



WARNING

BEFORE EACH HEATING SEASON a trained and qualified service technician should perform the inspections as per the VWH inspection and maintenance schedule in this manual. Failure to do so could result in death or serious injury.



WARNING

The combustion chamber insulation in this product contains ceramic fiber material. Ceramic fibers can be converted to cristobalite in very high temperature applications. The International Agency for Research on Cancer (IARC) has concluded, "Crystalline silica inhaled in the form of quartz or cristobalite from occupational sources is carcinogenic to humans (Group 1)."

- Avoid breathing dust and contact with skin and eyes.
- Use a NIOSH certified dust respirator (N95). This type of respirator is based on the OSHA requirements for cristobalite at the time this document was written. Other types of respirators may be needed depending on job site conditions. Current NIOSH recommendations can be found on the NIOSH website: <http://www.cdc.gov/niosh/homepage.html>. NIOSH approved respirators, manufacturers, and phone numbers are also listed on this website.
- Wear long-sleeved, loose fitting clothing, gloves, and eye protection.
- Apply enough water to the combustion chamber lining to prevent dust.
- Wash potentially contaminated clothes separately from other clothing. Rinse clothes washer thoroughly.

NIOSH stated First Aid.

- Eye: Irrigate immediately.
- Breathing: Fresh air.

B. Combustion Chamber Coil Cleaning Instructions

*Before beginning this procedure, have on hand the following items:

- a nylon, stainless steel, or brass brush (not steel)
 - gloves and eye protection
1. Shut down the VWH by using the following steps:
 - a. Close the gas valve. Shut down the unit, and wait for it to be cool to the touch.
 - b. Disconnect the condensate piping from the outside connection, (not from the VWH side), so flow from condensate reservoir can be observed.
 - c. Disconnect electrical connections from the gas valve, spark electrode, flame rectification probe, and combustion blower.
 - d. Remove the four (4) screws on the aluminum 3/4" NPT connector on the right side of the gas valve.
 - e. Disconnect the wiring connected to the combustion blower motor.
 - f. Remove the six (6) 10MM nuts from the burner plate assembly.
 - g. Pull the entire burner plate assembly with blower still attached towards you, while removing or pushing aside any wiring to allow removal of the assembly.
 2. Spray the coils liberally with a spray bottle filled with clear tap water. Confine the spray to the area being cleaned. Avoid getting the ceramic target wall wet. If the condensate system is blocked, use a vacuum to clear it.
 3. Scrub coils of any buildup with a nylon, stainless steel, or brass brush. Do not use a steel brush. Vacuum the debris from the coils.
 4. Spray the coils again with clear tap water. Confine the spray to the area being cleaned. Flush the combustion chamber with fresh water until it runs clear from the condensate reservoir. At this point, the VWH should be ready to be reassembled.
 - a. Inspect gaskets.
 - b. Reinstall the burner assembly

- c. Replace and tighten the six (6) 10MM nuts to the burner plate using staggered tightening sequence. (See detail.)
- d. Reconnect all wiring connections
- e. Inspect the gas valve. Ensure the O-ring is in place.
- f. Replace the four (4) screws on the aluminum connector on the gas valve. Turn the gas back on. (IMPORTANT: CHECK FOR GAS LEAKS!)
- g. Turn VWH power back on and create a heat demand. When VWH is lit observe condensate flow from the VWH. Be sure the VWH is operating properly.
- h. Reconnect the condensate piping to the outside condensate connection.

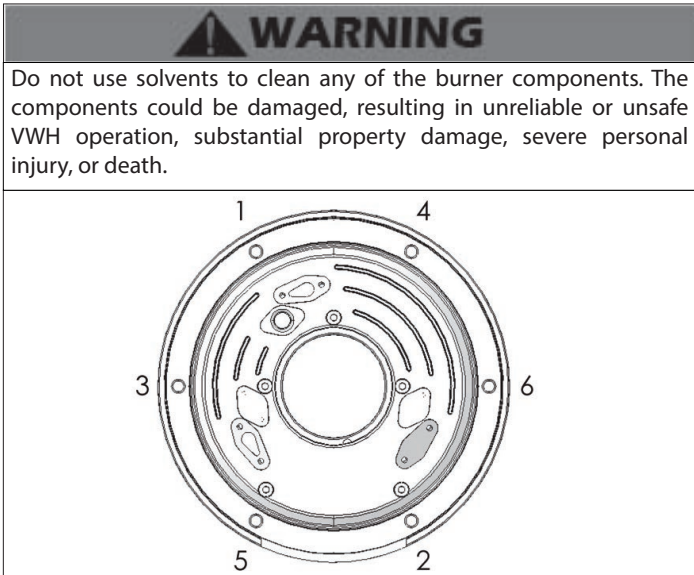

Figure 31 - Heat Exchanger Detail

C. Cleaning Water Side of Heat Exchanger

- 1. Make sure power is turned off to the VWH. Run water through the hot water system to ensure it is below room temperature.
- 2. Close isolation valves on the return and supply connections to the VWHs as shown in the piping diagrams in this manual. Slowly open the ball valves and release pressure into a bucket. Once pressure is released, connect a hose to the water line to flush the VWH. Scale removing solution may be used, but must be approved for use with stainless steel and FDA approved for use in a potable water system.
- 3. Thoroughly flush the heat exchanger before commissioning the unit back in service.

⚠ DANGER

Water temperature over 125°F can cause severe burns instantly or death from scalds. Children, disabled and elderly are at highest risk of being scalded. See instruction manual before setting temperature at water heater. Feel water before bathing or showering. Temperature limiting valves are available, see manual.

D. Maintaining the Condensate System

⚠ DANGER

The condensate trap assembly **MUST BE PROPERLY INSTALLED** according to these instructions when operating the VWH. Operating the VWH without the condensate trap assembly will cause flue gases to leak and result in serious personal injury or death.

⚠ DANGER

When servicing is complete, make sure the condensate collector cap is replaced securely. Failure to do so will cause venting issues that will result in serious injury or death.

- 1. Ensure the VWH is powered off and has had time to cool.
- 2. Remove the hose clamp attaching the condensate trap to the condensate hose from the heat exchanger. Remove the clear plastic hose from the hose barb. Remove the condensate hose clamp to detach the condensate trap from the drain tube. Remove the condensate trap from the VWH.
- 3. Remove the bottom cap from the condensate trap.
- 4. Flush trap with fresh water to remove debris from the trap. **NOTE:** Ensure the float moves freely within the trap. If the float does not move, DO NOT reinstall the trap.
- 5. When the condensate trap is sufficiently clean, reinstall the bottom cap on the trap. **NOTE:** Ensure all parts shown in Figure 32, Condensate Detail, are installed with the condensate trap. If any parts are missing, DO NOT reinstall the trap. Replace the entire assembly.

⚠ WARNING

Do not install the condensate assembly if a component is lost or missing. Replace the entire assembly. Failure to follow this warning could result in property damage, serious personal injury, or death.

- 6. Fill the condensate trap with fresh water prior to reassembly on the VWH.
- 7. Install the condensate trap on the condensate hose from the heat exchanger. Use the hose clamp to secure the trap. Attach the clear plastic hose onto the hose barb. Reinstall the condensate hose clamp to detach the condensate trap from the drain tube.

⚠ WARNING

Do not operate the VWH without the clear hose attached from the hose barb to the pressure switch. Failure to follow this warning could result in property damage, serious personal injury, or death.

- 8. If a condensate neutralizer kit is installed with the VWH, check the assembly when cleaning the condensate trap, and replenish the limestone chips if necessary. When replacing limestone chips, take care to ensure chips are no smaller than 1/2" to avoid blockage in condensate piping (for piping details, refer to condensate neutralizer installation instruction.)
- 9. Check condensate piping for sagging and/or leakage. Repair any sags or leaks before restoring power to the VWH.

CAUTION

It is very important that the condensate piping be no smaller than 3/4". To prevent sagging and maintain pitch, condensate piping should be supported with pipe supports, and pitched 1/4" per foot to allow for proper drainage. Failure to maintain proper pipe size and pitch could result in condensate leakage and potential water damage to property.

The condensate line must remain unobstructed, allowing free flow of condensate. If condensate freezes in the line, or if line is obstructed in any other manner, condensate can exit from the tee, resulting in potential water damage to property.

- 10. If the VWH has a condensate pump, ensure the pump operates properly before considering maintenance complete.

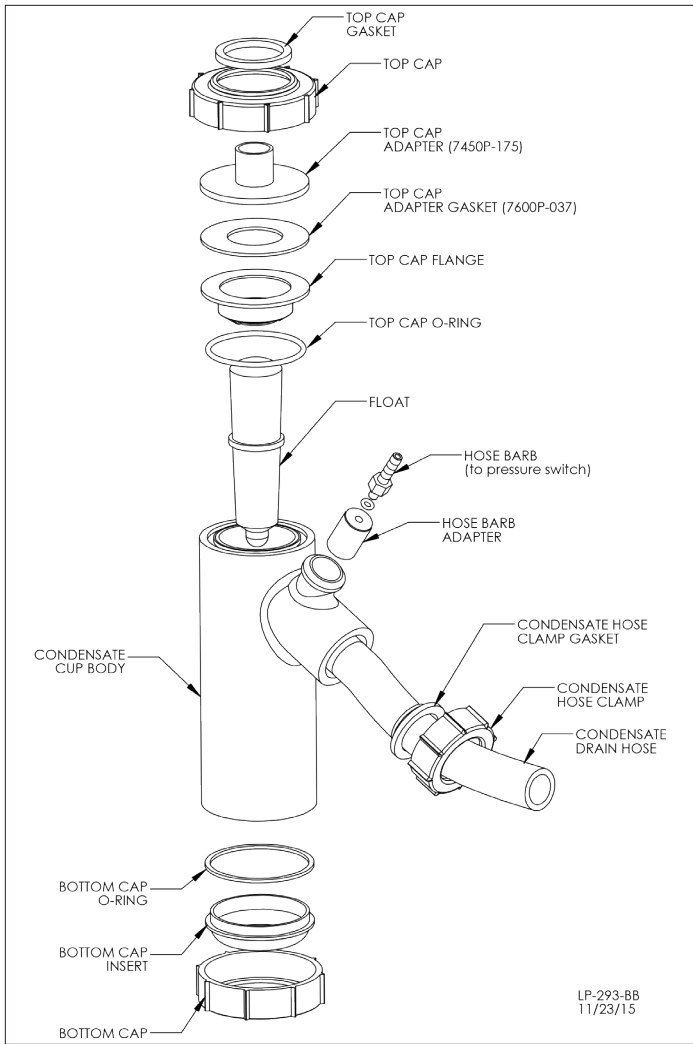

Figure 32 - Condensate Detail

Part 14 - Installation Checklist

Light Off Activities		Date Completed:	
1. Fill the Heating System	Check all piping and gas connections. Verify all are tight.		
	Pressurize system.	PSI	
	Add water to prime condensate cup.		
	Verify near VWH piping is properly supported.		
2. Check Gas Pipe	Leak test using locally approved methods (consult jurisdictional code book).		
	Check incoming gas pressure (3.5 to 14" WC).	Static WC	
	Check the "drop" on light off (less than 1" WC).	Dynamic WC	
3. Check Combustion	Check and adjust (if necessary) carbon dioxide content.	%CO2 High Fire	%CO2 Low Fire
	Check and adjust (if necessary) carbon monoxide content.	ppm CO High Fire	ppm CO Low Fire
4. Check Electrical Connections	Ensure all electrical connections of line voltage (pumps, etc.) and low voltage circuits (system sensor, outdoor sensor, etc.) are properly wired.		
5. Verify System Operation	Turn up thermostat to verify wiring connections.		
6. Record Ionization Current	Check uA reading at d7 on the status menu (see Start-Up section, this manual).	uA High Fire	uA Low Fire
7. Storage Tank	Verify safety and operation of the storage tank. Record settings.	DHW Setpoint	DHW Differential
8. Mixing Valve	Ensure thermostatic mixing valve is properly supported and installed.		
9. Convert the VWH	If necessary, convert the VWH to the proper fuel type.		
	Locate the stickers in the appropriate locations on the VWH.		
	Verify combustion settings after gas conversion - Carbon Dioxide.	%CO2 High Fire	%CO2 Low Fire
	Verify combustion settings after gas conversion - Carbon Monoxide.	ppm CO High Fire	ppm CO Low Fire
	Mail in conversion registration.		
Notes:			

Table 38 - Installation Checklist

Part 15 - Maintenance Report

CAUTION

In unusually dirty or dusty conditions, care must be taken to keep VWH cabinet door in place at all times. Failure to do so VOIDS the warranty.

WARNING

Allowing the VWH to operate with a dirty combustion chamber will hurt operation. Failure to clean the heat exchanger as needed by the installation location could result in VWH failure, property damage, personal injury, or death. Such product failures ARE NOT covered under warranty.

The VWH requires minimal periodic maintenance under normal conditions. However, in unusually dirty or dusty conditions, periodic vacuuming of the cover to maintain visibility of the display and indicators is recommended.

Periodic maintenance should be performed once a year by a qualified service technician to assure that all the equipment is operating safely and efficiently. The owner should make necessary arrangements with a qualified heating contractor for periodic maintenance of the VWH. Installer must also inform the owner that the lack of proper care and maintenance of the VWH may result in a hazardous condition.

Inspection Activities		Date Last Completed			
Piping		1st Year	2nd Year	3rd Year	4th Year*
Near VWH piping	Check VWH and system piping for any sign of leakage; make sure pipes are properly supported.				
Vent	Check condition of all vent pipes and joints. Ensure the vent piping terminations are free of obstructions and blockages.				
System		1st Year	2nd Year	3rd Year	4th Year*
Visual	Do a full visual inspection of all system components.				
Functional	Test all functions of the system (Heat, Safeties).				
Temperatures	Verify safe settings on VWH or anti-scald valve.				
	Verify programmed temperature settings.				
Electrical					
Connections	Check wire connections. Make sure connections are tight.				
Smoke and CO Detector	Verify devices are installed and working properly. Change batteries if necessary.				
Circuit Breakers	Check to see that the circuit breaker is clearly labeled. Exercise circuit breaker.				
Chamber / Burner		1st Year	2nd Year	3rd Year	4th Year*
Combustion Chamber	Check burner tube and combustion chamber coils. Clean according to maintenance section of manual. Vacuum combustion chamber. Replace any gaskets that show signs of damage.				
Spark Electrode	Clean. Set gap at 1/4" Clean probe with plumbers cloth to remove oxides.				
Combination Ignitor and Flame Probe	Check ionization in uA (d7 in Status Menu in Start-Up Procedures). Record high fire and low fire. Clean probe with plumbers cloth to remove oxides.				
Condensate		1st Year	2nd Year	3rd Year	4th Year*
Neutralizer	Check condensate neutralizer. Replace if necessary.				
Condensate Pipe	Disconnect condensate pipe. Clean out dirt. Fill with water to level of outlet and reinstall. (NOTE: Verify the flow of condensate, making sure that the hose is properly connected during final inspection.)				
Gas		1st Year	2nd Year	3rd Year	4th Year*
Pressure	Measure incoming gas pressure (3.5 to 14"WC).				
Pressure Drop	Measure drop in pressure on light off (no more than 1"WC).				
Check Gas Pipe for Leaks	Check gas piping. Test for leaks and signs of aging. Make sure all pipes are properly supported.				
Combustion		1st Year	2nd Year	3rd Year	4th Year*
CO / CO2 Levels	Check CO and CO2 levels in exhaust. See Start-Up Procedures for ranges. Record at high and low fire.				
Safeties		1st Year	2nd Year	3rd Year	4th Year*
ECO (Energy Cut Out)	Check continuity on flue and water ECO. Replace if corroded.				
Flow Switch	Activate heating call and monitor system to ensure flow switch and pump are operating correctly.				
Sensors	Check wiring. Verify through ohms reading.				
Final Inspection		1st Year	2nd Year	3rd Year	4th Year*
Check List	Verify that you have completed entire check list. WARNING: FAILURE TO DO SO COULD RESULT IN SERIOUS INJURY OR DEATH.				
Homeowner	Review what you have done with the homeowner.				

Table 39 - *Continue annual maintenance beyond the 4th year as required.

Part 16 - Replacement Parts

ITEM #	EP-220	Description
1	7450P-004	BOILER MODULE
2	7250P-160	CERAMIC TARGET WALL
3	7500P-109	M4 FLAT WASHER
4	7250P-704	M4 X 8 FLAT HEAD SCREW
5	7450P-300	BURNER DOOR
6	7450P-005	BURNER DOOR INSULATION
7	7450P-012	BURNER
8	7500P-074	GASKET - BURNER
9	7450P-007	AIR CHANNEL
10	7250P-206	M5 X 14MM TORX SCREWS - AIR CHANNEL
11	7500P-075	GASKET - AIR CHANNEL/BLOWER
12	7350P-159	COMBUSTION BLOWER (NATURAL GAS)
		COMBUSTION BLOWER (LP)
13	7250P-478	M5 X 12MM SOCKET CAP SCREW
14	7450P-367	AIR/GAS MIXER (NATURAL GAS)
	7450P-368	AIR/GAS MIXER (LP)
15	7500P-099	SCREWS - AIR/GAS MIXER
16	8600P-044	WASHER - AIR/GAS MIXER
17	7450P-407	FLARE X BSP FITTING
18	7450P-140	FLEXIBLE GAS LINE
19	7450P-907	GAS VALVE
20	7450P-143	FLARE X NPT FITTING
21	9500P-0030*	1/2" X CLOSE NIPPLE (LOCATION SHOWN)
22	7500P-067	M6 NUT - BURNER DOOR
23	7250P-005	GASKET - PROBE/ELECTRODE
24	7350P-020	SPARK ELECTRODE (W/GASKET)
25	7250P-069	SCREW M4 X 8MM - PROBE/ELECTRODE
26	7350P-022	FLAME RECTIFICATION PROBE (W/GASKET)
27	7250P-667	THERMISTOR
	7450P-280	THERMISTOR - VWH ONLY
28	7250P-096	WATER PRESSURE SWITCH - NPT THREAD
	7450P-133	BRASS PLUG - VWH ONLY
29	7700P-073	DUAL SUPPLY SENSOR
30	7500P-057	CONDENSATE HOSE
31	7450P-095	CONDENSATE COLLECTOR ASSY
32	7250P-210	HOSE CLAMP
33	7450P-199	1/4" NPT NIPPLE
34	7450P-197	AIR RELEASE VENT
35	7100P-044	NPT X HOSE BARB FITTING
36	7700P-002	1/2" NPT NUT
37	7450P-086	1/2" NPT X 3/4 PVC SWEAT ADAPTER
38	7250P-154	S.S. HOSE BARB - BLOCKED VENT PRESSURE SWITCH
39	7250P-152	O-RING - HOSE BARB
40	7250P-153	S.S. 10-32 HEX NUT
41	7450P-404	O - RING - GAS VALVE ADAPTER
42	7450P-402	GAS VALVE ADAPTER
43	7450P-406	SCREWS - GAS VALVE ADAPTER

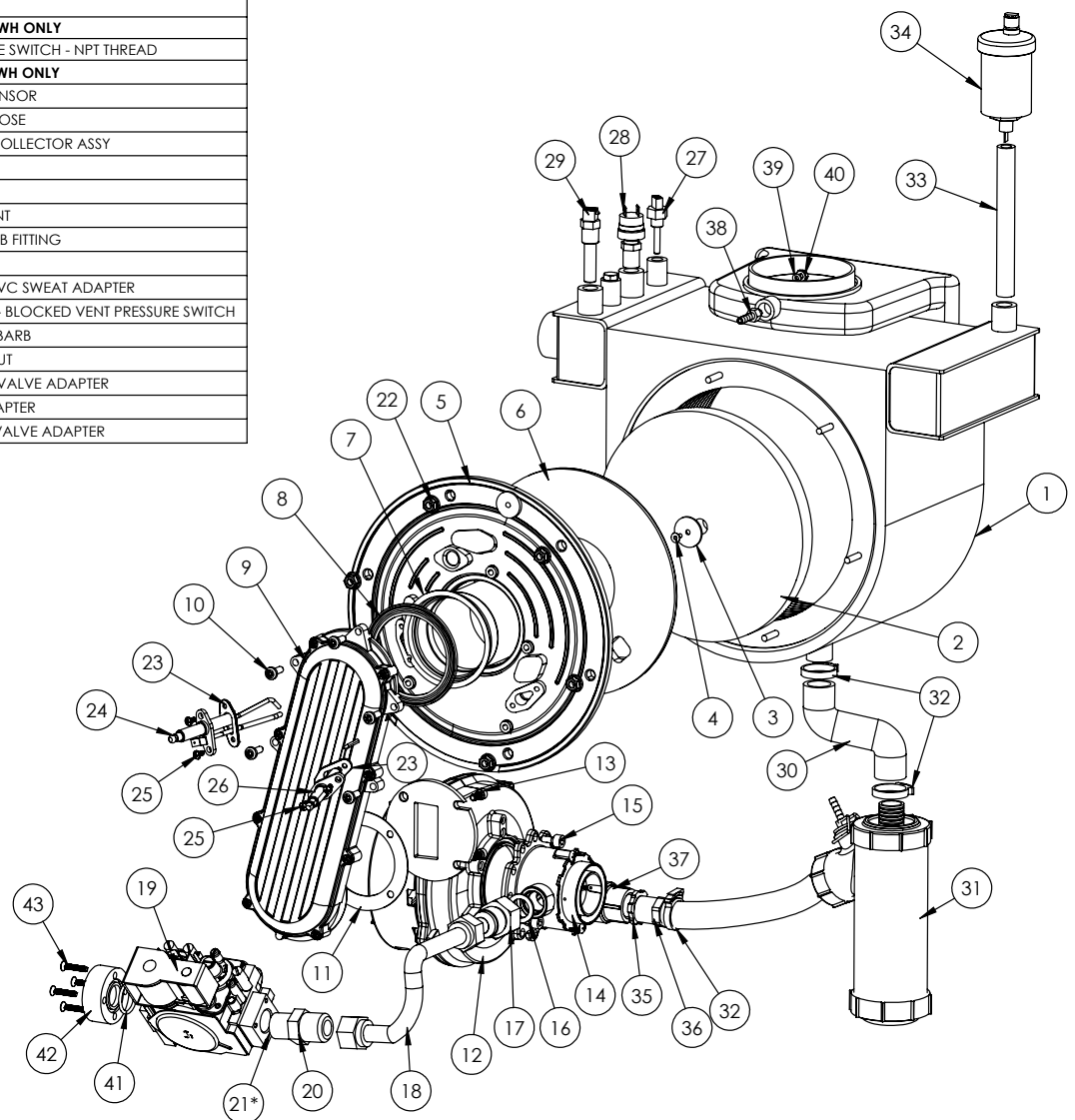

LP-551-D
03/17/21

Figure 33 - Combustion System Replacement Parts - 220kBTU Model

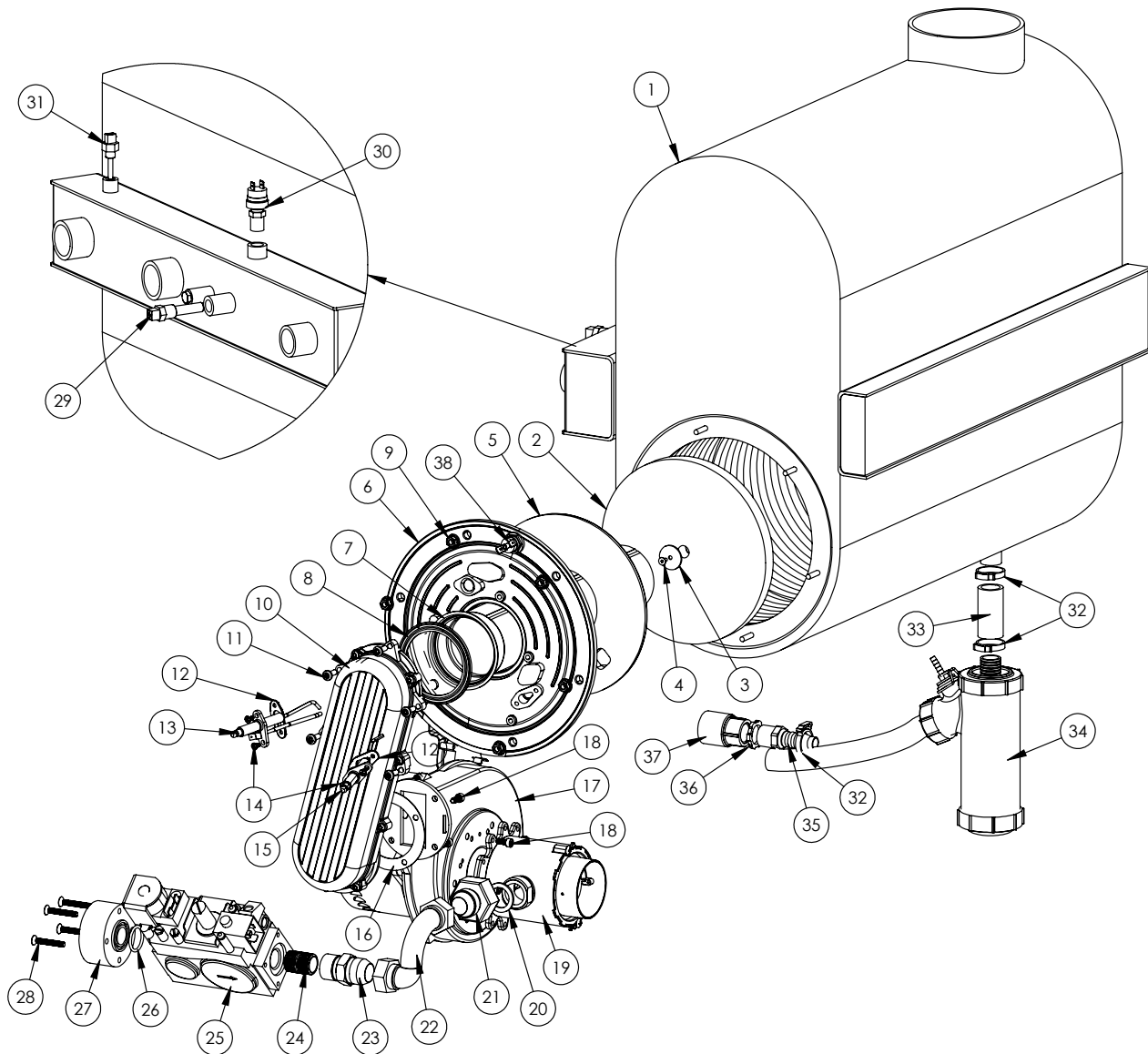

ITEM#	299	301	399	DESCRIPTION
1	7450P-014	7450P-015		BOILER MODULE
2		7250P-160		CERAMIC TARGET WALL
3		7500P-109		WASHER, FLAT M4 - TARGET WALL
4		7250P-704		SCREWS M4 X 8 FLAT HEAD - TARGET WALL
5		7450P-005		BURNER DOOR INSULATION
6		7450P-300		BURNER DOOR
7		7350P-031		BURNER - GFCI
8		7500P-074		GASKET - BURNER
9		7500P-067		NUT M6 - BURNER DOOR
10		7450P-007		AIR CHANNEL
11		7250P-206		TORX SCREWS M5 X 14MM - AIR CHANNEL
12		7250P-005		GASKET - PROBE/ELECTRODE
13		7350P-020		SPARK ELECTRODE W/GASKET
14		7250P-069		SCREWS M4 X 8MM - PROBE/ELECTRODE
15		7350P-022		FLAME RECTIFICATION PROBE W/GASKET
16		7500P-075		GASKET - AIR CHANNEL/BLOWER
17		7350P-159		COMBUSTION BLOWER
18		7250P-478		SCREWS M5 X 12MM - BLOWER
19	7450P-369		7450P-371	AIR/GAS MIXER (NATURAL GAS)
	7450P-370		7450P-372	AIR/GAS MIXER (LP GAS)

ITEM#	299	301	399	DESCRIPTION
20		8600P-044		GASKET - FLARE X BSP FITTING
21		7450P-407		FLARE X BSP FITTING
22		7450P-140		FLEXIBLE GAS LINE
23		7450P-143		FLARE X NPT FITTING
24		9500P-0030		CLOSE NIPPLE - 1/2"
25		7450P-908		GAS VALVE
26		7450P-404		O-RING - GAS VALVE ADAPTER
27		7450P-403		GAS VALVE ADAPTER
28		7450P-332		SCREWS - GAS VALVE ADAPTER
29		7700P-073		DUAL SUPPLY SENSOR
		7250P-096		WATER PRESSURE SWITCH (NPT THREAD)
30		7450P-133		BRASS PLUG - (VWH ONLY)
31		7250P-667		THERMISTOR
32		7250P-210		HOSE CLAMP
33		7500P-057		CONDENSATE HOSE
34		7450P-095		CONDENSATE TRAP KIT
35		7100P-044		HOSE BARB X 1/2" NPT
36		7700P-002		LOCKNUT - 1/2"
37		7450P-086		PVC ADAPTER - 3/4" X 1/2" FNPT
38		7450P-085		FLUE ECO SWITCH - 160 DEGREES

LP-550-R
03/17/21

Figure 34 - Combustion System Replacement Parts - 299 - 399kBTU Models

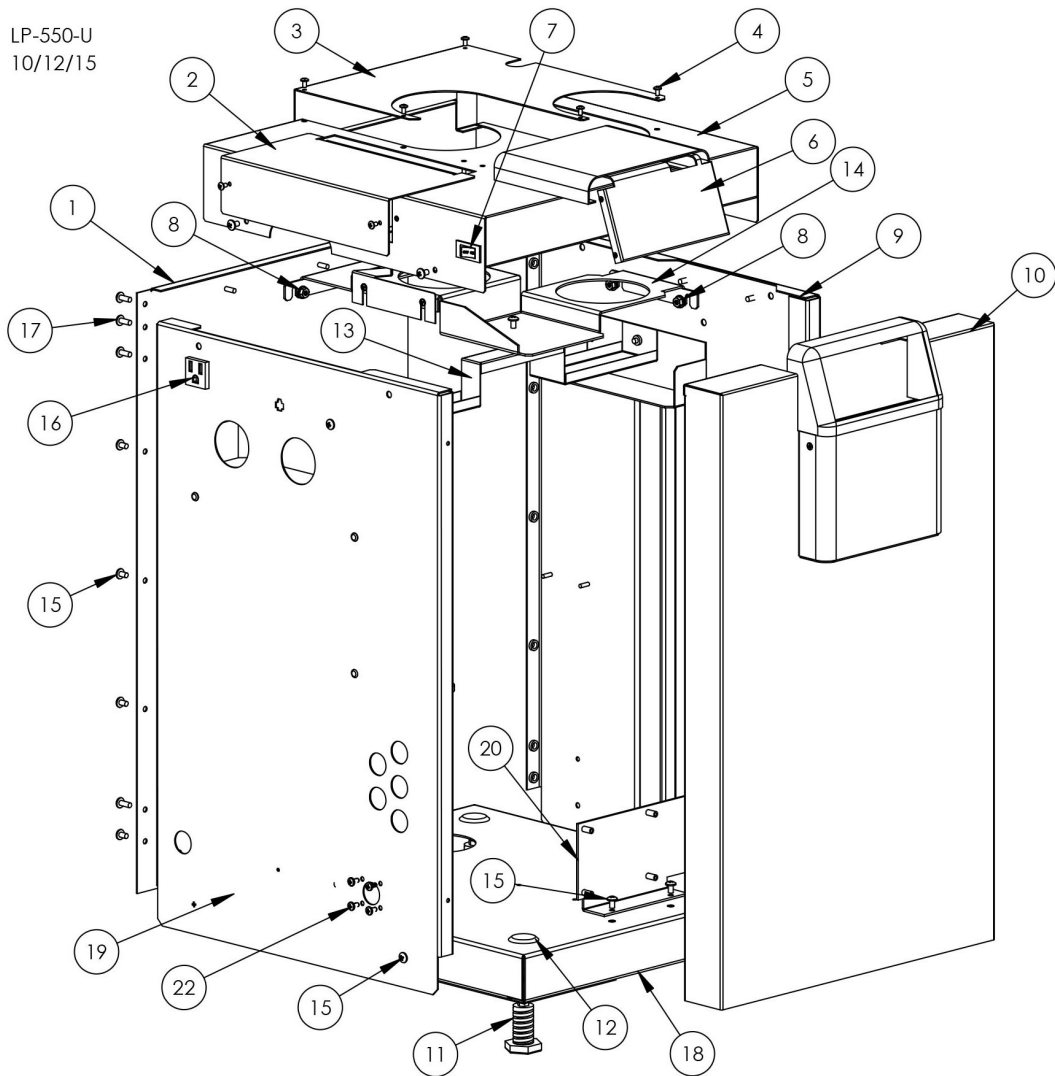

ITEM#	220	299/301	399	DESCRIPTION
1	7450P-039	7450P-065		JACKET - REAR
2	7450P-360			FIELD CONNECTION BOARD COVER
3	7450P-337	7450P-338		JACKET - TOP COVER, BACK
4	7450P-081			6-32 X 1/4 PAN HEAD SCREW - ACCESSORY PANELS
5	7450P-342	7450P-343	7450P-344	JACKET - TOP COVER, FRONT
6	7450P-349			JACKET - TOP COVER INSERT
7	7500P-087			POWER SWITCH
8	7450P-088			8-32 FLANGED NUT - AIR EXHAUST PLATE
9	7450P-317	7450P-318	7450P-319	JACKET - RIGHT SIDE
10	7450P-351			JACKET - FRONT COVER ASSEMBLY
11	7450P-121			LEVELING FEET
12	7450P-226			7/8 HOLE PLUG
13	7450P-076	7450P-077		MODULE HOLD-DOWN STRAP
14	7450P-074	7450P-149		AIR/EXHAUST SUPPORT PLATE
15	7450P-080			10-32 X 5/16 PAN HEAD SCREW - PANELS
16	7500P-037			CONVENIENCE OUTLET
17	7450P-098			10-32 x 1/2" PAN HEAD SCREW - BACK PANEL (BRACKET)
18	7450P-331	7450P-333	7450P-335	JACKET - BASE
19	7450P-311	7450P-312	7450P-313	JACKET - LEFT SIDE
20	7450P-373			FIELD CONNECTION BOARD MOUNTING PLATE
21	7450P-350	N/A		BOILER ACCESS COVER (NOT SHOWN)
22	7450P-144			M4 X 8MM SCREW - GAS VALVE INSTALLATION

Figure 35 - Replacement Parts - All Models

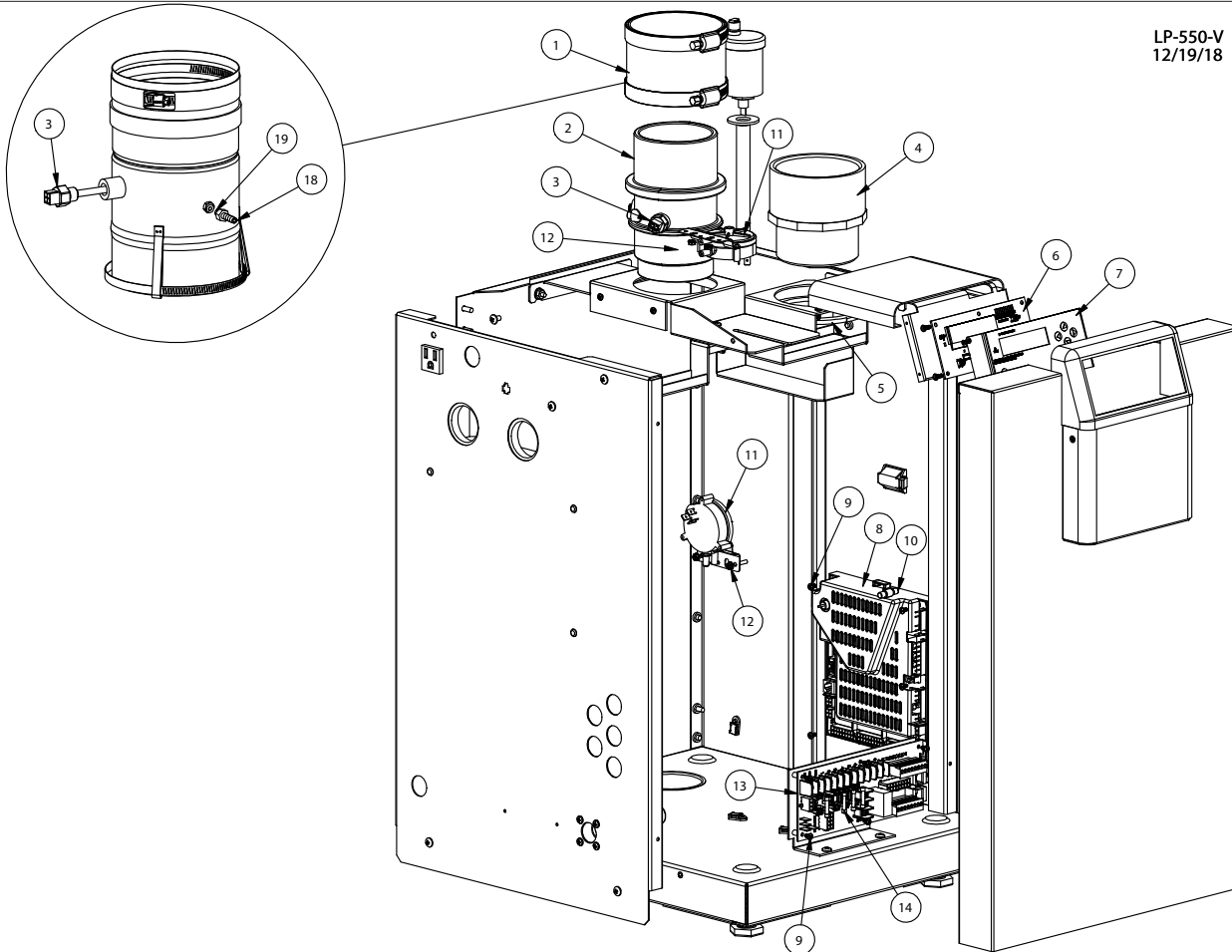

ITEM #	220	299/301	399	DESCRIPTION
1	7450P-282	7450P-157		C LAMP ALL - EXHAUST VENT ADAPTER
2	7450P-201	7450P-324		EXHAUST ADAPTER
3	7450P-176			DUAL FLUE SENSOR
4	7450P-030	7450P-031		AIR INLET ADAPTER
5	7450P-032	7450P-033		AIR INLET CONNECTOR NUT
6	7450P-028			DISPLAY BOARD
7	7450P-021			MEMBRANE TOUCHPAD
8	SEE CHART			CONTROL BOARD
9	7500P-115			6-32 X 1/4 PAD HEAD SCREW - ELECTRONIC BOARDS
10	7250P-378			FUSE - CONTROL BOARD - 6.3 AMPS
11	7250P-150			PRESSURE SWITCH
12	7450P-142			6-32 FLANGED NUT - PRESSURE SWITCH
13	7350P-370			FIELD CONNECTION BOARD
14	6300P-037			FUSE - FIELD CONNECTION BOARD - 2.0 AMPS
15	7450P-902	7450P-903		FLUE KIT (includes: items # 1, 2, 3)
16	7000P-805			PLASTIC TUBING - PRESSURE SWITCHES (NOT SHOWN)
17	7450P-354	7450P-356	7450P-358	120V WIRING HARNESS (NOT SHOWN)
18	7450P-355	7450P-357	7450P-359	LOW VOLTAGE WIRING HARNESS (NOT SHOWN)
19	7250P-154			HOSE BARB
20	7250P-152			O-RING - HOSE BARB
21	7450P-093			RIBBON CABLE - DISPLAY BOARD (NOT SHOWN)

Figure 36 - Cabinet Replacement Parts - All Models

Model	Control Board Part Numbers	
	NG	LP
220,000 BTU VWH	7450P-2109	7450P-2107
299,000 BTU / 301,000 BTU VWH	7450P-2113	7450P-2111
399,000 BTU VWH	7450P-2117	7450P-2115

Table 40 - Control Board Part Numbers

VWH Limited Warranty

HTP warrants each VWH and its parts to be free from defects in materials and workmanship according to the following terms, conditions, and time periods. UNLESS OTHERWISE NOTED THESE WARRANTIES COMMENCE ON THE DATE OF INSTALLATION. This limited warranty is only available to the **original consumer purchaser** (hereinafter "Owner") of the VWH, and is non-transferable.

Commercial Use Warranty

Five (5) years – Heat Exchanger, One (1) Year – Components

COVERAGE

- A. During the first year after the original date of installation, HTP warrants that it will repair or replace, at its option, any defective or malfunctioning component of the VWH with a component of equivalent size and current model. Replacement components will be warranted for ninety (90) days.
- B. Should a defect or malfunction result in a leakage of water from the VWH within the above-stated warranty periods due to defective material or workmanship, malfunction, or failure to comply with the above warranty, with such defect or malfunction having been verified by an authorized HTP representative, HTP will replace the defective or malfunctioning VWH with a replacement of the nearest comparable model available at the time of replacement. The replacement VWH will be warranted for the unexpired portion of the applicable warranty period of the original VWH.
- C. In the event of a leakage of water of a replacement VWH due to defective material or workmanship, malfunction, or failure to comply with the above warranty, HTP reserves the right to refund to the Owner the published wholesale price available at the date of manufacture of the original VWH.
- D. If government regulations, industry certification, or similar standards require the replacement VWH or component(s) to have features not found in the defective VWH or component(s), the Owner will be charged the difference in price represented by those required features. If the Owner pays the price difference for those required features and/or to upgrade the size and/or other features available on a new replacement VWH or component(s), the Owner will also receive a complete new limited warranty for that replacement VWH or component(s).
- E. If at the time of a request for service the Owner cannot provide a copy of the original sales receipt or the warranty registration, the warranty period for the VWH shall then be deemed to have commenced thirty (30) days after the date of manufacture of the VWH and NOT the date of installation of the VWH.
- F. This warranty extends only to VWHs utilized in water heating applications that have been properly installed by qualified professionals based upon the manufacturer's installation instructions.
- G. It is expressly agreed between HTP and the Owner that repair, replacement, or refund are the exclusive remedies of the Owner.

OWNER RESPONSIBILITIES

The Owner or Qualified Installer / Service Technician must:

1. Have a relief valve bearing the listing marks of the American Society of Mechanical Engineers (ASME) installed with the VWH assembly in accordance with federal, state, and local codes.
2. Have a vacuum relief valve certified to ANSI Z21.22 - Relief Valves for Hot Water Supply Systems installed with the VWH assembly in accordance with federal, state, and local codes and in installations prone to vacuum related damages.
3. Maintain the VWH in accordance with the maintenance procedure listed in the manufacturer's provided instructions. Preventive maintenance can help avoid any unnecessary breakdown of the VWH and keep it running at optimum efficiency.

4. Maintain all related system components in good operating condition.
5. Use the VWH in an open system, or in a closed system with a properly sized and installed thermal expansion tank.
6. Use the VWH at water pressures not exceeding the working pressure shown on the rating plate.
7. Keep the VWH free of damaging scale deposits.
8. Make provisions so if the VWH or any component or connection thereto should leak, the resulting flow of water will not cause damage to the area in which it is installed.

WARRANTY EXCLUSIONS

This limited warranty will not cover:

1. Any VWH purchased from an unauthorized dealer or online retailer.
2. Any VWH not installed by a qualified heating installer/service technician, or installations that do not conform to ANSI, CSA, and/or UL standards, as well as any applicable national or local building codes.
3. Service trips to teach you how to install, use, maintain, or to bring the VWH installation into compliance with local building codes and regulations.
4. The workmanship of any installer. The manufacturer disclaims and does not assume any liability of any nature caused by improper installation, repair, or maintenance.
5. Electricity or fuel costs, or increased or unrealized savings for same, for any reason whatsoever.
6. Any water damage arising, directly or indirectly, from any defect in the VWH or component part(s) or from its use.
7. Any incidental, consequential, special, or contingent damages or expenses arising, directly or indirectly, from any defect in the VWH or the use of the VWH.
8. Failure to locate the VWH in an area where leakage of the VWH or water line connections and the relief valve will not result in damage to the area adjacent to the VWH or lower floors of the structure, as well as failure to install the VWH with properly designed containment measures.
9. Any failed components of the heat system not manufactured by HTP as part of the VWH.
10. VWHs repaired or altered without the prior written approval of HTP.
11. Damages, malfunctions, or failures resulting from improper installation, or failure to install the VWH in accordance with applicable building codes/ordinances or good plumbing and electrical trade practices; or failure to operate and maintain the VWH in accordance with the manufacturer's provided instructions.
12. Damages, malfunctions, or failures resulting from failure to operate the VWH at pressures not exceeding the working pressure shown on the rating label.
13. Failure to operate the VWH in an open system, or in a closed system with a properly sized and installed thermal expansion tank.
14. Failure or performance problems caused by improper sizing of the VWH, expansion device, piping, or the gas supply line, the venting connection, combustion air openings, electric service voltage, wiring or fusing.
15. Damages, malfunctions, or failures caused by improper conversion from natural gas to LP gas or LP gas to natural gas.
16. Damages, malfunctions, or failures resulting from vacuum conditions.
17. Damages, malfunctions, or failures caused by operating the VWH with modified, altered, or unapproved parts.
18. Damages, malfunctions, or failures caused by abuse, accident, fire, flood, freeze, lightning, electrochemical reaction, acts of God and the like.
19. Failures (leaks) caused by operating the VWH in a corrosive or contaminated atmosphere.
20. Damages, malfunctions, or failures caused by operating the VWH with an empty or partially empty tank ("dry firing"), or failures caused

by operating the VWH when it is not supplied with potable water, free to circulate at all times.

21. Failure of the heater due to the accumulation of solid materials and lime deposits.
22. Any damage or failure resulting from improper water chemistry. WATER CHEMISTRY REQUIREMENTS - Water pH between 6.5 and 8.5. Hardness less than 7 grains (120 mg/L). Chloride concentration less than 100 ppm (mg/L). TDS less than 500 ppm (mg/L).
23. Any damages, malfunctions, or failures resulting from the use of dielectric unions.
24. Production of noise, taste, odors, discoloration, or rusty water.
25. VWHs replaced for cosmetic reasons.
26. Components of the VWH that are not defective, but must be replaced during the warranty period as a result of reasonable wear and tear.
27. Components of the VWH that are subject to warranties, if any, given by their manufacturers; HTP does not adopt these warranties.
28. Damages, malfunctions, or failures resulting from the use of any attachment(s) not supplied by HTP.
29. VWHs installed outside the fifty states (and the District of Columbia) of the United States of America and Canada.
30. VWHs moved from the original installation location.
31. VWHs that have had their rating labels removed.

PROCEDURES FOR WARRANTY SERVICE REQUESTS

Any claim for warranty assistance must be made immediately upon finding the issue. First, please consult the HTP Warranty Wizard (<http://www.htproducts.com/Warranty-Wizard.html>) to check warranty eligibility. You may also contact HTP Technical Support at 1-800-323-9651 for questions or assistance. Warranty coverage requires review and approval of the issue with HTP Technical Support or through the Warranty Wizard prior to a full unit replacement. Any claim for warranty reimbursement will be rejected if prior approval from HTP is not obtained in advance of a full unit replacement. Final determination will be made as part of the warranty claim process.

When submitting a warranty claim the following items are required:

1. **Proof of purchase or installation of the product** – Typically a copy of the invoice from the installing contractor, the receipt of the purchase of the product, or an original certificate of occupancy for a new home.
2. **Clear pictures (or video) of the following:**
 - a. Serial number tag (sticker)
 - b. The product
 - c. The product issue / failure whenever possible
 - d. A picture of the piping near the product
 - e. For gas fired products, a picture of the venting, including how it exits the building

All claims will be reviewed by HTP within three (3) business days. If additional information is required and requested by the HTP Claims Department you will have thirty (30) days to provide it. When all requested information is provided HTP will respond within three (3) business days. The claim will be automatically closed if requested information is not provided within thirty (30) days. Claims will not be reopened without HTP Warranty Supervisor approval.

During the claims process a product that must be replaced will be given a designation of either a) field scrap, or b) return to HTP. If the product must be returned to HTP, the returned product must arrive at HTP within thirty (30) days of the date of our request to return the product. After receipt of the returned product HTP may require as many as thirty (30) additional days for product testing. **NOTE: Any components or heaters returned to HTP for warranty analysis will become the property of HTP and will not be returned, even if credit is denied.**

If you have questions about the coverage of this warranty, please contact HTP at the following address or phone number: HTP, 272 Duchaine Blvd., New Bedford, MA, 02745, Attention: Warranty Service

Department, 1(800) 323-9651.

SERVICE, LABOR, AND SHIPPING COSTS

Except when specifically prohibited by the applicable state law, the Owner, and not the Manufacturer, shall be liable for and shall pay for all charges for labor or other expenses incurred in the removal, repair, or replacement of the VWH or any component part(s) claimed to be defective or any expense incurred to remedy any defect in the product. Such charges include, but are not necessarily limited to:

1. All freight, shipping, handling, and delivery costs of forwarding a new VWH or replacement part(s) to the owner.
2. All costs necessary or incidental in removing the defective VWH or component part(s) and installing a new VWH or replacement part(s).
3. All administrative fees incurred by the Owner, as well as material required to complete, and/or permits required for, installation of a new VWH or replacement part(s), and
4. All costs necessary or incidental in returning the defective VWH or component part(s) to a location designated by the manufacturer.

LIMITATIONS OF YOUR HTP WARRANTY AND REMEDIES

THE FOREGOING WARRANTIES ARE EXCLUSIVE AND ARE GIVEN AND ACCEPTED TO THE FURTHEST EXTENT UNDER APPLICABLE LAW IN LIEU OF ANY AND ALL OTHER WARRANTIES, EXPRESS OR IMPLIED, INCLUDING WITHOUT LIMITATION THE IMPLIED WARRANTIES OF MERCHANTABILITY AND FITNESS FOR A PARTICULAR PURPOSE AND ANY OBLIGATION, LIABILITY, RIGHT, CLAIM OR REMEDY IN CONTRACT OR TORT, WHETHER OR NOT ARISING FROM HTP'S NEGLIGENCE, ACTUAL OR IMPUTED. THE REMEDIES OF THE OWNER SHALL BE LIMITED TO THOSE PROVIDED HEREIN TO THE EXCLUSION OF ANY OTHER REMEDIES INCLUDING WITHOUT LIMITATION, INCIDENTAL OR CONSEQUENTIAL DAMAGES, SAID INCIDENTAL AND CONSEQUENTIAL DAMAGES INCLUDING, BUT NOT LIMITED TO, PROPERTY DAMAGE, LOST PROFIT OR DAMAGES ALLEGED TO HAVE BEEN CAUSED BY ANY FAILURE OF HTP TO MEET ANY OBLIGATION UNDER THIS AGREEMENT INCLUDING THE OBLIGATION TO REPAIR AND REPLACE SET FORTH ABOVE. NO AGREEMENT VARYING OR EXTENDING THE FOREGOING WARRANTIES, REMEDIES OR THIS LIMITATION WILL BE BINDING UPON HTP. UNLESS IN WRITING AND SIGNED BY A DULY AUTHORIZED OFFICER OF HTP. THE WARRANTIES STATED HEREIN ARE NOT TRANSFERABLE AND SHALL BE FOR THE BENEFIT OF THE OWNER ONLY.

NO OTHER WARRANTIES

This warranty gives you specific legal rights, and you may also have other rights that vary from state to state. Some states do not allow the exclusion or limitation of incidental or consequential damages so this limitation or exclusion may not apply to you.

These are the only written warranties applicable to the VWH manufactured and sold by HTP. HTP neither assumes nor authorizes anyone to assume for it any other obligation or liability in connection with said VWHs. HTP reserves the right to change specifications or discontinue models without notice.

Customer Installation Record Form

The following form should be completed by the qualified installer / service technician for you to keep as a record of the installation in case of a warranty claim. After reading the important notes at the bottom of the page, please also sign this document.

Customer's Name	
Date of Installation	
Installation Address	
Product Name / Serial Number(s)	
Comments	
Installer's Code / Name	
Installers Phone Number	
Signed by Installer	
Signed by Customer	
Installation Notes	

IMPORTANT

Customer: Please only sign after the qualified installer / service technician has fully reviewed the installation, safety, proper operation, and maintenance of the system. If the system has any problems please call the qualified installer / service technician. If you are unable to make contact, please call your sales representative.

Distributor / Dealer: Please insert contact details.