

## TROUBLESHOOTING

TROUBLESHOOTING	
Problem	Solution
<ul style="list-style-type: none"> <li>Unit will not operate.</li> </ul>	<ul style="list-style-type: none"> <li>✓ Check if unit is properly plugged in and outlet is energized.</li> <li>✓ Make sure unit turned ON.</li> <li>✓ Make sure filters are properly installed and rear grill is seated correctly.</li> </ul>
<ul style="list-style-type: none"> <li>Decreased air flow.</li> </ul>	<ul style="list-style-type: none"> <li>✓ Make sure nothing is blocking air inlet and filtered air outlets.</li> <li>✓ Check condition of the filters and replace if necessary.</li> <li>✓ Check filter to remove any plastic wrapping/packaging.</li> <li>✓ Ensure carbon filter is changed every 60-90 days.</li> </ul>
<ul style="list-style-type: none"> <li>Excessive Noise.</li> </ul>	<ul style="list-style-type: none"> <li>✓ Make sure parts are firmly positioned in place.</li> <li>✓ Open the air inlet grill and make sure that any plastic packaging was removed from the filters, if applicable.</li> </ul>
<ul style="list-style-type: none"> <li>The filter check indicator will not reset.</li> </ul>	<ul style="list-style-type: none"> <li>✓ Check condition of the filters and replace if necessary.</li> <li>✓ Press and hold the Filter Reset Button for 3 seconds under power on condition.</li> </ul>

## LEARNING MORE

For a wealth of information about your air purifier and other Holmes® products, visit our website at [www.holmesproducts.com](http://www.holmesproducts.com) or call 1-800-546-5637. For inquiries regarding recycling and proper disposal of this product, please contact your local waste management facility.

## AER1 FILTER SERIES®

**Congratulations! Your new air purifier is equipped with the Aer1® Allergen Performance Plus Filter.**

Filter Type	Technology	Consumer Benefit
Total Air	99% HEPA-Type technology. Infused with baking soda.	Ideal for dust reduction. Delivers 30% better air quality.
Odor Eliminator	10 times the odor fighting power. Contains baking soda, carbon and zeolite for odor control.	Ideal for eliminating odors from pets, tobacco smoke and cooking fumes.
Allergen Remover	99.97% True HEPA technology. Removes up to 99.97% of particles as small as 0.3 microns passing through the filter such as pollen, dust, mold and dander.	Ideal for allergy sufferers.
<b>THIS UNIT COMES WITH</b> Allergen Performance Plus	99.99% True HEPA technology. Helps remove up to 99.99% of particles as small as 0.3 microns passing through the filter such as pollen, dust, mold and dander.	Ideal for allergy sufferers.
Smoke Grabber	HEPA-type filtration. Triple layer protection specially formulated with Baking Soda, Carbon and Zeolite. Removes up to 99% of smoke and pollutants as small as 0.3 microns from air passing through the filters.	Ideal for reducing smoke and odors from smoke and VOC's.



© 2017 Sunbeam Products, Inc. doing business as Jarden Consumer Solutions. All Rights Reserved.  
 Distributed by Sunbeam Products, Inc. doing business as Jarden Consumer Solutions, Boca Raton, Florida 33431.  
 Sunbeam Products, Inc. is a subsidiary of Newell Brands Inc. (NYSE: NWL).

P.N. 190202  
 GCDS-HOL50515-BB

HAP702\_17EM1

Printed In China

## WARRANTY INFORMATION

### 3 YEAR LIMITED WARRANTY

Sunbeam Products, Inc. doing business as Jarden Consumer Solutions or if in Canada, Sunbeam Corporation (Canada) Limited doing business as Jarden Consumer Solutions (collectively "JCS") warrants that for a period of three years from the date of purchase, this product will be free from defects in material and workmanship. JCS, at its option, will repair or replace this product or any component of the product found to be defective during the warranty period. Replacement will be made with a new or remanufactured product or component. If the product is no longer available, replacement may be made with a similar product of equal or greater value. This is your exclusive warranty. Do NOT attempt to repair or adjust any electrical or mechanical functions on this product. Doing so will void this warranty.

This warranty is valid for the original retail purchaser from the date of initial retail purchase and is not transferable. Keep the original sales receipt. Proof of purchase is required to obtain warranty performance. JCS dealers, service centers, or retail stores selling JCS products do not have the right to alter, modify or any way change the terms and conditions of this warranty.

This warranty does not cover normal wear of parts or damage resulting from any of the following: negligent use or misuse of the product, use on improper voltage or current, use contrary to the operating instructions, disassembly, repair or alteration by anyone other than JCS or an authorized JCS service center. Further, the warranty does not cover: Acts of God, such as fire, flood, hurricanes and tornadoes.

#### What are the limits on JCS's Liability?

JCS shall not be liable for any incidental or consequential damages caused by the breach of any express, implied or statutory warranty or condition.

Except to the extent prohibited by applicable law, any implied warranty or condition of merchantability or fitness for a particular purpose is limited in duration to the duration of the above warranty.

JCS disclaims all other warranties, conditions or representations, express, implied, statutory or otherwise.

JCS shall not be liable for any damages of any kind resulting from the purchase, use or misuse of, or inability to use the product including incidental, special, consequential or similar damages or loss of profits, or for any breach of contract, fundamental or otherwise, or for any claim brought against purchaser by any other party.

Some provinces, states or jurisdictions do not allow the exclusion or limitation of incidental or consequential damages or limitations on how long an implied warranty lasts, so the above limitations or exclusion may not apply to you.

This warranty gives you specific legal rights, and you may also have other rights that vary from province to province, state to state or jurisdiction to jurisdiction.

#### How to Obtain Warranty Service

##### In the U.S.A.

If you have any questions regarding this warranty or would like to obtain warranty service, please call 1-800-546-5637 and a convenient service center address will be provided to you.

##### In Canada

If you have any questions regarding this warranty or would like to obtain warranty service, please call 1-800-546-5637 and a convenient service center address will be provided to you.

In the U.S.A., this warranty is offered by Sunbeam Products, Inc. doing business as Jarden Consumer Solutions located in Boca Raton, Florida 33431. In Canada, this warranty is offered by Sunbeam Corporation (Canada) Limited doing business as Jarden Consumer Solutions, located at 20 B Hereford Street, Brampton, Ontario L6Y 0M1. If you have any other problem or claim in connection with this product, please write our Consumer Service Department. **PLEASE DO NOT RETURN THIS PRODUCT TO ANY OF THESE ADDRESSES OR TO THE PLACE OF PURCHASE.**

# Holmes®

## Owner's Guide

HAP702



## Allergen Remover Air Purifier

with Performance Plus Filter

**PLEASE READ AND SAVE THESE IMPORTANT INSTRUCTIONS**

## IMPORTANT SAFEGUARDS

When using electrical appliances, basic safety precautions should always be followed to reduce the risk of fire, electric shock, and injury to persons. These precautions include:

1. Read all instructions before using the appliance.
2. To reduce the risk of fire or electric shock, plug the appliance directly into a 120V AC electrical outlet.
3. If the filter is covered by a bag when shipped, remove plastic bag before use.
4. Keep the cord out of heavy traffic areas. To avoid fire hazard, NEVER put the cord under rugs, near heat registers, radiators, stoves, or heaters.
5. DO NOT immerse the appliance in water or other liquids. Do not use near water.
6. Close supervision is necessary when any appliance is used by or near children, or disabled persons.
7. Always unplug the air purifier before moving or cleaning the unit, opening the grill, changing the filters and whenever the unit is not in use. To disconnect the unit, be sure to pull the plug and not the cord.
8. NEVER drop or insert any objects into the openings of the unit.
9. DO NOT operate any appliance with a damaged cord or plug. If the motor fan fails to operate or the unit has been dropped or damaged in any manner, return appliance to manufacturer for examination and/or repair.
10. Use appliance only for intended household use as described in this manual. Any other use not recommended by the manufacturer may cause fire, electric shock, or injury to persons. The use of attachments not recommended or sold by Jarden Consumer Solutions may cause injuries.
11. DO NOT use outdoors.
12. NEVER place on a soft surface such as a bed or sofa as this could cause the unit to tip over and block the air inlet or outlet grills.
13. Keep unit away from heated surfaces and open flames.

14. DO NOT attempt to repair or adjust any electrical or mechanical functions on this unit. Doing so may cause injuries and void your warranty. The inside of the unit contains no user serviceable parts. All servicing should be performed by Jarden Consumer Solutions or an authorized Jarden Consumer Solutions Center.
15. DO NOT place anything on top of unit.
16. Always turn the appliance off before unplugging it.
17. The ionizer may cause a static charge to build up on the air outlet grill. A static charge may be felt if the unit is not properly grounded. To avoid a static charge, plug the unit's three-prong plug into a grounded outlet. The static charge will not occur if the ionizer is off.
18. The ionizer in this appliance produces less ozone than the UL established limits of 50ppb (parts per billion). However, in high concentrations, ozone can be harmful to birds and small pets. To prevent ozone buildup, we suggest using the ionizer in well ventilated areas with the fan on.
19. This appliance should only be used in a room with temperatures between 40° F and 110° F.
20. To reduce the risk of fire or electric shock, DO NOT use this appliance with any solid-state speed control device.

## SAVE THESE INSTRUCTIONS

### THIS PRODUCT IS EQUIPPED WITH A 3-PRONG PLUG

To reduce the risk of electric shock, this equipment has a grounding type plug that has a third (grounding) pin. This plug will only fit into a grounding type power outlet. If the plug does not fit into the outlet, contact qualified personnel to install the proper outlet. Do not alter the plug in any way.

## FEATURES

### POWER CORD INSTRUCTIONS

- The length of cord used on this appliance was selected to reduce tangling or tripping hazards.
- If a longer cord is necessary, an approved extension cord may be used. The electrical rating of the extension cord must be equal to or greater than the electrical rating of the air purifier (see rating label marked on bottom of the product).
- Care must be taken to arrange the extension cord so that it will not drape over the countertop or tabletop where it can be pulled on by children or accidentally tripped over.

### GET TO KNOW YOUR AIR PURIFIER

This unit is compatible with all Aer1® Filters. This allows you to choose the filter that is just right for you. Below is information on each filter:

- TOTAL AIR** - Advanced Dust Eliminating Technology
- ODOR ELIMINATOR** - 10x the odor fighting power
- ALLERGEN REMOVER** - True HEPA technology improves air quality for allergy sufferers
- ALLERGEN PERFORMANCE PLUS** - True HEPA technology improves air quality for allergy sufferers.
- SMOKE GRABBER** - 99% effective at removing smoke from the air stream (\*as small as 0.3 microns from air passing through the filter)

### IONIZER

This appliance has an optional ionizer feature which, when turned on, releases negative ions into outgoing filtered air to help the air purification process.

#### What Are Ions?

Ions are tiny particles that carry a positive or negative charge. They exist naturally around us: in the air, water, and ground. Both positive and negative ions are colorless, odorless, and harmless.

#### How Does The Ionizer Work?

Negative ions help air purification by attaching themselves to very small airborne particles in the room. These particles take on a negative charge and may join with positively charged particles such as dust, pollen, smoke, and pet dander to form larger particles. These larger particles are then more easily captured by the filter system.

### Important Notes:

Your ionizer may produce an occasional popping or cracking sound. This is normal and occurs when a small buildup of ions is discharged.

After extended use, you may notice dust around the grills or front panel. This is caused by negative ions exiting the air outlet, evidence of the ionizer's air cleaning effectiveness. You can remove the dust with a soft brush or clean, damp cloth.

Larger particles may be attracted to positively charged surfaces throughout the home, like walls or floors.

- This may occur more frequently when the filter is nearing the end of its useful product life and unable to capture as many charged particles.
- Excessive amounts of pet dander, dust, or smoke may decrease the life expectancy of the filter and interfere with the ionization process.

To help prevent particles from attracting to surfaces throughout your home:

- You may want to run the ionizer less often.
- Check the condition of the filter more frequently.

**CAUTION:** The ionizer in this appliance produces less ozone than the UL established limits of 50ppb. However, in high concentrations, ozone can be harmful to birds and small pets. To prevent ozone buildup, we suggest using the ionizer in well ventilated areas with the air purifier fan on.

### HIGH, MEDIUM AND LOW SPEED SETTINGS

For optimum air filtration, operate your Holmes® air purifier continuously on the MEDIUM (Med) setting. Its rugged motor has been designed to give many years of use. For quieter operation (such as in a bedroom), select the LOW (Lo) setting. When high levels of air pollution are present, select the HIGH (Hi) setting to quickly circulate and filter the room air.

### FILTER CHECK INDICATOR

Your Holmes Air Purifier includes Aer1® Allergen Performance Plus Filter, specially designed to improve air quality for allergy sufferers!! The Aer1® Allergen Performance Plus filter last for 12 months. See back panel for other filter options.

## FEATURES - OPERATIONS CLEANING / MAINTENANCE

The Filter Check Indicator light is designed to remind you to check and change your filter every 11 months. To reset the Filter Check Indicator, press and hold the Filter Reset Button for 3 seconds only under working mode.

### BEFORE USE

1. Carefully unpack your Air Purifier. Select a firm level place where there are no obstructions to the air inlet or filtered air outlet.
2. Remove the air inlet grill and check if the filter is covered by a plastic bag. If it is, remove plastic bag before use.
3. The carbon filter is packed in a plastic bag in the box. Remove plastic bag, use the provided Velcro to attach the carbon filter onto the Aer1® filter. Then, place all filters back into the unit, and reinstall the air inlet grill (see Fig. 1).
4. DO NOT POINT FILTERED AIR OUTLET TOWARDS WALL.

### OPERATING INSTRUCTIONS

1. Plug into a 120V AC electrical outlet.
2. Select the desired operating speed; HIGH (Hi), MEDIUM (Med), LOW (Lo), by turning Speed Control Knob to the appropriate setting. For optimum air filtration, it is recommended to operate the air purifier continuously. Its rugged motor has been designed to give many years of use.
3. To release negative ions into the filtered air, press the ionizer button (⊗) to ON and the button will illuminate in blue.  
**NOTE:** The ionizer will not work unless the unit is running.

### CLEANING / MAINTENANCE INSTRUCTIONS

1. Turn the air purifier off and unplug it before cleaning.
2. The outside of the air purifier can be cleaned with a soft, clean dampened cloth.
3. The air inlet grill (reference Fig. 1) can be removed and washed in warm soapy water (not dishwasher safe). Dry before replacing in the unit.
4. The filtered air outlet can be cleaned of dust with a small, soft brush.

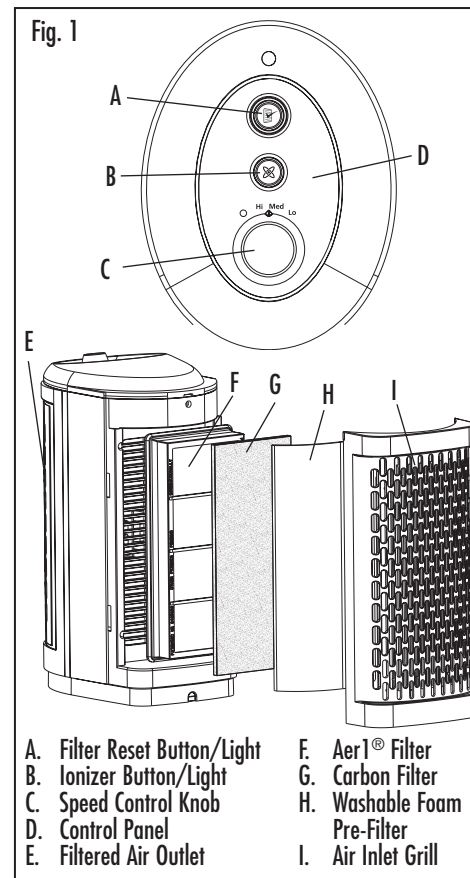

- A. Filter Reset Button/Light
- B. Ionizer Button/Light
- C. Speed Control Knob
- D. Control Panel
- E. Filtered Air Outlet
- F. Aer1® Filter
- G. Carbon Filter
- H. Washable Foam Pre-Filter
- I. Air Inlet Grill

5. If you wish to clean the inside of the air purifier, please only use a dry, soft cloth to wipe it down.  
**WARNING:** Do not allow moisture to come in contact with the main housing of the air purifier.

### FILTER REPLACEMENT INSTRUCTIONS

#### IMPORTANT:

- DO NOT attempt to wash and re-use the Aer1® Filters.
- If the filters are enclosed in plastic bags, remove them before use.

#### NOTE:

Every few weeks, check the condition of filter. Filter life

## FILTER REPLACEMENT

will vary, depending on air quality and usage (see below). Under normal conditions of continuous use, the Aer1® Total Air, Odor and Smoke Filter will last 4 months while the Allergen and Allergen Performance Plus Filter will last 12 months. Check the condition of the Carbon Filter for every 3-4 months and replace if needed. Carbon filter needs to be replaced every 60-90 days.

After approximately 11 months of operation, the Filter Check Indicator will light up to alert you to service the filters.

- This Filter Check indicator is to remind you to wash the foam pre-filter and replace your Aer1® Filter.

### To replace your filter:

1. Turn off and unplug the air purifier.
2. Open the air inlet grill and examine the black foam prefilter. Remove any dust or lint and wash in warm soapy water. Rinse, drip dry and place back into grill inlet.
3. Remove the used Aer1® filter from the unit by pulling it gently towards you and discard it. DO NOT attempt to clean the Aer1® filter.
4. To replace the carbon filter, simply remove the old carbon filter with the Velcro, and insert a new carbon filter in place after first removing the plastic bag. Using the new Velcro provided with the carbon filter to attach the new carbon filter onto the new Aer1® filter.

5. Install the new Aer1® filter into the unit.
6. Align the clip on the side of Aer1® filter with rails on the inside of the purifier unit. Gently slide the filter onto the rail. (Fig. 2)
7. Replace air inlet grill.
8. To reset the Filter Check Indicator, press and hold the Filter Reset Button for 3 seconds only under working mode when unit is powered on.

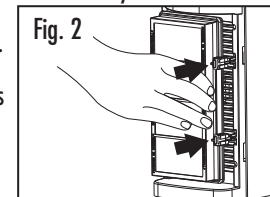

**NOTE:** Every time you power on the air purifier by selecting any speed setting, the Filter Check checks the current usage of the filter. If the filter timer has not reached the filter life, the indicator light will go off. If not, the indicator will remain lit until filter have been replaced and Filter Check Indicator ( ) has been reset (see instructions above).

Filters can be purchased at a retailer near you, online at [www.holmesproducts.com](http://www.holmesproducts.com).

Air Purifier Model Number	Filter Quantity Needed	Compatible with all filter models below	Filter Description
HAP702	1	HAPF30AT* HAPF30AO HAPF30AS HAPF300AH HAPF300AP (D filter) HAPF30 (A filter)	aer1® Total Air Filter aer1® Odor Filter aer1® Smoke Grabber Filter aer1® Allergen Remover Filter aer1® Allergen Performance Plus "D" Filter Holmes® "A" Filter
	1	BHOR31	Carbon Filter

\*HAPF30AT Come with the original box "HAPF30AT (equipped with this unit)"