

Owner's Manual & Safety Instructions

Save This Manual Keep this manual for the safety warnings and precautions, assembly, operating, inspection, maintenance and cleaning procedures. Write the product's serial number in the back of the manual near the assembly diagram (or month and year of purchase if product has no number). Keep this manual and the receipt in a safe and dry place for future reference.

20k

BauerTM

20112E-B

16" 14.5 AMP ELECTRIC CHAINSAW



Visit our website at: <http://www.harborfreight.com>
Email our technical support at: productsupport@harborfreight.com

57622

When unpacking, make sure that the product is intact and undamaged. If any parts are missing or broken, please call 1-888-866-5797 as soon as possible.

Copyright© 2020 by Harbor Freight Tools®. All rights reserved.
No portion of this manual or any artwork contained herein may be reproduced in any shape or form without the express written consent of Harbor Freight Tools. Diagrams within this manual may not be drawn proportionally. Due to continuing improvements, actual product may differ slightly from the product described herein.
Tools required for assembly and service may not be included.

⚠ WARNING

Read this material before using this product.
Failure to do so can result in serious injury.
SAVE THIS MANUAL.

Table of Contents

Safety	2	Maintenance	17
Specifications	8	Parts List and Diagram	22
Setup	8	Warranty	24
Operation	12		

SAFETY



SETUP

OPERATION

MAINTENANCE

WARNING SYMBOLS AND DEFINITIONS

	This is the safety alert symbol. It is used to alert you to potential personal injury hazards. Obey all safety messages that follow this symbol to avoid possible injury or death.
⚠ DANGER	Indicates a hazardous situation which, if not avoided, will result in death or serious injury.
⚠ WARNING	Indicates a hazardous situation which, if not avoided, could result in death or serious injury.
⚠ CAUTION	Indicates a hazardous situation which, if not avoided, could result in minor or moderate injury.
NOTICE CAUTION	Addresses practices not related to personal injury.

IMPORTANT SAFETY INFORMATION

General Power Tool Safety Warnings

⚠ WARNING

Read all safety warnings and all instructions.

Failure to follow the warnings and instructions may result in electric shock, fire and/or serious injury.

Save all warnings and instructions for future reference.

The term "power tool" in the warnings refers to your mains-operated (corded) power tool.

Work Area Safety

- 1. Keep work area clean and well lit.**
Cluttered or dark areas invite accidents.
- 2. Do not operate power tools in explosive atmospheres, such as in the presence of flammable liquids, gases or dust.** *Power tools create sparks which may ignite the dust or fumes.*
- 3. Keep children and bystanders away while operating a power tool.**
Distractions can cause you to lose control.

Electrical Safety

1. **Power tool plugs must match the outlet. Never modify the plug in any way. Do not use any adapter plugs with grounded power tools.** *Unmodified plugs and matching outlets will reduce risk of electric shock.*
2. **Avoid body contact with grounded surfaces such as pipes, radiators, ranges and refrigerators.** *There is an increased risk of electric shock if your body is grounded.*
3. **Do not expose power tools to rain or wet conditions.** *Water entering a power tool will increase the risk of electric shock.*
4. **Do not abuse the cord. Never use the cord for carrying, pulling or unplugging the power tool. Keep cord away from heat, oil, sharp edges or moving parts.** *Damaged or entangled cords increase the risk of electric shock.*
5. **When operating a power tool outdoors, use an extension cord suitable for outdoor use.** *Use of a cord suitable for outdoor use reduces the risk of electric shock.*
6. **If operating a power tool in a damp location is unavoidable, use a Ground Fault Circuit Interrupter (GFCI) protected supply.** *Use of a GFCI reduces the risk of electric shock.*

Personal Safety

1. **Stay alert, watch what you are doing and use common sense when operating a power tool. Do not use a power tool while you are tired or under the influence of drugs, alcohol or medication.** *A moment of inattention while operating power tools may result in serious personal injury.*
2. **Use personal protective equipment. Always wear eye protection.** *Protective equipment such as dust mask, non-skid safety shoes, hard hat, or hearing protection used for appropriate conditions will reduce personal injuries.*
3. **Prevent unintentional starting. Ensure the Trigger is in the off-position before connecting to power source, picking up or carrying the tool.** *Carrying power tools with your finger on the Trigger or energizing power tools that have the Trigger on invites accidents.*
4. **Do not overreach. Keep proper footing and balance at all times.** *This enables better control of the power tool in unexpected situations.*
5. **Dress properly. Do not wear loose clothing or jewelry. Keep your hair, clothing and gloves away from moving parts.** *Loose clothes, jewelry or long hair can be caught in moving parts.*
6. **If devices are provided for the connection of dust extraction and collection facilities, ensure these are connected and properly used.** *Use of dust collection can reduce dust-related hazards.*
7. **Only use safety equipment that has been approved by an appropriate standards agency.** *Unapproved safety equipment may not provide adequate protection. Eye protection must be ANSI-approved and breathing protection must be NIOSH-approved for the specific hazards in the work area.*

Power Tool Use and Care

1. **Do not force the power tool. Use the correct power tool for your application.** *The correct power tool will do the job better and safer at the rate for which it was designed.*
2. **Do not use the power tool if the Trigger does not turn it on and off.** *Any power tool that cannot be controlled with the Trigger is dangerous and must be repaired.*
3. **Disconnect the plug from the power source before making any adjustments, changing accessories, or storing power tools.** *Such preventive safety measures reduce the risk of starting the power tool accidentally.*
4. **Store idle power tools out of the reach of children and do not allow persons unfamiliar with the power tool or these instructions to operate the power tool.** *Power tools are dangerous in the hands of untrained users.*
5. **Maintain power tools. Check for misalignment or binding of moving parts, breakage of parts and any other condition that may affect the power tool's operation. If damaged, have the power tool repaired before use.** *Many accidents are caused by poorly maintained power tools.*

6. **Keep cutting tools sharp and clean.** *Properly maintained cutting tools with sharp cutting edges are less likely to bind and are easier to control.*

7. **Use the power tool, accessories and tool bits etc. in accordance with these instructions, taking into account the working conditions and the work to be performed.** *Use of the power tool for operations different from those intended could result in a hazardous situation.*

Service

Have your power tool serviced by a qualified repair person using only identical replacement parts.

This will ensure that the safety of the power tool is maintained.

Chain Saw Safety Warnings

1. **Keep all parts of the body away from the saw chain when the chain saw is operating. Before you start the chain saw, make sure the saw chain is not contacting anything.** *A moment of inattention while operating chain saws may cause entanglement of your clothing or body with the saw chain.*
2. **Always hold the chain saw with your right hand on the rear handle and your left hand on the front handle.** Holding the chain saw with a reversed hand configuration increases the risk of personal injury and should never be done.
3. **Hold the power tool by insulated gripping surfaces only, because the saw chain may contact hidden wiring or its own cord.** *Saw chains contacting a "live" wire may make exposed metal parts of the power tool "live" and could give the operator an electric shock.*
4. **Wear safety glasses and hearing protection. Further protective equipment for head, hands, legs and feet is recommended.** *Adequate protective clothing will reduce personal injury by flying debris or accidental contact with the saw chain.*
5. **Do not operate a chain saw in a tree.** *Operation of a chain saw while up in a tree may result in personal injury.*
6. **Always keep proper footing and operate the chain saw only when standing on fixed, secure and level surface.** *Slippery or unstable surfaces such as ladders may cause a loss of balance or control of the chain saw.*
7. **When cutting a limb that is under tension be alert for spring back.** *When the tension in the wood fibres is released the spring loaded limb may strike the operator and/or throw the chain saw out of control.*
8. **Use extreme caution when cutting brush and saplings.** *The slender material may catch the saw chain and be whipped toward you or pull you off balance.*
9. **Carry the chain saw by the front handle with the chain saw switched off and away from your body. When transporting or storing the chain saw always fit the guide bar cover.** *Proper handling of the chain saw will reduce the likelihood of accidental contact with the moving saw chain.*
10. **Follow instructions for lubricating, chain tensioning and changing accessories.** *Improperly tensioned or lubricated chain may either break or increase the chance for kickback.*
11. **Keep handles dry, clean, and free from oil and grease.** *Greasy, oily handles are slippery causing loss of control.*
12. **Cut wood only. Do not use chain saw for purposes not intended. For example: do not use chain saw for cutting plastic, masonry or non-wood building materials.** *Use of the chain saw for operations different than intended could result in a hazardous situation.*
13. **Causes and operator prevention of kickback:**

Kickback may occur when the nose or tip of the guide bar touches an object, or when the wood closes in and pinches the saw chain in the cut.

Tip contact in some cases may cause a sudden reverse reaction, kicking the guide bar up and back towards the operator.

Pinching the saw chain along the top of the guide bar may push the guide bar rapidly back towards the operator.

Either of these reactions may cause you to lose control of the saw which could result in serious personal injury. Do not rely exclusively upon the safety devices built into your saw. As a chain saw user, you should take several steps to keep your cutting jobs free from accident or injury.

Kickback is the result of tool misuse and/or incorrect operating procedures or conditions and can be avoided by taking proper precautions as given below:

- a. **Maintain a firm grip, with thumbs and fingers encircling the chain saw handles, with both hands on the saw and position your body and arm to allow you to resist kickback forces.** *Kickback forces can be controlled by the operator, if proper precautions are taken. Do not let go of the chain saw.*

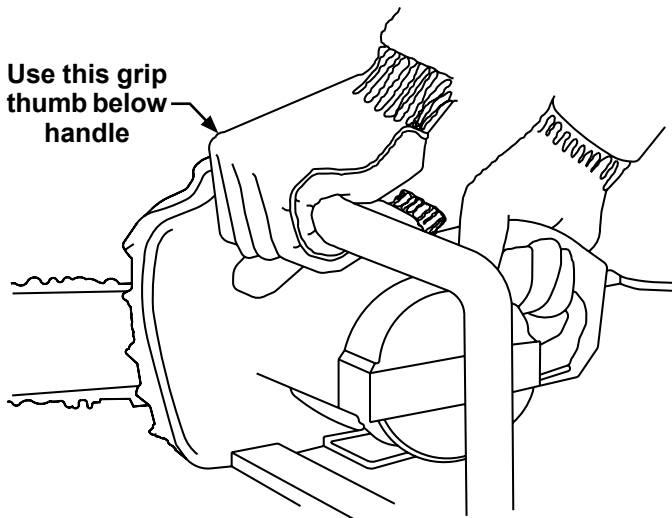

Figure A: Holding the Chain Saw

- b. **Do not overreach and do not cut above shoulder height.** *This helps prevent unintended tip contact and enables better control of the chain saw in unexpected situations.*
- c. **Only use replacement bars and chains specified by the manufacturer.** *Incorrect replacement bars and chains may cause chain breakage and/or kickback.*
- d. **Follow the manufacturer's sharpening and maintenance instructions for the saw chain.** *Decreasing the depth gauge height can lead to increased kickback.*

14. **Maintain labels and nameplates on the tool.** These carry important safety information. If unreadable or missing, contact Harbor Freight Tools for a replacement.
15. **Avoid unintentional starting.** Prepare to begin work before turning on the tool.
16. **Do not leave the tool unattended when it is plugged into an electrical outlet.** Turn off the tool, and unplug it from its electrical outlet before leaving.
17. **This product is not a toy.** Keep it out of reach of children.
18. **People with pacemakers should consult their physician(s) before use.** Electromagnetic fields in close proximity to heart pacemaker could cause pacemaker interference or pacemaker failure. In addition, people with pacemakers should:
 - Avoid operating alone.
 - Do not use with Trigger locked on.
 - Properly maintain and inspect to avoid electrical shock.
 - Properly ground power cord. Ground Fault Circuit Interrupter (GFCI) should also be implemented – it prevents sustained electrical shock.
19. **The warnings, precautions, and instructions discussed in this instruction manual cannot cover all possible conditions and situations that may occur.** It must be understood by the operator that common sense and caution are factors which cannot be built into this product, but must be supplied by the operator.



SAVE THESE INSTRUCTIONS.

⚠ WARNING



TO PREVENT ELECTRIC SHOCK AND DEATH FROM INCORRECT GROUNDING WIRE CONNECTION:

Check with a qualified electrician if you are in doubt as to whether the outlet is properly grounded. Do not modify the power cord plug provided with the tool. Never remove the grounding prong from the plug. Do not use the tool if the power cord or plug is damaged. If damaged, have it repaired by a service facility before use. If the plug will not fit the outlet, have a proper outlet installed by a qualified electrician.

Grounded Tools: Tools with Three Prong Plugs

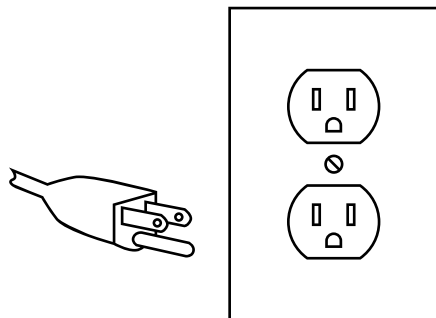

3-Prong Plug and Outlet

1. Tools marked with "Grounding Required" have a three wire cord and three prong grounding plug. The plug must be connected to a properly grounded outlet. If the tool should electrically malfunction or break down, grounding provides a low resistance path to carry electricity away from the user, reducing the risk of electric shock. **(See 3-Prong Plug and Outlet.)**

2. The grounding prong in the plug is connected through the green wire inside the cord to the grounding system in the tool. The green wire in the cord must be the only wire connected to the tool's grounding system and must never be attached to an electrically "live" terminal. **(See 3-Prong Plug and Outlet.)**
3. The tool must be plugged into an appropriate outlet, properly installed and grounded in accordance with all codes and ordinances. The plug and outlet should look like those in the preceding illustration. **(See 3-Prong Plug and Outlet.)**

Double Insulated Tools: Tools with Two Prong Plugs

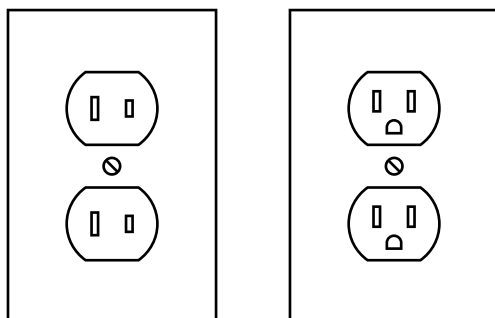

Outlets for 2-Prong Plug

1. Tools marked "Double Insulated" do not require grounding. They have a special double insulation system which satisfies OSHA requirements and complies with the applicable standards of Underwriters Laboratories, Inc., the Canadian Standard Association, and the National Electrical Code.
2. Double insulated tools may be used in either of the 120 volt outlets shown in the preceding illustration. **(See Outlets for 2-Prong Plug.)**

Extension Cords

1. **Grounded** tools require a three wire extension cord. **Double Insulated** tools can use either a two or three wire extension cord.
2. As the distance from the supply outlet increases, you must use a heavier gauge extension cord. Using extension cords with inadequately sized wire causes a serious drop in voltage, resulting in loss of power and possible tool damage. (See Table A.)
3. The smaller the gauge number of the wire, the greater the capacity of the cord. For example, a 14 gauge cord can carry a higher current than a 16 gauge cord. (See Table A.)
4. When using more than one extension cord to make up the total length, make sure each cord contains at least the minimum wire size required. (See Table A.)
5. If you are using one extension cord for more than one tool, add the nameplate amperes and use the sum to determine the required minimum cord size. (See Table A.)
6. If you are using an extension cord outdoors, make sure it is marked with the suffix "W-A" ("W" in Canada) to indicate it is acceptable for outdoor use.

7. Make sure the extension cord is properly wired and in good electrical condition. Always replace a damaged extension cord or have it repaired by a qualified electrician before using it.
8. Protect the extension cords from sharp objects, excessive heat, and damp or wet areas.

TABLE A: RECOMMENDED MINIMUM WIRE GAUGE FOR EXTENSION CORDS* (120/240 VOLT)

NAMEPLATE AMPERES (at full load)	EXTENSION CORD LENGTH				
	25'	50'	75'	100'	150'
0 – 2.0	18	18	18	18	16
2.1 – 3.4	18	18	18	16	14
3.5 – 5.0	18	18	16	14	12
5.1 – 7.0	18	16	14	12	12
7.1 – 12.0	18	14	12	10	-
12.1 – 16.0	14	12	10	-	-
16.1 – 20.0	12	10	-	-	-

* Based on limiting the line voltage drop to five volts at 150% of the rated amperes.

Symbology

	Double Insulated
	Intertek Testing Services NA, Inc.
V	Volts
~	Alternating Current
A	Amperes
n ₀ xxxx/min.	No Load Revolutions per Minute (RPM)
	WARNING marking concerning Risk of Eye Injury. Wear ANSI-approved safety goggles with side shields.
	Read the manual before set-up and/or use.
	WARNING marking concerning Risk of Fire. Do not cover ventilation ducts. Keep flammable objects away.

	WARNING marking concerning Risk of Electric Shock. Properly connect power cord to appropriate outlet.
	WARNING marking concerning Risk of Kickback. Contact of the guide bar tip with any object should be avoided.
	WARNING marking concerning Risk of Kickback. Tip contact can cause the guide bar to move suddenly upward and backward, which can cause serious injury.
	WARNING marking concerning Risk of Loss of Control. Do not operate the chain saw with only one hand.
	WARNING marking concerning Risk of Loss of Control. Always use two hands when operating the chain saw.
	WARNING marking concerning Saw Chain Orientation. Cutters must face in direction of rotation.

Specifications

Electrical Rating	120 VAC / 60 Hz / 14.5A	
Motor Speed	5800 RPM (No Load)	
Lubrication	Type	Bar and chain oil
	Capacity	6.8 fl oz (200 ml)
Cutting Attachment	16" Sprocket Nose Chain Guide Bar Low-Kickback Full Skip Chain Pitch: 3/8" Gauge: 0.050" # of links: 57	

Note: This electric chain saw is for cutting small logs and for lighter weight trimming jobs. A more powerful chain saw may be needed for heavy duty use.

Setup - Before Use:



Read the **ENTIRE IMPORTANT SAFETY INFORMATION** section at the beginning of this manual including all text under subheadings therein before set up or use of this product.

Note: For additional information regarding the parts listed in the following pages, refer to *Parts List and Diagram* on page 22.

Safety Device Explanation

1. Hand Guard—A guard that protects your hand on the Front Handle from the Saw Chain.
2. Chain Brake—A mechanical braking device designed to quickly stop the Chainsaw and Chain in the event of kickback. If kickback occurs, this safety feature is activated when the operator's hand strikes the Hand Guard / Chain Brake Lever and pushes it forward, stopping the Chain.
3. Trigger Lockout—A movable stop that prevents the unintentional operation of the Trigger until manually activated.
4. Low-Kickback Chain—A chain that complies with the kickback performance requirements of ANSI B175.1-1991 when tested on a representative sample of chain saws.

Components and Controls

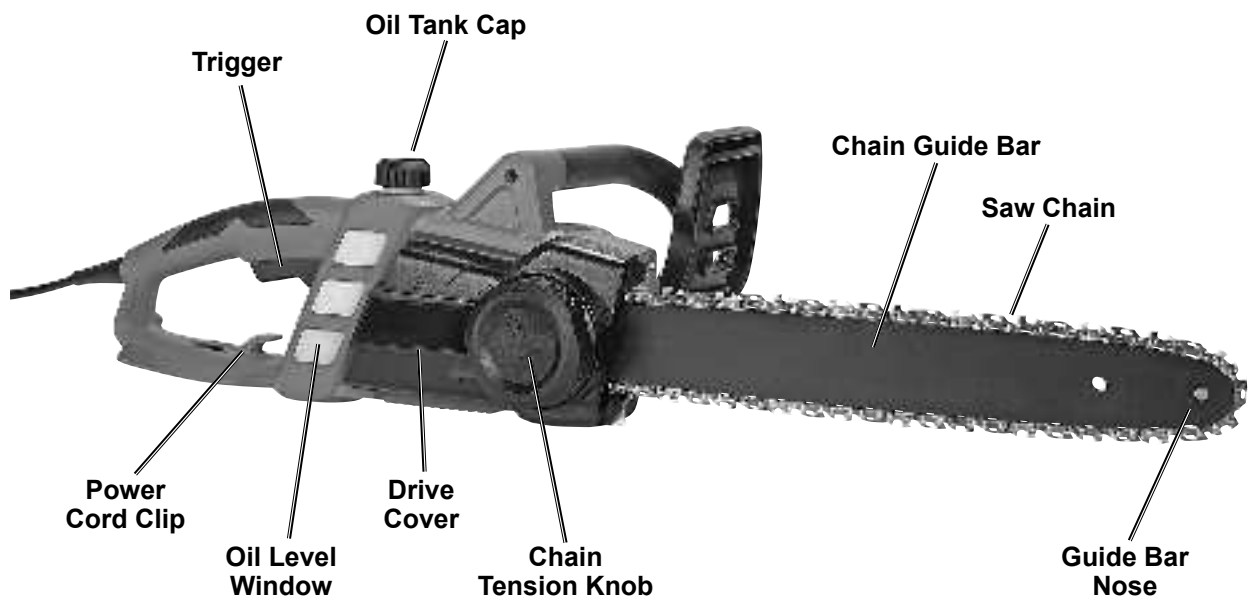
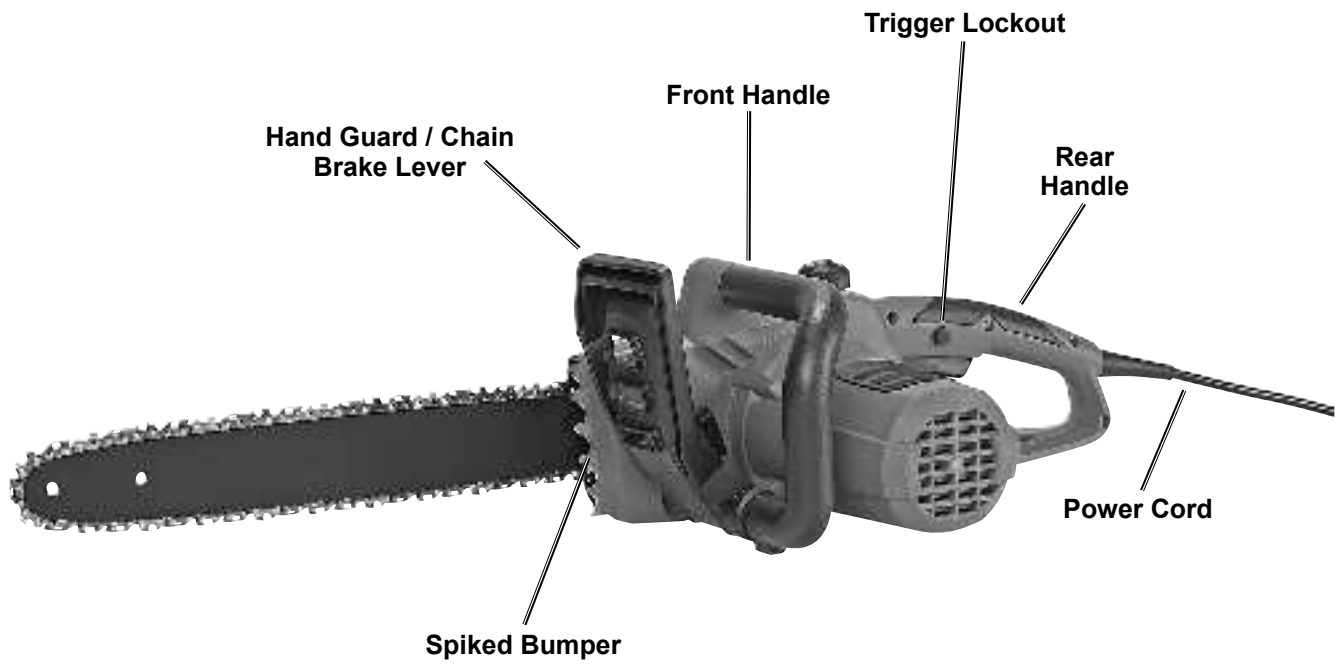

SAFETY

SETUP

OPERATION

MAINTENANCE

Guide Bar and Saw Chain Installation and Adjustment

SAFETY

SETUP

OPERATION

MAINTENANCE

⚠ WARNING

TO PREVENT SERIOUS INJURY FROM ACCIDENTAL OPERATION:

Make sure that the Trigger is in the off-position and unplug the tool from its electrical outlet before performing any procedure in this section.

Note: New Saw Chains often need to be tensioned several times during first use. Check a new Saw Chain's tension often when first using.

Follow the directions in the following sections for installing the Guide Bar and Saw Chain, for checking and adjusting Saw Chain tension, and for replacing the Saw Chain when necessary.

Guide Bar/Saw Chain Installation/Replacement

⚠ WARNING

Do not install a Saw Chain or Chain Guide Bar other than the size and type provided and listed in the Specifications Chart on page 8.

1. Soak the new Saw Chain overnight in Bar and Chain Oil (sold separately).
2. Loosen the Chain Tension Knob by turning counterclockwise and remove the Drive Cover.
3. If it is not already connected, attach the Bar Support Plate securely using the Screw through one of the holes in the Guide Bar.
4. Place the Saw Chain over the Guide Bar. The cutters of the Saw Chain must face away from the Chainsaw along the top edge of the Guide Bar. Fit the Chain links into the groove around the Guide Bar. Make sure the Bar Support Plate is facing outward.

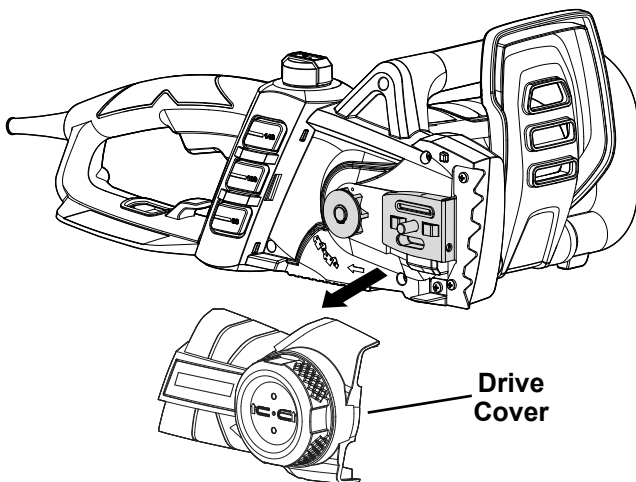

Figure B: Remove Drive Cover

3. If it is not already connected, attach the Bar Support Plate securely using the Screw through one of the holes in the Guide Bar.

WARNING! TO PREVENT SERIOUS INJURY: The Bar Support Plate is critical to allow the Guide Bar to properly tighten in place.

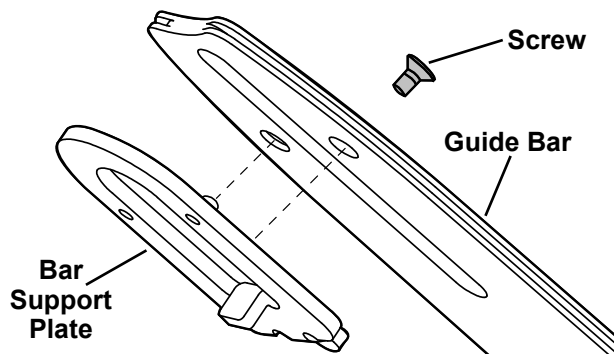

Figure C: Attach Bar Support Plate

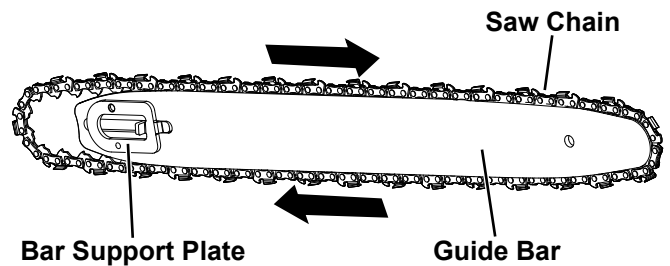
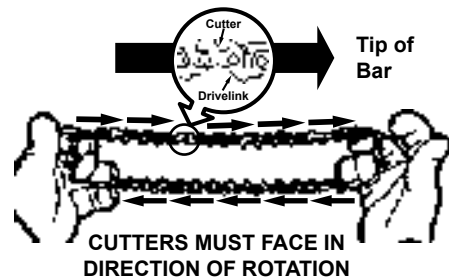

Figure D: Place Saw Chain



CUTTERS MUST FACE IN DIRECTION OF ROTATION

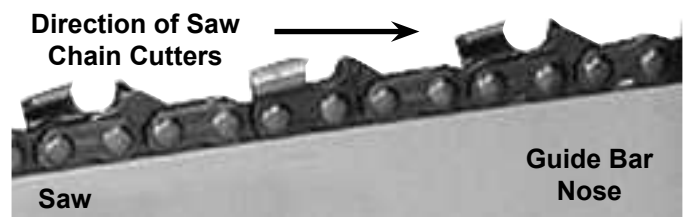
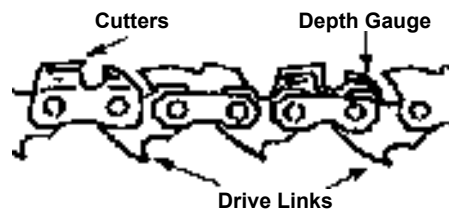

Figure E: Saw Chain Orientation

- Place the slotted end of the Chain Guide Bar over the two bar locating tabs and Guide Bar Bolt on the Press Block and place the Saw Chain over the Drive Sprocket. The Bar Support Plate must be on the outside of the Guide Bar. Check again that the Saw Chain cutters are aligned properly and the Saw Chain drive links are seated completely in the slot of the Guide Bar.

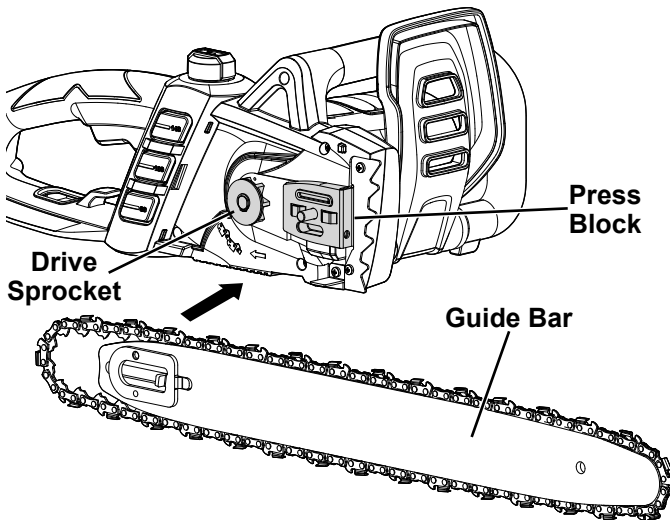

Figure F: Installing Chain Guide Bar

- Replace the Drive Cover. Using a gloved hand, pull Guide Bar forward **firmly** before tightening Chain Tension Knob clockwise **just until it is snug**.

Checking Saw Chain Tension

- Before using, check the Saw Chain tension.
- While wearing heavy-duty gloves, use your index finger and thumb to carefully grab the Saw Chain in the middle section under the Chain Guide Bar.
- Pull the Saw Chain away from the Guide Bar.
- The Saw Chain should snap back against the Guide Bar. The Chain should fit snugly in the groove of the Chain Guide Bar, yet you should still be able to slide the chain along the Chain Guide Bar by hand.
- There should be no sagging between the Guide Bar and Saw Chain on the *underside* of the Guide Bar.

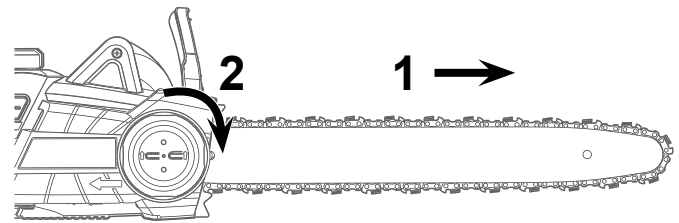

Figure G: Pull Guide Bar Forward

- Find a solid surface that will not damage the Saw Chain or Guide Bar. Rotate the Chainsaw so that the Guide Bar is **pressed firmly** against the surface. While under pressure, tighten the Chain Tension Knob securely.

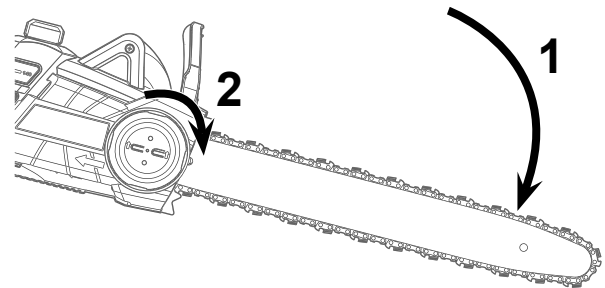

Figure H: Apply Pressure to Guide Bar Before Final Tightening

- After final tightening, check Saw Chain tension as explained in *Checking Saw Chain Tension* below to make sure it is properly adjusted.
- To retension Chain, turn the Chain Tension Knob counterclockwise three full turns, then retighten the Knob by repeating steps 6–8 above to reset the chain tension.

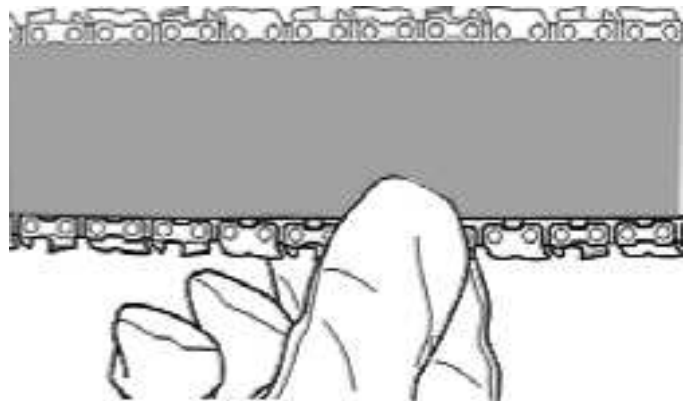

Figure I: Checking Saw Chain Tension

Operating Instructions



Read the **ENTIRE IMPORTANT SAFETY INFORMATION** section at the beginning of this manual including all text under subheadings therein before set up or use of this product.

SAFETY

Workpiece and Work Area Set Up

1. Designate a work area that is clean and well lit. The work area must not allow access by children or pets to prevent distraction and injury.
2. Route the extension cord along a safe route to reach the work area without creating a tripping hazard or exposing the extension cord to possible damage. The extension cord must reach the work area with enough extra length to allow free movement while working. Position the cord so that it will not be caught on branches and the like during cutting.
3. Secure the extension cord by snapping it in the Power Cord Clip so there will be no tension on the connection between the Power Cord and the extension cord.
4. There must not be objects, such as utility lines, nearby that will present a hazard while working.
5. Attach to outlet using a Residual Current Device or Ground Fault Circuit Interrupter (GFCI) with a tripping current of 30 mA or less.
6. A first-time user should, as a minimum practice, cut logs on a saw-horse or cradle before cutting down trees.

SETUP

Instructions concerning the proper techniques for basic felling, limbing, and cross-cutting

Felling a Tree

When bucking and felling operations are being performed by two or more persons at the same time, the felling operations should be separated from the bucking operation by a distance of at least twice the height of the tree being felled. Trees should not be felled in a manner that would endanger any person, strike any utility line or cause any property damage. If the tree does make contact with any utility line, the company should be notified immediately.

The chain saw operator should keep on the uphill side of the terrain as the tree is likely to roll or slide downhill after it is felled.

An escape path should be planned and cleared as necessary before cuts are started. The escape path should extend back and diagonally to the rear of the expected line of fall as illustrated in Figure J.

Before felling is started, consider the natural lean of the tree, the location of larger branches and the wind direction to judge which way the tree will fall.

Remove dirt, stones, loose bark, nails, staples and wire from the tree.

OPERATION

MAINTENANCE

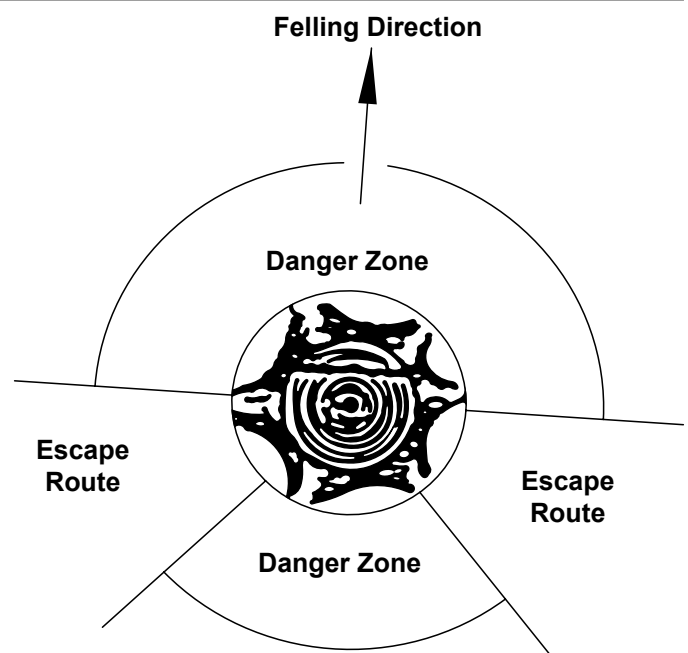

Figure J: Escape Routes

Notching Undercut

Make the notch 1/3 the diameter of the tree, perpendicular to the direction of falls as illustrated in Figure K.

Make the lower horizontal notching cut first. This will help to avoid pinching either the saw chain or the guide bar when the second notch is being made.

Felling Back Cut

Make the felling back cut at least 2 inches higher than the horizontal notching cut as illustrated in Figure K. Keep the felling back cut parallel to the horizontal notching cut. Make the felling back cut so enough wood is left to act as a hinge. The hinge wood keeps the tree from twisting and falling in the wrong direction. Do not cut through the hinge.

As the felling gets close to the hinge, the tree should begin to fall. If there is any chance that the tree may not fall in desired direction or it may rock back and bind the saw chain, stop cutting before the felling back cut is complete and use wedges of wood, plastic or aluminium to open the cut and drop the tree along the desired line of fall.

When the tree begins to fall remove the chain saw from the cut, stop the motor, put the chain saw down, then use the retreat path planned. Be alert for overhead limbs falling and watch your footing.

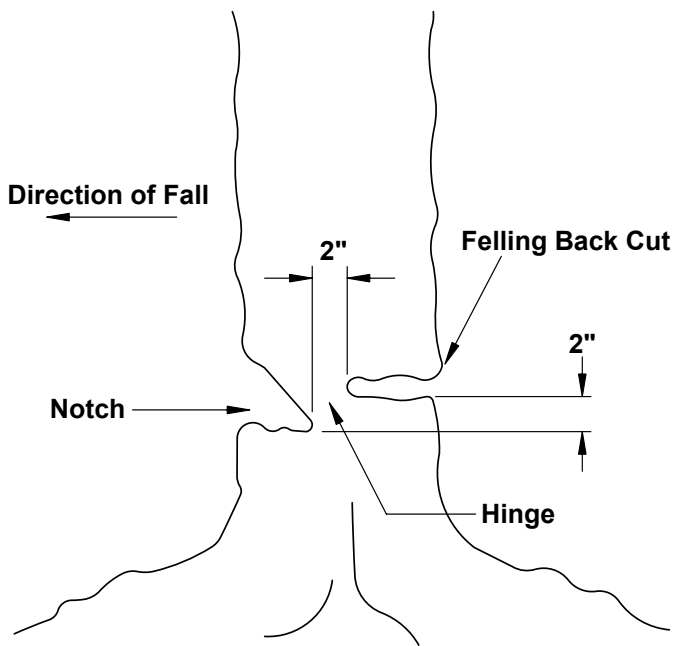
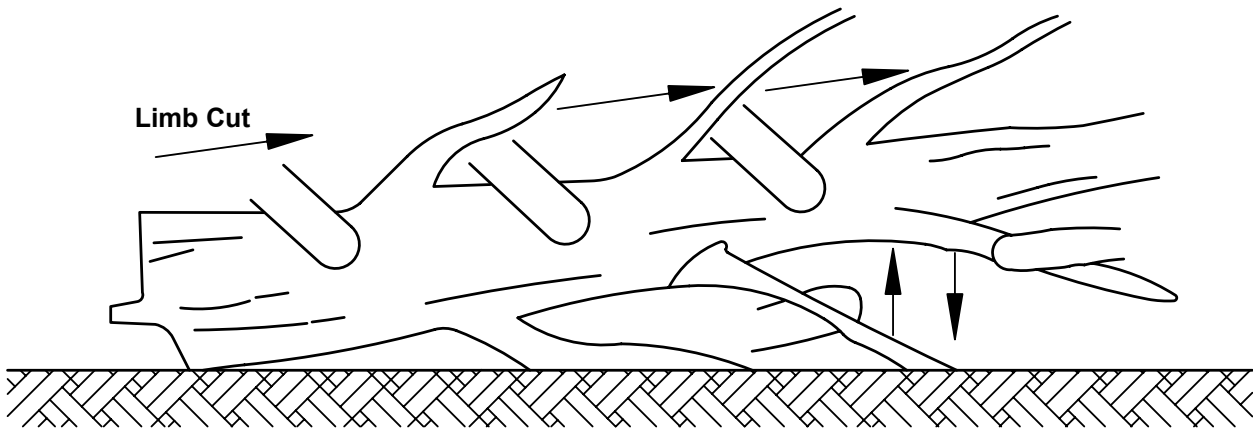

Figure K: Undercutting

Limbing a Tree

Limbing is removing the branches from a fallen tree. When limbing leave larger lower limbs to support the log off the ground. Remove the small limbs in one cut as illustrated in. Branches under tension should be cut from the bottom up to avoid binding the chain saw.



Keep work off ground leave support limbs until log is cut

Figure L: Tree Limbing

Bucking a Log

Bucking is cutting a log into lengths. It is important to make sure your footing is firm and your weight is evenly distributed on both feet. When possible, the log should be raised and supported by the use of limbs, logs or chocks. Follow the simple directions for easy cutting.

When the log is supported along its entire length as illustrated in Figure M, it is cut from the top (overbuck).

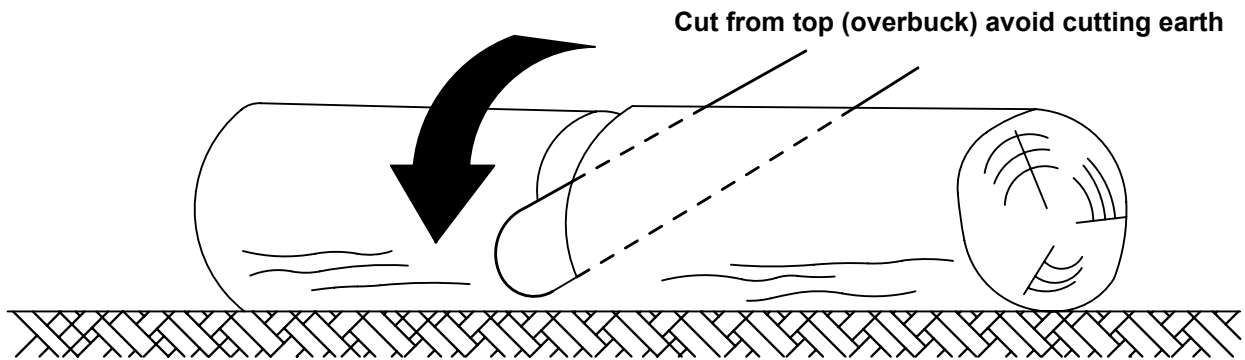

Figure M: Log Supported Along the Entire Length

When the log is supported on one end, as illustrated in Figure N, cut 1/3 the diameter from the underside (underbuck).

Then make the finished cut by overbucking to meet the first cut.

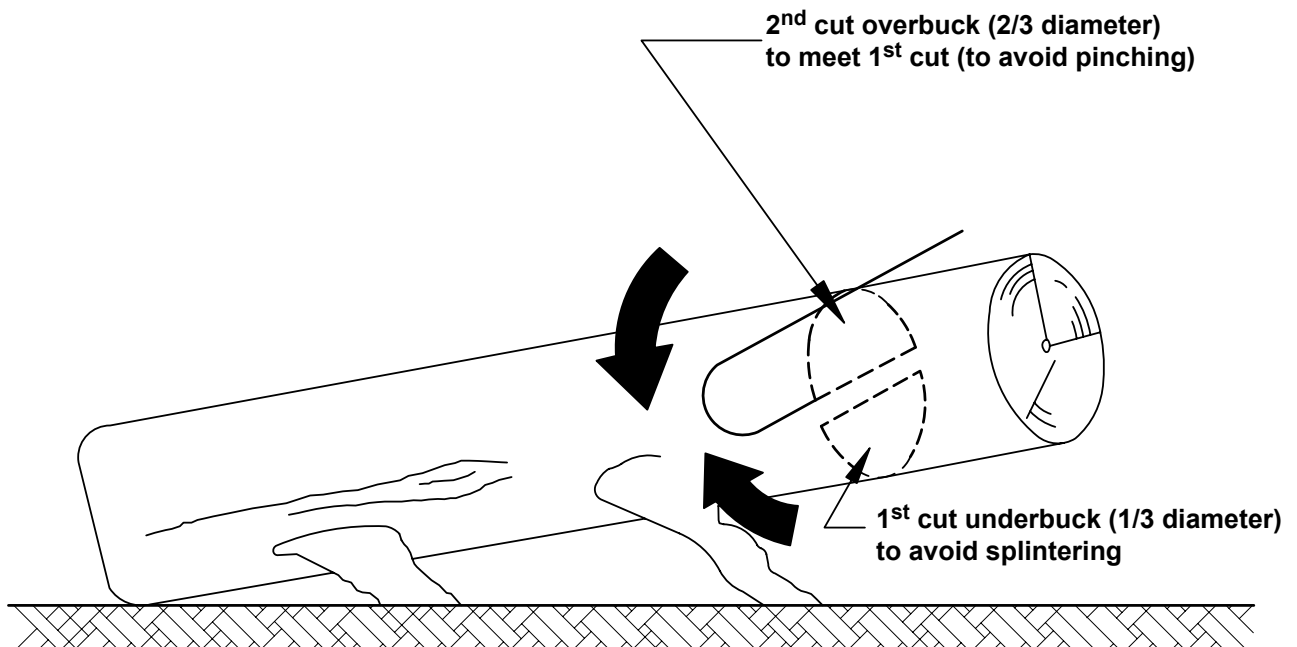

Figure N: Log Supported One End

Bauer[™]

Bucking a Log (continued)

When the log is supported on both ends, as illustrated in Figure O, cut 1/3 the diameter from the top (overbuck). Then make the finished cut by underbucking the lower 2/3 to meet the first cut.

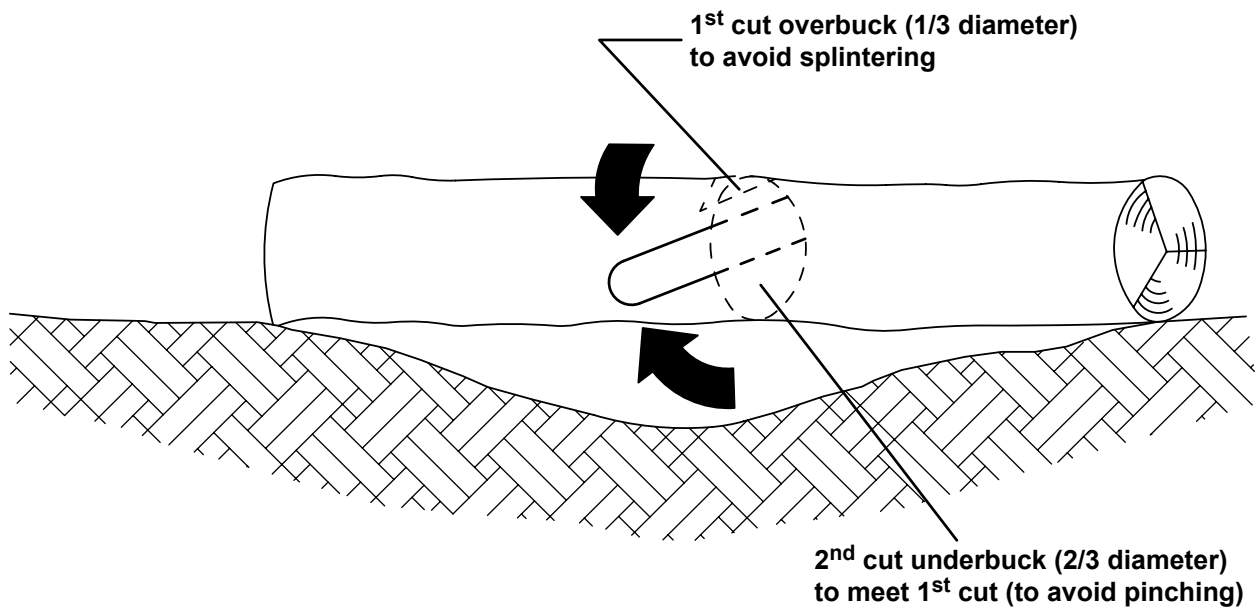
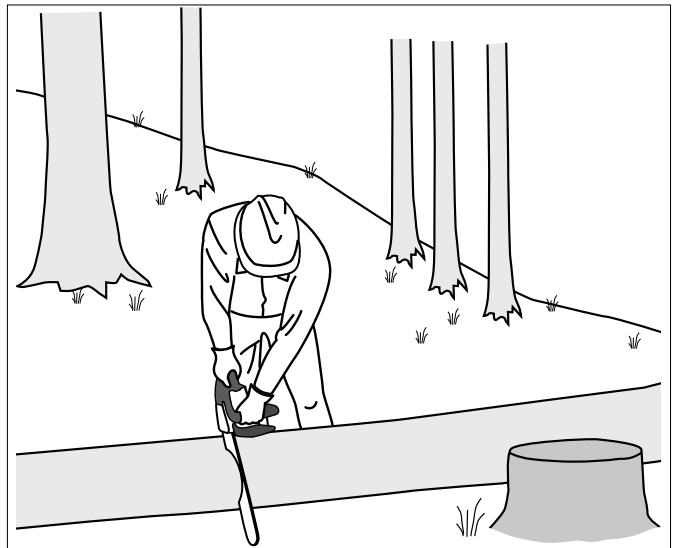

Figure O: Log Supported Both Ends

When bucking on a slope always stand on the uphill side of the log, as illustrated in Figure P. When "cutting through", to maintain complete control release the cutting pressure near the end of the cut without relaxing your grip on the chain saw handles. Don't let the chain contact the ground. After completing the cut, wait for the saw chain to stop before you move the chain saw. Always stop the motor before moving from tree to tree.



Stand on uphill side when cutting because log may roll

Figure P: Bucking a Log

Bauer™

General Operating Instructions

SAFETY

1. Before first use and before each use thereafter, remove the Oil Tank Cap. Inspect the Cap Gasket for damage. Fill the oil reservoir to just below fill plug with oil (not included). Refer to *Specifications Chart* on page 8 for oil type. Then replace the Oil Tank Cap. Oil is automatically applied to the Saw Chain during operation.
2. Make sure that the Trigger is in the off-position, then connect the outdoor rated extension cord (not included) to the Power Cord. Make sure the electrical cord is away from the cutting area.
3. Place the Hand Guard/Chain Brake Lever in normal operating (disengaged) position by pulling the Hand Guard back toward the Handle. Refer to Figure Q.

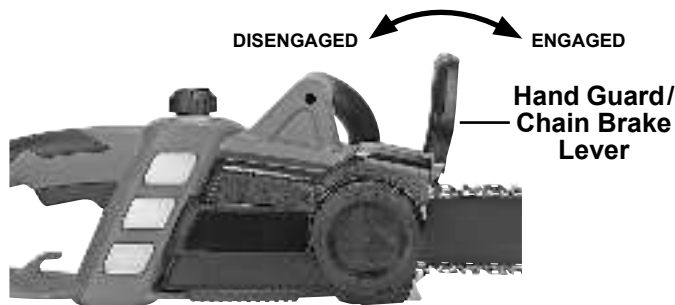

Figure Q: Chain Brake

NOTE: The Chainsaw will not operate unless the Hand Guard/Chain Brake Lever is in the disengaged position.

4. Grasp the Handles with both hands. Always grip the handle with the thumb and fingers encircling the handle as shown.

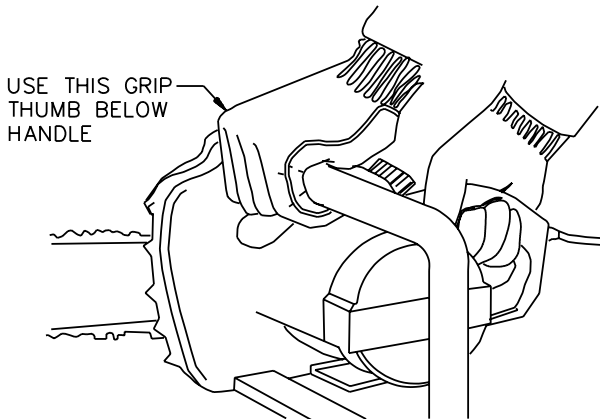

Figure R: Holding the Chain Saw

Note: Front Handle Guard not shown.

5. Stand in front of the wood to be cut with your feet firmly in place.
6. Push the Trigger Lockout button completely in, then squeeze and hold the Trigger. With the Chain Saw running, you may release pressure on the Lockout button. Releasing the Trigger will stop the motor.

NOTE: The Trigger cannot be activated unless the Trigger Lockout button is depressed.

DANGER! To prevent serious injury and death from kickback: Do not touch the Guide Bar Nose to the wood.

7. When the Chain Saw reaches full speed, begin cutting with a light, downward pressure against the bottom mid-section of the Saw Chain. Allow the Saw Chain to cut at its own rate. Applying too much pressure can damage the tool.

DANGER! To prevent serious injury and death when cutting loose, round wood stock, place the wood stock on a sawhorse, in a cradle, or use a timberjack (all sold separately) to avoid grabbing and throw back.

8. To prevent accidents, turn off the tool, unplug it, and place the Hand Guard / Chain Brake Lever forward in its engaged position after use.

9. When the Saw has cooled completely, clean thoroughly and cover the Chain Guide Bar with the Chain Guide Bar Sheath. Store the tool indoors out of children's reach.

SETUP

OPERATION

MAINTENANCE

Maintenance and Servicing



Procedures not specifically explained in this manual must be performed only by a qualified technician.

⚠️ WARNING

TO PREVENT SERIOUS INJURY FROM ACCIDENTAL OPERATION: Make sure that the Trigger is in the off-position and unplug the tool from its electrical outlet before performing any procedure in this section.

TO PREVENT SERIOUS INJURY FROM TOOL FAILURE: Do not use damaged equipment. If abnormal noise or vibration occurs, have the problem corrected before further use.

Cleaning, Maintenance, and Lubrication

- BEFORE EACH USE**, inspect the general condition of the tool. Check for:
 - loose hardware
 - misalignment or binding of moving parts
 - damaged cord/electrical wiring
 - cracked or broken parts
 - dull or damaged Saw Chain
 - any other condition that may affect its safe operation.
 - BEFORE FIRST USE AND BEFORE EACH USE THEREAFTER**, make sure the Oil Tank is filled with oil (not included). Refer to *Specifications Chart* on page 8 for oil type.
 - IF THE SAW CHAIN BECOMES LOOSE**, adjust the Saw Chain tension as described under *Guide Bar/Saw Chain Installation/Replacement* on page 10.
 - PERIODICALLY OR WHEN REPLACING SAW CHAIN**, turn the Chain Guide Bar over to distribute the wear on it. When doing this, the Bar Support Plate will need to be remounted to the other side of the Guide Bar. Replace the Guide Bar when bent, cracked, or when the Saw Chain moves excessively from side to side on the Guide Bar due to wear. Refer to *Chain Guide Bar Care* on page 18.
- WARNING! TO PREVENT SERIOUS INJURY: Replace the Saw Chain and Guide Bar only with an identical Saw Chain and Guide Bar.**
- AFTER USE**, wipe the outside surface of the Chain Saw with a clean, dry cloth. If necessary use a mild detergent. Do not use solvents. Do not immerse this tool in liquid.
 - ⚠️ WARNING! TO PREVENT SERIOUS INJURY: If the supply cord of this power tool is damaged, it must be replaced only by a qualified service technician.**

Sharpening/Replacing the Saw Chain

WARNING! TO PREVENT SERIOUS INJURY: Wear heavy-duty work gloves when handling the Saw Chain.

1. For smooth and safe operation, always keep the Saw Chain cutters sharp.
2. Have the cutters sharpened by a qualified technician when you notice any of the following symptoms:
 - a. The sawdust becomes powder-like.
 - b. You can't make the cut without extra force.
 - c. The Chain Saw does not cut straight.
 - d. Vibration increases.
3. A Saw Chain that is damaged or too worn to be restored to a useable condition by sharpening will need to be replaced. Refer to *Guide Bar/Saw Chain Installation/Replacement* on page 10.

WARNING! TO PREVENT SERIOUS INJURY: Replace the Saw Chain only with an identical Saw Chain.

Chain Guide Bar Care

1. Remove the Chain Guide Bar periodically to clean and lubricate.
2. Deburr rails of Guide Bar as needed. Use a flat file to make side edges square.
3. Remove sawdust and sap from the Bar Groove using a Guide Bar cleaning tool (sold separately), then lubricate the nose sprocket at the ports with grease.
5. The rails of the Guide Bar groove should always be parallel to each other. Place a ruler along the surface of the Guide Bar and Saw Chain. If there is a gap, the bar is normal.

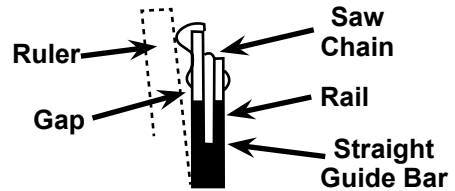

Figure T: Normal Guide Bar

If the ruler is flush with the Guide Bar and Saw Chain, or the Chain tilts to one side, then the Bar is worn and needs to be replaced.

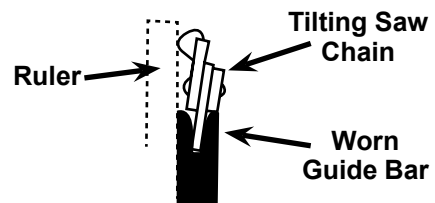

Figure U: Worn Guide Bar

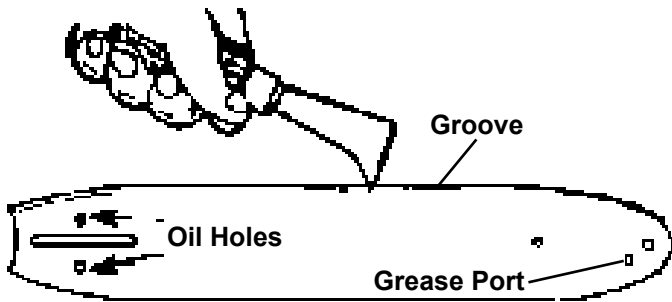

Figure S: Cleaning and Lubricating Guide Bar

4. Reverse the Guide Bar when replacing the Saw Chain to prevent uneven wear. When doing this, the Bar Support Plate will need to be remounted to the other side of the Guide Bar.

Cleaning, Maintenance, and Lubrication Schedule

Note: This maintenance schedule is intended solely as a general guide. If performance decreases or if equipment operates unusually, check systems immediately. The maintenance needs of each piece of equipment will differ depending on factors such as duty cycle, temperature, air quality, and other factors. If you have doubts about your ability to safely service this tool, have a qualified technician service the equipment instead.

Periodic Maintenance or When Replacing Saw Chain:

- a. Clean and lubricate Chain Guide Bar and turn over. When doing this, the Bar Support Plate will need to be remounted to the other side of the Guide Bar.
- b. Deburr Guide Bar as needed.
- c. Check Chain Sprocket for wear or damage.

Monthly Maintenance:

Clean Chain Oil Tank.

If Worn or Damaged:

- a. Replace Chain Guide Bar if it becomes worn, bent or damaged. When doing this, the Bar Support Plate will need to be remounted to the new Guide Bar.
- b. Sharpen or replace Saw Chain.

PLEASE READ THE FOLLOWING CAREFULLY

SAFETY

THE MANUFACTURER AND/OR DISTRIBUTOR HAS PROVIDED THE PARTS LIST AND ASSEMBLY DIAGRAM IN THIS MANUAL AS A REFERENCE TOOL ONLY. NEITHER THE MANUFACTURER OR DISTRIBUTOR MAKES ANY REPRESENTATION OR WARRANTY OF ANY KIND TO THE BUYER THAT HE OR SHE IS QUALIFIED TO MAKE ANY REPAIRS TO THE PRODUCT, OR THAT HE OR SHE IS QUALIFIED TO REPLACE ANY PARTS OF THE PRODUCT. IN FACT, THE MANUFACTURER AND/OR DISTRIBUTOR EXPRESSLY STATES THAT ALL REPAIRS AND PARTS REPLACEMENTS SHOULD BE UNDERTAKEN BY CERTIFIED AND LICENSED TECHNICIANS, AND NOT BY THE BUYER. THE BUYER ASSUMES ALL RISK AND LIABILITY ARISING OUT OF HIS OR HER REPAIRS TO THE ORIGINAL PRODUCT OR REPLACEMENT PARTS THERETO, OR ARISING OUT OF HIS OR HER INSTALLATION OF REPLACEMENT PARTS THERETO.

SETUP

OPERATION

MAINTENANCE

Record Product's Serial Number Here: _____

Note: If product has no serial number, record month and year of purchase instead.

Note: Some parts are listed and shown for illustration purposes only, and are not available individually as replacement parts. Specify UPC 193175418968 when ordering parts.

SAFETY

SETUP

OPERATION

MAINTENANCE

Parts List and Diagram

Parts List

SAFETY

SETUP

OPERATION

MAINTENANCE

Part	Description	Qty
1	Nut	2
2	Torsion Spring	2
3	Carbon Brush	2
4	Rear Bracket	1
5	Bearing	1
6	Rotor	1
8	Bearing	1
9	Stator	1
10	Front Bracket	1
11	Screw	2
12	Bracket	1
13	Self Tapping Screw	26
14	Brake Bracket	1
15	Switch	1
16	Pinion	1
17	Retaining Ring	2
19	Power Cord	1
20	Power Cord Sheath	1
21	Terminal Port	1
22	Cord Clamp	1
23	Inner Wire	1
24	Inner Wire	1
25	Inner Wire	1
27	Front Handle Assembly	1
28	Chain Brake Lever	1
29	Label	1
30	Decorative Cover	1
31	Housing	1
32	Bushing	1
33	Rotating Plate	1
34	Washer	4
35	Torsion Spring	1
36	Trigger	1
37	Trigger Lockout Button	1
38	Torsion Spring	1
39	Oil Tank Cap	1
40	Extension Spring	1
41	Rivet	2
42	Ring	1
43	Linkage	1
44	Extension Spring	1
45	Belt	1
46	Attachment Clip	1
47	Oil Tank O-Ring	1
48	Oil Tank	1
49	Oil Tube	1
50	Self Tapping Screw	1
51	Oil Exit	1
53	Compression Spring	1
54	Steel Ball	1
55	O-Ring	1
56	Pump Housing	1
57	Pump	1
58	O-Ring	1
59	Washer	1
60	Compression Spring	1

Part	Description	Qty
61	Pump Rod	1
62	Oil Tube	1
63	Bushing	1
64	Washer	4
65	Self Tapping Screw	1
66	Saw Chain	1
67	Self Tapping Screw	1
68	Chain Guide Bar	1
69	Bar Support Plate	1
70	Chain Sheath	1
71	Torsion Spring	1
72	Bushing	1
73	Rotating Block	1
74	Needle Bearing	1
75	Washer	1
76	Gear	1
77	Spindle	1
78	Washer	1
79	Bearing	1
80	Self Tapping Screw	2
82	Drive Sprocket	1
83	Self Tapping Screw	1
84	Oil Seal	1
85	Chain Retainer	1
86	Ring	1
87	Spiked Bumper	1
89	Compression Block	1
90	Cam	1
91	Drive Cover	1
92	Label	1
93	Clutch Drum	1
94	Compression Spring	1
95	Clamping Plate I	1
96	Clutch Ring Gear	1
97	Brake Disc I	1
98	Brake Disc II	1
99	Clamping Plate II	1
100	Self Tapping Screw	3
101	Spring	3
102	Self Tapping Screw	3
103	Pawl	3
104	Tube	3
105	Torsion Spring	3
106	Chain Tension Knob	1
107	Bushing	1
108	Washer	1
201	Motor Set	1
203	Inner Wire Set	1
204	Connecting Pole Set	1
205	Pump Assembly	1
206	Chain Guide Bar Assembly	1
207	Output Shaft	1
208	Clutch Assembly	1
209	Chain Tension Knob Assembly	1
301	Self Tapping Screw	2

Assembly Diagram

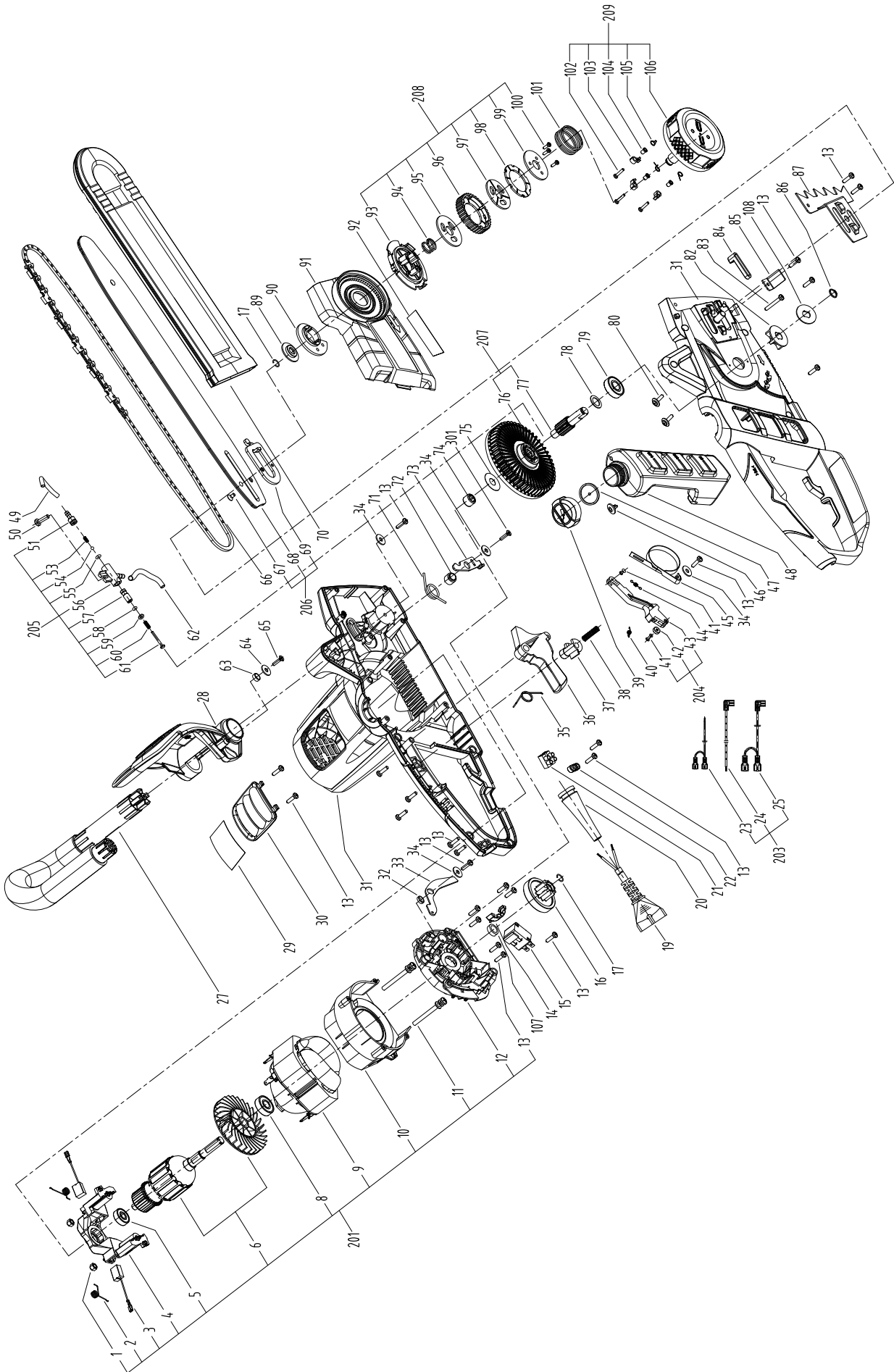

SAFETY

SETUP

OPERATION

MAINTENANCE

Limited 90 Day Warranty

Harbor Freight Tools Co. makes every effort to assure that its products meet high quality and durability standards, and warrants to the original purchaser that this product is free from defects in materials and workmanship for the period of 90 days from the date of purchase. This warranty does not apply to damage due directly or indirectly, to misuse, abuse, negligence or accidents, repairs or alterations outside our facilities, criminal activity, improper installation, normal wear and tear, or to lack of maintenance. We shall in no event be liable for death, injuries to persons or property, or for incidental, contingent, special or consequential damages arising from the use of our product. Some states do not allow the exclusion or limitation of incidental or consequential damages, so the above limitation of exclusion may not apply to you. THIS WARRANTY IS EXPRESSLY IN LIEU OF ALL OTHER WARRANTIES, EXPRESS OR IMPLIED, INCLUDING THE WARRANTIES OF MERCHANTABILITY AND FITNESS.

To take advantage of this warranty, the product or part must be returned to us with transportation charges prepaid. Proof of purchase date and an explanation of the complaint must accompany the merchandise. If our inspection verifies the defect, we will either repair or replace the product at our election or we may elect to refund the purchase price if we cannot readily and quickly provide you with a replacement. We will return repaired products at our expense, but if we determine there is no defect, or that the defect resulted from causes not within the scope of our warranty, then you must bear the cost of returning the product.

This warranty gives you specific legal rights and you may also have other rights which vary from state to state.

The logo for Bauer, featuring the word "Bauer" in a bold, italicized, sans-serif font. The letters are black with a white outline, and a small trademark symbol (TM) is located at the bottom right of the letter "r".

26541 Agoura Road • Calabasas, CA 91302 • 1-888-866-5797