

VENTILATION REQUIREMENTS FOR NAIL SPECIALTY SERVICES

GUIDANCE DOCUMENT FOR CONTRACTORS AND DESIGN PROFESSIONALS

Introduction

The New York State, Department of State has adopted a new regulation that requires all businesses which offer nail services to install ventilation that complies with at least the mechanical ventilation standards for nail salons that were issued as part of the 2015 International Mechanical Code (“2015 IMC”). A copy of the relevant 2015 IMC provisions is included of Appendix A. These standards have been incorporated into the New York State Uniform Fire Prevention and Building Code. The regulations require all existing businesses that provide nail services to meet the ventilation standards by calendar year 2021. All new businesses that are applying for a license on or after October 3, 2016, will need to comply with these same requirements by the time the business opens.

The ventilation standards require that businesses provide sufficient ventilation, including outdoor air and exhaust air, so that harmful contaminants, fumes and particles can be exhausted away from clients and workers. The regulations also require that businesses have a local exhaust system (a.k.a. source capture system) at each manicure and pedicure nail station to remove harmful substances at their source.

This document is intended to provide a contractor and design professional sufficient information to properly offer, design, and install a system that meets the ventilation requirements found within the regulations and the 2015 IMC. Examples of plans which comply with 2015 IMC requirements are included in Appendix B.

You may contact the Department of State with any questions at **518-474-4429**.

Ventilation Provisions

2015 Mechanical Code Requirements

The 2015 International Mechanical Code requires both general ventilation (fresh air and exhaust air) for nail salons and specific local exhaust requirements (source capture system) for each pedicure and manicure station.

The outdoor air (fresh air) rate required by the 2015 IMC will depend on a number of factors including but not limited to; the number of occupants, size of the nail salon, size of the ventilation ducts, the type of system, efficacy of the air distribution system and the amount of contaminants within the occupancy. These details will vary from salon to salon.

Steps for Compliance (Additional detail on each step to follow):

Step 1: Evaluate the existing ventilation system and determine existing capacity and air flow rates

Step 2: Determine the changes that will be required to meet the new required ventilation and exhaust rates

Step 3: Determine the best option for the type of local exhaust systems (source capture system) to be used

Step 4: Determine the best overall options for the salon

Step 1: Evaluation of Existing System

The first step in determining what work is required to bring the existing system into compliance is to do an evaluation of the existing system. An evaluation will first include determining the capacity of the existing ventilation and exhaust system. This step determines the current amount of air being moved within the existing system including, the amount of outside air (fresh air), amount of return air and the amount of exhaust air. This can be accomplished by reviewing existing as-built drawings, obtaining existing air balancing reports or by taking air readings of the existing system. Once the capacity of the existing system has been determined then the new requirements need to be established.

Step 2: Determine the Ventilation and Exhaust requirements:

Before Step 2 is described, a few important terms:

Definitions:

NAIL SALON. Means each building, or portion of a building, in which nail specialty services are offered or provided.

SOURCE CAPTURE SYSTEM. A mechanical exhaust system designed and constructed to capture air contaminants at their source and to exhaust such contaminants to the out-door atmosphere.

Requirements:

1. **Ventilation requirements:** A ventilation system that supplies outdoor airflow and exhaust air at a rate of not less than the *greater of*:
 - a) the ventilation standards for nail salons as set forth at Sections 401 and 403 of the 2015 IMC or
 - b) 50 cubic feet per minute for each nail station in the nail salon

2. **Specific Exhaust requirements:** A local exhaust system (source capture system) that has at least one exhaust inlet, capable of exhausting at least 50cfm, at each nail station
 - a) each such exhaust inlet to be factory-installed by the manufacturer of the nail station or;
 - b) field-installed at a location that is not more than 12 inches horizontally and not more than 12 inches vertically from the point of chemical application or where the customer's nails are placed when a nail specialty service is being performed;

The exhaust rate from such systems shall be permitted to be applied to the exhaust flow required by Table 403.3.1.1 of the 2015 IMC. Please see the examples below on how local exhaust system (source capture system) serves a nail station.

3. **Balanced Ventilation and Exhaust System.** Balanced in a manner to supply outdoor air at a rate equal to the rate of the exhaust;
4. **System operation:** The system must operate at all times when the nail salon is occupied by any person or persons.

Below is a general ventilation system schematic that shows different components that work together as a complete ventilation system serving a nail salon.

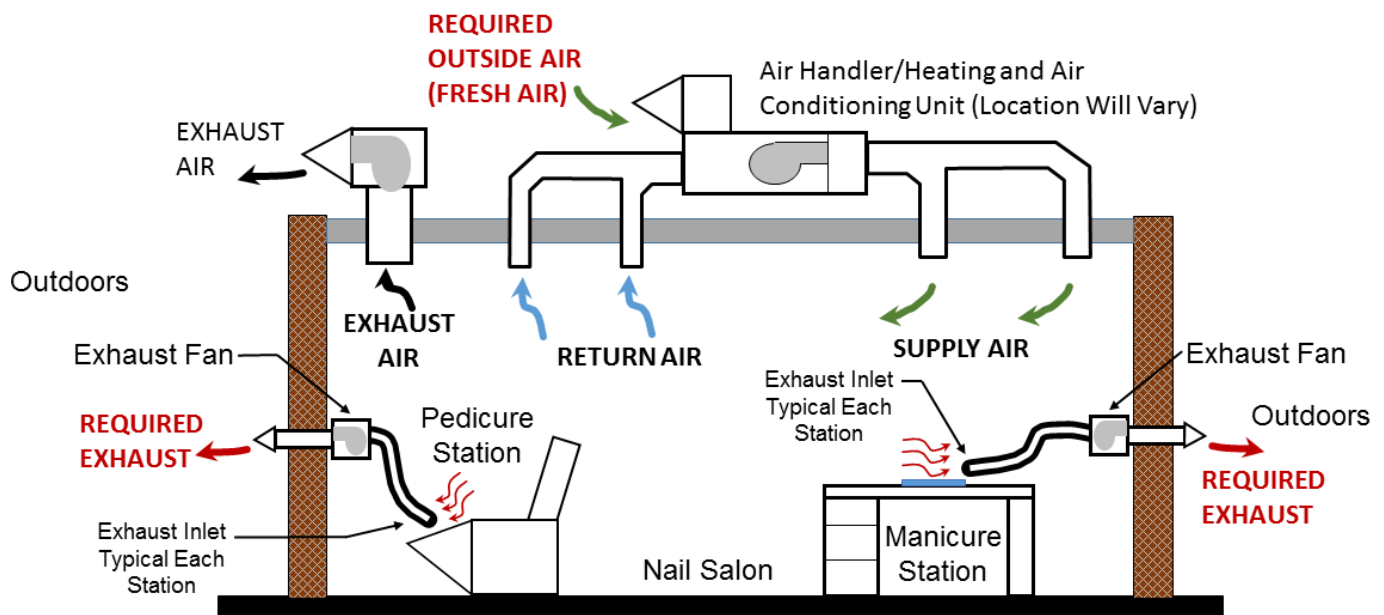

Sample Ventilation System

Step 3: Determine the best option for the type of Local Exhaust Systems (Source Capture Systems) to be used at each pedicure and manicure station

Depending on the layout of the nail stations in the salon, the exposure of exterior walls, and the existing exhaust system there may be several options available for complying with the local exhaust requirements.

Local Exhaust System (Source Capture Systems) options include:

1. A new nail station with factory installed ventilation; or
2. An existing nail station with a field-installed exhaust inlet; or
3. A field-installed local exhaust system used with an modified existing table; or
4. A standalone source capture system purchased as an add-on to a station.

In each of the options listed above, the local exhaust systems must exhaust to the outdoors either individually or grouped together into a common exhaust.

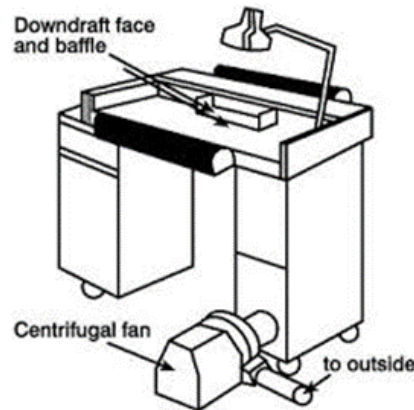

Example Nail Station with factory installed Local Exhaust (Source Capture System)

New Nail Station with Factory Installed Ventilation

A ventilated table is one that has a fan that draws the chemical vapors into a duct and prevents them from entering the room’s atmosphere. A ventilated table is an example of local exhaust because it prevents toxic chemicals from reaching the breathing zone of both nail technicians and clients. The ventilated table must be designed to vent contaminated air to the outside, not inside the salon.

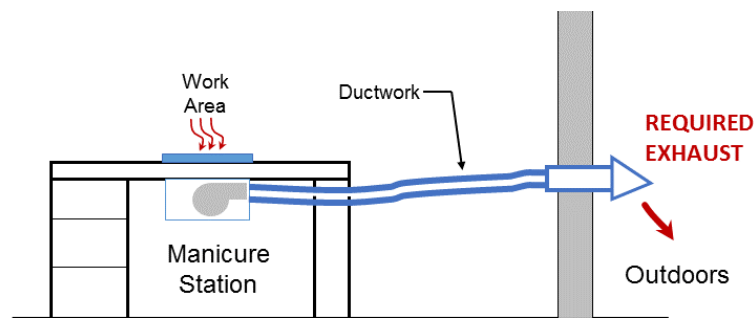

Ventilated Station with Built-in Exhaust Fan



Existing Nail Station with a Field-Installed Exhaust Inlet

A fixed or movable hood which is connected to an exhaust duct is an example of a local exhaust system (source capture system). A movable hood can be placed at each station over the nails (hands or feet) being serviced and will capture the chemical vapors at their source and exhaust them to the outdoors.

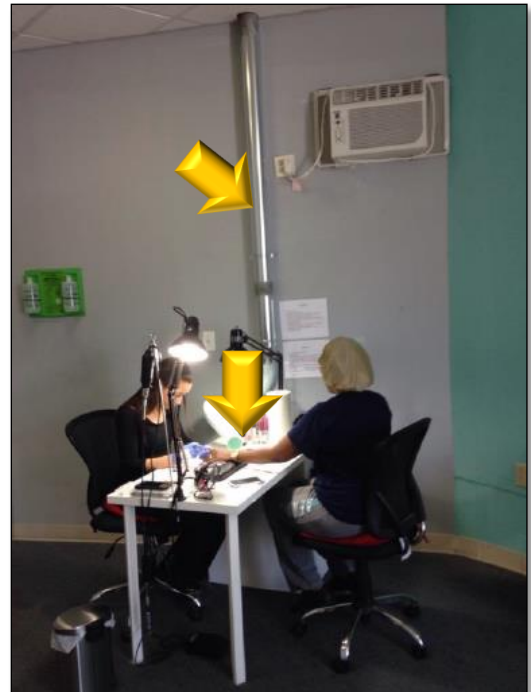
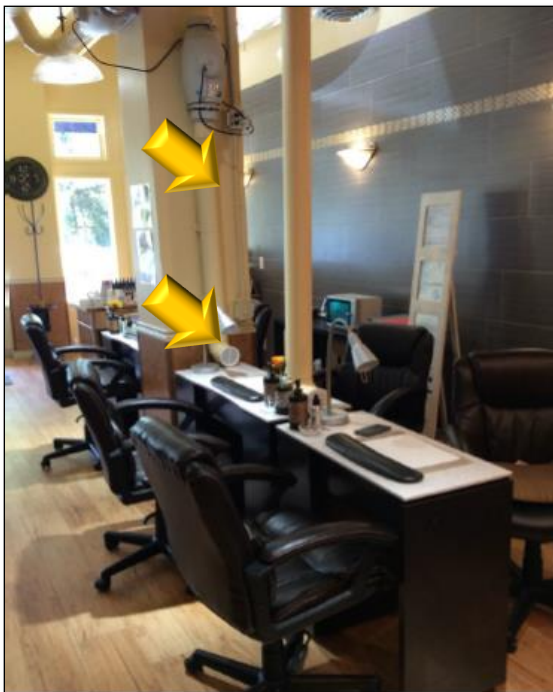

Modifying an Existing Table

To change a table that a client already owns into a ventilated one, make a penetration in the table top for an air intake (called the downdraft face). This downdraft face should be placed on the technician's side of the table. Cover the opening with a screen-like cover (or perforated plate). The client's side of the table should be a little higher than the technician's side. This will allow the client's hands to hang over the downdraft face and be as close as possible to the local exhaust ventilation (See Figure below).

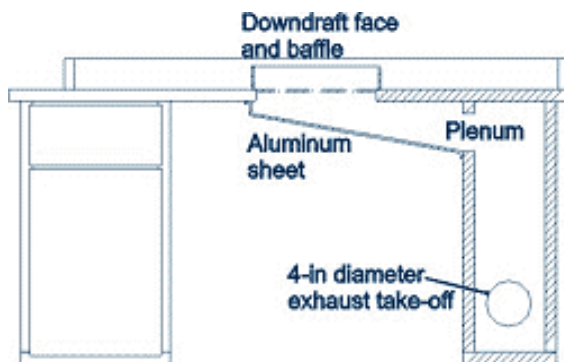

Make sure at least 50 CFM of air moves through the table downdraft to get rid of the chemicals, but more may be necessary based on the design.

Examples of a source capture system (local exhaust) for a pedicure station:

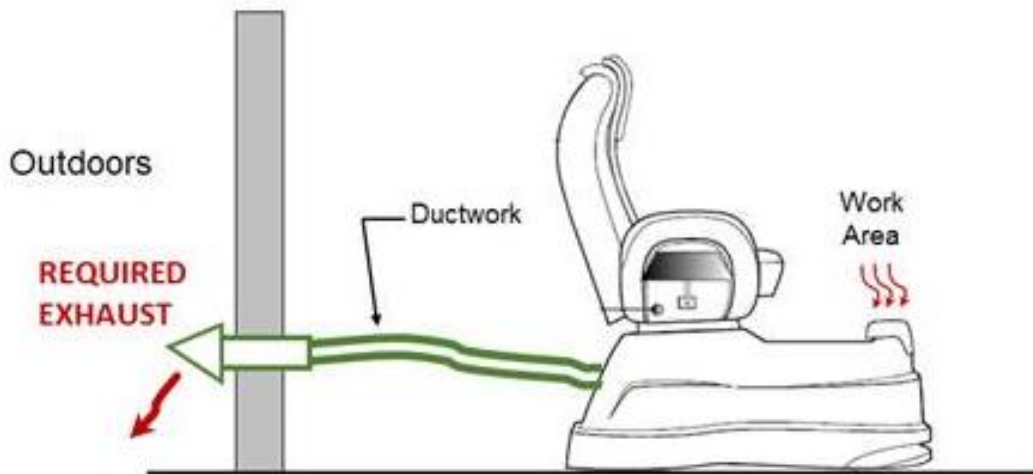

Pedicure Station with Built in Ventilation ducted to the outside

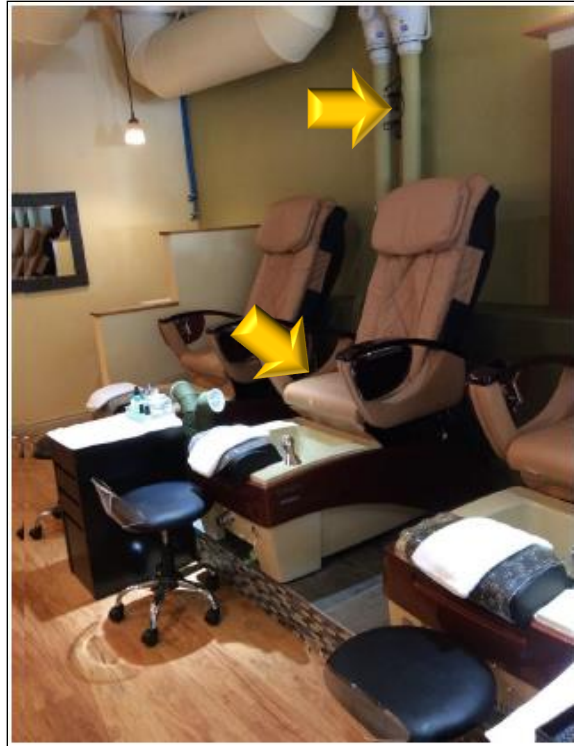

Pedicure Stations with Field Supplied Exhaust

Step 4: Determine the best overall option for the salon.

The existing ventilation system and the existing space configuration, along with the budget, will determine the options available for the salon. Additional items to consider include:

- Size and appearance of exposed ducts and equipment
- Indoor & outdoor equipment preferences
- Codes & standards
- Cooling/heating load
- Operating cost
- Maintenance cost

The best option for the salon will depend on the available budget and the desired aesthetics.

Example Application: (Using the 2015 IMC Chapter 4 – Ventilation Requirements)

A 1000 square foot Nail Salon is served by a single zone roof-top air handling unit for both heating and cooling by means of ducted ceiling supply registers and ceiling return grilles.

Please Note: This example is for a single zone system, additional steps need to be taken for other types of systems. Please see section 403 of the 2015 IMC.

STEP ONE: Determine Occupant Load (P_z) for the space

From Table 403.3.1.1 the Occupant Density for a nail salon is 25 people per 1000 sf.

$$P_z = 1000 \text{ ft}^2 \times 25 = 25 \text{ occupants}$$

STEP TWO: Determine Breathing Zone Outdoor Airflow (V_{bz})

$$V_{bz} = R_p P_z + R_a A_z \quad (\text{Equation 4-1})$$

where:

A_z = Zone floor area: the net occupiable floor area of the space or spaces in the zone.

P_z = Zone population: the number of people in the space or spaces in the zone.

R_p = People outdoor air rate: the outdoor airflow rate required per person from Table 403.3.1.1.

R_a = Area outdoor air rate: the outdoor airflow rate required per unit area from Table 403.3.1.1

Minimum Ventilation Rates (Table 403.3.1.1 – 2015 IMC)

Occupancy Classification	Occupant Density (#1000 FT ²)	People Outdoor Airflow rate in Breathing zone R _p CFM/Person	Area Outdoor airflow rate in Breathing zone, R _a CFM/FT ²	Exhaust Airflow Rate CFM/FT ²
Beauty Salon	25	20	0.12	0.6
Nail Salon	25	20	0.12	0.6

For footnotes refer to the 2015 IMC Table 403.3.1.1

From Table 403.3.1.1

$$R_p = 20 \text{ CFM/Person}$$

$$R_a = 0.12 \text{ CFM/Sq. Ft.}$$

Equation 4-1 can be solved:

$$V_{bz} = R_p P_z + R_a A_z$$

$$V_{bz} = (20 \text{ cfm/person} \times 25 \text{ people}) + (0.12 \text{ cfm/ft}^2 \times 1000 \text{ Sq. Ft.})$$

$$V_{bz} = (500) + (120) = 620 \text{ CFM}$$

STEP THREE: Determine Zone Outdoor Air Flow (V_{oz})

$$V_{oz} = V_{bz}/E_z \quad \text{Equation 4-2}$$

E_z = Zone Air Distribution Effectiveness

TABLE 403.3.1.1.1.2
ZONE AIR DISTRIBUTION EFFECTIVENESS^{a,b,c,d}

AIR DISTRIBUTION CONFIGURATION	E_z
Ceiling or floor supply of cool air	1.0 ^e
Ceiling or floor supply of warm air and floor return	1.0
Ceiling supply of warm air and ceiling return	0.8 ^f
Floor supply of warm air and ceiling return	0.7
Makeup air drawn in on the opposite side of the room from the exhaust and/or return	0.8
Makeup air drawn in near to the exhaust and/or return location	0.5

For SI: 1 foot = 304.8 mm, 1 foot per minute = 0.00506 m/s,

$$^{\circ}\text{C} = [(^{\circ}\text{F}) - 32]/1.8.$$

- a. "Cool air" is air cooler than space temperature.
- b. "Warm air" is air warmer than space temperature.
- c. "Ceiling" includes any point above the breathing zone.
- d. "Floor" includes any point below the breathing zone.
- e. Zone air distribution effectiveness of 1.2 shall be permitted for systems with a floor supply of cool air and ceiling return, provided that low-velocity displacement ventilation achieves unidirectional flow and thermal stratification.
- f. Zone air distribution effectiveness of 1.0 shall be permitted for systems with a ceiling supply of warm air, provided that supply air temperature is less than 15°F above space temperature and provided that the 150-foot-per-minute supply air jet reaches to within 4½ feet of floor level.

From Equation 4 -2:

$$V_{oz} = V_{bz}/E_z$$

From previous step: $V_{oz} = 620$ cfm

From Table 403.1.1.1.2 (Based on ceiling supply and ceiling return)

Cooling Mode: $E_z = 1.0$ $V_{oz} = 620$ CFM

Heating Mode: $E_z = 0.8$ $V_{oz} = 775$ CFM

The required Outdoor Air Rate:

$$V_{ot} = V_{oz} = 775 \text{ CFM}$$

In most cases the required outside air will be the deciding factor in in regards to balancing the system. In the case that the amount of exhaust is greater than the amount of required outside air, this amount would need to be adjusted to create a balanced system. In this case, there would need to be approximately 16 tables (at 50 cfm each =) in the space to have the exhaust rate exceed the required outdoor air rate. If that were the case the amount of outside air would need to be increased.

Determine the number of stations in the Salon:

8 Manicure Stations and 2 Pedicure Stations

Required Exhaust = 10 stations x 50 cfm = 500 CFM Exhaust

Each exhaust may be ducted separately or combined with other exhausts and ducted to the exterior. For the existing system, evaluation should determine if the existing outside air is adequate and the existing general exhaust must be adjusted or modified accordingly.

Check List for Mechanical Engineers / Contractors:

Evaluation of the existing System

- 1. Floor area of the Salon (square footage- SF) _____
 - 1a. Existing exhaust air supply (cfm) from the salon _____
 - 1b. Existing outdoor (fresh) air supply (cfm) into the salon _____
 - 1c. Number of Pedicure and Manicure Stations _____

Required ventilation and exhaust rates

- 2. Calculated Breathing Zone outdoor air rate _____ (V_{bz})
 - 2a. Zone Distribution effectiveness (E_z ; Table x) _____
 - 2b. Calculated Outdoor air rate (V_{oz} ; Equation x) _____
 - 2c. Single Zone system in Salon ($V_{ot} = V_{oz}$) _____
 - 2d. If Multi Zone or 100% Outdoor Air – Refer to 2015 IMC Section
 - 2e. Total Required exhaust for nail stations (Item (1c) x 50 cfm) _____
- 3. If required, outdoor air supply is tempered
- 4. Design complies with all applicable Local, State and Federal Codes.
- 5. Confirm that the recommended system design accounts for all manicure and pedicure work stations
- 6. Ensure that the recommended system design, when in operation, does not exceed the suggested noise level rate of 5 Sones (51 dBA) at the workstation

Regulations

In the case of a nail salon, a mechanical ventilation system which complies with the “2015 International Mechanical Code” (Publication Date: May 30, 2014, Third Printing), published by the International Code Council, Inc., and as amended by the NYS Building Standards and Codes 2016 Uniform Code Supplement (hereinafter referred to as the “2015 IMC”) such that it:

(i) has the capacity to supply outdoor airflow at a rate of not less than the **greater of**

(a) the ventilation standards for nail salons as set forth at Sections 401 and 403 of the 2015 IMC or

(b) 50 cubic feet per minute for each nail station in the nail salon;

(ii) includes a mechanical exhaust system that:

(a) is designed and constructed to capture all chemical vapors, fumes, dust and other air contaminants at their source and to exhaust such contaminants to the outdoor atmosphere;

(b) has at least one exhaust inlet for each nail station (each such exhaust inlet to be factory-installed by the manufacturer of the nail station or field-installed at a location that is not more than 12 inches horizontally and not more than 12 inches vertically from the point of chemical application or where the customer’s nails are placed when a nail specialty service is being performed);

(c) has the capacity to exhaust from the nail salon at a rate of not less than the greater of (1) the ventilation standards for nail salons as set forth at Sections 401 and 403 of the 2015 IMC or (2) 50 cubic feet per minute for each nail station in the nail salon;

(d) exhausts all exhaust air from the nail salon (including but not limited to all chemical vapors and fumes, dust, and other air contaminants and odors generated by or resulting from nail specialty services) to the outdoor atmosphere, with each exhaust discharge located at a point where it will not cause a nuisance to others and where the exhausted air (including but not limited to the exhausted chemical vapors and fumes, dust, and other air contaminants and odors) cannot be readily drawn in by the outdoor air intake components of the ventilation system; and

(e) exhausts all exhaust air from the nail salon (including but not limited to all chemical vapors and fumes, dust, and other air contaminants and

odors generated by or resulting from nail specialty services) in a manner that assures that no part of such exhaust air shall be recirculated into the nail salon or into any other space in the building, or transferred to any other space in the building;

(iii) is balanced in a manner to supply outdoor air at a rate equal to the rate of the exhaust; and

(iv) operates at or above the minimum supply outdoor airflow rate specified in subparagraph (i) of this paragraph and at or above the minimum exhaust rate specified in clause (c) of subparagraph (ii) of this paragraph at all times when the nail salon is occupied by any person or persons.

(c) No standard or requirement set forth in paragraph (6) of subdivision (b) of this section shall be construed as superseding, amending or otherwise affecting any higher or more restrictive standard or requirement applicable to appearance enhancement activities and/or to buildings. Failure to comply with any such higher or more restrictive standard or requirement may be a violation of the other applicable law or regulation, including, as the case may be, the State Uniform Fire Prevention and Building Code, New York City Construction Code, other building code, State Sanitary Code, State Industrial Code or environmental standards.

Appendix A

2015 IMC

floor area of the interior room or space, but not less than 20 square feet (1.86 m²). The minimum openable area to the outdoors shall be based on the total floor area being ventilated.

[BG] 402.4 **Openings below grade.** Where openings below grade provide required *natural ventilation*, the outside horizontal clear space measured perpendicular to the opening shall be one and one-half times the depth of the opening. The depth of the opening shall be measured from the average adjoining ground level to the bottom of the opening.

SECTION 403 MECHANICAL VENTILATION

403.1 **Ventilation system.** Mechanical ventilation shall be provided by a method of supply air and return or *exhaust air* except that mechanical ventilation air requirements for Group R-2, R-3 and R-4 occupancies three stories and less in height above grade plane shall be provided by an exhaust system, supply system or combination thereof. The amount of supply air shall be approximately equal to the amount of return and *exhaust air*. The system shall not be prohibited from producing negative or positive pressure. The system to convey *ventilation air* shall be designed and installed in accordance with Chapter 6.

403.2 **Outdoor air required.** The minimum outdoor airflow rate shall be determined in accordance with Section 403.3.

Exception: Where the *registered design professional* demonstrates that an engineered ventilation system design will prevent the maximum concentration of contaminants from exceeding that obtainable by the rate of outdoor air ventilation determined in accordance with Section 403.3, the minimum required rate of outdoor air shall be reduced in accordance with such engineered system design.

403.2.1 **Recirculation of air.** The outdoor air required by Section 403.3 shall not be recirculated. Air in excess of that required by Section 403.3 shall not be prohibited from being recirculated as a component of supply air to building spaces, except that:

1. Ventilation air shall not be recirculated from one *dwelling* to another or to dissimilar occupancies.
2. Supply air to a swimming pool and associated deck areas shall not be recirculated unless such air is dehumidified to maintain the relative humidity of the area at 60 percent or less. Air from this area shall not be recirculated to other spaces where more than 10 percent of the resulting supply airstream consists of air recirculated from these spaces.
3. Where mechanical exhaust is required by Note b in Table 403.3.1.1, recirculation of air from such spaces shall be prohibited. Recirculation of air that is contained completely within such spaces shall not be prohibited. Where recirculation of air is prohibited, all air supplied to such spaces shall be

exhausted, including any air in excess of that required by Table 403.3.1.1.

4. Where mechanical exhaust is required by Note g in Table 403.3.1.1, mechanical exhaust is required and recirculation from such spaces is prohibited where more than 10 percent of the resulting supply airstream consists of air recirculated from these spaces. Recirculation of air that is contained completely within such spaces shall not be prohibited.

403.2.2 **Transfer air.** Except where recirculation from such spaces is prohibited by Table 403.3.1.1, air transferred from occupiable spaces is not prohibited from serving as *makeup air* for required exhaust systems in such spaces as kitchens, baths, toilet rooms, elevators and smoking lounges. The amount of transfer air and *exhaust air* shall be sufficient to provide the flow rates as specified in Section 403.3.1.1. The required outdoor airflow rates specified in Table 403.3.1.1 shall be introduced directly into such spaces or into the occupied spaces from which air is transferred or a combination of both.

403.3 **Outdoor air and local exhaust airflow rates.** Group R-2, R-3 and R-4 occupancies three stories and less in height above grade plane shall be provided with outdoor air and local exhaust in accordance with Section 403.3.2. All other buildings intended to be occupied shall be provided with outdoor air and local exhaust in accordance with Section 403.3.1.

403.3.1 **Other buildings intended to be occupied.** The design of local exhaust systems and ventilation systems for outdoor air for occupancies other than Group R-2, R-3 and R-4 three stories and less above grade plane shall comply with Sections 403.3.1.1 through 403.3.1.5.

403.3.1.1 **Outdoor airflow rate.** Ventilation systems shall be designed to have the capacity to supply the minimum outdoor airflow rate, determined in accordance with this section. In each occupiable space, the ventilation system shall be designed to deliver the required rate of outdoor airflow to the *breathing zone*. The occupant load utilized for design of the ventilation system shall be not less than the number determined from the estimated maximum occupant load rate indicated in Table 403.3.1.1. Ventilation rates for occupancies not represented in Table 403.3.1.1 shall be those for a listed *occupancy* classification that is most similar in terms of occupant density, activities and building construction; or shall be determined by an *approved* engineering analysis. The ventilation system shall be designed to supply the required rate of *ventilation air* continuously during the period the building is occupied, except as otherwise stated in other provisions of the code.

With the exception of smoking lounges, the ventilation rates in Table 403.3.1.1 are based on the absence of smoking in occupiable spaces. Where smoking is anticipated in a space other than a smoking lounge, the

ventilation system serving the space shall be designed to provide ventilation over and above that required by Table 403.3.1.1 in accordance with accepted engineering practice.

Exception: The occupant load is not required to be determined based on the estimated maximum occupant load rate indicated in Table 403.3.1.1 where approved statistical data document the accuracy of an alternate anticipated occupant density.

403.3.1.1.1 Zone outdoor airflow. The minimum outdoor airflow required to be supplied to each zone shall be determined as a function of occupancy classification and space air distribution effectiveness in accordance with Sections 403.3.1.1.1.1 through 403.3.1.1.1.3.

403.3.1.1.1.1 Breathing zone outdoor airflow. The outdoor airflow rate required in the *breathing zone* (V_{bz}) of the *occupiable space* or spaces in a zone shall be determined in accordance with Equation 4-1.

$$V_{bz} = R_p P_z + R_a A_z \quad \text{(Equation 4-1)}$$

where:

A_z = Zone floor area: the *net occupiable floor area* of the space or spaces in the zone.

P_z = Zone population: the number of people in the space or spaces in the zone.

R_p = People outdoor air rate: the outdoor airflow rate required per person from Table 403.3.1.1.

R_a = Area outdoor air rate: the outdoor airflow rate required per unit area from Table 403.3.1.1.

403.3.1.1.1.2 Zone air distribution effectiveness. The zone air distribution effectiveness (E_z) shall be determined using Table 403.3.1.1.1.2.

TABLE 403.3.1.1.1.2
ZONE AIR DISTRIBUTION EFFECTIVENESS^{a,b,c,d}

AIR DISTRIBUTION CONFIGURATION	E_z
Ceiling or floor supply of cool air	1.0 ^a
Ceiling or floor supply of warm air and floor return	1.0
Ceiling supply of warm air and ceiling return	0.8 ^c
Floor supply of warm air and ceiling return	0.7
Makeup air drawn in on the opposite side of the room from the exhaust and/or return	0.8
Makeup air drawn in near to the exhaust and/or return location	0.5

For SI: 1 foot = 304.8 mm, 1 foot per minute = 0.00506 m/s, °C = [(°F) - 32]/1.8.

- a. "Cool air" is air cooler than space temperature.
- b. "Warm air" is air warmer than space temperature.
- c. "Ceiling" includes any point above the breathing zone.
- d. "Floor" includes any point below the breathing zone.

e. Zone air distribution effectiveness of 1.2 shall be permitted for systems with a floor supply of cool air and ceiling return, provided that low-velocity displacement ventilation achieves unidirectional flow and thermal stratification.

f. Zone air distribution effectiveness of 1.0 shall be permitted for systems with a ceiling supply of warm air, provided that supply air temperature is less than 15°F above space temperature and provided that the 150-foot-per-minute supply air jet reaches to within 4 1/2 feet of floor level.

403.3.1.1.1.3 Zone outdoor airflow. The zone outdoor airflow rate (V_{oz}), shall be determined in accordance with Equation 4-2.

$$V_{oz} = \frac{V_{bz}}{E_z} \quad \text{(Equation 4-2)}$$

403.3.1.1.2 System outdoor airflow. The outdoor air required to be supplied by each ventilation system shall be determined in accordance with Sections 403.3.1.1.2.1 through 403.3.1.1.2.3 as a function of system type and zone outdoor airflow rates.

403.3.1.1.2.1 Single zone systems. Where one air handler supplies a mixture of outdoor air and recirculated return air to only one zone, the system outdoor air intake flow rate (V_{ot}) shall be determined in accordance with Equation 4-3.

$$V_{ot} = V_{oz} \quad \text{(Equation 4-3)}$$

403.3.1.1.2.2 100-percent outdoor air systems. Where one air handler supplies only outdoor air to one or more zones, the system outdoor air intake flow rate (V_{ot}) shall be determined using Equation 4-4.

$$V_{ot} = \sum_{\text{all zones}} V_{oz} \quad \text{(Equation 4-4)}$$

403.3.1.1.2.3 Multiple zone recirculating systems. Where one air handler supplies a mixture of outdoor air and recirculated return air to more than one zone, the system outdoor air intake flow rate (V_{ot}) shall be determined in accordance with Sections 403.3.1.1.2.3.1 through 403.3.1.1.2.3.4.

403.3.1.1.2.3.1 Primary outdoor air fraction. The primary outdoor air fraction (Z_p) shall be determined for each zone in accordance with Equation 4-5.

$$Z_p = \frac{V_{oz}}{V_{pz}} \quad \text{(Equation 4-5)}$$

where:

V_{pz} = Primary airflow: The airflow rate supplied to the zone from the air-handling unit at which the outdoor air intake is located. It includes outdoor intake air and recirculated air from that air-handling unit but does not include air transferred or air recirculated to the zone by other means. For design purposes, V_{pz} shall be the zone design primary airflow

VENTILATION

rate, except for zones with variable air volume supply and V_{ps} shall be the lowest expected primary airflow rate to the zone when it is fully occupied.

403.3.1.1.2.3.2 System ventilation efficiency. The system ventilation efficiency (E_v) shall be determined using Table 403.3.1.1.2.3.2 or Appendix A of ASHRAE 62.1.

TABLE 403.3.1.1.2.3.2
SYSTEM VENTILATION EFFICIENCY^{a,b}

Max (Z_p)	E_v
≤ 0.15	1
≤ 0.25	0.9
≤ 0.35	0.8
≤ 0.45	0.7
≤ 0.55	0.6
≤ 0.65	0.5
≤ 0.75	0.4
> 0.75	0.3

a. Max (Z_p) is the largest value of Z_p calculated using Equation 4-5 among all the zones served by the system.

b. Interpolating between table values shall be permitted.

403.3.1.1.2.3.3 Uncorrected outdoor air intake. The uncorrected outdoor air intake flow rate (V_{ou}) shall be determined in accordance with Equation 4-6.

$$V_{ou} = D \sum_{all\ zones} R_p P_z + \sum_{all\ zones} R_g A_z \quad \text{(Equation 4-6)}$$

where:

D = Occupant diversity: the ratio of the system population to the sum of the zone populations, determined in accordance with Equation 4-7.

$$D = \frac{P_s}{\sum_{all\ zones} P_z} \quad \text{(Equation 4-7)}$$

where:

P_s = System population: The total number of occupants in the area served by the system. For design purposes, P_s shall be the maximum number of occupants expected to be concurrently in all zones served by the system.

403.3.1.1.2.3.4 Outdoor air intake flow rate. The outdoor air intake flow rate (V_{oi}) shall be determined in accordance with Equation 4-8.

$$V_{oi} = \frac{V_{ou}}{E_v} \quad \text{(Equation 4-8)}$$

403.3.1.2 Exhaust ventilation. Exhaust airflow rate shall be provided in accordance with the requirements

of Table 403.3.1.1. Outdoor air introduced into a space by an exhaust system shall be considered as contributing to the outdoor airflow required by Table 403.3.1.1.

403.3.1.3 System operation. The minimum flow rate of outdoor air that the ventilation system must be capable of supplying during its operation shall be permitted to be based on the rate per person indicated in Table 403.3.1.1 and the actual number of occupants present.

403.3.1.4 Variable air volume system control. Variable air volume air distribution systems, other than those designed to supply only 100-percent outdoor air, shall be provided with controls to regulate the flow of outdoor air. Such control system shall be designed to maintain the flow rate of outdoor air at a rate of not less than that required by Section 403.3 over the entire range of supply air operating rates.

403.3.1.5 Balancing. The ventilation air distribution system shall be provided with means to adjust the system to achieve not less than the minimum ventilation airflow rate as required by Sections 403.3 and 403.3.1.2. Ventilation systems shall be balanced by an approved method. Such balancing shall verify that the ventilation system is capable of supplying and exhausting the airflow rates required by Sections 403.3 and 403.3.1.2.

403.3.2 Group R-2, R-3 and R-4 occupancies, three stories and less. The design of local exhaust systems and ventilation systems for outdoor air in Group R-2, R-3 and R-4 occupancies three stories and less in height above grade plane shall comply with Sections 403.3.2.1 through 403.3.2.3.

403.3.2.1 Outdoor air for dwelling units. An outdoor air ventilation system consisting of a mechanical exhaust system, supply system or combination thereof shall be installed for each dwelling unit. Local exhaust or supply systems, including outdoor air ducts connected to the return side of an air handler, are permitted to serve as such a system. The outdoor air ventilation system shall be designed to provide the required rate of outdoor air continuously during the period that the building is occupied. The minimum continuous outdoor airflow rate shall be determined in accordance with Equation 4-9.

$$Q_{OA} = 0.01 A_{floor} + 7.5(N_{br} + 1) \quad \text{(Equation 4-9)}$$

where:

Q_{OA} = outdoor airflow rate, cfm

A_{floor} = floor area, ft²

N_{br} = number of bedrooms; not to be less than one

Exception: The outdoor air ventilation system is not required to operate continuously where the system has controls that enable operation for not less than 1 hour of each 4-hour period. The average outdoor air flow rate over the 4-hour period shall be not less than that prescribed by Equation 4-9.

VENTILATION

TABLE 403.3.1.1—continued
MINIMUM VENTILATION RATES

OCCUPANCY CLASSIFICATION	OCCUPANT DENSITY #/1000 FT ² ^a	PEOPLE OUTDOOR AIRFLOW RATE IN BREATHING ZONE, R _p , CFM/PERSON	AREA OUTDOOR AIRFLOW RATE IN BREATHING ZONE, R _a , CFM/FT ² ^a	EXHAUST AIRFLOW RATE CFM/FT ² ^a
Specialty shops				
Automotive motor-fuel dispensing stations ^b	—	—	—	1.5
Barber	25	7.5	0.06	0.5
Beauty salons ^b	25	20	0.12	0.6
Nail salons ^{b, h}	25	20	0.12	0.6
Embalming room ^b	—	—	—	2.0
Pet shops (animal areas) ^b	10	7.5	0.18	0.9
Supermarkets	8	7.5	0.06	—

For SI: 1 cubic foot per minute = 0.0004719 m³/s, 1 ton = 908 kg, 1 cubic foot per minute per square foot = 0.00508 m³/(s · m²), °C = [(°F) - 32]/1.8, 1 square foot = 0.0929 m².

- a. Based upon *net occupiable floor area*.
- b. Mechanical exhaust required and the recirculation of air from such spaces is prohibited. Recirculation of air that is contained completely within such spaces shall not be prohibited (see Section 403.2.1, Item 3).
- c. Spaces unheated or maintained below 50°F are not covered by these requirements unless the occupancy is continuous.
- d. Ventilation systems in enclosed parking garages shall comply with Section 404.
- e. Rates are per water closet or urinal. The higher rate shall be provided where the exhaust system is designed to operate intermittently. The lower rate shall be permitted only where the exhaust system is designed to operate continuously while occupied.
- f. Rates are per room unless otherwise indicated. The higher rate shall be provided where the exhaust system is designed to operate intermittently. The lower rate shall be permitted only where the exhaust system is designed to operate continuously while occupied.
- g. Mechanical exhaust is required and recirculation from such spaces is prohibited except that recirculation shall be permitted where the resulting supply airstream consists of not more than 10 percent air recirculated from these spaces. Recirculation of air that is contained completely within such spaces shall not be prohibited (see Section 403.2.1, Items 2 and 4).
- h. For nail salons, each manicure and pedicure station shall be provided with a *source capture* system capable of exhausting not less than 50 cfm per station. Exhaust inlets shall be located in accordance with Section 502.20. Where one or more required source capture systems operate continuously during occupancy, the exhaust rate from such systems shall be permitted to be applied to the exhaust flow rate required by Table 403.3.1.1 for the nail salon.

CHAPTER 5

EXHAUST SYSTEMS

SECTION 501 GENERAL

501.1 Scope. This chapter shall govern the design, construction and installation of mechanical exhaust systems, including exhaust systems serving clothes dryers and cooking appliances; hazardous exhaust systems; dust, stock and refuse conveyor systems; subslab soil exhaust systems; smoke control systems; energy recovery ventilation systems and other systems specified in Section 502.

501.2 Independent system required. Single or combined mechanical exhaust systems for environmental air shall be independent of all other exhaust systems. Dryer exhaust shall be independent of all other systems. Type I exhaust systems shall be independent of all other exhaust systems except as provided in Section 506.3.5. Single or combined Type II exhaust systems for food-processing operations shall be independent of all other exhaust systems. Kitchen exhaust systems shall be constructed in accordance with Section 505 for domestic equipment and Sections 506 through 509 for commercial equipment.

501.3 Exhaust discharge. The air removed by every mechanical exhaust system shall be discharged outdoors at a point where it will not cause a public nuisance and not less than the distances specified in Section 501.3.1. The air shall be discharged to a location from which it cannot again be readily drawn in by a ventilating system. Air shall not be exhausted into an attic, crawl space, or be directed onto walkways.

Exceptions:

1. Whole-house ventilation-type attic fans shall be permitted to discharge into the attic space of *dwelling units* having private attics.
2. Commercial cooking recirculating systems.
3. Where installed in accordance with the manufacturer's instructions and where mechanical or *natural ventilation* is otherwise provided in accordance with Chapter 4, *listed* and *labeled* domestic ductless range hoods shall not be required to discharge to the outdoors.

501.3.1 Location of exhaust outlets. The termination point of exhaust outlets and ducts discharging to the outdoors shall be located with the following minimum distances:

1. For ducts conveying explosive or flammable vapors, fumes or dusts: 30 feet (9144 mm) from property lines; 10 feet (3048 mm) from operable openings into buildings; 6 feet (1829 mm) from exterior walls and roofs; 30 feet (9144 mm) from combustible walls and operable openings into buildings which are in the direction of the exhaust discharge; 10 feet (3048 mm) above adjoining grade.

2. For other product-conveying outlets: 10 feet (3048 mm) from the property lines; 3 feet (914 mm) from exterior walls and roofs; 10 feet (3048 mm) from operable openings into buildings; 10 feet (3048 mm) above adjoining grade.
3. For all *environmental air* exhaust: 3 feet (914 mm) from property lines; 3 feet (914 mm) from operable openings into buildings for all occupancies other than Group U, and 10 feet (3048 mm) from mechanical air intakes. Such exhaust shall not be considered hazardous or noxious.
4. Exhaust outlets serving structures in flood hazard areas shall be installed at or above the elevation required by Section 1612 of the *International Building Code* for utilities and attendant equipment.
5. For specific systems see the following sections:
 - 5.1. Clothes dryer exhaust, Section 504.4.
 - 5.2. Kitchen hoods and other kitchen exhaust equipment, Sections 506.3.13, 506.4 and 506.5.
 - 5.3. Dust stock and refuse conveying systems, Section 511.2.
 - 5.4. Subslab soil exhaust systems, Section 512.4.
 - 5.5. Smoke control systems, Section 513.10.3.
 - 5.6. Refrigerant discharge, Section 1105.7.
 - 5.7. Machinery room discharge, Section 1105.6.1.

501.3.2 Exhaust opening protection. Exhaust openings that terminate outdoors shall be protected with corrosion-resistant screens, louvers or grilles. Openings in screens, louvers and grilles shall be sized not less than $\frac{1}{4}$ inch (6.4 mm) and not larger than $\frac{1}{2}$ inch (12.7 mm). Openings shall be protected against local weather conditions. Louvers that protect exhaust openings in structures located in hurricane-prone regions, as defined in the *International Building Code*, shall comply with AMCA Standard 550. Outdoor openings located in exterior walls shall meet the provisions for exterior wall opening protectives in accordance with the *International Building Code*.

501.4 Pressure equalization. Mechanical exhaust systems shall be sized to remove the quantity of air required by this chapter to be exhausted. The system shall operate when air is required to be exhausted. Where mechanical exhaust is required in a room or space in other than occupancies in R-3 and *dwelling units* in R-2, such space shall be maintained with a neutral or negative pressure. If a greater quantity of air is supplied by a mechanical ventilating supply system than is removed by a mechanical exhaust for a room, adequate means shall be provided for the natural or mechanical exhaust of the excess air supplied. If only a mechanical exhaust sys-

EXHAUST SYSTEMS

tem is installed for a room or if a greater quantity of air is removed by a mechanical exhaust system than is supplied by a mechanical ventilating supply system for a room, adequate *makeup air* shall be provided to satisfy the deficiency.

501.5 Ducts. Where exhaust duct construction is not specified in this chapter, such construction shall comply with Chapter 6.

SECTION 502 REQUIRED SYSTEMS

502.1 General. An exhaust system shall be provided, maintained and operated as specifically required by this section and for all occupied areas where machines, vats, tanks, furnaces, forges, salamanders and other *appliances, equipment* and processes in such areas produce or throw off dust or particles sufficiently light to float in the air, or which emit heat, odors, fumes, spray, gas or smoke, in such quantities so as to be irritating or injurious to health or safety.

502.1.1 Exhaust location. The inlet to an exhaust system shall be located in the area of heaviest concentration of contaminants.

[F] 502.1.2 Fuel-dispensing areas. The bottom of an air inlet or exhaust opening in fuel-dispensing areas shall be located not more than 18 inches (457 mm) above the floor.

502.1.3 Equipment, appliance and service rooms. *Equipment, appliance* and system service rooms that house sources of odors, fumes, noxious gases, smoke, steam, dust, spray or other contaminants shall be designed and constructed so as to prevent spreading of such contaminants to other occupied parts of the building.

[F] 502.1.4 Hazardous exhaust. The mechanical exhaust of high concentrations of dust or hazardous vapors shall conform to the requirements of Section 510.

[F] 502.2 Aircraft fueling and defueling. Compartments housing piping, pumps, air eliminators, water separators, hose reels and similar *equipment* used in aircraft fueling and defueling operations shall be adequately ventilated at floor level or within the floor itself.

[F] 502.3 Battery-charging areas for powered industrial trucks and equipment. Ventilation shall be provided in an *approved* manner in battery-charging areas for powered industrial trucks and *equipment* to prevent a dangerous accumulation of flammable gases.

[F] 502.4 Stationary storage battery systems. Stationary storage battery systems, as regulated by Section 608 of the *International Fire Code*, shall be provided with ventilation in accordance with this chapter and Section 502.4.1 or 502.4.2.

Exception: Lithium-ion and lithium metal polymer batteries shall not require additional ventilation beyond that which would normally be required for human occupancy of the space.

[F] 502.4.1 Hydrogen limit in rooms. For flooded lead acid, flooded nickel cadmium and VRLA batteries, the ventilation system shall be designed to limit the maximum

concentration of hydrogen to 1.0 percent of the total volume of the room.

[F] 502.4.2 Ventilation rate in rooms. Continuous ventilation shall be provided at a rate of not less than 1 cubic foot per minute per square foot (cfm/ft^2) [$0.00508 \text{ m}^3/(\text{s} \cdot \text{m}^2)$] of floor area of the room.

[F] 502.4.3 Supervision. Mechanical ventilation systems required by Section 502.4 shall be supervised by an approved central, proprietary or remote station service or shall initiate an audible and visual signal at a constantly attended on-site location.

[F] 502.5 Valve-regulated lead-acid batteries in cabinets. Valve-regulated lead-acid (VRLA) batteries installed in cabinets, as regulated by Section 608.6.2 of the *International Fire Code*, shall be provided with ventilation in accordance with Section 502.5.1 or 502.5.2.

[F] 502.5.1 Hydrogen limit in cabinets. The cabinet ventilation system shall be designed to limit the maximum concentration of hydrogen to 1.0 percent of the total volume of the cabinet during the worst-case event of simultaneous boost charging of all batteries in the cabinet.

[F] 502.5.2 Ventilation rate in cabinets. Continuous cabinet ventilation shall be provided at a rate of not less than 1 cubic foot per minute per square foot (cfm/ft^2) [$0.00508 \text{ m}^3/(\text{s} \cdot \text{m}^2)$] of the floor area covered by the cabinet. The room in which the cabinet is installed shall be ventilated as required by Section 502.4.1 or 502.4.2.

[F] 502.5.3 Supervision. Mechanical ventilation systems required by Section 502.5 shall be supervised by an approved central, proprietary or remote station service or shall initiate an audible and visual signal at a constantly attended on-site location.

[F] 502.6 Dry cleaning plants. Ventilation in dry cleaning plants shall be adequate to protect employees and the public in accordance with this section and DOL 29 CFR Part 1910.1000, where applicable.

[F] 502.6.1 Type II systems. Type II dry cleaning systems shall be provided with a mechanical ventilation system that is designed to exhaust 1 cubic foot of air per minute for each square foot of floor area ($1 \text{ cfm}/\text{ft}^2$) [$0.00508 \text{ m}^3/(\text{s} \cdot \text{m}^2)$] in dry cleaning rooms and in drying rooms. The ventilation system shall operate automatically when the dry cleaning *equipment* is in operation and shall have manual controls at an *approved* location.

[F] 502.6.2 Type IV and V systems. Type IV and V dry cleaning systems shall be provided with an automatically activated exhaust ventilation system to maintain an air velocity of not less than 100 feet per minute (0.51 m/s) through the loading door when the door is opened.

Exception: Dry cleaning units are not required to be provided with exhaust ventilation where an exhaust hood is installed immediately outside of and above the loading door which operates at an airflow rate as follows:

$$Q = 100 \times A_{LD} \quad \text{Equation 5-1}$$

502.20 Manicure and pedicure stations. Manicure and pedicure stations shall be provided with an exhaust system in accordance with Table 403.3.1.1, Note h. Manicure tables and pedicure stations not provided with factory-installed exhaust inlets shall be provided with exhaust inlets located not more than 12 inches (305 mm) horizontally and vertically from the point of chemical application.

Appendix B

These pictures and design plans are only examples of the different systems which might be available for the salon. Please consult with an appropriate professional to determine what systems might work best for you.

SCHEDULE:
 EF-1, ROOF MOUNTED DIRECT DRIVE
 450 CFM,
 MUA-1, MAKE UP AIR, 200 CFM, WITH HEATER

PER 2009 INTERNATIONAL MECHANICAL CODE, TABLE 403.3 MINIMUM VENTILATION RATES, FOR BEAUTY AND NAIL SALON, MINIMUM EXHAUST AIRFLOW RATE (CFM/SF) IS 0.6, THIS REQUIRES 425 CFM, BASED ON 724 SF, FLOOR AREA

PER 2009 INTERNATIONAL MECHANICAL CODE, TABLE 403.3 MINIMUM VENTILATION RATES, FOR BEAUTY AND NAIL SALON, MINIMUM EXHAUST AIRFLOW RATE (CFM) IS 25 PER OCCUPANT, THIS REQUIRES 350 CFM BASED ON 14 OCCUPANT PER SET UP OF MANICURE AND PEDICURE

PROVIDED 450 CFM EXHAUST VENTILATION IS OK.

PER 2009 INTERNATIONAL MECHANICAL CODE, TABLE 403.3 FOOT NOTE H, "For nail salons, the required exhaust shall include ventilation tables or other systems that capture the contaminants and odors at their source and are capable of exhausting a minimum of 50 cfm per station."
 PROVIDED 50 CFM AT EACH STATION

MAKER UP AIR MUST BE 0.12 CFM/SF. THIS REQUIRES 88 CFM BASED ON 724 SF.. PROVIDED 100 CFM IS ADEQUATE.

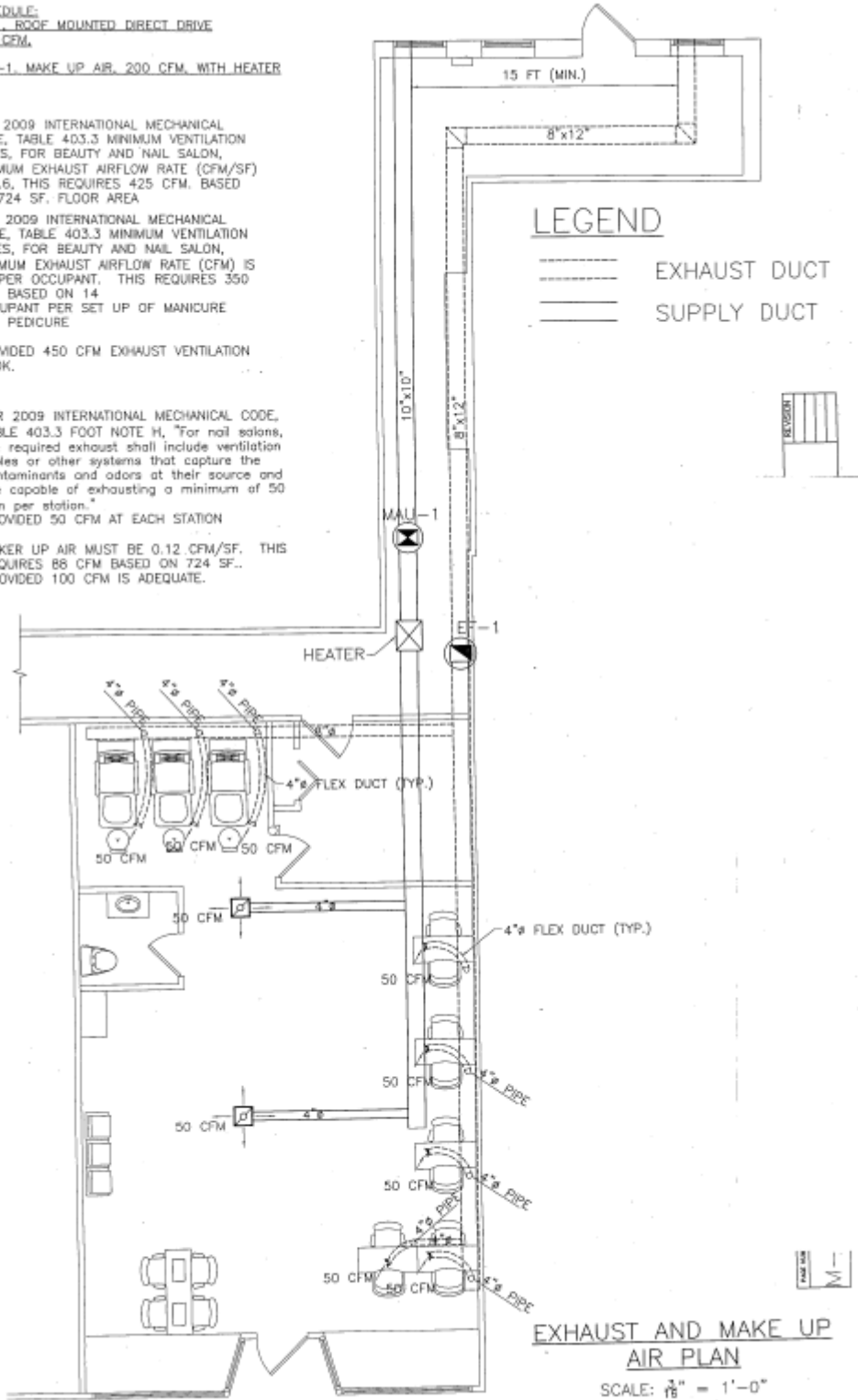

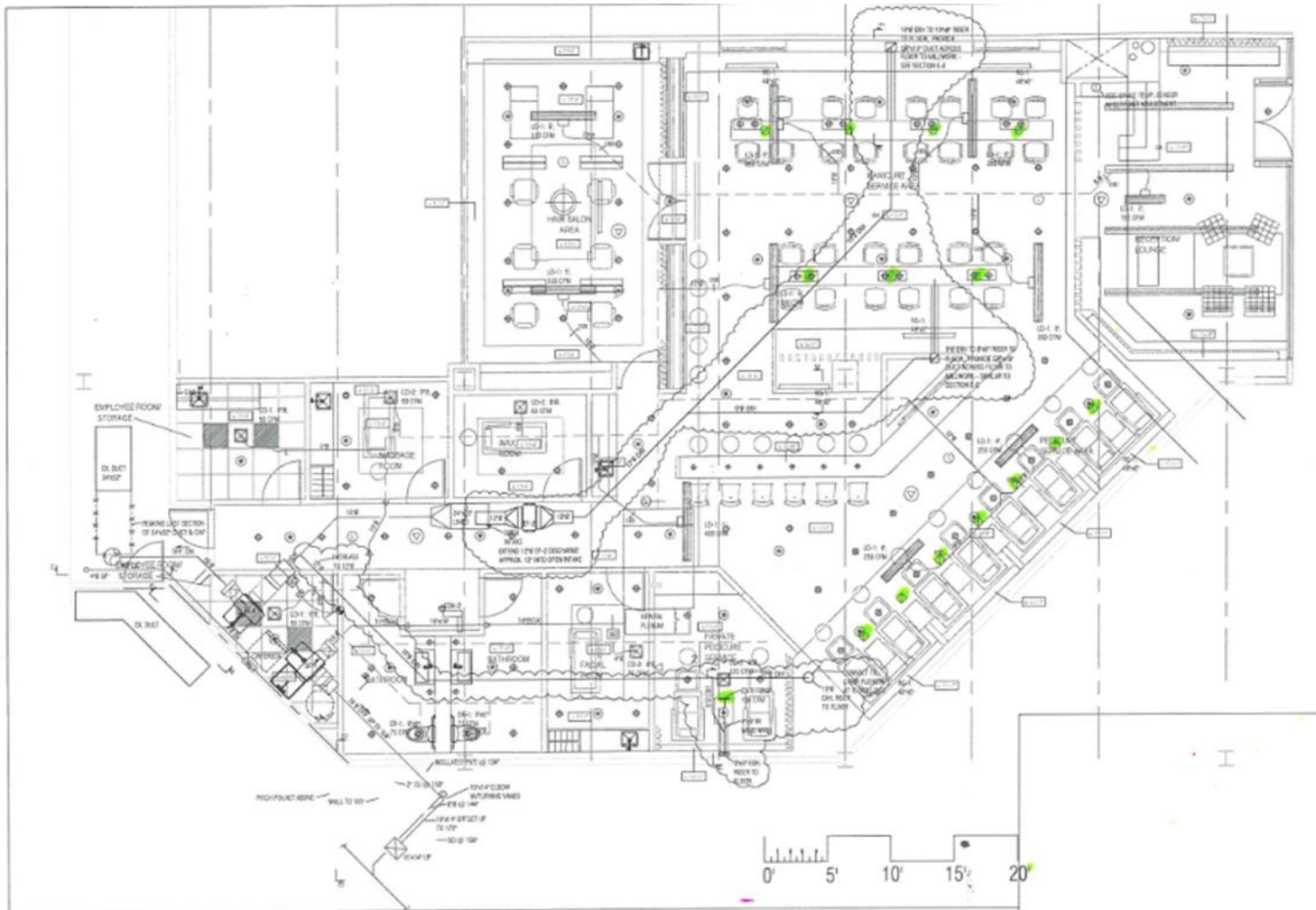

RP-2: OPEN/SHUT MODEL, ESP-ACTION (100 CPM/4°C), 120V, 3.2A, PROVIDE SPEED CONTROL SWITCH - MOUNTED AT PAN ABOVE CEILING. (DUAL PURPOSE: LOCAL, DISCONNECT AND SPEED ADJUSTMENT FOR AIR BALANCING). WIRE TO CIRCUIT PANEL THROUGH RIBBON "W" RELAY. RP-2 SHALL RUN WITH RP-1.
 PROVIDE TAPERED TRANSITION DUCTS FROM RP-2 TO 12".

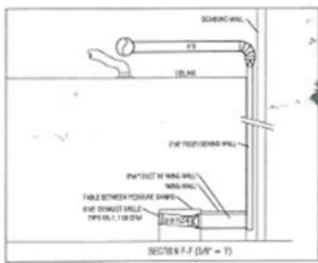
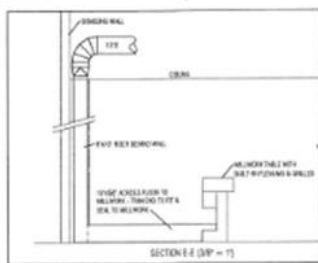

OWNER	
DESIGNER	
ENGINEER	
DATE	
SCALE	
PROJECT	
REVISIONS	
DRAWN BY: GWE SCALE: 1/4" = 1'-0" DATE: MARCH 15, 2016	
CHECKED BY: [Blank] DATE: [Blank]	
PROJECT TITLE: HVAC - LOCAL EXHAUST DUCT - 6/23/16	
SHEET NUMBER: SK-H2	