

Korinto Prime

**Espresso
120V 60Hz**

EN English

EVOCA S.p.A.
ad unico socio
Sede amministrativa e operativa: Via Roma 24
24030 Valbrembo (BG) Italia
Tel +39 035 606111
Fax +39 035 606463
www.evocagroup.com
Sede legale: Via Tommaso Grossi 2
20121 Milano (MI) Italia
Cap. Soc. € 41.138.297,00 i.v.
Reg. Impr. MI, Cod. Fisc. e P.IVA: 05035600963
Reg. Produttori A.E.E.: IT0802000001054
Cod. identificativo: IT 05035600963

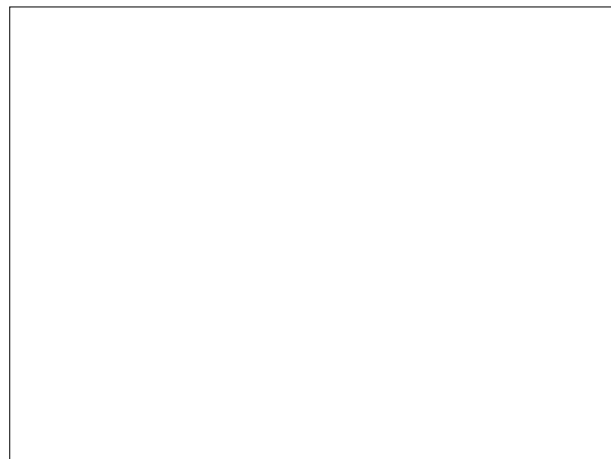

INTEGRATION OF RADIO MODULES

In compliance with the national laws in force, the manufacturer must check the compliance of the radio equipment with the essential requirements of the national legislation.

The procedure used to check compliance is at the manufacturer's discretion.

If a radio module is built in a "non-radio" equipment, the subject integrating the module will become the manufacturer of the end product and it must therefore check the compliance of the end product with the essential requirements of the national laws in force in the country of installation of the equipment.

As a matter of fact, the integration of radio modules in other products can influence the compliance of the end product with the essential requirements of the national laws in force.

DEFINITIONS ACCORDING TO THE LAW

The **manufacturer** is a natural person who or a public body which manufactures radio equipment and/or electric material or has it engineered, manufactured or marketed by putting its own trademark or name on it.

An **importer** or **distributor** who places radio equipment or electric material on the market by putting its own name or trademark becomes the manufacturer.

An **importer** or **distributor** who makes any change to radio equipment or electric material already placed on the market to such an extent that the said change may condition the compliance with the listed directives is held to be the manufacturer and it must therefore assume the relative obligations according to the said directives.

Symbology

The following symbols may be present inside the machines, according to models (signs of danger)



Attention: dangerous voltage
Power off before removing the cover



Attention
Danger of crushing your hands



Attention
Hot surface

The signs of danger must be readable and visible; they shall be neither hidden nor removed. Damaged or unreadable labels must be replaced.

Warnings

This document intended for the technical personnel is made available in the electronic format at the manufacturer's (reserved area web site).

FOR INSTALLATION

The installation and any subsequent maintenance operation shall be carried out by the personnel skilled and trained on the utilisation of the machine according to the rules in force

The use of kits and/or accessories not type-approved by the manufacturer can not guarantee the observance of safety standards, in particular for live parts.

The installer will be the sole person responsible for any damage improper installation may cause to the machine or to things and people.

The manufacturer declines all responsibility for the use of non type-approved components.

Assembly and any testing operation must be carried out by qualified personnel who have a specific knowledge of the machine operation from the point of view of electric safety and health rules.

The intactness of the machine and its compliance with the standards of relevant installations must be checked by skilled personnel at least once a year.

Package materials must be disposed of in observance of the environment.

For the vending machines of hot drinks only

The machine is equipped with an automatic washing system for the mixers with the relative water circuit and the brewing unit.

If the machine is not used for some time (weekends, etc.) even for pauses longer than two days, it is recommended to enable the automatic washing functions (e.g. before starting to use the VM).

FOR USE

The machine can be used by children over 8 years and by people having reduced physical, sensorial or mental skills under the supervision of people responsible for their safety or specifically trained on the use of the machine.

Children shall not be allowed to play with the machine by the people in charge of their supervision

Children shall not be allowed to clean or service the machine.

FOR THE ENVIRONMENT

Some tricks will help you to protect the environment:

- use biodegradable products to clean the machine;
- properly dispose of all the packages of the products used to fill and clean the machine;
- power off the machine during inactivity for energy saving.

FOR DISMANTLING AND DISPOSAL

When dismantling the machine, it is recommended to destroy the machine rating plate.



The symbol shows that the machine can not be disposed of as common waste, but it must be disposed of as it is established by the 2012/19/EU (Waste Electrical and Electronic Equipment - WEEE) European Directive and by the national laws arising out of it in order to prevent any negative consequence for environment and human health.

The differentiated collection of the machine at the end of its life is organised and managed by the manufacturer.

For the correct disposal of the machine contact the sales point where you have purchased the machine or our after-sales service.

The unlawful disposal of the machine implies the application of the administrative sanctions provided for by the rules in force.

Attention!

If the machine is equipped with a cooling system, the cooling unit contains HFC-R134a fluoridised greenhouse effect gas ruled by the Kyoto protocol, the total heating potential of which is equal to 1300.



THE INTERNATIONAL CERTIFICATION NETWORK

CERTIFICATE

CISQ/IMQ as an IQNet Partner hereby states that the organization

EVOCA SPA con socio unico

VIA ROMA 24 - 24030 VALBREMBO (BG)
VIA DEL CHIOSO 13 - 24030 MOZZO (BG)
VIA GRAZIA DELEDDA 16 - 24030 MAPELLO (BG)
VIA SALVO D'ACQUISTO 7/9 - 24050 GRASSOBBIO (BG)

for the following scope:

Design and manufacturing of coffee-based drink and snack & food dispensers

Further clarifications regarding the applicability of ISO 9001:2015 requirements may be obtained by consulting the organization

has implemented and maintains a

Quality Management System

which fulfills the requirements of the following standard

ISO 9001:2015

Issued on: 2017 - 11 - 27

First issued on: 1994 - 06 - 01

for the validity date, please refer to the original certificate issued by IMQ*

Registration Number: IT - 12979



Alex Stoichitoiu
President of IQNET



Ing. Claudio Provetti
President of CISQ

IQNet Partners:**

AENOR Spain AFNOR Certification France APCER Portugal CCC Cyprus CISQ Italy
CQC China CQM China CQS Czech Republic Cro Cert Croatia DQS Holding GmbH Germany FCAV Brazil
FONDONORMA Venezuela ICONTEC Colombia Inspecta Certification Finland INTECO Costa Rica
IRAM Argentina JQA Japan KFQ Korea MIRTEC Greece MSZT Hungary Nemko AS Norway NSAI Ireland PCBC Poland
Quality Austria Austria RR Russia SIGE México SII Israel SIQ Slovenia SIRIM QAS International Malaysia
SQS Switzerland SRAC Romania TEST St Petersburg Russia TSE Turkey Vincotte Belgium YUQS Serbia
IQNet is represented in the USA by: AFNOR Certification, CISQ, DQS Holding GmbH and NSAI Inc.

* This attestation is directly linked to the IQNet Partner's original certificate and shall not be used as a stand-alone document

** The list of IQNet partners is valid at the time of issue of this certificate. Updated information is available under www.iqnet-certification.com



THE INTERNATIONAL CERTIFICATION NETWORK

CERTIFICATE

CISQ/IMQ as an IQNet Partner hereby states that the organization

EVOCA SPA con socio unico

VIA ROMA 24 - 24030 VALBREMBO (BG)
VIA DEL CHIOSO 13 - 24030 MOZZO (BG)
VIA GRAZIA DELEDDA 16 - 24030 MAPELLO (BG)
VIA SALVO D'ACQUISTO 7/9 - 24050 GRASSOBBIO (BG)

for the following scope:

Design, manufacturing by laser cutting, punching, bending, welding of coils and assembling operations, of electronical and electromechanical vending machines

has implemented and maintains a

Environmental Management System

which fulfills the requirements of the following standard

ISO 14001:2015

Issued on: 2017 - 11 - 27

First issued on: 1997 - 12 - 19

for the validity date, please refer to the original certificate issued by IMQ*

Registration Number: IT - 8753



Alex Stoichitoiu
President of IQNET



Ing. Claudio Provetti
President of CISQ

IQNet Partners:**

AENOR Spain AFNOR Certification France APCER Portugal CCC Cyprus CISQ Italy
CQC China CQM China CQS Czech Republic Cro Cert Croatia DQS Holding GmbH Germany FCAV Brazil
FONDONORMA Venezuela ICONTEC Colombia Inspecta Certification Finland INTECO Costa Rica
IRAM Argentina JQA Japan KFQ Korea MIRTEC Greece MSZT Hungary Nemko AS Norway NSAI Ireland PCBC Poland
Quality Austria Austria RR Russia SIGE México SII Israel SIQ Slovenia SIRIM QAS International Malaysia
SQS Switzerland SRAC Romania TEST St Petersburg Russia TSE Turkey Vinçotte Belgium YUQS Serbia
IQNet is represented in the USA by: AFNOR Certification, CISQ, DQS Holding GmbH and NSAI Inc.

* This attestation is directly linked to the IQNet Partner's original certificate and shall not be used as a stand-alone document

** The list of IQNet partners is valid at the time of issue of this certificate. Updated information is available under www.iqnet-certification.com



THE INTERNATIONAL CERTIFICATION NETWORK

CERTIFICATE

CISQ/IMQ as an IQNet Partner hereby states that the organization

EVOCA SPA con socio unico

VIA ROMA 24 - 24030 VALBREMBO (BG)

MOZZO (BG) - MAPELLO (BG) - GRASSOBBIO (BG) - PONTE SAN PIETRO (BG) - ZANICA (BG)

for the following scope:

Design, manufacturing by laser cutting, punching, bending, welding of coils and assembling operations, of electronical and electromechanical vending machines

has implemented and maintains a
Health and Safety Management System
which fulfills the requirements of the following standard

BS OHSAS 18001:2007

Issued on: 2017 - 11 - 27

First issued on: 2014 - 11 - 28

for the validity date, please refer to the original certificate issued by IMQ*

Registration Number: IT - 97010



Alex Stoichitoiu
President of IQNET



Ing. Claudio Provetti
President of CISQ

IQNet Partners:**

AENOR Spain AFNOR Certification France APCER Portugal CCC Cyprus CISQ Italy
CQC China CQM China CQS Czech Republic Cro Cert Croatia DQS Holding GmbH Germany FCAV Brazil
FONDONORMA Venezuela ICONTEC Colombia Inspecta Certification Finland INTECO Costa Rica
IRAM Argentina JQA Japan KFQ Korea MIRTEC Greece MSZT Hungary Nemko AS Norway NSAI Ireland PCBC Poland
Quality Austria Austria RR Russia SIGE México SII Israel SIQ Slovenia SIRIM QAS International Malaysia
SQS Switzerland SRAC Romania TEST St Petersburg Russia TSE Turkey Vinçotte Belgium YUQS Serbia
IQNet is represented in the USA by: AFNOR Certification, CISQ, DQS Holding GmbH and NSAI Inc.

* This attestation is directly linked to the IQNet Partner's original certificate and shall not be used as a stand-alone document

** The list of IQNet partners is valid at the time of issue of this certificate. Updated information is available under www.iqnet-certification.com

English

INTRODUCTION	2	PROGRAMMING	23
TRANSPORT AND STORAGE	2	NORMAL OPERATION MODE	23
IN CASE OF FAILURE	3	NAVIGATION	24
IDENTIFICATION OF THE MACHINE AND ITS FEATURES	3	ACCESS TO PROGRAMMING	24
POSITIONING THE VENDING MACHINE	4	NAVIGATION MODE	24
TECHNICAL FEATURES	4	FILLER MENU	25
CLEANING AND FILLING	7	STATISTICS	25
HYGIENE AND CLEANING	8	INDIVIDUAL PRICE	26
USING THE DISPENSERS OF HOT DRINKS IN OPEN CANISTERS	8	MANAGEMENT OF CHANGE TUBES	26
CONTROLS AND INFORMATION	9	TEST DISPENSING	26
LOADING PRODUCTS	9	TECHNICIAN MENU	27
COFFEE BEANS	9	FAILURES	27
INSTANT PRODUCTS	9	PROGRAMMING PARAMETERS	28
CLEANING WASTE TRAYS	10	STATISTICS	36
CLEANING MIXERS AND FOOD CIRCUITS	11	TEST	38
CLEANING THE BREW UNIT	12	MISCELLANEOUS	39
CLEANING THE MILK TANK	12	MAINTENANCE	41
CLEANING AND FILLING THE WATER SUPPLY TANK	12	GENERAL FOREWORD	41
SERVICE INTERRUPTION	12	MAIN SWITCH	41
SERVICE FUNCTIONS	13	BREW UNIT MAINTENANCE WITH VARIABLE CHAMBER	42
INSTALLATION	14	CLEANING AT REGULAR INTERVALS	43
UNPACKING THE VENDING MACHINE	15	CLEANING MIXERS AND FOOD CIRCUITS	43
WATER SUPPLY	15	CLEANING THE SHELF AND INSTANT PRODUCT CANISTERS	45
ELECTRICAL CONNECTION	16	BOARD FUNCTION	45
PAYMENT SYSTEM ASSEMBLY	17	CPU ACTUATION BOARD	46
DECALCIFIER	17	SOFTWARE UPDATE	47
INSERTING SELECTION LABELS	17	USER INTERFACE BOARD	47
FIRST POWER ON	18	BOILER CONTROL BOARD	48
FILLING THE WATER CIRCUIT	18	EXPANSION BOARD FOR PAYMENT SYSTEMS	48
INITIALIZATION	19	BOILER HEAT PROTECTION	48
FIRST SANITISATION	19	APPENDIX	49
OPERATION	20		
BREW UNIT CYCLE WITH VARIABLE CHAMBER	20		
DECAFF DISPENSING CYCLE	21		
CONTROLLING AND ADJUSTING SETTINGS	21		
GRINDING REGULATION	22		
COFFEE DOSE REGULATION	22		

Introduction

The technical documentation supplied is an integral part of the equipment and it must therefore accompany the equipment whenever it is either moved or transferred to enable the various operators to consult it.

Before starting to install and use the machine, it is necessary to carefully read and understand the content of the documentation since it can supply important information on installation safety, utilisation rules and maintenance operations.

The manual is divided into three chapters.

The **first chapter** is intended to describe the ordinary filling and cleaning operations that shall be carried out in areas of the machine that can be accessed with the simple use of the door key, without using any other tool.

The **second chapter** contains the instructions for correct installation as well as the information necessary for optimal utilisation of the machine performance.

The **third chapter** is intended to describe the maintenance operations involving the use of tools for access to potentially dangerous areas.

The operations described in the second and third chapter must be carried out only by the personnel who have a specific knowledge of the machine operation from the point of view of electric safety and health rules.

TRANSPORT AND STORAGE

TRANSPORT

To avoid damaging the machine, loading and unloading operations shall be performed with great care.

It is possible to lift the machine by means of a motor-driven or manual lift truck by positioning the forks beneath the machine.

Please avoid:

- overturning the machine;
- dragging the machine by means of ropes or alike;
- lifting the machine by its sides;
- lifting the machine by means of slings or ropes
- shaking or impacting the machine and its package.

STORAGE

The storage environment needs to be dry and of a temperature between 32 and 104 °F.

If the appliance freezes, it must be conditioned in environments with temperatures between 32 and 104 °F.

Wait until the appliance's temperature reaches the same temperature as its surrounding environment before switching it on.

IN CASE OF FAILURE

In most cases, any technical problem can be solved by carrying out minor operations. As a consequence, we suggest carefully reading this manual before contacting the manufacturer.

In case of failures or malfunctions that can not be solved, please apply to:

EvocaS. p. A.
Via Roma 24
24030 Valbrembo
Italy - Tel. +39 035606111

IDENTIFICATION OF THE MACHINE AND ITS FEATURES

Every single machine is identified by a specific serial number that can be found on the rating plate arranged inside on the right side.

The plate is the only one recognised by the manufacturer and it contains all the data that enable the manufacturer to supply technical information of any kind in a quick and safe manner and to facilitate the management of spare parts.

Fig. 1

1. Product code
2. Type
3. Model
4. Operating voltage
5. Absorbed power
6. Boiler data
7. Serial number
8. Operating voltage frequency
9. Current
10. Water system features

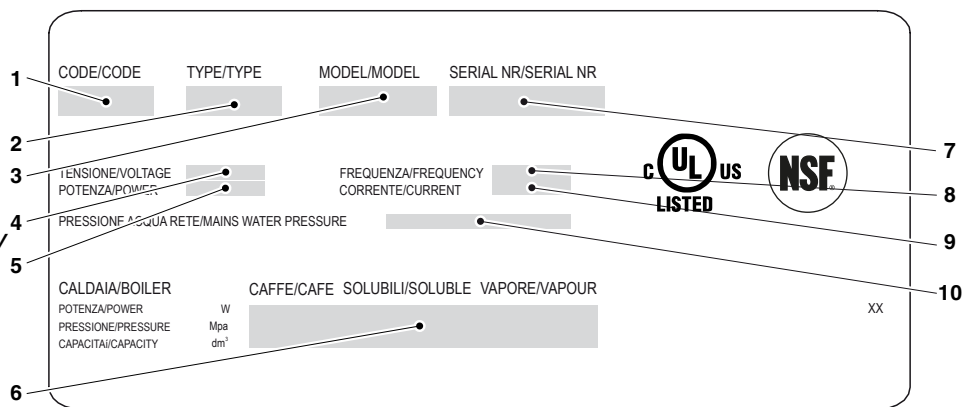

POSITIONING THE VENDING MACHINE

The machine is not suitable for installation outdoors. It must be installed in a dry room and **far from any source of heat** at a temperature ranging from 35.6 to 89.6°F It can not be installed in a room where water jets are used for cleaning (e.g. large kitchens, etc.).

The machine must be installed near a wall, but in such a way that the back is min. 2 in. far from the wall in order to provide for regular ventilation; in no case, it shall be covered with any piece of cloth or alike.

The maximum inclination shall not exceed 2 degrees. If necessary, level it by using the adjustable feet.

Positioning on a cabinet

The machine can be arranged on a table or any other proper support (recommended height 32.68 in.).

It is advisable to use - where possible - the cabinet intended to accommodate the waste tray, the water self-supply kit and, if water is very hard, the decalcifier.

TECHNICAL FEATURES

Height	in.	28,15
Height upper panel open	in.	36,22
Width	in.	13,03
Depth	in.	20,79
Overall dim. with open door	in.	28,5
Cabinet height	in.	32,68
Weight	Lbs.	72,75
Power supply voltage	V~	120
Power supply frequency	Hz	60
Maximum power	W	1400

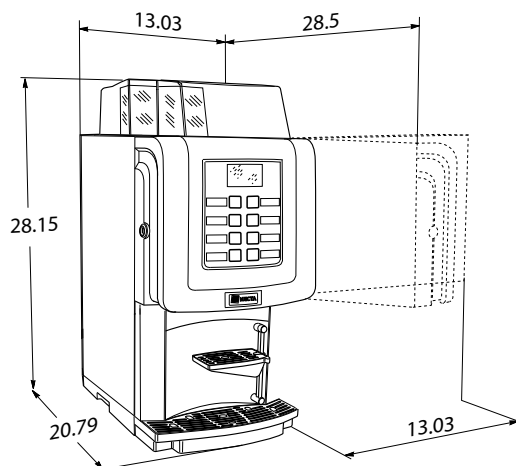

Fig. 2

CHAUFFE-EAU

Capacité de 20,29 oz avec résistance de 1100 W.

NOISE LEVEL

The weighted continuous equivalent sound pressure level is less than 70 dB.

PAYMENT SYSTEM

The machine can use special kits to mount payment systems with an Executive, MDB or BDV protocol.

The payment systems shall be arranged inside the side module (optional).

SALES PRICES

The machine can manage up to 4 different prices for each selection.

Prices can be active according to the (standard or promotional) time band you have set up.

Prices are grouped in 4 lists. For each one of the 4 lists, you can set up the price globally (the price is the same for all selections) and for every single selection.

WATER SUPPLY

- Mains: with a pressure between 0.05 and 0.85 MPa (0.5 and 8.5 bar)

or

- Tank: arranged in an external module or in the support cabinet..

POSSIBLE ADJUSTMENTS

- Coffee beans granulometry
- Coffee beans dose
- Volumetric water doses;
- Time-based instant product doses
- Boiler temperature adjustable from the menu

CONTROLS

- water presence
- coffee presence
- boiler operation temperature reached
- solid waste tray presence
- liquid waste tray presence

SAFETY DEVICES

- main switch
- door switch
- upper panel switch
- solid waste tray presence
- liquid waste tray presence
- boiler safety thermostats manually resettable
- air-break float jam (only if supplied by the mains)
- overflow solenoid valve (only if supplied by the mains)
- time-based protection for:
 - pump
 - coffee unit ratio-motor grinder
- heat protection of:
 - ingredient motors
 - coffee unit ratio-motor
 - electromagnets
 - pump
 - whipper motors
 - grinder motor
- protection with fuse board supply transformer

CANISTER CAPACITY

Canister capacities are expressed in grams and they may deviate from indications, depending upon the specific weight of products

- Coffee beans (1)	Lbs. 3,09
Coffee beans (2)	Lbs. 1,98
- Instant chocolate (3)	Lbs. 2,76
- Instant tea (4)	Lbs. 2,2
Instant coffee (4)	Lbs. 2,2

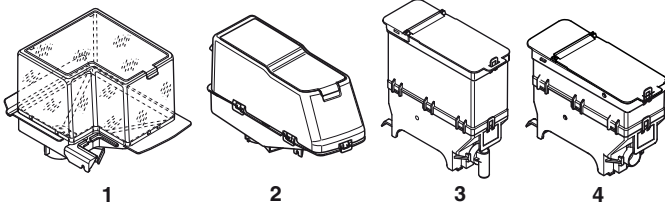

Fig. 3

ACCESSORIES

A wide range of accessories can be mounted on the machine to vary its performances:

The assembly kits are supplied with mounting and testing instructions that shall be strictly followed to preserve the machine safety.

The installer is the sole person responsible for any damage improper installation may cause to the machine or to things and people.

Important !!!

The use of kits not type-approved by the manufacturer can not guarantee the observance of safety standards, in particular for live parts.

The manufacturer declines all responsibility for the use of non type-approved components.

Assembly and any subsequent testing operation must be carried out by qualified personnel who have a specific knowledge of the machine operation from the point of view of electric safety and health rules.

Chapter 1 Cleaning and filling

MAIN SWITCH

A main switch outside the machine is intended to power off the machine.

Attention !!!

The line cable terminal board, the fuses and the interference suppressor remain anyway live.

DOOR SWITCH

When the door is open, you are not allowed to access any live part.

Ordinary filling and cleaning operations can be carried out in fully safe conditions.

UPPER PANEL SWITCH

When the upper panel is open, you are not allowed to access any live part.

Ordinary filling and cleaning operations can be carried out in fully safe conditions.

All the operations requiring the machine to be directly connected to a source of electricity must be only carried out by the personnel qualified and informed on the specific risks involved.

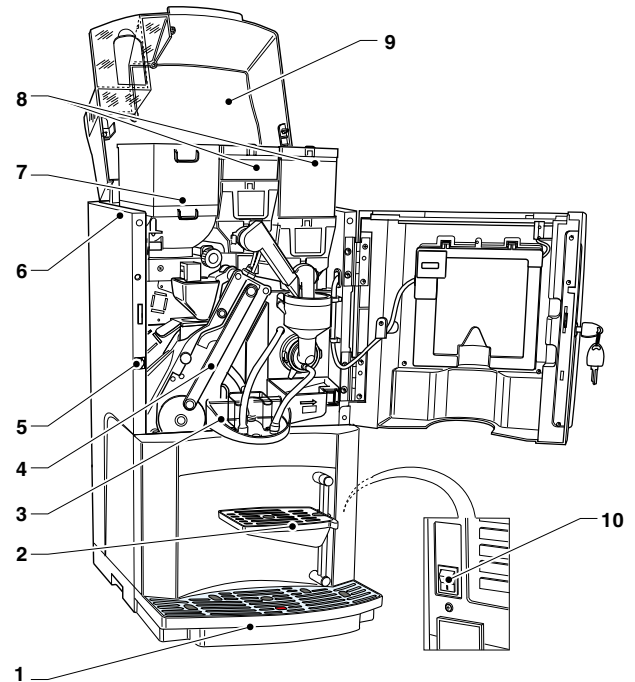

Fig. 4

1. Liquid waste tray
2. Cup support
3. Nozzle support
4. Brew unit
5. Door switch
6. Upper panel switch
7. Coffee beans canister
8. Instant powder canister
9. Upper panel
10. External main switch

HYGIENE AND CLEANING

This manual shows the potential critical points and gives the instructions necessary to control any bacterial proliferation.

On the basis of the health and safety rules in force, the operator of the vending machine shall apply the self-control procedures established according to the provisions of the HACCP (Hazard Analysis Critical Control Point) directive and the national laws.

At the time of the installation, it is necessary to completely sanitise the water circuits and the parts in contact with foodstuffs in order to remove any bacterium that may have built up during storage.

It is recommended to use sanitising products to clean the surfaces, even if not directly in contact with foodstuffs.

Some parts of the machine can be damaged by corrosive detergents.

The manufacturer disclaims all responsibility for any damage caused by the non-observance of the above or the use of aggressive or toxic chemical agents.

Never forget to power off the machine before carrying out any maintenance operation requiring the disassembly of components.

USING THE DISPENSERS OF HOT DRINKS IN OPEN CANISTERS

(e.g. plastic cups, pottery cups, jugs)

The dispensers of drinks in open canisters may be only used for selling and dispensing drinks obtained by:

- brewing coffee

- reconstituting instant or freeze-dry packed products.

These products shall be declared as "suitable for automatic dispensing" in open canisters by the manufacturer.

Products must be preserved in strict observance of the manufacturer's instructions for storage, preservation temperature and pull date.

Dispensed drinks shall be consumed immediately. Under no circumstance shall they be preserved and/or packed for later consumption

Any other use shall be considered as improper and thus potentially dangerous.

CONTROLS AND INFORMATION

The labels including the selections and instructions are supplied with the machine and they shall be inserted at the time of the installation. Refer to the selection dose table.

The controls and information for the user are arranged outside the door.

The “Programming” button, to access the machine functions, and “mixer wash” button are located inside the machine on the right side of the button board.

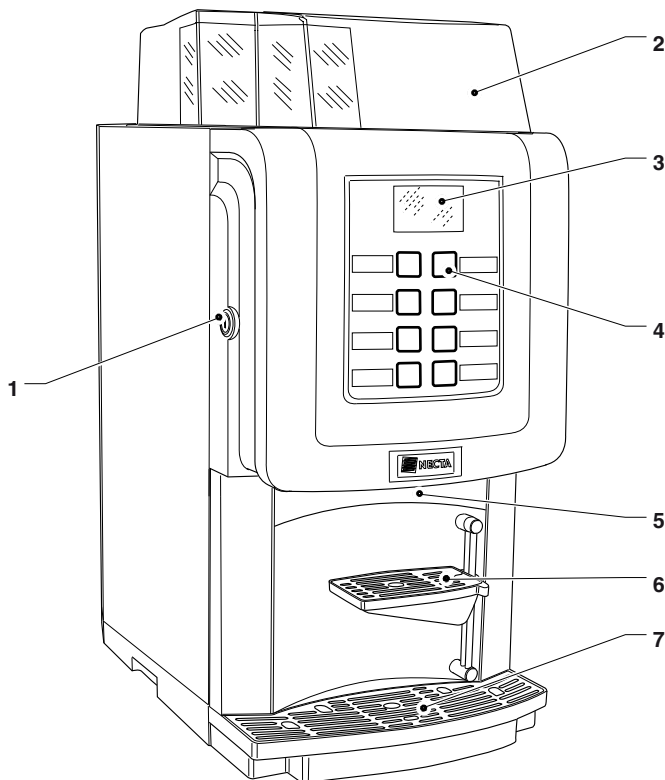

Fig. 5

1. Lock
2. Display
3. Selection label
4. Selection buttons
5. Dispensing nozzles
6. Cup support
7. Signal float
8. Liquid waste tray

LOADING PRODUCTS

Before loading products make sure that they have been preserved according to the producer’s instructions for storage, preservation temperature and pull date.

Load the products by observing the information supplied here below.

Products may even be loaded if canisters are partially full.

Do not exceed the maximum capacity of the canisters.

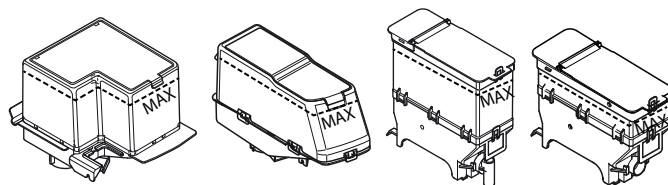

Fig. 6

COFFEE BEANS

Lift the cover and fill in the coffee canister; make sure that the canister shutter is completely open.

It is advisable to use good quality coffee to avoid any machine malfunction due to the presence of impurities.

INSTANT PRODUCTS

Lift the cover and fill in the instant powder canister with the product to be dispensed.

Never compress powder to avoid packing.

Make sure that the instant products you have loaded are not lumpy.

CLEANING WASTE TRAYS

LIQUID WASTE

When the signal float surfaces from the grill, empty the liquid waste tray promptly. It is advisable not to wait for the float signal, but to empty the tray at regular intervals.

To remove the tray:

- Took the tray by its sides, lift it slightly and pull.
- Empty the tray and wash it with a neutral detergent solution

SOLID WASTE

The coffee beans canister capacity is greater than the solid waste tray capacity (if the support cabinet is not used).

The equipment signals that the maximum number of coffee-based dispensing cycles has been reached. The following message will appear: "Empty the tray".

The machine will lock after some dispensing cycles.

If no solid waste tray is available, the machine is still ready to dispense instant drinks: the message "insert the tray" is displayed

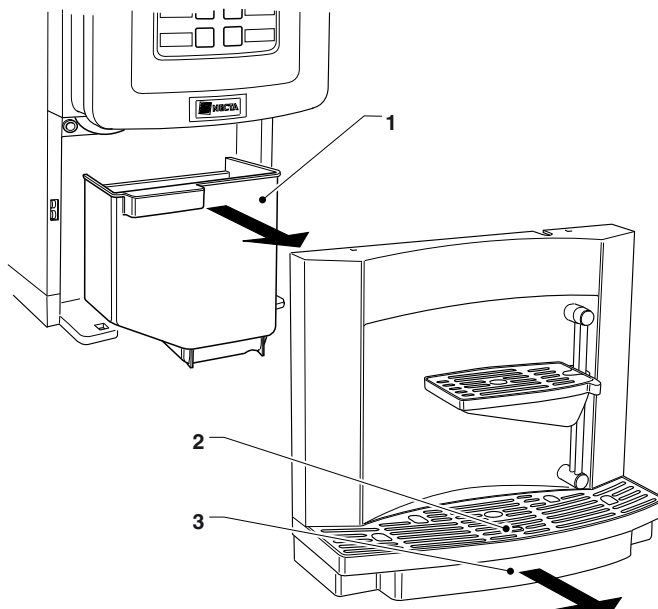

Fig. 7

1. Solid waste tray
2. Signal float
3. Liquid waste tray

CLEANING MIXERS AND FOOD CIRCUITS

The mixers and the conduits for dispensing instant drinks shall be carefully sanitised at the time of the installation of the machine and at least once a week or more frequently, according to the use of the machine, the inlet water quality and the products in use, in order to provide for hygiene on dispensing products.

It is absolutely forbidden to use water jets for cleaning.

The parts to be cleaned are:

- powder deposit drawer, powder funnel, mixers and instant drink dispensing conduit;
- dispensing nozzles;
- nozzle support;

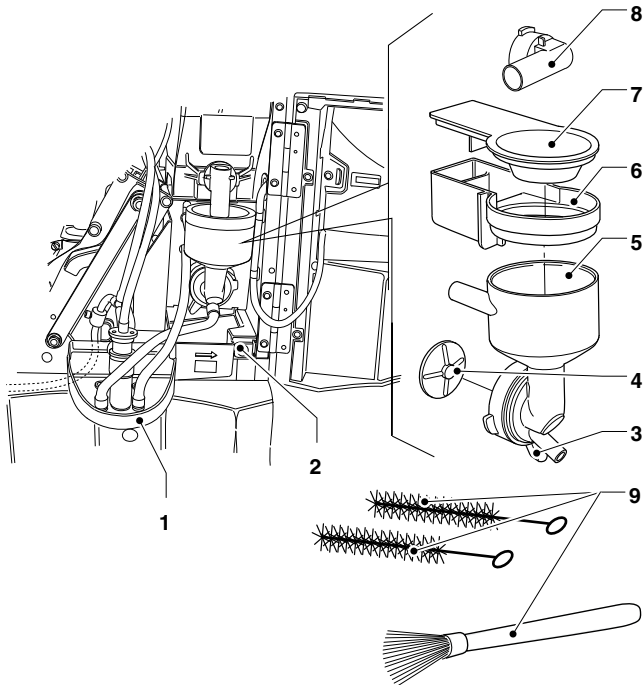

Fig. 8

1. Nozzle support
2. Nozzle support release button
3. Water funnel fastening ring nut
4. Mixer impeller
5. Water funnel
6. Powder deposit drawer
7. Instant powder funnel
8. Powder conveyor
9. Brushes for cleaning hoses and " splash zone "

To clean the mixers, act as follows:

- rotate the product conveyor upwards
- rotate the water funnel fastening ring nut counterclockwise and remove the powder funnels, the powder deposit drawers and the water funnels
- unscrew the mixer impeller; to unscrew, use a finger to hold the toothed disk mounted on the whipper motor shaft firm

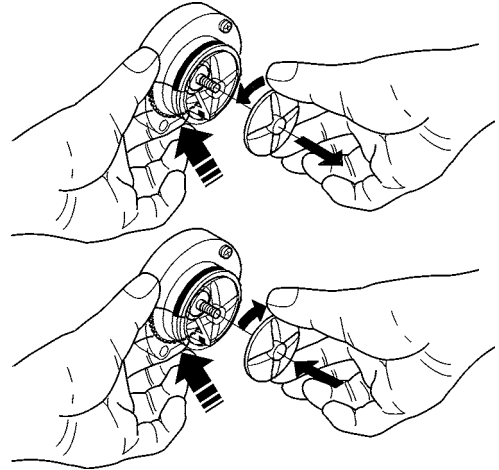

Fig. 9

Sanitise by making use of sanitising products.

- dip the components into a container with the sanitising solution you have prepared before for about 20' and make sure that you have mechanically removed visible residues and films by using, if necessary, pipe cleaners and brushes;
- rinse and carefully dry all parts
- reassemble the mixer impeller;
- re-position the water funnel and rotate the fastening ring nut clockwise
- reassemble the powder deposit drawers and the powder funnels
- rotate the powder conveyor downwards.

After having assembled the parts, act as follows, any way:

- Wash the mixers and add some drops of the sanitising solution into the various funnels.
- After having sanitised, rinse the parts abundantly to remove any residue of the solution in use.

All the operations requiring the machine to be directly connected to a source of electricity must be ONLY carried out by the personnel qualified and informed on the specific risks involved.

CLEANING THE BREW UNIT

Whenever you fill or at least once a week, it is recommended to remove any powder residue from the external parts of the brew unit, in particular in the funnel area, the filters and the scrapers.

CLEANING THE MILK TANK

Models with cappuccinatore only.

Every day or at the end of the service empty the milk tank and remove all residues; sanitise it and make sure that you have mechanically removed visible residues and films by using, if necessary, pipe cleaners or brushes.

CLEANING AND FILLING THE WATER SUPPLY TANK

Clean the tank at least once a week for the machines using the water tank

- Discharge the residual water from the tank
- Sanitise the tank; make sure that any visible residue and film has been removed by using pipe cleaners or and brushes.
- Fill in the tank with drinkable water up to the maximum level (specified on the tank)

SERVICE INTERRUPTION

If the machine should remain off for any reason for a long period of time, act as follows:

- empty the canisters completely and wash them carefully by means of sanitising products.
- empty the grinders completely and dispense till an empty message is displayed.
- close the cock upstream from the water supply tube and empty the water circuit completely
- detach the machine from the mains.

SERVICE FUNCTIONS

If enabled in the programming menu, some operations can be directly carried out when the door is closed by entering the relative password.

Press key 7 and hold it down for over two seconds.

Enter the relative password to:

- dispense several selections consecutively to fill in a jug (jug facilities);
- dispense a selection freely (for models with payment system only)
- lock-unlock the keyboard.
If the keyboard lock is active, the "INTERRUPTED SERVICE" message is displayed.
- mixer wash.
The mixer shall be washed every day and whenever products are loaded to prevent the product from accidentally falling (during the load cycle) and from clogging the mixer.

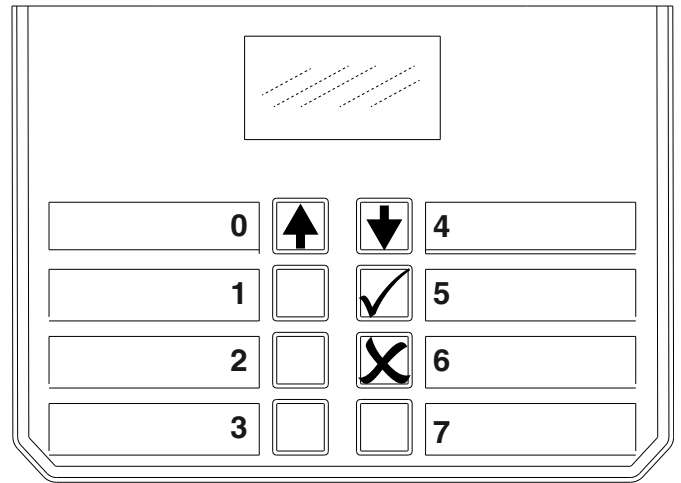

Fig. 10

Chapter 2 Installation

Installation and any subsequent maintenance operation must be carried out when the **machine is live** and, therefore, by the personnel skilled and trained on the use of the machine as well as aware of the specific risks such a condition may involve.

The machine must be installed in a dry room at a temperature ranging from 32 to 104°F. It can not be installed in a room where water jets are used for cleaning (e.g. large kitchens, etc.).

L'appareil doit être installé dans des environnements où il peut être surveillé par du personnel qualifié.

At the time of the installation, it is necessary to completely sanitise the water circuits and the parts in contact with foodstuffs in order to remove any bacterium that may have built up during storage.

MAIN SWITCH

A main switch outside the machine is intended to power off the machine.

Attention !!!

The line cable terminal board, the fuses and the interference suppressor remain anyway live.

DOOR SWITCH

When the door is open, you are not allowed to access any live part.

Only the parts protected by covers and signalled by the following symbol remain live inside the machine.



Before removing these covers, detach the power supply cable from the mains.

Insert the key into the slot to power on the machine (when the door is open).

The power on key shall not be left inside the machine, it must be kept by the skilled personnel trained on how to use the machine.

UPPER PANEL SWITCH

When the upper panel is open, you are not allowed to access any live part.

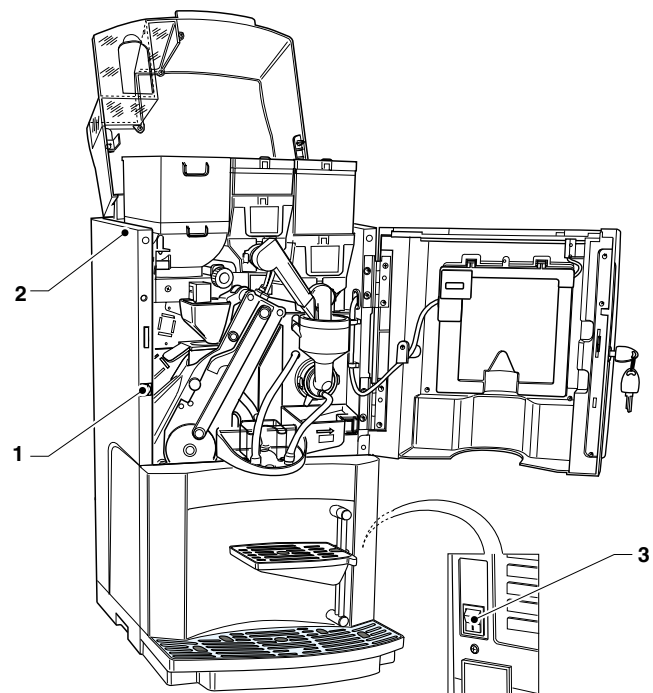

Fig. 11

1. Door switch
2. Upper panel switch
3. Main switch

UNPACKING THE VENDING MACHINE

After having unpacked the machine, make sure that the equipment is intact.

In case of doubt never use the equipment.

No packing material (plastic bags, foam polystyrene, nails, etc.) should be left within the reach of children since they are potential sources of danger.

Packing materials shall be disposed of in authorised dump sites and recyclable ones collected by specialised companies.

Important!!

The machine must be arranged in such a way that the maximum inclination will not exceed 2°.

If necessary, level it by using the adjustable feet supplied with the machine.

WATER SUPPLY

The vending machine must be supplied with drinkable water according to the provisions in force in the place of installation of the equipment.

WATER SUPPLY FROM THE TANK

For the models using a tank, sanitise and then fill in the tank with drinkable water

WATER SUPPLY FROM THE MAINS

For models with water supply from the mains only.

The mains pressure must range from 7,3 to 123,3 psig (0,5 - 8,5 bar).

Let water come out of the water network until it is limpid and free of any trace of dirt.

Connect the water mains with the 3/4" union of the water inlet solenoid valve by means of a tube (also available as a kit) that can support the mains pressure and of a type suitable for foodstuffs (min. inner diameter 6 mm.).

It is recommended to apply a cock on the water network outside the machine in an accessible position.

To connect the machine with the water network, use sets of new gaskets and tubes only.

Never re-use the existing material.

OVERFLOW DEVICE

The water inlet solenoid valve is complete with an overflow device that can mechanically lock the water inlet as a result of a malfunction of the solenoid valve or the boiler water level control gear.

To restore the normal operation, act as follows:

- discharge water in the overflow tube;
- close the water network cock outside the machine;
- loosen the union intended to fasten the supply tube of the solenoid valve to discharge the residual network pressure and tighten it again.
- open the cock and power on the machine.

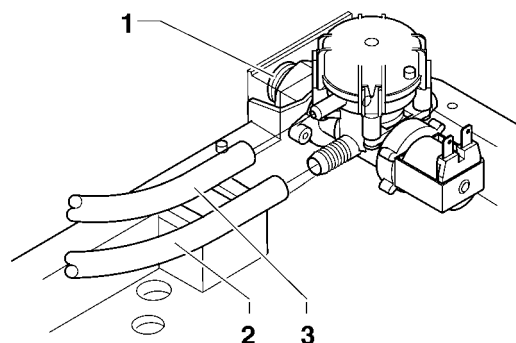

Fig. 12

1. 3/4" inlet union
2. Supply tube
3. Overflow tube

ELECTRICAL CONNECTION

The machine requires a single phase voltage of 120 V~

For connection make sure that the rating plate data correspond to the mains data, in particular: the supply voltage value must lie within the range recommended for the connection points;

It is absolutely necessary to use a main switch in compliance with the installation rules in force, placed in an accessible position. It shall be featured in such a way that it can support the maximum load required as well as ensure complete disconnection from the mains on the conditions of overvoltage category III and, therefore, the protection of circuits against earth faults, overloads and short-circuits.

The switch, the power socket and the corresponding plug shall be located in an accessible position.

The electrical safety of the machine is only ensured when the machine is correctly and efficiently grounded according to the safety standards in force.

It is necessary to check this fundamental safety requirement and, in case of doubt, to require professionally qualified personnel to check the installation carefully.

The supply cable is of a flexible type with a fixed plug.

It is forbidden to use adapters, multiple sockets and/or extensions.

The manufacturer disclaims all responsibility for any damage caused by the non-observance of the precautions mentioned above.

LINE CABLE REPLACEMENT

The power supply cable has a non-separable plug; The replacement of the connection cable shall be carried out only by qualified personnel and using only cables of the type SJTO 3x14AWG 105 °C BLACK with NEMA 5-15P certified plug.

To replace the cable, after disconnecting the device from the power supply, it is necessary to open the hinged lid and connect the new cable.

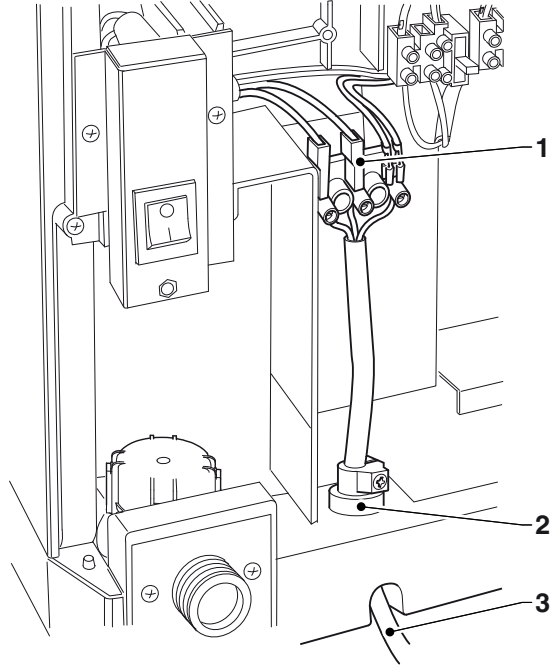

4. Connection terminal board
5. Cable clamp
6. Mains cable

PAYMENT SYSTEM ASSEMBLY

The machine is sold without any payment system. As a consequence, only the installer will be liable for any damage that may be caused to the machine or to things and persons by an incorrect installation of the payment system.

Payments systems, such as validators, “change-giver” and “cashless”, can be used by means of the specific kits.

Kits are equipped with specific instructions. Payment systems, such as “change giver”, must be physically housed in the special side module (optional).

DECALCIFIER

The machine is supplied without a decalcifier.

In case of connection with a network, the water of which is very hard, mount a decalcifier.

Use decalcifiers, the capacity of which is suitable for the actual use of the machine. In case of supply from the tank, filtering cartridges can be used.

The cartridges must be replaced at regular intervals, according to the water quality and the manufacturer’s instructions.

Decalcifiers, even available as an accessory, shall be regenerated or replaced according to the manufacturer’s instructions at regular intervals.

INSERTING SELECTION LABELS

Selection labels are supplied with the machine.

Use the labels according to the layout and the language (see the “selection dose” table).

Act as follows:

- Open the door
- Remove the button board cover
- Insert the selection labels into the slots. Observe the arrangement of the labels according to the layout you have chosen.
- Re-position the cover

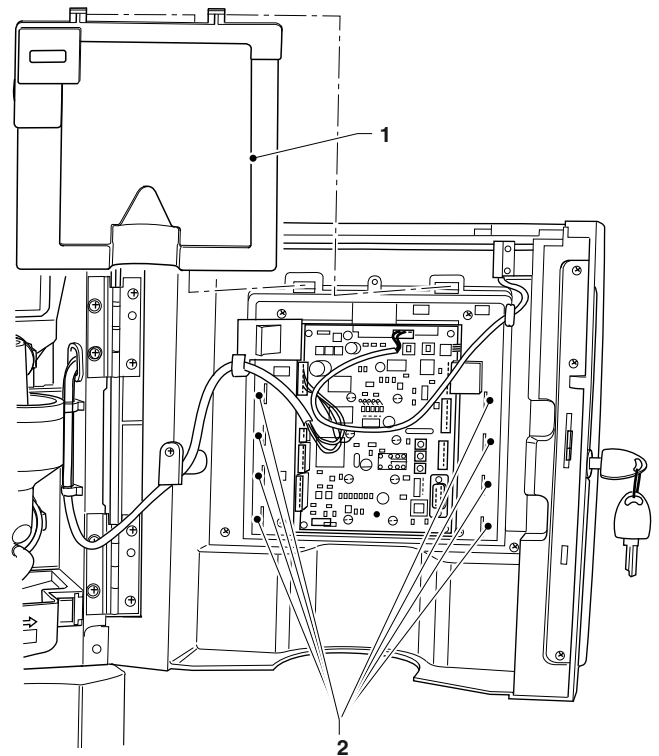

Fig. 13

1. Button board cover
2. Slots
3. Selection labels

FIRST POWER ON

As soon as you power on the machine for the first time, fill in the hydraulic circuit.

You can programme the machine to enable the function intended to display the checks you shall perform before setting the machine at work, i.e.:

- Tubing (nozzles, etc.)
- Mixer
- Powder conv. (powder conveyor)
- Coffee shutter
- Power on

The request "Do you confirm?" is displayed for all checks.

Press any selection key to continue.

The function intended to supply the list of preliminary checks can be enabled (disabled by default) from the programming menu.

The software release number of the machine is displayed at the end.

You can programme the machine to display the number of dispensing cycles you have made for some seconds.

The operator is prompted to select a drink after heating.

FILLING THE WATER CIRCUIT

MODELS WITH TANK

When you power on for the first time, carry out the installation procedure manually.

Start programming in the "technician" mode and use the "manual installation" special function of the "test" menu (see the relative chapter).

MODELS SUPPLIED BY THE MAINS

When powered on, the machine will check the air break conditions (full or empty), the pump and the boiler priming (either pressurised or not).

If necessary, the machine will automatically start an installation cycle, i.e.:

- the display will show "Installation" for the whole duration of the cycle;
- the mains solenoid valve is opened or the pump started to fill the air-break;
- the milk solenoid valve will open to bleed the air in the boiler and in the water circuit and to let 400 cc. water flow in.

Please Note: If there is no water during the installation cycle, the machine will stop till the water flow is restored or the machine is powered off.

important!!!

If a considerable amount of air bubbles is formed in the water circuit, e.g. due to maintenance, an installation cycle may be automatically performed as soon as the machine is powered on.

INITIALIZATION

This function shall be used in case of error of the data in the memory or if the software is replaced.

All the statistical data, with the exception of the general electronic counter, will be reset.

When the display is in the "Initialization" function, it is possible to initialize the machine by resetting all the default data.

When the confirmation key ✓ is pressed, the display will show the message "Confirm?". If the confirmation key ✓ is pressed again, some parameters will be requested such as:

- **NATION:** meaning the type of basic doses for the various selections (i.e. IT coffee = 60 cc - FR coffee = 106 cc).
The "nations" provided vary, depending on the model.

- **LAY OUT:** for each model and type of doses, there are a number of button-Selection Un Certain combinations among Which it is possible to choose (the For Each layout combinations at the doses are indicator-table selections Supplied with the machine).

- **TANK:** It defines whether the water is supplied:
0 - from mains
1 - from internal tank

By confirming the options, the message "Execution" is displayed for a few seconds..

FIRST SANITISATION

As soon as you install the machine, carefully disinfect the food circuits (brew unit, mixer, conduits for dispensing drinks, internal tanks, ...) in order to guarantee the hygiene of dispensed products.

It is absolutely forbidden to use water jets for cleaning.

Sanitise by making use of sanitising products.

Wash the mixers by adding some drops of sanitising solution; then, wash the brew unit completely.

After having sanitised, rinse the mixers abundantly to remove any residue of the solution in use.

To dispense water in the mixers, use the rinse function from the "wash" menu.

Important !!!

The machine is equipped with an automatic washing system for the mixers, the brew unit and the milk circuit.

If the machine is not used for a long time (week ends etc.), even for less than two days, it is recommended to enable the automatic washing functions (e.g. before starting to use the machine).

OPERATION

The following paragraphs describe the operation of the main components of the machine.

BREW UNIT CYCLE WITH VARIABLE CHAMBER

Whenever you request for a selection based on coffee beans, coffee will fall into the brew chamber arranged vertically.

The ratio-motor crank coupled on the disk outside the unit rotates by 180°, thus causing the brew chamber to swing.

The pump is activated and the water pressure will cause the upper piston to lower down into the brew chamber and slightly compress ground coffee.

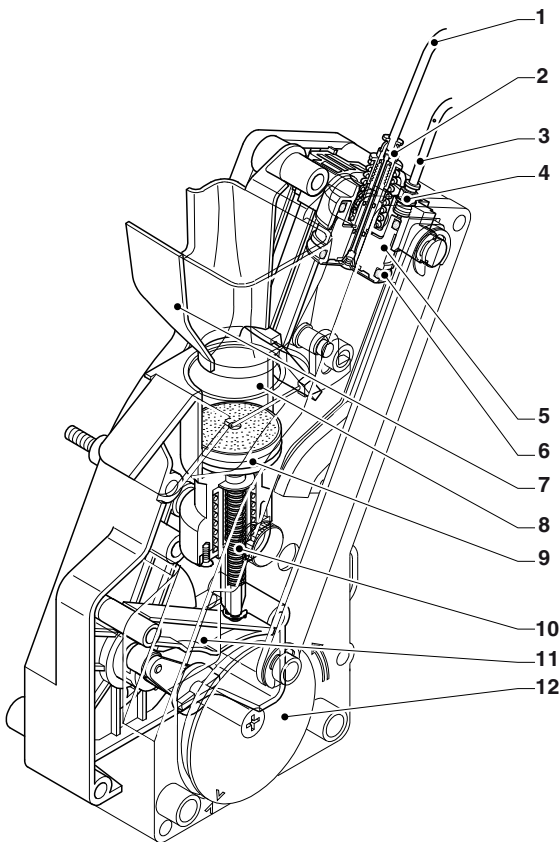

Fig. 14

1. Boiler connection tube
2. Central quick coupling
3. Piston pressure tube
4. Quick coupling for piston pressure tube
5. Upper piston
6. Upper piston gasket
7. Coffee funnel
8. Brewing chamber
9. Lower filter
10. Pre-brewing spring
11. Swinging lever
12. External disk

Due to the water pressure, the pre-brewing spring sinks and the lower piston goes down 4 mm, thus forming a water cushion which allows an even use of the coffee dose.

At the end of the dispensing cycle and during a 3-second pause, the pre-brewing spring will discharge the water layer through the third way of the dispensing solenoid valve, lightly pressing the used coffee dose.

The purge solenoid valve opens to discharge the upper piston pressure.

By completing its rotation, the ratio-motor makes the swinging lever lift the pistons and the coffee dose.

While the brewing chamber is returning to its vertical position, the scraper on the coffee funnel prevents the used coffee dose from moving, dropping it.

The lower piston returns to the bottom dead centre.

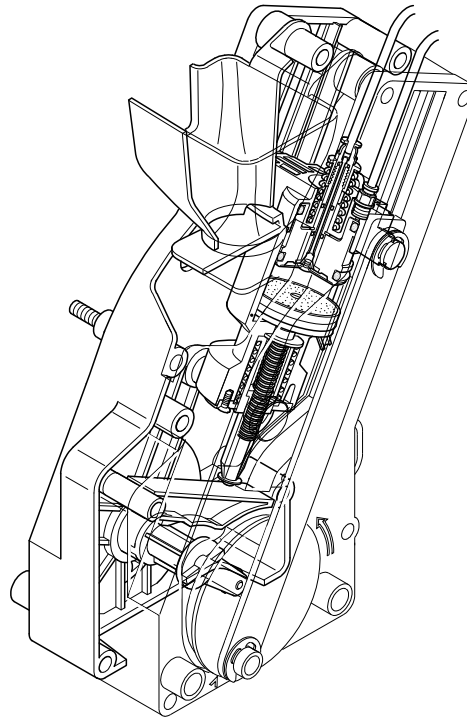

Fig. 15

DECAFF DISPENSING CYCLE

When the machines are supplied (whenever the decaff funnel is available), the decaff flap is locked

As required by the location, you may decide to unlock the flap in order to be able to pour decaffeinated coffee or alike manually

It is necessary to make sure that no other type of products is poured.

A magnet arranged on the flap for pouring decaff coffee will signal to the machine by means of a sensor on the door that the flap has been opened.

The following message will flash on and off on the display: decaffeinated

The selections based on decaffeinated coffee are dispensed without acting on the grinder.

The brew cycle is the same as the espresso coffee cycle.

If the decaff dispensing cycle is cancelled before dispensing, the “decaffeinated” pre-selection is cancelled.

The machine will rotate the brew unit to discharge the decaff power that has been poured.

CONTROLLING AND ADJUSTING SETTINGS

To achieve the best results compared with the product in use, it is recommended to check:

- The used coffee dose shall be slightly compressed and moistened.
- The granulometry of ground coffee
- The coffee dose of ground coffee
- The dispensing temperature
- The water dose.

GRINDING REGULATION

If it is necessary to change the grinding degree, properly act on the corresponding grinder knob:

to grind	knob rotation
coarsely	counterclockwise (grinding wheels are moved farther)
finely*	clockwise (grinding wheels are moved closer)

*The finer the grinding degree, the longer the time required to dispense the coffee and viceversa.

It is recommended to vary the grinding degree during the operation of the coffee-grinder motor.

Please Note: after having changed the grinding degree, make at least 2 selections to check the new granulometry of ground products more carefully.

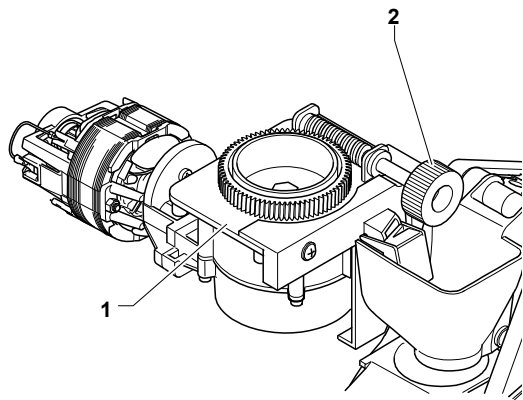

Fig. 16

1. Grinder
2. Grinding regulation knob

COFFEE DOSE REGULATION

A sensor is arranged on the grinder to count the rotations of the grinding wheels. This will enable the software intended to control the machine to establish the number of turns and, therefore, the number of coffee grams associated with every single selection.

Follow the programming procedures to establish how many grams of ground product (from 5.5 to 7.5 gr.) shall be associated with every single selection.

To take the dose, just remove the coffee unit and select the corresponding item from “Special functions” of the “Technician” menu.

Notes on Programming

The electronic control unit of the machine controls the use of many functions.

The programme of the machine contains a description of all the foreseen functions, including those which, for the specific configuration of the model (layout), are not used.

The machine is supplied together with:

- Selections layout, which contains the selections foreseen for the specific model
- Flow chart of the programming menu.

Described below is a summary of the main functions which are useful for managing the operation of the machine, not necessarily in the order in which they are displayed in the menu.

The software version can be updated using the appropriate systems (PC, UpKey, etc.)

The display messages which show the operation in progress are steady-on, while any action requested of the user flashes.

The status of the machine can be in three different modes.

Depending on the status in which the machine is, the buttons of the keyboard assume different functions.

NORMAL USER

- Machine start-up (door closure) with the execution of the foreseen checks.
- Operations that can be done with the door closed.
- Dispensing selection and messages to the user.

LOADER MENU

- Detection of statistical data and execution of simple checks on the operation and on the dispensed items.

TECHNICAL MENU

- Programming of the settings and of the performances of the machine.

NORMAL OPERATION MODE

The message requiring the user to select a drink will appear on the display during the normal operation.

The animation showing the drink preparation level is displayed during the dispensing cycle.

If the control system should find out a failure, an error message will appear and specify the type of problem.

At the end of the dispensing cycle, the display shows the message: DRINK READY

NAVIGATION

ACCESS TO PROGRAMMING

To access the programming menus, power on the machine when the door is open by acting on the door switch.

To access the programming mode, press the “programming” button arranged inside the machine door.

The machine has access to the “filler menu”, use key χ to switch from the “filler menu” to the “technician menu” and vice-versa.

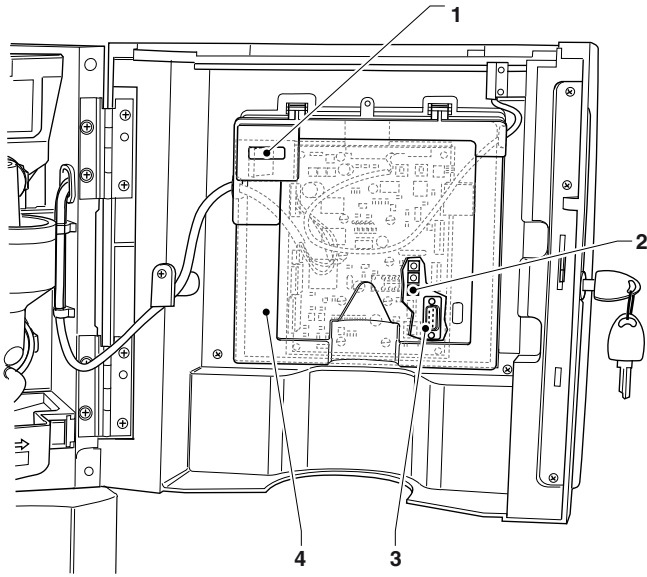

Fig. 17

1. General mechanical counter
2. Programming button
3. RS232 serial port
4. Button board cover

NAVIGATION MODE

The interaction between the system and the operator occurs through:

DISPLAY

Display intended to show the user messages or the menu items.

Programming menus are represented as follows:

```
Menu item
Selected menu item
Menu item
Menu item
Menu item
Menu item
TECH> 2.1
```

Selected menu item

The menu item on which the cursor is positioned

```
TECH> 2.1
```

It specifies the menu, in which we are acting (Filler or Technician), followed by the numeric position of the function, on which the cursor is placed (e.g. 2.1)

KEYBOARD

SCROLLING KEYS **↓** AND **↑** :

To scroll the menu items (functions).

To vary the logic status of a data item (ON/OFF) or to enter/modify alphanumeric values within functions, where required.

ENTER KEY **✓** :

To move from a menu to a sub-menu or to confirm the data item on the display.

EXIT KEY **✕** :

To go back from a sub-menu to the upper level menu or to cancel the function.

It is also used to move from the “Technician” mode to the “Filler” mode and vice versa.

NUMERIC VALUES OF KEYS

When the control software requires the operator to enter a password, the keyboard will assume the numeric values specified.

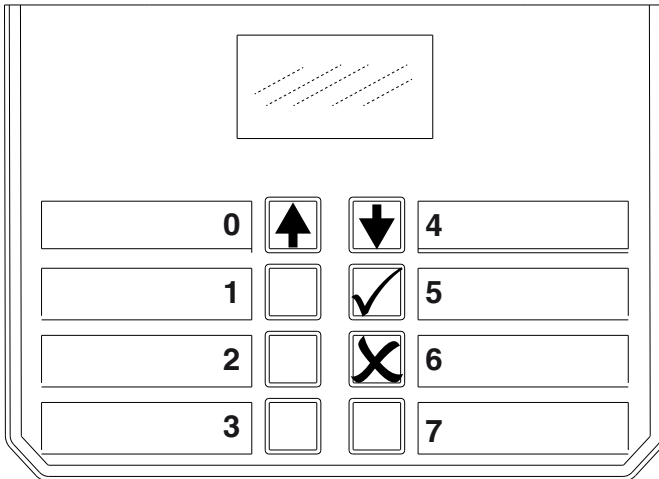

Fig. 18

FILLER MENU

STATISTICS

All the machine operation data are stored in total and relative counters that can be reset without losing total data.

PRINT

This function is intended to print the data that have been stored for the machine operation.

Connect an RS232 serial printer having 9600 baud rate, 8 data bits, no parity, 1 stop bit with the serial port on the button board in order to print all statistics, i.e.:

TOTAL

- 1 - counter by selection;
- 2 - counter by band;
- 3 - discount counter;
- 4 - failure counter;
- 5 - coin mechanism data.

RELATIVE

- 1 - counter by selection;
- 2 - counter by band;
- 3 - discount counter;
- 4 - failure counter;
- 5 - coin mechanism data.

The machine code, the date and the software release will be also printed.

To print, act as follows:

- From the print function press key **✓** to display “Do you confirm?”;
- connect the printer;
- Press the Enter key **✓** to start printing

DISPLAY

The function is intended to sequence-display the same data you can obtain by printing statistics.

Press the Enter key ✓ to sequence-display the following data:

TOTAL COUNTERS

- 1 - counter by selection;
- 2 - counter by band;
- 3 - discount counter;
- 4 - failure counter;
- 5 - coin mechanism data.

RELATIVE COUNTERS

- 1 - counter by selection;
- 2 - counter by band;
- 3 - discount counter;
- 4 - failure counter;
- 5 - coin mechanism data

DELETE

Statistics can be reset for relative counters either globally (all types of data) or selectively for:

- selections
- discounts
- failures
- coin mechanism data

Press the Enter key ✓ to display the blinking message: "Do you confirm?"

Press the Enter key ✓ to reset the statistics. The display shows the "Running" message during the operation and statistics are reset.

INDIVIDUAL PRICE

The machine can manage up to 4 different prices per selection, which can be active according to the time band you have set (standard or promotional) and/or the payment system in use.

Use this function to vary the sales price for every single selection by selecting among the price ranges available.

MANAGEMENT OF CHANGE TUBES

This function is active only if this operation can be carried out by the payment system you have set up.

Access the function to manually load or empty the change tubes.

If you confirm loading,

"Credit : ——" will appear on the display.

This is the value of the money made available in the tubes for the change. If you insert a coin into the validator, the display will increase the value of the money made available in the tubes for the change.

If you confirm unloading, you can establish the tube on which you wish to act. Whenever you press the Enter key ✓, a coin is ejected by the active tube.

TEST DISPENSING

Possible test dispensing cycles are listed here below (for every single selection):

- Complete dispensing
- Water-only dispensing
- Powder-only dispensing

Please Note For the selections based on espresso coffee, partial powder and water dispensing cycles are intended to dispense additions only; if no addition is involved in the selection, the display will show "Disabled Sel".

TECHNICIAN MENU

Press key **x** from the “Filler” mode to set the machine to the “Technician menu” mode.

Press key **x** to go back to the Filler mode from any first-level function.

FAILURES

The machine is equipped with several sensors intended to control the various functional units.

As soon as a malfunction is found out, the type of failure is displayed and the machine (or part of it) is set out of order.

The failures are stored in special counters. The failures managed by the software may be related to functional groups not available on the specific model.

CURRENT FAILURE READOUT

Function used to display the current failures.

Press the Enter key **✓** to display the current failures.

If there is no failure at the moment, press the Enter key **✓** to display the “Failure end” message.

Possible failures are listed here below:

- No water

For the models supplied from the tank: the machine stops if the magnetic sensor of the tank is activated.

or

For the models supplied from the mains: if the air-break microswitch remains closed for a minute, the water inlet solenoid valve is energised, waiting until the water flow is restored.

- Waste container full

Espresso coffee based selections are disabled as soon as you reach the number of used doses you have set up in the menu.

- Air-break

The machine is locked if the air-break microswitch has never signalled the lack of water after a well-defined number of volumetric counter pulses.

- Volumetric counter (impeller)

The volumetric counters (impellers) fail to count within a maximum time limit.

- Espresso boiler

The machine will stop working if after 10 minutes of heating from start-up or from last selection the water in the boiler has not reached the temperature.

- Steam boiler

The selections using steam are disabled if the boiler has failed to reach the operation temperature after the maximum heating time after the power on or after the latest selection

- coin box

if it receives a pulse for more than 2 seconds on a line of the validator or if the dialog with the coin box is interrupted for more than 30 seconds (Executive protocol) or 75 seconds (BDV protocol).

- Machine lock

The machine stops if it has reached the number of coffee and instant selections you have separately set up by means of the “selection counter” function

- Grinder lock

If the grinder is not rotating or it is rotating too slowly, the espresso coffee-based selections are disabled. The selections based on decaffeinated coffee remain available

- Espresso unit

It is due to a mechanical lock of the brew unit; the machine disables coffee-based selections.

- No coffee
If the grinder exceeds usual grinding speed for over 5 seconds, the selections based on espresso coffee are disabled. The selections of all instant products remain available
- Coffee dispenser
Coffee-based selections are disabled if the doser microswitch should signal the presence of coffee in the doser chamber after having released the dose of ground products.
- RAM data
One or more areas of the RAM memory contain altered data which was corrected with the default values. The machine continues to work, but it is preferable to proceed with the initialization as soon as possible.
- Coffee out of order
The machine stops when reaching the number of coffee selections you have separately set up by means of the "selection counter" function.
- Instant out of order
The machine stops when reaching the number of coffee selections you have separately set up by means of the "selection counter" function.

FAILURE RESET

Confirm the function to reset all current failures, if any.

PROGRAMMING PARAMETERS

CASH

Models with payment system only.

This group of functions is intended to manage all the parameters relative to the payment systems and sales prices.

PRICES OF SELECTIONS

For every single selection it is possible to set four different prices, the operation of which will vary according to the time bands, if enabled.

Prices can be programmed (from 0 to 65,535) globally (the same price for all selections) or on a selection basis, for each one of the 4 time bands.

If you have to sell most products at the same price, it will be advisable to programme the price globally and to change the price of the selections having a different sales price.

TIME BANDS

Four time bands can be programmed for the sale of products at different prices.

Time bands can be programmed by hour (from 00 to 23) and by minute (from 00 to 59) at the start and at the end.

If the start-of-band and end-of-band values are equal to 00.00, the band is disabled.

The time of reference is represented by an internal clock that can be programmed by: day/month/year week-day 1-7 and then by hour/minutes/seconds.

COIN MECHANISMS

You can decide which protocols to enable for the payment systems available and manage the relative functions.

The following payment systems are available:

- Executive
- Validators
- BDV
- MDB

If you choose one of the systems, you can manage its functions.

EXECUTIVE

The following payment systems are arranged for the Executive system:

- Standard
- Price Holding
- Coges
- U-Key
- Sida

VALIDATORS

When the display is positioned on the "Validat. Lines" function (line programming) of the "programming" menu, you can vary the value of the 6 coin lines of the validator from A to F.

BDV

The BDV protocol menus enable the user to define the following functions.

TYPE OF DISPENSING

To set the operation mode by multiple or single dispensing. In case of multiple dispensing, the change is not automatically given at the end of a successful delivery, but the credit will remain available for further dispensing. If you press the coin return button, the remaining credit will be returned if its value is lower than the maximum change value.

MAXIMUM CREDIT

Use this function to define the maximum accepted credit for inserted coins.

MAXIMUM CHANGE

You can set a limit on the total amount of the change the coin mechanism will pay as soon as you press the change button or after one single dispensing.

The credit exceeding the amount you have programmed by this function will be cashed.

CHANGE REFUSED

To enable/disable the credit return if no dispensing has been performed.

If enabled, this function will provide for the return of the coins even if the first dispensing cycle has not occurred.

If a delivery has failed for any reason whatsoever, the change will be returned, upon request.

ACCEPTED COINS

To define which coins shall be accepted among those recognised by the validator.

For the coin/value correspondence check the label showing the position of the coins on the coin mechanism.

COINS ACCEPTED FOR CHANGE

To program the refusal of a coin in case of "exact amount".

For the coin/value correspondence check the label showing the position of the coins on the coin mechanism.

EXACT CHANGE EQUATION

To define the combination of empty tubes intended to set the coin mechanism to the "exact amount" mode. All possible combinations of empty tubes are listed here below.

For reasons of simplicity, the combination is described with reference to tubes A, B and C, where tube A will receive the lowest-value coins and tube C the highest-value coins.

0	=	A or (B and C)
1	=	A and B and C
2	=	A and B only
3	=	A and (B or C)
4	=	A only
5	=	A or B only (default)
6	=	A or B or C
7	=	A or B only
8	=	A or C only
9	=	B and C only
10	=	B only
11	=	B or C only
12	=	C only

DISTRIBUTION BUTTONS

Use this function to enable or disable the buttons arranged on the coin mechanism in order to discharge the coins in the change tubes.

COINS ACCEPTED FOR CHANGE

To program the refusal of a coin in case of "exact amount".

For the coin/value correspondence check the label showing the position of the coins on the coin mechanism.

EXACT CHANGE EQUATION

To define the combination of empty tubes intended to set the coin mechanism to the "exact amount" mode. All possible combinations of empty tubes are listed here below.

For reasons of simplicity, the combination is described with reference to tubes A, B and C, where tube A will receive the lowest-value coins and tube C the highest-value coins.

0	=	A or (B and C)
1	=	A and B and C
2	=	A and B only
3	=	A and (B or C)
4	=	A only
5	=	A or B only (default)
6	=	A or B or C
7	=	A or B only
8	=	A or C only
9	=	B and C only
10	=	B only
11	=	B or C only
12	=	C only

DISTRIBUTION BUTTONS

Use this function to enable or disable the buttons arranged on the coin mechanism in order to discharge the coins in the change tubes.

C.P.C. UNIT

It is intended to inform the coin mechanism whether some peripheral units have been installed or removed from the serial connection (peripheral units of the C.P.C type - the default control unit is always enabled).

EXACT CHANGE (MINIMUM TUBE LEVEL)

To warn the user in advance to "Insert exact amount" by adding a number of coins between 0 and 15 to the number of coins that has been programmed to establish the state of full change tubes.

VMC FREE SALE

Most of the payment systems complete with a BDV protocol is intended to manage the free sale function.

However, there are some payment systems not having this function.

In this case, it is necessary to enable the VMC (vending machine control, disabled by default) free sale and to set the price of selections to zero if some selections are dispensed on a free basis.

MDB

The MDB protocol menus enable the user to define the following functions.

TYPE OF DISPENSING

To set the operation mode by multiple or single dispensing. In case of multiple dispensing, the change is not automatically given at the end of a successful delivery, but the credit will remain available for further dispensing. If you press the coin return button (if the function is enabled), the remaining credit will be returned up to the maximum change value.

CREDIT RETURN (ESCROW LEVER)

To enable/disable the credit return (by pressing the change return key) if no dispensing has been performed.

If enabled, this function will provide for the return of the coins even if the first dispensing cycle has not occurred.

If a delivery has failed for any reason whatsoever, the change will be returned.

MAXIMUM CREDIT

Use this function to define the maximum accepted credit for inserted coins.

MAXIMUM CHANGE

You can set a limit on the total amount of the change the coin mechanism will pay as soon as you press the change button or after one single dispensing.

The credit exceeding the amount you have programmed by this function will be cashed.

ACCEPTED COINS

To define which coins shall be accepted among those recognised by the validator when the change tubes are full.

For the coin/value correspondence check the coin mechanism configuration.

RETURNED COINS

To define which coins shall be used to give the change among those available in the tubes. This parameter is active only with the coin mechanisms not intended to manage the choice of the tube in use automatically (Auto changer payout).

For the coin/value correspondence check the coin mechanism configuration.

ACCEPTED BILLS

To define which bills shall be accepted among those recognised by the reader.

For the bill/value correspondence check the reader configuration.

MINIMUM TUBE LEVEL

To set a number of coins between 0 and 15 in order to establish the state of full change tubes and to warn the user to "insert the exact amount"

COINS ACCEPTED FOR EXACT CHANGE

To define which coins shall be accepted among those recognised by the validator when the machine is in the "exact amount" mode.

For the coin/value correspondence check the coin mechanism configuration.

BILLS ACCEPTED FOR EXACT CHANGE

To define which bills shall be accepted among those recognised by the reader when the machine is in the "exact amount" mode.

For the bill/value correspondence check the reader configuration.

COMMON FUNCTIONS**IMMEDIATE CHANGE**

The amount relative to a selection is generally cashed after the machine has sent the "Successful selection" signal.

If you enable this function, which is disabled by default, the cash signal is sent at the start of the dispensing cycle.

The setup of this parameter is compulsory.

DECIMAL POINT POSITION

To set up the decimal point position, i.e.:

0: decimal point disabled

1: XXX.X (one decimal digit after the point)

2: XX.XX (two decimal digits after the point)

3: X.XXX (three decimal digits after the point).

SELECTIONS

WATER DOSE

For every single selection you can set the water dose for every single product composing the selection; the display shows the name of the selection you are acting on.

MANAGEMENT OF MIXERS

For every single selection key you can set the duration of the mixing cycle for every single water dose composing the selection. The duration can be set in two different modes.

absolute

i.e. not depending upon the opening time of the solenoid valve. The duration of the mixing cycle is set in tenths of a second for instant models and in volumetric counter pulses for Espresso models.

relative

i.e. by way of difference, either in excess or in default, compared to the closing time of the solenoid valve.

The duration of the mixing cycle is always expressed in tenths of a second.

SOLENOID VALVE FLOW RATE

You can set the flow rate value of every single solenoid valve in cc/s (the cc/s value set by default is supplied by the selection dose table) to enable the user to calculate the cc that shall be dispensed.

POWDER DOSE

For every single selection key you can set the powder dose expressed in grams for every single product composing the selection. The display will show the name of the product you are acting on.

You can also programme the doses of a product "Globally", i.e. by acting on all selections by means of one single operation.

DOSER FLOW RATE

To set the flow rate value of every single doser in gr/s.

SELECTION STATE

You can define for every single selection key whether to enable it or not.

KEY/SELECTION ASSOCIATION

To change the order of the selections associated with the keyboard.

The display shows the list of selections in sequence. Press the destination key to store the association.

SELECTION NO. CHECK

To check the selection number associated with a key.

DISPENSING MACHINE PARAMETERS

BOILER TEMPERATURE

Use this function to set the operating temperature, expressed in °C, of the boiler/s. Press the Enter key ✓ from the function. The temperature value will flash on and off and it can be modified by pressing key ▲ and ▲ .

TANK

The unit can be supplied with water from the mains or from an internal tank.

Use this function to define:

- Tank OFF: water supply from the mains;
- Tank ON: water supply from a tank with water level sensor
- Equipped cabinet: water supply from a tank with no level control.
The last option is intended to override the coffee waste count in the tray.

Wash key enable Use this function to enable the operation of the mixer wash button. The key is generally disabled.

POWER ON CONTROLS

You can enable or disable (ON/OFF) the request to confirm the messages intended to test the machine status (Tubing...?, mixer...?, etc.) and press a key for confirmation.

BUZZER

If the function is enabled, the machine will produce a sound signal as soon as you press a key and at the end of the selection.

MAINTENANCE COUNTER SETUP

As soon as you access the “filler menu”, you can display the “replace the water filter” message after a programmable number of dispensing cycles.

If it is set up in the programming menu, you can reset the message by entering a password after having replaced the filter when the door is closed.

AUTOMATIC WASH

You can set the time at which you wish to wash the mixers automatically and to rotate the brewing units.

If you set 12.00 p.m., the function is disabled (default).

ENERGY SAVING

Use this function to power off the heating of boilers and/or the lights for external lighting in order to save electric energy whenever the machine is not used.

2 power-off time bands can be programmed on a weekly basis. The days of the week are identified by a progressive number (1= Monday, 2= Tuesday, etc.).

The same time band can not include days of different weeks.

If you should mistakenly set up overlapping time bands, the machine will remain on for the shortest period.

For example, if you wish to set up the energy saving bands to operate the machine from 07.00 a.m. to 10.00 p.m. during the days of the week and to let it off on Saturdays and on Sundays, you shall set up the time bands according to the following table by using the corresponding menu.

Day		1	2	3	4	5	6	7
Band 1	start	00.00	00.00	00.00	00.00	00.00	00.00	00.00
	end	07.00	07.00	07.00	07.00	07.00	23.59	23.59
Band 2	start	22.00	22.00	22.00	22.00	22.00	00.00	00.00
	end	23.59	23.59	23.59	23.59	23.59	00.00	00.00

DECAFF CYCLE

Enable this function to dispense the instant coffee powder (if available) in two cycles in order to improve the drink presentation.

- ON: to dispense first decaffeinated powder and then water
- OFF: to dispense powder and water at the same time.

EQUIPPED CABINET

Enable this function to manage the water level signaller as unavailable and to disable the coffee waste count.

The float and the coffee waste collection functions are performed by the devices in the cabinet.

SELECTION COUNTER

Use this function to lock the machine after a programmable number of coffee dispensing cycles and after a programmable number of instant dispensing cycles. As an alternative, you can lock the machine after a programmable number of dispensing cycles.

Since it is a control device that can be used by the Manager only, enter a 5-digit password to have access to it.

After having entered the password, you can set the number of dispensing cycles, after the performance of which the machine is locked, read the number of dispensing cycles you have already performed and reset the lock counters.

Please Note: Counters are set to zero by default;

If the counters are set to zero, this function is disabled.

NO COFFEE

Use this function to enable or disable the “pour coffee” message on the display if the grinder should exceed the usual grinding speed for over 5 seconds.

HEATING TIME OUT

After the power on, to enable the machine to reach operation conditions, the availability of selections is delayed by a programmable time interval.

WATER COUNTER ACTIVATION

If you enable this function, the mechanical counter will count hot water dispensing cycles as selections.

DISPLAY

LANGUAGE

It is possible to choose the language, among those foreseen by the software, used for the messages shown on the touchscreen.

PROMOTIONAL MESSAGE

ENABLING THE PROMOTIONAL MESSAGE

Use the function to enable the display of the promotional message you have set up.

PROMOTIONAL MESSAGE SETUP

The 4-line message can be composed by using **▲** and **▼** to scroll all available characters.

If you press the Enter key **✓** the first character you can modify will flash on and off. Press key **x** to store the message.

PROMOTIONAL IMAGE

To enable/disable the promotional image on the display in the normal operation mode:

- ON: the message “Select a drink” and the promotional image are alternated every 3 seconds in the normal operation mode
- OFF: only the message “Select a drink” is displayed in the normal operation mode

CONTRAST REGULATION

Use this function to regulate the display contrast from min. 5% to max. 99% (default).

PRE-SELECTIONS

Use this function to act on the selection-associated preselections available on a specific model and layout.

For every single preselection you can decide whether to enable it or not, the key for association, the change in the selection price and the change percentage of the product dose.

MISCELLANEOUS

JUG FACILITIES

On some models complete with a special key you can obtain a number (programmable from 1 to 9.5 by default) of cup-free selections in order to fill in a jug.

PASSWORD

PASSWORD SETUP

It is a 5-digit numeric code you are required to enter to access the programming mode. The value of this code is set to 00000 by default

PASSWORD ENABLE

To enable or disable the request for password function for access to the programming mode. The request for password is disabled by default.

COUNTER RESET PASSWORD

Use this function to set the password you shall type in the normal operation mode (door closed) to reset the selection counters.

If the password is set to 00000, the password is disabled.

MULTIPLE DISPENSING PASSWORD

To set the password you shall type in the normal operation mode (door closed) to dispense several selections in consecutive mode to fill in a jug (jug facilities).

If the password is set to 00000, the password is disabled.

FREE VEND PASSWORD

Enter the password to dispense a drink without inserting any credit.

KEYBOARD LOCK PASSWORD

Use the function to set up the password (to be entered when the door is closed) to enable/disable the selection keyboard lock.

The "Service interruption" message will appear on the display during the key lock.

If the password is set to 00000, the password is not active.

WASHING PASSWORD

Use this group of functions to set:

-Mixer washing password

Password to be entered in the normal operation mode (door closed) to wash the mixers.

The keyboard assumes the numeric values supplied by the figure at the beginning of the chapter.

-Unit washing password

Password to be entered in the normal operation mode (door closed) to wash the espresso unit.

The keyboard assumes the numeric values supplied by the figure at the beginning of the chapter.

TEST SELECTION PASSWORD

To set up the password you shall type in the normal operation mode (door closed) to access the maintenance/programming mode and to perform test selections.

If the password is set to 00000, the password is disabled.

FILTER RESET PASSWORD

Use this function to set up the password necessary to reset the "replace the water filter" message when the door is closed and to reset the corresponding counter after having replaced the filter.

FILLER MENU ENABLE

To set up which functions of the filler menu shall be enabled and which of them shall be disabled.

The reference numbers of the menus do not change even if some are disabled.

STOP SELECTION

To enable the “dispensing stop” function of a drink.

While dispensing a drink, you can stop the dispensing cycle manually by pressing the required selection key once again.

EXTRACTION FAN MANAGEMENT

Makes it possible to enable or disable the operation of the fan extracting instant powder residue and/or steam during the preparation of instant drinks.

- ON extractor fan in continuous operation
- OFF extractor fan in operation only during the preparation of the drink and for the 30 subsequent seconds.

STATISTICS

All the machine operation data are stored in total and relative counters that can be reset without losing total data.

ELECTRONIC COUNTER

DISPLAY THE ELECTRONIC COUNTER

An electronic counter is intended to store all the dispensing cycles you have performed since you last reset it in an aggregated manner.

RESET THE ELECTRONIC COUNTER

You can reset the electronic counter.

DISPLAY VENDS AT THE START-UP

To enable / disable the display of the total number of dispensing cycles that have been made since you last reset the statistics, while you are powering on the machine.

PRINT

This function is intended to print the data that have been stored for the machine operation.

Connect an RS232 serial printer having 9600 baud rate, 8 data bits, no parity, 1 stop bit with the serial port on the button board in order to print all statistics, i.e.:

TOTAL

- 1 - counter by selection;
- 2 - counter by band;
- 3 - discount counter;
- 4 - failure counter;
- 5 - coin mechanism data.

RELATIVE

- 1 - counter by selection;
- 2 - counter by band;
- 3 - discount counter;
- 4 - failure counter;
- 5 - coin mechanism data.

The machine code, the date and the software release will be also printed.

To print, act as follows:

- From the print function press key ✓ to display “Do you confirm?”;
- connect the printer;
- Press the Enter key ✓ to start printing

DISPLAY

The function is intended to sequence-display the same data you can obtain by printing statistics.

Press the Enter key ✓ to sequence-display the following data:

TOTAL COUNTERS

- 1 - counter by selection;
- 2 - counter by band;
- 3 - discount counter;
- 4 - failure counter;
- 5 - coin mechanism data.

RELATIVE COUNTERS

- 1 - counter by selection;
- 2 - counter by band;
- 3 - discount counter;
- 4 - failure counter;
- 5 - coin mechanism data

DELETE

Statistics can be reset for relative counters either globally (all types of data) or selectively for:

- selections
- discounts
- failures
- coin mechanism data

Press the Enter key ✓ to display the blinking message: “Do you confirm?”

Press the Enter key ✓ to reset the statistics. The display shows the “Running” message during the operation and statistics are reset.

MDB PROTOCOL AUDIT

- Aud 1 Money in the tubes
money currently available in the change tubes
- Aud 2 Money to the tubes
Money conveyed to the change tubes
- Aud 3 Money to the coin box
Money conveyed to the coin box
- Aud 4 Change returned
Total amount of the money that has been returned
- Aud 5 Surplus
Surplus money. Amounts paid by the customer in excess and not returned (in case no money is available for change)
- Aud 6 Unloading of tubes
Value of the coins dispensed by means of the “Manage tubes” function
- Aud 7 Loading of tubes
Value of the coins cashed by means of the manual loading function
- Aud 8 Cash sales
Value of the total sales made cash (coins + bills)
- Aud 9 Bills cashed
Value of the bills that have been cashed
- Aud 10 Charge key
Value of the money that has been re-charged on the key
- Aud 11 Key sale
Value of the money that has been cashed through key-dispensing
- Aud 12 Money dispensed manually
Value of the coins that have been manually dispensed through the dispensing buttons on the coin mechanism.
-

BDV PROTOCOL AUDIT

The coin mechanism data are intended to supply the following information in real currency:

- Aud 1 Money in the tubes
money currently available in the change tubes
- Aud 2 Money to the tubes
Money conveyed to the change tubes
- Aud 3 Money to the coin box
Money conveyed to the coin box
- Aud 4 Change returned
Total amount of the money that has been returned
- Aud 5 Money dispensed
Total amount of the money that has been manually dispensed
- Aud 6 Surplus
Surplus money. Amounts paid by the customer in excess and not returned (in case no money is available for change)
- Aud 7 Total sales
Total sales value
- Aud 8 Exact change
Sales value on the "Insert exact amount" condition
- Aud 9 Mixed dispensing
Total dispensing value paid in a different way, e.g. also other types of payment (C.P.C., coin)
- Aud 10 Manual load
Money inserted into the coin mechanism by means of the manual loading function

TEST

TEST DISPENSING CYCLES

Use this function to dispense the following for every single selection when the door is open and without inserting the amount required.

- complete selection
- water only
- powder only

SPECIAL FUNCTIONS

Use this group of functions to:

- Rotate the brew unit
- Release a ground dose
- Empty the boilers (open a solenoid valve for each boiler to let air in if the boiler is emptied for maintenance).
- Fill in the water circuit (manual installation)

AUTOTEST

The function is intended to check the operation of the main machine components half-automatically.

Confirm to start the autotest cycle of the component.

Press "quit / cancel" to skip the autotest for every single component.

Some checks occur automatically, others require the manual operation of the component under check.

The components under test are:

- ingredient motors activated for 2 seconds
- whipper motors activated for 2 seconds at the various speed rates
- Brew unit handled
- Wash button
- Keyboard
- Boiler temperature
- Buzzer
- Coin mechanism

MISCELLANEOUS

MACHINE DATA

The machine can store a series of codes intended to identify it at the time of acquiring statistics.

INSTALLATION DATE

Use this function to store the current system date - if properly set up - as the installation date.

The date is printed at the time of rolling out statistics.

MACHINE CODE

This function is used to change the eight-digit numeric code identifying the machine (0 by default)

OPERATOR CODE

The function is used to change the six-digit numeric code identifying the operator charged to manage groups of machines (0 by default).

INITIALISATION

When the display is set to the “Initialisation” function, you can initialise the machine by restoring all default data.

This function shall be used in case of a memory data error or if the software is replaced.

All statistic data are reset.

Confirm to start the initialisation.

The following parameters are required:

“country”

understood as the type of basic doses for the various selections

(e.g. IT coffee = 45 cc - FR coffee = 80 cc).

The “countries” made available according to models.

“lay out”

a well-defined number of Button-Selection combinations is available for selection for every single model and type of doses (the combinations available for every single lay-out are supplied by the selection dose table supplied with the machine)

Confirm the options to display the message “Running” for some seconds.

“tank”

To define whether water supply occurs:

- ON: water supply from the mains

- OFF: water supply from the internal tank

- Equipped cabinet: from the tank without any signaller

Confirm the options to display the message “Running” for some seconds.

“language”

To define the language used to display messages; use keys **▲** and **▼** to scroll available languages.

UP-KEY

SETUP MANAGEMENT

UPKEY -> VENDING MACHINE

After having inserted the Up key into the plug on the C.P.U. board, this function is used to select the setup file from the list on the display. Press the Enter key to load the setup file you have selected on the machine.

VENDING MACHINE ->UPKEY

After having inserted the Up key into the plug on the C.P.U. board, this function is used to save on the Up key a setup file with the same configuration currently available on the machine.

Please specify the name you wish to assign to the file (e.g. VENDM000.STP)

DELETE

Use this function to delete one or more than one setup file on the up key you have inserted.

DELETE ALL

Use this function to delete all the setup files on the up key you have inserted.

UPKEY STATISTICS MANAGEMENT

VENDING MACHINE ->UPKEY

Confirm this function after having inserted the Up key into the plug on the C.P.U. board to save on the up key the statistics file with all the statistical data currently available on the vending machine. Please specify the name you wish to assign to the file (e.g. VENDM000.STA)

DELETE

Use this function to delete one or more than one statistics file on the up key you have inserted.

DELETE ALL

Use this function to delete all the statistics files on the up key you have inserted.

Chapter 3 Maintenance

The intactness of the machine and its compliance with the standards of relevant installations must be checked by skilled personnel at least once a year.

Never forget to power off the machine before carrying out any maintenance operation requiring the disassembly of components.

The operations described here below must be carried out only by the personnel who have a specific knowledge of the machine operation from the point of view of electric safety and health rules.

GENERAL FOREWORD

To ensure the correct operation all over the time, the equipment must be serviced at regular intervals.

All necessary operations and the relative deadlines are listed here below. Obviously, they are merely indicative since they depend upon operating conditions (e.g. water hardness, humidity and room temperature, type of product in use, etc.).

The operations described by this chapter are not intended to exhaust all maintenance operations.

The most complex operations (e.g. boiler descaling) must be carried out by a technician having a specific knowledge of the vending machine.

In order to avoid any risk of oxidation or chemical corrosion in general, keep stainless steel surfaces well cleaned and painted by using neutral detergents (please avoid any solvent).

It is forbidden to use water jets to wash the machine.

MAIN SWITCH

When the door is open, you are not allowed to access any live part.

Only the parts protected by covers and signalled by the following symbol remain live inside the machine.



Before removing these covers, detach the power supply cable from the mains.

To power on the equipment when the door is open, just insert the key into the slot of the door switch.

You can close the door only after having removed the key from the main switch.

BREW UNIT MAINTENANCE WITH VARIABLE CHAMBER

The brew unit must be serviced, even if slightly, every 10,000 dispensing cycles or, any way, every 6 months.

To provide for maintenance, remove the unit and act as follows:

- Detach the teflon tube for connection with the boiler and the tube for hydraulic control of the upper piston from the upper piston by acting on coloured rings.
- Unscrew the knob fastening the unit to the shelf;
- Remove the brew unit.

Upper filter disassembly

- Unscrew the central quick coupling while retaining the spring.
- Extract the piston from the crosspiece.
- Disassemble the filter and the gasket from the piston.

Lower filter disassembly

- Extract the snap rings from the connecting rods and remove the connecting rods;
- Extract the snap rings from the deviating guides and remove the guides;
- Unscrew the screw from the outer disk
- Unscrew and remove the screws intended to fasten the support shoulders
- Remove the coffee funnel;
- Remove the internal brewing chamber
- Extract the snap ring intended to fasten the lower piston;
- Extract the piston from the brewing chamber and disassemble the filter.

Dip the components you have disassembled into a sanitising solution for 20 minutes. Replace the components if damaged and/or broken.

Rinse abundantly, dry everything and reassemble in the reverse order.

Important!!!

Check the efficiency of gaskets. Lubricate them by using grease for foodstuff.

Make sure that the tubes are properly inserted into the quick couplings.

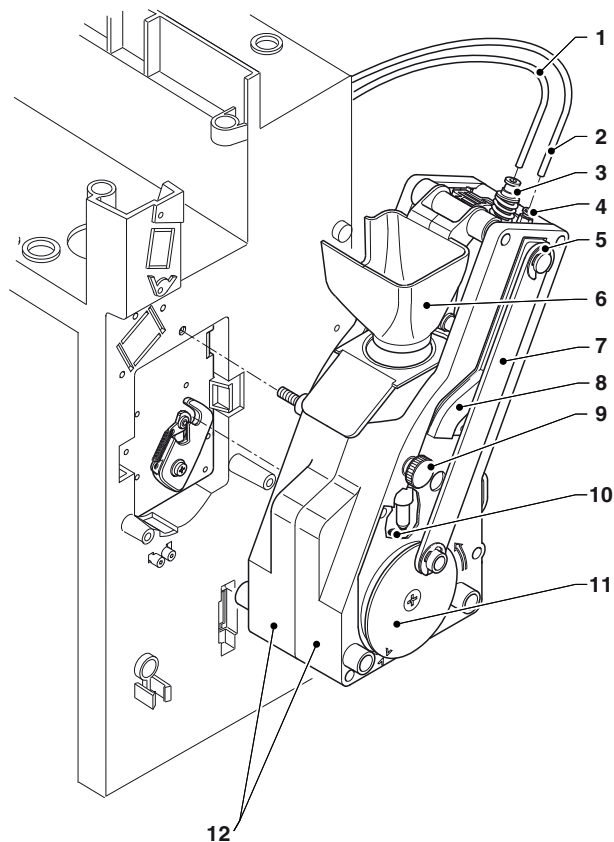

Fig. 19

1. Boiler connection tube
2. Upper piston operation tube
3. Central quick coupling
4. Side quick coupling
5. Connecting rod snap ring
6. Coffee funnel
7. Connecting rod
8. Deviating slide
9. Fastening knob
10. Lower piston snap ring
11. External disk
12. Half-shells

CLEANING AT REGULAR INTERVALS

The operator of an automatic vending machine is responsible for its hygiene and cleaning on the basis of the health and safety rules in force.

The machine is to be cleaned at regular intervals; it is recommended to use a luke-warm water solution and non aggressive detergents.

To clean metal parts, never use any product containing abrasive or corrosive substances.

The manufacturer disclaims all responsibility for any damage caused by the non-observance of the above or the use of aggressive or toxic chemical agents.

Attention !!!

To clean the machine, NEVER direct any water jet against the machine:

CLEANING MIXERS AND FOOD CIRCUITS

The mixers and the conduits for dispensing instant drinks shall be carefully sanitised at the time of the installation of the machine and at least once a week or more frequently, according to the use of the machine, the inlet water quality and the products in use, in order to provide for hygiene on dispensing products.

It is absolutely forbidden to use water jets for cleaning.

The parts to be cleaned are:

- powder deposit drawer, powder funnel, mixers and instant drink dispensing conduit;
- dispensing nozzles;
- nozzle support;

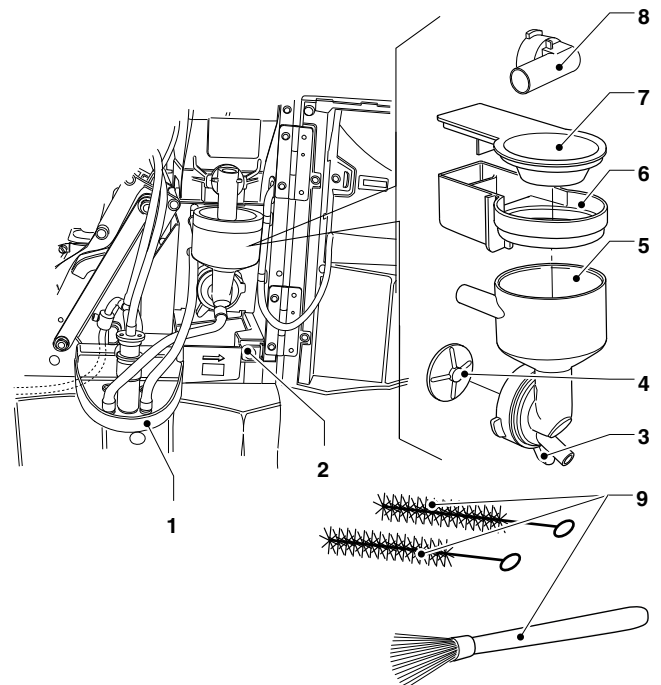

Fig. 20

1. Nozzle support
2. Nozzle support release button
3. Water funnel fastening ring nut
4. Mixer impeller
5. Water funnel
6. Powder deposit drawer
7. Instant powder funnel
8. Powder conveyor
9. Brushes for cleaning hoses and " splash zone "

To clean the mixers, act as follows:

- rotate the product conveyor upwards
- rotate the water funnel fastening ring nut counterclockwise and remove the powder funnels, the powder deposit drawers and the water funnels
- unscrew the mixer impeller; to unscrew, use a finger to hold the toothed disk mounted on the whipper motor shaft firm

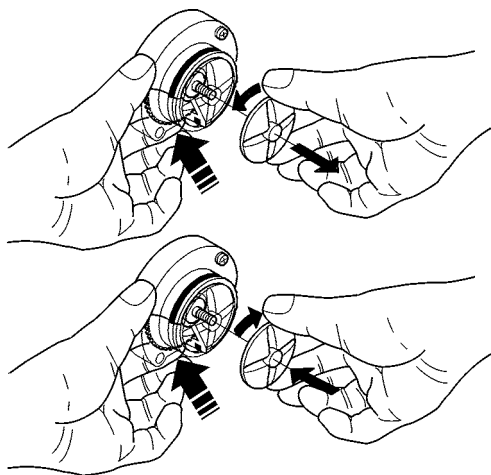

Fig. 21

Sanitise by making use of sanitising products.

- dip the components into a container with the sanitising solution you have prepared before for about 20' and make sure that you have mechanically removed visible residues and films by using, if necessary, pipe cleaners and brushes;
- rinse and carefully dry all parts
- reassemble the mixer impeller;
- re-position the water funnel and rotate the fastening ring nut clockwise
- reassemble the powder deposit drawers and the powder funnels
- rotate the powder conveyor downwards.

After having assembled the parts, act as follows, any way:

- Wash the mixers and add some drops of the sanitising solution into the various funnels.
- After having sanitised, rinse the parts abundantly to remove any residue of the solution in use.

All the operations requiring the machine to be directly connected to a source of electricity must be ONLY carried out by the personnel qualified and informed on the specific risks involved.

CLEANING THE SHELF AND INSTANT PRODUCT CANISTERS

- Remove the canisters from the machine;
- Disassemble the product outlet ports and extract the scrolls from the rear side of the canister;
- Clean all the parts by using a solution of hot water and sanitising products and dry them carefully.

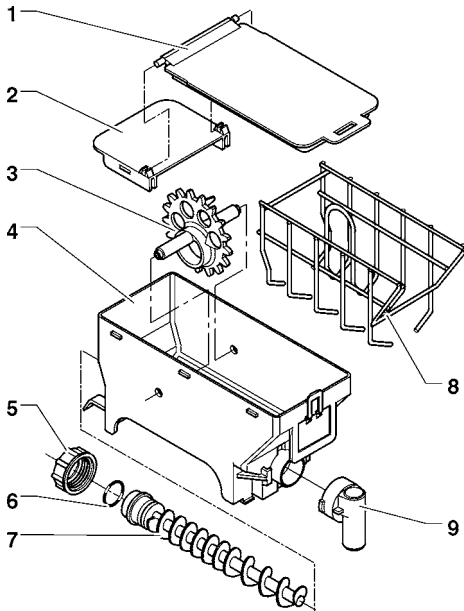

Fig. 22

1. Cover
2. Cover clip
3. Wheel
4. Canister body
5. Scroll fastening ring nut
6. Gasket
7. Scroll
8. Scraper
9. Powder outlet port

BOARD FUNCTION

The electronic boards are designed to be used on several equipment models.

If replaced or in order to change the machine performance, it will be necessary to check the configuration of the electronic boards and to download the corresponding software.

To access the electronic boards, remove the rear panel from the machine

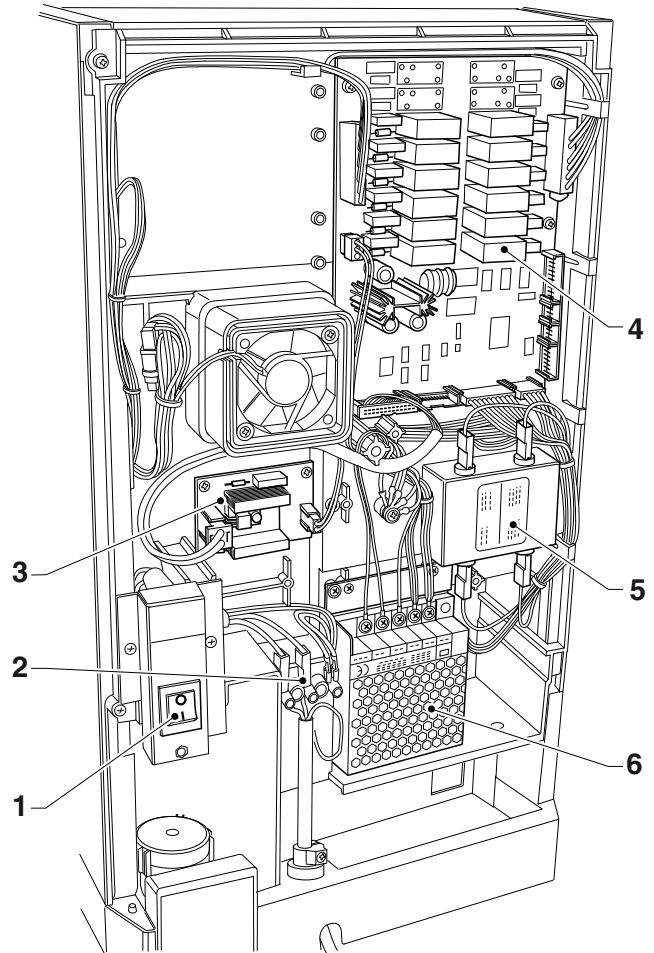

Fig. 23

1. Main switch
2. Connection terminal board
3. Espresso boiler control board
4. CPU / actuation board
5. Electrical filter
6. Power supply

CPU ACTUATION BOARD

- To process the information from the user interface board and the payment system;
- To process input signals;
- To activate/deactivate users and boiler boards;

The board is supplied by 15 Vac voltage, which is rectified and stabilised at 12 Vdc by the board itself.

15 Vac voltage is supplied by the transformer.

The transformer is protected by a 125 mA T fuse on the primary winding and by a 1.25 A T fuse on the secondary winding.

RE-LAY	USER* Espresso
K1	PM
K2	not used
K3	MF
K4	not used
K5	ER
K6	not used
K7	M
K8	ESP1
K9	EV1
K10	MD1
K11	EV2
K12	not used
K13	MD2
K14	EEA **
K15	not used
K16	MAC

*See the wiring diagram

** models supplied by the water mains

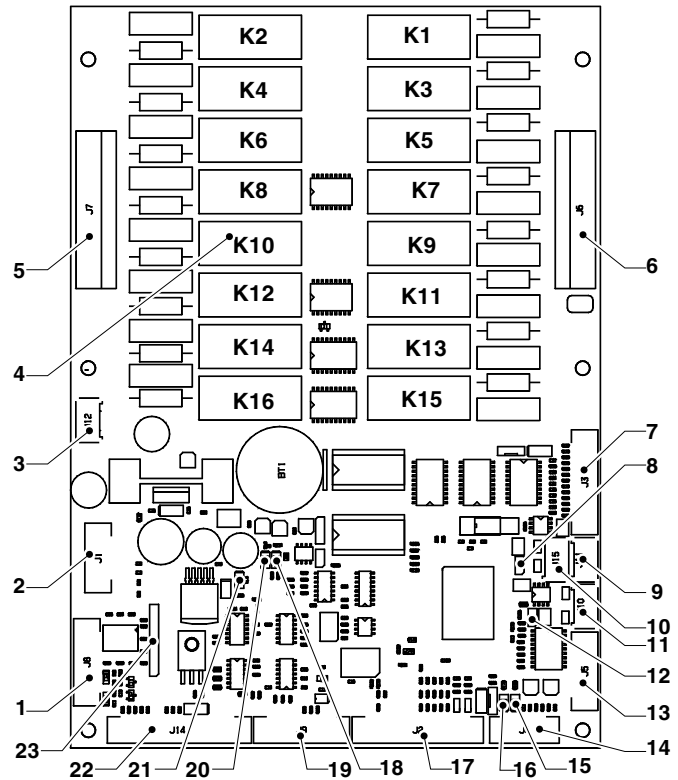

Fig. 24

- (J8) SPI connection
- (J1) Up Key connector
- (J12) Board supply
- Relay K1-...-K16
- (J7) Users
- (J6) Users
- (J3) Control signals
- (JP4) CAN-BUS 2 jumper
- (J11) CAN-BUS connection
- (J15) CAN-BUS 2 connection
- (J10) CAN-BUS connection
- (JP1) CAN-BUS jumper (closed)
- (J5) Relay expansion board (if any)
- (J4) Boiler control probes and boards
- (DL2) Boiler red led means heating steam (models with cappuccinatore)
- (DL1) Boiler red led means heating espresso
- (J2) Input signals
- (DL4) Red led "board reset"
- (J9) Not used
- (DL3) Green led "run"
- (DL5) Yellow led "+5V applied"
- (J14) User interface board
- (J13) Expansion board for payment systems

SOFTWARE UPDATE

The machine is equipped with Flash EPROM's that can be electrically rewritten. Use a proper program and system (personal computer, Up Key or alike) to rewrite the machine management software without replacing the EPROM's.

USER INTERFACE BOARD

The board is protected by a cover and arranged inside the door. It is intended to manage:

- the display,
- the selection keyboard
- the service buttons

The RS232 serial connector and/or USB is arranged on the board to fetch the statistics.

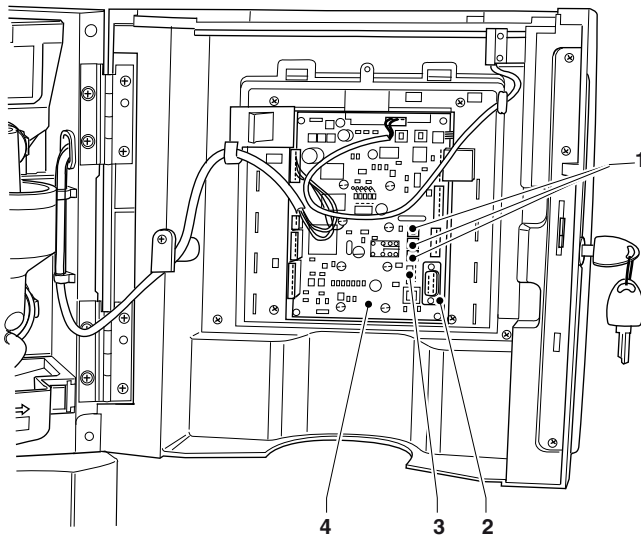

Fig. 25

1. Service buttons
2. RS232 serial port
3. USB connector
4. User interface board

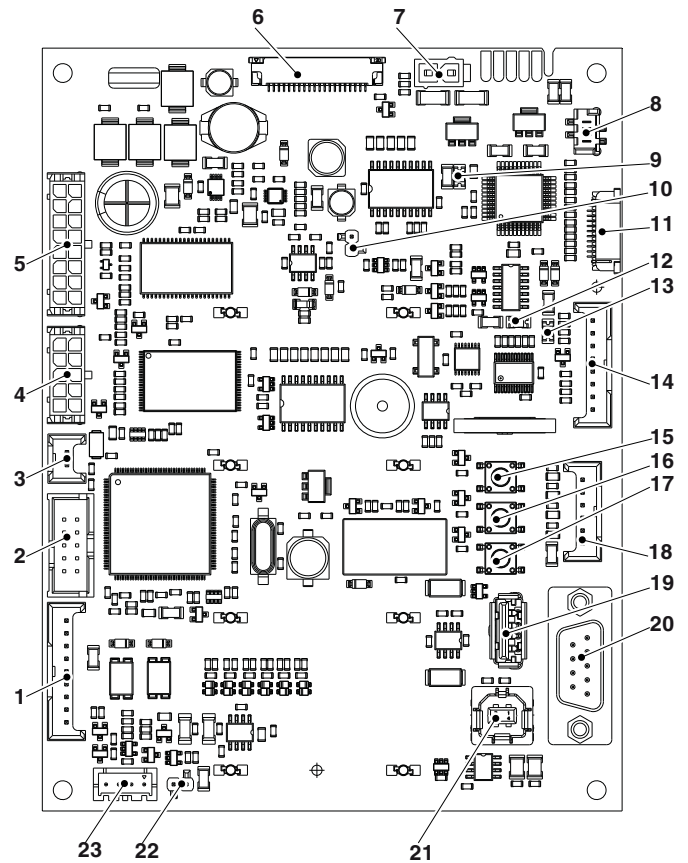

Fig. 26

1. (J15) Not used
2. (J12) Coin validator / acceptor
3. (J11) Mechanical counter
4. (J10) Coin validator / acceptor
5. (J4) CPU actuation board
6. (J5) Display
7. (J9) Decaff flap sensor (if mounted)
8. (J14) Door lighting
9. (DL3) green led RUN
10. Jumper (closed)
11. (J13) Not used
12. (DL2) red led RESET
13. (DL1) yellow led POWER
14. (J3) Programming interface
15. (SW4) Not used
16. (SW5) Brewer unit and mixer wash button (in programming mode)
17. (SW3) Programming button
18. (J6) SPI- Serial Peripheral Interface (if mounted)
19. (J8) USB connector
20. (C2) RS232 serial port
21. (J7) Not used
22. Jumper (closed)
23. (J16) Serial interface (if mounted)

BOILER CONTROL BOARD

The board is intended to control the trip of the boiler heating element.

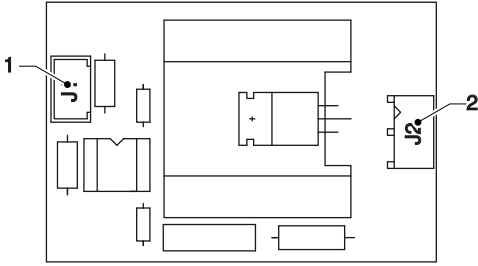

Fig. 27

1. J1 To the actuation board
2. J2 To the boiler heating element

EXPANSION BOARD FOR PAYMENT SYSTEMS

This board is supplied with the assembly kit of payment systems, such as “change giver” or “cashless”.

It shall be connected with the CPU actuation board by using the connector.

The SW1 configuration minidips shall be set up as follows:

- ON: MDB systems
- OFF: Executive / BDV systems

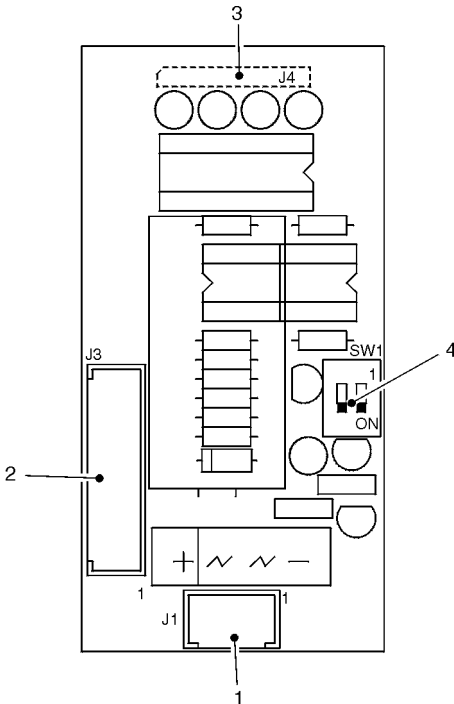

Fig. 28

1. MDB / BDV supply connector
2. Payment system connector (wiring supplied with the kit)
3. CPU actuation board connector
4. Configuration minidip

BOILER HEAT PROTECTION

A safety thermostat deactivates the boiler heating element whenever the safety temperature is achieved and/or exceeded.

If one or more than one thermostat should trip, check and remove the failure cause.

Reset the thermostats manually by pressing the button on the thermostat itself.

If the thermostats should trip in the absence of water, the boiler components as well as the control and safety components might have damaged: please replace them.

Appendix

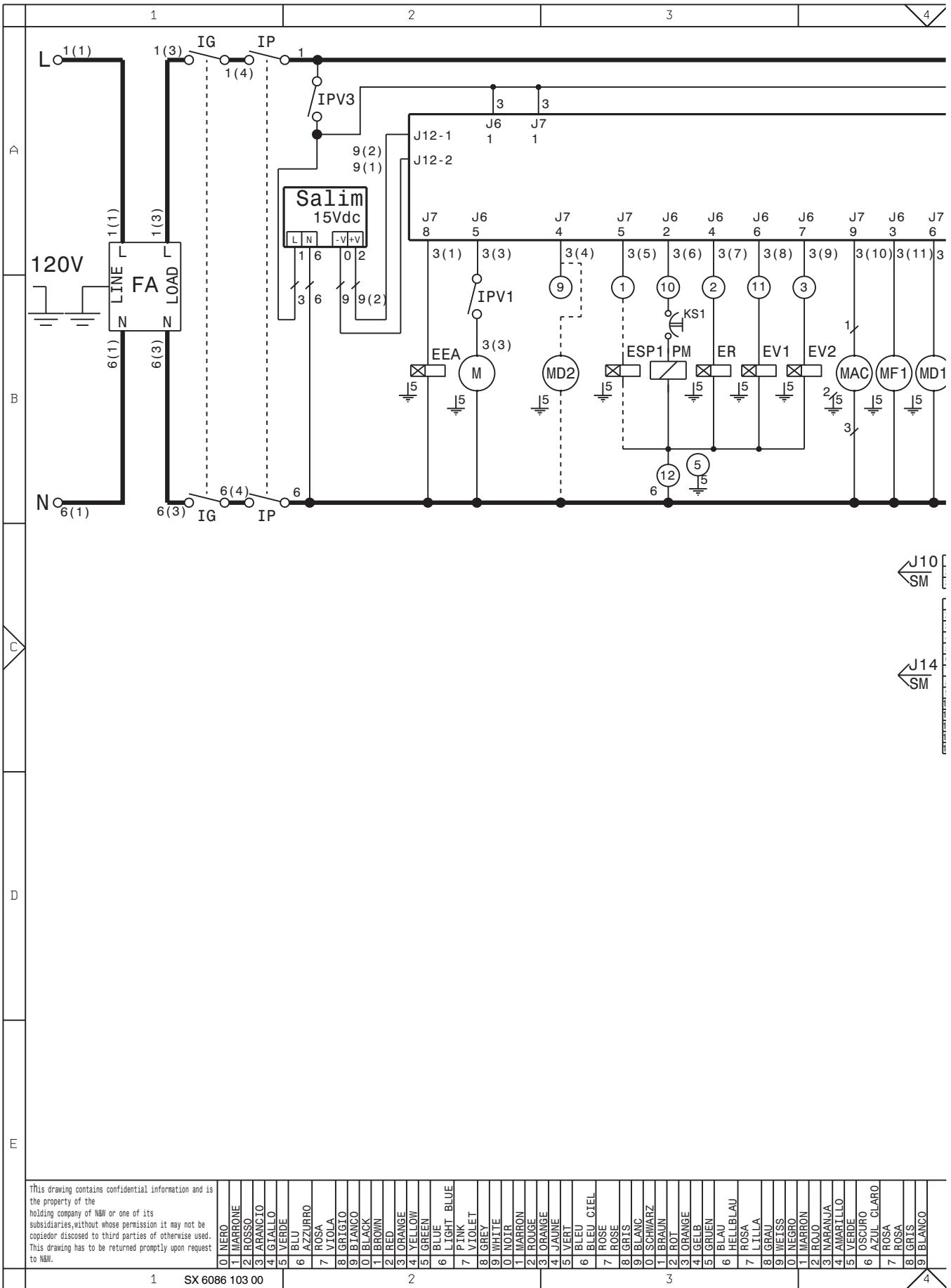

This drawing contains confidential information and is the property of the holding company of N&W or one of its subsidiaries, without whose permission it may not be copied or disclosed to third parties or otherwise used. This drawing has to be returned promptly upon request to N&W.

0	NERO	10	GRIGIO	20	VERDE
1	MARRONE	11	BIANCO	21	BLU
2	ROSSO	12	NERO	22	VIOLA
3	ARANCIO	13	GRIGIO	23	BIANCO
4	GIALLO	14	NERO	24	BIANCO
5	VERDE	15	NERO	25	VERDE
6	BLU	16	VERDE	26	ROSSO
7	AZZURRO	17	VERDE	27	ROSSO
8	ROSA	18	VERDE	28	ROSSO
9	VIOLA	19	VERDE	29	ROSSO
10	GRIGIO	20	VERDE	30	ROSSO
11	BIANCO	21	VERDE	31	ROSSO
12	NERO	22	VERDE	32	ROSSO
13	GRIGIO	23	VERDE	33	ROSSO
14	NERO	24	VERDE	34	ROSSO
15	VERDE	25	VERDE	35	ROSSO
16	BLU	26	VERDE	36	ROSSO
17	AZZURRO	27	VERDE	37	ROSSO
18	ROSA	28	VERDE	38	ROSSO
19	VIOLA	29	VERDE	39	ROSSO
20	GRIGIO	30	VERDE	40	ROSSO
21	BIANCO	31	VERDE	41	ROSSO
22	NERO	32	VERDE	42	ROSSO
23	GRIGIO	33	VERDE	43	ROSSO
24	NERO	34	VERDE	44	ROSSO
25	VERDE	35	VERDE	45	ROSSO
26	BLU	36	VERDE	46	ROSSO
27	AZZURRO	37	VERDE	47	ROSSO
28	ROSA	38	VERDE	48	ROSSO
29	VIOLA	39	VERDE	49	ROSSO
30	GRIGIO	40	VERDE	50	ROSSO
31	BIANCO	41	VERDE	51	ROSSO
32	NERO	42	VERDE	52	ROSSO
33	GRIGIO	43	VERDE	53	ROSSO
34	NERO	44	VERDE	54	ROSSO
35	VERDE	45	VERDE	55	ROSSO
36	BLU	46	VERDE	56	ROSSO
37	AZZURRO	47	VERDE	57	ROSSO
38	ROSA	48	VERDE	58	ROSSO
39	VIOLA	49	VERDE	59	ROSSO
40	GRIGIO	50	VERDE	60	ROSSO
41	BIANCO	51	VERDE	61	ROSSO
42	NERO	52	VERDE	62	ROSSO
43	GRIGIO	53	VERDE	63	ROSSO
44	NERO	54	VERDE	64	ROSSO
45	VERDE	55	VERDE	65	ROSSO
46	BLU	56	VERDE	66	ROSSO
47	AZZURRO	57	VERDE	67	ROSSO
48	ROSA	58	VERDE	68	ROSSO
49	VIOLA	59	VERDE	69	ROSSO
50	GRIGIO	60	VERDE	70	ROSSO
51	BIANCO	61	VERDE	71	ROSSO
52	NERO	62	VERDE	72	ROSSO
53	GRIGIO	63	VERDE	73	ROSSO
54	NERO	64	VERDE	74	ROSSO
55	VERDE	65	VERDE	75	ROSSO
56	BLU	66	VERDE	76	ROSSO
57	AZZURRO	67	VERDE	77	ROSSO
58	ROSA	68	VERDE	78	ROSSO
59	VIOLA	69	VERDE	79	ROSSO
60	GRIGIO	70	VERDE	80	ROSSO
61	BIANCO	71	VERDE	81	ROSSO
62	NERO	72	VERDE	82	ROSSO
63	GRIGIO	73	VERDE	83	ROSSO
64	NERO	74	VERDE	84	ROSSO
65	VERDE	75	VERDE	85	ROSSO
66	BLU	76	VERDE	86	ROSSO
67	AZZURRO	77	VERDE	87	ROSSO
68	ROSA	78	VERDE	88	ROSSO
69	VIOLA	79	VERDE	89	ROSSO
70	GRIGIO	80	VERDE	90	ROSSO
71	BIANCO	81	VERDE	91	ROSSO
72	NERO	82	VERDE	92	ROSSO
73	GRIGIO	83	VERDE	93	ROSSO
74	NERO	84	VERDE	94	ROSSO
75	VERDE	85	VERDE	95	ROSSO
76	BLU	86	VERDE	96	ROSSO
77	AZZURRO	87	VERDE	97	ROSSO
78	ROSA	88	VERDE	98	ROSSO
79	VIOLA	89	VERDE	99	ROSSO
80	GRIGIO	90	VERDE	100	ROSSO
81	BIANCO	91	VERDE	101	ROSSO
82	NERO	92	VERDE	102	ROSSO
83	GRIGIO	93	VERDE	103	ROSSO
84	NERO	94	VERDE	104	ROSSO
85	VERDE	95	VERDE	105	ROSSO
86	BLU	96	VERDE	106	ROSSO
87	AZZURRO	97	VERDE	107	ROSSO
88	ROSA	98	VERDE	108	ROSSO
89	VIOLA	99	VERDE	109	ROSSO
90	GRIGIO	100	VERDE	110	ROSSO
91	BIANCO	101	VERDE	111	ROSSO
92	NERO	102	VERDE	112	ROSSO
93	GRIGIO	103	VERDE	113	ROSSO
94	NERO	104	VERDE	114	ROSSO
95	VERDE	105	VERDE	115	ROSSO
96	BLU	106	VERDE	116	ROSSO
97	AZZURRO	107	VERDE	117	ROSSO
98	ROSA	108	VERDE	118	ROSSO
99	VIOLA	109	VERDE	119	ROSSO
100	GRIGIO	110	VERDE	120	ROSSO

CCG	GENERAL COUNTER	IP	DOOR SWITCH
CM1	COFFEE UNIT MOTOR CAM	IPF	FULL WASTE SWITCH
CV	VOLUMETRIC COUNTER	IPV1..	DISPENSING COMPARTMENT SWITCH
D	DIODE	IPV3	UPPER PANEL SWITCH
EEA	WATER INLET SOLENOID VALVE	IVA	EMPTY WATER SWITCH
ER	COFFEE DISPENSING SOLENOID VALVE	KC1..	COFFEE BOILER CUTOUT
ESP1..	DRAIN SOLENOID VALVE	LCD	LIQUID CRYSTAL DISPLAY
EV1..	INSTANT SOLENOID VALVES	M	COFFEE UNIT MOTOR
FA	RADIO INTERFERENCE SUPPRESSOR	MAC	GRINDER
IDEC	DECAFFEINATED DOOR SWITCH	MD1..	INGREDIENT MOTORS
IG	MAIN SWITCH	MF1..	INSTANT WHIPPER MOTORS

HYDRAULIC CIRCUIT

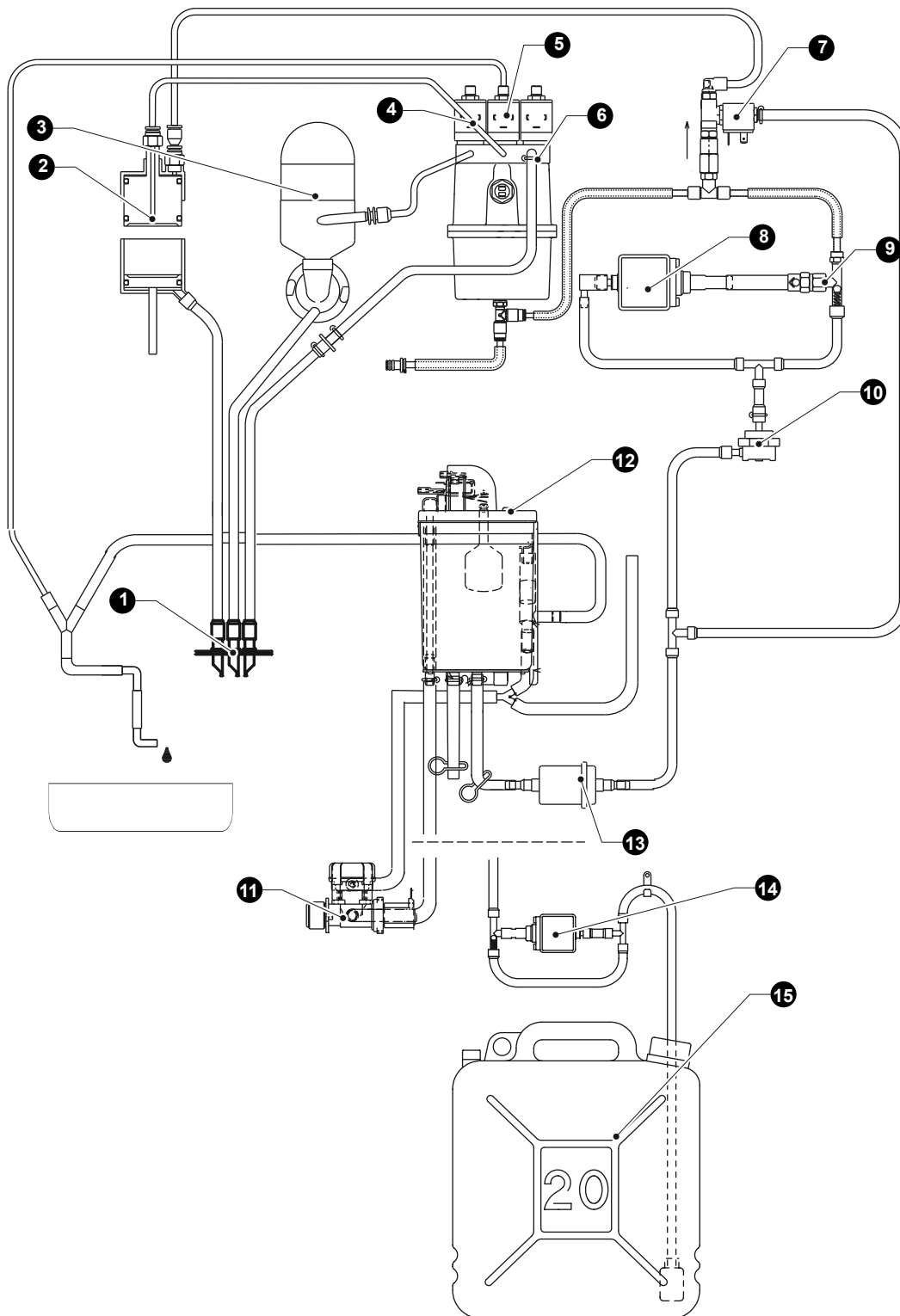

1. NOZZLES
2. BREW UNIT
3. MIXER
4. SOLENOID VALVES
5. BREW UNIT SOLENOID VALVE
6. BOILER
7. UPPER PISTON OPERATION SOLEINOID
8. VALVE
9. PUMP

10. BYPASS
11. VOLUMETRIC COUNTER
12. WATER INLET SOLENOID VALVE
13. AIR BREAK
14. MECHANICAL FILTER
15. SELF-SUPPLY PUMP
16. TANK

The Manufacturer reserves the right to modify the features of the equipment described in this publication without giving any prior notice. Moreover, it disclaims all responsibility for any inaccuracy contained in this publication that can be ascribed to printing and/or transcription errors.

All instructions, drawings, tables and information in general contained in this publication are confidential and can be neither entirely nor partially reproduced or transmitted to third parties without the written consent of the Manufacturer who has the sole ownership.

