

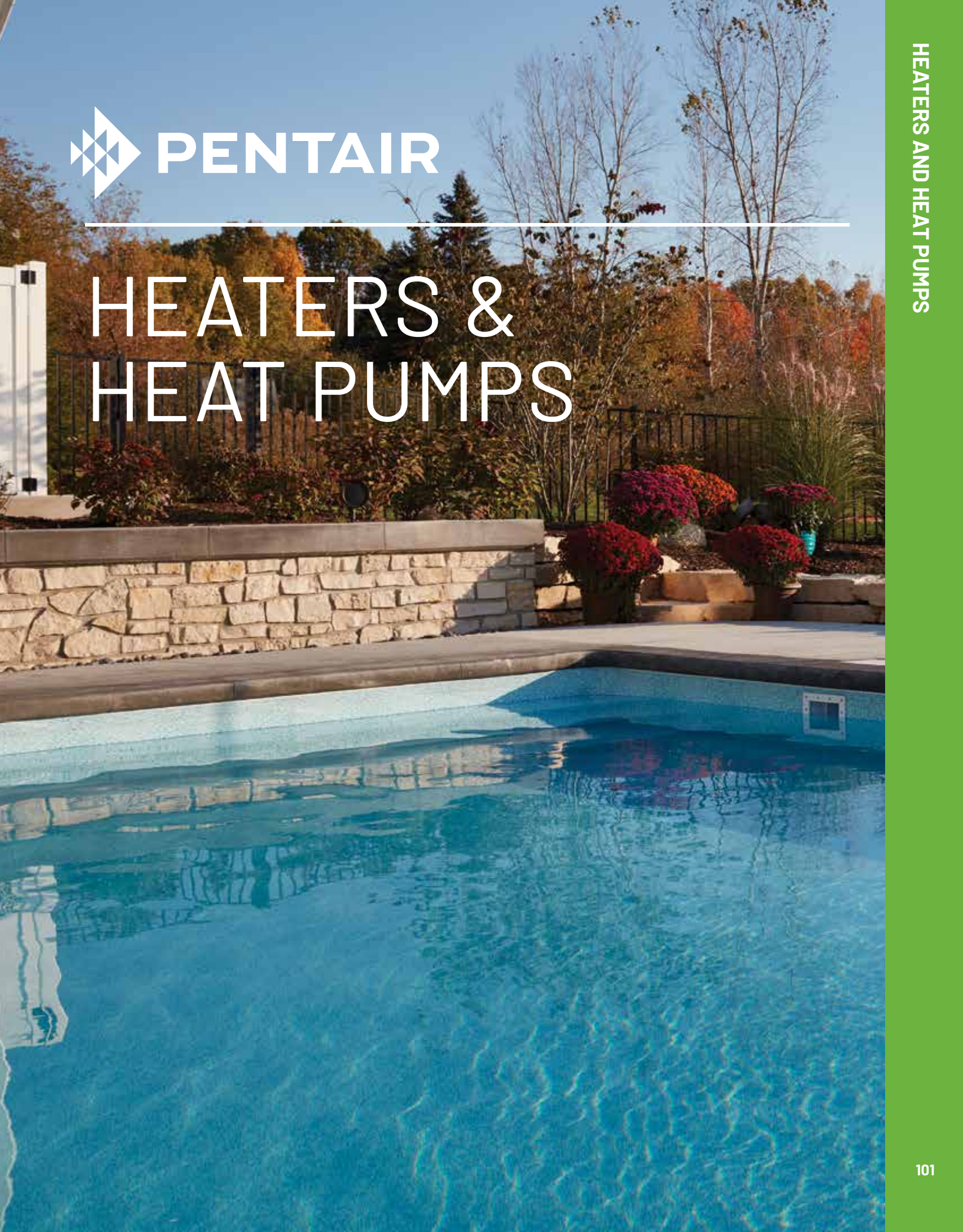

# HEATERS & HEAT PUMPS



# ULTRATEMP ETi<sup>®</sup> HEATER

## HIGH PERFORMANCE HYBRID HEATER

TRADEGRADE

eco select<sup>®</sup>



UltraTemp ETi Heater

First-Ever Dual-Fuel Heating Technology,  
delivering the fastest and most economical  
heating options

### Featured Highlights

- Available in Propane and Natural Gas
- Gas-Fired functionality for quick heat-ups
- Onboard intelligence delivers outstanding efficiency
- TitanTough™ Direct-Fire Pure Titanium gas heat exchanger assures corrosion-free performance for extra long life
- 93% thermal efficiency gas engine coupled with high performance heat pump
- Smart controls and space savings versus installing two separate units, gas heater and heat pump
- Automation ready with seamless interfacing with Pentair Control Systems
- High efficiency design (four selectable modes: Heat Pump only, Gas only, Hybrid, Dual)
- In "Dual" mode the heater runs both the heat pump and gas heater simultaneously for maximum heat output
- In "Hybrid" mode the heater runs state-of-the-art programming logic to determine the fastest and most economical way to heat your pool based on user input water temperature differential and time period
- Dual internal water bypass assembly automatically adjusts for water flows up to 120 GPM without the need for an external water bypass

### Ordering Information

Part #		Model	80/80/80* BTU/COP	80/63/80* BTU/COP	50/63/80* BTU/COP	Gas BTU	Freq (Hz)	Breaker Size (amp)	Phase	Volt	Ctn Wt.
BLACK	ALMOND										
<b>ULTRATEMP ETi HEATER</b>											
460970	460969	220K - Natural Gas	108,000/5.8	100,000/5.6	70,000/4.0	110,000	60	50	1	230	450
462043	462042	220K - Propane	108,000/5.8	100,000/5.6	70,000/4.0	110,000	60	50	1	230	450

\* Rating in accordance with ARI Standard 1160 (air temp. °F. / % relative humidity / water temp °F.)

**IMPORTANT NOTE: The Hybrid is tested & factory-configured for either Natural Gas or Propane Gas, and it cannot be converted from one fuel type to another in the field. Please order the specific model (Natural Gas or Propane) to match the fuel source of your intended application.**

The AHRI Certified<sup>®</sup> Mark is applied only to HVACR equipment and components that have been independently tested to certify manufacturers' performance claims are accurate. Visit [www.ahridirectory.org](http://www.ahridirectory.org) for a complete list of certified products.

CEC indicates that Heat Pump has been evaluated to California Title-20, listed in the California Energy Commission's (CEC) database of compliant heat pumps, and certified to use on Residential Swimming Pool Filtration Systems.

CALIFORNIA PROPOSITION 65 WARNING

⚠ **WARNING:** Cancer and Reproductive Harm.  
 ⚠ **AVERTISSEMENT:** Peut Causer le Cancer  
 et des Dommages au Système Reproducteur.  
 ⚠ **ADVERTENCIA:** Cáncer y Daño Reproductivo.

[www.p65warnings.ca.gov](http://www.p65warnings.ca.gov)

PN201514

# ULTRATEMP ETi<sup>®</sup> HEATER

## HIGH PERFORMANCE HYBRID HEATER

### Dimensions and Performance

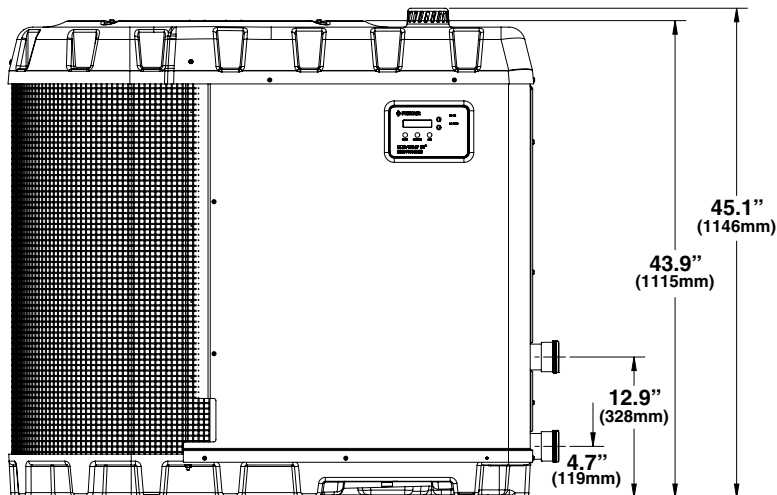
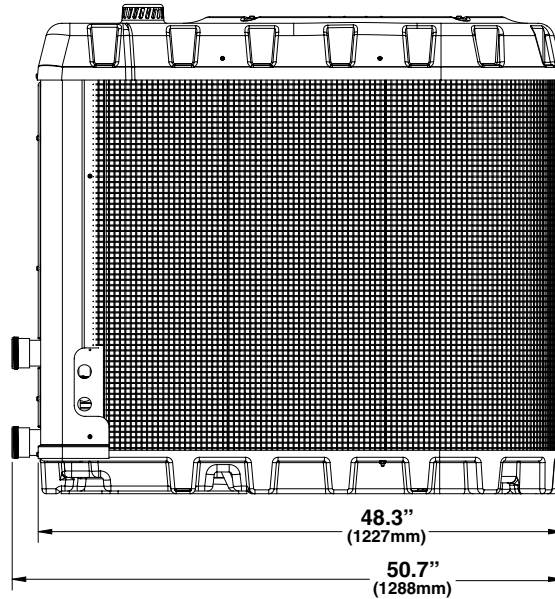
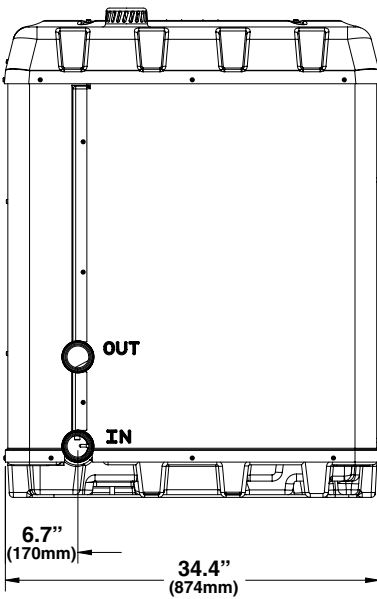

# ETi® 400

## HIGH EFFICIENCY HEATER

TRADEGRADE



ETi 400 Heater

### Featured Highlights

- TitanTough™ Direct-Fire Titanium ASME certified heat exchanger
- Certified for Ultra Low NOx Emissions
- Best-in-Class Energy Efficiency for fast heat up times and energy savings
- 4" PVC or CPVC vent up to 120 ft and 6" vent up to 300 ft long
- Indoor and Outdoor rating
- Ultra-Quiet operation
- Convenient 180 degrees rotating controls panel for left or right plumbing orientation
- Convenient front and rear gas connection capability
- Natural and Propane gas

The ETi 400 pool and spa heater brings you TitanTough Direct-Fire Titanium, the toughest ASME certified construction heat exchanger ever built. At 96% thermal efficiency, the ETi 400 heater has the highest efficiency ever built in its class. All this in a heater that operates with ultra-quiet noise level and out performs energy emissions standards.

### Ordering Information

Product	Gas Type	BTU (000's)	Crate Qty.	Crate Wt.
<b>ETi HEATER</b>				
461113	Natural	400 ASME	1	365
<b>ACCESSORIES</b>				
475971	Direct Air Intake KIT ( for indoor installations)		1	5
475612	Condensate Neutralizer Cartridge KIT		1	5
476072	Propane Gas Conversion Kit		1	2

**CALIFORNIA PROPOSITION 65 WARNING**

⚠ **WARNING:** Cancer and Reproductive Harm.  
 ⚠ **AVERTISSEMENT:** Peut Causer le Cancer et des Dommages au Système Reproducteur.  
 ⚠ **ADVERTENCIA:** Cáncer y Daño Reproductivo.  
[www.p65warnings.ca.gov](http://www.p65warnings.ca.gov)

See pages 412–416 for replacement parts.

# ETi<sup>®</sup> 400

## HIGH EFFICIENCY HEATER

### Dimensions and Performance

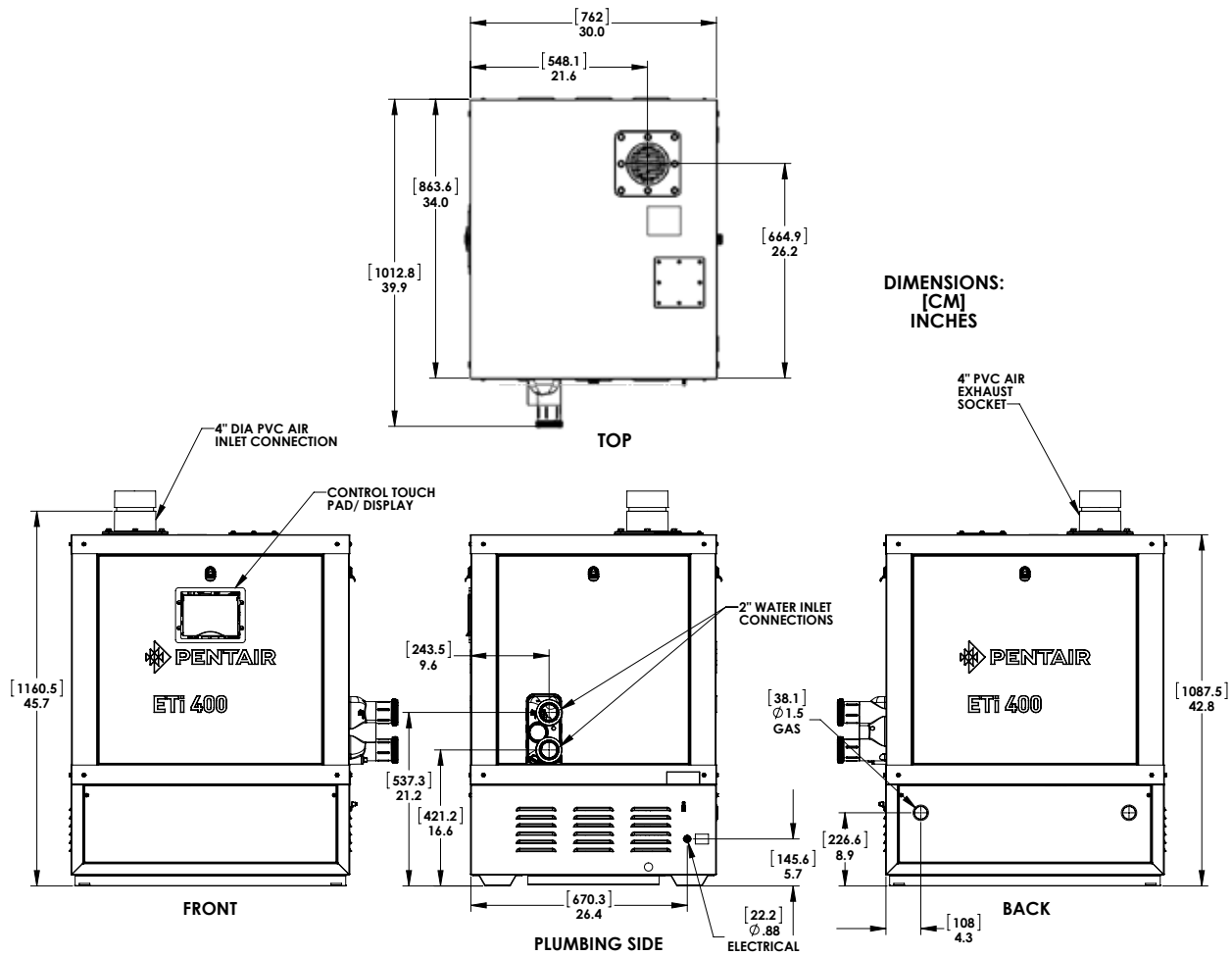

# MASTERTEMP® HEATER

## HIGH PERFORMANCE HEATER

### TRADEGRADE



MasterTemp High Performance Heater

#### Featured Highlights

- Heats up fast so no long waits before enjoying your pool or spa
- Best-in-class energy efficiency\*
- Manual gas shut-off when service is required
- Eco-friendly MasterTemp Heater is certified for low NOx emission and outperforms industry standards
- Rotating digital display allows for easy viewing
- Tough, rustproof exterior handles the heat and weathers the elements
- Certified for outdoor and indoor installations
- For Air Intake Kit order part number 461031

MasterTemp heaters offer all the efficiency, convenience and reliability features you want in a pool heater, plus a lot more. As easy to use as your home heating system, plus, user-friendly LCD display and troubleshoot icons make system operation and monitoring a snap. The compact design and super-quiet operation won't intrude on your poolside leisure time. Heavy-duty (HD) unit with cupro-nickel exchanger stands up to the harshest of applications, like low pH, high flow or heavy use.

### Ordering Information

Product	Gas Type	BTU (000's)	Carton Qty./Carton Wt. LBS
<b>MASTERTEMP HEATERS</b>			
460792	Natural	175	1/128
460793	Propane	175	1/128
460730	Natural	200	1/128
460731	Propane	200	1/128
461000	Natural	200 ASME	1/138
461001	Propane	200 ASME	1/138
460732	Natural	250	1/133
460733	Propane	250	1/133
460771	Natural	250 ASME	1/140
460772	Propane	250 ASME	1/140
461020	Natural	250 ASME HD	1/140
460806	Natural	250HD	1/136
460734	Natural	300	1/136
460735	Propane	300	1/136
460736	Natural	400	1/136
460737	Propane	400	1/136
460805	Natural	400HD	1/136
460775	Natural	400ASME	1/149
461021	Natural	400 ASME HD	1/149
460776	Propane	400ASME	1/149

Note:  
The MasterTemp High Performance Heater is certified for low NOx emissions.

Standard Copper Heat Exchanger  
84% Efficient.

Heavy-Duty (HD) Cupro-Nickel Heat Exchanger  
82% Efficient.

#### CALIFORNIA PROPOSITION 65 WARNING

⚠ **WARNING:** Cancer and Reproductive Harm.  
 ⚠ **AVERTISSEMENT:** Peut Causer le Cancer et des Dommages au Système Reproducteur.  
 ⚠ **ADVERTENCIA:** Cáncer y Daño Reproductivo.  
[www.p65warnings.ca.gov](http://www.p65warnings.ca.gov)

PN3017A

# MASTERTEMP® HEATER (CONT'D)

## HIGH PERFORMANCE HEATER

### Dimensions and Performance

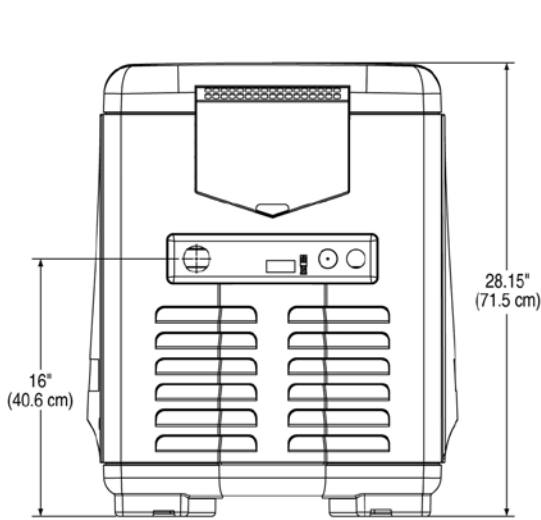

**FRONT**

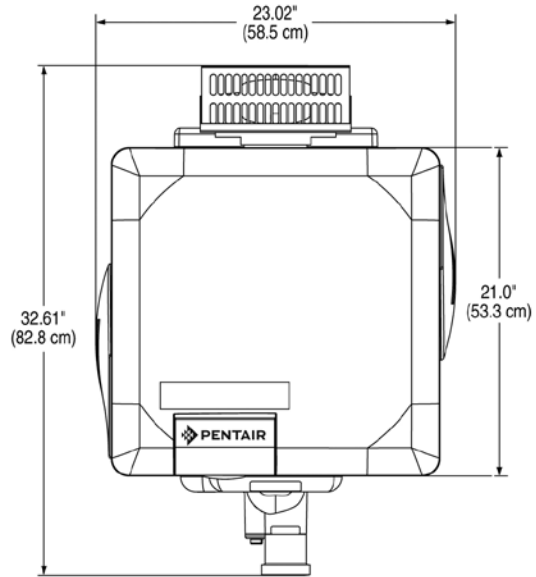

**TOP**

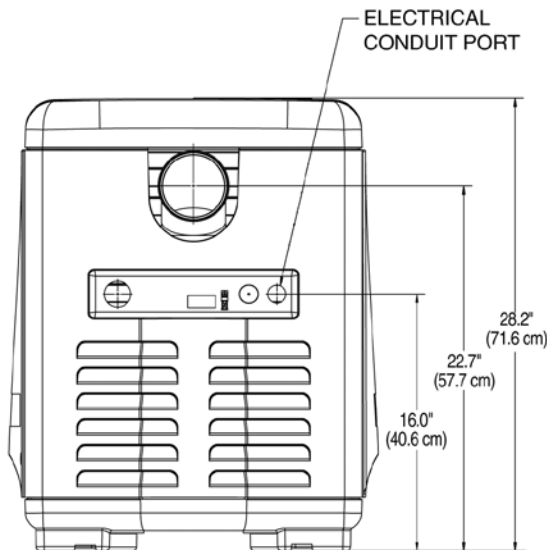

**EXHAUST SIDE**

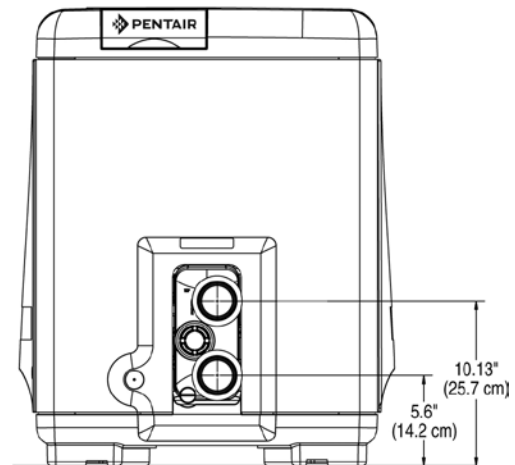

**PLUMBING SIDE**

See pages 417–421 for replacement parts.

# MASTERTEMP® 125

## HIGH PERFORMANCE HEATER

TRADEGRADE



MasterTemp 125 Heater

### Featured Highlights

- High-performance, affordable heater with premium features
- 82% energy efficiency is highest in class
- 1-1/2 in. Plumbing connection — ideal for smaller bodies of water, including aboveground pools, spas and in-ground pools up to 15,000 gallons
- Pre-mixed combustion technology for ultra-fast heat up
- Easy-to-use digital display/controller
- Certified for low NOx emissions
- Available in natural gas or propane gas
- Lightweight: 80 lbs. — easy to handle and ship
- Corrosion and UV-resistant enclosure
- 3/4 in. gas line up to 50 ft. from source
- Certified for outdoor and indoor installations
- For Air Intake Kit order part number 474845

The MasterTemp 125 Heater provides energy-savings and advanced operating features that were only available from much larger heaters. With its revolutionary pre-mixed gas combustion technology, the MasterTemp 125 Heater offers 82% thermal efficiency, the highest in its class. The advanced LCD display/controller provides more information and better control.

### Ordering Information

Product	Gas Type	BTU (000's)	Carton Qty.	Carton Wt.
<b>MASTERTEMP 125 HIGH PERFORMANCE HEATER</b>				
461058	Natural, without cord	125	1	100
461059	Natural, with cord	125	1	100
461060	LP, without cord	125	1	100
461061	LP, with cord	125	1	100

CALIFORNIA PROPOSITION 65 WARNING  
 ⚠️ **WARNING:** Cancer and Reproductive Harm.  
 ⚠️ **AVERTISSEMENT:** Peut Causer le Cancer et des Dommages au Système Reproducteur.  
 ⚠️ **ADVERTENCIA:** Cáncer y Daño Reproductivo.  
[www.p65warnings.ca.gov](http://www.p65warnings.ca.gov) P65.00174A



# MASTERTEMP® 125 (CONT'D)

## HIGH PERFORMANCE HEATER

### Dimensions and Performance

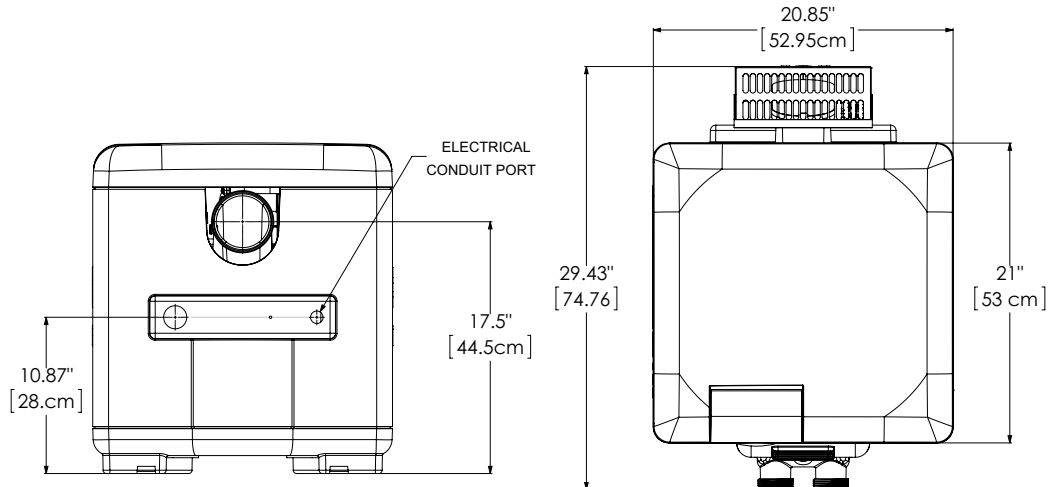

FRONT VIEW

TOP VIEW

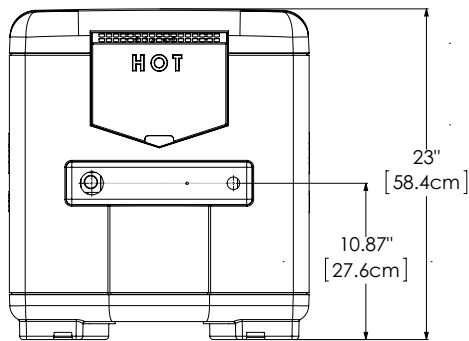

EXHAUST SIDE VIEW

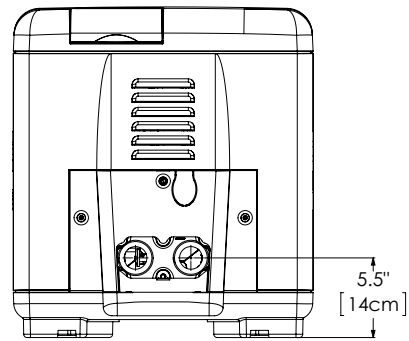

PLUMBING SIDE VIEW

# MAX-E-THERM®

## POOL AND SPA HEATER



TRADEGRADE



Max-E-Therm Pool and Spa Heater

### Featured Highlights

- Lightweight – Lightest heater in its class
- Best-in-class – energy efficiency\*
- Compact Design – Ideal for retro-fit installations
- Easy to Switch – Change gas sources with installation of separate orifice
- Environmentally Friendly – All units are low NOx
- Rustproof Housing – Sleek, matte black enclosure is made of Dura-Glas™ – an exclusive Sta-Rite material that handles the heat and weathers the elements
- Lower Operating Costs – 84% efficiency rating – rated 1st in its class for highest energy efficiency
- Custom or Retrofit – Direct-connects to Sta-Rite System: 3® Mod Media™ Filter or easily fits other systems
- Certified for outdoor and indoor installations
- For Air Intake Kit order part number 475002

For indoor or outdoor installations on pools and spas. Features include an LCD temperature readout with dual thermostat controls, temperature safety lockout, and 6-position control panel. PMG burner technology requires no outdoor draft hood. Proven Dura-Glas Resin provides rust-proof construction. Heavy-duty (HD) unit with cupro-nickel exchanger stands up to the harshest of applications, like low pH, high flow or heavy use.

### Ordering Information

Product	Description	BTU (000's)	Carton Wt.
<b>MAX-E-THERM POOL/SPA HEATER</b>			
SR200NA	Max-E-Therm 200 BTU Natural Gas Heater	200	131
SR200LP	Max-E-Therm 200 BTU Propane Gas Heater	200	131
SR200HD	Max-E-Therm 200 BTU Heavy Duty Heater	200	131
460767	Max-E-Therm 250 BTU ASME Natural Gas Heater	250	151
460768	Max-E-Therm 250 BTU ASME Propane Gas Heater	250	151
SR333NA	Max-E-Therm 333 BTU Natural Gas Heater	333	138
SR333LP	Max-E-Therm 333 BTU Propane Gas Heater	333	138
SR333HD	Max-E-Therm 333 BTU Heavy Duty Heater	333	138
SR400NA	Max-E-Therm 400 BTU Natural Gas Heater	400	138
SR400LP	Max-E-Therm 400 BTU Propane Gas Heater	400	138
SR400HD	Max-E-Therm 400 BTU Heavy Duty Heater	400	138
460763	Max-E-Therm 400 BTU ASME NA Heater	400	149
460764	Max-E-Therm 400 BTU ASME LP Heater	400	149

Note: The Max-E-Therm Heater is certified for low NOx emissions.

\* Standard Copper Heat Exchanger 84% Efficient.

Heavy Duty (HD) Cupro-Nickel Heat Exchanger 82% Efficient.

CALIFORNIA PROPOSITION 65 WARNING

⚠️ **WARNING:** Cancer and Reproductive Harm.  
 ⚠️ **AVERTISSEMENT:** Peut Causer le Cancer et des Dommages au Système Reproducteur.  
 ⚠️ **ADVERTENCIA:** Cáncer y Daño Reproductivo.  
[www.p65warnings.ca.gov](http://www.p65warnings.ca.gov)

# MAX-E-THERM® (CONT'D)

## POOL AND SPA HEATER

### Dimensions and Performance

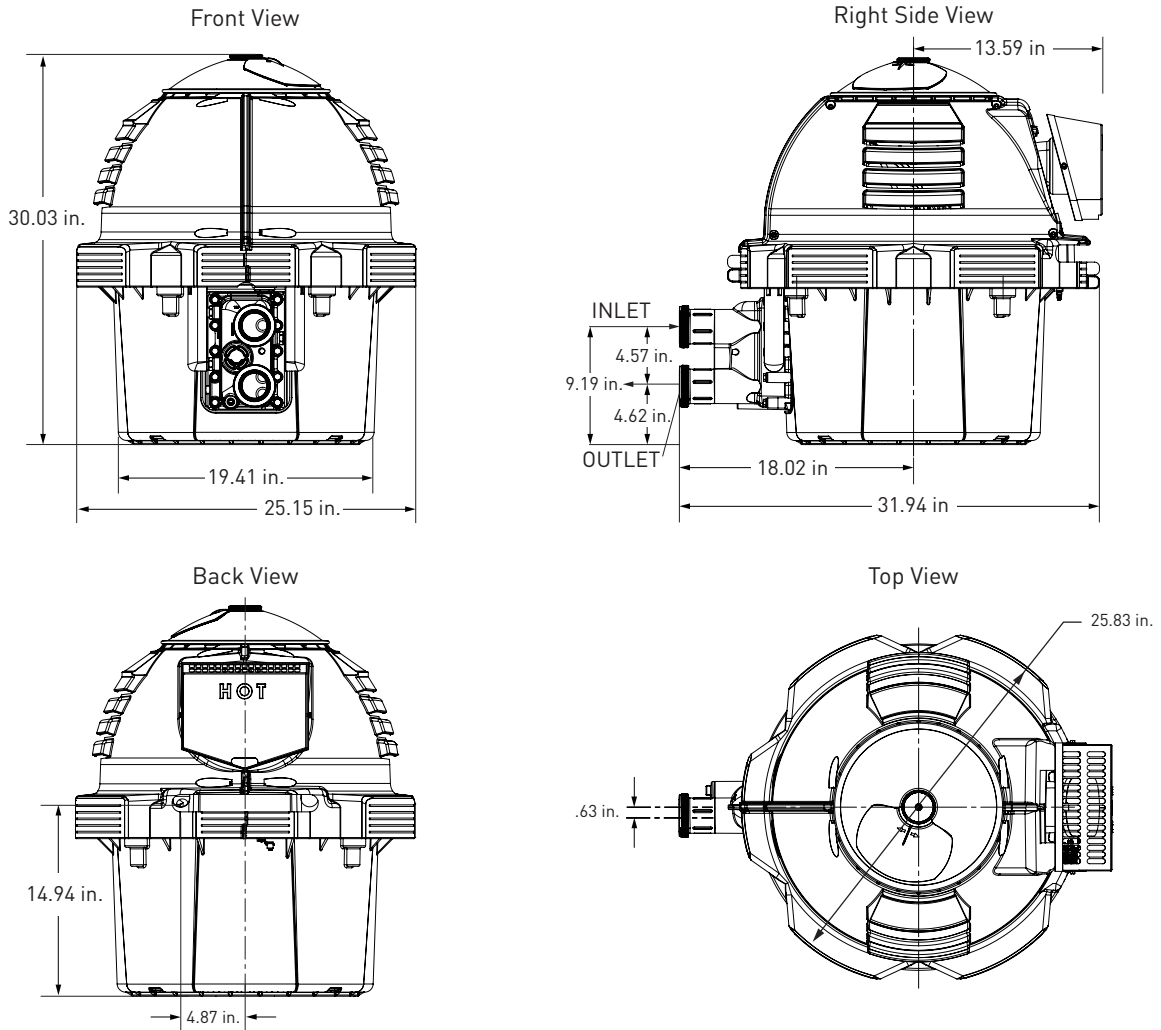

# MAX-E-THERM® AND MASTERTEMP® HEATER ACCESSORIES

## Ordering Information

Product	Description	Approx. Ship. Weight (Lbs.)
<b>VERTICAL VENTING – NEGATIVE PRESSURE</b>		
77707-0076	4 in. x 6 in. Metal Flue Collar	3
77707-0077	4 in. x 8 in. Metal Flue Collar	3
<b>HORIZONTAL OR VERTICAL VENTING – POSITIVE PRESSURE <sup>4</sup></b>		
77707-0086	Appliance Adapter, Stainless Steel – Manufactured by HeatFab® venting manufactured by Selkirk Corp. *	3
77707-0087	Appliance Adapter, Stainless Steel – Manufactured by Z-Flex U.S. Venting	3
<b>CONVERSION KITS – NATURAL GAS TO LPG</b>		
461063	NG to LP Conversion Kit - Model 125	1
460794	NG to LP Conversion Kit - Model 175	1
77707-1461	Conversion Kit NG-LPG 200K for Pool and Spa Heater	1
460741	NG to Propane Conversion Kit – Model 250	1
460755	NG to Propane Conversion Kit – Model 300	1
77707-1451	Conversion Kit NG-LPG 333K for Pool and Spa Heater	1
77707-1441	Conversion Kit NG-LPG 400K for Pool and Spa Heater	1
<b>CONVERSION KITS – LPG to NATURAL GAS</b>		
461062	LP to NG Conversion Kit - Model 125	1
460795	LP to NG Conversion Kit - Model 175	1
77707-1431	Conversion Kit LPG-NG for 200K Pool and Spa Heater	1
460742	Propane to NG Conversion Kit – Model 250	1
460756	Propane to NG Conversion Kit – Model 300	1
77707-1421	Conversion Kit LPG-NG for 333K Pool and Spa Heater	1
77707-1411	Conversion Kit LPG-NG for 400K Pool and Spa Heater	1
<b>HEATER ACCESSORIES</b>		
42001-0085S	Heater Bolt Down Bracket Kit (Max-E-Therm)	1
460738	Heater Bolt Down Bracket Kit (MasterTemp)	1
PKG 188Z	Union Package (2" Unions)	1
474974	Union Package (1-1/2" Unions)	1
U11-197P	2 in. Adapter (for service loop)	1
461031	Direct Air Intake Duct Kit (MasterTemp)	5
475002	Direct Air Intake Duct Kit (Max-E-Therm)	5
474845	Direct Air Intake Duct Kit (MasterTemp 125)	5
<b>SERVICE PROFESSIONAL PARTS KIT</b>		
461100	Pro Service Package – Heater Master Package of Water & Electrical System Parts. Includes many common repair parts for Pentair & Sta-Rite heaters in reusable hard case <sup>1</sup>	5
461101	Pro Service Package – Heaters Electrical System Parts. Includes common Electrical System repair parts for Pentair & Sta-Rite heaters in reusable hard case <sup>1</sup>	3
461102	Pro Service Package – Heaters Water System Parts. Includes common Water System repair parts for Pentair & Sta-Rite heaters in reusable hard case <sup>1</sup>	3

<sup>1</sup> Compatible with Pentair MasterTemp® High Performance Heaters, Sta-Rite Max-E-Therm® High Performance Heaters, Models 175/200/250/300/333/400. Not compatible with 125,000 BTU heater

See Engineering Data pages 593–604 for information on selecting the proper size heater and for gas supply and pipe sizing information.

\* HeatFab® is a registered trademark of Hart & Cooley, Inc.

# COMMERCIAL POWERMAX®

## HIGH PERFORMANCE ELECTRONIC IGNITION HEATER

### Featured Highlights

- Reliable operation in natural or propane models
- Fan-assisted and filtered combustion air
- Dual ignition systems for models greater than 750,000 BTU
- Built-in mixing system reduces condensation possibilities
- Fits through standard doorways
- Gas supply right or left side
- CSA Certified
- **CSD-1 and other options available. Contact factory for part numbers.**



Commercial PowerMax Heater

When performance is critical, the PowerMax Heater provides peak efficiency and easy maintenance in both indoor and outdoor applications. Seven sizes delivering up to 85% efficiency ratings and meeting all Low NOx requirements. PowerMax Heater is designed for operation to 10,000 foot elevation.

CALIFORNIA PROPOSITION 65 WARNING

**⚠ WARNING:** Cancer and Reproductive Harm.  
**⚠ AVERTISSEMENT:** Peut Causer le Cancer et des Dommages au Système Reproducteur.  
**⚠ ADVERTENCIA:** Cáncer y Daño Reproductivo.  
[www.p65warnings.ca.gov](http://www.p65warnings.ca.gov)

### Ordering Information

Product	BTUs (000's)	Installation	Gas Type	Pump System	Heat Exchanger	Carton Wt. (Lbs.)
COMMERCIAL POWERMAX NATURAL GAS MODELS						
PM0500NACC3BXN	500	Indoor/Outdoor	Natural	Pump Mounted	Copper	495
PM0750NACC3BXN	750	Indoor/Outdoor	Natural	Pump Mounted	Copper	575
PM1000NACC3BXN	1000	Indoor/Outdoor	Natural	Pump Mounted	Copper	685
PM1250NACC3BXN	1250	Indoor/Outdoor	Natural	Pump Mounted	Copper	730
PM1500NACC3BXN	1500	Indoor/Outdoor	Natural	Pump Mounted	Copper	830
PM1750NACC3BXN	1750	Indoor/Outdoor	Natural	Pump Mounted	Copper	880
PM2000NACC3BXN	2000	Indoor/Outdoor	Natural	Pump Mounted	Copper	1025
PM0500NACC3PXN	500	Indoor/Outdoor	Natural	Pump Mounted	CuproNickel	495
PM0750NACC3PXN	750	Indoor/Outdoor	Natural	Pump Mounted	CuproNickel	575
PM1000NACC3PXN	1000	Indoor/Outdoor	Natural	Pump Mounted	CuproNickel	685
PM1250NACC3PXN	1250	Indoor/Outdoor	Natural	Pump Mounted	CuproNickel	730
PM1500NACC3PXN	1500	Indoor/Outdoor	Natural	Pump Mounted	CuproNickel	830
PM1750NACC3PXN	1750	Indoor/Outdoor	Natural	Pump Mounted	CuproNickel	880
PM2000NACC3PXN	2000	Indoor/Outdoor	Natural	Pump Mounted	CuproNickel	1025
COMMERCIAL POWERMAX PROPANE GAS MODELS						
PM0500PACC3BXN	500	Indoor/Outdoor	Propane	Pump Mounted	Copper	495
PM0750PACC3BXN	750	Indoor/Outdoor	Propane	Pump Mounted	Copper	575
PM1000PACC3BXN	1000	Indoor/Outdoor	Propane	Pump Mounted	Copper	685
PM1250PACC3BXN	1250	Indoor/Outdoor	Propane	Pump Mounted	Copper	730
PM1500PACC3BXN	1500	Indoor/Outdoor	Propane	Pump Mounted	Copper	830
PM1750PACC3BXN	1750	Indoor/Outdoor	Propane	Pump Mounted	Copper	880
PM2000PACC3BXN	2000	Indoor/Outdoor	Propane	Pump Mounted	Copper	1025
PM0500PACC3PXN	500	Indoor/Outdoor	Propane	Pump Mounted	CuproNickel	495
PM0750PACC3PXN	750	Indoor/Outdoor	Propane	Pump Mounted	CuproNickel	575
PM1000PACC3PXN	1000	Indoor/Outdoor	Propane	Pump Mounted	CuproNickel	685
PM1250PACC3PXN	1250	Indoor/Outdoor	Propane	Pump Mounted	CuproNickel	730
PM1500PACC3PXN	1500	Indoor/Outdoor	Propane	Pump Mounted	CuproNickel	830
PM1750PACC3PXN	1750	Indoor/Outdoor	Propane	Pump Mounted	CuproNickel	880
PM2000PACC3PXN	2000	Indoor/Outdoor	Propane	Pump Mounted	CuproNickel	1025
POWERMAX STACKING SYSTEMS						
Product	Type	Heater Model	Product	Type	Heater Model	
CA000800	Rack	PM500	CA001100	Rack	PM1250	
CA000900	Rack	PM750	CA001200	Rack	PM1500, PM1750	
CA0001000	Rack	PM1000	CA001300	Rack	PM2000	

# COMMERCIAL POWERMAX® (CONT'D)

## HIGH PERFORMANCE ELECTRONIC IGNITION HEATER

### Dimensions and Performance

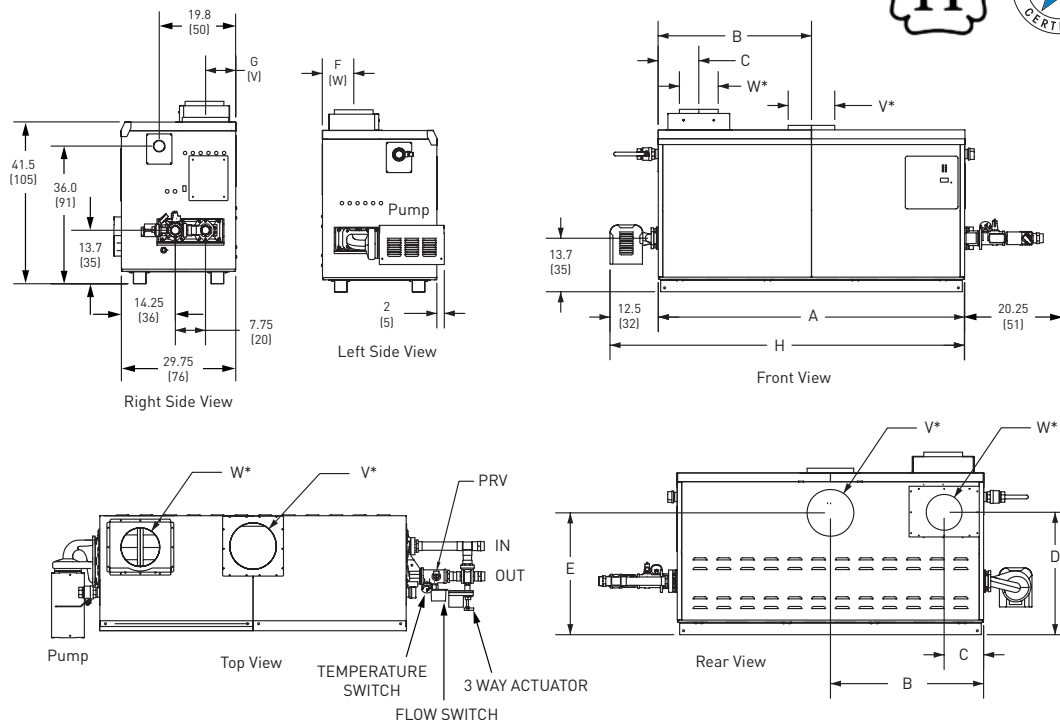

Dimensional Data Dimensions shown in inches, cm.

Size (000's)	A	B	C	D	E	F	G	H	Air Conn. W*	Vent Conn. V*	Horiz. Vent Pipe											
500	33½	85	15¾	40	5¾	15	29¾	76	32¾	83	7¾	20	8¾	22	46	117	6	15	8	15	6	15
750	45½	116	21¾	55	5¾	15	29¾	76	32¾	83	7¾	20	8¾	22	58	147	6	15	10	20	8	15
1000	57½	146	28¾	73	5¾	15	29¾	76	32¾	83	7¾	20	7	18	70	178	8	20	10	25	8	20
1250	68	172	34	86	10¼	26	30¾	78	29½	75	8¾	22	8¾	22	80	203	8	20	12	30	8	20
1500	78½	199	39¾	101	10¼	26	30¾	78	29½	75	8¾	22	8¾	22	91	231	8	20	12	30	8	20
1750	89	226	44½	113	10¼	26	30¾	78	29½	75	8¾	22	8¾	22	101	256	8	20	14	36	8	20
2000	99½	253	49¾	126	10¼	26	30¾	78	29½	75	8¾	22	8¾	22	112	284	12	30	14	36	12	30

\*Air and vent connections may be on top or back of the PowerMax, and are field convertible.

### Sizing Data

Indoor Model	Input <sup>1</sup> BTU/h x1000	Output <sup>1</sup> BTU/h x1000	Gas Conn. Size inches <sup>2</sup>	Heater Water Conn. Size inches <sup>2</sup>	Mixing System Water Conn. Size inches <sup>2</sup>	Shipping Weight lbs. kg
500	500	425	1¼	2	2	495 225
750	750	638	1¼	2	2	575 261
1000	999	849	1½	2½	2	685 311
1250	1250	1063	2	2½	2	730 331
1500	1500	1275	2	2½	2	830 377
1750	1750	1488	2	2½	2	880 400
2000	1999	1699	2	2½	2	1025 465

NOTES: 1. Input and output must be derated 2% per 1000 feet above sea level when installed above 2000 feet altitude.  
2. Dimensions are nominal.

Note: Contact factory at 1-800-831-7133 for replacement parts.

# COMMERCIAL MEGATHERM®

## HIGH PERFORMANCE ELECTRONIC IGNITION HEATER

### Featured Highlights

- Electronic ignition
- Built-in draft diverter (indoor models) simplifies installation
- Integral pump assures proper water flow (models 500-1825)
- High temperature refractory firebox liner to 2000° F for greater efficiency
- Easy-to-service header flanges
- Corrosion-resistant glass-lined headers
- CSA Certified
- **CSD-1 and other options available. Contact factory for part numbers**
- Start-up service by an authorized representative is strongly recommended before regular operation



Commercial  
MegaTherm  
Heater

#### CALIFORNIA PROPOSITION 65 WARNING

▲ **WARNING:** Cancer and Reproductive Harm.  
 ▲ **AVERTISSEMENT:** Peut Causer le Cancer et des Dommages au Système Reproducteur.  
 ▲ **ADVERTENCIA:** Cáncer y Daño Reproductivo.  
[www.p65warnings.ca.gov](http://www.p65warnings.ca.gov)

MegaTherm Pool Heaters are designed for commercial, institutional and large residential where economical performance and rapid heat-up are required. Available in indoor and outdoor models in both natural and propane. MegaTherm is design verified to the ANSI Z21.56 Standard for Gas-Fired Pool Heaters (Outdoor 5---1825 units are certified for use without the addition of a draft diverter or external vent. Indoor units incorporate a built-in draft diverter and require only vent piping.)

### Ordering Information

Product	BTUs (000's)	Installation	Gas Type	Pump System	Heat Exchanger	Carton Wt. (Lbs.)
<b>COMMERCIAL MEGATHERM NATURAL GAS MODELS</b>						
MT0500IN09C1PC	500	Indoor	Natural	Pump Mounted	Copper	808
MT0600IN09C1PC	600	Indoor	Natural	Pump Mounted	Copper	819
MT0715IN09C1PC	715	Indoor	Natural	Pump Mounted	Copper	873
MT0850IN09C1PC	850	Indoor	Natural	Pump Mounted	Copper	945
MT0999IN09C1PC	999	Indoor	Natural	Pump Mounted	Copper	1041
MT1010IN09C1PC	1010	Indoor	Natural	Pump Mounted	Copper	1041
MT1200IN09C1PC	1200	Indoor	Natural	Pump Mounted	Copper	1199
MT1430IN09C1PC	1430	Indoor	Natural	Pump Mounted	Copper	1280
MT1670IN09CBPC	1670	Indoor	Natural	Pump Mounted	Copper	1445
MT1825IN09CBPC	1825	Indoor	Natural	Pump Mounted	Copper	1570
MT0500IN09C1PN	500	Indoor	Natural	Pump Mounted	CuproNickel	808
MT0600IN09C1PN	600	Indoor	Natural	Pump Mounted	CuproNickel	819
MT0715IN09C1PN	715	Indoor	Natural	Pump Mounted	CuproNickel	873
MT0850IN09C1PN	850	Indoor	Natural	Pump Mounted	CuproNickel	945
MT0999IN09C1PN	999	Indoor	Natural	Pump Mounted	CuproNickel	1041
MT1010IN09C1PN	1010	Indoor	Natural	Pump Mounted	CuproNickel	1041
MT1200IN09C1PN	1200	Indoor	Natural	Pump Mounted	CuproNickel	1199
MT1430IN09C1PN	1430	Indoor	Natural	Pump Mounted	CuproNickel	1280
MT1670IN09CBPN	1670	Indoor	Natural	Pump Mounted	CuproNickel	1445
MT1825IN09CBPN	1825	Indoor	Natural	Pump Mounted	CuproNickel	1570
MT0500EN09CBPC	500	Outdoor	Natural	Pump Mounted	Copper	855
MT0600EN09CBPC	600	Outdoor	Natural	Pump Mounted	Copper	949
MT0715EN09CBPC	715	Outdoor	Natural	Pump Mounted	Copper	1050
MT0850EN09CBPC	850	Outdoor	Natural	Pump Mounted	Copper	1100
MT0999EN09CBPC	999	Outdoor	Natural	Pump Mounted	Copper	1240
MT1010EN09CBPC	1010	Outdoor	Natural	Pump Mounted	Copper	1240
MT1200EN09CBPC	1200	Outdoor	Natural	Pump Mounted	Copper	1410
MT1430EN09CBPC	1430	Outdoor	Natural	Pump Mounted	Copper	1570
MT1670EN09CBPC	1670	Outdoor	Natural	Pump Mounted	Copper	1622
MT1825EN09CBPC	1825	Outdoor	Natural	Pump Mounted	Copper	1725
MT0500EN09CBPN	500	Outdoor	Natural	Pump Mounted	CuproNickel	855

# COMMERCIAL MEGATHERM® (CONT'D)

## HIGH PERFORMANCE ELECTRONIC IGNITION HEATER

Product	BTUs (000's)	Installation	Gas Type	Pump System	Heat Exchanger	Carton Wt. (Lbs.)
<b>COMMERCIAL MEGATHERM NATURAL GAS MODELS</b>						
MT0600EN09CBPN	600	Outdoor	Natural	Pump Mounted	CuproNickel	949
MT0715EN09CBPN	715	Outdoor	Natural	Pump Mounted	CuproNickel	1050
MT0850EN09CBPN	850	Outdoor	Natural	Pump Mounted	CuproNickel	1100
MT0999EN09CBPN	999	Outdoor	Natural	Pump Mounted	CuproNickel	1240
MT1010EN09CBPN	1010	Outdoor	Natural	Pump Mounted	CuproNickel	1240
MT1200EN09CBPN	1200	Outdoor	Natural	Pump Mounted	CuproNickel	1410
MT1430EN09CBPN	1430	Outdoor	Natural	Pump Mounted	CuproNickel	1570
MT1670EN09CBPN	1670	Outdoor	Natural	Pump Mounted	CuproNickel	1622
MT1825EN09CBPN	1825	Outdoor	Natural	Pump Mounted	CuproNickel	1725
MT2000IN18CCAC	2000	Indoor	Natural	Less Pump	Copper	1950
MT2450IN18CCAC	2450	Indoor	Natural	Less Pump	Copper	2100
MT3050IN18CCAC	3050	Indoor	Natural	Less Pump	Copper	2250
MT3500IN18CCAC	3500	Indoor	Natural	Less Pump	Copper	2510
MT4050IN18CCAC	4050	Indoor	Natural	Less Pump	Copper	2750
MT4500IN18CCAC	4500	Indoor	Natural	Less Pump	Copper	2900
MT5000IN18CCAC	5000	Indoor	Natural	Less Pump	Copper	3200
MT2000IN18CCAN	2000	Indoor	Natural	Less Pump	CuproNickel	1950
MT2450IN18CCAN	2450	Indoor	Natural	Less Pump	CuproNickel	2100
MT3050IN18CCAN	3050	Indoor	Natural	Less Pump	CuproNickel	2250
MT3500IN18CCAN	3400	Indoor	Natural	Less Pump	CuproNickel	2510
MT4050IN18CCAN	4050	Indoor	Natural	Less Pump	CuproNickel	2750
MT4500IN18CCAN	4500	Indoor	Natural	Less Pump	CuproNickel	2900
MT5000IN18CCAN	5000	Indoor	Natural	Less Pump	CuproNickel	3200
MT2200EN18CCAC	2200	Outdoor	Natural	Less Pump	Copper	2320
MT2800EN18CCAC	2800	Outdoor	Natural	Less Pump	Copper	2500
MT3200EN18CCAC	3200	Outdoor	Natural	Less Pump	Copper	2840
MT3600EN18CCAC	3600	Outdoor	Natural	Less Pump	Copper	3175
MT4000EN18CCAC	4000	Outdoor	Natural	Less Pump	Copper	3940
MT4500EN18CCAC	4500	Outdoor	Natural	Less Pump	Copper	3790
MT2200EN18CCAN	2200	Outdoor	Natural	Less Pump	CuproNickel	2320
MT2800EN18CCAN	2800	Outdoor	Natural	Less Pump	CuproNickel	2500
MT3200EN18CCAN	3200	Outdoor	Natural	Less Pump	CuproNickel	2840
MT3600EN18CCAN	3600	Outdoor	Natural	Less Pump	CuproNickel	3175
MT4000EN18CCAN	4000	Outdoor	Natural	Less Pump	CuproNickel	3940
MT4500EN18CCAN	4500	Outdoor	Natural	Less Pump	CuproNickel	3790
<b>COMMERCIAL MEGATHERM PROPANE MODELS</b>						
MT0500IP09C1PC	500	Indoor	Propane	Pump Mounted	Copper	808
MT0600IP09C1PC	600	Indoor	Propane	Pump Mounted	Copper	819
MT0715IP09C1PC	715	Indoor	Propane	Pump Mounted	Copper	873
MT0850IP09C1PC	850	Indoor	Propane	Pump Mounted	Copper	945
MT0999IP09C1PC	999	Indoor	Propane	Pump Mounted	Copper	1041
MT1010IP09C1PC	1010	Indoor	Propane	Pump Mounted	Copper	1041
MT1200IP09C1PC	1200	Indoor	Propane	Pump Mounted	Copper	1199
MT1430IP09C1PC	1430	Indoor	Propane	Pump Mounted	Copper	1280
MT1670IP09CBPC	1670	Indoor	Propane	Pump Mounted	Copper	1445
MT1825IP09CBPC	1825	Indoor	Propane	Pump Mounted	Copper	1570
MT0500IP09C1PN	500	Indoor	Propane	Pump Mounted	CuproNickel	808
MT0600IP09C1PN	600	Indoor	Propane	Pump Mounted	CuproNickel	819
MT0715IP09C1PN	715	Indoor	Propane	Pump Mounted	CuproNickel	873
MT0850IP09C1PN	850	Indoor	Propane	Pump Mounted	CuproNickel	945



# COMMERCIAL MEGATHERM® (CONT'D)

## HIGH PERFORMANCE ELECTRONIC IGNITION HEATER

Product	BTUs (000's)	Installation	Gas Type	Pump System	Heat Exchanger	Carton Wt. (Lbs.)
COMMERCIAL MEGATHERM PROPANE MODELS						
MT0999IP09C1PN	999	Indoor	Propane	Pump Mounted	CuproNickel	1041
MT1010IP09C1PN	1010	Indoor	Propane	Pump Mounted	CuproNickel	1041
MT1200IP09C1PN	1200	Indoor	Propane	Pump Mounted	CuproNickel	1199
MT1430IP09C1PN	1430	Indoor	Propane	Pump Mounted	CuproNickel	1280
MT1670IP09CBPN	1670	Indoor	Propane	Pump Mounted	CuproNickel	1445
MT1825IP09CBPN	1825	Indoor	Propane	Pump Mounted	CuproNickel	1570
MT0500EP09CBPC	500	Outdoor	Propane	Pump Mounted	Copper	855
MT0600EP09CBPC	600	Outdoor	Propane	Pump Mounted	Copper	949
MT0715EP09CBPC	715	Outdoor	Propane	Pump Mounted	Copper	1050
MT0850EP09CBPC	850	Outdoor	Propane	Pump Mounted	Copper	1100
MT0999EP09CBPC	999	Outdoor	Propane	Pump Mounted	Copper	1240
MT1010EP09CBPC	1010	Outdoor	Propane	Pump Mounted	Copper	1240
MT1200EP09CBPC	1200	Outdoor	Propane	Pump Mounted	Copper	1410
MT1430EP09CBPC	1430	Outdoor	Propane	Pump Mounted	Copper	1570
MT1670EP09CBPC	1670	Outdoor	Propane	Pump Mounted	Copper	1622
MT1825EP09CBPC	1825	Outdoor	Propane	Pump Mounted	Copper	1725
MT0500EP09CBPN	500	Outdoor	Propane	Pump Mounted	CuproNickel	855
MT0600EP09CBPN	600	Outdoor	Propane	Pump Mounted	CuproNickel	949
MT0715EP09CBPN	715	Outdoor	Propane	Pump Mounted	CuproNickel	1050
MT0850EP09CBPN	850	Outdoor	Propane	Pump Mounted	CuproNickel	1100
MT0999EP09CBPN	999	Outdoor	Propane	Pump Mounted	CuproNickel	1240

### Dimensions and Performance

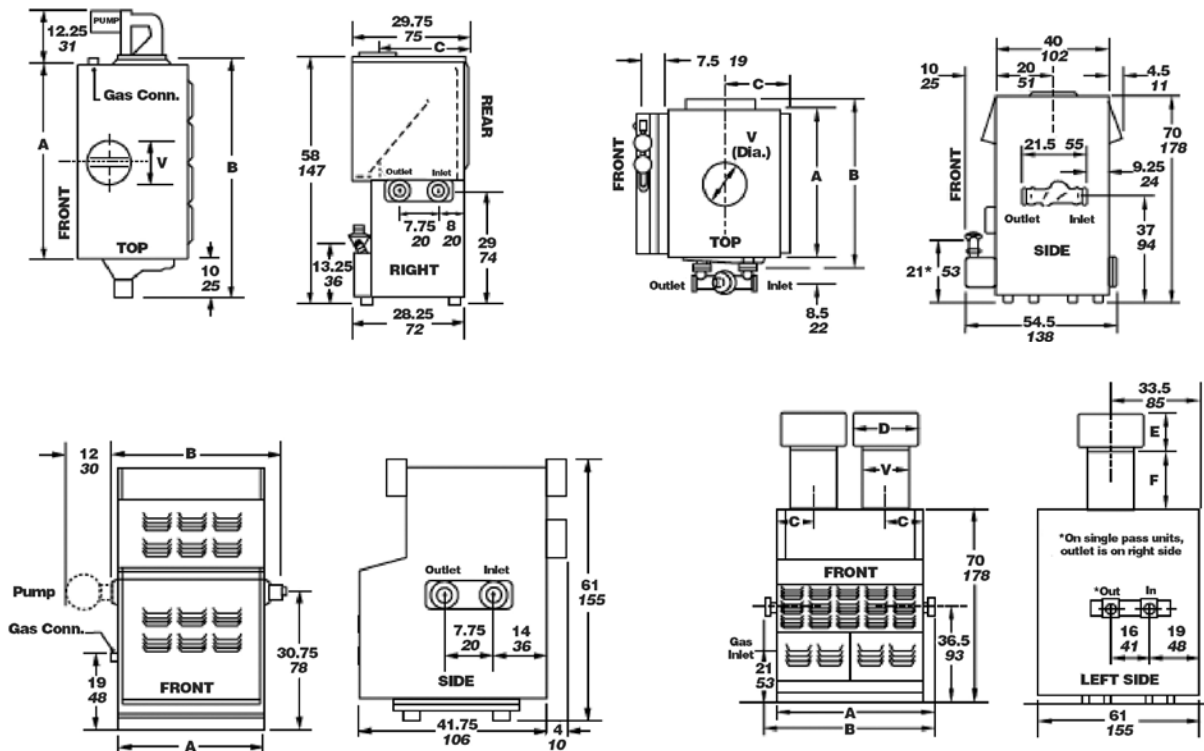

# ULTRATEMP® HEAT PUMP

## HIGH PERFORMANCE HEAT PUMP

TRADEGRADE



UltraTemp 120Q Heat Pump

The industry's first heat pump charged with non-ozone depleting refrigerant, R410A.

### Featured Highlights

- 100% titanium heat exchanger assures corrosion-free performance for extra long life
- LCD control board displays an intuitive menu-driven read out with easy to follow full word messages...no more codes
- AutoSet (time clock over-ride) feature monitors water temperature and turns the water circulation pump on and off as needed to maintain desired pool temperatures
- Automatic defrost feature senses refrigerant temperature and prevents freezing, allowing the heat pump to operate at even lower temperatures
- Compatible with ALL automated control packages
- Long-life corrosion resistant plastic composite cabinet stands up to severe climates and pool chemicals
- Emerson® Copeland Scroll® Compressor
- ETL listed for safe operation
- Thermostatic Expansion Valve (TXV) controls refrigerant flow for optimum efficiency and BTU output over a wider operating range
- Highest efficiency available, meets or exceeds existing codes and standards
- BTU and efficiency performance independently certified by the Air-Conditioning, Heating and Refrigeration Institute, AHRI

### Ordering Information

Part #		Model	80/80/80* BTU/COP	80/63/80* BTU/COP	50/63/80* BTU/COP	Freq (Hz)	Breaker Size (amp)	Phase	Volt	Ctn Qty.	Ctn Wt.	"A" Dim.
BLACK	ALMOND											
ULTRATEMP HEAT PUMPS												
460960	460930	70	75,000/5.9	70,000/5.7	50,000/4.0	60	40	1	230	1	290	33.5
460961	460931	90	90,000/5.8	85,000/5.6	60,000/4.0	60	50	1	230	1	300	33.5
460962	460932	110	110,000/6.1	101,000/5.8	70,000/4.0	60	50	1	230	1	271	45.5
460863	460833	120Q	127,000/5.7	120,000/5.5	80,000/4.0	60	50	1	230	1	270	48.1
460964	460934	140	145,000/5.8	135,000/5.6	90,000/4.0	60	50	1	230	1	335	45.5
460965	460935	120 H/C	125,000 Heat/5.5 71,000 Cool/4.1	118,000/5.3	80,000/4.0	60	50	1	230	1	283	45.5
460959	460958	140 H/C	140,000 Heat/5.6 71,000 Cool/4.1	132,000/5.4	85,000/4.0	60	50	1	230	1	344	45.5
460967	460937	120 C	122,000/5.5	114,000/5.3	76,000/4.0	60	50	3	230	1	264	45.5
460929	460928	140C	140,000/5.7	130,000/5.5	85,000/4.0	60	50	3	230	1	335	45.5

\* Rating in accordance with ARI Standard 1160 (air temp. °F. / % relative humidity / water temp °F.)

Emerson® is a registered trademark of Emerson Electric Co. and Copeland Scroll® is a registered trademark of Emerson Climate Technologies, Inc.

### Dimensions and Performance

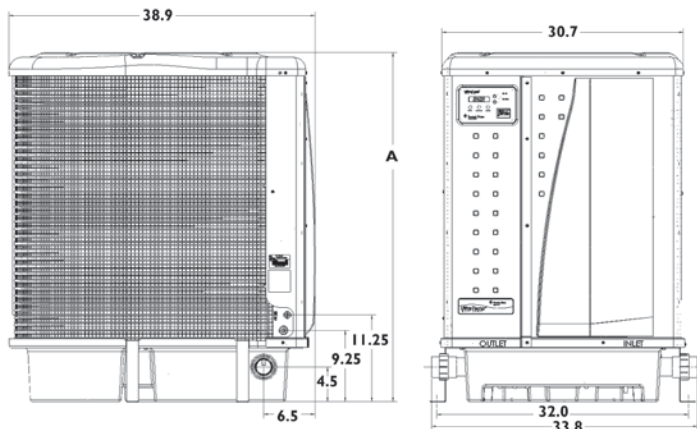

CALIFORNIA PROPOSITION 65 WARNING

⚠️ WARNING: Cancer and Reproductive Harm.  
 ⚠️ AVERTISSEMENT: Peut Causer le Cancer et des Dommages au Système Reproducteur.  
 ⚠️ ADVERTENCIA: Cáncer y Daño Reproductivo.

[www.p65warnings.ca.gov](http://www.p65warnings.ca.gov) PH201714



The AHRI Certified® Mark is applied only to HVACR equipment and components that have been independently tested to certify manufacturers' performance claims are accurate. Visit [www.ahridirectory.org](http://www.ahridirectory.org) for a complete list of certified products.

CEC indicates that Heat Pump has been evaluated to California Title-20, listed in the California Energy Commission's (CEC) database of compliant heat pumps, and certified to use on Residential Swimming Pool Filtration Systems.

See pages 456–457 for replacement parts.