

# MAHINDRA

T R A C T O R S

## OPERATOR MANUAL

### '16' Series

2816 HST



Click here to go on

[INDEX](#)

[Main Menu](#)



**Cultivate  
Your  
Dreams<sup>SM</sup>**

## ABOUT THIS MANUAL

This Manual has been prepared to assist you in following the correct procedure for break-in, operation and maintenance of your new Mahindra tractor.

Your tractor has been designed and built to give maximum performance, with good fuel economy and ease of operation under a wide variety of operating conditions. Prior to delivery, the tractor was carefully inspected, both at the factory and by your Mahindra dealer, to ensure that it reaches you in optimum condition. To maintain this condition and ensure trouble free performance, it is important that the routine services, as specified in this manual, are carried out at the recommended intervals.

We have enclosed a page on new tractor inspection sheets. The first sheet is the dealer's copy and should be removed by the dealer after the inspection has been carried out. The second sheet is your copy of the service performed. Ensure that you & the dealer sign both copies.

Read this manual carefully and keep it in a convenient place for future reference. If at any time you require advice concerning your tractor, do not hesitate to contact your authorised Mahindra dealer. He has trained personnel, genuine Mahindra parts and necessary equipments to undertake all your service requirements.

Mahindra USA Inc's. policy is one of continuous improvement, and the right to change prices, specifications or equipments at any time without notice is reserved.

All data given in this book is subject to production variations. Dimensions & weight are approximate only and the illustrations do not necessarily show tractors in standard condition. For exact information about any particular tractor, please consult your Mahindra dealer.

Off-Road Diesel Engine  
Emission Control System Warranty Statement

**mitsubishi**

**DIESEL ENGINE**

**MITSUBISHI HEAVY INDUSTRIES, LTD.**  
**GENERAL MACHINERY & SPECIAL VEHICLE HEADQUARTERS**

16 Series, Model - 2816 HST

[MUSA Website](#)

[Main Menu](#)

[Index](#)

[Full Screen](#)



[Search](#)



[Print](#)

[EXIT](#)

# Off-Road Diesel Engine

## Emission Control System Warranty Statement

### Emission Related System Defect Warranty

#### *Manufacturer Statement*

Mitsubishi Heavy Industries, Ltd. (MHI) will give a warranty condition, required by the U.S. Environmental Protection Agency(EPA) and the California Air Resource Board(CARB) to Original Equipment Manufacturers (OEMs) for small off-road engines purchased in 1997 and later which are used in U.S.A.

It is the OEMs responsibility to give the following warranty to the end-users for small off-road engines purchased in 1997 and later which are used in U.S.A.

The manufacturer of MHI small off-road engines has authorized equipment manufacturers to be the direct contact for all warranty and service related questions and/or repairs. All inquiries should be directed to equipment manufacturers only.

#### *Emission Control Warranty Statement*

Applicable only to engines purchased in U.S.A. in 1997 and thereafter which are used in U.S.A..

EPA emission control defects warranty statement – Your (Customer) defects warranty rights and obligations:

EPA and Mitsubishi Heavy Industries, Ltd. are pleased to explain the emission control system warranty on your 1997 and later small off-road engine. In U.S.A., new small off-road engines must be designed, built and equipped to meet the EPA stringent anti-smog standards. Mitsubishi Heavy Industries, Ltd. must warrant the emission control system on your small off-road engine for the periods of time listed below, provided there has been no abuse, neglect or improper maintenance of your small off-road engine.

Where a warrantable condition exists, the (OEMs) will repair your small off-road engine at no cost to you including diagnosis, parts and labor.

### ***Manufacturer's Emission Control Warranty Coverage***

Applicable only to engines purchased in U.S.A. in 1997 and thereafter which are used in U.S.A.

Emission control systems warranty coverage.

The small off-road engines are warranted as to emission control parts defects for a period, which is prescribed by US EPA CFR Part 89, subject to provisions as set forth hereafter. If any covered part on your engine is defective, the part will be repaired by (OEMs).

#### ***Owner's warranty responsibilities:***

As the small off-road engine owner, you are responsible for the performance of the required maintenance listed in your owner's manual. (OEMs) recommends that you retain all receipts covering maintenance on your small off-road engine. But (OEMs) cannot deny warranty solely for the lack of receipts or for your failure to ensure the performance of all scheduled maintenance.

As the small off-road engine owner, you should be aware, however, that OEMs may deny you warranty coverage if your small off-road engine or a part has failed due to abuse, neglect, improper maintenance or unapproved modifications.

You are responsible for presenting your small off-road engine to an authorized service dealer (authorized by OEMs) of small off-road engines as soon as a problem exists. The undisputed warranty repairs should be completed in a reasonable amount of time, not to exceed 30 days. If you have any question regarding your warranty rights and responsibilities, you should contact (Mahindra, USA Inc) at 1-800-561-9256. The emission warranty is a defects warranty. Defects are judged on normal engine performance.

The warranty is not related to an in-use emission test.

#### ***Specific Warranty Provisions***

The following are specific provisions relative to your emissions control systems warranty coverage.

#### ***Warranted Parts***

Coverage under this warranty extends only to the parts listed below (the emission control systems parts) to the extent these parts were present on the engine purchased.



#### Fuel injection system

- Fuel injection pump
- Fuel injectors

#### Inlet system

- Intake manifold

#### Exhaust system

- Exhaust manifold

#### Turbocharger system

- Turbocharger (if equipped)

#### Miscellaneous items used in above systems

- Cylinder Head Gasket
- Valve Stem Seal

#### ***Length of Coverage***

MHI warrants to the initial owner and each subsequent purchaser that the warranted parts shall be free from defects in materials and workmanship which cause the failure of the warranted part(s) for a period, which is prescribed by US EPA CFR Part 89, from the date the engine is delivered to a retail purchaser.

For all engines rated under 19kW and for constant speed engines rated under 37kW with rated speeds greater than or equal to 3,000 rpm, the warranty period is 3,000hours or 5 years of use, whichever first occurs.

For all other engines rated at or above 19kW, the warranty period is 5,000 hours or 7 years of use, whichever first occurs.

#### ***No Charge***

Repair or replacement of any warranted part will be performed at no charge to the owner, including diagnostic labor which leads to the determination that a warranted part is defective, if the diagnostic work is performed at an authorized service dealer of small off-road engines to whom OEMs would sell engines.

#### ***Claims and Coverage Exclusions***

Warranty claims shall be filled in accordance with the provisions of the OEMs engine warranty policy. Warranty coverage shall be excluded for failures of warranted parts

which are not original OEMs *parts* or because of abuse, neglect or improper maintenance as set forth in the OEMs engine warranty policy. OEMs is not liable to cover failures of warranted parts caused by the use of add-on, non-original, or modified parts.

### ***Maintenance***

Any warranted part which is not scheduled for replacement as required maintenance or which is scheduled only for regular inspection to the effect of “repair or replace as necessary” shall be warranted as to defects for the warranty period. Any warranted part which is scheduled for replacement as required maintenance shall be warranted as to defects only of the period of time up to the first scheduled replacement for that part. Any replacement part that is equivalent in performance and durability may be used in the performance of any maintenance or repairs. The owner is responsible for the performance of all required maintenance, as defined in the MHI owner’s manual.

### ***Consequential Coverage***

Coverage hereunder shall extend to the failure of any engine components caused by the failure of any warranted part still under warranty.

## INTRODUCTION

This instruction manual contains information on the operation, lubrication and maintenance of your tractor. The information contained is comprehensive and essential, and is designed to assist you, even if unexperienced, in utilizing your tractor.

How well your tractor continues to give satisfactory performance depends greatly upon the manner in which it is operated. It is, therefore, requested that this manual be read carefully and kept ready for use so that the operation and maintenance service will properly be carried out in order to keep the tractor in top mechanical condition at all times.

Should any information as to your tractor be required, consult your local dealer or distributor stating the machine and engine serial numbers of the tractor concerned. We are sure you will be happy with your tractor.

**NOTE:** Expressions such as *LEFT*, *RIGHT*, *FRONT*, or *REAR* used in this manual should be understood in accordance with following rules: *FRONT* means the front grill end while *REAR* means the lifting arm end of the tractor. *LEFT* or *RIGHT* means the left or righthand side of the tractor looking forward from operator's seat.

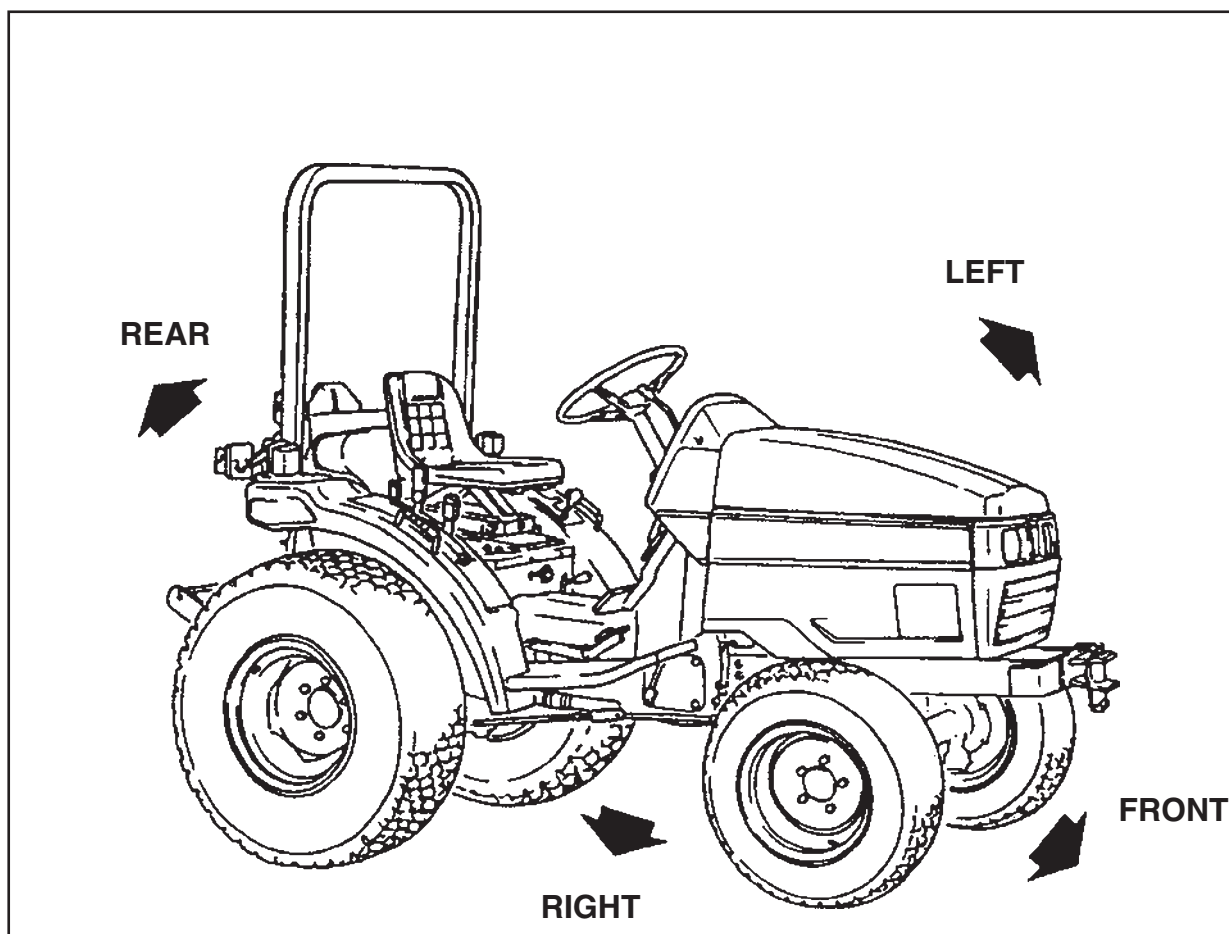



## SERIAL NUMBERS

Write your machine Model Number and Serial Numbers of major components on the lines provided. If needed, give these numbers to your dealer when you need parts or information for your machine.

1. TRACTOR MODEL NUMBER \_\_\_\_\_
2. TRACTOR SERIAL NUMBER \_\_\_\_\_
3. ENGINE SERIAL NUMBER \_\_\_\_\_
4. ROPS SERIAL NUMBER \_\_\_\_\_

### SERIAL NUMBER LOCATIONS

TRACTOR MODEL NUMBER AND SERIAL NUMBER PLATE

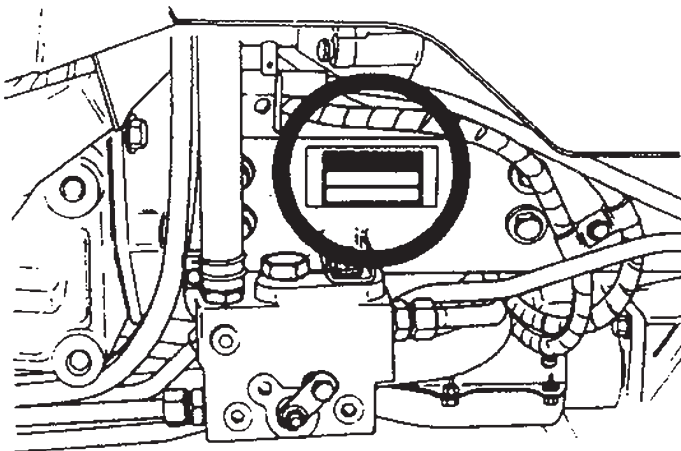

ROPS SERIAL NUMBER PLATE

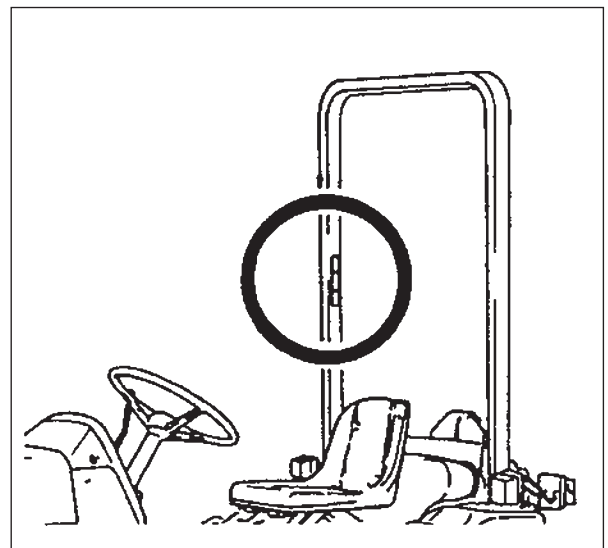

ENGINE SERIAL NUMBER

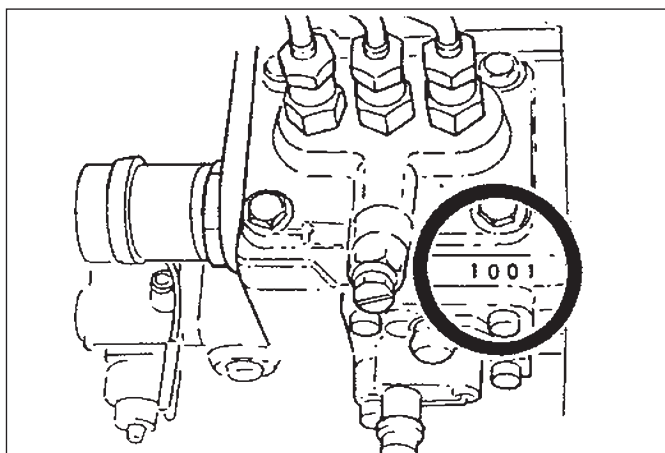

# GENERAL TABLE OF CONTENTS

Safety/Decals .....	1-19
Specifications .....	20-24
Instruments/Controls .....	25-41
Operating Instructions .....	42 - 62
Field Operation .....	63-77
Tires/Wheels/Spacing/Ballast .....	78-87
Lubrication/Filters/Fluids .....	88-115
Maintenance/Adjustments .....	116-122
Electrical System.....	123-130
Storage .....	131-132

## SAFETY PRECAUTIONS

REMEMBER: "SAFETY" IS ONLY A WORD UNTIL IT IS PUT IN TO PRACTICE

Improper handling of the tractor could lead to an accident. Prior to the operation of the tractor, be sure to read this Manual carefully and have a thorough understanding of all of the contents. In particular, the instructions given in this section entitled "Safety Precautions" must be strictly followed.

### A. GENERAL OPERATING SAFETY PRECAUTION

1. Observe all the safety precautions in this manual when operating the tractor.
2. Operate the tractor while wearing tight clothing that allows easy movement. Avoid loose jackets, mufflers, ties, scarves, or loose shirt sleeves to prevent from being caught by moving parts.

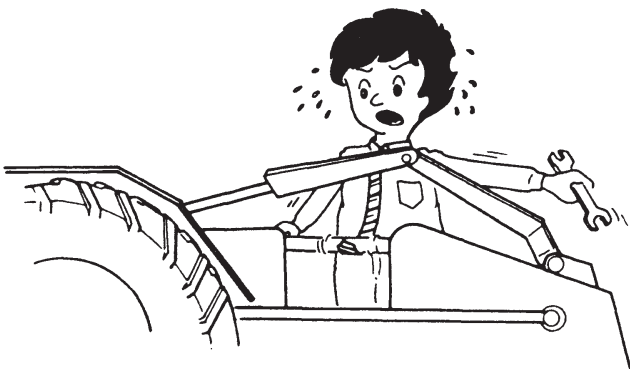

3. Always work when you are in good physical condition by taking sufficient rest to avoid overwork.
4. Do not allow children or adults having no knowledge of the tractor or tractor operation, to operate the tractor.

5. Never allow riders on the tractor, linkage drawbar or attachment while travelling and operating them.

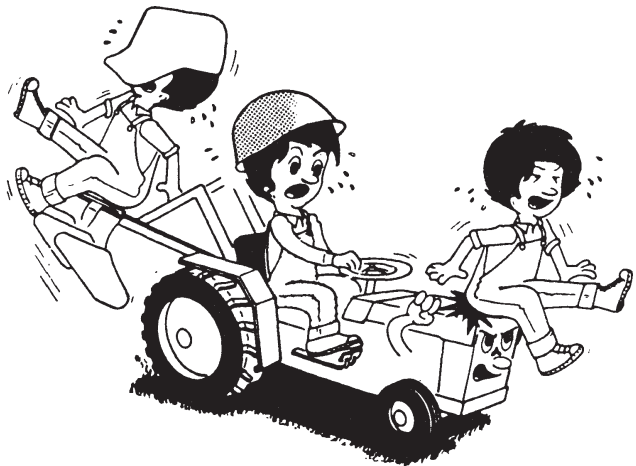

### B. BASIC SAFETY REQUIREMENTS FOR MAINTENANCE

Always follow these maintenance instructions before operating the tractor:

1. Immediately repair the head lights and work lamps required to conform to traffic regulations where the tractor is operated.
2. Keep tractor steps clean to avoid accidents due to slippage.

3. Cover the PTO shaft with a guard when not using.
4. Be sure to engage the brake and lower any attachment or implement before disassembling any part.
5. Never adjust or service the tractor when it is in motion or while the engine is running. Always adjust the brake or clutch properly in accordance with the adjusting procedure in the instruction book.
6. Do not remove the radiator cap while the engine is running. Shut down the engine and wait until it cools sufficiently. For removal, turn the cap to the first stop to relieve pressure. To replace the coolant, use the coolant recovery tank.
7. Hydraulic oil or fuel escaping under pressure can penetrate the skin, causing serious injury. Before disconnecting oil or fuel lines, be sure to relieve all pressure. Before restoring pressure after repair, be sure all connections are tight and all hydraulic components are in normal condition. If injured by leaked fluid, see a doctor immediately for proper treatment.
8. When refueling, be particularly careful first to stop the engine completely to prevent the fuel from igniting. Never refuel in the presence of an open flame or while smoking.

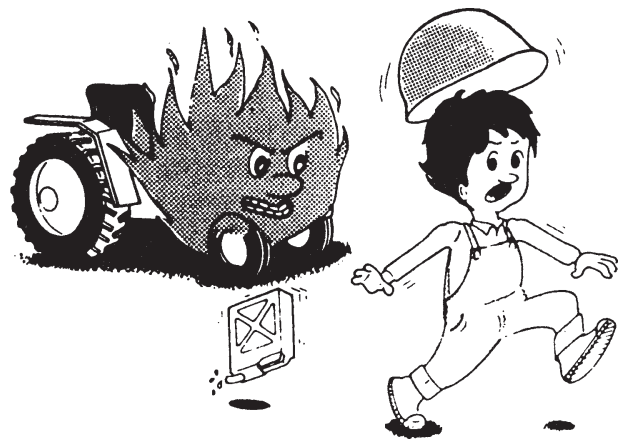

9. Before starting any work on electrical equipment or work that may cause you to touch the electrical part accidentally, first disconnect the battery cables. Never remove the rubber cap cover at the positive terminal of the battery cable end. Before connecting the battery to the charger, make sure that the charger switch is in "OFF" position.  
Be sure to connect the charger to the correct terminals on the battery (positive to positive, negative to negative).  
A great amount of hydrogen gas is generated by the battery when it is being charged. Take precautions against fire: Do not have any exposed flame in the area where you are working. Be sure not to cause any leakage of the electrolyte, since it will corrode the skin or clothing. In case of accident as described below, immediately seek first aid, and see a doctor immediately for proper treatment.
- a) If the diluted sulphuric acid from the battery has gotten into the eyes:  
Clean the eyes with a lot of clean running water for more than 15 minutes, while opening the eyes widely.
- b) If diluted sulphuric acid from the battery has been swallowed:  
Rinse the mouth with clean water immediately and drink a lot of raw eggs or milk. Lie down quietly.
- c) If diluted sulphuric acid has gotten on the skin of clothing:  
Wash away the diluted sulphuric acid completely with a lot of clean running water and neutralize with soap solution. Then rinse with water.
- d) If the diluted sulphuric acid is spilled:  
Wash away with a lot of water or neutralize with slacked lime or bicarbonate of soda.
10. Stop the engine and make sure the PTO shift lever is in Neutral before performing any of the following services, including.
- a) Removal of the propeller shaft between PTO and any attachment.
- b) Adjustment of PTO drive train and hitch.
- c) Adjustment or cleaning of PTO driven attachment.
11. The steering wheel always has built-in play to some extent, which is required for smooth meshing of sector gear and pinion gear.  
Always inspect the amount of the play. Do not operate the tractor if there is too much or too little play in the steering.



**C. OPERATION OF THE TRACTOR**

Before driving the tractor, follow these rules:

**C-1. Before starting and Driving the Tractor**

Operate the tractor only when seated properly in operator's seat and keep a firm grip on the steering wheel at all times.

Never attempt to perform any operation of the tractor from anywhere else, on or off the tractor. Always wear a "hard hat" when operating the tractor.

**C-2. Starting and Driving the Tractor**

Always operate the tractor at the proper speeds which enable you to keep the tractor in your complete control.

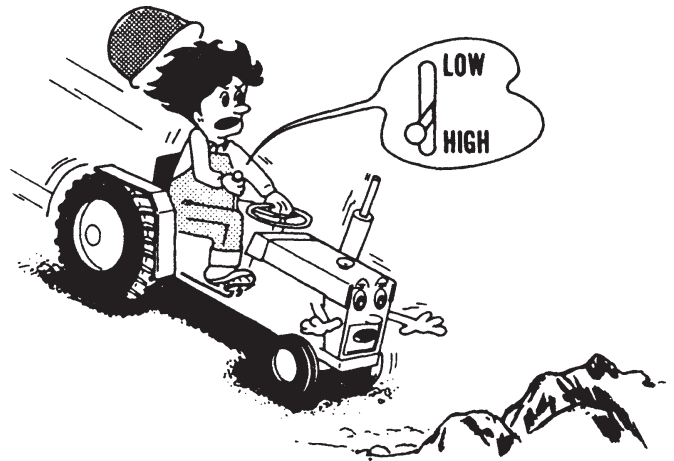

To start travelling, lower the engine speed and release the clutch pedal slowly. Before leaving the tractor, stop the engine, remove the key, apply the parking brake and make sure that the engine has come to a complete stop, and any attachment is completely touching the ground.

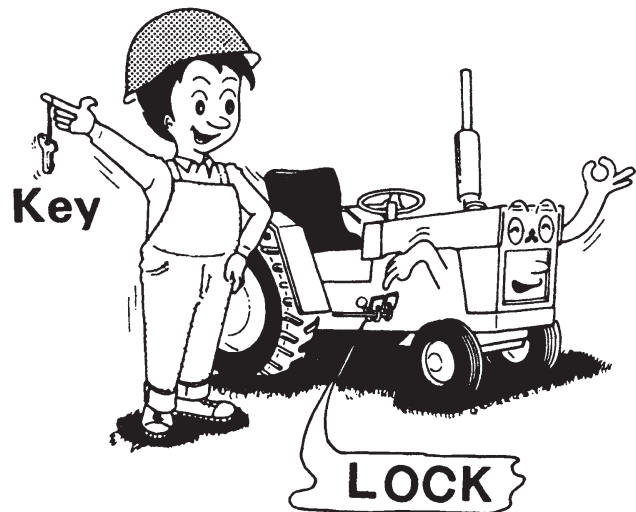

Slow down when operating the tractor on rough ground.



When starting the engine in an enclosed area or building, ensure proper ventilation by opening the doors and/or windows to prevent carbon monoxide inhalation. Mount the extension exhaust pipe on the tractor which has a cabin.

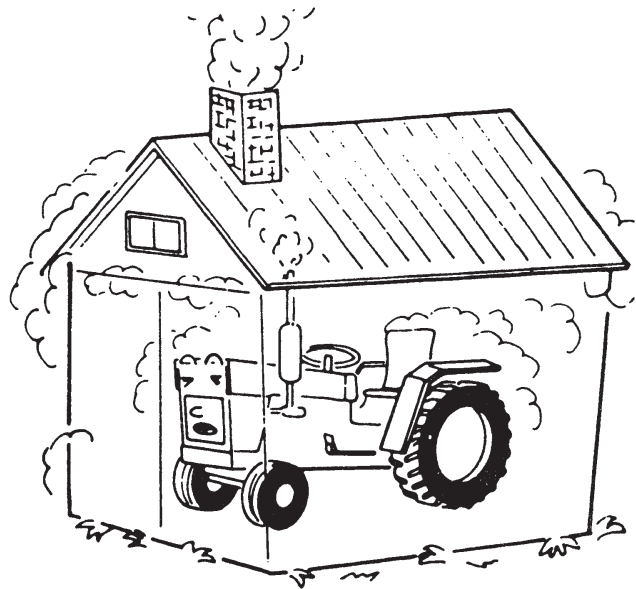

Never attempt to jump on or off a moving tractor.



When starting the tractor, operating any attachment or engaging the PTO make sure that no one is in the way, especially children.

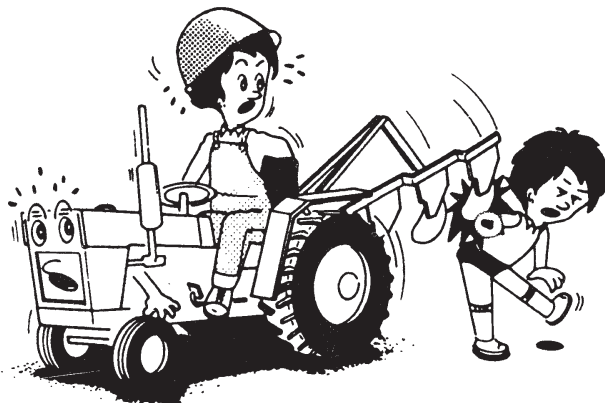

### C-3. Travelling on Roads and Streets

For travelling on roads and streets, be sure to lock both brake pedals together before driving to prevent either brake from acting independently.



Never operate the differential lock while driving at high speed or travelling on the road. For driving the 4-WD tractor on the road, be sure to place the 4-WD shift lever in OFF position.

### C-4. Steering and Turning the Tractor

Slow down your tractor and disengage the differential lock before going into a turn, being careful to prevent any attachments mounted on the front or rear from hitting anyone or anything.

### C-5. Towing and Operating on Hills

For towing work on downward slope, place the shift lever in low speed and use engine brake.

Never try to reduce the speed with brake only. Towing a heavy object on a hill is highly hazardous. Widen the tread of the tractor and mount the wheel weight or chassis weight to increase the stability and operate with extra precaution.



When operating the tractor on either a steep slope or flat ground, be sure not to suddenly steer, brake, clutch or operate attachments. Do not operate the tractor at the edge of cliff or steep slope. Be particularly careful right after the rain when soil is soft and may give way easily.



Avoid operating the tractor on an extreme slope that appears hazardous, when forced to operate on such slope, use extra care. Driving forward out of a ditch or mired condition or up a steep slope could cause tractor to tip over rearward. Back out of such situation if possible. If the situation does not permit you to back out, use the front wheel weight or the chassis weight for balancing the tractor lengthwise. Also in case any extra-heavy rear mounting attachment is used, try to obtain better balance in this manner.

C-6. Using Attachment  
To mount or operate attachment, follow the instruction manual for the particular attachment for safe operation.

For towing, be sure to use the drawbar only. Set the hitch point below the center line of the rear axle. When using a chain, never try to move forward abruptly.

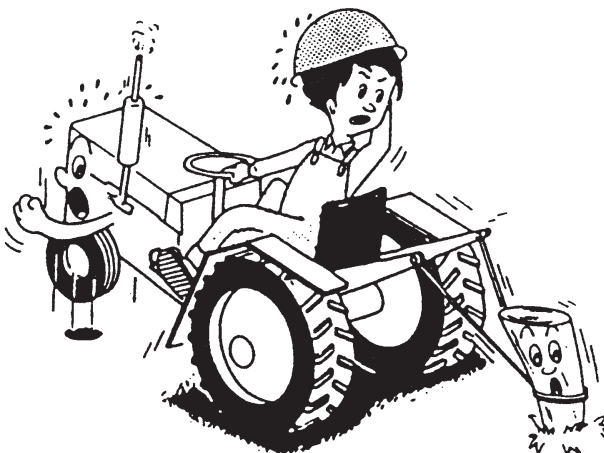
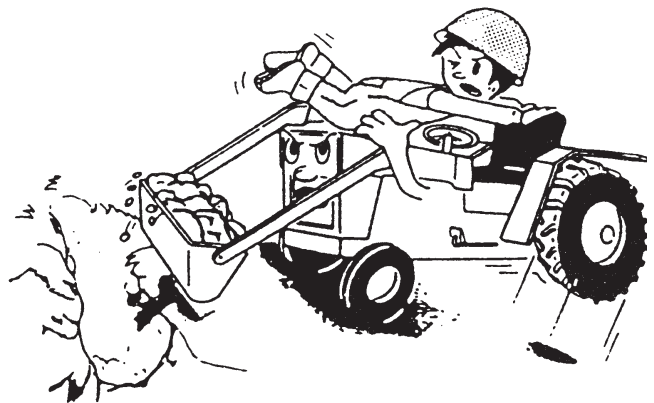

When using agricultural chemicals with an attachment on the tractor, always follow the instructions in the manual for the attachment as well as the instructions provided by the chemical manufacturer.

## DECALS

**IMPORTANT:** *Install new decals if the old decals are destroyed, lost, painted over or can not be read. When parts are replaced that have decals, make sure you install a new decal with each new part.*

**NOTE:** *New decals are available from your Dealer.*

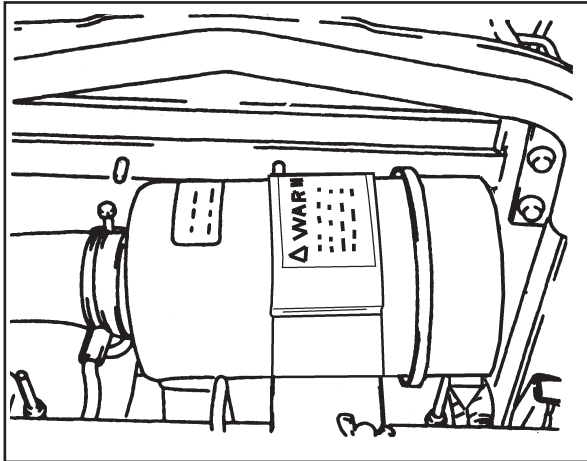

**! WARNING**

**EXPLOSION AND INJURY CAN RESULT FROM USE OF STARTING AIDS WITH HOT GLOW PLUGS. DO NOT INJECT GASOLINE OR ETHER IN AIR INTAKE.**

321-6864

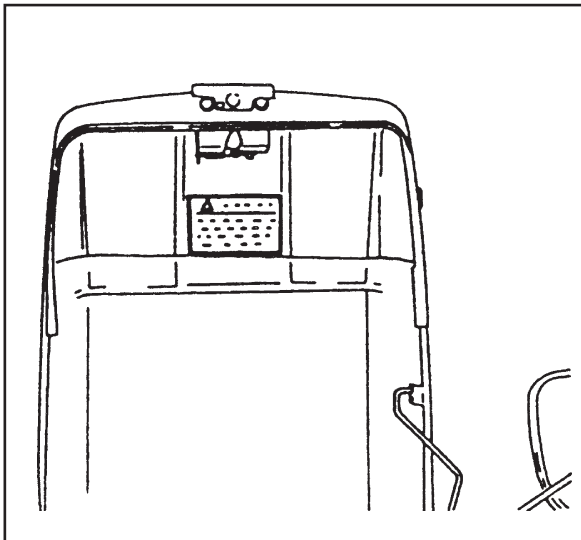

**! WARNING**

**BATTERIES CONTAIN ACID AND EXPLOSIVE GAS. EXPLOSION CAN RESULT FROM SPARKS, FLAMES, OR WRONG CABLE CONNECTIONS. TO CONNECT JUMPER CABLES OR CHARGER, SEE MANUAL(S) FOR THE CORRECT PROCEDURE. FAILURE TO FOLLOW THE ABOVE INSTRUCTIONS CAN CAUSE SERIOUS PERSONAL INJURY OR DEATH.**



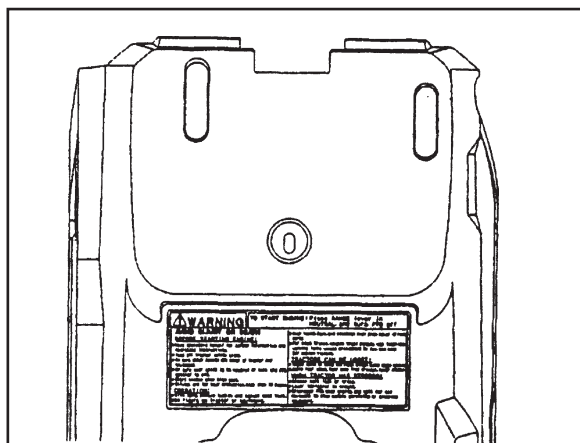

<p><b>WARNING</b> TO START ENGINE: Place RANGE lever in NEUTRAL, and turn PTO off.</p>	
<p><b>AVOID INJURY OR DEATH</b></p>	
<p><b>BEFORE STARTING ENGINE:</b></p> <ul style="list-style-type: none"> <li>Read operator's manual for safety information and operating instructions.</li> <li>Read all tractor safety signs.</li> <li>Be sure other people are clear of tractor and equipment.</li> <li>Be sure gear shift is in neutral or park and PTO control is off.</li> <li>Start engine only from seat.</li> <li>Shields are for your protection; keep them in place.</li> </ul>	
<p><b>OPERATION:</b></p> <ul style="list-style-type: none"> <li>With ROPS, always buckle and adjust seat belt.</li> <li>Keep riders on tractor or equipment.</li> </ul>	
<ul style="list-style-type: none"> <li>Keep hands, feet, and clothing away from power driven parts.</li> <li>For road travel, coupler brake pedals; use flashing warning lamps unless prohibited by law and keep 360° engine visible.</li> </ul>	
<p><b>TRACTORS CAN BE UPSET:</b></p> <ul style="list-style-type: none"> <li>Reduce speed on turns and rough ground; avoid steep slopes.</li> <li>Avoid rear upset. Pull only from drawbar; never higher.</li> </ul>	
<p><b>WHEN TRACTOR HAS STOPPED:</b></p> <ul style="list-style-type: none"> <li>Engage park lock or brake.</li> <li>Lower implement to ground.</li> <li>Disengage PTO, stop engine and wait for all movement to stop before servicing or clearing equipment.</li> </ul>	

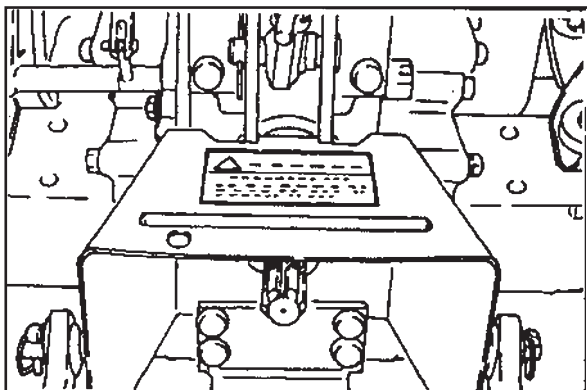

**WARNING**

**ROTATING MACHINE PARTS**

**STAY CLEAR, KEEP SHIELDS INSTALLED TO HELP PROTECT FROM CLOTHING ENTANGLEMENT AND INJURY.**

321-3710

## ROLL OVER PROTECTIVE STRUCTURE (ROPS)

### Foldable ROPS Frame



***When improperly operated, this tractor can roll over or upset. Use of the ROPS and seat belt minimize the possibility of injury or death if rollover or upset occurs. For low clearance use only, the ROPS can be lowered. No protection is provided in this position and the seat belt should not be fastened. For all other uses, secure the ROPS in the upright position and fasten the seat belt.***

M167A

ROPS is foldable so that the tractor can be operated in places such as orchards where the height is restricted. See Folding the ROPS in this manual.

### Normal Operating Position

For normal operation, including transport, always use the foldable ROPS in the secured upright position with a fastened seat belt for full rollover protection.

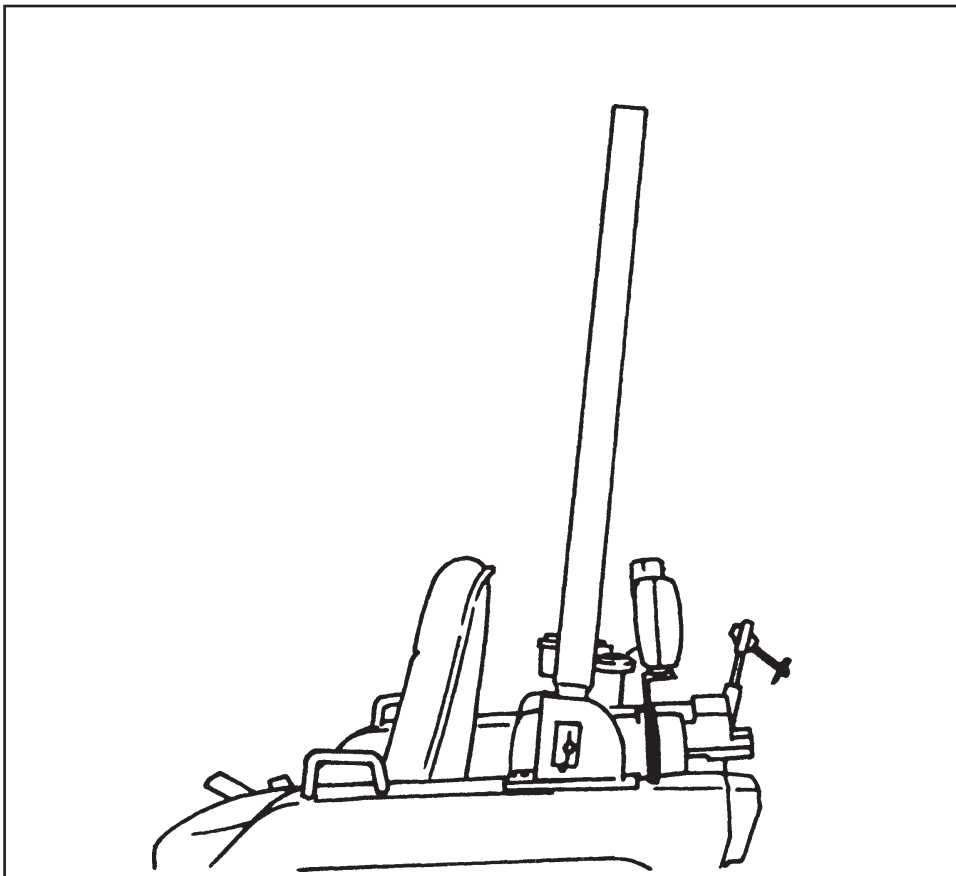

## Low Clearance Positions

For low clearance operation, such as operating in buildings, orchards or vineyards, the ROPS can be lowered and secured in the down position. No rollover protection is provided in the lowered positions and the seat belt should not be fastened. When the low clearance operation is completed, return the ROPS to the secured upright position for all other tractor uses and transport.

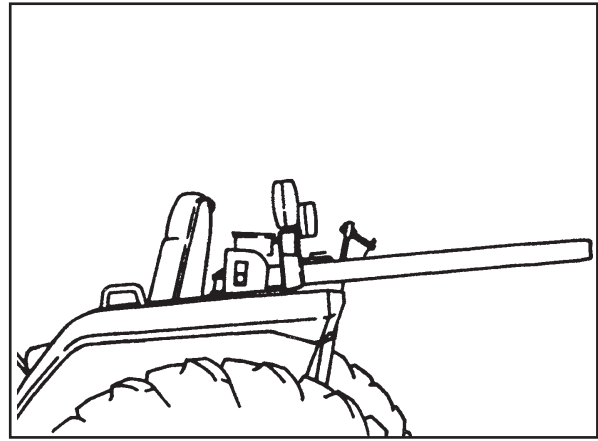
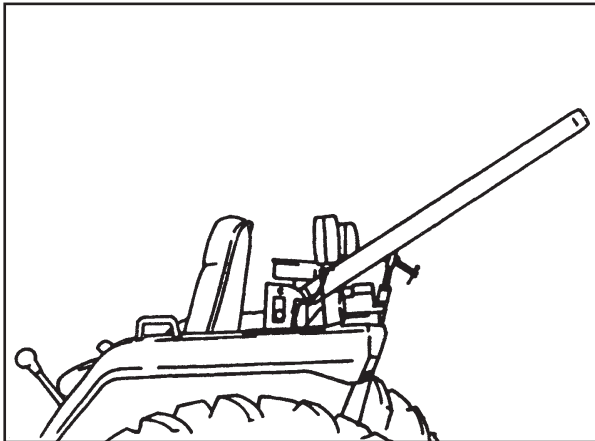

**IMPORTANT:** *When the ROPS frame is in the lowered position, make sure there is clearance between the frame and hitch mounted equipment. Slowly raise the hitch to maximum height to check for necessary clearance. For drawbar attached and/or PTO driven equipment, check for clearance including turning corners.*

## Tractor Roll Over

ROPS is a special safety unit. After an accident the ROPS must be replaced so that you will get the same protection as a new ROPS.

ROPS, the seat, the seat belts and all the mounting, accessories and wiring inside the operators protective area must be carefully checked after a tractor accident and all parts with damage should be replaced immediately. DO NOT TRY TO MAKE REPAIRS OR WELD ROPS.

## Safety Rules

1. Do not make modifications to the ROPS. Example, welding an accessory to the ROPS, or drilling a hole in the ROPS.
2. Special fasteners are used to install the operator protective parts. Replacement parts must be the same as given in the Parts Catalog for your tractor.

## ROPS Label

1. ROPS is equipped with a ROPS label.
2. The label contains the ROPS serial number and applicable standards.

MAHINDRA USA, INC.		FOR APPLICATION ON MAHINDRA TRACTORS 2816, 2816 4WD AGRICULTURAL Tractors	TYPE-CERTIFICATION FOR ROLLOVER PROTECTIVE STRUCTURES
ROPS SERIAL No.	CONFORMS TO OSHA REGULATION	1928-C	PROTECTION AFFORDED BY THIS ROPS WILL BE REDUCED IF THE ROPS IS ALTERED, HAS STRUCTURAL DAMAGE, OR HAS BEEN SUBJECT TO UPSET. SEE OPERATOR'S MANUAL FOR COM- PLETE INSTRUCTIONS AND INSPECTION REQUIREMENTS.
PERFORMANCE STANDARDS MEASURED IN ACCORDANCE WITH		S&E J1194/ ROPS MODEL NO. 2HVM-2	

## Folding the ROPS

**ROPS BAR  
(NORMAL OPERATING POSITION)**

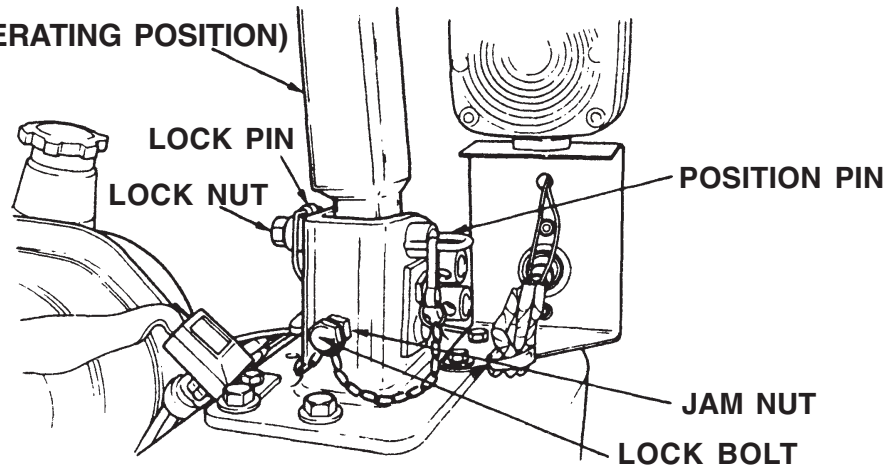

To fold the ROPS, put the tractor on level ground, put the range shift lever in the L position, apply the park brake and stop the engine.

**IMPORTANT:** *Do not fold the ROPS with a sunshade installed.*

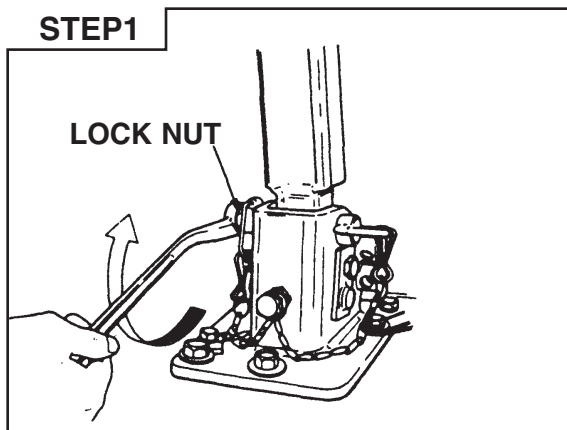

Remove the lock nuts.

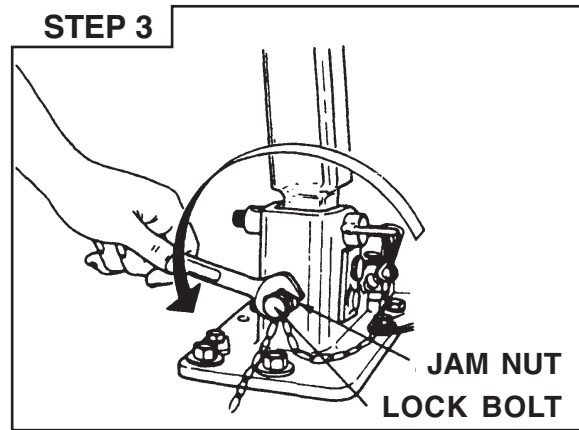

Loosen the jam nut on the lock bolts.

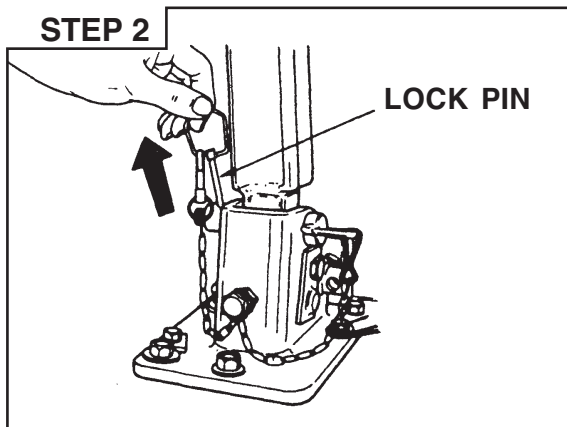

Remove the lock pins.

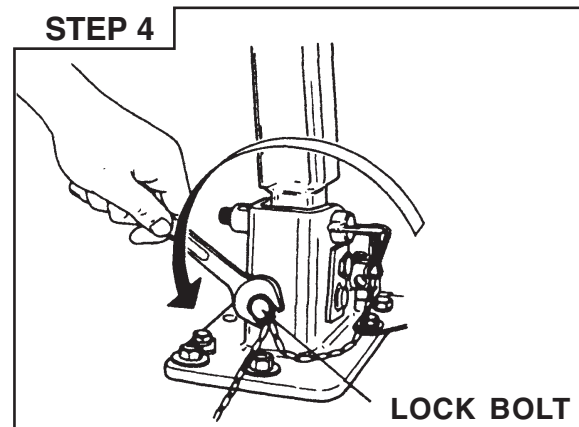

Loosen the lock bolts enough to permit the position pin to be removed. **DO NOT** remove pins until STEP 6.



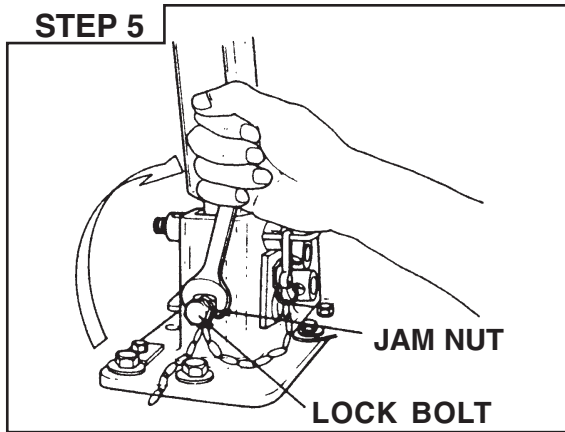

Tighten the jam nut on the lock bolts to a torque of 33 to 40 lb ft (44 to 54 Nm).

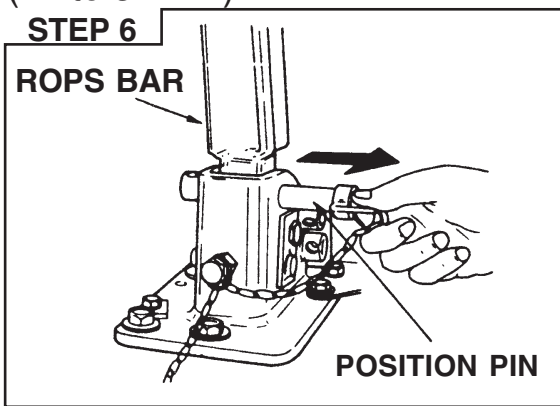

While holding the ROPS bar, CAREFULLY remove the position pins

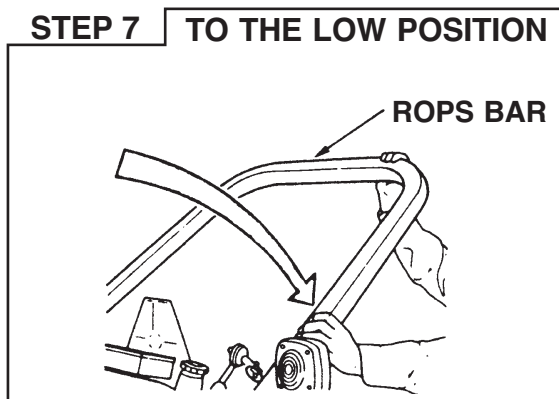

CAREFULLY move the ROPS bar to the desired position

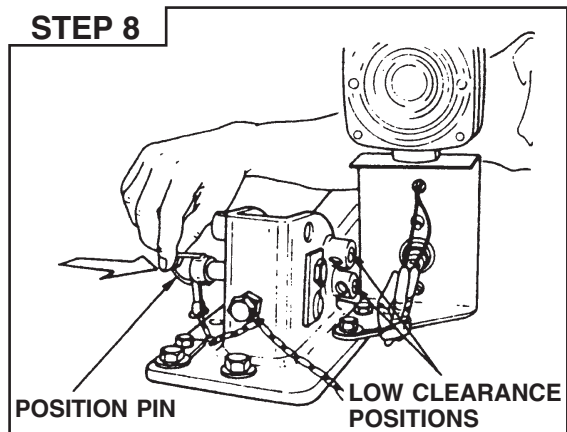

Install the position pins.

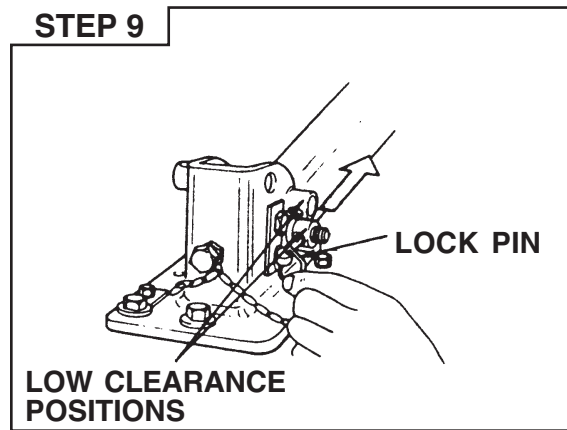

Install the lock pins.

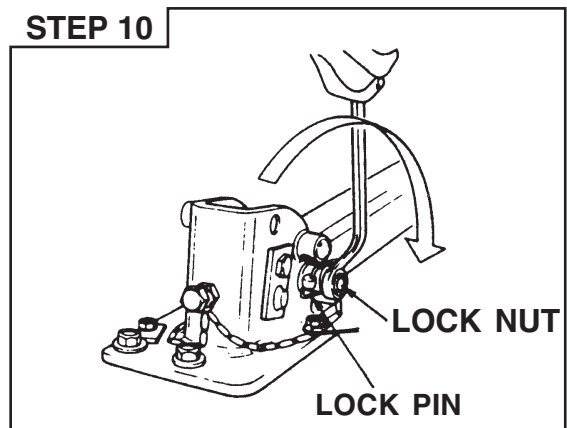

Install lock nuts and tighten to a torque of 33 to 40 lb ft (44 to 54 Nm).

**NOTE:** The lock nuts can be omitted for operator convenience, if the ROPS is folded frequently.

When the low clearance tractor operation is completed, return the ROPS to the secured upright position.

## Securing the ROPS in the Upright Position

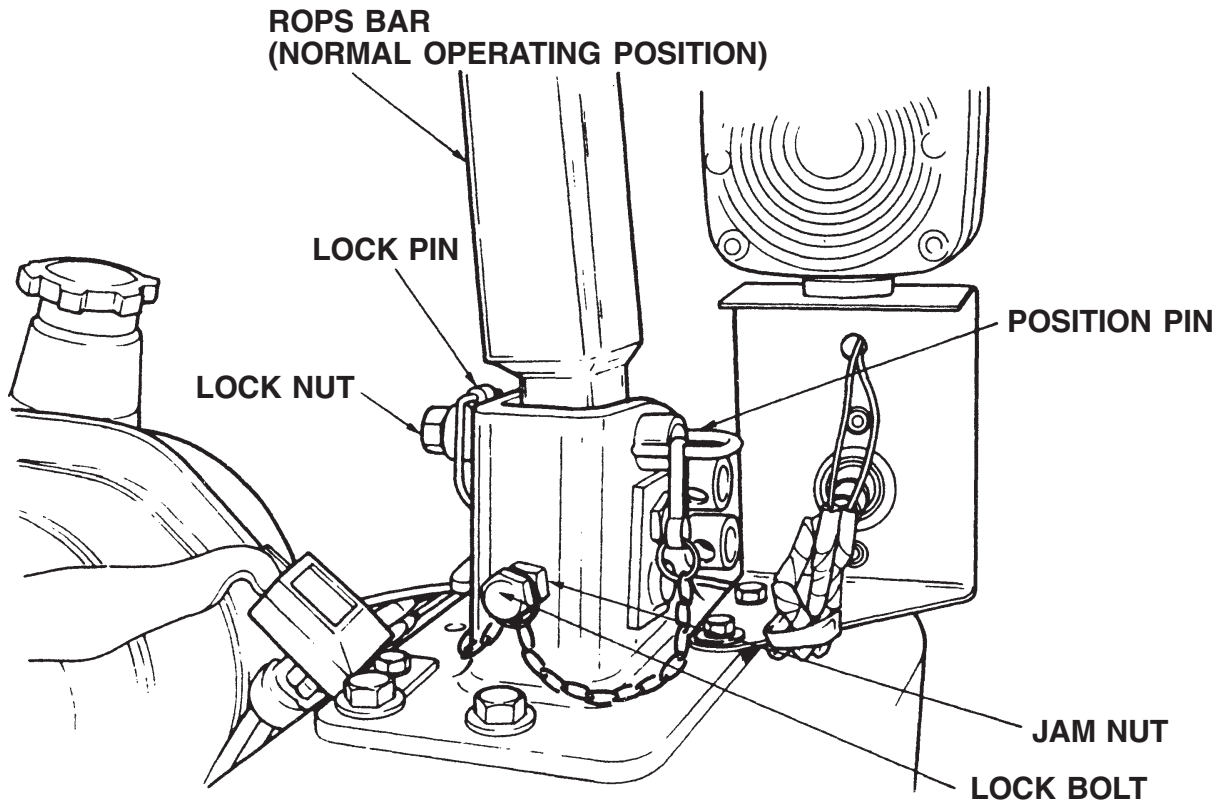

For normal operation, the ROPS must be in the secured upright position. Place the tractor on level ground, put the range shift lever in the L position, apply the park brake and stop the engine.

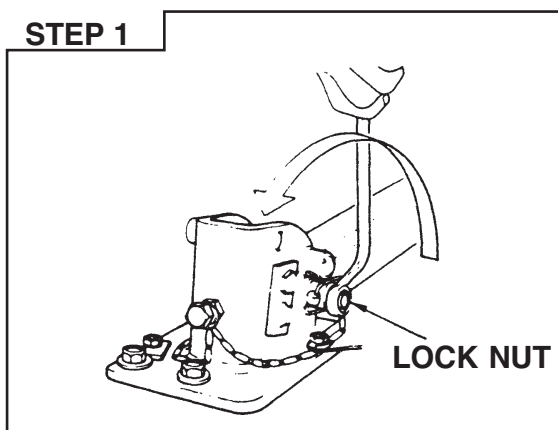

Remove the lock nuts.

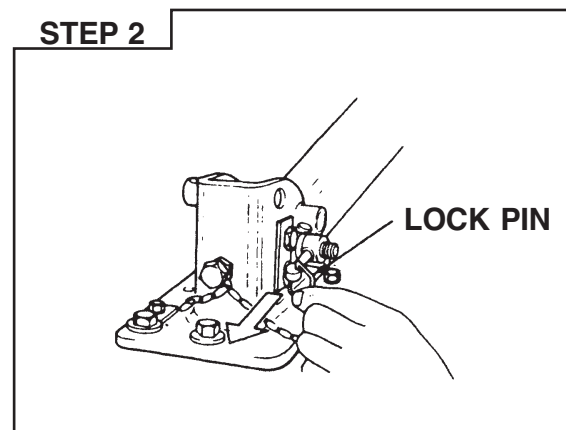

Remove the lock pins.

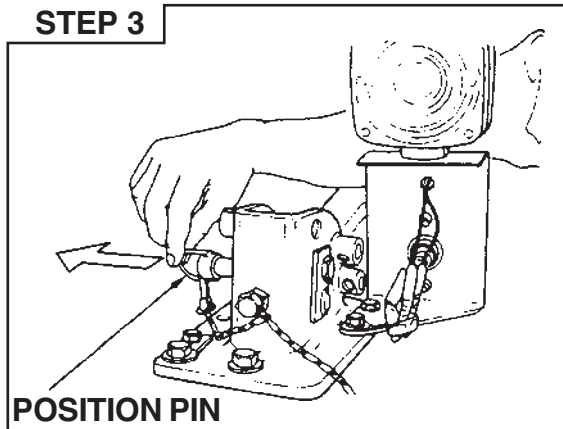

While holding the ROPS bar, CAREFULLY remove the position pins.

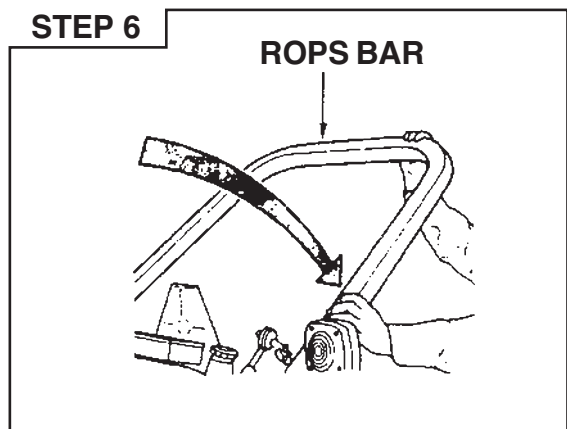

If the position pins cannot be installed, CAREFULLY lower the ROPS bar to the horizontal position.

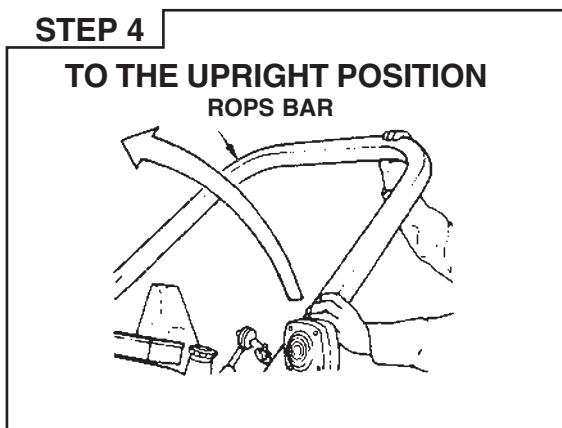

CAREFULLY raise the ROPS bar to the upright position.

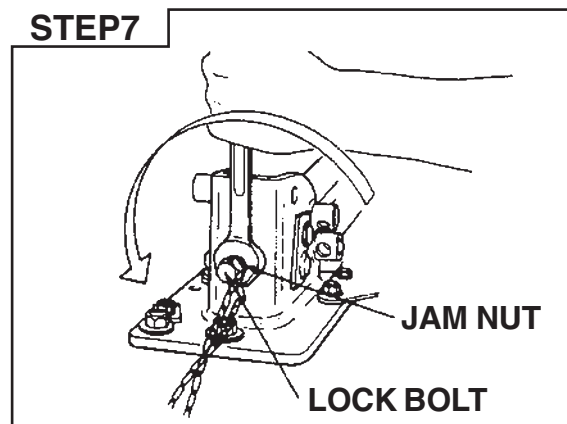

Loosen the jam nut on the lock bolts.

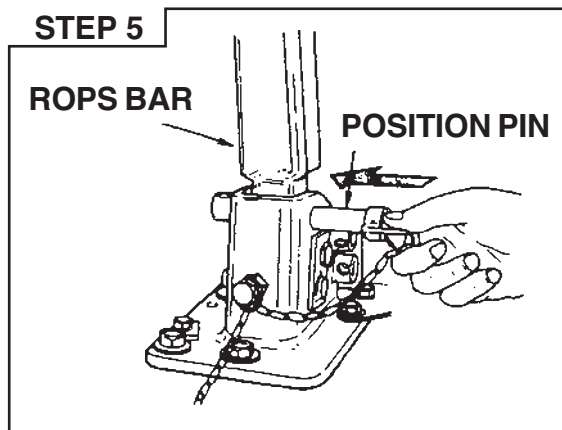

Install the position pins. If both pins can be installed, continue to STEP 10.

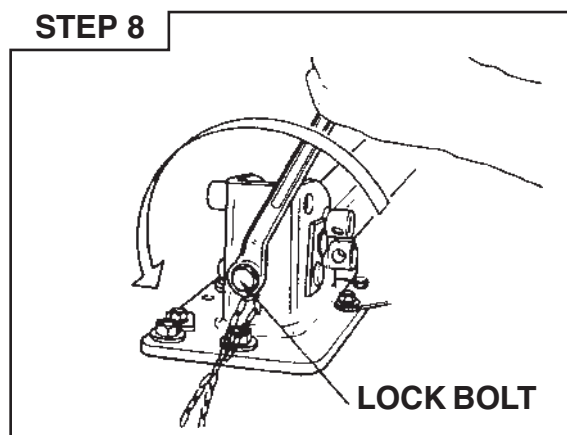

Loosen the lock bolts.

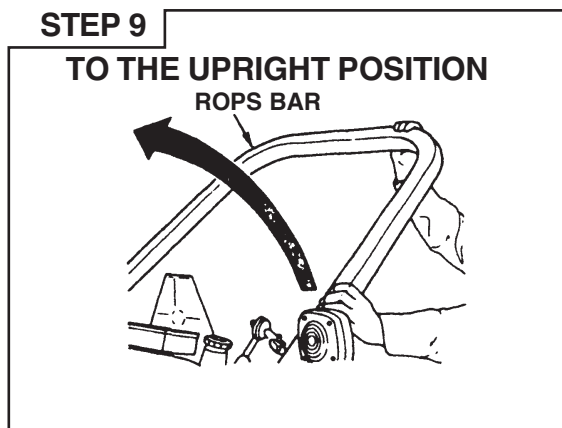
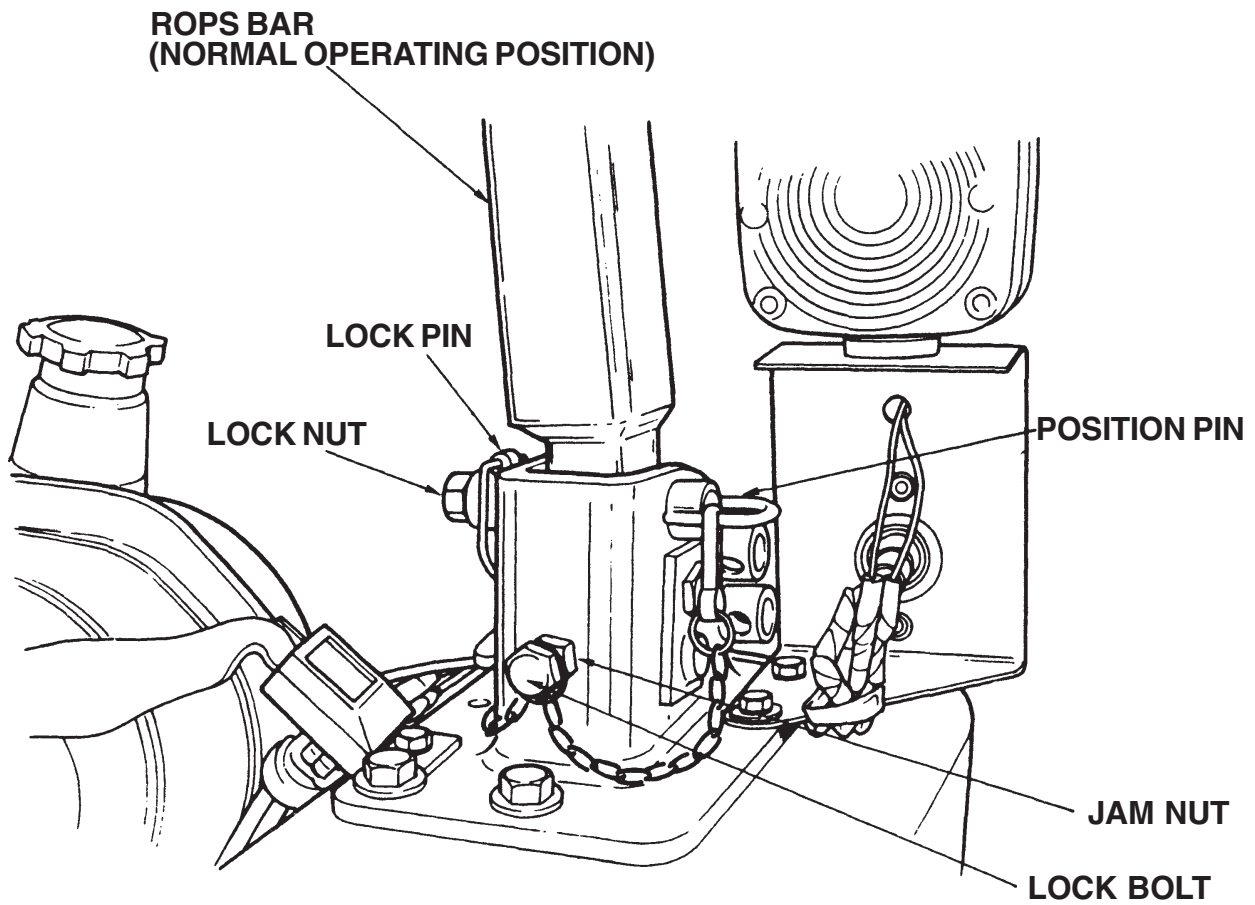

CAREFULLY move the ROPS bar to the upright position.

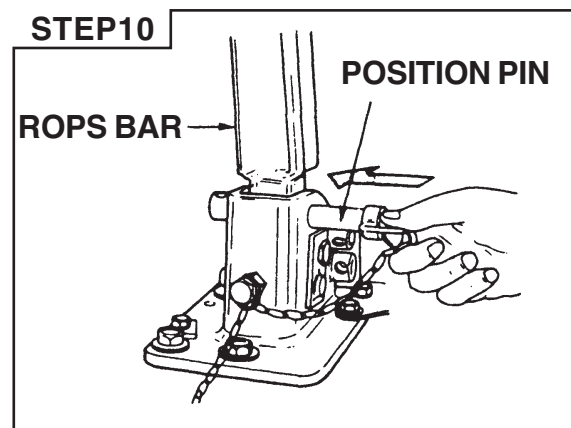

Install the position pins. Align the holes of the position pins and ROPS brackets so that the lock pins can be installed easily.

**STEP 11**

For tractors without a sunshade and for operators who frequently fold the ROPS for low clearance tractor operation, continue to STEP 15.

**STEP 12**

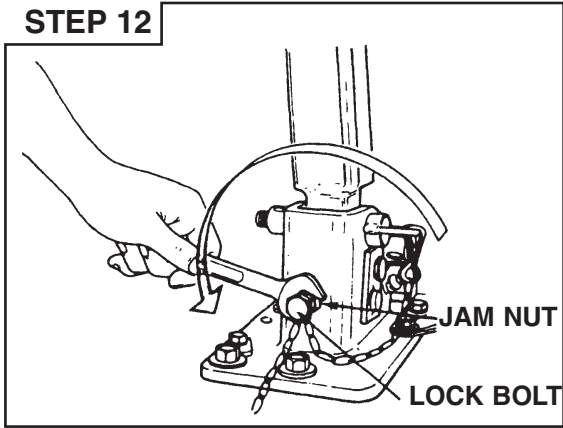

Loosen the jam nut on the lock bolts.

**STEP 13**

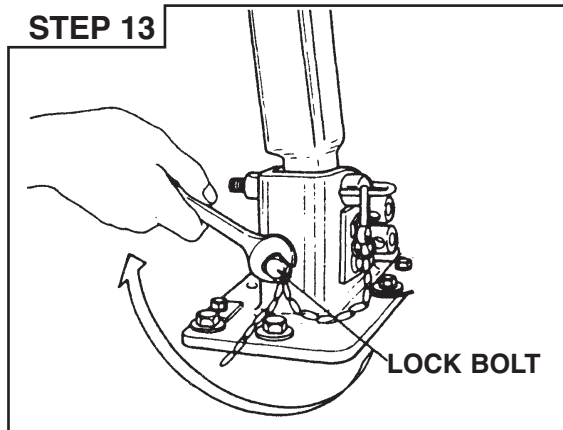

Tighten the lock bolts to a torque of 33 to 40 lb ft (44 to 54 Nm).

**STEP 14**

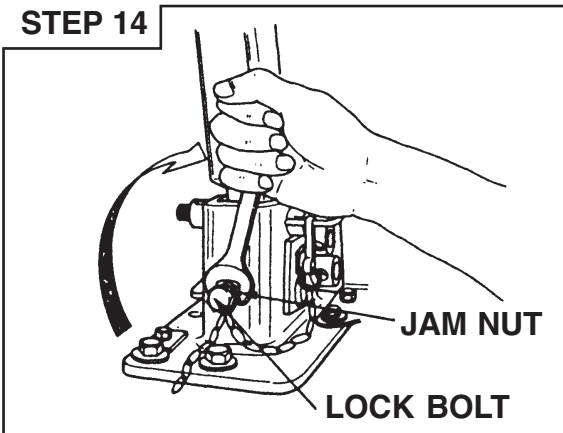

Tighten the jam nut on the lock bolts to a torque of 33 to 40 lb ft (44 to 54 Nm). Continue to STEP 17.

**STEP 15**

For tractors with a sunshade, STEP 12, STEP 13 and STEP 14 must be followed for using the lock bolts. On tractors without a sunshade, it is recommended that STEP 12, STEP 13 and STEP 14 be used, however, if ROPS is folded frequently for low clearance tractor operation, the following setup may be used:

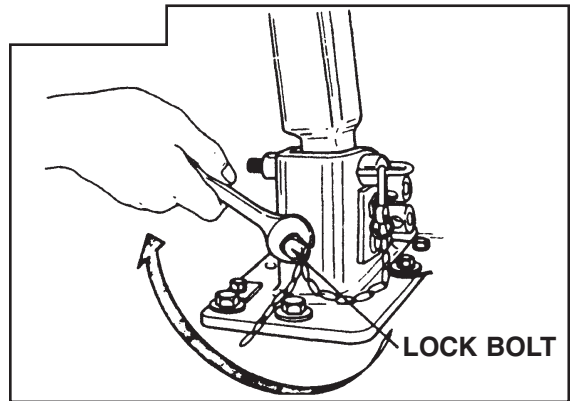

Tighten the lock bolt only enough to remove the looseness of the hinge joint. Push the ROPS bar forward to permit the position pin to be rotated and removed by hand.

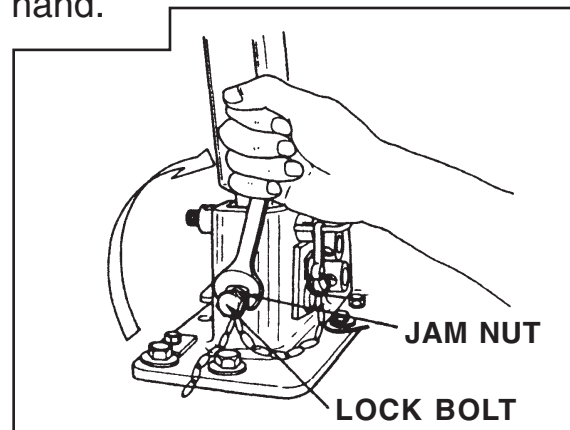

Tighten the jam nut on the lock bolts to a torque of 33 to 40 lb ft (44 to 54 Nm).

**STEP 16**

Check the assembly. If the position pins are too tight or loose, repeat STEP 15.

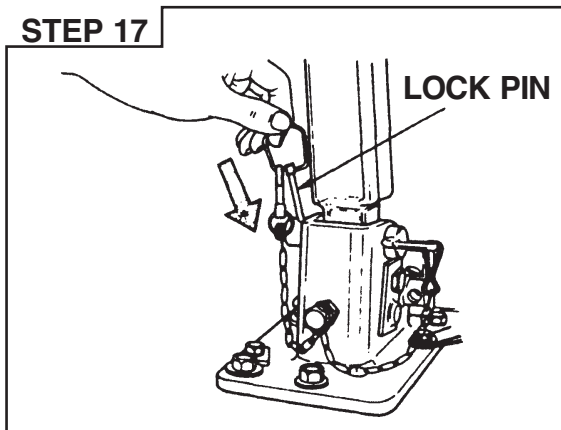
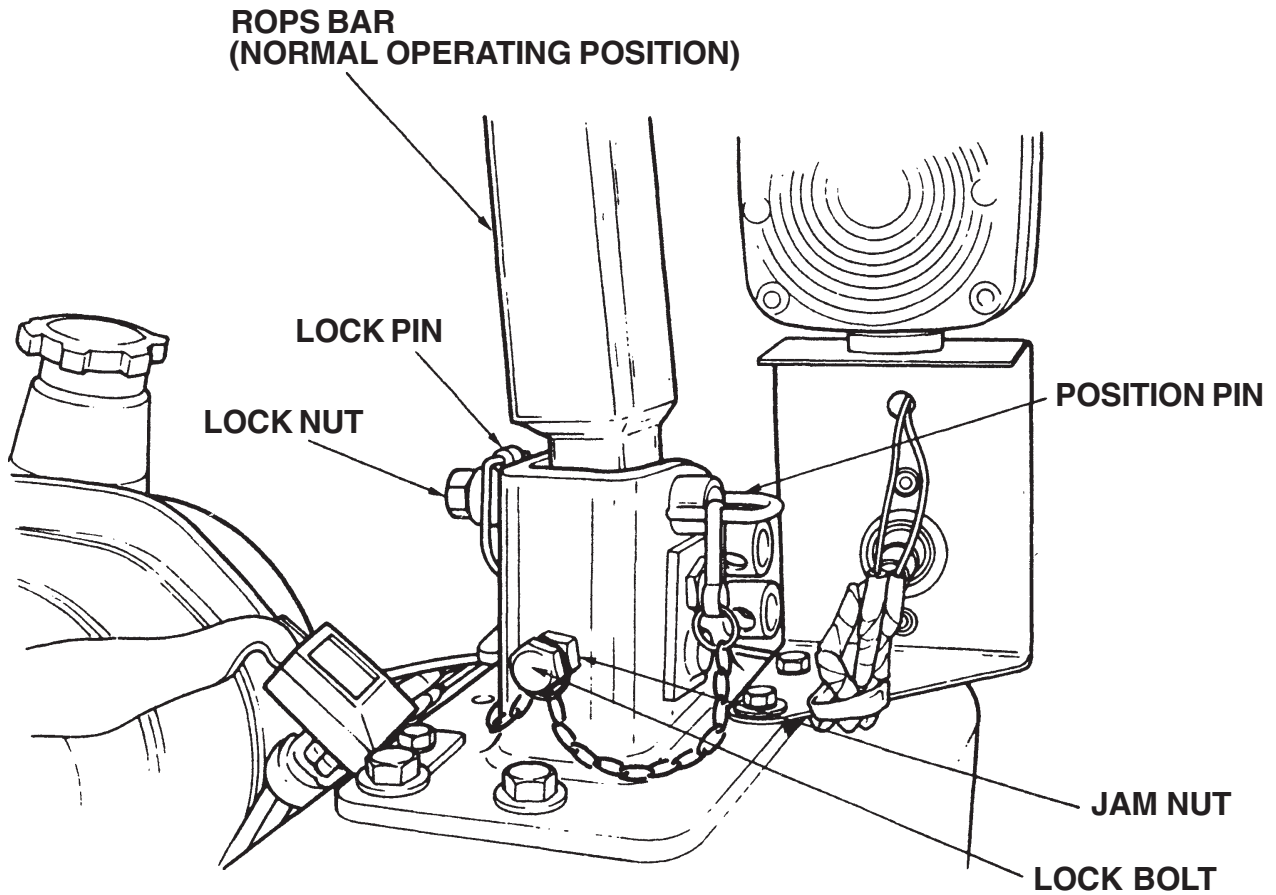

Install the lock pins.

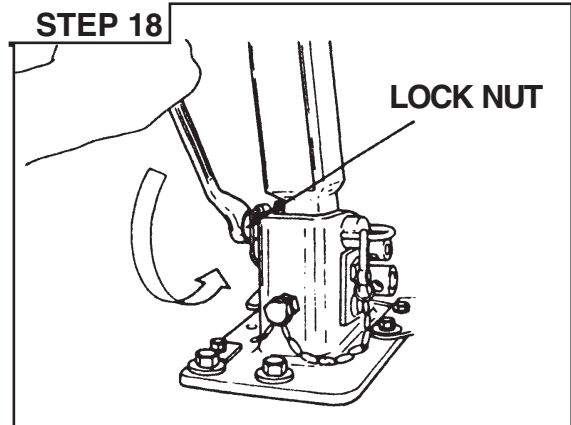

Install the lock nuts. Tighten the nuts to a torque of 33 to 40 lb ft (44 to 54 Nm).

**NOTE:** *The lock nut installation can be omitted for operator convenience if the ROPS is folded frequently.*

 **Rollover protection is provided only with proper assembly. Lock pins, hinge pins and position pins must be in place. Correct parts may be obtained from your dealer.** M234A



## DIESEL ENGINE

### General

Type	.....	Three Cylinder, Four Stroke Cycle, Valve in Cylinder Head, Cross Flow Porting	
Firing Order	.....	1 – 3 – 2	
Bore	2816	78mm (3.071 inch)	
Stroke	2816	92mm (3.622 inch)	
Piston Displacement	2816	1318cm <sup>3</sup> (80.43 Cubic Inch)	
Compression Ratio	2816	22.0 to 1	
Governor Engine Speed Without Load	2816	2730 to 2780 RPM	
Rated Engine Speed	2816	2600 RPM	
Engine Idle Speed	2816	950 to 1000 RPM	
*Maximum Horsepower (Manufacturing Rating)	2816	28HP at 2600 RPM	
Valve Clearance (Intake and Exhaust Cold Engine)	.....	0.25mm (0.010 inch)	

**IMPORTANT:** *Valve clearance adjustment must be made when the engine is not running and is cold.*

### Engine Lubrication System

Oil Pressure	2816	392kPa (57 PSI) at 2500 Engine RPM, with 10 W–30 Oil at 90° C (194° F)	
--------------	------	--	--

### Fuel System

Fuel Injection Pump	.....	BOSCH M Plunger In Line NIPPONDENSO	
Injection Pump Timing	.....	17 Degrees Before Top Dead Center (BTDC)	
Fuel Injectors	.....	Throttle Type, NIPPONDENSO	

\*Manufacturer’s estimate under standard condition and subject to change without prior notice.

## Air Intake System

Type ..... Dry Type Air Cleaning System

## Cooling System

Type ..... Pressure System, Thermostat Controlled Bypass, Impeller Type Pump

Radiator ..... Corrugated and Louver Fin Type

Thermostat ..... Start to Open at Approx. 82°C (180°F)  
Fully Open at 95°C (203°F)

Pressure Cap ..... 88.3 kPa (12.8 PSI)

Water Temperature ..... Thermometer on Instrument Panel

## POWER TRAIN

### Tractor Brakes

Type ..... Wet Disk Plate Type

Operation ..... Mechanical

Parking Brakes ..... Hand Operating Lock Type

### Transmission

Type  
Hydrostatic Drive ..... Hydrostatic Transmission with Three Ranges of Selective Sliding Gears

Gear Selection  
Hydrostatic Drive ..... 3 Speed ranges in Forward and Reverse with Variable Speeds

Shift Control  
Hydrostatic Drive ..... Actuated by Pedal on the RH Step and lever on the LH Fender

Oil Cooler ..... Hydrostatic Drive

PTO HP  
..... 21.1 HP

## Clutch

Type, Diameter  
Hydrostatic Drive ..... Dry, Single Disc, Diaphragm Type,  
215 mm (8.46 Inch)

Operation ..... Mechanical

## Mechanical Front Drive (MFD)

Front Axle ..... Spiral Bevel Gear Type Differential  
with Bevel Gear Type Reductions

## Differential Lock

Type  
Hydrostatic Drive ..... Controlled by Pedal on the LH Step  
and Mechanically Actuated

## Steering

Type of Steering ..... Hydrostatic Type

## Hitch System

Type ..... Three Point, Category I  
Type Control ..... Position Control  
Type Valve ..... Three Positions, Lift, Hold and lower  
Lifting Capacity at 24" behind Lift Point (Per ASAE S349.1)  
..... 750 kg (1653 Lb)

Type of Cylinder ..... Single Acting Type

## Hydraulic System

Hydraulic Pump Type .....	Front Mounted, Engine Driven, Pressure Loading Gear Type
Capacity	
Pump for Three Point Hitch .....	29.6ℓ/ min. (7.8 GPM) at 2600 Engine RPM
Pump for Power Steering .....	13.4ℓ/ min. (3.5 GPM) at 2600 Engine RPM
Maximum System Pressure .....	14710kPa (2133 PSI)
Remote Hydraulic Control Valve (OPTIONAL) .....	One Double Acting Type Auxiliary Valve Available
Auxiliary Connector .....	Front Hydraulic Block
Connector Size .....	9.5mm (3/8 inch)

## Rear Power Takeoff (PTO)

PTO Type	
Hydrostatic Drive .....	Live PTO
Location .....	At the rear of transmission
Rotation .....	Clockwise from rear of tractor
Shaft Size .....	34.9 mm (1.375 Inch) Diameter, 6 Splines
Speed .....	540 RPM at 2376 Engine RPM

## Mid Power Takeoff (PTO)

PTO Type	
Hydrostatic Drive .....	Live PTO
Location .....	At the Bottom of Transmission
Rotation .....	Clockwise from Rear of Tractor
Shaft Size .....	25.4 mm (1 Inch) Diameter, 15 Splines
Speed .....	2000 RPM at 2632 Engine RPM

## Drawbar

Type .....	Fixed Type
Distance from Hitch Hole to the End of PTO Shaft .....	85mm (3.346 inch)
Maximum Vertical Load on Drawbar .....	136kg (300lbs)

DIMENSIONS

---

OVERALL LENGTH (To end of lower link)	2920mm	115.0inch
OVERALL WIDTH (To end of tire)	1380mm	54.3inch
HEIGHT (To Top of Rops)	2140mm	84.3inch
WHEELBASE	1650mm	65.0inch
GROUND CLEARANCE	330mm	13.0inch
TURNING RADIUS (With brake assistance)	2400mm	94.5inch
WEIGHT	1075kg	2370.4lbs

## INSTRUMENTS AND INDICATORS

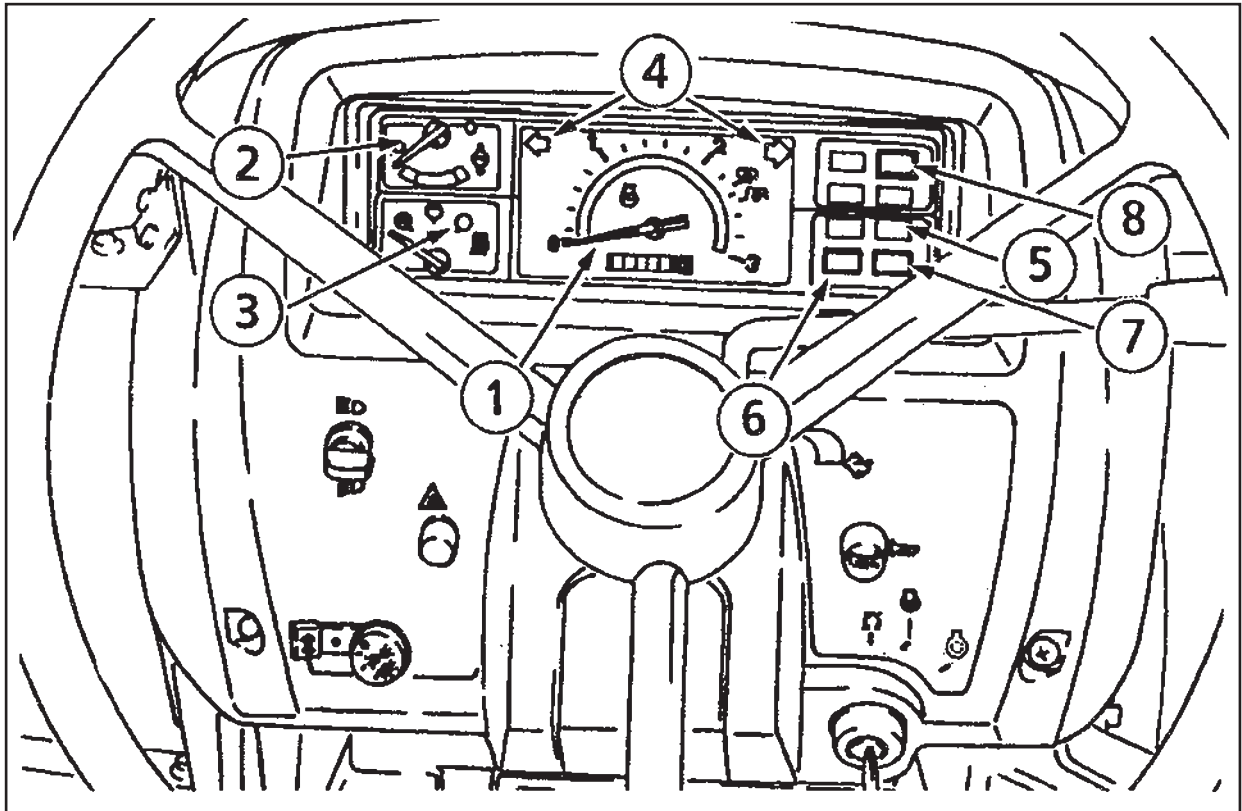

1. TACHOMETER AND HOURMETER – The tachometer shows the engine speed in revolutions per minute (RPM). A symbol on the face indicates the correct Power Takeoff (PTO) operating speed. The hourmeter shows the hours and tenths of hours that the engine has operated at an average RPM.

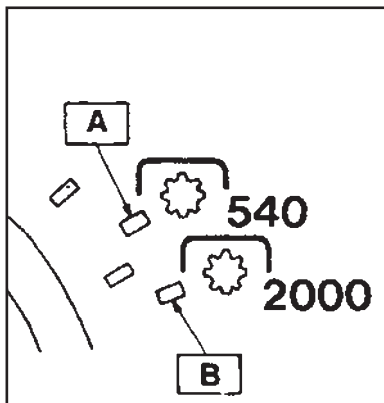
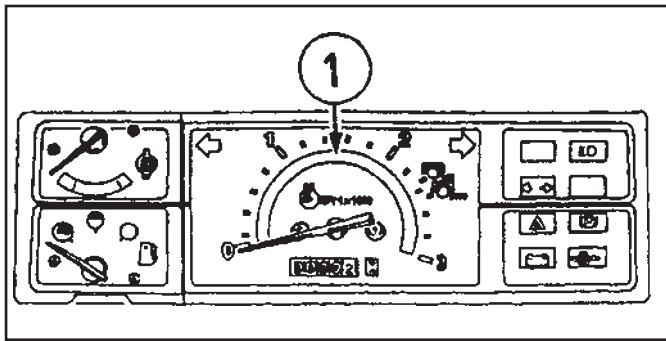

Yellow line **A** shows the 540 rpm of the Rear PTO speed.

Yellow line **B** shows the 2000 rpm of the MID PTO speed.



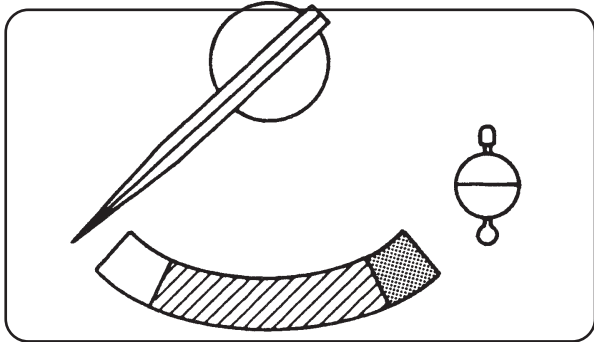

2. ENGINE COOLANT TEMPERATURE GAUGE – The gauge indicates the coolant temperature when the starter key switch is in the ON position.



The gauge has a yellow area, green area and red area:

Yellow area  .. The pointer is in this area when the engine is cool before and immediately after starting. Run the engine at 1500 RPM without load until the pointer indicates the green area.



Green area  .. The pointer is in this area when the coolant temperature is proper during engine operation.

Red area  .. If the engine overheats, the pointer moves right into this area.

In this case run the engine at 1500 RPM without load until the pointer indicates the green area. If the pointer still stays in the red area after three to five minutes, stop the engine immediately and check for the cause.

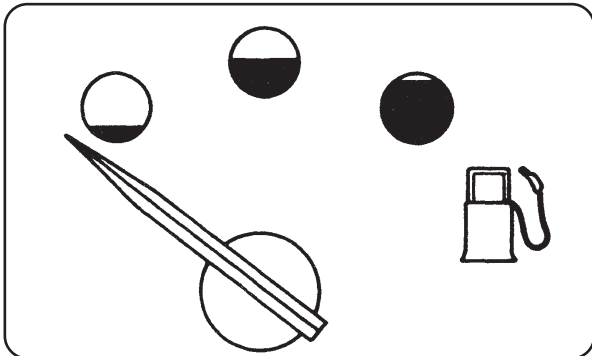
3. FUEL GAUGE – The meter shows how much fuel is in the tank. Fuel level is shown by three positions.



-  ..... Fuel is needed.
-  ..... Fuel tank is half filled with fuel.
-  ..... Fuel tank is full.

**NOTE:** The pointer can be in any position when the starter key switch is in the OFF position. To get a fuel level indication, turn the starter key switch to the ON position.

4. TURN SIGNAL INDICATORS – The LH indicator on the TACHOMETER will operate when the turn signal switch is turned to the left.

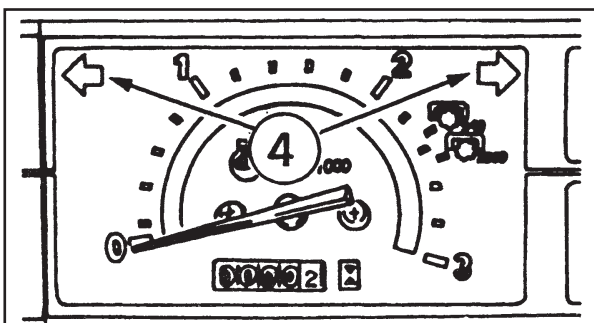

The RH indicator will operate when the switch is turned to the right. Both indicators will operate ON and OFF when Hazard switch is pushed down.

5. ENGINE GLOW PLUG INDICATOR – This signal indicates the correct functioning of the glow plug circuit. When the glow plugs have reached the correct temperature for engine starting, the glow plug indicator lamp will be put out.

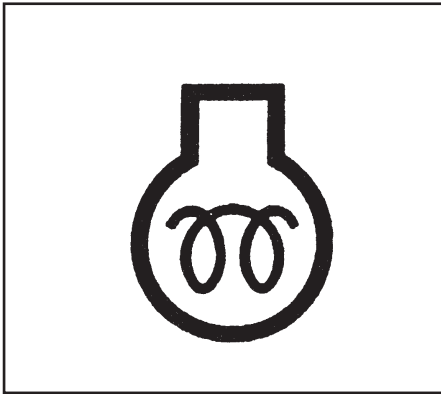

6. CHARGE INDICATOR – The charge indicator indicates the battery is being discharged. If the lamp illuminates during operation, stop the engine and check for the cause.

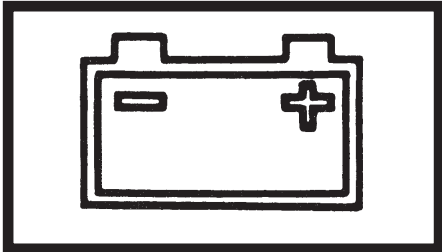

7. ENGINE OIL PRESSURE INDICATOR – The engine oil pressure indicator indicates low engine oil pressure. If the engine oil pressure drops below its normal pressure, the engine oil pressure indicator will come on. Shut off the engine immediately. Check for the cause.

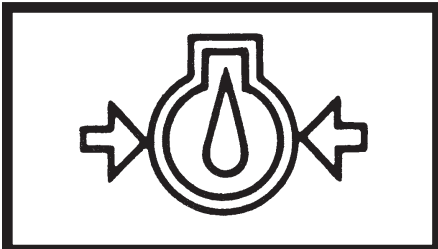

8. HIGH BEAM INDICATOR – This signal indicates the head lamp high beam is ON or OFF. The INDICATOR illuminates when the head lamp is on high beam position.

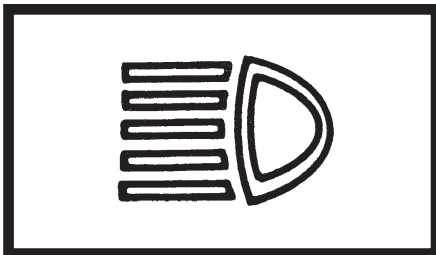

# OPERATING CONTROLS

## Control Switches

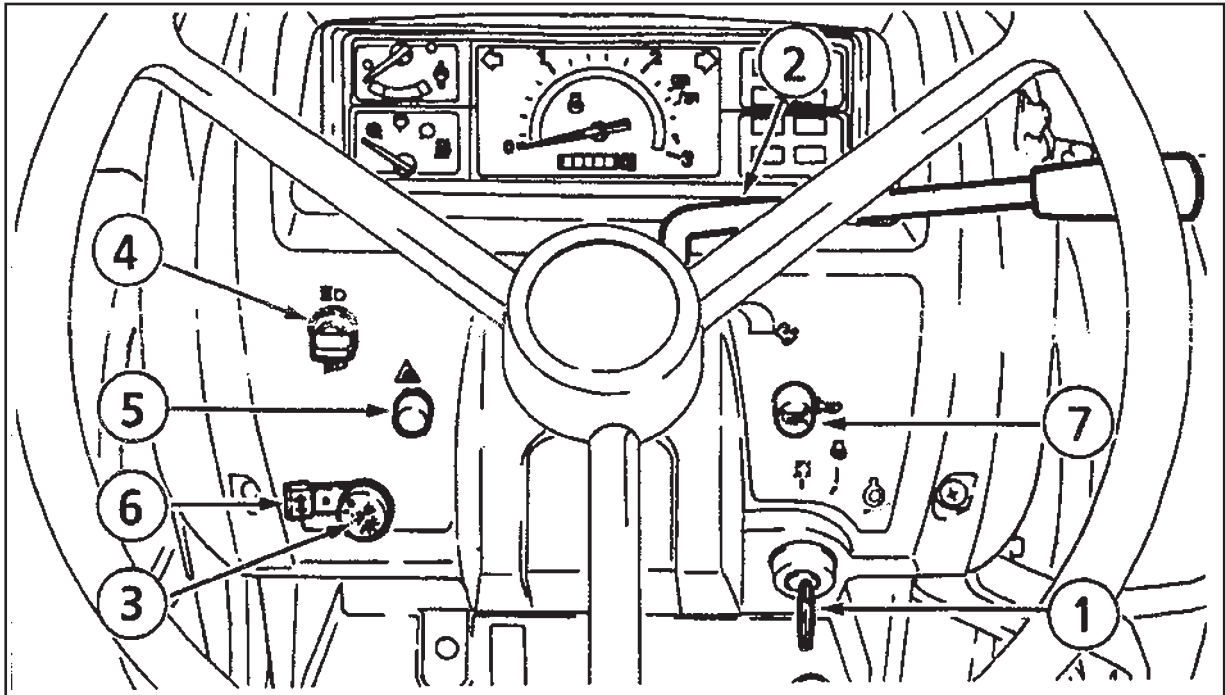

1. **STARTER KEY SWITCH** — The starter key switch can be removed with the switch in the OFF position. Four position switch as follows:

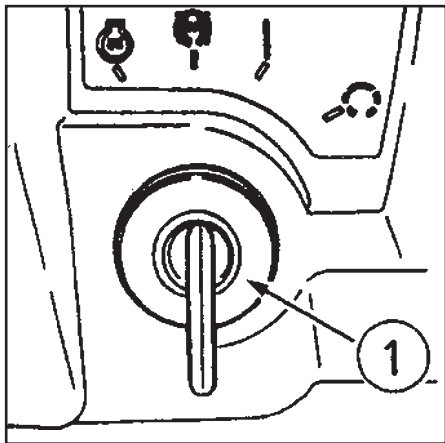

position— Engine and all lamps except the  
(OFF) turn signal and flasher lamps are turned off.



position— First position clockwise from  
(HEAT) OFF. In this position (Engine not  
& running) energizes the glow  
(ON) plugs. The charge indicator, glow plug indicator and oil pressure indicator will illuminate.

The fuel gauge and temperature gauge will show correct values.



position — Turn the key fully clockwise against the force of the  
(START) spring in the switch. The starter motor will turn the engine. Release the key immediately when engine starts.

**NOTE:** To prevent operation by persons not authorized and the possible discharge of the battery, remove the starter key when you leave the tractor.

**IMPORTANT:** Do not keep the starter key switch in the ON position for a long period of time when the engine is not operating.

2. ENGINE SPEED CONTROL LEVER – Move the engine speed control lever to the rear to increase engine speed. Move the engine speed control lever forward to decrease engine speed.

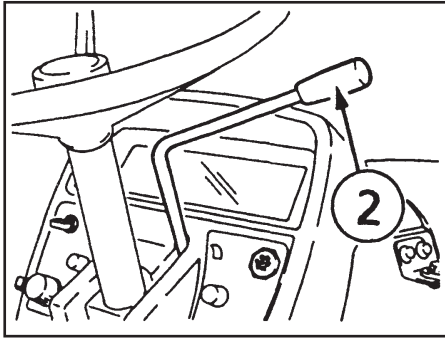

3. LAMP SWITCH – Three position switch as follows:

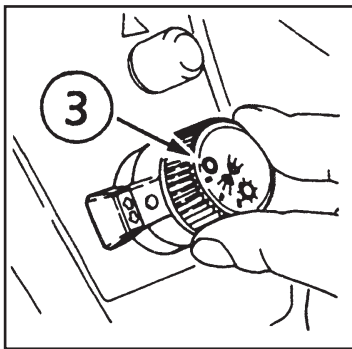

– ALL lamps are OFF. (Turn signal and flasher lamps can be turned on.)



– First position clockwise illuminates instrument panel lamp and rear red lamp.



– Second position clockwise illuminates headlamps, instrument panel and rear red lamp. Use dimmer switch to dim or brighten the headlamps.

4. DIMMER SWITCH – Move the dimmer switch to dim or brighten the head lamps, when lamp switch is in second position.

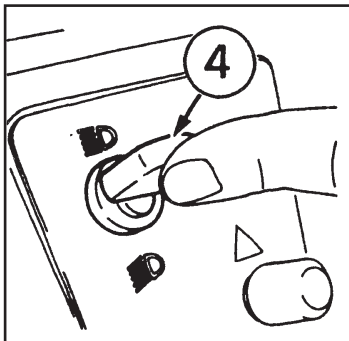

– Move the switch up to brighten the head lamps.



– Move the switch down to dim the head lamps.

5. FLASHER CONTROL BUTTON – To flash the Flasher Lamps whenever the tractor is operated or traveling on roads. Push the button to energize the lamps.

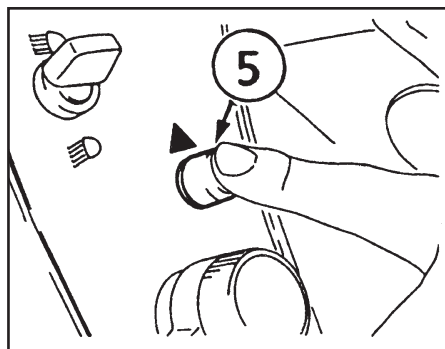

6. TURN SIGNAL SWITCH – To indicate that you are going to turn the tractor to the RIGHT, move the turn signal switch up. To indicate that you are going to turn the tractor to the LEFT, move the turn signal switch down. Center position is OFF.

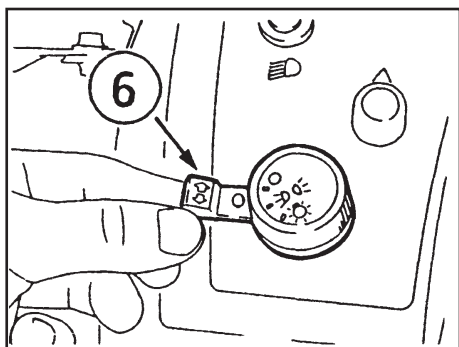

7. HORN BUTTON (OPTIONAL) — Press the button to energize the horn.

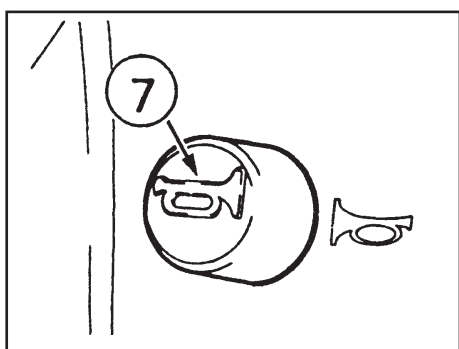

## Control Levers and Pedals (Hydrostatic Drive)

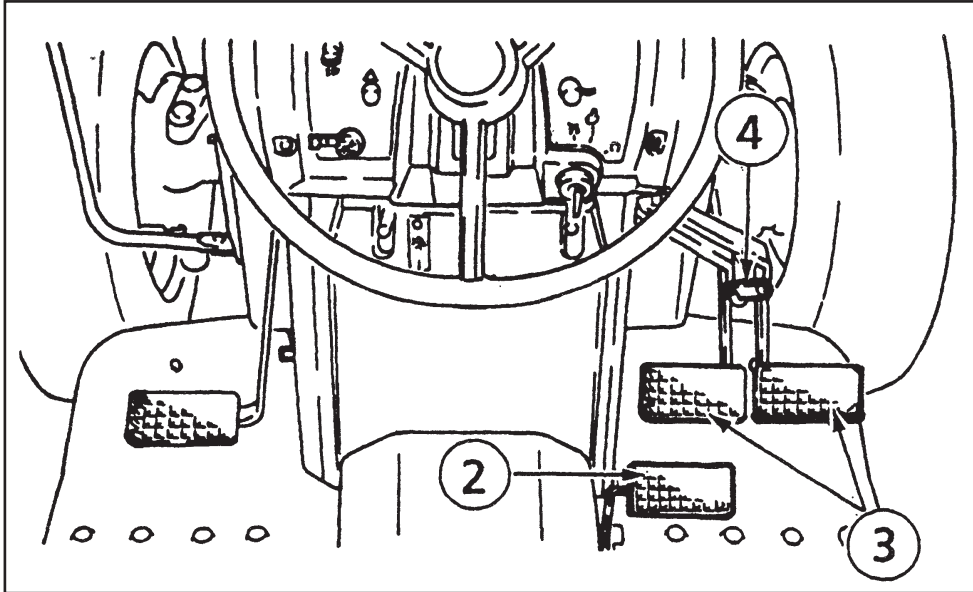

1. ACCELERATOR PEDAL (GEAR DRIVE ONLY) – Use this pedal when operating the tractor on the road. Push the pedal down to increase engine speed.

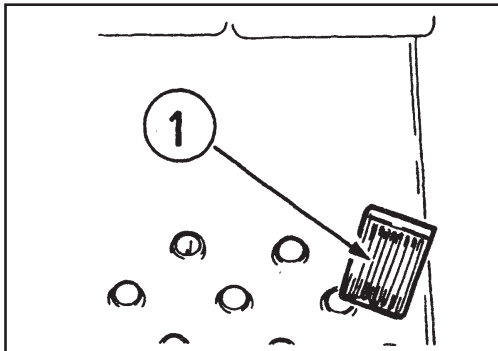

**NOTE:** *The engine speed control level must be set to give the slowest engine speed when the throttle pedal is used.*



2. SPEED RATIO CONTROL PEDAL (HYDROSTATIC DRIVE ONLY) –

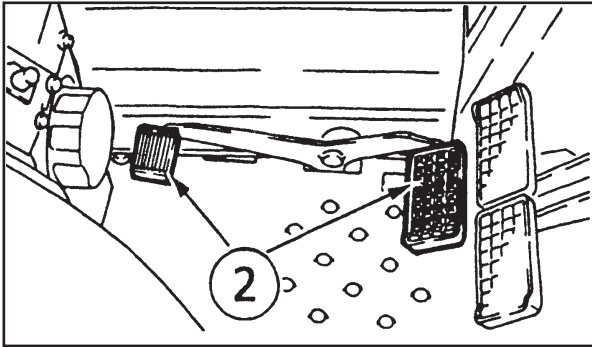

The control pedal is spring loaded to the center or neutral position. Push down on the front of the pedal to increase forward speed. Push down on the rear of the pedal to increase reverse speed.

3. BRAKE PEDALS — The brake pedals when locked together, provides

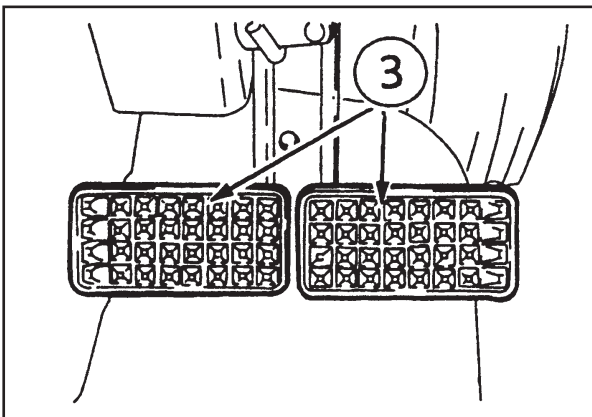

braking to both rear wheels for stopping the tractor. When the brake pedals are unlocked, the pedals are used for individual braking of the rear wheels to aid in turning the tractor in soft soil conditions.

Push the RH brake pedal down to slow or stop the RH rear tractor wheel, push the LH brake pedal down to slow or stop the LH rear wheel. The tractor will turn in the direction of the wheel that is slowed or stopped.

4. BRAKE PEDAL LOCK – The brake pedal lock is located at the brake

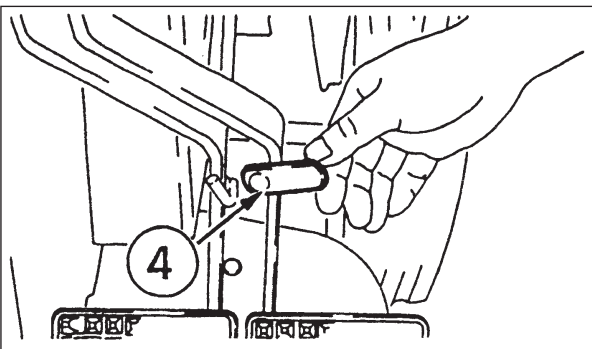

pedal arms and is used to lock the two brake pedals together so that both brakes are applied.



**CAUTION:** *Brake pedals must be locked together for road travel. This will insure uniform brake application and maximum stopping ability.*



**WARNING:** *Extra weight and bad traction conditions such as mud or ice increase your stopping distance. Remember that liquid in the tires, weights on the machine or wheels, tanks filled with fertilizer, herbicides or insecticides - all these add weight and increase the distance you need in which to stop.*

(Hydrostatic Drive)

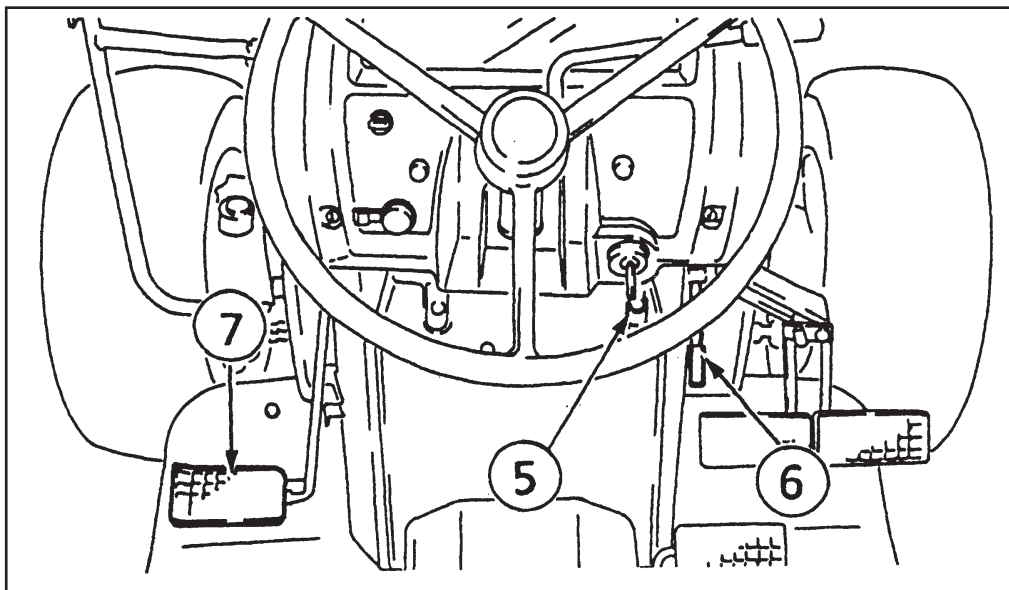

5. PARK BRAKE LEVER – The park brake must be on to prevent

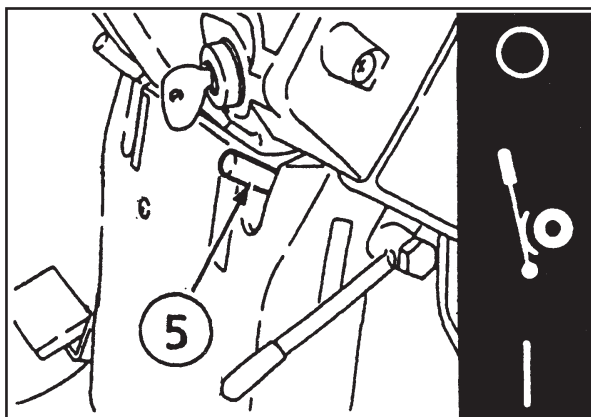

movement of the tractor during stationary power takeoff work or when the tractor is parked. To engage the park brake, lock the brake pedals together, push down on the brake pedals and move the park brake lever downward. Push the brake pedal down to release the park brake.

6. SPEED LOCK LEVER –

To keep a constant forward travel speed, move the lever fully upward, while holding the speed ratio control pedal at the desired speed. It does not work in reverse.

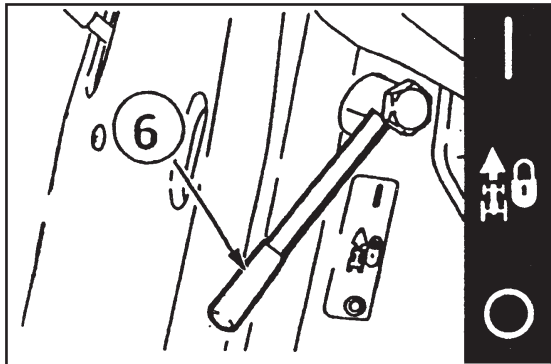

7. CLUTCH PEDAL — The clutch must be disengaged when starting the engine, stopping the tractor, storing the tractor and operating the following levers, gear shift lever, range lever, rear PTO lever, MID PTO lever, MFD lever, creep lever.

7-1. SINGLE CLUTCH

Pedal has two positions as follows:

1. Pedal completely released – Transmission and PTO engaged
2. Pedal completely depressed – Transmission and PTO disengaged

8. CLUTCH LOCK LATCH –

For long term storage, lock the clutch pedal in the disengaged position. This will prevent the clutch disc from sticking to the engine flywheel.

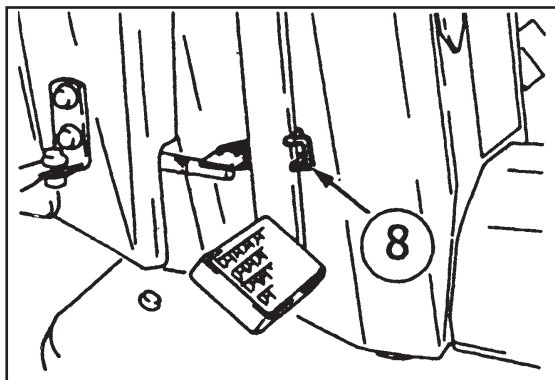

### (Hydrostatic Drive)

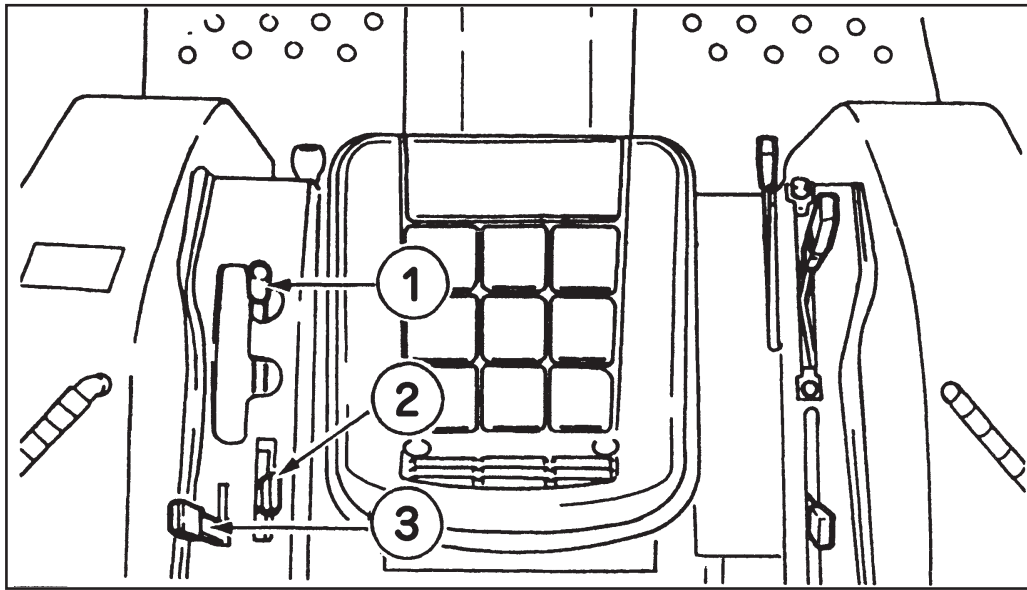

1. RANGE SHIFT LEVER — Move the range shift lever forward to place the transmission in L range. Move the lever to the rearward to place the transmission in M or H range. The center position between M and L or H and M places the transmission in N.

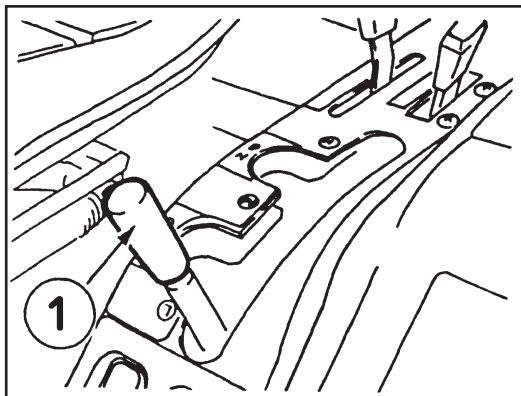

Move the lever to the rearward to place the transmission in M or H range. The center position between M and L or H and M places the transmission in N.

**NOTE:** *Be sure the range shift lever is In N (Engine start) slot when starting the engine.*

2. REAR PTO CONTROL LEVER – Move the lever forward to engage the REAR PTO. Move the lever rearward to disengage the Rear PTO.

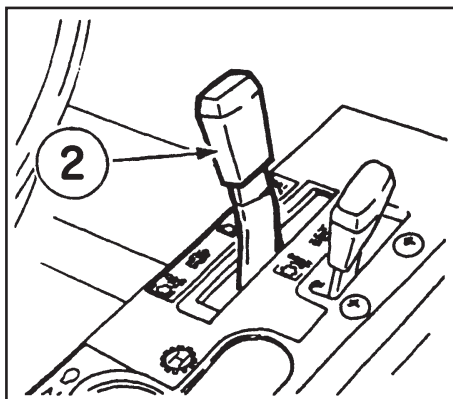

Move the lever rearward to disengage the Rear PTO.

**NOTE:** *Be sure the Rear PTO control lever is in OFF slot when starting the engine*

3. MID PTO CONTROL LEVER (IF EQUIPPED) — Move the lever forward to engage the MID PTO. Move the lever rearward to disengage the Mid PTO.

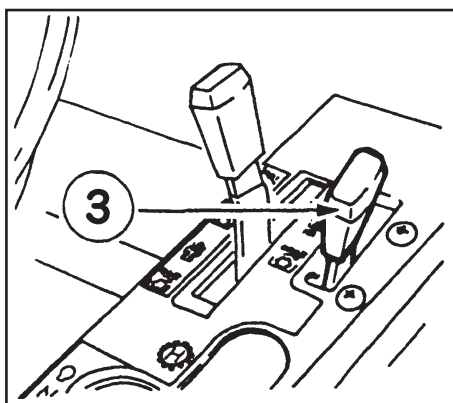

Move the lever rearward to disengage the Mid PTO.

**NOTE:** *Be sure the Mid PTO control lever is in OFF slot when starting the engine.*

**NOTE:**

1. *The Rear and Mid PTO shaft can be operated at the same time.*
2. *When not using the Mid PTO shaft, cover the shaft with the Mid PTO cover.*

(Hydrostatic Drive)

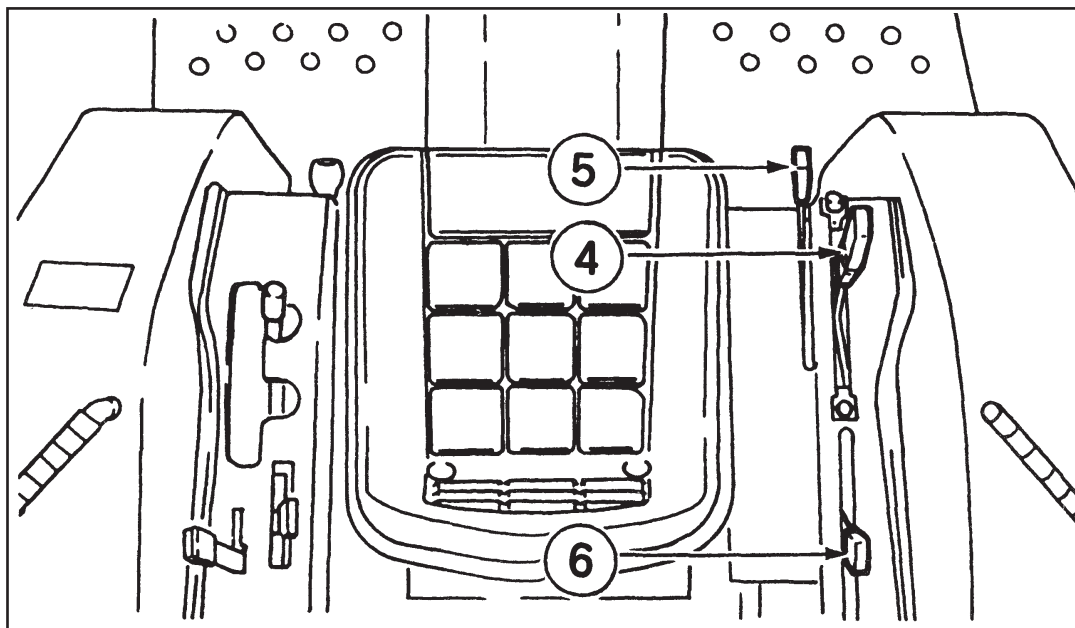

4. HITCH CONTROL LEVER – Use this lever to control the position of the hitch. Move the lever forward to lower the hitch to the required depth. Move the lever to the rear to raise the hitch to the required height.

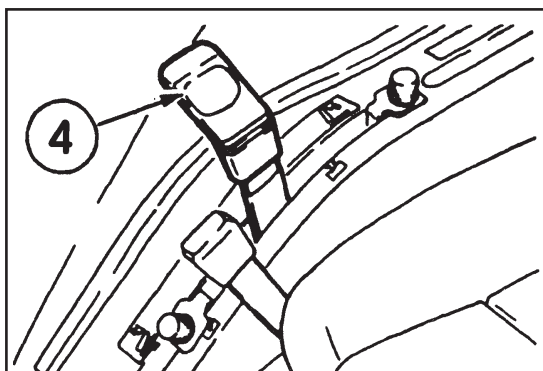



5. DRAFT CONTROL LEVER (IF EQUIPPED) –

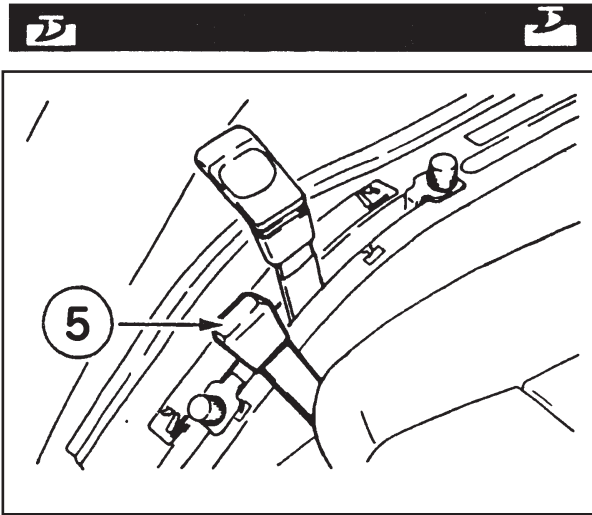

Use draft control with soil engaging implements to maintain a constant load on the tractor through variable soil conditions. For light load operation, move the lever to the rear. For heavy load operation, move the lever forward. To stop the draft control, move the lever fully forward. See Operating with Draft Control in this manual for more information.

6. REMOTE HYDRAULIC CONTROL LEVER, WITH FLOAT POSITION (IF EQUIPPED) –

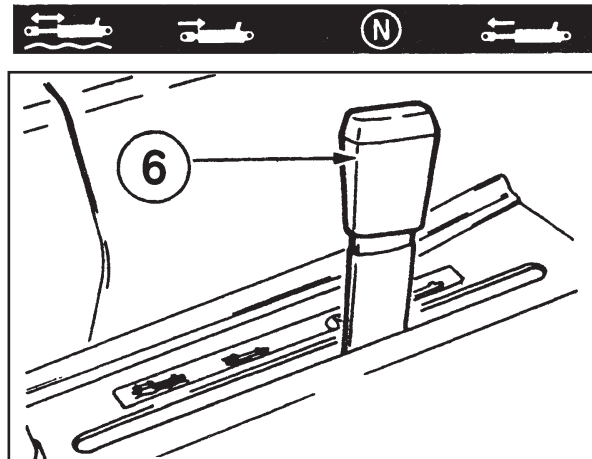

A double acting remote control valve is available for your tractor. The remote hydraulic control lever which operates the remote control valve is located on the RH side fender. See Remote Hydraulic Control in this manual for more information.

(Hydrostatic Drive)

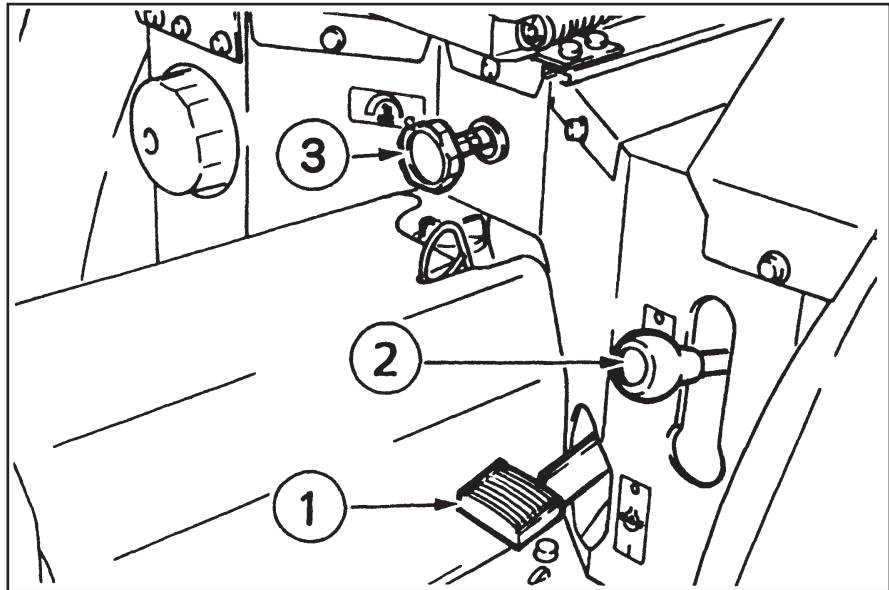

1. DIFFERENTIAL LOCK PEDAL – Push the pedal down to engage the differential lock. A spring inside the differential lock will push it out of engagement when pedal is released.

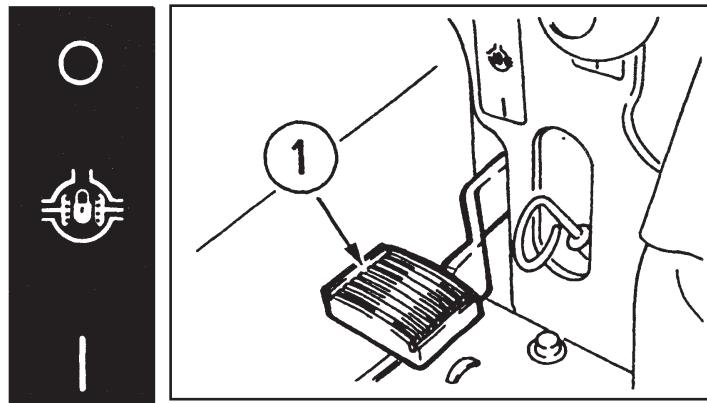

HYDROSTATIC DRIVE

**NOTE:** When engaging the differential lock, push the clutch pedal down or bring speed ratio control pedal to Neutral, to stop the wheels that are rotating, then push the differential lock pedal. Do not operate the differential lock pedal while the wheels are rotating.

 **Do not drive on roads, or at high speed anywhere, with the differential lock engaged. Difficult steering will occur, and can result in an accident. In field operation, use the differential lock for traction improvement, but release for turning at row ends.** M116

2. MFD CONTROL LEVER – To engage the MFD (Mechanical Front Drive), move the MFD control lever downward. Move the lever upward to disengage MFD (drive to the rear wheels only).

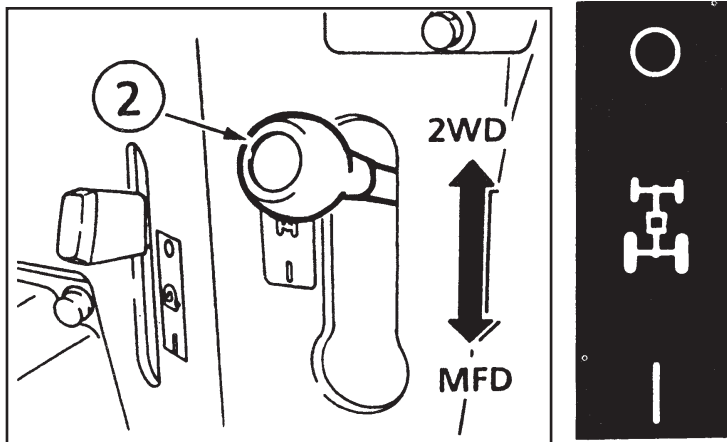

**IMPORTANT:** The clutch pedal must be pushed down to operate the MFD lever.

3. HYDRAULIC FLOW CONTROL KNOB – Use the hydraulic flow control knob to adjust the hitch lowering speed. Adjust the lowering speed to provide smooth operation of the hitch with the implement being used. Turn the knob fully clockwise to lock the hitch in position. See Hitch Lowering Speed Adjustment in this manual for more information.

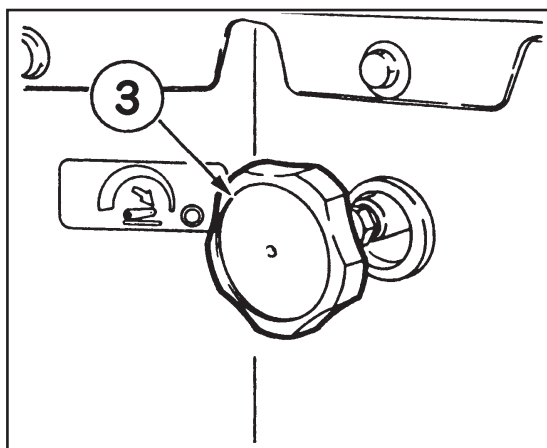

## OPERATORS SEAT

The seat can be adjusted in 5 fore/aft positions by the lever located under the RH side of the seat.

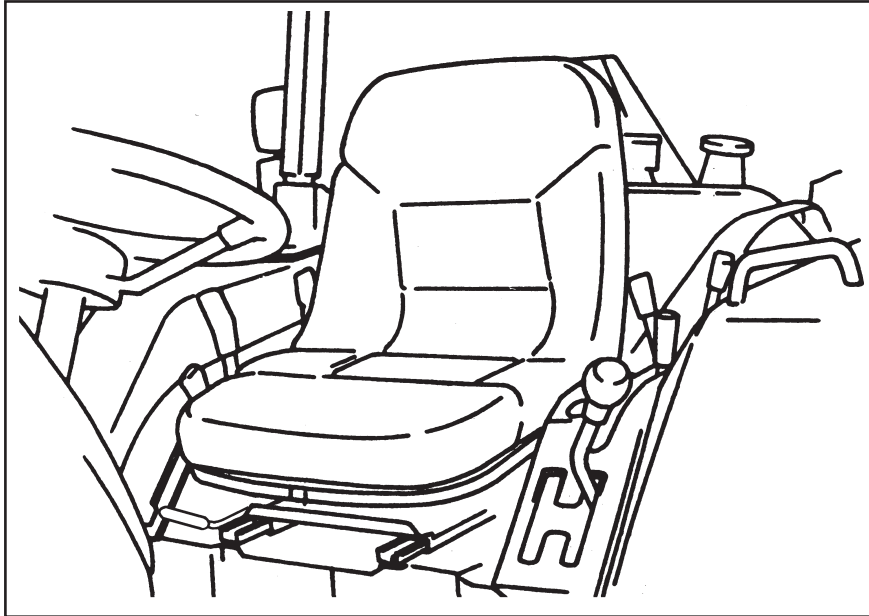

The seat is adjustable fore and aft by moving a lever.

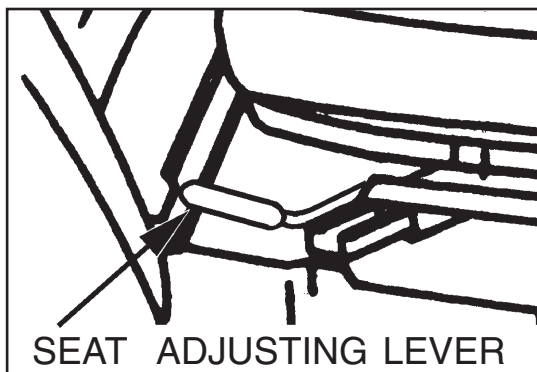

1. Move the lever upward.
2. Move the seat rearward or forward to the required position then release the lever.
3. Push the seat rearward to make sure that the lock is engaged.

## STEERING COLUMN TILT

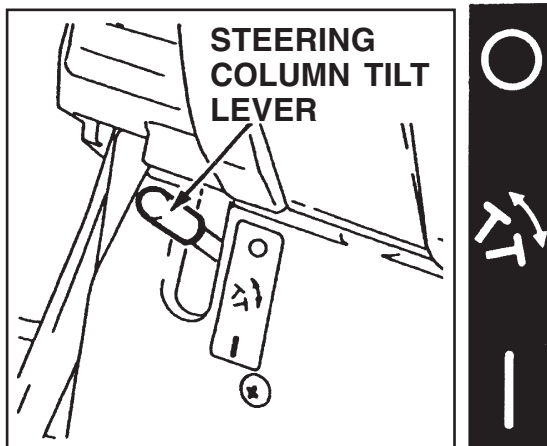

The steering wheel angle can be adjusted in three positions by the lever located under the steering column.

To adjust the position of the steering wheel, use following procedure.

1. Move the lever fully downward to disengage the latch from the column.
2. Move the steering wheel rearward or forward to the required position, then return the lever upward to lock the steering column.
3. Make sure that the lock is engaged.

## BEFORE STARTING THE ENGINE

Before starting your tractor for the first time and before each operating period after that, make these checks:

1. Make sure all persons who operate or do maintenance on the tractor understand that clean fuel is important.
2. Check all lubrication fittings for grease as given in the Lubrication Chart.
3. Check the oil level in the engine crankcase. Check the fluid level in the transmission.
4. Check the tractor fuel tank is filled with clean fuel that has the specifications given in this manual.

**NOTE:** *Clean around the fuel tank cap before you remove the cap.*

5. Check the fuel system, cooling system and engine oil pan for leaks.
6. Check the fan belt is adjusted correctly.
7. Remove any water or sediment from the fuel filter cup.
8. Check the air pressure of the tires.
9. Make sure the PTO safety guard is installed.
10. Check the coolant level in the radiator and reservoir bottle. Add water and ethylene glycol coolant as needed.

## RUN-IN PROCEDURE

If run-in instructions for a new engine are not followed, you can cause damage to piston rings and cylinder walls.

### LOAD

Never operate an engine immediately under full load. Allow the engine to warm up before operating it at full load. Run-in the engine carefully as shown in the table.

Period	Engine Speed Control Lever Position	Load
1st Hour	Fully advanced	Maintain engine speed 100 RPM above full load governed speed.
2nd Through 5th Hour	Fully advanced	Full load governed speed with occasional short periods of lighter load.

### NO LOAD

Do not run the engine at idle speed. When not operating the engine with a load, you can keep the correct engine operating temperature if you run the engine at approximately 1500 RPM.

### REAR WHEEL BOLTS

After the first 10 hours of operation, check the rear wheel bolts. Tighten all wheel bolts to the torque give in the Wheel Mounting Torques in this manual.

### FRONT WHEEL BOLTS

After the first 10 hours of operation, check the front wheel bolts. Tighten the bolts to the torques shown in the Wheel Mounting Torques in this manual.

### FRONT FRAME BOLTS

After the first 10 hours of operation, check the front frame bolts. Tighten the bolts to the torque shown below.

#### Front Frame Mounting Torques

Side (M12x35), 8 Bolts (4LH and 4RH)--- 83 to 93 Nm (61 to 69 lb ft)

### LOWER LINK BRACKET BOLTS

After the first 10 hours of operation, check the Lower Link Bracket bolts. Tighten the bolts to the correct tightening torque 39 to 44 Nm (29 to 33 lb ft).

## NORMAL STARTING PROCEDURE

**IMPORTANT:** *It is very important that enough lubricant reaches the engine parts before operating the engine at rated speed.*



**Operate controls only when seated in the operators seat.**

M137



**Engine can start with transmission in gear when neutral or safety start switch is by-passed:**

- 1. Do not connect across terminals on starter.**
- 2. Attach a booster battery by connecting the positive terminal of the booster battery to the “positive terminal” provided or to the positive terminal of the machine battery. Connect the negative terminal of the booster battery to the “negative terminal” provided or to the chassis of the machine.**

**Then use recommended starting procedures from operators seat.**

- 3. When necessary, repair electrical system components promptly so that “jump starting” will not be attempted.**

**Machine run-away can cause injury or death to operator and bystanders.**

M107C

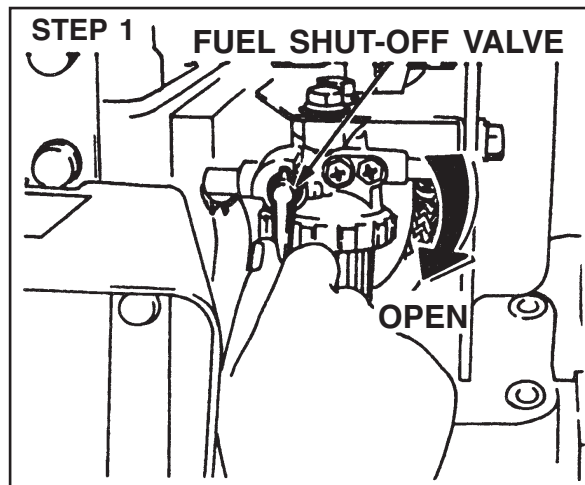

Make sure the fuel shut-off valve is open. The valve is located at the bottom RH side of the fuel tank.



**Before starting the engine, be sure all operating controls are in neutral or park lock position. This will eliminate accidental movement of the machine or start up of power driven equipment.**

M106D



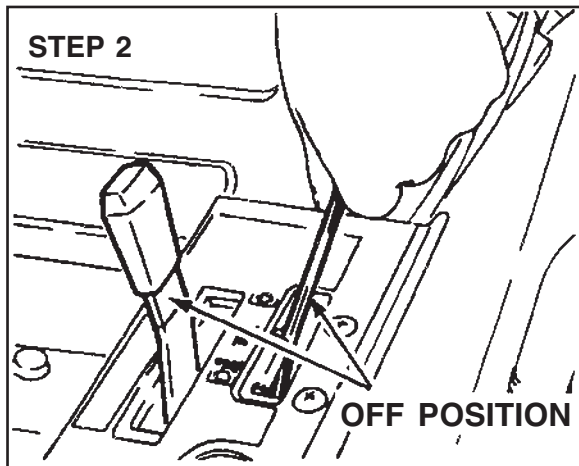

Put the REAR PTO and MID PTO control levers in the OFF (Engine start) slot.

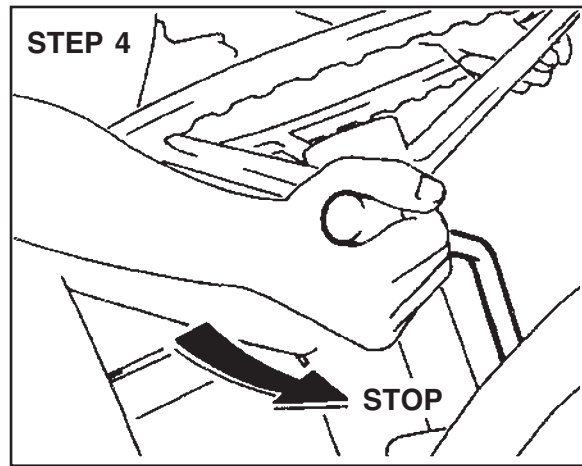

Put the engine speed control lever at the low idle position.

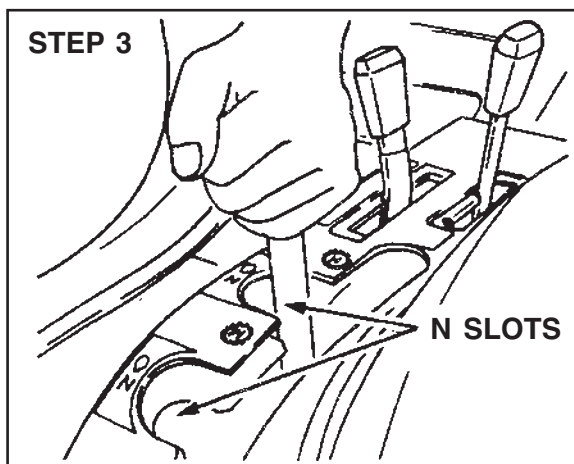

Put the range shift lever in the N (Engine start) slot.

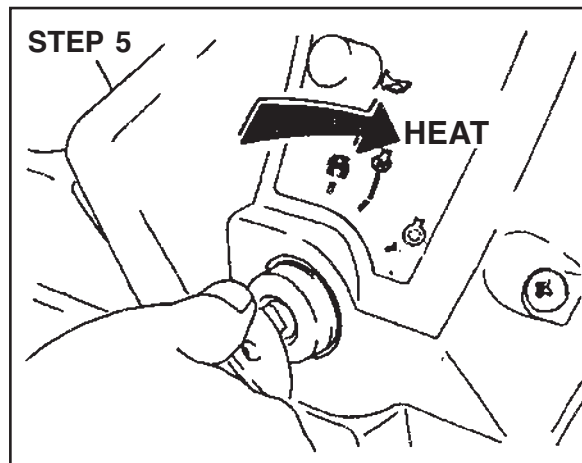

Turn the starter key switch to the heat & ON position. Wait until the glow plug indicator lamp is put out. (Approximately 1 to 3 seconds.)

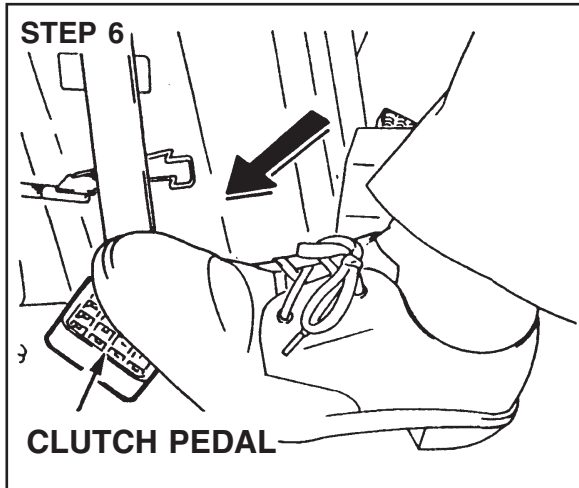

Push the clutch pedal down.

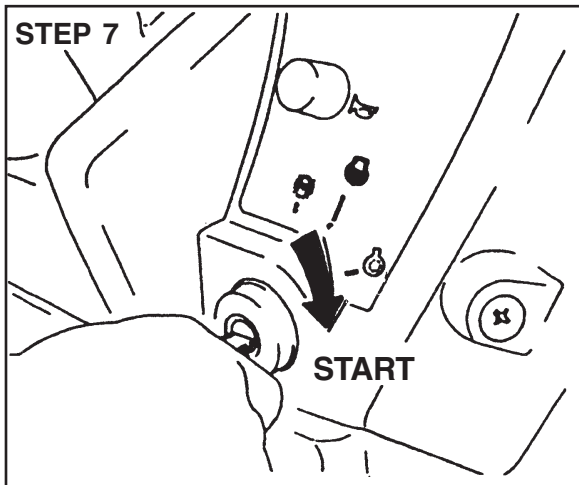

Turn key switch to start position until engine starts, but no more than 10 seconds, then release the key. Run engine for two minutes at 1500 RPM.

**STEP 8**

When the engine starts, check the oil pressure indicator and charge indicator. If the indicators stay on, stop the engine and find out what is wrong.

**NOTE:** *If the oil pressure indicator stays on after the engine starts, stop the engine and check the oil level in the crankcase. Add oil if necessary. Start the engine, if the indicator is still on, do not operate the engine. Operating the engine without oil pressure will damage engine bearings and other engine parts. See your dealer.*

**IMPORTANT:**

1. *If high idle position is used for starting, adjust the engine speed control lever to obtain about 1500 RPM as soon as the engine starts.*
2. *If the engine starts and then stops, wait for the starting motor to stop turning before you turn the key switch to START position again.*

3. *Do not use the starter motor for more than 10 seconds without stopping. Wait one minute between starts so the starter motor can cool.*
4. *If the engine stops when operating with a load, immediately start the engine again to prevent overheating caused by stopping the flow of oil for cooling and lubrication.*
5. *If the charge indicator comes on during operation, determine and correct the cause to avoid complete discharge of the battery and possible damage to other components of the electrical system. See your Dealer.*
6. *If the coolant temperature indicator comes on, remove the load and allow the engine to run at 1500 rpm until the indicator goes out. If the indicator does not go out within one minute, stop the engine and determine the cause.*

## Starting Procedure for Hydrostatic Drive Tractors After Transporting on Truck or Flatcar

**IMPORTANT:** *Hydrostatic transmission can jump into gear without warning, if the fluid leaks out of the control system. This can occur due to vibration if the tractor is transported on a truck or rail car. It can also happen if the transmission is drained or if the tractor sits still for very long periods. If any of these have happened, start the tractor as follows:*

1. Put the range shift control lever into the N (Engine start) slot and release the speed lock lever to permit the speed ratio control pedal to return to N (Neutral) position.
2. Lock the brake pedals together, press down on the brake pedals.
3. Pull the engine speed control lever and start the engine. Set the engine speed to about 1000 RPM.
4. Slowly move the range shift lever to H range for high speed engagement.

If gear clash is obvious the engine should be shut off immediately and the tractor unloaded by other means. Tow the tractor with the range shift lever in N (Neutral) to an area where the transmission can be checked by your Dealer. Refer to Towing the Tractor in this manual.

If there is no obvious gear clash, drive the tractor in the normal manner.

## STOPPING THE ENGINE

**IMPORTANT:** When stopping the engine after operating under heavy load, run the engine at 1500 RPM for a short period of time. This will allow the engine temperature to decrease gradually.

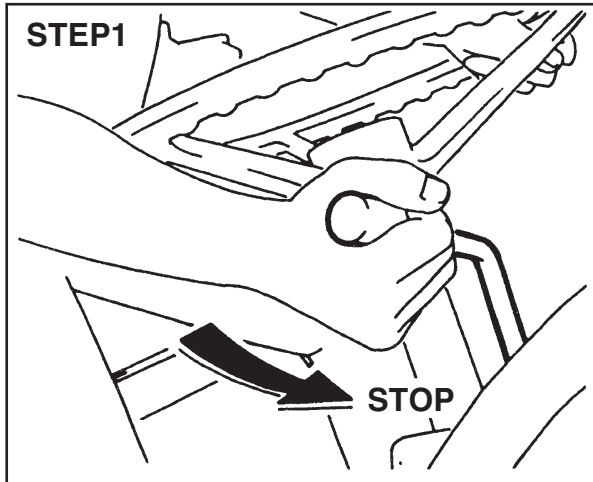

Move the engine speed control lever to run engine at idle speed for three to five minutes to decrease the temperature of engine.

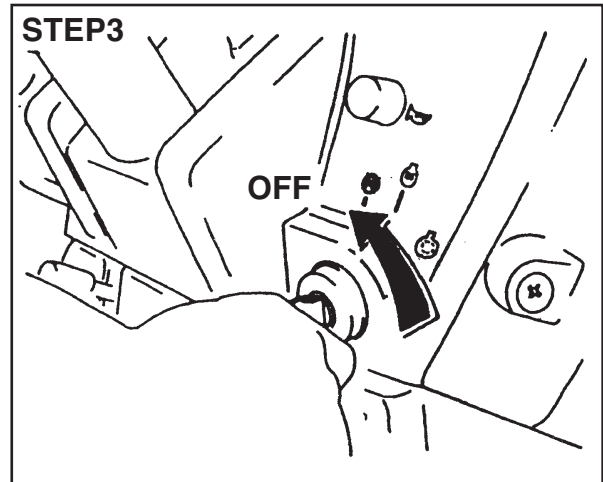

Turn the key switch to OFF position. Remove the key.

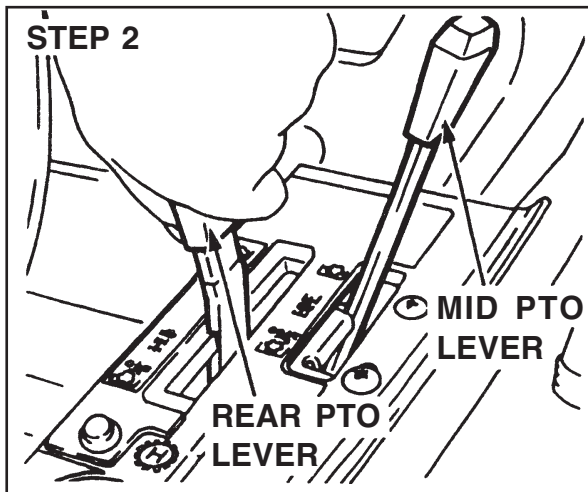

Put the REAR PTO control lever, MID PTO control lever and the range shift lever in the OFF or N (neutral) position.

## COLD TEMPERATURE OPERATION

To start and operate your tractor during cold ambient temperatures, use these procedures :

1. BATTERY – Must have a full charge.
2. FUEL – Must be clean and with no water. See Fuel Specifications in this manual.
3. ENGINE OIL – Must have the correct viscosity for the ambient temperature range.
4. TRANSMISSION HYDRAULIC FLUID – Use Hydraulic Transmission fluid.
5. COOLING SYSTEM – Must have ethylene glycol solution for protection.
6. TIRES – If there is liquid in the tires, the tires must have protection against temperatures below 0° C (32° F). See your Dealer.
7. STOPPING THE ENGINE – Run the engine at idle speed for a short period of time to permit the engine temperature to decrease before stopping.
8. CONDENSATION IN FUEL TANK – To prevent condensation in the fuel tank and water entering the fuel system, fill the fuel tank after each operating day.
9. FUEL FILTER CUP – During cold ambient temperatures, make sure you remove water from the fuel filter cup each day.

**NOTE :** *Do not use ether as a cold temperature starting aid.*

**IMPORTANT:** *To start engine during cold ambient temperatures, put the engine control level at the low idle position. After starting the engine, run at 1500rpm for approximately 5 minutes to warm the engine.*

**IMPORTANT:** *During cold ambient temperatures, never run the engine at low idle speed for long periods of time.*

During cold ambient temperatures, the engine will not heat to or keep the rated operating temperature at slow engine speeds. Slow engine speeds in cold temperatures can cause damage to the engine. Use the following procedures to warm the engine and transmission fluids, and to keep the correct operating temperatures.

1. WARMING THE ENGINE AND TRANSMISSION.

- A. To heat the transmission fluid to operating temperature, run the engine at 1500 RPM for approximately five minutes.

**IMPORTANT:** *Operating the tractor with cold transmission fluid can cause rough tractor operation with possible injury to the operator.*

2. KEEP ENGINE AT CORRECT OPERATING TEMPERATURE.

- A. Never run the engine below 1500 RPM.  
B. Put a cover in front of the grille to control the amount of air going through the radiator.

3. STOPPING THE ENGINE.

- A. Run the engine at slow speed for a short period of time. This will permit the engine temperature to decrease gradually before stopping the engine.

## TOWING

When towing a tractor, follow these rules:

1. Never pull the tractor faster than a ground speed of 16 Km/h (10 MPH).
2. Make sure all controls are in the neutral or OFF position.
3. Because of a possible loss of steering and brakes when the tractor engine is not running, use only a rigid towing bar and safety chains to pull the tractor.



***Make sure that the weight of a trailed vehicle that is not equipped with brakes, NEVER EXCEEDS the weight of the machine that is towing the vehicle. Stopping distance increases with increasing speed as the weight of the towed load increases, especially on hills and slopes.***

M114A

## HOW TO TRANSPORT TRACTOR

When you transport the tractor by truck or rail, follow these rules:

1. Hold the tractor with tie downs and block the wheels.
2. Hydrostatic Drive: Move the Speed Lock lever to OFF position and put the range shift lever in the L position.
3. Lock the brake pedals together, push the brake pedals down and move the park brake lever up to engage the park brake.



## HYDROSTATIC DRIVE TRANSMISSION

The Hydrostatic drive transmission has a forward/reverse hydrostatic section and a three-speed range section. This arrangement gives three forward and three reverse speeds range.

### Transmission Operation

1. Push the clutch pedal fully and stop the tractor. Move the range shift lever to the position needed, H, M or L.
  2. Release the clutch pedal slowly.
  3. Operate the speed ratio control pedal to move the tractor.
- To shift from reverse to forward or from forward to reverse, move the speed ratio control pedal without disengaging the clutch.

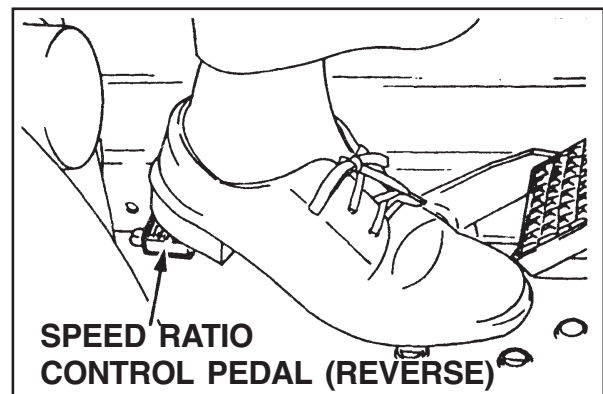
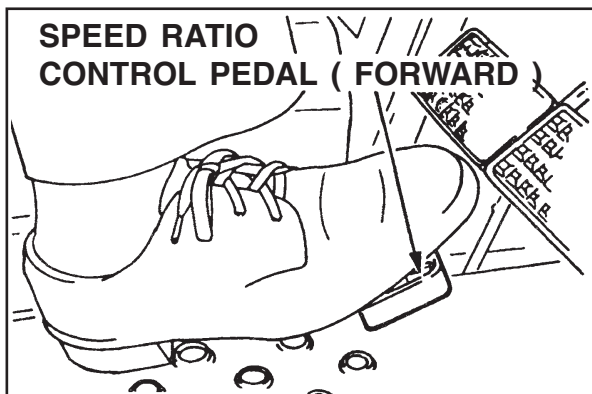
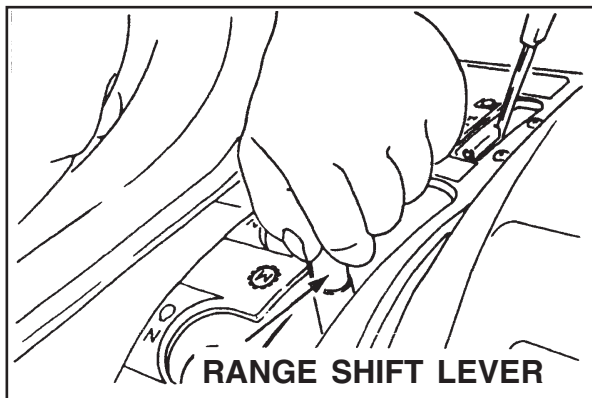

**IMPORTANT:** Before selecting a new range, stop the tractor and push the clutch pedal. Do not change range when the tractor is moving.



**Travel speed should be such that complete control and machine stability is maintained at all times. Where possible, avoid operating near ditches, embankments and holes. Reduce speed when turning, crossing slopes, and on rough, slick, or muddy surfaces.**

M109A

## DIFFERENTIAL LOCK

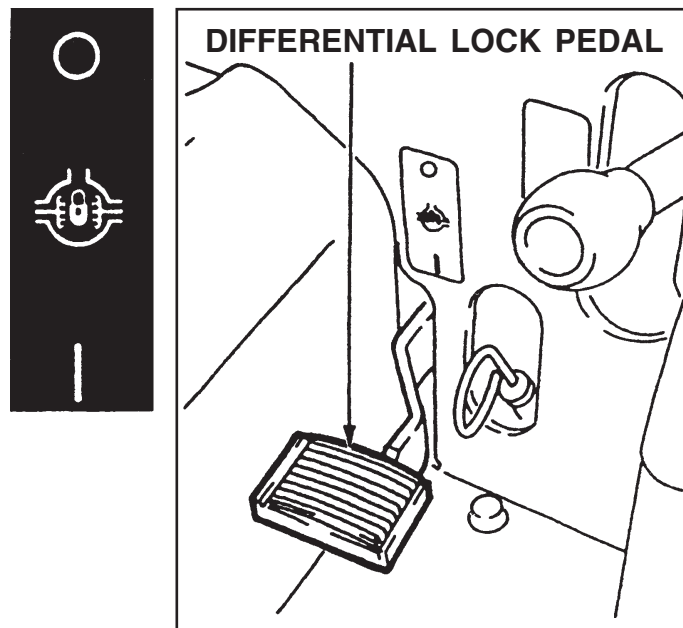

HYDROSTATIC DRIVE  
LEFT SIDE of the transmission

Your tractor has a differential lock that will make both rear wheels turn at the same speed. The differential lock prevents loss of power when one wheel does not have traction but the other wheel does have traction. It also provides a straight in line steering aid when opening up the field and to control implement overlap.

### TO ENGAGE THE DIFFERENTIAL LOCK:

Depress and hold the differential lock pedal down.

**IMPORTANT:** *Do not engage the differential lock while one rear wheel is rotating and the other rear wheel is stopped. Always stop the wheel that is rotating and then engage the differential lock.*

**IMPORTANT:** *When you engage or disengage the differential lock, the front wheels must be in the straight forward position. Before turning the tractor, disengage the differential lock.*

### TO DISENGAGE THE DIFFERENTIAL LOCK:

The differential lock will disengage when the differential lock pedal is released. If the differential lock does not disengage easily, push down on either brake pedal instantaneously.



**Do not drive on roads, or at high speed anywhere, with the differential lock engaged. Difficult steering will occur, and can result in an accident. In field operation, use the differential lock for traction improvement, but release for turning at row ends.**

M116

## POWER TAKEOFF (PTO)



**PTO driven machinery can cause serious injury or death, usually due to wrapped clothing. When required by the job to be in the drive shaft area, stay clear of rotating parts. Before working on the drive shaft, or servicing or clearing the driven machine, where applicable on this tractor, put the PTO clutch lever in the DISENGAGE position, the PTO lever in the NEUTRAL or OFF, and STOP the engine.**

M125A

### Rear PTO

The rear PTO is a 540 RPM with a 34.9 mm (1 3/8 inch) diameter 6 spline output shaft.

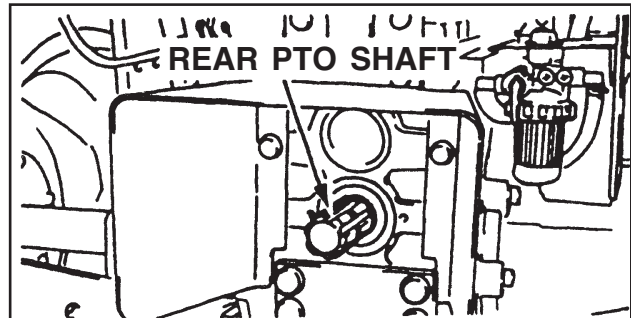

ENGAGE THE REAR PTO AS FOLLOWS:

1. Push the clutch pedal fully.
2. Move the PTO control lever forward or rearward.
3. Release the clutch pedal slowly.

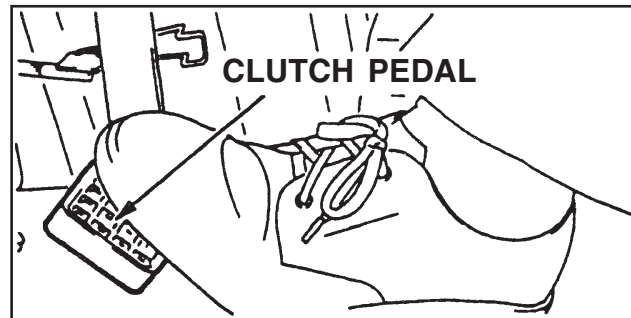

DISENGAGE THE REAR PTO AS FOLLOWS:

1. Push the clutch pedal fully.
2. Move the PTO control lever to the N (Engine Start) Slot.

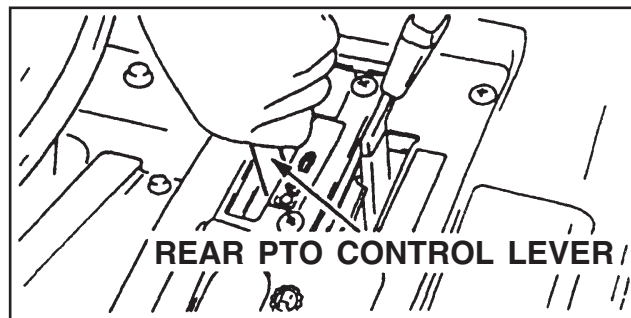

**NOTE:** Keep the PTO control lever in the OFF position when starting the engine and when the PTO is not being used.

3. Release the clutch pedal slowly.

The following table shows the required engine speed to get the required Rear PTO output shaft speed.

PTO Output Shaft Speed	Required Engine Speed
540 RPM	2356 RPM

## DIFFERENTIAL LOCK

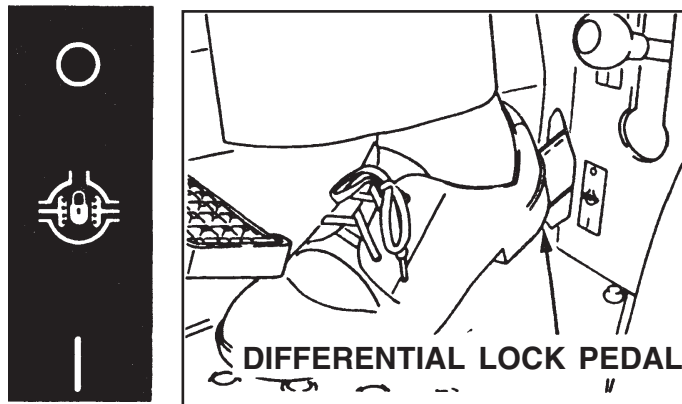

HYDROSTATIC DRIVE  
LEFT SIDE of the transmission

Your tractor has a differential lock that will make both rear wheels turn at the same speed. The differential lock prevents loss of power when one wheel does not have traction but the other wheel does have traction. It also provides a straight in line steering aid when opening up the field and to control implement overlap.

### TO ENGAGE THE DIFFERENTIAL LOCK:

Depress and hold the differential lock pedal down.

**IMPORTANT:** *Do not engage the differential lock while one rear wheel is rotating and the other rear wheel is stopped. Always stop the wheel that is rotating and then engage the differential lock.*

**IMPORTANT:** *When you engage or disengage the differential lock, the front wheels must be in the straight forward position. Before turning the tractor, disengage the differential lock.*

### TO DISENGAGE THE DIFFERENTIAL LOCK:

The differential lock will disengage when the differential lock pedal is released. If the differential lock does not disengage easily, push down on either brake pedal instantaneously.



***Do not drive on roads, or at high speed anywhere, with the differential lock engaged. Difficult steering will occur, and can result in an accident. In field operation, use the differential lock for traction improvement, but release for turning at row ends.***

M116

## POWER TAKEOFF (PTO)



***PTO driven machinery can cause serious injury or death, usually due to wrapped clothing. When required by the job to be in the drive shaft area, stay clear of rotating parts. Before working on the drive shaft, or servicing or clearing the driven machine, where applicable on this tractor, put the PTO clutch lever in the DISENGAGE position, the PTO lever in the NEUTRAL or OFF, and STOP the engine.***

M125A

### Rear PTO

The rear PTO is a 540 RPM with a 34.9 mm (1 3/8 inch) diameter 6 spline output shaft.

**ENGAGE THE REAR PTO AS FOLLOWS:**

1. Push the clutch pedal fully.
2. Move the PTO control lever forward or rearward.
3. Release the clutch pedal slowly.

**DISENGAGE THE REAR PTO AS FOLLOWS:**

1. Push the clutch pedal fully.
2. Move the PTO control lever to the OFF (Engine Start) slot.

**NOTE:** *Keep the PTO control lever in the OFF (Engine Start) slot when starting the engine and when the PTO is not being used.*

3. Release the clutch pedal slowly.

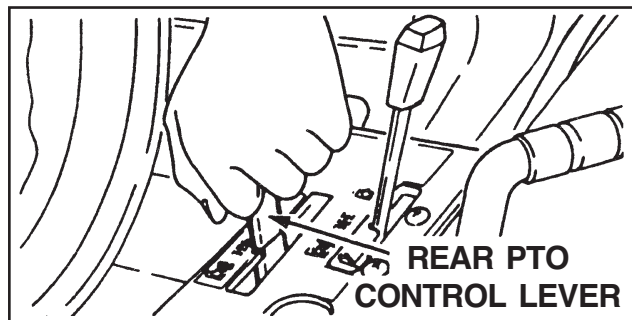
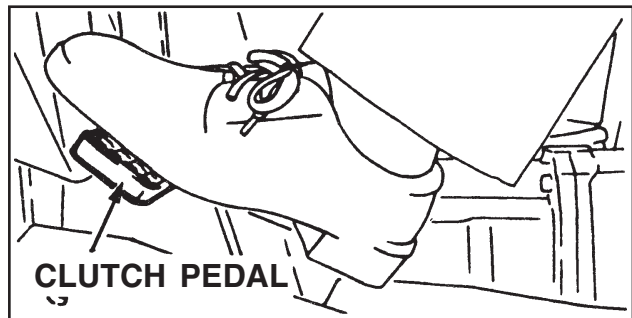
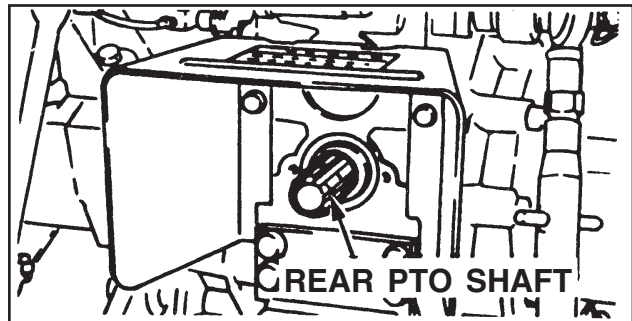

The following table shows the required engine speed to get the required Rear PTO output shaft speed.

PTO Output Shaft Speed	Required Engine Speed
540 RPM	2376 RPM

## Mid PTO

The Mid PTO has a 25.4 mm (1 inch) diameter 15 spline output shaft.

ENGAGE THE MID PTO AS FOLLOWS:

1. Push the clutch pedal fully.
2. Move the Mid PTO control lever forward.
3. Release the clutch pedal slowly.

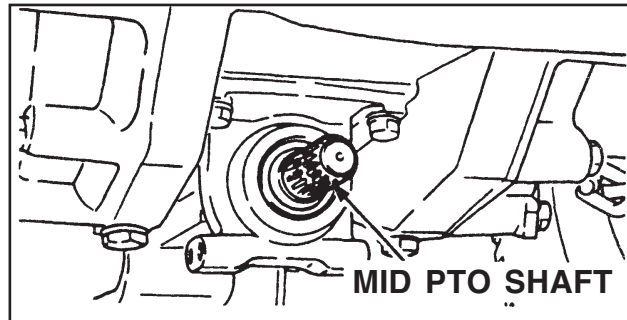

DISENGAGE THE MID PTO AS FOLLOWS:

1. Push the clutch pedal fully.
2. Move the Mid PTO control lever to the OFF (Engine Start) slot.

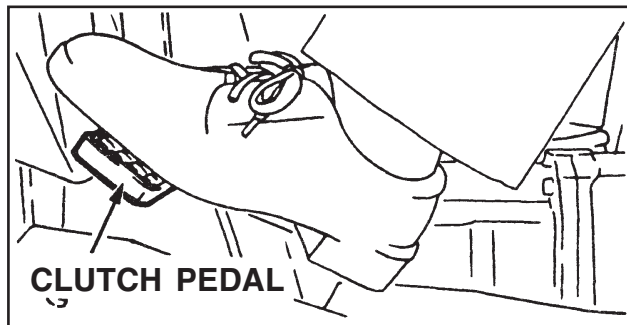

**NOTE:** *Keep the Mid PTO control lever in the OFF (Engine Start) slot when starting the engine and when the PTO is not being used.*

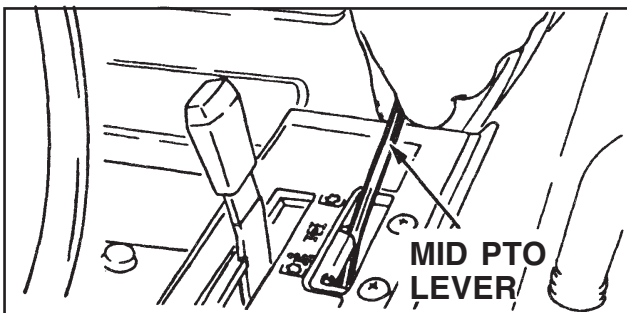

3. Release the clutch pedal.

The following table shows the required engine speed to get the required Mid PTO output shaft speed.

MID PTO Output Shaft Speed	Required Engine Speed
2000 RPM	2632 RPM



## POWER TAKEOFF GUARDS

All tractors have a safety guard for the Rear PTO shaft and a safety cover for the Mid PTO shaft

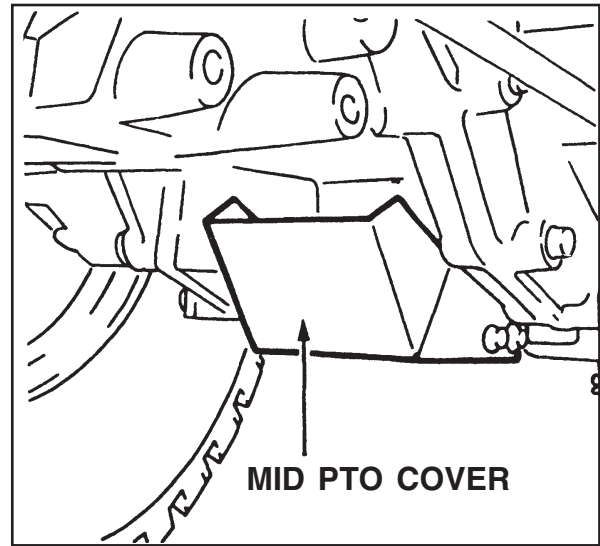
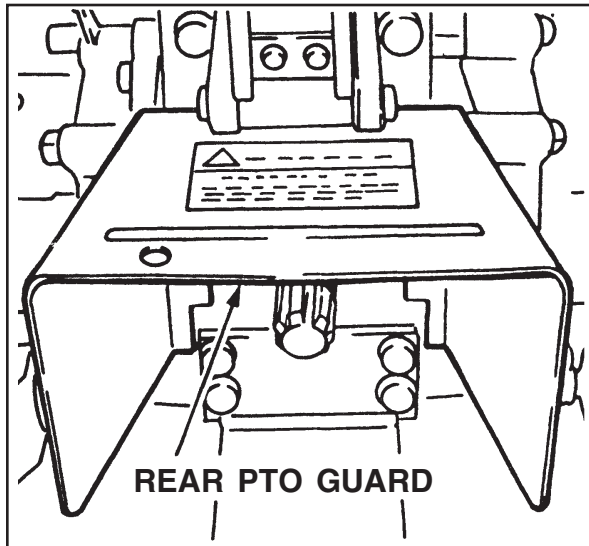

***Whenever a PTO driven machine is in operation, the PTO guard must be in place for most operations to prevent injury to the operator or bystanders. Where attachments, such as pumps, are installed on the PTO shaft (especially if the tractor PTO guard is moved upward or removed) extended shielding equivalent to the PTO guard must be installed with the attachment. Install the PTO guard to its original position immediately when the attachment is removed.***

M126A



## PTO OPERATING SAFETY

For the safe operation of the PTO, follow these safe operating procedures.

### Three Point Hitch Connecting Implements

1. Connect the implement to the hitch.  
See **THREE POINT HITCH SYSTEM** in this manual.
2. Connect the implement driveline to the tractor.
3. Check the driveline for correct length and for free telescopic movement by lifting and lowering hitch system. The correct length is important to prevent the driveline from hitting bottom or from separating in any tractor implement operating position.

### Drawbar Connecting Implements

1. Connect the implement hitch to the drawbar with a hardened steel pin. Make sure the pin is securely held in place with a cotter pin or lock pin and does not make contact with the implement driveline.
2. Connect the implement hitch to the tractor drawbar before connecting the implement driveline to the PTO.
3. Connect the implement driveline to the tractor. Check the driveline for correct length and for free telescopic movement. The correct length is important to prevent the driveline from hitting bottom or from separating in any tractor or implement operating position.

***PTO driven machinery can cause serious injury. Before working on or near the PTO shaft, or servicing or clearing the driven machine, put the PTO lever in the DISENGAGE position and STOP the engine.***

M154



***When doing stationary PTO work and dismounting from the tractor with the PTO running, keep clear of all moving parts as they are a potential safety hazard.***

M127

**IMPORTANT:** *Follow the implement manufacturers recommendations in adjusting and aligning the implement and implement driveline with the tractor.*

## DRAWBAR

Your tractor is equipped with a drawbar. Use the drawbar for connecting all pull-behind implements.

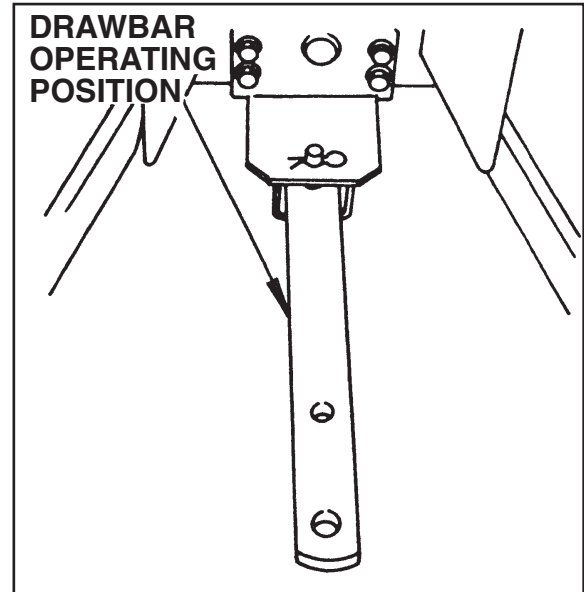
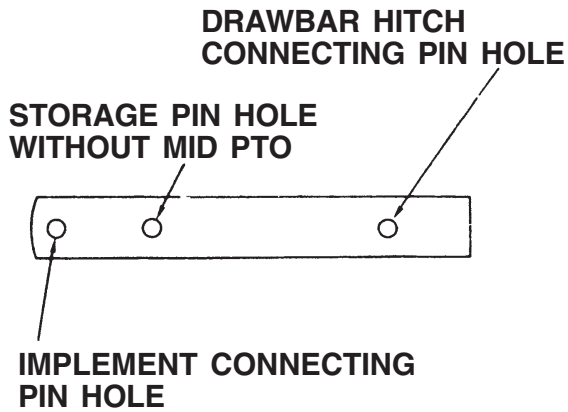

The drawbar must be in the storage position when using the three-point hitch.

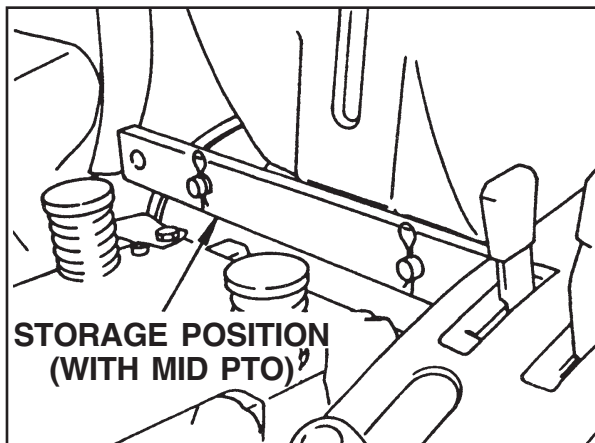

WITH MID PTO

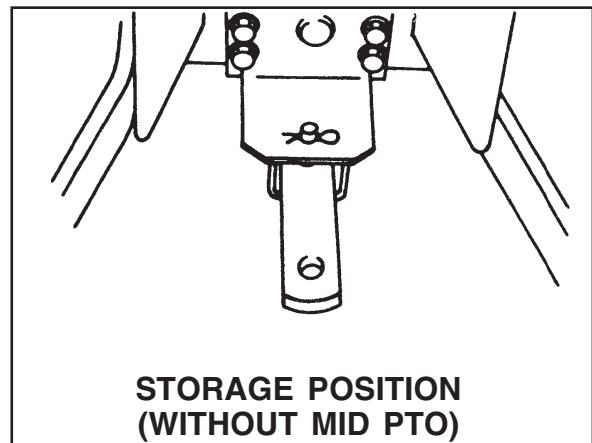

WITHOUT MID PTO



**Try to balance the load primarily on the implement wheels - as in loading a trailer or spreader. Avoid overloading the drawbar. Add front end weights for improved stability. Engage the clutch smoothly, avoid jerking and use the brakes cautiously to avoid jack-knifing.**

M117



**Rear upset can result if pulling from wrong location on tractor. Hitch only to the drawbar. Use 3 point hitch only with the implements designed for its use - not as a drawbar.**

M119

## WARNING LAMPS

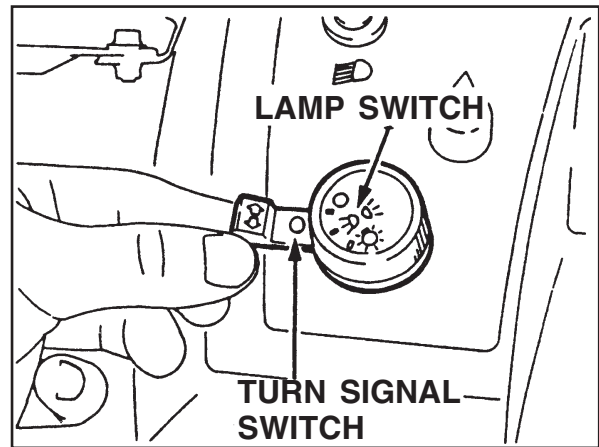
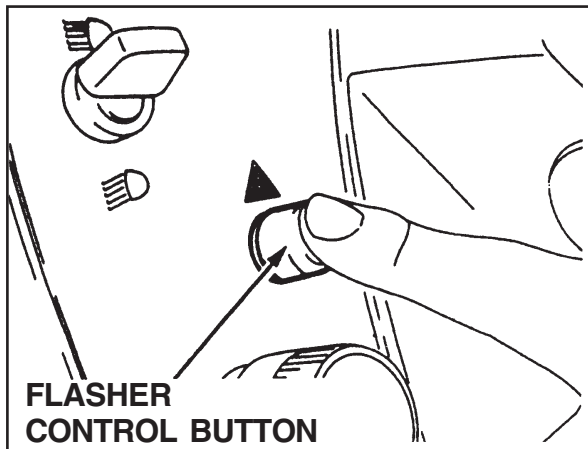

The lamp switch has three positions. Turn the switch clockwise to illuminate the headlamp, rear red lamp, and instrument panel lamps.

Push the flasher control button down to operate the amber warning lamps.

When the turn signal switch is moved upward to make a right turn, the RH warning lamp will illuminate ON and OFF and the LH lamp will illuminate continuously.

When the turn signal switch is moved downward to make a left turn, the LH warning lamp will illuminate ON and OFF and the RH lamp will illuminate continuously.

When the turn signal switch is returned to the center position, both warning lamps will illuminate ON and OFF.

**IMPORTANT:** *When towing an implement or wagon with the tractor, the complete rear area warning system (amber warning lamps, rear red lamp and SMV emblem) must be easily seen by any vehicle operator coming near the tractor.*

## REAR WORK LAMP (IF EQUIPPED)

The rear work lamp is turned on by the switch on the lamp. The starter key switch must be in the ON position before the work lamp can be turned on.

**IMPORTANT:** *Do not turn on the rear work lamp while travelling on public roads.*

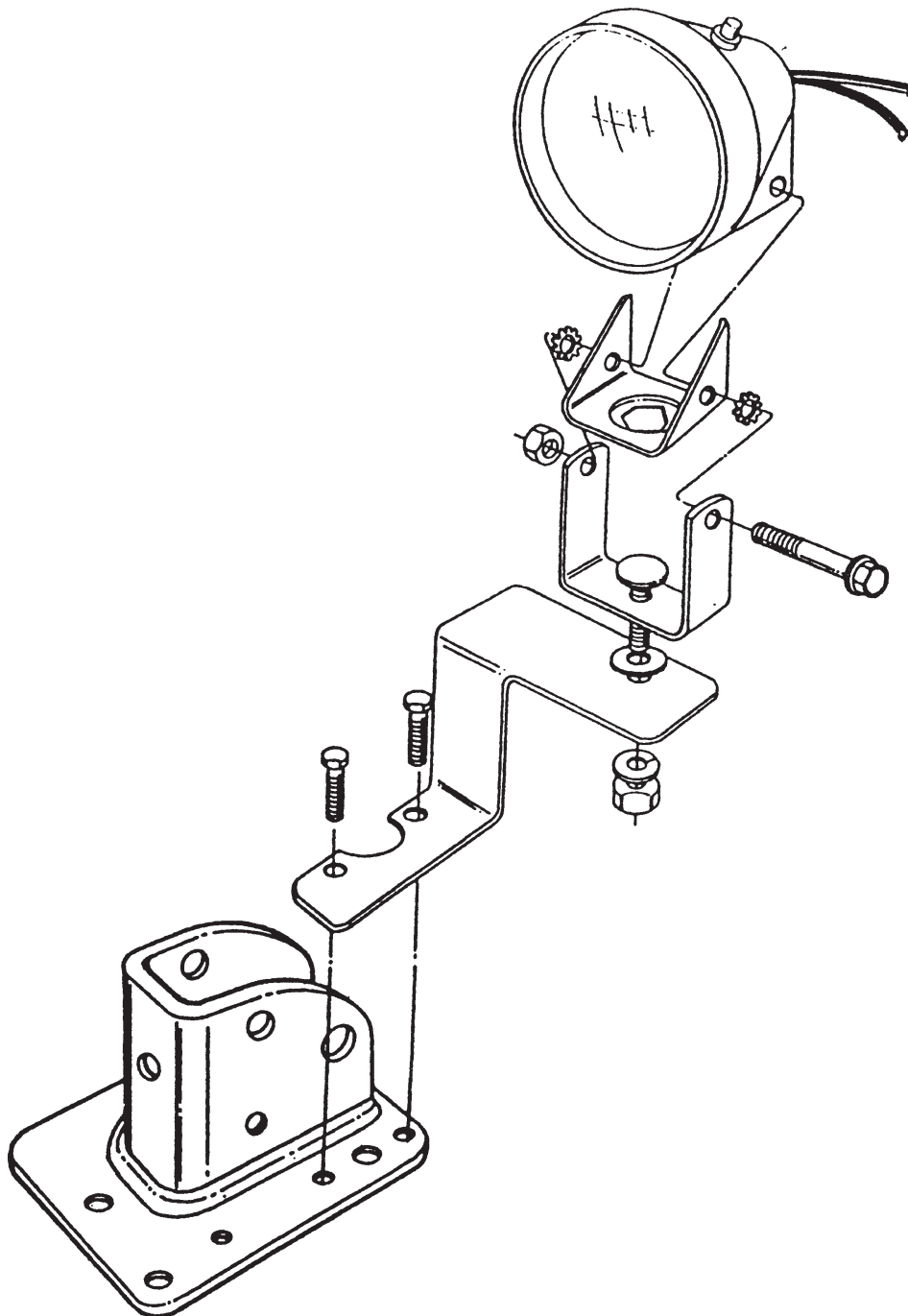

## CONNECTING IMPLEMENT TO DRAWBAR

The correct connection of the implement to the drawbar will prevent stress on both the tractor and the implement.

To assure proper tractor operation and optimum implement performance, the implement must be connected to the drawbar correctly.

1. Connect pull-behind implements to the drawbar only.

2. Use a hardened steel hitch pin to connect the implement to the drawbar. Make sure the pin is held securely in place with a lock pin.

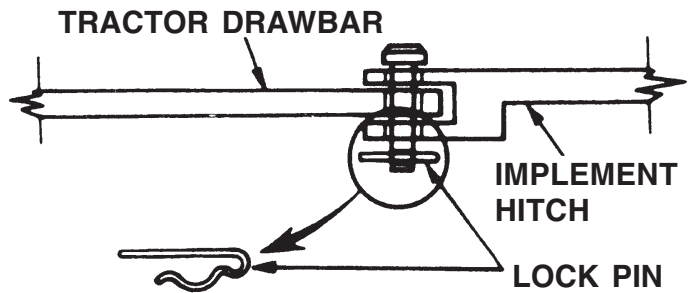

IMPLEMENT HITCH WITH CLEVIS

3. When working with the drawbar, raise the lower links as high as possible to prevent interference between the lower links and the implement.

4. The drawbar provides the standard hitch distance from the end of the PTO shaft to the centerline of the rear hole in the drawbar. This is necessary for safe PTO operation of trailing type equipment.

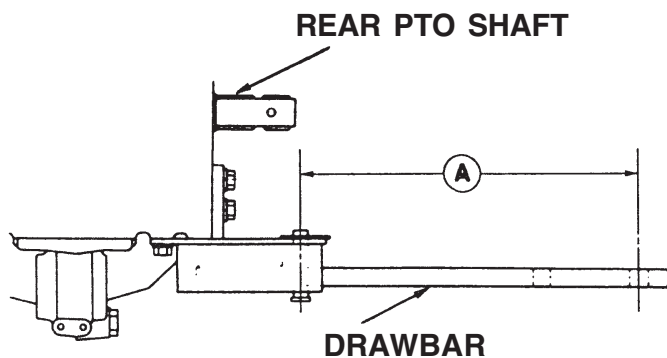

PTO RPM	PTO SHAFT DIAMETER	DIMENSION A
540	1.375 In. (34.9 mm)	14 In. (356 mm)

**IMPORTANT:** *The maximum fixed drawbar vertical load is 300 lbs (136 kg).*

## SAFETY CHAIN

When towing equipment on a highway, use a safety chain as an auxiliary connection between the tractor and the towed equipment. The safety chain must have a rating greater than the gross load of the towed equipment. Connect the chain to the tractor drawbar support and the towed equipment as shown in the illustration. Check the adjustment of the safety chain by turning the tractor completely to the right and left. Adjust the chain as necessary.

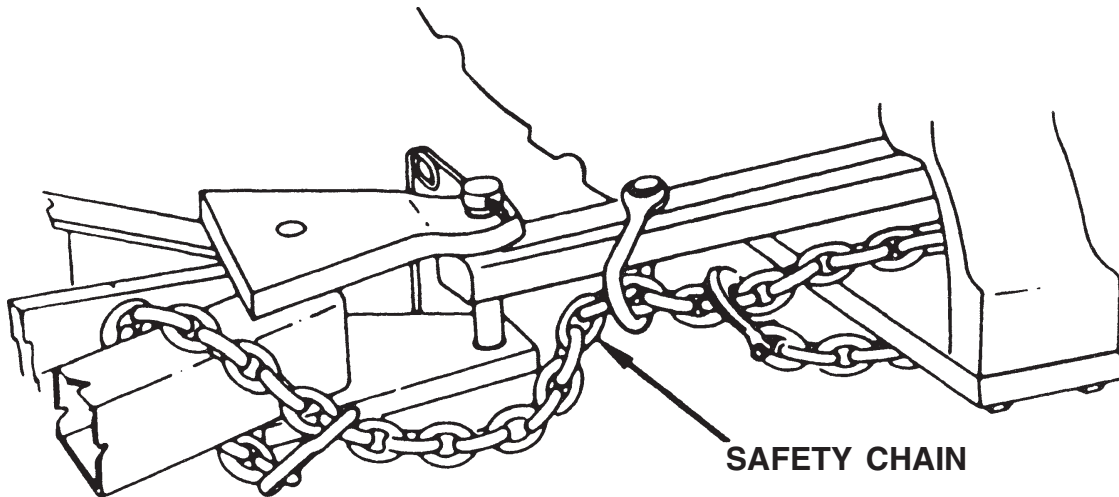

## THREE POINT HITCH SYSTEM

The three point hitch system gives position control and draft control (If equipped) of implements. This tractor is equipped with a category I hitch.

The three-point hitch dimensions are shown in the following table.

Implement identification Dimensions	Cat I implement
<b>A – Gap In top of implement mast</b>	<b>44.5 mm (1-3/4 inch)</b>
<b>B – Diameter of holes in top of Implement mast</b>	<b>19.1 mm (3/4 inch)</b>
<b>C – Diameter of hitch pins</b>	<b>22.2 mm (7/8 inch)</b>
<b>D – Lower Hitch Pin Inner Shoulder Spread</b>	<b>682.6 mm (26-7/8 Inch)</b>

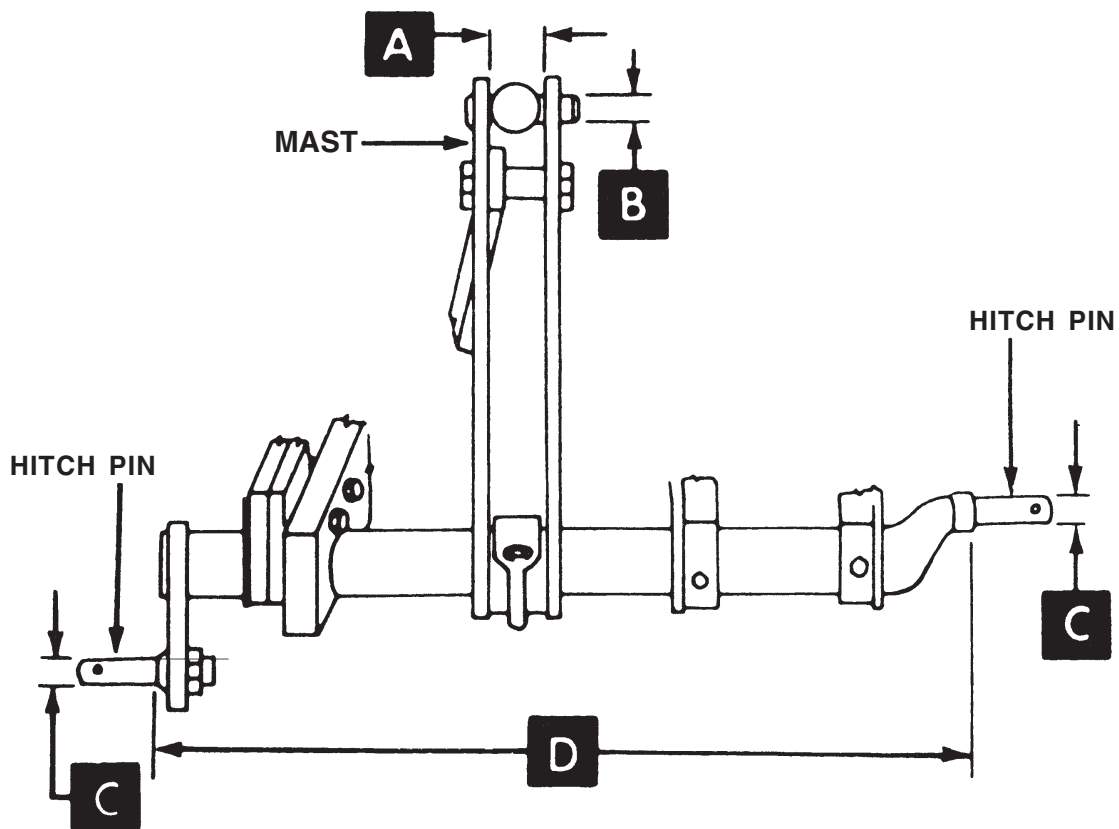



## HITCH SYSTEM ADJUSTMENTS

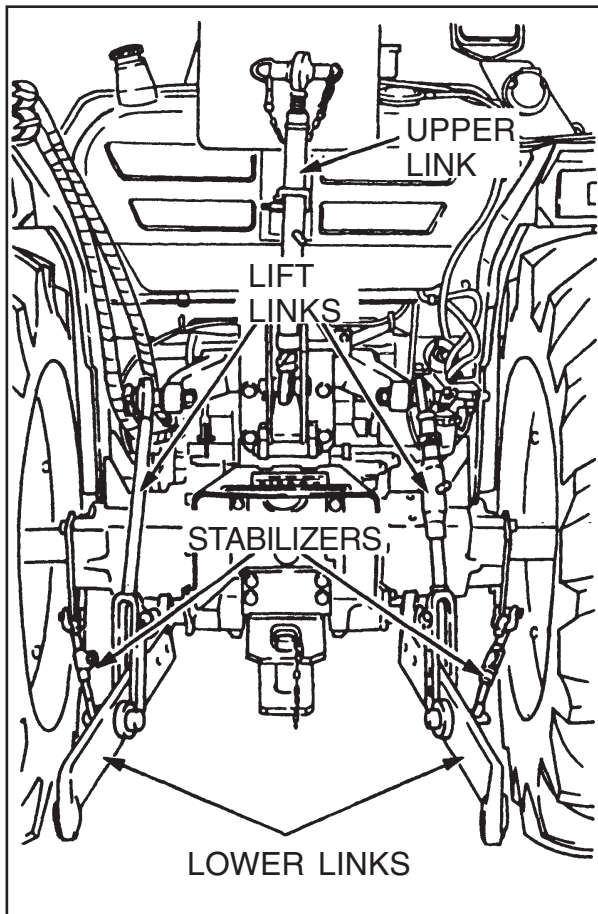

The upper and lower links must be adjusted correctly so the implement can work at the needed depth and the links are free to move up and down with the shape of the ground.

### Lift Links

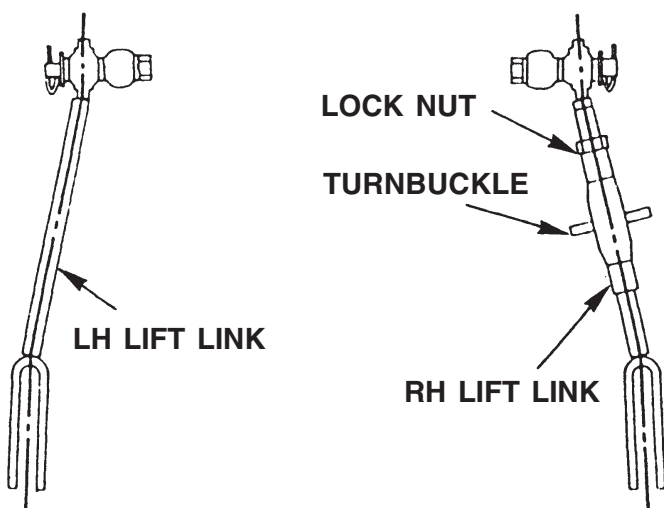

1. Connect the lift links to the tractor and to the lower links. Make sure the lift links are installed on the proper Sides as shown below.
2. The RH side lift link is adjustable by turnbuckle to obtain the desired position of the hitch point. Turn the turnbuckle clockwise to shorten the link or counter-clockwise to lengthen the link.

**IMPORTANT:** After the lift link is adjusted, make sure the locknut is tightened against the turnbuckle.

## Upper Link

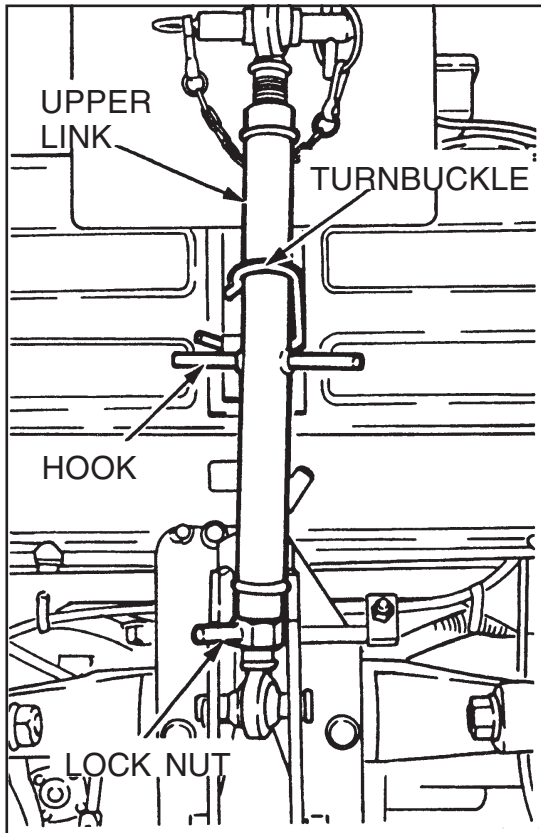

The length A of the upper link can be adjusted from 470 to 750 mm (18.5 to 29.5 inches).

Turn the turnbuckle clockwise to shorten the link or counterclockwise to lengthen the link.

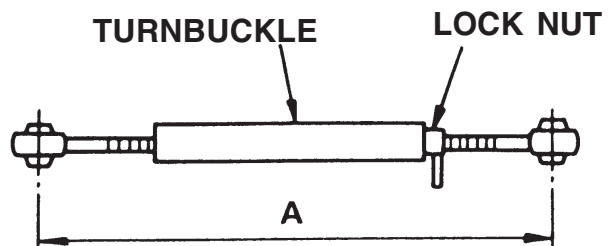

**IMPORTANT:** After the upper link is correctly adjusted, make sure the lock nut is tightened against the turnbuckle.

## Stabilizer

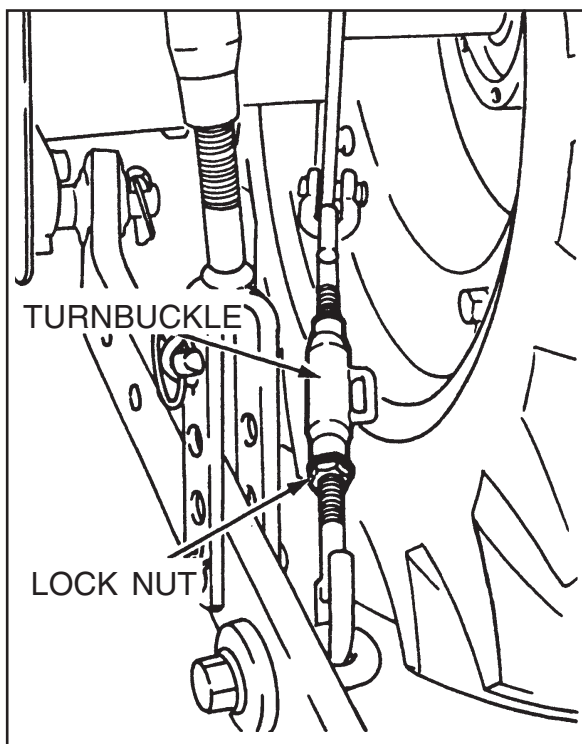

When side movement of the hitch is undesirable or hazardous, the lateral swing is adjusted by the turnbuckle on the stabilizer.

Turn the turnbuckle clockwise to lengthen the stabilizer or counterclockwise to shorten the stabilizer.

**IMPORTANT:** After making final adjustments carefully raise the implement to make sure that there is proper clearance between the implement and tractor components.

**NOTE:** Make sure the lock nut is tightened after adjusting the stabilizer.

## HITCH OPERATION

### Connecting Implement to Hitch

To connect an implement to the hitch, use the following procedure:

**NOTE:** *Be sure the tractor and implement are on level ground.*

1. Put the drawbar in the storage position.
2. Slowly move the tractor backwards to the implement.
3. When the hitch points on the tractor and implement are in the correct position, stop the tractor.
4. Apply the park brake and stop the engine.
5. Connect the implement to the Upper and Lower Links.
6. Adjust the Upper and Lower Links as necessary. See Hitch System Adjustments in this manual.

### Disconnecting Implement from Hitch

To disconnect an implement from the hitch, use the following procedure:

**NOTE:** *Be sure the tractor and implement are on level ground.*

1. Stop the tractor completely and apply the park brake.
2. Disengage the PTO, lower the implement to the ground.
3. Gear Drive: Place the gear shift and range shift levers in Neutral.  
Hydrostatic Drive: Release the speed lock lever, and place the range shift lever in Neutral.
4. Stop the engine and remove the key from the key switch before leaving the tractor.
5. Disconnect the implement from the hitch.

**NOTE:** *Be sure the tractor and implement are stable and free from any tendency to roll over.*

## Hitch Control Lever

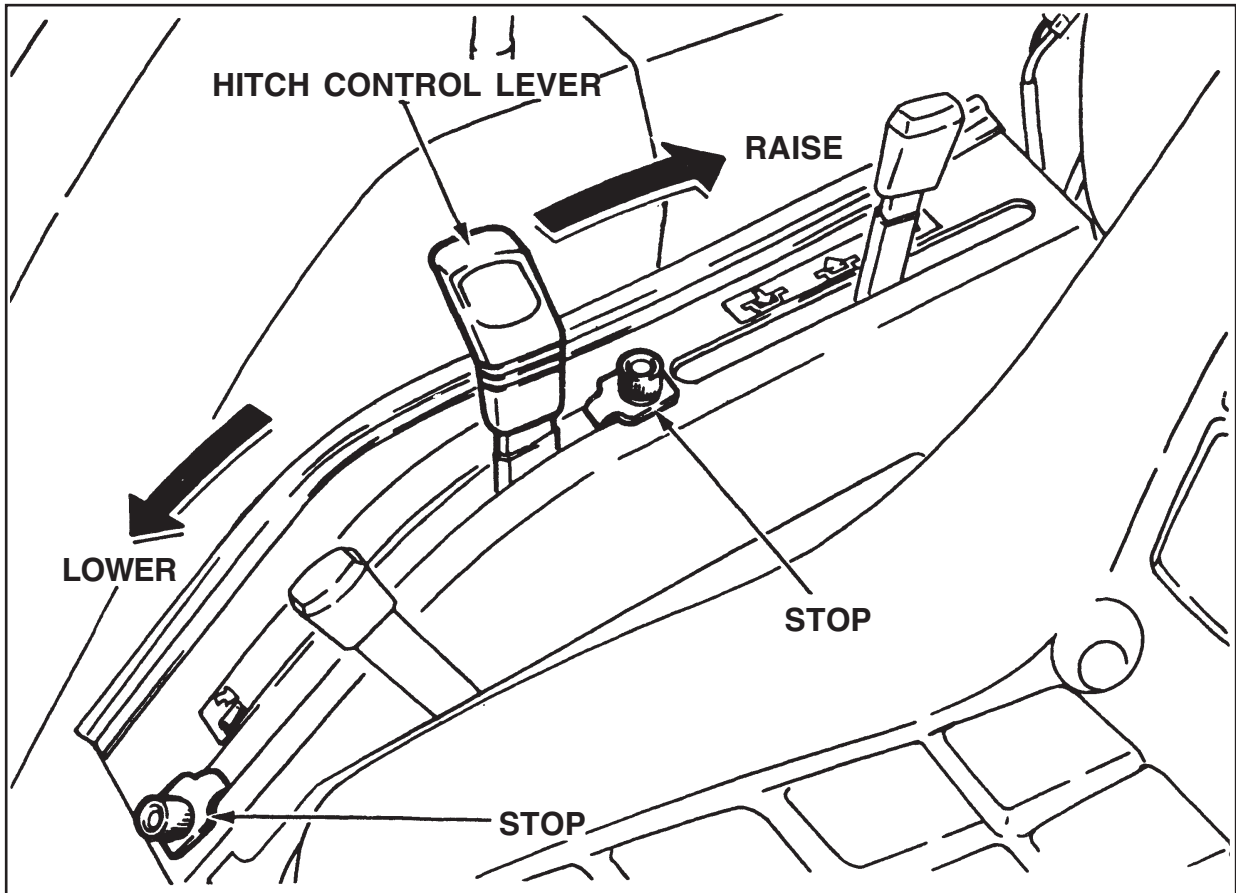

The hitch control lever is used to raise or lower the implement mounted to the three point hitch. To raise the hitch, move the lever to the rear. To lower the hitch, move the lever forward. Adjustable stops are provided for use whenever it is desirable to return the hitch control lever to the same operating position.

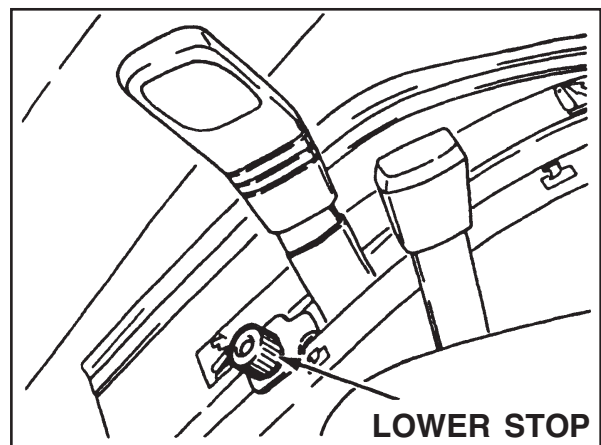
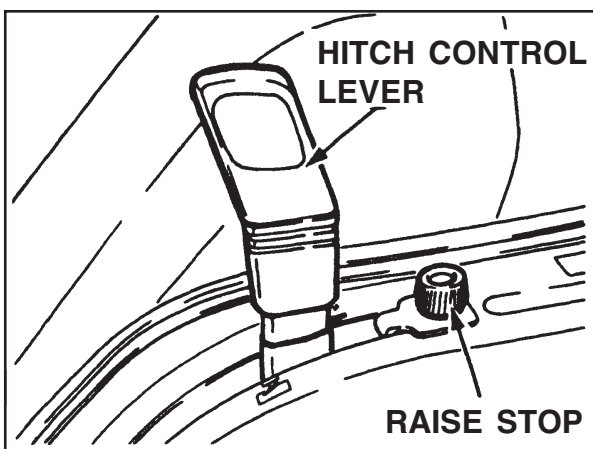

**IMPORTANT:** Position of the raise stop should not be set so rearward that a insufficient free play of the lift arms is available at the highest position when hitch control lever is moved until the lever is reached to the raise stop.

### Draft Control Lever (If Equipped)

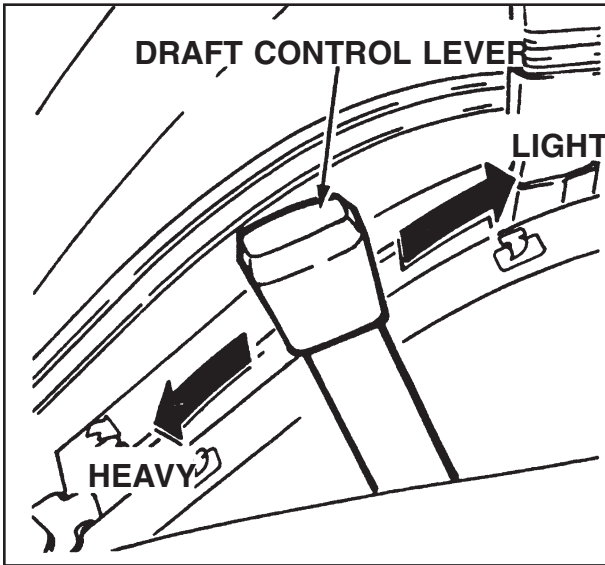

Draft control can be used to automatically lift and lower an implement to maintain a constant load through variable soil conditions. The amount of draft can be adjusted for the implement being used.

To select the correct position for the draft control lever, the tractor and implement must be operated in a field.

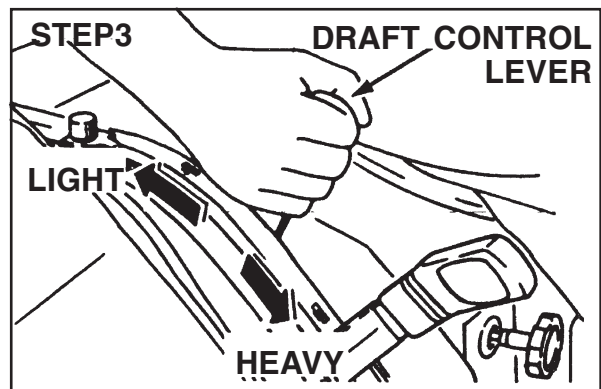
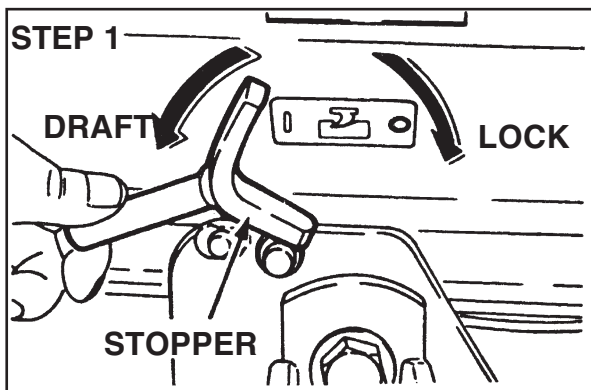

Lower the implement and rotate the stopper located on the top of the upper link bracket.

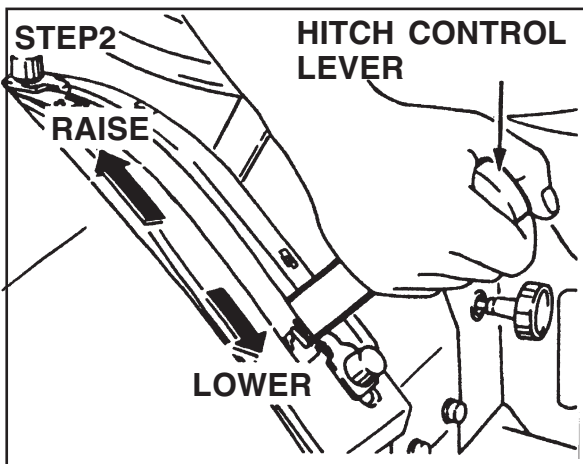

Move the draft control lever rearward to select the correct position of the lever. If the implement is lifting up, move the lever forward. If the engine RPM is decreasing, move the lever rearward. The depth of the implement will be automatically controlled by the draft on the implement.

Slowly move the hitch control lever forward until the implement is at the needed depth.

## Operating with Draft Control (IF EQUIPPED)

For example, the draft control adjustment for a moldboard plow is as follows:

1. Set the upper link at the 560 mm (22-inches) length, pin to pin.
2. Place the draft control lever at the center of its operating range.
3. Starting at the end of the field, move the hitch control lever fully forward to the LOWER position and drive ahead several feet.
4. Stop the tractor and adjust the length of the upper link to level the plow front to rear.
5. Adjust the lift link turnbuckle to level the plow side to side.
6. After the plow has been leveled, adjust the draft control lever either forward (to go deeper) or rearward (for shallower depth) until the desired depth is reached.
7. If the drop action of the plow is too fast, rotate the hydraulic flow control knob slowly until the plow reacts at the desired speed. See Hitch Lowering Speed Adjustment in this manual.
8. When the control levers are set for the field conditions, set the stop so the hitch control lever is returned to this position each time the plow is lowered into the ground.
9. When reaching the end of the field, move the hitch control lever rearward to lift the plow to transport position.
10. Re-enter the field and lower the plow by moving the hitch control lever forward to the stop.
11. The plow will maintain the desired depth as previously set by the draft control lever.



## Hitch Lowering Speed Adjustment

To adjust the hitch lowering speed, use the following procedure:

1. Move the hitch control lever forward to lower the implements.
2. Turn the hydraulic flow control knob to adjust the lowering speed. Turn the knob counter clockwise to increase the lowering speed. Turn the knob clockwise to decrease the speed or lock the hitch.
3. After adjusting the speed, raise the hitch and then lower it to check the speed.

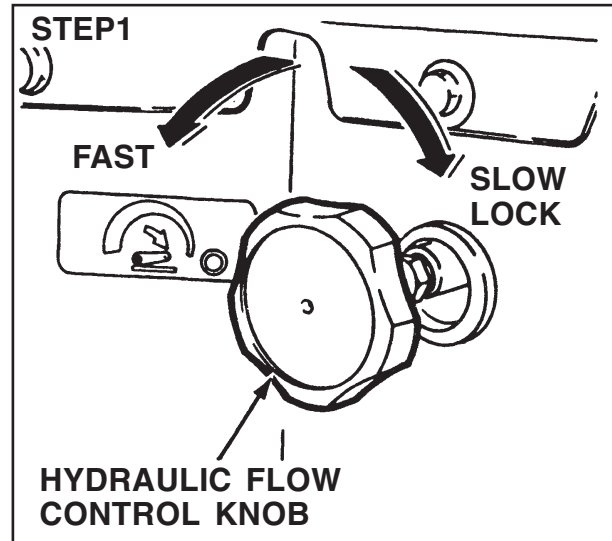

**NOTE:** When transporting the tractor on the road with the implement mounted on the three point hitch, always set the flow control knob to the LOCK position.

**IMPORTANT:** Never park a tractor with an implement in the raised position. Moving the control lever forward will lower the implement even though the engine is not running. If it is necessary to service the implement in the raised position, use jack stands to safely block the implement in place. Put the hydraulic flow control knob in the LOCK position.



**Lower or block elevated implements and other attachments before servicing or when leaving the equipment.**

M132A



## REMOTE HYDRAULIC CONTROL VALVE (IF EQUIPPED)

A double acting remote hydraulic control valve with a “float position”, is available from your Dealer or Factory Installed. If equipped, the control lever is located on the right side.

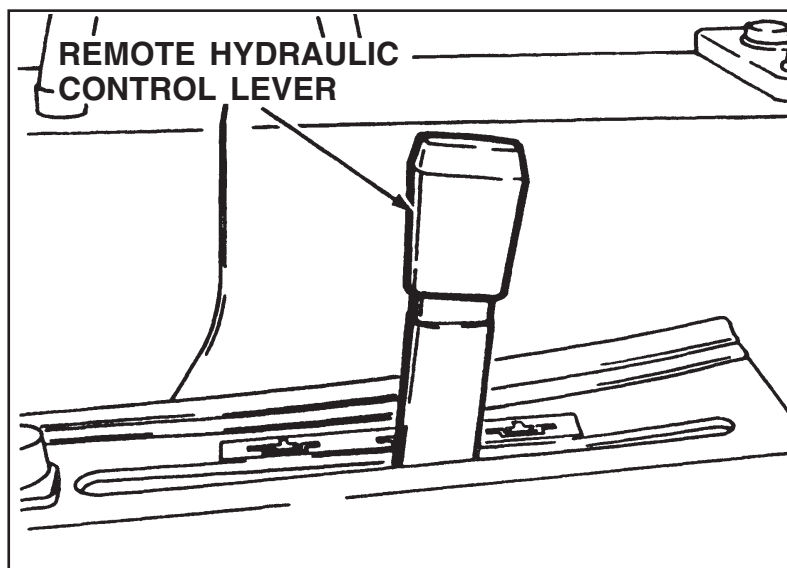

Connect the implement hoses to the remote hydraulic couplers so that the implement lowers when the control lever is pushed forward and raises when the lever is pulled rearward. Switch the hoses if the implement works in the opposite way.

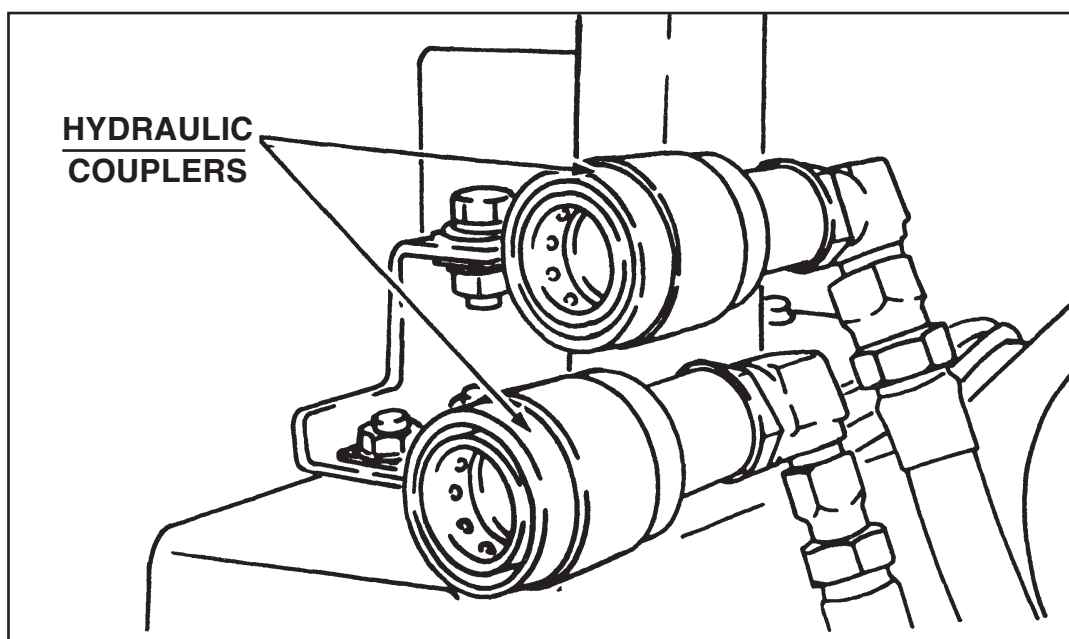

## REMOTE HYDRAULICS OPERATION (IF EQUIPPED)

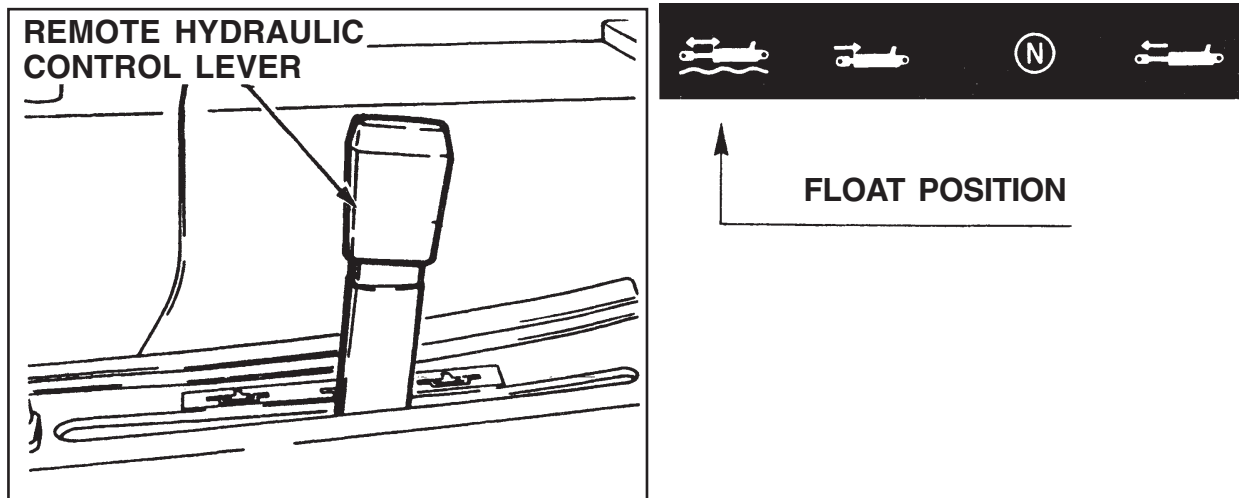

### Float Operation

To operate the remote hydraulics in a float condition, move the control lever fully forward to the detent position.

The lever will not return to neutral automatically when in the float position.

**IMPORTANT:** *If implement is attached that has single acting cylinders, always use the “FLOAT” position when lowering. Continual use of the “LOWER” position will cause overheating and possible damage to the hydraulic system.*

**NOTE:** *The control lever for the remote hydraulic valve must be in the neutral for the three point hitch to operate.*

**IMPORTANT:** *Never park a tractor with an implement in the raised position. Moving the control lever forward will lower the implement even though the engine is not running. If it is necessary to service the implement in the raised position, use jack stands to safely block the implement in place. Put the hydraulic flow control knob in the LOCK position.*

## HYDRAULIC BLOCK

A hydraulic block is located on the right side of the tractor. This block can provide an external hydraulic circuit for loader use or other applications. See your dealer.

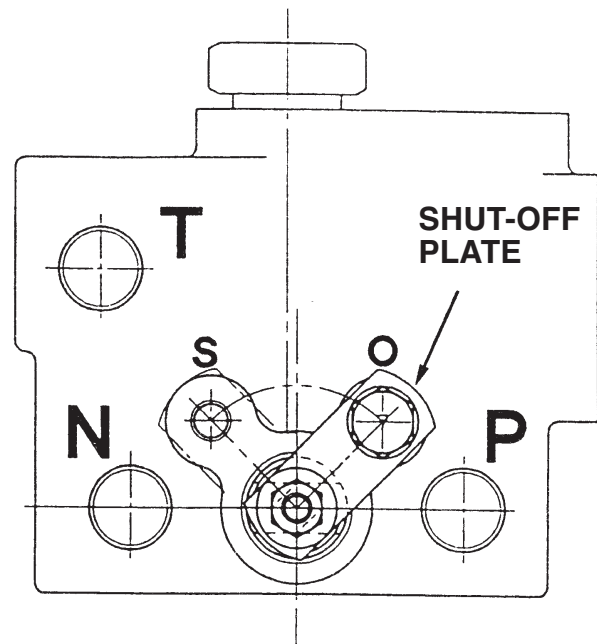
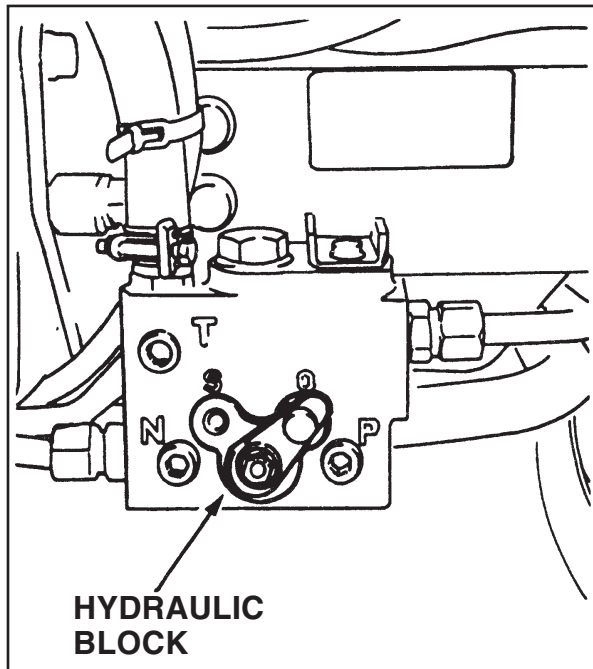

**IMPORTANT:** Never park a tractor with an implement in the raised position. Moving the control lever forward will lower the implement even though the engine is not running. If it is necessary to service the implement in the raised position, use jack stands to safely block the implement in place. Put the hydraulic flow control knob in the LOCK position.

**IMPORTANT:** Whenever the shut off plate is set at the "S" position, never plug the inlet and outlet of the Hydraulic block. Change the set position of shut-off plate to "O" position, if the remote attachment is not installed. Failure to do so will cause damage to the hydraulic system.

## Adding Fluid after Connecting Cylinders and Hoses

Operate the engine at a moderate idle speed. Set the stroke stop at the yoke end of the cylinder rod to provide maximum stroke. Then operate the cylinder in both directions about ten times, by moving the control lever up and down.

This will fill the cylinder and hoses with fluid and remove the air from the system. Fill the cylinder completely, stop the engine and check the fluid level with the transmission dipstick.

Add sufficient, clean specified fluid to bring the oil up to the proper level. See TRANSMISSION AND HYDRAULIC LUBRICATION in this manual.

**NOTE:** *If any of the hydraulic units are removed and replaced for any reason, check the oil level and add the specified fluid to the transmission to bring the oil up to the proper level.*



***When remote cylinders are connected to the hydraulic system, cycle the control lever about three times to remove air from the cylinder and hoses. With air in the system, raised equipment can drop accidentally and cause personal injury or machine damage.***

M133



***Hydraulic oil or diesel fuel leaking under pressure can penetrate the skin and cause infection or other injury.***

***To Prevent Personal Injury:***

***Relieve all pressure, before disconnecting fluid lines.***

***Before applying pressure, make sure all connections are tight and components are in good condition.***

***Never use your hand to check for suspected leaks under pressure.***

***Use a piece of cardboard or wood for this purpose.***

***If injured by leaking fluid, see your doctor immediately.***

M149A



***The implement should be lowered to the ground before uncoupling of the remote hydraulic hoses.***

M134



***Lower or block elevated implements and other attachments before servicing or when leaving the equipment.***

M132A



## TIRE AND RIM EQUIPMENT

### Tire Inflation Specifications

For normal tractor operation use the inflation pressure shown in the tire and wheel chart. The inflation pressure are based on cold inflation pressure recommendations by Tire and Rim Association Inc.

For maximum tractor performance always adjust the tire pressure, within the minimum/maximum range, to confirm with the actual load on the tires. Under normal conditions use the minimum pressure rating for general drawbar work. Use the higher pressure rating, up to the maximum, for heavy three point hitch mounted equipment, or heavy front end mounted equipment.

Example A shows the cross section of a tire inflated for maximum load but with a minimum load on the tire. The tire tread is not making full contact with the ground which will give poor performance.

Example B shows the cross section of a tire with the inflated pressure correctly adjusted to the toad on the tire. The tire tread is making full contact with the ground which will give maximum performance.

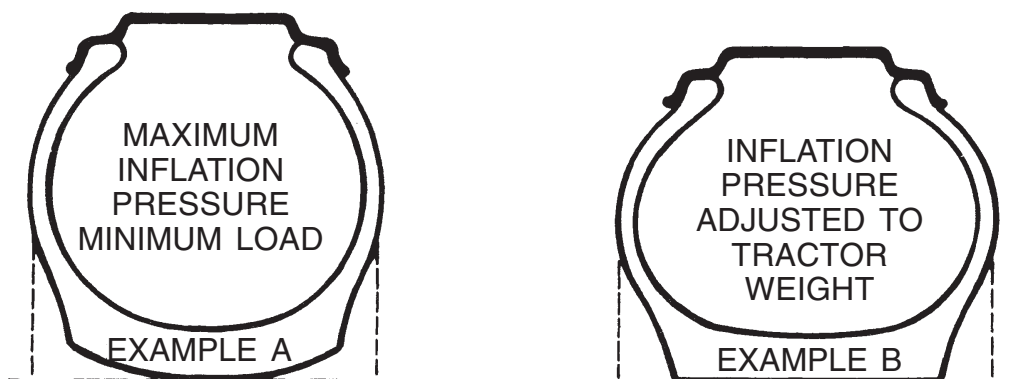

Tire pressure can also be adjusted as required to satisfy the following requirements.

- A. Severe Service. Tire pressure can be increased 28 kPa (4 PSI) more than the maximum pressure shown in the chart, for tires used in severe service. Severe service includes the furrow tire in regular plowing operations, the downhill tire in sidehill plowing and in other hillside operations.
- B. Tires with Liquid Ballast. Inflate the tires 14 kPa (2 PSI) more than the recommended pressure. This will compensate for aeration that occurs when the tires are in motion.

**IMPORTANT:** *During transportation on a railroad car or trailer, the tractor tires are often inflated to higher than normal operating pressures. Before using your tractor check the air pressure in the tires to make sure that the air pressure does not exceed the maximum pressures shown in the tire and wheel equipment chart.*



***A tire can explode during inflation and cause serious injury or death. Never increase air pressure beyond 35 PSI to seat the bead on the rim. Replace a tire if it has a defect. Replace a wheel rim which has cracks, wear or severe rust. Make sure that all the air is removed from a tire before removing the tire from the rim. Never use force on an inflated or partially inflated tire. Make sure the tire is correctly seated before inflating.***

M170

## Tire Load Capacity

The maximum load capacity, shown in the tire pressure and load capacity chart, is of the wheel with the tire inflated to the maximum pressure. Do not exceed the maximum load capacity of the tire.

### 2816

Position	Tire Size	Tire Type	Tire SLR (in.)	Tire Cap. @ 20 mph lb. @ psi	Rolling Circ. (in.)	Description
Rear	11.2x24	Ag Tire	20.1	1650 @ 18	130	4 ply, R-1
Front	7x16	Ag Tire	13.4	1100 @ 36	87	6 ply, R-1
Rear	15x19.5	Industrial Tire	17.9	4170 @ 30	117	6 ply, R-4
Front	27x8.50-15	Industrial Tire	12.3	1570 @ 40	80	6 ply, R-4
Rear	13.6x16	Turf Tire	17.5	1570 @ 14	115	4 ply, R-3
Front	25x8.50-14	Turf Tire	11.3	1060 @ 22	74	4 ply, R-3



## Check Air Pressure

**Tire Pressure Check Interval** ..... Every 50 hours of operation or weekly.

Check the condition of the tires and rims for wear or damage. Keep the tires inflated to the recommended pressures. See Tire and Wheel Specifications in this manual for recommended inflation pressures for each tire size.

For tires equipped with liquid ballast, check the air pressure as follows:

1. Use an air-water gauge. The valve must be at the bottom of the tire to get an accurate reading.
2. Use a standard air gauge as follows:
  - A. The valve must be at the top of the tire.
  - B. Measure the rim diameter.
  - C. Add 3.5 kPa (1/2 PSI) for each 305 mm (12 inches) of rim diameter to the standard gauge reading.

## Tire Inflation Procedure



***A tire can explode during inflation and cause serious injury or death. Never increase air pressure beyond 35 PSI to seat the bead on the rim. Replace a tire if it has a defect. Replace a wheel rim which has cracks, wear or severe rust. Make sure that all the air is removed from a tire before removing the tire from the rim. Never use force on an inflated or partially inflated tire. Make sure the tire is correctly seated before inflating.***

M170

DO NOT inflate a tire that has had a complete loss of air. If the tire has lost all air pressure, have a qualified tire mechanic service the tire.

To ADD air to a partly inflated tire, use the following procedure:

1. Use an air hose with a remote shutoff valve and a self-locking air chuck.
2. Stand behind the tread of the tire and make sure all persons are away from the side of the tire before you start to add air.
3. Inflate the tire to the recommended air pressure. DO NOT inflate the tire more than the recommended pressure.

**NOTE:** *Tires can be inflated 28 kPa (4 PSI) over maximum recommended in chart when tractor is used for heavy draft operation and ground compaction is not a problem.*

## WHEEL MOUNTING TORQUES

Front Wheel Disc to Axle Hub Bolts	118 to 132 Nm (87 to 98 lb ft)
Rear Wheel Disc to Axle Hub Bolts	118 to 132 Nm (87 to 98 lb ft)
Rear Wheel Rim to Wheel Disc Nuts	152 to 172 Nm (112 to 127 lb ft)

**IMPORTANT:** *Check the wheel bolts and nuts after the first 10 hours of operation and again after every 100 hours of operation. Also do this procedure any time the wheel or rim is removed.*

## FRONT WHEEL ADJUSTMENT

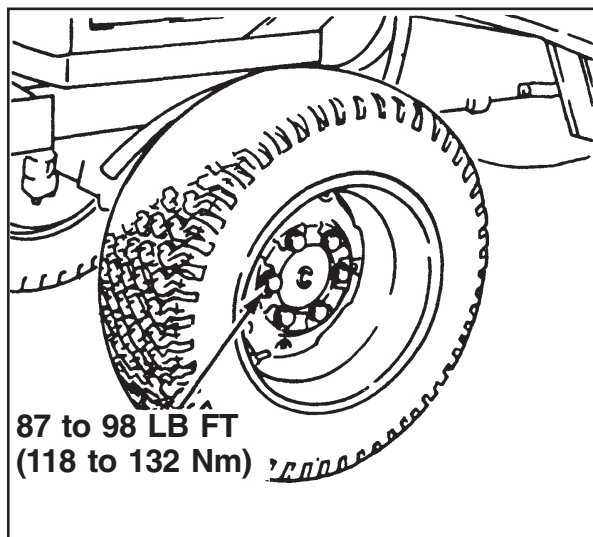

The front wheels are tightened with six bolts for MFD to the axle hubs.

Torques for wheel bolts and tie rod end nuts as follows:

BOLTS AND NUTS POSITIONS	TORQUE
Front wheel disc to axle hub bolts	118 to 132 Nm (87 to 98 LB FT)
Tie rod end nuts	59 to 88 Nm (43 to 65 LB FT)

Check the bolts to keep them tight at the intervals recommended in the Service Chart in this manual.

**NOTE:** *The front wheel of tires must always be assembled with the valve side out.*

## Toe-in Adjustment

TO CHECK THE TOE-IN, USE THE FOLLOWING PROCEDURE:

1. Put the tractor on level ground and the wheels in the straight ahead position.
2. Place chalk marks at points A on the centerlines of both front tires at the same height as the centerline of the hub cap.
3. Measure the distance ( $L_1$ ) between the chalk marks at points A.
4. Move the tractor forward a distance equal to one-half revolution of the front wheels.
5. The chalk marks will now be at points B. Measure the distance ( $L_2$ ) between the chalk marks at points B.
6. The figure of  $L_2$  minus  $L_1$  is the toe-in. Make sure the toe-in is adjusted properly. If not, adjust the toe-in.

FRONT AXLE TYPE	TOE-IN ( $L_2 - L_1$ )
MFD	0 to 0.20 INCH (0 to 5 mm)

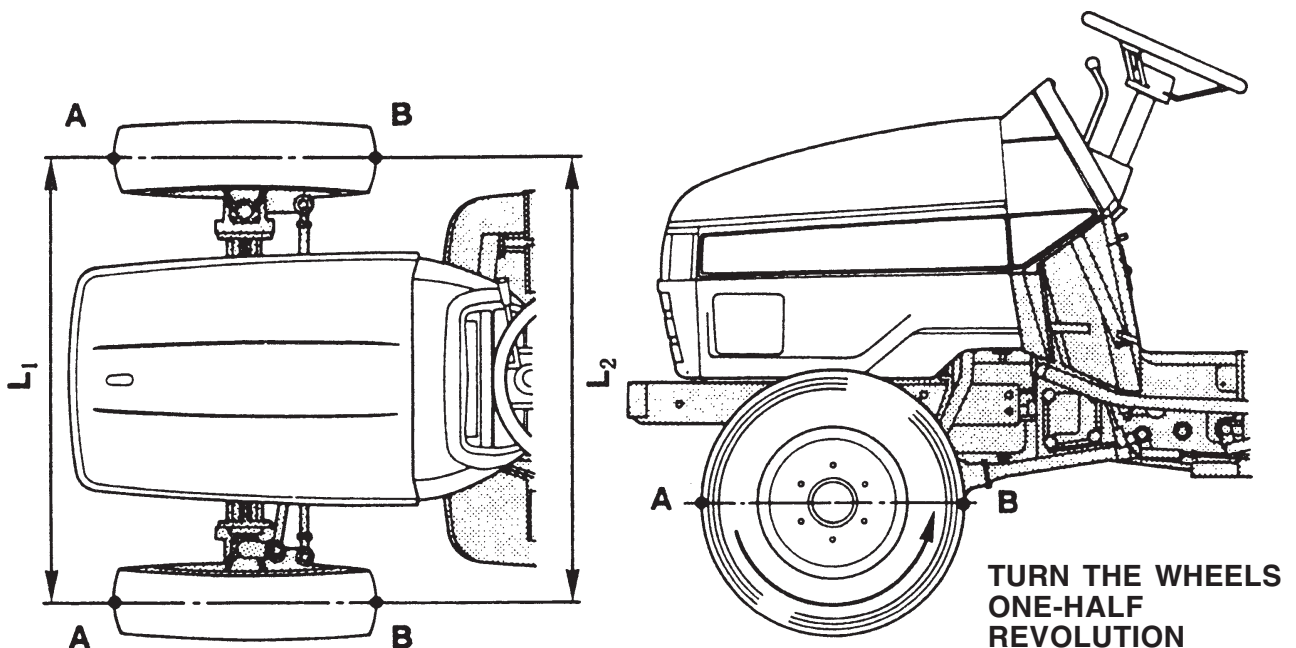

TO ADJUST THE TOE-IN, USE THE FOLLOWING PROCEDURE:

1. Loosen the lock nuts at both turnbuckle ends to allow the tie rod turnbuckle to turn freely.
2. Turn the turnbuckle to shorten or lengthen the tie rod length.
3. Make sure the correct toe-in is obtained. If not, adjust the tie rod length again.
4. After adjusting the toe-in, tighten both lock nuts to a torque of 59 to 88 Nm (43 to 65 lb ft).

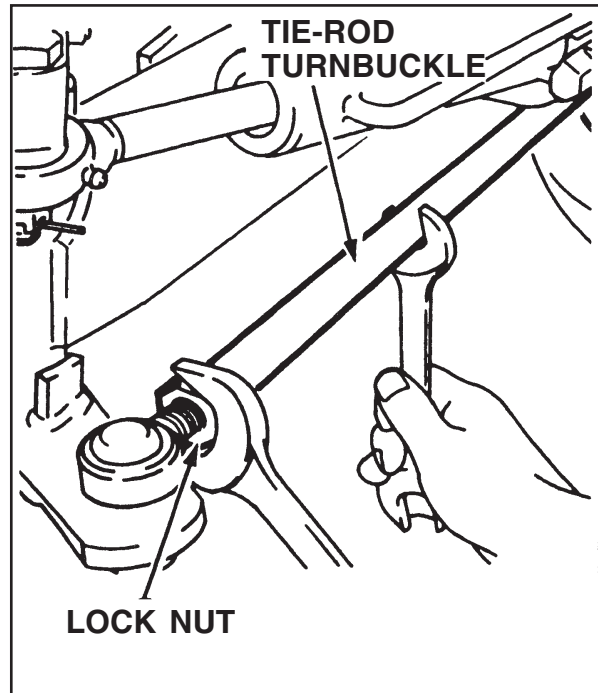

**NOTE:** 1. *The RH side Tie-Rod has a LH thread and the LH side Tie-Rod has a RH thread. When loosening or tightening the lock-nut, or adjusting the Tie-Rod, make sure that...*

(1) *RH side Tie-Rod*

- Unlock : Turn the lock-nut clockwise*
- Lock : Turn the lock-nut counterclockwise*
- Lengthen : Turn the Tie-Rod counterclockwise*
- Shorten : Turn the Tie-Rod clockwise*

(2) *LH side Tie-Rod*

- Unlock : Turn the lock-nut counterclockwise*
- Lock : Turn the lock-nut clockwise*
- Lengthen : Turn the Tie-Rod clockwise*
- Shorten : Turn the Tie-Rod counterclockwise*

2. *One turn of the Tie-Rod makes about 12 mm (a half inch) difference of the Toe-in.*

## TIRE SIZE COMBINATIONS – MFD

Your MFD Tractor must use front and rear tire combinations that are correctly matched. The use of recommended tire combinations will give maximum tractor performance, extended tire life and reduced wear on drive train components.

**IMPORTANT:** *The tire size combinations shown below are specified to provide matched ground speeds of the front and rear tires. Mixing worn and new tires or tires of different diameters or loaded radii can give incorrect ground speed match. When replacing tires, consult your Dealer.*

### MODEL NUMBER 2816

TIRE	SIZE	STYLE
Front	7-16	R1*
Rear	11.2-24	R1*
Front	25X8.50-14	R3*
Rear	13.6-16	R3*
Front	27X8.50-15	R4*
Rear	15-19.5	R4*

\*R-1 – Agricultural tread for general farming

\*R-3 – Turf tire

\*R-4 – Industrial tire

## TRACTOR BALLAST

Ballast for your tractor includes front end weights, rear wheel weights and liquid ballast in the rear tires. Front end weights improve the steering characteristic when heavy hitch loads cause a movement of tractor weight from the front to the rear wheels. Rear wheel weights and adding liquid to the rear tires increase traction by putting weight on the driving wheels.

**IMPORTANT:** *The Maximum operating weight of tractor should not exceed the following values. The operating weight of tractor includes the weight of tractor, operator, ballast weight and implement.*

Front Axle .....	970 kg
Rear Axle .....	1350 kg
Total.....	2200 kg

### Front End Weights (OPTIONAL)

Front end weights can be mounted on the front end bracket of the tractor with locking bolts and nuts. The weights, locking bolts and nuts are available from your Dealer. A maximum of six weights at 22 kg (49 lbs) each can be installed, depending on implement application and soil conditions.

Use front end weights as needed to provide effective steering control and front end stability and to achieve maximum operating efficiency and tractor field performance.

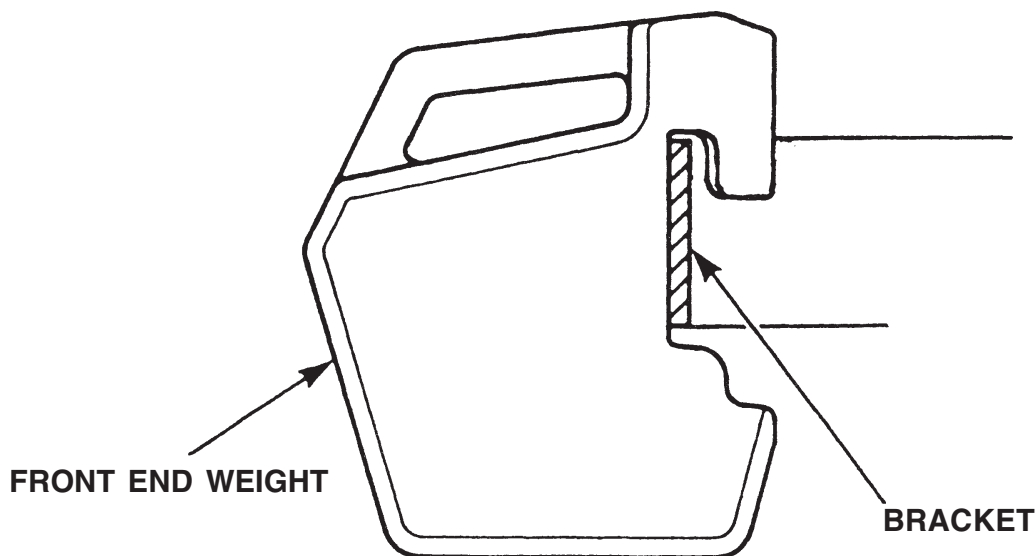



**NOTE:** When you have too much ballast installed on the tractor, you will see the clear shape of the tire tread in the ground which is an indication of no slippage. With too little ballast, the tire tread marks will not show because of the tire slippage.

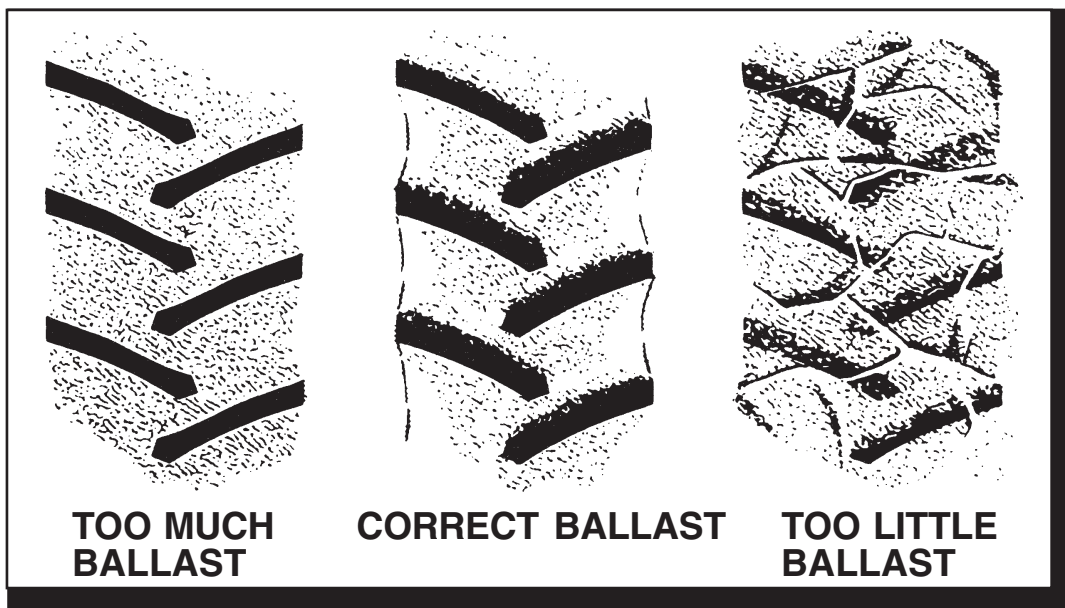

## HOOD

To do maintenance work on the engine lubrication system, cooling system, fuel system and air induction system, you must lift the tractor hood.

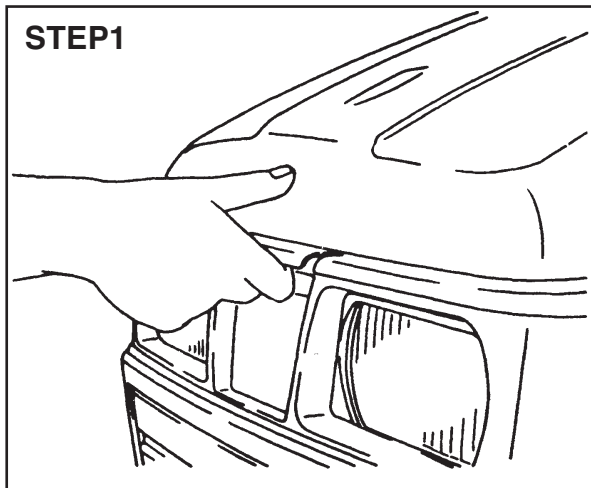

Pull the hood latch to release the hood.

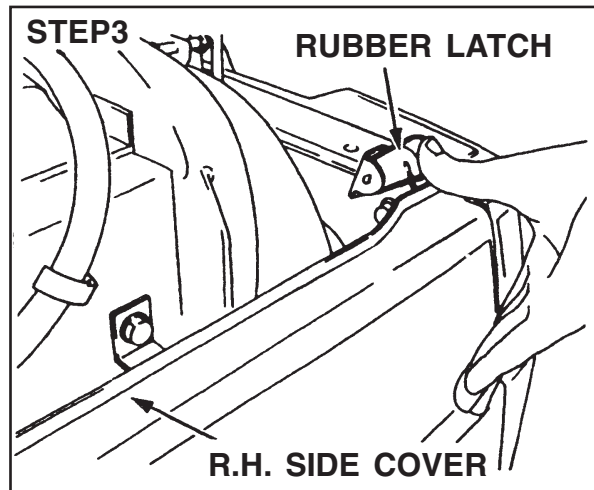

Unlock the rubber latches on top of each side cover to release the side cover.

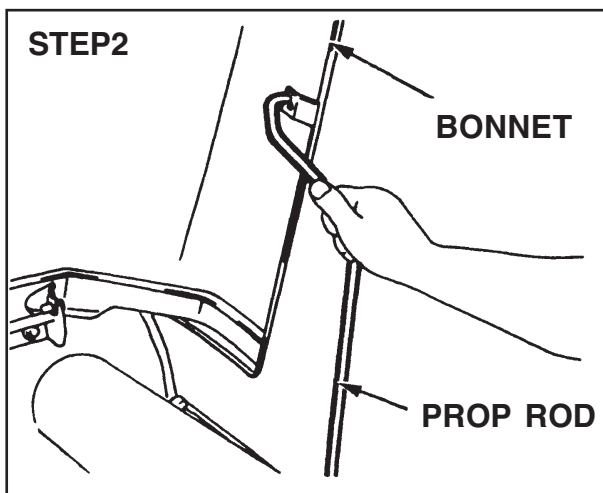

Lift the hood, and connect the Support Rod.

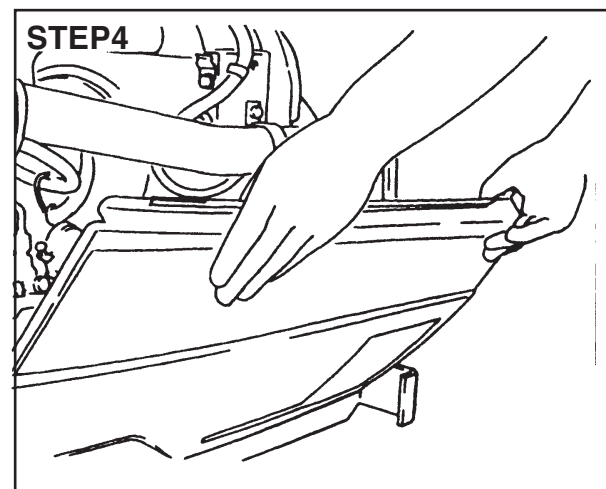

Remove both side covers.

## Lubrication Table

Application	Kind of Oil	API Classification	Ambient Temperature	Grade (SAE No.)		Description	Recommendation Oil Brand
				Single	Multi		
Engine	Engine Oil	CD	-10° C (14° F)	5W	5W-20	Use high Grade Diesel Oil	(For 15 W 40 oil) Citgo-Citgard 500 15W40 Exxon-XD3Extra 15W40 Chevron-Delo 400 15W40 Mobil-Devlac 1300 15W40 Shell-Rotella T 15W40 Texaco-Ursa Super Plus 15W40
			-20-0° C (-4-32° F)	10W*	10W-30 15W-40	Engine Oil	
			-10-10° C (14-50° F)	20W			
			0-20° C (32-68° F)	20	Use high Grade Diesel Oil		
			10-30° C (50-86° F)	30*			
			30° C (86° F)	40		20W-40	
Transmission oil, front diff. oil	Hydraulic Transmission Fluid		Hydraulic Transmission Fluid				Citgo-Transgard Tractor Hydraulic Fluids Exxon-Torque Fluid 58 Chevron-Chevron 1000 THF Mobil-Mobil Fluid 424 Shell-Donax TD Texaco-TDH oil Special
Grease Nipple	Grease	-					Use good grade grease, designed for pin and bushings on agricultural equipment. Lithium or aluminium complex type grease with high viscosity base oil, takiness and molybdenum disulfide are suitable. Grease approved for the NL GI certification mark GC-LB are recommended.

## SERVICE HOUR INTERVAL

Service your tractor at the intervals and locations given on the Lubrication and Service Chart. When you service your tractor, use only high quality lubricants.

### Engine Hourmeter

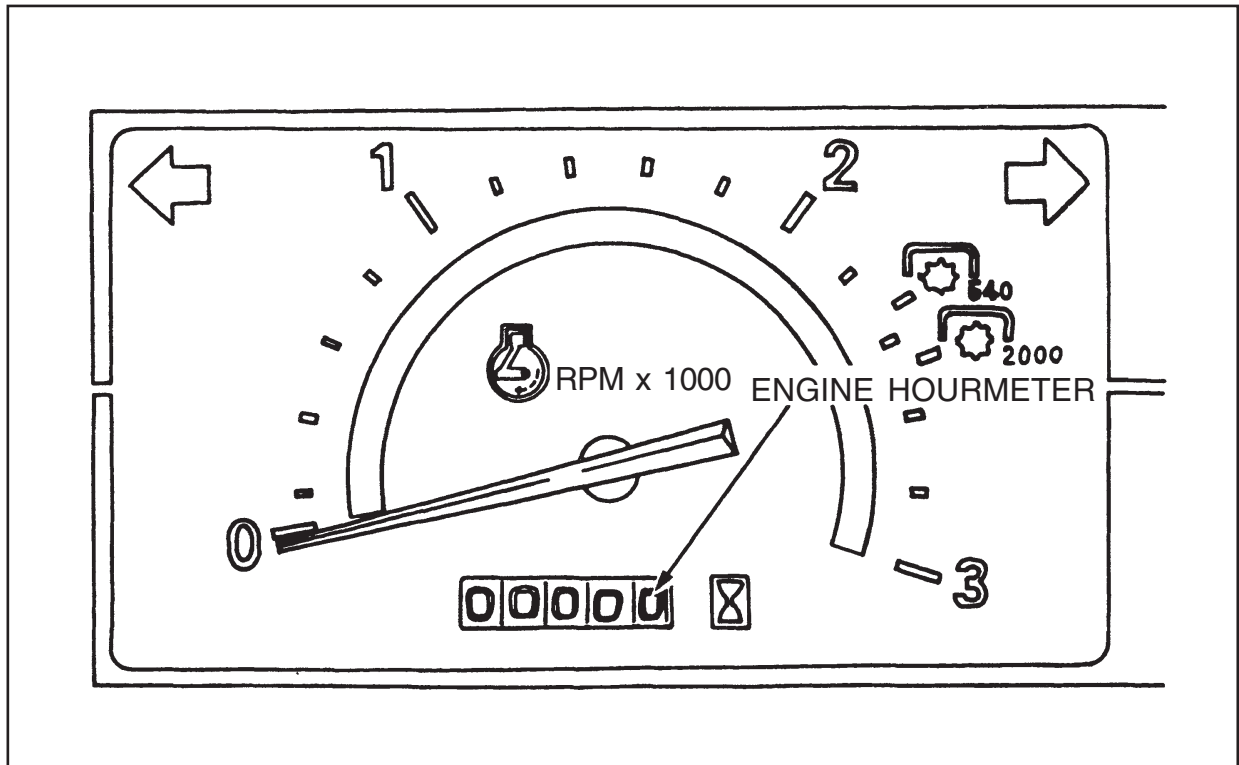

The engine hourmeter shows the amount of actual hours of the tractor has operated at an average RPM. The first number to the right displays tenths of an hour and is a black number on a white surface. The remaining numbers are white on black. Use the hourmeter along with the Lubrication Chart to service your tractor at the correct time periods.

## Service After First 50 Hours

1. Engine Oil  
Drain all the oil from the crankcase while the engine is warm and refill with new oil to the upper Notch (full) on the engine oil dipstick. See Engine Oil Change in this manual.
2. Engine Oil Filter  
Replace the engine oil filter. See Engine Oil Filter in this manual.
3. Transmission & Hydraulic System
  - (1) Transmission Oil  
Check the level of the transmission oil. Add the specified fluid as needed to maintain proper level. See Transmission Oil Level in this manual.
  - (2) Hydrostatic filter  
Replace the filter with a new one. See Hydrostatic Filter in this manual.
  - (3) Hydraulic filter  
Replace filter with a new one. See Hydraulic filter in this manual.
4. Front Axle Lubricant (MFD)  
Change the oil. See FRONT AXLE LUBRICATION (MFD) in this manual.
5. Radiator Core  
Inspect the radiator core and clean if necessary. See COOLING SYSTEM in this manual.
6. Hoses and Connections between Air Cleaner and Manifold.  
Inspect for loose fit or leakage. See AIR INDUCTION SYSTEM in this manual.
7. Water Pump, Fan and Alternator Belt Tension  
Check the belt for tension, replace if necessary. See Fan Belt Adjustment in this manual.

## SYSTEM CAPACITIES

SYSTEM	U.S. MEASURE	METRIC MEASURE	IMPERIAL MEASURE
Engine Oil no filter change with filter change	3.9 QTS 4.4 QTS	3.7 Litres 4.2 Litres	3.2 QTS 3.7 QTS
Fuel tank	7.9 Gallons	30 Litres	6.6 Gallons
Coolant engine and radiator coolant bottle	7.1 QTS 0.4 QTS	6.7 Litres 0.4 Litres	5.9 QTS 0.4 QTS
Transmission Oil hydrostatic drive	23.2 QTS	22 Litres	19.4 QTS
Front Axle MFD	4.2 QTS	4.0 Litres	3.5 QTS

SERVICE POINT	NO. OF POINTS	FREQUENCY IN HOURS				
		CLEAN	CHANGE	CHECK	GREASE	DRAIN
Engine Oil Level	1			10		
Front Axle Tie Rod	2				10	
Front Axle Pivot Pin	1				10	
Power Steering Cylinder End					10	
Brake Pedal Boss	2				10	
Transmission Oil Level	1			10		
Radiator Coolant Level	1			10		
Fuel Filter Cup	1	10		10		
Air Cleaner	1	10		10		
Fan Belt Tension	1			10		
Grill and Radiator Area	1	50		50		
Tire Pressure	4			50		
Fuel Tank Water Drain Plug	1					50
Engine Oil	1		100			
Wheel Retaining Bolts and Nuts				100		
Engine Oil Filter	1		200			
Transmission Oil	1		200			
Hydrostatic Filter (Hydrostatic Drive)	1		200			
Hydraulic Filter	1		200			
MFD-Front Axle Lubricant	1		200			
Clutch Pedal	1			200		
Brake Pedal	2			200		
Air Induction System	1			200		
Engine Valve Clearance (See Note 1)	b			200		
ROPS Equipment				200		
Cooling System		Y	Y			Y
Air Cleaner Filter Element (See Note 2)	1		AY			
All Linkage Pivot Points (See Note 3)	8	AY				
Threads of 3-Point Hitch Links	2				AY	
Fuel Filter	1		AY			
Hydraulic System				AY		
Battery Terminals		AY		AY		

MARK Y: Yearly or 1000 Hours, Whichever occur first.

AY: Yearly or as needed.

Note 1: Consult your Dealer.

Note 2: Replace element after 10 cleanings or yearly.

Note 3: Apply Gear Oil.



Fluid Levels and Filters

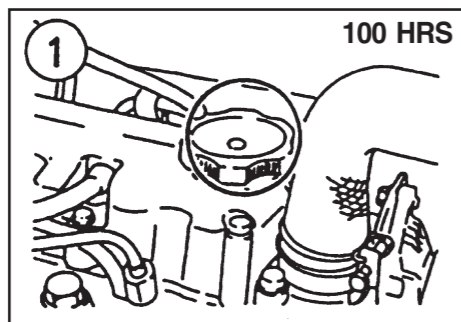

Engine Oil – Change

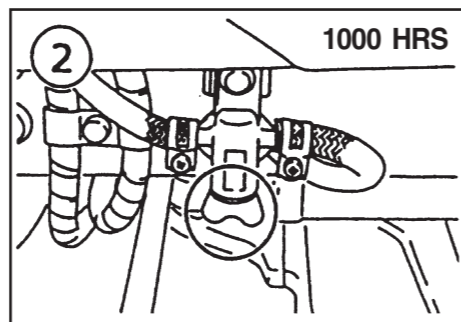

Radiator and Coolant – Drain, Flush and Fill

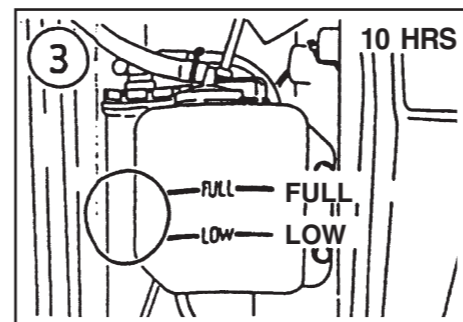

Coolant Recovery Reservoir – Check

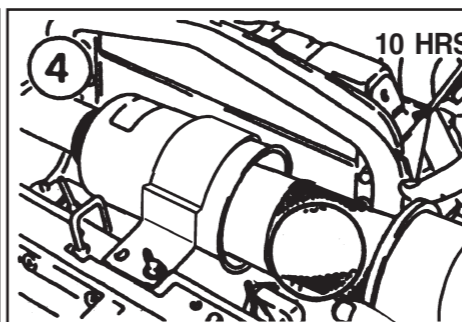

Air Cleaner – Clean

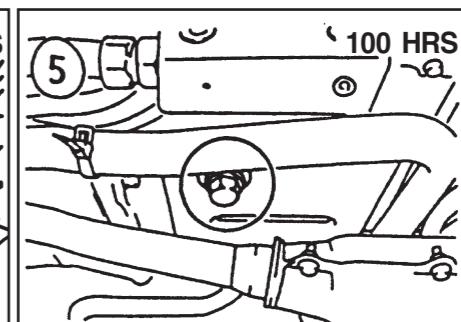

Engine Oil – Drain

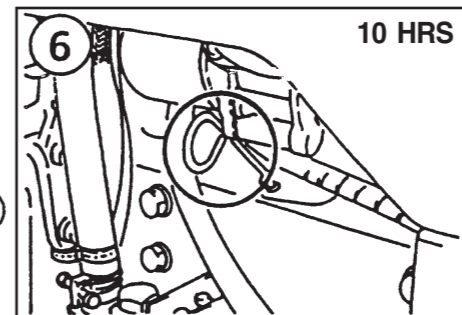
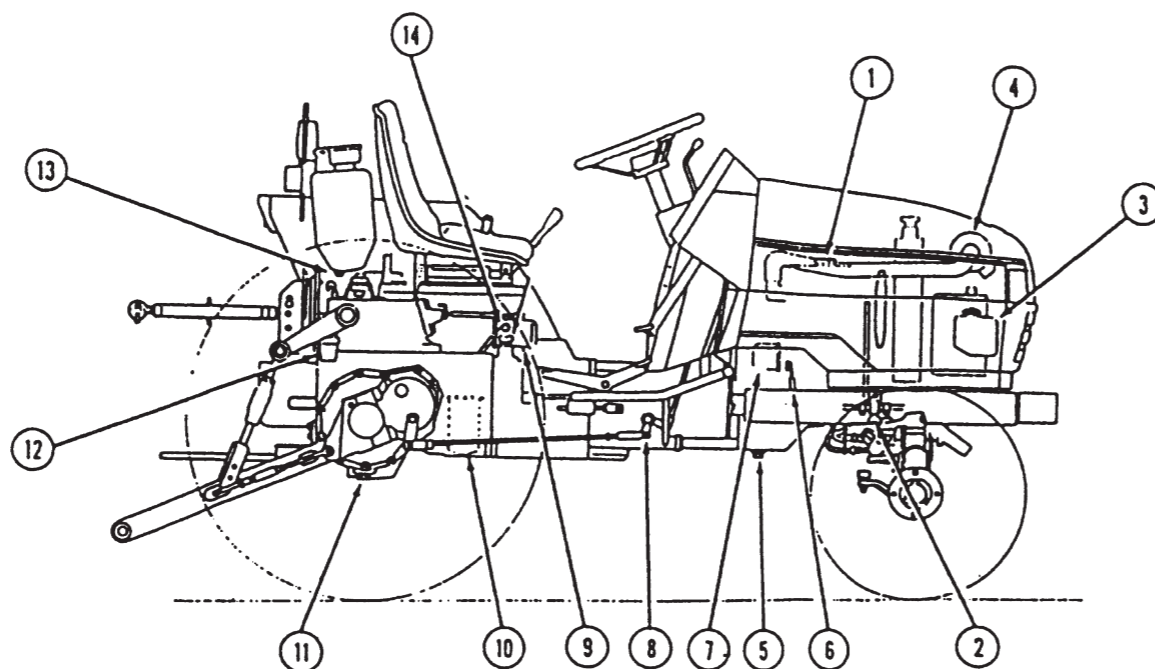

Engine Oil – Check

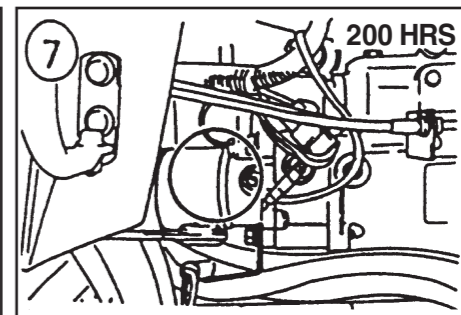

Engine Oil Filter – Change

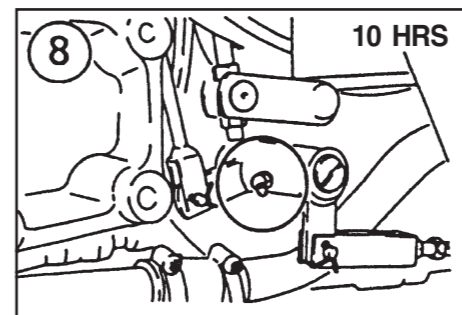

Brake Pedal – Grease

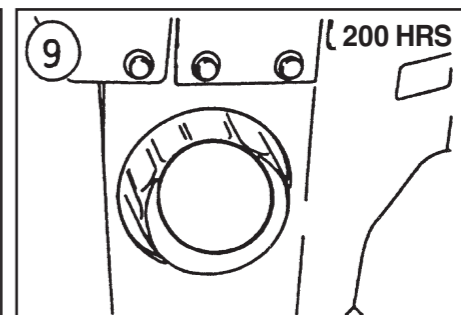

Hydrostatic Filter – Change

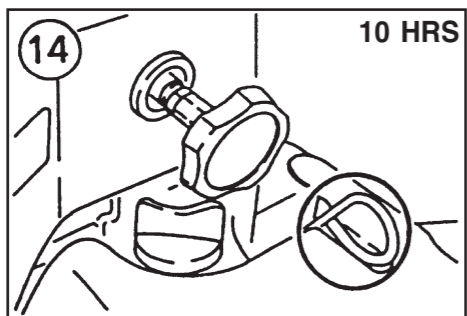

Transmission Oil – Check (Hydrostatic Drive)

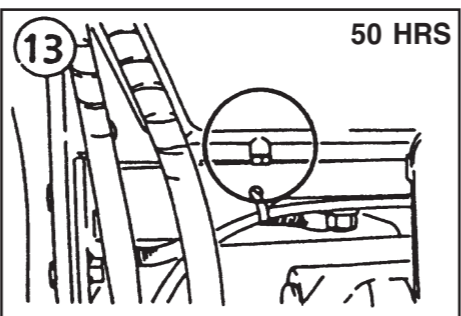

Fuel – Drain

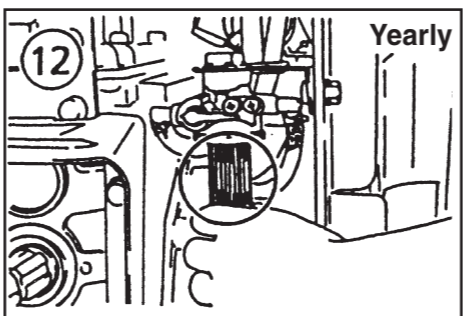

Fuel Filter – Change

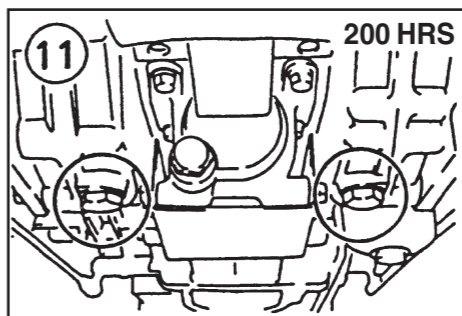

Transmission Oil – Change

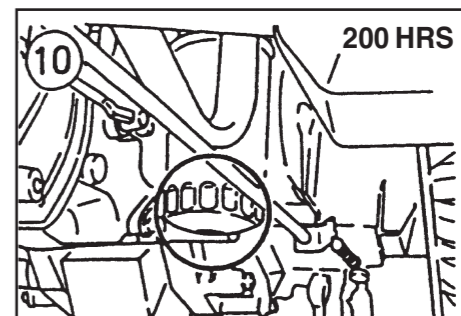

Hydraulic Filter – Change

FRONT AXLE

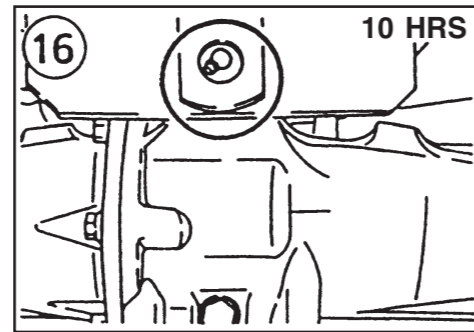

Front Axle Pivot Pin – Grease

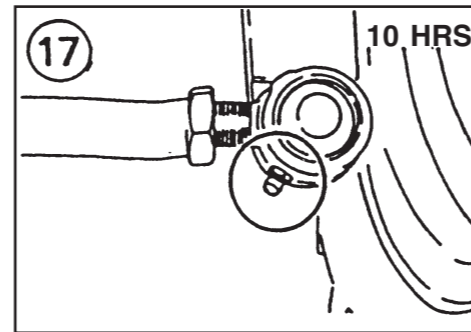

Tie Rod End – Grease

USE NLGI No.2 MULTIPURPOSE LITHIUM EP GREASE.

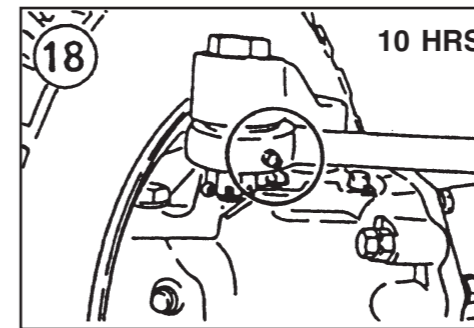

Power Steering Piston End – Grease

MFD

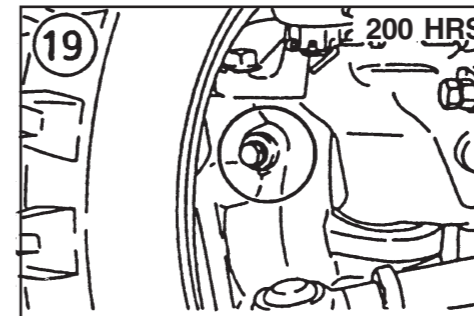
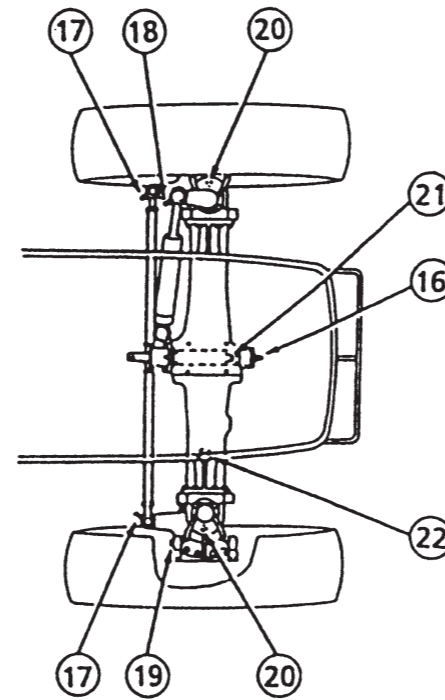

MFD Lubricant – Check

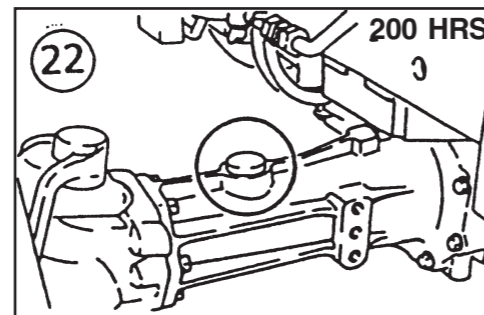

MFD Lubricant – Change

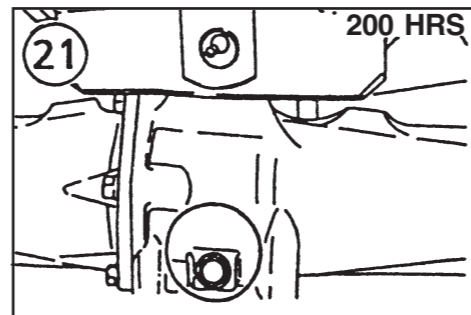

MFD Lubricant – Drain

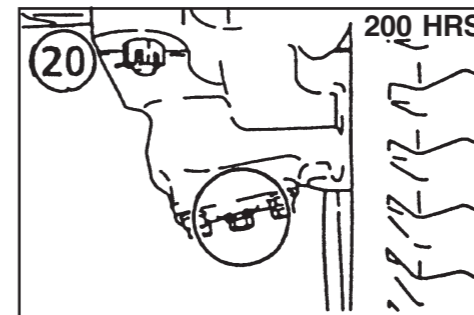

MFD Lubricant – Drain

## ENGINE LUBRICATION

### Service Specifications

Oil Level Check Interval .....	Daily
Oil Change Interval .....	Every 100 hours (See NOTE)
Oil Type .....	See Lubrication Table in this manual.
Oil Capacity – Without Filter Change .....	3.7 Litres (3.9 QT)
With Filter Change .....	4.2 Litres (4.4 QT)

**NOTE:** Change the engine oil after the first 50 hours of operation and then use the regular change interval. Change the engine oil more frequently when the operating conditions are severe, such as, operating under heavy load, starting and stopping with frequency, or operating in very high or very low ambient temperatures.

### Engine Oil Level

To check the engine oil level, put the tractor on level ground and stop the engine. Pull the dipstick out, wipe the dipstick with a dry cloth and install the dipstick to check the oil level. If the oil level is below the A(Add) mark, add oil to raise the oil level to the F(Full) mark.

Do not raise the oil level above the F(Full) mark.

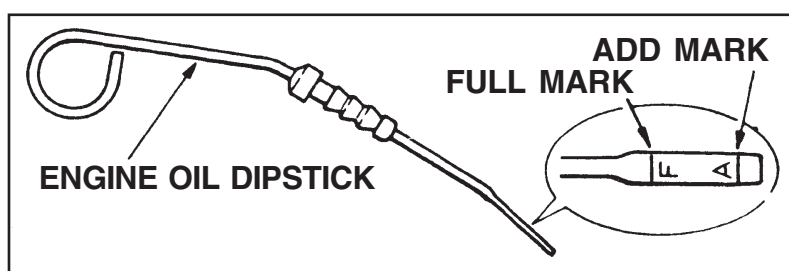
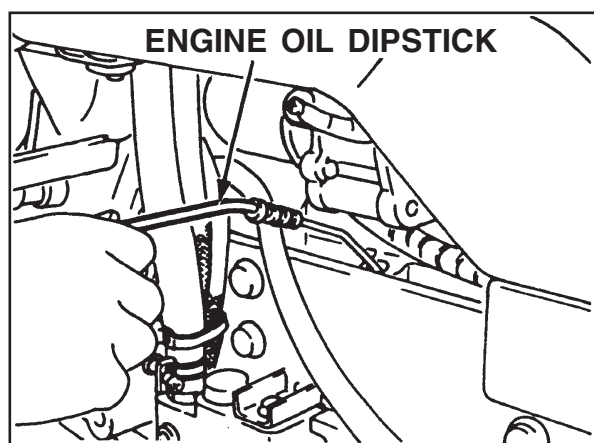

**IMPORTANT:** The level should be checked before starting or 5 minutes after the engine has been shut off.

## Engine Oil Change

To change the engine oil, put the tractor on level ground and stop the engine. Change the engine oil as follows:

**NOTE:** *For best results change the oil while the engine is still warm.*

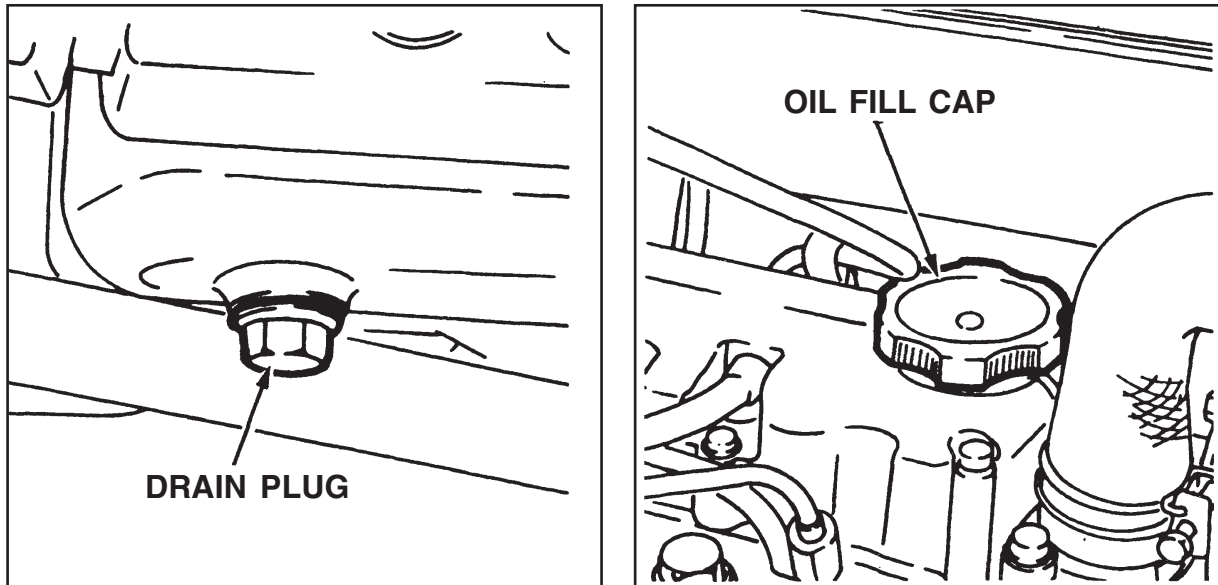

1. Remove the oil pan drain plug and drain the oil from the engine.
2. See Engine Oil Filter in this manual, if the filter is to be changed.
3. Install the drain plug in the oil pan. Tighten the plug to a torque of 50 to 60 Nm (36 to 43 lb ft).
4. Put the correct type and amount of new oil into the engine. See Engine Oil Selection in this manual for recommended oil type.

**IMPORTANT:** *Do not use the oil level dipstick as a guide when you fill the engine crankcase with oil. Always measure the amount of oil you install.*

5. Start the engine. Operate the engine for five minutes at 1200 rpm. Check for oil leaks at the filter base and drain plug.
6. Stop the engine. Wait approximately five minutes for the oil to return to the oil pan. Check the oil level on the dipstick and add oil if needed.

## Engine Oil Filter

Change Interval ..... Every 200 hours (See NOTE)

**NOTE:** *Change the engine oil filter after the first 50 hours of operation and then use the regular change interval.*

**IMPORTANT:** *Change the oil filter at the recommended time interval. Your Dealer has approved genuine filters. Do not use other type filters.*

Change the engine oil filter as follows:

1. Drain the oil from the engine. See Engine Oil Change in this manual.
2. Turn the oil filter counterclockwise to remove. Use a filter wrench, if necessary.
3. Apply clean oil to the O-ring on the new filter.
4. Install the filter. Turn the filter until the O-ring comes in contact with the case surface. Tighten the filter an additional  $2/3$  turn by hand.

**IMPORTANT:** *DO NOT use a filter wrench to install the oil filter. When the filter is too tight, you can cause damage to the O-ring and filter.*

5. Put new oil in the engine. See Engine Oil change in this manual.

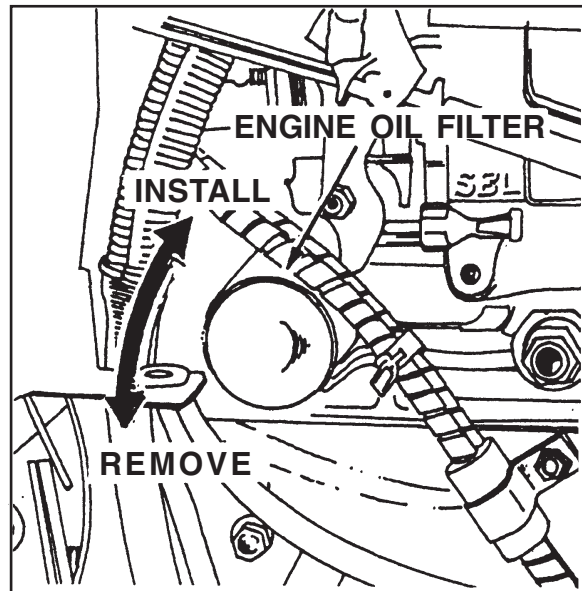



## COOLING SYSTEM

### Service Specifications

Coolant Change Interval ..... Every 1000 hours or once each year whichever occurs first

#### Capacity of System

Engine and Radiator ..... 6.7 Litres (7.1 QTS)  
Coolant Bottle ..... 0.4 Litres (0.4 QTS)

Thermostat ..... 82°C to 95°C (180°F to 203°F)

Radiator Cap Pressure ..... 88.2 kPa (12.8 PSI)

Daily before starting the engine, check the coolant level of the coolant reserve bottle. The coolant level should be between the “FULL” and “LOW” lines when the engine is cool.

### Pressure Cooling System



**Check and service cooling system according to maintenance instructions. Hot coolant can spray out if radiator cap is removed while system is hot. To remove radiator cap, let system cool, turn to first notch, then wait until all pressure is released. Scalding can result from fast removal of radiator cap.**

M305

1. The pressure cap on a pressure cooling system has a control valve that operates as a SAFETY RELIEF VALVE to keep the pressure within the system operating range. Operating the engine without a pressure cap or with a pressure cap that has a control valve that is not set to operate at the correct pressure, can cause damage.

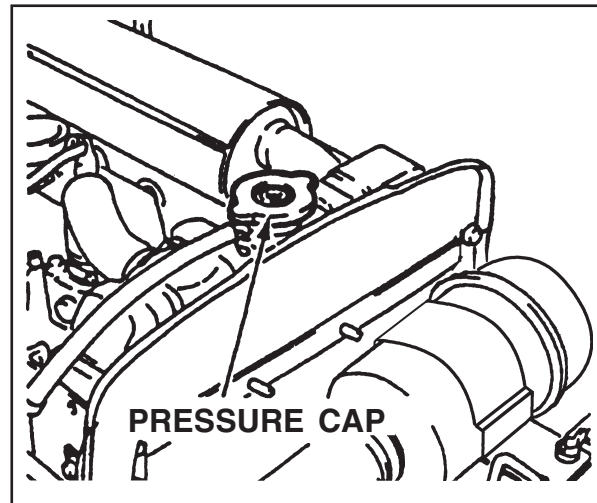

2. A pressure cooling system decreases the loss of coolant caused by evaporation or boiling. The system must have good seals at the radiator cap, hoses and hose connections. It is important that you stop ALL LEAKS OF ANY SIZE as soon as the leaks are found. A small leak can become a large flow when pressure is increased in the cooling system. While the tractor is in operation, a weak hose can break and cause injury or damage. Check all hoses and hose connections with frequency. KEEP HOSES, HOSE CONNECTIONS AND PRESSURE CAP IN GOOD CONDITION.

## Coolant Solutions

Your tractor cooling system is equipped with an ethylene glycol coolant solution that has a high boiling point.

**IMPORTANT:** *Change the coolant solution at the change interval recommended in this manual (See Lubrication and service Chart). The heat generated by the diesel engine causes a natural change in the inhibitors in the coolant which results in loss of corrosion protection. The loss of the inhibitors may cause water pump cavitation and cylinder block erosion.*

Install only ethylene glycol coolant solution in the cooling system. Use a good quality, high boiling point, ethylene glycol that does not have any additives to stop leaks. Do not install any rust inhibitors that are not approved. It is possible that the rust inhibitors and ethylene glycol will not mix and work against each other to decrease corrosion protection, form deposits in the cooling system and cause damage to the cooling system and the radiator.

Do not use a low boiling point, alcohol type coolant solution. The boiling point of alcohol is below the tractor minimum operating temperature, loss of coolant due to evaporation will result.

**IMPORTANT:** *Always have a minimum of 50 percent ethylene glycol coolant in the cooling system at all times and at all ambient temperature ranges. Do not install more than 50 percent ethylene glycol in the cooling system unless the ambient air temperature will be less than  $-37^{\circ}\text{C}$  ( $-34^{\circ}\text{F}$ ). More than 50 percent ethylene glycol decreases heat transfer and will cause the engine surface temperature to be higher than normal.*



## Cleaning The Cooling System

**IMPORTANT:** NEVER PUT COOLANT IN A HOT ENGINE: THE ENGINE BLOCK OR CYLINDER HEADS CAN GET CRACKS BECAUSE OF THE DIFFERENCE IN TEMPERATURE BETWEEN THE METAL AND THE COOLANT.

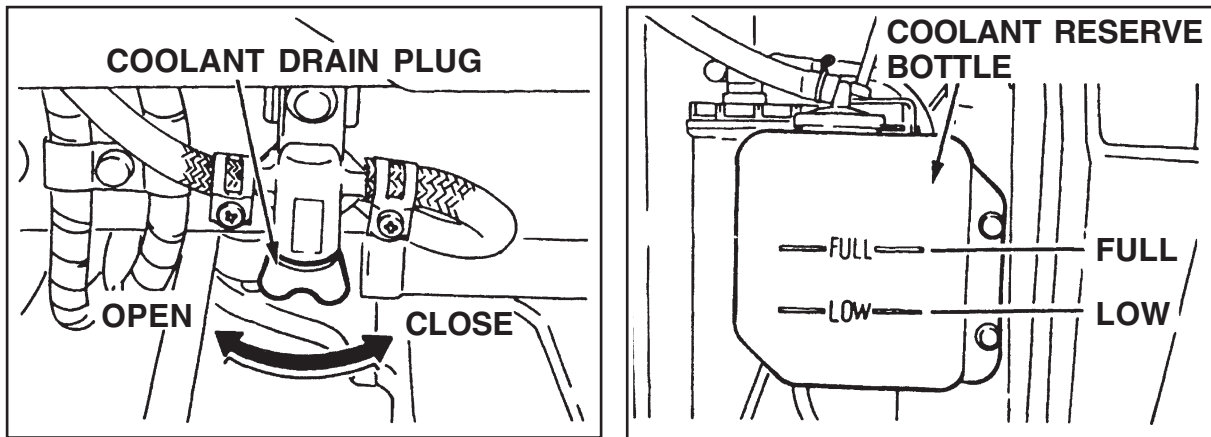

Clean the cooling system each time the coolant is changed. See the Lubrication and Service Chart in this manual for recommended change intervals. Clean the system as follows:

1. Remove the drain plug to drain the coolant. Close the plug after the system is empty.
2. Install a good type of radiator cleaner and fill the system with clean water. Follow the instructions given with the radiator cleaner.
3. Remove the radiator cleaner solution. Flush the system with clean water.
4. Fill the cooling system with the coolant solution specified in this manual. Install coolant system treatment (if required). See Coolant Solutions in this manual for more information.
5. Check the hoses, radiator, pump and water manifold for leaks.

**IMPORTANT:** Never drain the coolant when the engine is hot.

**NOTE:** After the cooling system is completely filled, run the engine for approximately five minutes to remove all air from the system. Check the coolant level and add coolant if needed.

## FUEL SYSTEM

### Service Specifications

Fuel Filter Cup Service Interval .....	Every 10 Hours
Fuel Filter Element Change .....	Replace when loss of power or misfiring occurs

This type filter cannot be cleaned. Change the filter when the engine is misfiring or a loss of power is evident. It is necessary to remove the air from the system after each replacement.

Only a filter recommended by your Dealer should be used, to be sure that it is both effective and capable of withstanding the required suction or pressure without damage to the filter element.

Fill the fuel tank at the end of each day to reduce condensation.

**NOTE:** *Do not fill the fuel tank to its full capacity. Space is required for vapor expansion in the event of a temperature change. A tank filled to capacity may overflow if exposed to a rise in temperature or direct sunlight.*

### Water Removal from the Filter Cup

Before starting each day's work, check for water or sediment in the filter cup. If water or sediment is in the cup, close the fuel shut-off valve, remove filter cup, clean and reinstall.

**NOTE:** *Be careful not to allow dirt, water and other foreign materials to get into the filter when cleaning the cup.*

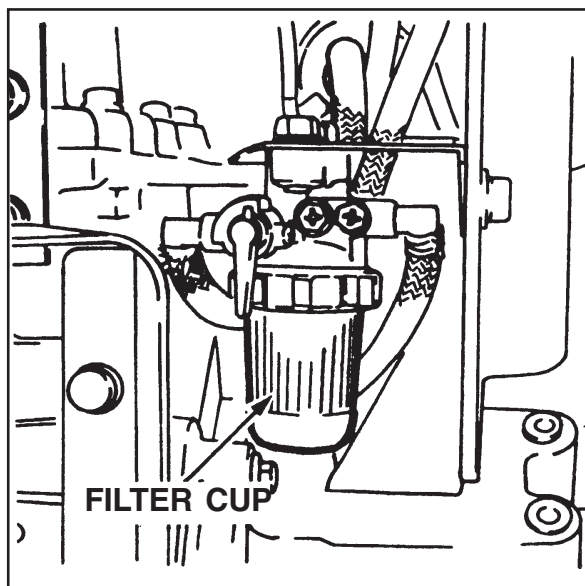

## Diesel Fuel Specifications

Use a good grade of Number Two Diesel Fuel in your Diesel Engine. Do not use other types or grades of fuel. The use of other fuels will result in loss of engine power and high fuel consumption.

**NOTE:** *When the temperature is very cold, the use of a mixture of Number one and Number Two Diesel Fuel is permitted for a short period of time. See your fuel Dealer for winter fuel requirements in your area.*

## Fuel Filter Element Replacement

To replace the filter element, use following procedure:

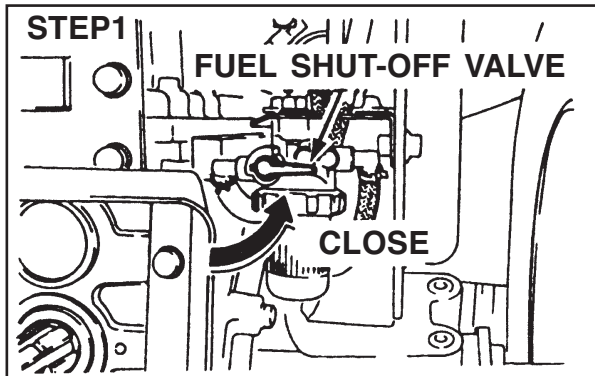

Close the fuel shut-off valve.

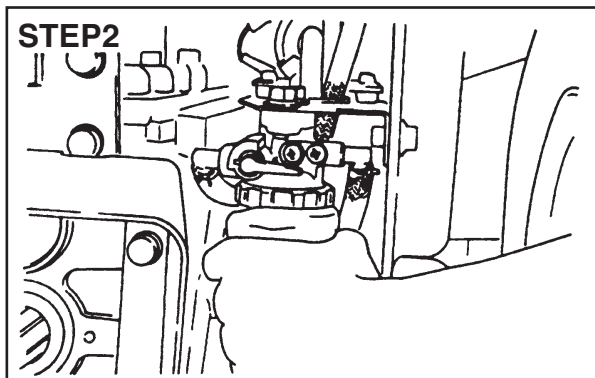

Clean the outside of the filter body and cup to prevent dirt or foreign materials from entering the system.

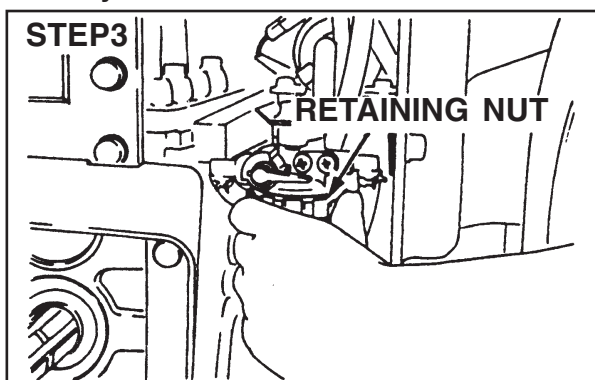

Loosen the filter cup retaining nut. Remove filter cup. Remove old filter element and clean inside of filter cup.

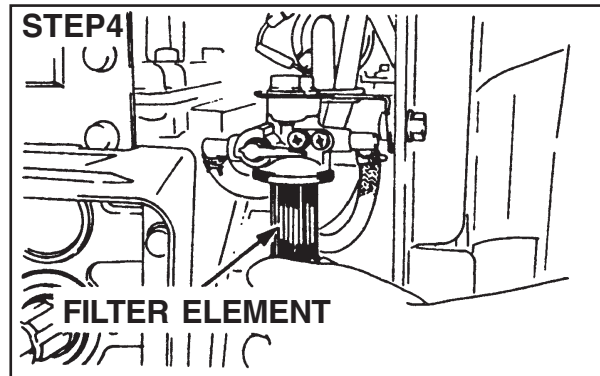

Install new filter element. Assemble filter cup and retaining nut to filter body.

**NOTE:** *Be sure O-ring is in place on the filter body and filter cup.*

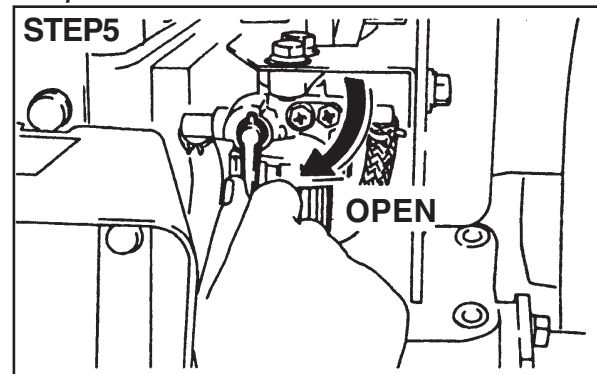

Open the fuel shut-off valve and vent the fuel system. See Fuel System Air removal in this manual.

### STEP 6

Clean fuel off the engine. Start the engine to check for fuel leaks around the filter, lines and fittings.

**NOTE:** *If the engine does not have power with a full load after you have done the filter service and removed the air from the system, see your Dealer to find and correct the cause.*

## Fuel System Air Removal

AIR MUST BE REMOVED FROM THE FUEL SYSTEM.  
AIR CAN ENTER THE FUEL SYSTEM WHEN:

1. An engine stopped from lack of fuel.
2. The fuel filter has been replaced or the filter cup has been cleaned.
3. Any connections between the injection pump and fuel tank have been loosened or disconnected for any reason.
4. The tractor has not been operated for an extended period of time.
5. The fuel pump has not operated correctly.

**NOTE:** *If the tractor has no fuel, it is possible to put fuel in the tank and start the engine without doing the air removal procedure, but a small amount of air can be in the filters. Air in the system will cause loss of power and stall the engine when a load is applied.*

To remove air from the fuel system, turn off the engine and use the following procedures:

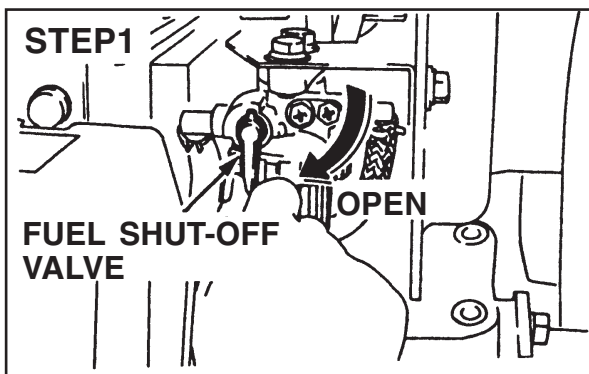

Open the fuel shut-off valve.

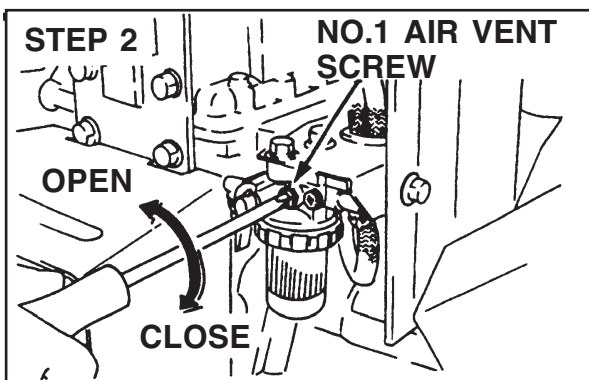

Loosen the No. 1 air vent screw on the fuel filter until the fuel flowing from the fuel filter is free of air bubbles. Tighten the No. 1 air vent screw.

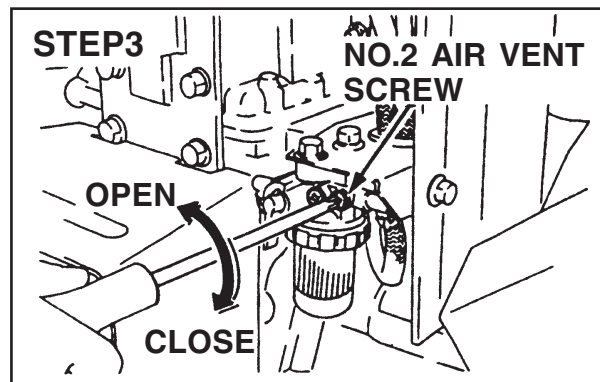

Loosen the No. 2 air vent screw until the fuel flowing is free of air bubbles.

Tighten the No. 2 air vent screw.

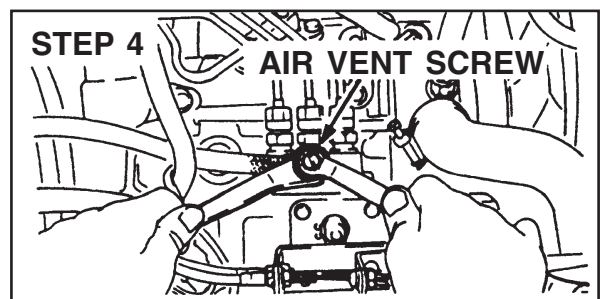

Loosen the air vent screw on the injection pump and turn the key switch "ON" position until the fuel flowing from the pump is free of air bubbles. Tighten the air vent screw.

## Fuel Injection Pump and Nozzle Check

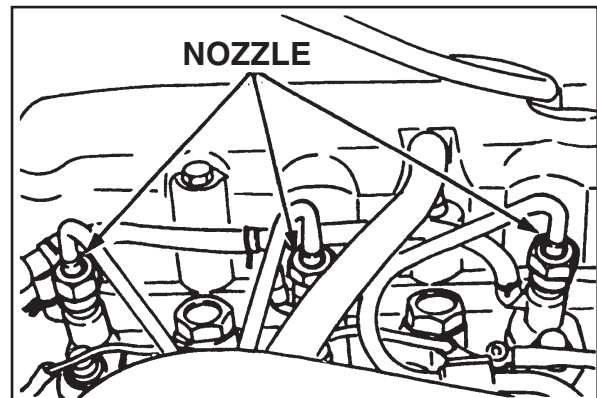
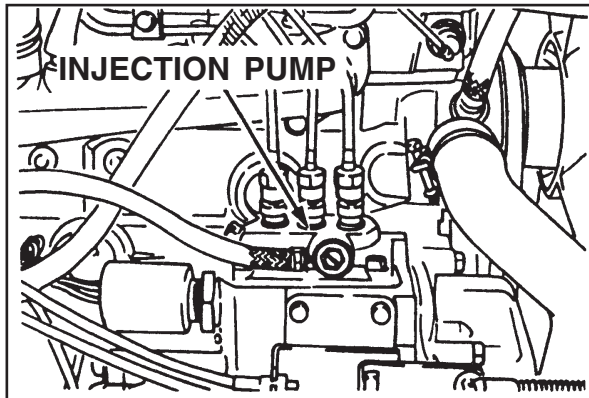

The fuel injection pump and nozzles are precision units and must be serviced only by your dealer.

The injection pump is correctly set and sealed at the factory and should not require an adjustment. Whenever adjustments or repairs are necessary, see your dealer. Do not tamper with any of the pump units.



***Hydraulic oil or diesel fuel leaking under pressure can penetrate the skin and cause infection or other injury.***

***To Prevent Personal Injury:***

***Relieve all pressure, before disconnecting fluid lines.***

***Before applying pressure, make sure all connections are tight and components are in good condition.***

***Never use your hand to check for suspected leaks under pressure.***

***Use a piece of cardboard or wood for this purpose.***

***If injured by leaking fluid, see your doctor immediately.***

M149A



## AIR INDUCTION SYSTEM

The air induction system components require service at different intervals according to local operating conditions.

### Service Specifications

Dump Valve .....	Clean daily or every 10 hours
Filter Element	
Clean Element .....	When necessary
Replace Element .....	After 10 cleanings or yearly
System Inspection .....	Every 200 hours or yearly whichever occurs first

Your tractor is equipped with a dry-type air cleaner with a replaceable element.

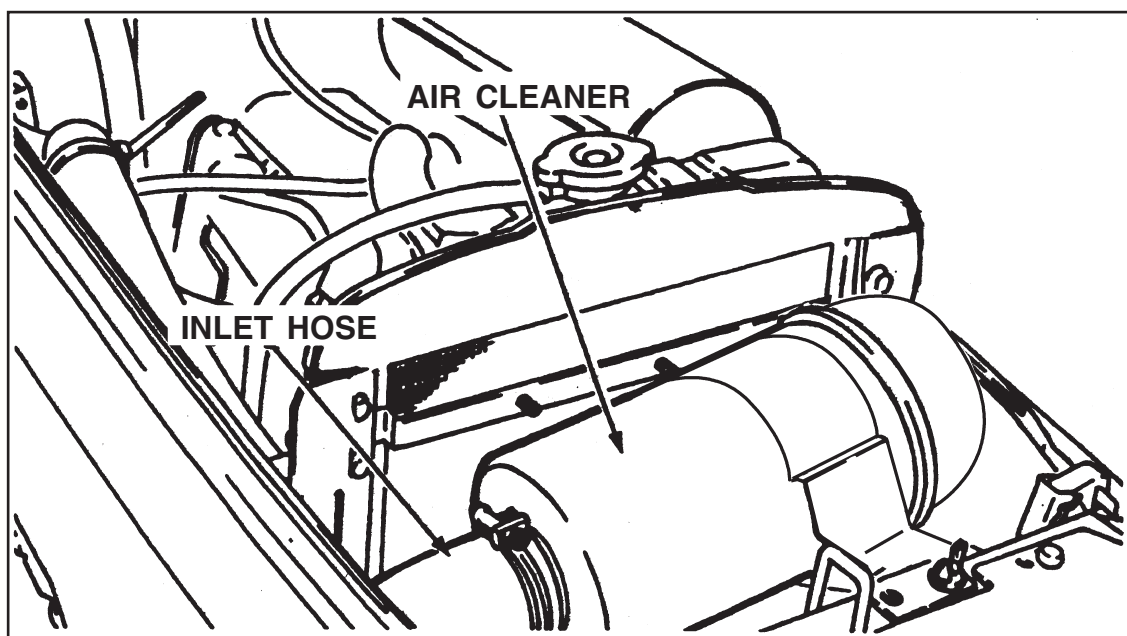

**IMPORTANT:** Service the air induction system at the given service intervals. Correct maintenance will add to the life of the engine. Keep all connections on the outlet hose tight.

### Dump Valve

The dust in a filter case should be dumped daily using the dump valve when operating in extremely dusty conditions.

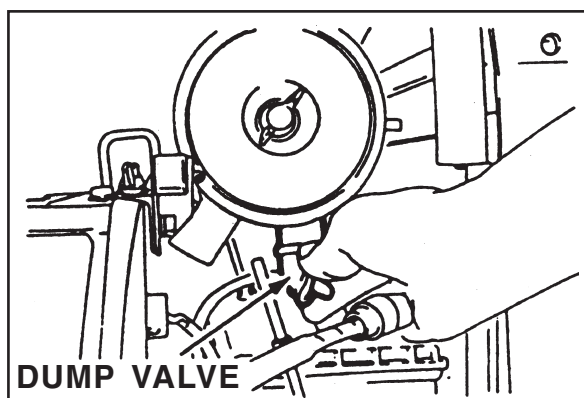



## Air Filter Element Removal

Avoid over servicing the air filter element. The filter element should be removed for cleaning only when restriction causes a power loss.

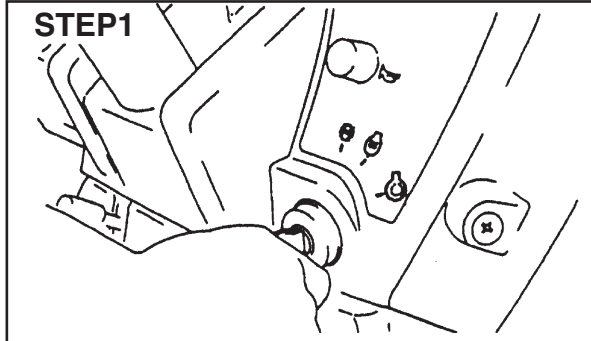

Stop the engine.

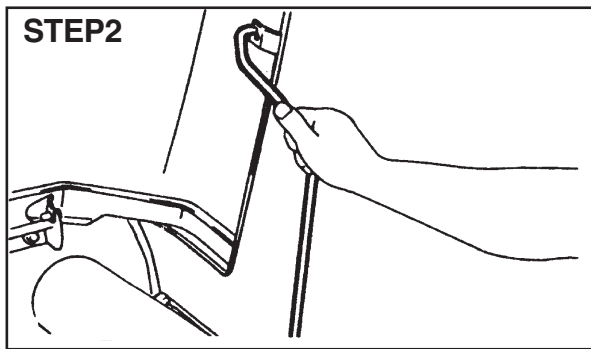

Lift the hood and connect the hood support rod.

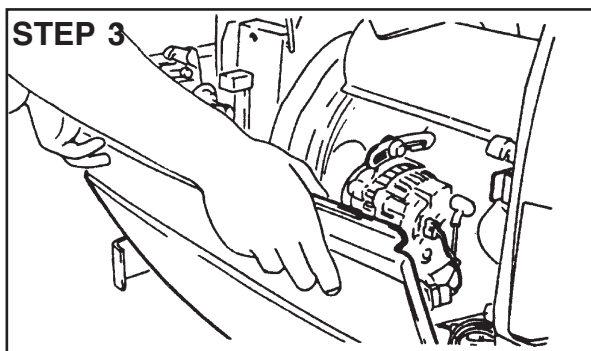

Remove the LH side cover.

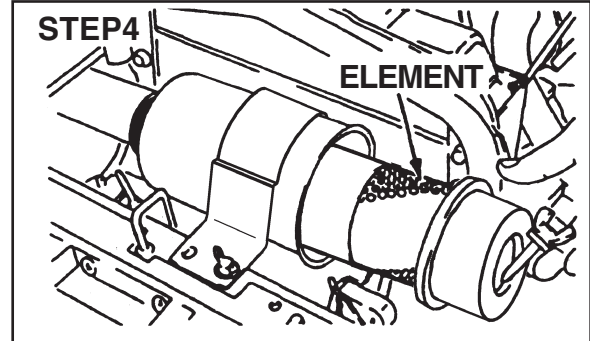

When servicing the air filter element, loosen the wing bolt and remove element by pulling it straight out very slowly and carefully. Clean interior of canister.

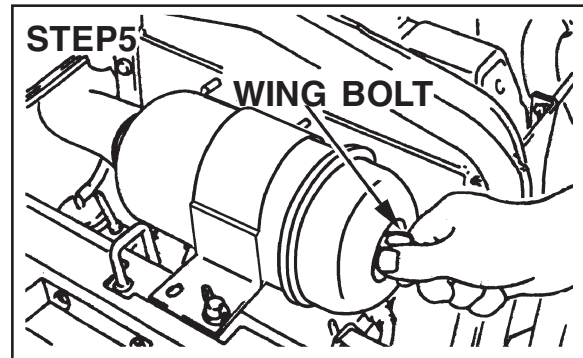

After replacing the new or cleaned element, install and tighten the wing bolt.

**NOTE:** *Never attempt to remove the element from the air cleaner while the engine is running.*

When installing the element, inspect the element gasket. If the gasket or element surface is damaged, replace the element immediately.

## Element Cleaning

Use clean, dry compressed air up and down the pleats on the clean side (inside) of the element. Continue this until the element is clean.

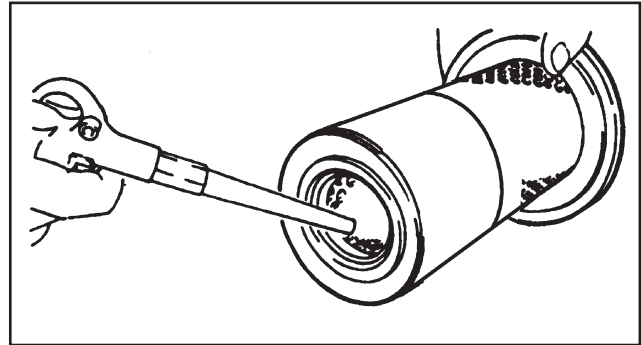
**NOTE:**

1. *The paper element must be handled with care. Do not hit the element against a hard surface.*
2. *Air pressure at the nozzle must not exceed 689 kPa (100 PSI).*
3. *It may be necessary to replace the element sooner if the time interval between servicing becomes short indicating the element does not respond to cleaning (soot contaminated).*

## System Inspection

Check the dump valve and the all hoses for cracks and wear. Replace if needed. All the connections on the hoses must be tight. All the gaskets must be in good condition and the bolts must be drawn up tight.

**NOTE:** *Inspect the hoses and connections after the first 50 hours of operation and replace when necessary.*

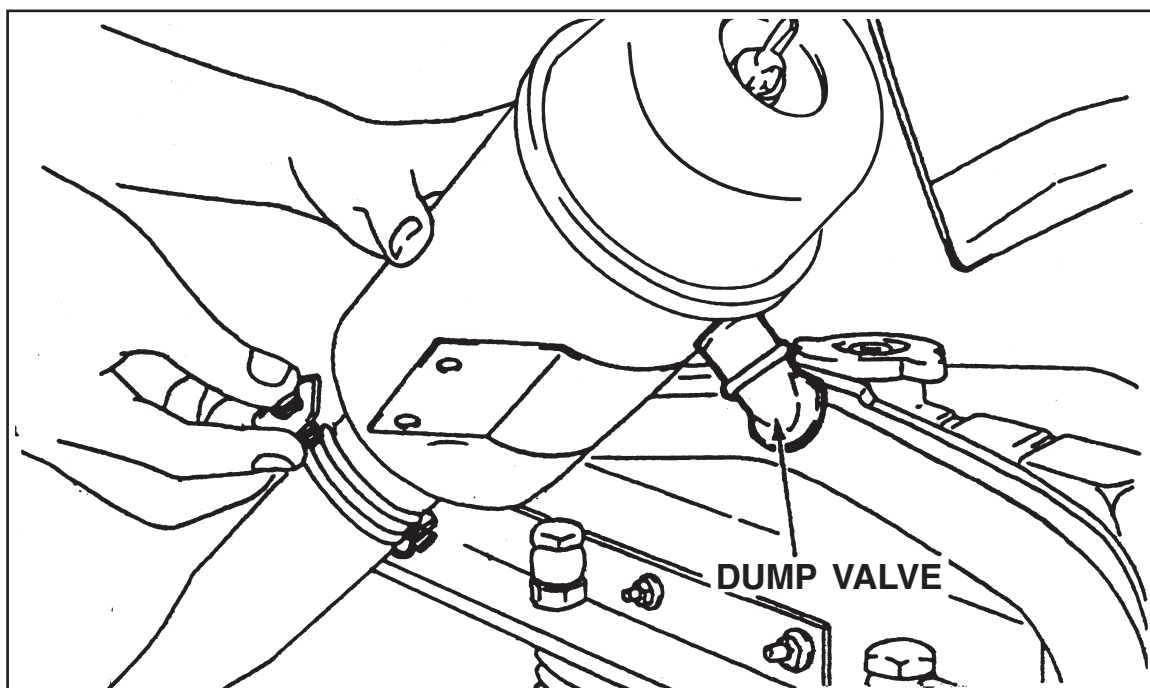

## TRANSMISSION & HYDRAULIC LUBRICATION

### Service Specifications

Oil Level Check Interval .....	Daily
Oil Change Interval.....	Every 200 hours.
Oil Capacity – Hydrostatic Drive .....	22 Litres (23.2 Quarts).
Oil Type – Hydrostatic Drive .....	Refer Lubrication table page 89.
Hydraulic System Check .....	Yearly inspect for leaks, cracks and abrasion. Tighten fittings or replace as needed.

### Transmission Oil Level (Hydrostatic Drive)

Before checking the oil level of the hydrostatic drive tractor, run the engine for three to five minutes at 1500 RPM with the speed ratio control lever, range shift lever and PTO control lever in Neutral or OFF position. Then check the oil level in the transmission.

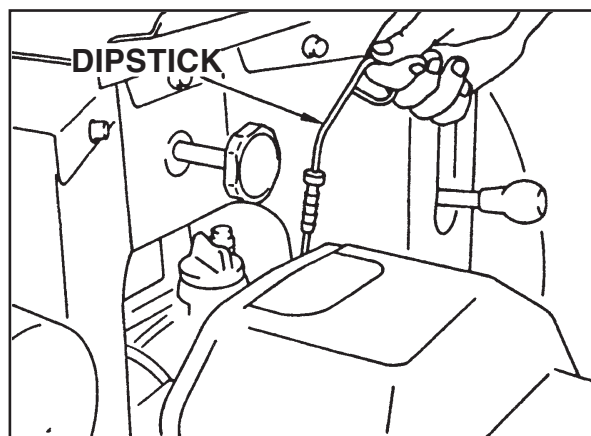

To check the transmission oil level, put the tractor on level ground.

Check the oil level on the transmission dipstick. If the oil level is below the lower line of the dipstick, add the recommended oil to the transmission to raise the oil level to the F (Full) marked position.

## Transmission Oil Change

Oil Change Interval ..... Every 200 hours

To change the transmission oil, use the following procedure:

1. Put the tractor on level ground, apply the park brake and stop the engine. Move the range shift lever to L position.
2. Remove the drain plugs from the transmission case.

**NOTE:** For best results, drain the oil when the oil is warm.

3. Replace the hydraulic filter. See Hydraulic Filter in this manual.
4. For the hydrostatic drive tractor, replace hydrostatic filter. See Hydrostatic Filter (Hydrostatic Drive) in this manual.
5. Install the drain plugs with a seal washer and tighten to a torque of 39 to 44 Nm (29 to 33 lb ft).
6. Add the recommended oil through the fill hole and check the oil level.
7. Start the engine and check for leaks.
8. Recheck the oil level after stopping the engine. If the oil level is low, add oil up to the specified level.

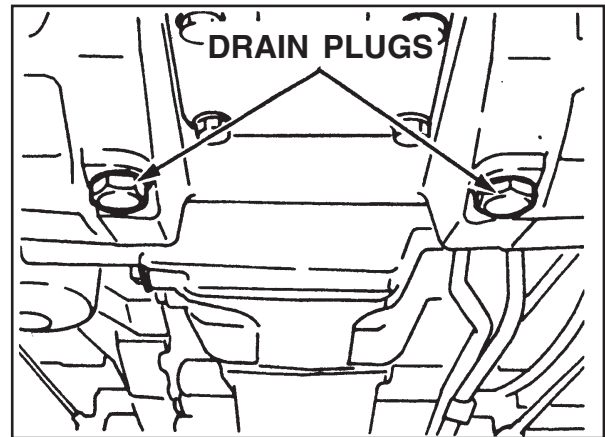

HYDROSTATIC DRIVE

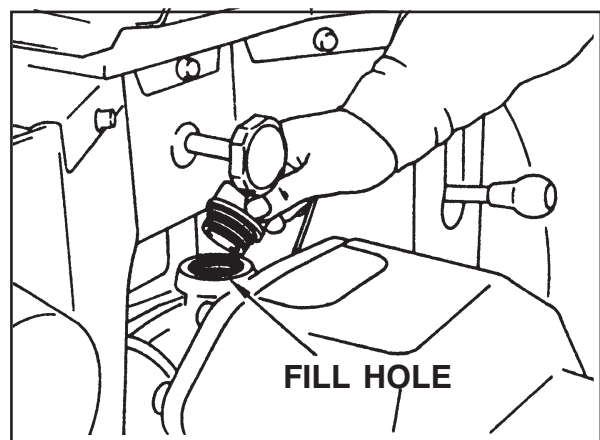

HYDROSTATIC DRIVE

## Hydraulic Filter (Hydrostatic Drive)

Change Interval ..... Every 200 hours (See NOTE)

**NOTE:** *Replace the hydraulic filter after the first 50 hours of operation and every 200 hours of operation thereafter. Your Dealer has approved genuine filters. Do not use other type filters.*

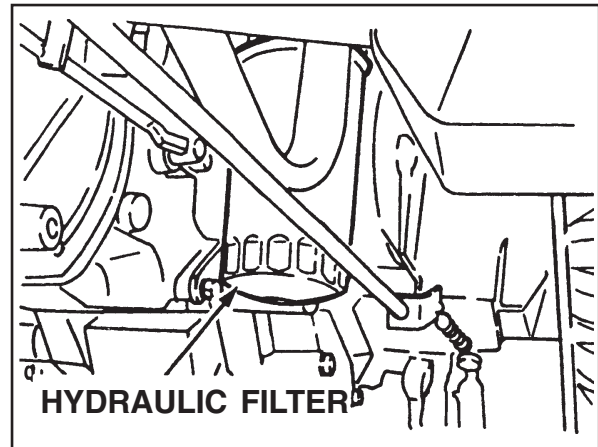

### CHANGE THE HYDRAULIC FILTER AS FOLLOWS:

1. Put the tractor on level ground, move the range shift lever to the L position and apply the park brake.
2. Put an oil canister under the hydraulic filter.
3. Turn the filter counterclockwise to remove. Use a filter wrench if necessary.
4. Apply clean oil to the O-ring on the new filter.
5. Install the filter. Turn the filter until the O-ring comes in contact with the case surface. Tighten the filter an additional 2/3 turn by hand.

**IMPORTANT:** *DO NOT use a filter wrench to install the hydraulic filter. When the filter is too tight, you can cause damage to the O-ring and filter.*

6. Wipe around the hydraulic filter with a dry cloth.
7. Change the transmission oil. See Transmission Oil Change in this manual.

## Hydrostatic System Filter (Hydrostatic Drive)

Filter Change Interval ..... Every 200 hours (See NOTE)

**NOTE:** Change the filter after the first 50 hours of operation and every 200 hours of operation thereafter. Replace the filter more frequently when operating under unusual dirt and dust conditions. Your Dealer has approved genuine filters. Do not use other type filters.

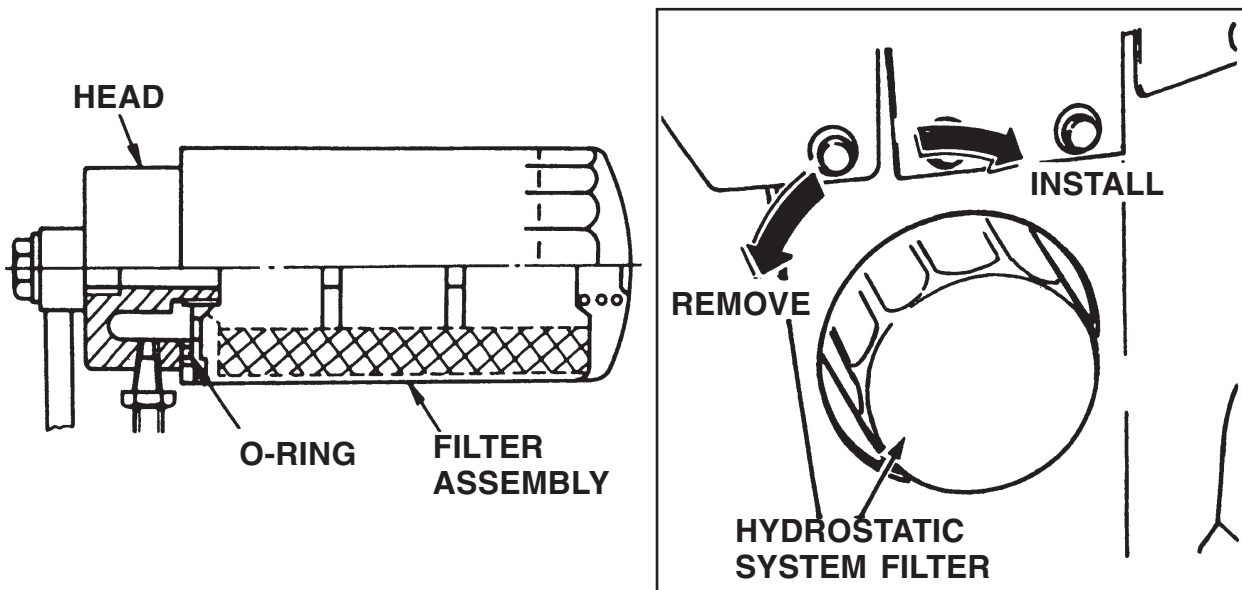

When the transmission fluid filter needs changing, change the filter as follows:

1. Drain the transmission oil. See Transmission Oil Change in this manual.
2. Remove the hydrostatic system filter by turning it counterclockwise. Use a filter wrench, if necessary.
3. Apply clean oil to the O-ring on the new filter.
4. Install the new filter. Turn the filter clockwise until the O-ring comes in contact with the filter head surface. Tighten the filter an additional 2/3 turn by hand.
5. Add the transmission oil through the fill port and check the oil level.
6. Run the engine and check for leaks.
7. After stopping the engine, check the oil level. If it is low, add clean oil.



## FRONT AXLE LUBRICATION (MFD)

### Service Specifications

Oil Change Interval .....	Every 200 hours (See NOTE)
Oil Capacity .....	4.0 Litres (4.2 Quarts)
Oil Type .....	SAE 85W-140 Gear Lubricant

**NOTE:** Change the oil after the first 50 hours of operation and then every 200 hours of operation.

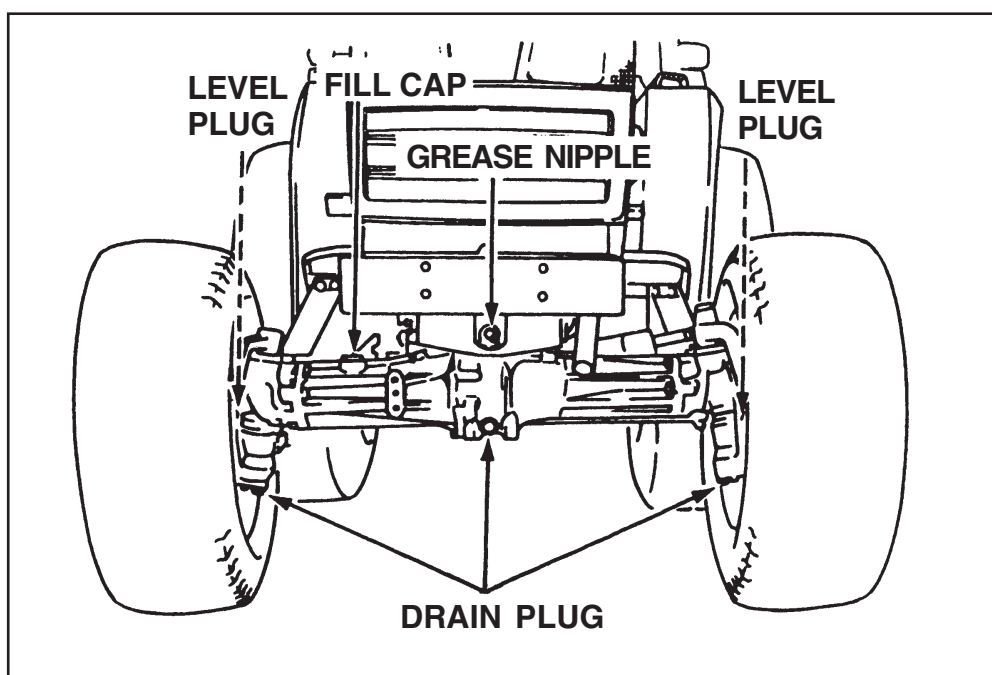

### Front Axle Oil Level

To check the front axle oil level, put the tractor on level ground. Remove the oil level plugs located on the rear of the both gear cases. If the oil level is low, add the recommended oil type through the fill hole located on the RH side of axle housing until the oil begins to flow out of the level plug holes.

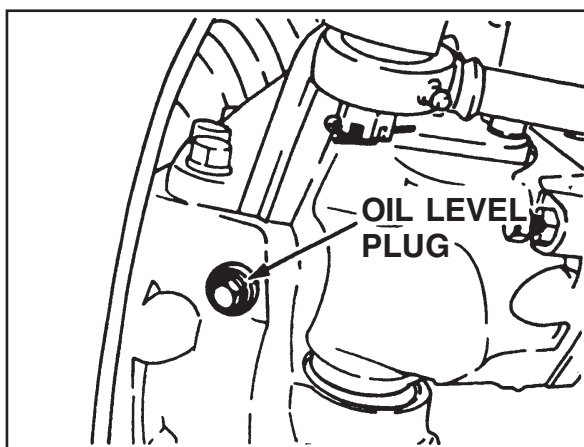



## Front Axle Oil Change

1. To change the front axle oil, put the tractor on level ground. Put the range lever in L, engage the park brake and stop the engine.

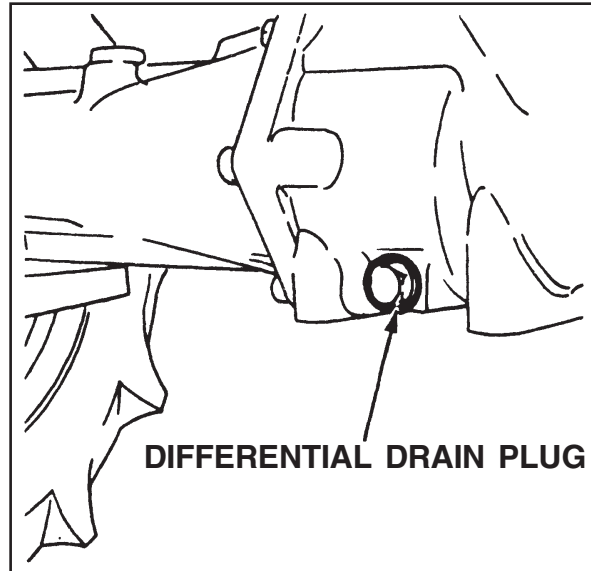
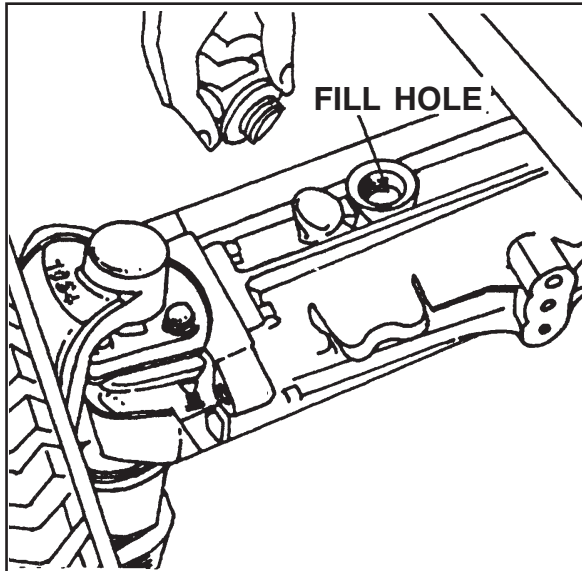

2. Remove the fill cap located on the axle housing, the differential drain plug located in the bottom of the housing and the gear case drain plugs located on the bottom of both side gear cases to drain the oil.

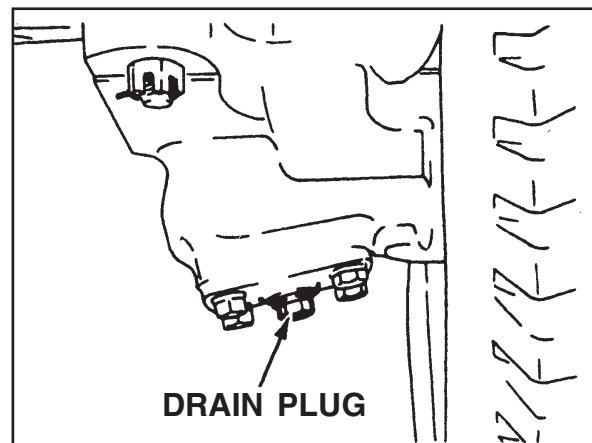

**NOTE:** For best results, drain the oil when the oil is warm.

3. Install the differential and both gear case drain plugs. Remove the oil level plugs located on both gear cases. Add the recommended oil through the fill hole until the oil begins to flow out of the level plug holes. Install the oil level plugs and the fill cap.

## COOLING SYSTEM

### Grille Screens and Radiator Area

#### Grille Screens and Radiator Area

Service Interval ..... Every 50 hours or more frequently if required.

To clean the radiator screen, put the tractor on level ground, apply the park brake and stop the engine.

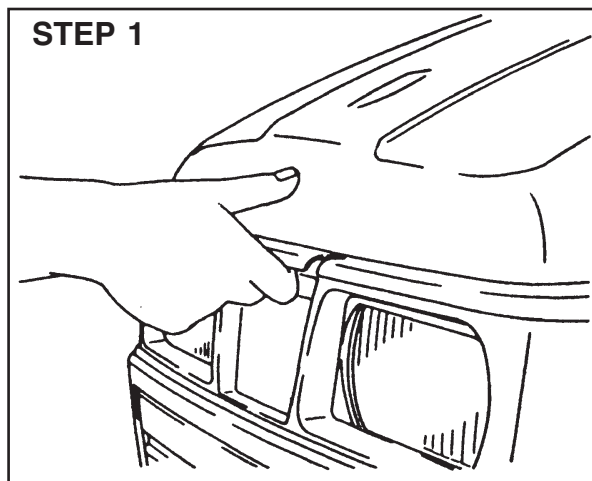

Lift and Lock the hood.

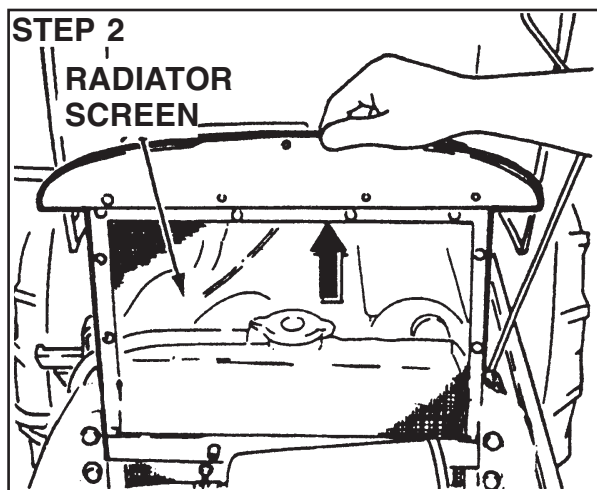

Lift the radiator screen.

#### STEP3

Clean the radiator screen and the surrounding area.

#### STEP4

Install the radiator screen.  
Lower the hood.

## Fan Belt Adjustment

Fan Belt Tension Check Interval ..... Daily or after 10 Hours

**NOTE:** *Adjust the belt tension after the first 50 hours of operation and replace when necessary.*

Measure the fan belt for correct tension. Check to see if the belt deflection is about 13mm (0.5 inch) when pushing the belt with 10 kg (22 lb) load at point ①.

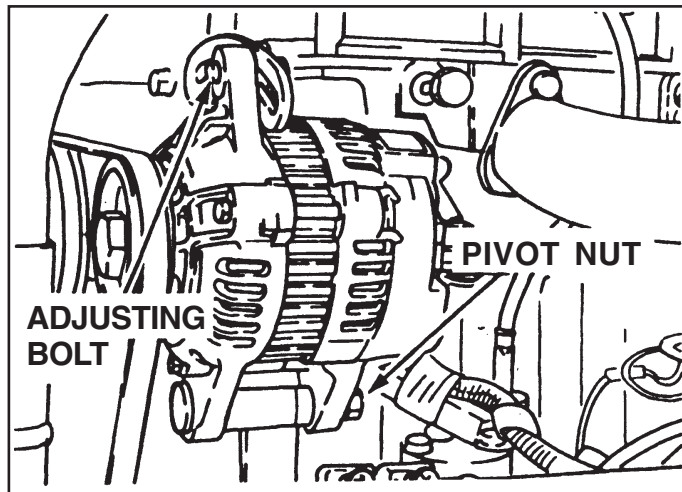
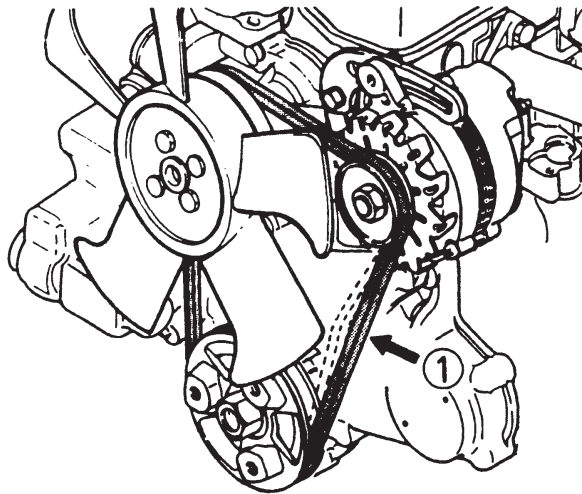

 **Rotating fan and belts. Contact can injure. Keep clear.** M150

To Adjust the fan belt tension loosen the adjusting bolt and pivot nut of the alternator. Move the alternator away from the engine until correct belt tension is reached. Tighten the adjusting bolt and pivot nut to a torque of 16 Nm (12 lb ft).

**NOTE:** *Too much tension will cause alternator and water pump bearing failure and belt wear. Too little tension will cause a decrease in alternator output and belt wear.*

## Fan Belt Replacement

To replace the fan belt, use following procedure:

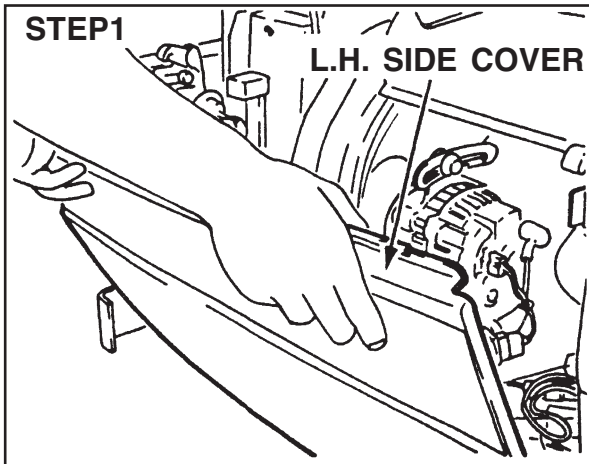

STEP 1  
L.H. SIDE COVER  
Raise the hood. Remove the LH side cover.

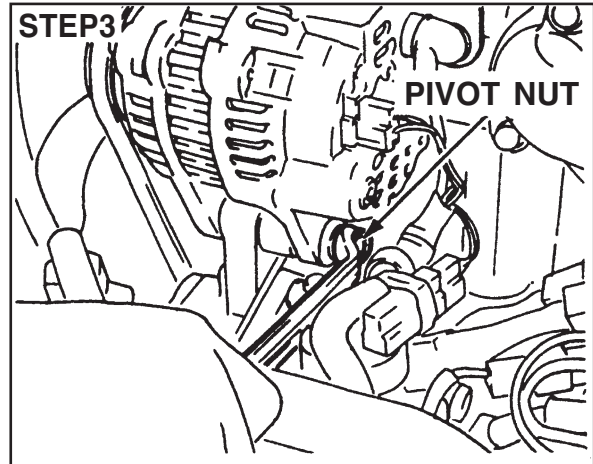

STEP 3  
PIVOT NUT  
Loosen the alternator pivot nut and push the alternator toward the engine to remove the belt.

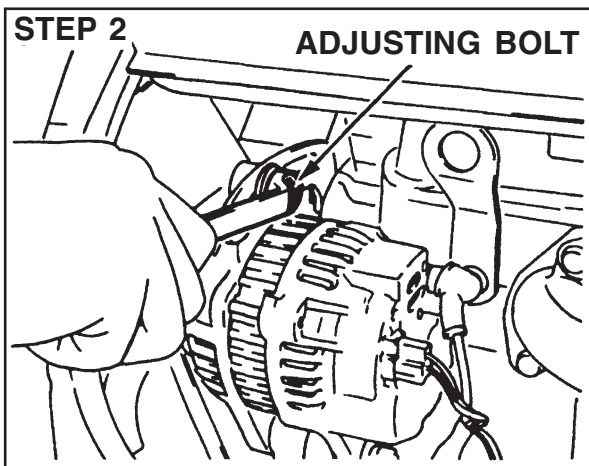

STEP 2  
ADJUSTING BOLT  
Loosen the alternator adjusting bolt.

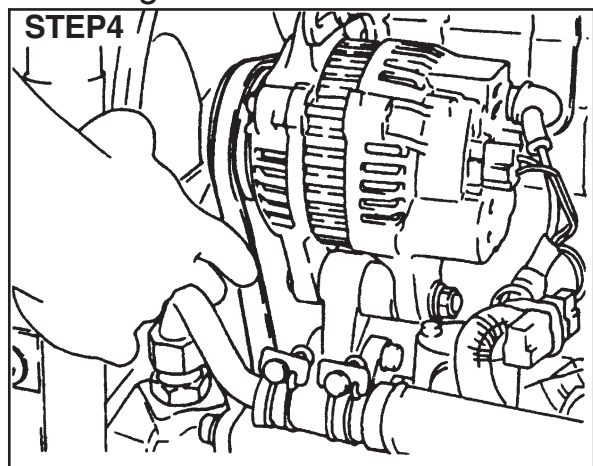

STEP 4  
Install new fan belt and adjust the belt tension. See Fan Belt Adjustment in this manual for instructions.

## CLUTCH PEDAL ADJUSTMENT

### Service Specifications

Clutch Pedal Check and Adjustment Interval .....	Every 200 hours of operation or yearly
Free Pedal Movement .....	20 – 30 mm (0.8 – 1.2 inch)
Max. Pedal Movement	
Single Clutch .....	85 – 90 mm (3.3 – 3.5 inch)

### Free Movement Adjustment

Clutch pedal free movement is very important and must be checked at the recommended intervals. If there is no free movement, the clutch disc will wear quickly. If there is too much free movement, the clutch will not disengage correctly and the transmission will be difficult to shift.

Put the tractor on level ground, move the range shift lever in the L position, apply the park brake, stop the engine and adjust the clutch pedal free movement as follows:

Push the clutch pedal down by hand, to measure the amount of pedal free movement.

The pedal free movement must be within the specification shown above.

Adjust the pedal free movement as necessary with the adjusting nuts on the clutch rod.

To increase free movement, turn the nuts in.

To decrease free movement, turn the nuts out. Tighten the nuts to a torque of 44 to 54 Nm (32 to 40 lb ft).

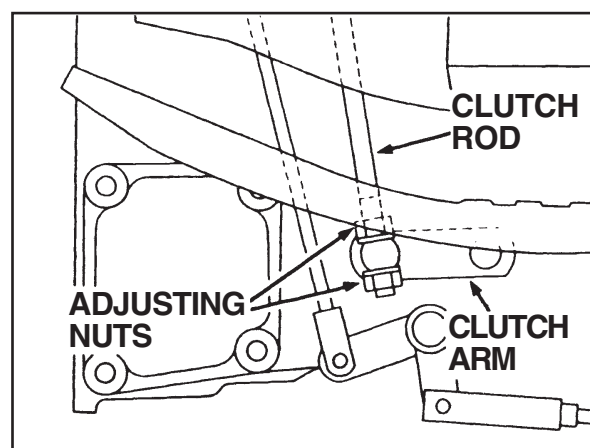
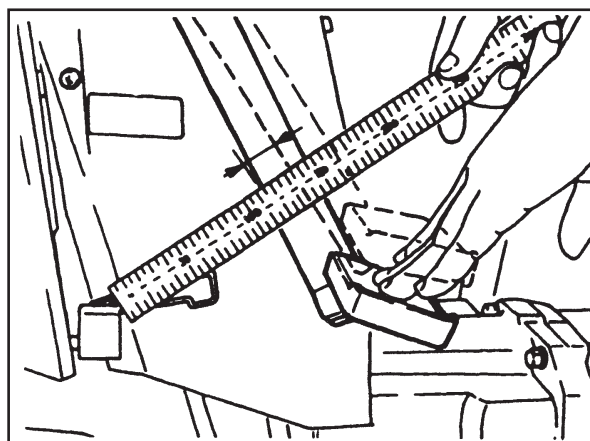

## Maximum Pedal Movement Adjustment

The Maximum Pedal Movement is very important and must be checked at the recommended intervals. If there is too little movement, the clutch can disengage. If there is too much movement, the clutch component parts can be damaged.

**NOTE:** *Adjust the Maximum Pedal Movement after adjusting the Free Movement.*

Put the tractor on level ground, move the range shift lever in the L position, apply the park brake, stop the engine and adjust the clutch pedal maximum movement as follows:

Push the clutch pedal down by hand to eliminate the pedal free movement.

Measure the distance between the stop bolt and the clutch pedal arm. The Maximum Pedal Movement must be within the specifications shown on the previous page.

Adjust the Maximum Pedal Movement as necessary with the stop bolt.

To increase Maximum Pedal Movement – Loosen the lock nut and turn the stop bolt in.

To decrease Maximum Pedal Movement – Loosen the lock nut and turn the stop bolt out.

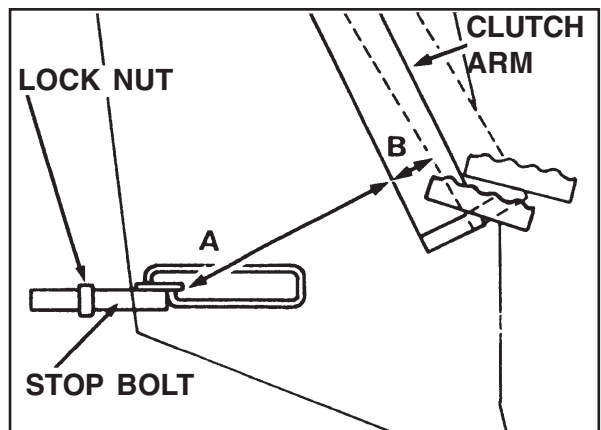
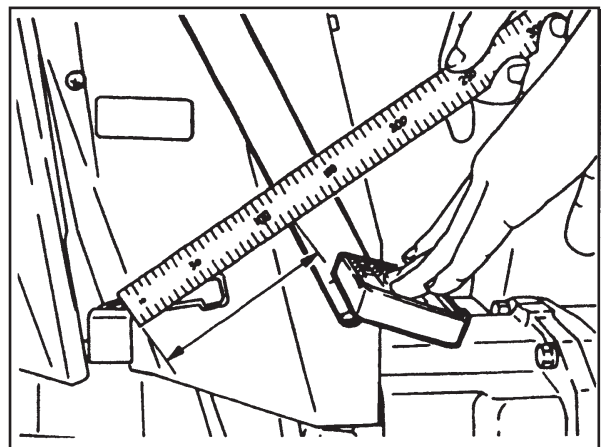



## BRAKE PEDAL ADJUSTMENT

### Service Specifications

Brake Pedal Check and Adjustment Interval ..... Every 200 hours or yearly  
 Free Pedal Movement Specification ..... 25 mm (1 inch)

Brake pedal free play is very important and must be checked at the recommended intervals. If there is no free movement, the brake shoes will wear quickly.

If there is too much free movement, accidents may occur. If there is not the same free movement between LH pedal and RH pedal, it may cause serious accidents.

Put the tractor on level ground, move the range lever in the L position. Stop the engine.

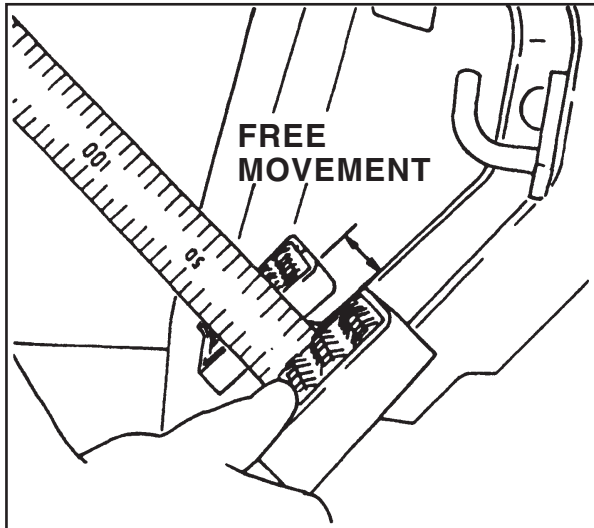

Loosen lock nut and rotate the brake rod to make a free play of 20 to 30 mm (0.79 to 1.18 in.) at the brake pedal.  
 With this much play obtained, tighten the lock nut.

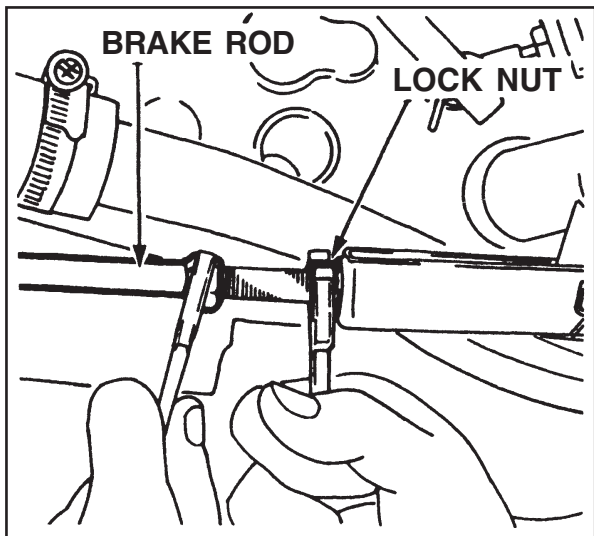

Confirm that the right and left brakes operate simultaneously by running the tractor.  
 If not, adjust both of them by means of the brake rods.



## RAISE STOP SETTING POSITION

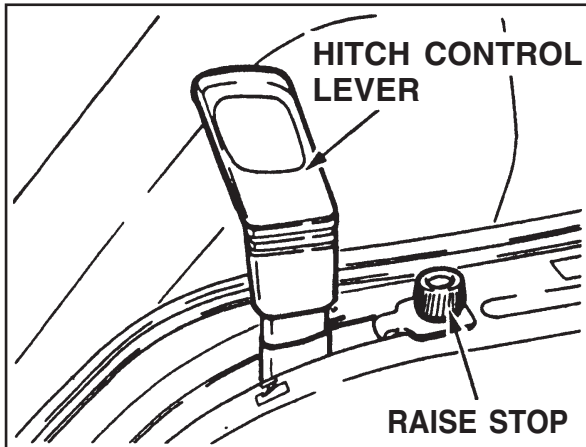

If raise stop setting position is incorrect, the hydraulic pump might be damaged. Therefore carefully adjust as below.

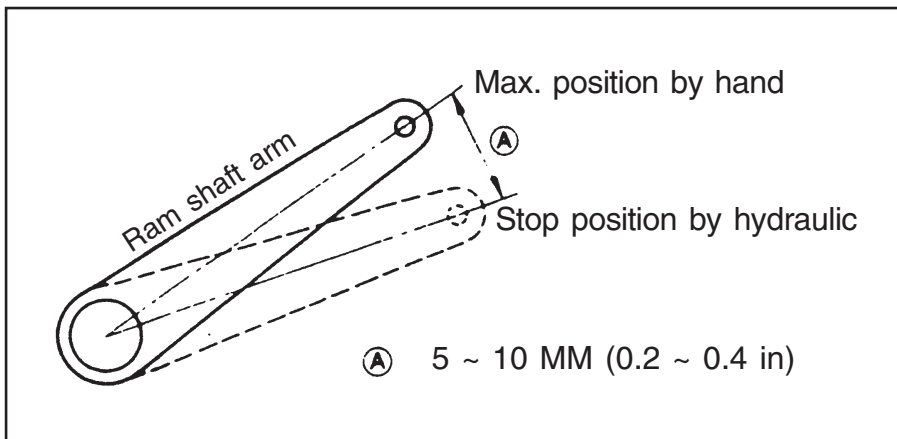

1. Disconnect an implement from the hitch. (See Disconnecting Implement from Hitch in this manual.)
2. Disconnect LH and RH lift rods from the lift arms.
3. Start the engine.
4. Move the hitch control lever rearward to raise the lift arm to the maximum lifting position.
5. With the arm so raised, stop the engine.
6. Check a free play of the lift arm to be 5 to 10 mm at the tip of the lift arm by hands.
7. If the insufficient free play is available, move the raise stop forward and check again with the same procedure as before.

## SPECIFICATIONS

### Electrical System

Type of System .....	12 Volt, Negative Ground
Battery .....	EXIED 58-60 12V-540CCA 9- <sup>13</sup> / <sub>16</sub> L; 7- <sup>13</sup> / <sub>16</sub> W; 7H
Alternator .....	12Volt, 50 Ampere Output
Voltage Regulator .....	IC Built in Alternator
Starter Motor .....	12 Volt, 1.6 kw with Solenoid Switch
Head Lamp .....	35 Watt
Flasher Lamp .....	32 Watt
Rear Red Lamp .....	8 Watt
Rear Working Lamp (If Equipped) .....	23 Watt
Panel Lamp .....	3.4 Watt
Turn Indicator Lamp .....	2.0 Watt
Indicator Lamp .....	2.0 Watt

### Fuses

Glow indicator lamp .....	10Amp
Charge indicator lamp, Engine oil pressure indicator lamp .....	10Amp
Engine Coolant Temperature Gauge, Fuel Gauge, Fuel Pump	
Head lamps, Rear Red Lamp, High Beam indicator lamp .....	15Amp
Instrument Panel Lamps	
Turn signal lamps .....	15Amp
Other optional electrical equipments .....	15Amp

## GENERAL SERVICE INFORMATION

### Alternator Charging System

Follow these general rules to prevent damage to the electrical system:

1. Before working on the electrical system, disconnect the battery cables.
2. Do not make a reverse battery connection.
3. When you use an auxiliary battery for starting, connect positive to positive and negative on the auxiliary battery to the tractor side rail as a ground.
4. When charging the tractor battery, disconnect the battery cables from the battery terminals. Do not use a battery charging machine for starting the tractor.
5. Never operate the tractor when the battery cables are disconnected.
6. When you do maintenance on the engine, prevent foreign material from entering the alternator.
7. If you must do welding, disconnect the battery. Put the welder ground cable as close as you can to the weld area. Do not put the ground cable where the current can flow through bearings or along channels with wire harnesses.

## Fuses

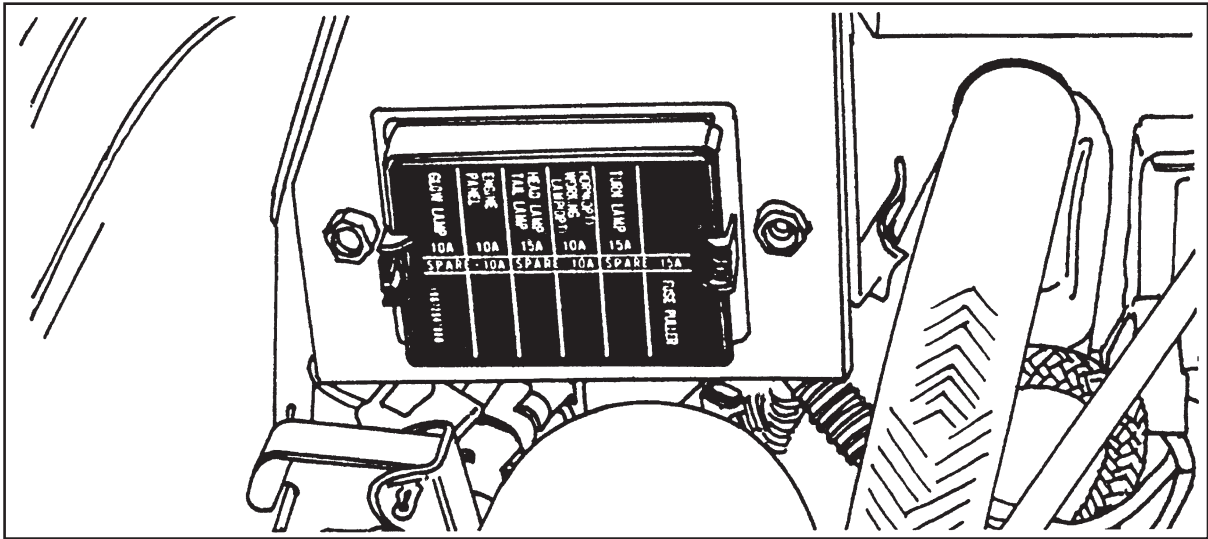

Cartridge type fuses are used for head lamps, rear red lamp, instrument lamps, turn signal and flasher lamps, and rear work lamp (if equipped). The fuses are located in the fuse block, R.H. rear of engine room. If a short circuit occurs, the fuse will burn out and break the circuit, preventing damage to the electrical system.

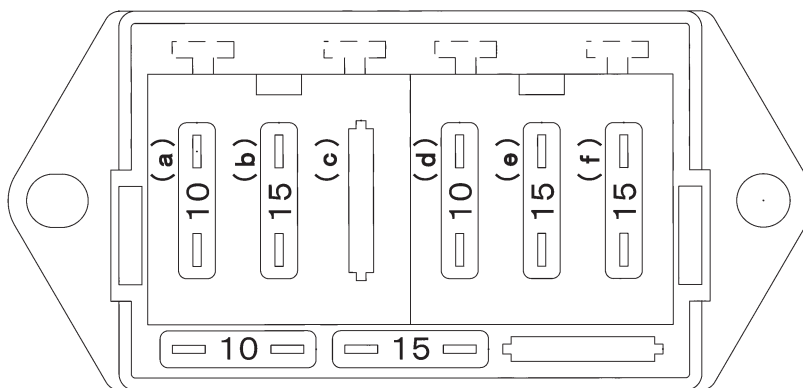

Fuse(a)(10 AMP) is for the glow plug indicator lamps.

Fuse(b)(15 AMP) is for turn lamps.

Fuse(d)(10 AMP) is for instrument panel lamps.

Fuse(e)(15 AMP) is for head lamps and tail lamps.

Fuse(f)(15 AMP) is for work lamps and horn.

## Line Fuse

If the electrical circuit is accidentally grounded or a reverse battery connection is made, the Line fuse located on the LH side of the engine will burn out and break the circuit to prevent the solenoid switch, wiring harness and alternator charging system from being damaged. If electrical problems occur, the Line fuse must be checked for continuity to determine if one of the circuits is broken, see your Dealer to replace and correct.

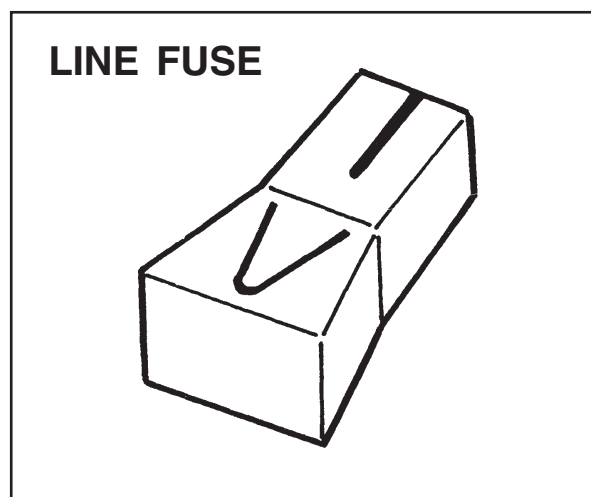
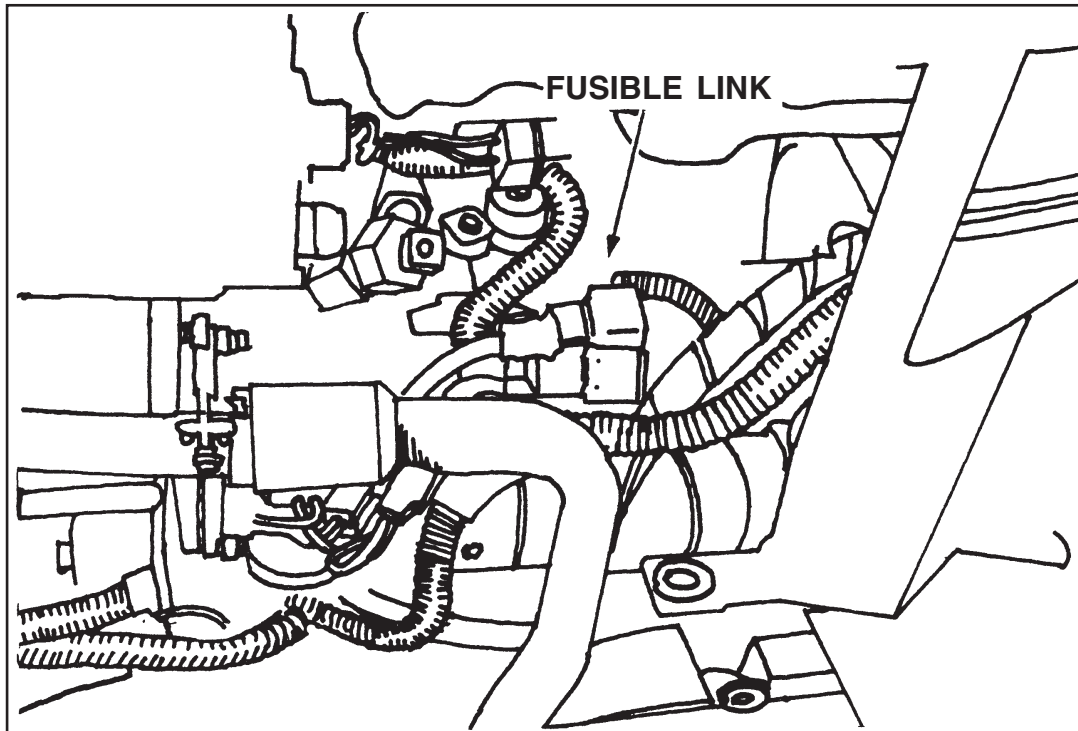

Two Line fuses are installed and the circuit can be identified by color of box.  
Red Box (50AMP): Solenoid switch circuit  
Yellow Box (60AMP): Wiring harness and alternator charging system

## BATTERY

### Auxiliary Battery Connections



**Engine can start with transmission in gear when neutral or safety start switch is by-passed:**

1. Do not connect across terminals on starter.
2. Attach a booster battery by connecting the positive terminal of the booster battery to the “positive terminal” provided or to the positive terminal of the machine battery. Connect the negative terminal of the booster battery to the “negative terminal” provided or to the chassis of the machine.

**Then use recommended starting procedures from operators seat.**

3. When necessary, repair electrical system components promptly so that “jump starting” will not be attempted.

**Machine run-away can cause injury or death to operator and bystanders.**

M107C

When connecting an auxiliary battery or charger to the tractor battery, make sure you connect positive to positive and negative on the auxiliary battery to the tractor side rail as a ground. Do not connect auxiliary battery cables across the terminals of the starter. Start the engine from the operator’s seat.

**IMPORTANT:** This is the only safe method to start the tractor engine with an external power supply. Any other method of starting can cause injury or death to the operator or other persons.

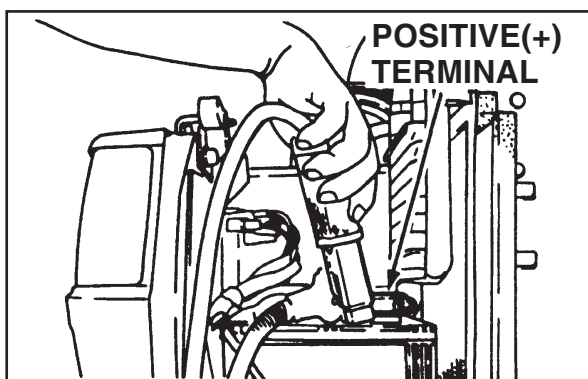

Connect the positive (+) cable clamp of the auxiliary battery to the positive cable terminal of the tractor battery.

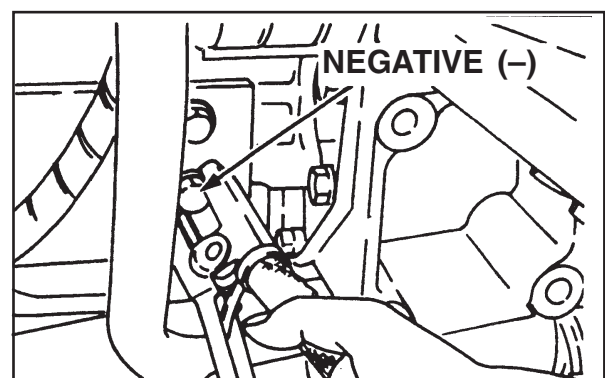

Connect the negative ( - ) cable clamp of the auxiliary battery to the tractor side rail as a ground.

**IMPORTANT:** Always connect the negative cable last and disconnect the negative cable first so you do not cause a spark at the battery. A spark can cause a battery explosion and cause injury.

**WARNING**

**BATTERIES CONTAIN ACID AND EXPLOSIVE GAS. EXPLOSION CAN RESULT FROM SPARKS, FLAMES, OR WRONG CABLE CONNECTIONS. TO CONNECT JUMPER CABLES OR CHARGER, SEE MANUAL(S) FOR THE CORRECT PROCEDURE. FAILURE TO FOLLOW THE ABOVE INSTRUCTIONS CAN CAUSE SERIOUS PERSONAL INJURY OR DEATH.**

321-6714

## Battery Cables and Terminals

The battery terminals must be kept clean and tight. A good method to clean terminals is to use Battery Saver. If Saver is not available, remove all corrosion with a wire brush, then wash with a weak solution of baking soda or ammonia. Put some petroleum jelly or light grease on terminals to prevent corrosion.

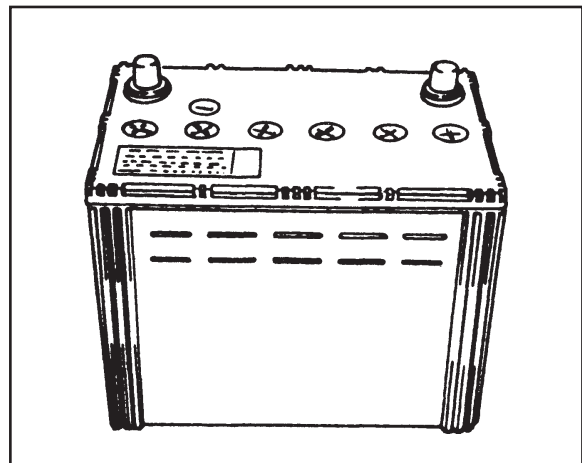

## Removal and Installation of Battery

To remove the battery disconnect the battery cables and remove the battery bracket. When the battery is installed, make sure the cables are installed on the correct terminals. This is a 12 volt, negative ground electrical system and must be so connected.

**NOTE:** *When disconnecting the battery, remove the negative cable first from the battery and reconnect it last for safety reasons.*

**IMPORTANT:** *Do not start or operate the engine with the electrical system not completely connected.*



## When Charging the Battery

**IMPORTANT:** *Battery can explode during boosting or charging. Always wear proper eye protection, such as a safety goggles.*

If the electric circuit inside the battery is broken, charging can generate a spark inside the battery which can cause it to explode.

If the battery is discharged, and the reason for discharge is unknown and if the lamps or horn do not indicate some battery voltage, check the battery with a volt meter for an open circuit using following procedure.

1. Disconnect the negative ( – ) cable.
2. Connect the volt meter across battery terminals.
3. If there is no voltage present, an open internal circuit is indicated. Replace the battery.
4. If voltage is present, the battery is OK to charge. Charge the battery with a current of 4 amperes for 5 to 10 hours. To charge the battery quickly for urgent need, use a current of 25 amperes for 30 minutes or less. A current larger than specified will cause liquid overflow due to foaming.
5. The specific gravity of electrolyte of a fully charged battery is 1.280 at 20°C (68°F).

### NOTE:

1. *If using a battery charger, be certain the charger is turned off before connecting to the battery.*
2. *Charge the battery in a well ventilated area.*
3. *Do not attempt to charge a frozen battery.*



***When working around storage batteries, remember that all of the exposed metal parts are “live”. Never lay a metal object across the terminals because a spark or short circuit may result.***

M145

## When Battery Is Not in Use

When the tractor is not in use, the battery will need a charge every three months to keep the specific gravity at or above 1.240. A storage battery not in use will slowly discharge. A battery that has discharged can freeze at low ambient temperature and cause damage to the battery and tractor.

## Head Lamp Adjustment

**NOTE:** To keep maximum ground and road illumination, check and adjust the head lamps from time to time. Tire wear and different tire sizes will change the setting.

The head lamps can be adjusted to various positions by adjusting the mounting screws in the rear of the head lamp unit.

1. Put the tractor on level ground near a wall with the front end to the wall and the head lamps 6.1 m (20 feet) from the wall.
2. Measure the distance from the ground to the center of the head lamp and put this dimension on the wall in the form of a horizontal line.
3. Put a second horizontal line on the wall 405mm (16 inches) lower than the first line. The center of the low head lamp beams must be on the second horizontal line, 405 mm (16 inches) below the first horizontal line. Adjust the head lamps up or down as needed.

**NOTE:** Some countries have different regulations for head lamp alignment and operation on a road. Check your local regulations.

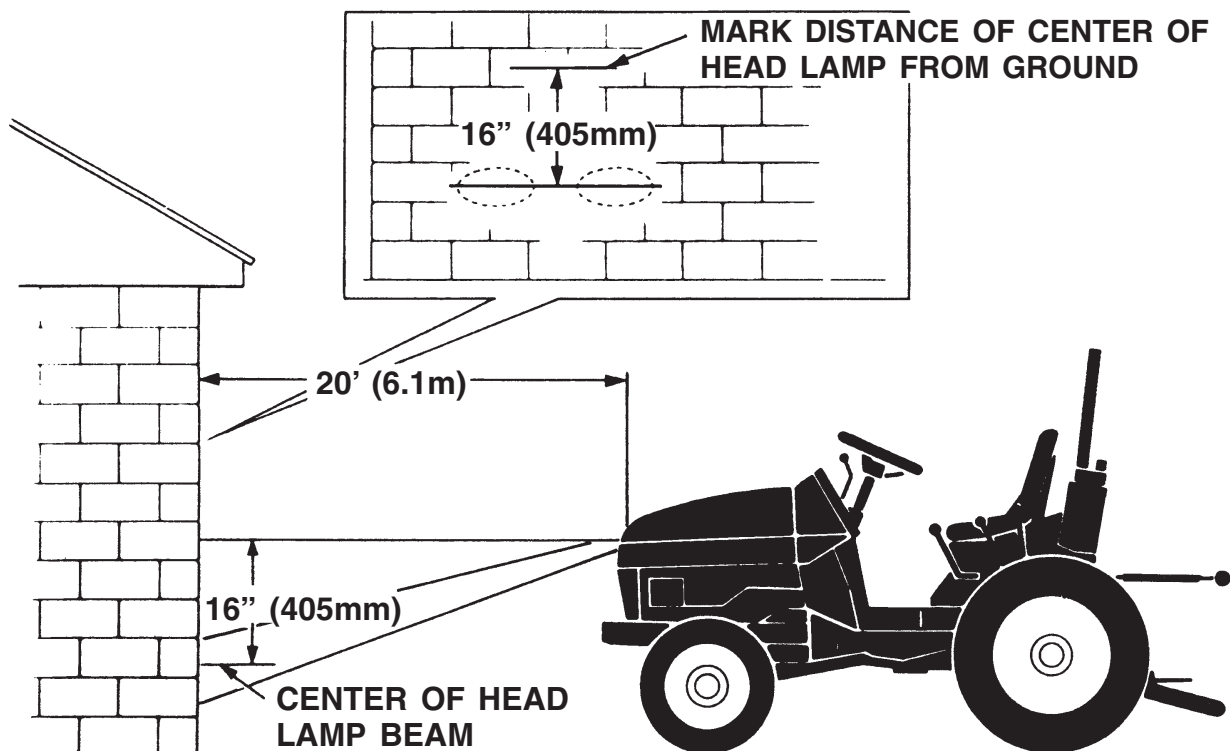

## STORING THE TRACTOR

When your tractor is not to be used for some time, it should be stored in a dry and protected place. Leaving your tractor outdoors, exposed to the elements, will shorten its life. Follow the procedure outlined below when your tractor is placed in storage for periods up to approximately six months. See your Dealer for the procedure on longer storage periods.

- A. Store the tractor so the tires are protected from light. Before storing the tractor, clean the tires thoroughly, Jack up the tractor, when it is to be out of service for a long period. If not jacked up, inflate the tires at regular intervals.
- B. Run the engine long enough to thoroughly warm the oil in the crankcase, and then drain the oil. Change the oil filter as instructed in Engine Oil Filter. Refill the crankcase with new oil as specified in Engine Oil Selection in this manual and run the engine for five minutes.
- C. Fill the fuel tank with a good grade of Number Two diesel engine fuel. If this grade has not been used regularly, drain the fuel and refill. Run the engine for about five minutes to circulate the fuel through the injection system.
- D. Drain, flush and fill the cooling system with an antifreeze mixture ratio to protect the engine to the lowest anticipated temperature or a minimum of 50% antifreeze and add cooling system conditioner. See COOLING SYSTEM in this manual.
- E. Do not remove the battery from the tractor, except for prolonged storage at below freezing temperature. The battery should be fully charged to prevent freezing of electrolyte. Disconnect the negative ground cable at the battery to prevent possible discharge.
- F. Clutch assembly may become bound together if a tractor is not used for an extended period of time. A clutch lock latch is provided on your tractor to lock the clutch in the disengaged position and should be used to prevent this condition if your tractor is not used for an extended period of time.

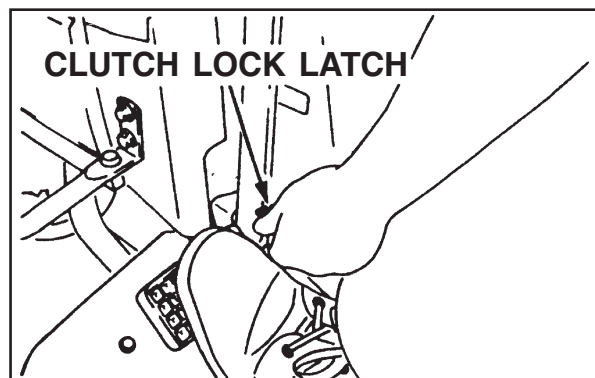

## REMOVING FROM STORAGE

Be sure that the grade of oil in the engine crankcase is as specified in Engine Oil Selection in this manual.

- A. Loosen the fuel tank drain plug and fuel filter cup, and be sure all water and sediment has drained from the fuel system before closing. Tighten the drain plug and replace the filter cup.
- B. Check the level of the coolant in the radiator.
- C. Check engine oil level.
- D. Check hydraulic fluid level.
- E. See that the battery is fully charged and that the terminal connections are clamped tightly.
- F. On hydrostatic drive tractors, follow the same procedure for starting as Starting Procedure for Hydrostatic Drive Tractors after Transporting on truck or flatcar in this manual.
- G. Start the engine and let it run slowly.

**IMPORTANT:** *Keep the doors wide open and move the machine outside of the storage room immediately to avoid danger from exhaust fumes. Do not accelerate the engine rapidly or operate it at high speed immediately after starting.*

**NOTE:** Mahindra Tractors