

Straight Line Diagram

(Including Drain Pipes)

Allegheny 2

January 2021

This document was produced by the Pennsylvania Department of Transportation (PENNDOT) as an internal management tool for State maintained highways and is not to be used for other purposes. The printed information was compiled from the Department's computerized Roadway Management System (RMS) and is subject to change without notice. Use of any or all of the printed information for purposes other than those intended by the Department may not satisfy other accuracy and completeness requirements and the Department does not warrant that such printed information is accurate or complete.

ROADWAY MANAGEMENT SYSTEM
INDEX FOR SR'S LOCATED IN THE COUNTY OF ALLEGHENY

SR	BGN	PAGE	END	PAGE	SR	BGN	PAGE	END	PAGE	SR	BGN	PAGE	END	PAGE
0008		1		26	1022	602		603		2029	735		735	
0019		27		67	1023	604		604		2030	736		737	
0022		68		81	1024	605		606		2031	738		743	
0028		82		113	1025	607		609		2032	744		745	
0030	114		131		1026	610		611		2033	746		746	
0048	132		149		1027	612		613		2034	747		748	
0050	150		169		1028	614		624		2035	749		750	
0051	170		219		1029	625		625		2036	751		751	
0060	220		230		1030	626		628		2037	752		758	
0065	231		248		1031	629		630		2038	759		759	
0079	249		276		1032	631		636		2039	760		760	
0088	277		285		1033	637		639		2040	761		770	
0121	286		291		1034	640		644		2041	771		772	
0130	292		305		1035	645		648		2042	773		775	
0136	306		312		1036	649		650		2043	776		777	
0148	313		321		1037	651		653		2044	778		781	
0279	322		339		1038	654		654		2045	782		785	
0286	340		344		1039	655		655		2046	786		791	
0366	345		347		1040	656		656		2047	792		792	
0376	348		390		1045	657		657		2048	793		799	
0400	391		410		1047	658		658		2049	800		802	
0579	411		413		1049	659		660		2050	803		804	
0791	414		417		2001	661		673		2051	805		808	
0837	418		450		2002	674		674		2052	809		809	
0885	451		468		2003	675		676		2053	810		811	
0906	469		469		2004	677		677		2054	812		814	
0910	470		487		2005	678		680		2055	815		815	
0978	488		496		2006	681		681		2056	816		816	
0980	497		497		2007	682		683		2057	817		818	
1001	498		524		2008	684		684		2058	819		829	
1002	525		525		2009	685		686		2059	830		831	
1003	526		530		2010	687		689		2060	832		832	
1004	531		532		2011	690		691		2061	833		834	
1005	533		534		2012	692		692		2062	835		835	
1006	535		541		2013	693		694		2063	836		837	
1007	542		542		2014	695		695		2064	838		839	
1008	543		544		2015	696		698		2065	840		845	
1009	545		546		2016	699		699		2066	846		850	
1010	547		549		2017	700		708		2067	851		852	
1011	550		552		2018	709		711		2068	853		853	
1012	553		556		2019	712		712		2069	854		855	
1013	557		569		2020	713		713		2070	856		857	
1014	570		572		2021	714		719		2071	858		859	
1015	573		580		2022	720		720		2072	860		860	
1016	581		583		2023	721		722		2073	861		864	
1017	584		585		2024	723		724		2074	865		867	
1018	586		586		2025	725		725		2075	868		875	
1019	587		594		2026	726		727		2076	876		879	
1020	595		599		2027	728		729		2078	880		881	
1021	600		601		2028	730		734		2079	882		882	

ROADWAY MANAGEMENT SYSTEM
 INDEX FOR SR'S LOCATED IN THE COUNTY OF ALLEGHENY

SR	BGN	PAGE	END	PAGE	SR	BGN	PAGE	END	PAGE	SR	BGN	PAGE	END	PAGE
2080	883		884		3005	965		968		3056	1092		1094	
2081	885		885		3006	969		971		3057	1095		1097	
2082	886		890		3007	972		973		3058	1098		1098	
2083	891		891		3008	974		974		3059	1099		1100	
2084	892		893		3009	975		982		3060	1101		1101	
2085	894		894		3010	983		984		3061	1102		1102	
2086	895		896		3011	985		986		3062	1103		1104	
2087	897		897		3012	987		988		3063	1105		1106	
2088	898		900		3013	989		990		3064	1107		1107	
2090	901		902		3014	991		993		3066	1108		1110	
2091	903		903		3015	994		996		3067	1111		1111	
2092	904		904		3016	997		998		3068	1112		1112	
2093	905		905		3017	999		1001		3069	1113		1123	
2094	906		907		3018	1002		1002		3070	1124		1129	
2095	908		908		3019	1003		1003		3071	1130		1134	
2096	909		909		3020	1004		1004		3072	1135		1137	
2097	910		910		3021	1005		1006		3073	1138		1138	
2098	911		911		3022	1007		1007		3074	1139		1143	
2099	912		912		3023	1008		1008		3075	1144		1145	
2100	913		913		3024	1009		1012		3077	1146		1154	
2101	914		914		3025	1013		1013		3078	1155		1157	
2102	915		915		3026	1014		1016		3079	1158		1159	
2104	916		916		3027	1017		1018		3080	1160		1160	
2105	917		917		3028	1019		1021		3081	1161		1162	
2106	918		918		3029	1022		1023		3082	1163		1164	
2107	919		919		3030	1024		1024		3083	1165		1166	
2108	920		923		3031	1025		1027		3084	1167		1167	
2110	924		926		3032	1028		1028		3085	1168		1169	
2112	927		928		3033	1029		1030		3086	1170		1170	
2114	929		930		3034	1031		1035		3087	1171		1172	
2116	931		932		3035	1036		1037		3088	1173		1175	
2118	933		934		3036	1038		1039		3089	1176		1182	
2120	935		935		3037	1040		1044		3090	1183		1183	
2122	936		939		3038	1045		1048		3091	1184		1185	
2124	940		940		3039	1049		1050		3092	1186		1187	
2126	941		941		3040	1051		1051		3093	1188		1188	
2128	942		943		3041	1052		1055		3094	1189		1190	
2129	944		944		3042	1056		1057		3095	1191		1191	
2144	945		945		3043	1058		1058		3096	1192		1193	
2146	946		946		3044	1059		1059		3097	1194		1194	
2152	947		947		3045	1060		1060		3098	1195		1199	
2183	948		948		3046	1061		1062		3099	1200		1200	
2208	949		950		3047	1063		1063		3100	1201		1201	
2248	951		951		3048	1064		1074		3101	1202		1203	
2308	952		952		3049	1075		1075		3102	1204		1204	
2380	953		953		3050	1076		1076		3103	1205		1207	
3001	954		954		3051	1077		1078		3104	1208		1209	
3002	955		955		3052	1079		1084		3105	1210		1210	
3003	956		958		3053	1085		1086		3106	1211		1211	
3004	959		964		3054	1087		1091		3108	1212		1214	

ROADWAY MANAGEMENT SYSTEM
 INDEX FOR SR'S LOCATED IN THE COUNTY OF ALLEGHENY

SR	BGN	PAGE	END	PAGE	SR	BGN	PAGE	END	PAGE	SR	BGN	PAGE	END	PAGE
31109	1215		1218		4036	1353		1358		6579	1468		1468	
31110	1219		1219		4037	1359		1359		8002	1469		1470	
31111	1220		1220		4039	1360		1362		8003	1471		1472	
31112	1221		1221		4040	1363		1363		8004	1473		1474	
31115	1222		1222		4041	1364		1364		8005	1475		1476	
31117	1223		1223		4042	1365		1366		8006	1477		1477	
31119	1224		1224		4043	1367		1371		8007	1478		1479	
3121	1225		1225		4044	1372		1372		8008	1480		1482	
3123	1226		1226		4045	1373		1373		8009	1483		1485	
3144	1227		1227		4046	1374		1374		8010	1486		1488	
3145	1228		1228		4047	1375		1375		8011	1489		1490	
3147	1229		1229		4048	1376		1376		8012	1491		1493	
3148	1230		1230		4049	1377		1380		8013	1494		1494	
3160	1231		1237		4050	1381		1381		8014	1495		1495	
3919	1238		1238		4051	1382		1383		8015	1496		1497	
4001	1239		1239		4052	1384		1389		8016	1498		1498	
4002	1240		1241		4053	1390		1393		8017	1499		1502	
4003	1242		1253		4054	1394		1395		8018	1503		1503	
4004	1254		1254		4055	1396		1396		8019	1504		1504	
4005	1255		1255		4056	1397		1398		8020	1505		1506	
4006	1256		1256		4057	1399		1402		8021	1507		1508	
4007	1257		1258		4059	1403		1403		8022	1509		1509	
4008	1259		1259		4060	1404		1405		8023	1510		1511	
4009	1260		1267		4061	1406		1407		8024	1512		1512	
4010	1268		1268		4062	1408		1408		8025	1513		1513	
4011	1269		1278		4063	1409		1412		8026	1514		1515	
4012	1279		1283		4064	1413		1415		8027	1516		1516	
4013	1284		1285		4065	1416		1417		8028	1517		1517	
4014	1286		1287		4066	1418		1418		8029	1518		1518	
4015	1288		1288		4067	1419		1422		8030	1519		1519	
4016	1289		1290		4068	1423		1429		8031	1520		1520	
4017	1291		1293		4069	1430		1430		8032	1521		1521	
4018	1294		1295		4070	1431		1438		8033	1522		1523	
4019	1296		1303		4071	1439		1439		8034	1524		1524	
4020	1304		1304		4072	1440		1440		8035	1525		1526	
4021	1305		1308		4073	1441		1441		8036	1527		1528	
4022	1309		1313		4074	1442		1442		8037	1529		1530	
4023	1314		1315		4075	1443		1443		8038	1531		1531	
4024	1316		1320		4076	1444		1445		8039	1532		1533	
4025	1321		1321		4078	1446		1446		8040	1534		1534	
4026	1322		1324		4080	1447		1448		8041	1535		1539	
4027	1325		1326		4084	1449		1450		8042	1540		1542	
4028	1327		1328		4086	1451		1453		8043	1543		1543	
4029	1329		1331		4088	1454		1454		8044	1544		1545	
4030	1332		1333		4099	1455		1456		8045	1546		1547	
4031	1334		1340		4153	1457		1457		8046	1548		1549	
4032	1341		1346		4154	1458		1458		8047	1550		1551	
4033	1347		1349		4165	1459		1459		8048	1552		1552	
4034	1350		1351		4265	1460		1460		8049	1553		1554	
4035	1352		1352		6279	1461		1467		8050	1555		1556	



December 30, 2020

Pennsylvania State Roads - Straight Line Diagrams

Contained within this document are the 2021 Pennsylvania Straight Line Diagram's (SLD's) for State Routes by county within a particular PennDOT district. At the end of each year, PennDOT takes a snapshot of its current SLD database and creates PDF files from the SLD snapshot. The SLD's are a graphical representation of State Routes (SR's) that PennDOT maintains. The information shown on the SLD's is generated from data found in PennDOT's Roadway Management System (RMS) database. The data from RMS is constantly being updated to match actual roadway inventory data found on Pennsylvania's state highways. PennDOT's SR system is explained briefly in this document along with symbol definitions for each type of roadway feature or attribute found on the SLD. This PDF version of the SLD contains an individual county list of all state roads found in that county. The SR's found on the list are linked to the actual pages that show the individual SLD's. To find an SLD for a particular road that you want, simply point to that road on the SR index list and click on it to jump to the beginning page of that SLD.

If you have any questions or comments concerning information found in this document, please contact Colin McClenahan, [Roadway Inventory and Testing Unit](#), [Asset Management Division](#), [Bureau of Maintenance and Operations](#), by calling (717) 783-0172.

Additional information on state owned highways is available from your local PENNDOT Engineering District Office, RMS Unit, RMS Coordinator.

Straight Line Diagram Disclaimer: This document is for informational purposes only and may be viewed by anyone. No part of the information contained in this document may be altered or redistributed without prior written consent of PENNDOT. Straight Line Diagram information is provided "as is" without warranty of any kind, either expressed or implied. This information could include technical inaccuracies or errors of omission. Changes may be made periodically to the information herein.

Copyright © 2020 by the Commonwealth of Pennsylvania. All rights reserved.



Asset Management Division Mission Statement

To protect and preserve Pennsylvania's infrastructure by providing meaningful, timely, and accurate pavement and roadway management, design, standards, strategies, inventory and condition, as well as fair, consistent and efficient application of Commonwealth laws and regulations.

CUSTOMER SERVICE RATING FORM

Straight Line Diagram (SLD) – Customer Service Rating

As means to improve customer service, we would like you to rate the product/ service you have received, by circling a “grade” from “A” (excellent) to “E” (fail).

A **B** **C** **D** **E**

If your rating is not an “A,” please let us know what we could do better.

Name and Organization (optional)

Thank You.

(Fold along line, and tape or staple together before mailing)

(Cut along dashed line)

Bureau of Maintenance and Operations
Asset Management Division – BOMO Annex
907 Elmerton Avenue
Harrisburg, PA 17110
ATTN: Colin McClenahan

PENNSYLVANIA DEPARTMENT OF TRANSPORTATION
Bureau of Maintenance and Operations, Asset Management Division

Location Referencing System (LRS) – Definitions, Uses & Testing

The Department's LRS, implemented in 1987, is the mechanism to designate the State highway network, to define roadway lengths, locations, and route connectivity, and to serve as the basis for the collection, storage, and integration of roadway information.

An LRS key is a unique series of numbers that identifies the location of each point or feature along a State route. The fourteen digit number is an integral part of the Roadway Management System (RMS) where roadway data is stored. 07/4016/0100/0857 is an example of an LRS key, which identifies County (CO) = 07, State Route (SR) = 4016, Segment (SEG) = 0100, and Offset = 0857.

County (CO)

Each of Pennsylvania's sixty-seven counties is identified by a number.

Name	#	Name	#	Name	#	Name	#
Adams	1	Clinton	18	Lackawanna	35	Potter	52
Allegheny	2	Columbia	19	Lancaster	36	Schuylkill	53
Armstrong	3	Crawford	20	Lawrence	37	Snyder	54
Beaver	4	Cumberland	21	Lebanon	38	Somerset	55
Bedford	5	Dauphin	22	Lehigh	39	Sullivan	56
Berks	6	Delaware	23	Luzerne	40	Susquehanna	57
Blair	7	Elk	24	Lycoming	41	Tioga	58
Bradford	8	Erie	25	McKean	42	Union	59
Bucks	9	Fayette	26	Mercer	43	Venango	60
Butler	10	Forest	27	Mifflin	44	Warren	61
Cambria	11	Franklin	28	Monroe	45	Washington	62
Cameron	12	Fulton	29	Montgomery	46	Wayne	63
Carbon	13	Greene	30	Montour	47	Westmoreland	64
Centre	14	Huntingdon	31	Northampton	48	Wyoming	65
Chester	15	Indiana	32	Northumberland	49	York	66
Clarion	16	Jefferson	33	Perry	50	Philadelphia	67
Clearfield	17	Juniata	34	Pike	51		

State Route (SR)

State Routes (SR's) are identified by four-digit numbers. SR numbers are assigned as follows:

- | | |
|--|-----------|
| 1. Traffic Routes: Routes designated as Interstates, US or PA Routes | 0001-0999 |
| 2. Quadrant Routes (Non-Traffic Routes) | 1001-4999 |
| 3. Relocated Traffic Routes | 6000-6999 |
| 4. Turned Back, Abandoned, or Null Routes | 7000-7999 |
| 5. Interchanges | 8001-8999 |
| 6. WYE's | 9101-9199 |
| 7. Rest Areas | 9201-9299 |
| 8. Truck Escape Ramps | 9301-9399 |
| 9. Others | 9401-9499 |

Even/Odd Convention: Even numbers are typically given to SR's in the East/West direction, and odd numbers to SR's that run North/South. This convention applies to Interstate Routes (except those that are Beltways or Spurs), and Quadrant Routes. This convention may or may not apply to PA or US Traffic Routes.

Hierarchy: If two or more traffic routes occupy the same section of roadway, the SR number is based on the "higher" type route, according to the following hierarchy. If the traffic routes are the same hierarchy class, then the SR number is assigned the lower numbered traffic route (Figure 1).

1. Interstates
2. U.S. Routes
3. PA Routes
4. Quadrant Routes

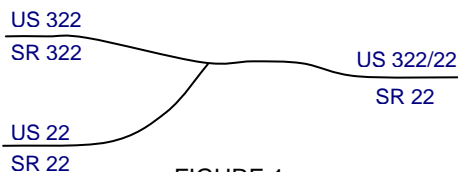

FIGURE 1

Other Numbering Conventions:

1. The first digit of a quadrant route is based on which quadrant of the county the route is located, as shown in the following diagram (Figure 2).
2. The last three digits of a Relocated Traffic Route are the same as the Traffic Route that was relocated.
3. Interchanges are numbered sequentially. Odd numbers are given to interchanges along SR's in the North/South direction; even numbers are given to interchanges along SR's in the East/West direction (Figure 3).
4. WYE's are given odd numbers if the connecting SR is odd numbered, and even numbers if the connecting SR is even numbered.
5. Rest Areas or Truck Escape Ramps are given odd numbers if they connect to the Southbound or Westbound side of an SR, and even numbers if they connect to the Northbound or Eastbound side.

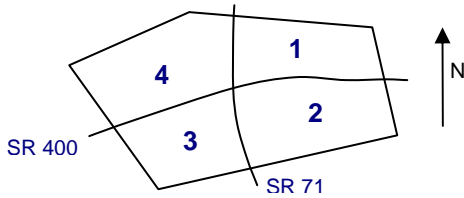

FIGURE 2

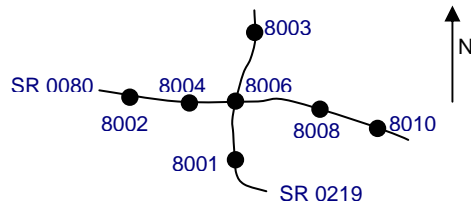

FIGURE 3

Segment (SEG)

State routes are divided into segments, which are approximately one-half mile long, and are identified by a four-digit number. Segment begin and end points are placed at physical features where possible. Segment numbers increase in the North or East direction, and typically by 10's (Figure 4). Segments are even numbered on undivided roadways, and in the Northbound or Eastbound direction of divided roadways. Segments are odd numbered in the Southbound or Westbound direction of divided roadways (Figure 5). Interstate segments are associated with the mile posts (Figure 6).

Undivided Roadways

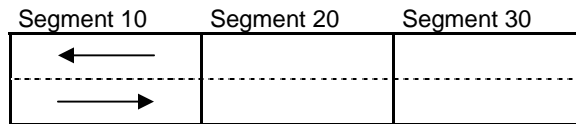

FIGURE 4

Divided Roadways

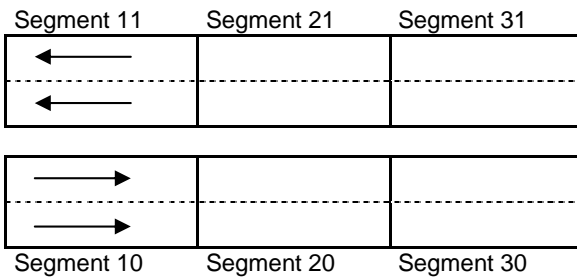

FIGURE 5

Interstate Roadways

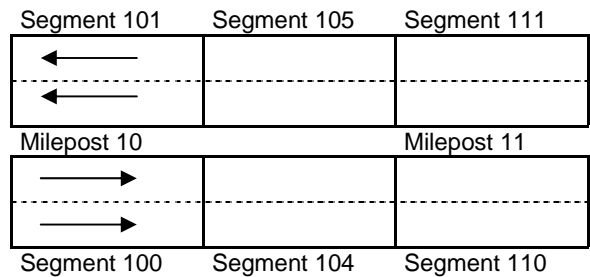

FIGURE 6

Turned Back, Abandoned, and Null Segments are given numbers in the range of 7000-7999. For two coincident State routes, the route with "lower" hierarchy is "nulled."

Segment numbering restarts on Traffic Routes at County boundaries, except Interstates (Figure 7).

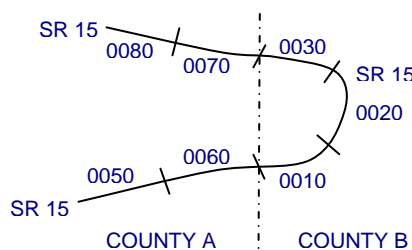

FIGURE 7

Offset

The offset, a subdivision of the segment, is the distance (in feet) from the beginning of the segment, expressed as a four-digit number. Offsets are measured in the increasing segment direction.

Segment Markers

Segment markers, which allow for easy identification of the LRS location on the State highway system, indicate the State route and segment number at the point that each segment is entered. If the beginning of a segment occurs at a physical feature, then the point of reference is at the physical feature and not the sign. At intersections, signs are used to identify beginning or ending State routes or segments.



Users of the LRS

Locations of all intersections, structures, and other points of interest are field verified and inventoried in the RMS. This information can be displayed on Straight Line Diagrams (SLD's) which can be viewed in the RMS, or hardcopy form. SLD books are refreshed and printed annually for distribution to the Department's District and County offices, as well as too many external entities.

A list of those within the Department that use the LRS to identify locations in the RMS and in the field includes personnel from the following organizations: Pavement Testing, County Maintenance, Traffic, Design, Surveys, Construction, Bridge, Permits, Crash Review, Planning and Programming, Posted & Bonded Roads, Tort Liability, and Emergency Management.

Users outside the Department include: County & Municipal governments, County 911, Planning Commissions, Federal Highway Administration, State & Local Police, Local Emergency Management, Delivery Services (UPS, Fed Ex, etc.), Fire Departments, Utility Companies, Contractors, and Consultants.

Without segment markers located in the field, all of these users would have to rely solely on the SLD, which would be extremely cumbersome at best and impossible for some.

Verification, QA & QC

In order to assure that LRS information is indicated properly in the RMS, on SLD's, and in the field, LRS Quality Assurance (QA) and Quality Commitment (QC) programs are performed each year. The Bureau of Maintenance and Operations, Asset Management Division, Roadway Inventory & Testing Unit (RITU) performs all Statewide QC testing. Field verification and QA is also performed by RITS, except in Engineering Districts 2-0, 11-0, and 12-0, where it is done "in-house." Each Engineering District is responsible for its own LRS completeness and maintenance with respect to the RMS.

Twenty percent of each county is field tested annually as part of the QA program, and five percent of each county is tested for the annual QC program. The goal of the QC program is to maintain at least 90% accuracy between the RMS and the actual field locations of highway features. Annual QC ratings are developed and reported to the Engineering Districts.









































Field testing is performed by two-person teams (a permanent employee that operates the test, and a temporary employee that drives the device) with the use of vans equipped with an on-board computer and a Data Measurement Subsystem. Testing is typically performed during the months of April through November.

Vehicle location and roadway features are displayed on the van's computer screen in SLD format, and the software accepts operator inputs verifying or modifying roadway feature locations, as well as comments. Though the system can function at greater speed, test speeds are typically less than 25 mph to ensure accuracy.

There are five categories of information that is verified and/or modified:

1. State Route Length
2. Segment Length
3. Roadway Geometry (lane count, pavement & shoulder types & widths)
4. Intersecting Feature Location (intersections & bridges)
5. Segment Marker Location

STRAIGHT LINE DIAGRAM (SLD) ANNUAL REFRESH ATTRIBUTE KEY PAGE 1 OF 2

 SEGMENT MARKER	 AHEAD LEFT INTER STATE OWNED	 RAILROAD CROSSING	 INTERSTATE MILEPOST
 TURNBACK	 AHEAD LEFT INTER NON-STATE	 RAILROAD OVER-PASS	 MFC BEGIN
 NULL	 AHEAD RIGHT INTE STATE OWNED	 OVER-PASS	 MUNICIPAL BOUNDARY
 UNDIVIDED HIGHWAY	 AHEAD RIGHT INTE NON-STATE	 BRIDGE END	 VILLAGE BEGIN
 PHYSICALLY DIVIDED	 BACK LEFT INTER STATE OWNED	 BRIDGE BEGIN	AH - LENGTH FORWARD TO NEXT SEGMENT BEGIN BK - LENGTH BACKWARD TO PREVIOUS SEGMENT BEGIN
 PAINT DIVIDED	 BACK LEFT INTER NON-STATE	 TUNNEL	
 INTERSECTION AHEAD	 BACK RIGHT INTER STATE OWNED	 SIGN STRUCTURE	MFC - MAINTENANCE FUNCTIONAL CLASS A = INTERSTATE EXPRESSWAY AND/OR PRINCIPLE ARTERIAL C = MINOR ARTERIAL D = COLLECTOR E = LOCAL ACCESS F = INTERCHANGE RAMP
 INTERSECTION BACK	 BACK RIGHT INTER NON-STATE	 P3 BRIDGE	
 REFERENCE AHEAD/BACK	 T-LEFT INTERSEC STATE OWNED	 RETAINING WALL	
 DIVIDED CONNECTOR	 T-LEFT INTERSEC NON-STATE	 BRIDGE/CULVERT UNDER FILL	NULL AND TURNBACK SEGMENTS ARE DISPLAYED IN THE DEPARTMENT'S ROADWAY MANAGEMENT SYSTEM (RMS) AS 100 FEET IN LENGTH. ACTUAL SEGMENT AND SECTION LENGTHS MAY VARY SIGNIFICANTLY
 CROSS INTERSEC STATE OWNED	 T-RIGHT INTERSEC STATE OWNED	 PIPE (STAMPP)	
 CROSS INTERSEC NON-STATE	 T-RIGHT INTERSEC NON-STATE	 ROTARY INTERSEC	

EXTRACT DATE: 12/21/2020 ROADWAY MANAGEMENT SYSTEM PAGE NUMBER: 1677
 PRINT DATE: 12/23/2020 SLD COUNTY/SR - ANNUAL PRINT COUNTY: ALLEGHENY
 DIR: S TOTAL LEN: .716 MI. DIST: 11-1 SR: 9460
 LEFT MUN: FINDLAY T RIGHT MUN: FINDLAY T

003779 FT

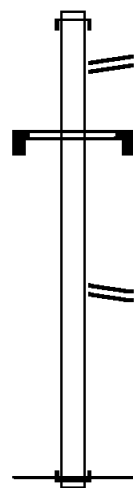

000000 FT

003779 FT
 INTER-AHD AIRPORT PY
 0010/3779 (SR0376 SEG 0514/2641)
 RAMP J RD
 0010/3582 (SR8112 SEG 0010/0000)
 SIGN: 4 CHORD TRUSS
 0010/2930 BMSID 02/0376/0514/1900
 FLAUGHERTY RUN/RAMP 20
 0010/1140 (SR8113 SEG 0510/3646)
 000000 FT 0 0 00000 0 00 0000+00
 NC CONNECTOR RD
 INTER-BK I-376E
 (SR0376 SEG 0510/1430)
 MFC BEGIN = F
 0010/0000 LENGTH(AH 3779 BK 0000)

EXTRACT DATE: 12/21/2020 ROADWAY MANAGEMENT SYSTEM PAGE NUMBER: 1676
 PRINT DATE: 12/23/2020 SLD COUNTY/SR - ANNUAL PRINT COUNTY: ALLEGHENY
 DIR: S TOTAL LEN: .094 MI. DIST: 11-1 SR: 9408
 LEFT MUN: PITTSBURGH C RIGHT MUN: PITTSBURGH C

000498 FT

000000 FT

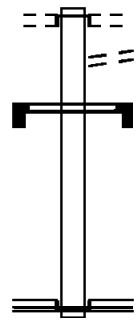

000498 FT
 INTER-AHD GEN ROBINSIN ST
 (CITY)
 ANDERSON ST
 0010/0498 (CITY)
 LC TO ANDERSON ST
 0010/0413 (CONN)
 SIGN: 4 CHORD TRUSS
 0010/0150 BMSID 02/0028/0010/0300
 000000 FT 0 0 00000 0 00 0000+00
 NC GEN ROBINSIN ST
 SR 0028 SH
 (SR0028 SEG 0010/0490)
 INTER-BK RIVER AV
 (CITY)
 MFC BEGIN = F
 0010/0000 LENGTH(AH 0498 BK 0000)

EXTRACT DATE: 12/21/2020 ROADWAY MANAGEMENT SYSTEM PAGE NUMBER: 1675
 PRINT DATE: 12/23/2020 SLD COUNTY/SR - ANNUAL PRINT COUNTY: ALLEGHENY
 DIR: N TOTAL LEN: .045 MI. DIST: 11-1 SR: 9406
 LEFT MUN: PITTSBURGH C RIGHT MUN: PITTSBURGH C

000239 FT
 000000 FT

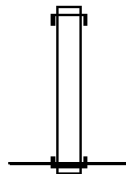

000239 FT
 INTER-AHD SR 0051 SH
 0010/0239 (SR0051 SEG 0441/1062)
 000000 FT 0 0 00000 0 00 0000+00
 NC ST TEUBEN ST CONN RAMP
 INTER-BK CROSS ST
 (SR0060 SEG 0004/0352)
 MFC BEGIN = F
 0010/0000 LENGTH(AH 0239 BK 0000)

EXTRACT DATE: 12/21/2020 ROADWAY MANAGEMENT SYSTEM PAGE NUMBER: 1674
 PRINT DATE: 12/23/2020 SLD COUNTY/SR - ANNUAL PRINT COUNTY: ALLEGHENY
 DIR: S TOTAL LEN: .038 MI. DIST: 11-1 SR: 9405
 LEFT MUN: BALDWIN B RIGHT MUN: BALDWIN B

000198 FT
 000000 FT

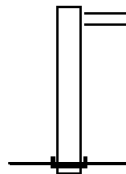

000198 FT KITTANNING ST
 0010/0198 (SR1003 SEG 0100/0102)
 000000 FT 0 0 00000 0 00 0000+00
 NC BU TLER ST CONNECTOR
 INTER-BK WILLIAM FLINN HW
 (SR0008 SEG 0201/0391)
 MFC BEGIN = F
 0010/0000 LENGTH(AH 0198 BK 0000)

EXTRACT DATE: 12/21/2020 ROADWAY MANAGEMENT SYSTEM PAGE NUMBER: 1673
 PRINT DATE: 12/23/2020 SLD COUNTY/SR - ANNUAL PRINT COUNTY: ALLEGHENY
 DIR: N TOTAL LEN: .110 MI. DIST: 11-1 SR: 9404
 LEFT MUN: SCOTT T RIGHT MUN: SCOTT T

000580 FT

000347 FT

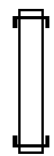

000580 FT
 INTER-AHD GREENTREE RD
 0250/0233 (SR3052 SEG 0151/1092)
 000347 FT 0 0 00000 0 00 0000+00
 NC RAMP B RD
 INTER-BK GREENTREE RD
 (SR0121 SEG 0041/0187)
 0250/0000 LENGTH(AH 0233 BK 0347)

000000 FT

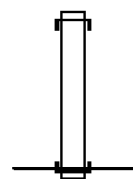

INTER-AHD GREENTREE RD
 0010/0347 (SR0121 SEG 0040/0261)
 000000 FT 0 0 00000 0 00 0000+00
 NC RAMP A RD
 INTER-BK COCHRAN RD
 (SR0121 SEG 0030/0445)
 MFC BEGIN = F
 0010/0000 LENGTH(AH 0347 BK 0000)

EXTRACT DATE: 12/21/2020 ROADWAY MANAGEMENT SYSTEM PAGE NUMBER: 1672
 PRINT DATE: 12/23/2020 SLD COUNTY/SR - ANNUAL PRINT COUNTY: ALLEGHENY
 DIR: B TOTAL LEN: .033 MI. DIST: 11-1 SR: 9403
 LEFT MUN: SHALER T RIGHT MUN: PITTSBURGH C

000172 FT
 000000 FT

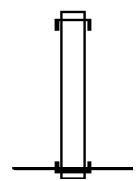

000172 FT
 INTER-AHD BUTLER PLANK RD
 0010/0172 (SR4060 SEG 0030/2180)
 000000 FT 0 0 000000 0 00 0000+00
 NC JU GHANDLE RD
 INTER-BK BUTLER PLANK RD
 (SR4060 SEG 0030/2290)
 MFC BEGIN = F
 0010/0000 LENGTH(AH 0172 BK 0000)

EXTRACT DATE: 12/21/2020 ROADWAY MANAGEMENT SYSTEM PAGE NUMBER: 1671
 PRINT DATE: 12/23/2020 SLD COUNTY/SR - ANNUAL PRINT COUNTY: ALLEGHENY

DIR: S TOTAL LEN: .058 MI. DIST: 11-1 SR: 9402
 LEFT MUN: PITTSBURGH C RIGHT MUN: PITTSBURGH C

SAW MILL RUN BL 000305 FT
 (SR0051 SEG 0421/0182)
 (SR0051 SEG 0420/0170) 0010/0305
 000000 FT

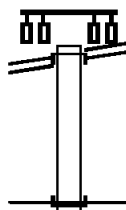

INTER-AHD WOODRUFF ST
 (CITY)
 SAW MILL RUN BL
 000305 FT (SR0051 SEG 0420/0170)
 (SR0051 SEG 0421/0182)
 0010/0305
 000000 FT 0 0 00000 0 00 0000+00
 NC WOODRUFF JUGHANDLE RD
 INTER-BK SAW MILL RUN BL
 (SR0051 SEG 0421/0468)
 MFC BEGIN = F
 0010/0000 LENGTH(AH 0305 BK 0000)

EXTRACT DATE: 12/21/2020 ROADWAY MANAGEMENT SYSTEM PAGE NUMBER: 1670
 PRINT DATE: 12/23/2020 SLD COUNTY/SR - ANNUAL PRINT COUNTY: ALLEGHENY
 DIR: E TOTAL LEN: .071 MI. DIST: 11-1 SR: 9401
 LEFT MUN: ROSS T RIGHT MUN: ROSS T

000375 FT

000375 FT
 INTER-AHD NELSON RUN RD
 (TWP)
 MCKNIGHT RD
 (SR4003 SEG 0017/0000)
 (SR4003 SEG 0016/0000)
 MCKNIGHT RD
 (SR4003 SEG 0016/0000)
 (SR4003 SEG 0017/0000)
 0010/0375
 000000 FT 0 0 00000 0 00 0000+00
 NC NE NELSON RUN JUGHANDLE RD
 INTER-BK MCKNIGHT RD
 (SR4003 SEG 0017/0260)
 MFC BEGIN = F
 0010/0000 LENGTH(AH 0375 BK 0000)

000000 FT

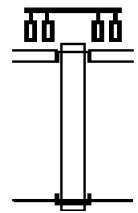

EXTRACT DATE: 12/21/2020 ROADWAY MANAGEMENT SYSTEM PAGE NUMBER: 1669
 PRINT DATE: 12/23/2020 SLD COUNTY/SR - ANNUAL PRINT COUNTY: ALLEGHENY
 DIR: N TOTAL LEN: .050 MI. DIST: 11-1 SR: 9301
 LEFT MUN: PITTSBURGH C RIGHT MUN: PITTSBURGH C

000263 FT
 000000 FT

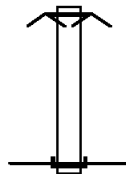

000263 FT CRASH BARRIER
 0010/0263 ROAD CLOSED AHEAD
 000000 FT 0 0 00000 0 00 0000+00
 NC TRUCK ESCAPE RAMP
 INTER-BK PENN LINCOLN PY
 (SR0376 SEG 0680/2553)
 MFC BEGIN = F
 0010/0000 LENGTH(AH 0263 BK 0000)

EXTRACT DATE: 12/21/2020 ROADWAY MANAGEMENT SYSTEM PAGE NUMBER: 1668
 PRINT DATE: 12/23/2020 SLD COUNTY/SR - ANNUAL PRINT COUNTY: ALLEGHENY
 DIR: B TOTAL LEN: .551 MI. DIST: 11-1 SR: 9202
 LEFT MUN: SOUTH FAYETTE T RIGHT MUN: SOUTH FAYETTE T

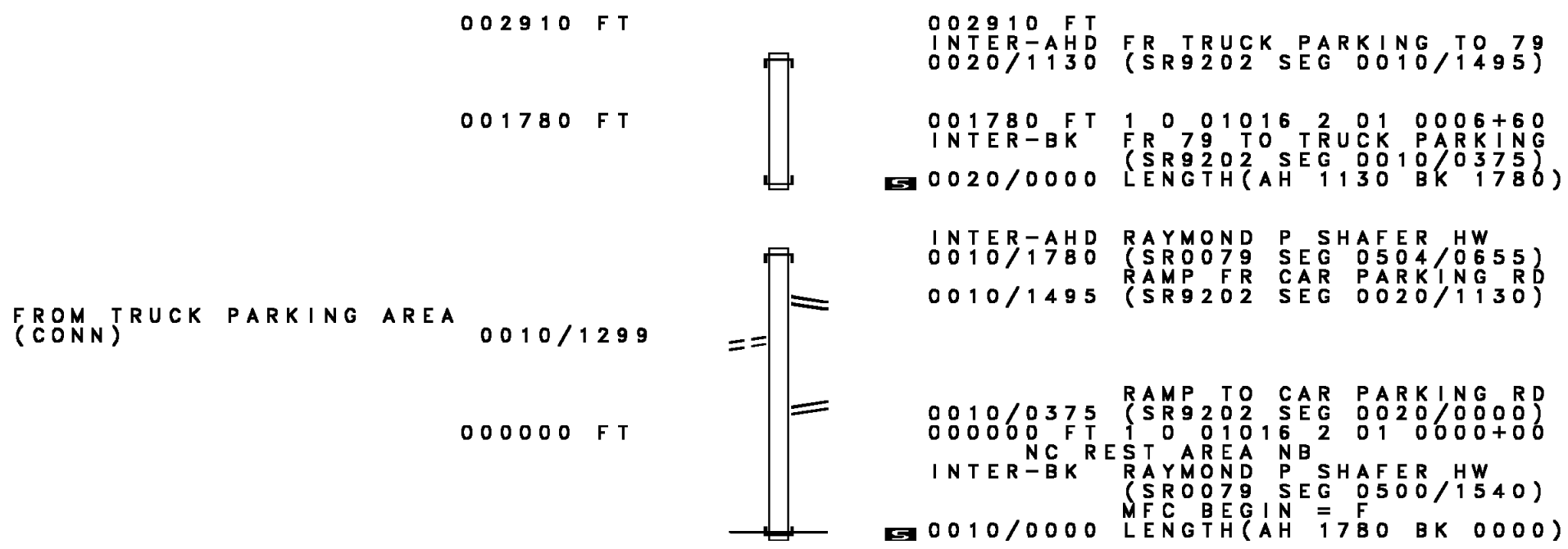

FROM TRUCK PARKING AREA
(CONN)

002910 FT

001780 FT

0010/1299

000000 FT

002910 FT
 INTER-AHD FR TRUCK PARKING TO 79
 (SR9202 SEG 0010/1495)

001780 FT 1 0 01016 2 01 0006+60
 INTER-BK FR 79 TO TRUCK PARKING
 (SR9202 SEG 0010/0375)
 S 0020/0000 LENGTH(AH 1130 BK 1780)

INTER-AHD RAYMOND P SHAFER HW
 0010/1780 (SR0079 SEG 0504/0655)
 RAMP FR CAR PARKING RD
 0010/1495 (SR9202 SEG 0020/1130)

0010/0375 RAMP TO CAR PARKING RD
 (SR9202 SEG 0020/0000)
 000000 FT 1 0 01016 2 01 0000+00
 INTER-BK NC REST AREA NB
 RAYMOND P SHAFER HW
 (SR0079 SEG 0500/1540)
 MFC BEGIN = F
 S 0010/0000 LENGTH(AH 1780 BK 0000)

DIR: B TOTAL LEN: .560 MI. DIST: 11-1 SR: 9201
 LEFT MUN: SOUTH FAYETTE T RIGHT MUN: SOUTH FAYETTE T

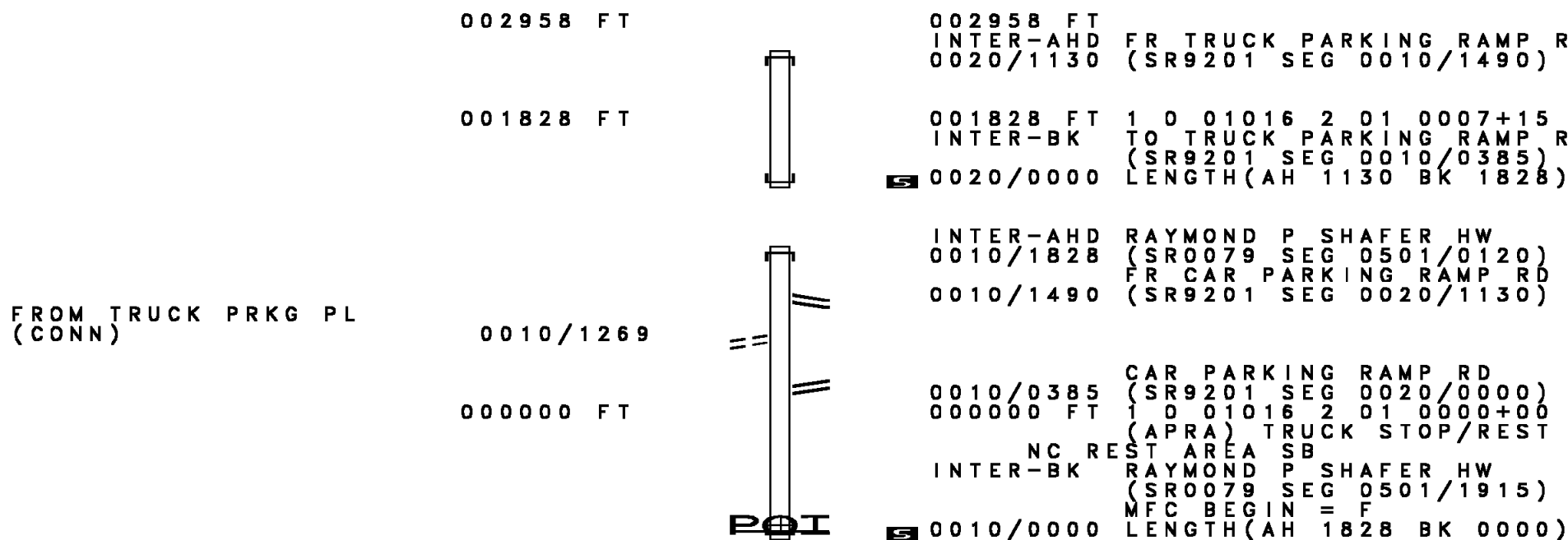

000966 FT

000966 FT
 INTER-AHD

LIBRARY RD
 (SR0088 SEG 0170/2302)
 SAW MILL RUN BL
 (SR0051 SEG 0340/0000)
 (SR0051 SEG 0341/0000)
 SAW MILL RUN BL
 (SR0051 SEG 0341/0000)
 (SR0051 SEG 0340/0000)

0010/0966

TO 0051/0340 SH

0010/0869

(CONN)
 IVYGLLEN ST
 (CITY)

0010/0863

0010/0376

BMSSEN 02/9120/0010/0330
 0 0 00000 0 00 0000+00

0010/0330

WEYMAN RUN
 BMSBG 02/9120/0010/0330
 0 0 00000 0 00 0000+00

000000 FT

000000 FT

NC SR 9120 CONNECTOR RD

INTER-BK

SAW MILL RUN BL
 (SR0051 SEG 0330/0817)

MFC BEGIN = F

0010/0000

LENGTH(AH 0966 BK 0000)

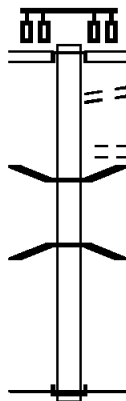

EXTRACT DATE: 12/21/2020 ROADWAY MANAGEMENT SYSTEM PAGE NUMBER: 1665
 PRINT DATE: 12/23/2020 SLD COUNTY/SR - ANNUAL PRINT COUNTY: ALLEGHENY
 DIR: S TOTAL LEN: .092 MI. DIST: 11-1 SR: 9115
 LEFT MUN: PITTSBURGH C RIGHT MUN: PITTSBURGH C

STEWART AV 000485 FT
 (SR3035 SEG 0030/0916) 0010/0485

000000 FT

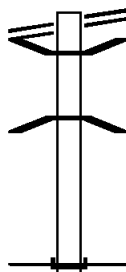

000485 FT PROVOST RD
 0010/0485 (SR3035 SEG 0030/0916)
 0010/0381 BMSSEN 02/9115/0010/0365
 0 0 00000 0 00 0000+00
 SAW MILL RUN
 0010/0365 BMSBG 02/9115/0010/0365
 000000 FT 0 0 00000 0 00 0000+00
 NC FA IRHAVEN RD
 INTER-BK SAW MILL RUN BL
 (SR0051 SEG 0331/0678)
 MFC BEGIN = F
 0010/0000 LENGTH(AH 0485 BK 0000)

EXTRACT DATE: 12/21/2020 ROADWAY MANAGEMENT SYSTEM PAGE NUMBER: 1664
 PRINT DATE: 12/23/2020 SLD COUNTY/SR - ANNUAL PRINT COUNTY: ALLEGHENY
 DIR: S TOTAL LEN: .258 MI. DIST: 11-1 SR: 9113
 LEFT MUN: MARSHALL T RIGHT MUN: MARSHALL T

001361 FT

000000 FT

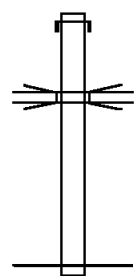

001361 FT
 INTER-AHD RAYMOND P SHAFER HW
 0010/1361 (SR0079 SEG 0771/1050)

SR 4054 FREEPORT R
 0010/0480 OP ID 02/4054/0010/0860
 000000 FT 0 0 00000 0 00 0000+00
 NC CO LLECTOR RD
 * REF-BK SR 9479 COLLECTOR RD
 (SR9479 SEG 0030/3281)
 MFC BEGIN = F
 BK-BUTLER (10)
 0010/0000 LENGTH(AH 1361 BK 0000)

EXTRACT DATE: 12/21/2020 ROADWAY MANAGEMENT SYSTEM PAGE NUMBER: 1663
 PRINT DATE: 12/23/2020 SLD COUNTY/SR - ANNUAL PRINT COUNTY: ALLEGHENY
 DIR: E TOTAL LEN: .044 MI. DIST: 11-1 SR: 9112
 LEFT MUN: MOON T RIGHT MUN: MOON T

000230 FT
 000000 FT

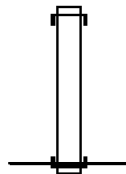

000230 FT
 INTER-AHD MONTOUR RUN RD
 0010/0230 (SR3072 SEG 0004/0300)
 000000 FT 0 0 00000 0 00 0000+00
 NC MONTOUR INT/RMP B SPUR RD
 INTER-BK MONTOUR RUN RD
 (SR3112 SEG 0010/0950)
 MFC BEGIN = F
 0010/0000 LENGTH(AH 0230 BK 0000)

EXTRACT DATE: 12/21/2020 ROADWAY MANAGEMENT SYSTEM PAGE NUMBER: 1662
 PRINT DATE: 12/23/2020 SLD COUNTY/SR - ANNUAL PRINT COUNTY: ALLEGHENY
 DIR: N TOTAL LEN: .249 MI. DIST: 11-1 SR: 9111
 LEFT MUN: WHITAKER B RIGHT MUN: WHITAKER B

001314 FT

000508 FT

000000 FT

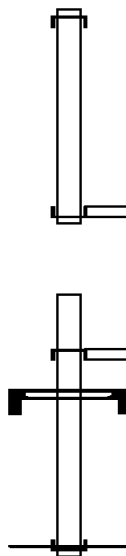

001314 FT
 INTER-AHD EIGHTH AV
 0020/0806 (SR0837 SEG 0360/0000)

000508 FT 0 0 00000 0 00 0000+00
 NC RAMP FR RANKIN BR
 RANKIN BR
 (CNTY)
 INTER-BK RAMP TO RANKIN BR
 (SR9111 SEG 0010/0508)
 0020/0000 LENGTH(AH 0806 BK 0508)

INTER-AHD RAMP FM RANKIN BR
 (SR9111 SEG 0020/0000)
 RANKIN BR
 0010/0508 (CNTY)
 SIGN: CANTILEVER
 0010/0026 BMSID 02/0837/0350/0000
 000000 FT 0 0 00000 0 00 0000+00
 NC RAMP TO RANKIN BR
 INTER-BK EIGHTH AV
 (SR0837 SEG 0350/0000)
 MFC BEGIN = F
 0010/0000 LENGTH(AH 0508 BK 0000)

EXTRACT DATE: 12/21/2020 ROADWAY MANAGEMENT SYSTEM PAGE NUMBER: 1661
PRINT DATE: 12/23/2020 SLD COUNTY/SR - ANNUAL PRINT COUNTY: ALLEGHENY

DIR: E TOTAL LEN: .034 MI. DIST: 11-1 SR: 9110
LEFT MUN: HARMAR T RIGHT MUN: HARMAR T

000180 FT
GULF LAB RD
(SR1008 SEG 0010/0154) 0010/0180
2 0 02215 4 00 0000+00 000000 FT
GIBSONIA RD
(SR0910 SEG 0451/0790) 0010/0000

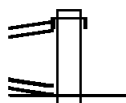

000180 FT
INTER-AHD GULF LAB RD
(SR1008 SEG 0010/0154)
000000 FT
NC CONN TO GULF LAB RD
MFC BEGIN = F
0010/0000 LENGTH(AH 0180 BK 0000)

EXTRACT DATE: 12/21/2020 ROADWAY MANAGEMENT SYSTEM PAGE NUMBER: 1660
 PRINT DATE: 12/23/2020 SLD COUNTY/SR - ANNUAL PRINT COUNTY: ALLEGHENY
 DIR: B TOTAL LEN: .195 MI. DIST: 11-1 SR: 9109
 LEFT MUN: EAST DEER T RIGHT MUN: EAST DEER T

001030 FT

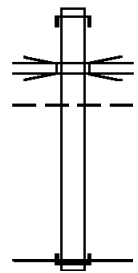

000000 FT

001030 FT
 INTER-AHD FREEPORT RD
 0010/1030 (SR1001 SEG 0330/0540)
 SR 1038
 0010/0490 OP ID 02/1038/0010/0059
 EAST DEER
 0010/0243 SPRINGDALE T
 000000 FT 0 0 00000 0 00 0000+00
 NC SPUR
 INTER-BK FREEPORT RD
 (SR1001 SEG 0320/2633)
 MFC BEGIN = B
 0010/0000 LENGTH(AH 1030 BK 0000)

EXTRACT DATE: 12/21/2020 ROADWAY MANAGEMENT SYSTEM PAGE NUMBER: 1659
PRINT DATE: 12/23/2020 SLD COUNTY/SR - ANNUAL PRINT COUNTY: ALLEGHENY

DIR: B TOTAL LEN: .211 MI. DIST: 11-1 SR: 9108
LEFT MUN: OHARA T RIGHT MUN: OHARA T

TO 1001/0140 SH
(CONN)

001112 FT

0010/0885

0 0 00000 0 00 0000+00 000000 FT
FREEPORT RD
(SR1002 SEG 0021/0697) 0010/0000

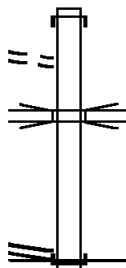

001112 FT
INTER-AHD FREEPORT RD
0010/1112 (SR1001 SEG 0140/1618)

SR 1002 EB
0010/0690 OP ID 02/1002/0020/0000

NC SPUR
INTER-BK FREEPORT RD
000000 FT (SR1001 SEG 0151/0000)

MFC BEGIN = F
0010/0000 LENGTH(AH 1112 BK 0000)

EXTRACT DATE: 12/21/2020 ROADWAY MANAGEMENT SYSTEM PAGE NUMBER: 1658
 PRINT DATE: 12/23/2020 SLD COUNTY/SR - ANNUAL PRINT COUNTY: ALLEGHENY
 DIR: B TOTAL LEN: .082 MI. DIST: 11-1 SR: 9107
 LEFT MUN: ETNA BOROUGH B RIGHT MUN: ETNA BOROUGH B

BRIDGE ST 000435 FT
 (SR1001 SEG 0040/1210) 0010/0435

0 0 00000 0 00 0000+00 000000 FT
 NORTH MAIN ST
 (SR1001 SEG 0040/1732) 0010/0000

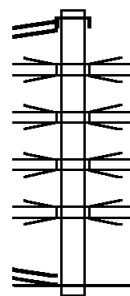

000435 FT
 INTER-AHD NORTH MAIN ST
 0010/0435 (SR1001 SEG 0040/1210)
 SR 8 SB
 0010/0392 OP ID 02/0008/0181/2418
 SR 8 NB
 0010/0335 OP ID 02/0008/0180/2416
 TR 28 S.B.
 0010/0290 OP ID 02/0028/0141/0000
 ALLEGHENY VAL EXPY
 0010/0130 OP ID 02/0028/0140/0000
 NC Y CONN
 MFC BEGIN = F
 0010/0000 LENGTH(AH 0435 BK 0000)

000514 FT

000274 FT

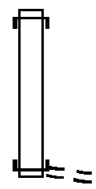

000514 FT
 INTER-AHD UNION AV
 0020/0240 (SR0978 SEG 0100/2414)
 000274 FT 0 0 00000 0 00 0000+00
 BOYS HOME RD
 (TWP)
 INTER-BK BATTLE RIDGE RD
 (SR3024 SEG 0060/0192)
 0020/0000 LENGTH(AH 0240 BK 0274)

000000 FT

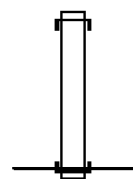

INTER-AHD BATTLE RIDGE RD
 0010/0274 (SR0978 SEG 0100/2004)
 000000 FT 0 0 00000 0 00 0000+00
 NC LEG A
 INTER-BK UNION AV
 (SR0978 SEG 0100/2414)
 MFC BEGIN = F
 0010/0000 LENGTH(AH 0274 BK 0000)

DIR: N TOTAL LEN: .117 MI. DIST: 11-1 SR: 9103
 LEFT MUN: MOON T RIGHT MUN: MOON T

UNIVERSITY BL 000620 FT
 (SR3109 SEG 0071/3095) 0020/0215
 0 0 00000 0 00 0000+00 000405 FT
 STOOPS FERRY RD
 (SR0051 SEG 0761/0240) 0020/0000

STOOPS FERRY RD
 (SR0051 SEG 0760/0360) 0010/0405
 0 0 00000 0 00 0000+00 000000 FT
 UNIVERSITY BL
 (SR0051 SEG 0750/2680) 0010/0000

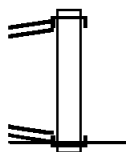
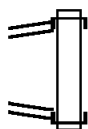

000620 FT
 INTER-AHD UNIVERSITY BL
 0020/0215 (SR3109 SEG 0071/3095)
 000405 FT OOPS FERRY INT/RMP D RD
 INTER-BK STOOPS FERRY RD
 (SR0051 SEG 0761/0240)
 0020/0000 LENGTH(AH 0215 BK 0405)

INTER-AHD STOOPS FERRY RD
 0010/0405 (SR0051 SEG 0760/0360)
 NC ST OOPS FERRY INT/RMP C RD
 INTER-BK UNIVERSITY BL
 000000 FT (SR0051 SEG 0750/2680)
 MFC BEGIN = F
 0010/0000 LENGTH(AH 0405 BK 0000)

EXTRACT DATE: 12/21/2020 ROADWAY MANAGEMENT SYSTEM PAGE NUMBER: 1655
 PRINT DATE: 12/23/2020 SLD COUNTY/SR - ANNUAL PRINT COUNTY: ALLEGHENY
 DIR: S TOTAL LEN: .099 MI. DIST: 11-1 SR: 9101
 LEFT MUN: PITTSBURGH C RIGHT MUN: PITTSBURGH C

0 0 00000 0 00 0000+00 000000 FT
 WESTERN AV
 (TBC)
 0010/0000

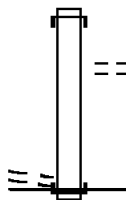

000521 FT
 INTER-AHD CHATEAU ST
 0010/0521 (SR3919 SEG 0010/0084)
 MANHATTAN ST
 0010/0055 (CITY)
 NC RAMP RD/TO CHATEAU ST
 INTER-BK WESTERN AV
 000000 FT (TBC)
 MFC BEGIN = F
 0010/0000 LENGTH(AH 0521 BK 0000)

002879 FT

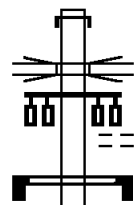

002879 FT
 INTER-AHD SAW MILL RUN BL
 0750/0800 (SR0051 SEG 0400/0125)
 BUSWAY LRT
 0750/0615 OP ID 02/7301/0000/9101
 WARRINGTON AV
 (CITY)

002079 FT

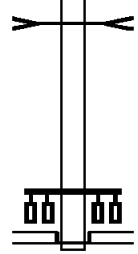

0750/0560 SIGN: 4 CHORD TRUSS
 0750/0440 BMSID 02/0051/0396/0585
 SAW MILL RUN
 STRUCTURE LENGTH 58 FT
 0750/0325 BMSID 02/0051/0396/0565
 002079 FT 1 0 00000 0 00 0000+00
 NC LI LIBERTY TN INT/RMP D RD
 WEST LIBERTY AV
 (SR3069 SEG 0090/0077)
 (SR3069 SEG 0091/0088)

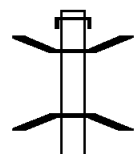

INTER-BK LIBERTY TN INT/RMP A RD
 (SR8151 SEG 0010/0568)
 0750/0000 LENGTH(AH 0800 BK 0555)

001524 FT

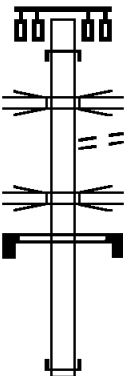

INTER-AHD PA 51 SB SAW MILL RUN B
 0510/0555 (SR0051 SEG 0397/0245)
 0510/0528 BMSEN 02/8151/0510/0420
 0 0 00000 0 00 0000+00
 RAMP C (8151 SB)
 0510/0420 BMSBG 02/8151/0510/0420
 001524 FT 1 0 00000 0 00 0000+00

DIR: N TOTAL LEN: .545 MI. DIST: 11-1 SR: 8151
 LEFT MUN: PITTSBURGH C RIGHT MUN: PITTSBURGH C

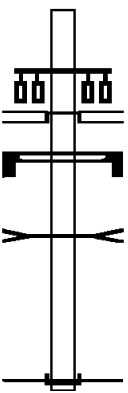
		NC LIBERTY TN INT/RMP E RD INTER-BK WEST LIBERTY AV (SR3069 SEG 0081/0664) 0510/0000 LENGTH(AH 0555 BK 0510)
		INTER-AHD WEST LIBERTY AV (SR3069 SEG 0091/0012) 0500/0510 SR 0051 NB 0500/0491 OP ID 02/0051/0396/0000 TO 3069/0081 SH 0500/0321 (CONN) RAMP E (8151 SB) 0500/0260 OP ID 02/8151/0510/0420 SIGN: 2 CHORD TRUSS 0500/0236 BMSID 02/8151/0500/0215 001014 FT 1 0 00000 0 00 0000+00 NC LIBERTY TN INT/RMP C RD INTER-BK SAW MILL RUN BL (SR0051 SEG 0397/0590) 0500/0000 LENGTH(AH 0510 BK 0446)
001014 FT		
		INTER-AHD SAW MILL RUN BL 0250/0445 (SR0051 SEG 0387/0852) 000568 FT 1 0 00000 0 00 0000+00 NC LIBERTY TN INT/RMP B RD INTER-BK WEST LIBERTY AV (SR3069 SEG 0080/0673) 0250/0000 LENGTH(AH 0446 BK 0568)
000568 FT		
		INTER-AHD RAMP D RD (SR8151 SEG 0750/0000) WEST LIBERTY AV (SR3069 SEG 0090/0077) (SR3069 SEG 0091/0088) 0010/0568 SIGN: 2 CHORD TRUSS 0010/0300 BMSID 02/8151/0010/0300 SAW MILL RUN STRUCTURE LENGTH 58 FT 0010/0040 BMSID 02/0051/0386/0860 000000 FT 1 0 00000 0 00 0000+00 NC LIBERTY TN INT/RMP A RD INTER-BK SAW MILL RUN BL (SR0051 SEG 0386/0905) MFC BEGIN = F 0010/0000 LENGTH(AH 0568 BK 0000)
000000 FT		

001153 FT

000684 FT

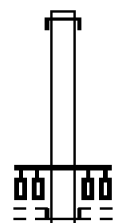

001153 FT
 INTER-AHD SR 0279 SH
 0750/0469 (SR0279 SEG 0032/0424)
 000684 FT 0 0 00000 0 00 0000+00
 NC HAZLETT ST INT/RAMP E RD
 EAST ST
 (CITY)

INTER-BK HAZLETT ST
 (CITY)
 0750/0000 LENGTH(AH 0469 BK 0684)

INTER-AHD HAZLETT ST
 (CITY)
 EAST ST
 (CITY)

0010/0684
 000000 FT 0 0 00000 0 00 0000+00
 NC HAZLETT ST INT/RAMP C RD
 INTER-BK SR 0279 SH
 (SR0279 SEG 0026/2084)
 MFC BEGIN = F
 0010/0000 LENGTH(AH 0684 BK 0000)

000000 FT

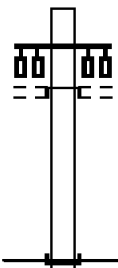

EXTRACT DATE: 12/21/2020 ROADWAY MANAGEMENT SYSTEM PAGE NUMBER: 1651
 PRINT DATE: 12/23/2020 SLD COUNTY/SR - ANNUAL PRINT COUNTY: ALLEGHENY
 DIR: E TOTAL LEN: .277 MI. DIST: 11-1 SR: 8130
 LEFT MUN: STOWE T RIGHT MUN: STOWE T



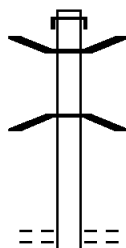





001460 FT

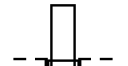

001105 FT

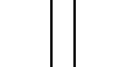
001460 FT
 INTER-AHD MCKEES ROCKS BR
 0750/0355 (SR3104 SEG 0020/0405)
 0750/0235 BMSSEN 02/3104/0020/0260
 0 00000 0 0 0000+00
 PED UNDERPAS
 0750/0221 BMSBG 02/3104/0020/0260
 001105 FT 0 0 00000 0 00 0000+00
 NC MCKEES RKS BR/RP 750 RD
 HELEN ST
 (BORO)
 INTER-BK RAMP 10 RD

DIR: E TOTAL LEN: .277 MI. DIST: 11-1 SR: 8130
 LEFT MUN: STOWE T RIGHT MUN: STOWE T

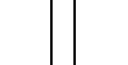
		0750/0000 (SR8130 SEG 0010/0360) LENGTH(AH 0355 BK 0370)
		INTER-AHD RAMP 250 RD (SR8130 SEG 0250/0000) HELEN ST (BORO)
000735 FT		0500/0370 0500/0158 BMSSEN 02/3104/0020/0260 0 00000 0 0 0000+00 PED UNDERPAS BMSBG 02/3104/0020/0260 000735 FT 0 0 00000 0 00 0000+00 NC MC KEES RKS BR/RP 500 RD
		INTER-BK MCKEES ROCKS BR (SR3104 SEG 0020/0405) 0500/0000 LENGTH(AH 0370 BK 0375)
		INTER-AHD MCKEES ROCKS BR 0250/0375 (SR3104 SEG 0011/0904) 0250/0319 BMSSEN 02/3104/0010/1095 0 00000 0 0 0000+00 MUNSON AVE. BMSBG 02/3104/0010/1095 000360 FT 0 0 00000 0 00 0000+00 NC MC KEES RKS BR/RP 250 RD
000360 FT		INTER-BK RAMP 500 RD (SR8130 SEG 0500/0370) 0250/0000 LENGTH(AH 0375 BK 0360)
		INTER-AHD RAMP 750 RD (SR8130 SEG 0750/0000) HELEN ST (BORO)
		0010/0360 0010/0108 BMSSEN 02/3104/0010/1095 0 00000 0 0 0000+00 MUNSON AVE. BMSBG 02/3104/0010/1095 0010/0050 SIGN: CANTILEVER
000000 FT		0010/0010 BMSID 02/8130/0010/0000 000000 FT 0 0 00000 0 00 0000+00 NC MC KEES RKS BR/RP 10 RD
		INTER-BK MCKEES ROCKS BR (SR3104 SEG 0010/0929) MFC BEGIN = F 0010/0000 LENGTH(AH 0360 BK 0000)

DIR: N TOTAL LEN: .738 MI. DIST: 11-1 SR: 8129
 LEFT MUN: HARRISON T RIGHT MUN: HARRISON T

003897 FT

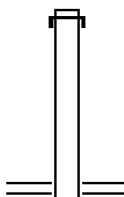

003897 FT
 INTER-AHD ALLEGHENY VALLEY EX
 0750/1117 (SR0028 SEG 0010/0319)

002780 FT

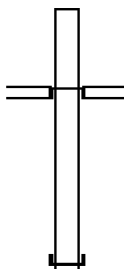

002780 FT 0 0 00000 0 00 0000+00
 NC MI LLERSTOWN INT/RMP L RD
 BAKERSTOWN RD
 (SR1028 SEG 0281/1152)
 0750/0000 LENGTH(AH 1117 BK 0909)

001871 FT

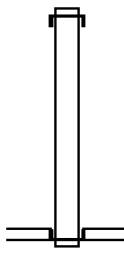

INTER-AHD MILLERSTOWN INT/RMP I R
 (SR8129 SEG 0250/0000)
 BAKERSTOWN RD
 (SR1028 SEG 0280/0573)
 (SR1028 SEG 0281/0569)
 0500/0909

001871 FT 0 0 00000 0 00 0000+00
 NC MI LLERSTOWN INT/RMP K RD
 INTER-BK ALLEGHENY VALLEY EX
 (SR0028 SEG 0491/1307)
 0500/0000 LENGTH(AH 0909 BK 0748)

001123 FT

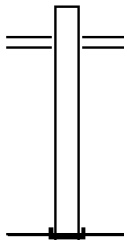

INTER-AHD ALLEGHENY VALLEY EX
 0250/0748 (SR0028 SEG 0481/1151)

001123 FT 0 0 00000 0 00 0000+00
 NC MI LLERSTOWN INT/RMP I RD
 BAKERSTOWN RD
 (SR1028 SEG 0281/0569)
 (SR1028 SEG 0280/0573)
 INTER-BK MILLERSTOWN INT/RMP K RD
 (SR8129 SEG 0500/0909)
 0250/0000 LENGTH(AH 0748 BK 1123)

000000 FT

BAKERSTOWN RD
 (SR1028 SEG 0281/1136)
 (SR1028 SEG 0280/1113)
 0010/1123

000000 FT 0 0 00000 0 00 0000+00
 NC MI LLERSTOWN INT/RMP J RD
 INTER-BK ALLEGHENY VALLEY EX
 (SR0028 SEG 0480/1320)
 MFC BEGIN = F
 0010/0000 LENGTH(AH 1123 BK 0000)

EXTRACT DATE: 12/21/2020 ROADWAY MANAGEMENT SYSTEM PAGE NUMBER: 1648
 PRINT DATE: 12/23/2020 SLD COUNTY/SR - ANNUAL PRINT COUNTY: ALLEGHENY
 DIR: S TOTAL LEN: 1.191 MI. DIST: 11-1 SR: 8128
 LEFT MUN: FINDLAY T RIGHT MUN: FINDLAY T

006287 FT

006287 FT
 INTER-AHD RAMP 250 RD
 (SR8128 SEG 0250/0000)
 MCCLAREN RD
 (SR3070 SEG 0107/0634)
 0500/1290 (SR3070 SEG 0106/0634)

004997 FT

004997 FT 0 0 00000 0 00 0000+00
 NC MCCLAREN INT/RMP 500 RD
 INTER-BK I-376 W
 (SR0376 SEG 0565/0565)
 0500/0000 LENGTH(AH 1290 BK 1448)

INTER-AHD I-376 W
 0250/1448 (SR0376 SEG 0561/0534)

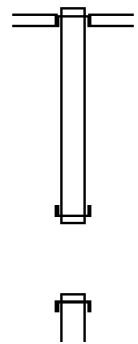

DIR: S TOTAL LEN: 1.191 MI. DIST: 11-1 SR: 8128
 LEFT MUN: FINDLAY T RIGHT MUN: FINDLAY T

003549 FT

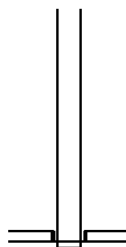

003549 FT 0 0 00000 0 00 0000+00
 NC MCCLAREN INT/RMP 250 RD
 MCCLAREN RD
 (SR3070 SEG 0107/0634)
 (SR3070 SEG 0106/0634)
 INTER-BK RAMP 10 RD
 (SR8128 SEG 0500/1290)
 0250/0000 LENGTH(AH 1448 BK 1629)

001920 FT

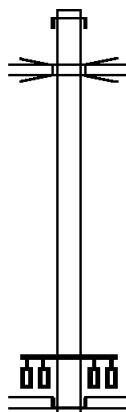

INTER-AHD I-376 N
 0020/1629 (SR0376 SEG 0560/2208)
 SR 3070 MCCLAREN E
 0020/1533 OP ID 02/3070/0106/0000
 001920 FT 0 0 00000 0 00 0000+00
 NC MCCLAREN INT/RMP 20 RD
 MCCLAREN RD (TBK)
 (TWP)
 MCCLAREN RD
 (SR3070 SEG 0104/0000)
 INTER-BK INDUSTRY DR
 (T354)
 0020/0000 LENGTH(AH 1629 BK 1920)

000000 FT

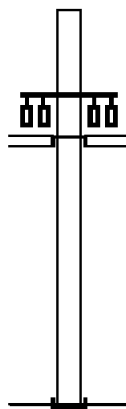

INTER-AHD INDUSTRY DR
 (T354)
 MCCLAREN RD
 (SR3070 SEG 0104/0000)
 MCCLAREN RD (TBK)
 (TWP)
 0010/1920
 000000 FT 0 0 00000 0 00 0000+00
 NC MCCLAREN INT/RMP 10 RD
 INTER-BK SR 0060 SH
 (SR0376 SEG 0560/0676)
 MFC BEGIN = F
 0010/0000 LENGTH(AH 1920 BK 0000)

002160 FT

002160 FT
 INTER-AHD STOOPS FERRY RD
 0750/1115 (SR0051 SEG 0750/0000)

001045 FT

001045 FT 0 0 00000 0 00 0000+00
 NC RAMP FR SEWICKLEY BR
 SEWICKLEY BR
 (SR4025 SEG 0010/0032)

INTER-BK RAMP TO SEWICKLEY BR
 (SR8127 SEG 0010/1045)
 0750/0000 LENGTH(AH 1115 BK 1045)

INTER-AHD RAMP FR SEWICKLEY BR
 (SR8127 SEG 0750/0000)
 SEWICKLEY BR
 (SR4025 SEG 0010/0032)

0010/1045

000000 FT

000000 FT 0 0 00000 0 00 0000+00
 NC RAMP TO SEWICKLEY BR
 INTER-BK STOOPS FERRY RD
 (SR0051 SEG 0740/0570)
 MFC BEGIN = F
 0010/0000 LENGTH(AH 1045 BK 0000)

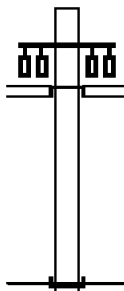
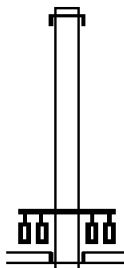

EXTRACT DATE: 12/21/2020 ROADWAY MANAGEMENT SYSTEM PAGE NUMBER: 1645
 PRINT DATE: 12/23/2020 SLD COUNTY/SR - ANNUAL PRINT COUNTY: ALLEGHENY
 DIR: N TOTAL LEN: .127 MI. DIST: 11-1 SR: 8126
 LEFT MUN: MCCANDLESS T RIGHT MUN: MCCANDLESS T

000670 FT

000000 FT

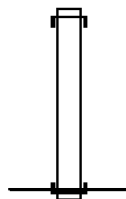

000670 FT
 INTER-AHD PEEBLES RD
 0010/0670 (SR4064 SEG 0010/0760)
 000000 FT 0 0 00000 0 00 0000+00
 NC RAMP A RD
 INTER-BK MCKNIGHT RD
 (SR4003 SEG 0090/2846)
 MFC BEGIN = F
 0010/0000 LENGTH(AH 0670 BK 0000)

EXTRACT DATE: 12/21/2020 ROADWAY MANAGEMENT SYSTEM PAGE NUMBER: 1644
 PRINT DATE: 12/23/2020 SLD COUNTY/SR - ANNUAL PRINT COUNTY: ALLEGHENY
 DIR: N TOTAL LEN: .456 MI. DIST: 11-1 SR: 8125
 LEFT MUN: PITTSBURGH C RIGHT MUN: PITTSBURGH C

002408 FT

001806 FT

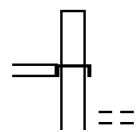
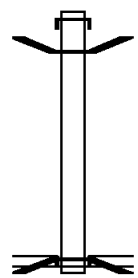

002408 FT
 INTER-AHD EAST OHIO ST
 0750/0602 (SR0028 SEG 0050/0742)
 0750/0347 BMSSEN 02/8125/0750/0000
 001806 FT 0 0 00000 0 00 0000+00
 NC RAMP D
 THIRTYFIRST ST BR
 (SR2122 SEG 0010/0085)
 INTER-BK RAMP E
 (SR8125 SEG 0010/0510)
 NO UNDERPASS INFORMATIO
 BMSBG 02/8125/0750/0000
 0750/0000 LENGTH(AH 0602 BK 0756)
 INTER-AHD RAMP F
 (SR8125 SEG 0250/0000)
 THIRTYFIRST ST BR
 0500/0756 (SR2122 SEG 0010/0000)
 RIALTO ST
 0500/0724 (CITY)

DIR: N TOTAL LEN: .456 MI. DIST: 11-1 SR: 8125
 LEFT MUN: PITTSBURGH C RIGHT MUN: PITTSBURGH C

001050 FT

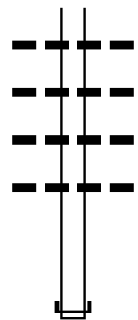

0500/0700 030 " DIA CIRC CONCR
 LEN=0030 INSTALLED 2013
 0500/0258 024 " DIA CIRC CONCR
 LEN=0020 INSTALLED 2013
 0500/0159 024 " DIA CIRC CONCR
 LEN=0023 INSTALLED 2013
 0500/0124 024 " DIA CIRC CONCR
 LEN=0041 INSTALLED 2013
 001050 FT 0 0 00000 0 00 0000+00
 NC RAMP C
 INTER-BK EAST OHIO ST
 (SR0028 SEG 0051/0840)
 0500/0000 LENGTH(AH 0756 BK 0540)

000510 FT

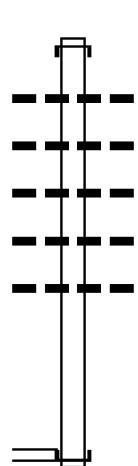

0250/0540 INTER-AHD EAST OHIO ST
 (SR0028 SEG 0041/1139)
 0250/0474 024 " DIA CIRC CONCR
 LEN=0020 INSTALLED 2013
 0250/0308 024 " DIA CIRC CONCR
 LEN=0009 INSTALLED 2013
 0250/0141 024 " DIA CIRC CONCR
 LEN=0020 INSTALLED 2013
 0250/0076 024 " DIA CIRC CONCR
 LEN=0011 INSTALLED 2013
 0250/0042 030 " DIA CIRC CONCR
 LEN=0012 INSTALLED 2013
 000510 FT 0 0 00000 0 00 0000+00
 NC RAMP F
 THIRTYFIRST ST BR
 (SR2122 SEG 0010/0000)
 INTER-BK RAMP C
 (SR8125 SEG 0500/0756)
 0250/0000 LENGTH(AH 0540 BK 0510)

000000 FT

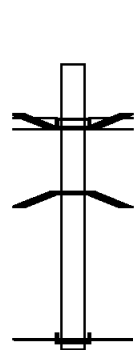

0010/0510 INTER-AHD BMS EN 02/8125/0010/0000
 RAMP D
 (SR8125 SEG 0750/0000)
 THIRTYFIRST ST BR
 (SR2122 SEG 0010/0085)
 0010/0250 0 0 00000 0 00 0000+00
 NO UNDERPASS INFORMATION
 BMSBG 02/8125/0010/0000
 000000 FT 0 0 00000 0 00 0000+00
 NC RAMP E
 INTER-BK EAST OHIO ST
 (SR0028 SEG 0040/1095)
 MFC BEGIN = F
 0010/0000 LENGTH(AH 0510 BK 0000)

EXTRACT DATE: 12/21/2020 ROADWAY MANAGEMENT SYSTEM PAGE NUMBER: 1642
 PRINT DATE: 12/23/2020 SLD COUNTY/SR - ANNUAL PRINT COUNTY: ALLEGHENY
 DIR: W TOTAL LEN: .071 MI. DIST: 11-1 SR: 8124
 LEFT MUN: EAST PITTSBURGH B RIGHT MUN: EAST PITTSBURGH B

BESSEMER AV
 (BORO)

000373 FT
 0250/0373
 000000 FT

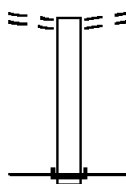

000373 FT LINDEN AV
 0250/0373 (BORO)
 000000 FT 0 0 00000 0 00 0000+00
 NC LINDEN AV RAMP RD
 INTER-BK LINCOLN HW
 (SR0030 SEG 0251/0673)
 MFC BEGIN = F
 0250/0000 LENGTH(AH 0373 BK 0000)

EXTRACT DATE: 12/21/2020 ROADWAY MANAGEMENT SYSTEM PAGE NUMBER: 1641
PRINT DATE: 12/23/2020 SLD COUNTY/SR - ANNUAL PRINT COUNTY: ALLEGHENY
DIR: N TOTAL LEN: 1.457 MI. DIST: 11-1 SR: 8121
LEFT MUN: PITTSBURGH C RIGHT MUN: PITTSBURGH C

007694 FT

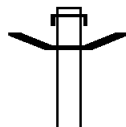

006592 FT

007694 FT
INTER-AHD E OHIO ST
0752/1102 (SR0028 SEG 0020/0740)
0752/0707 BMSN 02/8121/0752/0000
006592 FT 0 00000 0 0 0000+00
NC RAMP H FR 579 NB TO 28 SH

EXTRACT DATE: 12/21/2020
PRINT DATE: 12/23/2020

ROADWAY MANAGEMENT SYSTEM
SLD COUNTY/SR - ANNUAL PRINT

PAGE NUMBER: 1640
COUNTY: ALLEGHENY

DIR: N TOTAL LEN: 1.457 MI.
LEFT MUN: PITTSBURGH C

DIST: 11-1 SR: 8121
RIGHT MUN: PITTSBURGH C

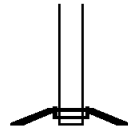

INTER-BK CROSSTOWN BL
(SR0579 SEG 0010/0410)
SR 8121 NB
BMSBG 02/8121/0752/0000
5 0752/0000 LENGTH(AH 1102 BK 0432)

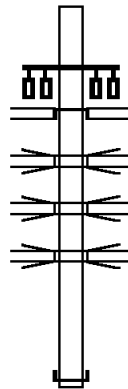

006160 FT

INTER-AHD MADISON AV
(SR4099 SEG 0010/0000)
E OHIO ST
(SR4084 SEG 0061/0285)
(SR4084 SEG 0060/0285)
0542/0432
0542/0230 OP ID SR 8108 0790:110 -
RAMP G 02/0279/0008/2090
0542/0103 OP ID 02/8121/0532/0229
RT 0028 SB
0542/0041 OP ID 02/0028/0021/0170
006160 FT 0 0 00000 0 00 0000+00
NC MA D ISON AV CON FR 28 SH
INTER-BK E OHIO ST
(SR0028 SEG 0020/0205)
5 0542/0000 LENGTH(AH 0432 BK 1128)

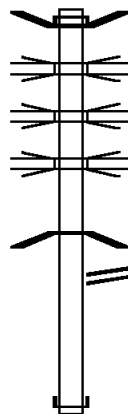

005032 FT

INTER-AHD BMSEN 02/8121/0532/0229
CROSSTOWN BL
0532/1128 (SR0579 SEG 0011/0405)
CROSSTOWN BL
0532/0556 OP ID 02/0579/0011/0000
I-579 HOV LN
0532/0475 OP ID 02/6579/0020/0000
CROSSTOWN BL
0532/0392 OP ID 02/0579/0010/0000
0 00000 0 0 0000+00
MADISON AVE.
0532/0229 BMSBG 02/8121/0532/0229
RAMP P RD
0532/0051 (SR8121 SEG 0522/0000)
005032 FT 0 0 00000 0 00 0000+00
NC RA MP G FR 28 SB TO 579 SH
INTER-BK OHIO ST
(SR0028 SEG 0021/0543)
5 0532/0000 LENGTH(AH 1128 BK 1278)



INTER-AHD I-279 S
0522/1278 (SR0279 SEG 0013/0805)
OTHER

EXTRACT DATE: 12/21/2020
PRINT DATE: 12/23/2020

ROADWAY MANAGEMENT SYSTEM
SLD COUNTY/SR - ANNUAL PRINT

PAGE NUMBER: 1639
COUNTY: ALLEGHENY

DIR: N TOTAL LEN: 1.457 MI.
LEFT MUN: PITTSBURGH C

DIST: 11-1 SR: 8121
RIGHT MUN: PITTSBURGH C

003754 FT

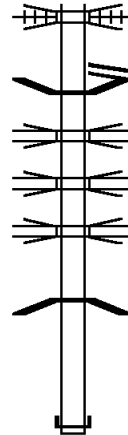

0522/1142 OVERPASS IS RR X-ING
RAMP B FR E OHIO ST
0522/0635 (SR8121 SEG 0252/0460)
0522/0565 BMSEN 02/8121/0522/0139
CROSS TOWN BL
0522/0436 OP ID 02/0579/0011/0000
I-579 HOV LN
0522/0345 OP ID 02/6579/0020/0000
CROSS TOWN BL
0522/0278 OP ID 02/0579/0010/0000
0 00000 0 0 0000+00
SR 0279 NB
0522/0110 BMSBG 02/8121/0522/0139
003754 FT 0 0 00000 0 00 0000+00
NC RAMP P RD
INTER-BK RAMP G FR 28 SB TO 579
(SR8121 SEG 0532/0051)
5 0522/0000 LENGTH(AH 1278 BK 0778)

002976 FT

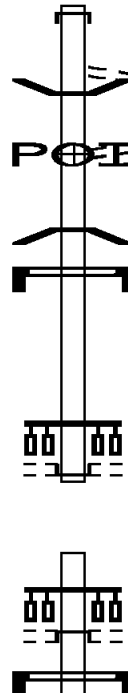

INTER-AHD E OHIO ST
0512/0778 (SR0028 SEG 0020/1665)
LC FROM HEINZ ST
0512/0632 (CONN)
0512/0451 BMSEN 02/8121/0512/0225
(APRA) H J HEINZ CO
HEINZ ST
0512/0446 (CITY)
0 00000 0 0 0000+00
SR 0028 SB
0512/0276 BMSBG 02/8121/0512/0225
SIGN: 4 CHORD TRUSS
0512/0080 BMSID 02/8121/0502/0765
002976 FT 0 0 00000 0 00 0000+00
NC RAMP J/E OHIO ST TO 28 SH
CHESTNUT ST
(CITY)
INTER-BK E OHIO ST
5 0512/0000 (SR4084 SEG 0060/0997)
LENGTH(AH 0778 BK 0842)
INTER-AHD E OHIO ST
0502/0842 (SR4084 SEG 0061/0997)
CHESTNUT ST
(CITY)
SIGN: 4 CHORD TRUSS
BMSID 02/8121/0502/0765

DIR: N TOTAL LEN: 1.457 MI. DIST: 11-1 SR: 8121
 LEFT MUN: PITTSBURGH C RIGHT MUN: PITTSBURGH C

002134 FT

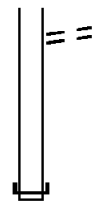

0502/0765 LC TO CHESTNUT ST
 (CONN)
 002134 FT 0 0 00000 0 00 0000+00
 NC RAMP K/28 SB TO E OHIO ST
 INTER-BK E OHIO ST
 (SR0028 SEG 0031/0000)
 0502/0000 LENGTH(AH 0842 BK 0460)

001674 FT

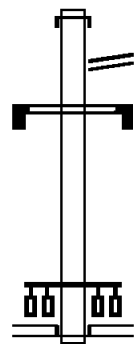

INTER-AHD RAMP P
 0252/0460 (SR8121 SEG 0522/0635)
 N CANAL ST
 0252/0334 (CITY)
 SIGN: CANTILEVER
 0252/0275 BMSID 02/8121/0252/0051
 001674 FT 0 0 00000 0 00 0000+00
 NC RAMP B FR E OHIO ST
 E OHIO ST
 (SR4084 SEG 0061/0000)
 (SR4084 SEG 0060/0000)
 INTER-BK EAST ST
 (SR4099 SEG 0011/0000)
 0252/0000 LENGTH(AH 0460 BK 0827)

000847 FT

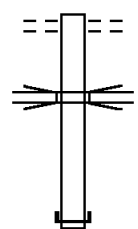

0022/0827 CHESTNUT ST
 (CITY)
 RAMP H
 0022/0100 OP ID 02/8121/0752/0000
 000847 FT 0 0 00000 0 00 0000+00
 NC RAMP N TO CHESTNUT ST
 INTER-BK E OHIO ST
 (SR0028 SEG 0020/0000)
 0022/0000 LENGTH(AH 0827 BK 0847)

000000 FT

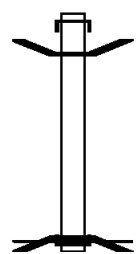

INTER-AHD E OHIO ST
 0012/0847 (SR0028 SEG 0010/0640)
 0012/0364 BMSEN 02/8121/0012/0000
 000000 FT 0 00000 0 0 0000+00
 NC RAMP A FR 279 NB TO 28 SH
 INTER-BK SR 0279 SH
 (SR0279 SEG 0008/4136)
 ANDERSON ST
 BMSBG 02/8121/0012/0000
 MFC BEGIN = F
 0012/0000 LENGTH(AH 0847 BK 0000)

000809 FT
 000467 FT

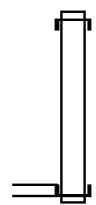

000809 FT
 INTER-AHD EAST OHIO ST
 0250/0342 (SR0028 SEG 0061/1554)
 000467 FT 0 0 00000 0 00 0000+00
 NC RAMP Q
 WASHINGTON CR. BR/40TH
 (SR2124 SEG 0010/2754)
 INTER-BK EVERGREEN RD
 (SR4009 SEG 0011/0000)
 0250/0000 LENGTH(AH 0342 BK 0467)

000000 FT

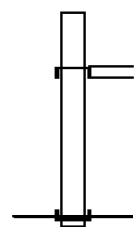

INTER-AHD EVERGREEN RD
 (SR4009 SEG 0010/0000)
 WASHINGTON CR BR/40TH S
 0010/0467 (SR2124 SEG 0010/2725)
 000000 FT 0 0 00000 0 00 0000+00
 NC RAMP P
 INTER-BK EAST OHIO ST
 (SR0028 SEG 0070/0000)
 MFC BEGIN = F
 0010/0000 LENGTH(AH 0467 BK 0000)

EXTRACT DATE: 12/21/2020 ROADWAY MANAGEMENT SYSTEM PAGE NUMBER: 1636
 PRINT DATE: 12/23/2020 SLD COUNTY/SR - ANNUAL PRINT COUNTY: ALLEGHENY
 DIR: E TOTAL LEN: .222 MI. DIST: 11-1 SR: 8119
 LEFT MUN: PITTSBURGH C RIGHT MUN: PITTSBURGH C

001174 FT
 000600 FT

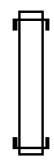

001174 FT
 INTER-AHD BL OF THE ALLIES
 0250/0574 (SR0885 SEG 0330/1055)
 000600 FT 0 0 00000 0 00 0000+00
 NC RAMP B RD
 INTER-BK FIFTH AV
 (CITY)
 0250/0000 LENGTH(AH 0574 BK 0600)

CITY OF PITTSBURGH ST
 (CITY)

0010/0588
 000000 FT

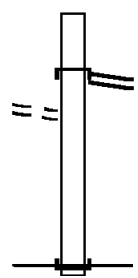

INTER-AHD FORBES AV
 (SR2108 SEG 0060/0000)
 0010/0600 (SR2108 SEG 0060/0000)
 FORBES AV
 000000 FT 0 0 00000 0 00 0000+00
 NC RAMP A RD
 INTER-BK BL OF THE ALLIES
 (SR0885 SEG 0331/0838)
 MFC BEGIN = F
 0010/0000 LENGTH(AH 0600 BK 0000)

EXTRACT DATE: 12/21/2020 ROADWAY MANAGEMENT SYSTEM PAGE NUMBER: 1635
 PRINT DATE: 12/23/2020 SLD COUNTY/SR - ANNUAL PRINT COUNTY: ALLEGHENY
 DIR: N TOTAL LEN: .846 MI. DIST: 11-1 SR: 8114
 LEFT MUN: FRAZER T RIGHT MUN: FRAZER T

004466 FT

004466 FT
 INTER-AHD RAMP C RD
 (SR8114 SEG 0250/0000)
 PITTSBURGH MILLS BL
 (SR1049 SEG 0011/1205)
 (SR1049 SEG 0010/1205)

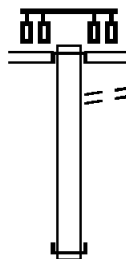

0500/0968
 TO 1049/0010 SH
 0500/0851 (CONN)

003498 FT

003498 FT 0 0 00000 0 00 0000+00
 NC RAMP D RD
 INTER-BK ALLEGHENY VALLEY EX
 (SR0028 SEG 0331/1537)
 0500/0000 LENGTH(AH 0968 BK 0335)

DIR: N TOTAL LEN: .846 MI. DIST: 11-1 SR: 8114
 LEFT MUN: SPRINGDALE T RIGHT MUN: SPRINGDALE T

003163 FT

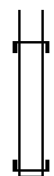

INTER-AHD RAMP C RD
 0252/0335 (SR8114 SEG 0250/0222)
 003163 FT 0 0 00000 0 00 0000+00
 NC RAMP C-1 RD
 INTER-BK PITTSBURGH MILLS BL
 (SR1049 SEG 0011/1461)
 0252/0000 LENGTH(AH 0335 BK 0916)

002247 FT

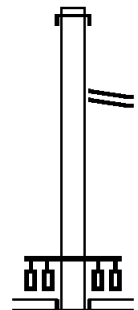

INTER-AHD ALLEGHENY VALLEY EX
 0250/0916 (SR0028 SEG 0321/2570)
 0250/0222 RAMP C-1 RD
 (SR8114 SEG 0252/0335)
 002247 FT 0 0 00000 0 00 0000+00
 NC RAMP C RD
 PITTSBURGH MILLS BL
 (SR1049 SEG 0011/1205)
 (SR1049 SEG 0010/1205)
 INTER-BK RAMP D RD
 (SR8114 SEG 0500/0968)
 0250/0000 LENGTH(AH 0916 BK 0780)

001467 FT

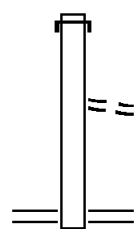

INTER-AHD ALLEGHENY VALLEY EX
 0020/0780 (SR0028 SEG 0330/0369)
 0020/0058 FROM 1049/0011 SH
 (CONN)
 001467 FT 0 0 00000 0 00 0000+00
 NC RAMP A RD
 PITTSBURGH MILLS BL
 (SR1049 SEG 0011/0279)
 0020/0000 LENGTH(AH 0780 BK 1467)

000000 FT

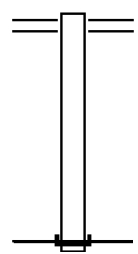

0010/1467 PITTSBURGH MILLS BL
 (SR1049 SEG 0010/0276)
 000000 FT 0 0 00000 0 00 0000+00
 NC RAMP B ROAD
 INTER-BK ALLEGHENY VALLEY EX
 (SR0028 SEG 0320/1780)
 MFC BEGIN = F
 0010/0000 LENGTH(AH 1467 BK 0000)

EXTRACT DATE: 12/21/2020 ROADWAY MANAGEMENT SYSTEM PAGE NUMBER: 1633
 PRINT DATE: 12/23/2020 SLD COUNTY/SR - ANNUAL PRINT COUNTY: ALLEGHENY
 DIR: N TOTAL LEN: 1.305 MI. DIST: 11-1 SR: 8113
 LEFT MUN: FINDLAY T RIGHT MUN: FINDLAY T

006893 FT
 006468 FT



006893 FT
 INTER-AHD RAMP 20 RD
 0520/0425 (SR8113 SEG 0510/0180)
 006468 FT 0 0 00000 0 00 0000+00
 NC FLAUGHERTY RUN/RMP 520 RD
 INTER-BK RAMP L RD
 (SR8072 SEG 0010/0809)
 0520/0000 LENGTH(AH 0425 BK 3646)

INTER-AHD FROM CONNECTOR RD

DIR: N TOTAL LEN: 1.305 MI. DIST: 11-1 SR: 8113
 LEFT MUN: FINDLAY T RIGHT MUN: FINDLAY T

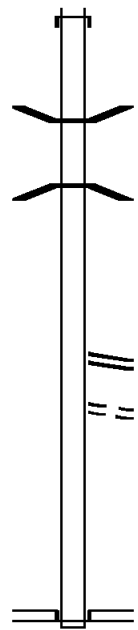

002822 FT

0510/3646 (SR9460 SEG 0010/1140)

0510/2427 BMS EN 02/8113/0510/2040
 0 00000 0 0 0000+00

0510/2040 SR 0376 EB
 BMSBG 02/8113/0510/2040

0510/0180 RAMP 520 RD
 (SR8113 SEG 0520/0425)
 FROM 3089/0120 SH

0510/0052 (CONN)
 002822 FT 0 0 00000 0 00 0000+00
 NC FLAUGHERTY RUN/RMP 510 RD

FLAUGHERTY RUN/RMP 500
 (SR8113 SEG 0500/2822)
 FLAUGHERTY RUN RD
 (SR3089 SEG 0120/0528)

INTER-BK CLINTON RD
 (SR3089 SEG 0120/0528)
 0510/0000 LENGTH(AH 3646 BK 2822)

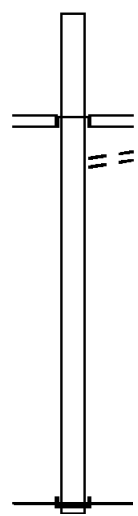

000000 FT

INTER-AHD FLAUGHERTY RUN RD
 (SR3089 SEG 0120/0528)
 FLAUGHERTY RUN/RMP 510
 (SR8113 SEG 0510/0000)
 CLINTON RD

0500/2822 (SR3089 SEG 0120/0528)
 TO 3089/0120 SH

0500/2700 (CONN)

000000 FT 0 0 00000 0 00 0000+00
 NC FLAUGHERTY RUN/RMP 500 RD
 INTER-BK AIRPORT PY

(SR0376 SEG 0511/2138)
 MFC BEGIN = F
 0500/0000 LENGTH(AH 2822 BK 0000)

DIR: S TOTAL LEN: .959 MI. DIST: 11-1 SR: 8112
 LEFT MUN: FINDLAY T RIGHT MUN: FINDLAY T

005061 FT

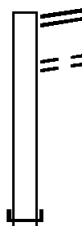

005061 FT FLAUGHERTY RUN RD
 0500/0768 (SR3089 SEG 0090/0000)
 TO 3089/0090 SH
 0500/0673 (CONN)

004293 FT

004293 FT 0 0 00000 0 00 0000+00
 NC CLINTON INT/RAMP G RD
 INTER-BK AIRPORT PY
 (SR0376 SEG 0521/2165)
 0500/0000 LENGTH(AH 0768 BK 1279)

INTER-AHD I-376 W
 0250/1279 (SR0376 SEG 0521/0021)

003014 FT



003014 FT 0 0 00000 0 00 0000+00
 NC RAMP I RD
 INTER-BK FLAUGHERTY RUN RD
 (SR3089 SEG 0090/0000)
 0250/0000 LENGTH(AH 1279 BK 1268)

INTER-AHD I-376 E
 0020/1268 (SR0376 SEG 0520/0838)

001746 FT



001746 FT 0 0 00000 0 00 0000+00
 NC RAMP H RD
 INTER-BK CLINTON RD
 (SR3089 SEG 0082/0917)
 0020/0000 LENGTH(AH 1268 BK 1746)

INTER-AHD CLINTON RD
 0010/1746 (SR3089 SEG 0082/0917)

0 0 00000 0 00 0000+00 000000 FT
 CONNECTOR RD
 (SR9460 SEG 0010/3582) 0010/0000

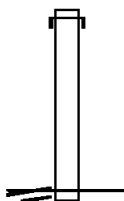

000000 FT
 NC RAMP J RD
 MFC BEGIN = F
 0010/0000 LENGTH(AH 1746 BK 0000)

008347 FT

007973 FT



008347 FT
 INTER-AHD RAMP KL
 0750/0374 (SR8111 SEG 0010/2180)
 007973 FT 0 0 00000 0 00 0000+00
 NC RAMP H
 INTER-BK TURNPIKE RAMP RD TOLL 5
 (TNPK)
 0750/0000 LENGTH(AH 0374 BK 1283)

RAMP KL
 (SR8111 SEG 0010/3660) 0500/1283

TURNPIKE RAMP RD TOLL 5
 (TNPK) 0500/0690

006690 FT

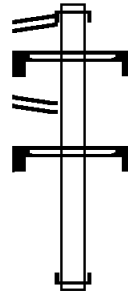

INTER-AHD MIDFIELD TERMINAL RD
 0500/1283 (CNTY)
 0500/0940 BMSID 02/8111/0500/0940
 SIGN: SHAPE OR TUBE
 SIGN: 4 CHORD TRUSS
 0500/0405 BMSID 02/8111/0500/0405
 006690 FT 0 0 00000 0 00 0000+00
 NC AIRPORT INT/RP 500 RD
 INTER-BK AIRPORT PY
 (SR0376 SEG 0525/2367)
 0500/0000 LENGTH(AH 1283 BK 2190)

INTER-AHD I-376 E
 0260/2190 (SR0376 SEG 0530/2081)
 SR 8111 (RAMP MT-
 0260/2134 OP ID 02/8111/0010/2439
 PA TPK (1-576)
 0260/1300 OP ID 02/7576/9900/0009
 PA TPK (1-576)
 0260/1226 OP ID 02/7576/9900/0010
 0260/1047 BMSEN 02/8111/0260/0738
 0 0 00000 0 00 0000+00
 SR 0376 EB
 0260/0738 BMSBG 02/8111/0260/0738
 TURNPIKE RAMP RD TOLL 5
 0260/0579 (TNPK)
 SIGN: SHAPE OR TUBE
 0260/0200 BMSID 02/8111/0260/0200
 004500 FT 0 0 00000 0 00 0000+00

004500 FT

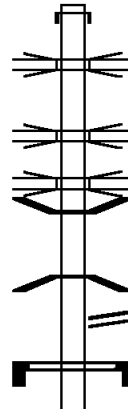

DIR: S TOTAL LEN: 1.581 MI. DIST: 11-1 SR: 8111
 LEFT MUN: FINDLAY T RIGHT MUN: FINDLAY T

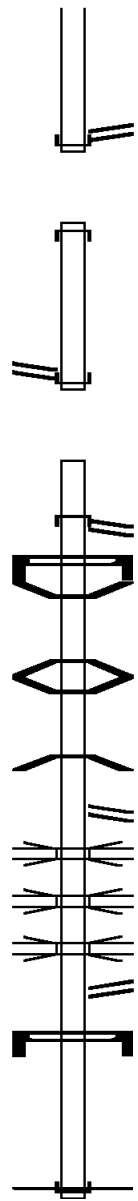

AIRPORT INT/RP 250 RD
 (SR8111 SEG 0250/0000)
 INTER-BK AIRPORT INT/RP 260 RD
 (CNTY) MIDFIELD TERMINAL RD
 0260/0000 LENGTH(AH 2190 BK 0840)

INTER-AHD I-376 W
 0250/0840 (SR0376 SEG 0525/2481)
 003660 FT 0 0 00000 0 00 0000+00
 INTER-BK AIRPORT INT/RP 250 RD
 (CNTY) MIDFIELD TERMINAL RD
 0250/0000 LENGTH(AH 0840 BK 3660)

INTER-AHD MIDFIELD TERMINAL RD
 (CNTY)
 RAMP 10 RD
 (SR8111 SEG 0500/1283)
 SIGN: SHAPE OR TUBE
 0010/3469 BMSID 02/8111/0010/3469
 0010/3346 BMSSEN 02/8111/0010/3185
 0 00000 0 0 0000+00
 TRNPK RAMP E
 0010/3185 BMSBG 02/8111/0010/3185
 0010/2791 BMSSEN 02/8111/0010/2439
 0 00000 0 0 0000+00
 SR 8111 (RAMP C)
 0010/2439 BMSBG 02/8111/0010/2439
 RAMP H
 (SR8111 SEG 0750/0374)
 PA TPK (I-576)
 0010/1631 OP ID 02/7576/9900/0010
 PA TPK (I-576)
 0010/1546 OP ID 02/7576/9900/0009
 PA TPK (RAMP D)
 0010/1026 OP ID 02/7576/9900/0012
 TURNPIKE RAMP RD TOLL 5
 0010/0899 (TNPK)
 SIGN: 4 CHORD TRUSS
 0010/0481 BMSID 02/8111/0010/0481
 000000 FT 0 0 00000 0 00 0000+00
 INTER-BK RAMP KL
 AIRPORT PY
 (SR0376 SEG 0524/2104)
 MFC BEGIN = F
 0010/0000 LENGTH(AH 3660 BK 0000)

003660 FT

RAMP 260 RD
 (SR8111 SEG 0260/0000) 0250/0000

000000 FT

EXTRACT DATE: 12/21/2020 ROADWAY MANAGEMENT SYSTEM PAGE NUMBER: 1628
 PRINT DATE: 12/23/2020 SLD COUNTY/SR - ANNUAL PRINT COUNTY: ALLEGHENY
 DIR: S TOTAL LEN: .998 MI. DIST: 11-1 SR: 8110
 LEFT MUN: MOON T RIGHT MUN: MOON T

005269 FT

005269 FT
 INTER-AHD I-376 W
 0500/1191 (SR0376 SEG 0571/2538)

004078 FT

004078 FT 0 0 00000 0 00 0000+00
 NC MOON INT/RAMP 500 RD
 INTER-BK BUSINESS 376 S
 (SR3160 SEG 0132/0000)
 0500/0000 LENGTH(AH 1191 BK 4078)

INTER-AHD BUSINESS 376 N
 0250/4078 (SR3160 SEG 0123/2912)

RETAINING WALL
 0250/2941 BMSID 02/8110/0250/2941
 0250/2940 BMSSEN 02/8110/0250/2010

0 0 00000 0 00 0000+00
 SR 3160 (BUS. 0376 WB)
 0250/2010 BMSBG 02/8110/0250/2010

000000 FT

000000 FT 0 0 00000 0 00 0000+00
 NC MOON INT/RAMP 250 RD
 INTER-BK AIRPORT PY
 (SR0376 SEG 0570/1143)
 MFC BEGIN = F
 0250/0000 LENGTH(AH 4078 BK 0000)

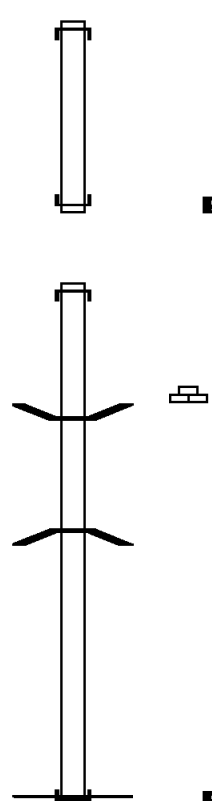

EXTRACT DATE: 12/21/2020 ROADWAY MANAGEMENT SYSTEM PAGE NUMBER: 1627
PRINT DATE: 12/23/2020 SLD COUNTY/SR - ANNUAL PRINT COUNTY: ALLEGHENY
DIR: N TOTAL LEN: .715 MI. DIST: 11-1 SR: 8107
LEFT MUN: PITTSBURGH C RIGHT MUN: PITTSBURGH C

003776 FT

003776 FT
INTER-AHD OHIO RIVER BL

DIR: N TOTAL LEN: .715 MI. DIST: 11-1 SR: 8107
 LEFT MUN: PITTSBURGH C RIGHT MUN: PITTSBURGH C

002254 FT

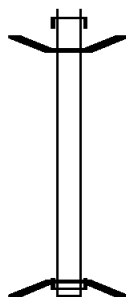

0260/1522 (SR0065 SEG 0002/1254)
 0260/1345 BMSEN 02/8107/0260/0000

002254 FT 0 0 00000 0 00 0000+00
 NC NO RTHSHORE INT/RP V RD
 INTER-BK SR 0279 SH
 (SR0279 SEG 0009/2598)
 LR1021 RP.B
 BMSBG 02/8107/0260/0000
 0260/0000 LENGTH(AH 1522 BK 0927)

001327 FT

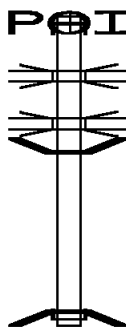

(APRA) PNC PARK/HEINZ F
 INTER-AHD LACOCK ST
 0250/0927 (CITY)
 SR 8107 RP.W
 0250/0890 OP ID 02/8107/0010/015B
 LR1021 RP.V
 0250/0759 OP ID 02/8107/0260/0000
 0250/0486 BMSEN 02/8107/0250/0000
 001327 FT 0 0 00000 0 00 0000+00
 NC NO RTHSHORE INT/RP B RD
 INTER-BK SR 0279 SH
 (SR0279 SEG 0009/3048)
 NO UNDERPASS INFORMATION
 BMSBG 02/8107/0250/0000
 0250/0000 LENGTH(AH 0927 BK 1327)

000000 FT

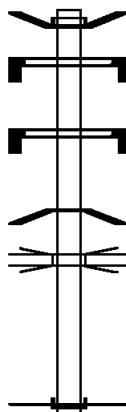

BMSEN 02/8107/0010/015B
 INTER-AHD I-279 N
 0010/1327 (SR0279 SEG 0008/2402)
 SIGN: CANTILEVER
 0010/1165 BMSID 02/8107/0010/1165
 SIGN: CANTILEVER
 0010/0392 BMSID 02/8107/0010/0392
 0 0 00000 0 00 0000+00
 SR 8107 RP.B
 0010/0159 BMSBG 02/8107/0010/015B
 SR 65 NB
 0010/0081 OP ID 02/0065/0002/0000
 000000 FT 0 0 00000 0 00 0000+00
 NC NO RTHSHORE INT/RP W RD
 INTER-BK OHIO RIVER BL
 (SR0065 SEG 0003/1685)
 MFC BEGIN = F
 0010/0000 LENGTH(AH 1327 BK 0000)

DIR: S TOTAL LEN: .434 MI. DIST: 11-1 SR: 8106
 LEFT MUN: MOON T RIGHT MUN: MOON T

002291 FT

001637 FT

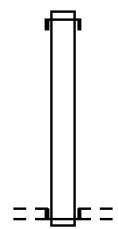

002291 FT
 INTER-AHD BUSINESS 0376
 0750/0654 (SR3160 SEG 0092/1660)
 001637 FT 0 0 00000 0 00 0000+00
 NC THORN RUN INT/RAMP A RD
 CLIFF MINE RD
 (CNTY)
 INTER-BK RAMP C RD
 (SR8106 SEG 0010/0589)
 0750/0000 LENGTH(AH 0654 BK 0546)

LC FROM THORN RUN RD ET
 (CONN)

0260/0060
 001091 FT

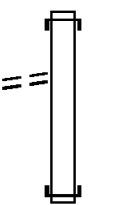

INTER-AHD BUSINESS 376 N
 0260/0546 (SR3160 SEG 0093/0344)
 001091 FT 0 0 00000 0 00 0000+00
 NC THORN RUN INT/RAMP D RD
 INTER-BK THORN RUN RD ET
 (T388)
 0260/0000 LENGTH(AH 0546 BK 0502)

LC TO THORN RUN RD ET
 (CONN)

0250/0380
 000589 FT

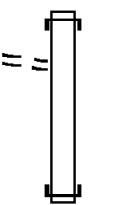

INTER-AHD THORN RUN RD ET
 0250/0502 (T388)
 000589 FT 0 0 00000 0 00 0000+00
 NC THORN RUN INT/RAMP B RD
 INTER-BK BUSINESS 60 SH
 (SR3160 SEG 0093/0801)
 0250/0000 LENGTH(AH 0502 BK 0589)

000000 FT

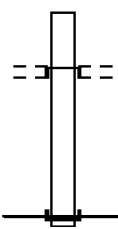

INTER-AHD RAMP A RD
 (SR8106 SEG 0750/0000)
 CORAOPOLIS HEIGHTS RD
 (CNTY)
 0010/0589
 000000 FT 0 0 00000 0 00 0000+00
 NC THORN RUN INT/RAMP C RD
 INTER-BK BUSINESS 376
 (SR3160 SEG 0092/0340)
 MFC BEGIN = F
 0010/0000 LENGTH(AH 0589 BK 0000)

EXTRACT DATE: 12/21/2020 ROADWAY MANAGEMENT SYSTEM PAGE NUMBER: 1624
PRINT DATE: 12/23/2020 SLD COUNTY/SR - ANNUAL PRINT COUNTY: ALLEGHENY

DIR: N TOTAL LEN: 1.091 MI. DIST: 11-1 SR: 8105
LEFT MUN: OHIO T RIGHT MUN: OHIO T

FROM 4021/0040 SH
(CONN)

005698 FT

0750/0153
004758 FT

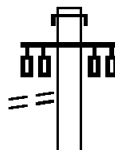

005698 FT
INTER-AHD 1-279 N
0750/0940 (SR0279 SEG 0086/0790)

0750/0153
004758 FT 0 0 00000 0 00 0000+00
NC CAMP HORNE INT/RAMP C RD

DIR: N TOTAL LEN: 1.091 MI. DIST: 11-1 SR: 8105
 LEFT MUN: OHIO T RIGHT MUN: OHIO T

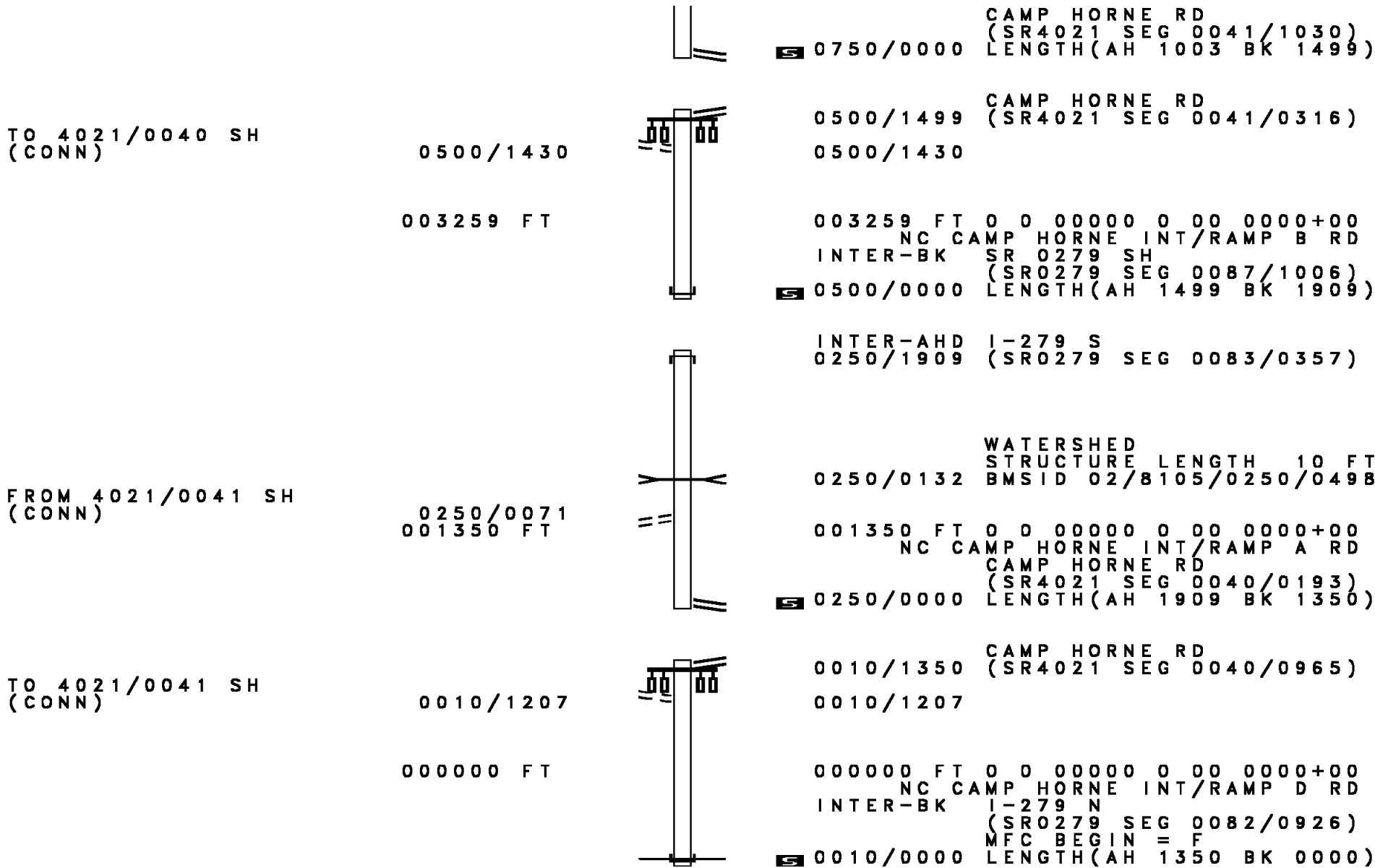

TO 4021/0040 SH
(CONN)

0500/1430

003259 FT

0750/0000 **S** CAMP HORNE RD
 (SR4021 SEG 0041/1030)
 LENGTH(AH 1003 BK 1499)

0500/1499 CAMP HORNE RD
 (SR4021 SEG 0041/0316)
 0500/1430

003259 FT 0 0 00000 0 00 0000+00
 NC CAMP HORNE INT/RAMP B RD
 INTER-BK SR 0279 SH
 (SR0279 SEG 0087/1006)
S 0500/0000 LENGTH(AH 1499 BK 1909)

INTER-AHD I-279 S
 0250/1909 (SR0279 SEG 0083/0357)

FROM 4021/0041 SH
(CONN)

0250/0071
 001350 FT

0250/0132 WATERSHED
 STRUCTURE LENGTH 10 FT
 BMSID 02/8105/0250/0498

001350 FT 0 0 00000 0 00 0000+00
 NC CAMP HORNE INT/RAMP A RD
 CAMP HORNE RD
 (SR4021 SEG 0040/0193)
S 0250/0000 LENGTH(AH 1909 BK 1350)

TO 4021/0041 SH
(CONN)

0010/1207

000000 FT

0010/1350 CAMP HORNE RD
 (SR4021 SEG 0040/0965)
 0010/1207

000000 FT 0 0 00000 0 00 0000+00
 NC CAMP HORNE INT/RAMP D RD
 INTER-BK I-279 N
 (SR0279 SEG 0082/0926)
 MFC BEGIN = F
S 0010/0000 LENGTH(AH 1350 BK 0000)

EXTRACT DATE: 12/21/2020 ROADWAY MANAGEMENT SYSTEM PAGE NUMBER: 1622
PRINT DATE: 12/23/2020 SLD COUNTY/SR - ANNUAL PRINT COUNTY: ALLEGHENY
DIR: E TOTAL LEN: 1.080 MI. DIST: 11-1 SR: 8104
LEFT MUN: ROSS T RIGHT MUN: ROSS T

005700 FT

005700 FT
INTER-AHD 1-279 N
0750/1299 (SR0279 SEG 0076/0355)

004401 FT

004401 FT 0 0 00000 0 00 0000+00
NC BELLEVUE INT/RMP 750 RD
UNION AV



DIR: E TOTAL LEN: 1.080 MI. DIST: 11-1 SR: 8104
 LEFT MUN: ROSS T RIGHT MUN: ROSS T

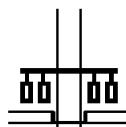

(SR4012 SEG 0060/1710)

INTER-BK RAMP RD
 (SR8104 SEG 0010/1855)
 0750/0000 LENGTH(AH 1299 BK 0961)

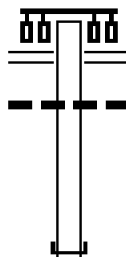

003440 FT

UNION AV
 (SR4012 SEG 0060/0270)
 0500/0961
 0500/0611 030 "DIA CIRC CONCR
 LEN=0060 INSTALLED 2009
 003440 FT 0 0 00000 0 00 0000+00
 NC BELLEVUE INT/RMP 500 RD
 INTER-BK I-279 S
 (SR0279 SEG 0073/0771)
 0500/0000 LENGTH(AH 0961 BK 1585)

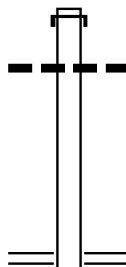

001855 FT

INTER-AHD I-279 S
 0250/1585 (SR0279 SEG 0067/2164)
 030 "DIA CIRC CONCR
 0250/1235 LEN=0060 INSTALLED 2009
 001855 FT 0 0 00000 0 00 0000+00
 NC BELLEVUE INT/RMP 250 RD
 UNION AV
 (SR4012 SEG 0060/0250)
 0250/0000 LENGTH(AH 1585 BK 1855)

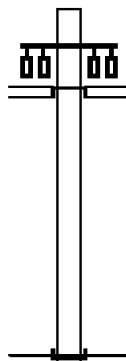

000000 FT

INTER-AHD RAMP RD
 (SR8104 SEG 0750/0000)
 UNION AV
 (SR4012 SEG 0060/1710)
 0010/1855
 000000 FT 0 0 00000 0 00 0000+00
 NC BELLEVUE INT/RMP 10 RD
 INTER-BK SR 0279 SH
 (SR0279 SEG 0066/2587)
 MFC BEGIN = F
 0010/0000 LENGTH(AH 1855 BK 0000)

EXTRACT DATE: 12/21/2020 ROADWAY MANAGEMENT SYSTEM PAGE NUMBER: 1620
 PRINT DATE: 12/23/2020 SLD COUNTY/SR - ANNUAL PRINT COUNTY: ALLEGHENY
 DIR: N TOTAL LEN: .882 MI. DIST: 11-1 SR: 8103
 LEFT MUN: PITTSBURGH C RIGHT MUN: PITTSBURGH C

004657 FT

004111 FT

002951 FT

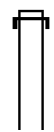
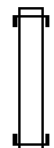

004657 FT
 INTER-AHD 1-279 N
 0760/0546 (SR0279 SEG 0056/0142)
 004111 FT 0 0 0000 0 0 00 0000+00
 NC PERRYSVILL AV INT/HOV RP
 INTER-BK 1-6279 N
 (SR6279 SEG 0090/0750)
 0760/0000 LENGTH(AH 0546 BK 1160)

INTER-AHD 1-279 N
 0750/1160 (SR0279 SEG 0056/0779)
 002951 FT 0 0 0000 0 00 0000+00
 NC PERRYSVLE AV INT/RP B RD

DIR: N TOTAL LEN: .882 MI. DIST: 11-1 SR: 8103
 LEFT MUN: PITTSBURGH C RIGHT MUN: PITTSBURGH C

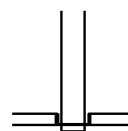

SR 4044 SH
 (SR4044 SEG 0010/0420)
 INTER-BK RAMP A RD
 (SR8103 SEG 0010/1180)
 0750/0000 LENGTH(AH 1160 BK 0867)

002084 FT

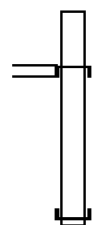

INTER-AHD PERRYSVILLE AV INT/RP D
 (SR8103 SEG 0250/0000)
 SR 4044 SH
 (SR4044 SEG 0010/0000)
 002084 FT 0 0 00000 0 00 0000+00
 NC PERRYSVILLE AV INT/RP C RD
 INTER-BK I-279 S
 (SR0279 SEG 0057/0815)
 0500/0000 LENGTH(AH 0867 BK 0188)

001896 FT

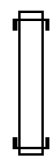

INTER-AHD I-6279 N
 0260/0188 (SR6279 SEG 0090/0000)
 001896 FT 0 0 00000 0 00 0000+00
 NC PRRYSVILLE AV IN/RP HOV RD
 INTER-BK I-279 S
 (SR0279 SEG 0053/2216)
 0260/0000 LENGTH(AH 0188 BK 0716)

001180 FT

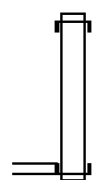

INTER-AHD I-279 S
 0250/0716 (SR0279 SEG 0053/1833)
 001180 FT 0 0 00000 0 00 0000+00
 NC PERRYSVILLE AV INT/RP D RD
 INTER-BK RAMP C RD
 (SR8103 SEG 0500/0867)
 SR 4044 CONN RD
 (SR4044 SEG 0010/0000) 0250/0000 LENGTH(AH 0716 BK 1180)

000000 FT

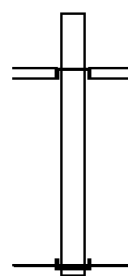

INTER-AHD RAMP B RD
 (SR8103 SEG 0750/0000)
 SR 4044 CONN RD
 (SR4044 SEG 0010/0420)
 000000 FT 0 0 00000 0 00 0000+00
 NC PERRYSVILLE AV INT/RP A RD
 INTER-BK I-279 N
 (SR0279 SEG 0052/1170)
 MFC BEGIN = F
 0010/0000 LENGTH(AH 1180 BK 0000)

005676 FT
 RAMP RD
 (SR8102 SEG 0040/0000) 0510/0530

004511 FT

RAMP RD
 (SR8102 SEG 0510/0000) 0500/0395

003105 FT

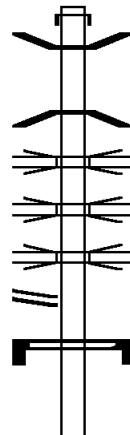
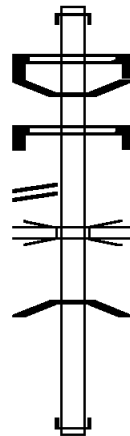

005676 FT
 INTER-AHD SR 6279 SH
 0510/1165 (SR6279 SEG 0070/0000)
 SIGN: CANTILEVER
 0510/0850 BMSID 02/8102/0510/0850
 0510/0817 BMSEN 02/8102/0510/0180
 SIGN: 4 CHORD TRUSS
 0510/0645 BMSID 02/8102/0510/0645
 SR 0279 NB
 0510/0195 OP ID 02/0279/0046/0000
 0 0 00000 0 00 0000+00
 EVERGREEN NB
 0510/0180 BMSBG 02/8102/0510/0180
 004511 FT 0 0 00000 0 00 0000+00
 NC MCKNIGHT RD INT/RMP TO HOV
 INTER-BK RAMP J RD
 0510/0000 (SR8102 SEG 0500/0395)
 LENGTH(AH 1165 BK 1406)
 INTER-AHD I-279 S
 0500/1406 (SR0279 SEG 0043/1791)
 0500/1393 BMSEN 02/8102/0500/0953
 0 0 00000 0 00 0000+00
 EVERGREEN ROAD NB
 0500/0953 BMSBG 02/8102/0500/0953
 I-279 S.B.
 0500/0635 OP ID 02/0279/0047/0000
 SR 6279 TO 279 NB
 0500/0585 OP ID 02/6279/0070/0330
 SR 0279 NB
 0500/0510 OP ID 02/0279/0046/0000
 SIGN: 4 CHORD TRUSS
 0500/0250 BMSID 02/8102/0500/0250
 003105 FT 0 0 00000 0 00 0000+00
 NC MCKNIGHT RD INT/RMP J RD
 INTER-BK MCKNIGHT RD

DIR: N TOTAL LEN: 1.075 MI. DIST: 11-1 SR: 8102
 LEFT MUN: PITTSBURGH C RIGHT MUN: PITTSBURGH C

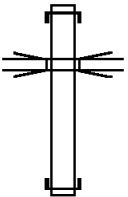
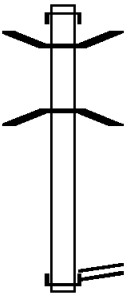
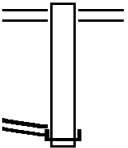
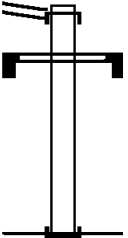
		<p>0500/0000 (SR4003 SEG 0011/1100) LENGTH(AH 1406 BK 0280)</p>
002825 FT		<p>INTER-AHD MCKNIGHT RD 0040/0280 (SR4003 SEG 0010/0505) SR 0279 NB 0040/0215 OP ID 02/0279/0046/0000 002825 FT 0 0 00000 0 00 0000+00 NC MC KNGHT RD INT/RMP FR HOV INTER-BK RAMP J RD (SR8102 SEG 0510/0530) 0040/0000 LENGTH(AH 0280 BK 1040)</p>
001785 FT		<p>INTER-AHD MCKNIGHT RD 0030/1040 (SR4003 SEG 0010/0585) 0030/0692 BMS EN 02/8102/0030/0445 0 0 00000 0 00 0000+00 SR 4009 NB 0030/0445 BMS BG 02/8102/0030/0445 001785 FT 0 0 00000 0 00 0000+00 RAMP K RD (SR8102 SEG 0020/0000) NC MC KNGHT RD INT/RMP I RD INTER-BK RAMP RD (SR8102 SEG 0010/1234) 0030/0000 LENGTH(AH 1040 BK 0551)</p>
001234 FT		<p>EVERGREEN RD 0020/0551 (SR4009 SEG 0111/2310) 001234 FT 0 0 00000 0 00 0000+00 NC MC KNGHT RD INT/RMP K RD INTER-BK RAMP RD (SR8102 SEG 0010/1234) 0020/0000 LENGTH(AH 0551 BK 1234)</p>
RAMP I RD (SR8102 SEG 0030/0000)		0020/0000
RAMP I RD (SR8102 SEG 0030/0000)		0010/1234
000000 FT		<p>INTER-AHD RAMP K RD 0010/1234 (SR8102 SEG 0020/0000) SIGN: 4 CHORD TRUSS 0010/0825 BMS ID 02/8102/0010/0825 000000 FT 0 0 00000 0 00 0000+00 NC MC KNGHT RD INT/RMP 10 RD INTER-BK I-279 N (SR0279 SEG 0042/0385) MFC BEGIN = F 0010/0000 LENGTH(AH 1234 BK 0000)</p>

001021 FT
 000559 FT

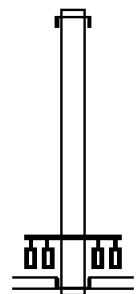

001021 FT
 INTER-AHD SR 0279 SH
 0510/0462 (SR0279 SEG 0037/1189)
 000559 FT 0 0 0000 0 0 00 0000+00
 NC VENTURE ST INT/RAMP F RD
 EAST ST
 (SR4003 SEG 0007/0000)
 (SR4003 SEG 0006/0000)
 EAST ST
 (CITY)

INTER-BK VENTURE ST
 (CITY)
 0510/0000 LENGTH(AH 0462 BK 0559)

000000 FT

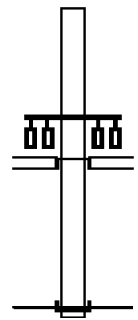

INTER-AHD VENTURE ST
 (CITY)
 EAST ST
 (CITY)
 EAST ST
 (SR4003 SEG 0007/0000)
 (SR4003 SEG 0006/0000)

0500/0559
 000000 FT 0 0 0000 0 00 0000+00
 NC VENTURE ST INT/RP H RD
 INTER-BK SR 0279 SH
 (SR0279 SEG 0037/2082)
 MFC BEGIN = F
 0500/0000 LENGTH(AH 0559 BK 0000)

001209 FT
 000734 FT

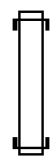

001209 FT
 INTER-AHD EAST ST
 0500/0475 (SR4099 SEG 0011/1665)
 000734 FT 0 0 00000 0 00 0000+00
 NC RAMP F RD
 INTER-BK SR 0279 SH
 (SR0279 SEG 0017/2300)
 0500/0000 LENGTH(AH 0475 BK 0734)

000000 FT

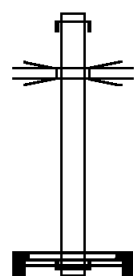

INTER-AHD I-279
 0010/0734 (SR0279 SEG 0016/2082)
 RAMP Q
 0010/0389 OP ID 02/0279/0016/1799
 000000 FT 0 0 00000 0 00 0000+00
 SIGN: CANTILEVER
 BMSID 02/8099/0010/0000
 NC RAMP S RD
 INTER-BK MADISON AV
 (SR4099 SEG 0010/1294)
 MFC BEGIN = F
 0010/0000 LENGTH(AH 0734 BK 0000)

EXTRACT DATE: 12/21/2020 ROADWAY MANAGEMENT SYSTEM PAGE NUMBER: 1614
 PRINT DATE: 12/23/2020 SLD COUNTY/SR - ANNUAL PRINT COUNTY: ALLEGHENY
 DIR: W TOTAL LEN: .168 MI. DIST: 11-1 SR: 8096
 LEFT MUN: PITTSBURGH C RIGHT MUN: PITTSBURGH C

000885 FT

000000 FT

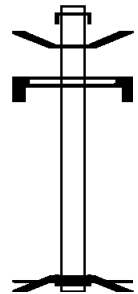

000885 FT
 INTER-AHD SECOND AV
 0500/0885 (CITY)
 0500/0405 BMS EN 02/8096/0500/0000
 SIGN: 4 CHORD TRUSS
 0500/0080 BMS ID 02/0376/0711/0699
 000000 FT 0 0 00000 0 00 0000+00
 NC 2ND AV/RAMP M RD
 INTER-BK PENN LINCOLN PY
 (SR0376 SEG 0711/0688)
 10TH ST
 BMSBG 02/8096/0500/0000
 MFC BEGIN = F
 0500/0000 LENGTH(AH 0885 BK 0000)

003378 FT

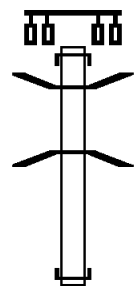

003378 FT
 INTER-AHD GRANT ST
 (CITY)
 0500/0600
 0500/0525 BMSEN 02/8095/0500/0487
 1 0 00764 0 04 0556+52
 I-376 WB
 0500/0487 BMSBG 02/8095/0500/0487
 002778 FT 0 0 00000 0 00 0000+00
 NC GRANT ST INT/RP E RD
 INTER-BK PENN LINCOLN PY
 (SR0376 SEG 0705/0988)
 0500/0000 LENGTH(AH 0600 BK 1280)

002778 FT

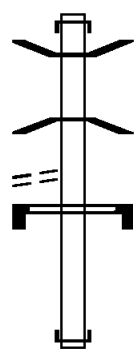

INTER-AHD RAMP A RD
 0270/1280 (SR8041 SEG 0250/4357)
 0270/0904 BMSEN 02/8095/0270/0367
 0 0 00000 0 00 0000+00
 PKWY OFF RP
 0270/0367 BMSBG 02/8095/0270/0367

LC FROM GRANT ST
 (CONN)

0270/0075

001498 FT

SIGN: CANTILEVER
 0270/0055 BMSID 02/8095/0270/0055
 001498 FT 0 0 00000 0 00 0000+00
 NC GRANT ST INT/RP F RD
 INTER-BK BL OF THE ALLIES
 (SR2208 SEG 0010/2596)
 0270/0000 LENGTH(AH 1280 BK 0511)

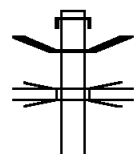

INTER-AHD PENN LINCOLN PY
 0260/0511 (SR0376 SEG 0701/0144)
 0260/0071 BMSEN 02/8095/0500/0487
 RAMP F
 0260/0034 OP ID 02/8095/0270/0367
 0 0 00000 0 00 0000+00
 I-376 WB

EXTRACT DATE: 12/21/2020
PRINT DATE: 12/23/2020

ROADWAY MANAGEMENT SYSTEM
SLD COUNTY/SR - ANNUAL PRINT

PAGE NUMBER: 1612
COUNTY: ALLEGHENY

DIR: E TOTAL LEN: .640 MI.
LEFT MUN: PITTSBURGH C

DIST: 11-1 SR: 8095
RIGHT MUN: PITTSBURGH C

000987 FT

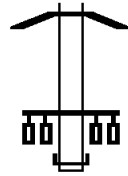

0260/0033 BMSBG 02/8095/0500/0487
000987 FT 0 0 00000 0 00 0000+00
NC GRANT ST INT/RP A RD

INTER-BK GRANT ST
(CITY)
0260/0000 LENGTH(AH 0511 BK 0437)

000550 FT

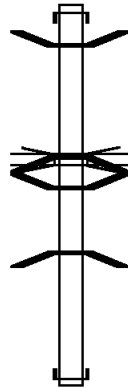

INTER-AHD GRANT ST
(CITY)
0020/0437 BMSEN 02/8095/0500/0487
0020/0402 0 0 00000 0 00 0000+00
RAMP F

OP ID 02/8095/0270/0367
I-376 WB

0020/0364 BMSBG 02/8095/0500/0487
0020/0301 BMSEN 02/8095/0020/0225
0 0 00000 0 00 0000+00
RAMP D

0020/0267 BMSBG 02/8095/0020/0225
000550 FT 0 0 00000 0 00 0000+00
NC GRANT ST INT/RP C RD

INTER-BK PENN LINCOLN PY
(SR0376 SEG 0700/0197)
0020/0000 LENGTH(AH 0437 BK 0550)

000000 FT

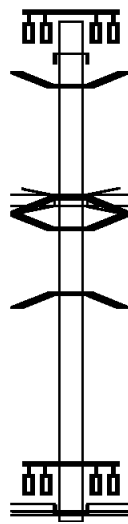

INTER-AHD GRANT ST
(CITY)
0010/0550 BMSEN 02/8095/0500/0487
0010/0543 0 0 00000 0 00 0000+00
RAMP F

OP ID 02/8095/0270/0367
I-376 WB

0010/0505 BMSBG 02/8095/0500/0487
0010/0312 BMSEN 02/8095/0010/0010
0 0 00000 0 00 0000+00
RAMP B (SR 8041)

0010/0010 BMSBG 02/8095/0010/0010
000000 FT 0 0 00000 0 00 0000+00
NC GRANT ST INT/RP B RD

SMITHFIELD ST
(SR3027 SEG 0030/0170)

INTER-BK FT PITT BL
(CITY)
MFC BEGIN = F

0010/0000 LENGTH(AH 0550 BK 0000)

000980 FT

000980 FT
 INTER-AHD STANWIX ST
 (CITY)
 FT PITT BL
 (CITY)
 FT PITT BL
 (CITY)
 0502/0444
 000536 FT 0 0 00000 0 00 0000+00
 MARKET ST
 OP ID 02/7301/0000/3121
 NC ST ANWIX ST INT/RMP 250 RD
 INTER-BK SR 376 SH
 (SR0376 SEG 0695/2981)
 0502/0000 LENGTH(AH 0444 BK 0536)

000536 FT

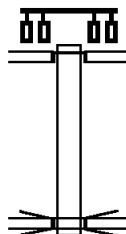

INTER-AHD SR 0376 SH
 0252/0536 (SR0376 SEG 0695/2017)
 0252/0394 BMSSEN 02/8094/0252/0041
 0 0 00000 0 00 0000+00
 MON WHARF
 0252/0069 BMSBG 02/8094/0252/0041
 NC ST ANWIX ST INT/RMP 500 RD
 FT PITT BL
 (CITY)
 FT PITT BL
 (CITY)
 INTER-BK STANWIX ST
 000000 FT (CITY)
 MFC BEGIN = F
 0252/0000 LENGTH(AH 0536 BK 0000)

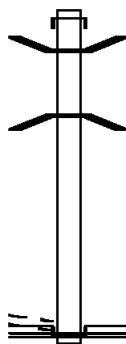

0 0 00000 0 00 0000+00 000000 FT
 LC TO FT PITT BL
 (CITY) 0252/0000

EXTRACT DATE: 12/21/2020 ROADWAY MANAGEMENT SYSTEM PAGE NUMBER: 1610
 PRINT DATE: 12/23/2020 SLD COUNTY/SR - ANNUAL PRINT COUNTY: ALLEGHENY
 DIR: N TOTAL LEN: .173 MI. DIST: 11-1 SR: 8092
 LEFT MUN: GLENFIELD B RIGHT MUN: GLENFIELD B

000915 FT

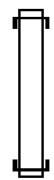

000915 FT
 INTER-AHD OHIO RIVER BL
 0260/0700 (SR0065 SEG 0141/0000)

000215 FT

000215 FT 0 0 00000 0 00 0000+00
 NC GL ENFIELD VD/RAMP E RD
 INTER-BK CENTER AV
 (SR4033 SEG 0008/0000)

5 0260/0000 LENGTH(AH 0700 BK 0215)

000000 FT

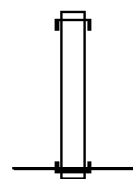

INTER-AHD CENTER AV
 0250/0215 (SR4033 SEG 0008/0000)
 000000 FT 0 0 00000 0 00 0000+00
 NC GL ENFIELD VD/RAMP D RD
 INTER-BK OHIO RIVER BL
 (SR0065 SEG 0140/0460)

5 0250/0000 LENGTH(AH 0215 BK 0000)

003039 FT

003039 FT
 INTER-AHD PARKWAY CENTER DR
 (SR3123 SEG 0010/0000)
 LC TO MALL DR

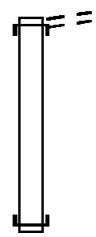

0500/1135 (CONN)
 RETAINING WALL
 0500/0750 BMSID 02/0376/0675/1900

001904 FT

001904 FT 0 0 00000 0 00 0000+00
 NC PARKWAY CNTR/RMP 500 RD
 INTER-BK PENN LINCOLN PY
 (SR0376 SEG 0675/1413)
 0500/0000 LENGTH(AH 1135 BK 1904)

INTER-AHD PENN LINCOLN PY
 0250/1904 (SR0376 SEG 0674/2118)

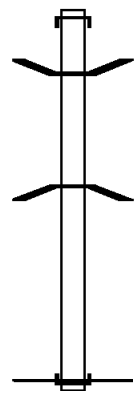

0250/1161 BMSEN 02/8091/0250/0940
 RETAINING WALL
 0250/0945 BMSID 02/8091/0250/1200
 0 0 00000 0 00 0000+00
 SR 0376 EB
 0250/0940 BMSBG 02/8091/0250/0940

000000 FT

000000 FT 0 0 00000 0 00 0000+00
 NC PARKWAY CNTR/RMP 250 RD
 INTER-BK PARKWAY CENTER DR
 (SR3123 SEG 0010/0000)
 MFC BEGIN = F
 0250/0000 LENGTH(AH 1904 BK 0000)

EXTRACT DATE: 12/21/2020 ROADWAY MANAGEMENT SYSTEM PAGE NUMBER: 1608
PRINT DATE: 12/23/2020 SLD COUNTY/SR - ANNUAL PRINT COUNTY: ALLEGHENY
DIR: E TOTAL LEN: .725 MI. DIST: 11-1 SR: 8090
LEFT MUN: ROBINSON T RIGHT MUN: ROBINSON T

003826 FT

002446 FT

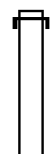

003826 FT
INTER-AHD PENN LCN PY SR 376/22/3
0750/1380 (SR0376 SEG 0610/0728)

002446 FT 0 0 00000 0 00 0000+00
NC RAMP D RD

DIR: E TOTAL LEN: .725 MI. DIST: 11-1 SR: 8090
 LEFT MUN: ROBINSON T RIGHT MUN: ROBINSON T

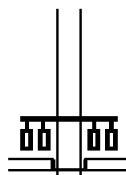

RIDGE RD
 (SR3145 SEG 0010/0133)
 (SR3145 SEG 0011/0125)

INTER-BK RAMP C RD
 (SR8090 SEG 0010/0839)
 0750/0000 LENGTH(AH 1380 BK 0388)

002058 FT

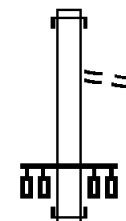

INTER-AHD PENN LCN PY SR 376/22/3
 0512/0388 (SR0376 SEG 0611/0468)
 LC FROM CAMPBELLS RUN R
 0512/0086 (CONN)
 002058 FT 0 0 00000 0 00 0000+00
 NC RAMP A RD

INTER-BK COMMONS BL
 (CNTY)
 0512/0000 LENGTH(AH 0388 BK 1219)

000839 FT

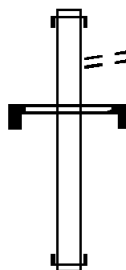

INTER-AHD COMMONS BL
 (CNTY)
 0502/1219 LC TO CAMPBELLS RUN RD
 0502/1128 (CONN)
 SIGN: 4 CHORD TRUSS
 0502/0762 BMSID 02/8090/0502/0762
 000839 FT 0 0 00000 0 00 0000+00
 NC RAMP B RD

INTER-BK PENN LCN PY SR 376/22/3
 (SR0376 SEG 0611/1841)
 0502/0000 LENGTH(AH 1219 BK 0839)

000000 FT

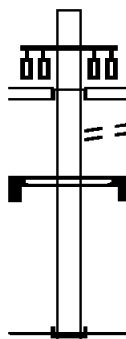

INTER-AHD RAMP D RD
 (SR8090 SEG 0750/0000)
 RIDGE RD
 (SR3145 SEG 0010/0097)
 0010/0839 TO 3145/0011 SH
 0010/0739 (CONN)
 SIGN: 4 CHORD TRUSS
 0010/0451 BMSID 02/8090/0010/0451
 000000 FT 0 0 00000 0 00 0000+00
 NC RAMP C RD

INTER-BK PENN LCN PY SR 376/22/3
 (SR0376 SEG 0604/1212)
 MFC BEGIN = F
 0010/0000 LENGTH(AH 0839 BK 0000)

001400 FT

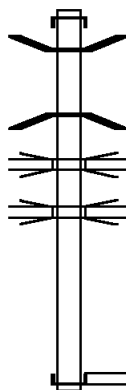

001400 FT
 INTER-AHD TARENTUM BR
 (SRO366 SEG 0033/0449)
 0020/0686 BMSSEN 02/8088/0020/0326
 0020/0666 BMSBG 02/8088/0020/0326
 0 0 00000 0 00 0000+00
 W FOURTH AVE
 0020/0359 BMSBG 02/8088/0020/0326
 A-9801, RMP A
 0020/0326 OP ID 02/0366/0032/0400
 TARENTUM BR.
 0020/0011 OP ID 02/0366/0032/0975
 000714 FT 1 1 09801 2 03 0000+00
 NC TR NTUM BR IN/RP FR 1ST AV
 ROSS ST
 (BORO)
 INTER-BK FIRST AV
 (BORO)
 0020/0000 LENGTH(AH 0686 BK 0714)

000714 FT

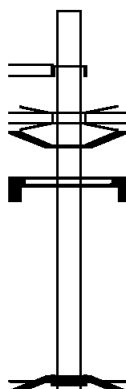

INTER-AHD FIRST AV
 (BORO)
 ROSS ST
 0010/0714 (BORO)
 TARENTUM BR.
 0010/0685 OP ID 02/0366/0032/0975
 0010/0323 BMSSEN 02/8088/0010/0000
 SIGN: 2 CHORD TRUSS
 0010/0009 BMSID 02/0366/0032/0485
 000000 FT 1 1 09801 2 02 0000+00
 NC TR NTUM BR IN/RP TO 1ST AV
 INTER-BK TARENTUM BR
 (SRO366 SEG 0032/0502)
 FOURTH AVE
 BMSBG 02/8088/0010/0000
 MFC BEGIN = F
 0010/0000 LENGTH(AH 0714 BK 0000)

000000 FT

004442 FT

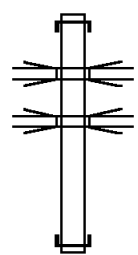

004041 FT

003678 FT

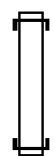

004442 FT
 INTER-AHD SR 2114 SH
 0510/0401 (SR2114 SEG 0010/1070)
 BOWMAN AVE
 0510/0400 OP ID 02/2107/0011/0000
 RAMP G 8086 NB
 0510/0110 OP ID 02/8086/0260/0704
 004041 FT 1 0 01066 2 01 0000+00
 NC RAMP E TO DUQ/MCKEESPT BR
 INTER-BK RAMP F TO BOWMAN AV
 (SR8086 SEG 0010/1419)
 0510/0000 LENGTH(AH 0401 BK 0363)

INTER-AHD SR 2114 SH
 0500/0363 (SR2114 SEG 0010/1210)
 003678 FT 1 0 01066 2 02 0000+00
 NC RAMP J RD/TO DUQ/MCKPT BR
 INTER-BK BOWMAN AV
 (CITY)
 0500/0000 LENGTH(AH 0363 BK 1013)

INTER-AHD RAMP F TO BOWMAN AV

EXTRACT DATE: 12/21/2020
PRINT DATE: 12/23/2020

ROADWAY MANAGEMENT SYSTEM
SLD COUNTY/SR - ANNUAL PRINT

PAGE NUMBER: 1604
COUNTY: ALLEGHENY

DIR: N TOTAL LEN: .841 MI.
LEFT MUN: MCKEESPORT C

DIST: 11-1 SR: 8086
RIGHT MUN: MCKEESPORT C

002665 FT

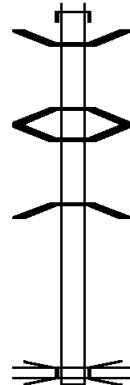

0260/1013 (SR8086 SEG 0010/1756)
0260/0853 BMSSEN 02/8086/0260/0704
0 0 00000 0 00 0000+00
RAMP E 8086 NB
0260/0727 BMSBG 02/8086/0260/0704
0260/0572 BMSSEN 02/8086/0260/0407
0 0 00000 0 00 0000+00
SR 2114 SB
0260/0407 BMSBG 02/8086/0260/0407
002665 FT 0 0 00000 0 00 0000+00
BOWMAN AVE
OP ID 02/2107/0011/0000
NC RAMP G RD/TO BOWMAN AV
INTER-BK SR 2114 SH
(SR2114 SEG 0011/1223)
5 0260/0000 LENGTH(AH 1013 BK 0775)

BOWMAN AV
(CITY)

0250/0594

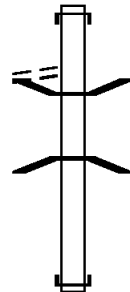

INTER-AHD FIFTH AV
0250/0775 (SR0148 SEG 0101/0000)
0250/0165 BMSSEN 02/8086/0250/0130
1 0 01066 2 05 0001+42
LOCAL STREET
0250/0130 BMSBG 02/8086/0250/0130
001890 FT 0 0 00000 0 00 0000+00
NC TO MCKEESPORT/ RAMP H RD
INTER-BK SR 2114 SH
(SR2114 SEG 0011/1377)
5 0250/0000 LENGTH(AH 0775 BK 1890)

001890 FT

RAMP G FR DUQ/MCKEESPT 0010/1756
(SR8086 SEG 0260/1013)
RAMP E TO DUQ/MCKEESPT 0010/1419
(SR8086 SEG 0510/0000)

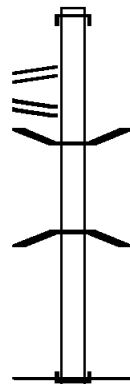

INTER-AHD BOWMAN AV
0010/1890 (CITY)
0010/1276 BMSSEN 02/8086/0010/0383
1 0 01066 2 02 0003+48
SR 0148 NB
0010/0383 BMSBG 02/8086/0010/0383
000000 FT 1 0 01066 2 04 0000+00
NC RAMP F RD/TO BOWMAN AV
INTER-BK FIFTH AV
(SR0148 SEG 0100/0000)
MFC BEGIN = F
5 0010/0000 LENGTH(AH 1890 BK 0000)

000000 FT

EXTRACT DATE: 12/21/2020 ROADWAY MANAGEMENT SYSTEM PAGE NUMBER: 1603
 PRINT DATE: 12/23/2020 SLD COUNTY/SR - ANNUAL PRINT COUNTY: ALLEGHENY
 DIR: E TOTAL LEN: .553 MI. DIST: 11-1 SR: 8084
 LEFT MUN: PLEASANT HILLS B RIGHT MUN: PLEASANT HILLS B

002922 FT

002598 FT

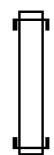

002922 FT
 INTER-AHD LEBANON CHURCH RD
 0760/0324 (SR2040 SEG 0091/0220)
 002598 FT 0 0 00000 0 00 0000+00
 NC PL PLEASANT HILLS INT/RP B-B RD
 INTER-BK SR 51 NB CLAIRTON BL
 (SR0051 SEG 0270/0650)
 0760/0000 LENGTH(AH 0324 BK 0382)

002216 FT

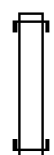







INTER-AHD SR 51 NB CLAIRTON BL
 0750/0382 (SR0051 SEG 0270/0690)
 002216 FT 2 0 02293 2 00 0000+00
 NC PL PLEASANT HILLS INT/RP B RD
 INTER-BK LEBANON CHURCH RD
 (SR2040 SEG 0091/0345)
 0750/0000 LENGTH(AH 0382 BK 0361)

001855 FT



INTER-AHD SR 51 SB CLAIRTON BL
 0510/0361 (SR0051 SEG 0271/0780)
 001855 FT 0 0 00000 0 00 0000+00

DIR: E TOTAL LEN: .553 MI. DIST: 11-1 SR: 8084
 LEFT MUN: PLEASANT HILLS B RIGHT MUN: PLEASANT HILLS B

		NC PLEASANT HILLS INT/RP C RD INTER-BK CURRY HOLLOW RD (SR2040 SEG 0081/3326) 0510/0000 LENGTH(AH 0361 BK 0374)
001481 FT		INTER-AHD CURRY HOLLOW RD 0500/0374 (SR2040 SEG 0081/3269) 001481 FT 2 0 02293 2 01 0000+00 NC PL ESN T HILLS INT/RP C-C RD INTER-BK SR 51 SB CLAIRTON BL (SR0051 SEG 0271/0830) 0500/0000 LENGTH(AH 0374 BK 0370)
001111 FT		INTER-AHD CURRY HOLLOW RD 0260/0370 (SR2040 SEG 0080/3360) 001111 FT 0 0 00000 0 00 0000+00 NC PL ESN T HILLS INT/RP D-D RD INTER-BK SR 51 SB CLAIRTON BL (SR0051 SEG 0271/0205) 0260/0000 LENGTH(AH 0370 BK 0397)
000714 FT		INTER-AHD SR 51 SB CLAIRTON BL 0250/0397 (SR0051 SEG 0271/0140) 000714 FT 2 0 02293 2 02 0000+00 NC PL EASN T HILLS INT/RP D RD INTER-BK CURRY HOLLOW RD (SR2040 SEG 0080/3305) 0250/0000 LENGTH(AH 0397 BK 0329)
000385 FT		INTER-AHD PA 51 NB CLAIRTON BL 0020/0329 (SR0051 SEG 0270/0335) 000385 FT 0 0 00000 0 00 0000+00 NC PL EASN T HILLS INT/RP A RD INTER-BK LEBANON CHURCH RD (SR2040 SEG 0090/0225) 0020/0000 LENGTH(AH 0329 BK 0385)
000000 FT		INTER-AHD LEBANON CHURCH RD 0010/0385 (SR2040 SEG 0090/0350) 000000 FT 2 0 02293 2 03 0000+00 NC PL ESN T HILLS INT/RP A-A RD INTER-BK SR 51 NB CLAIRTON BL (SR0051 SEG 0270/0290) MFC BEGIN = F 0010/0000 LENGTH(AH 0385 BK 0000)

005081 FT

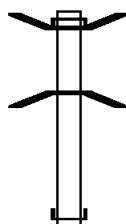

005081 FT BMS EN 02/8082/0750/0532
 INTER-AHD HIGHLAND PARK BR
 0750/0623 (SR1005 SEG 0020/0000)

004458 FT

0750/0532 BMSBG 02/8082/0750/0532
 004458 FT 0 0 00000 0 00 0000+00
 NC HGLND PRK BR INT/RP D RD
 INTER-BK ALLEGHENY RIVER BL
 (SR0008 SEG 0140/0389)
 0750/0000 LENGTH(AH 0623 BK 0544)

003914 FT



INTER-AHD FREEPORT RD
 0520/0544 (SR1001 SEG 0100/0951)
 003914 FT 0 0 00000 0 00 0000+00
 NC HGLND PRK BR INT/RP W RD
 INTER-BK HIGHLAND PARK BR
 (SR1005 SEG 0020/2364)
 0520/0000 LENGTH(AH 0544 BK 0995)

002919 FT

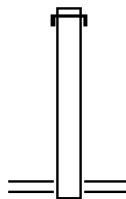

INTER-AHD HIGHLAND PARK BR
 0510/0995 (SR1005 SEG 0020/2844)
 002919 FT 0 0 00000 0 00 0000+00
 NC HGLND PRK BR INT/RP G RD
 FREEPORT RD
 (SR1001 SEG 0101/0992)
 0510/0000 LENGTH(AH 0995 BK 0932)

INTER-AHD FREEPORT RD
 0500/0932 (SR1001 SEG 0101/0975)

DIR: S TOTAL LEN: .962 MI. DIST: 11-1 SR: 8082
 LEFT MUN: OHARA T RIGHT MUN: OHARA T

TO 1001/0100 SH
 (CONN)

0500/0865
 001987 FT

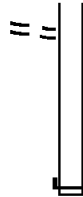

001987 FT 0 0 00000 0 00 0000+00
 NC HGH LND PRK BR INT/ RP F RD
 INTER-BK HIGHLAND PARK BR
 (SR1005 SEG 0020/2709)
 0500/0000 LENGTH(AH 0932 BK 0253)

001734 FT



INTER-AHD HIGHLAND PARK BR
 0270/0253 (SR1005 SEG 0021/2394)
 001734 FT 0 0 00000 0 00 0000+00
 NC HGH LND PRK BR INT/ RP X RD
 INTER-BK FREEPORT RD
 (SR1001 SEG 0100/0055)
 0270/0000 LENGTH(AH 0253 BK 0509)

001225 FT



INTER-AHD HIGHLAND PARK BR
 0260/0509 (SR1005 SEG 0021/2534)
 001225 FT 0 0 00000 0 00 0000+00
 NC HGH LND PRK BR INT/ RP K RD
 INTER-BK FREEPORT RD
 (SR1001 SEG 0101/0125)
 0260/0000 LENGTH(AH 0509 BK 0510)

TO 1001/0100 SH
 (CONN)

0250/0370



2 0 02260 2 05 0000+00 000715 FT
 HIGHLAND PARK BR
 (SR1005 SEG 0021/2763) 0250/0000

INTER-AHD FREEPORT RD
 0250/0510 (SR1001 SEG 0101/0000)
 000715 FT HLND PRK BR INT/ RP E RD
 INTER-BK RAMP A RD
 (SR8050 SEG 0010/1172)
 0250/0000 LENGTH(AH 0510 BK 0715)

000000 FT

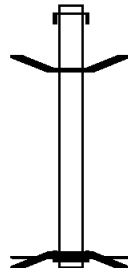

INTER-AHD ALLEGHENY RIVER BL
 0010/0715 (SR0008 SEG 0140/1649)
 0010/0090 BMS EN 02/8082/0010/0000
 000000 FT 2 0 02260 2 04 0000+00
 NC HGH LND PRK BR INT/ RP C RD
 INTER-BK HIGHLAND PARK BR
 (SR1005 SEG 0021/0000)
 NO UNDERPASS INFORMATIO
 BMSBG 02/8082/0010/0000
 MFC BEGIN = F
 0010/0000 LENGTH(AH 0715 BK 0000)

DIR: N TOTAL LEN: .264 MI. DIST: 11-1 SR: 8080
 LEFT MUN: MONROEVILLE B RIGHT MUN: MONROEVILLE B

001396 FT

000742 FT

000000 FT

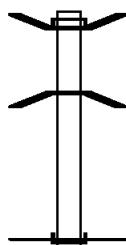
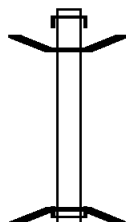

001396 FT
 INTER-AHD WILLIAM PENN HW
 0510/0654 (SR2048 SEG 0071/0640)
 0510/0167 BMSBN 02/8080/0500/0575
 000742 FT 1 0 00187 2 14 0000+00
 NC RAMP C RD
 INTER-BK MONROEVILLE MALL BL
 (BORO)
 SR 0022 EB
 BMSBG 02/8080/0500/0575
 0510/0000 LENGTH(AH 0654 BK 0742)

INTER-AHD BMSBN 02/8080/0500/0575
 0500/0742 MONROEVILLE MALL BL
 (BORO)
 0 0 00000 0 00 0000+00
 SR 0022 EB
 0500/0575 BMSBG 02/8080/0500/0575
 000000 FT 1 0 00187 2 13 0000+00
 NC RAMP D RD
 INTER-BK WILLIAM PENN HW
 (SR2048 SEG 0075/0000)
 MFC BEGIN = F
 0500/0000 LENGTH(AH 0742 BK 0000)

DIR: S TOTAL LEN: .372 MI. DIST: 11-1 SR: 8079
 LEFT MUN: ROSS T RIGHT MUN: ROSS T

001964 FT

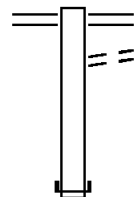

001964 FT BABCOCK BL
 0760/0422 (SR4011 SEG 0020/3035)
 LC TO 4011/0020 SH
 0760/0325 (CONN)
 001542 FT 0 0 00000 0 00 0000+00
 NC BA BABCOCK BL/RMP L RD
 INTER-BK MCKNIGHT RD
 (SR4003 SEG 0020/0415)
 0760/0000 LENGTH(AH 0422 BK 0561)

001542 FT

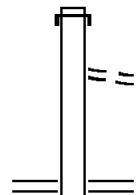

INTER-AHD MCKNIGHT RD
 0750/0561 (SR4003 SEG 0020/0605)
 LC FROM 4011/0020 SH
 0750/0080 (CONN)
 000981 FT 0 0 00000 0 00 0000+00
 NC BA BABCOCK BL/RMP H RD
 BABCOCK BL
 (SR4011 SEG 0020/2920)
 0750/0000 LENGTH(AH 0561 BK 0381)

000981 FT

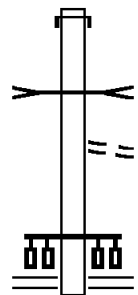

INTER-AHD MCKNIGHT RD
 0510/0381 (SR4003 SEG 0021/0460)
 MCKNIGHT RUN
 STRUCTURE LENGTH 12 FT
 0510/0338 BMSID 02/8079/0510/0338
 FROM 4011/0020 SH
 0510/0085 (CONN)
 000600 FT 0 0 00000 0 00 0000+00
 NC BA BABCOCK BL/RMP K RD
 BABCOCK BL
 (SR4011 SEG 0020/3270)
 0510/0000 LENGTH(AH 0381 BK 0600)

000600 FT

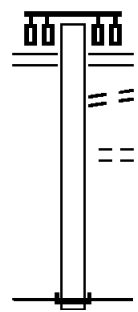

BABCOCK BL
 (SR4011 SEG 0020/3390)
 0500/0600 TO 4011/0020 SH
 0500/0525 (CONN)
 EVERGREEN RD (#2119-02)
 0500/0460 (CNTY)
 000000 FT 0 0 00000 0 00 0000+00
 NC BA BABCOCK BL/RMP G RD
 INTER-BK MCKNIGHT RD
 (SR4003 SEG 0021/0775)
 MFC BEGIN = F
 0500/0000 LENGTH(AH 0600 BK 0000)

000000 FT

DIR: N TOTAL LEN: 1.426 MI. DIST: 11-1 SR: 8078
 LEFT MUN: PITTSBURGH C RIGHT MUN: PITTSBURGH C

007528 FT

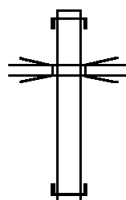

007528 FT
 INTER-AHD CROSSTOWN BL
 0520/0581 (SR0579 SEG 0003/1420)
 RAMP F 8078 SB
 0520/0353 OP ID 02/8078/0514/0018
 006947 FT 0 0 00000 0 00 0000+00
 NC CR CROSSTWN BL INT/RP 520 RD
 INTER-BK BIGELOW BL
 (SR0400 SEG 0005/1049)
 0520/0000 LENGTH(AH 0581 BK 1226)

006947 FT

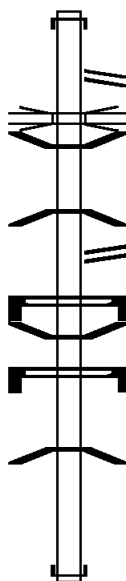

INTER-AHD CROSSTOWN BL
 0514/1226 (SR0579 SEG 0003/0800)
 RAMP G RD
 0514/1051 (SR8078 SEG 0252/0459)
 WEBSTER AVE
 0514/0944 OP ID 02/2146/0010/0000
 0514/0878 BMS EN 02/8078/0514/0370
 0 0 00000 0 0 0000+00
 RAMP D
 0514/0770 BMSBG 02/8078/0514/0370
 RAMP RD
 0514/0395 (SR8078 SEG 0512/0000)
 SIGN: 4 CHORD TRUSS
 0514/0381 BMSID 02/8078/0514/0369
 0514/0348 BMS EN 02/8078/0514/0018
 SIGN: 4 CHORD TRUSS
 0514/0040 BMSID 02/8078/0514/0040
 0 0 00000 0 0 0000+00
 RAMP C 8078 SB
 0514/0018 BMSBG 02/8078/0514/0018
 005721 FT 0 0 00000 0 00 0000+00
 NC BEDFORD AV/RAMP F RD
 INTER-BK BEDFORD AV
 (CITY)
 0514/0000 LENGTH(AH 1226 BK 0480)

005721 FT

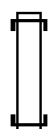

INTER-AHD RAMP D RD
 0512/0480 (SR8078 SEG 0262/0640)
 005241 FT 0 0 00000 0 00 0000+00
 NC CR STWN BL IT/RP TO 7TH AV
 INTER-BK RAMP F RD
 (SR8078 SEG 0514/0395)

005241 FT

DIR: N TOTAL LEN: 1.426 MI. DIST: 11-1 SR: 8078
 LEFT MUN: PITTSBURGH C RIGHT MUN: PITTSBURGH C

004908 FT  0512/0000 LENGTH(AH 0480 BK 0333)

004908 FT  INTER-AHD SEVENTH AV
 0510/0333 (CITY)
 004908 FT 1 0 00228 2 03 0000+00
 NC CR CROSSTWN BL INT/RP 510 RD
 INTER-BK RAMP J RD
 (SR8078 SEG 0500/1333)
 0510/0000 LENGTH(AH 0333 BK 1362)

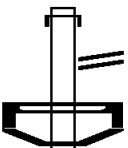
003546 FT  INTER-AHD BIGELOW BL
 0500/1362 (SR0400 SEG 0005/0360)
 RAMP 510 RD
 0500/1333 (SR8078 SEG 0510/0000)
 SIGN: 4 CHORD TRUSS
 0500/1137 BMSID 02/8078/0500/1310
 0500/1118 BMSEN 02/8078/0500/0000

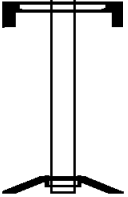
003546 FT  SIGN: 2 CHORD TRUSS
 0500/0438 BMSID 02/8078/0500/0610
 003546 FT 1 0 00228 2 00 0000+00
 NC CR CROSSTOWN BL INT/RP J RD
 INTER-BK CROSSTOWN BL
 (SR0579 SEG 0005/0515)
 NORFOLK SOUTHERN RAI RR
 BMSBG 02/8078/0500/0000
 0500/0000 LENGTH(AH 1362 BK 0774)

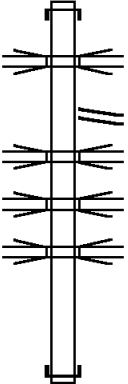
002772 FT  INTER-AHD SEVENTH AV
 0262/0774 (CITY)
 BIGELOW BLVD
 0262/0727 OP ID 02/0400/0005/0417
 RAMP RD
 0262/0640 (SR8078 SEG 0512/0480)
 RAMP F
 0262/0452 OP ID 02/8078/0514/0370
 SR 0579 SB
 0262/0328 OP ID 02/0579/0003/1060
 SR 0400 EB
 0262/0296 OP ID 02/0400/0004/0288
 002772 FT 0 0 00000 0 00 0000+00
 NC CR CROSSTOWN BL INT/RP D RD
 INTER-BK CROSSTOWN BL
 (SR0579 SEG 0002/0865)
 0262/0000 LENGTH(AH 0774 BK 0459)

EXTRACT DATE: 12/21/2020
PRINT DATE: 12/23/2020

ROADWAY MANAGEMENT SYSTEM
SLD COUNTY/SR - ANNUAL PRINT

PAGE NUMBER: 1595
COUNTY: ALLEGHENY

DIR: N TOTAL LEN: 1.426 MI.
LEFT MUN: PITTSBURGH C

DIST: 11-1 SR: 8078
RIGHT MUN: PITTSBURGH C

002313 FT

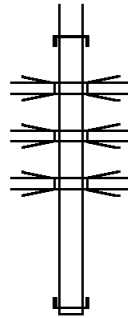

INTER-AHD RAMP F RD
0252/0459 (SR8078 SEG 0514/1051)
SR 0400 EB
0252/0410 OP ID 02/0400/0004/0288
WEBSTER AVE
0252/0353 OP ID 02/2146/0010/0000
BIGELOW BLVD
0252/0051 OP ID 02/0400/0005/0417
002313 FT 0 0 0000 0 00 0000+00
NC CR CROSS TOWN BL INT/RP G RD
INTER-BK SEVENTH AV
(CITY)
5 0252/0000 LENGTH(AH 0459 BK 1195)

001118 FT

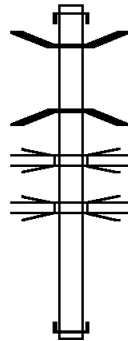

INTER-AHD BIGELOW BL
0020/1195 (SR0400 SEG 0004/1876)
0020/1085 BMS EN 02/8078/0020/0895
0 0 0000 0 00 0000+00
RAMP B NB
0020/0895 BMSBG 02/8078/0020/0895
I-579 HOV LN
0020/0486 OP ID 02/6579/0010/0054
RAMP F 8078 SB
0020/0300 OP ID 02/8078/0514/0018
001118 FT 0 0 0000 0 00 0000+00
NC CR CROSS TOWN BL INT/RP K RD
INTER-BK CROSS TOWN BL
(SR0579 SEG 0002/1470)
5 0020/0000 LENGTH(AH 1195 BK 1118)

000000 FT

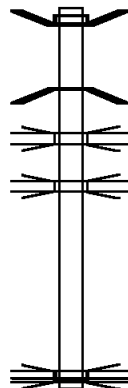

INTER-AHD BMS EN 02/8078/0010/0702
CROSS TOWN BL
0010/1118 (SR0579 SEG 0004/0480)
0 0 0000 0 00 0000+00
NORFOLK SOUTHERN RAI RR
0010/0708 BMSBG 02/8078/0010/0702
BIGELOW BLVD
0010/0665 OP ID 02/0400/0005/1346
RAMP 8078 EB
0010/0558 OP ID 02/8078/0020/0895
000000 FT 1 0 00228 2 01 0000+00
I-579 HOV LN
OP ID 02/6579/0010/0054
NC CR CROSS TOWN BL INT/RP B RD
INTER-BK BIGELOW BL
(SR0400 SEG 0004/1120)
MFC BEGIN = F
5 0010/0000 LENGTH(AH 1118 BK 0000)

DIR: E TOTAL LEN: .710 MI. DIST: 11-1 SR: 8077
 LEFT MUN: JEFFERSON HILLS B RIGHT MUN: JEFFERSON HILLS B

003751 FT

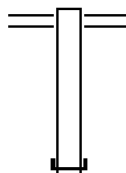

003751 FT RIDGE RD
 0262/0742 (SR2028 SEG 0040/2060)

003009 FT

003009 FT 0 0 00000 0 00 0000+00
 NC RIDGE RD INT/RAMP 262 RD
 INTER-BK CLAIRTON RD
 (SR0051 SEG 0131/3059)
 0262/0000 LENGTH(AH 0742 BK 0767)

002242 FT

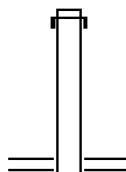

INTER-AHD CLAIRTON RD
 0252/0767 (SR0051 SEG 0131/2978)
 002242 FT 0 0 00000 0 00 0000+00
 NC RIDGE RD INT/RAMP 252 RD
 RIDGE RD
 (SR2028 SEG 0040/2060)
 0252/0000 LENGTH(AH 0767 BK 1105)

001137 FT

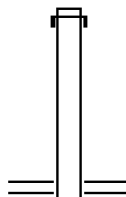

INTER-AHD CLAIRTON RD
 0020/1105 (SR0051 SEG 0130/2825)
 001137 FT 0 0 00000 0 00 0000+00
 NC RIDGE RD INT/RAMP 20 RD
 RIDGE RD
 (SR2028 SEG 0050/0325)
 0020/0000 LENGTH(AH 1105 BK 1137)

000000 FT

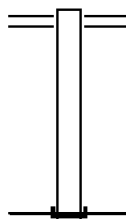

0010/1137 RIDGE RD
 (SR2028 SEG 0050/0325)
 000000 FT 0 0 00000 0 00 0000+00
 NC RIDGE RD INT/RAMP 10 RD
 INTER-BK CLAIRTON RD
 (SR0051 SEG 0130/2750)
 MFC BEGIN = F
 0010/0000 LENGTH(AH 1137 BK 0000)

001503 FT

001503 FT
 INTER-AHD RAMP D-2 RD
 (SR8076 SEG 0250/0000)
 PATTON ST
 (BORO)

001109 FT

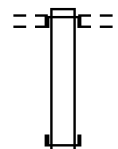

0500/0394
 001109 FT 1 0 00639 2 02 0000+00
 NC PATTON ST INT/RMP D3 RD
 INTER-BK BRIDGE ST/WATKINS AV
 (SR0130 SEG 0273/3042)
 0500/0000 LENGTH(AH 0394 BK 0553)

000556 FT

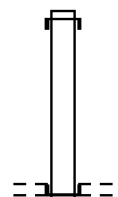

INTER-AHD BRIDGE ST/WATKINS AV
 0250/0553 (SR0130 SEG 0273/2084)
 000556 FT 1 0 00639 2 01 0000+00
 NC PATTON ST INT/RMP D2 RD
 PATTON ST
 (BORO)
 INTER-BK RAMP D-3 RD
 (SR8076 SEG 0500/0394)
 0250/0000 LENGTH(AH 0553 BK 0556)

000000 FT

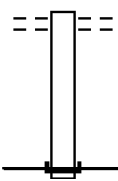

PATTON ST
 (BORO)
 0010/0556
 000000 FT 1 0 00639 2 00 0000+00
 NC PATTON ST INT/RMP D1 RD
 INTER-BK BRIDGE ST/WATKINS AV
 (SR0130 SEG 0272/2087)
 MFC BEGIN = F
 0010/0000 LENGTH(AH 0556 BK 0000)

DIR: N TOTAL LEN: .216 MI. DIST: 11-1 SR: 8075
 LEFT MUN: PITTSBURGH C RIGHT MUN: PITTSBURGH C

001142 FT



001142 FT
 INTER-AHD PENN LINCOLN PY
 0260/0293 (SR0376 SEG 0681/1787)
 000849 FT 1 0 00766 2 06 0000+00
 NC BANKSVILLE INT/RMP 260 RD
 INTER-BK BANKSVILLE RD
 (SR0019 SEG 0211/1100)
 0260/0000 LENGTH(AH 0293 BK 0172)

000849 FT

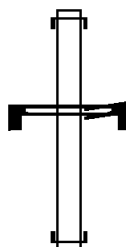

INTER-AHD BANKSVILLE RD
 0250/0172 (SR0019 SEG 0211/1211)
 SIGN: 4 CHORD TRUSS
 BMSID 02/8075/0250/0130
 SAWMILL RUN INT/RAMP C
 0250/0123 (SR8037 SEG 0260/2569)
 000677 FT 1 0 00766 2 05 0000+00
 NC BANKSVILLE INT/RMP 250 RD
 INTER-BK PENN LINCOLN PY
 (SR0376 SEG 0681/2347)
 0250/0000 LENGTH(AH 0172 BK 0677)

000677 FT

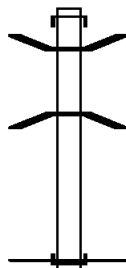

INTER-AHD BANKSVILLE RD
 0010/0677 (SR0019 SEG 0210/1190)
 0010/0240 BMSSEN 02/8075/0010/0189
 1 0 00766 2 10 0003+31
 SR 0019 NB
 0010/0189 BMSBG 02/8075/0010/0189
 000000 FT 2 0 02269 0 00 0112+80
 NC BANKSVILLE INT/RAMP E RD
 INTER-BK BANKSVILLE RD
 (SR0019 SEG 0211/0778)
 MFC BEGIN = F
 0010/0000 LENGTH(AH 0677 BK 0000)

000000 FT

EXTRACT DATE: 12/21/2020 ROADWAY MANAGEMENT SYSTEM PAGE NUMBER: 1591
PRINT DATE: 12/23/2020 SLD COUNTY/SR - ANNUAL PRINT COUNTY: ALLEGHENY

DIR: E TOTAL LEN: .507 MI. DIST: 11-1 SR: 8074
LEFT MUN: MOON T RIGHT MUN: MOON T

RAMP D SPUR RD
(SR8074 SEG 0264/0000)

002678 FT

0274/0375
002209 FT



002678 FT
INTER-AHD MONTOUR RUN RD
0274/0469 (SR3112 SEG 0011/0765)

002209 FT 0 0 00000 0 00 0000+00
NC MONTOUR INT/RMP D RD
INTER-BK AIRPORT PY

(SR0376 SEG 0585/0047)
5 0274/0000 LENGTH(AH 0469 BK 0225)

DIR: E TOTAL LEN: .507 MI. DIST: 11-1 SR: 8074
 LEFT MUN: MOON T RIGHT MUN: MOON T

001984 FT

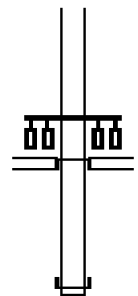

INTER-AHD MONTOUR RUN RD
 (SR3072 SEG 0004/0000)
 MONTOUR RUN RD
 (SR3112 SEG 0010/1005)
 MONTOUR RUN RD
 (SR3112 SEG 0011/1005)
 0264/0225
 001984 FT 0 0 00000 0 00 0000+00
 NC MONTOUR INT/RMP D SPUR RD
 INTER-BK RAMP D RD
 (SR8074 SEG 0274/0375)
 0264/0000 LENGTH(AH 0225 BK 0805)

001179 FT

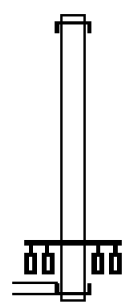

INTER-AHD AIRPORT PY
 0254/0805 (SR0376 SEG 0581/2317)
 001179 FT 0 0 00000 0 00 0000+00
 NC MONTOUR INT/RMP A RD
 MONTOUR RUN RD
 (SR3112 SEG 0011/1025)
 MONTOUR RUN RD
 (SR3112 SEG 0010/1025)
 INTER-BK MONTOUR RUN RD
 (SR3072 SEG 0005/0000)
 0254/0000 LENGTH(AH 0805 BK 0454)

000725 FT

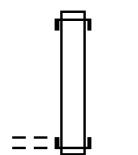

INTER-AHD AIRPORT PY
 0020/0454 (SR0376 SEG 0580/1969)
 000725 FT 0 0 00000 0 00 0000+00
 NC MONTOUR INT/RMP C & D RD
 INTER-BK MONTOUR RUN RD
 (SR3112 SEG 0011/0000)
 0020/0000 LENGTH(AH 0454 BK 0725)

CLIFF MINE RD
 (CNTY)

0020/0000

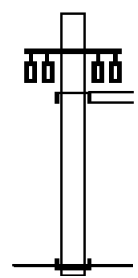

INTER-AHD MONTOUR RUN RD
 (SR3112 SEG 0010/0000)
 CLIFF MINE RD
 (CNTY)
 0010/0725
 000000 FT 0 0 00000 0 00 0000+00
 NC MONTOUR INT/RMP B RD
 INTER-BK AIRPORT PY
 (SR0376 SEG 0580/1691)
 MFC BEGIN = F
 0010/0000 LENGTH(AH 0725 BK 0000)

EXTRACT DATE: 12/21/2020 ROADWAY MANAGEMENT SYSTEM PAGE NUMBER: 1589
PRINT DATE: 12/23/2020 SLD COUNTY/SR - ANNUAL PRINT COUNTY: ALLEGHENY

DIR: N TOTAL LEN: .598 MI. DIST: 11-1 SR: 8073
LEFT MUN: WEST ELIZABETH B RIGHT MUN: WEST ELIZABETH B





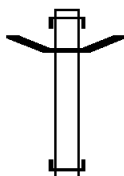

003157 FT

002386 FT

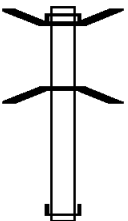

003157 FT
INTER-AHD DRAVOSBURG RD
0750/0771 (SR0837 SEG 0070/1517)
0750/0503 BMSSEN 02/8073/0750/0000
002386 FT 1 0 00330 2 00 0199+94
NC RAMP RD/TO SR 0837 SH
INTER-BK SR 51 NB SH
(SR0051 SEG 0110/1695)
NORFOLK SOUTHERN RAI RR

DIR: N TOTAL LEN: .598 MI. DIST: 11-1 SR: 8073
 LEFT MUN: WEST ELIZABETH B RIGHT MUN: WEST ELIZABETH B

		0750/0000	BMSBG 02/8073/0750/0000 LENGTH(AH 0771 BK 0180)
002206 FT		0542/0000	INTER-AHD SR 51 NB SH 0542/0180 (SR0051 SEG 0114/0460) 002206 FT 0 0 00000 0 00 0000+00 INTER-BK DRAVOSBURG RD (SR0837 SEG 0070/0348) 0542/0000 LENGTH(AH 0180 BK 0084)
002122 FT		0532/0000	INTER-AHD SR 51 NB SH 0532/0084 (SR0051 SEG 0114/0000) 0 00000 0 0 0000+00 SR 0837 NB SB 0532/0025 BMSBG 02/8073/0532/0040 002122 FT 0 0 00000 0 00 0000+00 NC RAMP RD/TO SR 0051 RD INTER-BK SR 51 SB SH (SR0051 SEG 0111/1926) 0532/0000 LENGTH(AH 0084 BK 0084)
002038 FT		0522/0000	INTER-AHD SR 51 SH 0522/0084 (SR0051 SEG 0115/0615) 002038 FT 0 0 00000 0 00 0000+00 NC RAMP RD/TO SR 0051 SH INTER-BK FIFTH ST (SR0837 SEG 0060/0464) 0522/0000 LENGTH(AH 0084 BK 0111)
001927 FT		0512/0000	INTER-AHD FIFTH ST 0512/0111 (SR0837 SEG 0060/0435) 001927 FT 0 0 00000 0 00 0000+00 INTER-BK SR 51 SH (SR0051 SEG 0114/0755) 0512/0000 LENGTH(AH 0111 BK 0174)
001753 FT		0510/0000	INTER-AHD DRAVOSBURG RD 0510/0174 (SR0837 SEG 0070/0341) 001753 FT 0 0 00000 0 00 0000+00 NC RAMP RD/TO SR 0837 SH INTER-BK SR 51 SB (SR0051 SEG 0115/0325) 0510/0000 LENGTH(AH 0174 BK 0159)

DIR: N TOTAL LEN: .598 MI. DIST: 11-1 SR: 8073
 LEFT MUN: WEST ELIZABETH B RIGHT MUN: WEST ELIZABETH B

001594 FT

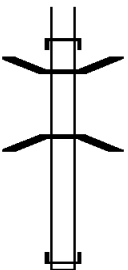

INTER-AHD SR 51 SB SH
 0502/0159 (SR0051 SEG 0121/0000)
 0502/0105 BMS EN 02/8073/0502/0053
 0 00000 0 0 0000+00
 SR 0837 NB SB
 0502/0053 BMSBG 02/8073/0502/0053
 001594 FT 0 0 00000 0 00 0000+00
 NC RAMP RD/TO SR 0051 SH
 INTER-BK SR 51 NB SH
 (SR0051 SEG 0120/0000)
 0502/0000 LENGTH(AH 0159 BK 0138)

001456 FT



INTER-AHD MARKET ST
 0260/0138 (BORO)
 001456 FT 0 0 00000 0 00 0000+00
 NC RAMP RD/TO 3RD ST
 INTER-BK HAYDEN BL
 (SR0051 SEG 0101/1326)
 0260/0000 LENGTH(AH 0138 BK 0251)

001205 FT



INTER-AHD HAYDEN BL
 0250/0251 (SR0051 SEG 0101/1107)
 001205 FT 0 0 00000 0 00 0000+00
 INTER-BK MARKET ST
 (BORO)
 0250/0000 LENGTH(AH 0251 BK 0620)

000585 FT

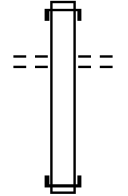

INTER-AHD HAYDEN BL
 0020/0620 (SR0051 SEG 0100/1535)
 THIRD ST
 0020/0145 (BORO)
 000585 FT 0 0 00000 0 00 0000+00
 NC RAMP RD/TO SR 0051 SH
 INTER-BK SECOND AV
 (SR2001 SEG 0191/0517)
 0020/0000 LENGTH(AH 0620 BK 0585)

000000 FT

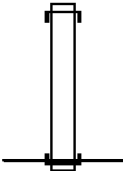

INTER-AHD THIRD ST
 0010/0585 (BORO)
 000000 FT 0 0 00000 0 00 0000+00
 NC RAMP RD/TO 3RD ST
 INTER-BK HAYDEN BL
 (SR0051 SEG 0100/1335)
 MFC BEGIN = F
 0010/0000 LENGTH(AH 0585 BK 0000)

EXTRACT DATE: 12/21/2020 ROADWAY MANAGEMENT SYSTEM PAGE NUMBER: 1586
PRINT DATE: 12/23/2020 SLD COUNTY/SR - ANNUAL PRINT COUNTY: ALLEGHENY
DIR: S TOTAL LEN: .738 MI. DIST: 11-1 SR: 8072
LEFT MUN: FINDLAY T RIGHT MUN: FINDLAY T

003894 FT



003894 FT
INTER-AHD CARGO RD
0750/1047 (SR3160 SEG 0032/1039)

DIR: S TOTAL LEN: .738 MI. DIST: 11-1 SR: 8072
 LEFT MUN: FINDLAY T RIGHT MUN: FINDLAY T

002847 FT

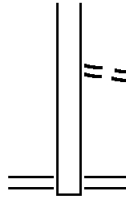

0750/0060 FROM 3089/0120 SH
 (CONN)
 002847 FT 1 0 01023 2 00 0000+00
 NC FLAUGHRTY RUN INT/ RP K RD
 CLINTON RD
 (SR3089 SEG 0120/0909)
 0750/0000 LENGTH(AH 1047 BK 1149)

001698 FT

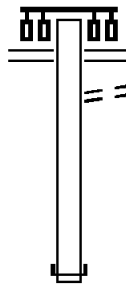

0500/1149 CLINTON RD
 (SR3089 SEG 0130/0303)
 0500/1085 TO 3089/0130 SH
 (CONN)
 001698 FT 0 0 00000 0 00 0000+00
 NC FLAUGHRTY RUN INT/ RP I RD
 INTER-BK CARGO RD
 (SR3160 SEG 0033/1185)
 0500/0000 LENGTH(AH 1149 BK 0805)

000893 FT



0250/0805 INTER-AHD CARGO RD
 (SR3160 SEG 0023/0549)
 0250/0070 FROM 3089/0130 SH
 (CONN)
 000893 FT 0 0 00000 0 00 0000+00
 NC FLAUGHRTY RUN INT/ RP J RD
 CLINTON RD
 (SR3089 SEG 0130/0303)
 0250/0000 LENGTH(AH 0805 BK 0893)

TO 3089/0120 SH
 (CONN)

0010/0812

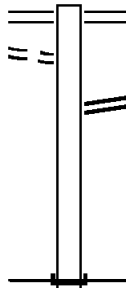

000000 FT

0010/0893 CLINTON RD
 (SR3089 SEG 0120/0909)
 0010/0809 RAMP TO AIRPORT PY
 (SR8113 SEG 0520/0000)
 000000 FT 1 0 01023 2 02 0000+00
 NC FLAUGHRTY RUN INT/ RP L RD
 INTER-BK CARGO RD
 (SR3160 SEG 0022/0680)
 MFC BEGIN = F
 0010/0000 LENGTH(AH 0893 BK 0000)

DIR: S TOTAL LEN: .620 MI. DIST: 11-1 SR: 8071
 LEFT MUN: MOON T RIGHT MUN: MOON T

003271 FT

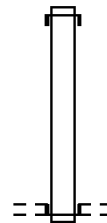

003271 FT
 INTER-AHD CARGO RD
 0750/0676 (SR3160 SEG 0052/0827)

002595 FT

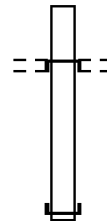

002595 FT 0 0 00000 0 00 0000+00
 NC CARGO INT/RAMP D RD
 INTERNATIONAL DR
 (TWP)
 INTER-BK RAMP C RD
 (SR8071 SEG 0010/0917)
 0750/0000 LENGTH(AH 0676 BK 0854)

001741 FT

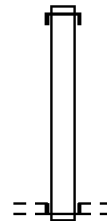

INTER-AHD RAMP B RD
 (SR8071 SEG 0250/0000)
 INTERNATIONAL DR
 (TWP)
 0500/0854
 001741 FT 0 0 00000 0 00 0000+00
 NC CARGO INT/RAMP A RD
 INTER-BK CARGO RD
 (SR3160 SEG 0053/1319)
 0500/0000 LENGTH(AH 0854 BK 0824)

000917 FT

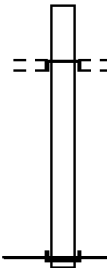

INTER-AHD CARGO RD
 0250/0824 (SR3160 SEG 0043/1973)
 000917 FT 0 0 00000 0 00 0000+00
 NC CARGO INT/RAMP B RD
 INTERNATIONAL DR
 (TWP)
 INTER-BK RAMP A RD
 (SR8071 SEG 0500/0854)
 0250/0000 LENGTH(AH 0824 BK 0917)

000000 FT



INTER-AHD RAMP D RD
 (SR8071 SEG 0750/0000)
 INTERNATIONAL DR
 (TWP)
 0010/0917
 000000 FT 0 0 00000 0 00 0000+00
 NC CARGO INT/RAMP C RD
 INTER-BK CARGO RD
 (SR3160 SEG 0042/1680)
 MFC BEGIN = F
 0010/0000 LENGTH(AH 0917 BK 0000)

EXTRACT DATE: 12/21/2020 ROADWAY MANAGEMENT SYSTEM PAGE NUMBER: 1583
PRINT DATE: 12/23/2020 SLD COUNTY/SR - ANNUAL PRINT COUNTY: ALLEGHENY

DIR: S TOTAL LEN: .754 MI. DIST: 11-1 SR: 8070
LEFT MUN: MOON T RIGHT MUN: MOON T

003979 FT

0 0 00000 0 00 0000+00 003353 FT
EWING RD

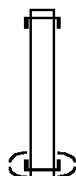

003979 FT
INTER-AHD BUSINESS 376 SH
0750/0626 (SR3160 SEG 0122/0354)

NC EWING INT/RAMP D RD
003353 FT (TWP)
INTER-BK EWING RD
(SR3070 SEG 0134/0098)

DIR: S TOTAL LEN: .754 MI. DIST: 11-1 SR: 8070
 LEFT MUN: MOON T RIGHT MUN: MOON T

(SR3070 SEG 0134/0098) 0750/0000



0750/0000 LENGTH(AH 0626 BK 1440)

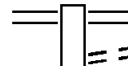

0500/1440 EWING RD
 (SR3070 SEG 0134/0836)
 TO 3070/0134 SH
 0500/1382 (CONN)

001913 FT

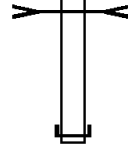

BR MCCLAREN
 STRUCTURE LENGTH 50 FT
 0500/0167 BMSID 02/8070/0500/0125
 001913 FT 0 0 00000 0 00 0000+00
 NC EW ING INT/RAMP A RD
 INTER-BK BUSINESS 376 SH
 (SR3160 SEG 0123/0687)
 0500/0000 LENGTH(AH 1440 BK 1098)

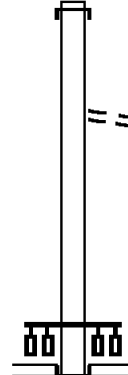

000815 FT

INTER-AHD BUSINESS 376 SH
 0250/1098 (SR3160 SEG 0113/1476)
 LC FROM EWING RD
 0250/0049 (CONN)
 000815 FT 0 0 00000 0 00 0000+00
 NC EW ING INT/RAMP B RD
 EWING RD
 (SR3070 SEG 0134/1150)
 (SR3070 SEG 0135/1211)
 EWING RD
 (TWP)
 INTER-BK HOOKSTOWN GRADE RD
 (SR3075 SEG 0044/1375)
 0250/0000 LENGTH(AH 1098 BK 0815)

EWING RD
 (SR3070 SEG 0135/0142) 0010/0815

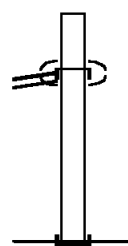

000000 FT

INTER-AHD EWING RD
 (SR3070 SEG 0135/0142)
 MOON-EWING RD
 0010/0815 (TWP)
 000000 FT 0 0 00000 0 00 0000+00
 NC EW ING INT/RAMP C RD
 INTER-BK BUSINESS 376 SH
 (SR3160 SEG 0112/2337)
 MFC BEGIN = F
 0010/0000 LENGTH(AH 0815 BK 0000)

DIR: E TOTAL LEN: .540 MI. DIST: 11-1 SR: 8069
 LEFT MUN: MCCANDLESS T RIGHT MUN: MCCANDLESS T

002850 FT

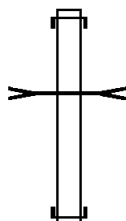

002850 FT
 INTER-AHD INGOMAR RD
 0750/0871 (SR4070 SEG 0040/1440)
 BR. PINE CR.
 STRUCTURE LENGTH 17 FT
 0750/0537 BMSID 02/8069/0750/0400
 001979 FT 1 0 00246 2 07 0000+00
 NC RAMP C RD
 INTER-BK MCKNIGHT RD
 (SR4003 SEG 0150/0445)
 0750/0000 LENGTH(AH 0871 BK 0687)

001979 FT

001292 FT

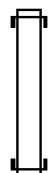

INTER-AHD MCKNIGHT RD
 0500/0687 (SR4003 SEG 0151/0720)
 001292 FT 1 0 00246 2 08 0000+00
 NC RAMP D RD
 INTER-BK INGOMAR RD
 (SR4070 SEG 0040/0852)
 0500/0000 LENGTH(AH 0687 BK 0692)

000600 FT

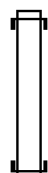

INTER-AHD MCKNIGHT RD
 0250/0692 (SR4003 SEG 0141/2143)
 000600 FT 1 0 00246 2 06 0000+00
 NC RAMP B RD
 INTER-BK INGOMAR RD
 (SR4070 SEG 0040/0645)
 0250/0000 LENGTH(AH 0692 BK 0600)

000000 FT

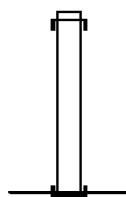

INTER-AHD INGOMAR RD
 0010/0600 (SR4070 SEG 0040/1610)
 000000 FT 1 0 00246 2 05 0000+00
 NC RAMP A RD
 INTER-BK MCKNIGHT RD
 (SR4003 SEG 0140/2101)
 MFC BEGIN = F
 0010/0000 LENGTH(AH 0600 BK 0000)

000980 FT

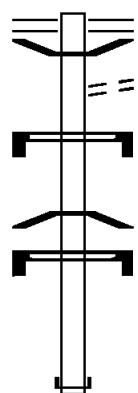

000980 FT BL OF THE ALLIES
 0750/0490 (SR2208 SEG 0020/1146)
 0750/0485 BMSSEN 02/8067/0750/0000
 TO 2208/0020 SH
 0750/0460 (CONN)
 SIGN: 4 CHORD TRUSS
 0750/0442 BMSID 02/8067/0750/0442
 0 0 00000 0 00 0000+00
 2ND AVENUE
 0750/0053 BMSBG 02/8067/0750/0000
 SIGN: 4 CHORD TRUSS
 0750/0014 BMSID 02/3069/0110/2330
 000490 FT 0 0 00000 0 00 0000+00
 NC RAMP A-2/LIBERTY BR.
 INTER-BK LIBERTY BR
 (SR3069 SEG 0110/2320)
 0750/0000 LENGTH(AH 0490 BK 0490)

000490 FT

INTER-AHD LIBERTY BR
 (SR3069 SEG 0111/2311)
 0010/0490
 SIGN: 4 CHORD TRUSS
 0010/0466 BMSID 02/3069/0110/2330
 0010/0443 BMSSEN 02/8067/0010/0000
 0 0 00000 0 00 0000+00
 2ND AVENUE
 0010/0011 BMSBG 02/8067/0010/0000
 000000 FT 0 0 00000 0 00 0000+00
 NC RAMP B-2/LIBERTY BR.
 INTER-BK BL OF THE ALLIES
 (SR2208 SEG 0020/1075)
 MFC BEGIN = F
 0010/0000 LENGTH(AH 0490 BK 0000)

000000 FT

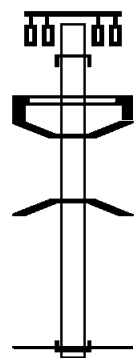

EXTRACT DATE: 12/21/2020 ROADWAY MANAGEMENT SYSTEM PAGE NUMBER: 1579
PRINT DATE: 12/23/2020 SLD COUNTY/SR - ANNUAL PRINT COUNTY: ALLEGHENY
DIR: N TOTAL LEN: .746 MI. DIST: 11-1 SR: 8066
LEFT MUN: HARRISON T RIGHT MUN: HARRISON T

003941 FT

003941 FT
INTER-AHD ALLEGHENY VALLEY EX

DIR: N TOTAL LEN: .746 MI. DIST: 11-1 SR: 8066
 LEFT MUN: HARRISON T RIGHT MUN: HARRISON T

002781 FT

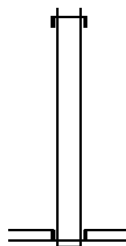

0750/1160 (SR0028 SEG 0430/3239)

002781 FT 1 0 01037 2 24 0000+00
 NC NA TRONA HTS INT/RAMP H RD
 BURTNER RD
 (SR1032 SEG 0040/0083)

INTER-BK RAMP G RD
 (SR8066 SEG 0010/0791)

0750/0000 LENGTH(AH 1160 BK 1159)

INTER-AHD RAMP E RD
 (SR8066 SEG 0250/0000)
 BURTNER RD

(SR1032 SEG 0031/0544)
 (SR1032 SEG 0030/0544)

001622 FT 1 0 01037 2 22 0000+00
 NC NA TRONA HTS INT/RAMP F RD

INTER-BK ALLEGHENY VALLEY EX
 (SR0028 SEG 0433/3187)

0500/0000 LENGTH(AH 1159 BK 0831)

INTER-AHD ALLEGHENY VALLEY EX
 0250/0831 (SR0028 SEG 0433/1155)

001622 FT

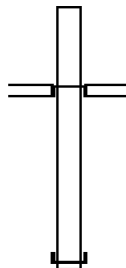

000791 FT 1 0 01037 2 21 0000+00
 NC NA TRONA HTS INT/RAMP E RD

BURTNER RD
 (SR1032 SEG 0031/0544)
 (SR1032 SEG 0030/0544)

INTER-BK RAMP F RD
 (SR8066 SEG 0500/1159)

0250/0000 LENGTH(AH 0831 BK 0791)

INTER-AHD RAMP H RD
 (SR8066 SEG 0750/0000)
 BURTNER RD

(SR1032 SEG 0040/0083)

000000 FT

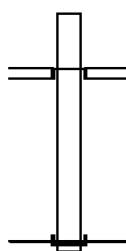

000000 FT 1 0 01037 2 23 0000+00
 NC NA TRONA HTS INT/RAMP G RD

INTER-BK ALLEGHENY VALLEY EX
 (SR0028 SEG 0430/1285)

MFC BEGIN = F
 0010/0000 LENGTH(AH 0791 BK 0000)

DIR: N TOTAL LEN: .346 MI. DIST: 11-1 SR: 8065
 LEFT MUN: PITTSBURGH C RIGHT MUN: PITTSBURGH C

001829 FT

001829 FT
 INTER-AHD BIRMINGHAM BR
 0250/0919 (SR2085 SEG 0011/2331)
 0250/0892 BMSEN 02/8065/0250/0000

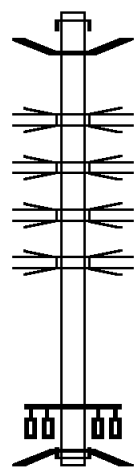

0250/0223 OP ID RAMP T 8004 EB 02/8004/0760/0000
 BLVD ALLIES WB
 0250/0196 OP ID 02/0885/0330/1797
 BLVD ALLIES SB
 0250/0113 OP ID 02/0885/0331/1302
 RAMP U WB
 0250/0025 OP ID 02/8004/0260/0020
 000910 FT 0 0 00000 0 00 0000+00
 NC BIRM BR INT/RP FR FORBES

000910 FT

INTER-BK FORBES AV
 (CITY)
 PARKWAY 1376
 BMSBG 02/8065/0250/0000
 0250/0000 LENGTH(AH 0919 BK 0910)

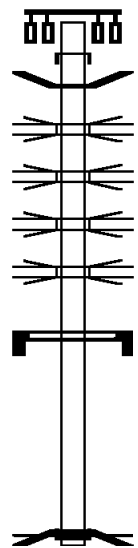

INTER-AHD FORBES AV
 (SR2308 SEG 0010/0000)
 0010/0910
 0010/0892 BMSEN 02/8065/0010/0000
 BLVD ALLIES SB
 0010/0831 OP ID 02/0885/0331/1302
 RAMP R
 0010/0777 OP ID 02/8004/0500/0732
 BLVD ALLIES WB
 0010/0700 OP ID 02/0885/0330/1797
 RAMP T 8004 EB
 0010/0659 OP ID 02/8004/0760/0000

000000 FT

SIGN: CANTILEVER
 0010/0020 BMSID 02/2085/0010/2318
 000000 FT 2 0 02266 2 00 0023+31
 NC BIRM BR INT/RP TO FORBES
 INTER-BK BIRMINGHAM BR
 (SR2085 SEG 0010/2314)
 RAMP V
 BMSBG 02/8065/0010/0000
 MFC BEGIN = F
 0010/0000 LENGTH(AH 0910 BK 0000)

EXTRACT DATE: 12/21/2020 ROADWAY MANAGEMENT SYSTEM PAGE NUMBER: 1576
PRINT DATE: 12/23/2020 SLD COUNTY/SR - ANNUAL PRINT COUNTY: ALLEGHENY

DIR: N TOTAL LEN: 1.140 MI. DIST: 11-1 SR: 8064
LEFT MUN: TARENTUM B RIGHT MUN: TARENTUM B

006017 FT

005812 FT

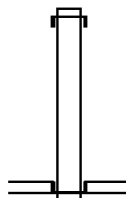

006017 FT
INTER-AHD RAMP 750 RD
0760/0205 (SR8064 SEG 0750/0390)
005812 FT 0 0 00000 0 00 0000+00
NC RAMP RD/TO RAMP RD 0750
ROSS ST
(SR0366 SEG 0013/0118)
INTER-BK RAMP 20 RD
(SR8064 SEG 0020/0429)
0760/0000 LENGTH(AH 0205 BK 0822)

RAMP 760 RD
(SR8064 SEG 0760/0205) 0750/0390
004990 FT

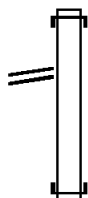

INTER-AHD ALLEG VALLEY EX
0750/0822 (SR0028 SEG 0400/0705)
004990 FT 0 0 00000 0 00 0000+00
NC RAMP F RD/TO SR 0028 SH
INTER-BK ROSS ST
(SR0366 SEG 0013/0390)
0750/0000 LENGTH(AH 0822 BK 1342)

DIR: N TOTAL LEN: 1.140 MI. DIST: 11-1 SR: 8064
 LEFT MUN: EAST DEER T RIGHT MUN: EAST DEER T

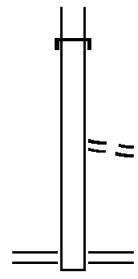

003648 FT

INTER-AHD ALLEG VALLEY EX
 0510/1342 (SR0028 SEG 0407/0260)
 FROM 1034/0073
 0510/0370 (CONN)
 003648 FT 0 0 00000 0 00 0000+00
 NC RAMP RD/TO SR 0028 SH
 BULL CREEK RD
 (SR1034 SEG 0072/0700)
 0510/0000 LENGTH(AH 1342 BK 1413)

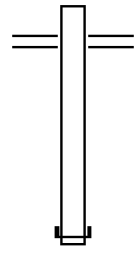

002235 FT

BULL CREEK RD
 (SR1034 SEG 0073/0696)
 0500/1413 (SR1034 SEG 0072/0683)
 002235 FT 1 0 01037 2 31 0000+00
 NC RAMP RD/TO SR 1034 SH
 INTER-BK ALLEG VALLEY EX
 (SR0028 SEG 0407/1335)
 0500/0000 LENGTH(AH 1413 BK 0429)

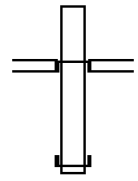

001806 FT

INTER-AHD RAMP 760 RD
 (SR8064 SEG 0760/0000)
 ROSS ST
 0020/0429 (SR0366 SEG 0012/0123)
 001806 FT 0 0 00000 0 00 0000+00
 INTER-BK RAMP 10 RD
 (SR8064 SEG 0010/1210)
 0020/0000 LENGTH(AH 0429 BK 1806)

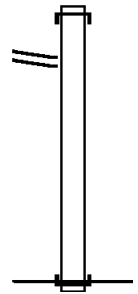

RAMP 20 RD (SR8064 SEG 0020/0000) 0010/1210

000000 FT

INTER-AHD ROSS ST
 0010/1806 (SR0366 SEG 0012/0755)
 000000 FT 0 0 00000 0 00 0000+00
 NC RAMP RD/TO SR 0366 SH
 INTER-BK ALLEG VALLEY EX
 (SR0028 SEG 0390/0945)
 MFC BEGIN = F
 0010/0000 LENGTH(AH 1806 BK 0000)

EXTRACT DATE: 12/21/2020 ROADWAY MANAGEMENT SYSTEM PAGE NUMBER: 1574
 PRINT DATE: 12/23/2020 SLD COUNTY/SR - ANNUAL PRINT COUNTY: ALLEGHENY
 DIR: S TOTAL LEN: .115 MI. DIST: 11-1 SR: 8063
 LEFT MUN: EAST PITTSBURGH B RIGHT MUN: EAST PITTSBURGH B

000605 FT

000000 FT

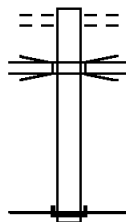

000605 FT BRADDOCK AV
 0750/0605 (BORO)
 0750/0578 MCKEESPRT BLVD
 000000 FT OP ID 02/2037/0090/0874
 1 0 01074 2 01 0000+00
 NC E PGH INT/ RMP B RD
 INTER-BK MCKEESPORT BL
 (SR2037 SEG 0101/0106)
 MFC BEGIN = F
 0750/0000 LENGTH(AH 0605 BK 0000)

002433 FT

001723 FT

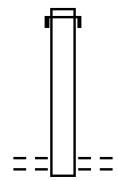

002433 FT
 INTER-AHD ALLEGHENY VALLEY EX
 0500/0710 (SR0028 SEG 0375/0260)
 001723 FT 0 0 00000 0 00 0000+00
 NC CR REIGHTON INT/RMP 500 RD
 BAILEYS RUN RD
 (CNTY)
 0500/0000 LENGTH(AH 0710 BK 1723)

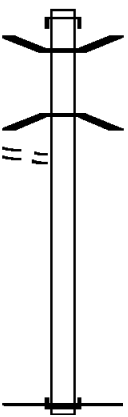

INTER-AHD CRAWFORD RUN RD (TBK)
 0010/1723 (TWP)
 0010/1614 BMSEN 02/8062/0010/1499
 1 0 01037 2 29 0021+43
 CRAWFORD RUN
 0010/1598 BMSBG 02/8062/0010/1499

LC TO CRAWFORD RUN RD
 (CONN)

0010/1586

000000 FT

000000 FT 1 0 01037 2 29 0000+00
 NC CR REIGHTON INT/RMP A RD
 INTER-BK ALLEGHENY VALLEY EX
 (SR0028 SEG 0350/1044)
 MFC BEGIN = F
 0010/0000 LENGTH(AH 1723 BK 0000)

001950 FT

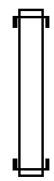

001950 FT
 INTER-AHD BALDWIN RD
 0500/0815 (SR2046 SEG 0140/0414)

001135 FT

001135 FT 1 0 00376 2 00 0000+00
 NC RAMP G RD
 INTER-BK LEBANON RD
 (SR0885 SEG 0211/0890)
 0500/0000 LENGTH(AH 0815 BK 0760)

000375 FT

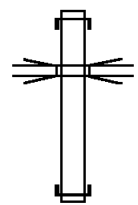

INTER-AHD MIFFLIN RD
 0250/0760 (SR0885 SEG 0201/0160)
 LEBANON RD.
 0250/0339 OP ID 02/0885/0210/0000
 000375 FT 1 0 00376 2 01 0000+00
 NC STREETS RUN INT/RMP H RD.
 INTER-BK MIFFLIN RD/RAMP ST
 (SR3098 SEG 0090/1919)
 0250/0000 LENGTH(AH 0760 BK 0375)

000000 FT

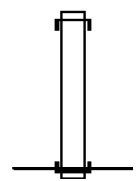

INTER-AHD MIFFLIN RD/RAMP ST
 0010/0375 (SR3098 SEG 0090/1919)
 000000 FT 1 0 00376 2 02 0000+00
 NC STREETS RUN INT/RMP J RD
 INTER-BK LEBANON RD
 (SR0885 SEG 0200/0445)
 MFC BEGIN = F
 0010/0000 LENGTH(AH 0375 BK 0000)

DIR: E TOTAL LEN: .579 MI. DIST: 11-1 SR: 8060
 LEFT MUN: SPRINGDALE T RIGHT MUN: SPRINGDALE T

003055 FT

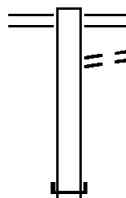

003055 FT HITE RD
 0760/0440 (SR1014 SEG 0020/1386)
 TO 1014/0021 SH

002615 FT

0760/0369 (CONN)
 002615 FT 1 0 01037 2 15 0000+00
 NC RAMP J RD

INTER-BK ALLEGHENY VALLEY EX
 (SR0028 SEG 0300/3170)
 0760/0000 LENGTH(AH 0440 BK 0370)

002245 FT

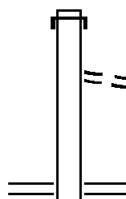

INTER-AHD ALLEGHENY VALLEY EX
 0750/0370 (SR0028 SEG 0310/0264)
 FROM 1014/0021 SH

0750/0075 (CONN)
 002245 FT 1 0 01037 2 14 0000+00
 NC RAMP K RD

HITE RD
 (SR1014 SEG 0020/1421)
 0750/0000 LENGTH(AH 0370 BK 0822)

001423 FT

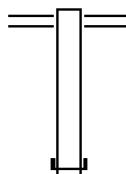

HITE RD
 0500/0822 (SR1014 SEG 0021/0361)

001423 FT 1 0 01037 2 17 0000+00
 NC RAMP M RD

INTER-BK ALLEGHENY VALLEY EX
 (SR0028 SEG 0311/0355)
 0500/0000 LENGTH(AH 0822 BK 1423)

000000 FT

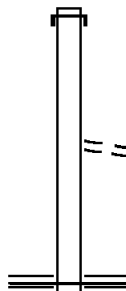

INTER-AHD ALLEGHENY VALLEY EX
 0250/1423 (SR0028 SEG 0301/1285)

FROM 1014/0020 SH
 0250/0135 (CONN)
 000000 FT 1 0 01037 2 16 0000+00
 NC RAMP L RD

HITE RD
 (SR1014 SEG 0020/0357)
 MFC BEGIN = F
 0250/0000 LENGTH(AH 1423 BK 0000)

EXTRACT DATE: 12/21/2020 ROADWAY MANAGEMENT SYSTEM PAGE NUMBER: 1570
 PRINT DATE: 12/23/2020 SLD COUNTY/SR - ANNUAL PRINT COUNTY: ALLEGHENY
 DIR: N TOTAL LEN: .974 MI. DIST: 11-1 SR: 8059
 LEFT MUN: PITTSBURGH C RIGHT MUN: PITTSBURGH C

005141 FT

W EIGHTH AV
 (SR8059 SEG 0290/0000) 0522/0110
 004321 FT

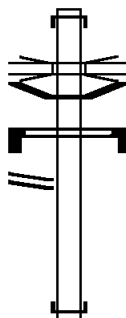

005141 FT
 INTER-AHD MIFFLIN RD
 0522/0820 (SR0885 SEG 0231/0000)
 SR 0885 NB
 0522/0383 OP ID 02/0885/0230/0539
 0522/0323 BMS EN 02/8059/0522/0000
 SIGN: CANTILEVER
 0522/0129 BMS ID 02/8059/0522/0140

004321 FT 0 00000 0 0 0000+00
 NC GLENWOOD BR INT/RAMP A RD
 INTER-BK W EIGHTH AV
 (SR0837 SEG 0430/0545)
 RAMP 8059 NB

EXTRACT DATE: 12/21/2020
PRINT DATE: 12/23/2020

ROADWAY MANAGEMENT SYSTEM
SLD COUNTY/SR - ANNUAL PRINT

PAGE NUMBER: 1569
COUNTY: ALLEGHENY

DIR: N TOTAL LEN: .974 MI.
LEFT MUN: PITTSBURGH C

DIST: 11-1 SR: 8059
RIGHT MUN: PITTSBURGH C



0522/0000 BMSBG 02/8059/0522/0000
LENGTH(AH 0820 BK 0330)

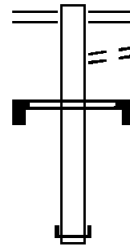

003991 FT

0512/0330 GLASS RUN RD
(SR3098 SEG 0081/0086)
TO 3098/0081 SH
0512/0251 (CONN)
SIGN: CANTILEVER
0512/0120 BMSID 02/8059/0512/0095
003991 FT 0 0 00000 0 00 0000+00
NC GL ENWOOD BR INT/RAMP E RD
INTER-BK SR 885/MIFFLIN RD
(SR0885 SEG 0221/1489)
0512/0000 LENGTH(AH 0330 BK 0428)



003563 FT

INTER-AHD SR 885/MIFFLIN RD
0502/0428 (SR0885 SEG 0221/0922)
003563 FT 0 0 00000 0 00 0000+00
NC GL ENWOOD BR INT/RAMP F RD
INTER-BK GLASS RUN RD
(SR3098 SEG 0070/0678)
0502/0000 LENGTH(AH 0428 BK 0324)

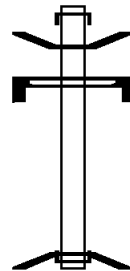

003239 FT

INTER-AHD MIFFLIN RD
0290/0324 (SR0885 SEG 0230/0498)
0290/0175 BMSID 02/8059/0290/0000
SIGN: CANTILEVER
0290/0110 BMSID 02/0837/0520/2145
003239 FT 0 00000 0 0 0000+00
NC GL ENWOOD BR INT/RAMP B RD
INTER-BK RAMP A RD
(SR8059 SEG 0522/0110)
RAMP D (8059 NB)
BMSBG 02/8059/0290/0000
0290/0000 LENGTH(AH 0324 BK 0920)

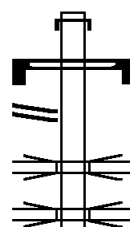

RAMP C SPUR RD
(SR8059 SEG 0270/0000) 0280/0635

INTER-AHD MIFFLIN RD
0280/0920 (SR0885 SEG 0221/1330)
SIGN: CANTILEVER
0280/0725 BMSID 02/8059/0280/0725
0280/0440 OP ID SR 0885 NB
SR 02/0885/0230/0000
0280/0020 OP ID SR 0837 SB
SR 02/0837/0431/0000

DIR: N TOTAL LEN: .974 MI. DIST: 11-1 SR: 8059
 LEFT MUN: PITTSBURGH C RIGHT MUN: PITTSBURGH C

002319 FT

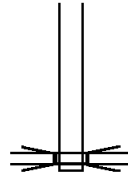

002319 FT 0 0 00000 0 00 0000+00
 RAMP B (8059 NB)
 OP ID 02/8059/0290/0000
 NC GL ENWOOD BR INT/RAMP C RD
 INTER-BK EIGHTH AV
 (SR0837 SEG 0453/0000)
 0280/0000 LENGTH(AH 0920 BK 0482)

001837 FT

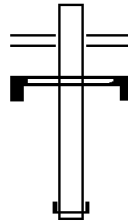

GLASS RUN RD
 (SR3098 SEG 0080/0243)
 (SR3098 SEG 0081/0255)
 SIGN: CANTILEVER
 0270/0482
 0270/0080 BMSID 02/8059/0270/0080
 001837 FT 0 0 00000 0 00 0000+00
 NC GL ENWOOD BR/RP C SPUR RD
 INTER-BK RAMP C RD
 (SR8059 SEG 0280/0635)
 0270/0000 LENGTH(AH 0482 BK 0607)

001230 FT

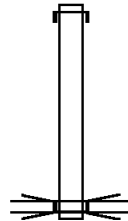

INTER-AHD MIFFLIN RD
 0262/0607 (SR0885 SEG 0220/2001)
 001230 FT 0 0 00000 0 00 0000+00
 SR 0837 SB
 OP ID 02/0837/0431/0000
 NC GL ENWOOD BR INT/RAMP D RD
 INTER-BK EIGHTH AV
 (SR0837 SEG 0453/0000)
 0262/0000 LENGTH(AH 0607 BK 1230)

000000 FT

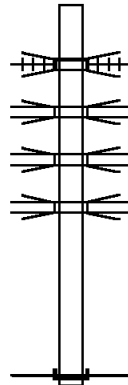

INTER-AHD EAST CARSON ST
 (SR0837 SEG 0452/0000)
 NORFOLK SOUTHERN
 0252/1230 OVERPASS IS RR X-ING
 RAMP A (8059 SB)
 0252/0840 OP ID 02/8059/0522/0000
 RAMP B (8059 NB)
 0252/0795 OP ID 02/8059/0290/0000
 SR 0837 SB
 0252/0765 OP ID 02/0837/0431/0000
 000000 FT 0 0 00000 0 00 0000+00
 NC RAMP RD/TO SR 0837 SH
 INTER-BK SR 885 NB MIFFLIN RD
 (SR0885 SEG 0220/1621)
 MFC BEGIN = F
 0252/0000 LENGTH(AH 1230 BK 0000)

FROM 0910/0450 SH
 (CONN)

002800 FT

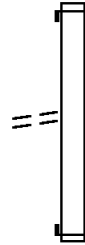

0750/0085
 001777 FT

002800 FT
 INTER-AHD ALLEGHENY VALLEY EX
 0750/1023 (SR0028 SEG 0270/2007)

001777 FT 1 0 01037 2 07 0000+00
 NC HARMAR INT/RAMP B RD
 INTER-BK GIBSONIA/INDIANOLA RD
 (SR0910 SEG 0451/0367)
 0750/0000 LENGTH(AH 1023 BK 0614)

001163 FT

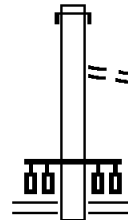

0512/0614 ALLEGHENY VALLEY EX
 (SR0028 SEG 0271/2465)
 FROM 0910/0445 SH
 (CONN)
 0512/0137 0 0 00000 0 00 0000+00
 NC HARMAR INT/RAMP C RD
 GIBSONIA/INDIANOLA RD
 (SR0910 SEG 0444/0046)
 0512/0000 LENGTH(AH 0614 BK 0666)

000497 FT

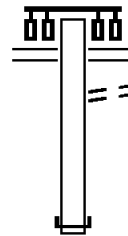

0502/0666 GIBSONIA/INDIANOLA RD
 (SR0910 SEG 0444/0000)
 TO 0910/0441 SH
 (CONN)
 0502/0583 0 0 00000 0 00 0000+00
 NC HARMAR INT/RAMP D RD
 INTER-BK ALLEGHENY VALLEY EX
 (SR0028 SEG 0271/3035)
 0502/0000 LENGTH(AH 0666 BK 0497)

TO 0910/0451 SH
 (CONN)

0010/0363
 000000 FT

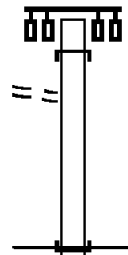

0010/0497 GIBSONIA/INDIANOLA RD
 (SR0910 SEG 0450/0688)
 000000 FT 1 0 01037 2 06 0000+00
 NC HARMAR INT/RAMP A RD
 INTER-BK ALLEGHENY VALLEY EX
 (SR0028 SEG 0270/0515)
 MFC BEGIN = F
 0010/0000 LENGTH(AH 0497 BK 0000)

EXTRACT DATE: 12/21/2020 ROADWAY MANAGEMENT SYSTEM PAGE NUMBER: 1566
 PRINT DATE: 12/23/2020 SLD COUNTY/SR - ANNUAL PRINT COUNTY: ALLEGHENY
 DIR: S TOTAL LEN: 1.213 MI. DIST: 11-1 SR: 8057
 LEFT MUN: DUQUESNE C RIGHT MUN: DUQUESNE C

006403 FT

006403 FT
 INTER-AHD SR 837 SH
 0272/2839 (SR0837 SEG 0270/0140)
 LINDEN ST
 0272/2698 (CITY)

FROM 8057/0010 SH
 (CONN)

0272/2300

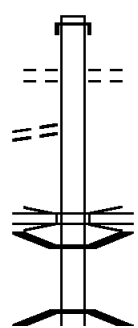

0272/1192 MCKEES.-DUQ.
 0272/0767 OP ID 02/2114/0020/0000
 BMS EN 02/8057/0272/0505
 0 00000 0 0 0000+00
 NO UNDERPASS INFORMATIO
 0272/0505 BMSBG 02/8057/0272/0505

DIR: S TOTAL LEN: 1.213 MI. DIST: 11-1 SR: 8057
 LEFT MUN: DUQUESNE C RIGHT MUN: DUQUESNE C

837 NB TO DUQ/MCKEESPT
 (SR8057 SEG 0262/0000) 0272/0390
 003564 FT



003564 FT 0 0 00000 0 00 0000+00
 NC RAMP RD/TO CENTER ST
 INTER-BK SR 837/RIVER RD
 (SR0837 SEG 0250/2884)
 0272/0000 LENGTH(AH 2839 BK 0817)

002747 FT

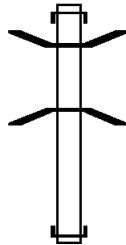

INTER-AHD DUQUESNE MCKEESPORT BR
 0262/0817 (SR2114 SEG 0031/0000)
 0262/0680 BMS EN 02/8057/0272/0110
 0 00000 0 0 0000+00
 RAMP B (8057 SB)
 0262/0110 BMSBG 02/8057/0272/0110
 002747 FT 0 0 00000 0 00 0000+00
 NC RAMP H RD/TO DUQ/MKSPT BR
 INTER-BK RAMP TO CENTER ST
 (SR8057 SEG 0272/0390)
 0262/0000 LENGTH(AH 0817 BK 1303)

RAMP FR SR 2114 TO 837
 (SR8057 SEG 0010/1444) 0252/0560
 001444 FT



INTER-AHD SR 837 SH/RIVER RD
 0252/1303 (SR0837 SEG 0250/2884)
 001444 FT 0 0 00000 0 00 0000+00
 NC RAMP RD/TO SR 837 SH
 INTER-BK DUQUESNE BL
 (SR2114 SEG 0031/0150)
 0252/0000 LENGTH(AH 1303 BK 1444)

TO 8057/0260 SH
 (CONN) 0010/0030
 000000 FT

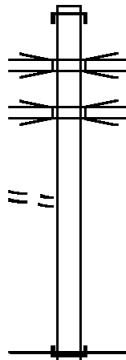

INTER-AHD RAMP TO SR 837 SB SH
 0010/1444 (SR8057 SEG 0252/0560)
 RAMP A SR 8057-NB
 0010/1226 OP ID 02/8057/0272/0110
 MCKEES -DUQ
 0010/1012 OP ID 02/2114/0020/0000
 000000 FT 1 0 00736 2 00 0000+00
 NC RAMP C RD/TO SR 837 SH
 INTER-BK DUQUESNE BL
 (SR2114 SEG 0030/0718)
 MFC BEGIN = F
 0010/0000 LENGTH(AH 1444 BK 0000)

002542 FT

002103 FT

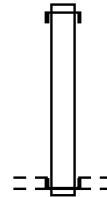

002542 FT
 INTER-AHD ALLEGHENY VALLEY EX
 0750/0439 (SR0028 SEG 0220/3078)
 002103 FT 1 0 01037 2 03 0000+00
 NC RIDC DRIVE INT/RAMP D RD
 GAMMA DR
 (T505)
 INTER-BK RAMP A RD
 (SR8056 SEG 0010/0690)
 0750/0000 LENGTH(AH 0439 BK 0583)

LC TO GAMMA DR
 (CONN)

0500/0451
 001520 FT



INTER-AHD GAMMA DR
 0500/0583 (T505)
 001520 FT 1 0 01037 2 02 0000+00
 NC RIDC DRIVE INT/RAMP C RD
 INTER-BK ALLEGHENY VALLEY EX
 (SR0028 SEG 0221/2893)
 0500/0000 LENGTH(AH 0583 BK 0830)

LC FROM GAMMA DR
 (CONN)

0250/0090
 000690 FT

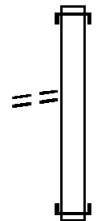

INTER-AHD ALLEGHENY VALLEY EX
 0250/0830 (SR0028 SEG 0221/1454)
 000690 FT 1 0 01037 2 01 0000+00
 NC RIDC DRIVE INT/RAMP B RD
 INTER-BK GAMMA DR
 (T505)
 0250/0000 LENGTH(AH 0830 BK 0690)

000000 FT

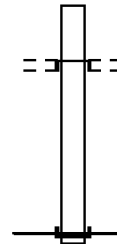

INTER-AHD RAMP D RD
 (SR8056 SEG 0750/0000)
 GAMMA DR
 (T505)
 0010/0690
 000000 FT 1 0 01037 2 00 0000+00
 NC RIDC DRIVE INT/RAMP A RD
 INTER-BK ALLEGHENY VALLEY EX
 (SR0028 SEG 0220/1960)
 MFC BEGIN = F
 0010/0000 LENGTH(AH 0690 BK 0000)

DIR: N TOTAL LEN: 1.532 MI. DIST: 11-1 SR: 8055
 LEFT MUN: PITTSBURGH C RIGHT MUN: PITTSBURGH C

008088 FT

008088 FT
 INTER-AHD OHIO RIVER BL
 0750/0680 (SR0019 SEG 0290/0000)
 CHATEAU ST
 0750/0442 (SR3919 SEG 0010/0000)
 SIGN: 2 CHORD TRUSS
 0750/0242 BMSID 02/8055/0750/0242
 LC FROM WESTERN AV
 0750/0050 (CONN)
 007408 FT 1 0 00652 2 11 0000+00
 NC FROM WEST END BR TO 19 N
 WESTERN AV
 (CITY)

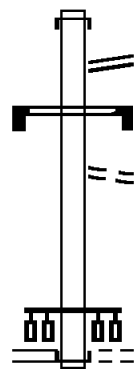

007408 FT

INTER-BK 65 NB TO WEST END BR
 (SR8055 SEG 0010/0438)
 0750/0000 LENGTH(AH 0680 BK 2481)

WEST END BR
 (SR0019 SEG 0280/2200)
 (SR0019 SEG 0281/2184) 0750/0000

INTER-AHD OHIO RIVER BL
 0530/2481 (SR0065 SEG 0005/1995)
 PED. WALKWAY
 0530/2355 OP ID 02/0065/0004/2033
 SR 19 NB
 0530/2335 OP ID 02/0019/0280/1347

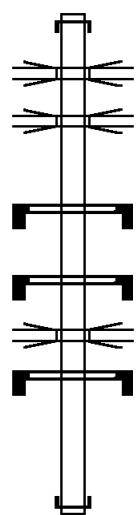

004927 FT

SIGN: 4 CHORD TRUSS
 0530/1400 BMSID 02/0019/0287/0300
 SIGN: 4 CHORD TRUSS
 0530/0700 BMSID 02/8055/0510/0400
 RT 0019 SB
 0530/0141 OP ID 02/0019/0291/1282
 SIGN: 4 CHORD TRUSS
 0530/0001 BMSID 02/8055/0530/1180
 004927 FT 0 0 00000 0 00 0000+00
 NC RAMP RD/TO SR 0065 SH
 INTER-BK BEAVER AV
 (CITY)
 0530/0000 LENGTH(AH 2481 BK 0459)

EXTRACT DATE: 12/21/2020
PRINT DATE: 12/23/2020

ROADWAY MANAGEMENT SYSTEM
SLD COUNTY/SR - ANNUAL PRINT

PAGE NUMBER: 1562
COUNTY: ALLEGHENY

DIR: N TOTAL LEN: 1.532 MI.
LEFT MUN: PITTSBURGH C

DIST: 11-1 SR: 8055
RIGHT MUN: PITTSBURGH C

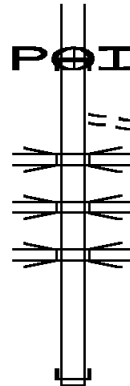

004468 FT

INTER-AHD (APRA) PNC PARK/HEINZ F
0520/0459 REEDSDALE ST
(CITY)
0520/0386 BEAVER AV
(CITY)
0520/0235 OP ID RAMP B NB
02/8055/0250/0000
0520/0065 OP ID PED. WALKWAY
02/0065/0004/2033
SR 19 NB
0520/0045 OP ID 02/0019/0280/1347
004468 FT 0 0 00000 0 00 0000+00
NC SR 65 SB TO REEDSDALE ST
INTER-BK OHIO RIVER BL
(SR0019 SEG 0287/0050)
5 0520/0000 LENGTH(AH 0459 BK 1061)

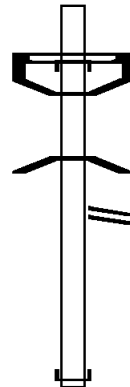

003407 FT

INTER-AHD SIGN: 4 CHORD TRUSS
0510/1061 BMSID 02/8055/0510/0400
WEST END BR
(SR0019 SEG 0281/1675)
0510/0935 BMSEN 02/8055/0510/0000
0 0 00000 0 00 0000+00
REEDSDALE ST
0510/0479 BMSBG 02/8055/0510/0000
RAMP 500 RD
0510/0425 (SR8055 SEG 0500/0523)
RETAINING WALL
5 0510/0270 BMSID 02/8055/0500/0173
003407 FT 0 0 00000 0 00 0000+00
NC SR 65 SB TO SR 19 SH
INTER-BK OHIO RIVER BL
(SR0019 SEG 0291/0000)
5 0510/0000 LENGTH(AH 1061 BK 0523)

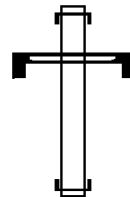

002884 FT

INTER-AHD RAMP 510 RD
0500/0523 (SR8055 SEG 0510/0425)
SIGN: 4 CHORD TRUSS
0500/0001 BMSID 02/8055/0500/0001
002884 FT 1 0 00652 2 12 0000+00
NC BEAVER AV TO WEST END BR
INTER-BK BEAVER AV
(CITY)
5 0500/0000 LENGTH(AH 0523 BK 0962)



INTER-AHD REEDSDALE ST
0260/0962 (CITY)

EXTRACT DATE: 12/21/2020
PRINT DATE: 12/23/2020

ROADWAY MANAGEMENT SYSTEM
SLD COUNTY/SR - ANNUAL PRINT

PAGE NUMBER: 1561
COUNTY: ALLEGHENY

DIR: N TOTAL LEN: 1.532 MI.
LEFT MUN: PITTSBURGH C

DIST: 11-1 SR: 8055
RIGHT MUN: PITTSBURGH C

001922 FT

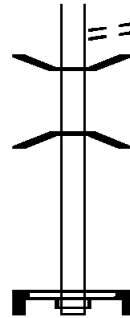

0260/0900 LC TO REEDSDALE ST
0260/0509 (CONN)
BMSSEN 02/8055/0260/0000
0 0 00000 0 00 0000+00
RAMP C EB
0260/0023 BMSBG 02/8055/0260/0000
001922 FT 0 0 00000 0 00 0000+00
SIGN: 4 CHORD TRUSS
BMSID 02/8055/0260/0001
NC RAMP TO REEDSDALE ST
INTER-BK RAMP 250 RD
(SR8055 SEG 0250/0370)
0260/0000 LENGTH(AH 0962 BK 1484)

000438 FT

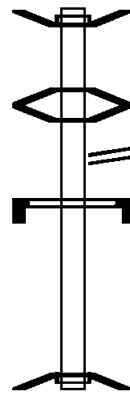

INTER-AHD BMSSEN 02/8055/0250/1251
0250/1484 OHIO RIVER BL
(SR0065 SEG 0005/0750)
0 0 00000 0 00 0000+00
FONTELLA ST.
0250/1171 BMSBG 02/8055/0250/1251
0250/0692 BMSSEN 02/8055/0250/0000
RAMP TO REEDSDALE ST
0250/0370 (SR8055 SEG 0260/0000)
SIGN: 4 CHORD TRUSS
0250/0319 BMSID 02/8055/0260/0001
000438 FT 1 0 00652 2 10 0000+00
NC FR WEST END BR TO 65 SH
INTER-BK WEST END BR
(SR0019 SEG 0280/1784)
RAMP C SB
0250/0000 BMSBG 02/8055/0250/0000
LENGTH(AH 1484 BK 0438)

WEST END BR
(SR0019 SEG 0280/2200)
(SR0019 SEG 0281/2184)

0010/0438

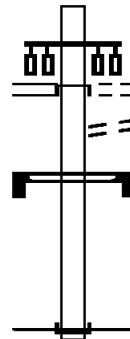

INTER-AHD CHATEAU ST
(SR8055 SEG 0750/0000)
WESTERN AV
(TBC)
0010/0438
0010/0350 LC TO WESTERN AV
(CONN)
SIGN: 4 CHORD TRUSS
0010/0220 BMSID 02/8055/0010/0220
000000 FT 1 0 00652 2 09 0000+00
NC 65 NB TO WEST END BR
INTER-BK OHIO RIVER BL
(SR0065 SEG 0004/1595)
MFC BEGIN = F
0010/0000 LENGTH(AH 0438 BK 0000)

000000 FT

EXTRACT DATE: 12/21/2020 ROADWAY MANAGEMENT SYSTEM PAGE NUMBER: 1560
 PRINT DATE: 12/23/2020 SLD COUNTY/SR - ANNUAL PRINT COUNTY: ALLEGHENY
 DIR: E TOTAL LEN: .762 MI. DIST: 11-1 SR: 8054
 LEFT MUN: OHARA T RIGHT MUN: OHARA T

004025 FT



003532 FT

004025 FT FOX CHAPEL RD
 (CNTY)
 0260/0493
 003532 FT 1 0 00070 2 12 0000+00
 NC RAMP O RD
 INTER-BK ALLEGHENY VALLEY EX
 (SR0028 SEG 0201/1455)

DIR: E TOTAL LEN: .762 MI. DIST: 11-1 SR: 8054
 LEFT MUN: OHARA T RIGHT MUN: OHARA T

LC FROM FOX CHAPEL RD
 (CONN)

0250/0071
 002781 FT

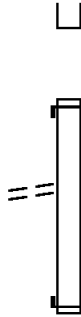

0260/0000 LENGTH(AH 0493 BK 0751)

INTER-AHD ALLEGHENY VALLEY EX
 0250/0751 (SR0028 SEG 0201/1076)

002781 FT 1 0 00070 2 14 0000+00

NC RAMP Q RD
 INTER-BK FOX CHAPEL RD
 (CNTY)

0250/0000 LENGTH(AH 0751 BK 0601)

LC TO/FROM FOX CHAPEL R
 (CONN)

0030/0458
 002180 FT

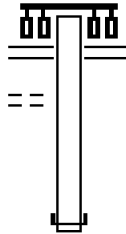

FREEPORT RD
 (SR1001 SEG 0130/1050)
 0030/0601

002180 FT 0 0 00000 0 00 0000+00
 NC RAMP RD/WATER WORKS ML RD
 INTER-BK RAMP N RD

(SR8054 SEG 0010/0726)
 0030/0000 LENGTH(AH 0601 BK 1048)

001132 FT

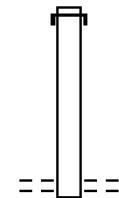

INTER-AHD ALLEGHENY VALLEY EX
 0020/1048 (SR0028 SEG 0200/1089)

001132 FT 1 0 00070 2 13 0000+00
 NC RAMP P RD

FOX CHAPEL RD
 (CNTY)
 0020/0000 LENGTH(AH 1048 BK 1132)

000000 FT

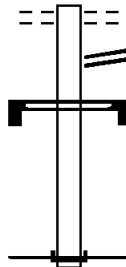

FOX CHAPEL RD
 (CNTY)
 RAMP TO MALL RD
 0010/0726 (SR8054 SEG 0030/0000)
 SIGN: 4 CHORD TRUSS

0010/0134 BMSID 02/8054/0010/0160
 000000 FT 1 0 00070 2 11 0000+00
 NC RAMP N RD

INTER-BK ALLEGHENY VALLEY EX
 (SR0028 SEG 0200/0784)
 MFC BEGIN = F
 0010/0000 LENGTH(AH 1132 BK 0000)

LC TO DELAFIELD AV
(CONN)

001785 FT

0760/0580
001056 FT



001785 FT
INTER-AHD DELAFIELD AV
0760/0729 (CITY)

001056 FT 1 0 00070 2 10 0000+00
NC DELAFIELD INT/RMP K RD
INTER-BK ALLEGHENY VALLEY EX
(SR0028 SEG 0190/0337)
0760/0000 LENGTH(AH 0729 BK 0755)

000301 FT



INTER-AHD ALLEGHENY VALLEY EX
0750/0755 (SR0028 SEG 0190/0438)

000301 FT 1 0 00070 2 09 0000+00
NC DELAFIELD INT/RMP L RD
INTER-BK DELAFIELD AV
(CITY)
0750/0000 LENGTH(AH 0755 BK 0301)

000000 FT

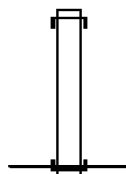

INTER-AHD ALLEGHENY VALLEY EX
0250/0301 (SR0028 SEG 0181/2080)

000000 FT 1 0 00070 2 08 0000+00
NC DELAFIELD INT/RMP J RD
INTER-BK SIXTH AV
(CITY)
MFC BEGIN = F
0250/0000 LENGTH(AH 0301 BK 0000)

DIR: E TOTAL LEN: .370 MI. DIST: 11-1 SR: 8051
 LEFT MUN: FORWARD T RIGHT MUN: FORWARD T

001954 FT

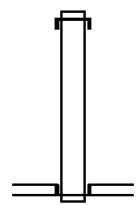

001954 FT
 INTER-AHD HAYDEN BL
 0750/0524 (SR0051 SEG 0020/0530)
 001430 FT 1 0 00288 2 03 0000+00
 NC RA INBOW RUN INT/RAMP D RD
 RAINBOW RUN RD
 (SR0136 SEG 0110/0320)
 INTER-BK RAMP A RD
 (SR8051 SEG 0010/0506)
 0750/0000 LENGTH(AH 0524 BK 0430)

001430 FT

001000 FT

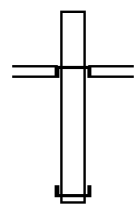

INTER-AHD RAMP B RD
 (SR8051 SEG 0250/0000)
 RAINBOW RUN RD
 0500/0430 (SR0136 SEG 0110/0000)
 001000 FT 1 0 00288 2 02 0000+00
 NC RA INBOW RUN INT/RAMP C RD
 INTER-BK HAYDEN BL
 (SR0051 SEG 0021/0450)
 0500/0000 LENGTH(AH 0430 BK 0494)

000506 FT

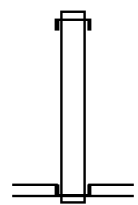

INTER-AHD HAYDEN BL
 0250/0494 (SR0051 SEG 0015/1620)
 000506 FT 1 0 00288 2 01 0000+00
 NC RA INBOW RUN INT/RAMP B RD
 RAINBOW RUN RD
 (SR0136 SEG 0110/0000)
 INTER-BK RAMP C RD
 (SR8051 SEG 0500/0430)
 0250/0000 LENGTH(AH 0494 BK 0506)

000000 FT

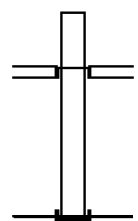

INTER-AHD RAMP D RD
 (SR8051 SEG 0750/0000)
 RAINBOW RUN RD
 0010/0506 (SR0136 SEG 0110/0320)
 000000 FT 1 0 00288 2 00 0000+00
 NC RA INBOW RUN INT/RAMP A RD
 INTER-BK HAYDEN BL
 (SR0051 SEG 0014/1632)
 MFC BEGIN = F
 0010/0000 LENGTH(AH 0506 BK 0000)

EXTRACT DATE: 12/21/2020 ROADWAY MANAGEMENT SYSTEM PAGE NUMBER: 1556
 PRINT DATE: 12/23/2020 SLD COUNTY/SR - ANNUAL PRINT COUNTY: ALLEGHENY
 DIR: S TOTAL LEN: .527 MI. DIST: 11-1 SR: 8050
 LEFT MUN: SHARPSBURG B RIGHT MUN: SHARPSBURG B

002781 FT
 002265 FT
 RAMP C RD
 (SR8050 SEG 0250/0000) 0750/0000

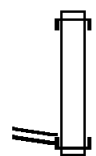

002781 FT
 INTER-AHD ALLEGHENY VALLEY EX
 0750/0516 (SR0028 SEG 0180/0215)
 002265 FT 1 0 00070 2 06 0000+00
 NC HGLND PRK BR INT/RP D RD
 INTER-BK HIGHLAND PARK BR
 (SR1005 SEG 0020/3126)
 5 0750/0000 LENGTH(AH 0516 BK 0517)

EXTRACT DATE: 12/21/2020
PRINT DATE: 12/23/2020

ROADWAY MANAGEMENT SYSTEM
SLD COUNTY/SR - ANNUAL PRINT

PAGE NUMBER: 1555
COUNTY: ALLEGHENY

DIR: S TOTAL LEN: .527 MI.
LEFT MUN: ASPINWALL B

DIST: 11-1 SR: 8050
RIGHT MUN: ASPINWALL B

001748 FT

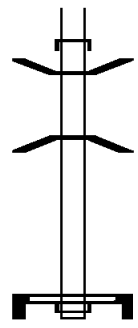

INTER-AHD RAMP A RD
0500/0517 (SR8050 SEG 0010/0695)
0500/0317 BMSSEN 02/8050/0500/0030
0 0 00000 0 00 0000+00
SR 0028 NB
0500/0030 BMSBG 02/8050/0500/0030
001748 FT 1 0 00070 2 05 0000+00
SIGN: 4 CHORD TRUSS
BMSID 02/0028/0181/0000
NC HG HHLND PRK BR INT/RP B RD
INTER-BK ALLEGHENY VALLEY EX
(SR0028 SEG 0171/2805)
5 0500/0000 LENGTH(AH 0517 BK 0576)

001172 FT

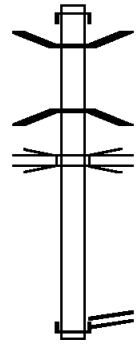

INTER-AHD ALLEGHENY VALLEY EX
0250/0576 (SR0028 SEG 0171/2070)
0250/0553 BMSSEN 02/8050/0250/0305
0 0 00000 0 00 0000+00
SR 0028 NB
0250/0305 BMSBG 02/8050/0250/0305
RAMP A SB
0250/0070 OP ID 02/8050/0010/0350
001172 FT 0 0 00000 0 00 0000+00
RAMP D RD
(SR8050 SEG 0750/0000)
NC HG HHLND PRK BR INT/RP C RD
INTER-BK HIGHLAND PARK BR
(SR1005 SEG 0020/3126)
5 0250/0000 LENGTH(AH 0576 BK 1172)

RAMP B RD
(SR8050 SEG 0500/0517) 0010/0695

000000 FT

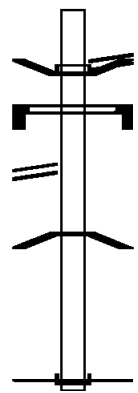

INTER-AHD BMSSEN 02/8050/0010/0350
HIGHLAND PARK BR
(SR1005 SEG 0021/2763)
RAMP E RD
0010/1172 (SR8082 SEG 0250/0000)
0010/0908 SIGN: 2 CHORD TRUSS
BMSID 02/8050/0010/0875
0 0 00000 0 00 0000+00
RAMP C NB
0010/0350 BMSBG 02/8050/0010/0350
000000 FT 1 0 00070 2 04 0000+00
NC HG HHLND PRK BR INT/RP A RD
INTER-BK ALLEGHENY VALLEY EX
(SR0028 SEG 0170/1530)
MFC BEGIN = F
5 0010/0000 LENGTH(AH 1172 BK 0000)

DIR: N TOTAL LEN: 1.254 MI. DIST: 11-1 SR: 8049
 LEFT MUN: PITTSBURGH C RIGHT MUN: PITTSBURGH C

006620 FT

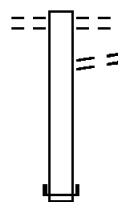

006620 FT CALIFORNIA AV
 0750/0575 (CITY)
 TO 0019/0330 SH
 0750/0442 (CONN)
 006045 FT 1 0 00246 2 04 0000+00
 NC RAMP 750 RD
 INTER-BK RAMP 0030 RD
 (SR8049 SEG 0030/1612)
 0750/0000 LENGTH(AH 0575 BK 0235)

006045 FT

0 0 00000 0 00 0000+00 005810 FT
 RAMP 250 RD
 (SR8049 SEG 0250/0580) 0260/0000



INTER-AHD RAMP 750 RD
 0260/0235 (SR8043 SEG 0750/1106)
 005810 FT
 NC RAMP 260 RD
 0260/0000 LENGTH(AH 0235 BK 1477)

004333 FT

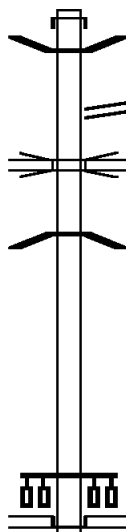

INTER-AHD OHIO RIVER BL
 0250/1477 (SR0019 SEG 0291/2684)
 0250/1207 BMSEN 02/8049/0250/0040
 0250/0580 RAMP 260 RD
 (SR8049 SEG 0260/0000)
 TR 65
 0250/0184 OP ID 02/0065/0012/0000
 0 0 00000 0 00 0000+00
 CHATEAU ST WB
 0250/0040 BMSBG 02/8049/0250/0040
 004333 FT 1 0 00246 2 02 0000+00
 NC RAMP 250 RD
 CALIFORNIA AV
 (SR4265 SEG 0011/0000)
 (SR4265 SEG 0010/0000)
 CALIFORNIA AV
 (SR4265 SEG 0010/0000)
 (SR4265 SEG 0011/0000)
 INTER-BK MARSHALL AV
 (SR0019 SEG 0330/0000)
 0250/0000 LENGTH(AH 1477 BK 2091)

DIR: N TOTAL LEN: 1.254 MI.
 LEFT MUN: PITTSBURGH C

DIST: 11-1 SR: 8049
 RIGHT MUN: PITTSBURGH C

MARSHALL AV
 (SR0019 SEG 0330/0786) 0030/2091

RAMP 10 RD
 (SR8049 SEG 0010/1299) 0030/1133

RAMP 20 RD
 (SR8049 SEG 0020/0000) 0030/0089
 002242 FT

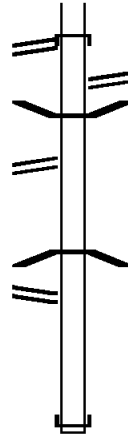

INTER-AHD MARSHALL AV
 0030/2091 (SR0019 SEG 0340/0000)
 RAMP 750 RD
 0030/1612 (SR8049 SEG 0750/0000)
 0030/1520 BMSSEN 02/8049/0030/0328

1 0 00652 2 02 0000+00
 CALIF. AVE
 0030/0297 BMSBG 02/8049/0030/0328

002242 FT 1 0 00652 2 02 0000+00
 NC RAMP 30 RD
 INTER-BK CHATEAU ST
 (SR3919 SEG 0010/3144)
 0030/0000 LENGTH(AH 2091 BK 0943)

001299 FT

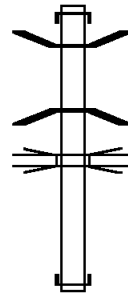

INTER-AHD OHIO RIVER BL
 0020/0943 (SR0065 SEG 0012/1165)
 0020/0762 BMSSEN 02/8049/0020/0206
 1 0 01039 2 00 0001+44
 NO UNDERPASS INFORMATION
 0020/0206 BMSBG 02/8049/0020/0206
 RAMP A NB
 0020/0011 OP ID 02/8049/0010/0019
 001299 FT 1 0 00652 2 00 0000+00
 NC RAMP 20 RD
 INTER-BK RAMP 30 RD
 (SR8049 SEG 0030/0089)
 0020/0000 LENGTH(AH 0943 BK 1299)

000000 FT

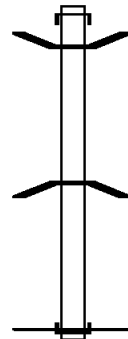

INTER-AHD RAMP 30 RD
 0010/1299 (SR8049 SEG 0030/1133)
 0010/1282 BMSSEN 02/8049/0010/0019
 1 0 00246 2 00 0000+35
 RAMP E NB
 0010/0019 BMSBG 02/8049/0010/0019
 000000 FT 1 0 00246 2 00 0000+00
 NC RAMP 10 RD
 INTER-BK OHIO RIVER BL
 (SR0019 SEG 0290/2811)
 MFC BEGIN = F
 0010/0000 LENGTH(AH 1299 BK 0000)

000970 FT
 000610 FT

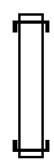

000970 FT
 INTER-AHD ETNA BP
 0020/0360 (SR0028 SEG 0121/0808)
 000610 FT 0 0 00000 0 00 0000+00
 NC ETNA INT/RMP TO SR 28 SH
 INTER-BK FREEPORT RD
 (SR1001 SEG 0010/0000)
 0020/0000 LENGTH(AH 0360 BK 0610)

000000 FT

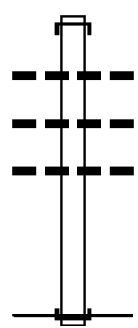

INTER-AHD FREEPORT RD
 0010/0610 (SR1001 SEG 0010/0000)
 024"H 24"W **UNKNOWN**
 0010/0603 LEN=0050 INSTALLED 2009
 024"H 24"W **UNKNOWN**
 0010/0474 LEN=0050 INSTALLED 2009
 024"H 24"W **UNKNOWN**
 0010/0305 LEN=0050 INSTALLED 2009
 000000 FT 1 0 00070 2 03 0000+00
 NC ETNA INT/RMP FR SR 28 SH
 INTER-BK ETNA BP
 (SR0028 SEG 0120/0000)
 MFC BEGIN = F
 0010/0000 LENGTH(AH 0610 BK 0000)

EXTRACT DATE: 12/21/2020 ROADWAY MANAGEMENT SYSTEM PAGE NUMBER: 1551
PRINT DATE: 12/23/2020 SLD COUNTY/SR - ANNUAL PRINT COUNTY: ALLEGHENY

DIR: S TOTAL LEN: .313 MI. DIST: 11-1 SR: 8047
LEFT MUN: UPPER ST CLAIR T RIGHT MUN: UPPER ST CLAIR T

001653 FT

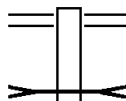

001653 FT MCLAUGHLIN RD
0760/0357 (SR3004 SEG 0080/0150)
MCLAUGHLIN
STRUCTURE LENGTH 16 FT
0760/0229 BMSID 02/8047/0760/0131

DIR: S TOTAL LEN: .313 MI.
 LEFT MUN: UPPER ST CLAIR T

DIST: 11-1 SR: 8047
 RIGHT MUN: UPPER ST CLAIR T

001296 FT

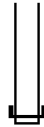

001296 FT 0 0 00000 0 00 0000+00
 NC MC LAUGH RUN INT/RP 760 RD
 INTER-BK WASHINGTON RD
 (SR0019 SEG 0060/0210)
 0760/0000 LENGTH(AH 0357 BK 0416)

000880 FT

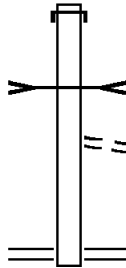

INTER-AHD WASHINGTON RD
 0750/0416 (SR0019 SEG 0060/0280)
 MCLAUGHLIN
 STRUCTURE LENGTH 16 FT
 0750/0119 BMSID 02/8047/0760/0131
 FROM 3004/0080 SH
 0750/0076 (CONN)
 000880 FT 2 0 02057 2 01 0000+00
 NC MC LAUGH RUN INT/RP 750 RD
 MCMURRAY RD
 (SR3004 SEG 0080/0190)
 0750/0000 LENGTH(AH 0416 BK 0402)

MCLAUGHLIN RD
 (SR3004 SEG 0070/3698) 0260/0402



0260/0402 TO 3004/0070 SH
 (CONN)
 MCLAUGHLIN
 STRUCTURE LENGTH 16 FT
 0260/0320 BMSID 02/8047/0260/0151
 0260/0258

OLD WASHINGTON RD
 (TWP) 0260/0135
 000478 FT

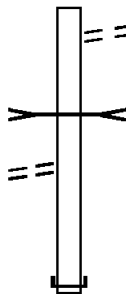

000478 FT 0 0 00000 0 00 0000+00
 NC MC LAUGH RN INT/RP 260 RD
 INTER-BK WASHINGTON RD
 (SR0019 SEG 0051/2195)
 0260/0000 LENGTH(AH 0402 BK 0478)

000000 FT

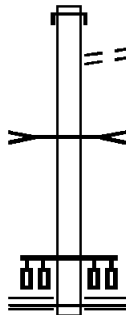

INTER-AHD WASHINGTON RD
 0250/0478 (SR0019 SEG 0051/2115)
 OLD WASHINGTON RD
 (TWP)
 MCLAUGHLIN
 STRUCTURE LENGTH 16 FT
 0250/0151 BMSID 02/8047/0260/0151
 000000 FT 2 0 02057 2 00 0000+00
 NC MC LAUGH RN INT/RP 250 RD
 MCLAUGHLIN RD
 (SR3004 SEG 0070/3685)
 0250/0000 MFC BEGIN = F
 LENGTH(AH 0478 BK 0000)

EXTRACT DATE: 12/21/2020 ROADWAY MANAGEMENT SYSTEM PAGE NUMBER: 1549
PRINT DATE: 12/23/2020 SLD COUNTY/SR - ANNUAL PRINT COUNTY: ALLEGHENY
DIR: N TOTAL LEN: .300 MI. DIST: 11-1 SR: 8046
LEFT MUN: SHALER T RIGHT MUN: SHALER T

001583 FT

001583 FT
INTER-AHD EVERGREEN RD

DIR: N TOTAL LEN: .300 MI. DIST: 11-1 SR: 8046
 LEFT MUN: SHALER T RIGHT MUN: SHALER T

TO 4009/0020 SH
 (CONN)

0500/0360

001176 FT

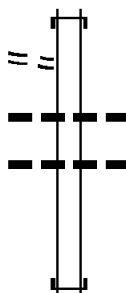

0500/0407 (SR4009 SEG 0020/0035)

0500/0319 024"H 24"W **UNKNOWN**
 LEN=0050 INSTALLED 2009
 0500/0159 024"H 24"W **UNKNOWN**
 LEN=0050 INSTALLED 2009
 001176 FT 1 0 00070 2 02 0191+22
 NC MI LLVALE INT/RMP E RD
 INTER-BK SR 28 EAST OHIO ST
 (SR0028 SEG 0081/1740)
 0500/0000 LENGTH(AH 0407 BK 0622)

000554 FT

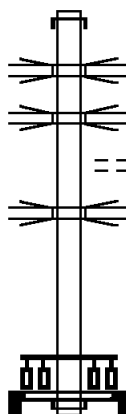

INTER-AHD SR 28 EAST OHIO ST
 0250/0622 (SR0028 SEG 0080/1195)
 RAMP A 8046 NB
 0250/0200 OP ID 02/8046/0010/0124
 RT 0028 NB
 0250/0135 OP ID 02/0028/0080/0981
 FROM 4009/0010 SH
 0250/0065 (CONN)
 RT 0028 SB
 0250/0051 OP ID 02/0028/0081/0515
 000554 FT 1 0 00070 2 01 0000+00
 SIGN: 3 CHORD TRUSS
 BMSID 02/0028/0080/0590
 NC MI LLVALE INT/RMP B RD
 INTER-BK EVERGREEN RD
 (SR4009 SEG 0010/1392)
 0250/0000 LENGTH(AH 0622 BK 0554)

TO 4009/0011 SH
 (CONN)

0010/0460

000000 FT



INTER-AHD EVERGREEN RD
 0010/0554 (SR4009 SEG 0010/1833)

0010/0406 OP ID RT 0028 NB
 0010/0179 BMSEN 02/8046/0010/0124
 1 0 00070 2 00 0003+62
 RAMP B 8046 NB
 0010/0124 BMSBG 02/8046/0010/0124
 000000 FT 1 0 00070 2 00 0000+00
 NC MI LLVALE INT/RMP A RD
 INTER-BK SR 28 EAST OHIO ST
 (SR0028 SEG 0080/0608)
 MFC BEGIN = F
 0010/0000 LENGTH(AH 0554 BK 0000)

EXTRACT DATE: 12/21/2020 ROADWAY MANAGEMENT SYSTEM PAGE NUMBER: 1547
PRINT DATE: 12/23/2020 SLD COUNTY/SR - ANNUAL PRINT COUNTY: ALLEGHENY
DIR: N TOTAL LEN: .806 MI. DIST: 11-1 SR: 8045
LEFT MUN: PITTSBURGH C RIGHT MUN: PITTSBURGH C

EXTRACT DATE: 12/21/2020
PRINT DATE: 12/23/2020

ROADWAY MANAGEMENT SYSTEM
SLD COUNTY/SR - ANNUAL PRINT

PAGE NUMBER: 1546
COUNTY: ALLEGHENY

DIR: N TOTAL LEN: .806 MI.
LEFT MUN: PITTSBURGH C

DIST: 11-1 SR: 8045
RIGHT MUN: PITTSBURGH C

LC FROM REEDSDALE AV
(CONN)

0750/0265
002268 FT

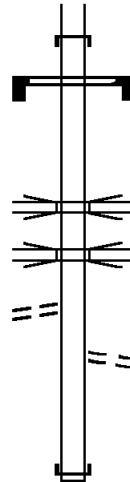

INTER-AHD OHIO RIVER BL
0750/1990 (SR0065 SEG 0003/1685)
SIGN: 4 CHORD TRUSS
0750/1913 BMSID 02/0065/0002/3060

0750/0513 OP ID SR 0065 SB
SR 0065 NB
0750/0432 OP ID 02/0065/0005/0000
0750/0432 OP ID 02/0065/0004/0000

0750/0062 LC FROM RIDGE AV
002268 FT (CONN)
0 0 0000 0 00 0000+00
NC N SHORE INT/RAMP 750 RD
INTER-BK RIDGE AV
(CITY)
0750/0000 LENGTH(AH 1990 BK 1780)

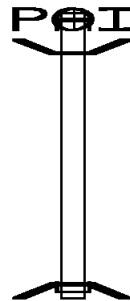

000488 FT

(APRA) PNC PARK/HEINZ F
INTER-AHD REEDSDALE ST
0250/1780 (CITY)
0250/1420 BMSEN 02/8045/0250/0000

000488 FT 1 0 01039 2 00 0000+00
NC N SHORE INT/RAMP 250 RD
INTER-BK OHIO RIVER BL
(SR0065 SEG 0002/0400)
SR 8045 RAMP FROM REEDS
BMSBG 02/8045/0250/0000
0250/0000 LENGTH(AH 1780 BK 0488)

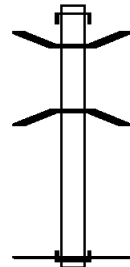

000000 FT

INTER-AHD OHIO RIVER BL
0010/0488 (SR0065 SEG 0004/0133)
0010/0487 BMSEN 02/0065/0004/0000
1 0 01039 2 15 0000+00
RAMP 8045 SB
0010/0354 BMSBG 02/0065/0004/0000
000000 FT 1 0 01039 2 15 0000+00
NC N SHORE INT/RAMP 10 RD
INTER-BK REEDSDALE ST
(CITY)
MFC BEGIN = F
0010/0000 LENGTH(AH 0488 BK 0000)

EXTRACT DATE: 12/21/2020 ROADWAY MANAGEMENT SYSTEM PAGE NUMBER: 1545
 PRINT DATE: 12/23/2020 SLD COUNTY/SR - ANNUAL PRINT COUNTY: ALLEGHENY
 DIR: S TOTAL LEN: .569 MI. DIST: 11-1 SR: 8044
 LEFT MUN: NORTH FAYETTE T RIGHT MUN: NORTH FAYETTE T

003005 FT

003005 FT
 INTER-AHD ROBINSON TWN CTR/RP B R
 (SR8044 SEG 0250/0000)
 SUMMIT PARL DR
 (TWP)
 ROBINSON TOWN CTR BL
 (TWP)

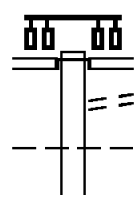

0500/0645
 0500/0506 LC TO ROB TWN CTR BL
 (CONN)
 NORTH FAYETTE
 ROBINSON T
 002360 FT 0 0 00000 0 00 0000+00

002360 FT

EXTRACT DATE: 12/21/2020
PRINT DATE: 12/23/2020

ROADWAY MANAGEMENT SYSTEM
SLD COUNTY/SR - ANNUAL PRINT

PAGE NUMBER: 1544
COUNTY: ALLEGHENY

DIR: S TOTAL LEN: .569 MI.
LEFT MUN: NORTH FAYETTE T

DIST: 11-1 SR: 8044
RIGHT MUN: NORTH FAYETTE T



NC ROBINSON TWN CTR/RP A RD
INTER-BK AIRPORT PY
(SR0376 SEG 0595/0676)
0500/0000 LENGTH(AH 0645 BK 1004)

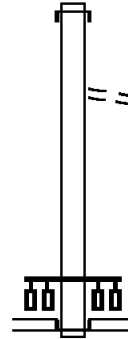

001356 FT

INTER-AHD AIRPORT PY
0250/1004 (SR0376 SEG 0591/1610)
0250/0140 LC FROM ROB TWN CTR BL
001356 FT (CONN)
0 0 00000 0 00 0000+00
NC ROBINSON TWN CTR/RP B RD
SUMMIT PARK DR
(TWP)
ROBINSON TOWN CTR BL
(TWP)

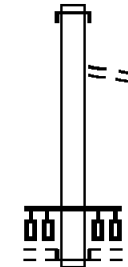

000712 FT

INTER-BK ROBINSON TWN CTR/RP A RD
(SR8044 SEG 0500/0645)
0250/0000 LENGTH(AH 1004 BK 0644)
INTER-AHD AIRPORT PY
0020/0644 (SR0376 SEG 0590/2490)
0020/0140 LC FROM SUMMIT PARK DR
000712 FT (CONN)
0 0 00000 0 00 0000+00
NC ROBINSON TWN CTR/RP D RD
SUMMIT PARK DR
(TWP)
INTER-BK MONYOUR CHURCH RD
(TWP)
0020/0000 LENGTH(AH 0644 BK 0712)

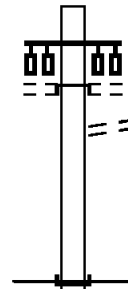

000000 FT

INTER-AHD MONTOUR CHURCH RD
(TWP)
SUMMIT PARK DR
(TWP)
0010/0712 LC TO SUMMIT PARK DR
0010/0565 (CONN)
000000 FT 0 0 00000 0 00 0000+00
NC ROBINSON TWN CTR/RP C RD
INTER-BK AIRPORT PY
(SR0376 SEG 0590/1787)
MFC BEGIN = F
0010/0000 LENGTH(AH 0712 BK 0000)

RAMP 260 RD
 (SR8049 SEG 0260/0235) 0750/1106

002168 FT

000513 FT

000000 FT

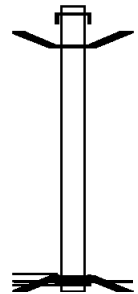
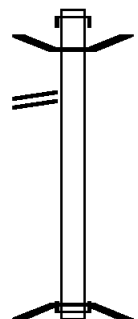

002168 FT
 INTER-AHD BEAVER AV
 0750/1655 (CITY)
 0750/1268 BMSEN 02/8043/0750/0000

000513 FT 0 0 00000 0 00 0000+00
 NC CA L/BEAVER INT/RMP 750 RD
 INTER-BK CALIFORNIA AV
 (SR4265 SEG 0011/0435)
 CHATEAU ST.
 BMSBG 02/8043/0750/0000
 0750/0000 LENGTH(AH 1655 BK 0513)

INTER-AHD CALIFORNIA AV
 0250/0513 (SR4265 SEG 0011/1520)
 0250/0324 BMSEN 02/8043/0250/0000
 000000 FT 1 0 01039 0 00 0949+96
 NC CA L/BEAVER INT/RMP 250 RD
 CALIFORNIA AV
 (CITY)
 INTER-BK CALIFORNIA AV
 (CITY)
 SR 0065 NB
 BMSBG 02/8043/0250/0000
 MFC BEGIN = F
 0250/0000 LENGTH(AH 0513 BK 0000)

DIR: N TOTAL LEN: 1.448 MI. DIST: 11-1 SR: 8042
 LEFT MUN: ETNA BOROUGH B RIGHT MUN: ETNA BOROUGH B

007646 FT

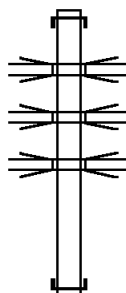

007646 FT
 INTER-AHD SR 28 NB
 0762/0821 (SR0028 SEG 0150/0000)
 TR 28 S.B.
 0762/0590 OP ID 02/0028/0141/0000
 SR 8 NB
 0762/0300 OP ID 02/0008/0180/2416
 RAMP 8042 NB
 0762/0020 OP ID 02/8042/0260/0409
 006825 FT 0 0 00000 0 00 0000+00
 NC 62ND ST BR INT/RP 750 RD
 INTER-BK SR 8 SB
 (SR0008 SEG 0181/3242)
 0762/0000 LENGTH(AH 0821 BK 0642)

006825 FT



INTER-AHD SR 8 NB
 0752/0642 (SR0008 SEG 0180/3275)
 006183 FT 0 0 00000 0 00 0000+00
 NC 62ND ST BR INT/RP 760 RD
 INTER-BK SR 28 SB
 (SR0028 SEG 0151/0000)
 0752/0000 LENGTH(AH 0642 BK 0551)

006183 FT

FROM 1001/0040 SH
 (CONN)

0520/0145

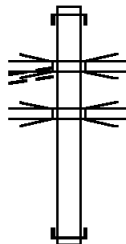

INTER-AHD RAMP FR SR8 TO SR 28 SB
 0520/0551 (SR8042 SEG 0510/0926)
 RAMP B SB
 0520/0145 OP ID 02/8042/0510/0056
 RAMP 8042 NB
 0520/0015 OP ID 02/8042/0260/0409
 005632 FT 0 0 00000 0 00 0000+00
 NC 62ND ST BRG INT/RP U RD
 INTER-BK BRIDGE ST
 (SR1001 SEG 0040/1023)
 0520/0000 LENGTH(AH 0551 BK 1086)

005632 FT

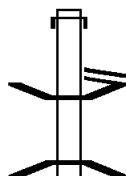

INTER-AHD SR 28 SB
 0510/1086 (SR0028 SEG 0131/1198)
 RAMP U RD
 0510/0926 (SR8042 SEG 0520/0551)
 0510/0600 BMS EN 02/8042/0510/0056
 0 0 00000 0 00 0000+00
 BRIDGE ST
 0510/0035 BMS BG 02/8042/0510/0056

EXTRACT DATE: 12/21/2020
PRINT DATE: 12/23/2020

ROADWAY MANAGEMENT SYSTEM
SLD COUNTY/SR - ANNUAL PRINT

PAGE NUMBER: 1541
COUNTY: ALLEGHENY

DIR: N TOTAL LEN: 1.448 MI.
LEFT MUN: ETNA BOROUGH B

DIST: 11-1 SR: 8042
RIGHT MUN: ETNA BOROUGH B

004546 FT

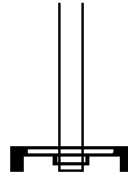

004546 FT 0 0 00000 0 00 0000+00
SIGN: 2 CHORD TRUSS
BMSID 02/0008/0181/3250
NC 62ND ST BR INT/RP 510 RD
INTER-BK SR 8 SB
(SR0008 SEG 0191/0000)
5 0510/0000 LENGTH(AH 1086 BK 1017)

003529 FT

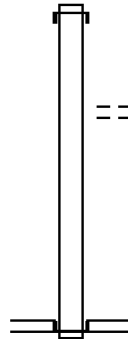

INTER-AHD 62ND ST BR
0280/1017 (SR0008 SEG 0181/1550)
0280/0055 POPLAR ST
003529 FT (BORO)
0 0 00000 0 00 0000+00
NC BR IDGE ST
BRIDGE ST
(SR1001 SEG 0040/1465)
RAMP T FR 28 NB TO N.MA
(SR8042 SEG 0250/0697)
INTER-BK BRIDGE ST
(SR1001 SEG 0040/1465)
5 0280/0000 LENGTH(AH 1017 BK 0424)

003105 FT

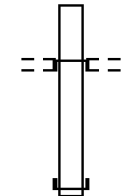

INTER-AHD MAIN ST
(CITY)
S MAIN ST
0270/0424 (BORO)
003105 FT 0 0 00000 0 00 0000+00
NC 62ND ST BRG INT/RP X RD
INTER-BK 62ND ST BR
(SR0008 SEG 0181/2500)
5 0270/0000 LENGTH(AH 0424 BK 0949)

002156 FT

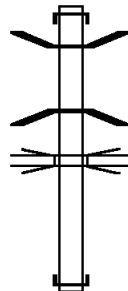

INTER-AHD SR 8 NB
0260/0949 (SR0008 SEG 0190/0000)
0260/0933 BMSSEN 02/8042/0260/0409
0 0 00000 0 00 0000+00
RAMP 8042 TO RT. 28 NB
0260/0409 BMSBG 02/8042/0260/0409
TR 28 S.B.
0260/0278 OP ID 02/0028/0141/0000
002156 FT 0 0 00000 0 00 0000+00
NC 62ND ST BR INT/RP 260 RD
INTER-BK SR 28 NB
(SR0028 SEG 0130/1460)
5 0260/0000 LENGTH(AH 0949 BK 0697)

EXTRACT DATE: 12/21/2020
PRINT DATE: 12/23/2020

ROADWAY MANAGEMENT SYSTEM
SLD COUNTY/SR - ANNUAL PRINT

PAGE NUMBER: 1540
COUNTY: ALLEGHENY

DIR: N TOTAL LEN: 1.448 MI.
LEFT MUN: ETNA BOROUGH B

DIST: 11-1 SR: 8042
RIGHT MUN: ETNA BOROUGH B

001459 FT

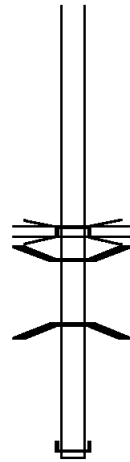

INTER-AHD BRIDGE ST
(SR1001 SEG 0040/1465)
SR 8 SB
OP ID 02/0008/0181/2418
BRIDGE ST
(SR1001 SEG 0040/1465)
BRIDGE ST RAMP RD
(SR8042 SEG 0280/0000)
BRIDGE ST
(SR8042 SEG 0022/1045)
0250/0697
0250/0658 BMSEN 02/8042/0250/0520
0 0 00000 0 00 0000+00
PINE CREEK
0250/0520
001459 FT BMSBG 02/8042/0250/0520
2 0 02260 2 02 0000+00
NC 62ND ST BRG INT/RP T RD
INTER-BK SR 28 NB
(SR0028 SEG 0130/1312)
5 0250/0000 LENGTH(AH 0697 BK 1045)

POPLAR ST
(BORO)

0022/1015

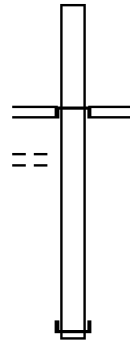

INTER-AHD BRIDGE ST
(SR1001 SEG 0040/1465)
RAMP T RD
(SR8042 SEG 0250/0697)
BRIDGE ST
0022/1045 (SR1001 SEG 0040/1465)
000414 FT 0 0 00000 0 00 0000+00
NC BRIDGE ST
INTER-BK 62ND ST BR
(SR0008 SEG 0180/1525)
5 0022/0000 LENGTH(AH 1045 BK 0414)

000000 FT

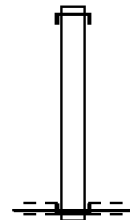

INTER-AHD 62ND ST BR
0012/0414 (SR0008 SEG 0180/2505)
000000 FT 0 0 00000 0 00 0000+00
NC 62ND STR BRG INT/RP Y RD
S MAIN ST
(BORO)
INTER-BK FIRST ST
(CITY)
MFC BEGIN = F
5 0012/0000 LENGTH(AH 0414 BK 0000)

EXTRACT DATE: 12/21/2020 ROADWAY MANAGEMENT SYSTEM PAGE NUMBER: 1539
PRINT DATE: 12/23/2020 SLD COUNTY/SR - ANNUAL PRINT COUNTY: ALLEGHENY
DIR: E TOTAL LEN: 2.432 MI. DIST: 11-1 SR: 8041
LEFT MUN: PITTSBURGH C RIGHT MUN: PITTSBURGH C

RAMP J RD
(SR8041 SEG 0260/0517) 0770/0620

012841 FT



012841 FT
INTER-AHD FT DUQUESNE BL
0770/0813 (CITY)

0770/0073 BMS EN 02/8041/0770/0043

EXTRACT DATE: 12/21/2020
PRINT DATE: 12/23/2020

ROADWAY MANAGEMENT SYSTEM
SLD COUNTY/SR - ANNUAL PRINT

PAGE NUMBER: 1538
COUNTY: ALLEGHENY

DIR: E TOTAL LEN: 2.432 MI.
LEFT MUN: PITTSBURGH C

DIST: 11-1 SR: 8041
RIGHT MUN: PITTSBURGH C

012028 FT

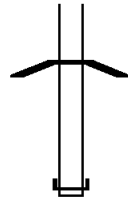

1 0 01039 2 04 0000+56
RAMP F 8041 EB
0770/0043 BMSBG 02/8041/0770/0043
012028 FT 1 0 01039 2 04 0000+00
NC RAMP E RD
INTER-BK RAMP C RD
(SR8041 SEG 0760/0180)
5 0770/0000 LENGTH(AH 0813 BK 0898)

011130 FT

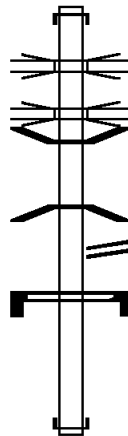

INTER-AHD 10TH ST BY-PASS
0760/0898 (SR2128 SEG 0010/0000)
SR 8041 NB RAMP H
0760/0509 OP ID 02/8041/0530/0140
SR 8041 EB RAMP J
0760/0470 OP ID 02/8041/0260/0072
0760/0280 BMSEN 02/8041/0760/0244
1 0 01039 2 02 0002+47
RAMP F (SR 8041) EB
0760/0244 BMSBG 02/8041/0760/0244
RAMP E RD
0760/0180 (SR8041 SEG 0770/0000)
SIGN: 4 CHORD TRUSS
0760/0150 BMSID 02/8041/0760/0150
011130 FT 1 0 01039 2 02 0000+00
NC RAMP C RD
INTER-BK SR 0279 SH
(SR0279 SEG 0006/1003)
5 0760/0000 LENGTH(AH 0898 BK 1295)

009835 FT

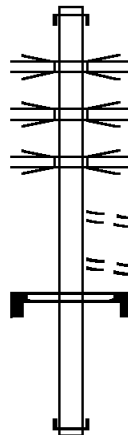

INTER-AHD SR 0279 SH
0750/1295 (SR0279 SEG 0006/0986)
RAMP C (FT PITT TO
0750/0750 OP ID 02/0279/0006/0000
RAMP Q 8039 SB
0750/0720 OP ID 02/8039/0520/0636
RAMP N 8039 NB
0750/0675 OP ID 02/8039/0500/0000
COMMONWEALTH PL
0750/0340 (CITY)
FT PITT BL
0750/0255 (CITY)
SIGN: SHAPE OR TUBE
0750/0025 BMSID 02/8041/0750/0050
009835 FT 1 0 01039 2 01 0000+00
NC RAMP B RD
INTER-BK PENN LINCOLN PY
(SR0376 SEG 0695/2099)
5 0750/0000 LENGTH(AH 1295 BK 0832)

EXTRACT DATE: 12/21/2020
PRINT DATE: 12/23/2020

ROADWAY MANAGEMENT SYSTEM
SLD COUNTY/SR - ANNUAL PRINT

PAGE NUMBER: 1537
COUNTY: ALLEGHENY

DIR: E TOTAL LEN: 2.432 MI.
LEFT MUN: PITTSBURGH C

DIST: 11-1 SR: 8041
RIGHT MUN: PITTSBURGH C

009003 FT

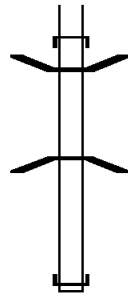

INTER-AHD RAMP G RD
0530/0832 (SR8041 SEG 0500/0825)
0530/0755 BMSEN 02/8041/0530/0140

0 0 00000 0 00 0000+00
SR 8041 SB RAMPD
0530/0140 BMSBG 02/8041/0530/0140
009003 FT 1 0 01039 2 08 0000+00
NC RAMP H RD
INTER-BK FT DUQUESNE BL
(CITY)
5 0530/0000 LENGTH(AH 0832 BK 0502)

008501 FT

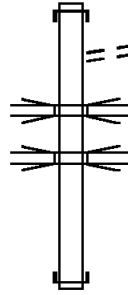

INTER-AHD FT DUQUESNE BL
0520/0502 (CITY)
LC TO COMMONWEALTH PL
0520/0435 (CONN)
RAMP E 8041 EB
0520/0190 OP ID 02/8041/0770/0043
RAMP C (SR 8041) E
0520/0138 OP ID 02/8041/0760/0244
008501 FT 1 0 01039 2 05 0000+00
NC RAMP F RD
INTER-BK RAMP D RD
(SR8041 SEG 0510/0880)
5 0520/0000 LENGTH(AH 0502 BK 1506)

RAMP F RD
(SR8041 SEG 0520/0000) 0510/0880

LC FROM FT DUQUESNE BL
(CONN) 0510/0225
006995 FT

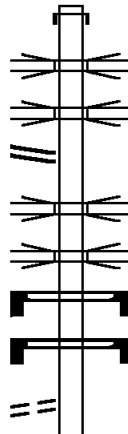

INTER-AHD SR 0279 SH
0510/1506 (SR0279 SEG 0007/0697)
I 279 RAMP F
0510/0920 OP ID 02/0279/0009/0351
LR 1039 NB
0510/0890 OP ID 02/0279/0008/0000

SR 8041 EB RAMP K
0510/0785 OP ID 02/8041/0270/0000
SR 8041 NB RAMP H
0510/0728 OP ID 02/8041/0530/0140
SIGN: 2 CHORD TRUSS
0510/0645 BMSID 02/8041/0510/0645
SIGN: 2 CHORD TRUSS
0510/0480 BMSID 02/8041/0510/0480

006995 FT 1 0 01039 2 03 0000+00

DIR: E TOTAL LEN: 2.432 MI. DIST: 11-1 SR: 8041
 LEFT MUN: PITTSBURGH C RIGHT MUN: PITTSBURGH C

RAMP H RD
 (SR8041 SEG 0530/0832) 0500/0825
 005986 FT

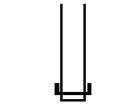

NC RAMP D RD
 INTER-BK 10TH ST BY-PASS
 (SR2128 SEG 0011/0000)
 0510/0000 LENGTH(AH 1506 BK 1009)

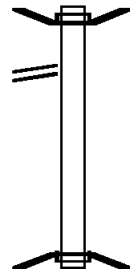

BMSEN 02/8041/0500/0000
 INTER-AHD SR 0279 SH
 0500/1009 (SR0279 SEG 0008/0405)

005986 FT 1 0 01039 2 00 0000+00

NC RAMP G RD
 INTER-BK 10TH ST BY-PASS
 (SR2128 SEG 0011/0112)
 ALLEGHENY RI
 BMSBG 02/8041/0500/0000
 0500/0000 LENGTH(AH 1009 BK 0674)

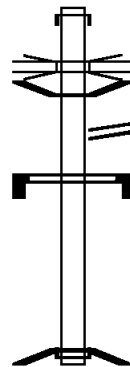

INTER-AHD 10TH ST BY-PASS
 0270/0674 (SR2128 SEG 0010/0000)
 SR 8041 NB RAMP H

0270/0225 OP ID 02/8041/0530/0140
 0270/0195 BMSEN 02/8041/0270/0000

RAMP J RD
 0270/0185 (SR8041 SEG 0260/0000)
 SIGN: 2 CHORD TRUSS

005312 FT

0270/0123 BMSID 02/8041/0270/0123
 005312 FT 1 0 01039 2 10 0000+75

NC RAMP K RD
 INTER-BK SR 0279 SH
 (SR0279 SEG 0009/0264)
 SR 8041 SB RAMP D
 BMSBG 02/8041/0270/0000
 0270/0000 LENGTH(AH 0674 BK 0517)

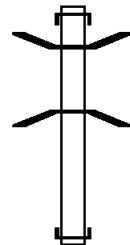

INTER-AHD RAMP E RD
 0260/0517 (SR8041 SEG 0770/0620)
 0260/0127 BMSEN 02/8041/0260/0072

1 0 01039 2 09 0001+17
 SR 8041 EB RAMP C

004795 FT

0260/0072 BMSBG 02/8041/0260/0072
 004795 FT 1 0 01039 2 09 0000+00

NC RAMP J RD
 INTER-BK RAMP K RD
 (SR8041 SEG 0270/0185)
 0260/0000 LENGTH(AH 0517 BK 4795)

RAMP F RD
 (SR8095 SEG 0270/1280) 0250/4357

FT PITT BL
 (CITY) 0250/2740

FT PITT BL
 (CITY) 0250/1115

000000 FT

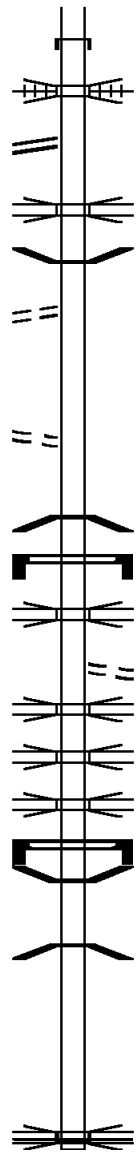

INTER-AHD PENN LINCOLN PY
 0250/4795 (SR0376 SEG 0704/1522)
 PORT AUTHORITY OF ALLEG
 0250/4368 OVERPASS IS RR X-ING

0250/3511 OP ID RAMP B (SR 8095) 02/8095/0010/0010
 0250/2899 BMSEN 02/8041/0250/1026

0250/1002 MONONGAHELA RIVER
 BMSBG 02/8041/0250/1026
 SIGN: CANTILEVER
 0250/0869 BMSID 02/8041/0250/0869
 I-376 WB
 0250/0638 OP ID 02/0376/0695/1642
 POINT STATE PARK RD
 0250/0450 (CITY)
 RAMP N 8039 NB
 0250/0440 OP ID 02/8039/0500/0000
 RAMP Q 8039 SB
 0250/0410 OP ID 02/8039/0520/0636
 RAMP C (FT PITT TO
 0250/0390 OP ID 02/0279/0006/0000
 SIGN: 2 CHORD TRUSS
 0250/0319 BMSID 02/8041/0250/0319
 0250/0247 BMSEN 02/8041/0250/0250
 1 0 01039 2 00 0000+00
 NO UNDERPASS INFORMATIO
 0250/0239 BMSBG 02/8041/0250/0250
 000000 FT 1 0 01039 2 00 0000+00
 SMITHFIELD
 OP ID 02/3027/0030/0000
 NC RAMP A RD
 INTER-BK SR 0279 SH
 (SR0279 SEG 0007/0639)
 MFC BEGIN = F
 0250/0000 LENGTH(AH 4795 BK 0000)

FROM 4068/0190 SH
 (CONN)

000934 FT

0750/0085
 000574 FT

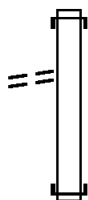

000934 FT
 INTER-AHD WILLIAM FLYNN HW
 0750/0360 (SR0008 SEG 0440/0380)

000574 FT 1 0 00072 2 02 0000+00
 NC BAKERSTOWN INT/RAMP B RD
 INTER-BK BAKERSTOWN RD
 (SR4068 SEG 0190/2130)
 0750/0000 LENGTH(AH 0360 BK 0310)

000264 FT

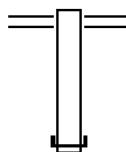

BAKERSTOWN RD
 0500/0310 (SR4068 SEG 0190/1950)
 000264 FT 1 0 00072 2 01 0000+00
 NC BAKERSTOWN INT/RAMP X RD
 INTER-BK WILLIAM FLYNN HW
 (SR0008 SEG 0441/0335)
 0500/0000 LENGTH(AH 0310 BK 0264)

000000 FT

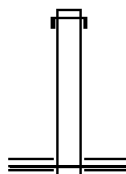

INTER-AHD WILLIAM FLYNN HW
 0250/0264 (SR0008 SEG 0431/2115)
 000000 FT 1 0 00072 2 03 0000+00
 NC BAKERSTOWN INT/RAMP R RD
 BAKERSTOWN RD
 (SR4068 SEG 0190/1772)
 MFC BEGIN = F
 0250/0000 LENGTH(AH 0264 BK 0000)

004038 FT

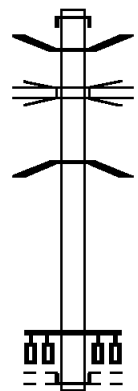

002937 FT

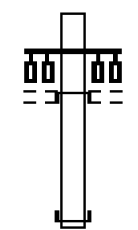

002714 FT

004038 FT
 INTER-AHD SR 0279 SH
 0520/1101 (SR0279 SEG 0007/0096)
 0520/0953 BMSEN 02/8039/0520/0636
 0520/0675 OP ID 02/0279/0006/0000
 1 0 00766 2 00 0000+75
 RAMP 8041 EB TO 376 EB
 0520/0636 BMSBG 02/8039/0520/0636
 002937 FT 1 0 00766 2 04 0000+00
 NC FT PITT BR INT/ RP Q RD
 COMMONWEALTH PL
 (CITY)
 INTER-BK LIBERTY AV
 (CITY)
 0520/0000 LENGTH(AH 1101 BK 0223)
 INTER-AHD BL OF THE ALLIES
 (SR2208 SEG 0010/0000)
 COMMONWEALTH PL
 (CITY)
 0510/0223
 002714 FT 1 0 00766 2 03 0000+00
 NC FT PITT BR INT/ RP R RD
 INTER-BK RAMP N RD
 (SR8039 SEG 0500/0389)
 0510/0000 LENGTH(AH 0223 BK 0696)

DIR: N TOTAL LEN: .765 MI. DIST: 11-1 SR: 8039
 LEFT MUN: PITTSBURGH C RIGHT MUN: PITTSBURGH C

002018 FT

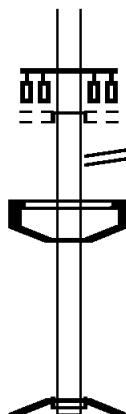

INTER-AHD LIBERTY AV
 (CITY)
 COMMONWEALTH PL
 (CITY)
 0500/0696
 0500/0389 RAMP R RD
 (SR8039 SEG 0510/0000)
 SIGN: 2 CHORD TRUSS
 0500/0260 BMSID 02/8039/0500/0625
 0500/0180 BMSEN 02/8039/0500/0000
 002018 FT 1 0 00766 2 00 0000+04
 NC FT PITT BR INT/RP N RD
 INTER-BK SR 0279 SH
 (SR0279 SEG 0006/0321)
 RAMP B 8041 NB
 BMSBG 02/8039/0500/0000
 0500/0000 LENGTH(AH 0696 BK 0962)

001056 FT

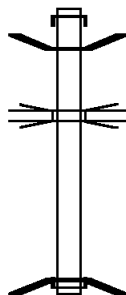

INTER-AHD WEST CARSON ST
 0250/0962 (SR0837 SEG 0590/0000)
 0250/0935 BMSEN 02/8039/0250/0000
 RAMP B 8039 NB
 0250/0160 OP ID 02/8039/0010/0332
 001056 FT 1 0 00766 2 00 0000+00
 NC FT PITT BR INT/RP A RD
 INTER-BK PENN LINCOLN PY
 (SR0376 SEG 0695/0405)
 STATION SQUARE ACCESS R
 BMSBG 02/8039/0250/0000
 0250/0000 LENGTH(AH 0962 BK 1056)

000000 FT

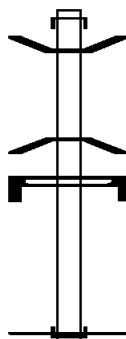

INTER-AHD PENN LINCOLN PY
 0010/1056 (SR0376 SEG 0694/0456)
 0010/1050 BMSEN 02/8039/0010/0332
 1 0 00766 2 01 0000+01
 RAMP A 8039 SB
 0010/0332 BMSBG 02/8039/0010/0332
 SIGN: CANTILEVER
 0010/0316 BMSID 02/8039/0010/0375
 000000 FT 1 0 00766 2 01 0000+00
 NC FT PITT BR INT/RP B RD
 INTER-BK WEST CARSON ST
 (SR0837 SEG 0591/0000)
 MFC BEGIN = F
 0010/0000 LENGTH(AH 1056 BK 0000)

000421 FT

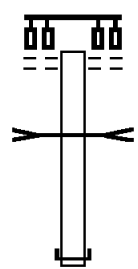

000421 FT CAMPBELLS RUN RD
 (CNTY)
 0500/0291
 CAMPBELLSRUN
 STRUCTURE LENGTH 22 FT
 0500/0129 BMSID 02/8038/0500/0129
 000130 FT 1 0 00765 2 10 0000+00
 NC CAMPBELLS RUN INT/RP C RD
 INTER-BK I-376
 (SR0376 SEG 0621/0796)
 0500/0000 LENGTH(AH 0291 BK 0130)

000130 FT

INTER-AHD PENN LCN PY SR376/22/30
 0020/0130 (SR0376 SEG 0614/2613)
 000000 FT 1 0 00765 2 08 0025+03
 NC CAMPBELLS RUN INT/RP B RD
 BOICE RD
 (SR3041 SEG 0054/2580)
 MFC BEGIN = F
 0020/0000 LENGTH(AH 0130 BK 0000)

000000 FT

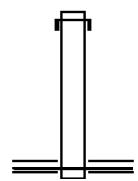

EXTRACT DATE: 12/21/2020 ROADWAY MANAGEMENT SYSTEM PAGE NUMBER: 1530
 PRINT DATE: 12/23/2020 SLD COUNTY/SR - ANNUAL PRINT COUNTY: ALLEGHENY
 DIR: S TOTAL LEN: .835 MI. DIST: 11-1 SR: 8037
 LEFT MUN: PITTSBURGH C RIGHT MUN: PITTSBURGH C

004408 FT
 003811 FT

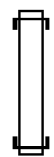

004408 FT
 INTER-AHD SAW MILL RUN BL
 0750/0597 (SR0051 SEG 0430/0669)
 003811 FT 1 0 00766 2 11 0000+00
 NC SAWMILL RUN INT/RAMP B RD
 INTER-BK PENN LINCOLN PY
 (SR0376 SEG 0684/2316)
 0750/0000 LENGTH(AH 0597 BK 2617)

BANKSVILLE INT/RMP 250
 (SR8075 SEG 0250/0123)
 BANKSVILLE INT/RMP 250
 (SR8075 SEG 0250/0123) 0260/2569

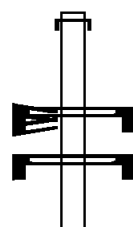

INTER-AHD BANKSVILLE RD
 0260/2617 (SR0019 SEG 0211/1211)
 0260/2569 SIGN: 4 CHORD TRUSS
 BMSID 02/8075/0250/0130
 0260/2160 SIGN: 4 CHORD TRUSS
 BMSID 02/0376/0684/0020
 SIGN: TRUSS MUL SPA

DIR: S TOTAL LEN: .835 MI. DIST: 11-1 SR: 8037
 LEFT MUN: PITTSBURGH C RIGHT MUN: PITTSBURGH C

001194 FT

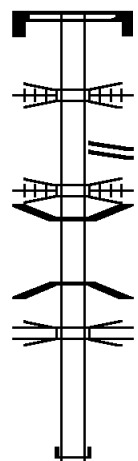

0260/1289 BMSID 02/0376/0684/0876
 0260/0670 OTHER
 0260/0615 OVERPASS IS RR X-ING
 (SR8037 SEG 0250/0677) SAWMILL RUN INT/RAMP A
 NORFOLK SOUTHERN
 0260/0570 OVERPASS IS RR X-ING
 0260/0373 BMSEN 02/8037/0260/0271
 1 0 00766 2 09 0000+00
 SAW MILL RUN
 0260/0317 BMSBG 02/8037/0260/0271
 RAMP A 8037 SB
 0260/0122 OP ID 02/8037/0250/0053
 001194 FT 1 0 00766 2 09 0000+00
 NC SAWMILL RUN INT/RAMP C RD
 INTER-BK WEST END BP
 (SR0019 SEG 0231/0600)
 0260/0000 LENGTH(AH 2617 BK 0677)

000517 FT

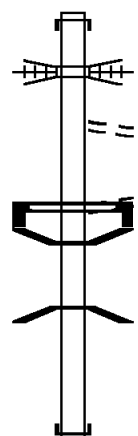

INTER-AHD SAWMILL RUN INT/RAMP C
 0250/0677 (SR8037 SEG 0260/0615)
 OTHER
 0250/0607 OVERPASS IS RR X-ING
 WOODVILLE AV
 0250/0567 (CITY)
 SIGN: 4 CHORD TRUSS
 BMSID 02/8037/0250/0465
 WOODVILLE AV
 0250/0468 (CITY)
 0250/0433 BMSEN 02/8037/0250/0053
 1 0 00766 2 10 0000+00
 RAMP C 8037 SB
 0250/0053 BMSBG 02/8037/0250/0053
 000517 FT 1 0 00766 2 10 0000+00
 NC SAWMILL RUN INT/RAMP A RD
 INTER-BK WEST END BP
 (SR0019 SEG 0230/0430)
 0250/0000 LENGTH(AH 0677 BK 0517)

000000 FT

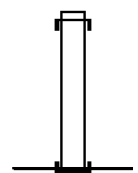

INTER-AHD SAW MILL RUN BL
 0010/0517 (SR0051 SEG 0431/0345)
 000000 FT 1 0 00766 2 08 0000+00
 NC SAWMILL RUN INT/RAMP D RD
 INTER-BK PENN LINCOLN PY
 (SR0376 SEG 0684/1922)
 MFC BEGIN = F
 0010/0000 LENGTH(AH 0517 BK 0000)

005160 FT

005160 FT
 INTER-AHD SR 22 E TO 60 S SH
 0760/0755 (SR0022 SEG 0140/1098)

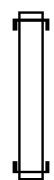

004405 FT

004405 FT 1 0 00765 2 05 0000+00
 NC RAMP B/TONIDALE INT RD
 INTER-BK PENN LCN PY SR376E22/30
 (SR0376 SEG 0600/0392)
 0760/0000 LENGTH(AH 0755 BK 1335)

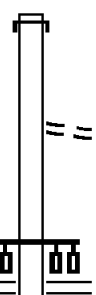

003070 FT

INTER-AHD PENN LCN PY SR376E22/30
 0750/1335 (SR0376 SEG 0600/1072)
 FROM 0022/0140 SH
 0750/0287 (CONN)
 003070 FT 1 0 00765 2 01 0000+00
 NC RAMP F/TONIDALE INT RD
 SR 0022 SH
 (SR0022 SEG 0141/0968)
 (SR0022 SEG 0140/0902)
 0750/0000 LENGTH(AH 1335 BK 0452)

LC TO CAMPBELLS RUN RD
 (CONN)

0500/0325
 002618 FT

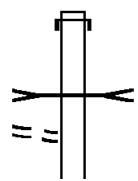

INTER-AHD CAMPBELLS RUN RD
 0500/0452 (CNTY)
 CAMPBELLS RN
 STRUCTURE LENGTH 9 FT
 0500/0353 BMSID 02/8036/0500/0353
 002618 FT 1 0 00765 2 00 0000+00

DIR: W TOTAL LEN: .977 MI. DIST: 11-1 SR: 8036
 LEFT MUN: ROBINSON T RIGHT MUN: ROBINSON T

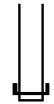

NC TONIDALE INT/RAMP E RD
 INTER-BK PENN LCN PY SR376W22/30
 (SR0376 SEG 0605/0378)
 0500/0000 LENGTH(AH 0452 BK 0787)

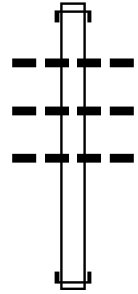

001831 FT

INTER-AHD SR 60 N TO SR22 & 30 W
 0260/0787 (SR0060 SEG 0230/1983)
 018 "DIA CIRC CONCR
 0260/0548 LEN=0026 INSTALLED 2010
 018 "DIA CIRC CONCR
 0260/0324 LEN=0042 INSTALLED 2010
 018 "DIA CIRC CONCR
 0260/0060 LEN=0027 INSTALLED 2010
 001831 FT 1 0 00765 2 02 0000+00
 NC RAMP C/TONIDALE INT RD
 INTER-BK PENN LINCOLN PY
 (SR0376 SEG 0595/2451)
 0260/0000 LENGTH(AH 0787 BK 0903)

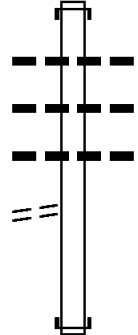

FROM 0060/0231 SH
 (CONN)

0250/0172
 000928 FT

INTER-AHD PENN LINCOLN PY
 0250/0903 (SR0376 SEG 0595/2155)
 024 "DIA CIRC CONCR
 0250/0710 LEN=0037 INSTALLED 2010
 018 "DIA CIRC CONCR
 0250/0366 LEN=0067 INSTALLED 2010
 018 "DIA CIRC CONCR
 0250/0217 LEN=0048 INSTALLED 2010
 000928 FT 1 0 00765 2 06 0000+00
 NC RAMP G/TONIDALE INT RD
 INTER-BK SR 60 N SH
 (SR0060 SEG 0230/1710)
 0250/0000 LENGTH(AH 0903 BK 0928)

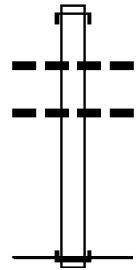

000000 FT

INTER-AHD SR 22 & 30 W SH
 0010/0928 (SR0022 SEG 0141/0511)
 018 "DIA CIRC CONCR
 0010/0350 LEN=0058 INSTALLED 2010
 024 "DIA CIRC CONCR
 0010/0152 LEN=0057 INSTALLED 2010
 000000 FT 0 0 00000 0 00 0000+00
 NC RAMP H/TONIDALE INT RD
 INTER-BK PENN LINCOLN PY
 (SR0376 SEG 0594/1950)
 MFC BEGIN = F
 0010/0000 LENGTH(AH 0928 BK 0000)

EXTRACT DATE: 12/21/2020 ROADWAY MANAGEMENT SYSTEM PAGE NUMBER: 1526
PRINT DATE: 12/23/2020 SLD COUNTY/SR - ANNUAL PRINT COUNTY: ALLEGHENY

DIR: N TOTAL LEN: .680 MI. DIST: 11-1 SR: 8035
LEFT MUN: GREENTREE B RIGHT MUN: GREENTREE B

003592 FT

003014 FT

002540 FT

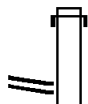
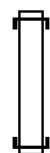

003592 FT
INTER-AHD PENN LINCOLN PY
0750/0578 (SR0376 SEG 0670/1936)
003014 FT 1 0 00765 2 32 0000+00
NC GR GREENTREE INT/RAMP A RD
INTER-BK GREENTREE RD
(SR0121 SEG 0080/0532)
S 0750/0000 LENGTH(AH 0578 BK 0474)

INTER-AHD PENN LINCOLN PY
0500/0474 (SR0376 SEG 0671/1807)
002540 FT 1 0 00765 2 33 0000+00
NC GR GREENTREE INT/RAMP J RD
INTER-BK GREENTREE RD
(SR3101 SEG 0010/0060)
S 0500/0000 LENGTH(AH 0474 BK 0792)

INTER-AHD GREENTREE RD
0270/0792 (SR0121 SEG 0081/1135)

RAMP H RD
(SR8035 SEG 0260/0000) 0270/0101

DIR: N TOTAL LEN: .680 MI. DIST: 11-1 SR: 8035
 LEFT MUN: GREENTREE B RIGHT MUN: GREENTREE B

001748 FT

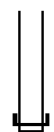

001748 FT 1 0 00765 2 30 0000+00
 NC GREENTREE INT/RAMP F RD
 INTER-BK PENN LINCOLN PY
 (SR0376 SEG 0671/1202)
 0270/0000 LENGTH(AH 0792 BK 0309)

001439 FT

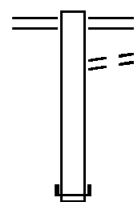

0260/0309 MANSFIELD AV
 (SR0121 SEG 0090/0615)
 TO 0121/0090 SH
 0260/0265 (CONN)
 001439 FT 1 0 00765 2 29 0000+00
 NC GREENTREE INT/RAMP H RD
 INTER-BK RAMP F RD
 (SR8035 SEG 0270/0101)
 0260/0000 LENGTH(AH 0309 BK 0413)

001026 FT

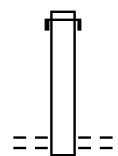

INTER-AHD PENN LINCOLN PY
 0250/0413 (SR0376 SEG 0671/0208)
 001026 FT 1 0 00765 2 28 0005+76
 NC GREENTREE INT/RAMP E RD
 POPLAR ST
 (BORO)
 0250/0000 LENGTH(AH 0413 BK 0500)

000526 FT

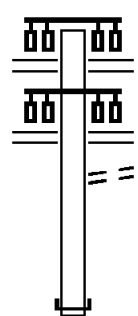

0020/0500 GREENTREE RD
 (SR0121 SEG 0081/0829)
 0020/0489 GREENTREE RD
 (SR0121 SEG 0080/0821)
 TO 0121/0081 SH
 0020/0385 (CONN)
 000526 FT 1 0 00765 2 27 0000+00
 NC GREENTREE INT/RAMP C RD
 INTER-BK PENN LINCOLN PY
 (SR0376 SEG 0670/0937)
 0020/0000 LENGTH(AH 0500 BK 0526)

000000 FT

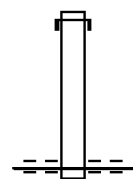

INTER-AHD PENN LINCOLN PY
 0010/0526 (SR0376 SEG 0670/0226)
 000000 FT 1 0 00765 2 31 0000+00
 NC GREENTREE INT/RAMP K RD
 POPLAR ST
 (BORO)
 MFC BEGIN = F
 0010/0000 LENGTH(AH 0526 BK 0000)

TO 3066/0090 SH (CONN)	001264 FT 0750/0102 001054 FT		001264 FT INTER-AHD OLD STEUBENVILLE PK 0750/0210 (SR3066 SEG 0080/1680) 001054 FT 1 0 00257 2 20 0000+00 NC TONIDALE INT/RAMP X RD INTER-BK SR 0022 SH (SR0022 SEG 0130/2628) 0750/0000 LENGTH(AH 0210 BK 0458)
LC TO MONTOUR CHURCH RD (CONN)	0500/0370 000596 FT		INTER-AHD MONTOUR CHURCH RD 0500/0458 (T430) 000596 FT 1 0 00257 2 19 0000+00 NC TONIDALE INT/RAMP V RD INTER-BK SR 0022 SH (SR0022 SEG 0131/3412) 0500/0000 LENGTH(AH 0458 BK 0596)
	000000 FT		INTER-AHD SR 0022 SH 0250/0596 (SR0022 SEG 0131/2357) 000000 FT 1 0 00257 2 18 0000+00 NC TONIDALE INT/RAMP U RD MONTOUR CHURCH RD (T430) MFC BEGIN = F 0250/0000 LENGTH(AH 0596 BK 0000)

EXTRACT DATE: 12/21/2020 ROADWAY MANAGEMENT SYSTEM PAGE NUMBER: 1523
 PRINT DATE: 12/23/2020 SLD COUNTY/SR - ANNUAL PRINT COUNTY: ALLEGHENY
 DIR: E TOTAL LEN: 1.117 MI. DIST: 11-1 SR: 8033
 LEFT MUN: CARNEGIE B RIGHT MUN: CARNEGIE B

005896 FT

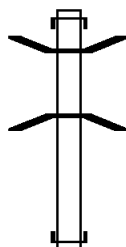

005896 FT
 INTER-AHD PENN LINCOLN PY
 0760/0909 (SR0376 SEG 0651/2358)
 0760/0325 BMS EN 02/8033/0760/0105
 0 0 00000 0 00 0000+00
 SR 0376 EB
 0760/0153 BMS BG 02/8033/0760/0105
 004987 FT 1 0 00765 2 23 0012+96
 NC CA RNEGIE INT/RAMP D RD
 INTER-BK RAMP B RD
 (SR8033 SEG 0750/0980)
 0760/0000 LENGTH(AH 0909 BK 1451)

004987 FT

RAMP D RD
 (SR8033 SEG 0760/0000) 0750/0980

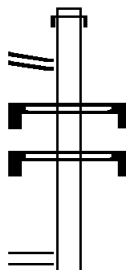

INTER-AHD PENN LINCOLN PY
 0750/1451 (SR0376 SEG 0650/2372)
 0750/0540 SIGN: 4 CHORD TRUSS
 BMS ID 02/8033/0750/0540
 SIGN: CANTILEVER
 0750/0024 BMS ID 02/8033/0750/0005
 003536 FT 1 0 00765 2 23 0000+00
 NC CA RNEGIE INT/RAMP B RD
 ANTHONY ST
 (TWP)

003536 FT

DIR: E TOTAL LEN: 1.117 MI. DIST: 11-1 SR: 8033
 LEFT MUN: CARNEGIE B RIGHT MUN: CARNEGIE B

RAMP C RD
 (SR8033 SEG 0010/0417) 0510/0500
 002426 FT

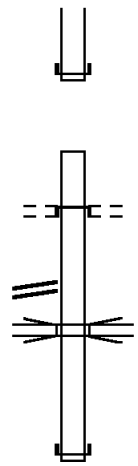

INTER-BK ACADEMY AV
 (SR3097 SEG 0010/1287)
 0750/0000 LENGTH(AH 1451 BK 1110)

INTER-AHD LYDIA ST
 (SR3058 SEG 0011/1082)
 ANTHONY ST
 0510/1110 (TWP)

0510/0020 OP ID PENN LINC PW
 002426 FT 1 0 00765 2 26 0011+93
 NC CA RNEGIE INT/RAMP E RD
 INTER-BK RAMP A RD
 (SR8033 SEG 0500/1125)
 0510/0000 LENGTH(AH 1110 BK 2009)

RAMP E RD
 (SR8033 SEG 0510/0000) 0500/1125
 000417 FT

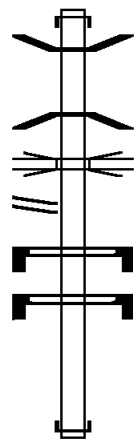

INTER-AHD CHESTNUT ST
 0500/2009 (SR3099 SEG 0011/0554)
 0500/1758 BMS EN 02/8033/0500/1248
 O O 00000 0 00 0000+00
 SR 0050 EB WB
 0500/1235 BMSBG 02/8033/0500/1248
 0500/1151 OP ID PENN LINC PW
 0500/0950 BMSID 02/8033/0500/0950
 SIGN: 4 CHORD TRUSS
 SIGN: CANTILEVER
 0500/0410 BMSID 02/8033/0500/0410
 000417 FT 1 0 00765 2 22 0023+12
 NC CA RNEGIE INT/RAMP A RD
 INTER-BK PENN LINCOLN PY
 (SR0376 SEG 0655/0070)
 0500/0000 LENGTH(AH 2009 BK 0417)

000000 FT

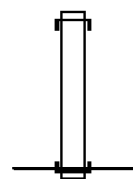

INTER-AHD RAMP A RD
 0010/0417 (SR8033 SEG 0510/0500)
 000000 FT 1 0 00765 2 24 0004+54
 NC CA RNEGIE INT/RAMP C RD
 INTER-BK PENN LINCOLN PY
 (SR0376 SEG 0650/1845)
 MFC BEGIN = F
 0010/0000 LENGTH(AH 0417 BK 0000)

EXTRACT DATE: 12/21/2020 ROADWAY MANAGEMENT SYSTEM PAGE NUMBER: 1521
 PRINT DATE: 12/23/2020 SLD COUNTY/SR - ANNUAL PRINT COUNTY: ALLEGHENY
 DIR: W TOTAL LEN: .232 MI. DIST: 11-1 SR: 8032
 LEFT MUN: NORTH FAYETTE T RIGHT MUN: NORTH FAYETTE T

FROM 3103/0040 SH
 (CONN)

001227 FT

0750/0109
 000561 FT

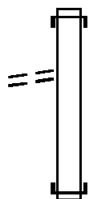

001227 FT
 INTER-AHD SR 0022 SH
 0750/0666 (SR0022 SEG 0120/0715)

000561 FT 1 0 00257 2 17 0000+00
 NC OAKDALE INT/RAMP Z RD
 INTER-BK MCKEE RD
 (SR3103 SEG 0040/1906)
 0750/0000 LENGTH(AH 0666 BK 0561)

000000 FT

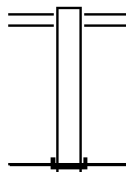

MCKEE RD
 0500/0561 (SR3103 SEG 0040/2355)
 000000 FT 1 0 00257 2 16 0000+00
 NC OAKDALE INT/RAMP Y RD
 INTER-BK SR 0022 SH
 (SR0022 SEG 0121/0625)
 MFC BEGIN = F
 0500/0000 LENGTH(AH 0561 BK 0000)

LC TO ROSSLYN RD
 (CONN)

000950 FT

0500/0679

000184 FT



000950 FT
 INTER-AHD ROSSLYN RD
 0500/0766 (BORO)

000184 FT 1 0 00765 2 21 0000+00
 NC RO ROSSLYN FRMS INT/RP G RD
 INTER-BK PENN LINCOLN PKWY
 (SR0376 SEG 0645/0209)
 0500/0000 LENGTH(AH 0766 BK 0184)

000000 FT

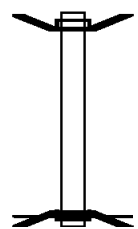

INTER-AHD BMS EN 02/8031/0010/0000
 ROSSLYN RD
 0010/0184 (BORO)
 000000 FT 1 0 00765 2 19 0011+57
 NC RO ROSSLYN FRMS INT/RP H RD
 INTER-BK ROSSLYN RD
 (BORO)
 SR 0376 EB
 BMSBG 02/8031/0010/0000
 MFC BEGIN = F
 0010/0000 LENGTH(AH 0184 BK 0000)

DIR: W TOTAL LEN: .638 MI. DIST: 11-1 SR: 8030
 LEFT MUN: NORTH FAYETTE T RIGHT MUN: NORTH FAYETTE T

003367 FT

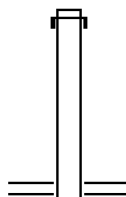

003367 FT
 INTER-AHD SR 22 SH
 0760/1013 (SR0022 SEG 0100/0167)

002354 FT

002354 FT 1 0 00257 2 14 0000+00
 NC HANKEY FARMS INT/RP S RD
 OAKDALE RD
 (SR3063 SEG 0030/0106)
 0760/0000 LENGTH(AH 1013 BK 0707)

001647 FT

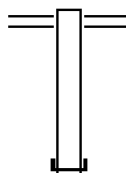

0750/0707 OAKDALE RD
 (SR3063 SEG 0030/0125)
 001647 FT 1 0 00257 2 15 0000+00
 NC HANKEY FARMS INT/RP T RD
 INTER-BK SR 22 SH
 (SR0022 SEG 0090/2670)
 0750/0000 LENGTH(AH 0707 BK 0901)

000746 FT

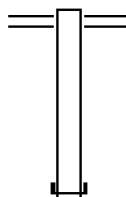

0510/0901 OAKDALE RD
 (SR3063 SEG 0030/1130)
 000746 FT 1 0 00257 2 13 0000+00
 NC HANKEY FARMS INT/RP R RD
 INTER-BK SR 22 SH
 (SR0022 SEG 0091/2602)
 0510/0000 LENGTH(AH 0901 BK 0746)

000000 FT

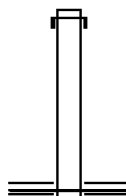

INTER-AHD SR 22 SH
 0500/0746 (SR0022 SEG 0091/2207)
 000000 FT 1 0 00257 2 12 0000+00
 NC HANKEY FARMS INT/RP Q RD
 OAKDALE RD
 (SR3063 SEG 0030/1150)
 MFC BEGIN = F
 0500/0000 LENGTH(AH 0746 BK 0000)

EXTRACT DATE: 12/21/2020 ROADWAY MANAGEMENT SYSTEM PAGE NUMBER: 1518
 PRINT DATE: 12/23/2020 SLD COUNTY/SR - ANNUAL PRINT COUNTY: ALLEGHENY
 DIR: N TOTAL LEN: .103 MI. DIST: 11-1 SR: 8029
 LEFT MUN: MARSHALL T RIGHT MUN: MARSHALL T

000542 FT
 000000 FT

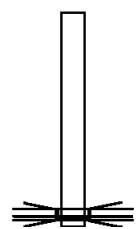

000542 FT AH-BUTLER (10)
 * REF-AHD RAMP D RD
 0010/0542 (SR8079 SEG 0012/0000)
 000000 FT 0 0 00000 0 00 0000+00
 SR 4054 FREEPORT R
 OP ID 02/4054/0010/0860
 NC RAMP D RD
 INTER-BK RAYMOND P SHAFFER HW
 (SR0079 SEG 0770/1816)
 MFC BEGIN = F
 0010/0000 LENGTH(AH 0542 BK 0000)

DIR: E TOTAL LEN: .584 MI. DIST: 11-1 SR: 8028
 LEFT MUN: NORTH FAYETTE T RIGHT MUN: NORTH FAYETTE T

003082 FT

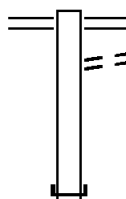

003082 FT LINCOLN HW
 0500/0639 (SR0030 SEG 0160/0854)
 TO 0030/0160 SH
 (CONN)

002443 FT

0500/0524
 002443 FT 1 0 00257 2 09 0000+00
 NC IMPERIAL INT/RAMP L RD
 INTER-BK SR 22 SH
 (SR0022 SEG 0061/1456)
 0500/0000 LENGTH(AH 0639 BK 0548)

001895 FT

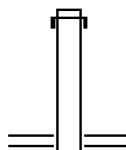

INTER-AHD SR 22 SH
 0250/0548 (SR0022 SEG 0061/0251)
 001895 FT 1 0 00257 2 08 0000+00
 NC IMPERIAL INT/RAMP K RD
 SR 30 LINCOLN HW
 (SR0030 SEG 0160/0755)
 0250/0000 LENGTH(AH 0548 BK 0811)

001084 FT

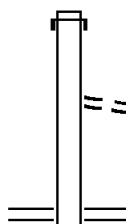

INTER-AHD SR 22 SH
 0020/0811 (SR0022 SEG 0060/0535)
 FROM 0978/0240 SH
 (CONN)
 0020/0120
 001084 FT 0 0 00000 0 00 0000+00
 NC IMPERIAL INT/RAMP O RD
 BATEMAN RD
 (SR0978 SEG 0240/0251)
 0020/0000 LENGTH(AH 0811 BK 1084)

000000 FT

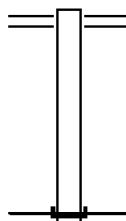

0010/1084 BATEMAN RD
 (SR0978 SEG 0240/0218)
 000000 FT 1 0 00257 2 10 0000+00
 NC IMPERIAL INT/RAMP N RD
 INTER-BK SR 22 SH
 (SR0022 SEG 0060/0000)
 MFC BEGIN = F
 0010/0000 LENGTH(AH 1084 BK 0000)

DIR: N TOTAL LEN: .979 MI. DIST: 11-1 SR: 8027
 LEFT MUN: MARSHALL T RIGHT MUN: MARSHALL T

005170 FT

005170 FT
 INTER-AHD 1-79 S
 0250/1911 (SR0079 SEG 0761/0702)

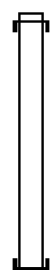

003259 FT

003259 FT 1 0 01021 2 06 0000+00
 NC MARSHALL INT/RAMP L RD
 INTER-BK PERRY HW
 (SR0019 SEG 0671/2029)
 0250/0000 LENGTH(AH 1911 BK 3259)

INTER-AHD PERRY HW
 0010/3259 (SR0019 SEG 0680/1515)

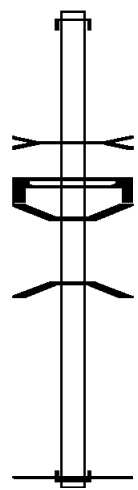

000000 FT

BR. BRUSH CR.
 STRUCTURE LENGTH 14 FT
 0010/2174 BMSID 02/8027/0010/2174
 SIGN: 3 CHORD TRUSS
 0010/1853 BMSID 02/8027/0010/1975
 0010/1419 BMSSEN 02/8027/0010/1172
 0 0 00000 0 00 0000+00
 SR 0079 SB
 0010/1172 BMSBG 02/8027/0010/1172
 000000 FT 1 0 01021 2 07 0000+00
 NC MARSHALL INT/RAMP W RD
 INTER-BK INTERSTATE 79 NB
 (SR0079 SEG 0764/0384)
 MFC BEGIN = F
 0010/0000 LENGTH(AH 3259 BK 0000)

EXTRACT DATE: 12/21/2020 ROADWAY MANAGEMENT SYSTEM PAGE NUMBER: 1515
PRINT DATE: 12/23/2020 SLD COUNTY/SR - ANNUAL PRINT COUNTY: ALLEGHENY
DIR: W TOTAL LEN: .560 MI. DIST: 11-1 SR: 8026
LEFT MUN: NORTH FAYETTE T RIGHT MUN: NORTH FAYETTE T

DIR: W TOTAL LEN: .560 MI. DIST: 11-1 SR: 8026
 LEFT MUN: NORTH FAYETTE T RIGHT MUN: NORTH FAYETTE T

002174 FT

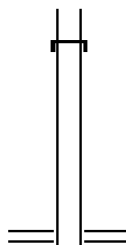

INTER-AHD SR 22 SH
 0760/0784 (SR0022 SEG 0040/0683)
 002174 FT 1 0 00257 2 06 0000+00
 NC NOBLESTOWN INT/RP G RD
 KELSO RD
 (SR3051 SEG 0050/0000)
 KELSO RD (TBK)
 (TWP)
 0760/0000 LENGTH(AH 0784 BK 0585)

001589 FT

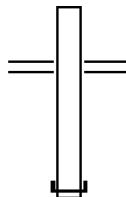

KELSO RD (TBK)
 (TWP)
 KELSO RD
 0750/0585 (SR3051 SEG 0050/0020)
 001589 FT 1 0 00257 2 07 0000+00
 NC NOBLESTOWN INT/RP H RD
 INTER-BK SR 22 SH
 (SR0022 SEG 0040/0295)
 0750/0000 LENGTH(AH 0585 BK 0994)

000595 FT

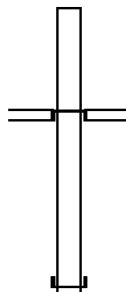

INTER-AHD RAMP E RD
 (SR8026 SEG 0250/0000)
 KELSO RD
 (SR3051 SEG 0050/0529)
 KELSO RD (TBK)
 (TWP)
 0500/0994
 000595 FT 1 0 00257 2 05 0000+00
 NC NOBLESTOWN INT/RP F RD
 INTER-BK SR 22 SH
 (SR0022 SEG 0041/1023)
 0500/0000 LENGTH(AH 0994 BK 0595)

000000 FT

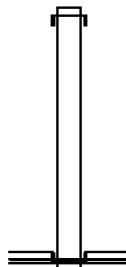

INTER-AHD SR 22 SH
 0250/0595 (SR0022 SEG 0031/2788)
 000000 FT 1 0 00257 2 04 0000+00
 NC NOBLESTOWN INT/RP E D
 KELSO RD
 (SR3051 SEG 0050/0529)
 KELSO RD (TBK)
 (TWP)
 INTER-BK RAMP F RD
 (SR8026 SEG 0500/0994)
 MFC BEGIN = F
 0250/0000 LENGTH(AH 0595 BK 0000)

003454 FT

003454 FT
 INTER-AHD INTERSTATE 79 SB
 0250/1835 (SR0079 SEG 0751/1486)

001619 FT

001619 FT 1 0 01021 2 04 0000+00
 NC WA WARRENDALE INT/RMP K RD
 WARRENDALE BAYNE RD
 (SR4052 SEG 0070/0415)
 (SR4052 SEG 0071/0412)
 WARRENDALE BAYNE RD
 (SR4052 SEG 0071/0412)
 (SR4052 SEG 0070/0415)

INTER-BK BRUSH CREEK RD
 (T476)
 0250/0000 LENGTH(AH 1835 BK 1619)

WARRENDALE BAYNE RD
 (SR4052 SEG 0071/1285)
 (SR4052 SEG 0070/1285)

0010/1619

000000 FT

000000 FT 1 0 01021 2 05 0000+00
 NC WA WARRENDALE INT/RMP J RD
 INTER-BK INTERSTATE 79 NB
 (SR0079 SEG 0750/2282)
 MFC BEGIN = F

0010/0000 LENGTH(AH 1619 BK 0000)

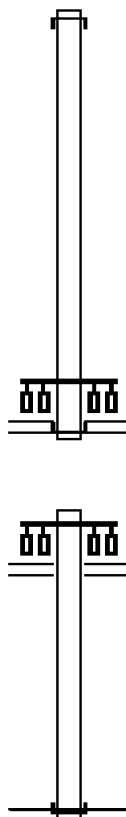

DIR: E TOTAL LEN: .586 MI. DIST: 11-1 SR: 8024
 LEFT MUN: NORTH FAYETTE T RIGHT MUN: NORTH FAYETTE T

003095 FT



003095 FT
 INTER-AHD SR 0022E SH
 0750/0508 (SR0022 SEG 0010/1715)
 002587 FT 1 0 00257 2 02 0000+00
 NC MC DONALD INT/RAMP C RD
 INTER-BK STEUBENVILLE PK
 (SR3121 SEG 0010/0531)
 0750/0000 LENGTH(AH 0508 BK 1101)

002587 FT

INTER-AHD WILLIAM PENN HW SR22W
 0260/1101 (SR0022 SEG 0261/2975)

001486 FT

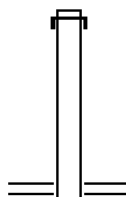

001486 FT 1 0 00257 2 01 0000+00
 NC MC DONALD INT/RAMP A RD
 POTATO GARDEN RUN RD
 (SR3071 SEG 0010/0465)
 0260/0000 LENGTH(AH 1101 BK 0907)

0250/0907 POTATO GARDEN RUN RD/98
 (SR3071 SEG 0010/0445)

000579 FT

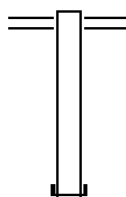

000579 FT 1 0 00257 2 00 0000+00
 NC MC DONALD INT/RAMP B RD
 INTER-BK SR 22 SH
 (SR0022 SEG 0011/0255)
 0250/0000 LENGTH(AH 0907 BK 0579)

000000 FT

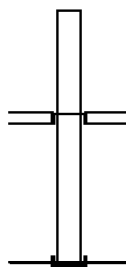

INTER-AHD STEUBENVILLE PK
 (SR3121 SEG 0010/0000)
 POTATO GARDEN RUN RD
 (SR3071 SEG 0010/0000)
 ROBINSON HW
 (SR0980 SEG 0010/0613)
 0010/0579
 000000 FT 1 0 00257 2 03 0000+00
 NC MC DONALD INT/RAMP D RD
 INTER-BK SR 0022 SH
 (SR0022 SEG 0010/0000)
 MFC BEGIN = F
 0010/0000 LENGTH(AH 0579 BK 0000)

EXTRACT DATE: 12/21/2020 ROADWAY MANAGEMENT SYSTEM PAGE NUMBER: 1511
 PRINT DATE: 12/23/2020 SLD COUNTY/SR - ANNUAL PRINT COUNTY: ALLEGHENY
 DIR: N TOTAL LEN: 1.001 MI. DIST: 11-1 SR: 8023
 LEFT MUN: FRANKLIN PARK B RIGHT MUN: FRANKLIN PARK B

005286 FT

004456 FT

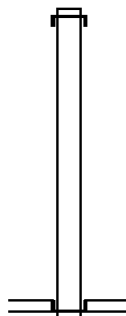

005286 FT
 INTER-AHD INTERSTATE 79 NB
 0750/0830 (SR0079 SEG 0730/2517)
 004456 FT 1 0 01021 2 03 0000+00
 NC BA WEXFORD INT/RP D RD
 BAYNE WEXFORD RD
 (SR4042 SEG 0040/1750)
 (SR4042 SEG 0041/1740)
 WEXFORD BAYNE RD
 (SR0910 SEG 0010/0000)
 (SR0910 SEG 0011/0000)
 INTER-BK RAMP C RD
 (SR8023 SEG 0010/1115)
 0750/0000 LENGTH(AH 0830 BK 2282)

DIR: N TOTAL LEN: 1.001 MI. DIST: 11-1 SR: 8023
 LEFT MUN: MARSHALL T RIGHT MUN: MARSHALL T

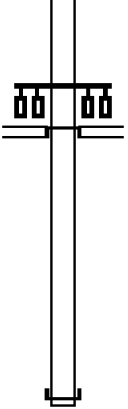
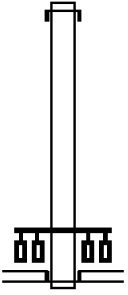
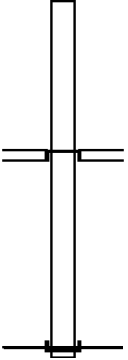
002174 FT		INTER-AHD BAYNE-WEXFORD INT/RP A (SR8023 SEG 0250/0000) BAYNE WEXFORD RD (SR4042 SEG 0040/0921) (SR4042 SEG 0041/0917) 0500/2282
001115 FT		002174 FT 1 0 01021 2 01 0000+00 NC BAYNE-WEXFORD INT/RP B RD INTER-BK INTERSTATE 79 SB (SR0079 SEG 0735/1157) 0500/0000 LENGTH(AH 2282 BK 1059) INTER-AHD INTERSTATE 79 SB 0250/1059 (SR0079 SEG 0731/0481) 001115 FT 1 0 01021 2 00 0000+00 NC BAYNE-WEXFORD INT/RP A RD BAYNE WEXFORD RD (SR4042 SEG 0041/0917) (SR4042 SEG 0040/0921) INTER-BK RAMP B RD (SR8023 SEG 0500/2282) 0250/0000 LENGTH(AH 1059 BK 1115)
000000 FT		INTER-AHD RAMP D RD (SR8023 SEG 0750/0000) BAYNE WEXFORD RD (SR4042 SEG 0041/1740) (SR4042 SEG 0040/1750) WEXFORD BAYNE RD (SR0910 SEG 0011/0000) (SR0910 SEG 0010/0000) 0010/1115 000000 FT 1 0 01021 2 02 0000+00 NC BAYNE-WEXFORD INT/RP C RD INTER-BK INTERSTATE 79 NB (SR0079 SEG 0730/0575) MFC BEGIN = F 0010/0000 LENGTH(AH 1115 BK 0000)

DIR: E TOTAL LEN: .429 MI. DIST: 11-1 SR: 8022
 LEFT MUN: MONROEVILLE B RIGHT MUN: MONROEVILLE B

002265 FT



002265 FT
 INTER-AHD PENN LINCOLN PY
 0260/0739 (SR0376 SEG 0841/1334)

001526 FT

001526 FT 1 0 00187 2 00 0000+00
 NC MONROEVILLE INT/RAMP L RD
 INTER-BK HAYMAKER RD
 (SR2057 SEG 0010/0855)
 0260/0000 LENGTH(AH 0739 BK 0451)

001075 FT

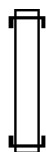

INTER-AHD PENN LINCOLN PY
 0250/0451 (SR0376 SEG 0841/0321)
 001075 FT 1 0 00187 2 07 0000+00
 NC RAMP J MONROEVILLE INT RD
 INTER-BK HAYMAKER RD
 (SR2057 SEG 0011/1080)
 0250/0000 LENGTH(AH 0451 BK 0506)

000569 FT



INTER-AHD HAYMAKER RD
 0020/0506 (SR2057 SEG 0010/0260)
 000569 FT 1 0 00187 2 00 0000+00
 NC RAMP M MONROEVILLE INT RD
 INTER-BK SR 0376 SH
 (SR0376 SEG 0840/1336)
 0020/0000 LENGTH(AH 0506 BK 0569)

000000 FT

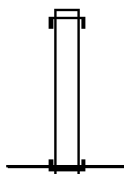

INTER-AHD HAYMAKER RD
 0010/0569 (SR2057 SEG 0011/0405)
 000000 FT 1 0 00187 2 08 0000+00
 NC MONROEVILLE INT/RAMP K RD
 INTER-BK PENN LINCOLN PY
 (SR0376 SEG 0840/0495)
 MFC BEGIN = F
 0010/0000 LENGTH(AH 0569 BK 0000)

EXTRACT DATE: 12/21/2020 ROADWAY MANAGEMENT SYSTEM PAGE NUMBER: 1508
PRINT DATE: 12/23/2020 SLD COUNTY/SR - ANNUAL PRINT COUNTY: ALLEGHENY

DIR: E TOTAL LEN: .580 MI. DIST: 11-1 SR: 8021
LEFT MUN: SEWICKLEY HILLS B RIGHT MUN: SEWICKLEY HILLS B

003060 FT

003060 FT

DIR: E TOTAL LEN: .580 MI. DIST: 11-1 SR: 8021
 LEFT MUN: SEWICKLEY HILLS B RIGHT MUN: SEWICKLEY HILLS B

002517 FT

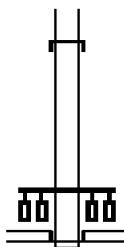

INTER-AHD INTERSTATE 79 NB
 0750/0543 (SR0079 SEG 0680/2302)
 002517 FT 1 0 01016 2 02 0000+00
 NC MT NEBO INT/RAMP D RD
 MT NEBO RD
 (SR4022 SEG 0030/0105)

INTER-BK RAMP B RD
 (SR8021 SEG 0010/0956)
 0750/0000 LENGTH(AH 0543 BK 0934)

001583 FT

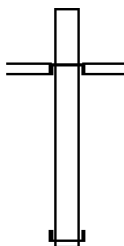

INTER-AHD RAMP A RD
 (SR8021 SEG 0250/0000)
 0500/0934 MT NEBO RD
 (SR4022 SEG 0010/0450)

001583 FT 1 0 01016 2 61 0000+00
 NC MT NEBO INT/RAMP C RD
 INTER-BK INTERSTATE 79 SB
 (SR0079 SEG 0681/2387)
 0500/0000 LENGTH(AH 0934 BK 0627)

000956 FT

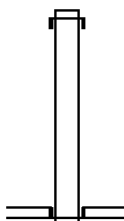

INTER-AHD RAYMOND P SHAFER HW
 0250/0627 (SR0079 SEG 0681/0784)
 000956 FT 1 0 01016 2 59 0000+00
 NC MT NEBO INT/RAMP A RD
 MT NEBO RD
 (SR4022 SEG 0010/0450)

INTER-BK RAMP C RD
 (SR8021 SEG 0500/0934)
 0250/0000 LENGTH(AH 0627 BK 0956)

000000 FT

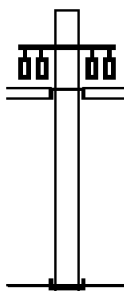

INTER-AHD RAMP D RD
 (SR8021 SEG 0750/0000)
 0010/0956 MT NEBO RD
 (SR4022 SEG 0030/0105)

000000 FT 1 0 01016 2 60 0000+00
 NC MT NEBO INT/RAMP B RD
 INTER-BK INTERSTATE 79 NB
 (SR0079 SEG 0680/0809)
 MFC BEGIN = F
 0010/0000 LENGTH(AH 0956 BK 0000)

EXTRACT DATE: 12/21/2020 ROADWAY MANAGEMENT SYSTEM PAGE NUMBER: 1506
PRINT DATE: 12/23/2020 SLD COUNTY/SR - ANNUAL PRINT COUNTY: ALLEGHENY
DIR: W TOTAL LEN: .893 MI. DIST: 11-1 SR: 8020
LEFT MUN: WILKINS T RIGHT MUN: WILKINS T

004713 FT

004713 FT
INTER-AHD RODI RD

DIR: W TOTAL LEN: .893 MI. DIST: 11-1 SR: 8020
 LEFT MUN: WILKINS T RIGHT MUN: WILKINS T

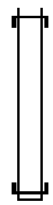
003584 FT  0760/1129 (SR0791 SEG 0020/0635)
 003584 FT 1 0 00187 2 04 0000+00
 NC PENN HILLS INT/RAMP E RD
 INTER-BK PENN LINCOLN PY
 (SR0376 SEG 0804/0575)
 0760/0000 LENGTH(AH 1129 BK 1483)

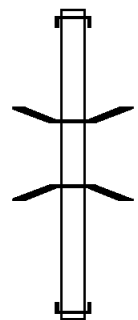
002101 FT  INTER-AHD PENN LINCOLN PY
 0750/1483 (SR0376 SEG 0804/1056)
 0750/0159 BMS EN 02/8020/0750/0112
 1 0 00187 2 05 0000+00
 SR 0791 NB
 0750/0112 BMS BG 02/8020/0750/0112
 002101 FT 1 0 00187 2 05 0000+00
 NC PENN HILLS INT/RAMP D RD
 INTER-BK RODI RD
 (SR0791 SEG 0021/0580)
 0750/0000 LENGTH(AH 1483 BK 0817)

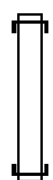
001284 FT  INTER-AHD RODI RD
 0500/0817 (SR0791 SEG 0020/1305)
 001284 FT 1 0 00187 2 06 0000+00
 NC PENN HILLS INT/RAMP F RD
 INTER-BK PENN LINCOLN PY
 (SR0376 SEG 0805/0507)
 0500/0000 LENGTH(AH 0817 BK 1284)

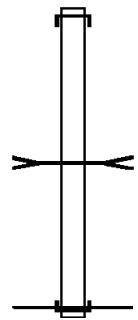
000000 FT  INTER-AHD PENN LINCOLN PY
 0250/1284 (SR0376 SEG 0801/1889)
 BR. CHALFONT
 STRUCTURE LENGTH 10 FT
 0250/0050 BMS ID 02/8020/0250/0050
 000000 FT 1 0 00187 2 03 0000+00
 NC PENN HILLS INT/RAMP C RD
 INTER-BK RODI RD
 (SR0791 SEG 0021/1595)
 MFC BEGIN = F
 0250/0000 LENGTH(AH 1284 BK 0000)

LC FROM GLENFIELD RD
(CONN)

002410 FT

0750/0136

001142 FT

000000 FT

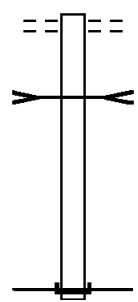
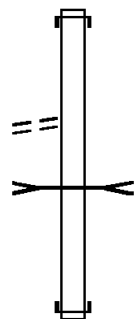

002410 FT
 INTER-AHD INTERSTATE 79 NB
 0750/1268 (SR0079 SEG 0664/0511)

0750/0066 KILBUCK RUN
 001142 FT STRUCTURE LENGTH 22 FT
 1 0 01016 2 62 0000+00
 NC GL ENFIELD INT/RAMP D RD
 INTER-BK GLENFIELD RD
 (CNTY)
 0750/0000 LENGTH(AH 1268 BK 1142)

0500/1142 GLENFIELD RD
 (CNTY)
 KILBUCK RUN
 0500/1031 STRUCTURE LENGTH 22 FT
 BMSID 02/8019/0500/1002

000000 FT 1 0 01016 2 63 0000+00
 NC GL ENFIELD INT/RAMP C RD
 INTER-BK RAYMOND P SHAFER HW
 (SR0079 SEG 0665/1147)
 MFC BEGIN = F
 0500/0000 LENGTH(AH 1142 BK 0000)

000833 FT
 000556 FT

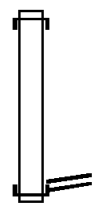

000833 FT
 INTER-AHD PENN LINCOLN PY WB
 0510/0277 (SR0376 SEG 0801/0092)
 000556 FT 1 0 00187 2 00 0000+00
 RAMP AU RD
 (SR8018 SEG 0500/0000)
 NC BU
 INTER-BK BUSINESS 22 INT/RAMP A RD
 WILLIAM PENN HW
 (SR2048 SEG 0011/0000)
 0510/0000 LENGTH(AH 0277 BK 0556)

000000 FT

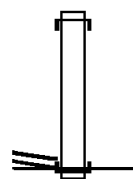

INTER-AHD OLD WILLIAM PENN HW
 0500/0556 (BORO)
 000000 FT 1 0 00187 2 02 0000+00
 NC BU
 INTER-BK BUSINESS 22 INT/RMP AU RD
 WILLIAM PENN HW
 (SR2048 SEG 0011/0000)
 MFC BEGIN = F
 0500/0000 LENGTH(AH 0556 BK 0000)

RAMP A RD
 (SR8018 SEG 0510/0000) 0500/0000

EXTRACT DATE: 12/21/2020 ROADWAY MANAGEMENT SYSTEM PAGE NUMBER: 1502
PRINT DATE: 12/23/2020 SLD COUNTY/SR - ANNUAL PRINT COUNTY: ALLEGHENY
DIR: N TOTAL LEN: 1.779 MI. DIST: 11-1 SR: 8017
LEFT MUN: GLENFIELD B RIGHT MUN: GLENFIELD B

009395 FT

009395 FT

DIR: N TOTAL LEN: 1.779 MI. DIST: 11-1 SR: 8017
 LEFT MUN: GLENFIELD B RIGHT MUN: GLENFIELD B

TO 4033/0010 SH
 (CONN)

0792/1189

008116 FT

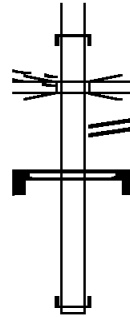

INTER-AHD DEER RUN RD
 0792/1279 (SR4033 SEG 0010/1552)
 RAMP A 8017 SB
 0792/1189 OP ID 02/8017/0762/1310
 RAMP B2 RD
 0792/0690 (SR8017 SEG 0772/0000)
 SIGN: 3 CHORD TRUSS
 0792/0345 BMSID 02/8017/0792/0345
 008116 FT 0 0 00000 0 00 0000+00
 NC GL ENFIELD INT/RAMP B3 RD
 INTER-BK INTERSTATE 79 NB
 (SR0079 SEG 0654/0000)
 0792/0000 LENGTH(AH 1279 BK 0357)

007759 FT

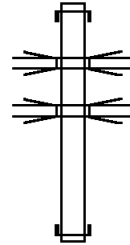

INTER-AHD RAMP A1 RD
 0782/0357 (SR8017 SEG 0762/0318)
 RAMP B2 (SR 8017)
 0782/0118 OP ID 02/8017/0772/1426
 RAMP 8017 SB
 0782/0013 OP ID 02/8017/0260/0403
 007759 FT 0 0 00000 0 00 0000+00
 NC GL ENFIELD INT/RAMP A2 RD
 INTER-BK RAMP S RD
 (SR8017 SEG 0250/0625)
 0782/0000 LENGTH(AH 0357 BK 1675)

RAMP B RD
 (SR8017 SEG 0752/0000) 0772/0970

006084 FT

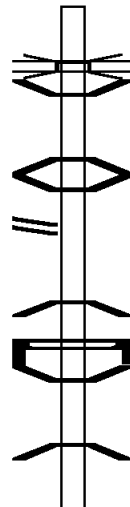

INTER-AHD OHIO RIVER BL
 (SR0065 SEG 0140/2305)
 SR 0079 NB
 0772/1675 OP ID 02/0079/0650/0000
 0772/1568 BMSEN 02/8017/0772/1426
 0 00000 0 0 0000+00
 RAMP A2 8017 NB
 0772/1534 BMSBG 02/8017/0772/1426
 0772/1364 BMSEN 02/8017/0772/0910
 0 00000 0 0 0000+00
 SR 4033
 0772/0944 BMSBG 02/8017/0772/0910
 SIGN: 3 CHORD TRUSS
 0772/0867 BMSID 02/8017/0772/0835
 0772/0390 BMSEN 02/8017/0772/0143
 0 00000 0 0 0000+00
 SR 4033
 0772/0143 BMSBG 02/8017/0772/0143
 006084 FT 0 0 00000 0 00 0000+00
 NC GL ENFIELD INT/RAMP B2 RD

DIR: N TOTAL LEN: 1.779 MI.
LEFT MUN: GLENFIELD B

DIST: 11-1 SR: 8017
RIGHT MUN: GLENFIELD B



INTER-BK RAMP B3 RD
(SR8017 SEG 0792/0690)
0772/0000 LENGTH(AH 1675 BK 2221)

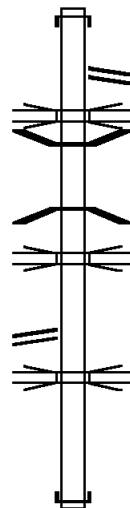

INTER-AHD INTERSTATE 79 SB
0762/2221 (SR0079 SEG 0655/0571)
RAMP A3 RD
0762/1830 (SR8017 SEG 0500/0341)
SR 0079 NB
0762/1599 OP ID 02/0079/0654/1019
0762/1468 BMS EN 02/8017/0762/1310
0 00000 0 0 0000+00
RAMP B3 NB
0762/1307 BMSBG 02/8017/0762/1310
RAMP B NB
0762/0975 OP ID 02/8017/0772/0143

RAMP A2 RD
(SR8017 SEG 0782/0357) 0762/0318

003863 FT

RAMP B2 8017 NB
0762/0090 OP ID 02/8017/0772/0910
003863 FT 0 0 00000 0 00 0000+00
NC GL GLENFIELD INT/RAMP A1 RD
INTER-BK OHIO RIVER BL
(SR0065 SEG 0140/1835)
0762/0000 LENGTH(AH 2221 BK 0266)

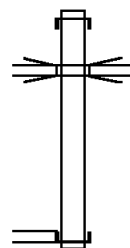

003597 FT

INTER-AHD OHIO RIVER BL
0754/0266 (SR0065 SEG 0141/1470)
RAMP B1 8017 SB
0754/0119 OP ID 02/8017/0752/0000
003597 FT 0 0 00000 0 00 0000+00
NC GL GLENFIELD INT/RAMP R RD
KILBUCK ST
(SR4033 SEG 0010/0000)
INTER-BK RAMP S RD
(SR8017 SEG 0250/1063)
0754/0000 LENGTH(AH 0266 BK 1013)

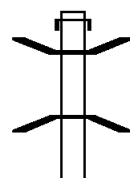

002584 FT

INTER-AHD OHIO RIVER BL
0752/1013 (SR0065 SEG 0141/1085)
0752/0656 BMS EN 02/8017/0752/0000
1 0 01016 2 45 0000+00
RAMP R
0752/0171 BMSBG 02/8017/0752/0000
002584 FT 0 0 00000 0 00 0000+00
NC GLENFIELD INT/RAMP B RD

DIR: N TOTAL LEN: 1.779 MI.
 LEFT MUN: GLENFIELD B

DIST: 11-1 SR: 8017
 RIGHT MUN: GLENFIELD B

FROM 4033/0010 SH
 (CONN)

0500/0150
 002243 FT

001063 FT

SR 8017/0790
 (SR8017 SEG 0782/0000) 0250/0625

000000 FT

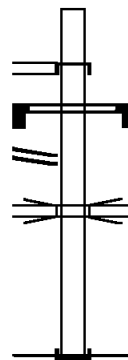
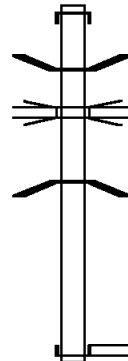

INTER-BK RAMP B2 RD
 (SR8017 SEG 0772/0970)
 0752/0000 LENGTH(AH 1013 BK 0341)

INTER-AHD RAMP A1 RD
 0500/0341 (SR8017 SEG 0762/1830)

002243 FT 1 0 01016 2 45 0000+00
 NC GL ENFIELD INT/RAMP A3 RD
 INTER-BK DEER RUN RD
 (SR4033 SEG 0010/1935)
 0500/0000 LENGTH(AH 0341 BK 1180)

INTER-AHD OHIO RIVER BL
 0260/1180 (SR0065 SEG 0150/0545)
 0260/0551 BMS EN 02/8017/0260/0403
 SR 0079 NB
 0260/0488 OP ID 02/0079/0650/0000
 1 0 01016 2 58 0004+07
 RAMP A2 8017 NB
 0260/0403 BMS BG 02/8017/0260/0403
 001063 FT 1 0 01016 2 54 0000+00
 NC GL ENFIELD INT/RAMP 4 RD
 KILBUCK ST
 (SR4033 SEG 0010/0000)
 INTER-BK CENTER AV
 (SR4033 SEG 0010/0000)
 0260/0000 LENGTH(AH 1180 BK 1063)

INTER-AHD RAMP R RD
 (SR8017 SEG 0754/0000)
 KILBUCK ST
 0250/1063 (SR4033 SEG 0010/0000)
 SIGN: 2 CHORD TRUSS
 0250/0975 BMS ID 02/8017/0250/0975

SR 0079 NB
 0250/0555 OP ID 02/0079/0650/0000
 000000 FT 1 0 01016 2 44 0000+00
 NC GL ENFIELD INT/RAMP S RD
 INTER-BK OHIO RIVER BL
 (SR0065 SEG 0151/0180)
 MFC BEGIN = F
 0250/0000 LENGTH(AH 1063 BK 0000)

000763 FT

000451 FT

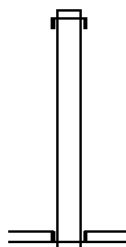

000763 FT
 INTER-AHD PENN LINCOLN PY
 0750/0312 (SR0376 SEG 0794/0504)
 000451 FT 1 0 00763 2 32 0000+00
 NC CHURCHILL INT/RAMP B RD
 CHURCHILL RD
 (SR2104 SEG 0010/1143)
 CHURCHILL RD
 (CNTY)
 INTER-BK HOLLAND RD
 (BORO)
 0750/0000 LENGTH(AH 0312 BK 0451)

000000 FT

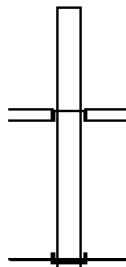

INTER-AHD HOLLAND RD
 (BORO)
 CHURCHILL RD
 (CNTY)
 CHURCHILL RD
 0010/0451 (SR2104 SEG 0010/1143)
 000000 FT 1 0 00763 2 31 0000+00
 NC CHURCHILL INT/RAMP A RD
 INTER-BK PENN LINCOLN PY
 (SR0376 SEG 0790/2506)
 MFC BEGIN = F
 0010/0000 LENGTH(AH 0451 BK 0000)

EXTRACT DATE: 12/21/2020 ROADWAY MANAGEMENT SYSTEM PAGE NUMBER: 1497
 PRINT DATE: 12/23/2020 SLD COUNTY/SR - ANNUAL PRINT COUNTY: ALLEGHENY
 DIR: E TOTAL LEN: 1.005 MI. DIST: 11-1 SR: 8015
 LEFT MUN: NEVILLE T RIGHT MUN: NEVILLE T

LC TO GRAND AV
 (CONN)

005308 FT

0500/0825

004319 FT

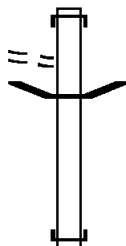

005308 FT
 INTER-AHD GRAND AV
 0500/0989 (CNTY)

0500/0606 BMSN 02/8015/0500/0000

004319 FT 1 0 01016 2 39 0002+14
 NC NEVILLE ISLAND INT/RP J RD
 INTER-BK INTERSTATE 79 SB
 (SR0079 SEG 0651/2399)
 GRAND AVENUE

DIR: E TOTAL LEN: 1.005 MI. DIST: 11-1 SR: 8015
 LEFT MUN: NEVILLE T RIGHT MUN: NEVILLE T

LC FROM GRAND AV
 (CONN)

0250/0295
 003097 FT

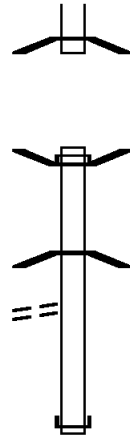

0500/0000 BMSBG 02/8015/0500/0000
 LENGTH(AH 0989 BK 1222)

INTER-AHD BMSEN 02/8015/0250/0587
 0250/1222 INTERSTATE 79 SB
 (SR0079 SEG 0651/1854)

0250/0587 0 0 00000 0 00 0000+00
 PITTSBURGH, CHARTIER RR
 BMSBG 02/8015/0250/0587

003097 FT 1 0 01016 2 38 0000+00
 NC NEVILLE ISLAND INT/RP H RD
 INTER-BK GRAND AV
 (CNTY)

0250/0000 LENGTH(AH 1222 BK 1131)

LC FROM GRAND AV
 (CONN)

0020/0160
 001966 FT

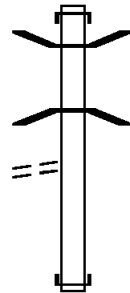

INTER-AHD INTERSTATE 79 NB
 0020/1131 (SR0079 SEG 0650/1805)
 0020/1112 BMSEN 02/8015/0020/0580

0020/0613 0 0 00000 0 00 0000+00
 OHIO RIVER
 BMSBG 02/8015/0020/0580

001966 FT 1 0 01016 2 37 0000+00
 NC NEVILLE ISLAND INT/RP E RD
 INTER-BK GRAND AV
 (CNTY)

0020/0000 LENGTH(AH 1131 BK 1966)

000000 FT

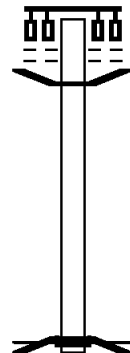

GRAND AV
 (CNTY)
 0010/1966
 0010/1370 BMSEN 02/8015/0010/0000

000000 FT 1 0 01016 2 36 0000+00
 NC NEVILLE ISLAND INT/RP D RD
 INTER-BK INTERSTATE 79 NB
 (SR0079 SEG 0650/0516)

OHIO RIVER
 BMSBG 02/8015/0010/0000
 MFC BEGIN = F
 0010/0000 LENGTH(AH 1966 BK 0000)

001448 FT

000682 FT

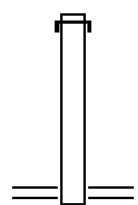

001448 FT
 INTER-AHD PENN LINCOLN PY
 0500/0766 (SR0376 SEG 0785/2328)
 000682 FT 1 0 00763 2 34 0001+35
 NC GREENSBURG PK INT/RP S RD
 WILLIAM PENN HW
 (SR2110 SEG 0031/0900)
 (SR2110 SEG 0030/0885)
 0500/0000 LENGTH(AH 0766 BK 0682)

000000 FT

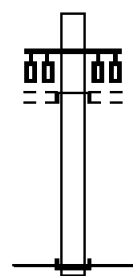

INTER-AHD MARBURY RD
 (BORO)
 GREENSBURG PK (3139-01)
 (CNTY)
 0010/0682
 000000 FT 1 0 00763 2 33 0000+00
 NC GREENSBURG PK INT/RP R RD
 INTER-BK PENN LINCOLN PY
 (SR0376 SEG 0784/1328)
 MFC BEGIN = F
 0010/0000 LENGTH(AH 0682 BK 0000)

FROM 0051/0630 SH
 (CONN)

003097 FT

003097 FT
 INTER-AHD INTERSTATE 79 SB
 0250/1462 (SR0079 SEG 0645/0025)

0250/0190
 001635 FT

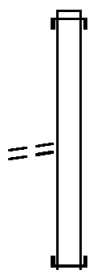

001635 FT 0 0 00000 0 00 0000+00
 NC GROVETON INT/RAMP F RD
 INTER-BK CORAOPOLIS BL
 (SR0051 SEG 0631/1855)
 0250/0000 LENGTH(AH 1462 BK 0645)

000990 FT

INTER-AHD INTERSTATE 79 NB
 0020/0645 (SR0079 SEG 0644/0472)
 MOON RUN CK
 STRUCTURE LENGTH 30 FT
 0020/0185 BMSID 02/8013/0010/0752
 000990 FT 1 0 01016 2 33 0000+00
 NC GROVETON INT/RAMP B RD
 CORAOPOLIS BL
 (SR0051 SEG 0630/0970)
 (SR0051 SEG 0631/0930)
 0020/0000 LENGTH(AH 0645 BK 0990)

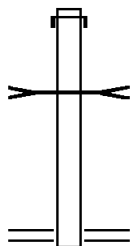

000000 FT

CORAOPOLIS BL
 (SR0051 SEG 0630/0970)
 (SR0051 SEG 0631/0930)
 TO 0051/0631 SH
 (CONN)
 MOON RUN CK
 STRUCTURE LENGTH 30 FT
 0010/0990 BMSID 02/8013/0010/0752
 0010/0950
 0010/0701
 000000 FT 1 0 01016 2 32 0000+00
 NC GROVETON INT/RAMP A RD
 INTER-BK INTERSTATE 79 NB
 (SR0079 SEG 0640/2281)
 MFC BEGIN = F
 0010/0000 LENGTH(AH 0990 BK 0000)

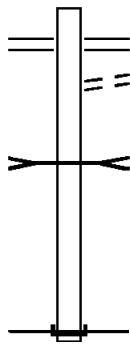

011108 FT
 RAMP G RD
 (SR8012 SEG 0500/1956) 0760/0477

010389 FT

RAMP A RD TO SR376W22&3
 (SR8012 SEG 0250/0000) 0750/1860

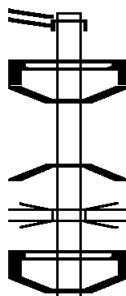
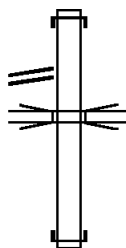

011108 FT
 INTER-AHD ARDMORE BL SR30W TO SRB
 0760/0719 (SR0030 SEG 0171/0255)

RAMP A 8012 WB
 0760/0446 OP ID 02/8012/0750/0550
 010389 FT 1 0 00763 2 28 0000+00
 NC ARDMORE BL INT/RAMP F RD
 INTER-BK PENN LINCOLN PY
 (SR0376 SEG 0780/0155)
 0760/0000 LENGTH(AH 0719 BK 1860)

INTER-AHD RAMP Y RD TO SR376E & 2
 0750/1860 (SR8012 SEG 0260/0000)
 SIGN: 4 CHORD TRUSS
 0750/1795 BMSID 02/8012/0750/1795
 0750/1583 BMSSEN 02/8012/0750/1423
 1 0 00763 2 24 0013+26
 SR 0008 NB
 0750/1436 BMSBG 02/8012/0750/1423
 SR 0376 EB
 0750/0991 OP ID 02/0376/0774/2858
 SIGN: 4 CHORD TRUSS
 0750/0710 BMSID 02/8012/0750/0710
 0750/0632 BMSSEN 02/8012/0750/0550

DIR: E TOTAL LEN: 2.104 MI. DIST: 11-1 SR: 8012
 LEFT MUN: WILKINSBURG B RIGHT MUN: WILKINSBURG B

008529 FT

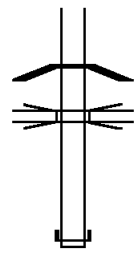

1 0 00763 2 24 0022+91
 RAMP F 8012 NB
 0750/0574 BMSBG 02/8012/0750/0550
 RAMP 8012 EB
 0750/0429 OP ID 02/8012/0280/2164
 008529 FT 1 0 00763 2 24 0000+00
 NC ARDMORE BL INT/RAMP A RD
 INTER-BK LINCOLN HW
 (SR0030 SEG 0181/0405)
 0750/0000 LENGTH(AH 1860 BK 1956)

006573 FT

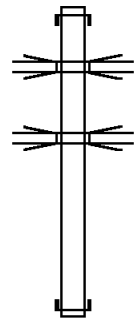

INTER-AHD RAMP F RD TO SR30W TO B
 0500/1956 (SR8012 SEG 0760/0477)
 RAMP A 8012 WB
 0500/1888 OP ID 02/8012/0750/0550
 SR 0376 EB
 0500/1066 OP ID 02/0376/0780/0641
 006573 FT 1 0 00763 2 29 0000+00
 NC ARDMORE BL INT/RAMP G RD
 INTER-BK PENN LINCOLN PY
 (SR0376 SEG 0781/1778)
 0500/0000 LENGTH(AH 1956 BK 3298)

003275 FT

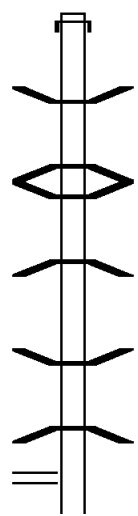

INTER-AHD PENN LINCOLN PY & 22 E
 0280/3298 (SR0376 SEG 0780/0939)
 0280/2217 BMSEN 02/8012/0280/2164
 0 0 00000 0 00 0000+00
 RAMP A 8012 WB
 0280/2164 BMSBG 02/8012/0280/2164
 0280/2006 BMSEN 02/8012/0280/1906
 0 0 00000 0 00 0000+00
 RT 0030 EB
 0280/1868 BMSBG 02/8012/0280/1906
 0280/0632 BMSEN 02/8012/0280/0516
 0 0 00000 0 00 0000+00
 SR 0376 EB
 0280/0516 BMSBG 02/8012/0280/0516
 RAMP Y RD
 0280/0340 (SR8012 SEG 0260/0597)
 003275 FT 1 0 00763 2 27 0000+00

DIR: E TOTAL LEN: 2.104 MI. DIST: 11-1 SR: 8012
 LEFT MUN: WILKINSBURG B RIGHT MUN: WILKINSBURG B

RAMP D RD TO SR376E & 22
 (SR8012 SEG 0280/0000) 0270/0645

001661 FT

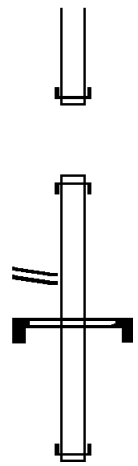

NC ARDMORE BL INT/RAMP D RD
 INTER-BK RAMP C RD
 (SR8012 SEG 0270/0645)
 0280/0000 LENGTH(AH 3298 BK 1614)
 INTER-AHD I-376W & PA 22/30W
 0270/1614 (SR0376 SEG 0775/0875)

ARDMORE BL INT/RAMP A R
 (SR8012 SEG 0250/0000) 0260/0000

001064 FT

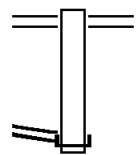

RAMP D RD TO SR376E & 2
 (SR8012 SEG 0280/0340)
 0260/0597
 001064 FT 1 0 00763 2 30 0007+00
 NC ARDMORE BL INT/RAMP Y RD
 INTER-BK RAMP A RD
 (SR8012 SEG 0750/1860)
 0260/0000 LENGTH(AH 0597 BK 0461)

000603 FT

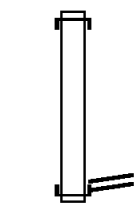

INTER-AHD I 376W & US22/30W
 0250/0461 (SR0376 SEG 0775/1704)
 000603 FT 0 0 00000 0 00 0000+00
 RAMP Y RD
 (SR8012 SEG 0260/0000)
 NC ARDMORE BL INT/RAMP A2 RD
 INTER-BK RAMP A RD
 (SR8012 SEG 0750/1860)
 0250/0000 LENGTH(AH 0461 BK 0603)

000000 FT

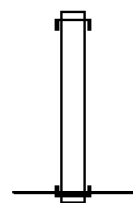

INTER-AHD ARDMORE BL SR30E
 0010/0603 (SR0030 SEG 0170/0460)
 000000 FT 1 0 00763 2 25 0000+00
 NC ARDMORE BL INT/RAMP B RD
 INTER-BK PENN LINCOLN PY
 (SR0376 SEG 0774/2171)
 MFC BEGIN = F
 0010/0000 LENGTH(AH 0603 BK 0000)

EXTRACT DATE: 12/21/2020 ROADWAY MANAGEMENT SYSTEM PAGE NUMBER: 1490
 PRINT DATE: 12/23/2020 SLD COUNTY/SR - ANNUAL PRINT COUNTY: ALLEGHENY
 DIR: E TOTAL LEN: 1.527 MI. DIST: 11-1 SR: 8011
 LEFT MUN: ROBINSON T RIGHT MUN: ROBINSON T

FROM 0060/0151 SH
 (CONN)

008063 FT

0750/0163
 007215 FT

005578 FT

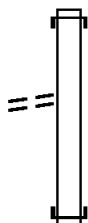





008063 FT
 INTER-AHD INTERSTATE 79 NB
 0750/0848 (SR0079 SEG 0600/1234)

007215 FT 1 0 01016 2 27 0000+00
 NC MOON RUN INT/RAMP B RD
 INTER-BK STEUBENVILLE PK
 (SR0060 SEG 0150/1620)
 0750/0000 LENGTH(AH 0848 BK 1637)

INTER-AHD STEUBENVILLE PK
 0510/1637 (SR0060 SEG 0150/2858)

005578 FT 1 0 01016 2 29 0000+00
 NC MOON RUN INT/RAMP D RD
 INTER-BK INTERSTATE 79 SB
 (SR0079 SEG 0601/1864)

DIR: E TOTAL LEN: 1.527 MI. DIST: 11-1 SR: 8011
 LEFT MUN: KENNEDY T RIGHT MUN: KENNEDY T

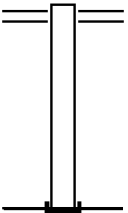
		<p>0510/0000 LENGTH(AH 1637 BK 1194)</p> <p>INTER-AHD INTERSTATE 79 SB 0500/1194 (SR0079 SEG 0601/1091)</p>
004384 FT		<p>004384 FT 1 0 01016 2 28 0000+00 NC MOON RUN INT/RAMP C RD INTER-BK STEUBENVILLE PK (SR0060 SEG 0150/2285)</p> <p>0500/0000 LENGTH(AH 1194 BK 1424)</p> <p>INTER-AHD STEUBENVILLE PK 0260/1424 (SR0060 SEG 0151/2366)</p>
002960 FT		<p>002960 FT 1 0 01016 2 30 0000+00 NC MOON RUN INT/RAMP E RD INTER-BK INTERSTATE 79 SB (SR0079 SEG 0595/2441)</p> <p>0260/0000 LENGTH(AH 1424 BK 1892)</p> <p>INTER-AHD INTERSTATE 79 SB 0250/1892 (SR0079 SEG 0595/1535)</p>
001068 FT		<p>001068 FT 1 0 01016 2 31 0000+00 NC MOON RUN INT/RAMP F RD INTER-BK STEUBENVILLE PK (SR0060 SEG 0151/3071)</p> <p>0250/0000 LENGTH(AH 1892 BK 1068)</p> <p>STEUBENVILLE PK 0010/1068 (SR0060 SEG 0151/1620)</p>
000000 FT		<p>000000 FT 1 0 01016 2 26 0000+00 NC MOON RUN INT/RAMP A RD INTER-BK INTERSTATE 79 NB (SR0079 SEG 0594/1959) MFC BEGIN = F</p> <p>0010/0000 LENGTH(AH 1068 BK 0000)</p>

EXTRACT DATE: 12/21/2020 ROADWAY MANAGEMENT SYSTEM PAGE NUMBER: 1488
 PRINT DATE: 12/23/2020 SLD COUNTY/SR - ANNUAL PRINT COUNTY: ALLEGHENY
 DIR: E TOTAL LEN: 1.549 MI. DIST: 11-1 SR: 8010
 LEFT MUN: EDGEWOOD B RIGHT MUN: EDGEWOOD B

008177 FT
 007769 FT

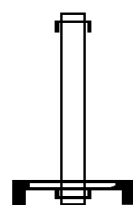

008177 FT
 INTER-AHD PENN LINCOLN PY
 0750/0408 (SR0376 SEG 0764/1050)
 007769 FT 1 0 00763 2 20 0000+00
 SIGN: CANTILEVER
 BMSID 02/8010/0750/0000
 NC BR BRADDOCK AV INT/RAMP G RD
 INTER-BK BRADDOCK AV
 (BORO)
 0750/0000 LENGTH(AH 0408 BK 1527)

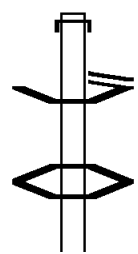

INTER-AHD PENN LINCOLN PY
 0540/1527 (SR0376 SEG 0761/2407)
 RAMP F RD
 0540/1380 (SR8010 SEG 0250/0936)
 0540/1268 BMSSEN 02/0376/0764/0000
 1 0 00763 2 18 0003+31
 RAMP B 8010 EB
 0540/1094 BMSBG 02/0376/0764/0000
 0540/0793 BMSSEN 02/8010/0540/0520
 1 0 00763 2 18 0003+31
 BRADDOCK AVE LOCAL

EXTRACT DATE: 12/21/2020
PRINT DATE: 12/23/2020

ROADWAY MANAGEMENT SYSTEM
SLD COUNTY/SR - ANNUAL PRINT

PAGE NUMBER: 1487
COUNTY: ALLEGHENY

DIR: E TOTAL LEN: 1.549 MI.
LEFT MUN: SWISSVALE B

DIST: 11-1 SR: 8010
RIGHT MUN: SWISSVALE B

LC FROM SWISSVALE AV
(CONN)

0540/0435
006242 FT

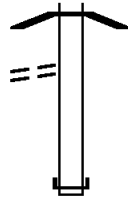

0540/0586 BMSBG 02/8010/0540/0520

006242 FT 1 0 00763 2 16 0000+00
NC BRADDOCK AV INT/RAMP E RD
INTER-BK BRADDOCK AV
(BORO)

5 0540/0000 LENGTH(AH 1527 BK 1096)

005146 FT

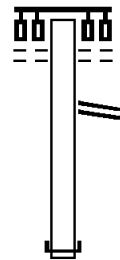

BRADDOCK AV
(BORO)
0520/1096
RAMP D RD
0520/0811 (SR8010 SEG 0510/0254)

005146 FT 1 0 00763 2 21 0000+00
NC BRADDOCK AV INT/RAMP H RD
INTER-BK PENN LINCOLN PY
(SR0376 SEG 0765/1693)

5 0520/0000 LENGTH(AH 1096 BK 0254)

004892 FT

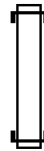

INTER-AHD RAMP H RD
0510/0254 (SR8010 SEG 0520/0811)
004892 FT 0 0 00000 0 00 0000+00
NC BRADDOCK AV INT/RAMP D RD
INTER-BK W SWISSVALE AV
(BORO)

5 0510/0000 LENGTH(AH 0254 BK 0623)

004269 FT

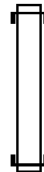

INTER-AHD GREENDALE AV
0500/0623 (BORO)
004269 FT 1 0 00763 2 18 0000+00
NC BRADDOCK AV INT/RAMP C RD
INTER-BK RAMP B RD
(SR8010 SEG 0020/1716)

5 0500/0000 LENGTH(AH 0623 BK 0936)

BRADDOCK AV INT/RAMP E
(SR8010 SEG 0540/1380) 0250/0936

003333 FT

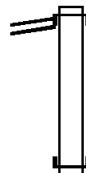

INTER-AHD PENN LINCOLN PY
0250/0936 (SR0376 SEG 0761/2385)

003333 FT 1 0 00763 2 19 0000+00
NC BRADDOCK AV INT/RAMP F RD
INTER-BK BRADDOCK AV
(BORO)

EXTRACT DATE: 12/21/2020
PRINT DATE: 12/23/2020

ROADWAY MANAGEMENT SYSTEM
SLD COUNTY/SR - ANNUAL PRINT

PAGE NUMBER: 1486
COUNTY: ALLEGHENY

DIR: E TOTAL LEN: 1.549 MI.
LEFT MUN: SWISSVALE B

DIST: 11-1 SR: 8010
RIGHT MUN: SWISSVALE B



0250/0000 LENGTH(AH 0936 BK 0220)

003113 FT

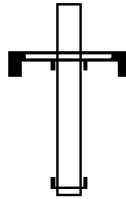

SIGN: CANTILEVER
BMSID 02/8010/0030/0400
INTER-AHD PENN LINCOLN PY
0030/0220 (SR0376 SEG 0764/0260)
003113 FT 1 0 00763 2 23 0000+00
NC BRADDOCK AV INT/RAMP X RD
INTER-BK MONONGAHELA AV
(BORO)

0030/0000 LENGTH(AH 0220 BK 1949)

001164 FT

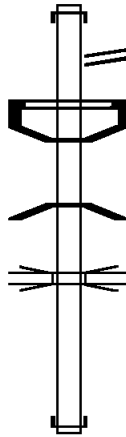

INTER-AHD BRADDOCK AV
0020/1949 (BORO)
RAMP C RD
0020/1716 (SR8010 SEG 0500/0000)
SIGN: 4 CHORD TRUSS
0020/1705 BMSID 02/8010/0020/1705
0020/1620 BMSEN 02/8010/0020/1507
1 0 00763 2 15 0015+88
BRADDOCK AVE LOCAL
0020/1507 BMSBG 02/8010/0020/1507

SR 0376 EB
0020/0800 OP ID 02/0376/0764/0000

001164 FT 1 0 00763 2 14 0004+50
NC BRADDOCK AV INT/RAMP B RD
INTER-BK RAMP A RD
(SR8010 SEG 0010/0250)

0020/0000 LENGTH(AH 1949 BK 1164)

RAMP B RD
(SR8010 SEG 0020/0000) 0010/0250

000000 FT

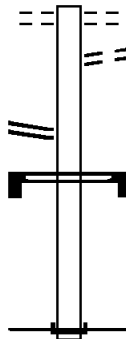

MONONGAHELA AV
0010/1164 (BORO)
LC TO MON AV
0010/1086 (CONN)

SIGN: CANTILEVER
BMSID 02/8010/0010/0171
000000 FT 1 0 00763 2 14 0000+00
NC BRADDOCK AV INT/RAMP A RD
INTER-BK PENN LINCOLN PY
(SR0376 SEG 0760/1791)
MFC BEGIN = F

0010/0000 LENGTH(AH 1164 BK 0000)

DIR: N TOTAL LEN: 3.338 MI. DIST: 11-1 SR: 8009
 LEFT MUN: ROBINSON T RIGHT MUN: ROBINSON T

017627 FT

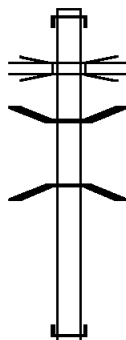

017627 FT
 INTER-AHD INTERSTATE 79 NB
 0770/2177 (SR0079 SEG 0580/2109)
 RAMP G 8009 376 EB
 0770/1645 OP ID 02/8009/0260/0293
 0770/0943 BMS EN 02/8009/0770/0820
 0 0 00000 0 00 0000+00
 BALDWIN RD COUNTY
 0770/0820 BMSBG 02/8009/0770/0820
 015450 FT 1 0 01016 2 25 0000+00
 NC PI TTSBURGH INT/RAMP F RD
 INTER-BK RAMP B RD
 (SR8009 SEG 0760/1315)
 0770/0000 LENGTH(AH 2177 BK 4227)

015450 FT

INTER-AHD INTERSTATE 79 SB
 0760/4227 (SR0079 SEG 0575/0963)

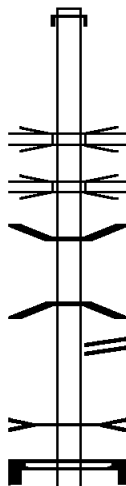

0760/3020 OP ID SR 0079 SB
 SR 0079 NB
 0760/2845 OP ID 02/0079/0575/2110
 0760/2135 BMS EN 02/8009/0760/1868
 0 0 00000 0 00 0000+00
 SR 0376 EB
 0760/1868 BMSBG 02/8009/0760/1868
 RAMP F RD
 0760/1315 (SR8009 SEG 0770/0000)
 BR. CMBLS. RUN
 STRUCTURE LENGTH 14 FT
 0760/1271 BMSID 02/8009/0760/1271
 SIGN: 3 CHORD TRUSS
 0760/1008 BMSID 02/8009/0760/1008

011223 FT

011223 FT 1 0 01016 2 21 0000+00
 NC PI TTSBURGH INT/RAMP B RD
 INTER-BK PENN LINCOLN PY
 (SR0376 SEG 0641/1245)
 0760/0000 LENGTH(AH 4227 BK 1022)

DIR: N TOTAL LEN: 3.338 MI.
 LEFT MUN: ROBINSON T

DIST: 11-1 SR: 8009
 RIGHT MUN: ROBINSON T

010201 FT

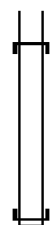

INTER-AHD PENN LCN PY SR376W22/30
 0750/1022 (SR0376 SEG 0635/1213)
 010201 FT 1 0 01016 2 24 0000+00
 NC PI TTTTSBURGH INT/RAMP E RD
 INTER-BK INTERSTATE 79 NB
 (SR0079 SEG 0580/1196)
 0750/0000 LENGTH(AH 1022 BK 1417)

008784 FT

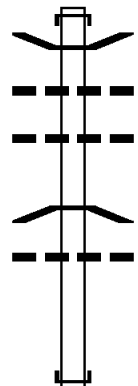

INTER-AHD PENN LCN PY SR376W22/30
 0510/1417 (SR0376 SEG 0631/2401)
 0510/0943 BMSSEN 02/8009/0510/0299
 018 "DIA CIRC PLASTIC
 0510/0461 LEN=0152 INSTALLED UNKN
 018 "DIA CIRC CONCR
 0510/0308 LEN=0025 INSTALLED UNKN
 0 0 00000 0 00 0000+00
 0510/0299 CAMPBELL'S RUN RD LOCAL
 BMSBG 02/8009/0510/0299
 018 "DIA CIRC CONCR
 0510/0120 LEN=0058 INSTALLED UNKN
 008784 FT 0 0 00000 0 00 0000+00
 NC PI TTTTSBURGH INT/RAMP H RD
 INTER-BK INTERSTATE 79 SB
 (SR0079 SEG 0581/2041)
 0510/0000 LENGTH(AH 1417 BK 1230)

007554 FT

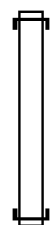

INTER-AHD PENN LCN PY SR376E22/30
 0270/1230 (SR0376 SEG 0634/0638)
 007554 FT 0 0 00000 0 00 0000+00
 NC PI TTTTSBURGH INT/RAMP D RD
 INTER-BK INTERSTATE 79 SB
 (SR0079 SEG 0581/0515)
 0270/0000 LENGTH(AH 1230 BK 3502)

INTER-AHD INTERSTATE 79 NB
 0260/3502 (SR0079 SEG 0584/0954)

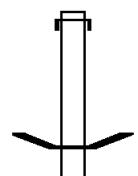

0260/1779 BMSSEN 02/8009/0260/0293
 030 "DIA CIRC METAL

DIR: N TOTAL LEN: 3.338 MI. DIST: 11-1 SR: 8009
 LEFT MUN: ROBINSON T RIGHT MUN: ROBINSON T

0260/1753 LEN=0097 INSTALLED UNKN
 0 0 00000 0 00 0000+00
 SR 0376 WB
 0260/0293 BMSBG 02/8009/0260/0293
 018 "DIA CIRC CONCR
 0260/0242 LEN=0035 INSTALLED UNKN
 018 "DIA CIRC CONCR
 0260/0121 LEN=0067 INSTALLED UNKN
 004052 FT 0 0 00000 0 00 0000+00
 NC PI
 INTER-BK PITTSBURGH INT/RAMP G RD
 (SR8009 SEG 0250/0996)
 0260/0000 LENGTH(AH 3502 BK 2674)

004052 FT

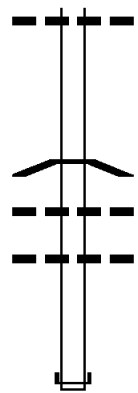

INTER-AHD INTERSTATE 79 SB
 0250/2674 (SR0079 SEG 0575/2305)

0250/1678 018 "DIA CIRC CONCR
 LEN=0059 INSTALLED 2007
 0250/1248 018 "DIA CIRC CONCR
 LEN=0057 INSTALLED 2007

RAMP G RD
 (SR8009 SEG 0260/0000) 0250/0996

001378 FT

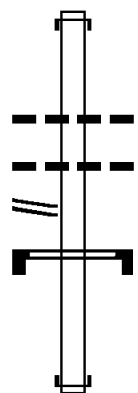

0250/0440 SIGN: 2 CHORD TRUSS
 BMSID 02/8009/0250/0100
 001378 FT 1 0 01016 2 22 0000+00
 NC PI
 INTER-BK PITTSBURGH INT/RAMP C RD
 PENN LCN PY SR376E22/30
 (SR0376 SEG 0630/1646)
 0250/0000 LENGTH(AH 2674 BK 1378)

INTER-AHD PENN LCN PY SR376E22/30
 0010/1378 (SR0376 SEG 0634/2553)
 0010/0985 BMSSEN 02/8009/0010/0693
 1 0 01016 2 20 0007+17
 CAMPBELLS RUN COUNTY
 0010/0720 BMSBG 02/8009/0010/0693

000000 FT

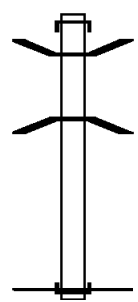

000000 FT 1 0 01016 2 20 0000+00
 NC PI
 INTER-BK PITTSBURGH INT/RAMP A RD
 INTERSTATE 79 NB
 (SR0079 SEG 0574/1956)
 MFC BEGIN = F
 0010/0000 LENGTH(AH 1378 BK 0000)

009754 FT
 LC TO MONITOR ST
 (CONN)
 0800/0083
 009486 FT

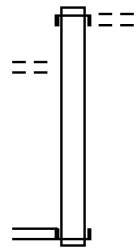

009754 FT
 INTER-AHD MONITOR ST
 (CITY)
 SALINE ST
 (CITY)
 0800/0268
 009486 FT 0 0 00000 0 00 0000+00
 NC FORWARD AV INT/RAMP F RD
 RAMP G RD
 (SR8008 SEG 0770/0195)
 INTER-BK LC FOR BEECHWOOD BL
 (CONN)
 0800/0000 LENGTH(AH 0268 BK 0268)

LC TO MONITOR ST
 (CONN)
 0790/0083
 009218 FT

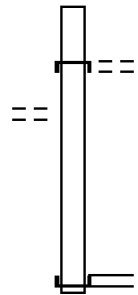

INTER-AHD MONITOR ST
 (CITY)
 SALINE ST
 (CITY)
 0790/0268
 009218 FT 1 0 00763 2 13 0000+00
 NC FORWARD AV INT./RAMP M RD
 RAMP G RD
 (SR8008 SEG 0770/0195)
 INTER-BK LC FROM BEECHWOOD BL
 (CONN)
 0790/0000 LENGTH(AH 0268 BK 2590)

LC FROM BEECHWOOD TO G
 (CONN)
 BEECHWOOD BL
 (CITY)
 0770/2321
 0770/2045

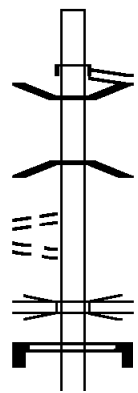

INTER-AHD RAMP A RD
 (SR8008 SEG 0250/0000)
 RAMP C RD
 0770/2590 (SR8008 SEG 0500/1715)
 0770/2442 BMSEN 02/8008/0510/0569
 0 0 00000 0 00 0000+00
 SR 0376 EB
 0770/2349 BMSBG 02/8008/0510/0569
 0770/1701 OP ID RAMP E 8008 EB
 02/8008/0750/0000
 SIGN: 4 CHORD TRUSS
 0770/1448 BMSID 02/8008/0770/1470
 RAMP H RD

EXTRACT DATE: 12/21/2020
PRINT DATE: 12/23/2020

ROADWAY MANAGEMENT SYSTEM
SLD COUNTY/SR - ANNUAL PRINT

PAGE NUMBER: 1481
COUNTY: ALLEGHENY

DIR: E TOTAL LEN: 1.847 MI.
LEFT MUN: PITTSBURGH C

DIST: 11-1 SR: 8008
RIGHT MUN: PITTSBURGH C

LC TO BEECHWOOD BL
(CONN)

0770/0195
006628 FT



0770/1375 (SR8008 SEG 0520/0833)
LR 763 RMP F
0770/1116 OP ID 02/2101/0010/0045
MURRAY AVE
0770/0734 OP ID 02/7301/0000/3066
MONITOR ST
0770/0370 (CITY)
RAMP M RD
(SR8008 SEG 0790/0000)
FORWARD AV INT./RAMP F RD
0770/0195 (SR8008 SEG 0800/0000)
006628 FT 1 0 00763 2 11 0000+00
NC FORWARD AV INT./RAMP G RD
INTER-BK BEECHWOOD BL
(CITY)
5 0770/0000 LENGTH(AH 2590 BK 0730)

(RAMP F) FORWARD AV
(SR2101 SEG 0010/0000)

0750/0598

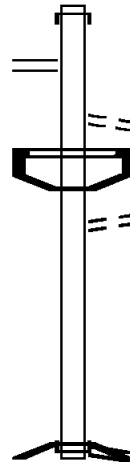

INTER-AHD BEECHWOOD BL
0750/0730 (CITY)
0750/0351 LC FROM GREENFIELD AV
(CONN)
SIGN: CANTILEVER
0750/0215 BMSID 02/8008/0750/0215
0750/0101 BMSSEN 02/8008/0750/0000
LC TO GREENFIELD AV
0750/0041 (CONN)
005898 FT 1 0 00763 2 08 0000+00
NC FORWARD AV INT./RAMP E RD
RAMP D RD
(SR8008 SEG 0510/1259)
INTER-BK PENN LINCOLN PY
(SR0376 SEG 0744/0136)
RAMP 8008 WB
BMSBG 02/8008/0750/0000
5 0750/0000 LENGTH(AH 0730 BK 0833)

1 0 00763 2 12 0000+15 005065 FT
(RAMP F) FORWARD AV
(SR2101 SEG 0010/0764) 0520/0000

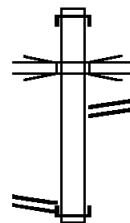

INTER-AHD RAMP G RD
0520/0833 (SR8008 SEG 0770/1375)
SR 0376 EB
0520/0380 OP ID 02/0376/0744/0762
RAMP C RD
0520/0045 (SR8008 SEG 0500/0000)
005065 FT FORWARD AV INT./RAMP H RD
INTER-BK FORWARD AV
(CITY)
5 0520/0000 LENGTH(AH 0833 BK 1259)

003806 FT

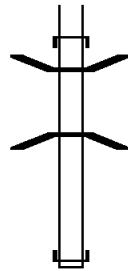

INTER-AHD RAMP E RD
 0510/1259 (SR8008 SEG 0750/0000)
 0510/0662 BMSSEN 02/8008/0510/0569
 1 0 00763 2 04 0022+28
 SR 0376 EB
 0510/0569 BMSBG 02/8008/0510/0569
 003806 FT 1 0 00763 2 07 0000+00
 NC FORWARD AV INT./RAMP D RD
 INTER-BK PENN LINCOLN PY
 (SR0376 SEG 0745/0038)
 5 0510/0000 LENGTH(AH 1259 BK 1715)

RAMP G RD
 (SR8008 SEG 0770/2590) 0500/1715

002091 FT

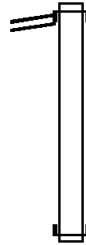

INTER-AHD RAMP A RD
 0500/1715 (SR8008 SEG 0250/0000)
 002091 FT 1 0 00763 2 06 0000+00
 NC FORWARD AV INT./RAMP C RD
 INTER-BK RAMP H RD
 (SR8008 SEG 0520/0045)
 5 0500/0000 LENGTH(AH 1715 BK 1553)

1 0 00763 2 04 0000+00 000538 FT
 RAMP G RD
 (SR8008 SEG 0770/2590) 0250/0000

000000 FT

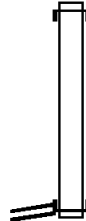

INTER-AHD PENN LINCOLN PY
 0250/1553 (SR0376 SEG 0741/0586)
 000538 FT RWARD AV INT./RAMP A RD
 INTER-BK RAMP C RD
 (SR8008 SEG 0500/1715)
 5 0250/0000 LENGTH(AH 1553 BK 0538)

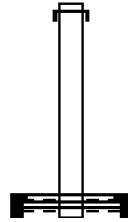

INTER-AHD PENN LINCOLN PY
 0010/0538 (SR0376 SEG 0740/1852)
 000000 FT 1 0 00763 2 05 0000+00
 SIGN: CANTILEVER
 BMSID 02/8008/0010/0000
 NC FORWARD AV INT./RAMP B RD
 BEECHWOOD BL
 (CITY)
 MFC BEGIN = F
 5 0010/0000 LENGTH(AH 0538 BK 0000)

EXTRACT DATE: 12/21/2020 ROADWAY MANAGEMENT SYSTEM PAGE NUMBER: 1479
PRINT DATE: 12/23/2020 SLD COUNTY/SR - ANNUAL PRINT COUNTY: ALLEGHENY
DIR: E TOTAL LEN: .732 MI. DIST: 11-1 SR: 8007
LEFT MUN: CARNEGIE B RIGHT MUN: CARNEGIE B

003866 FT



003866 FT
INTER-AHD INTERSTATE 79 SB
0512/0730 (SR0079 SEG 0561/1776)
FROM 3048/0191 SH

DIR: E TOTAL LEN: .732 MI. DIST: 11-1 SR: 8007
 LEFT MUN: CARNEGIE B RIGHT MUN: CARNEGIE B

003136 FT

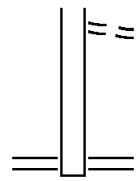

0512/0130 (CONN)
 003136 FT 0 0 00000 0 00 0000+00
 NC CA RNEGIE INT/RAMP C RD
 NOBLESTOWN RD
 (SR3048 SEG 0190/1538)
 (SR3048 SEG 0191/1470)
 5 0512/0000 LENGTH(AH 0730 BK 1191)

001945 FT

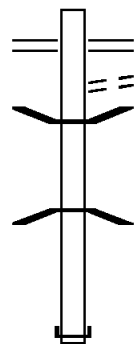

NOBLESTOWN RD
 (SR3048 SEG 0190/1538)
 (SR3048 SEG 0191/1470)
 TO 3048/0191 SH
 0502/1191 (CONN)
 0502/1048 (CONN)
 0502/0800 BMSEN 02/8007/0510/0131
 1 0 01016 2 13 0000+00
 ROBINSON RUN
 0502/0131 BMSBG 02/8007/0510/0131
 001945 FT 0 0 00000 0 00 0000+00
 NC CA RNEGIE INT/RAMP D RD
 INTER-BK INTERSTATE 79 SB
 (SR0079 SEG 0565/0000)
 5 0502/0000 LENGTH(AH 1191 BK 0810)

001135 FT

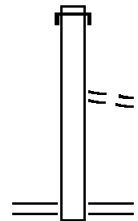

INTER-AHD INTERSTATE 79 NB
 0020/0810 (SR0079 SEG 0560/1248)
 FROM 3048/0190 SH
 0020/0138 (CONN)
 001135 FT 1 0 01016 2 13 0000+00
 NC CA RNEGIE INT/RAMP B RD
 NOBLESTOWN RD
 (SR3048 SEG 0190/2288)
 5 0020/0000 LENGTH(AH 0810 BK 1135)

000000 FT

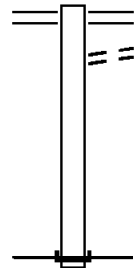

NOBLESTOWN RD
 (SR3048 SEG 0190/2288)
 TO 3048/0190 SH
 0010/1135 (CONN)
 0010/1064 (CONN)
 000000 FT 1 0 01016 2 12 0000+00
 NC CA RNEGIE INT/RAMP A RD
 INTER-BK INTERSTATE 79 NB
 (SR0079 SEG 0560/0649)
 MFC BEGIN = F
 5 0010/0000 LENGTH(AH 1135 BK 0000)

001718 FT

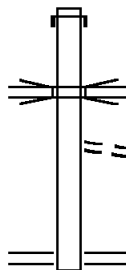

001718 FT
 INTER-AHD PENN LINCOLN PY
 0750/0869 (SR0376 SEG 0724/2572)

000849 FT

0750/0235 OP ID 02/0376 EB
 FROM 0885/0300 SH
 0750/0049 (CONN)
 000849 FT 1 0 00763 2 01 0000+00
 NC BA TATES ST INT/RAMP B RD
 BATES ST
 (SR0885 SEG 0300/0260)
 0750/0000 LENGTH(AH 0869 BK 0535)

000314 FT



INTER-AHD BATES ST
 0500/0535 (SR0885 SEG 0300/0363)
 000314 FT 1 0 00763 2 00 0011+63
 NC BA TATES ST INT/RAMP A RD
 INTER-BK PENN LINCOLN PY
 (SR0376 SEG 0725/2211)
 0500/0000 LENGTH(AH 0535 BK 0314)

000000 FT

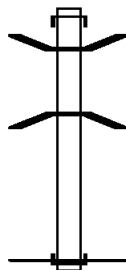

INTER-AHD BATES ST
 0250/0314 (SR0885 SEG 0300/0553)
 0250/0239 BMSSEN 02/8006/0250/0159
 1 0 00763 2 00 0003+09
 HODGE STREET LOCAL
 0250/0176 BMSBG 02/8006/0250/0159
 000000 FT 1 0 00763 2 03 0000+00
 NC BA TATES ST INT/RAMP D RD
 INTER-BK PENN LINCOLN PY
 (SR0376 SEG 0725/1491)
 MFC BEGIN = F
 0250/0000 LENGTH(AH 0314 BK 0000)

EXTRACT DATE: 12/21/2020 ROADWAY MANAGEMENT SYSTEM PAGE NUMBER: 1476
 PRINT DATE: 12/23/2020 SLD COUNTY/SR - ANNUAL PRINT COUNTY: ALLEGHENY
 DIR: E TOTAL LEN: 1.650 MI. DIST: 11-1 SR: 8005
 LEFT MUN: COLLIER T RIGHT MUN: COLLIER T

RAMP A RD
 (SR8005 SEG 0250/0726) 0750/0795

008713 FT

007193 FT

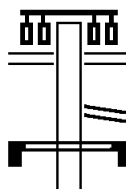
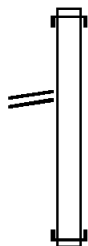

008713 FT
 INTER-AHD INTERSTATE 79 NB
 0750/1520 (SR0079 SEG 0544/0308)

007193 FT 1 0 01016 2 11 0000+00
 NC KIRWAN HTS INT/RAMP D RD
 INTER-BK WASHINGTON PK
 (SR0050 SEG 0151/1750)
 0750/0000 LENGTH(AH 1520 BK 2643)

WASHINGTON PK
 (SR0050 SEG 0151/1680)
 0260/2643
 KIRWAN HTS INT/RAMP C R
 0260/2542 (SR8005 SEG 0010/1502)
 SIGN: 3 CHORD TRUSS
 0260/2289 BMSID 02/8005/0260/2310

EXTRACT DATE: 12/21/2020
PRINT DATE: 12/23/2020

ROADWAY MANAGEMENT SYSTEM
SLD COUNTY/SR - ANNUAL PRINT

PAGE NUMBER: 1475
COUNTY: ALLEGHENY

DIR: E TOTAL LEN: 1.650 MI.
LEFT MUN: COLLIER T

DIST: 11-1 SR: 8005
RIGHT MUN: COLLIER T

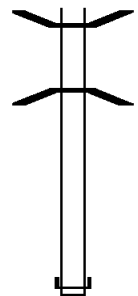

004550 FT

0260/1485 BMS EN 02/8005/0260/1235
1 0 01016 2 09 0000+00
SR 0079 NB
0260/1233 BMSBG 02/8005/0260/1235

004550 FT 1 0 01016 2 09 0000+00
NC KIRWAN HTS INT/RAMP B RD
INTER-BK INTERSTATE 79 SB
(SR0079 SEG 0541/1436)
0260/0000 LENGTH(AH 2643 BK 2935)

INTER-AHD INTERSTATE 79 SB
0250/2935 (SR0079 SEG 0541/0630)

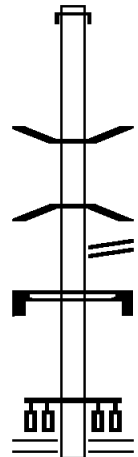

001615 FT

0250/1397 BMS EN 02/8005/0260/1235
1 0 01016 2 08 0000+00
SR 0079 NB
0250/1145 BMSBG 02/8005/0260/1235
RAMP D RD
0250/0726 (SR8005 SEG 0750/0795)
SIGN: 3 CHORD TRUSS
0250/0355 BMSID 02/8005/0260/2310
001615 FT 1 0 01016 2 08 0000+00
NC KIRWAN HTS INT/RAMP A RD
WASHINGTON PK
(SR0050 SEG 0151/1680)

0250/0000 LENGTH(AH 2935 BK 1615)

INTER-AHD WASHINGTON PK
0010/1615 (SR0050 SEG 0151/1565)

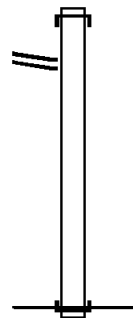

KIRWAN HTS INT/RAMP B R
(SR8005 SEG 0260/2542) 0010/1502

000000 FT

000000 FT 1 0 01016 2 10 0000+00
NC KIRWAN HTS INT/RAMP C RD
INTER-BK INTERSTATE 79 NB
(SR0079 SEG 0540/1636)
MFC BEGIN = F
0010/0000 LENGTH(AH 1615 BK 0000)

EXTRACT DATE: 12/21/2020 ROADWAY MANAGEMENT SYSTEM PAGE NUMBER: 1474
 PRINT DATE: 12/23/2020 SLD COUNTY/SR - ANNUAL PRINT COUNTY: ALLEGHENY
 DIR: W TOTAL LEN: .849 MI. DIST: 11-1 SR: 8004
 LEFT MUN: PITTSBURGH C RIGHT MUN: PITTSBURGH C

004483 FT

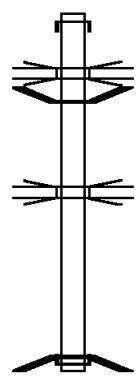

004483 FT
 INTER-AHD PENN LINCOLN PY
 0760/1297 (SR0376 SEG 0720/1259)
 RAMP V 8004 EB
 0760/1095 OP ID 02/8004/0750/0027
 0760/1054 BMSSEN 02/8004/0760/0000

003186 FT

SR 2085
 0760/0105 OP ID 02/2085/0010/224B
 003186 FT O O 00000 0 00 0000+00
 NC OAKLAND INT/RAMP T RD
 INTER-BK BL OF THE ALLIES
 (SR0885 SEG 0331/2443)
 BIRMINGHAM RAMP F
 BMSBG 02/8004/0760/0000
 5 0760/0000 LENGTH(AH 1297 BK 1347)

INTER-AHD FORBES AV
 0750/1347 (SR2308 SEG 0010/1296)
 0750/1237 BMSSEN 02/8004/0750/0027

EXTRACT DATE: 12/21/2020
PRINT DATE: 12/23/2020

ROADWAY MANAGEMENT SYSTEM
SLD COUNTY/SR - ANNUAL PRINT

PAGE NUMBER: 1473
COUNTY: ALLEGHENY

DIR: W TOTAL LEN: .849 MI.
LEFT MUN: PITTSBURGH C

DIST: 11-1 SR: 8004
RIGHT MUN: PITTSBURGH C

001839 FT

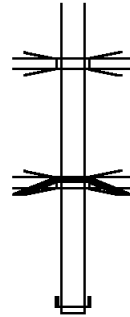

0750/0040 OP ID 02/8065/0010/0000
0 0 00000 0 00 0000+00
SR 2085
OP ID 02/2085/0010/224B
1376 EB
0750/0027 BMSBG 02/8004/0750/0027
001839 FT 0 0 00000 0 00 0000+00
NC OAKLAND INT/RAMP V RD
INTER-BK PENN LINCOLN PY
(SR0376 SEG 0720/0053)
5 0750/0000 LENGTH(AH 1347 BK 1162)

000677 FT

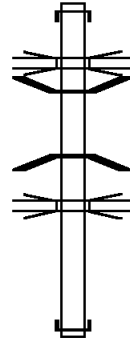

INTER-AHD BL OF THE ALLIES
0500/1162 (SR0885 SEG 0330/2719)
SR 2085
0500/0815 OP ID 02/2085/0010/224B
0500/0799 BMSBG 02/8004/0500/0732
1 0 00764 2 10 0004+95
BIRMINGHAM RAMP F
0500/0732 BMSBG 02/8004/0500/0732
BLVD ALLIES SB
0500/0215 OP ID 02/0885/0331/1302
000677 FT 1 0 00764 2 10 0000+00
NC OAKLAND INT/RAMP R RD
INTER-BK PENN LINCOLN PY
(SR0376 SEG 0721/0876)
5 0500/0000 LENGTH(AH 1162 BK 0677)

000000 FT

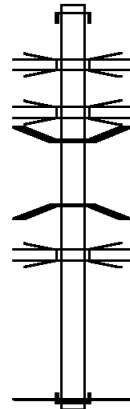

INTER-AHD PENN LINCOLN PY
0260/0677 (SR0376 SEG 0715/2158)
BLVD ALLIES SB
0260/0507 OP ID 02/0885/0331/1302
BLVD ALLIES WB
0260/0503 OP ID 02/0885/0330/1797
0260/0253 BMSBG 02/8004/0260/0020
0 0 00000 0 00 0000+00
BIRMINGHAM RAMP E
0260/0020 BMSBG 02/8004/0260/0020
SR 2085
0260/0003 OP ID 02/2085/0010/224B
000000 FT 0 0 00000 0 00 0000+00
NC OAKLAND INT/RAMP U RD
INTER-BK BL OF THE ALLIES
(SR0885 SEG 0330/2362)
MFC BEGIN = F
5 0260/0000 LENGTH(AH 0677 BK 0000)

EXTRACT DATE: 12/21/2020 ROADWAY MANAGEMENT SYSTEM PAGE NUMBER: 1472
 PRINT DATE: 12/23/2020 SLD COUNTY/SR - ANNUAL PRINT COUNTY: ALLEGHENY

DIR: E TOTAL LEN: 1.307 MI. DIST: 11-1 SR: 8003
 LEFT MUN: SOUTH FAYETTE T RIGHT MUN: SOUTH FAYETTE T

006902 FT

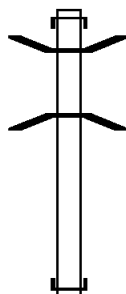

004980 FT

006902 FT
 INTER-AHD 1-79 N
 0750/1922 (SR0079 SEG 0524/1881)
 0750/1751 BMSSEN 02/8003/0750/1165
 1 0 01016 2 07 0000+00
 CHARTIERS CREEK
 0750/1185 BMSBG 02/8003/0750/1165

004980 FT 1 0 01016 2 07 0000+00
 NC BRIDGEVILLE INT/RAMP E RD
 INTER-BK MILLERS RUN RD
 (SR0050 SEG 0101/0803)
 5 0750/0000 LENGTH(AH 1922 BK 1295)

DIR: E TOTAL LEN: 1.307 MI. DIST: 11-1 SR: 8003
 LEFT MUN: SOUTH FAYETTE T RIGHT MUN: SOUTH FAYETTE T

003685 FT

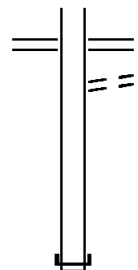

0260/1295 MILLERS RUN RD
 (SR0050 SEG 0090/2135)
 TO 0050/0090 SH
 0260/1147 (CONN)
 003685 FT 1 0 01016 2 06 0000+00
 NC BR RIDGEVILLE INT/RAMP D RD
 INTER-BK INTERSTATE 79 SB
 (SR0079 SEG 0525/0000)
 0260/0000 LENGTH(AH 1295 BK 1579)

002106 FT

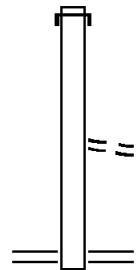

INTER-AHD I-79 S
 0250/1579 (SR0079 SEG 0521/1791)
 FROM 0050/0090 SH
 0250/0145 (CONN)
 002106 FT 1 0 01016 2 05 0000+00
 NC BR RIDGEVILLE INT/RAMP C RD
 MILLERS RUN RD
 (SR0050 SEG 0090/2135)
 0250/0000 LENGTH(AH 1579 BK 0906)

001200 FT

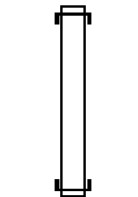

INTER-AHD I-79 N
 0020/0906 (SR0079 SEG 0520/2293)
 001200 FT 1 0 01016 2 04 0000+00
 NC BR RIDGEVILLE INT/RAMP B RD
 INTER-BK MILLERS RUN RD
 (SR0050 SEG 0100/0725)
 0020/0000 LENGTH(AH 0906 BK 1200)

000000 FT

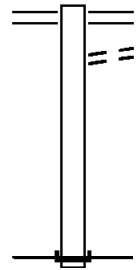

0010/1200 MILLERS RUN RD
 (SR0050 SEG 0100/0791)
 TO 0050/0100 SH
 0010/1093 (CONN)
 000000 FT 1 0 01016 2 03 0000+00
 NC BR RIDGEVILLE INT/RAMP A RD
 INTER-BK INTERSTATE 79 NB
 (SR0079 SEG 0520/1560)
 MFC BEGIN = F
 0010/0000 LENGTH(AH 1200 BK 0000)

DIR: E TOTAL LEN: 1.005 MI. DIST: 11-1 SR: 8002
 LEFT MUN: PITTSBURGH C RIGHT MUN: PITTSBURGH C

005309 FT

005309 FT
 INTER-AHD CENTRE AV
 (CITY)
 WASHINGTON PL
 (CITY)

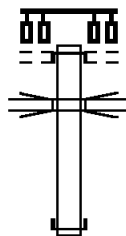

0300/0550 PEDESTRIAN
 0300/0208 OP ID 02/8002/0300/0208
 004759 FT 0 0 0000 0 00 0000+00
 NC RAMP M RD
 INTER-BK SR 0579 SH
 (SR0579 SEG 0002/0525)
 0300/0000 LENGTH(AH 0550 BK 0836)

004759 FT



INTER-AHD BMSEN 02/8002/0290/0490
 0290/0836 I-579 N
 (SR0579 SEG 0002/0000)
 1 0 01026 2 04 0005+17
 0290/0490 FORBES AVE
 BMSBG 02/8002/0290/0490
 SIGN: 2 CHORD TRUSS
 0290/0390 BMSID 02/8002/0290/0390
 SIGN: CANTILEVER
 0290/0051 BMSID 02/3069/0120/0295
 003923 FT 0 0 0000 0 00 0000+00
 NC RAMP L RD
 INTER-BK LIBERTY BR
 (SR3069 SEG 0120/0236)
 0290/0000 LENGTH(AH 0836 BK 1056)

003923 FT

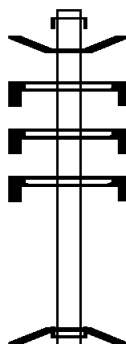

INTER-AHD I-579 N
 0280/1056 (SR0579 SEG 0002/0000)
 0280/0976 BMSEN 02/8002/0280/0000
 SIGN: CANTILEVER
 0280/0887 BMSID 02/8002/0280/0510
 SIGN: CANTILEVER
 0280/0493 BMSID 02/8002/0280/0900
 SIGN: CANTILEVER
 0280/0069 BMSID 02/8002/0280/0080
 002867 FT 0 0 0000 0 00 0000+00
 NC RAMP K RD
 INTER-BK BL OF THE ALLIES
 (SR0885 SEG 0350/2406)
 LIBERTY BR. APPR.
 BMSBG 02/8002/0280/0000

002867 FT

DIR: E TOTAL LEN: 1.005 MI. DIST: 11-1 SR: 8002
 LEFT MUN: PITTSBURGH C RIGHT MUN: PITTSBURGH C

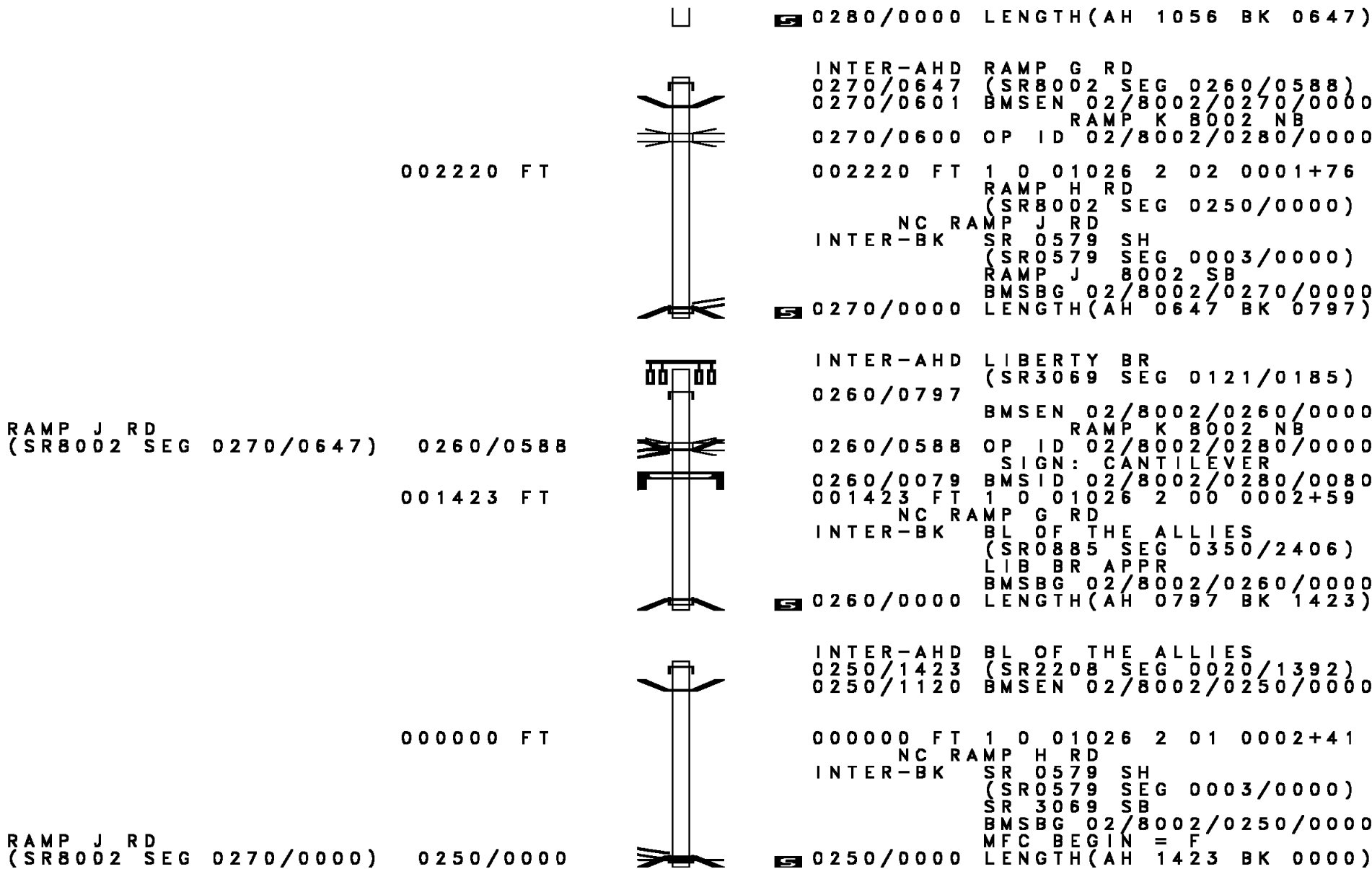

002220 FT

0280/0000 LENGTH(AH 1056 BK 0647)

INTER-AHD RAMP G RD
 0270/0647 (SR8002 SEG 0260/0588)
 0270/0601 BMSEN 02/8002/0270/0000
 RAMP K 8002 NB
 0270/0600 OP ID 02/8002/0280/0000

002220 FT 1 0 01026 2 02 0001+76
 RAMP H RD
 (SR8002 SEG 0250/0000)

NC RAMP J RD
 INTER-BK SR 0579 SH
 (SR0579 SEG 0003/0000)
 RAMP J 8002 SB
 BMSBG 02/8002/0270/0000

0270/0000 LENGTH(AH 0647 BK 0797)

RAMP J RD
 (SR8002 SEG 0270/0647) 0260/0588

001423 FT

INTER-AHD LIBERTY BR
 0260/0797 (SR3069 SEG 0121/0185)

BMSEN 02/8002/0260/0000
 RAMP K 8002 NB
 0260/0588 OP ID 02/8002/0280/0000
 SIGN: CANTILEVER

0260/0079 BMSID 02/8002/0280/0080
 001423 FT 1 0 01026 2 00 0002+59
 NC RAMP G RD

INTER-BK BL OF THE ALLIES
 (SR0885 SEG 0350/2406)
 LIB BR APPR
 BMSBG 02/8002/0260/0000

0260/0000 LENGTH(AH 0797 BK 1423)

000000 FT

INTER-AHD BL OF THE ALLIES
 0250/1423 (SR2208 SEG 0020/1392)
 0250/1120 BMSEN 02/8002/0250/0000

000000 FT 1 0 01026 2 01 0002+41
 NC RAMP H RD

INTER-BK SR 0579 SH
 (SR0579 SEG 0003/0000)
 SR 3069 SB
 BMSBG 02/8002/0250/0000
 MFC BEGIN = F

0250/0000 LENGTH(AH 1423 BK 0000)

RAMP J RD
 (SR8002 SEG 0270/0000) 0250/0000

DIR: B TOTAL LEN: 1.150 MI. DIST: 11-1 SR: 6579
 LEFT MUN: PITTSBURGH C RIGHT MUN: PITTSBURGH C

006074 FT

006074 FT
 INTER-AHD HOV LN TO/FR NORTHSHORE
 0020/2791 (SR6279 SEG 0020/2277)
 NORTH AVE
 0020/2519 OP ID 02/0279/0016/1235
 TRIPOLI ST
 0020/2406 OP ID 02/0279/0016/0998
 RETAINING WALL
 0020/1865 BMSID 02/6579/0020/1865
 RETAINING WALL
 0020/1864 BMSID 02/6579/0020/1864
 0020/1856 BMSID 02/6579/0020/0000

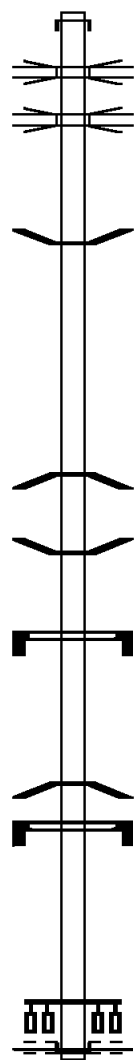

003283 FT

003283 FT 0 0 00000 0 00 0000+00
 NC HOV LN TO/FR MELLON AR RD
 E OHIO ST
 BMSBG 02/6579/0020/0000
 0020/0000 LENGTH(AH 2791 BK 3283)
 0010/2231 BMSID 02/6579/0010/0054
 SIGN: 2 CHORD TRUSS
 0010/1258 BMSID 02/6579/0010/1258

000000 FT

0 0 00000 0 00 0000+00
 SR 380 EB
 0010/0054 BMSBG 02/6579/0010/0054
 SIGN: 2 CHORD TRUSS
 0010/0010 BMSID 02/6579/0010/0010
 000000 FT 0 0 00000 0 00 0000+00
 NC I-579 HOV LN
 BEDFORD AV
 (CITY)
 INTER-BK MARIO LEMIEUX PL
 (CITY)
 MFC BEGIN = A
 0010/0000 LENGTH(AH 3283 BK 0000)

EXTRACT DATE: 12/21/2020 ROADWAY MANAGEMENT SYSTEM PAGE NUMBER: 1467
 PRINT DATE: 12/23/2020 SLD COUNTY/SR - ANNUAL PRINT COUNTY: ALLEGHENY
 DIR: B TOTAL LEN: 5.244 MI. DIST: 11-1 SR: 6279
 LEFT MUN: PITTSBURGH C RIGHT MUN: PITTSBURGH C

027686 FT

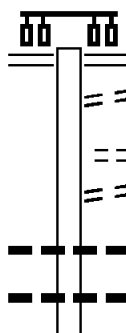

027686 FT PERRYSVILLE AV
 (SR0019 SEG 0430/1755)
 0090/3095 TO 0019/0430 SH
 (CONN)
 0090/3017 PARKING AREA ENTR
 (PARK)
 0090/2925 LC TO PARKING AREA
 (CONN)
 0090/2775 024 " DIA CIRC CONCR
 0090/2737 LEN=0050 INSTALLED UNKN
 024 " DIA CIRC CONCR
 0090/2688 LEN=0020 INSTALLED UNKN
 024 " DIA CIRC CONCR

DIR: B TOTAL LEN: 5.244 MI. DIST: 11-1 SR: 6279
 LEFT MUN: PITTSBURGH C RIGHT MUN: PITTSBURGH C

---	0090/2254	LEN=0050	INSTALLED	UNKN
---	0090/2240	LEN=0020	INSTALLED	UNKN
	0090/2110	OP ID 02/0279/0056/1458		
---	0090/1755	LEN=0050	INSTALLED	UNKN
---	0090/1341	LEN=0020	INSTALLED	UNKN
	0090/0750	RAMP TO SR 279 (SR8103 SEG 0760/0000)		
┌───┐	0090/0437	BMSID 02/6279/0090/0250		
	0090/0420	OP ID 02/4044/0010/0104		
┌───┐	0090/0013	BMSID 02/8103/0260/0128		
	0090/0000	LENGTH(AH 3095 BK 2334)		
---	0080/1799	LEN=0050	INSTALLED	UNKN
---	0080/1257	LEN=0030	INSTALLED	UNKN
---	0080/0807	LEN=0005	INSTALLED	UNKN
---	0080/0302	LEN=0005	INSTALLED	UNKN
0 0 00000 0 00 0000+00	024591 FT			
RAMP FROM SR 279				
(SR8103 SEG 0260/0188)	0090/0000			
0 0 00000 0 00 0000+00	022257 FT			
	0080/0000	OP ID 02/0019/0410/1068		
┌───┐	0070/2938	BMSID 02/0279/0046/2650		
---	0070/2659	LEN=0030	INSTALLED	UNKN
0 0 00000 0 00 0000+00				
RAMP J 8102 SB				
024 "DIA CIRC CONCR				
LEN=0050	0070/1137	INSTALLED	UNKN	
BMSEN 02/6279/0070/0330	0070/1130			
0 0 00000 0 00 0000+00				
RAMP J 8102 SB				
BMSBG 02/6279/0070/0330	0070/0330			
024 "DIA CIRC CONCR				
LEN=0050	0070/0265	INSTALLED	UNKN	
024 "DIA CIRC CONCR				

0 0 00000 0 00 0000+00 024591 FT
 RAMP FROM SR 279
 (SR8103 SEG 0260/0188) 0090/0000

022257 FT

DIR: B TOTAL LEN: 5.244 MI. DIST: 11-1 SR: 6279
 LEFT MUN: PITTSBURGH C RIGHT MUN: PITTSBURGH C

013151 FT

0050/0488	024 " DIA	CIRC CONCR
LEN=0050	INSTALLED	UNKN
0050/0255	024 " DIA	CIRC CONCR
LEN=0050	INSTALLED	UNKN
013151 FT	0 0 00000	0 0 00 0000+00
	MILROY ST	
5 0050/0000	OP ID 02/7301/0000/3136	LENGTH(AH 2319 BK 3418)
0040/3354	018 " DIA	CIRC CONCR
LEN=0050	INSTALLED	UNKN
0040/3049	018 " DIA	CIRC CONCR
LEN=0099	INSTALLED	UNKN
0040/2899	018 " DIA	CIRC CONCR
LEN=0050	INSTALLED	UNKN
0040/2800	018 " DIA	CIRC CONCR
LEN=0035	INSTALLED	UNKN
0040/2721	024 " DIA	CIRC CONCR
LEN=0035	INSTALLED	UNKN
0040/2554	018 " DIA	CIRC CONCR
LEN=0099	INSTALLED	UNKN
0040/2502	018 " DIA	CIRC CONCR
LEN=0099	INSTALLED	UNKN
0040/2425	018 " DIA	CIRC CONCR
LEN=0099	INSTALLED	UNKN
0040/2346	018 " DIA	CIRC CONCR
LEN=0099	INSTALLED	UNKN
	SIGN: 4 CHORD TRUSS	
0040/2336	BMSID 02/0279/0026/2623	
0040/2267	018 " DIA	CIRC CONCR
LEN=0099	INSTALLED	UNKN
0040/2199	018 " DIA	CIRC CONCR
LEN=0099	INSTALLED	UNKN
0040/2130	018 " DIA	CIRC CONCR
LEN=0099	INSTALLED	UNKN
0040/2026	018 " DIA	CIRC CONCR
LEN=0050	INSTALLED	UNKN
0040/1901	018 " DIA	CIRC CONCR
LEN=0050	INSTALLED	UNKN
0040/1809	018 " DIA	CIRC CONCR
LEN=0050	INSTALLED	UNKN
0040/1707	018 " DIA	CIRC CONCR
LEN=0050	INSTALLED	UNKN
	CHARLES ST	
0040/1629	OP ID 02/7301/0000/3109	
0040/1605	018 " DIA	CIRC CONCR
LEN=0050	INSTALLED	UNKN
0040/1506	018 " DIA	CIRC CONCR
LEN=0099	INSTALLED	UNKN
0040/1410	018 " DIA	CIRC CONCR
LEN=0050	INSTALLED	UNKN

DIR: B TOTAL LEN: 5.244 MI. DIST: 11-1 SR: 6279
 LEFT MUN: PITTSBURGH C RIGHT MUN: PITTSBURGH C

009733 FT

0040/1178	024 " DIA	CIRC	CONCR	LEN=0035	INSTALLED	UNKN
	SIGN: 4	CHORD	TRUSS			
0040/0906	BMSID 02/0279/0026/1224					
	018 " DIA	CIRC	CONCR			
0040/0850	LEN=0035	INSTALLED	UNKN			
	024 " DIA	CIRC	CONCR			
0040/0402	LEN=0035	INSTALLED	UNKN			
	018 " DIA	CIRC	CONCR			
0040/0252	LEN=0040	INSTALLED	UNKN			
0040/0130	BMSID 02/0279/0026/0284					
009733 FT	0 0 00000 0 0 00 0000+00					
	SUFFOLK ST LOCAL					
	BMSBG 02/0279/0026/0284					
0040/0000	LENGTH(AH 3418 BK 3762)					
	018 " DIA	CIRC	CONCR			
0030/3722	LEN=0030	INSTALLED	UNKN			
	018 " DIA	CIRC	CONCR			
0030/3440	LEN=0099	INSTALLED	UNKN			
	018 " DIA	CIRC	CONCR			
0030/3288	LEN=0099	INSTALLED	UNKN			
	018 " DIA	CIRC	CONCR			
0030/3137	LEN=0099	INSTALLED	UNKN			
	SIGN: 4	CHORD	TRUSS			
0030/3088	BMSID 02/0279/0022/2232					
	018 " DIA	CIRC	CONCR			
0030/3040	LEN=0099	INSTALLED	UNKN			
	018 " DIA	CIRC	CONCR			
0030/2939	LEN=0099	INSTALLED	UNKN			
	018 " DIA	CIRC	CONCR			
0030/2641	LEN=0099	INSTALLED	UNKN			
	018 " DIA	CIRC	CONCR			
0030/2271	LEN=0099	INSTALLED	UNKN			
	018 " DIA	CIRC	CONCR			
0030/1978	LEN=0099	INSTALLED	UNKN			
	018 " DIA	CIRC	CONCR			
0030/1879	LEN=0099	INSTALLED	UNKN			
	018 " DIA	CIRC	CONCR			
0030/1775	LEN=0099	INSTALLED	UNKN			
	PED. WALKWAY					
0030/1475	OP ID 02/0279/0022/0615					
	018 " DIA	CIRC	CONCR			
0030/1400	LEN=0050	INSTALLED	UNKN			
	018 " DIA	CIRC	CONCR			
0030/1046	LEN=0099	INSTALLED	UNKN			
	018 " DIA	CIRC	CONCR			
0030/1000	LEN=0050	INSTALLED	UNKN			
	018 " DIA	CIRC	CONCR			
0030/0882	LEN=0099	INSTALLED	UNKN			
	SIGN: 4	CHORD	TRUSS			

EXTRACT DATE: 12/21/2020
PRINT DATE: 12/23/2020

ROADWAY MANAGEMENT SYSTEM
SLD COUNTY/SR - ANNUAL PRINT

PAGE NUMBER: 1462
COUNTY: ALLEGHENY









DIR: B TOTAL LEN: 5.244 MI.
LEFT MUN: PITTSBURGH C

DIST: 11-1 SR: 6279
RIGHT MUN: PITTSBURGH C

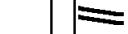
005971 FT

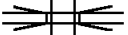
TO 0279/0013 SH
(CONN)

0020/0105

	0030/0790	BMSID 02/0279/0016/2545
---	0030/0649	018 "DIA CIRC CONCR LEN=0099 INSTALLED UNKN
---	0030/0321	018 "DIA CIRC CONCR LEN=0099 INSTALLED UNKN
---	0030/0235	024 "DIA CIRC CONCR LEN=0099 INSTALLED UNKN
---	0030/0045	018 "DIA CIRC CONCR LEN=0099 INSTALLED UNKN
	005971 FT	0 0 00000 0 00 0000+00 RAMP Q
	5 0030/0000	OP ID 02/0279/0016/1799 LENGTH(AH 3762 BK 2672)
---	0020/2577	018 "DIA CIRC CONCR LEN=0099 INSTALLED UNKN
---	0020/2503	018 "DIA CIRC CONCR LEN=0099 INSTALLED UNKN
	0020/2277	HOV LN TO/FR MELLON ARE (SR6579 SEG 0020/2791)
---	0020/2249	018 "DIA CIRC CONCR LEN=0099 INSTALLED UNKN
	0020/2164	SIGN: 4 CHORD TRUSS BMSID 02/0279/0017/1253 NORTH AVE
	0020/2119	OP ID 02/0279/0016/1235
---	0020/2049	018 "DIA CIRC CONCR LEN=0099 INSTALLED UNKN
	0020/1904	TRIPOLI ST OP ID 02/0279/0016/0998
---	0020/1188	024 "DIA CIRC CONCR LEN=0005 INSTALLED UNKN
	0020/0995	E. OHIO ST. OP ID 02/4084/0060/0035
---	0020/0787	024 "DIA CIRC CONCR LEN=0099 INSTALLED UNKN
	0020/0685	CROSSTOWN BL OP ID 02/0579/0011/0000
---	0020/0660	024 "DIA CIRC CONCR LEN=0050 INSTALLED UNKN
	0020/0647	28 SB TO 279 SB OP ID 02/8121/0522/0139
---	0020/0425	024 "DIA CIRC CONCR LEN=0050 INSTALLED UNKN
	0020/0295	SIGN: CANTILEVER BMSID 02/6279/0020/0269
---	0020/0154	018 "DIA CIRC CONCR LEN=0060 INSTALLED UNKN

OHIO RIVER BL (SR0065 SEG 0021/0000) OHIO RIVER BL (SR0065 SEG 0021/0000) NC OHIO RIVER BL FR CALIF AV TO SR 4265 (SR8043 SEG 0250/0513) CALIF AV SB TO BEAVER A (SR8043 SEG 0750/0000) RAMP F NB OP ID 02/8049/0030/0328 TO SR 4265/0010 SH (CONN) 1 0 00652 0 00 0058+27 000000 FT NC CALIFORNIA AV CALIFORNIA AV TO SR 65 (SR8049 SEG 0250/0000) MARSHALL AV (SR0019 SEG 0330/0000) MFC BEGIN = B LENGTH(AH 2327 BK 0000)	002327 FT REF-AHD * 0011/2327 0011/1520 0011/0435 0011/0299 0011/0257 000000 FT 0011/0000		* 001939 FT REF-AHD 0010/1939 0010/1550 0010/0700 0010/0699 0010/0550 0010/0390 0010/0267 0010/0250 0010/0127 000000 FT NC CA 0010/0000	OHIO RIVER BL (SR0065 SEG 0012/3380) OHIO RIVER BL (SR0065 SEG 0012/3380) 018 "DIA CIRC CONCR LEN=0099 INSTALLED UNKN 018 "DIA CIRC CONCR LEN=0050 INSTALLED UNKN (APRA) CONRAIL INTERMOD CALIFORNIA AV (CITY) HALSEY PL (CITY) 024 "DIA CIRC METAL LEN=0030 INSTALLED UNKN 024 "DIA CIRC METAL LEN=0050 INSTALLED UNKN FROM 8049/0750 SH (CONN) 018 "DIA CIRC CONCR LEN=0040 INSTALLED UNKN FROM 0019/0330 SH (CONN) 1 0 00652 0 00 0058+27 NC CA CALIFORNIA AV CALIFORNIA AV TO SR 65 (SR8049 SEG 0250/0000) MARSHALL AV (SR0019 SEG 0330/0000) MFC BEGIN = B LENGTH(AH 1939 BK 0000)
--	---	--	--	---

EXTRACT DATE: 12/21/2020 ROADWAY MANAGEMENT SYSTEM PAGE NUMBER: 1459
 PRINT DATE: 12/23/2020 SLD COUNTY/SR - ANNUAL PRINT COUNTY: ALLEGHENY
 DIR: B TOTAL LEN: .151 MI. DIST: 11-1 SR: 4165
 LEFT MUN: GLENFIELD B RIGHT MUN: GLENFIELD B

000799 FT

000000 FT

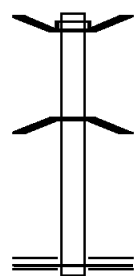

000799 FT BMS EN 02/4165/0010/0019
 INTER-AHD PHILLIPS LN
 0010/0799 (TWP)

 0 0 00000 0 00 0000+00
 S.R. 0065 SOUTHBOUND
 0010/0019 BMSBG 02/4165/0010/0019
 000000 FT 0 0 00000 0 00 0000+00
 NC GL ENFIELD VIADUCT RD
 CENTER AV
 (SR4033 SEG 0008/0055)
 MFC BEGIN = E
 0010/0000 LENGTH(AH 0799 BK 0000)

EXTRACT DATE: 12/21/2020 ROADWAY MANAGEMENT SYSTEM PAGE NUMBER: 1458
 PRINT DATE: 12/23/2020 SLD COUNTY/SR - ANNUAL PRINT COUNTY: ALLEGHENY
 DIR: B TOTAL LEN: .006 MI. DIST: 11-1 SR: 4154
 LEFT MUN: SHALER T RIGHT MUN: SHALER T

000033 FT
 000000 FT

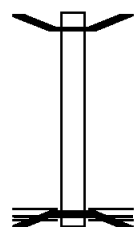

* 000033 FT BMS EN 02/4154/0010/0000
 REF-AHD PRIVATE DR
 0010/0033 (PRDR)
 000000 FT 0 0 00000 0 00 0000+00
 NC BR RIDGE OVER L PINE CR
 LITTLE PINE CREEK RD
 (SR4017 SEG 0040/0580)
 L PINE CREEK
 BMSBG 02/4154/0010/0000
 MFC BEGIN = E
 0010/0000 LENGTH(AH 0033 BK 0000)

EXTRACT DATE: 12/21/2020 ROADWAY MANAGEMENT SYSTEM PAGE NUMBER: 1457
 PRINT DATE: 12/23/2020 SLD COUNTY/SR - ANNUAL PRINT COUNTY: ALLEGHENY
 DIR: B TOTAL LEN: .007 MI. DIST: 11-1 SR: 4153
 LEFT MUN: SHALER T RIGHT MUN: SHALER T

000035 FT
 000000 FT

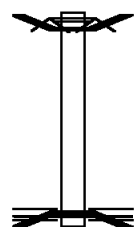

000035 FT WILSON ST
 ROAD CLOSED AHEAD
 0010/0035 BMSBN 02/4153/0010/0000
 000000 FT 000000000000000000000000+00
 NC WILSON ST
 LITTLE PINE CREEK RD
 (SR4017 SEG 0030/0950)
 LITTLE PINE CREEK
 BMSBG 02/4153/0010/0000
 MFC BEGIN = E
 0010/0000 LENGTH(AH 0035 BK 0000)

DIR: N TOTAL LEN: .321 MI. DIST: 11-1 SR: 4099
 LEFT MUN: PITTSBURGH C RIGHT MUN: PITTSBURGH C

Segment Description	Stationing	Length (FT)	Notes
RAMP F RD (SR8099 SEG 0500/0475) INTER-AHD	0011/1665	001665	
RAMP Q RD FR MADISON AV (CONN)	0011/1605		
018 "H 48" W CON BOX CUL	0011/1559		LEN=0999 INSTALLED UNKN
015 "DIA CIRC CONCR	0011/1524		LEN=0050 INSTALLED UNKN
015 "DIA CIRC CONCR	0011/1489		LEN=0999 INSTALLED UNKN
LC TO NORTH AV (CONN)	0011/1164		
NORTH AV (CITY)	0011/1100		
018 "DIA CIRC CONCR	0011/0955		LEN=0099 INSTALLED UNKN
TRIPOLI ST (CITY)	0011/0910		
018 "DIA CIRC CONCR	0011/0877		LEN=0099 INSTALLED UNKN
* REF-AHD	0010/1697	001697	EAST ST (CITY) LC TO EAST ST (CITY)
	0010/1582		018 "DIA CIRC CONCR LEN=0999 INSTALLED UNKN
	0010/1535		024 "DIA CIRC CONCR LEN=0999 INSTALLED UNKN
	0010/1514		VISTA ST (CITY)
	0010/1416		015 "DIA CIRC CONCR LEN=0999 INSTALLED UNKN
	0010/1388		018 "H 48" W CON BOX CUL LEN=0999 INSTALLED UNKN
	0010/1316		CONCORD ST (CITY)
	0010/1294		RAMP S RD (SR8099 SEG 0010/0000)
	0010/1265		015 "DIA CIRC CONCR LEN=0999 INSTALLED UNKN
	0010/1180		SPRING GARDEN AV (CITY)
	0010/1137		016 "DIA CIRC CONCR LEN=0099 INSTALLED UNKN
	0010/1058		BLOSSOM WY (CITY)
	0010/1046		018 "DIA CIRC CONCR LEN=0999 INSTALLED UNKN
	0010/0920		TRIPOLI ST (CITY)

DIR: N TOTAL LEN: .321 MI. DIST: 11-1 SR: 4099
 LEFT MUN: PITTSBURGH C RIGHT MUN: PITTSBURGH C

Stationing	Description	Stationing	Description
0010/0862	016 "DIA CIRC CONCR LEN=0099 INSTALLED UNKN	0010/0811	016 "DIA CIRC CONCR LEN=0099 INSTALLED UNKN
0011/0791	018 "DIA CIRC CONCR LEN=0099 INSTALLED UNKN	0010/0770	LOVITT WAY (CITY)
0011/0730	THROPP ST (CITY)	0010/0722	016 "DIA CIRC CONCR LEN=0099 INSTALLED UNKN
0011/0645	018 "DIA CIRC CONCR LEN=0099 INSTALLED UNKN	0010/0637	016 "DIA CIRC CONCR LEN=0099 INSTALLED UNKN
0011/0610	SUISMON ST (CITY)	0010/0620	016 "DIA CIRC CONCR SUISMON ST (CITY)
0011/0582	015 "DIA CIRC CONCR LEN=0030 INSTALLED UNKN	0010/0563	012"H 36"W CON BOX CUL LEN=0999 INSTALLED UNKN
0011/0484	018 "DIA CIRC CONCR LEN=0099 INSTALLED UNKN	0010/0551	016 "DIA CIRC CONCR LEN=0030 INSTALLED UNKN
0011/0460	SHAWANO ST (CITY)	0010/0460	012"H 01"W CON BOX CUL PERALTA ST (CITY)
0011/0310	FORELAND ST (CITY)	0010/0255	PHINEAS ST (CITY)
0011/0160	EMLIN ST (CITY)	0010/0160	016 "DIA CIRC CONCR LEN=0099 INSTALLED UNKN
0010/0120	SIGN: CANTILEVER	0010/0120	BMSID 02/4099/0010/0120
0010/0038	018 "DIA CIRC CONCR LEN=0999 INSTALLED UNKN	0010/0038	018 "DIA CIRC CONCR LEN=0999 INSTALLED UNKN
000000 FT	2 0 00000 0 00 0000+00 000000 FT	000000 FT	0 0 00000 0 00 0000+00
NC EAST ST	OHIO ST	NC MA	MADISON AV
(SR4084 SEG 0060/0000)	(SR4084 SEG 0061/0000)	OHIO ST	(SR4084 SEG 0060/0285)
			(SR4084 SEG 0061/0285)
RAMP B FR E OHIO ST	INTER-BK	INTER-BK	MADISON AV CONN FR 28 S
(SR8121 SEG 0252/0000)			(SR8121 SEG 0542/0432)
MFC BEGIN = C			MFC BEGIN = C
LENGTH(AH 1665 BK 0000)	0011/0000	0010/0000	LENGTH(AH 1697 BK 0000)

EXTRACT DATE: 12/21/2020 ROADWAY MANAGEMENT SYSTEM PAGE NUMBER: 1454
PRINT DATE: 12/23/2020 SLD COUNTY/SR - ANNUAL PRINT COUNTY: ALLEGHENY

DIR: B TOTAL LEN: .074 MI. DIST: 11-1 SR: 4088
LEFT MUN: SEWICKLEY HEIGHTS B RIGHT MUN: SEWICKLEY HEIGHTS B

LITTLE SEWICKLEY RD 000391 FT
(SR4032 SEG 0100/0000) 0010/0391

0 0 00000 0 00 0000+00 000000 FT
AUDUBON RD
(SR4034 SEG 0010/0470) 0010/0000

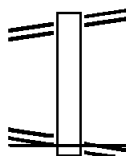

000391 FT LITTLE SEWICKLEY RD
0010/0391 (SR4032 SEG 0100/0000)
NC DUFF CITY RD
AUDUBON RD
000000 FT (SR4034 SEG 0010/0470)
MFC BEGIN = E
5 0010/0000 LENGTH(AH 0391 BK 0000)

DIR: B TOTAL LEN: 1.975 MI. DIST: 11-1 SR: 4086
 LEFT MUN: MCCANDLESS T RIGHT MUN: MCCANDLESS T

009398 FT

2 0 02130 0 00 0058+76 006148 FT
 OAKRIDGE DR
 (TWP) 0030/0000

0040/0665	LEN=0050	INSTALLED UNKN
	015 " DIA	CIRC CONCR
0040/0414	LEN=0045	INSTALLED UNKN
	FROM 0019/0550	SH
0040/0178	(CONN)	
009398 FT	2 0 02130 0 00	0094+35
	NC BL	AZIER DR
		PERRY HW
	(SR0019	SEG 0561/0000)
	(SR0019	SEG 0560/0000)
	MFC BEGIN = E	
0040/0000	LENGTH(AH 1030	BK 3250)
0030/3122	BMSSEN 02/4086/0030/3062	
	2 0 02130 0 00	0092+40
		PINE CREEK
0030/3086	BMSBG 02/4086/0030/3062	
	024 " DIA	CIRC CONCR
0030/2357	LEN=0035	INSTALLED UNKN
	024 " DIA	CIRC CONCR
0030/2110	LEN=0008	INSTALLED UNKN
	BELLCREST RD	
0030/2052	(TWP)	
	018 " DIA	CIRC CONCR
0030/1816	LEN=0035	INSTALLED UNKN
	018 " DIA	CIRC CONCR
0030/1229	LEN=0030	INSTALLED UNKN
	018 " DIA	CIRC CONCR
0030/0982	LEN=0030	INSTALLED UNKN
	018 " DIA	CIRC METAL
0030/0511	LEN=0030	INSTALLED UNKN
	018 " DIA	CIRC METAL
0030/0245	LEN=0035	INSTALLED UNKN
006148 FT		
0030/0000	LENGTH(AH 3250	BK 3690)
	HARMONY DR	
0020/3641	(TWP)	
	018 " DIA	CIRC CONCR
0020/3640	LEN=0024	INSTALLED UNKN
	036 " DIA	CIRC METAL
0020/3550	LEN=0030	INSTALLED UNKN
	015 " DIA	CIRC OTHER
0020/3045	LEN=0040	INSTALLED UNKN
	018 " DIA	CIRC CONCR
0020/2650	LEN=0099	INSTALLED UNKN
	012 " DIA	CIRC CONCR
0020/2540	LEN=0099	INSTALLED UNKN
	018 " DIA	CIRC CONCR

EXTRACT DATE: 12/21/2020
PRINT DATE: 12/23/2020

ROADWAY MANAGEMENT SYSTEM
SLD COUNTY/SR - ANNUAL PRINT

PAGE NUMBER: 1451
COUNTY: ALLEGHENY

DIR: B TOTAL LEN: 1.975 MI.
LEFT MUN: MCCANDLESS T

DIST: 11-1 SR: 4086
RIGHT MUN: MCCANDLESS T

MEINERT RD
(T496)

0020/1705

BARRINGTON DR
(TWP)

0010/2022

002458 FT

000000 FT

0020/2418	LEN=0035	INSTALLED UNKN
0020/2333	HIGHVIEW RD (TWP)	
0020/2332	036"H 36"W CON BOX CUL LEN=0099	INSTALLED UNKN
0020/1997	016"DIA CIRC CONCR LEN=0035	INSTALLED UNKN
0020/1860	018"DIA CIRC CONCR LEN=0035	INSTALLED UNKN
0020/1280	015"DIA CIRC CONCR LEN=0099	INSTALLED UNKN
0020/1078	012"DIA CIRC METAL LEN=0099	INSTALLED UNKN
0020/1050	018"DIA CIRC CONCR LEN=0024	INSTALLED UNKN
0020/0446	018"DIA CIRC METAL LEN=0030	INSTALLED UNKN
0020/0137	015"DIA CIRC CONCR LEN=0040	INSTALLED UNKN
002458 FT	2 0 02130 0 00 0022+49 MCCANDLESS	
0020/0000	FRANKLIN PARK B LENGTH(AH 3690 BK 2458)	
0010/1931	036"DIA CIRC CONCR LEN=0030	INSTALLED UNKN
0010/1186	012"DIA CIRC METAL LEN=0035	INSTALLED UNKN
0010/1050	018"DIA CIRC CONCR LEN=0040	INSTALLED UNKN
0010/0945	012"DIA CIRC CONCR LEN=0030	INSTALLED UNKN
0010/0271	024"DIA CIR PLASTIC LEN=0099	INSTALLED UNKN
0010/0179	018"DIA CIRC CONCR LEN=0030	INSTALLED UNKN
000000 FT	2 0 02130 0 00 0000+00 BRANDT SCHOOL RD (CNTY)	
0010/0000	NC P I NE CREEK RD INTER-BK BRANDT SCHOOL RD (CNTY)	
0010/0000	MFC BEGIN = D LENGTH(AH 2458 BK 0000)	

RAMP J/E OHIO ST TO 28 001066 FT
 (SR8121 SEG 0512/0000) INTER-AHD
 CHESTNUT ST
 (CITY)
 0061/0997
 LC TO CHESTNUT ST
 (CONN) 0061/0952
 SIGN: 4 CHORD TRUSS
 BMSID 02/4084/0060/0710 0061/0700
 099"H 01"W **UNKNOWN**
 LEN=0099 INSTALLED UNKN 0061/0575
 MADISON AV CONN FR 28 N
 (SR8121 SEG 0542/0432)
 MADISON AV
 (SR4099 SEG 0011/0000)
 (SR4099 SEG 0010/0000)
 BMS EN 02/4084/0060/0035 0061/0285
 0061/0269

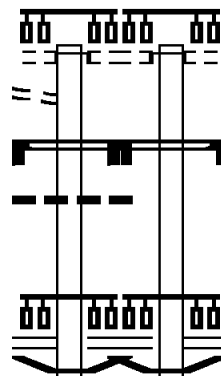

001066 FT
 INTER-AHD RAMP J/E OHIO ST TO 28
 (SR8121 SEG 0512/0000)
 CHESTNUT ST
 (CITY)
 0060/0997
 SIGN: 4 CHORD TRUSS
 BMSID 02/4084/0060/0710 0060/0710
 MADISON AV CONN FR 28 N
 (SR8121 SEG 0542/0432)
 MADISON AV
 (SR4099 SEG 0011/0000)
 (SR4099 SEG 0010/0000)
 0060/0285
 0060/0269 BMS EN 02/4084/0060/0035

EXTRACT DATE: 12/21/2020
PRINT DATE: 12/23/2020

ROADWAY MANAGEMENT SYSTEM
SLD COUNTY/SR - ANNUAL PRINT

PAGE NUMBER: 1449
COUNTY: ALLEGHENY

DIR: B TOTAL LEN: .202 MI.
LEFT MUN: PITTSBURGH C

DIST: 11-1 SR: 4084
RIGHT MUN: PITTSBURGH C

CROSSTOWN BL
OP ID 02/0579/0010/0000 0061/0250
I-579 HOV LN
OP ID 02/6579/0020/0000 0061/0165
CROSSTOWN BL
OP ID 02/0579/0011/0000 0061/0060
O O 00000 0 00 0000+00
LR 1021 HOV
BMSBG 02/4084/0060/0035 0061/0035

O O 00000 0 00 0000+00 000069 FT
NC E OHIO ST
RAMP B FR E OHIO ST
(SR8121 SEG 0252/0000)
EAST ST
(SR4099 SEG 0010/0000)
(SR4099 SEG 0011/0000)

MFC BEGIN = C
LENGTH(AH 0997 BK 1099) 0061/0000
000069 FT

LENGTH(AH 2848 BK 0618) 000069 FT
7041/0000
000069 FT
LENGTH(AH 0618 BK 0069) 7035/0000
BMSEN 02/7301/0000/3118
RIDGE AV
(CITY) REF-AHD
0033/0069

018"H 01"W UNKN CONC
LEN=0024 INSTALLED UNKN 0033/0044
O O 00000 0 0 0000+00 000000 FT
NC RIDGE AV
RIDGE AV REF-BK
(CITY)

BRIDGE CLOSED
NORFOLK SOUTHERN RAI RR
BMSBG 02/7301/0000/3118
MFC BEGIN = C
LENGTH(AH 0069 BK 0070) 0033/0000
000000 FT

LENGTH(AH 0070 BK 1450) 7031/0000
000000 FT
000000 FT
000000 FT

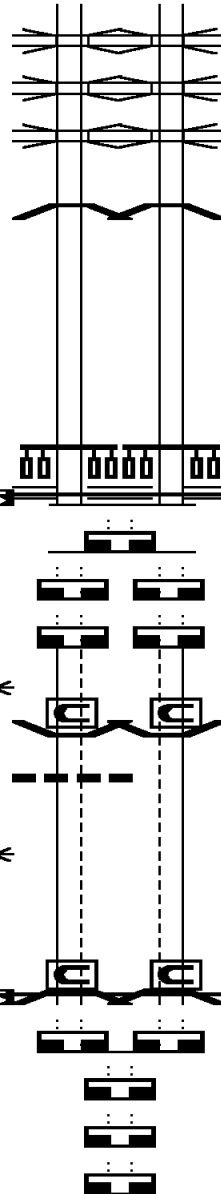

0060/0245
0060/0165
0060/0060
0060/0035
000069 FT
NC E

* REF-BK

0060/0000
000069 FT
7050/0000
000069 FT
7040/0000
000069 FT
7034/0000

* REF-AHD

0032/0069

000000 FT
NC R

* REF-BK

0032/0000
000000 FT
7030/0000
000000 FT
7020/0000
000000 FT
7010/0000
000000 FT
7006/0000

CROSSTOWN BL
OP ID 02/0579/0010/0000
I-579 HOV LN
OP ID 02/6579/0020/0000
CROSSTOWN BL
OP ID 02/0579/0011/0000
O O 00000 0 00 0000+00
LR 1021 HOV
BMSBG 02/4084/0060/0035
000000 0 00 0000+00
OHIO ST
RAMP B FR E OHIO ST
(SR8121 SEG 0252/0000)
EAST ST
(SR4099 SEG 0010/0000)
(SR4099 SEG 0011/0000)

RIDGE AV
(CITY)
MFC BEGIN = C
LENGTH(AH 0997 BK 1099)

LENGTH(AH 1099 BK 3513)
LENGTH(AH 3513 BK 0581)
LENGTH(AH 0581 BK 0069)
BMSEN 02/7301/0000/3118
RIDGE AV
(CITY)

2 0 02350 0 00 0005+74

RIDGE AV
(CITY)
BRIDGE CLOSED
NORFOLK SOUTHERN RAI RR
BMSBG 02/7301/0000/3118
MFC BEGIN = C
LENGTH(AH 0069 BK 0086)

LENGTH(AH 0086 BK 1450)
LENGTH(AH 1450 BK 1381)
LENGTH(AH 1381 BK 1966)
LENGTH(AH 1966 BK 0000)

EXTRACT DATE: 12/21/2020 ROADWAY MANAGEMENT SYSTEM PAGE NUMBER: 1448
 PRINT DATE: 12/23/2020 SLD COUNTY/SR - ANNUAL PRINT COUNTY: ALLEGHENY
 DIR: B TOTAL LEN: 1.734 MI. DIST: 11-1 SR: 4080
 LEFT MUN: KILBUCK T RIGHT MUN: KILBUCK T

009153 FT

008622 FT

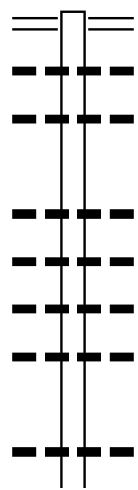

009153 FT OHIO RIVER BL
 (SR0065 SEG 0130/0487)
 0050/0531 (SR0065 SEG 0131/0525)
 018 " DIA CIRC CONCR
 0050/0520 LEN=0050 INSTALLED UNKN
 015 " DIA CIRC CONCR
 0050/0242 LEN=0040 INSTALLED UNKN
 008622 FT 2 0 02350 0 00 0005+74
 0050/0000 LENGTH(AH 0531 BK 2976)
 012 " DIA CAST IRON
 0040/2788 LEN=0040 INSTALLED UNKN
 024 " DIA CIRC METAL
 0040/2373 LEN=0050 INSTALLED UNKN
 024 " DIA CIRC CONCR
 0040/2309 LEN=0050 INSTALLED UNKN
 018 " DIA CIRC CONCR
 0040/2125 LEN=0060 INSTALLED UNKN
 018 " DIA CIR PLASTIC
 0040/1059 LEN=0060 INSTALLED UNKN

DIR: B TOTAL LEN: 1.734 MI. DIST: 11-1 SR: 4080
 LEFT MUN: KILBUCK T RIGHT MUN: KILBUCK T

UNKNOWN RD
(T456)

005646 FT
0040/0000

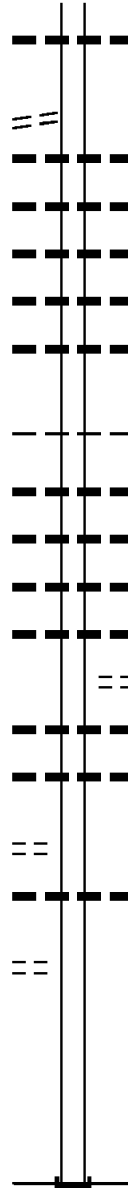

0040/0206	018 " DIA	CIRC METAL	LEN=0060	INSTALLED UNKN
005646 FT	2 0 02350	0 00 0035+40		
5 0040/0000	NC TOMS RUN RD	LENGTH(AH 2976 BK 1787)		
0030/1561	018 " DIA	CIRC METAL	LEN=0049	INSTALLED UNKN
0030/1245	015 " DIA	CIRC METAL	LEN=0040	INSTALLED UNKN
0030/0719	015 " DIA	CIRC METAL	LEN=0040	INSTALLED UNKN
0030/0152	015 " DIA	CIRC METAL	LEN=0040	INSTALLED UNKN
0030/0020	015 " DIA	CIRC METAL	LEN=0040	INSTALLED UNKN
003859 FT	2 0 02350	0 00 0053+06		
5 0030/0000	KILBUCK ALEPPO T	LENGTH(AH 1787 BK 2401)		
0020/2300	015 " DIA	CIRC METAL	LEN=0040	INSTALLED UNKN
0020/2140	015 " DIA	CIRC METAL	LEN=0032	INSTALLED UNKN
0020/1910	018 " DIA	CIRC CONCR	LEN=0040	INSTALLED UNKN
0020/1670	018 " DIA	CIRC CONCR	LEN=0030	INSTALLED UNKN
0020/1668	HILL RD (TWP)			
0020/1591	018 " DIA	CIRC CONCR	LEN=0126	INSTALLED UNKN
0020/1414	018 " DIA	CIRC CONCR	LEN=0030	INSTALLED UNKN
0020/0587	024 " DIA	CIR PLASTIC	LEN=0040	INSTALLED UNKN
2 0 02350 0 00 0077+00	001458 FT			
BERDINE DR (TWP)	0020/0000	5 0020/0000	LENGTH(AH 2401 BK 1458)	
000000 FT	000000 FT	2 0 02350 0 00 0092+19		
	INTER-BK DUFF RD (T452) MFC BEGIN = E			
	5 0010/0000	LENGTH(AH 1458 BK 0000)		

EXTRACT DATE: 12/21/2020 ROADWAY MANAGEMENT SYSTEM PAGE NUMBER: 1446
PRINT DATE: 12/23/2020 SLD COUNTY/SR - ANNUAL PRINT COUNTY: ALLEGHENY
DIR: B TOTAL LEN: .000 MI. DIST: 11-1 SR: 4078
LEFT MUN: RICHLAND T RIGHT MUN: RICHLAND T

000000 FT



000000 FT
7010/0000 LENGTH(AH 1383 BK 0000)

EXTRACT DATE: 12/21/2020 ROADWAY MANAGEMENT SYSTEM PAGE NUMBER: 1445
 PRINT DATE: 12/23/2020 SLD COUNTY/SR - ANNUAL PRINT COUNTY: ALLEGHENY
 DIR: B TOTAL LEN: 1.552 MI. DIST: 11-1 SR: 4076
 LEFT MUN: RICHLAND T RIGHT MUN: RICHLAND T

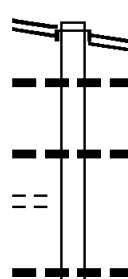
	008197 FT		008197 FT	
BAKERSTOWN RD (SR4068 SEG 0150/1790)	0030/3392		INTER-AHD	HILLCREST DR (TWP)
			0030/3392	BAKERSTOWN RD (SR4068 SEG 0150/1790)
			0030/3259	024 " DIA CIRC CONCR LEN=0050 INSTALLED UNKN
FOGGY HOLLOW DR (TWP)	0030/2082		0030/2388	018 " DIA CIRC CONCR LEN=0080 INSTALLED UNKN
			0030/1378	036 " DIA CIRC CONCR LEN=0045 INSTALLED UNKN

DIR: B TOTAL LEN: 1.552 MI. DIST: 11-1 SR: 4076
 LEFT MUN: RICHLAND T RIGHT MUN: RICHLAND T

CHESSROWN AV
 (T824)

0030/0165
 004805 FT

2 0 02108 0 00 0072+33 001142 FT
 DAMBACH AV
 (T580)

2 0 02108 0 00 0083+97 000000 FT
 THREE DEGREE RD
 (SR4031 SEG 0180/3013) 0010/0000

0030/0524	015 " DIA	CIRC CONCR
	LEN=0040	INSTALLED UNKN
0030/0159	020 " DIA	CIRC METAL
004805 FT	LEN=0055	INSTALLED UNKN
0030/0000	2 0 02108 0 00 0035+45	LENGTH(AH 3392 BK 3663)
0020/3532	024 " DIA	CIRC CONCR
	LEN=0040	INSTALLED UNKN
0020/3195	044 " DIA	CIR PLASTIC
	LEN=0040	INSTALLED UNKN
0020/2874	020 " DIA	CIR PLASTIC
	LEN=0040	INSTALLED UNKN
0020/2185	016 " DIA	CIRC CONCR
	LEN=0045	INSTALLED UNKN
0020/1895	016 " DIA	CIRC CONCR
	LEN=0040	INSTALLED UNKN
0020/1551	016 " DIA	CIRC CONCR
	LEN=0040	INSTALLED UNKN
0020/1303	024 " DIA	CIRC METAL
	LEN=0035	INSTALLED UNKN
0020/1101	014 " DIA	CIRC CONCR
	LEN=0030	INSTALLED UNKN
0020/0949	018 " DIA	CIRC METAL
	LEN=0035	INSTALLED UNKN
0020/0811	024 " DIA	CIRC CONCR
	LEN=0035	INSTALLED UNKN
0020/0362	018 " DIA	CIRC OTHER
	LEN=0035	INSTALLED UNKN
0020/0157	016 " DIA	CIRC CONCR
001142 FT	LEN=0099	INSTALLED UNKN
0020/0000	LENGTH(AH 3663 BK 1142)	
0010/0985	015 " DIA	CIRC CONCR
	LEN=0060	INSTALLED UNKN
0010/0806	SECOND ST (T560)	
0010/0794	018 " DIA	CIRC METAL
	LEN=0030	INSTALLED UNKN
0010/0200	FIRST ST (T257)	
	NC VA LENCIA RD	
000000 FT	BABCOCK BL (SR4031 SEG 0180/3013)	
0010/0000	MFC BEGIN = D LENGTH(AH 1142 BK 0000)	

EXTRACT DATE: 12/21/2020 ROADWAY MANAGEMENT SYSTEM PAGE NUMBER: 1443
 PRINT DATE: 12/23/2020 SLD COUNTY/SR - ANNUAL PRINT COUNTY: ALLEGHENY
 DIR: B TOTAL LEN: .088 MI. DIST: 11-1 SR: 4075
 LEFT MUN: ROSS T RIGHT MUN: ROSS T

ROCHESTER RD 000465 FT
 (SR4011 SEG 0100/0525) 0010/0465
 000000 FT

LOWRIES RUN RD
 (SR4021 SEG 0070/2810) 0010/0000

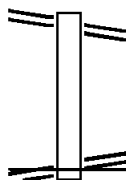

000465 FT ROCHESTER RD
 0010/0465 (SR4011 SEG 0100/0525)
 000000 FT 0 0 00000 0 00 0000+00
 LOWRIES RUN RD
 (SR4021 SEG 0070/2810)
 NC RO CHESTER CONNECTOR
 MFC BEGIN = E
 0010/0000 LENGTH(AH 0465 BK 0000)

EXTRACT DATE: 12/21/2020 ROADWAY MANAGEMENT SYSTEM PAGE NUMBER: 1442
PRINT DATE: 12/23/2020 SLD COUNTY/SR - ANNUAL PRINT COUNTY: ALLEGHENY
DIR: B TOTAL LEN: .000 MI. DIST: 11-1 SR: 4074
LEFT MUN: PINE T RIGHT MUN: PINE T

000000 FT



000000 FT
7010/0000 LENGTH(AH 1372 BK 0000)

DIR: B TOTAL LEN: .290 MI. DIST: 11-1 SR: 4073
 LEFT MUN: PINE T RIGHT MUN: PINE T

001532 FT

001532 FT
 INTER-AHD MANOR RD
 (T697)
 PERRY HW
 (SR0019 SEG 0621/0000)
 0010/1532 PERRY HW
 (SR0019 SEG 0610/2946)
 0010/1498 016 " DIA CIRC CONCR
 0010/1307 LEN=0020 INSTALLED UNKN
 0010/1221 016 " DIA CIRC CONCR
 LEN=0020 INSTALLED UNKN
 (APRA) WEXFORD VOLUNTEER
 WEXFORD VOLUNTEER FIRE
 (PRDR)
 0010/0631 016 " DIA CIRC CONCR
 0010/0101 LEN=0099 INSTALLED UNKN
 026 " DIA CIRC CONCR
 0010/0037 LEN=0030 INSTALLED UNKN
 000000 FT 0 0 00000 0 00 0000+00
 NC NO NORTH CHAPEL DR
 WEXFORD RD
 (SR0910 SEG 0060/1130)
 0010/0000 MFC BEGIN = E
 LENGTH(AH 1532 BK 0000)

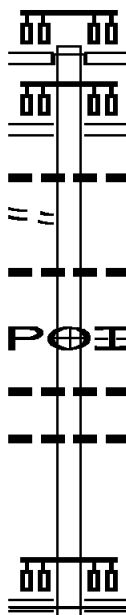

FROM 0019/0610 SH
 (CONN)

0010/1274

000000 FT

000021 FT
 000021 FT
 000021 FT

 000000 FT

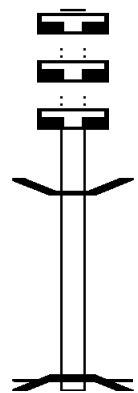

000021 FT
 7020/0000 LENGTH(AH 3207 BK 2140)
 000021 FT
 7014/0000 LENGTH(AH 2140 BK 0297)
 000021 FT
 7010/0000 LENGTH(AH 0297 BK 0021)
 BMSSEN 02/4072/0010/0000
 * REF-AHD (TBK) SLOOP RD
 0010/0021 (TWP)
 000000 FT 2 0 02102 0 00 0005+62
 NC SLOOP RD
 * REF-BK (TBK) SLOOP RD
 (TWP)
 LOWRIES RUN
 BMSBG 02/4072/0010/0000
 MFC BEGIN = E
 0010/0000 LENGTH(AH 0021 BK 0000)

001507 FT

000000 FT

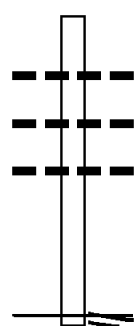

```

* 001507 FT
  REF-AHD GLENFIELD RD
  0010/1507 (CNTY)
           018 "DIA CIRC CONCR
           LEN=0035 INSTALLED UNKN
           180 "DIA CIRC CONCR UNKN
  0010/0895 LEN=0030 INSTALLED UNKN
           018 "DIA CIRC CONCR
  0010/0490 LEN=0030 INSTALLED UNKN
  000000 FT 0 0 00000 0 00 0000+00
           NC KI LBUCK ST
           KILBUCK ST
           (SR4033 SEG 0010/1424)
           MFC BEGIN = C
  0010/0000 LENGTH(AH 1507 BK 0000)
  
```

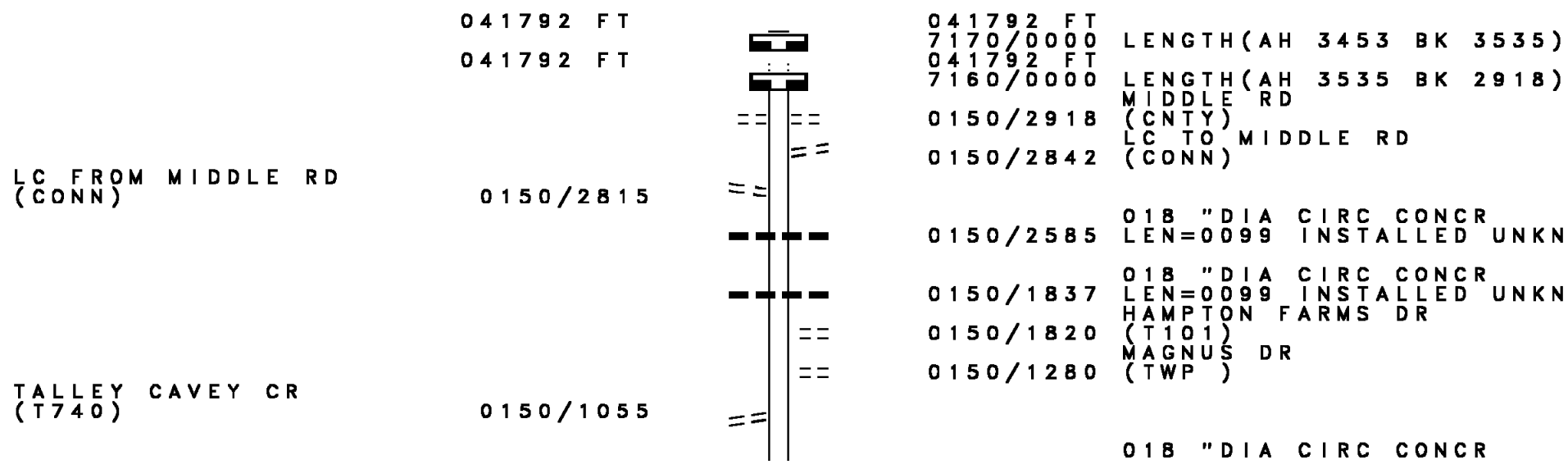

LC FROM MIDDLE RD
(CONN)

TALLEY CAVEY CR
(T740)

041792 FT
041792 FT

0150/2815

0150/1055

041792 FT
7170/0000 LENGTH(AH 3453 BK 3535)
041792 FT
7160/0000 LENGTH(AH 3535 BK 2918)
MIDDLE RD
(CNTY)
0150/2918 LC TO MIDDLE RD
(CONN)
0150/2842
0150/2585 018 " DIA CIRC CONCR
LEN=0099 INSTALLED UNKN
0150/1837 018 " DIA CIRC CONCR
LEN=0099 INSTALLED UNKN
HAMPTON FARMS DR
(T101)
MAGNUS DR
0150/1820
0150/1280 (TWP)

018 " DIA CIRC CONCR

DIR: B TOTAL LEN: 7.915 MI. DIST: 11-1 SR: 4070
 LEFT MUN: HAMPTON T RIGHT MUN: HAMPTON T

TALLEY CAVEY CR
 (T740)

0150/0250
 038874 FT



0150/0345 LEN=0040 INSTALLED UNKN

038874 FT 1 0 00390 0 00 0030+88
 018 " DIA CIRC CONCR
 LEN=0035 INSTALLED UNKN

0150/0000 LENGTH(AH 2918 BK 2936)
 018 " DIA CIRC CONCR

0140/2865 LEN=0040 INSTALLED UNKN
 HIDDEN POND DR

0140/2327 (T103)
 018 " DIA CIRC CONCR

0140/1973 LEN=0030 INSTALLED UNKN

TALLEY CAVEY RD
 (TWP)

0140/1710



0140/1381 HAMPTON VALLEY DR
 (TWP)

0140/0860 SCHOOL RD
 (TWP)

0140/0694 018 " DIA CIRC CONCR
 LEN=0064 INSTALLED UNKN

0140/0322 018 " DIA CIRC CONCR
 LEN=0040 INSTALLED UNKN

0140/0158 018 " DIA CIRC CONCR
 LEN=0099 INSTALLED UNKN

035938 FT

035938 FT 1 0 00390 0 00 0000+00
 NC W I LDWOOD RD ET

WILLIAM FLINN HW
 (SR0008 SEG 0341/1480)
 (SR0008 SEG 0340/1505)



0140/0000 MFC BEGIN = D
 LENGTH(AH 2936 BK 2987)

0130/2930 018 " DIA CIRC CONCR
 LEN=0064 INSTALLED UNKN

0130/2528 018 " DIA CIRC CONCR
 LEN=0030 INSTALLED UNKN

0130/2128 018 " DIA CIRC CONCR
 LEN=0030 INSTALLED UNKN

0130/1668 018 " DIA CIRC CONCR
 LEN=0030 INSTALLED UNKN

BELLA VISTA DR
 (T578)

0130/1386

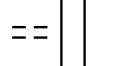

0130/1364 018 " DIA CIRC CONCR
 LEN=0030 INSTALLED UNKN

0130/1033 024 " DIA CIRC CONCR
 LEN=0030 INSTALLED UNKN

0130/0566 BMSSEN 02/4070/0130/0537
 2 0 02280 0 01 0125+22

CROUSE RUN

DIR: B TOTAL LEN: 7.915 MI. DIST: 11-1 SR: 4070
 LEFT MUN: HAMPTON T RIGHT MUN: HAMPTON T

ROAD NAME	START	END	LENGTH	STATUS	DETAILS
GROUSE RUN RD (TWP)	0130/0449	0130/0432	032951 FT	==	0130/0537 BMSBG 02/4070/0130/0537 018 " DIA CIRC CONCR LEN=0030 INSTALLED UNKN 032951 FT 2 0 02280 0 01 0122+46 5 0130/0000 LENGTH(AH 2987 BK 1225)
GREENWOOD DR (TWP)	0124/0932	0124/0510		==	TRILLIUM TRAIL RD (TWP)
ROLAND RD (TWP)	0124/0510	0124/0475		==	012 " DIA CIR PLASTIC LEN=0040 INSTALLED UNKN
		0124/0445		==	018 " DIA CIRC CONCR LEN=0030 INSTALLED 2002
		0124/0058	031726 FT	==	018 " DIA CIRC CONCR LEN=0005 INSTALLED UNKN 031726 FT 0 0 00000 0 00 0000+00 SYLVAN DR (T991)
		0124/0000		5	5 0124/0000 LENGTH(AH 1225 BK 2920)
LUCY DR (TWP)	0120/2735	0120/2839		==	018 " DIA CIRC CONCR LEN=0081 INSTALLED UNKN
OAKHURST AV (TWP)	0120/2350	0120/1969		==	030 " DIA CIR PLASTIC LEN=0099 INSTALLED UNKN
		0120/1900		==	VITULLO DR (TWP)
MAPLEHURST AV (TWP)	0120/1770	0120/0520		==	018 " DIA CIRC CONCR LEN=0502 INSTALLED UNKN
		0120/0360		==	WILDWOOD SAMPLE RD (SR4067 SEG 0030/0000)
WEST HARDIES RD (SR4067 SEG 0030/0000)	0120/0360	0120/0000	028806 FT	==	5 0120/0000 LENGTH(AH 2920 BK 3291) 0110/3244 BMSEN 02/4070/0110/2852 2 0 02280 0 01 0076+78
		0110/2852		==	WILLOW RUN BMSBG 02/4070/0110/2852
		0110/2817		==	018 " DIA CIRC CONCR LEN=0060 INSTALLED 2002 024 " DIA CIRC CONCR

DIR: B TOTAL LEN: 7.915 MI. DIST: 11-1 SR: 4070
 LEFT MUN: HAMPTON T RIGHT MUN: HAMPTON T

Location	Segment ID	Start Station	End Station	Length	Material	Notes
VENTURE DR (TWP)	0110/2613			LEN=0060	INSTALLED UNKN	
				030 "DIA	CIRC CONCR	
	0110/2158			LEN=0060	INSTALLED UNKN	
				024 "DIA	CIRC METAL	
	0110/1916			LEN=0040	INSTALLED UNKN	
				012 "DIA	CIR PLASTIC	
	0110/1375			LEN=0050	INSTALLED UNKN	
				018 "DIA	CIRC METAL	
	0110/1326			LEN=0010	INSTALLED UNKN	
				030 "DIA	CIRC CONCR	
2 0 02280 0 01 0048+46 025515 FT HARDT RD (SR4065 SEG 0010/0000)	0110/1325			LEN=0030	INSTALLED UNKN	
				024 "DIA	CIRC METAL	
	0110/0960			LEN=0001	INSTALLED UNKN	
				024 "DIA	CIRC CONCR	
	0110/0959			LEN=0040	INSTALLED UNKN	
				018 "DIA	CIRC CONCR	
	0110/0705			LEN=0099	INSTALLED UNKN	
				018 "DIA	CIRC CONCR	
	0110/0272			LEN=0099	INSTALLED UNKN	
				025515 FT		
MONTOUR RD (T988)	0110/0000			LENGTH(AH 3291 BK 2601)		
	0100/2514			BMSSEN 02/4070/0100/2496		
AU SABLE DR (TWP)	0100/2471			2 0 02280 0 01 0022+40		
				MONTOUR RUN		
COUNTRY LN (TWP)	0100/2365			BMSBG 02/4070/0100/2496		
	0100/2109			018 "DIA CIRC CONCR		
ANDREWS DR (TWP)	0100/1430			LEN=0099 INSTALLED UNKN		
				ENT TO CO WASTE STATIO		
	0100/1045			(TWP)		
ANDREWS DR (TWP)	0100/0987			012 "DIA CIRC CONCR		
				LEN=0099 INSTALLED UNKN		
ANDREWS DR (TWP)	0100/0665			018 "DIA CIRC CONCR		
				LEN=0060 INSTALLED UNKN		
ANDREWS DR (TWP)	0100/0608			018 "H 00 "W MULT CONCR		
				LEN=0060 INSTALLED 2019		
ANDREWS DR (TWP)	0100/0570			018 "DIA CIR PLASTIC		
				LEN=0060 INSTALLED 2019		
	0100/0195			022914 FT		
	022914 FT			2 0 02280 0 01 0022+40		
				LENGTH(AH 2601 BK 2230)		
				018 "DIA CIR PLASTIC		

DIR: B TOTAL LEN: 7.915 MI. DIST: 11-1 SR: 4070
 LEFT MUN: HAMPTON T RIGHT MUN: HAMPTON T

MANSIONS DR
 (TWP)

0090/0787

020684 FT

018509 FT

NORTH PARK ENT RD
 (CNTY)

0070/0710

0090/2030	LEN=0035	INSTALLED	2002
0090/1770	MCCANDLESS T		
0090/1700	BMSEN 02/4070/0090/1659		
	2 0 02280 0 00 0016+57		
	PINE CREEK		
0090/1659	BMSBG 02/4070/0090/1659		
	018 "DIA CIRC PLASTIC		
0090/1160	LEN=0040	INSTALLED	2002
	OLD BABCOCK RD		
0090/0775	(TWP)		
	018 "DIA CIRC CONCR		
0090/0411	LEN=0045	INSTALLED	UNKN
020684 FT	2 0 02280 0 00 0000+00		
	NC WI LDWOOD RD		
	BABCOCK BL		
	(SR4031 SEG 0070/0000)		
0090/0000	LENGTH(AH 2230 BK 2175)		
	018 "DIA CIRC CONCR		
0080/1835	LEN=0099	INSTALLED	UNKN
	018 "DIA CIRC CONCR		
0080/1622	LEN=0040	INSTALLED	UNKN
	018 "DIA CIRC CONCR		
0080/1313	LEN=0045	INSTALLED	UNKN
	012 "DIA CIRC CONCR		
0080/1018	LEN=0040	INSTALLED	UNKN
	018 "DIA CIRC CONCR		
0080/0818	LEN=0040	INSTALLED	UNKN
	018 "DIA CIRC CONCR		
0080/0245	LEN=0099	INSTALLED	UNKN
	OLD INGOMAR RD		
0080/0234	(CNTY)		
018509 FT	2 0 02279 0 00 0184+75		
0080/0000	LENGTH(AH 2175 BK 1697)		
	018 "DIA CIRC CONCR		
0070/1598	LEN=0099	INSTALLED	UNKN
	018 "DIA CIRC CONCR		
0070/1423	LEN=0099	INSTALLED	UNKN
	018 "DIA CIRC CONCR		
0070/1175	LEN=0099	INSTALLED	UNKN
	018 "DIA CIRC CONCR		
0070/0979	LEN=0099	INSTALLED	UNKN
	(APRA) NORTH PARK		
0070/0710	015 "DIA CIRC CONCR		
0070/0669	LEN=0061	INSTALLED	UNKN

POI

DIR: B TOTAL LEN: 7.915 MI. DIST: 11-1 SR: 4070
 LEFT MUN: MCCANDLESS T RIGHT MUN: MCCANDLESS T

2 0 02279 0 00 0168+30 016812 FT
 NORTH PARK ENT RD
 (CNTY) 0070/0000

GRUBBS RD (TBK)
 (TWP) 0060/0927

013628 FT

LC TO BLAZIER DR
 (CONN) 0050/2020

BLAZIER DR
 (TWP) 0050/1950

LC TO BLAZIER DR
 (CONN) 0050/1892

Stationing	Length	Material	Notes
0070/0000	1697	012" DIA CIRC CONCR	BK 3184
0060/2883	0035	018" DIA CIRC CONCR	INSTALLED UNKN
0060/2624	0035	018" DIA CIRC CONCR	INSTALLED UNKN
0060/2243	0035	018" DIA CIRC CONCR	INSTALLED UNKN
0060/1945	0099	018" DIA CIRC CONCR	INSTALLED UNKN
0060/1716	0099	018" DIA CIRC CONCR	INSTALLED UNKN
0060/1649	0080	060" DIA CIRC CONCR	INSTALLED UNKN
0060/1569		KUMMER RD (TWP)	
0060/1479	0035	018" DIA CIRC CONCR	INSTALLED UNKN
0060/1057	0040	018" DIA CIRC CONCR	INSTALLED UNKN
0060/0679	0050	018" DIA CIRC CONCR	INSTALLED UNKN
0060/0178	0099	024" DIA CIRC CONCR	INSTALLED UNKN
0060/0000	3184	018" DIA CIRC CONCR	BK 3313
0050/2357	0040	018" DIA CIRC CONCR	INSTALLED UNKN
0050/1973	0030	018" DIA CIRC CONCR	INSTALLED UNKN
0050/1950		POWERS DRIVE (TWP)	
0050/1933	0099	036" DIA CIRC CONCR	INSTALLED UNKN
0050/1777	0099	018" DIA CIRC CONCR	INSTALLED UNKN

DIR: B TOTAL LEN: 7.915 MI. DIST: 11-1 SR: 4070
 LEFT MUN: MCCANDLESS T RIGHT MUN: MCCANDLESS T

Segment Description	Start Station	End Station	Material / Notes
	010315 FT	0050/0511	018 " DIA CIRC CONCR LEN=0035 INSTALLED UNKN
		010315 FT	2 0 02279 0 00 0104+75 SARATOGA DR (TWP)
		0050/0000	LENGTH(AH 3313 BK 1808) RAMP A RD (SR8069 SEG 0010/0600)
RAMP C RD (SR8069 SEG 0750/0871)	0040/1440	0040/1286	BMS EN 02/4070/0040/1265 2 0 02279 0 00 0097+94 BR. PINE CR.
		0040/1265	BMS BG 02/4070/0040/1265 MCKNIGHT RD. NB
RAMP D RD (SR8069 SEG 0500/0000)	0040/0852	0040/1057	OP ID 02/4003/0150/0000
		0040/0645	RAMP B RD (SR8069 SEG 0250/0000) DELL LN (TWP)
		0040/0480	018 " DIA CIRC CONCR LEN=0060 INSTALLED UNKN
008507 FT		0040/0068	2 0 02279 0 00 0085+25
		0040/0000	LENGTH(AH 1808 BK 1417) 012 " DIA CIRC METAL LEN=0099 INSTALLED UNKN
		0030/1147	018 " DIA CIRC METAL LEN=0099 INSTALLED UNKN
		0030/0793	NORTHVIEW DR (TWP)
		0030/0451	018 " DIA CIRC CONCR LEN=0099 INSTALLED UNKN
		0030/0363	018 " DIA CIRC CONCR LEN=0099 INSTALLED UNKN
007090 FT		0030/0057	2 0 02279 0 00 0071+73 PERRY HW (SR0019 SEG 0551/0000) (SR0019 SEG 0550/0000)
		0030/0000	LENGTH(AH 1417 BK 3494)
		0020/2479	024 " DIA CIRC METAL LEN=0099 INSTALLED UNKN
		0020/1482	024 " DIA CIRC METAL LEN=0035 INSTALLED UNKN

DIR: B TOTAL LEN: 7.915 MI. DIST: 11-1 SR: 4070
 LEFT MUN: MCCANDLESS T RIGHT MUN: MCCANDLESS T

Location / TWP / Conn	Segment ID	Length	Material / Notes
VALLEY VIEW RD (TWP)	0020/1020		
	0020/0775	024 " DIA	CIRC METAL INSTALLED UNKN
	0020/0380	024 " DIA	CIRC CONCR INSTALLED 2002
KREPP CT (TWP)	0020/0160		
	0020/0021	024 " DIA	CIRC METAL INSTALLED UNKN
	0020/0002	024 " DIA	CIRC OTHER INSTALLED UNKN
003596 FT	003596 FT	2 0 02279	0 00 0036+17
		SUNSET RD (TWP)	
GROSICK RD (TWP)	0010/3000		LENGTH(AH 3494 BK 3596)
		HARDING RD (TWP)	
BELLCREST RD (TWP)	0010/2432		
		HARMONY DR (TWP)	
MCCUTCHEON AV (TWP)	0010/1505		
		VALLEY RD (TWP)	
BRANT AV (TWP)	0010/0995		
EAST RD (TWP)	0010/0560		
	0010/0310	030 " DIA	CIRC CONCR INSTALLED UNKN
	0010/0123	018 " DIA	CIRC CONCR INSTALLED UNKN
LINDSAY RD (TWP)			
LC TO INGOMAR RD (CONN)	0010/0116		
	000000 FT	2 0 02279	0 00 0000+00
		HIGHLAND ROAD (CNTY)	
		NC IN INGOMAR RD	
		INTER-BK INGOMAR HTS RD (TWP)	
INGOMAR RD (CNTY)	0010/0000		MFC BEGIN = C LENGTH(AH 3596 BK 0000)

DIR: B TOTAL LEN: .390 MI. DIST: 11-1 SR: 4069
 LEFT MUN: PINE T RIGHT MUN: PINE T

002060 FT

000000 FT

WALLACE RD (SR4068 SEG 0090/1420) 0010/0000

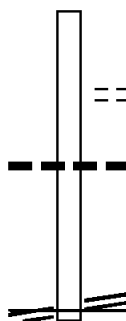

* 002060 FT AH-BUTLER (10)
 REF-AHD WARRENDALE RD
 0010/2060 (SR3019 SEG 0010/0000)
 WEST GROVE TRACE RD
 0010/1175 (TWP)
 018 " DIA CIRC CONCR
 0010/0506 LEN=0035 INSTALLED UNKN
 000000 FT 2 0 02139 0 00 0000+00
 WALLACE RD
 (SR4068 SEG 0090/1420)
 NC MARS RD
 MFC BEGIN = D
 0010/0000 LENGTH(AH 2060 BK 0000)

DIR: E TOTAL LEN: 9.115 MI. DIST: 11-1 SR: 4068
 LEFT MUN: RICHLAND T RIGHT MUN: RICHLAND T

048108 FT

RAMP B RD
 (SR8040 SEG 0750/0000) 0190/2130
 TO 8040/0750 SH 0190/2050
 (CONN)

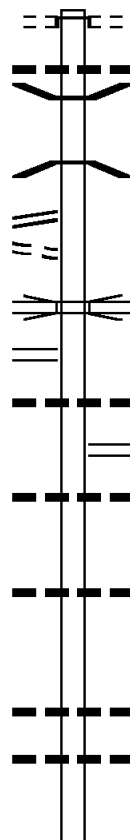

045455 FT

048125 FT
 INTER-AHD BAKERSTOWN RD
 (SR1028 SEG 0010/0000)
 HECKERT RD
 (T760)
 0190/2653 018 " DIA CIRC CONCR
 0190/2406 LEN=0030 INSTALLED UNKN
 0190/2388 BMSSEN 02/4068/0190/2378
 2 0 02273 0 00 0213+57
 DEER CREEK
 0190/2378 BMSBG 02/4068/0190/2378

0190/2006 OP ID RT 0008 NB
 RAMP X RD 02/0008/0440/0000
 (SR8040 SEG 0500/0310)
 0190/1950 018 " DIA CIRC METAL
 LEN=0099 INSTALLED UNKN
 RAMP R RD
 0190/1846 (SR8040 SEG 0250/0000)
 018 " DIA CIRC CONCR
 0190/1772 LEN=0040 INSTALLED UNKN

0190/1695 018 " DIA CIRC CONCR
 LEN=0099 INSTALLED UNKN

0190/0617 018 " DIA CIRC CONCR
 LEN=0099 INSTALLED UNKN

045472 FT 2 0 02273 0 00 0190+41
 012 " DIA CIRC CONCR
 LEN=0015 INSTALLED UNKN
 0190/0000 LENGTH(AH 2653 BK 2218)
 018 " DIA CIRC CONCR
 0180/1883 LEN=0099 INSTALLED UNKN

DIR: E TOTAL LEN: 9.115 MI. DIST: 11-1 SR: 4068
 LEFT MUN: RICHLAND T RIGHT MUN: RICHLAND T

Stationing	Location	Material	Length	Notes
043237 FT		012 " DIA CIR	0053	UNKNOWN
043254 FT		LEN=0099		INSTALLED UNKN
0180/0000		2 0 02273 0 00	0167+49	LENGTH(AH 2218 BK 2115)
041122 FT		012 " DIA CIRC METAL	0712	INSTALLED UNKN
041139 FT		2 0 02273 0 00	0146+34	FAITH WY (TWP)
0170/0000		LEN=0036		INSTALLED UNKN
0170/0000		018 " DIA CIR	0000	CONCR
0160/3069		LEN=0050		INSTALLED UNKN
0160/2935		018 " DIA CIRC CONCR		LEN=0099 INSTALLED UNKN
0160/1892		MERIDIAN RD (CNTY)		
0160/1570		012 " DIA CIR	0000	CONCR
0160/1455		LEN=0030		INSTALLED UNKN
0160/1158		POLLOCK DR (TWP)		
0160/1158		018 " DIA CIR	0000	CONCR
0160/1158		LEN=0040		INSTALLED UNKN
037653 FT		037670 FT		
0160/0000		LEN=0000		LENGTH(AH 3469 BK 3735)
0150/3710		GRUBBS RD (T584)		
0150/3350		STATION HILL RD (CNTY)		
0150/3320		018 " DIA CIR	0000	CONCR
0150/3295		LEN=0030		INSTALLED UNKN
0150/2873		018 " DIA CIR	0000	CONCR
0150/2708		LEN=0027		INSTALLED UNKN
0150/2524		BMS EN 02/4068/0150/2524		
0150/2524		2 0 02273 0 00	0099+58	CSX RR
0150/2524		BMS BG 02/4068/0150/2524		

DIR: E TOTAL LEN: 9.115 MI. DIST: 11-1 SR: 4068
 LEFT MUN: RICHLAND T RIGHT MUN: RICHLAND T

ROAD NAME	SEGMENT	START STATION	END STATION	LENGTH (FT)	DESCRIPTION
VALENCIA RD	(SR4076 SEG 0030/3392)	0150/1790	0150/1759	31	018" DIA CIRC CONCR LEN=0035 INSTALLED UNKN
		0150/1759	0150/0995	764	018" DIA CIRC CONCR LEN=0027 INSTALLED UNKN HILLCREST DR (TWP)
		0150/0995	0150/0000	995	016" DIA CIRC CONCR LEN=0045 INSTALLED UNKN
		0150/0000	0140/3143	1495	012" DIA CIRC CONCR LEN=0030 INSTALLED UNKN
		0140/3143	0140/2985	158	016" DIA CIRC CONCR LEN=0030 INSTALLED UNKN
		0140/2985	0140/2196	789	MONTOUR RD (T576)
		0140/2196	0140/0992	1204	FARVUE DR (TWP)
		0140/0992	0140/0369	623	016" DIA CIRC CONCR LEN=0036 INSTALLED UNKN
		0140/0369	0140/0038	331	RICHLAND PINE T
		0140/0038	0140/0000	38	016" DIA CIRC CONCR LEN=0036 INSTALLED UNKN
OLD STATE RD	(T574)	0130/3310	0130/1668	1642	018" DIA CIR PLASTIC LEN=0040 INSTALLED UNKN
		0130/1668	0130/1150	518	
BRIERLY LN	(TWP)	0130/1150	0130/0659	491	
TERRYWOOD LN	(TWP)	0130/0659	026529	25670	KERSTOWN RD

EXTRACT DATE: 12/21/2020
PRINT DATE: 12/23/2020

ROADWAY MANAGEMENT SYSTEM
SLD COUNTY/SR - ANNUAL PRINT

PAGE NUMBER: 1426
COUNTY: ALLEGHENY

DIR: E TOTAL LEN: 9.115 MI.
LEFT MUN: PINE T

DIST: 11-1 SR: 4068
RIGHT MUN: PINE T

2 0 02273 0 00 0000+00 026512 FT
BABCOCK BL
(SR4031 SEG 0160/1599) 0130/0000
026512 FT

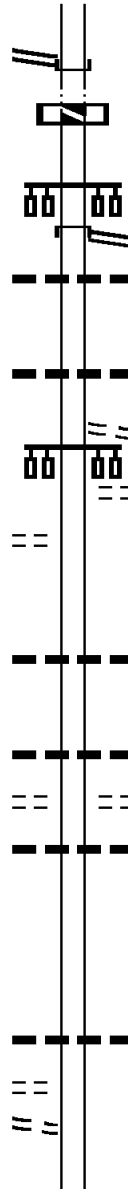

INTER-BK BABCOCK BL
(SR4031 SEG 0160/1599)
LTH AH 003579 BK 000100
0130/0000
026529 FT
7124/0000
INTER-AHD BABCOCK BL
(SR4031 SEG 0160/0000)

BABCOCK BL
(SR4031 SEG 0160/0000)
0120/2406
018 " DIA CIRC CONCR
0120/2088 LEN=0065 INSTALLED UNKN

0120/0943 016 " DIA CIRC CONCR
LEN=0035 INSTALLED UNKN
LC FROM PINE RICHLAND S
0120/0881 (CONN)
PINE RCHLND SCHOOL ENT
(PRDR)
0120/0836

POPLAR LN
(PRDR) 0120/0800
024106 FT

024123 FT 2 0 02272 0 00 0271+00
0120/0000 LENGTH(AH 2406 BK 2471)
016 " DIA CIR PLASTIC
0110/2075 LEN=0030 INSTALLED UNKN

OAK PARK DR
(TWP) 0110/0705
021635 FT

0110/0908 018 " DIA CIRC CONCR
LEN=0025 INSTALLED UNKN
EAST RIDGE DR
0110/0705 (TWP)
095 " DIA CIRC CONCR
0110/0670 LEN=0099 INSTALLED UNKN
021652 FT 2 0 02272 0 00 0225+08
0110/0000 LENGTH(AH 2471 BK 3870)

TREESDALE DR
(T560) 0100/2320
LC FROM TREESDALE DR
(CONN) 0100/2250

0100/2386 024 " DIA CIRC CONCR
LEN=0030 INSTALLED UNKN

DRAINAGE
STRUCTURE LENGTH 16 FT

DIR: E TOTAL LEN: 9.115 MI. DIST: 11-1 SR: 4068
 LEFT MUN: PINE T RIGHT MUN: PINE T

Location / Segment	Start Station	End Station	Length (FT)	Material / Notes
ORCHARD DR (TWP)	0100/1565	0100/2090	0100/2090	BMSID 02/4068/0100/2090
		0100/2036	0100/2036	020" DIA CIRC CONCR
		0100/1565	0100/1565	LEN=0033 INSTALLED UNKN SOUTH LAKE DR (TWP)
	017765 FT	0100/0070	017782 FT	FROM 4063/0070 SH (CONN)
		0100/0000	0100/0000	2 0 02272 0 00 0186+60 PEARCE MILL RD (SR4063 SEG 0070/2633)
		0090/2471	0090/2471	LENGTH(AH 3870 BK 2507) 018" DIA CIRC METAL LEN=0072 INSTALLED UNKN
MARS RD (SR4069 SEG 0010/0000)	0090/1420	0090/0995	0090/0995	030" DIA CIRC CONCR LEN=0045 INSTALLED UNKN
2 0 02272 0 00 0161+45	015258 FT	015275 FT	015275 FT	
CONRAD DR (T601)	0090/0000	0090/0000	0090/0000	LENGTH(AH 2507 BK 2079)
	013179 FT	0080/0532	0080/0532	PINE PARK DR (PRDR)
		0080/0374	0080/0374	018" DIA CIRC CONCR
		013196 FT	013196 FT	LEN=0100 INSTALLED UNKN
		0080/0000	0080/0000	2 0 02272 0 00 0141+16 LENGTH(AH 2079 BK 2152)
		0070/2018	0070/2018	018" DIA CIR PLASTIC LEN=0040 INSTALLED UNKN
DEAN RD (T524)	0070/0755	0070/0560	0070/0560	WINDWOOD DR (T918)
		0070/0532	0070/0532	012" DIA CIR PLASTIC
	011027 FT	011044 FT	011044 FT	LEN=0015 INSTALLED UNKN
		0070/0000	0070/0000	2 0 02272 0 00 0114+56 LENGTH(AH 2152 BK 1946)

DIR: E TOTAL LEN: 9.115 MI. DIST: 11-1 SR: 4068
 LEFT MUN: PINE T RIGHT MUN: PINE T

BEAVER CT
(TWP)

0060/1243

== ==

0060/1243 RABOLD DR
(TWP)

--- ---

0060/0353 018 "DIA CIRC OTHER
LEN=0050 INSTALLED UNKN
018 "DIA CIRC CONCR

009081 FT

--- ---

0060/0057 009098 FT 2 0 02272 0 00 0096+00
NC BAKERSTOWN/WARRENDALE RD
FOX RIDGE DR
(TWP)

PINKERTON RD
(T900)

0050/0360

==

5 0060/0000 LENGTH(AH 1946 BK 0742)

--- ---

0050/0331 024 "DIA CIRC CONCR
LEN=0060 INSTALLED UNKN
I-76

008339 FT

--- ---

0050/0225 008356 FT 2 0 02272 0 00 0092+37
NC WA WARRENDALE RD
GRAHAM RD
(SR4052 SEG 0150/0000)

WARRENDALE RD
(SR4052 SEG 0150/0000)

0050/0000

==

5 0050/0000 LENGTH(AH 0742 BK 2667)

--- ---

0040/2614 018 "DIA CIRC OTHER
LEN=0064 INSTALLED UNKN
TRINITY WY

==

0040/2273 (PRDR)

--- ---

0040/1317 015 "DIA CIRC CONCR
LEN=0037 INSTALLED UNKN

--- ---

0040/0968 030 "DIA CIRC CONCR
LEN=0036 INSTALLED UNKN
TWIN OAK DR

==

0040/0740 (T506)

--- ---

0040/0465 018 "DIA CIRC METAL
LEN=0036 INSTALLED UNKN
030"H 30"W ELLIPTICAL*

005672 FT

--- ---

0040/0281 005689 FT 2 0 02137 0 00 0060+24
TWIN OAK DR
(T506)

==

5 0040/0000 LENGTH(AH 2667 BK 1586)

--- ---

0030/1323 018 "DIA CIR UNKNOWN
LEN=0064 INSTALLED UNKN

--- ---

0030/1008 018 "DIA CIR PLASTIC
LEN=0064 INSTALLED UNKN

015 "DIA CIR PLASTIC

DIR: E TOTAL LEN: 9.115 MI. DIST: 11-1 SR: 4068
 LEFT MUN: PINE T RIGHT MUN: PINE T

Location	Segment ID	Length (FT)	Material	Status	Notes
MARRWOOD DR (PRDR)	0030/0390	004086	015" DIA CIRC CONCR	INSTALLED UNKN	
	0030/0210	004103	015" DIA CIRC CONCR	INSTALLED UNKN	
	0030/0000	004103	018" DIA CIRC CONCR	INSTALLED UNKN	LENGTH(AH 1586 BK 3603)
PINE HOLLOW DR (TWP)	0020/3203	0020/3442	018" DIA CIRC CONCR	INSTALLED UNKN	
	0020/3058	0020/2568	018" DIA CIRC CONCR	INSTALLED UNKN	
	0020/2568	0020/2445	016" DIA CIRC CONCR	INSTALLED UNKN	ENGLISH RD (T711)
	0020/1838	0020/1565	015" DIA CIRC CONCR	INSTALLED UNKN	
	0020/1565	0020/1328	016" DIA CIRC CONCR	INSTALLED UNKN	GEORGETOWNE CT (PRDR)
TANGLEWOOD DR (TWP)	0020/0640	0020/0961	016" DIA CIRC CONCR	INSTALLED UNKN	
	0020/0636	0020/0636	024" DIA CIRC CONCR	INSTALLED UNKN	VILLAGE RUN RD (TWP)
SWINDERMAN RD (T834)	0020/0000	000483	MFC BEGIN = D	INSTALLED UNKN	LENGTH(AH 3603 BK 0500)
	0012/0392	0012/0030	016" DIA CIRC CONCR	INSTALLED UNKN	LC TO VILLAGE RUN RD (CONN)
PERRY HW (SR0019 SEG 0620/1013)	0013/0030	000000	016" DIA CIRC CONCR	INSTALLED UNKN	NC WALLACE RD PERRY HW (SR0019 SEG 0620/1013)
WALLACE RD (TWP)	INTER-BK	INTER-BK	WALLACE RD (TWP)	INSTALLED UNKN	MFC BEGIN = D
	0013/0000	0012/0000	LENGTH(AH 0483 BK 0000)	INSTALLED UNKN	LENGTH(AH 0500 BK 0000)

DIR: B TOTAL LEN: 5.069 MI. DIST: 11-1 SR: 4067
 LEFT MUN: HAMPTON T RIGHT MUN: HAMPTON T

Left Side Description	Left Side Stationing	Right Side Stationing	Right Side Description
MIDDLE RD (CNTY)	026764 FT 0110/2481	026764 FT 0110/2481	MIDDLE RD (CNTY)
			PRINCE PHILLIP CT (TWP)
		0110/2025	036 " DIA CIRC METAL
		0110/1724	LEN=0040 INSTALLED UNKN
		0110/1410	BRONWYN CT (TWP)
WINDY HILL DR (TWP)	0110/0525		
		0110/0317	018 " DIA CIRC CONCR
2 0 02126 0 04 0438+00	024283 FT	024283 FT	LEN=0099 INSTALLED UNKN
FAWN HAVEN DR (T923)	0110/0000	0110/0000	CARTERTON DR (T101)
		0100/1635	LENGTH(AH 2481 BK 1766)
		0100/1490	018 " DIA CIRC METAL
		0100/1226	LEN=0040 INSTALLED UNKN
		0100/0720	018 " DIA CIRC METAL
		0100/0219	LEN=0040 INSTALLED UNKN
2 0 02126 0 04 0420+23	022517 FT	022517 FT	CAMBERLY DR (T101)
TURNER RD (T976)	0100/0000	0100/0000	012 " DIA CIRC CONCR
		0090/1800	LEN=0060 INSTALLED UNKN
		0090/0886	BARDONNER RD (T600)
		020625 FT	LENGTH(AH 1766 BK 1892)
		0080/1490	012 " DIA CIRC CONCR
		0080/1024	LEN=0060 INSTALLED UNKN
DEVENY LA (T917)	0080/1490	0080/0717	018 " DIA CIR PLASTIC
		0080/0715	LEN=0099 INSTALLED UNKN
		0080/0495	2 0 02126 0 04 0401+31
RANALLI DR (T963)	018600 FT	018600 FT	LENGTH(AH 1892 BK 2025)
			018 " DIA CIRC CONCR
			LEN=0035 INSTALLED UNKN
			018 " DIA CIRC METAL
			LEN=0035 INSTALLED UNKN
			POLO FIELDS DR (PRDR)
			2 0 02126 0 04 0380+24
			NC EAST HARDIES RD

EXTRACT DATE: 12/21/2020
PRINT DATE: 12/23/2020

ROADWAY MANAGEMENT SYSTEM
SLD COUNTY/SR - ANNUAL PRINT

PAGE NUMBER: 1421
COUNTY: ALLEGHENY

DIR: B TOTAL LEN: 5.069 MI.
LEFT MUN: HAMPTON T

DIST: 11-1 SR: 4067
RIGHT MUN: HAMPTON T

EXECUTIVE DR
(TWP)
MALLARD DR
(TWP)

RICHLAND RD
(T602)

0070/1820

0070/1640

0070/0640

015828 FT

014434 FT

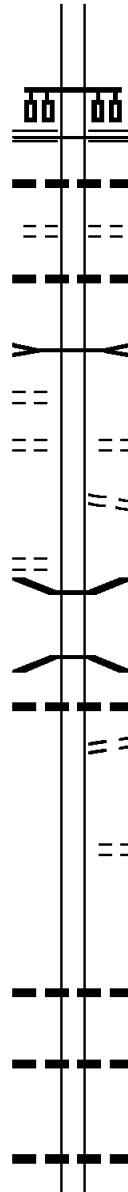

0080/0000

0070/2396

0070/2380

0070/1993

0070/1880

0070/1640

0070/1387

0070/0497

0070/0360

0070/0290

0070/0265

0070/0000

0060/0931

0060/0000

0050/3455

0050/2558

0050/1563

WILLIAM FLYNN HW
(SR0008 SEG 0380/0000)
(SR0008 SEG 0381/0000)

MFC BEGIN = E
LENGTH(AH 2025 BK 2772)
012 "DIA CIRC CONCR
LEN=0035 INSTALLED UNKN
N PIONEER RD
(T961)
018 "DIA CIRC CONCR
LEN=0060 INSTALLED UNKN
CROUSE RUN
STRUCTURE LENGTH 12 FT
BMSID 02/4067/0070/1880

STELLA DR
(T916)
OLD HARDIES RD
(T935)

BMS EN 02/7076/9900/3858
2 0 02126 0 04 0350+07
1-76

BMS BG 02/7076/9900/3858
018 "DIA CIRC CONCR
LEN=0004 INSTALLED UNKN
PIONEER RD
(T760)

2 0 02126 0 04 0350+07
LENGTH(AH 2772 BK 1394)
LAKEWOOD DR
(T758)

2 0 02126 0 04 0336+12
LENGTH(AH 1394 BK 3483)
012 "DIA CIRC CONCR
LEN=0030 INSTALLED UNKN

018 "DIA CIRC CONCR
LEN=0060 INSTALLED UNKN

018 "DIA CIRC CONCR
LEN=0099 INSTALLED UNKN
LAKEVIEW DR

DIR: B TOTAL LEN: 5.069 MI. DIST: 11-1 SR: 4067
 LEFT MUN: HAMPTON T RIGHT MUN: HAMPTON T

GIBSON RD
 (T983)
 OAK HILL RD
 (T994)

0050/0955

==

0050/1540 (TWP)

==

0050/0911

012"H 00"W MULT CONCR
 LEN=0060 INSTALLED UNKN
 LAKEVIEW DR

==

0050/0540

(T681)
 018"DIA CIRC METAL
 LEN=0045 INSTALLED UNKN

010951 FT

0050/0163

2 0 02126 0 03 0306+75

5 0050/0000

LENGTH(AH 3483 BK 1312)
 018"DIA CIRC CONCR

==

0040/1262

LEN=0030 INSTALLED UNKN

ARNOLD AV
 (T584)

0040/0425
 009639 FT

==

0040/0425

LAKEWOOD RD
 (T942)
 2 0 02126 0 03 0288+77

==

5 0040/0000

LAH RD
 (T679)
 LENGTH(AH 1312 BK 3418)

==

0030/3127

036"DIA CIRC CONCR
 LEN=0099 INSTALLED UNKN

==

0030/3110

036"DIA CIRC CONCR
 LEN=0045 INSTALLED UNKN

BANKS SCHOOL RD
 (T673)
 ANKENY DR
 (PRDR)

0030/1920

==

0030/2490

WICKLINE RD
 (T993)
 018"DIA CIRC CONCR

==

0030/1933

LEN=0099 INSTALLED UNKN
 018"DIA CIRC METAL

==

0030/1925

LEN=0015 INSTALLED UNKN

0030/1345

==

0030/0930

018"DIA CIRC CONCR
 LEN=0099 INSTALLED UNKN

==

0030/0929

036"DIA CIRC CONCR
 LEN=0040 INSTALLED UNKN

==

0030/0815

HOLLYWOOD DR
 (PRDR)

JOSEPHINE DR
 (T984)

0030/0620

==

0030/0632

018"DIA CIRC CONCR
 LEN=0099 INSTALLED UNKN

==

0030/0620

018"DIA CIRC METAL
 LEN=0035 INSTALLED UNKN

==

0030/0555

LAUREL RD
 (PRDR)

MULBERRY LN

DIR: B TOTAL LEN: 5.069 MI. DIST: 11-1 SR: 4067
 LEFT MUN: HAMPTON T RIGHT MUN: HAMPTON T

006221 FT

```

    ==
    ---
    0030/0270 (PRDR)
    018 " DIA CIRC CONCR
    ---
    0030/0105 LEN=0099 INSTALLED UNKN
    024 " DIA CIRC PLASTIC
    ---
    0030/0086 LEN=0030 INSTALLED UNKN
    024 " DIA CIRC PLASTIC
    ---
    0030/0070 LEN=0099 INSTALLED UNKN
    006221 FT 2 0 02126 0 01 0254+44
    NC WEST HARDIES RD
    WILDWOOD RD
    (SR4070 SEG 0120/0360)
    
```

```

    ==
    ---
    0030/0000 MFC BEGIN = D
    LENGTH(AH 3418 BK 3524)
    024 " DIA CIRC CONCR
    ---
    0020/3453 LEN=0050 INSTALLED UNKN
    
```

```

    ---
    0020/1890 024 " DIA CIRC CONCR
    LEN=0040 INSTALLED UNKN
    ---
    0020/1722 018 " DIA CIRC METAL
    LEN=0035 INSTALLED UNKN
    ---
    0020/1702 018 " DIA CIRC METAL
    LEN=0035 INSTALLED UNKN
    WILLOW OAK DR
    ---
    0020/1701 (PRDR)
    024 " DIA CIRC CONCR
    ---
    0020/1379 LEN=0035 INSTALLED UNKN
    
```

002697 FT

```

    002697 FT 2 0 02126 0 01 0219+07
    0020/0000 LENGTH(AH 3524 BK 2697)
    
```

```

    ==
    0010/1515 MCCASLIN RIDGE DR
    (PRDR)
    
```

000000 FT

```

    ---
    0010/0177 018 " DIA CIRC CONCR
    LEN=0045 INSTALLED UNKN
    000000 FT 2 0 02126 0 01 0192+13
    NC WILDWOOD SAMPLE RD
    SAMPLE RD
    (SR4026 SEG 0060/0000)
    MFC BEGIN = E
    0010/0000 LENGTH(AH 2697 BK 0000)
    
```

EXTRACT DATE: 12/21/2020 ROADWAY MANAGEMENT SYSTEM PAGE NUMBER: 1418
PRINT DATE: 12/23/2020 SLD COUNTY/SR - ANNUAL PRINT COUNTY: ALLEGHENY
DIR: B TOTAL LEN: .000 MI. DIST: 11-1 SR: 4066
LEFT MUN: RICHLAND T RIGHT MUN: RICHLAND T

000000 FT
000000 FT



000000 FT
7020/0000 LENGTH(AH 2598 BK 1092)
000000 FT
7010/0000 LENGTH(AH 1092 BK 0000)

DIR: B TOTAL LEN: 2.645 MI. DIST: 11-1 SR: 4065
 LEFT MUN: RICHLAND T RIGHT MUN: RICHLAND T

Stationing	Segment Description	Length (FT)	Notes
013968	INTER-AHD	013968	LAKESIDE DR (T996)
0050/3034	GIBSONIA RD (SR0910 SEG 0160/0000)	0050/3034	GIBSONIA RD (SR0910 SEG 0160/0000)
0050/2940	018" DIA CIRC CONCR	0050/2940	LEN=0025 INSTALLED UNKN
0050/2320	NORTHFIELD DR (T611)	0050/2320	NORTHFIELD DR (T611)
0050/1110	CRESTVIEW DR (T792)	0050/1110	CRESTVIEW DR (T792)
010934	018" DIA CIRC CONCR	010934	LEN=0025 INSTALLED UNKN
0050/0000	NORTHFIELD DR (T611)	0050/0000	NORTHFIELD DR (T611)
0040/2180	OAKCREST DR (T445)	0040/2180	OAKCREST DR (T445)
0040/1501	018" DIA CIRC CONCR	0040/1501	LEN=0040 INSTALLED UNKN
0040/0430	FAIRVIEW RD (T823)	0040/0430	FAIRVIEW RD (T823)
0040/0054	018" DIA CIRC CONCR	0040/0054	LEN=0040 INSTALLED UNKN
007976	024" DIA CIRC CONCR	007976	LEN=0099 INSTALLED UNKN
0040/0000	BMSBG 02/4065/0030/0895	0040/0000	PA TPK (1-76)
0030/1160	BMSBG 02/4065/0030/0895	0030/1160	RICHLAND
0030/1102	024" DIA CIRC CONCR	0030/1102	LEN=0099 INSTALLED UNKN
0030/0895	018" DIA CIRC CONCR	0030/0895	LEN=0040 INSTALLED UNKN
0030/0860	HAMPTON T	0030/0860	HAMPTON T

EXTRACT DATE: 12/21/2020
PRINT DATE: 12/23/2020

ROADWAY MANAGEMENT SYSTEM
SLD COUNTY/SR - ANNUAL PRINT

PAGE NUMBER: 1416
COUNTY: ALLEGHENY

DIR: B TOTAL LEN: 2.645 MI.
LEFT MUN: RICHLAND T

DIST: 11-1 SR: 4065
RIGHT MUN: RICHLAND T

Stationing	Length	Material	Notes
006257 FT	0030/0808	024 " DIA CIRC CONCR	LEN=0040 INSTALLED UNKN
	0030/0300	015 " DIA CIRC CONCR	LEN=0040 INSTALLED UNKN
	0030/0020	018 " DIA CIRC CONCR	LEN=0032 INSTALLED UNKN
	006257 FT	2 0 02191 0 00 0062+55	OAKHILL RD (T994)
	0030/0000	LENGTH(AH 1719 BK 3261)	LAKEMONT DR (T941)
	0020/2475	018 " DIA CIRC CONCR	LEN=0040 INSTALLED UNKN
	0020/2256	DELO DR	(TWP)
	0020/1805	018 " DIA CIRC CONCR	LEN=0040 INSTALLED UNKN
	0020/1299	RIHN STRASSE RD	(TWP)
	0020/0835	018 " DIA CIRC CONCR	LEN=0080 INSTALLED UNKN
002996 FT	002996 FT	2 0 02191 0 00 0029+62	DEGENHARDT RD (T423)
	0020/0000	LENGTH(AH 3261 BK 2996)	WILLOW RUN CT (PRDR)
	0010/2553	018 " DIA CIRC CONCR	LEN=0048 INSTALLED UNKN
	0010/2424	LC TO BANKS SCHOOL RD	(CONN)
	0010/2010	BANKS SCHOOL RD	(T673)
	0010/1925	024 " DIA CIRC METAL	LEN=0050 INSTALLED UNKN
	0010/1203	018 " DIA CIRC CONCR	LEN=0070 INSTALLED UNKN
	0010/0635	018 " DIA CIRC CONCR	LEN=0040 INSTALLED UNKN
000000 FT	000000 FT	2 0 02191 0 00 0000+00	NC HARDT RD WILDWOOD RD (SR4070 SEG 0110/0000)
	0010/0000	MFC BEGIN = D	LENGTH(AH 2996 BK 0000)

EXTRACT DATE: 12/21/2020 ROADWAY MANAGEMENT SYSTEM PAGE NUMBER: 1415
 PRINT DATE: 12/23/2020 SLD COUNTY/SR - ANNUAL PRINT COUNTY: ALLEGHENY
 DIR: B TOTAL LEN: 2.697 MI. DIST: 11-1 SR: 4064
 LEFT MUN: MCCANDLESS T RIGHT MUN: MCCANDLESS T

014238 FT

014238 FT
 INTER-AHD

HEMLOCK DR
 (CNTY)
 HEMLOCK DR
 (CNTY)
 LC TO / FROM HEMLOCK DR
 (CONN)
 TOWNE SQ DR
 (TWP)
 TOWNE CT
 (TWP)

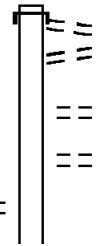

PRESIDENTIAL DR
 (TWP)

0050/2150

==

DIR: B TOTAL LEN: 2.697 MI. DIST: 11-1 SR: 4064
 LEFT MUN: MCCANDLESS T RIGHT MUN: MCCANDLESS T

Location / Description	Segment ID	Length (FT)	Notes / Details
MEADOW RD (TWP)	0050/1484	0050	015" DIA CIRC METAL INSTALLED UNKN SPRINGFIELD DR
	0050/1230		(TWP)
	0050/0720		WENDY VIEW DR (TWP)
HOSACK ELEM SCHOOL ENT (PRDR)	0050/0280		
	011164 FT	011164	024" DIA CIRC CONCR INSTALLED UNKN 2 0 02128 0 00 0025+23 PRIVATE DR (PRDR) LENGTH(AH 3074 BK 2744)
2 0 02128 0 00 0000+00 CUMBERLAND RD (TWP)	0040/1274		
	008420 FT	008420	SAMPLE RD (SR4026 SEG 0010/0000)
LOCUST ST (TWP)	0040/0000		LENGTH(AH 2744 BK 1676)
KNOLL ST (TWP)	0030/1170		
	0030/0300		
DUNCAN AV (SR4024 SEG 0060/0000)	006744 FT	006744	012"H 24"W CON BOX CUL LEN=0040 INSTALLED UNKN 2 0 02126 0 01 0070+22 DUNCAN AV (SR4024 SEG 0060/0000)
	0030/0000		MFC BEGIN = D LENGTH(AH 1676 BK 3495)
PEEBLES SCHOOL RD (TWP)	0020/3341		012" DIA CIRC CONCR LEN=0099 INSTALLED UNKN
	0020/3186		018" DIA CIRC CONCR LEN=0030 INSTALLED UNKN
	0020/2080		PARKWAY RD (TWP)
	0020/1430		ELAINE DR (TWP)

EXTRACT DATE: 12/21/2020
PRINT DATE: 12/23/2020

ROADWAY MANAGEMENT SYSTEM
SLD COUNTY/SR - ANNUAL PRINT

PAGE NUMBER: 1413
COUNTY: ALLEGHENY

DIR: B TOTAL LEN: 2.697 MI.
LEFT MUN: MCCANDLESS T

DIST: 11-1 SR: 4064
RIGHT MUN: MCCANDLESS T

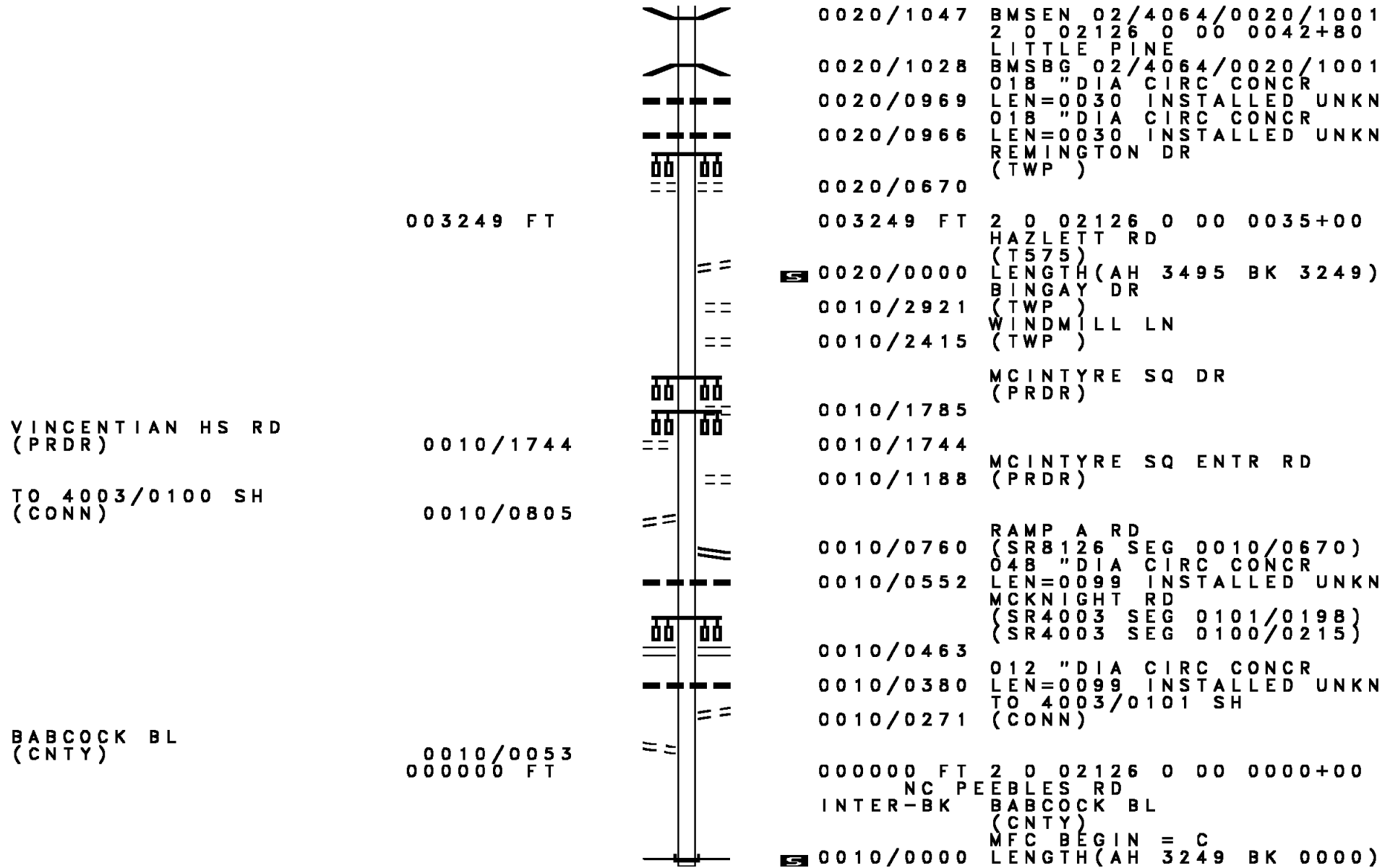

EXTRACT DATE: 12/21/2020 ROADWAY MANAGEMENT SYSTEM PAGE NUMBER: 1412
PRINT DATE: 12/23/2020 SLD COUNTY/SR - ANNUAL PRINT COUNTY: ALLEGHENY
DIR: B TOTAL LEN: 3.707 MI. DIST: 11-1 SR: 4063
LEFT MUN: PINE T RIGHT MUN: PINE T

019574 FT



019574 FT WARRENDALE RD
0070/2633 (SR4068 SEG 0100/0000)
TO SR 4068/0100

DIR: B TOTAL LEN: 3.707 MI. DIST: 11-1 SR: 4063
 LEFT MUN: PINE T RIGHT MUN: PINE T

PINE PARK DR
 (TWP)

2 0 02141 0 00 0124+14 012403 FT
 GRAHAM RD
 (SR4052 SEG 0160/2608) 0050/0000

	0070/2576	(CONN)	
	0070/2201	018 " DIA CIR PLASTIC	
	0070/2054	LEN=0030 INSTALLED UNKN	
	0070/1643	018 " DIA CIR METAL	
	0070/1264	LEN=0042 INSTALLED UNKN	
		018 " DIA CIR METAL	
		LEN=0099 INSTALLED UNKN	
		TREE LINE DR	
		(TWP)	
016941 FT	0070/0118	018 " DIA CIR METAL	
	016941 FT	LEN=0030 INSTALLED UNKN	
	0070/0000	2 0 02141 0 00 0169+52	
		LENGTH(AH 2633 BK 2649)	
0060/2435			
	0060/1511	MORELLI LN	
	0060/1028	(TWP)	
	0060/0837	018 " DIA CIR CONCR	
	0060/0660	LEN=0035 INSTALLED UNKN	
	0060/0482	018 " DIA CIR METAL	
014292 FT	0060/0000	LEN=0042 INSTALLED UNKN	
		018 " DIA CIR METAL	
		LEN=0045 INSTALLED UNKN	
		018 " DIA CIR METAL	
		LEN=0045 INSTALLED UNKN	
		2 0 02141 0 00 0143+03	
		LENGTH(AH 2649 BK 1889)	
	0050/1484	018 " DIA CIR METAL	
	0050/1365	LEN=0042 INSTALLED UNKN	
	0050/0793	018 " DIA CIR METAL	
	0050/0644	LEN=0036 INSTALLED UNKN	
	0050/0298	012 " DIA CIR PLASTIC	
	0050/0129	LEN=0042 INSTALLED UNKN	
	0050/0010	018 " DIA CIR METAL	
		LEN=0065 INSTALLED UNKN	
		012 " DIA CIR METAL	
		LEN=0099 INSTALLED UNKN	
		018 " DIA CIR CONCR	
		LEN=0050 INSTALLED UNKN	
		018 " DIA CIR METAL	
		LEN=0040 INSTALLED UNKN	
	0050/0000	LENGTH(AH 1889 BK 2587)	
	0040/2304	024 " DIA CIR PLASTIC	
		LEN=0052 INSTALLED UNKN	

DIR: B TOTAL LEN: 3.707 MI. DIST: 11-1 SR: 4063
 LEFT MUN: PINE T RIGHT MUN: PINE T

009816 FT

006995 FT

0040/2018	024 " DIA	CIR PLASTIC
	LEN=0035	INSTALLED UNKN
0040/1834	018 " DIA	CIRC METAL
	LEN=0035	INSTALLED UNKN
0040/1475	015 " DIA	CIRC METAL
	LEN=0030	INSTALLED UNKN
0040/1183	018 " DIA	CIR UNKNOWN
	LEN=0036	INSTALLED UNKN
0040/0835	018 " DIA	CIR UNKNOWN
	LEN=0036	INSTALLED UNKN
0040/0552	018 " DIA	CIR UNKNOWN
	LEN=0040	INSTALLED UNKN
0040/0335	012 " DIA	CIRC METAL
	LEN=0030	INSTALLED UNKN
0040/0030	018 " DIA	CIR PLASTIC
	LEN=0050	INSTALLED 1997
009816 FT	2 0 02141	0 00 0098+00
	LOGAN RD	
	(T554)	
0040/0000	LENGTH(AH 2587 BK 2821)	
0030/2642	BMSSEN 02/4063/0030/2634	
	2 0 02141	0 00 0096+49
	N. FORK PINE	
0030/2634	BMSBG 02/4063/0030/2634	
	018 " DIA	CIR PLASTIC
0030/2281	LEN=0070	INSTALLED UNKN
	018 " DIA	CIRC CONCR
0030/2088	LEN=0048	INSTALLED UNKN
	PA TPK (1-76)	
0030/1779	OP ID 02/7076/9900/3357	
	012 " DIA	CIRC CONCR
0030/1610	LEN=0030	INSTALLED UNKN
	ALPINE LN	
0030/1585	(PRDR)	
	024 " DIA	CIR PLASTIC
0030/1353	LEN=0038	INSTALLED UNKN
	015 " DIA	CIRC CONCR
0030/0987	LEN=0042	INSTALLED UNKN
	018 " DIA	CIRC CONCR
0030/0177	LEN=0042	INSTALLED UNKN
006995 FT	2 0 02141	0 00 0070+15
0030/0000	LENGTH(AH 2821 BK 3818)	
	018 " DIA	CIRC CONCR
0020/3748	LEN=0040	INSTALLED UNKN
	018 " DIA	CIRC CONCR
0020/3091	LEN=0048	INSTALLED UNKN
	018 " DIA	CIRC CONCR
0020/2730	LEN=0044	INSTALLED UNKN

EXTRACT DATE: 12/21/2020
PRINT DATE: 12/23/2020

ROADWAY MANAGEMENT SYSTEM
SLD COUNTY/SR - ANNUAL PRINT

PAGE NUMBER: 1409
COUNTY: ALLEGHENY

DIR: B TOTAL LEN: 3.707 MI.
LEFT MUN: PINE T

DIST: 11-1 SR: 4063
RIGHT MUN: PINE T

Stationing	Length	Material	Notes
0020/2444	0040	018" DIA CIRC CONCR	INSTALLED UNKN
0020/2304	0030	012" DIA CIRC CONCR	INSTALLED UNKN
0020/1977	0040	018" DIA CIR UNKNOWN	INSTALLED UNKN
0020/1696	0040	018" DIA CIRC OTHER	INSTALLED UNKN
0020/1013	0050	018" DIA CIRC CONCR	INSTALLED UNKN
0020/0420		ENDERS LN (PRDR)	
0020/0280	0120	018" DIA CIRC CONCR	INSTALLED UNKN
0020/0184	0035	084"H 72"W CONC STRUCT	INSTALLED UNKN
0020/0028	0060	036" DIA CIRC CONCR	INSTALLED UNKN
003177 FT	2 0 02141 0 00 0031+84		
0020/0000		LENGTH(AH 3818 BK 3177)	
0010/3143		FROM 0910/0090 SH (CONN)	
0010/3075		SALEM HOLLOW RD (SR0910 SEG 0090/0788)	
0010/2750	0051	018" DIA CIRC METAL	INSTALLED UNKN
0010/2360	0040	018" DIA CIRC CONCR	INSTALLED UNKN
0010/1733	0045	015" DIA CIRC METAL	INSTALLED UNKN
0010/1610	0050	018" DIA CIRC CONCR	INSTALLED UNKN
0010/1280	0055	018" DIA CIRC CONCR	INSTALLED UNKN
0010/0847	0040	015" DIA CIRC CONCR	INSTALLED UNKN
0010/0640	0012	024" DIA CIRC CONCR	INSTALLED UNKN
0010/0076			
000000 FT		036"H 36"W METAL ARCH	
		2 0 02141 0 00 0000+00	
		PEARCE MILL RD INTER-BK (CNTY)	
		MFC BEGIN = D	
		LENGTH(AH 3177 BK 0000)	

DIR: B TOTAL LEN: .740 MI. DIST: 11-1 SR: 4062
 LEFT MUN: SHALER T RIGHT MUN: SHALER T

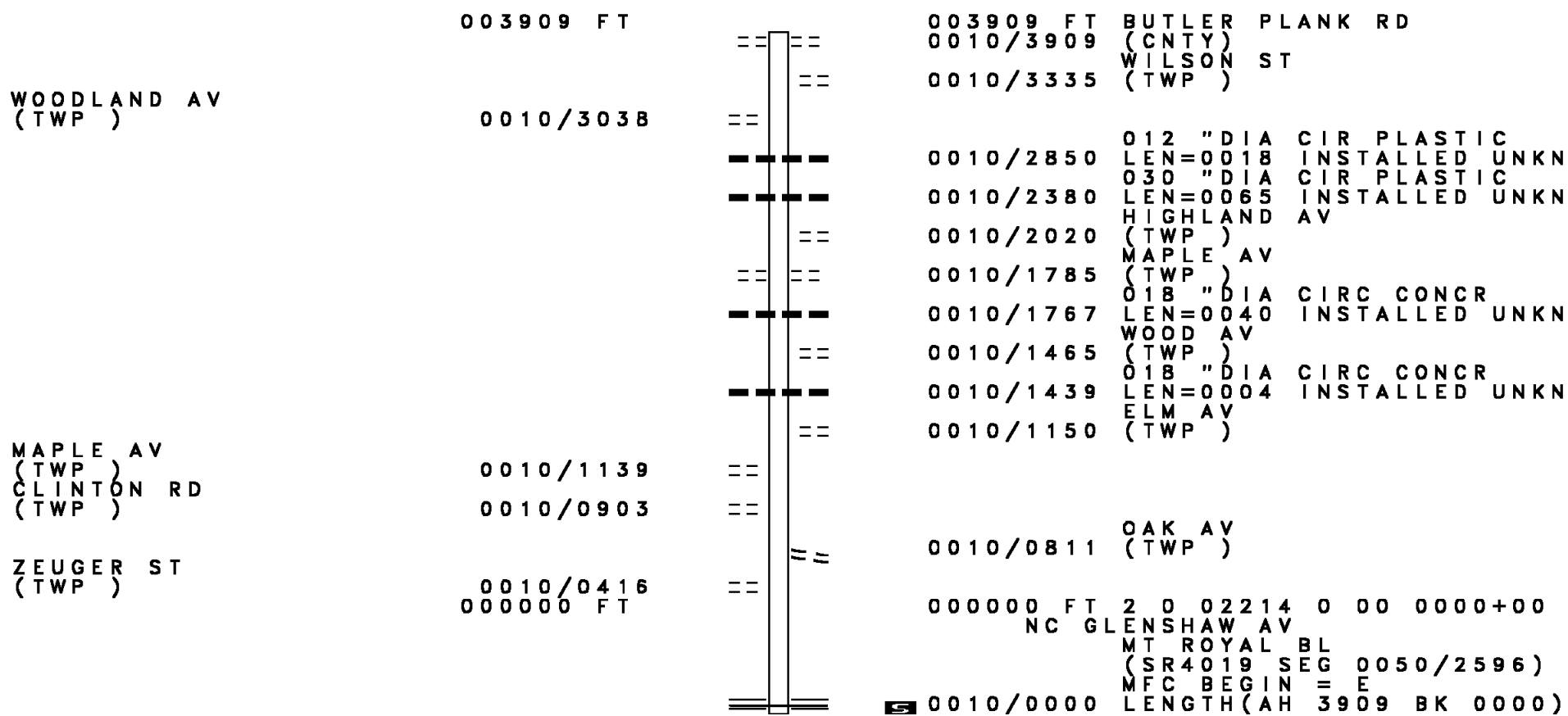

WOODLAND AV
(TWP)

MAPLE AV
(TWP)
CLINTON RD
(TWP)

ZEUGER ST
(TWP)

003909 FT

0010/3038

0010/1139
0010/0903

0010/0416
000000 FT

003909 FT BUTLER PLANK RD
 0010/3909 (CNTY)
 0010/3335 WILSON ST
 (TWP)

 0010/2850 012 " DIA CIR PLASTIC
 LEN=0018 INSTALLED UNKN
 030 " DIA CIR PLASTIC
 0010/2380 LEN=0065 INSTALLED UNKN
 HIGHLAND AV
 0010/2020 (TWP)
 MAPLE AV
 0010/1785 (TWP)
 0010/1767 018 " DIA CIRC CONCR
 LEN=0040 INSTALLED UNKN
 WOOD AV
 0010/1465 (TWP)
 0010/1439 018 " DIA CIRC CONCR
 LEN=0004 INSTALLED UNKN
 ELM AV
 0010/1150 (TWP)

 0010/0811 OAK AV
 (TWP)

 000000 FT 2 0 02214 0 00 0000+00
 NC GL ENSHAW AV
 MT ROYAL BL
 (SR4019 SEG 0050/2596)
 MFC BEGIN = E
 5 0010/0000 LENGTH(AH 3909 BK 0000)

EXTRACT DATE: 12/21/2020 ROADWAY MANAGEMENT SYSTEM PAGE NUMBER: 1407
 PRINT DATE: 12/23/2020 SLD COUNTY/SR - ANNUAL PRINT COUNTY: ALLEGHENY
 DIR: B TOTAL LEN: 1.511 MI. DIST: 11-1 SR: 4061
 LEFT MUN: PINE T RIGHT MUN: PINE T

	007978 FT		007978 FT	AH-BUTLER (10)
			* REF-AHD	FRANKLIN RD
FREEPORT RD			0030/2070	(SR3021 SEG 0010/0000)
(SR4054 SEG 0030/3363)	0030/1475	==	0030/1475	MT PLEASANT RD (T727)
MT PLEASANT RD		==		
(T478)	0030/0803	==		
		---	0030/0240	01B "DIA CIRC CONCR
	005908 FT	---	005908 FT	LEN=0050 INSTALLED UNKN
		==		2 0 02131 0 00 0058+22
		==		WILD CHERRY DR
				(TWP)

DIR: B TOTAL LEN: 1.511 MI. DIST: 11-1 SR: 4061
 LEFT MUN: PINE T RIGHT MUN: PINE T

003891 FT

000000 FT

5	0030/0000	LENGTH(AH 2070 BK 2017)
		024 " DIA CIRC METAL
	0020/1542	LEN=0040 INSTALLED UNKN
		MACINTOSH DR
	0020/1432	(TWP)
		024 " DIA CIRC CONCR
	0020/1400	LEN=0099 INSTALLED UNKN
		018 " DIA CIRC CONCR
	0020/1143	LEN=0060 INSTALLED UNKN
		015 " DIA CIRC CONCR
	0020/0512	LEN=0038 INSTALLED UNKN
		MINNOCK DR
	0020/0497	(TWP)
	003891 FT	2 0 02131 0 00 0037+46
5	0020/0000	LENGTH(AH 2017 BK 3891)
		015 " DIA CIRC CONCR
	0010/3780	LEN=0030 INSTALLED UNKN
		015 " DIA CIRC CONCR
	0010/3333	LEN=0030 INSTALLED UNKN
		015 " DIA CIRC METAL
	0010/2872	LEN=0050 INSTALLED UNKN
		024 " DIA CIRC CONCR
	0010/2342	LEN=0060 INSTALLED UNKN
		015 " DIA CIRC CONCR
	0010/2047	LEN=0024 INSTALLED UNKN
		LAVELLE LN
	0010/1486	(TWP)
		018 " DIA CIRC CONCR
	0010/1428	LEN=0030 INSTALLED UNKN
	0010/0576	BMS EN 02/4061/0010/0485
		2 0 02131 0 00 0000+82
		PA TURNPIKE
	0010/0406	BMSBG 02/4061/0010/0485
		018 " DIA CIRC CONCR
	0010/0375	LEN=0050 INSTALLED UNKN
	0010/0100	BMS EN 02/4061/0010/0087
		2 0 02131 0 00 0000+82
		BRUSH RUN
	0010/0087	BMSBG 02/4061/0010/0087
		072 "H 72 "W CON BOX CUL
	0010/0083	LEN=0024 INSTALLED UNKN
	000000 FT	2 0 02131 0 00 0000+00
		VILLAGE: PINE TOWNSHIP
		NC FRANKLIN RD
		BAKERSTOWN/WARRENDALE R
		(SR4052 SEG 0120/0699)
		MFC BEGIN = D
5	0010/0000	LENGTH(AH 3891 BK 0000)

EXTRACT DATE: 12/21/2020 ROADWAY MANAGEMENT SYSTEM PAGE NUMBER: 1405
PRINT DATE: 12/23/2020 SLD COUNTY/SR - ANNUAL PRINT COUNTY: ALLEGHENY

DIR: B TOTAL LEN: 1.382 MI. DIST: 11-1 SR: 4060
LEFT MUN: SHALER T RIGHT MUN: SHALER T

WILLIAM FLYNN HW 007295 FT
(SR0008 SEG 0280/0548)
(SR0008 SEG 0281/0515) 0030/3013
GIANT EAGLE ENTR
(PRDR) 0030/2431
JUGNANDLE RD
(SR9403 SEG 0010/0000) 0030/2290
JUGHANDLE RD
(SR9403 SEG 0010/0172) 0030/2180
SUTTER RD

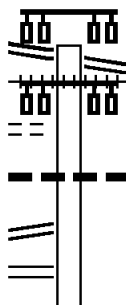

007295 FT WILLIAM FLYNN HW
(SR0008 SEG 0280/0548)
0030/3013 (SR0008 SEG 0281/0515)
0030/2948 (AAR 145714S)#TRKS 01
0030/2431
0030/2381 072 "DIA CIRC CONCR
LEN=0001 INSTALLED UNKN

DIR: B TOTAL LEN: 1.382 MI. DIST: 11-1 SR: 4060
 LEFT MUN: SHALER T RIGHT MUN: SHALER T

(TWP)

0030/2097

2 0 02249 0 01 0041+28 004282 FT
 FOR SR 4060 AND 4060
 (CONN)

0030/0000

FOR SR 4060 AND 4060
 (CONN)

0020/1793

002165 FT

000000 FT

MOUNT ROYAL BL
 (SR4019 SEG 0070/1005) 0010/0000

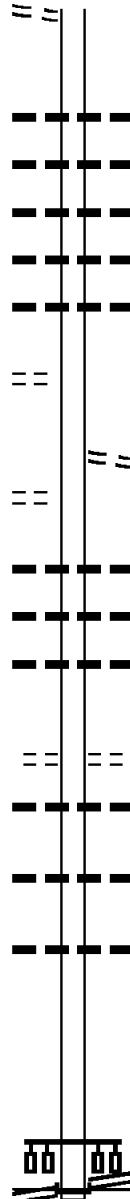

0030/0982 020 " DIA CIRC CONCR
 LEN=0042 INSTALLED UNKN
 018"H 18"W OTHER STRUC
 0030/0709 LEN=0032 INSTALLED UNKN
 018 "DIA CIRC CONCR
 0030/0395 LEN=0041 INSTALLED UNKN
 036"H 36"W ELLIP CONC
 0030/0242 LEN=0103 INSTALLED UNKN
 018 "DIA CIRC METAL
 0030/0115 LEN=0168 INSTALLED UNKN
 004282 FT

S 0030/0000 LENGTH(AH 3013 BK 2117)
 NC BU TLER PLANK RD
 BUTLER PLANK ROAD
 0020/1952 (CNTY)

0020/0931 030 " DIA CIRC CONCR
 LEN=0050 INSTALLED UNKN
 030 "DIA CIRC METAL
 0020/0573 LEN=0045 INSTALLED UNKN
 024 "DIA CIRC CONCR
 0020/0025 LEN=0060 INSTALLED UNKN
 002165 FT 2 0 02249 0 00 0018+87
 VIRGINIA AV
 (TWP)

S 0020/0000 LENGTH(AH 2117 BK 2165)
 036"H 00"W MULT METAL
 0010/2148 LEN=0099 INSTALLED UNKN

0010/1500 018 "DIA CIRC CONCR
 LEN=0040 INSTALLED UNKN

0010/0898 018 "DIA CIRC CONCR
 LEN=0030 INSTALLED UNKN

000000 FT 2 0 02249 0 00 0000+00
 MOUNT ROYAL BL
 (SR4019 SEG 0070/1005)
 NC KLEBER RD

INTER-BK VILSACK RD
 (CNTY)

S 0010/0000 MFC BEGIN = C
 LENGTH(AH 2165 BK 0000)

DIR: B TOTAL LEN: .140 MI. DIST: 11-1 SR: 4059
 LEFT MUN: PINE T RIGHT MUN: PINE T

OLD STATE RD ET
 (T562)

000740 FT

0010/0152

000000 FT

BABCOCK BL
 (SR4031 SEG 0180/1084) 0010/0000



* 000740 FT AH-BUTLER (10)
 REF-AHD BUTLER COUNTY LN
 0010/0740 (SR3015 SEG 0010/0000)
 BRANCH OF BREAKNECK
 STRUCTURE LENGTH 13 FT
 0010/0590 BMSID 02/4059/0010/0590

0010/0102 018 " DIA CIRC CONCR
 LEN=0025 INSTALLED UNKN
 000000 FT 1 0 00309 0 00 0019+36
 BABCOCK BL
 (SR4031 SEG 0180/1084)
 NC MARS VALENCIA RD ET
 MFC BEGIN = D
 0010/0000 LENGTH(AH 0740 BK 0000)

EXTRACT DATE: 12/21/2020 ROADWAY MANAGEMENT SYSTEM PAGE NUMBER: 1402
PRINT DATE: 12/23/2020 SLD COUNTY/SR - ANNUAL PRINT COUNTY: ALLEGHENY

DIR: B TOTAL LEN: 3.964 MI. DIST: 11-1 SR: 4057
LEFT MUN: OHIO T RIGHT MUN: OHIO T

020932 FT

MT NEBO RD
(SR4022 SEG 0050/1160) 0070/3992



019827 FT
INTER-AHD ROOSEVELT RD
(CNTY)
MT NEBO RD
0070/3992 (SR4022 SEG 0050/1160)

DIR: B TOTAL LEN: 3.964 MI. DIST: 11-1 SR: 4057
 LEFT MUN: OHIO T RIGHT MUN: OHIO T

TOMS RUN RD
 (T456)

0070/3080

016940 FT

014247 FT

==	0070/3860	TO 4022/0050 SH (CONN)
---	0070/3809	018" DIA CIRC CONCR LEN=0099 INSTALLED UNKN
==	0070/3015	GENE DR (T511)
---	0070/2390	024" DIA CIRC CONCR LEN=0030 INSTALLED UNKN
==	0070/2354	CRIMSON DR (CNTY)
---	0070/2313	024" DIA CIRC CONCR LEN=0030 INSTALLED UNKN
---	0070/2230	024" DIA CIRC CONCR LEN=0030 INSTALLED UNKN
---	0070/1900	024" DIA CIRC CONCR LEN=0030 INSTALLED UNKN
---	0070/1534	024" DIA CIRC CONCR LEN=0030 INSTALLED UNKN
---	0070/0346	024" DIA CIRC CONCR LEN=0030 INSTALLED UNKN
---	015835 FT	2 0 02125 0 01 0170+12
5	0070/0000	LENGTH(AH 3992 BK 2693)
---	0060/2077	024" DIA CIRC CONCR LEN=0030 INSTALLED UNKN
==	0060/2025	CRAWFORD RD (T470)
---	0060/1670	024" DIA CIRC CONCR LEN=0030 INSTALLED UNKN
---	0060/0647	024" DIA CIRC CONCR LEN=0030 INSTALLED UNKN
==	0060/0195	GILLELAND LA (TWP)
---	013142 FT	HARMONY RD (T458)
5	0060/0000	2 0 02125 0 01 0142+48 LENGTH(AH 2693 BK 3939)
---	0050/3012	024" DIA CIRC CONCR LEN=0030 INSTALLED UNKN
---		024" DIA CIRC CONCR

DIR: B TOTAL LEN: 3.964 MI. DIST: 11-1 SR: 4057
 LEFT MUN: OHIO T RIGHT MUN: OHIO T

	0050/2675	LEN=0030	INSTALLED UNKN
		024 "DIA	CIRC CONCR
	0050/2260	LEN=0030	INSTALLED UNKN
		GREENVISTA RD	
	0050/1565	(TWP)	
		018 "DIA	CIRC CONCR
	0050/1548	LEN=0099	INSTALLED UNKN
		015 "DIA	CIRC CONCR
	0050/1242	LEN=0099	INSTALLED UNKN
		024 "DIA	CIRC CONCR
	0050/0802	LEN=0030	INSTALLED UNKN
		024 "DIA	CIRC CONCR
	0050/0315	LEN=0030	INSTALLED UNKN
		024 "DIA	CIRC CONCR
010308 FT	0050/0045	LEN=0030	INSTALLED UNKN
	009203 FT	2 0 02125	0 01 0102+66
		OHIO	
		KILBUCK T	
	0050/0000	LENGTH(AH 3939 BK 3717)	
		024 "DIA	CIR PLASTIC
	0040/3298	LEN=0030	INSTALLED UNKN
		024 "DIA	CIRC CONCR
	0040/2576	LEN=0030	INSTALLED UNKN
		024 "DIA	CIRC CONCR
	0040/1483	LEN=0030	INSTALLED UNKN
		024 "DIA	CIRC CONCR
	0040/1178	LEN=0099	INSTALLED UNKN
		024 "DIA	CIRC CONCR
	0040/0853	LEN=0030	INSTALLED UNKN
		024 "DIA	CIRC CONCR
	0040/0555	LEN=0030	INSTALLED UNKN
		015 "DIA	CIRC CONCR
006591 FT	0040/0290	LEN=0099	INSTALLED UNKN
	005486 FT	2 0 02125	0 01 0066+37
	0040/0000	LENGTH(AH 3717 BK 1051)	
		018 "DIA	CIRC CONCR
	0030/0400	LEN=0099	INSTALLED UNKN
		024 "DIA	CIRC CONCR
	0030/0135	LEN=0030	INSTALLED UNKN
005540 FT	004435 FT	2 0 02125	0 01 0055+86
		EICHER RD	
		(T535)	
	0030/0000	LENGTH(AH 1051 BK 3635)	
		015 "DIA	CIRC CONCR
	0020/3634	LEN=0099	INSTALLED UNKN

DIR: B TOTAL LEN: 3.964 MI. DIST: 11-1 SR: 4057
 LEFT MUN: KILBUCK T RIGHT MUN: KILBUCK T

Stationing	Segment	Length	Material	Notes
001905 FT	0020/2930	0099	012 " DIA CIRC CONCR	INSTALLED UNKN
	0020/2190	0604	018 " DIA CIRC CONCR	INSTALLED UNKN
	0020/1586	0536	018 " DIA CIRC CONCR	INSTALLED UNKN
	0020/1050	0030	012 " DIA CIRC CONCR	INSTALLED UNKN
001905 FT	000800 FT	2 0 02125 0 01		0019+51 KILBUCK EMSWORTH B
CLEARVIEW AV (TWP)	0010/0725	0020/0000		LENGTH(AH 3635 BK 0800)
	0010/0650		EICHER RD (TWP)	
	0010/0415		NC ROOSEVELT RD ROOSEVELT AV (TWP)	
BRYSON AV (TWP)	0010/0250	000000 FT		2 0 02125 0 00 0000+00 NC LOCUST ST CENTER AV (TWP) MFC BEGIN = E EMSWORTH
	001105 FT	0010/0000		LTH AH 000800 BK 001105
SUPERIOR ST (TWP)	0005/0900			
GLENN ST (TWP)	0005/0825			
CHESTNUT ST (TWP)	0005/0620			
WALNUT ST (TWP)	0005/0385			
2 0 02125 0 00 0000+00	000000 FT			
OHIO RIVER BL (SRO065 SEG 0110/0310)				
NC LOCUST ST				
OHIO RIVER BL (SRO065 SEG 0110/0310)				
MFC BEGIN = E				
LENGTH(AH 1105 BK 0000)	0005/0000	000000 FT		7004/0000 LTH AH 001105 BK 000000

EXTRACT DATE: 12/21/2020 ROADWAY MANAGEMENT SYSTEM PAGE NUMBER: 1398
PRINT DATE: 12/23/2020 SLD COUNTY/SR - ANNUAL PRINT COUNTY: ALLEGHENY

DIR: B TOTAL LEN: .942 MI. DIST: 11-1 SR: 4056
LEFT MUN: MCCANDLESS T RIGHT MUN: MCCANDLESS T

004976 FT

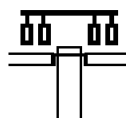

004976 FT
INTER-AHD

BABCOCK BL
(CNTY)
MCKNIGHT RD
(SR4003 SEG 0110/0000)
(SR4003 SEG 0111/0000)

0020/2576

DIR: B TOTAL LEN: .942 MI. DIST: 11-1 SR: 4056
 LEFT MUN: MCCANDLESS T RIGHT MUN: MCCANDLESS T

FOX RIDGE RD
 (T324)
 AACHEN PL
 (TWP)

0020/1085
 0020/0795

EDWOOD RD
 (T872)

0020/0030
 002400 FT

ELEANOR ST
 (T876)
 LOUISE ST
 (TWP)

0010/0730
 0010/0400
 000000 FT

Station	Description	Material	Length	Notes
0020/1605	LINDISFARNE DR (T448)	015" DIA	CIRC OTHER	
0020/1300		LEN=0035	INSTALLED	UNKN
0020/1268		018" DIA	CIRC CONCR	
0020/1240		LEN=0028	INSTALLED	UNKN
		002"H 03"W	CON BOX CUL	
		LEN=0028	INSTALLED	UNKN
0020/0225		018" DIA	CAST IRON	
		LEN=0025	INSTALLED	UNKN
0020/0200		012" DIA	CIRC CONCR	
		LEN=0020	INSTALLED	UNKN
002400 FT	EDWOOD RD (T872)	1 0 00246	1 00 0024+52	
0020/0000	LENGTH(AH 2576 BK 2400)	018" DIA	CIRC CONCR	
0010/2120		LEN=0070	INSTALLED	UNKN
0010/2100		018" DIA	CIRC CONCR	
		LEN=0040	INSTALLED	UNKN
0010/2037		012" DIA	CIRC CONCR	
		LEN=0023	INSTALLED	UNKN
0010/1920		018" DIA	CIRC CONCR	
		LEN=0118	INSTALLED	UNKN
0010/1258		024" DIA	CIRC CONCR	
		LEN=0070	INSTALLED	UNKN
0010/1192		018" DIA	CIRC CONCR	
		LEN=0025	INSTALLED	UNKN
0010/0907		024" DIA	CIRC CONCR	
		LEN=0050	INSTALLED	UNKN
0010/0840		012" DIA	CIRC CONCR	
		LEN=0010	INSTALLED	UNKN
000000 FT	NC PERRYMONT RD	1 0 00246	1 00 0000+00	
	PERRY HW	(SR0019 SEG 0520/0000)		
0010/0000	MFC BEGIN = D	LENGTH(AH 2400 BK 0000)		

EXTRACT DATE: 12/21/2020 ROADWAY MANAGEMENT SYSTEM PAGE NUMBER: 1396
 PRINT DATE: 12/23/2020 SLD COUNTY/SR - ANNUAL PRINT COUNTY: ALLEGHENY
 DIR: B TOTAL LEN: .545 MI. DIST: 11-1 SR: 4055
 LEFT MUN: MARSHALL T RIGHT MUN: MARSHALL T

002878 FT

* 002878 FT
 REF-AHD FRIEL RD
 0010/2878 (BORO)

000000 FT

000000 FT 2 0 02025 0 00 0000+00
 WARRENDALE BAYNE RD
 (CNTY)
 NC PGH ROCHESTER RD
 INTER-BK ROBINSON DR
 (T483)
 MFC BEGIN = E
 0010/0000 LENGTH(AH 2878 BK 0000)

WARRENDALE BAYNE RD
 (CNTY)

0010/0000

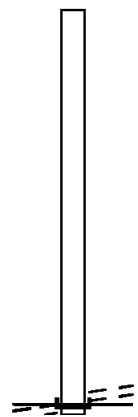

EXTRACT DATE: 12/21/2020 ROADWAY MANAGEMENT SYSTEM PAGE NUMBER: 1395
 PRINT DATE: 12/23/2020 SLD COUNTY/SR - ANNUAL PRINT COUNTY: ALLEGHENY
 DIR: B TOTAL LEN: 1.568 MI. DIST: 11-1 SR: 4054
 LEFT MUN: PINE T RIGHT MUN: PINE T

FRANKLIN RD
 (SR4061 SEG 0030/1475) 0030/3363

008281 FT

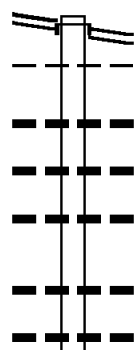

008281 FT
 INTER-AHD MT PLEASANT RD
 (T727)
 FRANKLIN RD
 (SR4061 SEG 0030/1475)
 PINE
 MARSHALL T
 018 " DIA CIRC METAL
 LEN=0040 INSTALLED UNKN
 018 " DIA CIRC CONCR
 LEN=0050 INSTALLED UNKN
 024 " DIA CIRC METAL
 LEN=0050 INSTALLED UNKN
 024 " DIA CIR PLASTIC
 LEN=0048 INSTALLED UNKN
 024 " DIA CAST IRON
 LEN=0040 INSTALLED UNKN

DIR: B TOTAL LEN: 1.568 MI. DIST: 11-1 SR: 4054
 LEFT MUN: MARSHALL T RIGHT MUN: MARSHALL T

Stationing	Notes	Stationing	Notes
004918 FT	0030/0395	012 " DIA CIRC OTHER	
	004918 FT	LEN=0046 INSTALLED UNKN	
	0030/0000	2 0 02224 0 01 0045+82	
		LENGTH(AH 3363 BK 3480)	
		LC FOR RIDGE DR	
	0020/3096	(CONN)	
		RIDGE DR	
	0020/3083	(T519)	
		018 " DIA CIRC OTHER	
	0020/2967	LEN=0066 INSTALLED UNKN	
		012 " DIA CIRC METAL	
	0020/2530	LEN=0036 INSTALLED UNKN	
		TRIBAL LN	
	0020/1553	(PRDR)	
		VENANGO TR	
	0020/1131	(TWP)	
		048 " DIA CIRC CONCR	
	0020/1020	LEN=0055 INSTALLED UNKN	
001438 FT	001438 FT	2 0 02224 0 01 0010+00	
		ALEAH DR	
		(TWP)	
		MFC BEGIN = E	
	0020/0000	LENGTH(AH 3480 BK 1438)	
	0010/1260	BMS EN 02/4054/0010/0860	
		018 " DIA CIRC CONCR	
	0010/1212	LEN=0084 INSTALLED UNKN	
		2 0 02224 0 00 0000+00	
		SR 0079 NB	
	0010/0838	BMSBG 02/4054/0010/0860	
		018 " DIA CIRC CONCR	
	0010/0759	LEN=0060 INSTALLED UNKN	
		018 " DIA CIRC CONCR	
	0010/0462	LEN=0075 INSTALLED UNKN	
		SHERATON DR	
	0010/0440	(T484)	
000000 FT	000000 FT	2 0 02224 0 00 0000+00	
		NC FR	
		REEPOR RD	
		PERRY HW	
		(SR0019 SEG 0680/3090)	
		INTER-BK	
		EMERYVILLE DR	
		(T877)	
		MFC BEGIN = D	
	0010/0000	LENGTH(AH 1438 BK 0000)	

DUTILH RD
(T484)

0010/0440
000000 FT

019850 FT

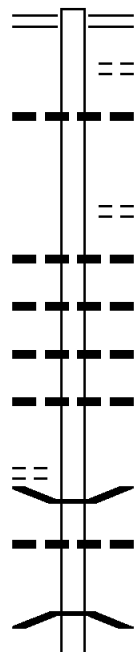

019850 FT MINGO RD
 0080/2777 (SR4051 SEG 0050/0000)
 TYBURN DR
 (TWP)
 0080/2540 015 " DIA CIRC CONCR
 0080/2430 LEN=0040 INSTALLED UNKN

 MALBEC LN
 (TWP)
 0080/1379 015 " DIA CIRC CONCR
 0080/1140 LEN=0050 INSTALLED UNKN
 0080/0860 018 " DIA CIR PLASTIC
 LEN=0015 INSTALLED UNKN
 0080/0627 015 " DIA CIRC METAL
 LEN=0060 INSTALLED UNKN
 0080/0412 015 " DIA CIRC METAL
 017073 FT LEN=0048 INSTALLED UNKN

 0080/0000 LENGTH(AH 2777 BK 2526)
 0070/2368 BMSBN 02/4053/0070/2127
 018 " DIA CIRC CONCR
 0070/2300 LEN=0050 INSTALLED UNKN
 2 0 02104 0 00 0028+97
 SR 0079 NB
 0070/2127 BMSBG 02/4053/0070/2127

2 0 02104 0 00 0028+20 017073 FT
 VALLEY RD
 (TWP) 0080/0000

NEELY SCHOOL RD

DIR: B TOTAL LEN: 3.759 MI. DIST: 11-1 SR: 4053
 LEFT MUN: MARSHALL T RIGHT MUN: MARSHALL T

Location / Stationing	Stationing	Notes	Stationing	Notes
(TWP)	0070/1850	==		
		==	0070/1570	MARSHALL CAMPUS RD (PRDR)
STRAWBERRY LN (TWP)	0070/1365	==		
		---	0070/1032	018 " DIA CIRC CONCR LEN=0050 INSTALLED UNKN
		---	0070/0385	024 " DIA CIRC CONCR LEN=0050 INSTALLED UNKN
014547 FT		---	014547 FT	2 0 02104 0 00 0053+68 SHENOT RD (TWP)
		==	0070/0000	MFC BEGIN = E LENGTH(AH 2526 BK 2663) 048"H 60"W CON BOX CUL
		---	0050/2537	LEN=0030 INSTALLED UNKN
		---	0050/2471	BMSSEN 02/4053/0050/2465 0 0 00000 0 00 0000+00 BR. BRUSH CR.
		---	0050/2465	BMSBG 02/4053/0050/2465 MARSHALL
		---	0050/2460	BRADFORDWOODS B CRYSTAL SPRING RD
		==	0050/2390	(BORO)
		---	0050/2155	018 " DIA CIRC CONCR LEN=0048 INSTALLED UNKN
		---	0050/1505	018 " DIA CIRC CONCR LEN=0040 INSTALLED UNKN
		==	0050/1005	OAKGROVE RD (BORO)
OAKGROVE RD (BORO)	0050/0925	==		
		---	0050/0250	015 " DIA CIRC CONCR LEN=0032 INSTALLED UNKN
		---	0050/0031	015 " DIA CIRC CONCR LEN=0040 INSTALLED UNKN
011884 FT		---	011884 FT	2 0 02135 0 01 0279+34 015 " DIA CIRC CONCR LEN=0060 INSTALLED UNKN BRADFORD RD (BORO)
		==	0050/0000	LENGTH(AH 2663 BK 2783)
		---	0040/2531	015 " DIA CIRC CONCR LEN=0040 INSTALLED UNKN
		---	0040/2206	015 " DIA CIR PLASTIC LEN=0075 INSTALLED UNKN
		---		015 " DIA CIRC CONCR

EXTRACT DATE: 12/21/2020
PRINT DATE: 12/23/2020

ROADWAY MANAGEMENT SYSTEM
SLD COUNTY/SR - ANNUAL PRINT

PAGE NUMBER: 1391
COUNTY: ALLEGHENY

DIR: B TOTAL LEN: 3.759 MI.
LEFT MUN: BRADFORDWOODS B

DIST: 11-1 SR: 4053
RIGHT MUN: BRADFORDWOODS B

GLENMORE RD
(BORO)

0040/1606

0040/1862 LEN=0060 INSTALLED UNKN
015 "DIA CIRC CONCR
0040/1663 LEN=0040 INSTALLED UNKN
GLENMORE RD
0040/1626 (BORO)

009101 FT

0040/1070 015 "DIA CIRC CONCR
LEN=0099 INSTALLED UNKN
0040/0378 048 "DIA CIRC METAL
LEN=0060 INSTALLED UNKN
009101 FT 2 0 02135 0 00 0249+32
BRADFORDWOODS
MARSHALL T

PEACHSTONE LN
(PRDR)

0034/2377

0040/0000 LENGTH(AH 2783 BK 2605)
018 "DIA CIRC METAL
0034/2434 LEN=0048 INSTALLED UNKN
MANOR RD
0034/2377 (T699)

0 0 00000 0 00 0000+00 006496 FT
SUMMIT DR
(TWP)

0034/0000

0034/1322 018 "DIA CIRC CONCR
LEN=0040 INSTALLED UNKN
0034/1055 015 "DIA CIR PLASTIC
LEN=0040 INSTALLED UNKN
0034/0865 015 "DIA CIR PLASTIC
LEN=0060 INSTALLED UNKN

005056 FT

0034/0084 024 "DIA CIRC CONCR
LEN=0040 INSTALLED UNKN
006496 FT COUNTRY OAK DR
(TWP)
0034/0000 LENGTH(AH 2605 BK 1440)
018 "DIA CIRC CONCR
0030/1258 LEN=0040 INSTALLED UNKN
LAUREL CREST DR
0030/0946 (TWP)
0030/0685 018 "DIA CIRC CONCR
LEN=0032 INSTALLED UNKN
0030/0050 018 "DIA CIRC CONCR
LEN=0050 INSTALLED UNKN
005056 FT 2 0 02135 0 00 0210+90
NC WEXFORD RUN RD
WEXFORD BAYNE RD
(SR0910 SEG 0030/1140)

INTER-BK WEXFORD RUN RD (TBK)
(TWP)

EXTRACT DATE: 12/21/2020
PRINT DATE: 12/23/2020

ROADWAY MANAGEMENT SYSTEM
SLD COUNTY/SR - ANNUAL PRINT

PAGE NUMBER: 1390
COUNTY: ALLEGHENY

DIR: B TOTAL LEN: 3.759 MI.
LEFT MUN: MARSHALL T

DIST: 11-1 SR: 4053
RIGHT MUN: MARSHALL T

MEINERT RD
(TWP)

HARMONY RD
(PRDR)

LINDEN RD
(TWP)

005056 FT

0020/1958

003098 FT

0010/2408

0010/0965

000000 FT

000000 FT

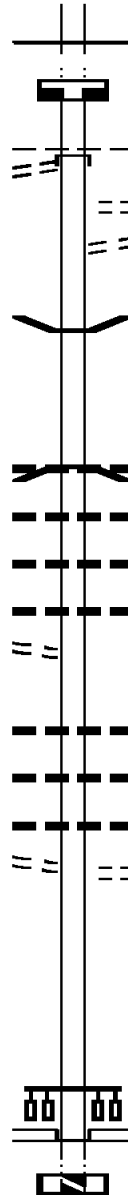

5 0030/0000 MFC BEGIN = D
005056 FT LENGTH(AH 1440 BK 0100)
7024/0000
INTER-AHD RICHARD RD (TBK)
0020/1958 LENGTH(AH 0100 BK 1958)
(TWP)
0020/1490 MCCANDLESS T
FOREST TRAILS DR
0020/0970 (TWP)
PINE VALLEY CT
(PRDR)

0020/0016 BMS EN 02/4053/0020/0000
003098 FT 2 0 02135 0 00 0089+20
072"H 72"W CON BOX CUL
LEN=0124 INSTALLED UNKN
WEXFORD RUN

5 0020/0000 BMSBG 02/4053/0020/0000
LENGTH(AH 1958 BK 3098)
018 " DIA CIRC CONCR
0010/3050 LEN=0040 INSTALLED UNKN
018 " DIA CIRC CONCR
0010/2860 LEN=0040 INSTALLED UNKN
018 " DIA CIRC CONCR
0010/2689 LEN=0040 INSTALLED UNKN

0010/1739 018 " DIA CIRC CONCR
LEN=0040 INSTALLED UNKN
0010/1420 018 " DIA CIRC CONCR
LEN=0040 INSTALLED UNKN
0010/1120 018 " DIA CIRC CONCR
LEN=0040 INSTALLED UNKN
0010/0965 FOREST OAKS DR
(TWP)

000000 FT 2 0 02135 0 00 0057+04
NC RICHARD RD
PERRY HW
(SR0019 SEG 0591/1618)
(SR0019 SEG 0590/1481)

INTER-BK REICHOLD RD (TBK)
(TWP)

5 0010/0000 LTH AH 003098 BK 000100
000000 FT
7008/0000 LTH AH 000100 BK 000000

DIR: B TOTAL LEN: 6.993 MI. DIST: 11-1 SR: 4052
 LEFT MUN: PINE T RIGHT MUN: PINE T

PEARCE MILL RD 036858 FT
 (SR4063 SEG 0050/0000) 0160/2608

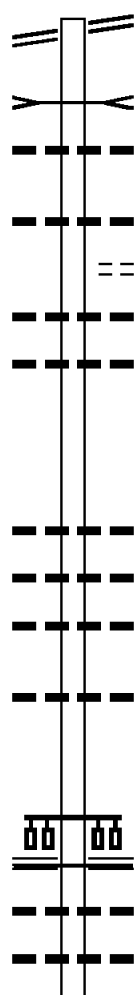

034250 FT

031730 FT

WARRENDALE RD 0150/0000
 (SR4068 SEG 0050/0000)

036922 FT PEARCE MILL RD
 0160/2608 (SR4063 SEG 0050/0000)
 BR-N-FK-PINE
 STRUCTURE LENGTH 13 FT
 0160/2240 BMSID 02/4052/0160/2240
 060"H 84"W CONCR ARCH
 0160/2235 LEN=0063 INSTALLED UNKN
 030 " DIA CIRC CONCR
 0160/1537 LEN=0060 INSTALLED UNKN
 ENGLISH RD
 (T711)
 018 " DIA CIRC CONCR
 0160/1248 LEN=0040 INSTALLED UNKN
 036 " DIA CIRC CONCR
 0160/0742 LEN=0064 INSTALLED UNKN
 034314 FT 2 0 02225 0 00 0025+01
 0160/0000 LENGTH(AH 2608 BK 2520)
 0150/1369 018 " DIA CIRC CONCR
 LEN=0064 INSTALLED UNKN
 060 " DIA CIRC CONCR
 0150/1125 LEN=0050 INSTALLED UNKN
 036 " DIA CIRC CONCR
 0150/0798 LEN=0040 INSTALLED UNKN
 018 " DIA CIRC CONCR
 0150/0045 LEN=0064 INSTALLED UNKN
 031794 FT 2 0 02225 0 00 0000+00
 NC GR AHAM RD
 WALLACE RD
 (SR4068 SEG 0050/0000)
 MFC BEGIN = E
 0150/0000 LENGTH(AH 2520 BK 1065)
 060 " DIA CIRC CONCR
 0140/0977 LEN=0045 INSTALLED UNKN
 018 " DIA CIRC CONCR
 0140/0695 LEN=0054 INSTALLED UNKN

EXTRACT DATE: 12/21/2020
PRINT DATE: 12/23/2020

ROADWAY MANAGEMENT SYSTEM
SLD COUNTY/SR - ANNUAL PRINT

PAGE NUMBER: 1388
COUNTY: ALLEGHENY

DIR: B
LEFT MUN: PINE T

TOTAL LEN: 6.993 MI.

DIST: 11-1
RIGHT MUN: PINE T

SR: 4052

Stationing	Structure	Material	Length	Notes
030665 FT				
030729 FT			2 0 02272 0 00 0081+72	
0140/0000			LENGTH(AH 1065 BK 2064)	
0130/1859			018 " DIA CIRC CONCR	
			LEN=0040 INSTALLED UNKN	
0130/1554			018 " DIA CIRC CONCR	
			LEN=0036 INSTALLED UNKN	
			BR BRUSH CRK	
0130/1067			STRUCTURE LENGTH 10 FT	
			BMSID 02/4052/0130/1067	
			018 " DIA CIRC CONCR	
0130/0465			LEN=0001 INSTALLED UNKN	
			018 " DIA CIRC CONCR	
0130/0012			LEN=0040 INSTALLED UNKN	
028601 FT			028665 FT	
			2 0 02272 0 00 0060+71	
			PINE	
			MARSHALL T	
0130/0000			LENGTH(AH 2064 BK 1291)	
0120/0906			BMSEN 02/4052/0120/0860	
			2 0 02272 0 00 0056+83	
			BRUSH CREEK	
0120/0881			BMSBG 02/4052/0120/0860	
			084"H 72"W CONC STRUCT	
0120/0591			LEN=0034 INSTALLED UNKN	
027374 FT			2 0 02272 0 00 0048+33	
0120/0000			LENGTH(AH 1291 BK 3904)	
			018 " DIA CIRC CONCR	
0110/3217			LEN=0036 INSTALLED UNKN	
			018 " DIA CIRC METAL	
0110/2712			LEN=0048 INSTALLED UNKN	
			015 " DIA CIRC CONCR	
0110/2577			LEN=0999 INSTALLED UNKN	
			018 " DIA CIRC CONCR	
0110/2356			LEN=0062 INSTALLED UNKN	
			018 " DIA CIR PLASTIC	
0110/1310			LEN=0080 INSTALLED UNKN	
			NORTHGATE DR	
0110/1302			(T482)	
0110/1100			BMSEN 02/4052/0110/1089	
			2 0 02272 0 00 0020+01	
			BR. BRUSH CR.	
0110/1089			BMSBG 02/4052/0110/1089	
			020 " DIA CIRC CONCR	
0110/0934			LEN=0099 INSTALLED UNKN	
			HARMONY RD	

DIR: B TOTAL LEN: 6.993 MI. DIST: 11-1 SR: 4052
 LEFT MUN: MARSHALL T RIGHT MUN: MARSHALL T

023406 FT		0110/0410 (T388)	
		023470 FT	2 0 02272 0 00 0009+21
		0110/0000	LENGTH(AH 3904 BK 0883)
			024 "DIA CIRC CONCR
		0100/0770	LEN=0025 INSTALLED UNKN
			FROM 0019/0660 SH
022523 FT		0100/0153	(CONN)
		022587 FT	2 0 02272 0 00 0000+00
			PERRY HW
			(SR0019 SEG 0660/1040)
		0100/0000	MFC BEGIN = D
			LENGTH(AH 0883 BK 0784)
		0090/0718	018 "DIA CIRC CONCR
			LEN=0060 INSTALLED UNKN
		0090/0630	024 "DIA CIRC CONCR
			LEN=0020 INSTALLED UNKN
FROM 0019/0661 SH			WILLIAMSBURG PL
(CONN)	0091/0536		(TB76)
0 0 00000 0 00 0000+00	021754 FT	0090/0306	2 0 02271 0 00 0076+68
LENGTH(AH 0769 BK 1340)	0091/0000	021803 FT	0090/0000
			LENGTH(AH 0784 BK 1339)
			018 "DIA CIRC CONCR
LC TO WARRENDALE VILLAG		0080/0892	LEN=0014 INSTALLED UNKN
(CONN)	0081/0725		WARRENDALE VILLAGE DR
WARRENDALE VILLAGE DR			(PRDR)
(TWP)			WHEATLAND RD
WHEATLAND RD	0081/0640	0080/0640	(T469)
(T469)			018 "DIA CIRC CONCR
		0080/0620	LEN=0100 INSTALLED UNKN
			018 "DIA CIRC CONCR
		0080/0027	LEN=0074 INSTALLED UNKN
2 0 02271 0 00 0063+51	020414 FT	020464 FT	2 0 02271 0 00 0063+65
LENGTH(AH 1340 BK 2330)	0081/0000	0080/0000	LENGTH(AH 1339 BK 2380)
018 "DIA CIRC CONCR			
LEN=0090 INSTALLED UNKN	0071/1955		
BRANDT RD			
(T848)	0071/1725		
WARRENDALE INT/RMP J RD		0070/1785	BRANDT RD
(SR8025 SEG 0010/1619)	0071/1285		(T848)
			WARRENDALE INT/RMP J RD
		0070/1285	(SR8025 SEG 0010/1619)
			024 "DIA CIR UNKNOWN
		0070/1229	LEN=0096 INSTALLED UNKN
			SR 0079 NB

DIR: B TOTAL LEN: 6.993 MI. DIST: 11-1 SR: 4052
 LEFT MUN: MARSHALL T RIGHT MUN: MARSHALL T

OP ID	SR	SB	LEN	LC TO	CONN	BRUSH CREEK RD	RAMP K RD	SR8025 SEG	0250/0000	0071/1130	0071/0982	0071/0590	0071/0560	0071/0412	0071/0000	0060/3847	0060/3633	0060/3385	0060/3199	0060/3005	0060/2873	0060/2465	0060/2268	0060/2082	0060/1706	0060/1454	0060/1281	0060/1021	0060/0744	0060/0423	0060/0010	014102 FT	0070/1070	0070/0915	0070/0415	0070/0040	0070/0000	0060/3847	0060/3633	0060/3385	0060/3199	0060/3005	0060/2465	0060/2268	0060/2082	0060/1706	0060/1454	0060/1281	0060/0744	0060/0423	0060/0010	014102 FT	OP ID	SR	SB	LEN	LC TO	CONN	BRUSH CREEK RD	RAMP K RD	SR8025 SEG	0250/0000	018 "DIA CIRC CONCR	LEN=0040	INSTALLED UNKN	2 0 02271 0 00 0039+64	018084 FT	MFC BEGIN = C	LENGTH(AH 2330 BK 3982)	0071/0000	0060/3847	0060/3633	0060/3385	0060/3199	0060/3005	0060/2465	0060/2268	WOODHURST TERRACE	(TWP)	018 "DIA CIR PLASTIC	LEN=0050	INSTALLED UNKN	018 "DIA CIRC CONCR	LEN=0099	INSTALLED UNKN	018 "DIA CIRC CONCR	LEN=0045	INSTALLED UNKN	018 "DIA CIRC CONCR	LEN=0045	INSTALLED UNKN	018 "DIA CIRC CONCR	LEN=0099	INSTALLED UNKN	018 "DIA CIRC CONCR	LEN=0099	INSTALLED UNKN	TYBURN DR	(T880)	018 "DIA CIRC CONCR	LEN=0050	INSTALLED UNKN	018 "DIA CIRC CONCR	LEN=0045	INSTALLED UNKN	018 "DIA CIRC CONCR	LEN=0045	INSTALLED UNKN	2 0 02271 0 00 0000+00
02/0079/0754/0907	0079	SB	0096	BRUSH CREEK RD	(CONN)	BRUSH CREEK RD	RAMP K RD	(SR8025 SEG 0250/0000)		0071/1130	0071/0982	0071/0590	0071/0560	0071/0412	0071/0000	0060/3847	0060/3633	0060/3385	0060/3199	0060/3005	0060/2873	0060/2465	0060/2268	0060/2082	0060/1706	0060/1454	0060/1281	0060/1021	0060/0744	0060/0423	0060/0010	014102 FT	0070/1070	0070/0915	0070/0415	0070/0040	0070/0000	0060/3847	0060/3633	0060/3385	0060/3199	0060/3005	0060/2465	0060/2268	WOODHURST TERRACE	(TWP)	018 "DIA CIR PLASTIC	LEN=0050	INSTALLED UNKN	018 "DIA CIRC CONCR	LEN=0099	INSTALLED UNKN	018 "DIA CIRC CONCR	LEN=0045	INSTALLED UNKN	018 "DIA CIRC CONCR	LEN=0045	INSTALLED UNKN	018 "DIA CIRC CONCR	LEN=0099	INSTALLED UNKN	TYBURN DR	(T880)	018 "DIA CIRC CONCR	LEN=0050	INSTALLED UNKN	018 "DIA CIRC CONCR	LEN=0045	INSTALLED UNKN	018 "DIA CIRC CONCR	LEN=0045	INSTALLED UNKN	2 0 02271 0 00 0000+00																																				

DIR: B TOTAL LEN: 6.993 MI. DIST: 11-1 SR: 4052
 LEFT MUN: MARSHALL T RIGHT MUN: MARSHALL T

Stationing	Notes	Stationing	Notes
014102 FT	INTER-BK	0060/0000	PLEASANT HILL RD (SR4051 SEG 0050/2822)
		014102 FT	WARRENDALE BAYNE RD
		7054/0000	WARRENDALE BAYNE RD (TB)
		INTER-AHD	(TWP)
			MFC BEGIN = C
		0050/2424	LTH AH 003982 BK 000100
			LTH AH 000100 BK 002424
			WARRENDALE BAYNE RD (TB)
			(TWP)
			WARRENDALE BAYNE RD (TB)
			(TWP)
CIDERBERRY DR (TWP)		0050/1851	018 "DIA CIRC CONCR
			LEN=0036 INSTALLED UNKN
		0050/1194	018 "DIA CIRC METAL
			LEN=0055 INSTALLED UNKN
		0050/1031	018 "DIA CIR UNKNOWN
			LEN=0099 INSTALLED UNKN
		0050/0811	018 "DIA CIRC METAL
			LEN=0040 INSTALLED UNKN
		0050/0256	018 "DIA CIRC METAL
			LEN=0099 INSTALLED UNKN
011678 FT		011678 FT	2 0 02058 0 00 0116+44
			PINE GROVE RD
			(TWP)
		0050/0000	LENGTH(AH 2424 BK 2021)
			ARCHBERRY DR
		0040/1661	(PRDR)
		0040/1411	018 "DIA CIRC CONCR
			LEN=0036 INSTALLED UNKN
		0040/1105	018 "DIA CIRC CONCR
			LEN=0040 INSTALLED UNKN
		0040/0837	018 "DIA CIRC CONCR
			LEN=0040 INSTALLED UNKN
009657 FT		009657 FT	2 0 02058 0 00 0095+37
		0040/0000	LENGTH(AH 2021 BK 2059)
ANTLER POINT DR (T856)		0030/1480	018 "DIA CIRC CONCR
			LEN=0034 INSTALLED UNKN
SABLE CT (TWP)		0030/0604	GROOMES CT
KNOB RD (TBK)			(TWP)
(TWP)		0030/0292	

DIR: B TOTAL LEN: 6.993 MI. DIST: 11-1 SR: 4052
 LEFT MUN: MARSHALL T RIGHT MUN: MARSHALL T

AUDUBON DR
 (TWP)

007598 FT

0020/3614

003811 FT

000000 FT

WOODLAND RD
 (T725)

0010/0000

0030/0264	018 " DIA	CIRC	CONCR	LEN=0099	INSTALLED	UNKN
0030/0026	018 " DIA	CIRC	METAL	LEN=0040	INSTALLED	UNKN
007598 FT	2 0 02058	0 00	0075+70			
0030/0000	LENGTH(AH	2059	BK 3787)			
0020/3433	COPPER CREEK LN					
0020/3002	018 " DIA	CIRC	CONCR	LEN=0036	INSTALLED	UNKN
0020/2050	030 " DIA	CIRC	METAL	LEN=0070	INSTALLED	UNKN
0020/1598	SPANG RD					
0020/0681	024 " DIA	CIRC	CONCR	LEN=0038	INSTALLED	UNKN
003811 FT	2 0 02058	0 00	0038+24			
0020/0000	LENGTH(AH	3787	BK 3811)			
0010/3474	018 " DIA	CIRC	CONCR	LEN=0032	INSTALLED	UNKN
0010/2699	018 " DIA	CIRC	CONCR	LEN=0032	INSTALLED	UNKN
0010/2188	018 " DIA	CIRC	CONCR	LEN=0034	INSTALLED	UNKN
0010/1772	018 " DIA	CIRC	CONCR	LEN=0040	INSTALLED	UNKN
0010/1338	018 " DIA	CIRC	CONCR	LEN=0040	INSTALLED	UNKN
0010/1169	018 " DIA	CIRC	CONCR	LEN=0034	INSTALLED	UNKN
0010/0060	018 " DIA	CIRC	METAL	LEN=0020	INSTALLED	UNKN
000000 FT	2 0 02058	0 00	0000+00			
	NC PL					
	LEASANT HILL RD					
	GOLDEN GROVE RD					
	(SR2006	SEG	0130/0000)			
	INTER-BK	LOVI RD				
	(SR2006	SEG	0130/0000)			
	MFC BEGIN	=	E			
0010/0000	LENGTH(AH	3811	BK 0000)			

DIR: B TOTAL LEN: 2.625 MI. DIST: 11-1 SR: 4051
 LEFT MUN: MARSHALL T RIGHT MUN: MARSHALL T

WARRENDALE BAYNE RD (TWP) 013858 FT
 (CNTY) 0050/2822

GREENBRIAR DR 0050/1135
 (TWP)

ROLLING HILLS DR 0050/0335
 (TWP)

011036 FT

2 0 02133 0 01 0089+44 008657 FT
 BAUER LN
 (PRDR) 0040/0000

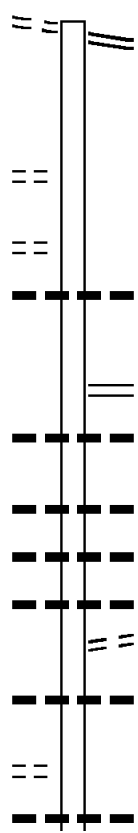

013858 FT WARRENDALE BAYNE RD
 0050/2822 (SR4052 SEG 0060/0000)

0050/0044 018 " DIA CIRC CONCR
 011036 FT LEN=0030 INSTALLED UNKN
 2 0 02133 0 01 0114+13
 WEXFORD RUN RD
 (SR4053 SEG 0080/2777)
 5 0050/0000 LENGTH(AH 2822 BK 2379)
 015 " DIA CIRC METAL
 0040/2013 LEN=0040 INSTALLED UNKN
 0040/1281 015 " DIA CIRC METAL
 LEN=0040 INSTALLED UNKN
 0040/1114 018 " DIA CIRC METAL
 LEN=0040 INSTALLED UNKN
 0040/0933 015 " DIA CIRC CONCR
 LEN=0050 INSTALLED UNKN
 VALLEY RD
 (T428)
 0040/0422 048 " DIA CIRC METAL
 0040/0055 LEN=0050 INSTALLED UNKN
 008657 FT
 5 0040/0000 LENGTH(AH 2379 BK 3446)
 015 " DIA CIRC METAL
 0030/3400 LEN=0050 INSTALLED UNKN

STONEGATE DR (TWP) 0030/0750
 STONEGATE DR (TWP) 0030/0678

005211 FT

STATE GAME LANDS RD (TB (T901) 0020/1004

003325 FT

MARSHALL HEIGHTS DR (TWP) 0010/0266
 000000 FT

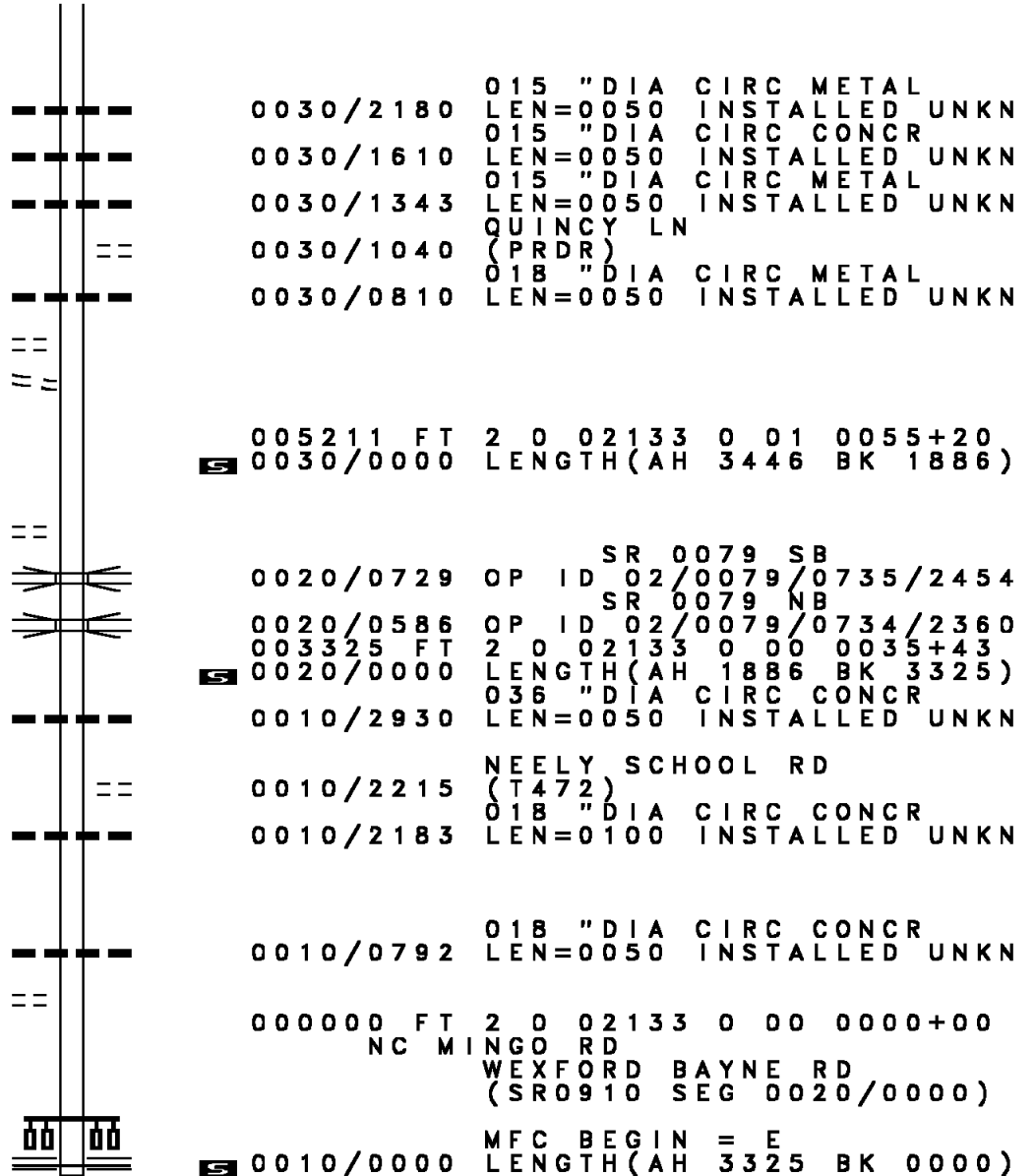

0030/2180 015 \" DIA CIRC METAL
 LEN=0050 INSTALLED UNKN
 0030/1610 015 \" DIA CIRC CONCR
 LEN=0050 INSTALLED UNKN
 0030/1343 015 \" DIA CIRC METAL
 LEN=0050 INSTALLED UNKN
 QUINCY LN
 (PRDR)
 0030/1040 018 \" DIA CIRC METAL
 LEN=0050 INSTALLED UNKN
 0030/0810 018 \" DIA CIRC METAL
 LEN=0050 INSTALLED UNKN

005211 FT 2 0 02133 0 01 0055+20
 0030/0000 LENGTH(AH 3446 BK 1886)

SR 0079 SB
 OP ID 02/0079/0735/2454
 SR 0079 NB
 0020/0729 0020/0586 OP ID 02/0079/0734/2360
 003325 FT 2 0 02133 0 00 0035+43
 0020/0000 LENGTH(AH 1886 BK 3325)

0010/2930 036 \" DIA CIRC CONCR
 LEN=0050 INSTALLED UNKN
 NEELY SCHOOL RD
 (T472)
 0010/2215 018 \" DIA CIRC CONCR
 LEN=0100 INSTALLED UNKN
 0010/2183 018 \" DIA CIRC CONCR
 LEN=0050 INSTALLED UNKN

0010/0792 018 \" DIA CIRC CONCR
 LEN=0050 INSTALLED UNKN
 000000 FT 2 0 02133 0 00 0000+00
 NC MINGO RD
 WEXFORD BAYNE RD
 (SR0910 SEG 0020/0000)

MFC BEGIN = E
 0010/0000 LENGTH(AH 3325 BK 0000)

EXTRACT DATE: 12/21/2020 ROADWAY MANAGEMENT SYSTEM PAGE NUMBER: 1381
 PRINT DATE: 12/23/2020 SLD COUNTY/SR - ANNUAL PRINT COUNTY: ALLEGHENY
 DIR: B TOTAL LEN: .002 MI. DIST: 11-1 SR: 4050
 LEFT MUN: MARSHALL T RIGHT MUN: MARSHALL T

000010 FT

000000 FT

000000 FT

000000 FT

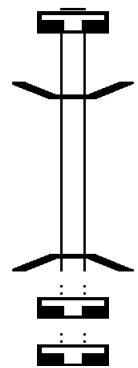

000010 FT
 7024/0000 LENGTH(AH 1860 BK 0010)
 BMSSEN 02/4050/0022/0000
 * REF-AHD SHENOT RD
 0022/0010 (TWP)
 000000 FT 2 0 00000 0 00 0000+00
 NC SHENOT RD
 * REF-BK SHENOT RD
 (TWP)
 BRANCH OF BRUSH CREEK
 BMSBG 02/4050/0022/0000
 0022/0000 LENGTH(AH 0010 BK 1112)
 000000 FT
 7020/0000 LENGTH(AH 1112 BK 1750)
 000000 FT
 7010/0000 LENGTH(AH 1750 BK 0000)

EXTRACT DATE: 12/21/2020 ROADWAY MANAGEMENT SYSTEM PAGE NUMBER: 1380
 PRINT DATE: 12/23/2020 SLD COUNTY/SR - ANNUAL PRINT COUNTY: ALLEGHENY
 DIR: B TOTAL LEN: 4.503 MI. DIST: 11-1 SR: 4049
 LEFT MUN: FRANKLIN PARK B RIGHT MUN: FRANKLIN PARK B

023774 FT

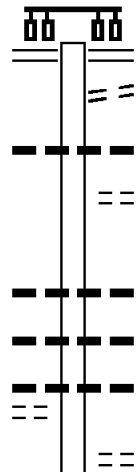

023774 FT BAYNE WEXFORD RD
 (SR4042 SEG 0041/0000)
 (SR4042 SEG 0040/0000)
 0100/3247 TO 4042/0040 SH
 (CONN)
 0100/3125 01B "DIA CIRC CONCR
 0100/2931 LEN=0099 INSTALLED UNKN
 CARMODY CT
 0100/2698 (PRDR)
 0100/1714 01B "DIA CIRC CONCR
 LEN=0030 INSTALLED UNKN
 0100/1401 01B "DIA CIRC CONCR
 LEN=0099 INSTALLED UNKN
 0100/1150 01B "DIA CIRC CONCR
 LEN=0050 INSTALLED UNKN
 0100/0899 POLLAR DR
 (TWP)

SAVANNAH LN
 (PRDR)

0100/1149

DIR: B TOTAL LEN: 4.503 MI. DIST: 11-1 SR: 4049
 LEFT MUN: FRANKLIN PARK B RIGHT MUN: FRANKLIN PARK B

Location	Segment	Length (FT)	Material	Notes
	0100/0644	020527	024 " DIA CIRC METAL	LEN=0099 INSTALLED UNKN
	020527 FT		020527 FT	1 0 00678 0 00 0206+12
	0100/0000		LENGTH(AH 3247 BK 2558)	
GEORGETOWN DR (PRDR)	0090/1630			
MCKINNEY RD (TWP)	0090/1482		018 " DIA CIR PLASTIC	LEN=0099 INSTALLED UNKN
MCKINNEY RD (TWP)	0090/0809	017969	LAUREL DR (TWP)	
	017969 FT		017969 FT	1 0 00678 0 00 0180+40
	0090/0000		LENGTH(AH 2558 BK 3493)	
	0080/2740		018 " DIA CIRC CONCR	LEN=0045 INSTALLED UNKN
	0080/2429		018 " DIA CIRC CONCR	LEN=0045 INSTALLED UNKN
MOONEY LN (TWP)	0080/2390			
MYSTIC VALLEY RD (TWP)	0080/2210			
	0080/2100		040 " DIA CIRC CONCR	LEN=0088 INSTALLED UNKN
	0080/1756		LAPLACE POINT CT (TWP)	
	0080/1374		018 " DIA CIRC CONCR	LEN=0040 INSTALLED UNKN
	0080/1160		018 " DIA CIRC CONCR	LEN=0099 INSTALLED UNKN
NORMAN DR (TWP)	0080/0942			
	0080/0680		018 " DIA CIRC CONCR	LEN=0099 INSTALLED UNKN
	0080/0198		FROM 4011/0210 (CONN)	
ROCHESTER RD (SR4011 SEG 0220/0000)	0080/0095	014476	ROCHESTER RD (SR4011 SEG 0220/0000)	
	014476 FT		0080/0095	1 0 00678 0 00 0145+27
	0080/0000		TO SR 4011/0210 (CONN)	
LOCUST RD (TWP)	0080/0000		LENGTH(AH 3493 BK 1748)	

EXTRACT DATE: 12/21/2020
PRINT DATE: 12/23/2020

ROADWAY MANAGEMENT SYSTEM
SLD COUNTY/SR - ANNUAL PRINT

PAGE NUMBER: 1378
COUNTY: ALLEGHENY

DIR: B TOTAL LEN: 4.503 MI.
LEFT MUN: FRANKLIN PARK B

DIST: 11-1 SR: 4049
RIGHT MUN: FRANKLIN PARK B

WHARREY DR
(TWP)

012728 FT

0060/0634

SALT DOME
(PRDR)
SHIPLEY LN
(PRDR)

0050/1649

0050/1228

1 0 00678 0 00 0097+57
BLACKBURN HTS DR
(TWP)

010123 FT

0050/0000

DEER VALLEY DR
(TWP)

0040/0659

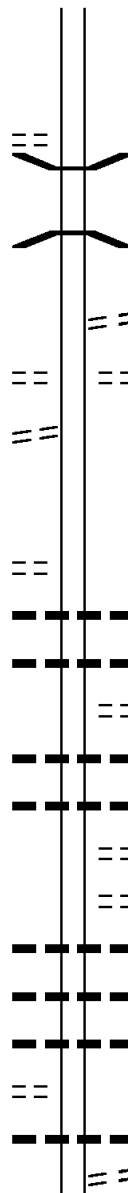

012728 FT 1 0 00678 0 00 0125+64
0070/0000 LENGTH(AH 1748 BK 0746)

0060/0538 BMS EN 02/4049/0060/0175
1 0 00678 0 00 0122+36

0060/0210 SR 0079 NB
011982 FT BMSBG 02/4049/0060/0175
1 0 00678 0 00 0120+61

0060/0000 BLAINES WY
(PRDR)
LENGTH(AH 0746 BK 1859)
LIN POINT CT
0050/1649 (PRDR)

010123 FT

0050/0000 LENGTH(AH 1859 BK 3553)

018 " DIA CIRC CONCR

LEN=0050 INSTALLED UNKN

099 " DIA CIRC CONCR

LEN=0099 INSTALLED UNKN

MCDEVITT RD

(T466)

018 " DIA CIRC CONCR

LEN=0099 INSTALLED UNKN

018 " DIA CIRC CONCR

LEN=0099 INSTALLED UNKN

STERLING CT

(TWP)

SQUIRE RIDGE DR

(TWP)

018 " DIA CIRC CONCR

LEN=0035 INSTALLED UNKN

018 " DIA CIRC CONCR

LEN=0035 INSTALLED UNKN

018 " DIA CIRC CONCR

LEN=0035 INSTALLED UNKN

0040/1006

018 " DIA CIRC CONCR

LEN=0035 INSTALLED UNKN

MONTGOMERY RD

(TWP)

0040/0175

0040/0158

EXTRACT DATE: 12/21/2020
PRINT DATE: 12/23/2020

ROADWAY MANAGEMENT SYSTEM
SLD COUNTY/SR - ANNUAL PRINT

PAGE NUMBER: 1377
COUNTY: ALLEGHENY

DIR: B TOTAL LEN: 4.503 MI.
LEFT MUN: FRANKLIN PARK B

DIST: 11-1 SR: 4049
RIGHT MUN: FRANKLIN PARK B

Stationing	Description	Stationing	Description
006570 FT		006570 FT	1 0 00678 0 00 0065+34 FRANKLIN PARK OHIO T
		0040/0000	LENGTH(AH 3553 BK 3076)
		0030/2450	012 "DIA CIRC CONCR LEN=0099 INSTALLED UNKN AMICITIA LN
		0030/2400	(TWP)
		0030/1505	CYPRESS KNOLL DR (TWP)
OHIO TWP BALLFIELD ENT (PARK)	0030/1208	0030/1141	018 "DIA CIR PLASTIC LEN=0070 INSTALLED UNKN MCCREA RD (TWP)
		0030/0606	018 "DIA CIRC CONCR LEN=0099 INSTALLED UNKN
		0030/0185	003494 FT 1 0 00678 0 00 0034+85 003494 FT LENGTH(AH 3076 BK 3301) PLAYER LN
		0030/0000	(TWP)
		0020/3255	018 "DIA CIRC CONCR LEN=0099 INSTALLED UNKN
		0020/3057	018 "DIA CIRC CONCR LEN=0040 INSTALLED UNKN
OHIO TWP COMM PARK ENT (PARK)	0020/2371	0020/2655	018 "DIA CIRC CONCR LEN=0099 INSTALLED UNKN
		0020/2038	018 "DIA CIRC CONCR LEN=0099 INSTALLED UNKN
RIDGE RD (T452)	0020/1745	0020/1275	LAUREL OAK DR (TWP)
		0020/1031	018 "DIA CIRC CONCR LEN=0088 INSTALLED UNKN
		0020/1020	018 "DIA CIRC CONCR LEN=0030 INSTALLED UNKN SYL RD (PRDR)
		0020/0475	000193 FT
1 0 00678 0 00 0001+61 FOR SR 4022 AND 4049 (CONN)	000193 FT 0020/0000	0020/0000	LENGTH(AH 3301 BK 0193) NC NI
		000000 FT	MT NEBO RD (SR4022 SEG 0050/0249)
1 0 00678 0 00 0000+00 MT NEBO RD (SR4022 SEG 0050/0249)	000000 FT 0010/0000	0010/0000	MFC BEGIN = D LENGTH(AH 0193 BK 0000)

EXTRACT DATE: 12/21/2020 ROADWAY MANAGEMENT SYSTEM PAGE NUMBER: 1376
 PRINT DATE: 12/23/2020 SLD COUNTY/SR - ANNUAL PRINT COUNTY: ALLEGHENY
 DIR: B TOTAL LEN: .010 MI. DIST: 11-1 SR: 4048
 LEFT MUN: MCCANDLESS T RIGHT MUN: MCCANDLESS T

000052 FT

 000000 FT

 000000 FT

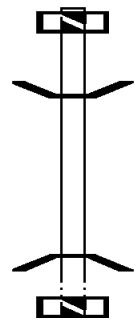

000052 FT
 7020/0000 LTH AH 000100 BK 000052
 BMSBN 02/4048/0010/0001
 * REF-AHD GRUBBS RD (TBK)
 0010/0052 (TWP)
 000000 FT 2 0 02190 0 00 0004+49
 NC GRUBBS RD
 * REF-BK GRUBBS RD (TBK)
 (TWP)
 PINE CREEK
 BMSBG 02/4048/0010/0001
 5 0010/0000 LTH AH 000052 BK 000100
 000000 FT
 7008/0000 LTH AH 000100 BK 000000

000025 FT		000025 FT	
000025 FT		7040/0000	LENGTH(AH 3190 BK 3500)
000025 FT		000025 FT	
000025 FT		7030/0000	LENGTH(AH 3500 BK 3500)
		000025 FT	
		7020/0000	LENGTH(AH 3500 BK 3302)
		000025 FT	
		7014/0000	LENGTH(AH 3302 BK 0025)
			BMSBN 02/4047/0012/0000
		* REF-AHD	MARKMAN PARK RD
		0012/0025	(TWP)
000000 FT		000000 FT	0 0 00000 0 00 0000+00
		NC MA	MARKMAN PARK RD
		* REF-BK	MARKMAN PARK RD
			(TWP)
			BIG SEWICKLEY CREEK
			BMSBG 02/4047/0012/0000
		5 0012/0000	LENGTH(AH 0025 BK 0172)
		000000 FT	
000000 FT		7010/0000	LENGTH(AH 0172 BK 0000)

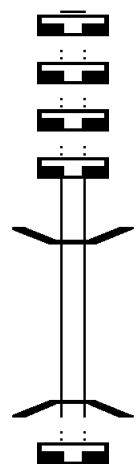

EXTRACT DATE: 12/21/2020 ROADWAY MANAGEMENT SYSTEM PAGE NUMBER: 1374
 PRINT DATE: 12/23/2020 SLD COUNTY/SR - ANNUAL PRINT COUNTY: ALLEGHENY
 DIR: B TOTAL LEN: .004 MI. DIST: 11-1 SR: 4046
 LEFT MUN: FRANKLIN PARK B RIGHT MUN: FRANKLIN PARK B

000019 FT

 000000 FT

 000000 FT

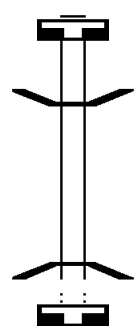

000019 FT
 7014/0000 LENGTH(AH 0794 BK 0019)
 BMSBN 02/4046/0010/0000
 * REF-AHD WEXFORD RUN RD (TBK)
 0010/0019 (BORO)
 000000 FT 2 0 02149 0 00 0019+69
 NC WEXFORD RUN RD
 * REF-BK WEXFORD RUN RD (TBK)
 (BORO)
 PINE CREEK
 BMSBG 02/4046/0010/0000
 5 0010/0000 LENGTH(AH 0019 BK 1874)
 000000 FT
 7010/0000 LENGTH(AH 1874 BK 0000)

BIG SEWICKLEY CREEK RD 003859 FT
 (SR4036 SEG 0130/0000) 0020/1852

002007 FT

BEADNELL RD
 (BORO)

0010/0610

000000 FT

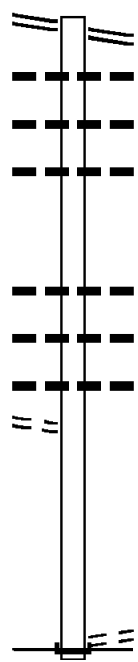

003859 FT BIG SEWICKLEY CREEK RD
 0020/1852 (SR4036 SEG 0130/0000)
 015 " DIA CIRC METAL
 0020/1310 LEN=0020 INSTALLED 2005
 024 " DIA CIR PLASTIC
 0020/1197 LEN=0036 INSTALLED UNKN
 016 " DIA CIRC METAL
 0020/0603 LEN=0048 INSTALLED UNKN
 002007 FT 2 0 02083 0 00 0020+02
 0020/0000 LENGTH(AH 1852 BK 2007)
 018 " DIA CIRC METAL
 0010/1900 LEN=0050 INSTALLED UNKN
 018 " DIA CIR PLASTIC
 0010/1333 LEN=0099 INSTALLED UNKN
 018 " DIA CIR PLASTIC
 0010/0931 LEN=0040 INSTALLED UNKN
 000000 FT 2 0 02083 0 00 0000+00
 CAMPMEETING RD (#1062)
 (CNTY)
 NC HI TZEL HILL RD
 INTER-BK CAMPMEETING RD (#1062)
 (CNTY)
 MFC BEGIN = E
 0010/0000 LENGTH(AH 2007 BK 0000)

FROM 0019/0420 SH
 (CONN)

000678 FT

0010/0575

000000 FT

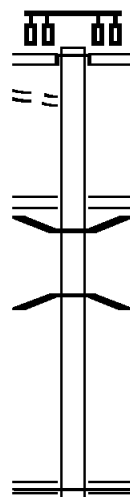

000678 FT
 INTER-AHD

0010/0678

0010/0420
 0010/0370

0010/0104
 000000 FT
 NC TO

5 0010/0000

CEMETERY LN
 (CNTY)
 PERRY HW
 (SR0019 SEG 0420/1895)

PERRYSVILLE AV INT/ RP B
 (SRB103 SEG 0750/0000)
 PERRYSVILLE AV INT/ RP A
 (SRB103 SEG 0010/1180)
 BMSSEN 02/4044/0010/0104
 0 0 00000 0 00 0000+00
 1021 I 279
 BMSBG 02/4044/0010/0104
 0 0 00000 0 00 0000+00
 SR 19/SR 8103 SH
 RAMP C RD
 (SRB103 SEG 0500/0867)
 PERRYSVILLE AV INT/ RP D
 (SRB103 SEG 0250/0000)
 MFC BEGIN = E
 LENGTH(AH 0678 BK 0000)

EXTRACT DATE: 12/21/2020 ROADWAY MANAGEMENT SYSTEM PAGE NUMBER: 1371
PRINT DATE: 12/23/2020 SLD COUNTY/SR - ANNUAL PRINT COUNTY: ALLEGHENY
DIR: B TOTAL LEN: 3.942 MI. DIST: 11-1 SR: 4043
LEFT MUN: FRANKLIN PARK B RIGHT MUN: FRANKLIN PARK B

EXTRACT DATE: 12/21/2020
PRINT DATE: 12/23/2020

ROADWAY MANAGEMENT SYSTEM
SLD COUNTY/SR - ANNUAL PRINT

PAGE NUMBER: 1370
COUNTY: ALLEGHENY

DIR: B TOTAL LEN: 3.942 MI.
LEFT MUN: FRANKLIN PARK B

DIST: 11-1 SR: 4043
RIGHT MUN: FRANKLIN PARK B

1 1 03755 0 00 0024+00 018405 FT
LINBROOK PARK
(TWP) 0100/0000

BROWN RD
(TWP) 0090/0725

016571 FT

	INTER-AHD	BIG SEWICKLEY CREEK RD
	0100/2410	(SR4036 SEG 0140/3982)
		WARRENDALE BAYNE RD (TB
	0100/2175	(CNTY)
	0100/2057	BMSSEN 02/4043/0100/2021
		1 1 03755 0 00 0003+72
		BR. OF BIG SEWICKLEY CR
	0100/2021	BMSBG 02/4043/0100/2021
		072"H 72"W CONC STRUCT
	0100/1780	LEN=0032 INSTALLED UNKN
		018 " DIA CIRC CONCR
	0100/1545	LEN=0099 INSTALLED UNKN
		015 " DIA CIRC CONCR
	0100/1015	LEN=0032 INSTALLED UNKN
		015 " DIA CIRC CONCR
	0100/0765	LEN=0032 INSTALLED UNKN
		015 " DIA CIRC CONCR
	0100/0650	LEN=0032 INSTALLED UNKN
		024 " DIA CIRC CONCR
	0100/0290	LEN=0036 INSTALLED UNKN
	018405 FT	
	0100/0000	LENGTH(AH 2410 BK 1834)
		018 " DIA CIRC CONCR
	0090/1460	LEN=0030 INSTALLED UNKN
		015 " DIA CIRC CONCR
	0090/1050	LEN=0030 INSTALLED UNKN
		024 " DIA CIRC CONCR
	0090/0795	LEN=0030 INSTALLED UNKN
		012 " DIA CIRC CONCR
	0090/0610	LEN=0030 INSTALLED UNKN
		012 " DIA CIRC CONCR
	0090/0250	LEN=0030 INSTALLED UNKN
	016571 FT	1 1 03755 0 00 0042+28
		GAME LANDS RD (TBK)
		(TWP)
	0090/0000	LENGTH(AH 1834 BK 2392)
	0080/2314	BMSSEN 02/4043/0080/2334
		1 1 03755 0 00 0066+57
		BRANCH OF BIG SEWICKLEY
	0080/2291	BMSBG 02/4043/0080/2334
		072"H 72"W CON BOX CUL
	0080/2265	LEN=0040 INSTALLED UNKN
		012 " DIA CIRC CONCR
	0080/1578	LEN=0032 INSTALLED UNKN
		HARTMAN LN
	0080/1536	(PRDR)

EXTRACT DATE: 12/21/2020
PRINT DATE: 12/23/2020

ROADWAY MANAGEMENT SYSTEM
SLD COUNTY/SR - ANNUAL PRINT

PAGE NUMBER: 1369
COUNTY: ALLEGHENY

DIR: B TOTAL LEN: 3.942 MI.
LEFT MUN: FRANKLIN PARK B

DIST: 11-1 SR: 4043
RIGHT MUN: FRANKLIN PARK B

Stationing	Notes	Stationing	Notes
		0080/1415	018 " DIA CIRC CONCR LEN=0032 INSTALLED UNKN
		0080/1215	018 " DIA CIRC CONCR LEN=0032 INSTALLED UNKN
		0080/0770	015 " DIA CIRC CONCR LEN=0032 INSTALLED UNKN
		0080/0560	012 " DIA CIRC CONCR LEN=0030 INSTALLED UNKN
		0080/0420	015 " DIA CIRC CONCR LEN=0030 INSTALLED UNKN
		0080/0070	024 " DIA CIRC CONCR LEN=0030 INSTALLED UNKN
014179 FT		014179 FT	1 1 03755 0 00 0066+57 ROCHESTER RD (SR4011 SEG 0240/3245) NC BIG SEWICKLEY CREEK RD MFC BEGIN = C
		0080/0000	LENGTH(AH 2392 BK 2156) 072"H 72"W CONCR ARCH
		0070/2090	LEN=0024 INSTALLED UNKN
		0070/2072	BMSSEN 02/4043/0070/2031 2 0 02322 0 00 0091+08 RIPPLING RUN
		0070/2056	BMSBG 02/4043/0070/2031
		0070/1715	024 " DIA CIRC CONCR LEN=0040 INSTALLED UNKN
		0070/0905	024 " DIA CIRC CONCR LEN=0030 INSTALLED UNKN
		0070/0505	024 " DIA CIRC OTHER LEN=0030 INSTALLED UNKN
		0070/0095	BMSSEN 02/4043/0070/0078 084"H 72"W CON BOX CUL
		0070/0090	LEN=0030 INSTALLED UNKN 2 0 02322 0 00 0071+06 BRANCH OF RIPPLING RUN
		0070/0078	BMSBG 02/4043/0070/0078
012023 FT		012023 FT	2 0 02322 0 00 0070+45 NC CAMP MEETING DUFF CITY RD INTER-BK MAGEE RD ET (TBK) (TWP)
CAMP MEETING RD (SR4032 SEG 0120/3318)		0070/0000	MFC BEGIN = D
012023 FT		012023 FT	LENGTH(AH 2156 BK 4006)
012023 FT		7060/0000	LENGTH(AH 4006 BK 2286)
012023 FT		012023 FT	
012023 FT		7050/0000	LENGTH(AH 2286 BK 0114)
		012023 FT	
		7048/0000	LENGTH(AH 0114 BK 2674)
		INTER-AHD	MAGEE RD ET (TBK)

DIR: B TOTAL LEN: 3.942 MI. DIST: 11-1 SR: 4043
 LEFT MUN: FRANKLIN PARK B RIGHT MUN: FRANKLIN PARK B

CHEVIOT RD
 (TWP)

0040/1820

MAGEE RD
 (SR4041 SEG 0030/1126)

009349 FT

0040/0000

DEERE CT
 (TWP)

0030/2625

SWEETWATER DR
 (TWP)

0030/2278

006415 FT

0040/2674	(TWP)	018 " DIA	CIRC CONCR
0040/2604	LEN=0040	INSTALLED	UNKN
0040/1305	018 " DIA	CIRC CONCR	INSTALLED UNKN
0040/1164	FRANKLIN PARK	SEWICKLEY HILLS B	
0040/0565	018 " DIA	CIRC CONCR	INSTALLED UNKN
009349 FT	2 0 02121	0 00	0093+57
0040/0000	NC MA	MAGEE RD ET	LENGTH(AH 2674 BK 2934)
0030/2730	MCCORMICK CT	(TWP)	
0030/2478	018 " DIA	CIRC CONCR	INSTALLED UNKN
0030/1930	024 " DIA	CIRC CONCR	INSTALLED UNKN
0030/1797	015 " DIA	CIR PLASTIC	INSTALLED UNKN
0030/1682	SEWICKLEY HILLS	OHIO T	
0030/1479	015 " DIA	CIRC METAL	INSTALLED UNKN
0030/1218	015 " DIA	CIRC METAL	INSTALLED UNKN
0030/0965	015 " DIA	CIRC METAL	INSTALLED UNKN
0030/0664	015 " DIA	CIRC METAL	INSTALLED UNKN
0030/0495	015 " DIA	CIRC METAL	INSTALLED UNKN
0030/0150	018 " DIA	CIRC METAL	INSTALLED UNKN
006415 FT	2 0 02121	0 00	0063+88
0030/0000	OHIO	SEWICKLEY HILLS B	LENGTH(AH 2934 BK 2433)
0020/1915	04B " DIA	CIRC CONCR	INSTALLED UNKN
0020/1690	072 "H 72 "W	CON BOX CUL	INSTALLED UNKN
0020/1689	BMS	SEN 02/4043/0020/164B	

EXTRACT DATE: 12/21/2020
PRINT DATE: 12/23/2020

ROADWAY MANAGEMENT SYSTEM
SLD COUNTY/SR - ANNUAL PRINT

PAGE NUMBER: 1367
COUNTY: ALLEGHENY

DIR: B TOTAL LEN: 3.942 MI.
LEFT MUN: SEWICKLEY HILLS B

DIST: 11-1 SR: 4043
RIGHT MUN: SEWICKLEY HILLS B

003982 FT

000000 FT

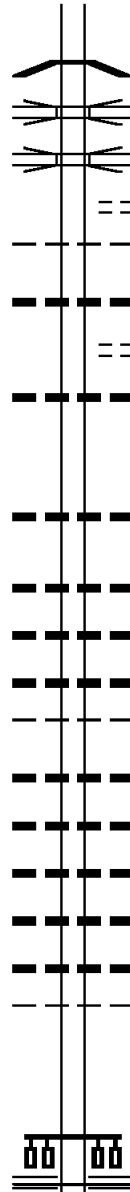

2 0 02121 0 00 0056+03
KILBUCK RUN
0020/1648 BMSBG 02/4043/0020/1648
SR 79 SB
0020/1484 OP ID 02/0079/0691/0194
SR 0079 NB
0020/1349 OP ID 02/0079/0690/0106
ASCOT DR
0020/1094 (TWP)
SEWICKLEY HILLS
0020/1079 OHIO T
024 "DIA CIRC METAL
0020/0890 LEN=0050 INSTALLED UNKN
BRIGHTON DR
0020/0859 (TWP)
030 "DIA CIRC METAL
0020/0775 LEN=0060 INSTALLED UNKN
003982 FT 2 0 02121 0 00 0039+71
5 0020/0000 LENGTH(AH 2433 BK 3982)
018 "DIA CIRC CONCR
0010/3766 LEN=0060 INSTALLED UNKN
018 "DIA CIRC CONCR
0010/2935 LEN=0050 INSTALLED UNKN
018 "DIA CIRC CONCR
0010/2635 LEN=0048 INSTALLED UNKN
018 "DIA CIRC CONCR
0010/2260 LEN=0048 INSTALLED UNKN
OHIO
0010/2063 SEWICKLEY HILLS B
018 "DIA CIRC METAL
0010/1854 LEN=0048 INSTALLED UNKN
018 "DIA CIRC CONCR
0010/1300 LEN=0050 INSTALLED UNKN
018 "DIA CIRC CONCR
0010/1006 LEN=0050 INSTALLED UNKN
018 "DIA CIRC CONCR
0010/0723 LEN=0040 INSTALLED UNKN
018 "DIA CIRC CONCR
0010/0590 LEN=0050 INSTALLED UNKN
SEWICKLEY HILLS
0010/0586 OHIO T
000000 FT 2 0 02121 0 00 0000+00
NC RE ED MUD HOLLOW RD
MT NEBO ROAD
(SR4022 SEG 0030/0355)
0010/0000 MFC BEGIN = E
5 0010/0000 LENGTH(AH 3982 BK 0000)

DIR: B TOTAL LEN: 1.852 MI. DIST: 11-1 SR: 4042
 LEFT MUN: FRANKLIN PARK B RIGHT MUN: FRANKLIN PARK B

WEXFORD BAYNE RD 009767 FT
 (SR0910 SEG 0011/0000) INTER-AHD
 RAMP D RD
 (SR8023 SEG 0750/0000)
 RAMP C RD
 (SR8023 SEG 0010/1115) 0041/1740
 BMS EN 02/4042/0040/1295 0041/1466

2 0 02323 0 00 0093+63
 SR 0079 NB
 BMSBG 02/4042/0040/1295 0041/1262
 012 "DIA CIRC CONCR
 LEN=0040 INSTALLED UNKN 0041/1140
 RAMP B RD
 (SR8023 SEG 0500/2282)
 RAMP A RD
 (SR8023 SEG 0250/0000)
 0041/0917

SUNNY HILL RD
 (T695) 0041/0668

018 "DIA CIRC CONCR

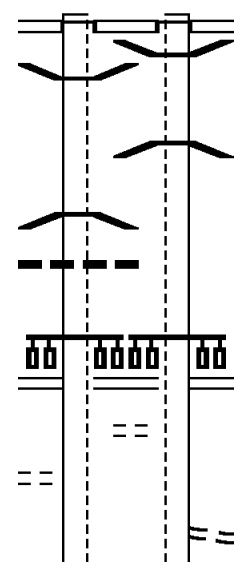

009777 FT
 INTER-AHD WEXFORD BAYNE RD
 (SR0910 SEG 0010/0000)
 RAMP D RD
 (SR8023 SEG 0750/0000)
 RAMP C RD
 (SR8023 SEG 0010/1115) 0040/1750
 0040/1497 BMS EN 02/4042/0040/1295

2 0 02323 0 00 0082+19
 SR 0079 NB
 BMSBG 02/4042/0040/1295
 0040/1293

RAMP B RD
 (SR8023 SEG 0500/2282)
 RAMP A RD
 (SR8023 SEG 0250/0000)
 0040/0921

SUNNY HILL RD
 (T695) 0040/0680

FROM 4049/0100 SH
 (CONN) 0040/0145









DIR: B TOTAL LEN: 1.852 MI. DIST: 11-1 SR: 4042
 LEFT MUN: FRANKLIN PARK B RIGHT MUN: FRANKLIN PARK B

Stationing	Notes	Stationing	Notes
LEN=0099 INSTALLED UNKN 0041/0104 2 0 02323 0 00 0082+19 008027 FT NICHOLSON RD (SR4049 SEG 0100/3247) MFC BEGIN = C LENGTH(AH 1740 BK 3067) 0041/0000		008027 FT 2 0 02323 0 00 0082+19 NICHOLSON RD (SR4049 SEG 0100/3247) MFC BEGIN = C LENGTH(AH 1750 BK 3067) 012 "DIA CIRC CONCR LEN=0035 INSTALLED UNKN 018 "DIA CIRC CONCR LEN=0099 INSTALLED UNKN WATERFRONT CORPORATE PR (PRDR)	
STONE MANSION RD (TWP) 0030/1465	==	0030/1465	
004960 FT		004960 FT 2 0 02323 0 00 0049+85 S 0030/0000 LENGTH(AH 3067 BK 2843) RUSTIC RIDGE DR (TWP)	
FOX CHASE DR (TWP) 0020/2255	==	0020/2260	
		0020/1430 018 "DIA CIRC CONCR LEN=0035 INSTALLED UNKN 018 "DIA CIRC CONCR LEN=0035 INSTALLED UNKN	
LOVETT LN (TWP) 0020/0850	==	0020/0913	
002117 FT		002117 FT 2 0 02323 0 00 0021+21 PRIVATE DR (PRDR) S 0020/0000 LENGTH(AH 2843 BK 2117)	
		0010/1287 012 "DIA CIRC CONCR LEN=0099 INSTALLED UNKN PEGHER LN (TWP)	
		0010/1005 012 "DIA CIRC CONCR LEN=0099 INSTALLED UNKN	
		0010/0935 012 "DIA CIRC CONCR LEN=0035 INSTALLED UNKN	
		0010/0658 012 "DIA CIRC CONCR LEN=0035 INSTALLED UNKN	
		0010/0369 012 "DIA CIRC CONCR LEN=0035 INSTALLED UNKN	
000000 FT		000000 FT 2 0 02323 0 00 0000+00 NC WE XFORD BAYNE RD ROCHESTER RD (SR4011 SEG 0240/0000) MFC BEGIN = C	
FAIRMONT CH RD (TWP) ROCHESTER RD (SR4011 SEG 0240/0000) 0010/0000	==	S 0010/0000 LENGTH(AH 2117 BK 0000)	

DIR: B TOTAL LEN: .999 MI. DIST: 11-1 SR: 4041
 LEFT MUN: SEWICKLEY HILLS B RIGHT MUN: SEWICKLEY HILLS B

Segment Description	Start Station	End Station	Length (FT)	Material / Notes
MAGEE RD ET (SR4043 SEG 0040/0000)	0030/1126	005276 FT	005276 FT	RED MUD HOLLOW RD (SR4043 SEG 0040/0000) HARVESTER CT (TWP)
	0030/0530	0030/0530	0030/0530	018" DIA CIRC CONCR LEN=0040 INSTALLED UNKN
	0030/0180	004150 FT	004150 FT	2 0 02119 0 00 0041+58
SEWICKLEY HILLS DR (TWP)	0020/1817	0030/0000	0030/0000	LENGTH(AH 1126 BK 2149)
	0020/1620	0020/1620	0020/1620	014" DIA CIRC CONCR LEN=0025 INSTALLED UNKN
PACER DR (TWP)	0020/1129	0020/0842	0020/0842	018" DIA CIRC CONCR LEN=0040 INSTALLED UNKN
	0020/0250	0020/0250	0020/0250	018" DIA CIRC CONCR LEN=0030 INSTALLED UNKN
	0020/0000	002001 FT	002001 FT	2 0 02119 0 00 0020+00
	0010/1868	0020/0000	0020/0000	LENGTH(AH 2149 BK 2001)
	0010/1270	0010/1868	0010/1868	018" DIA CIRC CONCR LEN=0036 INSTALLED UNKN
	0010/0895	0010/1270	0010/1270	018" DIA CIRC CONCR LEN=0070 INSTALLED UNKN
	0010/0681	0010/0895	0010/0895	LEGACY DR (PRDR)
	000000 FT	0010/0681	0010/0681	015" DIA CIRC CONCR LEN=0040 INSTALLED UNKN
	000000 FT	000000 FT	000000 FT	2 0 02119 0 00 0000+00
	0010/0000	000000 FT	000000 FT	NC MA INTER-BK MAGEE RD (CNTY) MFC BEGIN = E
	0010/0000	0010/0000	0010/0000	LENGTH(AH 2001 BK 0000)

EXTRACT DATE: 12/21/2020 ROADWAY MANAGEMENT SYSTEM PAGE NUMBER: 1363
 PRINT DATE: 12/23/2020 SLD COUNTY/SR - ANNUAL PRINT COUNTY: ALLEGHENY
 DIR: B TOTAL LEN: .000 MI. DIST: 11-1 SR: 4040
 LEFT MUN: FRANKLIN PARK B RIGHT MUN: FRANKLIN PARK B

000000 FT		000000 FT	
000000 FT		7050/0000	LENGTH(AH 1016 BK 1854)
000000 FT		000000 FT	
000000 FT		7040/0000	LENGTH(AH 1854 BK 3016)
000000 FT		000000 FT	
000000 FT		7030/0000	LENGTH(AH 3016 BK 2829)
000000 FT		000000 FT	
000000 FT		7020/0000	LTH AH 002829 BK 000100
		000000 FT	
		7010/0000	LTH AH 000100 BK 000000

EXTRACT DATE: 12/21/2020 ROADWAY MANAGEMENT SYSTEM PAGE NUMBER: 1362
 PRINT DATE: 12/23/2020 SLD COUNTY/SR - ANNUAL PRINT COUNTY: ALLEGHENY

DIR: B TOTAL LEN: 2.672 MI. DIST: 11-1 SR: 4039
 LEFT MUN: FRANKLIN PARK B RIGHT MUN: FRANKLIN PARK B

014110 FT

012946 FT

0050/1876

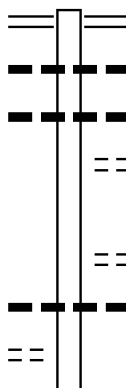

014110 FT CAMP MEETING RD
 0060/1164 (SR4032 SEG 0120/0000)
 018 " DIA CIRC CONCR
 0060/1035 LEN=0045 INSTALLED UNKN
 015 " DIA CIRC CONCR
 0060/0807 LEN=0042 INSTALLED UNKN
 HENRY LN
 (TWP)
 0060/0354
 012946 FT 2 0 02117 0 00 0130+45
 0060/0000 LENGTH(AH 1164 BK 2714)
 THEODORA LN
 (PRDR)
 0050/2622 015 " DIA CIRC CONCR
 0050/2376 LEN=0042 INSTALLED UNKN

HUNT RD
 (TWP)

PLEUGHAL RD

DIR: B TOTAL LEN: 2.672 MI. DIST: 11-1 SR: 4039
 LEFT MUN: FRANKLIN PARK B RIGHT MUN: FRANKLIN PARK B

Stationing	Description	Material	Length	Notes
0050/1765	(TWP)	015 " DIA CIRC METAL		
0050/1667		LEN=0060 INSTALLED UNKN		
0050/0873		015 " DIA CIRC CONCR		
0050/0873		LEN=0075 INSTALLED UNKN		
010232 FT				
0050/0000	FRANKLIN PARK	2 0 02117 0 00 0103+26		LENGTH(AH 2714 BK 3387)
0040/3372	SEWICKLEY HILLS B	018 " DIA CIRC CONCR		
0040/3250		LEN=0030 INSTALLED UNKN		
0040/2944		015 " DIA CIRC CONCR		
0040/2944		LEN=0030 INSTALLED UNKN		
0040/2616		015 " DIA CIRC CONCR		
0040/2616		LEN=0045 INSTALLED UNKN		
0040/1732		015 " DIA CIRC CONCR		
0040/1732		LEN=0045 INSTALLED UNKN		
0040/1453		015 " DIA CIRC CONCR		
0040/1453		LEN=0050 INSTALLED UNKN		
0040/1100		018 " DIA CIRC CONCR		
0040/1100		LEN=0100 INSTALLED UNKN		
0040/0747		018 " DIA CIRC CONCR		
0040/0747		LEN=0050 INSTALLED UNKN		
0040/0395		015 " DIA CIRC CONCR		
0040/0395		LEN=0070 INSTALLED UNKN		
0040/0091		018 " DIA CIRC CONCR		
0040/0091		LEN=0030 INSTALLED UNKN		
006845 FT				
006845 FT		2 0 02117 0 00 0068+12		
	LITTLE SEWICKLEY CREEK	(SR4034 SEG 0020/1033)		
	NC HENRY RD			
	INTER-BK	LITTLE SEWICKLEY CREEK		
		(SR4034 SEG 0020/1033)		
006845 FT				
006845 FT		LTH AH 003387 BK 000100		
	LITTLE SEWICKLEY CREEK			
	(SR4034 SEG 0020/0403)			
0030/0359		LTH AH 000100 BK 000359		
	INTER-AHD	LITTLE SEWICKLEY CREEK		
		(SR4034 SEG 0020/0403)		
	BMS EN	02/4039/0030/0327		
		2 0 02117 0 00 0044+75		
	LITTLE SEWIC			
	BMS BG	02/4039/0030/0327		
0030/0286				
006486 FT				
006486 FT		2 0 02117 0 00 0044+75		
	SEWICKLEY HILLS			
	SEWICKLEY HEIGHTS B			

LITTLE SEWICKLEY CREEK
 (SR4034 SEG 0020/0403)

BARBERRY RD
 (TWP)

EXTRACT DATE: 12/21/2020
PRINT DATE: 12/23/2020

ROADWAY MANAGEMENT SYSTEM
SLD COUNTY/SR - ANNUAL PRINT

PAGE NUMBER: 1360
COUNTY: ALLEGHENY

DIR: B TOTAL LEN: 2.672 MI.
LEFT MUN: SEWICKLEY HILLS B

DIST: 11-1 SR: 4039
RIGHT MUN: SEWICKLEY HILLS B

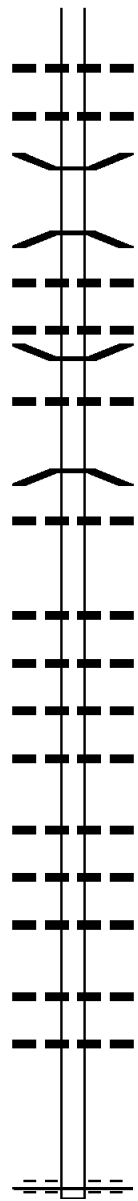

003809 FT

000000 FT

ID	Start	End	Length	Material	Status
5 0030/0000			LENGTH(AH 0359 BK 2677)		
			015" DIA CIRC CONCR		
0020/2510			LEN=0036	INSTALLED	UNKN
			012" DIA CIRC CONCR		
0020/2220			LEN=0035	INSTALLED	UNKN
0020/1366			BMSSEN 02/4039/0020/1353		
			0 0 000000 0 00 0000+00		
			LITTLE SEWICKLY CREEK		
0020/1353			BMSBG 02/4039/0020/1353		
			072"H 72"W CON BOX CUL		
0020/1345			LEN=0025	INSTALLED	UNKN
			018" DIA CIRC CONCR		
0020/0750			LEN=0050	INSTALLED	UNKN
0020/0480			BMSSEN 02/4039/0020/0467		
			060"H 72"W CON BOX CUL		
0020/0470			LEN=0024	INSTALLED	UNKN
			0 0 000000 0 00 0000+00		
			LITTLE SEWICKLY CREEK		
0020/0467			BMSBG 02/4039/0020/0467		
			015" DIA CIRC CONCR		
0020/0112			LEN=0030	INSTALLED	UNKN
003809 FT			2 0 02117 0 00 0017+98		
5 0020/0000			LENGTH(AH 2677 BK 3809)		
			012" DIA CIRC CONCR		
0010/3730			LEN=0045	INSTALLED	UNKN
			036" DIA CIRC METAL		
0010/3360			LEN=0032	INSTALLED	UNKN
			015" DIA CIRC CONCR		
0010/3140			LEN=0048	INSTALLED	UNKN
			015" DIA CIRC CONCR		
0010/2800			LEN=0036	INSTALLED	UNKN
			024" DIA CIRC CONCR		
0010/2140			LEN=0060	INSTALLED	UNKN
			015" DIA CIRC CONCR		
0010/1600			LEN=0045	INSTALLED	UNKN
			015" DIA CIRC CONCR		
0010/1125			LEN=0040	INSTALLED	UNKN
			012" DIA CIRC CONCR		
0010/0420			LEN=0060	INSTALLED	UNKN
			018" DIA CIRC CONCR		
0010/0036			LEN=0075	INSTALLED	UNKN
000000 FT			2 0 02117 0 00 0000+00		
			NC AU DUBON RD		
			MAGEE RD		
			(CNTY)		
			MFC BEGIN = E		
5 0010/0000			LENGTH(AH 3809 BK 0000)		

DIR: B TOTAL LEN: .920 MI. DIST: 11-1 SR: 4037
 LEFT MUN: SEWICKLEY HEIGHTS B RIGHT MUN: SEWICKLEY HEIGHTS B

004855 FT

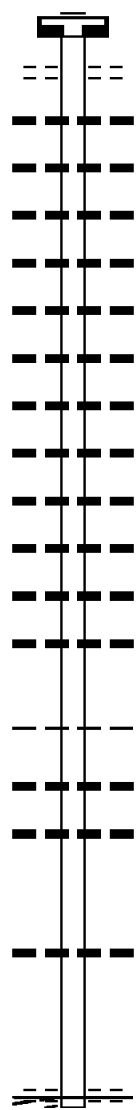

004855 FT
 7030/0000 LENGTH(AH 2859 BK 3045)
 BACKBONE RD (TBK)
 (TWP)
 0020/3045 015 "DIA CIRC OTHER
 LEN=0099 INSTALLED UNKN
 0020/2844 018 "DIA CIRC CONCR UNKN
 LEN=0030 INSTALLED UNKN
 0020/2691 018 "DIA CIRC CONCR UNKN
 LEN=0099 INSTALLED UNKN
 0020/2382 024 "DIA CIRC CONCR UNKN
 LEN=0060 INSTALLED UNKN
 0020/2131 018 "DIA CIRC CONCR UNKN
 LEN=0099 INSTALLED UNKN
 0020/1930 018 "DIA CIRC CONCR UNKN
 LEN=0040 INSTALLED UNKN
 0020/1774 024 "DIA CIRC CONCR UNKN
 LEN=0099 INSTALLED UNKN
 0020/1442 018 "DIA CIRC CONCR UNKN
 LEN=0040 INSTALLED UNKN
 0020/1309 018 "DIA CIRC CONCR UNKN
 LEN=0050 INSTALLED UNKN
 0020/1122 018 "DIA CIRC CONCR UNKN
 LEN=0050 INSTALLED UNKN
 0020/0844 036 "DIA CIRC METAL UNKN
 0020/0502 018 "DIA CIRC METAL UNKN
 0020/0174 018 "DIA CIRC METAL UNKN
 001810 FT 001810 FT 1 1 00134 0 00 0000+00
 SEWICKLEY HEIGHTS
 EDGEWORTH B
 0020/0000 LENGTH(AH 3045 BK 1810)
 036 "DIA CIRC METAL UNKN
 0010/1682 015 "DIA CIR PLASTIC UNKN
 0010/1350 015 "DIA CIR PLASTIC UNKN
 0010/0088 018 "DIA CIRC METAL UNKN
 000000 FT 1 1 00148 0 00 0000+00
 NC WA Y HOLLOW RD
 WOODLAND RD
 (TWP)
 MFC BEGIN = E
 0010/0000 LENGTH(AH 1810 BK 0000)

001810 FT

000000 FT

CREEK DR
 (TWP)

0010/0000

DIR: B TOTAL LEN: 5.631 MI. DIST: 11-1 SR: 4036
 LEFT MUN: ECONOMY B RIGHT MUN: ECONOMY B

029733 FT

029733 FT
 INTER-AHD BIG SEWICKLEY CREEK RD
 0140/3982 (SR4043 SEG 0100/2410)

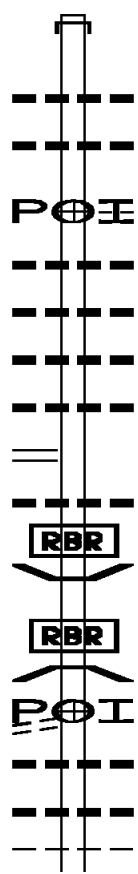

0140/3280 015 " DIA CIRC CONCR
 LEN=0040 INSTALLED UNKN
 0140/2870 018 " DIA CIRC METAL
 LEN=0310 INSTALLED UNKN
 (APRA) BOURIL TRAILER C
 BOURIL TRAILER CT RD
 0140/2740 (PRDR)
 018 " DIA CIRC CONCR
 0140/2448 LEN=0040 INSTALLED UNKN
 015 " DIA CIRC METAL
 0140/1950 LEN=0040 INSTALLED UNKN
 018 " DIA CIRC CONCR
 0140/1525 LEN=0040 INSTALLED UNKN
 015 " DIA CIRC CONCR
 0140/1195 LEN=0040 INSTALLED UNKN

CONWAY WALLROSE RD
 (SR2005 SEG 0010/0000) 0140/1055

0140/0980 048"H 60"W CON BOX CUL
 LEN=0040 INSTALLED UNKN

AMSLER RIDGE RD
 (T686) 0140/0825

0140/0978 BMS EN 02/4036/0140/0961
 0 0 00000 0 00 0000+00
 P3
 BR. BIG SEWICKLEY CREEK
 0140/0961 BMSBG 02/4036/0140/0961

0140/0825 (APRA) ORCHARD ESTATE T
 015 " DIA CIRC METAL
 0140/0475 LEN=0040 INSTALLED UNKN
 018 " DIA CIRC METAL
 0140/0165 LEN=0040 INSTALLED UNKN
 025751 FT 1 0 00820 0 00 0269+53
 ECONOMY

025751 FT

EXTRACT DATE: 12/21/2020
PRINT DATE: 12/23/2020

ROADWAY MANAGEMENT SYSTEM
SLD COUNTY/SR - ANNUAL PRINT

PAGE NUMBER: 1357
COUNTY: ALLEGHENY

DIR: B TOTAL LEN: 5.631 MI.
LEFT MUN: ECONOMY B

DIST: 11-1 SR: 4036
RIGHT MUN: ECONOMY B

Stationing	Length	Notes
0140/0000		BELL ACRES B
0130/3485		LENGTH(AH 3982 BK 3970)
		BMSSEN 02/4036/0130/3392
		0 0 00000 0 00 0000+00
		BIG SEWICKLEY CREEK
0130/3392		BMSBG 02/4036/0130/3392
0130/3340		HOPKINS CHURCH RD (TWP)
0130/3151		BMSSEN 02/4036/0130/3135
		0 0 00000 0 00 0000+00
		P3
		UNT BIG SEWICKLEY CREEK
0130/3135		BMSBG 02/4036/0130/3135
		048"H 60"W CON BOX CUL
0130/3130		LEN=0040 INSTALLED UNKN
		CAMP MEETING RD ET
0130/3110		(TWP)
		015 " DIA CIRC CONCR
0130/2625		LEN=0040 INSTALLED UNKN
		015 " DIA CIRC CONCR
0130/2065		LEN=0040 INSTALLED UNKN
		015 " DIA CIRC CONCR
0130/1700		LEN=0050 INSTALLED UNKN
		015 " DIA CIRC CONCR
0130/1170		LEN=0050 INSTALLED UNKN
		015 " DIA CIRC CONCR
0130/0885		LEN=0050 INSTALLED UNKN
		018 " DIA CIRC METAL
0130/0435		LEN=0060 INSTALLED UNKN
021781 FT		1 0 00820 0 00 0253+87
		HITZEL HILL RD
		(SR4045 SEG 0020/1852)
0130/0000		LENGTH(AH 3970 BK 3397)
		015 " DIA CIRC CONCR
0110/3285		LEN=0099 INSTALLED UNKN
		012 " DIA CIRC CONCR
0110/3182		LEN=0099 INSTALLED UNKN
		BARLEY RD
0110/2644		(TWP)
		018 " DIA CIRC CONCR
0110/2570		LEN=0040 INSTALLED UNKN
		018 " DIA CIRC CONCR
0110/2046		LEN=0040 INSTALLED UNKN
		MAGURA RD
0110/1813		(TWP)
		024 " DIA CIRC CONCR
0110/1444		LEN=0048 INSTALLED UNKN

021781 FT

DIR: B TOTAL LEN: 5.631 MI. DIST: 11-1 SR: 4036
 LEFT MUN: BELL ACRES B RIGHT MUN: BELL ACRES B

Stationing	Length	Notes	Material	Status
0110/1080	018 " DIA		CIRC CONCR	INSTALLED UNKN
0110/0821	036 " DIA		CIRC CONCR	INSTALLED UNKN
0110/0560	018 " DIA		CIRC CONCR	INSTALLED UNKN
0110/0156	LEN=0048		BMSSEN 02/4036/0110/0065	INSTALLED UNKN
0110/0065	018 " DIA		CIRC CONCR	INSTALLED UNKN
018384 FT	BMSBG 02/4036/0110/0065		BELL ACRES	
0110/0000	018 " DIA	3397 BK 1383	CIRC CONCR	INSTALLED UNKN
0100/1145	LEN=0099		CIRC CONCR	INSTALLED UNKN
0100/0970	018 " DIA		CIRC CONCR	INSTALLED UNKN
0100/0580	LEN=0030		CIRC CONCR	INSTALLED UNKN
0100/0565	018 " DIA		CIRC CONCR	INSTALLED UNKN
0100/0365	015 " DIA		CIRC CONCR	INSTALLED UNKN
0100/0041	LEN=0036		CIRC CONCR	INSTALLED UNKN
017001 FT	BMSSEN 02/4036/0100/0000		BELL ACRES	
0100/0000	1 0 00820 0 00 0171+34		BR. BIG SEWIC	
0090/1463	BMSBG 02/4036/0100/0000		BELL ACRES	
0090/1438	LEN=0045		CIRC CONCR	INSTALLED UNKN
0090/1100	024 " DIA		CIRC CONCR	INSTALLED UNKN
0090/0655	LEN=0036		CIRC CONCR	INSTALLED UNKN
0090/0275	024 " DIA		CIRC CONCR	INSTALLED UNKN
0090/0020	LEN=0096		CIRC CONCR	INSTALLED UNKN
015343 FT	018 " DIA		CIRC CONCR	INSTALLED UNKN
0090/0000	LEN=0036		CIRC CONCR	INSTALLED UNKN
0080/2925	018 " DIA		CIRC CONCR	INSTALLED UNKN
0080/2897	030 " DIA	1658 BK 3251	CIRC CONCR	INSTALLED UNKN
0080/2760	LEN=0036		CIRC CONCR	INSTALLED UNKN
0080/2760	018 " DIA		CIRC CONCR	INSTALLED UNKN

EXTRACT DATE: 12/21/2020 ROADWAY MANAGEMENT SYSTEM PAGE NUMBER: 1355
 PRINT DATE: 12/23/2020 SLD COUNTY/SR - ANNUAL PRINT COUNTY: ALLEGHENY
 DIR: B TOTAL LEN: 5.631 MI. DIST: 11-1 SR: 4036
 LEFT MUN: ECONOMY B RIGHT MUN: ECONOMY B

Station	Description	Material	Status
0080/2382	018" DIA	CIRC CONCR	INSTALLED UNKN
0080/2233	018" DIA	CIRC CONCR	INSTALLED UNKN
0080/1830	018" DIA	CIRC CONCR	INSTALLED UNKN
0080/1400	018" DIA	CIRC CONCR	INSTALLED UNKN
0080/1200	018" DIA	CIRC CONCR	INSTALLED UNKN
0080/0515	(APRA) WINE CONSTRUCTION RD		
0080/0480	018" DIA	CIRC CONCR	INSTALLED UNKN
0080/0272	018" DIA	CIRC CONCR	INSTALLED UNKN
012092 FT	1 0 00820 0 00 0121+46		
0080/0000	ECONOMY BELL ACRES B		
0070/2776	LENGTH(AH 3251 BK 2786)		
0070/2675	BMSBG 02/4036/0070/2675		
0070/2675	1 0 00820 0 00 0120+76		
0070/2675	BIG SEW. CR.		
0070/2370	BMSBG 02/4036/0070/2675		
0070/1791	(APRA) WINE CONSTRUCTION RD		
0070/1791	(APRA) WINE CONCRETE PR		
0070/1719	TURKEY FOOT RD (TWP)		
0070/1694	BMSBG 02/4036/0070/1676		
0070/1676	1 0 00820 0 00 0110+80		
0070/1676	P3 UNT BIG SEWICKLEY CREEK		
0070/1601	BMSBG 02/4036/0070/1676		
0070/1396	STEELBAR AV (TWP)		
0070/1060	024" DIA	CIRC CONCR	INSTALLED UNKN
0070/0952	018" DIA	CIRC CONCR	INSTALLED UNKN
0070/0490	024" DIA	CIRC CONCR	INSTALLED UNKN

WINE CONSTRUCTION RD (PRDR)
 WINE CONSTRUCTION RD (PRDR)

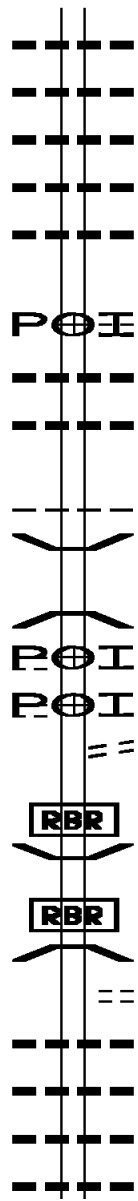

DIR: B TOTAL LEN: 5.631 MI. DIST: 11-1 SR: 4036
 LEFT MUN: BELL ACRES B RIGHT MUN: BELL ACRES B

Location	Stationing	Notes	Structure	Material	Status
	009306 FT	0070/0220	024" DIA	CIRC CONCR	INSTALLED UNKN
		009306 FT	1'0" DIA	00820'0"00	0094+06
			SUNSET DR		
			(TWP)		
		0070/0000	LENGTH(AH 2786 BK 2343)		
		0060/2085	018" DIA	CIRC CONCR	INSTALLED UNKN
		0060/1920	018" DIA	CIRC CONCR	INSTALLED UNKN
			(APRA)	SEMACK TRAILER CO	
			NC BIG	SEWICKLEY CREEK RD	
MERRIMAN RD (TWP)	0060/1665	0060/1665	WOODCREST AV		
			(TWP)		
		0060/1160	024" DIA	CIRC CONCR	INSTALLED UNKN
			LEN=0050		
			MAPLE ST		
			(TWP)		
		0060/1036	018" DIA	CIRC CONCR	INSTALLED UNKN
			LEN=0096		
		0060/0995	018" DIA	CIRC CONCR	INSTALLED UNKN
			LEN=0036		
		0060/0635	018" DIA	CIRC CONCR	INSTALLED UNKN
			LEN=0042		
		0060/0455	018" DIA	CIRC CONCR	INSTALLED UNKN
			LEN=0054		
		0060/0362	SANDS AV		
			(TWP)		
	006963 FT	0060/0320	1'0" DIA	00820'0"00	0070+89
		006963 FT	LENGTH(AH 2343 BK 2314)		
		0060/0000	018" DIA	CIRC CONCR	INSTALLED UNKN
			LEN=0036		
		0050/2215	018" DIA	CIRC CONCR	INSTALLED UNKN
			LEN=0040		
		0050/1890	BELL ACRES		
			LEET T		
		0050/1672	018" DIA	CIRC CONCR	INSTALLED UNKN
			LEN=0040		
		0050/1670	018" DIA	CIRC METAL	INSTALLED UNKN
			LEN=0005		
		0050/1665	LUNAK DR		
			(TWP)		
		0050/1172			
FRANK ST (TWP)	0050/1141				
			024"H 48"W CON BOX CUL		
		0050/1140	LEN=0099		INSTALLED UNKN
WILLOW ST (TWP)	0050/0844				
ECKERST (TWP)	0050/0553				

DIR: B TOTAL LEN: 5.631 MI. DIST: 11-1 SR: 4036
 LEFT MUN: LEET T RIGHT MUN: LEET T

STREET NAME	STREET TYPE	START STATION	END STATION	LENGTH (FT)	DESCRIPTION	STATUS
NEELY ST	(TWP)	0050/0272	004649	004649	018" DIA CIRC CONCR	INSTALLED UNKN
					LEN=0070	
					1 0 00820 0 00 0047+35	
					036"H 72"W CON BOX CUL	
					LEN=0099	INSTALLED UNKN
					LENGTH(AH 2314 BK 2645)	
					015" DIA CIRC CONCR	
					LEN=0040	INSTALLED UNKN
					024"H 48"W CON BOX CUL	
					LEN=0030	INSTALLED UNKN
					036"H 60"W CON BOX CUL	
					LEN=0032	INSTALLED UNKN
					018" DIA CIRC CONCR	
					LEN=0030	INSTALLED UNKN
					015" DIA CIRC CONCR	
					LEN=0015	INSTALLED UNKN
MAIN ST	(TWP)	0040/0409				
					NC AM BRIDGE AV	
					MOUND ST	
					(TWP)	
					ORCHARD ST	
					(TWP)	
					LENGTH(AH 2645 BK 1246)	
					LEET	
					LEETSDALE B	
					018" DIA CIRC METAL	
					LEN=0040	INSTALLED UNKN
					DAVIS RD	
					(TWP)	
					1 0 00820 0 00 0006+05	
					NC MA IN ST	
					BEAVER ST	
					(TWP)	
					LENGTH(AH 1246 BK 0758)	
					018" DIA CIRC CONCR	
					LEN=0040	INSTALLED UNKN
					018" DIA CIRC CONCR	
					LEN=0040	INSTALLED UNKN
					1 0 00820 0 00 0000+00	
					NC CR OSS ST	
					OHIO RIVER BL	
					(SR0065 SEG 0271/2540)	
					(SR0065 SEG 0270/2535)	
					MFC BEGIN = C	
					LENGTH(AH 0758 BK 0000)	

DIR: B TOTAL LEN: 1.078 MI. DIST: 11-1 SR: 4035
 LEFT MUN: SEWICKLEY HEIGHTS B RIGHT MUN: SEWICKLEY HEIGHTS B

SCAIFE RD
 (CNTY)

005691 FT
 0020/2540

003151 FT

000000 FT

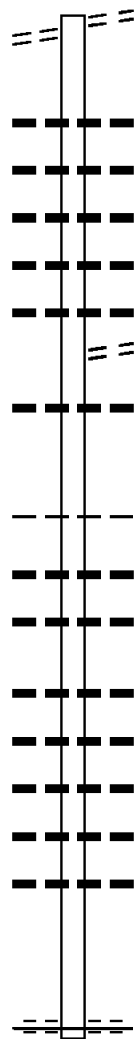

005691 FT SCAIFE RD
 0020/2540 (CNTY)

0020/1362	018 " DIA	CIRC CONCR
	LEN=0030	INSTALLED UNKN
0020/1014	024 " DIA	CIR PLASTIC
	LEN=0030	INSTALLED UNKN
0020/0871	015 " DIA	CIRC METAL
	LEN=0040	INSTALLED UNKN
0020/0679	015 " DIA	CIRC CONCR
	LEN=0030	INSTALLED UNKN
0020/0258	015 " DIA	CIRC CONCR
	LEN=0015	INSTALLED UNKN
0020/0130	ST PAUL'S LUTHERAN CEM	
	(PRDR)	
0020/0012	024 " DIA	CIR PLASTIC
	LEN=0024	INSTALLED UNKN
003151 FT	2 0 02094	0 00 0030+55
	NC HA RTLE RD	
	SEWICKLEY HEIGHTS	
	SEWICKLEY HILLS B	
0020/0000	LENGTH(AH 2540 BK 3151)	
0010/2593	024 " DIA	CIRC CONCR
	LEN=0024	INSTALLED UNKN
0010/2474	015 " DIA	CIRC CONCR
	LEN=0024	INSTALLED UNKN
0010/1632	015 " DIA	CIRC CONCR
	LEN=0045	INSTALLED UNKN
0010/1266	018 " DIA	CIRC CONCR
	LEN=0033	INSTALLED UNKN
0010/0911	024 " DIA	CIRC CONCR
	LEN=0045	INSTALLED UNKN
0010/0435	015 " DIA	CIRC CONCR
	LEN=0048	INSTALLED UNKN
0010/0146	015 " DIA	CIRC CONCR
	LEN=0028	INSTALLED UNKN
000000 FT	2 0 02094	0 00 0000+00
	NC LA NG RD	
	GLENFIELD RD (TBK)	
	(CNTY)	
	MFC BEGIN = E	
0010/0000	LENGTH(AH 3151 BK 0000)	

DIR: B TOTAL LEN: 2.061 MI. DIST: 11-1 SR: 4034
 LEFT MUN: FRANKLIN PARK B RIGHT MUN: FRANKLIN PARK B

MAGEE RD ET (TBK)
 (TWP)

010880 FT
 0040/1681

010880 FT

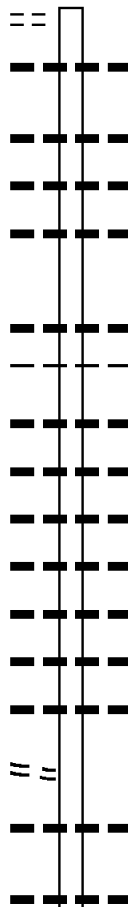

009199 FT

2 0 02090 0 00 0068+78 006811 FT
 FAIR HILL RD
 (TWP) 0030/0000

0040/1550	015 " DIA	CIRC METAL
	LEN=0030	INSTALLED UNKN
0040/0900	018 " DIA	CIRC METAL
	LEN=0030	INSTALLED UNKN
0040/0660	018 " DIA	CIRC METAL
	LEN=0025	INSTALLED UNKN
0040/0317	018 " DIA	CIRC CONCR
	LEN=0024	INSTALLED UNKN
009199 FT	2 0 02090	0 00 0092+66
S 0040/0000	LENGTH(AH 1681 BK 2388)	
0030/2323	018 " DIA	CIRC CONCR
	LEN=0030	INSTALLED UNKN
0030/2244	FRANKLIN PARK	
	SEWICKLEY HILLS B	
0030/2061	018 " DIA	CIRC CONCR
	LEN=0050	INSTALLED UNKN
0030/1560	032 " DIA	CIRC METAL
	LEN=0064	INSTALLED UNKN
0030/1417	018 " DIA	CIR PLASTIC
	LEN=0030	INSTALLED 2018
0030/1338	015 " DIA	CIRC METAL
	LEN=0030	INSTALLED UNKN
0030/1020	015 " DIA	CIRC METAL
	LEN=0030	INSTALLED UNKN
0030/0750	015 " DIA	CIRC CONCR
	LEN=0040	INSTALLED UNKN
0030/0573	018 " DIA	CIRC CONCR
	LEN=0001	INSTALLED UNKN
006811 FT		
S 0030/0000	LENGTH(AH 2388 BK 3071)	
0020/3046	048 " DIA	CIRC METAL
	LEN=0040	INSTALLED UNKN
0020/2419	012 " DIA	CIRC CONCR
	LEN=0050	INSTALLED UNKN

DIR: B TOTAL LEN: 2.061 MI. DIST: 11-1 SR: 4034
 LEFT MUN: SEWICKLEY HILLS B RIGHT MUN: SEWICKLEY HILLS B

HENRY RD
 (SR4039 SEG 0040/0000) 0020/1033

003740 FT

HUNT RD
 (TWP) 0010/0815

DUFF CITY RD
 (SR4088 SEG 0010/0000) 0010/0470

2 0 02090 0 00 0000+00 000000 FT
 FERN HOLLOW RD
 (SR4032 SEG 0090/2300) 0010/0000

0020/1818	066 " DIA	CIRC CONCR
	LEN=0070	INSTALLED UNKN
0020/1532	018 " DIA	CIRC CONCR
	LEN=0030	INSTALLED UNKN
0020/1082	018 " DIA	CIRC CONCR
	LEN=0040	INSTALLED UNKN
0020/0855	048 " DIA	CIRC CONCR
	LEN=0064	INSTALLED UNKN
	LITTLE SEWICKLEY CREEK RD	
	AUDUBON RD	
0020/0403	(SR4039 SEG 0030/0359)	
	018 " DIA	CIRC CONCR
	LEN=0064	INSTALLED UNKN
0020/0379	2 0 02090	0 00 0037+87
003740 FT	018 " DIA	CIR PLASTIC
	LEN=0030	INSTALLED 2018
0020/0000	LENGTH(AH 3071 BK 3740)	
0010/3495	SEWICKLEY HILLS	
	SEWICKLEY HEIGHTS B	
0010/3086	SEWICKLEY HEIGHTS	
	SEWICKLEY HILLS B	
0010/2675	036 " DIA	CIRC CONCR
	LEN=0040	INSTALLED UNKN
0010/2204	018 " DIA	CIRC CONCR
	LEN=0040	INSTALLED UNKN
0010/1958	018 " DIA	CIRC CONCR
	LEN=0026	INSTALLED UNKN
	SEWICKLEY HILLS	
0010/1693	SEWICKLEY HEIGHTS B	
	018 " DIA	CIRC CONCR
0010/1584	LEN=0040	INSTALLED UNKN
0010/0898	054 " DIA	CIRC CONCR
	LEN=0040	INSTALLED UNKN
0010/0546	018 " DIA	CIRC METAL
	LEN=0040	INSTALLED UNKN
0010/0113	024 " DIA	CIRC CONCR
	LEN=0026	INSTALLED UNKN
	DUBON RD	
	FERN HOLLOW RD	
000000 FT	(SR4032 SEG 0090/2300)	
	MFC BEGIN = E	
0010/0000	LENGTH(AH 3740 BK 0000)	

EXTRACT DATE: 12/21/2020 ROADWAY MANAGEMENT SYSTEM PAGE NUMBER: 1349
 PRINT DATE: 12/23/2020 SLD COUNTY/SR - ANNUAL PRINT COUNTY: ALLEGHENY
 DIR: B TOTAL LEN: 2.558 MI. DIST: 11-1 SR: 4033
 LEFT MUN: SEWICKLEY HEIGHTS B RIGHT MUN: SEWICKLEY HEIGHTS B

013505 FT

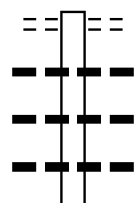

013505 FT	GLEN MITCHELL RD
0060/3443	(BORO)
	018 " DIA CIRC METAL
0060/3385	LEN=0035 INSTALLED UNKN
	012 " DIA CIRC CONCR
0060/3089	LEN=0099 INSTALLED UNKN
	018 " DIA CIRC CONCR
0060/2690	LEN=0035 INSTALLED UNKN
	012 " DIA CIRC CONCR

DIR: B TOTAL LEN: 2.558 MI. DIST: 11-1 SR: 4033
 LEFT MUN: SEWICKLEY HEIGHTS B RIGHT MUN: SEWICKLEY HEIGHTS B

Location / Description	Segment ID	Length (FT)	Material / Notes
	0060/2133	LEN=0035	INSTALLED UNKN
	0060/1190	LEN=0040	012 " DIA CIRC CONCR INSTALLED UNKN
	0060/0816	LEN=0040	012 " DIA CIRC METAL INSTALLED UNKN
010062 FT	010062 FT	2 0 02098 0 00 0000+00	FERRY RD
	0060/0000	LENGTH(AH 3443 BK 2049)	(SR4030 SEG 0010/0000)
	0050/1510	LEN=0040	018 " DIA CIRC CONCR INSTALLED UNKN
008013 FT	008013 FT	2 0 02096 0 00 0062+62	NC MERRIMAN RD
REDGATE RD (SR4028 SEG 0030/2739) TO MERRIMAN RD (CONN)	0050/0000	007581 FT	SEWICKLEY HEIGHTS GLENFIELD B
	0044/0000	LENGTH(AH 0432 BK 1361)	NORTH DR (TWP)
MERRIMAN RD (TWP)	0030/1222		
	0030/0010	LEN=0099	030 " DIA CIRC CONCR INSTALLED UNKN
006220 FT	006220 FT	2 0 00000 0 00 0000+00	(APRA) 79 INDUSTRIAL PA OVERLOOK DR (TWP)
POE	0030/0000	LENGTH(AH 1361 BK 2774)	
SCHOOL ST (TWP)	0020/0600		
003446 FT	003446 FT	2 0 02123 0 00 0023+57	LENGTH(AH 2774 BK 2350)

DIR: B TOTAL LEN: 2.558 MI. DIST: 11-1 SR: 4033
 LEFT MUN: GLENFIELD B RIGHT MUN: GLENFIELD B

RAMP A3 RD
 (SR8017 SEG 0500/0000) 0010/1935
 TO 8017/0500 SH
 (CONN) 0010/1820

FROM 8017/0792 SH
 (CONN) 0010/1613
 RAMP B3 RD
 (SR8017 SEG 0792/1279) 0010/1552

2 0 02123 0 00 0000+00 001096 FT
 RAMP R RD
 (SR8017 SEG 0754/0000)
 RAMP S RD
 (SR8017 SEG 0250/1063)
 RAMP 4 RD
 (SR8017 SEG 0260/0000) 0010/0000

GLENFIELD VIADUCT BR
 (SR4165 SEG 0010/0000) 0008/0055

0 0 00000 0 00 0000+00 000000 FT
 SR 8092 SH
 (SR8092 SEG 0260/0000) 0008/0000

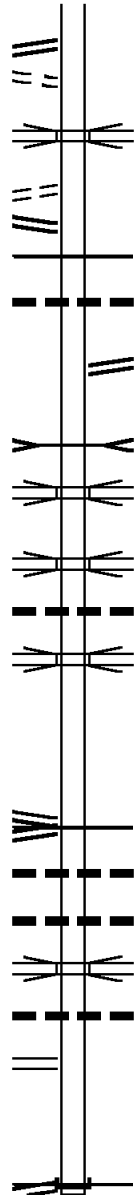

SR 0079 NB
 0010/1751 OP ID 02/0079/0654/1019

0010/1447 MFC BEGIN = D
 018 "DIA CIRC CONCR
 0010/1438 LEN=0092 INSTALLED UNKN
 KILBUCK ST
 (SR4071 SEG 0010/0000)
 NC DEER RUN RD

KILBUCK RUN
 STRUCTURE LENGTH 82 FT
 0010/1075 BMSID 02/4033/0010/1055
 RAMP B NB

0010/0972 OP ID 02/8017/0772/0143

RAMP B2 8017 NB
 0010/0220 OP ID 02/8017/0772/0910
 018 "DIA CIRC CONCR
 0010/0142 LEN=0030 INSTALLED UNKN
 SR 0065 NB

0010/0068 OP ID 02/0065/0140/1735
 001096 FT

NC KILBUCK ST
 MFC BEGIN = C
 0010/0000 LENGTH(AH 2350 BK 1096)
 018 "DIA CIRC CONCR

0008/1064 LEN=0030 INSTALLED UNKN
 018 "DIA CIRC CONCR
 0008/0961 LEN=0030 INSTALLED UNKN
 RAMP B1 8017 SB

0008/0957 OP ID 02/8017/0752/0000
 012 "DIA CIRC CONCR
 0008/0607 LEN=0030 INSTALLED UNKN

NC CENTER AV
 INTER-BK SR 8092 SH
 000000 FT (SR8092 SEG 0250/0215)
 MFC BEGIN = D
 0008/0000 LENGTH(AH 1096 BK 0000)

DIR: B TOTAL LEN: 6.169 MI. DIST: 11-1 SR: 4032
 LEFT MUN: FRANKLIN PARK B RIGHT MUN: FRANKLIN PARK B

032571 FT

032571 FT
 INTER-AHD CAMPMEETING DUFF CITY R
 (SR4043 SEG 0070/0000)
 MAGEE RD ET (TBK)
 (TWP)
 0120/3318 018 "DIA CIRC CONCR
 0120/2980 LEN=0040 INSTALLED UNKN
 015 "DIA CIRC OTHER
 0120/2552 LEN=0040 INSTALLED UNKN
 024 "DIA CIRC CONCR
 0120/2063 LEN=0040 INSTALLED UNKN
 018 "DIA CIRC CONCR
 0120/1793 LEN=0040 INSTALLED UNKN
 024 "DIA CIRC OTHER
 0120/1500 LEN=0070 INSTALLED UNKN
 018 "DIA CIRC CONCR
 0120/0889 LEN=0040 INSTALLED UNKN
 018 "DIA CIRC CONCR
 0120/0570 LEN=0040 INSTALLED UNKN
 029253 FT 2 0 02322 0 00 0037+20
 036 "DIA CIRC CONCR
 LEN=0060 INSTALLED UNKN
 HENRY RD
 (SR4039 SEG 0060/1164)
 5 0120/0000 LENGTH(AH 3318 BK 3700)
 036 "DIA CIRC CONCR
 0110/3110 LEN=0060 INSTALLED UNKN

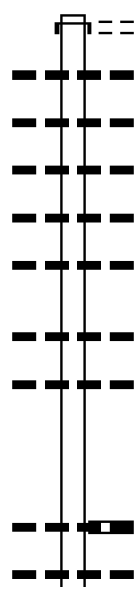

029253 FT

EXTRACT DATE: 12/21/2020
PRINT DATE: 12/23/2020

ROADWAY MANAGEMENT SYSTEM
SLD COUNTY/SR - ANNUAL PRINT

PAGE NUMBER: 1345
COUNTY: ALLEGHENY

DIR: B TOTAL LEN: 6.169 MI.
LEFT MUN: FRANKLIN PARK B

DIST: 11-1 SR: 4032
RIGHT MUN: FRANKLIN PARK B

HOPKINS CHURCH RD
(TWP)
WESTHOLME DR
(TWP)

0110/2261
0110/1934

CAMPMEETING RD
(CNTY)

025553 FT
0110/0000

022637 FT

---	---	0110/2610	018 "DIA CIRC METAL LEN=0040 INSTALLED UNKN
==	---	0110/1812	018 "DIA CIRC CONCR LEN=0048 INSTALLED UNKN
==	---	0110/1391	018 "DIA CIRC METAL LEN=0040 INSTALLED UNKN
---	---	0110/0920	META DR (TWP)
---	---	0110/0562	FRANKLIN PARK BELL ACRES B
==	---	0110/0524	HAMILTON DR (TWP)
---	---	0110/0519	018 "DIA CIRC CONCR LEN=0040 INSTALLED UNKN
---	---	025553 FT	2 0 02322 0 00 0000+00
==	---	0110/0000	NC CAMPMEETING RD LENGTH(AH 3700 BK 2916)
---	---	0100/2915	018 "DIA CIRC CONCR LEN=0100 INSTALLED UNKN
---	---	0100/2824	015 "DIA CIRC CONCR LEN=0040 INSTALLED UNKN
---	---	0100/2351	018 "DIA CIRC CONCR LEN=0040 INSTALLED UNKN
---	---	0100/2255	BELL ACRES SEWICKLEY HILLS B
---	---	0100/2013	015 "DIA CIRC METAL LEN=0040 INSTALLED UNKN
---	---	0100/0953	015 "DIA CIRC CONCR LEN=0040 INSTALLED UNKN
---	---	0100/0710	SEWICKLEY HILLS SEWICKLEY HEIGHTS B
---	---	0100/0432	018 "DIA CIRC CONCR LEN=0040 INSTALLED UNKN
---	---	0100/0047	018 "DIA CIRC CONCR LEN=0040 INSTALLED UNKN
---	---	022637 FT	2 0 02321 0 00 0046+85
==	---	0100/0000	DUFF CITY RD (SR4088 SEG 0010/0391)
==	---	0090/2300	LENGTH(AH 2916 BK 2695) AUDUBON RD (SR4034 SEG 0010/0000)

RBR

EXTRACT DATE: 12/21/2020
PRINT DATE: 12/23/2020

ROADWAY MANAGEMENT SYSTEM
SLD COUNTY/SR - ANNUAL PRINT

PAGE NUMBER: 1344
COUNTY: ALLEGHENY

DIR: B TOTAL LEN: 6.169 MI.
LEFT MUN: SEWICKLEY HEIGHTS B

DIST: 11-1 SR: 4032
RIGHT MUN: SEWICKLEY HEIGHTS B

019942 FT

017984 FT

	0090/2214	BMS	SEN	02/4032/0090/2202	20023210000041+20
					P3
					LITTLE SEWICKLEY CK TRI
	0090/2202	BMS	SBG	02/4032/0090/2202	018 "DIA CIRC CONCR
					LEN=0032 INSTALLED UNKN
	0090/2029				012 "DIA CIRC CONCR
					LEN=0048 INSTALLED UNKN
	0090/1890				012 "DIA CIRC CONCR
					LEN=0048 INSTALLED UNKN
	0090/1692				015 "DIA CIRC CONCR
					LEN=0048 INSTALLED UNKN
	0090/1229				024 "DIA CIRC CONCR
					LEN=0048 INSTALLED UNKN
	0090/0882				018 "DIA CIRC CONCR
					LEN=0040 INSTALLED UNKN
	0090/0344				019942 FT
					019942 FT
					0090/0000 LENGTH(AH 2695 BK 1958)
					SEWICKLEY HEIGHTS
					BELL ACRES B
	0080/1947				018 "DIA CIRC CONCR
					LEN=0048 INSTALLED UNKN
	0080/1863				060 "DIA CIRC CONCR
					LEN=0036 INSTALLED UNKN
	0080/1633				BMS
					SEN 02/4032/0080/1521
	0080/1539				20023210000015+25
					BR. LIT. SEWIK
					BMS
					SBG 02/4032/0080/1521
					BELL ACRES
	0080/1475				SEWICKLEY HEIGHTS B
					018 "DIA CIRC CONCR
	0080/0912				LEN=0040 INSTALLED UNKN
					018 "DIA CIRC CONCR
	0080/0419				LEN=0048 INSTALLED UNKN
					FERN HOLLOW RD
					(CNTY)
	0080/0045				017984 FT
					017984 FT
					NC FERN HOLLOW RD
					MFC BEGIN = D
					0080/0000 LENGTH(AH 1958 BK 2918)
					018 "DIA CIRC CONCR
	0070/2802				LEN=0120 INSTALLED UNKN
					LC FOR FERN HOLLOW RD
					(CONN)
					018 "DIA CIRC CONCR
	0070/2182				LEN=0040 INSTALLED UNKN
					018 "DIA CIRC CONCR
	0070/1963				LEN=0040 INSTALLED UNKN
					018 "DIA CIRC CONCR

DIR: B TOTAL LEN: 6.169 MI. DIST: 11-1 SR: 4032
 LEFT MUN: SEWICKLEY HEIGHTS B RIGHT MUN: SEWICKLEY HEIGHTS B

---	0070/1705	LEN=0040	INSTALLED	UNKN
---	0070/1486	LEN=0048	INSTALLED	UNKN
---	0070/1185	LEN=0040	INSTALLED	UNKN
---	0070/0993	LEN=0040	INSTALLED	UNKN
---	0070/0930	LEN=0040	INSTALLED	UNKN
---	0070/0730	LEN=0040	INSTALLED	UNKN
---	0070/0296	LEN=0040	INSTALLED	UNKN
---	0070/0012	LEN=0040	INSTALLED	UNKN
---	015066 FT	2 0 02219	0 00 0073+30	
---	0070/0000	LENGTH(AH	2918 BK 1346)	
---	0060/1299	LEN=0040	INSTALLED	UNKN
---	0060/1092	LEN=0040	INSTALLED	UNKN
---	0060/0693	LEN=0040	INSTALLED	UNKN
---	0060/0409	LEN=0040	INSTALLED	UNKN
---	0060/0255	LEN=0040	INSTALLED	UNKN
---	0060/0184	LEN=0040	INSTALLED	UNKN
==	0060/0031			
==	013720 FT	2 0 02219	0 00 0059+91	
---	0060/0000	LENGTH(AH	1346 BK 3112)	
---	0050/2949	LEN=0040	INSTALLED	UNKN
---	0050/2678	LEN=0048	INSTALLED	UNKN
---	0050/2425	BACKBONE RD		
---	0050/2360	LEN=0100	INSTALLED	UNKN
---	0050/2288	LC FOR BACKBONE RD		
---	0050/2040	LEN=0048	INSTALLED	UNKN
---	0050/1801	LEN=0048	INSTALLED	UNKN
---		018 "DIA	CIRC CONCR	

015066 FT

BACKBONE RD
(TWP)

0060/0031
013720 FT

DIR: B TOTAL LEN: 6.169 MI. DIST: 11-1 SR: 4032
 LEFT MUN: SEWICKLEY HEIGHTS B RIGHT MUN: SEWICKLEY HEIGHTS B

---	0050/1542	LEN=0040	INSTALLED UNKN
---	0050/1196	LEN=0040	INSTALLED UNKN
---	0050/0234	024 " DIA CIRC CONCR	LEN=0100 INSTALLED UNKN
---	0050/0099	018 " DIA CIRC CONCR	LEN=0040 INSTALLED UNKN
---	010608 FT	2 0 02219 0 00 0027+44	
---	5 0050/0000	LENGTH(AH 3112 BK 2623)	SEWICKLEY HEIGHTS
---	0040/2571	BELL ACRES B	
---	0040/1709	018 " DIA CIRC CONCR	LEN=0072 INSTALLED UNKN
---	0040/1399	018 " DIA CIRC CONCR	LEN=0032 INSTALLED UNKN
---	0040/0882	018 " DIA CIRC CONCR	LEN=0032 INSTALLED UNKN
---	0040/0291	018 " DIA CIRC CONCR	LEN=0040 INSTALLED UNKN
---	0040/0208	036 " H 00 " W MULT CONCR	LEN=0060 INSTALLED UNKN
---	0040/0197	" "	
---	0040/0150	018 " DIA CIR PLASTIC	LEN=0040 INSTALLED UNKN
---	007985 FT	2 0 02219 0 00 0000+00	BELL ACRES
---	5 0040/0000	LEET T	LENGTH(AH 2623 BK 2814)
---	0030/2741	018 " DIA CIRC METAL	LEN=0040 INSTALLED UNKN
---	0030/2579	018 " DIA CIRC CONCR	LEN=0060 INSTALLED UNKN
---	0030/2435	018 " DIA CIRC METAL	LEN=0099 INSTALLED UNKN
---	0030/1570	018 " DIA CIRC CONCR	LEN=0032 INSTALLED UNKN
---	0030/1336	036 " DIA CIRC CONCR	LEN=0048 INSTALLED UNKN
---	0030/0816	018 " DIA CIRC METAL	LEN=0099 INSTALLED UNKN
---	0030/0498	036 " H 60 " W CON BOX CUL	LEN=0096 INSTALLED UNKN
---	0030/0355	018 " DIA CIRC CONCR	LEN=0099 INSTALLED UNKN
---		018 " DIA CIRC CONCR	

010608 FT

SEVIN RD
(TWP)

007985 FT

DIR: B TOTAL LEN: 6.169 MI. DIST: 11-1 SR: 4032
 LEFT MUN: LEET T RIGHT MUN: LEET T

005171 FT

003016 FT

000000 FT

0030/0247	LEN=0099	INSTALLED UNKN
018 "DIA	CIRC CONCR	
0030/0037	LEN=0032	INSTALLED UNKN
005171 FT	2 0 02115	0 00 0054+50
0030/0000	LENGTH(AH 2814 BK 2155)	
0020/2118	EDGEWORTH B	
018 "DIA	CIRC METAL	
0020/1810	LEN=0060	INSTALLED UNKN
018 "DIA	CIRC METAL	
0020/1695	LEN=0060	INSTALLED UNKN
018 "DIA	CIRC CONCR	
0020/1049	LEN=0060	INSTALLED UNKN
018 "DIA	CIRC CONCR	
0020/0590	LEN=0080	INSTALLED UNKN
018 "DIA	CIRC CONCR	
0020/0349	LEN=0060	INSTALLED UNKN
003016 FT	2 0 02115	0 00 0030+49
018 "DIA	CIRC CONCR	
0020/0000	LEN=0040	INSTALLED UNKN
LENGTH(AH 2155 BK 3016)		
WOODLAND RD		
0010/2590	(TWP)	
018 "DIA	CIRC CONCR	
0010/2213	LEN=0040	INSTALLED UNKN
018 "DIA	CIR PLASTIC	
0010/1961	LEN=0050	INSTALLED UNKN
018 "DIA	CIRC CONCR	
0010/1862	LEN=0060	INSTALLED UNKN
018 "DIA	CIRC CONCR	
0010/1565	LEN=0052	INSTALLED UNKN
018 "DIA	CIRC CONCR	
0010/1360	LEN=0050	INSTALLED UNKN
018 "DIA	CIRC CONCR	
0010/1265	LEN=0048	INSTALLED UNKN
018 "DIA	CIRC CONCR	
0010/1168	LEN=0048	INSTALLED UNKN
018 "DIA	CIRC CONCR	
0010/0957	LEN=0048	INSTALLED UNKN
018 "DIA	CIRC CONCR	
0010/0732	LEN=0048	INSTALLED UNKN
018 "DIA	CIRC CONCR	
0010/0477	LEN=0050	INSTALLED UNKN
000000 FT	2 0 02115	0 00 0000+00
NC LI	TITLE SEWICKLEY CREEK RD	
BEAVER ST		
(TWP)		
MFC BEGIN = E		
0010/0000	LENGTH(AH 3016 BK 0000)	

EXTRACT DATE: 12/21/2020 ROADWAY MANAGEMENT SYSTEM PAGE NUMBER: 1340
PRINT DATE: 12/23/2020 SLD COUNTY/SR - ANNUAL PRINT COUNTY: ALLEGHENY

DIR: B TOTAL LEN: 8.565 MI. DIST: 11-1 SR: 4031
LEFT MUN: PINE T RIGHT MUN: PINE T

045222 FT

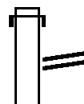

045222 FT
INTER-AHD THREE DEGREE RD
0180/3070 (SR3007 SEG 0010/0000)
VALENCIA RD
0180/3013 (SR4076 SEG 0010/0000)
018 " DIA CIRC CONCR

DIR: B TOTAL LEN: 8.565 MI. DIST: 11-1 SR: 4031
 LEFT MUN: PINE T RIGHT MUN: PINE T

JAMES ST
 (TWP) 0180/1868

MARS VALENCIA RD
 (SR4059 SEG 0010/0000) 0180/1084

042152 FT

MACLEOD LN
 (PRDR) 0170/2181

038436 FT

WARRENDALE RD
 (SR4068 SEG 0120/2406) 036572 FT
 0160/0000

0180/3009	LEN=0040	INSTALLED UNKN
0180/2170	018" DIA CIRC METAL LEN=0025	INSTALLED UNKN
0180/1885	018"H 18"W BOX CULVERT LEN=0099	INSTALLED UNKN
0180/0883	OLD STATE RD (T574) BR. BREAKNECK STRUCTURE LENGTH 13 FT	
0180/0759	BMSID 02/4031/0180/0794	
042152 FT	2 0 02328 0 01 0734+96	
0180/0000	LENGTH(AH 3070 BK 3716) 018" DIA CIR PLASTIC	
0170/3588	LEN=0060	INSTALLED UNKN
0170/3272	015" DIA CIRC CONCR LEN=0050	INSTALLED UNKN
0170/2075	024" DIA CIRC CONCR LEN=0100	INSTALLED UNKN
0170/0907	012" DIA CIR PLASTIC LEN=0040	INSTALLED UNKN
0170/0690	SILVER PINES DR (TWP)	
038436 FT	2 0 02328 0 01 0699+26	
0170/0000	LENGTH(AH 3716 BK 1864) WARRENDALE RD	
0160/1599	(SR4068 SEG 0130/0000)	
0160/0533	018" DIA CIRC METAL LEN=0040	INSTALLED UNKN
036572 FT	2 0 02328 0 01 0680+00	
0160/0000	LENGTH(AH 1864 BK 2830)	
0150/1635	BABCOCK ESTATE LN (PRDR)	

DIR: B TOTAL LEN: 8.565 MI. DIST: 11-1 SR: 4031
 LEFT MUN: PINE T RIGHT MUN: PINE T

Location	Segment ID	Length	Material	Notes
LOGAN RD (T554)	0150/1601	0150/1602	015 "DIA CIRC CONCR	LEN=0060 INSTALLED UNKN
		0150/0952	018 "DIA CIRC METAL	LEN=0040 INSTALLED UNKN
	033742 FT	033742 FT	2 0 02328 0 01	0650+28 LENGTH(AH 2830 BK 3537)
		0140/2385	GRAN SASSO LN (PRDR)	
NORTHBROOK DR (TWP)		0140/1680	018 "DIA CIRC CONCR	LEN=0035 INSTALLED UNKN
		0140/1135	PALOMINO DR (T927)	
		0140/0800	099"H 01"W **UNKNOWN**	LEN=0040 INSTALLED UNKN
		0140/0594	NORTH PINE CR (T512)	
	0140/0298	030205 FT	2 0 02328 0 01	0616+31 NORTH PINE CR (T512)
	030205 FT	0140/0000	0130/3211	LEN=0040 INSTALLED UNKN
IVY DR (TWP)		0130/3004	018 "DIA CIRC CONCR	LEN=0040 INSTALLED UNKN
		0130/2946	024 "DIA CIRC CONCR	LEN=0060 INSTALLED UNKN
		0130/2880	018 "DIA CIRC CONCR	LEN=0030 INSTALLED UNKN
		0130/2307	SNOWBERRY LN (TWP)	
		0130/1979	018 "DIA CIRC CONCR	LEN=0050 INSTALLED UNKN
TIERRA VISTA DR (TWP)		0130/1879	012 "DIA CIRC CONCR	LEN=0100 INSTALLED UNKN
	0130/1750		018 "DIA CIRC METAL	

DIR: B TOTAL LEN: 8.565 MI. DIST: 11-1 SR: 4031
 LEFT MUN: PINE T RIGHT MUN: PINE T

Stationing	Segment	Length	Material	Status
	0130/1470	LEN=0035	INSTALLED	UNKN
	0130/0143	LEN=0030	018 " DIA CIRC METAL	INSTALLED UNKN
2 0 02328 0 01 0580+59	026625 FT		GIBSONIA RD	
WEXFORD RD			(SR0910 SEG 0120/0000)	
(SR0910 SEG 0120/0000)	0130/0000		MFC BEGIN = D	
	0130/0000		LENGTH(AH 3580 BK 3552)	
	0120/3434		TO 0910/0120 SH	
	0120/3035		(CONN)	
	0120/2624		015 " DIA CIRC OTHER	INSTALLED UNKN
			018 " DIA CIRC OTHER	INSTALLED UNKN
SKYLARK DR	0120/2294			
(T419)				
	0120/2275		015 " DIA CIRC CONCR	INSTALLED UNKN
JACKSON RD	0120/1799		DEER PATH LN	
(T558)			(PRDR)	
	0120/1690		012 " DIA CIRC OTHER	INSTALLED UNKN
			LEN=0050	
	023073 FT			
	0120/0000		2 0 02328 0 01 0545+36	
			LENGTH(AH 3552 BK 3175)	
	0110/2523		KARRINGTON DR	
			(TWP)	
	0110/1340		018 " DIA CIRC METAL	INSTALLED UNKN
	0110/1191		MISTY VALLEY LN	
			(TWP)	
	019898 FT			
	0110/0000		2 0 02328 0 01 0513+46	
			LENGTH(AH 3175 BK 3212)	
	0100/2750		018 " DIA CIRC CONCR	INSTALLED UNKN
	0100/2675		OLD BABCOCK BL	
			(CNTY)	
	0100/2529		018 " DIA CIRC CONCR	INSTALLED UNKN
			LEN=0050	

EXTRACT DATE: 12/21/2020
PRINT DATE: 12/23/2020

ROADWAY MANAGEMENT SYSTEM
SLD COUNTY/SR - ANNUAL PRINT

PAGE NUMBER: 1336
COUNTY: ALLEGHENY

DIR: B
LEFT MUN: PINE T

TOTAL LEN: 8.565 MI.

DIST: 11-1
RIGHT MUN: PINE T

SR: 4031

Location	Stationing	Length	Notes
	0100/1916	018 "	DIA CIRC CONCR
	0100/1768	LEN=0080	INSTALLED UNKN
		PINE	
		MCCANDLESS T	
	0100/1056	018 "	DIA CIRC CONCR
	0100/0979	LEN=0035	INSTALLED UNKN
		024 "	DIA CIRC CONCR
	0100/0657	LEN=0080	INSTALLED UNKN
		OLD BABCOCK RD	
		(TWP)	
	0100/0181	018 "	DIA CIRC CONCR
016686 FT	016686 FT	LEN=0080	INSTALLED UNKN
		2 0 02328 0 01 0481+01	
		NORTH VILLA DR	
		(TWP)	
	0100/0000	LENGTH(AH 3212 BK 1599)	
OLDE VILLA DR (TWP)	0090/0986		SOUTH VILLA DR
		(TWP)	
	0090/0637		LAKE MARSHALL DR
		(TWP)	
	0090/0384	018 "	DIA CIRC CONCR
		LEN=0035	INSTALLED UNKN
	0090/0053	018 "	DIA CIRC CONCR
015087 FT	015087 FT	LEN=0035	INSTALLED UNKN
		2 0 02328 0 01 0465+13	
	0090/0000	LENGTH(AH 1599 BK 2985)	
	0080/2618	015 "	DIA CIRC CONCR
		LEN=0035	INSTALLED UNKN
	0080/2214	099 "	DIA CIRC CONCR
		LEN=2214	INSTALLED UNKN
	0080/1686	015 "	DIA CIRC CONCR
		LEN=0035	INSTALLED UNKN
	0080/1355	018 "	DIA CIRC CONCR
		LEN=0060	INSTALLED UNKN
IRWIN RD (CNTY)	0080/1101		
	0080/1054	018 "	DIA CIRC CONCR
		LEN=0080	INSTALLED UNKN
	0080/0998		LAKE MARSHALL DR
		(TWP)	
	0080/0648	018 "	DIA CIRC CONCR
		LEN=0080	INSTALLED UNKN
	0080/0319	024 "	DIA CIRC CONCR
012102 FT	012102 FT	LEN=0080	INSTALLED UNKN
		2 0 02328 0 01 0436+75	
		(APRA) NORTH PARK	
PEARCE MILL RD (CNTY)	0080/0000	LENGTH(AH 2985 BK 1308)	
		099 "H 00 "W UNKN CONC	

EXTRACT DATE: 12/21/2020
PRINT DATE: 12/23/2020

ROADWAY MANAGEMENT SYSTEM
SLD COUNTY/SR - ANNUAL PRINT

PAGE NUMBER: 1335
COUNTY: ALLEGHENY

DIR: B TOTAL LEN: 8.565 MI.
LEFT MUN: MCCANDLESS T

DIST: 11-1 SR: 4031
RIGHT MUN: MCCANDLESS T

2 0 02328 0 01 0422+28 010794 FT
INGOMAR RD
(SR4070 SEG 0090/0000) 0070/0000

OLD INGOMAR RD
(CNTY)

0060/1864

WEST RIDGE RD
(TWP)

008106 FT

0060/0000

OLD BABCOCK RD
(CNTY)

2 0 02328 0 01 0384+18 006971 FT
MONTGOMERY RD

(TWP)
COLE RD
(TWP)

0050/0000

0040/0602

0070/1152	LEN=1152	INSTALLED UNKN
0070/1119	BMSSEN 02/4031/0070/1080	2 0 02328 0 01 0434+47
	N. PARK LAKE	
0070/1080	BMSBG 02/4031/0070/1080	
0070/0955	099 "DIA CIRC CONCR	
0070/0650	LEN=0020	INSTALLED UNKN
	099 "H 00 "W UNKN CONC	
0070/0355	LEN=0020	INSTALLED UNKN
	099 "H 00 "W UNKN CONC	
010794 FT	WILDWOOD RD	
	(SR4070 SEG 0090/0000)	
5 0070/0000	LENGTH(AH 1308 BK 2688)	
	099 "H 00 "W **UNKNOWN**	
0060/2613	LEN=0020	INSTALLED UNKN
	099 "H 00 "W **UNKNOWN**	
0060/2296	LEN=0020	INSTALLED UNKN
0060/2168	BMSSEN 02/4031/0060/2089	2 0 02328 0 01 0416+82
	DRAIN PIPE	
0060/2146	BMSBG 02/4031/0060/2089	
	099 "H 00 "W **UNKNOWN**	
0060/1958	LEN=0020	INSTALLED UNKN
	018 "DIA CIRC CONCR	
0060/1358	LEN=0020	INSTALLED UNKN
	099 "H 00 "W **UNKNOWN**	
0060/0979	LEN=0020	INSTALLED UNKN
	099 "H 00 "W **UNKNOWN**	
0060/0759	LEN=0020	INSTALLED UNKN
	LC FOR HEMLOCK DR	
0060/0149	(CONN)	
008106 FT	2 0 02328 0 01 0395+34	
	HEMLOCK DR	
	(TWP)	
5 0060/0000	LENGTH(AH 2688 BK 1135)	
	PRESIDENTIAL DR	
	(TWP)	
0050/0789	018 "DIA CIRC CONCR	
0050/0255	LEN=0040	INSTALLED UNKN
	006971 FT	
5 0050/0000	LENGTH(AH 1135 BK 1081)	

DIR: B TOTAL LEN: 8.565 MI. DIST: 11-1 SR: 4031
 LEFT MUN: MCCANDLESS T RIGHT MUN: MCCANDLESS T

Stationing	Distance	Right of Way	Notes
2 0 02328 0 01 0373+47	005890 FT	0040/0484	EMERY DR (TWP) 018" DIA CIRC CONCR LEN=0040 INSTALLED UNKN
PARKVIEW DR (TWP)	0040/0000	0040/0235	005890 FT
		0030/1464	LENGTH(AH 1081 BK 1770) HEDWIG DR (TWP) 018" DIA CIRC CONCR LEN=0040 INSTALLED UNKN
	004120 FT	0030/0875	018" DIA CIRC CONCR LEN=0045 INSTALLED UNKN
COTTINGHAM DR (TWP)	0020/2054	0030/0310	004120 FT 2 0 02328 0 01 0356+07
SHEFFIELD CT (TWP)	0020/1719	0030/0000	LENGTH(AH 1770 BK 2404)
		0020/1500	018" DIA CIRC CONCR LEN=0040 INSTALLED UNKN
LC FOR KUMMER RD (CONN)	0020/0126	0020/1090	APPLE HILL LN (TWP)
2 0 02328 0 01 0331+30	001716 FT	0020/0050	CHERRY LN (PRDR) 001716 FT
KUMMER RD (TWP)	0020/0000	0020/0000	LENGTH(AH 2404 BK 1716)
		0010/0973	LC FROM UPMC HOSPITAL D (CONN)
WHITLEY DR (TWP)	0010/0945	0010/0913	UPMC PASSAVANT HOSP DR (PRDR) 024" DIA CIRC CONCR LEN=0075 INSTALLED UNKN
	000000 FT	0010/0500	000000 FT 2 0 02328 0 01 0314+28 NC BA
			BABCOCK BL UPMC PASSAVANT HOSP DR (PRDR)
CUMBERLAND RD (SR4024 SEG 0040/0000)	0010/0000	INTER-BK	BABCOCK BL (SR4024 SEG 0040/0000) MFC BEGIN = C
		0010/0000	LENGTH(AH 1716 BK 0000)

EXTRACT DATE: 12/21/2020 ROADWAY MANAGEMENT SYSTEM PAGE NUMBER: 1333
PRINT DATE: 12/23/2020 SLD COUNTY/SR - ANNUAL PRINT COUNTY: ALLEGHENY
DIR: B TOTAL LEN: 1.184 MI. DIST: 11-1 SR: 4030
LEFT MUN: ALEPPO T RIGHT MUN: ALEPPO T

006252 FT

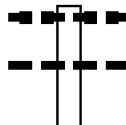

006252 FT 015 " DIA CIR PLASTIC
LEN=0040 INSTALLED 2015
GLENFIELD RD
0030/2396 (CNTY)
018 " DIA CIRC CONCR
0030/2351 LEN=0020 INSTALLED UNKN

DIR: B TOTAL LEN: 1.184 MI. DIST: 11-1 SR: 4030
 LEFT MUN: ALEPPO T RIGHT MUN: ALEPPO T

003856 FT

5

001684 FT

5

000000 FT

0030/1392	024 " DIA	CIRC CONCR
	LEN=0050	INSTALLED UNKN
0030/1188	072 " DIA	CIRC CONCR
	LEN=0064	INSTALLED UNKN
0030/1090	015 " DIA	CIRC CONCR
	LEN=0045	INSTALLED UNKN
0030/0835	018 " DIA	CIRC OTHER
	LEN=0064	INSTALLED UNKN
0030/0695	018 " DIA	CIRC CONCR
	LEN=0064	INSTALLED UNKN
0030/0432	036 " DIA	CIRC METAL
	LEN=0045	INSTALLED UNKN
0030/0249	018 " DIA	CIRC CONCR
	LEN=0045	INSTALLED UNKN
003856 FT	2 0 02096	0 00 0121+47
5 0030/0000	LENGTH(AH	2396 BK 2172)
	018 " DIA	CIRC CONCR
0020/2161	LEN=0030	INSTALLED UNKN
	ALEPPO	
0020/2063	SEWICKLEY	HEIGHTS B
	018 " DIA	CIRC CONCR
0020/1778	LEN=0040	INSTALLED UNKN
	018 " DIA	CIRC CONCR
0020/1414	LEN=0050	INSTALLED UNKN
	030 " DIA	CIRC CONCR
0020/1122	LEN=0035	INSTALLED UNKN
	015 " DIA	CIRC CONCR
0020/0821	LEN=0055	INSTALLED UNKN
	036 " DIA	CIRC CONCR
0020/0606	LEN=0060	INSTALLED UNKN
	018 " DIA	CIRC CONCR
0020/0396	LEN=0057	INSTALLED UNKN
	018 " DIA	CIRC CONCR
0020/0157	LEN=0045	INSTALLED UNKN
	2 0 02096	0 00 0100+00
5 0020/0000	LENGTH(AH	2172 BK 1684)
	018 " DIA	CIRC CONCR
0010/1036	LEN=0025	INSTALLED UNKN
	018 " DIA	CIRC CONCR
0010/0990	LEN=0040	INSTALLED UNKN
	018 " DIA	CIRC CONCR
0010/0878	LEN=0040	INSTALLED UNKN
	000000 FT	2 0 02096 0 00 0082+78
	NC FERRIMAN RD	
	MERRIMAN RD	
	(SR4033 SEG	0060/0000)
	MFC BEGIN = E	
5 0010/0000	LENGTH(AH	1684 BK 0000)

EXTRACT DATE: 12/21/2020 ROADWAY MANAGEMENT SYSTEM PAGE NUMBER: 1331
PRINT DATE: 12/23/2020 SLD COUNTY/SR - ANNUAL PRINT COUNTY: ALLEGHENY
DIR: B TOTAL LEN: 2.610 MI. DIST: 11-1 SR: 4029
LEFT MUN: FRANKLIN PARK B RIGHT MUN: FRANKLIN PARK B

ROCHESTER RD 013783 FT
(SR4011 SEG 0190/0000) 0050/2716

HAVEN HILL RD
(T654) 0050/1565

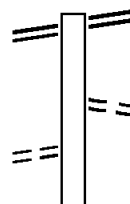

013783 FT ROCHESTER RD
0050/2716 (SR4011 SEG 0190/0000)

0050/1850 WALRUTH RD
(TWP)

EXTRACT DATE: 12/21/2020
PRINT DATE: 12/23/2020

ROADWAY MANAGEMENT SYSTEM
SLD COUNTY/SR - ANNUAL PRINT

PAGE NUMBER: 1330
COUNTY: ALLEGHENY

DIR: B TOTAL LEN: 2.610 MI.
LEFT MUN: FRANKLIN PARK B

DIST: 11-1 SR: 4029
RIGHT MUN: FRANKLIN PARK B

FERN HILL LN
(PRDR)

0050/0220
011067 FT

NEUHART LN
(PRDR)

0040/3112

MCDEVITT RD
(T643)

0040/1740

007538 FT

0050/0661	018 " DIA CIRC CONCR
0050/0630	LEN=0035 INSTALLED UNKN
	STURBRIDGE DR
	(TWP)
011067 FT	2 0 02127 0 00 0110+75
0050/0000	LENGTH(AH 2716 BK 3529)
0040/2870	018 " DIA CIRC CONCR
0040/2700	LEN=0045 INSTALLED UNKN
0040/2500	024 " DIA CIRC CONCR
0040/2385	LEN=0045 INSTALLED UNKN
0040/2260	060 " DIA CIR PLASTIC
0040/2095	LEN=0045 INSTALLED UNKN
0040/2000	060 " DIA CIRC CONCR
0040/1750	LEN=0045 INSTALLED UNKN
0040/1052	018 " DIA CIRC CONCR
0040/0805	LEN=0030 INSTALLED UNKN
0040/0567	012 " DIA CIRC CONCR
0040/0251	LEN=0040 INSTALLED UNKN
007538 FT	018 " DIA CIR PLASTIC
0040/0000	LEN=0040 INSTALLED UNKN
0030/3529	2 0 02127 0 00 0075+44
0030/3427	LENGTH(AH 3529 BK 3796)
0030/3330	018 " DIA CIRC CONCR
0030/3094	LEN=0030 INSTALLED UNKN
0030/2990	018 " DIA CIRC CONCR
	LEN=0030 INSTALLED UNKN
	012 " DIA CIRC CONCR
	LEN=0030 INSTALLED UNKN
	024 " DIA CIRC CONCR
	LEN=0030 INSTALLED UNKN
	018 " DIA CIRC CONCR
	LEN=0030 INSTALLED UNKN
	012 " DIA CIRC CONCR

DIR: B TOTAL LEN: 2.610 MI. DIST: 11-1 SR: 4029
 LEFT MUN: FRANKLIN PARK B RIGHT MUN: FRANKLIN PARK B

MONTGOMERY RD
 (T654)

0030/2010

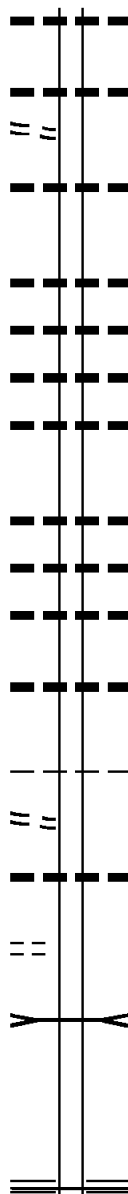

0030/2726 LEN=0030 INSTALLED UNKN

0030/2109 018 "DIA CIRC CONCR
 LEN=0030 INSTALLED UNKN

0030/1983 018 "DIA CIRC METAL
 LEN=0030 INSTALLED UNKN

0030/1061 024 "DIA CIRC CONCR
 LEN=0030 INSTALLED UNKN

0030/0840 024 "DIA CIRC CONCR
 LEN=0030 INSTALLED UNKN

0030/0592 024 "DIA CIRC CONCR
 LEN=0030 INSTALLED UNKN

003742 FT

0030/0429 024 "DIA CIRC CONCR
 LEN=0030 INSTALLED UNKN

003742 FT 2 0 02127 0 00 0037+16

0030/0000 LENGTH(AH 3796 BK 1527)

0020/1385 024 "DIA CIRC METAL
 LEN=0030 INSTALLED UNKN

0020/1156 018 "DIA CIRC METAL
 LEN=0030 INSTALLED UNKN

0020/0893 012 "DIA CIRC CONCR
 LEN=0099 INSTALLED UNKN

002215 FT

0020/0170 018 "DIA CIRC CONCR
 LEN=0040 INSTALLED UNKN

002215 FT 2 0 02127 0 00 0022+09
 FRANKLIN PARK

0020/0000 OHIO T LENGTH(AH 1527 BK 2215)

ANDERSON RD
 (TWP)

0010/2100

0010/1763 012 "DIA CIRC CONCR
 LEN=0030 INSTALLED UNKN

DOUGLAS RD
 (TWP)

0010/0900

0010/0880 TRIB. TO BEAR RUN
 STRUCTURE LENGTH 7 FT

000000 FT

000000 FT 2 0 02127 0 00 0000+00
 NC MC

ALEER RD
 MT NEBO RD

(SR4022 SEG 0070/1370)
 MFC BEGIN = D

0010/0000 LENGTH(AH 2215 BK 0000)

EXTRACT DATE: 12/21/2020 ROADWAY MANAGEMENT SYSTEM PAGE NUMBER: 1328
 PRINT DATE: 12/23/2020 SLD COUNTY/SR - ANNUAL PRINT COUNTY: ALLEGHENY
 DIR: B TOTAL LEN: 1.172 MI. DIST: 11-1 SR: 4028
 LEFT MUN: ALEPPO T RIGHT MUN: ALEPPO T

MERRIMAN RD 006189 FT
 (SR4033 SEG 0050/0000) 0030/2739

SHIELDS LN
 (PRDR)

0030/0465
 003450 FT

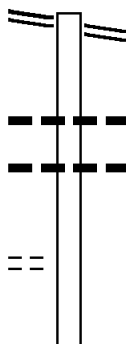

006189 FT MERRIMAN RD
 0030/2739 (SR4033 SEG 0050/0000)

0030/1636 018 " DIA CIRC CONCR
 LEN=0032 INSTALLED UNKN
 0030/1550 018 " DIA CIRC CONCR
 LEN=0032 INSTALLED UNKN

003450 FT 2 0 02096 0 00 0034+30
 NC REDGATE RD
 0030/0000 LENGTH(AH 2739 BK 2343)

DIR: B TOTAL LEN: 1.172 MI. DIST: 11-1 SR: 4028
 LEFT MUN: ALEPPO T RIGHT MUN: ALEPPO T

RHODES AV
(TWP)

0020/0940

```

    0020/2156 018 " DIA CIRC CONCR
               LEN=0030 INSTALLED UNKN
    0020/2020 018 " DIA CIRC CONCR
               LEN=0030 INSTALLED UNKN
    0020/1674 018 " DIA CIRC CONCR
               LEN=0030 INSTALLED UNKN
    0020/1670 012 " DIA CIRC CONCR
               LEN=0040 INSTALLED UNKN
    
```

001107 FT

```

    0020/0775 018 " DIA CIRC CONCR
               LEN=0030 INSTALLED UNKN
    0020/0620 018 " DIA CIRC CONCR
               LEN=0030 INSTALLED UNKN
    0020/0458 018 " DIA CIRC CONCR
               LEN=0032 INSTALLED UNKN
    001107 FT 2 0 02096 0 00 0010+85
               NC REDGATE/RIVER RD
    
```

RIVER AV
(TWP)

0010/1050

```

    0020/0000 018 " DIA CIRC CONCR
               LEN=0030 INSTALLED UNKN
    0010/0824 018 " DIA CIRC CONCR
               LEN=0030 INSTALLED UNKN
    0010/0815 018 " DIA CIRC CONCR
               LEN=0032 INSTALLED UNKN
    0010/0793 2 0 02096 0 00 0010+85
               NC REDGATE RD
    0010/0824 BMSEN 02/4028/0010/0815
               2 0 02096 0 00 0008+26
    0010/0815 HAYS RUN
               BMSBG 02/4028/0010/0815
    0010/0793 048"H 48"W CON BOX CUL
               LEN=0024 INSTALLED UNKN
    0010/0155 018 " DIA CIRC CONCR
               LEN=0020 INSTALLED UNKN
    0010/0085 024 " DIA CIRC CONCR
               LEN=0015 INSTALLED UNKN
    0010/0084 HAYSVILLE
               GLEN OSBORNE B
    0010/0050 BEAVER RD
               (TWP)
    000000 FT 2 0 02096 0 00 0000+00
               NC RIVER RD
    (SR0065 SEG 0181/0000)
    (SR0065 SEG 0180/0000)
    FROM 0065/0170 SH
    (CONN)
    INTER-BK RIVER RD
               (TWP)
    MFC BEGIN = E
    0010/0000 LENGTH(AH 1107 BK 0000)
    
```

EXTRACT DATE: 12/21/2020 ROADWAY MANAGEMENT SYSTEM PAGE NUMBER: 1326
 PRINT DATE: 12/23/2020 SLD COUNTY/SR - ANNUAL PRINT COUNTY: ALLEGHENY
 DIR: B TOTAL LEN: 1.363 MI. DIST: 11-1 SR: 4027
 LEFT MUN: FRANKLIN PARK B RIGHT MUN: FRANKLIN PARK B

ROCHESTER RD
 (SR4011 SEG 0180/0000) 0020/3731
 OAKRIDGE LN
 (PRDR) 0020/3100

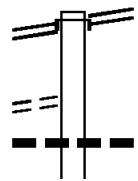

007195 FT INTER-AHD
 0020/3731 INGOMAR HTS RD
 (TWP)
 (SR4011 SEG 0180/0000)
 0020/3050 015 " DIA CIRC CONCR
 LEN=0060 INSTALLED UNKN
 015 " DIA CIRC CONCR

DIR: B TOTAL LEN: 1.363 MI. DIST: 11-1 SR: 4027
 LEFT MUN: FRANKLIN PARK B RIGHT MUN: FRANKLIN PARK B

Street Name	Segment ID	Length	Material	Status
	0020/2943	LEN=0999	018" DIA CIRC CONCR	INSTALLED UNKN
	0020/2764	LEN=0025	018" DIA CIRC METAL	INSTALLED UNKN
	0020/1909	LEN=0030	012" DIA CIRC CONCR	INSTALLED UNKN
	0020/1905	LEN=0099	018" DIA CIRC CONCR	INSTALLED UNKN
OAKLEAF LN (TWP)	0020/1490			
	0020/0980		CLOVER HILL RD (TWP)	
	0020/0785	LEN=0050	018" DIA CIRC CONCR	INSTALLED UNKN
	0020/0505		FIELD CLUB DR (TWP)	
LA COSTA CT (TWP)	0020/0120			
	003464 FT			
	003464 FT		2 0 02129 0 00 0144+71	FARMINGTON CT (TWP)
AURORA DR (TWP)	0010/2980			LENGTH(AH 3731 BK 3464)
	0010/2330	LEN=0048	018" DIA CIRC CONCR	INSTALLED UNKN
COUNTRY CLUB DR (TWP)	0010/2220			
	0010/2116	LEN=0066	018" DIA CIRC CONCR	INSTALLED UNKN
	0010/1855		WHITE OAK CT (TWP)	
	0010/1839	LEN=0054	018" DIA CIRC CONCR	INSTALLED UNKN
	0010/1480	LEN=0036	018" DIA CIRC CONCR	INSTALLED UNKN
PANNO LN (TWP)	0010/1300			
	0010/0965	LEN=0060	018" DIA CIRC CONCR	INSTALLED UNKN
	0010/0725	LEN=0050	018" DIA CIRC CONCR	INSTALLED UNKN
	000000 FT			
	000000 FT		2 0 02129 0 00 0108+58	NC RE IS RUN RD INTER-BK ARNDT RD (SR4022 SEG 0100/0000) MFC BEGIN = C
ARNDT RD (SR4022 SEG 0100/0000)	0010/0000			LENGTH(AH 3464 BK 0000)

EXTRACT DATE: 12/21/2020 ROADWAY MANAGEMENT SYSTEM PAGE NUMBER: 1324
PRINT DATE: 12/23/2020 SLD COUNTY/SR - ANNUAL PRINT COUNTY: ALLEGHENY

DIR: B TOTAL LEN: 2.646 MI. DIST: 11-1 SR: 4026
LEFT MUN: HAMPTON T RIGHT MUN: HAMPTON T

013969 FT

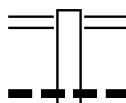

013969 FT MT ROYAL BL
0060/3512 (SR4019 SEG 0150/0000)

0060/2630 018 "DIA CIRC CONCR
LEN=0040 INSTALLED UNKN

DIR: B TOTAL LEN: 2.646 MI. DIST: 11-1 SR: 4026
 LEFT MUN: HAMPTON T RIGHT MUN: HAMPTON T

OAK LN
(TWP)

0060/2012

2 0 02136 0 00 0000+00 010457 FT
 WILDWOOD SAMPLE RD
 (SR4067 SEG 0010/0000) 0060/0000

009814 FT

WINCHESTER DR
(T978)

0040/0834

2 0 02126 0 01 0158+83 007124 FT
 HEMLOCK DR
 (T572) 0040/0000

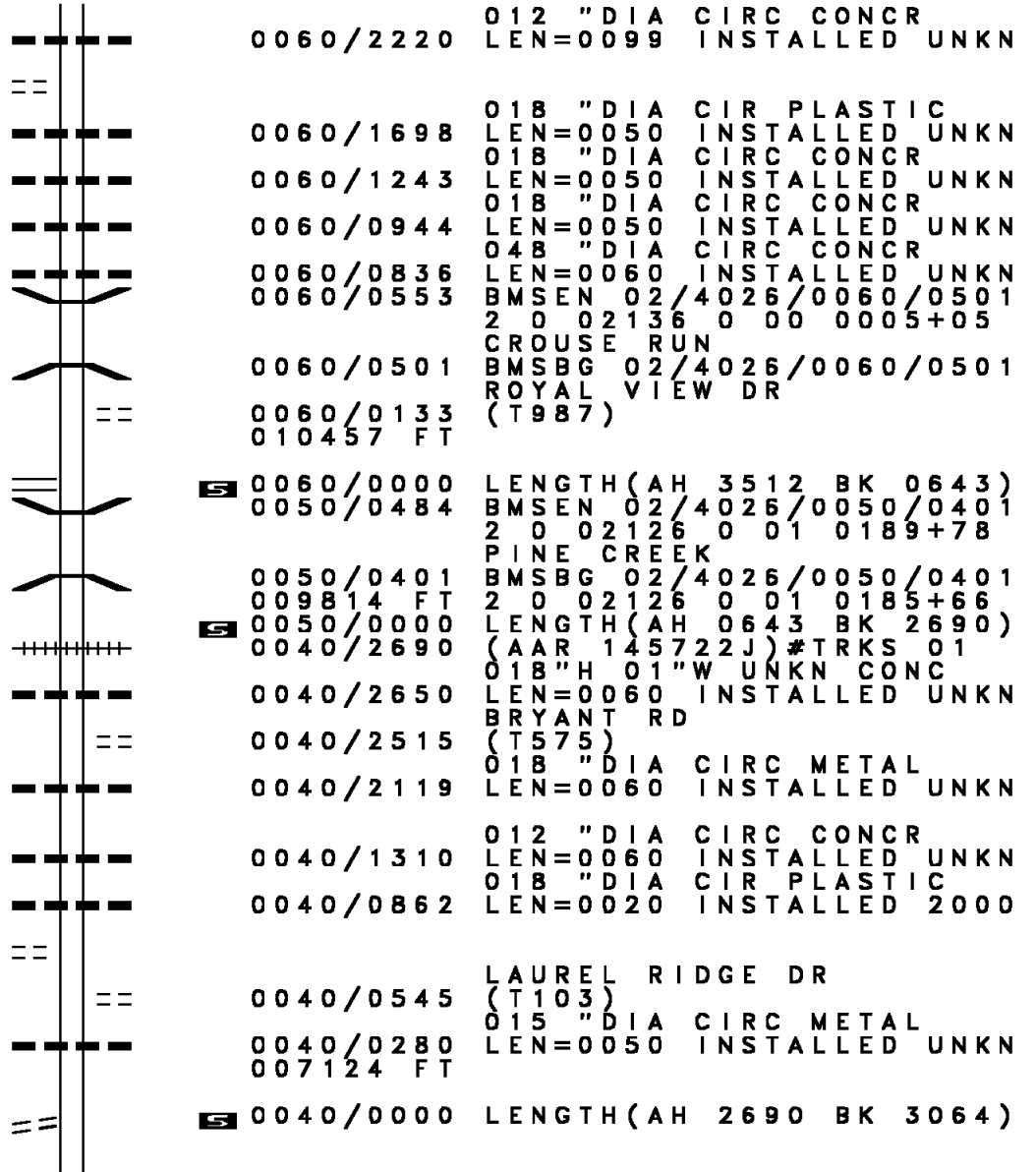

0060/2220 012 " DIA CIRC CONCR
 LEN=0099 INSTALLED UNKN

0060/1698 018 " DIA CIR PLASTIC
 LEN=0050 INSTALLED UNKN

0060/1243 018 " DIA CIRC CONCR
 LEN=0050 INSTALLED UNKN

0060/0944 018 " DIA CIRC CONCR
 LEN=0050 INSTALLED UNKN

0060/0836 048 " DIA CIRC CONCR
 LEN=0060 INSTALLED UNKN

0060/0553 BMSSEN 02/4026/0060/0501
 2 0 02136 0 00 0005+05
 CROUSE RUN

0060/0501 BMSBG 02/4026/0060/0501
 ROYAL VIEW DR

0060/0133 (T987)
 010457 FT

S 0060/0000 LENGTH(AH 3512 BK 0643)
 0050/0484 BMSSEN 02/4026/0050/0401
 2 0 02126 0 01 0189+78

0050/0401 PINE CREEK
 BMSBG 02/4026/0050/0401
 2 0 02126 0 01 0185+66

S 0050/0000 LENGTH(AH 0643 BK 2690)
 (AAR 145722J)#TRKS 01

0040/2690 018"H 01"W UNKN CONC
 LEN=0060 INSTALLED UNKN

0040/2650 BRYANT RD
 (T575)

0040/2515 018 " DIA CIRC METAL
 LEN=0060 INSTALLED UNKN

0040/2119 012 " DIA CIRC CONCR
 LEN=0060 INSTALLED UNKN

0040/1310 018 " DIA CIR PLASTIC
 LEN=0020 INSTALLED 2000

0040/0862 LAUREL RIDGE DR
 (T103)

0040/0545 015 " DIA CIRC METAL
 LEN=0050 INSTALLED UNKN

0040/0280 007124 FT
 007124 FT

S 0040/0000 LENGTH(AH 2690 BK 3064)

Location / TWP	Segment ID	Length (FT)	Material / Details
	004060	FT	2 0 02126 0 01 0127+36 HAMPTON MCCANDLESS T
	0030/0000		LENGTH(AH 3064 BK 1447) 048 " DIA CIRC CONCR
NORTHGATE DR (TWP)	0020/1211		LEN=0040 INSTALLED UNKN
HIGHMEADOW DR (TWP)	0020/0201		ARDEN DR (TWP)
	002613	FT	2 0 02126 0 01 0113+66 HUBBARD RD (TWP)
	0020/0000		LENGTH(AH 1447 BK 2613) 018 " DIA CIR PLASTIC
	0010/2280		LEN=0040 INSTALLED UNKN
	0010/1540		018 " DIA CIR PLASTIC LEN=0050 INSTALLED UNKN
COLLINGTON SQ (TWP)	0010/1450		RINGEISEN RD (T647)
	0010/1202		015 " DIA CIRC CONCR LEN=0050 INSTALLED UNKN
	0010/0950		EASTVIEW RD (TWP)
	0010/0615		EASTVIEW RD (TWP)
	0010/0450		048 " DIA CIRC METAL LEN=0100 INSTALLED UNKN
	0010/0205		018 " DIA CIRC CONCR LEN=0250 INSTALLED UNKN
	000000	FT	2 0 02126 0 01 0087+47 NC SAMPLE RD PEEBLES ROAD (SR4064 SEG 0040/0000)
	INTER-BK		CUMBERLAND RD (TWP)
	0010/0000		MFC BEGIN = E LENGTH(AH 2613 BK 0000)

002570 FT

002570 FT
 INTER-AHD BROAD ST
 (BORO)
 OHIO RIVER BL
 (SR0065 SEG 0201/1070)
 (SR0065 SEG 0200/1080)
 0010/2570 TO 0065/0201 SH
 0010/2449 (CONN)
 0010/2317 KRAMER ST
 (TWP)
 0010/1974 BMSEN 02/4025/0010/0097
 0010/1014 SEWICKLEY
 MOON T
 1 0 00652 7 00 0024+55
 LR 76
 0010/0122 BMSBG 02/4025/0010/0097
 RAMP FR SEWICKLEY BR
 (SR8127 SEG 0750/0000)
 RAMP TO SEWICKLEY BR
 (SR8127 SEG 0010/1045)
 0010/0032
 000000 FT 1 0 00652 7 00 0025+43
 NC SEWICKLEY BR
 STOOPS FERRY RD
 (SR0051 SEG 0741/1020)
 0010/0000 MFC BEGIN = B
 LENGTH(AH 2570 BK 0000)

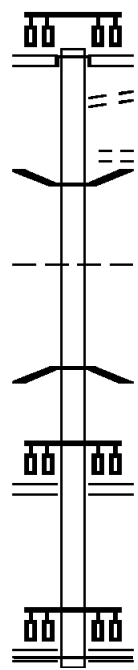

000000 FT

DIR: B TOTAL LEN: 5.008 MI. DIST: 11-1 SR: 4024
 LEFT MUN: SHALER T RIGHT MUN: SHALER T

	026444 FT		026444 FT	ELFINWILD RD (TWP) WILLIAM FLYNN HW (SR0008 SEG 0291/1610) (SR0008 SEG 0290/1635)
			0120/2237	
			0120/2183	(AAR 145718U)#TRKS 01
FELICITY AV (TWP)	0120/2135		0120/2135	
			0120/1460	024 "DIA CIR PLASTIC LEN=0099 INSTALLED UNKN
			0120/1145	WILLETT RD (TWP)
			0120/1144	018 "DIA CIR PLASTIC LEN=0050 INSTALLED UNKN
			0120/0765	ROSE DR (TWP)
HOLLY SPRINGS DR (TWP)	0120/0660		0120/0595	018 "DIA CIRC CONCR LEN=0099 INSTALLED UNKN
			0120/0077	012 "DIA CIRC CONCR LEN=0099 INSTALLED UNKN
2 0 02221 0 00 0019+48 024207 FT LAUREL HILL RD (TWP)	0120/0000		024207 FT	
			0120/0000	LENGTH(AH 2237 BK 1934) 018 "DIA CIRC CONCR
			0110/1665	LEN=0035 INSTALLED UNKN
			0110/1015	ROSEBRIAR AV (TWP)
			0110/0730	018 "DIA CIRC CONCR LEN=0200 INSTALLED UNKN 018 "DIA CIRC CONCR

DIR: B TOTAL LEN: 5.008 MI. DIST: 11-1 SR: 4024
 LEFT MUN: SHALER T RIGHT MUN: SHALER T

Stationing	Segment	Length	Material	Status
0110/0500	018" DIA	LEN=0035	CIRC CONCR	INSTALLED UNKN
0110/0380	018" DIA	LEN=0035	CIRC CONCR	INSTALLED UNKN
0110/0263	018" DIA	LEN=0030	CIRC CONCR	INSTALLED UNKN
022273 FT	2 0 02221	0 00 0000+00		
	MT ROYAL BL			
	(SR4019 SEG 0110/0000)			
	NC EL FINWILD RD			
	INTER-BK MT ROYAL BL			
	(SR4019 SEG 0110/0000)			
022273 FT	LTH AH	001934 BK 000100		
	7104/0000	LTH AH 000100 BK 001670		
	INTER-AHD MOUNT ROYAL BL			
	(SR4019 SEG 0110/0555)			
0100/1670	HAMPTON T			
	018" DIA	LEN=0035	CIRC CONCR	INSTALLED UNKN
0100/1275				
	012" DIA	LEN=0050	CIRC CONCR	INSTALLED UNKN
0100/1215	LINWOOD DR			
	(T803)			
0100/0645	024" DIA	LEN=0035	CIRC CONCR	INSTALLED UNKN
0100/0627	024" DIA	LEN=0035	CIRC CONCR	INSTALLED UNKN
0100/0269	024" DIA	LEN=0035	CIRC CONCR	INSTALLED UNKN
020603 FT				
0100/0000		LENGTH(AH 1670 BK 2424)		
	018" DIA	LEN=0099	CIRC CONCR	INSTALLED UNKN
0090/1739	OHIO DR			
	(T802)			
0090/1495	036" DIA	LEN=0099	CIRC CONCR	INSTALLED UNKN
0090/1415	012" DIA	LEN=0030	CIRC CONCR	INSTALLED UNKN
0090/0942	024" DIA	LEN=0035	CIRC CONCR	INSTALLED UNKN
0090/0721				
0090/0505				
	018" DIA	LEN=0030	CIRC CONCR	INSTALLED UNKN
0090/0485	018" DIA	LEN=0030	CIRC CONCR	INSTALLED UNKN
0090/0115				
018179 FT	1 1 04097	0 00 0057+19		

EXTRACT DATE: 12/21/2020
PRINT DATE: 12/23/2020

ROADWAY MANAGEMENT SYSTEM
SLD COUNTY/SR - ANNUAL PRINT

PAGE NUMBER: 1318
COUNTY: ALLEGHENY

DIR: B TOTAL LEN: 5.008 MI.
LEFT MUN: HAMPTON T

DIST: 11-1 SR: 4024
RIGHT MUN: HAMPTON T

LEGENDARY LN
(T100) 0080/0370

1 1 04097 0 00 0037+16 016212 FT
WYLAND AV
(T563) 0080/0000

WALLACE RD
(TWP) 0070/1840
COYNE AV
(TWP) 0070/1260

LC TO DUNCAN AV
(CONN) 0070/0088

1 1 04097 0 00 0000+00 012530 FT
DUNCAN AV
(CNTY) 0070/0000
LC TO DUNCAN AV
(CONN) 0060/2266

==	0080/1730	==	5 0090/0000	LENGTH(AH 2424 BK 1967) LINWOOD DR (TBO3)
---	0080/1580	---	0080/1580	018 "DIA CIRC CONCR LEN=0045 INSTALLED UNKN OAKBROOK CT
==	0080/1430	==	0080/1430	(TWP)
---	0080/1086	---	0080/1086	018 "DIA CIRC CONCR LEN=0099 INSTALLED UNKN
==	0080/0370	==		LAMMERTON DR (TWP)
==	0080/0215	==	0080/0215	016212 FT
==	0080/0000	==	5 0080/0000	LENGTH(AH 1967 BK 3682) 018 "DIA CIRC CONCR
---	0070/3550	---	0070/3550	LEN=0060 INSTALLED UNKN
---	0070/3280	---	0070/3280	015 "DIA CIRC CONCR LEN=0035 INSTALLED UNKN
---	0070/3077	---	0070/3077	HAMPTON MCCANDLESS T
---	0070/2995	---	0070/2995	015 "DIA CIRC CONCR LEN=0040 INSTALLED UNKN
==	0070/2630	==	0070/2630	POST RD (TWP)
---	0070/1925	---	0070/1925	018 "DIA CIRC CONCR LEN=0055 INSTALLED UNKN
==	0070/1840	==	0070/1840	GUYTON RD (TWP)
==	0070/1260	==		FOXCROFT LN (TWP)
---	0070/0920	---	0070/0920	018 "DIA CIRC CONCR LEN=0035 INSTALLED UNKN
---	0070/0612	---	0070/0612	018 "DIA CIRC CONCR
---	0070/0250	---	0070/0250	LEN=0030 INSTALLED UNKN
---	0070/0090	---	0070/0090	018 "DIA CIRC CONCR LEN=0080 INSTALLED UNKN
==	0070/0000	==		NC FERGUSON RD THOMPSON RUN RD (CNTY)
==	0060/2266	==	5 0070/0000	MFC BEGIN = D LENGTH(AH 3682 BK 2380)

DIR: B TOTAL LEN: 5.008 MI. DIST: 11-1 SR: 4024
 LEFT MUN: MCCANDLESS T RIGHT MUN: MCCANDLESS T

ROYAL MANOR DR
 (TWP) 0060/1551

ROYAL MANOR DR
 (TWP) 0060/0952

1 1 03756 0 00 0026+58 010150 FT
 PEEBLES RD
 (SR4064 SEG 0030/0000) 0060/0000

2 0 02328 0 01 0314+28 005744 FT
 HOSPITAL ENTRANCE RD
 (PRDR)
 BABCOCK BL

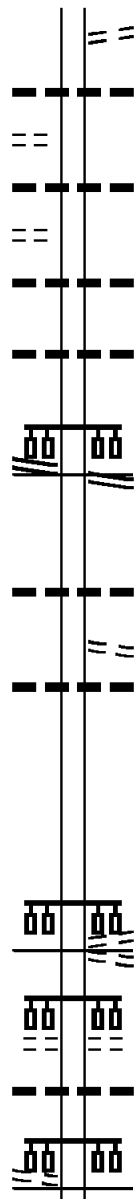

0060/2195 LC TO THOMPSON RUN RD
 (CONN)
 096 " DIA CIRC CONCR
 0060/1865 LEN=0099 INSTALLED UNKN

0060/1101 018 " DIA CIRC CONCR
 LEN=0035 INSTALLED UNKN

0060/0869 018 " DIA CIRC CONCR
 LEN=0035 INSTALLED UNKN

0060/0017 024 " DIA CIRC CONCR
 LEN=0060 INSTALLED UNKN

010150 FT PEEBLES RD
 (SR4064 SEG 0030/0000)
 MFC BEGIN = C
 0060/0000 LENGTH(AH 2380 BK 2641)

0050/1434 072"H 60"W CONCR ARCH
 LEN=0075 INSTALLED UNKN
 REMINGTON DR

0050/1200 (TWP)

0050/1151 018"H 18"W CON BOX CUL
 LEN=0035 INSTALLED UNKN

007509 FT 1 1 03756 0 00 0000+00
 BABCOCK BL
 (CNTY)
 NC DUNCAN AV

DUNCAN AV
 (TWP)
 MFC BEGIN = D
 0050/0000 LENGTH(AH 2641 BK 1765)

0040/1001 PROVIDENCE BL
 (TWP)

0040/0590 030 " DIA CIRC CONCR
 LEN=0050 INSTALLED UNKN
 005744 FT
 NC BABCOCK BL
 MFC BEGIN = C

DIR: B TOTAL LEN: 5.008 MI. DIST: 11-1 SR: 4024
 LEFT MUN: MCCANDLESS T RIGHT MUN: MCCANDLESS T

Segment ID	Start Station	End Station	Length (ft)	Material / Notes
(SR4031 SEG 0010/0000)	0040/0000	0040/0000	0	LENGTH(AH 1765 BK 3518) 018" DIA CIRC CONCR
FOXHUNT RD (TWP)	0030/2900	0030/3297	397	LEN=0030 INSTALLED UNKN
STALTER DR (TWP)	0030/2450	0030/2883	433	024" DIA CIRC CONCR LEN=0040 INSTALLED UNKN
PLATEAU DR (TWP)	0030/1860	0030/2848	988	ADVENT WY (TWP)
LANCELOT DR (TWP)	0030/1770	0030/1664	106	024" DIA CIRC CONCR LEN=0099 INSTALLED UNKN
		0030/1485	225	MCKNIGHT RD (SR4003 SEG 0131/0000) (SR4003 SEG 0130/0000)
GUENEVERE DR (TWP)	0030/1364	0030/1198	166	018" DIA CIRC CONCR LEN=0035 INSTALLED UNKN
2 0 02181 0 00 0022+37	002226 FT	002226 FT	0	
CROMWELL DR (TWP)	0030/0000	0030/0000	0	LENGTH(AH 3518 BK 1420) 024" DIA CIRC CONCR
PANNIER RD (TWP)	0020/0907	0020/1415	508	LEN=0020 INSTALLED UNKN
SAGINAW DR (TWP)	0020/0591	000806 FT	215	
	000806 FT	0020/0000	2000	2 0 02181 0 00 0008+09 LENGTH(AH 1420 BK 0806) PERRY KNOLL DR (TWP)
	000000 FT	0010/0248	248	018" DIA CIRC CONCR LEN=0030 INSTALLED UNKN
		0010/0110	110	2 0 02181 0 00 0000+00 NC CUMBERLAND RD PERRY HW (SR0019 SEG 0531/2620) (SR0019 SEG 0530/3110)
		0010/0000	110	MFC BEGIN = D LENGTH(AH 0806 BK 0000)

EXTRACT DATE: 12/21/2020 ROADWAY MANAGEMENT SYSTEM PAGE NUMBER: 1315
 PRINT DATE: 12/23/2020 SLD COUNTY/SR - ANNUAL PRINT COUNTY: ALLEGHENY
 DIR: B TOTAL LEN: 1.314 MI. DIST: 11-1 SR: 4023
 LEFT MUN: BEN AVON HEIGHTS B RIGHT MUN: BEN AVON HEIGHTS B

PERRYSVILLE RD 006936 FT
 (SR4021 SEG 0010/2335) 0020/3224
 OXFORD RD
 (BORO) 0020/2645

 NORWOOD RD
 (BORO) 0020/2376

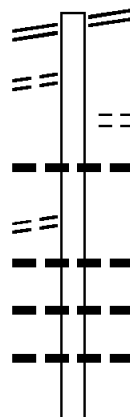

006936 FT PERRYSVILLE RD
 0020/3224 (SR4021 SEG 0010/2335)

 0020/2600 CANTERBURY RD
 (BORO)
 0020/2522 018 "DIA CIRC CONCR
 LEN=0030 INSTALLED UNKN

 0020/2358 018 "DIA CIRC CONCR
 LEN=0050 INSTALLED UNKN
 0020/2264 018 "DIA CIRC CONCR
 LEN=0030 INSTALLED UNKN
 0020/2180 018 "DIA CIRC CONCR
 LEN=0030 INSTALLED UNKN

DIR: B TOTAL LEN: 1.314 MI. DIST: 11-1 SR: 4023
 LEFT MUN: BEN AVON HEIGHTS B RIGHT MUN: BEN AVON HEIGHTS B

Location	Segment ID	Length (FT)	Material	Notes
	0020/1105		018" DIA CIRC CONCR	LEN=0035 INSTALLED UNKN
	0020/0724		018" DIA CIRC CONCR	LEN=0040 INSTALLED UNKN
	0020/0472		018" DIA CIRC CONCR	LEN=0060 INSTALLED UNKN
	0020/0164		015" DIA CIRC CONCR	LEN=0040 INSTALLED UNKN
003712 FT	003712 FT		2 0 02212 0 00 0039+03	BEN AVON HEIGHTS
SEMPLE ST (BORO)	0020/0000		KILBUCK T	LENGTH(AH 3224 BK 3712)
0010/3395				
	0010/3082		018" DIA CIRC CONCR	LEN=0040 INSTALLED UNKN
	0010/3075		KILBUCK	AVALON B
	0010/2818		030" DIA CIRC CONCR	LEN=0050 INSTALLED UNKN
	0010/2754		018" DIA CIRC CONCR	LEN=0045 INSTALLED UNKN
	0010/2579		015" DIA CIRC CONCR	LEN=0035 INSTALLED UNKN
	0010/1729		BMS EN 02/4023/0010/1690	2 0 02212 0 00 0016+96
	0010/1713		SPRUCE RUN	BMSBG 02/4023/0010/1690
FREDRICK ST (BORO)	0010/1605		GARDNER ST	(BORO)
0010/1580				
	0010/1072		018" DIA CIRC CONCR	LEN=0035 INSTALLED UNKN
	0010/0661		024" DIA CIRC CONCR	LEN=0099 INSTALLED UNKN
	0010/0328		ERDNER AV	(BORO)
CENTER AV (BORO)	0010/0100			
000000 FT	000000 FT		2 0 02212 0 00 0000+00	NC NEW BRIGHTON RD
			UNION AV	(SR4012 SEG 0040/0275)
HOME AV (BORO)	0010/0000		INTER-BK STARR AV	(SR4012 SEG 0040/0275)
	0010/0000		MFC BEGIN = D	LENGTH(AH 3712 BK 0000)

DIR: B TOTAL LEN: 5.753 MI. DIST: 11-1 SR: 4022
 LEFT MUN: ROSS T RIGHT MUN: ROSS T

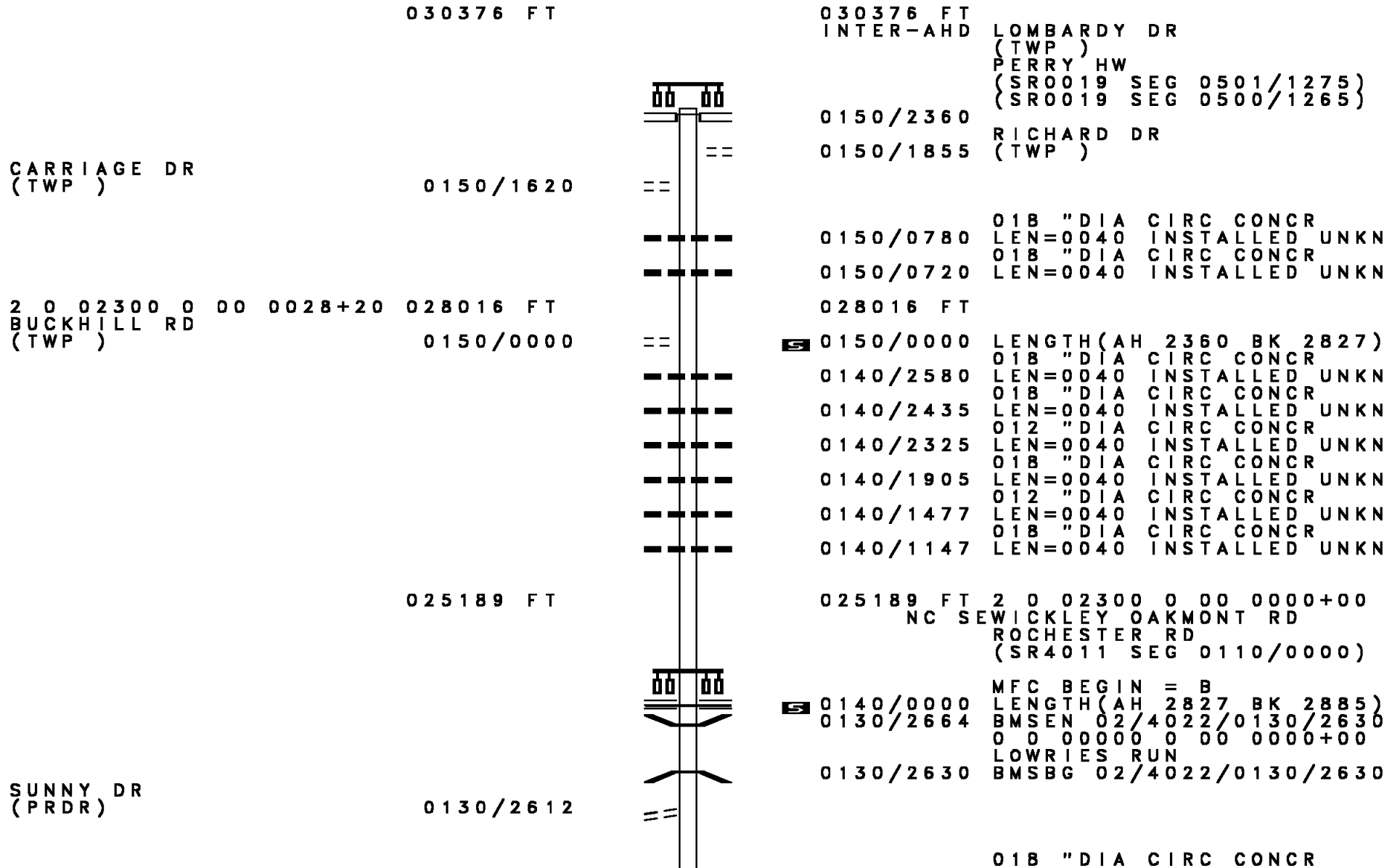

DIR: B TOTAL LEN: 5.753 MI. DIST: 11-1 SR: 4022
 LEFT MUN: ROSS T RIGHT MUN: ROSS T

Location / Description	Stationing	Length	Material / Notes
	0130/1590	LEN=0099	INSTALLED UNKN
	0130/0815	LEN=0040	018 " DIA CIRC CONCR INSTALLED UNKN
022304 FT	022304 FT	2 0 02129 0 00 0035+14	
	0130/0000	LENGTH(AH 2885 BK 2161)	
	0120/1115		BROOKMEADE DR (TWP)
N HILLS SCHOOL DST/REIS (PRDR)	0120/0642		
	0120/0272	LEN=0040	016 " DIA CIRC CONCR INSTALLED UNKN
SHARBOT DR (TWP)	020143 FT	2 0 02129 0 00 0050+58	
	020143 FT		LOUISE RD (TWP)
	0120/0000	LENGTH(AH 2161 BK 3123)	ROSS FRANKLIN PARK B (TWP)
	0110/2846		KAREN DR (TWP)
	0110/2626	LEN=0040	018 " DIA CIRC CONCR INSTALLED UNKN
	0110/1748	LEN=0099	020 " DIA CIRC CONCR INSTALLED UNKN
WASHINGTON LN (TWP)	0110/1731		
	0110/1258		HERMITAGE DR (TWP)
	0110/0781	LEN=0040	016 " DIA CIRC CONCR INSTALLED UNKN
	0110/0675	LEN=0040	012 " DIA CIR PLASTIC INSTALLED UNKN
	0110/0230	LEN=0040	018 " DIA CIRC CONCR INSTALLED UNKN
	0110/0104	LEN=0040	018 " DIA CIRC CONCR INSTALLED UNKN
017020 FT	017020 FT	2 0 02129 0 00 0080+30	
	0110/0000	LENGTH(AH 3123 BK 2699)	
	0100/2696	LEN=0040	018 " DIA CIRC CONCR INSTALLED UNKN
	0100/2173		BRIARWOOD DR (TWP)
	0100/1998	LEN=0040	016 " DIA CIRC CONCR INSTALLED UNKN

EXTRACT DATE: 12/21/2020
PRINT DATE: 12/23/2020

ROADWAY MANAGEMENT SYSTEM
SLD COUNTY/SR - ANNUAL PRINT

PAGE NUMBER: 1311
COUNTY: ALLEGHENY

DIR: B TOTAL LEN: 5.753 MI.
LEFT MUN: FRANKLIN PARK B

DIST: 11-1 SR: 4022
RIGHT MUN: FRANKLIN PARK B

Station	Distance (FT)	Segment	Notes	Material	Length (FT)	SR	Notes
		0100/1305	WINDCREST DR	(TWP)			
		0100/1109	018" DIA	CIRC CONCR	LEN=0099		INSTALLED UNKN
		0100/0240	018" DIA	CIRC CONCR	LEN=0040		INSTALLED UNKN
	014321	014321 FT	2 0 02129	0 00 0108+58			
		0100/0000	NC REIS RUN RD	MFC BEGIN = D			
REIS RUN RD		0100/0000	(SR4027 SEG 0010/0000)	LENGTH(AH 2699 BK 2039)			
		0090/1684	020" DIA	CIRC CONCR	LEN=0040		INSTALLED UNKN
		0090/1390	020" DIA	CIRC CONCR	LEN=0040		INSTALLED UNKN
FOREST RIDGE DR		0090/1305	(TWP)				
		0090/0775	018" DIA	CIRC CONCR	LEN=0040		INSTALLED UNKN
	012282	012282 FT	2 0 02100	0 00 0021+53			
		0090/0000	LENGTH(AH 2039 BK 2153)				
		0080/2136	018" DIA	CIRC METAL	LEN=0040		INSTALLED UNKN
		0080/2100	FRANKLIN PARK				
		0080/1630	OHIO T	018" DIA	CIR UNKNOWN	LEN=0040	INSTALLED UNKN
		0080/1290	(APRA) BEAR RUN DR				
		0080/1135	(PRDR)	018" DIA	CIRC CONCR	LEN=0040	INSTALLED UNKN
		0080/0615	018" DIA	CIRC CONCR	LEN=0040		INSTALLED UNKN
		0080/0225	018" DIA	CIRC CONCR	LEN=0040		INSTALLED UNKN
	010129	010129 FT	2 0 02100	0 00 0000+00			
		0080/0000	MT NEBO RD				
		0080/0000	(CNTY)				
		0080/0000	NC ARNDT RD	LENGTH(AH 2153 BK 2106)			
		0070/1825	SR 0279 NB	OP ID 02/0279/0102/2158			
		0070/1725	SR 0279 SB	OP ID 02/0279/0103/2399			
		0070/1558	BEAR RUN	STRUCTURE LENGTH 43 FT			
		0070/1558	BMS ID 02/4022/0070/1582				

DIR: B TOTAL LEN: 5.753 MI. DIST: 11-1 SR: 4022
 LEFT MUN: OHIO T RIGHT MUN: OHIO T

Location / Segment	Start Station	End Station	Length (FT)	Notes
MCALEER RD (SR4029 SEG 0010/0000)	0070/1370			
	0070/1305			018 " DIA CIRC CONCR LEN=0040 INSTALLED UNKN
	0070/1250			018 " DIA CIRC CONCR LEN=0099 INSTALLED UNKN
CHERYL DR (TWP)	0060/1526		008023 FT	
	0060/1520			024 " DIA CIRC CONCR LEN=0040 INSTALLED UNKN
	0060/1293			018 " DIA CIRC CONCR LEN=0040 INSTALLED UNKN
	0060/1193			036 " DIA CIRC CONCR LEN=0099 INSTALLED UNKN
GARY DR (T655)	0060/0000		006060 FT	
	0060/0080			024 " DIA CIR PLASTIC LEN=0040 INSTALLED UNKN
	0060/0000			LENGTH(AH 1963 BK 2022)
ROOSEVELT RD (CNTY)	0050/1160		0050/1335	FROM 4057/0070 SH (CONN)
	0050/1200			018 " DIA CIRC CONCR LEN=0040 INSTALLED 2019
	0050/1160			ROOSEVELT RD (SR4057 SEG 0070/3992)
	0050/0749			018 " DIA CIRC CONCR LEN=0040 INSTALLED 2019
	0050/0430			HIGH POINT RD (T464)
	0050/0370			012 " DIA CIRC CONCR LEN=0099 INSTALLED UNKN
OLD MT NEBO RD (CNTY)	0050/0249		004038 FT	
NICHOLSON RD (SR4049 SEG 0010/0000)	0050/0050			018 " DIA CIRC CONCR LEN=0040 INSTALLED 2019
	0050/0000			LENGTH(AH 2022 BK 2305)
FOR SR 4022 AND 4049 (CONN)				024 " DIA CIRC METAL

DIR: B TOTAL LEN: 5.753 MI. DIST: 11-1 SR: 4022
 LEFT MUN: OHIO T RIGHT MUN: OHIO T

RIDGE RD
(T452)

0040/1540

RED MUD HOLLOW RD
(SR4043 SEG 0010/0000)

0030/0355

001733 FT

000866 FT

000580 FT

000000 FT

0040/2082	LEN=0038	INSTALLED 2019
	RITTER RD	
	(TWP)	
	DUFF RD	
	(T450)	
0040/2045	024" DIA	CIRC ALUMIN
0040/1881	LEN=0040	INSTALLED 2020
	LC TO DUFF RD	
	(CONN)	
	024" DIA	CIRC ALUMIN
0040/1796	LEN=0040	INSTALLED 2019
	024" DIA	CIRC CONCR
0040/0922	LEN=0099	INSTALLED UNKN
	001733 FT	2 0 02278 0 00 0017+57
0040/0000	LENGTH(AH 2305	BK 0867)
0030/0355	RAMP D RD	
	(SR8021 SEG 0750/0000)	
	RAMP B RD	
	(SR8021 SEG 0010/0956)	
0030/0105	000866 FT	2 0 02278 0 00 0006+58
	OHIO	
	SEWICKLEY HILLS B	
0030/0000	LENGTH(AH 0867	BK 0286)
0020/0286	BMSBN 02/4022/0020/0000	
000580 FT	2 0 02278 0 00 0004+75	
	SR 0079 NB	
	BMSBG 02/4022/0020/0000	
0020/0000	LENGTH(AH 0286	BK 0580)
	018" DIA	CIRC CONCR
0010/0579	LEN=0040	INSTALLED 2012
	RAMP C RD	
	(SR8021 SEG 0500/0934)	
	RAMP A RD	
	(SR8021 SEG 0250/0000)	
0010/0450	000000 FT	2 0 02278 0 00 0000+00
	NC MT	
	GLENFIELD RD	
	(CNTY)	
	BLACKBURN RD	
	(CNTY)	
	MFC BEGIN = C	
0010/0000	LENGTH(AH 0580	BK 0000)

EXTRACT DATE: 12/21/2020 ROADWAY MANAGEMENT SYSTEM PAGE NUMBER: 1308
 PRINT DATE: 12/23/2020 SLD COUNTY/SR - ANNUAL PRINT COUNTY: ALLEGHENY
 DIR: B TOTAL LEN: 3.295 MI. DIST: 11-1 SR: 4021
 LEFT MUN: ROSS T RIGHT MUN: ROSS T

ROCHESTER RD 017396 FT
 (SR4011 SEG 0100/0000) 0070/3359
 ROCHESTER CONNECTOR
 (SR4075 SEG 0010/0000) 0070/2810

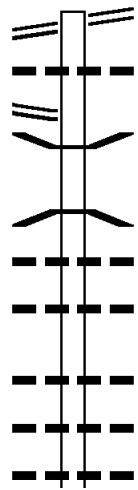

017396 FT ROCHESTER RD
 0070/3359 (SR4011 SEG 0100/0000)
 072 " DIA CIRC CONCR
 0070/3244 LEN=0099 INSTALLED UNKN
 0070/2423 BMS EN 02/4021/0070/2411
 2 0 02299 0 00 0020+45
 LOWRIES RUN
 0070/2385 BMSBG 02/4021/0070/2411
 018 " DIA CIRC CONCR
 0070/2233 LEN=0099 INSTALLED UNKN
 018 " DIA CIRC CONCR
 0070/1914 LEN=0099 INSTALLED UNKN
 018 " DIA CIRC CONCR
 0070/1037 LEN=0030 INSTALLED UNKN
 018 " DIA CIRC METAL
 0070/0821 LEN=0030 INSTALLED UNKN
 018 " DIA CIRC CONCR
 0070/0667 LEN=0099 INSTALLED UNKN

DIR: B TOTAL LEN: 3.295 MI. DIST: 11-1 SR: 4021
 LEFT MUN: ROSS T RIGHT MUN: ROSS T

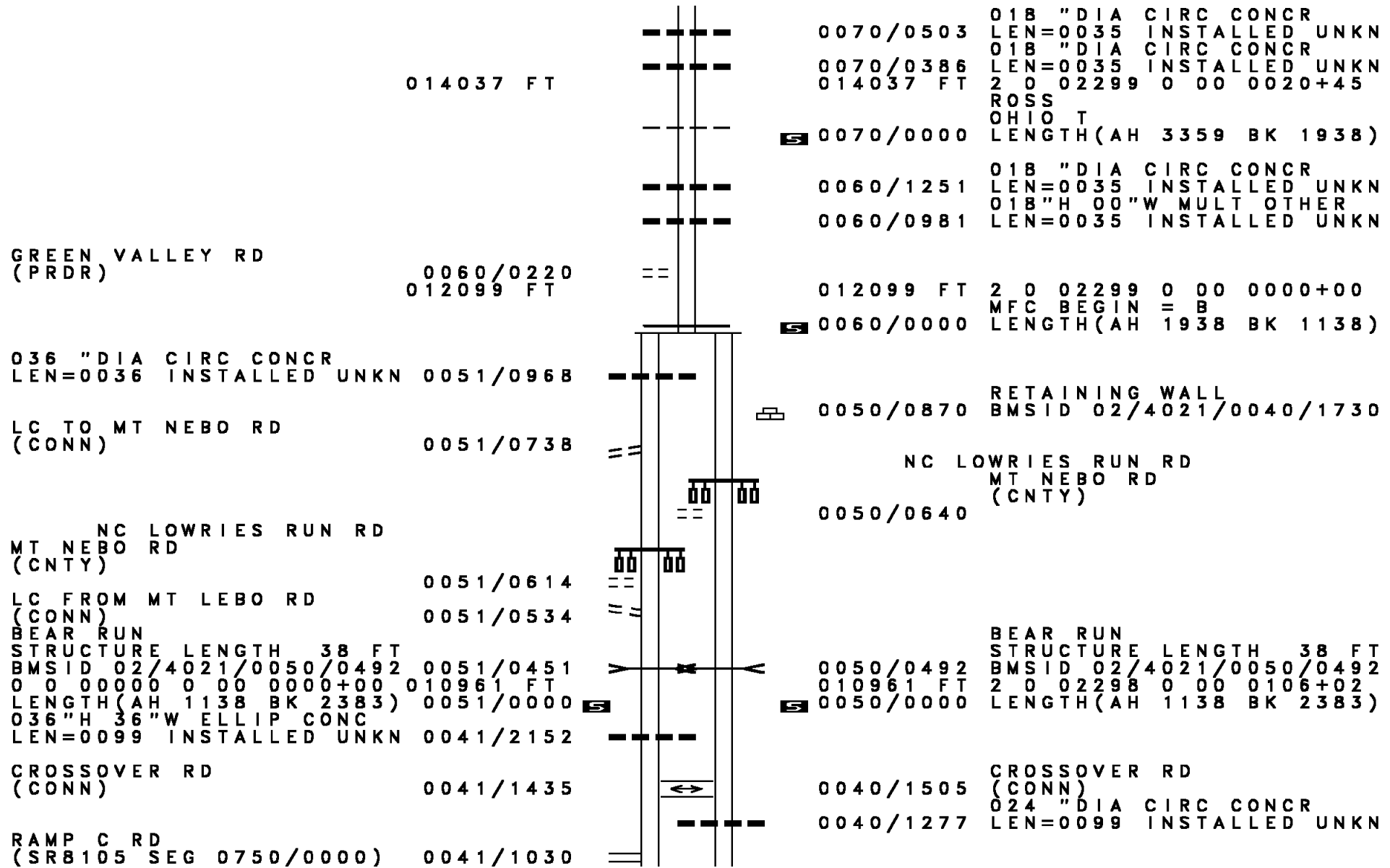

DIR: B TOTAL LEN: 3.295 MI. DIST: 11-1 SR: 4021
 LEFT MUN: OHIO T RIGHT MUN: OHIO T

FROM 8105/0010 SH
 (CONN) 0041/0834
 SR 0279 NB
 OP ID 02/0279/0082/2122 0041/0673
 SR 0279 SB
 OP ID 02/0279/0083/2369 0041/0574
 TO 8105/0250 SH
 (CONN) 0041/0350
 RAMP B RD
 (SR8105 SEG 0500/1499) 0041/0316
 0 0 00000 0 00 0000+00 008578 FT
 JOSEPHS LN
 (TWP)
 NC CAMP HORNE RD
 CAMP HORNE RD
 (CNTY)
 MFC BEGIN = B
 LENGTH(AH 2383 BK 1658) 0041/0000
 LC FROM CAMP HORNE RD
 (CONN) 0030/1530
 LC TO HOME DEPOT DR
 (CONN) 0030/1003
 HOME DEPOT DR
 (PRDR) 0030/0910
 LC FROM HOME DEPOT DR
 (CONN) 0030/0810
 2 0 02298 0 00 0068+00 006920 FT
 PLAZA ENTRANCE RD
 (PRDR) 0030/0000
 LC FROM PLAZA
 (CONN) 0020/3808
 FORESTWOOD DR
 (PRDR) 0020/3260
 GASS RD

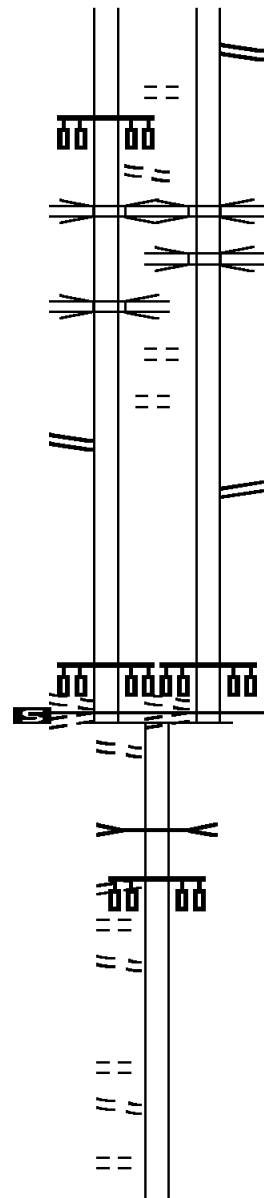

0040/0965 RAMP D RD
 (SR8105 SEG 0010/1350)
 TO 8105/0750 SH
 0040/0897 (CONN)
 SR 0279 NB
 OP ID 02/0279/0082/2122 0040/0650
 SR 0279 SB
 OP ID 02/0279/0083/2369 0040/0570
 FROM 8105/0500 SH
 (CONN) 0040/0333
 RAMP A RD
 (SR8105 SEG 0250/0000)
 008578 FT 2 0 02298 0 00 0083+43
 JOSEPHS LN
 (TWP)
 NC CAMP HORNE RD
 CAMP HORNE RD
 (CNTY)
 MFC BEGIN = B
 LENGTH(AH 2383 BK 1658) 0040/0000
 LOWRIES RUN
 STRUCTURE LENGTH 50 FT
 BMSID 02/4021/0030/1477 0030/1477
 NC BEN AVON RD
 0030/0910
 006920 FT
 LENGTH(AH 1658 BK 3880) 0030/0000
 GASS RD

DIR: B TOTAL LEN: 3.295 MI. DIST: 11-1 SR: 4021
 LEFT MUN: OHIO T RIGHT MUN: OHIO T

Segment ID	Length	Material	Notes
(SR4014 SEG 0010/0000) 0020/2930	0020/2930	018 " DIA CIRC CONCR	LEN=0099 INSTALLED UNKN
	0020/2615	024 " DIA CIRC CONCR	LEN=0040 INSTALLED UNKN
	0020/1045	018 " DIA CIRC CONCR	LEN=0005 INSTALLED UNKN
003040 FT	003040 FT	2 0 02298 0 00 0029+53	OHIO KILBUCK T
THORNRIDGE RD (TWP) 0010/3000	0020/0000	LENGTH(AH 3880 BK 3040)	
	0010/2975	COURTNEY MILL RD (TWP) KILBUCK	
LYNTON LN (TWP) 0010/2755	0010/2782	BEN AVON HEIGHTS B	
	0010/2335	NC BEN AVON HTS RD NEW BRIGHTON RD (SR4023 SEG 0020/3224)	
WILSON DR (TWP) 0010/2140	0010/2080	BANBURY LN (TWP)	
	0010/1210	BEN AVON HEIGHTS KILBUCK T	
WILSON DR (TWP) 0010/0995	0010/0984	012 " DIA CIRC CONCR	LEN=0099 INSTALLED UNKN
	0010/0564	AVON PARK ENTRANCE RD (PARK)	
	0010/0540	024 " DIA CIRC CONCR	LEN=0099 INSTALLED UNKN
MERTON RD (TWP) 0010/0270	000000 FT	2 0 02298 0 00 0000+00	NC PE PERRYSVILLE RD
	* REF-BK	PERRYSVILLE AV (TWP)	
	0010/0000	MFC BEGIN = D LENGTH(AH 3040 BK 0000)	

EXTRACT DATE: 12/21/2020 ROADWAY MANAGEMENT SYSTEM PAGE NUMBER: 1304
PRINT DATE: 12/23/2020 SLD COUNTY/SR - ANNUAL PRINT COUNTY: ALLEGHENY

DIR: B TOTAL LEN: .000 MI. DIST: 11-1 SR: 4020
LEFT MUN: HAMPTON T RIGHT MUN: HAMPTON T

000000 FT
000000 FT



000000 FT
7020/0000 LENGTH(AH 3406 BK 3580)
000000 FT
7010/0000 LENGTH(AH 3580 BK 0000)

DIR: B TOTAL LEN: 7.477 MI. DIST: 11-1 SR: 4019
 LEFT MUN: HAMPTON T RIGHT MUN: HAMPTON T

Stationing / Description	Stationing / Description	Notes
039477 FT	039477 FT	WILLIAM FLYNN HW (SR0008 SEG 0330/1830) (SR0008 SEG 0331/1842)
0150/2758	0150/3001	
0150/2521		HAMPTON LN (T932)
	0150/2300	018" DIA CIRC CONCR
	0150/2215	LEN=0040 INSTALLED UNKN
	0150/2182	018" DIA CIRC METAL
	0150/1900	LEN=0100 INSTALLED UNKN
	0150/1897	018" DIA CIRC METAL
	0150/1600	LEN=0040 INSTALLED 1997 CRAIGHEAD RD (T995)
	0150/1550	015" DIA CIRC METAL
	0150/1043	LEN=0060 INSTALLED UNKN
	036476 FT	018" DIA CIRC CONCR
	0150/0000	LEN=0040 INSTALLED UNKN
	0140/2893	LENGTH(AH 3001 BK 3006) BRISTOL CT (TWP)
	0140/1845	015" DIA CIRC CONCR
	0140/1455	LEN=0060 INSTALLED UNKN
	0140/1000	LORELAND RD (TWP)
		MILLER DR (T951)
OLD MT ROYAL BL (T953) ELBA LN (TWP)		
TOWNSHIP RD (TWP)		
MAPLE LN (TWP)		
1 0 00807 0 00 0343+34 036476 FT SAMPLE RD (SR4026 SEG 0060/3512)		
CARRIAGE HOUSE DR (TWP)		
LE DONNE DR (TWP)		
SPRING LN (TWP)		
ROYAL VIEW DR (T987)		

DIR: B TOTAL LEN: 7.477 MI. DIST: 11-1 SR: 4019
 LEFT MUN: HAMPTON T RIGHT MUN: HAMPTON T

Stationing	Segment	Length	Notes
1 0 00807 0 00 0316+14 033470 FT	HARLO DR (T936)	0140/0000	LYNNHAVEN DR (T946) LOCUST LN (TWP)
VALLEY VIEW DR (T574)		0130/2934	LENGTH(AH 3006 BK 3796) 018 " DIA CIRC CONCR LEN=0050 INSTALLED UNKN HERRON RD (T494)
TROTTER DR (T975)		0130/1239	TALL TIMBER DR (T969)
ALPHA DR (TWP)		0130/0544	018 " DIA CIRC CONCR LEN=0099 INSTALLED UNKN 036 " DIA CIRC CONCR LEN=0060 INSTALLED UNKN
		0130/0389	018 " DIA CIRC CONCR LEN=0045 INSTALLED UNKN
		0130/0329	018 " DIA CIRC CONCR LEN=0040 INSTALLED UNKN
		0130/0294	018 " DIA CIRC CONCR LEN=0040 INSTALLED UNKN
		0130/0214	018 " DIA CIRC CONCR LEN=0040 INSTALLED UNKN
029674 FT		0130/0079	BMSSEN 02/4019/0130/0000
		029674 FT	1 0 00807 0 00 0273+77 PINE CREEK
		0130/0000	BMSBG 02/4019/0130/0000 LENGTH(AH 3796 BK 2375) TONER AV (T496)
		0120/2000	018 " DIA CIRC CONCR LEN=0040 INSTALLED UNKN
		0120/1880	BMSSEN 02/4019/0120/1771
		0120/1874	0 0 00000 0 00 0000+00 CSX RR
LC FOR DUNCAN AV (CONN)		0120/1470	BMSBG 02/4019/0120/1771 DUNCAN AV

DIR: B TOTAL LEN: 7.477 MI. DIST: 11-1 SR: 4019
 LEFT MUN: HAMPTON T RIGHT MUN: HAMPTON T

Street Name	Segment	Length (FT)	Notes
DUNCAN AV (CNTY)	0120/1320		(CNTY) MFC BEGIN = D
1 0 00807 0 00 0251+58	027299 FT		015 "DIA CIRC CONCR LEN=0050 INSTALLED UNKN
PARKVIEW LN (T959)	0120/0000		0120/0074 027299 FT
LAKE AV (T567)	0110/2975		5 0120/0000 LENGTH(AH 2375 BK 3218)
WYLAND AV (T563)	0110/2570		0110/2790 NAOMI TERRACE (T990)
ISABELLA AV (T570)	0110/1375		0110/2229 MINA DR (T955)
FERGUSON RD (SR4024 SEG 0100/1670)	0110/0555		0110/1656 VICTORIA DR (T403)
			0110/1167 018 "DIA CIRC METAL LEN=0050 INSTALLED UNKN
			0110/0351 HAMPTON AV (T559)
			0110/0295 BMSEN 02/4019/0110/0136
			0110/0218 HAMPTON SHALER T
	024081 FT		1 0 00807 0 00 0220+50
			BRANCH OF PINE CREEK
			0110/0190 BMSBG 02/4019/0110/0136
			024081 FT 1 0 00807 0 00 0219+16
			ELFINWILD RD (SR4024 SEG 0110/0000)
			5 0110/0000 LENGTH(AH 3218 BK 1575)
DE HAVEN AV (TWP)	0100/0305		0100/0873 018 "DIA CIRC CONCR LEN=0050 INSTALLED UNKN
	022506 FT		022506 FT 1 0 00807 0 00 0203+37
WOODLAND RD (TWP)	0090/2110		GRANDVIEW AV (TWP)
			5 0100/0000 LENGTH(AH 1575 BK 2324)

DIR: B TOTAL LEN: 7.477 MI. DIST: 11-1 SR: 4019
 LEFT MUN: SHALER T RIGHT MUN: SHALER T

Left Side Description	Left Side Stationing	Right Side Description	Right Side Stationing
ELFINWILD LN (TWP)	0090/1940	ILLINOIS DR (TWP)	0090/1940
		018 " DIA CIRC CONCR	0090/1724
		LEN=0040 INSTALLED UNKN	
		WILLETT RD	0090/1520
EADE AV (TWP)	0090/0935		
MARIAN AV (TWP)	0090/0655	CHURCH AV (TWP)	0090/0805
BRIDLE RD (TWP)	0090/0365	ORCHARD AV (TWP)	0090/0530
		DEHAVEN ST (PRDR)	0090/0310
		036 " DIA CIRC CONCR	0090/0175
	020182 FT	LEN=0050 INSTALLED UNKN	020182 FT
		1 0 00807 0 00 0180+18	
		SUTTER RD (TWP)	
ROYAL COURT DR (TWP)	0080/1310	LENGTH(AH 2324 BK 1748)	0090/0000
HARTLE RD (TWP)	0080/0775		
ARDEN DR (TWP)	0080/0405	012"H 18"W CON BOX CUL	0080/0755
1 0 00807 0 00 0162+63 018434 FT		LEN=0050 INSTALLED UNKN	
SCOTT AV (SR4018 SEG 0030/3333)	0080/0000	CEMETERY ENTRANCE (TWP)	0080/0405
WOODLAND AV (TWP)	0070/1905		018434 FT
IOLA AV (TWP)	0070/1465	LENGTH(AH 1748 BK 2384)	0080/0000
VILSACK RD (CNTY)	0070/1005	018 " DIA CIRC CONCR	0070/1313
		LEN=0047 INSTALLED UNKN	
MOREWOOD RD (TWP)	0070/0510	KLEBER RD (SR4060 SEG 0010/0000)	0070/1005
1 0 00807 0 00 0138+72 016050 FT		015 " DIA CIRC CONCR	0070/0965
MEADOW RD		LEN=0040 INSTALLED UNKN	
			016050 FT

DIR: B TOTAL LEN: 7.477 MI. DIST: 11-1 SR: 4019
 LEFT MUN: SHALER T RIGHT MUN: SHALER T

Location	Segment	Start	End	Notes
(TWP)	0070/0000	==	==	
MCELHENY RD	0060/3300	==	==	5 0070/0000 LENGTH(AH 2384 BK 3640) WOOD PL
(TWP)	0060/3300	==	==	(TWP)
SHAW PL	0060/2046	==	==	
(TWP)	0060/2046	==	==	
PARK CIRCLE	0060/1979	==	==	0060/2015 SHAW PL
(TWP)	0060/1979	==	==	(TWP)
CAMPBELL PL	0060/0785	==	==	
(TWP)	0060/0785	==	==	
	012410 FT	---	---	0060/0250 018 " DIA CIRC CONCR LEN=0050 INSTALLED UNKN 012410 FT 1 0 00807 0 00 0102+32 GARDEN PL
WETZEL RD	0060/0000	==	==	5 0060/0000 LENGTH(AH 3640 BK 3427)
(SR4006 SEG 0010/2491)	0060/0000	==	==	018 " DIA CIRC METAL
ELLEN ST	0050/3073	==	==	0050/3390 LEN=0040 INSTALLED UNKN
(TWP)	0050/3073	==	==	
		---	---	0050/3020 018 " DIA CIRC METAL LEN=0004 INSTALLED UNKN
		==	==	0050/2596 GLENSHAW AV (SR4062 SEG 0010/0000)
		---	---	0050/2537 018 " DIA CIRC METAL LEN=0030 INSTALLED UNKN
HOFFMAN ST	0050/2471	==	==	
(TWP)	0050/2471	==	==	
		---	---	0050/2040 018 " DIA CIRC METAL LEN=0030 INSTALLED UNKN
GLENN AV	0050/2010	==	==	0050/2010 GLENN AV (CNTY)
(TWP)	0050/2010	==	==	018 " DIA CIRC METAL
		---	---	0050/1880 LEN=0030 INSTALLED UNKN
		---	---	0050/1690 018 " DIA CIRC METAL LEN=0010 INSTALLED UNKN
DOLORES DR	0050/1647	==	==	
(TWP)	0050/1647	==	==	
		---	---	0050/1520 018 " DIA CIRC METAL LEN=0045 INSTALLED UNKN
SEEL ST	0050/1325	==	==	
(TWP)	0050/1325	==	==	
				018 " DIA CIRC METAL

DIR: B TOTAL LEN: 7.477 MI. DIST: 11-1 SR: 4019
 LEFT MUN: SHALER T RIGHT MUN: SHALER T

STREET NAME	ADDRESS	STATUS	RIGHT OF WAY	LENGTH	TYPE	INSTALLATION	REMARKS
	0050/1320	==	0050/1320	LEN=0040	018" DIA	INSTALLED	UNKN
	0050/1248	==	0050/1248	LEN=0040	018" DIA	INSTALLED	UNKN
BRAUN ST	0050/1070	==	0050/1070	LEN=0040	018" DIA	INSTALLED	UNKN
(TWP)							
HOMER PL	0050/0824	==	0050/0824	LEN=0040	018" DIA	INSTALLED	UNKN
(TWP)							
	0050/0617	==	0050/0617	LEN=0030	018" DIA	INSTALLED	UNKN
	0050/0593	==	0050/0593	LEN=0030	018" DIA	INSTALLED	UNKN
GENESSEE ST	0050/0565	==	0050/0565	LEN=0030	018" DIA	INSTALLED	UNKN
(TWP)							
	0050/0300	==	0050/0300	LEN=0030	018" DIA	INSTALLED	UNKN
LITTLEWOOD ST	0050/0259	==	0050/0259	LEN=0030	018" DIA	INSTALLED	UNKN
(TWP)							
	008983 FT	==	008983 FT	LEN=0030	018" DIA	INSTALLED	UNKN
	0050/0000	==	0050/0000	LEN=0030	018" DIA	INSTALLED	UNKN
UNDERCLIFF ST	0040/2041	==	0040/2041	LEN=0030	018" DIA	INSTALLED	UNKN
(TWP)							
	0040/1761	==	0040/1761	LEN=0050	018" DIA	INSTALLED	UNKN
CARLISLE DR	0040/1717	==	0040/1717	LEN=0050	018" DIA	INSTALLED	UNKN
(TWP)							
	0040/1516	==	0040/1516	LEN=0040	018" DIA	INSTALLED	UNKN
	0040/1375	==	0040/1375	LEN=0040	018" DIA	INSTALLED	UNKN
WILLJOHN ST	0040/1365	==	0040/1365	LEN=0040	018" DIA	INSTALLED	UNKN
(TWP)							
	0040/1165	==	0040/1165	LEN=0040	018" DIA	INSTALLED	UNKN
	0040/0799	==	0040/0799	LEN=0030	018" DIA	INSTALLED	UNKN
	0040/0695	==	0040/0695	LEN=0030	018" DIA	INSTALLED	UNKN
PENNVIEW ST	0040/0670	==	0040/0670	LEN=0040	018" DIA	INSTALLED	UNKN
(TWP)							
	0040/0395	==	0040/0395	LEN=0030	018" DIA	INSTALLED	UNKN
LAMESA ST							

DIR: B TOTAL LEN: 7.477 MI. DIST: 11-1 SR: 4019
 LEFT MUN: SHALER T RIGHT MUN: SHALER T

Stationing	Length	Notes	Stationing	Length	Notes
(TWP)	0040/0350	==			
		==	0040/0130		KENNETH DR (TWP)
1 0 00807 0 00 0046+99	006880 FT	---	0040/0090		018 " DIA CIRC CONCR
IRENE ST (TWP)		---	006880 FT		LEN=0040 INSTALLED UNKN
	0040/0000	==	5 0040/0000		LENGTH(AH 2103 BK 1735)
		---	0030/1712		018 " DIA CIRC CONCR
CHERRY WY (TWP)	0030/1408	==			LEN=0040 INSTALLED UNKN
		---	0030/1078		018 " DIA CIRC CONCR
		---	0030/0815		LEN=0040 INSTALLED UNKN
		---	0030/0790		018 " DIA CIRC METAL GRANT AV (TWP)
RIDGE AV (TWP)	0030/0690	==			
		==			GRANT ST (TWP)
SHORT ST (TWP)	0030/0115	==	0030/0115		HERMAN ST (TWP)
	005145 FT	==	005145 FT		1 0 00807 0 00 0029+50
		---			NC MT ROYAL BL SHALER
BEYRLEYE AV (TWP)	0030/0000	==	5 0030/0000		ETNA BOROUGH B LENGTH(AH 1735 BK 1696)
		---			BITTNER ST (TWP)
		---	0020/1349		MOUNT HOPE ST (TWP)
LEHR AV (TWP)	0020/1079	==			
		---	0020/1103		
		---			HIGHLAND AV (TWP)
		---	0020/0510		ANGLE WAY (TWP)
VILSACK ST (TWP)	0020/0355	==			
		---	0020/0384		
		---			WEIBLE ST (TWP)
		---	0020/0259		018 " DIA CIRC CONCR
1 0 00807 0 00 0012+53	003449 FT	---	0020/0237		LEN=0040 INSTALLED UNKN
WILSON ST (SR4017 SEG 0015/0000)	0020/0000	---	003449 FT		ANT AV
	003449 FT	---			INTER-BK WILSON ST (SR4017 SEG 0010/0179)
		---	5 0020/0000		LTH AH 001696 BK 000100
		---	003449 FT		

EXTRACT DATE: 12/21/2020
PRINT DATE: 12/23/2020

ROADWAY MANAGEMENT SYSTEM
SLD COUNTY/SR - ANNUAL PRINT

PAGE NUMBER: 1296
COUNTY: ALLEGHENY

DIR: B TOTAL LEN: 7.477 MI.
LEFT MUN: ETNA BOROUGH B

DIST: 11-1 SR: 4019
RIGHT MUN: ETNA BOROUGH B

DEWEY ST
(TWP)

0010/1110

SULLIVAN WAY
(TWP)

0010/0395

002208 FT

MAPLEWOOD ST
(TWP)

0004/0905

HIGH ST
(TWP)

0004/0515

WALNUT ST
(TWP)

0004/0152
000000 FT

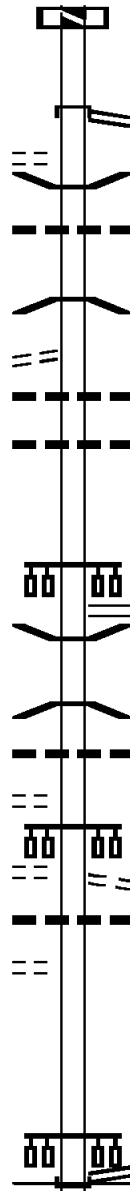

7012/0000 LTH AH 000100 BK 001241
INTER-AHD WILSON ST
(SR4017 SEG 0010/0000)
WILSON ST
0010/1241 (SR4017 SEG 0010/0000)

0010/1062 BMS EN 02/4019/0010/1001
018 "DIA CIRC CONCR
0010/0995 LEN=0030 INSTALLED UNKN
1 0 00807 0 00 0000+00
PINE CREEK
0010/0993 BMSBG 02/4019/0010/1001

0010/0209 018 "DIA CIRC CONCR
LEN=0030 INSTALLED UNKN
0010/0035 018 "DIA CIRC CONCR
LEN=0030 INSTALLED UNKN
002208 FT 1 0 00807 0 00 0000+00
NC CR
ESCENT ST
KITTANNING ST
(SR1003 SEG 0101/0195)
(SR1003 SEG 0100/0195)

5 0010/0000 LENGTH(AH 1241 BK 2208)
0004/1966 BMS EN 02/4019/0004/183B
1 0 00072 0 00 0018+38
PINE CREEK
0004/1880 BMSBG 02/4019/0004/183B
0004/1345 018 "DIA CIRC CONCR
LEN=0001 INSTALLED UNKN

0004/0515 BRIDGE ST
(TWP)
018 "DIA CIRC CONCR
0004/0475 LEN=0040 INSTALLED UNKN
000000 FT 1 0 00072 0 00 0000+00
FREEPORT RD
(SR1001 SEG 0040/0000)
NC BUTLER ST

INTER-BK BUTLER ST
(SR1001 SEG 0040/0000)
MFC BEGIN = C
5 0004/0000 LENGTH(AH 2208 BK 0000)

Location / Description	Segment ID	Length (FT)	Notes
007803 FT			MT ROYAL BL (SR4019 SEG 0080/0000)
	0030/3333		HENRIETTA ST (TWP)
	0030/2720		
SHERWOOD RD (TWP)	0030/2595		
PHILLIPS AV (TWP)	0030/2025		024 " DIA CIRC CONCR LEN=0001 INSTALLED UNKN OAKWOOD RD
HERRON LN (TWP)	0030/1500		HAMILTON AV (TWP)
SHALER ELEM SCHOOL ENT (PRDR)	0030/0717		ROGERS ELEM SCHOOL ENT (PRDR)

DIR: B TOTAL LEN: 1.478 MI. DIST: 11-1 SR: 4018
 LEFT MUN: SHALER T RIGHT MUN: SHALER T

Stationing	Location	Stationing	Location	Notes
004470 FT		004470 FT	2 0 02122 0 00 0041+51	
			CLARE ST	
			(TWP)	
			NC SCOTT AV	
			SCOTT AV	
			(TWP)	
		0030/0000	LENGTH(AH 3333 BK 3190)	
			BREEZEWOOD DR	
		0020/2790	(TWP)	
			036"H 48"W ELLIP CONC	
		0020/2752	LEN=0099 INSTALLED UNKN	
			018 "DIA CIRC CONCR	
		0020/2276	LEN=0030 INSTALLED UNKN	
SULLIVAN DR (TWP)			018 "DIA CIRC CONCR	
	0020/1980		LEN=0010 INSTALLED UNKN	
			042 "DIA CIRC CONCR	
		0020/1939	LEN=0001 INSTALLED UNKN	
SUTTER RD (TWP)			NC CLARE ST	
	0020/1452		PICTWOOD DR	
			(TWP)	
		0020/1020	078 "DIA CIRC CONCR	
		0020/0967	LEN=0033 INSTALLED UNKN	
PHYLLIS DR (TWP)			SHALER	
ANGELINE DR (TWP)			ROSS T	
	0020/0735		2 0 02122 0 00 0013+94	
	0020/0635		LENGTH(AH 3190 BK 1280)	
			018 "DIA CIRC OTHER	
	001280 FT		LEN=0099 INSTALLED UNKN	
			018 "DIA CIR PLASTIC	
AMITY RD (TWP)			LEN=0014 INSTALLED UNKN	
	0010/0305		BMS EN 02/4018/0010/0216	
			2 0 02122 0 00 0002+35	
			LTL PINE CR.	
	000000 FT		BMSBG 02/4018/0010/0216	
			2 0 02122 0 00 0000+00	
			THOMPSON RUN RD	
			(CNTY)	
THOMPSON RUN RD (CNTY)			NC SUTTER RD	
	0010/0000		MFC BEGIN = D	
			LENGTH(AH 1280 BK 0000)	

DIR: B TOTAL LEN: 2.660 MI. DIST: 11-1 SR: 4017
LEFT MUN: SHALER T RIGHT MUN: SHALER T

WIBLE RUN RD
(CNTY)

014044 FT
0060/2731

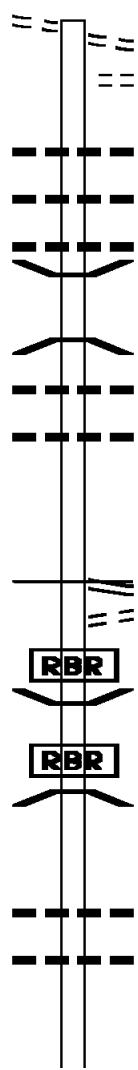

011313 FT

009040 FT

012589 FT WIBLE RUN RD
0060/2731 (CNTY)
WISE LN
0060/2364 (PRDR)
0060/1695 018 " DIA CIRC CONCR
LEN=0060 INSTALLED UNKN
072 " DIA CIRC METAL
0060/1156 0060 INSTALLED UNKN
072 " DIA CIRC METAL
0060/0989 0060 INSTALLED UNKN
0060/0452 BMSSEN 02/4017/0060/0398
2 0 02120 0 00 0026+02
LITTLE PINE CREEK
0060/0398 BMSBG 02/4017/0060/0398
018 " DIA CIRC CONCR
0060/0150 0030 INSTALLED UNKN
024 " DIA CIRC CONCR
0060/0035 0035 INSTALLED UNKN
009858 FT 2 0 02120 0 00 0030+36
NC WEITZEL RD
WETZEL RD
(SR4006 SEG 0010/0000)
MFC BEGIN = D
5 0060/0000 LENGTH(AH 2731 BK 2273)
KIWANIS PARK RD
0050/1793 (BORO)
0050/0924 BMSSEN 02/4017/0050/0880
2 0 02153 0 02 0102+15
P3
LITTLE PINE
0050/0880 BMSBG 02/4017/0050/0880
007585 FT 2 0 02153 0 02 0093+35
5 0050/0000 LENGTH(AH 2273 BK 3162)
018 " DIA CIRC CONCR
0040/3115 0099 INSTALLED UNKN
018 " DIA CIRC CONCR
0040/2825 0040 INSTALLED UNKN

024 " DIA CIRC CONCR

EXTRACT DATE: 12/21/2020
PRINT DATE: 12/23/2020

ROADWAY MANAGEMENT SYSTEM
SLD COUNTY/SR - ANNUAL PRINT

PAGE NUMBER: 1291
COUNTY: ALLEGHENY

DIR: B TOTAL LEN: 2.660 MI.
LEFT MUN: ETNA BOROUGH B

DIST: 11-1 SR: 4017
RIGHT MUN: ETNA BOROUGH B

2 0 02153 0 00 0000+00 002013 FT
BORO ALLEY
(BORO)
JONES ST
(BORO)
0020/0000
ALLEY
(BORO)
0015/1195 ==
MARTHA ST
(BORO)
0015/0900 ==
MAPLE AL
(BORO)
0015/0840 ==
WENDLIN ST
(BORO)
0015/0525 ==
099 "DIA CONC CR
LEN=0099 INSTALLED UNKN 0015/0183
BORO RD
(BORO)
0015/0165 ==
CHURCH ST
(BORO)
0015/0110 ==
0 0 00000 0 00 0000+00 000558 FT
GRANT AV
(SR4019 SEG 0020/0000)
NC WILSON ST
MFC BEGIN = E
LENGTH(AH 1455 BK 0179) 0015/0000
2 0 02153 0 00 0000+00 000379 FT
CRESCENT ST
(SR4019 SEG 0010/1241) 0010/0000
UNKNOWN ST
(TWP)
0004/0137
000000 FT

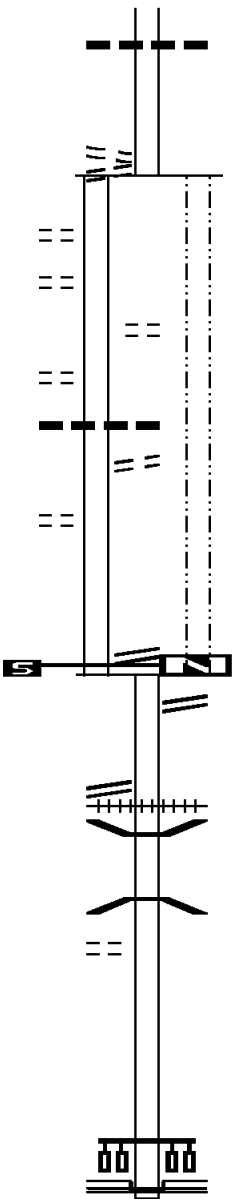

0020/0010 012"H 24"W CON BOX CUL
000558 FT LEN=0020 INSTALLED UNKN
NC WILSON ST
0020/0000 LTH AH 000588 BK 000100
000558 FT
7014/0000 LTH AH 000100 BK 000179
GRANT AV
0010/0179 (SR4019 SEG 0020/0000)
000379 FT
0010/0000 LENGTH(AH 0179 BK 0379)
0004/0290 (AAR 145709V)#TRKS 01
0004/0255 BMSSEN 02/4017/0004/0194
2 0 02192 0 00 0047+60
PINE CREEK
0004/0194 BMSBG 02/4017/0004/0194
000000 FT 0 0 00000 0 00 0000+00
NC GRANT AV
WILLIAM FLYNN HW
(SR0008 SEG 0200/0757)
(SR0008 SEG 0201/0800)
INTER-BK CATHERINE ST
(TWP)
MFC BEGIN = E
0004/0000 LENGTH(AH 0379 BK 0000)

DIR: B TOTAL LEN: 1.518 MI. DIST: 11-1 SR: 4016
 LEFT MUN: ROSS T RIGHT MUN: ROSS T

THOMPSON RUN RD
 (CNTY)

008014 FT
 0030/2904

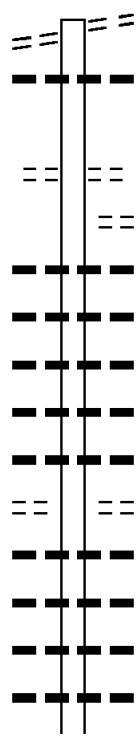

008014 FT THOMPSON RUN RD
 0030/2904 (CNTY)
 0030/2830 018 " DIA CIRC CONCR
 LEN=0030 INSTALLED UNKN

0030/1760 GOLDSMITH RD
 (TWP)
 0030/1380 DORAY DR
 (TWP)
 0030/1344 016 " DIA CIRC CONCR
 LEN=0028 INSTALLED UNKN
 0030/1238 012 " DIA CIRC CONCR
 LEN=0028 INSTALLED UNKN
 0030/1127 018 " DIA CIRC CONCR
 LEN=0030 INSTALLED UNKN
 0030/0944 012 " DIA CIRC CONCR
 LEN=0028 INSTALLED UNKN
 0030/0669 012 " DIA CIRC CONCR
 LEN=0028 INSTALLED UNKN

SANGREE RD
 (TWP)

0030/0590

0030/0590 TWIN OAKS DR
 (TWP)
 0030/0535 012 " DIA CIRC CONCR
 LEN=0028 INSTALLED UNKN
 0030/0378 012 " DIA CIRC CONCR
 LEN=0028 INSTALLED UNKN
 0030/0317 036 " DIA CIRC CONCR
 LEN=0099 INSTALLED UNKN
 0030/0158 048 " DIA CIRC CONCR
 LEN=0065 INSTALLED UNKN
 005110 FT 2 0 02192 0 00 0047+60

005110 FT

DIR: B TOTAL LEN: 1.518 MI. DIST: 11-1 SR: 4016
 LEFT MUN: ROSS T RIGHT MUN: ROSS T

WOODLAND RD
(TWP)

0020/1720

FAIRLEY RD
(TWP)

0020/1680

WIMER DR
(TWP)

0020/0950

002382 FT

FROM 4003/0061 SH
(CONN)

0010/2219

KENTZEL RD
(TWP)

0010/1361

SIMON AV
(TWP)

ELIZABETH LN
(TWP)

0010/0912

000000 FT

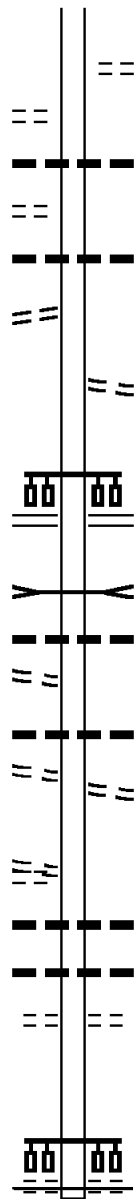

0030/0000 LENGTH(AH 2904 BK 2728)
 PARK PL
 0020/2165 (TWP)

0020/1697 036 "DIA CIRC METAL
 LEN=0060 INSTALLED UNKN

0020/1380 018 "DIA CIRC CONCR
 LEN=0030 INSTALLED UNKN

0020/0209 FROM 4003/0050 SH
 002382 FT (CONN)
 2 0 02192 0 00 0026+55
 MCKNIGHT RD
 (SR4003 SEG 0061/0000)
 (SR4003 SEG 0060/0000)

0020/0000 LENGTH(AH 2728 BK 2382)
 MCKNIGHT RUN

0010/2319 STRUCTURE LENGTH 12 FT
 BMSID 02/4016/0010/2343
 024 "DIA CIRC METAL
 0010/2245 LEN=0099 INSTALLED UNKN

0010/1880 018 "DIA CIRC CONCR
 LEN=0045 INSTALLED UNKN

0010/1361 KENTZEL RD
 (TWP)

0010/0829 018 "DIA CIRC CONCR
 LEN=0055 INSTALLED UNKN

0010/0636 018 "DIA CIRC CONCR
 LEN=0040 INSTALLED UNKN
 EVERGREEN RD

0010/0209 (CNTY)
 000000 FT 2 0 02192 0 00 0000+00
 NC S I EBERT RD
 BABCOCK BL
 (CNTY)

0010/0000 MFC BEGIN = C
 LENGTH(AH 2382 BK 0000)

EXTRACT DATE: 12/21/2020 ROADWAY MANAGEMENT SYSTEM PAGE NUMBER: 1288
PRINT DATE: 12/23/2020 SLD COUNTY/SR - ANNUAL PRINT COUNTY: ALLEGHENY
DIR: B TOTAL LEN: .000 MI. DIST: 11-1 SR: 4015
LEFT MUN: ROSS T RIGHT MUN: ROSS T

000000 FT



000000 FT
7010/0000 LENGTH(AH 0100 BK 0000)

DIR: B TOTAL LEN: 1.537 MI. DIST: 11-1 SR: 4014
 LEFT MUN: ROSS T RIGHT MUN: ROSS T

Street Name	Start Station	End Station	Length (FT)	Notes
HIGHLAND AV (SR4012 SEG 0080/0000) FROM 4012/0080 SH (CONN)	0040/1503	0040/1355	008115 FT	INTER-AHD
MEDINAH DR (TWP)	0040/0550	0040/0275	006612 FT	024 " DIA CIRC CONCR LEN=0065 INSTALLED UNKN 036 " DIA CIRC CONCR LEN=0080 INSTALLED UNKN PEONY AV (TWP) LILAC AV (TWP) 2 0 02089 0 00 0068+45 ROSE AV (TWP)
GOLF DR (TWP)	0030/2315	0030/2330	0030/2330	5 LENGTH(AH 1503 BK 2490) 018 " DIA CIRC CONCR LEN=0040 INSTALLED UNKN
IVY RD (TWP)	0030/1345	0030/1265	0030/1265	HIGHVIEW AV (TWP) 018 " DIA CIRC CONCR LEN=0035 INSTALLED UNKN
WEDGEWOOD DR (TWP)	0030/1075	0030/1053	0030/1053	018 " DIA CIRC CONCR LEN=0030 INSTALLED UNKN

DIR: B TOTAL LEN: 1.537 MI. DIST: 11-1 SR: 4014
 LEFT MUN: ROSS T RIGHT MUN: ROSS T

Address Range	Notes	Stationing	Notes
WEDGEWOOD DR (TWP) 0030/0785			
LORELI LN (TWP) 0030/0560			
MARION DR (TWP) 0030/0000			
LOGAN DR (TWP) 0020/1170			
VALLEY HI DR (TWP) 0020/1020			
			SUNSETVIEW DR (TWP) 0030/0650
			004122 FT
			0030/0000 LENGTH(AH 2490 BK 2056)
			0020/2023 018 "DIA CIRC CONCR
			0020/1770 LEN=0030 INSTALLED UNKN
			TIMBERLANE DR (TWP)
			0020/1441 012 "DIA CIRC CONCR
			LEN=0099 INSTALLED UNKN
			0020/0841 024 "DIA CIRC CONCR
			LEN=0040 INSTALLED UNKN
			0020/0588 018 "DIA CIRC CONCR
			LEN=0035 INSTALLED UNKN
			0020/0272 018 "DIA CIRC CONCR
			LEN=0035 INSTALLED UNKN
002066 FT			2 0 02089 0 00 0022+17
			0020/0000 LENGTH(AH 2056 BK 2066)
			0010/2015 018 "DIA CIRC CONCR
			LEN=0045 INSTALLED UNKN
			0010/1726 018 "DIA CIRC CONCR
			LEN=0072 INSTALLED UNKN
			SR 0279 NB
			OP ID 02/0279/0076/1613
			SR 0279 SB
			OP ID 02/0279/0077/1752
			ROSS
			OHIO T
			RETAINING WALL
			BMSID 02/4014/0010/0444
			099 "DIA CIR UNKNOWN
			0010/0194 LEN=0099 INSTALLED UNKN
000000 FT			2 0 02089 0 00 0000+00
			BEN AVON RD
			(SR4021 SEG 0020/2930)
			NC GA SS RD
			INTER-BK BEN AVON RD
			(SR4021 SEG 0020/2930)
			MFC BEGIN = D
			0010/0000 LENGTH(AH 2066 BK 0000)

EXTRACT DATE: 12/21/2020 ROADWAY MANAGEMENT SYSTEM PAGE NUMBER: 1285
PRINT DATE: 12/23/2020 SLD COUNTY/SR - ANNUAL PRINT COUNTY: ALLEGHENY
DIR: B TOTAL LEN: .950 MI. DIST: 11-1 SR: 4013
LEFT MUN: SHALER T RIGHT MUN: SHALER T

WIBLE RUN RD
(CNTY)

005015 FT
0020/2778

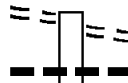

005015 FT WIBLE RUN RD
0020/2778 (CNTY)
0020/2725 018 " DIA CIRC CONCR
LEN=0045 INSTALLED UNKN

DIR: B TOTAL LEN: .950 MI. DIST: 11-1 SR: 4013
 LEFT MUN: SHALER T RIGHT MUN: SHALER T

Stationing	Description	Length	Material	Status
0020/2485	018" DIA CIRC CONCR	LEN=0045	INSTALLED	UNKN
0020/2192	018" DIA CIRC CONCR	LEN=0045	INSTALLED	UNKN
0020/1853	018" DIA CIRC CONCR	LEN=0045	INSTALLED	UNKN
0020/1550	VENICE RD (CNTY)			
0020/0750	024" DIA CIRC CONCR	LEN=0030	INSTALLED	UNKN
0020/0678	LUPINE DR (BORO)			
0020/0270	018" DIA CIRC CONCR	LEN=0030	INSTALLED	UNKN
0020/0266	002237 FT			
0020/0000	LENGTH(AH 2778 BK 2237) HEATHER DR (BORO)			
0010/2018	018" DIA CIRC CONCR	LEN=0045	INSTALLED	UNKN
0010/1796	018" DIA CIRC CONCR	LEN=0045	INSTALLED	UNKN
0010/1772	018" DIA CIRC CONCR	LEN=0030	INSTALLED	UNKN
0010/1631	FENWAY RD (BORO)			
0010/1279	018" DIA CIRC CONCR	LEN=0045	INSTALLED	UNKN
0010/1073	018" DIA CIRC CONCR	LEN=0045	INSTALLED	UNKN
0010/0978	012" DIA CIRC CONCR	LEN=0040	INSTALLED	UNKN
0010/0673	012" DIA CIRC CONCR	LEN=0040	INSTALLED	UNKN
0010/0525	018" DIA CIRC CONCR	LEN=0099	INSTALLED	UNKN
0010/0254	018" DIA CIRC CONCR	LEN=0099	INSTALLED	UNKN
0010/0246	SEAVEY RD (BORO)			
000000 FT	2 0 02151 0 00 0000+00 NC S			
0010/0000	PARKER ST (SR4004 SEG 0030/0000) MFC BEGIN = E LENGTH(AH 2237 BK 0000)			

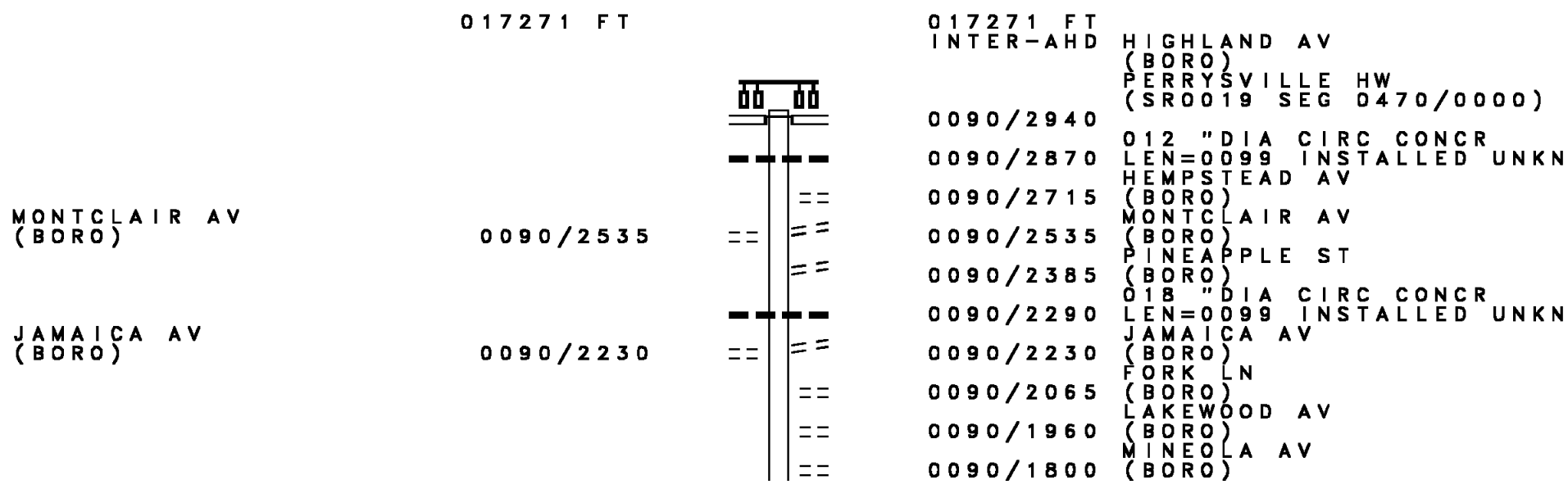

EXTRACT DATE: 12/21/2020
PRINT DATE: 12/23/2020

ROADWAY MANAGEMENT SYSTEM
SLD COUNTY/SR - ANNUAL PRINT

PAGE NUMBER: 1282
COUNTY: ALLEGHENY

DIR: B TOTAL LEN: 3.271 MI.
LEFT MUN: WEST VIEW B

DIST: 11-1 SR: 4012
RIGHT MUN: WEST VIEW B

Left Side Description	Left Side Stationing	Right Side Description	Right Side Stationing
WELLINGTON DR (BORO)	0090/1525	BRONX AV (BORO)	0090/1525
		015" DIA CIRC CONCR	
OAKMONT DR (BORO)	0090/1207	LEN=0040 INSTALLED UNKN	0090/1476
		WEST VIEW	
		ROSS T	0090/1025
		015" DIA CIRC CONCR	
		LEN=0040 INSTALLED UNKN	0090/1001
		COLUMBIA AV	
		(BORO)	0090/0680
		CORNE LL AV	
		(BORO)	0090/0325
		018" DIA CIRC CONCR	
	014331 FT	LEN=0040 INSTALLED UNKN	0090/0287
		2 0 02089 0 00 0090+76	014331 FT
PINEHURST DR (BORO)	0080/0706	LENGTH(AH 2940 BK 0939)	5 0090/0000
		LEHIGH AV	
TO 4014/0040 SH (CONN)	0080/0185	(BORO)	0080/0465
		ANN ARBOR AV	
		(BORO)	0080/0185
		FROM 4012/0070 SH	
		(CONN)	0080/0130
2 0 02089 0 00 0082+82	013392 FT		013392 FT
GASS RD (SR4014 SEG 0040/1503)	0080/0000	5 0080/0000	
		GH LAND AV	
		LENGTH(AH 0939 BK 1895)	
		018" DIA CIRC CONCR	
		LEN=0099 INSTALLED UNKN	0070/1805
		TO 4012/0080 SH	
		(CONN)	0070/1786
		BORO RD	
		(BORO)	0070/1461
		CASPER AV	
		(BORO)	0070/1025
COURTNEY MILL RD (BORO)	0070/0820		
		018" DIA CIR PLASTIC	
		LEN=0050 INSTALLED UNKN	0070/0110
	011497 FT	2 0 02211 0 00 0110+74	011497 FT
		MFC BEGIN = C	
		5 0070/0000	
		LENGTH(AH 1895 BK 2005)	
RAMP RD (SR8104 SEG 0750/0000)		RAMP RD (SR8104 SEG 0750/0000)	
RAMP RD (SR8104 SEG 0010/1855)		RAMP RD (SR8104 SEG 0010/1855)	

DIR: B TOTAL LEN: 3.271 MI. DIST: 11-1 SR: 4012
 LEFT MUN: ROSS T RIGHT MUN: ROSS T

BMS EN 02/4012/0060/1190 0061/1710
 0 0 00000 0 00 0000+00 0061/1608
 1021.309+91
 BMSBG 02/4012/0060/1190 0061/1190

RAMP RD
 (SR8104 SEG 0500/0961) 0061/0270

RAMP RD
 (SR8104 SEG 0250/0000) 0061/0205
 0 0 00000 0 00 0000+00 009492 FT
 MFC BEGIN = C
 LENGTH(AH 2005 BK 2765) 0061/0000

EDIES WY
 (BORO) 0050/1075

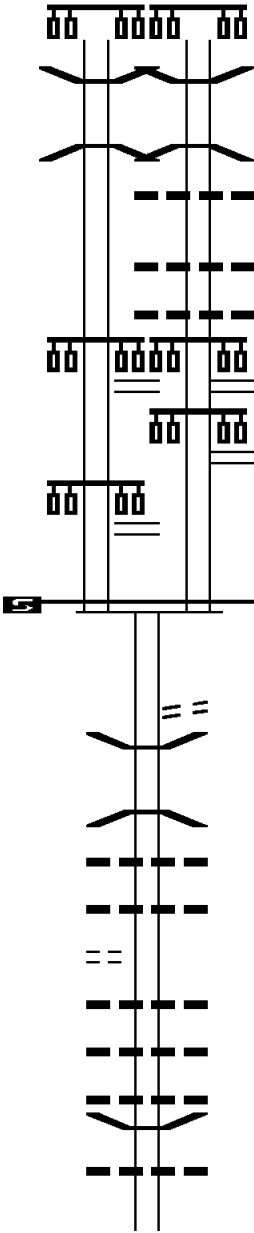

0060/1710
 0060/1608 BMS EN 02/4012/0060/1190
 0 0 00000 0 00 0000+00
 1021.309+91
 BMSBG 02/4012/0060/1190
 018 "DIA CIRC CONCR
 LEN=0070 INSTALLED UNKN

0060/1190
 0060/1120 018 "DIA CIRC CONCR
 LEN=0150 INSTALLED 2009
 018 "DIA CIRC CONCR
 LEN=0115 INSTALLED UNKN

0060/0450
 0060/0350 RAMP RD
 (SR8104 SEG 0500/0961)

0060/0270
 0060/0250 RAMP RD
 (SR8104 SEG 0250/0000)

009492 FT 2 0 02211 0 00 0090+34
 MFC BEGIN = C
 LENGTH(AH 2005 BK 2765)

0050/1320 WILLIAMS ST
 (BORO)
 0050/1295 BMS EN 02/4012/0050/1285
 2 0 02211 0 00 0079+29
 SPRUCE RUN

0050/1285 BMSBG 02/4012/0050/1285
 060"H 72"W CON BOX CUL
 0050/1257 LEN=0059 INSTALLED UNKN
 018 "DIA CIRC CONCR
 0050/1096 LEN=0059 INSTALLED UNKN

0050/1037 018 "DIA CIRC CONCR
 LEN=0013 INSTALLED UNKN
 0050/1024 018 "DIA CIRC CONCR
 LEN=0032 INSTALLED UNKN
 018 "DIA CIRC CONCR

0050/0780 LEN=0032 INSTALLED UNKN
 0050/0513 BMS EN 02/4012/0050/0500
 060"H 72"W CON BOX CUL
 0050/0501 LEN=0038 INSTALLED UNKN
 2 0 02211 0 00 0072+47
 SPRUCE RUN

EXTRACT DATE: 12/21/2020
PRINT DATE: 12/23/2020

ROADWAY MANAGEMENT SYSTEM
SLD COUNTY/SR - ANNUAL PRINT

PAGE NUMBER: 1280
COUNTY: ALLEGHENY

DIR: B TOTAL LEN: 3.271 MI.
LEFT MUN: ROSS T

DIST: 11-1 SR: 4012
RIGHT MUN: ROSS T

Stationing	Street Name	Notes	Stationing	Notes
006727 FT			0050/0500	BMSBG 02/4012/0050/0500
			006727 FT	2 0 02211 0 00 0059+65
				NORTHGATE HS DR
				(PRDR)
				ROSS
				BELLEVUE B
			0050/0000	LENGTH(AH 2765 BK 3101)
				018 "DIA CIRC CONCR
			0040/2850	LEN=0065 INSTALLED UNKN
				018 "DIA CIRC CONCR
			0040/2663	LEN=0080 INSTALLED UNKN
				BELLEVUE
			0040/2543	ROSS T
				018 "DIA CIRC CONCR
			0040/2462	LEN=0080 INSTALLED UNKN
				018 "DIA CIRC CONCR
			0040/2124	LEN=0070 INSTALLED UNKN
SEDALIA AV (BORO)	0040/1715			ROSS
			0040/1552	BELLEVUE B
ERDNER AV (BORO)	0040/1469			018 "DIA CIRC CONCR
			0040/1418	LEN=0050 INSTALLED UNKN
CHESTER AV (BORO)	0040/1195			NORTH AV
			0040/1195	(BORO)
				MEANS AV
			0040/1070	(BORO)
				018 "DIA CIRC CONCR
			0040/1067	LEN=0020 INSTALLED UNKN
				BAND ST
			0040/0884	(BORO)
				BELLEVUE
			0040/0821	AVALON B
				018 "DIA CIRC CONCR
			0040/0747	LEN=0010 INSTALLED UNKN
				018 "DIA CIRC CONCR
			0040/0740	LEN=0007 INSTALLED UNKN
				ORCHARD AV
			0040/0705	(BORO)
				SHADE AV
			0040/0446	(BORO)
NEW BRIGHTON RD (SR4023 SEG 0010/0000)				
HOME AV (BORO)	0040/0275		0040/0275	
				AVALON
			0040/0208	BELLEVUE B
003626 FT			003626 FT	2 0 02211 0 00 0032+64

DIR: B TOTAL LEN: 3.271 MI. DIST: 11-1 SR: 4012
 LEFT MUN: AVALON B RIGHT MUN: AVALON B

CLINTON AV
 (BORO)
 ALLEY
 (BORO)

0030/0370
 0030/0195
 002591 FT

HAMILTON AV
 (BORO)

0020/0920

BELLEVUE RD
 (BORO)

0020/0575

ROOSEVELT AV
 (BORO)

0020/0000

000000 FT



NC UNION AV
 0040/0000 LENGTH(AH 3101 BK 1035)
 018" DIA CIRC CONCR
 0030/0800 LEN=0010 INSTALLED UNKN
 002591 FT 2 0 02211 0 00 0025+98
 LINCOLN AV
 (BORO)
 0030/0000 LENGTH(AH 1035 BK 1473)
 018" DIA CIRC CONCR
 0020/1194 LEN=0020 INSTALLED UNKN
 0020/0877 018" DIA CIRC CONCR
 LEN=0099 INSTALLED UNKN
 0020/0695 018" DIA CIRC CONCR
 LEN=0007 INSTALLED UNKN
 WEST AV
 0020/0575 (BORO)
 018" DIA CIRC CONCR
 0020/0574 LEN=0004 INSTALLED UNKN
 018" DIA CIRC CONCR
 0020/0508 LEN=0040 INSTALLED UNKN
 024" DIA CIRC CONCR
 0020/0163 LEN=0040 INSTALLED UNKN
 001118 FT 2 0 02211 0 00 0011+27
 NC STARR AV
 ROOSEVELT AV
 (BORO)
 0020/0000 LENGTH(AH 1473 BK 1118)
 MEADE AV
 (BORO)
 RIVERVIEW AV
 (BORO)
 0010/0318 2 0 02211 0 00 0000+00
 0010/0120 NC RIVERVIEW AV
 000000 FT OHIO RIVER BL
 (SR0065 SEG 0051/1250)
 (SR0065 SEG 0050/1215)
 OHIO RIVER BL
 (SR0065 SEG 0050/1215)
 (SR0065 SEG 0051/1250)
 MFC BEGIN = C
 0010/0000 LENGTH(AH 1118 BK 0000)

BIG SEWICKLEY CREEK RD 059251 FT
 (SR4043 SEG 0080/0000) 0240/3245

056006 FT

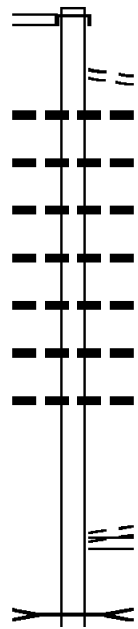

059251 FT
 INTER-AHD
 0240/3245 CAMP MEETING RD
 (SR4043 SEG 0080/0000)
 FAIRMOUNT CHURCH RD
 (BORO)
 0240/3175 018 " DIA CIRC CONCR
 LEN=0076 INSTALLED UNKN
 0240/3160 018 " DIA CIRC CONCR
 LEN=0025 INSTALLED UNKN
 0240/2708 015 " DIA CIRC CONCR
 LEN=0099 INSTALLED UNKN
 0240/2235 018 " DIA CIRC METAL
 LEN=0040 INSTALLED UNKN
 0240/1736 018 " DIA CIRC OTHER
 LEN=0035 INSTALLED UNKN
 0240/1400 018 " DIA CIRC CONCR
 LEN=0040 INSTALLED UNKN
 0240/0812 018 " DIA CIRC CONCR
 LEN=0076 INSTALLED UNKN
 0240/0330 2 0 02267 0 00 0296+26
 056006 FT FAIRMOUNT CHURCH RD
 (PRDR)
 BAYNE WEXFORD RD
 (SR4042 SEG 0010/0000)
 0240/0000 LENGTH(AH 3245 BK 2895)
 E. RIPPLING
 STRUCTURE LENGTH 12 FT
 0230/2826 BMSID 02/4011/0230/284B

DIR: B TOTAL LEN: 11.222 MI. DIST: 11-1 SR: 4011
 LEFT MUN: FRANKLIN PARK B RIGHT MUN: FRANKLIN PARK B

Stationing	Notes	Segment ID	Material	Length	Status
0230/2243	095 " DIA	CIRC CONCR	LEN=0099	INSTALLED UNKN	
0230/1395	MEINERT FARM LN (PRDR)				
0230/1219	018 " DIA	CIRC CONCR	LEN=0040	INSTALLED UNKN	
0230/0995	FRAZIER LN (PRDR)				
0230/0951	072 " DIA	CIRC CONCR	LEN=0045	INSTALLED UNKN	
0230/0328	018 " DIA	CIRC CONCR	LEN=0070	INSTALLED UNKN	
053111 FT	2 0 02267 0 00 0267+06				
0230/0000	LENGTH(AH 2895 BK 3852)				
0220/3686	CASTLETOWN CT (PRDR)				
0220/3608	018 " DIA	CIRC METAL	LEN=0159	INSTALLED UNKN	
0220/3360	018 " DIA	CIR PLASTIC	LEN=0032	INSTALLED UNKN	
0220/3214	024 " DIA	CIRC CONCR	LEN=0159	INSTALLED UNKN	
0220/2839	018 " DIA	CIRC CONCR	LEN=0038	INSTALLED UNKN	
0220/2426	018 " DIA	CIRC CONCR	LEN=0055	INSTALLED UNKN	
MARBLE LN (PRDR)	0220/1893				
CARRIAGE LN (PRDR)	0220/1089				
049259 FT	0220/0778				
	0220/0321				
	049259 FT				
FROM 4049/0080 SH (CONN)	0210/2238				
	0210/2215				
	0210/1742				
	TO 4049/0080 SH (CONN)				
	012 " DIA	CIRC CONCR	LEN=0099	INSTALLED UNKN	
	018 " DIA	CIRC CONCR			

EXTRACT DATE: 12/21/2020
PRINT DATE: 12/23/2020

ROADWAY MANAGEMENT SYSTEM
SLD COUNTY/SR - ANNUAL PRINT

PAGE NUMBER: 1276
COUNTY: ALLEGHENY

DIR: B TOTAL LEN: 11.222 MI.
LEFT MUN: FRANKLIN PARK B

DIST: 11-1 SR: 4011
RIGHT MUN: FRANKLIN PARK B

Stationing	Length	Notes	Stationing	Length	Notes
			0210/1633	LEN=0040	INSTALLED UNKN
			0210/1593	BMS EN 02/4011/0210/1415	
				2 0 02267 0 00 0216+51	
				SR 0079 NB	
			0210/1248	BMSBG 02/4011/0210/1415	
				018 "DIA CIRC CONCR	
			0210/1215	LEN=0040	INSTALLED UNKN
				PIONEER DR	
			0210/0889	(BORO)	
				015 "DIA CIRC CONCR	
			0210/0701	LEN=0099	INSTALLED UNKN
2 0 02267 0 00 0205+20	046918 FT		046918 FT		
PAULOSKI DR					
(BORO)	0210/0000		0210/0000	LENGTH(AH 2341 BK 2291)	
				018 "DIA CIRC CONCR	
			0200/2041	LEN=0030	INSTALLED UNKN
FRANKLIN FIELDS DR				SETTLERS DR	
(BORO)	0200/1375		0200/1375	(BORO)	
				018 "DIA CIRC CONCR	
			0200/1004	LEN=0020	INSTALLED UNKN
				SHEVLIN RD	
			0200/0940	(BORO)	
				MORROW LN	
2 0 02267 0 00 0182+43	044627 FT		0200/0325	(PRDR)	
SYLMAR DR			044627 FT		
(BORO)	0200/0000		0200/0000	LENGTH(AH 2291 BK 1872)	
				LOIS LN	
			0190/1256	(BORO)	
				018 "DIA CIRC CONCR	
HAVEN DR			0190/0906	LEN=0040	INSTALLED UNKN
(BORO)	0190/0860			015 "DIA CIRC CONCR	
				LEN=0025	INSTALLED UNKN
			0190/0460	015 "DIA CIRC CONCR	
				LEN=0030	INSTALLED UNKN
2 0 02267 0 00 0163+60	042755 FT		0190/0155	LEN=0030	INSTALLED UNKN
MC ALEER RD			042755 FT		
(SR4029 SEG 0050/2716)	0190/0000		0190/0000	LENGTH(AH 1872 BK 3371)	
MILBERT DR					
(BORO)	0180/2385				
			0180/2210	INGOMAR RD	
				(CNTY)	

EXTRACT DATE: 12/21/2020
PRINT DATE: 12/23/2020

ROADWAY MANAGEMENT SYSTEM
SLD COUNTY/SR - ANNUAL PRINT

PAGE NUMBER: 1275
COUNTY: ALLEGHENY

DIR: B TOTAL LEN: 11.222 MI.
LEFT MUN: FRANKLIN PARK B

DIST: 11-1 SR: 4011
RIGHT MUN: FRANKLIN PARK B

Segment	Stationing	Length	Material	Status
OAKLEAF LN (BORO)	0180/1235		018 " DIA CIRC CONCR	UNKN
			LEN=0030	INSTALLED
			012 " DIA CIRC CONCR	UNKN
			LEN=0030	INSTALLED
			018 " DIA CIRC CONCR	UNKN
			LEN=0030	INSTALLED
			DUNCAN DR (BORO)	
2 0 02267 0 00 0130+22	039384 FT	039384 FT	018 " DIA CIRC CONCR	UNKN
REIS RUN RD (SR4027 SEG 0020/3731)	0180/0000		LEN=0035	INSTALLED
CRESTVIEW DR (BORO)	0170/3175		INGOMAR HEIGHTS RD (BORO)	
CRESTVIEW DR (BORO)	0170/2695		LENGTH(AH 3371 BK 3662)	
OLD ORCHARD RD (BORO)	0170/1895		WOOD ACRES CT (BORO)	
			024 " DIA CIRC CONCR	UNKN
			LEN=0030	INSTALLED
			BEN FRANKLIN DR (BORO)	
SANDHURST DR (BORO)	0170/0749		018 " DIA CIRC CONCR	UNKN
			LEN=0045	INSTALLED
			012 " DIA CIRC CONCR	UNKN
			LEN=0099	INSTALLED
2 0 02267 0 00 0093+28	035722 FT	035722 FT	FRANKLIN PARK MCCANDLESS T	
KING WILLIAM DR (BORO)	0170/0000		LENGTH(AH 3662 BK 2764)	
			015 " DIA CIRC CONCR	UNKN
			LEN=0045	INSTALLED
			018 " DIA CIR PLASTIC	UNKN
			LEN=0045	INSTALLED
			018 " DIA CIRC CONCR	UNKN
			LEN=0045	INSTALLED
			018 " DIA CIRC CONCR	UNKN
			LEN=0045	INSTALLED
			021 " DIA CIRC METAL	UNKN
			LEN=0036	INSTALLED 2020
			048 " DIA CIRC CONCR	

DIR: B TOTAL LEN: 11.222 MI. DIST: 11-1 SR: 4011
 LEFT MUN: MCCANDLESS T RIGHT MUN: MCCANDLESS T

Street Name	Stationing	Length	Material	Notes
	0160/0373	LEN=0070	INSTALLED UNKN	
	0160/0086	LEN=0055	INSTALLED UNKN	
032958 FT	032958 FT	2 0 02267	0 00 0065+85	SLOOP RD (TBK)
	0160/0000	LENGTH(AH 2764 BK 3792)		(TWP)
	0150/3734	LEN=0055	INSTALLED UNKN	
	0150/3570	LEN=0045	INSTALLED UNKN	
	0150/3011	LEN=0045	INSTALLED UNKN	
	0150/2682	LEN=0050	INSTALLED UNKN	
	0150/2458	LEN=0045	INSTALLED UNKN	
	0150/2164	LEN=0050	INSTALLED UNKN	
FASSINGER LN (TWP)	0150/1500		VILLAGE DR (PRDR)	
	0150/0931	LEN=0045	INSTALLED UNKN	
	0150/0630	LEN=0045	INSTALLED UNKN	
029166 FT	0150/0212	LEN=0045	INSTALLED UNKN	
	029166 FT	2 0 02267	0 00 0027+40	
	0150/0000	LENGTH(AH 3792 BK 1876)		MCCANDLESS
	0140/1857		ROSS T	
	0140/1721	LEN=0099	INSTALLED UNKN	
	0140/1103	LEN=0099	INSTALLED UNKN	
OLD ENGLISH RD (TWP)	0140/1024		BR. LOWRIES	
	0140/0958	STRUCTURE LENGTH 12 FT		BMSID 02/4011/0140/1047
	0140/0716	LEN=0035	INSTALLED UNKN	
027290 FT	0140/0353	LEN=0099	INSTALLED UNKN	
	027290 FT	2 0 02267	0 00 0007+78	
	0140/0000	LENGTH(AH 1876 BK 1328)		
	0120/0432	BMSID 02/4011/0120/0415		

DIR: B TOTAL LEN: 11.222 MI. DIST: 11-1 SR: 4011
 LEFT MUN: ROSS T RIGHT MUN: ROSS T

Stationing / Description	Length / Notes	Material / Details
0120/0370	025962 FT	LOWRIES RUN BMSBG 02/4011/0120/0415 MILBERT LN (TWP)
0120/0199	025962 FT	2 0 02332 0 00 0100+14
0120/0000	0110/2513	LENGTH(AH 1328 BK 2567) 015 "DIA CIRC CONCR LEN=0050 INSTALLED UNKN
0110/1882	0110/1882	(APRA) SUNBELT RENTALS 018 "DIA CIRC CONCR LEN=0050 INSTALLED UNKN
0110/1652	0110/1652	018 "DIA CIRC CONCR LEN=0050 INSTALLED UNKN
0110/1429	0110/1429	015 "DIA CIRC CONCR LEN=0045 INSTALLED UNKN
0110/1251	0110/1251	018 "DIA CIR PLASTIC LEN=0099 INSTALLED UNKN
0110/0845	0110/0845	015 "DIA CIRC CONCR LEN=0125 INSTALLED UNKN
0110/0740	0110/0740	015 "DIA CIRC CONCR LEN=0190 INSTALLED UNKN
0110/0497	0110/0497	015 "DIA CIRC CONCR LEN=0099 INSTALLED UNKN
0110/0013	023395 FT	2 0 02332 0 00 0074+95 REIS RUN RD (SR4022 SEG 0140/0000)
0110/0000	0110/0000	MFC BEGIN = C LENGTH(AH 2567 BK 1768) BR. LOWRIES R STRUCTURE LENGTH 9 FT
0100/1616	0100/1616	BMSID 02/4011/0100/1612 NOCKLYN DR (TWP)
0100/1546	0100/1546	015 "DIA CIRC CONCR LEN=0099 INSTALLED UNKN
0100/0488	0100/0488	012 "DIA CIRC CONCR LEN=0099 INSTALLED UNKN
0100/0309	021627 FT	2 0 02332 0 00 0058+50 BEN AVON & LOWRIES RD (SR4021 SEG 0070/3359)
0100/0000	0100/0000	MFC BEGIN = B LENGTH(AH 1768 BK 3179) 015 "DIA CIRC CONCR LEN=0045 INSTALLED UNKN
0090/2882	0090/2882	015 "DIA CIRC CONCR LEN=0045 INSTALLED UNKN

SUNBELT RENTALS
(PRDR)

ROCHESTER CONNECTOR
(SR4075 SEG 0010/0465)

2 0 02332 0 00 0058+50 021627 FT
 BEN AVON & LOWRIES RD
 (SR4021 SEG 0070/3359) 0100/0000

DIR: B TOTAL LEN: 11.222 MI. DIST: 11-1 SR: 4011
 LEFT MUN: ROSS T RIGHT MUN: ROSS T

Location	Segment ID	Length (FT)	Material	Status
	0090/2686	0030	015 " DIA CIRC CONCR	INSTALLED UNKN
	0090/2307	0055	018 " DIA CIRC CONCR	INSTALLED UNKN
	0090/2285		HILLENDALE RD (TWP)	
	0090/2257	0099	018 " DIA CIRC CONCR	INSTALLED UNKN
	0090/2061	0030	018 " DIA CIRC CONCR	INSTALLED UNKN
	0090/1587	0100	018 " DIA CIRC CONCR	INSTALLED UNKN
	0090/1197	0035	018 " DIA CIRC CONCR	INSTALLED UNKN
	0090/0586	0045	036 " DIA CIRC CONCR	INSTALLED UNKN
	0090/0364	0055	018 " DIA CIRC CONCR	INSTALLED UNKN
	018448 FT	02332	2 0 02332 0 00 0025+44	
CROSS CREEK CT (BORO)	0090/0000		018 " DIA CIRC CONCR	INSTALLED UNKN
	0080/1749		ROSS WEST VIEW B	
HIDDEN VALLEY DR (BORO)	0080/1646		018 " DIA CIRC CONCR	INSTALLED UNKN
	0080/0856		018 " DIA CIRC CONCR	INSTALLED UNKN
BELLEVUE AV (TWP)	0080/0425		015 " DIA CIRC CONCR	INSTALLED UNKN
	0070/1940		015920 FT	
	0080/0000		WEST VIEW ROSS T	LENGTH(AH 3179 BK 2528)
	0070/1926		018 " DIA CIR PLASTIC	INSTALLED UNKN
	0070/1700		VIRGINIA TERRACE (TWP)	

DIR: B TOTAL LEN: 11.222 MI. DIST: 11-1 SR: 4011
 LEFT MUN: ROSS T RIGHT MUN: ROSS T

Location	Stationing	Length	Material	Notes
	0070/1297	0050	036" DIA CIRC METAL	INSTALLED UNKN
	0070/0678	0100	018" DIA CIRC CONCR	INSTALLED UNKN
	0070/0641		NORTH HILLS HS ENT RD	(TWP)
013363 FT	013363 FT	2 0 02331 0 00 0024+80		LENGTH(AH 2557 BK 2450)
GLENMORE AV (TWP)	0060/1505		SIXTH AV (TWP)	
	0060/0990	0035	018" DIA CIRC CONCR	INSTALLED UNKN
	0060/0795	0999	018" DIA CIRC CONCR	INSTALLED UNKN
010913 FT	0060/0165	0040	015"H 36"W ELLIP CONC	INSTALLED UNKN
	010913 FT	2 0 02331 0 00 0048+32		LENGTH(AH 2450 BK 1882)
	0050/1698	0045	018" DIA CIRC CONCR	INSTALLED UNKN
	0050/1453	0150	018" DIA CIRC METAL	INSTALLED UNKN
	0050/1350	0040	018" DIA CIRC CONCR	INSTALLED UNKN
	0050/0850	0040	015" DIA CIRC CONCR	INSTALLED UNKN
	0050/0640		UPPER ARROWHEAD RD	(TWP)
	0050/0630	0045	018" DIA CIRC CONCR	INSTALLED UNKN
	0050/0460		LOWER ARROWHEAD RD	(TWP)
EVERGREEN HTS DR (TWP)	0050/0355	0040	018" DIA CIRC CONCR	INSTALLED UNKN
009031 FT	0050/0340	16 FT	GIRTY'S RUN STRUCTURE	LENGTH 16 FT
	009031 FT	2 0 02331 0 00 0069+12	BMSID 02/4011/0050/0340	
			BABCOCK BL (CNTY)	
			NC ROCHESTER RD	

DIR: B TOTAL LEN: 11.222 MI. DIST: 11-1 SR: 4011
 LEFT MUN: ROSS T RIGHT MUN: ROSS T

CEMETERY LN
(TWP)

0040/1252

006111 FT

BROOKVIEW LN
(BORO)

0020/2740

---	5 0050/0000	LENGTH(AH 1882 BK 2920)
---	0040/2497	018 " DIA CIRC CONCR LEN=0065 INSTALLED UNKN
---	0040/1615	018 " DIA CIRC CONCR LEN=0075 INSTALLED UNKN
---	0040/1375	018 " DIA CIRC CONCR LEN=0055 INSTALLED UNKN
==	0040/1252	
---	0040/1124	018 " DIA CIRC CONCR LEN=0010 INSTALLED UNKN
---	0040/0874	018 " DIA CIRC CONCR LEN=0088 INSTALLED UNKN
	006111 FT	2 0 02328 0 00 0061+38 MFC BEGIN = C
---	5 0040/0000	LENGTH(AH 2920 BK 3567)
==	0020/3390	RAMP G RD (SR8079 SEG 0500/0600)
---	0020/3370	018 " DIA CIRC CONCR LEN=0020 INSTALLED UNKN
==	0020/3351	FROM 8079/0500 (CONN)
==	0020/3324	TO 8079/0510 SH (CONN)
==	0020/3270	RAMP K RD (SR8079 SEG 0510/0000)
---	0020/3239	BMS EN 02/4011/0020/3220 0 0 0000 0 00 0000+00
---	0020/3220	MCKNIGHT RUN BMSBG 02/4011/0020/3220
---	0020/3110	MCKNIGHT RD OP ID 02/4003/0020/0000
---	0020/3035	RAMP L RD (SR8079 SEG 0760/0422)
==	0020/2981	FROM 8079/0760 (CONN)
==	0020/2969	TO 8079/0750 SH (CONN)
---	0020/2927	018 " DIA CIRC CONCR LEN=0176 INSTALLED UNKN
---	0020/2920	RAMP H RD (SR8079 SEG 0750/0000)
==	0020/2722	PARK PL (BORO)

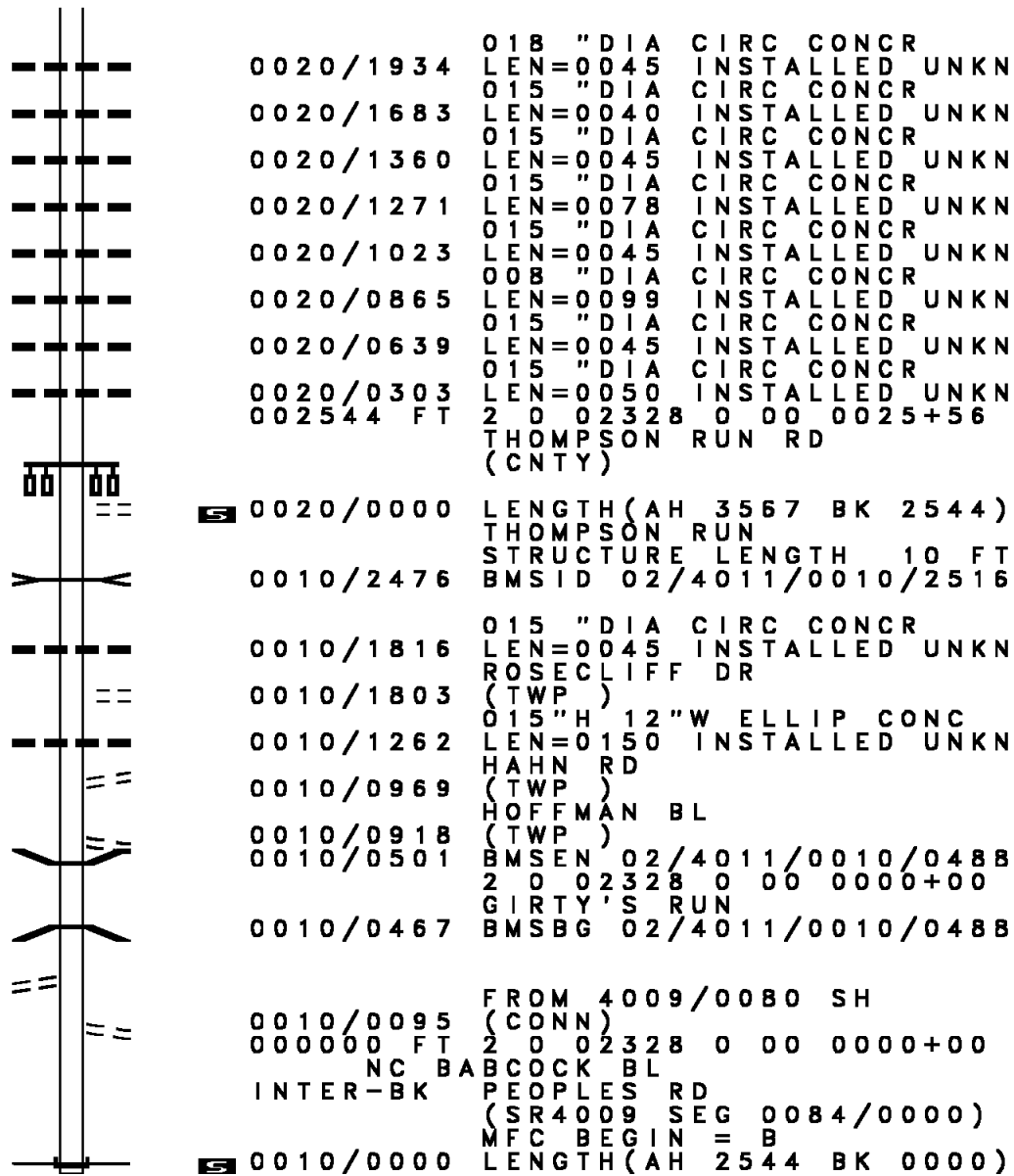

ROCKRIDGE RD (TWP)

0010/0420

000000 FT

DIR: B TOTAL LEN: .672 MI. DIST: 11-1 SR: 4010
 LEFT MUN: PITTSBURGH C RIGHT MUN: PITTSBURGH C

COLBY ST
 (CITY)

003550 FT

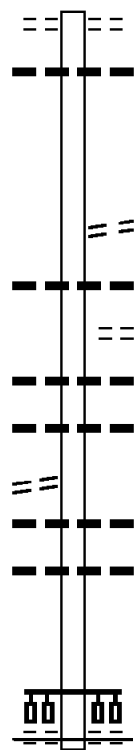

003550 FT SPRING GARDEN RD
 0020/1717 (CNTY)
 018 " DIA CIRC CONCR
 0020/1470 LEN=0060 INSTALLED UNKN

001833 FT

001833 FT 2 0 02114 0 00 0023+60
 0020/0000 LENGTH(AH 1717 BK 1833)
 NORTHVIEW ESTATES ENT R
 0010/1667 (CITY)
 024 " DIA CIRC CONCR
 0010/1390 LEN=0040 INSTALLED UNKN
 SCHOOL ENT RD
 0010/1355 (CITY)
 015 " DIA CIRC CONCR
 0010/1060 LEN=0050 INSTALLED UNKN
 015 " DIA CIRC CONCR
 0010/0825 LEN=0060 INSTALLED UNKN

0010/0790

0010/0535 018 " DIA CIRC CONCR
 LEN=0030 INSTALLED UNKN
 018 " DIA CIRC CONCR
 0010/0231 LEN=0050 INSTALLED UNKN
 000000 FT 2 0 02114 0 00 0000+00
 NC MT PLEASANT RD
 EAST ST
 (CITY)

000000 FT

0010/0000 MFC BEGIN = E
 LENGTH(AH 1833 BK 0000)

EVERGREEN RD INTER-AHD
 (SR4003 SEG 0006/2889)
 MCKNIGHT RD
 (SR4003 SEG 0006/2889) 0111/2937
 018 "DIA CIRC CONCR
 LEN=0099 INSTALLED UNKN 0111/2881
 024411 FT

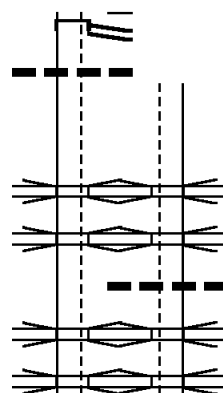

RAMP J SR4003 SB T
 OP ID 02/8102/0500/0953 0111/2803
 I-279 S.B.
 OP ID 02/0279/0047/0000 0111/2721
 SR 6279 TO 279 NB
 OP ID 02/6279/0070/0330 0111/2679
 RAMP 8102
 OP ID 02/8102/0510/0180 0111/2640

027172 FT
 RAMP J SR4003 SB T
 OP ID 02/8102/0500/0953
 MCKNIGHT RD
 (SR4003 SEG 0010/0040)
 (SR4003 SEG 0011/0045)
 I-279 S.B.
 OP ID 02/0279/0047/0000
 016 "DIA CIRC CONCR
 LEN=0040 INSTALLED UNKN
 SR 6279 TO 279 NB
 OP ID 02/6279/0070/0330
 RAMP 8102
 OP ID 02/8102/0510/0180

EXTRACT DATE: 12/21/2020
PRINT DATE: 12/23/2020

ROADWAY MANAGEMENT SYSTEM
SLD COUNTY/SR - ANNUAL PRINT

PAGE NUMBER: 1266
COUNTY: ALLEGHENY

DIR: N TOTAL LEN: 4.623 MI.
LEFT MUN: PITTSBURGH C

DIST: 11-1 SR: 4009
RIGHT MUN: PITTSBURGH C

SR	OP ID	DESCRIPTION	LEN	STATUS	UNKN	0111/	0110/	SR	OP ID	DESCRIPTION	LEN	STATUS	UNKN
0279 NB	02/0279/0046/0000	RAMP I				0111/2581	0110/2403	0279 NB	02/0279/0046/0000	RAMP I			
0279 NB	02/8102/0030/0445	"DIA CIRC CONCR	0099	INSTALLED	UNKN	0111/2534	0110/2353	0279 NB	02/8102/0030/0445	"DIA CIRC CONCR	0099	INSTALLED	UNKN
0279 NB	02/8102/0030/0445	RAMP K RD				0111/2504		0279 NB	02/8102/0030/0445	RAMP K RD			
0279 NB	02/8102/0030/0445	(SR8102 SEG 0020/0551)				0111/2310		0279 NB	02/8102/0030/0445	(SR8102 SEG 0020/0551)			
015	"DIA CIRC CONCR	LEN=0040	INSTALLED	UNKN		0111/2193	0110/2115		RAMP K RD	(SR8102 SEG 0020/0551)			
015	"DIA CIRC CONCR	LEN=0045	INSTALLED	UNKN		0111/1852	0110/1990		020 "DIA CIRC CONCR	LEN=0045	INSTALLED	UNKN	
	UNKNOWN RD	(CONN)				0111/1756	0110/1550		UNKNOWN RD	(CONN)			
	UNKNOWN RD	(CONN)				0111/1352	0110/1215		UNKNOWN RD	(CONN)			
018	"DIA CIRC CONCR	LEN=0040	INSTALLED	UNKN		0111/1333	0110/0665		MT TROY RD (#2312-02)	(CNTY)			
	MT TROY RD (#2312-02)	(CNTY)				0111/0800	0110/0604		IVORY AV (#2312-01)	(CNTY)			
	IVORY AV (#2312-01)	(CNTY)				0111/0757	0110/0272		LC TO IVORY AV	(CONN)			
	LC FROM MT TROY RD	(CONN)					0110/0018		018 "DIA CIRC CONCR	LEN=0099	INSTALLED	UNKN	
							0110/0018		018 "DIA CIRC CONCR	LEN=0035	INSTALLED	UNKN	
1 0 00805 0 01 0195+07 021474 FT							021667 FT	1 0 00805 0 01 0195+86					
PITTSBURGH							0110/0000	LENGTH(AH 2624 BK 3628)					
ROSS T							0100/3595	PITTSBURGH					
LENGTH(AH 2937 BK 3465) 0111/0000							0100/3233	ROSS T					
							0100/2784	018 "DIA CIRC CONCR	LEN=0050	INSTALLED	UNKN		
							0100/2077	018 "DIA CIRC CONCR	LEN=0050	INSTALLED	UNKN		
								018 "DIA CIRC CONCR	LEN=0050	INSTALLED	UNKN		

DIR: N TOTAL LEN: 4.623 MI. DIST: 11-1 SR: 4009
 LEFT MUN: ROSS T RIGHT MUN: ROSS T

Stationing	Description	Stationing	Description
0100/1833	030 " DIA CIRC CONCR LEN=0075 INSTALLED UNKN	0100/1544	015 " DIA CIRC CONCR LEN=0099 INSTALLED UNKN
0100/0638	015 " DIA CIRC CONCR LEN=0099 INSTALLED UNKN	0100/0350	015 " DIA CIRC CONCR LEN=0099 INSTALLED UNKN
018039 FT	1 0 00805 0 01 0159+58 018009 FT LENGTH(AH 3465 BK 1942) 0101/0000 BMSBG 02/4009/0090/2151 0091/1698	0100/0000	1 0 00805 0 01 0159+58 NC EVERGREEN RD LENGTH(AH 3628 BK 1968)
0090/1709	BMSBG 02/4009/0090/2151 0 0 00000 0 00 0000+00 BR. GIRTYS RN	0090/1697	BMSBG 02/4009/0090/2151
0090/1546	018 " DIA CIRC CONCR LEN=0040 INSTALLED UNKN	0090/0896	NELSON RUN RD (TWP) PEOPLES TOWNSHIP RD (TWP)
0091/0881	NELSON RUN RD (TWP) PEOPLES TOWNSHIP RD (TWP) 018 " DIA CIRC CONCR LEN=0099 INSTALLED UNKN	0091/0629	018 " DIA CIRC CONCR LEN=0099 INSTALLED UNKN
0090/0024	BMSBG 02/4009/0090/0470 0091/0024 1 0 00805 0 01 0135+01 016067 FT NC EVERGREEN RD	0090/0024	BMSBG 02/4009/0090/0470
0090/0000	BR. GIRTYS RN BMSBG 02/4009/0090/0470 MFC BEGIN = C LENGTH(AH 1942 BK 0473) 0091/0000	016071 FT	1 0 00805 0 01 0139+74 BR. GIRTYS RN BMSBG 02/4009/0090/0470 MFC BEGIN = C
0084/0212	015594 FT	0090/0000	LENGTH(AH 1968 BK 0473) 024 " DIA CIRC CONCR LEN=0001 INSTALLED UNKN
0084/0000	015598 FT NC PEOPLES RD BABCOCK BL (SR4011 SEG 0010/0000) MFC BEGIN = C LENGTH(AH 0473 BK 1648)	0084/0000	1 0 00805 0 01 0135+04 NC PEOPLES RD BABCOCK BL (SR4011 SEG 0010/0000) MFC BEGIN = C LENGTH(AH 0473 BK 1648)

EXTRACT DATE: 12/21/2020
PRINT DATE: 12/23/2020

ROADWAY MANAGEMENT SYSTEM
SLD COUNTY/SR - ANNUAL PRINT

PAGE NUMBER: 1264
COUNTY: ALLEGHENY

DIR: N TOTAL LEN: 4.623 MI.
LEFT MUN: ROSS T

DIST: 11-1 SR: 4009
RIGHT MUN: ROSS T

Location	Stationing	Length	Notes
SCHUETZEN PARK RD (TWP)	0080/1511		TO 4011/0010 SH
	0080/1408		(CONN) BMSSEN 02/4009/0080/1434 1 0 00805 0 01 0126+99 GIRTYS RUN
	0080/1375		BMSBG 02/4009/0080/1434 CHURCH RD
	0080/1294		(TWP) BMSSEN 02/4009/0080/0891 1 0 00805 0 01 0117+97 GIRTYS RUN
	0080/0834		BMSBG 02/4009/0080/0891 020 " DIA CIRC CONCR
SCHUETZEN PARK RD (TWP)	0080/0574	013946 FT	LEN=0040 INSTALLED UNKN
	013950 FT		1 0 00805 0 01 0117+97 NC BA ABCOCK BL
SHAFER RD (TWP)	0080/0000		LENGTH(AH 1648 BK 2209)
	0070/1940		ROSS SHALER T
	0070/1856		018 " DIA CIR PLASTIC LEN=0030 INSTALLED 2017
	0070/1809		BMSSEN 02/4009/0070/1766 1 0 00805 0 01 0114+32 GIRTYS RUN
	0070/1766		BMSBG 02/4009/0070/1766
SHAFER RD (TWP)	0070/1070		GREENHILL RD (TWP)
	0070/0861		BMSSEN 02/4009/0070/0786 1 0 00805 0 01 0104+38 GIRTY RUN
	0070/0786		BMSBG 02/4009/0070/0786
	0070/0463		014 " DIA CIRC METAL LEN=0045 INSTALLED UNKN
	0070/0308		018 " DIA CIRC CONCR LEN=0099 INSTALLED UNKN
SHAFER RD (TWP)	0070/0042	011737 FT	BMSSEN 02/4009/0070/0000 1 0 00805 0 01 0096+62 GIRTYS RUN
	0070/0000		BMSBG 02/4009/0070/0000 LENGTH(AH 2209 BK 1686) EVERGREEN RD (#2119-01)
	0060/1600		(CNTY) BMSSEN 02/4009/0060/0967 1 0 00805 0 01 0089+75 GIRTYS RUN

DIR: N TOTAL LEN: 4.623 MI. DIST: 11-1 SR: 4009
 LEFT MUN: SHALER T RIGHT MUN: SHALER T

Stationing	Description	Stationing	Description
		0060/0981	BMSBG 02/4009/0060/0967 ST LUKE ST
		0060/0615	(TWP)
010051 FT		0060/0492	016 " DIA CIRC CONCR LEN=0030 INSTALLED UNKN
GEYER RD (SR4002 SEG 0020/2632)	0060/0000	010055 FT	1 0 00805 0 01 0080+05 ALLEY
		0050/0725	(TWP) LENGTH(AH 1686 BK 1044) EVERGREEN RD
		0050/0691	(CNTY) SHALER
1 0 00805 0 01 0069+30	009007 FT	0050/0379	MILLVALE B 012 " DIA CIRC CONCR LEN=0030 INSTALLED UNKN
NORTH AV (TWP)	0050/0000	009011 FT	MFC BEGIN = B LENGTH(AH 1044 BK 1767) TOWNSHIP RD
		0040/1661	(TWP)
		0040/1649	BMSEN 02/4009/0040/1605 0 0 00000 0 00 0000+00 GIRTYS RUN
		0040/1618	BMSBG 02/4009/0040/1605 018 " DIA CIRC CONCR
LC FOR NORTH AV (CONN)	0040/1537	0040/1586	LEN=0099 INSTALLED UNKN
		0040/1050	018 "H 36 "W CON BOX CUL LEN=0099 INSTALLED UNKN
BESSE ST (TWP)	0040/1005	0040/0992	018 " DIA CIRC CONCR LEN=0030 INSTALLED UNKN
		0040/0912	HAWTHORNE RD (TWP)
		0040/0680	018 " DIA CIRC CONCR LEN=0030 INSTALLED UNKN
		0040/0341	024 "H 36 "W CON BOX CUL LEN=0099 INSTALLED UNKN SEAVEY RD
		0040/0315	(TWP) MFC BEGIN = C
		0040/0141	018 " DIA CIRC CONCR LEN=0042 INSTALLED UNKN FRANKLIN ST
FRANKLIN ST (TWP)	0040/0100	0040/0100	(TWP)
	007240 FT	0040/0031	BMSEN 02/4009/0040/0000
		007244 FT	1 0 00805 0 01 0051+84 NC NORTH AV

DIR: N TOTAL LEN: 4.623 MI. DIST: 11-1 SR: 4009
 LEFT MUN: MILLVALE B RIGHT MUN: MILLVALE B

Street Name	Stationing	Notes	Material / Length	Installation Status
EMMA ST (TWP)	0030/2115	==	5 0040/0000	GIRTY RUN BMSBG 02/4009/0040/0000 LENGTH(AH 1767 BK 2458)
	0030/2108	---	0030/2108	018 "DIA CIRC CONCR LEN=0099 INSTALLED UNKN
FREDERICK ST (TWP)	0030/2045	==	0030/2045	DAVID ST
	0030/1736	---	0030/1736	BMSSEN 02/4009/0030/1705 1 0 00805 0 01 0043+34 GIRTY RUN
JOHN ST (TWP)	0030/1705	---	0030/1705	BMSBG 02/4009/0030/1705
	0030/1669	==	0030/1644	018 "DIA CIRC CONCR LEN=0030 INSTALLED UNKN
KLOPFER ST (TWP)	0030/1360	==	0030/1331	015 "DIA CIRC CONCR LEN=0030 INSTALLED UNKN
	0030/0985	---	0030/1130	LAWRENCE ST (TWP) GRAY WAY (TWP)
BUTLER ST (TWP)	0020/2464	---	0030/0915	024 "DIA CIRC CONCR LEN=0030 INSTALLED UNKN
	0020/2172	---	0030/0738	018 "H 12" W CON BOX CUL LEN=0099 INSTALLED UNKN
BUTLER ST (TWP)	0020/1935	---	0030/0515	FRIDAY RD (#2131) (CNTY)
	0020/1538	==	0030/0510	024 "DIA CIRC CONCR LEN=0030 INSTALLED UNKN
	004782 FT	---	0030/0182	018 "DIA CIRC CONCR LEN=0083 INSTALLED UNKN
		---	004786 FT	1 0 00805 0 01 0027+22 NC EV ERGREEN RD MILLVALE SHALER T
		---	5 0030/0000	LENGTH(AH 2458 BK 2679)
		---	0020/2464	024 "DIA CIRC CONCR LEN=0035 INSTALLED UNKN
		---	0020/2172	001 "DIA CAST IRON LEN=0001 INSTALLED UNKN
		---	0020/1935	024 "DIA CAST IRON LEN=0020 INSTALLED UNKN

DIR: N TOTAL LEN: 4.623 MI. DIST: 11-1 SR: 4009
 LEFT MUN: SHALER T RIGHT MUN: SHALER T

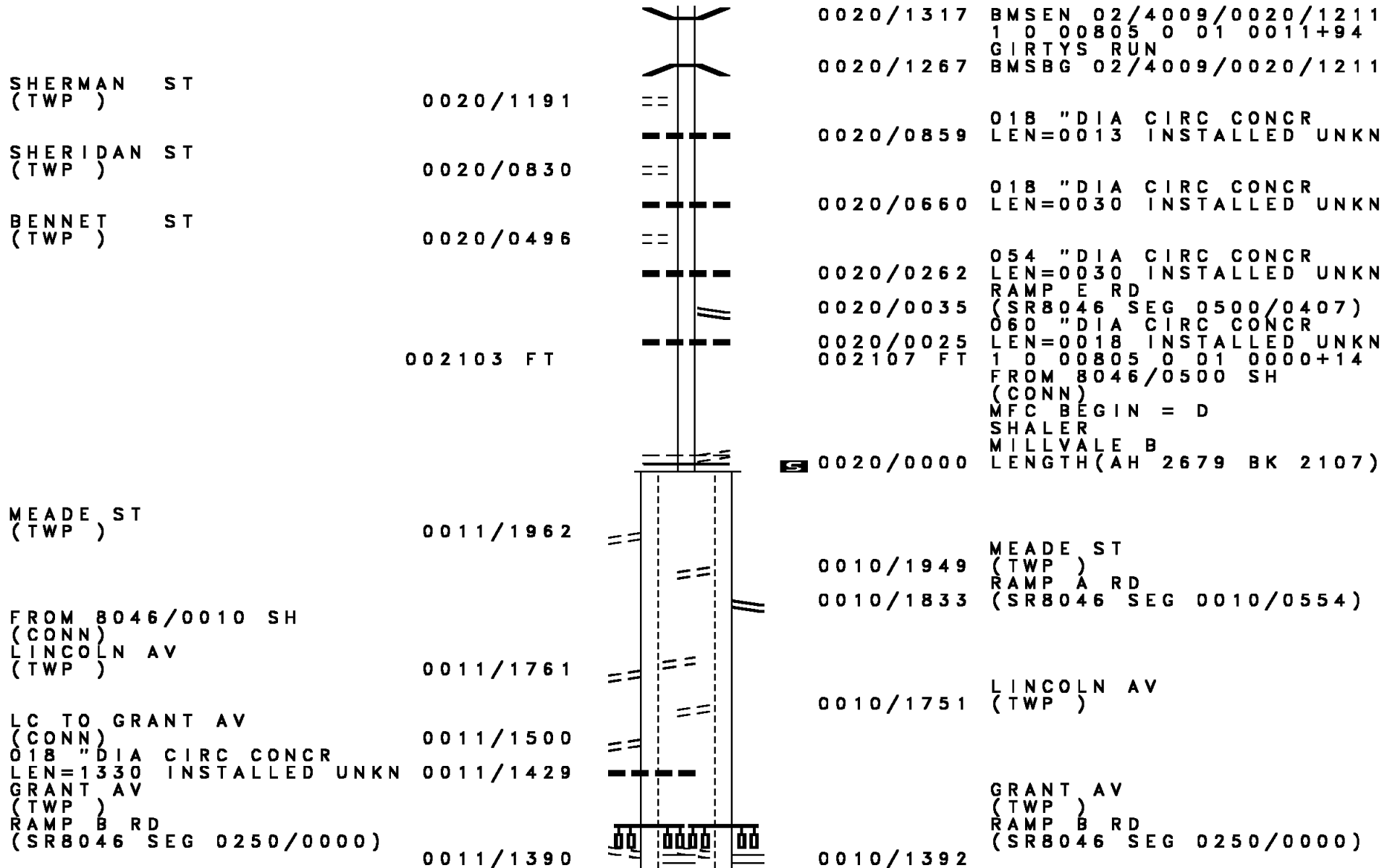

EXTRACT DATE: 12/21/2020
PRINT DATE: 12/23/2020

ROADWAY MANAGEMENT SYSTEM
SLD COUNTY/SR - ANNUAL PRINT

PAGE NUMBER: 1260
COUNTY: ALLEGHENY

DIR: N TOTAL LEN: 4.623 MI.
LEFT MUN: MILLVALE B

DIST: 11-1 SR: 4009
RIGHT MUN: MILLVALE B

018 "H 24"W ELLIP CONC
LEN=0099 INSTALLED UNKN 0011/1368
MARYLAND AV
(TWP) 0011/1297

OP ID RT 0028 SB
02/0028/0081/0515 0011/1250

SIGN: 3 CHORD TRUSS
BMSID 02/4009/0010/1170 0011/1179

RIVER FRONT DR
(TWP) 0011/1117

018 "DIA CIRC CONCR
LEN=0099 INSTALLED UNKN 0011/0745

SIGN: 4 CHORD TRUSS
BMSID 02/0028/0081/0048 0011/0689

FROM 0028/0071 SH
(CONN) 0011/0590

018 "DIA CIRC CONCR
LEN=0099 INSTALLED UNKN 0011/0575

SIGN: CANTILEVER
BMSID 02/4009/0011/0770 0011/0157

1 0 00805 0 00 0000+00 000000 FT
NC EAST OHIO ST

WASHINGTON CR BR/40TH S
(SR2124 SEG 0010/2754)

RAMP Q INTER-BK
(SR8120 SEG 0250/0000)

MFC BEGIN = D
LENGTH(AH 2103 BK 0000) 0011/0000

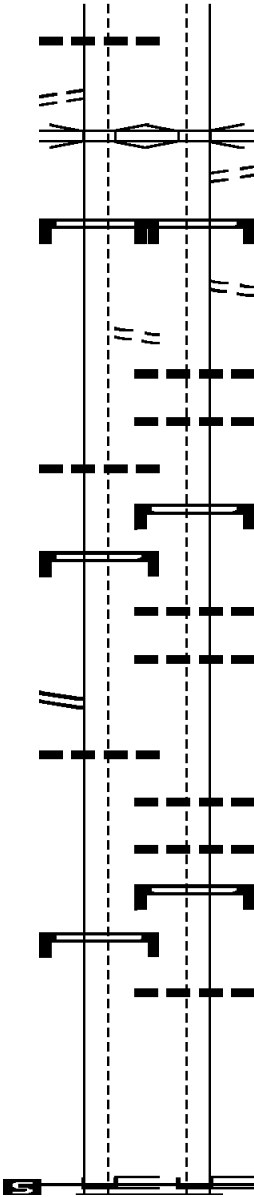

0010/1300 OP ID RT 0028 SB
TO 8046/0250 SH

0010/1239 (CONN)

0010/1187 SIGN: 3 CHORD TRUSS
BMSID 02/4009/0010/1170

0010/1169 RIVER FRONT DR
(TWP)

0010/1098 018 "DIA CIRC CONCR
LEN=0999 INSTALLED UNKN

0010/0971 018 "DIA CIRC CONCR
LEN=0999 INSTALLED UNKN

0010/0694 SIGN: 4 CHORD TRUSS
BMSID 02/0028/0081/0048

0010/0654 018 "DIA CIRC CONCR
LEN=0099 INSTALLED UNKN

0010/0631 018 "DIA CIRC CONCR
LEN=0099 INSTALLED UNKN

0010/0443 016 "DIA CIRC CONCR
LEN=0999 INSTALLED UNKN

0010/0260 095 "DIA CIRC CONCR
LEN=0999 INSTALLED UNKN

0010/0177 SIGN: CANTILEVER
BMSID 02/4009/0011/0770

0010/0110 018 "DIA CIRC CONCR
LEN=0099 INSTALLED UNKN

000000 FT 1 0 00805 0 00 0000+00
NC EAST OHIO ST

WASHINGTON CR BR/40TH S
(SR2124 SEG 0010/2725)

INTER-BK FROM 28N TO 40TH ST BR
(SR8120 SEG 0010/0467)

MFC BEGIN = D
LENGTH(AH 2107 BK 0000)

EXTRACT DATE: 12/21/2020 ROADWAY MANAGEMENT SYSTEM PAGE NUMBER: 1259
 PRINT DATE: 12/23/2020 SLD COUNTY/SR - ANNUAL PRINT COUNTY: ALLEGHENY
 DIR: B TOTAL LEN: .251 MI. DIST: 11-1 SR: 4008
 LEFT MUN: RESERVE T RIGHT MUN: RESERVE T

001327 FT

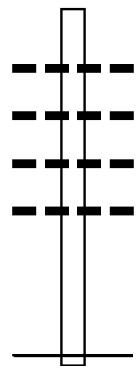

000000 FT

```

001327 FT
* REF-AHD WILLIAMS RD
0010/1327 (CITY)
018 "DIA CIRC CONCR
0010/0796 LEN=0040 INSTALLED UNKN
018 "DIA CIRC CONCR
0010/0620 LEN=0040 INSTALLED UNKN
018 "DIA CIRC CONCR
0010/0460 LEN=0050 INSTALLED UNKN
018 "DIA CIR PLASTIC
0010/0204 LEN=0040 INSTALLED UNKN
000000 FT 2 0 02116 0 00 0005+00
NC WI LLIAMS RD
* REF-BK LAMAR ST
(CITY)
MFC BEGIN = C
5 0010/0000 LENGTH(AH 1327 BK 0000)
  
```

	004212 FT				005022 FT	SPRING GARDEN AV
					0030/0868	(TWP)
					0030/0430	PITTSBURGH
						RESERVE T
					0030/0365	RESERVE
						PITTSBURGH C
					0030/0164	PITTSBURGH
						RESERVE T
					NC WI	CKLINES LN
						PITTVIEW AV
						(CNTY)
						MFC BEGIN = E
					0030/0000	LENGTH(AH 0868 BK 0810)
					0024/0327	LUTY AV
						(TWP)
					0024/0293	RESERVE
						PITTSBURGH C
					0024/0084	012 "DIA CIRC METAL
					003344 FT	LEN=0020 INSTALLED UNKN
						0 0 00000 0 00 0000+00
						MT TROY RD

COWLEY ST
(TWP)

2 0 02118 0 00 0041+79 003344 FT
 RIALTO ST
 (TWP)
 RESERVE
 PITTSBURGH C

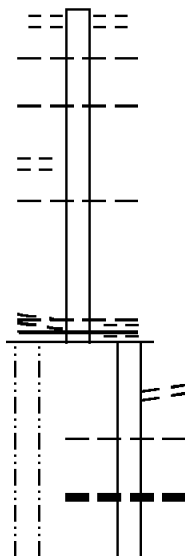

DIR: B TOTAL LEN: .951 MI. DIST: 11-1 SR: 4007
 LEFT MUN: PITTSBURGH C RIGHT MUN: PITTSBURGH C

Stationing	Notes	Material	Length	Installation
LTH AH 000810 BK 000385	003344 FT 7025/0000	INTER-AHD	0024/0000	LENGTH(AH 0810 BK 0385)
	002959 FT	NC PITTSVIEW AV	0020/0385	LENGTH(AH 0385 BK 2959)
		RESERVE T	0010/2920	012 " DIA CIRC METAL
PITTSVIEW AV (TWP)	0010/2759	RESERVE T	0010/2800	LEN=0099 INSTALLED UNKN
		RESERVE T	0010/2580	LEN=0030 INSTALLED UNKN
		RESERVE T	0010/2575	LEN=0030 INSTALLED UNKN
		RESERVE T	0010/1915	LEN=0030 INSTALLED UNKN
		RESERVE T	0010/1590	LEN=0030 INSTALLED UNKN
		RESERVE T	0010/1282	LEN=0025 INSTALLED UNKN
		RESERVE T	0010/0802	LEN=0099 INSTALLED UNKN
LONSDALE ST (TWP)	0010/0758	RESERVE T	0010/0781	LEN=0030 INSTALLED UNKN
		RESERVE T	0010/0652	LEN=0099 INSTALLED UNKN
		RESERVE T	0010/0316	LEN=0070 INSTALLED UNKN
		RESERVE T	0010/0084	LEN=0099 INSTALLED UNKN
	000000 FT	RESERVE T	0010/0063	LEN=0099 INSTALLED UNKN
		RESERVE T	000000 FT	2 0 02118 0 00 0000+00
AMPERE ST (TWP)	0010/0000	RESERVE T	0010/0000	LENGTH(AH 2959 BK 0000)

002491 FT

002491 FT
 INTER-AHD GARDEN PL
 (TWP)
 MOUNT ROYAL BL
 (SR4019 SEG 0060/0000)
 0010/2491 096 " DIA CIR UNKNOWN
 0010/2125 LEN=0099 INSTALLED UNKN
 018 " DIA CIRC CONCR
 0010/2071 LEN=0040 INSTALLED UNKN
 036 " DIA CIRC CONCR
 0010/1590 LEN=0099 INSTALLED UNKN
 KIWANIS PK
 0010/1500 (TWP)

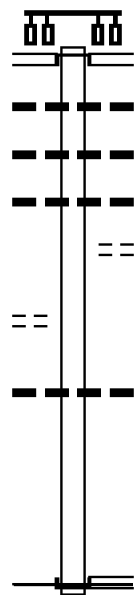



VOLLMER DR
 (TWP)

0010/0781

000000 FT

0010/0110 018 " DIA CIRC CONCR
 LEN=0035 INSTALLED UNKN
 000000 FT 2 0 02120 0 00 0030+36
 NC WE TZEL RD
 LITTLE PINE CREEK RD
 (SR4017 SEG 0060/0000)
 LITTLE PINE CREEK RD
 (SR4017 SEG 0060/0000)
 MFC BEGIN = D
 0010/0000 LENGTH(AH 2491 BK 0000)

EXTRACT DATE: 12/21/2020 ROADWAY MANAGEMENT SYSTEM PAGE NUMBER: 1255
 PRINT DATE: 12/23/2020 SLD COUNTY/SR - ANNUAL PRINT COUNTY: ALLEGHENY
 DIR: B TOTAL LEN: .000 MI. DIST: 11-1 SR: 4005
 LEFT MUN: SHALER T RIGHT MUN: SHALER T

000000 FT		000000 FT	
000000 FT		7030/0000 FT	LENGTH(AH 1177 BK 2798)
000000 FT		000000 FT	
		7020/0000 FT	LENGTH(AH 2798 BK 3239)
		000000 FT	
		7010/0000 FT	LENGTH(AH 3239 BK 0000)

Stationing	Description	Material	Length	Notes
004770 FT	HILL ST (TWP)			
0030/1822				
002400 FT	SOOSE RD (SR4013 SEG 0010/0000)			
0030/0000				
0010/2085	OLD SOOSE RD (TWP)			
0010/2025	EMERSON RD (TWP)			
000000 FT				
004770 FT	INTER-AHD FRIDAY RD (TWP)			
0030/2370				
0030/1217	KOHLER ST (TWP)			
0030/0745	018" DIA CIRC CONCR	LEN=0025	INSTALLED UNKN	
0030/0436	018" DIA CIRC CONCR	LEN=0035	INSTALLED UNKN	
0030/0072	036"H 72"W CON BOX CUL	LEN=0035	INSTALLED UNKN	
002400 FT	NC PARKER ST	2 0 02285	0 00 0023+23	
0030/0000	LENGTH(AH 2370 BK 2400)			
0010/2224	018" DIA CIRC CONCR	LEN=0035	INSTALLED UNKN	
0010/0958	018" DIA CIRC CONCR	LEN=0040	INSTALLED UNKN	
0010/0779	012" DIA CIRC CONCR	LEN=0014	INSTALLED UNKN	
0010/0337	012" DIA CIRC CONCR	LEN=0238	INSTALLED UNKN	
0010/0215	012" DIA CIRC CONCR	LEN=0099	INSTALLED UNKN	
0010/0065	ELBE DR (TWP)			
000000 FT	NC SEAVEY RD	2 0 02285	0 00 0000+00	
REF-BK	SEAVEY RD (TWP)			
0010/0000	MFC BEGIN = C			
0010/0000	LENGTH(AH 2400 BK 0000)			

EXTRACT DATE: 12/21/2020 ROADWAY MANAGEMENT SYSTEM PAGE NUMBER: 1253
PRINT DATE: 12/23/2020 SLD COUNTY/SR - ANNUAL PRINT COUNTY: ALLEGHENY

DIR: N TOTAL LEN: 8.460 MI. DIST: 11-1 SR: 4003
LEFT MUN: MCCANDLESS T RIGHT MUN: MCCANDLESS T

PERRY HW INTER-AHD
(SRO019 SEG 0571/0255) 044670 FT
SARVER LN

|| - ||

043944 FT
INTER-AHD PERRY HW

EXTRACT DATE: 12/21/2020
PRINT DATE: 12/23/2020

ROADWAY MANAGEMENT SYSTEM
SLD COUNTY/SR - ANNUAL PRINT

PAGE NUMBER: 1252
COUNTY: ALLEGHENY

DIR: N TOTAL LEN: 8.460 MI.
LEFT MUN: MCCANDLESS T

DIST: 11-1 SR: 4003
RIGHT MUN: MCCANDLESS T

Segment Description	Stationing	Notes	Stationing	Notes
(TWP) PERRY HW (SR0019 SEG 0571/0255)	0161/2268	==	0160/1470	(SR0019 SEG 0570/0000) PERRY HW (SR0019 SEG 0570/0000)
BMSBG 02/4003/0161/0599 1 0 00246 7 00 0146+26 SR 19 NB 018 "DIA CIRC CONCR LEN=0099 INSTALLED UNKN	0161/0708		0160/0960	018 "DIA CIRC CONCR LEN=0030 INSTALLED UNKN
BMSBG 02/4003/0161/0599 018 "DIA CIRC CONCR LEN=0099 INSTALLED UNKN	0161/0020			
1 0 00246 7 00 0140+45 LENGTH(AH 2268 BK 3905)	0161/0000	S	042474 FT S 0160/0000	1 0 00246 7 00 0140+45 LENGTH(AH 1470 BK 3952) PINE CREEK RD (SR4086 SEG 0040/1030)
PINE CREEK RD (TBK) (TWP)	0151/3465		0150/3460	PINE CREEK RD (TBK) (TWP)
			0150/3345	020 "DIA CIRC CONCR LEN=0030 INSTALLED UNKN
			0150/3065	018 "DIA CIRC CONCR LEN=0999 INSTALLED UNKN
BMSBG 02/4003/0150/2163 1 0 00246 7 00 0121+98 PINE CREEK BMSBG 02/4003/0150/2163 LC TO BLAZIER DR (CONN)	0151/2217		0150/2227	BMSBG 02/4003/0150/2163 1 0 00246 7 00 0121+98 PINE CREEK BMSBG 02/4003/0150/2163
	0151/2153		0150/2163	
	0151/1900	==		
BLAZIER DR (TWP)	0151/1800		0150/1890	LC FROM BLAZIER DR (CONN) BLAZIER DR (TWP)
			0150/1845	
			0150/1767	LC TO BLAZIER DR (CONN)
LC TO BLAZIER DR (CONN)	0151/1750	==		
018 "DIA CIRC CONCR LEN=0099 INSTALLED UNKN	0151/1562	---		
036 "DIA CIRC CONCR LEN=0099 INSTALLED UNKN	0151/0885	---		
RAMP D RD (SR8069 SEG 0500/0687)	0151/0720	==	0150/0775	095 "DIA CIRC CONCR LEN=0099 INSTALLED UNKN

EXTRACT DATE: 12/21/2020
PRINT DATE: 12/23/2020

ROADWAY MANAGEMENT SYSTEM
SLD COUNTY/SR - ANNUAL PRINT

PAGE NUMBER: 1251
COUNTY: ALLEGHENY

DIR: N TOTAL LEN: 8.460 MI.
LEFT MUN: MCCANDLESS T

DIST: 11-1 SR: 4003
RIGHT MUN: MCCANDLESS T

Stationing	Structure	Length	Notes
0150/0475	095 " DIA CIRC CONCR	LEN=0099	INSTALLED UNKN
0150/0445	RAMP C RD	(SR8069 SEG 0750/0000)	
0150/0144	BMSID 02/4003/0150/0000	038522 FT	1 0 00246 7 00 0101+17 038497 FT
0150/0000	SR 4070 INGOMAR RD		SR 4070 INGOMAR RD
0150/0000	BMSBG 02/4003/0150/0000		BMSBG 02/4003/0150/0000
0140/2475	LENGTH(AH 3952 BK 2489)		095 " DIA CIRC CONCR
0140/2279	LEN=0099		INSTALLED UNKN
0140/2279	BR. PINE CR.	STRUCTURE LENGTH 17 FT	
0140/2101	BMSID 02/4003/0140/2279		BMSID 02/4003/0140/2279
0140/1690	RAMP B RD	(SR8069 SEG 0250/0692)	
0140/1400	0140/2143		RAMP A RD
0140/1030	(SR8069 SEG 0010/0000)		018 " DIA CIRC CONCR
0140/0780	LEN=0099		INSTALLED UNKN
0140/0440	018 " DIA CIRC CONCR		LEN=0099
0140/0040	LEN=0099		INSTALLED UNKN
0140/0000	1 0 00246 7 00 0076+21 036016 FT		018 " DIA CIRC CONCR
0140/0000	LENGTH(AH 2481 BK 1977)	0141/0000	LEN=0099
0130/1715	ARCADIA DR		INSTALLED UNKN
0130/1269	(TWP)		018 " DIA CIRC CONCR
0130/0970	ARCADIA DR		LEN=0099
0130/0673	(TWP)		INSTALLED UNKN
034034 FT	018 " DIA CIRC CONCR		LEN=0099
034034 FT	LEN=0099		INSTALLED UNKN
034034 FT	018 "H 24 "W CON BOX CUL		LEN=0099
034034 FT	LEN=0099		INSTALLED UNKN
034034 FT	018 " DIA CIRC CONCR		LEN=0030
034034 FT	LEN=0030		INSTALLED UNKN
034034 FT	1 0 00246 7 00 0056+34 034039 FT		
034034 FT	CUMBERLAND RD		
034034 FT	(SR4024 SEG 0030/1485)		
034034 FT	(SR4024 SEG 0030/1485)		

DIR: N TOTAL LEN: 8.460 MI. DIST: 11-1 SR: 4003
LEFT MUN: MCCANDLESS T RIGHT MUN: MCCANDLESS T

Stationing	Structure	Length	Material	Status	Stationing	Structure	Length	Material	Status
0131/0000					0130/0000				
					0120/2364	024" DIA CIRC CONCR	0040	INSTALLED	UNKN
					0120/2020	018" DIA CIRC CONCR	0099	INSTALLED	UNKN
					0120/1816	018" DIA CIRC CONCR	0055	INSTALLED	UNKN
					0120/1650	018" DIA CIRC CONCR	0045	INSTALLED	UNKN
					0120/1520	024" DIA CIRC CONCR	0050	INSTALLED	UNKN
					0120/1503	LC FROM DUNCAN AV (CONN)			
DUNCAN AV (TWP)						DUNCAN AV (TWP)			
0121/1372					0120/1367				
BR. LIT. PINE STRUCTURE LENGTH 9 FT					0120/0845	BR. LIT. PINE STRUCTURE LENGTH 9 FT			
BMSID 02/4003/0120/1320						BMSID 02/4003/0120/1320			
095" DIA CIRC CONCR									
LEN=0099 INSTALLED UNKN									
0121/0606									
1 0 00246 7 00 0028+71					031312 FT	1 0 00246 7 00 0028+71			
031317 FT					0120/0000	LENGTH(AH 2722 BK 2504)			
LENGTH(AH 2722 BK 2540)									
0121/0000									
018" DIA CIRC CONCR									
LEN=0036 INSTALLED UNKN									
0111/2270									
018" DIA CIRC CONCR					0110/2265	018" DIA CIRC CONCR			
LEN=0036 INSTALLED UNKN						LEN=0050 INSTALLED UNKN			
0111/1980									
018" DIA CIRC CONCR									
LEN=0036 INSTALLED UNKN									
0111/1660									
018" DIA CIRC CONCR									
LEN=0036 INSTALLED UNKN									
0111/1290									
					0110/0745	018" DIA CIRC CONCR			
						LEN=0035 INSTALLED UNKN			
					0110/0143	LC TO BABCOCK BL (CONN)			
					028808 FT	1 0 00246 7 00 0000+00			
						PERRYMONT RD			
						(SR4056 SEG 0020/2576)			
						BABCOCK BL			
						(CNTY)			
LENGTH(AH 2540 BK 1667)					0110/0000	LENGTH(AH 2504 BK 1560)			
0111/0000						LC TO BABCOCK RD			

DIR: N TOTAL LEN: 8.460 MI. DIST: 11-1 SR: 4003
 LEFT MUN: MCCANDLESS T RIGHT MUN: MCCANDLESS T

Segment Description	Stationing	Material	Status	Notes
MALIBRAN DR (TWP)	0101/1328	018 "DIA CIRC CONCR	INSTALLED UNKN	0100/1349 (CONN)
LEN=0095	0101/1230	018 "DIA CIRC CONCR	INSTALLED UNKN	
018 "DIA CIRC CONCR	0101/1148	LEN=0100	INSTALLED UNKN	
LC TO BABCOCK BL (CONN)	0101/0900			
018 "DIA CIRC CONCR	0101/0486	LEN=0999	INSTALLED UNKN	0100/0576 FROM 4064/0010 SH (CONN)
PEEBLES RD (SR4064 SEG 0010/0463)				PEEBLES RD (SR4064 SEG 0010/0463)
BABCOCK BL (SR4064 SEG 0010/0463)	0101/0198			0100/0215 BABCOCK RD (SR4064 SEG 0010/0463)
FROM 4064/0010 SH (CONN)	0101/0074			
2 0 02302 0 00 0244+71	027110			027248 FT 2 0 02302 0 00 0244+18
MCCANDLESS ROSS T				MCCANDLESS ROSS T
LENGTH(AH 1667 BK 3151)	0101/0000			0100/0000 LENGTH(AH 1560 BK 3259) RAMP A RD (SR8126 SEG 0010/0000)
018 "DIA CIRC CONCR	0091/2598	LEN=0099	INSTALLED UNKN	0090/2846 018 "DIA CIRC CONCR LEN=0055 INSTALLED UNKN
MCINTYRE RD (TBK) (TWP)	0091/1820			0090/2610
018 "DIA CIRC CONCR	0091/1415	LEN=0099	INSTALLED UNKN	0090/2075 018 "DIA CIRC CONCR LEN=0001 INSTALLED UNKN
MCINTYRE RD (TBK) (TWP)	0091/0780			MCINTYRE RD (TBK) (TWP)
018 "DIA CIRC CONCR	0091/0780	LEN=0099	INSTALLED UNKN	0090/1820
018 "DIA CIRC CONCR	0091/0614	LEN=0099	INSTALLED UNKN	0090/1150 LC TO MCINTYRE RD (CONN)
2 0 02302 0 00 0213+22	023959			0090/0760 024 "DIA CIRC CONCR LEN=0099 INSTALLED UNKN
				0090/0760
				0090/0495 018 "DIA CIRC CONCR LEN=0036 INSTALLED UNKN
				018 "DIA CIRC CONCR LEN=0055 INSTALLED UNKN
				0090/0230 018 "DIA CIRC CONCR LEN=0055 INSTALLED UNKN
				023989 FT 2 0 02302 0 00 0209+24

EXTRACT DATE: 12/21/2020
PRINT DATE: 12/23/2020

ROADWAY MANAGEMENT SYSTEM
SLD COUNTY/SR - ANNUAL PRINT

PAGE NUMBER: 1248
COUNTY: ALLEGHENY

DIR: N TOTAL LEN: 8.460 MI.
LEFT MUN: ROSS T

DIST: 11-1 SR: 4003
RIGHT MUN: ROSS T

BROWNS LN
(TWP)

JOHANNNA DR
(TWP)

LENGTH(AH 3151 BK 1758) 0091/0000
024 "DIA CIRC CONCR
LEN=0036 INSTALLED UNKN 0081/1350
SIGN: CANTILEVER
BMSID 02/4003/0081/1157 0081/1201

2 0 02302 0 00 0195+80 022201 FT
MCKNIGHT CR
(TWP)
ROSS PARK MALL DR
(PRDR)

LENGTH(AH 1758 BK 2985) 0081/0000

095 "DIA CIRC CONCR
LEN=0099 INSTALLED UNKN 0071/2545

ROSS TOWNE CT
(PRDR)
PATRICK PL
(TWP)

0071/1255

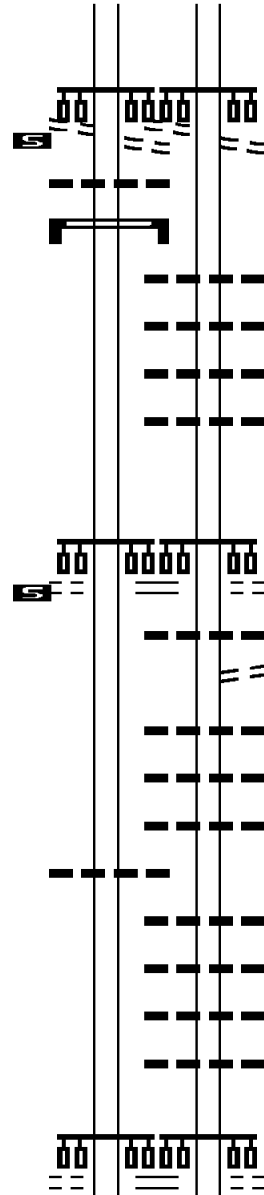

BROWNS LN
(TWP)

JOHANNNA DR
(TWP)

LENGTH(AH 3259 BK 1782)

018 "DIA CIRC CONCR
LEN=0036 INSTALLED UNKN
018 "DIA CIRC CONCR
LEN=0040 INSTALLED UNKN
018 "DIA CIRC CONCR
LEN=0036 INSTALLED UNKN
018 "DIA CIRC CONCR
LEN=0099 INSTALLED UNKN
2 0 02302 0 00 0193+36
MCKNIGHT CR
(TWP)

ROSS PARK MALL DR
(PRDR)

LENGTH(AH 1782 BK 2923)

036 "DIA CIRC CONCR
LEN=0099 INSTALLED UNKN
LC TO ROSS PARK MALL
(CONN)
018 "DIA CIRC CONCR
LEN=0024 INSTALLED UNKN
018 "DIA CIRC CONCR
LEN=0036 INSTALLED UNKN
018 "DIA CIRC CONCR
LEN=0040 INSTALLED UNKN

036 "DIA CIRC CONCR
LEN=0036 INSTALLED UNKN
012"H 24"W CON BOX CUL
LEN=0099 INSTALLED UNKN
018 "DIA CIRC CONCR
LEN=0099 INSTALLED UNKN
018 "DIA CIRC CONCR
LEN=1206 INSTALLED UNKN
ROSS TOWNE CT
(PRDR)

PATRICK PL
(TWP)

0070/1205

DIR: N TOTAL LEN: 8.460 MI. DIST: 11-1 SR: 4003
 LEFT MUN: ROSS T RIGHT MUN: ROSS T

Segment Description	Stationing	Material	Length	Status
018 "DIA CIRC CONCR LEN=0099 INSTALLED UNKN	0071/0705			
2 0 02302 0 00 0166+80 019216 FT LENGTH(AH 2985 BK 1346)	0071/0000			
024 "DIA CIRC CONCR LEN=0099 INSTALLED UNKN	0061/1034			
KENTZEL RD (TWP)	0061/0970			
024 "DIA CIRC CONCR LEN=0036 INSTALLED UNKN	0061/0787			
TO 4016/0010 SH (CONN)	0061/0127			
2 0 02302 0 00 0152+68 017870 FT SIEBERT RD (SR4016 SEG 0020/0000)	0061/0000			
SIEBERT RD (SR4016 SEG 0020/0000)	0061/0000			
LENGTH(AH 1346 BK 1596)	0061/0000			
024 "DIA CIRC CONCR LEN=0099 INSTALLED UNKN	0051/1313			
048 "DIA CIRC CONCR				
LC TO PATRICK PL (CONN)	0070/1130			
018 "DIA CIRC CONCR LEN=0123 INSTALLED UNKN	0070/1121			
024 "DIA CIRC CONCR LEN=0036 INSTALLED UNKN	0070/1110			
018 "DIA CIRC CONCR LEN=0099 INSTALLED UNKN	0070/0714			
018 "DIA CIRC CONCR LEN=0036 INSTALLED UNKN	0070/0328			
018 "DIA CIRC CONCR LEN=0040 INSTALLED UNKN	0070/0277			
2 0 02302 0 00 0166+53 OLD MCKNIGHT RD (TWP)	0070/0000			
LENGTH(AH 2923 BK 1395)	0070/0000			
048 "DIA CIRC CONCR LEN=0099 INSTALLED UNKN	0060/1355			
LC TO OLD MCKNIGHT RD (CONN)	0060/1160			
036 "DIA CIRC CONCR LEN=0099 INSTALLED UNKN	0060/0576			
024 "DIA CIRC CONCR LEN=0099 INSTALLED UNKN	0060/0215			
2 0 02302 0 00 0152+19 SIEBERT RD (SR4016 SEG 0020/0000)	0060/0000			
SIEBERT RD (SR4016 SEG 0020/0000)	0060/0000			
LENGTH(AH 1395 BK 1768)	0060/0000			
TO 4016/0020 SH (CONN)	0050/1520			
024 "H 36" W ELLIP CONC LEN=0035 INSTALLED UNKN	0050/1305			
018 "DIA CIRC CONCR LEN=0099 INSTALLED UNKN	0050/1205			

DIR: N TOTAL LEN: 8.460 MI. DIST: 11-1 SR: 4003
 LEFT MUN: ROSS T RIGHT MUN: ROSS T

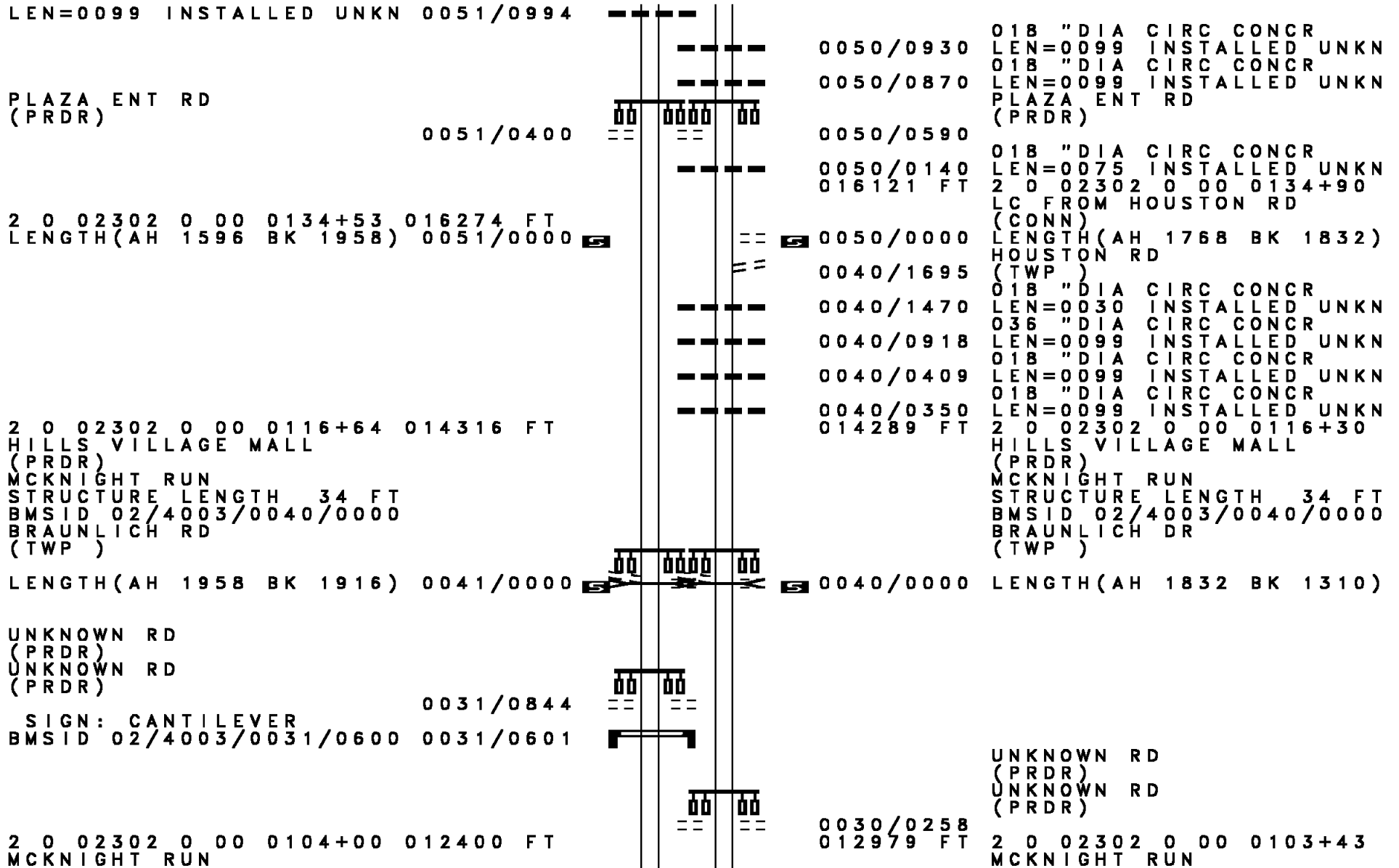

EXTRACT DATE: 12/21/2020
PRINT DATE: 12/23/2020

ROADWAY MANAGEMENT SYSTEM
SLD COUNTY/SR - ANNUAL PRINT

PAGE NUMBER: 1245
COUNTY: ALLEGHENY

DIR: N
LEFT MUN: ROSS T

TOTAL LEN: 8.460 MI.

DIST: 11-1
RIGHT MUN: ROSS T

SR: 4003

STRUCTURE LENGTH 12 FT
BMSID 02/4003/0030/0000
LENGTH(AH 1916 BK 1118) 0031/0000

MCKNIGHT RUN
STRUCTURE LENGTH 12 FT
BMSID 02/4003/0020/1051 0021/1051
SIGN: CANTILEVER

BMSID 02/4003/0021/1035 0021/1035
RAMP G RD
(SR8079 SEG 0500/0000) 0021/0775

MCKNIGHT RUN
STRUCTURE LENGTH 15 FT
BMSID 02/4003/0020/1096 0021/0632

RAMP K RD
(SR8079 SEG 0510/0381) 0021/0460

BMSEN 02/4003/0020/0000 0021/0221
2 0 02302 0 00 0086+55 011282 FT

BABCOCK BLVD
BMSBG 02/4003/0020/0000
LENGTH(AH 1118 BK 2818) 0021/0000

018 "DIA CIRC CONCR
LEN=0099 INSTALLED UNKN 0017/2530

JUGHANDLE RD
(SR9401 SEG 0010/0000) 0017/0260
2 0 02302 0 00 0054+04 008464 FT

JUGHANDLE RD
(SR9401 SEG 0010/0375)

NELSON RUN RD
(TWP)

LENGTH(AH 2818 BK 3540) 0017/0000

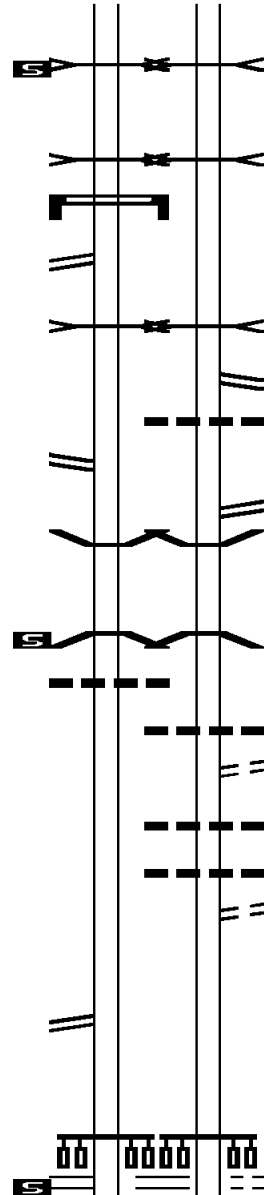

STRUCTURE LENGTH 12 FT
BMSID 02/4003/0030/0000
LENGTH(AH 1310 BK 1700)

MCKNIGHT RUN
STRUCTURE LENGTH 12 FT
BMSID 02/4003/0020/1051

MCKNIGHT RUN
STRUCTURE LENGTH 15 FT
BMSID 02/4003/0020/1096

RAMP H RD
(SR8079 SEG 0750/0561)
012 "DIA CIRC CONCR
LEN=0048 INSTALLED UNKN

RAMP L RD
(SR8079 SEG 0760/0000)
BMSEN 02/4003/0020/0000
2 0 02302 0 00 0086+55

BABCOCK BLVD
BMSBG 02/4003/0020/0000
LENGTH(AH 1700 BK 2851)

012 "DIA CIRC CONCR
LEN=0099 INSTALLED UNKN
LC TO BROOKVIEW LN
(CONN)

018 "DIA CIRC CONCR
LEN=0099 INSTALLED UNKN
018 "DIA CIR PLASTIC

LEN=0099 INSTALLED UNKN
STEVENS DR
(TWP)

2 0 02302 0 00 0054+04
JUGHANDLE RD
(SR9401 SEG 0010/0375)

NELSON RUN RD
(TWP)

LENGTH(AH 2851 BK 3378)

DIR: N TOTAL LEN: 8.460 MI. DIST: 11-1 SR: 4003
 LEFT MUN: ROSS T RIGHT MUN: ROSS T

018 "DIA CIRC CONCR LEN=0040 INSTALLED UNKN 0015/3175	---	0014/2950	015 "DIA CIRC CONCR LEN=0099 INSTALLED UNKN
018 "DIA CIRC CONCR LEN=0040 INSTALLED UNKN 0015/2876	---	0014/2643	015 "DIA CIRC CONCR LEN=0099 INSTALLED UNKN
018 "DIA CIRC CONCR LEN=0099 INSTALLED UNKN 0015/2597	---	0014/2344	018 "DIA CIRC CONCR LEN=0099 INSTALLED UNKN
018 "DIA CIRC CONCR LEN=0024 INSTALLED UNKN 0015/0979 LC TO WEST VIEW AV (CONN) 0015/0617	--- ==	0014/0362	018 "DIA CIRC CONCR LEN=0099 INSTALLED UNKN LC FROM NELSON RD (CONN)
018 "DIA CIRC CONCR LEN=0099 INSTALLED UNKN 0015/0567 LC FROM WEST VIEW AV (CONN) 0015/0504	--- ==	0014/0150 005050 FT	2 0 02302 0 00 0020+53 004924 FT LC TO NELSON RD (CONN) ROSS PITTSBURGH C LENGTH(AH 3540 BK 1919) 0015/0000
2 0 02302 0 00 0020+53 004924 FT LC TO NELSON RD (CONN) ROSS PITTSBURGH C LENGTH(AH 3540 BK 1919) 0015/0000	== ---	0014/0000	018 "DIA CIRC CONCR LEN=0024 INSTALLED UNKN BMSSEN 02/4003/0010/1709
BMSSEN 02/4003/0010/1709 0011/1782 0 0 00000 0 00 0000+00 LC TO NELSON RD (CONN) NELSON RUN	--- ==	0010/1876 0010/1821	2 0 02302 0 00 0019+38 NELSON RUN BMSBG 02/4003/0010/1709
BMSBG 02/4003/0010/1709 0011/1670 SIGN: CANTILEVER BMSID 02/4003/0011/1575 0011/1575 IVORY AVE	--- ---	0010/1230	OP ID 02/7301/0000/2262 0011/1215 RAMP J RD (SR8102 SEG 0500/0000) 0011/1100
OP ID 02/7301/0000/2262 0011/1215 RAMP J RD (SR8102 SEG 0500/0000) 0011/1100	== ---	0010/0585	RAMP I RD (SR8102 SEG 0030/1040) RAMP RD

DIR: N TOTAL LEN: 8.460 MI. DIST: 11-1 SR: 4003
LEFT MUN: PITTSBURGH C RIGHT MUN: PITTSBURGH C

Station	Description	Station	Description
0011/0450	SR 0279 NB	0010/0505	(SR8102 SEG 0040/0280)
0011/0345	RAMP 8102	0010/0415	OP ID SR 0279 NB
0011/0258	I-279 S.B.	0010/0309	OP ID RAMP 8102
0011/0045	RAMP J SR4003 SB T	0010/0206	OP ID I-279 S.B.
0011/0000	EVERGREEN RD	0010/0040	EVERGREEN RD
003005 FT	(SR4009 SEG 0110/2624)	003015 FT	(SR4009 SEG 0110/2624)
0011/0000	NC MCKNIGHT RD	0010/0000	OP ID RAMP J SR4003 SB T
0007/2850	MFC BEGIN = B	0006/3015	NC MCKNIGHT RD
0007/2565	LEN=0025 INSTALLED UNKN	0006/2889	MFC BEGIN = B
0007/1940	CITY AL	0006/2585	LEN=0099 INSTALLED UNKN
0007/1846	(CITY)	0006/2582	EVERGREEN RD
0007/1750	DEWEY AV	0006/1940	(SR4009 SEG 0111/2937)
0007/1663	(CITY)	0006/1764	CITY AL
0007/1560	GRIBBLE ST	0006/1598	(CITY)
	(CITY)		DEWEY AV
			(CITY)
			024 "DIA CIRC CONCR
			LEN=0099 INSTALLED UNKN
			018 "DIA CIRC CONCR
			LEN=0055 INSTALLED UNKN
			024 "DIA CIRC CONCR
			LEN=0099 INSTALLED UNKN

DIR: N TOTAL LEN: 8.460 MI. DIST: 11-1 SR: 4003
 LEFT MUN: PITTSBURGH C RIGHT MUN: PITTSBURGH C

Stationing	Description	Material	Length	Notes
0006/1442	018 "DIA CIRC CONCR	LEN=0075	INSTALLED UNKN	
0007/1330	020 "DIA CIRC CONCR	LEN=0025	INSTALLED UNKN	
0006/1304	020 "DIA CIRC CONCR	LEN=0099	INSTALLED UNKN	
0006/1160	BAYTREE ST (CITY)			
0007/1165	018 "DIA CIRC CONCR	LEN=0099	INSTALLED UNKN	
0007/1126	018 "DIA CIRC CONCR	LEN=0025	INSTALLED UNKN	
0007/1058	018 "DIA CIRC CONCR	LEN=0055	INSTALLED UNKN	
0006/1005	018 "DIA CIRC CONCR	LEN=0099	INSTALLED UNKN	
0006/0961	018 "DIA CIRC CONCR	LEN=0099	INSTALLED UNKN	
0007/0923	018 "DIA CIRC CONCR	LEN=0030	INSTALLED UNKN	
0006/0913	018 "DIA CIRC CONCR	LEN=0099	INSTALLED UNKN	
0006/0666	018 "DIA CIRC CONCR	LEN=0099	INSTALLED UNKN	
0007/0580	LC TO EAST ST (CONN)			
0006/0535	020 "DIA CIRC CONCR	LEN=0099	INSTALLED UNKN	
0007/0358	EAST ST (CITY)			
0006/0327	EAST ST (CITY)			
0006/0302	018 "DIA CIRC CONCR	LEN=0055	INSTALLED UNKN	
0006/0078	018 "DIA CIRC CONCR	LEN=0099	INSTALLED UNKN	
000000 FT	0 0 00000 0 00 0000+00 000000 FT			
	RAMP NC EVERGREEN RD			
	(SR8101 SEG 0510/0000)			
	VENTURE ST INT/ RP H RD			
	(SR8101 SEG 0500/0559)			
	VENTURE ST (CITY)			
	EAST ST INTER-BK			
	(CITY)			
	MFC BEGIN = C			
	LENGTH(AH 3005 BK 0000) 0007/0000			
	0006/0000			
	EAST ST INTER-BK			
	(CITY)			
	MFC BEGIN = C			
	LENGTH(AH 3015 BK 0000)			

EXTRACT DATE: 12/21/2020 ROADWAY MANAGEMENT SYSTEM PAGE NUMBER: 1241
PRINT DATE: 12/23/2020 SLD COUNTY/SR - ANNUAL PRINT COUNTY: ALLEGHENY
DIR: B TOTAL LEN: 1.016 MI. DIST: 11-1 SR: 4002
LEFT MUN: SHALER T RIGHT MUN: SHALER T

005362 FT

005362 FT
INTER-AHD UNKNOWN RD

DIR: B TOTAL LEN: 1.016 MI. DIST: 11-1 SR: 4002
 LEFT MUN: SHALER T RIGHT MUN: SHALER T

Location	Stationing	Notes
GLENWOOD AV (TWP)	0020/2555	0020/2632 (TWP) BABCOCK BL (SR4009 SEG 0060/0000)
		0020/2333 BMS EN 02/4002/0020/2353 2 0 02112 0 00 0027+34 BR. ANCH OF GIRTY S RUN
		0020/2318 BMSBG 02/4002/0020/2353 018 "DIA CIRC METAL
		0020/1775 LEN=0045 INSTALLED UNKN 018 "DIA CIRC METAL
		0020/1458 LEN=0045 INSTALLED UNKN
WYNNE ST (TWP)	0020/1440	
		0020/1249 015 "DIA CIRC METAL LEN=0027 INSTALLED UNKN
		0020/1044 015 "DIA CIRC METAL LEN=0045 INSTALLED UNKN
		0020/0821 015 "DIA CIRC METAL LEN=0040 INSTALLED UNKN
		0020/0498 015 "DIA CIRC METAL LEN=0045 INSTALLED UNKN
		0020/0427 036 "DIA CIRC METAL LEN=0099 INSTALLED UNKN
002730 FT	002730 FT	2 0 02112 0 00 0027+34 SHALER RESERVE T
		0020/0000 LENGTH(AH 2632 BK 2730) 095 "DIA CIR UNKNOWN
		0010/2704 LEN=0052 INSTALLED UNKN 018 "DIA CIRC CONCR
		0010/2483 LEN=0055 INSTALLED UNKN 018 "DIA CIRC CONCR
		0010/2202 LEN=0099 INSTALLED UNKN
		0010/1511 018 "DIA CIRC CONCR LEN=0040 INSTALLED UNKN
GEYER RD ET (TWP)	0010/0955	
		0010/0770 018 "DIA CIRC METAL LEN=0040 INSTALLED UNKN
GEYER RD ET (TWP)	0010/0230	GEYER RD ET
000000 FT	000000 FT	2 0 02112 0 00 0000+00 MT TROY RD (CNTY)
MT TROY RD (CNTY)	0010/0000	NC GEYER RD MFC BEGIN = C 0010/0000 LENGTH(AH 2730 BK 0000)

EXTRACT DATE: 12/21/2020 ROADWAY MANAGEMENT SYSTEM PAGE NUMBER: 1239
PRINT DATE: 12/23/2020 SLD COUNTY/SR - ANNUAL PRINT COUNTY: ALLEGHENY
DIR: N TOTAL LEN: .000 MI. DIST: 11-1 SR: 4001
LEFT MUN: PITTSBURGH C RIGHT MUN: PITTSBURGH C

000000 FT
000000 FT



000000 FT
7014/0000 LTH AH 000100 BK 000692
000000 FT
7010/0000 LENGTH(AH 0692 BK 0000)

DIR: N TOTAL LEN: .595 MI. DIST: 11-1 SR: 3919
 LEFT MUN: PITTSBURGH C RIGHT MUN: PITTSBURGH C

Stationing	Description	Material / Notes
003144 FT	INTER-AHD	CHATEAU ST (CITY)
0010/3144	ADAMS ST	TO 0019/0280 SH (SR8049 SEG 0030/0000)
0010/3074	WARNER ST	(CITY)
0010/2915	COLUMBUS AV	(CITY)
0010/2748	LAKE ST	(CITY)
0010/2579	LC FROM BEAVER AV	(CITY)
0010/2521	JUNIATA ST	(CONN)
0010/2410	LC TO BEAVER AV	(CITY)
0010/2269	RUSH ST	(CITY)
0010/2238	FRANKLIN ST	(CITY)
0010/2065	LIVERPOOL ST	(CITY)
0010/1725	PENNSYLVANIA AV	(CITY)
0010/1375	STEDMAN ST	(CITY)
0010/1200	SHEFFIELD ST	(CITY)
0010/1020	HAMLIN ST	(CITY)
0010/0841	NORTH AV	(CITY)
0010/0683	FAULSEY WAY	(CITY)
0010/0513	018 " DIA CIRC CONCR	LEN=0099 INSTALLED UNKN
0010/0287	024 " DIA CIRC CONCR	LEN=0099 INSTALLED UNKN
0010/0245	RAMP RD/TO CHATEAU ST	(SR9101 SEG 0010/0521)
0010/0084	1 0 00246 0 00 0060+30	000000 FT
0010/0000	INTER-BK	CHATEAU ST (SR8055 SEG 0750/0442) MFC BEGIN = C

LTH AH 003144 BK 000000 000000 FT 7011/0000

EXTRACT DATE: 12/21/2020 ROADWAY MANAGEMENT SYSTEM PAGE NUMBER: 1237
PRINT DATE: 12/23/2020 SLD COUNTY/SR - ANNUAL PRINT COUNTY: ALLEGHENY

DIR: E TOTAL LEN: 6.959 MI. DIST: 11-1 SR: 3160
LEFT MUN: MOON T RIGHT MUN: MOON T

AIRPORT PY 036288 FT
(SR0376 SEG 0575/2165) INTER-AHD
AIRPORT PY
(SR0376 SEG 0575/2165) 0133/2785

SR 8110 (RAMP WS-C
OP ID 02/8110/0250/2010 0133/0900

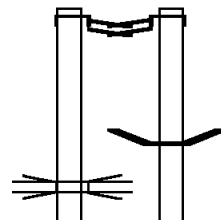

036746 FT
INTER-AHD AIRPORT PY
(SR0376 SEG 0574/2256)
AIRPORT PY
(SR0376 SEG 0574/2256)
0132/2390

0132/1245 BMS EN 02/3160/0132/0858

1 0 01057 0 00 0141+05

DIR: E TOTAL LEN: 6.959 MI. DIST: 11-1 SR: 3160
LEFT MUN: MOON T RIGHT MUN: MOON T

Station	Description	Length	Structure	Notes
0132/0858	376 EASTBOUND BMSBG	02/3160	OP ID 02/8110	(RAMP WS-C)
0132/0520	SIGN: 4 CHORD TRUSS	02/8110	0250/2010	
0132/0375	BMSID 02/3160	0132/0375	1 0 01057 0 00	0141+05
034356 FT	RAMP RD	(SR8110 SEG 0500/0000)		
0132/0000	LENGTH(AH 2390 BK 3710)			
0123/3120	018 "DIA CIRC CONCR			
LEN=0050	INSTALLED UNKN			
0123/2912	RAMP RD			
(SR8110 SEG 0250/4078)				
0123/2752	SIGN: 4 CHORD TRUSS			
BMSID 02/3160/0122/2722				
0122/2695	SIGN: 4 CHORD TRUSS			
BMSID 02/3160/0122/2722				
0123/2142	SIGN: CANTILEVER			
BMSID 02/3160/0123/2142				
0123/1616	018 "DIA CIRC CONCR			
LEN=0099	INSTALLED UNKN			
0122/1342	SIGN: CANTILEVER			
BMSID 02/3160/0122/1342				
0123/0997	SIGN: CANTILEVER			
BMSID 02/3160/0123/0997				
0122/0911	015 "DIA CIRC CONCR			
LEN=0050	INSTALLED UNKN			
0123/0687	RAMP A RD			
(SR8070 SEG 0500/0000)				
0122/0531	024 "DIA CIRC CONCR			
LEN=0060	INSTALLED UNKN			
0122/0354	RAMP D RD			
030646 FT	(SR8070 SEG 0750/0626)			
0122/0000	1 0 01057 0 00			
0106+18	LENGTH(AH 3710 BK 3387)			
0112/2942	OP ID 02/3070/0134/0277			
0112/2918	036 "DIA CIRC CONCR			
LEN=0040	INSTALLED UNKN			
0112/2555	024 "DIA CIRC CONCR			
LEN=0040	INSTALLED UNKN			
0112/2337	RAMP C RD			
(SR8070 SEG 0010/0000)				
UNKNOWN	UNKNOWN			
STRUCTURE LENGTH 12 FT				
0112/1934	BMSID 02/3160/0112/1899			

DIR: E TOTAL LEN: 6.959 MI. DIST: 11-1 SR: 3160
LEFT MUN: MOON T RIGHT MUN: MOON T

RAMP B RD (SR8070 SEG 0250/1098)	0113/1476	0112/1478	018 "DIA CIRC CONCR LEN=0040	INSTALLED UNKN
		0112/1110	018 "DIA CIRC CONCR LEN=0099	INSTALLED UNKN
015 "DIA CIRC CONCR LEN=0050	INSTALLED UNKN 0113/0490	0112/0821	018 "DIA CIRC CONCR LEN=0099	INSTALLED UNKN
015 "DIA CIRC CONCR LEN=0050	INSTALLED UNKN 0113/0180	0112/0480	018 "DIA CIRC CONCR LEN=0099	INSTALLED UNKN
1 0 01057 0 00 0072+37 026870 FT LENGTH(AH 3396 BK 2492)	0113/0000	0112/0170 027259 FT 0112/0000	018 "DIA CIRC CONCR LEN=0099	INSTALLED UNKN 1 0 01057 0 00 0072+65 LENGTH(AH 3387 BK 2494)
018 "DIA CIRC CONCR LEN=0065	INSTALLED UNKN 0103/2326			
018 "DIA CIRC CONCR LEN=0005	INSTALLED UNKN 0103/1968			
018 "DIA CIRC CONCR LEN=0040	INSTALLED UNKN 0103/1218			
012 "DIA CIRC CONCR LEN=0045	INSTALLED UNKN 0103/0570			
015 "DIA CIRC CONCR LEN=0040	INSTALLED UNKN 0103/0270			
1 0 01057 0 00 0047+44 024378 FT LENGTH(AH 2492 BK 1931)	0103/0000	024765 FT 0102/0000	1 0 01057 0 00 0047+50 LENGTH(AH 2494 BK 1955)	
SMALL CREEK STRUCTURE LENGTH 10 FT BMSID 02/3160/0092/1945	0093/1921	0092/1900 0092/1660	SMALL CREEK STRUCTURE LENGTH 10 FT BMSID 02/3160/0092/1945 RAMP A RD (SR8106 SEG 0750/0654)	
018 "DIA CIRC CONCR LEN=0099	INSTALLED UNKN 0093/1551			
018 "DIA CIRC CONCR LEN=0099	INSTALLED UNKN 0093/1180			
CLIFF MINE OP ID 02/3073/0010/0000	0093/0941	0092/0965	CLIFF MINE OP ID 02/3073/0010/0000	
RAMP B RD (SR8106 SEG 0250/0000)	0093/0801			
RAMP D RD (SR8106 SEG 0260/0546)	0093/0344			
1 0 01057 0 00 0027+40 022447 FT LENGTH(AH 1931 BK 2960)	0093/0000	0092/0340 022810 FT 0092/0000	RAMP C RD (SR8106 SEG 0010/0000) 1 0 01057 0 00 0027+11 LENGTH(AH 1955 BK 2846)	

DIR: E TOTAL LEN: 6.959 MI. DIST: 11-1 SR: 3160
 LEFT MUN: MOON T RIGHT MUN: MOON T

015 "DIA CIRC METAL LEN=0099 INSTALLED UNKN 0083/2651 SIGN: CANTILEVER BMSID 02/3160/0083/2610 0083/2610		0082/2846	012 "DIA CIRC CONCR LEN=0050 INSTALLED UNKN
AIRSIDE BUS PARK ENTR {CNTY} {APRA} AIRSIDE BUSINESS 0083/1710 099 "DIA CIRC CONCR LEN=0025 INSTALLED UNKN 0083/1523		0082/2471	018 "DIA CIRC METAL LEN=0099 INSTALLED UNKN
AIRSIDE BUS PARK ENTR (CNTY)		0082/1376	018 "DIA CIRC CONCR LEN=0035 INSTALLED UNKN
		0082/1173	018 "DIA CIRC CONCR LEN=0040 INSTALLED UNKN
		0082/0940	015 "DIA CIRC CONCR LEN=0030 INSTALLED UNKN
		0082/0900	LC FR AIRSIDE BUS PARK {CONN}
AIRSIDE BUS PARK ENTR (CNTY)		0082/0755	{APRA} AIRSIDE BUSINESS AIRSIDE BUS PARK ENTR (CNTY)
015 "DIA CIRC CONCR LEN=0025 INSTALLED UNKN 0083/0760		0082/0674	LC TO AIRSIDE BUS PARK {CONN}
015 "DIA CIRC CONCR LEN=0025 INSTALLED UNKN 0083/0715		0082/0517	015 "DIA CIRC CONCR LEN=0040 INSTALLED UNKN
		0082/0310	015 "DIA CIRC CONCR LEN=0040 INSTALLED UNKN
012 "DIA CIRC CONCR LEN=0030 INSTALLED UNKN 0083/0260 TO 3109/0010 SH {CONN} 0083/0149 1 0 01057 0 00 0000+00 019487 FT		0082/0206	LC FROM HORIZON DR {CONN}
HORIZON DR (CNTY)		019964 FT	1 0 01057 0 00 0000+00 HORIZON DR (CNTY)
UNIVERSITY BL {SR3109 SEG 0011/0000}			UNIVERSITY BL {SR3109 SEG 0011/0000}
{SR3109 SEG 0010/0000}			{SR3109 SEG 0010/0000}
UNIVERSITY BL {SR3109 SEG 0011/0000}			UNIVERSITY BL {SR3109 SEG 0011/0000}
{SR3109 SEG 0010/0000}			{SR3109 SEG 0010/0000}

DIR: E TOTAL LEN: 6.959 MI. DIST: 11-1 SR: 3160
 LEFT MUN: MOON T RIGHT MUN: MOON T

Stationing	Description	Stationing	Description
0083/0000	LENGTH(AH 2960 BK 3362)	0082/0000	LENGTH(AH 2846 BK 3566)
0073/3261	FROM 3109/0011 SH (CONN)	0072/3496	LC TO HORIZON DR (CONN)
0073/2929	SIGN: CANTILEVER BMSID 02/3160/0073/3231	0072/2872	018 "DIA CIRC CONCR LEN=0060 INSTALLED UNKN
0073/2079	HANGAR SERVICE RD (GOVT)	0072/2580	018 "DIA CIRC CONCR LEN=0030 INSTALLED UNKN
0073/0000	000000 000 0000+00 016125 FT LENGTH(AH 3362 BK 3664)	0072/2304	018 "DIA CIRC CONCR LEN=0030 INSTALLED UNKN HANGAR SERVICE RD (GOVT)
		0072/2241	LC TO HANGAR SERVICE RD (CONN)
		0072/2145	018 "DIA CIRC CONCR LEN=0099 INSTALLED UNKN
		0072/0000	016398 FT 000000 000 0000+00 LENGTH(AH 3566 BK 3539)
0063/0674	018 "DIA CIRC CONCR LEN=0030 INSTALLED UNKN NC BUSINESS 376	0062/2110	018 "DIA CIRC CONCR LEN=0099 INSTALLED UNKN (APRA) FED EX/UPS AIR D
0063/0000	000000 000 0000+00 012461 FT LENGTH(AH 3664 BK 2212)	0062/2069	FED EX/UPS AIR DEPOT EX (PRDR)
		0062/0789	018 "DIA CIRC CONCR LEN=0080 INSTALLED UNKN
		0062/0000	012859 FT 000000 000 0000+00 NC BUSINESS 376 LENGTH(AH 3539 BK 1811)

DIR: E TOTAL LEN: 6.959 MI. DIST: 11-1 SR: 3160
LEFT MUN: MOON T RIGHT MUN: MOON T

RAMP A RD
(SR8071 SEG 0500/0000) 0053/1319
018 "DIA CIRC CONCR
LEN=0070 INSTALLED UNKN 0053/1218

INTERNATIONAL DRIV
OP ID 02/3147/0010/0000 0053/0445

1 0 01023 0 00 0028+67 010249 FT
LENGTH(AH 2212 BK 2357) 0053/0000

RAMP B RD
(SR8071 SEG 0250/0824) 0043/1973

018 "DIA CIRC CONCR
LEN=0130 INSTALLED UNKN 0043/1280
018 "DIA CIRC CONCR
LEN=0140 INSTALLED UNKN 0043/1008
024 "DIA CIRC CONCR
LEN=0120 INSTALLED UNKN 0043/0677
018 "DIA CIRC CONCR
LEN=0130 INSTALLED UNKN 0043/0398
MOON
FINDLAY T 0043/0169

1 0 01023 0 00 0052+24 007892 FT
LENGTH(AH 2357 BK 2839) 0043/0000
SIGN: CANTILEVER
BMSID 02/3160/0043/0244 0033/2798

SIGN: 3 CHORD TRUSS
BMSID 02/3160/0033/1485 0033/1485
RAMP I RD
(SR8072 SEG 0500/0000) 0033/1185
018 "DIA CIRC CONCR
LEN=0160 INSTALLED UNKN 0033/1048

0052/0827 RAMP D RD
(SR8071 SEG 0750/0676)
018 "DIA CIRC CONCR
LEN=0099 INSTALLED UNKN
0052/0490

INTERNATIONAL DRIV
OP ID 02/3147/0010/0000
0052/0125 011048 FT
1 0 01023 0 00 0018+11
LENGTH(AH 1811 BK 2487)
018 "DIA CIRC CONCR
LEN=0099 INSTALLED UNKN
0052/0000

RAMP C RD
(SR8071 SEG 0010/0000)
SIGN: CANTILEVER
BMSID 02/3160/0042/1398
MOON
FINDLAY T
0042/2060
0042/1680
0042/1398
0042/1348

SIGN: CANTILEVER
BMSID 02/3160/0042/0096
008561 FT
1 0 01023 0 00 0043+00
LENGTH(AH 2487 BK 3067)
0042/0096
0042/0000

018 "DIA CIRC CONCR
LEN=0130 INSTALLED UNKN
0032/2225

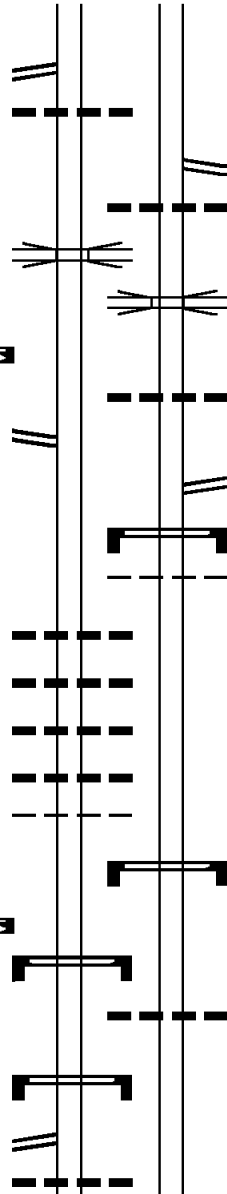

DIR: E TOTAL LEN: 6.959 MI. DIST: 11-1 SR: 3160
LEFT MUN: FINDLAY T RIGHT MUN: FINDLAY T

018 "DIA CIRC CONCR LEN=0130 INSTALLED UNKN 0033/0693	0032/1039 RAMP K RD (SR8072 SEG 0750/1047)
1 0 01023 0 00 0079+52 005053 FT LENGTH(AH 2839 BK 1400) 0033/0000	005494 FT 1 0 01023 0 00 0079+95 0032/0000 LENGTH(AH 3067 BK 1505)
MOON CLINTON RD OP ID 02/3089/0130/0031 0023/1400	0022/1505 OP ID 02/3089/0130/0031 MOON CLINTON RD
RAMP J RD (SR8072 SEG 0250/0805) 0023/0549	0022/0680 RAMP L RD (SR8072 SEG 0010/0000)
024 "DIA CIRC CONCR LEN=0120 INSTALLED UNKN 0023/0188	003989 FT 1 0 01023 0 00 0106+27 0022/0000 LENGTH(AH 1505 BK 3989)
1 0 01023 0 00 0106+84 003653 FT LENGTH(AH 1400 BK 3653) 0023/0000	0012/3989 OP ID 02/3088/0050/0000 HKSTWN.GR.RD
HKSTWN.GR.RD OP ID 02/3088/0050/0000 0013/3653	0012/2079 BMS EN 02/3160/0012/1527
018 "DIA CIRC CONCR LEN=0099 INSTALLED UNKN 0013/1781	1 0 01023 0 00 0128+17 I-376 WB 0012/1527 BMSBG 02/3160/0012/1527
BEAVER VALLEY EX (SR0376 SEG 0501/1787)	0012/1450 018 "DIA CIRC CONCR LEN=0050 INSTALLED UNKN
NC CARGO RD BEAVER VALLEY EX INTER-BK	0012/1328 018 "DIA CIRC CONCR LEN=0050 INSTALLED UNKN
(SR0376 SEG 0501/1787)	0012/0711 018 "DIA CIRC CONCR LEN=0070 INSTALLED UNKN
MFC BEGIN = B	000000 FT 1 0 01023 0 00 0128+17 BEAVER VALLEY EX
LENGTH(AH 3653 BK 0000) 0013/0000	(SR0376 SEG 0500/0903) NC CARGO RD INTER-BK BEAVER VALLEY EX
	(SR0376 SEG 0500/0903) MFC BEGIN = B
	0012/0000 LENGTH(AH 3989 BK 0000)

EXTRACT DATE: 12/21/2020 ROADWAY MANAGEMENT SYSTEM PAGE NUMBER: 1230
 PRINT DATE: 12/23/2020 SLD COUNTY/SR - ANNUAL PRINT COUNTY: ALLEGHENY
 DIR: B TOTAL LEN: .027 MI. DIST: 11-1 SR: 3148
 LEFT MUN: SOUTH FAYETTE T RIGHT MUN: SOUTH FAYETTE T

000141 FT

000000 FT

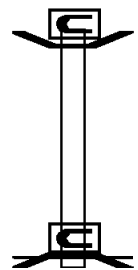

000141 FT BMS EN 02/3148/0010/0000
 * REF-AHD COUNTY LINE RD
 (CNTY)
 0010/0141
 000000 FT 0 0 00000 0 00 0000+00
 NC CO COUNTY LINE RD BRIDGE
 * REF-BK COUNTY LINE RD
 (CNTY)
 BRIDGE CLOSED
 SR 0079 NB
 BMSBG 02/3148/0010/0000
 MFC BEGIN = E
 0010/0000 LENGTH(AH 0141 BK 0000)

EXTRACT DATE: 12/21/2020 ROADWAY MANAGEMENT SYSTEM PAGE NUMBER: 1229
 PRINT DATE: 12/23/2020 SLD COUNTY/SR - ANNUAL PRINT COUNTY: ALLEGHENY
 DIR: B TOTAL LEN: .030 MI. DIST: 11-1 SR: 3147
 LEFT MUN: MOON T RIGHT MUN: MOON T

000159 FT
 000000 FT

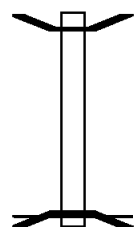

000159 FT BMS EN 02/3147/0010/0000
 * REF-AHD INTERNATIONAL DR
 0010/0159 (TWP)
 000000 FT 0 0 00000 0 00 0000+00
 NC IN INTERNATIONAL DR
 * REF-BK INTERNATIONAL DR
 (TWP)
 INTERSTATE 376 WB
 BMSBG 02/3147/0010/0000
 MFC BEGIN = E
 0010/0000 LENGTH(AH 0159 BK 0000)

EXTRACT DATE: 12/21/2020 ROADWAY MANAGEMENT SYSTEM PAGE NUMBER: 1227
PRINT DATE: 12/23/2020 SLD COUNTY/SR - ANNUAL PRINT COUNTY: ALLEGHENY

DIR: E TOTAL LEN: .042 MI. DIST: 11-1 SR: 3144
LEFT MUN: ROBINSON T RIGHT MUN: ROBINSON T

ROBINSON TOWN CTR BL	000224 FT				000224 FT	ROBINSON TOWN CTR BL
(TWP)	REF-AHD	*			REF-AHD	(TWP)
BMSSEN 02/3144/0020/0024	0021/0224				0020/0224	BMSSEN 02/3144/0020/0024
0 0 00000 0 00 0000+00	0021/0200				0020/0200	0 0 00000 0 00 0000+00
SR 0376 EB						SR 0376 EB
BMSBG 02/3144/0020/0024	0021/0024				0020/0024	BMSBG 02/3144/0020/0024
0 0 00000 0 00 0000+00	000000 FT				000000 FT	0 0 00000 0 00 0000+00
NC ROBINSON TOWN CTR BL					NC RO	ROBINSON TOWN CTR BL
ROBINSON TOWN CTR BL	REF-BK	*			REF-BK	SUMMIT PARK DR
(TWP)						(TWP)
MFC BEGIN = E						MFC BEGIN = E
LENGTH(AH 0224 BK 0000)	0021/0000				0020/0000	LENGTH(AH 0224 BK 0000)

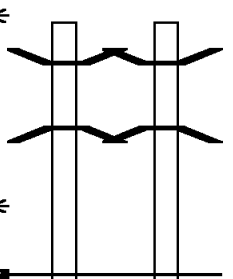

DIR: B TOTAL LEN: .202 MI. DIST: 11-1 SR: 3123
 LEFT MUN: GREENTREE B RIGHT MUN: GREENTREE B

LC FROM 3101/0010 SH
 (CONN)

001065 FT

0010/0980

000000 FT

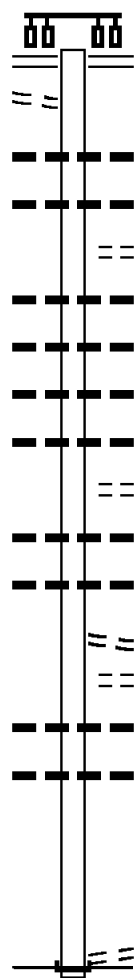

001065 FT GREENTREE RD
 (SR3101 SEG 0010/1440)

0010/1065

0010/0914	020 " DIA CIRC CONCR
	LEN=0025 INSTALLED UNKN
0010/0773	018 " DIA CIRC CONCR
	LEN=0025 INSTALLED UNKN
0010/0710	PARKWAY CENTER INN ENT
	(PRDR)
0010/0663	018 " DIA CIRC CONCR
	LEN=0119 INSTALLED UNKN
0010/0653	020 " DIA CIRC CONCR
	LEN=0025 INSTALLED UNKN
0010/0540	020 " DIA CIRC CONCR
	LEN=0025 INSTALLED UNKN
0010/0368	020 " DIA CIRC CONCR
	LEN=0025 INSTALLED UNKN
0010/0330	PARKWAY CENTER OFFICE R
	(PRDR)
0010/0250	018 " DIA CIRC CONCR
	LEN=0025 INSTALLED UNKN
0010/0131	020 " DIA CIRC CONCR
	LEN=0025 INSTALLED UNKN
0010/0115	LC FROM MALL RD
	(CONN)
0010/0045	PARKWAY CENTER MALL RD
	(PRDR)
0010/0044	016 " DIA CIRC CONCR
	LEN=0015 INSTALLED UNKN
0010/0024	016 " DIA CIRC CONCR
	LEN=0015 INSTALLED UNKN
000000 FT	0 0 00000 0 00 0000+00
	LC TO MALL RD
	(CONN)
	NC PARKWAY CENTER DR
INTER-BK	SR 8091 SH
	(SR8091 SEG 0250/0000)
	MFC BEGIN = C
0010/0000	LENGTH(AH 1065 BK 0000)

DIR: B TOTAL LEN: .101 MI. DIST: 11-1 SR: 3121
 LEFT MUN: NORTH FAYETTE T RIGHT MUN: NORTH FAYETTE T

000531 FT

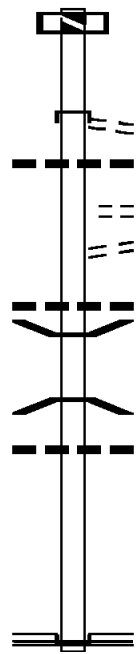

000000 FT

POTATO GARDEN RUN RD (SR3071 SEG 0010/0000) 0010/0000

000531 FT
 7014/0000 INTER-AHD LTH AH 000100 BK 000531
 RAMP C RD (SR8024 SEG 0750/0000)
 LC FOR STEUBENVILLE PK (CONN)
 0010/0531 015 " DIA CIRC CONCR
 0010/0515 LEN=0045 INSTALLED UNKN
 STEUBENVILLE PK (T865)
 0010/0465 LC TO STEUBENVILLE PK
 (CONN)
 0010/0385 015 " DIA CIRC CONCR
 0010/0320 LEN=0035 INSTALLED UNKN
 0010/0259 BMSSEN 02/3121/0010/0096
 1 0 00257 0 00 0005+02
 MONTOUR RAILROAD COM RR
 0010/0096 BMSBG 02/3121/0010/0096
 015 " DIA CIRC CONCR
 0010/0070 LEN=0050 INSTALLED UNKN
 000000 FT 1 0 00257 0 00 0003+95
 NC ST STEUBENVILLE PK
 ROBINSON HW
 (SR0980 SEG 0010/0613)
 INTER-BK RAMP D RD
 (SR8024 SEG 0010/0579)
 MFC BEGIN = E
 0010/0000 LENGTH(AH 0531 BK 0000)

BEVERLY RD (CNTY)	002150 FT		002150 FT INTER-AHD BANKSVILLE RD (SR0019 SEG 0150/0000)
	0010/2150		0010/2150 024 " DIA CIRC CONCR LEN=0050 INSTALLED UNKN
PARKER DR (TWP)	0010/1755		0010/1815 ANNAPOLIS AV (BORO)
			0010/1100 DELL AV (BORO)
EDWARD AV (TWP)	0010/0835		0010/1065 MT LEBANON DORMONT B
MARTIN AV (TWP)	0010/0585		0010/0100 RALEIGH AV (BORO)
			000000 FT NC MCFARLAND RD
2 0 02347 0 00 0000+00 000000 FT			000000 FT INTER-BK WEST LIBERTY AV (SR3069 SEG 0031/0000)
WASHINGTON RD (SR3069 SEG 0030/0000)	0010/0000		0010/0000 MFC BEGIN = B LENGTH(AH 2150 BK 0000)
(SR3069 SEG 0031/0000)			

DIR: B TOTAL LEN: .863 MI. DIST: 11-1 SR: 3117
 LEFT MUN: COLLIER T RIGHT MUN: COLLIER T

004559 FT

004559 FT NOBLESTOWN RD
 (SR3048 SEG 0180/0515)
 0020/2518 (SR3048 SEG 0181/0490)
 018 "DIA CIRC CONCR
 0020/2293 LEN=0099 INSTALLED UNKN
 FIRST ST
 (TWP)
 0020/2283 018 "DIA CIRC CONCR
 0020/2170 LEN=0099 INSTALLED UNKN
 LC FOR SOUTH EWING RD
 (CONN)
 0020/2109 SOUTH EWING RD
 (TWP)
 0020/1937 NOBLESTOWN ROAD EB
 0020/1879 OP ID 02/3048/0190/0000
 0020/1581 (AAR 508042U)#TRKS 01
 018 "DIA CIRC CONCR
 0020/1170 LEN=0027 INSTALLED UNKN
 0020/1120 BMS EN 02/3117/0020/108B
 2 0 02343 0 00 0031+22
 ROBINSON RUN
 0020/1056 BMSBG 02/3117/0020/108B
 018 "DIA CIRC METAL
 0020/0971 LEN=0024 INSTALLED UNKN

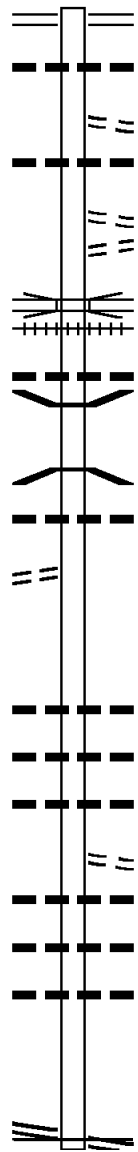

CLUXTON RD
 (TWP)

0020/0771
 002041 FT

002041 FT 2 0 02343 0 00 0019+73
 NC NOBLESTOWN RD ET
 5 0020/0000 LENGTH(AH 2518 BK 2041)
 018 "DIA CIRC METAL
 0010/1886 LEN=0045 INSTALLED UNKN
 018 "DIA CIRC METAL
 0010/1739 LEN=0040 INSTALLED UNKN
 018 "DIA CIRC METAL
 0010/1545 LEN=0040 INSTALLED UNKN
 SPRING ST
 (TWP)
 0010/1334 018 "DIA CIRC METAL
 0010/1290 LEN=0035 INSTALLED UNKN
 015 "DIA CIRC CONCR
 0010/0817 LEN=0035 INSTALLED UNKN
 012 "DIA CIR PLASTIC
 0010/0779 LEN=0060 INSTALLED UNKN
 NC DORRINGTON RD
 HILL TOP RD
 000000 FT (SR3052 SEG 0060/0000)
 MFC BEGIN = E
 5 0010/0000 LENGTH(AH 2041 BK 0000)

2 0 02343 0 00 0000+00 000000 FT
 HILL TOP RD
 (SR3052 SEG 0060/0000) 0010/0000

EXTRACT DATE: 12/21/2020 ROADWAY MANAGEMENT SYSTEM PAGE NUMBER: 1222
PRINT DATE: 12/23/2020 SLD COUNTY/SR - ANNUAL PRINT COUNTY: ALLEGHENY
DIR: E TOTAL LEN: .000 MI. DIST: 11-1 SR: 3115
LEFT MUN: MOON T RIGHT MUN: MOON T

000000 FT



000000 FT
7010/0000 LENGTH(AH 0196 BK 0000)

MONTOUR INT/RMP A RD 001025 FT
 (SR8074 SEG 0254/0000)
 MONTOUR RUN RD
 (SR3072 SEG 0004/0000)
 (SR3072 SEG 0005/0000)

 RAMP D SPUR RD 0011/1025
 (SR8074 SEG 0264/0225)
 RAMP A RD
 (SR3072 SEG 0005/0000)
 (SR3072 SEG 0004/0000)

 RAMP D RD 0011/0005
 (SR8074 SEG 0274/0469)
 AIRPORT PKWY EB
 OP ID 02/0376/0584/0097 0011/0495

 0 0 0000 0 00 0000+00 000000 FT
 NC MONTOUR RUN RD
 CLIFF MINE RD
 (CNTY)

 MONTOUR INT/RMP B RD INTER-BK
 (SR8074 SEG 0020/0000)
 MFC BEGIN = C
 LENGTH(AH 1025 BK 0000) 0011/0000

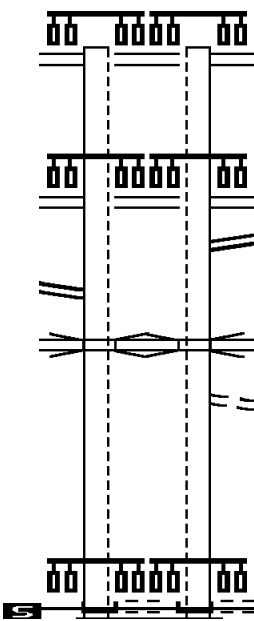

001025 FT MONTOUR INT/RMP A RD
 (SR8074 SEG 0254/0000)
 MONTOUR RUN RD
 (SR3072 SEG 0004/0000)
 (SR3072 SEG 0005/0000)

 0010/1025 RAMP D SPUR RD
 (SR8074 SEG 0264/0225)
 RAMP A RD
 (SR3072 SEG 0005/0000)
 (SR3072 SEG 0004/0000)

 0010/1005 RAMP B SPUR RD
 (SR9112 SEG 0010/0000)

 0010/0950

 0010/0495 AIRPORT PKWY EB
 OP ID 02/0376/0584/0097
 LC FROM CLIFF MINE RD
 (CONN)
 0010/0070 0 0 0000 0 00 0000+00
 000000 FT NC MONTOUR RUN RD
 CLIFF MINE RD
 (CNTY)

 INTER-BK MONTOUR INT/RMP B RD
 (SR8074 SEG 0010/0725)
 MFC BEGIN = C
 LENGTH(AH 1025 BK 0000) 0010/0000

EXTRACT DATE: 12/21/2020 ROADWAY MANAGEMENT SYSTEM PAGE NUMBER: 1220
 PRINT DATE: 12/23/2020 SLD COUNTY/SR - ANNUAL PRINT COUNTY: ALLEGHENY
 DIR: B TOTAL LEN: .133 MI. DIST: 11-1 SR: 3111
 LEFT MUN: CRESCENT T RIGHT MUN: CRESCENT T

MCGOVERN BL 000702 FT
 (SR0051 SEG 0810/1075) 0010/0702

000000 FT

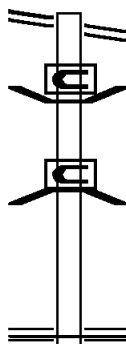

000702 FT MCGOVERN BL
 0010/0702 (SR0051 SEG 0810/1075)
 0010/0093 BMSSEN 02/3111/0010/0080
 2 0 02243 0 00 0007+57
 BRIDGE CLOSED
 SHOUSE RUN
 0010/0080 BMSBG 02/3111/0010/0080
 000000 FT 2 0 02243 0 00 0006+74
 NC BOCKTOWN RD
 BOCKTOWN RD
 (SR3094 SEG 0040/0000)
 MFC BEGIN = E
 0010/0000 LENGTH(AH 0702 BK 0000)

EXTRACT DATE: 12/21/2020 ROADWAY MANAGEMENT SYSTEM PAGE NUMBER: 1219
 PRINT DATE: 12/23/2020 SLD COUNTY/SR - ANNUAL PRINT COUNTY: ALLEGHENY
 DIR: B TOTAL LEN: .031 MI. DIST: 11-1 SR: 3110
 LEFT MUN: PITTSBURGH C RIGHT MUN: PITTSBURGH C

000164 FT

000000 FT

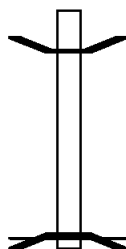

```

000164 FT
* REF-AHD      SHALER ST
0010/0164      (CITY)
0010/0140      BMSEN 02/3110/0010/0001
000000 FT      0 0 00000 0 00 0000+00
                 NC SHALER ST
* REF-BK      SHALER ST
                 (CITY)
                 ROUTE 19 SB
                 BMSBG 02/3110/0010/0001
                 MFC BEGIN = E
5 0010/0000      LENGTH(AH 0164 BK 0000)
  
```

DIR: N TOTAL LEN: 3.159 MI. DIST: 11-1 SR: 3109
 LEFT MUN: MOON T RIGHT MUN: MOON T

Segment ID	Material	Length (ft)	Year	Stationing	Notes
016682	INTER-AHD	FT		0071/3218	
(SR0051 SEG 0760/0000)					
0071/3095					
(SR9103 SEG 0020/0215)					
018 "DIA CIRC CONCR					
LEN=0040	INSTALLED	2002		0071/2877	
018 "DIA CIRC CONCR					
LEN=0040	INSTALLED	2002		0071/2626	
018 "DIA CIRC CONCR					
LEN=0040	INSTALLED	2002		0071/2100	
018 "DIA CIRC CONCR					
LEN=0040	INSTALLED	2002		0071/1917	
018 "DIA CIRC CONCR					
LEN=0040	INSTALLED	2002		0071/1716	
018 "DIA CIRC CONCR					
LEN=0040	INSTALLED	2002		0071/1361	
024 "DIA CIRC CONCR					
LEN=0040	INSTALLED	2002		0071/1161	
018 "DIA CIRC CONCR					
LEN=0040	INSTALLED	2002		0071/0834	
018 "DIA CIRC CONCR					
LEN=0040	INSTALLED	2002		0071/0545	
024 "DIA CIRC CONCR					
LEN=0040	INSTALLED	2002		0071/0351	
018 "DIA CIRC CONCR					
LEN=0040	INSTALLED	2002		0071/0138	
018 "DIA CIRC CONCR					
LEN=0040	INSTALLED	2002		0071/0070	
018 "DIA CIRC CONCR					
LEN=0040	INSTALLED	2002		0071/0050	
1 0 00076 0 03 0749+10				013464 FT	
016671	INTER-AHD	FT		0070/3103	
(SR0051 SEG 0761/0000)					
0070/2037	018 "DIA CIRC CONCR				LEN=0045 INSTALLED UNKN
0070/1850	018 "DIA CIRC CONCR				LEN=0045 INSTALLED UNKN
0070/1636	018 "DIA CIRC CONCR				LEN=0045 INSTALLED UNKN
0070/1276	018 "DIA CIRC CONCR				LEN=0045 INSTALLED UNKN
013568	FT	1 0 00076 0 03 0748+95			

DIR: N TOTAL LEN: 3.159 MI. DIST: 11-1 SR: 3109
 LEFT MUN: MOON T RIGHT MUN: MOON T

Stationing	Description	Stationing	Description
0071/0000	LENGTH(AH 3218 BK 1825)	0070/0000	LENGTH(AH 3103 BK 1957)
	018 "DIA CIRC CONCR	0060/1810	LEN=0030 INSTALLED UNKN
	LEN=0040 INSTALLED 2002	0060/1505	LEN=0040 INSTALLED UNKN
NARROWS RUN		0060/1478	NARROWS RUN
STRUCTURE LENGTH 10 FT			STRUCTURE LENGTH 10 FT
BMSID 02/3109/0060/1452		0060/1032	018 "DIA CIRC CONCR
018 "DIA CIRC CONCR			LEN=0040 INSTALLED UNKN
LEN=0040 INSTALLED 2002		0060/0753	018 "DIA CIRC CONCR
018 "DIA CIRC CONCR			LEN=0040 INSTALLED UNKN
LEN=0040 INSTALLED 2002		011611 FT	1 0 00076 0 03 0766+85
018 "DIA CIRC CONCR			OLD NARROWS RUN RD
LEN=0040 INSTALLED 2002			(T134)
1 0 00076 0 03 0767+35		0060/0000	LENGTH(AH 1957 BK 2069)
011639 FT			018 "DIA CIRC CONCR
OLD NARROWS RUN RD		0050/1845	LEN=0040 INSTALLED 2002
(T134)		0050/1579	018 "DIA CIRC CONCR
LENGTH(AH 1825 BK 2087)			LEN=0040 INSTALLED 2002
0061/0000		0050/0716	018 "DIA CIRC CONCR
018 "DIA CIRC CONCR			LEN=0040 INSTALLED 2002
LEN=0060 INSTALLED 2002		0050/0470	018 "DIA CIRC CONCR
018 "DIA CIRC CONCR			LEN=0246 INSTALLED UNKN
LEN=0060 INSTALLED 2002		0050/0157	018 "DIA CIRC CONCR
			LEN=0002 INSTALLED 2002
1 0 00076 0 03 0788+25		009542 FT	1 0 00076 0 03 0788+25
009552 FT		0050/0000	LENGTH(AH 2069 BK 3259)
LENGTH(AH 2087 BK 3258)			018 "DIA CIRC CONCR
0051/0000		0040/3081	LEN=0080 INSTALLED 2002
			018 "DIA CIRC CONCR
		0040/2796	LEN=0099 INSTALLED 2002
			018 "DIA CIRC CONCR
		0040/2530	LEN=0040 INSTALLED 2002
			GRANT DR
		0040/2313	(TWP)
GRANT DR			
(TWP)			
0041/2275			018 "DIA CIRC CONCR

EXTRACT DATE: 12/21/2020
PRINT DATE: 12/23/2020

ROADWAY MANAGEMENT SYSTEM
SLD COUNTY/SR - ANNUAL PRINT

PAGE NUMBER: 1216
COUNTY: ALLEGHENY

DIR: N TOTAL LEN: 3.159 MI.
LEFT MUN: MOON T

DIST: 11-1 SR: 3109
RIGHT MUN: MOON T

(APRA) ROBERT MORRIS UN
SHOPPING PLAZA ENT RD
(PRDR)
CAMPUS DR
(TWP)

FARMHAVEN DR
(TWP)
018 "DIA CIRC CONCR
LEN=0030 INSTALLED 2002
WESTRIDGE DR
(TWP)
012 "DIA CIRC CONCR
LEN=0030 INSTALLED UNKN
2 0 02003 0 01 0475+44 006294 FT
BRODHEAD RD
(SR3077 SEG 0150/0000)
BEAVER GRADE RD
(SR3077 SEG 0150/0000)

LENGTH(AH 3258 BK 1504) 0041/0000

012 "DIA CIRC CONCR
LEN=0030 INSTALLED UNKN
WEST HILLS SHOPPING CTR
(PRDR)
LC FROM CARNOT RD
(CONN)

0031/0715

CARNOT RD
(TWP)
1 1 04625 0 00 0098+95 004790 FT
MOON CLINTON RD
(SR3090 SEG 0020/3114)

LENGTH(AH 1504 BK 2501) 0031/0000

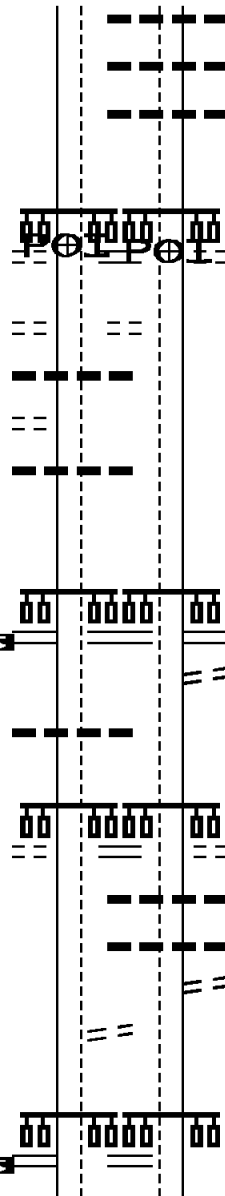

0040/2212 LEN=0099 INSTALLED 2002
018 "DIA CIRC CONCR
0040/1969 LEN=0040 INSTALLED 2002
018 "DIA CIRC CONCR
0040/1662 LEN=0100 INSTALLED 2002
(APRA) ROBERT MORRIS UN
SHOPPING PLAZA ENT RD
(PRDR)
CAMPUS DR
(TWP)

0040/1435

FARMHAVEN DR
(TWP)

0040/0705

006283 FT 2 0 02003 0 01 0475+44
BRODHEAD RD
(SR3077 SEG 0150/0000)
BEAVER GRADE RD
(SR3077 SEG 0150/0000)

0040/0000 LENGTH(AH 3259 BK 1473)
TO 3077/0144 SH
0030/1397 (CONN)

WEST HILLS SHOPPING CTR
(PRDR)
LC FROM CARNOT RD
(CONN)

0030/0713

0030/0588 018 "DIA CIRC CONCR
LEN=0099 INSTALLED 2002
0030/0230 018 "DIA CIRC CONCR
LEN=0099 INSTALLED 2002
CARNOT RD
(TWP)

004810 FT 1 1 04625 0 00 0098+95
MOON CLINTON RD
(SR3090 SEG 0020/3114)

0030/0000 LENGTH(AH 1473 BK 2504)
018 "DIA CIRC CONCR

DIR: N TOTAL LEN: 3.159 MI. DIST: 11-1 SR: 3109
 LEFT MUN: MOON T RIGHT MUN: MOON T

Stationing	Right of Way	Structure	Material	Length	Installation	Notes
0020/2130	0020/1505	018 "DIA	CIRC CONCR	LEN=0099	INSTALLED 2002	TIGER TR (TWP)
0021/1058	0020/1049	018 "DIA	CIRC CONCR	LEN=0145	INSTALLED UNKN	
0020/0847	0020/0718	018 "DIA	CIRC CONCR	LEN=0044	INSTALLED 2002	
0020/0113	0020/0113	012 "DIA	CIRC CONCR	LEN=0099	INSTALLED 2002	
1 1 04625 0 00 0075+05 002289 FT	002306 FT	1 1 04625 0 00 0075+05	PATTON DR	(T330)		
0021/0000	0020/0000	018 "DIA	CIRC CONCR	LEN=0099	INSTALLED UNKN	ROSEMONT DR (T348)
0011/2106	0010/2135					
0011/1410						PORT AUTHORITY DR (TWP)
0011/1298	0010/1323					PORTVUE DR (TWP)
0011/1281	0010/1308					
SIGN: CANTILEVER						
BMSID 02/3109/0011/0613	0011/0589					
018 "DIA CIRC CONCR	0011/0488					
LEN=0040 INSTALLED 2002						
TO 3160/0073 SH	0010/0127					FROM 3160/0083 SH (CONN)
(CONN)						
1 1 04625 0 00 0050+85 000000 FT	000000 FT	1 1 04625 0 00 0050+85	NC UN	UNIVERSITY BL		
BUSINESS 376 SH						
(SR3160 SEG 0083/0000)						
BUSINESS 376 SH						
(SR3160 SEG 0083/0000)						
HORIZON DR	INTER-BK					
(CNTY)						
MFC BEGIN = B						
LENGTH(AH 2289 BK 0000)	0011/0000					0010/0000 LENGTH(AH 2306 BK 0000)

DIR: B TOTAL LEN: 3.133 MI. DIST: 11-1 SR: 3108
 LEFT MUN: NORTH FAYETTE T RIGHT MUN: NORTH FAYETTE T

ROADWAY	START STATION	END STATION	LENGTH	DESCRIPTION
BATEMAN RD (SR0978 SEG 0190/0000)	016541 FT	0070/2453	0070/2453	INTER-AHD NORTH BRANCH RD (SR0978 SEG 0190/0000)
		0070/2059	0070/2059	036 "DIA CIRC CONCR
		0070/1787	0070/1787	LEN=0065 INSTALLED UNKN
		0070/1466	0070/1466	018 "DIA CIRC METAL
		0070/0924	0070/0924	LEN=0050 INSTALLED UNKN
		0070/0664	0070/0664	018 "DIA CIRC CONCR
		0070/0527	0070/0527	LEN=0045 INSTALLED UNKN
OLD MILL RD (PRDR)	0070/0100			018 "DIA CIRC CONCR
	014088 FT			LEN=0070 INSTALLED UNKN
		0070/0084	0070/0084	036 "DIA CIRC CONCR
		014088 FT	014088 FT	LEN=0055 INSTALLED UNKN
		0070/0000	0070/0000	015 "DIA CIRC CONCR
		0060/1400	0060/1400	LEN=0075 INSTALLED UNKN
DONALDSON RD (TBK) (TWP)	0060/1375			1 0 00680 0 00 0144+78 LENGTH(AH 2453 BK 1973) WHITTENGALE RD (SR3057 SEG 0050/3451)
		0060/1344	0060/1344	048 "DIA CIRC CONCR
		0060/1234	0060/1234	LEN=0060 INSTALLED UNKN
		0060/0987	0060/0987	018 "DIA CIRC CONCR
		0060/0689	0060/0689	LEN=0055 INSTALLED UNKN
		0060/0369	0060/0369	015 "DIA CIRC CONCR
		0060/0135	0060/0135	LEN=0060 INSTALLED UNKN
	012115 FT			018 "DIA CIRC CONCR
		0060/0000	0060/0000	LEN=0045 INSTALLED UNKN
		0050/2156	0050/2156	018 "DIA CIRC CONCR
				LEN=0050 INSTALLED UNKN
				1 0 00680 0 00 0125+05 LENGTH(AH 1973 BK 2580)
				036 "DIA CIR PLASTIC
				LEN=0065 INSTALLED UNKN
				015 "DIA CIRC CONCR

EXTRACT DATE: 12/21/2020
PRINT DATE: 12/23/2020

ROADWAY MANAGEMENT SYSTEM
SLD COUNTY/SR - ANNUAL PRINT

PAGE NUMBER: 1213
COUNTY: ALLEGHENY

DIR: B TOTAL LEN: 3.133 MI.
LEFT MUN: NORTH FAYETTE T

DIST: 11-1 SR: 3108
RIGHT MUN: NORTH FAYETTE T

KELSO RD
(T874)

009535 FT

0040/1431

006534 FT

0050/1806	LEN=0045	INSTALLED UNKN
	024 "DIA	CIRC CONCR
0050/1259	LEN=0100	INSTALLED UNKN
	015 "DIA	CIRC CONCR
0050/0869	LEN=0045	INSTALLED UNKN
	015 "DIA	CIRC CONCR
0050/0557	LEN=0060	INSTALLED UNKN
	018 "DIA	CIRC OTHER
0050/0130	LEN=0030	INSTALLED UNKN
009535 FT	1 0 00680	0 00 0098+87
5 0050/0000	LENGTH(AH	2580 BK 3001)
	036"H 36"W	CON BOX CUL
0040/2980	LEN=0040	INSTALLED UNKN
	018 "DIA	CIR PLASTIC
	LEN=0030	INSTALLED UNKN
	NORTH RD	
0040/2915	(SR3059	SEG 0040/2532)
	018 "DIA	CIRC CONCR
0040/2273	LEN=0050	INSTALLED UNKN
	018 "DIA	CIRC CONCR
0040/1773	LEN=0040	INSTALLED UNKN
	FINKS RUN RD	
0040/1495	(TWP)	
	018 "DIA	CIR PLASTIC
0040/1485	LEN=0060	INSTALLED UNKN
0040/1245	BMS EN 02/3108/0040/1239	
	1 0 00680	0 00 0068+45
	N.BR.ROBINSON	
0040/1213	BMSBG 02/3108/0040/1239	
006534 FT	1 0 00680	0 00 0068+45
	024 "DIA	CIRC CONCR
5 0040/0000	LEN=0020	INSTALLED UNKN
	LENGTH(AH	3001 BK 3338)
	HANS RD	
	(T807)	
	036 "DIA	CIRC CONCR
0030/2634	LEN=0080	INSTALLED UNKN
	036 "DIA	CIRC CONCR
0030/2377	LEN=0080	INSTALLED UNKN
0030/1414	BMS EN 02/3108/0030/1395	

RBR

EXTRACT DATE: 12/21/2020
PRINT DATE: 12/23/2020

ROADWAY MANAGEMENT SYSTEM
SLD COUNTY/SR - ANNUAL PRINT

PAGE NUMBER: 1212
COUNTY: ALLEGHENY

DIR: B TOTAL LEN: 3.133 MI.
LEFT MUN: NORTH FAYETTE T

DIST: 11-1 SR: 3108
RIGHT MUN: NORTH FAYETTE T

SEABRIGHT RD
(SR3053 SEG 0010/0000) 0030/1300

003196 FT

000715 FT

000000 FT



1 0 00680 0 00 0048+62
P3
B NORTH BR ROBINSON RUN
BMSBG 02/3108/0030/1395

0030/1395

0030/1196 LEN=0030 "DIA CIRC CONCR INSTALLED UNKN
0030/0647 LEN=0050 "DIA CIRC CONCR INSTALLED UNKN
0030/0214 LEN=0055 "DIA CIRC CONCR INSTALLED UNKN
0030/0031 LEN=0065 "DIA CIRC METAL INSTALLED UNKN
003196 FT 1 0 00680 0 00 0034+80
S 0030/0000 LENGTH(AH 3338 BK 2481)
0020/2272 018 "DIA CIR PLASTIC INSTALLED UNKN
0020/1938 015 "DIA CIRC OTHER INSTALLED UNKN
0020/1635 015 "DIA CIRC CONCR INSTALLED UNKN

MCWREATH RD
(T407)
0020/0705 015 "DIA CIRC CONCR INSTALLED UNKN
0020/0649 LEN=0055 INSTALLED UNKN

000715 FT 1 0 00680 0 00 0009+36
S 0020/0000 LENGTH(AH 2481 BK 0715)
VALLEY ST (TBK)
0010/0485 (TWP)
0010/0470 030 "DIA CIRC CONCR INSTALLED UNKN

RBR

0010/0187 BMSBG 02/3108/0010/0174
1 0 00680 1 00 0001+84
P3
N. BRANCH ROBINSON RUN
BMSBG 02/3108/0010/0174
0010/0174 1 0 00680 1 00 0000+00
000000 FT NC NO

* REF-BK NORTH BRANCH RD
(SR4067 SEG 0020/1164)
MFC BEGIN = D
BK-WASHINGTON (62)

S 0010/0000 LENGTH(AH 0715 BK 0000)

SIGN: CANTILEVER
 BMSID 02/0837/0590/3119001686 FT
 WEST CARSON ST INTER-AHD
 (SR0837 SEG 0590/3099)
 CARSON ST
 (SR0837 SEG 0590/3099) 0011/1686
 BMSEN 02/3106/0010/0704 0011/0921
 1 0 00076 7 00 0000+00
 WEST END CIRCLE
 OP ID 02/0837/0600/0000
 SAW MILL RUN
 BMSBG 02/3106/0010/0704 0011/0885
 1 0 00076 7 00 0000+00 000000 FT
 CARSON ST
 (SR0051 SEG 0450/0665)
 NC WEST CARSON ST
 WEST CARSON ST INTER-BK
 (SR0051 SEG 0450/0665)
 MFC BEGIN = B
 LENGTH(AH 1686 BK 0000) 0011/0000

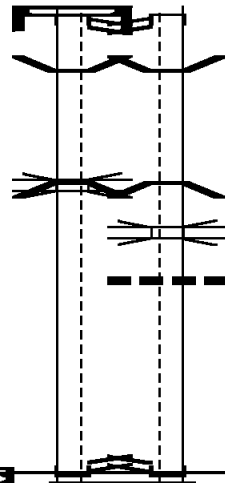

001582 FT
 INTER-AHD WEST CARSON ST
 (SR0837 SEG 0591/3077)
 CARSON ST
 (SR0837 SEG 0591/3077)
 0010/1582
 0010/0782 BMSEN 02/3106/0010/0704
 1 0 00076 7 00 0001+48
 SAW MILL RUN
 BMSBG 02/3106/0010/0704
 WEST END CIRCLE
 0010/0746
 OP ID 02/0837/0600/0000
 012 " DIA CIRC CONCR
 0010/0170 LEN=0020 INSTALLED UNKN
 000000 FT 1 0 00076 7 00 0000+00
 CARSON ST
 (SR0051 SEG 0450/0581)
 NC WEST CARSON ST
 INTER-BK WEST CARSON ST
 (SR0051 SEG 0450/0581)
 MFC BEGIN = B
 0010/0000 LENGTH(AH 1582 BK 0000)

EXTRACT DATE: 12/21/2020 ROADWAY MANAGEMENT SYSTEM PAGE NUMBER: 1210
 PRINT DATE: 12/23/2020 SLD COUNTY/SR - ANNUAL PRINT COUNTY: ALLEGHENY
 DIR: E TOTAL LEN: .005 MI. DIST: 11-1 SR: 3105
 LEFT MUN: FINDLAY T RIGHT MUN: FINDLAY T

000024 FT

 000000 FT

 000000 FT

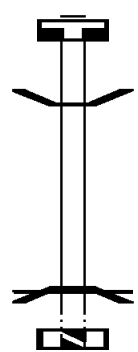

000024 FT
 7032/0000 LENGTH(AH 0105 BK 0024)
 BMSBN 02/3105/0030/0000
 * REF-AHD SANTIAGO RD
 0030/0024 (TWP)
 000000 FT 2 0 02005 0 00 0048+78
 NC SA SANTIAGO RD
 * REF-BK SANTIAGO RD
 (TWP)
 S.FK.MONTOUR
 BMSBG 02/3105/0030/0000
 MFC BEGIN = E
 5 0030/0000 LTH AH 000024 BK 000100
 000000 FT
 7010/0000 LTH AH 000100 BK 000000

DIR: E TOTAL LEN: 1.105 MI. DIST: 11-1 SR: 3104
 LEFT MUN: MCKEES ROCKS B RIGHT MUN: MCKEES ROCKS B

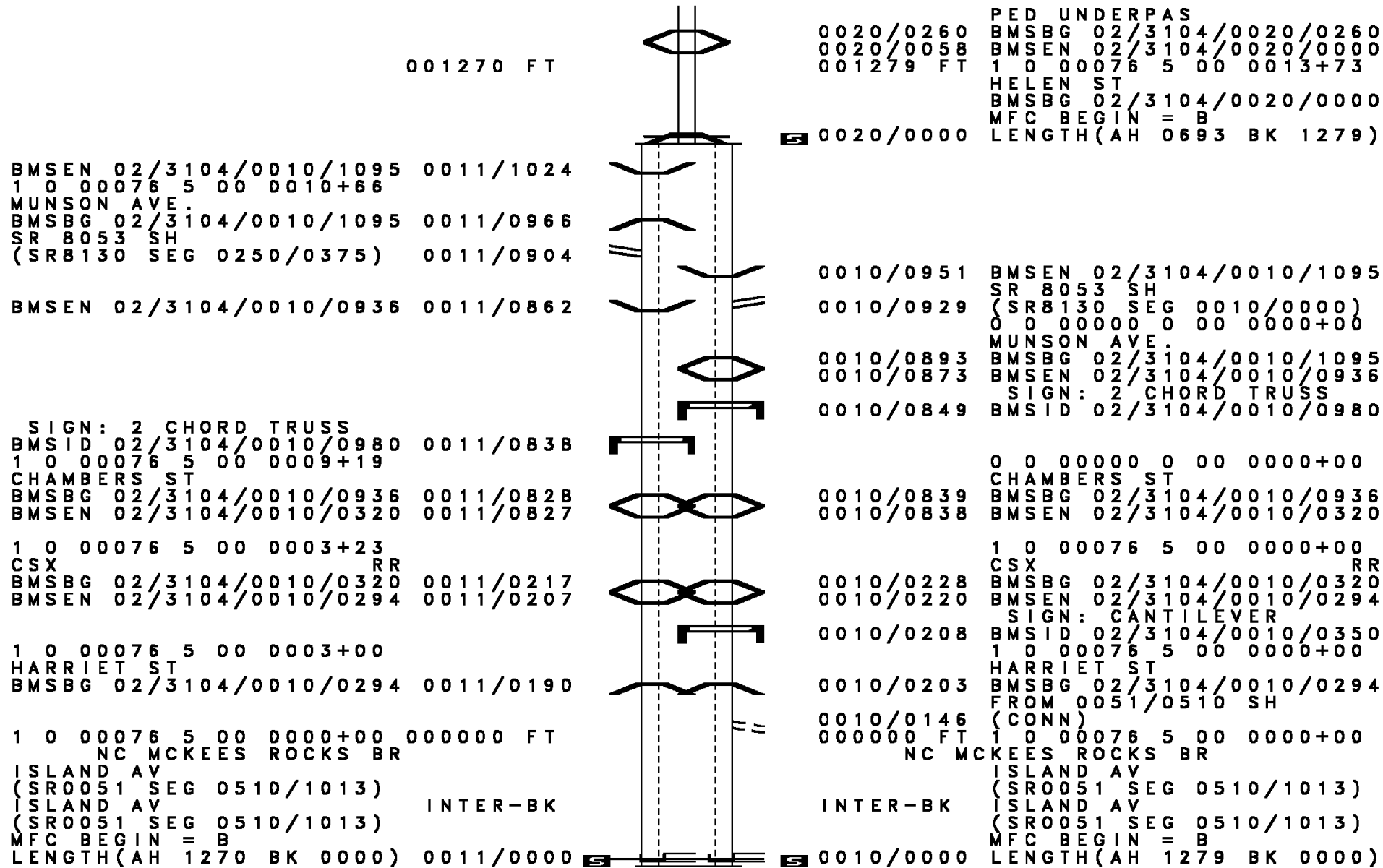

001270 FT

0020/0260
 0020/0058
 001279 FT

PED UNDERPAS
 BMSBG 02/3104/0020/0260
 BMSSEN 02/3104/0020/0000
 1 0 00076 5 00 0013+73
 HELEN ST
 BMSBG 02/3104/0020/0000
 MFC BEGIN = B
 LENGTH(AH 0693 BK 1279)

BMSSEN 02/3104/0010/1095 0011/1024
 1 0 00076 5 00 0010+66
 MUNSON AVE
 BMSBG 02/3104/0010/1095 0011/0966
 SR 8053 SH
 (SR8130 SEG 0250/0375) 0011/0904

BMSSEN 02/3104/0010/0936 0011/0862

0010/0951
 0010/0929

BMSSEN 02/3104/0010/1095
 SR 8053 SH
 (SR8130 SEG 0010/0000)
 0 0 00000 0 00 0000+00
 MUNSON AVE
 BMSBG 02/3104/0010/1095
 BMSSEN 02/3104/0010/0936
 SIGN: 2 CHORD TRUSS
 BMSID 02/3104/0010/0980

SIGN: 2 CHORD TRUSS
 BMSID 02/3104/0010/0980 0011/0838
 1 0 00076 5 00 0009+19
 CHAMBERS ST
 BMSBG 02/3104/0010/0936 0011/0828
 BMSSEN 02/3104/0010/0320 0011/0827

1 0 00076 5 00 0003+23
 CSX RR
 BMSBG 02/3104/0010/0320 0011/0217
 BMSSEN 02/3104/0010/0294 0011/0207

0010/0893
 0010/0873
 0010/0849

0 0 00000 0 00 0000+00
 CHAMBERS ST
 BMSBG 02/3104/0010/0936
 BMSSEN 02/3104/0010/0320

1 0 00076 5 00 0003+00
 HARRIET ST
 BMSBG 02/3104/0010/0294 0011/0190

0010/0228
 0010/0220
 0010/0208
 0010/0203

1 0 00076 5 00 0000+00
 CSX RR
 BMSBG 02/3104/0010/0320
 BMSSEN 02/3104/0010/0294
 SIGN: CANTILEVER
 BMSID 02/3104/0010/0350
 1 0 00076 5 00 0000+00
 HARRIET ST
 BMSBG 02/3104/0010/0294
 FROM 0051/0510 SH
 (CONN)

1 0 00076 5 00 0000+00 000000 FT
 NC MCKEES ROCKS BR
 ISLAND AV
 (SR0051 SEG 0510/1013)
 ISLAND AV INTER-BK
 (SR0051 SEG 0510/1013)
 MFC BEGIN = B
 LENGTH(AH 1270 BK 0000) 0011/0000

0010/0146
 000000 FT

1 0 00076 5 00 0000+00
 NC MCKEES ROCKS BR
 ISLAND AV
 (SR0051 SEG 0510/1013)
 ISLAND AV INTER-BK
 (SR0051 SEG 0510/1013)
 MFC BEGIN = B
 LENGTH(AH 1279 BK 0000)

0010/0000

EXTRACT DATE: 12/21/2020 ROADWAY MANAGEMENT SYSTEM PAGE NUMBER: 1207
 PRINT DATE: 12/23/2020 SLD COUNTY/SR - ANNUAL PRINT COUNTY: ALLEGHENY
 DIR: B TOTAL LEN: 2.305 MI. DIST: 11-1 SR: 3103
 LEFT MUN: NORTH FAYETTE T RIGHT MUN: NORTH FAYETTE T

FROM 3066/0050 SH
 (CONN)
 CROSSROADS DR
 (PRDR)

012173 FT
 0040/3071
 0040/2741

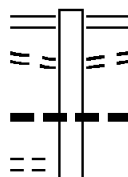

012173 FT STEUBENVILLE PK
 0040/3204 (SR3066 SEG 0060/0000)
 TO 3066/0060 SH
 0040/3071 (CONN)
 018" DIA CIRC CONCR
 0040/2836 LEN=0040 INSTALLED 2002

EXTRACT DATE: 12/21/2020
PRINT DATE: 12/23/2020

ROADWAY MANAGEMENT SYSTEM
SLD COUNTY/SR - ANNUAL PRINT

PAGE NUMBER: 1206
COUNTY: ALLEGHENY

DIR: B TOTAL LEN: 2.305 MI.
LEFT MUN: NORTH FAYETTE T

DIST: 11-1 SR: 3103
RIGHT MUN: NORTH FAYETTE T

CCAC WEST HILLS CTR
(PRDR)

0040/1494

008969 FT

2 0 02013 0 00 0059+21 005969 FT
ROBB HILL RD (TBK)
(BORO)

0030/0000

0040/2534	018 "DIA CIRC CONCR LEN=0050 INSTALLED 2002 RAMP Y RD (SR8032 SEG 0500/0561)
0040/2355	024 "DIA CIRC CONCR LEN=0099 INSTALLED UNKN RT 0022 EB
0040/2252	OP ID 02/0022/0120/0000 TO 8032/0750 SH (CONN)
0040/1976	RAMP Z RD
0040/1906	(SR8032 SEG 0750/0000)
0040/1494	018 "DIA CIRC CONCR LEN=0040 INSTALLED 2002
0040/1119	018 "DIA CIRC CONCR LEN=0045 INSTALLED 2002
0040/0820	2 0 02013 0 00 0091+62 OLD MCKEE RD (BORO)
0040/0000	LENGTH(AH 3204 BK 3000)
0030/2320	018 "DIA CIRC CONCR LEN=0039 INSTALLED 2002
0030/1940	018 "DIA CIRC CONCR LEN=0035 INSTALLED 2002 BR. N. BR. ROB STRUCTURE LENGTH 19 FT
0030/1552	BMSID 02/3103/0030/1552
0030/1344	012 "DIA CIRC CONCR LEN=0040 INSTALLED 2002 BORO RD (BORO)
0030/1065	012 "DIA CIRC CONCR LEN=0045 INSTALLED 2002
0030/0956	018 "DIA CIRC METAL LEN=0045 INSTALLED 2002
0030/0677	018 "DIA CIRC CONCR LEN=0045 INSTALLED 2002
0030/0000	LENGTH(AH 3000 BK 2747) BR. N. BR. ROBN STRUCTURE LENGTH 20 FT
0020/2676	BMSID 02/3103/0020/2697
0020/2424	018 "DIA CIRC CONCR LEN=0088 INSTALLED UNKN 018 "DIA CIRC CONCR

DIR: B TOTAL LEN: 2.305 MI. DIST: 11-1 SR: 3103
 LEFT MUN: NORTH FAYETTE T RIGHT MUN: NORTH FAYETTE T

0020/2089	LEN=0088	INSTALLED UNKN
0020/1750	036" DIA	CIRC CONCR
0020/1628	LEN=0088	INSTALLED UNKN
0020/1440	PTC RD	(PRDR)
0020/1024	018" DIA	CIRC CONCR
0020/0690	LEN=0080	INSTALLED UNKN
0020/0505	018" DIA	CIRC CONCR
0020/0199	LEN=0080	INSTALLED UNKN
0020/0021	036" H 60"	W ELLIP METAL
003222 FT	LEN=0080	INSTALLED UNKN
003222 FT	2 0 02013 0 00 0031+86	TRIB TO ROBIN RUN
0020/0000	STRUCTURE LENGTH	9 FT
0010/2903	BMSID 02/3103/0020/0000	LENGTH(AH 2747 BK 3222)
0010/2588	018" DIA	CIRC CONCR
0010/2328	LEN=0120	INSTALLED UNKN
0010/2055	018" DIA	CIRC CONCR
0010/1718	LEN=0150	INSTALLED UNKN
0010/1361	036" H 60"	W ELLIP METAL
0010/1077	LEN=0060	INSTALLED UNKN
0010/0817	012" DIA	CIRC CONCR
0010/0584	LEN=0040	INSTALLED 2002
0010/0300	024" DIA	CIRC CONCR
INTER-BK MCKEE RD	LEN=0050	INSTALLED UNKN
000000 FT	024" DIA	CIRC CONCR
(SR0978 SEG 0150/3115)	LEN=0110	INSTALLED UNKN
0010/0000	018" DIA	CIRC CONCR
	LEN=0090	INSTALLED UNKN
	018" DIA	CIRC CONCR
	LEN=0100	INSTALLED UNKN
	018" DIA	CIRC CONCR
	LEN=0040	INSTALLED UNKN
	018" DIA	CIRC CONCR
	LEN=0040	INSTALLED UNKN
	NC MCKEE RD	
	INTER-BK MCKEE RD	
	000000 FT	(SR0978 SEG 0150/3115)
		MFC BEGIN = C
	0010/0000	LENGTH(AH 3222 BK 0000)

MARKO TRAILER PK
(PRDR)

0010/2867

2 0 02013 0 00 0000+00 000000 FT
 OAKDALE RD
 (SR0978 SEG 0150/3115) 0010/0000

EXTRACT DATE: 12/21/2020 ROADWAY MANAGEMENT SYSTEM PAGE NUMBER: 1204
PRINT DATE: 12/23/2020 SLD COUNTY/SR - ANNUAL PRINT COUNTY: ALLEGHENY
DIR: B TOTAL LEN: .000 MI. DIST: 11-1 SR: 3102
LEFT MUN: PITTSBURGH C RIGHT MUN: PITTSBURGH C

000000 FT



000000 FT
7010/0000 LTH AH 000100 BK 000000

EXTRACT DATE: 12/21/2020 ROADWAY MANAGEMENT SYSTEM PAGE NUMBER: 1203
 PRINT DATE: 12/23/2020 SLD COUNTY/SR - ANNUAL PRINT COUNTY: ALLEGHENY
 DIR: B TOTAL LEN: 1.211 MI. DIST: 11-1 SR: 3101
 LEFT MUN: PITTSBURGH C RIGHT MUN: PITTSBURGH C

KEARNS AV
 (CITY)

006394 FT

0020/2722

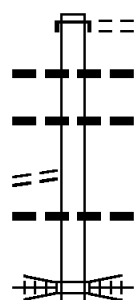

006394 FT
 INTER-AHD GREENTREE RD
 (CITY)
 WOODVILLE AV
 (CITY)
 0020/3331 018 " DIA CIRC METAL
 0020/3286 LEN=0035 INSTALLED UNKN
 018 " DIA CIRC METAL
 0020/2970 LEN=0099 INSTALLED UNKN
 018 " DIA CIRC METAL
 0020/2674 LEN=0099 INSTALLED UNKN
 0020/2005 NORFOLK SOUTHERN
 OVERPASS IS RR X-ING

DIR: B TOTAL LEN: 1.211 MI. DIST: 11-1 SR: 3101
 LEFT MUN: PITTSBURGH C RIGHT MUN: PITTSBURGH C

Location / Segment	Segment ID	Length	Notes / Details
LAMPE AV (CITY)	0020/1195		JUNIUS ST (CITY)
	0020/0905		018 "DIA CIRC METAL LEN=0050 INSTALLED UNKN
	0020/0616		018 "DIA CIRC CONCR LEN=0099 INSTALLED UNKN
LC TO BEE ST (CONN) BEE ST (BORO)	0020/0606		
	003063 FT	003063 FT	RIDGEMONT DR (CITY) 018 "DIA CIRC CONCR LEN=0030 INSTALLED UNKN 1 0 00802 0 04 0237+27 HAMBURG ST (CITY) PITTSBURGH GREENTREE B LENGTH(AH 3331 BK 3063)
WARRIORS RD (BORO)	0010/2984		
	0010/2884		
MANSFIELD AV (SR0121 SEG 0090/0000)	0010/2530		018 "DIA CIRC CONCR LEN=0030 INSTALLED UNKN
	0010/1917		MCKINNEY LN (BORO)
	0010/1440		PARKWAY CENTER DR (SR3123 SEG 0010/1065)
	0010/1373		TO 3123/0010 SH (CONN)
MANSFIELD AV (SR0121 SEG 0090/0000)	0010/1116		
	0010/0842		018 "DIA CIRC CONCR LEN=0030 INSTALLED UNKN
	0010/0313		018 "DIA CIRC CONCR LEN=0062 INSTALLED UNKN
	0010/0111		018 "DIA CIRC CONCR LEN=0062 INSTALLED UNKN
MANSFIELD AV (SR0121 SEG 0090/0000)	000000 FT	000000 FT	RAMP J RD (SR8035 SEG 0500/0000) 1 0 00802 0 04 0233+18 NC GR
	0010/0000	0010/0000	INTER-BK GREENTREE RD (SR0121 SEG 0090/0000) MFC BEGIN = C LENGTH(AH 3063 BK 0000)

Stationing	Segment Description	Length (FT)	Notes
0020/2348	JOSEPH RD (SR3098 SEG 0040/0000)	004362	GLASS RUN RD (SR3098 SEG 0040/0000) GENSLE RD (BORO) 018" DIA CIRC CONCR LEN=0040 INSTALLED UNKN
0020/1854		0020	WALTON RD (BORO) 018" DIA CIRC CONCR LEN=0040 INSTALLED UNKN
0020/1560		0020	018" DIA CIRC CONCR LEN=0040 INSTALLED UNKN
0020/1367		0020	018" DIA CIRC CONCR LEN=0433 INSTALLED UNKN
0020/0934		0020	SCHIECK RD (BORO) 2 0 02286 0 00 0020+15 CHURCHVIEW AV (BORO)
0010/1947	NC GLASS RUN RD MELLOTT RD (BORO)	0010	LENGTH(AH 2348 BK 2014) 018"H 01"W **UNKNOWN** LEN=0035 INSTALLED UNKN
0010/1265	ANDRADE ST (BORO)	0010	
0010/1010	MELVINA AV (BORO)	0010	
0010/0810	WILLETT AV (CNTY)	0010	
000000	NC CHURCHVIEW AV WAIDLER AV (BORO)	000000	2 0 02286 0 00 0000+00
0010/0440	INTER-BK CHURCHVIEW AV (BORO)	0010	
000000	MFC BEGIN = C	000000	
0010/0000	INTER-BK CHURCHVIEW AV (BORO)	0010	LENGTH(AH 2014 BK 0000)

EXTRACT DATE: 12/21/2020 ROADWAY MANAGEMENT SYSTEM PAGE NUMBER: 1200
 PRINT DATE: 12/23/2020 SLD COUNTY/SR - ANNUAL PRINT COUNTY: ALLEGHENY
 DIR: B TOTAL LEN: .105 MI. DIST: 11-1 SR: 3099
 LEFT MUN: CARNEGIE B RIGHT MUN: CARNEGIE B

RAMP E RD	REF-AHD	* -
(SR8033 SEG 0500/2009)	0011/0554	
JANE ST		
(BORO)	0011/0480	==
018 "DIA CIRC CONCR		
LEN=0030 INSTALLED UNKN	0011/0430	--- ---
HAYS AL		
(BORO)	0011/0185	== ==
018 "DIA CIRC CONCR		
LEN=0099 INSTALLED UNKN	0011/0035	--- ---
2 0 02254 0 00 0003+42 000000 FT		
NC MANSFIELD BL/CHESTNUT ST		
CHESTNUT ST		
(BORO)		
CHESTNUT ST		
(SR3048 SEG 0250/0000)		
MANSFIELD BL	INTER-BK	
(SR3048 SEG 0250/0000)	000554 FT	
MFC BEGIN = D		
LENGTH(AH 0554 BK 0000)	0011/0000	
		000480 FT
		000000 FT
		7010/0000 LTH AH 000100 BK 000000

EXTRACT DATE: 12/21/2020 ROADWAY MANAGEMENT SYSTEM PAGE NUMBER: 1199
 PRINT DATE: 12/23/2020 SLD COUNTY/SR - ANNUAL PRINT COUNTY: ALLEGHENY
 DIR: B TOTAL LEN: 3.130 MI. DIST: 11-1 SR: 3098
 LEFT MUN: PITTSBURGH C RIGHT MUN: PITTSBURGH C

RAMP J RD 016517 FT
 (SR8061 SEG 0010/0375) 0090/1919

MIFFLIN RD
 (CITY) 0090/1335

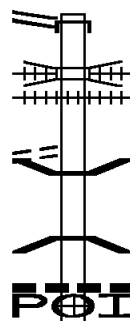

INTER-AHD RAMP H RD
 0090/1919 (SR8061 SEG 0250/0000)
 0090/1633 CSX RAIL TRANSPORTATION
 0090/1566 OVERPASS IS RR X-ING
 (AAR 853123S)#TRKS 01
 0090/1264 BMS EN 02/7301/0000/2862
 20 02286 0 00 0129+00
 0090/1230 STREETS RUN
 BMSBG 02/7301/0000/2862
 0090/1200 012 " DIA CIRC CONCR
 LEN=0099 INSTALLED UNKN
 (APRA) PETER J. CARUSO

DIR: B TOTAL LEN: 3.130 MI. DIST: 11-1 SR: 3098
 LEFT MUN: PITTSBURGH C RIGHT MUN: PITTSBURGH C

Segment Description	Segment ID	Start Station	End Station	Length (FT)	Notes
BALDWIN ST (CITY)	0090/0000	0090/0000	0090/0000	014598 FT	
018 "DIA CIRC CONCR LEN=0030 INSTALLED UNKN MIFFLIN RD (SR0885 SEG 0220/1318)	0081/0418	0081/0418	0081/0405		
RAMP C SPUR RD (SR8059 SEG 0270/0482)	0081/0255	0081/0255	0081/0180		
SR 0885 SB OP ID 02/0885/0221/1106	0081/0180	0081/0180	0081/0086		
RAMP E RD (SR8059 SEG 0512/0330) FROM 8059/0512 SH (CONN)	0081/0086	0081/0086	0081/0024		
2 0 02286 0 00 0123+70	014044 FT	0081/0024	0081/0000		
MFC BEGIN = C LENGTH(AH 0554 BK 0863)	0081/0000	0081/0000	0070/0831		
018 "DIA CIRC CONCR LEN=0035 INSTALLED UNKN	0090/0695	0090/0695	0090/0363		
018 "DIA CIRC CONCR LEN=0035 INSTALLED UNKN	0090/0363	0090/0363	0090/0127		
FROM 3098/0080 SH (CONN)	0090/0127	0090/0127	0090/0025		
012 "DIA CIRC CONCR LEN=0025 INSTALLED UNKN	0090/0025	0090/0025	014605 FT		
2 0 02286 0 00 0129+00	014605 FT	014605 FT	0090/0000		
NC RAMP ST BALDWIN RD MFC BEGIN = E LENGTH(AH 1919 BK 0561)	0090/0000	0090/0000	0080/0484		
015 "DIA CIRC CONCR LEN=0035 INSTALLED UNKN	0080/0484	0080/0484	0080/0468		
TO 3098/0090 SH (CONN)	0080/0468	0080/0468	0080/0400		
MIFFLIN RD (SR0885 SEG 0220/1318)	0080/0400	0080/0400	0080/0350		
018 "DIA CIRC CONCR LEN=0030 INSTALLED UNKN	0080/0350	0080/0350	0080/0243		
RAMP C SPUR RD (SR8059 SEG 0270/0482)	0080/0243	0080/0243	0080/0235		
018 "DIA CIRC CONCR LEN=0030 INSTALLED UNKN	0080/0235	0080/0235	0080/0177		
SR 0885 SB OP ID 02/0885/0221/1106	0080/0177	0080/0177	0080/0115		
018 "DIA CIRC CONCR LEN=0099 INSTALLED UNKN	0080/0115	0080/0115	0080/0086		
GLENWOOD BR INT/RAMP E (SR8059 SEG 0512/0330)	0080/0086	0080/0086	014044 FT		
2 0 02286 0 00 0123+70	014044 FT	014044 FT	0080/0000		
MFC BEGIN = C LENGTH(AH 0561 BK 0863)	0080/0000	0080/0000	0070/0831		
024 "DIA CIRC CONCR LEN=0099 INSTALLED UNKN	0070/0831	0070/0831	0070/0821		
024 "DIA CIRC CONCR LEN=0025 INSTALLED UNKN	0070/0821	0070/0821	0070/0678		
RAMP F RD (SR8059 SEG 0502/0000)	0070/0678	0070/0678			

EXTRACT DATE: 12/21/2020
PRINT DATE: 12/23/2020

ROADWAY MANAGEMENT SYSTEM
SLD COUNTY/SR - ANNUAL PRINT

PAGE NUMBER: 1197
COUNTY: ALLEGHENY

DIR: B TOTAL LEN: 3.130 MI.
LEFT MUN: PITTSBURGH C

DIST: 11-1 SR: 3098
RIGHT MUN: PITTSBURGH C

GLASS RUN RD EXT
(CITY)

0070/0505
013181 FT

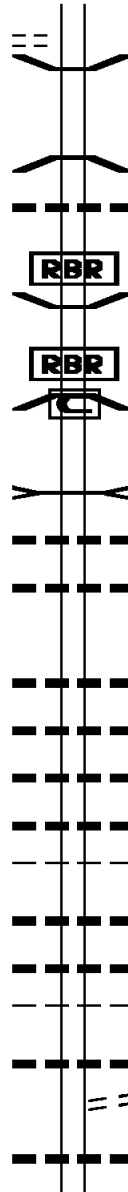

0070/0022	BMSEN 02/3098/0070/0000
013181 FT	2 0 02286 0 00 0114+58
	GLASS RUN
0070/0000	BMSBG 02/3098/0070/0000
	LENGTH(AH 0863 BK 1955)
	018 "DIA CIRC CONCR
0060/1393	LEN=0070 INSTALLED UNKN
0060/1161	BMSEN 02/3098/0060/1125
	2 0 02286 0 00 0106+81
	P3
	GLASS RUN
0060/1140	BMSBG 02/3098/0060/1125
0060/0873	
	KLEIBER RUN
	STRUCTURE LENGTH 8 FT
0060/0865	BMSID 02/3098/0060/0865
	036"H 00"W MULT METAL
0060/0852	LEN=0050 INSTALLED UNKN
	012 "DIA CIRC CONCR
0060/0437	LEN=0065 INSTALLED UNKN
011226 FT	2 0 02286 0 00 0094+93
0060/0000	LENGTH(AH 1955 BK 3980)
	024 "DIA CIRC METAL
0050/3863	LEN=0070 INSTALLED UNKN
	012 "DIA CIRC CONCR
0050/3630	LEN=0050 INSTALLED UNKN
	018 "DIA CIRC CONCR
0050/3515	LEN=0055 INSTALLED UNKN
	018 "DIA CIRC METAL
0050/3196	LEN=0070 INSTALLED UNKN
	PITTSBURGH
0050/3145	BALDWIN B
	018 "DIA CIR PLASTIC
0050/2924	LEN=0065 INSTALLED UNKN
	018 "DIA CIRC CONCR
0050/2575	LEN=0040 INSTALLED UNKN
	BALDWIN
0050/2495	PITTSBURGH C
	018 "DIA CIRC CONCR
0050/2279	LEN=0045 INSTALLED UNKN
	CATHELL ST
0050/2026	(CITY)
	036 "DIA CIRC CONCR
0050/1956	LEN=0045 INSTALLED UNKN
	012 "DIA CIRC CONCR

011226 FT

EXTRACT DATE: 12/21/2020
PRINT DATE: 12/23/2020

ROADWAY MANAGEMENT SYSTEM
SLD COUNTY/SR - ANNUAL PRINT

PAGE NUMBER: 1196
COUNTY: ALLEGHENY

DIR: B TOTAL LEN: 3.130 MI.
LEFT MUN: PITTSBURGH C

DIST: 11-1 SR: 3098
RIGHT MUN: PITTSBURGH C

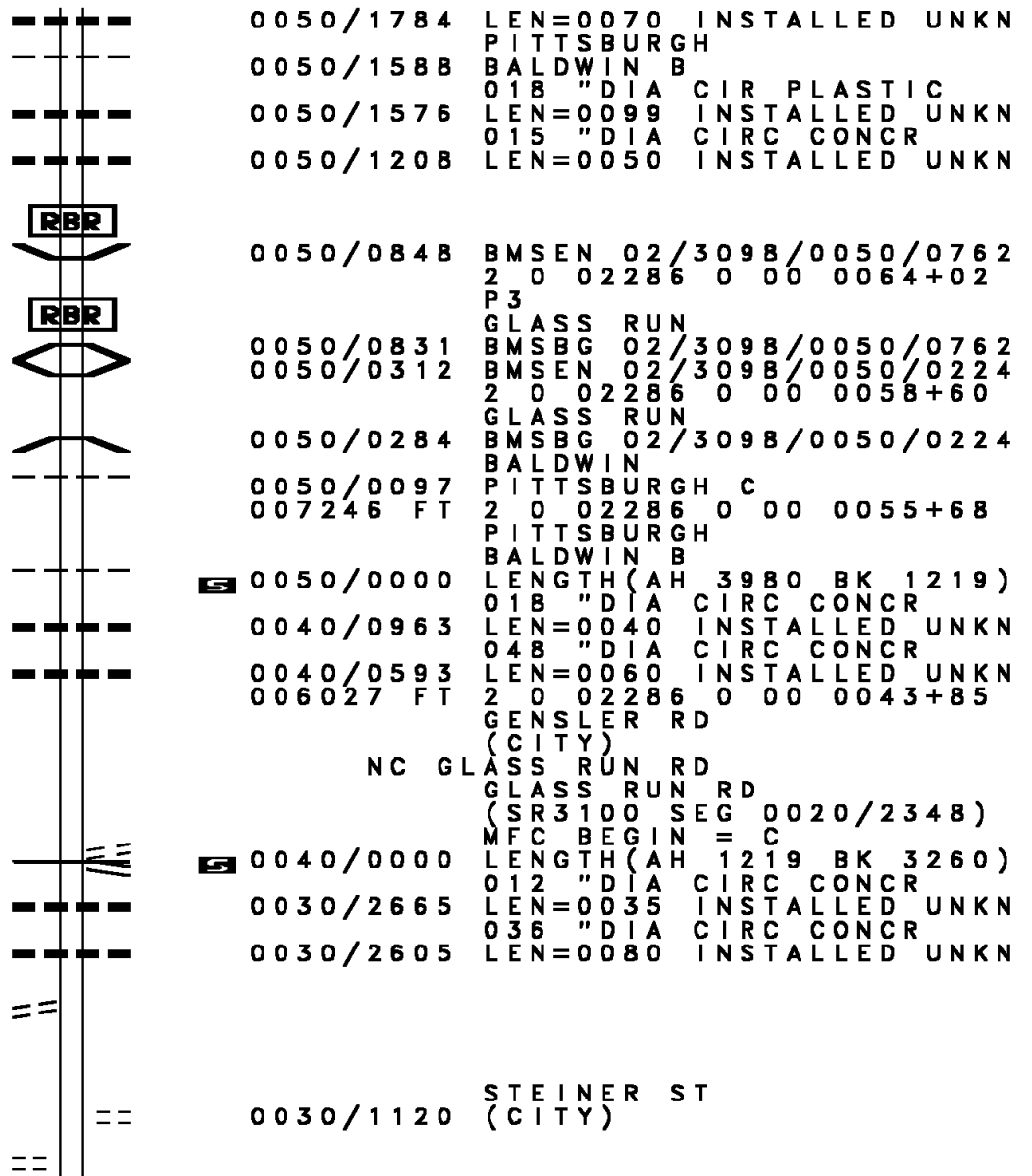

JOHN RD
(CITY)

0030/2595

STEINER ST
(CITY)

0030/1040

DIR: B TOTAL LEN: 3.130 MI. DIST: 11-1 SR: 3098
 LEFT MUN: BALDWIN B RIGHT MUN: BALDWIN B

CENTER ST
(CITY)

0030/0150
002767 FT

AGNEW RD
(CITY)

0020/0975

ABEL AV
(CITY)

0020/0810

PENN AV
(CITY)

0020/0260
001017 FT

MIDDLE ST
(BORO)

0010/0655

000000 FT

0030/1000	015 "DIA	CIRC CONCR	
	LEN=0060	INSTALLED	UNKN
002767 FT	2 0 02091	0 00	0027+80
	CUSTER AV		
	(CITY)		
0030/0000	LENGTH(AH 3260	BK 1750)	
	012 "DIA	CIRC CONCR	
0020/1495	LEN=0052	INSTALLED	UNKN
	BRINWOOD AV		
	(CITY)		
0020/1460	012 "DIA	CIRC CONCR	
	LEN=0052	INSTALLED	UNKN
0020/1242	CALVERT AV		
	(CITY)		
0020/1005	NC JOSEPH ST		
	018 "DIA	CIRC CONCR	
0020/0814	LEN=0050	INSTALLED	UNKN
0020/0800	012 "DIA	CIRC CONCR	
	LEN=0035	INSTALLED	UNKN
0020/0420	018 "DIA	CIRC CONCR	
	LEN=0050	INSTALLED	UNKN
	ALAN AV		
	(CITY)		
0020/0380	018 "DIA	CIRC CONCR	
	LEN=0070	INSTALLED	UNKN
0020/0301			
001017 FT	2 0 02091	0 00	0010+15
0020/0000	LENGTH(AH 1750	BK 1017)	
	012 "DIA	CIRC CONCR	
0010/0981	LEN=0040	INSTALLED	UNKN
0010/0222	BALDWIN		
	PITTSBURGH C		
000000 FT	2 0 02091	0 00	0000+00
	NC AGNEW AV		
	BECKS RUN ROAD		
	(CNTY)		
INTER-BK	AGNEW AV		
	(CITY)		
	MFC BEGIN = D		
0010/0000	LENGTH(AH 1017	BK 0000)	

EXTRACT DATE: 12/21/2020 ROADWAY MANAGEMENT SYSTEM PAGE NUMBER: 1194
 PRINT DATE: 12/23/2020 SLD COUNTY/SR - ANNUAL PRINT COUNTY: ALLEGHENY
 DIR: N TOTAL LEN: .244 MI. DIST: 11-1 SR: 3097
 LEFT MUN: CARNEGIE B RIGHT MUN: CARNEGIE B

LTH AH 000100 BK 000000 000000 FT 7011/0000

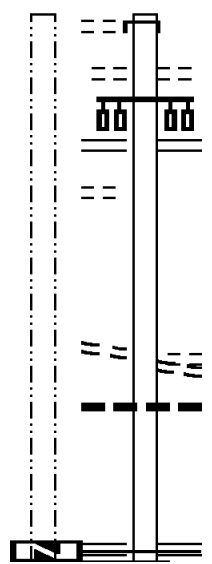

INTER-AHD PENN LINCOLN PY
 (SR8033 SEG 0750/0000)
 ANTHONY ST
 0010/1287 (BORO)
 HAYS AL
 0010/1085 (BORO)
 CHESTNUT ST
 (SR3056 SEG 0020/0000)
 0010/0905 ALLEY
 0010/0775 (BORO)
 ALLEY
 (BORO)
 BOQUET ST
 (BORO)
 ALLEY
 0010/0155 (BORO)
 018" DIA CIRC CONCR
 0010/0128 LEN=0099 INSTALLED UNKN
 000000 FT 2 0 02256 0 00 0000+00
 NC AC ACADEMY ST
 WASHINGTON AV
 (SR0050 SEG 0212/1425)
 MFC BEGIN = B
 0010/0000 LENGTH(AH 1287 BK 0000)

EXTRACT DATE: 12/21/2020 ROADWAY MANAGEMENT SYSTEM PAGE NUMBER: 1193
 PRINT DATE: 12/23/2020 SLD COUNTY/SR - ANNUAL PRINT COUNTY: ALLEGHENY
 DIR: B TOTAL LEN: 1.028 MI. DIST: 11-1 SR: 3096
 LEFT MUN: CRESCENT T RIGHT MUN: CRESCENT T

005427 FT

MCGOVERN BL
 (SR0051 SEG 0810/2005) 0020/2501

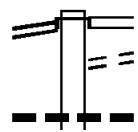

005427 FT
 INTER-AHD PORTER ST
 (TWP)
 MCGOVERN BL
 0020/2501 (SR0051 SEG 0810/2005)
 MOXON ST
 (TWP)
 0020/2356 018 " DIA CIRC METAL
 0020/2316 LEN=0040 INSTALLED UNKN

DIR: B TOTAL LEN: 1.028 MI. DIST: 11-1 SR: 3096
 LEFT MUN: CRESCENT T RIGHT MUN: CRESCENT T

GLEN HAYS DR
 (TWP)

0020/0215
 002926 FT

OLD HARPER RD
 (TWP)

0010/0845

OLD HARPER RD
 (TWP)

0010/0130
 000000 FT

0020/2103	018 " DIA	CIRC CONCR
	LEN=0040	INSTALLED UNKN
0020/2017	015 " DIA	CIR UNKNOWN
	LEN=0040	INSTALLED UNKN
0020/1697	018 " DIA	CIRC METAL
	LEN=0040	INSTALLED UNKN
0020/1293	018 " DIA	CIRC METAL
	LEN=0040	INSTALLED UNKN
0020/1061	018 " DIA	CIR PLASTIC
	LEN=0040	INSTALLED UNKN
0020/0646	018 " DIA	CIRC CONCR
	LEN=0040	INSTALLED UNKN
0020/0561	DAISY LN (TWP)	
0020/0383	018 " DIA	CIRC CONCR
	LEN=0035	INSTALLED UNKN
002926 FT	2 0 02067 0 00 0028+00	
0020/0000	LENGTH(AH 2501 BK 2926)	
0010/2800	018 " DIA	CIRC CONCR
	LEN=0036	INSTALLED UNKN
0010/2540	018 " DIA	CIRC CONCR
	LEN=0040	INSTALLED UNKN
0010/2257	018 " DIA	CIRC CONCR
	LEN=0040	INSTALLED UNKN
0010/1934	018 " DIA	CIRC CONCR
	LEN=0040	INSTALLED UNKN
0010/1670	REYNARD DR (TWP)	
0010/1345	CREST DR (TWP)	
0010/1002	018 " DIA	CIRC CONCR
	LEN=0040	INSTALLED UNKN
0010/0490	CREST DR (TWP)	
0010/0200	PRIMROSE LN (TWP)	
000000 FT	2 0 02067 0 00 0028+00	
	BOCKTOWN RD (SR3094 SEG 0010/0434)	
	NC HARPER RD INTER-BK BOCKTOWN RD (SR3094 SEG 0010/0434)	
0010/0000	MFC BEGIN = E LENGTH(AH 2926 BK 0000)	

SR	SH	SEG	LEN	DESCRIPTION	SR	SH	SEG	LEN	DESCRIPTION	STATUS
0051	SH	0550/0000	0010/3848	NEVILLE RD	0051	SH	0550/0000	0010/3848	INTER-AHD	
0051	SH	0550/0000	0010/3755	NEVILLE RD	0051	SH	0550/0000	0010/3755	INTER-AHD	
0051	SH	0550/0000	0010/3479	NEVILLE RD	0051	SH	0550/0000	0010/3479	018" DIA	CIRC CONC
0051	SH	0550/0000	0010/3285	NEVILLE RD	0051	SH	0550/0000	0010/3285	018" DIA	CIRC CONC
0051	SH	0550/0000	0010/3082	NEVILLE RD	0051	SH	0550/0000	0010/3082	036" DIA	CIRC CONC
0051	SH	0550/0000	0010/2880	NEVILLE RD	0051	SH	0550/0000	0010/2880	018" DIA	CIRC CONC
0051	SH	0550/0000	0010/2680	NEVILLE RD	0051	SH	0550/0000	0010/2680	018" DIA	CIRC CONC
0051	SH	0550/0000	0010/2480	NEVILLE RD	0051	SH	0550/0000	0010/2480	018" DIA	CIRC CONC
0051	SH	0550/0000	0010/2276	NEVILLE RD	0051	SH	0550/0000	0010/2276	018" DIA	CIRC CONC
0051	SH	0550/0000	0010/2080	NEVILLE RD	0051	SH	0550/0000	0010/2080	018" DIA	CIRC CONC
0051	SH	0550/0000	0010/1858	NEVILLE RD	0051	SH	0550/0000	0010/1858	018" DIA	CIRC CONC
0051	SH	0550/0000	0010/1688	NEVILLE RD	0051	SH	0550/0000	0010/1688	018" DIA	CIRC CONC
0051	SH	0550/0000	0010/1305	NEVILLE RD	0051	SH	0550/0000	0010/1305	018" DIA	CIRC CONC
0051	SH	0550/0000	0010/1048	NEVILLE RD	0051	SH	0550/0000	0010/1048	018" DIA	CIRC CONC
0051	SH	0550/0000	0010/0834	NEVILLE RD	0051	SH	0550/0000	0010/0834	018" DIA	CIRC CONC
0051	SH	0550/0000	0010/0599	NEVILLE RD	0051	SH	0550/0000	0010/0599	018" DIA	CIRC CONC
0051	SH	0550/0000	0010/0374	NEVILLE RD	0051	SH	0550/0000	0010/0374	018" DIA	CIRC CONC
0051	SH	0550/0000	0010/0214	NEVILLE RD	0051	SH	0550/0000	0010/0214	018" DIA	CIRC CONC
0051	SH	0550/0000	000000	NEVILLE RD	0051	SH	0550/0000	000000	2 0 02109	0 00 0000+00
0051	SH	0550/0000	000000	NEVILLE RD	0051	SH	0550/0000	000000	018" DIA	CIRC CONC
0051	SH	0550/0000	000000	NEVILLE RD	0051	SH	0550/0000	000000	LEN=0040	INSTALLED UNKN
0051	SH	0550/0000	000000	NEVILLE RD	0051	SH	0550/0000	000000	NC NE	VILLE RD
0051	SH	0550/0000	000000	NEVILLE RD	0051	SH	0550/0000	000000	MCCOY RD	
0051	SH	0550/0000	000000	NEVILLE RD	0051	SH	0550/0000	000000	(TWP)	
0051	SH	0550/0000	000000	NEVILLE RD	0051	SH	0550/0000	000000	MFC BEGIN = D	
0051	SH	0550/0000	000000	NEVILLE RD	0051	SH	0550/0000	000000	LENGTH(AH	3848 BK 0000)

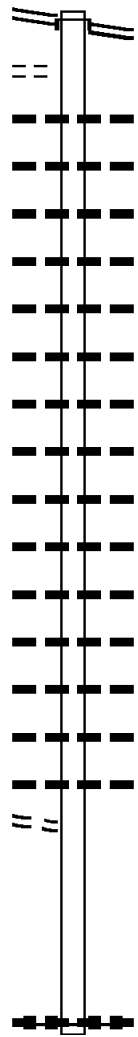

DRESSLER AV
(TWP)

0010/0214
000000 FT

5 0010/0000 LENGTH(AH 3848 BK 0000)

	007720 FT		007720 FT	MCGOVERN BL
			0040/0676	(SR0051 SEG 0810/0545)
			0040/0425	PROSPECT ST (TWP)
RAVINE ST (TWP)	0040/0030			
2 0 02243 0 00 0006+74	007044 FT		0040/0010	030 " DIA CIRC CONCR
SUGARGROVE RD			007044 FT	LEN=0060 INSTALLED UNKN
(SR3111 SEG 0010/0000)	0040/0000		5 0040/0000	LENGTH(AH 0676 BK 1978)
			0030/1962	018 " DIA CIRC CONCR
			0030/1625	LEN=0060 INSTALLED UNKN
				018 " DIA CIRC CONCR
			0030/0581	LEN=0050 INSTALLED UNKN
				018 " DIA CIRC CONCR
			0030/0445	LEN=0060 INSTALLED UNKN
				048 " DIA CIRC METAL
				LEN=0048 INSTALLED UNKN
				SHOUSE RUN
				STRUCTURE LENGTH 10 FT

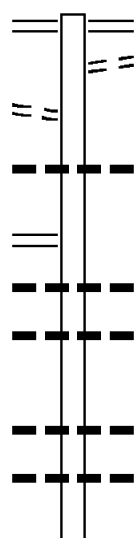

DIR: B TOTAL LEN: 1.462 MI. DIST: 11-1 SR: 3094
LEFT MUN: CRESCENT T RIGHT MUN: CRESCENT T

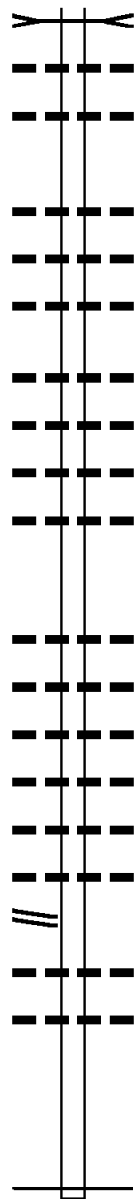

005066 FT

002476 FT

HARPER RD
(SR3096 SEG 0010/0000) 0010/0434

000000 FT

0030/0440	BMSID 02/3094/0030/0440
0030/0395	018 "DIA CIRC METAL
0030/0050	LEN=0050 INSTALLED UNKN
005066 FT	018 "DIA CIRC PLASTIC
0030/0000	LEN=0070 INSTALLED UNKN
0020/2574	2 0 02234 0 00 0052+06
0020/2040	LENGTH(AH 1978 BK 2590)
0020/1665	018 "DIA CIRC CONCR
0020/0913	LEN=0030 INSTALLED UNKN
0020/0550	018 "DIA CIRC METAL
0020/0395	LEN=0030 INSTALLED UNKN
0020/0024	015 "DIA CIRC METAL
002476 FT	LEN=0030 INSTALLED UNKN
0020/0000	015 "DIA CIRC CONCR
0010/1806	LEN=0028 INSTALLED UNKN
0010/1689	018 "DIA CIRC PLASTIC
0010/1506	LEN=0040 INSTALLED UNKN
0010/1338	018 "DIA CIRC PLASTIC
0010/1164	LEN=0035 INSTALLED UNKN
0010/0573	018 "DIA CIRC PLASTIC
0010/0426	LEN=0030 INSTALLED UNKN
0010/0125	018 "DIA CIRC PLASTIC
000000 FT	LEN=0030 INSTALLED UNKN
* REF-BK	2 0 02234 0 00 0000+00
0010/0000	NC BOCKTOWN RD
	BOCKTOWN RD
	(SR3040 SEG 0010/2208)
	MFC BEGIN = E
	BK-BEAVER (04)
	LENGTH(AH 2476 BK 0000)

DIR: B TOTAL LEN: 1.286 MI. DIST: 11-1 SR: 3093
 LEFT MUN: STOWE T RIGHT MUN: STOWE T

Stationing	Description	Stationing	Description
006789 FT		006789 FT	SAW MILL RUN BL (SR0051 SEG 0570/0000)
		0030/2561	018 " DIA CIRC CONCR LEN=0040 INSTALLED UNKN STOWE KENNEDY T
		0030/1799	STO-ROX SCHOOL ENTR RD (PRDR)
		0030/1377	STO-ROX SCHOOL ENTR RD (PRDR)
		0030/0775	018 " DIA CIRC CONCR LEN=0040 INSTALLED 2002
		0030/0440	2 0 02258 0 00 0042+23
004228 FT		0030/0202	LENGTH(AH 2561 BK 1803)
		004228 FT	015 " DIA CIRC CONCR LEN=0030 INSTALLED UNKN
		0020/1193	
2 0 02258 0 00 0024+20	002425 FT	002425 FT	
CASTLEVIEW DR (PRDR)	0020/0000	0020/0000	LENGTH(AH 1803 BK 2425) MARINO LN (PRDR)
		0010/2050	018 " DIA CIRC CONCR LEN=0040 INSTALLED UNKN FLEMING PARK RD (TWP)
		0010/1879	018 " DIA CIRC CONCR LEN=0035 INSTALLED UNKN
		0010/1470	
WREN DR (TWP)	0010/1245	0010/1431	015 " DIA CIR PLASTIC LEN=0030 INSTALLED UNKN BARBARA DR (TWP)
		0010/1188	018 " DIA CIRC METAL LEN=0027 INSTALLED UNKN
		0010/0760	2 0 02258 0 00 0000+00 NC EWING RD MCCOY RD (TWP)
000000 FT		0010/0287	MFC BEGIN = E
		000000 FT	LENGTH(AH 2425 BK 0000)

005885 FT

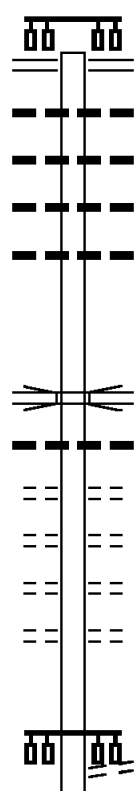

003962 FT

003190 FT

005885 FT ISLAND AV
 (SR0051 SEG 0520/0000)
 0040/1923 012 " DIA CIRC CONCR
 0040/1570 LEN=0040 INSTALLED UNKN
 012"H 01"W UNK PLASTIC
 0040/1265 LEN=0040 INSTALLED UNKN
 012"H 01"W UNK PLASTIC
 0040/0980 LEN=0040 INSTALLED UNKN
 012"H 01"W UNK PLASTIC
 0040/0725 LEN=0040 INSTALLED UNKN
 003962 FT 2 0 02027 0 00 0044+13
 MCCOY ROAD
 OP ID 02/3092/0040/0000
 NC TUNNEL WY
 0040/0000 LENGTH(AH 1923 BK 0772)
 012"H 01"W **UNKNOWN**
 0030/0670 LEN=0099 INSTALLED UNKN
 RIDGE AV
 0030/0635 (TWP)
 UNKNOWN RD
 0030/0405 (TWP)
 WOODWARD AV
 0030/0286 (TWP)
 UNKNOWN RD
 0030/0145 (TWP)
 003190 FT 2 0 02027 0 00 0032+43
 BROADWAY ST
 (TWP)
 NC SEVENTH ST
 0030/0000 LENGTH(AH 0772 BK 0959)

EXTRACT DATE: 12/21/2020
PRINT DATE: 12/23/2020

ROADWAY MANAGEMENT SYSTEM
SLD COUNTY/SR - ANNUAL PRINT

PAGE NUMBER: 1186
COUNTY: ALLEGHENY

DIR: B TOTAL LEN: 1.115 MI.
LEFT MUN: STOWE T

DIST: 11-1 SR: 3092
RIGHT MUN: STOWE T

Stationing	Distance	Right of Way	Notes
		LC FROM VALLEY ST	
	0020/0900	(CONN)	
		VALLEY ST	
		(TWP)	
	0020/0839	DOHRMAN ST	
		(TWP)	
	0020/0525		
	0020/0485	012"H 01"W **UNKNOWN**	
002231 FT		LEN=0040 INSTALLED UNKN	
	002231 FT	2 0 02027 0 00 0022+24	
		NINTH ST	
		(TWP)	
	0020/0000	LENGTH(AH 0959 BK 2231)	
		012"H 01"W **UNKNOWN**	
	0010/2200	LEN=0040 INSTALLED UNKN	
		ELEVENTH ST	
		(TWP)	
	0010/1727	012"H 01"W **UNKNOWN**	
		LEN=0050 INSTALLED UNKN	
	0010/1680	TWELFTH ST	
		(TWP)	
	0010/1445	012"H 01"W **UNKNOWN**	
		LEN=0050 INSTALLED UNKN	
	0010/1425	012"H 01"W **UNKNOWN**	
		LEN=0050 INSTALLED UNKN	
	0010/1415	012"H 01"W **UNKNOWN**	
		LEN=0050 INSTALLED UNKN	
		THIRTEENTH ST	
		(TWP)	
	0010/1183	012"H 01"W **UNKNOWN**	
		LEN=0050 INSTALLED UNKN	
	0010/1180	012"H 01"W **UNKNOWN**	
		LEN=0050 INSTALLED UNKN	
	0010/1140	012"H 01"W **UNKNOWN**	
		LEN=0050 INSTALLED UNKN	
		FOURTEENTH ST	
		(TWP)	
	0010/0905	012"H 01"W **UNKNOWN**	
		LEN=0050 INSTALLED UNKN	
	0010/0870	012"H 01"W **UNKNOWN**	
		LEN=0050 INSTALLED UNKN	
		FIFTEENTH ST	
		(TWP)	
	0010/0644	012"H 01"W **UNKNOWN**	
		LEN=0050 INSTALLED UNKN	
	0010/0640	012"H 01"W **UNKNOWN**	
		LEN=0050 INSTALLED UNKN	
	0010/0595	012"H 01"W **UNKNOWN**	
		LEN=0050 INSTALLED UNKN	
		012"H 04"W **UNKNOWN**	
		LEN=0050 INSTALLED UNKN	
000000 FT		000000 FT	
		2 0 02027 0 00 0000+00	
		PINE HOLLOW RD	
		(CNTY)	
PINE HOLLOW RD		NC BR ROADWAY ST	
(CNTY)		MFC BEGIN = C	
	0010/0000	LENGTH(AH 2231 BK 0000)	

EXTRACT DATE: 12/21/2020 ROADWAY MANAGEMENT SYSTEM PAGE NUMBER: 1185
 PRINT DATE: 12/23/2020 SLD COUNTY/SR - ANNUAL PRINT COUNTY: ALLEGHENY
 DIR: B TOTAL LEN: 1.760 MI. DIST: 11-1 SR: 3091
 LEFT MUN: KENNEDY T RIGHT MUN: KENNEDY T

CORAOPOLIS BL 009294 FT
 (SR0051 SEG 0610/0000) 0030/2291

HEMINGWAY LN 0030/1057
 (PRDR)

007003 FT

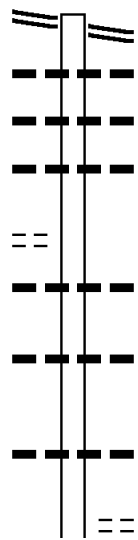

009294 FT CORAOPOLIS BL
 0030/2291 (SR0051 SEG 0610/0000)
 0030/2039 018 "DIA CIRC CONCR
 LEN=0065 INSTALLED UNKN
 0030/1918 072 "DIA CIRC CONCR
 LEN=0080 INSTALLED UNKN
 030 "DIA CIRC CONCR
 0030/1805 LEN=0080 INSTALLED UNKN
 ==
 0030/1017 015 "DIA CIRC CONCR
 LEN=0045 INSTALLED UNKN
 0030/0253 018 "DIA CIRC CONCR
 LEN=0060 INSTALLED UNKN
 007003 FT 2 0 02210 0 00 0070+40
 0030/0000 LENGTH(AH 2291 BK 3635)
 018 "DIA CIRC CONCR
 0020/3471 LEN=0035 INSTALLED UNKN
 ==
 0020/2670 JENNY LN
 (TWP)

DIR: B TOTAL LEN: 1.760 MI. DIST: 11-1 SR: 3091
 LEFT MUN: KENNEDY T RIGHT MUN: KENNEDY T

Street Name	Segment ID	Length	Material	Status
	0020/2345		NOLTE LN (TWP)	
	0020/2103		015" DIA CIRC METAL	INSTALLED UNKN
DOWNSDR (TWP)	0020/1990			
	0020/1669		012" DIA CIRC CONCR	INSTALLED UNKN
HERBST MANOR (TWP)	0020/1475			
	0020/1018		015" DIA CIRC CONCR	INSTALLED UNKN
VIGNE RD (TWP)	0020/0785			
	0020/0318		012" DIA CIRC CONCR	INSTALLED UNKN
TIMBER LN (TWP)	0020/0305			
2002210000034+05	003368 FT			
ROSE AV (TWP)	0020/0000			
	0010/3329		015" DIA CIRC CONCR	INSTALLED UNKN
	0010/3290		WASHINGTON ST (TWP)	
MARY ST (TWP)	0010/2910			
	0010/2552		018" DIA CIRC CONCR	INSTALLED UNKN
	0010/2209		GRANT ST (TWP)	
	0010/1886		HAUBRICK ST (TWP)	
	0010/1695		AGNES ST (TWP)	
	0010/1678		018" DIA CIRC CONCR	INSTALLED UNKN
BOSTIAN DR (TWP)	0010/1270			
	0010/0727		018" DIA CIRC METAL	INSTALLED UNKN
	0010/0107		GREEN OAK DR (TWP)	
000000 FT	000000 FT		20022100000000+00	
			NC HERBST RD	
			MCKEESROCKS FRST GROVE (CNTY)	
			MFC BEGIN = E	
	0010/0000		LENGTH(AH 3368 BK 0000)	

DIR: B TOTAL LEN: 1.029 MI. DIST: 11-1 SR: 3090
 LEFT MUN: MOON T RIGHT MUN: MOON T

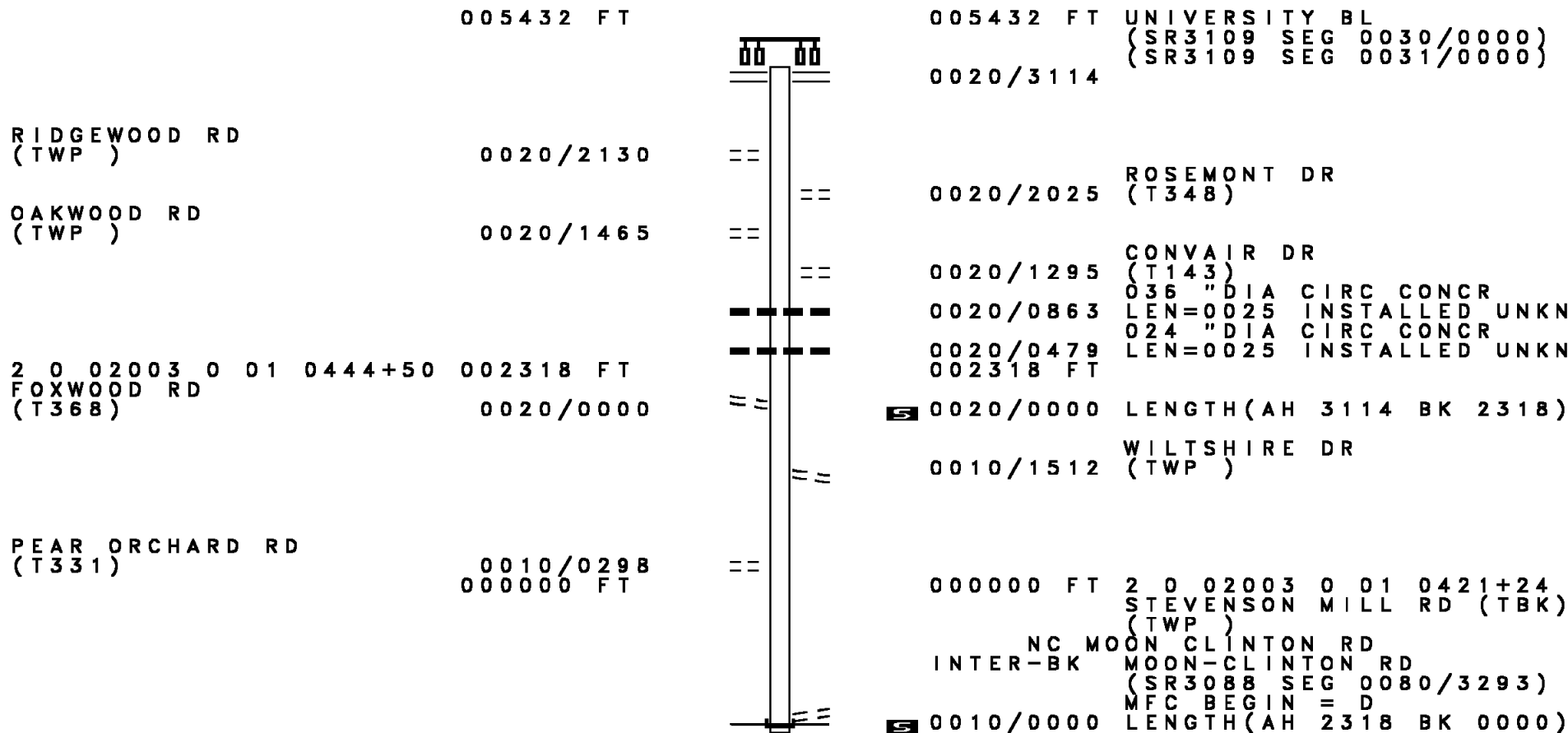

DIR: B TOTAL LEN: 8.420 MI. DIST: 11-1 SR: 3089
 LEFT MUN: MOON T RIGHT MUN: MOON T

044456 FT

044454 FT
 INTER-AHD

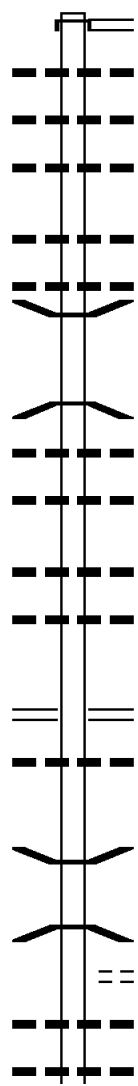

MCGOVERN RD
 (SR0051 SEG 0790/0000)
 MCGOVERN RD
 (SR0051 SEG 0790/0000)
 0190/2571 018 "DIA CIRC CONCR
 LEN=0099 INSTALLED UNKN
 0190/2428 018 "DIA CIRC CONCR
 LEN=0099 INSTALLED UNKN
 0190/2226 015 "DIA CIRC CONCR
 LEN=0045 INSTALLED UNKN
 0190/1650 018 "DIA CIRC CONCR
 LEN=0055 INSTALLED UNKN
 0190/0975 018 "DIA CIRC CONCR
 LEN=0045 INSTALLED UNKN
 0190/0623 BMSSEN 02/3089/0190/0001
 0190/0068 2 0 02242 0 00 0022+17
 041883 FT FLAUGHERTY RUN
 BMSBG 02/3089/0190/0001
 0190/0000 LENGTH(AH 2571 BK 2217)
 018 "DIA CIRC CONCR
 0180/1685 LEN=0040 INSTALLED UNKN
 018 "DIA CIRC METAL
 0180/1163 LEN=0080 INSTALLED UNKN
 018 "DIA CIRC CONCR
 0180/0475 LEN=0070 INSTALLED UNKN
 018 "DIA CIRC CONCR
 0180/0056 LEN=0042 INSTALLED UNKN
 039668 FT 2 0 02242 0 00 0000+00
 BRODHEAD RD
 (SR3077 SEG 0190/1315)
 0180/0000 LENGTH(AH 2217 BK 3402)
 036 "DIA CIRC CONCR
 0170/3261 LEN=0060 INSTALLED UNKN
 0170/1975 BMSSEN 02/3089/0170/1964
 2 0 02303 0 00 0125+11
 BR. FLAUGH. RU
 0170/1964 BMSBG 02/3089/0170/1964
 FOXWOOD RD
 (PRDR)
 0170/1411 036 "DIA CIRC ALUMIN
 LEN=0058 INSTALLED UNKN
 0170/1365 012 "DIA CIRC CONCR
 0170/1356 LEN=0052 INSTALLED UNKN

041885 FT

039668 FT

DIR: B TOTAL LEN: 8.420 MI. DIST: 11-1 SR: 3089
 LEFT MUN: MOON T RIGHT MUN: MOON T

Stationing	Description	Material	Length	Notes
0170/0769	036 " DIA	CIRC CONCR	LEN=0099	INSTALLED UNKN
0170/0370	015 " DIA	CIRC CONCR	LEN=0050	INSTALLED UNKN
0170/0243	BMSSEN 02/3089/0170/0183		2 0 02303 0 00 0107+23	FLAUGHERTY
0170/0183	BMSBG 02/3089/0170/0183		2 0 02303 0 00 0105+02	
036264 FT	0170/0000	LENGTH(AH 3402 BK 3469)		
0160/3289	015 " DIA	CIRC CONCR	LEN=0055	INSTALLED UNKN
0160/2750	BECKS RUN RD			(T114)
0160/2712	015 " DIA	CIRC CONCR	LEN=0075	INSTALLED UNKN
0160/2229	015 " DIA	CIRC CONCR	LEN=0060	INSTALLED UNKN
0160/1807	FLAUGHERTY			STRUCTURE LENGTH 10 FT
0160/1238	BMSID 02/3089/0160/1807			
0160/0817	015 " DIA	CIRC CONCR	LEN=0099	INSTALLED UNKN
0160/0372	015 " DIA	CIRC CONCR	LEN=0040	INSTALLED UNKN
0160/0026	018 " DIA	CIRC CONCR	LEN=0099	INSTALLED UNKN
032797 FT	0160/0000	LENGTH(AH 3469 BK 3540)		
0150/3364	018 " DIA	CIRC CONCR	LEN=0070	INSTALLED UNKN
0150/3310	015 " DIA	CIRC CONCR	LEN=0042	INSTALLED UNKN
0150/3001	015 " DIA	CIRC CONCR	LEN=0045	INSTALLED UNKN
0150/2681	015 " DIA	CIRC OTHER	LEN=0080	INSTALLED UNKN
0150/2241	018 " DIA	CIRC CONCR	LEN=0080	INSTALLED UNKN
0150/2136	JACKSON RD			(TWP)
0150/1642	030 " DIA	CIRC CONCR	LEN=0045	INSTALLED UNKN
0150/1192	024 " DIA	CIRC CONCR	LEN=0042	INSTALLED UNKN
0150/0525	060 " DIA	CIRC CONCR	LEN=0080	INSTALLED UNKN

SHELBOURNE DR
(PRDR)

DIR: B TOTAL LEN: 8.420 MI. DIST: 11-1 SR: 3089
 LEFT MUN: MOON T RIGHT MUN: MOON T

Stationing / Description	Stationing	Length / Description	Material / Notes
029257 FT	0150/0241	015 " DIA CIRC CONCR	LEN=0055 INSTALLED UNKN
	029255 FT	2 0 02303 0 00 0034+95	
	0150/0000	LENGTH(AH 3540 BK 3537)	015 " DIA CIRC CONCR
	0140/3217	LEN=0080	INSTALLED UNKN
	0140/2372	MOON FINDLAY T	
	0140/2303	015 " DIA CIRC CONCR	LEN=0055 INSTALLED UNKN
	0140/2095	JACKSON RD (T499)	
	0140/1888	015 " DIA CIRC CONCR	LEN=0060 INSTALLED UNKN
	0140/1584	015 " DIA CIRC CONCR	LEN=0065 INSTALLED UNKN
SPRING RUN EXT RD (CNTY)	0140/1170		
	0140/1116	015 " DIA CIRC CONCR	LEN=0055 INSTALLED UNKN
	0140/0834	012 " DIA CIRC CONCR	LEN=0040 INSTALLED UNKN
	0140/0411	018 " DIA CIR PLASTIC	LEN=0040 INSTALLED 1998
2 0 02303 0 00 0000+00 HOOKSTOWN GRADE RD (TBK (TWP))	025720 FT	MOON-CLINTON RD	
	0140/0000	(SR3088 SEG 0060/0000)	
	0140/0000	LENGTH(AH 3537 BK 1012)	018 " DIA CIRC CONCR
	0130/0862	LEN=0099	INSTALLED UNKN
TO 8072/0250 SH (CONN)	0130/0412	FROM 8072/0500 SH (CONN)	
	0130/0412	RAMP J RD (SR8072 SEG 0250/0000)	
	0130/0303	RAMP I RD (SR8072 SEG 0500/1149)	
024708 FT	0130/0131	BMS EN 02/3089/0130/0031	
	024706 FT	2 0 02003 0 00 0322+10	
	0130/0000	BUS 376 EB	
	0130/0000	BMSBG 02/3089/0130/0031	
	0120/1081	LENGTH(AH 1012 BK 1083)	018 " DIA CIR PLASTIC
	0120/1080	LEN=0018	INSTALLED 2018
FROM 8072/0010 SH (CONN)	0120/0946	018 " DIA CIR PLASTIC	LEN=0048 INSTALLED 2018
		RAMP L RD	

DIR: B TOTAL LEN: 8.420 MI. DIST: 11-1 SR: 3089
 LEFT MUN: FINDLAY T RIGHT MUN: FINDLAY T

TO 8113/0510 SH
 (CONN) 0120/0637

FLAUGHERTY RUN/RMP 500
 (SR8113 SEG 0500/2822)
 RAMP 510 RD
 (SR8113 SEG 0510/0000) 0120/0528

FROM 8113/0500 SH
 (CONN) 0120/0372

023625 FT

023625 FT

023385 FT

BMSEN 02/3089/0082/1452 0083/1709
 0 0 00000 0 00 0000+00
 SR 0376 EB
 BMSBG 02/3089/0082/1452 0083/1439

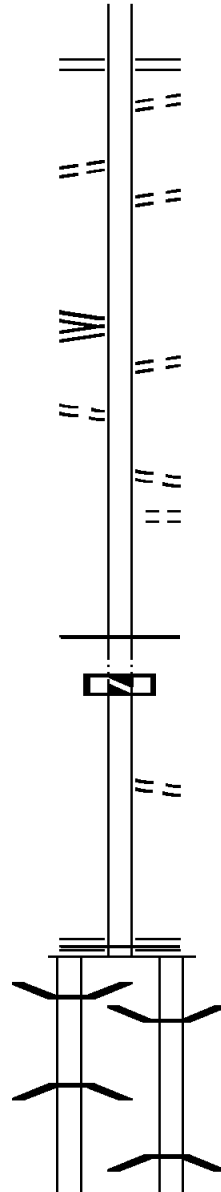

(SR8072 SEG 0010/0893)
 RAMP J RD
 0120/0909 (SR8072 SEG 0750/0000)
 TO 8072/0750 SH
 0120/0813 (CONN)
 FOR SR 3089N TO 3089N
 (CONN)
 NC FLAUGHERTY RUN RD
 0120/0610
 FOR SR 3089N TO 3089N
 (CONN)
 0120/0437
 FOR SR 3089N TO 3089N
 (CONN)
 COURT ST
 (TWP)
 COURT ST
 (TWP)
 0120/0116 (TWP)
 023623 FT 2 0 02003 0 00 0302+80
 * REF-BK FLAUGHERTY RUN RD
 (TWP)
 MFC BEGIN = C
 0120/0000 LTH AH 001083 BK 000100
 023623 FT
 7100/0000 LTH AH 000100 BK 000240
 * REF-AHD FLAUGHERTY RUN RD
 0090/0240 (TWP)
 FROM 8112/0500 SH
 (CONN)
 0090/0097 (CONN)
 023383 FT 2 0 02003 0 00 0250+67
 RAMP I RD
 (SR8112 SEG 0250/0000)
 RAMP FROM I 376
 (SR8112 SEG 0500/0768)
 MFC BEGIN = D
 0090/0000 LENGTH(AH 0240 BK 1957)
 0082/1706 BMSEN 02/3089/0082/1452
 2 0 02003 0 00 0216+43
 SR 0376 EB
 0082/1436 BMSBG 02/3089/0082/1452
 015 " DIA CIRC CONCR

DIR: B TOTAL LEN: 8.420 MI. DIST: 11-1 SR: 3089
 LEFT MUN: FINDLAY T RIGHT MUN: FINDLAY T

Location / Description	Segment ID	Length (FT)	Material / Notes
RAMP H RD (SR8112 SEG 0020/0000) FROM RAMP J RD (SR8112 SEG 0010/1746)	0082/1227	LEN=0099	INSTALLED UNKN
	0082/0917		
	0082/0837	LEN=0040	INSTALLED UNKN
	0082/0644	LEN=0099	INSTALLED UNKN
SWEENEY DR (PRDR) UNKNOWN (PRDR) 0 0 00000 0 00 0000+00 MFC BEGIN = D LENGTH(AH 1959 BK 1333)	0083/0223	021426 FT	
	0082/0223	021426 FT	
	0083/0000		
	0082/0000		
	0080/0685	LEN=0099	INSTALLED UNKN
	0080/0505	LEN=0099	INSTALLED UNKN
	0080/0260	LEN=0035	INSTALLED UNKN
020093 FT	020093 FT		
	0080/0000		
	0070/1930		
CLINTON LAKE RD (PRDR)	0070/1665		
	0070/1548	LEN=0060	INSTALLED UNKN
	0070/1472		
	0070/1415	LEN=0099	INSTALLED UNKN
	0070/1200	LEN=0040	INSTALLED UNKN
	0070/0602	LEN=0040	INSTALLED UNKN
	0070/0248	LEN=0300	INSTALLED UNKN
TO 0030/0050 SH (CONN)	0070/0134	017635 FT	
	017635 FT	2 0 02003 0 00	0191+96

DIR: B TOTAL LEN: 8.420 MI. DIST: 11-1 SR: 3089
 LEFT MUN: FINDLAY T RIGHT MUN: FINDLAY T

WILSON RD
 (TWP)

0060/2050

015457 FT

012450 FT

010771 FT

009166 FT

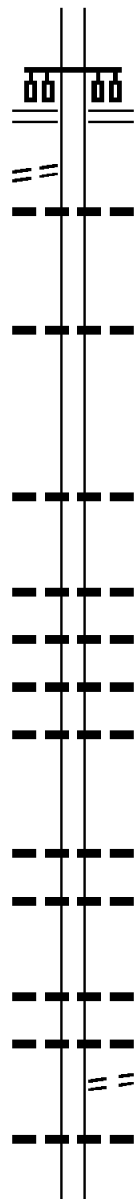

NC CLINTON RD
 LINCOLN HW
 (SR0030 SEG 0060/0000)

0070/0000 LENGTH(AH 2458 BK 2178)

0060/1691 018 "DIA CIR PLASTIC
 LEN=0030 INSTALLED UNKN

0060/0325 018 "DIA CIRC METAL
 LEN=0035 INSTALLED UNKN
 015457 FT 2 0 02003 0 00 0169+91
 0060/0000 LENGTH(AH 2178 BK 3007)

0050/1783 018 "DIA CIRC CONCR
 LEN=0035 INSTALLED UNKN

0050/0840 018 "DIA CIR PLASTIC
 LEN=0030 INSTALLED UNKN

0050/0365 015 "DIA CIRC METAL
 LEN=0045 INSTALLED UNKN

0050/0287 015 "DIA CIRC METAL
 LEN=0042 INSTALLED UNKN

0050/0067 018 "DIA CIR PLASTIC
 LEN=0099 INSTALLED UNKN
 012450 FT 2 0 02003 0 00 0139+93
 0050/0000 LENGTH(AH 3007 BK 1679)

0040/0860 030 "DIA CIRC CONCR
 LEN=0030 INSTALLED UNKN

0040/0387 024 "DIA CIRC CONCR
 LEN=0030 INSTALLED UNKN
 010771 FT 2 0 02003 0 00 0123+14
 0040/0000 LENGTH(AH 1679 BK 1605)

0030/1160 018 "DIA CIRC METAL
 LEN=0035 INSTALLED UNKN

0030/0990 030 "DIA CIRC CONCR
 LEN=0030 INSTALLED UNKN

0030/0570 POINT PARK RD
 (TWP)
 018 "DIA CIR PLASTIC

0030/0550 LEN=0045 INSTALLED UNKN
 009166 FT 2 0 02003 0 00 0108+21
 0030/0000 LENGTH(AH 1605 BK 1238)

EXTRACT DATE: 12/21/2020 ROADWAY MANAGEMENT SYSTEM PAGE NUMBER: 1175
PRINT DATE: 12/23/2020 SLD COUNTY/SR - ANNUAL PRINT COUNTY: ALLEGHENY

DIR: B TOTAL LEN: 1.771 MI. DIST: 11-1 SR: 3088
LEFT MUN: MOON T RIGHT MUN: MOON T

MOON CLINTON RD

009352 FT



009352 FT
7090/0000 LENGTH(AH 0884 BK 3293)
INTER-AHD STEVENSON MILL RD (TBK)

DIR: B TOTAL LEN: 1.771 MI. DIST: 11-1 SR: 3088
 LEFT MUN: MOON T RIGHT MUN: MOON T

(SR3090 SEG 0010/0000) 0080/3293

0080/3293 (TWP)
 MCLAUGHLIN RD
 0080/3022 (T290)
 024 " DIA CIRC CONCR
 0080/2876 LEN=0035 INSTALLED UNKN
 018 " DIA CIRC CONCR
 0080/2830 LEN=0035 INSTALLED UNKN
 018 " DIA CIRC METAL
 0080/2708 LEN=0072 INSTALLED UNKN

PEAR ORCHARD RD
 (T331)

0080/1374

POE
 0080/1577 (APRA) WILLIAMS SCOTSMAN
 WILLIAMS SCOTSMAN ENT R
 (PRDR)

006059 FT

0080/1300 LUNAR LN
 (TWP)
 018 " DIA CIRC CONCR
 0080/0400 LEN=0050 INSTALLED UNKN
 006059 FT 2 0 02003 0 01 0387+98
 5 0080/0000 LENGTH(AH 3293 BK 2849)
 INTERNATIONAL DR
 0070/2771 (TWP)
 010"H 06"W CON BOX CUL
 0070/2600 LEN=0099 INSTALLED UNKN
 018 " DIA CIRC CONCR
 0070/2010 LEN=0050 INSTALLED UNKN
 MCCUTCHEON RD
 0070/1960 (T282)
 018 " DIA CIRC CONCR
 0070/1856 LEN=0030 INSTALLED UNKN
 018 " DIA CIRC CONCR
 0070/1462 LEN=0025 INSTALLED UNKN

MERCURY DR
 (TWP)

0070/0575

2 0 02003 0 01 0360+53 003210 FT
 BECKS RUN RD
 (T114)

0070/0000

0070/0100 MOON ENLOW RD
 (T835)
 003210 FT MOON
 5 0070/0000 FINDLAY T
 LENGTH(AH 2849 BK 2591)
 BOUNDARY ST
 0060/2200 (T499)
 018 " DIA CIRC CONCR
 0060/2064 LEN=0025 INSTALLED UNKN

STARRY AV
 (TWP)

0060/2030

EXTRACT DATE: 12/21/2020
PRINT DATE: 12/23/2020

ROADWAY MANAGEMENT SYSTEM
SLD COUNTY/SR - ANNUAL PRINT

PAGE NUMBER: 1173
COUNTY: ALLEGHENY

DIR: B TOTAL LEN: 1.771 MI.
LEFT MUN: FINDLAY T

DIST: 11-1 SR: 3088
RIGHT MUN: FINDLAY T

FLAUGHERTY RUN RD
(SR3089 SEG 0140/0000)

000619 FT

0060/0000
000619 FT

000345 FT

000345 FT

000030 FT

000030 FT

000030 FT

000000 FT

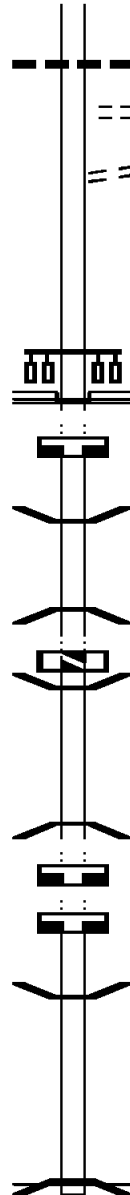

0060/1158 018 " DIA CIRC CONCR
LEN=0040 INSTALLED UNKN
USA BUS RD
0060/1003 (TWP)

0060/0153 LC TO USA BUS RD
000619 FT (CONN)
2 0 02003 0 01 0333+66
NC MO ON-CLINTON RD
CLINTON RD
(SR3089 SEG 0140/0000)

INTER-BK HOOKSTOWN GRADE RD (TBK
(TWP)
MFC BEGIN = D
0060/0000 LENGTH(AH 2591 BK 0100)
000619 FT

7052/0000 LENGTH(AH 0100 BK 0274)
BMSSEN 02/3088/0050/0000
* REF-AHD HOOKSTOWN GRADE RD (TBK
000345 FT (TWP)
000345 FT 2 0 02208 0 00 0094+62

0050/0000 BUSINESS 376WB
000345 FT BMSBG 02/3088/0050/0000
7040/0000 LTH AH 000274 BK 000100
0032/0315 LTH AH 000100 BK 000315
000030 FT BMSSEN 02/3088/0032/0000
0 0 00000 0 00 0000+00
* REF-BK HOOKSTOWN GRADE RD
(TWP)

0032/0000 SR 0376 WB
000030 FT BMSBG 02/3088/0032/0000
7014/0000 LENGTH(AH 0315 BK 0032)
000030 FT LENGTH(AH 0032 BK 0100)
7012/0000 LENGTH(AH 0100 BK 0030)

* REF-AHD HOOKSTOWN GRADE RD (TBK
0010/0030 (TWP)
000000 FT 2 0 02208 0 00 0000+00
NC HO OKSTOWN GRADE RD
* REF-BK HOOKSTOWN GRADE RD
(T319)

RAREDON RUN
BMSBG 02/3088/0010/0001
MFC BEGIN = E
0010/0000 LENGTH(AH 0030 BK 0000)

DIR: B TOTAL LEN: 2.193 MI. DIST: 11-1 SR: 3087
 LEFT MUN: MOON T RIGHT MUN: MOON T

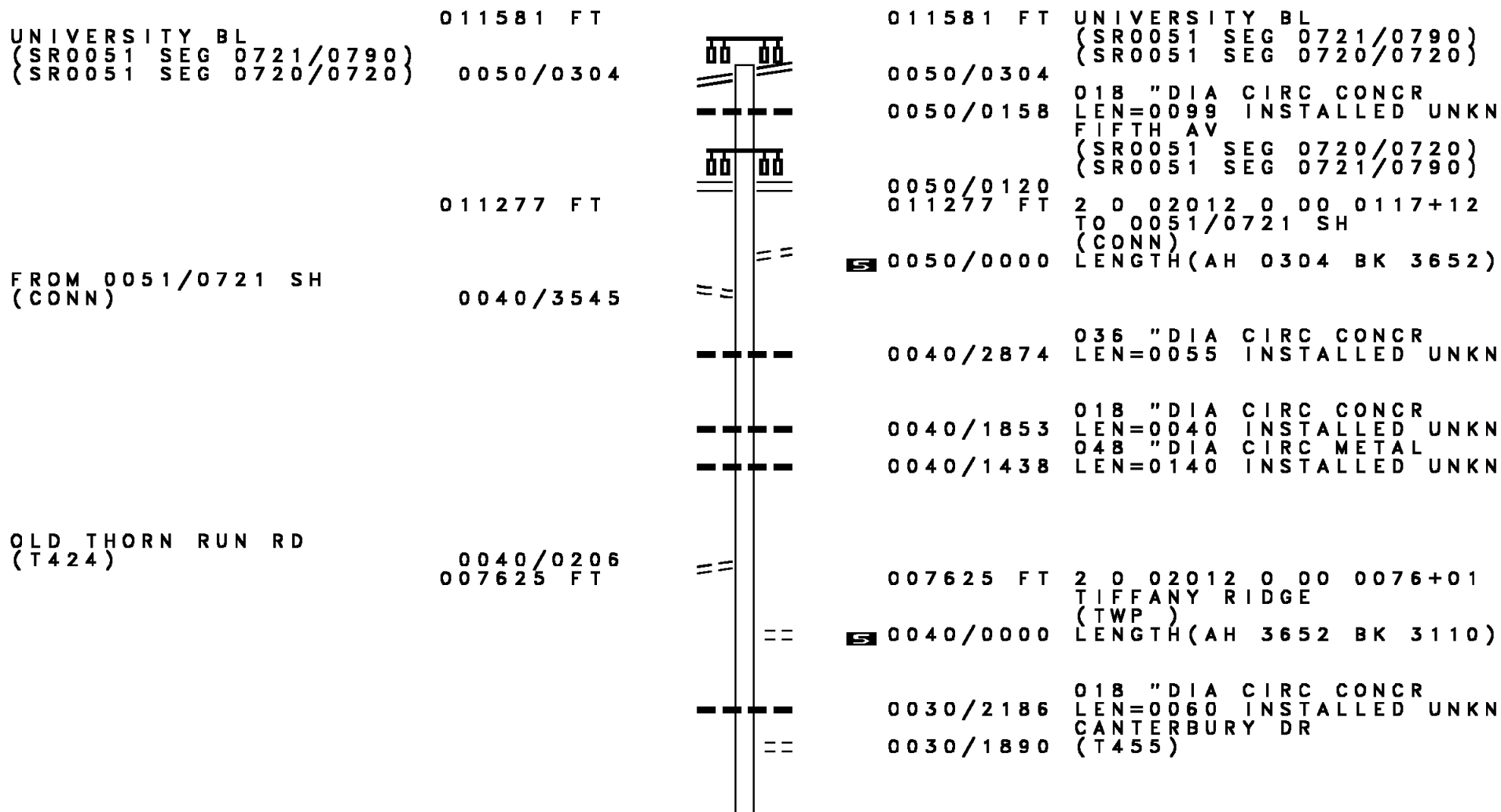

DIR: B TOTAL LEN: 2.193 MI. DIST: 11-1 SR: 3087
 LEFT MUN: MOON T RIGHT MUN: MOON T

OLD THORN RUN RD
 (T424) 0030/0415
 2 0 02012 0 00 0045+07 004515 FT
 BAINTREE RD
 (TWP) 0030/0000

CURRY CT
 (PRDR) 0020/1239

2 0 02012 0 00 0019+75 001983 FT
 SHARON RD
 (T364) 0020/0000

SANDHURST DR
 (T360) 0010/1170

TOTTENHAM DR
 (T392) 0010/0755

000000 FT

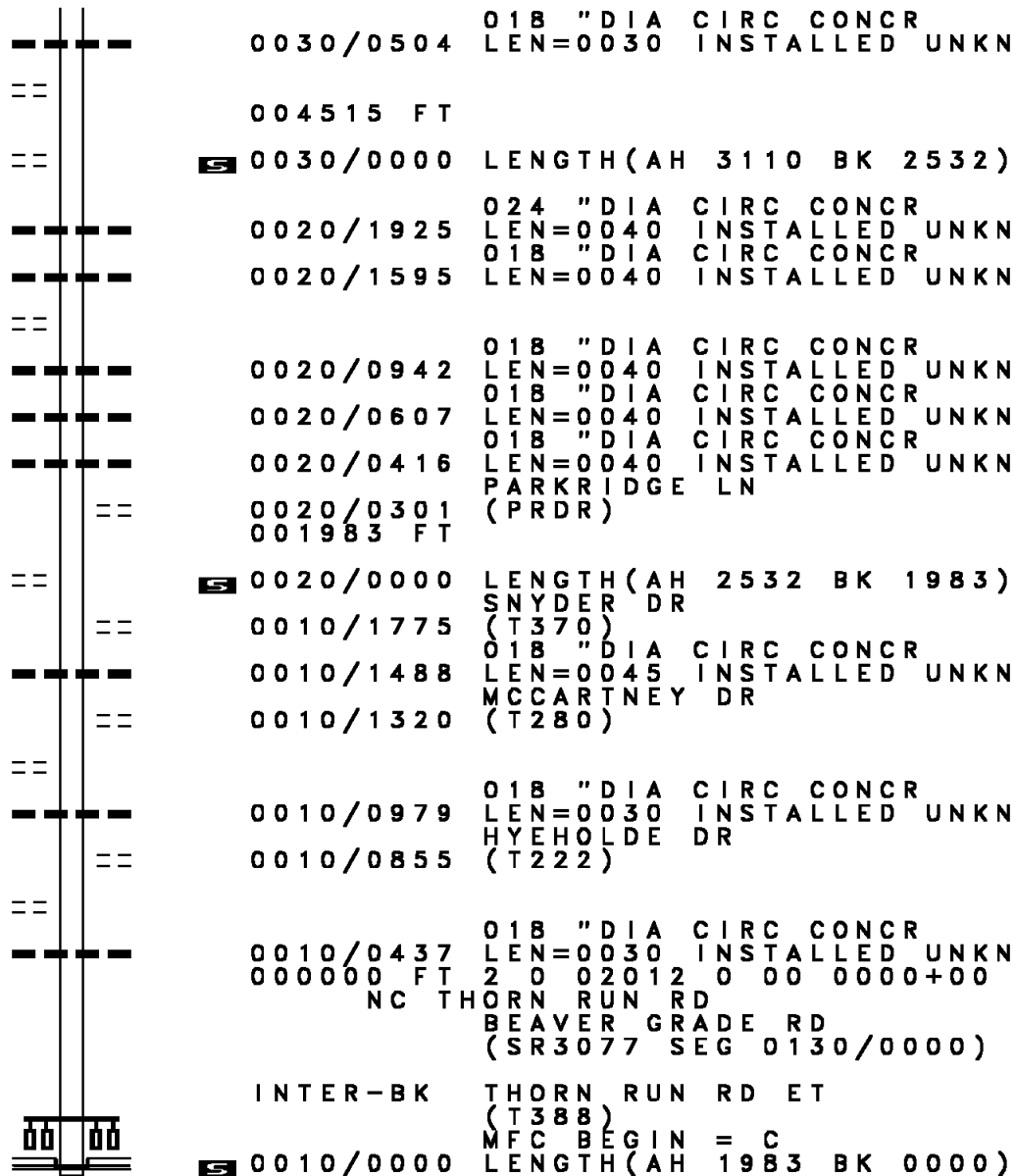

INTER-BK THORN RUN RD ET
 (T388)
 MFC BEGIN = C
 LENGTH(AH 1983 BK 0000)

EXTRACT DATE: 12/21/2020 ROADWAY MANAGEMENT SYSTEM PAGE NUMBER: 1170
 PRINT DATE: 12/23/2020 SLD COUNTY/SR - ANNUAL PRINT COUNTY: ALLEGHENY
 DIR: B TOTAL LEN: .034 MI. DIST: 11-1 SR: 3086
 LEFT MUN: NORTH FAYETTE T RIGHT MUN: NORTH FAYETTE T

000177 FT

000000 FT

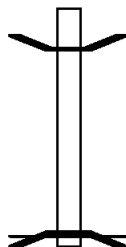

000177 FT
 * REF-AHD MONTOUR CHURCH RD
 0010/0177 (TWP)
 0010/0162 BMS EN 02/3086/0010/0001
 000000 FT 0 0 00000 0 00 0000+00
 NC MO
 * REF-BK MONTOUR CHURCH RD
 (TWP)
 US 22
 BMSBG 02/3086/0010/0001
 MFC BEGIN = E
 0010/0000 LENGTH(AH 0177 BK 0000)

EXTRACT DATE: 12/21/2020 ROADWAY MANAGEMENT SYSTEM PAGE NUMBER: 1169
 PRINT DATE: 12/23/2020 SLD COUNTY/SR - ANNUAL PRINT COUNTY: ALLEGHENY
 DIR: B TOTAL LEN: 1.655 MI. DIST: 11-1 SR: 3085
 LEFT MUN: ROBINSON T RIGHT MUN: ROBINSON T

008739 FT

008739 FT CORAOPOLIS BL
 (SR0051 SEG 0631/2115)
 0040/2229 (SR0051 SEG 0630/2115)
 TO 0051/0631 SH
 0040/2094 (CONN)

FROM 0051/0631 SH
 (CONN)

0040/2068

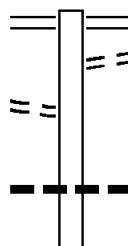

0040/1297 048 " DIA CIRC METAL
 LEN=0150 INSTALLED UNKN
 036 " DIA CIRC METAL

EXTRACT DATE: 12/21/2020
PRINT DATE: 12/23/2020

ROADWAY MANAGEMENT SYSTEM
SLD COUNTY/SR - ANNUAL PRINT

PAGE NUMBER: 1168
COUNTY: ALLEGHENY

DIR: B TOTAL LEN: 1.655 MI.
LEFT MUN: ROBINSON T

DIST: 11-1 SR: 3085
RIGHT MUN: ROBINSON T

Stationing	Right-of-Way	Length	Material	Status
006510 FT	0040/0693	LEN=0100	INSTALLED	UNKN
	006510 FT	2 0 02021 0 00 0065+65		
	0040/0000	LENGTH(AH 2229 BK 2007)		
	0030/1668	018 " DIA CIRC CONCR		
	0030/1549	LEN=0040 INSTALLED UNKN		
	0030/1331	018 " DIA CIRC CONCR		
	0030/0842	LEN=0045 INSTALLED UNKN		
	0030/0507	018 " DIA CIRC CONCR		
	004503 FT	BELLAN LN (TWP)		
	0030/0297	015 " DIA CIRC CONCR		
	004503 FT	LEN=0040 INSTALLED UNKN		
	0030/0000	VERNER RD (TWP)		
	0020/1469	2 0 02021 0 00 0044+99		
	0020/1120	LENGTH(AH 2007 BK 2056)		
	0020/0517	018 " DIA CIRC CONCR		
	002447 FT	LEN=0040 INSTALLED UNKN		
	0020/0000	2 0 02021 0 00 0024+51		
	0010/2135	LENGTH(AH 2056 BK 2447)		
	0010/1607	PHILOMENA DR (TWP)		
	0010/1550	018 " DIA CIRC CONCR		
	0010/1132	LEN=0040 INSTALLED UNKN		
	0010/1035	ZENOBIA DR (TWP)		
	0010/0856	018 " DIA CIRC CONCR		
	0010/0634	LEN=0040 INSTALLED UNKN		
	000000 FT	SCHOOL DR (TWP)		
	000000 FT	018 " DIA CIRC CONCR		
	NC NO	LEN=0040 INSTALLED UNKN		
	000000 FT	018 " DIA CIRC CONCR		
	000000 FT	LEN=0040 INSTALLED UNKN		
	000000 FT	2 0 02021 0 00 0000+00		
	000000 FT	ORTH FOREST GROVE RD		
	000000 FT	EWINGS MILL RD		
	000000 FT	(SR3074 SEG 0110/0000)		
	000000 FT	MFC BEGIN = C		
	0010/0000	LENGTH(AH 2447 BK 0000)		

SOUTH PETRIE RD
(SR3083 SEG 0010/0000) 0010/1125

SPRING RUN RD ET
(CNTY)

004092 FT
0020/1872

002220 FT

000000 FT

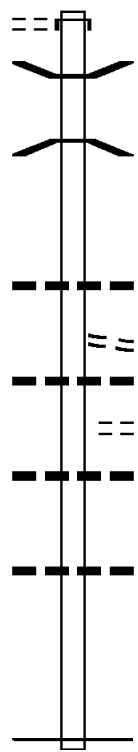

004092 FT INTER-AHD SPRING RUN RD ET
 0020/1872 (CNTY)
 0020/1240 BMS EN 02/3084/0020/1034
 2 0 02095 0 00 0018+05
 SR 3076 WB
 0020/1019 BMSBG 02/3084/0020/1034
 002220 FT 2 0 02095 0 00 0018+05
 0020/0000 LENGTH(AH 1872 BK 2220)
 018 "DIA CIRC METAL
 0010/1839 LEN=0050 INSTALLED UNKN
 PICKENS RD
 0010/1600 (TWP)
 018 "DIA CIRC CONCR
 0010/1500 LEN=0050 INSTALLED UNKN
 LC TO PICKENS RD
 0010/1460 (CONN)
 018 "DIA CIRC CONCR
 0010/0980 LEN=0030 INSTALLED UNKN
 018 "DIA CIRC METAL
 0010/0017 LEN=0025 INSTALLED UNKN
 000000 FT 2 0 02095 0 00 0041+00
 NC EC
 * REF-BK CONOMY GRADE RD
 GRINGO CLINTON RD
 (SR3011 SEG 0010/0000)
 MFC BEGIN = E
 BK-BEAVER (04)
 0010/0000 LENGTH(AH 2220 BK 0000)

EXTRACT DATE: 12/21/2020 ROADWAY MANAGEMENT SYSTEM PAGE NUMBER: 1166
 PRINT DATE: 12/23/2020 SLD COUNTY/SR - ANNUAL PRINT COUNTY: ALLEGHENY
 DIR: B TOTAL LEN: 1.841 MI. DIST: 11-1 SR: 3083
 LEFT MUN: ROBINSON T RIGHT MUN: ROBINSON T

PITTSBURGH AV
 (TWP)

009722 FT
 0040/3265

2 0 02264 0 00 0085+20 006457 FT
 COKETOWN RD
 (TWP)

006457 FT
 0040/0000

	<p>009722 FT CORAOPOLIS BL 0040/3265 (SR0051 SEG 0640/0700)</p> <p>0040/2129 015 " DIA CIRC METAL LEN=0035 INSTALLED UNKN</p> <p>0040/1506 012 " DIA CIRC CONCR LEN=0035 INSTALLED UNKN TR. MONT. RUN STRUCTURE LENGTH 12 FT</p> <p>0040/1157 BMSID 02/3083/0040/1300 048"H 00"W MULT CONCR</p> <p>0040/1142 018 " DIA CIRC METAL LEN=0060 INSTALLED UNKN</p> <p>0040/0619 018 " DIA CIRC METAL LEN=0060 INSTALLED UNKN</p> <p>006457 FT</p> <p>5 0040/0000 LENGTH(AH 3265 BK 2299) 018 " DIA CIR PLASTIC LEN=0050 INSTALLED UNKN</p> <p>0030/1740 018 " DIA CIRC METAL LEN=0055 INSTALLED UNKN</p> <p>0030/1380 018 " DIA CIRC METAL LEN=0045 INSTALLED UNKN</p> <p>0030/1137 018 " DIA CIRC METAL LEN=0045 INSTALLED UNKN</p>
--	--

EXTRACT DATE: 12/21/2020
PRINT DATE: 12/23/2020

ROADWAY MANAGEMENT SYSTEM
SLD COUNTY/SR - ANNUAL PRINT

PAGE NUMBER: 1165
COUNTY: ALLEGHENY

DIR: B TOTAL LEN: 1.841 MI.
LEFT MUN: ROBINSON T

DIST: 11-1 SR: 3083
RIGHT MUN: ROBINSON T

Stationing	Notes	Stationing	Notes
		0030/0836	LEN=0025 INSTALLED 2003 018 "DIA CIRC METAL
004158 FT		0030/0581	LEN=0045 INSTALLED UNKN
		004158 FT	2 0 02264 0 00 0041+98 NC NORTH PETRIE RD ROAD CLOSED ROAD CLOSED BACK
004158 FT		0030/0000	LTH AH 002299 BK 000100
		004158 FT	
		7024/0000	LTH AH 000100 BK 001400 ROAD CLOSED
		0020/1400	ROAD CLOSED AHEAD
		0020/1340	018 "DIA CIRC CONCR LEN=0050 INSTALLED UNKN PLAINVIEW DR
		0020/1140	(TWP) 018 "DIA CIRC CONCR
		0020/0762	LEN=0099 INSTALLED UNKN UNKNOWN RD
		0020/0231	(TWP)
2 0 02264 0 00 0027+74	002758 FT	0020/0000	LENGTH(AH 1400 BK 2758) 015 "DIA CIRC CONCR
BURATTI DR		0010/2504	LEN=0099 INSTALLED 2006 CAMELOT CR
(TWP)	0020/0000	0010/2200	(TWP) 015 "DIA CIR PLASTIC
		0010/2183	LEN=0024 INSTALLED UNKN
JEFF DR		0010/1600	
(TWP)	0010/1600	0010/1440	018 "DIA CIRC CONCR LEN=0035 INSTALLED UNKN
		0010/0784	018 "DIA CIRC CONCR LEN=0050 INSTALLED UNKN
		0010/0543	015 "DIA CIRC CONCR LEN=0056 INSTALLED UNKN
ALLEY		0010/0530	
(TWP)	0010/0530	0010/0431	
SCHULER LN		0010/0431	
(TWP)	0010/0431	0010/0329	024 "DIA CIRC CONCR LEN=0045 INSTALLED UNKN
	000000 FT	000000 FT	2 0 02264 0 00 0000+00 NC SOUTH PETRIE RD NORTH FOREST GROVE RD (SR3085 SEG 0010/1125) MFC BEGIN = E
		0010/0000	LENGTH(AH 2758 BK 0000)

EXTRACT DATE: 12/21/2020 ROADWAY MANAGEMENT SYSTEM PAGE NUMBER: 1164
 PRINT DATE: 12/23/2020 SLD COUNTY/SR - ANNUAL PRINT COUNTY: ALLEGHENY
 DIR: B TOTAL LEN: 1.729 MI. DIST: 11-1 SR: 3082
 LEFT MUN: FINDLAY T RIGHT MUN: FINDLAY T

LINCOLN HW
 (SR0030 SEG 0020/0000) 0010/3512

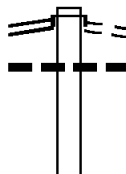

009131 FT
 INTER-AHD LINCOLN HW
 (SR0030 SEG 0020/0000)
 HEBRON RD
 (T302)
 0010/3512 015 " DIA CIRC CONCR
 0010/3257 LEN=0018 INSTALLED UNKN

015 " DIA CIRC CONCR

EXTRACT DATE: 12/21/2020
PRINT DATE: 12/23/2020

ROADWAY MANAGEMENT SYSTEM
SLD COUNTY/SR - ANNUAL PRINT

PAGE NUMBER: 1163
COUNTY: ALLEGHENY

DIR: B TOTAL LEN: 1.729 MI.
LEFT MUN: FINDLAY T

DIST: 11-1 SR: 3082
RIGHT MUN: FINDLAY T

UNKNOWN RD
(PRDR)

0010/0029
005619 FT

002303 FT

000000 FT

0010/1952	LEN=0030	INSTALLED UNKN
005619 FT	1 0 00115 7 00 0000+00	FINDLAY
0010/0000	LENGTH(AH 3512 BK 3316)	INDEPENDENCE T
0006/2770	LEN=0040	INSTALLED UNKN
0006/2390	LEN=0040	INSTALLED UNKN
0006/2085	LEN=0040	INSTALLED UNKN
0006/0895	LEN=0035	INSTALLED UNKN
0006/0588	LEN=0032	INSTALLED UNKN
0006/0025	BMSSEN 02/3082/0006/0000	
002303 FT	1 0 00115 7 03 0267+81	BR. RACCOON
0006/0000	BMSBG 02/3082/0006/0000	LENGTH(AH 3316 BK 2303)
0004/0820	LEN=0035	INSTALLED UNKN
0004/0761	(T391)	SUNNY HILL RD
0004/0475	LEN=0035	INSTALLED UNKN
0004/0386	LEN=0032	INSTALLED UNKN
0004/0215	LEN=0032	INSTALLED UNKN
000000 FT	1 0 00115 7 03 0244+77	CLINTON FRANKFORT RD
INTER-BK	(SR4002 SEG 0090/0000)	CLINTON FRANKFORT RD
	(SR4002 SEG 0090/0000)	MFC BEGIN = D
0004/0000	LENGTH(AH 2303 BK 0000)	

DIR: B TOTAL LEN: 1.676 MI. DIST: 11-1 SR: 3081
 LEFT MUN: CORAOPOLIS B RIGHT MUN: CORAOPOLIS B

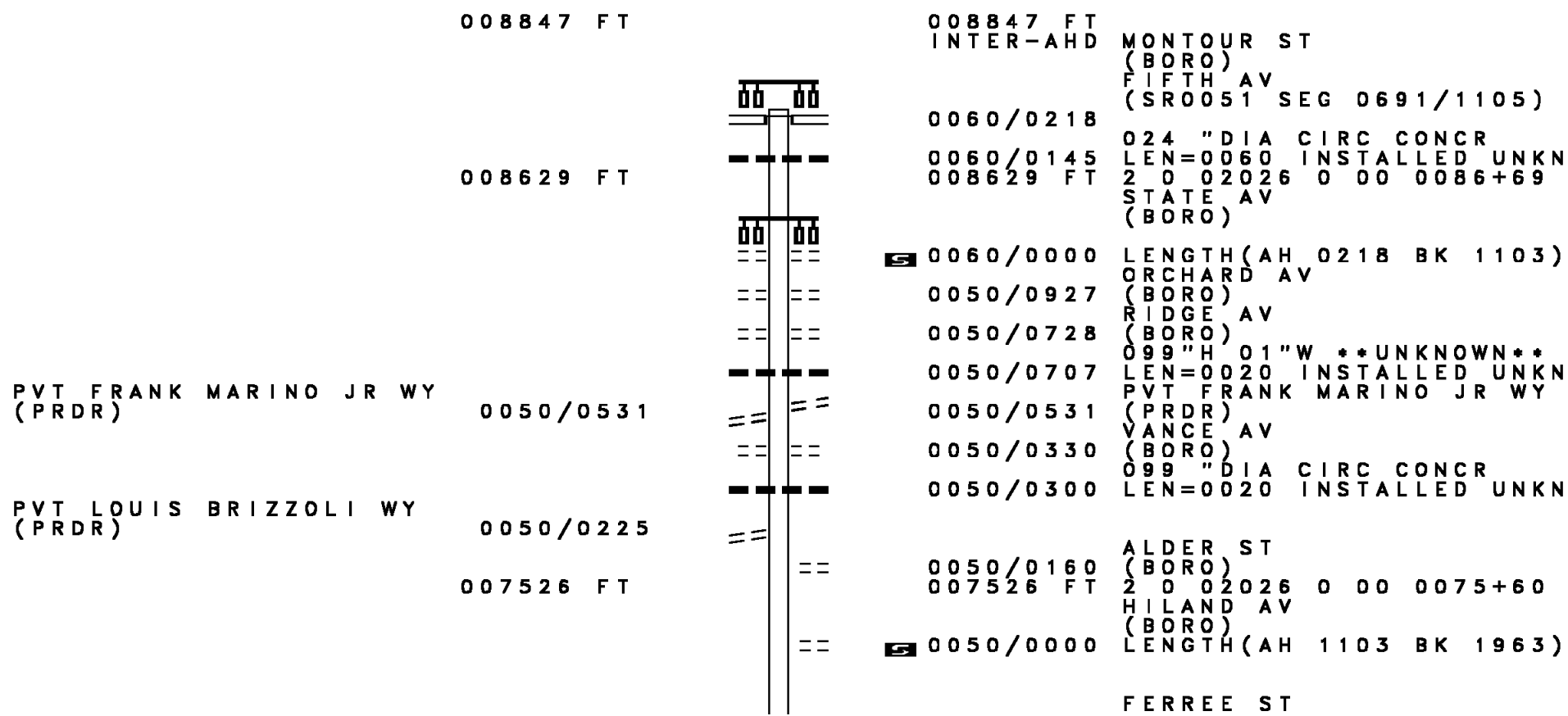

DIR: B TOTAL LEN: 1.676 MI. DIST: 11-1 SR: 3081
 LEFT MUN: CORAOPOLIS B RIGHT MUN: CORAOPOLIS B

Stationing	Length	Description	Material	Status
0040/1055		(BORO)		
0040/1029		096" DIA	CIRC CONCR	INSTALLED UNKN
0040/0450		VINE ST		
005563 FT	2 0 0 2026 0 00	0056+00		
		NC MO		
		GRACE ST		
		(BORO)		
0040/0000		LENGTH(AH 1963 BK 1549)		
0030/1514		018" DIA	CIRC CONCR	INSTALLED UNKN
		CORAOPOLIS		
		MOON T		
0030/0738		018" DIA	CIRC CONCR	INSTALLED UNKN
0030/0697		015" DIA	CIR PLASTIC	INSTALLED 2002
0030/0385		WOODCREST AV		
		(TWP)		
2 0 0 2026 0 00		0040+42		
ROSEDALE AV		004014 FT		
(TWP)		0030/0000		
		0030/0000		LENGTH(AH 1549 BK 1676)
		FELICIAN DR		
		(TWP)		
		0020/0926		
		0020/0634		018" DIA CIRC CONCR
LAUREL DR				INSTALLED UNKN
(PRDR)		0020/0440		
		0020/0034		012" DIA CIRC CONCR
		002338 FT		INSTALLED UNKN
		002338 FT		2 0 0 2026 0 00
				0024+30
				POCOCEN DR
				(TWP)
		0020/0000		LENGTH(AH 1676 BK 2338)
		0010/1450		MCKEE LN
CRAIGWOOD DR				(TWP)
(PRDR)		0010/0915		POCOCEN DR
				(TWP)
		000000 FT		
		000000 FT		2 0 0 2026 0 00
				0000+00
				NC MO
				NTOUR ST ET
				HASSAM RD
				(SR3074 SEG 0050/0000)
				MFC BEGIN = D
		0010/0000		LENGTH(AH 2338 BK 0000)

EXTRACT DATE: 12/21/2020 ROADWAY MANAGEMENT SYSTEM PAGE NUMBER: 1160
 PRINT DATE: 12/23/2020 SLD COUNTY/SR - ANNUAL PRINT COUNTY: ALLEGHENY
 DIR: B TOTAL LEN: .256 MI. DIST: 11-1 SR: 3080
 LEFT MUN: FINDLAY T RIGHT MUN: FINDLAY T

LINCOLN HW 001350 FT
 (SR0030 SEG 0092/0934) 0040/1350

2 0 02245 0 00 0000+00 000000 FT
 BURGETTSTOWN RD 0040/0000
 (SR3078 SEG 0070/1905) 000000 FT
 000000 FT
 000000 FT

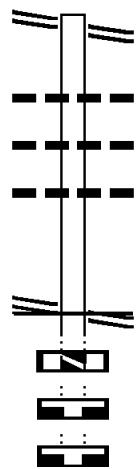

001350 FT LINCOLN HW
 0040/1350 (SR0030 SEG 0092/0934)

0040/0671 018 " DIA CIRC CONCR
 LEN=0025 INSTALLED UNKN
 0040/0275 018 " DIA CIRC METAL
 LEN=0025 INSTALLED UNKN
 0040/0226 018 " DIA CIR PLASTIC
 LEN=0030 INSTALLED UNKN
 NC BU BURGETTSTOWN RD
 BURGETTSTOWN RD
 000000 FT (SR3078 SEG 0070/1905)
 MFC BEGIN = D
 5 0040/0000 LTH AH 001350 BK 000100
 000000 FT
 7030/0000 LTH AH 000100 BK 001472
 000000 FT
 7020/0000 LENGTH(AH 1472 BK 4514)
 000000 FT
 7010/0000 LENGTH(AH 4514 BK 0000)

DIR: B TOTAL LEN: 1.516 MI. DIST: 11-1 SR: 3079
 LEFT MUN: CORAOPOLIS B RIGHT MUN: CORAOPOLIS B

008007 FT

1 1 00793 0 00 0038+20 007788 FT
 STATE AV
 (BORO)

0070/0000
 007494 FT

ALDER AL
 (BORO)
 1 1 00793 0 00 0025+94 006564 FT
 HILAND AV
 (BORO)

0050/0085
 006564 FT

0050/0000

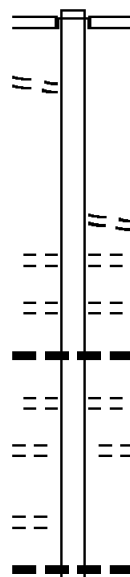

008007 FT
 INTER-AHD CHESTNUT ST
 (BORO)
 FIFTH AV
 (SR0051 SEG 0691/2360)

0070/0219
 007788 FT

5 0070/0000 NC CHESTNUT ST
 LENGTH(AH 0219 BK 0294)
 007494 FT 1 1 00793 0 00 0035+26
 NC STATE AV

5 0060/0000 STATE AV
 LENGTH(AH 0294 BK 0930)
 RIDGE AV
 (BORO)

0050/0595 (BORO)
 ELM AL
 (BORO)

0050/0420
 0050/0250 018 " DIA CIRC CONCR
 LEN=0040 INSTALLED UNKN
 VANCE AV
 (BORO)

0050/0245 (BORO)
 HILAND AV
 (BORO)

0050/0085 (BORO)
 006564 FT

5 0050/0000 LENGTH(AH 0930 BK 1569)
 018 " DIA CIRC CONCR
 0040/1378 LEN=0035 INSTALLED UNKN

DIR: B TOTAL LEN: 1.516 MI. DIST: 11-1 SR: 3079
 LEFT MUN: CORAOPOLIS B RIGHT MUN: CORAOPOLIS B

Stationing	Street Name	Material	Length	Notes
0040/1049		018" DIA CIRC CONCR	LEN=0035	INSTALLED UNKN
0040/0875		018" DIA CIRC CONCR	LEN=0099	INSTALLED UNKN
0040/0819		PARK DR (BORO)		
0040/0718		018" DIA CIRC CONCR	LEN=0035	INSTALLED UNKN
0040/0579		018" DIA CIRC CONCR	LEN=0035	INSTALLED UNKN
0040/0380		015" DIA CIRC CONCR	LEN=0035	INSTALLED UNKN
004995 FT			1 1 00793 0 00 0010+52	
0040/0000	SUMAC AV (BORO)	NC MAPLE ST		LENGTH(AH 1569 BK 0776)
004219 FT	1 1 00793 0 00 0000+00 SCHOOL ST (TWP)	024" DIA CIRC CONCR	LEN=0030	INSTALLED UNKN
0030/0000		CORAOPOLIS MOON T		LENGTH(AH 0776 BK 2555)
0020/2170		018" DIA CIRC CONCR	LEN=0035	INSTALLED UNKN
0020/1793		CHARLTON HTS RD (T138)		
0020/1418	SCHAEFER BL (TWP)			
0020/1400	WOODLAWN DR (T411)			MFC BEGIN = E
0020/0792		024" DIA CIRC CONCR	LEN=0035	INSTALLED UNKN
0020/0650		SEIBERT DR (TWP)		
001664 FT	2 0 02320 0 00 0179+49 IRIS LN (PRDR)			
0020/0000				LENGTH(AH 2555 BK 1664)
000000 FT		015" DIA CIRC CONCR	LEN=0060	INSTALLED UNKN
0010/0017			2 0 02320 0 00 0163+55	
0010/0000	CORAOPOLIS HEIGHTS RD (SR3074 SEG 0040/0000)	NC MAPLE ST ET HASSAM RD (SR3074)		MFC BEGIN = D LENGTH(AH 1664 BK 0000)

DIR: B TOTAL LEN: 3.847 MI. DIST: 11-1 SR: 3078
 LEFT MUN: FINDLAY T RIGHT MUN: FINDLAY T

LINCOLN HW 020310 FT
 (SR0030 SEG 0100/0000) 0070/2582

BURGETTSTOWN RD
 (SR3080 SEG 0040/0000) 0070/1905

017728 FT

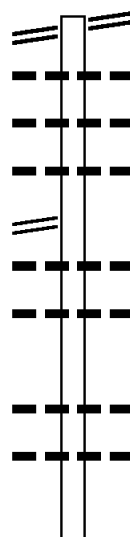

020310 FT	LINCOLN HW
0070/2582	(SR0030 SEG 0100/0000)
0070/2455	012 " DIA CIRC CONCR
0070/2305	LEN=0056 INSTALLED UNKN
0070/2060	018 " DIA CIRC CONCR
	LEN=0056 INSTALLED UNKN
	012 " DIA CIRC CONCR
	LEN=0040 INSTALLED 1999
	036 " DIA CIRC CONCR
0070/1790	LEN=0036 INSTALLED UNKN
	015 " DIA CIRC CONCR
0070/1555	LEN=0036 INSTALLED UNKN
	015 " DIA CIRC CONCR
0070/0435	LEN=0100 INSTALLED UNKN
	024 " DIA CIRC CONCR
0070/0067	LEN=0036 INSTALLED UNKN
017728 FT	2 0 02245 0 00 0179+95
0070/0000	LENGTH(AH 2582 BK 3018)

DIR: B TOTAL LEN: 3.847 MI. DIST: 11-1 SR: 3078
 LEFT MUN: FINDLAY T RIGHT MUN: FINDLAY T

Stationing	Notes	Material	Length	Start	End	Remarks
	--- ---	015" DIA CIRC CONCR	0060/1266			LEN=0036 INSTALLED UNKN
	--- ---	015" DIA CIRC CONCR	0060/0848			LEN=0036 INSTALLED UNKN
014710 FT		2 0 02245 0 00 0149+94	014710 FT			LENGTH(AH 3018 BK 1979)
	5	024" DIA CIR PLASTIC	0060/0000			LEN=0020 INSTALLED 2001
	--- ---	015" DIA CIRC CONCR	0050/1631			LEN=0036 INSTALLED UNKN
012731 FT		2 0 02245 0 00 0130+15	012731 FT			LENGTH(AH 1979 BK 3011)
	5	012" DIA CIRC CONCR	0050/0000			LEN=0030 INSTALLED UNKN
	--- ---	0040/2726				ROBINSON RD
	==	0040/2535				(T491)
	--- ---	015"H 00"W MULT CONCR	0040/0837			LEN=0042 INSTALLED UNKN
009720 FT		2 0 02245 0 00 0100+04	009720 FT			LENGTH(AH 3011 BK 2255)
	5	018" DIA CIRC CONCR	0040/0000			LEN=0036 INSTALLED UNKN
	--- ---	018" DIA CIRC CONCR	0030/2100			LEN=0036 INSTALLED UNKN
	--- ---	015" DIA CIRC CONCR	0030/1864			LEN=0036 INSTALLED UNKN
	--- ---	015" DIA CIRC CONCR	0030/1396			LEN=0036 INSTALLED UNKN
	--- ---	BMS EN 02/3078/0030/0125	0030/0143			2 0 02245 0 00 0078+76
	--- ---	POTATO GARDEN RUN	0030/0125			
007465 FT		BMSBG 02/3078/0030/0125	007465 FT			2 0 02245 0 00 0077+60
	--- ---	POTATO GARDEN RUN RD				(SR3071 SEG 0040/0000)
	5	LENGTH(AH 2255 BK 2799)	0030/0000			
	==					
	==					

MCNALL RD
(T822)

0020/2323

DIR: B TOTAL LEN: 3.847 MI. DIST: 11-1 SR: 3078
 LEFT MUN: FINDLAY T RIGHT MUN: FINDLAY T

WILLIAM DR
 (PRDR)

0020/1048

2 0 02245 0 00 0037+97 004666 FT
 WESTPORT RD
 (TWP)

0020/0000

OLD BURGETTSTOWN RD
 (SR3161 SEG 0004/0000)

0010/3706

000000 FT

0020/1769	012"H 24"W ELLIP CONC LEN=0050	INSTALLED UNKN
0020/1100	024 "DIA CIRC CONCR LEN=0040	INSTALLED 2002
0020/0372	018 "DIA CIRC CONCR LEN=0372	INSTALLED UNKN
0020/0287	018 "DIA CIRC CONCR LEN=0025	INSTALLED UNKN
0020/0000	LENGTH(AH 2799 BK 4666) 018 "DIA CIRC CONCR	
0010/4593	LEN=0035	INSTALLED UNKN
0010/4150	018 "DIA CIRC CONCR LEN=0035	INSTALLED UNKN
0010/4032	018 "DIA CIRC CONCR LEN=0040	INSTALLED UNKN
0010/3889	(APRA) SOLAR DR SOLAR DR (PRDR)	
0010/3834	030 "DIA CIRC METAL LEN=0040	INSTALLED UNKN
0010/2739	015 "DIA CIRC CONCR LEN=0036	INSTALLED UNKN
0010/2306	015 "DIA CIRC CONCR LEN=0036	INSTALLED UNKN
0010/1991	018 "DIA CIRC CONCR LEN=0040	INSTALLED UNKN
0010/1713	018 "DIA CIRC CONCR LEN=0036	INSTALLED UNKN
0010/0845	015 "DIA CIRC CONCR LEN=0036	INSTALLED UNKN
0010/0027	015 "DIA CIRC CONCR LEN=0036	INSTALLED UNKN
000000 FT	2 0 02245 0 00 0000+00 NC BU	RIDGETOWN RD (TWP)
* REF-BK	MFC BEGIN = D	
0010/0000	LENGTH(AH 4666 BK 0000)	

EXTRACT DATE: 12/21/2020 ROADWAY MANAGEMENT SYSTEM PAGE NUMBER: 1154
 PRINT DATE: 12/23/2020 SLD COUNTY/SR - ANNUAL PRINT COUNTY: ALLEGHENY
 DIR: B TOTAL LEN: 10.398 MI. DIST: 11-1 SR: 3077
 LEFT MUN: MOON T RIGHT MUN: MOON T

054902 FT

BOGGS AV
(TWP)

0230/0965

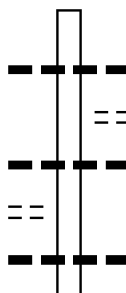

* 054639 FT AH-BEAVER (04)
 REF-AHD BRODHEAD RD
 0230/2064 (SR3007 SEG 0010/0000)
 0230/1919 018" DIA CIRC CONCR
 LEN=0050 INSTALLED UNKN
 HUNTSRIDGE DR
 0230/1660 (TWP)
 0230/1305 024"H 24"W CON BOX CUL
 LEN=0060 INSTALLED UNKN
 0230/0939 015" DIA CIRC CONCR
 LEN=0034 INSTALLED UNKN
 015" DIA CIRC CONCR

DIR: B TOTAL LEN: 10.398 MI. DIST: 11-1 SR: 3077
 LEFT MUN: MOON T RIGHT MUN: MOON T

Segment	Start Station	End Station	Length	Notes
COUNTRY LN (TWP)	052838 FT	0230/0585	LEN=0036	INSTALLED UNKN
		052575 FT	1 0 00076 0 04 0980+55	
		0230/0000	LENGTH(AH 2064 BK 2830) 012 "DIA CIRC CONCR	
WESTERN AV (T405)	0220/2321	0220/2555	LEN=0099	INSTALLED UNKN
		0220/1800	EASTERN AV (T173)	
		0220/1660	OAKES PLACE LN (TWP)	
SPRING RUN RD ET (CNTY) BONNIE BRAE DR (PRDR)	0220/1565	0220/1361	LEN=0040	INSTALLED UNKN
		0220/1046	018 "DIA CIRC CONCR BAUN DR (T416)	
	050008 FT	0220/0162	LEN=0040	INSTALLED UNKN
ESTATE DR (TWP)		049745 FT	1 0 00076 0 04 0952+43	
		0220/0000	018 "DIA CIRC CONCR SPRING RUN RD (CNTY) MOON CRESCENT T LENGTH(AH 2830 BK 2395)	
	047613 FT	0210/1757	HART DR (TWP)	
	0210/1747	CRESCENT MOON T		
	0210/1098	LOCUST RD (TWP)		
	0210/0725	HARVEST CT (PRDR)		
	047350 FT	1 0 00076 0 04 0911+73		
	0210/0000	PURDY RD (T335) 018 "DIA CIRC CONCR LEN=0050	INSTALLED UNKN	
	0200/2493	LENGTH(AH 2395 BK 2706) OLDE STABLE LN (TWP)		
	0200/2270	018 "DIA CIRC CONCR LEN=0050	INSTALLED UNKN	

DIR: B TOTAL LEN: 10.398 MI. DIST: 11-1 SR: 3077
 LEFT MUN: MOON T RIGHT MUN: MOON T

1 0 00076 0 04 0902+13 044907 FT
 BOGGS SCHOOL RD
 (T120) 0200/0000

041342 FT

0200/1992	018 " DIA	CIRC CONCR
	LEN=0060	INSTALLED UNKN
0200/1731	018 " DIA	CIRC CONCR
	LEN=0060	INSTALLED UNKN
0200/1473	018 " DIA	CIRC CONCR
	LEN=0060	INSTALLED UNKN
0200/1227	015 " DIA	CIRC METAL
	LEN=0075	INSTALLED UNKN
0200/0701	018 " DIA	CIRC CONCR
	LEN=0331	INSTALLED UNKN
0200/0019	018 " DIA	CIRC CONCR
044644 FT	LEN=0040	INSTALLED UNKN
0200/0000	LENGTH(AH 2706 BK 3565)	
	018 " DIA	CIRC CONCR
0190/3448	LEN=0070	INSTALLED UNKN
	018 " DIA	CIRC CONCR
0190/3093	LEN=0060	INSTALLED UNKN
	018 " DIA	CIRC CONCR
0190/2725	LEN=0044	INSTALLED UNKN
0190/2219	BMSSEN 02/3077/0190/2185	
	1 0 00076 0 04 0887+11	
	BOGGS RUN	
0190/2190	BMSBG 02/3077/0190/2185	
	0190/1459	BMSSEN 02/3077/0190/1401
	1 0 00076 0 04 0879+33	
	FLAUGHERTY RUN	
0190/1401	BMSBG 02/3077/0190/1401	
	FLAUGHERTY RUN RD	
0190/1315	(SR3089 SEG 0180/0000)	
	018 "H 00 "W MULT CONCR	
0190/0966	LEN=0099	INSTALLED UNKN
	018 " DIA	CIRC CONCR
0190/0475	LEN=0100	INSTALLED UNKN
	018 " DIA	CIRC CONCR
0190/0250	LEN=0072	INSTALLED UNKN
	018 " DIA	CIRC CONCR
0190/0035	LEN=0060	INSTALLED UNKN
041079 FT	1 0 00076 0 04 0865+27	
0190/0000	LENGTH(AH 3565 BK 3728)	
	015 " DIA	CIRC CONCR
0180/3370	LEN=0070	INSTALLED UNKN
	015 " DIA	CIRC CONCR
0180/3026	LEN=0070	INSTALLED UNKN
	018 " DIA	CIRC CONCR
0180/2795	LEN=0110	INSTALLED UNKN
	018 " DIA	CIRC CONCR

DIR: B TOTAL LEN: 10.398 MI. DIST: 11-1 SR: 3077
 LEFT MUN: MOON T RIGHT MUN: MOON T

Location	Segment ID	Length (FT)	Material / Notes
	0180/2339	0036	INSTALLED UNKN
	0180/2141	0040	INSTALLED UNKN
	0180/1969	0008	INSTALLED 2016
	0180/1762	0050	INSTALLED UNKN
	0180/1591	0050	INSTALLED UNKN
	0180/1258	0065	INSTALLED UNKN
	0180/1025	0065	INSTALLED UNKN
	0180/0760	0050	INSTALLED UNKN
	0180/0472	037614	APPLE BLOSSOM WY (TWP)
	0180/0000	037351	SHAFFER RD (T363)
LANDING LANE (TWP)	0170/2277		LENGTH(AH 3728 BK 2641)
	0170/1953		MCCLAFFERTY LN (TWP)
	0170/1778		INSTALLED UNKN
	0170/1570		GRANT DR (TWP)
BEACON HILL DR (T113)	0170/1507		
	0170/1232		INSTALLED UNKN
BEACON HILL DR (T113)	0170/1075		
ELM LN (T113)	0170/0878		
	0170/0242		INSTALLED UNKN
	0170/0103	034973	COLLEGE PARK DR (PRDR)
	0170/0000	034710	COLLEGE PARK DR (PRDR)
COLONY WEST APT RD (PRDR)	0170/0000		LENGTH(AH 2641 BK 0754)
	0150/0660		INSTALLED UNKN

DIR: B TOTAL LEN: 10.398 MI. DIST: 11-1 SR: 3077
 LEFT MUN: MOON T RIGHT MUN: MOON T

Segment	Start Station	End Station	Length (FT)	Notes
(PRDR)	0150/0556	034219	034219	NC BR
FROM 3109/0030 SH (CONN)	0144/1370	0144/1383	013	UNIVERSITY BL (SR3109 SEG 0041/0000) (SR3109 SEG 0040/0000)
CARNOT RD (T134)	0144/1232	0144/1240	8	018" DIA CIRC CONCR LEN=0050 INSTALLED UNKN
	0144/1185	0144/1240	55	018" DIA CIRC CONCR LEN=0099 INSTALLED UNKN
	0144/0881	0144/1185	304	CARNOT RD (T134)
	0144/0828	0144/0881	53	SHARON RD (T364) 018" DIA CIRC CONCR LEN=0150 INSTALLED UNKN
	0144/0789	0144/0828	39	018" DIA CIRC CONCR LEN=0060 INSTALLED UNKN
	032744	032481	263	0 0 00000 0 00 0000+00
	0144/0000	0140/2240	1440	PARISH PL (PRDR) LENGTH(AH 1475 BK 2625) 018" DIA CIRC CONCR LEN=0036 INSTALLED UNKN
TIGER TR (PRDR)	0140/1762	0140/1762	0	
POLO CLUB ENT & EXIT RD (PRDR)	0140/1420	0140/1762	342	
	0140/0526	0140/1420	894	012" DIA CIRC CONCR LEN=0048 INSTALLED UNKN
	0140/0500	0140/0526	26	LOZER DR (T263)
	0140/0330	0140/0500	170	024" DIA CIRC CONCR LEN=0032 INSTALLED UNKN
FOREST GREEN RD (PRDR)	0140/0265	029856	29856	
2 0 02320 0 00 0041+09 STOCKER DR (TWP)	0140/0000	0130/1315	1315	LENGTH(AH 2625 BK 1651) SANLIN DR (PRDR)

DIR: B TOTAL LEN: 10.398 MI. DIST: 11-1 SR: 3077
 LEFT MUN: MOON T RIGHT MUN: MOON T

Stationing	Length	Description	Notes
2 0 02320 0 00 0057+38	028468 FT	THORN RUN RD ET	
(T388)	0130/0000	LIBRARY ENT RD	LENGTH(AH 1651 BK 1489)
(TWP)	0120/1270		
MOON TWP MUN CTR RD	0120/1045	048 " DIA CIRC CONCR	LEN=0099 INSTALLED UNKN
(TWP)	0120/0865	BEAVER TRUST COMP DR	(PRDR)
MOON TWP MUN CTR RD	0120/0865	018 " DIA CIRC CONCR	LEN=0060 INSTALLED UNKN
(TWP)	0120/0000	CORAOPOLIS HEIGHTS RD	(SR3074 SEG 0010/0000)
2 0 02320 0 00 0072+34	026979 FT		
CORAOPOLIS HEIGHTS RD	0120/0000		LENGTH(AH 1489 BK 1694)
(TWP)	0110/1450	018 " DIA CIRC CONCR	LEN=0030 INSTALLED UNKN
	0110/1255	015 " DIA CIRC CONCR	LEN=0035 INSTALLED UNKN
	0110/1100	015 " DIA CIRC CONCR	LEN=0035 INSTALLED UNKN
	0110/0936	018 " DIA CIRC CONCR	LEN=0035 INSTALLED UNKN
	0110/0895	ENTRY RD	(T204)
CORPORATE CENTER DR	0110/0415		
(PRDR)	025285 FT		
	025022 FT	2 0 02319 0 00 0260+25	GLADDWOOD RD
	0110/0000	(T202)	LENGTH(AH 1694 BK 2507)
	0100/2285	018 " DIA CIRC CONCR	LEN=0035 INSTALLED UNKN
CHERRINGTON CORP CTR RD	0100/1890		
(PRDR)	0100/1072	018 " DIA CIRC CONCR	LEN=0030 INSTALLED UNKN
	022778 FT	2 0 02319 0 00 0235+10	HAYESWOLD DR
		(T218)	

DIR: B TOTAL LEN: 10.398 MI. DIST: 11-1 SR: 3077
 LEFT MUN: MOON T RIGHT MUN: MOON T

Stationing	Segment Length	Material / Notes
019819 FT	0100/0000	LENGTH(AH 2507 BK 2696)
	0090/1948	018 " DIA CIR UNKNOWN LEN=0050 INSTALLED UNKN
	0090/1649	018 " DIA CIR UNKNOWN LEN=0045 INSTALLED UNKN
	0090/0973	018 " DIA CIR PLASTIC LEN=0045 INSTALLED UNKN
	0090/0637	024 " DIA CIRC CONCR LEN=0038 INSTALLED UNKN
	0090/0072	018 " DIA CIRC CONCR LEN=0038 INSTALLED UNKN
2 0 02319 0 00 0208+18 020082 FT EWING RD (TBC)	0090/0000	019819 FT EWING RD (TBC)
	0080/0728	018 " DIA CIRC CONCR LEN=0038 INSTALLED UNKN
2 0 02319 0 00 0188+36 018100 FT MCCORMICK RD (T281)	0080/0000	017837 FT LENGTH(AH 1982 BK 2474)
	0070/1787	018 " DIA CIRC CONCR LEN=0040 INSTALLED UNKN
	0070/1415	EWINGS MILL RD (T175)
	0070/0991	018 " DIA CIRC CONCR LEN=0042 INSTALLED UNKN
2 0 02319 0 00 0163+35 015626 FT LOCUST DR (T269)	0070/0000	015363 FT LENGTH(AH 2474 BK 2587)
	0060/2443	HUNTERS RUN DR (TWP)
OLDE MANOR LN (TWP)	0060/1375	018 " DIA CIRC CONCR LEN=0032 INSTALLED UNKN MCCORMICK ELEM SCH RD (PRDR)
FALLBROOK DR	0060/0460	BERTLEY RIDGE DR (T457) BENJAMIN CT

DIR: B TOTAL LEN: 10.398 MI. DIST: 11-1 SR: 3077
 LEFT MUN: MOON T RIGHT MUN: MOON T

Stationing	Description	Notes
0060/0194	(TWP)	0060/0194 (TWP)
013039 FT		018" DIA CIRC CONCR LEN=0030 INSTALLED UNKN
0050/2575	LC TO CHERRINGTON LN (CONN)	012776 FT 2 0 02319 0 00 0137+64
0050/2480	CHERRINGTON LN (T139)	0060/0000 LENGTH(AH 2587 BK 3020)
0050/2240		015" DIA CIRC CONCR LEN=0032 INSTALLED UNKN
0050/1614		PENFOLDS PL (PRDR)
0050/1069		015" DIA CIRC CONCR LEN=0028 INSTALLED UNKN
0050/0805	CHERRINGTON MANOR RD (PRDR)	DUCKHORN DR (PRDR)
010019 FT		009756 FT 2 0 02319 0 00 0099+73
0040/2852		0050/0000 LTH AH 003020 BK 002944 036" DIA CIRC CONCR LEN=0040 INSTALLED UNKN
0040/1356		018" DIA CIRC CONCR LEN=0075 INSTALLED UNKN
0040/0923		018" DIA CIRC CONCR LEN=0110 INSTALLED UNKN
0040/0495		018" DIA CIRC CONCR LEN=0050 INSTALLED UNKN
0040/0295	TO 3072/0040 SH (CONN)	018" DIA CIRC CONCR LEN=0060 INSTALLED UNKN
007075 FT	2 0 02319 0 00 0068+52 CLEVER RD (SR3072 SEG 0040/0785)	0040/0030 006812 FT INTER-BK CLEVER RD (SR3072 SEG 0040/0785)
0040/0000		0040/0000 LTH AH 002944 BK 000100
007075 FT		006812 FT
0033/0263	CLEVER RD (SR3072 SEG 0060/0713)	7034/0000 LTH AH 000100 BK 000100
006812 FT	CLEVER RD (TWP)	
0033/0000	ROBINSON T 0 0 00000 0 00 0000+00 MFC BEGIN = C LENGTH(AH 0263 BK 3057)	006812 FT 7032/0000 LTH AH 000100 BK 003057

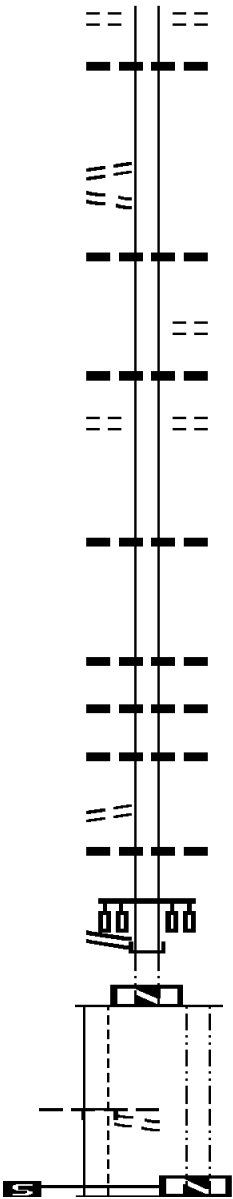

DIR: B TOTAL LEN: 10.398 MI. DIST: 11-1 SR: 3077
 LEFT MUN: ROBINSON T RIGHT MUN: ROBINSON T

Stationing	Right of Way	Structure	Material	Length	Notes
0030/3057	LC TO CLEVER RD (CONN)	ROBINSON T	018" DIA CIRC CONCR	LEN=0060	INSTALLED UNKN
0030/2870			018" DIA CIRC CONCR	LEN=0032	INSTALLED UNKN
0030/2110			018" DIA CIRC CONCR	LEN=0050	INSTALLED UNKN
0030/1865			018" DIA CIRC CONCR	LEN=0040	INSTALLED UNKN
0030/1620			018" DIA CIRC CONCR	LEN=0060	INSTALLED UNKN
0030/0612			018" DIA CIRC CONCR	LEN=0040	INSTALLED UNKN
2 0 02319 0 00 0016+77 003755 FT					
ROBIN RD (TWP)					
0030/0000					
0020/1627			024" DIA CIRC CONCR	LEN=0040	INSTALLED UNKN
MEADE DR (TWP)					
0020/0970					
0020/0886			018" DIA CIRC CONCR	LEN=0030	INSTALLED UNKN
0020/0650			018" DIA CIRC CONCR	LEN=0030	INSTALLED UNKN
002079 FT					
002079 FT					
0020/0000					
BELL COURT RD (TWP)					
0010/1817					
0010/1335					
WAVERLY CT (TWP)					
0010/0921					
000000 FT					
0010/0071			018" DIA CIR PLASTIC	LEN=0120	INSTALLED 1999
000000 FT					
NC BEAVER GRADE RD					
STEUBENVILLE PK					
(SR0060 SEG 0200/0000)					
0010/0000					
MFC BEGIN = C					
0010/0000					
LENGTH(AH 2079 BK 0000)					

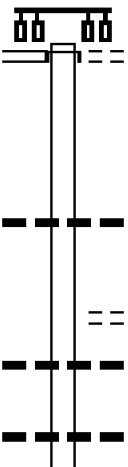
	012225 FT		012225 FT	EWING INT-RAMP B RD
EWING RD			INTER-AHD	(SR8070 SEG 0250/0000)
{SR3070 SEG 0135/1211}				EWING RD
{SR3070 SEG 0134/1150}	0044/1375		0044/1375	(TWP)
	010850 FT		010850 FT	2 0 00000 0 00 0000+00
			0044/0000	LENGTH(AH 1375 BK 0914)
			0040/0543	018 "DIA CIRC CONCR
	009936 FT		009936 FT	LEN=0035 INSTALLED UNKN
				2 0 02006 0 00 0096+14
				MCCORMICK RD
			0040/0000	(T281)
			0030/3340	LENGTH(AH 0914 BK 3363)
			0030/2446	015 "DIA CIRC CONCR
				LEN=0045 INSTALLED UNKN
				018 "DIA CIRC CONCR
				LEN=0040 INSTALLED UNKN
				012 "DIA CIR PLASTIC

DIR: B TOTAL LEN: 2.315 MI. DIST: 11-1 SR: 3075
 LEFT MUN: MOON T RIGHT MUN: MOON T

2 0 02006 0 00 0062+60 006573 FT
 HIRSHINGER RD
 (T372) 0030/0000

FED EX DR
 (TWP) 0020/0059
 003284 FT

000000 FT

0030/2337	LEN=0050	INSTALLED UNKN
0030/1546		NOBLE WOODS DR (TWP)
006573 FT		
0030/0000	LENGTH(AH 3363 BK 3289)	018 "DIA CIRC CONCR
0020/3240	LEN=0030	INSTALLED UNKN
0020/1563	LEN=0035	015 "DIA CIRC CONCR INSTALLED UNKN
0020/1018	LEN=0035	015 "DIA CIRC CONCR INSTALLED UNKN
0020/1006		MONTCLAIR DR (PRDR)
0020/0031	LEN=0055	018 "DIA CIRC CONCR INSTALLED UNKN
003284 FT		2 0 02006 0 00 0029+52
0020/0000	LENGTH(AH 3289 BK 3284)	
0010/2234	LEN=0070	015 "DIA CIRC CONCR INSTALLED UNKN
0010/1859	LEN=0045	018 "DIA CIRC CONCR INSTALLED UNKN
0010/1477	LEN=0035	015 "DIA CIRC CONCR INSTALLED UNKN
0010/1162	LEN=0060	018 "DIA CIRC CONCR INSTALLED UNKN
0010/0445	LEN=0040	018 "DIA CIRC CONCR INSTALLED UNKN
000000 FT		2 0 02006 0 00 0000+00 NC HO
0010/0000	LENGTH(AH 3284 BK 0000)	OKSTOWN GRADE RD MONTOUR RUN RD (SR3072 SEG 0030/0311) MFC BEGIN = E

EXTRACT DATE: 12/21/2020 ROADWAY MANAGEMENT SYSTEM PAGE NUMBER: 1143
PRINT DATE: 12/23/2020 SLD COUNTY/SR - ANNUAL PRINT COUNTY: ALLEGHENY
DIR: B TOTAL LEN: 5.034 MI. DIST: 11-1 SR: 3074
LEFT MUN: ROBINSON T RIGHT MUN: ROBINSON T



EXTRACT DATE: 12/21/2020
PRINT DATE: 12/23/2020

ROADWAY MANAGEMENT SYSTEM
SLD COUNTY/SR - ANNUAL PRINT

PAGE NUMBER: 1142
COUNTY: ALLEGHENY

DIR: B TOTAL LEN: 5.034 MI.
LEFT MUN: ROBINSON T

DIST: 11-1 SR: 3074
RIGHT MUN: ROBINSON T

Stationing	Notes	Stationing	Notes
026021 FT		INTER-AHD 0120/0556	FOREST GROVE RD (CNTY)
		026021 FT	0 0 00000 0 00 0000+00
		INTER-BK	FOREST GROVE RD (CNTY)
			SR 0079 SB
026021 FT		5 0120/0000	BMSBG 02/3074/0120/0001
		026021 FT	LTH AH 000556 BK 003240
FOREST GROVE RD (CNTY)		7112/0000	LTH AH 003240 BK 002007
0110/2007		INTER-AHD	SILVER LN (TWP)
		0110/2007	ELCO DR (TWP)
		0110/1760	EVELYN DR (TWP)
		0110/1125	WILLIAMS DR (TWP)
024014 FT		024014 FT	2 0 02296 0 00 0019+88
NORTH FOREST GROVE RD (SR3085 SEG 0010/0000) MARKS DR (PRDR)		NC FOREST GROVE RD	MFC BEGIN = C
0110/0000		5 0110/0000	LENGTH(AH 2007 BK 2070)
0100/1734			LEONA LN (TWP)
		0100/1275	GRAYDON DR (TWP)
		0100/1046	018 " DIA CIRC CONCR LEN=0048 INSTALLED UNKN
		0100/0926	018 " DIA CIRC CONCR LEN=0048 INSTALLED UNKN
		0100/0650	FLYNN DR (PRDR)
021944 FT		0100/0398	2 0 02062 0 00 0079+74
		021944 FT	WENDT DR (PRDR)
		5 0100/0000	LENGTH(AH 2070 BK 1775)
		0090/0143	018 " DIA CIRC CONCR LEN=0048 INSTALLED UNKN
020169 FT		020169 FT	2 0 02062 0 00 0059+68
		5 0090/0000	LENGTH(AH 1775 BK 2072)
		0080/1905	018 " DIA CIRC CONCR LEN=0048 INSTALLED UNKN

EXTRACT DATE: 12/21/2020
PRINT DATE: 12/23/2020

ROADWAY MANAGEMENT SYSTEM
SLD COUNTY/SR - ANNUAL PRINT

PAGE NUMBER: 1141
COUNTY: ALLEGHENY

DIR: B TOTAL LEN: 5.034 MI.
LEFT MUN: ROBINSON T

DIST: 11-1 SR: 3074
RIGHT MUN: ROBINSON T

Stationing	Material	Length	Notes
018097 FT	0080/1527	LEN=0048	018 "DIA CIRC CONCR INSTALLED UNKN
	0080/1189	LEN=0048	018 "DIA CIRC CONCR INSTALLED UNKN
	0080/0867	LEN=0048	018 "DIA CIRC CONCR INSTALLED UNKN
	0080/0355		HICKMAN RD
	0080/0153		(TWP)
	018097 FT		BMS EN 02/3074/0080/0000
			2 0 0 02062 0 00 0041+30
			MONTOUR RUN
			BMSBG 02/3074/0080/0000
			ROBINSON
			MOON T
	0080/0000	LENGTH(AH	2072 BK 1636)
	0070/1431	LEN=0060	018 "DIA CIRC CONCR INSTALLED UNKN
	0070/1105	LEN=0048	018 "DIA CIR PLASTIC INSTALLED UNKN
	0070/0768	LEN=0048	018 "DIA CIRC CONCR INSTALLED UNKN
	0070/0483	LEN=0048	018 "DIA CIRC CONCR INSTALLED UNKN
016461 FT	0070/0173	LEN=0048	018 "DIA CIRC CONCR INSTALLED UNKN
	016461 FT		2 0 0 02062 0 00 0021+76
	0070/0000	LENGTH(AH	1636 BK 2321)
	0060/2217	LEN=0048	018 "DIA CIRC CONCR INSTALLED UNKN
	0060/1860	LEN=0060	018 "DIA CIRC CONCR INSTALLED UNKN
	0060/1611	LEN=0048	018 "DIA CIRC CONCR INSTALLED UNKN
	0060/1335	LEN=0048	018 "DIA CIRC CONCR INSTALLED UNKN
	0060/1057	LEN=0048	018 "DIA CIRC CONCR INSTALLED UNKN
	0060/0800	LEN=0050	018 "DIA CIRC CONCR INSTALLED UNKN
	0060/0522	LEN=0050	018 "DIA CIRC CONCR INSTALLED UNKN
014140 FT	0060/0236	LEN=0050	018 "DIA CIRC CONCR INSTALLED UNKN
	014140 FT		2 0 0 02062 0 00 0000+00
			NC EWINGS MILL RD
	0060/0000	LENGTH(AH	2321 BK 1220)
	0050/1133	LEN=0020	018 "DIA CIRC CONCR INSTALLED UNKN
	0050/1120	LEN=0050	018 "DIA CIRC CONCR INSTALLED UNKN

DIR: B TOTAL LEN: 5.034 MI. DIST: 11-1 SR: 3074
 LEFT MUN: MOON T RIGHT MUN: MOON T

Location	Segment	Length (FT)	Material	Status
FRANKLIN PL (TWP)	0050/1083		018" DIA CIRC CONCR	LEN=0048 INSTALLED UNKN
1 1 02386 0 00 0038+18	012920 FT			
MONTOUR ST ET (SR3081 SEG 0010/0000)	0050/0000		018" DIA CIRC METAL	LEN=0040 INSTALLED UNKN
KEY GARDEN DR (T246)	0040/3380		018" DIA CIRC CONCR	LEN=0040 INSTALLED UNKN
	0040/3310		ESSEX KNOLL DR (T420)	
	0040/2634		018" DIA CIRC METAL	LEN=0040 INSTALLED UNKN
	0040/2403		ESSEX KNOLL DR (T420)	
	0040/2070		024" DIA CIRC CONCR	LEN=0048 INSTALLED UNKN
	0040/1797		CHAUCER CT (TWP)	
	0040/1560		018" DIA CIRC CONCR	LEN=0060 INSTALLED UNKN
PHILOMENA DR (T332)	0040/1155		WINDSOR DR (T442)	
	0040/1147		036" DIA CIRC CONCR	LEN=0040 INSTALLED UNKN
	0040/0883		018" DIA CIRC CONCR	LEN=0040 INSTALLED UNKN
	0040/0771		STILLWOOD DR (T374)	
CHARLTON HTS RD (T138)	0040/0135			
009094 FT				
MAPLE ST ET (SR3079 SEG 0010/0000)	0040/0000		018" DIA CIRC CONCR	LEN=0048 INSTALLED UNKN
	0030/1145		PINE ACRE LN (PRDR)	
	0030/0775			
OAKHAVEN DR (TWP)	0030/0480			
007381 FT				
	0030/0000		2 0 02320 0 00 0146+09	
			EWING RD (TBC)	
			LENGTH(AH 1713 BK 3554)	
			FITZRANDOLPH DR	

DIR: B TOTAL LEN: 5.034 MI. DIST: 11-1 SR: 3074
 LEFT MUN: MOON T RIGHT MUN: MOON T

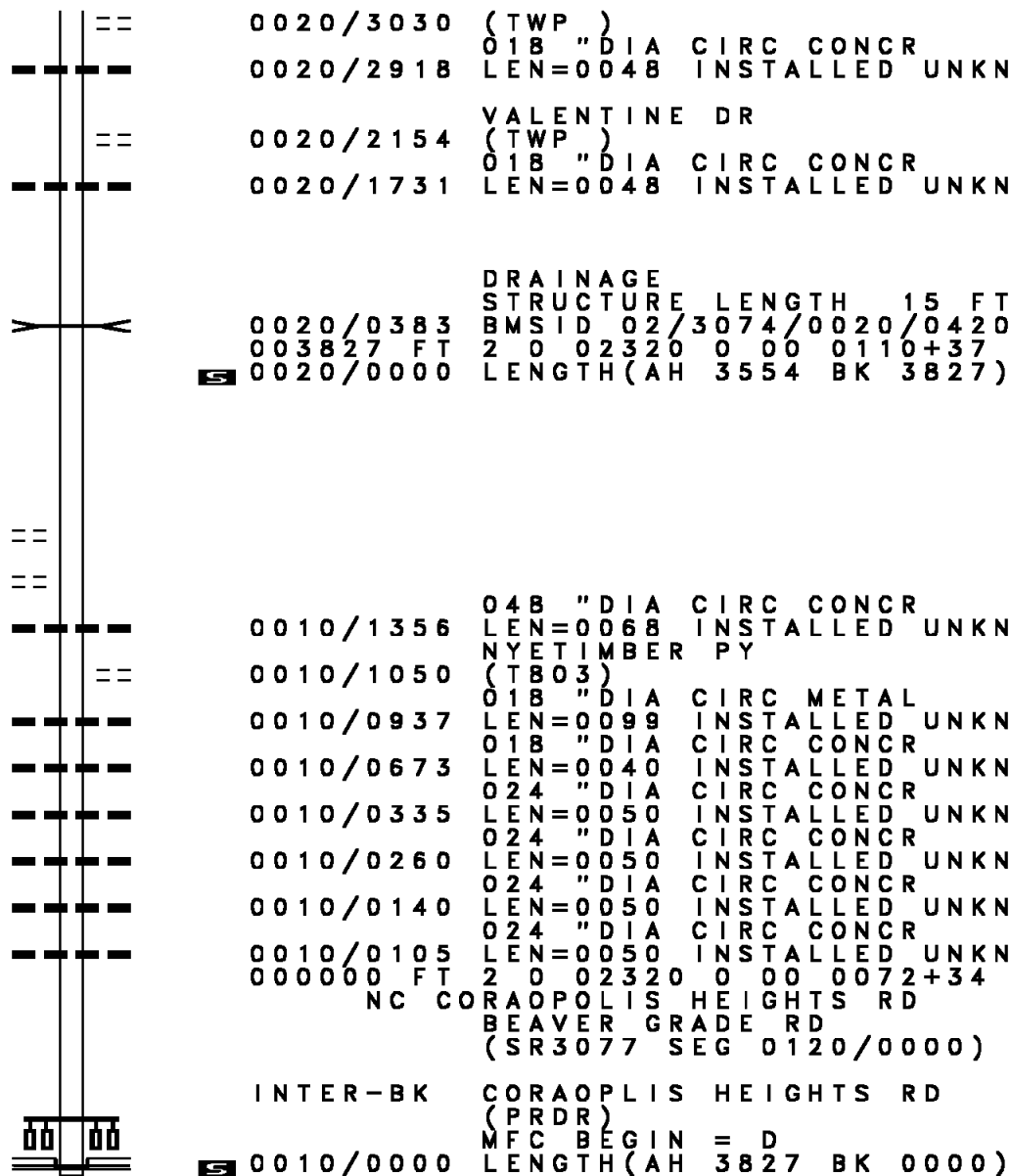

0020/3030 (TWP)
 018 " DIA CIRC CONCR
 0020/2918 LEN=0048 INSTALLED UNKN
 VALENTINE DR
 (TWP)
 0020/2154 018 " DIA CIRC CONCR
 0020/1731 LEN=0048 INSTALLED UNKN
 DRAINAGE
 STRUCTURE LENGTH 15 FT
 0020/0383 BMSID 02/3074/0020/0420
 003827 FT 2 0 02320 0 00 0110+37
 0020/0000 LENGTH(AH 3554 BK 3827)
 003827 FT
 WINDY WILLOWS DR
 (T409)
 SNYDER DR
 (T145)
 0010/1960
 0010/1407
 0010/1356 048 " DIA CIRC CONCR
 LEN=0068 INSTALLED UNKN
 NYETIMBER PY
 (T803)
 0010/1050 018 " DIA CIRC METAL
 LEN=0099 INSTALLED UNKN
 0010/0937 018 " DIA CIRC CONCR
 LEN=0040 INSTALLED UNKN
 0010/0673 024 " DIA CIRC CONCR
 LEN=0050 INSTALLED UNKN
 0010/0335 024 " DIA CIRC CONCR
 LEN=0050 INSTALLED UNKN
 0010/0260 024 " DIA CIRC CONCR
 LEN=0050 INSTALLED UNKN
 0010/0140 024 " DIA CIRC CONCR
 LEN=0050 INSTALLED UNKN
 0010/0105 024 " DIA CIRC CONCR
 LEN=0050 INSTALLED UNKN
 000000 FT 2 0 02320 0 00 0072+34
 NC CO
 CORAOPOLIS HEIGHTS RD
 BEAVER GRADE RD
 (SR3077 SEG 0120/0000)
 INTER-BK
 CORAOPOLIS HEIGHTS RD
 (PRDR)
 MFC BEGIN = D
 0010/0000 LENGTH(AH 3827 BK 0000)

WINDY WILLOWS DR
 (T409)
 SNYDER DR
 (T145)

EXTRACT DATE: 12/21/2020 ROADWAY MANAGEMENT SYSTEM PAGE NUMBER: 1138
 PRINT DATE: 12/23/2020 SLD COUNTY/SR - ANNUAL PRINT COUNTY: ALLEGHENY
 DIR: B TOTAL LEN: .030 MI. DIST: 11-1 SR: 3073
 LEFT MUN: MOON T RIGHT MUN: MOON T

000158 FT
 000000 FT

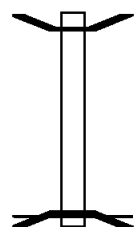

000158 FT BMS EN 02/3073/0010/0000
 * REF-AHD CORAOPOLIS HEIGHTS RD
 0010/0158 (TWP)
 000000 FT 0 0 00000 0 00 0000+00
 NC CO
 * REF-BK CORAOPOLIS HEIGHTS RD
 (TWP)
 SR 3160
 BMSBG 02/3073/0010/0000
 MFC BEGIN = E
 0010/0000 LENGTH(AH 0158 BK 0000)

Location / Description	Start Station	End Station	Length (FT)	Notes / Details
	012485	012485	0	
	012485	012485	0	
	0060	0060	0	
VENTANA DR (TWP)	0060	0055	5	
	011772	011772	0	
OLD BEAVER GRADE RD (CNTY)	0050	01165	1115	
	0050	0020	30	
LC TO BEAVER GRADE RD (CONN)	010082	010082	0	
	012518	012518	0	
	7080	0000	7080	LENGTH(AH 2119 BK 2498)
	012518	0000	12518	LENGTH(AH 2498 BK 0713)
	7070	0000	7070	CLEVER RD (TBK)
	0060	0713	653	BEAVER GRADE RD (SR3077 SEG 0033/0263)
	0060	0546	266	072" DIA CIRC CONCR
	0060	0526	20	LEN=0100 INSTALLED UNKN
	011805	011805	0	BR MONTR RUN
	0060	0000	6000	STRUCTURE LENGTH 8 FT
	0050	1548	1048	BMSID 02/3072/0060/0526
	0050	1165	465	2 0 02319 0 00 0057+00
	0050	0671	571	LENGTH(AH 0713 BK 1690)
	0050	0430	430	018" DIA CIRC CONCR
	0050	0121	121	LEN=0100 INSTALLED UNKN
	010115	010115	0	(APRA) AAA/MULTIPHASE C
	0050	0000	5000	BR. MONTOUR
	0050	0000	5000	STRUCTURE LENGTH 18 FT
	0050	0000	5000	BMSID 02/3072/0050/0671
	0050	0000	5000	(APRA) UNIVERSAL SPECIA
	0050	0000	5000	UNIVERSAL SPECIALTIES R
	0050	0000	5000	(PRDR)
	0050	0000	5000	BMSEN 02/3072/0050/0000
	010115	010115	0	2 0 02319 0 00 0083+96
	0050	0000	5000	MONTOUR RUN
	0050	0000	5000	BMSBG 02/3072/0050/0000
	0050	0000	5000	LENGTH(AH 1690 BK 1003)

DIR: E TOTAL LEN: 2.371 MI. DIST: 11-1 SR: 3072
 LEFT MUN: ROBINSON T RIGHT MUN: ROBINSON T

BEAVER GRADE RD
 (SR3077 SEG 0040/0000) 0040/0785
 FROM 3077/0040 SH
 (CONN) 0040/0633

009079 FT

HOOKSTOWN GRADE RD
 (SR3075 SEG 0010/0000) 0030/0311

005539 FT

LC TO FEDEX DR
 (CONN) 0015/2507

FEDEX DR
 (TWP) 0015/2369

LC FROM FEDEX DR
 (CONN) 0015/2298

PARK MANOR DR
 (TWP)

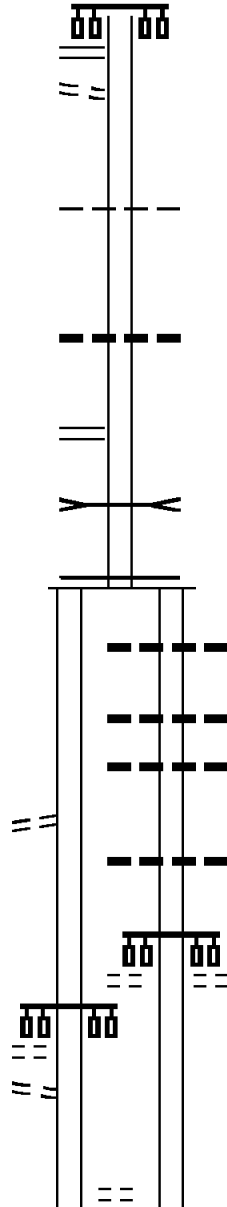

0040/0785

009112 FT 2 0 02306 0 00 0090+54
 0040/0000 LENGTH(AH 1003 BK 3540)
 ROBINSON
 0030/2972 MOON T

0030/1507 012 " DIA CIRC CONCR
 LEN=1097 INSTALLED UNKN

0030/0270 TROUT RUN
 STRUCTURE LENGTH 14 FT
 BMSID 02/3072/0020/2554
 005572 FT 2 0 02306 0 00 0058+26
 MFC BEGIN = C
 0030/0000 LENGTH(AH 3540 BK 3376)

0014/3360 018 " DIA CIRC CONCR
 LEN=0026 INSTALLED UNKN

0014/2907 018 " DIA CIRC CONCR
 LEN=0033 INSTALLED UNKN

0014/2578 018 " DIA CIRC CONCR
 LEN=0099 INSTALLED UNKN

0014/2483 018 " DIA CIRC CONCR
 LEN=0033 INSTALLED UNKN

FEDEX DR
 (TWP)
 PARK MANOR BL
 (TWP)

0014/2374

DIR: E TOTAL LEN: 2.371 MI. DIST: 11-1 SR: 3072
 LEFT MUN: MOON T RIGHT MUN: MOON T

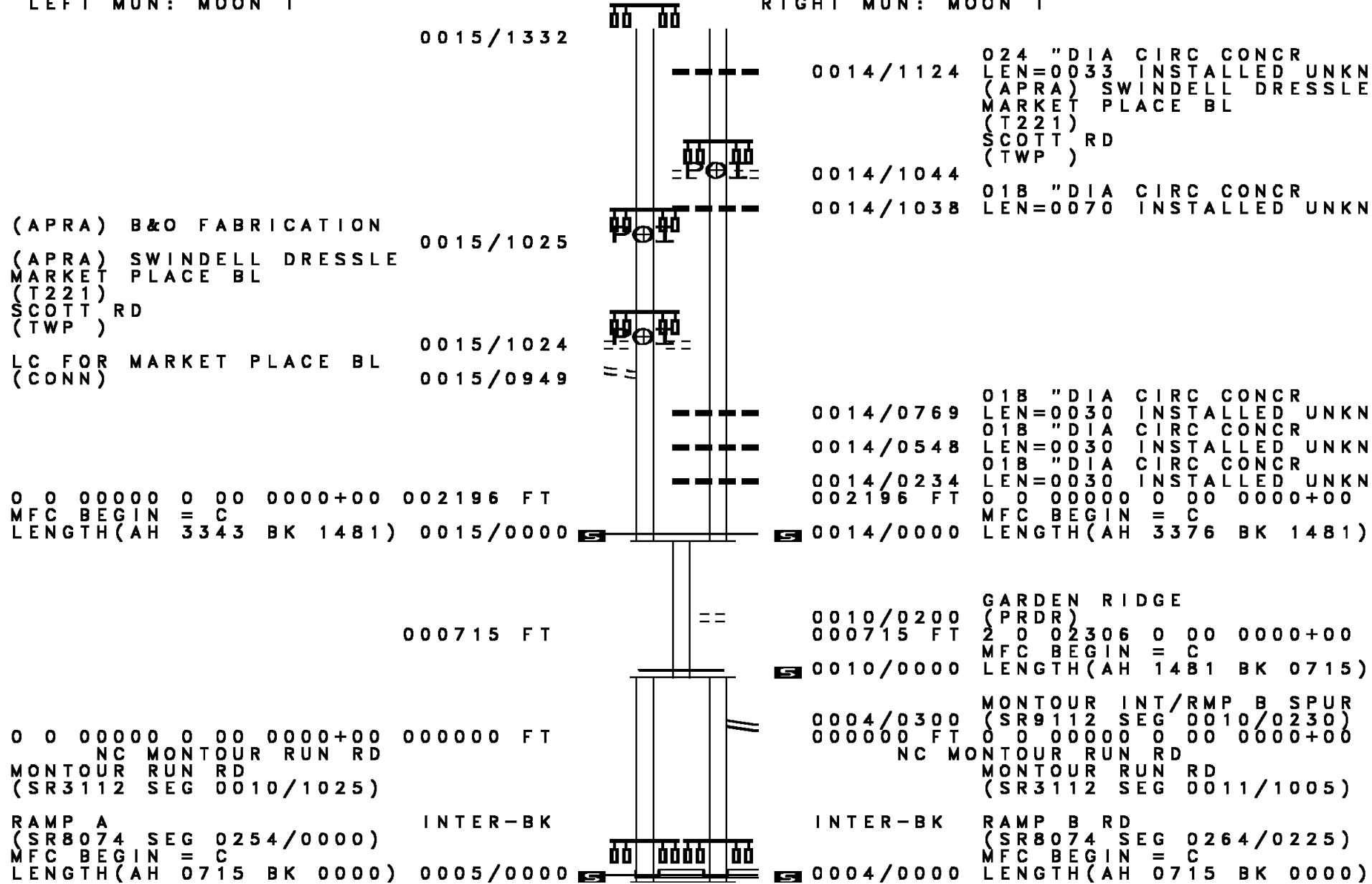

(APRA) B&O FABRICATION
 (APRA) SWINDELL DRESSLE
 MARKET PLACE BL
 (T221)
 SCOTT RD
 (TWP)
 LC FOR MARKET PLACE BL
 (CONN)

0 0 00000 0 00 0000+00 002196 FT
 MFC BEGIN = C
 LENGTH(AH 3343 BK 1481)

0 0 00000 0 00 0000+00 000000 FT
 NC MONTOUR RUN RD
 MONTOUR RUN RD
 (SR3112 SEG 0010/1025)
 RAMP A INTER-BK
 (SR8074 SEG 0254/0000)
 MFC BEGIN = C
 LENGTH(AH 0715 BK 0000)

0014/1124 024 " DIA CIRC CONCR
 LEN=0033 INSTALLED UNKN
 (APRA) SWINDELL DRESSLE
 MARKET PLACE BL
 (T221)
 SCOTT RD
 (TWP)
 0014/1044

0014/1038 018 " DIA CIRC CONCR
 LEN=0070 INSTALLED UNKN

0014/0769 018 " DIA CIRC CONCR
 LEN=0030 INSTALLED UNKN
 0014/0548 018 " DIA CIRC CONCR
 LEN=0030 INSTALLED UNKN
 0014/0234 018 " DIA CIRC CONCR
 LEN=0030 INSTALLED UNKN
 002196 FT 0 0 00000 0 00 0000+00
 MFC BEGIN = C
 LENGTH(AH 3376 BK 1481)

0010/0200 GARDEN RIDGE
 (PRDR)
 000715 FT 2 0 02306 0 00 0000+00
 MFC BEGIN = C
 LENGTH(AH 1481 BK 0715)

0004/0300 MONTOUR INT/RMP B SPUR
 (SR9112 SEG 0010/0230)
 000000 FT 0 0 00000 0 00 0000+00
 NC MONTOUR RUN RD
 MONTOUR RUN RD
 (SR3112 SEG 0011/1005)

INTER-BK RAMP B RD
 (SR8074 SEG 0264/0225)
 MFC BEGIN = C
 LENGTH(AH 0715 BK 0000)

EXTRACT DATE: 12/21/2020 ROADWAY MANAGEMENT SYSTEM PAGE NUMBER: 1134
PRINT DATE: 12/23/2020 SLD COUNTY/SR - ANNUAL PRINT COUNTY: ALLEGHENY
DIR: B TOTAL LEN: 6.235 MI. DIST: 11-1 SR: 3071
LEFT MUN: FINDLAY T RIGHT MUN: FINDLAY T

032923 FT

* 032923 FT AH-BEAVER (04)
REF-AHD CORKBOCKTOWN RD
0110/1612 (SR3025 SEG 0010/0000)

031311 FT

031311 FT 2 0 02069 0 00 0315+05
FERGUSON RD
(T503)

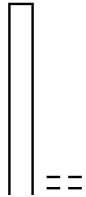

DIR: B TOTAL LEN: 6.235 MI. DIST: 11-1 SR: 3071
 LEFT MUN: FINDLAY T RIGHT MUN: FINDLAY T

BACKBONE RD
 (TWP)

0100/3150

028136 FT

024439 FT

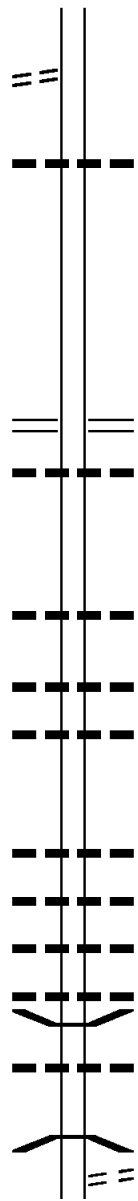

5 0110/0000 LENGTH(AH 1612 BK 3175)

0100/2140 018 "DIA CIRC CONCR
 LEN=0048 INSTALLED UNKN

028136 FT 2 0 02069 0 00 0282+01
 NC CO RKBOCKTOWN RD
 LINCOLN HW

5 0100/0000 LENGTH(AH 3175 BK 3697)
 018 "DIA CIRC CONCR
 0090/3188 LEN=0048 INSTALLED UNKN

0090/1580 015 "DIA CIRC CONCR
 LEN=0050 INSTALLED UNKN

0090/0912 018 "DIA CIRC CONCR
 LEN=0040 INSTALLED UNKN

0090/0436 018 "DIA CIRC CONCR
 LEN=0048 INSTALLED UNKN
 024439 FT 2 0 02069 0 00 0245+10
 5 0090/0000 LENGTH(AH 3697 BK 3719)

0080/2850 018 "DIA CIRC CONCR
 LEN=0040 INSTALLED UNKN

0080/2430 015 "DIA CIRC CONCR
 LEN=0050 INSTALLED UNKN

0080/2100 018 "DIA CIRC CONCR
 LEN=0040 INSTALLED UNKN

0080/1962 024 "DIA CIRC CONCR
 LEN=0050 INSTALLED UNKN

0080/1703 BMSSEN 02/3071/0080/1685
 048"H 60"W CONC STRUCT

0080/1698 018 "DIA CIRC CONCR
 LEN=0040 INSTALLED UNKN

2 0 02069 0 00 0224+76
 BR POTATO GARDEN RUN
 0080/1685 BMSBG 02/3071/0080/1685
 MOODY ROAD
 0080/1320 (T306)

DIR: B TOTAL LEN: 6.235 MI. DIST: 11-1 SR: 3071
 LEFT MUN: FINDLAY T RIGHT MUN: FINDLAY T

STROUSS RD
 (T453)

0080/1200

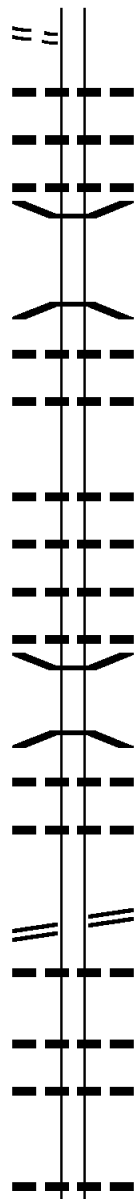

0080/1024

024 " DIA CIRC CONCR
 LEN=0040 INSTALLED UNKN

0080/0843

024 " DIA CIRC CONCR
 LEN=0020 INSTALLED UNKN

0080/0450

018 " DIA CIR PLASTIC
 LEN=0050 INSTALLED UNKN

020720 FT

0080/0012

BMSSEN 02/3071/0080/0001
 2 0 02069 0 00 0207+97

020720 FT

BR. POTATO GARDEN RUN
 BMSBG 02/3071/0080/0001

5 0080/0000

LENGTH(AH 3719 BK 3914)
 015 " DIA CIRC CONCR

0070/3654

LEN=0040 INSTALLED UNKN
 015 " DIA CIR PLASTIC

0070/3292

LEN=0060 INSTALLED UNKN

0070/2100

018 " DIA CIR PLASTIC
 LEN=0060 INSTALLED 2001

0070/1880

024 " DIA CIRC CONCR
 LEN=0015 INSTALLED UNKN

0070/1675

018 " DIA CIRC CONCR
 LEN=0040 INSTALLED UNKN

0070/1532

018 " DIA CIRC CONCR
 LEN=0040 INSTALLED UNKN

0070/1248

BMSSEN 02/3071/0070/1220
 2 0 02069 0 00 0180+43

0070/1220

PO. GDN RUN
 BMSBG 02/3071/0070/1220
 018 " DIA CIRC CONCR

0070/1100

LEN=0048 INSTALLED UNKN
 018 " DIA CIRC CONCR

016806 FT

0070/0572

LEN=0048 INSTALLED UNKN
 2 0 02069 0 00 0168+68

016806 FT

WASHINGTON RD
 (SR3089 SEG 0020/0610)

WASHINGTON RD
 (SR3089 SEG 0020/0610)

0070/0000

5 0070/0000

LENGTH(AH 3914 BK 1651)
 048 " DIA CIRC CONCR

0060/1372

LEN=0048 INSTALLED UNKN

0060/0759

018 " DIA CIRC CONCR
 LEN=0040 INSTALLED UNKN

0060/0291

012 " DIA CIRC CONCR
 LEN=0048 INSTALLED UNKN

015155 FT

015155 FT

2 0 02069 0 00 0151+28
 LENGTH(AH 1651 BK 2083)
 018 " DIA CIR PLASTIC

5 0060/0000

0050/2025

LEN=0040 INSTALLED UNKN

DIR: B TOTAL LEN: 6.235 MI. DIST: 11-1 SR: 3071
 LEFT MUN: FINDLAY T RIGHT MUN: FINDLAY T

Stationing	Description	Material	Length	Notes
0050/1639	018" DIA CIRC CONCR	LEN=0048	INSTALLED UNKN	
0050/0811	072"H 72"W CONC STRUCT	LEN=0040	INSTALLED UNKN	
0050/0774	BMSSEN 02/3071/0050/0822	0 0 00000 0 00 0000+00		
0050/0760	BR. POTATOE	BMSBG 02/3071/0050/0822		
0050/0180	024" DIA CIRC CONCR	LEN=0150	INSTALLED UNKN	
0050/0086	OP ID 02/7576/9900/0285	PA TPK (1-576)		
013072 FT	2 0 02069 0 00 0130+45			
0050/0000	OP ID 02/7576/9900/0286	PA TPK (1-576)	LENGTH(AH 2083 BK 3167)	
0040/2029	018" DIA CIRC METAL	LEN=0050	INSTALLED UNKN	
0040/1787	018" DIA CIRC METAL	LEN=0050	INSTALLED UNKN	
0040/0669	018" DIA CIR PLASTIC	LEN=0060	INSTALLED UNKN	
0040/0288	009905 FT	2 0 02069 0 00 0099+30		
009905 FT	BURGETTSTOWN RD	(SR3078 SEG 0030/0000)		
0040/0000	LENGTH(AH 3167 BK 3268)			
0030/3210	018" DIA CIR PLASTIC	LEN=0040	INSTALLED 2001	
0030/2646	015" DIA CIRC METAL	LEN=0060	INSTALLED UNKN	
0030/2210	012" DIA CIRC CONCR	LEN=0050	INSTALLED UNKN	
0030/1584	015" DIA CIR PLASTIC	LEN=0060	INSTALLED UNKN	
006637 FT	2 0 02069 0 00 0066+75			
0030/0000	LENGTH(AH 3268 BK 3245)			
0020/2850	024" DIA CIRC CONCR	LEN=0040	INSTALLED UNKN	

MCNALL RD
(T822)

DIR: B TOTAL LEN: 6.235 MI. DIST: 11-1 SR: 3071
 LEFT MUN: FINDLAY T RIGHT MUN: FINDLAY T

Stationing	Structure / Notes	Material / Dimensions	Status
0020/1360	072" H 72" W CON BOX CUL	LEN=0030	INSTALLED UNKN
0020/0799	015" DIA CIRC METAL	LEN=0040	INSTALLED UNKN
003392 FT	2 0 02069 0 00 0033+94	018" DIA CIR PLASTIC	LEN=0060 INSTALLED 2003
0020/0000	BOGGS RD (SR3070 SEG 0010/0000)	LENGTH(AH 3245 BK 3392)	
0010/2923	018" DIA CIRC CONCR	LEN=0040	INSTALLED UNKN
0010/2635	018" DIA CIRC CONCR	LEN=0050	INSTALLED UNKN
0010/2455	024" DIA CIRC CONCR	LEN=0050	INSTALLED UNKN
0010/1634	018" DIA CIR PLASTIC	LEN=0048	INSTALLED UNKN
0010/0891	024" DIA CIRC CONCR	LEN=0040	INSTALLED UNKN
0010/0605	FINDLAY NORTH FAYETTE T		
0010/0500	RAMP A RD (SR8024 SEG 0260/0000)		
0010/0465	RAMP B RD (SR8024 SEG 0250/0907)		
0010/0445	018" DIA CIRC CONCR	LEN=0075	INSTALLED UNKN
0010/0295	SR 22 EB		
0010/0289	OP ID 02/0022/0010/0659	036" DIA CIRC CONCR	LEN=0060 INSTALLED UNKN
000000 FT	NC PO TATO GARDEN RUN RD	2 0 02069 0 00 0000+00	
INTER-BK	RAMP D RD (SR8024 SEG 0010/0579)		
	STEUBENVILLE PK (SR3121 SEG 0010/0000)		
	ROBINSON HW (SR0980 SEG 0010/0613)		
0010/0000	MFC BEGIN = D	LENGTH(AH 3392 BK 0000)	

OLD STEUBENVILLE PK (TWP)

EXTRACT DATE: 12/21/2020 ROADWAY MANAGEMENT SYSTEM PAGE NUMBER: 1129
 PRINT DATE: 12/23/2020 SLD COUNTY/SR - ANNUAL PRINT COUNTY: ALLEGHENY
 DIR: B TOTAL LEN: 1.991 MI. DIST: 11-1 SR: 3070
 LEFT MUN: MOON T RIGHT MUN: MOON T

010510 FT



010501 FT

010449 FT
 7184/0000 LENGTH(AH 2066 BK 0009)
 INTER-AHD EWING RD (TBK)
 0182/0009 (TWP)
 010440 FT 0 0 00000 0 00 0000+00

EXTRACT DATE: 12/21/2020
PRINT DATE: 12/23/2020

ROADWAY MANAGEMENT SYSTEM
SLD COUNTY/SR - ANNUAL PRINT

PAGE NUMBER: 1128
COUNTY: ALLEGHENY

DIR: B
LEFT MUN: MOON T

TOTAL LEN: 1.991 MI.

DIST: 11-1
RIGHT MUN: MOON T

SR: 3070

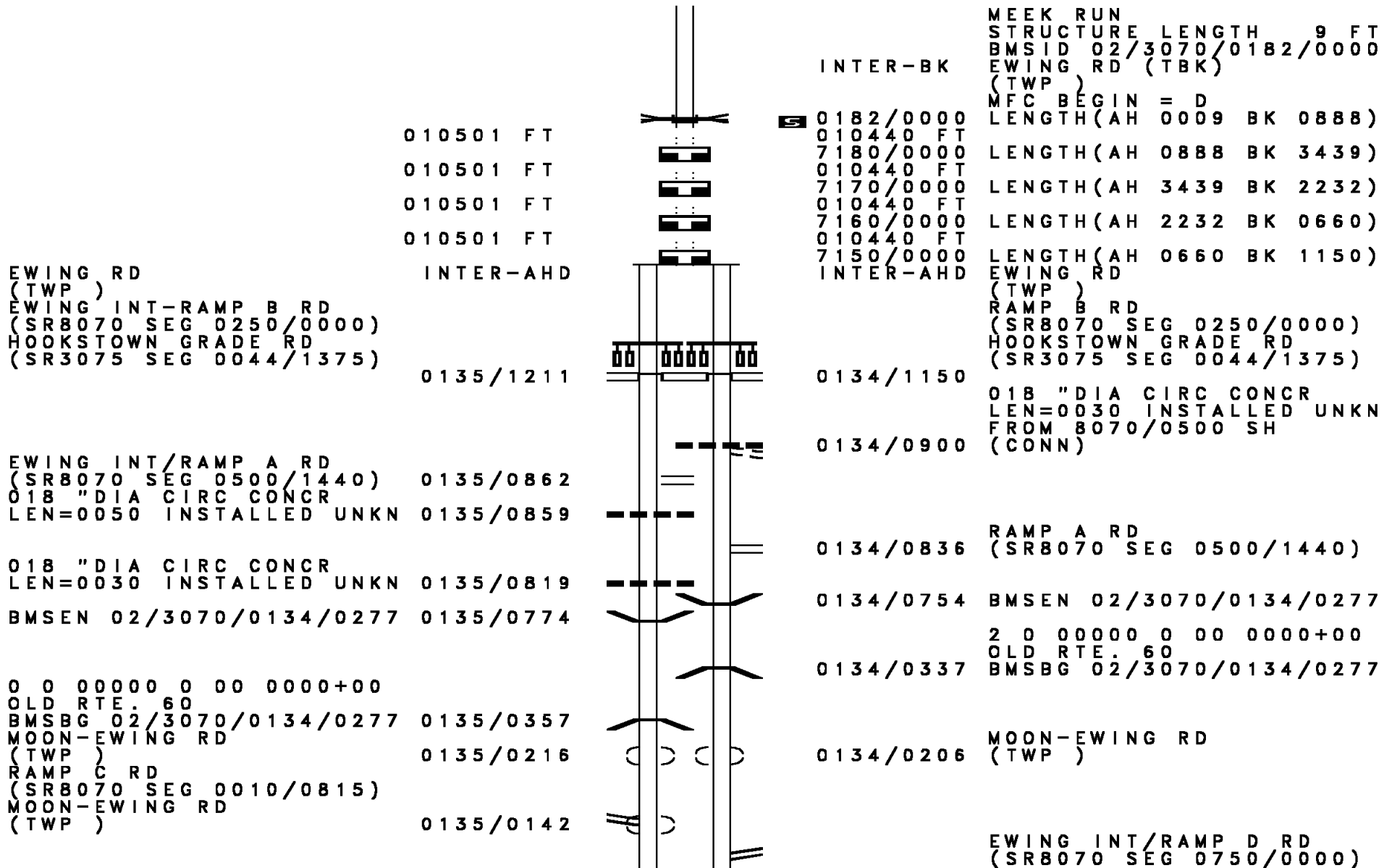

DIR: B TOTAL LEN: 1.991 MI. DIST: 11-1 SR: 3070
 LEFT MUN: MOON T RIGHT MUN: MOON T

MOON-EWING RD
 (TWP)
 FOR SR 3070E TO 3070W
 (CONN)

0 0 00000 0 00 0000+00 009290 FT
 MFC BEGIN = E
 LENGTH(AH 1211 BK 1604) 0135/0000

SABRE RD
 (GOVT)

0135/0077

0134/0098

0134/0060
 009290 FT

0134/0000

007686 FT

0130/0254
 007686 FT

0130/0000

005101 FT

0120/1957

0120/1598

0120/1098

0120/0727

0120/0263

005101 FT

005101 FT

0120/0000
 005101 FT

* 7114/0000
 REF-AHD

0112/1111

0112/0752

0112/0752

RAMP D RD
 (SR8070 SEG 0750/0000)
 MOON-EWING RD
 (TWP)

MOON-EWING RD
 (TWP)
 FOR SR 3070E TO 3070W
 (CONN)
 2 0 00000 0 00 0000+00
 MFC BEGIN = E
 LENGTH(AH 1150 BK 1604)

018 " DIA CIRC CONCR
 LEN=0035 INSTALLED UNKN
 2 0 02018 0 00 0026+12
 CEMETERY ENT RD
 (PRDR)
 LENGTH(AH 1604 BK 2585)

018 " DIA CIRC CONCR
 LEN=0045 INSTALLED UNKN
 018 " DIA CIRC CONCR
 LEN=0045 INSTALLED UNKN
 018 " DIA CIRC CONCR
 LEN=0099 INSTALLED UNKN
 018 " DIA CIRC CONCR
 LEN=0065 INSTALLED UNKN
 018 " DIA CIRC CONCR
 LEN=0030 INSTALLED UNKN
 2 0 02018 0 00 0000+00
 CORAOPOLIS CLIFFMINES R
 (CNTY)

INTER-BK EWING RD
 CORAOPOLIS CLIFFMINES R
 (CNTY)
 LTH AH 002585 BK 000100

* LTH AH 000100 BK 001111
 CORAOPOLIS CLIFFMINES R
 (CNTY)

FINDLAY T
 MCCLARENS RU
 STRUCTURE LENGTH 16 FT
 BMSID 02/3070/0112/0725

DIR: B TOTAL LEN: 1.991 MI. DIST: 11-1 SR: 3070
 LEFT MUN: FINDLAY T RIGHT MUN: FINDLAY T

0 0 00000 0 00 0000+00 003990 FT
 MUSTANG DR
 (GOVT) 0112/0000

RAMP 250 RD
 (SR8128 SEG 0250/0000)
 RAMP 500 RD
 (SR8128 SEG 0500/1290)
 MFC BEGIN = E 0107/0634
 BMSSEN 02/3070/0106/0000 0107/0434
 0 0 00000 0 00 0000+00
 SR 8109 (RAMP AD)
 BMSBG 02/3070/0106/0000 0107/0107

0 0 00000 0 00 0000+00 001215 FT
 MFC BEGIN = C
 LENGTH(AH 0912 BK 0471) 0107/0000
 PENN DOT STOCKPILE # 04
 (GOVT) 0104/0345
 000744 FT

000744 FT

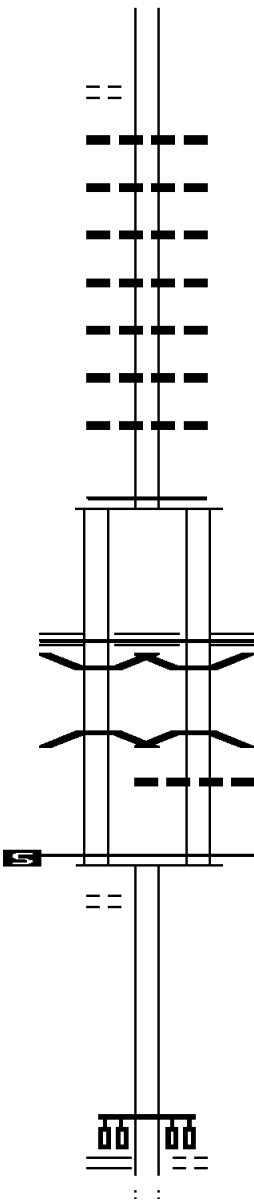

003990 FT
 0112/0000 LENGTH(AH 1111 BK 1863)
 018 " DIA CIRC CONCR
 0108/1411 LEN=0040 INSTALLED UNKN
 018 " DIA CIRC CONCR
 0108/1211 LEN=0040 INSTALLED UNKN
 018 " DIA CIRC CONCR
 0108/1012 LEN=0040 INSTALLED UNKN
 018 " DIA CIRC CONCR
 0108/0814 LEN=0040 INSTALLED UNKN
 018 " DIA CIRC CONCR
 0108/0618 LEN=0040 INSTALLED UNKN
 018 " DIA CIRC CONCR
 0108/0421 LEN=0040 INSTALLED UNKN
 018 " DIA CIRC CONCR
 0108/0224 LEN=0040 INSTALLED UNKN
 002127 FT 0 0 00000 0 00 0000+00
 MFC BEGIN = E
 0108/0000 LENGTH(AH 1863 BK 0912)

RAMP 250 RD
 (SR8128 SEG 0250/0000)
 RAMP 500 RD
 (SR8128 SEG 0500/1290)
 MFC BEGIN = E 0106/0634
 BMSSEN 02/3070/0106/0000 0106/0431
 0 0 00000 0 00 0000+00
 SR 8109 (RAMP AD)
 BMSBG 02/3070/0106/0000 0106/0104
 0106/0066 0106/0066
 001215 FT 0 0 00000 0 00 0000+00
 MFC BEGIN = C
 0106/0000 LENGTH(AH 0912 BK 0471)

000744 FT 0 0 00000 0 00 0000+00
 RAMP 20 RD
 (SR8128 SEG 0020/0000)
 RAMP 10 RD
 (SR8128 SEG 0010/1920)
 INDUSTRY DR
 (T354)

* REF-BK MCCLAREN RD (TBK)
 (TWP)
 0104/0000 LENGTH(AH 0471 BK 1005)
 000744 FT

EXTRACT DATE: 12/21/2020
PRINT DATE: 12/23/2020

ROADWAY MANAGEMENT SYSTEM
SLD COUNTY/SR - ANNUAL PRINT

PAGE NUMBER: 1125
COUNTY: ALLEGHENY

DIR: B TOTAL LEN: 1.991 MI.
LEFT MUN: FINDLAY T

DIST: 11-1 SR: 3070
RIGHT MUN: FINDLAY T

ENLOW RD
(CNTY)

000744 FT		7102/0000	LENGTH(AH 1005 BK 0970)
000744 FT		000744 FT	
000744 FT		7100/0000	LENGTH(AH 0970 BK 3047)
000744 FT		000744 FT	
		7090/0000	LENGTH(AH 3047 BK 2434)
		000744 FT	
		7082/0000	LENGTH(AH 2434 BK 0287)
		* REF-AHD	BMSSEN 02/3070/0080/0246
		0080/0287	MCCLAREN RD (TBK)
			(TWP)
			2 0 02016 0 00 0002+52
			BR. MONTOUR
		0080/0246	BMSBG 02/3070/0080/0246
		0080/0237	BMSSEN 02/3070/0080/0205
			FINDLAY
		0080/0221	NORTH FAYETTE T
			2 0 02016 0 00 0002+04
			BR MONTOUR RUN
000457 FT		0080/0205	BMSBG 02/3070/0080/0205
		000457 FT	2 0 02016 0 00 0000+00
			CLIFF MINE RD
			(CNTY)
			NC MCCLAREN RD
			ALLEGHENY RD
			(TWP)
		INTER-BK	MAIN ST (TBK)
			(TWP)
			MFC BEGIN = C
0080/0000		0080/0000	LENGTH(AH 0287 BK 0100)
000457 FT		000457 FT	
		7074/0000	LENGTH(AH 0100 BK 0032)
			BMSSEN 02/3070/0070/0000
		* REF-AHD	MAIN ST (TBK)
		0070/0032	(TWP)
000425 FT		000425 FT	2 0 02289 0 00 0052+12
			NC ST EUBENVILLE PK
		* REF-BK	MAIN ST (TBK)
			(TWP)
			MONTOUR RUN
		0070/0000	BMSBG 02/3070/0070/0000
000425 FT		000425 FT	LENGTH(AH 0032 BK 0162)
		7066/0000	LENGTH(AH 0162 BK 0032)
			BMSSEN 02/3070/0064/0000
		* REF-AHD	SANTIAGO RD (TBK)
			(TWP)
			BRIDGE POSTED (TONS)
		0064/0032	FINDLAY T
000393 FT		000393 FT	2 0 02005 0 00 0094+98
		REF-BK	SANTIAGO RD (TBK)

EXTRACT DATE: 12/21/2020
PRINT DATE: 12/23/2020

ROADWAY MANAGEMENT SYSTEM
SLD COUNTY/SR - ANNUAL PRINT

PAGE NUMBER: 1124
COUNTY: ALLEGHENY

DIR: B TOTAL LEN: 1.991 MI.
LEFT MUN: FINDLAY T

DIST: 11-1 SR: 3070
RIGHT MUN: FINDLAY T

Stationing	Structure	Description	Notes
000393 FT	[P]	0064/0000 000393 FT 7062/0000	(TWP) SGL 35 COMB 40 MONTOUR RUN BMSBG 02/3070/0064/0000 LENGTH(AH 0032 BK 2642)
000384 FT	[AHD]	* REF-AHD 0060/0009 000384 FT	BMSSEN 02/3070/0060/0000 SANTIAGO RD (TBK) (TWP) 2 0 02005 0 00 0068+25 NC SA
000384 FT	[BK]	* REF-BK	SANTIAGO RD (TBK) (TWP)
000384 FT	[AHD]	0060/0000 000384 FT 7050/0000	BR MONTOUR BMSBG 02/3070/0060/0000 LENGTH(AH 0009 BK 1838)
000384 FT	[BK]	000384 FT 7042/0000	LENGTH(AH 1838 BK 2199)
000375 FT	[AHD]	* REF-AHD	LENGTH(AH 2199 BK 0009) BMSSEN 02/3070/0040/0000 BOGGS RD (TBK) (TWP)
000375 FT	[BK]	* REF-BK	2 0 02014 0 00 0000+00 BOGGS RD (TBK) (TWP)
000375 FT	[AHD]	0040/0000 000375 FT 7030/0000	BRIDGE CLOSED BR. S. FK. MONT BMSBG 02/3070/0040/0000 LENGTH(AH 0009 BK 3172)
000375 FT	[BK]	000375 FT 7020/0000	LENGTH(AH 3172 BK 1311)
000375 FT	[AHD]	000375 FT 7012/0000	LENGTH(AH 1311 BK 2474)
	[BK]	7012/0000	LENGTH(AH 2474 BK 0375)
	[AHD]	INTER-AHD	BOGGS RD (TBK) (TWP)
	[BK]	0010/0375	BUGAY LN (TWP)
BFI/IMPERIAL LANDFILL D (PRDR)	[AHD]	0010/0320 000000 FT	(APRA) BFI/IMPERIAL LAN 2 0 02014 0 00 0000+00 NC BOGGS RD
	[BK]	0010/0000	POTATO GARDEN RUN RD (SR3071 SEG 0020/0000) MFC BEGIN = D LENGTH(AH 0375 BK 0000)

DIR: N TOTAL LEN: 5.574 MI. DIST: 11-1 SR: 3069
 LEFT MUN: PITTSBURGH C RIGHT MUN: PITTSBURGH C

SIXTH AV 029366 FT
 (CITY) INTER-AHD
 FORBES AV
 (CITY)
 FORBES AV
 (CITY)
 RAMP J B002 SB 0121/0840
 OP ID 02/8002/0270/0000 0121/0790
 018 "DIA CIRC CONCR
 LEN=0020 INSTALLED UNKN 0121/0685

 018 "DIA CIRC CONCR
 LEN=0030 INSTALLED UNKN 0121/0483

 018 "DIA CIRC CONCR
 LEN=0028 INSTALLED UNKN 0121/0268

 RAMP G RD
 (SR8002 SEG 0260/0797) 0121/0185

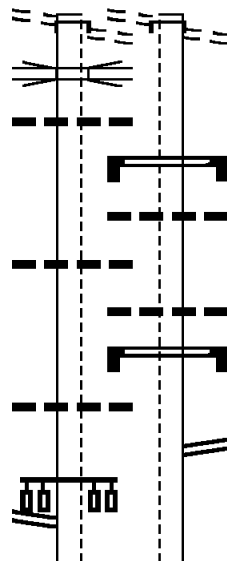

029430 FT
 INTER-AHD SIXTH AV
 (CITY)
 FORBES AV
 (CITY)
 FORBES AV
 (CITY)
 0120/0827

 0120/0639 SIGN: CANTILEVER
 BMSID 02/3069/0120/0655
 0120/0635 018 "DIA CIRC CONCR
 LEN=0030 INSTALLED UNKN

 0120/0435 018 "DIA CIRC CONCR
 LEN=0030 INSTALLED UNKN
 0120/0268 SIGN: CANTILEVER
 BMSID 02/3069/0120/0295

 0120/0236 RAMP L RD
 (SR8002 SEG 0290/0000)

RAMP K B002 NB

DIR: N TOTAL LEN: 5.574 MI. DIST: 11-1 SR: 3069
 LEFT MUN: PITTSBURGH C RIGHT MUN: PITTSBURGH C

OP ID	DESCRIPTION	STATION	LENGTH	TYPE	OP ID	DESCRIPTION	STATION	LENGTH	TYPE
OP ID 02/8002/0280/0000	RAMP K 8002 NB	0121/0085			OP ID 02/8002/0280/0000	RAMP 8002 NB RAMP			
OP ID 02/8002/0260/0000	RAMP 8002 NB RAMP	0121/0065			OP ID 02/8002/0260/0000	RAMP H EB			
OP ID 02/8002/0250/0000	RAMP H EB	0121/0035			OP ID 02/8002/0250/0000	BLVD OF THE ALLIES			
2 0 02270 0 00 0089+83	028526 FT				2 0 02270 0 00 0089+52	028603 FT			
OP ID 02/2208/0020/0321	BLVD OF THE ALLIES	0121/0000			OP ID 02/2208/0020/0321	LENGTH(AH 0827 BK 2829)			
LENGTH(AH 0840 BK 2826)		0111/2814			LENGTH(AH 0827 BK 2829)				
BMSID 02/3069/0110/2735	SIGN: 2 CHORD TRUSS	0111/2735			BMSID 02/3069/0110/2735	SIGN: 2 CHORD TRUSS			
BMSID 02/3069/0110/2735	SIGN: 4 CHORD TRUSS	0111/2325			BMSID 02/3069/0110/2735	SIGN: 4 CHORD TRUSS			
BMSID 02/3069/0110/2330	RAMP B-2 RD	0111/2311			BMSID 02/3069/0110/2330	RAMP A-2 RD			
(SR8067 SEG 0010/0490)					(SR8067 SEG 0750/0000)				
SIGN: 4 CHORD TRUSS					SIGN: CANTILEVER				
BMSID 02/3069/0110/1100		0111/1152			BMSID 02/3069/0110/1433				
BMSID 02/3069/0110/1100					SIGN: 4 CHORD TRUSS				
SIGN: CANTILEVER					BMSID 02/3069/0110/1100				
BMSID 02/3069/0111/0500		0111/0500			SIGN: CANTILEVER				
BMSID 02/3069/0111/0500					BMSID 02/3069/0110/0756				
LC TO MCARDLE RD					SIGN: CANTILEVER				
(CONN)		0111/0185			BMSID 02/3069/0110/0450				
0 0 00000 0 00 0000+00					LC FROM MCARDLE RD				
CARSON ST					(CONN)				
BMSBG 02/3069/0110/0135		0111/0151			0 0 00000 0 00 0000+00				
MCARDLE RD					CARSON ST				
(CITY)		0111/0100			BMSBG 02/3069/0110/0135				
					MCARDLE RD				
					(CITY)				
2 0 02270 0 00 0061+70					LC TO MCARDLE RD				
SIGN: CANTILEVER					(CONN)				
BMSID 02/3069/0111/0015					0111/0018				
NC LIBERTY BR					025774 FT				
LENGTH(AH 2826 BK 5895)		0111/0000			2 0 02270 0 00 0061+70				
					NC LIBERTY BR				
					LENGTH(AH 2829 BK 5898)				

DIR: N TOTAL LEN: 5.574 MI. DIST: 11-1 SR: 3069
 LEFT MUN: PITTSBURGH C RIGHT MUN: PITTSBURGH C

2 0 02270 0 00 0002+51 019805 FT
 MT WASHINGTN
 OP ID 02/3069/0101/0000
 NC LIBERTY TN
 LENGTH(AH 5895 BK 0250) 0101/0000
 BMSID 02/3069/0090/0152 0091/0213
 2 0 02270 0 00 0001+62
 SAW MILL RUN
 BMSBG 02/3069/0090/0152 0091/0170
 LIBERTY TN INT/RMP D RD
 (SR8151 SEG 0750/0000)
 LIBERTY TN INT/RMP A RD
 (SR8151 SEG 0010/0568)
 018 "DIA CIRC CONCR
 LEN=0099 INSTALLED 2002 0091/0060
 LIBERTY TN INT/RMP C RD
 (SR8151 SEG 0500/0510)
 2 0 02270 0 00 0000+00 019555 FT
 SR 0051 NB
 OP ID 02/0051/0396/0000
 LENGTH(AH 0250 BK 0851) 0091/0000
 FROM 8151/0500 SH
 (CONN) 0081/0768
 SIGN: 3 CHORD TRUSS
 BMSID 02/3069/0080/0600 0081/0725
 LIBERTY TN INT/RMP E RD
 (SR8151 SEG 0510/0000) 0081/0664

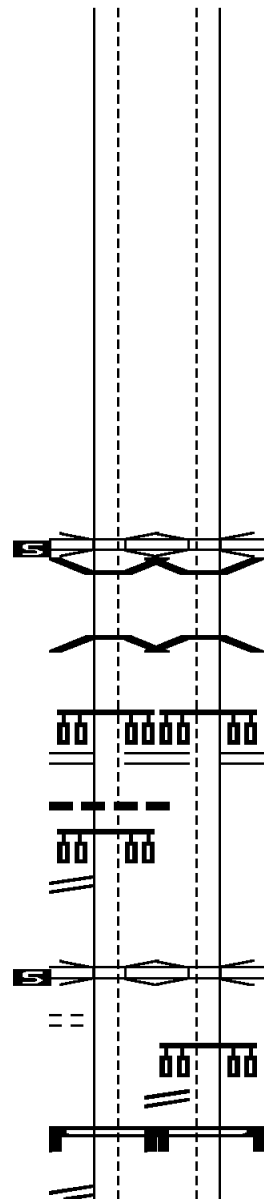

019876 FT 2 0 02270 0 00 0002+51
 MT WASHINGTN
 OP ID 02/3069/0100/0000
 NC LIBERTY TN
 LENGTH(AH 5898 BK 0280)
 BMSID 02/3069/0090/0152
 2 0 02270 0 00 0001+62
 SAW MILL RUN
 BMSBG 02/3069/0090/0152 0090/0172
 LIBERTY TN INT/RMP D RD
 (SR8151 SEG 0750/0000)
 LIBERTY TN INT/RMP A RD
 (SR8151 SEG 0010/0568)
 0090/0077
 019596 FT 2 0 02270 0 00 0000+00
 SR 0051 NB
 OP ID 02/0051/0396/0000
 LENGTH(AH 0280 BK 0801)
 LIBERTY TN INT/RMP C RD
 (SR8151 SEG 0500/0510)
 SIGN: 3 CHORD TRUSS
 BMSID 02/3069/0080/0600 0080/0738
 0080/0712

EXTRACT DATE: 12/21/2020
PRINT DATE: 12/23/2020

ROADWAY MANAGEMENT SYSTEM
SLD COUNTY/SR - ANNUAL PRINT

PAGE NUMBER: 1120
COUNTY: ALLEGHENY

DIR: N TOTAL LEN: 5.574 MI.
LEFT MUN: PITTSBURGH C

DIST: 11-1 SR: 3069
RIGHT MUN: PITTSBURGH C

Structure ID	Description	Material	Length (ft)	Stationing	Notes
0080/0673	LIBERTY TN INT/RMP B RD	(SR8151 SEG 0250/0000)			SIGN: CANTILEVER
0080/0611	BMSID 02/3069/0080/0405	NORFOLK SOUTHERN			
0080/0473	OVERPASS IS RR X-ING	S-BUSWAY			
0081/0496	NORFOLK SOUTHERN OVERPASS IS RR X-ING				
0081/0465	OP ID 02/7301/0000/9500	018 "DIA CIRC CONCR	LEN=0099	INSTALLED UNKN	
0081/0450					
0081/0433	PIONEER AV (CITY)				
0081/0418	HARGROVE ST (CITY)				
0081/0227	DAWN AV (CITY)				
0080/0413	PIONEER AV (CITY)				
0080/0360	HARGROVE ST (CITY)				
0080/0187	DAWN AV (CITY)				
0080/0067	018 "DIA CIRC CONCR	LEN=0099	INSTALLED UNKN		
018795 FT	1 0 00806 0 02 0368+86				
0080/0000	LENGTH(AH 0801 BK 0533)				
1 0 00806 0 02 0366+34	018704 FT				
0081/0000	PORT AUTHORITY OF ALLEG OVERPASS IS RR X-ING				
0081/0000	LENGTH(AH 0851 BK 0349)				
0070/0200	018 "DIA CIRC CONCR	LEN=0040	INSTALLED UNKN		
0070/0110	018 "DIA CIRC CONCR	LEN=0060	INSTALLED UNKN		
0070/0075	PAT BUSWAY RD (CNTY)				
018262 FT	1 0 00806 0 02 0363+03				
0070/0000	LENGTH(AH 0533 BK 2650)				
0061/2715	018 "DIA CIRC CONCR	LEN=0024	INSTALLED UNKN		
0061/2385	018 "DIA CIRC CONCR	LEN=0048	INSTALLED UNKN		
0060/2521	018 "DIA CIRC METAL	LEN=0048	INSTALLED UNKN		
0060/2160	018 "DIA CIRC CONCR	LEN=0048	INSTALLED UNKN		

EXTRACT DATE: 12/21/2020
PRINT DATE: 12/23/2020

ROADWAY MANAGEMENT SYSTEM
SLD COUNTY/SR - ANNUAL PRINT

PAGE NUMBER: 1119
COUNTY: ALLEGHENY

DIR: N TOTAL LEN: 5.574 MI.
LEFT MUN: PITTSBURGH C

DIST: 11-1 SR: 3069
RIGHT MUN: PITTSBURGH C

018 "DIA CIRC CONCR
LEN=0048 INSTALLED UNKN 0061/2035

BROOKSIDE AV
(CITY) 0061/1737

018 "DIA CIRC CONCR
LEN=0099 INSTALLED UNKN 0061/1630

018 "DIA CIRC CONCR
LEN=0090 INSTALLED UNKN 0061/1220

CAPE MAY AV
(CITY) 0061/0777

1 0 00806 0 02 0337+14 015571 FT
LENGTH(AH 2784 BK 3740) 0061/0000

HADDON WAY
(CITY)

CAPITAL WAY
(CITY) 0051/3383

CURRANHILL AV
(CITY) 0051/3321

018 "DIA CIRC CONCR
LEN=0048 INSTALLED UNKN 0051/2920

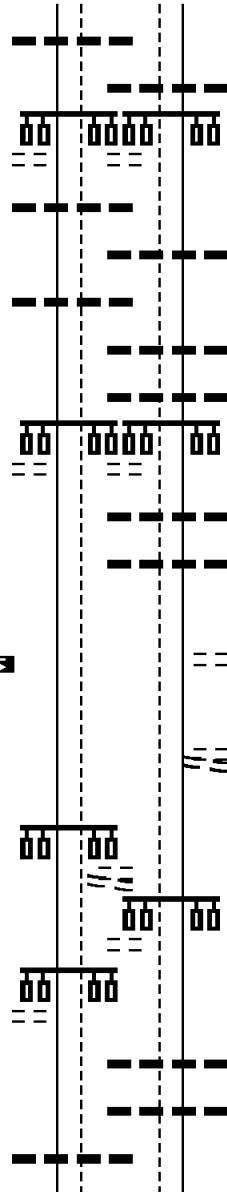

0060/1776

0060/1710

0060/1390

0060/1140

0060/0820

0060/0770

0060/0440

0060/0060
015612 FT

0060/0000

0050/3359

0050/3310

0050/3260

0050/2980

018 "DIA CIRC CONCR
LEN=0048 INSTALLED UNKN
BROOKSIDE AV
(CITY)

018 "DIA CIRC METAL
LEN=0015 INSTALLED UNKN

018 "DIA CIRC CONCR
LEN=0015 INSTALLED UNKN
018 "DIA CIRC CONCR
LEN=0048 INSTALLED UNKN
CAPE MAY AV
(CITY)

018 "DIA CIRC CONCR
LEN=0015 INSTALLED UNKN
018 "DIA CIRC CONCR
LEN=0048 INSTALLED UNKN
1 0 00806 0 02 0337+32
STETSON ST
(CITY)
LENGTH(AH 2650 BK 3726)
HADDON WAY
(CITY)
CAPITAL WAY
(CITY)

CURRANHILL AV
(CITY)

012 "DIA CIRC CONCR
LEN=0015 INSTALLED UNKN
018 "DIA CIRC CONCR
LEN=0048 INSTALLED UNKN

018 "DIA CIRC CONCR

DIR: N TOTAL LEN: 5.574 MI. DIST: 11-1 SR: 3069
 LEFT MUN: PITTSBURGH C RIGHT MUN: PITTSBURGH C

Segment ID	Material	Length	Stationing	Notes	Stationing	Material	Length	Notes
018	"DIA CIRC METAL	LEN=0050	INSTALLED UNKN	0051/2565	0050/2660	LEN=0015	INSTALLED UNKN	
PEOLA RD (CITY)			0051/2313		0050/2278	PEOLA RD (CITY)		
RAY AV (CITY)			0051/2227		0050/2192	RAY AV (CITY)		
030	"DIA CIRC CONCR	LEN=0099	INSTALLED UNKN	0051/2110	0050/1900	012 "DIA CIRC CONCR	LEN=0015	INSTALLED UNKN
PAULINE AV (CITY)			0051/1690		0050/1670	PAULINE AV (CITY)		
099	"DIA CIRC CONCR	LEN=0099	INSTALLED UNKN	0051/1575	0050/1300	018 "DIA CIRC METAL	LEN=0015	INSTALLED UNKN
018	"DIA CIRC CONCR	LEN=0048	INSTALLED UNKN	0051/1250	0050/0912	BELLE ISLE AV (CITY)		
BELLE ISLE AV (CITY)			0051/0944		0050/0425	SARANAC AV (CITY)		
SARANAC AV (CITY)			0051/0461					
018	"DIA CIRC CONCR	LEN=0099	INSTALLED UNKN	0051/0275				
BROOKLINE BL (CITY)			0051/0089					
1 0 00806 0 02 0299+85 011831 FT					011886 FT	1 0 00806 0 02 0299+85		
WENZELL AV (CITY)					0050/0000	BROOKLINE BL (CITY)		
LENGTH(AH 3740 BK 2989)			0051/0000		0040/2982	LENGTH(AH 3726 BK 3018)		
					0040/2736	WENZELL AV (CITY)		
018	"DIA CIRC CONCR	LEN=0048	INSTALLED UNKN			012 "DIA CIRC CONCR	LEN=0048	INSTALLED UNKN

EXTRACT DATE: 12/21/2020
PRINT DATE: 12/23/2020

ROADWAY MANAGEMENT SYSTEM
SLD COUNTY/SR - ANNUAL PRINT

PAGE NUMBER: 1117
COUNTY: ALLEGHENY

DIR: N TOTAL LEN: 5.574 MI.
LEFT MUN: PITTSBURGH C

DIST: 11-1 SR: 3069
RIGHT MUN: PITTSBURGH C

Stationing	Material	Notes	Stationing	Material	Notes
LEN=0048	INSTALLED UNKN	0041/2645	0040/2570	018 "DIA CIRC CONCR	LEN=0048 INSTALLED UNKN
018 "DIA CIRC CONCR			0040/2269	018 "DIA CIRC METAL	LEN=0048 INSTALLED UNKN
LEN=0048	INSTALLED UNKN	0041/2470	0040/1945	PITTSBURGH	
018 "DIA CIRC CONCR			0040/1937	DORMONT B	
LEN=0099	INSTALLED UNKN	0041/2161	0040/1895	024 "DIA CIRC CONCR	LEN=0055 INSTALLED UNKN
EDGEHILL AV				EDGEHILL AV	
(BORO)				(BORO)	
018 "DIA CIRC CONCR		0041/1905			
LEN=0048	INSTALLED UNKN	0041/1850			
PITTSBURGH					
DORMONT B		0041/1815			
BLAINE ST					
(BORO)		0041/1730			
018 "DIA CIRC CONCR					
LEN=0024	INSTALLED 2011	0041/1684			
DORMONT					
PITTSBURGH C		0041/1607			
PITTSBURGH					
DORMONT B		0041/1522			
LASALLE AV					
(BORO)		0041/1505			
KEY AV					
(BORO)		0041/1200			
018 "DIA CIRC CONCR					
LEN=0025	INSTALLED 2011	0041/1149			
PIONEER AV					
(BORO)		0041/0851			
ANDERSON WAY					
(BORO)		0041/0700			
ILLINOIS AV					
(BORO)		0041/0585			
018 "DIA CIRC CONCR					
LEN=0048	INSTALLED UNKN	0041/0520			
POTOMAC AV					

DIR: N TOTAL LEN: 5.574 MI. DIST: 11-1 SR: 3069
 LEFT MUN: DORMONT B RIGHT MUN: DORMONT B

Street Name	Segment ID	Start Station	End Station	Material	Length (ft)	Status
DORMONT AV (BORO)	0031/1089	0030/1330	0030/1270	018" DIA CIRC CONCR	0015	INSTALLED UNKN
DORMONT AV (BORO)	0031/1032	0030/1060	0030/1020	018" DIA CIRC CONCR	0015	INSTALLED UNKN
PARK BL (BORO)	0031/0827	0030/0805	0030/0790	018" DIA CIRC CONCR	0015	INSTALLED UNKN
BILTMORE AV (BORO)	0031/0575	0030/0615	0030/0565	018" DIA CIRC CONCR	0516	INSTALLED UNKN
BILTMORE AV (BORO)	0031/0571	0030/0548	0030/0347	018" DIA CIRC CONCR	0099	INSTALLED UNKN
BILTMORE AV (BORO)	0031/0563	0030/0060	0030/0015	018" DIA CIRC CONCR	0048	INSTALLED UNKN
018" DIA CIRC CONCR	0031/0280	006436 FT	1 0 00806 0 02 0246+20			
018" DIA CIRC CONCR	0031/0015					
1 0 00806 0 02 0245+70	006402 FT					
NC WEST LIBERTY AV						
MCFARLAND RD (SR3119 SEG 0010/0000)	0031/0000	0030/0000	0020/3377	018" DIA CIRC CONCR	0099	INSTALLED UNKN
DORMONT MT LEBANON T						
LENGTH(AH 2440 BK 3463)						
018" DIA CIRC CONCR	0021/3240					
PEERMONT AV (BORO)						

DIR: N TOTAL LEN: 5.574 MI. DIST: 11-1 SR: 3069
 LEFT MUN: MT LEBANON T RIGHT MUN: MT LEBANON T

Stationing	Description	Stationing	Description
0021/3185		0020/3167	PEERMONT AV (BORO)
018 "DIA CIRC CONCR LEN=0099 INSTALLED UNKN SCOTT RD (SR3037 SEG 0080/1893)	0021/2990	0020/2886	SCOTT RD (SR3037 SEG 0080/1893)
	0021/2905	0020/2600	CHURCH PL (TWP)
CHURCH PL (TWP)	0021/2615	0020/2345	018 "DIA CIRC CONCR LEN=0015 INSTALLED UNKN BOWER HILL RD (TWP)
BOWER HILL RD (TWP)	0021/2315	0020/2320	
	0021/1765	0020/1800	018 "DIA CIRC CONCR LEN=0099 INSTALLED UNKN OAK WAY (TWP)
OAK WAY (TWP)	0021/1360	0020/1785	
	0021/1050	0020/1415	018 "DIA CIRC CONCR LEN=0099 INSTALLED UNKN FLORENCE PL (TWP)
FLORENCE PL (TWP)	0021/0935	0020/1380	
018 "DIA CIRC CONCR LEN=0099 INSTALLED UNKN SHADY DR (TWP)	0021/0615	0020/0945	SHADY DR (TWP)
ACADEMY AV (TWP)	0021/0305	0020/0620	ACADEMY AV (TWP)
	0021/0000	0020/0310	CEDAR BL (TWP)
CEDAR BL (TWP)		0020/02953 FT	
1 0 00806 0 02 0210+35 002939 FT		1 0 00806 0 02 0210+85	
ALFRED ST (TWP)		ALFRED ST (TWP)	
LENGTH(AH 3463 BK 2939)	0021/0000	LENGTH(AH 3483 BK 2953)	0020/0000
		CENTRAL SQ (TWP)	0010/2719
CENTRAL SQ (TWP)	0011/2710		
		018 "DIA CIRC METAL LEN=0048 INSTALLED UNKN	0010/1865

DIR: N TOTAL LEN: 5.574 MI. DIST: 11-1 SR: 3069
 LEFT MUN: MT LEBANON T RIGHT MUN: MT LEBANON T

Segment Description	Segment ID	Diagram	Segment ID	Segment Description
LEBANON AV (TWP)	0011/1796		0010/1796	LEBANON AV (TWP)
018 "DIA CIRC CONCR LEN=0110 INSTALLED UNKN CASTLE SHANNON BL (SR3044 SEG 0010/0000)	0011/1776		0010/1660	CASTLE SHANNON BL (SR3044 SEG 0010/0000)
HAZEL DR (TWP)	0011/1275		0010/1280	HAZEL DR (TWP)
JEFFERSON DR (TWP)	0011/0916		0010/0990	018 "DIA CIRC CONCR LEN=0048 INSTALLED UNKN JEFFERSON DR (TWP)
018 "DIA CIRC CONCR LEN=0048 INSTALLED UNKN JEFFERSON DR (TWP)	0011/0865		0010/0934	JEFFERSON DR (TWP)
HIGHLAND RD (TWP)	0011/0739		0010/0859	JEFFERSON DR (TWP)
018 "DIA CIRC CONCR LEN=0048 INSTALLED UNKN COCHRAN RD (SR0019 SEG 0120/0000) NC WASHINGTON RD	0011/0560		0010/0754	HIGHLAND RD (TWP)
WASHINGTON RD (SR0019 SEG 0120/0000) MFC BEGIN = B LENGTH(AH 2939 BK 0000)	0011/0000		0010/0680	018 "DIA CIRC CONCR LEN=0015 INSTALLED UNKN
			0010/0165	018 "DIA CIRC CONCR LEN=0048 INSTALLED UNKN COCHRAN RD (SR0019 SEG 0120/0000) NC WASHINGTON RD
			000000 FT	
			000000 FT	



EXTRACT DATE: 12/21/2020 ROADWAY MANAGEMENT SYSTEM PAGE NUMBER: 1112
PRINT DATE: 12/23/2020 SLD COUNTY/SR - ANNUAL PRINT COUNTY: ALLEGHENY
DIR: B TOTAL LEN: .000 MI. DIST: 11-1 SR: 3068
LEFT MUN: NORTH FAYETTE T RIGHT MUN: NORTH FAYETTE T

000000 FT



000000 FT
7010/0000 LENGTH(AH 3215 BK 0000)

EXTRACT DATE: 12/21/2020 ROADWAY MANAGEMENT SYSTEM PAGE NUMBER: 1111
 PRINT DATE: 12/23/2020 SLD COUNTY/SR - ANNUAL PRINT COUNTY: ALLEGHENY
 DIR: B TOTAL LEN: .000 MI. DIST: 11-1 SR: 3067
 LEFT MUN: NORTH FAYETTE T RIGHT MUN: NORTH FAYETTE T

LENGTH(AH 1520 BK 2057)	7021/0000			000000 FT	
	000000 FT			7020/0000	LENGTH(AH 1380 BK 2165)
LENGTH(AH 2057 BK 0000)	7011/0000			000000 FT	
				7010/0000	LENGTH(AH 2165 BK 0000)

LTH AH 000870 BK 001725 019233 FT
 RAMP X RD 7091/0000
 (SR8034 SEG 0750/0210) 0080/1680

LC FOR MONTOUR CHURCH R
 (CONN) 0080/1304
 MONTOUR CHURCH RD
 (T430) 0080/1095

017508 FT

1 0 00257 0 01 0344+70 016040 FT
 CLIFFMINE RD (#6293-02) 0070/0000
 (CNTY)

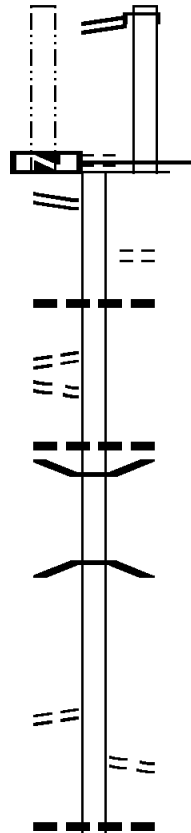

020103 FT
 INTER-AHD SR 0022 SH
 (SR0022 SEG 0140/0000)
 SR 0022 SH
 0090/0870 (SR0022 SEG 0140/0000)
 019233 FT 0 0 00000 0 00 0000+00
 FROM 8034/0750 SH
 (CONN)
 MFC BEGIN = D
 0090/0000 LENGTH(AH 0870 BK 1725)
 BAYER RD
 (CNTY)
 0080/1456 018 " DIA CIRC CONCR
 0080/1395 LEN=0050 INSTALLED UNKN
 018 " DIA CIRC CONCR
 0080/0588 LEN=0055 INSTALLED UNKN
 0080/0144 BMSSEN 02/3066/0080/0000
 017508 FT 1 0 00257 0 02 0357+31
 SR 0022
 BMSBG 02/3066/0080/0000
 0080/0000 LENGTH(AH 1725 BK 1468)
 016040 FT
 0070/0000 LENGTH(AH 1468 BK 2780)
 STONESIPHER RD
 0060/2660 (TWP)
 018 " DIA CIRC CONCR
 0060/1852 LEN=0055 INSTALLED UNKN

DIR: B TOTAL LEN: 3.807 MI. DIST: 11-1 SR: 3066
 LEFT MUN: NORTH FAYETTE T RIGHT MUN: NORTH FAYETTE T

Street Name	Stationing	Notes	Material	Length	Other
	0060/1550		018 " DIA CIRC CONCR	LEN=0050	INSTALLED UNKN
	0060/1255		015 " DIA CIRC CONCR	LEN=0055	INSTALLED UNKN
	013260 FT		FROM 3103/0040 SH		
	013260 FT		(CONN)		
	0060/0000		1 0 00257 0 01 0317+64		
	0050/2181		MCKEE RD		
	0050/2077		(SR3103 SEG 0040/3204)		
			LENGTH(AH 2780 BK 2294)		
			TO 3103/0040 SH		
			(CONN)		
			UNKNOWN RD		
			(PRDR)		
PALOMINO DR (T812)	0050/0905		018 " DIA CIRC CONCR	LEN=0045	INSTALLED UNKN
	010966 FT		018 " DIA CIRC CONCR	LEN=0050	INSTALLED UNKN
FARMCREST DR (T818)	0040/2145		HANKEY FARMS DR		
	0040/0915		(T380)		
HAWTHORNE DR (TWP)	0040/1160		1 0 00257 0 01 0294+36		
	0040/0706		LENGTH(AH 2294 BK 2627)		
	008339 FT		HANKEY FARMS DR		
	0040/0489		(T380)		
	0030/1669		015 " DIA CIRC CONCR	LEN=0099	INSTALLED UNKN
MAHONEY RD (T370)	0030/1355		018 " DIA CIRC CONCR	LEN=0065	INSTALLED UNKN
	0030/0525		1 0 00257 0 01 0267+48		
			LENGTH(AH 2627 BK 1858)		
			OLD LINCOLN HW EAST		
			(T471)		
			OAKDALE RD		
			(SR3063 SEG 0030/1900)		
			OLD LINCOLN HW WEST		
			(T471)		
			015 " DIA CIRC CONCR		

DIR: B TOTAL LEN: 3.807 MI. DIST: 11-1 SR: 3066
 LEFT MUN: NORTH FAYETTE T RIGHT MUN: NORTH FAYETTE T

Stationing	Description	Length	Material	Status
006481 FT		0030/0243	LEN=0085	INSTALLED UNKN
		006481 FT	1 0 00257 0 01 0248+36	
		0030/0000	LENGTH(AH 1858 BK 3008)	
			015 "DIA CIRC CONCR	
		0020/2921	LEN=0099	INSTALLED UNKN
			018 "DIA CIRC CONCR	
		0020/1851	LEN=0055	INSTALLED UNKN
			015 "DIA CIRC CONCR	
		0020/1453	LEN=0050	INSTALLED UNKN
WALDEN WY (T862)		0020/1038		
			018 "DIA CIRC CONCR	
		0020/0908	LEN=0055	INSTALLED UNKN
			018 "DIA CIRC CONCR	
1 0 00257 0 01 0218+64		003473 FT		
LOGAN RD (T346)		0020/0000		
			LENGTH(AH 3008 BK 3473)	
			015 "DIA CIRC CONCR	
		0010/2236	LEN=0080	INSTALLED UNKN
			024 "DIA CIRC CONCR	
		0010/1765	LEN=0050	INSTALLED UNKN
			E STEUBEN ST (T439)	
		0010/1102	012 "DIA CIRC CONCR	
		0010/0797	LEN=0099	INSTALLED UNKN
			018 "DIA CIRC CONCR	
		0010/0173	LEN=0070	INSTALLED UNKN
			FROM 0030/0160 SH	
		0010/0112	(CONN)	
WEST ALLEGHENY RD (TWP)		0010/0090		
TO 0030/0150 SH (CONN)		000000 FT		
			1 0 00257 0 01 0184+76	
			LINCOLN HW (SR0030 SEG 0160/0000)	
			NC STEUBENVILLE PK	
			INTER-BK STEUBENVILLE PK (T865)	
LINCOLN HW (SR0030 SEG 0160/0000)		0010/0000	MFC BEGIN = D	
			LENGTH(AH 3473 BK 0000)	

NIKE SITE RD 003209 FT
 (SR3039 SEG 0030/0000) 0010/3209

UNKNOWN RD 0010/1642
 (BORO)

FRANKLIN ST 0010/0585
 (TWP) 000000 FT

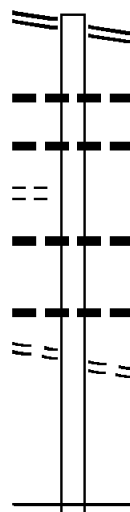

003209 FT NIKE SITE RD
 0010/3209 (SR3039 SEG 0030/0000)

0010/2546 018 " DIA CIRC METAL
 LEN=0035 INSTALLED UNKN
 0010/2223 018 " DIA CIRC METAL
 LEN=0040 INSTALLED UNKN

0010/1406 018 " DIA CIRC METAL
 LEN=0030 INSTALLED UNKN

0010/0679 018 " DIA CIR PLASTIC
 LEN=0099 INSTALLED UNKN
 FRANKLIN ST

0010/0585 (TWP)
 000000 FT 2 0 02342 0 01 0034+09

* REF-BK GREGG STATION RD
 (TWP)

MFC BEGIN = E
 0010/0000 LENGTH(AH 3209 BK 0000)

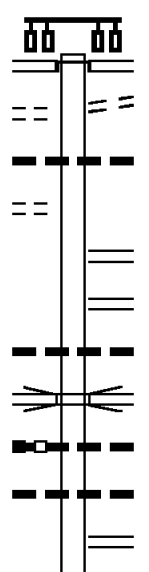
	008463 FT		008463 FT	MAHONEY RD (T370) STEUBENVILLE PK (SR3066 SEG 0030/1355)
OLD LINCOLN HW (BORO)	0030/1720		0030/1900	INTER-AHD
DIXIE DR (T838)	0030/1395		0030/1720	OLD LINCOLN HW (BORO) 018 " DIA CIRC METAL LEN=0099 INSTALLED UNKN
			0030/1403	
			0030/1150	HANKEY FARMS INT/RP Q R (SR8030 SEG 0500/0000) RAMP R RD
			0030/1130	(SR8030 SEG 0510/0901) 018 " DIA CIRC METAL
			0030/1031	LEN=0099 INSTALLED UNKN RT 0022 EB
			0030/0889	OP ID 02/0022/0090/1802 024 " DIA CIR PLASTIC
VIRGINIA DR (T833)	0030/0760		0030/0760	LEN=0230 INSTALLED 2015 018 " DIA CIRC CONCR
			0030/0336	LEN=0060 INSTALLED UNKN RAMP T RD
			0030/0125	(SR8030 SEG 0750/0707) RAMP S RD

EXTRACT DATE: 12/21/2020
PRINT DATE: 12/23/2020

ROADWAY MANAGEMENT SYSTEM
SLD COUNTY/SR - ANNUAL PRINT

PAGE NUMBER: 1105
COUNTY: ALLEGHENY

DIR: B TOTAL LEN: 1.603 MI.
LEFT MUN: NORTH FAYETTE T

DIST: 11-1 SR: 3063
RIGHT MUN: NORTH FAYETTE T

Stationing	Description	Segment	Material	Status
006563 FT		0030/0106	(SR8030 SEG 0760/0000)	
		018 "DIA	CIRC CONCR	
		0030/0035	LEN=0060	INSTALLED UNKN
		006563 FT	1 1 00325 0 00 0062+04	
		0030/0000	LENGTH(AH 1900 BK 3381)	
		018 "DIA	CIRC CONCR	
		0020/3125	LEN=0099	INSTALLED UNKN
		0020/2122	018 "DIA	CIRC CONCR
			LEN=0040	INSTALLED UNKN
		0020/1861	048 "DIA	CIRC CONCR
			LEN=0048	INSTALLED UNKN
		0020/1740	036 "DIA	CIRC CONCR
			LEN=0048	INSTALLED UNKN
		0020/0716	036 "DIA	CIRC CONCR
			LEN=0048	INSTALLED UNKN
PENN DOT STOCKPILE #4 (GOVT)		0020/0674	==	
PENN DOT STOCKPILE #4 (GOVT)		0020/0488	POT	
		0020/0488	(APRA) PENN DOT MAINTEN	
		018 "DIA	CIRC CONCR	
		0020/0440	LEN=0040	INSTALLED UNKN
003182 FT		003182 FT	1 1 00325 0 00 0029+91	
		0020/0000	LENGTH(AH 3381 BK 3182)	
		048 "DIA	CIRC CONCR	
		0010/3120	LEN=0040	INSTALLED UNKN
		0010/2489	036 "DIA	CIRC CONCR
			LEN=0048	INSTALLED UNKN
		0010/1939	036 "DIA	CIRC CONCR
			LEN=0020	INSTALLED UNKN
		0010/1149	018 "DIA	CIRC CONCR
			LEN=0072	INSTALLED UNKN
		0010/1083	ROBB HILL RD (TBK)	
			(BORO)	
		0010/0247	018 "DIA	CIRC CONCR
			LEN=0040	INSTALLED UNKN
		0010/0168	018 "DIA	CIRC CONCR
			LEN=0099	INSTALLED UNKN
000000 FT		000000 FT	1 1 00325 0 00 0000+00	
			NC OAKDALE RD	
		INTER-BK	OAKDALE RD	
			(SR0978 SEG 0180/0000)	
		0010/0000	MFC BEGIN = D	
			LENGTH(AH 3182 BK 0000)	

NORTH BRANCH RD
(SR0978 SEG 0180/0000) 0010/0000

EXTRACT DATE: 12/21/2020 ROADWAY MANAGEMENT SYSTEM PAGE NUMBER: 1104
PRINT DATE: 12/23/2020 SLD COUNTY/SR - ANNUAL PRINT COUNTY: ALLEGHENY
DIR: B TOTAL LEN: .986 MI. DIST: 11-1 SR: 3062
LEFT MUN: GREENTREE B RIGHT MUN: GREENTREE B

005206 FT



005206 FT
INTER-AHD MANSFIELD AV
(SR0121 SEG 0100/0000)
POPLAR ST

DIR: B TOTAL LEN: .986 MI. DIST: 11-1 SR: 3062
 LEFT MUN: GREENTREE B RIGHT MUN: GREENTREE B

Street Name / Segment	Start Station	End Station	Length (FT)	Notes / Details
POPLAR ST (SR0121 SEG 0100/0000)	0020/2534	0020/2534		(BORO)
SCHOOL ST (BORO)	0020/2300	0020/2383		LC TO POPLAR ST (CONN)
HOLIDAY DR (PRDR)	0020/1440	0020/1854		020 "DIA CIRC CONCR LEN=0025 INSTALLED UNKN GREENTREE COMMONS (PRDR)
		0020/1440		020 "DIA CIRC CONCR LEN=0068 INSTALLED UNKN
		0020/1346		020 "DIA CIRC CONCR LEN=0035 INSTALLED UNKN
		0020/0996		020 "DIA CIRC CONCR LEN=0030 INSTALLED UNKN
		0020/0648		018 "DIA CIRC CONCR LEN=0050 INSTALLED UNKN
		0020/0468		018 "DIA CIRC CONCR LEN=0025 INSTALLED UNKN
	002672 FT	0020/0092	002672 FT	2 0 02354 0 00 0026+73 TRUMBULL DR (BORO)
ANDERSEN DR (BORO)	0010/2310	0020/0000		LENGTH(AH 2534 BK 2672)
		0010/2177		016 "DIA CIRC CONCR LEN=0099 INSTALLED UNKN
		0010/1995		030 "DIA CIRC CONCR LEN=0070 INSTALLED UNKN
PA MACARONI CO RD (PRDR)	0010/1630	0010/1601		030 "DIA CIRC CONCR LEN=0099 INSTALLED UNKN
		0010/0348		018 "DIA CIRC CONCR LEN=0099 INSTALLED UNKN
		0010/0190		018 "DIA CIRC METAL LEN=0030 INSTALLED UNKN
		0010/0070		024"H 01"W **UNKNOWN** LEN=0030 INSTALLED UNKN NC MANSFIELD AV
2 0 02354 0 00 0000+00	000000 FT	000000 FT		NOBLESTOWN RD (SR0050 SEG 0240/2365)
NOBLESTOWN RD (SR0050 SEG 0240/2365)	0010/0000	0010/0000		MFC BEGIN = C LENGTH(AH 2672 BK 0000)

EXTRACT DATE: 12/21/2020 ROADWAY MANAGEMENT SYSTEM PAGE NUMBER: 1102
 PRINT DATE: 12/23/2020 SLD COUNTY/SR - ANNUAL PRINT COUNTY: ALLEGHENY
 DIR: B TOTAL LEN: .003 MI. DIST: 11-1 SR: 3061
 LEFT MUN: NORTH FAYETTE T RIGHT MUN: NORTH FAYETTE T

000018 FT

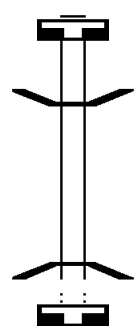

 000000 FT

 000000 FT



000018 FT
 7014/0000 LENGTH(AH 0100 BK 0018)
 BMSBN 02/3061/0010/0000
 * REF-AHD PATTRIDGE LN
 0010/0018 (TWP)
 000000 FT 2 0 02007 0 00 0001+86
 NC PA PATTRIDGE LN
 * REF-BK PATTRIDGE LN
 (TWP)
 HALF CROWN R
 BMSBG 02/3061/0010/0000
 5 0010/0000 LENGTH(AH 0018 BK 0100)
 000000 FT
 7004/0000 LENGTH(AH 0100 BK 0000)

EXTRACT DATE: 12/21/2020 ROADWAY MANAGEMENT SYSTEM PAGE NUMBER: 1101
 PRINT DATE: 12/23/2020 SLD COUNTY/SR - ANNUAL PRINT COUNTY: ALLEGHENY
 DIR: B TOTAL LEN: .000 MI. DIST: 11-1 SR: 3060
 LEFT MUN: NORTH FAYETTE T RIGHT MUN: NORTH FAYETTE T

000000 FT		000000 FT	
000000 FT		7030/0000	LENGTH(AH 0832 BK 0034)
000000 FT		000000 FT	
		7018/0000	LENGTH(AH 0034 BK 1174)
		000000 FT	
		7010/0000	LENGTH(AH 1174 BK 0000)

DIR: B TOTAL LEN: 2.209 MI. DIST: 11-1 SR: 3059
 LEFT MUN: NORTH FAYETTE T RIGHT MUN: NORTH FAYETTE T

011662 FT

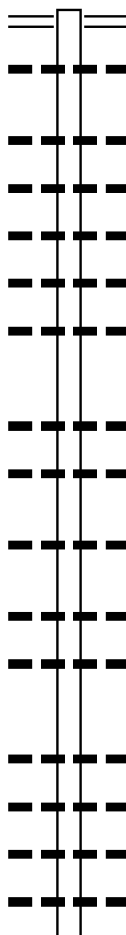

Segment	Material	Length	Notes
011662 FT	NORTH BRANCH RD		
0040/2532	(SR3108 SEG 0040/2915)		
012 " DIA	CIRC CONCR		
0040/2362	LEN=0099		INSTALLED UNKN
0040/1533	015 " DIA		CIRC CONCR INSTALLED UNKN
0040/1005	015 " DIA		CIRC METAL INSTALLED UNKN
0040/0834	015 " DIA		CIRC CONCR INSTALLED UNKN
0040/0572	015 " DIA		CIRC CONCR INSTALLED UNKN
0040/0437	012 " DIA		CIRC CONCR INSTALLED UNKN
009130 FT	2 0 02011 1 00 0023+84		
0040/0000	LENGTH(AH 2532 BK 2378)		
0034/2175	015 " DIA		CIRC CONCR INSTALLED UNKN
0034/1942	015 " DIA		CIRC CONCR INSTALLED UNKN
0034/1047	015 " DIA		CIRC CONCR INSTALLED UNKN
0034/0343	024 " DIA		CIRC CONCR INSTALLED UNKN
0034/0040	024 " DIA		CIRC CONCR INSTALLED UNKN
006752 FT	2 0 02011 0 00 0047+30		
0034/0000	LENGTH(AH 2378 BK 2834)		
0030/2391	018 " DIA		CIRC CONCR INSTALLED UNKN
0030/2335	036 " DIA		CIRC CONCR INSTALLED UNKN
0030/1806	024 " DIA		CIRC CONCR INSTALLED UNKN
0030/1433	015 " DIA		CIRC CONCR INSTALLED UNKN
	015 " DIA		CIRC CONCR INSTALLED 2002

EXTRACT DATE: 12/21/2020
PRINT DATE: 12/23/2020

ROADWAY MANAGEMENT SYSTEM
SLD COUNTY/SR - ANNUAL PRINT

PAGE NUMBER: 1099
COUNTY: ALLEGHENY

DIR: B TOTAL LEN: 2.209 MI.
LEFT MUN: NORTH FAYETTE T

DIST: 11-1 SR: 3059
RIGHT MUN: NORTH FAYETTE T

Stationing	Length	Material	Status
0030/1110	LEN=0030	024" DIA CIRC METAL	INSTALLED UNKN
0030/0701	LEN=0030	018" DIA CIRC CONCR	INSTALLED UNKN
0030/0326	LEN=0030	018" DIA CIRC CONCR	INSTALLED UNKN
0030/0193	LEN=0035	006" H 12" W CON BOX CUL	INSTALLED UNKN
0030/0035	LEN=0035	2 0 02011 0 00 0075+64	INSTALLED UNKN
003918 FT	003918 FT	LENGTH(AH 2834 BK 1622)	
		DAWN ST (TB24)	
0020/1400	LEN=0040	024" DIA CIRC CONCR	INSTALLED UNKN
0020/0837	LEN=0040	018" DIA CIRC CONCR	INSTALLED UNKN
0020/0650	LEN=0040	018" DIA CIRC CONCR	INSTALLED UNKN
0020/0505	LEN=0040	015" DIA CIRC CONCR	INSTALLED 2002
0020/0145	LEN=0040	LC TO SITARIK RD	INSTALLED UNKN
0020/0128	LEN=0040	(CONN)	
002296 FT	002296 FT	2 0 02011 0 00 0091+86	
		SITARIK RD (T023)	
0020/0000	0020/0000	LENGTH(AH 1622 BK 2296)	
		018" DIA CIRC CONCR	
0010/1682	LEN=0030	018" DIA CIR PLASTIC	INSTALLED UNKN
0010/1503	LEN=0030	024" DIA CIRC CONCR	INSTALLED UNKN
0010/1390	LEN=0030	018" DIA CIRC CONCR	INSTALLED UNKN
0010/1148	LEN=0030	018" DIA CIRC CONCR	INSTALLED UNKN
0010/0992	LEN=0030	018" DIA CIRC CONCR	INSTALLED UNKN
0010/0738	LEN=0030	012" DIA CIRC CONCR	INSTALLED UNKN
0010/0431	LEN=0030	012" DIA CIRC METAL	INSTALLED UNKN
0010/0182	LEN=0020	2 0 02011 0 00 0115+13	INSTALLED 1997
000000 FT	000000 FT	NC NO	
		NOBLESTOWN RD (TBK)	
		(TWP)	
		MFC BEGIN = E	
0010/0000	0010/0000	LENGTH(AH 2296 BK 0000)	

GATEWAY DR
(TWP)

DIR: B TOTAL LEN: .205 MI. DIST: 11-1 SR: 3058
 LEFT MUN: CARNEGIE B RIGHT MUN: CARNEGIE B

RAMP E RD	INTER-AHD	
(SR8033 SEG 0510/1110)	001082 FT	000715 FT ANTHONY ST
ANTHONY ST	0011/1082	7010/1069 (TWP)
(TWP)		
HAYS ST	0011/0896	
(TWP)		
CHESTNUT ST	0011/0715	
(SR3056 SEG 0010/0340)		
UNKNOWN RD	0011/0592	
(TWP)		
SANSBURY ST	0011/0444	
(TWP)		
018 " DIA CIRC CONCR		
LEN=0020 INSTALLED UNKN	0011/0423	
2 0 02255 0 00 0000+00	000000 FT	
WASHINGTON AV		
(SR0050 SEG 0212/1660)		
NC LYDIA ST		
WASHINGTON AV		
(SR0050 SEG 0212/1660)		
MFC BEGIN = B		
LENGTH(AH 1082 BK 0000)	0011/0000	000000 FT
		7010/0000 LTH AH 001069 BK 000000

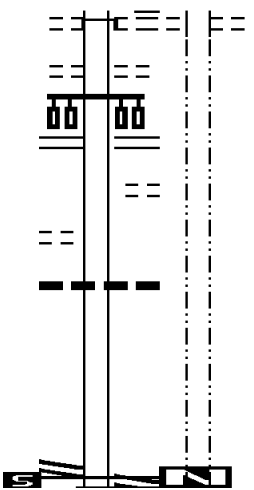

DIR: B TOTAL LEN: 2.215 MI. DIST: 11-1 SR: 3057
 LEFT MUN: NORTH FAYETTE T RIGHT MUN: NORTH FAYETTE T

011693 FT

011693 FT

011675 FT

011675 FT

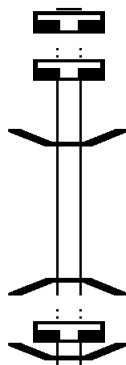

011693 FT

7082/0000

011693 FT

7072/0000

* REF-AHD

0070/0018

011675 FT

* REF-BK

0070/0000

011675 FT

7064/0000

LENGTH(AH 3624 BK 3406)

LENGTH(AH 3406 BK 0018)

BMSBN 02/3057/0070/0001

DONALDSON RD (TBK)

(TWP)

2 0 02008 0 00 0044+14

DONALDSON RD (TBK)

(TWP)

ROBINSON RUN

BMSBG 02/3057/0070/0001

LENGTH(AH 0018 BK 2625)

LENGTH(AH 2625 BK 0028)

BMSBN 02/3057/0060/0000

EXTRACT DATE: 12/21/2020
PRINT DATE: 12/23/2020

ROADWAY MANAGEMENT SYSTEM
SLD COUNTY/SR - ANNUAL PRINT

PAGE NUMBER: 1096
COUNTY: ALLEGHENY

DIR: B TOTAL LEN: 2.215 MI.
LEFT MUN: NORTH FAYETTE T

DIST: 11-1 SR: 3057
RIGHT MUN: NORTH FAYETTE T

011647 FT

011647 FT

008196 FT

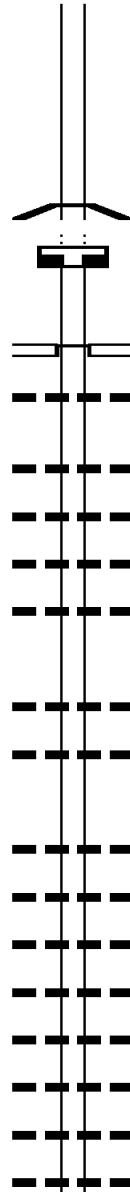

* REF-AHD	DONALDSON RD (TBK)
0060/0028	(TWP)
011647 FT	2 0 02008 0 00 0093+84
NC DO	DONALDSON RD
* REF-BK	DONALDSON RD (TBK)
	(TWP)
	ROBINSON RUN
	BMSBG 02/3057/0060/0000
5 0060/0000	LENGTH(AH 0028 BK 0045)
011647 FT	
7060/0000	LENGTH(AH 0045 BK 3451)
INTER-AHD	DONALDSON RD (TBK)
	(TWP)
	NORTH BRANCH RD
0050/3451	(SR3108 SEG 0060/1400)
	018 "DIA CIRC CONCR
0050/3154	LEN=0040 INSTALLED UNKN
	024 "DIA CIRC CONCR
0050/2346	LEN=0040 INSTALLED UNKN
	018 "DIA CIRC CONCR
0050/2206	LEN=0040 INSTALLED UNKN
	018 "DIA CIRC CONCR
0050/2026	LEN=0040 INSTALLED UNKN
	018 "DIA CIRC CONCR
0050/1726	LEN=0040 INSTALLED UNKN
	018 "DIA CIRC CONCR
0050/0654	LEN=0040 INSTALLED UNKN
	018 "DIA CIRC CONCR
0050/0274	LEN=0099 INSTALLED UNKN
008196 FT	2 0 02204 0 00 0034+58
5 0050/0000	LENGTH(AH 3451 BK 2192)
	018 "DIA CIRC CONCR
0040/1842	LEN=0040 INSTALLED UNKN
	018 "DIA CIRC CONCR
0040/1511	LEN=0040 INSTALLED UNKN
	024 "DIA CIRC CONCR
0040/1320	LEN=0040 INSTALLED UNKN
	018 "DIA CIRC CONCR
0040/1132	LEN=0040 INSTALLED UNKN
	018 "DIA CIRC CONCR
0040/1042	LEN=0040 INSTALLED UNKN
	015 "DIA CIRC CONCR
0040/0901	LEN=0040 INSTALLED UNKN
	018 "DIA CIRC CONCR
0040/0339	LEN=0040 INSTALLED UNKN
	018 "DIA CIRC CONCR
0040/0041	LEN=0040 INSTALLED UNKN

EXTRACT DATE: 12/21/2020
PRINT DATE: 12/23/2020

ROADWAY MANAGEMENT SYSTEM
SLD COUNTY/SR - ANNUAL PRINT

PAGE NUMBER: 1095
COUNTY: ALLEGHENY

DIR: B TOTAL LEN: 2.215 MI.
LEFT MUN: NORTH FAYETTE T

DIST: 11-1 SR: 3057
RIGHT MUN: NORTH FAYETTE T

2 0 02204 0 00 0056+50 006004 FT
SITARIK RD
(PRDR)

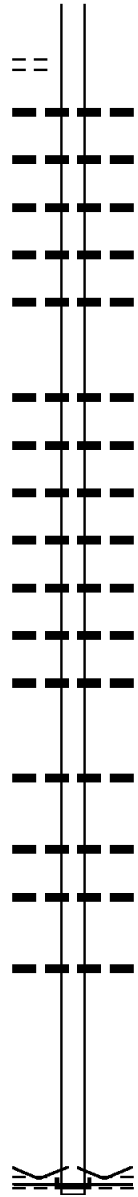

0040/0000

004168 FT

002206 FT

000000 FT

NOBLESTOWN RD (TBK)
(TWP)

0010/0000

006004 FT

5	0040/0000	LENGTH(AH 2192 BK 1836)
		018 "DIA CIRC CONCR UNKN
	0030/1676	LEN=0040 INSTALLED UNKN
		018 "DIA CIRC CONCR UNKN
	0030/1428	LEN=0040 INSTALLED UNKN
		018 "DIA CIRC CONCR UNKN
	0030/1100	LEN=0040 INSTALLED UNKN
		018 "DIA CIRC CONCR UNKN
	0030/0721	LEN=0040 INSTALLED UNKN
		018 "DIA CIRC CONCR UNKN
	0030/0286	LEN=0040 INSTALLED UNKN
	004168 FT	2 0 02204 0 00 0074+86
5	0030/0000	LENGTH(AH 1836 BK 1962)
		036 "DIA CIRC CONCR UNKN
	0020/1637	LEN=0040 INSTALLED UNKN
		036 "DIA CIRC CONCR UNKN
	0020/1157	LEN=0040 INSTALLED UNKN
		018 "DIA CIRC CONCR UNKN
	0020/0961	LEN=0040 INSTALLED UNKN
		018 "DIA CIRC CONCR UNKN
	0020/0740	LEN=0040 INSTALLED UNKN
		018 "DIA CIRC METAL UNKN
	0020/0399	LEN=0040 INSTALLED UNKN
		024 "DIA CIRC CONCR UNKN
	0020/0117	LEN=0040 INSTALLED UNKN
		018 "DIA CIRC METAL UNKN
	0020/0035	LEN=0040 INSTALLED UNKN
	002206 FT	2 0 02204 0 00 0095+00
5	0020/0000	LENGTH(AH 1962 BK 2206)
		018 "DIA CIRC CONCR UNKN
	0010/2025	LEN=0040 INSTALLED UNKN
		018 "DIA CIR PLASTIC UNKN
	0010/1422	LEN=0040 INSTALLED UNKN
		018 "DIA CIRC CONCR UNKN
	0010/1128	LEN=0040 INSTALLED UNKN
		024 "DIA CIRC CONCR UNKN
	0010/0337	LEN=0040 INSTALLED UNKN
	000000 FT	2 0 02204 0 00 0116+95
		VILLAGE: N. FAYETTE TWP
		NC WHITTENGALE RD
		WEST STATE ST
		(TWP)
		NOBLESTOWN RD (TBK)
		(TWP)
		MFC BEGIN = E
5	0010/0000	LENGTH(AH 2206 BK 0000)

EXTRACT DATE: 12/21/2020 ROADWAY MANAGEMENT SYSTEM PAGE NUMBER: 1094
PRINT DATE: 12/23/2020 SLD COUNTY/SR - ANNUAL PRINT COUNTY: ALLEGHENY
DIR: B TOTAL LEN: 1.270 MI. DIST: 11-1 SR: 3056
LEFT MUN: SCOTT T RIGHT MUN: SCOTT T

006704 FT



006704 FT
INTER-AHD GREEN VALLEY DR
(PRDR)

DIR: B TOTAL LEN: 1.270 MI. DIST: 11-1 SR: 3056
 LEFT MUN: SCOTT T RIGHT MUN: SCOTT T

2 0 02038 0 00 0058+29 005508 FT
 WISE RD
 (BORO) 0040/0000
 CREST LN
 (BORO) 0030/2935

WOODRIDGE DR
 (BORO) 0030/1967

WOODRUFF DR
 (BORO) 0030/0185

002276 FT

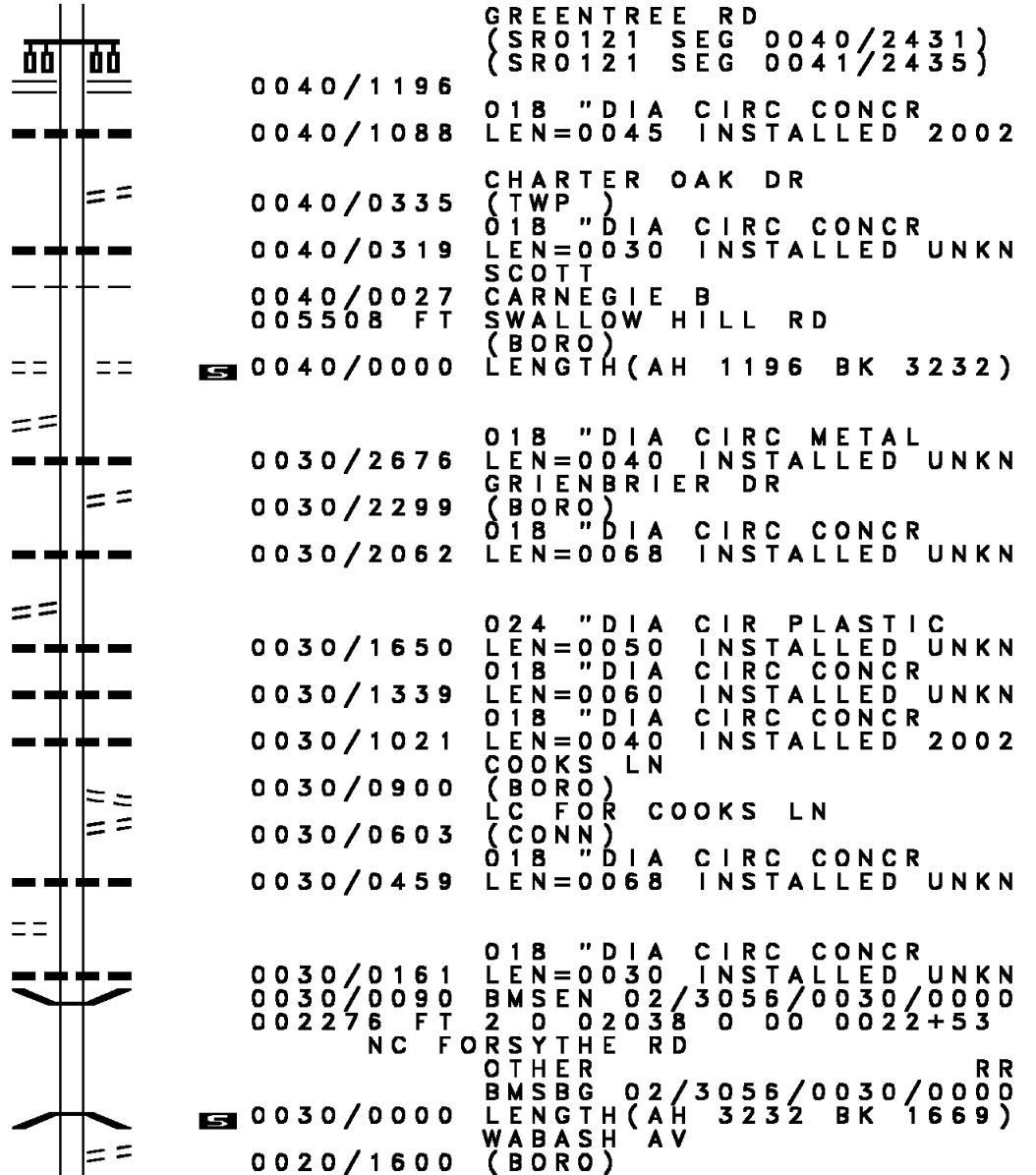

GREENTREE RD
 (SR0121 SEG 0040/2431)
 (SR0121 SEG 0041/2435)
 0040/1196
 0040/1088 018 "DIA CIRC CONCR
 LEN=0045 INSTALLED 2002
 CHARTER OAK DR
 (TWP)
 0040/0335 018 "DIA CIRC CONCR
 0040/0319 LEN=0030 INSTALLED UNKN
 SCOTT
 0040/0027 CARNEGIE B
 005508 FT SWALLOW HILL RD
 (BORO)
 0040/0000 LENGTH(AH 1196 BK 3232)
 018 "DIA CIRC METAL
 0030/2676 LEN=0040 INSTALLED UNKN
 GRIENBRIER DR
 (BORO)
 0030/2299 018 "DIA CIRC CONCR
 0030/2062 LEN=0068 INSTALLED UNKN
 024 "DIA CIR PLASTIC
 0030/1650 LEN=0050 INSTALLED UNKN
 018 "DIA CIRC CONCR
 0030/1339 LEN=0060 INSTALLED UNKN
 018 "DIA CIRC CONCR
 0030/1021 LEN=0040 INSTALLED 2002
 COOKS LN
 (BORO)
 0030/0900 LC FOR COOKS LN
 (CONN)
 0030/0603 018 "DIA CIRC CONCR
 0030/0459 LEN=0068 INSTALLED UNKN
 018 "DIA CIRC CONCR
 0030/0161 LEN=0030 INSTALLED UNKN
 0030/0090 BMS EN 02/3056/0030/0000
 002276 FT 2 0 02038 0 00 0022+53
 NC FORSYTHE RD
 OTHER RR
 BMSBG 02/3056/0030/0000
 0030/0000 LENGTH(AH 3232 BK 1669)
 WABASH AV
 (BORO)
 0020/1600

DIR: B TOTAL LEN: 1.270 MI. DIST: 11-1 SR: 3056
 LEFT MUN: CARNEGIE B RIGHT MUN: CARNEGIE B

HENRY LN
 (BORO)
 SUMMIT ST
 (BORO)

RIDGE AV (TBK)
 (BORO)

0020/1185

0020/0265

000607 FT

000000 FT

0020/1410	012 " DIA	CIRC CONCR
	LEN=0030	INSTALLED UNKN
0020/1405	BORO AL	
	(BORO)	
0020/1228	PATTERSON AV	
	(BORO)	
0020/1218	018 " DIA	CIRC CONCR
	LEN=0030	INSTALLED UNKN
0020/0921	018 " DIA	CIRC CONCR
	LEN=0030	INSTALLED UNKN
0020/0693	018 " DIA	CIRC CONCR
	LEN=0006	INSTALLED UNKN
0020/0588	018 " DIA	CIRC CONCR
	LEN=0020	INSTALLED UNKN
0020/0480	018 " DIA	CIRC CONCR
	LEN=0030	INSTALLED UNKN
0020/0290	018 " DIA	CIRC CONCR
	LEN=0030	INSTALLED UNKN
0020/0265	RIDGE AV	
	(BORO)	
0020/0245	018 " DIA	CIRC CONCR
	LEN=0019	INSTALLED UNKN
0020/0228	015 " DIA	CIRC METAL
	LEN=0035	INSTALLED UNKN
0020/0160	PLUM AV	
	(BORO)	
0020/0131	018 " DIA	CIRC CONCR
	LEN=0030	INSTALLED UNKN
000607 FT	2 0 02038	0 00 0005+77
	NC CH	CHESTNUT ST/FORSYTHE RD
		ACADEMY ST
		(SR3097 SEG 0010/0905)
0020/0000	LENGTH(AH 1669 BK 0607)	
	LYDIA ST	
	(SR3058 SEG 0011/0715)	
0010/0340	2 0 02038	0 00 0000+00
000000 FT	NC CH	CHESTNUT ST
		MAIN ST
		(SR0050 SEG 0220/0421)
INTER-BK	CHESTNUT ST	
	(SR3048 SEG 0250/0362)	
	MFC BEGIN = C	
0010/0000	LENGTH(AH 0607 BK 0000)	

EXTRACT DATE: 12/21/2020 ROADWAY MANAGEMENT SYSTEM PAGE NUMBER: 1091
 PRINT DATE: 12/23/2020 SLD COUNTY/SR - ANNUAL PRINT COUNTY: ALLEGHENY
 DIR: B TOTAL LEN: 4.770 MI. DIST: 11-1 SR: 3054
 LEFT MUN: CARNEGIE B RIGHT MUN: CARNEGIE B

VETERANS WY
(BORO)

CHURCH ST
(BORO)

025187 FT

0090/2845

0090/2310

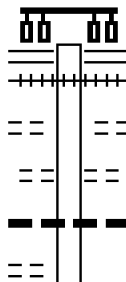

025187 FT

0090/2937

0090/2900

0090/2845

0090/2715

0090/2564

MAIN ST
(SR3048 SEG 0221/0000)
(SR3048 SEG 0220/0000)

(AAR 508034C)#TRKS 01

ALLEY
(BORO)

LOGAN ST
(BORO)

024" DIA CIRC METAL
LEN=0025 INSTALLED UNKN

DIR: B TOTAL LEN: 4.770 MI. DIST: 11-1 SR: 3054
 LEFT MUN: CARNEGIE B RIGHT MUN: CARNEGIE B

Street Name	Segment ID	Start Station	End Station	Notes
SEVENTH AV (BORO)	0090/1800	0090/1800	0090/1710	
COLLIER AV (BORO)	0090/1710	0090/1710	0090/1419	
CUBBAGE ST (BORO)	0090/1419	0090/1419	0090/1377	
		0090/1377	0090/1128	
		0090/1128	0090/1045	
		0090/1045	0090/1035	
COLECREST ST (TWP)	0090/0951	0090/0951	0090/0951	
		0090/0951	0090/0900	
PRESTLEY ST (TWP)	0090/0785	0090/0785	0090/0785	
		0090/0785	0090/0620	
		0090/0620	0090/0504	
		0090/0504	0090/0411	
DELFRED DR (TWP)	0090/0225	0090/0225	0090/0225	
	022250 FT			
		0090/0017	0090/0017	018 "DIA CIRC CONCR LEN=0060 INSTALLED UNKN
		022250 FT	022250 FT	BMSID 02/3054/0090/0017 2 0 02037 0 00 0074+91
		0090/0000	0090/0000	LENGTH(AH 2937 BK 2536)
		0080/1170	0080/1143	018 "DIA CIRC CONCR LEN=0060 INSTALLED UNKN
		0080/1143	0080/0760	BMSEN 02/3054/0080/0760 2 0 02037 0 00 0089+15
		0080/0760	0080/0760	SR 0079 NB BMSBG 02/3054/0080/0760
		0080/0573	0080/0573	018 "DIA CIRC CONCR LEN=0099 INSTALLED UNKN

DIR: B TOTAL LEN: 4.770 MI. DIST: 11-1 SR: 3054
 LEFT MUN: COLLIER T RIGHT MUN: COLLIER T

Location	Segment ID	Length	Material	Status	Notes	
019714 FT	0080/0314	0099	018" DIA CIRC CONCR	INSTALLED	UNKN	
	019714 FT	2002037	0000102+14			
	0080/0000	2536	018" DIA CIRC CONCR	INSTALLED	UNKN	
0070/1480	0070/1845	0099	018" DIA CIRC CONCR	INSTALLED	UNKN	
	0070/1491	0100	018" DIA CIRC CONCR	INSTALLED	UNKN	
	0070/1184	0065	018" DIA CIRC METAL	INSTALLED	UNKN	
0070/0873	0070/0873	0065	018" DIA CIRC CONCR	INSTALLED	UNKN	
	0070/0443	0055	015" DIA CIRC CONCR	INSTALLED	UNKN	
	0070/0263	017614 FT	2002037	0000123+44		
0070/0000	0070/0000	2748	018" DIA CIRC METAL	INSTALLED	UNKN	
	0060/2583	0045	018" DIA CIR PLASTIC	INSTALLED	UNKN	
	0060/2489	0050	018" DIA CIRC CONCR	INSTALLED	UNKN	
	0060/2299	0045	018" DIA CIR PLASTIC	INSTALLED	UNKN	
	0060/2133	0045	054" DIA CIRC CONCR	INSTALLED	UNKN	
	0060/2022	0055	018" DIA CIR PLASTIC	INSTALLED	UNKN	
	0060/1823	0040	018" DIA CIRC METAL	INSTALLED	2005	
	0060/1321	0040	024" DIA CIRC CONCR	INSTALLED	1997	
	0060/1169	0040	018" DIA CIRC CONCR	INSTALLED	UNKN	
	014866 FT	014866 FT	2002037	0000149+97		
		0060/0000	2748	018" DIA CIR PLASTIC	INSTALLED	UNKN
		0050/2362	0040	015" DIA CIR PLASTIC	INSTALLED	UNKN
	0050/1265	0050/1820	0055	015" DIA CIR PLASTIC	INSTALLED	UNKN

DIR: B TOTAL LEN: 4.770 MI. DIST: 11-1 SR: 3054
 LEFT MUN: COLLIER T RIGHT MUN: COLLIER T

2 0 02037 0 00 0175+25 012468 FT
 BALDWIN RD ET
 (TWP)
 RIDGE RD
 (TWP)

CENTENNIAL DR
 (TWP)

2 0 02037 0 00 0212+54 008741 FT
 MCMICHAEL RD
 (SR3041 SEG 0040/0000) 0040/0000

0050/0498	018 " DIA	CIR PLASTIC
0050/0320	LEN=0040	INSTALLED UNKN
012468 FT	LANGER LN	(TWP)
0050/0000	NC EWING RD	LENGTH(AH 2398 BK 3727)
0040/3699	FORT PITT RD	(TWP)
0040/3462	018 " DIA	CIRC METAL
0040/3172	LEN=0099	INSTALLED UNKN
0040/2883	018 " DIA	CIRC METAL
0040/2310	LEN=0050	INSTALLED UNKN
0040/2102	018 " DIA	CIRC CONCR
0040/1940	LEN=0075	INSTALLED UNKN
0040/1363	018 " DIA	CIRC METAL
0040/0646	LEN=0060	INSTALLED UNKN
0040/0286	018 " DIA	CIRC METAL
0040/0099	LEN=0055	INSTALLED UNKN
008741 FT	018 " DIA	CIRC CONCR
0040/0000	LEN=0045	INSTALLED UNKN
0030/2945	018 " DIA	CIR PLASTIC
0030/2494	LEN=0025	INSTALLED UNKN
0030/2202	018 " DIA	CIR PLASTIC
0030/1882	LEN=0070	INSTALLED UNKN
0030/1578	018 " DIA	CIRC METAL
0030/1231	LEN=0060	INSTALLED UNKN
0030/0707	018 " DIA	CIRC METAL
	LEN=0080	INSTALLED UNKN
	030 " DIA	CIRC CONCR
	LEN=0075	INSTALLED UNKN
	BRYNA LN	(TWP)

DIR: B TOTAL LEN: 4.770 MI. DIST: 11-1 SR: 3054
 LEFT MUN: COLLIER T RIGHT MUN: COLLIER T

2 0 02028 0 00 0053+61 005382 FT
 COWAN RD
 (SR3043 SEG 0010/0000) 0030/0000

0030/0476	018 " DIA	CIR PLASTIC
LEN=0050	COWAN RD	INSTALLED 2003
0030/0155	(TWP)	
005382 FT		
5 0030/0000	LENGTH(AH 3359 BK 3161)	
0020/3096	018 " DIA	CIR PLASTIC UNKN
0020/2923	LEN=0070	INSTALLED UNKN
0020/2517	018 " DIA	CIR PLASTIC UNKN
0020/2060	LEN=0055	INSTALLED UNKN
0020/1859	018 " DIA	CIRC CONCR UNKN
0020/1758	LEN=0099	INSTALLED UNKN
0020/1388	024 " DIA	CIR PLASTIC UNKN
0020/1188	LEN=0070	INSTALLED UNKN
0020/0978	012 " DIA	CIRC CONCR UNKN
0020/0737	LEN=0090	INSTALLED UNKN
0020/0541	018 " DIA	CIR PLASTIC UNKN
002221 FT	LEN=0080	INSTALLED UNKN
5 0020/0000	015 " DIA	CIR PLASTIC UNKN
0010/2199	LEN=0055	INSTALLED UNKN
0010/2005	018 " DIA	CIR PLASTIC UNKN
0010/1698	LEN=0050	INSTALLED UNKN
0010/1384	018 " DIA	CIR PLASTIC UNKN
	LEN=0045	INSTALLED UNKN
	018 " DIA	CIR PLASTIC UNKN
	LEN=0045	INSTALLED UNKN
	072 " DIA	CIRC CONCR UNKN
	LEN=0090	INSTALLED UNKN
	2 0 02028 0 00 0022+00	
	5 LENGTH(AH 3161 BK 2221)	
	018 " DIA	CIR PLASTIC UNKN
	LEN=0040	INSTALLED UNKN
	018 " DIA	CIRC METAL UNKN
	LEN=0040	INSTALLED UNKN
	018 " DIA	CIRC METAL UNKN
	LEN=0040	INSTALLED UNKN
	012 " DIA	CIRC CONCR UNKN
	LEN=0099	INSTALLED UNKN
	018 " DIA	CIRC CONCR
	LEN=0040	INSTALLED 2017
000000 FT	000000 FT	
	2 0 02028 0 00 0000+00	
	PINKERTON RUN RD (TBK)	
	(TWP)	
	NC BA LDWIN RD	
	MFC BEGIN = E	
5 0010/0000	LENGTH(AH 2221 BK 0000)	

PINKERTON RUN RD (TBK)
 (TWP) 0010/0000

DIR: B TOTAL LEN: 2.916 MI. DIST: 11-1 SR: 3053
 LEFT MUN: NORTH FAYETTE T RIGHT MUN: NORTH FAYETTE T

015396 FT

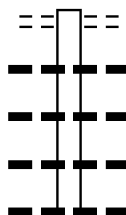

015396 FT STEUBENVILLE PK
 0060/1898 (TB65)
 015 "DIA CIRC CONCR
 LEN=0030 INSTALLED UNKN
 0060/1826 015 "DIA CIRC CONCR
 LEN=0035 INSTALLED UNKN
 0060/1473 095 "DIA CIRC CONCR
 LEN=0040 INSTALLED UNKN
 0060/1046 015 "DIA CIRC CONCR
 LEN=0040 INSTALLED UNKN
 0060/0620 015 "DIA CIRC CONCR
 LEN=0040 INSTALLED UNKN

013498 FT

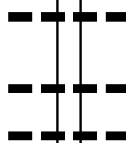

013498 FT 2 0 02340 0 00 0135+08
 0060/0000 LENGTH(AH 1898 BK 2005)
 015 "DIA CIRC CONCR
 0050/1720 LEN=0030 INSTALLED 2002
 012 "DIA CIRC CONCR
 0050/1100 LEN=0030 INSTALLED UNKN
 015 "DIA CIR UNKNOWN
 0050/0884 LEN=0050 INSTALLED UNKN

011493 FT

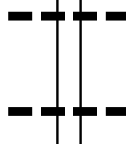

0050/0202 015 "DIA CIRC CONCR
 LEN=0032 INSTALLED UNKN
 011493 FT 2 0 02340 0 00 0115+03
 0050/0000 LENGTH(AH 2005 BK 2355)
 015 "DIA CIRC CONCR
 0040/2273 LEN=0036 INSTALLED UNKN
 024 "DIA CIRC METAL
 0040/1776 LEN=0050 INSTALLED UNKN

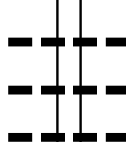

0040/0978 015 "DIA CIRC CONCR
 LEN=0028 INSTALLED UNKN
 015 "DIA CIRC CONCR
 0040/0784 LEN=0024 INSTALLED UNKN
 012 "DIA CIRC CONCR
 0040/0635 LEN=0035 INSTALLED UNKN

009138 FT

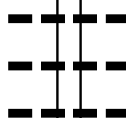

009138 FT 2 0 02340 0 00 0091+48
 0040/0000 LENGTH(AH 2355 BK 3086)
 012 "DIA CIRC CONCR
 0030/2730 LEN=0030 INSTALLED 2002
 012 "DIA CIRC CONCR
 0030/2552 LEN=0030 INSTALLED UNKN
 015 "DIA CIRC CONCR
 0030/2291 LEN=0030 INSTALLED UNKN

012 "DIA CIRC CONCR

EXTRACT DATE: 12/21/2020
PRINT DATE: 12/23/2020

ROADWAY MANAGEMENT SYSTEM
SLD COUNTY/SR - ANNUAL PRINT

PAGE NUMBER: 1085
COUNTY: ALLEGHENY

DIR: B TOTAL LEN: 2.916 MI.
LEFT MUN: NORTH FAYETTE T

DIST: 11-1 SR: 3053
RIGHT MUN: NORTH FAYETTE T

RED DOG RD
(TWP)
COMMODORE DR
(TWP)

006052 FT

0020/1630

0020/1519

003004 FT

000000 FT

0030/0914	LEN=0030	INSTALLED UNKN
012 "DIA	CIRC CONCR	
0030/0598	LEN=0050	INSTALLED UNKN
006052 FT	2 0 02340	0 00 0060+55
018 "DIA	CIRC CONCR	
0030/0000	LEN=0050	INSTALLED UNKN
LENGTH(AH	3086 BK 3048)	
018 "DIA	CIRC CONCR	
0020/2825	LEN=0050	INSTALLED UNKN
0020/1495	018 "DIA	CIR PLASTIC
LEN=0050	INSTALLED UNKN	
0020/0730	018 "DIA	CIR PLASTIC
LEN=0040	INSTALLED UNKN	
024 "DIA	CIRC CONCR	
0020/0255	LEN=0040	INSTALLED UNKN
003004 FT	2 0 02340	0 00 0030+09
0020/0000	LENGTH(AH	3048 BK 3004)
018 "DIA	CIRC CONCR	
0010/2825	LEN=0050	INSTALLED UNKN
018 "DIA	CIRC CONCR	
0010/2428	LEN=0050	INSTALLED UNKN
SOVEREIGN CT		
0010/2309	(PRDR)	
018 "DIA	CIRC CONCR	
0010/2040	LEN=0099	INSTALLED UNKN
018 "DIA	CIR PLASTIC	
0010/1971	LEN=0060	INSTALLED UNKN
018 "DIA	CIRC CONCR	
0010/1545	LEN=0050	INSTALLED UNKN
018 "DIA	CIRC CONCR	
0010/1346	LEN=0050	INSTALLED UNKN
018 "DIA	CIR PLASTIC	
0010/1195	LEN=0050	INSTALLED UNKN
018 "DIA	CIRC CONCR	
0010/0664	LEN=0050	INSTALLED UNKN
012"H 24"W	ELLIP METAL	
0010/0171	LEN=0030	INSTALLED UNKN
000000 FT	2 0 02340	0 00 0000+00
NC SE	ABR	RIGHT RD
	NORTH BRANCH RD	
	(SR3108	SEG 0030/1300)
	MFC BEGIN = E	
0010/0000	LENGTH(AH	3004 BK 0000)

DIR: B TOTAL LEN: 5.759 MI. DIST: 11-1 SR: 3052
 LEFT MUN: SCOTT T RIGHT MUN: SCOTT T

COCHRAN RD (SR0121 SEG 0040/0000) GREENTREE RD (SR0121 SEG 0041/0000) (SR0121 SEG 0040/0000)	030364 FT INTER-AHD	030407 FT INTER-AHD	COCHRAN RD (SR0121 SEG 0041/0000) GREENTREE RD (SR0121 SEG 0041/0000) (SR0121 SEG 0040/0000)
	0151/1277	0150/1368	
024 "DIA CIRC CONCR LEN=0030 INSTALLED UNKN RAMP B RD (SR9404 SEG 0250/0233)	0151/1114 0151/1092	0150/1222 0150/1126	024 "DIA CIRC CONCR LEN=0040 INSTALLED UNKN SCOTT MT LEBANON T
018 "DIA CIRC CONCR LEN=0040 INSTALLED UNKN	0151/0851	0150/0976	024 "DIA CIRC CONCR LEN=0040 INSTALLED UNKN
018 "DIA CIRC CONCR LEN=0040 INSTALLED UNKN	0151/0601	0150/0707	018 "DIA CIRC CONCR LEN=0040 INSTALLED UNKN
018 "DIA CIRC CONCR LEN=0045 INSTALLED UNKN	0151/0411	0150/0473	018 "DIA CIRC CONCR LEN=0040 INSTALLED UNKN
036 "DIA CIRC CONCR LEN=0050 INSTALLED UNKN 1 0 00802 0 02 0086+50 029087 FT MT LEBANON SCOTT T	0151/0111	029039 FT	1 0 00802 0 02 0086+50 MT LEBANON SCOTT T
LENGTH(AH 1277 BK 1017) 018 "DIA CIRC CONCR LEN=0045 INSTALLED UNKN VIRGINA MANSIONS DR (PRDR)	0151/0000 0141/0742 0141/0630	0150/0000	LENGTH(AH 1368 BK 0740) VIRGINA MANSIONS DR (PRDR)
BMS EN 02/3052/0140/0415 1 0 00802 0 01 0065+34 GEORGES RUN BMSBG 02/3052/0140/0415	0141/0502 0141/0481	0140/0435	
	0140/0311	0140/0290	BMS EN 02/3052/0140/0415 1 0 00802 0 01 0060+96 GEORGES RUN BMSBG 02/3052/0140/0415 1 0 00802 0 01 0060+96
		028299 FT	

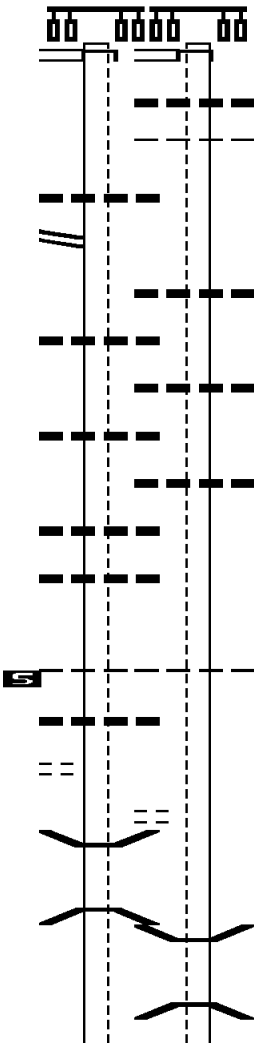

DIR: B TOTAL LEN: 5.759 MI. DIST: 11-1 SR: 3052
 LEFT MUN: SCOTT T RIGHT MUN: SCOTT T

Stationing	Length	Material	Notes
0060+96	028070 FT	018 "DIA CIRC CONCR	LEN=0050 INSTALLED UNKN
0060+96	0141/0000	024 "DIA CIRC CONCR	LEN=0050 INSTALLED UNKN
0130+0664	0130/0664	024 "DIA CIRC CONCR	LEN=0050 INSTALLED UNKN
0130+0370	0130/0370	024 "DIA CIRC CONCR	LEN=0050 INSTALLED UNKN
0130+0350	0130/0350	024 "DIA CIRC CONCR	LEN=0050 INSTALLED UNKN
0131+0370	0131/0370	024 "DIA CIRC CONCR	LEN=0050 INSTALLED UNKN
0131+0345	0131/0345	024 "DIA CIRC CONCR	LEN=0050 INSTALLED UNKN
0130+0307	0130/0307	024 "DIA CIRC CONCR	LEN=0050 INSTALLED UNKN
0130+0250	0130/0250	024 "DIA CIRC CONCR	LEN=0050 INSTALLED UNKN
0130+0244	0130/0244	024 "DIA CIRC CONCR	LEN=0047 INSTALLED UNKN
0130+0223	0130/0223	024 "DIA CIRC CONCR	LEN=0030 INSTALLED UNKN
0131+0240	0131/0240	024 "DIA CIRC CONCR	LEN=0020 INSTALLED UNKN
0131+0230	0131/0230	024 "DIA CIRC CONCR	LEN=0020 INSTALLED UNKN
0057+35	027457 FT	024 "DIA CIRC CONCR	LEN=0040 INSTALLED UNKN
0057+35	027455 FT	024 "DIA CIRC CONCR	LEN=0040 INSTALLED UNKN
0131+0000	0131/0000	024 "DIA CIRC CONCR	LEN=0040 INSTALLED UNKN
0130+0000	0130/0000	024 "DIA CIRC CONCR	LEN=0040 INSTALLED UNKN
0110+0624	0110/0624	018 "DIA CIRC CONCR	LEN=0035 INSTALLED UNKN
025395 FT	025393 FT	018 "DIA CIRC CONCR	LEN=0035 INSTALLED UNKN
0110+0000	0110/0000	018 "DIA CIRC CONCR	LEN=0035 INSTALLED UNKN
0100+2414	0100/2414	018 "DIA CIRC CONCR	LEN=0070 INSTALLED UNKN
0100+2190	0100/2190	018 "DIA CIRC CONCR	LEN=0035 INSTALLED UNKN
0100+2045	0100/2045	018 "DIA CIRC CONCR	LEN=0035 INSTALLED UNKN

HOPE HOLLOW RD
 (TWP)
 SWALLOW HILL RD
 (TWP)

OLD GREENTREE RD
 (TWP)
 012 "DIA CIRC CONCR
 LEN=0020 INSTALLED UNKN

1 0 00802 0 00 0057+35 027457 FT
 MFC BEGIN = B
 LENGTH(AH 0613 BK 2062) 0131/0000

URSULA DR
 (TWP)

018 "DIA CIRC CONCR
 LEN=0050 INSTALLED UNKN
 LENGTH(AH 0740 BK 0844)
 024 "DIA CIRC CONCR
 LEN=0050 INSTALLED UNKN
 HOPE HOLLOW RD
 (TWP)
 SWALLOW HILL RD
 (TWP)

SWALLOW HILL RD
 (TWP)
 OLD GREENTREE RD
 (TWP)
 024 "DIA CIRC CONCR
 LEN=0047 INSTALLED UNKN
 024 "DIA CIRC CONCR
 LEN=0030 INSTALLED UNKN

024 "DIA CIRC CONCR
 LEN=0040 INSTALLED UNKN
 1 0 00802 0 00 0057+35
 MFC BEGIN = B
 LENGTH(AH 0844 BK 2062)

018 "DIA CIRC CONCR
 LEN=0035 INSTALLED UNKN
 1 0 00802 0 00 0033+05
 OLD GREENTREE RD
 (TWP)
 KERR RD
 (TWP)
 LENGTH(AH 2062 BK 2517)
 018 "DIA CIRC CONCR
 LEN=0070 INSTALLED UNKN
 018 "DIA CIRC CONCR
 LEN=0035 INSTALLED UNKN

DIR: B TOTAL LEN: 5.759 MI. DIST: 11-1 SR: 3052
 LEFT MUN: SCOTT T RIGHT MUN: SCOTT T

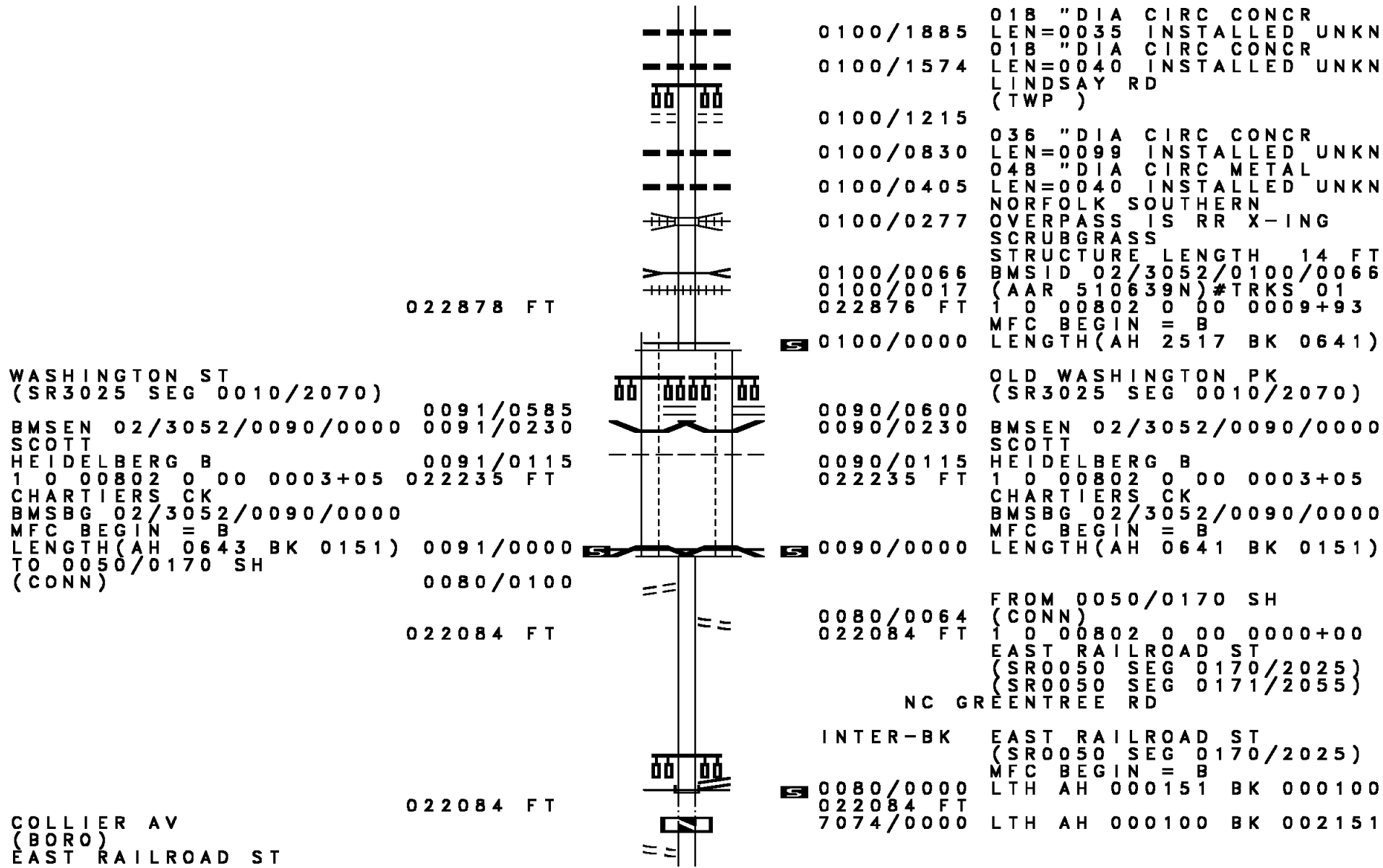

WASHINGTON ST
 (SR3025 SEG 0010/2070)
 BMS EN 02/3052/0090/0000 0091/0585
 SCOTT 0091/0230
 HEIDELBERG B 0091/0115
 1 0 00802 0 00 0003+05 022235 FT
 CHARTIERS CK
 BMSBG 02/3052/0090/0000
 MFC BEGIN = B
 LENGTH(AH 0643 BK 0151) 0091/0000
 TO 0050/0170 SH
 (CONN) 0080/0100

COLLIER AV
 (BORO)
 EAST RAILROAD ST

0100/1885 018 " DIA CIRC CONCR
 LEN=0035 INSTALLED UNKN
 0100/1574 018 " DIA CIRC CONCR
 LEN=0040 INSTALLED UNKN
 LINDSAY RD
 (TWP)
 0100/1215
 0100/0830 036 " DIA CIRC CONCR
 LEN=0099 INSTALLED UNKN
 048 " DIA CIRC METAL
 0100/0405 LEN=0040 INSTALLED UNKN
 NORFOLK SOUTHERN
 0100/0277 OVERPASS IS RR X-ING
 SCRUBGRASS
 STRUCTURE LENGTH 14 FT
 0100/0066 BMSID 02/3052/0100/0066
 0100/0017 (AAR 510639N) #TRKS 01
 022876 FT 1 0 00802 0 00 0009+93
 MFC BEGIN = B
 0100/0000 LENGTH(AH 2517 BK 0641)
 OLD WASHINGTON PK
 (SR3025 SEG 0010/2070)
 0090/0600
 0090/0230 BMS EN 02/3052/0090/0000
 SCOTT
 HEIDELBERG B
 0090/0115 1 0 00802 0 00 0003+05
 022235 FT CHARTIERS CK
 BMSBG 02/3052/0090/0000
 MFC BEGIN = B
 0090/0000 LENGTH(AH 0641 BK 0151)
 FROM 0050/0170 SH
 (CONN)
 0080/0064 1 0 00802 0 00 0000+00
 022084 FT EAST RAILROAD ST
 (SR0050 SEG 0170/2025)
 (SR0050 SEG 0171/2055)
 NC GREENTREE RD
 INTER-BK EAST RAILROAD ST
 (SR0050 SEG 0170/2025)
 MFC BEGIN = B
 0080/0000 LTH AH 000151 BK 000100
 022084 FT
 7074/0000 LTH AH 000100 BK 002151

DIR: B TOTAL LEN: 5.759 MI.
 LEFT MUN: HEIDELBERG B

DIST: 11-1 SR: 3052
 RIGHT MUN: HEIDELBERG B

Segment ID	Start Station	End Station	Length (FT)	Material / Notes
(SR0050 SEG 0180/0000)	0070/2151	0070/2151		COAL RD (BORO)
WEST RAILROAD ST (BORO)	0070/2065	0070/2065		
WALNUT ST ET (BORO)	0070/2005	0070/2005		
ELM WY (BORO)	0070/1835	0070/1835		
ELLSWORTH AV (BORO)	0070/1675	0070/1675		018 " DIA CIR PLASTIC LEN=0030 INSTALLED UNKN
LONG ST (BORO)	0070/1505	0070/1505		
HAYS ST (BORO)	0070/1350	0070/1350		
SHORT ST (BORO)	0070/1195	0070/1195		018 " DIA CIRC CONCR LEN=0030 INSTALLED UNKN
		0070/1021		012 " DIA CIRC CONCR LEN=0050 INSTALLED UNKN
		0070/0616		036 " DIA CIRC CONCR LEN=0040 INSTALLED UNKN
2 0 02022 0 00 0200+91 019933 FT			019933 FT	
GARFIELD AV (BORO)	0070/0000	0070/0000		LENGTH(AH 2151 BK 2956) HEIDELBERG
		0060/2769		COLLIER T
		0060/2751		018 " DIA CIRC CONCR LEN=0030 INSTALLED UNKN
		0060/2586		024 " DIA CIRC CONCR LEN=0030 INSTALLED UNKN
		0060/2584		BMSSEN 02/3052/0060/2289 2 0 02022 0 00 0169+29 SR 0079 NB
		0060/2289		BMSBG 02/3052/0060/2289
		0060/1800		018 " DIA CIRC CONCR LEN=0045 INSTALLED UNKN
		0060/1608		018 " DIA CIR PLASTIC LEN=0040 INSTALLED UNKN
		0060/1385		018 " DIA CIRC METAL LEN=0035 INSTALLED UNKN
		0060/0910		018 " DIA CIRC CONCR LEN=0040 INSTALLED UNKN
CLUBHOUSE RD (TWP)	0060/0630			018 " DIA CIRC CONCR

DIR: B TOTAL LEN: 5.759 MI. DIST: 11-1 SR: 3052
 LEFT MUN: COLLIER T RIGHT MUN: COLLIER T

Location / Segment	Length (FT)	Segment ID	Material / Details
DORRINGTON RD (SR3117 SEG 0010/0000)	016977 FT	0060/0000	0060/0609 LEN=0030 INSTALLED UNKN 015" DIA CIR PLASTIC
		0060/0133	0060/0133 LEN=0056 INSTALLED UNKN 016977 FT 2 0 02022 0 00 0171+35
		0060/0000	NC COLLIER AV LENGTH(AH 2956 BK 3834)
		0050/3024	018" DIA CIRC METAL LEN=0035 INSTALLED UNKN
		0050/2280	018" DIA CIRC METAL LEN=0099 INSTALLED UNKN
BRECKENRIDGE DR (TWP)	0050/1058	0050/1260	CHERRY HILL DR (TWP)
2 0 02022 0 00 0134+33 BRECKENRIDGE DR (TWP)	013143 FT	013143 FT	
		0050/0000	LENGTH(AH 3834 BK 2930) DRAINAGE STRUCTURE LENGTH 15 FT
		0040/2600	BMSID 02/3052/0040/2600 SHERWOOD DR
		0040/2410	(TWP)
		0040/1350	CARNOUSTIE DR (TWP)
		0040/1214	024" DIA CIR PLASTIC LEN=0045 INSTALLED UNKN
		0040/0720	024" DIA CIRC METAL LEN=0040 INSTALLED UNKN
	010213 FT	010213 FT	2 0 02022 0 00 0104+53 FORSYTHE RD
		0040/0000	(SR3031 SEG 0040/3734) LENGTH(AH 2930 BK 3495) CROWN PL
		0030/2990	(TWP) DRAINAGE STRUCTURE LENGTH 15 FT
ANNANDALE DR (TWP)	0030/2585	0030/2664	BMSID 02/3052/0030/2633
COLLIER TWP MUN BLDG EN (TWP)	0030/2456		

DIR: B TOTAL LEN: 5.759 MI. DIST: 11-1 SR: 3052
 LEFT MUN: COLLIER T RIGHT MUN: COLLIER T

Left Side Description	Left Side Stationing	Right Side Stationing	Right Side Description
WALKERS MILL RD (SR3028 SEG 0050/0000)	0030/1735	0030/2005	PINEHURST DR (TWP)
		0030/1735	BOYDS RUN RD (SR3028 SEG 0050/0000)
		0030/1664	036 " DIA CIR PLASTIC LEN=0055 INSTALLED UNKN
WALKERS RIDGE RD (TWP)	0030/0733		
	006718 FT	0030/0561	CAMBRIDGE DR (TWP)
		006718 FT	2 0 02022 0 00 0069+75 PVT SAYER RD (TWP)
		0030/0000	LENGTH(AH 3495 BK 3419)
		0020/2373	012 " DIA CIRC METAL LEN=0040 INSTALLED UNKN
		0020/1787	018 " DIA CIR PLASTIC LEN=0060 INSTALLED UNKN
		0020/1038	018 " DIA CIRC CONCR LEN=0060 INSTALLED UNKN
	003299 FT	003299 FT	2 0 02022 0 00 0035+11
		0020/0000	LENGTH(AH 3419 BK 3299)
		0010/3102	018 " DIA CIRC CONCR LEN=0050 INSTALLED UNKN
ROYAL OAK DR (TWP)	0010/1263	0010/1754	TUSCANY RIDGE DR (TWP)
		0010/1322	018 " DIA CIRC METAL LEN=0030 INSTALLED UNKN
		0010/0630	012 " DIA CIRC CONCR LEN=0030 INSTALLED UNKN
	000000 FT	000000 FT	2 0 02022 0 00 0000+00
THOMS RUN RD (CNTY)	0010/0000		THOMS RUN RD (CNTY) NC HI LL TOP RD MFC BEGIN = D
		0010/0000	LENGTH(AH 3299 BK 0000)

EXTRACT DATE: 12/21/2020 ROADWAY MANAGEMENT SYSTEM PAGE NUMBER: 1078
PRINT DATE: 12/23/2020 SLD COUNTY/SR - ANNUAL PRINT COUNTY: ALLEGHENY

DIR: B TOTAL LEN: .109 MI. DIST: 11-1 SR: 3051
LEFT MUN: NORTH FAYETTE T RIGHT MUN: NORTH FAYETTE T

000577 FT



000577 FT
7052/0000 LENGTH(AH 0262 BK 0529)
INTER-AHD KELSO RD (TBK)
(TWP)

EXTRACT DATE: 12/21/2020
PRINT DATE: 12/23/2020

ROADWAY MANAGEMENT SYSTEM
SLD COUNTY/SR - ANNUAL PRINT

PAGE NUMBER: 1077
COUNTY: ALLEGHENY

DIR: B TOTAL LEN: .109 MI.
LEFT MUN: NORTH FAYETTE T

DIST: 11-1 SR: 3051
RIGHT MUN: NORTH FAYETTE T

Distance (FT)	Diagram	Stationing	Description
		0050/0529	RAMP E RD (SR8026 SEG 0250/0000)
		0050/0427	RAMP F RD (SR8026 SEG 0500/0994)
		0050/0296	BMSSEN 02/3051/0050/0296 RT 22 EAST 018" DIA CIRC CONCR LEN=0036 INSTALLED UNKN
000048 FT		0050/0020	RAMP G RD (SR8026 SEG 0750/0585)
		000048 FT	MFC BEGIN = D 1 0 00396 0 00 0007+86
		INTER-BK	RAMP H RD (SR8026 SEG 0760/0000)
000048 FT		0050/0000	KELSO RD (TBK)
		000048 FT	(TWP)
		7048/0000	LENGTH(AH 0529 BK 1249)
		* REF-AHD	LENGTH(AH 1249 BK 0018)
000030 FT		0040/0018	BMSSEN 02/3051/0040/0000
		000030 FT	KELSO RD (TBK)
		* REF-BK	(TWP)
		1 0 00396 0 01 0022+24	HALF CROWN
000030 FT		0040/0000	BMSBG 02/3051/0040/0000
		000030 FT	LENGTH(AH 0018 BK 3519)
000030 FT		7040/0000	LENGTH(AH 3519 BK 2261)
000030 FT		000030 FT	LENGTH(AH 2261 BK 2016)
000030 FT		7030/0000	LENGTH(AH 2016 BK 3029)
000030 FT		000030 FT	LENGTH(AH 3029 BK 0030)
		7020/0000	BMSSEN 02/3051/0010/0001
		000030 FT	KELSO RD (TBK)
000000 FT		* REF-AHD	(TWP)
		0010/0030	1 0 00396 0 01 0131+23
		000000 FT	NC KE LSO RD
		* REF-BK	KELSO RD (TBK)
			(TWP)
000000 FT		0010/0000	N. BRANCH ROBINSON RUN
		000000 FT	BMSBG 02/3051/0010/0001
		7008/0000	LENGTH(AH 0030 BK 0163)
			LENGTH(AH 0163 BK 0000)

DIR: B TOTAL LEN: 1.245 MI. DIST: 11-1 SR: 3050
 LEFT MUN: COLLIER T RIGHT MUN: COLLIER T

THOMS RUN RD
 (CNTY)

006573 FT
 0020/2821

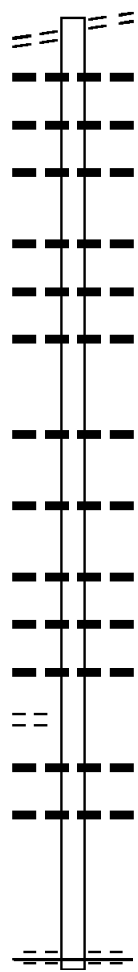

003752 FT

SFC SITMAN RD
 (TWP)

0010/0875

000000 FT

Segment ID	Length (FT)	Material	Installation	Notes
0020/2821	0020	012 " DIA	CIRC CONCR	THOMS RUN RD (CNTY)
0020/2372	0040	018 " DIA	CIRC CONCR	INSTALLED UNKN
0020/2075	0040	018 " DIA	CIRC CONCR	INSTALLED UNKN
0020/1870	0040	018 " DIA	CIRC CONCR	INSTALLED UNKN
0020/1194	0060	024 " DIA	CIR PLASTIC	INSTALLED 2002
0020/0926	0040	015 " DIA	CIRC CONCR	INSTALLED UNKN
0020/0530	0048	024 " DIA	CIR PLASTIC	INSTALLED UNKN
0020/0000	2821	2 0 02346	0 00 0028+23	LENGTH(AH 2821 BK 3752)
0010/3742	0040	018 " DIA	CIR PLASTIC	INSTALLED 1997
0010/3011	0040	018 " DIA	CIRC CONCR	INSTALLED UNKN
0010/2251	0040	036 " DIA	CIR PLASTIC	INSTALLED 2005
0010/1882	0040	018 " DIA	CIR PLASTIC	INSTALLED UNKN
0010/1394	0040	018 " DIA	CIRC CONCR	INSTALLED UNKN
0010/0626	0040	018 " DIA	CIRC CONCR	INSTALLED UNKN
0010/0150	0050	018 " DIA	CIRC CONCR	INSTALLED UNKN
000000 FT	0065	2 0 02346	0 00 0065+93	NC ST
0010/0000	3752	MFC BEGIN = E		THOMS HOLLOW RD (CNTY) THOMS RUN RD (CNTY) MFC BEGIN = E LENGTH(AH 3752 BK 0000)

000014 FT

000000 FT

000000 FT

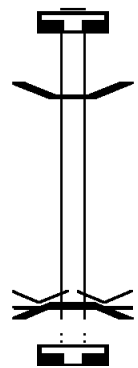

000014 FT
 7014/0000 LENGTH(AH 0100 BK 0014)
 BMSSEN 02/3049/0010/0000
 * REF-AHD VALLEY ST (TBK)
 0010/0014 (TWP)
 000000 FT 2 0 02010 0 00 0012+58
 VILLAGE: N.FAYETTE TWP
 NC VA LLEY ST
 * REF-BK VALLEY ST (TBK)
 (TWP)
 N.BR. ROBINS.
 BMSBG 02/3049/0010/0000
 MFC BEGIN = E
 0010/0000 LENGTH(AH 0014 BK 0100)
 000000 FT
 7004/0000 LENGTH(AH 0100 BK 0000)

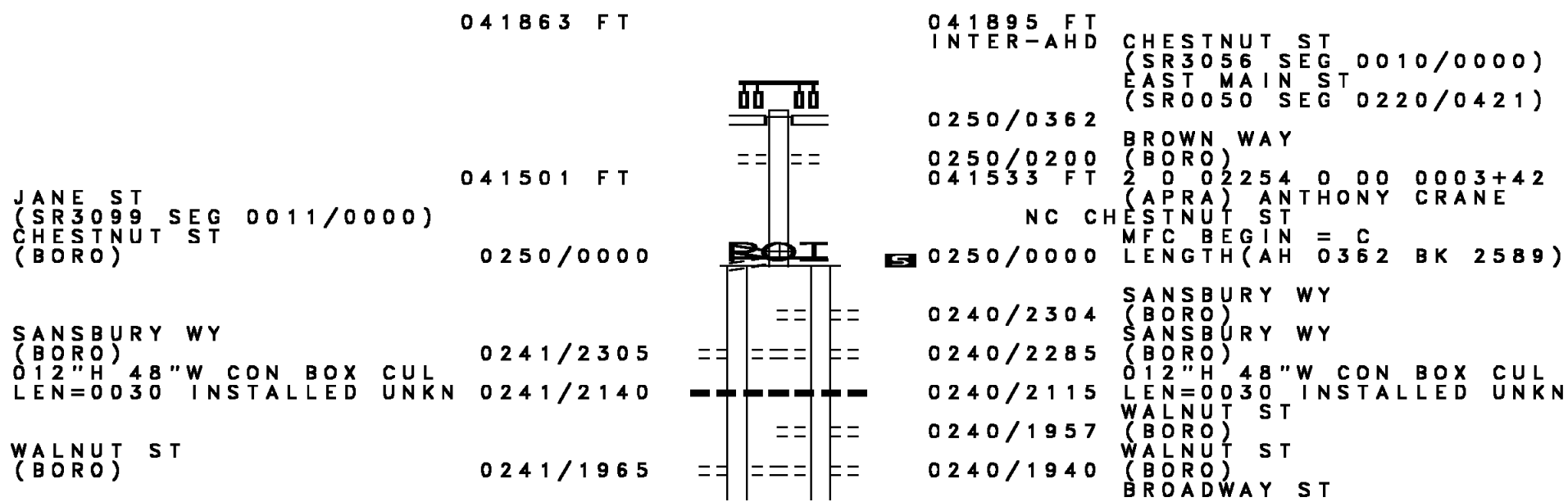

DIR: B TOTAL LEN: 7.935 MI. DIST: 11-1 SR: 3048
 LEFT MUN: CARNEGIE B RIGHT MUN: CARNEGIE B

BROADWAY ST
 (BORO)

018 "DIA CIRC CONCR 0241/1515
 LEN=0040 INSTALLED UNKN 0241/1190

MARY ST
 (BORO) 0241/1030

(AAR 510642W)#TRKS 01 0241/0942

BMS EN 02/3048/0240/0693 0241/0888
 2 0 02037 0 00 0018+90

CHARTIERS CK
 BMSBG 02/3048/0240/0693 0241/0691
 NC MANSFIELD BL

CAMPBELLS RUN RD
 (CNTY)

CHARTIERS AV
 (BORO) 0241/0515
 012 "DIA CIRC CONCR
 LEN=0024 INSTALLED UNKN 0241/0415

018 "DIA CIRC CONCR
 LEN=0030 INSTALLED UNKN 0241/0265

018 "DIA CIRC CONCR
 LEN=0030 INSTALLED UNKN 0241/0105

2 0 02037 0 00 0025+79 038896 FT
 JEFFERSON ST
 (BORO)

LENGTH(AH 2605 BK 0335) 0241/0000

018 "DIA CIRC CONCR
 LEN=0099 INSTALLED UNKN 0231/0280

012 "DIA CIRC CONCR
 LEN=0099 INSTALLED UNKN 0231/0120

0 0 00000 0 00 0000+00 038561 FT
 SECOND ST
 (BORO)

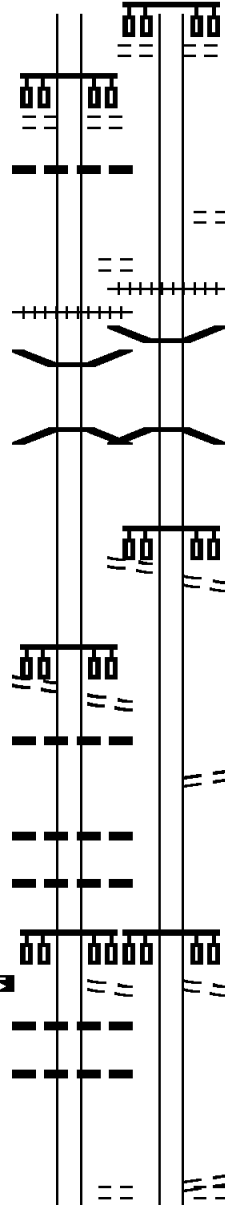

0240/1515 (BORO)

0240/1027 MARY ST
 (BORO)

0240/0940 (AAR 510642W)#TRKS 01

0240/0890 BMS EN 02/3048/0240/0693

2 0 02037 0 00 0018+90
 CHARTIERS CK

0240/0693 BMSBG 02/3048/0240/0693

CAMPBELLS RUN RD
 (CNTY)

0240/0517 CHARTIERS AV
 (BORO)

NC MANSFIELD BL

0240/0411 LC TO CHARTIERS AV
 (CONN)

038944 FT 2 0 02037 0 00 0025+79
 JEFFERSON ST
 (BORO)

0240/0000 LENGTH(AH 2589 BK 0345)

038599 FT 2 0 02037 0 00 0030+00
 LC TO MCDERMOTT PL
 (CONN)

SECOND ST
 (BORO)

DIR: B TOTAL LEN: 7.935 MI. DIST: 11-1 SR: 3048
 LEFT MUN: CARNEGIE B RIGHT MUN: CARNEGIE B

LENGTH(AH 0335 BK 1619)	0231/0000	0220/0000	LENGTH(AH 0345 BK 1619)
018 "DIA CIRC CONCR LEN=0024 INSTALLED UNKN THIRD ST (BORO)	0221/1460	0220/1470	018 "DIA CIRC CONCR LEN=0030 INSTALLED UNKN THIRD ST (BORO)
0221/1285	0220/1280	024 "DIA CIRC CONCR LEN=0030 INSTALLED UNKN	
018 "DIA CIRC CONCR LEN=0024 INSTALLED UNKN	0221/1160	0220/1160	024 "DIA CIRC CONCR LEN=0030 INSTALLED UNKN
FOURTH ST (BORO)	0221/0938	0220/0940	FOURTH ST (BORO)
024 "DIA CIRC CONCR LEN=0028 INSTALLED UNKN	0221/0931	0220/0800	018 "DIA CIRC CONCR LEN=0030 INSTALLED UNKN
024 "DIA CIRC CONCR LEN=0028 INSTALLED UNKN	0221/0795	0220/0630	018 "DIA CIRC CONCR LEN=0030 INSTALLED UNKN
024 "DIA CIRC CONCR LEN=0030 INSTALLED UNKN	0221/0625	0220/0480	FIFTH ST (BORO)
FIFTH ST (BORO)	0221/0472	0220/0460	018 "DIA CIRC CONCR LEN=0030 INSTALLED UNKN
018 "DIA CIRC CONCR LEN=0030 INSTALLED UNKN	0221/0460	0220/0290	018 "DIA CIRC CONCR LEN=0030 INSTALLED UNKN
018 "DIA CIRC CONCR LEN=0030 INSTALLED UNKN	0221/0290	0220/0140	SIXTH ST (BORO)
SIXTH ST (BORO)	0221/0135	0220/0120	018 "DIA CIRC CONCR LEN=0030 INSTALLED UNKN
018 "DIA CIRC CONCR LEN=0030 INSTALLED UNKN	0221/0120	036980 FT	02037 0 00 0045+48 CUBBAGE ST (SR3054 SEG 0090/2937)
0 0 0000 0 00 0000+00 036942 FT CUBBAGE ST (SR3054 SEG 0090/2937)			

DIR: B TOTAL LEN: 7.935 MI. DIST: 11-1 SR: 3048
 LEFT MUN: CARNEGIE B RIGHT MUN: CARNEGIE B

Stationing	Description	Stationing	Description
0221/0000	LENGTH(AH 1619 BK 1305)	0220/0000	LENGTH(AH 1619 BK 1305)
0211/1220	018 "DIA CIRC CONCR LEN=0030 INSTALLED UNKN SEVENTH ST (BORO)	0210/1250	018 "DIA CIRC CONCR LEN=0030 INSTALLED UNKN
0211/1160		0210/1160	SEVENTH ST (BORO)
0211/0985	(APRA) SCOTT METALS 018 "DIA CIRC CONCR LEN=0030 INSTALLED UNKN EIGHTH ST (BORO)	0210/1000	024 "DIA CIRC METAL LEN=0030 INSTALLED UNKN
0211/0898	018 "DIA CIRC CONCR LEN=0030 INSTALLED UNKN	0210/0985	(APRA) SCOTT METALS EIGHTH ST (BORO)
0211/0538	024 "DIA CIRC CONCR LEN=0030 INSTALLED UNKN (APRA) INDUSTRIAL SITES HAMMOND ST (BORO)	0210/0910	018 "DIA CIRC CONCR LEN=0030 INSTALLED UNKN
0211/0480	0211/0480	0210/0475	(APRA) INDUSTRIAL SITES HAMMOND ST (BORO)
0211/0048	BR.CHARTIERS STRUCTURE LENGTH 9 FT BMSID 02/3048/0210/0069 0 0 0000 0 00 0000+00 035637 FT	0210/0040	BR.CHARTIERS STRUCTURE LENGTH 9 FT BMSID 02/3048/0210/0069 2 0 02335 0 00 0000+00 PRESTLEY ST (BORO)
0211/0000	CARNEGIE COLLIER T LENGTH(AH 1305 BK 0755)	0210/0000	CARNEGIE COLLIER T LENGTH(AH 1305 BK 0772)
0201/0564	(AAR 508052A)#TRKS 01	0200/0572	(AAR 508052A)#TRKS 01
034882 FT		0200/0412	018 "DIA CIRC CONCR LEN=0022 INSTALLED UNKN 2 0 02246 0 00 0487+56 NC W MAIN ST CAMP HILL RD (TWP)
0201/0000	LENGTH(AH 0755 BK 3097)	0200/0000	LENGTH(AH 0772 BK 3115)
0191/3066	018 "DIA CIRC CONCR LEN=0099 INSTALLED UNKN	0190/2663	BMSEN 02/3048/0190/2382
0191/2600	BMSEN 02/3048/0190/2382		
0191/2298	2 0 02246 0 00 0487+65 ROBINSON RUN BMSBG 02/3048/0190/2382		
		0452+05	FROM 8007/0010 SH

DIR: B TOTAL LEN: 7.935 MI. DIST: 11-1 SR: 3048
 LEFT MUN: COLLIER T RIGHT MUN: COLLIER T

Segment Description	Segment ID	Stationing	Notes
CARNEGIE INT/RAMP B RD (SR8007 SEG 0020/0000)	0190/2361		(CONN) ROBINSON RUN BMSBG 02/3048/0190/2382
CARNEGIE INT/RAMP A RD (SR8007 SEG 0010/1135)	0191/2245		
018 "DIA CIRC CONCR LEN=0099 INSTALLED UNKN	0191/2112		
SR 0079 NB OP ID 02/0079/0560/1630	0191/1964		
SR 0079 SB OP ID 02/0079/0561/1617	0191/1842		
012 "DIA CIRC CONCR LEN=0030 INSTALLED UNKN	0191/1795		
TO 8007/0512 SH (CONN)	0191/1639		
RAMP C RD (SR8007 SEG 0512/0000)	0191/1470		
RAMP D RD (SR8007 SEG 0502/1191)	0191/1320		
FROM 8007/0502 SH (CONN)	0191/1320		
018 "DIA CIRC CONCR LEN=0030 INSTALLED UNKN	0191/0793		
BMSEN 02/3048/0191/0000	0191/0596		
2 0 02246 0 00 0458+01 031785 FT	031788 FT		
SR 3117			
BMSBG 02/3048/0191/0000	0190/0000		
LENGTH(AH 3097 BK 0613)	0180/0515		
NOBLESTOWN RD ET (SR3117 SEG 0020/2518)	0180/0167		
018 "DIA CIRC CONCR LEN=0035 INSTALLED UNKN	0181/0150		
			CARNEGIE INT/RAMP C RD (SR8007 SEG 0512/0000) CARNEGIE INT/RAMP D RD (SR8007 SEG 0502/1191)
			018 "DIA CIRC CONCR LEN=0035 INSTALLED UNKN
			BMSEN 02/3048/0190/0000 2 0 02246 0 00 0452+05 SR 3117 BMSBG 02/3048/0190/0000 LENGTH(AH 3115 BK 0616) NOBLESTOWN RD ET (SR3117 SEG 0020/2518) 018 "DIA CIRC CONCR LEN=0099 INSTALLED UNKN

DIR: B TOTAL LEN: 7.935 MI. DIST: 11-1 SR: 3048
 LEFT MUN: COLLIER T RIGHT MUN: COLLIER T

STATION	DESCRIPTION	STATION	DESCRIPTION
2 0 02246 0 00 0447+69 031172 FT		031172 FT	2 0 02246 0 00 0447+69
MFC BEGIN = C			MFC BEGIN = C
LENGTH(AH 0613 BK 3178) 0181/0000		0180/0000	LENGTH(AH 0616 BK 3178)
		0170/2819	CAROL DR (TWP)
ST JOHNS DR (TWP)	0170/2791		
		0170/1150	018 "DIA CIRC CONCR LEN=0036 INSTALLED UNKN
		0170/0680	012 "DIA CIRC CONCR LEN=0036 INSTALLED UNKN
		0170/0245	012 "DIA CIRC CONCR LEN=0036 INSTALLED UNKN
		0170/0147	(APRA) MARTIN BROWER FE MARTIN BROWER FERRIS DR (PRDR)
	027994 FT	027994 FT	2 0 02246 0 00 0419+06
		0170/0000	024 "DIA CIR PLASTIC LEN=0168 INSTALLED UNKN LENGTH(AH 3178 BK 2881)
		0160/1400	024 "DIA CIRC METAL LEN=0060 INSTALLED UNKN
		0160/1159	SCOTTS RUN STRUCTURE LENGTH 13 FT BMSID 02/3048/0160/1159
SCOTTS RUN RD (TWP)	0160/1130		
		0160/0741	036 "DIA CIRC METAL LEN=0030 INSTALLED UNKN
SEDLAR LN (TWP)	0160/0209		
		0160/0150	016 "DIA CIRC METAL LEN=0025 INSTALLED UNKN
	025113 FT	025113 FT	2 0 02246 0 00 0390+30
		0160/0000	(APRA) COLLIER FOUNDATI WALKERS MILL RD (SR3028 SEG 0050/3749) LENGTH(AH 2881 BK 3239)
COLLIER STONE CO DR (PRDR)	0160/0000		
		0150/2569	BMS EN 02/3048/0150/2556 2 0 02246 0 00 0383+51
		0150/2556	BR ROBINSON BMSBG 02/3048/0150/2556

DIR: B TOTAL LEN: 7.935 MI. DIST: 11-1 SR: 3048
 LEFT MUN: COLLIER T RIGHT MUN: COLLIER T

Street Name	Segment ID	Length (FT)	Notes
HIGHLANDVIEW AV (TWP)	0150/1753		
	0150/1787		BMS EN 02/3048/0150/1800 2 0 02246 0 00 0368+47 BR. ROBINSON
	0150/1777		BMSBG 02/3048/0150/1800
	0150/1728		WALNUT AV (TWP)
	0150/1053		BMS EN 02/3048/0150/1043 2 0 02246 0 00 0368+47 BRANCH OF ROBINSON RUN
	0150/1043		BMSBG 02/3048/0150/1043 018 "DIA CIR PLASTIC
MCMICHAEL RD (SR3041 SEG 0010/0000)	0150/0820	021874 FT	LEN=0099 INSTALLED UNKN LINDEN AV (TWP)
	0150/0405	021874 FT	COLUMBIA AV (TWP)
	0150/0000		2 0 02246 0 00 0357+85 SUNNYSIDE AV (TWP) LENGTH(AH 3239 BK 3689)
WALKER AV (TWP)	0140/2946		
TOMEY RD (TWP)	0140/1610		
	0140/1505		OLD NOBLESTOWN RD (TWP)
	0140/1465		018 "DIA CIRC METAL LEN=0048 INSTALLED UNKN
STONEGATE DR (TWP)	0140/0960		
	0140/0479		024 "DIA CIR PLASTIC LEN=0055 INSTALLED UNKN
BARRINGTON DR (TWP)	0140/0292	018185 FT	
	0140/0000		2 0 02246 0 00 0321+03 NIKE SITE RD (SR3039 SEG 0030/2104) LENGTH(AH 3689 BK 1932)
	0130/1470		018 "DIA CIRC CONCR LEN=0099 INSTALLED UNKN 018 "DIA CIR PLASTIC

DIR: B TOTAL LEN: 7.935 MI. DIST: 11-1 SR: 3048
 LEFT MUN: COLLIER T RIGHT MUN: COLLIER T

Stationing	Description	Length	Material	Status
0130/0651	018" DIA CIRC CONCR	LEN=0040	INSTALLED	UNKN
0130/0265	018" DIA CIRC CONCR	LEN=0036	INSTALLED	UNKN
016253 FT	2 0 02246 0 00 0301+28			
0130/0000	LENGTH(AH 1932 BK 2165)			
0120/2110	018" DIA CIRC CONCR	LEN=0048	INSTALLED	UNKN
0120/0908	024" DIA CIRC CONCR	LEN=0060	INSTALLED	UNKN
0120/0585	018" DIA CIRC CONCR	LEN=0048	INSTALLED	UNKN
0120/0425	012" DIA CIRC CONCR	LEN=0040	INSTALLED	UNKN
RBR				
0120/0015	BMSBN 02/3048/0120/0000			
014088 FT	2 0 02246 0 00 0279+43			
RBR				
0120/0000	P3 BRANCH OF ROBINSON RUN			
0110/1520	BMSBG 02/3048/0120/0000			
0110/1185	LENGTH(AH 2165 BK 1964)			
0110/0463	018" DIA CIRC CONCR	LEN=0048	INSTALLED	UNKN
012124 FT	018" DIA CIRC CONCR	LEN=0036	INSTALLED	UNKN
0110/0000	018" DIA CIR PLASTIC	LEN=0040	INSTALLED	UNKN
0100/3340	LENGTH(AH 1964 BK 3422)			
0100/3331	BMSBN 02/3048/0100/3319			
0100/3319	COLLIER NORTH FAYETTE T			
0100/2614	2 0 02246 0 00 0258+31			
0100/2275	BRANCH OF ROBINSON RUN			
0100/2222	BMSBG 02/3048/0100/3319			
0100/2030	018" DIA CIRC CONCR	LEN=0040	INSTALLED	UNKN
	012" DIA CIRC CONCR	LEN=0040	INSTALLED	UNKN
	018" DIA CIRC CONCR	LEN=0060	INSTALLED	UNKN
	018" DIA CIRC CONCR	LEN=0060	INSTALLED	UNKN

2 0 02246 0 00 0259+68 012124 FT
 PINKERTON RUN RD (TBK)
 (TWP) 0110/0000

EXTRACT DATE: 12/21/2020
PRINT DATE: 12/23/2020

ROADWAY MANAGEMENT SYSTEM
SLD COUNTY/SR - ANNUAL PRINT

PAGE NUMBER: 1066
COUNTY: ALLEGHENY

DIR: B TOTAL LEN: 7.935 MI.
LEFT MUN: NORTH FAYETTE T

DIST: 11-1 SR: 3048
RIGHT MUN: NORTH FAYETTE T

Location	Stationing	Material	Length	Notes
	0100/1770	018 " DIA CIRC CONCR	LEN=0060	INSTALLED UNKN
	0100/0960	024 " DIA CIR PLASTIC	LEN=0048	INSTALLED UNKN
008702 FT	0100/0564	018 " DIA CIRC CONCR	LEN=0099	INSTALLED UNKN
	008702 FT	2 0 02246 0 00 0224+87		(APRA) RINKER MATERIALS GREGG STATION RD (T365)
POE	0100/0000		LENGTH(AH 3422 BK 2352)	
	0090/1405	024 " DIA CIRC CONCR	LEN=0045	INSTALLED UNKN
	0090/1125	012 " DIA CIRC METAL	LEN=0099	INSTALLED UNKN
006350 FT	0090/0460	018 " DIA CIRC CONCR	LEN=0050	INSTALLED UNKN
	006350 FT	2 0 02246 0 00 0201+39		
	0090/0000		LENGTH(AH 2352 BK 2379)	
	0080/1684	018 " DIA CIRC CONCR	LEN=0099	INSTALLED UNKN
HILL RD (TWP)	0080/0940			
	0080/0579	NORTH FAYETTE OAKDALE B		
COTTONWOOD DR (TWP)	0080/0225	(APRA) OAKDALE INDUSTRI INDUSTRIAL PARK DR		
	003971 FT	(PRDR)		
	0080/0000	2 0 02246 0 00 0177+30		
FAYETTE AV (BORO)	0070/1280		LENGTH(AH 2379 BK 1552)	
	0070/1260	018 " DIA CIR UNKNOWN	LEN=1111	INSTALLED UNKN
VINCENNES AV (BORO)	0070/0974			
HASTINGS AV (BORO)	0070/0700			
BRIDGE ST (BORO)	0070/0339			
	0070/0092	099 "H 18 "W **UNKNOWN**	LEN=0030	INSTALLED UNKN
	0070/0088	BMS EN 02/3048/0070/0039		
		2 0 02246 0 00 0162+19		

EXTRACT DATE: 12/21/2020
PRINT DATE: 12/23/2020

ROADWAY MANAGEMENT SYSTEM
SLD COUNTY/SR - ANNUAL PRINT

PAGE NUMBER: 1065
COUNTY: ALLEGHENY

DIR: B TOTAL LEN: 7.935 MI.
LEFT MUN: OAKDALE B

DIST: 11-1 SR: 3048
RIGHT MUN: OAKDALE B

UNION AV
(SR0978 SEG 0130/0332)
STATE ST
(TWP)

002419 FT

002419 FT

0060/1215

0060/0823

001204 FT

001204 FT

001196 FT

001196 FT

001196 FT

001177 FT

001177 FT

001177 FT

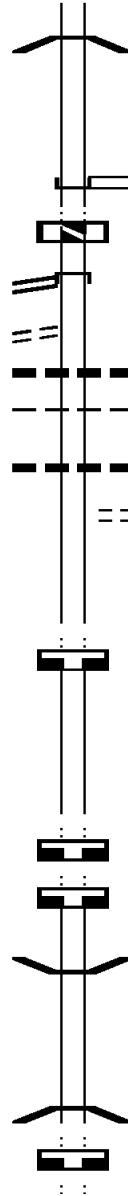

0070/0039
002419 FT

INTER-BK

0070/0000
002419 FT
7064/0000
INTER-AHD
0060/1215

0060/0588

0060/0200

0060/0080

0060/0018
001204 FT
* REF-BK

0060/0000
001204 FT
* 7054/0000
* REF-AHD

0052/0008
001196 FT
* REF-BK

0052/0000
001196 FT
* 7050/0000

001196 FT
* 7044/0000
* REF-AHD

0042/0019
001177 FT
* REF-BK

0042/0000
001177 FT
* 7040/0000

001177 FT

N. BR. ROBINSO
BMSBG 02/3048/0070/0039
2 0 02246 0 00 0161+87
UNION AV
(SR0978 SEG 0130/0521)
UNION AV
(SR0978 SEG 0130/0521)
LTH AH 001552 BK 000100
LTH AH 000100 BK 001215
UNION AV
(SR0978 SEG 0130/0332)

018 " DIA CIRC CONCR
LEN=0030 INSTALLED UNKN
OAKDALE

NORTH FAYETTE T
015 " DIA CIRC CONCR
LEN=0099 INSTALLED UNKN
GORMLEY AV

(TWP)
2 0 02204 1 00 0000+00
NOBLESTOWN RD (TBK)
(TWP)

LENGTH(AH 1215 BK 0048)

LENGTH(AH 0048 BK 0008)
MARION AV (TBK)
(TWP)

2 0 02246 0 00 0161+27
NOBLESTOWN RD (TBK)
(TWP)

LENGTH(AH 0008 BK 2441)

LENGTH(AH 2441 BK 1193)

LENGTH(AH 1193 BK 0019)
BMSSEN 02/3048/0042/0000
NOBLESTOWN RD (TBK)
(TWP)

2 0 02246 0 00 0124+69
NOBLESTOWN RD (TBK)
(TWP)

BRANCH ROBINSON RUN
BMSBG 02/3048/0042/0000
LENGTH(AH 0019 BK 2455)

LENGTH(AH 2455 BK 2325)

EXTRACT DATE: 12/21/2020
PRINT DATE: 12/23/2020

ROADWAY MANAGEMENT SYSTEM
SLD COUNTY/SR - ANNUAL PRINT

PAGE NUMBER: 1064
COUNTY: ALLEGHENY

DIR: B TOTAL LEN: 7.935 MI.
LEFT MUN: NORTH FAYETTE T

DIST: 11-1 SR: 3048
RIGHT MUN: NORTH FAYETTE T

Stationing	Notes	Stationing	Notes
		7034/0000	LENGTH(AH 2325 BK 0023) BMSSEN 02/3048/0032/0001
001154 FT	* REF-AHD 0032/0023 001154 FT	* REF-BK 0032/0000 001154 FT	NOBLESTOWN RD (TBK) (TWP) 2 0 02246 0 00 0076+58 NOBLESTOWN RD (TBK) (TWP) BRANCH ROBINSON RUN BMSBG 02/3048/0032/0001
001154 FT		7030/0000	LENGTH(AH 0675 BK 3645)
001154 FT		7020/0000	LENGTH(AH 3645 BK 0841)
001154 FT		7016/0000	LENGTH(AH 0841 BK 0009)
001145 FT	* REF-AHD 0014/0009 001145 FT	* REF-BK 0014/0000 001145 FT	NOBLESTOWN RD (TBK) (BORO) 2 0 02246 0 00 0024+91 BR. ROBINSON STRUCTURE LENGTH 9 FT BMSID 02/3048/0014/0000
001145 FT		7012/0000	LENGTH(AH 1349 BK 1145)
		0010/1145	NOBLESTOWN RD (TBK) (BORO) 018 " DIA CIRC CONCR LEN=0045 INSTALLED UNKN LAUREL HILL RD (SR3024 SEG 0010/0000) NORTH FAYETTE MCDONALD B
DEMPE ST (BORO)	0010/0590	0010/0415	MEADOW ST (BORO)
MILLER ST (BORO)	0010/0108	0010/0108	MILLER ST (BORO)
000000 FT		0010/0080	036 " DIA CIR PLASTIC LEN=0040 INSTALLED UNKN 2 0 02246 0 00 0000+00
		000000 FT	NOBLESTOWN RD LINCOLN AV (SR4012 SEG 0210/1777) MFC BEGIN = C BK-WASHINGTON (62)
		* REF-BK 0010/0000	LENGTH(AH 1145 BK 0000)

EXTRACT DATE: 12/21/2020 ROADWAY MANAGEMENT SYSTEM PAGE NUMBER: 1063
PRINT DATE: 12/23/2020 SLD COUNTY/SR - ANNUAL PRINT COUNTY: ALLEGHENY
DIR: B TOTAL LEN: .000 MI. DIST: 11-1 SR: 3047
LEFT MUN: BALDWIN B RIGHT MUN: BALDWIN B

000000 FT



000000 FT
7010/0000 LENGTH(AH 2539 BK 0000)

DIR: B TOTAL LEN: 1.277 MI. DIST: 11-1 SR: 3046
 LEFT MUN: BALDWIN B RIGHT MUN: BALDWIN B

STREETS	RUN	RD	LEN	SEG	START	END	FT	CONCR	UNKN
WILLOCK RD			0030	0010	0000	1483	0030/1483		
(SR2041									
006745 FT									
005262 FT									
2 0 02099	0	00	0041+00		004020		FT		
OAKRIDGE	DR								
006745 FT									
INTER-AHD									
0030			1483				0030/1483		
0030			1384				0030/1384		
0030			0958				0030/0958		
0030			0530				0030/0530		
0030			0215				0030/0215		
005262							005262 FT		
2 0 02099	0	00	0052+96						
JANIE	DR								
(TWP									
5			0030		0000		0030/0000		
0020			1025				0020/1025		
0020			0824				0020/0824		
0020			0363				0020/0363		
0020			0263				0020/0263		
0020			0059				0020/0059		
004020							004020 FT		
BRENTWOOD									
WHITEHALL									

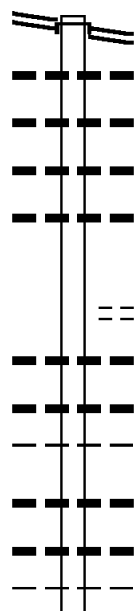

STREETS RUN RD
 (SR2046 SEG 0040/1635)
 STREETS RUN RD
 (SR2046 SEG 0040/1635)
 018 "DIA CIRC CONCR
 LEN=0099 INSTALLED UNKN
 018 "DIA CIRC CONCR
 LEN=0099 INSTALLED UNKN
 018 "DIA CIRC CONCR
 LEN=0040 INSTALLED UNKN
 016 "DIA CIRC CONCR
 LEN=0099 INSTALLED UNKN
 2 0 02099 0 00 0052+96
 JANIE DR
 (TWP)
 LENGTH (AH 1483 BK 1242)
 018 "DIA CIRC CONCR
 LEN=0024 INSTALLED UNKN
 018 "DIA CIRC CONCR
 LEN=0099 INSTALLED UNKN
 BALDWIN
 BRENTWOOD B
 018 "DIA CIRC CONCR
 LEN=0099 INSTALLED UNKN
 018 "DIA CIRC CONCR
 LEN=0099 INSTALLED UNKN
 BRENTWOOD
 WHITEHALL B

DIR: B TOTAL LEN: 1.277 MI. DIST: 11-1 SR: 3046
 LEFT MUN: BRENTWOOD B RIGHT MUN: BRENTWOOD B

Location / Segment	Segment ID	Length (ft)	Material	Notes
(TWP)	0020/0000			
	0010/3802	0099	018" DIA CIRC CONCR	INSTALLED UNKN
	0010/3530	0099	018" DIA CIRC CONCR	INSTALLED UNKN
	0010/3288	0099	024" DIA CIRC CONCR	INSTALLED UNKN
	0010/3142	0099	018" DIA CIRC CONCR	INSTALLED UNKN
	0010/2852	0099	012" DIA CIRC CONCR	INSTALLED UNKN
	0010/2666	0099	018" DIA CIRC CONCR	INSTALLED UNKN
	0010/2479		FRICH DR (TWP)	
	0010/2406	0099	018" DIA CIRC CONCR	INSTALLED UNKN
	0010/1745	0036	018" DIA CIRC CONCR	INSTALLED UNKN
GIRARD RD (TWP)	0010/1728			
	0010/1540		NC DOYLE RD DOYLE RD (TWP)	
DALLETT RD (TWP)	0010/1468			
	0010/1422	0036	018" DIA CIRC CONCR	INSTALLED UNKN
	0010/1246	0036	018" DIA CIRC CONCR	INSTALLED UNKN
PROSPECT AV (TWP)	0010/0961			
	0010/0806	0036	024" DIA CIRC CONCR	INSTALLED UNKN
	0010/0493	0036	018" DIA CIRC CONCR	INSTALLED UNKN
	0010/0345	0030	018" DIA CIRC CONCR	INSTALLED UNKN
	0010/0259		WHITEHALL BRENTWOOD B	
	0010/0100	0060	018" H 18" W CON BOX CUL	INSTALLED UNKN
000000 FT		02099	2 0 02099 0 00 0000+00	
			CLAIRTON BL (SR0051 SEG 0301/0000) (SR0051 SEG 0300/0000)	
CLAIRTON BL (SR0051 SEG 0300/0000) (SR0051 SEG 0301/0000)	0010/0000		NC ST ILLEY RD MFC BEGIN = D	
	0010/0000	4020	LENGTH(AH 4020 BK 0000)	

DIR: B TOTAL LEN: .575 MI. DIST: 11-1 SR: 3044
 LEFT MUN: MT LEBANON T RIGHT MUN: MT LEBANON T

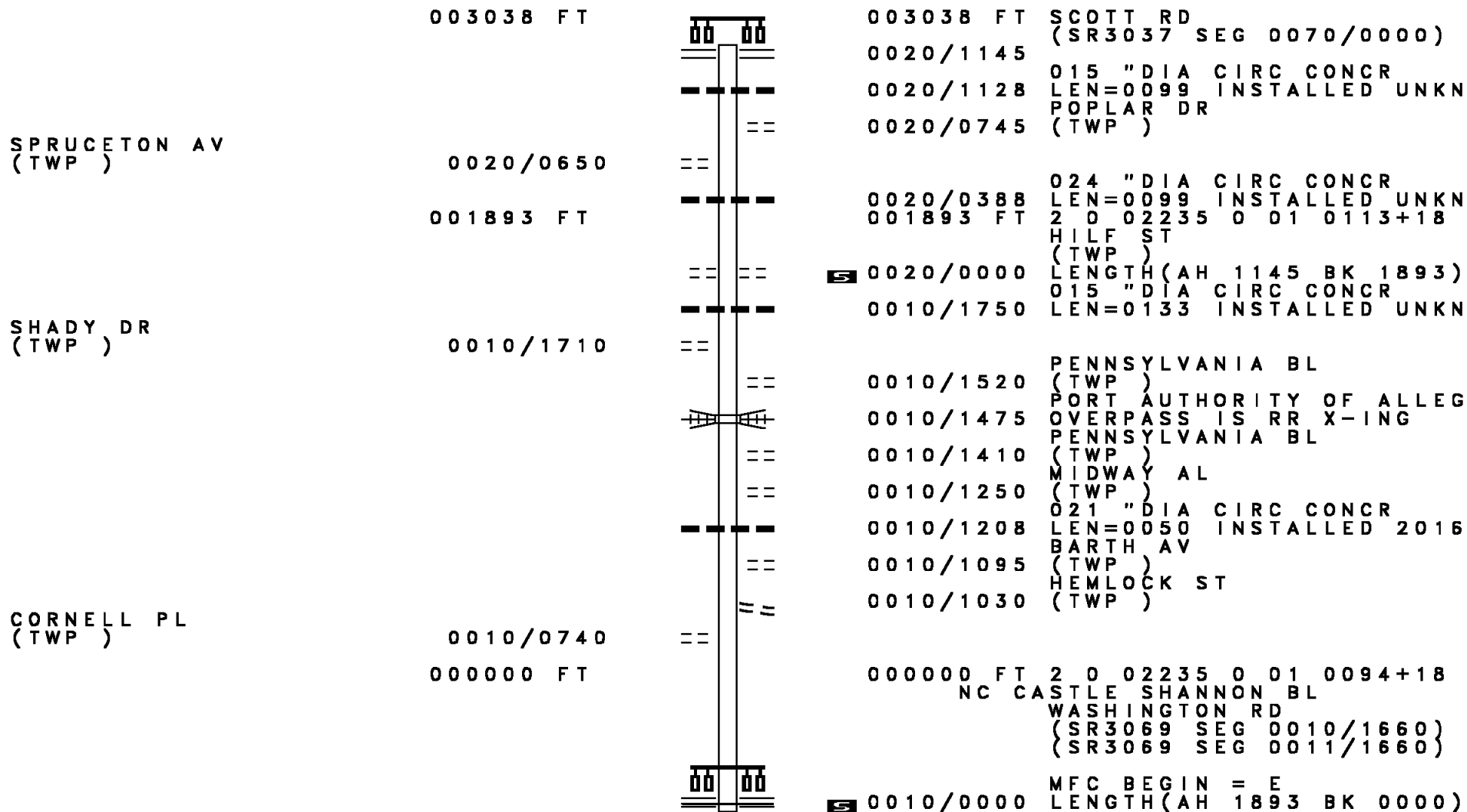

MCMICHAEL RD 003970 FT
 (SR3041 SEG 0050/1160) 0020/2117

2 0 02341 0 00 0019+53 001853 FT
 JOYCE DR
 (TWP) 0020/0000

000000 FT

BALDWIN RD
 (SR3054 SEG 0030/0000) 0010/0000

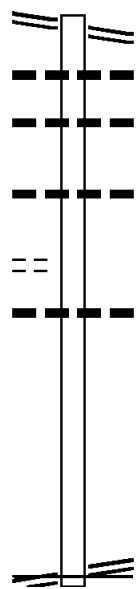

003970 FT MCMICHAEL RD
 0020/2117 (SR3041 SEG 0050/1160)
 015 "DIA CIRC CONCR
 0020/1700 LEN=0028 INSTALLED UNKN
 012 "DIA CIRC OTHER
 0020/1115 LEN=0022 INSTALLED UNKN

012 "DIA CIRC CONCR
 0020/0506 LEN=0022 INSTALLED UNKN
 001853 FT

5 0020/0000 LENGTH(AH 2117 BK 1853)
 012 "DIA CIRC CONCR
 0010/1823 LEN=0022 INSTALLED UNKN

000000 FT 2 0 02341 0 00 0000+00
 BALDWIN RD
 (SR3054 SEG 0030/0000)
 NC COWAN RD
 MFC BEGIN = E
 5 0010/0000 LENGTH(AH 1853 BK 0000)

EXTRACT DATE: 12/21/2020 ROADWAY MANAGEMENT SYSTEM PAGE NUMBER: 1057
 PRINT DATE: 12/23/2020 SLD COUNTY/SR - ANNUAL PRINT COUNTY: ALLEGHENY
 DIR: B TOTAL LEN: 1.020 MI. DIST: 11-1 SR: 3042
 LEFT MUN: CASTLE SHANNON B RIGHT MUN: CASTLE SHANNON B

005384 FT

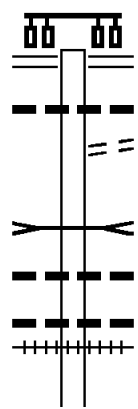

004566 FT

005384 FT CASTLE SHANNON BL
 (SR3037 SEG 0050/0897)
 0040/0818 018 " DIA CIRC CONCR
 0040/0812 LEN=0040 INSTALLED UNKN
 TO 3037/0050 SH
 0040/0730 (CONN)
 BR. SAW MILL
 STRUCTURE LENGTH 12 FT
 0040/0344 BMSID 02/3042/0040/0344
 018 " DIA CIRC CONCR
 0040/0290 LEN=0040 INSTALLED UNKN
 018 " DIA CIRC CONCR
 0040/0241 LEN=0040 INSTALLED UNKN
 0040/0230 (AAR 472797H) #TRKS 11
 004566 FT 2 0 02086 0 00 0045+25
 COOKE LN

DIR: B TOTAL LEN: 1.020 MI. DIST: 11-1 SR: 3042
 LEFT MUN: CASTLE SHANNON B RIGHT MUN: CASTLE SHANNON B

Street Name	Segment	Length	Notes
COOKE LN (TWP)	0030/1930		0040/0000 (TWP) LENGTH(AH 0818 BK 1966)
BRUCEWOOD LN (TWP)	0030/1200		HOODRIDGE DR (TWP) 0030/0935
	002600 FT		0030/0005 018 "DIA CIRC CONCR LEN=0024 INSTALLED UNKN 2 0 02086 0 00 0025+80 CASTLE SHANNON MT LEBANON T
ORCHARD DR (TWP)	0020/1276		0030/0000 LENGTH(AH 1966 BK 1433) 018 "DIA CIRC CONCR LEN=0040 INSTALLED UNKN
	001167 FT		0020/0951 018 "DIA CIRC CONCR LEN=0040 INSTALLED UNKN 0020/0615 018 "DIA CIRC CONCR LEN=0040 INSTALLED UNKN
ROCKLYNN PL (TWP)	0010/1080		001167 FT 2 0 02086 0 00 0011+37 0020/0000 LENGTH(AH 1433 BK 1167)
	0010/1057		018 "DIA CIR UNKNOWN LEN=0040 INSTALLED UNKN
	0010/0695		018 "DIA CIR UNKNOWN LEN=0040 INSTALLED UNKN
	0010/0420		ROYCROFT AV (TWP)
TO 0019/0100 SH (CONN)	0010/0095		HOODRIDGE LN (TWP) FROM 0019/0100 SH (CONN)
	000000 FT		0010/0095 018 "DIA CIR UNKNOWN LEN=0040 INSTALLED UNKN 0010/0094 018 "DIA CIR UNKNOWN LEN=0040 INSTALLED UNKN 000000 FT 2 0 02086 0 00 0000+00 NC MT WASHINGTON RD (SRO019 SEG 0101/1623) (SRO019 SEG 0100/1660)
			MFC BEGIN = C 0010/0000 LENGTH(AH 1167 BK 0000)

DIR: B TOTAL LEN: 4.931 MI. DIST: 11-1 SR: 3041
 LEFT MUN: ROBINSON T RIGHT MUN: ROBINSON T

026036 FT

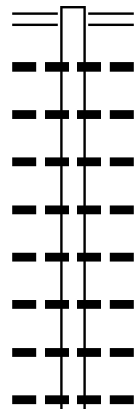

026036 FT STEUBENVILLE PK
 0080/2765 (SR0060 SEG 0190/0000)
 018 " DIA CIRC CONCR
 0080/2760 LEN=0040 INSTALLED UNKN
 018 " DIA CIRC CONCR
 0080/2607 LEN=0045 INSTALLED UNKN
 018 " DIA CIRC CONCR
 0080/2225 LEN=0055 INSTALLED UNKN
 012 " DIA CIRC METAL
 0080/1877 LEN=0099 INSTALLED UNKN
 018 " DIA CIRC CONCR
 0080/1537 LEN=0050 INSTALLED UNKN
 018 " DIA CIRC CONCR
 0080/1211 LEN=0070 INSTALLED UNKN
 018 " DIA CIRC CONCR
 0080/0787 LEN=0080 INSTALLED UNKN
 036 " DIA CIRC CONCR
 0080/0648 LEN=0070 INSTALLED UNKN

023271 FT

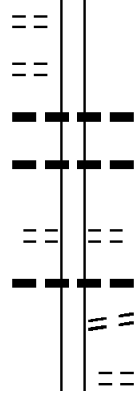

023271 FT 2 0 02037 0 00 0324+68
 0080/0000 LENGTH(AH 2765 BK 3544)
 0070/3240 024 " DIA CIRC CONCR
 LEN=0050 INSTALLED UNKN
 018 " DIA CIRC CONCR
 0070/2815 LEN=0050 INSTALLED UNKN
 0070/2154 WALNUT DR
 (TWP)
 012 " DIA CIRC CONCR
 0070/2104 LEN=0040 INSTALLED UNKN
 GLASS RD
 (TWP)
 0070/1559 VENEZE DR
 (TWP)
 0070/1329 (TWP)

BEECH DR
 (TWP)
 MOON RUN PARK RD
 (TWP)

0070/3373
 0070/3280

DIR: B TOTAL LEN: 4.931 MI. DIST: 11-1 SR: 3041
 LEFT MUN: ROBINSON T RIGHT MUN: ROBINSON T

TIDBALL RD
 (T445)

0070/1105

019727 FT

CHURCH HILL RD
 (T443)

0060/0465

2 0 02037 0 00 0258+72 016597 FT
 CAMPBELLS RUN RD
 (CNTY)

0060/0000
 016597 FT

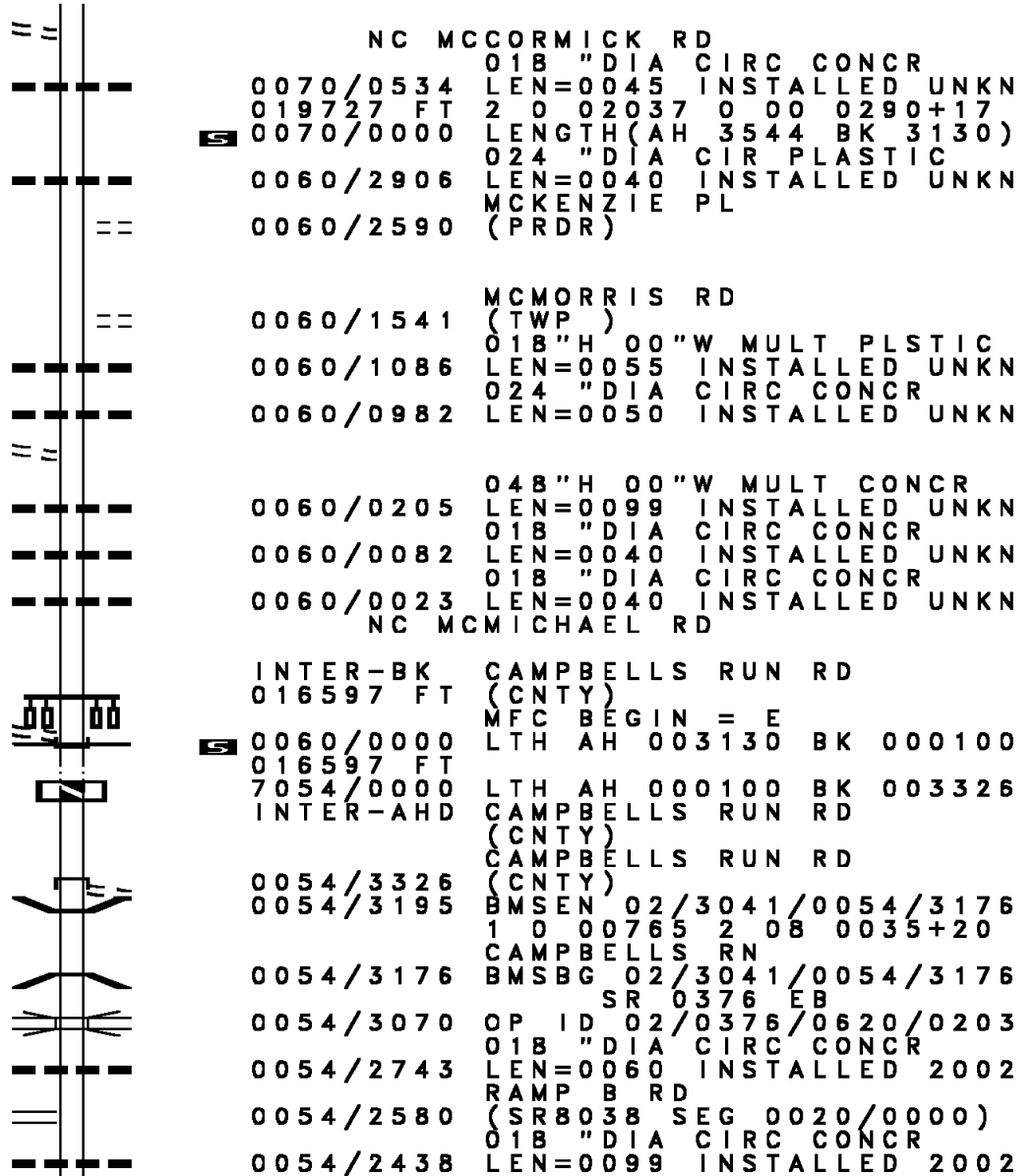

NC MCCORMICK RD
 018" DIA CIRC CONCR
 0070/0534 LEN=0045 INSTALLED UNKN
 019727 FT 2 0 02037 0 00 0290+17
 0070/0000 LENGTH(AH 3544 BK 3130)
 024" DIA CIR PLASTIC
 0060/2906 LEN=0040 INSTALLED UNKN
 MCKENZIE PL
 0060/2590 (PRDR)
 MCMORRIS RD
 (TWP)
 018"H 00"W MULT PLSTIC
 0060/1086 LEN=0055 INSTALLED UNKN
 024" DIA CIRC CONCR
 0060/0982 LEN=0050 INSTALLED UNKN
 048"H 00"W MULT CONCR
 0060/0205 LEN=0099 INSTALLED UNKN
 018" DIA CIRC CONCR
 0060/0082 LEN=0040 INSTALLED UNKN
 018" DIA CIRC CONCR
 0060/0023 LEN=0040 INSTALLED UNKN
 NC MC MICHAEL RD
 INTER-BK CAMPBELLS RUN RD
 016597 FT (CNTY)
 MFC BEGIN = E
 0060/0000 LTH AH 003130 BK 000100
 016597 FT
 7054/0000 LTH AH 000100 BK 003326
 INTER-AHD CAMPBELLS RUN RD
 (CNTY)
 CAMPBELLS RUN RD
 (CNTY)
 0054/3326
 0054/3195 BMS EN 02/3041/0054/3176
 1 0 00765 2 08 0035+20
 CAMPBELLS RN
 0054/3176 BMSBG 02/3041/0054/3176
 SR 0376 EB
 0054/3070 OP ID 02/0376/0620/0203
 018" DIA CIRC CONCR
 0054/2743 LEN=0060 INSTALLED 2002
 RAMP B RD
 0054/2580 (SR8038 SEG 0020/0000)
 018" DIA CIRC CONCR
 0054/2438 LEN=0099 INSTALLED 2002

Location	Segment ID	Length	Material	Installation	Notes
PARK WEST PL (TWP)	0054/1555		018 " DIA	CIRC CONCR	INSTALLED 2002
	0054/1396		018 " DIA	CIRC METAL	INSTALLED 2002
	0054/1201				
RIDGE RD (CNTY)	0054/0610		018 " DIA	CIRC CONCR	INSTALLED 2002
	0054/0050	013271 FT	018 " DIA	CIRC CONCR	INSTALLED UNKN
	0054/0000		2 0 02037	0 00 0250+79	RIDGE RD (TWP) NC BO YCE RD ROBINSON COLLIER T
COWAN RD (SR3043 SEG 0020/2117)	0050/1605		018 " DIA	CIRC CONCR	INSTALLED UNKN
	0050/1597		018 " DIA	CIR PLASTIC	INSTALLED UNKN
	0050/1422		MERCHANT LN		(PRDR)
BALDWIN RD (SR3054 SEG 0040/0000)	0050/0933		018 " DIA	CIRC METAL	INSTALLED UNKN
	0050/0680	011362 FT	MILLER DR		(TWP)
	0050/0000		2 0 02037	0 00 0239+41	BURRELL DR (TWP)
BALDWIN RD (SR3054 SEG 0040/0000)	0040/2372		018 " DIA	CIRC METAL	INSTALLED UNKN
	0040/1297		018 " DIA	CIRC CONCR	INSTALLED UNKN
	0040/0765		018 " DIA	CIRC CONCR	INSTALLED UNKN
BALDWIN RD (SR3054 SEG 0040/0000)	0040/0548	008720 FT	018 " DIA	CIRC CONCR	INSTALLED UNKN
	0040/0000		2 0 02037	0 00 0212+54	BALDWIN RD (SR3054 SEG 0040/0000)
	0040/0000		012 " DIA	CIRC CONCR	LENGTH(AH 2642 BK 1748)

DIR: B TOTAL LEN: 4.931 MI. DIST: 11-1 SR: 3041
 LEFT MUN: COLLIER T RIGHT MUN: COLLIER T

---	---	0030/1690	LEN=0099	INSTALLED	UNKN
---	---	0030/0790	018 "DIA	CIRC CONCR	
---	---	0030/0242	LEN=0040	INSTALLED	2002
---	---	006972 FT	018 "DIA	CIRC CONCR	
---	---	006972 FT	LEN=0099	INSTALLED	UNKN
---	---	5 0030/0000	2 0 02039	0 00 0070+11	
---	---	0020/3193	LENGTH(AH	1748 BK 3494)	
---	---	0020/2752	018 "DIA	CIRC CONCR	
---	---	0020/2081	LEN=0035	INSTALLED	2002
---	---	0020/1350	018 "DIA	CIRC CONCR	
---	---	0020/0958	LEN=0040	INSTALLED	2002
---	---	0020/0600	012 "DIA	CIRC METAL	
---	---	0020/0319	LEN=0065	INSTALLED	UNKN
---	---	003478 FT	024 "DIA	CIRC METAL	
---	---	5 0020/0000	LEN=0060	INSTALLED	UNKN
---	---	0010/2916	018 "DIA	CIRC CONCR	
---	---	0010/2492	LEN=0050	INSTALLED	UNKN
---	---	0010/2307	018 "DIA	CIRC METAL	
---	---	0010/2115	LEN=0045	INSTALLED	UNKN
---	---	0010/1413	2 0 02039	0 00 0034+73	
---	---	0010/1110	5 0020/0000	LENGTH(AH	3494 BK 3478)
---	---	000000 FT	018 "DIA	CIRC METAL	
---	---	NC MC	LEN=0060	INSTALLED	UNKN
---	---	000000 FT	018 "DIA	CIRC METAL	
---	---	000000 FT	LEN=0060	INSTALLED	UNKN
---	---	000000 FT	018 "DIA	CIRC METAL	
---	---	000000 FT	LEN=0055	INSTALLED	UNKN
---	---	000000 FT	018 "DIA	CIRC CONCR	
---	---	000000 FT	LEN=0099	INSTALLED	UNKN
---	---	000000 FT	018 "DIA	CIRC METAL	
---	---	000000 FT	LEN=0099	INSTALLED	UNKN
---	---	000000 FT	018 "DIA	CIRC CONCR	
---	---	000000 FT	LEN=0040	INSTALLED	UNKN
---	---	000000 FT	2 0 02039	0 00 0000+00	
---	---	000000 FT	NC MC	MICHAEL RD	
---	---	000000 FT		NOBLESTOWN RD	
---	---	000000 FT		(SR3048 SEG 0150/0820)	
---	---	000000 FT	INTER-BK	LINDEN AV	
---	---	000000 FT		(TWP)	
---	---	000000 FT		MFC BEGIN = D	
---	---	000000 FT	5 0010/0000	LENGTH(AH	3478 BK 0000)

006972 FT

003478 FT

COLUMBIA AV
(TWP)

0010/0590
000000 FT

EXTRACT DATE: 12/21/2020 ROADWAY MANAGEMENT SYSTEM PAGE NUMBER: 1051
 PRINT DATE: 12/23/2020 SLD COUNTY/SR - ANNUAL PRINT COUNTY: ALLEGHENY
 DIR: B TOTAL LEN: .000 MI. DIST: 11-1 SR: 3040
 LEFT MUN: COLLIER T RIGHT MUN: COLLIER T

000000 FT
 000000 FT
 000000 FT



000000 FT
 7030/0000 LENGTH(AH 1194 BK 2462)
 000000 FT
 7020/0000 LENGTH(AH 2462 BK 2576)
 000000 FT
 7010/0000 LENGTH(AH 2576 BK 0000)

EXTRACT DATE: 12/21/2020 ROADWAY MANAGEMENT SYSTEM PAGE NUMBER: 1050
PRINT DATE: 12/23/2020 SLD COUNTY/SR - ANNUAL PRINT COUNTY: ALLEGHENY
DIR: B TOTAL LEN: 1.226 MI. DIST: 11-1 SR: 3039
LEFT MUN: COLLIER T RIGHT MUN: COLLIER T

NOBLESTOWN RD

006471 FT

006471 FT NOBLESTOWN RD

DIR: B TOTAL LEN: 1.226 MI. DIST: 11-1 SR: 3039
 LEFT MUN: COLLIER T RIGHT MUN: COLLIER T

(SR3048 SEG 0140/0000) 0030/2104

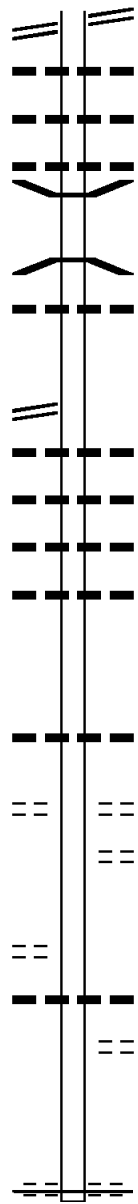

0030/2104 (SR3048 SEG 0140/0000)
 012 "DIA CIRC CONCR
 0030/1780 LEN=0060 INSTALLED UNKN
 018 "DIA CIRC CONCR
 0030/1475 LEN=0060 INSTALLED UNKN
 018 "DIA CIRC CONCR
 0030/1090 LEN=0060 INSTALLED UNKN
 0030/1057 BMS EN 02/3039/0030/0682
 2 0 02030 0 00 0052+84
 ROBINSON RUN
 0030/0682 BMS BG 02/3039/0030/0682
 018 "DIA CIRC CONCR
 0030/0646 LEN=0036 INSTALLED UNKN

2 0 02030 0 00 0043+86 004367 FT
 GREGG STATION RD
 (SR3064 SEG 0010/3209) 0030/0000

0030/0000 LENGTH(AH 2104 BK 2614)
 018 "DIA CIRC CONCR
 0020/2550 LEN=0060 INSTALLED UNKN
 018 "DIA CIRC CONCR
 0020/2357 LEN=0060 INSTALLED UNKN
 024 "DIA CIRC CONCR
 0020/2120 LEN=0060 INSTALLED UNKN
 024 "DIA CIRC CONCR
 0020/1867 LEN=0060 INSTALLED UNKN

2 0 02030 0 00 0017+61 001753 FT
 LOBAUGH ST
 (TWP) 0020/0000

0020/0300 018 "DIA CIRC CONCR
 001753 FT LEN=0099 INSTALLED UNKN
 MESSERSCHMIDT RD
 (TWP)
 0020/0000 LENGTH(AH 2614 BK 1753)
 CAREY RD
 (TWP)
 0010/1535

PINDER RD
 (TWP) 0010/0580

0010/0550 012 "DIA CIRC CONCR
 LEN=0040 INSTALLED UNKN
 MANOR DR
 (PRDR)
 0010/0172 2 0 02030 0 00 0000+00
 000000 FT NC NI KE SITE RD
 THOMS RUN RD
 (TWP)
 MFC BEGIN = E
 0010/0000 LENGTH(AH 1753 BK 0000)

LIBRARY RD 011071 FT
 (SR0088 SEG 0110/0210) 0051/3611
 BMSEN 02/3038/0050/3347 0051/3484
 2 0 02060 0 00 0108+12
 PORT AUTHORITY OF AL RR
 BMSBG 02/3038/0050/3347 0051/3372
 WILLOW AV
 (BORO)
 CEMETARY ENT
 (PRDR) 0051/3199
 024 "DIA CIRC CONCR
 LEN=0099 INSTALLED UNKN 0051/2892

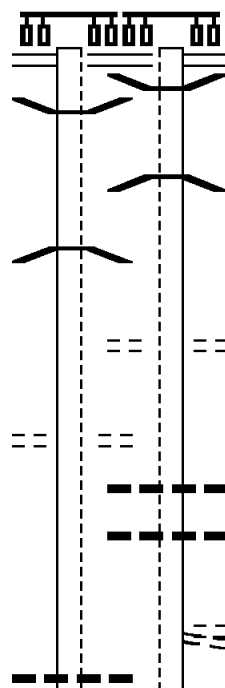

011104 FT LIBRARY RD
 (SR0088 SEG 0110/0210)
 0050/3587
 0050/3502 BMSEN 02/3038/0050/3347
 2 0 02060 0 00 0108+12
 PORT AUTHORITY OF AL RR
 BMSBG 02/3038/0050/3347
 WILLOW AV
 (BORO)
 CEMETARY DR
 (PRDR) 0050/3222
 0050/3147 018 "DIA CIRC CONCR
 LEN=0035 INSTALLED UNKN
 0050/2988 018 "DIA CIRC CONCR
 LEN=0035 INSTALLED UNKN
 FRANKLIN DR
 (BORO)
 0050/2888 OLD CONNOR RD
 (BORO)

DIR: E TOTAL LEN: 2.103 MI. DIST: 11-1 SR: 3038
 LEFT MUN: BETHEL PARK B RIGHT MUN: BETHEL PARK B

Location / Description	Stationing	Length	Material / Notes
FRANKLIN DR (BORO)			
OLD CONNOR RD (BORO)	0051/2867		
018 "DIA CIRC CONCR			
LEN=0035 INSTALLED UNKN	0051/2632		
018 "DIA CIRC CONCR			
LEN=0050 INSTALLED UNKN	0051/2400		
018 "DIA CIRC CONCR			
LEN=0035 INSTALLED UNKN	0051/2126		
WILLOW HEATH DR (TWP)	0051/1606		
012 "DIA CIRC CONCR			
LEN=0099 INSTALLED UNKN	0051/1603		
LC TO GREENRIDGE RD (CONN)	0051/1354		
GREENRIDGE RD (TWP)	0051/1275		
018 "DIA CIRC CONCR			
LEN=0099 INSTALLED UNKN	0051/1225		
OREGON TR (TWP)	0051/1214		
OREGON TR (TWP)	0050/1228		
016 "DIA CIRC CONCR			
LEN=0099 INSTALLED UNKN	0050/0565		
MARSHALL DR (TWP)			
WOODRIDGE DR (TWP)			
WOODRIDGE DR (TWP)	0050/0548		
MARSHALL DR (TWP)			
WOODRIDGE DR (TWP)			
2 0 02060 0 00 0074+56	0051/0550		
BETHEL PARK MT LEBANON T	007460 FT	007517 FT	2 0 02060 0 00 0073+32
018 "DIA CIRC CONCR			
LEN=0035 INSTALLED UNKN	0050/0000		
LENGTH(AH 3611 BK 2675)	0051/0000		LENGTH(AH 3587 BK 2673)

DIR: E TOTAL LEN: 2.103 MI. DIST: 11-1 SR: 3038
 LEFT MUN: MT LEBANON T RIGHT MUN: MT LEBANON T

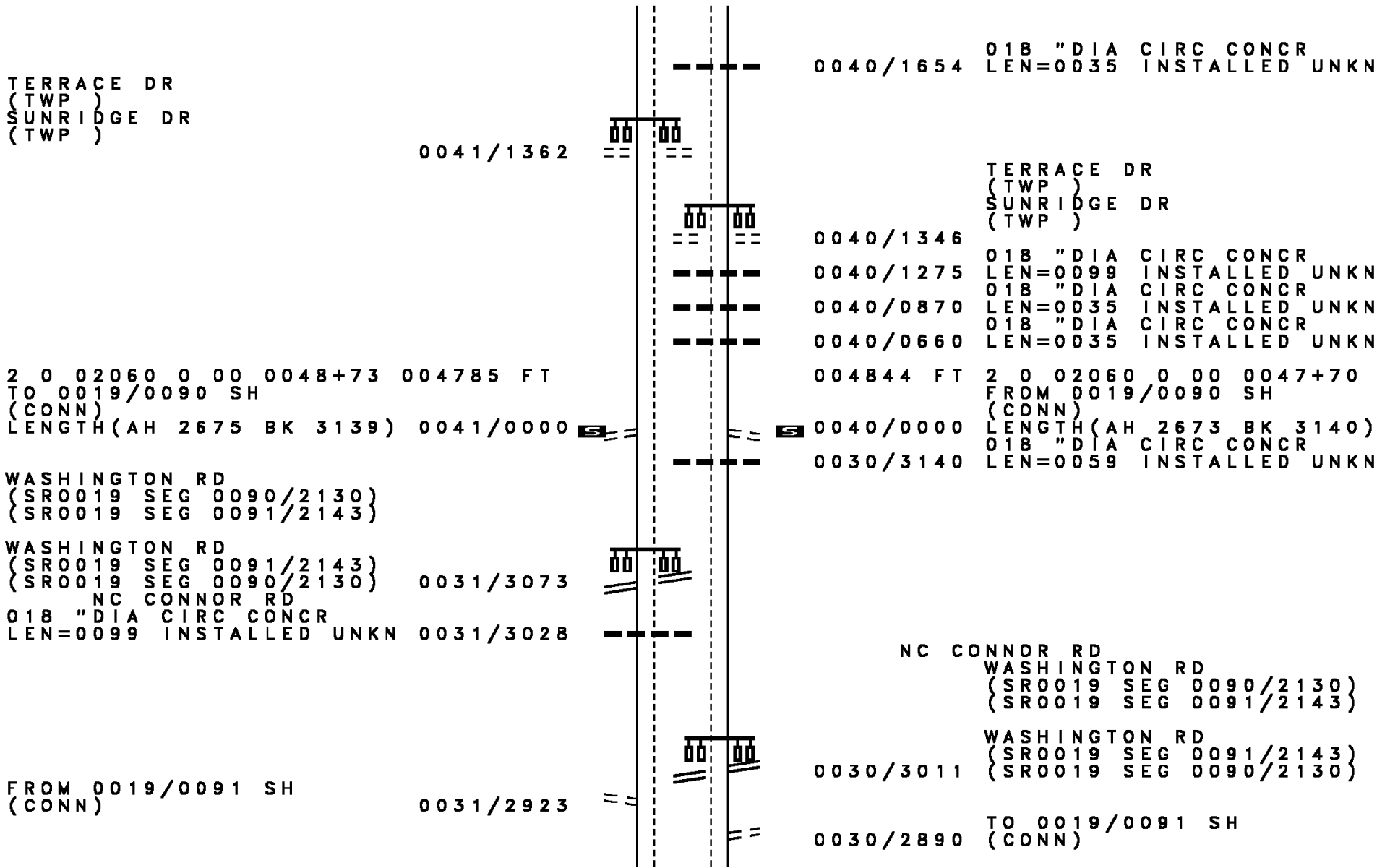

TERRACE DR
 (TWP)
 SUNRIDGE DR
 (TWP)

0041/1362

0040/1654 018 "DIA CIRC CONCR
 LEN=0035 INSTALLED UNKN

TERRACE DR
 (TWP)
 SUNRIDGE DR
 (TWP)

0040/1346

018 "DIA CIRC CONCR
 LEN=0099 INSTALLED UNKN

0040/1275

018 "DIA CIRC CONCR
 LEN=0035 INSTALLED UNKN

0040/0870

018 "DIA CIRC CONCR
 LEN=0035 INSTALLED UNKN

0040/0660

2 0 02060 0 00 0048+73 004785 FT
 TO 0019/0090 SH
 (CONN)
 LENGTH(AH 2675 BK 3139) 0041/0000

004844 FT 2 0 02060 0 00 0047+70
 FROM 0019/0090 SH
 (CONN)

0040/0000

LENGTH(AH 2673 BK 3140)
 018 "DIA CIRC CONCR

0030/3140

LEN=0059 INSTALLED UNKN

WASHINGTON RD
 (SR0019 SEG 0090/2130)
 (SR0019 SEG 0091/2143)

WASHINGTON RD
 (SR0019 SEG 0091/2143)
 (SR0019 SEG 0090/2130) 0031/3073
 018 "DIA CIRC CONCR
 LEN=0099 INSTALLED UNKN 0031/3028

NC CONNOR RD
 WASHINGTON RD
 (SR0019 SEG 0090/2130)
 (SR0019 SEG 0091/2143)

FROM 0019/0091 SH
 (CONN)

0031/2923

0030/3011

WASHINGTON RD
 (SR0019 SEG 0091/2143)
 (SR0019 SEG 0090/2130)

0030/2890

TO 0019/0091 SH
 (CONN)

DIR: E TOTAL LEN: 2.103 MI. DIST: 11-1 SR: 3038
 LEFT MUN: MT LEBANON T RIGHT MUN: MT LEBANON T

Segment Description	Start Station	End Station	Notes
016 "DIA CIRC CONCR LEN=0099 INSTALLED UNKN LC TO GALLERIA DR (CONN) GALLERIA MALL (PRDR)	0031/2219	0031/2166	
LC FROM GALLERIA MALL (CONN)	0031/2091	0031/2030	
016 "DIA CIRC CONCR LEN=0099 INSTALLED UNKN	0031/1660		
2 0 02060 0 00 0015+75 001646 FT OLD GILKESON RD (TWP) LENGTH(AH 3139 BK 1646) PAINTERS RUN STRUCTURE LENGTH 21 FT BMSID 02/3038/0010/1407	0031/0000	0011/1421	
LC TO CEDAR BL (CONN)	0011/0202		
CEDAR BL (CNTY)	0011/0084		
2 0 02060 0 00 0000+00 000000 FT LC FROM CEDAR BL (CONN) NC GILKESON RD PAINTERS RUN RD (CNTY) MFC BEGIN = B LENGTH(AH 1646 BK 0000)	0011/0000		
GALLERIA DR (PRDR)	0030/2009		
018 "DIA CIRC CONCR LEN=0035 INSTALLED UNKN	0030/1507		
018 "DIA CIRC CONCR LEN=0035 INSTALLED UNKN	0030/1315		
018 "DIA CIRC CONCR LEN=0035 INSTALLED UNKN	0030/0785		
018 "DIA CIRC CONCR LEN=0035 INSTALLED UNKN	0030/0591		
2 0 02060 0 00 0015+75 001704 FT OLD GILKESON RD (TWP) LENGTH(AH 3140 BK 1704) PAINTERS RUN STRUCTURE LENGTH 21 FT BMSID 02/3038/0010/1407	0030/0000	0010/1404	
CEDAR BL (CNTY)	0010/0100		
018 "DIA CIRC CONCR LEN=0035 INSTALLED UNKN	0010/0076		
2 0 02060 0 00 0000+00 000000 FT NC GILKESON RD PAINTERS RUN RD (CNTY) MFC BEGIN = B LENGTH(AH 1704 BK 0000)	0010/0000		

EXTRACT DATE: 12/21/2020 ROADWAY MANAGEMENT SYSTEM PAGE NUMBER: 1044
PRINT DATE: 12/23/2020 SLD COUNTY/SR - ANNUAL PRINT COUNTY: ALLEGHENY
DIR: B TOTAL LEN: 3.260 MI. DIST: 11-1 SR: 3037
LEFT MUN: MT LEBANON T RIGHT MUN: MT LEBANON T

017213 FT

017213 FT WASHINGTON RD

EXTRACT DATE: 12/21/2020
PRINT DATE: 12/23/2020

ROADWAY MANAGEMENT SYSTEM
SLD COUNTY/SR - ANNUAL PRINT

PAGE NUMBER: 1043
COUNTY: ALLEGHENY

DIR: B TOTAL LEN: 3.260 MI.
LEFT MUN: MT LEBANON T

DIST: 11-1 SR: 3037
RIGHT MUN: MT LEBANON T

WASHINGTON RD
(SR3069 SEG 0020/2886) 0080/1893

015320 FT

Station	Description
0080/1893	(SR3069 SEG 0020/2907) (SR3069 SEG 0021/2905) 024" DIA CIRC CONCR
0080/1800	LEN=0065 INSTALLED UNKN 018" DIA CIRC CONCR
0080/1415	LEN=0030 INSTALLED UNKN 018" DIA CIRC CONCR
0080/1090	LEN=0050 INSTALLED UNKN 018" DIA CIRC CONCR
0080/0840	LEN=0030 INSTALLED UNKN PIEDMONT AV
0080/0830	(BORO) MT LEBANON
0080/0818	DORMONT B FIFTH AL
0080/0690	(BORO) 018" DIA CIRC CONCR
0080/0640	LEN=0200 INSTALLED UNKN LATONIA AV
0080/0555	(BORO) SIXTH AL
0080/0415	(BORO) EASTMONT AV
0080/0275	(BORO) SEVENTH AL
0080/0140	(BORO) 2 0 02059 0 00 0032+30
015320 FT	BEACON HILL AV (BORO) DORMONT MT LEBANON T
0080/0000	LENGTH(AH 1893 BK 3169) 018" DIA CIRC CONCR
0070/2826	LEN=0070 INSTALLED UNKN 018" DIA CIRC CONCR
0070/2376	LEN=0099 INSTALLED UNKN ROSEMONT AV
0070/2317	(TWP) CATALPA PL
0070/2011	(TWP) 024" DIA CIRC CONCR
0070/1750	LEN=0055 INSTALLED UNKN JONQUIL PL
0070/1729	(TWP) 012"H 24"W ELLIP CONC
0070/1593	LEN=0080 INSTALLED UNKN BROADMOOR AV
0070/1401	(TWP) 018" DIA CIRC CONCR
0070/1125	LEN=0099 INSTALLED UNKN

DIR: B TOTAL LEN: 3.260 MI. DIST: 11-1 SR: 3037
 LEFT MUN: MT LEBANON T RIGHT MUN: MT LEBANON T

Street Name	Segment	Stationing	Material	Length	Notes
BIRCH AV (TWP)	0070/0911		018" DIA CIRC CONCR	LEN=0099	INSTALLED UNKN
	0070/0729		024" DIA CIRC CONCR	LEN=0099	INSTALLED UNKN
	0070/0335		BIRCH AV (TWP)		
CASTLE SHANNON BL (SR3044 SEG 0020/1145)	0070/0320				
	0070/0079		015" DIA CIRC CONCR	LEN=0099	INSTALLED UNKN
CYPRESS WY (TWP)	0070/0055	012151 FT	SUNSET DR (TWP)		
	0070/0000	012151 FT	2 0 02059 0 00 0000+00		
	0060/1254		015" DIA CIR PLASTIC	LENGTH(AH 3169 BK 1287)	
COOKE LN (TWP)	0060/1143		018" DIA CIRC CONCR	LEN=0035	INSTALLED UNKN
	0060/1085		015" DIA CIRC CONCR	LEN=0099	INSTALLED UNKN
	0060/0770		018" DIA CIRC CONCR	LEN=0030	INSTALLED UNKN
	0060/0000	010864 FT	2 0 02235 0 01 0137+52		
MT LEBANON BL (SR3042 SEG 0040/0818)	0050/2285		ANAWANDA AV (TWP)		
	0050/1796		015" DIA CIRC CONCR	LENGTH(AH 1287 BK 2580)	
	0050/1785		018" DIA CIRC CONCR	LEN=0035	INSTALLED UNKN
	0050/1538		CRYSTAL DR (TWP)		
MT LEBANON BL (SR3042 SEG 0040/0818)	0050/1450		018" DIA CIRC CONCR	LEN=0035	INSTALLED UNKN
	0050/1373		MT LEBANON CASTLE SHANNON B		
	0050/1117		024" DIA CIRC CONCR	LEN=0030	INSTALLED UNKN
	0050/0897				

DIR: B TOTAL LEN: 3.260 MI. DIST: 11-1 SR: 3037
 LEFT MUN: CASTLE SHANNON B RIGHT MUN: CASTLE SHANNON B

MIDDLEBORO RD
(BORO)

ANDREA DR
(BORO)

TO 3009/0100 SH
(CONN)

0020/0633
003294 FT

0010/2830

0010/0070
000000 FT

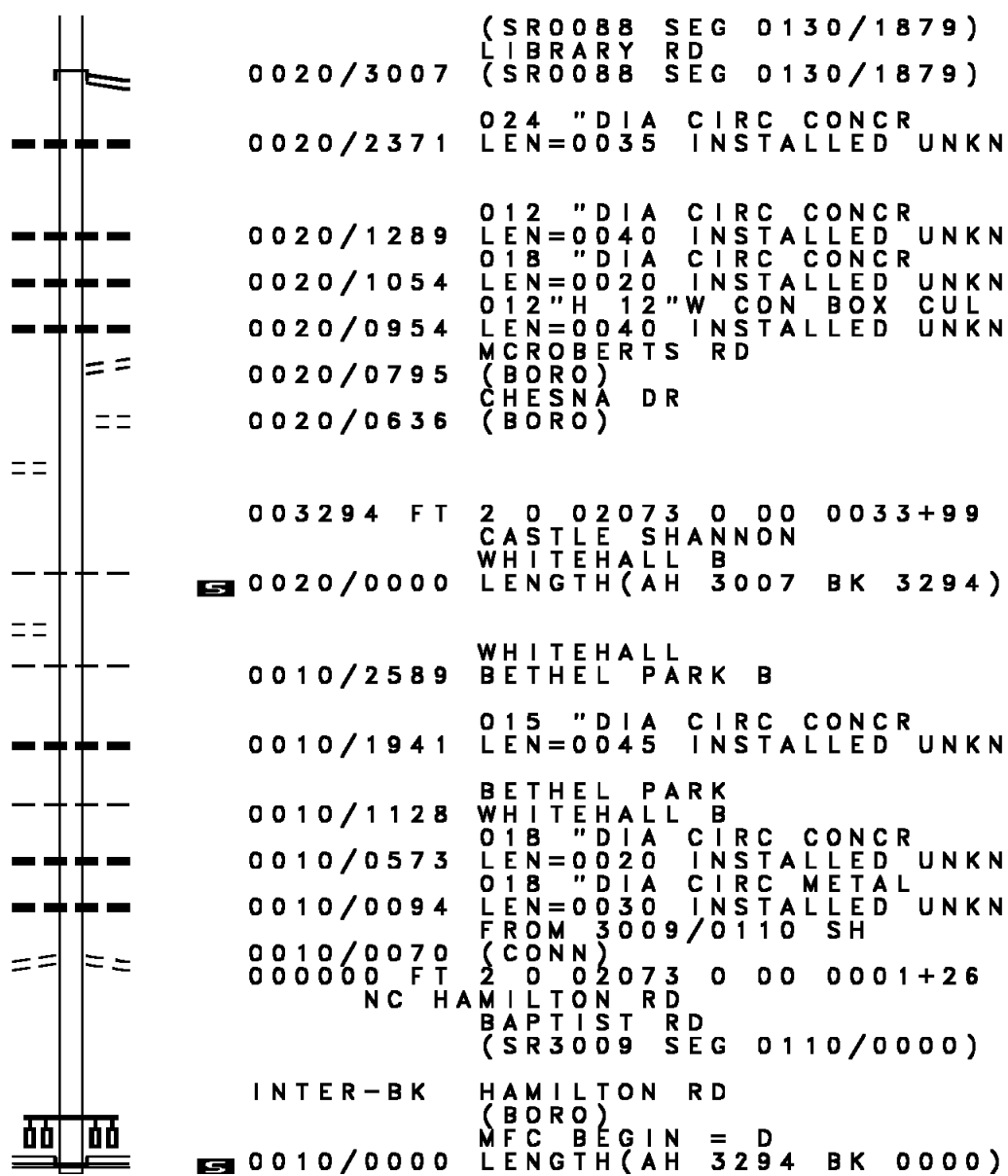

(SR0088 SEG 0130/1879)
 LIBRARY RD
 (SR0088 SEG 0130/1879)
 0020/3007
 0020/2371 024 " DIA CIRC CONCR
 LEN=0035 INSTALLED UNKN
 0020/1289 012 " DIA CIRC CONCR
 LEN=0040 INSTALLED UNKN
 0020/1054 018 " DIA CIRC CONCR
 LEN=0020 INSTALLED UNKN
 0020/0954 012"H 12"W CON BOX CUL
 LEN=0040 INSTALLED UNKN
 MCROBERTS RD
 0020/0795 (BORO)
 CHESNA DR
 0020/0636 (BORO)
 003294 FT 2 0 02073 0 00 0033+99
 CASTLE SHANNON
 WHITEHALL B
 0020/0000 LENGTH(AH 3007 BK 3294)
 WHITEHALL
 BETHEL PARK B
 0010/2589
 0010/1941 015 " DIA CIRC CONCR
 LEN=0045 INSTALLED UNKN
 BETHEL PARK
 WHITEHALL B
 0010/1128 018 " DIA CIRC CONCR
 LEN=0020 INSTALLED UNKN
 0010/0573 018 " DIA CIRC CONCR
 LEN=0020 INSTALLED UNKN
 0010/0094 018 " DIA CIRC METAL
 LEN=0030 INSTALLED UNKN
 FROM 3009/0110 SH
 0010/0070 (CONN)
 000000 FT 2 0 02073 0 00 0001+26
 NC HA MILTON RD
 BAPTIST RD
 (SR3009 SEG 0110/0000)
 INTER-BK HAMILTON RD
 (BORO)
 MFC BEGIN = D
 0010/0000 LENGTH(AH 3294 BK 0000)

EXTRACT DATE: 12/21/2020 ROADWAY MANAGEMENT SYSTEM PAGE NUMBER: 1039
PRINT DATE: 12/23/2020 SLD COUNTY/SR - ANNUAL PRINT COUNTY: ALLEGHENY

DIR: B TOTAL LEN: 1.377 MI. DIST: 11-1 SR: 3036
LEFT MUN: UPPER ST CLAIR T RIGHT MUN: UPPER ST CLAIR T

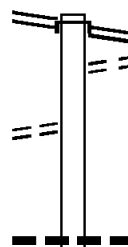
	007269 FT		007269 FT	
WASHINGTON RD			INTER-AHD	FORT COUCH RD
(SR0019 SEG 0084/0000)				(CNTY)
(SR0019 SEG 0085/0000)	0030/2783		0030/2783	WASHINGTON RD
			0030/2627	(SR0019 SEG 0085/0000)
PHILLIPS DR				(SR0019 SEG 0084/0000)
(TWP)	0030/2344			TO 0019/0081 SH
				(CONN)
			0030/1067	018 "DIA CIRC CONCR
				LEN=0080 INSTALLED UNKN

DIR: B TOTAL LEN: 1.377 MI. DIST: 11-1 SR: 3036
 LEFT MUN: UPPER ST CLAIR T RIGHT MUN: UPPER ST CLAIR T

ROAD NAME	SR	SEG	START STATION	END STATION	LENGTH (FT)	DESCRIPTION
MEADOW CREST DR (TWP)	0030	0745				WARWICK DR (TWP)
2 0 02053 0 00 0027+23	004486	FT				018 " DIA CIRC CONCR LEN=0050 INSTALLED UNKN
SEEGAR CR (TWP)	0030	0000				SEEGAR RD (T237) LENGTH(AH 2783 BK 2340) GLO MIN DR (TWP)
CLEARVIEW DR (TWP)	0020	1525				MIRANDA RD (TWP)
QUIGG DR (TWP)	0020	0341				030 " DIA CIRC CONCR LEN=0050 INSTALLED UNKN
002146 FT						2 0 02053 0 00 0055+00 HARROGATE RD (TWP)
SKENDER DR (TWP)	0010	1777				LENGTH(AH 2340 BK 2146)
						012 " DIA CIRC CONCR LEN=0003 INSTALLED UNKN
						018 " DIA CIRC CONCR LEN=0030 INSTALLED UNKN
						012 " DIA CIRC CONCR LEN=0030 INSTALLED UNKN
						018 " DIA CIRC CONCR LEN=0030 INSTALLED UNKN
TUSCANY DR (TWP)	0010	0706				LITTLE MEADOW RD (TWP)
						036 " DIA CIRC METAL LEN=0040 INSTALLED UNKN
						036 " DIA CIRC METAL LEN=0099 INSTALLED UNKN
000000 FT						2 0 02053 0 00 0072+24 MCMILLAN RD (SR3034 SEG 0090/1735)
MCMILLAN RD (SR3034 SEG 0090/1735)	0010	0000				NC FORT COUCH RD MFC BEGIN = D LENGTH(AH 2146 BK 0000)

EXTRACT DATE: 12/21/2020 ROADWAY MANAGEMENT SYSTEM PAGE NUMBER: 1037
 PRINT DATE: 12/23/2020 SLD COUNTY/SR - ANNUAL PRINT COUNTY: ALLEGHENY
 DIR: B TOTAL LEN: 1.566 MI. DIST: 11-1 SR: 3035
 LEFT MUN: WHITEHALL B RIGHT MUN: WHITEHALL B

SAW MILL RUN BL 008268 FT
 (SR0051 SEG 0331/0117)
 (SR0051 SEG 0330/0165) 0030/1136

FAIRHAVEN RD
 (SR9115 SEG 0010/0485) 0030/0916
 007132 FT

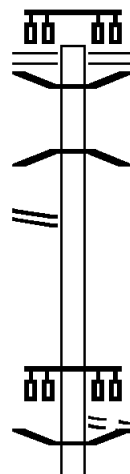

008268 FT SAW MILL RUN BL
 (SR0051 SEG 0330/0165)
 (SR0051 SEG 0331/0117)
 0030/1136
 0030/1022 BMS EN 02/3035/0030/1023
 0 0 00000 0 00 0000+00
 WEYMAN RUN
 0030/1007 BMSBG 02/3035/0030/1023
 NC STEWART AV
 007132 FT 0 0 00000 0 00 0000+00
 NC PROVOST RD
 PROVOST RD
 (CNTY)
 0030/0000 LENGTH (AH 1136 BK 3459)
 0020/3256 BMS EN 02/3035/0020/3237
 2 0 02075 0 00 0069+38

DIR: B TOTAL LEN: 1.566 MI. DIST: 11-1 SR: 3035
 LEFT MUN: WHITEHALL B RIGHT MUN: WHITEHALL B

Location	Segment ID	Length	Material	Notes
	0020/3244		SAW MILL RUN	BMSBG 02/3035/0020/3237
	0020/2125		018 " DIA CIRC CONCR	LEN=0060 INSTALLED UNKN
	0020/1785		018 " DIA CIRC CONCR	LEN=0070 INSTALLED UNKN
	0020/1307		048 " DIA CIRC CONCR	LEN=0050 INSTALLED UNKN
	0020/1290		HEINEN ST	(BORO)
Mcroberts St (Boro)	0020/1140			
	003673 FT			
	003673 FT		2 0 02075 0 00 0038+26	FOXWOOD MANOR DR (BORO)
	0020/0000			LENGTH(AH 3459 BK 3673)
	0010/2974		018 " DIA CIRC CONCR	LEN=0065 INSTALLED UNKN
	0010/2767		018 " DIA CIRC CONCR	LEN=0110 INSTALLED UNKN
Hennig Rd (Boro)	0010/2715			
	0010/2585		WHITE HAMPTON LN	(BORO)
	0010/2320		018 " DIA CIRC CONCR	LEN=0099 INSTALLED UNKN
South Passage Dr (Boro)	0010/1840			
	0010/0950		WEYMAN PLAZA ENT	(PRDR)
Village Ln (Boro)	0010/0820			
	0010/0055		018 " DIA CIRC CONCR	LEN=0099 INSTALLED UNKN
000000 FT	000000 FT		2 0 02075 0 00 0000+00	NC WEYMAN RD BAPTIST RD (SR3009 SEG 0130/0000)
	INTER-BK		DOVERDELL RD	(BORO)
	0010/0000		MFC BEGIN = D	LENGTH(AH 3673 BK 0000)

EXTRACT DATE: 12/21/2020
PRINT DATE: 12/23/2020

ROADWAY MANAGEMENT SYSTEM
SLD COUNTY/SR - ANNUAL PRINT

PAGE NUMBER: 1035
COUNTY: ALLEGHENY

DIR: B TOTAL LEN: 4.561 MI.
LEFT MUN: MT LEBANON T

DIST: 11-1 SR: 3034
RIGHT MUN: MT LEBANON T

Left Side	Segment Length	Right Side	Segment Length	Notes
	024081 FT	024081 FT		BOWER HILL RD (CNTY)
WORCESTER DR (TWP)	0110/2755	0110/3024		MORELAND DR (CNTY)
		0110/2755		018" DIA CIRC CONCR
		0110/2597		LEN=0040 INSTALLED UNKN
		0110/2189		018" DIA CIRC CONCR
		0110/1745		LEN=0040 INSTALLED UNKN
				018" DIA CIRC CONCR
PEMBROKE DR (TWP)	0110/1670	0110/1115		LEN=0048 INSTALLED UNKN
		0110/0900		MORELAND DR (TWP)
		0110/0724		018" DIA CIRC CONCR
BETHANY DR (TWP)	0110/0340			LEN=0048 INSTALLED UNKN
				NC KE LSO RD
		0110/0334		018" DIA CIRC CONCR
				LEN=0040 INSTALLED UNKN
		0110/0063		018" DIA CIRC CONCR
				LEN=0040 INSTALLED UNKN
	021057 FT	021057 FT		2 0 02050 0 02 0222+14
		0110/0000		LENGTH(AH 3024 BK 1589)
				018" DIA CIRC CONCR
		0100/1405		LEN=0050 INSTALLED UNKN
				018" DIA CIRC CONCR
		0100/0918		LEN=0048 INSTALLED UNKN
				MT LEBANON
		0100/0789		UPPER ST CLAIR T
				018" DIA CIRC CONCR
		0100/0579		LEN=0040 INSTALLED UNKN
				018" DIA CIRC CONCR
		0100/0277		LEN=0040 INSTALLED UNKN
				018" DIA CIRC CONCR
		0100/0025		LEN=0040 INSTALLED UNKN
				2 0 02050 0 02 0204+09
	019468 FT	019468 FT		PAINTERS RUN RD (CNTY)
				NC RO BB HOLLOW RD
		INTER-BK		PAINTERS RUN RD (CNTY)
				0100/0000 LTH AH 001589 BK 000100
		019468 FT		019468 FT
		7094/0000		LTH AH 000100 BK 002577
		INTER-AHD		PAINTERS RUN RD (CNTY)
PAINTERS RUN RD				

EXTRACT DATE: 12/21/2020
PRINT DATE: 12/23/2020

ROADWAY MANAGEMENT SYSTEM
SLD COUNTY/SR - ANNUAL PRINT

PAGE NUMBER: 1034
COUNTY: ALLEGHENY

DIR: B TOTAL LEN: 4.561 MI.
LEFT MUN: UPPER ST CLAIR T

DIST: 11-1 SR: 3034
RIGHT MUN: UPPER ST CLAIR T

(CNTY)

0090/2577

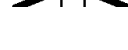
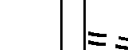
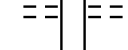
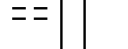
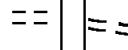
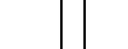
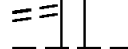

0090/2577

0090/2087

0090/1735

0090/1685

0090/1403

0090/1080

016891 FT

0090/0000

0080/3595

0080/3184

0080/3096

0080/2470

0080/2350

0080/1830

0080/1775

0080/1025

0080/0730

0080/0715

0080/0702

0080/0534

0080/0511

0080/0498

015 " DIA CIRC METAL
LEN=0040 INSTALLED UNKN
FORT COUCH RD
(SR3036 SEG 0010/0000)
018 " DIA CIRC METAL
LEN=0040 INSTALLED UNKN

018 " DIA CIRC CONCR
LEN=0040 INSTALLED UNKN
018 " DIA CIRC METAL
LEN=0040 INSTALLED UNKN

TROTWOOD WEST DR
(T357)
LENGTH(AH 2577 BK 3902)
018 " DIA CIRC CONCR
LEN=0040 INSTALLED UNKN

018 " DIA CIRC CONCR
LEN=0040 INSTALLED UNKN
SEEGAR RD
(T377)

018 " DIA CIRC CONCR
LEN=0040 INSTALLED UNKN
018 " DIA CIRC CONCR
LEN=0040 INSTALLED UNKN
ORR RD
(T369)

024 " DIA CIRC METAL
LEN=0050 INSTALLED UNKN

048 " DIA CIRC CONCR
LEN=0048 INSTALLED UNKN
072"H 48"W CON BOX CUL
LEN=0048 INSTALLED UNKN
BMSSEN 02/3034/0080/0702
2 0 02050 0 02 0145+38
BRMCLAUGHLIN

BMSBG 02/3034/0080/0702
072"H 48"W CON BOX CUL
LEN=0048 INSTALLED UNKN
BMSSEN 02/3034/0080/0498
2 0 02050 0 02 0143+38
BRMCLAUGHLIN
BMSBG 02/3034/0080/0498

WATTERSON CT
(CNTY)

0090/1437

2 0 02050 0 02 0171+72 016891 FT
COOK SCHOOL RD
(T357)

0090/0000

UPPER ST CLAIR DR
(TWP)

0080/3543

EXTRACT DATE: 12/21/2020
PRINT DATE: 12/23/2020

ROADWAY MANAGEMENT SYSTEM
SLD COUNTY/SR - ANNUAL PRINT

PAGE NUMBER: 1033
COUNTY: ALLEGHENY

DIR: B TOTAL LEN: 4.561 MI.
LEFT MUN: UPPER ST CLAIR T

DIST: 11-1 SR: 3034
RIGHT MUN: UPPER ST CLAIR T

Address	Segment ID	Material	Length	Notes
	0080/0324	018" DIA CIRC CONCR	LEN=0040	INSTALLED UNKN
	0080/0051	018" DIA CIRC CONCR	LEN=0040	INSTALLED UNKN
012989 FT	012989 FT	2 0 02050 0 02	0138+43	
	0080/0000	LENGTH(AH 3902 BK 0938)		
	0070/0778	018" DIA CIRC CONCR	LEN=0040	INSTALLED UNKN
	0070/0764	048" H 72" W CON BOX CUL	LEN=0048	INSTALLED UNKN
	0070/0736	BMSBG 02/3034/0070/0719	2 0 02050 0 01	0136+07
	0070/0719	BR. MCLAUGHLIN RUN		
	0070/0428	BMSBG 02/3034/0070/0719		WOODLANDS CR
	0070/0252	(PRDR)	BMSBG 02/3034/0070/0237	2 0 02050 0 01
	0070/0237	BR MCLAUGHLIN		0131+30
012051 FT	012051 FT	BMSBG 02/3034/0070/0237		
	0070/0205	048" H 72" W CON BOX CUL	LEN=0048	INSTALLED UNKN
	012051 FT	2 0 02050 0 01	0128+98	
		NC MC MILLAN RD		
		MCLAUGHLIN RUN RD		
		(SR3004 SEG 0060/0000)		
	0070/0000	MFC BEGIN = D	LENGTH(AH 0938 BK 3330)	
	0060/3306	018" DIA CIR PLASTIC	LEN=0040	INSTALLED UNKN
	0060/3189	BMSBG 02/3034/0060/3159	2 0 02050 0 01	0127+37
	0060/3159	MCLAUGHLIN		
		BMSBG 02/3034/0060/3159		
PINEHURST DR (TWP)	0060/2960			
PINEVIEW DR (TWP)	0060/2524			
WELLINGTON DR (TWP)	0060/1501			
CHARTWELL DR (TWP)	0060/0280			
	0060/2010	018" DIA CIRC CONCR	LEN=0040	INSTALLED UNKN
	0060/1050	TIFFANY DR (TWP)		
	0060/0487	018" DIA CIRC METAL	LEN=4035	INSTALLED UNKN
		018" DIA CIRC METAL		

EXTRACT DATE: 12/21/2020
PRINT DATE: 12/23/2020

ROADWAY MANAGEMENT SYSTEM
SLD COUNTY/SR - ANNUAL PRINT

PAGE NUMBER: 1032
COUNTY: ALLEGHENY

DIR: B TOTAL LEN: 4.561 MI.
LEFT MUN: UPPER ST CLAIR T

DIST: 11-1 SR: 3034
RIGHT MUN: UPPER ST CLAIR T

Stationing	Segment	Length	Notes
008721 FT	0060/0276	LEN=0099	INSTALLED UNKN
	008721 FT	2 0 02050 0 01 0094+73	MONTCLAIR DR
		(TWP)	
	0060/0000	LENGTH(AH 3330 BK 1939)	
		018 "DIA CIRC CONCR	
	0050/1395	LEN=0040	INSTALLED UNKN
006782 FT			
	006782 FT	2 0 02050 0 01 0075+22	OLD MEADOW RD
		(TWP)	
	0050/0000	LENGTH(AH 1939 BK 2235)	
	0040/1149	OLD LESNETT RD	(T371)
	0040/0535	018 "DIA CIRC CONCR	LEN=0040 INSTALLED UNKN
PENNSYLVANIA AV (TWP)	0040/0465		
	0040/0386	018 "DIA CIRC CONCR	LEN=0040 INSTALLED UNKN
NEW YORK ST (TWP)	0040/0240		
	004547 FT	2 0 02050 0 00 0052+88	018 "DIA CIRC CONCR
		LEN=0040	INSTALLED UNKN
		LENGTH(AH 2235 BK 0777)	
		OLD LESNETT RD	
HARDING ST (TWP)	0030/0599	(TWP)	
		OLD MEADOW RD	
		(TWP)	
	0030/0411		
SARAH ST (TWP)	0030/0305		
	0030/0128	015 "DIA CIRC CONCR	LEN=0040 INSTALLED UNKN
	003770 FT	SNETT RD	
		BANK ST	
		(SR3005 SEG 0060/0000)	
2 0 02050 0 00 0045+06	003770 FT	LTH AH 000777 BK 000100	
BANK ST			
(SR3005 SEG 0060/0000)	0030/0000		
	003770 FT		
	7020/0000	LTH AH 000100 BK 003770	
		BANK ST	
		(SR3005 SEG 0050/3082)	
		MAYVIEW RD	
		(SR3005 SEG 0050/3082)	
		BRIDGEVILLE B	

DIR: B TOTAL LEN: 4.561 MI. DIST: 11-1 SR: 3034
 LEFT MUN: BRIDGEVILLE B RIGHT MUN: BRIDGEVILLE B

Street Name	Segment ID	Length	Material	Status
WINFIELD ST (BORO)	0010/2845	0010/3524	018 "DIA CIRC CONCR	INSTALLED UNKN
ELIZABETH ST (BORO)	0010/2515	0010/2785	018 "DIA CIRC CONCR	INSTALLED UNKN
SPRUCE ST (BORO)	0010/2350	0010/2120	018 "DIA CIRC CONCR	INSTALLED UNKN
ELM ST (BORO)	0010/1975	0010/1444	018 "DIA CIRC CONCR	INSTALLED UNKN
CHESTNUT ST (BORO)	0010/1600	0010/1250	018 "DIA CIRC CONCR	INSTALLED UNKN
GREGG AV (BORO)	0010/1215	0010/0985	018 "DIA CIRC CONCR	INSTALLED UNKN
ORCHARD AV (BORO)	0010/0985	0010/0770	018 "DIA CIRC CONCR	INSTALLED UNKN
ALLEY (BORO)	0010/0770	0010/0648	018 "DIA CIRC CONCR	INSTALLED UNKN
DEWEY AV (BORO)	0010/0635	0010/0613	BMS EN 02/3034/0010/0521	0 0 00000 0 00 0000+00
WERNER AV (BORO)	0010/0471	0010/0521	PITTSBURGH AND OHIO RR	BMSBG 02/3034/0010/0521
		0010/0315	018 "DIA CIRC CONCR	INSTALLED UNKN
		0010/0185	018 "DIA CIRC CONCR	INSTALLED UNKN
	000000 FT	000000 FT	2 0 02352 0 00 0037+62	
			NC CHARTIERS ST	
			WASHINGTON AV	
			(SR0050 SEG 0120/0408)	
			INTER-BK CHURCH ST	
			(BORO)	
			MFC BEGIN = E	
			LENGTH(AH 3770 BK 0000)	

DIR: B TOTAL LEN: 2.190 MI. DIST: 11-1 SR: 3033
 LEFT MUN: MT LEBANON T RIGHT MUN: MT LEBANON T

Stationing	Location	Stationing	Location	Notes
011562 FT	SWALLOW HILL RD (TWP)	011562 FT	BOWER HILL RD (CNTY)	
		0040/2030	018 " DIA CIRC CONCR	
		0040/1825	LEN=0035	INSTALLED UNKN
		0040/1082	018 " DIA CIRC CONCR	
		0040/0859	LEN=0040	INSTALLED UNKN
		0040/0404	018 " DIA CIRC CONCR	
		009532 FT	LEN=0055	INSTALLED UNKN
		0040/0404	036 " DIA CIRC CONCR	
		009532 FT	LEN=0090	INSTALLED UNKN
		009532 FT	2 0 02042 0 00 0099+08	
		NC SE	GAR RD RAVEN DR (TWP) MT LEBANON SCOTT T	
0040/0000		5 0040/0000	LENGTH(AH 2030 BK 3389)	
		0030/3300	018 " DIA CIRC CONCR	
		0030/2799	LEN=0090	INSTALLED UNKN
		0030/2498	018 " DIA CIRC CONCR	
		0030/1640	LEN=0065	INSTALLED UNKN
		0030/1395	018 " DIA CIRC CONCR	
		0030/0520	LEN=0070	INSTALLED UNKN
		0030/0250	018 " DIA CIRC CONCR	
006143 FT		006143 FT	LEN=0045	INSTALLED 2002
		0030/0000	2 0 02042 0 00 0061+25	
		5 0030/0000	018 " DIA CIRC CONCR	
		0020/2713	LEN=0050	INSTALLED UNKN
		0020/2403	LENGTH(AH 3389 BK 3060)	
		0020/2105	018 " DIA CIRC CONCR	
		0020/2016	LEN=0060	INSTALLED UNKN
			018 " DIA CIRC CONCR	
			LEN=0263	INSTALLED 2002
			018 " DIA CIRC CONCR	
			LEN=0100	INSTALLED UNKN
			018 " DIA CIRC CONCR	
			LEN=0065	INSTALLED UNKN

DIR: B TOTAL LEN: 2.190 MI. DIST: 11-1 SR: 3033
 LEFT MUN: SCOTT T RIGHT MUN: SCOTT T

Stationing	Description	Structure	Material	Status
0020/1795	018" DIA	CIRC	CONCR	INSTALLED UNKN
0020/1680	LEN=0060	SCRUBGRASS	RUN	
0020/1641	STRUCTURE LENGTH 33 FT	BMSID 02/3033/0020/1681	072" DIA	CIRC METAL
0020/1423	LEN=0055			INSTALLED UNKN
0020/1103	024" DIA	CIRC	CONCR	INSTALLED UNKN
0020/0468	LEN=0045			INSTALLED UNKN
0020/0184	018" DIA	CIRC	CONCR	INSTALLED UNKN
0020/0048	LEN=0100			INSTALLED UNKN
003083 FT	018" DIA	CIRC	CONCR	INSTALLED UNKN
0020/0000	LEN=0040			INSTALLED UNKN
0010/3000	NC SC	CRUBGRASS	RD	LENGTH(AH 3060 BK 3083)
0010/2897	018"H 12"W	ELLIP	CONC	INSTALLED 2002
0010/2698	LEN=0015			INSTALLED 2002
0010/2428	018" DIA	CIRC	CONCR	INSTALLED UNKN
0010/1776	LEN=0040			INSTALLED UNKN
0010/1611	018" DIA	CIRC	CONCR	INSTALLED UNKN
0010/1248	LEN=0060			INSTALLED UNKN
0010/1054	018" DIA	CIRC	CONCR	INSTALLED 2002
0010/1027	LEN=0035			INSTALLED 2002
0010/0632	ROOSEVELT ST			(TWP)
0010/0095	018" DIA	CIR	PLASTIC	INSTALLED UNKN
000000 FT	LEN=0099			INSTALLED UNKN
000000 FT	2 0 02042 0 00 0000+00			
0010/0000	NC MA	IN ST	VANADIUM RD	(CNTY)
0010/0000	MFC BEGIN = D			LENGTH(AH 3083 BK 0000)

OLD SCRUBGRASS RD
(TWP)

2 0 02042 0 00 0030+95
 SCOTT TWP VET MEMORIAL
 (TWP)

WABASH ALLEY
(PRDR)

EXTRACT DATE: 12/21/2020 ROADWAY MANAGEMENT SYSTEM PAGE NUMBER: 1028
 PRINT DATE: 12/23/2020 SLD COUNTY/SR - ANNUAL PRINT COUNTY: ALLEGHENY
 DIR: B TOTAL LEN: .042 MI. DIST: 11-1 SR: 3032
 LEFT MUN: SOUTH FAYETTE T RIGHT MUN: SOUTH FAYETTE T

000221 FT
 000000 FT

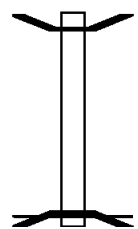

000221 FT BMS EN 02/3032/0010/0000
 * REF-AHD ALPINE RD
 0010/0221 (TWP)
 000000 FT 2 0 02046 0 00 0081+86
 * REF-BK NC ALPINE RD
 ALPINE RD
 (TWP)
 SR 0079 SB
 BMSBG 02/3032/0010/0000
 MFC BEGIN = D
 0010/0000 LENGTH(AH 0221 BK 0000)

EXTRACT DATE: 12/21/2020 ROADWAY MANAGEMENT SYSTEM PAGE NUMBER: 1027
PRINT DATE: 12/23/2020 SLD COUNTY/SR - ANNUAL PRINT COUNTY: ALLEGHENY

DIR: B TOTAL LEN: 2.338 MI. DIST: 11-1 SR: 3031
LEFT MUN: COLLIER T RIGHT MUN: COLLIER T

012346 FT

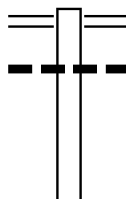

012346 FT HILLTOP RD
0040/3734 (SR3052 SEG 0040/0000)
018 " DIA CIRC CONCR
0040/3682 LEN=0072 INSTALLED UNKN

MUIRFIELD DR

DIR: B TOTAL LEN: 2.338 MI. DIST: 11-1 SR: 3031
 LEFT MUN: COLLIER T RIGHT MUN: COLLIER T

NEVILLEWOOD DR
 (TWP)
 WILLIAMSBURG CT
 (TWP)
 GLEN ABBEY CT
 (TWP)
 NORMANDY CT
 (TWP)

0040/1835
 0040/1615
 0040/1200
 0040/0795

008612 FT

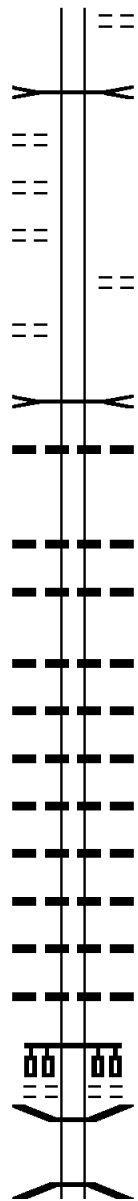

0040/2117 (TWP)
 DRAINAGE
 STRUCTURE LENGTH 15 FT
 BMSID 02/3031/0040/1907
 0040/1888
 0040/1035 ST MELLION DR
 (TWP)
 DRAINAGE
 STRUCTURE LENGTH 15 FT
 BMSID 02/3031/0040/0407
 018 " DIA CIRC CONCR
 LEN=0060 INSTALLED UNKN
 2 0 02043 0 00 0087+49
 0040/0110 LENGTH(AH 3734 BK 3981)
 018 " DIA CIRC CONCR
 LEN=0060 INSTALLED UNKN
 0030/3828 018 " DIA CIRC CONCR
 LEN=0060 INSTALLED UNKN
 0030/3598 018 " DIA CIRC CONCR
 LEN=0053 INSTALLED UNKN
 0030/2924 018 " DIA CIR PLASTIC
 LEN=0055 INSTALLED UNKN
 0030/2675 018 " DIA CIR PLASTIC
 LEN=0055 INSTALLED UNKN
 0030/2362 024 " DIA CIRC METAL
 LEN=0060 INSTALLED UNKN
 0030/2138 024 " DIA CIRC CONCR
 LEN=0070 INSTALLED UNKN
 0030/1908 024 " DIA CIRC CONCR
 LEN=0070 INSTALLED UNKN
 0030/1713 018 " DIA CIRC CONCR
 LEN=0070 INSTALLED UNKN
 0030/1486 018 " DIA CIRC CONCR
 LEN=0065 INSTALLED UNKN
 0030/1200 NC F O RSYTHE RD
 THOMS RUN RD
 (CNTY)
 0030/0785
 0030/0707 BMS EN 02/3031/0030/0551
 2 0 02043 0 00 0053+31
 CHARTIERS CK
 0030/0551 BMSBG 02/3031/0030/0551

EXTRACT DATE: 12/21/2020
PRINT DATE: 12/23/2020

ROADWAY MANAGEMENT SYSTEM
SLD COUNTY/SR - ANNUAL PRINT

PAGE NUMBER: 1025
COUNTY: ALLEGHENY

DIR: B TOTAL LEN: 2.338 MI.
LEFT MUN: COLLIER T

DIST: 11-1 SR: 3031
RIGHT MUN: COLLIER T

Location	Stationing	Length	Notes
POE	0030/0448		(APRA) LANE CONSTRUCTION RD
	0030/0385		(PRDR)
	004631 FT		024 "DIA CIRC CONCR
	0030/0000		LEN=0060 INSTALLED UNKN
	0020/2730		2 0 02043 0 00 0047+57
	0020/2700		LENGTH(AH 3981 BK 2876)
	0020/2416		020 "DIA CIRC CONCR
	0020/2700		LEN=0030 INSTALLED UNKN
	0020/2416		BMSSEN 02/3031/0020/2416
	0020/2000		2 0 02043 0 00 0042+97
	0020/1729		SR 0079 NB
	0020/1388		BMSBG 02/3031/0020/2416
	0020/1275		018 "DIA CIRC CONCR
	0020/1021		LEN=0070 INSTALLED UNKN
	0020/0720		018 "DIA CIRC METAL
JONES DR (BORO)	0020/0597		LEN=0040 INSTALLED UNKN
2 0 02043 0 00 0015+83	001755 FT		024 "DIA CIRC CONCR
PERRETT ST (BORO)	0020/0000		LEN=0055 INSTALLED UNKN
CHARLET ST (BORO)	0010/1168		024 "DIA CIRC METAL
	0010/0621		LEN=0070 INSTALLED UNKN
HILL ST (BORO)	0010/0615		024 "DIA CIRC CONCR
	0010/0297		LEN=0040 INSTALLED UNKN
	0010/0161		018 "DIA CIRC CONCR
	0010/0038		LEN=0045 INSTALLED UNKN
	000000 FT		2 0 02043 0 00 0000+00
			NC PR RESTLEY RD
			WASHINGTON RD
			(SRO050 SEG 0130/0995)
			MFC BEGIN = E
			LENGTH(AH 1755 BK 0000)

EXTRACT DATE: 12/21/2020 ROADWAY MANAGEMENT SYSTEM PAGE NUMBER: 1024
 PRINT DATE: 12/23/2020 SLD COUNTY/SR - ANNUAL PRINT COUNTY: ALLEGHENY
 DIR: B TOTAL LEN: .054 MI. DIST: 11-1 SR: 3030
 LEFT MUN: COLLIER T RIGHT MUN: COLLIER T

000287 FT
 000000 FT

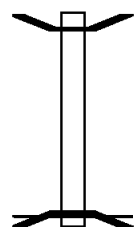

000287 FT BMS EN 02/3030/0010/0000
 * REF-AHD STEEN RD
 0010/0287 (TWP)
 000000 FT 0 0 00000 0 00 0000+00
 NC ST STEEN RD
 * REF-BK STEEN RD
 (TWP)
 SR 0079 NB
 BMSBG 02/3030/0010/0000
 MFC BEGIN = E
 0010/0000 LENGTH(AH 0287 BK 0000)

DIR: B TOTAL LEN: 2.394 MI. DIST: 11-1 SR: 3029
 LEFT MUN: SOUTH FAYETTE T RIGHT MUN: SOUTH FAYETTE T

Location	Start Station	End Station	Length (FT)	Material / Notes
BATTLE RIDGE RD (SR3024 SEG 0080/0000)	012639	0040/3034	0040/3034	015" DIA CIRC CONCR
				LEN=0056 INSTALLED UNKN
				012" DIA CIRC CONCR
				LEN=0099 INSTALLED UNKN
WINCHESTER DR (TWP)	0040/2720			006" DIA CIR PLASTIC
				LEN=0020 INSTALLED 2002
SYGAN RD (TWP)	0040/2368			018" DIA CIRC CONCR
				LEN=0045 INSTALLED UNKN
				018" DIA CIRC CONCR
				LEN=0045 INSTALLED UNKN
				018" DIA CIRC CONCR
				LEN=0045 INSTALLED UNKN
RIDGEVIEW DR (TWP)	0040/0910			018" DIA CIRC CONCR
				LEN=0036 INSTALLED UNKN
VALLEYVIEW DR (TWP)	0040/0605			015" DIA CIRC CONCR
				LEN=0040 INSTALLED UNKN
				015" DIA CIRC CONCR
				LEN=0040 INSTALLED UNKN
				2 0 02034 0 00 0031+08
				GILMORE HILL RD
				(TWP)
				LENGTH(AH 3034 BK 3369)
				018" DIA CIRC CONCR
				LEN=0050 INSTALLED UNKN
				018" DIA CIRC CONCR
				LEN=0035 INSTALLED UNKN
				024" DIA CIRC CONCR

EXTRACT DATE: 12/21/2020
PRINT DATE: 12/23/2020

ROADWAY MANAGEMENT SYSTEM
SLD COUNTY/SR - ANNUAL PRINT

PAGE NUMBER: 1022
COUNTY: ALLEGHENY

DIR: B TOTAL LEN: 2.394 MI.
LEFT MUN: SOUTH FAYETTE T

DIST: 11-1 SR: 3029
RIGHT MUN: SOUTH FAYETTE T

KINGSBROOK DR
(TWP)

0030/1562

BERKLEY RIDGE DR
(TWP)

0030/0438
006236 FT

PIN OAK DR
(TWP)

0020/0909

002633 FT

PETRICCA DR
(TWP)

0010/2182

2 0 02034 0 00 0126+19 000000 FT
PRESTON SYGAN RD
(SR3028 SEG 0010/2580) 0010/0000

0030/2342	LEN=0050	INSTALLED UNKN
0030/1040		NORTHRIDGE DR (TWP) 018 "DIA CIRC CONCR LEN=0040 INSTALLED UNKN
0030/0681		LEN=0040 INSTALLED UNKN
006236 FT	2 0 02034 0 00 0064+96	024 "DIA CIRC CONCR LEN=0050 INSTALLED UNKN
0030/0000	LENGTH(AH 3369 BK 3603)	012"H 24"W ELLIP CONC LEN=0025 INSTALLED UNKN
0020/3120		018 "DIA CIRC CONCR LEN=0045 INSTALLED UNKN
0020/2885		LEN=0052 INSTALLED UNKN
0020/2218		018 "DIA CIRC CONCR LEN=0052 INSTALLED UNKN
0020/2095		DUTCH HILL RD (TWP) 018 "DIA CIRC CONCR LEN=0099 INSTALLED UNKN
0020/1988		LEN=0099 INSTALLED UNKN
0020/0458		018 "DIA CIRC CONCR LEN=0045 INSTALLED UNKN
0020/0000	LENGTH(AH 3603 BK 2633)	2 0 02034 0 00 0100+86 002633 FT 0020/0000
0010/1872		018 "DIA CIRC CONCR LEN=0050 INSTALLED UNKN
0010/1655		018"H 18"W ELLIP CONC LEN=0050 INSTALLED UNKN
0010/1229		018 "DIA CIRC CONCR LEN=0040 INSTALLED UNKN
0010/0700		018 "DIA CIRC CONCR LEN=0050 INSTALLED UNKN
0010/0108		012"H 12"W ELLIP CONC LEN=0070 INSTALLED 2002
000000 FT		NC OAK RIDGE RD PRESTON SYGAN RD (SR3028 SEG 0010/2580) MFC BEGIN = E
0010/0000	LENGTH(AH 2633 BK 0000)	0010/0000

DIR: B TOTAL LEN: 3.521 MI. DIST: 11-1 SR: 3028
 LEFT MUN: COLLIER T RIGHT MUN: COLLIER T

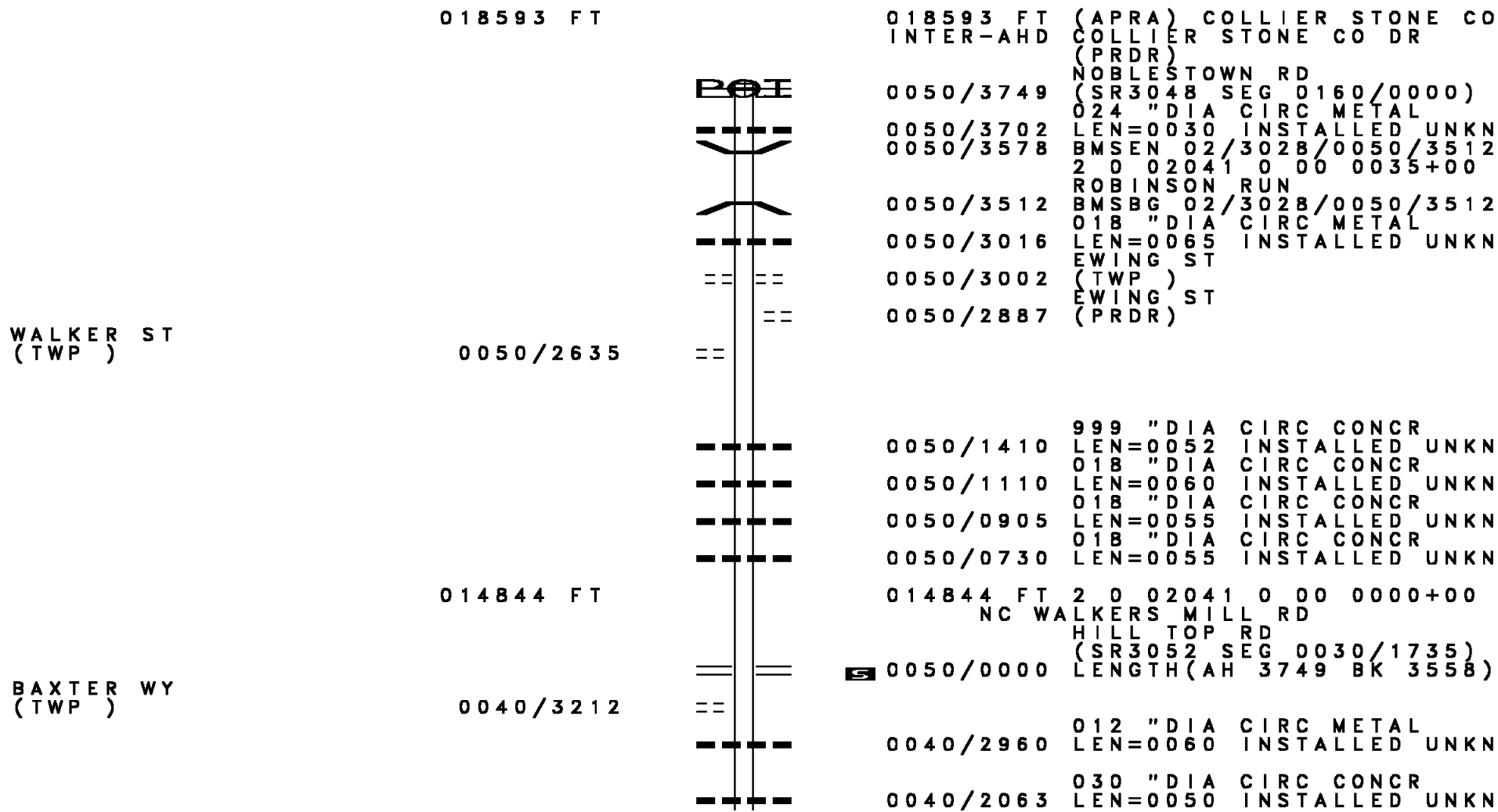

018593 FT

018593 FT (APRA) COLLIER STONE CO
 INTER-AHD (COLLIER STONE CO DR
 (PRDR)
 NOBLESTOWN RD
 (SR3048 SEG 0160/0000)
 0050/3749 024 " DIA CIRC METAL
 0050/3702 LEN=0030 INSTALLED UNKN
 0050/3578 BMSSEN 02/3028/0050/3512
 2 0 02041 0 00 0035+00
 ROBINSON RUN
 0050/3512 BMSBG 02/3028/0050/3512
 018 " DIA CIRC METAL
 0050/3016 LEN=0065 INSTALLED UNKN
 EWING ST
 (TWP)
 0050/3002 EWING ST
 (PRDR)
 0050/2887

WALKER ST
 (TWP)

0050/2635

014844 FT

0050/1410 999 " DIA CIRC CONCR
 LEN=0052 INSTALLED UNKN
 0050/1110 018 " DIA CIRC CONCR
 LEN=0060 INSTALLED UNKN
 0050/0905 018 " DIA CIRC CONCR
 LEN=0055 INSTALLED UNKN
 0050/0730 018 " DIA CIRC CONCR
 LEN=0055 INSTALLED UNKN
 014844 FT 2 0 02041 0 00 0000+00
 NC WA LKERS MILL RD
 HILL TOP RD
 (SR3052 SEG 0030/1735)
 0050/0000 LENGTH(AH 3749 BK 3558)

BAXTER WY
 (TWP)

0040/3212

0040/2960 012 " DIA CIRC METAL
 LEN=0060 INSTALLED UNKN
 0040/2063 030 " DIA CIRC CONCR
 LEN=0050 INSTALLED UNKN

DIR: B TOTAL LEN: 3.521 MI. DIST: 11-1 SR: 3028
 LEFT MUN: COLLIER T RIGHT MUN: COLLIER T

DEER HOLLOW RD
 (TWP)

0040/0755

011286 FT

2 0 02344 0 00 0000+00
 THOMS RUN RD
 (CNTY)

007561 FT
 0030/0000
 007561 FT

0040/1300	018 " DIA	CIRC METAL	LEN=0099	INSTALLED UNKN
0040/0860	030 " DIA	CIRC CONCR	LEN=0055	INSTALLED UNKN
0040/0490	036 " DIA	CIR PLASTIC	LEN=0060	INSTALLED UNKN
0040/0246	024 " DIA	CIRC METAL	LEN=0035	INSTALLED UNKN
0040/0015	030 " DIA	CIRC CONCR	LEN=0040	INSTALLED UNKN
011286 FT	2 0 02344	0 00 0037+28	LENGTH(AH 3558 BK 3725)	
0030/3050	018 " DIA	CIR PLASTIC	LEN=0030	INSTALLED UNKN
0030/2641	018 " DIA	CIRC METAL	LEN=0050	INSTALLED UNKN
0030/1900	036 " DIA	CIRC CONCR	LEN=0050	INSTALLED UNKN
0030/0728	036 " DIA	CIRC METAL	LEN=0060	INSTALLED UNKN
0030/0074	018 " DIA	CIRC METAL	LEN=0030	INSTALLED UNKN
007561 FT	YDS RUN RD			
INTER-BK	THOMS RUN RD			
0030/0000	(CNTY)			
007561 FT	LTH AH	003725	BK	000100
7024/0000	LTH AH 000100 BK 003755			
INTER-AHD	THOMS RUN RD			
0020/3755	(CNTY)			
0020/3686	THOMS RUN RD			
0020/3666	COLLIER			
0020/3634	SOUTH FAYETTE T			
0020/3285	BMSSEN	02/3028/0020/3633	1 0 00397 0 00 0074+52	
0020/2822	THOMS RUN			
	BMSBG	02/3028/0020/3633		
	018 " DIA	CIRC CONCR		
	LEN=0099	INSTALLED UNKN		
	012 " DIA	CIRC OTHER		
	LEN=0050	INSTALLED UNKN		

EXTRACT DATE: 12/21/2020
PRINT DATE: 12/23/2020

ROADWAY MANAGEMENT SYSTEM
SLD COUNTY/SR - ANNUAL PRINT

PAGE NUMBER: 1019
COUNTY: ALLEGHENY

DIR: B TOTAL LEN: 3.521 MI.
LEFT MUN: SOUTH FAYETTE T

DIST: 11-1 SR: 3028
RIGHT MUN: SOUTH FAYETTE T

Location / Description	Segment ID	Length (FT)	Material / Notes
	0020/2663		018 " DIA CIRC CONCR LEN=0099 INSTALLED UNKN
	0020/2386		012 " DIA CIRC CONCR LEN=0099 INSTALLED UNKN
	0020/2136		012 " DIA CIRC CONCR LEN=0045 INSTALLED UNKN
	0020/1364		024 " DIA CIRC CONCR LEN=0055 INSTALLED UNKN
	003806 FT	003806 FT	1 0 00397 0 00 0037+97 (APRA) REICHOLD CHEMICA REICHOLD PLANT ENTRANCE (PRDR)
NEWBURY HIGHLAND (PRDR)	0020/0000		POE 5 0020/0000 LENGTH(AH 3755 BK 3806)
	0010/3211		015 " DIA CIRC CONCR LEN=0050 INSTALLED UNKN
	0010/2934		018 " DIA CIRC CONCR LEN=0050 INSTALLED UNKN
	0010/2715		015 "H 15 "W BOX CULVRT* LEN=0055 INSTALLED UNKN
OAK RIDGE RD (SR3029 SEG 0010/0000)	0010/2580		
	0010/2400		018 " DIA CIRC CONCR LEN=0099 INSTALLED UNKN
	0010/1955		012 " DIA CIRC CONCR LEN=0045 INSTALLED UNKN
	0010/1512		018 " DIA CIRC CONCR LEN=0025 INSTALLED UNKN
	0010/1191		015 " DIA CIRC CONCR LEN=0025 INSTALLED UNKN
	0010/0841		015 " DIA CIRC CONCR LEN=0999 INSTALLED UNKN
	0010/0295		BRANCH OF MILLERS RUN STRUCTURE LENGTH 23 FT BMSID 02/3028/0010/0295
VERNER ST (TWP)	0010/0255		
SECOND AV (TWP)	0010/0210		
	000000 FT		
	0010/0146		NORFOLK SOUTHERN OVERPASS IS RR X-ING
	000000 FT		1 0 00397 0 00 0000+00 NC PR RESTO SYGAN RD MILLERS RUN RD (SR3026 SEG 0060/0000) MFC BEGIN = E
	5 0010/0000		LENGTH(AH 3806 BK 0000)

EXTRACT DATE: 12/21/2020 ROADWAY MANAGEMENT SYSTEM PAGE NUMBER: 1018
PRINT DATE: 12/23/2020 SLD COUNTY/SR - ANNUAL PRINT COUNTY: ALLEGHENY

DIR: N TOTAL LEN: .438 MI. DIST: 11-1 SR: 3027
LEFT MUN: PITTSBURGH C RIGHT MUN: PITTSBURGH C

002310 FT

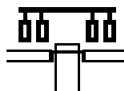

002298 FT
INTER-AHD

SMITHFIELD ST
(CITY)
BL OF THE ALLIES
(SR2208 SEG 0011/2105)
(SR2208 SEG 0010/2105)

0030/0600

FIRST AV

DIR: N TOTAL LEN: .438 MI. DIST: 11-1 SR: 3027
 LEFT MUN: PITTSBURGH C RIGHT MUN: PITTSBURGH C

FT PITT BL
 (CITY)

0030/0170

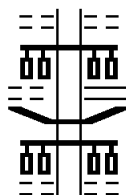

0030/0380 (CITY)
 FT PITT BL
 (SR8095 SEG 0010/0000)
 0030/0170
 0030/0156 BMSEN 02/3027/0030/0000
 RAMP TO SR 8095/0010
 (CITY)

001710 FT

0030/0075
 001698 FT 0 0 00000 0 00 0000+00
 EB CONNECTOR
 BMSBG 02/3027/0030/0000
 MFC BEGIN = C
 LENGTH(AH 0600 BK 1184)

BMSEN 02/3027/0020/0000
 BRIDGE POSTED (TONS)

0021/1182



0030/0000
 0020/1182 BMSEN 02/3027/0020/0000
 BRIDGE POSTED (TONS)

2 0 02265 0 00 0004+64 000526 FT

SGL 23 COMB
 STATION SQUARE STREET
 BMSBG 02/3027/0020/0000
 LENGTH(AH 1184 BK 0526) 0021/0000
 BMSEN 02/3027/0010/0458 0011/0514
 0 0 00000 0 00 0000+00
 NO UNDERPASS INFORMATIO
 BMSBG 02/3027/0010/0458 0011/0499



000514 FT 2 0 02265 0 00 0004+64
 SGL 23 COMB
 STATION SQUARE STREET
 BMSBG 02/3027/0020/0000
 LENGTH(AH 1184 BK 0514) 0020/0000
 BMSEN 02/3027/0010/0458 0010/0514
 0 0 00000 0 00 0000+00
 NO UNDERPASS INFORMATIO

BMSEN 02/3027/0010/0248 0011/0316
 0 0 00000 0 00 0000+00

ACCESS RD
 BMSBG 02/3027/0010/0248 0011/0280



0 0 00000 0 00 0000+00 000000 FT

NC SMITHFIELD ST BR
 CARSON ST
 (SR0837 SEG 0561/0931)

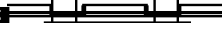

0010/0499
 0010/0490
 0010/0420
 0010/0319
 0010/0316
 0 0 00000 0 00 0000+00

ACCESS RD
 BMSBG 02/3027/0010/0248
 018 "DIA CIRC CONCR
 LEN=0015 INSTALLED UNKN

0010/0280
 0010/0072
 000000 FT 2 0 02265 0 00 0000+00

NC SMITHFIELD ST BR
 CARSON ST
 (SR0837 SEG 0561/0931)

0010/0248
 018 "DIA CIRC CONCR
 LEN=0015 INSTALLED UNKN

0010/0280
 018 "DIA CIRC CONCR
 LEN=0015 INSTALLED UNKN

0010/0072
 000000 FT 2 0 02265 0 00 0000+00

NC SMITHFIELD ST BR
 CARSON ST
 (SR0837 SEG 0561/0931)

PAT BUS TN INTER-BK
 (CNTY)
 MFC BEGIN = C
 LENGTH(AH 0526 BK 0000) 0011/0000

INTER-BK PAT BUS TN
 (CNTY)
 MFC BEGIN = C
 LENGTH(AH 0514 BK 0000)

DIR: B TOTAL LEN: 2.457 MI. DIST: 11-1 SR: 3026
 LEFT MUN: SOUTH FAYETTE T RIGHT MUN: SOUTH FAYETTE T

012974 FT
 FROM 0050/0091 SH (CONN)
 0060/1826
 1 0 00545 0 01 0199+00 010897 FT
 PRESTO SYGAN RD
 (SR3028 SEG 0010/0000) 0060/0000



012974 FT MILLERS RUN RD
 (SR0050 SEG 0090/0000)
 (SR0050 SEG 0091/0000)
 0060/2077 TO 0050/0081 SH
 0060/1826 (CONN)
 0060/1406 BMSSEN 02/3026/0060/1332
 1 0 00545 0 01 0212+51
 MILLER'S RUN
 0060/1332 BMSBG 02/3026/0060/1332
 018 " DIA CIRC METAL
 0060/1014 LEN=0050 INSTALLED UNKN
 018 " DIA CIRC CONCR
 0060/0778 LEN=0050 INSTALLED UNKN
 (APRA) INDUSTRIAL PARK
 INDUSTRIAL PARK ENT RD
 0060/0270 (PRDR)
 048"H 72"W CON BOX CUL
 0060/0064 LEN=0040 INSTALLED UNKN
 0060/0052 BMSSEN 02/3026/0060/0038
 1 0 00545 0 01 0199+63
 BR. MILLER'S
 0060/0038 BMSBG 02/3026/0060/0038
 010897 FT
 5 0060/0000 LENGTH(AH 2077 BK 2206)
 018 " DIA CIRC CONCR
 0050/1880 LEN=0040 INSTALLED UNKN
 018 " DIA CIRC CONCR
 0050/1650 LEN=0040 INSTALLED UNKN
 024 " DIA CIRC CONCR
 0050/1320 LEN=0040 INSTALLED UNKN
 018 " DIA CIRC CONCR

EXTRACT DATE: 12/21/2020
PRINT DATE: 12/23/2020

ROADWAY MANAGEMENT SYSTEM
SLD COUNTY/SR - ANNUAL PRINT

PAGE NUMBER: 1015
COUNTY: ALLEGHENY

DIR: B TOTAL LEN: 2.457 MI.
LEFT MUN: SOUTH FAYETTE T

DIST: 11-1 SR: 3026
RIGHT MUN: SOUTH FAYETTE T

FIRST AV
(TWP)
SYGAN RD
(TWP)

0050/0254

008691 FT

SHERMAN ST
(TWP)

0040/1140

GRANT ST
(TWP)
1 0 00545 0 01 0148+74
MORGAN HILL RD
(TWP)

0040/0505

005864 FT
0040/0000

0050/1145	LEN=0099	INSTALLED UNKN
018 "DIA	CIRC CONCR	
0050/0850	LEN=0099	INSTALLED UNKN
024 "DIA	CIRC CONCR	
0050/0413	LEN=0048	INSTALLED 2009
NORFOLK SOUTHERN		
0050/0403	OVERPASS IS RR X-ING	
0050/0288	BMS EN 02/3026/0050/0149	
1 0 00545 0 01 0168+00		
MILLERS RUN CREEK		
0050/0093	BMSBG 02/3026/0050/0149	
018 "DIA	CIRC CONCR	
0050/0080	LEN=0035	INSTALLED UNKN
008691 FT	1 0 00545 0 01 0168+00	
WABASH AV (TWP)		
0050/0000	LENGTH(AH 2206 BK 2827)	
018 "DIA	CIRC CONCR	
0040/2779	LEN=0026	INSTALLED 2009
018 "DIA	CIRC CONCR	
0040/2634	LEN=0057	INSTALLED 2009
018 "DIA	CIRC CONCR	
0040/2511	LEN=0099	INSTALLED UNKN
018 "DIA	CIRC CONCR	
0040/2331	LEN=0060	INSTALLED 2009
018 "DIA	CIRC CONCR	
0040/1848	LEN=0035	INSTALLED UNKN
CENTRAL AV (TWP)		
0040/1355	036 "DIA	CIRC CONCR
LEN=0035	INSTALLED UNKN	
0040/1100	016 "DIA	CIRC CONCR
LEN=0040	INSTALLED UNKN	
005864 FT		
0040/0000	LENGTH(AH 2827 BK 3289)	
016 "DIA	CIRC CONCR	
0030/2650	LEN=0040	INSTALLED UNKN
016 "DIA	CIRC CONCR	
0030/1630	LEN=0040	INSTALLED UNKN
016 "DIA	CIRC CONCR	

EXTRACT DATE: 12/21/2020
PRINT DATE: 12/23/2020

ROADWAY MANAGEMENT SYSTEM
SLD COUNTY/SR - ANNUAL PRINT

PAGE NUMBER: 1014
COUNTY: ALLEGHENY

DIR: B TOTAL LEN: 2.457 MI.
LEFT MUN: SOUTH FAYETTE T

DIST: 11-1 SR: 3026
RIGHT MUN: SOUTH FAYETTE T

ROADWAY	START	END	LEN	STATUS	DETAILS
	0030/1378		0040	INSTALLED UNKN	012" DIA CIRC CONCR
	0030/1032		0030	INSTALLED UNKN	018" DIA CIRC CONCR
	0030/0727		0099	INSTALLED UNKN	024" DIA CIRC CONCR
	0030/0610		0099	INSTALLED UNKN	018" DIA CIRC CONCR
	0030/0580		0015	INSTALLED UNKN	018" DIA CIRC CONCR
	0030/0271		0099	INSTALLED UNKN	CREST ST
	0030/0260				(TWP)
002575 FT	0030/0070				BMS EN 02/3026/0030/0000
	002575 FT				1 0 00545 0 01 0116+11
					MILLER'S RUN
	0030/0000				BMS BG 02/3026/0030/0000
					LENGTH(AH 3289 BK 1086)
	0020/0953				SOUTH FAYETTE ST
					(TWP)
CUDDY LN (TWP)	0020/0897				
MORGAN HILL RD (TWP)	0020/0837				
	0020/0815		0040	INSTALLED UNKN	018" DIA CIRC CONCR
	0020/0006		0040	INSTALLED UNKN	015" DIA CIRC CONCR
001489 FT	001489 FT				1 0 00545 0 01 0104+97
	0020/0000				(AAR 003875*)#TRKS 01
					LENGTH(AH 1086 BK 1489)
	0010/0880		0060	INSTALLED UNKN	018" DIA CIRC CONCR
OLD OAKDALE RD (TWP)	0010/0825				
LC FROM OLD OAKDALE RD (CONN)	0010/0791				
	0010/0735		0040	INSTALLED UNKN	018" DIA CIRC CONCR
	0010/0065		0050	INSTALLED UNKN	016" DIA CIRC METAL
000000 FT	000000 FT				1 0 00545 0 01 0090+17
					NC MI LLERS RUN RD
					INTER-BK RIDGE ST
BATTLE RIDGE RD (SR0978 SEG 0040/0000)	0010/0000				(SR0978 SEG 0040/0000)
					MFC BEGIN = D
	0010/0000				LENGTH(AH 1489 BK 0000)

CHURCH ST
(TWP)

002070 FT

0010/1165

000000 FT

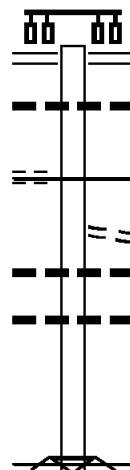

002070 FT GREENTREE RD
 (SR3052 SEG 0091/0585)
 (SR3052 SEG 0090/0600)
 0010/2070
 0010/2010 018 "DIA CIRC CONCR
 LEN=0099 INSTALLED UNKN
 0010/1165 MFC BEGIN = E
 SCOTT TWP VET MEMORIAL
 0010/1027 (TWP)
 0010/0881 018 "DIA CIRC CONCR
 LEN=0099 INSTALLED UNKN
 018 "DIA CIRC CONCR
 0010/0341 LEN=0099 INSTALLED UNKN
 000000 FT 1 0 00802 7 00 0002+34
 NC OLD WASHINGTON PK
 MFC BEGIN = D
 ROAD CLOSED
 ROAD CLOSED BACK
 0010/0000 LENGTH(AH 2070 BK 0000)

DIR: B TOTAL LEN: 4.477 MI. DIST: 11-1 SR: 3024
 LEFT MUN: SOUTH FAYETTE T RIGHT MUN: SOUTH FAYETTE T

Location	Segment ID	Length (FT)	Start Date	Material	Status
THOMS RUN & OAKDALE RD (CNTY)	0090/1220	023639	1993	018" DIA CIRC CONCR	UNKN
	0090/1608	023639	1993	018" DIA CIRC CONCR	UNKN
	0090/1238	023639	1993	018" DIA CIRC CONCR	UNKN
	0090/0819	023639	1993	018" DIA CIRC METAL	UNKN
THOMS RUN RD (CNTY)	0090/0425	021646	1993	018" DIA CIRC CONCR	UNKN
	0090/0178	021646	1993	018" DIA CIRC CONCR	UNKN
	0090/0000	021646	1993	024" DIA CIRC CONCR	UNKN
NESBIT RD (TWP)	0070/2254	019752	1993	015" DIA CIRC CONCR	UNKN
	0070/1774	019752	1993	012" DIA CIRC CONCR	UNKN
NESBIT RD (TWP)	0070/1567	019752	1993	018" DIA CIRC CONCR	UNKN
	0070/1144	019752	1993	018" DIA CIRC CONCR	UNKN
	0070/0808	019752	1993	018" DIA CIRC CONCR	UNKN
	0070/0000	019752	1993	018" DIA CIRC CONCR	UNKN

EXTRACT DATE: 12/21/2020
PRINT DATE: 12/23/2020

ROADWAY MANAGEMENT SYSTEM
SLD COUNTY/SR - ANNUAL PRINT

PAGE NUMBER: 1011
COUNTY: ALLEGHENY

DIR: B TOTAL LEN: 4.477 MI.
LEFT MUN: SOUTH FAYETTE T

DIST: 11-1 SR: 3024
RIGHT MUN: SOUTH FAYETTE T

1 1 04624 0 00 0042+48 016383 FT
RUTHERGLEN DR
(TWP) 0070/0000

WOODBRIIDGE DR
(TWP) 0060/2182
BOYS HOME RD
(TWP) 0060/1985

SR 9104 SH
(SR9104 SEG 0020/0000) 0060/0192
012304 FT

BATTLE RIDGE RD
(SR0978 SEG 0100/2210) 0060/0000
012304 FT

016383 FT OLD OAKDALE RD
(TWP)
5 0070/0000 LENGTH(AH 3369 BK 4079)
015 "DIA CIRC CONCR
0060/3533 LEN=0055 INSTALLED UNKN
015 "DIA CIRC CONCR
0060/2980 LEN=2881 INSTALLED UNKN
018 "DIA CIRC CONCR
0060/2726 LEN=0055 INSTALLED UNKN
018 "DIA CIRC CONCR
0060/2430 LEN=0040 INSTALLED UNKN
012 "DIA CIRC CONCR
0060/1708 LEN=0030 INSTALLED UNKN
018 "DIA CIRC CONCR
0060/1570 LEN=0099 INSTALLED UNKN
018 "DIA CIRC CONCR
0060/1350 LEN=0060 INSTALLED UNKN
FRYES LN
0060/0339 (TWP)
012304 FT 1 1 04624 0 00 0000+00
NC BA TTLE RIDGE RD
INTER-BK BATTLE RIDGE RD
(SR0978 SEG 0100/2210)
MFC BEGIN = D
5 0060/0000 LTH AH 004079 BK 000100
012304 FT
7054/0000 LTH AH 000100 BK 001624
INTER-AHD BATTLE RIDGE RD
(SR0978 SEG 0100/0000)
BATTLE RIDGE RD
(SR0978 SEG 0100/0000)
0050/1624 (SR0978 SEG 0100/0000)
018 "DIA CIRC CONCR
0050/1581 LEN=0050 INSTALLED UNKN
FOR SR 0978 AND 3024
(CONN)
0050/1235 018 "DIA CIRC CONCR
0050/1171 LEN=0050 INSTALLED UNKN
018 "DIA CIRC CONCR
0050/0488 LEN=0040 INSTALLED UNKN
015 "DIA CIRC CONCR
0050/0093 LEN=0045 INSTALLED UNKN

EXTRACT DATE: 12/21/2020
PRINT DATE: 12/23/2020

ROADWAY MANAGEMENT SYSTEM
SLD COUNTY/SR - ANNUAL PRINT

PAGE NUMBER: 1010
COUNTY: ALLEGHENY

DIR: B TOTAL LEN: 4.477 MI.
LEFT MUN: SOUTH FAYETTE T

DIST: 11-1 SR: 3024
RIGHT MUN: SOUTH FAYETTE T

010680 FT

	010680 FT	1 0 00681 0 00 0158+75
	0050/0000	LENGTH(AH 1624 BK 3957)
---	0040/3395	018 "DIA CIRC CONCR
---	0040/3196	LEN=0040 INSTALLED UNKN
==	0040/3124	015 "DIA CIRC CONCR
		LEN=0040 INSTALLED UNKN
		GRANITE DR
		(TWP)
---	0040/2269	018 "DIA CIRC CONCR
---	0040/1995	LEN=0040 INSTALLED UNKN
---	0040/1812	018 "DIA CIRC CONCR
---	0040/1539	LEN=0040 INSTALLED UNKN
==	0040/1182	018 "DIA CIRC METAL
		LEN=0050 INSTALLED UNKN
		BROWN LN
		(TWP)
---	0040/0832	018 "DIA CIRC CONCR
---	0040/0525	LEN=0050 INSTALLED UNKN
---	0040/0408	018 "DIA CIRC CONCR
==	0040/0316	LEN=0050 INSTALLED UNKN

006723 FT

	006723 FT	2 0 02032 0 00 0067+72
	0040/0000	LENGTH(AH 3957 BK 2675)
---	0030/2070	015 "DIA CIRC METAL
---	0030/1444	LEN=0075 INSTALLED UNKN
---	0030/1405	018 "DIA CIRC METAL
==	0030/1405	LEN=0060 INSTALLED UNKN

CEMETERY HILL RD
(TWP)

0030/1439

	0030/1405	CECIL STURGEON RD
		(TWP)
---	0030/0652	018 "DIA CIRC CONCR
		LEN=0040 INSTALLED UNKN

004048 FT

	004048 FT	2 0 02032 0 00 0041+99
	0030/0000	LENGTH(AH 2675 BK 3042)
---	0020/2832	015 "DIA CIRC OTHER
---	0020/2600	LEN=0060 INSTALLED UNKN
---	0020/2600	018 "DIA CIRC CONCR
---	0020/2600	LEN=0055 INSTALLED UNKN
---	0020/2600	018 "DIA CIRC CONCR

EXTRACT DATE: 12/21/2020
PRINT DATE: 12/23/2020

ROADWAY MANAGEMENT SYSTEM
SLD COUNTY/SR - ANNUAL PRINT

PAGE NUMBER: 1009
COUNTY: ALLEGHENY

DIR: B TOTAL LEN: 4.477 MI.
LEFT MUN: SOUTH FAYETTE T

DIST: 11-1 SR: 3024
RIGHT MUN: SOUTH FAYETTE T

RECORD AV
(TWP)

0020/0353

EASTGROVE AV
(TWP)

0010/0540

001006 FT

000000 FT

---	0020/2270	LEN=0055	INSTALLED UNKN
---	0020/2000	LEN=0080	INSTALLED UNKN
---	0020/1720	LEN=0065	INSTALLED UNKN
---	0020/1471	LEN=0050	INSTALLED 2006
---	0020/1380	SOUTH FAYETTE MCDONALD B	
==	0020/1010	(TWP) OUTLOOK AV	
==	0020/0694	(TWP) 018 "DIA CIRC CONCR	
---	0020/0672	LEN=0040	INSTALLED UNKN
---	0020/0558	LEN=0040	INSTALLED UNKN
==	0020/0200	018 "DIA CIRC CONCR	LEN=0020 INSTALLED UNKN
==	0020/0166	(BORO) 018 "DIA CIRC CONCR	
---	0020/0046	LEN=0025	INSTALLED UNKN
---	001006 FT	2 0 02032 0 00 0010+14	LAURELHILL RD (TBK)
==	0020/0000	NC ROBINSON RUN RD LENGTH(AH 3042 BK 1006)	
---	0010/0588	LEN=0025	INSTALLED UNKN
==	0010/0540	(TWP) 018 "DIA CIRC CONCR	
---	0010/0380	LEN=0025	INSTALLED UNKN
==	0010/0375	(TWP) 024 "DIA CIRC CONCR	
---	0010/0212	LEN=0025	INSTALLED UNKN
---	0010/0103	BMSSEN 02/3024/0010/0060 2 0 02032 0 00 0000+59	
---	0010/0060	ROBINSON RUN BMSBG 02/3024/0010/0060	
---	000000 FT	2 0 02032 0 00 0000+00	NC MA IN ST/LAURELHILL RD
---	0010/0000	NOBLESTOWN RD (SR3048 SEG 0010/1065) MFC BEGIN = E	
---	0010/0000	LENGTH(AH 1006 BK 0000)	

EXTRACT DATE: 12/21/2020 ROADWAY MANAGEMENT SYSTEM PAGE NUMBER: 1008
 PRINT DATE: 12/23/2020 SLD COUNTY/SR - ANNUAL PRINT COUNTY: ALLEGHENY
 DIR: B TOTAL LEN: .060 MI. DIST: 11-1 SR: 3023
 LEFT MUN: SOUTH FAYETTE T RIGHT MUN: SOUTH FAYETTE T

000315 FT

000000 FT

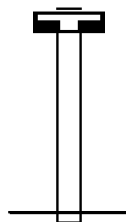

000315 FT
 7012/0000 LENGTH(AH 1422 BK 0315)
 * REF-AHD KENNEWEG AV
 0010/0315 (TWP)
 000000 FT 2 0 02262 0 00 0093+82
 NC KE NNEWEG AV
 * REF-BK CECIL-REISSING RD
 (TWP)
 MFC BEGIN = E
 0010/0000 LENGTH(AH 0315 BK 0000)

BERRINGTON CT
(PRDR)

003044 FT

0010/2749

BRAUN RD
(SR3020 SEG 0020/2071) 0010/0065

000000 FT

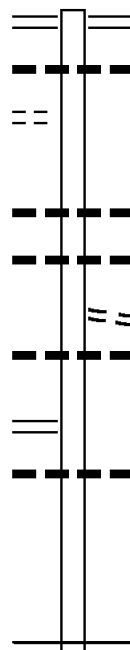

003044 FT LIBRARY RD
 0010/3044 (SR0088 SEG 0020/0000)
 018 " DIA CIRC METAL
 0010/2970 LEN=0050 INSTALLED UNKN

018 " DIA CIRC METAL
 LEN=0099 INSTALLED UNKN
 036 " DIA CIRC CONCR
 0010/1130 LEN=0099 INSTALLED UNKN
 CASTLE DR
 (PRDR)
 018 " DIA CIRC CONCR
 0010/0896 LEN=0099 INSTALLED UNKN

024 " DIA CIRC METAL
 LEN=0099 INSTALLED UNKN
 2 0 02064 0 00 0000+00
 NC CHURCH HILL RD

* REF-BK CHURCH HILL RD
 (SR1015 SEG 0070/2049)
 MFC BEGIN = E
 BK-WASHINGTON (62)
 0010/0000 LENGTH(AH 3044 BK 0000)

DIR: B TOTAL LEN: 1.310 MI. DIST: 11-1 SR: 3021
 LEFT MUN: JEFFERSON HILLS B RIGHT MUN: JEFFERSON HILLS B

KNIGHT RD (TBK)
 (BORO)

006915 FT

0030/3105

SCHEINBACH RD
 (BORO)

0030/1045

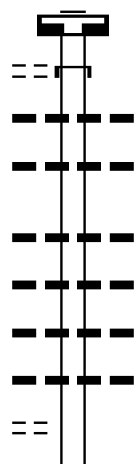

006915 FT
 7040/0000 LENGTH(AH 3050 BK 3105)
 INTER-AHD WALTON RD
 0030/3105 (SR3007 SEG 0010/0000)
 018 "DIA CIRC METAL
 0030/2744 LEN=0030 INSTALLED UNKN
 018 "DIA CIR PLASTIC
 0030/2616 LEN=0040 INSTALLED UNKN
 018 "DIA CIR PLASTIC
 0030/1994 LEN=0050 INSTALLED UNKN
 018 "DIA CIRC METAL
 0030/1751 LEN=0045 INSTALLED UNKN
 018 "DIA CIRC CONCR
 0030/1460 LEN=0030 INSTALLED UNKN
 015 "DIA CIRC CONCR
 0030/1239 LEN=0030 INSTALLED UNKN

DIR: B TOTAL LEN: 1.310 MI. DIST: 11-1 SR: 3021
 LEFT MUN: JEFFERSON HILLS B RIGHT MUN: JEFFERSON HILLS B

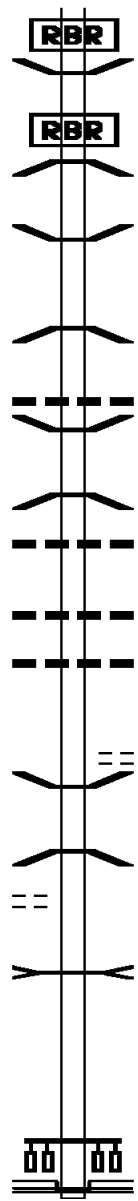

003810 FT

001453 FT

STATE ST
(BORO)

0010/0460

000000 FT

0030/0972 BMS EN 02/3021/0030/0941
 2 0 02066 0 01 0247+16
 P3
 LOBBS RUN
 0030/0941 BMSBG 02/3021/0030/0941

0030/0034 BMS EN 02/3021/0030/0000
 003810 FT 2 0 02066 0 01 0256+60
 LOBBS RUN
 BMSBG 02/3021/0030/0000
 0030/0000 LENGTH(AH 3105 BK 2357)

024 " DIA CIRC CONCR
 LEN=0040 INSTALLED UNKN
 0020/1715 BMS EN 02/3021/0020/1147
 0020/1175 2 0 02066 0 02 0280+94
 LOBBS RUN
 0020/1145 BMSBG 02/3021/0020/1147
 015 " DIA CIRC CONCR
 0020/0788 LEN=0030 INSTALLED UNKN

015 " DIA CIR PLASTIC
 LEN=0060 INSTALLED UNKN
 018 " DIA CIR PLASTIC
 0020/0037 LEN=0050 INSTALLED UNKN
 001453 FT 2 0 02066 0 02 0280+94
 0020/0000 LENGTH(AH 2357 BK 1453)
 LOBBS ST

0010/1283 (BORO)
 0010/0947 BMS EN 02/3021/0010/0907
 2 0 02066 0 02 0286+39
 LOBB'S RUN
 0010/0907 BMSBG 02/3021/0010/0907

LOBBS RUN
 STRUCTURE LENGTH 34 FT
 0010/0218 BMSID 02/3021/0010/0218
 000000 FT 2 0 02066 0 02 0295+37
 NC WA ALTON RD
 RIVER RD
 (SR0837 SEG 0010/2565)

INTER-BK GLASSHOUSE RD
 (BORO)
 MFC BEGIN = E
 0010/0000 LENGTH(AH 1453 BK 0000)

MITCH HAVEN DR
(TWP)

COUNTRY RD
(TWP)

2 0 02065 0 00 0000+00 000000 FT
 CLIFTON RD
 (SR3004 SEG 0140/1119) 0010/0000

004145 FT

0020/1735

0020/0655

002074 FT

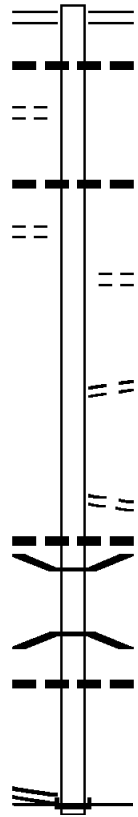

004145 FT CHURCH HILL RD
 0020/2071 (SR3022 SEG 0010/0065)
 030 "DIA CIRC CONCR
 0020/1760 LEN=0040 INSTALLED 2002

0020/0926 018 "DIA CIRC CONCR
 LEN=0079 INSTALLED UNKN

BETSY DR
 (TWP)
 0020/0519 2 0 02065 0 00 0020+40
 002074 FT LENGTH(AH 2071 BK 2074)
 IRISHTOWN RD
 (TWP)
 NC BRAUN RD

0010/0804 MAPLE SPRING RD
 (TWP)
 018 "DIA CIRC CONCR
 0010/0511 LEN=0060 INSTALLED UNKN
 0010/0260 BMSBN 02/3020/0010/0227
 2 0 02065 0 00 0002+63

0010/0227 PINEY FORK
 BMSBG 02/3020/0010/0227
 018 "DIA CIRC CONCR
 0010/0107 LEN=0040 INSTALLED 2002









NC IRISHTOWN RD ET
 INTER-BK CLIFTON RD
 000000 FT (SR3004 SEG 0140/1119)
 MFC BEGIN = E
 0010/0000 LENGTH(AH 2074 BK 0000)

EXTRACT DATE: 12/21/2020 ROADWAY MANAGEMENT SYSTEM PAGE NUMBER: 1003
PRINT DATE: 12/23/2020 SLD COUNTY/SR - ANNUAL PRINT COUNTY: ALLEGHENY
DIR: B TOTAL LEN: .000 MI. DIST: 11-1 SR: 3019
LEFT MUN: JEFFERSON HILLS B RIGHT MUN: JEFFERSON HILLS B

000000 FT
000000 FT



000000 FT
7020/0000 LENGTH(AH 2545 BK 2917)
000000 FT
7010/0000 LENGTH(AH 2917 BK 0000)

000049 FT		000049 FT 7028/0000	LENGTH(AH 0865 BK 0026)
		* REF-AHD 0026/0026 000023 FT	BMSBN 02/3018/0026/0000 SCHEINBACH RD (TBK) (TWP) 2 0 02068 0 00 0049+18 P3
000023 FT		* REF-BK	SCHEINBACH RD (TBK) (TWP)
		0026/0000 000023 FT 7024/0000	LOBBS RUN BMSBG 02/3018/0026/0000 LENGTH(AH 0026 BK 0600)
000023 FT			LENGTH(AH 0600 BK 0023) BMSBN 02/3018/0020/0000
		* REF-AHD 0020/0023 000000 FT	SCHEINBACH RD (TBK) (TWP) 2 0 02068 0 00 0042+87
000000 FT		* REF-BK NC S C	SCHEINBACH RD SCHEINBACH RD (TBK) (TWP)
		0020/0000 000000 FT 7020/0000	LOBBS RUN BMSBG 02/3018/0020/0000 MFC BEGIN = E
000000 FT			LENGTH(AH 0023 BK 1495)
000000 FT		000000 FT 7010/0000	LENGTH(AH 1495 BK 2700) LENGTH(AH 2700 BK 0000)

DIR: B TOTAL LEN: 3.106 MI. DIST: 11-1 SR: 3017
 LEFT MUN: JEFFERSON HILLS B RIGHT MUN: JEFFERSON HILLS B

Location	Start Station	End Station	Length (FT)	Notes
STEINBACH DR (BORO)	016400	0070/1784	0070	COCHRAN MILL RD ROAD CLOSED BACK
	0070/1694	0070/0994	0070	018" DIA CIRC CONCR LEN=0035 INSTALLED UNKN
STEINBACH DR (BORO)	0070/0654	0070/0669	0070	COCHRAN MILL RD ROAD CLOSED AHEAD
	014616	0070/0279	0070	015" DIA CIRC CONCR LEN=0060 INSTALLED UNKN
NEILSON RD (BORO)	014616	0070/0274	0070	024" DIA CIRC CONCR LEN=0060 INSTALLED UNKN
	0060/0346	014616	014616	018" DIA CIRC CONCR LEN=0036 INSTALLED UNKN
HILL VIEW DR (BORO)	0060/0346	0070/0000	0060	2 0 02085 0 00 0114+95 KLEIN RD (BORO)
	0060/0161	0060/1019	0060	LENGTH(AH 1784 BK 1066) 018" DIA CIRC CONCR LEN=0040 INSTALLED UNKN
HILL VIEW DR (BORO)	013550	0060/0862	0060	018" DIA CIRC CONCR LEN=0090 INSTALLED UNKN
		0060/0371	0060	015" DIA CIRC CONCR LEN=0099 INSTALLED UNKN
	013550	0060/0360	0060	024" DIA CIRC CONCR LEN=0099 INSTALLED UNKN
			013550	2 0 02085 0 00 0126+26 GILL HALL RD (CNTY) NC COCHRAN MILL RD

DIR: B TOTAL LEN: 3.106 MI. DIST: 11-1 SR: 3017
 LEFT MUN: JEFFERSON HILLS B RIGHT MUN: JEFFERSON HILLS B

Stationing	Description	Notes
0060/0000	LENGTH(AH 1066 BK 2057)	
0050/1340	018 "DIA CIRC CONCR LEN=0048 INSTALLED UNKN	
011493 FT		
0050/0315	018 "DIA CIRC CONCR LEN=0040 INSTALLED UNKN	
011493 FT	2 0 02087 0 00 0115+98	
0050/0000	LENGTH(AH 2057 BK 3875) CASSIA DR	
0040/3319	(BORO) TANGELO DR	
0040/2944	(BORO)	
0040/2915	018 "DIA CIRC CONCR LEN=0040 INSTALLED UNKN	
NEW WORLD DR (BORO)	0040/2880	
INDEPENDENCE DR (BORO)	0040/2148	TANGELO DR (BORO)
SEAN CT (BORO)	0040/1785	018 "DIA CIRC CONCR LEN=0040 INSTALLED UNKN
OLD HICKORY LN (BORO)	0040/1710	
	0040/1345	024 "DIA CIRC CONCR LEN=0040 INSTALLED UNKN
	0040/1072	018 "DIA CIRC CONCR LEN=0040 INSTALLED UNKN
	0040/0710	018 "DIA CIRC CONCR LEN=0040 INSTALLED UNKN
	0040/0505	018 "DIA CIRC CONCR LEN=0040 INSTALLED UNKN
2 0 02087 0 00 0076+77 007618 FT PINEY FORK RD (SR3014 SEG 0060/1035)	007618 FT	PETERS CREEK RD (BORO)
	0040/0000	LENGTH(AH 3875 BK 3272) BMSSEN 02/3017/0030/3059 2 0 02087 0 00 0074+98
	0030/3132	PETERS CREEK
	0030/3074	BMSBG 02/3017/0030/3059 048"H 54"W CONC STRUCT
	0030/3048	LEN=0040 INSTALLED UNKN NORFOLK SOUTHERN
	0030/2503	OVERPASS IS RR X-ING
	0030/2343	048 "DIA CIRC CONCR LEN=0040 INSTALLED UNKN
	0030/2324	048 "DIA CIRC CONCR LEN=0048 INSTALLED UNKN

DIR: B TOTAL LEN: 3.106 MI. DIST: 11-1 SR: 3017
 LEFT MUN: JEFFERSON HILLS B RIGHT MUN: JEFFERSON HILLS B

004346 FT

002303 FT

000000 FT

0030/1508	024 " DIA CIRC CONCR	LEN=0040	INSTALLED UNKN
0030/1465	024 " DIA CIRC CONCR	LEN=0040	INSTALLED UNKN
0030/1422	012 " DIA CIRC CONCR	LEN=0040	INSTALLED UNKN
0030/1366	OP ID 02/7043/9900/5069	PA TPK (TOLL 43, S	
0030/1272	OP ID 02/7043/9900/5069	PA TPK (TOLL 43, N	
0030/0715	018 " DIA CIRC CONCR	LEN=0040	INSTALLED UNKN
0030/0381	018 " DIA CAST IRON	LEN=0040	INSTALLED UNKN
004346 FT	2 0 02087 0 00 0043+82		
0030/0000	RIDGE RD	(SR2028 SEG 0010/0000)	LENGTH(AH 3272 BK 2043)
0020/1320	018 " DIA CIRC CONCR	LEN=0099	INSTALLED UNKN
0020/1305	HEATH RD	(BORO)	
0020/1191	018 " DIA CIRC METAL	LEN=0040	INSTALLED UNKN
0020/0965	018 " DIA CIRC CONCR	LEN=0040	INSTALLED UNKN
0020/0955	018 " DIA CIRC METAL	LEN=0010	INSTALLED UNKN
0020/0232	UNKNOWN RD	(BORO)	
002303 FT	2 0 02087 0 00 0022+86		
0020/0000	BEDELL RD	(BORO)	LENGTH(AH 2043 BK 2303)
0010/1505	018 " DIA CIRC METAL	LEN=0040	INSTALLED UNKN
0010/1190	015 " DIA CIRC OTHER	LEN=0099	INSTALLED UNKN
000000 FT	2 0 02087 0 00 0000+00		
INTER-BK	NC GI LL HALL RD		
0010/0000	STONE CHURCH RD	(SR1008 SEG 0040/3689)	MFC BEGIN = D
0010/0000	LENGTH(AH 2303 BK 0000)		

EXTRACT DATE: 12/21/2020 ROADWAY MANAGEMENT SYSTEM PAGE NUMBER: 998
 PRINT DATE: 12/23/2020 SLD COUNTY/SR - ANNUAL PRINT COUNTY: ALLEGHENY
 DIR: B TOTAL LEN: 1.283 MI. DIST: 11-1 SR: 3016
 LEFT MUN: SOUTH PARK T RIGHT MUN: SOUTH PARK T

SNOWDEN RD 006773 FT
 (SR3015 SEG 0040/0810) 0030/1855

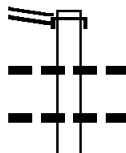

006773 FT
 INTER-AHD SNOWDEN RD
 0030/1855 (SR3015 SEG 0040/0810)
 0030/1746 036 " DIA CIR PLASTIC
 0030/1700 018 " DIA CIR CONCR
 020 " DIA CIR PLASTIC

DIR: B TOTAL LEN: 1.283 MI. DIST: 11-1 SR: 3016
 LEFT MUN: SOUTH PARK T RIGHT MUN: SOUTH PARK T

MT VERNON OF SOUTH PARK (PRDR) 0030/0427

004918 FT

RIDGE RD (TWP)
 RIGGS RD (T945)

0020/0486

2 0 02202 0 00 0024+84 KIRKBY DR (T960)

002736 FT

0020/0000

DARA DR (T954)
 AMY DR (T937)

0010/1760

0010/1285

000000 FT

0030/1199	LEN=0060	018 "DIA	CIRC PLASTIC	INSTALLED UNKN
0030/0904	LEN=0010	DARCY DR		INSTALLED UNKN
0030/0549		(TWP)		
0030/0284	LEN=0045	018 "DIA	CIRC CONCR	INSTALLED UNKN
0030/0055	LEN=0040	024 "DIA	CIRC CONCR	INSTALLED UNKN
004918 FT	2 0 02202	0 00	0047+29	
0030/0000	LENGTH(AH	1855	BK 2182)	
0020/1575	LEN=0035	018 "DIA	CIRC METAL	INSTALLED UNKN
0020/1185		HERTFORD DR		
0020/0716		(TWP) MARIA'S WY (PRDR)		
		NC RIGGS RD		
0020/0330	LEN=0045	018 "DIA	CIRC CONCR	INSTALLED UNKN
002736 FT				
0020/0000	LENGTH(AH	2182	BK 2736)	
		RIDGE RD		
0010/1760		(T562)		
0010/1037	LEN=0050	018 "DIA	CIRC METAL	INSTALLED UNKN
0010/0886	LEN=0065	018 "DIA	CIRC CONCR	INSTALLED UNKN
0010/0371	LEN=0040	024 "DIA	CIRC CONCR	INSTALLED UNKN
000000 FT	2 0 02202	0 00	0000+00	
	VILLAGE:	SOUTH PARK TWP		
	PINEY FORK RD			
	(SR3014	SEG 0020/0000)		
	INTER-BK	SINGLE TRACK RD		
	PINEY FORK RD			
	(SR3014	SEG 0020/0000)		
	MFC BEGIN = E			
0010/0000	LENGTH(AH	2736	BK 0000)	

EXTRACT DATE: 12/21/2020 ROADWAY MANAGEMENT SYSTEM PAGE NUMBER: 996
 PRINT DATE: 12/23/2020 SLD COUNTY/SR - ANNUAL PRINT COUNTY: ALLEGHENY
 DIR: B TOTAL LEN: 2.215 MI. DIST: 11-1 SR: 3015
 LEFT MUN: SOUTH PARK T RIGHT MUN: SOUTH PARK T

011693 FT

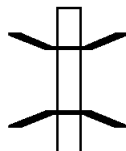

* 011693 FT
 REF-AHD COCHRANS MILL RD
 0040/2239 (TWP)
 0040/2213 BMSEN 02/3015/0040/2094
 0 0 0000 0 00 0000+00
 LICK RUN CREEK
 0040/2189 BMSBG 02/3015/0040/2094
 018 " DIA CIRC CONCR

DIR: B TOTAL LEN: 2.215 MI. DIST: 11-1 SR: 3015
 LEFT MUN: SOUTH PARK T RIGHT MUN: SOUTH PARK T

Location	Segment ID	Length	Material	Notes
	0040/1750	LEN=0050	018" DIA CIR PLASTIC	INSTALLED UNKN
	0040/1453	LEN=0040	018" DIA CIR PLASTIC	INSTALLED UNKN
	0040/1100	LEN=0035	018" DIA CIR CONCR	INSTALLED UNKN
	0040/1096	CSX RAIL OVERPASS	IS RR X-ING	
	0040/0894	LEN=0040	024" DIA CIR PLASTIC	INSTALLED UNKN
RIGGS RD (SR3016 SEG 0030/1855)	0040/0810			
	0040/0680	LEN=0040	018" DIA CIR METAL	INSTALLED UNKN
FELIX DR (PRDR)	0040/0079	009454 FT		
	0040/0000	009454 FT	2 0 02085 0 00 0076+37	LENGTH(AH 2239 BK 3863)
	0030/3598	LEN=0048	024" DIA CIR CONCR	INSTALLED UNKN
ROYAL PARK BL (TWP)	0030/3420			
	0030/3375	LEN=0050	018" DIA CIR METAL	INSTALLED UNKN
	0030/2823	LEN=0040	018" DIA CIR PLASTIC	INSTALLED UNKN
	0030/2251	LEN=0040	015" DIA CIR METAL	INSTALLED UNKN
	0030/2119	LEN=0040	018" DIA CIR PLASTIC	INSTALLED UNKN
	0030/1165	LEN=0035	018" DIA CIR CONCR	INSTALLED UNKN
	0030/1106	LEN=0099	015" DIA CIR METAL	INSTALLED UNKN
CONNOR DR (T936)	0030/0975			
	0030/0836	LEN=0040	018" DIA CIR PLASTIC	INSTALLED UNKN
	0030/0262	LEN=0040	018" DIA CIR CONCR	INSTALLED UNKN
	0030/0020	LEN=0030	012" DIA CIR CONCR	INSTALLED UNKN
	0030/0000	005591 FT	2 0 02085 0 00 0044+24	LENGTH(AH 3863 BK 3601)
	0020/3316	LEN=0040	018" DIA CIR CONCR	INSTALLED UNKN

SHEPLAR DR
(T982)

Station	Description	Station	Description
0020/2253	STATION ST (TWP)	0020/1353	SUNNY DR (TWP)
0020/0853		0020/0768	015" DIA CIRC CONCR LEN=0040 INSTALLED UNKN
		0020/0726	CSX RAIL TRANSPORTATION OVERPASS IS RR X-ING
		0020/0648	018" DIA CIRC CONCR LEN=0040 INSTALLED UNKN
001990 FT		0020/0039	012"H 24"W CONC STRUCT LEN=0040 INSTALLED UNKN
		001990 FT	2 0 02085 0 00 0000+00 PINEY FORK RD (SR3014 SEG 0050/0000)
		0020/0000	ROAD CLOSED LENGTH(AH 3601 BK 0288)
001702 FT		0014/0078	ROAD CLOSED BACK
		0014/0062	BMS EN 02/3015/0010/0283
001702 FT		001702 FT	2 0 02066 0 01 0169+46 PETERS' CREEK
		0014/0000	BMSBG 02/3015/0010/0283
		001702 FT	LTH AH 000288 BK 000100
		7012/0000	ROAD CLOSED ROAD CLOSED AHEAD
		0010/1702	JEFFERSON HILLS B
		0010/1095	018" DIA CIR PLASTIC LEN=0030 INSTALLED UNKN
		0010/1008	018" DIA CIRC METAL LEN=0040 INSTALLED UNKN
		0010/0750	024" DIA CIR PLASTIC LEN=0048 INSTALLED UNKN
		0010/0682	015" DIA CIRC METAL LEN=0060 INSTALLED UNKN
		0010/0142	018" DIA CIRC CONCR LEN=0099 INSTALLED UNKN
000000 FT		000000 FT	2 0 02066 0 01 0169+46 NC SNOWDEN RD STONE CHURCH RD (SR1008 SEG 0040/3345)
		0010/0000	MFC BEGIN = E LENGTH(AH 1702 BK 0000)

EXTRACT DATE: 12/21/2020 ROADWAY MANAGEMENT SYSTEM PAGE NUMBER: 993
 PRINT DATE: 12/23/2020 SLD COUNTY/SR - ANNUAL PRINT COUNTY: ALLEGHENY
 DIR: B TOTAL LEN: 3.312 MI. DIST: 11-1 SR: 3014
 LEFT MUN: SOUTH PARK T RIGHT MUN: SOUTH PARK T

017485 FT

016450 FT

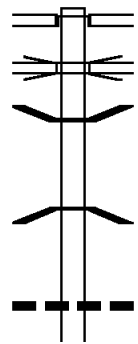

017485 FT INTER-AHD PETERS CREEK RD
 (BORO)
 0060/1035 GILL HALL RD
 (SR3017 SEG 0040/0000)
 W&LE RAILROAD
 0060/0710 OP ID 02/3014/0060/0710
 0060/0041 BMS EN 02/3014/0060/0000
 016450 FT 0 0 00000 0 00 0000+00
 LICK RUN
 BMSBG 02/3014/0060/0000
 5 0060/0000 LENGTH(AH 1035 BK 3375)
 0050/2208 024 " DIA CIRC CONCR
 LEN=0099 INSTALLED 2002
 PITTSBURGH & LAKE ERIE

DIR: B TOTAL LEN: 3.312 MI. DIST: 11-1 SR: 3014
 LEFT MUN: SOUTH PARK T RIGHT MUN: SOUTH PARK T

0 0 00000 0 00 0000+00 013075 FT
 SNOWDEN RD
 (SR3015 SEG 0020/0000) 0050/0000

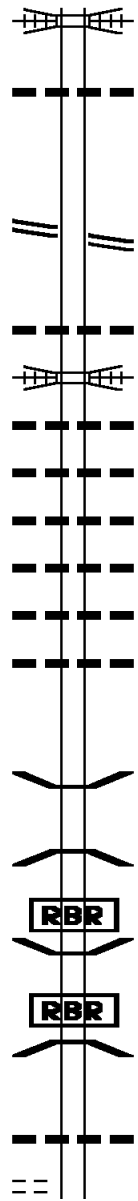

0050/1995 OVERPASS IS RR X-ING
 0050/1245 030 "DIA CIRC CONCR
 LEN=0099 INSTALLED 2002
 013075 FT SNOWDEN RD
 (SR3015 SEG 0020/0000)
 0050/0000 LENGTH(AH 3375 BK 3705)
 0040/2800 012"H 18"W ELLIP OTHER
 LEN=0035 INSTALLED UNKN
 CSX RAIL TRANSPORTATION
 0040/2450 OVERPASS IS RR X-ING
 0040/2380 012"H 18"W CON BOX CUL
 LEN=0020 INSTALLED 2002
 0040/2370 012"H 18"W CON BOX CUL
 LEN=0040 INSTALLED 2002
 0040/2040 018 "DIA CIRC CONCR
 LEN=0040 INSTALLED 2002
 0040/1545 018 "DIA CIRC CONCR
 LEN=0050 INSTALLED UNKN
 0040/1418 018 "DIA CIRC CONCR
 LEN=0040 INSTALLED 2002
 0040/1150 024 "DIA CIRC CONCR
 LEN=0040 INSTALLED 2002
 009370 FT 2 0 02066 0 00 0096+03
 0040/0000 LENGTH(AH 3705 BK 3200)
 0030/2852 BMSFN 02/3014/0030/2831
 2 0 02066 0 00 0086+05
 PINEY FORK
 0030/2804 BMSBG 02/3014/0030/2831
 0030/2275 BMSFN 02/3014/0030/2261
 2 0 02066 0 00 0063+70
 P3
 PINEY FORK
 0030/2230 BMSBG 02/3014/0030/2261
 0030/1050 018 "DIA CIRC CONCR
 LEN=0099 INSTALLED 2002

009370 FT

CONNOR RD
 (T936)

0030/0999

DIR: B TOTAL LEN: 1.872 MI. DIST: 11-1 SR: 3013
 LEFT MUN: SOUTH PARK T RIGHT MUN: SOUTH PARK T

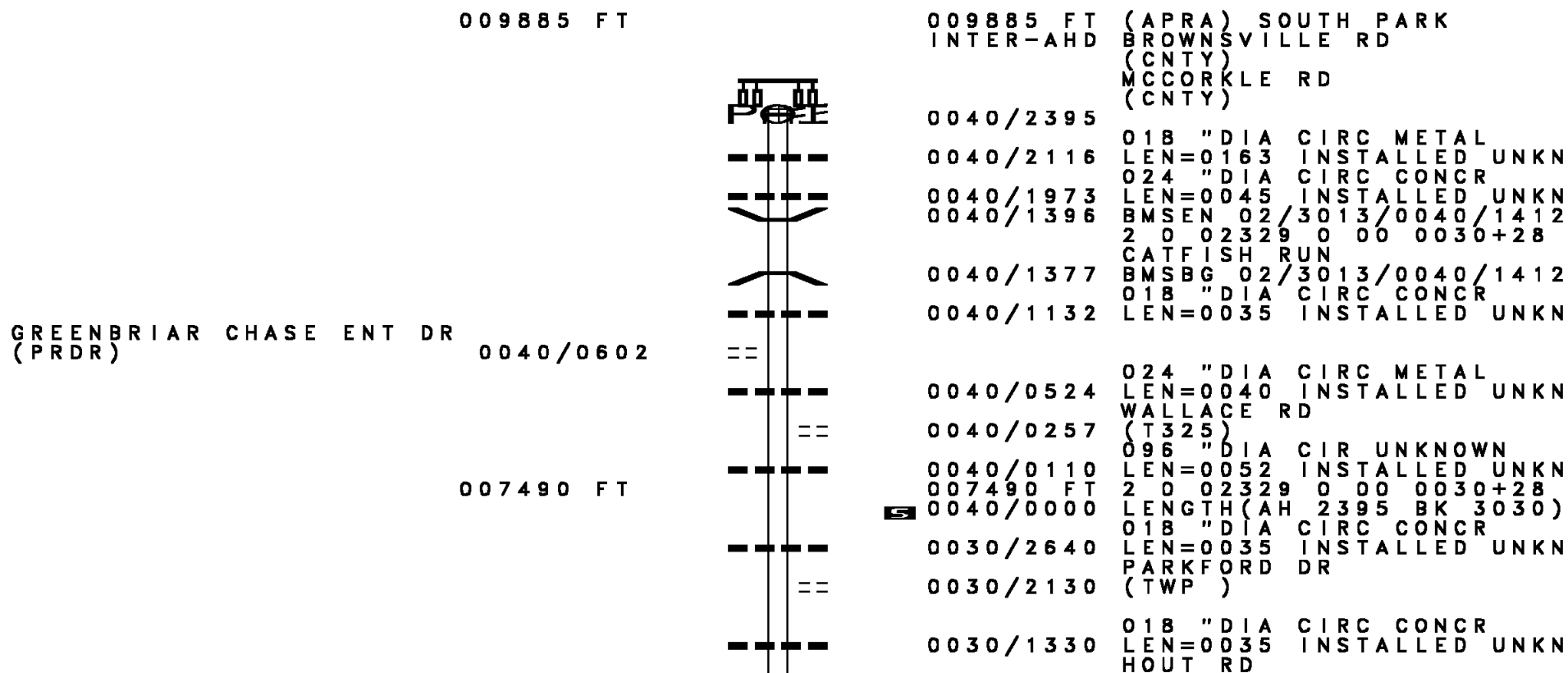

009885 FT

009885 FT (APRA) SOUTH PARK
 INTER-AHD BROWNSVILLE RD
 (CNTY)
 MCCORKLE RD
 (CNTY)

0040/2395 018 " DIA CIRC METAL
 LEN=0163 INSTALLED UNKN
 0040/2116 024 " DIA CIRC CONCR
 LEN=0045 INSTALLED UNKN
 0040/1973 BMSBG 02/3013/0040/1412
 0040/1396 2 0 02329 0 00 0030+28
 CATFISH RUN
 0040/1377 BMSBG 02/3013/0040/1412
 018 " DIA CIRC CONCR
 0040/1132 LEN=0035 INSTALLED UNKN

GREENBRIAR CHASE ENT DR
 (PRDR) 0040/0602

007490 FT

0040/0524 024 " DIA CIRC METAL
 LEN=0040 INSTALLED UNKN
 WALLACE RD
 (T325)
 0040/0257 096 " DIA CIR UNKNOWN
 LEN=0052 INSTALLED UNKN
 0040/0110 2 0 02329 0 00 0030+28
 007490 FT LENGTH(AH 2395 BK 3030)
 0040/0000 018 " DIA CIRC CONCR
 LEN=0035 INSTALLED UNKN
 0030/2640 PARKFORD DR
 (TWP)
 0030/2130
 0030/1330 018 " DIA CIRC CONCR
 LEN=0035 INSTALLED UNKN
 HOUT RD

DIR: B TOTAL LEN: 1.872 MI. DIST: 11-1 SR: 3013
 LEFT MUN: SOUTH PARK T RIGHT MUN: SOUTH PARK T

SOUTHWELL DR
 (T948) 0030/0684
 BROWNSVILLE LIBRARY RD
 (CNTY) 0030/0185

2 0 02329 0 00 0000+00 004460 FT
 BROWNSVILLE RD
 (CNTY) 0030/0000

SEBOLT RD
 (T903) 0010/1510

CENTRAL DR
 (T901) 0010/0311

2 0 02330 0 00 0000+00 000000 FT
 CENTRAL DR
 (T901) 0010/0000

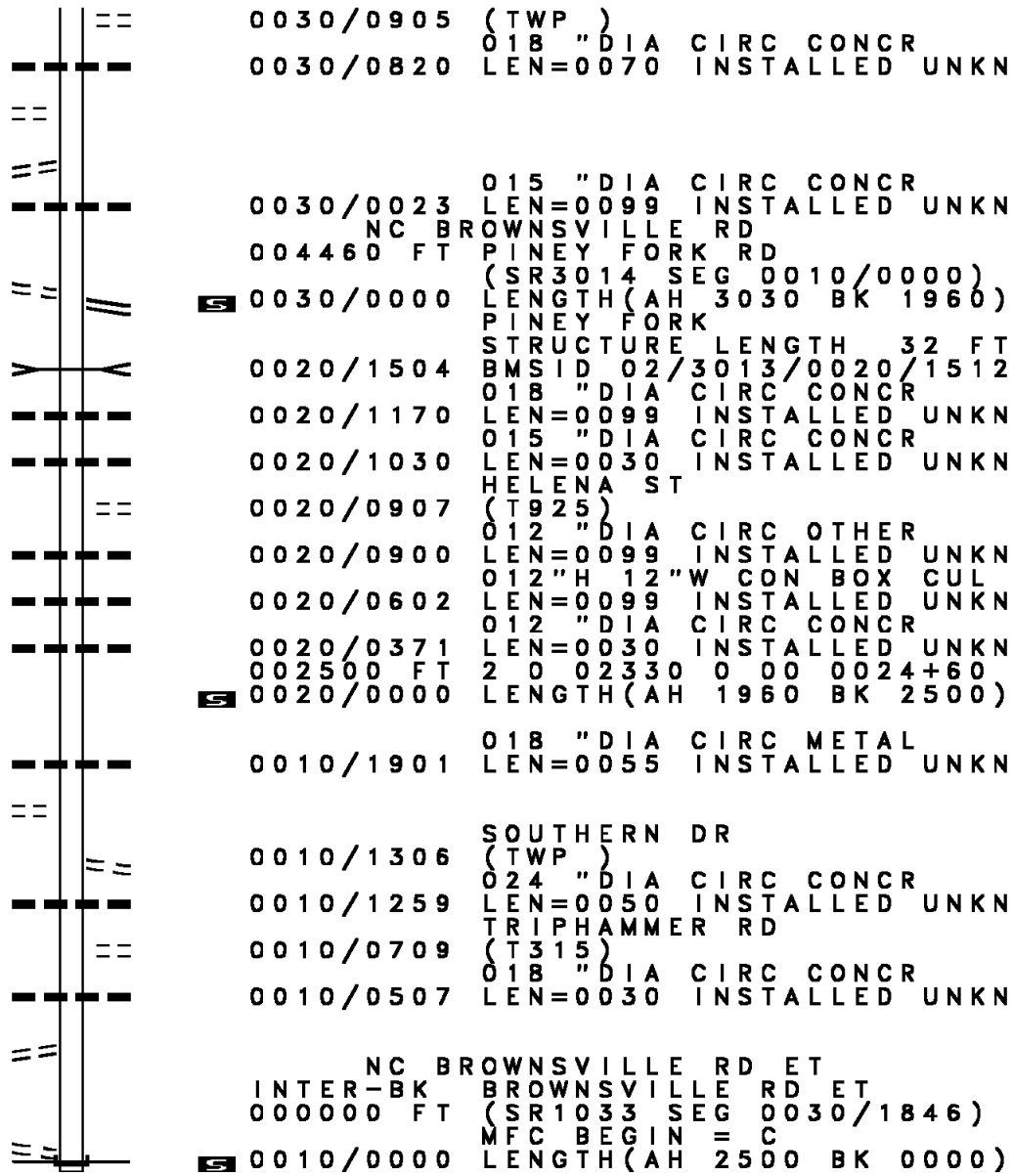

0030/0905 (TWP)
 018 " DIA CIRC CONCR
 0030/0820 LEN=0070 INSTALLED UNKN
 0030/0023 015 " DIA CIRC CONCR
 LEN=0099 INSTALLED UNKN
 NC BR BROWNSVILLE RD
 004460 FT PINEY FORK RD
 (SR3014 SEG 0010/0000)
 0030/0000 LENGTH(AH 3030 BK 1960)
 PINEY FORK
 STRUCTURE LENGTH 32 FT
 BMSID 02/3013/0020/1512
 0020/1504 018 " DIA CIRC CONCR
 0020/1170 LEN=0099 INSTALLED UNKN
 015 " DIA CIRC CONCR
 0020/1030 LEN=0030 INSTALLED UNKN
 HELENA ST
 0020/0907 (T925)
 012 " DIA CIRC OTHER
 0020/0900 LEN=0099 INSTALLED UNKN
 012"H 12"W CON BOX CUL
 0020/0602 LEN=0099 INSTALLED UNKN
 012 " DIA CIRC CONCR
 0020/0371 LEN=0030 INSTALLED UNKN
 002500 FT 2 0 02330 0 00 0024+60
 0020/0000 LENGTH(AH 1960 BK 2500)
 0010/1901 018 " DIA CIRC METAL
 LEN=0055 INSTALLED UNKN
 0010/1306 SOUTHERN DR
 (TWP)
 024 " DIA CIRC CONCR
 0010/1259 LEN=0050 INSTALLED UNKN
 TRIPHAMMER RD
 0010/0709 (T315)
 018 " DIA CIRC CONCR
 0010/0507 LEN=0030 INSTALLED UNKN
 NC BR BROWNSVILLE RD ET
 INTER-BK BROWNSVILLE RD ET
 000000 FT (SR1033 SEG 0030/1846)
 MFC BEGIN = C
 0010/0000 LENGTH(AH 2500 BK 0000)

DIR: B TOTAL LEN: 1.962 MI. DIST: 11-1 SR: 3012
 LEFT MUN: SOUTH PARK T RIGHT MUN: SOUTH PARK T

STEWART RD (SR3011 SEG 0030/0000)	010358 FT 0040/2086		010358 FT INTER-AHD BERRYMAN AV 0040/2086 (SR3011 SEG 0030/0000)
OLD POST RD (TWP)	0040/1010		0040/1010 ALBERTA DR (T887)
2 0 02077 0 00 0067+00 SLEEPY HOLLOW RD (TWP)	008272 FT 0040/0000		0040/0569 048 " DIA CIRC CONCR 008272 FT LEN=0099 INSTALLED UNKN
MARIPAT DR (T941)	0030/1244		5 0040/0000 LENGTH(AH 2086 BK 1841) 0030/1764 BMS EN 02/3012/0030/1784 2 0 02077 0 00 0085+57 SLEEPYHOLLOW
2 0 02077 0 00 0085+57 MCCONKEY RD (CNTY) LC FROM MCCONKEY RD (CONN)	006431 FT 0030/0000 0020/3669		0030/1753 BMSBG 02/3012/0030/1784 015 " DIA CIRC CONCR 0030/1247 LEN=0099 INSTALLED UNKN
			0030/1160 036 " DIA CIRC METAL LEN=0045 INSTALLED UNKN
			0030/0089 036 " DIA CIRC METAL 006431 FT LEN=0045 INSTALLED UNKN
			5 0030/0000 LENGTH(AH 1841 BK 3741)
			0020/3452 015 " DIA CIRC CONCR LEN=0100 INSTALLED 1999 024 " DIA CIRC CONCR

DIR: B TOTAL LEN: 1.962 MI. DIST: 11-1 SR: 3012
 LEFT MUN: SOUTH PARK T RIGHT MUN: SOUTH PARK T

CORRAL CT
(TWP)

0020/2565

0020/3215	LEN=0010	INSTALLED	1999
018 "DIA	CIRC	CONCR	
0020/2812	LEN=0040	INSTALLED	1999
KINGS SCHOOL RD			
(TWP)			
SOUTH PARK			
BETHEL PARK B			
018 "DIA	CIRC	CONCR	
0020/2520	LEN=0099	INSTALLED	1999
024 "DIA	CIRC	CONCR	
0020/2240	LEN=0012	INSTALLED	1999
018 "DIA	CIRC	CONCR	
0020/1982	LEN=0040	INSTALLED	1999
018 "DIA	CIRC	CONCR	
0020/1767	LEN=0040	INSTALLED	1999
PLANTATION DR			
(TWP)			
018 "DIA	CIRC	CONCR	
0020/1474	LEN=0040	INSTALLED	1999
018 "DIA	CIRC	CONCR	
0020/0823	LEN=0040	INSTALLED	1999
018 "DIA	CIRC	CONCR	
0020/0559	LEN=0040	INSTALLED	1999
018 "DIA	CIRC	CONCR	
0020/0227	LEN=0040	INSTALLED	1999
002690 FT	2 0 02077	0 00 0120+47	
0020/0000	LENGTH(AH	3741 BK 2690)	

002690 FT

TWIN HILLS DR
(PARK)

0010/2260

018 "DIA	CIRC	CONCR	
LEN=0999	INSTALLED	1999	
CLAYTONIA DR			
(TWP)			
018 "DIA	CIRC	CONCR	
0010/2165	LEN=0045	INSTALLED	1999
0010/1939	LEN=0045	INSTALLED	1999
018 "DIA	CIRC	METAL	
0010/1332	LEN=0040	INSTALLED	1999
018 "DIA	CIRC	METAL	
0010/0827	LEN=0040	INSTALLED	1999

TWIN HILLS DR
(PARK)

0010/0193
000000 FT

000000 FT	2 0 02077	0 00 0149+85	
LIBRARY RD			
(SR0088 SEG 0060/0950)			
NC ST			
TOLTZ RD			
MFC BEGIN = D			
0010/0000	LENGTH(AH	2690 BK 0000)	

LIBRARY RD
(SR0088 SEG 0060/0950) 0010/0000

DIR: B TOTAL LEN: 2.030 MI. DIST: 11-1 SR: 3011
 LEFT MUN: BETHEL PARK B RIGHT MUN: BETHEL PARK B

LIBRARY RD (SR0088 SEG 0020/2664)	010717 FT 0040/3376		010717 FT 0040/3376	LIBRARY RD (SR0088 SEG 0020/2664)
		==	0040/3356	018 "DIA CIRC CONCR LEN=0014 INSTALLED UNKN MC PHERSON AV
		==	0040/3065	(TWP) BOYER AV
		==	0040/2720	(TWP) 015 "DIA CIRC CONCR LEN=0035 INSTALLED UNKN
		==	0040/2678	MURRAY AV
		==	0040/2100	(TWP)
WILSON AV (TWP)	0040/1955	==		
HARDING AV (TWP)	0040/1780	==		
MAIN BL (TWP)	0040/1520	==		
		==	0040/1505	036 "DIA CIRC METAL LEN=0045 INSTALLED UNKN
		==	0040/1403	018 "DIA CIRC CONCR LEN=0129 INSTALLED UNKN
TRUMAN AV (TWP)	0040/1245	==		
		==	0040/1005	018 "DIA CIRC CONCR LEN=0035 INSTALLED UNKN LONG AV
		==	0040/0795	(TWP) 018 "DIA CIRC OTHER LEN=0055 INSTALLED UNKN
		==	0040/0716	
ANNETTE AV (TWP)	0040/0695	==		
LEONA AV (TWP)	0040/0435	==		
AMELIA AV (TWP)	0040/0175	==		
	007341 FT			
		==	007341 FT	2 0 02077 0 00 0033+96 CENTERMAN AV (TWP) BETHEL PARK SOUTH PARK T
		==	0040/0000	LENGTH(AH 3376 BK 1215)
BROAD ST (TB73)	0030/0465	==		
		==	0030/0465	BROAD ST (TB85)
		==	0030/0463	018 "DIA CIRC CONCR LEN=0099 INSTALLED UNKN
	006126 FT		006126 FT	2 0 02077 0 00 0046+86 NC BERRYMAN AV

DIR: B TOTAL LEN: 2.030 MI. DIST: 11-1 SR: 3011
 LEFT MUN: SOUTH PARK T RIGHT MUN: SOUTH PARK T

Location / Description	Stationing	Length	Material / Notes
	0030/0000		STOLTZ RD (SR3012 SEG 0040/2086) LENGTH(AH 1215 BK 3910)
	0020/3386		024" DIA CIRC CONCR ROSEMARY LN LEN=0099 INSTALLED UNKN
	0020/3145		(T928) 036" DIA CIRC METAL LEN=0050 INSTALLED UNKN
	0020/2859		018" DIA CIRC METAL LEN=0060 INSTALLED UNKN
	0020/2084		015"H 18"W ELLIP METAL LEN=0050 INSTALLED UNKN
SOUTH PARK SCHOOL ENT R (PRDR)	0020/0210	002216 FT	015" DIA CIRC CONCR LEN=0065 INSTALLED UNKN
	0020/0000		2 0 02079 0 00 0038+10 LENGTH(AH 3910 BK 2216)
	0010/1590		BMS EN 02/3011/0010/1585 036"H 48"W CONC STRUCT LEN=0040 INSTALLED UNKN
	0010/1588		2 0 02079 0 00 0058+45 BR. PINEYFORK
	0010/1580		BMSBG 02/3011/0010/1585 018" DIA CIRC CONCR
	0010/1301		LEN=0045 INSTALLED UNKN OAKHILL DR
BRANDIS AV (TWP)	0010/1228		(TWP)
	0010/0868		095"H 95"W UNKN CONC LEN=0060 INSTALLED UNKN PINE HILL RD
	0010/0820		(TWP)
	0010/0324		BMS EN 02/3011/0010/0295 2 0 02079 0 00 0058+45 PINEY FORK
	0010/0298		BMSBG 02/3011/0010/0295 NC ST
2 0 02079 0 00 0061+70 000000 FT BROWNSVILLE RD (TWP)	0010/0000	000000 FT	BROWNSVILLE RD (TWP) MFC BEGIN = D
	0010/0000		LENGTH(AH 2216 BK 0000)

DIR: B TOTAL LEN: 2.000 MI. DIST: 11-1 SR: 3010
 LEFT MUN: BETHEL PARK B RIGHT MUN: BETHEL PARK B

Street Name	Segment ID	Length (FT)	Notes
		010561 FT	LIBRARY RD (SR0088 SEG 0040/1110)
	0040/2694		(AAR 145708N)#TRKS 02
	0040/2598		BR. PINEY FK
			STRUCTURE LENGTH 18 FT
	0040/2565		BMSID 02/3010/0040/2609
BETHEL TERRACE DR (PRDR)	0040/2531		
CLARK AV (BORO)	0040/2218		
	0040/1886		018 " DIA CIRC CONCR LEN=0099 INSTALLED UNKN GLENDALE DR
	0040/1779		(BORO)
	0040/1697		018 " DIA CIRC CONCR LEN=0040 INSTALLED UNKN KEYSTONE DR
	0040/1485		(BORO)
GATEWOOD DR (BORO)	0040/0885		
	0040/0850		024 " DIA CIRC CONCR LEN=0099 INSTALLED UNKN
	0040/0626		018 " DIA CIRC CONCR LEN=0099 INSTALLED UNKN DELAWARE AV
	0040/0315		(BORO)
	007867 FT		2 0 02061 0 00 0028+09
	0040/0000		LENGTH(AH 2694 BK 2792)
O'NEILL DR (BORO)	0030/2443		024 " DIA CIRC OTHER LEN=0080 INSTALLED UNKN
CLARENE DR (BORO)	0030/2125		
	0030/1518		018 " DIA CIRC CONCR LEN=0045 INSTALLED UNKN

DIR: B TOTAL LEN: 2.000 MI. DIST: 11-1 SR: 3010
 LEFT MUN: BETHEL PARK B RIGHT MUN: BETHEL PARK B

WILAMIT DR
 (BORO)

0030/0720

005075 FT

2 0 02061 0 00 0082+95 002369 FT
 SOUTHPARK RD
 (SR3009 SEG 0040/3065) 0020/0000

000000 FT

==	0030/1517	FAIRVIEW DR (BORO)
---	0030/0975	018 " DIA CIRC CONCR LEN=0099 INSTALLED UNKN
==	0030/0524	IRISHTOWN RD (BORO)
---	0030/0370	018 " DIA CIRC CONCR LEN=0099 INSTALLED UNKN
==	0030/0344	PATTERSON RD (BORO)
---	0030/0237	018 " DIA CIRC CONCR LEN=0099 INSTALLED UNKN
---	005075 FT	2 0 02061 0 00 0056+20
---	0030/0000	LENGTH(AH 2792 BK 2706) 018 " DIA CIRC CONCR
---	0020/2698	LEN=0035 INSTALLED UNKN
---	0020/2241	015 " DIA CIRC CONCR LEN=0099 INSTALLED UNKN
---	0020/0472	018 " DIA CIRC CONCR LEN=0040 INSTALLED UNKN
---	002369 FT	SOUTHPARK RD (SR3009 SEG 0040/3065)
---	0020/0000	LENGTH(AH 2706 BK 2369) 018 " DIA CIRC CONCR
---	0010/2171	LEN=0030 INSTALLED UNKN
---	0010/1759	018 " DIA CIRC CONCR LEN=0060 INSTALLED UNKN
==	0010/1135	EASTVIEW RD (BORO)
==	0010/0685	GREENWALD RD (BORO)
---	0010/0492	MCLAUGHLIN STRUCTURE LENGTH 14 FT BMSID 02/3010/0010/0471
---	0010/0053	018 " DIA CIRC CONCR LEN=0040 INSTALLED UNKN
---	000000 FT	2 0 02061 0 00 0106+92
---		NC LOGAN RD
---		BETHEL CHURCH RD (BORO)
---	0010/0000	MFC BEGIN = D LENGTH(AH 2369 BK 0000)

ROADWAY	STATION	DESCRIPTION	LENGTH	STATUS
	036932	FT INTER-AHD		
	0130/3073	BROWNSVILLE RD (CNTY)		
PROVOST RD (CNTY)	0130/3073	BROWNSVILLE RD (CNTY)		
	0130/3000	018 " DIA CIRC CONCR	LEN=0050	INSTALLED UNKN
	0130/2719	018 " DIA CIRC CONCR	LEN=0033	INSTALLED UNKN
	0130/2705	NORWIN RD (TWP)		
PANAMA LODGE DR (TWP)	0130/2575	018 " DIA CIRC METAL	LEN=2412	INSTALLED UNKN
	0130/2341	018 " DIA CIRC CONCR	LEN=0048	INSTALLED UNKN
OLD BOSTON RD (TWP)	0130/2178	018 " DIA CIRC CONCR	LEN=0099	INSTALLED UNKN
	0130/2136	018 " DIA CIRC CONCR	LEN=0099	INSTALLED UNKN
	0130/2126	018 " DIA CIRC CONCR	LEN=0099	INSTALLED UNKN
	0130/1894	015 " DIA CIRC CONCR	LEN=0048	INSTALLED UNKN
	0130/1690	018 " DIA CIRC CONCR	LEN=0048	INSTALLED UNKN
BALDWIN MANOR RD	0130/1480	018 " DIA CIRC CONCR	LEN=0048	INSTALLED UNKN

DIR: B TOTAL LEN: 6.995 MI. DIST: 11-1 SR: 3009
 LEFT MUN: WHITEHALL B RIGHT MUN: WHITEHALL B

Location / TWP	Segment ID	Length	Material / Notes
(TWP)	0130/1260		018 " DIA CIRC CONCR
	0130/1236		LEN=0099 INSTALLED UNKN
	0130/1235		018 " DIA CIRC CONCR
	0130/1205		LEN=0099 INSTALLED UNKN
	0130/0996		018 " DIA CIRC CONCR
	0130/0812		LEN=0092 INSTALLED UNKN
PLYMOUTH RD (TWP)	0130/0680		018 " DIA CIRC CONCR
	0130/0570		LEN=0040 INSTALLED UNKN
	0130/0530		018 " DIA CIRC CONCR
	0130/0336		LEN=0099 INSTALLED UNKN
	0130/0110		018 " DIA CIRC CONCR
	033846 FT	033846 FT	LEN=0048 INSTALLED UNKN
WEYMAN RD (SR3035 SEG 0010/0000)	0130/0000		2 0 02063 0 01 0287+90 DOVERDELL RD (TWP)
	0120/1956		LENGTH(AH 3086 BK 2098) 036 " DIA CIRC METAL
GROVE RD (TWP)	0120/1825		LEN=0035 INSTALLED UNKN
	0120/0866		018 " DIA CIRC METAL
	0120/0865		LEN=0040 INSTALLED UNKN
	0120/0410		LACHMAN DR (TWP)
	031748 FT	031748 FT	018 " DIA CIRC CONCR
	0120/0000		LEN=0040 INSTALLED UNKN
	0110/1260		2 0 02063 0 00 0266+74 WINDVALE RD (TWP)
	0110/0630		LENGTH(AH 2098 BK 1987)
	0110/0210		018 " DIA CIRC CONCR
			LEN=0060 INSTALLED UNKN
			MCKEE RD (TWP)
			GARDENVILLE RD (TWP)

DIR: B TOTAL LEN: 6.995 MI. DIST: 11-1 SR: 3009
 LEFT MUN: WHITEHALL B RIGHT MUN: WHITEHALL B

(CONN) 0110/0070

2 0 02063 0 00 0246+64 029761 FT
 HAMILTON RD
 (SR3037 SEG 0010/0000) 0110/0000

FROM 3037/0010 SH
 (CONN) 0100/3561

COOL SPRINGS DR
 (PRDR) 0100/2627

MILLENNIUM DR
 (PRDR) 0100/0130
 026122 FT

KEVIN DR
 (TWP) 0090/1672

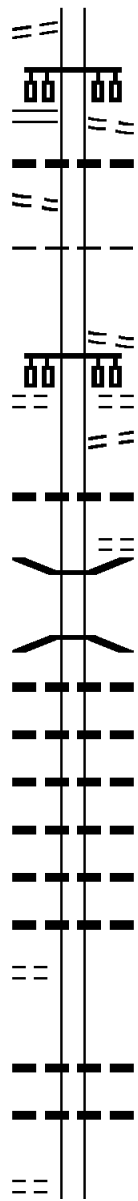

029761 FT HAMILTON RD
 (BORO)
 LENGTH(AH 1987 BK 3639)
 018 "DIA CIRC CONCR
 0100/3600 LEN=0099 INSTALLED UNKN

0100/3483 WHITEHALL
 BETHEL PARK B
 LC FROM LOWES DR
 (CONN)
 0100/2702 LOWES DR
 (PRDR)

0100/2627 LC TO LOWES DR
 (CONN)
 0100/2556 018 "DIA CIRC CONCR
 LEN=0099 INSTALLED UNKN
 DEMARCHI DR
 (TWP)

0100/2000 BMSSEN 02/3009/0100/1943
 2 0 02063 0 00 0229+54
 OTHER RR
 0100/1930 BMSBG 02/3009/0100/1943
 018 "DIA CIRC CONCR
 0100/1529 LEN=0050 INSTALLED UNKN
 018 "DIA CIRC CONCR
 0100/1270 LEN=0100 INSTALLED UNKN
 018 "DIA CIRC CONCR
 0100/0914 LEN=0050 INSTALLED UNKN
 018 "DIA CIRC CONCR
 0100/0665 LEN=0050 INSTALLED UNKN
 018 "DIA CIRC CONCR
 0100/0384 LEN=0050 INSTALLED UNKN
 018 "DIA CIRC CONCR
 0100/0157 LEN=0060 INSTALLED UNKN

026122 FT 2 0 02063 0 00 0210+86
 0100/0000 LENGTH(AH 3639 BK 2654)
 018 "DIA CIRC CONCR
 0090/2585 LEN=0048 INSTALLED UNKN
 018 "DIA CIRC CONCR
 0090/2400 LEN=0048 INSTALLED UNKN

DIR: B TOTAL LEN: 6.995 MI. DIST: 11-1 SR: 3009
 LEFT MUN: BETHEL PARK B RIGHT MUN: BETHEL PARK B

ROADWAY	START	END	LENGTH	DESCRIPTION
HORNING RD (TWP)	0090/1450	0090/1450		
	0090/1430	0090/1430	0060	018" DIA CIRC CONCR INSTALLED UNKN
	0090/0443	0090/0443	0035	024" DIA CIRC CONCR INSTALLED UNKN
	0090/0278	0090/0278	0035	024" DIA CIRC CONCR INSTALLED UNKN
	0090/0139	0090/0139	0035	024" DIA CIRC CONCR INSTALLED UNKN
	023468 FT	023468 FT		2 0 02063 0 00 0181+12
BROUGHTON RD (SR2040 SEG 0030/0000)	0090/0000	0090/0000	2654	BROUGHTON RD (SR2040 SEG 0030/0000) LENGTH(AH 2654 BK 2048) 018" DIA CIRC CONCR
	0080/1945	0080/1945	0048	INSTALLED UNKN
HIGBEE DR (TWP)	0080/0928	0080/0928		
	0080/0093	0080/0093	0020	018" DIA CIRC CONCR INSTALLED UNKN
	021420 FT	021420 FT		2 0 02063 0 00 0162+76
	0080/0000	0080/0000	2048	ROLLING GREEN DR (TWP) LENGTH(AH 2048 BK 3893) 024" DIA CIRC CONCR
	0070/3521	0070/3521	0099	INSTALLED UNKN
TO 0088/0070 SH (CONN)	0070/2798	0070/2798		LC FOR CORRIGAN DR (CONN) CORRIGAN DR (TWP)
LIBRARY RD (SR0088 SEG 0070/0000)	0070/2690	0070/2690		LIBRARY RD (SR0088 SEG 0070/0000) TO 0088/0060 SH
	0070/2583	0070/2583		(CONN)
	0070/2475	0070/2475	0035	015" DIA CIRC CONCR INSTALLED UNKN
	0070/2165	0070/2165	0024	018" DIA CIRC CONCR INSTALLED UNKN
				018" DIA CIRC CONCR

EXTRACT DATE: 12/21/2020
PRINT DATE: 12/23/2020

ROADWAY MANAGEMENT SYSTEM
SLD COUNTY/SR - ANNUAL PRINT

PAGE NUMBER: 978
COUNTY: ALLEGHENY

DIR: B TOTAL LEN: 6.995 MI.
LEFT MUN: BETHEL PARK B

DIST: 11-1 SR: 3009
RIGHT MUN: BETHEL PARK B

SONNYBROOK CT
(TWP)

0070/1306

2 0 02063 0 00 0123+75 017527 FT
LIBRARY AV
(TWP)

0070/0000

PENNSYLVANIA AV
(TWP)

0060/1735

---	0070/2155	LEN=0088	INSTALLED	UNKN
==	0070/2130	BUICK ST (TWP)		
---	0070/2053	015 "DIA	CIRC CONCR	
---	0070/1730	LEN=0048	INSTALLED	UNKN
---	0070/1460	018 "DIA	CIRC CONCR	
---	0070/1460	LEN=0048	INSTALLED	UNKN
---	0070/1460	018 "DIA	CIRC CONCR	
---	0070/1460	LEN=0100	INSTALLED	UNKN
==	0070/1194	018 "DIA	CIRC CONCR	
---	0070/1194	LEN=0048	INSTALLED	UNKN
==	0070/1155	STUDEBAKER ST (TWP)		
==	0070/0920	MADISON AV (TWP)		
---	0070/0875	018 "DIA	CIRC CONCR	
---	0070/0875	LEN=0136	INSTALLED	UNKN
---	0070/0730	018 "DIA	CIRC CONCR	
---	0070/0730	LEN=0048	INSTALLED	UNKN
---	0070/0560	018 "DIA	CIRC CONCR	
---	0070/0560	LEN=0048	INSTALLED	UNKN
==	0070/0530	PARK AV (TWP)		
---	0070/0138	018 "DIA	CIRC CONCR	
---	0070/0138	LEN=0048	INSTALLED	UNKN
00	0070/0085	BRIGHTWOOD RD (CNTY)		
00	0070/0036	(AAR 873416A)#TRKS 02		
017527 FT	017527 FT			
00	0070/0000	LENGTH(AH 3893 BK 2547)		
---	0060/2520	024 "DIA	CIRC CONCR	
---	0060/2520	LEN=0099	INSTALLED	UNKN
---	0060/1947	018 "DIA	CIRC CONCR	
---	0060/1947	LEN=0181	INSTALLED	UNKN
==	0060/1910	PENNSYLVANIA AV (TWP)		
---	0060/1766	018 "DIA	CIRC CONCR	
---	0060/1766	LEN=0099	INSTALLED	UNKN
==	0060/1280	018 "DIA	CIRC CONCR	
---	0060/1280	LEN=0060	INSTALLED	UNKN
==	0060/1105	CHESTNUT ST (TWP)		
---	0060/1100	012 "DIA	CIRC CONCR	
---	0060/1100	LEN=0035	INSTALLED	UNKN

EXTRACT DATE: 12/21/2020
PRINT DATE: 12/23/2020

ROADWAY MANAGEMENT SYSTEM
SLD COUNTY/SR - ANNUAL PRINT

PAGE NUMBER: 977
COUNTY: ALLEGHENY

DIR: B TOTAL LEN: 6.995 MI.
LEFT MUN: BETHEL PARK B

DIST: 11-1 SR: 3009
RIGHT MUN: BETHEL PARK B

BERTHA ST
(TWP) 0060/0358
2 0 02063 0 00 0098+48 014980 FT
TEXAS AV
(TWP) 0060/0000
CHURCH RD
(TWP) 0050/1735

2 0 02063 0 00 0077+14 012849 FT
CAROLINA DR
(TWP) 0050/0000

LOGAN RD
(SR3010 SEG 0020/0000) 0040/3065

OAKLYN RD
(TWP) 0040/2094

VOSS RD
(TWP) 0040/1718

CRESTVIEW DR
(TWP) 0040/1636

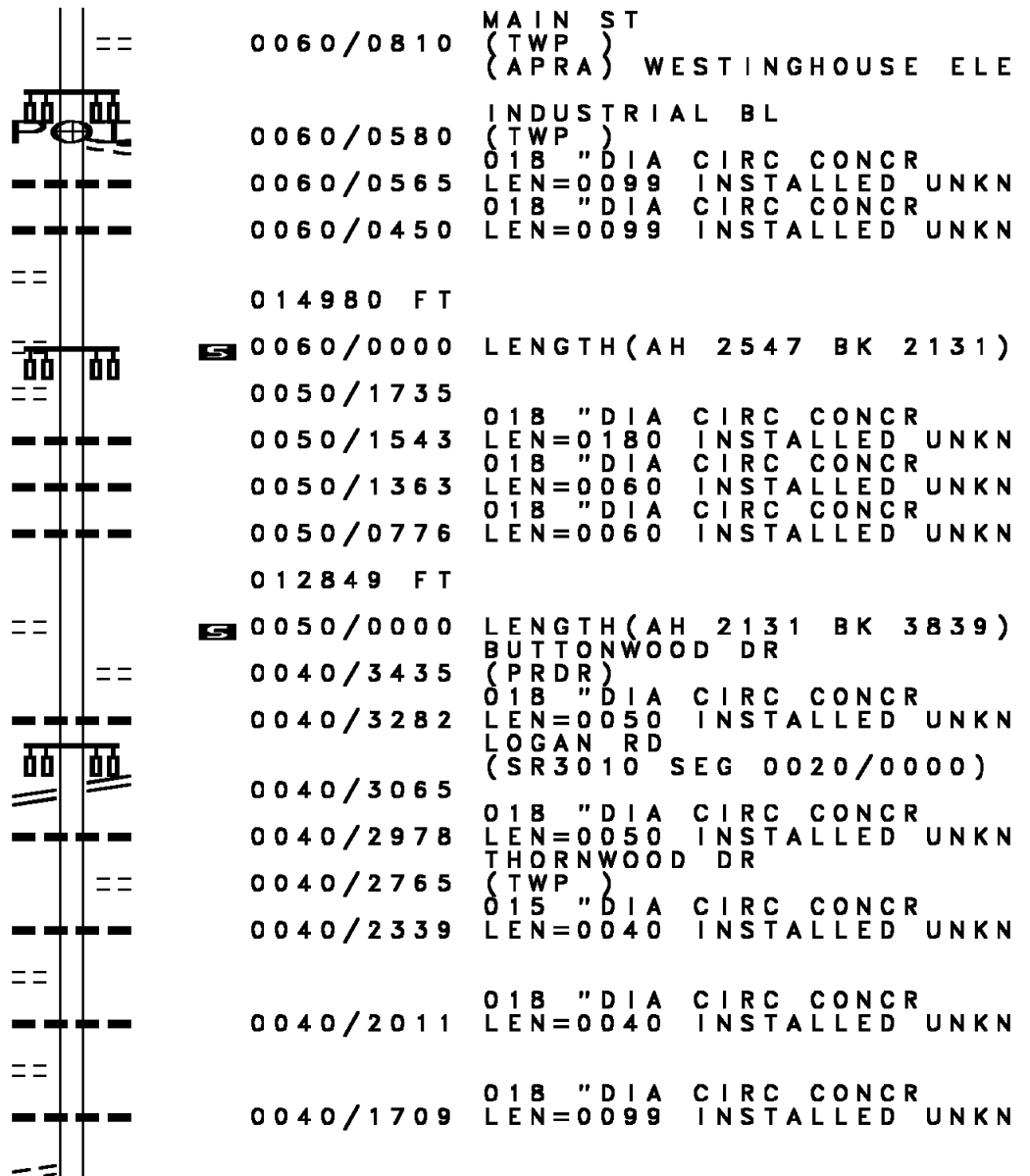

EXTRACT DATE: 12/21/2020
PRINT DATE: 12/23/2020

ROADWAY MANAGEMENT SYSTEM
SLD COUNTY/SR - ANNUAL PRINT

PAGE NUMBER: 975
COUNTY: ALLEGHENY

DIR: B TOTAL LEN: 6.995 MI.
LEFT MUN: BETHEL PARK B

DIST: 11-1 SR: 3009
RIGHT MUN: BETHEL PARK B

PINEHAVEN DR
(TWP)

0030/0590

2 0 02063 0 00 0000+00
MCMURRY RD
(SR3004 SEG 0100/1967)

005152 FT
0030/0000
005152 FT

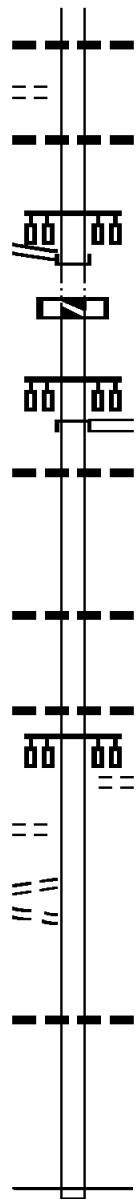

0030/0600 018 "DIA CIRC CONCR
LEN=0035 INSTALLED UNKN

0030/0367 015 "DIA CIRC CONCR
LEN=0030 INSTALLED UNKN
NC SOUTH PARK RD

005152 FT
INTER-BK MCMURRAY RD
(SR3004 SEG 0100/1967)
5 0030/0000 LTH AH 003858 BK 000100
005152 FT

7024/0000 LTH AH 000100 BK 002309
INTER-AHD MCMURRAY RD
(SR3004 SEG 0110/0000)
CLIFTON RD
(SR3004 SEG 0110/0000)

0020/2309
0020/1940 015 "DIA CIRC CONCR
LEN=0099 INSTALLED UNKN

002843 FT

0020/0336 015 "DIA CIRC CONCR
LEN=0040 INSTALLED UNKN
2 0 02240 0 00 0035+17
5 0020/0000 LENGTH(AH 2309 BK 2843)

0010/2501 018 "DIA CIRC METAL
LEN=0040 INSTALLED UNKN
LIMESTONE DR
(TWP)

0010/2295

DIABLO DR
(TWP)
HOLLYDALE DR
(TWP)
HOLLYDALE DR
(TWP)

0010/1945

0010/1554

0010/1470

000000 FT

0010/0400 018 "DIA CIRC CONCR
LEN=0048 INSTALLED UNKN
2 0 02240 0 00 0000+00
NC MCMURRAY RD

* REF-BK MCMURRAY RD
(SR1002 SEG 0130/2299)
MFC BEGIN = C
BK-WASHINGTON (62)
5 0010/0000 LENGTH(AH 2843 BK 0000)

EXTRACT DATE: 12/21/2020 ROADWAY MANAGEMENT SYSTEM PAGE NUMBER: 974
 PRINT DATE: 12/23/2020 SLD COUNTY/SR - ANNUAL PRINT COUNTY: ALLEGHENY
 DIR: B TOTAL LEN: .006 MI. DIST: 11-1 SR: 3008
 LEFT MUN: UPPER ST CLAIR T RIGHT MUN: UPPER ST CLAIR T

000031 FT

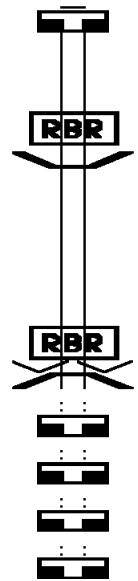

000031 FT
 7044/0000 LENGTH(AH 0278 BK 0031)
 * REF-AHD MORROW RD (TBK)
 0042/0031 (TWP)

000000 FT

0042/0021 BMS EN 02/3008/0042/0000
 000000 FT 2 0 02052 0 00 0055+84
 P3
 VILLAGE: UPPER ST CLAIR
 NC MORROW RD
 * REF-BK MORROW RD (TBK)
 (TWP)

000000 FT

5 0042/0000 MCLAUGHLIN RUN
 000000 FT BMSBG 02/3008/0042/0000
 7040/0000 LENGTH(AH 0031 BK 2663)

000000 FT

7030/0000 LENGTH(AH 2663 BK 2912)

000000 FT

7020/0000 LENGTH(AH 2912 BK 2077)

000000 FT

7010/0000 LENGTH(AH 2077 BK 2116)

7010/0000 LENGTH(AH 2116 BK 0000)

EXTRACT DATE: 12/21/2020 ROADWAY MANAGEMENT SYSTEM PAGE NUMBER: 973
PRINT DATE: 12/23/2020 SLD COUNTY/SR - ANNUAL PRINT COUNTY: ALLEGHENY
DIR: B TOTAL LEN: 1.311 MI. DIST: 11-1 SR: 3007
LEFT MUN: JEFFERSON HILLS B RIGHT MUN: JEFFERSON HILLS B

006924 FT

006924 FT SCOTIA HOLLOW RD

EXTRACT DATE: 12/21/2020
PRINT DATE: 12/23/2020

ROADWAY MANAGEMENT SYSTEM
SLD COUNTY/SR - ANNUAL PRINT

PAGE NUMBER: 972
COUNTY: ALLEGHENY

DIR: B TOTAL LEN: 1.311 MI.
LEFT MUN: JEFFERSON HILLS B

DIST: 11-1 SR: 3007
RIGHT MUN: JEFFERSON HILLS B

Stationing	Notes	Stationing	Notes
		0020/3496	(CNTY)
		0020/3477	024 " DIA CIRC CONCR LEN=0050 INSTALLED 1999
		0020/3258	018 " DIA CIRC METAL LEN=0030 INSTALLED 1999
		0020/3215	GUTHRIE DR (BORO)
		0020/1945	PENNSYLVANIA AV (BORO)
		0020/1325	018 " DIA CIRC METAL LEN=0070 INSTALLED 1999
		0020/1074	018 " DIA CIRC METAL LEN=0055 INSTALLED 1999
		0020/0794	018 " DIA CIRC METAL LEN=0030 INSTALLED 1998
		0020/0167	048 " DIA CIRC METAL LEN=0070 INSTALLED 1999
003428 FT		003428 FT	2 0 02070 0 00 0039+74 RIVERVIEW RD (BORO)
		0020/0000	LENGTH(AH 3496 BK 3428)
		0010/2365	036 " DIA CIRC METAL LEN=0065 INSTALLED 1998
		0010/1809	024 " DIA CIRC CONCR LEN=0050 INSTALLED UNKN
		0010/1455	BMSSEN 02/3007/0010/1433 2 0 02070 0 00 0019+44 BR. LOBBS RUN
		0010/1433	BMSBG 02/3007/0010/1433
DALE ST (BORO)		0010/1305	
		0010/1092	018 " DIA CIRC METAL LEN=0028 INSTALLED 1998
		0010/1012	018 " DIA CIRC METAL LEN=0028 INSTALLED 1998
		000000 FT	000000 FT 2 0 02070 0 00 0000+00
			NC WA LTON RD INTER-BK ASHLAND AV (SR3021 SEG 0030/3105) MFC BEGIN = E
KNIGHT RD (TBK) (BORO)		0010/0000	LENGTH(AH 3428 BK 0000)

DIR: B TOTAL LEN: 3.071 MI. DIST: 11-1 SR: 3006
 LEFT MUN: UPPER ST CLAIR T RIGHT MUN: UPPER ST CLAIR T

	016216 FT		016216 FT	INTER-AHD	BOYCE RD (T335)
					WASHINGTON RD (SR0019 SEG 0021/1021) (SR0019 SEG 0020/1271)
			0060/1904		THORNTREE DR (TWP)
			0060/1541		FAIRGREEN DR (TWP)
BOYCE SCHOOL RD (TWP)	0060/0630		0060/0775		015 " DIA CIRC CONCR LEN=0030 INSTALLED UNKN
			0060/0463		018 " DIA CIRC METAL LEN=0030 INSTALLED UNKN
2 0 02046 0 01 0233+13 014312 FT			0060/0214		
SCHOOL EXIT DR	0060/0000		014312 FT		
(PRDR)			5 0060/0000	LENGTH(AH 1904 BK 3308)	

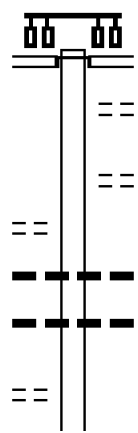

DIR: B TOTAL LEN: 3.071 MI. DIST: 11-1 SR: 3006
 LEFT MUN: UPPER ST CLAIR T RIGHT MUN: UPPER ST CLAIR T

MORTON RD
 (TWP)

0050/2191

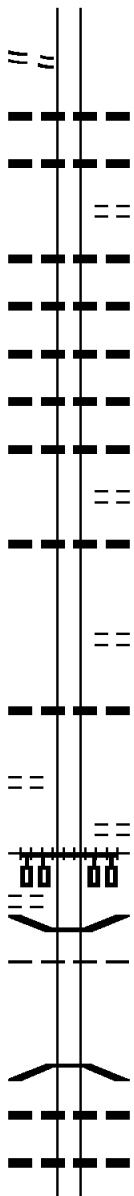

0050/1981 018 " DIA CIRC CONCR
 LEN=0040 INSTALLED UNKN
 0050/1682 015 " DIA CIRC CONCR
 LEN=0035 INSTALLED UNKN
 MILLWOOD DR
 (TWP)
 0050/1600 018 " DIA CIRC CONCR
 LEN=0030 INSTALLED UNKN
 0050/1390 018 " DIA CIRC CONCR
 LEN=0030 INSTALLED UNKN
 0050/1089 018 " DIA CIRC CONCR
 LEN=0030 INSTALLED UNKN
 0050/0844 018 " DIA CIRC CONCR
 LEN=0035 INSTALLED UNKN
 0050/0551 018 " DIA CIRC CONCR
 LEN=0055 INSTALLED UNKN
 0050/0285 018 " DIA CIRC CONCR
 LEN=0030 INSTALLED UNKN
 BINGHAM DR
 (TWP)
 0050/0195 024 " DIA CIRC CONCR
 LEN=0035 INSTALLED UNKN
 011004 FT 2 0 02046 0 01 0200+05
 011004 FT OLD BOYCE STATION RD
 (TWP)
 0050/0000 LENGTH(AH 3308 BK 3060)
 0040/2291 024 " DIA CIRC CONCR
 LEN=0050 INSTALLED UNKN
 HIDDEN VALLEY DR
 (TWP)
 0040/1335 (AAR 510618V)#TRKS 01
 0040/0813
 0040/0340
 0040/0098 BMSBN 02/3006/0040/0000
 UPPER ST CLAIR
 SOUTH FAYETTE T
 007944 FT 2 0 02046 0 01 0170+06
 CHARTIERS CK
 BMSBG 02/3006/0040/0000
 0040/0000 LENGTH(AH 3060 BK 2389)
 0030/2281 018 " DIA CIRC CONCR
 LEN=0040 INSTALLED UNKN
 0030/2150 024 " DIA CIRC CONCR
 LEN=0099 INSTALLED UNKN
 MAYVIEW RD

MAPLE LN
 (TWP)

0040/1482

BOYCE PLAZA RD
 (TWP)

0040/0340

007944 FT

EXTRACT DATE: 12/21/2020
PRINT DATE: 12/23/2020

ROADWAY MANAGEMENT SYSTEM
SLD COUNTY/SR - ANNUAL PRINT

PAGE NUMBER: 969
COUNTY: ALLEGHENY

DIR: B TOTAL LEN: 3.071 MI.
LEFT MUN: SOUTH FAYETTE T

DIST: 11-1 SR: 3006
RIGHT MUN: SOUTH FAYETTE T

Stationing	Right-of-Way	Structure	Material	Status
0030/1940	(SR3005 SEG 0020/0000)			
0030/1440	018 "DIA	CIRC	CONCR	INSTALLED UNKN
0030/0830	018 "DIA	CIRC	CONCR	INSTALLED UNKN
0030/0597	018 "DIA	CIRC	CONCR	INSTALLED UNKN
005555 FT	2 0 02046 0 01 0145+78			
0030/0000	LENGTH(AH 2389 BK 1850)			
0020/1757	015 "DIA	CIRC	CONCR	INSTALLED UNKN
0020/1533	018 "DIA	CIRC	CONCR	INSTALLED UNKN
0020/1440	015 "DIA	CIR	PLASTIC	INSTALLED UNKN
0020/1152	018 "DIA	CIRC	CONCR	INSTALLED UNKN
0020/0772	018 "DIA	CIRC	CONCR	INSTALLED UNKN
0020/0542	018 "DIA	CIRC	CONCR	INSTALLED UNKN
0020/0030	018 "DIA	CIR	PLASTIC	INSTALLED UNKN
003705 FT	HUNTING RIDGE RD			
0020/0000	LENGTH(AH 1850 BK 3705)			
0010/3337	MEETING HOUSE RD			
0010/3092	(TWP)			
0010/2809	018 "DIA	CIRC	CONCR	INSTALLED UNKN
0010/1830	015 "DIA	CIRC	CONCR	INSTALLED UNKN
0010/1510	SUMMIT RIDGE DR			
0010/1160	(TWP)			
000000 FT	2 0 02046 0 01 0090+24			
	NC BO YCE RD			
	WASHINGTON PK			
	(SR3003 SEG 0020/2418)			
	MFC BEGIN = C			
0010/0000	LENGTH(AH 3705 BK 0000)			

EXTRACT DATE: 12/21/2020
PRINT DATE: 12/23/2020

ROADWAY MANAGEMENT SYSTEM
SLD COUNTY/SR - ANNUAL PRINT

PAGE NUMBER: 967
COUNTY: ALLEGHENY

DIR: B TOTAL LEN: 3.924 MI.
LEFT MUN: BRIDGEVILLE B

DIST: 11-1 SR: 3005
RIGHT MUN: BRIDGEVILLE B

STREET NAME	STREET ID	TYPE	START	END	DESCRIPTION
ELM ST (BORO)	0060/1853	==			
SPRUCE ST (BORO)	0060/1659	==			
ELIZABETH ST (BORO)	0060/1497	==			
		==			0060/1565 GRANDVIEW ST (BORO)
		---			0060/1132 018 " DIA CIRC CONCR LEN=0048 INSTALLED UNKN
		---			0060/0854 018 " DIA CIRC CONCR LEN=0048 INSTALLED UNKN
		---			0060/0444 018 " DIA CIRC CONCR LEN=0048 INSTALLED UNKN
		---			WINFIELD ST (BORO)
		---			0060/0111 018 " DIA CIRC CONCR LEN=0068 INSTALLED UNKN
	016177 FT				016177 FT 2 0 02050 0 00 0045+06 LESNETT RD (SR3034 SEG 0030/0000) BRIDGEVILLE UPPER ST CLAIR T
CHARTIERS ST (SR3034 SEG 0010/3770)	0050/3082	==			5 0060/0000 LENGTH(AH 3255 BK 3150) NC BANK ST
		---			0050/2185 018 " DIA CIR PLASTIC LEN=0050 INSTALLED UNKN
		>---			BR. CHARTIERS STRUCTURE LENGTH 8 FT
		==			0050/1585 BMSID 02/3005/0050/1585 MORROW RD
		==			0050/0998 (TWP)
		==			0050/0650 OAK PARK CT (TWP)
		---			0050/0581 018 " DIA CIRC CONCR LEN=0030 INSTALLED UNKN
GALAXY CR (TWP)	0050/0335	==			
	013027 FT				013027 FT 2 0 02318 0 00 0071+25 STAR RIDGE DR (TWP)
		==			5 0050/0000 LENGTH(AH 3150 BK 3314)
		---			0040/3100 036 " DIA CIRC CONCR LEN=0070 INSTALLED UNKN

DIR: B TOTAL LEN: 3.924 MI. DIST: 11-1 SR: 3005
 LEFT MUN: UPPER ST CLAIR T RIGHT MUN: UPPER ST CLAIR T

POLARIS CR
 (TWP)

0040/1887

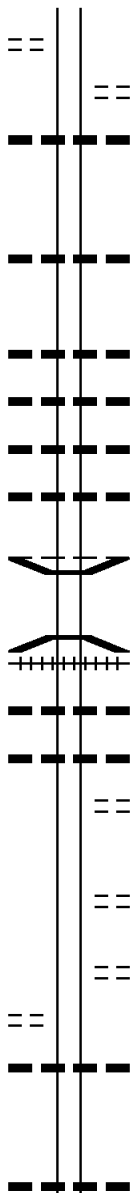

0040/1652 SKYRIDGE DR
 (TWP)
 018 " DIA CIRC CONCR
 0040/1438 LEN=0050 INSTALLED UNKN

009713 FT

0040/0155 018 " DIA CIRC CONCR
 009713 FT LEN=0048 INSTALLED UNKN
 5 0040/0000 2 0 02318 0 00 0037+80
 LENGTH(AH 3314 BK 3753)
 0030/3475 024 " DIA CIRC OTHER
 LEN=0051 INSTALLED UNKN
 0030/3141 018 " DIA CIRC CONCR
 LEN=0048 INSTALLED UNKN
 0030/2754 018 " DIA CIRC CONCR
 LEN=0048 INSTALLED UNKN
 0030/2650 018 " DIA CIRC CONCR
 LEN=0314 INSTALLED UNKN
 BMSSEN 02/3005/0030/2441
 UPPER ST CLAIR
 0030/2570 SOUTH FAYETTE T
 2 0 02318 0 00 0023+72
 CHARTIERS CREEK
 0030/2441 BMSBG 02/3005/0030/2441
 0030/2296 (AAR 510621D)#TRKS 01
 0030/2275 018 " DIA CIRC CONCR
 LEN=0128 INSTALLED UNKN
 0030/2151 018 " DIA CIRC METAL
 LEN=0128 INSTALLED UNKN
 0030/2149 SERPENTINE DR
 (TWP)

0030/1006 HASTINGS CRESCENT RD
 (TWP)

0030/0366 HASTINGS PARK DR
 (TWP)

SUNSET DR
 (TWP)

0030/0275

005960 FT

0030/0205 018 " DIA CIRC CONCR
 005960 FT LEN=0027 INSTALLED UNKN
 5 0030/0000 2 0 02318 0 00 0000+00
 LENGTH(AH 3753 BK 3581)
 0020/2721 018 " DIA CIRC CONCR
 LEN=0050 INSTALLED UNKN

EXTRACT DATE: 12/21/2020
PRINT DATE: 12/23/2020

ROADWAY MANAGEMENT SYSTEM
SLD COUNTY/SR - ANNUAL PRINT

PAGE NUMBER: 965
COUNTY: ALLEGHENY

DIR: B TOTAL LEN: 3.924 MI.
LEFT MUN: SOUTH FAYETTE T

DIST: 11-1 SR: 3005
RIGHT MUN: SOUTH FAYETTE T

Stationing	Notes	Structure	Material	Length
0020/2288	018" DIA CIRC CONCR	--- ---	INSTALLED UNKN	LEN=0048
0020/1950	060"H 72"W CON BOX CUL	--- ---	INSTALLED UNKN	LEN=0048
0020/1887	BMSSEN 02/3005/0020/1873	--- ---	2 0 02051 0 00 0042+39	
0020/1873	BR CHARTIERS	--- ---	BMSBG 02/3005/0020/1873	
0020/1437	018" DIA CIRC CONCR	--- ---	INSTALLED UNKN	LEN=0040
0020/1151	018" DIA CIRC CONCR	--- ---	INSTALLED UNKN	LEN=0040
0020/0654	018" DIA CIRC CONCR	--- ---	INSTALLED UNKN	LEN=0048
0020/0325	018" DIA CIRC CONCR	--- ---	INSTALLED UNKN	LEN=0040
0020/0108	018" DIA CIRC CONCR	--- ---	INSTALLED UNKN	LEN=0048
002379 FT	2 0 02051 0 00 0023+09	--- ---	BOYCE RD	
	(SR3006 SEG 0030/1940)			
0020/0000	LENGTH(AH 3581 BK 2379)	==		
0010/2325	BMSSEN 02/3005/0010/2313	--- ---	060" DIA CIR PLASTIC	
0010/2317	LEN=0048 INSTALLED UNKN	--- ---	0 0 00000 0 00 0000+00	
0010/2313	BR CHARTIERS	--- ---	BMSBG 02/3005/0010/2313	
0010/1663	(APRA) PHILLIPS IND PAR	==	PHILLIPS DR	
0010/1225	(PRDR)	POE	018" DIA CIRC CONCR	
0010/1210	LEN=0048 INSTALLED UNKN	--- ---	SCOTT RD	
0010/0635	(TWP)	==	072" DIA CIRC CONCR	
0010/0350	LEN=0040 INSTALLED UNKN	--- ---		
000000 FT	2 0 02051 0 00 0000+00	==	YVIEW RD	
NC MA			MAYVIEW RD	
* REF-BK	(SR1011 SEG 0020/2813)		MFC BEGIN = D	
	BK-WASHINGTON (62)			
0010/0000	LENGTH(AH 2379 BK 0000)	==		

DIR: B TOTAL LEN: 7.602 MI. DIST: 11-1 SR: 3004
 LEFT MUN: BETHEL PARK B RIGHT MUN: BETHEL PARK B

Location	Start Station	End Station	Length (FT)	Material / Notes
	040141		FT	LIBRARY RD (SR0088 SEG 0020/0340)
	0150/3476			
TIMBERRIDGE RD (TWP)	0150/3180			015 "DIA CIRC CONCR LEN=0055 INSTALLED UNKN
				018 "DIA CIRC CONCR LEN=0040 INSTALLED UNKN
AIREDALE DR (TWP)	0150/1930			042 "DIA CIRC METAL LEN=0030 INSTALLED UNKN
				018 "DIA CIRC CONCR LEN=0055 INSTALLED UNKN
				055 "DIA CIRC CONCR LEN=0065 INSTALLED UNKN
2 0 02327 0 00 0097+34 KINGS SCHOOL RD (BORO)	036665		FT	
	0150/0000			5 0150/0000 LENGTH(AH 3476 BK 2646)
				018 "DIA CIRC CONCR LEN=0100 INSTALLED UNKN
				018 "DIA CIRC CONCR LEN=0040 INSTALLED 2002 IRISHTOWN RD (SR3020 SEG 0010/0000)
COPSEWOOD DR (BORO) IRISHTOWN RD (BORO)	0140/0710			
	034019		FT	
				055 "DIA CIRC METAL LEN=0050 INSTALLED UNKN
				2 0 02327 0 00 0071+00 BRUSH RUN RD (BORO)
				5 0140/0000 LENGTH(AH 2646 BK 2875)
				018 "DIA CIRC CONCR LEN=0030 INSTALLED UNKN
				018 "DIA CIRC METAL LEN=0020 INSTALLED UNKN
VANVOORHIS DR (BORO)	0130/1730			
				015 "DIA CIRC CONCR LEN=0054 INSTALLED UNKN

EXTRACT DATE: 12/21/2020
PRINT DATE: 12/23/2020

ROADWAY MANAGEMENT SYSTEM
SLD COUNTY/SR - ANNUAL PRINT

PAGE NUMBER: 963
COUNTY: ALLEGHENY

DIR: B TOTAL LEN: 7.602 MI.
LEFT MUN: BETHEL PARK B

DIST: 11-1 SR: 3004
RIGHT MUN: BETHEL PARK B

DUBLIN RD
(BORO)

0130/0327
031144 FT

PENNWOOD CT
(BORO)

0120/0720

029391 FT

DASHWOOD DR
(BORO)

0110/2230

WASHINGTON SCHOOL RD
(PRDR)

0110/0325

Stationing	Material	Length	Notes
0130/1331	HAVENGATE DR (BORO)		
0130/1086	018" DIA CIRC CONCR	LEN=0040	INSTALLED UNKN
0130/0636	018" DIA CIRC CONCR	LEN=0040	INSTALLED UNKN
0130/0327	ROCKY RIDGE RD (BORO)		
031144 FT	2 0 02327 0 00		0043+00
0130/0000	THUNDERWOOD DR (BORO)		
0120/1750	LENGTH(AH 2875 BK 1753)		
0120/1686	036" DIA CIRC METAL	LEN=0099	INSTALLED 2002
0120/1680	036" DIA CIRC CONCR	LEN=0030	INSTALLED 2003
0120/1418	LC FOR THUNDERWOOD DR (CONN)		
	030" DIA CIR PLASTIC	LEN=0049	INSTALLED UNKN
0120/0720	MANOAH DR (BORO)		
0120/0635			
029391 FT	2 0 02327 0 00		0023+74
0120/0000	LENGTH(AH 1753 BK 2303)		
0110/1946	015" DIA CIRC METAL	LEN=0035	INSTALLED UNKN
0110/1258	012" DIA CIR PLASTIC	LEN=0040	INSTALLED 2002
0110/1136	018" DIA CIRC CONCR	LEN=0150	INSTALLED 2002
0110/0873	018" DIA CIRC CONCR	LEN=0040	INSTALLED 2002
0110/0461	018" DIA CIRC CONCR	LEN=0199	INSTALLED 2002
0110/0448	018" DIA CIRC CONCR	LEN=0040	INSTALLED 2002
0110/0327	OP ID 02/7407/3004/1111		
0110/0325	HIGHFIELD RD (BORO)		
0110/0300	018" DIA CIRC CONCR	LEN=0040	INSTALLED 2002
	018" DIA CIR PLASTIC		

EXTRACT DATE: 12/21/2020
PRINT DATE: 12/23/2020

ROADWAY MANAGEMENT SYSTEM
SLD COUNTY/SR - ANNUAL PRINT

PAGE NUMBER: 962
COUNTY: ALLEGHENY

DIR: B TOTAL LEN: 7.602 MI.
LEFT MUN: BETHEL PARK B

DIST: 11-1 SR: 3004
RIGHT MUN: BETHEL PARK B

Segment ID	Length (FT)	Start Station	End Station	Notes
027088	027088	0110/0040	0110/0040	LEN=0040 INSTALLED 2002
		027088	2 0 02327 0 00 0000+00	MCMURRAY RD (SR3009 SEG 0020/2309)
				NC CLIFTON RD
		0110/0000	0110/0000	LENGTH(AH 2303 BK 2601) 018 "DIA CIRC METAL
		0100/2141	0100/2141	LEN=0035 INSTALLED UNKN
SOUTH PARK RD (SR3009 SEG 0030/0000)	0100/1967	0100/1967	0100/1967	BETHEL PARK UPPER ST CLAIR T SOUTHRIDGE DR (BORO)
		0100/1960	0100/1960	015 "DIA CIRC CONCR LEN=0035 INSTALLED UNKN
		0100/1435	0100/1435	
		0100/0953	0100/0953	
		0100/0050	0100/0050	018 "DIA CIRC CONCR LEN=0040 INSTALLED 2002
024487	024487	024487	2 0 02240 0 00 0083+19	
		0100/0000	0100/0000	LENGTH(AH 2601 BK 1590) 018 "DIA CIRC CONCR
		0096/1385	0096/1385	LEN=0110 INSTALLED 2002 JOHNSTON RD (TWP)
		0096/1008	0096/1008	
		0096/0245	0096/0245	018 "DIA CIRC CONCR LEN=0040 INSTALLED UNKN
022897	022897	022897	0 0 00000 0 00 0000+00	
		0096/0000	0096/0000	HARROW RD (TWP) LENGTH(AH 1590 BK 2550) 024 "DIA CIRC CONCR
		0090/1960	0090/1960	LEN=0025 INSTALLED UNKN
		0090/1246	0090/1246	WILTSHIRE DR (TWP)
		0090/0928	0090/0928	018 "DIA CIRC CONCR LEN=0090 INSTALLED UNKN
RUTHFRED DR (TWP)	0090/0480	0090/0480	0090/0480	
		0090/0428	0090/0428	MCLAUGHLIN STRUCTURE LENGTH 13 FT BMSID 02/3004/0090/0428
2 0 02240 0 00 0118+22	020347	020347	020347	
BETHEL CHURCH RD (TWP)	0090/0000	0090/0000	0090/0000	LENGTH(AH 2550 BK 2475)

DIR: B TOTAL LEN: 7.602 MI. DIST: 11-1 SR: 3004
 LEFT MUN: UPPER ST CLAIR T RIGHT MUN: UPPER ST CLAIR T

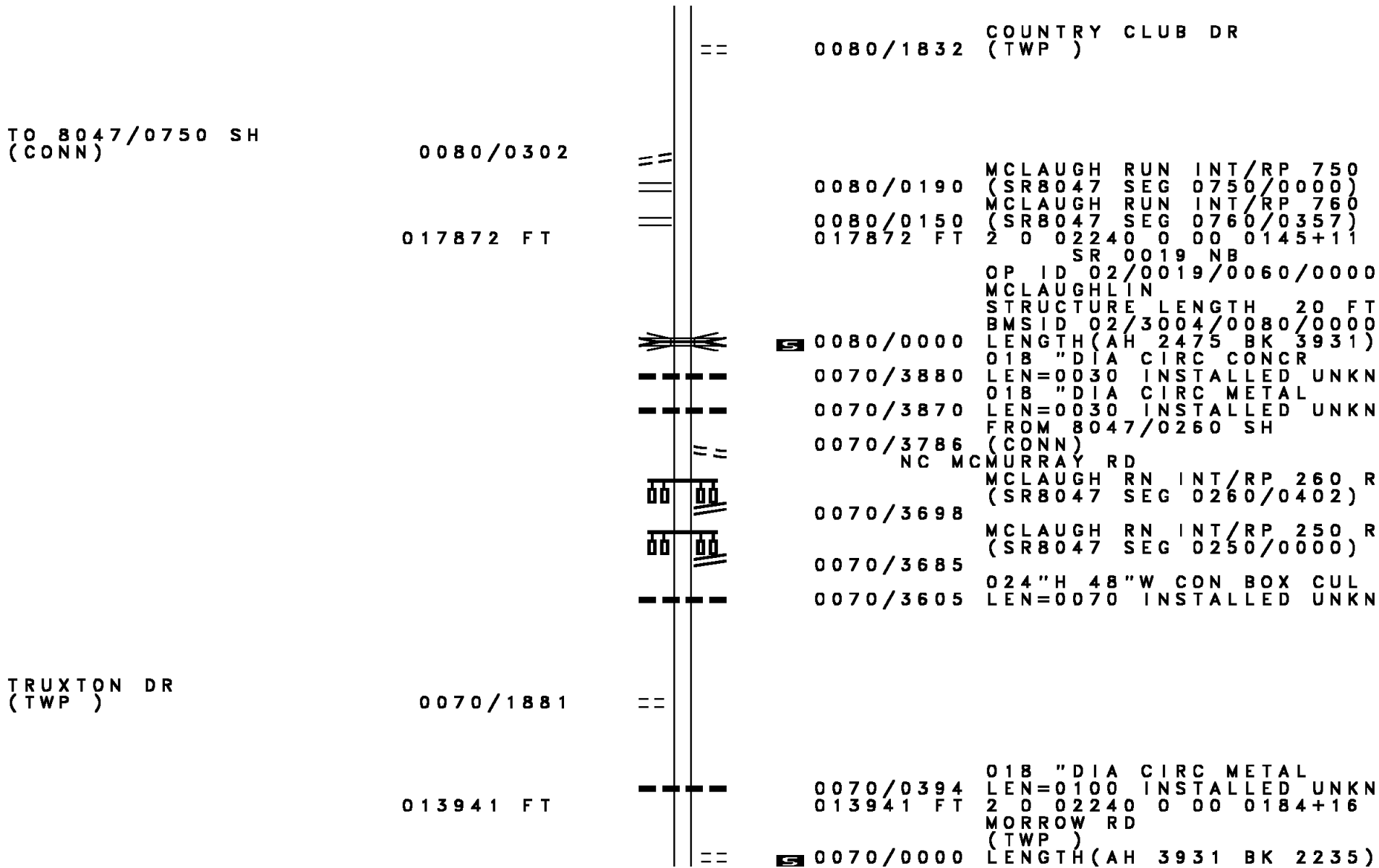

TO 8047/0750 SH
(CONN)

0080/0302

017872 FT

TRUXTON DR
(TWP)

0070/1881

013941 FT

0080/1832 COUNTRY CLUB DR
(TWP)

0080/0190 MCLAUGH RUN INT/RP 750
(SR8047 SEG 0750/0000)
 0080/0150 MCLAUGH RUN INT/RP 760
(SR8047 SEG 0760/0357)
 017872 FT 2 0 02240 0 00 0145+11
 SR 0019 NB

OP ID 02/0019/0060/0000
 MCLAUGHLIN
 STRUCTURE LENGTH 20 FT
 BMSID 02/3004/0080/0000
 0080/0000 LENGTH(AH 2475 BK 3931)
 018" DIA CIRC CONCR
 0070/3880 LEN=0030 INSTALLED UNKN
 018" DIA CIRC METAL
 0070/3870 LEN=0030 INSTALLED UNKN
 FROM 8047/0260 SH

0070/3786 (CONN)
 NC MC MURRAY RD
 MCLAUGH RN INT/RP 260 R
(SR8047 SEG 0260/0402)

0070/3698 MCLAUGH RN INT/RP 250 R
(SR8047 SEG 0250/0000)

0070/3685 024"H 48"W CON BOX CUL
 0070/3605 LEN=0070 INSTALLED UNKN

0070/0394 018" DIA CIRC METAL
 013941 FT LEN=0100 INSTALLED UNKN
 2 0 02240 0 00 0184+16
 MORROW RD
 (TWP)
 0070/0000 LENGTH(AH 3931 BK 2235)

DIR: B TOTAL LEN: 7.602 MI. DIST: 11-1 SR: 3004
 LEFT MUN: UPPER ST CLAIR T RIGHT MUN: UPPER ST CLAIR T

Stationing	Material	Length	Notes
0060/2199	018" DIA CIRC CONCR	LEN=0040	INSTALLED UNKN
0060/1902	018" DIA CIRC CONCR	LEN=0040	INSTALLED UNKN
0060/1391	095"H 01"W	LEN=0099	**UNKNOWN** INSTALLED UNKN
0060/1331	046" DIA CIRC CONCR	LEN=0036	INSTALLED UNKN
011706 FT	2 0 02240 0 00 0206+30		LESNETT RD (PRDR)
MCMILLAN RD (SR3034 SEG 0070/0000) 0060/0000	060" DIA CIRC CONCR	LENGTH(AH 2235 BK 0733)	
0050/0578	018" DIA CIRC CONCR	LEN=0100	INSTALLED UNKN
0050/0290	018" DIA CIRC METAL	LEN=0050	INSTALLED UNKN
010973 FT	018" DIA CIRC METAL	LEN=0035	INSTALLED UNKN
010973 FT	2 0 02240 0 00 0214+30		
0050/0000	LENGTH(AH 0733 BK 3257)		
0040/2409	018" DIA CIRC CONCR	LEN=0048	INSTALLED UNKN
0040/1647	018" DIA CIRC METAL	LEN=0050	INSTALLED 2002
0040/0672	018" DIA CIRC CONCR	LEN=0030	INSTALLED UNKN
0040/0186	036" DIA CIR PLASTIC	LEN=0080	INSTALLED 2002
007716 FT	2 0 02240 0 00 0245+02		
0040/0000	LENGTH(AH 3257 BK 3219)		
0030/0344	024" DIA CIRC METAL	LEN=0044	INSTALLED UNKN
004497 FT	2 0 02240 0 00 0277+00		UPPER ST CLAIR

EXTRACT DATE: 12/21/2020
PRINT DATE: 12/23/2020

ROADWAY MANAGEMENT SYSTEM
SLD COUNTY/SR - ANNUAL PRINT

PAGE NUMBER: 959
COUNTY: ALLEGHENY

DIR: B TOTAL LEN: 7.602 MI.
LEFT MUN: UPPER ST CLAIR T

DIST: 11-1 SR: 3004
RIGHT MUN: UPPER ST CLAIR T

Stationing	Notes	Stationing	Notes
		0030/0000	BRIDGEVILLE B LENGTH(AH 3219 BK 1859)
		0020/0601	BMSBN 02/3004/0020/0546 BRIDGE POSTED (TONS) 2 0 02353 0 00 0013+95 SGL 28 COMB 36
002638 FT		0020/0546	MCLAUGHLIN BMSBG 02/3004/0020/0546 2 0 02353 0 00 0019+77
		002638 FT	COOLIDGE ST (BORO)
		0020/0000	LENGTH(AH 1859 BK 2638)
		0010/1675	SPRUCE ST (BORO)
		0010/1275	LAUREL ST (BORO)
		0010/1270	018 " DIA CIRC CONCR LEN=0035 INSTALLED UNKN
		0010/1251	018 " DIA CIR PLASTIC LEN=0070 INSTALLED UNKN
		0010/1208	MAPLE ST (BORO)
		0010/1140	BMSBN 02/3004/0010/1092 018 " DIA CIRC CONCR
		0010/1130	LEN=0070 INSTALLED UNKN 2 0 02353 0 00 0035+04
		0010/1092	MCLAUGHLIN RUN BMSBG 02/3004/0010/1092
		0010/0748	018 " DIA CIRC CONCR LEN=0020 INSTALLED UNKN
		0010/0510	018 " DIA CIRC CONCR LEN=0015 INSTALLED UNKN
RIDGE RD (BORO)		0010/0451	
MILL ST (BORO)		0010/0265	BALDWIN ST (BORO)
		0010/0228	018 " DIA CAST IRON LEN=0020 INSTALLED UNKN
000000 FT		000000 FT	2 0 02353 0 00 0045+91 NC MC LAUGHLIN RUN RD BOWER HILL RD (CNTY)
		0010/0000	MFC BEGIN = C LENGTH(AH 2638 BK 0000)

WASHINGTON AV INTER-AHD
 (SR0050 SEG 0120/0000)
 MILLERS RUN RD 016921 FT
 (SR0050 SEG 0120/0000) 0061/0771

FROM 0050/0100 SH
 (CONN) 0061/0665
 018 "DIA CIRC CONCR
 LEN=0020 INSTALLED UNKN 0061/0652

018 "DIA CIRC CONCR
 LEN=0020 INSTALLED UNKN 0061/0506
 018 "DIA CIRC CONCR
 LEN=0045 INSTALLED UNKN 0061/0311
 018 "DIA CIRC CONCR
 LEN=0025 INSTALLED UNKN 0061/0195
 018 "DIA CIRC CONCR
 LEN=0025 INSTALLED UNKN 0061/0160
 0 0 00000 0 00 0000+00 016150 FT
 DANIELL DR
 (TWP)

MFC BEGIN = C
 LENGTH(AH 0771 BK 3134) 0061/0000

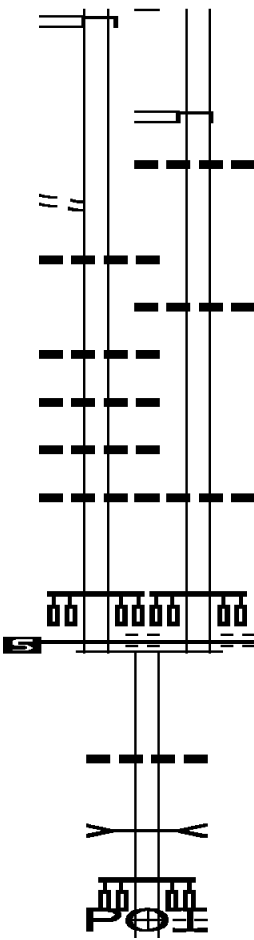

016897 FT
 INTER-AHD WASHINGTON AV
 (SR0050 SEG 0120/0000)
 MILLERS RUN RD
 (SR0050 SEG 0120/0000)
 018 "DIA CIRC CONCR
 LEN=0020 INSTALLED UNKN

0060/0747
 0060/0708 018 "DIA CIRC CONCR
 LEN=0020 INSTALLED UNKN

0060/0536 018 "DIA CIRC CONCR
 LEN=0020 INSTALLED UNKN

0060/0160 018 "DIA CIRC CONCR
 LEN=0025 INSTALLED UNKN
 1 0 00108 0 00 0158+04
 DANIELL DR
 (TWP)

0060/0000 MFC BEGIN = C
 LENGTH(AH 0747 BK 3134)

0050/1790 018 "DIA CIRC CONCR
 LEN=0040 INSTALLED UNKN
 COAL RUN
 STRUCTURE LENGTH 18 FT
 BMSID 02/3003/0050/1326
 (APRA) BURSCA BUSINESS
 BURSCA DR
 (PRDR)

0050/1307

0050/1236

DIR: B TOTAL LEN: 3.205 MI. DIST: 11-1 SR: 3003
 LEFT MUN: SOUTH FAYETTE T RIGHT MUN: SOUTH FAYETTE T

NORTH FREEDOM DR
 (TWP)

0050/0300

== ==

013016 FT

--- ---

MELROSE CT
 (TWP)

0040/2005

==

--- ---

00 00

==

010027 FT

--- ---

--- ---

FAIRVIEW DR
 (TWP)

0030/2430

==

==

--- ---

--- ---

--- ---

--- ---

--- ---

006668 FT

0050/0300

0050/0240

013016 FT

5 0050/0000

0040/2281

0040/1713

0040/1658

0040/1069

0040/0360

0040/0358

0040/0043

5 0040/0000

0030/2439

0030/2395

0030/2349

0030/2058

0030/1410

0030/1276

0030/0758

006668 FT

SOUTH FREEDOM DR

(TWP)

018 "DIA CIRC CONCR

LEN=0032 INSTALLED UNKN

1 0 00108 0 00 0129+62

LENGTH(AH 3134 BK 2989)

021 "DIA CIRC CONCR

LEN=0040 INSTALLED UNKN

018 "DIA CIRC CONCR

LEN=0020 INSTALLED UNKN

TWIN PONDS LN

(TWP)

018 "DIA CIRC CONCR

LEN=0020 INSTALLED UNKN

PINEWOOD DR

(TWP)

018 "DIA CIRC CONCR

LEN=0050 INSTALLED UNKN

018 "DIA CIRC OTHER

LEN=0030 INSTALLED UNKN

1 0 00108 0 00 0099+60

LENGTH(AH 2989 BK 3359)

018 "DIA CIRC CONCR

LEN=0045 INSTALLED UNKN

OLD OAK DR

(TWP)

018 "DIA CIRC CONCR

LEN=0030 INSTALLED UNKN

012 "DIA CIRC CONCR

LEN=0099 INSTALLED UNKN

018 "DIA CIRC CONCR

LEN=0055 INSTALLED UNKN

024 "DIA CIRC CONCR

LEN=0052 INSTALLED UNKN

015 "DIA CIRC CONCR

LEN=0040 INSTALLED UNKN

1 0 00108 0 00 0066+23

EXTRACT DATE: 12/21/2020
PRINT DATE: 12/23/2020

ROADWAY MANAGEMENT SYSTEM
SLD COUNTY/SR - ANNUAL PRINT

PAGE NUMBER: 956
COUNTY: ALLEGHENY

DIR: B TOTAL LEN: 3.205 MI.
LEFT MUN: SOUTH FAYETTE T

DIST: 11-1 SR: 3003
RIGHT MUN: SOUTH FAYETTE T

ALPINE RD
(TWP)

0030/0000

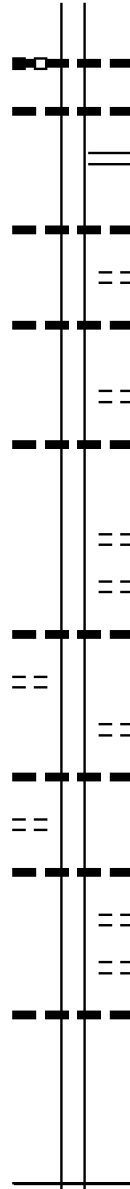

S 0030/0000

0020/2736

0020/2418

0020/1630

0020/1066

0020/1000

0020/0289

0020/0160

S 0020/0000

0010/3037

0010/2728

0010/2470

MARION DR
(TWP)

0010/1901

0010/1350

0010/1300

FIELDCREST DR
(TWP)

0010/1113

0010/0990

0010/0835

0010/0680

000000 FT

* REF-BK

S 0010/0000

018 " DIA CIRC CONCR
LEN=0040 INSTALLED UNKN
LENGTH(AH 3359 BK 3294)
018 " DIA CIRC CONCR
LEN=0030 INSTALLED UNKN
BOYCE RD
(SR3006 SEG 0010/0000)
018 " DIA CIRC CONCR
LEN=0035 INSTALLED UNKN
MEETING HOUSE RD
(TWP)
024 " DIA CIRC CONCR
LEN=0005 INSTALLED UNKN
EMPIRE DR
(TWP)
072"H 24"W CON BOX CUL
LEN=0040 INSTALLED UNKN
1 0 00108 0 00 0035+24
LENGTH(AH 3294 BK 3374)
SPRING HOUSE PL
(TWP)
TOFTREES DR
(TWP)
018 " DIA CIRC CONCR
LEN=0099 INSTALLED UNKN
SADDLEWOOD DR
(TWP)
018"H 21"W ELLIP CONC
LEN=0099 INSTALLED UNKN
048 " DIA CIRC CONCR
LEN=0080 INSTALLED UNKN
SUNDIAL LN
(TWP)
SUNDANCE DR
(TWP)
018 " DIA CIRC CONCR
LEN=0099 INSTALLED UNKN
1 0 00108 0 00 0000+00
NC WA WASHINGTON PK
WASHINGTON PK
(SR1009 SEG 0260/1619)
MFC BEGIN = C
BK-WASHINGTON (62)
LENGTH(AH 3374 BK 0000)

EXTRACT DATE: 12/21/2020 ROADWAY MANAGEMENT SYSTEM PAGE NUMBER: 955
 PRINT DATE: 12/23/2020 SLD COUNTY/SR - ANNUAL PRINT COUNTY: ALLEGHENY
 DIR: B TOTAL LEN: .014 MI. DIST: 11-1 SR: 3002
 LEFT MUN: UPPER ST CLAIR T RIGHT MUN: UPPER ST CLAIR T

000072 FT
 000000 FT

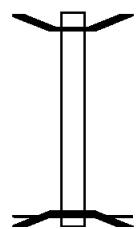







000072 FT BMS EN 02/3002/0010/0000
 * REF-AHD COUNTRY CLUB DR
 0010/0072 (TWP)
 000000 FT 0 0 00000 0 00 0000+00
 NC CO COUNTRY CLUB DR
 * REF-BK COUNTRY CLUB DR
 (TWP)
 02057.98+75
 BMSBG 02/3002/0010/0000
 MFC BEGIN = E
 0010/0000 LENGTH(AH 0072 BK 0000)

DIR: B TOTAL LEN: .976 MI. DIST: 11-1 SR: 3001
 LEFT MUN: SOUTH FAYETTE T RIGHT MUN: SOUTH FAYETTE T

Stationing	Notes	Stationing	Description
005152 FT		005152 FT	MILLER'S RUN RD
004766 FT		0030/0386	(SR0978 SEG 0020/0000)
		004766 FT	1 0 00545 0 00 0048+44
		0030/0000	LENGTH(AH 0386 BK 1381)
			KRISTOFF LN
		0020/0885	(TB70)
		0020/0336	012 " DIA CIRC METAL
003385 FT		003385 FT	LEN=0030 INSTALLED UNKN
			1 0 00545 0 00 0034+05
		0020/0000	(AAR 472842A)#TRKS 01
			LENGTH(AH 1381 BK 3385)
		0010/3120	024 " DIA CIRC CONCR
			LEN=0045 INSTALLED UNKN
		0010/2856	012 " DIA CIRC METAL
			LEN=0030 INSTALLED UNKN
REED ST (TWP)		0010/2566	BMS EN 02/3001/0010/2554
			1 0 00545 0 00 0025+57
		0010/2554	BR. MILLER'S
			BMSBG 02/3001/0010/2554
		0010/1471	NORFOLK SOUTHERN
			OVERPASS IS RR X-ING
CECIL STURGEON RD (TWP)		0010/0908	024 " DIA CIRC METAL
			LEN=0099 INSTALLED UNKN
		0010/0006	018 " DIA CIR PLASTIC
		000000 FT	LEN=0040 INSTALLED 2004
			1 0 00545 0 00 0000+00
		* REF-BK	MILLER'S RUN RD
			MILLER'S RUN RD
			(SR1021 SEG 0010/1295)
			MFC BEGIN = E
			BK-WASHINGTON (62)
000000 FT		0010/0000	LENGTH(AH 3385 BK 0000)

EXTRACT DATE: 12/21/2020 ROADWAY MANAGEMENT SYSTEM PAGE NUMBER: 953
 PRINT DATE: 12/23/2020 SLD COUNTY/SR - ANNUAL PRINT COUNTY: ALLEGHENY
 DIR: E TOTAL LEN: .000 MI. DIST: 11-1 SR: 2380
 LEFT MUN: PITTSBURGH C RIGHT MUN: PITTSBURGH C

LENGTH(AH 0918 BK 1648)	7031/0000			000000 FT					
	000000 FT			7030/0000	LTH	AH	000907	BK	001670
LENGTH(AH 1648 BK 0876)	7021/0000			000000 FT					
	000000 FT			7020/0000	LTH	AH	001670	BK	000915
LENGTH(AH 0876 BK 0000)	7011/0000			000000 FT					
	000000 FT			7010/0000	LTH	AH	000915	BK	000000

EXTRACT DATE: 12/21/2020 ROADWAY MANAGEMENT SYSTEM PAGE NUMBER: 952
 PRINT DATE: 12/23/2020 SLD COUNTY/SR - ANNUAL PRINT COUNTY: ALLEGHENY
 DIR: E TOTAL LEN: .388 MI. DIST: 11-1 SR: 2308
 LEFT MUN: PITTSBURGH C RIGHT MUN: PITTSBURGH C

LTH AH 002250 BK 000000 000000 FT 7011/0000

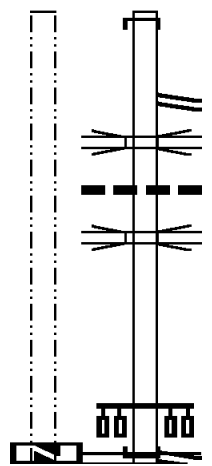

002049 FT
 INTER-AHD FORBES AV
 0010/2049 (SR2108 SEG 0060/0000)

 0010/1296 RAMP V RD
 (SR8004 SEG 0750/1347)
 BLVD ALLIES SB
 0010/0902 OP ID 02/0885/0331/1302
 018 " DIA CIRC CONCR
 0010/0360 LEN=0100 INSTALLED UNKN
 BLVD ALLIES WB
 0010/0355 OP ID 02/0885/0330/1797
 000000 FT 0 0 00000 0 00 0000+00
 NC FORBES AV

 INTER-BK RAMP FROM BIRMINGHAM BR
 (SR8065 SEG 0010/0910)
 FORBES AV
 (CITY)
 MFC BEGIN = B
 0010/0000 LENGTH(AH 2049 BK 0000)

EXTRACT DATE: 12/21/2020 ROADWAY MANAGEMENT SYSTEM PAGE NUMBER: 951
PRINT DATE: 12/23/2020 SLD COUNTY/SR - ANNUAL PRINT COUNTY: ALLEGHENY
DIR: E TOTAL LEN: .000 MI. DIST: 11-1 SR: 2248
LEFT MUN: PITTSBURGH C RIGHT MUN: PITTSBURGH C

000000 FT



000000 FT
7010/0000 LENGTH(AH 2472 BK 0000)

EXTRACT DATE: 12/21/2020 ROADWAY MANAGEMENT SYSTEM PAGE NUMBER: 950
 PRINT DATE: 12/23/2020 SLD COUNTY/SR - ANNUAL PRINT COUNTY: ALLEGHENY
 DIR: E TOTAL LEN: .794 MI. DIST: 11-1 SR: 2208
 LEFT MUN: PITTSBURGH C RIGHT MUN: PITTSBURGH C

004191 FT

RAMP H RD
 (SR8002 SEG 0250/1423) 0020/1392



* 004182 FT
 REF-AHD BL OF ALLIES
 0020/1509 (SR0885 SEG 0351/2149)
 0020/1487 BMS EN 02/2208/0020/0321

0020/1228 FROM 8067/0750 SH
 (CONN)
 0020/1146 RAMP A-2 LIBERTY BR
 (SR8067 SEG 0750/0490)
 0020/1075 RAMP B-2 LIBERTY BR
 (SR8067 SEG 0010/0000)
 0020/0961 SIGN: 4 CHORD TRUSS
 BMS ID 02/2208/0020/0955

1 0 00120 0 00 0044+68

DIR: E TOTAL LEN: .794 MI. DIST: 11-1 SR: 2208
 LEFT MUN: PITTSBURGH C RIGHT MUN: PITTSBURGH C

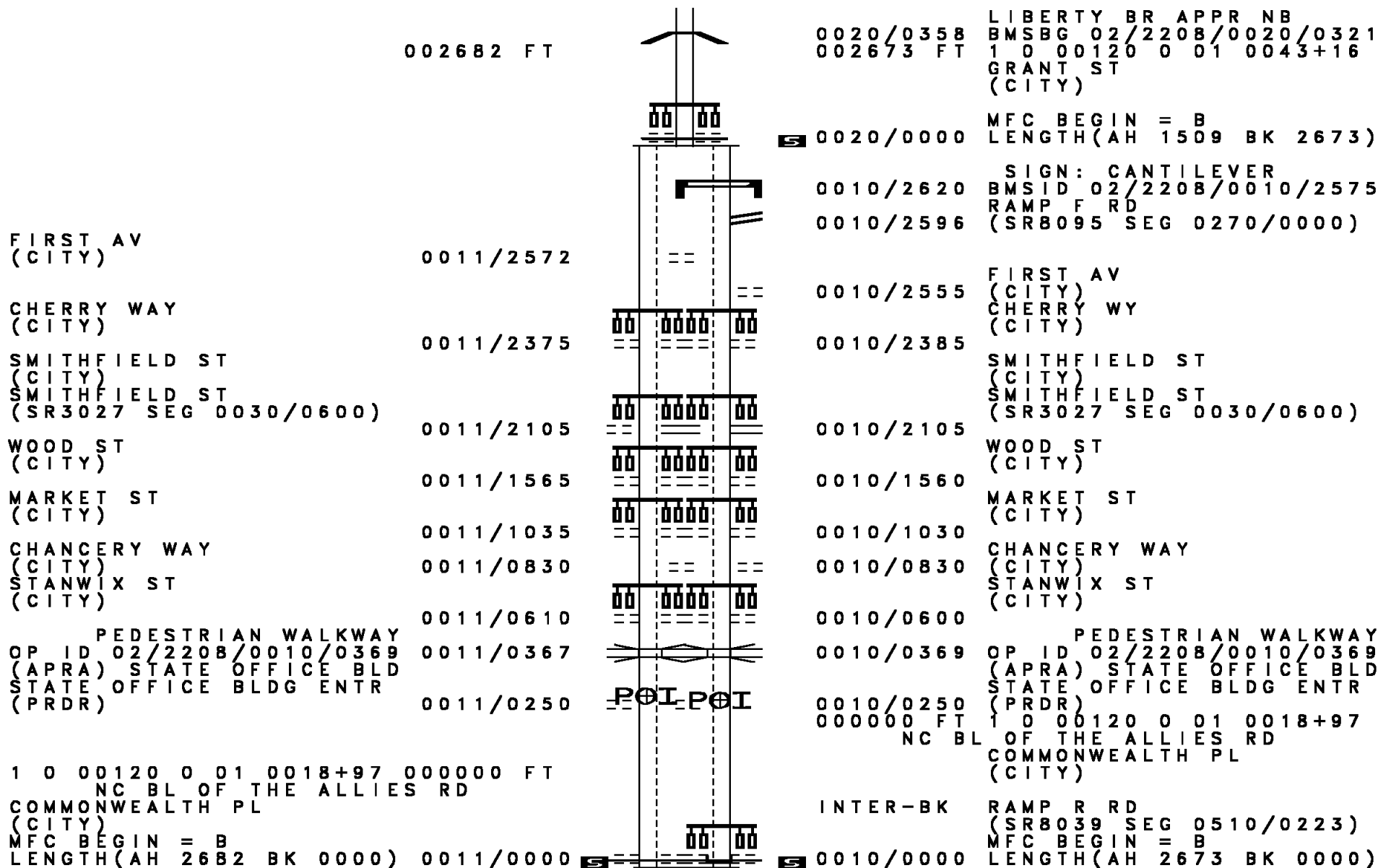

002682 FT

0020/0358
002673 FT

LIBERTY BR APPR NB
 BMSBG 02/2208/0020/0321
 1 0 00120 0 01 0043+16
 GRANT ST
 (CITY)

5 0020/0000 MFC BEGIN = B
 LENGTH(AH 1509 BK 2673)

0010/2620 SIGN: CANTILEVER
 BMSID 02/2208/0010/2575
 0010/2596 RAMP F RD
 (SR8095 SEG 0270/0000)

FIRST AV
 (CITY) 0011/2572

0010/2555 FIRST AV
 (CITY)
 0010/2385 CHERRY WY
 (CITY)

CHERRY WAY
 (CITY) 0011/2375

SMITHFIELD ST
 (CITY) 0011/2105
 SMITHFIELD ST
 (SR3027 SEG 0030/0600)

0010/2105 SMITHFIELD ST
 (CITY)
 SMITHFIELD ST
 (SR3027 SEG 0030/0600)

WOOD ST
 (CITY) 0011/1565

0010/1560 WOOD ST
 (CITY)

MARKET ST
 (CITY) 0011/1035

0010/1030 MARKET ST
 (CITY)

CHANCERY WAY
 (CITY) 0011/0830

0010/0830 CHANCERY WAY
 (CITY)

STANWIX ST
 (CITY) 0011/0610

0010/0600 STANWIX ST
 (CITY)

PEDESTRIAN WALKWAY
 OP ID 02/2208/0010/0369 0011/0367

0010/0369 PEDESTRIAN WALKWAY
 OP ID 02/2208/0010/0369

(APRA) STATE OFFICE BLDG ENTR
 STATE OFFICE BLDG ENTR 0011/0250

(PRDR) STATE OFFICE BLDG ENTR
 STATE OFFICE BLDG ENTR 0010/0250

1 0 00120 0 01 0018+97 000000 FT
 NC BL OF THE ALLIES RD

000000 FT 1 0 00120 0 01 0018+97
 NC BL OF THE ALLIES RD

COMMONWEALTH PL
 (CITY) 0011/0000

0010/0000 COMMONWEALTH PL
 (CITY)

MFC BEGIN = B
 LENGTH(AH 2682 BK 0000) 0011/0000

INTER-BK RAMP R RD
 (SR8039 SEG 0510/0223)
 MFC BEGIN = B
 LENGTH(AH 2673 BK 0000)

DIR: B TOTAL LEN: .110 MI. DIST: 11-1 SR: 2183
 LEFT MUN: EAST PITTSBURGH B RIGHT MUN: EAST PITTSBURGH B

ACCESS RD
(PRDR)

000583 FT

0010/0530

000000 FT

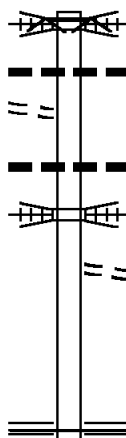

000583 FT UNKNOWN RD
 ROAD CLOSED AHEAD
 UNION & PENNSYLVANIA &
 0010/0583 OVERPASS IS RR X-ING
 009 "DIA CIRC CONCR
 0010/0560 LEN=0098 INSTALLED UNKN

 0010/0487 009 "DIA CIRC CONCR
 LEN=0098 INSTALLED UNKN
 UNION & PENNSYLVANIA &
 0010/0464 OVERPASS IS RR X-ING
 ACCESS RD
 0010/0402 (PRDR)
 000000 FT 1 0 01074 2 01 0000+00
 NC RAMP A/BRADDOCK AV
 BRADDOCK AV
 (SR2083 SEG 0023/0342)
 (SR2083 SEG 0022/0345)
 MFC BEGIN = E
 0010/0000 LENGTH(AH 0583 BK 0000)

DIR: E TOTAL LEN: .163 MI. DIST: 11-1 SR: 2152
 LEFT MUN: WILKINS T RIGHT MUN: WILKINS T

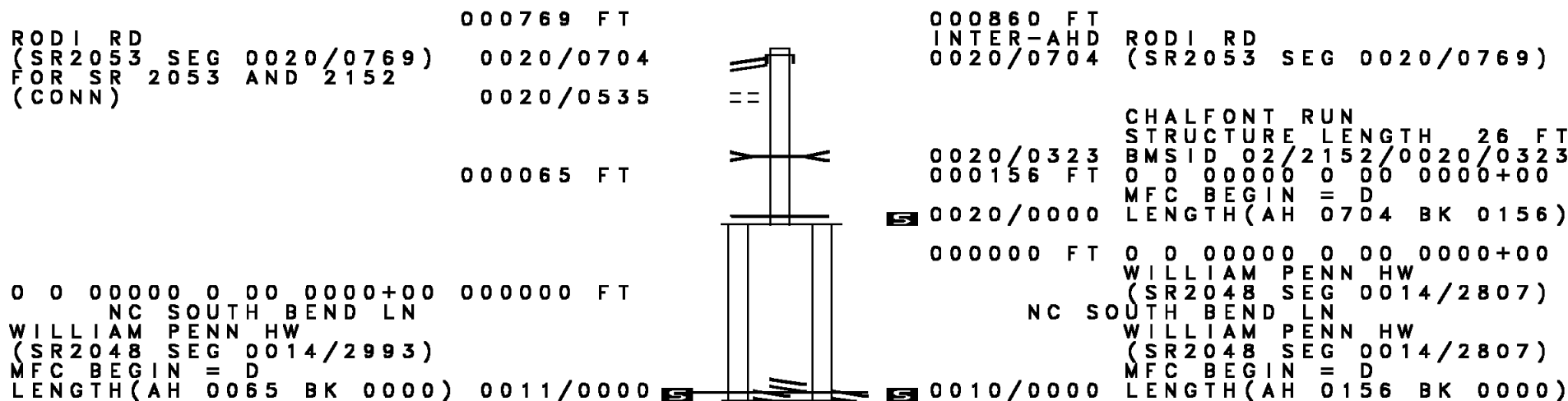

EXTRACT DATE: 12/21/2020 ROADWAY MANAGEMENT SYSTEM PAGE NUMBER: 946
 PRINT DATE: 12/23/2020 SLD COUNTY/SR - ANNUAL PRINT COUNTY: ALLEGHENY
 DIR: B TOTAL LEN: .050 MI. DIST: 11-1 SR: 2146
 LEFT MUN: PITTSBURGH C RIGHT MUN: PITTSBURGH C

000265 FT
 000000 FT

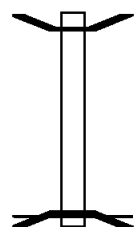

000265 FT BMS EN 02/2146/0010/0000
 * REF-AHD BIGELOW BL
 0010/0265 (CITY)
 000000 FT 0 0 00000 0 00 0000+00
 NC BI
 * REF-BK SEVENTH AV
 (CITY)
 RAMP E (8078 SB)
 BMSBG 02/2146/0010/0000
 MFC BEGIN = C
 0010/0000 LENGTH(AH 0265 BK 0000)

EXTRACT DATE: 12/21/2020 ROADWAY MANAGEMENT SYSTEM PAGE NUMBER: 945
 PRINT DATE: 12/23/2020 SLD COUNTY/SR - ANNUAL PRINT COUNTY: ALLEGHENY
 DIR: E TOTAL LEN: .032 MI. DIST: 11-1 SR: 2144
 LEFT MUN: PITTSBURGH C RIGHT MUN: PITTSBURGH C

BMSFN 02/2144/0010/0000000170 FT		000170 FT	BMSFN 02/2144/0010/0000
CENTRE AV	REF-AHD	REF-AHD	CENTRE AV
(CITY)	0011/0170	0010/0170 (CITY)	(CITY)
0 0 00000 0 00 0000+00 000000 FT		000000 FT	0 0 00000 0 00 0000+00
NC CENTRE AV		NC CENTRE AV	NC CENTRE AV
CENTRE AV	REF-BK	REF-BK	CENTRE AV
(CITY)			(CITY)
I-579 NB			I-579 NB
BMSBG 02/2144/0010/0000			BMSBG 02/2144/0010/0000
MFC BEGIN = C			MFC BEGIN = C
LENGTH(AH 0170 BK 0000) 0011/0000		0010/0000	LENGTH(AH 0170 BK 0000)

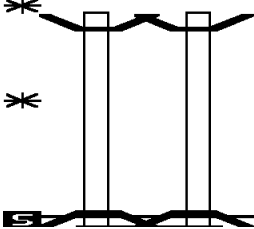

EXTRACT DATE: 12/21/2020 ROADWAY MANAGEMENT SYSTEM PAGE NUMBER: 944
 PRINT DATE: 12/23/2020 SLD COUNTY/SR - ANNUAL PRINT COUNTY: ALLEGHENY
 DIR: B TOTAL LEN: .034 MI. DIST: 11-1 SR: 2129
 LEFT MUN: MONROEVILLE B RIGHT MUN: MONROEVILLE B

000182 FT

000000 FT

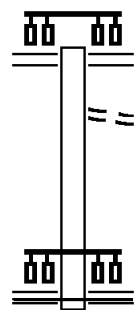

000182 FT GOLDEN MILE HW
 (SR0286 SEG 0010/0603)
 0010/0182 FROM 0022/0281 SH
 0010/0077 (CONN)
 000000 FT 0 0 00000 0 00 0000+00
 NC ALPINE VILLAGE DR
 NEW WM PENN HW
 (SR0022 SEG 0280/0925)
 (SR0022 SEG 0281/0840)
 0010/0000 MFC BEGIN = F
 LENGTH(AH 0182 BK 0000)

ELEVENTH ST 003868 FT
 (CITY) INTER-AHD
 SMALLMAN ST
 (CITY)
 PGH CONV CENTER PARKING 0011/3868
 (CITY)
 099 "DIA CIRC CONCR 0011/3739
 LEN=0040 INSTALLED UNKN 0011/3660
 099 "DIA CIRC CONCR 0011/3650
 LEN=0040 INSTALLED UNKN 0011/3650
 WATERFRONT PL
 (CITY) 0011/3611
 OTHER
 OVERPASS IS RR X-ING
 NC ELEVENTH ST
 BMS EN 02/7301/0000/3149 0011/2935

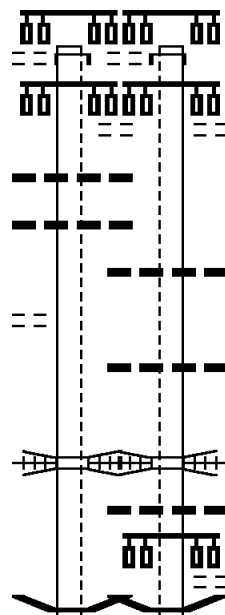

003974 FT
 INTER-AHD
 ELEVENTH ST
 (CITY)
 SMALLMAN ST
 (CITY)
 PGH CONV CENTER PARKING 0010/3974
 (CITY)
 0010/3857
 018 "DIA CIRC CONCR
 LEN=0035 INSTALLED UNKN 0010/3750
 099 "DIA CIRC CONCR
 LEN=0040 INSTALLED UNKN 0010/3650
 NC ELEVENTH ST
 OTHER
 OVERPASS IS RR X-ING 0010/3423
 099 "DIA CIRC CONCR
 LEN=0040 INSTALLED UNKN 0010/3200
 TENTH ST
 (CITY)
 0010/3104
 0010/3087 BMS EN 02/7301/0000/3149

DIR: N TOTAL LEN: .753 MI. DIST: 11-1 SR: 2128
 LEFT MUN: PITTSBURGH C RIGHT MUN: PITTSBURGH C

Project Description	Project ID	Project Length	Project Location
TENTH ST (CITY)	0011/2911		
NO UNDERPASS INFORMATION (APRA) PGH CONVENTION C TENTH ST (CITY)	0011/2859		
099 "DIA CIRC CONCR LEN=0040 INSTALLED UNKN	0011/2525		
FT DUQUESNE BL (CITY)	0011/2362		
099 "DIA CIRC CONCR LEN=0040 INSTALLED UNKN	0011/2083		
OP ID 02/7301/0000/2014	0011/2059		
SEVENTH ST	0011/1513		
SIGN: 4 CHORD TRUSS	0011/1253		
BMSID 02/2128/0010/1418	0011/0950		
OP ID 02/7301/0000/2012	0011/0950		
SIGN: 4 CHORD TRUSS	0011/0143		
RAMP G RD (SR8041 SEG 0500/0000)	0011/0112		
LC FROM FT DUQUESNE BL (CONN)			
NC TENTH ST BY-PASS			
RAMP D RD (SR8041 SEG 0510/0000)	INTER-BK		
MFC BEGIN = B			
LENGTH(AH 3868 BK 0000)	0011/0000		
NO UNDERPASS INFORMATION (APRA) PGH CONVENTION C TENTH ST (CITY)	0010/3011		
099 "DIA CIRC CONCR LEN=0040 INSTALLED UNKN	0010/3008		
FT DUQUESNE BL (CITY)	0010/2542		
099 "DIA CIRC CONCR LEN=0040 INSTALLED UNKN	0010/2525		
OP ID 02/7301/0000/2014	0010/2248		
099 "DIA CIRC CONCR LEN=0040 INSTALLED UNKN	0010/2083		
SEVENTH ST	0010/1700		
SIGN: 4 CHORD TRUSS	0010/1440		
BMSID 02/2128/0010/1418	0010/1137		
OP ID 02/7301/0000/2012	0010/1137		
099 "DIA CIRC CONCR LEN=0040 INSTALLED UNKN	0010/0400		
FANCOURT ST	0010/0163		
OP ID 02/7301/0000/3143			
000000 FT 1 0 01039 4 00 0000+00			
RAMP K RD (SR8041 SEG 0270/0674)			
NC TENTH ST BY-PASS			
RAMP C RD (SR8041 SEG 0760/0898)			
MFC BEGIN = B			
LENGTH(AH 3974 BK 0000)	0010/0000		

EXTRACT DATE: 12/21/2020 ROADWAY MANAGEMENT SYSTEM PAGE NUMBER: 941
 PRINT DATE: 12/23/2020 SLD COUNTY/SR - ANNUAL PRINT COUNTY: ALLEGHENY

DIR: B TOTAL LEN: .103 MI. DIST: 11-1 SR: 2126
 LEFT MUN: PENN HILLS T RIGHT MUN: PENN HILLS T

HUNTER RD 000545 FT
 (SR2080 SEG 0060/2275) 0010/0545

000000 FT

VALEMONT DR
 (TWP)
 HAMIL RD
 (SR2078 SEG 0030/2250) 0010/0000

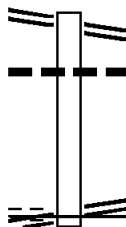

000545 FT HUNTER RD
 0010/0545 (SR2080 SEG 0060/2275)
 018 " DIA CIR PLASTIC
 0010/0085 LEN=0045 INSTALLED UNKN
 000000 FT 2 0 02165 1 00 0000+00
 HAMIL RD
 (SR2078 SEG 0030/2250)
 NC VA LEMONT DR
 MFC BEGIN = E
 0010/0000 LENGTH(AH 0545 BK 0000)

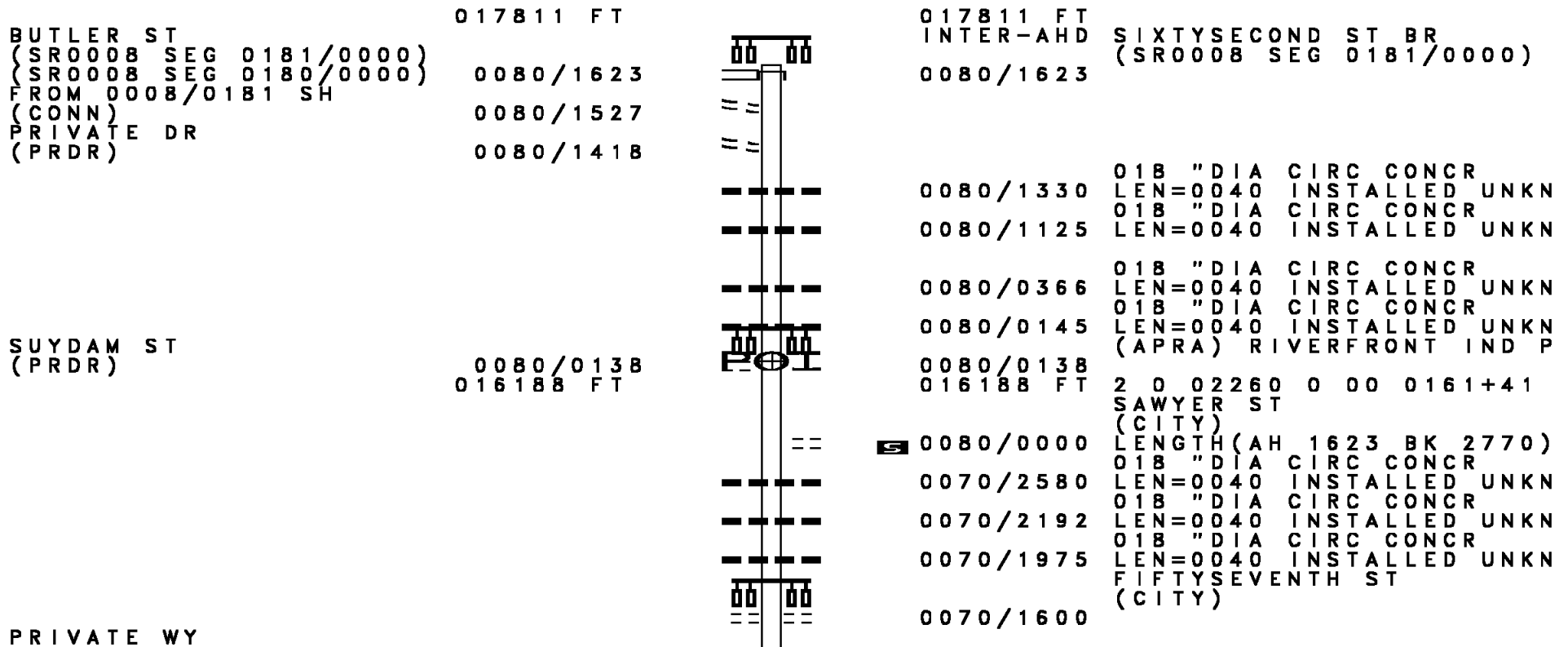

DIR: B TOTAL LEN: 3.373 MI. DIST: 11-1 SR: 2122
 LEFT MUN: PITTSBURGH C RIGHT MUN: PITTSBURGH C

(CITY)	0070/1305	==	==	0070/1045	FIFTYSIXTH ST (CITY)
		==	==		
		==	==		
	013418 FT	==	==	0070/0445 013418 FT	FIFTYFIFTH ST (CITY)
		==	==		2 0 02260 0 00 0133+59 FIFTYFOURTH ST (CITY)
		==	==	0070/0000	LENGTH(AH 2770 BK 2726)
		==	==	0060/2700	012"H 20"W CON BOX CUL LEN=0099 INSTALLED UNKN
		==	==	0060/2275	FIFTYTHIRD ST (CITY)
		==	==	0060/1945	MCCANDLESS AV (CITY)
		==	==	0060/1420	FIFTYSECOND ST (CITY)
		==	==	0060/0965	018 "DIA CIRC CONCR LEN=0040 INSTALLED UNKN
FIFTYFIRST ST (CITY)	0060/0600	==	==	0060/0600	STANTON AV (CITY)
FIFTIETH ST (CITY)	0060/0400	==	==		
2 0 02260 0 00 0106+45 010692 FT	0060/0400	==	==	010692 FT	
FORTYNINTH ST (CITY)	0060/0000	==	==	0060/0000	LENGTH(AH 2726 BK 1927)
FORTYEIGHTH ST (CITY)		==	==		
PLUMMER ST (CITY)	0050/1460	==	==	0050/1460	
UMPIRE WAY (CITY)	0050/0890	==	==		
FORTYSEVENTH ST (CITY)	0050/0750	==	==		
HOME ST (CITY)	0050/0555	==	==		
		==	==		FORTYSIXTH ST (CITY)
	008765 FT	==	==	0050/0275 008765 FT	2 0 02260 0 00 0087+01 FORTYFIFTH ST (CITY)
		==	==	0050/0000	LENGTH(AH 1927 BK 2100)

DIR: B TOTAL LEN: 3.373 MI. DIST: 11-1 SR: 2122
 LEFT MUN: PITTSBURGH C RIGHT MUN: PITTSBURGH C

Street Name (City)	Stationing	Notes	Street Name (City)	Stationing	Notes
			FORTYFOURTH ST (CITY)	0040/1810	
			FORTYTHIRD ST (CITY)	0040/1465	
FORTYSECOND ST (CITY)	0040/1295		FORTYSECOND ST (CITY)	0040/1335	
			MAIN ST (CITY)	0040/1130	
FORTYFIRST ST (CITY)	0040/0980	POI	(APRA) MILL EQUIPMENT C	0040/0980	
			FISK ST (CITY)	0040/0880	
ALMOND WAY (CITY)	0040/0800				
			FORTIETH ST (CITY)	0040/0580	
	006665 FT		2 0 02260 0 00 0065+95	006665 FT	
			THIRTYNINTH ST (CITY)		
LODI WY (CITY)	0030/1880		LENGTH(AH 2100 BK 2029)	0040/0000	
			THIRTYEIGHTH ST (CITY)	0030/1730	
			ATER WAY (CITY)	0030/1595	
THIRTYSEVENTH ST (CITY)	0030/1475				
			THIRTYSEVENTH ST (CITY)	0030/1460	
			THIRTYSIXTH ST (CITY)	0030/1220	
THIRTYSIXTH ST (CITY)	0030/1125				
			THIRTYFIFTH ST (CITY)	0030/0768	
THIRTYFIFTH ST (CITY)	0030/0540				
			018"H 18"W CON BOX CUL	0030/0033	
	004636 FT		LEN=0050 INSTALLED UNKN	004636 FT	
			2 0 02260 0 00 0045+45		
			PENN AV (CITY)		
			THIRTYFOURTH ST		

EXTRACT DATE: 12/21/2020
PRINT DATE: 12/23/2020

ROADWAY MANAGEMENT SYSTEM
SLD COUNTY/SR - ANNUAL PRINT

PAGE NUMBER: 936
COUNTY: ALLEGHENY

DIR: B TOTAL LEN: 3.373 MI.
LEFT MUN: PITTSBURGH C

DIST: 11-1 SR: 2122
RIGHT MUN: PITTSBURGH C

THIRTYFIRST ST
(CITY)

003608 FT

0016/0030
003074 FT

000000 FT

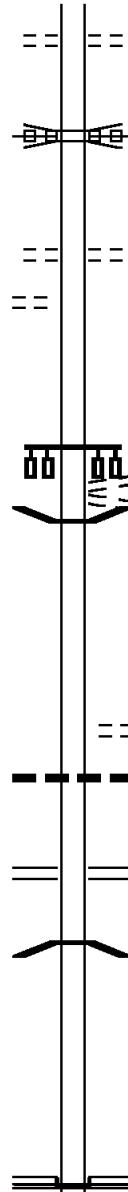

0030/0000 (CITY) LENGTH(AH 2029 BK 1028)
CSX RAIL TRANSPORTATION
OVERPASS IS RR X-ING
THIRTYTHIRD ST
0020/0443 (CITY)
003608 FT 2 0 02260 0 00 0026+09
NC BUTLER ST
THIRTYSECOND ST
0020/0000 (CITY) LENGTH(AH 1028 BK 0534)
003074 FT 0 0 00000 0 00 0000+00
THIRTYFIRST ST
(CITY)
NC PENN AV
PENN AV
(CITY)
0016/0000 (CITY) LENGTH(AH 0534 BK 3074)
0010/2775 BMSEN 02/2122/0010/0025
RIVER AV
(CITY)
014 " DIA CAST IRON
0010/0115 LEN=0090 INSTALLED 2013
RAMP D
(SR8125 SEG 0750/0000)
RAMP E
0010/0085 (SR8125 SEG 0010/0510)
2 0 02260 0 00 0000+00
SMALLMAN ST
0010/0046 BMSBG 02/2122/0010/0025
000000 FT 2 0 02260 0 00 0000+00
NC THIRTYFIRST ST BR
RAMP C
(SR8125 SEG 0500/0756)
RAMP F
(SR8125 SEG 0250/0000)
INTER-BK RIALTO ST
(CITY)
MFC BEGIN = B
0010/0000 (CITY) LENGTH(AH 3074 BK 0000)

002566 FT

002566 FT
 INTER-AHD

MARLBORO AV
 (BORO)
 ARDMORE BL
 (SR0008 SEG 0011/0920)

0020/1810
 0020/1488
 0020/0971

018 " DIA CIRC CONCR
 LEN=0050 INSTALLED UNKN
 WILKINSBURG
 BRADDOCK HILLS B

000756 FT

0020/0222
 0020/0157
 000756 FT
 0020/0000

BRADDOCK HILLS
 EDGEWOOD B
 018 " DIA CIRC CONCR
 LEN=0040 INSTALLED UNKN
 2 0 02230 0 00 0009+90
 LENGTH(AH 1810 BK 0756)

0010/0653
 0010/0129
 0010/0128

001 " DIA CIRC CONCR
 LEN=0001 INSTALLED UNKN
 018 " DIA CIRC CONCR
 LEN=0001 INSTALLED UNKN
 018 " DIA CIRC CONCR
 LEN=0030 INSTALLED UNKN

MCKELVEY AV
 (BORO)

0010/0100

000000 FT

0010/0080
 000000 FT

FOR SR 2051 AND 2120
 (CONN)
 2 0 02230 0 00 0000+00
 MAPLE AV
 (SR2051 SEG 0090/1062)

NC BR
 0010/0000

INTON RD
 MFC BEGIN = C
 LENGTH(AH 0756 BK 0000)

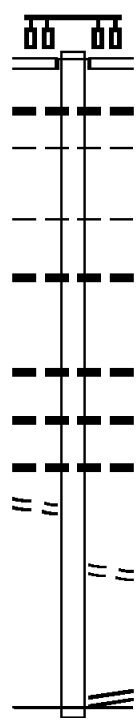

EXTRACT DATE: 12/21/2020 ROADWAY MANAGEMENT SYSTEM PAGE NUMBER: 934
 PRINT DATE: 12/23/2020 SLD COUNTY/SR - ANNUAL PRINT COUNTY: ALLEGHENY
 DIR: B TOTAL LEN: 1.378 MI. DIST: 11-1 SR: 2118
 LEFT MUN: WHITE OAK B RIGHT MUN: WHITE OAK B

007277 FT

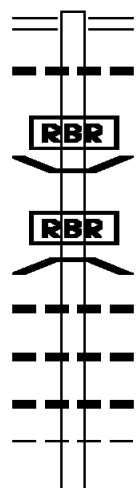

007277 FT LONG RUN RD
 (SR0048 SEG 0201/0000)
 0020/3963 (SR0048 SEG 0200/0000)
 018 " DIA CIRC CONCR
 0020/3909 LEN=0080 INSTALLED UNKN

 0020/3619 BMS EN 02/2118/0020/3544
 2 0 02178 0 00 0069+75
 P3
 LONG RUN
 0020/3559 BMSBG 02/2118/0020/3544
 018 " DIA CIRC CONCR
 0020/3449 LEN=0080 INSTALLED UNKN
 036 " DIA CIRC CONCR
 0020/3423 LEN=0026 INSTALLED UNKN
 036 " DIA CIRC CONCR
 0020/2980 LEN=0020 INSTALLED UNKN
 WHITE OAK
 0020/2688 MCKEESPORT C
 018 " DIA CIRC METAL

DIR: B TOTAL LEN: 1.378 MI. DIST: 11-1 SR: 2118
 LEFT MUN: MCKEESPORT C RIGHT MUN: MCKEESPORT C

Street Name	Segment	Length (FT)	Material	Status
	0020/2128	0040	024" DIA CIRC METAL	INSTALLED UNKN
	0020/1835	0040	018" DIA CIRC METAL	INSTALLED UNKN
	0020/1660	0040	CIRC METAL	INSTALLED UNKN
			CENTER ST ET	
			(CITY)	
			NC RI PPLE RD	
			STEPANIK RD	
	0020/1260		(CITY)	
			024" DIA CIRC CONCR	
	0020/0706	0035		INSTALLED UNKN
	003314 FT	003314 FT	2 0 02178 0 00 0031+78	
			VILLAGE: WHITE OAK B	
			MCKEESPORT	
			VERSAILLES B	
	0020/0000	3963	LENGTH(AH 3963 BK 3314)	
			018" DIA CIRC CONCR	
	0010/3082	0035		INSTALLED UNKN
CENTER GROVE RD (PRDR)	0010/2800			
HARPHEN DR (BORO)	0010/2225			
	0010/2122	0030	018" DIA CIRC CONCR	INSTALLED UNKN
	0010/1731	0025	018" DIA CIRC METAL	INSTALLED UNKN
BASSI DR (BORO)	0010/1430			
	0010/0960	0080	015" DIA CIRC METAL	INSTALLED UNKN
			ALLEY	
	0010/0945		(BORO)	
SPRUCE ST (BORO)	0010/0845			
	0010/0729	0080	018" DIA CIRC CONCR	INSTALLED UNKN
			ALLEY	
	0010/0240		(BORO)	
	0010/0029	0030	018" DIA CIRC CONCR	INSTALLED UNKN
	000000 FT	000000 FT	2 0 02178 0 00 0000+00	
			VILLAGE: VERSAILLES B	
			WALNUT ST	
			(SR0048 SEG 0140/0000)	
			NC CENTER ST	
WALNUT ST (SR0048 SEG 0140/0000)	0010/0000		MFC BEGIN = C	
	0010/0000	3314	LENGTH(AH 3314 BK 0000)	

EXTRACT DATE: 12/21/2020 ROADWAY MANAGEMENT SYSTEM PAGE NUMBER: 932
PRINT DATE: 12/23/2020 SLD COUNTY/SR - ANNUAL PRINT COUNTY: ALLEGHENY
DIR: B TOTAL LEN: 1.212 MI. DIST: 11-1 SR: 2116
LEFT MUN: WEST MIFFLIN B RIGHT MUN: WEST MIFFLIN B

006399 FT



006399 FT
INTER-AHD HOMESTEAD DUQUESNE RD
(CNTY)

EXTRACT DATE: 12/21/2020
PRINT DATE: 12/23/2020

ROADWAY MANAGEMENT SYSTEM
SLD COUNTY/SR - ANNUAL PRINT

PAGE NUMBER: 931
COUNTY: ALLEGHENY

DIR: B TOTAL LEN: 1.212 MI.
LEFT MUN: WEST MIFFLIN B

DIST: 11-1 SR: 2116
RIGHT MUN: WEST MIFFLIN B

003738 FT

000000 FT

PGH MCKEESPORT BL
(SR2045 SEG 0040/1720) 0010/0000

	==	0020/2661	HOMESTEAD DUQUESNE RD (CNTY)
---	---	0020/2592	018 " DIA CIRC CONCR LEN=0099 INSTALLED UNKN
---	---	0020/2104	018 " DIA CIRC METAL LEN=0045 INSTALLED UNKN
---	---	0020/1737	024 " DIA CIRC CONCR LEN=0040 INSTALLED UNKN
---	---	0020/1350	BMSSEN 02/2116/0020/1260 2 0 02084 0 00 0049+92 BR. THOMPSON
---	---	0020/1260	BMSBG 02/2116/0020/1260 018 " DIA CIRC CONCR
---	---	0020/1075	LEN=0099 INSTALLED UNKN 036 " DIA CIRC METAL
---	---	0020/0814	LEN=0005 INSTALLED UNKN 018 " DIA CIRC METAL
---	---	0020/0666	LEN=0035 INSTALLED UNKN 018 " DIA CIRC METAL
---	---	0020/0450	LEN=0015 INSTALLED UNKN 036 " DIA CIRC CONCR
---	---	0020/0163	LEN=0099 INSTALLED UNKN 2 0 02084 0 00 0037+67
	---	003738 FT	WEST MIFFLIN DRAVOSBURG B
	---	5 0020/0000	LENGTH(AH 2661 BK 3738)
---	---	0010/2664	018 " DIA CIRC CONCR LEN=0035 INSTALLED UNKN
---	---	0010/2080	018 "H 00 "W MULT METAL LEN=0040 INSTALLED UNKN
---	---	0010/1845	018 " DIA CIRC CONCR LEN=0099 INSTALLED UNKN
---	---	0010/1762	018 "H 00 "W MULT METAL LEN=0040 INSTALLED UNKN
	==	0010/1130	RIDGEVIEW DR (BORO)
---	---	0010/1055	018 " DIA CIRC CONCR LEN=0099 INSTALLED UNKN
	==	0010/0545	LUSCOMBE LN (BORO)
	---	000000 FT	2 0 02084 0 00 0000+00 PGH MCKEESPORT BL (SR2045 SEG 0040/1720)
	---		NC BETTIS RD
	---	5 0010/0000	MFC BEGIN = C LENGTH(AH 3738 BK 0000)

SR 0837 SH
 (SR0837 SEG 0271/0000)
 CENTER ST
 (CITY)
 LINDEN ST
 (CITY)

005292 FT
 INTER-AHD

004980 FT
 INTER-AHD

SR 0837 SH
 (SR0837 SEG 0270/0000)
 CENTER ST
 (CITY)
 LINDEN ST
 (CITY)

0031/1440

0030/1304

FR SR 2114 TO SR 837 S
 (SR8057 SEG 0252/0000)
 1 0 00736 0 00 0369+18
 837 NB TO DUQ/MCKEESPT
 (SR8057 SEG 0262/0817)
 NC DUQUESNE BL
 MFC BEGIN = B
 LENGTH(AH 1440 BK 2394)

0031/0150
 003852 FT

SR 2114 TO 837S RAMP RD
 (SR8057 SEG 0010/0000)

003676 FT 1 0 00736 0 00 0369+00
 NC DUQUESNE BL

0030/0000 LENGTH(AH 1304 BK 2394)
 0020/2281 BMS EN 02/2114/0020/0000
 SIGN: CANTILEVER
 0020/2225 BMS ID 02/2114/0020/2180

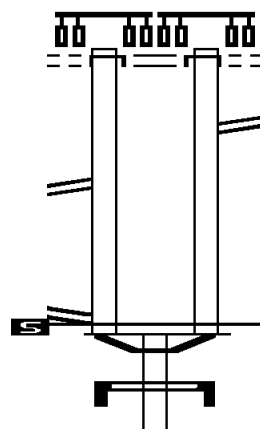

DIR: E TOTAL LEN: .734 MI. DIST: 11-1 SR: 2112
 LEFT MUN: EAST PITTSBURGH B RIGHT MUN: EAST PITTSBURGH B

Segment Description	Start Station	End Station	Length (FT)	Notes
TRI-BORO AV { SR2037 SEG 0101/1371 } { SR2037 SEG 0100/1263 }	0020/2791	0020/2687	003820	
TRI-BORO AV { SR2037 SEG 0100/1263 } { SR2037 SEG 0101/1371 }	0020/2687	0020/2635	003877	INTER-AHD
BRADDOCK AV (BORO) BRADDOCK AV { SR2037 SEG 0101/1371 } { SR2037 SEG 0100/1263 }	0020/2635	0020/2540		UNION & PENNSYLVANIA & OVERPASS IS RR X-ING 018 " DIA CIRC CONCR LEN=0099 INSTALLED UNKN
BRADDOCK AV { SR2037 SEG 0100/1263 } { SR2037 SEG 0101/1371 }	0020/2540	0020/2373		DYNAMO WAY (BORO) 018 " DIA CIRC CONCR LEN=0099 INSTALLED UNKN
UNION & PENNSYLVANIA & OVERPASS IS RR X-ING 018 " DIA CIRC CONCR LEN=0099 INSTALLED UNKN	0020/2373	0020/2235		WOOD ST (BORO) 018 " DIA CIRC CONCR LEN=0099 INSTALLED UNKN
DYNAMO WAY (BORO) 018 " DIA CIRC CONCR LEN=0099 INSTALLED UNKN	0020/2235	0020/2060		018 " DIA CIRC CONCR LEN=0099 INSTALLED UNKN
WOOD ST (BORO) 018 " DIA CIRC CONCR LEN=0099 INSTALLED UNKN	0020/2060	0020/1918		018 " DIA CIRC CONCR LEN=0040 INSTALLED UNKN
018 " DIA CIRC CONCR LEN=0099 INSTALLED UNKN	0020/1918	0020/1570		018 " DIA CIRC CONCR LEN=0099 INSTALLED UNKN
024 " DIA CIRC CONCR LEN=0035 INSTALLED UNKN	0020/1570	0020/1388		018 " DIA CIRC CONCR LEN=0035 INSTALLED UNKN
018 " DIA CIRC CONCR LEN=0035 INSTALLED UNKN	0020/1388	0020/1000		048 " DIA CIRC CONCR LEN=0099 INSTALLED UNKN
048 " DIA CIRC CONCR LEN=0099 INSTALLED UNKN	0020/1000	0020/0940		SOUTH ST (BORO) 015 " DIA CIRC CONCR LEN=0048 INSTALLED UNKN
SOUTH ST (BORO) 015 " DIA CIRC CONCR LEN=0048 INSTALLED UNKN	0020/0999	0020/0760		018 " DIA CIRC CONCR LEN=0048 INSTALLED UNKN
015 " DIA CIRC CONCR LEN=0048 INSTALLED UNKN	0020/0940	0020/0450		024 " DIA CIRC CONCR LEN=0048 INSTALLED UNKN
018 " DIA CIRC CONCR LEN=0048 INSTALLED UNKN	0020/0760			
024 " DIA CIRC CONCR LEN=0048 INSTALLED UNKN	0020/0450			

DIR: E TOTAL LEN: .734 MI. DIST: 11-1 SR: 2112
 LEFT MUN: EAST PITTSBURGH B RIGHT MUN: EAST PITTSBURGH B

NORTH AV
 (BORO)

0020/0360

001029 FT

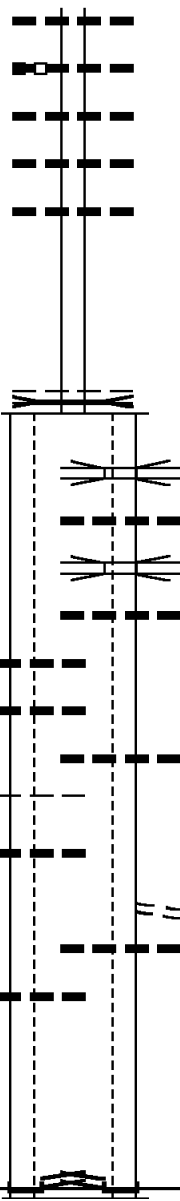

0020/0380 LEN=0040 INSTALLED UNKN
 048 "DIA CIRC CONCR
 0020/0360 LEN=0045 INSTALLED UNKN
 018 "DIA CIRC CONCR
 0020/0313 LEN=0048 INSTALLED UNKN
 018 "DIA CIRC CONCR
 0020/0237 LEN=0048 INSTALLED UNKN
 024 "DIA CIRC CONCR
 0020/0099 LEN=0048 INSTALLED UNKN
 001086 FT 1 0 00639 0 00 0026+65
 FALLS RUN
 STRUCTURE LENGTH 12 FT
 BMSID 02/2112/0030/0000
 MFC BEGIN = B
 EAST PITTSBURGH
 NORTH BRADDOCK B
 LENGTH(AH 2791 BK 1086)
 SR 0030 WB
 0010/1056 OP ID 02/0030/0231/0001
 018 "DIA CIRC CONCR
 0010/0935 LEN=0050 INSTALLED UNKN
 SR 0030 EAST
 0010/0924 OP ID 02/0030/0230/0001
 018 "DIA CIRC CONCR
 0010/0911 LEN=0050 INSTALLED UNKN
 018 "DIA CIRC CONCR
 LEN=0050 INSTALLED UNKN 0011/0860
 018 "DIA CIRC CONCR
 LEN=0050 INSTALLED UNKN 0011/0590
 0010/0402 018 "DIA CIR PLASTIC
 LEN=0099 INSTALLED UNKN
 NORTH BRADDOCK
 CHALFANT B 0011/0280
 018 "DIA CIRC CONCR
 LEN=0050 INSTALLED UNKN 0011/0230
 0010/0217 LINDBERG RD
 (BORO)
 018 "DIA CIRC CONCR
 0010/0195 LEN=0040 INSTALLED UNKN
 000000 FT 1 0 00639 0 00 0000+00
 LINCOLN HW
 (SR0030 SEG 0221/2650)
 NC ELECTRIC AV
 LINCOLN HW INTER-BK
 (SR0030 SEG 0221/2650)
 MFC BEGIN = B
 LENGTH(AH 1029 BK 0000) 0011/0000
 NC EL
 INTER-BK
 LINCOLN HW
 (SR0030 SEG 0220/2633)
 MFC BEGIN = B
 LENGTH(AH 1086 BK 0000)

018 "DIA CIRC CONCR
 LEN=0050 INSTALLED UNKN 0011/0860
 018 "DIA CIRC CONCR
 LEN=0050 INSTALLED UNKN 0011/0590
 NORTH BRADDOCK
 CHALFANT B 0011/0280
 018 "DIA CIRC CONCR
 LEN=0050 INSTALLED UNKN 0011/0230
 018 "DIA CIRC CONCR
 LEN=0050 INSTALLED UNKN 0011/0050
 1 0 00639 0 00 0000+00 000000 FT
 LINCOLN HW
 (SR0030 SEG 0221/2650)
 NC ELECTRIC AV
 LINCOLN HW INTER-BK
 (SR0030 SEG 0221/2650)
 MFC BEGIN = B
 LENGTH(AH 1029 BK 0000) 0011/0000

DIR: B TOTAL LEN: 2.014 MI. DIST: 11-1 SR: 2110
 LEFT MUN: CHURCHILL B RIGHT MUN: CHURCHILL B

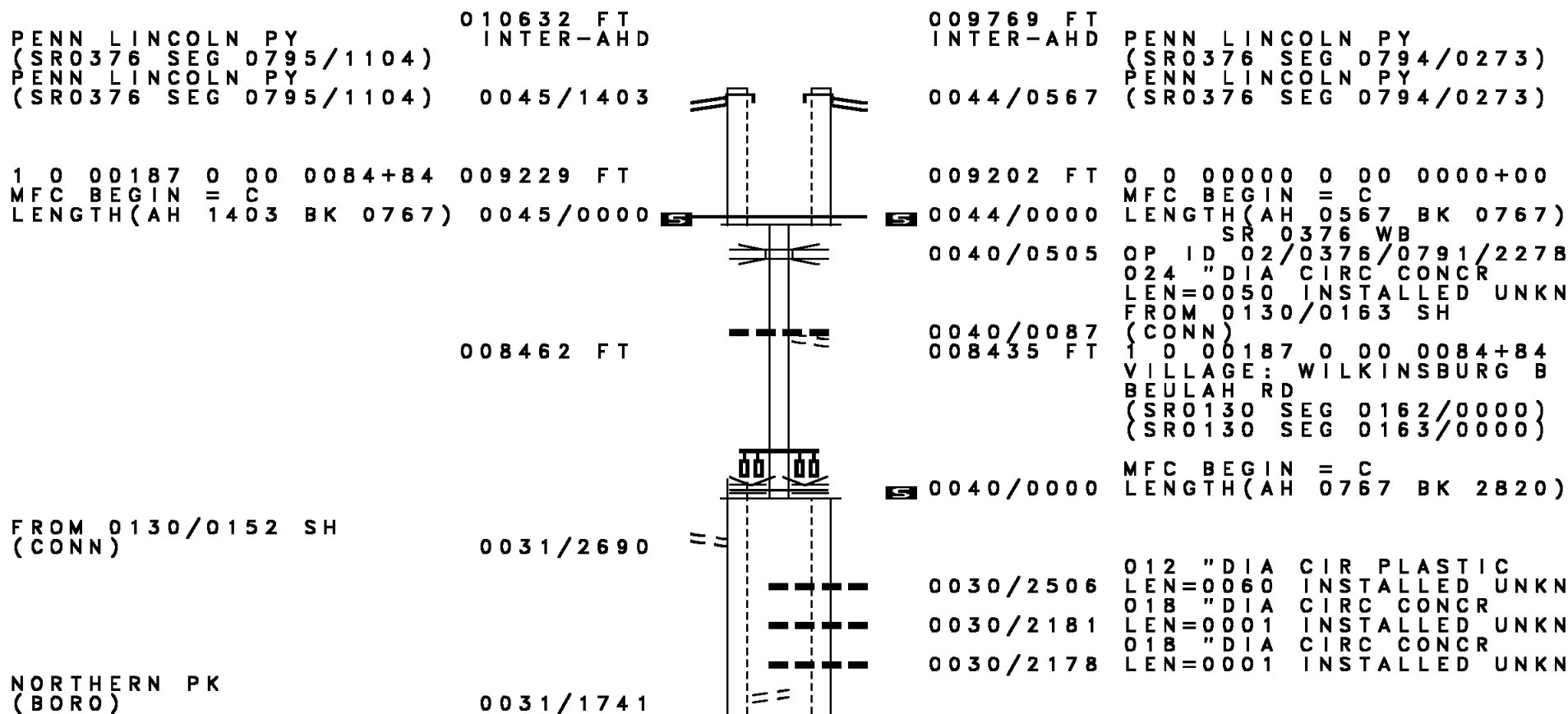

DIR: B TOTAL LEN: 2.014 MI. DIST: 11-1 SR: 2110
 LEFT MUN: CHURCHILL B RIGHT MUN: CHURCHILL B

Segment Description	Start Station	End Station	Length	Notes
018 "DIA CIRC CONCR LEN=0060 INSTALLED UNKN	0031/1625			
MC CREA RD (BORO)	0031/0930			
RAMP S RD (SR8014 SEG 0500/0000)	0031/0900			
OLD GATE RD (BORO)	0031/0890			
HARMAIN RD (BORO)	0031/0705			
CHURCHILL WILKINSBURG B	0031/0786			
BLACKRIDGE RD (BORO)	0031/0590			
1 0 00187 0 00 0049+20 005615 FT GRAHAM BL (CNTY)				
MFC BEGIN = C LENGTH(AH 2847 BK 2811)	0031/0000			
JACKSON ST (BORO)	0020/2010			
FINDLEY DR E (BORO)	0020/1405			
FINDLEY DR (BORO)	0020/0995			
0030/1710				NORTHERN PK (BORO)
0030/0920				MC CREA RD (BORO)
0030/0885				RAMP S RD (SR8014 SEG 0500/0000)
0030/0881				OLD GATE RD (BORO)
0030/0700				HARMAIN RD (BORO)
0030/0659				CHURCHILL WILKINSBURG B
0030/0580 005615 FT				BLACKRIDGE RD (BORO)
0030/0000				1 0 00187 0 00 0049+20 VILLAGE: WILKINSBUG B GRAHAM BL (CNTY)
0020/2219				MFC BEGIN = C LENGTH(AH 2820 BK 2811) 012"H 36"W CON BOX CUL LEN=0040 INSTALLED UNKN GREENSBURG PK (CNTY)
0020/2105				LIMECREST RD (BORO)
0020/1935				WILLIAM PENN CT (BORO)
0020/1890				012"H 36"W CON BOX CUL LEN=0050 INSTALLED UNKN
0020/1604				018 "DIA CIRC CONCR LEN=0001 INSTALLED UNKN
0020/1500				018 "DIA CIRC CONCR LEN=0001 INSTALLED UNKN
0020/1221				018 "DIA CIRC CONCR LEN=0001 INSTALLED UNKN BEACON HILL RD (BORO)
0020/0995				018 "DIA CIRC CONCR LEN=0001 INSTALLED UNKN
0020/0948				FAIRMONT ST

EXTRACT DATE: 12/21/2020
PRINT DATE: 12/23/2020

ROADWAY MANAGEMENT SYSTEM
SLD COUNTY/SR - ANNUAL PRINT

PAGE NUMBER: 924
COUNTY: ALLEGHENY

DIR: B TOTAL LEN: 2.014 MI.
LEFT MUN: WILKINSBURG B

DIST: 11-1 SR: 2110
RIGHT MUN: WILKINSBURG B

BRINKER ST
(BORO)

0020/0600

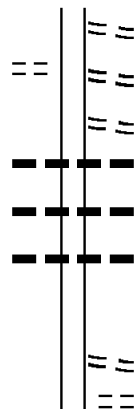

0020/0785 (BORO)
HARVEST WAY
0020/0600 (BORO)
SUMMIT ST
0020/0410 (BORO)
018 "DIA CIRC CONCR
LEN=0056 INSTALLED UNKN
0020/0400 018 "DIA CIRC CONCR
LEN=0001 INSTALLED UNKN
0020/0198 018 "DIA CIRC CONCR
LEN=0001 INSTALLED UNKN
0020/0060 1 0 00187 0 00 0028+46
002804 FT SUPERIOR ST
(BORO)
5 0020/0000 LENGTH(AH 2811 BK 2804)
WOODLAWN CEMETERY DR
0010/2465 (BORO)

WEBER ST
(BORO)

0010/2347

LC TO PRINCETON BL
(CONN)

0010/1612

PRINCETON BL
(BORO)

0010/1503

EAST ST
(BORO)
ANGELA DR
(BORO)

0010/0677

0010/0485

BELMONT ST
(BORO)

0010/0119

000000 FT

PRINCETON BL
(BORO)
0010/1503
PASTURE WY
(BORO)
0010/1385
MIDLAND ST
(BORO)
018 "DIA CIRC CONCR
LEN=0030 INSTALLED UNKN
0010/0407 DELL WAY
(BORO)
0010/0218
018 "DIA CIRC CONCR
LEN=0050 INSTALLED UNKN
000000 FT 1 0 00187 0 00 0000+00
VILLAGE: WILKINSBURG B
ARDMORE BL
(SR0008 SEG 0030/1130)
NC PENN AV
INTER-BK ROSS AV
(BORO)
MFC BEGIN = C
5 0010/0000 LENGTH(AH 2804 BK 0000)

PENN AV
(SR0008 SEG 0030/1130) 0010/0000

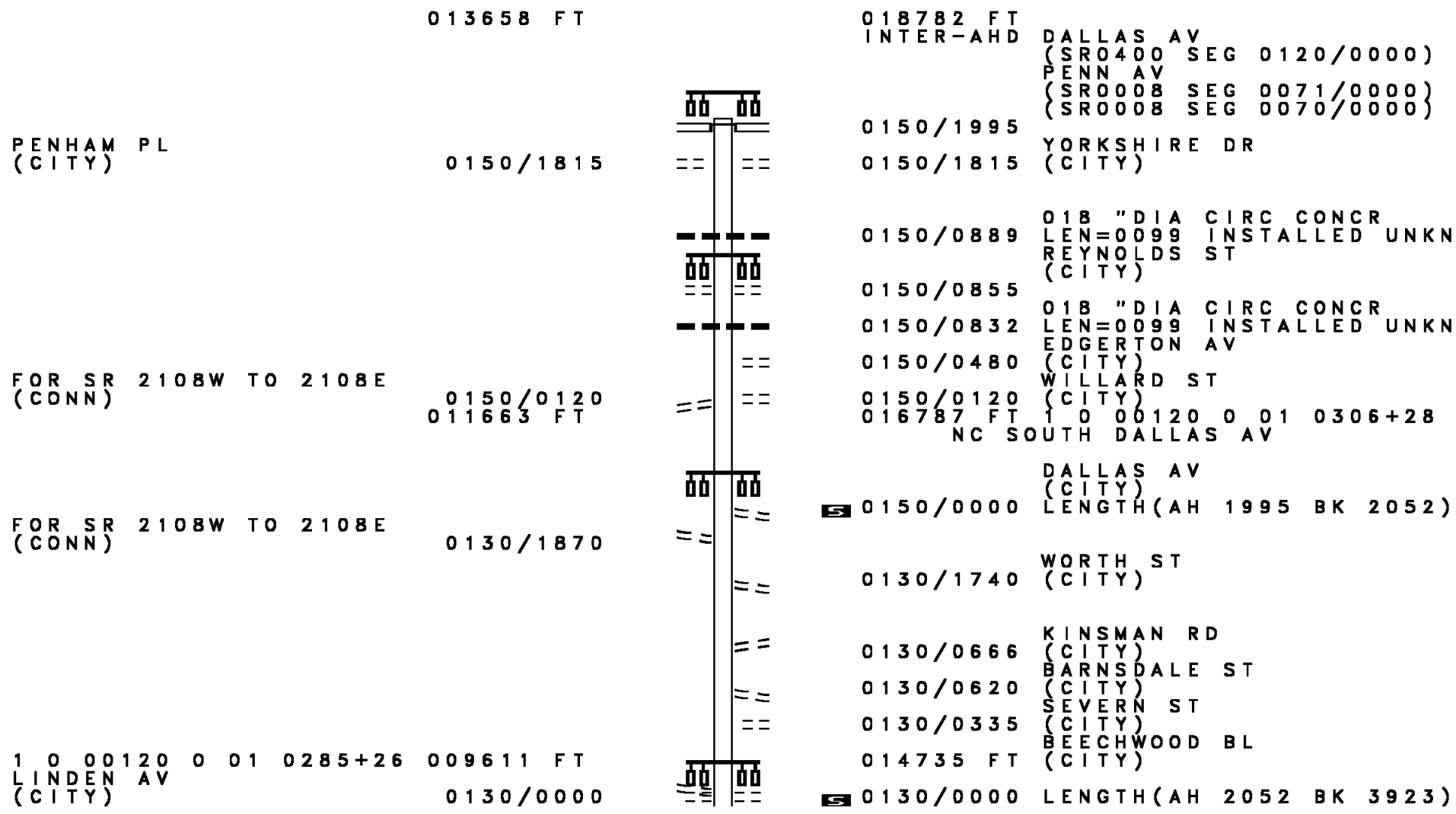

EXTRACT DATE: 12/21/2020
PRINT DATE: 12/23/2020

ROADWAY MANAGEMENT SYSTEM
SLD COUNTY/SR - ANNUAL PRINT

PAGE NUMBER: 922
COUNTY: ALLEGHENY

DIR: E TOTAL LEN: 3.557 MI.
LEFT MUN: PITTSBURGH C

DIST: 11-1 SR: 2108
RIGHT MUN: PITTSBURGH C

Street Name	Project ID	Notes	Project ID	Notes
			0120/3520	DENNISTON ST (CITY)
				SHADY AV (CITY)
			0120/3136	
			0120/2975	024"H 24"W CON BOX CUL LEN=0099 INSTALLED UNKN
WOODLAND RD (PRDR)	0120/2665			
			0120/2200	MURRAY AV (CITY)
WOODLAND RD (PRDR)	0120/2095			
			0120/1880	012"H 12"W CON BOX CUL LEN=0099 INSTALLED UNKN
MURRAY HILL AV (CITY)	0120/1778			
			0120/1600	NEGLEY AV (CITY)
NEGLEY AV (CITY)	0120/1600		0120/1600	
			0120/1390	012"H 12"W CON BOX CUL LEN=0040 INSTALLED UNKN
WIGHTMAN ST (CITY)	0120/1067		0120/1067	WIGHTMAN ST (CITY)
			0120/0665	BELLEROCK ST (CITY)
			0120/0615	010"H 18"W CON BOX CUL LEN=0099 INSTALLED UNKN
FAIR OAKS ST (CITY)	0120/0295		0120/0295	FAIR OAKS ST (CITY)
	005688 FT		010812 FT	1 0 00120 0 01 0246+11
WILKINS AV (CITY)	0120/0000		0120/0000	NC WILKINS AV LENGTH(AH 3923 BK 2282)
			0110/1690	BEELERMONT PL (CITY)
OLYMPIA PL (PRDR)	0110/1235			
GATEWOOD DR (PRDR)	0110/1035			
			0110/0833	018 "DIA CIRC CONCR LEN=0099 INSTALLED UNKN
UNGER LN (CITY)	0110/0715			
PENTON RD (PRDR)	0110/0521			
	003406 FT		008530 FT	1 0 00120 0 01 0211+60 (APRA) CARNEGIE MELLON FORBES AV

POI

DIR: E TOTAL LEN: 3.557 MI. DIST: 11-1 SR: 2108
 LEFT MUN: PITTSBURGH C RIGHT MUN: PITTSBURGH C

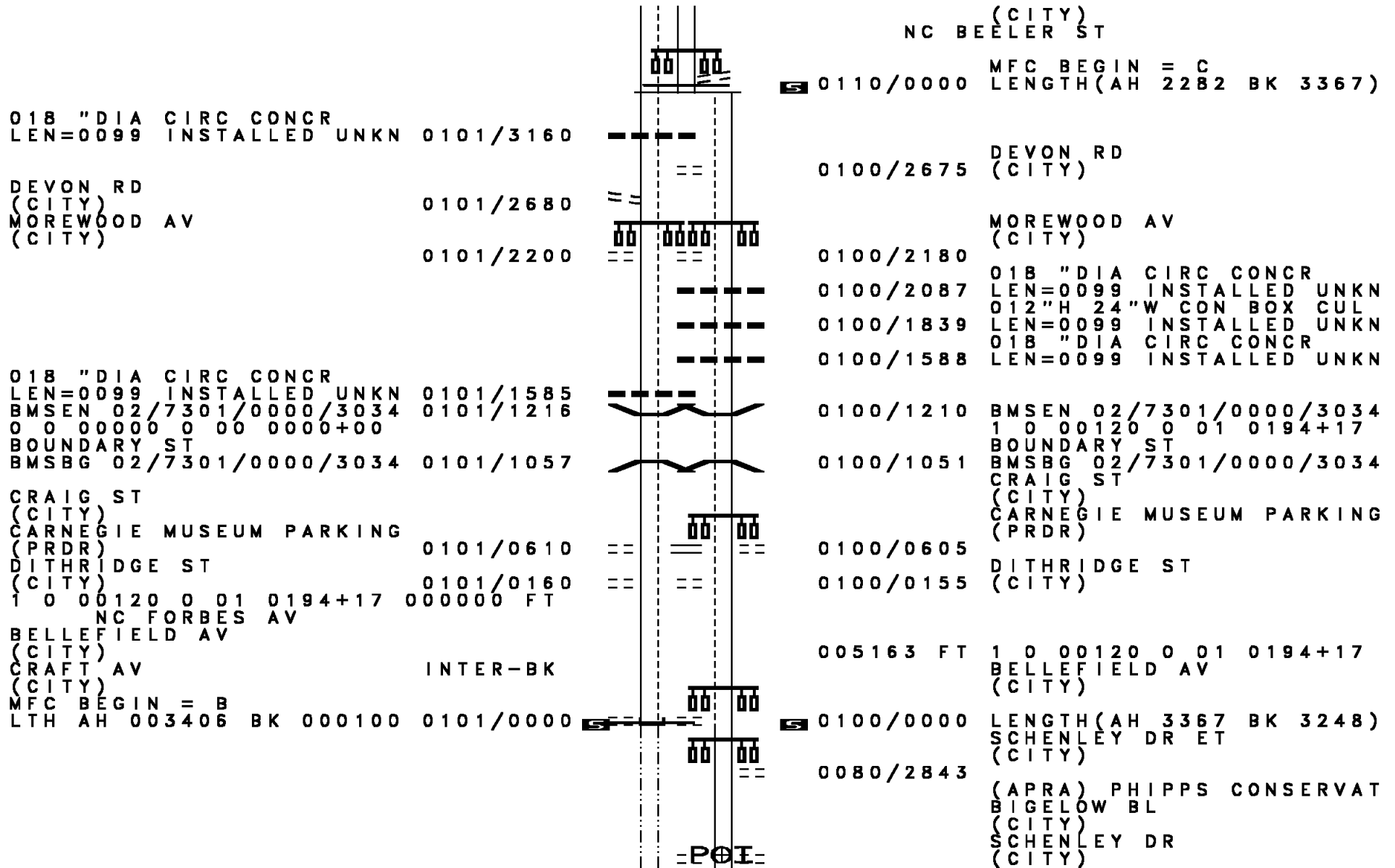

EXTRACT DATE: 12/21/2020
PRINT DATE: 12/23/2020

ROADWAY MANAGEMENT SYSTEM
SLD COUNTY/SR - ANNUAL PRINT

PAGE NUMBER: 920
COUNTY: ALLEGHENY

DIR: E TOTAL LEN: 3.557 MI.
LEFT MUN: PITTSBURGH C

DIST: 11-1 SR: 2108
RIGHT MUN: PITTSBURGH C

LTH AH 000100 BK 000100 000000 FT
7081/0000

LTH AH 000100 BK 000100 000000 FT
7071/0000

LTH AH 000100 BK 000000 000000 FT
7061/0000

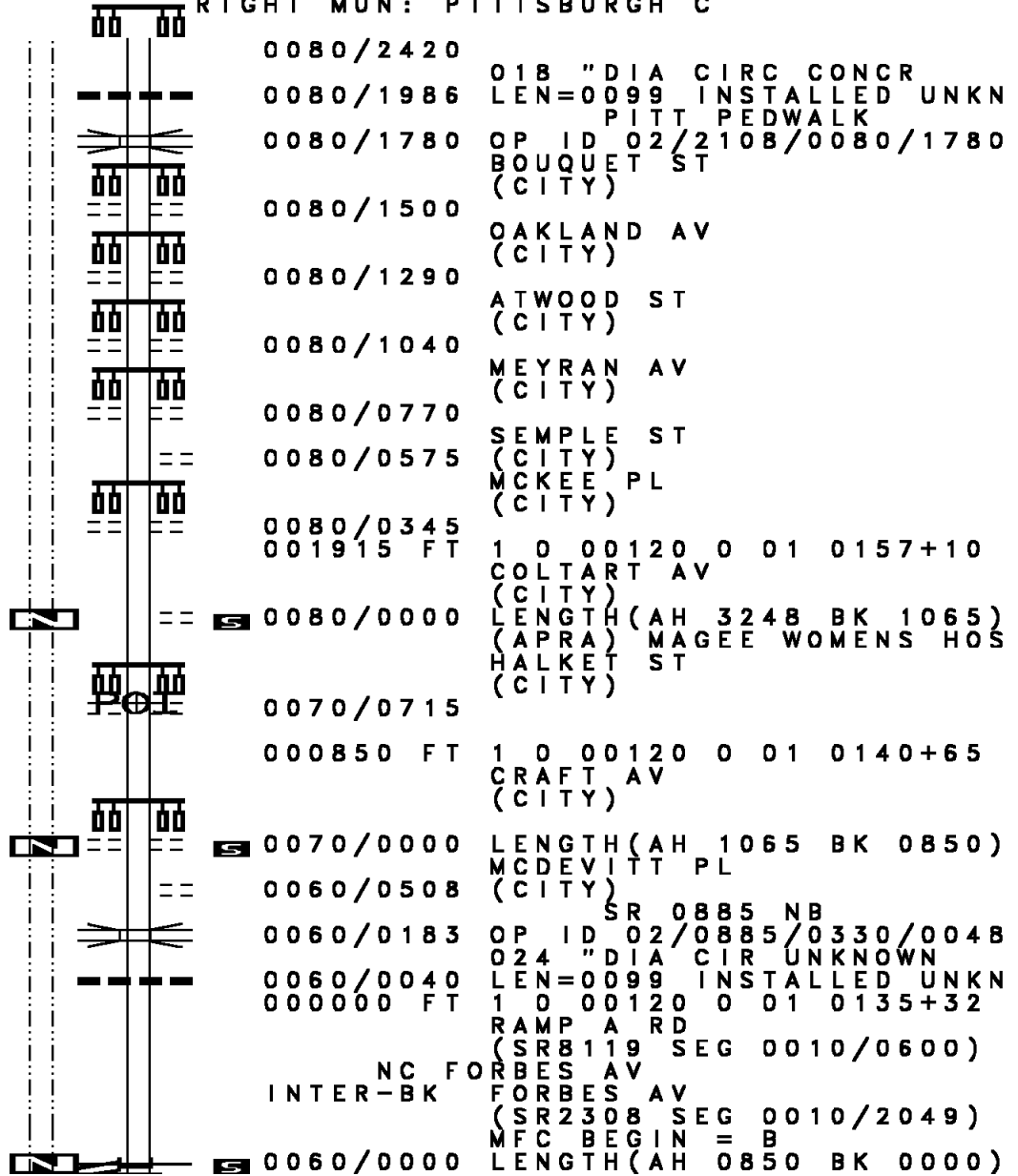

0080/2420 018 " DIA CIRC CONCR
0080/1986 LEN=0099 INSTALLED UNKN
PITT PEDWALK
0080/1780 OP ID 02/2108/0080/1780
BOUQUET ST
(CITY)
0080/1500 OAKLAND AV
(CITY)
0080/1290 ATWOOD ST
(CITY)
0080/1040 MEYRAN AV
(CITY)
0080/0770 SEMPLE ST
(CITY)
0080/0575 MCKEE PL
(CITY)
0080/0345 1 0 00120 0 01 0157+10
001915 FT COLTART AV
(CITY)
0080/0000 LENGTH(AH 3248 BK 1065)
(APRA) MAGEE WOMENS HOS
HALKET ST
(CITY)
0070/0715 000850 FT 1 0 00120 0 01 0140+65
CRAFT AV
(CITY)
0070/0000 LENGTH(AH 1065 BK 0850)
MCDEVITT PL
(CITY)
0060/0508 SR 0885 NB
0060/0183 OP ID 02/0885/0330/0048
024 " DIA CIR UNKNOWN
0060/0040 LEN=0099 INSTALLED UNKN
000000 FT 1 0 00120 0 01 0135+32
RAMP A RD
(SR8119 SEG 0010/0600)
NC FO RBES AV
INTER-BK FORBES AV
(SR2308 SEG 0010/2049)
MFC BEGIN = B
0060/0000 LENGTH(AH 0850 BK 0000)

EXTRACT DATE: 12/21/2020 ROADWAY MANAGEMENT SYSTEM PAGE NUMBER: 919
 PRINT DATE: 12/23/2020 SLD COUNTY/SR - ANNUAL PRINT COUNTY: ALLEGHENY
 DIR: B TOTAL LEN: .071 MI. DIST: 11-1 SR: 2107
 LEFT MUN: MCKEESPORT C RIGHT MUN: MCKEESPORT C

BMS EN 02/2107/0011/0000 REF-AHD *
 BOWMAN AV 0011/0374 *
 (CITY) 000000 FT
 2 0 02199 0 00 0000+00 000000 FT
 NC BOWMAN AV
 BOWMAN AV REF-BK *
 (CITY)
 RAMP E
 BMS BG 02/2107/0011/0000
 MFC BEGIN = C 000000 FT
 LENGTH(AH 0374 BK 0000) 0011/0000 7010/0000 LTH AH 000374 BK 000000

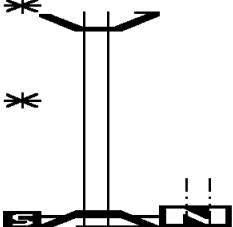

SALTSBURG RD 002863 FT
 (SR0400 SEG 0330/2285) 0010/2863



000000 FT

002863 FT SALTSBURG RD
 0010/2863 (SR0400 SEG 0330/2285)

0010/1039 018 " DIA CIRC CONCR
 LEN=0080 INSTALLED UNKN
 ATLAS ST
 0010/1005 (TWP)
 024"H 24"W ELLIP METAL
 0010/0461 LEN=0024 INSTALLED UNKN
 SCHOOL ST
 0010/0448 (SR2056 SEG 0010/1744)
 COAL ST
 0010/0413 (TWP)
 0010/0392 018 " DIA CIRC CONCR
 LEN=0035 INSTALLED UNKN
 0010/0258 018 " DIA CIRC CONCR
 LEN=0025 INSTALLED UNKN
 0010/0235 018 " DIA CIRC CONCR
 LEN=0020 INSTALLED UNKN
 0010/0054 018 " DIA CIRC METAL
 LEN=0080 INSTALLED UNKN
 000000 FT 2 0 02199 0 00 0000+00
 NC RE ITER RD
 UNIVERSAL RD
 (CNTY)
 MFC BEGIN = E
 0010/0000 LENGTH(AH 2863 BK 0000)

EXTRACT DATE: 12/21/2020 ROADWAY MANAGEMENT SYSTEM PAGE NUMBER: 917
 PRINT DATE: 12/23/2020 SLD COUNTY/SR - ANNUAL PRINT COUNTY: ALLEGHENY
 DIR: B TOTAL LEN: .005 MI. DIST: 11-1 SR: 2105
 LEFT MUN: ELIZABETH T RIGHT MUN: ELIZABETH T

000028 FT
 000000 FT

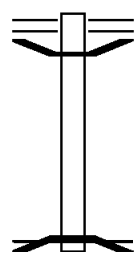

000028 FT LOVEDALE RD
 0010/0028 (SR2010 SEG 0020/0537)
 0010/0024 BMS EN 02/2105/0010/0000
 000000 FT 0 0 00000 0 00 0000+00
 NC ROSS ST
 * REF-BK ROSS ST
 (TWP)
 WYLIE RUN
 BMSBG 02/2105/0010/0000
 MFC BEGIN = E
 0010/0000 LENGTH(AH 0028 BK 0000)

001143 FT

001143 FT INTER-AHD CHURCHILL RD
 (CNTY)
 HOLLAND RD
 (BORO)
 RAMP B RD
 (SR8016 SEG 0750/0000)
 RAMP A RD
 (SR8016 SEG 0010/0451)
 0010/1143 018 "DIA CIRC CONCR
 0010/0924 LEN=0030 INSTALLED UNKN

 018 "DIA CIRC CONCR
 0010/0106 LEN=0072 INSTALLED UNKN
 FROM 0130/0173 SH
 0010/0062 (CONN)
 000000 FT 1 0 00741 4 00 0000+00
 (APRA) WESTINGHOUSE RES
 NC CHURCHILL RD
 BEULAH RD
 (SRO130 SEG 0172/0230)
 (SRO130 SEG 0173/0220)

 INTER-BK HELEN DR
 (PRDR)
 MFC BEGIN = D
 0010/0000 LENGTH(AH 1143 BK 0000)

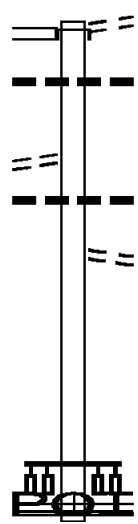

TO 0130/0173 SH
 (CONN)

0010/0165

000000 FT

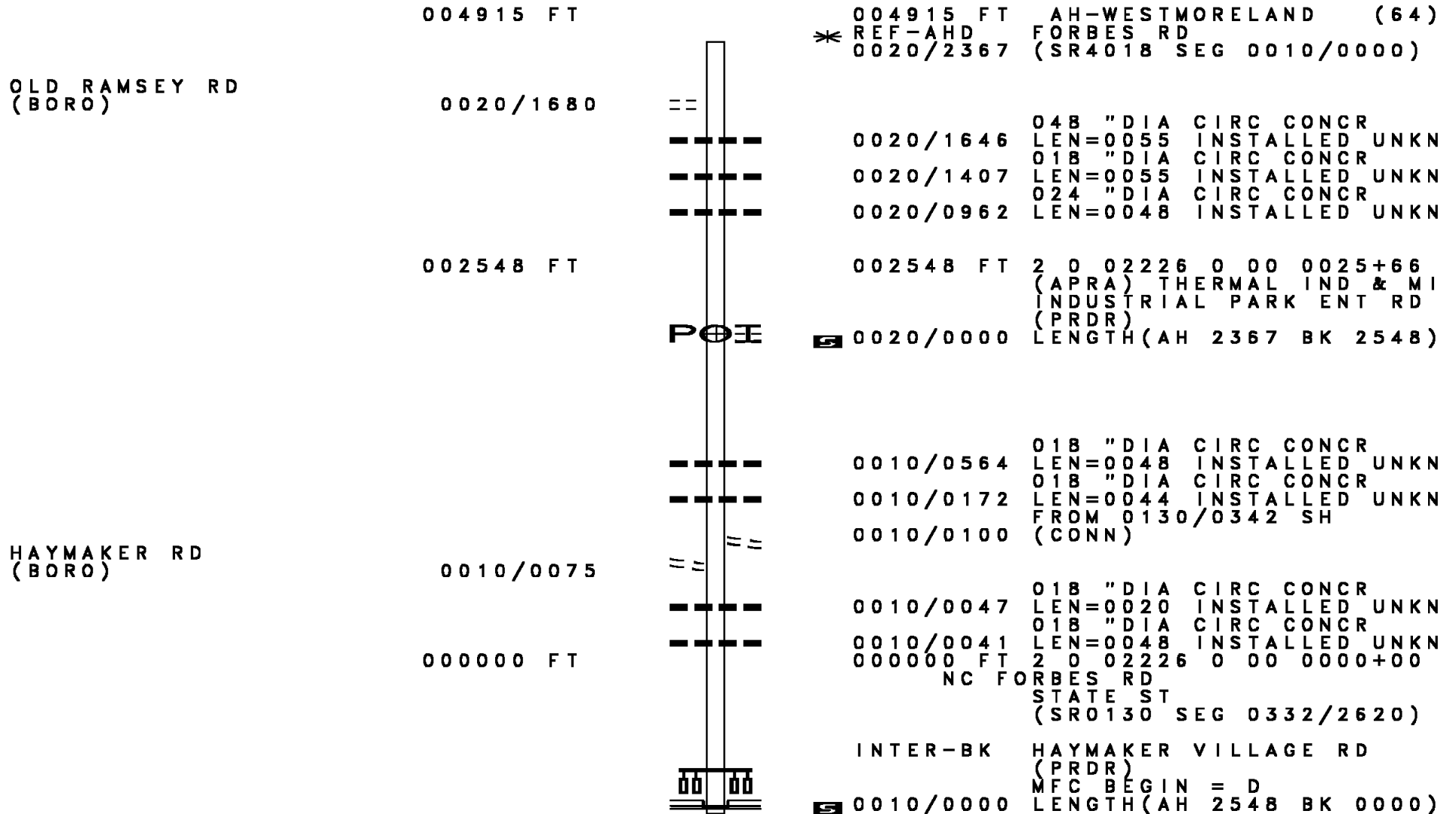

EXTRACT DATE: 12/21/2020 ROADWAY MANAGEMENT SYSTEM PAGE NUMBER: 914
 PRINT DATE: 12/23/2020 SLD COUNTY/SR - ANNUAL PRINT COUNTY: ALLEGHENY
 DIR: B TOTAL LEN: .145 MI. DIST: 11-1 SR: 2101
 LEFT MUN: PITTSBURGH C RIGHT MUN: PITTSBURGH C

RAMP H RD 000764 FT
 (SR8008 SEG 0520/0000) 0010/0764

000000 FT

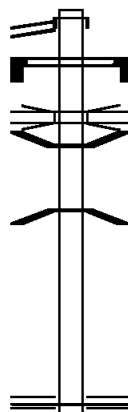

INTER-AHD FORWARD AV
 0010/0764 (CITY)
 SIGN: CANTILEVER
 0010/0706 BMSID 02/2101/0010/0900
 SR 0376 EB
 0010/0417 OP ID 02/0376/0744/0762
 0010/0089 BMSEN 02/2101/0010/0045
 0 0 00000 0 00 0000+00
 LR 763 RMP G
 0010/0057 BMSBG 02/2101/0010/0045
 000000 FT 1 0 00763 2 10 0000+00
 NC FORWARD AV INT./RAMP F RD
 RAMP E RD
 (SR8008 SEG 0750/0598)
 RAMP E RD
 (SR8008 SEG 0750/0598)
 MFC BEGIN = E
 0010/0000 LENGTH(AH 0764 BK 0000)

EXTRACT DATE: 12/21/2020 ROADWAY MANAGEMENT SYSTEM PAGE NUMBER: 913
PRINT DATE: 12/23/2020 SLD COUNTY/SR - ANNUAL PRINT COUNTY: ALLEGHENY
DIR: B TOTAL LEN: .000 MI. DIST: 11-1 SR: 2100
LEFT MUN: MONROEVILLE B RIGHT MUN: MONROEVILLE B

000000 FT
000000 FT



000000 FT
7020/0000 LENGTH(AH 3783 BK 3699)
000000 FT
7010/0000 LENGTH(AH 3699 BK 0000)

EXTRACT DATE: 12/21/2020 ROADWAY MANAGEMENT SYSTEM PAGE NUMBER: 912
 PRINT DATE: 12/23/2020 SLD COUNTY/SR - ANNUAL PRINT COUNTY: ALLEGHENY
 DIR: B TOTAL LEN: .022 MI. DIST: 11-1 SR: 2099
 LEFT MUN: MONROEVILLE B RIGHT MUN: MONROEVILLE B

000116 FT
 000000 FT

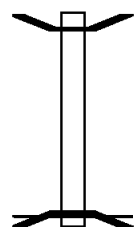

000116 FT BMS EN 02/2099/0010/0000
 * REF-AHD GARDEN CITY RD
 0010/0116 (BORO)
 000000 FT 0 0 00000 0 00 0000+00
 NC GA GARDEN CITY RD
 * REF-BK GARDEN CITY RD
 (BORO)
 187PAR, 18138
 BMSBG 02/2099/0010/0000
 MFC BEGIN = E
 0010/0000 LENGTH(AH 0116 BK 0000)

001670 FT

001670 FT
 INTER-AHD KENNYWOOD BL
 (SR0837 SEG 0340/1745)
 KENNYWOOD BL
 (SR0837 SEG 0341/1770)
 0010/1670 018 " DIA CIRC CONCR
 0010/1582 LEN=0033 INSTALLED UNKN
 018 " DIA CIRC CONCR
 0010/1572 LEN=0030 INSTALLED UNKN
 018 " DIA CIRC CONCR
 0010/1262 LEN=0045 INSTALLED UNKN

 0010/0200 024 " DIA CIRC CONCR
 LEN=0135 INSTALLED UNKN
 WHITAKER
 0010/0178 WEST MIFFLIN B
 000000 FT 1 0 00736 7 00 0000+00
 NC MI MIFFLIN ST
 WHITAKER WY
 (SR2049 SEG 0030/1991)
 INTER-BK MIFFLIN ST
 (BORO)
 MFC BEGIN = D
 0010/0000 LENGTH(AH 1670 BK 0000)

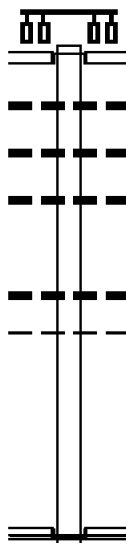

000000 FT

EXTRACT DATE: 12/21/2020 ROADWAY MANAGEMENT SYSTEM PAGE NUMBER: 910
 PRINT DATE: 12/23/2020 SLD COUNTY/SR - ANNUAL PRINT COUNTY: ALLEGHENY
 DIR: B TOTAL LEN: .025 MI. DIST: 11-1 SR: 2097
 LEFT MUN: CHURCHILL B RIGHT MUN: CHURCHILL B

000132 FT
 000000 FT

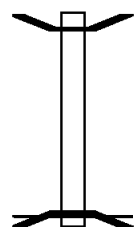

000132 FT BMS EN 02/2097/0010/0000
 * REF-AHD GREENSBURG PK
 0010/0132 (BORO)
 000000 FT 0 0 00000 0 00 0000+00
 * REF-BK NC GR GREENSBURG PK
 GREENSBURG PK
 (BORO)
 SR 0376 EB
 BMSBG 02/2097/0010/0000
 MFC BEGIN = C
 0010/0000 LENGTH(AH 0132 BK 0000)

EXTRACT DATE: 12/21/2020 ROADWAY MANAGEMENT SYSTEM PAGE NUMBER: 909
 PRINT DATE: 12/23/2020 SLD COUNTY/SR - ANNUAL PRINT COUNTY: ALLEGHENY
 DIR: B TOTAL LEN: .359 MI. DIST: 11-1 SR: 2096
 LEFT MUN: PORT VUE B RIGHT MUN: PORT VUE B

RIVER RD 001896 FT
 (SR2027 SEG 0030/0835) 0010/1896

1 0 00392 5 00 0001+20
 TO 0148/0040 SH
 (CONN)

0010/0129
 000000 FT

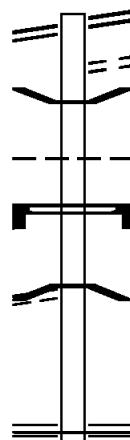

001896 FT RIVER RD
 0010/1896 (SR2027 SEG 0030/0835)
 LIBERTY WY
 0010/1700 (TWP)
 0010/1382 BMSEN 02/2096/0010/0129

 0010/0615 PORT VUE
 MCKEESPORT C
 SIGN: CANTILEVER
 0010/0580 BMSID 02/2096/0010/0580

 0010/0129 LR 02259
 BMSBG 02/2096/0010/0129
 000000 FT 1 0 00392 5 00 0000+00
 NC FIFTEENTH ST
 WALNUT ST
 (SR0148 SEG 0040/2097)
 MFC BEGIN = C
 0010/0000 LENGTH(AH 1896 BK 0000)

EXTRACT DATE: 12/21/2020 ROADWAY MANAGEMENT SYSTEM PAGE NUMBER: 908
 PRINT DATE: 12/23/2020 SLD COUNTY/SR - ANNUAL PRINT COUNTY: ALLEGHENY
 DIR: B TOTAL LEN: .014 MI. DIST: 11-1 SR: 2095
 LEFT MUN: EDGEWOOD B RIGHT MUN: EDGEWOOD B

000072 FT
 000000 FT

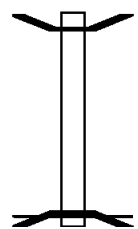

000072 FT BMS EN 02/2095/0010/0000
 * REF-AHD CHESTNUT ST
 0010/0072 (BORO)
 000000 FT 0 0 00000 0 00 0000+00
 * REF-BK NC CH CHESTNUT ST
 (BORO)
 PARKWAY EAST
 BMSBG 02/2095/0010/0000
 MFC BEGIN = E
 0010/0000 LENGTH(AH 0072 BK 0000)

EXTRACT DATE: 12/21/2020 ROADWAY MANAGEMENT SYSTEM PAGE NUMBER: 907
PRINT DATE: 12/23/2020 SLD COUNTY/SR - ANNUAL PRINT COUNTY: ALLEGHENY
DIR: E TOTAL LEN: .356 MI. DIST: 11-1 SR: 2094
LEFT MUN: MCKEESPORT C RIGHT MUN: MCKEESPORT C

001873 FT

001882 FT

DIR: E TOTAL LEN: .356 MI. DIST: 11-1 SR: 2094
 LEFT MUN: MCKEESPORT C RIGHT MUN: MCKEESPORT C

LYSLE BL (SR0148 SEG 0071/0000) WALNUT ST (CITY) WALNUT ST (SR0148 SEG 0071/0000) (SR0148 SEG 0070/0000)	INTER-AHD				INTER-AHD	LYSLE BL (SR0148 SEG 0071/0000) WALNUT ST (CITY) WALNUT ST (SR0148 SEG 0070/0000) (SR0148 SEG 0071/0000)
	0011/1873				0010/1882	
MARKET ST (CITY)	0011/1425				0010/1425	MARKET ST (CITY)
					0010/1395	MARKET ST (CITY)
018 "DIA CIRC CONCR LEN=0020 INSTALLED UNKN STRAWBERRY WY (CITY) 020 "DIA CIR UNKNOWN LEN=0020 INSTALLED UNKN GIBSON WY (CITY)	0011/1356 0011/1225 0011/1201 0011/1100					
					0010/1075	GIBSON WY (CITY)
					0010/1003	024 "DIA CIRC CONCR LEN=0099 INSTALLED UNKN
024 "DIA CIRC CONCR LEN=0020 INSTALLED UNKN	0011/1028					
					0010/0825	009 "DIA CIRC CONCR LEN=0099 INSTALLED UNKN
BMSBN 02/2094/0010/0059	0011/0825				0010/0793	BMSBN 02/2094/0010/0059
ROMINE ST (CITY)	0011/0140				0010/0132	ROMINE ST (CITY)
1 0 00392 4 00 0018+30 RIVER ROAD BMSBG 02/2094/0010/0059 1 0 00392 4 00 0018+79 000000 FT NC LYSLE BL/JEROME ST BR	0011/0064					
					0010/0032	1 0 00392 4 00 0018+79 RIVER ROAD BMSBG 02/2094/0010/0059 000000 FT 1 0 00392 4 00 0018+79 NC JEROME ST BR/LYSLE BL
RIVER RD (SR2027 SEG 0070/0618) FIFTH AV (SR2021 SEG 0121/0525) MFC BEGIN = B LENGTH(AH 1873 BK 0000)	INTER-BK 0011/0000				INTER-BK 0010/0000	RIVER RD (SR2027 SEG 0070/0618) FIFTH AV (SR2021 SEG 0121/0525) MFC BEGIN = B LENGTH(AH 1882 BK 0000)

EXTRACT DATE: 12/21/2020 ROADWAY MANAGEMENT SYSTEM PAGE NUMBER: 905
 PRINT DATE: 12/23/2020 SLD COUNTY/SR - ANNUAL PRINT COUNTY: ALLEGHENY
 DIR: B TOTAL LEN: .014 MI. DIST: 11-1 SR: 2093
 LEFT MUN: EDGEWOOD B RIGHT MUN: EDGEWOOD B

000073 FT
 000000 FT

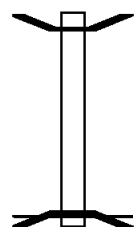

000073 FT BMS EN 02/2093/0010/0000
 * REF-AHD EDGEWOOD AV
 0010/0073 (BORO)
 000000 FT 0 0 00000 0 00 0000+00
 NC ED GEWOOD AV
 * REF-BK EDGEWOOD AV
 (BORO)
 PARKWAY EAST
 BMSBG 02/2093/0010/0000
 MFC BEGIN = E
 0010/0000 LENGTH(AH 0073 BK 0000)

EXTRACT DATE: 12/21/2020 ROADWAY MANAGEMENT SYSTEM PAGE NUMBER: 904
 PRINT DATE: 12/23/2020 SLD COUNTY/SR - ANNUAL PRINT COUNTY: ALLEGHENY
 DIR: B TOTAL LEN: .047 MI. DIST: 11-1 SR: 2092
 LEFT MUN: PENN HILLS T RIGHT MUN: PENN HILLS T

000250 FT
 000000 FT

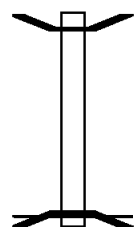

```

000250 FT BMS EN 02/2092/0010/0000
* REF-AHD JEFFERSON HTS RD
0010/0250 (TWP )
000000 FT 0 0 00000 0 00 0000+00
NC JEFFERSON HTS RD BRIDGE
* REF-BK JEFFERSON HTS RD
(TWP )
I-376 EB
BMSBG 02/2092/0010/0000
MFC BEGIN = E
5 0010/0000 LENGTH(AH 0250 BK 0000)
  
```

EXTRACT DATE: 12/21/2020 ROADWAY MANAGEMENT SYSTEM PAGE NUMBER: 903
 PRINT DATE: 12/23/2020 SLD COUNTY/SR - ANNUAL PRINT COUNTY: ALLEGHENY
 DIR: B TOTAL LEN: .014 MI. DIST: 11-1 SR: 2091
 LEFT MUN: EDGEWOOD B RIGHT MUN: EDGEWOOD B

000074 FT
 000000 FT

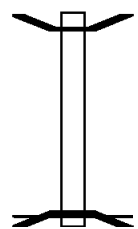

000074 FT BMS EN 02/2091/0010/0000
 * REF-AHD LAUREL ST
 0010/0074 (BORO)
 000000 FT 0 0 00000 0 00 0000+00
 NC LAUREL ST
 * REF-BK LAUREL ST
 (BORO)
 PARKWAY EAST
 BMSBG 02/2091/0010/0000
 MFC BEGIN = E
 0010/0000 LENGTH(AH 0074 BK 0000)

010232 FT

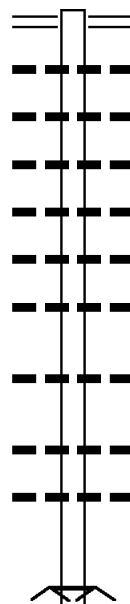

006394 FT

010232 FT	GREENSBURG RD
0030/3838	(SRO366 SEG 0102/2360)
	018 "DIA CIRC CONCR
0030/3744	LEN=0040 INSTALLED UNKN
	018 "DIA CIRC METAL
0030/3306	LEN=0030 INSTALLED UNKN
	018 "DIA CIRC CONCR
0030/3036	LEN=0040 INSTALLED UNKN
	018 "DIA CIRC CONCR
0030/2684	LEN=0040 INSTALLED UNKN
	018 "DIA CIRC CONCR
0030/2257	LEN=0048 INSTALLED UNKN
	024 "DIA CIRC CONCR
0030/1998	LEN=0048 INSTALLED UNKN
	024 "DIA CIRC CONCR
0030/1234	LEN=0048 INSTALLED UNKN
	018 "DIA CIRC CONCR
0030/0412	LEN=0040 INSTALLED UNKN
	018 "DIA CIRC CONCR
0030/0231	LEN=0040 INSTALLED UNKN
006394 FT	2 0 02218 0 00 0070+13
	WEBSTER RD
	ROAD CLOSED AHEAD
0030/0000	LENGTH(AH 3838 BK 2877)

EXTRACT DATE: 12/21/2020
PRINT DATE: 12/23/2020

ROADWAY MANAGEMENT SYSTEM
SLD COUNTY/SR - ANNUAL PRINT

PAGE NUMBER: 901
COUNTY: ALLEGHENY

DIR: B TOTAL LEN: 1.938 MI.
LEFT MUN: PLUM BOROUGH B

DIST: 11-1 SR: 2090
RIGHT MUN: PLUM BOROUGH B

Stationing	Material	Length	Notes
0020/2871	024" DIA CIR PLASTIC	LEN=0099	INSTALLED UNKN
0020/2870	024" DIA CIR CONC	LEN=0050	INSTALLED UNKN
0020/2469	018" DIA CIR CONC	LEN=0040	INSTALLED UNKN
0020/2238	018" DIA CIR CONC	LEN=0040	INSTALLED UNKN
0020/1870	018" DIA CIR CONC	LEN=0040	INSTALLED UNKN
0020/1700	015" DIA CIR METAL	LEN=0040	INSTALLED UNKN
0020/1400	015" DIA CIR METAL	LEN=0040	INSTALLED UNKN
0020/1189	018" DIA CIR CONC	LEN=0040	INSTALLED UNKN
0020/0817	024" DIA CIR CONC	LEN=0040	INSTALLED UNKN
0020/0705	024" DIA CIR CONC	LEN=0040	INSTALLED UNKN
003517 FT	2 0 02218 0 00 0035+30		
0020/0000	018" DIA CIR CONC	LEN=0040	INSTALLED UNKN
0010/3025	LENGTH(AH 2877 BK 3517) 018" DIA CIR CONC	LEN=0040	INSTALLED UNKN
0010/2689	018" DIA CIR CONC	LEN=0040	INSTALLED UNKN
0010/2476	024" DIA CIR CONC	LEN=0045	INSTALLED UNKN
0010/2069	018" DIA CIR CONC	LEN=0040	INSTALLED UNKN
0010/1665	018" DIA CIR CONC	LEN=0040	INSTALLED UNKN
0010/1143	018" DIA CIR CONC	LEN=0040	INSTALLED UNKN
0010/0794	018" DIA CIR CONC	LEN=0040	INSTALLED UNKN
0010/0765	042"H 18"W ELLIPTICAL*	LEN=0020	INSTALLED 2016
000000 FT	2 0 02218 0 00 0000+00		
LOGANS FERRY RD (SR2075 SEG 0150/0000)	NC WE BSTER RD SARDIS RD (SR2088 SEG 0010/0000) LEECHBURG RD (SR2075 SEG 0150/0000) MFC BEGIN = D		
0010/0000	LENGTH(AH 3517 BK 0000)		

EXTRACT DATE: 12/21/2020 ROADWAY MANAGEMENT SYSTEM PAGE NUMBER: 900
PRINT DATE: 12/23/2020 SLD COUNTY/SR - ANNUAL PRINT COUNTY: ALLEGHENY
DIR: B TOTAL LEN: 3.512 MI. DIST: 11-1 SR: 2088
LEFT MUN: PLUM BOROUGH B RIGHT MUN: PLUM BOROUGH B

018541 FT



* 018541 FT
REF-AHD LOGAN FERRY RD
0070/3045 (BORO)

DIR: B TOTAL LEN: 3.512 MI. DIST: 11-1 SR: 2088
 LEFT MUN: PLUM BOROUGH B RIGHT MUN: PLUM BOROUGH B

Stationing	Length	Material	Notes
0070/2125	0035	018" DIA CIRC CONCR	INSTALLED UNKN
0070/1193	0030	015" DIA CIRC CONCR	INSTALLED UNKN
0070/0278	0030	024" DIA CIRC METAL	INSTALLED UNKN
015496 FT	2 0 02164 0 00 0030+28		
0070/0000	LENGTH(AH 3045 BK 2242)	018" DIA CIRC CONCR	
0060/2071	0035	018" DIA CIRC CONCR	INSTALLED UNKN
0060/1140	0035	018" DIA CIRC METAL	INSTALLED UNKN
0060/0660	0030	018" DIA CIRC METAL	INSTALLED UNKN
013254 FT		DRENNAN RD	
RENTON RD		(BORO)	
(SR2072 SEG 0010/0000)	0060/0000	LENGTH(AH 2242 BK 2069)	
0050/1053	0030	018" DIA CIRC CONCR	INSTALLED UNKN
0050/0672	0030	018" DIA CIRC CONCR	INSTALLED UNKN
011185 FT	2 0 02164 0 00 0073+88		
0050/0000	LENGTH(AH 2069 BK 1999)		
0040/1091	0030	018" DIA CIRC CONCR	INSTALLED UNKN
0040/0980	0099	012" DIA CIRC CONCR	INSTALLED UNKN
0040/0019	0040	013" DIA CIRC METAL	INSTALLED UNKN
009186 FT	2 0 02164 0 00 0093+87		
0040/0000	LENGTH(AH 1999 BK 2590)	OLD LEECHBURG RD	(SR2076 SEG 0070/1570)

DIR: B TOTAL LEN: 3.512 MI. DIST: 11-1 SR: 2088
 LEFT MUN: PLUM BOROUGH B RIGHT MUN: PLUM BOROUGH B

FIELD CLUB RD
 (PRDR)

0030/1118

006596 FT

2 0 02164 0 00 0151+65 003371 FT
 MCCALISTER DR
 (BORO)

0020/0000

000000 FT

WEBSTER RD
 (SR2090 SEG 0010/0000) 0010/0000

0030/1304	018 "DIA	CIRC CONCR	LEN=0030	INSTALLED UNKN
0030/0524	012 "DIA	CIRC CONCR	LEN=0099	INSTALLED UNKN
006596 FT	2 0 02164	0 00 0119+97		
0030/0000	LENGTH(AH	2590 BK 3225)		
0020/2742	018 "DIA	CIRC CONCR	LEN=0030	INSTALLED UNKN
0020/2379	024 "DIA	CIRC CONCR	LEN=0030	INSTALLED UNKN
0020/1502	018 "DIA	CIRC METAL	LEN=0050	INSTALLED UNKN
0020/1216	018 "DIA	CIRC CONCR	LEN=0099	INSTALLED UNKN
0020/0661	018 "DIA	CIRC CONCR	LEN=0099	INSTALLED UNKN
0020/0612	018 "DIA	CIR PLASTIC	LEN=0030	INSTALLED UNKN
0020/0604	018 "DIA	CIRC CONCR	LEN=0099	INSTALLED UNKN
003371 FT				
0020/0000	LENGTH(AH	3225 BK 3371)		
0010/2454	018 "DIA	CIRC CONCR	LEN=0035	INSTALLED UNKN
0010/1074	024 "DIA	CIRC METAL	LEN=0055	INSTALLED UNKN
0010/1055	HARRIS RD	(BORO)		
0010/0694	018 "DIA	CIRC CONCR	LEN=0001	INSTALLED UNKN
000000 FT	2 0 02164	0 00 0185+81		
	VILLAGE: PLUM BOROUGH			
	NC SA	ARDIS RD		
	LEECHBURG RD			
INTER-BK	(SR2075	SEG 0150/0000)		
	(SR2075	SEG 0150/0000)		
	MFC BEGIN = D			
0010/0000	LENGTH(AH	3371 BK 0000)		

EXTRACT DATE: 12/21/2020 ROADWAY MANAGEMENT SYSTEM PAGE NUMBER: 897
 PRINT DATE: 12/23/2020 SLD COUNTY/SR - ANNUAL PRINT COUNTY: ALLEGHENY
 DIR: B TOTAL LEN: .032 MI. DIST: 11-1 SR: 2087
 LEFT MUN: NORTH VERSAILLES T RIGHT MUN: NORTH VERSAILLES T

000170 FT
 000000 FT

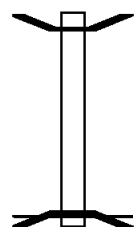

000170 FT BMSBN 02/2087/0010/0001
 * REF-AHD GREENSBURG PK
 0010/0170 (TWP)
 000000 FT 0 0 00000 0 00 0000+00
 * REF-BK NC GR GREENSBURG PK
 GREENSBURG PK
 (TWP)
 ROUTE 30
 BMSBG 02/2087/0010/0001
 MFC BEGIN = C
 0010/0000 LENGTH(AH 0170 BK 0000)

DIR: B TOTAL LEN: 1.911 MI. DIST: 11-1 SR: 2086
 LEFT MUN: PLUM BOROUGH B RIGHT MUN: PLUM BOROUGH B

Location	Start Station	End Station	Description	Material	Status	Year
TILIO DR (BORO)	010092	010092	INTER-AHD	NEW TEXAS RD	INSTALLED	UNKN
	0040	0040	2702	(SR2075 SEG 0120/0000)		
	0040	0040	2645	048 "DIA CIRC CONCR	INSTALLED	UNKN
	0040	0040	1798	018 "DIA CIRC CONCR	INSTALLED	UNKN
	0040	0040	1400	018 "DIA CIRC CONCR	INSTALLED	UNKN
	0040	0040	0822	018 "DIA CIRC CONCR	INSTALLED	2012
	007390	007390	0115	048 "DIA CIRC CONCR	INSTALLED	UNKN
	0040	0040	0000	2 0 02237 0 00 0170+17		
	0030	0030	2470	024 "DIA CIRC CONCR	INSTALLED	UNKN
	0030	0030	2102	018 "DIA CIRC CONCR	INSTALLED	2012
ELICKER RD (BORO)	0030	0030	1750	024 "DIA CIRC CONCR	INSTALLED	UNKN
	0030	0030	1290	012"H 12"W CON BOX CUL	INSTALLED	UNKN
	0030	0030	0883	018 "DIA CIRC CONCR	INSTALLED	2012
	0030	0030	0514	024 "DIA CIRC CONCR	INSTALLED	2012
	0030	0030	0300	015 "DIA CIR PLASTIC	INSTALLED	UNKN
	004440	004440	0034	018 "DIA CIRC CONCR	INSTALLED	2012
	0030	0030	0000	2 0 02237 0 00 0138+24		
	0020	0020	1545	015 "DIA CIRC CONCR	INSTALLED	2012
	0020	0020	0830	036 "DIA CIRC CONCR	INSTALLED	UNKN
	0020	0020	0680	036 "DIA CIRC CONCR	INSTALLED	UNKN

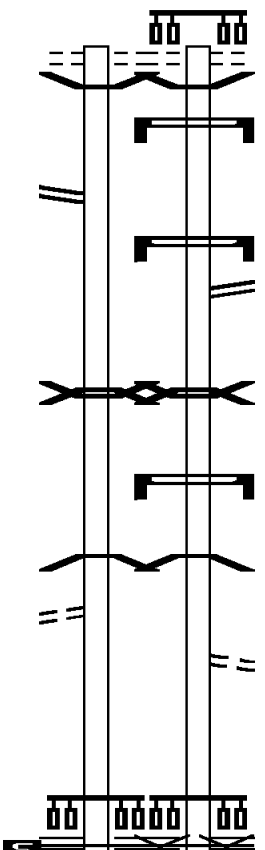
<p>FIFTH AV (CITY) BMSSEN 02/2085/0010/2248</p> <p>RAMP FR FORBES AV (SR8065 SEG 0250/0919)</p> <p>2 0 02266 4 00 0000+00 BMSSEN 02/2085/0010/0586 BLVD ALLIES BMSBG 02/2085/0010/2248</p> <p>2 0 02266 0 00 0005+89 MONONGAHELA RIVER BMSBG 02/2085/0010/0586 TO 0837/0520 SH (CONN)</p> <p>2 0 02266 0 00 0000+00 000000 FT NC BIRMINGHAM BR CARSON ST (SR0837 SEG 0520/1892)</p> <p>MFC BEGIN = B LENGTH(AH 3450 BK 0000)</p>	<p>003450 FT</p> <p>0011/3450 0011/3330</p> <p>0011/2331</p> <p>0011/2248</p> <p>0011/0586 0011/0120</p> <p>000000 FT</p> <p>0011/0000</p> 	<p>003419 FT FIFTH AV (CITY) 0010/3419 0010/3330 BMSSEN 02/2085/0010/2248 0010/3211 SIGN STRUCTURE BMSID 02/2085/0010/3195</p> <p>0010/2318 SIGN: CANTILEVER BMSID 02/2085/0010/2318 RAMP TO FORBES AV 0010/2314 (SR8065 SEG 0010/0000) 2 0 02266 4 00 0000+00 BMSSEN 02/2085/0010/0586 BLVD ALLIES 0010/2248 BMSBG 02/2085/0010/2248</p> <p>0010/1065 SIGN: CANTILEVER BMSID 02/2085/0010/1065 2 0 02266 0 00 0005+89 MONONGAHELA RIVER 0010/0586 BMSBG 02/2085/0010/0586</p> <p>0010/0110 FROM 0837/0520 SH (CONN) 000000 FT 2 0 02266 4 00 0000+00 VILLAGE: PITTSBURGH C NC BIRMINGHAM BR CARSON ST (SR0837 SEG 0520/1892)</p> <p>0010/0000 MFC BEGIN = B LENGTH(AH 3419 BK 0000)</p>
--	--	--

EXTRACT DATE: 12/21/2020
PRINT DATE: 12/23/2020

ROADWAY MANAGEMENT SYSTEM
SLD COUNTY/SR - ANNUAL PRINT

PAGE NUMBER: 892
COUNTY: ALLEGHENY

DIR: E TOTAL LEN: 1.960 MI.
LEFT MUN: PLUM BOROUGH B

DIST: 11-1 SR: 2084
RIGHT MUN: PLUM BOROUGH B

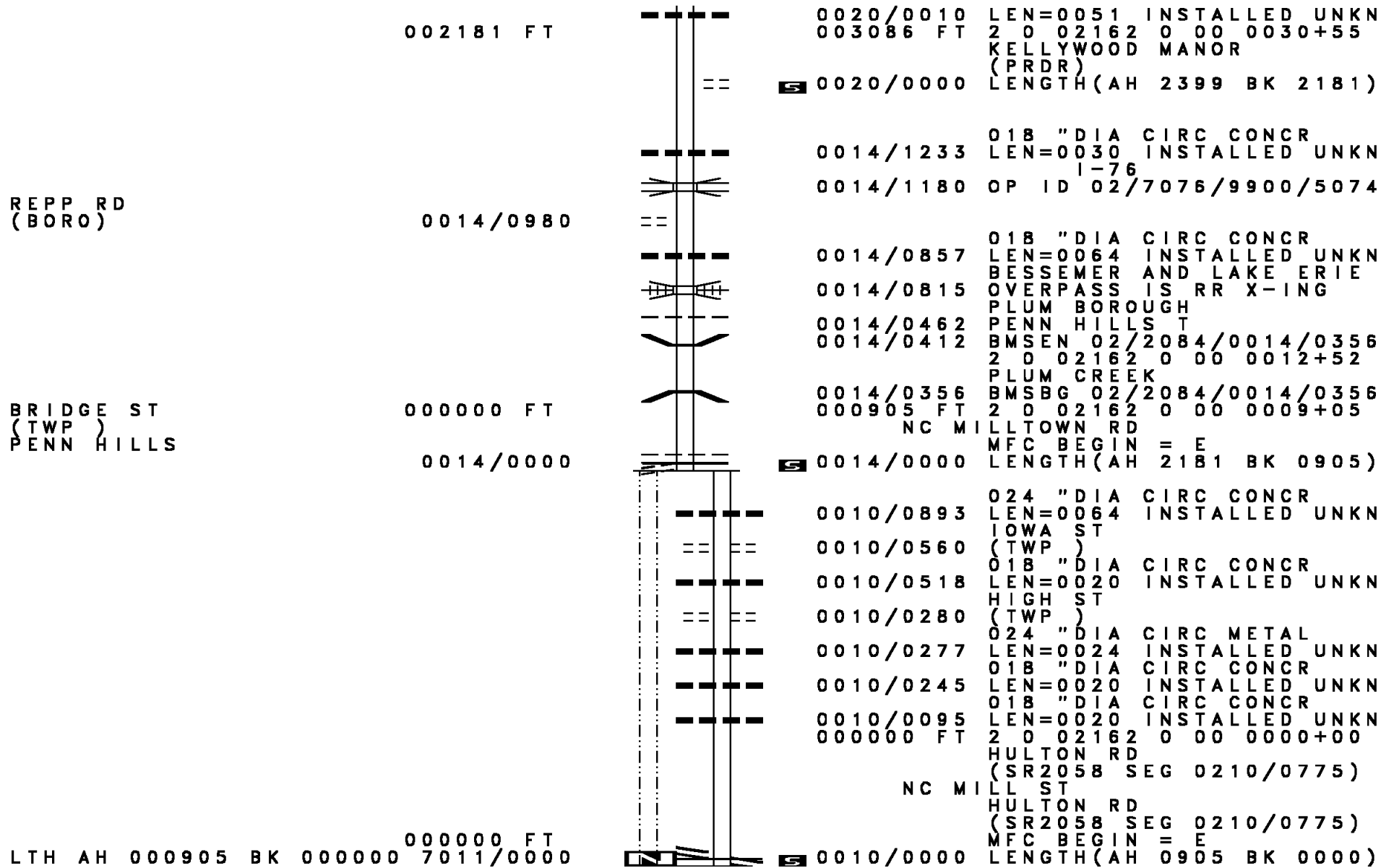

DIR: B TOTAL LEN: .500 MI. DIST: 11-1 SR: 2083
 LEFT MUN: EAST PITTSBURGH B RIGHT MUN: EAST PITTSBURGH B

002576 FT
 INTER-AHD
 TRI-BORO AV
 (SR2037 SEG 0090/0860)
 TRI-BORO AV
 (SR2037 SEG 0090/0860) 0033/1231
 BMS EN 02/2083/0032/0000 0033/1192
 TR 30
 OP ID 02/0030/0260/0000 0033/1055

1 0 01074 1 00 0012+57 001345 FT
 MAIN STREET
 BMSBG 02/2083/0032/0000
 LENGTH(AH 1231 BK 0489) 0033/0000
 018 "DIA CIRC CONCR
 LEN=0026 INSTALLED UNKN 0023/0463
 RAMP A RD
 (SR2183 SEG 0010/0000) 0023/0342
 1 0 01074 1 00 0017+26 000856 FT
 MFC BEGIN = B
 LENGTH(AH 0489 BK 0856) 0023/0000

000000 FT

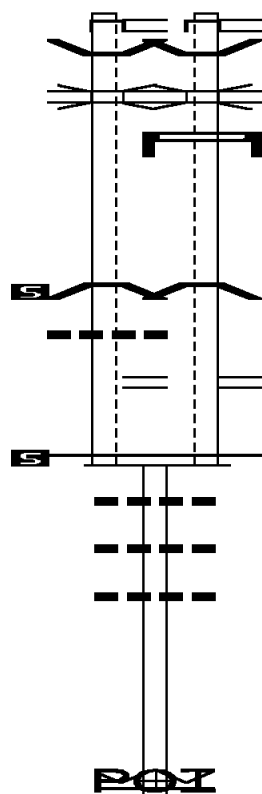

002641 FT
 INTER-AHD
 TRI-BORO AV
 (SR2037 SEG 0090/0860)
 TRI-BORO AV
 (SR2037 SEG 0090/0860) 0032/1295
 BMS EN 02/2083/0032/0000 0032/1192
 TR 30
 OP ID 02/0030/0260/0000
 SIGN: CANTILEVER
 BMSID 02/2083/0032/1288

001346 FT 1 0 01074 1 00 0012+57
 MAIN STREET
 BMSBG 02/2083/0032/0000
 LENGTH(AH 1295 BK 0490)

0022/0345 RAMP A RD
 (SR2183 SEG 0010/0000)
 000856 FT 1 0 01074 1 00 0017+26
 MFC BEGIN = B
 LENGTH(AH 0490 BK 0856)
 018 "DIA CIRC CONCR
 LEN=0040 INSTALLED UNKN
 018 "DIA CIRC CONCR
 LEN=0045 INSTALLED UNKN
 024 "DIA CIRC CONCR
 LEN=0045 INSTALLED UNKN
 000000 FT 1 0 01074 1 00 0026+15
 (APRA) USX MON VALLEY-E
 VILLAGE: E. PITTSBURGH
 NC BR
 * REF-BK BRADDOCK AV
 BRADDOCK AV
 (BORO)
 MFC BEGIN = B
 0012/0000 LENGTH(AH 0856 BK 0000)

EXTRACT DATE: 12/21/2020 ROADWAY MANAGEMENT SYSTEM PAGE NUMBER: 890
 PRINT DATE: 12/23/2020 SLD COUNTY/SR - ANNUAL PRINT COUNTY: ALLEGHENY
 DIR: B TOTAL LEN: 5.379 MI. DIST: 11-1 SR: 2082
 LEFT MUN: PLUM BOROUGH B RIGHT MUN: PLUM BOROUGH B

028400 FT

028400 FT
 INTER-AHD

LOGANS FERRY RD
 (SR2075 SEG 0180/0915)
 LOGANS FERRY RD
 (SR2075 SEG 0180/0915)
 FOR SR 2075 AND 2082
 (CONN)
 015" DIA CIRC CONCR
 LEN=0099 INSTALLED UNKN

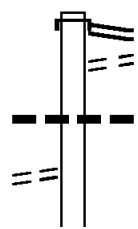

BARKING RD
 (BORO)

0130/2163

DIR: B TOTAL LEN: 5.379 MI. DIST: 11-1 SR: 2082
 LEFT MUN: PLUM BOROUGH B RIGHT MUN: PLUM BOROUGH B

Stationing	Length	Material	Notes
025441 FT	0130/0540	018 " DIA CIRC CONCR	LEN=0060 INSTALLED UNKN
	025441 FT	1 0 00677 0 00 0158+40	
	0130/0000	LENGTH(AH 2959 BK 2419)	
	0120/1900	018 " DIA CIRC CONCR	LEN=0050 INSTALLED UNKN
	0120/1732	018 " DIA CIRC CONCR	LEN=0040 INSTALLED UNKN
	0120/1224	018 " DIA CIRC CONCR	LEN=0099 INSTALLED UNKN
	0120/1063	018 " DIA CIRC CONCR	LEN=0050 INSTALLED UNKN
	0120/0858	018 " DIA CIRC CONCR	LEN=0035 INSTALLED UNKN
023022 FT	023022 FT	1 0 00677 0 00 0135+62	KERR RD
	0120/0000	(T752) LENGTH(AH 2419 BK 3414)	
	0110/2589	018 " DIA CIRC CONCR	LEN=0050 INSTALLED UNKN
	0110/2390	018 " DIA CIRC CONCR	LEN=0050 INSTALLED UNKN
	0110/2225	RAMPARTS BL (BORO)	
	0110/1223	018 " DIA CIRC CONCR	LEN=0050 INSTALLED UNKN
	0110/1185	REPP RD (BORO)	
	0110/0990	018 " DIA CIRC CONCR	LEN=0050 INSTALLED UNKN
	0110/0760	018 " DIA CIRC CONCR	LEN=0050 INSTALLED UNKN
1 0 00677 0 00 0103+47 019608 FT	019608 FT		
RIVER RD (BORO)	0110/0000	LENGTH(AH 3414 BK 3185)	
	0100/2917	018 " DIA CIRC CONCR	LEN=0050 INSTALLED UNKN
	0100/2530	018 " DIA CIRC CONCR	LEN=0050 INSTALLED UNKN
	0100/2023	018 " DIA CIRC CONCR	LEN=0050 INSTALLED UNKN

EXTRACT DATE: 12/21/2020
PRINT DATE: 12/23/2020

ROADWAY MANAGEMENT SYSTEM
SLD COUNTY/SR - ANNUAL PRINT

PAGE NUMBER: 888
COUNTY: ALLEGHENY

DIR: B TOTAL LEN: 5.379 MI.
LEFT MUN: PLUM BOROUGH B

DIST: 11-1 SR: 2082
RIGHT MUN: PLUM BOROUGH B

1 0 00677 0 00 0071+62 016423 FT
SMITH POWER ELECTRIC RD
(PRDR) 0100/0000

013505 FT

-- --	0100/1488	LEN=0050	INSTALLED	UNKN
		018 "DIA	CIRC CONCR	
-- --	0100/1109	LEN=0050	INSTALLED	UNKN
		018 "DIA	CIRC CONCR	
-- --	0100/0927	LEN=0050	INSTALLED	UNKN
	016423 FT			
==	5 0100/0000	LENGTH(AH 3185 BK 2918)		
		018 "DIA	CIRC CONCR	
-- --	0090/2570	LEN=0050	INSTALLED	UNKN
		036 "DIA	CIRC CONCR	
-- --	0090/2342	LEN=0060	INSTALLED	UNKN
		024 "DIA	CIRC CONCR	
-- --	0090/2187	LEN=0060	INSTALLED	UNKN
		018 "DIA	CIRC CONCR	
-- --	0090/1780	LEN=0050	INSTALLED	UNKN
		018 "DIA	CIRC CONCR	
-- --	0090/1478	LEN=0050	INSTALLED	UNKN
		018 "DIA	CIRC CONCR	
-- --	0090/1197	LEN=0040	INSTALLED	1997
		018 "DIA	CIRC CONCR	
-- --	0090/0592	LEN=0060	INSTALLED	UNKN
		018 "DIA	CIRC CONCR	
-- --	0090/0371	LEN=0060	INSTALLED	UNKN
		018 "DIA	CIRC CONCR	
-- --	0090/0049	LEN=0060	INSTALLED	UNKN
		018 "DIA	CIRC CONCR	
	013505 FT	1 0 00677 0 00 0039+62		
	5 0090/0000	LENGTH(AH 2918 BK 3580)		
		018 "DIA	CIRC CONCR	
-- --	0080/3240	LEN=0099	INSTALLED	UNKN
		RIDGEMEAD	FIELDS DR	
		(BORO)		
-- --	0080/2830	018 "DIA	CIRC CONCR	
		LEN=0040	INSTALLED	UNKN
-- --	0080/2494	018 "DIA	CIRC CONCR	
		LEN=0040	INSTALLED	UNKN
-- --	0080/2254	018 "DIA	CIRC CONCR	
		LEN=0035	INSTALLED	UNKN
-- --	0080/1507	018 "DIA	CIRC CONCR	
		LEN=0035	INSTALLED	UNKN
-- --	0080/1260	018 "DIA	CIRC CONCR	
		LEN=0035	INSTALLED	UNKN
-- --	0080/0912	018 "DIA	CIRC CONCR	
		LEN=0050	INSTALLED	UNKN
-- --	0080/0638	018 "DIA	CIRC CONCR	
		LEN=0050	INSTALLED	UNKN
-- --	0080/0518	015 "DIA	CIRC CONCR	
		LEN=0035	INSTALLED	UNKN

DIR: B TOTAL LEN: 5.379 MI.
 LEFT MUN: PLUM BOROUGH B

DIST: 11-1 SR: 2082
 RIGHT MUN: PLUM BOROUGH B

009925 FT

009925 FT 1 0 00677 0 00 0000+00
 NC CO XCOMB HILL RD
 HULTON RD
 (SR2058 SEG 0270/0535)

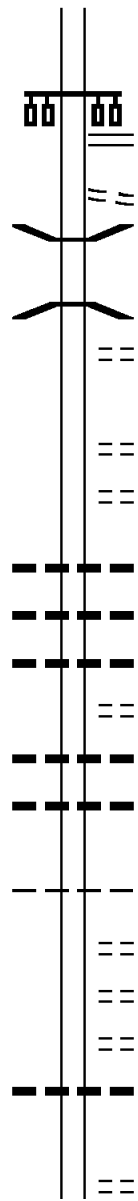

0080/0000 LENGTH(AH 3580 BK 1592)
 TO SR 2058/0270
 (CONN)

0070/1503
 0070/0635 BMS EN 02/2082/0070/0380
 2 0 02287 0 00 0253+85
 PA TURNPIKE

0070/0383 BMSBG 02/2082/0070/0380
 FAIRWAYS DR

008333 FT

0070/0180 (BORO)
 008333 FT 2 0 02287 0 00 0253+85
 PRIVATE DR
 (PRDR)

0070/0000 LENGTH(AH 1592 BK 1714)
 FIFTEENTH ST
 (BORO)

0060/0599 018 " DIA CIRC CONCR
 LEN=0035 INSTALLED UNKN
 012 " DIA CIRC CONCR

0060/0591 LEN=0041 INSTALLED 2017
 018 " DIA CIRC CONCR
 0060/0445 LEN=0040 INSTALLED UNKN
 THIRTEENTH ST

0060/0295 (BORO)
 012 " DIA CIRC CONCR
 LEN=0035 INSTALLED UNKN
 012 " DIA CIRC CONCR

006619 FT

0060/0016 LEN=0040 INSTALLED UNKN
 006619 FT 2 0 02287 0 00 0271+15
 PLUM BOROUGH

OAKMONT B
 0060/0000 LENGTH(AH 1714 BK 1463)
 TWELFTH ST
 (BORO)

0050/1200 ELEVENTH ST
 (BORO)
 0050/0800 TENTH ST
 (BORO)

0050/0395 (BORO)
 018 " DIA CIRC CONCR
 LEN=0027 INSTALLED 2017
 0 0 00000 0 00 0000+00

005156 FT

005156 FT NINTH ST
 (BORO)

0050/0000 LENGTH(AH 1463 BK 2289)

DIR: B TOTAL LEN: 5.379 MI. DIST: 11-1 SR: 2082
 LEFT MUN: OAKMONT B RIGHT MUN: OAKMONT B

Location / Description	Segment ID	Length (FT)	Notes / Details
WADE LN (BORO)	0022/1760		EIGHTH ST (BORO) 024" DIA CIRC CONCR LEN=0040 INSTALLED UNKN
	0022/1837		024" DIA CIRC CONCR LEN=0099 INSTALLED UNKN
	0022/1502		018" DIA CIRC CONCR LEN=0040 INSTALLED UNKN
	0022/1501		SEVENTH ST (BORO) 018" DIA CIRC CONCR LEN=0045 INSTALLED UNKN
DALZELL WY (BORO)	0022/0261		FIFTH ST (BORO)
OAKMONT AV (BORO)	0022/0066	002867 FT	ORCHARD AV (BORO) ALLEGHENY RIVER BL (BORO) 0022/0066 (AAR 051623Y) #TRKS 01 0022/0027 0 0 00000 0 00 0000+00 002867 FT MFC BEGIN = C
ALLEGHENY AV (TBK) (BORO)	0020/0779		0022/0000 LENGTH(AH 2289 BK 0819) ALLEGHENY AV (SR2073 SEG 0110/3017) THIRD ST (BORO)
2 0 02236 0 00 0020+54 SECOND ST (BORO)	0020/0000	002048 FT	0020/0268 (BORO) 002048 FT OAKMONT HARMAR T 0020/0000 LENGTH(AH 0819 BK 1923) 0012/1633 BMS EN 02/2082/0012/0000
		000125 FT	000125 FT 0 0 00000 0 00 0000+00 ALLEGHENY RIVER BMSBG 02/2082/0012/0000
		000000 FT	0012/0000 LENGTH(AH 1923 BK 0125) 000000 FT 2 0 02236 0 00 0000+00 NC HU LTON BRIDGE RD FREEPORT RD (SR1001 SEG 0200/1852)
			0010/0000 MFC BEGIN = B LENGTH(AH 0125 BK 0000)

EXTRACT DATE: 12/21/2020 ROADWAY MANAGEMENT SYSTEM PAGE NUMBER: 885
 PRINT DATE: 12/23/2020 SLD COUNTY/SR - ANNUAL PRINT COUNTY: ALLEGHENY
 DIR: B TOTAL LEN: .122 MI. DIST: 11-1 SR: 2081
 LEFT MUN: MONROEVILLE B RIGHT MUN: MONROEVILLE B

000644 FT

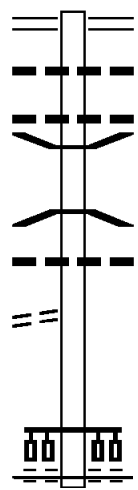

LC TO MONROEVILLE BL
 (CONN)

0010/0104
 000000 FT

000644 FT NORTHERN PK
 0010/0644 (SR2050 SEG 0020/2550)
 018 " DIA CIRC CONCR
 0010/0571 LEN=0099 INSTALLED UNKN
 018 " DIA CIRC CONCR
 0010/0550 LEN=0025 INSTALLED UNKN
 0010/0291 BMSSEN 02/2081/0010/0181
 2 0 02233 7 00 0003+73
 BUSINESS ROUTE US 22 EA
 0010/0181 BMSBG 02/2081/0010/0181
 018 " DIA CIRC CONCR
 0010/0110 LEN=0035 INSTALLED UNKN

 000000 FT 2 0 02233 7 00 0000+00
 NC OLD NORTHERN PIKE
 MONROEVILLE BL
 (CNTY)
 0010/0000 MFC BEGIN = C
 LENGTH(AH 0644 BK 0000)

DIR: B TOTAL LEN: 2.432 MI. DIST: 11-1 SR: 2080
 LEFT MUN: PENN HILLS T RIGHT MUN: PENN HILLS T

COLORADO ST
(TWP)

0040/1850

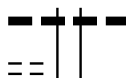

0040/1877 LEN=0055 INSTALLED UNKN

004065 FT



0040/0014 BMS EN 02/2080/0040/0000
 004065 FT 2 0 02196 0 02 0115+91
 NC HUNTER RD

5

BRANCH OF PLUM CREEK
 BMSBG 02/2080/0040/0000
 LENGTH(AH 3016 BK 2098)
 018 "DIA CIRC CONCR

0030/1885 LEN=0030 INSTALLED UNKN



018 "DIA CIRC CONCR
 0030/1071 LEN=0025 INSTALLED UNKN
 BARGER ST

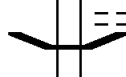

(TWP)
 0030/1035 BMS EN 02/2080/0030/0321
 0030/0463 2 0 02196 0 02 0131+95
 PLUM CREEK

DARK HOLLOW RD
(TWP)

0030/0245

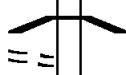

0030/0321 BMSBG 02/2080/0030/0321

001967 FT

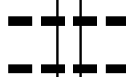

015 "DIA CIRC CONCR
 0030/0085 LEN=0030 INSTALLED UNKN
 018 "DIA CIR PLASTIC

0030/0080 LEN=0099 INSTALLED UNKN
 001967 FT 2 0 02196 0 02 0136+39
 PENN HILLS

5

OAKMONT B
 LENGTH(AH 2098 BK 1967)
 012 "DIA CIRC CONCR

0010/1648 LEN=0025 INSTALLED UNKN

SIXTH ST
(BORO)

0010/1330

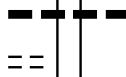

018 "DIA CIRC CONCR
 0010/0881 LEN=0025 INSTALLED UNKN
 018 "DIA CIRC CONCR

0010/0697 LEN=0020 INSTALLED UNKN

000000 FT

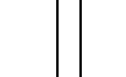

000000 FT 2 0 02196 0 02 0156+39
 NC PLUM ST

5

ALLEGHENY RIVER BL
 (SR2073 SEG 0070/0000)
 MFC BEGIN = D
 0010/0000 LENGTH(AH 1967 BK 0000)

FALLEN TIMBER RD
(TWP)

004667 FT
0020/2293

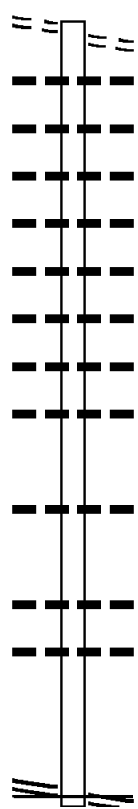

Stationing	Length	Material	Notes
0020/2293	0021	" DIA	CIR PLASTIC
0020/1879	LEN=0035	INSTALLED	UNKN
0020/1830	0021	" DIA	CIR PLASTIC
0020/1773	LEN=0035	INSTALLED	UNKN
0020/1521	0021	" DIA	CIR PLASTIC
0020/1101	LEN=0030	INSTALLED	UNKN
0020/0519	0018	" DIA	CIR PLASTIC
0020/0374	LEN=0030	INSTALLED	UNKN
0020/0014	0021	" DIA	CIRC CONCR
002374 FT	LEN=0045	INSTALLED	UNKN
0020/0000	0018	" DIA	CIRC METAL
0010/2090	LEN=0099	INSTALLED	UNKN
0010/1150	0018	" DIA	CIRC METAL
0010/0715	LEN=0035	INSTALLED	UNKN
	0018	" DIA	CIR PLASTIC
	LEN=0099	INSTALLED	UNKN
	2 0 02124	0 00	0025+00
	LENGTH(AH	2293	BK 2374)
	0018	" DIA	CIRC METAL
	LEN=0030	INSTALLED	UNKN
	0028	" DIA	CIR PLASTIC
	LEN=0099	INSTALLED	UNKN
	0018	" DIA	CIRC METAL
	LEN=0030	INSTALLED	UNKN

2 0 02124 0 00 0000+00 000000 FT
 DOUGLAS RUN RD
 (SR2017 SEG 0070/0000) 0010/0000

NC NICHOLS HILL RD
 DOUGLAS RUN RD
 000000 FT (SR2017 SEG 0070/0000)
 MFC BEGIN = C
 0010/0000 LENGTH(AH 2374 BK 0000)

DIR: B TOTAL LEN: 1.835 MI. DIST: 11-1 SR: 2078
 LEFT MUN: PENN HILLS T RIGHT MUN: PENN HILLS T

Location / Segment	Length (FT)	Stationing	Notes
INDIANA RD (SR2070 SEG 0020/0000)	009689 FT	0040/1385	INDIANA RD (SR2070 SEG 0020/0000) 018" DIA CIRC CONCR LEN=0040 INSTALLED UNKN
JADE DR (TWP)	0040/0791		018" DIA CIRC CONCR LEN=0048 INSTALLED UNKN
2 0 02165 0 00 0062+86 HUNTER RD (SR2080 SEG 0060/2736)	008304 FT	0040/0000	MFC BEGIN = D LENGTH(AH 1385 BK 2742) 018" DIA CIRC CONCR LEN=0099 INSTALLED UNKN
		0030/2740	FOLTZ DR (TWP) 018" DIA CIRC CONCR LEN=0040 INSTALLED UNKN
		0030/2590	
		0030/2301	
VALEMONT DR (SR2126 SEG 0010/0000) VALEMONT DR (TWP)	0030/2250		018" DIA CIRC CONCR LEN=0050 INSTALLED UNKN
SARA LN (TWP)	0030/1815		
GOLDEN GATE DR (TWP)	0030/1430		
LC TO BAVALE DR (CONN)	0030/0650		018" DIA CIRC CONCR LEN=0050 INSTALLED UNKN
BAVALE DR (TWP)	0030/0565		018" DIA CIR PLASTIC LEN=0048 INSTALLED UNKN
	005562 FT	0030/0148	018" DIA CIRC CONCR LEN=0048 INSTALLED UNKN
		0030/0000	2 0 02165 0 00 0034+67 LENGTH(AH 2742 BK 3497) 018" DIA CIRC CONCR LEN=0045 INSTALLED UNKN
ELM DR (TWP)	0020/2900		
SUMMIT DR (TWP)			
DAVIDSON DR (TWP)	0020/2445		
		0020/2300	018" DIA CIRC CONCR LEN=0048 INSTALLED UNKN

028435 FT

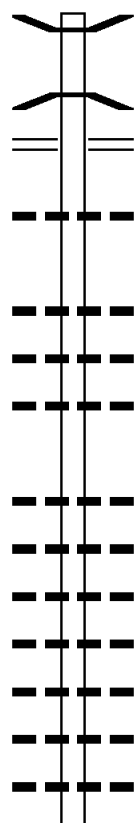

* 028435 FT BMS EN 02/2076/0100/1366
 REF-AHD MYERS DR
 0100/1427 (BORO)
 2 0 02166 0 01 0270+30
 PUCKETA CR
 0100/1366 BMSBG 02/2076/0100/1366
 GREENSBURG RD
 0100/1125 (SR0366 SEG 0122/0760)
 018 " DIA CIR PLASTIC
 LEN=0030 INSTALLED UNKN
 027008 FT 2 0 02166 0 01 0270+30
 0100/0000 LENGTH(AH 1427 BK 3787)
 018 " DIA CIR PLASTIC
 0090/3665 LEN=0035 INSTALLED UNKN
 018 " DIA CIRC METAL
 0090/3377 LEN=0030 INSTALLED UNKN
 018 " DIA CIRC METAL
 0090/2949 LEN=0035 INSTALLED UNKN
 018 " DIA CIRC CONCR
 0090/1854 LEN=0035 INSTALLED UNKN
 018 " DIA CIRC METAL
 0090/1639 LEN=0030 INSTALLED UNKN
 018 " DIA CIRC CONCR
 0090/1088 LEN=0024 INSTALLED UNKN
 036 " DIA CIRC METAL
 0090/0842 LEN=0050 INSTALLED UNKN
 024 " DIA CIRC METAL
 0090/0514 LEN=0025 INSTALLED UNKN
 024 " DIA CIRC OTHER
 0090/0245 LEN=0030 INSTALLED UNKN
 018 " DIA CIRC METAL
 0090/0092 LEN=0030 INSTALLED UNKN
 023221 FT 2 0 02166 0 01 0232+43

027008 FT

023221 FT

DIR: B TOTAL LEN: 5.385 MI. DIST: 11-1 SR: 2076
 LEFT MUN: PLUM BOROUGH B RIGHT MUN: PLUM BOROUGH B

	0090/0000	LENGTH(AH 3787 BK 3232)
---	0080/2907	018 " DIA CIRC METAL
---	0080/2400	LEN=0030 INSTALLED UNKN
		018 " DIA CIRC METAL
---	0080/1263	LEN=0030 INSTALLED UNKN
		018 " DIA CIRC METAL
		LEN=0030 INSTALLED UNKN
019989 FT	019989 FT	2 0 02166 0 01 0200+11
	0080/0000	LENGTH(AH 3232 BK 2481)
---	0070/2312	018 " DIA CIRC METAL
---	0070/1996	LEN=0030 INSTALLED UNKN
---	0070/1589	018 " DIA CIRC METAL
---	0070/1570	LEN=0030 INSTALLED UNKN
		018 " DIA CIR PLASTIC
		LEN=0024 INSTALLED UNKN
		SARDIS RD
		(SR2088 SEG 0040/0000)
---	0070/0898	024 " DIA CIRC CONCR
---	0070/0562	LEN=0040 INSTALLED UNKN
---	0070/0214	018 " DIA CIRC METAL
017508 FT	017508 FT	LEN=0035 INSTALLED UNKN
	0070/0000	2 0 02166 0 01 0175+30
---	0060/2368	LENGTH(AH 2481 BK 2614)
---	0060/2354	018 " DIA CIRC METAL
---	0060/1836	LEN=0030 INSTALLED UNKN
---	0060/1603	018 " DIA CIRC METAL
---	0060/1457	LEN=0030 INSTALLED UNKN
		018 " DIA CIRC CONCR
		LEN=0030 INSTALLED UNKN
		018 " DIA CIRC CONCR
		LEN=0030 INSTALLED UNKN
		018 " DIA CIRC CONCR
		LEN=0050 INSTALLED UNKN
		018 " DIA CIRC CONCR
		LEN=0080 INSTALLED UNKN
---	0060/0680	001 " DIA CIR UNKNOWN
---	0060/0313	LEN=0040 INSTALLED UNKN
		024 " DIA CIRC METAL
		LEN=0035 INSTALLED UNKN
ROSS HOLLOW RD (BORO)	0060/0257	
	0060/0156	BMS EN 02/2076/0060/0133
		2 0 02166 0 01 0150+58

DIR: B TOTAL LEN: 5.385 MI. DIST: 11-1 SR: 2076
 LEFT MUN: PLUM BOROUGH B RIGHT MUN: PLUM BOROUGH B

Street Name	Segment ID	Length	Material	Notes
	0030/3593		2 0 02166 0 01	0076+15 BR. LITTLE PLUM CREEK BMSBG 02/2076/0030/3593
WINDY OAK DR (BORO)	0030/2629		018 " DIA CIRC CONCR	LEN=0030 INSTALLED UNKN
	0030/2516		024 " DIA CIRC CONCR	LEN=0035 INSTALLED UNKN
	0030/1920		SCHOOL RD (BORO)	
	0030/1585		MEADOW HILL DR (BORO)	
	0030/1131		VALLEY FIELDS DR (BORO)	
GREENDALE DR (BORO)	0030/0851		018 " DIA CIRC CONCR	LEN=0030 INSTALLED UNKN
	004013 FT			
	0030/0000	004013 FT	2 0 02166 0 01	0040+80 LENGTH(AH 3735 BK 2394) 018 " DIA CIRC CONCR
	0020/2316		LEN=0035	INSTALLED UNKN
	0020/1587		018 " DIA CIRC CONCR	LEN=0035 INSTALLED UNKN
	001619 FT			
	0020/0000	001619 FT	2 0 02166 0 01	0016+86 PINTO DR (BORO) LENGTH(AH 2394 BK 1619)
SHERRI DR (BORO)	0010/1130		018 " DIA CIR PLASTIC	LEN=0030 INSTALLED UNKN
ALLEGHENY AV (BORO)	0010/0603			
	000000 FT			
UNITY TRESTLE RD (CNTY)	0010/0000	000000 FT	2 0 02166 0 00	0000+00 UNITY TRESTLE RD (CNTY) NC OLD LEECHBURG RD MFC BEGIN = E LENGTH(AH 1619 BK 0000)

051301 FT

051301 FT

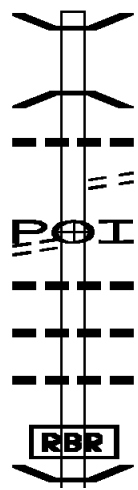

* REF-AHD

0190/2404

AH-WESTMORELAND (64)
 BMS EN 02/2075/0190/2329
 LOGANS FERRY RD
 (SR4085 SEG 0010/0000)
 2 0 02237 0 00 0407+04
 PUCKETA CK.

0190/2329

BMSBG 02/2075/0190/2329
 018 "DIA CIRC CONCR
 LEN=0035 INSTALLED UNKN
 COLUMBIA RD
 (BORO)

0190/1956

0190/1948

0190/1779

(APRA) ITS & PENN GLENN
 017 "DIA CIRC CONCR
 LEN=0040 INSTALLED UNKN
 018 "DIA CIRC CONCR
 LEN=0040 INSTALLED UNKN
 024 "DIA CIRC METAL
 LEN=0035 INSTALLED UNKN

0190/1622

0190/1400

0190/0801

POI

RBR

OIL CO RD
 (PRDR)

0190/1779

BMS EN 02/2075/0190/0000

DIR: B TOTAL LEN: 9.716 MI. DIST: 11-1 SR: 2075
 LEFT MUN: PLUM BOROUGH B RIGHT MUN: PLUM BOROUGH B

Stationing	Description	Material	Length	Status
0160/1557	018 " DIA CIR PLASTIC	LEN=0040	INSTALLED UNKN	
0160/0771	024 " DIA CIRC METAL	LEN=0040	INSTALLED UNKN	
040556 FT	040556 FT 2 0 02237 0 00 0299+93			
0160/0000	LENGTH(AH 3506 BK 1543)			
0150/1010	015 " DIA CIRC METAL	LEN=0040	INSTALLED UNKN	
039013 FT	039013 FT 2 0 02237 0 00 0284+50			
	WEBSTER RD			
	(SR2090 SEG 0010/0000)			
	NC LOGANS FERRY RD			
	SARDIS RD			
	(SR2088 SEG 0010/0000)			
0150/0000	LENGTH(AH 1543 BK 3613)			
0140/2410	024 " DIA CIR PLASTIC	LEN=0035	INSTALLED UNKN	
0140/1170	018 " DIA CIRC CONCR	LEN=0035	INSTALLED UNKN	
0140/0750	024 " DIA CIRC OTHER	LEN=0030	INSTALLED UNKN	
0140/0036	018 " DIA CIR PLASTIC	LEN=0045	INSTALLED UNKN	
035400 FT				
0140/0000	LENGTH(AH 3613 BK 3649)			
0130/1981	018 " DIA CIR PLASTIC	LEN=0035	INSTALLED UNKN	
0130/1090	018 " DIA CIRC CONCR	LEN=0035	INSTALLED UNKN	
	018 " DIA CIRC CONCR			

2 0 02237 0 00 0248+37 035400 FT
 SHEARER RD
 (BORO) 0140/0000
 CHERRYWOOD DR
 (BORO) 0130/3505

EXTRACT DATE: 12/21/2020
PRINT DATE: 12/23/2020

ROADWAY MANAGEMENT SYSTEM
SLD COUNTY/SR - ANNUAL PRINT

PAGE NUMBER: 872
COUNTY: ALLEGHENY

DIR: B TOTAL LEN: 9.716 MI.
LEFT MUN: PLUM BOROUGH B

DIST: 11-1 SR: 2075
RIGHT MUN: PLUM BOROUGH B

2 0 02237 0 00 0212+20 031751 FT
ELICKER RD
(BORO) 0130/0000

LEECHBURG RD
(SR2086 SEG 0040/2702) 030180 FT
0120/0000

OLD LEECHBURG RD
(SR2076 SEG 0030/3735) 0100/1770

CENTER NEW TEXAS RD

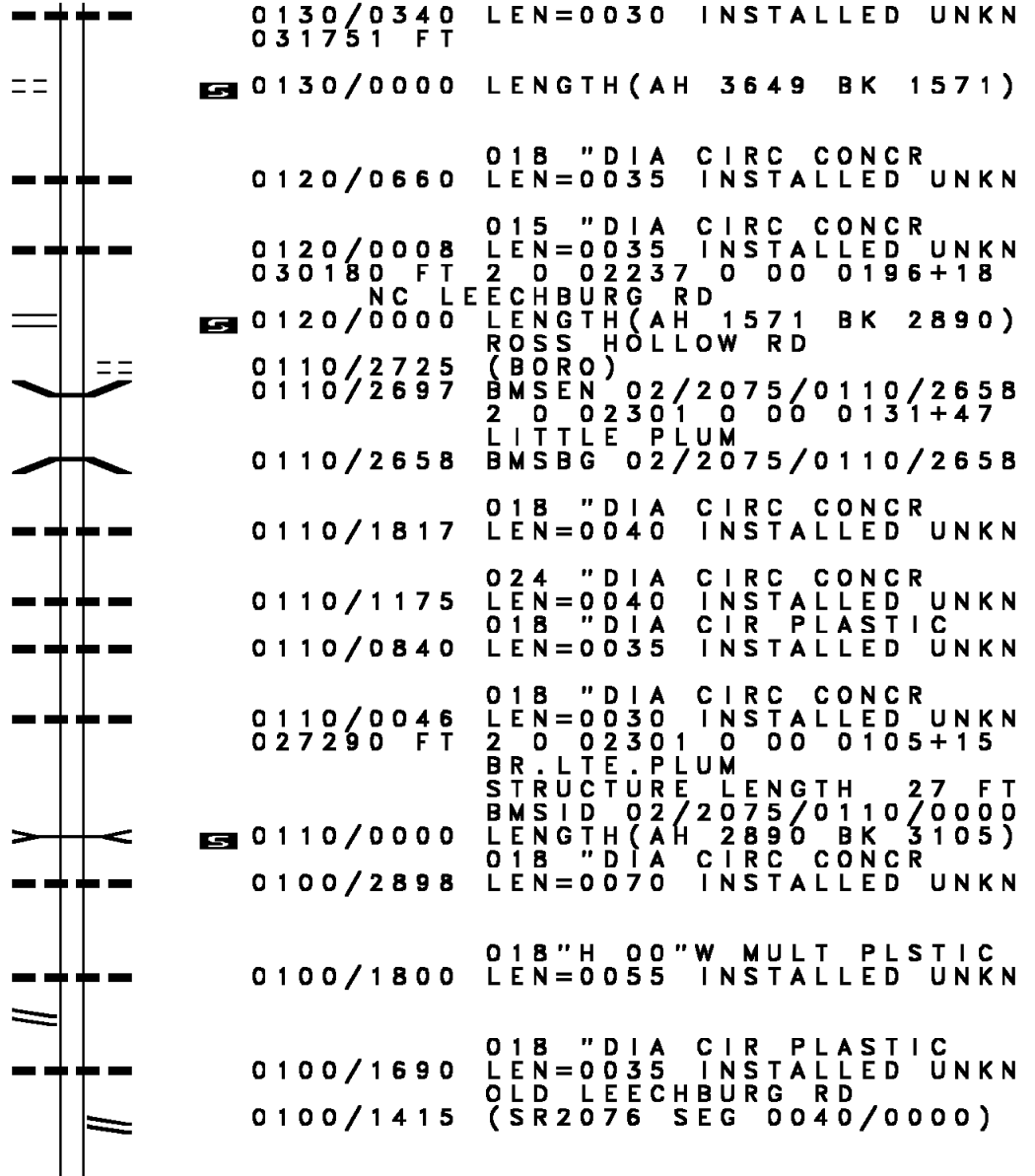

DIR: B TOTAL LEN: 9.716 MI. DIST: 11-1 SR: 2075
 LEFT MUN: PLUM BOROUGH B RIGHT MUN: PLUM BOROUGH B

(BORO)

0100/0680

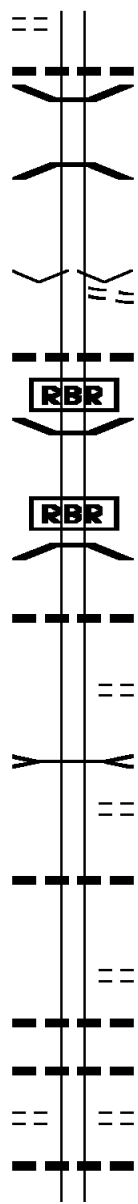

024185 FT

0100/0500 018 " DIA CIRC CONCR
 0100/0380 LEN=0030 INSTALLED UNKN
 BMSSEN 02/2075/0100/0368
 2 0 02301 0 00 0077+50
 BR. L TLE. PLUM
 0100/0368 BMSBG 02/2075/0100/0368
 024185 FT 2 0 02301 0 00 0073+90
 VILLAGE: PLUM B
 RENTON RD
 (CNTY)
 S 0100/0000 LENGTH(AH 3105 BK 1409)
 0090/0681 024 " DIA CIRC OTHER
 LEN=0035 INSTALLED UNKN
 0090/0011 BMSSEN 02/2075/0090/0000
 022776 FT 2 0 02301 0 00 0059+87
 P3
 BR. L. PLUM CR
 S 0090/0000 BMSBG 02/2075/0090/0000
 LENGTH(AH 1409 BK 2632)
 0080/1875 012 " DIA CIR PLASTIC
 LEN=0099 INSTALLED UNKN
 SEPTEMBER DR
 (PRDR)
 BR. L. PLUM CR
 STRUCTURE LENGTH 15 FT
 0080/1126 BMSID 02/2075/0080/1126
 SCARLET DR
 (PRDR)
 0080/0957
 0080/0350 015 " DIA CIRC CONCR
 020144 FT LEN=0099 INSTALLED UNKN
 2 0 02301 0 00 0033+48
 MALLISEE RD
 (BORO)
 S 0080/0000 LENGTH(AH 2632 BK 3338)
 0070/3177 018 " DIA CIR UNKNOWN
 LEN=0035 INSTALLED UNKN
 036 " DIA CIRC CONCR
 0070/2663 LEN=0035 INSTALLED UNKN
 BRIARWOOD LN
 (BORO)
 0070/2415 018 " DIA CIRC CONCR
 LEN=0030 INSTALLED UNKN
 0070/2190 020 " DIA CIRC CONCR

ROCKLAND DR
 (BORO)

0070/2415

DIR: B TOTAL LEN: 9.716 MI. DIST: 11-1 SR: 2075
 LEFT MUN: PLUM BOROUGH B RIGHT MUN: PLUM BOROUGH B

ROCKLAND DR
 (BORO)

0070/1530

0070/1966	LEN=0040	INSTALLED UNKN
020 "DIA	CIRC CONCR	
0070/1763	LEN=0040	INSTALLED UNKN
020 "DIA	CIRC CONCR	
0070/1374	LEN=0040	INSTALLED UNKN
020 "DIA	CIRC CONCR	
0070/1210	LEN=0040	INSTALLED UNKN
018 "DIA	CIRC CONCR	
0070/0990	LEN=0040	INSTALLED UNKN
018 "DIA	CIRC CONCR	
0070/0708	LEN=0040	INSTALLED UNKN

016806 FT

016806 FT 2 0 02301 0 00 0000+00

PARK ENT RD
 (CNTY)
 PARK ENT RD
 (CNTY)

0060/2765

0060/2540

0070/0000	LENGTH(AH 3338 BK 3335)	
0060/3210	LEN=0030	INSTALLED UNKN
0060/2540	(APRA) BOYCE PARK ENT R	
0060/2490	012 "DIA	CIR PLASTIC
0060/2197	LEN=0030	INSTALLED UNKN
0060/1916	020 "DIA	CIRC CONCR
0060/1740	LEN=0040	INSTALLED UNKN
0060/1450	020 "DIA	CIRC CONCR
0060/1140	LEN=0030	INSTALLED UNKN
0060/0903	024 "DIA	CIRC METAL
0060/0600	LEN=0040	INSTALLED UNKN
020 "DIA	CIRC CONCR	
018 "DIA	CIRC CONCR	
020 "DIA	CIRC CONCR	
LEN=0030	INSTALLED UNKN	

013471 FT

013471 FT 2 0 02159 0 00 0134+96

0060/0000	LENGTH(AH 3335 BK 3498)	
0050/3326	020 "DIA	CIRC CONCR
LEN=0040	INSTALLED UNKN	
0050/2306	015 "DIA	CIRC METAL
LEN=0040	INSTALLED UNKN	
MCKIM DR		

DIR: B TOTAL LEN: 9.716 MI. DIST: 11-1 SR: 2075
 LEFT MUN: PLUM BOROUGH B RIGHT MUN: PLUM BOROUGH B

Street Name	Segment ID	Length	Material	Status	Notes
CARPENTER DR (BORO)	0050/2180		018" DIA CIRC CONCR	INSTALLED	UNKN
	0050/2157		LEN=0040		
YETTMAN DR (BORO)	0050/1910		018" DIA CIRC METAL	INSTALLED	2007
	0050/1685		LEN=0025		
KNOLLVIEW DR (BORO)	0050/1531		024" DIA CIRC CONCR	INSTALLED	UNKN
	0050/0649		LEN=0030		
LINDSEY LN (CNTY)	0050/0375		015" DIA CIRC CONCR	INSTALLED	UNKN
	0050/0054	009973 FT	LEN=0040		
FALLS VILLAGE RD (PRDR)	0040/1902		018" DIA CIRC CONCR	INSTALLED	UNKN
	0040/0720		LEN=0030		
	0040/0190	006634 FT	018" DIA CIRC CONCR	INSTALLED	UNKN
	0040/0000		LEN=0040		
	0030/2440		024" DIA CIRC CONCR	INSTALLED	UNKN
	0030/1943		LEN=0030		
	0030/1865		018" DIA CIRC CONCR	INSTALLED	UNKN
	0030/1583		LEN=0040		

EXTRACT DATE: 12/21/2020
PRINT DATE: 12/23/2020

ROADWAY MANAGEMENT SYSTEM
SLD COUNTY/SR - ANNUAL PRINT

PAGE NUMBER: 868
COUNTY: ALLEGHENY

DIR: B TOTAL LEN: 9.716 MI.
LEFT MUN: PLUM BOROUGH B

DIST: 11-1 SR: 2075
RIGHT MUN: PLUM BOROUGH B

Stationing	Notes	Stationing	Notes
		0030/0678	018 " DIA CIRC CONCR LEN=0080 INSTALLED UNKN
		0030/0557	018 " DIA CIRC CONCR LEN=0060 INSTALLED UNKN
		0030/0280	024 " DIA CIRC CONCR LEN=0050 INSTALLED UNKN
004105 FT		0030/0069	024 " DIA CIRC CONCR LEN=0045 INSTALLED UNKN
		004105 FT	2 0 02159 0 00 0041+60 GOLDEN MILE HW (SR0286 SEG 0050/0000)
		0030/0000	MFC BEGIN = C LENGTH(AH 2529 BK 1717)
		0020/1623	BMSBN 02/2075/0020/1591 2 0 02159 0 00 0039+89
		0020/1591	ABERS CREEK BMSBG 02/2075/0020/1591
		0020/1404	018 " DIA CIRC CONCR LEN=0045 INSTALLED UNKN
		0020/1228	012 " DIA CIRC CONCR LEN=0035 INSTALLED UNKN
		0020/0741	018 " DIA CIRC CONCR LEN=0045 INSTALLED UNKN
		0020/0500	KANE RD (BORO)
002388 FT		002388 FT	2 0 02159 0 00 0023+21 NC NEW TEXAS RD
OLD FRANKSTOWN RD (SR2066 SEG 0110/1708) PLUM BOROUGH MONROEVILLE B		0020/0000	SAGAMORE HILL DR (BORO) LENGTH(AH 1717 BK 2388)
		0010/1220	
MCCLURE RD (BORO)		0010/1167	020 " DIA CIRC CONCR LEN=0030 INSTALLED UNKN
		0010/0540	LOGAN FERRY RD (BORO)
MOUNTAIN VIEW DR (BORO)		0010/0111	020 " DIA CIRC METAL LEN=0030 INSTALLED UNKN
000000 FT		000000 FT	2 0 02159 0 00 0000+00 VILLAGE: PLUM B
		* REF-BK	NC OLD FRANKSTOWN RD (BORO)
		0010/0000	MFC BEGIN = D LENGTH(AH 2388 BK 0000)

DIR: B TOTAL LEN: 3.012 MI. DIST: 11-1 SR: 2074
 LEFT MUN: PENN HILLS T RIGHT MUN: PENN HILLS T

OLD HULTON RD
 (TWP)

015902 FT

0070/1835

013959 FT

012329 FT

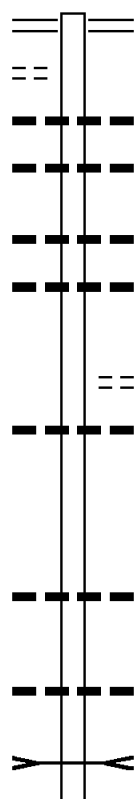

015902 FT MILLTOWN RD
 0070/1943 (SR2058 SEG 0200/0000)

0070/1725 018 " DIA CIRC METAL
 LEN=0040 INSTALLED UNKN
 0070/1290 018 " DIA CIRC CONCR
 LEN=0050 INSTALLED UNKN

0070/0662 018 " DIA CIRC CONCR
 LEN=0050 INSTALLED UNKN
 0070/0375 018 " DIA CIRC CONCR
 LEN=0050 INSTALLED UNKN

013959 FT 2 0 02287 0 00 0106+21
 COLLEGE ST
 (TWP)
 0070/0000 LENGTH(AH 1943 BK 1630)
 024 " DIA CIRC CONCR
 0060/1434 LEN=0060 INSTALLED UNKN

012329 FT 2 0 02287 0 00 0089+91
 0060/0000 LENGTH(AH 1630 BK 2126)
 0050/1842 018 " DIA CIRC CONCR
 LEN=0048 INSTALLED UNKN

0050/0689 018 " DIA CIRC CONCR
 LEN=0048 INSTALLED UNKN
 CALDWELL CK
 STRUCTURE LENGTH 18 FT
 0050/0578 BMSID 02/2074/0050/0578
 CESSNA LN

DIR: B TOTAL LEN: 3.012 MI. DIST: 11-1 SR: 2074
 LEFT MUN: PENN HILLS T RIGHT MUN: PENN HILLS T

Location / Segment	Start Station	End Station	Length (FT)	Notes / Details
	010203	010203	0	0050/0505 (PRDR)
	010203	010203	0	010203 FT 2 0 02287 0 00 0068+43
	0050	0000	0	5 0050/0000 LENGTH(AH 2126 BK 1947)
	0040	1747	0	018 "DIA CIRC CONCR
	0040	1500	0	LEN=0048 INSTALLED UNKN
	0040	1196	0	018 "DIA CIRC CONCR
	0040	1091	0	LEN=0048 INSTALLED UNKN
INDIANA RD (SR2070 SEG 0010/0000)	0040	1050	0	015 "DIA CIRC CONCR
	0040	0671	0	LEN=0048 INSTALLED UNKN
	0040	0547	0	BMSBN 02/2074/0040/0511
	0040	0542	0	048"H 60"W CON BOX CUL
	0040	0535	0	LEN=0040 INSTALLED UNKN
	0040	0531	0	WOODSIDE LN (TWP)
	008256	008256	0	2 0 02287 0 00 0054+29
	0040	0531	0	CALDWELL RUN
	008256	008256	0	BMSBG 02/2074/0040/0511
	0040	0000	0	2 0 02287 0 00 0049+03
	0030	2183	0	5 0040/0000 LENGTH(AH 1947 BK 2840)
MILBREN DR (TWP)	0030	2090	0	018 "DIA CIRC CONCR
	0030	2052	0	LEN=0048 INSTALLED UNKN
	0030	2043	0	MISSION DR (TWP)
	0030	1674	0	024 "DIA CIRC CONCR
	0030	0920	0	LEN=0048 INSTALLED UNKN
RICHEY DR (TWP)	0030	0855	0	018 "DIA CIRC CONCR
	0030	0092	0	LEN=0048 INSTALLED UNKN
HAMIL RD (SR2078 SEG 0020/0000)	0030	0092	0	MCGREGOR DR (TWP)
	005416	005416	0	2 0 02287 0 00 0021+56
			0	NC HU LTON RD
			0	HULTON RD (SR2078 SEG 0010/2065)

EXTRACT DATE: 12/21/2020
PRINT DATE: 12/23/2020

ROADWAY MANAGEMENT SYSTEM
SLD COUNTY/SR - ANNUAL PRINT

PAGE NUMBER: 865
COUNTY: ALLEGHENY

DIR: B TOTAL LEN: 3.012 MI.
LEFT MUN: PENN HILLS T

DIST: 11-1 SR: 2074
RIGHT MUN: PENN HILLS T

CLAYMONT DR
(TWP)

0020/2015

ROCKCLIFF RD
(TWP)

001882 FT

0020/0000

000000 FT

0030/0000	MFC BEGIN = D LENGTH(AH 2840 BK 3534) ARNOLD DR (TWP)
0020/3180	018 " DIA CIRC CONCR
0020/3038	LEN=0048 INSTALLED UNKN
0020/2473	024 " DIA CIRC CONCR LEN=0050 INSTALLED UNKN
0020/1847	018 " DIA CIRC CONCR LEN=0060 INSTALLED UNKN BROOKE LN (TWP)
0020/1585	018 " DIA CIRC CONCR
0020/1286	LEN=0120 INSTALLED UNKN
0020/1122	012 " DIA CIRC METAL LEN=0040 INSTALLED UNKN
0020/0938	024 " DIA CIR PLASTIC LEN=0197 INSTALLED UNKN
0020/0741	018 " DIA CIRC CONCR LEN=0050 INSTALLED UNKN
001882 FT	001882 FT 2 0 02044 0 01 0022+81 ROCKCLIFF RD (TWP)
0020/0000	0020/0000 LENGTH(AH 3534 BK 1882) 018 " DIA CIRC METAL
0010/1710	LEN=0040 INSTALLED UNKN
0010/1468	015 " DIA CIR PLASTIC LEN=0099 INSTALLED UNKN
0010/1403	036 " DIA CIR PLASTIC LEN=0048 INSTALLED UNKN
0010/1104	018 " DIA CIRC CONCR LEN=0048 INSTALLED UNKN
0010/0793	018 " DIA CIRC CONCR LEN=0040 INSTALLED UNKN
0010/0605	OLD RD (TWP)
000000 FT	000000 FT 2 0 02044 0 00 0000+00 VILLAGE: PENN HILLS T NC PO POKETA RD VERONA RD (CNTY)
INTER-BK	POKETA RD (TWP)
0010/0000	MFC BEGIN = E LENGTH(AH 1882 BK 0000)

EXTRACT DATE: 12/21/2020 ROADWAY MANAGEMENT SYSTEM PAGE NUMBER: 864
 PRINT DATE: 12/23/2020 SLD COUNTY/SR - ANNUAL PRINT COUNTY: ALLEGHENY
 DIR: B TOTAL LEN: 3.091 MI. DIST: 11-1 SR: 2073
 LEFT MUN: OAKMONT B RIGHT MUN: OAKMONT B

016316 FT
 016316 FT
 016316 FT

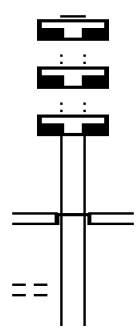

016321 FT
 7128/0000 LENGTH(AH 0412 BK 0486)
 016321 FT
 7124/0000 LENGTH(AH 0486 BK 1197)
 016321 FT
 7120/0000 LENGTH(AH 1197 BK 3017)
 INTER-AHD ALLEGHENY AV
 (BORO)
 HULTON RD
 0110/3017 (SR2082 SEG 0020/0779)

ARCHIE ST
 (BORO)

0110/2285

095 "DIA CIRC CONCR

DIR: B TOTAL LEN: 3.091 MI. DIST: 11-1 SR: 2073
 LEFT MUN: OAKMONT B RIGHT MUN: OAKMONT B

ANN ST (BORO) 0110/0900
 MARYLAND AV (BORO) 0110/0455
 ADVANCE WAY (BORO) 0110/0160
 2 0 02196 0 02 0183+40 013299 FT
 DELAWARE AV (BORO) 0110/0000
 CALIFORNIA AV (BORO) 0080/0558
 COLLEGE AV (BORO) 0080/0105
 ALLEG AV (BORO)
 OAKMONT VERONA B 0061/1374
 BMSSEN 02/2073/0060/1121 0061/1228
 2 0 02247 0 00 0368+58
 PLUM CREEK
 BMSBG 02/2073/0060/1121 0061/1183

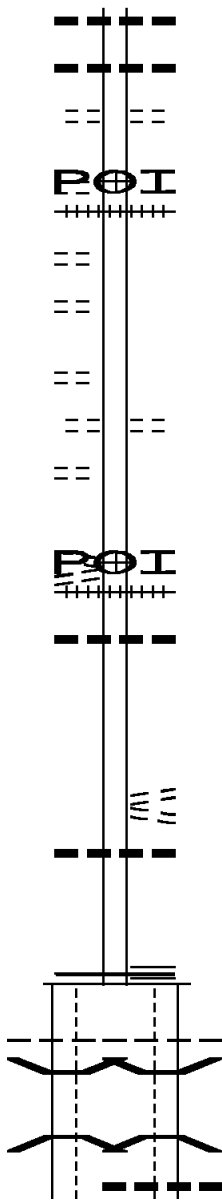

0110/2022 LEN=0040 INSTALLED UNKN
 095 "DIA CIRC CONCR
 0110/1702 LEN=0099 INSTALLED UNKN
 PENNSYLVANIA AV
 (BORO)
 0110/1595
 0110/0900 (APRA) TRUCKING/INDUSTR
 0110/0885 (AAR 510899G)#TRKS 01
 013304 FT
 0110/0000 LENGTH(AH 3017 BK 1403)
 WASHINGTON AV
 (BORO)
 0080/0917
 (APRA) EDGEWATER STEEL
 NC AL LEGHENY AV
 0080/0061 (AAR 510906P)#TRKS 01
 024 "DIA CIRC CONCR
 0080/0030 LEN=0077 INSTALLED UNKN
 011901 FT 2 0 02196 0 02 0162+86
 ALLEGHENY RIVER BL
 (BORO)
 NC CO LLEGE AV
 COLLEGE AV
 (BORO)
 0080/0000 LENGTH(AH 1403 BK 0651)
 018 "DIA CIRC CONCR
 0070/0343 LEN=0099 INSTALLED UNKN
 011250 FT 2 0 02196 0 02 0156+39
 PLUM ST
 (SR2080 SEG 0010/0000)
 MFC BEGIN = B
 0070/0000 LENGTH(AH 0651 BK 1451)
 OAKMONT VERONA B
 0060/1196 BMSSEN 02/2073/0060/1121
 0060/1166 2 0 02247 0 00 0368+58
 PLUM CREEK
 0060/1121 BMSBG 02/2073/0060/1121
 024 "DIA CIRC CONCR
 0060/1076 LEN=0055 INSTALLED UNKN

DIR: B TOTAL LEN: 3.091 MI. DIST: 11-1 SR: 2073
 LEFT MUN: VERONA B RIGHT MUN: VERONA B

Item	Description	Length	Start	End	Notes
018	"DIA CIRC CONCR	LEN=0099	INSTALLED UNKN	0061/0920	
018	"DIA CIRC CONCR	LEN=0099	INSTALLED UNKN	0061/0675	
BMS	SEN 02/2073/0060/0245	0061/0352	0060/0314	BMS	SEN 02/2073/0060/0245
2 0	02247 0 00 0359+64			2 0	02247 0 00 0355+71
SERVICE	ROAD			SERVICE	ROAD
BMS	BG 02/2073/0060/0245	0061/0280	0060/0242	BMS	BG 02/2073/0060/0245
024	"DIA CIRC CONCR	LEN=0055	INSTALLED UNKN	0060/0125	
018	"DIA CIRC CONCR	LEN=0099	INSTALLED UNKN	0061/0190	
LC	FROM FRONT ST			LC	FROM FRONT ST
(CONN)		0061/0145	0060/0075	(CONN)	
018	"DIA CIRC CONCR	LEN=0099	INSTALLED UNKN	0061/0018	
2 0	02247 0 00 0355+36	009728 FT	009799 FT	2 0	02247 0 00 0355+71
LENGTH(AH	1517 BK 0564)	0061/0000	0060/0000	LENGTH(AH	1451 BK 0635)
FRONT	ST			FRONT	ST
(BORO)		0051/0470	0050/0472	(BORO)	
UNION	ST			UNION	ST
(BORO)		0051/0240	0050/0240	(BORO)	
2 0	02247 0 00 0350+51	009164 FT	009164 FT	2 0	02247 0 00 0350+85
CENTER	AV			CENTER	AV
(BORO)				(BORO)	
MFC	BEGIN = B			MFC	BEGIN = B
LENGTH(AH	0564 BK 1494)	0051/0000	0050/0000	LENGTH(AH	0635 BK 1494)
SOUTH	AV			SOUTH	AV
(BORO)		0040/0860	(BORO)		
WILDWOOD	AV			WILDWOOD	AV
(BORO)		0040/0535	(BORO)		
JAMES	ST			JAMES	ST
(BORO)		0040/0425	(BORO)		
2 0	02247 0 00 0336+16	007670 FT	007670 FT		
LC	TO/FROM JAMES ST				
(CONN)					
LC	FOR JONES ST				
(CONN)		0030/1434	0040/0000	(CONN)	
018	"DIA CIRC CONCR	LEN=0099	INSTALLED UNKN	0030/0965	
018	"DIA CIRC CONCR	LEN=0099	INSTALLED UNKN	0030/0330	
018	"DIA CIRC CONCR	LEN=0033	INSTALLED UNKN	0030/0033	
2 0	02247 0 00 0321+35	006235 FT	006235 FT	2 0	02247 0 00 0321+35
LENGTH(AH	1435 BK 3037)	0030/0000	0030/0000	LENGTH(AH	1435 BK 3037)

DIR: B TOTAL LEN: 3.091 MI. DIST: 11-1 SR: 2073
 LEFT MUN: PENN HILLS T RIGHT MUN: PENN HILLS T

RIVER TOWN SHOPPING CTR
 (PRDR) 0020/2356

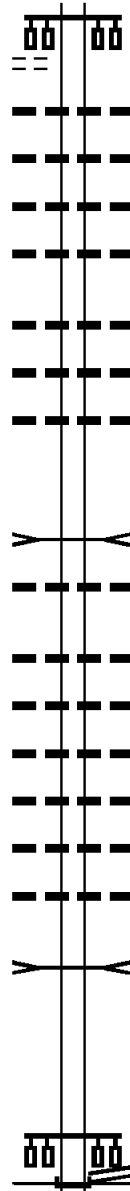

003198 FT

000000 FT

0020/2356	018 " DIA	CIRC	CONCR	
	LEN=0030	INSTALLED	UNKN	
0020/1915	018 " DIA	CIRC	CONCR	
	LEN=0030	INSTALLED	UNKN	
0020/1743	018 " DIA	CIRC	CONCR	
	LEN=0030	INSTALLED	UNKN	
0020/1395	018 " DIA	CIRC	CONCR	
	LEN=0030	INSTALLED	UNKN	
0020/1121	018 " DIA	CIRC	CONCR	
	LEN=0030	INSTALLED	UNKN	
0020/0439	018 " DIA	CIRC	CONCR	
	LEN=0030	INSTALLED	UNKN	
0020/0120	018 " DIA	CIRC	CONCR	
	LEN=0030	INSTALLED	UNKN	
0020/0010	018 " DIA	CIRC	CONCR	
	LEN=0099	INSTALLED	UNKN	
003198 FT	2 0 02247	0 00	0291+42	
	SMALL CREEK			
		STRUCTURE LENGTH	8 FT	
	BMSID 02/2073/0020/0000			
0020/0000	LENGTH(AH 3037 BK 3198)			
	018 " DIA	CIRC	CONCR	
0010/2710	LEN=0099	INSTALLED	UNKN	
0010/1940	018 " DIA	CIRC	CONCR	
	LEN=0099	INSTALLED	UNKN	
0010/1923	028 " DIA	CIRC	CONCR	
	LEN=0099	INSTALLED	UNKN	
0010/1522	018 " DIA	CIRC	CONCR	
	LEN=0004	INSTALLED	UNKN	
0010/1273	018 " DIA	CIRC	CONCR	
	LEN=0004	INSTALLED	UNKN	
0010/1001	095"H 10"W	**UNKNOWN**		
	LEN=0099	INSTALLED	UNKN	
0010/0719	018 " DIA	CIRC	CONCR	
	LEN=0006	INSTALLED	UNKN	
	SANDY CREEK			
		STRUCTURE LENGTH	32 FT	
	BMSID 02/2073/0010/0272			
0010/0272	2 0 02247	0 00	0259+87	
000000 FT	SANDY CREEK RD			
	(SRO130 SEG 0072/0000)			
	NC ALLEGHENY RIVER BL			
	INTER-BK	ALLEGHENY RIVER BL		
		(SRO130 SEG 0072/0000)		
		MFC BEGIN	= B	
0010/0000	LENGTH(AH 3198 BK 0000)			

006090 FT

* 006090 FT AH-WESTMORELAND (64)
 REF-AHD DRENNEN RD
 0020/3254 (SR4032 SEG 0010/0000)
 018 " DIA CIR PLASTIC
 0020/2780 LEN=0060 INSTALLED UNKN

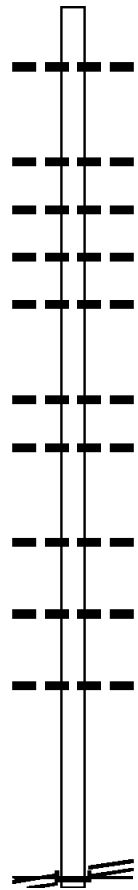

0020/1825 018 " DIA CIRC CONCR
 LEN=0050 INSTALLED UNKN
 018 " DIA CIRC METAL
 0020/1314 LEN=0045 INSTALLED UNKN
 018 " DIA CIR PLASTIC
 0020/0723 LEN=0035 INSTALLED UNKN
 018 " DIA CIR PLASTIC
 0020/0390 LEN=0040 INSTALLED UNKN
 002836 FT 2 0 02001 0 00 0030+00
 5 0020/0000 LENGTH(AH 3254 BK 2836)
 018 " DIA CIR PLASTIC
 0010/2570 LEN=0040 INSTALLED UNKN
 018 " DIA CIR PLASTIC
 0010/2552 LEN=0040 INSTALLED UNKN

002836 FT

0010/1555 018 " DIA CIR PLASTIC
 LEN=0040 INSTALLED UNKN

0010/0674 018 " DIA CAST IRON
 LEN=0040 INSTALLED UNKN

000000 FT

0010/0042 018 " DIA CIR PLASTIC
 000000 FT 2 0 02001 0 00 0000+00
 SARDIS RD
 (SR2088 SEG 0060/0000)

NC RE NTON RD
 INTER-BK RENTON RD
 (BORO)
 MFC BEGIN = E
 5 0010/0000 LENGTH(AH 2836 BK 0000)

SARDIS RD
 (SR2088 SEG 0060/0000) 0010/0000

EXTRACT DATE: 12/21/2020 ROADWAY MANAGEMENT SYSTEM PAGE NUMBER: 859
 PRINT DATE: 12/23/2020 SLD COUNTY/SR - ANNUAL PRINT COUNTY: ALLEGHENY
 DIR: B TOTAL LEN: 1.534 MI. DIST: 11-1 SR: 2071
 LEFT MUN: PENN HILLS T RIGHT MUN: PENN HILLS T

008098 FT

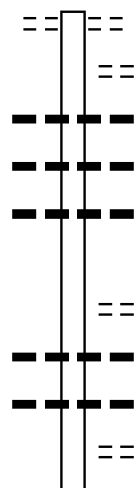

007190 FT

008098 FT SECOND AV
 0030/0908 (TWP)
 INDIAN CREEK RD
 0030/0560 (TWP)
 018 " DIA CIRC CONCR
 0030/0406 LEN=0035 INSTALLED UNKN
 018 " DIA CIR PLASTIC
 0030/0205 LEN=0035 INSTALLED UNKN
 018 " DIA CIR PLASTIC
 0030/0005 LEN=0030 INSTALLED UNKN
 007190 FT 2 0 02168 0 00 0070+26
 QUINCY DR
 (TWP)
 5 0030/0000 LENGTH(AH 0908 BK 3703)
 018 " DIA CIR PLASTIC
 0020/3631 LEN=0035 INSTALLED UNKN
 018 " DIA CIR PLASTIC
 0020/3425 LEN=0035 INSTALLED UNKN
 IRWIN ST
 (TWP)
 0020/3175 018 " DIA CIR PLASTIC

DIR: B TOTAL LEN: 1.534 MI. DIST: 11-1 SR: 2071
 LEFT MUN: PENN HILLS T RIGHT MUN: PENN HILLS T

QUINCY DR
(TWP)

0020/2515

BELVOIR DR
(TWP)

0020/1930

003487 FT

ST ROSE DR
(TWP)
 SETON RD
(TWP)
 SHANNON HEIGHTS DR
(TWP)

0010/3020
 0010/2645
 0010/2135

000000 FT

0020/3167	LEN=0035	INSTALLED UNKN
	024 "DIA	CIR PLASTIC
0020/2612	LEN=0040	INSTALLED UNKN
	QUINCY DR	
0020/2515	(TWP)	
	018 "DIA	CAST IRON
0020/2398	LEN=0001	INSTALLED UNKN
	018 "DIA	CIRC CONCR
0020/2340	LEN=0030	INSTALLED UNKN
	018 "DIA	CIRC CONCR
0020/2220	LEN=0040	INSTALLED UNKN
	018 "DIA	CIR PLASTIC
0020/1608	LEN=0035	INSTALLED UNKN
	018 "DIA	CIR PLASTIC
0020/1125	LEN=0030	INSTALLED UNKN
	EDGECREST DR	
0020/0398	(TWP)	
	018 "DIA	CIRC CONCR
0020/0209	LEN=0030	INSTALLED UNKN
003487 FT	2 0 02168 0 00 0035+00	
	DALE CREST RD	
	(TWP)	
0020/0000	LENGTH(AH 3703 BK 3487)	
	024 "DIA	CIR PLASTIC
0010/3407	LEN=0025	INSTALLED UNKN
	018 "DIA	CIRC CONCR
0010/0962	LEN=0030	INSTALLED UNKN
	018 "DIA	CIRC CONCR
0010/0938	LEN=0030	INSTALLED UNKN
	FAIRVIEW DR	
0010/0875	(TWP)	
	018 "DIA	CIRC CONCR
0010/0448	LEN=0030	INSTALLED UNKN
000000 FT	2 0 02168 0 00 0000+00	
	NC SHANNON RD	
	HAMIL RD	
	(SR2078 SEG 0020/0210)	
	MFC BEGIN = C	
0010/0000	LENGTH(AH 3487 BK 0000)	

EXTRACT DATE: 12/21/2020 ROADWAY MANAGEMENT SYSTEM PAGE NUMBER: 857
PRINT DATE: 12/23/2020 SLD COUNTY/SR - ANNUAL PRINT COUNTY: ALLEGHENY
DIR: B TOTAL LEN: 1.443 MI. DIST: 11-1 SR: 2070
LEFT MUN: PENN HILLS T RIGHT MUN: PENN HILLS T

HULTON RD

007620 FT

007620 FT HULTON RD

DIR: B TOTAL LEN: 1.443 MI. DIST: 11-1 SR: 2070
LEFT MUN: PENN HILLS T RIGHT MUN: PENN HILLS T

(SR2058 SEG 0210/0135) 0030/2641

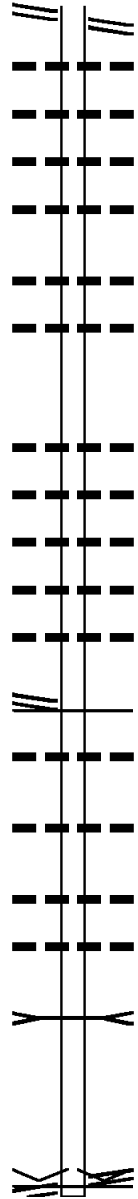

0030/2641 (SR2058 SEG 0210/0135)
018 "DIA CIRC CONCR
LEN=0040 INSTALLED UNKN
0030/2470 018 "DIA CIRC CONCR
LEN=0035 INSTALLED UNKN
0030/2027 018 "DIA CIRC CONCR
LEN=0035 INSTALLED UNKN
0030/1845 018 "DIA CIRC CONCR
LEN=0035 INSTALLED UNKN
0030/1530 018 "DIA CIRC CONCR
LEN=0035 INSTALLED UNKN

004979 FT

0030/0895 018 "DIA CIRC CONCR
LEN=0035 INSTALLED UNKN
0030/0688 018 "DIA CIRC CONCR
LEN=0035 INSTALLED UNKN

2 0 02165 0 00 0076+89 002713 FT
HAMIL RD
(SR2078 SEG 0040/1385) 0020/0000

004979 FT 2 0 02165 0 00 0099+59
5 0030/0000 LENGTH(AH 2641 BK 2266)
018 "DIA CIRC CONCR
LEN=0035 INSTALLED UNKN
0020/1928 018 "DIA CIRC CONCR
LEN=0035 INSTALLED UNKN
0020/1402 018 "DIA CIRC METAL
LEN=0030 INSTALLED UNKN
0020/1161 048 "DIA CIRC METAL
LEN=0030 INSTALLED UNKN
0020/0625 018 "DIA CIR PLASTIC
LEN=0080 INSTALLED UNKN
0020/0441
002713 FT

000000 FT

5 0020/0000 MFC BEGIN = D
LENGTH(AH 2266 BK 2713)
018 "DIA CIR PLASTIC
LEN=0064 INSTALLED UNKN
0010/2698 024 "DIA CIRC CONCR
LEN=0064 INSTALLED UNKN
0010/1853 018 "DIA CIRC CONCR
LEN=0030 INSTALLED UNKN
0010/1044 018 "DIA CIRC CONCR
LEN=0006 INSTALLED 2002
0010/0674 SMALL STREAM
STRUCTURE LENGTH 11 FT

HULTON RD
(SR2074 SEG 0040/1050) 0010/0000

0010/0134 BMSID 02/2070/0010/0134
000000 FT 2 0 02196 0 00 0000+00
VILLAGE: PENN HILLS T
HULTON RD
NC INDIANA RD
(SR2074 SEG 0040/1050)
MFC BEGIN = E
5 0010/0000 LENGTH(AH 2713 BK 0000)

EXTRACT DATE: 12/21/2020 ROADWAY MANAGEMENT SYSTEM PAGE NUMBER: 855
PRINT DATE: 12/23/2020 SLD COUNTY/SR - ANNUAL PRINT COUNTY: ALLEGHENY
DIR: B TOTAL LEN: .931 MI. DIST: 11-1 SR: 2069
LEFT MUN: PENN HILLS T RIGHT MUN: PENN HILLS T

DIR: B TOTAL LEN: .931 MI. DIST: 11-1 SR: 2069
 LEFT MUN: PENN HILLS T RIGHT MUN: PENN HILLS T

ROAD NAME (LOCALITY)	START	END	TYPE	STATUS
MT CARMEL RD (CNTY)	0020/3198	0020/3198	INTER-AHD	MT CARMEL RD (CNTY)
LEMINGTON AV (TWP)	0020/2435	0020/2435		MASON RD (TWP)
ROSS RD (TWP)	0020/1920	0020/2145	018 "DIA	CIRC CONCR INSTALLED UNKN
		0020/1361	024 "DIA	CIRC CONCR INSTALLED UNKN
		0020/1330		BEECHFORD RD (TWP)
		0020/1084	018 "DIA	CIRC CONCR INSTALLED UNKN
		0020/0740		OZAN ST (TWP)
		0020/0724	018 "DIA	CIRC CONCR INSTALLED UNKN
ROBINIA DR (TWP)	0020/0555	001719 FT	2 0	02197 0 00 0016+71
		0020/0000		LACKADORE AV (CITY)
		0010/1430	018 "DIA	CIRC CONCR INSTALLED UNKN
		0010/1425		FERNDAL ST (CITY)
		0010/0610	018 "DIA	CIRC CONCR INSTALLED UNKN
		0010/0350	018 "DIA	CIRC CONCR INSTALLED UNKN
		0010/0335		PERCHMENT ST (CITY)
		0010/0240	018 "DIA	CIRC CONCR INSTALLED UNKN
ROD WAY (CITY)	0010/0220	000000 FT	2 0	02197 0 00 0000+00
		0010/0000		LACKADORE ST (CITY)
		0010/0000		FRANKSTOWN AV (CITY)
		0010/0000		MFC BEGIN = E
		0010/0000		LENGTH(AH 1719 BK 0000)

DIR: E TOTAL LEN: .269 MI. DIST: 11-1 SR: 2068
 LEFT MUN: NORTH VERSAILLES T RIGHT MUN: NORTH VERSAILLES T

LINCOLN HW 001385 FT
 {SR0030 SEG 0281/1080}
 {SR0030 SEG 0280/1269}

FROM 0030/0280 SH
 (CONN) 0011/1232
 024 "DIA CIRC METAL 0011/1230
 LEN=0100 INSTALLED UNKN
 024 "DIA CIRC METAL 0011/1069
 LEN=0020 INSTALLED UNKN
 024 "DIA CIRC METAL 0011/0812
 LEN=0100 INSTALLED UNKN
 024 "DIA CIRC METAL 0011/0592
 LEN=0090 INSTALLED UNKN
 024 "DIA CIRC METAL 0011/0348
 LEN=0020 INSTALLED UNKN

1 0 00686 0 00 0000+00 000000 FT
 NC NAVY MARINE CORP WY
 PITTSBURGH MCKEESPORT B
 {SR2037 SEG 0061/0000}
 {SR2037 SEG 0060/0000}

PORT PERRY RD INTER-BK
 (TWP)
 MFC BEGIN = B
 LENGTH(AH 1385 BK 0000) 0011/0000

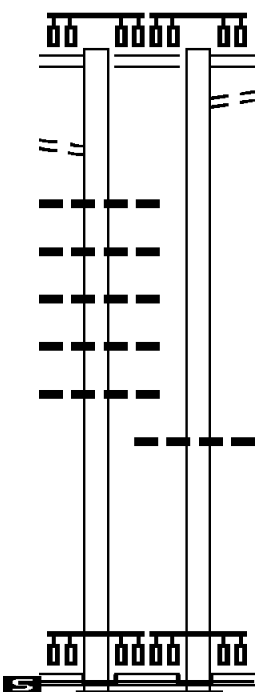

001418 FT LINCOLN HW
 {SR0030 SEG 0281/1080}
 {SR0030 SEG 0280/1269}

0010/1418
 0010/1270 TO 0030/0280 SH
 (CONN)

0010/0075 018 "DIA CIRC CONCR
 000000 FT 1 0 00686 0 00 0000+00
 NC NAVY MARINE CORP WY
 PITTSBURGH MCKEESPORT B
 {SR2037 SEG 0061/0000}
 {SR2037 SEG 0060/0000}

INTER-BK PORT PERRY RD
 (TWP)
 MFC BEGIN = B
 LENGTH(AH 1418 BK 0000) 0010/0000

EXTRACT DATE: 12/21/2020 ROADWAY MANAGEMENT SYSTEM PAGE NUMBER: 852
 PRINT DATE: 12/23/2020 SLD COUNTY/SR - ANNUAL PRINT COUNTY: ALLEGHENY
 DIR: B TOTAL LEN: 1.622 MI. DIST: 11-1 SR: 2067
 LEFT MUN: PENN HILLS T RIGHT MUN: PENN HILLS T

SALTSBURG RD 008563 FT
 (SR0400 SEG 0310/0000) 0030/3540

MAPLE LO DR 0030/1940
 (TWP)

HALL DR 0030/1600
 (TWP)

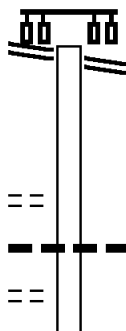

008563 FT SALTSBURG RD
 0030/3540 (SR0400 SEG 0310/0000)

0030/1685 024 "DIA CIRC CONCR
 LEN=0010 INSTALLED UNKN

018 "DIA CIRC CONCR

DIR: B TOTAL LEN: 1.622 MI. DIST: 11-1 SR: 2067
 LEFT MUN: PENN HILLS T RIGHT MUN: PENN HILLS T

SHENANDOAH DR
 (TWP)

0030/0495

005023 FT

ORCHARD DR
 (TWP)

0020/0640

002541 FT

UNIVERSAL RD
 (CNTY)

0010/0000

0030/1071	LEN=0048	015 "DIA	CIRC CONC	INSTALLED UNKN
0030/0664	LEN=0048			INSTALLED UNKN
0030/0374	LEN=0040	018 "DIA	CIRC CONC	INSTALLED UNKN
0030/0335		CRESCENT	GARDEN DR	(TWP)
005023 FT	2 0 02017	0 00	0050+00	
0030/0000	LENGTH(AH	3540 BK	2482)	
0020/2406	LEN=0081	048 "DIA	CIRC CONC	INSTALLED UNKN
0020/2329	LEN=0040	018 "DIA	CIRC CONC	INSTALLED UNKN
0020/1896	LEN=0100	018 "DIA	CIRC CONC	INSTALLED UNKN
0020/1671	LEN=0100	012 "DIA	CIRC CONC	INSTALLED UNKN
0020/1115		CANAVERAL DR		(TWP)
0020/0318	LEN=0040	018 "DIA	CIRC CONC	INSTALLED UNKN
002541 FT	2 0 02017	0 00	0025+00	
0020/0000	LENGTH(AH	2482 BK	2541)	
0010/2410	LEN=0048	060 "DIA	CIRC METAL	INSTALLED UNKN
0010/2390	LEN=0035	036 "DIA	CIRC CONC	INSTALLED UNKN
0010/2148	LEN=0035	018 "DIA	CIRC CONC	INSTALLED UNKN
0010/2020		BALE DR		(TWP)
0010/1169	LEN=0048	018 "DIA	CIRC CONC	INSTALLED UNKN
0010/1025	LEN=0048	018 "DIA	CIRC METAL	INSTALLED UNKN
0010/0693	LEN=0048	012 "DIA	CIRC CONC	INSTALLED UNKN
0010/0277	LEN=0197	018 "DIA	CIRC METAL	INSTALLED UNKN
000000 FT	2 0 02017	0 00	0000+00	
0010/0000		UNIVERSAL RD		(CNTY)
0010/0000		NC ST	TOTLER RD	MFC BEGIN = D
0010/0000	LENGTH(AH	2541 BK	0000)	

EXTRACT DATE: 12/21/2020 ROADWAY MANAGEMENT SYSTEM PAGE NUMBER: 850
 PRINT DATE: 12/23/2020 SLD COUNTY/SR - ANNUAL PRINT COUNTY: ALLEGHENY
 DIR: B TOTAL LEN: 5.444 MI. DIST: 11-1 SR: 2066
 LEFT MUN: PLUM BOROUGH B RIGHT MUN: PLUM BOROUGH B

028743 FT

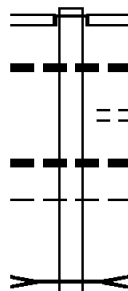

028743 FT
 INTER-AHD SAGAMORE HILL DR
 (BORO)
 NEW TEXAS RD
 (SR2075 SEG 0020/0000)
 0110/1708 018" DIA CIRC METAL
 0110/1325 LEN=0001 INSTALLED UNKN
 VERLINDEN DR
 0110/1065 (BORO)
 018" DIA CIR UNKNOWN
 0110/1033 LEN=0999 INSTALLED UNKN
 PLUM BOROUGH
 0110/0922 MONROEVILLE B
 ABERS CREEK
 STRUCTURE LENGTH 25 FT
 0110/0360 BMSID 02/2066/0110/0360

DIR: B TOTAL LEN: 5.444 MI. DIST: 11-1 SR: 2066
 LEFT MUN: MONROEVILLE B RIGHT MUN: MONROEVILLE B

Stationing	Location	Segment	Material	Length	Notes
027035 FT		0110/0160 027035 FT	018" DIA CIR PLASTIC LEN=0040 INSTALLED UNKN	2 0 02213 0 01 0262+32	GOLDEN MILE HW (SR0286 SEG 0040/0000)
		0110/0000	MONROEVILLE PLUM BOROUGH B	LENGTH(AH 1708 BK 2351)	
		0100/2207	018" DIA CIRC CONCR LEN=0030 INSTALLED UNKN		OLD ABERS CREEK RD
		0100/2177			(CNTY)
		0100/1121	018" DIA CIRC CONCR LEN=0030 INSTALLED UNKN		
024684 FT		0100/0190 024684 FT	018" DIA CIRC CONCR LEN=0064 INSTALLED UNKN	2 0 02213 0 01 0238+86	
		0100/0000		LENGTH(AH 2351 BK 3321)	
		0090/2535	018" DIA CIRC CONCR LEN=0035 INSTALLED UNKN		
		0090/2280	024" DIA CIRC CONCR LEN=0035 INSTALLED UNKN		
		0090/1958	018" DIA CIRC CONCR LEN=0030 INSTALLED UNKN		
		0090/1667	018" DIA CIRC CONCR LEN=0030 INSTALLED UNKN		
		0090/1036	036" DIA CIRC CONCR LEN=0030 INSTALLED UNKN		
BALKAN DR (PRDR)		0090/0835			
		0090/0785	018" DIA CIRC METAL LEN=0064 INSTALLED UNKN		
2 0 02213 0 01 0206+45 LINDSEY LN (CNTY)		021363 FT 0090/0000			
		0090/0000		LENGTH(AH 3321 BK 3069)	
		0080/3025	018" H 48" W CON BOX CUL LEN=0030 INSTALLED UNKN		HOCHBERG RD
		0080/2985			(BORO)
PIERSON RUN RD (CNTY)		0080/2420			
		0080/1976			BMS EN 02/2066/0080/1920

EXTRACT DATE: 12/21/2020
PRINT DATE: 12/23/2020

ROADWAY MANAGEMENT SYSTEM
SLD COUNTY/SR - ANNUAL PRINT

PAGE NUMBER: 848
COUNTY: ALLEGHENY

DIR: B TOTAL LEN: 5.444 MI.
LEFT MUN: PLUM BOROUGH B

DIST: 11-1 SR: 2066
RIGHT MUN: PLUM BOROUGH B

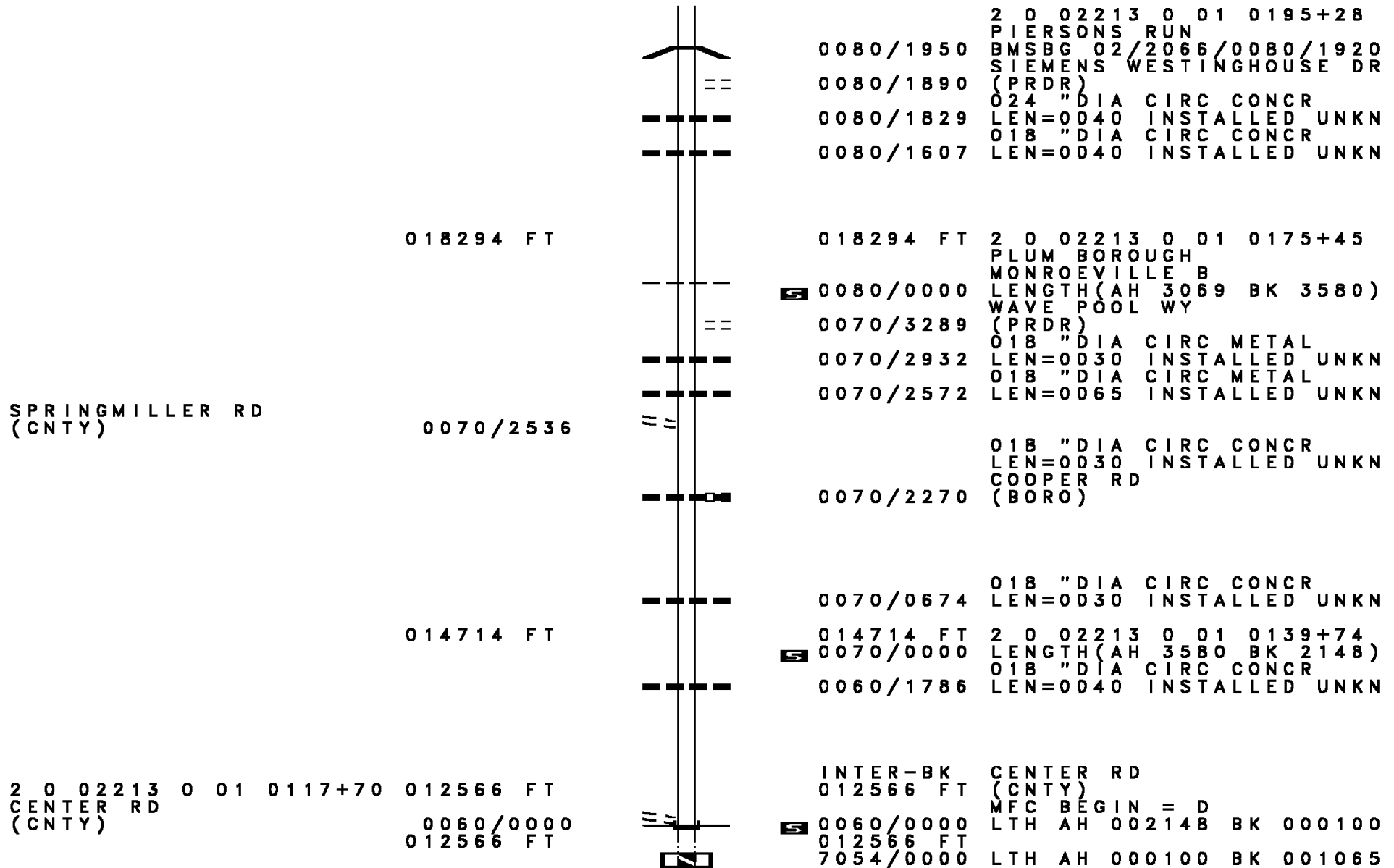

EXTRACT DATE: 12/21/2020
PRINT DATE: 12/23/2020

ROADWAY MANAGEMENT SYSTEM
SLD COUNTY/SR - ANNUAL PRINT

PAGE NUMBER: 847
COUNTY: ALLEGHENY

DIR: B TOTAL LEN: 5.444 MI.
LEFT MUN: MONROEVILLE B

DIST: 11-1 SR: 2066
RIGHT MUN: MONROEVILLE B

LC FOR CENTER RD
(CONN)

0050/0931

011501 FT

TES TEX CO
(PRDR)

0040/1144

HERRMANN RD
(PRDR)

0040/0750

009012 FT

DAVIDSON RD
(BORO)

0030/1851

BELMONT BL
(BORO)

0030/1615

INTER-AHD	CENTER RD
0050/1065	(CNTY) CENTER RD (CNTY) 018" DIA CIRC CONCR LEN=0040 INSTALLED UNKN
0050/0940	036" DIA CIRC CONCR LEN=0050 INSTALLED UNKN MONROEVILLE PLUM BOROUGH B 2 0 02213 0 00 0107+74 PLUM BOROUGH MONROEVILLE B 5 0050/0000 LENGTH(AH 1065 BK 2489) THELWAY DR 0040/2160 (BORO) 018"H 18"W CON BOX CUL LEN=0099 INSTALLED UNKN
0040/1257	024" DIA CIRC CONCR LEN=0030 INSTALLED UNKN
0040/1144	(APRA) IDL CO DEXTER DR (BORO) 0040/0983 018" DIA CIRC CONCR LEN=0030 INSTALLED UNKN
0040/0822	0040/0750
0040/0010	BMS EN 02/2066/0040/0000 2 0 02213 0 00 0090+45 THOMPSON RUN BMSBG 02/2066/0040/0000 5 0040/0000 LENGTH(AH 2489 BK 2072)
0030/1802	024" DIA CIRC CONCR LEN=0064 INSTALLED UNKN
0030/1340	018" DIA CIRC CONCR LEN=0064 INSTALLED UNKN MONROEVILLE PLUM BOROUGH B 024" DIA CIRC METAL LEN=0064 INSTALLED UNKN LOGAN FERRY RD
0030/1129	
0030/1027	

DIR: B TOTAL LEN: 5.444 MI. DIST: 11-1 SR: 2066
 LEFT MUN: PLUM BOROUGH B RIGHT MUN: PLUM BOROUGH B

CARRIAGE BL
 (BORO)

0030/0380
 006940 FT

0030/0650 (BORO)

006940 FT 2 0 02213 0 00 0069+98
 5 0030/0000 LENGTH(AH 2072 BK 3466)

0020/2794 018 "DIA CIR PLASTIC
 LEN=0298 INSTALLED UNKN
 GOLF RIDGE DR

0020/2780 (BORO)
 0020/2481 015 "DIA CIR CONCR
 LEN=0030 INSTALLED UNKN
 PLUM BOROUGH

0020/1897 PENN HILLS T
 0020/1808 BMSEN 02/2066/0020/1794
 2 0 02213 0 00 0053+03

0020/1794 THOMPSON RUN
 BMSBG 02/2066/0020/1794

0020/1182 018 "DIA CIRC CONCR
 LEN=0030 INSTALLED UNKN

003474 FT

003474 FT 2 0 02213 0 00 0035+09
 NC OL D FRANKSTOWN RD
 5 0020/0000 LENGTH(AH 3466 BK 3474)

0010/3280 018 "DIA CIR PLASTIC
 LEN=0060 INSTALLED UNKN

0010/2730 018 "DIA CIR PLASTIC
 LEN=0040 INSTALLED UNKN

0010/2433 018 "DIA CIRC CONCR
 LEN=0040 INSTALLED UNKN

0010/2150 018 "DIA CIRC CONCR
 LEN=0040 INSTALLED UNKN

HILL ST
 (TWP) 0010/0908
 SCHOOL ST
 (SR2056 SEG 0010/0000) 0010/0540

THOMPSON RUN RD
 (SR2065 SEG 0120/2570) 0010/0190

2 0 02213 0 00 0000+00 000000 FT
 MAIN ST
 (TWP) 0010/0000

0010/0432 018 "DIA CIRC METAL
 LEN=0099 INSTALLED UNKN
 THOMPSON RUN RD

0010/0190 (SR2065 SEG 0120/2570)
 NC LO TT RD

000000 FT MAIN ST
 (TWP)

5 0010/0000 MFC BEGIN = E
 LENGTH(AH 3474 BK 0000)

EXTRACT DATE: 12/21/2020 ROADWAY MANAGEMENT SYSTEM PAGE NUMBER: 845
 PRINT DATE: 12/23/2020 SLD COUNTY/SR - ANNUAL PRINT COUNTY: ALLEGHENY
 DIR: B TOTAL LEN: 5.340 MI. DIST: 11-1 SR: 2065
 LEFT MUN: PENN HILLS T RIGHT MUN: PENN HILLS T

UNIVERSAL RD 028196 FT
 (CNTY) 0120/2667
 LOTT RD
 (SR2066 SEG 0010/0190) 0120/2570
 CORD ST
 (TWP) 0120/1705
 WILLOW ST
 (TWP) 0120/1465

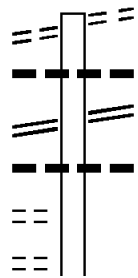

028196 FT UNIVERSAL RD
 0120/2667 (CNTY)
 018 " DIA CIRC CONCR
 0120/2656 LEN=0064 INSTALLED UNKN
 LOTT RD
 0120/2570 (SR2066 SEG 0010/0190)
 018 " DIA CIR PLASTIC
 0120/2103 LEN=0045 INSTALLED UNKN

DIR: B TOTAL LEN: 5.340 MI. DIST: 11-1 SR: 2065
 LEFT MUN: PENN HILLS T RIGHT MUN: PENN HILLS T

Location	Segment	Length	Material	Status
PINE ST (TWP)	0120/1225	==		
	0120/1088	024 " DIA	CIRC CONCR	INSTALLED UNKN
POPLAR ST (TWP)	0120/0925	==		
	025529 FT	0120/0152	018 " DIA	CIRC CONCR
		025529 FT	1 0 00745	0 00 0070+40
		5 0120/0000	LENGTH(AH 2667 BK 3659)	
		0110/3515	018 " DIA	CIRC CONCR
		0110/3175	018 " DIA	CIRC CONCR
		0110/3056	018 " DIA	CIRC CONCR
		0110/2855	018 " DIA	CIRC CONCR
		0110/2215	018 " DIA	CIRC CONCR
		0110/1858	018 " DIA	CIRC CONCR
		0110/1441	018 " DIA	CIRC CONCR
		0110/0666	018 " DIA	CIRC CONCR
		0110/0440	024 " DIA	CIRC CONCR
		0110/0230	018 " DIA	CIRC CONCR
	021870 FT	021870 FT	1 0 00745	0 00 0034+10
		5 0110/0000	(AAR 858954U)#TRKS 01	LENGTH(AH 3659 BK 3333)
		0100/2398	BMS EN 02/2065/0100/2381	PENN HILLS
		0100/2394	MONROEVILLE B	1 0 00745 0 00 0023+92
		0100/2381	THOMPSON RUN	BMSBG 02/2065/0100/2381
		0100/2018	018 " DIA	CIRC CONCR
		0100/1846	018 " DIA	CIRC CONCR
FREY RD (SR2063 SEG 0010/0000)	0100/1800	==		

DIR: B TOTAL LEN: 5.340 MI. DIST: 11-1 SR: 2065
 LEFT MUN: MONROEVILLE B RIGHT MUN: MONROEVILLE B

MCCULLY DR
 (BORO)

018537 FT

0090/0850

016438 FT

0100/0852	018 " DIA CIRC CONCR
0100/0678	LEN=0035 INSTALLED UNKN
0100/0390	018 " DIA CIRC CONCR
018537 FT	LEN=0040 INSTALLED UNKN
	018 " DIA CIRC CONCR
	LEN=0045 INSTALLED UNKN
	1 0 00745 0 00 0000+00
	OLD WILLIAM PENN HW
	(BORO)
0100/0000	LENGTH(AH 3333 BK 2099)
0090/2067	BMSSEN 02/2065/0090/2021
	1 0 00744 0 01 0112+79
	LEAK RUN
0090/2047	BMSBG 02/2065/0090/2021
0090/1545	018 " DIA CIRC METAL
0090/1429	LEN=0045 INSTALLED UNKN
0090/1427	036 " DIA CIRC CONCR
	LEN=0045 INSTALLED UNKN
	PARKWAY EAST EB
	OP ID 02/0376/0820/0342
	THOMPSON RUN RD
0090/0480	ROAD CLOSED BACK
	036 " DIA CIRC CONCR
0090/0055	LEN=0040 INSTALLED UNKN
016438 FT	1 0 00744 0 01 0092+42
0090/0000	LENGTH(AH 2099 BK 3929)
	THOMPSON RUN RD
0080/3061	ROAD CLOSED AHEAD
0080/3020	012 " DIA CIRC CONCR
	LEN=0030 INSTALLED UNKN
	NORTHERN PK
0080/2970	(SR2050 SEG 0010/0000)
	012 " DIA CIRC CONCR
0080/2615	LEN=0030 INSTALLED UNKN
	012 " DIA CIRC CONCR
0080/2361	LEN=0030 INSTALLED UNKN
	012 " DIA CIRC CONCR
0080/2179	LEN=0030 INSTALLED UNKN
	024 " DIA CIRC CONCR
0080/0836	LEN=0020 INSTALLED UNKN
	WM. PENN HWY
0080/0616	OP ID 02/2048/0050/0000

EXTRACT DATE: 12/21/2020
PRINT DATE: 12/23/2020

ROADWAY MANAGEMENT SYSTEM
SLD COUNTY/SR - ANNUAL PRINT

PAGE NUMBER: 842
COUNTY: ALLEGHENY

DIR: B TOTAL LEN: 5.340 MI.
LEFT MUN: MONROEVILLE B

DIST: 11-1 SR: 2065
RIGHT MUN: MONROEVILLE B

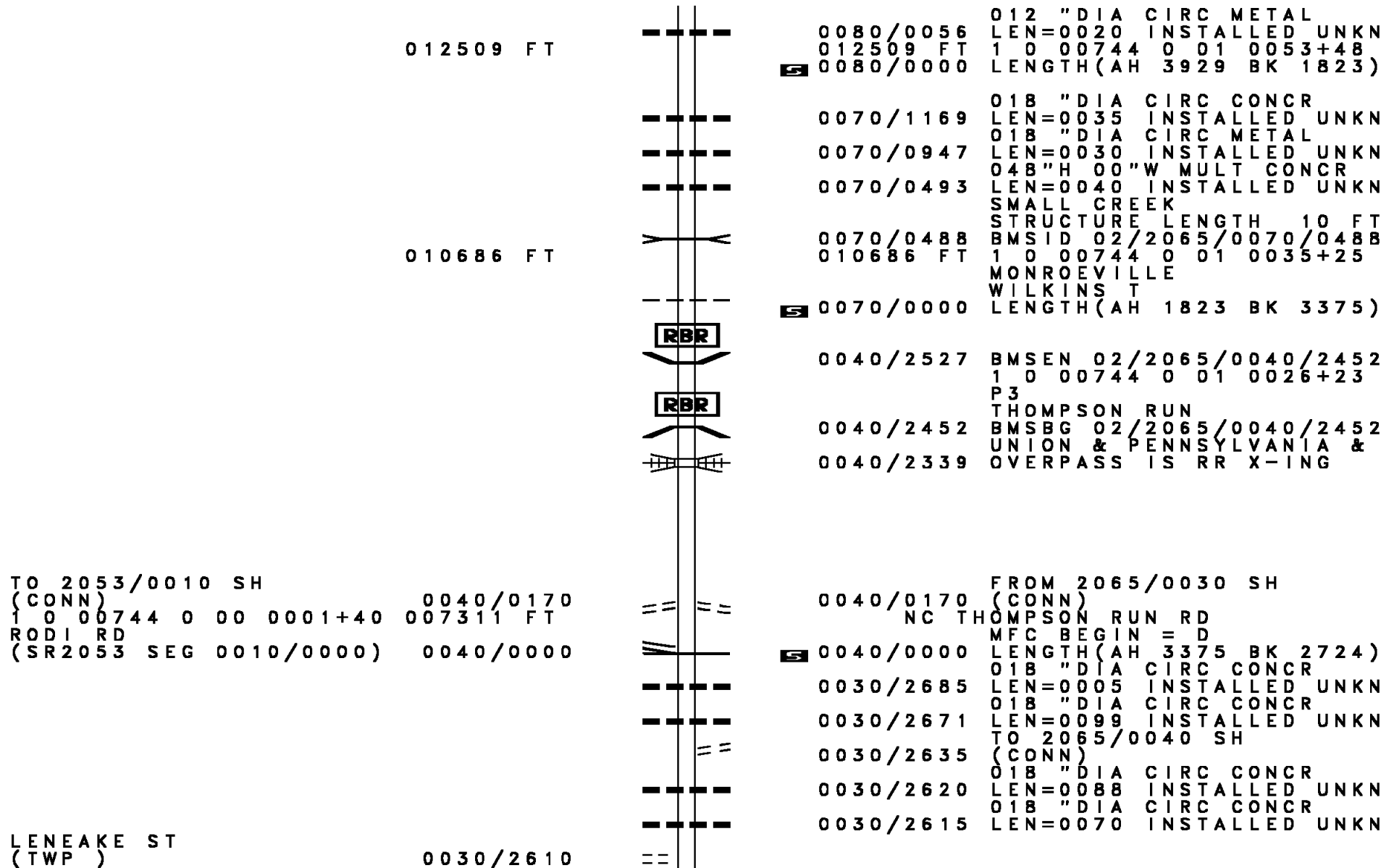

TO 2053/0010 SH
(CONN) 0040/0170
1 0 00744 0 00 0001+40 007311 FT
RODI RD
(SR2053 SEG 0010/0000) 0040/0000

LENEAKE ST
(TWP)

0080/0056 012 " DIA CIRC METAL
LEN=0020 INSTALLED UNKN
012509 FT 1 0 00744 0 01 0053+48
5 0080/0000 LENGTH(AH 3929 BK 1823)
0070/1169 018 " DIA CIRC CONCR
LEN=0035 INSTALLED UNKN
0070/0947 018 " DIA CIRC METAL
LEN=0030 INSTALLED UNKN
0070/0493 048" H 00" W MULT CONCR
LEN=0040 INSTALLED UNKN
SMALL CREEK
STRUCTURE LENGTH 10 FT
0070/0488 BMSID 02/2065/0070/0488
010686 FT 1 0 00744 0 01 0035+25
MONROEVILLE
WILKINS T
5 0070/0000 LENGTH(AH 1823 BK 3375)
0040/2527 BMSEN 02/2065/0040/2452
1 0 00744 0 01 0026+23
P3
THOMPSON RUN
0040/2452 BMSBG 02/2065/0040/2452
UNION & PENNSYLVANIA &
0040/2339 OVERPASS IS RR X-ING
0040/0170 FROM 2065/0030 SH
(CONN)
NC THOMPSON RUN RD
MFC BEGIN = D
5 0040/0000 LENGTH(AH 3375 BK 2724)
0030/2685 018 " DIA CIRC CONCR
LEN=0005 INSTALLED UNKN
0030/2671 018 " DIA CIRC CONCR
LEN=0099 INSTALLED UNKN
TO 2065/0040 SH
(CONN)
0030/2635 018 " DIA CIRC CONCR
LEN=0088 INSTALLED UNKN
0030/2620 018 " DIA CIRC CONCR
LEN=0070 INSTALLED UNKN

DIR: B TOTAL LEN: 5.340 MI. DIST: 11-1 SR: 2065
 LEFT MUN: WILKINS T RIGHT MUN: WILKINS T

LINHART ST
 (TWP)
 HARRISON RD
 (TWP)

0030/2480

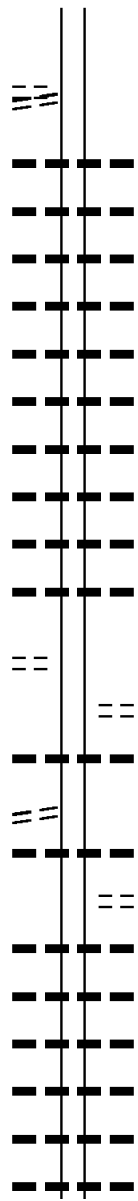

0030/1840	036 " DIA	CIRC CONCR	LEN=0060	INSTALLED UNKN
0030/1834	036 " DIA	CIRC CONCR	LEN=0040	INSTALLED UNKN
0030/1689	018 " DIA	CIRC CONCR	LEN=0030	INSTALLED UNKN
0030/1472	024 " DIA	CIRC CONCR	LEN=0040	INSTALLED UNKN
0030/1377	018 " DIA	CIRC CONCR	LEN=0030	INSTALLED UNKN
0030/1180	018 " DIA	CIRC CONCR	LEN=0040	INSTALLED UNKN
0030/1080	012 " DIA	CIRC CONCR	LEN=0030	INSTALLED UNKN
0030/0813	018 " DIA	CIRC CONCR	LEN=0044	INSTALLED UNKN
0030/0770	018 " DIA	CIRC METAL	LEN=0030	INSTALLED UNKN
0030/0551	018 " DIA	CIRC CONCR	LEN=0040	INSTALLED UNKN
004587 FT				
0030/0000	5	RAILROAD ST	LENGTH(AH 2724 BK 3668)	
0020/3090	(TWP)			
0020/3079	036 " DIA	CIRC CONCR	LEN=0088	INSTALLED UNKN
0020/2736	018 " DIA	CIRC METAL	LEN=0020	INSTALLED UNKN
0020/2735	JONES AV (TWP)			
0020/2709	018 " DIA	CIRC METAL	LEN=0035	INSTALLED UNKN
0020/2615	018 " DIA	CIRC METAL	LEN=0030	INSTALLED UNKN
0020/2508	018 " DIA	CIRC CONCR	LEN=0035	INSTALLED UNKN
0020/2364	018 " DIA	CIRC CONCR	LEN=0030	INSTALLED UNKN
0020/2211	018 " DIA	CIR PLASTIC	LEN=0030	INSTALLED UNKN
0020/1745	018 " DIA	CIRC CONCR	LEN=0030	INSTALLED UNKN

1 0 00743 0 01 0052+20 004587 FT
 CHURCHILL RD
 (CNTY)

0030/0000

MCMASTERS AV
 (TWP)

0020/2977

DIR: B TOTAL LEN: 5.340 MI. DIST: 11-1 SR: 2065
 LEFT MUN: WILKINS T RIGHT MUN: WILKINS T

MCMASTERS AV
(BORO)

0020/0530

LARIMER AV
(BORO)

0010/0896

MELLON AL
(BORO)

0010/0585

OSBORNE ST
(BORO)

0010/0120
000000 FT

0020/1586	018" DIA CIRC CONCR	LEN=0099	INSTALLED UNKN
0020/1500	RAILROAD ST	(TWP)	
0020/1493	WILKINS		
0020/1010	TURTLE CREEK B	PATTERSON AL	
0020/0530	(BORO)	LINE WY	
0020/0491	018" DIA CIRC CONCR	LEN=0099	INSTALLED UNKN
0020/0095	MCCLELLAND ST	(BORO)	
0020/0055	018"H 09"W UNKN CONC	LEN=0025	INSTALLED UNKN
000919 FT	1 0 00743 0 01 0015+39		
0020/0000	LENGTH(AH 3668 BK 0919)		
	NC LARIMER AV		
0010/0714	UNION & PENNSYLVANIA &		
0010/0631	OVERPASS IS RR X-ING		
0010/0600	018" DIA CIRC CONCR	LEN=0035	INSTALLED UNKN
	018" DIA CIRC CONCR	LEN=0065	INSTALLED UNKN
	RAILROAD ST	(BORO)	
0010/0585	CHURCH ST	(BORO)	
0010/0361	018" DIA CIRC CONCR	LEN=0030	INSTALLED UNKN
0010/0349	018" DIA CIRC CONCR	LEN=0030	INSTALLED UNKN
0010/0150	018" DIA CIRC CONCR	LEN=0030	INSTALLED UNKN
0010/0142	018" DIA CIRC CONCR	LEN=0030	INSTALLED UNKN
000000 FT	1 0 00743 0 00 0000+00		
	NC THOMPSON ST		
	TRIBORO EX		
	(SRO130 SEG 0252/0890)		
	(SRO130 SEG 0253/0915)		
	INTER-BK THOMPSON ST		
	(BORO)		
	MFC BEGIN = C		
0010/0000	LENGTH(AH 0919 BK 0000)		

EXTRACT DATE: 12/21/2020 ROADWAY MANAGEMENT SYSTEM PAGE NUMBER: 839
 PRINT DATE: 12/23/2020 SLD COUNTY/SR - ANNUAL PRINT COUNTY: ALLEGHENY
 DIR: B TOTAL LEN: 1.468 MI. DIST: 11-1 SR: 2064
 LEFT MUN: PENN HILLS T RIGHT MUN: PENN HILLS T

007750 FT

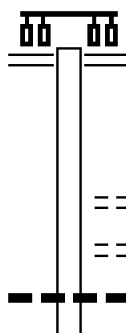

006776 FT

007750 FT FRANKSTOWN RD
 (SR0400 SEG 0270/0000)
 0040/0974

006776 FT 2 0 02145 0 01 0068+34
 SAGE DR
 (TWP)
 0040/0000 LENGTH(AH 0974 BK 1583)
 ALTHEA RD
 (TWP)
 0030/1260
 0030/1082 018 " DIA CIR PLASTIC
 LEN=0020 INSTALLED UNKN
 024 " DIA CIRC METAL

DIR: B TOTAL LEN: 1.468 MI. DIST: 11-1 SR: 2064
 LEFT MUN: PENN HILLS T RIGHT MUN: PENN HILLS T

SPRINGDALE DR
 (TWP)

Segment ID	Length (FT)	Material	Notes
0030/1071	LEN=0040	INSTALLED	UNKN
0030/1020			
0030/1008	LEN=0099	024 " DIA CIRC METAL	INSTALLED UNKN
0030/0851	LEN=0045	018 " DIA CIRC CONCR	INSTALLED UNKN
0030/0329	LEN=0040	024 " DIA CIRC METAL	INSTALLED UNKN
0030/0291	LEN=0099	036 " DIA CIRC METAL	INSTALLED UNKN
0030/0101	LEN=0045	018 " DIA CIR PLASTIC	INSTALLED UNKN
005193 FT	005193 FT	2 0 02145 0 01 0049+34	
0030/0000	LENGTH(AH 1583 BK 2366)	048 " DIA CIRC CONCR	
0020/1919	LEN=0035	048 " DIA CIRC METAL	INSTALLED UNKN
0020/1544	LEN=0035	048 " DIA CIRC CONCR	INSTALLED UNKN
0020/0948	LEN=0060	036 " DIA CIRC CONCR	INSTALLED UNKN
0020/0765	LEN=0030	018 " DIA CIR PLASTIC	INSTALLED UNKN
0020/0290	LEN=0035	018 " DIA CIRC METAL	INSTALLED UNKN
0020/0101	LEN=0030	018 " DIA CIRC CONCR	INSTALLED UNKN
002827 FT	002827 FT	2 0 02145 0 01 0026+64	
0020/0000	LENGTH(AH 2366 BK 2827)	018 " DIA CIRC CONCR	
0010/2680	LEN=0045		INSTALLED UNKN
0010/2026	BMS EN 02/2064/0010/2012	2 0 02145 0 01 0022+95	
0010/2012	BMS BG 02/2064/0010/2012	LIME HOLLOW RUN	
0010/0231			
000000 FT	000000 FT	005 "H 05 "W CONC STRUCT	
	000000 FT	2 0 02145 0 00 0000+00	
		NC LIME HOLLOW RD	
		COAL HOLLOW RD	
		(SRO 130 SEG 0102/0395)	
		MFC BEGIN = D	
0010/0000	LENGTH(AH 2827 BK 0000)		

UNKNOWN RD
 (TWP)

EXTRACT DATE: 12/21/2020 ROADWAY MANAGEMENT SYSTEM PAGE NUMBER: 837
 PRINT DATE: 12/23/2020 SLD COUNTY/SR - ANNUAL PRINT COUNTY: ALLEGHENY
 DIR: B TOTAL LEN: 1.296 MI. DIST: 11-1 SR: 2063
 LEFT MUN: PENN HILLS T RIGHT MUN: PENN HILLS T

UNIVERSAL RD
 (CNTY)

006845 FT
 0020/3374

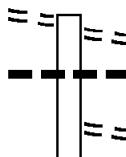

006845 FT UNIVERSAL RD
 0020/3374 (CNTY)
 0020/3140 024 " DIA CIRC CONCR
 0020/2860 LEN=0040 INSTALLED UNKN
 BEACHTREE RD
 (TWP)

DIR: B TOTAL LEN: 1.296 MI. DIST: 11-1 SR: 2063
 LEFT MUN: PENN HILLS T RIGHT MUN: PENN HILLS T

LAURIE DR
 (TWP)

0020/0535

003471 FT

CAMERON DR
 (TWP)

0010/2545

000000 FT

THOMPSON RUN RD
 (SR2065 SEG 0100/1800) 0010/0000

0020/2232	018 " DIA	CIRC CONCR
	LEN=0040	INSTALLED UNKN
0020/1874	018 " DIA	CIRC METAL
	LEN=0030	INSTALLED UNKN
0020/1542	018 " DIA	CIRC METAL
	LEN=0030	INSTALLED UNKN
0020/1291	018 " DIA	CIRC CONCR
	LEN=0060	INSTALLED UNKN
0020/0945	018 " DIA	CIRC CONCR
	LEN=0045	INSTALLED UNKN
0020/0388	024 " DIA	CIRC CONCR
	LEN=0080	INSTALLED UNKN
0020/0265	018 " DIA	CIRC CONCR
	LEN=0075	INSTALLED UNKN
0020/0000	2 0 02174	0 00 0033+48
	LENGTH(AH 3374 BK 3471)	
0010/3240	018 " DIA	CIRC CONCR
	LEN=0040	INSTALLED UNKN
0010/3067	018 " DIA	CIRC METAL
	LEN=0060	INSTALLED UNKN
0010/2717	018 " DIA	CIRC METAL
	LEN=0030	INSTALLED UNKN
0010/2306	024 "H 00 "W	** UNKNOWN **
	LEN=0001	INSTALLED UNKN
0010/1823	024 " DIA	CIRC METAL
	LEN=0045	INSTALLED UNKN
0010/1556	018 " DIA	CIRC METAL
	LEN=0035	INSTALLED UNKN
0010/1305	018 " DIA	CIRC METAL
	LEN=0080	INSTALLED UNKN
0010/0770	024 " DIA	CIRC METAL
	LEN=0040	INSTALLED UNKN
0010/0425	018 " DIA	CIRC CONCR
	LEN=0040	INSTALLED UNKN
0010/0151	BMSFN 02/2063/0010/0125	
	PENN HILLS	
0010/0138	MONROEVILLE B	
	2 0 02174	0 00 0001+43
	THOMPSON RUN	
0010/0125	BMSBG 02/2063/0010/0125	
000000 FT	2 0 02174	0 00 0000+00
	THOMPSON RUN RD	
	(SR2065 SEG 0100/1800)	
	NC FREY RD	
	MFC BEGIN = E	
0010/0000	LENGTH(AH 3471 BK 0000)	

EXTRACT DATE: 12/21/2020 ROADWAY MANAGEMENT SYSTEM PAGE NUMBER: 835
PRINT DATE: 12/23/2020 SLD COUNTY/SR - ANNUAL PRINT COUNTY: ALLEGHENY
DIR: B TOTAL LEN: .000 MI. DIST: 11-1 SR: 2062
LEFT MUN: PENN HILLS T RIGHT MUN: PENN HILLS T

000000 FT
000000 FT



000000 FT
7020/0000 LENGTH(AH 2050 BK 2469)
000000 FT
7010/0000 LENGTH(AH 2469 BK 0000)

DIR: B TOTAL LEN: 1.920 MI. DIST: 11-1 SR: 2061
 LEFT MUN: PENN HILLS T RIGHT MUN: PENN HILLS T

Location	Start Station	End Station	Length	Material	Status
LOUGEAY RD (CNTY)	010135 FT	0030/3733	010135 FT	INTER-AHD	JEFFERSON RD (CNTY)
			0030/3490	018 " DIA	CIRC CONCR
			0030/3103	LEN=0035	INSTALLED UNKN
			0030/2888	015 " DIA	CIRC CONCR
			0030/2866	LEN=0035	INSTALLED UNKN
			0030/2715	018 " DIA	CIRC CONCR
				LEN=0040	INSTALLED UNKN
				KEY DR	
				(BORO)	
				018 " DIA	CIRC CONCR
STOWE DR (BORO)	0030/2690		0030/2161	LEN=0035	INSTALLED UNKN
			0030/1842	018 " DIA	CIRC CONCR
			0030/1612	LEN=0035	INSTALLED UNKN
			0030/1040	018 " DIA	CIRC CONCR
JEFFERSON HEIGHTS RD (BORO)	0030/1040		0030/1038	LEN=0030	INSTALLED UNKN
				PAYNE DR	
				(BORO)	
				018 " DIA	CIRC CONCR
				LEN=0040	INSTALLED UNKN
			018 " DIA	CIR PLASTIC	
			LEN=0048	INSTALLED UNKN	
			018 " DIA	CIRC CONCR	
			LEN=0048	INSTALLED UNKN	
			2 0 02195	0 00 0063+96	
			EVERGREEN DR		
			(BORO)		
			5 0030/0000	LENGTH (AH 3733 BK 2926)	
				KILTIE DR	
			(BORO)		
			0020/2575	(APRA) TURNERS DAIRY FA	
				TURNERS DAIRY FARM RD	

POI

DIR: B TOTAL LEN: 1.920 MI. DIST: 11-1 SR: 2061
 LEFT MUN: PENN HILLS T RIGHT MUN: PENN HILLS T

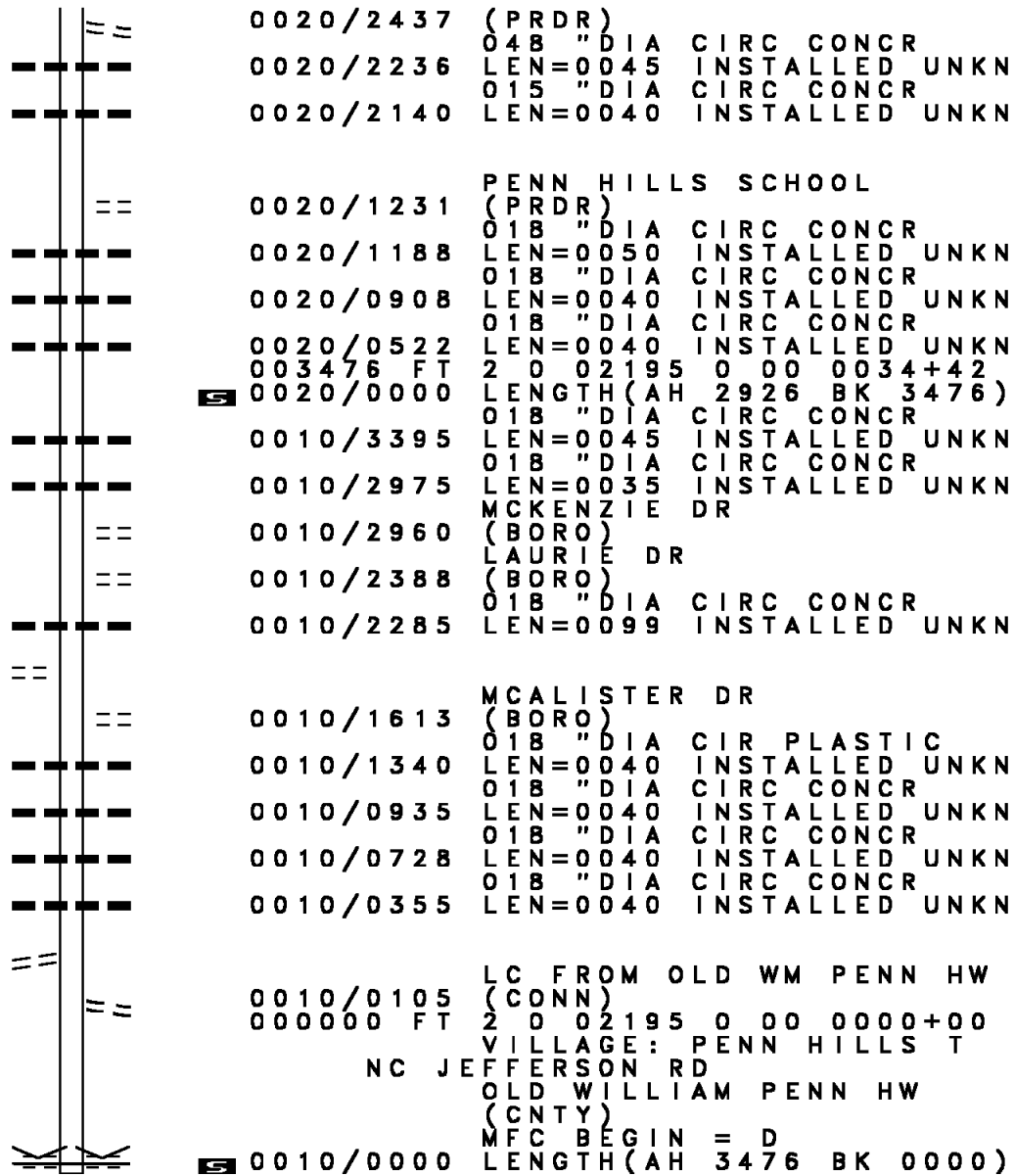

003476 FT

KNICKERBOCKER DR
(BORO)

0010/1980

LC TO OLD WM PENN HW
(CONN)

0010/0137

000000 FT

0020/2437 (PRDR)
 048 " DIA CIRC CONCR
 0020/2236 LEN=0045 INSTALLED UNKN
 015 " DIA CIRC CONCR
 0020/2140 LEN=0040 INSTALLED UNKN

PENN HILLS SCHOOL
 (PRDR)
 0020/1231 018 " DIA CIRC CONCR
 0020/1188 LEN=0050 INSTALLED UNKN
 018 " DIA CIRC CONCR
 0020/0908 LEN=0040 INSTALLED UNKN
 018 " DIA CIRC CONCR
 0020/0522 LEN=0040 INSTALLED UNKN

003476 FT
 0020/0000 2 0 02195 0 00 0034+42
 LENGTH(AH 2926 BK 3476)
 018 " DIA CIRC CONCR
 0010/3395 LEN=0045 INSTALLED UNKN
 018 " DIA CIRC CONCR
 0010/2975 LEN=0035 INSTALLED UNKN

MCKENZIE DR
 (BORO)
 LAURIE DR
 (BORO)
 0010/2960 018 " DIA CIRC CONCR
 0010/2388 LEN=0099 INSTALLED UNKN

MCALISTER DR
 (BORO)
 0010/1613 018 " DIA CIR PLASTIC
 0010/1340 LEN=0040 INSTALLED UNKN
 018 " DIA CIRC CONCR
 0010/0935 LEN=0040 INSTALLED UNKN
 018 " DIA CIRC CONCR
 0010/0728 LEN=0040 INSTALLED UNKN
 018 " DIA CIRC CONCR
 0010/0355 LEN=0040 INSTALLED UNKN

LC FROM OLD WM PENN HW
 (CONN)
 0010/0105 2 0 02195 0 00 0000+00
 000000 FT VILLAGE: PENN HILLS T
 NC JEFFERSON RD
 OLD WILLIAM PENN HW
 (CNTY)
 MFC BEGIN = D
 0010/0000 LENGTH(AH 3476 BK 0000)

Location	Segment ID	Length (FT)	Material / Notes
VINE ST (TWP)	0020/2060	004844	INTER-AHD VINE ST (TWP) LINCOLN RD (CNTY) OSAGE AL (TWP)
CHASKE ST (TWP)	0020/1570	0020	NC VINE ST 018" DIA CIRC METAL LEN=0001 INSTALLED UNKN
	0020/1072	0020	HARVEST DR (TWP) 018" DIA CIRC CONCR LEN=0080 INSTALLED UNKN
	0020/0000	002544	2 0 02170 0 00 0025+70 LENGTH(AH 2300 BK 2544)
GROVE RD (TWP)	0010/1260	0010	018" DIA CIRC CONCR LEN=0035 INSTALLED UNKN
	0010/1278	0010	024" DIA CIRC CONCR LEN=0035 INSTALLED UNKN
	0010/0971	0010	018" DIA CIRC CONCR LEN=0029 INSTALLED UNKN
	0010/0707	0010	012" DIA CIRC CONCR LEN=0099 INSTALLED UNKN
	0010/0617	0010	012" DIA CIRC CONCR LEN=0099 INSTALLED UNKN
	0010/0405	0010	012" DIA CIRC METAL LEN=0099 INSTALLED UNKN
URBAN DR (TWP)	0010/0100	0010	018" DIA CIRC CONCR LEN=0080 INSTALLED UNKN
	0010/0069	000000	2 0 02170 0 00 0000+00 MT CARMEL RD (CNTY)
MT CARMEL RD (CNTY)	0010/0000	0010	NC ABER RD MFC BEGIN = E LENGTH(AH 2544 BK 0000)

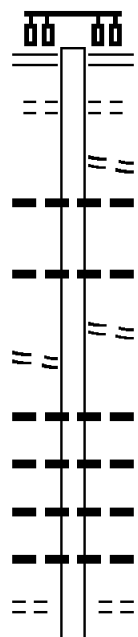
	007470 FT		007470 FT FRANKSTOWN RD (SR0400 SEG 0250/1450)
			0030/3125 CLEMATIS BL (TWP)
			0030/2790 GARDENIA DR (TWP)
			0030/2535 018 " DIA CIRC CONCR LEN=0030 INSTALLED UNKN
			0030/2418 018 " DIA CIRC CONCR LEN=0040 INSTALLED UNKN
			0030/1755 ELIZABETH DR (TWP)
			0030/1750 012 " DIA CIRC CONCR LEN=0040 INSTALLED UNKN
			0030/1677 018 " DIA CIRC CONCR LEN=0030 INSTALLED UNKN
			0030/1140 018 " DIA CIRC CONCR LEN=0030 INSTALLED UNKN
			0030/0908 018 " DIA CIRC CONCR LEN=0030 INSTALLED UNKN
			0030/0563 018 " DIA CIRC CONCR LEN=0030 INSTALLED UNKN
			0030/0545 JOAN DR (TWP)
			0030/0545 024 " DIA CIRC CONCR
DATURA DR (TWP)	0030/1711		
PARIS RD (TWP)	0030/0545		

EXTRACT DATE: 12/21/2020
PRINT DATE: 12/23/2020

ROADWAY MANAGEMENT SYSTEM
SLD COUNTY/SR - ANNUAL PRINT

PAGE NUMBER: 830
COUNTY: ALLEGHENY

DIR: B TOTAL LEN: 1.415 MI.
LEFT MUN: PENN HILLS T

DIST: 11-1 SR: 2059
RIGHT MUN: PENN HILLS T

PENTLAND DR
(TWP)

004345 FT

0020/0640

002225 FT

000000 FT

0030/0374	LEN=0040	018 "DIA	CIRC	UNKN	INSTALLED
0030/0099	LEN=0099	018 "DIA	CIRC	UNKN	INSTALLED
004345 FT	2 0 02002	0 00	0043+97		
0030/0000	LENGTH(AH	3125	BK	2120)	
0020/1974	LEN=0030	018 "DIA	CIRC	UNKN	INSTALLED
0020/1560	LEN=0040	018 "DIA	CIRC	UNKN	INSTALLED
0020/1430	SAYLONG DR	(TWP)			
0020/1323	LEN=0040	018 "DIA	CIRC	UNKN	INSTALLED
0020/1182	LEN=0040	018 "DIA	CIRC	UNKN	INSTALLED
0020/0735	ROSEWOOD DR	(TWP)			
0020/0515	LEN=0035	018 "DIA	CIRC	UNKN	INSTALLED
0020/0320	LEN=0040	018 "DIA	CIRC	UNKN	INSTALLED
0020/0204	LEN=0040	018 "DIA	CIRC	UNKN	INSTALLED
002225 FT	2 0 02002	0 00	0019+84		
0020/0000	LENGTH(AH	2120	BK	2225)	
0010/2206	LEN=0040	018 "DIA	CIRC	UNKN	INSTALLED
0010/2008	LEN=0040	018 "DIA	CIRC	UNKN	INSTALLED
0010/1775	LEN=0040	018 "DIA	CIRC	UNKN	INSTALLED
0010/1330	PAT SENACA PK	(PARK)			
0010/0323	CHALFANT RUN	STRUCTURE LENGTH	15 FT		
0010/0033	BMSID	02/2059/0010/0342			
000000 FT	LEN=0040	018 "DIA	CIRC	UNKN	INSTALLED
NC LONG RD	2 0 02002	0 00	0000+00		
BEULAH RD	(SRO130	SEG	0142/1184)		
MFC BEGIN = D					
0010/0000	LENGTH(AH	2225	BK	0000)	

EXTRACT DATE: 12/21/2020 ROADWAY MANAGEMENT SYSTEM PAGE NUMBER: 829
 PRINT DATE: 12/23/2020 SLD COUNTY/SR - ANNUAL PRINT COUNTY: ALLEGHENY
 DIR: E TOTAL LEN: 10.016 MI. DIST: 11-1 SR: 2058
 LEFT MUN: PLUM BOROUGH B RIGHT MUN: PLUM BOROUGH B

HULTON RD 052861 FT
 (SR2082 SEG 0080/0000) 0270/0535

FROM SR 2082/0070
 (CONN)

0270/0479
 052326 FT

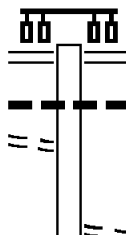

052883 FT COXCOMB HILL RD
 0270/0535 (SR2082 SEG 0080/0000)
 0270/0514 018 " DIA CIRC CONCR
 LEN=0099 INSTALLED UNKN
 052348 FT 2 0 02287 0 00 0234+91
 PENNSYLVANIA AV
 (BORO)

EXTRACT DATE: 12/21/2020
PRINT DATE: 12/23/2020

ROADWAY MANAGEMENT SYSTEM
SLD COUNTY/SR - ANNUAL PRINT

PAGE NUMBER: 828
COUNTY: ALLEGHENY

DIR: E TOTAL LEN: 10.016 MI.
LEFT MUN: PLUM BOROUGH B

DIST: 11-1 SR: 2058
RIGHT MUN: PLUM BOROUGH B

Street Name	Stationing	Notes	
NORTHERN AV (BORO)	0260/0550 050842 FT	0270/0000 LENGTH(AH 0535 BK 1484) 024 "DIA CIRC CONCR 0260/1178 LEN=0024 INSTALLED UNKN LINCOLN AV (BORO) 0260/0905 024 "DIA CIRC CONCR 0260/0701 LEN=0050 INSTALLED UNKN	
	CENTER AV (BORO)	0250/0980	050864 FT 2 0 02287 0 00 0220+10 JEFFERSON AV (BORO) 0260/0000 LENGTH(AH 1484 BK 1377) 015 "DIA CIRC CONCR 0250/0987 LEN=0099 INSTALLED UNKN
		EASTERN AV (BORO)	0250/0125
HASKELL DR (PRDR)	0240/1210		0250/0074 024 "DIA CIRC CONCR LEN=0072 INSTALLED UNKN 049465 FT 2 0 02287 0 00 0206+42 (AAR 051621K)#TRKS 02 0250/0000 LENGTH(AH 1377 BK 1247)
	KIRKPATRICK DR (BORO)	0230/1225	0240/0940 018 "DIA CIRC CONCR LEN=0034 INSTALLED UNKN 0240/0432 018 "DIA CIRC CONCR LEN=0099 INSTALLED UNKN 0240/0057 BMSSEN 02/2058/0240/0019 2 0 02287 0 00 0194+36 BR. PLUM CR. 0240/0044 BMSBG 02/2058/0240/0019 048218 FT 2 0 02287 0 00 0194+00 MORATH LN (BORO) 0240/0000 LENGTH(AH 1247 BK 1731) 018 "DIA CIRC CONCR 0230/1308 LEN=0099 INSTALLED UNKN
		0230/1118	018 "DIA CIRC OTHER LEN=0030 INSTALLED UNKN

EXTRACT DATE: 12/21/2020
PRINT DATE: 12/23/2020

ROADWAY MANAGEMENT SYSTEM
SLD COUNTY/SR - ANNUAL PRINT

PAGE NUMBER: 827
COUNTY: ALLEGHENY

DIR: E TOTAL LEN: 10.016 MI.
LEFT MUN: PLUM BOROUGH B

DIST: 11-1 SR: 2058
RIGHT MUN: PLUM BOROUGH B

2 0 02287 0 00 0175+79 046487 FT
KIRKPATRICK DR
(BORO)

0230/0000

HULTON ARBORS
(PRDR)

0220/1170

044826 FT

COLGAN TE
(TWP)
INDIANA RD

0210/0435

0230/0805	018 " DIA	CIRC OTHER	LEN=0032	INSTALLED UNKN
0230/0715	018 " DIA	CIRC CONCR	LEN=0099	INSTALLED UNKN
0230/0615	018 " DIA	CIRC CONCR	LEN=0032	INSTALLED UNKN
0230/0208	018 " DIA	CIRC CONCR	LEN=0032	INSTALLED UNKN
046509 FT				
5 0230/0000	LENGTH(AH 1731 BK 1661)			
0220/1557	BMS EN 02/2058/0220/1476			
	2 0 02287 0 00 0174+97			
	PLUM CREEK			
0220/1504	BMSBG 02/2058/0220/1476			
	PLUM BOROUGH			
0220/1402	PENN HILLS T			
	HULTON ESTATES			
	(PRDR)			
0220/0095	018 " DIA	CIRC CONCR	LEN=0036	INSTALLED UNKN
0220/0014	018 " DIA	CIRC CONCR	LEN=0036	INSTALLED UNKN
044848 FT				
5 0220/0000	LENGTH(AH 1661 BK 2970)			
	018 " DIA	CIRC CONCR	LEN=0099	INSTALLED UNKN
0210/2746	018 " DIA	CIR PLASTIC	LEN=0040	INSTALLED UNKN
0210/2181	018 " DIA	CIRC CONCR	LEN=0032	INSTALLED UNKN
0210/1919	018 " DIA	CIRC CONCR	LEN=0028	INSTALLED UNKN
0210/1505	IOWA ST			
0210/1470	(TWP)			
0210/1100	HIGH ST			
	(TWP)			
0210/0833	015 " DIA	CIRC CONCR	LEN=0099	INSTALLED UNKN
0210/0775	MILL ST			
	(SR2084 SEG 0010/0000)			
0210/0660	024 " DIA	CIRC METAL	LEN=0046	INSTALLED UNKN
0210/0435	018 " DIA	CIRC CONCR	LEN=0035	INSTALLED UNKN

DIR: E TOTAL LEN: 10.016 MI. DIST: 11-1 SR: 2058
 LEFT MUN: PENN HILLS T RIGHT MUN: PENN HILLS T

(SR2070 SEG 0030/2641) 0210/0135
 2 0 02287 0 00 0130+49 041856 FT
 OLD HULTON RD
 (TWP) 0210/0000
 041379 FT
 HULTON RD
 (SR2074 SEG 0070/1943) 0200/0000

2 0 02304 0 00 0027+02 039383 FT
 NEWFIELD DR
 (TWP) 0190/0000

MERRY DR
 (TWP) 0180/1280

036633 FT

041878 FT	
5 0210/0000	LENGTH(AH 2970 BK 0477)
041401 FT	2 0 02287 0 00 0125+58
	NC HU LTON RD
5 0200/0000	LENGTH(AH 0477 BK 1996)
0190/1562	018 "DIA CIRC CONCR
	LEN=0052 INSTALLED UNKN
0190/1290	036 "DIA CIRC CONCR
	LEN=0055 INSTALLED UNKN
0190/1060	018 "DIA CIRC CONCR
	LEN=0038 INSTALLED UNKN
0190/0866	018 "DIA CIRC CONCR
	LEN=0040 INSTALLED UNKN
0190/0623	018 "DIA CIRC CONCR
	LEN=0036 INSTALLED UNKN
0190/0480	018 "DIA CIRC CONCR
	LEN=0042 INSTALLED UNKN
0190/0085	024 "DIA CIRC CONCR
039405 FT	LEN=0070 INSTALLED UNKN
5 0190/0000	LENGTH(AH 1996 BK 2750)
0180/2360	JODIE LN
	(TWP)
0180/2345	018 "DIA CIRC CONCR
	LEN=0045 INSTALLED UNKN
0180/1573	018 "DIA CIRC CONCR
	LEN=0034 INSTALLED UNKN
0180/1386	018 "DIA CIRC CONCR
	LEN=0045 INSTALLED UNKN
0180/1378	BMSSEN 02/2058/0180/1370
	2 0 02304 0 00 0107+71
0180/1370	BRANCH OF PLUM CREEK
	BMSBG 02/2058/0180/1370
0180/1368	018 "DIA CIRC CONCR
	LEN=0099 INSTALLED UNKN
0180/1280	JODIE LN
	(TWP)
0180/1280	MARY ST
	(TWP)
0180/1008	018 "DIA CIRC CONCR
	LEN=0026 INSTALLED UNKN
0180/0810	018 "DIA CIRC CONCR
	LEN=0024 INSTALLED UNKN
0180/0450	018 "DIA CIRC CONCR
	LEN=0026 INSTALLED UNKN
036655 FT	2 0 02304 0 00 0094+01

EXTRACT DATE: 12/21/2020
PRINT DATE: 12/23/2020

ROADWAY MANAGEMENT SYSTEM
SLD COUNTY/SR - ANNUAL PRINT

PAGE NUMBER: 825
COUNTY: ALLEGHENY

DIR: E TOTAL LEN: 10.016 MI.
LEFT MUN: PENN HILLS T

DIST: 11-1 SR: 2058
RIGHT MUN: PENN HILLS T

Street Name	Stationing	Notes	Material	Length
BARCKHOFF ST (TWP)	0170/1350	==	018 " DIA CIRC CONCR	LEN=0099
AUBURN ST (TWP)	0170/0800	==	018 " DIA CIRC CONCR	LEN=0028
2 0 02237 0 00 0077+00 SUTTON DR (TWP)	034967 FT 0170/0000	==	018 " DIA CIRC CONCR	LEN=0099
		==	0170/0000	LENGTH(AH 1666 BK 2421)
		---	012 " DIA CAST IRON	LEN=0046
		---	018 " DIA CIRC CONCR	LEN=0055
		---	048 " DIA CIRC METAL	LEN=0050
		---	(APRA) PENN HILLS PUBLIC WKS Y	
		POE	0160/0343	(PRDR)
		---	020 " DIA CIRC CONCR	LEN=0042
	032546 FT	---	0160/0125	032568 FT
		==	0160/0000	LENGTH(AH 2421 BK 2753)
GARDEN DR (PRDR)	0150/2200	==	050 " DIA CIRC METAL	LEN=0030
UNKNOWN RD (TWP)	0150/1595	==	0150/2580	LEN=0099
		---	018 " DIA CIRC CONCR	LEN=0099
		---	018 " DIA CIRC CONCR	LEN=0099
COURTNEY DR (TWP)	0150/1025	==	0150/1616	LEN=0099
		---	099 " DIA CIRC CONCR	LEN=0099
		---	024 " DIA CIRC METAL	LEN=0040
		---	0150/1557	LEN=0040
		---	0150/1326	LEN=0040
		==	024 " DIA CIRC CONCR	

DIR: E TOTAL LEN: 10.016 MI. DIST: 11-1 SR: 2058
 LEFT MUN: PENN HILLS T RIGHT MUN: PENN HILLS T

2 0 02237 0 00 0024+00 029793 FT
 CLOVERLEAF RD
 (TWP) 0150/0000

RICHEY DR
 (TWP) 0140/1015

027079 FT

027079 FT

HULTON RD
 (SR2078 SEG 0010/0000) 0130/0539

2 0 02309 0 00 0067+36 026540 FT
 CLEVELAND DR
 (TWP) 0130/0000
 UNIONGREEN DR
 (TWP) 0120/2990

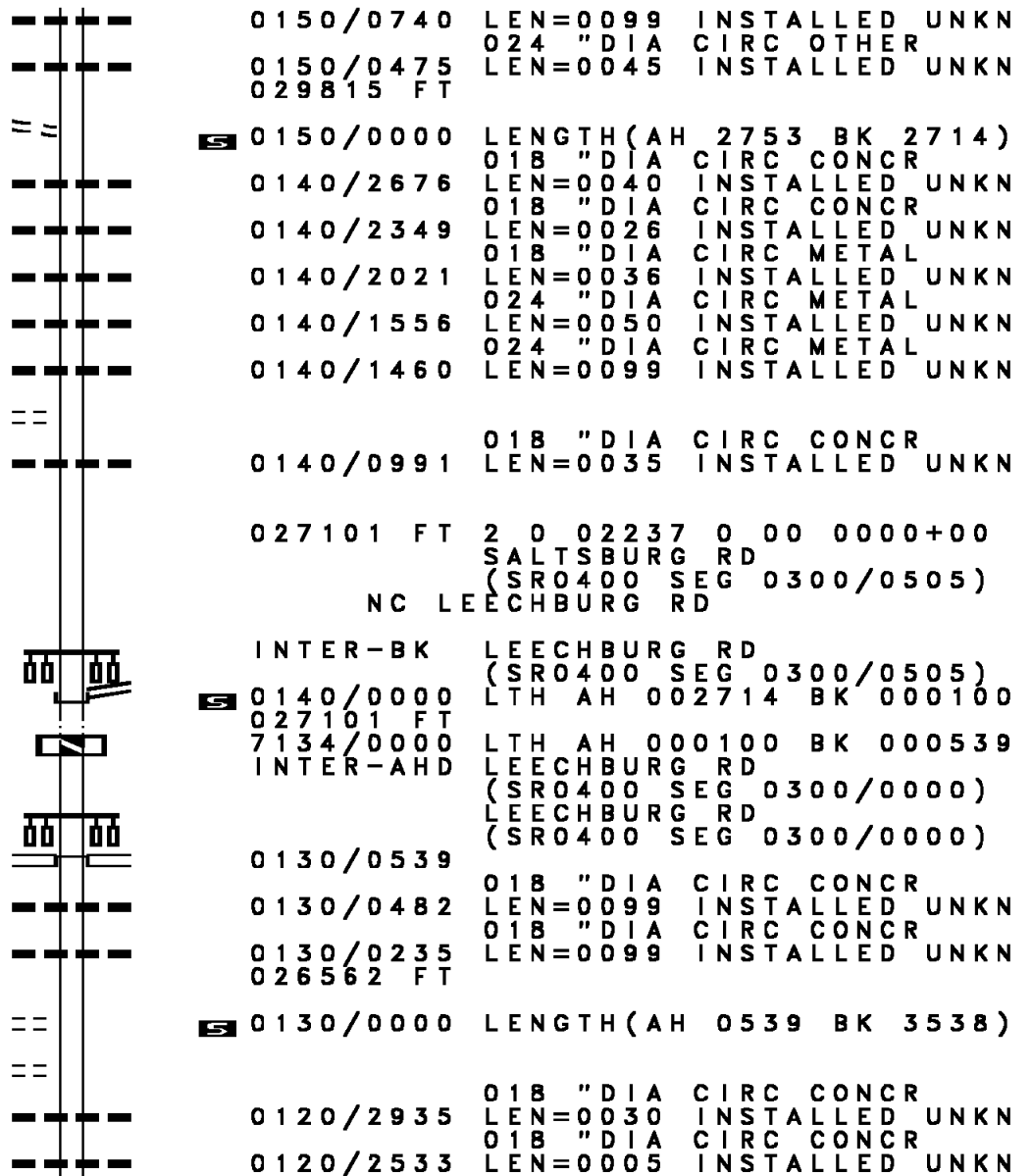

0150/0740 LEN=0099 INSTALLED UNKN
 024 " DIA CIRC OTHER UNKN
 0150/0475 LEN=0045 INSTALLED UNKN
 029815 FT

S 0150/0000 LENGTH(AH 2753 BK 2714)
 018 " DIA CIRC CONCR
 0140/2676 LEN=0040 INSTALLED UNKN
 018 " DIA CIRC CONCR
 0140/2349 LEN=0026 INSTALLED UNKN
 018 " DIA CIRC METAL
 0140/2021 LEN=0036 INSTALLED UNKN
 024 " DIA CIRC METAL
 0140/1556 LEN=0050 INSTALLED UNKN
 024 " DIA CIRC METAL
 0140/1460 LEN=0099 INSTALLED UNKN

0140/0991 018 " DIA CIRC CONCR
 LEN=0035 INSTALLED UNKN

027101 FT 2 0 02237 0 00 0000+00
 SALTSBURG RD
 (SR0400 SEG 0300/0505)
 NC LEECHBURG RD

INTER-BK LEECHBURG RD
 (SR0400 SEG 0300/0505)
 S 0140/0000 LTH AH 002714 BK 000100
 027101 FT
 7134/0000 LTH AH 000100 BK 000539
 INTER-AHD LEECHBURG RD
 (SR0400 SEG 0300/0000)
 LEECHBURG RD
 (SR0400 SEG 0300/0000)

0130/0539 018 " DIA CIRC CONCR
 LEN=0099 INSTALLED UNKN
 0130/0482 018 " DIA CIRC CONCR
 LEN=0099 INSTALLED UNKN
 0130/0235 026562 FT

S 0130/0000 LENGTH(AH 0539 BK 3538)

0120/2935 018 " DIA CIRC CONCR
 LEN=0030 INSTALLED UNKN
 018 " DIA CIRC CONCR
 0120/2533 LEN=0005 INSTALLED UNKN

DIR: E TOTAL LEN: 10.016 MI. DIST: 11-1 SR: 2058
 LEFT MUN: PENN HILLS T RIGHT MUN: PENN HILLS T

Street Name	Address	Length	Material	Status
		0120/2240	018" DIA	CIRC CONCR
			LEN=0099	INSTALLED UNKN
			SHERWOOD DR	
		0120/2100	(TWP)	
		0120/1814	018" DIA	CIR UNKNOWN
			LEN=0099	INSTALLED UNKN
ALMAR DR	0120/1525			
(TWP)				
VINCENT DR	0120/0750		SYCAMORE DR	
(TWP)			(TWP)	
CRESENT PINES DR	0120/0185		018" DIA	CIRC CONCR
(TWP)			LEN=0099	INSTALLED UNKN
	023002 FT		024" DIA	CIRC CONCR
			LEN=0072	INSTALLED UNKN
			2 0 02309 0 00 0031+96	
			EARLWOOD RD	
			(TWP)	
			LENGTH(AH 3538 BK 0879)	
			STEPHENS LN	
ZIEGER AV	0110/0115		(TWP)	
(TWP)				
2 0 02309 0 00 0023+28	022123 FT		036" DIA	CIRC CONCR
ROSEDALE ST			LEN=0010	INSTALLED UNKN
(TWP)	0110/0000			
BOWER AV	0100/1790		LENGTH(AH 0879 BK 2320)	
(TWP)				
			KIM LN	
			(TWP)	
2 0 02309 0 00 0000+00	019803 FT		018" DIA	CIRC CONCR
VERONA RD			LEN=0050	INSTALLED UNKN
(CNTY)	0100/0000			
HUDSON ST			NC SALTSBURG RD	
(TWP)			LENGTH(AH 2320 BK 1340)	
			015" DIA	CIRC CONCR
			LEN=0036	INSTALLED UNKN
			018" DIA	CIRC CONCR
			LEN=0030	INSTALLED UNKN
THIRD ST				

DIR: E TOTAL LEN: 10.016 MI. DIST: 11-1 SR: 2058
 LEFT MUN: PENN HILLS T RIGHT MUN: PENN HILLS T

Location / Notes	Segment ID	Length (FT)	Material / Details
(TWP)	0090/0520		
	018463 FT		
TO 0130/0092 SH (CONN)	0080/0951		
SANDY CREEK RD (SR0130 SEG 0092/0255)	0080/0710		
	0080/0669		
	0080/0643		
	017012 FT		
	0080/0592		
	017034 FT		
	0080/0000		
	0070/3290		
	0070/2769		
	0070/2302		
LINCOLN RD (CNTY)	0070/1800		
	0070/1732		
	0070/1730		
	0070/1608		
	0070/1335		
	0070/0873		
	0070/0519		
	013468 FT		
	013490 FT		
	0070/0000		
	0060/2000		
	0060/1986		

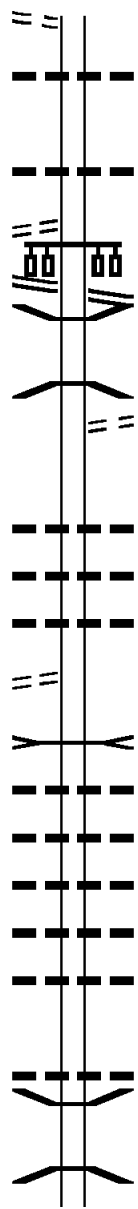

018 " DIA CIRC METAL
 LEN=0045 INSTALLED UNKN
 2 0 02308 0 00 0090+22
 LENGTH(AH 1340 BK 1451)
 018 " DIA CIRC CONCR
 LEN=0045 INSTALLED UNKN
 COAL HOLLOW RD
 (SR0130 SEG 0092/0255)
 BMSID 02/2058/0080/0643
 2 0 02308 0 00 0082+23
 SANDY CREEK
 BMSBG 02/2058/0080/0643
 TO 0130/0092 SH
 (CONN)
 2 0 02308 0 00 0075+24
 LENGTH(AH 1451 BK 3544)
 018 " DIA CIR PLASTIC
 LEN=0028 INSTALLED UNKN
 018 " DIA CIRC CONCR
 LEN=0052 INSTALLED UNKN
 015 " DIA CIRC METAL
 LEN=0065 INSTALLED UNKN
 BR. SANDY CR.
 STRUCTURE LENGTH 11 FT
 BMSID 02/2058/0070/1732
 048"H 00"W MULT METAL
 LEN=0050 INSTALLED UNKN
 018 " DIA CIRC CONCR
 LEN=0006 INSTALLED UNKN
 018 " DIA CIRC CONCR
 LEN=0006 INSTALLED UNKN
 018 " DIA CIRC CONCR
 LEN=0006 INSTALLED UNKN
 018 " DIA CIRC CONCR
 LEN=0004 INSTALLED UNKN
 2 0 02308 0 00 0040+09
 018 " DIA CIRC CONCR
 LEN=0004 INSTALLED UNKN
 LENGTH(AH 3544 BK 2296)
 BMSID 02/2058/0060/1937
 2 0 02308 0 00 0036+50
 SANDY CREEK
 BMSBG 02/2058/0060/1937
 024 " DIA CIRC CONCR

EXTRACT DATE: 12/21/2020
PRINT DATE: 12/23/2020

ROADWAY MANAGEMENT SYSTEM
SLD COUNTY/SR - ANNUAL PRINT

PAGE NUMBER: 821
COUNTY: ALLEGHENY

DIR: E TOTAL LEN: 10.016 MI.
LEFT MUN: PENN HILLS T

DIST: 11-1 SR: 2058
RIGHT MUN: PENN HILLS T

2 0 02308 0 00 0017+25 011172 FT
MT CARMEL RD
(CNTY) 0060/0000

009461 FT

018 "DIA CIRC METAL
LEN=0020 INSTALLED UNKN 0041/2030

018 "DIA CIRC CONCR
LEN=1189 INSTALLED UNKN 0041/1288

PENN HILLS
WILKINSBURG B 0041/1060

WILKINSBURG WATER AUTH

0060/1858	LEN=0030	INSTALLED UNKN
0060/1686	LEN=0034	INSTALLED UNKN
0060/1250	LEN=0030	INSTALLED UNKN
0060/0803	BMSSEN 02/2058/0060/0700	2 0 02308 0 00 0017+25
0060/0792	BMSBG 02/2058/0060/0700	036"H 72"W CONC STRUCT
0060/0785	LEN=0030	INSTALLED UNKN
0060/0606	LEN=0040	INSTALLED 199B
0060/0258	LEN=0030	INSTALLED UNKN
0060/0000	LENGTH(AH 2296 BK 1711)	018 "DIA CIRC CONCR
0050/1683	LEN=0060	INSTALLED UNKN
0050/1227	LEN=0050	INSTALLED UNKN
0050/0830	VERONA RD	(TWP)
0050/0788	LEN=0025	INSTALLED UNKN
009483 FT	2 0 02308 0 00 0000+00	NC VERONA RD
		FRANKSTOWN RD
		(SR0400 SEG 0180/0000)
		(SR0400 SEG 0181/0000)
0050/0000	MFC BEGIN = C	LENGTH(AH 1711 BK 2088)
0040/2044	LEN=0035	INSTALLED UNKN
0040/1240	LEN=0035	INSTALLED UNKN
0040/1060	LEN=0020	INSTALLED UNKN
0040/0898	LEN=0020	INSTALLED UNKN

EXTRACT DATE: 12/21/2020
PRINT DATE: 12/23/2020

ROADWAY MANAGEMENT SYSTEM
SLD COUNTY/SR - ANNUAL PRINT

PAGE NUMBER: 819
COUNTY: ALLEGHENY

DIR: E TOTAL LEN: 10.016 MI.
LEFT MUN: WILKINSBURG B

DIST: 11-1 SR: 2058
RIGHT MUN: WILKINSBURG B

Left Side Description	Left Side Stationing	Right Side Description	Right Side Stationing
LABELLE AV (BORO)	0021/1360	LABELLE AV (BORO)	0020/1370
NC PARK AV		BESSICA ST (BORO)	
BESSICA ST (BORO)			
PARK AV (BORO)	0021/1080	PARK AV (BORO)	0020/1090
CROSB LIE ST (BORO)	0021/0735	CROSB LIE ST (BORO)	0020/0735
BURNS ST (BORO)	0021/0053		
2 0 02228 0 01 0028+70 001719 FT		0020/0040 (BORO)	
PARK AV (BORO)		001708 FT	
NC MONTIER ST		2 0 02228 0 01 0028+70	
MONTIER ST (BORO)		PARK AV (BORO)	
LENGTH(AH 2580 BK 1719) 0021/0000		NC MONTIER ST (BORO)	
NC PARK AV		MONTIER ST (BORO)	
		LENGTH(AH 2595 BK 1708)	
SWISSVALE AV (BORO)			
GLENN AV (BORO)	0011/1295	SWISSVALE AV (BORO)	
		GLENN AV (BORO)	
HILL AV (BORO)	0011/0940	0010/1300	
NORTH AV (BORO)	0011/0635	NC PARK AV	
GRAF WY (BORO)	0011/0475	HILL AV (BORO)	0010/0950
WALLACE AV (BORO)	0011/0320	NORTH AV (BORO)	0010/0635
		GRAF WY (BORO)	0010/0475
TAYLOR WY (BORO)	0011/0165	WALLACE AV (BORO)	0010/0325
2 0 02228 0 00 0000+00 000000 FT		TAYLOR WY (BORO)	0010/0165
NC SWISSVALE AV		000000 FT	
PENN AV (SR0008 SEG 0030/1760)		2 0 02228 0 00 0000+00	
		NC SWISSVALE AV	
SWISSVALE AV (BORO)	INTER-BK	PENN AV (SR0008 SEG 0030/1760)	
MFC BEGIN = C			
LENGTH(AH 1719 BK 0000) 0011/0000		SWISSVALE AV (BORO)	
		MFC BEGIN = C	
		LENGTH(AH 1708 BK 0000)	

003719 FT

003743 FT
 INTER-AHD

LOGANS FERRY RD
 (BORO)
 BEATTY RD

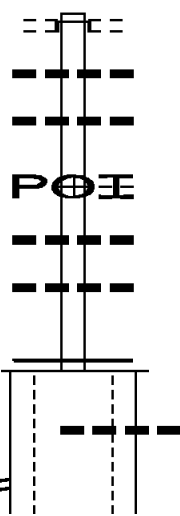

0024/1271

(CNTY)

0024/0895

018 " DIA CIRC CONCR
 LEN=0040 INSTALLED UNKN

0024/0691

018 " DIA CIRC CONCR
 LEN=0054 INSTALLED UNKN

0024/0460

(APRA) THERMAL TRANSFER
 SECO DR

0024/0450

(BORO)
 018 " DIA CIRC CONCR
 LEN=0040 INSTALLED UNKN

002448 FT

0024/0160

018 " DIA CIRC CONCR
 LEN=0011 INSTALLED UNKN

002472 FT

0 0 00000 0 00 0000+00

5 0024/0000

MFC BEGIN = B
 LENGTH(AH 1271 BK 1339)

LC TO OLD WILLIAM PENN
 (CONN)
 OLD WILLIAM PENN HW

0021/1071

0020/1204

024 " DIA CIRC CONCR
 LEN=0099 INSTALLED UNKN

OLD WILLIAM PENN HW

EXTRACT DATE: 12/21/2020
PRINT DATE: 12/23/2020

ROADWAY MANAGEMENT SYSTEM
SLD COUNTY/SR - ANNUAL PRINT

PAGE NUMBER: 817
COUNTY: ALLEGHENY

DIR: N TOTAL LEN: .709 MI.
LEFT MUN: MONROEVILLE B

DIST: 11-1 SR: 2057
RIGHT MUN: MONROEVILLE B

(BORO) 0021/0954
024 "DIA CIRC CONCR
LEN=0099 INSTALLED UNKN 0021/0765

018 "DIA CIRC CONCR
LEN=0099 INSTALLED UNKN 0021/0596
018 "DIA CIRC CONCR
LEN=0099 INSTALLED UNKN 0021/0480

018 "DIA CIRC CONCR
LEN=0099 INSTALLED UNKN 0021/0231

CLOVER DR
(BORO) 0021/0145

PENNDOT STOCKPILE #9
(GOVT) 0021/0076
0 0 00000 0 00 0000+00 001133 FT
LENGTH(AH 1315 BK 1133) 0021/0000
SIGN: 4 CHORD TRUSS
BMSID 02/2057/0010/1082 0011/1110
RAMP J RD
(SR8022 SEG 0250/0000) 0011/1080

SR 0376 WB
OP ID 02/0376/0841/0913 0011/0750
SR 0376 EB
OP ID 02/0376/0840/0872 0011/0617
RAMP K RD
(SR8022 SEG 0010/0569) 0011/0405

2 0 02105 0 00 0027+69 000000 FT
NC HAYMAKER RD
WILLIAM PENN HW
(SR2048 SEG 0111/0000)
(SR2048 SEG 0110/0000)

MOSSIDE BL INTER-BK
(SRO048 SEG 0401/2769)
MFC BEGIN = B
LENGTH(AH 1133 BK 0000) 0011/0000

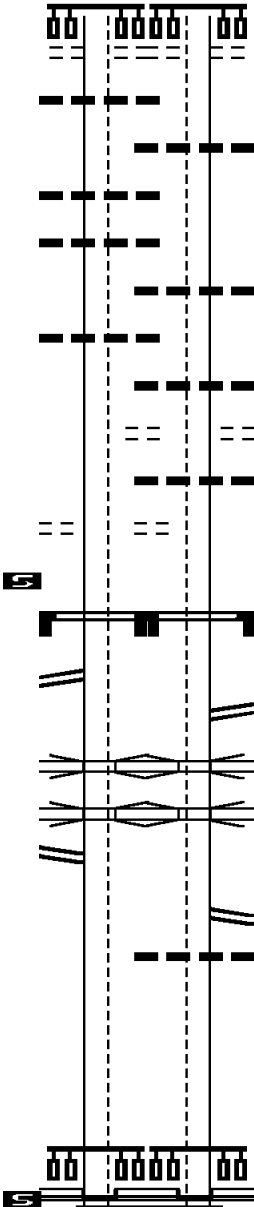

(BORO) 0020/0933
024 "DIA CIRC CONCR
LEN=0099 INSTALLED UNKN 0020/0665

018 "DIA CIRC CONCR
LEN=0099 INSTALLED UNKN 0020/0435

018 "DIA CIRC CONCR
LEN=0060 INSTALLED UNKN 0020/0184
CLOVER DR
(BORO) 0020/0135
018 "DIA CIRC CONCR
LEN=0030 INSTALLED UNKN 0020/0084
PENNDOT STOCKPILE #9
(GOVT) 0020/0076
2 0 02105 0 00 0048+50
LENGTH(AH 1339 BK 1133) 0020/0000
SIGN: 4 CHORD TRUSS
BMSID 02/2057/0010/1082 0010/1118

RAMP L RD
(SR8022 SEG 0260/0000) 0010/0855
SR 0376 WB
OP ID 02/0376/0841/0913 0010/0735
SR 0376 EB
OP ID 02/0376/0840/0872 0010/0593

RAMP M RD
(SR8022 SEG 0020/0506) 0010/0260
018 "DIA CIRC CONCR
LEN=0072 INSTALLED UNKN 0010/0097
2 0 02105 0 00 0027+69
NC HAYMAKER RD
WILLIAM PENN HW
(SR2048 SEG 0110/0000)
(SR2048 SEG 0111/0000)

MOSSIDE BL INTER-BK
(SRO048 SEG 0400/2733)
MFC BEGIN = B
LENGTH(AH 1133 BK 0000) 0010/0000

EXTRACT DATE: 12/21/2020 ROADWAY MANAGEMENT SYSTEM PAGE NUMBER: 816
 PRINT DATE: 12/23/2020 SLD COUNTY/SR - ANNUAL PRINT COUNTY: ALLEGHENY
 DIR: B TOTAL LEN: .330 MI. DIST: 11-1 SR: 2056
 LEFT MUN: PENN HILLS T RIGHT MUN: PENN HILLS T

REITER RD 001744 FT
 (SR2106 SEG 0010/0448) 0010/1744

000000 FT

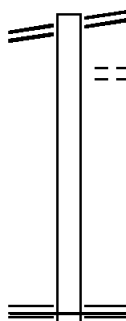

001744 FT REITER RD
 0010/1744 (SR2106 SEG 0010/0448)
 0010/1700 COAL ST
 (TWP)

000000 FT 2 0 02227 0 00 0000+00
 NC SCHOOL ST
 LOTT ST
 (SR2066 SEG 0010/0540)
 MFC BEGIN = E
 0010/0000 LENGTH(AH 1744 BK 0000)

EXTRACT DATE: 12/21/2020 ROADWAY MANAGEMENT SYSTEM PAGE NUMBER: 815
PRINT DATE: 12/23/2020 SLD COUNTY/SR - ANNUAL PRINT COUNTY: ALLEGHENY
DIR: B TOTAL LEN: .000 MI. DIST: 11-1 SR: 2055
LEFT MUN: MONROEVILLE B RIGHT MUN: MONROEVILLE B

000000 FT
000000 FT



000000 FT
7020/0000 LENGTH(AH 2826 BK 2993)
000000 FT
7010/0000 LENGTH(AH 2993 BK 0000)

EXTRACT DATE: 12/21/2020 ROADWAY MANAGEMENT SYSTEM PAGE NUMBER: 814
 PRINT DATE: 12/23/2020 SLD COUNTY/SR - ANNUAL PRINT COUNTY: ALLEGHENY
 DIR: B TOTAL LEN: 2.128 MI. DIST: 11-1 SR: 2054
 LEFT MUN: MONROEVILLE B RIGHT MUN: MONROEVILLE B

011233 FT

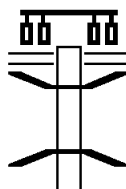

011236 FT WILLIAM PENN HW
 {SR0022 SEG 0281/0305}
 {SR0022 SEG 0280/0365}
 0050/1250
 0050/0832 BMS EN 02/2054/0050/0803
 2 0 02176 0 01 0107+66
 THOMPSON RUN
 0050/0803 BMSBG 02/2054/0050/0803
 ABERS CREEK RD

DIR: B TOTAL LEN: 2.128 MI. DIST: 11-1 SR: 2054
 LEFT MUN: MONROEVILLE B RIGHT MUN: MONROEVILLE B

Location	Segment ID	Length (FT)	Material / Notes
VALERIE CR (BORO)	0050/0675		(BORO)
	0050/0285		018" DIA CIRC CONCR INSTALLED UNKN
	0050/0121		018" DIA CIRC CONCR INSTALLED UNKN
	009983 FT	009986 FT	2 0 02176 0 01 0099+15
	5 0050/0000		LENGTH(AH 1250 BK 2940)
		0040/2410	015" DIA CIRC METAL INSTALLED UNKN
0040/1225	0040/1992		018" DIA CIRC METAL INSTALLED UNKN
	0040/1125		MARIA LN (BORO)
	0040/0775		WEST PATTY LN (BORO)
007043 FT	007046 FT		2 0 02176 0 01 0068+35
	5 0040/0000		LENGTH(AH 2940 BK 3722)
DEAUVILLE DR (BORO)	0030/2775		LAVALE DR (BORO)
	0030/2339		018" DIA CIR PLASTIC INSTALLED UNKN
	0030/2055		OAK POINTE DR (BORO)
LAURA LEE DR (BORO)	0030/1963		018" DIA CIRC CONCR INSTALLED UNKN
	0030/1530		BERKELEY WY (PRDR)
PENN VIEW DR (BORO)	0030/1426		018" DIA CIRC CONCR INSTALLED UNKN
	0030/1262		018" DIA CIRC CONCR INSTALLED UNKN
	0030/0968		LEN=0040 INSTALLED UNKN
003321 FT	0030/0815		
	0030/0136		BMS EN 02/7076/9900/5668
	003324 FT		2 0 02176 0 00 0032+93
			1-76
			BMSBG 02/7076/9900/5668

DIR: B TOTAL LEN: 2.128 MI. DIST: 11-1 SR: 2054
 LEFT MUN: MONROEVILLE B RIGHT MUN: MONROEVILLE B

WESTINGHOUSE DR
 (PRDR) 0021/1260

OLD HAYMAKER RD
 (BORO) 0021/0255
 018 "DIA CIRC CONCR
 LEN=0030 INSTALLED UNKN 0021/0107
 018 "DIA CIRC CONCR
 LEN=0030 INSTALLED UNKN 0021/0023
 2 0 02176 0 00 0019+30 001947 FT
 MOSSIDE BL
 (SR0048 SEG 0401/0000)
 (SR0048 SEG 0400/0000)

MOSSIDE BL
 (SR0048 SEG 0401/0000)
 (SR0048 SEG 0400/0000)
 MFC BEGIN = C
 LENGTH(AH 1374 BK 1947) 0021/0000
 DAUGHERTY DR
 (BORO) 0010/1526

WHITEHEAD LN
 (BORO) 0010/0428

000000 FT

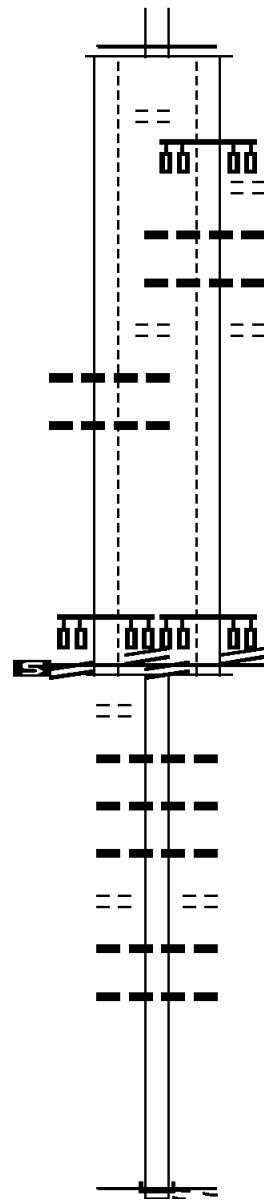

0030/0000 MFC BEGIN = C
 LENGTH(AH 3722 BK 1377)

WESTINGHOUSE DR
 (PRDR) 0020/1240
 0020/1166 018 "DIA CIRC CONCR
 LEN=0060 INSTALLED UNKN
 018 "DIA CIRC CONCR
 0020/0832 LEN=0060 INSTALLED UNKN
 FROM 0048/0380 SH
 (CONN) 0020/0245

001947 FT 2 0 02176 0 00 0019+30
 MOSSIDE BL
 (SR0048 SEG 0401/0000)
 (SR0048 SEG 0400/0000)

MOSSIDE BL
 (SR0048 SEG 0400/0000)
 (SR0048 SEG 0401/0000)
 MFC BEGIN = C
 LENGTH(AH 1377 BK 1947) 0020/0000

0010/1253 015 "DIA CIRC CONCR
 LEN=0099 INSTALLED UNKN
 0010/0938 024 "DIA CIRC CONCR
 LEN=0030 INSTALLED UNKN
 018 "DIA CIRC CONCR
 0010/0900 LEN=0035 INSTALLED UNKN
 FAIRVIEW DR
 (BORO) 0010/0428
 012"H 12"W CON BOX CUL
 LEN=0099 INSTALLED UNKN
 018 "DIA CIRC METAL
 0010/0013 LEN=0060 INSTALLED UNKN
 000000 FT 2 0 02176 0 00 0000+00
 NC NO

0010/0000 INTER-BK MONROEVILLE BL
 (CNTY)
 MFC BEGIN = C
 LENGTH(AH 1947 BK 0000)

DIR: B TOTAL LEN: 1.140 MI. DIST: 11-1 SR: 2053
 LEFT MUN: WILKINS T RIGHT MUN: WILKINS T

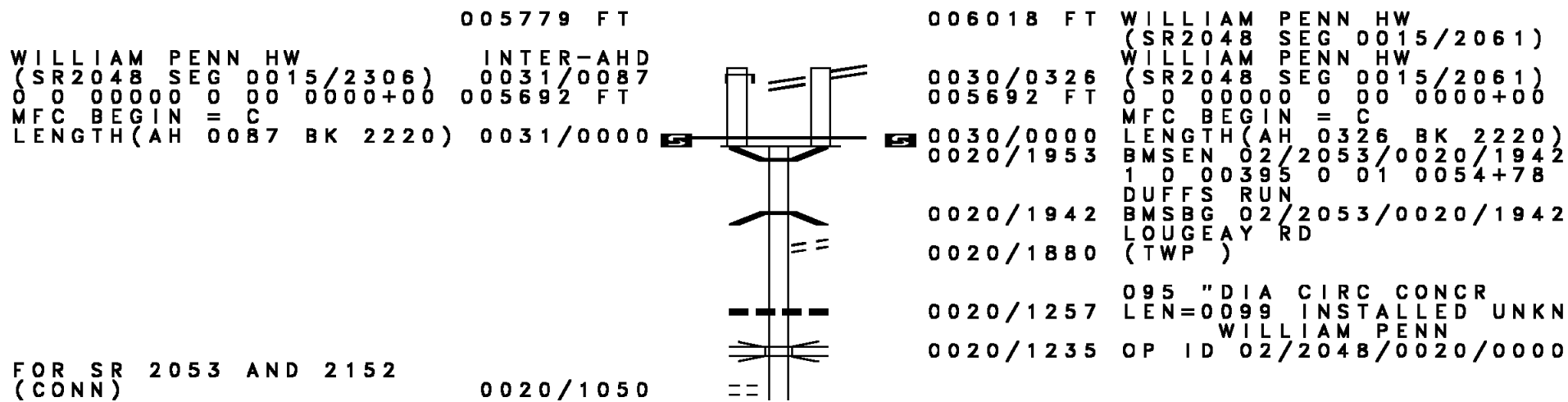

DIR: B TOTAL LEN: 1.140 MI. DIST: 11-1 SR: 2053
 LEFT MUN: WILKINS T RIGHT MUN: WILKINS T

SOUTH BEND LN
 (SR2152 SEG 0020/0704) 0020/0769
 003472 FT

BAKER ST
 (TWP) 0010/1470

000000 FT

0020/0888	048 " DIA	CIRC CONCR	LEN=0035	INSTALLED UNKN
003472 FT	1 0 00395	0 01 0034+50		
0020/0000	LENGTH(AH 2220 BK 3472)	018 " DIA	CIRC CONCR	
0010/2919	LEN=0020	INSTALLED UNKN		
0010/2808	012 " DIA	CIRC CONCR		
0010/2752	LEN=0099	INSTALLED UNKN		
0010/2628	PENN CENTER BL			
0010/2089	(TWP)	018 " DIA	CIRC CONCR	
0010/2084	LEN=0030	INSTALLED UNKN		
0010/1870	018 " DIA	CIRC CONCR		
0010/1755	LEN=0040	INSTALLED UNKN		
0010/1481	015 " DIA	CIRC CONCR		
0010/1005	LEN=0030	INSTALLED UNKN		
0010/0857	018 " DIA	CIRC CONCR		
0010/0550	LEN=0035	INSTALLED UNKN		
0010/0265	018 " DIA	CIRC CONCR		
0010/0105	LEN=0010	INSTALLED UNKN		
0010/0022	018 " DIA	CIRC CONCR		
000000 FT	LEN=0040	INSTALLED UNKN		
	FROM 2065/0040 SH			
	(CONN)			
	CHALFONT RUN			
	STRUCTURE LENGTH 64 FT			
	BMSID 02/2053/0010/0022			
	1 0 00395 0 00 0000+00			
	NC RD			
	LARIMER AV			
	(SR2065 SEG 0040/0000)			
	INTER-BK			
	LARIMER AV			
	(SR2065 SEG 0040/0000)			
	MFC BEGIN = C			
0010/0000	LENGTH(AH 3472 BK 0000)			

DIR: B TOTAL LEN: 1.070 MI. DIST: 11-1 SR: 2052
 LEFT MUN: WEST MIFFLIN B RIGHT MUN: WEST MIFFLIN B

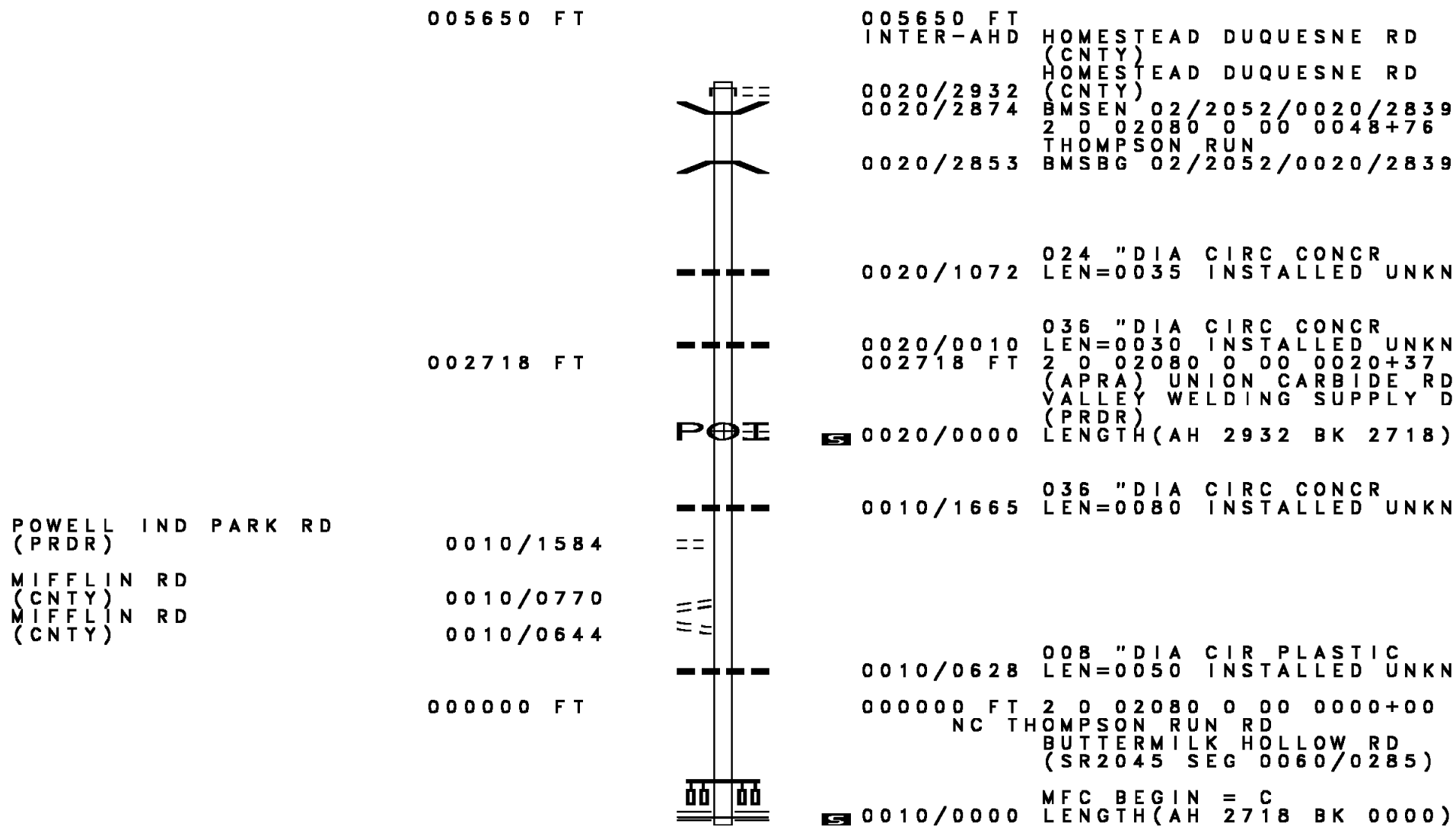

005650 FT

005650 FT
 INTER-AHD HOMESTEAD DUQUESNE RD
 (CNTY)
 HOMESTEAD DUQUESNE RD
 (CNTY)
 0020/2932
 0020/2874 BMSEN 02/2052/0020/2839
 2 0 02080 0 00 0048+76
 THOMPSON RUN
 0020/2853 BMSBG 02/2052/0020/2839

002718 FT

0020/1072 024 " DIA CIRC CONCR
 LEN=0035 INSTALLED UNKN
 0020/0010 036 " DIA CIRC CONCR
 002718 FT LEN=0030 INSTALLED UNKN
 2 0 02080 0 00 0020+37
 (APRA) UNION CARBIDE RD
 VALLEY WELDING SUPPLY D
 (PRDR)
 0020/0000 LENGTH(AH 2932 BK 2718)

POWELL IND PARK RD
 (PRDR)

0010/1584

MIFFLIN RD
 (CNTY)
 MIFFLIN RD
 (CNTY)

0010/0770

0010/0644

000000 FT

0010/1665 036 " DIA CIRC CONCR
 LEN=0080 INSTALLED UNKN
 0010/0628 008 " DIA CIR PLASTIC
 LEN=0050 INSTALLED UNKN
 000000 FT 2 0 02080 0 00 0000+00
 NC THOMPSON RUN RD
 BUTTERMILK HOLLOW RD
 (SR2045 SEG 0060/0285)
 0010/0000 MFC BEGIN = C
 LENGTH(AH 2718 BK 0000)

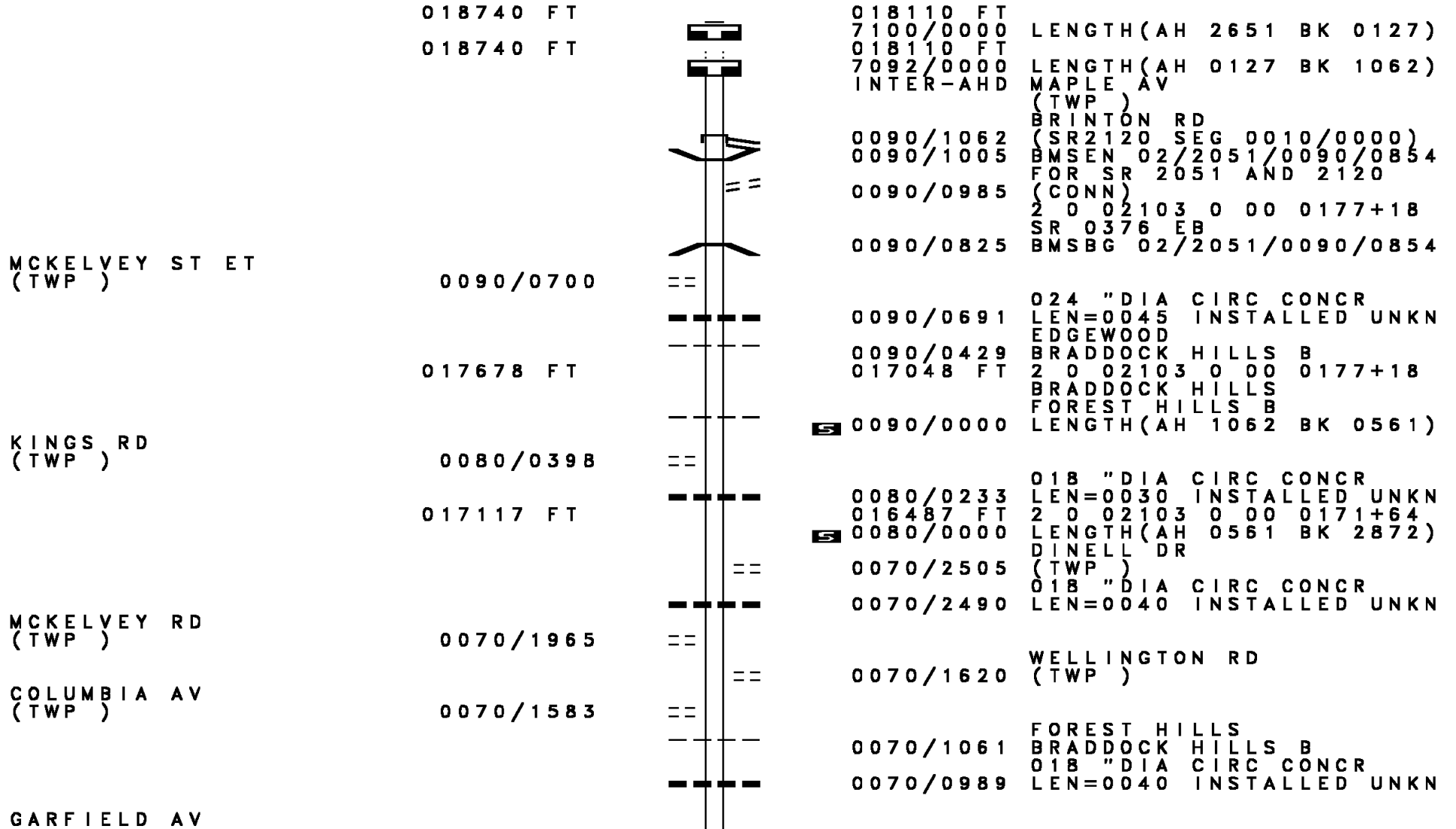

DIR: B TOTAL LEN: 3.549 MI. DIST: 11-1 SR: 2051
 LEFT MUN: BRADDOCK HILLS B RIGHT MUN: BRADDOCK HILLS B

Location / Segment	Stationing	Length (FT)	Material / Notes
(TWP)	0070/0325		
2 0 02103 0 00 0142+62	014245	FT	
WILKINS AV (TWP)	0070/0000		012 " DIA CIRC CONCR LEN=0035 INSTALLED UNKN BRADDOCK RD (CNTY) 5 0070/0000 LENGTH(AH 2872 BK 3041) 018 " DIA CIRC CONCR LEN=0040 INSTALLED UNKN
FOURTH ST (CNTY)	0060/2349		
	0060/2259		FAIRFAX RD (TWP) 012 " DIA CIRC METAL LEN=0040 INSTALLED UNKN 018 " DIA CIRC CONCR LEN=0040 INSTALLED UNKN RIDGE RD (TWP) 0060/1284 018 " DIA CIRC CONCR LEN=0040 INSTALLED UNKN
	0060/1769		
	0060/1309		
	0060/1271		
	011204	FT	
	010574	FT	2 0 02103 0 00 0111+93 5 0060/0000 LENGTH(AH 3041 BK 3805) 018 " DIA CIRC CONCR LEN=0050 INSTALLED UNKN 018 " DIA CIRC CONCR LEN=0060 INSTALLED UNKN
	0050/3473		
	0050/3122		
	0050/2420		018 " DIA CIRC CONCR LEN=0060 INSTALLED UNKN 024 " DIA CIR PLASTIC LEN=0060 INSTALLED UNKN YOST BL (CNTY) 0050/1770
	0050/2340		
	007399	FT	
	006769	FT	2 0 02103 0 00 0074+35 NC BR INTON RD BRADDOCK HILLS NORTH BRADDOCK B 5 0050/0000 LENGTH(AH 3805 BK 2701) GEN BRADDOCK DR (TWP) 018 " DIA CIRC CONCR LEN=0040 INSTALLED UNKN
LOCUST ST (TWP)	0050/0000		
	0040/2635		
	0040/2165		

DIR: B TOTAL LEN: 3.549 MI. DIST: 11-1 SR: 2051
 LEFT MUN: NORTH BRADDOCK B RIGHT MUN: NORTH BRADDOCK B

Segment Description	Stationing	Notes	Stationing	Notes
UNKNOWN RD (TWP)	0040/1700	==		
		==	0040/1620	TURNER ST (TWP)
MARY ST (TWP)	0040/1105	==		
		==	0040/0625	PRESTON ST (TWP)
		---	0040/0318	018" DIA CIRC CONCR LEN=0030 INSTALLED UNKN
PALLAS ST (TWP)		---		
WOLF AV (TWP)	0040/0315	==		
		==	0040/0140	NC WOLF AV EVANS WY (TWP)
		---	0040/0099	018" DIA CIR UNKNOWN LEN=0030 INSTALLED UNKN
	004698 FT	---	004068 FT	2 0 02103 0 00 0046+91
		---		NC PALLAS ST
		==	0040/0000	PALLAS ST (TWP) LENGTH(AH 2701 BK 2827)
		==	0030/2490	SHERIDAN ST (TWP)
		---	0030/2474	018" DIA CIRC CONCR LEN=0030 INSTALLED UNKN
QUARRY ST (TWP)	0030/1885	==		
		---	0030/1882	018" DIA CIRC CONCR LEN=0040 INSTALLED UNKN
		==	0030/1320	BOWERS ST (TWP)
		---	0030/1113	018" DIA CIRC CONCR LEN=0015 INSTALLED UNKN
		---	0030/1101	012"H 08"W CON BOX CUL LEN=0030 INSTALLED UNKN
RAVINE ST (TWP)	0030/1037	==		
		---	0030/0726	018" DIA CIRC CONCR LEN=0040 INSTALLED UNKN
TERRACE ST (TWP)	0030/0565	==		
		==	0030/0115	SOUTH AV (TWP)
		---	0030/0093	018" DIA CIRC CONCR LEN=0020 INSTALLED UNKN
		---		NC BRINTON AV
2 0 02103 0 00 0018+71 001871 FT		---	001241 FT	NORTH BRADDOCK

DIR: B TOTAL LEN: 3.549 MI. DIST: 11-1 SR: 2051
 LEFT MUN: NORTH BRADDOCK B RIGHT MUN: NORTH BRADDOCK B

Location / Segment	Start Station	End Station	Length	Notes
MURDOUGH ST (TWP)	0030/0000	0030/0000	0.000	EAST PITTSBURGH B
				LENGTH(AH 2827 BK 1101)
				015" DIA CIRC CONCR
				LEN=0025 INSTALLED UNKN
RIDGE AV (TWP)	0020/0940	0020/0940	0.000	RIDGE AV (TWP)
				018" DIA CIRC CONCR
				LEN=0060 INSTALLED UNKN
				MAPLE ST (TWP)
				0020/0815 (TWP)
				ISABELLA AL
				0020/0680 (TWP)
				HOWARD ST (TWP)
				0020/0540 (TWP)
				CHRISTINA AL
				0020/0405 (TWP)
				FRANKLIN ST (TWP)
				0020/0270 (TWP)
				JEFFERSON AL
				0020/0135 (TWP)
				018" DIA CIRC CONCR
				LEN=0040 INSTALLED UNKN
2 0 02103 0 00 0007+73 000770 FT				
CENTER ST (TWP)				
MAIN ST (TWP)	0020/0000			NC MAIN ST
				0020/0000 LTH AH 001101 BK 000100
2 0 02103 0 00 0001+34 000140 FT				
GRANDVIEW AV (CITY)				
CENTER ST (SR2051 SEG 0010/0140)				
MFC BEGIN = C				
LENGTH(AH 0630 BK 0140) 0015/0000				
				000140 FT
				7014/0000 LTH AH 000100 BK 000140
				INTER-AHD GRANDVIEW AV (CITY)
				CENTER ST (SR2051 SEG 0015/0000)
				GRANDVIEW AV (CITY)
				0010/0140 (CITY)
000000 FT				2 0 02103 0 00 0000+00
				NC CENTER ST
				LINCOLN HW (SR0030 SEG 0250/0000)
				(SR0030 SEG 0251/0000)
				MFC BEGIN = C
				0010/0000 LENGTH(AH 0140 BK 0000)

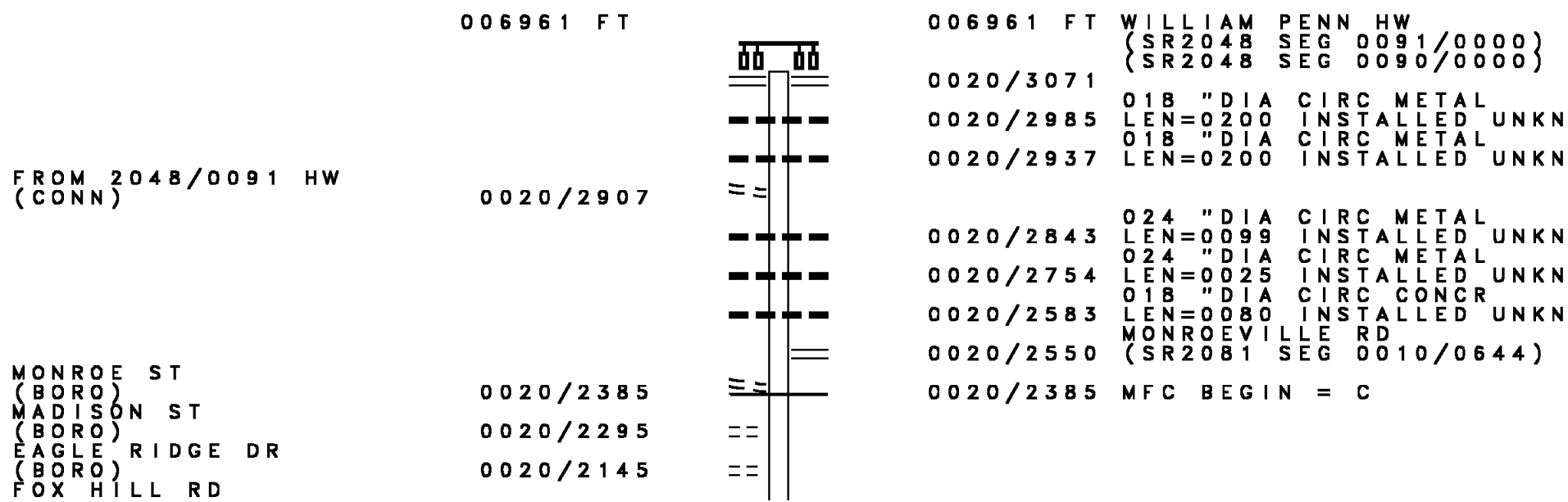

FROM 2048/0091 HW
(CONN)

MONROE ST
(BORO)
MADISON ST
(BORO)
EAGLE RIDGE DR
(BORO)
FOX HILL RD

006961 FT

0020/2907

0020/2385
0020/2295
0020/2145

006961 FT WILLIAM PENN HW
(SR2048 SEG 0091/0000)
(SR2048 SEG 0090/0000)
0020/3071
0020/2985 018 " DIA CIRC METAL
LEN=0200 INSTALLED UNKN
0020/2937 018 " DIA CIRC METAL
LEN=0200 INSTALLED UNKN

0020/2843 024 " DIA CIRC METAL
LEN=0099 INSTALLED UNKN
0020/2754 024 " DIA CIRC METAL
LEN=0025 INSTALLED UNKN
0020/2583 018 " DIA CIRC CONCR
LEN=0080 INSTALLED UNKN
0020/2550 MONROEVILLE RD
(SR2081 SEG 0010/0644)
0020/2385 MFC BEGIN = C

DIR: B TOTAL LEN: 1.318 MI. DIST: 11-1 SR: 2050
 LEFT MUN: MONROEVILLE B RIGHT MUN: MONROEVILLE B

Street Name	Segment ID	Start Station	End Station	Material / Notes
(BORO)	0020/1795	==	==	
	0020/1490	---	---	BORO AL (BORO)
	0020/1289	---	---	024" DIA CIRC CONCR LEN=0040 INSTALLED UNKN
	0020/0503	---	---	018" DIA CIRC CONCR LEN=0030 INSTALLED UNKN
VENSEL LN (PRDR)	0020/0450	==	==	
	0020/0440	---	---	018" DIA CIRC CONCR LEN=0030 INSTALLED UNKN
	0020/0065	==	==	SUMMERS DR (BORO)
003890 FT	003890 FT	2 0 02233	0 00 0039+00	SEAMAN LN (BORO)
	0020/0000	---	---	LENGTH(AH 3071 BK 3890) 024" DIA CIRC CONCR
	0010/3431	---	---	LEN=0030 INSTALLED UNKN CIRBUS LN
	0010/3180	==	==	(BORO)
	0010/2750	==	==	HOLT LN (BORO)
KEIBLER LN (BORO)	0010/2605	==	==	
LORETTA DR (BORO)	0010/1965	==	==	
HARPER LN (BORO)	0010/1315	==	==	
	0010/1308	---	---	018" DIA CIRC METAL LEN=0030 INSTALLED UNKN
	0010/1070	---	---	018" DIA CIRC METAL LEN=0020 INSTALLED UNKN
	0010/1015	==	==	HALLS DR (BORO)
	0010/0873	---	---	018" DIA CIRC METAL LEN=0040 INSTALLED UNKN
	0010/0745	---	---	018" DIA CIRC METAL LEN=0040 INSTALLED UNKN
	0010/0532	---	---	018" DIA CIRC METAL LEN=0035 INSTALLED UNKN
000000 FT	000000 FT	2 0 02233	0 00 0000+00	NC NO
	0010/0000	---	---	ORTHERN PK THOMPSON RUN RD (SR2065 SEG 0080/2970) MFC BEGIN = D LENGTH(AH 3890 BK 0000)

EXTRACT DATE: 12/21/2020 ROADWAY MANAGEMENT SYSTEM PAGE NUMBER: 802
 PRINT DATE: 12/23/2020 SLD COUNTY/SR - ANNUAL PRINT COUNTY: ALLEGHENY
 DIR: B TOTAL LEN: 2.396 MI. DIST: 11-1 SR: 2049
 LEFT MUN: MUNHALL B RIGHT MUN: MUNHALL B

012653 FT

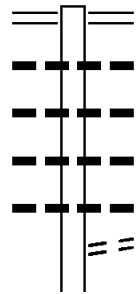

012653 FT	EIGHTH AV
0050/2188	(SR0837 SEG 0360/2771)
	018 " DIA CIRC CONCR
0050/2108	LEN=0060 INSTALLED UNKN
	018 " DIA CIRC CONCR
0050/1812	LEN=0060 INSTALLED UNKN
	018 " DIA CIRC CONCR
0050/1512	LEN=0060 INSTALLED UNKN
	018 " DIA CIRC CONCR
0050/1228	LEN=0060 INSTALLED UNKN
	HIGHWOOD ST
0050/1023	(BORO)
	018 " DIA CIRC CONCR

DIR: B TOTAL LEN: 2.396 MI. DIST: 11-1 SR: 2049
 LEFT MUN: MUNHALL B RIGHT MUN: MUNHALL B

Street Name	Segment ID	Length (FT)	Material	Notes
	0050/0702		LEN=0060 018" DIA CIRC CONCR	INSTALLED UNKN
	0050/0452		LEN=0060 018" DIA CIRC CONCR	INSTALLED UNKN
	0050/0161		LEN=0060	INSTALLED UNKN
	010465 FT	010465	2 0 02185 0 00 0148+02	
	0050/0000		LENGTH(AH 2188 BK 1038)	
	0040/0770		LARKSPUR ST (BORO)	
	0040/0385		MARIGOLD ST (BORO)	
	0040/0099		015" DIA CIRC PLASTIC	INSTALLED UNKN
	009427 FT	009427	2 0 02185 0 00 0137+85	
			NC WHITAKER WY	
			SCHWAB AV (BORO)	
			MUNHALL WHITAKER B	
	0040/0000		LENGTH(AH 1038 BK 3351)	
FRANK ST (BORO)	0030/3213		RIVERVIEW BL (BORO)	
			ARKANSAS AV (BORO)	
OAK ST (BORO)	0030/2703			
HAMILTON ST (BORO)	0030/2523			
	0030/2510		018" DIA CIRC PLASTIC	INSTALLED UNKN
	0030/2438		LEN=0040 CHALFONT ST (BORO)	
	0030/2336		012" DIA CIRC PLASTIC	INSTALLED UNKN
GRANT AV (BORO)	0030/2330			
	0030/2017		015" DIA CIRC PLASTIC	INSTALLED UNKN
MIFFLIN ST (BORO)	0030/1991		LEN=0040 MIFFLIN ST (SR2098 SEG 0010/0000)	
			MIDWAY DR (BORO)	
	0030/1730		WHITAKER WEST MIFFLIN B	
MAGNOLIA ST (BORO)	0030/1650		LC TO MIDWAY DR	
ELM ST (BORO)	0030/1303		(CONN)	

DIR: B TOTAL LEN: 2.396 MI. DIST: 11-1 SR: 2049
 LEFT MUN: WEST MIFFLIN B RIGHT MUN: WEST MIFFLIN B

MAPLE ST
 (BORO)
 KENNETT ST
 (BORO)

0030/0590
 0030/0335
 006076 FT

2 0 02185 0 00 0070+37 002674 FT
 LAURA AV
 (BORO)

0020/0000

KENNY ST
 (BORO)

0010/1814

000000 FT

==	==	0030/0964	OAK ST (BORO)
==	==		NC WHITAKER ST
==	==	006076 FT	2 0 02185 0 00 0104+31 NC MAPLE ST
==	==	5 0030/0000	MAPLE ST (BORO) LENGTH(AH 3351 BK 3402) SCHOOL ST
==	==	0020/3104	(BORO)
==	==	0020/2825	BEECH ST (BORO)
==	==	0020/2636	DIVISION ST (BORO)
---	---	0020/2400	018 " DIA CIRC CONCR LEN=0040 INSTALLED UNKN
==	==	0020/1482	FRANK ST (BORO)
==	==	0020/0325	GLENCAIRN ST (BORO)
==	==	002674 FT	
==	==	5 0020/0000	LENGTH(AH 3402 BK 2674) CORBIN ST
==	==	0010/2347	(BORO)
---	---	0010/1860	018 " DIA CIRC CONCR LEN=0048 INSTALLED UNKN
==	==		NC ELIZA ST
==	==	0010/1351	ELIZA ST (BORO)
---	---	0010/1225	018 " DIA CIRC CONCR LEN=0040 INSTALLED UNKN
---	---	0010/0595	018 " DIA CIRC CONCR LEN=0099 INSTALLED UNKN
---	---	000000 FT	2 0 02185 0 00 0043+76 NC EASTMAN ST
==	==	5 0010/0000	GREENSPRINGS AV (CNTY) MFC BEGIN = D LENGTH(AH 2674 BK 0000)

SIGN: 4 CHORD TRUSS
 BMSID 02/2048/0120/0596024836 FT
 PENN LINCOLN HY INTER-AHD
 (SR0022 SEG 0251/0000)
 PENN LINCOLN PY
 (SR0376 SEG 0845/0334) 0121/0760

SIGN: STRUC MOUNTED
 BMSID 02/2048/0121/0135 0121/0177
 RAMP E&H
 OP ID 02/7076/9900/5624 0121/0146

1 0 00187 0 01 0365+83 024076 FT
 LENGTH(AH 0760 BK 1357) 0121/0000

TURNPIKE RAMP RD
 (TNPK) 0111/1180
 TURNPIKE RAMP RD
 (TNPK) 0111/0730
 OP ID 02/0376/0840/1706 0111/0634

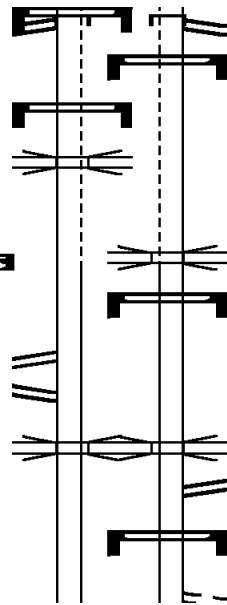

025303 FT
 INTER-AHD PENN LINCOLN HW
 (SR0022 SEG 0250/0000)
 PENN LINCOLN PY
 0120/0600 (SR0376 SEG 0844/0798)
 SIGN: 4 CHORD TRUSS
 0120/0596 BMSID 02/2048/0120/0596

024703 FT 1 0 00187 0 01 0366+42
 RAMP E&H
 OP ID 02/7076/9900/5624
 LENGTH(AH 0600 BK 1518)
 SIGN: STRUC MOUNTED
 0110/1460 BMSID 02/2048/0110/1460

0110/0683 OP ID 1-376 OVER BUSINES
 TURNPIKE RAMP RD
 (TNPK)
 0110/0490 SIGN: CANTILEVER
 0110/0360 BMSID 02/2048/0110/0360
 FROM 0048/0400 SH
 0110/0111 (CONN)

EXTRACT DATE: 12/21/2020
PRINT DATE: 12/23/2020

ROADWAY MANAGEMENT SYSTEM
SLD COUNTY/SR - ANNUAL PRINT

PAGE NUMBER: 798
COUNTY: ALLEGHENY

DIR: E TOTAL LEN: 4.792 MI.
LEFT MUN: MONROEVILLE B

DIST: 11-1 SR: 2048
RIGHT MUN: MONROEVILLE B

1 0 00187 0 01 0350+74 022719 FT
HAYMAKER RD
(SR2057 SEG 0010/0000)
(SR2057 SEG 0011/0000)
MOSSIDE BL
(SR0048 SEG 0401/2769)
(SR0048 SEG 0400/2733)

LENGTH(AH 1357 BK 2349) 0111/0000

018 "DIA CIRC CONCR
LEN=0099 INSTALLED UNKN 0101/2097
FOX PLAN DR
(BORO) 0101/2065

MCMASTERS DR
(BORO)
LOWE'S DR
(PRDR) 0101/1765

024 "DIA CIRC CONCR
LEN=0099 INSTALLED UNKN 0101/1453
012 "DIA CIRC CONCR
LEN=0099 INSTALLED UNKN 0101/1167
018 "DIA CIRC CONCR
LEN=0099 INSTALLED UNKN 0101/0904

PENN PLACE
(PRDR)
MIRACLE MILE SHOPPING C
(PRDR) 0101/0747

018 "DIA CIR PLASTIC
LEN=0099 INSTALLED UNKN 0101/0612
018 "DIA CIRC CONCR
LEN=0099 INSTALLED UNKN 0101/0343
1 0 00187 0 01 0327+17 020370 FT
CENTER RD
(CNTY)

STROSCHEIN RD

023185 FT 1 0 00187 0 01 0350+74
HAYMAKER RD
(SR2057 SEG 0010/0000)
(SR2057 SEG 0011/0000)
MOSSIDE BL
(SR0048 SEG 0400/2733)
(SR0048 SEG 0401/2769)

LENGTH(AH 1518 BK 2369)
TO 0048/0401 SH
0110/0000
0100/2224 (CONN)

FOX PLAN DR
(BORO)
LC FROM LOWE'S DR
(CONN)
MCMASTERS DR
(BORO)
LOWE'S DR
(PRDR) 0100/1868
0100/1800
0100/1701
0100/1481
LC TO LOWE'S DR
(CONN)
018 "DIA CIRC CONCR
LEN=0099 INSTALLED UNKN

LC FROM MIRACLE MILE SH
(CONN)
PENN PLACE
(PRDR)
MIRACLE MILE SHOPPING C
(PRDR) 0100/0832
0100/0765
0100/0702
LC TO MIRACLE MILE SHOP
(CONN)

020816 FT 1 0 00187 0 01 0327+15
CENTER RD
(CNTY)

STROSCHEIN RD

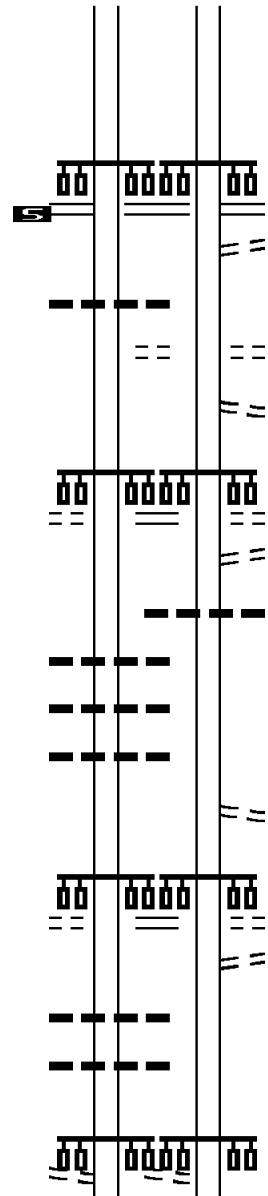

EXTRACT DATE: 12/21/2020
PRINT DATE: 12/23/2020

ROADWAY MANAGEMENT SYSTEM
SLD COUNTY/SR - ANNUAL PRINT

PAGE NUMBER: 797
COUNTY: ALLEGHENY

DIR: E TOTAL LEN: 4.792 MI.
LEFT MUN: MONROEVILLE B

DIST: 11-1 SR: 2048
RIGHT MUN: MONROEVILLE B

(CNTY)	LENGTH(AH	BK	0101/0000								(CNTY)	LENGTH(AH	BK	2461)
024 "DIA CIRC CONCR	2349	2491	0101/0000	S	==	==	S	0100/0000				2369	2461	
LEN=0099 INSTALLED UNKN			0091/2282		---	---								
018 "DIA CIRC CONCR			0091/2012		---	---								
LEN=0099 INSTALLED UNKN			0091/1740		---	---								
018 "DIA CIRC CONCR			0091/1493		---	---								
LEN=0099 INSTALLED UNKN			0091/1493		---	---								
DUFF RD (BORO)					00	0000	00				DUFF RD (BORO)			
			0091/0995		==	==		0090/1005						
018 "DIA CIRC CONCR			0091/0737		---	---								
LEN=0099 INSTALLED UNKN			0091/0511		---	---								
018 "DIA CIRC CONCR			0091/0341		---	---								
LEN=0099 INSTALLED UNKN			0091/0341		---	---								
018 "DIA CIRC CONCR			0091/0319		---	---								
LEN=0099 INSTALLED UNKN			0091/0319		---	---								
TO 2050/0020 SH														
(CONN)			0091/0145		==	==								
095 "DIA CIRC CONCR			0091/0088		---	---								
LEN=0099 INSTALLED UNKN			0091/0088		---	---								
1 0 00187 0 01 0304+28			017879 FT					018355 FT			1 0 00187 0 01 0304+28			
NORTHERN PK											NORTHERN PK			
(SR2050 SEG 0020/3071)					00	0000	00				(SR2050 SEG 0020/3071)			
LENGTH(AH 2491 BK 0635)			0091/0000	S	==	==	S	0090/0000			LENGTH(AH 2461 BK 0631)			
018 "DIA CIRC CONCR			0081/0330		---	---								
LEN=0001 INSTALLED UNKN			0081/0330		---	---								
1 0 00187 0 01 0296+80			017244 FT					0080/0048			018 "DIA CIRC CONCR			
SR 2081								017724 FT			LEN=0099 INSTALLED UNKN			
OP ID 02/2081/0010/0181											1 0 00187 0 01 0296+80			
LENGTH(AH 0635 BK 3825)			0081/0000	S	==	==	S	0080/0000			SR 2081			
					---	---					OP ID 02/2081/0010/0181			
					---	---					LENGTH(AH 0631 BK 3228)			
					---	---					024 "DIA CIRC CONCR			
					---	---					LEN=0099 INSTALLED UNKN			
					---	---					018 "DIA CIRC CONCR			
					---	---					LEN=0099 INSTALLED UNKN			
					---	---					018 "DIA CIRC CONCR			
					---	---					LEN=0099 INSTALLED UNKN			
					---	---					018 "DIA CIRC CONCR			
					---	---					LEN=0099 INSTALLED UNKN			
VALUE DR					00	0000	00				VALUE DR			
(PRDR)					==	==					(PRDR)			
CHUCK E CHEESE ENTR					---	---					CHUCK E CHEESE ENTR			
(PRDR)					---	---					(PRDR)			
			0075/2767		==	==		0074/2195						
					---	---					024 "DIA CIRC METAL			

DIR: E TOTAL LEN: 4.792 MI. DIST: 11-1 SR: 2048
 LEFT MUN: MONROEVILLE B RIGHT MUN: MONROEVILLE B

Item ID	Description	Stationing	Length	Material	Status
0074/2036			LEN=0099	INSTALLED	UNKN
SIGN: CANTILEVER					
BMSID 02/2048/0075/2450		0075/2477			
018 "DIA CIRC CONCR			LEN=0099	INSTALLED	UNKN
HOLIDAY CTR RD		0075/2295			
(PRDR)					
MALL ENT RD					
(PRDR)					
		0075/2189			
0074/1739			LEN=0099	INSTALLED	UNKN
018 "DIA CIRC CONCR			LEN=0099	INSTALLED	UNKN
HOLIDAY CTR RD					
(PRDR)					
MALL ENT RD					
(PRDR)					
0074/1605			LEN=0099	INSTALLED	UNKN
018 "DIA CIRC CONCR			LEN=0099	INSTALLED	UNKN
0074/1433			LEN=0099	INSTALLED	UNKN
018 "DIA CIRC CONCR			LEN=0099	INSTALLED	UNKN
0074/1135			LEN=0099	INSTALLED	UNKN
018 "DIA CIRC CONCR			LEN=0345	INSTALLED	UNKN
0075/1416					
018 "DIA CIRC CONCR			LEN=0099	INSTALLED	UNKN
0075/0921					
018 "DIA CIRC CONCR			LEN=0099	INSTALLED	UNKN
0075/0670					
MURRAY LN					
(PRDR)		0075/0560			
018 "DIA CIRC CONCR			LEN=0099	INSTALLED	UNKN
0075/0542					
(APRA) MONROEVILLE EXPO		0075/0264			
1 0 00187 0 01 0262+08			013419 FT		
RAMP D RD					
(SR8080 SEG 0500/0000)					
LENGTH(AH 3825 BK 0901)		0075/0000			
0074/0140			LEN=0099	INSTALLED	UNKN
014496 FT					
1 0 00187 0 01 0264+12					
MURRAY LN					
(PRDR)					
LENGTH(AH 3228 BK 1515)		0074/0000			
0070/0725					
RAMP FR MONROEVILLE MAL					
(PRDR)					
RAMP C RD					
(SR8080 SEG 0510/0654)		0071/0640			
RAMP 8080 NB					
OP ID 02/8080/0500/0575		0071/0490			
0070/0542					
0070/0318					
OP ID 02/8080/0500/0575					
(APRA) MONROEVILLE EXPO					
RAMP TO MONROEVILLE MAL					
(BORO)					
1 0 00187 0 01 0251+48					
MARK DR					
(BORO)					
LENGTH(AH 1515 BK 0450)		0070/0000			
018 "DIA CIRC CONCR			LEN=0099	INSTALLED	UNKN
0060/0133			LEN=0099	INSTALLED	UNKN
012531 FT					
1 0 00187 0 01 0244+38					
011954 FT					
1 0 00187 0 01 0244+56					

DIR: E TOTAL LEN: 4.792 MI. DIST: 11-1 SR: 2048
 LEFT MUN: MONROEVILLE B RIGHT MUN: MONROEVILLE B

Stationing	Description	Stationing	Description
0061/0000	LENGTH(AH 0564 BK 1999) 8 FT	0060/0000	LENGTH(AH 0450 BK 2067) 8 FT
0051/1929	BR. THOMPSON	0050/1992	BR. THOMPSON
0051/1850	STRUCTURE LENGTH 8 FT	0050/1932	STRUCTURE LENGTH 8 FT
0051/1769	BMSID 02/2048/0050/2040	0050/1855	BMSID 02/2048/0050/2040
0051/1273	LC FROM SAMS CLUB RD	0050/1252	LC FROM KOHLS ENT RD
0051/1252	(CONN)	0050/0800	(CONN)
009955 FT	SAMS CLUB RD	010464 FT	SAMS CLUB RD
0051/0000	(PRDR)	0050/0000	(PRDR)
0041/1300	KOHLS ENT RD	0040/1336	KOHLS ENT RD
0041/0928	(PRDR)	0040/1099	(PRDR)
008588 FT	PEP BOYS	0040/0988	PEP BOYS
0041/0000	(PRDR)	0040/0943	(PRDR)
008588 FT	HOME DEPOT	0040/0873	HOME DEPOT
0041/0000	(PRDR)	009089 FT	(PRDR)
0041/0000	LC TO HOME DEPOT RD	0040/0000	LC TO HOME DEPOT RD
0041/0000	(CONN)	0030/2490	(CONN)
008588 FT	PLAZA EXIT RD		
0041/0000	(PRDR)		
0041/0000	LENGTH(AH 1367 BK 2683) 8 FT		
0041/0000	KINGSTON DR		
0041/0000	(TWP)		
0041/0000	PLAZA EXIT RD		
0041/0000	(PRDR)		
0041/0000	LENGTH(AH 1375 BK 2575) 8 FT		
0041/0000	LC TO PLAZA RD		
0041/0000	(CONN)		

DIR: E TOTAL LEN: 4.792 MI. DIST: 11-1 SR: 2048
 LEFT MUN: WILKINS T RIGHT MUN: WILKINS T

Segment Description	Stationing	Structure	Length	Material	Status
LC TO SHEETZ RD (CONN)	0031/1996	0030/2160	095"	DIA CIRC CONCR	LEN=0099 INSTALLED UNKN
SHEETZ RD (PRDR)					
PENN CTR BL (TWP)					
LC FROM SHEETZ RD (CONN)	0031/1910	0030/1810	018"	DIA CIRC CONCR	LEN=0690 INSTALLED UNKN
	0031/1860	0030/1038	024"	DIA CIRC CONCR	LEN=0783 INSTALLED UNKN
LC TO SHOP N SAVE PZ (CONN)	0031/0853	0030/0627			
SHOP N SAVE PZ (PRDR)					
LC FROM SHOP N SAVE PZ (CONN)	0031/0748				
	0031/0668				
1 0 00187 0 01 0183+64 005905 FT		006514 FT	1 0 00187 0 01 0184+37		
LENGTH(AH 2683 BK 0989)	0031/0000	0030/0000	LENGTH(AH 2575 BK 1112)		
HAWTHORNE DR (TWP)			HAWTHORNE DR (TWP)		
BMSBG 02/2048/0020/0000	0021/0640	0020/0620	BMSBG 02/2048/0020/0000		
1 0 00187 0 01 0173+25 004916 FT		0020/0266	1 0 00187 0 01 0173+25		
LR 395		005402 FT	LR 395		
BMSBG 02/2048/0020/0000			BMSBG 02/2048/0020/0000		
WILKINS			WILKINS		
CHURCHILL B			CHURCHILL B		
LENGTH(AH 0989 BK 3034)	0021/0000	0020/0000	LENGTH(AH 1112 BK 3067)		
			SOUTH BEND LN (SR2152 SEG 0011/0000)		
		0014/2993	018" DIA CIRC CONCR		
		0014/2851	LEN=0099 INSTALLED UNKN		
		0014/2807	SOUTH BEND LN (SR2152 SEG 0010/0000)		
		0014/2759	024" DIA CIRC CONCR		
018" DIA CIRC CONCR			LEN=0099 INSTALLED UNKN		
LEN=0099 INSTALLED UNKN	0015/2629				
CHALFONT RUN			CHALFONT RUN		
STRUCTURE LENGTH 16 FT		0014/2361	STRUCTURE LENGTH 16 FT		
BMSID 02/2048/0014/1156	0015/2345		BMSID 02/2048/0014/1156		

DIR: E TOTAL LEN: 4.792 MI. DIST: 11-1 SR: 2048
 LEFT MUN: CHURCHILL B RIGHT MUN: CHURCHILL B

Segment Description	Stationing	Length	Notes
RODI RD (SR2053 SEG 0031/0087)	0015/2306		
RODI RD (SR2053 SEG 0030/0326)	0015/2061		
CHALFONT RUN STRUCTURE LENGTH 16 FT			
BMSID 02/2048/0014/0290	0015/1439		0014/1888 018 "DIA CIRC CONCR LEN=0099 INSTALLED UNKN
MERRIE WOODE DR (BORO)	0015/1083		0014/1442 CHALFONT RUN STRUCTURE LENGTH 16 FT BMSID 02/2048/0014/0290 MERRIE WOODE DR (BORO)
TO 0791/0010 SH (CONN)	0015/0080		0014/1122 024 "DIA CIRC CONCR LEN=0099 INSTALLED UNKN
1 0 00187 0 01 0162+80	001882 FT		0014/1062 024 "DIA CIRC CONCR LEN=0099 INSTALLED UNKN
NOTTINGHAM DR (BORO)			0014/0736 018 "DIA CIRC CONCR LEN=0099 INSTALLED UNKN
RODI RD (SR0791 SEG 0010/0000)			0014/0437 002335 FT 1 0 00187 0 01 0154+32 NOTTINGHAM DR (BORO) RODI RD (SR0791 SEG 0010/0000)
LENGTH(AH 3034 BK 1882)	0015/0000		
FROM 0791/0010 SH (CONN)	0011/1809		
SIGN: 4 CHORD TRUSS			
BMSID 02/2048/0010/1790	0011/1336		0014/0000 LENGTH(AH 3067 BK 2335) SIGN: 4 CHORD TRUSS BMSID 02/2048/0010/1790
SR 0376 EB			
OP ID 02/0376/0800/0915	0011/0595		
SIGN: 4 CHORD TRUSS			
BMSID 02/2048/0011/0081	0011/0081		0010/1790 HUNTINGDON DR (BORO)
1 0 00187 0 01 0135+86	000000 FT		
RAMP RD (SR8018 SEG 0500/0000)			
NC WILLIAM PENN HW			
RAMP A RD (SR8018 SEG 0510/0000)	INTER-BK		
MFC BEGIN = B			
LENGTH(AH 1882 BK 0000)	0011/0000		000000 FT 1 0 00187 0 01 0135+86 SIGN: 4 CHORD TRUSS BMSID 02/0376/0794/2465 PENN LINCOLN PY (SR0376 SEG 0794/2546) NC WI LLIAM PENN HW INTER-BK PENN LINCOLN PY (SR0376 SEG 0794/2546) MFC BEGIN = B LENGTH(AH 2335 BK 0000)

STREETS RUN RD 003912 FT
 (SR2046 SEG 0060/0000) 0010/3912

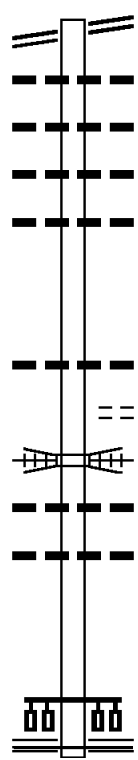

000000 FT

003912 FT STREETS RUN RD
 0010/3912 (SR2046 SEG 0060/0000)
 024 " DIA CIRC CONCR
 0010/3637 LEN=0035 INSTALLED UNKN
 018 " DIA CIRC CONCR
 0010/3387 LEN=0050 INSTALLED UNKN
 024 " DIA CIRC CONCR
 0010/3102 LEN=0035 INSTALLED UNKN
 024 " DIA CIRC CONCR
 0010/2725 LEN=0030 INSTALLED UNKN

 0010/1189 024 " DIA CIRC CONCR
 LEN=0035 INSTALLED UNKN
 SOUTH TAYLOR ENVIRO PRK
 0010/0825 (PRDR)
 UNION & PENNSYLVANIA &
 0010/0466 OVERPASS IS RR X-ING
 024 " DIA CIRC CONCR
 0010/0390 LEN=0050 INSTALLED UNKN
 018 " DIA CIRC CONCR
 0010/0094 LEN=0035 INSTALLED UNKN
 000000 FT 2 0 02207 0 00 0039+65
 NC DE LWAR RD
 LEBANON CHURCH RD
 (SR2040 SEG 0111/1200)
 (SR2040 SEG 0110/1306)
 MFC BEGIN = D
 0010/0000 LENGTH(AH 3912 BK 0000)

EXTRACT DATE: 12/21/2020 ROADWAY MANAGEMENT SYSTEM PAGE NUMBER: 791
PRINT DATE: 12/23/2020 SLD COUNTY/SR - ANNUAL PRINT COUNTY: ALLEGHENY
DIR: B TOTAL LEN: 4.659 MI. DIST: 11-1 SR: 2046
LEFT MUN: PITTSBURGH C RIGHT MUN: PITTSBURGH C

024597 FT

POI

024597 FT (APRA) PETER J. CARUSO
INTER-AHD BALDWIN RD
(SR3098 SEG 0090/1155)

EXTRACT DATE: 12/21/2020
PRINT DATE: 12/23/2020

ROADWAY MANAGEMENT SYSTEM
SLD COUNTY/SR - ANNUAL PRINT

PAGE NUMBER: 790
COUNTY: ALLEGHENY

DIR: B TOTAL LEN: 4.659 MI.
LEFT MUN: PITTSBURGH C

DIST: 11-1 SR: 2046
RIGHT MUN: PITTSBURGH C

RAMP G RD
(SR8061 SEG 0500/0815) 0140/0414

023075 FT

COMER ST
(CITY) 0130/1265

GANGES WY
(CITY) 0130/0060
020913 FT

019625 FT

017494 FT

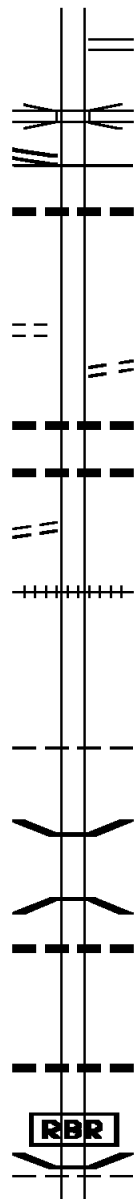

0140/1522 RAMP ST
(SR3098 SEG 0090/1155)

0140/0793 OP ID LEBANON RD.
02/0885/0210/0000

0140/0414 MFC BEGIN = E
024 "DIA CIRC CONCR
LEN=0040 INSTALLED UNKN
023075 FT 2 0 02076 0 00 0109+85
5 0140/0000 LENGTH(AH 1522 BK 2162)

0130/1138 CALERA ST
(CITY)
018 "DIA CIRC CONCR
LEN=0030 INSTALLED UNKN
018 "DIA CIRC CONCR
0130/0352 LEN=0030 INSTALLED UNKN

020913 FT 2 0 02229 0 00 0209+20
(AAR 145519S)#TRKS 01
5 0130/0000 LENGTH(AH 2162 BK 1288)

019625 FT 2 0 02229 0 00 0196+61
5 0100/0000 LENGTH(AH 1288 BK 2131)
0090/2031 BALDWIN B

0090/0884 BMS EN 02/2046/0090/0869
2 0 02229 0 00 0183+80
BRSTREETS RUN

0090/0869 BMSBG 02/2046/0090/0869
015 "DIA CIRC CONCR
LEN=0035 INSTALLED UNKN
017494 FT 2 0 02229 0 00 0175+05
NC BALDWIN RD

5 0090/0000 LENGTH(AH 2131 BK 2201)
018 "DIA CIRC CONCR
0080/1694 LEN=0040 INSTALLED UNKN

0080/1104 BMS EN 02/2046/0080/1088
BALDWIN

EXTRACT DATE: 12/21/2020
PRINT DATE: 12/23/2020

ROADWAY MANAGEMENT SYSTEM
SLD COUNTY/SR - ANNUAL PRINT

PAGE NUMBER: 789
COUNTY: ALLEGHENY

DIR: B TOTAL LEN: 4.659 MI.
LEFT MUN: BALDWIN B

DIST: 11-1 SR: 2046
RIGHT MUN: BALDWIN B

2 0 02229 0 00 0153+21 015293 FT
BRENTWOOD RD
(CNTY) 0080/0000

012605 FT

---	0080/1098	WEST MIFFLIN B 2 0 02229 0 00 0164+00 P3
[RBR]	0080/1088	STREETS RUN
+++++	0080/0889	BMSBG 02/2046/0080/1088 (AAR 145521T)#TRKS 01
---	0080/0315	WEST MIFFLIN BALDWIN B
[RBR]	0080/0314	BMSEN 02/2046/0080/0256 2 0 02229 0 00 0155+80 P3
[RBR]	0080/0256	STREETS RUN BMSBG 02/2046/0080/0256 015293 FT
==	5 0080/0000	LENGTH(AH 2201 BK 2688) 018 "DIA CIRC CONCR LEN=0030 INSTALLED UNKN
---	0070/2633	018 "DIA CIRC CONCR LEN=0030 INSTALLED UNKN
---	0070/2597	018 "DIA CIRC CONCR LEN=0030 INSTALLED UNKN
---	0070/1924	018 "DIA CIRC CONCR LEN=0030 INSTALLED UNKN
---	0070/1586	018 "DIA CIRC CONCR LEN=0030 INSTALLED UNKN
---	0070/1147	018 "DIA CIRC CONCR LEN=0060 INSTALLED UNKN
---	0070/0955	018 "DIA CIR PLASTIC LEN=0070 INSTALLED UNKN
+++++	0070/0914	(AAR 145522A)#TRKS 01 018 "DIA CIRC CONCR LEN=0099 INSTALLED UNKN
---	0070/0588	015 "DIA CIRC CONCR LEN=0035 INSTALLED UNKN
---	0070/0569	036 "DIA CIRC CONCR LEN=0045 INSTALLED UNKN
---	0070/0337	2 0 02229 0 00 0126+98 012605 FT
---	0070/0000	STREETS RUN STRUCTURE LENGTH 18 FT BMSID 02/2046/0070/0000 BALDWIN WEST MIFFLIN B
---	5 0070/0000	LENGTH(AH 2688 BK 2259) 018 "DIA CIRC CONCR LEN=0035 INSTALLED UNKN
---	0060/2140	018 "DIA CIRC CONCR LEN=0035 INSTALLED UNKN
---	0060/2020	018 "DIA CIRC CONCR LEN=0035 INSTALLED UNKN
+++++	0060/1693	(AAR 145523G)#TRKS 01

EXTRACT DATE: 12/21/2020
PRINT DATE: 12/23/2020

ROADWAY MANAGEMENT SYSTEM
SLD COUNTY/SR - ANNUAL PRINT

PAGE NUMBER: 788
COUNTY: ALLEGHENY

DIR: B TOTAL LEN: 4.659 MI.
LEFT MUN: WEST MIFFLIN B

DIST: 11-1 SR: 2046
RIGHT MUN: WEST MIFFLIN B

PROSPECT RD
(CNTY)

0060/0849

010346 FT

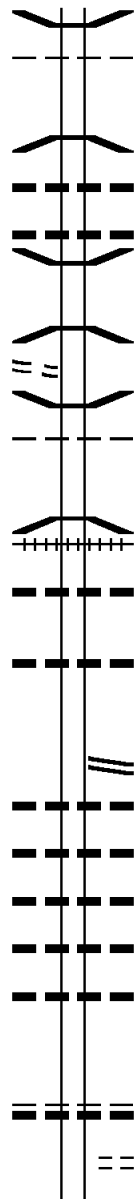

0060/1634	BMS	SEN	02/2046/0060/1614
0060/1632	WEST	MIFFLIN	BALDWIN B
0060/1598	BMS	SBG	02/2046/0060/1614
0060/1377	LEN=0040	INSTALLED	UNKN
0060/1250	LEN=0035	INSTALLED	UNKN
0060/0891	BMS	SEN	02/2046/0060/0867
0060/0883	BMS	SBG	02/2046/0060/0867
0060/0811	BMS	SEN	02/2046/0060/0781
0060/0794	WEST	MIFFLIN	B
0060/0781	BMS	SBG	02/2046/0060/0781
0060/0768	(AAR 145524N)	#TRKS	01
0060/0700	LEN=0049	INSTALLED	2010
0060/0078	LEN=0040	INSTALLED	UNKN
010346 FT	2 0 02229 0 00	0103+98	DELWAR RD
0060/0000	(SR2047	SEG 0010/3912)	LENGTH(AH 2259 BK 2087)
0050/1950	LEN=0040	INSTALLED	UNKN
0050/1803	LEN=0050	INSTALLED	UNKN
0050/1450	LEN=0060	INSTALLED	UNKN
0050/1245	LEN=0040	INSTALLED	UNKN
0050/0982	LEN=0040	INSTALLED	UNKN
0050/0326	LEN=0040	INSTALLED	UNKN
0050/0315	LEN=0040	INSTALLED	UNKN

DIR: B TOTAL LEN: 4.659 MI. DIST: 11-1 SR: 2046
 LEFT MUN: BALDWIN B RIGHT MUN: BALDWIN B

008259 FT

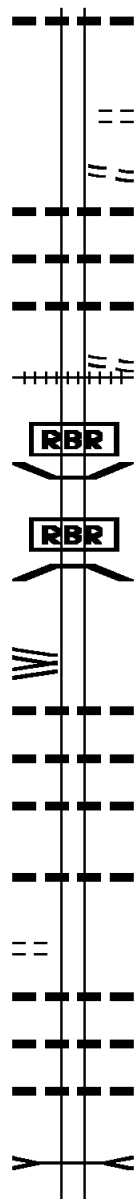

0050/0220 LEN=0040 INSTALLED UNKN
 008259 FT 2 0 02229 0 00 0082+59
 STARK WY
 (BORO)
 5 0050/0000 LENGTH(AH 2087 BK 2487)
 SPRINGDALE ST
 (BORO)
 0040/2425 015 " DIA CIRC CONCR
 0040/2350 LEN=0040 INSTALLED UNKN
 018 " DIA CIRC CONCR
 0040/2250 LEN=0032 INSTALLED UNKN
 018 " DIA CIRC CONCR
 0040/1995 LEN=0032 INSTALLED UNKN
 MISSIONARY RD
 (BORO)
 0040/1797
 0040/1744 (AAR 145525V)#TRKS 01

RBR

0040/1718 BMS EN 02/2046/0040/1678
 2 0 02229 0 00 0074+73

RBR

P3
 0040/1678 STREETS RUN
 BMSBG 02/2046/0040/1678

WILLOCK RD
 (SR2041 SEG 0010/0000)
 DOYLE RD
 (SR3046 SEG 0030/1483) 0040/1635

2 0 02229 0 00 0057+79 005772 FT
 SPANGLER ST
 (BORO) 0040/0000

0040/1253 018 " DIA CIRC CONCR
 LEN=0040 INSTALLED UNKN
 0040/0936 018 " DIA CIRC CONCR
 LEN=0040 INSTALLED UNKN
 0040/0680 018 " DIA CIRC CONCR
 LEN=0040 INSTALLED UNKN
 0040/0017 048 " DIA CIRC CONCR
 005772 FT LEN=0040 INSTALLED UNKN

5 0040/0000 LENGTH(AH 2487 BK 1734)
 018 " DIA CIRC CONCR
 0030/1206 LEN=0040 INSTALLED UNKN
 018 " DIA CIRC CONCR
 0030/1039 LEN=0040 INSTALLED UNKN
 018 " DIA CIRC CONCR
 0030/0734 LEN=0040 INSTALLED UNKN
 STREETS RUN
 STRUCTURE LENGTH 20 FT
 0030/0580 BMSID 02/2046/0030/0580
 OLD CLAIRTON RD

DIR: B TOTAL LEN: 4.659 MI. DIST: 11-1 SR: 2046
 LEFT MUN: BALDWIN B RIGHT MUN: BALDWIN B

Location	Segment ID	Length (FT)	Material / Notes
	0030/0450		(BORO)
	0030/0445		018" DIA CIRC METAL
004038 FT	004038 FT		LEN=0099 INSTALLED UNKN 2 0 02229 0 00 0040+47 CLAIRTON BL (SR0051 SEG 0281/0295) (SR0051 SEG 0280/0210)
	0030/0000		BALDWIN WHITEHALL B LENGTH(AH 1734 BK 2668)
	0020/2582		018" DIA CIRC CONCR
	0020/2216		LEN=0032 INSTALLED UNKN
	0020/1920		018" DIA CIRC CONCR
	0020/1625		LEN=0099 INSTALLED UNKN
FLAMINGO RD (BORO)	0020/1440		024" DIA CIRC CONCR
	0020/1421		LEN=0060 INSTALLED UNKN
ROBERTA ST (BORO)	0020/1095		036" DIA CIRC CONCR
	0020/0988		LEN=0099 INSTALLED UNKN
001370 FT	001370 FT		2 0 02229 0 00 0013+77 HARTER CR (BORO)
	0020/0000		LENGTH(AH 2668 BK 1370)
	0010/0373		018" DIA CIRC CONCR
	0010/0099		LEN=0040 INSTALLED UNKN
PARKVUE ET (BORO) LC TO BROWNSVILLE RD (CONN)	0010/0087		018" DIA CIR PLASTIC
	0010/0087		LEN=0099 INSTALLED UNKN
000000 FT	000000 FT		LC FROM BROWNSVILLE RD (CONN) 2 0 02229 0 00 0000+00 NC ST STREETS RUN RD BROWNSVILLE RD (CNTY)
	0010/0000		MFC BEGIN = C LENGTH(AH 1370 BK 0000)

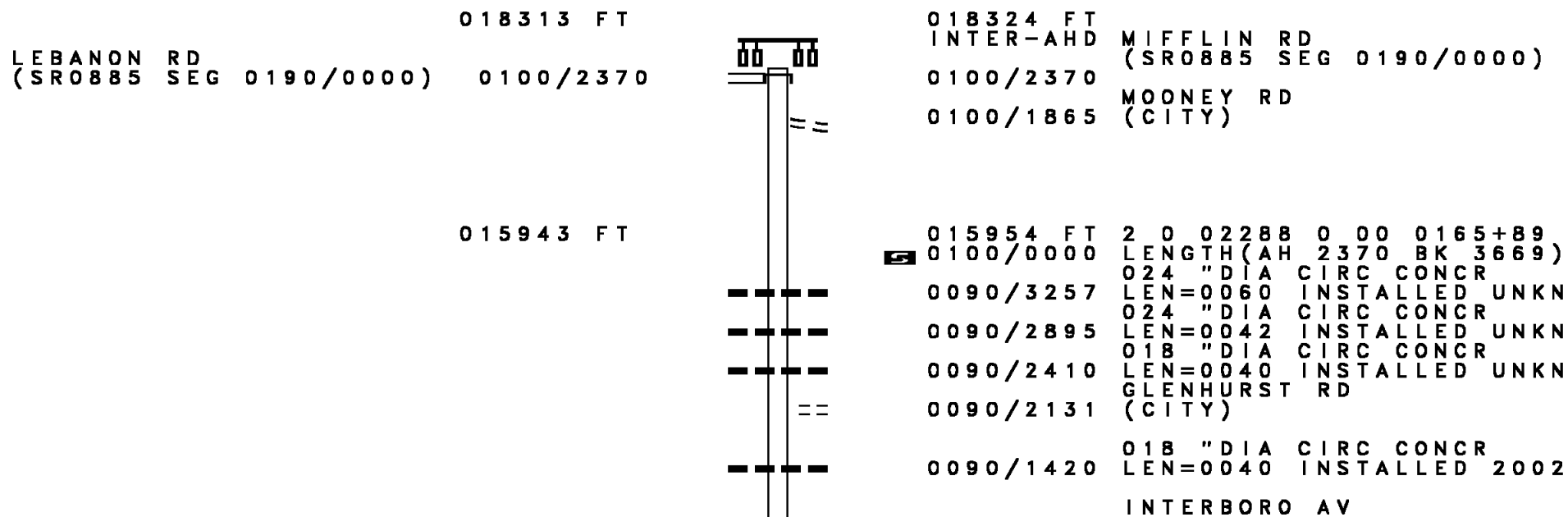

DIR: N TOTAL LEN: 3.470 MI. DIST: 11-1 SR: 2045
 LEFT MUN: PITTSBURGH C RIGHT MUN: PITTSBURGH C

BEGGS ST
 (CITY)
 KEEFE ST
 (CITY)

0090/0565
 0090/0212
 012274 FT

MOHRBACH ST
 (CITY)

0080/0172
 011036 FT

BUTTERMILK HOLLOW RD
 (SR2040 SEG 0170/2377)

0050/3142

DUNLAP ST
 (BORO)

0050/2850

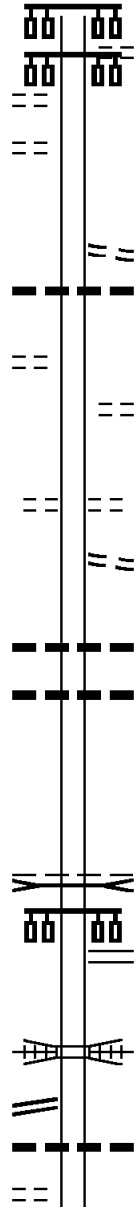

(CITY)
 0090/0679
 0090/0565
 012285 FT 2 0 02288 0 00 0129+00
 MCBRIDE ST
 (CITY)
 0090/0000 LENGTH(AH 3669 BK 1238)
 018 " DIA CIRC METAL
 0080/0940 LEN=0040 INSTALLED UNKN
 MOHRBACH ST
 (CITY)
 0080/0140 2 0 02288 0 00 0115+77
 011047 FT LENGTH(AH 1238 BK 2135)
 0080/0000 MCELHINNY AV
 (CITY)
 0070/1827 MIFFLIN RD
 (CITY)
 0070/1635
 0070/0493 018 " DIA CIRC CONCR
 LEN=0010 INSTALLED UNKN
 0070/0149 018 " DIA CIRC CONCR
 LEN=0052 INSTALLED UNKN
 008901 FT 008912 FT 2 0 02288 0 00 0095+35
 NC MIFFLIN RD
 THOMPSON RUN
 STRUCTURE LENGTH 18 FT
 BMSID 02/2045/0070/0000
 PITTSBURGH
 WEST MIFFLIN B
 0070/0000 LENGTH(AH 2135 BK 0380)
 THOMPSON RUN RD
 (SR2052 SEG 0010/0000)
 0060/0285 2 0 02288 0 00 0090+38
 008532 FT UNION & PENNSYLVANIA &
 OVERPASS IS RR X-ING
 0060/0000 LENGTH(AH 0380 BK 3496)
 NC BUTTERMILK HOLLOW RD
 0050/2915 018 " DIA CIRC CONCR
 LEN=0045 INSTALLED UNKN

EXTRACT DATE: 12/21/2020
PRINT DATE: 12/23/2020

ROADWAY MANAGEMENT SYSTEM
SLD COUNTY/SR - ANNUAL PRINT

PAGE NUMBER: 783
COUNTY: ALLEGHENY

DIR: N TOTAL LEN: 3.470 MI.
LEFT MUN: WEST MIFFLIN B

DIST: 11-1 SR: 2045
RIGHT MUN: WEST MIFFLIN B

PARK AV
(PRDR)

0050/0181
005025 FT

LC TO LEBANON CHURCH RD
(CONN)

0040/2267

LEBANON CHURCH RD
(CNTY)

0040/2049

002575 FT

BMS EN 02/2045/0030/0841
BRIDGE POSTED (TONS)
2 0 02288 0 00 0019+08
SGL 22 COMB 27
UNION RAILROAD COMPA RR

0031/1147

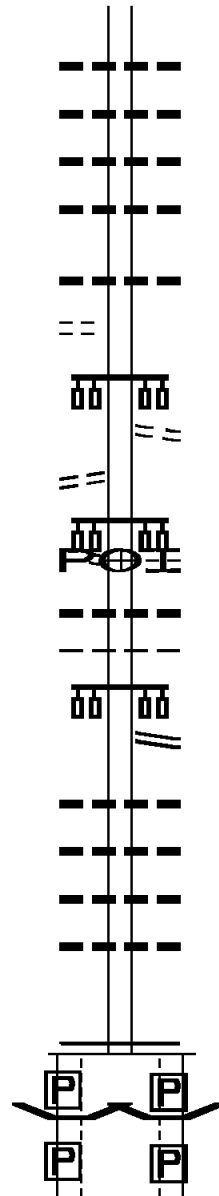

0050/2163 018 " DIA CIRC CONCR
LEN=0040 INSTALLED UNKN
0050/1737 018 " DIA CIRC CONCR
LEN=0032 INSTALLED UNKN
0050/1515 015 " DIA CIRC CONCR
LEN=0040 INSTALLED 2002
0050/1100 018 " DIA CIRC METAL
LEN=0045 INSTALLED UNKN

0050/0394 018 " DIA CIRC CONCR
LEN=0010 INSTALLED UNKN

005036 FT 2 0 02288 0 00 0055+00
BETTIS PLANT DR
(PRDR)
5 0050/0000 LENGTH(AH 3496 BK 2450)

(APRA) BECHTEL BETTIS I
BETTIS PLANT DR
(PRDR)

0040/2049 018 " DIA CIRC CONCR
LEN=0040 INSTALLED UNKN
WEST MIFFLIN
0040/1770 DRAVOSBURG B

0040/1720 BETTIS RD
(SR2116 SEG 0010/0000)

0040/0989 018 " DIA CIRC CONCR
LEN=0080 INSTALLED UNKN
0040/0685 018 " DIA CIRC CONCR
LEN=0075 INSTALLED UNKN
0040/0368 018 " DIA CIRC CONCR
LEN=0040 INSTALLED 2002
0040/0122 018 " DIA CIRC CONCR
LEN=0099 INSTALLED UNKN

002586 FT 2 0 02288 0 00 0030+58
NC PI TTSBURGH MCKEESPORT BL
MFC BEGIN = B
5 0040/0000 LENGTH(AH 2450 BK 1176)

0030/1006 BMS EN 02/2045/0030/0841
BRIDGE POSTED (TONS)
2 0 02288 0 00 0027+55
SGL 22 COMB 27
UNION RAILROAD COMPA RR

EXTRACT DATE: 12/21/2020 ROADWAY MANAGEMENT SYSTEM PAGE NUMBER: 781
 PRINT DATE: 12/23/2020 SLD COUNTY/SR - ANNUAL PRINT COUNTY: ALLEGHENY
 DIR: B TOTAL LEN: 3.150 MI. DIST: 11-1 SR: 2044
 LEFT MUN: DUQUESNE C RIGHT MUN: DUQUESNE C

STOCKTON WY
 (TWP)

016630 FT

0070/2795

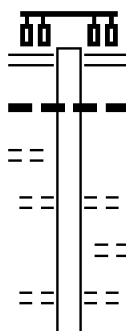

016630 FT DUQUESNE BL
 (SR0837 SEG 0300/1540)
 (SR0837 SEG 0301/1535)
 0070/2947
 0070/2900 012 " DIA CIRC CONCR
 LEN=0099 INSTALLED UNKN
 LIBERTY ST
 (TWP)
 RICHFORD ST
 (TWP)
 OVERLAND AV
 (TWP)
 0070/2135 018 " DIA CIRC METAL

DIR: B TOTAL LEN: 3.150 MI. DIST: 11-1 SR: 2044
 LEFT MUN: DUQUESNE C RIGHT MUN: DUQUESNE C

HARDEN AV
 (TWP)
 MILLER AV
 (TWP)

0070/0840
 0070/0520
 013683 FT

HOFFMAN BL
 (TWP)

0060/0534

2 0 02082 0 00 0066+08
 LC FOR SHADY LN
 (CONN)

010957 FT
 0060/0000

SHADY LN
 (TWP)
 LC TO HOMEVILLE RD
 (CONN)

0050/0154
 0050/0080
 009997 FT

0070/2022	LEN=0072	INSTALLED UNKN
0070/1955	018 "DIA	CIRC METAL
0070/1605	LEN=0030	INSTALLED UNKN
0070/1320	DUNBLANE ST	
0070/1265	(TWP)	
	CLOMEL ST	
	(TWP)	
	018 "DIA	CIRC CONCR
	LEN=0099	INSTALLED UNKN
	DUQUESNE PLACE DR	
	(TWP)	
	2 0 02082 0 01 0093+46	
	LENGTH(AH 2947 BK 2726)	
	012 "DIA	CIRC CONCR
0060/2710	LEN=0099	INSTALLED UNKN
0060/2542	DUQUESNE	
0060/2488	WEST MIFFLIN B	
0060/2317	018 "DIA	CIRC CONCR
0060/2106	LEN=0035	INSTALLED UNKN
0060/1903	018 "DIA	CIRC METAL
	LEN=0099	INSTALLED UNKN
	018 "DIA	CIRC METAL
	LEN=0030	INSTALLED UNKN
	018 "DIA	CIRC CONCR
	LEN=0030	INSTALLED UNKN
	024 "DIA	CIRC CONCR
	LEN=0088	INSTALLED UNKN
	018 "DIA	CIRC CONCR
	LEN=0088	INSTALLED UNKN
	024 "DIA	CIRC CONCR
	LEN=0088	INSTALLED UNKN
	0060/0439	
	010957 FT	
	LENGTH(AH 2726 BK 0960)	
	018 "DIA	CIRC CONCR
	LEN=0040	INSTALLED UNKN
	018 "DIA	CIRC CONCR
	LEN=0088	INSTALLED UNKN
	LC FROM HOMEVILLE RD	
	(CONN)	
	2 0 02082 0 00 0056+62	

EXTRACT DATE: 12/21/2020
PRINT DATE: 12/23/2020

ROADWAY MANAGEMENT SYSTEM
SLD COUNTY/SR - ANNUAL PRINT

PAGE NUMBER: 779
COUNTY: ALLEGHENY

DIR: B TOTAL LEN: 3.150 MI.
LEFT MUN: WEST MIFFLIN B

DIST: 11-1 SR: 2044
RIGHT MUN: WEST MIFFLIN B

Location / Description	Segment ID	Length (FT)	Material / Notes
LC FROM HOMEVILLE RD (CONN)	0040/1681		
ROBERTA DR (TWP)	0040/1405		
CONSTITUTION AV (TWP)	0040/0360		
	008213 FT		
WALKER DR (TWP)	0030/1809		
LONGVUE DR (TWP)	0030/1328		
CLUBVUE DR (TWP)	0030/0959		
	005481 FT		
HOMESTEAD DUQUESNE RD (CNTY)	0020/0948		
OLD BRIERLY LN (TWP)	0020/0241		
	003588 FT		
HOMEVILLE RD (CNTY)	0050/0000		LENGTH(AH 0960 BK 1784)
	0040/1700		018" DIA CIRC CONCR
	0040/1681		LEN=0099 INSTALLED UNKN
			LC TO HOMEVILLE RD (CONN)
	008213 FT		2 0 02185 0 00 0022+06
	0040/0000		LENGTH(AH 1784 BK 2732)
	0030/1670		018"H 18"W CON BOX CUL
	0030/1639		LEN=0030 INSTALLED UNKN
			018" DIA CIR PLASTIC
			LEN=0054 INSTALLED UNKN
	0030/0395		018" DIA CIRC CONCR
			LEN=0099 INSTALLED UNKN
	0030/0193		018" DIA CIRC CONCR
			LEN=0099 INSTALLED UNKN
	005481 FT		2 0 02185 0 00 0000+00
	0030/0000		LENGTH(AH 2732 BK 1893)
	0020/1533		WEST MIFFLIN MUNHALL B
			HOMESTEAD DUQUESNE RD (CNTY)
	0020/0948		
	0020/0938		MUNHALL WEST MIFFLIN B
			024" DIA CIRC CONCR
	0020/0707		LEN=0099 INSTALLED UNKN
			018" DIA CIRC CONCR
	0020/0511		LEN=0030 INSTALLED UNKN
			024" DIA CIRC CONCR
	0020/0503		LEN=0030 INSTALLED UNKN
	003588 FT		2 0 02082 0 00 0035+74

DIR: B TOTAL LEN: 3.150 MI. DIST: 11-1 SR: 2044
 LEFT MUN: WEST MIFFLIN B RIGHT MUN: WEST MIFFLIN B

Street Name	Segment ID	Start Station	End Station	Notes
TOWNE DR (TWP)	0010/3290	0010/3100	0010/3015	NC COMMONWEALTH AV S 0020/0000 LENGTH(AH 1893 BK 3588) 018 " DIA CIRC CONCR LEN=0040 INSTALLED UNKN 018 "H 01" W ELLIP CONC LEN=0088 INSTALLED UNKN
		0010/2970	0010/2873	BALL AV (TWP) 018 " DIA CIRC CONCR LEN=0040 INSTALLED UNKN
HILLCREST DR (TWP)	0010/2010	0010/2275	0010/1891	EAST BRIERLY DR (TWP) WEST MIFFLIN MUNHALL B WEST BRIERLY DR (TWP)
		0010/1885	0010/1682	018 " DIA CIRC CONCR LEN=0040 INSTALLED UNKN 012 " DIA CIRC CONCR LEN=0099 INSTALLED UNKN
SHADY AV (TWP) ROBERTA DR (TWP)	0010/1375	0010/1470	0010/0625	ASPEN ST (TWP) 018 " DIA CIRC CONCR LEN=0030 INSTALLED UNKN
		0010/0585	0010/0573	036 " DIA CIRC CONCR LEN=0030 INSTALLED UNKN
		0010/0315	0010/0133	POPLAR ST (TWP) 018 " DIA CIRC CONCR LEN=0088 INSTALLED UNKN
000000 FT		0010/0104	000000 FT	MUNHALL PITTSBURGH C 2 0 02082 0 00 0000+00 NC BR IERLY LN INTERBORO AV (TWP)
MAIN ST (TWP)	0010/0000	0010/0000	0010/0000	INTER-BK WEST RUN RD (CNTY) MFC BEGIN = C S 0010/0000 LENGTH(AH 3588 BK 0000)

(APRA) COUNTY AIRPORT E010664 FT
 COUNTY AIRPORT ENT RD INTER-AHD
 (CNTY)
 LEBANON CHURCH RD
 (SR2040 SEG 0140/1203)
 (SR2040 SEG 0141/1274)
 0061/0511
 018 "DIA CIRC CONCR
 LEN=0030 INSTALLED UNKN 0061/0200
 2 0 02101 0 00 0003+90 010153 FT
 MFC BEGIN = C
 LENGTH(AH 0511 BK 2334) 0061/0000

LIVINGSTON RD
 (TWP) 0050/1255

MILLPORT RD
 (TWP) 0050/0635

SKYPORT RD
 (TWP) 0050/0335

2 0 02101 0 01 0028+02 007819 FT
 LINDA LN
 (TWP) 0050/0000

BEVERLY DR
 (TWP) 0040/1160

LEBANON MANOR DR
 (TWP) 0040/0365
 006028 FT

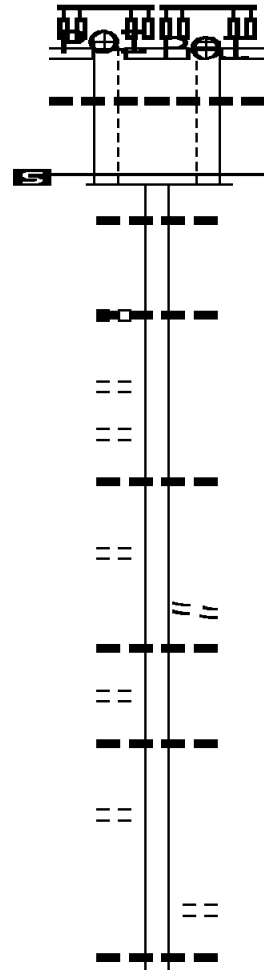

010669 FT (APRA) COUNTY AIRPORT E
 INTER-AHD COUNTY AIRPORT ENT RD
 (CNTY)
 LEBANON CHURCH RD
 (SR2040 SEG 0141/1274)
 (SR2040 SEG 0140/1203)
 0060/0516
 018 "DIA CIRC CONCR
 LEN=0030 INSTALLED UNKN
 2 0 02101 0 00 0003+90
 MFC BEGIN = C
 LENGTH(AH 0516 BK 2334)
 015 "DIA CIRC CONCR
 LEN=0035 INSTALLED UNKN

0050/2160

0050/1255 018 "DIA CIRC CONCR
 LEN=0088 INSTALLED UNKN

0050/0080 018 "DIA CIRC CONCR
 LEN=0030 INSTALLED UNKN

0040/1667 LENGTH(AH 2334 BK 1791)
 (PRDR) CHERRY LN
 018 "DIA CIRC CONCR
 LEN=0999 INSTALLED UNKN

0040/1450

0040/0996 018 "DIA CIRC CONCR
 LEN=0035 INSTALLED UNKN

006028 FT 2 0 02101 0 01 0049+42
 VILLAGE LN
 (TWP)
 LENGTH(AH 1791 BK 1299)
 018 "DIA CIRC METAL
 LEN=0035 INSTALLED UNKN

0040/0000

0030/1280

DIR: B TOTAL LEN: 2.021 MI.
 LEFT MUN: WEST MIFFLIN B

DIST: 11-1 SR: 2043
 RIGHT MUN: WEST MIFFLIN B

Stationing	Description	Material	Length	Notes
0030/1007	018 " DIA CIRC CONCR	LEN=0035	INSTALLED UNKN	
0030/0783	018 " DIA CIRC CONCR	LEN=0035	INSTALLED UNKN	
0030/0729	LEBANON SCHOOL RD (TWP)			
004729 FT	2 0 02101 0 01 0061+95			
0030/0000	PHILLIP MURRAY RD (SR2034 SEG 0010/0000)	LENGTH(AH 1299 BK 2203)		
0020/1950	FOR SR 2034 AND 2043 (CONN)			
0020/1419	(APRA) USX MON VALLEY-I			
0020/1045	MON VALLEY-IRVIN WRKS R (PRDR)			
0020/0330	018 " DIA CIRC CONCR	LEN=0035	INSTALLED UNKN	
0020/0000	2 0 02355 0 00 0024+95	LENGTH(AH 2203 BK 2526)		
0010/2303	018 " DIA CIRC CONCR	LEN=0035	INSTALLED UNKN	
0010/2245	018 " DIA CIRC CONCR	LEN=0035	INSTALLED UNKN	
0010/2156	018 " DIA CIRC CONCR	LEN=0035	INSTALLED UNKN	
0010/2100	018 " DIA CIRC CONCR	LEN=0035	INSTALLED UNKN	
0010/1809	018 " DIA CIRC CONCR	LEN=0035	INSTALLED UNKN	
0010/1450	024 " DIA CIRC CONCR	LEN=0035	INSTALLED UNKN	
0010/1094	024 " DIA CIRC CONCR	LEN=0035	INSTALLED UNKN	
0010/0395	024 " DIA CIRC CONCR	LEN=0035	INSTALLED UNKN	
0010/0190	018 " DIA CIRC CONCR	LEN=0050	INSTALLED UNKN	
000000 FT	2 0 02355 0 00 0000+00			
0010/0000	NC CAMP HOLLOW RD INTER-BK NEW ENGLAND RD (CNTY)	MFC BEGIN = C		
0010/0000	018 " DIA CIRC CONCR	LENGTH(AH 2526 BK 0000)		

LC TO NEW ENGLAND RD (CONN)

0010/0135
 000000 FT

NEW ENGLAND RD (CNTY)

0010/0000

DIR: B TOTAL LEN: 2.305 MI. DIST: 11-1 SR: 2042
 LEFT MUN: WEST MIFFLIN B RIGHT MUN: WEST MIFFLIN B

012169 FT
 012169 FT
 012169 FT

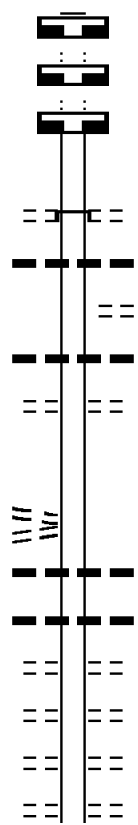

012169 FT
 7080/0000 LENGTH(AH 0986 BK 1630)
 012169 FT
 7070/0000 LENGTH(AH 1630 BK 2299)
 012169 FT
 7060/0000 LENGTH(AH 2299 BK 2427)
 INTER-AHD KENNEDY AV
 (TWP)
 MIFFLIN ST
 (TWP)
 0050/2427 018 "DIA CIRC CONCR
 0050/2380 LEN=0048 INSTALLED UNKN
 THOMAS ST
 (TWP)
 0050/2175 018 "DIA CIRC CONCR
 0050/1940 LEN=0030 INSTALLED UNKN
 MELLON ST
 (TWP)
 0050/1930 (TWP)

TAFT AV
 (TWP)
 TEXAS AV
 (TWP)

0050/1300

NC TEXAS AV
 0050/1285 018 "DIA CIRC CONCR
 LEN=0035 INSTALLED UNKN
 0050/1284 015 "DIA CIRC CONCR
 LEN=0040 INSTALLED UNKN
 ALLEY
 (TWP)
 MAINE AV
 (TWP)
 0050/0975 ALLEY
 (TWP)
 0050/0810 VERMONT AV
 (TWP)
 0050/0650 (TWP)

DIR: B TOTAL LEN: 2.305 MI. DIST: 11-1 SR: 2042
 LEFT MUN: WEST MIFFLIN B RIGHT MUN: WEST MIFFLIN B

Left Side Description	Left Side Stationing	Right Side Description	Right Side Stationing
		ALLEY (TWP)	0050/0485
		HIGHLAND AV (TWP)	0050/0325
	009742 FT	ALLEY (TWP)	0050/0160
		PENN AV (TWP)	009742 FT
		NC TAFT AV	2 0 02078 0 00 0097+83
		TAFT AV (TWP)	
		MFC BEGIN = E	
		LENGTH(AH 2427 BK 3289)	0050/0000
		018 " DIA CIRC CONCR	0040/3184
		LEN=0030 INSTALLED UNKN	0040/2960
		018 " DIA CIRC CONCR	
		LEN=0040 INSTALLED UNKN	
EMERSON ELEMENTARY SCHO (PRDR)	0040/2630		
		NEEL ST (TWP)	0040/2620
EMERSON ELEMENTARY SCHO (PRDR)	0040/2321		
VERMONT AV (TWP)		MCGINLEY AV (TWP)	
RIDGE AV (TWP)	0040/1795	VERMONT AV (TWP)	0040/1795
		018 " DIA CIRC CONCR	0040/1671
CONLIN ST (TWP)	0040/1440	LEN=0075 INSTALLED UNKN	
		SCOTT DR (TWP)	0040/0900
CAROLINA AV (TWP)	0040/0400	018 " DIA CIRC CONCR	0040/0401
2 0 02078 0 00 0065+00	006453 FT	LEN=0040 INSTALLED UNKN	
WORTON BL (TWP)	0040/0000	006453 FT	
DUCHESS AV (TWP)	0030/2675	NC PA AV/SKYLINE DR	0040/0000
		LENGTH(AH 3289 BK 2883)	
		ALBERTA CR (TWP)	0030/2675
		018 " DIA CIRC CONCR	0030/2380
REUBEN DR (TWP)	0030/2360	LEN=0040 INSTALLED UNKN	
		NC PENNSYLVANIA AV	
		018 " DIA CIRC CONCR	0030/1610
		LEN=0032 INSTALLED UNKN	
		018 " DIA CIRC CONCR	

DIR: B TOTAL LEN: 2.305 MI. DIST: 11-1 SR: 2042
 LEFT MUN: WEST MIFFLIN B RIGHT MUN: WEST MIFFLIN B

Stationing	Distance	Notes	Material	Status
	0030/1267		LEN=0032	INSTALLED UNKN
003570 FT	0030/0277	018 " DIA CIRC CONCR	LEN=0048	INSTALLED UNKN
	003570 FT	2 0 02078 0 00 0035+59		
		WEST MIFFLIN		
		DRAVOSBURG B		
	0030/0000	LENGTH(AH 2883 BK 2343)		
	0020/2218	018 " DIA CIRC CONCR	LEN=0050	INSTALLED UNKN
	0020/1555	018 " DIA CIRC CONCR	LEN=0050	INSTALLED UNKN
	0020/0987	018 " DIA CIRC CONCR	LEN=0050	INSTALLED UNKN
	0020/0660	018 " DIA CIRC CONCR	LEN=0050	INSTALLED UNKN
001227 FT	0020/0305	018 " DIA CIRC CONCR	LEN=0040	INSTALLED UNKN
	001227 FT	2 0 02078 0 00 0012+83		
		018 " DIA CIRC CONCR	LEN=0040	INSTALLED UNKN
		NC SKYLINE DR		
		RAYMOND ST		
		(TWP)		
	0020/0000	LENGTH(AH 2343 BK 1227)		
	0010/1223	018 " DIA CIRC CONCR	LEN=0040	INSTALLED UNKN
SIXTH ST (TWP)	0010/0935			
	0010/0685	018 " DIA CIRC CONCR	LEN=0032	INSTALLED UNKN
		CHRISTINA ST		
	0010/0655	(TWP)		
	0010/0450	018 " DIA CIRC CONCR	LEN=0032	INSTALLED UNKN
		MC CLURE ST		
		(TWP)		
MC CLURE ST (TWP)	0010/0335	NC GO		
	0010/0290	018 " DIA CIRC CONCR	LEN=0032	INSTALLED UNKN
000000 FT	000000 FT	2 0 02078 0 00 0000+00		
		NC FIFTH ST		
		RAVINE ST		
		(TWP)		
		INTER-BK FIFTH ST		
		(TWP)		
		MFC BEGIN = D		
	0010/0000	LENGTH(AH 1227 BK 0000)		

EXTRACT DATE: 12/21/2020 ROADWAY MANAGEMENT SYSTEM PAGE NUMBER: 772
 PRINT DATE: 12/23/2020 SLD COUNTY/SR - ANNUAL PRINT COUNTY: ALLEGHENY
 DIR: B TOTAL LEN: 1.070 MI. DIST: 11-1 SR: 2041
 LEFT MUN: WHITEHALL B RIGHT MUN: WHITEHALL B

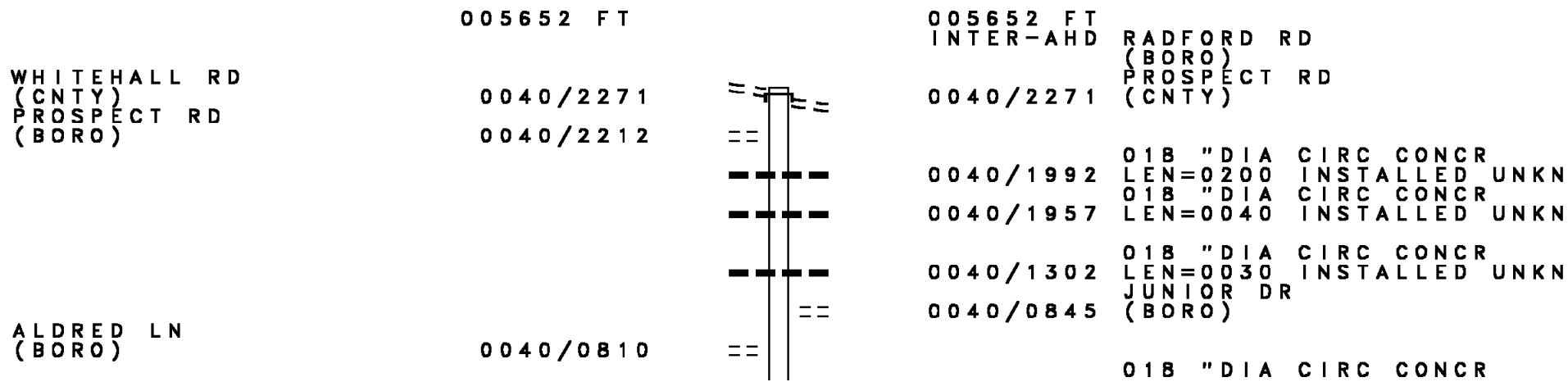

EXTRACT DATE: 12/21/2020
PRINT DATE: 12/23/2020

ROADWAY MANAGEMENT SYSTEM
SLD COUNTY/SR - ANNUAL PRINT

PAGE NUMBER: 771
COUNTY: ALLEGHENY

DIR: B TOTAL LEN: 1.070 MI.
LEFT MUN: WHITEHALL B

DIST: 11-1 SR: 2041
RIGHT MUN: WHITEHALL B

Segment ID	Length (FT)	Start Station	End Station	Material	Status	Notes
0040/0504				LEN=0030	INSTALLED UNKN	SENIOR ST
0040/0480				(BORO)		
003381 FT				2 0 02250	0 00 0033+50	JULIE DR
				(BORO)		MACEK DR
				(BORO)		WHITEHALL
				BALDWIN B		LENGTH(AH 2271 BK 2090)
0040/0000				RIDGE DR		
0030/1736				(BORO)		018 "DIA CIRC CONCR
0030/1726				LEN=0025	INSTALLED UNKN	018 "DIA CIRC CONCR
0030/1699				LEN=0025	INSTALLED UNKN	018 "DIA CIRC CONCR
0030/1455				LEN=0030	INSTALLED UNKN	018 "DIA CIRC CONCR
0030/1092				LEN=0030	INSTALLED UNKN	018 "DIA CIRC CONCR
BLUFF ST (BORO)						
0030/0990						
				018 "DIA CIRC CONCR		
0030/0925				LEN=0035	INSTALLED UNKN	018 "DIA CIRC CONCR
0030/0460				LEN=0030	INSTALLED UNKN	SHORT ST
				(BORO)		024 "DIA CIRC CONCR
0030/0235				LEN=0099	INSTALLED UNKN	2 0 02250 0 00 0012+91
001291 FT				ROBBINS DR		(BORO)
				LENGTH(AH 2090 BK 1291)		GODEC DR
0030/0000				(BORO)		
0010/1095						
				018 "DIA CIRC METAL		
0010/0268				LEN=0150	INSTALLED 2002	036 "DIA CIRC CONCR
0010/0118				LEN=0045	INSTALLED UNKN	2 0 02250 0 00 0000+00
000000 FT				STREETS RUN RD		(SR2046 SEG 0040/1635)
				INTER-BK E		WILLOCK RD
				STREETS RUN RD		(SR2046 SEG 0040/1635)
DOYLE RD (SR3046 SEG 0030/1483)				MFC BEGIN = E		
0010/0000				LENGTH(AH 1291 BK 0000)		

DIR: B TOTAL LEN: 7.048 MI. DIST: 11-1 SR: 2040
 LEFT MUN: WEST MIFFLIN B RIGHT MUN: WEST MIFFLIN B

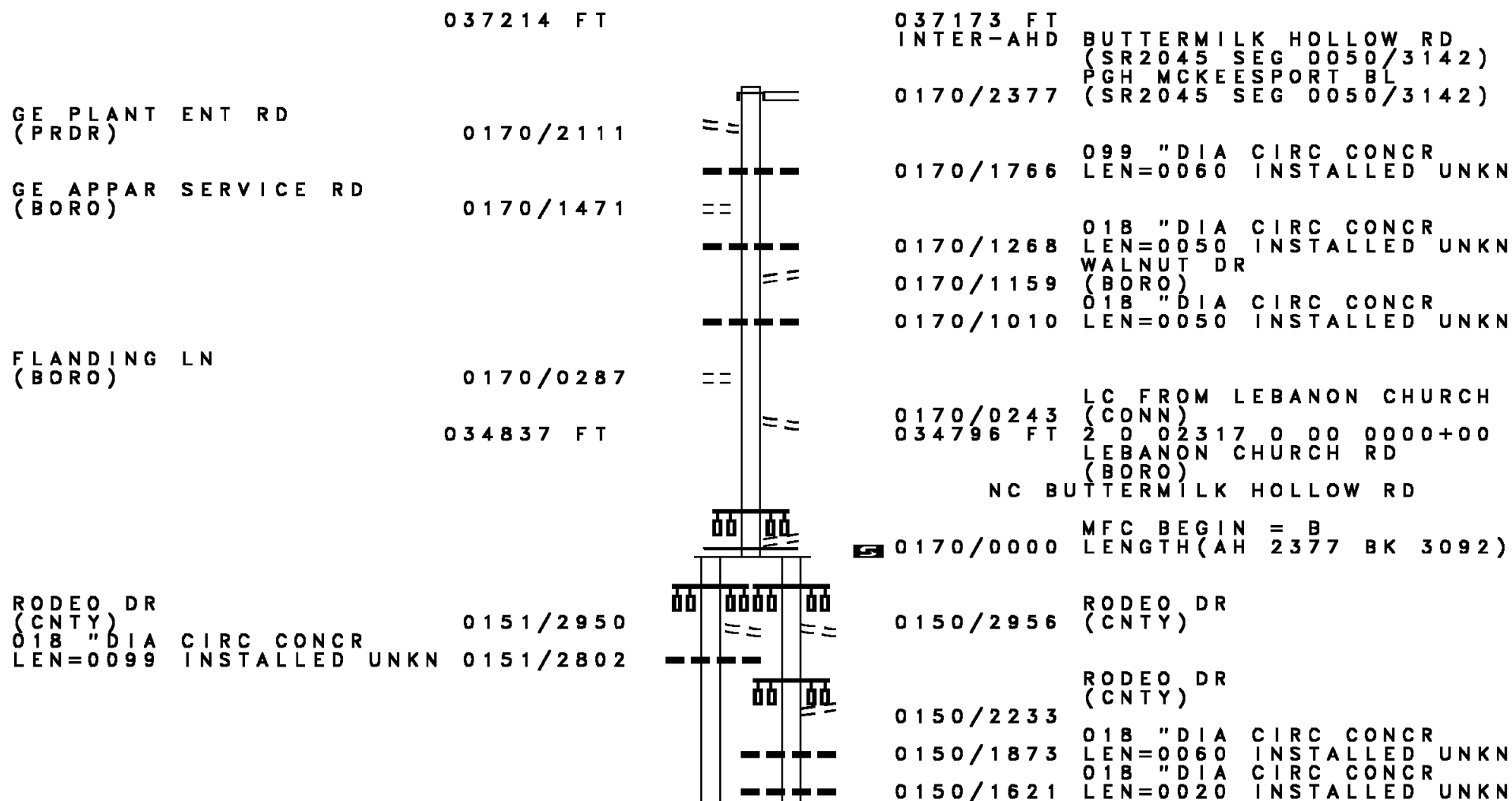

DIR: B TOTAL LEN: 7.048 MI. DIST: 11-1 SR: 2040
 LEFT MUN: WEST MIFFLIN B RIGHT MUN: WEST MIFFLIN B

Stationing	Description	Material	Length	Status	Notes
2 0 02292 0 00 0123+16 031759 FT	CURRY HOLLOW RD				
(BORO)					
LENGTH(AH 3078 BK 1956)		0151/0000		5	== ==
015 "DIA CIRC CONCR					5 0150/0000
LEN=0020 INSTALLED UNKN		0141/1881			
(APRA) COUNTY AIRPORT E					
COUNTY AIRPORT ENT RD					
(CNTY)					
CAMP HOLLOW RD					
(SR2043 SEG 0060/0516)					
(SR2043 SEG 0061/0511)					
018 "DIA CIRC CONCR		0141/1274			0140/1203
LEN=0040 INSTALLED UNKN		0141/1038			
018 "DIA CIRC CONCR					0140/1000
LEN=0140 INSTALLED UNKN		0141/0938			018 "DIA CIRC CONCR
018 "DIA CIRC CONCR					LEN=0020 INSTALLED UNKN
LEN=0040 INSTALLED UNKN		0141/0790			
018 "DIA CIRC CONCR					0140/0740
LEN=0050 INSTALLED UNKN					018 "DIA CIRC CONCR
018 "DIA CIRC CONCR					LEN=0020 INSTALLED UNKN
LEN=0040 INSTALLED UNKN		0141/0627			
024 "DIA CIRC CONCR					0140/0649
LEN=0040 INSTALLED UNKN		0141/0523			018 "DIA CIRC CONCR
024 "DIA CIRC CONCR					LEN=0099 INSTALLED UNKN
LEN=0040 INSTALLED UNKN					018 "DIA CIRC CONCR
					LEN=0099 INSTALLED UNKN
					LEBANON SCHOOL RD
					(BORO)
2 0 02292 0 00 0103+49 029803 FT					0140/0229
LENGTH(AH 1956 BK 2116)		0141/0000		5	029806 FT
					5 0140/0000
					018 "DIA CIRC CONCR
					LEN=0099 INSTALLED UNKN
028 "DIA CIRC CONCR					
LEN=0040 INSTALLED UNKN		0131/1274			
018 "DIA CIRC CONCR					
LEN=0099 INSTALLED UNKN		0131/0874			
					018 "DIA CIRC CONCR

EXTRACT DATE: 12/21/2020
PRINT DATE: 12/23/2020

ROADWAY MANAGEMENT SYSTEM
SLD COUNTY/SR - ANNUAL PRINT

PAGE NUMBER: 768
COUNTY: ALLEGHENY

DIR: B TOTAL LEN: 7.048 MI.
LEFT MUN: WEST MIFFLIN B

DIST: 11-1 SR: 2040
RIGHT MUN: WEST MIFFLIN B

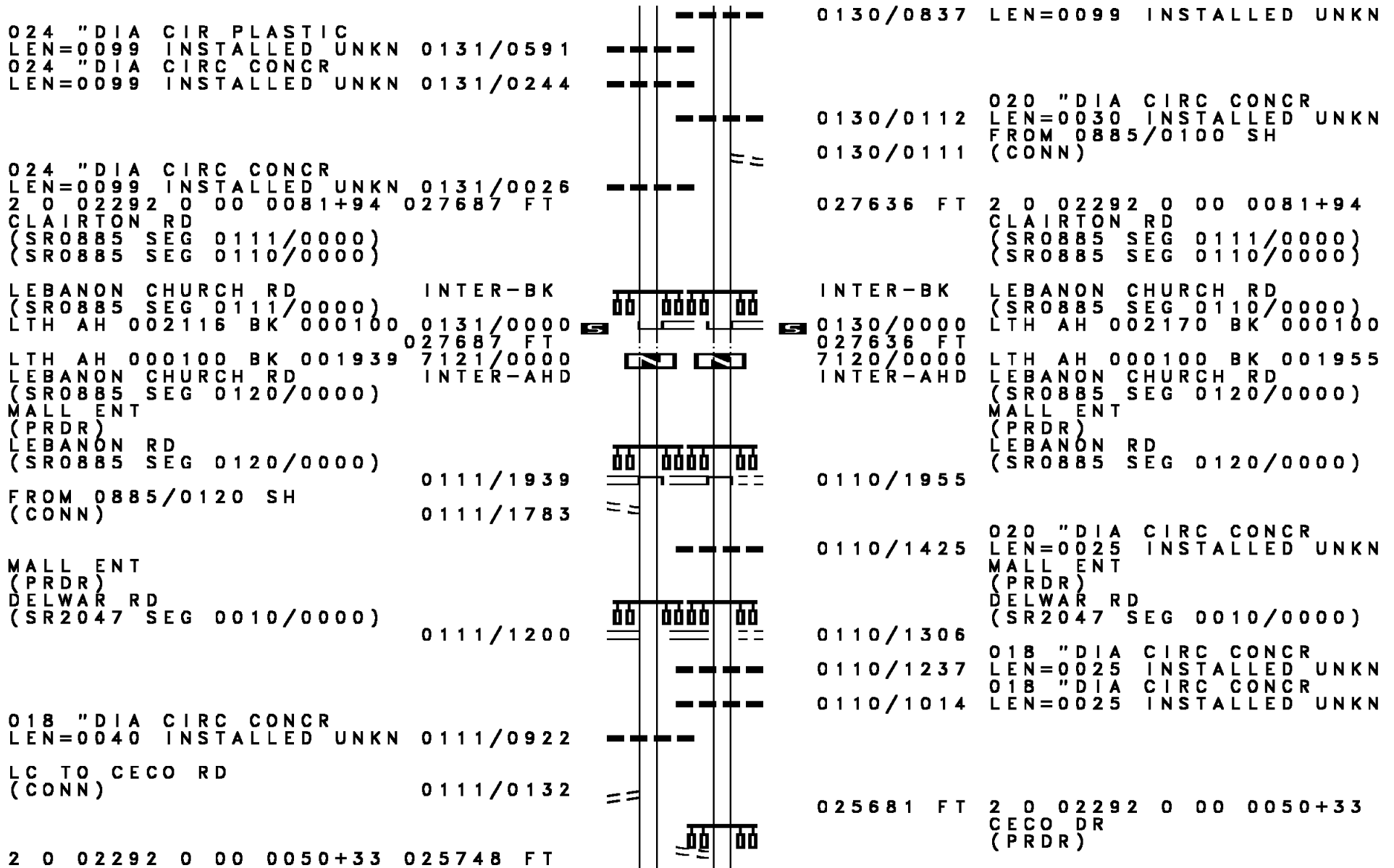

DIR: B TOTAL LEN: 7.048 MI. DIST: 11-1 SR: 2040
 LEFT MUN: WEST MIFFLIN B RIGHT MUN: WEST MIFFLIN B

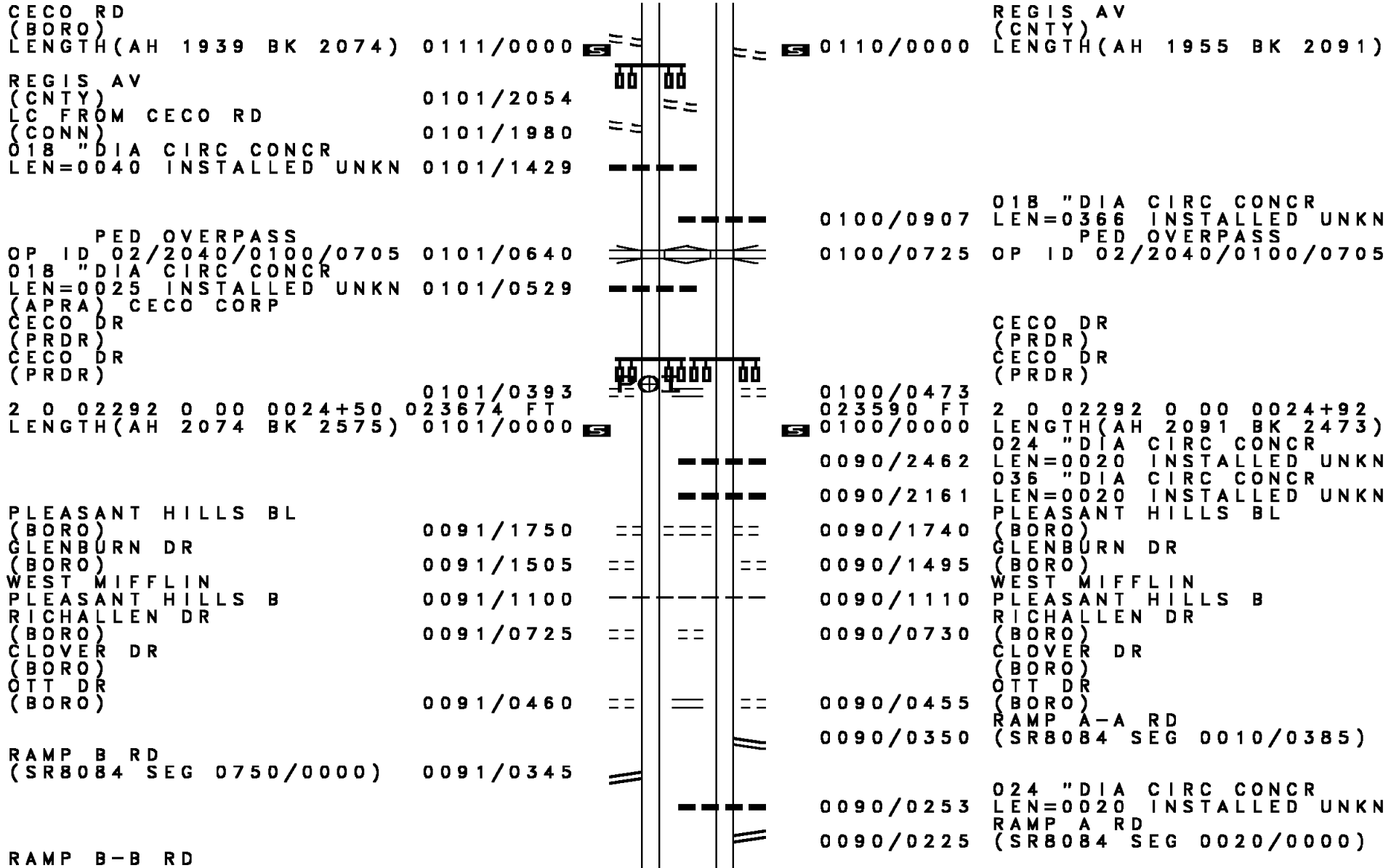

DIR: B TOTAL LEN: 7.048 MI. DIST: 11-1 SR: 2040
 LEFT MUN: PLEASANT HILLS B RIGHT MUN: PLEASANT HILLS B

Segment ID	Segment Description	Stationing	Length	Notes
(SR8084 SEG 0760/0324)		0091/0220		
2 0 02292 0 00 0000+00		021099 FT		
SR 0051 NB				
OP ID 02/0051/0270/0445				
NC LEBANON CHURCH RD				
LENGTH(AH 2575 BK 3478)		0091/0000		
RAMP C RD		(SR8084 SEG 0510/0000)	0081/3326	
RAMP C-C RD		(SR8084 SEG 0500/0374)	0081/3269	
018 "DIA CIRC CONCR		LEN=0025 INSTALLED UNKN	0081/3218	
018 "DIA CIRC CONCR		LEN=0025 INSTALLED UNKN	0081/2980	
GREEN DR (BORO)				
MARHOEFER DR (BORO)				
BLISS DR (BORO)				
018 "DIA CIRC CONCR		LEN=0064 INSTALLED UNKN	0081/1416	
018 "DIA CIRC CONCR		LEN=0025 INSTALLED UNKN	0081/1161	
ARBOR LN (BORO)				
BMSEN 02/2040/0080/0640		0081/0939		
2 0 02294 0 00 0034+87		0081/0704		
CSX				
		0090/0131		
		021117 FT		
		024 "DIA CIRC CONCR		
		LEN=0020 INSTALLED UNKN		
		2 0 02292 0 00 0000+00		
		SR 0051 NB		
		OP ID 02/0051/0270/0445		
		NC LEBANON CHURCH RD		
		LENGTH(AH 2473 BK 3530)		
		018 "DIA CIRC CONCR		
		LEN=0025 INSTALLED UNKN		
		0080/3435		
		RAMP D-D RD		
		(SR8084 SEG 0260/0370)		
		0080/3360		
		RAMP D RD		
		(SR8084 SEG 0250/0000)		
		0080/3305		
		018 "DIA CIRC CONCR		
		LEN=0025 INSTALLED UNKN		
		0080/3245		
		GREEN DR (BORO)		
		0080/2840		
		018 "DIA CIRC CONCR		
		LEN=0064 INSTALLED UNKN		
		0080/2666		
		BLISS DR (BORO)		
		0080/2475		
		018 "DIA CIRC CONCR		
		LEN=0064 INSTALLED UNKN		
		0080/2101		
		HADDAD LN (BORO)		
		0080/1935		
		ARBOR LN (BORO)		
		0080/0960		
		0080/0722		
		BMSEN 02/2040/0080/0640		

EXTRACT DATE: 12/21/2020
PRINT DATE: 12/23/2020

ROADWAY MANAGEMENT SYSTEM
SLD COUNTY/SR - ANNUAL PRINT

PAGE NUMBER: 765
COUNTY: ALLEGHENY

DIR: B TOTAL LEN: 7.048 MI.
LEFT MUN: PLEASANT HILLS B

DIST: 11-1 SR: 2040
RIGHT MUN: PLEASANT HILLS B

BMSBG 02/2040/0080/0640 0081/0622

OLD CURRY HOLLOW RD
(BORO) 0081/0558
2 0 02294 0 00 0034+87 0 17621 FT
LENGTH(AH 3478 BK 3336) 0081/0000
LC TO PLAZA ENT
(CONN) 0071/2786
PLAZA ENT
(PRDR) 0071/2726

LC FROM PLAZA ENT
(CONN) 0071/2660
004"H 03"W CON BOX CUL
LEN=0025 INSTALLED UNKN 0071/2505
KEEPORT DR
(BORO) 0071/2135

(APRA) JEFFERSON MEMORI
CEMETARY ENT
(PRDR) 0071/1895

KEENAN DR
(BORO) 0071/1684

018 "DIA CIRC CONCR
LEN=0020 INSTALLED UNKN 0071/1301

018 "DIA CIRC CONCR
LEN=0020 INSTALLED UNKN 0071/0615

024 "DIA CIRC CONCR
LEN=0045 INSTALLED 2013 0071/0280

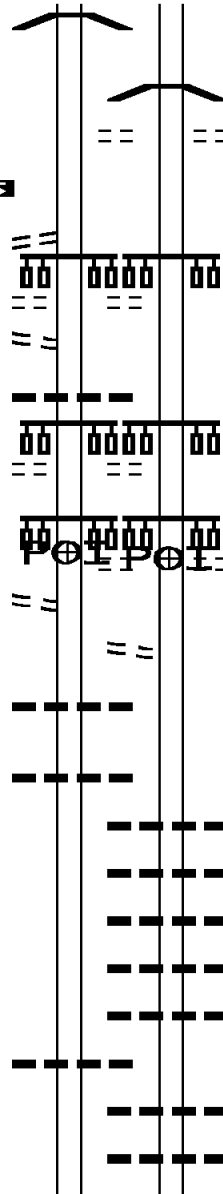

0080/0640

0080/0580

0080/0000

0070/2674

0070/2100

0070/1870

0070/1648

0070/0519

0070/0440

0070/0387

0070/0305

0070/0287

0070/0206

0070/0187

2 0 02294 0 00 0041+54
CSX RR
BMSBG 02/2040/0080/0640
OLD CURRY HOLLOW RD
(BORO)
2 0 02294 0 00 0035+25
LENGTH(AH 3530 BK 3293)

PLAZA ENT
(PRDR)

KEEPORT DR
(BORO)

(APRA) JEFFERSON MEMORI
CEMETARY ENT
(PRDR)

KEENAN DR
(BORO)

024 "DIA CIRC CONCR
LEN=0018 INSTALLED 2013
018 "DIA CIRC CONCR
LEN=0099 INSTALLED UNKN
024 "DIA CIRC CONCR
LEN=0014 INSTALLED 2013
018 "DIA CIRC CONCR
LEN=0099 INSTALLED UNKN
024 "DIA CIRC CONCR
LEN=0014 INSTALLED 2013

018 "DIA CIRC CONCR
LEN=0099 INSTALLED UNKN
024 "DIA CIRC CONCR
LEN=0014 INSTALLED 2013
018 "DIA CIRC CONCR

DIR: B TOTAL LEN: 7.048 MI. DIST: 11-1 SR: 2040
 LEFT MUN: PLEASANT HILLS B RIGHT MUN: PLEASANT HILLS B

Location / Description	Segment ID	Length (ft)	Material / Notes	Installation Status
LC TO BROWNSVILLE RD (CONN)	0071/0087			
024" DIA CIRC CONCR	0071/0062			
LEN=0024 INSTALLED 2013	0071/0041			
018" DIA CIRC CONCR	0071/0041			
LEN=0020 INSTALLED UNKN				
2 0 02294 0 00 0000+00 014285 FT				
NC CURRY HOLLOW RD	0070/0007	014294 FT	012" H 24" W CON BOX CUL	LEN=0099 INSTALLED UNKN
BROWNSVILLE RD (CNTY)			NC CURRY HOLLOW RD	
			BROWNSVILLE RD (CNTY)	
LENGTH(AH 3336 BK 1551)	0071/0000			
LC FROM BROWNSVILLE RD (CONN)	0065/1464			
			0070/0000	LENGTH(AH 3293 BK 1560)
			0064/1193	024" DIA CIRC CONCR
				LEN=0017 INSTALLED 2013
			0064/1182	024" DIA CIRC CONCR
				LEN=0010 INSTALLED 2013
NORFOLK SOUTHERN OVERPASS IS RR X-ING	0065/1181			
024" DIA CIRC CONCR	0065/1169			
LEN=0025 INSTALLED 2013			0064/1127	NORFOLK SOUTHERN OVERPASS IS RR X-ING
			0064/1103	024" DIA CIRC CONCR
				LEN=0014 INSTALLED 2013
			0064/1082	PLEASANT HILLS BALDWIN B
PLEASANT HILLS BALDWIN B	0065/1120			
024" DIA CIRC CONCR	0065/1079			
LEN=0025 INSTALLED 2013			0064/0993	024" DIA CIRC CONCR
				LEN=0014 INSTALLED 2013
FIFTH ST (TWP)	0065/1016			
024" DIA CIRC CONCR	0065/0969			
LEN=0025 INSTALLED 2013			0064/0912	024" DIA CIRC CONCR
				LEN=0016 INSTALLED 2013
024" DIA CIRC CONCR	0065/0914			
LEN=0040 INSTALLED 2013			0064/0793	024" DIA CIRC CONCR
				LEN=0014 INSTALLED 2013
			0064/0697	BALDWIN JEFFERSON HILLS B
				024" DIA CIRC CONCR
			0064/0663	LEN=0030 INSTALLED 2013
SIXTH ST				SIXTH ST

DIR: B TOTAL LEN: 7.048 MI. DIST: 11-1 SR: 2040
 LEFT MUN: BALDWIN B RIGHT MUN: BALDWIN B

(T926) 0065/0675

BALDWIN 0065/0660
 JEFFERSON HILLS B
 240 "DIA CIRC CONCR
 LEN=0005 INSTALLED 2013 0065/0638

BMS EN 02/2040/0064/0086 0065/0449
 0 0 00000 0 00 0000+00
 LICK RUN
 BMSBG 02/2040/0064/0086 0065/0425
 JEFFERSON HILLS
 SOUTH PARK T 0065/0407
 024 "DIA CIRC CONCR
 LEN=0003 INSTALLED 2013 0065/0379

FOR SR 2040W TO 2040W
 (CONN) 0065/0326

NC BROWNSVILLE RD
 BROWNSVILLE RD
 (CNTY) 0065/0232

FOR SR 2040W TO 2040W
 (CONN) 0065/0140

0 0 00000 0 00 0000+00 012734 FT
 HORNING RD
 (CNTY)
 CURRY RD
 (CNTY)

MFC BEGIN = B

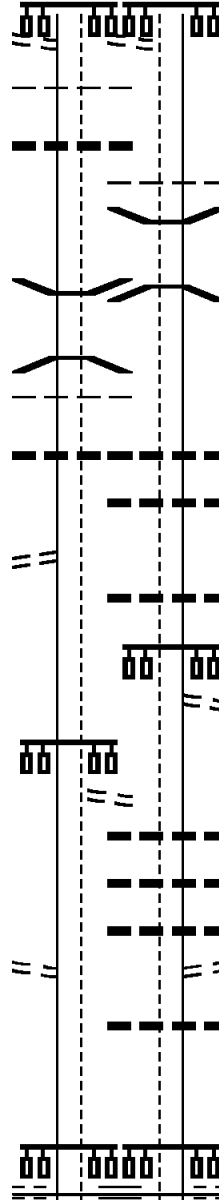

0064/0628 (T926)

0064/0444 JEFFERSON HILLS
 0064/0428 SOUTH PARK T
 BMS EN 02/2040/0064/0086
 0 0 00000 0 00 0000+00
 LICK RUN
 0064/0404 BMSBG 02/2040/0064/0086

0064/0379 048 "DIA CIRC CONCR
 LEN=0016 INSTALLED 2013
 0064/0378 024 "DIA CIRC CONCR
 LEN=0043 INSTALLED 2013

0064/0252 024 "DIA CIRC CONCR
 LEN=0037 INSTALLED 2013
 NC BROWNSVILLE RD

0064/0235 BROWNSVILLE RD
 (CNTY)

0064/0196 024 "DIA CIRC CONCR
 LEN=0042 INSTALLED 2013

0064/0189 024 "DIA CIRC CONCR
 LEN=0029 INSTALLED 2013

0064/0177 024 "DIA CIRC CONCR
 LEN=0034 INSTALLED 2013
 LC TO BROWNSVILLE RD

0064/0140 (CONN)
 0064/0116 024 "DIA CIRC CONCR
 LEN=0059 INSTALLED 2013

012734 FT
 0 0 00000 0 00 0000+00
 HORNING RD
 (CNTY)
 CURRY RD
 (CNTY)

MFC BEGIN = B

DIR: B TOTAL LEN: 7.048 MI. DIST: 11-1 SR: 2040
 LEFT MUN: SOUTH PARK T RIGHT MUN: SOUTH PARK T

LENGTH(AH 1551 BK 1233)	0065/0000			5	0064/0000	LENGTH(AH 1560 BK 1233)
		---	---			024 "DIA CIRC CONCR
		---	---		0060/1178	LEN=0043 INSTALLED 2013
		---	---		0060/1059	024 "DIA CIRC CONCR
		---	---		0060/0974	LEN=0027 INSTALLED 2013
		---	---			024 "DIA CIRC CONCR
		---	---			LEN=0027 INSTALLED 2013
PIKE ST (TWP)	0060/0753	==				
2 0 02295 0 00 0114+85	011501 FT				011501 FT	
VILLA DR (T880)	0060/0000	==		5	0060/0000	LENGTH(AH 1233 BK 3294)
			==		0050/3135	PARK ST (T611)
		---	---		0050/3133	018 "DIA CIRC CONCR
		---	---			LEN=0025 INSTALLED UNKN
		---	---		0050/2440	018 "DIA CIRC CONCR
		---	---		0050/2219	LEN=0060 INSTALLED UNKN
		---	---			018 "DIA CIRC CONCR
		---	---		0050/1383	LEN=0030 INSTALLED UNKN
		---	---			018 "DIA CIRC CONCR
CONVERSE DR (TWP)	0050/1355	==			0050/1383	LEN=0025 INSTALLED UNKN
					0050/0682	SOUTH PARK
		---	---		0050/0647	BETHEL PARK B
		---	---			018 "DIA CIRC CONCR
		---	---		0050/0469	LEN=0035 INSTALLED UNKN
		---	---			018 "DIA CIRC CONCR
		---	---		0050/0023	LEN=0025 INSTALLED UNKN
	008207 FT	---	---		008207 FT	018 "DIA CIRC CONCR
		---	---			LEN=0060 INSTALLED UNKN
WILLIS RD (TWP)	0050/0000	==	==	5	0050/0000	2 0 02295 0 00 0088+80
						LINHART DR
						(CNTY)
						LENGTH(AH 3294 BK 2166)
					0040/1006	EAST PARK DR
		---	---		0040/0609	(CNTY)
		---	---			002"H 02"W CON BOX CUL
		---	---		0040/0168	LEN=0060 INSTALLED UNKN
	006041 FT	---	---		006041 FT	REGENCY PL
SURREY WOODS RD		---	---			(TWP)

DIR: B TOTAL LEN: 7.048 MI. DIST: 11-1 SR: 2040
 LEFT MUN: BETHEL PARK B RIGHT MUN: BETHEL PARK B

Stationing	Description	Length	Material	Notes
0040/0000	(TWP)			
0030/2316		0035	018" H 18" W CON BOX CUL	INSTALLED UNKN
0030/1846		0050	015" DIA CIRC CONCR	INSTALLED UNKN
0030/0906		0060	018" DIA CIRC CONCR	INSTALLED UNKN
003643 FT	BAPTIST RD			
0030/0000	(SR3009 SEG 0090/0000)	0035	018" DIA CIRC CONCR	INSTALLED UNKN
0020/1542		0035	018" DIA CIRC CONCR	INSTALLED UNKN
001959 FT				
0020/0000	2 0 02295 0 00 0019+75 PAXTON DR (BORO)	0020	015" DIA CIRC CONCR	INSTALLED UNKN
0010/1129		0020	015" DIA CIRC CONCR	INSTALLED UNKN
0010/1105	JORDAN ST (BORO)			
0010/0900	PINETTE ST (BORO)			
0010/0565	GERHOLD ST (BORO)			
0010/0378		0034	024" DIA CIRC CONCR	INSTALLED UNKN
0010/0344		0020	024" DIA CIRC CONCR	INSTALLED UNKN
0010/0336		0020	024" DIA CIRC CONCR	INSTALLED UNKN
000000 FT				
000000 FT	2 0 02295 0 00 0000+00 NC BR			
0010/0000	BROUGHTON RD LIBRARY RD (SR0088 SEG 0090/1635)			
0010/0000	INTER-BK BETHEL CHURCH RD (CNTY) MFC BEGIN = B			
0010/0000		1959	018" DIA CIRC CONCR	INSTALLED UNKN

BROADWAY ST
(TWP)

004468 FT
 004468 FT
 0020/0860

003608 FT

000000 FT

004468 FT	004468 FT	7030/0000	LENGTH(AH 1589 BK 0191)
004468 FT	004468 FT	004468 FT	
	* REF-AHD	7022/0000	LENGTH(AH 0191 BK 0860)
	0020/0860	0020/0860	WASHINGTON ST
			(TWP)
		0020/0850	024 " DIA CIRC CONCR
			LEN=0047 INSTALLED UNKN
		0020/0540	015 " DIA CIRC CONCR
			LEN=0080 INSTALLED UNKN
			WOOD ST
		0020/0525	(TWP)
			012 " DIA CIRC CONCR
		0020/0258	LEN=0099 INSTALLED UNKN
		003608 FT	2 0 02088 0 00 0034+25
			ELM ST
		0020/0000	(TWP)
			LENGTH(AH 0860 BK 3608)
		0010/3359	018 " DIA CIRC CONCR
			LEN=0035 INSTALLED UNKN
			MARVIN AVE
		0010/3270	(TWP)
			018 " DIA CIRC CONCR
		0010/3145	LEN=0035 INSTALLED UNKN
			015 " DIA CIRC CONCR
		0010/3000	LEN=0030 INSTALLED UNKN
			015 " DIA CIRC CONCR
		0010/2820	LEN=0035 INSTALLED UNKN
			018 " DIA CIRC CONCR
		0010/2478	LEN=0030 INSTALLED UNKN
			024 " DIA CIR PLASTIC
		0010/2280	LEN=0035 INSTALLED UNKN
			018 "H 05" W BOX CULVERT
		0010/1878	LEN=0035 INSTALLED UNKN
			018 " DIA CIRC CONCR
		0010/1423	LEN=0040 INSTALLED UNKN
		0010/0553	018 " DIA CIRC CONCR
		000000 FT	LEN=0040 INSTALLED UNKN
			2 0 02088 0 00 0000+00
			NC WA WASHINGTON RD
			WALNUT ST
			(SRO148 SEG 0141/2490)
			(SRO148 SEG 0140/2475)
			MFC BEGIN = E
		0010/0000	LENGTH(AH 3608 BK 0000)

FROM 2001/0300 SH
 (CONN)

TO 0837/0150 SH
 (CONN)

002442 FT

0010/2330

0010/0090
 000000 FT

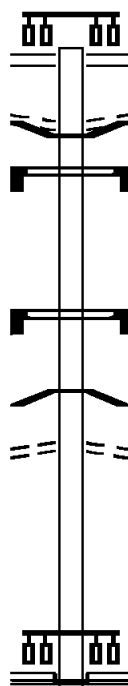

002442 FT GLASSPORT ELIZABETH RD
 (SR2001 SEG 0300/0910)
 0010/2442
 BMSID 02/2038/0010/0140
 TO 2001/0300 SH
 0010/2330 (CONN)
 SIGN: 4 CHORD TRUSS
 0010/2147 BMSID 02/2038/0010/2147

SIGN: 4 CHORD TRUSS
 0010/0363 BMSID 02/2038/0010/0363
 1 0 00736 4 00 0004+02
 MONONGAHELA
 0010/0140 BMSBG 02/2038/0010/0140
 FROM 0837/0150 SH
 0010/0090 (CONN)
 000000 FT 1 0 00736 4 00 0000+00
 NC GLASSPORT-CLAIRTON BR
 STATE ST
 (SR0837 SEG 0151/0365)
 (SR0837 SEG 0150/0360)

INTER-BK CARNEGIE ST
 (CITY)
 MFC BEGIN = C
 0010/0000 LENGTH(AH 2442 BK 0000)

024741 FT
 INTER-AHD

TRI-BORO AV
 (SR0130 SEG 0253/0000)
 SHAW ST
 (TWP)
 BROWN AV
 (SR0130 SEG 0253/0000)
 (SR0130 SEG 0252/0000)

0101/3837

018 "DIA CIRC CONCR
 LEN=0048 INSTALLED UNKN 0101/3035
 018 "DIA CIRC CONCR
 LEN=0048 INSTALLED UNKN 0101/2887

PENN AV ET
 (BORO)

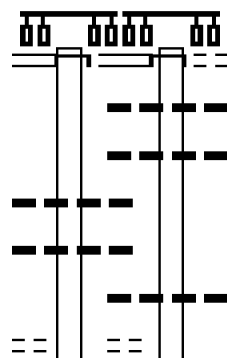

024603 FT
 INTER-AHD

TRI-BORO AV
 (SR0130 SEG 0252/0000)
 SHAW ST
 (TWP)
 BROWN AV
 (SR0130 SEG 0253/0000)
 (SR0130 SEG 0252/0000)

0100/3691

0100/3333

0100/3023

018 "DIA CIRC CONCR
 LEN=0040 INSTALLED UNKN
 018 "DIA CIRC CONCR
 LEN=0040 INSTALLED UNKN

0100/2703

018 "DIA CIRC CONCR
 LEN=0040 INSTALLED UNKN
 PENN AV ET
 (BORO)

EXTRACT DATE: 12/21/2020
PRINT DATE: 12/23/2020

ROADWAY MANAGEMENT SYSTEM
SLD COUNTY/SR - ANNUAL PRINT

PAGE NUMBER: 757
COUNTY: ALLEGHENY

DIR: B TOTAL LEN: 4.686 MI.
LEFT MUN: TURTLE CREEK B

DIST: 11-1 SR: 2037
RIGHT MUN: TURTLE CREEK B

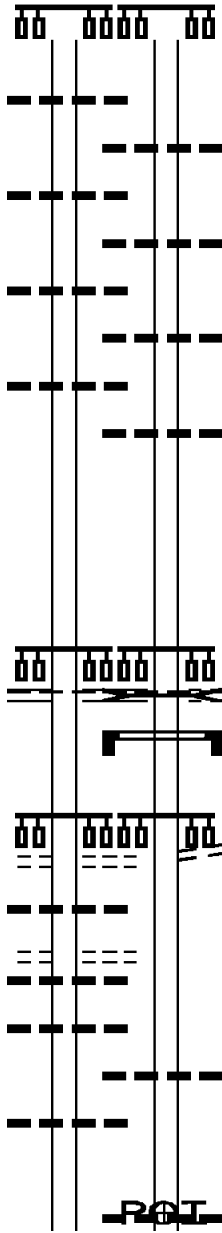

018 "DIA CIRC CONCR 0101/2481
LEN=0048 INSTALLED UNKN 0101/2232
018 "DIA CIRC CONCR 0101/2075
LEN=0099 INSTALLED UNKN 0101/2075
018 "DIA CIRC CONCR 0101/1734
LEN=0045 INSTALLED UNKN 0101/1734
018 "DIA CIRC CONCR 0101/1430
LEN=0040 INSTALLED UNKN 0101/1430

0100/2383
0100/2053
0100/1844
0100/1500
0100/1287

018 "DIA CIRC CONCR
LEN=0040 INSTALLED UNKN
018 "DIA CIRC CONCR
LEN=0099 INSTALLED UNKN
018 "DIA CIRC CONCR
LEN=0040 INSTALLED UNKN
018 "DIA CIRC CONCR
LEN=0045 INSTALLED UNKN
NC TR I-BORO AV
FALLS RUN
STRUCTURE LENGTH 12 FT
BMSID 02/2112/0030/0000
BRADDOCK AV
(BORO)
ELECTRIC AV
(SR2112 SEG 0020/2791)

ELECTRIC AV
(SR2112 SEG 0020/2687)
TURTLE CREEK
EAST PITTSBURGH B 0101/1371

0100/1263
0100/1100
0100/0895
TURTLE CREEK
EAST PITTSBURGH B
SIGN: 3 CHORD TRUSS
BMSID 02/2037/0100/1100
LC TO BRADDOCK AV
(BORO)
BEECH ST
(BORO)

BEECH ST
(BORO)
018 "DIA CIRC CONCR 0101/1012
LEN=0024 INSTALLED UNKN 0101/0949
CABLE AV
(BORO) 0101/0712
LEN=0024 INSTALLED UNKN 0101/0710
018 "DIA CIRC CONCR 0101/0708
LEN=0024 INSTALLED UNKN 0101/0708
018 "DIA CIRC CONCR 0101/0404
LEN=0024 INSTALLED UNKN 0101/0404

0100/0595
0100/0570
(APRA) KEYSTONE COMMONS
018 "DIA CIRC CONCR
LEN=0113 INSTALLED UNKN
KEYSTONE COMMONS ENT RD

EXTRACT DATE: 12/21/2020
PRINT DATE: 12/23/2020

ROADWAY MANAGEMENT SYSTEM
SLD COUNTY/SR - ANNUAL PRINT

PAGE NUMBER: 754
COUNTY: ALLEGHENY

DIR: B TOTAL LEN: 4.686 MI.
LEFT MUN: NORTH VERSAILLES T

DIST: 11-1 SR: 2037
RIGHT MUN: NORTH VERSAILLES T

Segment Description	Stationing	Length	Material	Notes
018 "DIA CIRC CONCR LEN=0040 INSTALLED UNKN	0061/0422	0060/1045	LEN=0040	INSTALLED UNKN
1 0 01074 0 00 0000+00 011552 FT PORT PERRY RD (TWP) NAVY MARINE CORP WY (SR2068 SEG 0011/0000) (SR2068 SEG 0010/0000)	0061/0000	0060/0753	LEN=0040	INSTALLED UNKN
MFC BEGIN = B LENGTH(AH 2520 BK 1959)	0061/0000	0060/0225	LEN=0040	INSTALLED UNKN
LC FROM PORT PERRY RD (CONN)	0051/1840	011545 FT	011545 FT	
MARYLAND AV (TWP)	0051/0805	0050/1850	LEN=0040	INSTALLED UNKN
PINE WY (TWP)	0051/0250	0050/1736	LEN=0040	INSTALLED UNKN
2 0 02291 0 00 0029+52 009593 FT OVERHILL DR (TWP) LENGTH(AH 1959 BK 2475) PINE WY (TWP)	0051/0000	0050/1479	LEN=0040	INSTALLED UNKN
BROWN PL (TWP)	0041/1430	0050/1276	LEN=0040	INSTALLED UNKN
SPRUCE WY	0040/1361	0050/0776	LEN=0040	INSTALLED UNKN
		0050/0511	LEN=0040	INSTALLED UNKN
		0050/0505	LEN=0040	INSTALLED UNKN
		0050/0214	LEN=0040	INSTALLED UNKN
		0050/0194	LEN=0040	INSTALLED UNKN
		0050/0000	LEN=0040	INSTALLED UNKN
		0040/2035	LEN=0099	INSTALLED UNKN
		0040/1906	LEN=0099	INSTALLED UNKN
		0040/1435	LEN=0099	INSTALLED UNKN
		0040/1361	LEN=0099	INSTALLED UNKN

	004421 FT				004421 FT ALICE MINE RD
					0020/1328 ROAD CLOSED BACK
2 0 02081 0 00 0031+64	003093 FT				ALICE MINE RD
FOSTER ST	0020/0000				ROAD CLOSED AHEAD
(BORO)	0010/2915				0020/0246
WALL AV					003093 FT
(BORO)					0020/0000 LENGTH(AH 1328 BK 3093)
					0010/2637 048 " DIA CIRC CONCR
					LEN=2637 INSTALLED UNKN
					024 " DIA CIRC CONCR
					LEN=0040 INSTALLED UNKN
					JEFFERSON HILLS
					CLAIRTON C
					CLAIRTON
					JEFFERSON HILLS B
					SHORT ST
					(BORO)
					024 " DIA CIRC CONCR
					LEN=0040 INSTALLED UNKN
					024 " DIA CIRC CONCR
					LEN=0100 INSTALLED UNKN
					024 " DIA CIRC CONCR
					LEN=0070 INSTALLED UNKN
					2 0 02081 0 00 0000+00
					CLAIRTON RD
					(SR0885 SEG 0040/0000)
					NC WA LL RD
					MFC BEGIN = E
CLAIRTON RD					0010/0000 LENGTH(AH 3093 BK 0000)
(SR0885 SEG 0040/0000)	0010/0000				

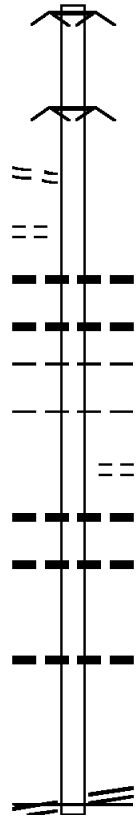

DIR: B TOTAL LEN: 2.089 MI. DIST: 11-1 SR: 2035
 LEFT MUN: NORTH VERSAILLES T RIGHT MUN: NORTH VERSAILLES T

Stationing	Segment	Description	Material	Status
011029 FT	0040/3558	LINCOLN HW	HW	INSTALLED UNKN
	0040/3346	(SR0030 SEG 0321/0905)		
	0040/3006	(SR0030 SEG 0320/0895)		
	0040/2687	018 " DIA CIRC CONCR		
	0040/2412	LEN=0040 INSTALLED UNKN		
		021 " DIA CIRC CONCR		
		LEN=0020 INSTALLED UNKN		
		018 " DIA CIRC CONCR		
		LEN=0040 INSTALLED UNKN		
		021 " DIA CIRC CONCR		
		LEN=0015 INSTALLED UNKN		
		036 " DIA CIRC CONCR		
		LEN=0040 INSTALLED UNKN		
		030 " DIA CIRC CONCR		
		LEN=0072 INSTALLED UNKN		
		018 " DIA CIRC CONCR		
		LEN=0040 INSTALLED UNKN		
		DENNING WY		
		(TWP)		
		036 " DIA CIRC CONCR		
		LEN=0030 INSTALLED UNKN		
		007471 FT		
		2 0 02029 0 00 0075+05		
		LENTH(AH 3558 BK 3683)		
		018 " DIA CIRC CONCR		
		LEN=0067 INSTALLED UNKN		
		018 " DIA CIRC CONCR		
		LEN=0035 INSTALLED UNKN		
		018 " DIA CIRC CONCR		
		LEN=0035 INSTALLED UNKN		
		NORTH VERSAILLES		
		WHITE OAK B		

NITA ST
(TWP)

0040/2395

007471 FT

UPPER HECKMAN RD
(TWP)

0030/2589

DIR: B TOTAL LEN: 2.089 MI. DIST: 11-1 SR: 2035
 LEFT MUN: NORTH VERSAILLES T RIGHT MUN: NORTH VERSAILLES T

Stationing	Description	Material	Length	Status
0030/1714	018 " DIA	CIRC CONCR	LEN=0030	INSTALLED UNKN
0030/1390	036 " DIA	CIRC CONCR	LEN=0030	INSTALLED UNKN
0030/0980	018 " DIA	CIRC CONCR	LEN=0045	INSTALLED UNKN
0030/0640	018 " DIA	CIRC CONCR	LEN=0050	INSTALLED UNKN
0030/0009	BMS EN 02/2035/0030/0000			
003788 FT	2 0 02029 0 00 0038+22			
	BR JACKS RUN			
0030/0000	BMSBG 02/2035/0030/0000			
0020/1111	LENGTH(AH 3683 BK 1352)			
	BMS EN 02/2035/0020/1103			
	2 0 02029 0 00 0035+70			
	BR JACKS RUN			
0020/1103	BMSBG 02/2035/0020/1103			
0020/0595	018 " DIA	CIRC CONCR	LEN=0035	INSTALLED UNKN
0020/0360	018 " DIA	CIRC CONCR	LEN=0030	INSTALLED UNKN
0020/0026	018 " DIA	CIRC CONCR	LEN=0035	INSTALLED UNKN
002436 FT				
0020/0000	LENGTH(AH 1352 BK 2436)			
0010/1936	018 " DIA	CIRC CONCR	LEN=0030	INSTALLED UNKN
0010/1726	018 " DIA	CIRC CONCR	LEN=0035	INSTALLED UNKN
0010/1415	018 " DIA	CIRC CONCR	LEN=0035	INSTALLED UNKN
0010/1328	018 " DIA	CIRC CONCR	LEN=0035	INSTALLED UNKN
0010/1230	018 " DIA	CIRC CONCR	LEN=0035	INSTALLED UNKN
0010/0833	018 " DIA	CIRC CONCR	LEN=0035	INSTALLED UNKN
0010/0279	006 " DIA	CIR PLASTIC	LEN=0180	INSTALLED UNKN
0010/0033	024 " DIA	CIRC METAL	LEN=0072	INSTALLED UNKN
000000 FT	2 0 02029 0 00 0000+00			
	NC MC			
	JACKS RUN RD			
	(SRO048 SEG 0240/0110)			
	MFC BEGIN = E			
0010/0000	LENGTH(AH 2436 BK 0000)			

EXTRACT DATE: 12/21/2020 ROADWAY MANAGEMENT SYSTEM PAGE NUMBER: 748
 PRINT DATE: 12/23/2020 SLD COUNTY/SR - ANNUAL PRINT COUNTY: ALLEGHENY
 DIR: B TOTAL LEN: 1.122 MI. DIST: 11-1 SR: 2034
 LEFT MUN: WEST MIFFLIN B RIGHT MUN: WEST MIFFLIN B

005925 FT

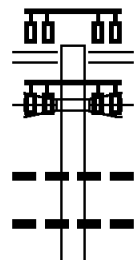

005925 FT DRAVOSBURG RD
 (SR0837 SEG 0200/0000)
 0030/0893
 0030/0845 UNION & PENNSYLVANIA &
 0030/0842 OVERPASS IS RR X-ING
 (BORO)
 0030/0463 01B " DIA CIRC METAL
 LEN=0040 INSTALLED UNKN
 0030/0224 01B " DIA CIRC CONCR
 LEN=0014 INSTALLED UNKN

KINGS RD

DIR: B TOTAL LEN: 1.122 MI. DIST: 11-1 SR: 2034
 LEFT MUN: WEST MIFFLIN B RIGHT MUN: WEST MIFFLIN B

Location / Segment	Segment ID	Length (FT)	Notes / Details
(BORO)	0030/0140	005032	FT
LIBRTRY PULTRUSIONS ENT (PRDR)	0020/0980		
MCGOWAN AV (BORO)	0020/0315		
PEAR AL (BORO)	0020/0131	003687	FT
GM METAL FAB DIV ENT RD (PRDR)	0010/3448		
GM METAL FAB DIV ENT RD (PRDR)	0010/3255		
LEBANON SCHOOL RD (BORO)	0010/1955		
MAXIM CRANE ENT RD (PRDR)	0010/0222	000000	FT
CAMP HOLLOW RD (SR2043 SEG 0030/0000)	0010/0000		
	005032	FT	2 0 02101 0 03 0111+08 UNION & PENNSYLVANIA & OVERPASS IS RR X-ING
	0030/0000		LENGTH(AH 0893 BK 1345) 018 "DIA CIRC CONCR
	0020/1219		LEN=0040 INSTALLED UNKN
	0020/0908		018 "DIA CIRC CONCR LEN=0040 INSTALLED UNKN
	0020/0255		018 "DIA CIRC CONCR LEN=0040 INSTALLED UNKN
	003687	FT	2 0 02101 0 03 0097+90 UNION & PENNSYLVANIA & OVERPASS IS RR X-ING
	0020/0000		LENGTH(AH 1345 BK 3687) (APRA) USX MON VALLEY-1 MON VALLEY-IRVIN WORKS
	0010/3555		(PRDR) (APRA) GM METAL FAB DIV MON VALLEY-IRVIN WORKS
	0010/3448		(PRDR)
	0010/3065		018 "DIA CIRC CONCR LEN=0040 INSTALLED UNKN
			NC LEBANON SCHOOL RD
	0010/0274		FOR SR 2034 AND 2043 (CONN)
	0010/0222	000000	FT (APRA) MAXIM CRANE RENT CAMP HOLLOW RD (SR2043 SEG 0030/0000) NC PHILLIP MURRAY RD MFC BEGIN = D
	0010/0000		LENGTH(AH 3687 BK 0000)

EXTRACT DATE: 12/21/2020 ROADWAY MANAGEMENT SYSTEM PAGE NUMBER: 745
 PRINT DATE: 12/23/2020 SLD COUNTY/SR - ANNUAL PRINT COUNTY: ALLEGHENY
 DIR: B TOTAL LEN: 1.452 MI. DIST: 11-1 SR: 2032
 LEFT MUN: WEST MIFFLIN B RIGHT MUN: WEST MIFFLIN B

Street Name	City	Stationing	Length (FT)	Structure Details
TIMOTHY DR	(CITY)	0030/1530	007664	0030/2658 (CNTY) 060"H 60"W CON BOX CUL LEN=0035 INSTALLED UNKN 018" DIA CIR PLASTIC
GINA DR	(CITY)	0030/0425	007664	0030/2140 LEN=0030 INSTALLED UNKN 018"H 18"W CON BOX CUL 0030/2070 LEN=0030 INSTALLED UNKN 018" DIA CIRC METAL
PINE RUN RD	(CITY)	0030/0155	007664	0030/1737 LEN=0040 INSTALLED UNKN 018" DIA CIRC CONCR 0030/1183 LEN=0030 INSTALLED UNKN 018" DIA CIRC CONCR 0030/0350 LEN=0099 INSTALLED UNKN

DIR: B TOTAL LEN: 1.452 MI. DIST: 11-1 SR: 2032
 LEFT MUN: WEST MIFFLIN B RIGHT MUN: WEST MIFFLIN B

Stationing	Description	Material	Length	Notes
005006 FT				
0020/1490	FROM 0885/0091 SH (CONN)			
0020/0850	NORTH AV (CITY)			
0020/0771	KELLY LN (PRDR)			
003392 FT				
0020/0000	WEST MIFFLIN PLEASANT HILLS B			
0010/0105				
000000 FT				
0010/0220 SH (CONN)				
005006 FT				
0030/0000	MFC BEGIN = D LENGTH(AH 2658 BK 1614)			
0020/1440	024 " DIA CIRC METAL LEN=0020			INSTALLED UNKN
0020/0722	030 " DIA CIRC CONCR LEN=0035			INSTALLED UNKN
003392 FT				
0020/0000	WEST MIFFLIN JEFFERSON HILLS B LENGTH(AH 1614 BK 3392)			
0010/3300	018 " DIA CIRC CONCR LEN=0099			INSTALLED UNKN
0010/1513	STEEL CENTER VO TECH EN (PRDR)			
0010/1331	018 " DIA CIRC METAL LEN=0030			INSTALLED UNKN
0010/0942	JEFFERSON HILLS PLEASANT HILLS B			
0010/0572	036 " DIA CIRC METAL LEN=0050			INSTALLED UNKN
0010/0570	048 " DIA CIRC METAL LEN=0040			INSTALLED UNKN
000000 FT				
NC LEWIS RUN RD				
000000 FT				
0010/0000	CLAIRTON BL (SR0051 SEG 0221/1049) (SR0051 SEG 0220/0975)			
0010/0000	INTER-BK LINDSAY SNYDER DR (BORO) MFC BEGIN = C LENGTH(AH 3392 BK 0000)			

DIR: B TOTAL LEN: 5.324 MI. DIST: 11-1 SR: 2031
 LEFT MUN: NORTH VERSAILLES T RIGHT MUN: NORTH VERSAILLES T

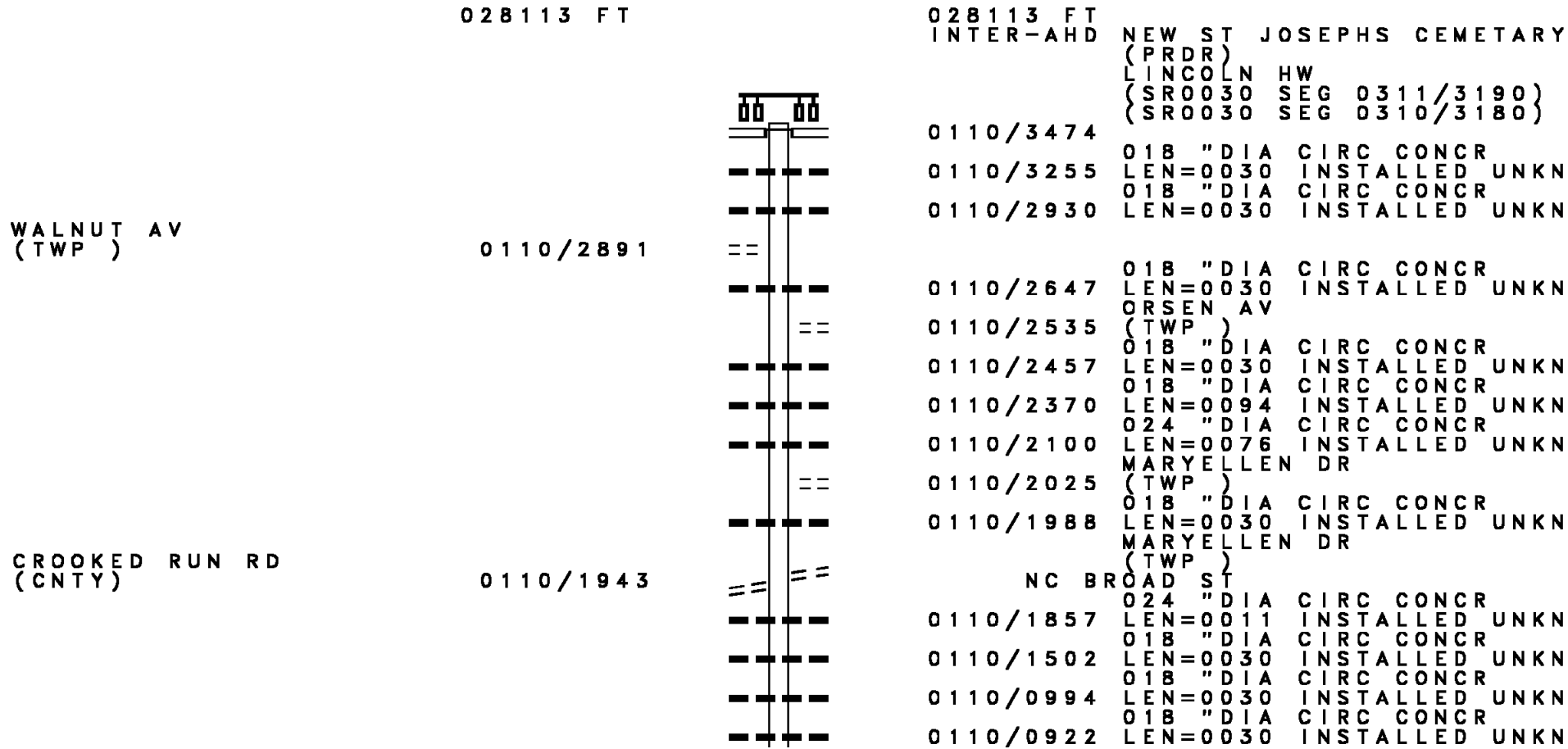

028113 FT

028113 FT
 INTER-AHD

NEW ST JOSEPHS CEMETARY
 (PRDR)
 LINCOLN HW
 (SR0030 SEG 0311/3190)
 (SR0030 SEG 0310/3180)

0110/3474
 0110/3255
 0110/2930

018 "DIA CIRC CONCR
 LEN=0030 INSTALLED UNKN
 018 "DIA CIRC CONCR
 LEN=0030 INSTALLED UNKN

0110/2891

0110/2647
 0110/2535

018 "DIA CIRC CONCR
 LEN=0030 INSTALLED UNKN
 ORSEN AV
 (TWP)

WALNUT AV
 (TWP)

0110/2457
 0110/2370
 0110/2100

018 "DIA CIRC CONCR
 LEN=0030 INSTALLED UNKN
 018 "DIA CIRC CONCR
 LEN=0094 INSTALLED UNKN
 024 "DIA CIRC CONCR
 LEN=0076 INSTALLED UNKN

0110/2025
 0110/1988

018 "DIA CIRC CONCR
 LEN=0030 INSTALLED UNKN
 MARYELLEN DR
 (TWP)

CROOKED RUN RD
 (CNTY)

0110/1943

0110/1857
 0110/1502

024 "DIA CIRC CONCR
 LEN=0011 INSTALLED UNKN
 018 "DIA CIRC CONCR
 LEN=0030 INSTALLED UNKN

0110/0994
 0110/0922

018 "DIA CIRC CONCR
 LEN=0030 INSTALLED UNKN
 018 "DIA CIRC CONCR
 LEN=0030 INSTALLED UNKN

NC BR ROAD ST

DIR: B TOTAL LEN: 5.324 MI. DIST: 11-1 SR: 2031
 LEFT MUN: NORTH VERSAILLES T RIGHT MUN: NORTH VERSAILLES T

Street Name	Stationing	Material	Length	Notes
	0110/0644	024 " DIA CIRC METAL	LEN=0030	INSTALLED UNKN
024639 FT	024639 FT	1 0 00288 0 00 0808+57		DIANE DR (TWP)
	0110/0000			LENGTH(AH 3474 BK 2213)
	0100/1102	024 " DIA CIRC CONCR	LEN=0056	INSTALLED UNKN
	0100/0785	HERBERT ST (TWP)		
BLANCHARD LN (TWP)	0100/0140	018 " DIA CIRC CONCR	LEN=0030	INSTALLED UNKN
	0100/0018	018 " DIA CIRC METAL	LEN=0030	INSTALLED UNKN
022426 FT	022426 FT	1 0 00288 0 00 0786+40		MILLARD AV (TWP)
	0100/0000			LENGTH(AH 2213 BK 3943)
	0090/3550	018 " DIA CIRC CONCR	LEN=0030	INSTALLED UNKN
NAYSMITH RD (TWP)	0090/3515			
	0090/2951	015 " DIA CIRC CONCR	LEN=0035	INSTALLED UNKN
	0090/2310	015 " DIA CIRC CONCR	LEN=0035	INSTALLED UNKN
	0090/2245	HECKMAN RD (TWP)		NORTH VERSAILLES WHITE OAK B
	0090/1551	024 " DIA CIRC CONCR	LEN=0030	INSTALLED UNKN
	0090/1330	CARMELLA DR (TWP)		
018483 FT	018483 FT	1 0 00288 0 00 0747+03		CARMELLA DR (TWP)
	0090/0000			LENGTH(AH 3943 BK 1034)
	0080/0927	ALLEY (BORO)		

DIR: B TOTAL LEN: 5.324 MI. DIST: 11-1 SR: 2031
 LEFT MUN: WHITE OAK B RIGHT MUN: WHITE OAK B

Street Name	Segment ID	Length	Material	Notes
	0070/1985		FOSTER ST (BORO)	
	0070/1599		024" DIA CIRC CONCR	LEN=0030 INSTALLED UNKN
	0070/1570		CENTER ST (BORO)	
	0070/1553		024" DIA CIRC CONCR	LEN=0088 INSTALLED UNKN
	0070/0970		AULD ST (BORO)	
	0070/0763		024" DIA CIRC CONCR	LEN=0011 INSTALLED 2013
	0070/0377		024" DIA CIRC CONCR	LEN=0035 INSTALLED 2013
MYERS LN (BORO)	0070/0295	013820 FT		
			1 0 00288 0 00 0700+49	MCCLURE LN (BORO)
UNKNOWN RD (PRDR)	0060/3605			LENGTH(AH 3629 BK 3708)
	0060/2922		KELLY ST (BORO)	
	0060/2354		WILLARD ST (BORO)	
	0060/2103		024" DIA CIRC CONCR	LEN=0015 INSTALLED 2013
COOK ST (BORO)	0060/2038			
HENDERSON RD (BORO)	0060/1867		GUICE ST (BORO)	
	0060/1786		024" DIA CIRC CONCR	LEN=0015 INSTALLED 2013
	0060/0034	010112 FT		024" DIA CIRC CONCR
			1 0 00288 0 00 0662+78	ENT TO SHOPPING CENTER (PRDR)
TO 0048/0211 SH (CONN)	0040/0354			LENGTH(AH 3708 BK 0754)
	0040/0334			FROM 0048/0220 SH (CONN)

EXTRACT DATE: 12/21/2020
PRINT DATE: 12/23/2020

ROADWAY MANAGEMENT SYSTEM
SLD COUNTY/SR - ANNUAL PRINT

PAGE NUMBER: 739
COUNTY: ALLEGHENY

DIR: B TOTAL LEN: 5.324 MI.
LEFT MUN: WHITE OAK B

DIST: 11-1 SR: 2031
RIGHT MUN: WHITE OAK B

LONG RUN RD
(SR0048 SEG 0220/0000) 0040/0232

FROM 0048/0210 SH
(CONN) 0040/0113

009358 FT

OAKVIEW DR
(BORO) 0030/1585

005913 FT

WHITE OAK BORO ST DEPT
(BORO) 0020/2251



0040/0232

0040/0200

0040/0100

0040/0032

009358 FT

0040/0000

0030/3225

0030/2436

0030/2404

0030/1908

0030/1896

0030/1836

0030/1775

0030/1411

0030/0946

0030/0740

005913 FT

0030/0000

0020/2641

0020/1949

JACKS RUN RD
(SR0048 SEG 0220/0000)

018 "DIA CIRC CONCR
LEN=0050 INSTALLED UNKN

018 "DIA CIRC CONCR
LEN=0099 INSTALLED UNKN
BMSSEN 02/2031/0040/0000
BRIDGE POSTED (TONS)
2 0 02310 0 00 0002+21
SGL 33 COMB 40

LONG RUN
BMSBG 02/2031/0040/0000
LENGTH(AH 0754 BK 3445)
018 "DIA CIRC CONCR
LEN=0060 INSTALLED UNKN

BMSSEN 02/2031/0030/2404
2 0 02310 0 00 0036+98

LONG RUN
BMSBG 02/2031/0030/2404
LC FROM OAK PARK MALL
(CONN)

018 "DIA CIRC CONCR
LEN=0071 INSTALLED UNKN
ENTR OAK PARK MALL
(PRDR)

LC TO OAK PARK MALL
(CONN)

030 "DIA CIRC CONCR
LEN=0040 INSTALLED UNKN
018 "DIA CIRC CONCR
LEN=0035 INSTALLED UNKN
018 "DIA CIRC CONCR
LEN=0030 INSTALLED UNKN

2 0 02310 0 00 0036+98
LENGTH(AH 3445 BK 2641)

048 "DIA CIRC CONCR
LEN=0080 INSTALLED UNKN

018 "DIA CIRC CONCR
LEN=0040 INSTALLED UNKN
018 "DIA CIRC CONCR

EXTRACT DATE: 12/21/2020
PRINT DATE: 12/23/2020

ROADWAY MANAGEMENT SYSTEM
SLD COUNTY/SR - ANNUAL PRINT

PAGE NUMBER: 738
COUNTY: ALLEGHENY

DIR: B TOTAL LEN: 5.324 MI.
LEFT MUN: WHITE OAK B

DIST: 11-1 SR: 2031
RIGHT MUN: WHITE OAK B

RANKIN RD
(BORO)

0020/0220

003272 FT

COULTERVILLE RD
(CNTY)

0010/1731

000000 FT

0020/1729	LEN=0050	INSTALLED UNKN
0020/1467	MCCCLINTOCK RD (SR2024 SEG 0010/0000)	
0020/1353	018 "DIA CIRC CONCR	LEN=0080 INSTALLED UNKN
0020/0894	018 "DIA CIRC CONCR	LEN=0099 INSTALLED UNKN
0020/0690	018 "DIA CIRC CONCR	LEN=0030 INSTALLED UNKN
0020/0315	018 "DIA CIRC CONCR	LEN=0030 INSTALLED UNKN
0020/0048	018 "DIA CIR PLASTIC	LEN=0080 INSTALLED UNKN
0020/0025	015 "DIA CIRC CONCR	LEN=0040 INSTALLED UNKN
0020/0000	2 0 02310 0 00 0063+37	STEWARTSVILLE HOLLOW RD (SR2022 SEG 0010/0000)
0010/3263	LENGTH(AH 2641 BK 3272)	BMS EN 02/2031/0010/3245
0010/3245	2 0 02310 0 00 0063+86	BR. LONG RUN
0010/2755	BMS BG 02/2031/0010/3245	018 "DIA CIRC CONCR
0010/2097	LEN=0035	INSTALLED UNKN
0010/2081	018 "DIA CIRC CONCR	LEN=0030 INSTALLED UNKN
0010/1731	MASON RD (BORO)	018 "DIA CIRC CONCR
0010/1682	LEN=0060	INSTALLED UNKN
0010/0697	018 "DIA CIRC CONCR	LEN=0035 INSTALLED UNKN
0010/0045	018 "DIA CIRC CONCR	LEN=0035 INSTALLED UNKN
000000 FT	2 0 02310 0 00 0096+24	NC LINCOLN WY
* REF-BK	LINCOLN WY (SR3022 SEG 0010/0000)	MFC BEGIN = C
0010/0000	BK-WESTMORELAND (64)	LENGTH(AH 3272 BK 0000)

DIR: B TOTAL LEN: 2.141 MI. DIST: 11-1 SR: 2030
 LEFT MUN: CLAIRTON C RIGHT MUN: CLAIRTON C

011304 FT

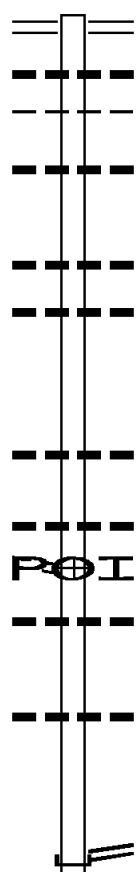

011304 FT STATE ST
 0040/2162 (SR0837 SEG 0170/1555)
 030 "DIA CIRC CONCR
 0040/1810 LEN=0045 INSTALLED UNKN
 CLAIRTON
 0040/1750 JEFFERSON HILLS B
 060 "DIA CIRC METAL
 0040/1203 LEN=0040 INSTALLED UNKN

009142 FT

0040/0255 048 "DIA CIRC CONCR
 LEN=0075 INSTALLED UNKN
 018 "DIA CIRC CONCR
 0040/0085 LEN=0040 INSTALLED 2002
 009142 FT 2 0 02182 0 00 0090+47
 0040/0000 LENGTH(AH 2162 BK 3423)

DUQUESNE LIGHT RD
 (PRDR)

0030/1488



0030/2391 018 "DIA CIRC CONCR
 LEN=0035 INSTALLED UNKN
 0030/1537 018 "DIA CIRC CONCR
 LEN=0035 INSTALLED UNKN
 0030/1488 (APRA) MT VIEW SUBSTATI
 018 "DIA CIRC CONCR
 0030/1163 LEN=0040 INSTALLED UNKN

005719 FT

0030/0047 018 "DIA CIRC CONCR
 LEN=0030 INSTALLED UNKN
 005719 FT 2 0 02182 0 00 0056+52
 CLAIRTON RD
 (SR0885 SEG 0040/2510)
 LLER RD
 INTER-BK MI CLAIRTON RD
 (SR0885 SEG 0040/2510)

DIR: B TOTAL LEN: 2.141 MI. DIST: 11-1 SR: 2030
 LEFT MUN: JEFFERSON HILLS B RIGHT MUN: JEFFERSON HILLS B

CLAIRTON RD
 (SR0885 SEG 0050/0000)
 FOR SR 0885 AND 2030
 (CONN)

005719 FT

0020/2567
 0020/2324

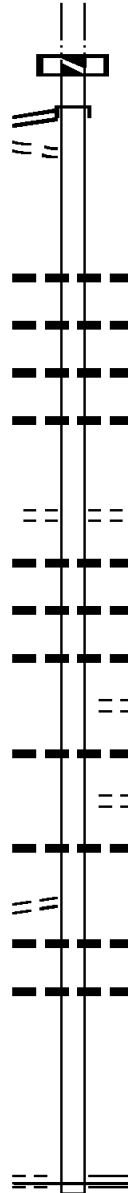

0030/0000 LTH AH 003423 BK 000100
 005719 FT
 7024/0000 LTH AH 000100 BK 002567
 INTER-AHD CLAIRTON RD
 0020/2567 (SR0885 SEG 0050/0000)

003152 FT

0020/1080 018 " DIA CIRC CONCR
 LEN=0030 INSTALLED UNKN
 0020/0568 018 " DIA CIRC CONCR
 LEN=0099 INSTALLED UNKN
 0020/0235 018 " DIA CIRC CONCR
 LEN=0035 INSTALLED UNKN
 0020/0036 018 " DIA CIRC METAL
 LEN=0099 INSTALLED UNKN
 003152 FT 2 0 02182 0 00 0030+84
 SAMUEL DR

0020/0000 LENGTH(AH 2567 BK 3152)
 0010/2718 018 " DIA CIRC METAL
 LEN=0099 INSTALLED UNKN
 0010/2254 018 " DIA CIRC METAL
 LEN=0099 INSTALLED UNKN
 0010/2067 018 " DIA CIRC METAL
 LEN=0099 INSTALLED UNKN
 PAYNE HILL EST RD
 0010/2036 (PRDR)
 0010/1914 018 " DIA CIRC METAL
 LEN=0040 INSTALLED 2002
 REEDSDALE DR
 0010/1725 (BORO)
 0010/1289 024 " DIA CIRC CONCR
 LEN=0050 INSTALLED UNKN

OLD PAYNE HILL RD
 (BORO)

0010/0810

000000 FT











0010/0556 028 " DIA CIRC CONCR
 LEN=0040 INSTALLED 2002
 0010/0065 030 " DIA CIRC CONCR
 LEN=0030 INSTALLED UNKN
 000000 FT 2 0 02182 0 00 0000+00
 NC PA A
 TURNPIKE RAMP RD TOLL 4
 (TNPK)
 TURNPIKE RAMP RD TOLL 4
 (TNPK)
 MFC BEGIN = E

JEFFERSON BL
 (TNPK)

0010/0000

0010/0000 LENGTH(AH 3152 BK 0000)

EXTRACT DATE: 12/21/2020 ROADWAY MANAGEMENT SYSTEM PAGE NUMBER: 735
 PRINT DATE: 12/23/2020 SLD COUNTY/SR - ANNUAL PRINT COUNTY: ALLEGHENY
 DIR: B TOTAL LEN: .000 MI. DIST: 11-1 SR: 2029
 LEFT MUN: CLAIRTON C RIGHT MUN: CLAIRTON C

000000 FT		000000 FT	
000000 FT		7060/0000	LENGTH(AH 0145 BK 2858)
000000 FT		000000 FT	
000000 FT		7050/0000	LENGTH(AH 2858 BK 2488)
000000 FT		000000 FT	
000000 FT		7040/0000	LENGTH(AH 2488 BK 2557)
000000 FT		000000 FT	
000000 FT		7030/0000	LENGTH(AH 2557 BK 4162)
000000 FT		000000 FT	
000000 FT		7020/0000	LENGTH(AH 4162 BK 1015)
		000000 FT	
		7010/0000	LENGTH(AH 1015 BK 0000)

EXTRACT DATE: 12/21/2020 ROADWAY MANAGEMENT SYSTEM PAGE NUMBER: 734
 PRINT DATE: 12/23/2020 SLD COUNTY/SR - ANNUAL PRINT COUNTY: ALLEGHENY
 DIR: B TOTAL LEN: 4.519 MI. DIST: 11-1 SR: 2028
 LEFT MUN: CLAIRTON C RIGHT MUN: CLAIRTON C

023861 FT

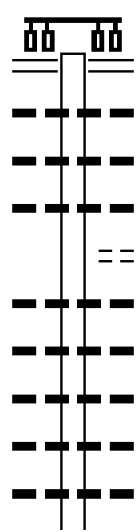

023861 FT	STATE ST	(SR0837	SEG 0100/0000)
0090/2021	018 " DIA	CIRC	CONCR
0090/1930	LEN=0030	INSTALLED	UNKN
0090/1744	018 " DIA	CIRC	CONCR
0090/1585	LEN=0030	INSTALLED	UNKN
0090/1465	036 " DIA	CIRC	CONCR
0090/1400	LEN=0167	INSTALLED	UNKN
0090/1185	HILL ST		
0090/0983	(CITY)		
0090/0790	018 " DIA	CIRC	CONCR
0090/0585	LEN=0030	INSTALLED	UNKN
	018 " DIA	CIRC	CONCR
	LEN=0030	INSTALLED	UNKN
	018 " DIA	CIRC	CONCR
	LEN=0030	INSTALLED	UNKN
	018 " DIA	CIRC	CONCR
	LEN=0035	INSTALLED	UNKN
	018 " DIA	CIRC	CONCR

DIR: B TOTAL LEN: 4.519 MI. DIST: 11-1 SR: 2028
 LEFT MUN: CLAIRTON C RIGHT MUN: CLAIRTON C

THIRD ST
 (CITY)
 CHERRY AV
 (CITY)

021840 FT

0090/0000

0080/1850

---	0090/0387	LEN=0035	INSTALLED UNKN
---	0090/0201	LEN=0099	INSTALLED 2012
---	0090/0052	LEN=0035	INSTALLED UNKN
---	021840 FT	2 0 02360	0 00 0072+27
---		THIRD ST	
==	0090/0000	LENGTH(AH 2021 BK 1979)	
==	0080/1850		
---	0080/1849	LEN=0126	INSTALLED UNKN
---	0080/1681	LEN=0035	INSTALLED UNKN
---		STEWART AV	
==	0080/1670		
---	0080/1544	LEN=0035	INSTALLED UNKN
---		MILLER AV	
==	0080/1541		
---	0080/1476	LEN=0035	INSTALLED UNKN
---	0080/1397	LEN=0035	INSTALLED UNKN
---		MULBERRY AV	
==	0080/1390		
---		FIFTH ST	
==	0080/0926		
---	0080/0925	LEN=0035	INSTALLED UNKN
---	0080/0878	LEN=0003	INSTALLED UNKN
---	0080/0875	LEN=0035	INSTALLED 2002
---	0080/0637	LEN=0030	INSTALLED UNKN
---	0080/0391	LEN=0035	INSTALLED UNKN
---		SIXTH ST	
==	0080/0380		
---	0080/0185	LEN=0002	INSTALLED UNKN
---		FROM 2028/0070 SH	
---	0080/0145	(CONN)	
---	019861 FT	2 0 02360	0 00 0052+47
---		NC ST CLAIR AV	
---	0080/0000	LENGTH(AH 1979 BK 3531)	

ST CLAIR AV
 (CITY)

019861 FT

0080/0000

EXTRACT DATE: 12/21/2020
PRINT DATE: 12/23/2020

ROADWAY MANAGEMENT SYSTEM
SLD COUNTY/SR - ANNUAL PRINT

PAGE NUMBER: 732
COUNTY: ALLEGHENY

DIR: B TOTAL LEN: 4.519 MI.
LEFT MUN: CLAIRTON C

DIST: 11-1 SR: 2028
RIGHT MUN: CLAIRTON C

WORTHINGTON AV
(CITY)

0070/3020

JEFFERSON DR
(CITY)

0070/1600

WASHINGTON AV
(CITY)

0070/0355

SOLTIS DR
(CITY)
PEARL DR
(CITY)

016330 FT

0070/0000

0060/1657

014603 FT

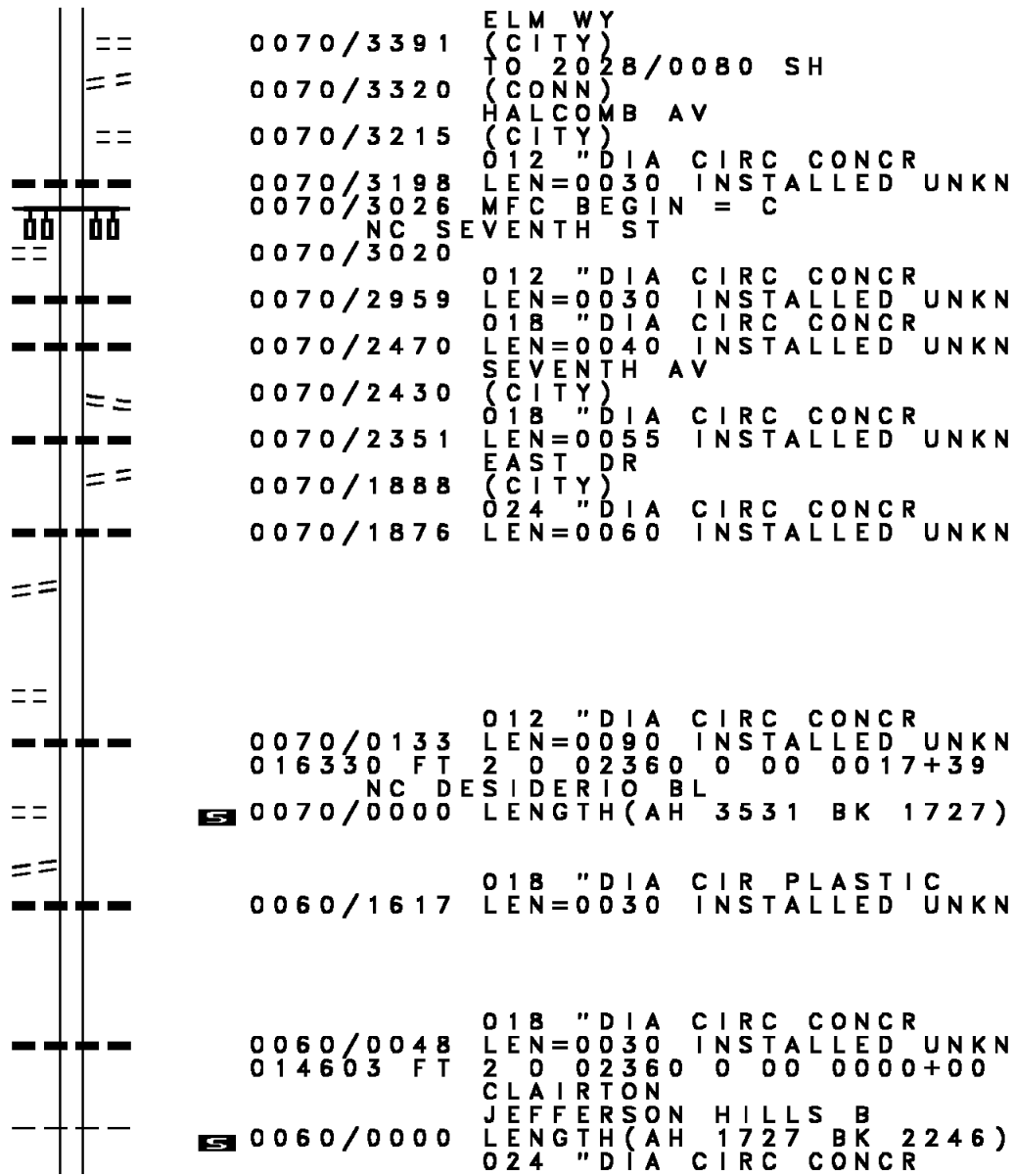

0070/3391 ELM WY
(CITY)
TO 2028/0080 SH
0070/3320 (CONN)
HALCOMB AV
0070/3215 (CITY)
012 " DIA CIRC CONCR
LEN=0030 INSTALLED UNKN
0070/3198 MFC BEGIN = C
0070/3026 NC SEVENTH ST
0070/3020 012 " DIA CIRC CONCR
LEN=0030 INSTALLED UNKN
0070/2959 018 " DIA CIRC CONCR
LEN=0040 INSTALLED UNKN
0070/2470 SEVENTH AV
(CITY)
0070/2430 018 " DIA CIRC CONCR
LEN=0055 INSTALLED UNKN
0070/2351 EAST DR
(CITY)
0070/1888 024 " DIA CIRC CONCR
LEN=0060 INSTALLED UNKN
0070/1876
0070/0133 012 " DIA CIRC CONCR
LEN=0090 INSTALLED UNKN
016330 FT 2 0 02360 0 00 0017+39
NC DESIDERIO BL
0070/0000 LENGTH(AH 3531 BK 1727)
0060/1617 018 " DIA CIR PLASTIC
LEN=0030 INSTALLED UNKN
0060/0048 018 " DIA CIRC CONCR
LEN=0030 INSTALLED UNKN
014603 FT 2 0 02360 0 00 0000+00
CLAIRTON
JEFFERSON HILLS B
0060/0000 LENGTH(AH 1727 BK 2246)
024 " DIA CIRC CONCR

DIR: B TOTAL LEN: 4.519 MI. DIST: 11-1 SR: 2028
 LEFT MUN: JEFFERSON HILLS B RIGHT MUN: JEFFERSON HILLS B

CENTURY DR
(BORO)

0050/0845

012357 FT

SHORT ST
(BORO)

0040/1235

010177 FT

007576 FT

0050/2234	LEN=0040	INSTALLED UNKN
0050/1300	HIGH RD (BORO)	
0050/0325	TO SR 0051 RAMP RD (SR8077 SEG 0020/0000)	
0050/0121	FROM SR 0051 RAMP RD (SR8077 SEG 0010/1137)	
012357 FT	BMS EN 02/2028/0050/0000	
	2 0 02203 0 00 0098+31	
	SR 0051 NB	
	BMSBG 02/2028/0050/0000	
0050/0000	LENGTH(AH 2246 BK 2180)	
	018 "DIA CIRC CONCR	
0040/2145	LEN=0040 INSTALLED UNKN	
	TO SR 0051 RAMP RD (SR8077 SEG 0252/0000)	
	FR SR8077 & SR51 RAMP R (SR8077 SEG 0262/0742)	
	015 "DIA CIRC METAL	
0040/1521	LEN=0045 INSTALLED UNKN	
	SCOTIA HOLLOW RD (CNTY)	
0040/1515		
	LARKSPUR DR (BORO)	
	015 "DIA CIR PLASTIC	
0040/0403	LEN=0030 INSTALLED UNKN	
010177 FT	2 0 02203 0 00 0057+60	
	CHERRYWOOD DR (BORO)	
0040/0000	LENGTH(AH 2180 BK 2601)	
	024 "DIA CIR PLASTIC	
0034/0910	LEN=0055 INSTALLED UNKN	
	018 "DIA CIRC CONCR	
0034/0460	LEN=0050 INSTALLED UNKN	
007576 FT	2 0 02203 0 00 0057+60	
	SILER DR (BORO)	
0034/0000	LENGTH(AH 2601 BK 2511)	
	018 "DIA CIR PLASTIC	
0030/2421	LEN=0050 INSTALLED UNKN	

DIR: B TOTAL LEN: 4.519 MI. DIST: 11-1 SR: 2028
 LEFT MUN: JEFFERSON HILLS B RIGHT MUN: JEFFERSON HILLS B

Location	Segment ID	Length	Material	Status
	0030/2126	0035	018" DIA CIR PLASTIC	INSTALLED UNKN
	0030/1646	0040	018" DIA CAST IRON	INSTALLED UNKN
	0030/0796	0040	018" DIA CIRC METAL	INSTALLED UNKN
	0030/0444	0035	018" DIA CAST IRON	INSTALLED UNKN
	0030/0061	0035	018" DIA CIRC METAL	INSTALLED UNKN
005065 FT	005065 FT	2 0 02203 0 00 0025+13	DALE RD (BORO)	
	0030/0000		LENGTH(AH 2511 BK 2550)	
GANLEY RD (BORO)	0020/1829	0040	015" DIA CIRC CONCR	INSTALLED UNKN
	0020/1527	0040	015"H 00"W MULT CONCR	INSTALLED UNKN
	0020/0559	0035	018" DIA CIR PLASTIC	INSTALLED UNKN
002515 FT	002515 FT	2 0 02203 0 00 0000+00	KNIGHT RD (BORO)	
	0020/0000		LENGTH(AH 2550 BK 2515)	
	0010/2433	0040	024" DIA CIRC CONCR	INSTALLED UNKN
	0010/1968	0050	018" DIA CIRC CONCR	INSTALLED UNKN
CASTOR LN (BORO)	0010/1965			
	0010/0963	0055	024" DIA CIRC CONCR	INSTALLED UNKN
NEW UNNAMED RD (BORO)	0010/0944			
SCENIC CT (BORO)	0010/0746			
000000 FT	000000 FT	2 0 02066 0 01 0169+46	NC RIDGE RD GILL HALL RD (SR3017 SEG 0030/0000) MFC BEGIN = D	
	0010/0000		LENGTH(AH 2515 BK 0000)	

DIR: B TOTAL LEN: 2.317 MI. DIST: 11-1 SR: 2027
 LEFT MUN: MCKEESPORT C RIGHT MUN: MCKEESPORT C

JEROME ST BR/LYSLE BL 012233 FT
 (SR2094 SEG 0011/0000)
 (SR2094 SEG 0010/0000) 0070/0618

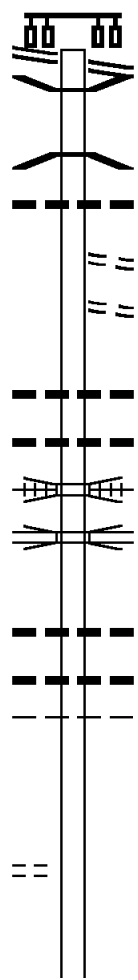

012233 FT FIFTH AV
 (SR2021 SEG 0120/0528)
 (SR2021 SEG 0121/0525)
 0070/0618 BMSSEN 02/7304/0000/1003
 0070/0592 2 0 02259 0 00 0202+27
 CSX RR
 0070/0509 BMSBG 02/7304/0000/1003
 024 " DIA CIRC CONCR
 0070/0137 LEN=0096 INSTALLED UNKN
 RAMP NO. 1 D
 0070/0110 (CITY)
 REBECCA ST
 (CITY)
 0070/0070 2 0 02259 0 00 0202+27
 011615 FT LENGTH(AH 0618 BK 0798)
 0070/0000 018 " DIA CIRC CONCR
 0060/0580 LEN=0040 INSTALLED UNKN
 018 " DIA CIRC CONCR
 0060/0295 LEN=0040 INSTALLED UNKN
 PITTSBURGH & LAKE ERIE
 0060/0199 OVERPASS IS RR X-ING
 JEROME STREET
 0060/0110 OP ID 02/2094/0010/0059
 010817 FT 2 0 02259 0 00 0196+25
 018 " DIA CIRC CONCR
 0060/0000 LEN=0099 INSTALLED UNKN
 LENGTH(AH 0798 BK 1871)
 018 " DIA CIRC CONCR
 0050/1742 LEN=0084 INSTALLED UNKN
 MCKEESPORT
 0050/1306 PORT VUE B

2 0 02259 0 00 0175+44 008946 FT
 CAROTHERS RD
 (BORO) 0050/0000

008946 FT
 0050/0000 LENGTH(AH 1871 BK 3351)

DIR: B TOTAL LEN: 2.317 MI. DIST: 11-1 SR: 2027
 LEFT MUN: PORT VUE B RIGHT MUN: PORT VUE B

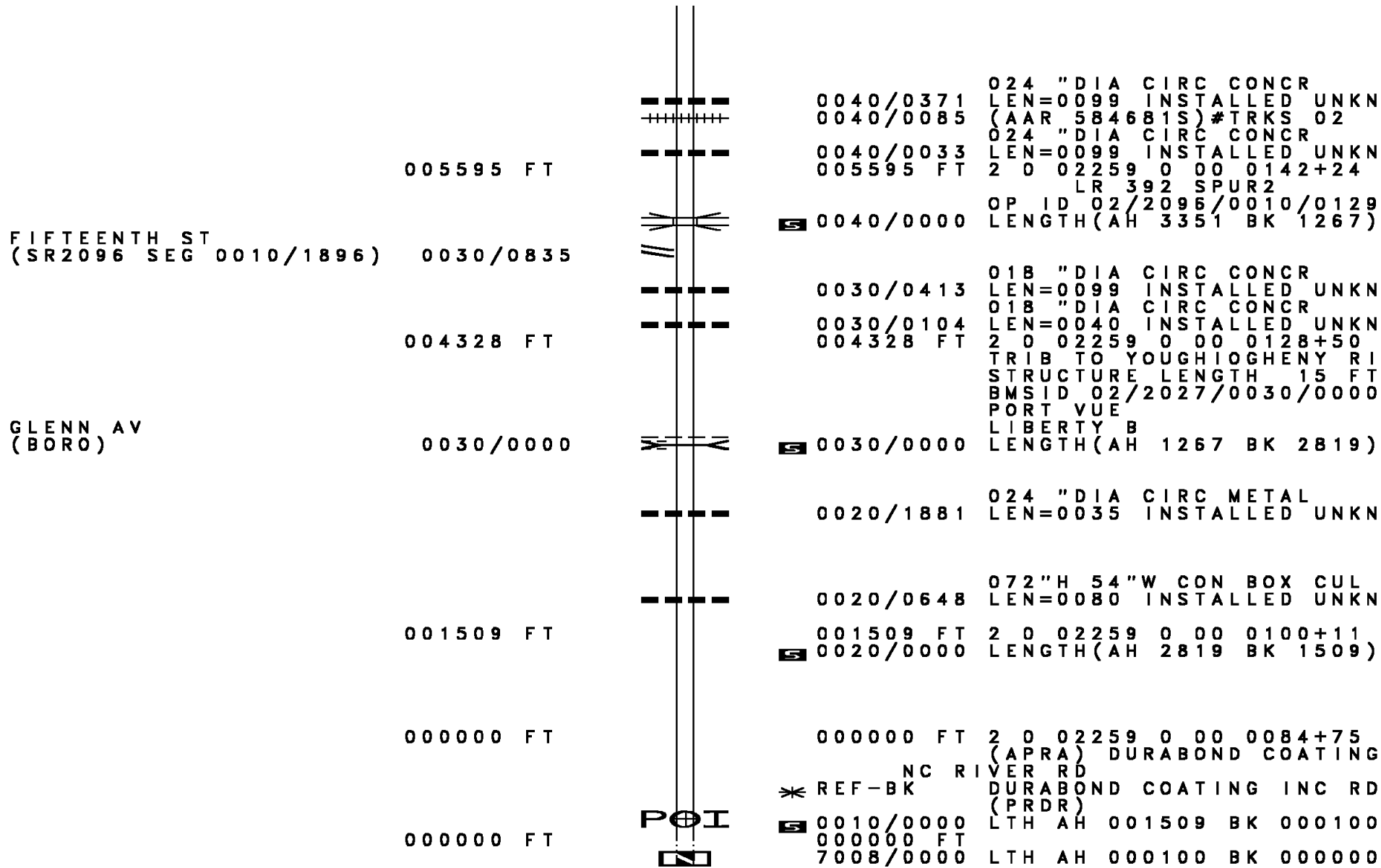

005595 FT

FIFTEENTH ST
 (SR2096 SEG 0010/1896) 0030/0835

004328 FT

GLENN AV
 (BORO) 0030/0000

001509 FT

000000 FT

000000 FT

0040/0371 024 " DIA CIRC CONCR
 LEN=0099 INSTALLED UNKN
 0040/0085 (AAR 584681S) #TRKS 02
 024 " DIA CIRC CONCR
 0040/0033 LEN=0099 INSTALLED UNKN
 005595 FT 2 0 02259 0 00 0142+24
 LR 392 SPUR2
 OP ID 02/2096/0010/0129
 5 0040/0000 LENGTH(AH 3351 BK 1267)
 0030/0413 018 " DIA CIRC CONCR
 LEN=0099 INSTALLED UNKN
 0030/0104 018 " DIA CIRC CONCR
 004328 FT LEN=0040 INSTALLED UNKN
 2 0 02259 0 00 0128+50
 TRIB TO YOUGHIOGHENY RI
 STRUCTURE LENGTH 15 FT
 BMSID 02/2027/0030/0000
 PORT VUE
 LIBERTY B
 5 0030/0000 LENGTH(AH 1267 BK 2819)
 0020/1881 024 " DIA CIRC METAL
 LEN=0035 INSTALLED UNKN
 0020/0648 072"H 54"W CON BOX CUL
 LEN=0080 INSTALLED UNKN
 001509 FT 2 0 02259 0 00 0100+11
 5 0020/0000 LENGTH(AH 2819 BK 1509)
 000000 FT 2 0 02259 0 00 0084+75
 (APRA) DURABOND COATING
 NC RIVER RD
 * REF-BK DURABOND COATING INC RD
 (PRDR)
 5 0010/0000 LTH AH 001509 BK 000100
 000000 FT
 7008/0000 LTH AH 000100 BK 000000

EXTRACT DATE: 12/21/2020
PRINT DATE: 12/23/2020

ROADWAY MANAGEMENT SYSTEM
SLD COUNTY/SR - ANNUAL PRINT

PAGE NUMBER: 726
COUNTY: ALLEGHENY

DIR: B TOTAL LEN: 1.447 MI.
LEFT MUN: NORTH VERSAILLES T

DIST: 11-1 SR: 2026
RIGHT MUN: NORTH VERSAILLES T

GREENSBURG PK
(CNTY)

SECOND ST
(TWP)

004023 FT

004023 FT

0014/2988

001035 FT

0010/0370

000000 FT

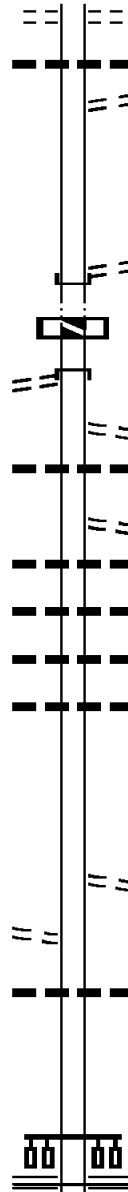

0020/0495 (TWP)
018 " DIA CIR PLASTIC
0020/0490 LEN=0030 INSTALLED UNKN
UNKNOWN RD
0020/0180 (TWP)
004023 FT 2 0 02193 0 00 0000+00
GREENSBURG PK
(CNTY)
NC KL
INTER-BK LINE AV
GREENSBURG PK
(CNTY)
0020/0000 LTH AH 001440 BK 000100
004023 FT
7016/0000 LTH AH 000100 BK 002988
INTER-AHD GREENSBURG PK
0014/2988 (CNTY)
CASTLE AV
0014/2495 (TWP)
036 " DIA CIRC CONCR
0014/2070 LEN=0035 INSTALLED UNKN
CASTLE AV
0014/2019 (TWP)
018 " DIA CIRC CONCR
0014/1940 LEN=0048 INSTALLED UNKN
018 " DIA CIRC CONCR
0014/1500 LEN=0025 INSTALLED UNKN
036 " DIA CIRC METAL
0014/1124 LEN=0025 INSTALLED UNKN
018 " DIA CIRC CONCR
0014/0971 LEN=0030 INSTALLED UNKN
001035 FT 2 0 02194 0 00 0022+04
NC F FIRST ST
FIRST ST
(TWP)
0014/0000 LENGTH(AH 2988 BK 1035)
036 "H 36 "W CON BOX CUL
0010/0203 LEN=0056 INSTALLED UNKN
000000 FT 2 0 02194 0 00 0011+54
NC V VERSAILLES AV
MCKEESPORT BL
(SR2037 SEG 0081/0000)
(SR2037 SEG 0080/0000)
0010/0000 MFC BEGIN = E
LENGTH(AH 1035 BK 0000)

Stationing	Description	Material / Details
005998 FT	INTER-AHD	WEST SMITHFIELD ST (SR2018 SEG 0020/0000)
0020/3353		WEST SMITHFIELD ST (SR2018 SEG 0020/0000)
0020/3333	CAROTHERS WY (BORO)	
0020/3185	LIBERTY WY (CNTY)	NC LIBERTY WY MFC BEGIN = C
0020/2236		015 " DIA CIRC OTHER LEN=0040 INSTALLED UNKN
0020/1400		024 " DIA CIRC METAL LEN=0350 INSTALLED UNKN
0020/1057		015 " DIA CIRC METAL LEN=0032 INSTALLED UNKN
0020/0915	WILLOW DR (PRDR)	
002645 FT		018 " DIA CIR PLASTIC LEN=0250 INSTALLED UNKN
0020/0500		2 0 02056 0 00 0032+72 SILVERLEAF DR (BORO)
0020/0000		LENGTH(AH 3353 BK 2645) 018 " DIA CIR PLASTIC LEN=0099 INSTALLED UNKN
0010/2520		EVERGREEN DR (PRDR)
0010/1795		018 " DIA CIR PLASTIC LEN=0050 INSTALLED UNKN
0010/1005		DOUGLAS DR (PRDR)
0010/0975		036 " DIA CIRC CONCR LEN=0050 INSTALLED UNKN
0010/0866		018 " DIA CIR PLASTIC LEN=0060 INSTALLED UNKN
0010/0756		036 " DIA CIRC METAL LEN=0060 INSTALLED UNKN
0010/0450	PIERCE RD (BORO)	NC FINNEY RD BOSTON HOLLOW RD (SR0048 SEG 0100/2110)
000000 FT		MFC BEGIN = E
2 0 02056 0 00 0058+18		LENGTH(AH 2645 BK 0000)
000000 FT	BOSTON HOLLOW RD (SR0048 SEG 0100/2110)	
0010/0000		

EXTRACT DATE: 12/21/2020 ROADWAY MANAGEMENT SYSTEM PAGE NUMBER: 724
PRINT DATE: 12/23/2020 SLD COUNTY/SR - ANNUAL PRINT COUNTY: ALLEGHENY

DIR: B TOTAL LEN: 1.789 MI. DIST: 11-1 SR: 2024
LEFT MUN: WHITE OAK B RIGHT MUN: WHITE OAK B

009448 FT

* 009448 FT AH-WESTMORELAND (64)
REF-AHD CARPENTER LN
0030/2610 (SR4019 SEG 0010/0000)

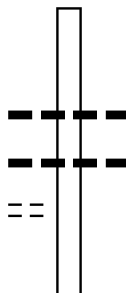

0030/1674 018 " DIA CIRC METAL
LEN=0099 INSTALLED UNKN
0030/1302 095 " DIA CIRC CONCR
LEN=0040 INSTALLED UNKN

ANGORA GARDENS PARK
(PARK)

0030/0960

015 " DIA CIR PLASTIC

DIR: B TOTAL LEN: 1.789 MI. DIST: 11-1 SR: 2024
 LEFT MUN: WHITE OAK B RIGHT MUN: WHITE OAK B

Stationing	Segment	Length	Material	Status
006838	FT	0075	INSTALLED	UNKN
0030/0000	MCCLINTOCK RD (SR2033 SEG 0010/0000)	2610	018 "DIA CIR PLASTIC	UNKN
0020/3205		0050	MESSINGER LN	UNKN
0020/2995			(BORO)	
0020/2505			WHITETAILE LN	UNKN
0020/2100	SYLVAN DR (BORO)	0050	018 "DIA CIR PLASTIC	UNKN
0020/1955		0050	018 "DIA CIR PLASTIC	UNKN
0020/1749		0080	INSTALLED	UNKN
0020/0503		0030	015 "DIA CIRC METAL	UNKN
0020/0230			LAUREL LN (BORO)	
0020/0081		0030	012 "DIA CIRC OTHER	UNKN
003488	FT	02180	2 0 02180 0 00 0035+20	UNKN
0020/0000		3350	015 "DIA CIRC METAL	UNKN
0010/3357		0035	INSTALLED	UNKN
0010/2286		0035	018 "DIA CIR PLASTIC	UNKN
0010/1709		0070	018 "DIA CIRC METAL	UNKN
0010/1441		0099	018 "DIA CIR PLASTIC	UNKN
0010/0707		0099	018 "DIA CIRC CONCR	UNKN
0010/0070		0070	018 "DIA CIRC METAL	UNKN
000000	FT	02180	2 0 02180 0 00 0000+00	UNKN
0010/0000	LINCOLN WY (SR2031 SEG 0020/1467)	3488	NC MCCLINTOCK RD MFC BEGIN = E	UNKN

Location / Segment	Start Station	End Station	Length (FT)	Material / Notes
BELLBRIDGE RD (SR2021 SEG 0030/0000)	0050/2517	0050/2212	012737 FT	018" DIA CIRC CONCR LEN=0045 INSTALLED UNKN
		0050/2026		012" DIA CIR PLASTIC LEN=0035 INSTALLED UNKN
ABES WAY (BORO)	0050/0365	0040/1939	010220 FT	018" DIA CIR PLASTIC LEN=0040 INSTALLED UNKN
	0040/1705	0040/1126		018" DIA CIRC CONCR LEN=0099 INSTALLED UNKN
		0040/0537		024" DIA CIRC CONCR LEN=0035 INSTALLED UNKN
		0040/0038		018" DIA CIR PLASTIC LEN=0045 INSTALLED UNKN
LINDEN RD (BORO)	0040/1590	0030/1655	008008 FT	018" DIA CIRC CONCR LEN=0056 INSTALLED UNKN
		0030/1400		018" DIA CIRC CONCR LEN=0047 INSTALLED 1999

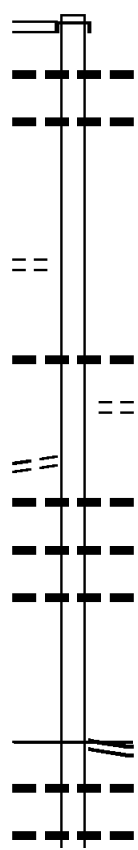

DIR: B TOTAL LEN: 2.412 MI. DIST: 11-1 SR: 2023
 LEFT MUN: LINCOLN B RIGHT MUN: LINCOLN B

Stationing	Description	Material	Length	Notes
006035 FT	0030/0925	018" DIA CIRC METAL	LEN=0045	INSTALLED UNKN
	006035 FT	2 0 02071 0 00	0060+22	
	0030/0000	LENGTH(AH 1973 BK 2226)		
	0020/1880	018" DIA CIR PLASTIC	LEN=0012	INSTALLED 1999
003809 FT	0020/0453	018" DIA CIRC CONCR	LEN=0040	INSTALLED UNKN
	0020/0215	024" DIA CIR PLASTIC	LEN=0035	INSTALLED UNKN
	003809 FT	2 0 02071 0 00	0038+29	
	0020/0000	NC HA HARRISON HOLLOW RD	LENGTH(AH 2226 BK 3809)	
	0010/3414	018" DIA CIR PLASTIC	LEN=0035	INSTALLED UNKN
	0010/3178	018" DIA CIRC METAL	LEN=0030	INSTALLED UNKN
	0010/3100	018" DIA CIRC METAL	LEN=0030	INSTALLED UNKN
	0010/2625	036" DIA CIRC METAL	LEN=0040	INSTALLED UNKN
	0010/2375	018" DIA CIR UNKNOWN	LEN=0035	INSTALLED UNKN
	0010/1999	018" DIA CIRC METAL	LEN=0060	INSTALLED UNKN
	0010/1718	018" DIA CIRC METAL	LEN=0040	INSTALLED UNKN
	0010/1410	018" DIA CIRC OTHER	LEN=0040	INSTALLED UNKN
	0010/1055	018" DIA CIRC METAL	LEN=0035	INSTALLED UNKN
	0010/0743	018" DIA CIRC METAL	LEN=0035	INSTALLED UNKN
	0010/0394	BMSFN 02/2023/0010/0381	2 0 02071 0 00	0004+01
	0010/0381	BR. WYLIE RUN	BMSBG 02/2023/0010/0381	
000000 FT	0010/0194	018" DIA CIRC CONCR	LEN=0056	INSTALLED UNKN
	000000 FT	2 0 02071 0 00	0000+00	
		LOVEDALE RD	(SR2010 SEG 0030/2445)	
		NC HA HARRISON RD		
		MFC BEGIN = E		
	0010/0000	LENGTH(AH 3809 BK 0000)		

LOVEDALE RD (SR2010 SEG 0030/2445) 0010/0000

DIR: B TOTAL LEN: .888 MI. DIST: 11-1 SR: 2022
 LEFT MUN: WHITE OAK B RIGHT MUN: WHITE OAK B

2 0 02232 0 00 0034+76 003465 FT
 TANGLEVIEW RD
 (TWP) 0020/0000

004686 FT

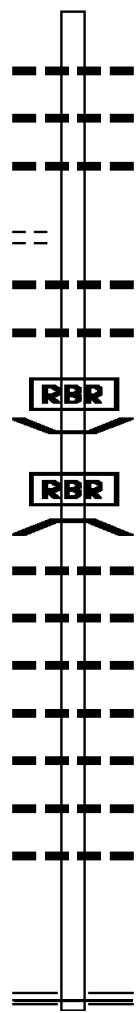

* 004686 FT AH-WESTMORELAND (64)
 REF-AHD COLONIAL MANOR RD
 0020/1221 (SR3024 SEG 0010/0000)
 024 "DIA CIR PLASTIC
 0020/0790 LEN=0060 INSTALLED UNKN
 018 "DIA CIRC CONCR
 0020/0625 LEN=0100 INSTALLED UNKN
 018 "DIA CIRC CONCR
 0020/0320 LEN=0045 INSTALLED UNKN
 003465 FT
 5 0020/0000 LENGTH(AH 1221 BK 3465)
 024 "DIA CIR PLASTIC
 0010/3327 LEN=0045 INSTALLED UNKN
 018 "DIA CIRC CONCR
 0010/3066 LEN=0045 INSTALLED UNKN

 0010/2642 BMS EN 02/2022/0010/2622
 2 0 02232 0 00 0026+34
 P3
 UNT TO LONG RUN
 0010/2622 BMSBG 02/2022/0010/2622
 024 "DIA CIR PLASTIC
 0010/2514 LEN=0050 INSTALLED UNKN
 036 "DIA CIRC CONCR
 0010/2226 LEN=0080 INSTALLED UNKN
 024 "DIA CIR PLASTIC
 0010/1964 LEN=0045 INSTALLED UNKN
 024 "DIA CIRC CONCR
 0010/1550 LEN=0050 INSTALLED UNKN
 024 "DIA CIR PLASTIC
 0010/1436 LEN=0045 INSTALLED UNKN
 024 "DIA CIR PLASTIC
 0010/1038 LEN=0055 INSTALLED UNKN
 024 "DIA CIR PLASTIC
 0010/0465 LEN=0045 INSTALLED UNKN
 000000 FT 2 0 02232 0 00 0000+00
 NC ST STEWARTSVILLE HOLLOW RD
 LINCOLN WY
 (SR2031 SEG 0020/0000)
 MFC BEGIN = D
 5 0010/0000 LENGTH(AH 3465 BK 0000)

000000 FT

LYSLE BL 028935 FT
 (SR2094 SEG 0010/0000) INTER-AHD

RIVER RD
 (SR2027 SEG 0070/0618) 0121/0525
 2 0 02357 0 00 0224+24 028410 FT
 NC FIFTH AV
 FIFTH AV
 (CITY)

MFC BEGIN = D
 LENGTH(AH 0525 BK 1553) 0121/0000

SIXTH ST
 (CITY) 0110/1255

DAWSON ST
 (CITY) 0110/0940

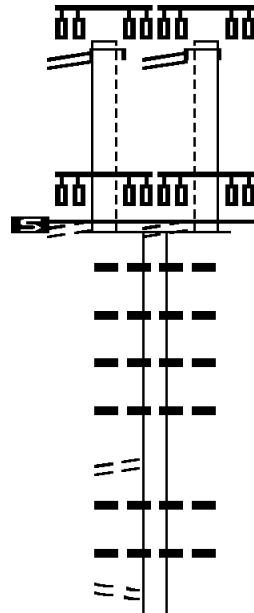

028938 FT LYSLE BL
 INTER-AHD (SR2094 SEG 0011/0000)

0120/0528 RIVER RD
 028410 FT (SR2027 SEG 0070/0618)
 NC FIFTH AV 2 0 02357 0 00 0224+24
 FIFTH AV
 (CITY)

MFC BEGIN = D
 LENGTH(AH 0528 BK 1553) 0120/0000

0110/1510 018 "DIA CIRC CONCR
 LEN=0015 INSTALLED UNKN

0110/1460 018 "DIA CIRC CONCR
 LEN=0015 INSTALLED UNKN

0110/1297 018 "DIA CIRC CONCR
 LEN=0099 INSTALLED UNKN

0110/1282 018 "DIA CIRC CONCR
 LEN=0099 INSTALLED UNKN

0110/1151 018 "DIA CIRC CONCR
 LEN=0030 INSTALLED UNKN

0110/1010 018 "DIA CIRC CONCR
 LEN=0030 INSTALLED UNKN

DIR: B TOTAL LEN: 5.481 MI. DIST: 11-1 SR: 2021
 LEFT MUN: MCKEESPORT C RIGHT MUN: MCKEESPORT C

Stationing	Street Name	Segment ID	Material	Length	Status
0110/0657		018 " DIA	CIRC CONCR	LEN=0099	INSTALLED UNKN
0110/0647		MCKEESPORT	PORT VUE B		
0110/0383		018 " DIA	CIRC CONCR	LEN=0015	INSTALLED UNKN
0110/0167		018 " DIA	CIRC CONCR	LEN=0005	INSTALLED UNKN
0110/0060		018 " DIA	CIRC CONCR	LEN=0005	INSTALLED UNKN
026857 FT					
0110/0000	NC REBECCA ST				LENGTH(AH 1553 BK 1251)
0100/1150					
0100/1095					
0100/0972	GARFIELD ST				
0100/0870	(BORO) HUNTER ST				
0100/0840	(BORO) 012 " DIA	CIRC OTHER	LEN=0025	INSTALLED UNKN	
0100/0510	(BORO) ELMWOOD ST				
025606 FT					
0100/0000	2 0 02357 0 00 0196+82	NC WA SHINGTON BL/REBECCA ST			LENGTH(AH 1251 BK 1385)
0090/1160	(BORO) J F KENNEDY RD				
0090/1120	(BORO) 018 " DIA	CIR PLASTIC	LEN=0099	INSTALLED UNKN	
0090/1030	(CONN) ROMINE RD				
0090/0885	(BORO) 012 " DIA	CIRC CONCR	LEN=0050	INSTALLED UNKN	
0090/0520	(BORO) 012 " DIA	CIRC CONCR	LEN=0099	INSTALLED UNKN	
0090/0490	(BORO) 012 " DIA	CIR PLASTIC	LEN=0099	INSTALLED UNKN	
0090/0266	(BORO) 015 " DIA	CIR PLASTIC	LEN=0030	INSTALLED UNKN	
0090/0114	(BORO) 015 " DIA	CIRC CONCR	LEN=0030	INSTALLED UNKN	

DIR: B TOTAL LEN: 5.481 MI. DIST: 11-1 SR: 2021
 LEFT MUN: PORT VUE B RIGHT MUN: PORT VUE B

Left Side	Segment	Right Side	Description
	024221 FT	024221 FT	2 0 02357 0 00 0182+90 SAN JUAN DR (BORO)
	==	5 0090/0000	LENGTH(AH 1385 BK 2119) DERSAM AV (BORO)
	==	0080/1690	(BORO)
	---	0080/1352	01B "DIA CIRC CONCR LEN=0040 INSTALLED UNKN
EDMUNDSON AV (BORO)	0080/1325	==	
	==	0080/1005	MCCLELLAND DR (BORO)
RIVERVIEW RD (BORO)	0080/0840	==	
BELLAIRE ST (BORO)	0080/0375	==	
	---	0080/0315	01B "DIA CIRC CONCR LEN=0048 INSTALLED UNKN
2 0 02357 0 00 0161+80 SANTA MONICA ST (BORO)	022102 FT 0080/0000	022102 FT 5 0080/0000	LENGTH(AH 2119 BK 2066) 015 "DIA CIRC CONCR LEN=0030 INSTALLED UNKN
	---	0070/1775	BURBANK ST (BORO)
	==	0070/1715	(BORO)
	---	0070/1656	01B "DIA CIRC CONCR LEN=0045 INSTALLED UNKN
	==	0070/1345	WOODLAND ST (BORO)
	---	0070/1255	01B "DIA CIRC CONCR LEN=0070 INSTALLED UNKN
	---	0070/1020	01B "DIA CIRC CONCR LEN=0040 INSTALLED UNKN
	---	0070/0490	01B "DIA CIRC CONCR LEN=0050 INSTALLED UNKN
	==	0070/0150	MCCCLURE RD (BORO)
	020036 FT	020036 FT	2 0 02357 0 00 0141+30 PORTSMOUTH DR (BORO)
	==	5 0070/0000	LENGTH(AH 2066 BK 3693) S ALLEGHENY ELEM SCHOOL (PRDR)
	==	0060/3475	RED DOG ST (BORO)
	==	0060/3225	(BORO)
	---	0060/3220	01B "DIA CIRC CONCR LEN=0040 INSTALLED UNKN
	---	0060/3206	PORT VUE GLASSPORT B

DIR: B TOTAL LEN: 5.481 MI. DIST: 11-1 SR: 2021
 LEFT MUN: PORT VUE B RIGHT MUN: PORT VUE B

Street Name (BORO)	Segment ID	Length (FT)	Material	Notes
OLA AV (BORO)	0060/2365			
EMIL ST (BORO)	0060/2157			
RIDGE ST (BORO)	0060/1390		018 "DIA CIRC CONCR	LEN=0040 INSTALLED UNKN
SUMMIT AV (BORO)	0060/1220			
2 0 02357 0 00 0104+48 016343 FT SUNSHINE ST (BORO)		016343 FT		
FIRST ST (BORO)	0060/0000		018 "DIA CIRC CONCR	LEN=0040 INSTALLED UNKN
	0060/0000		018 "DIA CIRC CONCR	LEN=0040 INSTALLED UNKN
	0050/3646		018 "DIA CIRC CONCR	LEN=0040 INSTALLED UNKN
	0050/3130		018 "DIA CIRC CONCR	LEN=0040 INSTALLED UNKN
SCENIC ST (BORO)	0050/2875		SCENIC ST (BORO)	PENNSYLVANIA AV (BORO)
	0050/2835			
	0050/2460		EDMUNDSON DR (BORO)	
	0050/1656		018 "DIA CIRC CONCR	LEN=0048 INSTALLED UNKN
	0050/1364		018 "DIA CIRC CONCR	LEN=0048 INSTALLED UNKN
KOLLAR DR (BORO)	0050/0835		GLASSPORT LIBERTY B	
ORCHARD ST (BORO)	0050/0565		018 "DIA CIRC CONCR	LEN=0048 INSTALLED UNKN
			018 "DIA CIRC CONCR	

DIR: B TOTAL LEN: 5.481 MI. DIST: 11-1 SR: 2021
 LEFT MUN: LIBERTY B RIGHT MUN: LIBERTY B

Location	Segment	Length	Material	Status
012400 FT	0050/0400	0048	LEN=0048	INSTALLED UNKN
	012400 FT	2 0 02357	0 00 0065+10	SOUTH ALLEGHENY HS ENT (BORO)
	0050/0000		LENGTH(AH 3943 BK 3872)	
BORO RD (BORO)	0040/2833	018	" DIA CIRC CONCR	LEN=0025 INSTALLED UNKN
	0040/2769		CENTER ST (CNTY)	
0040/1560	0040/1251	018	" DIA CIRC CONCR	LEN=0040 INSTALLED UNKN
	0040/0847	015	" DIA CIRC CONCR	LEN=0048 INSTALLED UNKN
WASHINGTON CT (BORO)	0040/0040	018	" DIA CIRC CONCR	LEN=0045 INSTALLED UNKN
	008528 FT	2 0 02357	0 00 0026+42	PORT VUE RD (CNTY)
	0040/0000		LENGTH(AH 3872 BK 2626)	
LIBERTY LINCOLN B	0030/2604		LIBERTY LINCOLN B	
	0030/1847	024	" DIA CIRC CONCR	LEN=0040 INSTALLED UNKN
SUNSET LN (BORO)	0030/1790		TAYLOR ST (BORO)	
	0030/1310			
VIRGINIA DR (BORO)	0030/0660			
	0030/0080		DEER LN (BORO)	
005902 FT	0030/0067	018	" DIA CIRC CONCR	LEN=0040 INSTALLED UNKN
	005902 FT	2 0 02357	0 00 0000+00	NC LIBERTY WY PORT VUE RD

EXTRACT DATE: 12/21/2020
PRINT DATE: 12/23/2020

ROADWAY MANAGEMENT SYSTEM
SLD COUNTY/SR - ANNUAL PRINT

PAGE NUMBER: 714
COUNTY: ALLEGHENY

DIR: B TOTAL LEN: 5.481 MI.
LEFT MUN: LINCOLN B

DIST: 11-1 SR: 2021
RIGHT MUN: LINCOLN B

003057 FT

000000 FT

Stationing	Material	Length	Notes
0030+00	015" DIA CIRC PLASTIC	0075	INSTALLED UNKN
0020+28	015" DIA CIRC CONCR	0048	INSTALLED UNKN
0020+22	015" DIA CIRC CONCR	0048	INSTALLED UNKN
0020+18	018" DIA CIRC CONCR	0048	INSTALLED UNKN
0020+13	015" DIA CIRC CONCR	0048	INSTALLED UNKN
0020+04	015" DIA CIRC CONCR	0048	INSTALLED UNKN
0030+57	018" DIA CIRC CONCR	0035	INSTALLED UNKN
0020+00	018" DIA CIRC CONCR	0035	INSTALLED UNKN
0010+30	015" DIA CIRC CONCR	0035	INSTALLED UNKN
0010+30	018" DIA CIRC CONCR	0008	INSTALLED UNKN
0010+29	018" DIA CIRC CONCR	0050	INSTALLED UNKN
0010+25	018" DIA CIRC CONCR	0048	INSTALLED UNKN
0010+17	018" DIA CIRC CONCR	0048	INSTALLED UNKN
0010+09	018" DIA CIRC CONCR	0070	INSTALLED UNKN
0010+09	018" DIA CIRC CONCR	0035	INSTALLED UNKN
0010+08	018" DIA CIRC CONCR	0035	INSTALLED UNKN
0010+06	060" DIA CIRC CONCR	0080	INSTALLED UNKN
0010+05	HEATH'S RUN STRUCTURE	12 FT	
0010+04	BMSID 02/2021/0010/0494		
0010+00	018" DIA CIRC CONCR	0020	INSTALLED 1998
0000+00	NC BE LL BRIDGE RD		
0010+00	LINCOLN BL		
0010+00	(SR2001 SEG 0270/0000)		
0010+00	MFC BEGIN = D		
0010+00	018" DIA CIRC CONCR	0035	INSTALLED UNKN

000468 FT

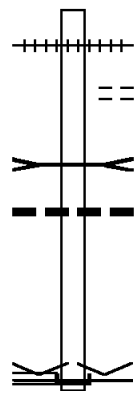



000000 FT

BLYTHEDALE RD
 (SR2017 SEG 0080/0000) 0010/0000

000468 FT
 * REF-AHD DOUGLAS RUN RD
 0010/0468 (CNTY)
 0010/0417 (AAR 584720F) #TRKS 01
 MCPHERSON ST
 0010/0380 (TWP)
 DOUGLAS RUN
 STRUCTURE LENGTH 39 FT
 0010/0225 BMSID 02/2020/0010/0225
 024 " DIA CIRC CONCR
 0010/0125 LEN=0040 INSTALLED UNKN
 000000 FT 2 0 02315 0 00 0083+08
 VILLAGE: ELIZABETH TWP
 NC DOUGLAS RUN RD
 INTER-BK BLYTHEDALE RD
 (SR2017 SEG 0080/0000)
 MFC BEGIN = C
 0010/0000 LENGTH(AH 0468 BK 0000)

EXTRACT DATE: 12/21/2020 ROADWAY MANAGEMENT SYSTEM PAGE NUMBER: 712
 PRINT DATE: 12/23/2020 SLD COUNTY/SR - ANNUAL PRINT COUNTY: ALLEGHENY
 DIR: B TOTAL LEN: .000 MI. DIST: 11-1 SR: 2019
 LEFT MUN: ELIZABETH T RIGHT MUN: ELIZABETH T

000000 FT		000000 FT	
000000 FT		7030/0000 FT	LENGTH(AH 3138 BK 1364)
000000 FT		000000 FT	
		7020/0000 FT	LENGTH(AH 1364 BK 2643)
		000000 FT	
		7010/0000 FT	LENGTH(AH 2643 BK 0000)

EXTRACT DATE: 12/21/2020 ROADWAY MANAGEMENT SYSTEM PAGE NUMBER: 711
PRINT DATE: 12/23/2020 SLD COUNTY/SR - ANNUAL PRINT COUNTY: ALLEGHENY
DIR: B TOTAL LEN: 1.992 MI. DIST: 11-1 SR: 2018
LEFT MUN: ELIZABETH T RIGHT MUN: ELIZABETH T

010520 FT

010520 FT
INTER-AHD

BOSTON GREENOCK RD
(CNTY)
RENZIE ST
(SR2017 SEG 0200/3168)
WALNUT ST



EXTRACT DATE: 12/21/2020
PRINT DATE: 12/23/2020

ROADWAY MANAGEMENT SYSTEM
SLD COUNTY/SR - ANNUAL PRINT

PAGE NUMBER: 710
COUNTY: ALLEGHENY

DIR: B TOTAL LEN: 1.992 MI.
LEFT MUN: ELIZABETH T

DIST: 11-1 SR: 2018
RIGHT MUN: ELIZABETH T

YATES ST
(TWP)

0040/1833

1 0 00687 0 00 0185+50 007713 FT
LOWER CALHOUN RD
(BORO)

0040/0000

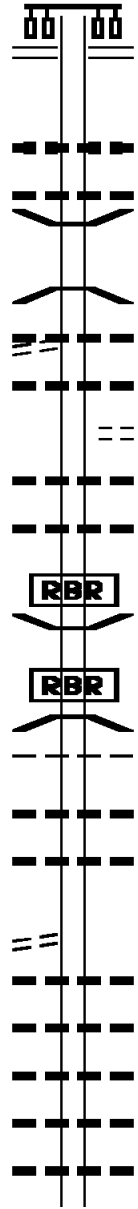

(SR0048 SEG 0130/0000)
0040/2807 018 "DIA CIRC CONCR
LEN=0080 INSTALLED UNKN
DONNER ST
(TWP)
0040/2674 018 "DIA CIRC CONCR
LEN=0030 INSTALLED UNKN
0040/2673 BMSBG 02/2018/0040/218B
0040/2231 1 0 00687 0 00 0192+55
CREEK
0040/2212 BMSBG 02/2018/0040/218B
018 "DIA CIRC CONCR
0040/1833 LEN=0040 INSTALLED UNKN
012 "DIA CIRC CONCR
0040/1533 LEN=0030 INSTALLED UNKN
RACK ST
(TWP)
0040/1056 012 "DIA CIRC CONCR
LEN=0030 INSTALLED UNKN
0040/1025 072 "H 72 "W CON BOX CUL
LEN=0035 INSTALLED UNKN
0040/0783
0040/0742 BMSBG 02/2018/0040/0721
1 0 00687 0 00 0185+50
P3
0040/0721 UNNAMED CREEK
BMSBG 02/2018/0040/0721
ELIZABETH
LINCOLN B
0040/0376 018 "DIA CIRC CONCR
0040/0305 LEN=0035 INSTALLED UNKN
012 "DIA CIRC CONCR
0040/0064 LEN=0064 INSTALLED UNKN
007713 FT
0040/0000 LENGTH(AH 2807 BK 3485)
018 "DIA CIRC CONCR
0030/3419 LEN=0030 INSTALLED UNKN
048 "DIA CIRC CONCR
0030/3031 LEN=0050 INSTALLED UNKN
030 "DIA CIRC CONCR
0030/2766 LEN=0080 INSTALLED UNKN
015 "DIA CIRC CONCR
0030/2450 LEN=0030 INSTALLED UNKN
018 "DIA CIRC CONCR
0030/2077 LEN=0030 INSTALLED UNKN
018 "DIA CIRC CONCR

DIR: B TOTAL LEN: 1.992 MI. DIST: 11-1 SR: 2018
 LEFT MUN: LINCOLN B RIGHT MUN: LINCOLN B

004228 FT

000667 FT

000000 FT

0030/1502	LEN=0030	INSTALLED UNKN
0030/1423	LEN=0030	INSTALLED UNKN
0030/1148	LEN=0030	INSTALLED UNKN
0030/0959	LEN=0030	INSTALLED UNKN
0030/0557	LEN=0030	INSTALLED UNKN
0030/0210	LEN=0050	INSTALLED UNKN
004228 FT	1 0 00687	0 00 0149+46
0030/0000	LENGTH(AH 3485 BK 3561)	
0020/3409	LEN=0080	INSTALLED UNKN
0020/3037	LEN=0030	INSTALLED UNKN
0020/2881	LEN=0030	INSTALLED UNKN
0020/2416	LEN=0040	INSTALLED UNKN
0020/2163	LEN=0040	INSTALLED UNKN
0020/1424	LEN=0035	INSTALLED UNKN
0020/1160	LEN=0040	INSTALLED UNKN
0020/0506	LEN=0040	INSTALLED UNKN
0020/0236	LEN=0060	INSTALLED UNKN
000667 FT	1 0 00687	0 00 0113+85
	LIBERTY WY (SR2025 SEG 0020/3353)	
	NC WEST SMITHFIELD ST CAROTHERS WY (BORO)	
0020/0000	MFC BEGIN = D	
000000 FT	LENGTH(AH 3561 BK 0667)	
	1 0 00687	0 00 0107+00
	NC LIBERTY WY HARRISON HOLLOW RD (SR2023 SEG 0040/0000)	
	INTER-BK WEST SMITHFIELD ST (SR2023 SEG 0040/0000)	
0010/0000	MFC BEGIN = C	
	LENGTH(AH 0667 BK 0000)	

SMITHFIELD ST 047473 FT
 (SR2018 SEG 0040/2807)
 WALNUT ST 0200/3168
 (SR0048 SEG 0130/0000)

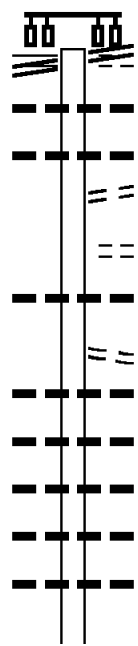

047473 FT WALNUT ST
 (SR0048 SEG 0130/0000)
 SMITHFIELD ST
 (CNTY)
 0200/3168
 0200/3120 018 " DIA CIRC CONCR
 LEN=0099 INSTALLED UNKN
 0200/2890 015 " DIA CIR PLASTIC
 LEN=0099 INSTALLED UNKN
 LC TO SMITHFIELD ST
 0200/2868 (CONN)
 MEADE ST
 0200/2800 (TWP)
 0200/2700 018 " DIA CIRC CONCR
 LEN=0099 INSTALLED UNKN
 HOLSING ST
 0200/2547 (TWP)
 0200/2228 018 " DIA CIRC CONCR
 LEN=0060 INSTALLED UNKN
 0200/2130 018 " DIA CIRC CONCR
 LEN=0050 INSTALLED UNKN
 0200/1845 018 " DIA CIRC CONCR
 LEN=0075 INSTALLED UNKN
 0200/1582 018 " DIA CIRC CONCR
 LEN=0075 INSTALLED UNKN
 0200/1100 018 " DIA CIRC CONCR
 LEN=0065 INSTALLED UNKN

DIR: B TOTAL LEN: 8.991 MI. DIST: 11-1 SR: 2017
 LEFT MUN: ELIZABETH T RIGHT MUN: ELIZABETH T

2 0 02311 0 00 0020+46 044305 FT
 TURKEYFOOT RD
 (TWP)

RIDGE RD (TBK)
 (TWP)
 COUNTRY CLUB DR
 (TWP)

Stationing	Length	Material	Notes
0200/0187	0050	018" DIA CIRC CONCR	INSTALLED UNKN
044305 FT			
0200/0000	3168	LENGTH(AH 3168 BK 2068)	
0190/1870	0040	018" DIA CIRC CONCR	INSTALLED UNKN
0190/1597	0040	018" DIA CIRC CONCR	INSTALLED UNKN
0190/1270	0040	018" DIA CIRC CONCR	INSTALLED UNKN
042237 FT			
042237 FT			2 0 02311 0 00 0000+00
			NC RENZIE ST
			BUENA VISTA/GREENOCK RD
			(CNTY)
0190/0000	2068	LENGTH(AH 2068 BK 3869)	
0180/3560	0050	018" DIA CIR PLASTIC	INSTALLED UNKN
0180/3381	0050	018" DIA CIRC CONCR	INSTALLED UNKN
0180/2671	0050	018" DIA CIRC CONCR	INSTALLED UNKN
0180/2285	0040	018" DIA CIRC CONCR	INSTALLED UNKN
0180/1975	0045	018" DIA CIRC CONCR	INSTALLED UNKN
0180/1695	0040	018" DIA CIRC CONCR	INSTALLED UNKN
0180/1335	0050	018" DIA CIRC CONCR	INSTALLED UNKN
0180/0601		BMS EN 02/2017/0180/0496	
			2 0 02312 0 00 0090+64
			BRIDGE CLOSED
			DITCH
0180/0591		BMS BG 02/2017/0180/0496	
0180/0517	0040	018" DIA CIRC CONCR	INSTALLED UNKN
0180/0412		KOCH DR	
		(TWP)	
		COLONIAL DR	
0180/0094		(TWP)	

EXTRACT DATE: 12/21/2020
PRINT DATE: 12/23/2020

ROADWAY MANAGEMENT SYSTEM
SLD COUNTY/SR - ANNUAL PRINT

PAGE NUMBER: 706
COUNTY: ALLEGHENY

DIR: B TOTAL LEN: 8.991 MI.
LEFT MUN: ELIZABETH T

DIST: 11-1 SR: 2017
RIGHT MUN: ELIZABETH T

Stationing	Right-of-Way	Structure	Material	Status
038368 FT	038368 FT	2 0 02312 0 00 0090+64	COLONIAL DR	
		(TWP)		
	0180/0000	LENGTH(AH 3869 BK 2499)		
		015 "DIA CIRC CONCR		
	0170/2420	LEN=0040	INSTALLED	UNKN
FREDERICK DR (PRDR)	0170/2043			
		LARCHFIELD DR		
		(TWP)		
	0170/1885	018 "DIA CIRC CONCR		
		LEN=0050	INSTALLED	UNKN
	0170/1700	NC GR	REENOCK BUENA VISTA RD	
		DUNCAN STATION RD		
		(TWP)		
	0170/1675	018 "DIA CIRC CONCR		
		LEN=0040	INSTALLED	UNKN
	0170/1408	018 "DIA CIRC CONCR		
		LEN=0040	INSTALLED	UNKN
	0170/1139	015 "DIA CIRC CONCR		
		LEN=0040	INSTALLED	UNKN
	0170/0855	018 "DIA CIRC CONCR		
		LEN=0040	INSTALLED	UNKN
	0170/0735	024 "DIA CIR PLASTIC		
		LEN=0040	INSTALLED	UNKN
	0170/0482	036 "DIA CIRC CONCR		
		LEN=0065	INSTALLED	UNKN
	0170/0175	2 0 02312 0 00 0065+06		
	035869 FT	NC GR	REENOCK RD	
BROADLAWN DR (TWP)	0170/0000	LENGTH(AH 2499 BK 2997)		
		018 "DIA CIRC CONCR		
	0160/2850	LEN=0040	INSTALLED	UNKN
		018 "DIA CIRC CONCR		
	0160/2216	LEN=0040	INSTALLED	UNKN
		018 "DIA CIRC CONCR		
	0160/1600	LEN=0040	INSTALLED	UNKN
		015 "DIA CIRC CONCR		
	0160/1350	LEN=0040	INSTALLED	UNKN
		018 "DIA CIR PLASTIC		
	0160/1100	LEN=0040	INSTALLED	UNKN
		018 "DIA CIRC CONCR		
	0160/0584	LEN=0050	INSTALLED	UNKN
		018 "DIA CIRC CONCR		
	0160/0244	LEN=0040	INSTALLED	UNKN
		018 "DIA CIRC CONCR		
	0160/0086	LEN=0050	INSTALLED	UNKN
	032872 FT	2 0 02312 0 00 0039+37	HENDERSON RD	

EXTRACT DATE: 12/21/2020
PRINT DATE: 12/23/2020

ROADWAY MANAGEMENT SYSTEM
SLD COUNTY/SR - ANNUAL PRINT

PAGE NUMBER: 705
COUNTY: ALLEGHENY

DIR: B TOTAL LEN: 8.991 MI.
LEFT MUN: ELIZABETH T

DIST: 11-1 SR: 2017
RIGHT MUN: ELIZABETH T

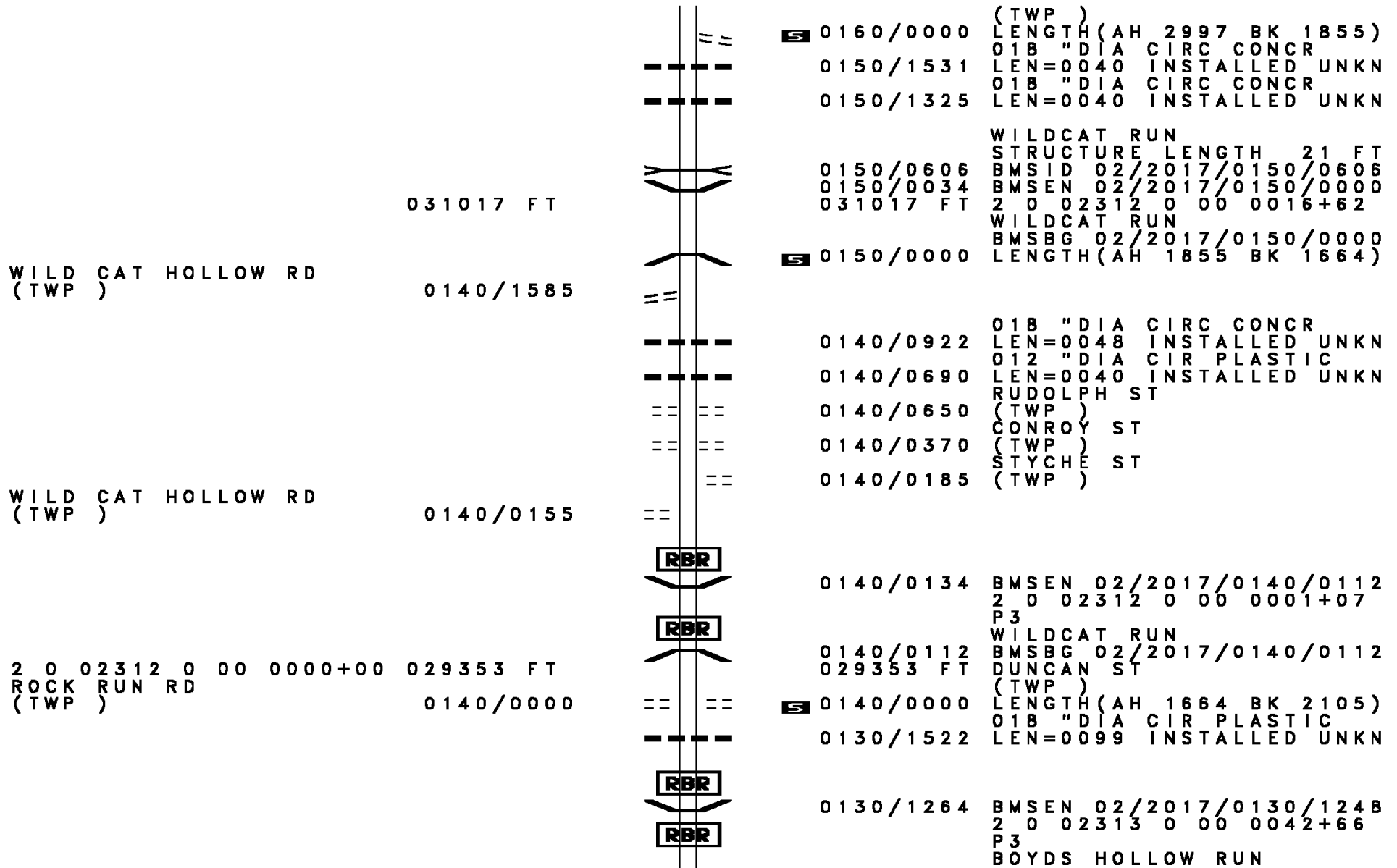

DIR: B TOTAL LEN: 8.991 MI. DIST: 11-1 SR: 2017
 LEFT MUN: ELIZABETH T RIGHT MUN: ELIZABETH T

BOYD HOLLOW RD (TBK)
 (TWP)

0130/1215

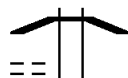

0130/1248 BMSBG 02/2017/0130/1248

027248 FT

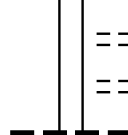

MCCORKLE CT
 (TWP)
 FELLA BAUM ST
 (TWP)
 015 " DIA CIRC CONCR
 LEN=0099 INSTALLED UNKN
 027248 FT 2 0 02313 0 00 0024+86
 NC IN D USTRY RD
 BUCHAN ST
 (TWP)

LINK DR
 (TWP)

0120/1078

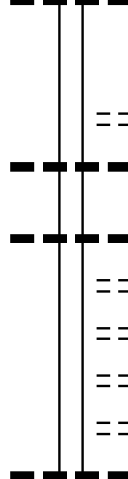

5 0130/0000 LENGTH(AH 2105 BK 3059)
 024 " DIA CIRC CONCR
 0120/2600 LEN=0040 INSTALLED 1997
 015 " DIA CIRC CONCR
 0120/1972 LEN=0035 INSTALLED UNKN
 WHITEMAN ST
 (TWP)
 CARPENTER LN
 (TWP)
 0120/1544 (TWP)
 MILTON ST
 (TWP)
 0120/1276 (TWP)
 PATTON ST
 (TWP)
 0120/1156 (TWP)
 048"H 48"W CON BOX CUL
 0120/1130 LEN=0040 INSTALLED UNKN

024189 FT

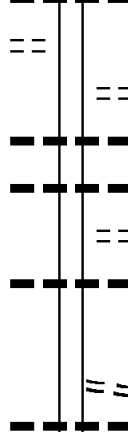

ELWAY ST
 (TWP)
 018 " DIA CIRC CONCR
 0120/0890 LEN=0035 INSTALLED UNKN
 018 " DIA CIRC CONCR
 0120/0485 LEN=0040 INSTALLED UNKN
 0120/0323 FOWLES AV
 (TWP)
 018 " DIA CIRC CONCR
 0120/0170 LEN=0040 INSTALLED UNKN
 024189 FT 2 0 02313 0 00 0000+00
 INDUSTRY RD
 (TWP)
 5 0120/0000 LENGTH(AH 3059 BK 2809)
 018 " DIA CIRC METAL
 0110/2278 LEN=0050 INSTALLED UNKN

EXTRACT DATE: 12/21/2020
PRINT DATE: 12/23/2020

ROADWAY MANAGEMENT SYSTEM
SLD COUNTY/SR - ANNUAL PRINT

PAGE NUMBER: 703
COUNTY: ALLEGHENY

DIR: B TOTAL LEN: 8.991 MI.
LEFT MUN: ELIZABETH T

DIST: 11-1 SR: 2017
RIGHT MUN: ELIZABETH T

BOYDS LN
(PRDR)

0110/0812

021380 FT

2 0 02314 0 00 0052+56 019528 FT
FALLEN TIMBER RD
(TWP)

0100/0000

016384 FT

0110/0946	018 " DIA CIRC METAL LEN=0050 INSTALLED UNKN
0110/0712	024 " DIA CIRC CONCR LEN=0050 INSTALLED UNKN
0110/0670	018 " DIA CIRC CONCR LEN=0075 INSTALLED UNKN
021380 FT	2 0 02314 0 00 0075+90 TONEY DR (TWP)
0110/0000	LENGTH(AH 2809 BK 1852)
0100/1140	018 " DIA CIRC CONCR LEN=0048 INSTALLED UNKN
0100/0850	018 " DIA CIRC CONCR LEN=0048 INSTALLED UNKN
0100/0630	018 " DIA CIRC CONCR LEN=0040 INSTALLED UNKN
019528 FT	
0100/0000	LENGTH(AH 1852 BK 3144)
0090/3101	018 " DIA CIRC CONCR LEN=0048 INSTALLED UNKN
0090/1750	018 " DIA CIRC CONCR LEN=0040 INSTALLED UNKN
0090/1442	012 " DIA CIRC CONCR LEN=0040 INSTALLED UNKN
0090/0713	012 " DIA CIRC CONCR LEN=0040 INSTALLED UNKN
0090/0324	018 " DIA CIRC CONCR LEN=0040 INSTALLED UNKN
016384 FT	2 0 02314 0 00 0021+36 SHALER ST (TWP)
0090/0000	LENGTH(AH 3144 BK 2135)
0080/1990	TRIBUTARY R STRUCTURE LENGTH 8 FT BMSID 02/2017/0080/1971 OFFSHORE DR (TWP)
0080/1820	OFFSHORE DR (TWP)

DIR: B TOTAL LEN: 8.991 MI. DIST: 11-1 SR: 2017
 LEFT MUN: ELIZABETH T RIGHT MUN: ELIZABETH T

FOR SR 2017S TO 2017S
 (CONN) 0080/0071

014249 FT

FOR SR 2017S TO 2017S
 (CONN) 0070/1497

2 0 02315 0 00 0066+86 012644 FT
 NICHOLS HILL RD
 (SR2079 SEG 0010/0000) 0070/0000

2 0 02315 0 00 0044+72 010235 FT
 ROUND HILL RD

0080/1208	024 "DIA	CIRC	CONCR	LEN=0080	INSTALLED	UNKN
0080/0474	015 "DIA	CIRC	CONCR	LEN=0040	INSTALLED	UNKN
0080/0061	018 "DIA	CIRC	CONCR	LEN=0050	INSTALLED	UNKN
014249 FT	2 0 02314	0 00	0000+00	DOUGLAS RUN RD (SR2020 SEG 0010/0000)		
	NC BL	YTHEDALE	RD	MFC BEGIN = D	LENGTH(AH 2135 BK 1605)	
0080/0000	018 "DIA	CIRC	CONCR	LEN=0060	INSTALLED	UNKN
0070/1250	024 "DIA	CIRC	CONCR	LEN=0060	INSTALLED	UNKN
0070/1042	018 "DIA	CIRC	CONCR	LEN=0040	INSTALLED	UNKN
0070/0750	018 "DIA	CIRC	CONCR	LEN=0040	INSTALLED	UNKN
0070/0315	024 "DIA	CIRC	CONCR	LEN=0040	INSTALLED	UNKN
0070/0220	024 "DIA	CIRC	CONCR	LEN=0040	INSTALLED	UNKN
0070/0048	024 "DIA	CIRC	METAL	LEN=0040	INSTALLED	UNKN
0070/0045	024 "DIA	CIRC	CONCR	LEN=0048	INSTALLED	UNKN
012644 FT	LENGTH(AH 1605 BK 2409)					
0070/0000	018 "DIA	CIRC	CONCR	LEN=0040	INSTALLED	UNKN
0060/2395	018 "DIA	CIRC	CONCR	LEN=0040	INSTALLED	1997
0060/2150	BMSSEN	02/2017/0060/1842	2 0 02315 0 00 0061+37			
0060/1860	BR.	DOUGLAS	BMSBG 02/2017/0060/1842			
0060/1842	018 "DIA	CIRC	CONCR	LEN=0040	INSTALLED	1997
0060/0695	018 "DIA	CIRC	CONCR	LEN=0040	INSTALLED	1997
0060/0170	MFC BEGIN = C					
010235 FT						

DIR: B TOTAL LEN: 8.991 MI. DIST: 11-1 SR: 2017
 LEFT MUN: ELIZABETH T RIGHT MUN: ELIZABETH T

Segment Description	Start Station	End Station	Length	Notes
(CNTY) LC TO ROUNDHILL RD (CONN)	0060/0000	0050/1130		5 0060/0000 LENGTH(AH 2409 BK 1368)
LC FROM ROUNDHILL RD (CONN)	0050/1025	0050/1058		DOUGLAS RUN STRUCTURE LENGTH 50 FT BMSID 02/2017/0050/1058
2 0 02315 0 00 0037+46 BERDAR DR (TWP)	008867 FT	0050/0805	008867 FT	024 " DIA CIRC CONCR LEN=0040 INSTALLED UNKN 018 " DIA CIRC CONCR LEN=0040 INSTALLED UNKN
BERDAR DR (TWP)	0050/0000	0040/2930		5 0050/0000 LENGTH(AH 1368 BK 2962) 018 " DIA CIRC CONCR LEN=0040 INSTALLED UNKN 018 " DIA CIRC CONCR LEN=0040 INSTALLED UNKN 018 " DIA CIRC CONCR LEN=0040 INSTALLED UNKN
BERDAR DR (TWP)	0040/2201	0040/2587		0040/2450
	0040/2065	0040/1689		FOREST HILL RD (TWP) 018 " DIA CIRC CONCR LEN=0032 INSTALLED UNKN
	0040/1069	0040/1045		BMSSEN 02/2017/0040/1045 2 0 02315 0 00 0010+20 GILLESPIE
	0040/1045	0040/0696		BMSBG 02/2017/0040/1045 BMSSEN 02/2017/0040/0681 2 0 02315 0 00 0006+56 GILLESPIE RUN
	0040/0681	0040/0475		BMSBG 02/2017/0040/0681 SKILLET HILL RD (TWP) 012 " DIA CIR PLASTIC LEN=0047 INSTALLED 2000
	0040/0457	0040/0363		BMSSEN 02/2017/0040/0342 2 0 02315 0 00 0003+06 GILLESPIE RUN
	0040/0342	0040/0072		BMSBG 02/2017/0040/0342 018 " DIA CIRC CONCR LEN=0040 INSTALLED UNKN
STATE RD (CNTY)	005905 FT	0040/0000	005905 FT	2 0 02315 0 00 0000+00 NC DOUGLAS RUN RD 5 0040/0000 LENGTH(AH 2962 BK 2902) 0030/2857 BMSSEN 02/2017/0030/2834

EXTRACT DATE: 12/21/2020
PRINT DATE: 12/23/2020

ROADWAY MANAGEMENT SYSTEM
SLD COUNTY/SR - ANNUAL PRINT

PAGE NUMBER: 700
COUNTY: ALLEGHENY

DIR: B TOTAL LEN: 8.991 MI.
LEFT MUN: ELIZABETH T

DIST: 11-1 SR: 2017
RIGHT MUN: ELIZABETH T

Stationing	Length	Material	Notes
0030/2834	1 0 00685 0 00 0058+26	GILLESPIE	BMSBG 02/2017/0030/2834
0030/1874	018 " DIA	CIRC METAL	LEN=0035 INSTALLED UNKN
0030/1639	015 " DIA	CIRC METAL	LEN=0035 INSTALLED UNKN
0030/1546	018 " DIA	CIRC CONCR	LEN=0040 INSTALLED UNKN
0030/1175	018 " DIA	CIRC CONCR	LEN=0048 INSTALLED UNKN
0030/0780	015 " DIA	CIRC CONCR	LEN=0040 INSTALLED UNKN
0030/0647	018 " DIA	CIR PLASTIC	LEN=0048 INSTALLED UNKN
0030/0505	018 " DIA	CIRC CONCR	LEN=0040 INSTALLED UNKN
0030/0337	015 " DIA	CIRC METAL	LEN=0040 INSTALLED UNKN
003003 FT	003003 FT	1 0 00685 0 00 0048+39	
0030/0000	018 " DIA	CIR PLASTIC	LEN=0040 INSTALLED UNKN
0010/2863	018 " DIA	CIRC CONCR	LENGTH(AH 2902 BK 3003)
0010/2488	018 " DIA	CIR PLASTIC	LEN=0040 INSTALLED UNKN
0010/2067	012 " DIA	CIRC CONCR	LEN=0040 INSTALLED UNKN
0010/1824	012 " DIA	CIR PLASTIC	LEN=0040 INSTALLED UNKN
0010/1525	012 " DIA	CIR PLASTIC	LEN=0050 INSTALLED UNKN
0010/1431	BR GILLES R.	STRUCTURE	LENGTH 19 FT
	BMSID 02/2017/0010/1040	036"H 00"W	MULT PLSTIC
	0010/1431	LEN=0050	INSTALLED UNKN
	0010/0490	048 " DIA	CIRC CONCR
	0010/0150	018 " DIA	CIRC CONCR
000000 FT	000000 FT	1 0 00685 0 00 0000+00	
		WEST NEWTON RD	(SR0136 SEG 0120/2310)
		NC LONG HOLLOW RD	MFC BEGIN = D
WEST NEWTON RD			
(SR0136 SEG 0120/2310)	0010/0000	0010/0000	LENGTH(AH 3003 BK 0000)

EXTRACT DATE: 12/21/2020 ROADWAY MANAGEMENT SYSTEM PAGE NUMBER: 699
PRINT DATE: 12/23/2020 SLD COUNTY/SR - ANNUAL PRINT COUNTY: ALLEGHENY
DIR: B TOTAL LEN: .000 MI. DIST: 11-1 SR: 2016
LEFT MUN: ELIZABETH B RIGHT MUN: ELIZABETH B

000000 FT
000000 FT



000000 FT
7020/0000 LENGTH(AH 3163 BK 3134)
000000 FT
7010/0000 LENGTH(AH 3134 BK 0000)

LTH AH 000100 BK 000547 012075 FT
 7061/0000
 FOURTH AV
 (BORO)
 0050/0260
 011528 FT

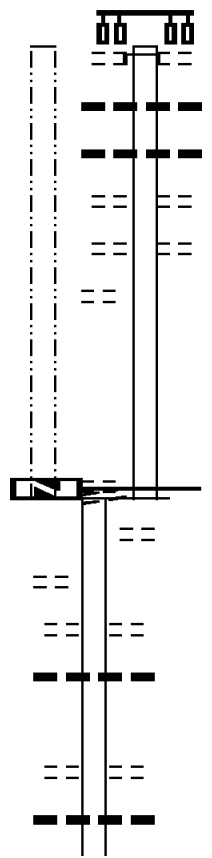

013104 FT
 INTER-AHD THIRD ST
 (BORO)
 MARKET ST/TO SR 51 SB
 (BORO)
 0060/1029 020 " DIA CIRC CONCR
 0060/1005 LEN=0035 INSTALLED UNKN
 018 " DIA CIRC CONCR
 0060/0753 LEN=0040 INSTALLED UNKN
 PLUM ST
 (BORO)
 0060/0735 STRAWBERRY ST
 (BORO)
 0060/0455 WALNUT ST
 (BORO)
 0060/0190
 012075 FT 2 0 02055 0 00 0120+56
 NC TH THIRD AV
 BAYARD ST
 (BORO)
 THIRD AV
 (BORO)
 MFC BEGIN = D
 0060/0000 LENGTH(AH 1029 BK 0547)
 TANNER AL
 (BORO)
 0050/0400
 FIFTH AV
 (BORO)
 018 " DIA CIRC CONCR
 0050/0155 LEN=0040 INSTALLED UNKN
 011528 FT 2 0 02055 0 00 0115+03
 SIXTH AV
 (BORO)
 0050/0000 LENGTH(AH 0547 BK 1219)
 018 " DIA CIRC CONCR
 0040/1218 LEN=0040 INSTALLED UNKN
 018 " DIA CIRC CONCR

EXTRACT DATE: 12/21/2020
PRINT DATE: 12/23/2020

ROADWAY MANAGEMENT SYSTEM
SLD COUNTY/SR - ANNUAL PRINT

PAGE NUMBER: 697
COUNTY: ALLEGHENY

DIR: B TOTAL LEN: 2.482 MI.
LEFT MUN: ELIZABETH B

DIST: 11-1 SR: 2015
RIGHT MUN: ELIZABETH B

Street Name	Segment ID	Length	Material	Notes
	0040/1047	LEN=0040	018" DIA CIRC CONCR	SEVENTH AV (BORO) INSTALLED UNKN
	0040/0888	LEN=0040	018" DIA CIRC CONCR	EIGHTH AV (BORO) INSTALLED UNKN
	0040/0885	LEN=0040	018" DIA CIRC CONCR	NINTH AV (BORO) INSTALLED UNKN
				NC BAYARD ST
WILLIAMSPORT RD (BORO) NINTH AV (BORO)	0040/0465			NC NINTH AV
	0040/0182	LEN=0040	015" DIA CIRC CONCR	INSTALLED UNKN
ELEVENTH ST (T580)	0040/0150	010309 FT		ELIZABETH FORWARD T
TWELFTH ST (T581)	0040/0000			NC MULBERRY ST
	0030/2570	LEN=0040	015" DIA CIRC CONCR	INSTALLED UNKN
FERRY ST (T579)	0030/2255			
BRAUFT ST (T582)	0030/2080			
	0030/1919	LEN=0040	018" DIA CIRC METAL	INSTALLED UNKN
THIRTEENTH ST (T601)	0030/1895			
FOURTEENTH ST (T600)	0030/1725			
	0030/1675	LEN=0040	018" DIA CIRC CONCR	INSTALLED 2002
FIFTEENTH ST (T599)	0030/1560			
SIXTEENTH ST (T598)	0030/1400			
	0030/1386	LEN=0020	018" DIA CIRC CONCR	INSTALLED UNKN
	0030/1380	LEN=0040	018" DIA CIRC CONCR	INSTALLED 2002
WALKER RD (T597)	0030/1160			
	0030/0855	LEN=0040	018" DIA CIRC CONCR	INSTALLED UNKN
	0030/0579	LEN=0045	018" DIA CIR PLASTIC	INSTALLED UNKN
	007629 FT	007629 FT	2 0 02055 0 00	0075+99

DIR: B TOTAL LEN: 2.482 MI. DIST: 11-1 SR: 2015
 LEFT MUN: FORWARD T RIGHT MUN: FORWARD T

Stationing	Description	Material	Status
0030/0000	HOMEPLACE DR (T577)	015" DIA CIRC METAL	INSTALLED UNKN
0020/3585	LEN=0035	015" DIA CIRC METAL	INSTALLED UNKN
0020/3218	LEN=0035	015" DIA CIRC METAL	INSTALLED UNKN
0020/3080	MEMORY DR (T576)	015" DIA CIRC METAL	INSTALLED UNKN
0020/2674	LEN=0030	015" DIA CIRC OTHER	INSTALLED UNKN
0020/0709	LEN=0035	015" DIA CIRC OTHER	INSTALLED UNKN
003876 FT	2 0 02055 0 00 0038+85		
0020/0000	LENGTH(AH 3753 BK 3876)	018" DIA CIRC CONCR	INSTALLED UNKN
0010/3609	LEN=0040	018" DIA CIRC CONCR	INSTALLED UNKN
0010/3557	LEN=0030	015" DIA CIRC METAL	INSTALLED UNKN
0010/3176	LEN=0040	015" DIA CIRC METAL	INSTALLED UNKN
0010/2564	LEN=0030	015" DIA CIRC METAL	INSTALLED UNKN
0010/1346	LEN=0012	018" DIA CIRC CONCR	INSTALLED 2015
0010/1328	LEN=0072	018" DIA CIRC CONCR	INSTALLED UNKN
0010/0481	SADDLER'S HOLLOW RD (T594)	015" DIA CIRC CONCR	INSTALLED UNKN
0010/0349	LEN=0030	018" DIA CIRC CONCR	INSTALLED UNKN
0010/0129	LEN=0050	015" DIA CIRC CONCR	INSTALLED UNKN
000000 FT	000000 FT 2 0 02055 0 00 0000+00		
0010/0000	WARREN HILL RD (TWP) NC WI LLIAMSPORT RD MFC BEGIN = D	015" DIA CIRC CONCR	INSTALLED UNKN
0010/0000	WARREN HILL RD (TWP)	LENGTH(AH 3876 BK 0000)	INSTALLED UNKN

000025 FT

 000000 FT

 000000 FT
 000000 FT
 000000 FT

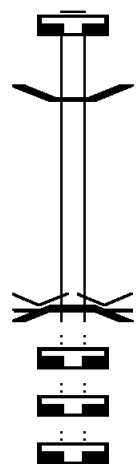

000025 FT
 7034/0000 LENGTH(AH 1102 BK 0025)
 BMSSEN 02/2014/0032/0000
 * REF-AHD BOYD HOLLOW RD (TBK)
 0032/0025 (TWP)
 000000 FT 2 0 02111 0 00 0086+96
 VILLAGE: ELIZABETH TWP
 NC BO YD HOLLOW RD
 * REF-BK BOYD HOLLOW RD (TBK)
 (TWP)
 BOYDS HOLLOW
 BMSBG 02/2014/0032/0000
 MFC BEGIN = E
 5 0032/0000 LENGTH(AH 0025 BK 2164)
 000000 FT
 7030/0000 LENGTH(AH 2164 BK 2838)
 000000 FT
 7020/0000 LENGTH(AH 2838 BK 3677)
 000000 FT
 7010/0000 LENGTH(AH 3677 BK 0000)

DIR: B TOTAL LEN: 1.900 MI. DIST: 11-1 SR: 2013
 LEFT MUN: FORWARD T RIGHT MUN: FORWARD T

Stationing	Description	Material	Length	Status
010033 FT	INTER-AHD			
0030/3569	ROBERTS HOLLOW RD (CNTY) MENTOR RD (SR2011 SEG 0060/0000) GUFFEY RD (T311)			
0030/3235	015" DIA	CIRC CONCR		
0030/3224	LEN=0064	INSTALLED UNKN		
0030/3025	036" DIA	CIRC CONCR		
	LEN=0030	INSTALLED UNKN		
HILLCREST ST (T410)				
0030/2690				
	024" DIA	CIRC CONCR		
0030/1567	LEN=0045	INSTALLED UNKN		
	018" DIA	CIRC CONCR		
0030/1221	LEN=0040	INSTALLED UNKN		
	018" DIA	CIRC CONCR		
0030/1010	LEN=0040	INSTALLED UNKN		
	036" DIA	CIRC METAL		
0030/0627	LEN=0050	INSTALLED UNKN		
006464 FT				
1 0 00684 0 00 0065+06 006464 FT				
WISE LN (PRDR)				
0030/0000				
	LENGTH(AH 3569 BK 3410)			
	018" DIA	CIRC CONCR		
0020/3154	LEN=0064	INSTALLED UNKN		

EXTRACT DATE: 12/21/2020
PRINT DATE: 12/23/2020

ROADWAY MANAGEMENT SYSTEM
SLD COUNTY/SR - ANNUAL PRINT

PAGE NUMBER: 693
COUNTY: ALLEGHENY

DIR: B TOTAL LEN: 1.900 MI.
LEFT MUN: FORWARD T









DIST: 11-1 SR: 2013
RIGHT MUN: FORWARD T

003054 FT

000000 FT

0020/3030	024 " DIA	CIRC CONCR
	LEN=0045	INSTALLED UNKN
0020/2525	018 " DIA	CIRC CONCR
	LEN=0040	INSTALLED UNKN
0020/2412	018 " DIA	CIRC CONCR
	LEN=0045	INSTALLED UNKN
0020/1850	018 " DIA	CIRC CONCR
	LEN=0040	INSTALLED UNKN
0020/1448	018 " DIA	CIRC CONCR
	LEN=0040	INSTALLED UNKN
0020/1193	018 " DIA	CIRC CONCR
	LEN=0035	INSTALLED UNKN
0020/1044	BMSFN 02/2013/0020/1026	
	1 0 00684 0 00 0041+24	
	BRANCH OF BECKETS RUN	
0020/1026	BMSBG 02/2013/0020/1026	
	018 " DIA	CIRC CONCR
0020/0503	LEN=0035	INSTALLED UNKN
003054 FT	1 0 00684 0 00 0030+75	
	018 " DIA	CIR PLASTIC
	LEN=0099	INSTALLED 1999
0020/0000	LENGTH(AH 3410 BK 3054)	
	018 " DIA	CIRC CONCR
0010/2813	LEN=0020	INSTALLED UNKN
	018 " DIA	CIRC CONCR
0010/2295	LEN=0020	INSTALLED UNKN
	TUNNEL HOLLOW RD	
0010/2000	(T305)	
0010/1594	BMSFN 02/2013/0010/1574	
	1 0 00684 0 00 0015+97	
	BR. OF BECKETS RUN	
0010/1574	BMSBG 02/2013/0010/1574	
	018 " DIA	CIRC CONCR
0010/1270	LEN=0020	INSTALLED UNKN
	018 " DIA	CIRC CONCR
0010/0986	LEN=0040	INSTALLED UNKN
	018 " DIA	CIRC CONCR
0010/0612	LEN=0040	INSTALLED UNKN
0010/0577	BMSFN 02/2013/0010/0556	
	1 0 00684 0 00 0005+48	
	BR. BECKETS	
0010/0556	BMSBG 02/2013/0010/0556	
	018 " DIA	CIRC CONCR
0010/0121	LEN=0025	INSTALLED UNKN
000000 FT	1 0 00684 0 00 0000+00	
	NC EL	
	LA HOLLOW RD	
	RAINBOW RUN RD	
	(SRO136 SEG 0090/0000)	
	MFC BEGIN = D	
0010/0000	LENGTH(AH 3054 BK 0000)	

EXTRACT DATE: 12/21/2020 ROADWAY MANAGEMENT SYSTEM PAGE NUMBER: 692
 PRINT DATE: 12/23/2020 SLD COUNTY/SR - ANNUAL PRINT COUNTY: ALLEGHENY
 DIR: B TOTAL LEN: .000 MI. DIST: 11-1 SR: 2012
 LEFT MUN: ELIZABETH T RIGHT MUN: ELIZABETH T

000000 FT		000000 FT	
000000 FT		7050/0000	LENGTH(AH 2431 BK 2421)
000000 FT		000000 FT	
000000 FT		7040/0000	LENGTH(AH 2421 BK 3675)
000000 FT		000000 FT	
000000 FT		7030/0000	LENGTH(AH 3675 BK 2203)
000000 FT		000000 FT	
000000 FT		7020/0000	LENGTH(AH 2203 BK 2398)
		000000 FT	
		7010/0000	LENGTH(AH 2398 BK 0000)

DIR: B TOTAL LEN: 2.684 MI. DIST: 11-1 SR: 2011
 LEFT MUN: ELIZABETH T RIGHT MUN: ELIZABETH T

HAYDEN BL 014174 FT
 (SR0051 SEG 0061/0000) 0070/1850

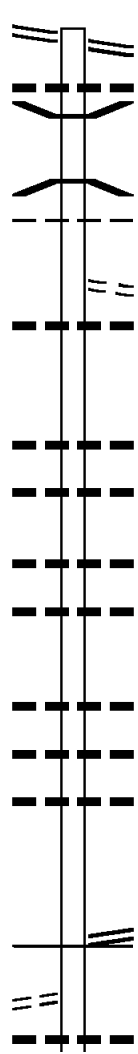

014174 FT HAYDEN BL
 0070/1850 (SR0051 SEG 0061/0000)
 048"H 72"W CON BOX CUL
 0070/1720 LEN=0099 INSTALLED UNKN
 0070/1683 BMSEN 02/2011/0070/1668
 2 0 02036 0 00 0160+76
 FALL. TIMBER
 0070/1668 BMSBG 02/2011/0070/1668
 ELIZABETH
 0070/1646 FORWARD T
 HUTCHINSON RD
 0070/1120 (T313)
 018 " DIA CIRC CONCR
 0070/0708 LEN=0040 INSTALLED UNKN
 012324 FT 2 0 02036 0 00 0160+76
 0070/0000 LENGTH(AH 1850 BK 3774)
 024 " DIA CIRC CONCR
 0060/3550 LEN=0040 INSTALLED UNKN
 018 " DIA CIRC CONCR
 0060/3021 LEN=0040 INSTALLED UNKN
 018 " DIA CIRC CONCR
 0060/2376 LEN=0040 INSTALLED UNKN
 018 " DIA CIRC CONCR
 0060/1989 LEN=0040 INSTALLED UNKN
 018 " DIA CIRC CONCR
 0060/1044 LEN=0040 INSTALLED UNKN
 018 " DIA CIRC CONCR
 0060/0789 LEN=0040 INSTALLED UNKN
 018 " DIA CIRC CONCR
 0060/0546 LEN=0040 INSTALLED UNKN
 008550 FT 2 0 02036 0 00 0123+02
 ROBERTS HOLLOW RD
 (SR2013 SEG 0030/3569)
 NC MENTOR RD
 MFC BEGIN = D
 0060/0000 LENGTH(AH 3774 BK 2131)
 NC ROBERTS HOLLOW RD
 036 " DIA CIRC CONCR
 0040/1914 LEN=0060 INSTALLED UNKN

012324 FT

008550 FT

ROBERTS HOLLOW RD
 (CNTY)

0040/1966

DIR: B TOTAL LEN: 2.684 MI. DIST: 11-1 SR: 2011
 LEFT MUN: FORWARD T RIGHT MUN: FORWARD T

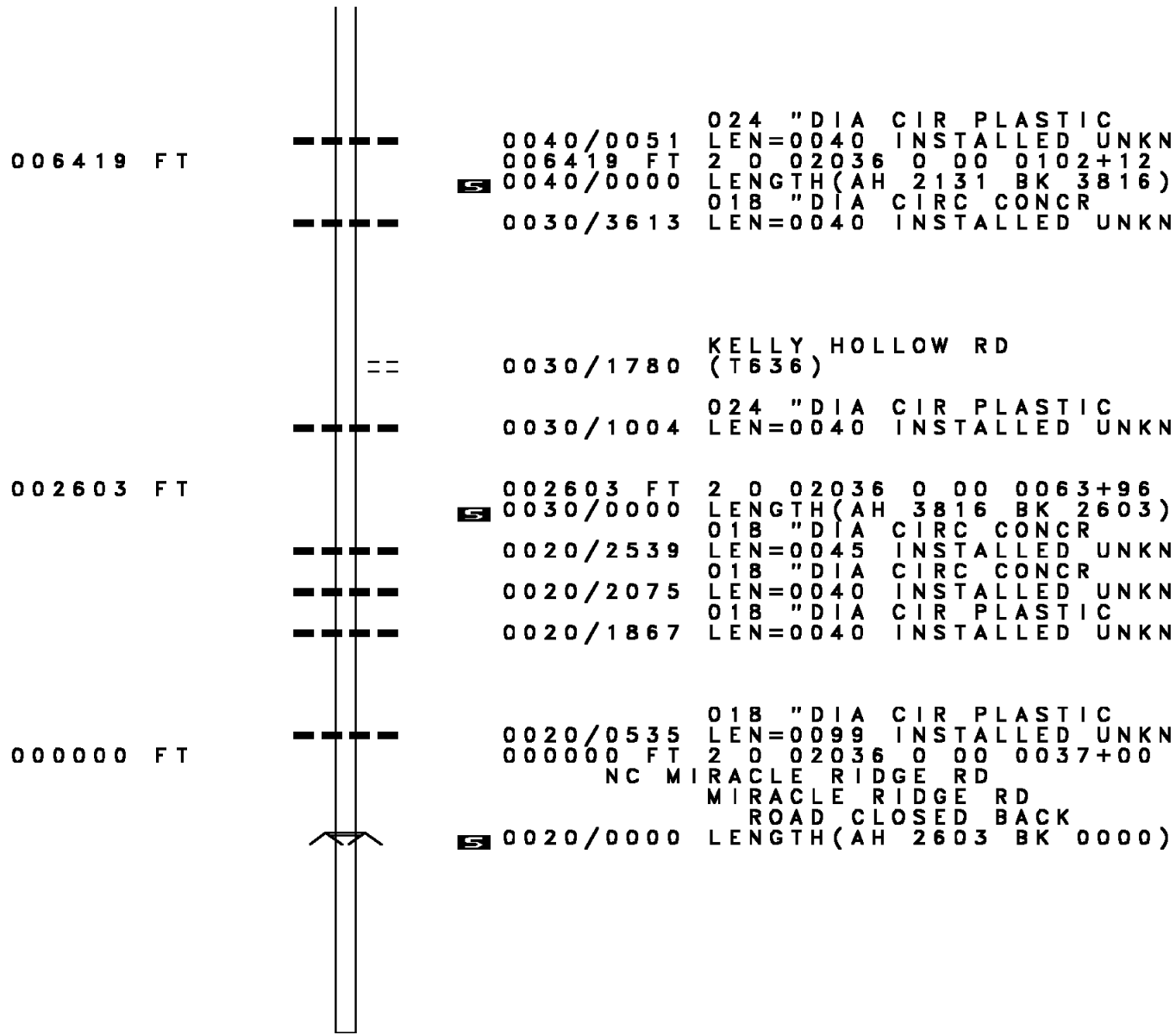

006419 FT 0040/0051 024 " DIA CIR PLASTIC
 006419 FT 2 0 02036 0 00 0102+12 LEN=0040 INSTALLED UNKN
 0040/0000 LENGTH(AH 2131 BK 3816)
 0030/3613 018 " DIA CIRC CONCR LEN=0040 INSTALLED UNKN

0030/1780 KELLY HOLLOW RD
 (T636)

0030/1004 024 " DIA CIR PLASTIC
 LEN=0040 INSTALLED UNKN
 002603 FT 002603 FT 2 0 02036 0 00 0063+96
 0030/0000 LENGTH(AH 3816 BK 2603)
 0020/2539 018 " DIA CIRC CONCR LEN=0045 INSTALLED UNKN
 0020/2075 018 " DIA CIRC CONCR LEN=0040 INSTALLED UNKN
 0020/1867 018 " DIA CIR PLASTIC LEN=0040 INSTALLED UNKN

000000 FT 0020/0535 018 " DIA CIR PLASTIC
 000000 FT 2 0 02036 0 00 0037+00 LEN=0099 INSTALLED UNKN
 NC MI MIRACLE RIDGE RD
 MIRACLE RIDGE RD
 ROAD CLOSED BACK
 0020/0000 LENGTH(AH 2603 BK 0000)

DIR: B TOTAL LEN: 2.428 MI. DIST: 11-1 SR: 2010
 LEFT MUN: ELIZABETH T RIGHT MUN: ELIZABETH T

BOSTON HOLLOW RD 012821 FT
 (SR0048 SEG 0090/2725) 0040/2971

PIERCE RD
 (TWP) 0040/1435
 ELIZABETH
 LINCOLN B 0040/1091

LIBERTY WY
 (CNTY) 0040/0945

009850 FT

HARRISON RD
 (SR2023 SEG 0010/0000) 0030/2445

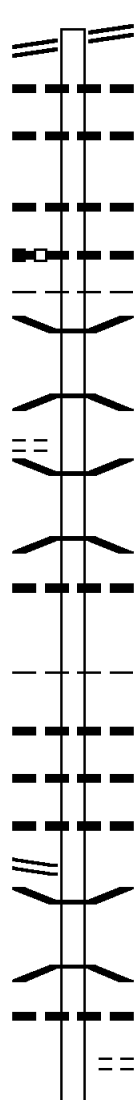

012821 FT BOSTON HOLLOW RD
 0040/2971 (SR0048 SEG 0090/2725)
 0040/2564 024 " DIA CIRC CONCR
 LEN=0035 INSTALLED UNKN
 0040/2510 018 " DIA CIRC CONCR
 LEN=0030 INSTALLED UNKN
 018 " DIA CIRC METAL
 0040/1653 LEN=0070 INSTALLED UNKN
 024 " DIA CIRC CONCR
 0040/1435 LEN=0050 INSTALLED UNKN
 0040/0998 BMS EN 02/2010/0040/0988
 2 0 02305 0 00 0108+40
 WYLIE RUN
 0040/0988 BMSBG 02/2010/0040/0988
 0040/0719 BMS EN 02/2010/0040/0693
 2 0 02305 0 00 0105+38
 WYLIE RUN
 0040/0693 BMSBG 02/2010/0040/0693
 018 " DIA CIRC CONCR
 0040/0344 LEN=0030 INSTALLED UNKN
 009850 FT 2 0 02305 0 00 0098+29
 ELIZABETH
 LINCOLN B
 0040/0000 LENGTH(AH 2971 BK 3333)
 018 " DIA CIRC METAL
 0030/3288 LEN=0030 INSTALLED UNKN
 030 " DIA CIR PLASTIC
 0030/2918 LEN=0035 INSTALLED UNKN
 018 " DIA CIRC CONCR
 0030/2567 LEN=0030 INSTALLED UNKN
 0030/2311 BMS EN 02/2010/0030/2303
 2 0 02305 0 00 0088+09
 WYLIE RUN
 0030/2303 BMSBG 02/2010/0030/2303
 018 " DIA CIR PLASTIC
 0030/1879 LEN=0099 INSTALLED UNKN
 JACKTOWN RD
 (BORO)
 0030/1755 018 " DIA CIRC CONCR

EXTRACT DATE: 12/21/2020
PRINT DATE: 12/23/2020

ROADWAY MANAGEMENT SYSTEM
SLD COUNTY/SR - ANNUAL PRINT

PAGE NUMBER: 688
COUNTY: ALLEGHENY

DIR: B TOTAL LEN: 2.428 MI.
LEFT MUN: LINCOLN B

DIST: 11-1 SR: 2010
RIGHT MUN: LINCOLN B

FUEHRER DR
(BORO)

0030/1395

006517 FT

0030/1409	LEN=0030	INSTALLED UNKN
0030/1153	BMS EN 02/2010/0030/1122 2 0 02305 0 00 0075+91 BR. WYLIE RUN	
0030/1122	BMSBG 02/2010/0030/1122 LINCOLN	
0030/1025	ELIZABETH T	
0030/0555	BMS EN 02/2010/0030/0537 2 0 02305 0 00 0070+39 WYLIE RUN	
0030/0537	BMSBG 02/2010/0030/0537 024 "DIA CIRC CONCR	
0030/0405	LEN=0035 INSTALLED UNKN 018 "DIA CIRC CONCR	
0030/0045	LEN=0040 INSTALLED UNKN 2 0 02305 0 00 0065+55 MILL HILL RD (SR2008 SEG 0010/0000) ELIZABETH LINCOLN B	
0030/0000	LENGTH(AH 3333 BK 3063) 018 "DIA CIRC CONCR	
0020/2691	LEN=0030 INSTALLED UNKN 018 "DIA CIRC CONCR	
0020/2431	LEN=0030 INSTALLED UNKN 018 "DIA CIRC CONCR	
0020/2267	LEN=0025 INSTALLED UNKN 018 "DIA CIRC CONCR	
0020/1940	LEN=0025 INSTALLED UNKN 024 "DIA CIRC CONCR	
0020/1771	LEN=0040 INSTALLED UNKN 018 "DIA CIRC CONCR	
0020/1635	LEN=0030 INSTALLED UNKN 012 "DIA CIRC CONCR	
0020/1345	LEN=0034 INSTALLED UNKN 015 "DIA CIRC CONCR	
0020/1324	LEN=0035 INSTALLED UNKN 036 "DIA CIRC METAL	
0020/1055	LEN=0025 INSTALLED UNKN 018 "DIA CIRC CONCR	
0020/0976	LEN=0025 INSTALLED UNKN ROSS ST	
0020/0537	(SR2105 SEG 0010/0028) 018 "DIA CIRC CONCR	
0020/0430	LEN=0025 INSTALLED UNKN 018 "DIA CIRC CONCR	
0020/0101	LEN=0025 INSTALLED UNKN	
0020/0032	BMS EN 02/2010/0020/008B	

DIR: B TOTAL LEN: 2.428 MI. DIST: 11-1 SR: 2010
 LEFT MUN: LINCOLN B RIGHT MUN: LINCOLN B

Stationing / Description	Segment / Details	Material / Notes
003454 FT	0020/0020	018 " DIA CIRC CONCR LEN=0020 INSTALLED UNKN
	003454 FT	2 0 02305 0 00 0033+21 WYLIE RUN
	0020/0000	BMSBG 02/2010/0020/0088 LENGTH(AH 3063 BK 3454)
	0010/3319	LINCOLN ELIZABETH T
	0010/3010	SCOTT ST (TWP)
	0010/2974	018 " DIA CIRC CONCR LEN=0020 INSTALLED UNKN
	0010/2930	PENN ST (TWP)
	0010/2527	018 " DIA CIRC CONCR LEN=0020 INSTALLED UNKN
	0010/2380	ROSS ST (TWP)
		RBR
	0010/2253	BMSEN 02/2010/0010/2238 2 0 02305 0 00 0022+29 P3
	0010/2238	BR WYLIE RUN BMSBG 02/2010/0010/2238
	0010/1195	018 " DIA CIRC CONCR LEN=0020 INSTALLED UNKN
	0010/1160	(APRA) ROTELICA CO ROTELICA CO RD (PRDR)
	0010/0959	018 " DIA CIRC CONCR LEN=0020 INSTALLED UNKN
	0010/0595	018 " DIA CIRC CONCR LEN=0020 INSTALLED UNKN
PENNDOT STOCK PILE YARD (GOVT)	0010/0447	
	000000 FT	
	0010/0230	018 " DIA CIRC CONCR LEN=0020 INSTALLED UNKN
	000000 FT	2 0 02305 0 00 0000+00 NC LOVEDALE RD LINCOLN BL (SR2001 SEG 0230/1255)
	INTER-BK	ATLANTIC AV (TWP)
MCKEESPORT RD (SR2001 SEG 0230/1255)	0010/0000	MFC BEGIN = C LENGTH(AH 3454 BK 0000)

DIR: B TOTAL LEN: 1.830 MI. DIST: 11-1 SR: 2009
 LEFT MUN: FORWARD T RIGHT MUN: FORWARD T

Street Name	Stationing	Length	Material	Notes
WILLIAMSPORT RD (CNTY)	009665 FT	0030/3463	018" DIA CIRC CONCR	LEN=0060 INSTALLED UNKN
		0030/3338	018" DIA CIRC CONCR	LEN=0064 INSTALLED UNKN
		0030/2800	060"H 66"W CONCR ARCH	LEN=0040 INSTALLED UNKN
		0030/2205	018" DIA CIRC CONCR	LEN=0030 INSTALLED UNKN
BARKER LN (PRDR)	0030/0659	0030/0485	015" DIA CIRC CONCR	LEN=0030 INSTALLED UNKN
	0030/0375	006202 FT	2 0 02173 0 00 0054+42	LENGTH(AH 3463 BK 2301)
BRUSSALIS LN (PRDR)	0030/0375	006202 FT	CANTONI LN	(T615)
	006202 FT	0030/0000		

DIR: B TOTAL LEN: 1.830 MI. DIST: 11-1 SR: 2009
 LEFT MUN: FORWARD T RIGHT MUN: FORWARD T

SCHEDADT DR
 (PRDR)

0020/2063

003901 FT

000000 FT

0020/1889	036 " DIA CIRC CONCR LEN=0050 INSTALLED UNKN
0020/1402	LARGE ST (T612)
0020/1343	036 " DIA CIRC OTHER LEN=0045 INSTALLED UNKN
0020/0653	024 " DIA CIR PLASTIC LEN=0040 INSTALLED UNKN
0020/0280	018 " DIA CIRC CONCR LEN=0035 INSTALLED UNKN
003901 FT	2 0 02173 0 00 0031+00
0020/0000	LENGTH(AH 2301 BK 3901)
0010/3848	048 " DIA CIR PLASTIC LEN=0040 INSTALLED UNKN
0010/3600	018 " DIA CIRC METAL LEN=0035 INSTALLED UNKN
0010/3139	024 " DIA CIRC METAL LEN=0040 INSTALLED UNKN
0010/3056	024 " DIA CIRC METAL LEN=0035 INSTALLED UNKN
0010/2768	018 " DIA CIRC CONCR LEN=0035 INSTALLED UNKN
0010/2287	024 " DIA CIRC CONCR LEN=0030 INSTALLED UNKN
0010/2117	018 " DIA CIRC CONCR LEN=0035 INSTALLED UNKN
0010/1692	BMSSEN 02/2009/0010/1672 2 0 02173 0 00 0008+90 SUNFISH RUN
0010/1672	BMSBG 02/2009/0010/1672
0010/1543	015 " DIA CIRC CONCR LEN=0030 INSTALLED UNKN
0010/0805	MIRACLE RIDGE RD (SR2011 SEG 0010/0000)
0010/0256	BMSSEN 02/2009/0010/0247 0 0 00000 0 00 0000+00 SUNFISH RUN
0010/0247	BMSBG 02/2009/0010/0247
0010/0215	OAK DR (T408)
000000 FT	2 0 02173 0 00 0000+00
NC SU	NNYSIDE HOLLOW RD RAINBOW RUN RD (SRO136 SEG 0050/1415)
0010/0000	MFC BEGIN = E LENGTH(AH 3901 BK 0000)

DIR: B TOTAL LEN: .761 MI. DIST: 11-1 SR: 2008
 LEFT MUN: ELIZABETH T RIGHT MUN: ELIZABETH T

004018 FT

004018 FT INTER-AHD CIRCLE DR (TWP) SCENERY DR (SR0048 SEG 0070/1445)

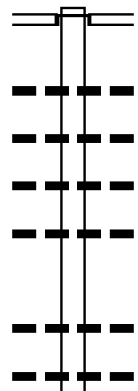

0020/2080 018 " DIA CIRC CONCR LEN=0030 INSTALLED UNKN
 0020/1320 018 " DIA CIRC CONCR LEN=0030 INSTALLED UNKN
 0020/1154 018 " DIA CIRC CONCR LEN=0030 INSTALLED UNKN
 0020/0860 018 " DIA CIRC METAL LEN=0040 INSTALLED UNKN
 048 " DIA CIRC METAL LEN=0040 INSTALLED UNKN
 0020/0461 018 " DIA CIRC METAL LEN=0040 INSTALLED UNKN
 001938 FT 1 0 00689 0 00 0019+54
 0020/0000 LENGTH(AH 2080 BK 1938) 018 " DIA CIR PLASTIC LEN=0030 INSTALLED 1997
 0010/1716 018 " DIA CIR PLASTIC LEN=0040 INSTALLED UNKN
 0010/1250 024 " DIA CIRC METAL LEN=0040 INSTALLED UNKN
 018 " DIA CIR PLASTIC LEN=0040 INSTALLED 1997
 018 " DIA CIRC METAL LEN=0050 INSTALLED UNKN

001938 FT

JACKTOWN RD (TWP)

0010/1215

0010/0801 024 " DIA CIRC METAL LEN=0040 INSTALLED UNKN
 018 " DIA CIR PLASTIC LEN=0040 INSTALLED 1997
 018 " DIA CIRC METAL LEN=0050 INSTALLED UNKN

RBR

0010/0077 BMS EN 02/2008/0010/0053 1 0 00689 0 00 0000+47 P3

RBR

000000 FT

0010/0053 WYLIE RUN BMSBG 02/2008/0010/0053 000000 FT 1 0 00689 0 00 0000+00 NC MI LL HILL RD LOVEDALE RD (SR2010 SEG 0030/0000) MFC BEGIN = E 0010/0000 LENGTH(AH 1938 BK 0000)

DIR: B TOTAL LEN: 2.193 MI. DIST: 11-1 SR: 2007
 LEFT MUN: FORWARD T RIGHT MUN: FORWARD T

011580 FT

011580 FT
 INTER-AHD

WILLIAM PENN RD
 (T614)

PANGBURN HOLLOW RD
 (CNTY)

0060/2976
 0060/2958

BMSSEN 02/2007/0060/2941
 1 0 00394 0 00 0114+58

0060/2941

BMSBG 02/2007/0060/2941
 018 "DIA CIRC CONCR

0060/2629

LEN=0060 INSTALLED UNKN
 018 "DIA CIRC CONCR

0060/2410

LEN=0060 INSTALLED UNKN
 024 "DIA CIRC CONCR

0060/2300

LEN=0060 INSTALLED UNKN
 018 "DIA CIRC CONCR

0060/1705

LEN=0060 INSTALLED UNKN
 018 "DIA CIRC CONCR

0060/1500

LEN=0060 INSTALLED UNKN
 024 "DIA CIRC CONCR

0060/1313

LEN=0100 INSTALLED UNKN
 018 "DIA CIRC CONCR

0060/1211

LEN=0050 INSTALLED UNKN
 018 "DIA CIRC CONCR

0060/0847

LEN=0050 INSTALLED UNKN
 018 "DIA CIRC CONCR

0060/0525

LEN=0060 INSTALLED UNKN

008604 FT

008604 FT

1 0 00394 0 00 0085+13

0060/0000

LENGTH(AH 2976 BK 1599)
 060 "DIA CIRC CONCR

0050/1490

LEN=0150 INSTALLED UNKN
 018 "DIA CIRC CONCR

0050/1192

LEN=0099 INSTALLED UNKN

0050/0124

018 "DIA CIRC CONCR
 LEN=0040 INSTALLED UNKN

007005 FT

1 0 00394 0 00 0069+14 007005 FT
 RACCOON RUN RD
 (SR2005 SEG 0010/0000) 0050/0000

0050/0000

LENGTH(AH 1599 BK 2940)

0040/2050

018 "DIA CIRC CONCR
 LEN=0099 INSTALLED UNKN

0040/1729

018 "DIA CIRC CONCR
 LEN=0099 INSTALLED UNKN

0040/1665

KENNETH ST
 (T613)

RIDGE RD
 (T608)

0040/1520

ELM DR

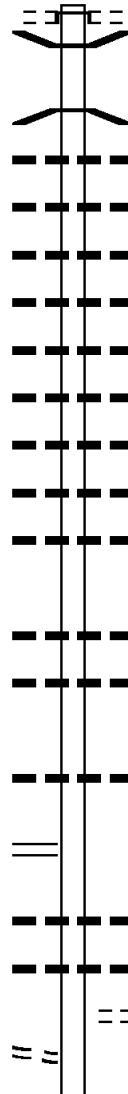

DIR: B TOTAL LEN: 2.193 MI. DIST: 11-1 SR: 2007
 LEFT MUN: FORWARD T RIGHT MUN: FORWARD T

MUNGER ST
(T643)

0040/0555

004065 FT

001264 FT

000000 FT

BUNOLA RIVER RD
(SR2001 SEG 0010/1770) 0010/0000

0040/1487	(T649)	018" DIA	CIRC	CONCR	
0040/1096	LEN=0040		INSTALLED	UNKN	
0040/0855	LEN=0099	015" DIA	CIRC	CONCR	
0040/0604	(T593)	MANOWN RD	INSTALLED	UNKN	
		PERRY MILL R			
		STRUCTURE	LENGTH	10 FT	
0040/0404	BMSID 02/2007/0040/0404				
004065 FT	1 0 00394 0 00 0035+00				
		MALERIE LN			
		(T403)			
0040/0000	LENGTH(AH 2940 BK 2801)	018" DIA	CIRC	CONCR	
0030/2364	LEN=0050		INSTALLED	UNKN	
		018" DIA	CIRC	CONCR	
0030/1529	LEN=0099		INSTALLED	UNKN	
		018" DIA	CIRC	CONCR	
0030/1265	LEN=0099		INSTALLED	UNKN	
		018" DIA	CIRC	CONCR	
0030/1139	LEN=0099		INSTALLED	UNKN	
		018" DIA	CIRC	CONCR	
0030/0829	LEN=0099		INSTALLED	UNKN	
		018" DIA	CIRC	CONCR	
0030/0557	LEN=0099		INSTALLED	UNKN	
		018" DIA	CIRC	CONCR	
0030/0443	LEN=0099		INSTALLED	UNKN	
		018" DIA	CIRC	CONCR	
0030/0273	LEN=0099		INSTALLED	UNKN	
		018" DIA	CIRC	CONCR	
0030/0026	LEN=0050		INSTALLED	UNKN	
001264 FT	1 0 00394 0 00 0006+99				
		LENGTH(AH 2801 BK 1264)			
0030/0000	018" DIA	CIRC	CONCR		
		018" DIA	CIRC	CONCR	
0010/1011	LEN=0099		INSTALLED	UNKN	
		018" DIA	CIRC	CONCR	
0010/0809	LEN=0099		INSTALLED	UNKN	
		024" DIA	CIRC	CONCR	
0010/0187	LEN=0040		INSTALLED	UNKN	
000000 FT	1 0 00394 0 00 0000+00				
		BUNOLA RIVER RD			
		(SR2001 SEG 0010/1770)			
		NC RIVER HILL RD			
		MFC BEGIN = D			
0010/0000	LENGTH(AH 1264 BK 0000)				

000014 FT

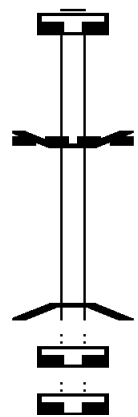

000000 FT

000000 FT

000000 FT

000014 FT
 7034/0000 LENGTH(AH 3356 BK 0014)
 * REF-AHD BMSBN 02/2006/0030/0000
 PARK AV (TBK)
 (TWP)
 042"H 42"W CONC STRUCT
 0030/0014 LEN=0036 INSTALLED UNKN
 000000 FT 1 0 00688 0 00 0075+43
 NC HA
 * REF-BK HAPPY HOLLOW RD
 HAPPY HOLLOW RD (TBK)
 (TWP)
 BR.WYLIE RUN
 BMSBG 02/2006/0030/0000
 5 0030/0000 LENGTH(AH 0014 BK 3877)
 000000 FT
 7020/0000 LENGTH(AH 3877 BK 3546)
 000000 FT
 7010/0000 LENGTH(AH 3546 BK 0000)

EXTRACT DATE: 12/21/2020 ROADWAY MANAGEMENT SYSTEM PAGE NUMBER: 680
 PRINT DATE: 12/23/2020 SLD COUNTY/SR - ANNUAL PRINT COUNTY: ALLEGHENY
 DIR: B TOTAL LEN: 3.732 MI. DIST: 11-1 SR: 2005
 LEFT MUN: FORWARD T RIGHT MUN: FORWARD T

BUNOLA RIVER RD 019704 FT
 (SR2001 SEG 0110/0000) 0070/1739

017965 FT

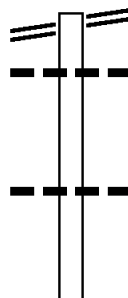

019704 FT BUNOLA RIVER RD
 0070/1739 (SR2001 SEG 0110/0000)
 0070/1364 024 " DIA CIRC CONCR
 LEN=0045 INSTALLED UNKN

0070/0065 048 " DIA CIR PLASTIC
 017965 FT LEN=0040 INSTALLED UNKN
 5 0070/0000 2 0 02040 0 01 0186+08
 LENGTH(AH 1739 BK 3809)

DIR: B TOTAL LEN: 3.732 MI. DIST: 11-1 SR: 2005
 LEFT MUN: FORWARD T RIGHT MUN: FORWARD T

008258 FT



008258 FT 2 0 02040 0 01 0089+38
 KELLY RUN
 BMSBG 02/2005/0040/0001
 0040/0000 LENGTH(AH 2215 BK 3168)

0030/2119 015 "DIA CIRC METAL
 LEN=0030 INSTALLED UNKN
 0030/1915 030 "DIA CIRC METAL
 LEN=0050 INSTALLED UNKN

0030/0965 015 "DIA CIRC METAL
 LEN=0040 INSTALLED UNKN
 0030/0468 015 "DIA CIRC METAL
 LEN=0045 INSTALLED UNKN

005090 FT

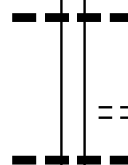

0030/0267 015 "DIA CIRC METAL
 LEN=0040 INSTALLED UNKN
 005090 FT 2 0 02040 0 01 0057+70
 LITTLE RD
 (T307)
 0030/0000 LENGTH(AH 3168 BK 1528)
 0020/1390 015 "DIA CIRC METAL
 LEN=0035 INSTALLED UNKN

003562 FT

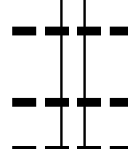





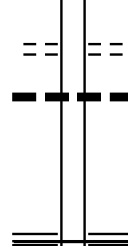







003562 FT 2 0 02040 0 01 0042+78
 0020/0000 LENGTH(AH 1528 BK 3562)
 0010/2468 015 "DIA CIRC CONCR
 LEN=0035 INSTALLED UNKN
 0010/1688 015 "DIA CIRC METAL
 LEN=0035 INSTALLED UNKN
 0010/1297 048 "DIA CIR PLASTIC
 LEN=0040 INSTALLED UNKN

000000 FT

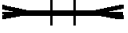

0010/0310 RIDGE RD
 (T608)
 0010/0275 018 "DIA CIR PLASTIC
 LEN=0030 INSTALLED UNKN
 000000 FT 2 0 02040 0 00 0000+00
 NC RA CCOON RUN RD
 RIVER HILL RD
 (SR2007 SEG 0050/0000)
 MFC BEGIN = E
 0010/0000 LENGTH(AH 3562 BK 0000)

000008 FT		000008 FT	
000008 FT		7070/0000	LENGTH(AH 3246 BK 0816)
000008 FT		000008 FT	
000008 FT		7060/0000	LENGTH(AH 0816 BK 3427)
000008 FT		000008 FT	
000008 FT		7050/0000	LENGTH(AH 3427 BK 3459)
000008 FT		000008 FT	
000008 FT		7040/0000	LTH AH 003459 BK 000100
000008 FT		000008 FT	
000008 FT		7034/0000	LTH AH 000100 BK 002577
000008 FT		000008 FT	
000008 FT		7030/0000	LENGTH(AH 2577 BK 3319)
000008 FT		000008 FT	
000008 FT		7020/0000	LENGTH(AH 3319 BK 1200)
		000008 FT	
		7014/0000	LENGTH(AH 1200 BK 0008)
		* REF-AHD	WEIGELS HILL RD (TBK)
000000 FT		0010/0008	(TWP)
		000000 FT	
		NC WE	1 1 00568 0 00 0023+35
			WEIGEL HILL RD
			BR.FALLEN TIM
			STRUCTURE LENGTH 7 FT
			BMSID 02/2004/0010/0000
		* REF-BK	WEIGELS HILL RD (TBK)
			(TWP)
			MFC BEGIN = D
000000 FT		5 0010/0000	LENGTH(AH 0008 BK 2335)
		000000 FT	
		7008/0000	LENGTH(AH 2335 BK 0000)

EXTRACT DATE: 12/21/2020 ROADWAY MANAGEMENT SYSTEM PAGE NUMBER: 676
PRINT DATE: 12/23/2020 SLD COUNTY/SR - ANNUAL PRINT COUNTY: ALLEGHENY

DIR: B TOTAL LEN: 1.305 MI. DIST: 11-1 SR: 2003
LEFT MUN: FORWARD T RIGHT MUN: FORWARD T

006890 FT

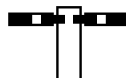

006890 FT 018 " DIA CIRC CONCR
LEN=0042 INSTALLED UNKN
BUNOLA RIVER RD
0030/2915 (SR2001 SEG 0080/0000)

DIR: B TOTAL LEN: 1.305 MI. DIST: 11-1 SR: 2003
 LEFT MUN: FORWARD T RIGHT MUN: FORWARD T

SALKA LN
(PRDR)

0030/1966

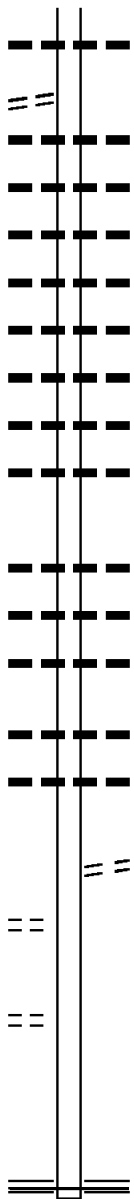

0030/1988	018 " DIA	CIRC CONCR
	LEN=0042	INSTALLED UNKN
0030/1890	018 " DIA	CIRC CONCR
	LEN=0042	INSTALLED UNKN
0030/1691	048"H 24"W	ELLIP CONC
	LEN=0040	INSTALLED UNKN
0030/1465	018 " DIA	CIRC CONCR
	LEN=0042	INSTALLED UNKN
0030/1297	018 " DIA	CIRC CONCR
	LEN=0042	INSTALLED UNKN
0030/0751	018 " DIA	CIRC CONCR
	LEN=0042	INSTALLED UNKN
0030/0600	036 " DIA	CIRC CONCR
	LEN=0040	INSTALLED UNKN
0030/0270	018 " DIA	CIR PLASTIC
	LEN=0040	INSTALLED UNKN
0030/0138	036 " DIA	CIRC CONCR
	LEN=0045	INSTALLED UNKN
003975 FT	2 0 02155	0 00 0040+33
0030/0000	LENGTH(AH 2915 BK 1966)	
0020/1868	036 " DIA	CIRC CONCR
	LEN=0048	INSTALLED UNKN
0020/1378	024 " DIA	CIRC CONCR
	LEN=0045	INSTALLED UNKN
0020/0956	024 " DIA	CIRC CONCR
	LEN=0038	INSTALLED UNKN
0020/0337	018 " DIA	CIRC CONCR
	LEN=0040	INSTALLED UNKN
0020/0087	018 " DIA	CIRC CONCR
	LEN=0040	INSTALLED UNKN
002009 FT	2 0 02155	0 00 0020+45
	MCVICKER LN (T319)	
0020/0000	LENGTH(AH 1966 BK 2009)	
0010/1955		
0010/0795		
000000 FT	2 0 02155	0 00 0000+00
	NC CHURCH HOLLOW RD	
	RACCOON RUN RD	
	(SR2005 SEG 0050/0000)	
	MFC BEGIN = E	
0010/0000	LENGTH(AH 2009 BK 0000)	

BERRY LN
(T318)

ELKHORN RD
(T308)

EXTRACT DATE: 12/21/2020 ROADWAY MANAGEMENT SYSTEM PAGE NUMBER: 674
PRINT DATE: 12/23/2020 SLD COUNTY/SR - ANNUAL PRINT COUNTY: ALLEGHENY
DIR: B TOTAL LEN: .000 MI. DIST: 11-1 SR: 2002
LEFT MUN: GLASSPORT B RIGHT MUN: GLASSPORT B

000000 FT
000000 FT



000000 FT
7020/0000 LENGTH(AH 2986 BK 3006)
000000 FT
7010/0000 LENGTH(AH 3006 BK 0000)

DIR: B TOTAL LEN: 13.300 MI. DIST: 11-1 SR: 2001
 LEFT MUN: GLASSPORT B RIGHT MUN: GLASSPORT B

	070226 FT		067682 FT (APRA) WESTINGHOUSE ELE INTER-AHD OHIO AV (BORO) WALL ST (BORO)
		POE	0300/2405
		---	018 " DIA CIRC CONCR LEN=0709 INSTALLED UNKN
		---	018 " DIA CIRC CONCR LEN=0099 INSTALLED UNKN
		---	018 " DIA CIRC CONCR LEN=0024 INSTALLED UNKN
		---	018 " DIA CIRC CONCR LEN=0097 INSTALLED UNKN
		┌───┐	SIGN: CANTILEVER 0300/1170 BMSID 02/2001/0300/1170
TO 2038/0010 SH (CONN)	0300/1010	==	
		┌───┐	018 " DIA CIRC CONCR LEN=0015 INSTALLED UNKN
GLASSPORT CLAIRTON BR (SR2038 SEG 0010/2442)	0300/0910	┌───┐	0300/0942
		┌───┐	0300/0910
		---	018 " DIA CIRC CONCR LEN=0099 INSTALLED UNKN
FROM 2038/0010 SH (CONN)	0300/0825	==	
		┌───┐	SIGN: CANTILEVER 0300/0626 BMSID 02/2001/0300/0626
	067821 FT		065277 FT 2 0 02239 0 00 0659+08 GLASSPORT LINCOLN B
		---	0300/0000 LENGTH(AH 2405 BK 1804) 036 " DIA CIRC CONCR
		---	0290/1448 LEN=0040 INSTALLED UNKN

		---	018 " DIA CIRC CONCR LEN=0007 INSTALLED UNKN
		---	024 " DIA CIRC CONCR LEN=0002 INSTALLED UNKN
		---	SMALL CREEK STRUCTURE LENGTH 10 FT

DIR: B TOTAL LEN: 13.300 MI. DIST: 11-1 SR: 2001
 LEFT MUN: LINCOLN B RIGHT MUN: LINCOLN B

066017 FT

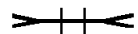

0290/0055 BMSID 02/2001/0290/0055
 063473 FT 2 0 02239 0 00 0640+00



5 0290/0000 LENGTH(AH 1804 BK 2835)



035 "DIA CIR UNKNOWN
 0280/2355 LEN=0035 INSTALLED UNKN



018 "DIA CIRC CONC
 0280/2350 LEN=0099 INSTALLED UNKN



024 "DIA CIRC CONC
 0280/1900 LEN=0045 INSTALLED UNKN



018 "DIA CIRC CONC
 0280/1316 LEN=0030 INSTALLED UNKN



018 "DIA CIRC CONC
 0280/1177 LEN=0045 INSTALLED UNKN



018 "DIA CIRC CONC
 0280/0915 LEN=0045 INSTALLED UNKN



018 "DIA CIRC CONC
 0280/0273 LEN=0030 INSTALLED UNKN

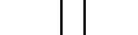

018 "DIA CIRC CONC
 0280/0272 LEN=0173 INSTALLED UNKN



018 "DIA CIRC CONC
 0280/0035 LEN=0040 INSTALLED UNKN

063182 FT



060638 FT 2 0 02239 0 00 0611+34

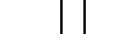

5 0280/0000 LENGTH(AH 2835 BK 2137)



018 "DIA CIRC CONC
 0270/2032 LEN=0045 INSTALLED UNKN



018 "DIA CIRC CONC
 0270/1635 LEN=0045 INSTALLED UNKN



018 "DIA CIRC CONC
 0270/1288 LEN=0042 INSTALLED UNKN



018 "DIA CIRC CONC
 0270/0936 LEN=0040 INSTALLED UNKN



FRANTI'S RUN
 STRUCTURE LENGTH 16 FT

061045 FT



0270/0201 BMSID 02/2001/0270/0201
 058501 FT 2 0 02239 0 00 0589+90

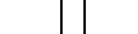

NC LINCOLN BL
 BELLBRIDGE RD

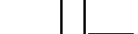

5 0270/0000 LENGTH(AH 2137 BK 3940)



016 "DIA CIRC METAL
 0260/3866 LEN=3767 INSTALLED UNKN



018 "DIA CIRC CONC
 0260/2752 LEN=0099 INSTALLED UNKN

DIR: B TOTAL LEN: 13.300 MI. DIST: 11-1 SR: 2001
 LEFT MUN: LINCOLN B RIGHT MUN: LINCOLN B

057105 FT

054908 FT

CHIZ BROTHERS DR
 (PRDR)

0240/1199

---	0260/2441	018 " DIA	CIRC CONCR
---		LEN=0032	INSTALLED UNKN
---	0260/2120	018 " DIA	CIRC CONCR
---		LEN=0040	INSTALLED UNKN
---	0260/1775	018 " DIA	CIRC CONCR
---		LEN=0020	INSTALLED UNKN
---	0260/1711	024 " DIA	CIRC CONCR
---		LEN=0781	INSTALLED UNKN
---	0260/0930	024 " DIA	CIRC CONCR
---		LEN=0036	INSTALLED UNKN
---	0260/0707	024 " DIA	CIRC CONCR
---		LEN=0040	INSTALLED UNKN
	054561 FT	2 0 02239	0 00 0550+99
		NC GLASSPORT-ELIZABETH RD	
	0260/0000	LENGTH(AH 3940 BK 2197)	
---	0250/1898	018 " DIA	CIR UNKNOWN
---		LEN=0040	INSTALLED UNKN
	0250/0985	036 " DIA	CIRC CONCR
		LEN=0036	INSTALLED UNKN
	0250/0967	BMSSEN 02/2001/0250/0958	
		2 0 02239	0 00 0538+59
		BURNS RUN	
	0250/0958	BMSBG 02/2001/0250/0958	
		018 " DIA	CIR UNKNOWN
	0250/0575	LEN=0099	INSTALLED UNKN
		018 " DIA	CIRC CONCR
	0250/0242	LEN=0036	INSTALLED UNKN
	052364 FT	2 0 02239	0 00 0529+02
		NC MC KEESPORT RD	
	0250/0000	LENGTH(AH 2197 BK 2367)	
		024 " DIA	CIRC CONCR
	0240/2217	LEN=0099	INSTALLED UNKN
		018 " DIA	CIRC CONCR
	0240/2094	LEN=0099	INSTALLED UNKN
		018 " DIA	CIRC OTHER
	0240/1432	LEN=0060	INSTALLED UNKN
		018 " DIA	CIRC CONCR
	0240/1379	LEN=0099	INSTALLED UNKN
		(APRA)	CHIZ BROTHERS CO
	0240/1199	018 " DIA	CIR UNKNOWN
		LEN=0099	INSTALLED UNKN
	0240/0839	MABLE DR	
		(BORO)	
	0240/0765		

POI

==

DIR: B TOTAL LEN: 13.300 MI. DIST: 11-1 SR: 2001
 LEFT MUN: LINCOLN B RIGHT MUN: LINCOLN B

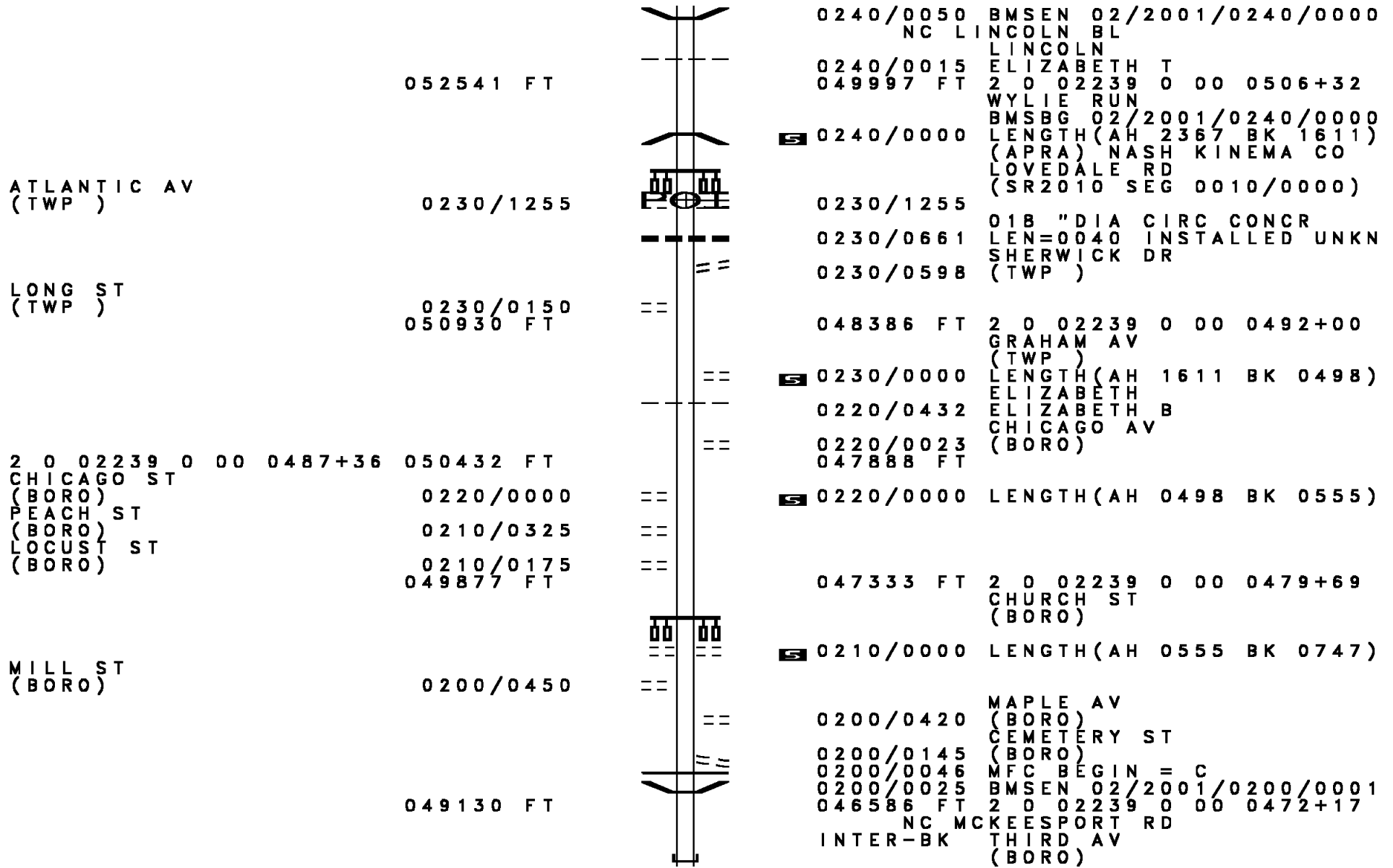

052541 FT

ATLANTIC AV
(TWP)

0230/1255

LONG ST
(TWP)

0230/0150
050930 FT

2 0 02239 0 00 0487+36
 CHICAGO ST (BORO)
 PEACH ST (BORO)
 LOCUST ST (BORO)

0220/0000
 0210/0325
 0210/0175
 049877 FT

MILL ST
(BORO)

0200/0450

049130 FT

0240/0050 BMS EN 02/2001/0240/0000
 NC LINCOLN BL
 LINCOLN
 0240/0015 ELIZABETH T
 049997 FT 2 0 02239 0 00 0506+32
 WYLIE RUN
 BMSBG 02/2001/0240/0000
 S 0240/0000 LENGTH(AH 2367 BK 1611)
 (APRA) NASH KINEMA CO
 LOVEDALE RD
 (SR2010 SEG 0010/0000)
 0230/1255 01B "DIA CIRC CONCR
 0230/0661 LEN=0040 INSTALLED UNKN
 SHERWICK DR
 0230/0598 (TWP)
 048386 FT 2 0 02239 0 00 0492+00
 GRAHAM AV
 (TWP)
 S 0230/0000 LENGTH(AH 1611 BK 0498)
 ELIZABETH
 0220/0432 ELIZABETH B
 CHICAGO AV
 (BORO)
 0220/0023
 047888 FT (BORO)
 S 0220/0000 LENGTH(AH 0498 BK 0555)
 047333 FT 2 0 02239 0 00 0479+69
 CHURCH ST
 (BORO)
 S 0210/0000 LENGTH(AH 0555 BK 0747)
 0200/0420 MAPLE AV
 (BORO)
 0200/0145 CEMETERY ST
 (BORO)
 0200/0046 MFC BEGIN = C
 0200/0025 BMS EN 02/2001/0200/0001
 046586 FT 2 0 02239 0 00 0472+17
 NC MC
 INTER-BK KEESPORT RD
 THIRD AV
 (BORO)

DIR: B TOTAL LEN: 13.300 MI.
 LEFT MUN: ELIZABETH B

DIST: 11-1 SR: 2001
 RIGHT MUN: ELIZABETH B

FALLEN TIMBER RUN
 BMSBG 02/2001/0200/0001
 LTH AH 000747 BK 000544

LC FROM THIRD ST
 (CONN) 0191/0690
 PARK ST
 (BORO) 0191/0615 ==
 TO SR 51 NB RAMP RD
 (SR8073 SEG 0020/0000) 0191/0517 ==
 ROUTE 51 NORTH
 OP ID 02/0051/0110/0000 0191/0372 ==
 018 "DIA CIRC CONCR
 LEN=0068 INSTALLED UNKN 0191/0352 ---
 LOWER MILL ST
 (BORO) 0191/0285 ==
 018 "DIA CIRC CONCR
 LEN=0068 INSTALLED UNKN 0191/0241 ---
 018 "DIA CIRC CONCR
 LEN=0024 INSTALLED UNKN 0191/0234 ---
 018 "DIA CIRC CONCR
 LEN=0024 INSTALLED UNKN 0191/0151 ---
 2 0 02239 0 00 0467+00 048187 FT
 MARKET ST/TO SR 51 SB
 (BORO)
 LENGTH(AH 0943 BK 1601) 0191/0000 [S] == [N]
 PLUM ST
 (BORO) 0181/1321 == ==
 STRAWBERRY ST
 (BORO) 0181/1045 == ==
 018 "DIA CIRC CONCR
 LEN=0011 INSTALLED 2012 0181/0787 ---
 WALNUT ST
 (BORO) 0181/0778 == ==
 030 "DIA CIRC CONCR
 LEN=0011 INSTALLED 2012 0181/0606 ---
 BAYARD ST
 (BORO) 0181/0575 == ==
 018 "DIA CIRC CONCR
 LEN=0011 INSTALLED 2012 0181/0396 ---
 MULBERRY ST
 (BORO) 0181/0307 == ==
 NC SECOND AV
 SECOND AV
 (BORO) 0181/0162 ==
 0 0 00000 0 00 0000+00 046586 FT
 THIRD AV
 (BORO)
 MFC BEGIN = D
 LENGTH(AH 1601 BK 1230) 0181/0000 [S] == [N]

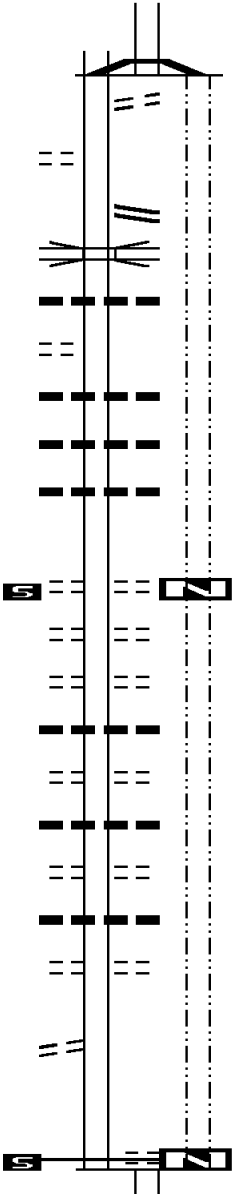

046586 FT
 7190/0000 LTH AH 000544 BK 000304

046586 FT
 7180/0000 LTH AH 000304 BK 001230
 INTER-AHD THIRD AV

DIR: B TOTAL LEN: 13.300 MI. DIST: 11-1 SR: 2001
 LEFT MUN: ELIZABETH B RIGHT MUN: ELIZABETH B

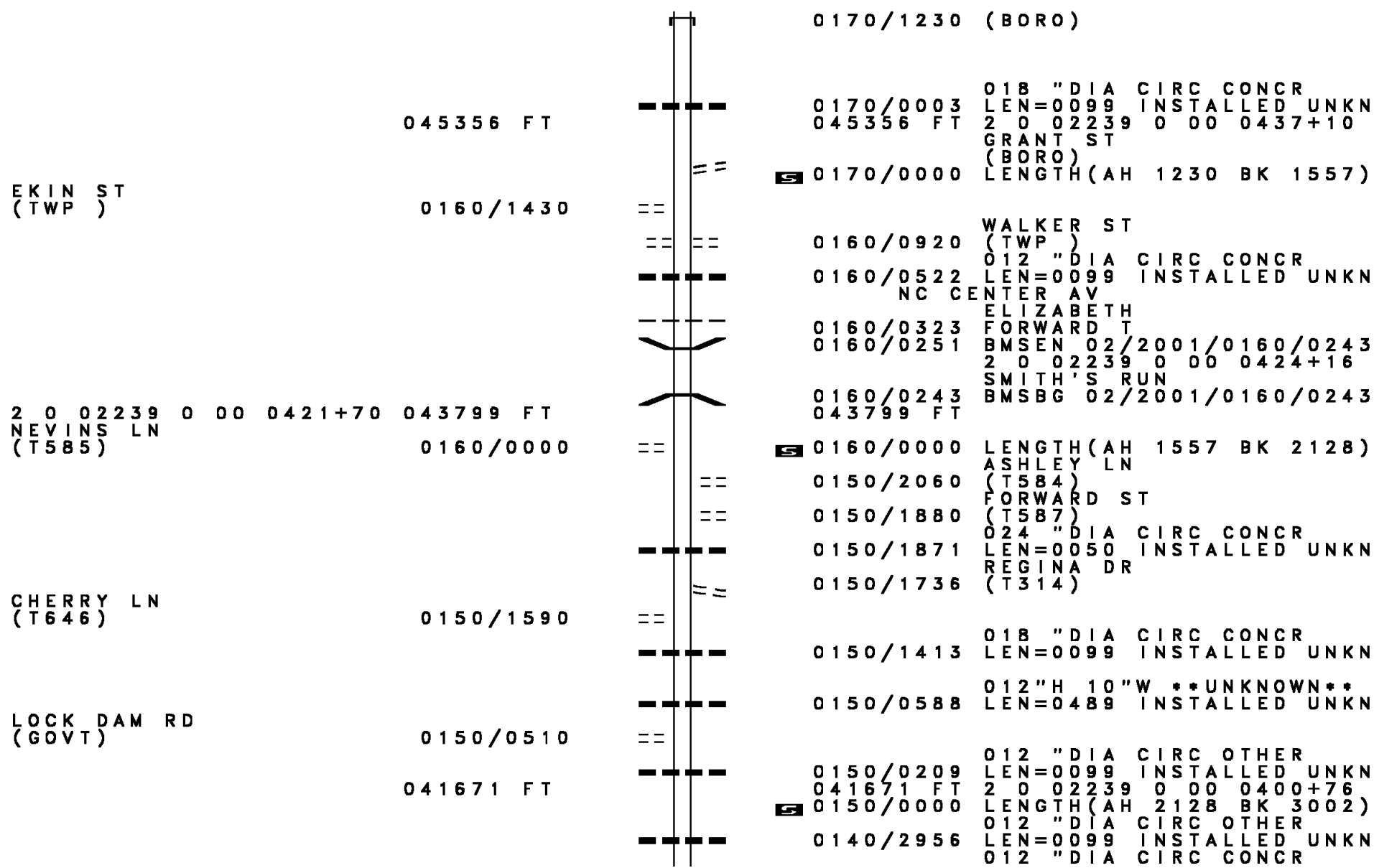

0170/1230 (BORO)

045356 FT

0170/0003
045356 FT

018 " DIA CIRC CONCR
LEN=0099 INSTALLED UNKN
2 0 02239 0 00 0437+10
GRANT ST
(BORO)
LENGTH(AH 1230 BK 1557)

EKIN ST
(TWP)

0160/1430

0170/0000

0160/0920

WALKER ST
(TWP)
012 " DIA CIRC CONCR
LEN=0099 INSTALLED UNKN
NC CENTER AV

2 0 02239 0 00 0421+70
NEVINS LN
(T585)

0160/0000

0160/0522

0160/0323
0160/0251

ELIZABETH
FORWARD T
BMSSEN 02/2001/0160/0243
2 0 02239 0 00 0424+16
SMITH'S RUN
BMSBG 02/2001/0160/0243

CHERRY LN
(T646)

0150/1590

0160/0000

0150/2060

LENGTH(AH 1557 BK 2128)
ASHLEY LN
(T584)
FORWARD ST
(T587)

LOCK DAM RD
(GOVT)

0150/0510

0150/1871

0150/1736

024 " DIA CIRC CONCR
LEN=0050 INSTALLED UNKN
REGINA DR
(T314)

041671 FT

0150/0209
041671 FT

0150/0000

0140/2956

018 " DIA CIRC CONCR
LEN=0099 INSTALLED UNKN
012 "H 10" W **UNKNOWN**
LEN=0489 INSTALLED UNKN
012 " DIA CIRC OTHER
LEN=0099 INSTALLED UNKN
2 0 02239 0 00 0400+76
LENGTH(AH 2128 BK 3002)
012 " DIA CIRC OTHER
LEN=0099 INSTALLED UNKN
012 " DIA CIRC CONCR

DIR: B TOTAL LEN: 13.300 MI. DIST: 11-1 SR: 2001
 LEFT MUN: FORWARD T RIGHT MUN: FORWARD T

0140/2477	LEN=0099	INSTALLED	UNKN
015 "DIA	CIRC	OTHER	UNKN
0140/2281	LEN=0099	INSTALLED	UNKN
015 "DIA	CIRC	CONCR	UNKN
0140/2042	LEN=1943	INSTALLED	UNKN
018 "DIA	CIRC	CONCR	UNKN
0140/1907	LEN=1808	INSTALLED	UNKN
018 "DIA	CIRC	CONCR	UNKN
0140/1874	LEN=0099	INSTALLED	UNKN
018 "DIA	CIRC	CONCR	UNKN
0140/1758	LEN=0099	INSTALLED	UNKN
024 "DIA	CIRC	CONCR	UNKN
0140/1628	LEN=0099	INSTALLED	UNKN
018 "DIA	CIRC	CONCR	UNKN
0140/1450	LEN=0020	INSTALLED	UNKN
018 "DIA	CIRC	CONCR	UNKN
0140/1437	LEN=0099	INSTALLED	UNKN
012 "DIA	CIRC	CONCR	UNKN
0140/1410	LEN=0099	INSTALLED	UNKN
036 "DIA	CIRC	CONCR	UNKN
0140/1350	LEN=0040	INSTALLED	UNKN
024 "DIA	CIRC	CONCR	UNKN
0140/1205	LEN=0099	INSTALLED	UNKN
018 "DIA	CIRC	CONCR	UNKN
0140/1060	LEN=0099	INSTALLED	UNKN
018 "DIA	CIRC	CONCR	UNKN
0140/0939	LEN=0099	INSTALLED	UNKN
012 "DIA	CIRC	CONCR	UNKN
0140/0770	LEN=0099	INSTALLED	UNKN
015 "DIA	CIRC	CONCR	UNKN
0140/0732	LEN=0099	INSTALLED	UNKN
012 "DIA	CIRC	CONCR	UNKN
0140/0636	LEN=0036	INSTALLED	UNKN
015 "DIA	CIRC	CONCR	UNKN
0140/0410	LEN=0035	INSTALLED	UNKN
015 "DIA	CIRC	CONCR	UNKN
0140/0024	LEN=0035	INSTALLED	UNKN
038669 FT	2 0 02239	0 00 037 1+08	
0140/0000	LENGTH(AH	3002 BK 1910)	
024 "DIA	CIRC	METAL	
0130/1786	LEN=0042	INSTALLED	UNKN
0130/1175	018 "DIA	CIRC	OTHER
LEN=0099	INSTALLED	UNKN	
0130/0243	BMS EN 02/2001/0130/0130		
2 0 02239	0 00 035 1+30		



RIVERVIEW RD
(T641)

038669 FT
0130/1189

DIR: B TOTAL LEN: 13.300 MI. DIST: 11-1 SR: 2001
 LEFT MUN: FORWARD T RIGHT MUN: FORWARD T

Stationing	Length	Material	Notes
0130/0151	036759 FT	P3 PERRY MILL	BMSBG 02/2001/0130/0130 PANGBURN HOLLOW RD
0130/0065	036759 FT	(CNTY)	
0130/0000	0120/2299	2 0 02239 0 00 0351+30	LENGTH(AH 1910 BK 2384) LC TO/FRO PANGBRN HLLW (CNTY)
0120/1180	0120/1032	012 "DIA	CIR PLASTIC LEN=0099 INSTALLED UNKN
0120/1032		010 "DIA	CIRC METAL LEN=0030 INSTALLED UNKN
0120/0295	034375 FT	015 "DIA	CIRC CONCR LEN=0036 INSTALLED UNKN
0120/0000	0120/0000	2 0 02239 0 00 0327+68	LENGTH(AH 2384 BK 2261)
0110/2260	0110/2122	015 "DIA	CIRC CONCR LEN=0138 INSTALLED UNKN
0110/2122	0110/2039	012 "DIA	CIRC CONCR LEN=0099 INSTALLED UNKN
0110/2039	0110/1894	015 "DIA	CIRC CONCR LEN=0084 INSTALLED UNKN
0110/1894	0110/1608	015 "DIA	CIR PLASTIC LEN=0145 INSTALLED UNKN
0110/1608	0110/1531	018 "DIA	CIRC CONCR LEN=1475 INSTALLED UNKN
0110/1531	0110/1389	018 "DIA	CIR PLASTIC LEN=0099 INSTALLED UNKN
0110/1389	0110/1184	018 "DIA	CIRC CONCR LEN=0099 INSTALLED UNKN
0110/1184	0110/0130	015 "DIA	CIRC CONCR LEN=0045 INSTALLED UNKN
0110/0130	0110/0112	BMS EN 02/2001/0110/0112	2 0 02239 0 00 0305+84 KELLY RUN
0110/0112	032114 FT	BMSBG 02/2001/0110/0112	2 0 02239 0 00 0304+77 RACCOON RUN RD
0110/0000	0110/0000	(SR2005 SEG 0070/1739)	LENGTH(AH 2261 BK 2629)
0100/2309	0100/2234	015 "H 02 "W	BOX CULVERT LEN=0032 INSTALLED UNKN
0100/2234		015 "H 02 "W	BOX CULVERT LEN=0032 INSTALLED UNKN

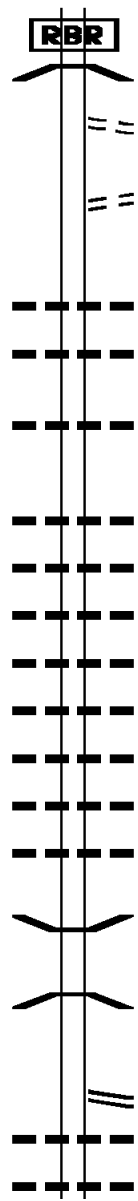

DIR: B TOTAL LEN: 13.300 MI. DIST: 11-1 SR: 2001
 LEFT MUN: FORWARD T RIGHT MUN: FORWARD T

TO/FROM WATERFRONT RD
 (CONN)

0100/0110
 029485 FT

SEA BREEZE RD
 (PRDR)

0090/2568

026872 FT

---	0100/1717	015 " DIA	CIRC CONCR
---		LEN=0035	INSTALLED UNKN
---	0100/1414	015 " DIA	CIRC CONCR
---		LEN=0032	INSTALLED UNKN
---	0100/1202	012 " DIA	CIRC CONCR
---		LEN=0099	INSTALLED UNKN
---	0100/0949	015 " DIA	CIR PLASTIC
---		LEN=0032	INSTALLED UNKN
---	0100/0585	018 " DIA	CIR PLASTIC
---		LEN=0002	INSTALLED UNKN
POI	0100/0110	(APRA)	EVANFORD PARK &
==	029485 FT	2 0 02239 0 00	0278+43
==		(PRDR)	RIVERVIEW GOLF COURSE E
S	0100/0000	LENGTH(AH 2629 BK 2613)	
---		012 " DIA	CIR UNKNOWN
---	0090/2457	LEN=0099	INSTALLED UNKN
---		018 " DIA	CIRC CONCR
POI	0090/2314	LEN=0099	INSTALLED UNKN
---	0090/1760	(APRA)	EVANFORD PARK &
---		018 " DIA	CIRC CONCR
---	0090/1723	LEN=0099	INSTALLED UNKN
---		018 " DIA	CIRC CONCR
---	0090/0793	LEN=0035	INSTALLED UNKN
---		015 " DIA	CIRC CONCR
---	0090/0523	LEN=0099	INSTALLED UNKN
---		015 " DIA	CIRC OTHER
---	0090/0377	LEN=0099	INSTALLED UNKN
	026872 FT	2 0 02239 0 00	0253+78
S	0090/0000	LENGTH(AH 2613 BK 1518)	
---		012 " DIA	CIRC CONCR
---	0080/1516	LEN=0024	INSTALLED UNKN
---		012 " H 10 " W	**UNKNOWN**
---	0080/1063	LEN=0032	INSTALLED UNKN
---		012 " DIA	CIRC CONCR
---	0080/0836	LEN=0032	INSTALLED UNKN
RBR			
---	0080/0349	BMS EN 02/2001/0080/0335	
		2 0 02239 0 00	0240+51
		P3	
RBR		TRIB TO MON	
---	0080/0335	BMSBG 02/2001/0080/0335	
		024 " H 05 " W	CONCR ARCH

DIR: B TOTAL LEN: 13.300 MI. DIST: 11-1 SR: 2001
 LEFT MUN: FORWARD T RIGHT MUN: FORWARD T

Street Name	Segment ID	Length	Material	Status
DRAKE ST (T588)	0080/0175	025354 FT	0080/0331	LEN=0024 INSTALLED UNKN
			025354 FT	2 0 02239 0 00 0237+12 CHURCH HOLLOW RD (SR2003 SEG 0030/2915) LENGTH(AH 1518 BK 2359)
DRAKE ST (T588)	0070/2025		0080/0000	LEN=0099 INSTALLED UNKN
			0070/1814	015 "DIA CIRC OTHER LEN=0099 INSTALLED UNKN
RICHMOND ST (T590) KERR ST (T592)	0070/1465		0070/1476	018 "DIA CIRC CONCR LEN=0036 INSTALLED UNKN
	0070/1045		0070/1032	024 "DIA CIRC OTHER LEN=0099 INSTALLED UNKN
			0070/0280	012 "DIA CIRC OTHER LEN=0099 INSTALLED UNKN
	022995 FT		0070/0162	018"H 02"W ELLIP CONC LEN=0040 INSTALLED UNKN
			0070/0000	2 0 02239 0 00 0211+63 LENGTH(AH 2359 BK 3336)
			0060/3315	018 "DIA CIRC OTHER LEN=0036 INSTALLED UNKN
			0060/3026	018 "DIA CIR PLASTIC LEN=0099 INSTALLED UNKN
			0060/2465	024 "DIA CIRC OTHER LEN=0099 INSTALLED UNKN
CLIFF MILL DR (PRDR)	0060/2430		0060/2430	(APRA) UNIVAR DR 018 "DIA CIR PLASTIC LEN=0099 INSTALLED UNKN
			0060/2088	015 "DIA CIRC OTHER LEN=0032 INSTALLED UNKN
			0060/1618	024 "DIA CIRC OTHER LEN=0065 INSTALLED UNKN
			0060/1312	018 "DIA CIRC CONCR LEN=0791 INSTALLED UNKN
			0060/0890	024 "DIA CIRC CONCR LEN=0075 INSTALLED UNKN
	019659 FT		0060/0282	018 "DIA CIRC CONCR LEN=0070 INSTALLED UNKN
			0060/0150	2 0 02239 0 00 0177+26 LENGTH(AH 3336 BK 2917)
			0060/0000	015 "DIA CIRC OTHER

DIR: B TOTAL LEN: 13.300 MI. DIST: 11-1 SR: 2001
 LEFT MUN: FORWARD T RIGHT MUN: FORWARD T

016742 FT

014181 FT

0050/2375	LEN=0040	INSTALLED UNKN
	024 "DIA	CIRC METAL
0050/1975	LEN=0040	INSTALLED UNKN
	015 "DIA	CIRC OTHER
0050/1384	LEN=0036	INSTALLED UNKN
	015 "DIA	CIRC OTHER
0050/1056	LEN=0036	INSTALLED UNKN
	048 "DIA	CIRC OTHER
0050/0434	LEN=0070	INSTALLED UNKN
016742 FT	2 0 02239	0 00 0148+09
0050/0000	LENGTH(AH	2917 BK 2561)
	015 "DIA	CIRC OTHER
0040/2160	LEN=0040	INSTALLED UNKN
	ELKHORN RD	
0040/1870	048"H 48"W	CONC STRUCT
0040/1848	LEN=0030	INSTALLED UNKN
	015 "DIA	CIRC OTHER
0040/1145	LEN=0030	INSTALLED UNKN
	021 "DIA	CIRC CONCR
0040/1140	LEN=0030	INSTALLED 2016
	021 "DIA	CIRC CONCR
0040/1080	LEN=0030	INSTALLED 2016
	018 "DIA	CIRC CONCR
0040/0993	LEN=0099	INSTALLED UNKN
	021 "DIA	CIRC CONCR
0040/0880	LEN=0030	INSTALLED 2016
	015 "DIA	CIRC OTHER
0040/0793	LEN=0032	INSTALLED UNKN
	021 "DIA	CIRC CONCR
0040/0740	LEN=0030	INSTALLED 2016
	021 "DIA	CIRC CONCR
0040/0590	LEN=0030	INSTALLED 2016
	021 "DIA	CIRC CONCR
0040/0500	LEN=0030	INSTALLED 2016
	021 "DIA	CIRC CONCR
0040/0420	LEN=0030	INSTALLED 2016
	018 "DIA	CIRC CONCR
0040/0388	LEN=0099	INSTALLED UNKN
	018 "DIA	CIRC CONCR
0040/0371	LEN=0099	INSTALLED UNKN
	021 "DIA	CIRC CONCR
0040/0280	LEN=0030	INSTALLED 2016
	021 "DIA	CIRC CONCR
0040/0065	LEN=0030	INSTALLED 2016
	018 "DIA	CIRC CONCR
0040/0023	LEN=0099	INSTALLED UNKN
014181 FT	2 0 02239	0 00 0122+48

DIR: B TOTAL LEN: 13.300 MI. DIST: 11-1 SR: 2001
 LEFT MUN: FORWARD T RIGHT MUN: FORWARD T

	0040/0000	LENGTH(AH	2561	BK	3849)
	027	"DIA	CIRC	CONCR	
---	0030/3654	LEN=0004	INSTALLED		2016
	018	"DIA	CIRC	OTHER	
---	0030/3624	LEN=0032	INSTALLED		UNKN
	018	"DIA	CIRC	OTHER	
---	0030/3174	LEN=0036	INSTALLED		UNKN
	018	"DIA	CIRC	METAL	
---	0030/2963	LEN=0036	INSTALLED		UNKN
	015	"DIA	CIRC	CONCR	
---	0030/2673	LEN=0026	INSTALLED		UNKN
	024	"DIA	CIRC	CONCR	
---	0030/2292	LEN=0048	INSTALLED		UNKN
	024	"DIA	CIRC	OTHER	
---	0030/1956	LEN=0042	INSTALLED		UNKN
	015	"DIA	CIRC	OTHER	
---	0030/1687	LEN=0055	INSTALLED		UNKN
	018	"DIA	CIRC	CONCR	
---	0030/1271	LEN=0099	INSTALLED		UNKN
	024	"DIA	CIRC	CONCR	
---	0030/0705	LEN=0035	INSTALLED		UNKN
	024	"DIA	CIRC	CONCR	
---	0030/0422	LEN=0035	INSTALLED		UNKN
	024	"DIA	CIRC	CONCR	
---	0030/0109	LEN=0040	INSTALLED		UNKN
	010332	FT	2 0 02239	0 00 0085+85	
	0030/0000	LENGTH(AH	3849	BK	3909)
	024	"DIA	CIRC	CONCR	
---	0024/3640	LEN=0099	INSTALLED		UNKN
	024	"DIA	CIRC	CONCR	
---	0024/3443	LEN=0099	INSTALLED		UNKN
	018	"DIA	CIRC	CONCR	
---	0024/3185	LEN=0099	INSTALLED		UNKN
	024	"DIA	CIRC	CONCR	
---	0024/2663	LEN=0099	INSTALLED		UNKN
	018	"DIA	CIRC	CONCR	
---	0024/2562	LEN=0099	INSTALLED		UNKN
	018	"DIA	CIRC	CONCR	
---	0024/1968	LEN=0099	INSTALLED		UNKN
	024	"DIA	CIRC	CONCR	
---	0024/1472	LEN=0099	INSTALLED		UNKN
	024	"DIA	CIRC	CONCR	
---	0024/1470	LEN=0099	INSTALLED		UNKN
	018	"DIA	CIRC	CONCR	
---	0024/0918	LEN=0099	INSTALLED		UNKN
	006423	FT	2 0 02239	0 00 0057+47	
	0024/0000	LENGTH(AH	3909	BK	2512)

010332 FT

006423 FT

EXTRACT DATE: 12/21/2020
PRINT DATE: 12/23/2020

ROADWAY MANAGEMENT SYSTEM
SLD COUNTY/SR - ANNUAL PRINT

PAGE NUMBER: 661
COUNTY: ALLEGHENY

DIR: B TOTAL LEN: 13.300 MI.
LEFT MUN: FORWARD T

DIST: 11-1 SR: 2001
RIGHT MUN: FORWARD T

Stationing	Notes	Material	Length	Notes	
0020/1353		015" DIA CIRC CONCR	LEN=0099	INSTALLED UNKN	
0020/1085		015" DIA CIRC CONCR	LEN=0986	INSTALLED UNKN	
0020/0810		018" DIA CIRC CONCR	LEN=0045	INSTALLED UNKN	
0020/0290		018" DIA CIR PLASTIC	LEN=0045	INSTALLED UNKN	
003911 FT			2 0 02239	0 00 0029+26	
0020/0000		LENGTH(AH	2512 BK	3911)	
0010/3745		024" DIA CIRC CONCR	LEN=0099	INSTALLED UNKN	
0010/3452		024" DIA CIRC CONCR	LEN=0099	INSTALLED UNKN	
0010/3375		036" DIA CIRC CONCR	LEN=0099	INSTALLED UNKN	
0010/3136		018" DIA CIRC CONCR	LEN=0040	INSTALLED UNKN	
0010/2847		012" DIA CIR PLASTIC	LEN=0099	INSTALLED UNKN	
0010/2587		018" DIA CIRC CONCR	LEN=0099	INSTALLED UNKN	
0010/2100		015" DIA CIRC CONCR	LEN=0045	INSTALLED UNKN	
0010/1770		RIVER HILL RD	(SR2007 SEG	0010/0000)	
0010/1512		024"H 24"W	ELLIP CONC	LEN=0045	INSTALLED UNKN
0010/1433		012" DIA CIRC CONCR	LEN=0045	INSTALLED UNKN	
0010/0960		015" DIA CIRC CONCR	LEN=0010	INSTALLED UNKN	
0010/0851		015" DIA CIRC CONCR	LEN=0055	INSTALLED UNKN	
0010/0621					
0010/0605		012" DIA CIR UNKNOWN	LEN=0045	INSTALLED UNKN	
0010/0120		FROM 0136/0020 SH	(CONN)		
000000 FT			2 0 02239	0 00 0000+00	
		(APRA) MID MON CENTER			
	NC BU	NOLA RIVER RD			
		MONONGAHELA CITY BR			
		(SR0136 SEG	0010/1835)		
	INTER-BK	DELBERT'S DR			
		(PRDR)			
		MFC BEGIN = D			
POE		0010/0000	LENGTH(AH	3911 BK 0000)	

EXTRACT DATE: 12/21/2020 ROADWAY MANAGEMENT SYSTEM PAGE NUMBER: 660
 PRINT DATE: 12/23/2020 SLD COUNTY/SR - ANNUAL PRINT COUNTY: ALLEGHENY
 DIR: E TOTAL LEN: .309 MI. DIST: 11-1 SR: 1049
 LEFT MUN: FRAZER T RIGHT MUN: FRAZER T

(APRA) PITTSBURGH MILLS	001629 FT				001624 FT	(APRA) PITTSBURGH MILLS
PITTSBURGH MILLS MALL	REF-AHD	* POI	POI *		REF-AHD	PITTSBURGH MILLS MALL
(PRDR)	0011/1629				0010/1624	(PRDR)
SIGN: 3 CHORD TRUSS						SIGN: 3 CHORD TRUSS
BMSID 02/1046/0010/1492	0011/1477				0010/1492	BMSID 02/1046/0010/1492



DIR: E TOTAL LEN: .309 MI. DIST: 11-1 SR: 1049
 LEFT MUN: FRAZER T RIGHT MUN: FRAZER T

RAMP C-1 RD (SR8114 SEG 0252/0000)	0011/1461								
					0010/1296	FROM 8114/0500 SH (CONN)			
RAMP C RD (SR8114 SEG 0250/0000)						RAMP C RD (SR8114 SEG 0250/0000)			
RAMP D RD (SR8114 SEG 0500/0968)	0011/1205				0010/1205	RAMP D RD (SR8114 SEG 0500/0968)			
018 "DIA CIRC CONCR LEN=0035 INSTALLED UNKN	0011/1135								
					0010/1141	018 "DIA CIRC CONCR LEN=0099 INSTALLED UNKN			
BMS EN 02/1049/0010/0830 0 00000 0 0 0000+00	0011/1090				0010/1109	BMS EN 02/1049/0010/0830 0 00000 0 0 0000+00			
SR 0028 NB						SR 0028 NB			
BMS BG 02/1049/0010/0830	0011/0811				0010/0830	BMS BG 02/1049/0010/0830			
018 "DIA CIRC CONCR LEN=0035 INSTALLED UNKN	0011/0795								
					0010/0790	018 "DIA CIRC CONCR LEN=0030 INSTALLED UNKN			
SIGN: 3 CHORD TRUSS					0010/0774	SIGN: 3 CHORD TRUSS			
BMS ID 02/1046/0010/0774	0011/0761				0010/0774	BMS ID 02/1046/0010/0774			
					0010/0609	018 "DIA CIRC CONCR LEN=0099 INSTALLED UNKN			
TO 8114/0020 SH (CONN)	0011/0367								
018 "DIA CIRC CONCR LEN=0099 INSTALLED UNKN	0011/0354								
RAMP A RD (SR8114 SEG 0020/0000)									
RAMP B RD (SR8114 SEG 0010/1467)	0011/0279								
						RAMP A RD (SR8114 SEG 0020/0000)			
						RAMP B RD (SR8114 SEG 0010/1467)			
					0010/0276				
					0010/0137	FROM 1014/0055 SH (CONN)			
TO 1014/0055 SH (CONN)	0011/0124								
0 0 00000 0 00 0000+00 000000 FT					000000 FT	0 0 00000 0 00 0000+00			
NC PITTSBURGH MILLS BL						NC PI TTSBURGH MILLS BL			
TAWNEY RUN RD (SR1014 SEG 0055/0627)						TAWNEY RUN RD (SR1014 SEG 0054/0627)			
(SR1014 SEG 0054/0627)						(SR1014 SEG 0055/0627)			
MFC BEGIN = E						MFC BEGIN = E			
LENGTH(AH 1629 BK 0000)	0011/0000				0010/0000	LENGTH(AH 1624 BK 0000)			

EXTRACT DATE: 12/21/2020 ROADWAY MANAGEMENT SYSTEM PAGE NUMBER: 658
 PRINT DATE: 12/23/2020 SLD COUNTY/SR - ANNUAL PRINT COUNTY: ALLEGHENY
 DIR: B TOTAL LEN: .005 MI. DIST: 11-1 SR: 1047
 LEFT MUN: HARRISON T RIGHT MUN: HARRISON T

000029 FT

000000 FT

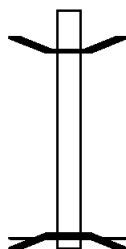

000029 FT
 * REF-AHD DONNELLVILLE RD
 0010/0029 (TWP)
 0010/0028 BMSBN 02/1047/0010/0000
 000000 FT 0 0 00000 0 00 0000+00
 NC DO
 * REF-BK DONNELLVILLE BRIDGE
 DONNELLVILLE RD
 (TWP)
 LITTLE BUL CREEK RUN
 BMSBG 02/1047/0010/0000
 MFC BEGIN = E
 0010/0000 LENGTH(AH 0029 BK 0000)

EXTRACT DATE: 12/21/2020
PRINT DATE: 12/23/2020

ROADWAY MANAGEMENT SYSTEM
SLD COUNTY/SR - ANNUAL PRINT

PAGE NUMBER: 657
COUNTY: ALLEGHENY

DIR: B TOTAL LEN: .972 MI.
LEFT MUN: WEST DEER T

DIST: 11-1 SR: 1045
RIGHT MUN: WEST DEER T

005130 FT

* 005130 FT
REF-AHD CANNON HILL RD
0020/2168 (TWP)
0020/2055 018 " DIA CIRC CONCR
LEN=0040 INSTALLED UNKN
0020/1885 084 "H 60 "W CON BOX CUL
LEN=0099 INSTALLED UNKN
0020/1835 BMSSEN 02/1045/0020/1847
2 0 02167 0 00 0030+05
BR. BULL CR.
0020/1823 BMSBG 02/1045/0020/1847
018 " DIA CIRC CONCR
0020/1469 LEN=0050 INSTALLED UNKN
018 " DIA CIRC CONCR
0020/1300 LEN=0050 INSTALLED UNKN
024 " DIA CIRC CONCR
0020/1131 LEN=0060 INSTALLED UNKN
018 " DIA CIRC CONCR
0020/0797 LEN=0040 INSTALLED 2002
024 " DIA CIRC CONCR
0020/0360 LEN=0060 INSTALLED UNKN
002962 FT 2 0 02167 0 00 0030+05
5 0020/0000 LENGTH(AH 2168 BK 2962)
018 " DIA CIRC METAL
0010/2856 LEN=0040 INSTALLED UNKN
024 " DIA CIRC CONCR
0010/2256 LEN=0050 INSTALLED UNKN
048 " DIA CIRC METAL
0010/2133 LEN=0060 INSTALLED UNKN
024 " DIA CIRC METAL
0010/1979 LEN=0055 INSTALLED UNKN
018 " DIA CIRC METAL
0010/1685 LEN=0050 INSTALLED UNKN
015 " DIA CIRC METAL
0010/1283 LEN=0004 INSTALLED UNKN
018 " DIA CIR PLASTIC
0010/1058 LEN=0196 INSTALLED UNKN
024 " DIA CIRC CONCR
0010/0739 LEN=0045 INSTALLED UNKN
000000 FT 2 0 02167 0 00 0000+00
NC AR MSTRONG RD
BAKERSTOWN RD
(SR1028 SEG 0090/0090)
MFC BEGIN = E
5 0010/0000 LENGTH(AH 2962 BK 0000)

002962 FT

000000 FT

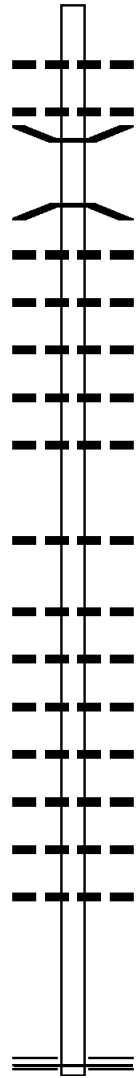

EXTRACT DATE: 12/21/2020 ROADWAY MANAGEMENT SYSTEM PAGE NUMBER: 656
 PRINT DATE: 12/23/2020 SLD COUNTY/SR - ANNUAL PRINT COUNTY: ALLEGHENY
 DIR: B TOTAL LEN: .041 MI. DIST: 11-1 SR: 1040
 LEFT MUN: EAST DEER T RIGHT MUN: EAST DEER T

000215 FT
 000000 FT

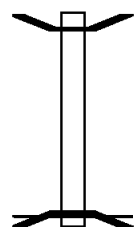

000215 FT BMS EN 02/1040/0010/0000
 * REF-AHD BAKERSTOWN RD
 0010/0215 (TWP)
 000000 FT 1 0 01037 0 01 1030+11
 * REF-BK NC BAKERSTOWN RD
 BAKERSTOWN RD
 (TWP)
 SR 28 NB
 BMSBG 02/1040/0010/0000
 MFC BEGIN = E
 0010/0000 LENGTH(AH 0215 BK 0000)

EXTRACT DATE: 12/21/2020 ROADWAY MANAGEMENT SYSTEM PAGE NUMBER: 655
 PRINT DATE: 12/23/2020 SLD COUNTY/SR - ANNUAL PRINT COUNTY: ALLEGHENY
 DIR: B TOTAL LEN: .165 MI. DIST: 11-1 SR: 1039
 LEFT MUN: HARRISON T RIGHT MUN: HARRISON T

000871 FT
 000539 FT
 000000 FT

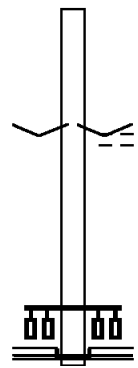

000871 FT AH-BUTLER (10)
 * REF-AHD SILVERVILLE RD
 0020/0332 (SR2017 SEG 0010/0000)
 000539 FT 1 0 00388 1 00 0007+46
 VILLAGE: HARRISON TWP
 ACEE DR
 (TWP)
 S 0020/0000 LENGTH(AH 0332 BK 0539)
 000000 FT 1 0 00388 1 00 0000+00
 NC S I LVERVILLE RD
 BAKERSTOWN RD
 (SR1028 SEG 0290/0000)
 INTER-BK ALTER RD
 (TWP)
 MFC BEGIN = D
 S 0010/0000 LENGTH(AH 0539 BK 0000)

EXTRACT DATE: 12/21/2020 ROADWAY MANAGEMENT SYSTEM PAGE NUMBER: 654
 PRINT DATE: 12/23/2020 SLD COUNTY/SR - ANNUAL PRINT COUNTY: ALLEGHENY
 DIR: B TOTAL LEN: .303 MI. DIST: 11-1 SR: 1038
 LEFT MUN: EAST DEER T RIGHT MUN: EAST DEER T

001602 FT

001602 FT AH-WESTMORELAND (64)
 BMS EN 02/1038/0010/0059
 * REF-AHD NINTH ST
 0010/1602 (SR0056 SEG 0004/0000)
 SIGN: CANTILEVER
 0010/1420 BMS ID 02/1038/0010/1420

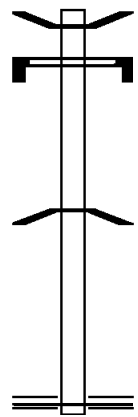

000000 FT

1 0 00188 0 00 0000+00
 SR9109
 0010/0074 BMSBG 02/1038/0010/0059
 000000 FT 1 0 00188 0 00 0000+00
 NC NEW KENSINGTON BR
 FREEPORT RD
 (SR1001 SEG 0320/3122)
 FREEPORT RD
 (SR1001 SEG 0320/3122)
 MFC BEGIN = B
 0010/0000 LENGTH(AH 1602 BK 0000)

DIR: B TOTAL LEN: 2.588 MI. DIST: 11-1 SR: 1037
 LEFT MUN: FAWN T RIGHT MUN: FAWN T

Stationing	Notes	Structure	Stationing	Notes
013662 FT			013662 FT	AH-BUTLER (10)
			* REF-AHD	EKASTOWN RD
0040/3084	== ==		0040/3189	(SR2009 SEG 0010/0000)
0040/2905	==			BEALE RD (TWP)
OLD MILL RD (TWP)			0040/2870	STANGLER DR (TWP)
CIRCLE CT (TWP)			0040/2670	048 " DIA CIRC CONCR LEN=0024 INSTALLED UNKN NC EKASTOWN RD
			0040/2380	BAKERSTOWN RD (SR1028 SEG 0270/0000)
BAKERSTOWN RD (SR1028 SEG 0270/0000)			0040/1891	036 " DIA CIRC CONCR LEN=0050 INSTALLED UNKN
FREEDOM LN (PRDR)			0040/0992	060 " DIA CIRC CONCR LEN=0060 INSTALLED UNKN
			0040/0667	084 " DIA CIRC METAL LEN=0020 INSTALLED UNKN
			0040/0660	099 " DIA CIRC CONCR LEN=0099 INSTALLED UNKN
			010473 FT	2 0 02222 0 00 0105+01
			0040/0000	LENGTH(AH 3189 BK 3329) 048 " DIA CIRC METAL
			0030/3285	LEN=0045 INSTALLED UNKN
			0030/3112	024 " DIA CIRC CONCR LEN=0045 INSTALLED UNKN
			0030/2491	012 " DIA CIRC CONCR LEN=0020 INSTALLED UNKN
			0030/2396	060 " DIA CIRC METAL LEN=0045 INSTALLED UNKN
			0030/2294	030 " DIA CIRC METAL LEN=0060 INSTALLED UNKN
			0030/2176	
			0030/2016	018 " DIA CIRC METAL LEN=0040 INSTALLED UNKN
			0030/1532	020 " H 01 " W * * UNKNOWN * *
			0030/1408	LEN=0016 INSTALLED UNKN 018 " DIA CIRC CONCR LEN=0035 INSTALLED UNKN
KUHN'S LN (PRDR)				

DIR: B TOTAL LEN: 2.588 MI. DIST: 11-1 SR: 1037
 LEFT MUN: FAWN T RIGHT MUN: FAWN T

DONNELLVILLE RD
 (TWP) 0030/1229
 LC FOR DONNELLVILLE RD
 (CONN) 0030/1105

007144 FT

0030/0862	015 " DIA CIRC CONCR LEN=0050 INSTALLED UNKN SHADY OAK LN
0030/0717	(PRDR) FAWN
0030/0446	HARRISON T SR 0028 SB
0030/0426	OP ID 02/0028/0461/2413 SR 0028 NB
0030/0284	OP ID 02/0028/0460/2380 BR. LITTLE BU STRUCTURE LENGTH 12 FT
0030/0118	BMSID 02/1037/0030/0180 2 0 02222 0 00 0071+64
007144 FT	ALTER RD (TWP)
5 0030/0000	LENGTH (AH 3329 BK 3544)
0020/3535	040 " DIA CIRC CONCR LEN=0030 INSTALLED UNKN
0020/3305	036 " DIA CIRC METAL LEN=0040 INSTALLED UNKN
0020/3272	018 " DIA CIRC METAL LEN=0030 INSTALLED UNKN
0020/3072	070 " DIA CIR PLASTIC LEN=0035 INSTALLED UNKN
0020/2900	040 " DIA CIRC METAL LEN=0080 INSTALLED UNKN
0020/2814	060 " DIA CIRC METAL LEN=0050 INSTALLED UNKN
0020/2525	018 " DIA CIRC METAL LEN=0050 INSTALLED UNKN
0020/2368	060 " DIA CIRC METAL LEN=0035 INSTALLED UNKN
0020/2236	024 " DIA CIRC METAL LEN=0030 INSTALLED UNKN
0020/2158	024 " DIA CIRC METAL LEN=0040 INSTALLED UNKN
0020/1930	060 " DIA CIRC METAL LEN=0040 INSTALLED UNKN
0020/1822	024 " DIA CIR PLASTIC LEN=0024 INSTALLED UNKN
0020/1720	018 " DIA CIR PLASTIC LEN=0050 INSTALLED 2018
0020/1628	012 " DIA CIRC METAL LEN=0025 INSTALLED UNKN CLARKS LN

DIR: B TOTAL LEN: 2.588 MI. DIST: 11-1 SR: 1037
 LEFT MUN: HARRISON T RIGHT MUN: HARRISON T

2 0 02222 0 00 0036+38 003600 FT
 ESQUIRE DR
 (TWP) 0020/0000

HARBISON ST
 (TWP) 0010/1134
 STEWART ST
 (TWP) 0010/0985

UNKNOWN RD
 (TWP) 0010/0745

000000 FT

0020/1530	(PRDR)	
0020/1513	018 " DIA CIR PLASTIC LEN=0018 INSTALLED 2018	
0020/1467	015 " DIA CIRC METAL LEN=0035 INSTALLED UNKN	
0020/1345	018 " DIA CIR PLASTIC LEN=0018 INSTALLED 2018	
0020/0145	060 " DIA CIR PLASTIC LEN=0025 INSTALLED UNKN	
0020/0000	LENGTH(AH 3544 BK 3600) 018 " DIA CIRC CONCR	
0010/3448	LEN=0018 INSTALLED UNKN	
0010/2250	RAMBLER DR (TWP) 048 " DIA CIRC METAL	
0010/2036	LEN=0035 INSTALLED UNKN PRIMROSE LN	
0010/1895	(TWP) 024 " DIA CIRC CONCR	
0010/1564	LEN=0001 INSTALLED UNKN OLIVE AV	
0010/1485	(TWP) 024 " DIA CIRC METAL	
0010/1246	LEN=0040 INSTALLED UNKN	
0010/0774	036 " DIA CIRC CONCR LEN=0040 INSTALLED UNKN	
0010/0705	VILLAGE GREEN RD (TWP) 018 " DIA CIRC METAL	
0010/0428	LEN=0040 INSTALLED UNKN	
000000 FT	2 0 02222 0 00 0000+00 NC SA XONBURG RD FREEPORT RD (SR1001 SEG 0471/1375)	
0010/0000	MFC BEGIN = D LENGTH(AH 3600 BK 0000)	

EXTRACT DATE: 12/21/2020 ROADWAY MANAGEMENT SYSTEM PAGE NUMBER: 650
 PRINT DATE: 12/23/2020 SLD COUNTY/SR - ANNUAL PRINT COUNTY: ALLEGHENY
 DIR: B TOTAL LEN: 2.055 MI. DIST: 11-1 SR: 1036
 LEFT MUN: INDIANA T RIGHT MUN: INDIANA T

REPUBLIC AV
 (TWP)

010852 FT
 0060/1710
 009110 FT

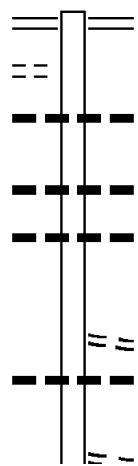

010852 FT GIBSONIA RD
 0060/1742 (SR0910 SEG 0390/0315)
 0060/1382 018 " DIA CIRC CONCR
 LEN=0040 INSTALLED UNKN
 0060/0712 018 " DIA CIRC CONCR
 LEN=0040 INSTALLED UNKN
 0060/0143 018 " DIA CIRC CONCR
 LEN=0040 INSTALLED UNKN
 009110 FT 2 0 02142 0 00 0090+90
 OLD MILL RD
 (T624)
 0060/0000 LENGTH(AH 1742 BK 2467)
 018 " DIA CIRC CONCR
 0050/2314 LEN=0040 INSTALLED UNKN
 0050/1638 VINEYARD LN
 (PRDR)

DIR: B TOTAL LEN: 2.055 MI. DIST: 11-1 SR: 1036
 LEFT MUN: INDIANA T RIGHT MUN: INDIANA T

Stationing	Description	Material	Length	Notes
0050/1619	018" DIA	CIRC CONCR	LEN=0040	INSTALLED UNKN
0050/1133	018" DIA	CIRC CONCR	LEN=0099	INSTALLED UNKN
006643 FT				
0050/0000	2 0 02142 0 00	0065+54	LENGTH(AH 2467 BK 2508)	
0040/2433	018" DIA	CIRC CONCR	LEN=0040	INSTALLED UNKN
0040/1742	015" DIA	CIRC CONCR	LEN=0040	INSTALLED UNKN
0040/1481	015" DIA	CIRC CONCR	LEN=0040	INSTALLED UNKN
0040/0911	015" DIA	CIRC CONCR	LEN=0040	INSTALLED UNKN
004135 FT				
0040/0000	2 0 02142 0 00	0019+52	LENGTH(AH 2508 BK 2077)	
0030/2057	015" DIA	CIRC CONCR	LEN=0040	INSTALLED UNKN
0030/1480	024" DIA	CIRC CONCR	LEN=0040	INSTALLED UNKN
0030/0602	018" DIA	CIRC CONCR	LEN=0048	INSTALLED UNKN
0030/0430	WAGON WHEEL LN			(PRDR)
002058 FT				
0030/0000	2 0 02142 0 00	0019+52	LENGTH(AH 2077 BK 2058)	
0020/1349	CHATHAM LN			(PRDR)
0020/1275	015" DIA	CIRC CONCR	LEN=0040	INSTALLED UNKN
000000 FT				
000000 FT	2 0 02142 0 00	0000+00		
	DORSEYVILLE RD			(CNTY)
	NC INDIANOLA RD			
	INTER-BK DORSEYVILLE RD			(CNTY)
000000 FT				
000000 FT	7010/0000		LENGTH(AH 2058 BK 1731)	
			LENGTH(AH 1731 BK 0000)	

2 0 02142 0 00 0040+69 004135 FT
 BLUE RUN RD
 (T611)

EXTRACT DATE: 12/21/2020 ROADWAY MANAGEMENT SYSTEM PAGE NUMBER: 648
 PRINT DATE: 12/23/2020 SLD COUNTY/SR - ANNUAL PRINT COUNTY: ALLEGHENY
 DIR: B TOTAL LEN: 4.197 MI. DIST: 11-1 SR: 1035
 LEFT MUN: FAWN T RIGHT MUN: FAWN T

022158 FT

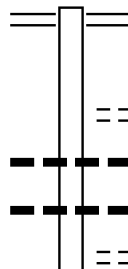

022158 FT BAKERSTOWN RD
 0080/3465 (SR1028 SEG 0260/0000)

0080/2445 TRANQUILITY BASE DR
 (PRDR)
 095 " DIA CIRC METAL
 0080/2277 LEN=0098 INSTALLED UNKN
 018 " DIA CIRC METAL
 0080/2233 LEN=0030 INSTALLED UNKN
 FAWN DR
 0080/1665 (PRDR)

DIR: B TOTAL LEN: 4.197 MI. DIST: 11-1 SR: 1035
 LEFT MUN: FAWN T RIGHT MUN: FAWN T

RIDGE GARDEN LN
 (PRDR)

0080/0865

018693 FT

015862 FT

SUGAR LOAF LN
 (PRDR)
 FAWN ELEM SCHOOL ENT
 (PRDR)

0060/0715

0060/0525
 014204 FT

0080/1480	018 " DIA	CIRC METAL	LEN=0035	INSTALLED UNKN
0080/1222	018 " DIA	CIRC CONCR	LEN=0099	INSTALLED UNKN
0080/1205	PRINGLE DR (TWP)			
0080/0870	018 " DIA	CIR UNKNOWN	LEN=0099	INSTALLED UNKN
0080/0390	018 " DIA	CIRC CONCR	LEN=0035	INSTALLED UNKN
018693 FT	2 0 02179	0 00 0200+21		
0080/0000	LENGTH(AH	3465 BK 2831)		
0070/1960	036 " DIA	CIRC METAL	LEN=0054	INSTALLED UNKN
0070/1716	024 " DIA	CIRC METAL	LEN=0024	INSTALLED UNKN
0070/1535	DONNELLVILLE RD (T717)			
0070/1429	024 " DIA	CIRC METAL	LEN=0020	INSTALLED UNKN
0070/0654	024 " DIA	CIRC METAL	LEN=0020	INSTALLED UNKN
0070/0296	018 " DIA	CIR PLASTIC	LEN=0030	INSTALLED UNKN
0070/0020	015 " DIA	CIRC METAL	LEN=0030	INSTALLED UNKN
015862 FT	2 0 02179	0 00 0171+63		
0070/0000	LENGTH(AH	2831 BK 1658)		
0060/1600	036 " DIA	CIRC CONCR	LEN=0099	INSTALLED UNKN
0060/1411	024 " DIA	CIRC CONCR	LEN=0040	INSTALLED UNKN
0060/1206	018 " DIA	CIRC CONCR	LEN=0045	INSTALLED UNKN
0060/0750	BURTNER RD (SR1032	SEG 0010/0000)		
0060/0715	012 " DIA	CIR PLASTIC	LEN=0099	INSTALLED UNKN
014204 FT	2 0 02179	0 00 0141+85		
0060/0000	LENGTH(AH	1658 BK 3221)		
0050/3187	018 " DIA	CIRC METAL	LEN=0060	INSTALLED UNKN

DIR: B TOTAL LEN: 4.197 MI. DIST: 11-1 SR: 1035
 LEFT MUN: FAWN T RIGHT MUN: FAWN T

Street Name	Segment ID	Length	Material	Status
	0050/1967		018 "DIA CIRC METAL	LEN=0099 INSTALLED UNKN
	0050/1185		018 "DIA CIRC METAL	LEN=0035 INSTALLED UNKN
ALTA VISTA RD (TWP)	0050/1076			
	0050/0826		018 "DIA CIRC CONCR	LEN=0040 INSTALLED UNKN
	0050/0266		018 "DIA CIRC CONCR	LEN=0040 INSTALLED UNKN
	010983 FT		010983 FT	2 0 02179 0 00 0109+75
BOVARD LN (PRDR)	0040/2830		0050/0000	LENGTH(AH 3221 BK 2956)
	0040/1980		018 "DIA CIRC METAL	LEN=0050 INSTALLED UNKN
	0040/1328		018 "DIA CIRC METAL	LEN=0040 INSTALLED UNKN
METZ RD (T772)	0040/0910			
	0040/0787		018 "DIA CIRC METAL	LEN=0035 INSTALLED UNKN
	0040/0638		018 "DIA CIRC METAL	LEN=0035 INSTALLED UNKN
	008027 FT		008027 FT	2 0 02179 0 00 0080+19
	0040/0000		0040/0000	LENGTH(AH 2956 BK 2014)
	0030/1880		018 "DIA CIRC METAL	LEN=0035 INSTALLED UNKN
FIELD CREST LN (PRDR)	0030/1585			
MOUNTAIN VIEW RD (PRDR)	0030/1215			
	0030/1155		018 "DIA CIRC METAL	LEN=0040 INSTALLED UNKN
WESLEY DR (PRDR)	0030/1025			
	0030/0385		BEDNAR LN	(PRDR)
SOBER LN (PRDR)	0030/0335			
NAGY LN (PRDR)	0030/0120			

DIR: B TOTAL LEN: 4.197 MI. DIST: 11-1 SR: 1035
 LEFT MUN: FAWN T RIGHT MUN: FAWN T

Location	Segment ID	Length (FT)	Material	Notes
KIPP LN (PRDR)	006013	FT		
	0020/3155			
	0020/3107		018 " DIA CIRC METAL	LEN=0060 INSTALLED UNKN
	0020/2192		018 " DIA CIRC CONCR	LEN=0099 INSTALLED UNKN
	0020/1609		018 " DIA CIRC METAL	LEN=0050 INSTALLED UNKN
REYNARD DR (TWP)	0020/0873		018 " DIA CIRC METAL	LEN=0045 INSTALLED UNKN
	0020/0596		018 " DIA CIRC METAL	LEN=0030 INSTALLED UNKN
	0020/0014		024 " DIA CIR PLASTIC	LEN=0099 INSTALLED UNKN
	002766	FT		
	0020/0000			LENGTH(AH 3247 BK 2766)
TOUR-ED MINE ENTR RD (PRDR)	0010/1763			PENNDOT STOCKPILE ENT (GOVT)
	0010/1619		018 " DIA CIRC CONCR	LEN=0099 INSTALLED UNKN
	0010/1437		018 " DIA CIRC CONCR	LEN=0030 INSTALLED UNKN
	0010/1236		018 " DIA CIRC CONCR	LEN=0030 INSTALLED UNKN
	0010/1035		018 " DIA CIRC CONCR	LEN=0030 INSTALLED UNKN
	0010/0783		018 " DIA CIRC CONCR	LEN=0030 INSTALLED UNKN
	0010/0503		018 " DIA CIRC CONCR	LEN=0030 INSTALLED UNKN
	0010/0278		018 " DIA CIRC CONCR	LEN=0030 INSTALLED UNKN
	000000	FT		
	000000			LENGTH(AH 2766 BK 0000)

NC R I DGE RD
 BULL CREEK RD
 (SR1034 SEG 0073/0527)
 (SR1034 SEG 0072/0518)
 MFC BEGIN = D

EXTRACT DATE: 12/21/2020 ROADWAY MANAGEMENT SYSTEM PAGE NUMBER: 644
PRINT DATE: 12/23/2020 SLD COUNTY/SR - ANNUAL PRINT COUNTY: ALLEGHENY
DIR: B TOTAL LEN: 4.181 MI. DIST: 11-1 SR: 1034
LEFT MUN: HARRISON T RIGHT MUN: HARRISON T

ROSS ST

022074 FT
INTER-AHD

022041 FT
INTER-AHD ROSS ST

EXTRACT DATE: 12/21/2020
PRINT DATE: 12/23/2020

ROADWAY MANAGEMENT SYSTEM
SLD COUNTY/SR - ANNUAL PRINT

PAGE NUMBER: 643
COUNTY: ALLEGHENY

DIR: B TOTAL LEN: 4.181 MI.
LEFT MUN: HARRISON T

DIST: 11-1 SR: 1034
RIGHT MUN: HARRISON T

(SR0366 SEG 0013/0000)
OP ID RT 0028 NB 0073/1415
RT 0028 SB 0073/1331
OP ID 02/0028/0407/0000 0073/1246
018 "DIA CIRC CONCR
LEN=0040 INSTALLED UNKN
TO 8064/0510 SH 0073/0980
(CONN)
RAMP RD/TO SR 0028 SH 0073/0969
(SR8064 SEG 0510/0000)
018 "DIA CIRC CONCR 0073/0786
LEN=0050 INSTALLED UNKN

RAMP FR 28S TO SR1034 W
(SR8064 SEG 0500/1413) 0073/0696
RIDGE RD
(SR1035 SEG 0010/0000) 0073/0527
0 0 0000 0 00 0000+00 020659 FT
MFC BEGIN = C
LENGTH(AH 1415 BK 1362) 0073/0000

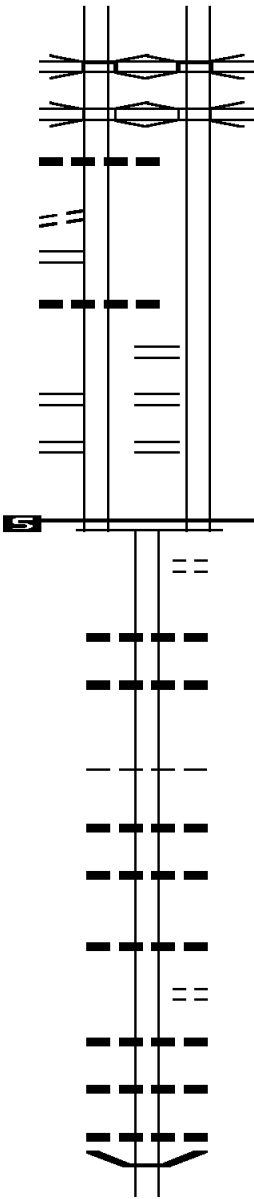

(SR0366 SEG 0012/0000)
OP ID RT 0028 NB 0072/1382
RT 0028 SB 0072/1314
OP ID 02/0028/0400/0000
020659 FT
RAMP RD/TO SR 0028 SH 0072/0700
(SR8064 SEG 0510/0000)
RAMP FR 28S TO SR1034 E 0072/0683
(SR8064 SEG 0500/1413)
RIDGE RD
(SR1035 SEG 0010/0000) 0072/0518
0 0 0000 0 00 0000+00 020659 FT
MFC BEGIN = C
LENGTH(AH 1382 BK 1362) 0072/0000
GRIMM RD (TWP)
0070/1060
0070/0327
0070/0142
019297 FT
0070/0000
0060/3222
0060/2943
0060/2188
0060/2160
0060/2079
0060/1766
0060/1545
0060/1098
018 "DIA CIRC CONCR
LEN=0040 INSTALLED UNKN
018 "DIA CIRC CONCR
LEN=0060 INSTALLED UNKN
2 0 02276 0 00 0055+23
HARRISON
FAWN T
LENGTH(AH 1362 BK 3345)
018 "DIA CIRC CONCR
LEN=0040 INSTALLED UNKN
018 "DIA CIR PLASTIC
LEN=0040 INSTALLED UNKN
036 "DIA CIRC METAL
LEN=0040 INSTALLED UNKN
IRON BRIDGE LN
(PRDR)
018 "DIA CIRC CONCR
LEN=0040 INSTALLED UNKN
018 "DIA CIR PLASTIC
LEN=0040 INSTALLED UNKN
018 "DIA CIRC CONCR
LEN=0040 INSTALLED UNKN
BMSSEN 02/1034/0060/1089
2 0 02276 0 00 0077+43

019297 FT

DIR: B TOTAL LEN: 4.181 MI. DIST: 11-1 SR: 1034
 LEFT MUN: FAWN T RIGHT MUN: FAWN T

METZ RD
(T772)

0060/0830

KERR AV
(TWP)

0060/0330
015952 FT

HUSTON DR
(PRDR)

0050/2380

012166 FT

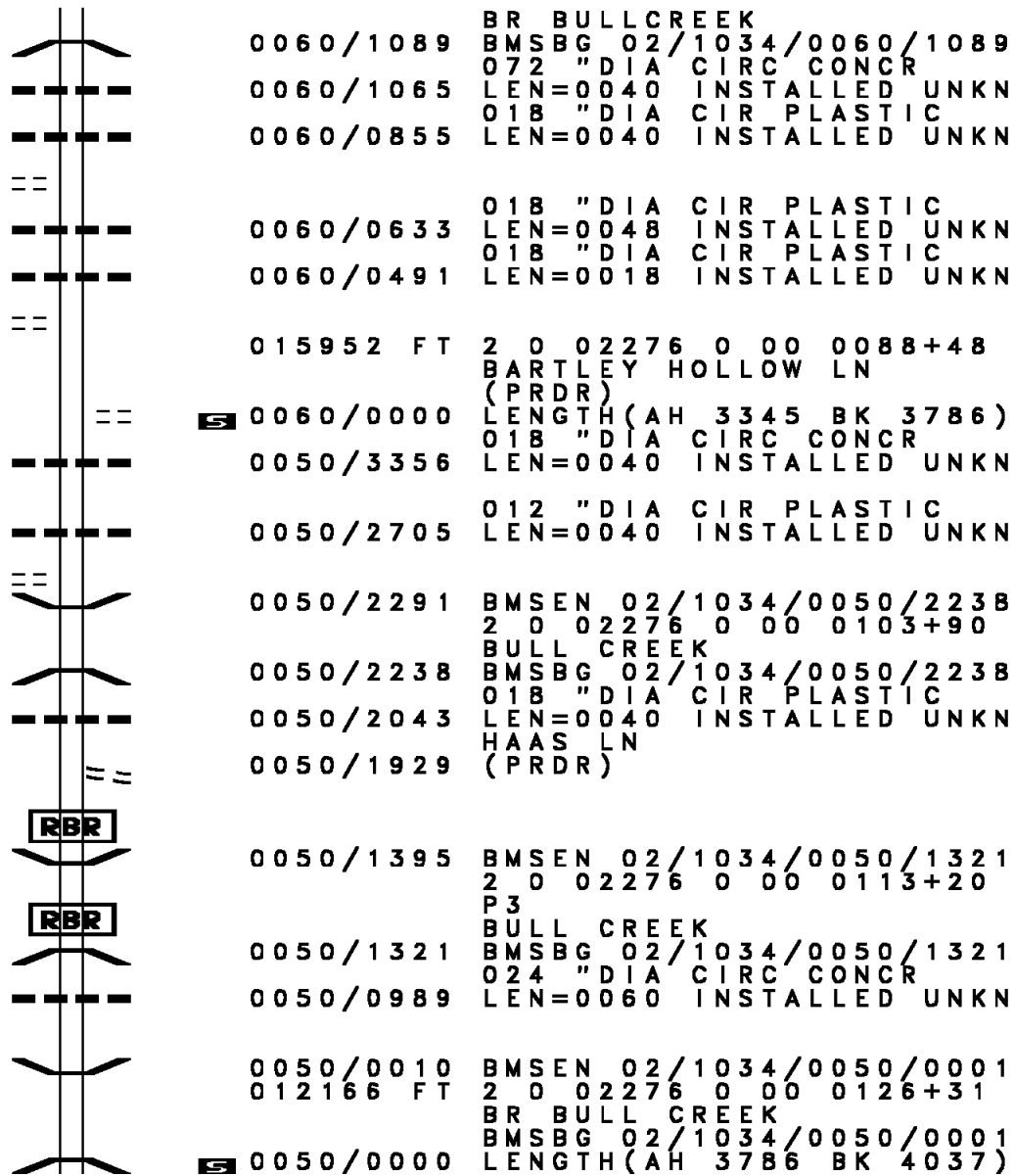

DIR: B TOTAL LEN: 4.181 MI. DIST: 11-1 SR: 1034
 LEFT MUN: FAWN T RIGHT MUN: FAWN T

JONES HOLLOW RD
 (PRDR)

0040/3933

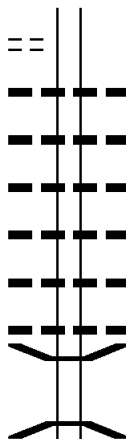

0040/3540 018 " DIA CIR PLASTIC
 LEN=0060 INSTALLED 2006
 0040/3286 015 " DIA CIRC CONCR
 LEN=0040 INSTALLED UNKN
 0040/2878 024 " DIA CIRC CONCR
 LEN=0040 INSTALLED UNKN
 0040/2424 018 " DIA CIRC METAL
 LEN=0040 INSTALLED UNKN
 0040/1947 018 " DIA CIRC METAL
 LEN=0048 INSTALLED UNKN
 0040/1419 018 " DIA CIRC CONCR
 LEN=0079 INSTALLED UNKN
 0040/1352 BMSSEN 02/1034/0040/1330
 2 0 02276 0 00 0153+25
 HOWES RUN
 BMSBG 02/1034/0040/1330

HOWES RUN RD
 (SR1033 SEG 0010/0000)

0040/1195



0040/0442 015 " DIA CIRC CONCR
 LEN=0040 INSTALLED UNKN
 0040/0071 BMSSEN 02/1034/0040/0000
 008129 FT 2 0 02276 0 00 0166+06
 BULL CREEK
 BMSBG 02/1034/0040/0000
 5 0040/0000 LENGTH(AH 4037 BK 2839)
 LUMBER LN
 (PRDR)
 0030/2785

CREEKSIDE LN
 (PRDR)

0030/2202



0030/2099 018 " DIA CIRC CONCR
 LEN=0060 INSTALLED UNKN

WOODROW LN
 (PRDR)

0030/2035

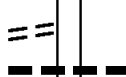

0030/1680 018 " DIA CIRC CONCR
 LEN=0048 INSTALLED UNKN

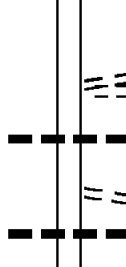

JOHNSON AV
 (PRDR)
 BETUSH RD
 (PRDR)
 0030/0910 018 " DIA CIRC CONCR
 LEN=0048 INSTALLED UNKN
 ORRIS RD
 (PRDR)
 0030/0395 048 "H 48" W CON BOX CUL
 LEN=0048 INSTALLED UNKN
 005290 FT 2 0 02276 0 00 0194+64

005290 FT

LARDINTOWN RD
 (SR1031 SEG 0010/0000) 0010/2610

002927 FT

000000 FT

0030/0000	LENGTH(AH 2839 BK 2363) 036"H 36"W CON BOX CUL
0020/1991	LEN=0048 INSTALLED UNKN
0020/1060	018 " DIA CIRC CONCR LEN=0048 INSTALLED UNKN
0020/0600	MASON RD (TWP)
0020/0541	024 " DIA CIRC CONCR LEN=0048 INSTALLED UNKN
0020/0485	LC TO/FROM MASON RD (CONN)
0020/0398	018 " DIA CIRC CONCR LEN=0048 INSTALLED UNKN
002927 FT	2 0 02276 0 00 0218+27
0020/0000	LENGTH(AH 2363 BK 2927) 072 " DIA CIRC CONCR
0010/2698	LEN=0040 INSTALLED UNKN
0010/2608	RUSTIC LN (PRDR)
0010/2565	JACOBS LN (PRDR)
0010/2318	018 " DIA CIRC CONCR LEN=0040 INSTALLED UNKN
0010/1828	018 " DIA CIRC CONCR LEN=0040 INSTALLED UNKN
0010/1442	018 " DIA CIRC CONCR LEN=0040 INSTALLED UNKN
0010/1153	048 " DIA CIRC CONCR LEN=0040 INSTALLED UNKN
0010/0700	DELLENBAUGH RD (TWP)
0010/0475	SR 908 ET (SR1030 SEG 0050/2305) FOR SR 1028 AND 1034
0010/0165	(CONN)
0010/0084	BR. BULL CR. STRUCTURE LENGTH 13 FT BMSID 02/1034/0010/0084
000000 FT	2 0 02276 0 00 0248+31
	NC BU
	MILLERSTOWN RD (RT 908) (SR1028 SEG 0180/0060)
	INTER-BK THOMPSON RD (T721)
	MFC BEGIN = C
0010/0000	LENGTH(AH 2927 BK 0000)

EXTRACT DATE: 12/21/2020 ROADWAY MANAGEMENT SYSTEM PAGE NUMBER: 639
 PRINT DATE: 12/23/2020 SLD COUNTY/SR - ANNUAL PRINT COUNTY: ALLEGHENY
 DIR: B TOTAL LEN: 2.423 MI. DIST: 11-1 SR: 1033
 LEFT MUN: FAWN T RIGHT MUN: FAWN T

012792 FT

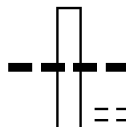

* 012792 FT HOWES RUN RD
 REF-AHD (TWP)
 0050/3701 015 " DIA CIRC CONCR
 0050/3663 LEN=0030 INSTALLED UNKN
 LONESOME HOLLOW LN
 0050/3450 (PRDR)

EXTRACT DATE: 12/21/2020
PRINT DATE: 12/23/2020

ROADWAY MANAGEMENT SYSTEM
SLD COUNTY/SR - ANNUAL PRINT

PAGE NUMBER: 638
COUNTY: ALLEGHENY

DIR: B TOTAL LEN: 2.423 MI.
LEFT MUN: FAWN T

DIST: 11-1 SR: 1033
RIGHT MUN: FAWN T

DONAHUE LN
(PRDR)

009091 FT

0040/1695

006470 FT

0050/3357	015 " DIA	CIRC CONCR
0050/2937	LEN=0035	INSTALLED UNKN
0050/2610	018 " DIA	CIRC CONCR
0050/2125	LEN=0030	INSTALLED UNKN
0050/1780	018 " DIA	CIRC METAL
0050/1571	LEN=0030	INSTALLED UNKN
0050/1442	018 " DIA	CIRC CONCR
0050/0931	LEN=0030	INSTALLED UNKN
0050/0455	030 " DIA	CIRC CONCR
0050/0063	LEN=0030	INSTALLED UNKN
009091 FT	048 " DIA	CIRC METAL
	LEN=0040	INSTALLED UNKN
	018 " DIA	CIRC METAL
	LEN=0035	INSTALLED UNKN
	2 0 02177	0 00 0091+33
	BAKERSTOWN RD	
	(SR1028 SEG 0240/0000)	
	MFC BEGIN = E	
0050/0000	LENGTH(AH 3701 BK 2621)	
0040/2456	024 " DIA	CIRC CONCR
0040/2280	LEN=0035	INSTALLED UNKN
0040/1706	015 " DIA	CIRC CONCR
	LEN=0030	INSTALLED UNKN
	015 " DIA	CIRC METAL
	LEN=0040	INSTALLED UNKN
0040/1576	BMS EN 02/1033/0040/1558	
	2 0 02177	0 00 0078+01
	MCDOWELL RUN	
0040/1558	BMSBG 02/1033/0040/1558	
	FAWN TWP MNCPL BDG ENT	
0040/1487	(TWP)	
0040/1300	024 " DIA	CIRC CONCR
	LEN=0030	INSTALLED UNKN
0040/0785	JESSIE LN	
	(PRDR)	
0040/0655	MCKINNEY LN	
	(PRDR)	
0040/0381	024 " DIA	CIRC CONCR
006470 FT	LEN=0040	INSTALLED UNKN
	2 0 02177	0 00 0065+02
	DONNELLVILLE RD	
	(T717)	

EXTRACT DATE: 12/21/2020
PRINT DATE: 12/23/2020

ROADWAY MANAGEMENT SYSTEM
SLD COUNTY/SR - ANNUAL PRINT

PAGE NUMBER: 637
COUNTY: ALLEGHENY

DIR: B TOTAL LEN: 2.423 MI.
LEFT MUN: FAWN T

DIST: 11-1 SR: 1033
RIGHT MUN: FAWN T

Stationing	Segment	Length	Material	Status
	0040/0000	2621	BK 2505	
	0030/2234	0030	024" DIA CIRC CONCR	INSTALLED UNKN
	0030/2006	0030	018" DIA CIR PLASTIC	INSTALLED UNKN
	0030/1925		CLARICE LN (PRDR)	
	0030/0938	0050	024" DIA CIRC CONCR	INSTALLED UNKN
	0030/0869	0050	024" DIA CIRC CONCR	INSTALLED UNKN
	0030/0626	0030	018" DIA CIRC CONCR	INSTALLED UNKN
	0030/0419	0050	030" DIA CIRC CONCR	INSTALLED UNKN
	0030/0152	0030	018" DIA CIRC CONCR	INSTALLED UNKN
003965 FT	003965 FT	2 0 02177	0 00 0039+79	
	0030/0000	2505	BK 2123	
	0020/1860	0040	024" DIA CIRC METAL	INSTALLED UNKN
	0020/1840		LEASURE LN (PRDR)	
	0020/1359	0045	024" DIA CIRC METAL	INSTALLED UNKN
	0020/0850	0030	024" DIA CIR PLASTIC	INSTALLED UNKN
	0020/0706	0045	018" DIA CIRC METAL	INSTALLED UNKN
001842 FT	0020/0025	0020/0000	BMS EN 02/1033/0020/0000	
	001842 FT	2 0 02177	0 00 0018+34	
			HOWES RUN	
	0020/0000	2123	BK 1842	
	0010/1139	0040	012" DIA CIRC CONCR	INSTALLED UNKN
	0010/0035	0030	018" DIA CIRC METAL	INSTALLED UNKN
000000 FT	000000 FT	2 0 02177	0 00 0000+00	
			NC HOWES RUN RD	
			BULL CREEK RD	
			(SR1034 SEG 0040/1195)	
			MFC BEGIN = D	
	0010/0000	1842	BK 0000	

EXTRACT DATE: 12/21/2020 ROADWAY MANAGEMENT SYSTEM PAGE NUMBER: 636
 PRINT DATE: 12/23/2020 SLD COUNTY/SR - ANNUAL PRINT COUNTY: ALLEGHENY
 DIR: B TOTAL LEN: 5.647 MI. DIST: 11-1 SR: 1032
 LEFT MUN: HARRISON T RIGHT MUN: HARRISON T

029817 FT

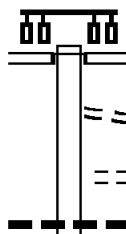

029817 FT
 INTER-AHD VETERANS LN
 (TWP)
 FREEPORT RD
 (SR1001 SEG 0491/0665)
 (SR1001 SEG 0490/0660)
 0110/3706 YORK DR
 0110/3620 (TWP)
 0110/2960 PORTLAND DR
 (TWP)
 0110/2768 01B " DIA CIR UNKNOWN
 LEN=0040 INSTALLED UNKN

DIR: B TOTAL LEN: 5.647 MI. DIST: 11-1 SR: 1032
 LEFT MUN: HARRISON T RIGHT MUN: HARRISON T

Address	Segment ID	Length	Material	Status
	0110/2566	024" DIA	CIRC CONCR	LEN=0099 INSTALLED UNKN
ALLEGHENY DR (TWP)	0110/1470			
	0110/1163	WILDLIFE LN (PRDR)		
	0110/0941	072" DIA	CIRC CONCR	LEN=0099 INSTALLED UNKN
	0110/0231	LOTHLORIEN LN (PRDR)		
2 0 02160 0 00 0133+13 026111 FT JACQUELINE DR (TWP)	0110/0000	026111 FT		LENGTH(AH 3706 BK 1826)
ALLEGHENY DR (TWP)	0100/1009			
	0100/0846	018" DIA	CIRC CONCR	LEN=0001 INSTALLED UNKN
	0100/0195	RANDOLPH DR (TWP)		
024285 FT CHERRYBARK DR (TWP)	0090/2219	024285 FT		2 0 02160 0 00 0114+87 LENGTH(AH 1826 BK 2381)
	0090/2187	018" DIA	CIRC CONCR	LEN=0050 INSTALLED UNKN
	0090/1949	018" DIA	CIRC CONCR	LEN=0099 INSTALLED UNKN
	0090/1647	018" DIA	CIR PLASTIC	LEN=0099 INSTALLED UNKN
	0090/1325	018" DIA	CIRC CONCR	LEN=0099 INSTALLED UNKN
	0090/1020	018" DIA	CIRC CONCR	LEN=0099 INSTALLED UNKN
	0090/0710	024" DIA	CIRC CONCR	LEN=0099 INSTALLED UNKN
	0090/0376	018" DIA	CIRC METAL	LEN=0099 INSTALLED UNKN
	0090/0281	018" DIA	CIRC CONCR	LEN=0099 INSTALLED UNKN
021904 FT	0090/0000	021904 FT		2 0 02160 0 00 0092+02 LENGTH(AH 2381 BK 3970)
	0080/3870	018" DIA	CIRC CONCR	LEN=0099 INSTALLED UNKN
	0080/3356	018" DIA	CIRC CONCR	LEN=0099 INSTALLED UNKN

DIR: B TOTAL LEN: 5.647 MI. DIST: 11-1 SR: 1032
 LEFT MUN: HARRISON T RIGHT MUN: HARRISON T

Location	Segment ID	Length (FT)	Material	Status
	0080/3007	024"	DIA CIRC METAL	INSTALLED UNKN
	0080/2809	018"	DIA CIRC METAL	INSTALLED UNKN
	0080/2069	036"	DIA CIRC CONCR	INSTALLED UNKN
	0080/1340	084"	H 48" W CON BOX CUL	INSTALLED UNKN
017934 FT	0080/0000	017934 FT	2 0 02160 0 00 0051+52	LENGTH(AH 3970 BK 1651)
	0070/1465	036"	DIA CIRC CONCR	INSTALLED UNKN
	0070/1455		PULASKI DR (TWP)	
	0070/1353		KARNS RD (TWP)	
016283 FT	0070/0426	016283 FT	018" DIA CIRC METAL	INSTALLED UNKN
	0070/0000	016283 FT	2 0 02160 0 00 0034+78	LENGTH(AH 1651 BK 3513)
	0060/3416	015"	DIA CIRC METAL	INSTALLED UNKN
BUCHANAN ST (TWP)	0060/3270		MCWILLIAMS DR (TWP)	
	0060/2810	036"	DIA CIRC CONCR	INSTALLED UNKN
HIGH ST (TWP)	0060/2426		VAN DOREN DR (TWP)	
	0060/2225		LAWEST DR (TWP)	
	0060/1665		SHAWNEE DR (TWP)	
MURDOCK AV (TWP)	0060/1175			
ORCHARD AL (TWP)	0060/0800			
COTTAGE AV (TWP)	0060/0665			
	0060/0387		ADAMS ST (TWP)	

DIR: B TOTAL LEN: 5.647 MI. DIST: 11-1 SR: 1032
 LEFT MUN: HARRISON T RIGHT MUN: HARRISON T

Stationing / Description	Stationing	Stationing	Description
ADAMS ST (TWP)	0060/0375		
TO 1001/0460 SH (CONN)	0060/0295		
FREEPORT RD (SR1001 SEG 0460/1835)	0060/0205	0060/0205	FREEPORT RD (SR1001 SEG 0460/1835)
2 0 02160 0 00 0000+00	012770 FT	012770 FT	FREEPORT RD (SR1001 SEG 0461/1690)
FREEPORT RD (SR1001 SEG 0461/1690)	0060/0000	0060/0000	MFC BEGIN = E
		0050/2157	LENGTH(AH 3513 BK 2309)
		0050/1837	040 " DIA CIRC METAL
		0050/1730	LEN=0020 INSTALLED UNKN
CAROLINE ST (TWP)	0050/1730	0050/1730	018 " DIA CIRC METAL
		0050/1585	LEN=0030 INSTALLED UNKN
			BEACON ST (TWP)
ALLEY (TWP)	0050/1560		012 " DIA CIR PLASTIC
		0050/1475	LEN=0099 INSTALLED UNKN
NEELY ST (TWP)	0050/1420		ALLEY (TWP)
ALLEY (TWP)	0050/1280		
		0050/1255	SPRINGHILL RD (TWP)
GLENN AV (TWP)	0050/1145	0050/1204	LILAC ST (TWP)
		0050/1105	ALLEY (TWP)
SYLVAN PK (TWP)	0050/0970	0050/0950	HARVARD AV (TWP)
		0050/0800	ALLEY (TWP)
		0050/0635	PENNSYLVANIA AV (TWP)
MELROSE AV (TWP)	0050/0475	0050/0475	ALLEY (TWP)
		0050/0315	PRINCETON AV (TWP)
		0050/0155	ALLEY (TWP)

EXTRACT DATE: 12/21/2020
PRINT DATE: 12/23/2020

ROADWAY MANAGEMENT SYSTEM
SLD COUNTY/SR - ANNUAL PRINT

PAGE NUMBER: 632
COUNTY: ALLEGHENY

DIR: B TOTAL LEN: 5.647 MI.
LEFT MUN: HARRISON T

DIST: 11-1 SR: 1032
RIGHT MUN: HARRISON T

010461 FT

010461 FT

RT 0028 SB
OP ID 02/0028/0433/1947 0031/0830

RT 0028 NB
OP ID 02/0028/0430/1987 0031/0732
RAMP F RD
(SR8066 SEG 0500/1159)
RAMP E RD
(SR8066 SEG 0250/0000) 0031/0544

0 0 00000 0 00 0000+00 007854 FT
MFC BEGIN = D
LENGTH(AH 0911 BK 3954) 0031/0000

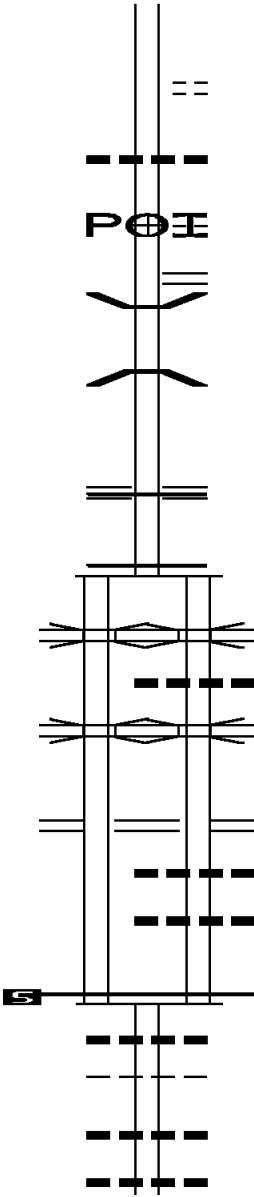

0050/0000 LENGTH(AH 2309 BK 1696)
0040/1038 048 "DIA CIRC CONCR
LEN=0030 INSTALLED UNKN
(APRA) J V MFG
OLD BURTNER RD
0040/0792 (PRDR)
PLEASANTVILLE RD
0040/0382 (SR1027 SEG 0040/3204)
0040/0348 BMSEN 02/1032/0040/0311
2 0 02158 0 00 0084+55
LITTLE BULL CREEK
0040/0311 BMSBG 02/1032/0040/0311
RAMP H RD
(SR8066 SEG 0750/0000)
RAMP G RD
(SR8066 SEG 0010/0791)
0040/0083 MFC BEGIN = C
008765 FT 2 0 02158 0 00 0084+55
MFC BEGIN = D
0040/0000 LENGTH(AH 1696 BK 0911)

RT 0028 SB
OP ID 02/0028/0433/1947 0030/0839
030 "DIA CIRC CONCR
LEN=0099 INSTALLED UNKN
RT 0028 NB
OP ID 02/0028/0430/1987 0030/0749
RAMP F RD
(SR8066 SEG 0500/1159)
RAMP E RD
(SR8066 SEG 0250/0000)
0030/0544 012 "DIA CIRC CONCR
LEN=0060 INSTALLED UNKN
018 "DIA CIRC CONCR
LEN=0030 INSTALLED UNKN
2 0 02220 0 00 0014+94
MFC BEGIN = D
LENGTH(AH 0911 BK 3954) 0030/0000
018 "DIA CIRC CONCR
LEN=0030 INSTALLED UNKN
HARRISON
FAWN T
024"H 01"W **UNKNOWN**
LEN=0040 INSTALLED UNKN
024 "DIA CIRC CONCR
LEN=0025 INSTALLED UNKN

DIR: B TOTAL LEN: 5.647 MI. DIST: 11-1 SR: 1032
 LEFT MUN: FAWN T RIGHT MUN: FAWN T

STRUCTURE	LENGTH	CR
0020/3031	036" H 00" W	MULT METAL
0020/3013	LEN=0040	INSTALLED UNKN
0020/2618	024" DIA	CIRC CONCR UNKN
0020/2428	LEN=0030	INSTALLED UNKN
0020/2181	024" DIA	CIRC CONCR UNKN
0020/1870	LEN=0035	INSTALLED UNKN
0020/1688	018" DIA	CIRC CONCR UNKN
0020/1344	LEN=0099	INSTALLED UNKN
	030" DIA	CIRC CONCR UNKN
	LEN=0006	INSTALLED UNKN
	018" DIA	CIRC CONCR UNKN
	LEN=0035	INSTALLED UNKN
0020/0286	2 0 02220 0 00 0054+06	
003900 FT	LENGTH(AH 3954 BK 3900)	
0020/0000	060" DIA	CIRC CONCR UNKN
0010/3700	LEN=0030	INSTALLED UNKN
	024" DIA	CIRC CONCR UNKN
	LEN=0099	INSTALLED UNKN
	018" DIA	CIRC CONCR UNKN
0010/2985	LEN=0030	INSTALLED UNKN
	048" DIA	CIRC CONCR UNKN
0010/2480	LEN=0030	INSTALLED UNKN
	072" DIA	CIRC CONCR UNKN
0010/2203	LEN=0004	INSTALLED UNKN
0010/1295	024" DIA	CIRC CONCR UNKN
	LEN=0035	INSTALLED UNKN
0010/0020	018" DIA	CIRC CONCR UNKN
	LEN=0099	INSTALLED UNKN
000000 FT	NC BU RTNER RD	
	RIDGE RD	
	(SR1035 SEG 0060/0750)	
	MFC BEGIN = D	
0010/0000	LENGTH(AH 3900 BK 0000)	

SWAGER LN
(PRDR)

0010/2157

BACHMAN RD
(T303)

0010/0989

2 0 02220 0 00 0091+51 000000 FT
 RIDGE RD
 (SR1035 SEG 0060/0750) 0010/0000

EXTRACT DATE: 12/21/2020 ROADWAY MANAGEMENT SYSTEM PAGE NUMBER: 630
 PRINT DATE: 12/23/2020 SLD COUNTY/SR - ANNUAL PRINT COUNTY: ALLEGHENY
 DIR: B TOTAL LEN: 1.788 MI. DIST: 11-1 SR: 1031
 LEFT MUN: FAWN T RIGHT MUN: FAWN T

009440 FT

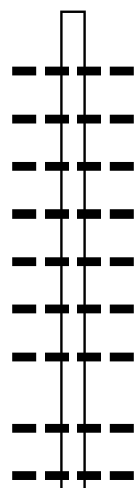

* 009440 FT AH-BUTLER (10)
 REF-AHD LARDINTOWN RD
 0040/2431 (SR2011 SEG 0010/0000)
 018 " DIA CIRC METAL
 0040/2266 LEN=0040 INSTALLED UNKN
 018 " DIA CIR PLASTIC
 0040/2132 LEN=0001 INSTALLED UNKN
 018 " DIA CIRC METAL
 0040/1968 LEN=0001 INSTALLED UNKN
 024 " DIA CIRC CONCR
 0040/1750 LEN=0001 INSTALLED UNKN
 001 " DIA CIR UNKNOWN
 0040/1552 LEN=0001 INSTALLED UNKN
 001 " DIA CIR UNKNOWN
 0040/1321 LEN=0001 INSTALLED UNKN
 001 "H 01 "W **UNKNOWN**
 0040/0968 LEN=0040 INSTALLED UNKN
 018 " DIA CIRC METAL
 0040/0263 LEN=0033 INSTALLED UNKN
 018 " DIA CIR PLASTIC
 0040/0123 LEN=0080 INSTALLED UNKN

DIR: B TOTAL LEN: 1.788 MI. DIST: 11-1 SR: 1031
 LEFT MUN: FAWN T RIGHT MUN: FAWN T

007009 FT

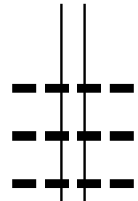

007009 FT 2 0 02175 0 00 0070+55
 5 0040/0000 LENGTH(AH 2431 BK 3337)
 018 " DIA CIRC CONCR
 0030/3072 LEN=0080 INSTALLED UNKN
 018 " DIA CIRC CONCR
 0030/2861 LEN=0040 INSTALLED UNKN
 018 " DIA CIRC CONCR
 0030/2772 LEN=0040 INSTALLED UNKN

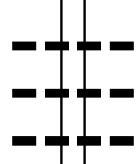

018 " DIA CIRC CONCR
 0030/1713 LEN=0080 INSTALLED UNKN
 018 " DIA CIRC CONCR
 0030/1282 LEN=0040 INSTALLED UNKN
 018 " DIA CIRC CONCR
 0030/1084 LEN=0040 INSTALLED UNKN

003672 FT

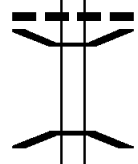

018 " DIA CIRC CONCR
 0030/0437 LEN=0040 INSTALLED UNKN
 0030/0058 BMSBG 02/1031/0030/0001
 003672 FT 2 0 02175 0 00 0037+18
 LARDINTOWN RUN
 BMSBG 02/1031/0030/0001
 5 0030/0000 LENGTH(AH 3337 BK 1949)

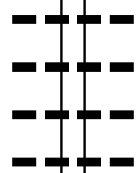

018 " DIA CIRC CONCR
 0020/1134 LEN=0099 INSTALLED UNKN
 018 " DIA CIR PLASTIC
 0020/0710 LEN=0099 INSTALLED UNKN
 018 " DIA CIRC METAL
 0020/0324 LEN=0099 INSTALLED UNKN
 048 " DIA CIRC METAL
 0020/0129 LEN=0048 INSTALLED UNKN

001723 FT

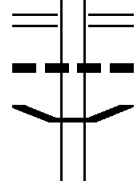

001723 FT 2 0 02175 0 00 0016+42
 BAKERSTOWN RD
 (SR1028 SEG 0190/0000)
 5 0020/0000 LENGTH(AH 1949 BK 1723)
 018 " DIA CIRC METAL
 0010/1173 LEN=0220 INSTALLED UNKN

000000 FT

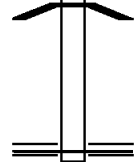

0010/0387 BMSBG 02/1031/0010/0310
 2 0 02175 0 00 0003+13
 BULL CREEK
 0010/0310 BMSBG 02/1031/0010/0310
 000000 FT 2 0 02175 0 00 0000+00
 NC LARDINTOWN RD
 BULL CREEK RD
 (SR1034 SEG 0010/2610)
 MFC BEGIN = E
 5 0010/0000 LENGTH(AH 1723 BK 0000)

EXTRACT DATE: 12/21/2020 ROADWAY MANAGEMENT SYSTEM PAGE NUMBER: 628
 PRINT DATE: 12/23/2020 SLD COUNTY/SR - ANNUAL PRINT COUNTY: ALLEGHENY
 DIR: B TOTAL LEN: 2.726 MI. DIST: 11-1 SR: 1030
 LEFT MUN: FAWN T RIGHT MUN: FAWN T

014392 FT

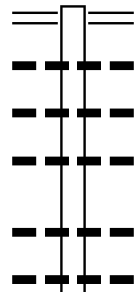

014392 FT	BULL CREEK RD
0050/2305	(SR1034 SEG 0010/0475)
	018 " DIA CIR PLASTIC
0050/1964	LEN=0035 INSTALLED UNKN
	018 " DIA CIR PLASTIC
0050/1457	LEN=0030 INSTALLED UNKN
	018 " DIA CIR PLASTIC
0050/1140	LEN=0030 INSTALLED UNKN
	018 " DIA CIR PLASTIC
0050/0501	LEN=0040 INSTALLED UNKN
	018 " DIA CIR PLASTIC
0050/0480	LEN=0060 INSTALLED UNKN

DIR: B TOTAL LEN: 2.726 MI. DIST: 11-1 SR: 1030
 LEFT MUN: FAWN T RIGHT MUN: FAWN T

Stationing	Description	Material	Length	Status
012087 FT	0050/0250	018" DIA CIR PLASTIC	LEN=0060	INSTALLED UNKN
	0050/0033	FAWN		
	012087 FT	FRAZER T	2 0 02 188	0 00 0114+47
	0050/0000	LENGTH(AH	2305 BK 1962)	
	0040/1953	018" DIA CIR PLASTIC	LEN=0040	INSTALLED UNKN
	0040/1626	018" DIA CIR PLASTIC	LEN=0050	INSTALLED UNKN
	0040/1405	018" DIA CIR PLASTIC	LEN=0040	INSTALLED UNKN
	0040/0908	018" DIA CIR PLASTIC	LEN=0040	INSTALLED UNKN
	0040/0760	018" DIA CIR PLASTIC	LEN=0040	INSTALLED UNKN
	0040/0322	018" DIA CIR PLASTIC	LEN=0035	INSTALLED UNKN
010125 FT	0040/0184	018" DIA CIR PLASTIC	LEN=0030	INSTALLED UNKN
	010125 FT	2 0 02 188	0 00 0094+62	
	0040/0000	LENGTH(AH	1962 BK 2044)	
	0030/1965	018" DIA CIR PLASTIC	LEN=0068	INSTALLED UNKN
	0030/1904	RUBY LN (TWP)		
	0030/1372	018" DIA CIR PLASTIC	LEN=0035	INSTALLED UNKN
	0030/1161	018" DIA CIR PLASTIC	LEN=0040	INSTALLED UNKN
	0030/0025	TARENTUM BAKERSTOWN RD (CNTY)		
008081 FT	008081 FT			
0030/0000	0030/0000	LENGTH(AH	2044 BK 3880)	
	0020/3755	LC FOR BAKERSTOWN RD (CONN)		
	0020/3273	018" DIA CIR PLASTIC	LEN=0050	INSTALLED UNKN
	0020/2914	018" DIA CIR PLASTIC	LEN=0050	INSTALLED UNKN
UNKNOWN RD (T943)	0020/2738			
	0020/2640	036"H 00"W MULT CONCR	LEN=0040	INSTALLED UNKN
	0020/2618	BR OF LITTLE DEER CREEK STRUCTURE LENGTH 10 FT		
		BMSID	02/1030/0020/2618	

DIR: B TOTAL LEN: 2.726 MI. DIST: 11-1 SR: 1030
 LEFT MUN: FRAZER T RIGHT MUN: FRAZER T

UNKNOWN RD
(T943)

0020/0060
004201 FT

LC FOR RSSLTN RD
(CONN) 0010/0135
2 0 02188 0 00 0006+58 000693 FT
LC FOR RSSLTN RD
(CONN) 0010/0000

2 0 02188 0 00 0000+00 000000 FT
RUSSELTON RD
(SR1015 SEG 0130/1595) 0004/0000

0020/2534	024 " DIA	CIR PLASTIC
	LEN=0040	INSTALLED UNKN
0020/2218	018 " DIA	CIR PLASTIC
	LEN=0030	INSTALLED UNKN
0020/2124	FRAZER WEST DEER T	
	018 " DIA	CIR PLASTIC
	LEN=0040	INSTALLED UNKN
0020/1865	018 " DIA	CIR PLASTIC
	LEN=0035	INSTALLED UNKN
0020/1630	018 " DIA	CIRC METAL
	LEN=0060	INSTALLED UNKN
0020/0477	018 " DIA	CIR PLASTIC
	LEN=0050	INSTALLED UNKN
0020/0348	018 " DIA	CIR PLASTIC
	LEN=0030	INSTALLED UNKN
004201 FT	2 0 02188 0 00 0035+08	
	NC MILLERSTOWN RD	
0020/0000	LENGTH(AH 3880 BK 3508)	
	036 " DIA	CIRC CONCR
0010/3442	LEN=0040	INSTALLED UNKN
0010/2893	018 " DIA	CIR PLASTIC
	LEN=0030	INSTALLED UNKN
0010/2555	015 " DIA	CIR PLASTIC
	LEN=0040	INSTALLED UNKN
0010/2444	018 " DIA	CIR PLASTIC
	LEN=0040	INSTALLED UNKN
0010/1288	024 " DIA	CIRC METAL
	LEN=0050	INSTALLED UNKN
0010/0675	021 " DIA	CIRC CONCR
	LEN=0040	INSTALLED UNKN
000693 FT		
0010/0000	LENGTH(AH 3508 BK 0693)	
	018 " DIA	CIR PLASTIC
0004/0683	LEN=0040	INSTALLED UNKN
	NC 908 EXTENSION	
000000 FT	RUSSELTON RD	
	(SR1015 SEG 0130/1595)	
	MFC BEGIN = D	
0004/0000	LENGTH(AH 0693 BK 0000)	

007040 FT

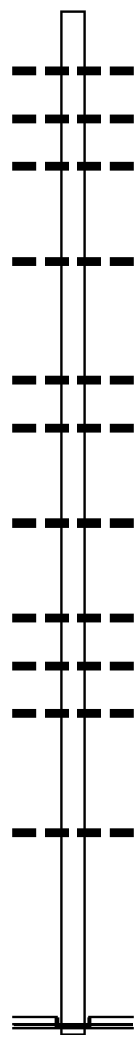

007040 FT
 * REF-AHD DEER CREEK RD
 0020/3540 (TWP)
 024 " DIA CIR PLASTIC
 0020/3033 LEN=0055 INSTALLED UNKN
 018 " DIA CIRC METAL
 0020/2827 LEN=0040 INSTALLED UNKN
 018 " DIA CIRC METAL
 0020/2530 LEN=0040 INSTALLED UNKN

 0020/1389 018 " DIA CIR PLASTIC
 LEN=0040 INSTALLED UNKN

 0020/0111 018 " DIA CIRC METAL
 LEN=0040 INSTALLED UNKN
 018 " DIA CIRC METAL
 0020/0060 LEN=0040 INSTALLED UNKN
 003500 FT 2 0 02163 0 00 0035+00
 0020/0000 LENGTH(AH 3540 BK 3500)
 018 " DIA CIRC METAL
 0010/3308 LEN=0060 INSTALLED UNKN

 0010/2212 015 " DIA CIRC METAL
 LEN=0040 INSTALLED 2002
 024 " DIA CIRC METAL
 0010/1870 LEN=0030 INSTALLED UNKN
 018 " DIA CIRC METAL
 0010/1795 LEN=0040 INSTALLED UNKN

 0010/0344 018 " DIA CIRC METAL
 LEN=0040 INSTALLED UNKN
 000000 FT 2 0 02163 0 00 0035+00
 NC DEE ER CREEK RD
 BAKERSTOWN RD
 (SR1028 SEG 0050/0000)
 INTER-BK BAIRD FORD RD
 (CNTY)
 MFC BEGIN = E
 0010/0000 LENGTH(AH 3500 BK 0000)

003500 FT

000000 FT

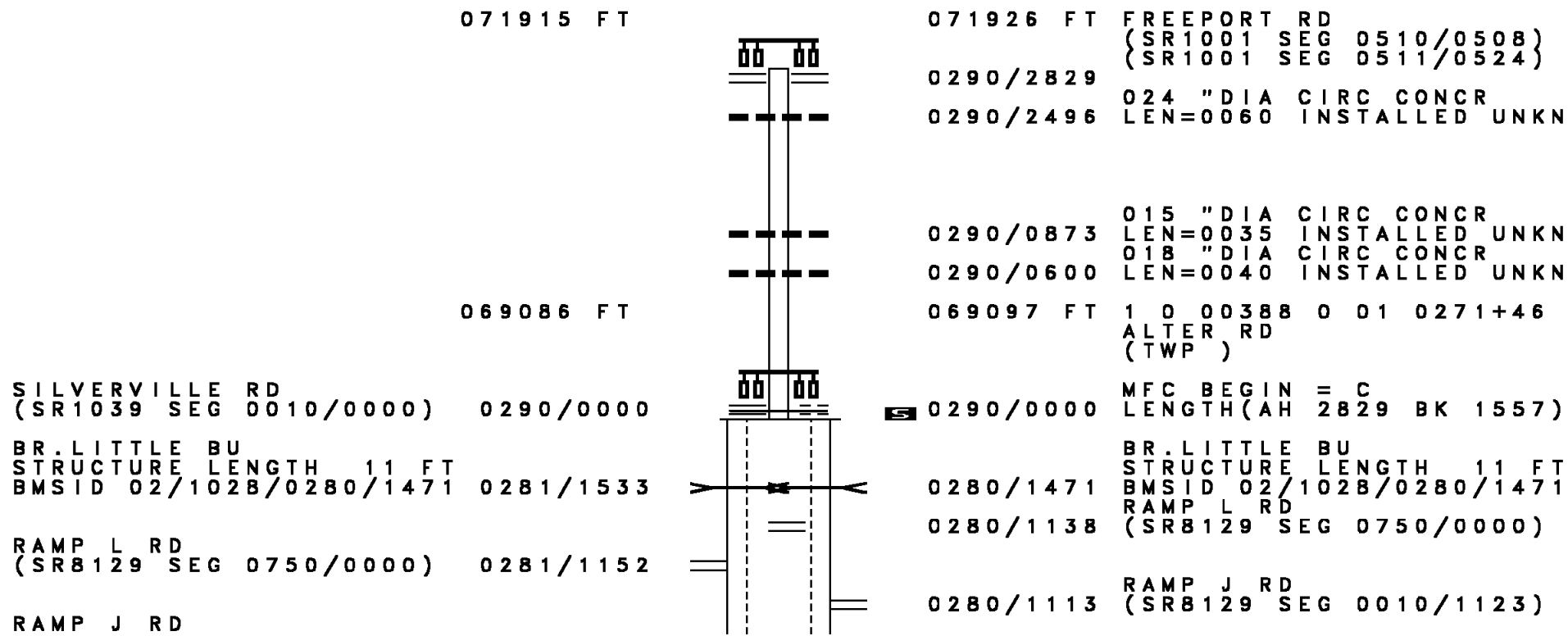

071915 FT

071926 FT FREEPORT RD
 (SR1001 SEG 0510/0508)
 (SR1001 SEG 0511/0524)
 0290/2829
 0290/2496 024 " DIA CIRC CONCR
 LEN=0060 INSTALLED UNKN

069086 FT

0290/0873 015 " DIA CIRC CONCR
 LEN=0035 INSTALLED UNKN
 0290/0600 018 " DIA CIRC CONCR
 LEN=0040 INSTALLED UNKN
 069097 FT 1 0 00388 0 01 0271+46
 ALTER RD
 (TWP)

SILVERVILLE RD
 (SR1039 SEG 0010/0000) 0290/0000
 BR. LITTLE BU
 STRUCTURE LENGTH 11 FT
 BMSID 02/1028/0280/1471 0281/1533
 RAMP L RD
 (SR8129 SEG 0750/0000) 0281/1152
 RAMP J RD

0290/0000 MFC BEGIN = C
 LENGTH(AH 2829 BK 1557)
 BR. LITTLE BU
 STRUCTURE LENGTH 11 FT
 BMSID 02/1028/0280/1471
 RAMP L RD
 (SR8129 SEG 0750/0000)
 RAMP J RD
 (SR8129 SEG 0010/1123)

DIR: B TOTAL LEN: 13.622 MI. DIST: 11-1 SR: 1028
 LEFT MUN: FAWN T RIGHT MUN: FAWN T

Stationing	Right of Way	Length	Material	Status
0260/2264	STOEBENER LN	LEN=0025	CIRC CONC	INSTALLED UNKN
0260/2050	(PRDR)			
0260/2023	018" DIA	LEN=0040	CIRC CONC	INSTALLED UNKN
0260/1771	018" DIA	LEN=0040	CIRC CONC	INSTALLED UNKN
0260/1429	015" DIA	LEN=0035	CIRC CONC	INSTALLED UNKN
0260/0972	018" DIA	LEN=0040	CIRC CONC	INSTALLED UNKN
0260/0395	KOEDEL DR			
060255 FT	(PRDR)			
060255 FT	RIDGE RD	1 0 00388 0 00 0177+56		
0260/0000	(SR1035 SEG 0080/3465)	LENGTH(AH 3852 BK 1802)		
0250/1645	GREENHAVEN DR (PRDR)			
0250/0890	015" DIA	LEN=0035	CIRC CONC	INSTALLED UNKN
0250/0653	024" DIA	LEN=0045	CIRC CONC	INSTALLED UNKN
058453 FT	BR. MCDOWELL	1 0 00388 0 00 0159+55		
058453 FT	STRUCTURE LENGTH 9 FT			
0250/0000	BMSID 02/1028/0250/0000	LENGTH(AH 1802 BK 2920)		
0240/2920	099" DIA	LEN=0080	CIR UNKNOWN	INSTALLED UNKN
0240/2209	018" DIA	LEN=0099	CIRC METAL	INSTALLED UNKN
0240/2135	BARR RD (PRDR)			
0240/1973	018" DIA	LEN=0099	CIRC CONC	INSTALLED UNKN
0240/1845	015" DIA	LEN=0040	CIRC CONC	INSTALLED UNKN
0240/1664	024" DIA	LEN=0040	CIRC CONC	INSTALLED UNKN
0240/1362	099" DIA	LEN=0040	CIR UNKNOWN	INSTALLED UNKN
0240/1280	LESLIE LN (PRDR)			
0240/1019	015" DIA	LEN=0040	CIRC CONC	INSTALLED UNKN
BRADLEY LN				

DIR: B TOTAL LEN: 13.622 MI. DIST: 11-1 SR: 1028
 LEFT MUN: FAWN T RIGHT MUN: FAWN T

Stationing	Notes	Material	Length
0240/0770	==	015 " DIA CIRC CONCR	LEN=0040
0240/0671	---	HEATHER LN	INSTALLED UNKN
0240/0645	==	(PRDR)	
0240/0104	---	MCDOWELL RUN	STRUCTURE LENGTH 12 FT
055533 FT	---	BMSID 02/1028/0240/0122	1 0 00388 0 00 0130+36
0240/0000	==	HOWES RUN RD	(SR1033 SEG 0050/0000)
0230/2322	---	LEN=0040	INSTALLED UNKN
0230/1980	---	018 " DIA CIR PLASTIC	LEN=0050
0230/1945	==	LOOKOUT LN	(PRDR)
0230/1725	---	015 " DIA CIRC CONCR	LEN=0045
0230/1330	==	CUSTER LN	(PRDR)
0230/0903	---	018 " DIA CIRC CONCR	LEN=0030
0230/0900	==	024 " DIA CIRC CONCR	LEN=0060
053040 FT	---	1 0 00388 0 00 0106+13	LEN=0060
0230/0000	==	LEN=0035	INSTALLED UNKN
0220/1754	---	015 " DIA CIRC CONCR	LEN=0035
0220/0909	---	018 " DIA CIRC CONCR	LEN=0040
0220/0667	---	015 " DIA CIRC CONCR	LEN=0035
051256 FT	---	1 0 00388 0 00 0087+75	LEN=0035
0220/0000	==	HOWES RUN	STRUCTURE LENGTH 9 FT
0210/2020	---	BMSID 02/1028/0220/0000	036"H 00"W **UNKNOWN**
	---	LEN=0070	INSTALLED UNKN
		015 " DIA CIRC CONCR	

LETTRICK LN
(PRDR)

DIR: B TOTAL LEN: 13.622 MI. DIST: 11-1 SR: 1028
 LEFT MUN: FAWN T RIGHT MUN: FAWN T

Stationing	Description	Length	Material	Status
049216 FT	0210/0835	LEN=0040	INSTALLED UNKN	
	015" DIA CIRC CONCR			
	0210/0510	LEN=0040	INSTALLED UNKN	
	MEANDER LN			
	0210/0430	(PRDR)		
	049216 FT	1 0 00388 0 00 0067+18		
	0210/0000	LENGTH(AH 2040 BK 2028)		
	0200/1325	016"H 16"W CON BOX CUL		
	0200/0563	LEN=0040	INSTALLED UNKN	
	0200/0207	024" DIA CIR PLASTIC		
	0200/0033	LEN=0040	INSTALLED UNKN	
	047188 FT	015" DIA CIRC CONCR		
1 0 00388 0 00 0046+90 047188 FT	0200/0000	LEN=0042	INSTALLED UNKN	
MARTIN RD (T770)	0200/0000	LENGTH(AH 2028 BK 2600)		
	0190/2364	018" DIA CIRC CONCR		
	0190/2050	LEN=0045	INSTALLED UNKN	
	0190/1744	015" DIA CIRC CONCR		
	0190/1470	LEN=0038	INSTALLED UNKN	
	0190/1263	036" DIA CIRC CONCR		
	0190/1054	LEN=0035	INSTALLED UNKN	
	0190/0776	015" DIA CIRC CONCR		
	0190/0452	LEN=0030	INSTALLED UNKN	
044588 FT	044588 FT	1 0 00388 0 00 0021+06		
	NC BA	KERSTOWN RD		
		LARDINTOWN RD		
	0190/0000	(SR1031 SEG 0020/0000)		
	0180/1810	LENGTH(AH 2600 BK 2051)		
		BMS EN 02/1028/0180/1751		
		1 0 00388 0 00 0017+95		
		P3		
		LARDINTOWN R		



EXTRACT DATE: 12/21/2020
PRINT DATE: 12/23/2020

ROADWAY MANAGEMENT SYSTEM
SLD COUNTY/SR - ANNUAL PRINT

PAGE NUMBER: 619
COUNTY: ALLEGHENY

DIR: B TOTAL LEN: 13.622 MI.
LEFT MUN: FAWN T

DIST: 11-1 SR: 1028
RIGHT MUN: FAWN T

THOMPSON RD
(T721)

0180/0060
042537 FT

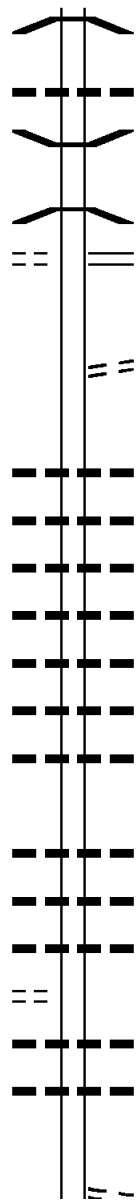

0180/1751 BMSBG 02/1028/0180/1751

0180/1107 099 "DIA CIRC CONCR
LEN=0030 INSTALLED UNKN

0180/0479 BMSEN 02/1028/0180/0430
1 0 00388 0 00 0004+63
BULL CREEK

0180/0430 BMSBG 02/1028/0180/0430
BULL CREEK RD

0180/0060 (SR1034 SEG 0010/0000)
042537 FT 1 0 00388 0 00 0000+00

0180/0000 NC BA KERSTOWN RD (ROUTE 908)
LENGTH(AH 2051 BK 3709)
FOR SR 1028 AND 1034

0170/3624 (CONN)

0170/2643 015 "DIA CIRC CONCR
LEN=0035 INSTALLED UNKN

0170/2495 015 "DIA CIRC CONCR
LEN=0035 INSTALLED UNKN

0170/1913 024 "DIA CIRC METAL
LEN=0035 INSTALLED UNKN

0170/1515 018 "DIA CIRC OTHER
LEN=0030 INSTALLED UNKN

0170/1117 018 "DIA CIRC OTHER
LEN=0030 INSTALLED UNKN

0170/0608 018 "DIA CIRC CONCR
LEN=0030 INSTALLED UNKN

038828 FT

0170/0421 036 "DIA CIRC CONCR
LEN=0030 INSTALLED UNKN

0170/0000 018 "DIA CIRC METAL
LENGTH(AH 3709 BK 1712)

0160/1595 018 "DIA CIRC METAL
LEN=0040 INSTALLED UNKN

0160/1253 099 "DIA CIR UNKNOWN
LEN=0045 INSTALLED UNKN

0160/0830 018 "DIA CIRC CONCR
LEN=0075 INSTALLED UNKN

CALLEN LN
(PRDR)

0160/0650

0160/0592 018 "DIA CIRC CONCR
LEN=0050 INSTALLED UNKN

0160/0354 012 "DIA CIRC CONCR
LEN=0030 INSTALLED UNKN

037116 FT

037116 FT 2 0 02275 0 00 0068+47
NC BA KERSTOWN RD

THOMM LN
(PRDR)

DIR: B TOTAL LEN: 13.622 MI. DIST: 11-1 SR: 1028
 LEFT MUN: FAWN T RIGHT MUN: FAWN T

2 0 02275 0 00 0029+38 033236 FT
 BLANCHARD RD
 (T719) 0150/0000

NORRIS LN
 (PRDR) 0130/0903

0160/0000	LENGTH(AH 1712 BK 3880)
0150/3872	024 "DIA CIRC METAL LEN=0099 INSTALLED UNKN
0150/3862	FAWN WEST DEER T
0150/3300	040 "DIA CIRC METAL LEN=0099 INSTALLED UNKN
0150/2500	024 "DIA CIRC METAL LEN=0099 INSTALLED UNKN
0150/1610	024 "DIA CIR PLASTIC LEN=0040 INSTALLED UNKN
0150/0355	040 "DIA CIRC METAL LEN=0040 INSTALLED UNKN
033236 FT	
0150/0000	LENGTH(AH 3880 BK 2992)
0140/2580	024 "DIA CIR UNKNOWN LEN=0030 INSTALLED UNKN
0140/2212	024 "DIA CIR PLASTIC LEN=0050 INSTALLED UNKN
0140/1408	018 "DIA CIRC CONCR LEN=0030 INSTALLED UNKN
0140/0986	LC FOR BAKERSTOWN RD (CONN)
0140/0920	018 "DIA CIRC CONCR LEN=0100 INSTALLED UNKN
0140/0791	015 "DIA CIRC CONCR LEN=0060 INSTALLED UNKN
	BAKERSTOWN RD (CNTY)
	NC MI ILLERSTOWN RD
0140/0286	018 "DIA CIRC CONCR LEN=0030 INSTALLED UNKN
0140/0143	FOR SR 1015 AND 1028 (CONN)
0140/0044	024 "DIA CIRC CONCR LEN=0099 INSTALLED UNKN
030244 FT	2 0 02275 0 00 0000+00 RUSSELLTON RD (SR1015 SEG 0160/3282)
0140/0000	LENGTH(AH 2992 BK 1293)
	018 "DIA CIRC CONCR

EXTRACT DATE: 12/21/2020
PRINT DATE: 12/23/2020

ROADWAY MANAGEMENT SYSTEM
SLD COUNTY/SR - ANNUAL PRINT

PAGE NUMBER: 617
COUNTY: ALLEGHENY

DIR: B TOTAL LEN: 13.622 MI.
LEFT MUN: WEST DEER T

DIST: 11-1 SR: 1028
RIGHT MUN: WEST DEER T

Stationing	Structure	Material	Length	Notes
	0130/0834	LEN=0025		INSTALLED UNKN
	0130/0825	BMSFN 02/1028/0130/0706		
		2 0 02274 0 00 0290+09		
	0130/0692	BMSBG 02/1028/0130/0706		
		BESSEMER AND LAKE ER RR		
		SAXONBURG BL		
	0130/0665	(SR1013 SEG 0330/0000)		
		028"H 36"W CON BOX CUL		
028951 FT	0130/0518	LEN=0040		INSTALLED UNKN
	028951 FT	2 0 02274 0 00 0290+09		
	0130/0000	LENGTH(AH 1293 BK 0645)		
		024 "DIA CIRC CONCR		
028306 FT	0120/0190	LEN=0099		INSTALLED UNKN
	028306 FT	2 0 02274 0 00 0283+64		
	0120/0000	LENGTH(AH 0645 BK 1917)		
		024 "DIA CIR PLASTIC		
STEWART ST (PRDR)	0110/1236	LEN=0040		INSTALLED UNKN
	0110/1178			
		018 "DIA CIR PLASTIC		
	0110/0866	LEN=0028		INSTALLED UNKN
026389 FT	026389 FT	2 0 02274 0 00 0264+42		
	0110/0000	LENGTH(AH 1917 BK 2428)		
		024 "DIA CIRC CONCR		
	0100/2153	LEN=0065		INSTALLED UNKN
		040 "DIA CIRC CONCR		
	0100/1180	LEN=0050		INSTALLED UNKN
		015 "DIA CIRC CONCR		
	0100/0956	LEN=0044		INSTALLED UNKN
CHRISTY RD (T658)	0100/0320			
	023961 FT			
	023961 FT	2 0 02274 0 00 0240+14		
	0100/0000	LENGTH(AH 2428 BK 2489)		
		018 "DIA CIRC OTHER		
	0090/2295	LEN=0025		INSTALLED UNKN
		018 "DIA CIRC METAL		
	0090/1346	LEN=0025		INSTALLED UNKN
		018 "DIA CIR PLASTIC		
	0090/0661	LEN=0025		INSTALLED UNKN
ARMSTRONG RD (SR1045 SEG 0010/0000)	0090/0090			
	021472 FT			
	021472 FT	2 0 02274 0 00 0215+15		

DIR: B TOTAL LEN: 13.622 MI. DIST: 11-1 SR: 1028
 LEFT MUN: WEST DEER T RIGHT MUN: WEST DEER T

2 0 02274 0 00 0185+47 018473 FT
 RITTMAN RD
 (T532) 0080/0000

LILAC LN
 (PRDR) 0060/0187
 012709 FT

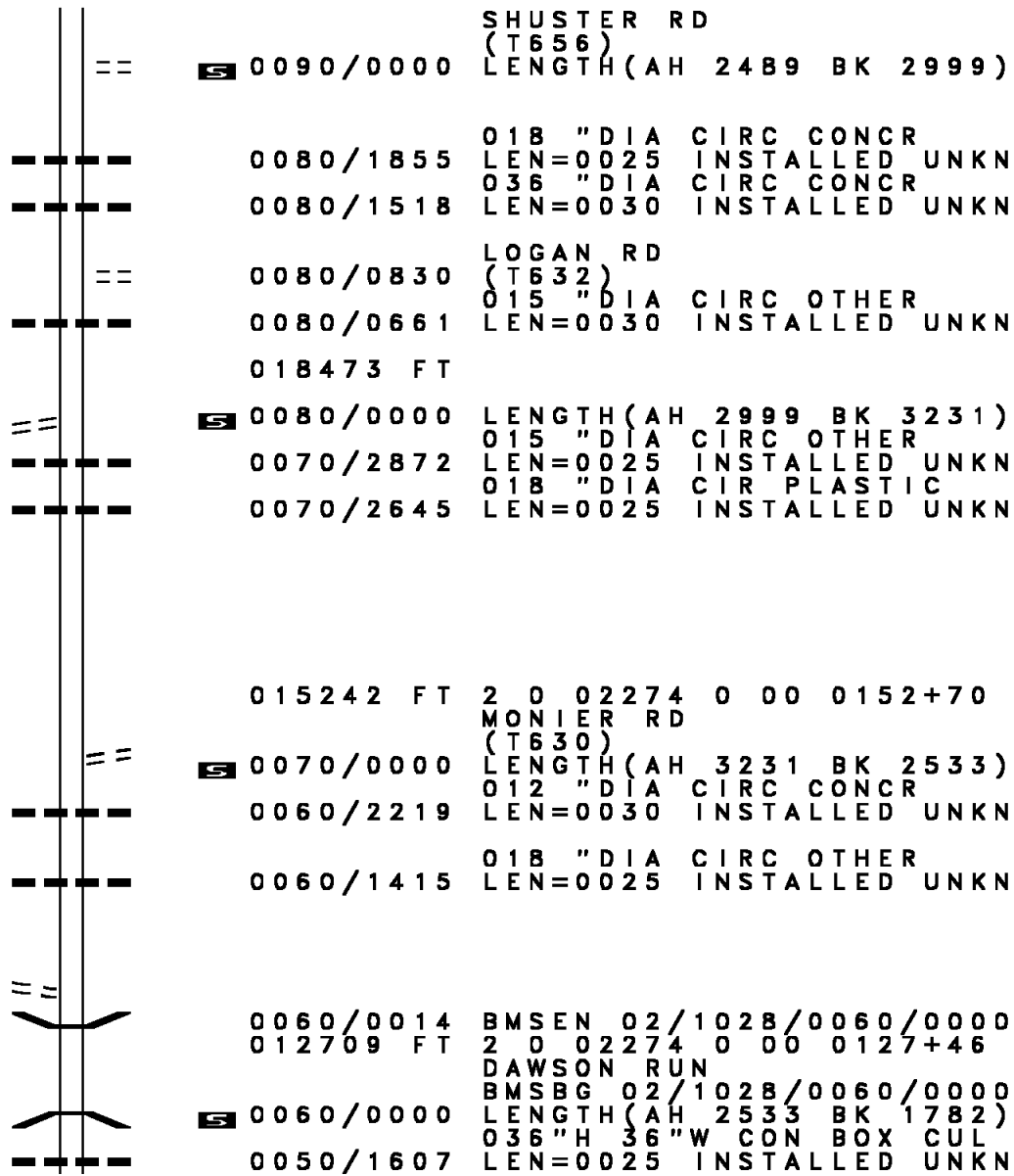

SHUSTER RD
 (T656)
 LENGTH(AH 2489 BK 2999)

0080/1855 018 " DIA CIRC CONCR
 LEN=0025 INSTALLED UNKN
 0080/1518 036 " DIA CIRC CONCR
 LEN=0030 INSTALLED UNKN

LOGAN RD
 (T632)
 0080/0830 015 " DIA CIRC OTHER
 LEN=0030 INSTALLED UNKN

018473 FT
 0080/0000 LENGTH(AH 2999 BK 3231)
 0070/2872 015 " DIA CIRC OTHER
 LEN=0025 INSTALLED UNKN
 0070/2645 018 " DIA CIR PLASTIC
 LEN=0025 INSTALLED UNKN

015242 FT 015242 FT 2 0 02274 0 00 0152+70
 MONIER RD
 (T630)
 0070/0000 LENGTH(AH 3231 BK 2533)
 0060/2219 012 " DIA CIRC CONCR
 LEN=0030 INSTALLED UNKN
 0060/1415 018 " DIA CIRC OTHER
 LEN=0025 INSTALLED UNKN

0060/0014 BMS EN 02/1028/0060/0000
 012709 FT 2 0 02274 0 00 0127+46
 DAWSON RUN
 BMSBG 02/1028/0060/0000
 0060/0000 LENGTH(AH 2533 BK 1782)
 0050/1607 036 "H 36 "W CON BOX CUL
 LEN=0025 INSTALLED UNKN

EXTRACT DATE: 12/21/2020
PRINT DATE: 12/23/2020

ROADWAY MANAGEMENT SYSTEM
SLD COUNTY/SR - ANNUAL PRINT

PAGE NUMBER: 615
COUNTY: ALLEGHENY

DIR: B TOTAL LEN: 13.622 MI.
LEFT MUN: WEST DEER T

DIST: 11-1 SR: 1028
RIGHT MUN: WEST DEER T

Stationing	Segment	Length	Notes
010927 FT	0050/0599	0050	024 " DIA CIRC CONCR LEN=0025 INSTALLED UNKN
	0050/0112	0050	018 " DIA CIRC CONCR LEN=0024 INSTALLED UNKN
DEER CREEK RD (SR1029 SEG 0010/0000)	0050/0000	0050	2 0 02274 0 00 0109+45 BAIRD FORD RD (CNTY) LENGTH(AH 1782 BK 2255)
	0040/1370	0040	HUNTER RD (TWP)
	0040/0644	0040	018 " DIA CIR PLASTIC LEN=0025 INSTALLED UNKN
2 0 02274 0 00 0086+85 GLASGOW RD (T680)	008672 FT	008672	
	0040/0000	0040	LENGTH(AH 2255 BK 3708)
	0030/3560	0030	018 " DIA CIRC CONCR LEN=0040 INSTALLED UNKN
	0030/3319	0030	015 " DIA CIRC METAL LEN=0025 INSTALLED UNKN
	0030/3205	0030	012 " DIA CIR PLASTIC LEN=0030 INSTALLED UNKN
	0030/3101	0030	SHEPHARD RD (T618)
	0030/2631	0030	BMSSEN 02/1028/0030/2614 2 0 02274 0 00 0076+05
DONALDSON RD (T618)	0030/2470	0030	DEER CREEK BMSBG 02/1028/0030/2614
	0030/2418	0030	BMSSEN 02/1028/0030/2408 2 0 02274 0 00 0073+84
	0030/2408	0030	BR. DEER CR. BMSBG 02/1028/0030/2408
	0030/0955	0030	024 " DIA CIRC CONCR LEN=0030 INSTALLED UNKN
004964 FT	0030/0142	0030	015 " DIA CIRC CONCR LEN=0022 INSTALLED UNKN
	004964 FT	004964	2 0 02274 0 00 0049+36
	0030/0000	0030	LENGTH(AH 3708 BK 2536)
	0020/2411	0020	012 " DIA CIRC CONCR LEN=0030 INSTALLED UNKN

DIR: B TOTAL LEN: 13.622 MI. DIST: 11-1 SR: 1028
 LEFT MUN: WEST DEER T RIGHT MUN: WEST DEER T

CARL LN
(T617)

0020/1320

BETTY LN
(T619)
 PEACO WY
(PRDR)
 VAN VELSOR DR
(TWP)

0020/0880

0020/0503

0020/0328

002428 FT

CIRCLE DR
(T616)

0010/0810

000000 FT

0020/2196	OLD BAKERSTOWN RD (TWP)
0020/2126	099 " DIA CIR UNKNOWN LEN=0045 INSTALLED UNKN
0020/1950	015 " DIA CIR CONCR LEN=0040 INSTALLED UNKN
0020/1799	018 " DIA CIR METAL LEN=0100 INSTALLED UNKN
0020/1564	OLD BAKERSTOWN RD (TWP)
0020/1280	MCKALLOFF RD (T944)
0020/1069	018 " DIA CIR METAL LEN=0045 INSTALLED UNKN
0020/0046	015 " DIA CIR CONCR LEN=0030 INSTALLED UNKN
002428 FT	2 0 02274 0 00 0024+52 MCKALLOFF RD (T944)
0020/0000	WEST DEER RICHLAND T LENGTH(AH 2536 BK 2428)
0010/2000	MCMORRAN RD (T506)
0010/0783	018 " DIA CIR PLASTIC LEN=0035 INSTALLED UNKN
0010/0342	BMSBN 02/1028/0010/0312 2 0 02274 0 00 0003+22 BR. DEER CRK.
0010/0332	BMSBG 02/1028/0010/0312
000000 FT	2 0 02274 0 00 0000+00 NC BA
INTER-BK	KERSTOWN RD HECKERT RD (T760)
0010/0000	BAKERSTOWN RD (SR4068 SEG 0190/2653) MFC BEGIN = C LENGTH(AH 2428 BK 0000)

007694 FT

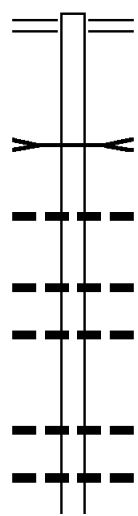

007694 FT BURTNER RD
 0040/3204 (SR1032 SEG 0040/0382)

LITTLE BULL CREEK
 STRUCTURE LENGTH 48 FT
 0040/2018 BMSID 02/1027/0040/2046

0040/1187 036 " DIA CIRC CONCR
 LEN=0030 INSTALLED UNKN

0040/0324 018 " DIA CIRC CONCR
 LEN=0050 INSTALLED UNKN
 018 " DIA CIR PLASTIC

004490 FT

0040/0099 0040/0000 2 0 02158 0 00 0047+29
 LENGTH(AH 3204 BK 1736)

0030/1426 018 " DIA CIRC CONCR
 LEN=0045 INSTALLED UNKN
 012 " DIA CIRC CONCR
 0030/0979 012 " DIA CIRC CONCR
 LEN=0070 INSTALLED UNKN

EXTRACT DATE: 12/21/2020
PRINT DATE: 12/23/2020

ROADWAY MANAGEMENT SYSTEM
SLD COUNTY/SR - ANNUAL PRINT

PAGE NUMBER: 612
COUNTY: ALLEGHENY

DIR: B TOTAL LEN: 1.457 MI.
LEFT MUN: HARRISON T

DIST: 11-1 SR: 1027
RIGHT MUN: HARRISON T

Stationing	Distance	Notes	Stationing	Distance	Notes
			0030/0978	LEN=0040	INSTALLED UNKN
			0030/0747	BMS EN 02/1027/0030/0723	
				2 0 02158 0 00	0031+23
				LITTLE BULL CREEK	
			0030/0700	BMSBG 02/1027/0030/0723	
002754 FT			002754 FT	2 0 02158 0 00	0031+23
				JUNIATA RD	
				(TWP)	
			0030/0000	LENGTH(AH 1736 BK 2567)	
				018 " DIA	CIRC CONCR
			0020/2547	LEN=0040	INSTALLED UNKN
				018 " DIA	CIRC CONCR
			0020/2309	LEN=0045	INSTALLED UNKN
				018 " DIA	CIRC CONCR
			0020/2079	LEN=0045	INSTALLED UNKN
				018 " DIA	CIRC CONCR
			0020/1996	LEN=0045	INSTALLED UNKN
				016 " DIA	CIRC CONCR
			0020/1814	LEN=0040	INSTALLED UNKN
				018 " DIA	CIRC CONCR
			0020/1743	LEN=0045	INSTALLED UNKN
				FIFTH AV	
				(TWP)	
				FOURTH AV	
			0020/1350	(TWP)	
				018 " DIA	CIRC CONCR
			0020/1282	LEN=0045	INSTALLED UNKN
				018 " DIA	CIRC CONCR
			0020/0830	LEN=0164	INSTALLED UNKN
				018 " DIA	CIRC CONCR
			0020/0603	LEN=0015	INSTALLED UNKN
				048 " DIA	CIRC CONCR
			0020/0585	LEN=0045	INSTALLED UNKN
			000187 FT		
2 0 02158 0 00 0005+59	000187 FT			NC PL	LEASANTVILLE RD
CARLISLE ST			0020/0000	LENGTH(AH 2567 BK 0187)	
(TWP)	0020/0000			020 " DIA	CIRC CONCR
			0012/0133	LEN=0099	INSTALLED UNKN
				OREGON AV	
				(TWP)	
				NC CARLISLE ST	
			0012/0024	(TWP)	
000000 FT			000000 FT	2 0 02158 0 00	0003+86
				NC OREGON AV	
				MFC BEGIN = E	
			0012/0000	LENGTH(AH 0187 BK 0386)	
000000 FT			000000 FT		
			7010/0000	LENGTH(AH 0386 BK 0000)	

EXTRACT DATE: 12/21/2020 ROADWAY MANAGEMENT SYSTEM PAGE NUMBER: 611
PRINT DATE: 12/23/2020 SLD COUNTY/SR - ANNUAL PRINT COUNTY: ALLEGHENY

DIR: B TOTAL LEN: 1.159 MI. DIST: 11-1 SR: 1026
LEFT MUN: WEST DEER T RIGHT MUN: WEST DEER T

MAHAFFY RD 006117 FT
(SR1019 SEG 0150/0000) 0030/0787



006117 FT
INTER-AHD CREIGHTON-RUSSELLTON RD
0030/0787 (SR1019 SEG 0150/0000)
018 "DIA CIRC CONCR

DIR: B TOTAL LEN: 3.953 MI. DIST: 11-1 SR: 1025
 LEFT MUN: WEST DEER T RIGHT MUN: WEST DEER T

SAXONBURG BL 020873 FT
 (SR1013 SEG 0260/0820) 0070/3488

REAGHARD DR 0070/2460
 (TWP)

MCCLURE RD 0070/1640
 (T652)

017385 FT

016081 FT

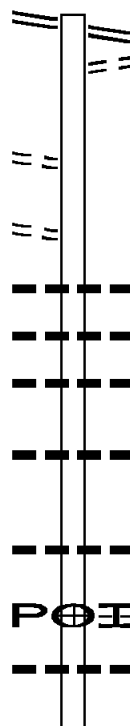

020873 FT SAXONBURG BL
 0070/3488 (SR1013 SEG 0260/0820)
 0070/3393 FOR SR 1013 AND 1025
 (CONN)

0070/1618 024 " DIA CIRC METAL
 LEN=0045 INSTALLED UNKN
 0070/1612 012 " DIA CIRC ALUMIN
 LEN=0099 INSTALLED UNKN
 0070/1100 024 " DIA CIRC CONCR
 LEN=0040 INSTALLED UNKN

0070/0405 018 " DIA CIRC METAL
 LEN=0075 INSTALLED UNKN
 017385 FT 2 0 02152 0 00 0035+30
 5 0070/0000 LENGTH(AH 3488 BK 1304)
 0060/0949 024 " DIA CIRC CONCR
 LEN=0040 INSTALLED UNKN
 (APRA) DEER LAKE SCHOOL
 DEER LAKE SCHOOL RD
 0060/0653 (PRDR)
 0060/0178 024 " DIA CIRC CONCR
 LEN=0040 INSTALLED UNKN
 016081 FT 2 0 02152 0 00 0048+73
 STARR RD

EXTRACT DATE: 12/21/2020
PRINT DATE: 12/23/2020

ROADWAY MANAGEMENT SYSTEM
SLD COUNTY/SR - ANNUAL PRINT

PAGE NUMBER: 608
COUNTY: ALLEGHENY

DIR: B TOTAL LEN: 3.953 MI.
LEFT MUN: WEST DEER T

DIST: 11-1 SR: 1025
RIGHT MUN: WEST DEER T

Location / Segment	Segment ID	Length (FT)	Material / Notes	
SUNSET DR (TWP)	0060/0000		(SR1026 SEG 0010/0000) MFC BEGIN = D LENGTH(AH 1304 BK 3661) LINDEN DR	
	0050/3360		(T953) 018" DIA CIR PLASTIC	
	0050/3232		LEN=0040 INSTALLED UNKN LINDEN DR	
	0050/3223		(T953)	
	0050/2190		DEER PARK DR (T950)	
WOODHILL DR	0050/1868		(T948)	
	0050/1955			
012420 FT				
RUSSELLTON/DORSEYVILLE (SR1020 SEG 0100/2944)	0050/0000		(SR1020 SEG 0100/2944) LENGTH(AH 3661 BK 3595) 018" DIA CIRC METAL	
	0040/3155		LEN=0040 INSTALLED UNKN 018" DIA CIR PLASTIC	
	0040/2945		LEN=0040 INSTALLED UNKN	
	0040/2020		018" DIA CIRC CONCR LEN=0040 INSTALLED UNKN	
	0040/1580		012" DIA CIRC CONCR LEN=0040 INSTALLED UNKN	
	0040/1302		018" DIA CIRC CONCR LEN=0040 INSTALLED UNKN	
	0040/0667		018" DIA CIRC CONCR LEN=0040 INSTALLED UNKN	
	008825 FT			
	MILL DAM RD (SR1023 SEG 0030/0139)	0040/0000		WEST DEER INDIANA T LENGTH(AH 3595 BK 2655)
		0030/2042		018" DIA CIRC CONCR LEN=0040 INSTALLED UNKN 018" DIA CIRC CONCR

DIR: B TOTAL LEN: 3.953 MI. DIST: 11-1 SR: 1025
 LEFT MUN: INDIANA T RIGHT MUN: INDIANA T

006170 FT

```

    ---|--- 0030/1570 LEN=0040 INSTALLED UNKN
    ---|--- 0030/0931 018 "DIA CIRC METAL
    ---|--- LEN=0040 INSTALLED UNKN
    ---|--- 0030/0250 018 "DIA CIRC METAL
    ---|--- 006170 FT LEN=0050 INSTALLED UNKN
    ---|--- 2 0 02156 0 00 0202+87
    ---|--- MARSHALL HILL RD
    ---|--- (T669)
    == 5 0030/0000 LENGTH(AH 2655 BK 3258)
    
```

002912 FT

```

    ---|--- 0020/1121 018 "DIA CIRC METAL
    ---|--- LEN=0045 INSTALLED UNKN
    ---|--- 0020/1095 018 "DIA CIRC CONCR
    ---|--- LEN=0040 INSTALLED UNKN
    ---|--- 0020/0855 018 "DIA CIRC METAL
    ---|--- LEN=0040 INSTALLED UNKN
    ---|--- 0020/0714 018 "DIA CIR PLASTIC
    ---|--- LEN=0080 INSTALLED UNKN
    ---|--- 0020/0525 018 "DIA CIR UNKNOWN
    ---|--- LEN=0040 INSTALLED UNKN
    ---|--- 002912 FT 2 0 02156 0 00 0170+06
    ---|--- 5 0020/0000 LENGTH(AH 3258 BK 2912)
    
```

000000 FT

```

    ---|--- 0010/1530 018 "DIA CIRC CONCR
    ---|--- LEN=0045 INSTALLED UNKN
    ---|--- 0010/1274 012 "DIA CIRC CONCR
    ---|--- LEN=0040 INSTALLED UNKN
    ---|--- 0010/0920 024 "DIA CIR UNKNOWN
    ---|--- LEN=0040 INSTALLED UNKN
    ---|--- 0010/0441 012 "DIA CIRC CONCR
    ---|--- LEN=0040 INSTALLED UNKN
    ---|--- 0010/0357 018 "DIA CIRC METAL
    ---|--- 000000 FT LEN=0240 INSTALLED UNKN
    ---|--- 2 0 02156 0 00 0140+86
    ---|--- 012 "DIA CIRC METAL
    ---|--- LEN=0080 INSTALLED UNKN
    
```

RICH HILL RD (TBK)
 (TWP)

0010/0000

```

    ---|--- NC RICH HILL RD
    ---|--- INTER-BK LEFEVER HILL RD
    ---|--- (SR1016 SEG 0060/0000)
    ---|--- MFC BEGIN = E
    ---|--- 5 0010/0000 LENGTH(AH 2912 BK 0000)
    
```

DIR: B TOTAL LEN: 2.195 MI. DIST: 11-1 SR: 1024
 LEFT MUN: WEST DEER T RIGHT MUN: WEST DEER T

ASHLEY RD
(T628)

011587 FT

0030/0804

007713 FT

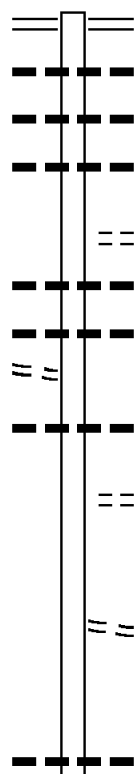

011587 FT SAXONBURG BL
 0030/3874 (SR1013 SEG 0250/0895)
 024 "DIA CIRC CONCR
 0030/3442 LEN=0040 INSTALLED UNKN
 024 "DIA CIRC CONCR
 0030/3281 LEN=0035 INSTALLED UNKN
 024 "DIA CIRC ALUMIN
 0030/2728 LEN=0001 INSTALLED UNKN

 YORK WY
 (TWP)
 0030/2110 024 "DIA CIRC CONCR
 0030/1940 LEN=0035 INSTALLED UNKN
 036 "DIA CIRC CONCR
 0030/1349 LEN=0055 INSTALLED UNKN

 036 "DIA CIRC CONCR
 0030/0763 LEN=0055 INSTALLED UNKN

 KELLY CT
 (PRDR)
 0030/0105 2 0 02148 0 00 0119+30
 007713 FT NC STARZ RD
 STARZ RD
 (TWP)
 5 0030/0000 LENGTH(AH 3874 BK 3850)

 024 "DIA CIRC CONCR
 0020/2277 LEN=0099 INSTALLED UNKN

DIR: B TOTAL LEN: 2.195 MI. DIST: 11-1 SR: 1024
 LEFT MUN: WEST DEER T RIGHT MUN: WEST DEER T

BRYSON RD
 (SR1022 SEG 0050/2462) 0020/1585

2 0 02148 0 00 0080+14 003863 FT
 PRIVATE DR
 (PRDR) 0020/0000
 LC FOR PRIVATE DR
 (CONN) 0010/3645

MOUNTAIN VIEW RD
 (T670) 0010/0260

2 0 02148 0 00 0043+97 000000 FT
 GIBSONIA RD
 (SR0910 SEG 0290/0000) 0010/0000

0020/1885	030 " DIA	CIRC CONCR
	LEN=0040	INSTALLED UNKN
0020/1701	024 " DIA	CIRC CONCR
	LEN=0099	INSTALLED UNKN
0020/1609	018 " DIA	CIRC CONCR
	LEN=0040	INSTALLED UNKN
0020/1410	036 "H 24 "W	ELLIP METAL
	LEN=0099	INSTALLED UNKN
0020/0872	036 " DIA	CIR PLASTIC
	LEN=0040	INSTALLED UNKN
0020/0793	048 " DIA	CIRC CONCR
	LEN=0030	INSTALLED UNKN
0020/0283	018 " DIA	CIRC CONCR
	LEN=0030	INSTALLED UNKN
0020/0031	015 " DIA	CIRC CONCR
003863 FT	LEN=0030	INSTALLED UNKN
0020/0000	LENGTH(AH 3850 BK 3863)	
0010/3509	015 " DIA	CIRC CONCR
	LEN=0030	INSTALLED UNKN
0010/3016	018 " DIA	CIRC CONCR
	LEN=0030	INSTALLED UNKN
0010/2366	BMS EN 02/1024/0010/2346 2 0 02148 0 00 0065+01 BR. DEER CR.	
0010/2346	BMS BG 02/1024/0010/2346	
0010/1911	018 " DIA	CIRC CONCR
	LEN=0030	INSTALLED UNKN
0010/1421	024 " DIA	CIRC CONCR
	LEN=0030	INSTALLED UNKN
0010/1333	024 " DIA	CIRC CONCR
	LEN=0030	INSTALLED UNKN
0010/1075	018 " DIA	CIRC CONCR
	LEN=0035	INSTALLED UNKN
0010/0872	036 " DIA	CIRC CONCR
	LEN=0025	INSTALLED UNKN
000000 FT	NC MOUNTAIN VIEW RD GIBSONIA RD (SR0910 SEG 0290/0000) MFC BEGIN = E	
0010/0000	LENGTH(AH 3863 BK 0000)	

EXTRACT DATE: 12/21/2020 ROADWAY MANAGEMENT SYSTEM PAGE NUMBER: 604
 PRINT DATE: 12/23/2020 SLD COUNTY/SR - ANNUAL PRINT COUNTY: ALLEGHENY
 DIR: B TOTAL LEN: .026 MI. DIST: 11-1 SR: 1023
 LEFT MUN: WEST DEER T RIGHT MUN: WEST DEER T

RICH HILL RD
 (SR1025 SEG 0040/0000) 000139 FT
 0030/0139
 000000 FT

 000000 FT
 000000 FT
 000000 FT

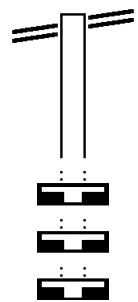

000139 FT RICH HILL RD
 0030/0139 (SR1025 SEG 0040/0000)
 000000 FT 2 0 02189 0 00 0082+00
 NC MILL DAM RD
 * REF-BK MILL DAM RD
 (TWP)
 5 0030/0000 LENGTH(AH 0139 BK 2212)
 000000 FT
 7022/0000 LENGTH(AH 2212 BK 3120)
 000000 FT
 7020/0000 LENGTH(AH 3120 BK 2878)
 000000 FT
 7010/0000 LENGTH(AH 2878 BK 0000)

DIR: B TOTAL LEN: 2.465 MI. DIST: 11-1 SR: 1022
 LEFT MUN: WEST DEER T RIGHT MUN: WEST DEER T

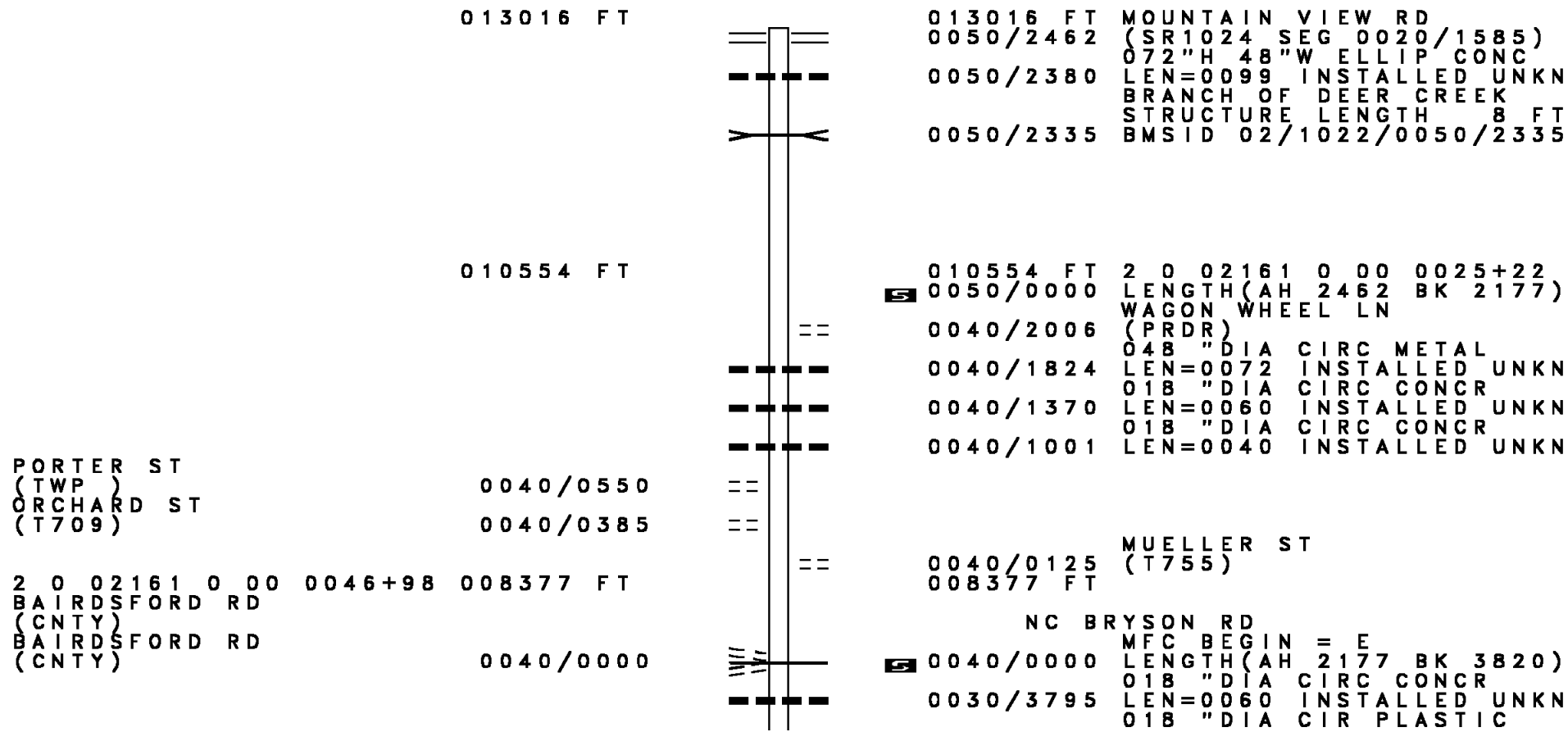

013016 FT

013016 FT MOUNTAIN VIEW RD
 0050/2462 (SR1024 SEG 0020/1585)
 072"H 48"W ELLIP CONC
 0050/2380 LEN=0099 INSTALLED UNKN
 BRANCH OF DEER CREEK
 STRUCTURE LENGTH 8 FT
 0050/2335 BMSID 02/1022/0050/2335

010554 FT

010554 FT 2 0 02161 0 00 0025+22
 0050/0000 LENGTH(AH 2462 BK 2177)
 WAGON WHEEL LN
 0040/2006 (PRDR)
 048 " DIA CIRC METAL
 0040/1824 LEN=0072 INSTALLED UNKN
 018 " DIA CIRC CONCR
 0040/1370 LEN=0060 INSTALLED UNKN
 018 " DIA CIRC CONCR
 0040/1001 LEN=0040 INSTALLED UNKN

PORTER ST
 (TWP) 0040/0550
 ORCHARD ST
 (T709) 0040/0385

2 0 02161 0 00 0046+98 008377 FT
 BAIRDSFORD RD
 (CNTY)
 BAIRDSFORD RD
 (CNTY) 0040/0000

0040/0125 MUELLER ST
 008377 FT (T755)
 NC BRYSON RD
 MFC BEGIN = E
 0040/0000 LENGTH(AH 2177 BK 3820)
 018 " DIA CIRC CONCR
 0030/3795 LEN=0060 INSTALLED UNKN
 018 " DIA CIR PLASTIC

DIR: B TOTAL LEN: 2.465 MI. DIST: 11-1 SR: 1022
 LEFT MUN: WEST DEER T RIGHT MUN: WEST DEER T

LOCUST ST
(TWP)

PINE LN
(TWP)

0030/1805

0030/1180

004557 FT

002562 FT

000000 FT

---	0030/3413	LEN=0050	INSTALLED UNKN
---	0030/2988	024 "DIA	CIRC CONCR
---	0030/2918	LEN=0035	INSTALLED 2002
---	0030/2450	018 "DIA	CIRC CONCR
==	0030/2398	LEN=0040	INSTALLED UNKN
---	0030/2102	MUELLER ST	
---	0030/1805	(T755)	
==	0030/1805	018 "DIA	CIRC CONCR
---	0030/1202	LEN=0040	INSTALLED UNKN
---	0030/1202	018 "DIA	CIRC CONCR
==	0030/1202	LEN=0050	INSTALLED 1998
---	0030/1180	SPRUCE AV	
==	0030/0775	(TWP)	
---	0030/0390	PINE LN	
---	0030/0390	(TWP)	
==	0030/0115	GILLNER LN	
---	0030/0115	(TWP)	
---	0030/0000	018 "DIA	CIRC CONCR
---	0030/0000	LEN=0060	INSTALLED UNKN
---	0030/0000	DILLNER LN	
---	0030/0000	(TWP)	
---	0030/0000	2 0 02150 0 04 0165+81	
---	0030/0000	LENGTH(AH 3820 BK 1995)	
---	0020/1331	024 "DIA	CIRC CONCR
---	0020/0975	LEN=0040	INSTALLED UNKN
---	0020/0975	018 "DIA	CIRC METAL
---	0020/0401	LEN=0040	INSTALLED UNKN
---	0020/0401	DAWSON RUN	
---	0020/0401	STRUCTURE LENGTH 23 FT	
---	0020/0401	BMSID 02/1022/0020/0401	
---	0020/0000	2 0 02150 0 03 0141+92	
---	0020/0000	LENGTH(AH 1995 BK 2562)	
---	0010/1900	018 "DIA	CIRC CONCR
---	0010/1900	LEN=0040	INSTALLED UNKN
---	0010/1064	024 "DIA	CIRC CONCR
---	0010/1064	LEN=0060	INSTALLED UNKN
---	000000 FT	000000 FT	2 0 02150 0 02 0177+03
---	0010/0000	NC OAK RD	
---	0010/0000	GIBSONIA RD	
---	0010/0000	(SR0910 SEG 0270/0000)	
---	0010/0000	MFC BEGIN = D	
---	0010/0000	LENGTH(AH 2562 BK 0000)	

DIR: B TOTAL LEN: 2.281 MI. DIST: 11-1 SR: 1021
 LEFT MUN: FRAZER T RIGHT MUN: FRAZER T

	012043 FT		012043 FT	
BUTLER LOGAN RD			INTER-AHD	TAWNEY RUN RD
(SR1019 SEG 0060/0000)	0050/0869			(SR1014 SEG 0060/2118)
				BUTLER LOGAN RD
			0050/0869	(SR1019 SEG 0060/0000)
			0050/0585	024 " DIA CIRC METAL
	011174 FT		011174 FT	LEN=0040 INSTALLED UNKN
				2 0 02171 0 00 0111+67
				RIDDLE RUN RD
				(T951)
				NC MU
				MURRAY HILL RD
				MURRAY HILL RD
				(T947)
			0050/0000	LENGTH (AH 0869 BK 3313)
				OAK LN
			0040/3168	(PRDR)
				IVANS LN
			0040/3010	(PRDR)
				018 " DIA CIR UNKNOWN
			0040/2655	LEN=0040 INSTALLED UNKN
				024 " DIA CIRC METAL
			0040/2140	LEN=0204 INSTALLED UNKN
				024 " DIA CIR PLASTIC
			0040/1940	LEN=0040 INSTALLED UNKN
				024 " DIA CIRC METAL
			0040/1625	LEN=0040 INSTALLED UNKN
				018 " DIA CIR UNKNOWN
			0040/1422	LEN=0040 INSTALLED UNKN
				024 " DIA CIR UNKNOWN
			0040/0878	LEN=0040 INSTALLED UNKN
				018 " DIA CIR UNKNOWN



DIR: B TOTAL LEN: 2.281 MI. DIST: 11-1 SR: 1021
 LEFT MUN: FRAZER T RIGHT MUN: FRAZER T

	0040/0537	LEN=0040	INSTALLED UNKN
		FRAZER	
	0040/0355	SPRINGDALE T	
		036 " DIA	CIRC CONCR
007861 FT	0040/0340	LEN=0035	INSTALLED UNKN
	007861 FT	2 0 02171	0 00 0076+89
	0040/0000	LENGTH(AH	3313 BK 2123)
		018 " DIA	CIR PLASTIC
	0030/1511	LEN=0050	INSTALLED 2004
		048 " DIA	CIRC CONCR
	0030/1334	LEN=0040	INSTALLED UNKN
		048 " DIA	CIRC METAL
	0030/0974	LEN=0040	INSTALLED UNKN
		024 " DIA	CIRC CONCR
	0030/0620	LEN=0040	INSTALLED UNKN
		018 " DIA	CIRC CONCR
005738 FT	0030/0260	LEN=0035	INSTALLED UNKN
	005738 FT	2 0 02171	0 00 0057+51
	0030/0000	LENGTH(AH	2123 BK 1832)
		018 " DIA	CIR UNKNOWN
	0020/1518	LEN=0040	INSTALLED UNKN
		018 " DIA	CIR PLASTIC
	0020/0756	LEN=0040	INSTALLED UNKN
003906 FT	003906 FT	2 0 02171	0 00 0037+45
	0020/0000	LENGTH(AH	1832 BK 3906)
		018"H 00"W	MULT PLSTIC
	0010/3507	LEN=0040	INSTALLED UNKN
		015 " DIA	CIRC METAL
	0010/1525	LEN=0040	INSTALLED UNKN
		018 " DIA	CIRC METAL
	0010/1353	LEN=0055	INSTALLED UNKN
		VALLEY VIEW DR	
	0010/1300	(TWP)	
		018"H 09"W	**UNKNOWN**
000000 FT	0010/0555	LEN=0099	INSTALLED UNKN
	000000 FT	2 0 02171	0 00 0000+00
		NC RI	
		DDLE RUN RD	
		FREEMONT RD	
		(SR1001 SEG	0300/0775)
		MFC BEGIN =	D
	0010/0000	LENGTH(AH	3906 BK 0000)

EXTRACT DATE: 12/21/2020 ROADWAY MANAGEMENT SYSTEM PAGE NUMBER: 599
 PRINT DATE: 12/23/2020 SLD COUNTY/SR - ANNUAL PRINT COUNTY: ALLEGHENY
 DIR: B TOTAL LEN: 4.942 MI. DIST: 11-1 SR: 1020
 LEFT MUN: WEST DEER T RIGHT MUN: WEST DEER T

EAST UNION RD
 (TWP)

026093 FT

0100/2944

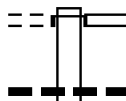

026093 FT
 INTER-AHD

0100/2944

0100/2275

MICHAEL RD
 (T026)
 RICH HILL RD
 (SR1025 SEG 0050/0000)
 024 "DIA CIRC CONCR
 LEN=0030 INSTALLED UNKN

EXTRACT DATE: 12/21/2020
PRINT DATE: 12/23/2020

ROADWAY MANAGEMENT SYSTEM
SLD COUNTY/SR - ANNUAL PRINT

PAGE NUMBER: 598
COUNTY: ALLEGHENY

DIR: B TOTAL LEN: 4.942 MI.
LEFT MUN: WEST DEER T

DIST: 11-1 SR: 1020
RIGHT MUN: WEST DEER T

SUNNYHILL DR
(PRDR)

023149 FT

0090/2575

020058 FT

2 0 02223 0 00 0086+31 019842 FT
SAXONBURG BL
(SR1013 SEG 0190/2120)
RUSSELLTON RD

0100/1904	018 " DIA CIRC CONCR LEN=0030 INSTALLED UNKN
0100/1493	LC TO/FROM ASPEN AV (CONN)
0100/1445	ASPEN AV (PRDR)
0100/0625	JOSEPH ST (TWP)
0100/0600	018 " DIA CIRC CONCR LEN=0030 INSTALLED UNKN
023149 FT	2 0 02223 0 00 0117+97
0100/0000	LENGTH(AH 2944 BK 3091)
0090/2555	COFFEE LN (TWP)
0090/2024	018 " DIA CIRC CONCR LEN=0030 INSTALLED UNKN
0090/0905	018 " DIA CIR PLASTIC LEN=0030 INSTALLED UNKN
0090/0845	012 " DIA CIR PLASTIC LEN=0030 INSTALLED UNKN
0090/0805	012 " DIA CIR PLASTIC LEN=0030 INSTALLED UNKN
0090/0695	DEERTON ST (TWP)
0090/0639	018 " DIA CIRC CONCR LEN=0099 INSTALLED UNKN
0090/0583	024 " DIA CIRC METAL LEN=0060 INSTALLED UNKN
0090/0140	018 " DIA CIRC CONCR LEN=0030 INSTALLED 2017
0090/0065	CHRISTINE RD (T650)
0090/0064	018 " DIA CIRC METAL LEN=0519 INSTALLED UNKN
0090/0045	BMSSEN 02/1020/0090/0001 2 0 02223 0 00 0088+97
0090/0001	CUNNINGHAM RUN BMSBG 02/1020/0090/0001
020058 FT	2 0 02223 0 00 0088+97
0090/0000	LENGTH(AH 3091 BK 0216)
INTER-BK	NC RU SSELLTON/DORSEYVILLE RD SAXONBURG BL (SR1013 SEG 0190/2120) MFC BEGIN = D

EXTRACT DATE: 12/21/2020
PRINT DATE: 12/23/2020

ROADWAY MANAGEMENT SYSTEM
SLD COUNTY/SR - ANNUAL PRINT

PAGE NUMBER: 597
COUNTY: ALLEGHENY

DIR: B TOTAL LEN: 4.942 MI.
LEFT MUN: WEST DEER T

DIST: 11-1 SR: 1020
RIGHT MUN: WEST DEER T

(T628)

0080/0000
019842 FT

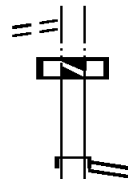

0080/0000 LTH AH 000216 BK 000100
019842 FT
7074/0000 LTH AH 000100 BK 003148
INTER-AHD SAXONBURG BL
(SR1013 SEG 0190/1060)
SAXONBURG BL
(SR1013 SEG 0190/1060)

SNITZER RD
(TWP)
STARZ RD
(TWP)

0070/2090
0070/2040

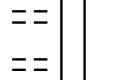

0070/2036 018 " DIA CIRC CONCR
LEN=0060 INSTALLED UNKN
018 " DIA CIRC METAL
0070/1641 LEN=0050 INSTALLED UNKN
018 " DIA CIRC METAL
0070/1450 LEN=0050 INSTALLED UNKN
018 " DIA CIRC METAL
0070/1275 LEN=0050 INSTALLED UNKN
018 " DIA CIRC METAL
0070/0986 LEN=0050 INSTALLED UNKN
018 " DIA CIRC METAL
0070/0330 LEN=0045 INSTALLED UNKN
018 " DIA CIRC METAL
0070/0245 LEN=0045 INSTALLED UNKN
016694 FT 2 0 02223 0 00 0054+72
0070/0000 LENGTH(AH 3148 BK 2907)
018 " DIA CIRC METAL
0060/2895 LEN=0040 INSTALLED UNKN
018 " DIA CIRC CONCR
0060/2541 LEN=0050 INSTALLED UNKN
018 " DIA CIRC METAL
0060/2172 LEN=0050 INSTALLED UNKN
015 " DIA CIRC METAL
0060/1925 LEN=0040 INSTALLED UNKN
036 " DIA CIRC METAL
0060/1132 LEN=0045 INSTALLED UNKN
024 " DIA CIR PLASTIC
0060/1107 LEN=0099 INSTALLED UNKN
024 " DIA CIR PLASTIC
0060/0402 LEN=0045 INSTALLED UNKN
018 " DIA CIRC METAL
0060/0185 LEN=0040 INSTALLED UNKN
013787 FT 2 0 02223 0 00 0025+65
0060/0000 LENGTH(AH 2907 BK 2583)

016694 FT

013787 FT

DIR: B TOTAL LEN: 4.942 MI. DIST: 11-1 SR: 1020
 LEFT MUN: WEST DEER T RIGHT MUN: WEST DEER T

Address / Description	Segment ID	Length	Material / Notes
GREENTREE LN (PRDR)	0050/2421	0050/2498	018" DIA CIRC METAL INSTALLED UNKN
DEER SPRING LN (PRDR)	0050/1695	0050/0913	018" DIA CIRC METAL INSTALLED UNKN
		0050/0657	015" DIA CIRC CONCR INSTALLED UNKN
		0050/0034	015" DIA CIRC CONCR INSTALLED UNKN
2 0 02223 0 00 0000+00 011204 FT GIBSONIA RD (SR0910 SEG 0290/1615)	0050/0000	011204 FT	NC CAMPBELL RD GIBSONIA RD (SR0910 SEG 0290/1615) MFC BEGIN = E
	011204 FT	7044/0000	LTH AH 000100 BK 000100
		INTER-AHD	GIBSONIA RD (SR0910 SEG 0310/0000)
		0040/3667	GIBSONIA RD (SR0910 SEG 0310/0000)
		0040/3621	036" DIA CIRC CONCR INSTALLED UNKN
		0040/3502	018" DIA CIRC CONCR INSTALLED UNKN
		0040/1422	024" DIA CIRC CONCR INSTALLED UNKN
REBECCA RESIDENCE DR (PRDR)	0040/1242	0040/0278	PALOMINO DR (PRDR)
		0040/0227	018" DIA CIRC CONCR INSTALLED UNKN
007537 FT		007537 FT	2 0 02132 0 00 0075+33
		0040/0000	LENGTH(AH 3667 BK 3706)
		0030/3449	018" DIA CIRC CONCR INSTALLED UNKN
			018" DIA CIRC CONCR

DIR: B TOTAL LEN: 4.942 MI. DIST: 11-1 SR: 1020
 LEFT MUN: WEST DEER T RIGHT MUN: WEST DEER T

RITZ LN
(PRDR)

0030/1664

MARTIN RD
(T678)

0030/0930

003831 FT

0030/3160	LEN=0040	INSTALLED UNKN
	018 "DIA	CIRC CONCR
0030/2918	LEN=0040	INSTALLED UNKN
	018 "DIA	CIRC CONCR
0030/2518	LEN=0040	INSTALLED UNKN
	CEDAR RIDGE ET	
	(T261)	
0030/2085	018 "DIA	CIRC CONCR
0030/2035	LEN=0040	INSTALLED UNKN
	024 "DIA	CIR PLASTIC
0030/1500	LEN=0001	INSTALLED UNKN
	024 "DIA	CIR PLASTIC
0030/1107	LEN=0099	INSTALLED UNKN
	024 "DIA	CIR PLASTIC
0030/0896	LEN=0040	INSTALLED 2006
	CEDAR GLEN DR	
	(TWP)	
0030/0755	012 "DIA	CIR PLASTIC
0030/0733	LEN=0040	INSTALLED UNKN
	2 0 02132 0 00	0038+16
	LENGTH(AH 3706 BK 2052)	
	TREMONT DR	
	(TWP)	
	018 "DIA	CIRC CONCR
0020/0582	LEN=0006	INSTALLED UNKN
	SPRING VALLEY DR	
	(TWP)	
0020/0345	2 0 02132 0 00	0017+64
001779 FT	WEST DEER	
	HAMPTON T	
	LENGTH(AH 2052 BK 1779)	
	MEADOW CREST DR	
	(TWP)	
0010/0969	036 "DIA	CIR PLASTIC
	LEN=0030	INSTALLED UNKN
	APPLE RIDGE DR	
	(TWP)	
	NC CEDAR RIDGE RD	
	MIDDLE RD	
	(CNTY)	
	MFC BEGIN = D	
	LENGTH(AH 1779 BK 0000)	

2 0 02132 0 00 0000+00 000000 FT
 MIDDLE RD
 (CNTY) 0010/0000

EXTRACT DATE: 12/21/2020 ROADWAY MANAGEMENT SYSTEM PAGE NUMBER: 594
 PRINT DATE: 12/23/2020 SLD COUNTY/SR - ANNUAL PRINT COUNTY: ALLEGHENY
 DIR: B TOTAL LEN: 9.009 MI. DIST: 11-1 SR: 1019
 LEFT MUN: EAST DEER T RIGHT MUN: EAST DEER T

046962 FT

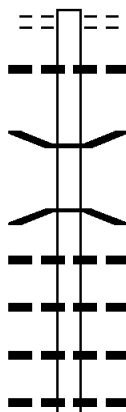

046962 FT BAILEYS RUN RD
 0220/3677 (CNTY)
 0220/3577 018 " DIA CIRC METAL
 LEN=0035 INSTALLED UNKN
 0220/2412 BMS EN 02/1019/0220/2386
 2 0 02154 0 00 0025+25
 DAYS RUN
 0220/2386 BMSBG 02/1019/0220/2386
 018 " DIA CIRC METAL
 0220/2313 LEN=0030 INSTALLED UNKN
 018 " DIA CIR PLASTIC
 0220/2217 LEN=0038 INSTALLED 2019
 018 " DIA CIRC CONCR
 0220/1870 LEN=0040 INSTALLED UNKN
 036 " DIA CIRC CONCR
 0220/1550 LEN=0040 INSTALLED UNKN

EXTRACT DATE: 12/21/2020
PRINT DATE: 12/23/2020

ROADWAY MANAGEMENT SYSTEM
SLD COUNTY/SR - ANNUAL PRINT

PAGE NUMBER: 593
COUNTY: ALLEGHENY

DIR: B TOTAL LEN: 9.009 MI.
LEFT MUN: EAST DEER T

DIST: 11-1 SR: 1019
RIGHT MUN: EAST DEER T

Stationing	Structure	Material	Length	Notes
0220/1445		01B " DIA CIRC CONCR	LEN=0035	INSTALLED UNKN
0220/1198		BMSSEN 02/1019/0220/1167	2 0 02154 0 00 0025+25	DAYS RUN
0220/1167		BMSBG 02/1019/0220/1167		
0220/1130		01B " DIA CIRC CONCR	LEN=0030	INSTALLED UNKN
0220/0656		01B " DIA CIRC CONCR	LEN=0030	INSTALLED UNKN
0220/0532		01B " DIA CIRC CONCR	LEN=0099	INSTALLED UNKN
0220/0029		BMSSEN 02/1019/0220/0000	2 0 02154 0 00 0036+94	DAYS RUN RD
043285 FT		NC DA		
		* REF-BK		
043285 FT		BMSBG 02/1019/0220/0000	LENGTH(AH 4280 BK 0167)	
043285 FT		7210/0000	LENGTH(AH 0167 BK 0564)	
043285 FT		043285 FT		
		* REF-AHD		
043268 FT		0206/0017	LENGTH(AH 0564 BK 0017)	
		* REF-BK		
043268 FT		BMSBG 02/1019/0206/0000	LENGTH(AH 0017 BK 2581)	
		* REF-AHD		
043250 FT		0200/0018	LENGTH(AH 2581 BK 0018)	
		* REF-BK		
043250 FT		BMSBG 02/1019/0200/0000	LENGTH(AH 0018 BK 0208)	
043250 FT		7200/0000	LENGTH(AH 0208 BK 2963)	
043250 FT		043250 FT		
043250 FT		7190/0000	LENGTH(AH 2963 BK 2530)	
043250 FT		043250 FT		

DIR: B TOTAL LEN: 9.009 MI. DIST: 11-1 SR: 1019
 LEFT MUN: FRAZER T RIGHT MUN: FRAZER T

Stationing	Length (FT)	Material / Notes
043250	7180/0000	LENGTH(AH 2530 BK 2204)
	043250	FT
	7174/0000	LENGTH(AH 2204 BK 0864)
	* REF-AHD	CREIGHTON HOLLOW RD
	0170/0864	(TWP)
	0170/0503	012 " DIA CIR PLASTIC
		LEN=0045 INSTALLED UNKN
	0170/0494	018 " DIA CIR PLASTIC
	042386	LEN=0040 INSTALLED UNKN
2 0 02154 0 00 0190+39	042386	FT
PARK ENT RD		
(PARK)	0170/0000	LENGTH(AH 0864 BK 3480)
	024 " DIA	CIRC CONCR
	0160/3475	LEN=0070 INSTALLED UNKN
	015 " DIA	CIRC METAL
	0160/2964	LEN=0040 INSTALLED UNKN
	018 " DIA	CIRC METAL
	0160/2433	LEN=0040 INSTALLED UNKN
	048 " DIA	CIRC CONCR
	0160/2340	LEN=0060 INSTALLED UNKN
		PARK ENT RD
	0160/2330	(PARK)
	018 " DIA	CIRC CONCR
	0160/2027	LEN=0040 INSTALLED UNKN
	024 " DIA	CIRC CONCR
	0160/1772	LEN=0040 INSTALLED UNKN
		PARK ENT RD
	0160/1000	(PARK)
	018 " DIA	CIRC CONCR
	0160/0969	LEN=0050 INSTALLED UNKN
	018 " DIA	CIRC CONCR
	0160/0705	LEN=0040 INSTALLED UNKN
	018 " DIA	CIRC CONCR
	0160/0174	LEN=0040 INSTALLED UNKN
	2 0 02154 0 00 0224+87	FT
	038906	FT
		FRAZER
		WEST DEER T
	0160/0000	LENGTH(AH 3480 BK 1226)
		PARK ENT
	0150/0595	(PARK)
		PARK ENT
	0150/0495	(PARK)
		060 " DIA CIRC CONCR
	0150/0289	LEN=0035 INSTALLED UNKN
		NC CR REIGHTON HOLLOW RD
		MFC BEGIN = E
2 0 02154 0 00 0237+54	037680	FT
CREIGHTON-RUSSELLTON RD		
(SR1026 SEG 0030/0787)	0150/0000	LENGTH(AH 1226 BK 2046)

DIR: B TOTAL LEN: 9.009 MI. DIST: 11-1 SR: 1019
 LEFT MUN: WEST DEER T RIGHT MUN: WEST DEER T

035634 FT

032630 FT

ROCKPOINTE
(PRDR)

0120/0990

029737 FT

0140/1419	018 "DIA	CIRC CONCR	LEN=0040	INSTALLED UNKN
0140/0815	018 "DIA	CIRC CONCR	LEN=0050	INSTALLED UNKN
0140/0198	018 "DIA	CIRC CONCR	LEN=0060	INSTALLED UNKN
035634 FT	2 0 02325	0 00 0030+04		
0140/0000	LENGTH(AH	2046 BK 3004)		
0130/2851	018 "DIA	CIRC CONCR	LEN=0050	INSTALLED UNKN
0130/2179	018 "DIA	CIRC CONCR	LEN=0055	INSTALLED UNKN
0130/1804	018 "DIA	CIRC CONCR	LEN=0050	INSTALLED UNKN
0130/1325	018 "DIA	CIRC CONCR	LEN=0070	INSTALLED UNKN
0130/1072	018 "DIA	CIRC CONCR	LEN=0060	INSTALLED UNKN
0130/0826	018 "DIA	CIRC CONCR	LEN=0080	INSTALLED UNKN
0130/0581	018 "DIA	CIRC CONCR	LEN=0070	INSTALLED UNKN
0130/0312	018 "DIA	CIRC CONCR	LEN=0060	INSTALLED UNKN
0130/0030	018 "DIA	CIRC CONCR	LEN=0050	INSTALLED UNKN
032630 FT	2 0 02325	0 00 0000+00		
	NC CR	REIGHTON RUN RD		
		BAILEYS RUN RD		
		(CNTY)		
0130/0000	LENGTH(AH	3004 BK 2893)		
0120/1366	018 "DIA	CIRC CONCR	LEN=0030	INSTALLED UNKN
0120/1145	018 "DIA	CIR UNKNOWN	LEN=0099	INSTALLED UNKN
0120/0840	018 "DIA	CIRC CONCR	LEN=0099	INSTALLED UNKN
0120/0186	018 "DIA	CIRC METAL	LEN=0060	INSTALLED UNKN
029737 FT	2 0 02171	0 00 0287+90		

EXTRACT DATE: 12/21/2020
PRINT DATE: 12/23/2020

ROADWAY MANAGEMENT SYSTEM
SLD COUNTY/SR - ANNUAL PRINT

PAGE NUMBER: 590
COUNTY: ALLEGHENY

DIR: B TOTAL LEN: 9.009 MI.
LEFT MUN: WEST DEER T

DIST: 11-1 SR: 1019
RIGHT MUN: WEST DEER T

Stationing	Segment	Length	Material	Notes
0120/0000				WEST DEER FRAZER T
0110/2097				LENGTH(AH 2893 BK 2238) 018" DIA CIRC CONCR
0110/1685				LEN=0040 INSTALLED UNKN 018" DIA CIRC CONCR
0110/1360				LEN=0050 INSTALLED UNKN GRACE LN (PRDR)
0110/1235				018" DIA CIRC CONCR
0110/0829				LEN=0060 INSTALLED UNKN 018" DIA CIRC CONCR
0110/0331				LEN=0060 INSTALLED UNKN 018" DIA CIRC CONCR
0110/0110				LEN=0030 INSTALLED UNKN LC TO/FR CRAWFORD RUN R (CONN)
027499 FT				CRAWFORD RUN RD (TBK) (CNTY)
0110/0000				LENGTH(AH 2238 BK 1466) 018" DIA CIRC CONCR
0104/1143				LEN=0060 INSTALLED UNKN
026033 FT				
0104/0000				LENGTH(AH 1466 BK 2575) 018" DIA CIRC METAL
0100/2185				LEN=0030 INSTALLED UNKN 018" DIA CIRC CONCR
0100/1793				LEN=0030 INSTALLED UNKN 018" DIA CIRC METAL
0100/1380				LEN=0040 INSTALLED UNKN 015" DIA CIRC CONCR
0100/0930				LEN=0030 INSTALLED UNKN
023458 FT				
0100/0000				LENGTH(AH 2575 BK 3660) 018" DIA CIR PLASTIC
0090/2902				LEN=0035 INSTALLED UNKN 018" DIA CIRC CONCR
0090/2870				LEN=0030 INSTALLED UNKN
0090/2106				018" DIA CIRC CONCR LEN=0035 INSTALLED UNKN
0090/1830				CLARKS PIKE RD

DIR: B TOTAL LEN: 9.009 MI. DIST: 11-1 SR: 1019
 LEFT MUN: FRAZER T RIGHT MUN: FRAZER T

2 0 02171 0 00 0188+70 019798 FT
 YUTES RUN RD
 (T702) 0090/0000

PEACHTREE LN
 (TWP) 0070/1551

016975 FT

013860 FT

==	0090/1778	(T607)			
---	0090/1776	018 " DIA	CIRC METAL		
		LEN=0030	INSTALLED	UNKN	
---	0090/0781	018 " DIA	CIRC CONCR		
		LEN=0030	INSTALLED	UNKN	
---	0090/0511	018 " DIA	CIRC CONCR		
	019798 FT	LEN=0030	INSTALLED	UNKN	
==	5 0090/0000	LENGTH(AH 3660 BK 2823)			
---	0080/2765	018 " DIA	CIRC CONCR		
		LEN=0099	INSTALLED	UNKN	
---	0080/2250	017 " DIA	CIRC CONCR		
		LEN=0030	INSTALLED	UNKN	
		BARTRAM LN			
==	0080/2025	(PRDR)			
---	0080/1912	018 " DIA	CIRC CONCR		
		LEN=0030	INSTALLED	UNKN	
---	0080/0998	018 " DIA	CIR PLASTIC		
		LEN=0030	INSTALLED	UNKN	
	016975 FT	2 0 02171 0 00 0159+85			
==	5 0080/0000	LENGTH(AH 2823 BK 3115)			
---	0070/3046	018 " DIA	CIRC CONCR		
		LEN=0040	INSTALLED	UNKN	
		FRAZER #2 LN			
==	0070/2873	(TWP)			
---	0070/1457	018 " DIA	CIRC CONCR		
		LEN=0099	INSTALLED	UNKN	
---	0070/1197	024 " DIA	CIRC CONCR		
		LEN=0040	INSTALLED	UNKN	
---	0070/0303	015 " DIA	CIRC METAL		
		LEN=0040	INSTALLED	UNKN	
		DIVISION RD			
==	0070/0243	(TWP)			
	013860 FT	2 0 02171 0 00 0128+70			
==	5 0070/0000	LENGTH(AH 3115 BK 0921)			
---	0060/0606	018 " DIA	CIRC CONCR		
		LEN=0030	INSTALLED	UNKN	

DIR: B TOTAL LEN: 9.009 MI. DIST: 11-1 SR: 1019
 LEFT MUN: FRAZER T RIGHT MUN: FRAZER T

TAWNEY RUN RD
 (SR1014 SEG 0060/2118) 0060/0000

012939 FT

011633 FT

009182 FT

0060/0564	BMS EN 02/1019/0060/0149
	2 0 0 2171 0 00 0120+99
	1037,409+42
0060/0149	BMSBG 02/1019/0060/0149
	018 " DIA CIRC METAL
0060/0134	LEN=0030 INSTALLED UNKN
	018 " DIA CIRC METAL
0060/0038	LEN=0072 INSTALLED UNKN
012939 FT	2 0 0 2171 0 00 0120+32
	NC BU
	UTLER LOGAN RD
	MURRAY HILL RD
	(SR1021 SEG 0050/0869)
	MFC BEGIN = D
0060/0000	LENGTH(AH 0921 BK 1306)
	018 " DIA CIRC CONCR
0050/1258	LEN=0030 INSTALLED UNKN
	018 " DIA CIRC CONCR
0050/1029	LEN=0030 INSTALLED UNKN
	018 " DIA CIRC CONCR
0050/0725	LEN=0078 INSTALLED UNKN
	018 " DIA CIRC METAL
0050/0464	LEN=0099 INSTALLED UNKN
011633 FT	2 0 0 2257 0 00 0122+79
0050/0000	LENGTH(AH 1306 BK 2451)
	018 " DIA CIR PLASTIC
0040/2340	LEN=0040 INSTALLED UNKN
	018 " DIA CIR PLASTIC
0040/2031	LEN=0040 INSTALLED UNKN
	018 " DIA CIRC METAL
0040/1100	LEN=0040 INSTALLED UNKN
	018 " DIA CIR PLASTIC
0040/0230	LEN=0050 INSTALLED UNKN
009182 FT	2 0 0 2257 0 00 0098+28
0040/0000	LENGTH(AH 2451 BK 2906)
	FRAZER
0030/2877	SPRINGDALE T
	KERR RD
	(TWP)
0030/2220	018 " DIA CIR PLASTIC
0030/1977	LEN=0099 INSTALLED UNKN
	024 " DIA CIR PLASTIC
0030/1625	LEN=0035 INSTALLED UNKN
	018 " DIA CIRC CONCR
0030/0726	LEN=0099 INSTALLED UNKN

DIR: B TOTAL LEN: 9.009 MI. DIST: 11-1 SR: 1019
 LEFT MUN: SPRINGDALE T RIGHT MUN: SPRINGDALE T

Stationing	Description	Material / Notes
2 0 02257 0 00 0069+32 006276 FT	SHRADER ST (TWP)	0030/0000 LENGTH(AH 2906 BK 3500)
		060 " DIA CIRC CONCR LEN=0035 INSTALLED UNKN
		018 " DIA CIR PLASTIC LEN=0038 INSTALLED 2018
BUCKNELL DR (TWP)	0020/1920	
RACHEL ST (TWP)	0020/1470	
SYCAMORE RIDGE DR (TWP)	0020/1135	MELZENA ST (TWP)
WILLIAMS ST (TWP)	0020/0760	
COLFAX ST (TWP)	0020/0545	024 " DIA CIRC METAL LEN=0030 INSTALLED UNKN
	002776 FT	NC BUTLER RD 018 " DIA CIRC METAL LEN=0040 INSTALLED 1997
		2 0 02257 0 00 0034+32 NC HENDERSON DR STANLEY AV (TWP)
		0020/0000 LENGTH(AH 3500 BK 2776)
		0010/2518 SPRINGDALE B
MARION AV (TWP)	0010/1685	
SCHOOL ST (TWP)	0010/1550	
HIGHLAND ST (BORO)	0010/1210	
ORCHARD ST (BORO)	0010/0620	018 " DIA CIRC CONCR LEN=0099 INSTALLED UNKN
		018 " DIA CIR PLASTIC LEN=0035 INSTALLED UNKN
2 0 02257 0 00 0006+94 000000 FT	WILLOW ST (BORO)	0010/0000
		NC BUTLER ST (TBK) MFC BEGIN = E
		0010/0000 LENGTH(AH 2776 BK 0000)

EXTRACT DATE: 12/21/2020 ROADWAY MANAGEMENT SYSTEM PAGE NUMBER: 586
 PRINT DATE: 12/23/2020 SLD COUNTY/SR - ANNUAL PRINT COUNTY: ALLEGHENY
 DIR: B TOTAL LEN: .047 MI. DIST: 11-1 SR: 1018
 LEFT MUN: OHARA T RIGHT MUN: OHARA T

000250 FT
 000000 FT

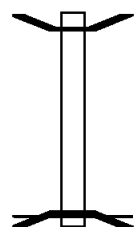

000250 FT BMS EN 02/1018/0010/0000
 * REF-AHD ALPHA DR
 0010/0250 (TWP)
 000000 FT 0 0 00000 0 00 0000+00
 NC ALPHA DR
 * REF-BK ALPHA DR
 (TWP)
 SR 0028 NB
 BMSBG 02/1018/0010/0000
 MFC BEGIN = E
 0010/0000 LENGTH(AH 0250 BK 0000)

DIR: B TOTAL LEN: 1.405 MI. DIST: 11-1 SR: 1017
 LEFT MUN: SPRINGDALE T RIGHT MUN: SPRINGDALE T

Stationing	Description	Material / Details
007421 FT	INTER-AHD	YUTES RUN RD (T702)
0030/1820		018 "DIA CIRC CONCR
0030/1497		LEN=0040 INSTALLED 2002
0030/1294		018 "DIA CIRC CONCR
0030/1109		LEN=0030 INSTALLED UNKN
		018 "DIA CIRC CONCR
		LEN=0065 INSTALLED UNKN
0030/1080		018 "DIA CIRC CONCR
		LEN=0040 INSTALLED 2002
		018 "DIA CIRC METAL
		LEN=0060 INSTALLED UNKN
		018 "DIA CIRC METAL
		LEN=0055 INSTALLED UNKN
0030/0731		SR 0028 SB
0030/0208	OP ID 02/0028/0311/1744	SR 0028 NB
0030/0141	OP ID 02/0028/0310/1477	
005601 FT	2 0 02169 0 00 0049+45	TAWNEY RUN RD
	(SR1014 SEG 0040/0000)	
	NC YU	TES RUN RD
	MFC BEGIN = E	
0030/0000	LTH AH 001820 BK 000100	
005601 FT		
7024/0000	LTH AH 000100 BK 002705	
INTER-AHD	HITE RD	
0020/2705	(SR1014 SEG 0030/0365)	
	ISOBEL ST	
0020/2330	(TWP)	
0020/2255		
		024 "DIA CIRC METAL
		LEN=0064 INSTALLED UNKN
		PLATE DR
		(TWP)

HIGH ST
(TWP)

HITE RD
(SR1014 SEG 0030/0365)

SCHOOL ST
(TWP)

LOW GRADE RD

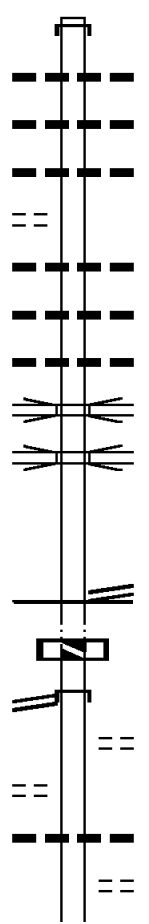

DIR: B TOTAL LEN: 1.405 MI. DIST: 11-1 SR: 1017
 LEFT MUN: SPRINGDALE T RIGHT MUN: SPRINGDALE T

(TWP)

0020/2010

==

==

==

==

==

==

==

==

==

==

==

==

==

==

==

==

==

==

0020/1956 THOMPSON RUN RD
 (TWP)
 015 " DIA CIRC CONCR
 0020/1930 LEN=0040 INSTALLED UNKN
 ORCHARD ST
 (TWP)
 0020/1595 CAMBRIDGE MANOR RD
 (TWP)

CENTER ST
 (TWP)
 SPRINGWOOD SQ
 (PRDR)
 MAPLE ST
 (TWP)

0020/1095

0020/0735

0020/0530

002896 FT

0020/0240 MCKINLEY AV
 (TWP)
 2 0 02169 0 00 0029+17
 PARKWAY DR
 (TWP)

5 0020/0000 SPRINGDALE
 CHESWICK B
 LENGTH(AH 2705 BK 2896)
 001 " DIA CIRC CONCR
 0010/2517 LEN=0001 INSTALLED UNKN
 015 " DIA CIRC CONCR
 0010/2338 LEN=0020 INSTALLED UNKN
 015 " DIA CIRC CONCR
 0010/2335 LEN=0020 INSTALLED UNKN
 FAIRMONT ST
 (BORO)
 0010/2115 015 " DIA CIRC CONCR
 0010/1948 LEN=0030 INSTALLED UNKN
 015 " DIA CIRC CONCR
 0010/1788 LEN=0030 INSTALLED UNKN
 LINDEN ET
 (BORO)
 0010/1745 015 " DIA CIRC CONCR
 0010/1454 LEN=0030 INSTALLED UNKN
 001 " DIA CIRC CONCR
 0010/1205 LEN=0112 INSTALLED UNKN
 015 " DIA CIRC CONCR
 0010/1069 LEN=0020 INSTALLED 2002
 SPRUCE ST
 (BORO)
 0010/0515 2 0 02169 0 00 0000+00
 000000 FT
 NC P I LLOW AV
 PITTSBURGH ST
 (SR1001 SEG 0260/0950)

000000 FT

5 0010/0000 MFC BEGIN = C
 LENGTH(AH 2896 BK 0000)

DIR: B TOTAL LEN: 2.698 MI. DIST: 11-1 SR: 1016
 LEFT MUN: FRAZER T RIGHT MUN: FRAZER T

014247 FT
 014247 FT
 014247 FT
 014247 FT

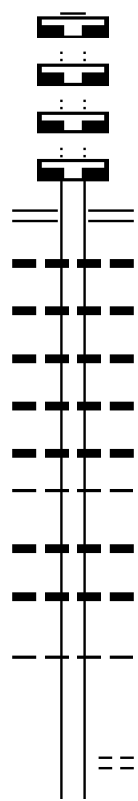

014247 FT
 7160/0000 LENGTH(AH 0636 BK 3111)
 014247 FT
 7150/0000 LENGTH(AH 3111 BK 3677)
 014247 FT
 7140/0000 LENGTH(AH 3677 BK 3493)
 014247 FT
 7130/0000 LENGTH(AH 3493 BK 3773)
 BUTLER LOGAN RD
 (SR1019 SEG 0104/0000)
 0110/3773 018 " DIA CIR PLASTIC
 LEN=0048 INSTALLED UNKN
 0110/3294 024 " DIA CIRC METAL
 LEN=0048 INSTALLED UNKN
 0110/2720 018 " DIA CIRC CONCR
 LEN=0048 INSTALLED UNKN
 0110/2519 018 " DIA CIRC METAL
 LEN=0040 INSTALLED UNKN
 0110/2068 018 " DIA CIRC METAL
 LEN=0040 INSTALLED UNKN
 0110/1766 018 " DIA CIR PLASTIC
 LEN=0040 INSTALLED UNKN
 0110/1533 024 " DIA CIRC CONCR
 LEN=0040 INSTALLED UNKN
 0110/1335 018 " DIA CIR PLASTIC
 LEN=0040 INSTALLED UNKN
 0110/0877 024 " DIA CIRC CONCR
 LEN=0040 INSTALLED UNKN
 0110/0133 FRAZER
 INDIANA T
 010474 FT 2 0 02156 0 00 0037+67
 BAJACK LN
 (PRDR)
 0110/0000 LENGTH(AH 3773 BK 3737)
 018 " DIA CIR PLASTIC

FRAZER
 INDIANA T

0110/1533

010474 FT

DIR: B TOTAL LEN: 2.698 MI. DIST: 11-1 SR: 1016
 LEFT MUN: INDIANA T RIGHT MUN: INDIANA T

Stationing	Length	Material	Notes
0100/3409	LEN=0032	018 "DIA CIR PLASTIC	INSTALLED UNKN
0100/3029	LEN=0032	018 "DIA CIR PLASTIC	INSTALLED UNKN
0100/2644	LEN=0032	018 "DIA CIR PLASTIC	INSTALLED UNKN
0100/2348	LEN=0032	018 "DIA CIR PLASTIC	INSTALLED UNKN
0100/2045	LEN=0032	018 "DIA CIRC CONCR	INSTALLED UNKN
0100/1534	LEN=0032	024 "DIA CIR PLASTIC	INSTALLED UNKN
0100/1124	LEN=0040	018 "DIA CIRC CONCR	INSTALLED UNKN
0100/0984	LEN=0040	018 "DIA CIRC CONCR	INSTALLED UNKN
0100/0536	LEN=0040	018 "DIA CIRC CONCR	INSTALLED UNKN
006737 FT	2 0 02156	0 00 0074+66	
0100/0000	LENGTH(AH 3737 BK 1255)	018 "DIA CIR PLASTIC	
0090/0821	LEN=0040	018 "DIA CIRC CONCR	INSTALLED UNKN
005482 FT	2 0 02156	0 00 0087+57	
0090/0000	LENGTH(AH 1255 BK 2792)	KISSICK LN (PRDR)	
0080/2140		NC LOG CABIN RD LITTLE DEER CREEK RD (SR1015 SEG 0060/0000)	
0080/2015	BMS EN 02/1016/0080/1980	2 0 02156 0 00 0095+93	
0080/1980	BMS BG 02/1016/0080/1980	P3 LITTLE DEER	
0080/1700	OVERPASS IS RR X-ING	BESSEMER AND LAKE ERIE	
0080/1359	LEN=0040	018 "DIA CIRC CONCR	INSTALLED UNKN
0080/1050		HARBARGER LN (PRDR)	
0080/0690		CHALLENGE LN (PRDR)	
0080/0490	LEN=0040	018 "DIA CIRC CONCR	INSTALLED 2015
0080/0091	LEN=0048	024 "DIA CIRC CONCR	INSTALLED UNKN

EXTRACT DATE: 12/21/2020
PRINT DATE: 12/23/2020

ROADWAY MANAGEMENT SYSTEM
SLD COUNTY/SR - ANNUAL PRINT

PAGE NUMBER: 581
COUNTY: ALLEGHENY

DIR: B TOTAL LEN: 2.698 MI.
LEFT MUN: INDIANA T

DIST: 11-1 SR: 1016
RIGHT MUN: INDIANA T

LEFEVER HILL RD
(SR1025 SEG 0010/0000)

002690 FT

000733 FT

000177 FT

000660/0000

000177 FT

000177 FT

000154 FT

000154 FT

000154 FT

000154 FT

000000 FT

000000 FT

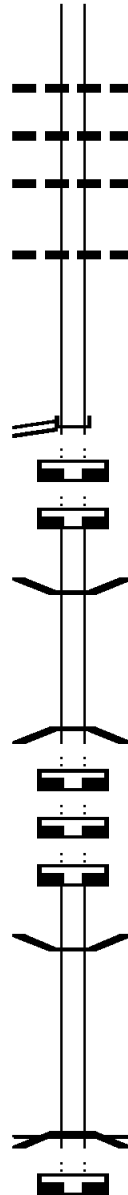

002690 FT 2 0 02156 0 00 0115+00
[S] 0080/0000 LENGTH(AH 2792 BK 1957)
0070/1389 01B "DIA CIRC CONCR
LEN=0040 INSTALLED UNKN
0070/1336 01B "DIA CIRC CONCR
LEN=0040 INSTALLED UNKN
0070/1058 01B "DIA CIRC CONCR
LEN=0040 INSTALLED UNKN
01B "DIA CIRC CONCR
0070/0177 LEN=0040 INSTALLED UNKN
000733 FT 2 0 02156 0 00 0135+52
[S] 0070/0000 LENGTH(AH 1957 BK 0556)
000177 FT 2 0 02156 0 00 0140+86
NC LEFEVER HILL RD
INTER-BK RICH HILL RD (TBK)
(TWP)
[S] 0060/0000 LENGTH(AH 0556 BK 1940)
000177 FT
7050/0000 LENGTH(AH 1940 BK 2727)
000177 FT
7040/0000 LENGTH(AH 2727 BK 0023)
BMSBN 02/1016/0032/0000
* REF-AHD COVE RUN RD (TBK)
(TWP)
000154 FT 2 0 02110 0 00 0087+55
* REF-BK COVE RUN RD (TBK)
(TWP)
LONG RUN
BMSBG 02/1016/0032/0000
[S] 0032/0000 LENGTH(AH 0023 BK 3292)
000154 FT
7030/0000 LENGTH(AH 3292 BK 2849)
000154 FT
7020/0000 LENGTH(AH 2849 BK 0579)
000154 FT
7014/0000 LENGTH(AH 0579 BK 0154)
BMSBN 02/1016/0010/0000
* REF-AHD COVE RUN RD (TBK)
(TWP)
000000 FT 2 0 02110 0 00 0019+30
NC COVE RUN RD
* REF-BK COVE RUN RD (TBK)
(TWP)
DEER CREEK
BMSBG 02/1016/0010/0000
MFC BEGIN = E
[S] 0010/0000 LENGTH(AH 0154 BK 1952)
000000 FT
7010/0000 LENGTH(AH 1952 BK 0000)

EXTRACT DATE: 12/21/2020 ROADWAY MANAGEMENT SYSTEM PAGE NUMBER: 580
 PRINT DATE: 12/23/2020 SLD COUNTY/SR - ANNUAL PRINT COUNTY: ALLEGHENY
 DIR: B TOTAL LEN: 8.348 MI. DIST: 11-1 SR: 1015
 LEFT MUN: WEST DEER T RIGHT MUN: WEST DEER T

044075 FT

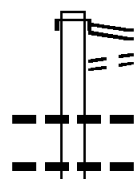

044075 FT
 INTER-AHD BAKERSTOWN RD
 (SR1028 SEG 0140/0000)
 BAKERSTOWN RD
 0160/3282 (SR1028 SEG 0140/0000)
 FOR SR 1015 AND 1028
 0160/3135 (CONN)
 015 " DIA CIRC CONCR
 0160/2929 LEN=0040 INSTALLED UNKN
 018 " DIA CIR PLASTIC
 0160/2457 LEN=0030 INSTALLED UNKN

DIR: B TOTAL LEN: 8.348 MI. DIST: 11-1 SR: 1015
 LEFT MUN: WEST DEER T RIGHT MUN: WEST DEER T

---	---	0160/2091	018 " DIA	CIRC CONCR
---	---		LEN=0040	INSTALLED UNKN
---	---	0160/1953	018 " DIA	CIRC METAL
---	---		LEN=0050	INSTALLED UNKN
---	---	0160/1691	018 " DIA	CIRC CONCR
---	---		LEN=0050	INSTALLED UNKN
---	---	0160/1085	024 " DIA	CIRC METAL
---	---		LEN=0055	INSTALLED UNKN
---	---	0160/0354	018 " DIA	CIR PLASTIC
---	---		LEN=0040	INSTALLED UNKN
---	---	040793 FT	2 0 02307	0 01 0409+95
---	---	0160/0000	LENGTH(AH	3282 BK 3335)
---	---		018 " DIA	CIRC METAL
---	---	0150/3092	LEN=0050	INSTALLED UNKN
---	---		001 " DIA	CIRC CONCR
---	---	0150/2523	LEN=0070	INSTALLED UNKN
---	---		015 " DIA	CIRC OTHER
---	---	0150/2055	LEN=0045	INSTALLED UNKN
---	---	0150/1247	018 " DIA	CIRC CONCR
---	---		LEN=0035	INSTALLED 2002
---	---	0150/0741	024 " DIA	CIRC CONCR
---	---		LEN=0045	INSTALLED UNKN
---	---	0150/0217	015 " DIA	CIRC CONCR
---	---	037458 FT	LEN=0030	INSTALLED UNKN
---	---	0150/0000	LENGTH(AH	3335 BK 3393)
---	---		015 " DIA	CIR PLASTIC
---	---	0140/2947	LEN=0600	INSTALLED UNKN
---	---		018 " DIA	CIRC METAL
---	---	0140/2748	LEN=0030	INSTALLED UNKN
---	---		015 " DIA	CIR PLASTIC
---	---	0140/2324	LEN=0035	INSTALLED UNKN
---	---		018 " DIA	CIR PLASTIC
---	---	0140/1865	LEN=0040	INSTALLED UNKN
---	---	0140/0925	018 "H 00 "W	MULT PLSTIC
---	---		LEN=0040	INSTALLED UNKN
---	---	0140/0635	018 " DIA	CIRC CONCR
---	---		LEN=0040	INSTALLED UNKN
---	---	0140/0620	SUPERIOR RD	(TWP)
---	---	034065 FT	2 0 02307	0 01 0342+24
---	---		FAWN ST	(TWP)

040793 FT

2 0 02307 0 01 0376+60 037458 FT
 BENJAMIN ST
 (TWP)

034065 FT

EXTRACT DATE: 12/21/2020
PRINT DATE: 12/23/2020

ROADWAY MANAGEMENT SYSTEM
SLD COUNTY/SR - ANNUAL PRINT

PAGE NUMBER: 577
COUNTY: ALLEGHENY

DIR: B TOTAL LEN: 8.348 MI.
LEFT MUN: WEST DEER T

DIST: 11-1 SR: 1015
RIGHT MUN: WEST DEER T

MICHAEL RD
(T026)

0120/0134
028279 FT

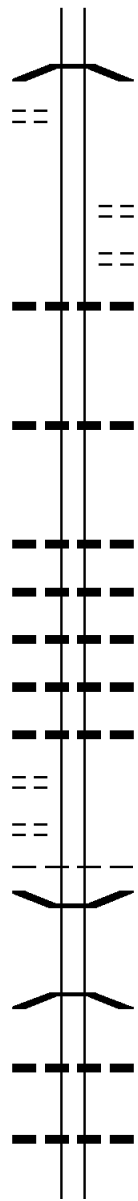

0 0 00000 0 00 0000+00
CREEK
0120/0138 BMSBG 02/1015/0120/0138

028279 FT 2 0 02307 0 01 0284+76
SCHOOL ST

5 0120/0000 LENGTH(AH 3064 BK 2421)
CEDARWOOD CR

0110/2172 (TWP)
0110/2026 018 "DIA CIRC METAL
LEN=0020 INSTALLED UNKN

0110/0766 018 "DIA CIRC CONCR
LEN=0060 INSTALLED UNKN

025858 FT

5 0110/0000 025858 FT 2 0 02307 0 01 0260+53
LENGTH(AH 2421 BK 2381)

0100/2202 024 "DIA CIR PLASTIC
LEN=0065 INSTALLED UNKN

0100/1931 015 "DIA CIRC CONCR
LEN=0035 INSTALLED UNKN

0100/1636 015 "DIA CIRC CONCR
LEN=0040 INSTALLED UNKN

0100/1191 015 "DIA CIRC CONCR
LEN=0035 INSTALLED UNKN

0100/0857 018 "DIA CIRC METAL
LEN=0080 INSTALLED UNKN

MCARTHUR DR
(TWP)
SIXTH WY
(TWP)

0100/0832

0100/0627

023477 FT

0100/0043 WEST DEER
INDIANA T

0100/0011 BMSEN 02/1015/0100/0038
023477 FT 2 0 02307 0 01 0236+39

5 0100/0000 CREEK
BMSBG 02/1015/0100/0038
LENGTH(AH 2381 BK 2493)

0090/1761 015 "DIA CIRC CONCR
LEN=0025 INSTALLED UNKN

0090/1134 015 "DIA CIRC CONCR
LEN=0065 INSTALLED UNKN

015 "DIA CIRC CONCR

EXTRACT DATE: 12/21/2020
PRINT DATE: 12/23/2020

ROADWAY MANAGEMENT SYSTEM
SLD COUNTY/SR - ANNUAL PRINT

PAGE NUMBER: 575
COUNTY: ALLEGHENY

DIR: B TOTAL LEN: 8.348 MI.
LEFT MUN: INDIANA T

DIST: 11-1 SR: 1015
RIGHT MUN: INDIANA T

DUQUESNE LIGHT LN
(PRDR)

0060/3525

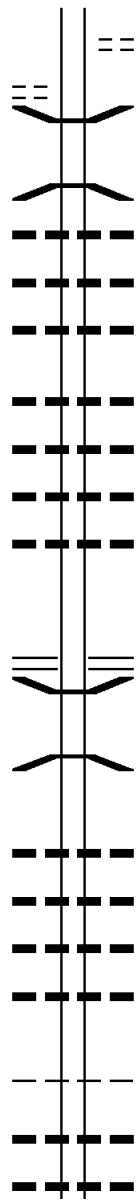

(TWP)
5 0070/0000 LENGTH(AH 3932 BK 3587)
0060/3489 BMS EN 02/1015/0060/3476
0 0 00000 0 00 0000+00
LTLE DR CRK
0060/3476 BMSBG 02/1015/0060/3476
018 " DIA CIR PLASTIC
0060/2970 LEN=0072 INSTALLED UNKN
018 " DIA CIR PLASTIC
0060/2710 LEN=0070 INSTALLED UNKN
018 " DIA CIR PLASTIC
0060/2375 LEN=0070 INSTALLED UNKN
018 " DIA CIR PLASTIC
0060/1675 LEN=0040 INSTALLED 2002
018 " DIA CIRC CONCR
0060/1259 LEN=0030 INSTALLED UNKN
018 " DIA CIRC CONCR
0060/0920 LEN=0006 INSTALLED 2002
012 " DIA CIRC METAL
0060/0353 LEN=0018 INSTALLED 2002
012802 FT 2 0 02307 0 01 0128+93
NC LI TTLE DEER CREEK RD
LOG CABIN RD
(SR1016 SEG 0080/2140)
5 0060/0000 LENGTH(AH 3587 BK 2936)
0050/2743 BMS EN 02/1015/0050/2728
0 0 00000 0 00 0000+00
BR DEER CR
0050/2728 BMSBG 02/1015/0050/2728
018 " DIA CIRC CONCR
0050/1580 LEN=0035 INSTALLED UNKN
030 " DIA CIRC CONCR
0050/1326 LEN=0035 INSTALLED UNKN
024 " DIA CIR PLASTIC
0050/0782 LEN=0040 INSTALLED UNKN
024 " DIA CIRC CONCR
0050/0540 LEN=0040 INSTALLED UNKN
009866 FT 2 0 02307 0 01 0099+57
5 0050/0000 LENGTH(AH 2936 BK 3863)
INDIANA
0040/3666 HARMAR T
015 " DIA CIR PLASTIC
0040/3662 LEN=0040 INSTALLED UNKN
024 " DIA CIRC CONCR
0040/3528 LEN=0040 INSTALLED UNKN

012802 FT

LEFEVER HILL RD
(SR1016 SEG 0080/2140)

0060/0000

009866 FT

DIR: B TOTAL LEN: 8.348 MI. DIST: 11-1 SR: 1015
 LEFT MUN: HARMAR T RIGHT MUN: HARMAR T

Stationing	Description	Material	Length	Notes
0040/3146	012" DIA CIRC CONCR	LEN=1218	INSTALLED UNKN	HIGHLAND WOODS RD
0040/3055	(PRDR)			
0040/1928	024" DIA CIRC CONCR	LEN=0250	INSTALLED UNKN	
0040/1678	024" DIA CIRC CONCR	LEN=0276	INSTALLED UNKN	
0040/1380	012" DIA CIR PLASTIC	LEN=0035	INSTALLED UNKN	
0040/1029	024" DIA CIRC CONCR	LEN=0165	INSTALLED UNKN	
0040/0705	DOMINIC LN			(TWP)
0040/0465	ELEANOR ST			(TWP)
0040/0190	018" DIA CIRC CONCR	LEN=0040	INSTALLED 2002	HITE RD
006003 FT	(SR1014 SEG 0010/0000)			
0040/0000	LENGTH(AH 3863 BK 1767)			
0034/1401	018" DIA CIRC CONCR	LEN=0040	INSTALLED 2002	BECKMAN ST
0034/1360	(TWP)			
0034/1085				
0034/1046	015" DIA CIRC CONCR	LEN=0040	INSTALLED UNKN	
0034/0665				
0034/0245				
004236 FT	0 0 00000 0 00 0000+00			
0034/0000	MFC BEGIN = C			
0030/1358	LENGTH(AH 1767 BK 1845)			
0030/1120	BMS EN 02/1015/0030/1307			
0030/1102	024" DIA CIRC CONCR	LEN=0070	INSTALLED 2002	
	0 0 00000 0 00 0000+00			
	SR 0028 NB			
	BMSBG 02/1015/0030/1307			
0031/0876	018" DIA CIRC CONCR	LEN=0060	INSTALLED UNKN	
0030/0819	018" DIA CIRC CONCR	LEN=0065	INSTALLED UNKN	

2 0 02307 0 01 0060+80 006003 FT
 NIXON RD
 (T859)

HODEL ST
 (T821)

BUSINESS CENTER DR
 (PRDR)
 HARMAR DR
 (T851)

018" DIA CIRC CONCR
 LEN=0060 INSTALLED UNKN 0031/0876

TO 1008/0030 SH

DIR: B TOTAL LEN: 8.348 MI. DIST: 11-1 SR: 1015
 LEFT MUN: HARMAR T RIGHT MUN: HARMAR T

Item	Material	Length	Notes
(CONN)		0031/0630	
018 "DIA	CIRC CONCR		
LEN=0030	INSTALLED UNKN	0031/0617	
018 "DIA	CIRC CONCR		
LEN=0030	INSTALLED UNKN	0031/0610	
018 "DIA	CIRC CONCR		
LEN=0030	INSTALLED UNKN	0031/0369	
018 "DIA	CIRC CONCR		
LEN=0040	INSTALLED UNKN	0031/0053	
0 0 00000	0 00 0000+00	002391 FT	
MFC BEGIN = C			
LENGTH(AH 1845 BK 1218)		0031/0000	
		0030/0565	018 "DIA CIRC CONCR LEN=0030 INSTALLED UNKN
		0030/0560	015 "DIA CIRC CONCR LEN=0040 INSTALLED 2002
		0030/0316	012 "DIA CIR PLASTIC LEN=0040 INSTALLED UNKN GULF LAB RD
		0030/0270	(SR1008 SEG 0030/2184)
		0030/0003	018 "DIA CIRC CONCR LEN=0003 INSTALLED UNKN
		002391 FT	2 0 02307 0 00 0021+39 MFC BEGIN = C
		0030/0000	LENGTH(AH 1845 BK 1218) BESSEMER AND LAKE ERIE OVERPASS IS RR X-ING NC RU SELLTON RD
		0020/0959	015 "DIA CIR PLASTIC LEN=0025 INSTALLED UNKN
		0020/0222	015 "DIA CIRC CONCR LEN=0050 INSTALLED UNKN
001173 FT		001173 FT	2 0 02307 0 00 0011+50
		0020/0000	LENGTH(AH 1218 BK 1173) CENTER AV (T795)
		0010/0710	001 "H 01 "W UNK PLASTIC LEN=0001 INSTALLED UNKN
		0010/0558	001 "DIA CIR UNKNOWN LEN=0001 INSTALLED UNKN
		0010/0546	012 "DIA CIR PLASTIC LEN=0040 INSTALLED UNKN
		0010/0412	LINCOLN AV (T549)
		0010/0170	015 "DIA CIRC METAL LEN=0030 INSTALLED UNKN
000000 FT		000000 FT	2 0 02307 0 00 0000+00 NC PE ARL AV FREEPORT RD (SR1001 SEG 0250/1506) MFC BEGIN = C
		0010/0000	LENGTH(AH 1173 BK 0000)

EXTRACT DATE: 12/21/2020 ROADWAY MANAGEMENT SYSTEM PAGE NUMBER: 572
 PRINT DATE: 12/23/2020 SLD COUNTY/SR - ANNUAL PRINT COUNTY: ALLEGHENY
 DIR: B TOTAL LEN: 2.168 MI. DIST: 11-1 SR: 1014
 LEFT MUN: FRAZER T RIGHT MUN: FRAZER T

011404 FT

011449 FT
 INTER-AHD MURRAY HILL RD
 (SR1021 SEG 0050/0869)
 BUTLER LOGAN RD
 0060/2118 (SR1019 SEG 0060/0000)

009286 FT

009331 FT 2 0 02217 0 00 0048+04
 MFC BEGIN = D
 5 0060/0000 LENGTH(AH 2118 BK 0974)

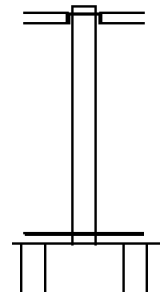

TO SR 1049/0010 SH

DIR: B TOTAL LEN: 2.168 MI. DIST: 11-1 SR: 1014
 LEFT MUN: FRAZER T RIGHT MUN: FRAZER T

(CONN) PITTSBURGH MILLS BL (SR1049 SEG 0010/0000) (SR1049 SEG 0011/0000) FROM SR 1049/0011 SH (CONN) 0 0 00000 0 00 0000+00 MFC BEGIN = D LENGTH(AH 0936 BK 1226)	0055/0802 0055/0627 0055/0518 008350 FT 0055/0000	== == == == =	0054/0627 008357 FT 0054/0000	PITTSBURGH MILLS BL (SR1049 SEG 0011/0000) (SR1049 SEG 0010/0000) 0 0 00000 0 00 0000+00 MFC BEGIN = D LENGTH(AH 0974 BK 1226)
	007124 FT	---	007131 FT	2 0 02217 0 00 0026+91 FRAZER SPRINGDALE T LENGTH(AH 1226 BK 2715)
	004409 FT	---	0040/0815	072 "DIA CIRC CONCR LEN=0048 INSTALLED UNKN
YUTES RUN RD (SR1017 SEG 0030/0000)	0040/0000	==	004416 FT	2 0 02217 0 00 0000+00 NC TAWNEY RUN RD LENGTH(AH 2715 BK 1200)
		==	0030/1030	SPRING ST (TWP)
	003209 FT	==	0030/0365	NC MAIN ST PILLOW AV (SR1017 SEG 0020/2705) MFC BEGIN = D
		==	003216 FT	0 0 00000 0 00 0000+00 SCHOOL ST (TWP)
		==	0030/0000	MFC BEGIN = C LENGTH(AH 1200 BK 1726)
TO 8060/0750 SH (CONN) RAMP K RD (SR8060 SEG 0750/0000) 018 "DIA CIRC CONCR LEN=0020 INSTALLED UNKN	0021/1497 0021/1408 0021/1390	== == ---		
RAMP J RD		==	0020/1421	RAMP K RD (SR8060 SEG 0750/0000)

DIR: B TOTAL LEN: 2.168 MI. DIST: 11-1 SR: 1014
 LEFT MUN: SPRINGDALE T RIGHT MUN: SPRINGDALE T

Stationing / Description	Stationing / Description	Stationing / Description	Stationing / Description
(SR8060 SEG 0760/0440) 0021/1361		0020/1386 RAMP J RD (SR8060 SEG 0760/0440)	
FROM 8060/0760 SH (CONN) 0021/1290		0020/0941 SPRINGDALE HARMAR T	
SPRINGDALE HARMAR T 0021/0883		0020/0766 BMSSEN 02/1014/0020/0399 2 0 02216 0 00 0019+91	
BMSSEN 02/1014/0020/0399 0021/0782		SR 0028 NB	
2 0 02216 0 00 0019+91		0020/0485 BMSBG 02/1014/0020/0399	
SR 0028 NB		RAMP L RD	
BMSBG 02/1014/0020/0399 0021/0501		0020/0357 (SR8060 SEG 0250/0000)	
		0020/0356 RAMP M RD (SR8060 SEG 0500/0822)	
RAMP L RD (SR8060 SEG 0250/0000) 0021/0369			
RAMP M RD (SR8060 SEG 0500/0822) 0021/0361		0020/0194 TO 8060/0250 SH (CONN)	
		0020/0079 HITE RD ET (TWP)	
HITE RD ET (TWP) 0021/0090		001490 FT 2 0 02216 0 00 0016+18	
2 0 02216 0 00 0016+73 001490 FT		MFC BEGIN = C	
MFC BEGIN = C		0020/0000 LENGTH(AH 1726 BK 1490)	
LENGTH(AH 1719 BK 1490) 0021/0000			
HILL TOP LN (TWP) 0010/1175			
		0010/0450 018 "DIA CIRC CONCR LEN=0030 INSTALLED UNKN	
ROBERTS ST (TWP) 0010/0380		0010/0368 018 "DIA CIR PLASTIC LEN=0040 INSTALLED UNKN	
		0010/0300 018 "DIA CIRC CONCR LEN=0035 INSTALLED UNKN	
		0010/0170 BAKER AL (TWP)	
UNKNOWN AL (TWP) 0010/0130			
000000 FT		000000 FT 2 0 02216 0 00 0000+00	
		(APRA) ACTION INDUSTRIE	
		NC HI	
		RUSSELLTON RD (SR1015 SEG 0040/0000)	
		INTER-BK NIXON RD (T585)	
		MFC BEGIN = C	
		0010/0000 LENGTH(AH 1490 BK 0000)	

POE

DIR: B TOTAL LEN: 13.576 MI. DIST: 11-1 SR: 1013
 LEFT MUN: WEST DEER T RIGHT MUN: WEST DEER T

HENRY RD
(T759)

071681 FT

* 071681 FT AH-BUTLER (10)
 REF-AHD SAXONBURG BL
 0350/3380 (SR2007 SEG 0010/0000)

0350/2440 DAWSON RD
(T721)

0350/1437 015"H 01"W **UNKNOWN**
 LEN=0060 INSTALLED UNKN

0350/1360

0350/0794 018 " DIA CIRC CONCR
 LEN=0100 INSTALLED UNKN

068301 FT

0350/0353 020"H 02"W **UNKNOWN**
 LEN=0060 INSTALLED UNKN
 068301 FT 2 0 02248 0 00 0708+91
 0350/0000 LENGTH(AH 3380 BK 2856)

0340/2741 015"H 02"W **UNKNOWN**
 LEN=0100 INSTALLED UNKN

0340/1768 018 " DIA CIRC CONCR
 LEN=0099 INSTALLED UNKN

0340/0600 018 " DIA CIRC CONCR
 LEN=0040 INSTALLED UNKN

0340/0300 018 " DIA CIRC CONCR
 LEN=0099 INSTALLED UNKN

0340/0197 024 " DIA CIRC CONCR
 LEN=0035 INSTALLED UNKN

065445 FT

0340/0163 018 " DIA CIR PLASTIC
 LEN=0034 INSTALLED UNKN
 065445 FT 2 0 02248 0 00 0679+82

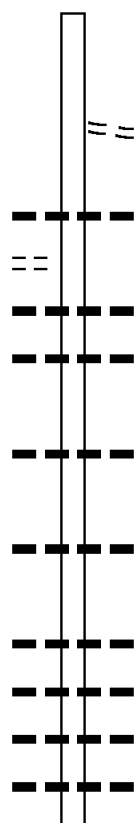

DIR: B TOTAL LEN: 13.576 MI. DIST: 11-1 SR: 1013
 LEFT MUN: WEST DEER T RIGHT MUN: WEST DEER T

Location	Segment	Length (FT)	Material / Notes
	0340/0000		LENGTH(AH 2856 BK 1249)
	0330/0497		018 "DIA CIR PLASTIC LEN=0010 INSTALLED UNKN
064196 FT	0330/0147	064196 FT	012 "DIA CIRC CONCR LEN=0020 INSTALLED UNKN 2 0 02248 0 00 0667+64 BAKERSTOWN RD (SR1028 SEG 0130/0665) MFC BEGIN = D
	0330/0000		LENGTH(AH 1249 BK 2719)
LAKEVIEW DR (TWP)	0320/2120		
	0320/2078		018 "DIA CIRC CONCR LEN=0099 INSTALLED UNKN
MORETTI DR (PRDR)	0320/1880		
SKYLINE DR (TWP)	0320/1750		
HIGHLAND DR (TWP)	0320/1420		
061477 FT	0320/0589	061477 FT	018 "DIA CIRC CONCR LEN=0080 INSTALLED UNKN 2 0 02248 0 00 0640+60
	0320/0000		LENGTH(AH 2719 BK 2168)
	0310/1738		BMSSEN 02/1013/0310/1726 2 0 02248 0 00 0636+12 BR LIT DEER
	0310/1726		BMSBG 02/1013/0310/1726
POPLAR ST (T901)	0310/1580		
	0310/0845		018 "DIA CIRC CONCR LEN=0030 INSTALLED UNKN
HAWTHORNE LN (TWP)	0310/0820		
059309 FT	0310/0010	059309 FT	018 "DIA CIRC CONCR LEN=0020 INSTALLED UNKN 2 0 02248 0 00 0621+26 FORD ST (T807)
	0310/0000		LENGTH(AH 2168 BK 1888)
	0300/1868		018 "DIA CIRC CONCR LEN=0015 INSTALLED UNKN

DIR: B TOTAL LEN: 13.576 MI. DIST: 11-1 SR: 1013
 LEFT MUN: WEST DEER T RIGHT MUN: WEST DEER T

ROAD NAME	START	END	LEN	UNIT	DESCRIPTION	STATUS
KAUFMAN RD (T707)	0300	0660				
	0300	0593	018	" DIA	CIRC CONCR	INSTALLED UNKN
	0300	0463	018	" DIA	CIRC METAL	INSTALLED UNKN
	0300	0110	018	" DIA	CIRC CONCR	INSTALLED UNKN
	057421	FT	2 0	02248	0 00	0599+48
CURTISVILLE RD (T810)	0290	1630				
	0290	1617	018	" DIA	CIRC CONCR	INSTALLED UNKN
	0290	1152	024	" DIA	CIRC CONCR	INSTALLED UNKN
	0290	2044	072	" DIA	CIRC CONCR	INSTALLED UNKN
	0290	2032	024	" DIA	CIRC CONCR	INSTALLED UNKN
LOGAN RD (T632)	0280	0575				
	0280	0411				
	0280	0397	018	" DIA	CIRC CONCR	INSTALLED UNKN
	053685	FT	2 0	02248	0 00	0562+22
	0270	0287	084	" DIA	CIRC METAL	INSTALLED UNKN
STONECREST DR (TWP)	0260	2747				
	0260	2188				
	0270	0043	018	" DIA	CIRC CONCR	INSTALLED UNKN
	053145	FT	2 0	02248	0 00	0556+82
	0270	0000	018	" DIA	CIRC CONCR	INSTALLED UNKN

5

5

5

5

MCKRELL RD
(T632)
 018 " DIA CIRC CONCR
 LEN=0035 INSTALLED UNKN
 2 0 02248 0 00 0562+22
 LENGTH(AH 1269 BK 0540)
 BMSSEN 02/1013/0270/0276
 084 " DIA CIRC METAL
 LEN=0030 INSTALLED UNKN
 2 0 02248 0 00 0559+58
 BR. L. DR. CRK.
 BMSBG 02/1013/0270/0276
 018 " DIA CIRC CONCR
 LEN=0035 INSTALLED UNKN
 2 0 02248 0 00 0556+82
 LENGTH(AH 0540 BK 3002)

DIR: B TOTAL LEN: 13.576 MI. DIST: 11-1 SR: 1013
 LEFT MUN: WEST DEER T RIGHT MUN: WEST DEER T

ROADWAY NAME (CNTY)	START POINT	END POINT	LENGTH (FT)	DESCRIPTION
BAIRDFORD RD (CNTY)	0260/0315	0260/0595	050143 FT	FOR SR 1013 AND 1025 (CONN) EAST UNION RD (SR1025 SEG 0070/3488) 018" DIA CIR UNKNOWN LEN=0040 INSTALLED UNKN
	0260/0029	0260/0000	050143 FT	018" DIA CIR PLASTIC LEN=0035 INSTALLED UNKN 2 0 02248 0 00 0526+67 LENGTH(AH 3002 BK 1509)
WEST STARZ RD (SR1024 SEG 0030/3874)	0250/0895	0250/0812	048634 FT	018" DIA CIRC CONCR LEN=0030 INSTALLED UNKN
	0250/0066	0250/0000	048634 FT	018" DIA CIRC CONCR LEN=0099 INSTALLED UNKN 2 0 02248 0 00 0511+13 LENGTH(AH 1509 BK 2461)
	0240/1830	0240/1805	046173 FT	018" DIA CIRC CONCR LEN=0028 INSTALLED UNKN REAGHARD DR (TWP)
	0240/1738	0240/1489		018" H 18" W ELLIP CONC LEN=0099 INSTALLED UNKN 018" DIA CIR PLASTIC
	0240/1053	0240/0720		024" DIA CIRC CONCR LEN=0030 INSTALLED UNKN RAMSEY RD (T673)
	0240/0705	0240/0705	046173 FT	024" DIA CIR PLASTIC LEN=0099 INSTALLED UNKN
	0220/2197	0220/2188		2 0 02248 0 00 0487+43 BURGER RD (TWP) LENGTH(AH 2461 BK 2244) BMSSEN 02/1013/0220/1288 2 0 02248 0 00 0486+51 BR CUNNINGHM
	0220/2188	0220/2187		BMSBG 02/1013/0220/1288 036" H 00" W MULT METAL LEN=0025 INSTALLED UNKN

DIR: B TOTAL LEN: 13.576 MI. DIST: 11-1 SR: 1013
 LEFT MUN: WEST DEER T RIGHT MUN: WEST DEER T

GRUBBS RD
 (TWP)
 QUIGLEY RD
 (T753)

0220/2085
 0220/1775

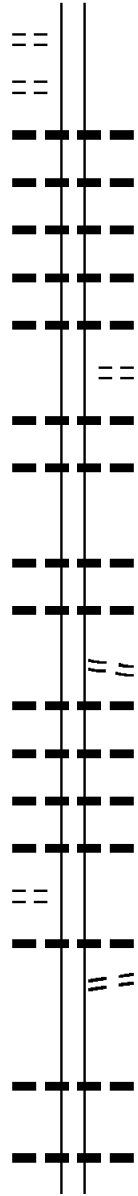

043929 FT

5

ITINGER RD
 (TWP)

0210/0735

041760 FT

5

040476 FT

0220/1695	015 " DIA	CIRC METAL
	LEN=0030	INSTALLED UNKN
0220/1535	018 " DIA	CIRC CONCR
	LEN=0035	INSTALLED UNKN
0220/1201	018 " DIA	CIRC CONCR
	LEN=0040	INSTALLED UNKN
0220/0934	018 " DIA	CIRC CONCR
	LEN=0060	INSTALLED UNKN
0220/0890	024 " DIA	CIRC CONCR
	LEN=0099	INSTALLED UNKN
	TRUMP RD	
0220/0865	(T672)	
	018 " DIA	CIRC CONCR
	LEN=0045	INSTALLED UNKN
	018 " DIA	CIRC CONCR
	LEN=0060	INSTALLED UNKN
0220/0146	2 0 02248	0 00 0464+16
043929 FT	LENGTH(AH 2244 BK 2169)	
5 0220/0000	018 " DIA	CIRC CONCR
	LEN=0045	INSTALLED UNKN
	018 " DIA	CIRC CONCR
	LEN=0008	INSTALLED UNKN
	SAXONY RD	
	(TWP)	
	018 " DIA	CIRC CONCR
	LEN=0050	INSTALLED UNKN
	015 " DIA	CIRC METAL
	LEN=0029	INSTALLED UNKN
	060 " DIA	CIRC CONCR
	LEN=0100	INSTALLED UNKN
	018 " DIA	CIRC CONCR
	LEN=0040	INSTALLED UNKN
0210/0827	015 " DIA	CIRC CONCR
	LEN=0045	INSTALLED UNKN
	MCCLURE RD	
	(T652)	
0210/0266	2 0 02248	0 00 0442+72
041760 FT	LENGTH(AH 2169 BK 1284)	
5 0210/0000	018 " DIA	CIRC CONCR
	LEN=0045	INSTALLED UNKN
	024 " DIA	CIRC CONCR
	LEN=0040	INSTALLED UNKN
0200/0309	2 0 02248	0 00 0429+53
040476 FT	LENGTH(AH 2169 BK 1284)	

DIR: B TOTAL LEN: 13.576 MI. DIST: 11-1 SR: 1013
 LEFT MUN: WEST DEER T RIGHT MUN: WEST DEER T

ROAD NAME	SR	LEN	START	END	TYPE	STATUS	DETAILS
RUSSELLTON RD (T628)	0190	2120	0200/0000	0190/2605	LENGTH (AH 1284 BK 2679)	018" DIA CIRC CONCR	LEN=0091 INSTALLED UNKN
			0190/2120	0190/2120	RUSSELLTON DORSEYVILLE	(SR1020 SEG 0080/0000)	015" DIA CIRC METAL
				0190/2099	LEN=0040	INSTALLED UNKN	012" DIA CIR UNKNOWN
				0190/1685	LEN=0050	INSTALLED UNKN	
CAMPBELL DR (SR1020 SEG 0070/3148)	0190	1060			WEST DEER		
				0190/0903	INDIANA T		
				0190/0493	048" DIA CIR UNKNOWN	LEN=0035	INSTALLED UNKN
				0190/0484	004" DIA CIR UNKNOWN	LEN=0035	INSTALLED UNKN
				0190/0070	012" DIA CIRC CONCR	LEN=0040	INSTALLED UNKN
				0190/0064	018" DIA CIRC CONCR	LEN=0035	INSTALLED UNKN
		037797 FT		037797 FT	2 0 02248 0 00 0403+50		
MAPLE TERRACE DR (PRDR)	0180	0350			LENGTH (AH 2679 BK 0896)		
EVERGREEN LN (PRDR)	0180	0181			015" DIA CIRC CONCR		
2 0 02248 0 00 0395+52		036901 FT			LEN=0002	INSTALLED UNKN	
MONTICELLO DR (TWP)	0180	0000			HALIBURTON LN		
					(TWP)		
					ALPINE VILLAGE DR		
					(T707)		
PAUL DR (PRDR)	0170	0525			015" DIA CIRC CONCR		
					LEN=0002	INSTALLED UNKN	
					018" DIA CIRC CONCR		
		035672 FT			LEN=0002	INSTALLED UNKN	
					2 0 02248 0 00 0382+00		
					ALPINE VILLAGE DR		
					(T707)		
					018" DIA CIRC CONCR		
					LEN=0040	INSTALLED UNKN	
FOSSIL RIDGE RD	0170	0000			LENGTH (AH 1229 BK 2715)		

DIR: B TOTAL LEN: 13.576 MI. DIST: 11-1 SR: 1013
 LEFT MUN: INDIANA T RIGHT MUN: INDIANA T

(PRDR)

0160/2570

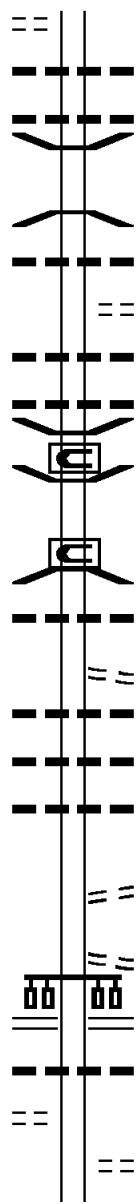

0160/2057 018 " DIA CIRC CONCR
 LEN=0040 INSTALLED UNKN
 0160/2052 018 " DIA CIRC CONCR
 LEN=0040 INSTALLED UNKN
 0160/2021 BMSSEN 02/1013/0160/1928
 2 0 02248 0 00 0354+95
 DEER CREEK
 0160/1928 BMSBG 02/1013/0160/1928
 018 " DIA CIRC CONCR
 0160/1903 LEN=0040 INSTALLED UNKN
 PENNDOT STOCK PILE YARD
 0160/1545 (GOVT)
 018 " DIA CIRC CONCR
 0160/1368 LEN=0040 INSTALLED UNKN
 018 " DIA CIRC CONCR
 0160/1208 LEN=0040 INSTALLED UNKN
 0160/1168 BMSSEN 02/7076/9900/4313
 BMSSEN 02/1013/0160/0890
 0160/1162 2 0 02248 0 00 0354+95
 BRIDGE CLOSED
 PA TURNPIKE (I-76)
 0160/0890 BMSBG 02/1013/0160/0890
 018 " DIA CIRC CONCR
 0160/0730 LEN=0025 INSTALLED UNKN
 OLD SAXONBURG BL
 0160/0605 (TWP)
 018 " DIA CIRC CONCR
 0160/0551 LEN=0099 INSTALLED UNKN
 018 " DIA CIRC CONCR
 0160/0548 LEN=0020 INSTALLED UNKN
 018 " DIA CIRC OTHER
 0160/0280 LEN=0080 INSTALLED UNKN
 032957 FT 2 0 02248 0 00 0354+95
 0160/0000 LENGTH(AH 2715 BK 1646)
 OLD SAXONBURG RD
 0150/1430 (TWP)
 LC FROM 0910/0340 SH
 0150/1225 (CONN)
 GIBSONIA RD
 (SR0910 SEG 0340/0000)
 0150/1155 048 " DIA CIRC CONCR
 0150/1080 LEN=0100 INSTALLED UNKN
 0150/0970 ==
 0150/0825 CEMETERY LN
 (TWP)
 HEATHERGATE DR

032957 FT

BERG DR
 (TWP)

0150/0970

DIR: B TOTAL LEN: 13.576 MI. DIST: 11-1 SR: 1013
 LEFT MUN: INDIANA T RIGHT MUN: INDIANA T

Street Name	Segment	Length (FT)	Stationing	Notes
VERANDA LN (PRDR)	0150/0670		(TWP)	024 " DIA CIRC CONCR
	0150/0370		LEN=0035	INSTALLED UNKN
	0150/0246		012 " DIA CIRC CONCR	LEN=0099 INSTALLED UNKN
MCCLELLAND DR (TWP)	0150/0034	031311 FT	(PRDR)	JOHN SMITH LN
	031311 FT		2 0 02248 0 00	0343+60
	0150/0000	0140/2830	5	LENGTH(AH 1646 BK 3043)
CHARLES ST (TWP)	0140/2559		WEBER DR	(T764)
	0140/2197		005 " DIA CIRC METAL	LEN=0024 INSTALLED UNKN
	0140/2180		024 " DIA CIRC CONCR	LEN=0024 INSTALLED UNKN
SHELBY LN (PRDR)	0140/1646		FOX CHPL MID SCHL ENT R	(TWP)
	0140/1077		APPLE LN	(PRDR)
	0140/0950		024 " H 00 " W MULT CONCR	LEN=0030 INSTALLED UNKN
SMITH FARM LN (PRDR)	028268 FT	028268 FT	2 0 02248 0 00	0308+13
	028268 FT		024 " H 00 " W MULT CONCR	LEN=0099 INSTALLED UNKN
	0140/0000	0130/0890	5	NC SA XONBURG BL LENGTH(AH 3043 BK 1385)
SMITH FARM LN (PRDR)	0130/0167	026883 FT	BMS EN 02/1013/0130/0132	2 0 02248 0 00 0295+74
	0130/0155		BLUE RUN	BMSBG 02/1013/0130/0132
	026883 FT		2 0 02248 0 00	0294+48
SMITH FARM LN (PRDR)	0130/0000		DORSEYVILLE RD	(CNTY)
	0120/3149	0120/3373	5	LENGTH(AH 1385 BK 3622)
	0120/3149		015 " DIA CIRC OTHER	LEN=0035 INSTALLED UNKN
			018 " DIA CIRC CONCR	

DIR: B TOTAL LEN: 13.576 MI. DIST: 11-1 SR: 1013
 LEFT MUN: INDIANA T RIGHT MUN: INDIANA T

Location / Description	Segment ID	Length	Material / Notes	Status
HABERSTICH LN (PRDR)	0120/2652	LEN=0035	VALLEY LN	INSTALLED UNKN
	0120/2191	(PRDR)		
HABERSTICH LN (PRDR)	0120/2039			
	0120/1609	015 "DIA CIRC OTHER LEN=0040		INSTALLED UNKN
LC TO/FROM HARTWOOD AC (CONN)	023261 FT			
	0110/0794	023261 FT 2 0 02248 0 00 0257+99 LENGTH(AH 3622 BK 1367)		
LC TO/FROM HARTWOOD AC (CONN)	0110/1330	012 "DIA CIRC CONCR LEN=0030		INSTALLED UNKN
	0110/0415	036 "DIA CIRC CONCR LEN=0030		INSTALLED UNKN
HARTWOOD ACRES PS (CNTY)	0110/0109	015 "DIA CIRC OTHER LEN=0030		INSTALLED UNKN
	0110/0000	021894 FT LENGTH(AH 1367 BK 2925)		
FOX HUNT RD (TWP)	0100/2165	WESTCHESTER DR (TWP) 024 "DIA CIRC CONCR		
	0100/2124	LEN=0030		INSTALLED UNKN
FOX HUNT RD (TWP)	0100/1397	015 "DIA CIRC CONCR LEN=0035		INSTALLED UNKN
	0100/1020			
FOX HUNT RD (TWP)	0100/0895	015 "DIA CIRC CONCR LEN=0065		INSTALLED UNKN
	0100/0446	018 "DIA CIRC CONCR LEN=0035		INSTALLED UNKN
FOX HUNT RD (TWP)	018969 FT	018969 FT 2 0 02248 0 00 0215+13 LENGTH(AH 2925 BK 1656)		
	0100/0000	018 "DIA CIRC CONCR LEN=0081		INSTALLED UNKN
FOX HUNT RD (TWP)	0090/1547	084 "DIA CIRC METAL LEN=0030		INSTALLED UNKN
	0090/1466	BMSSEN 02/1013/0090/1450		
FOX HUNT RD (TWP)	0090/1458	2 0 02248 0 00 0213+07 STREAM		
	0090/1450	BMSBG 02/1013/0090/1450		

FIVE ACRES DR
(PRDR)

0090/1225

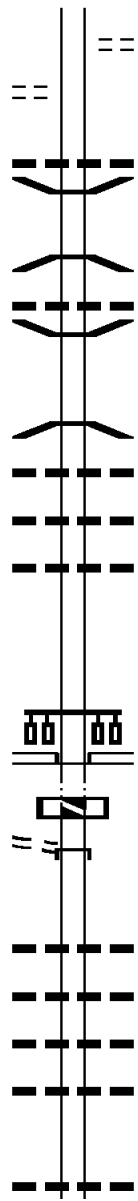

017313 FT

015755 FT

HARTS RUN RD
(SR1010 SEG 0060/2378)

0080/0000
015755 FT

KLEIN RD
(T772)

0070/0494
015261 FT

013784 FT

0090/1385 MALLARD DR
(TWP)

0090/0617 018 " DIA CIRC CONCR
 0090/0324 LEN=0035 INSTALLED UNKN
 BMSBG 02/1013/0090/0313
 2 0 02248 0 00 0201+72
 BR. LTLE. PINE

0090/0313 015 " DIA CIRC CONCR
 0090/0173 LEN=0040 INSTALLED UNKN
 0090/0019 BMSBG 02/1013/0090/0000
 017313 FT 2 0 02248 0 00 0199+55
 BR. LTLE. PINE

0090/0000 BMSBG 02/1013/0090/0000
 LENGTH(AH 1656 BK 1558)

0080/1008 018 " DIA CIRC OTHER
 024 " DIA CIRC OTHER
 0080/0516 LEN=0030 INSTALLED UNKN
 018 " DIA CIR PLASTIC

0080/0300 LEN=0020 INSTALLED UNKN
 015755 FT 2 0 02248 0 00 0182+95
 NC SA XONBURG RD
 HARTS RUN RD
 (SR1006 SEG 0060/0000)

INTER-BK SAXONBURG BL
 (SR1006 SEG 0060/0000)

0080/0000 LTH AH 001558 BK 000100
 015755 FT 7074/0000

0070/0494 INTER-AHD SAXONBURG BL
 (SR1006 SEG 0040/0000)
 015261 FT 2 0 02248 0 00 0152+80

0070/0000 LENGTH(AH 0494 BK 1477)
 024 " DIA CIRC CONCR

0060/1401 LEN=0045 INSTALLED UNKN
 060 " DIA CIRC CONCR

0060/1068 LEN=0050 INSTALLED UNKN
 072 " DIA CIRC CONCR

0060/0719 LEN=0099 INSTALLED UNKN
 084 " DIA CIRC OTHER

0060/0419 LEN=0065 INSTALLED UNKN
 013784 FT 2 0 02248 0 00 0137+00
 048 " DIA CIRC CONCR

0060/0000 LEN=0055 INSTALLED UNKN
 LENGTH(AH 1477 BK 1109)

EXTRACT DATE: 12/21/2020
PRINT DATE: 12/23/2020

ROADWAY MANAGEMENT SYSTEM
SLD COUNTY/SR - ANNUAL PRINT

PAGE NUMBER: 559
COUNTY: ALLEGHENY

DIR: B TOTAL LEN: 13.576 MI.
LEFT MUN: INDIANA T

DIST: 11-1 SR: 1013
RIGHT MUN: INDIANA T

SHADY LN
(PRDR)

0050/0571

2 0 02248 0 00 0126+72 012675 FT
FRANCIONI LN
(PRDR)

0050/0000

BERRY HILL RD
(T943)

0040/1765

	0050/0694	BMSEN 02/1013/0050/0634 2 0 02248 0 00 0132+78 LITTLE PINE
	0050/0634	BMSBG 02/1013/0050/0634 012 " DIA CIRC CONCR
	0050/0624	LEN=0030 INSTALLED UNKN 012 " DIA CIRC CONCR
	0050/0583	LEN=0040 INSTALLED UNKN
	0050/0320	018 " DIA CIRC UNKNOWN LEN=0040 INSTALLED UNKN 048 " DIA CIRC OTHER
	0050/0200	LEN=0035 INSTALLED UNKN 012675 FT INDIANA
	0050/0000	CHARA T LENGTH(AH 1109 BK 3979) 036 " DIA CIRC CONCR
	0040/3932	LEN=0030 INSTALLED UNKN 018 " DIA CIRC OTHER
	0040/3783	LEN=0030 INSTALLED UNKN 048 " DIA CIRC OTHER
	0040/3730	LEN=0084 INSTALLED UNKN 018 " DIA CIRC CONCR
	0040/3461	LEN=0035 INSTALLED UNKN 048 " DIA CIRC OTHER
	0040/3413	LEN=0035 INSTALLED UNKN 060 " DIA CIRC CONCR
	0040/2963	LEN=0040 INSTALLED UNKN 038 " DIA CIRC CONCR
	0040/2837	LEN=0035 INSTALLED UNKN 056 " DIA CIRC CONCR
	0040/2705	LEN=0035 INSTALLED UNKN 018 " DIA CIRC CONCR
	0040/2325	LEN=0030 INSTALLED UNKN BROWNSHILL RD
	0040/1790	(T943)
	0040/1750	048 "H 60 "W CON BOX CUL LEN=0099 INSTALLED UNKN 015 " DIA CIRC METAL
	0040/1500	LEN=0080 INSTALLED UNKN 024 " DIA CIRC CONCR
	0040/1154	LEN=0035 INSTALLED UNKN 048 " DIA CIRC OTHER
	0040/0816	LEN=0035 INSTALLED UNKN 036 " DIA CIRC CONCR
	0040/0379	LEN=0035 INSTALLED UNKN 060 " DIA CIRC CONCR

DIR: B TOTAL LEN: 13.576 MI. DIST: 11-1 SR: 1013
 LEFT MUN: OHARA T RIGHT MUN: OHARA T

008696 FT

004963 FT

---	0040/0294	LEN=0030	INSTALLED UNKN
---		018 "DIA	CIRC CONCR
---	0040/0137	LEN=0035	INSTALLED UNKN
RBR			
---	0040/0011	BMS EN 02/1013/0040/0000	
	008696 FT	2 0 02248 0 00 0086+98	
		P3	
		B. LIT. PINE	
		BMSBG 02/1013/0040/0000	
5	0040/0000	LENGTH(AH 3979 BK 3733)	
---		048 "DIA	CIRC CONCR
---	0030/3608	LEN=0030	INSTALLED UNKN
---		036 "DIA	CIRC CONCR
---	0030/3133	LEN=0040	INSTALLED UNKN
		CALMWOOD RD	
		(TWP)	
==	0030/2990	048 "DIA	CIRC CONCR
---	0030/2973	LEN=0040	INSTALLED UNKN
---		018 "DIA	CIRC CONCR
---	0030/2778	LEN=0045	INSTALLED UNKN
---		018 "DIA	CIRC CONCR
---	0030/2367	LEN=0035	INSTALLED UNKN
---		018 "DIA	CIRC OTHER
---	0030/2317	LEN=0030	INSTALLED UNKN
---		036 "DIA	CIRC CONCR
---	0030/2069	LEN=0050	INSTALLED UNKN
---		018 "DIA	CIRC METAL
---	0030/1535	LEN=0040	INSTALLED UNKN
---		015 "DIA	CIRC METAL
---	0030/1003	LEN=0035	INSTALLED UNKN
---		018 "DIA	CIRC METAL
---	0030/0852	LEN=0035	INSTALLED UNKN
---		018 "DIA	CIRC CONCR
---	0030/0759	LEN=0065	INSTALLED UNKN
---		048 "DIA	CIRC METAL
---	0030/0694	LEN=0045	INSTALLED UNKN
---		018 "DIA	CIRC CONCR
---	0030/0562	LEN=0099	INSTALLED UNKN
RBR			
---	0030/0480	BMS EN 02/1013/0030/0428	
		2 0 02248 0 00 0053+83	
		P3	
		LT PINE CK	
		BMSBG 02/1013/0030/0428	
	0030/0428	2 0 02248 0 00 0049+55	
	004963 FT	OHARA	

EXTRACT DATE: 12/21/2020
PRINT DATE: 12/23/2020

ROADWAY MANAGEMENT SYSTEM
SLD COUNTY/SR - ANNUAL PRINT

PAGE NUMBER: 557
COUNTY: ALLEGHENY

DIR: B TOTAL LEN: 13.576 MI.
LEFT MUN: OHARA T

DIST: 11-1 SR: 1013
RIGHT MUN: OHARA T

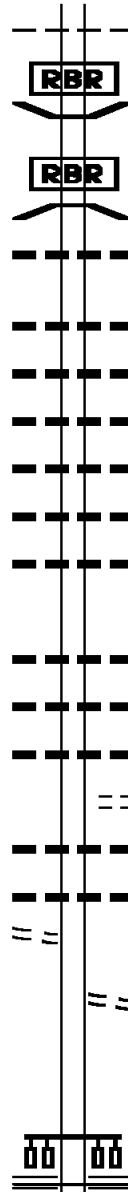

0030/0000 SHALER T
LENGTH(AH 3733 BK 2925)

0020/2287 BMS EN 02/1013/0020/2226
2 0 02248 0 00 0042+64
P3

0020/2226 LITTLE PINE
BMSBG 02/1013/0020/2226
094 "DIA CIRC CONCR

0020/1661 LEN=0030 INSTALLED UNKN

0020/1014 072 "DIA CIRC CONCR
LEN=0030 INSTALLED UNKN

0020/0924 084 "DIA CIRC CONCR
LEN=0030 INSTALLED UNKN

0020/0684 036 "DIA CIRC METAL
LEN=0030 INSTALLED UNKN

0020/0531 036 "DIA CIRC CONCR
LEN=0030 INSTALLED UNKN

0020/0194 048 "DIA CIRC CONCR
LEN=0019 INSTALLED UNKN

0020/0035 018 "DIA CIRC CONCR
LEN=0140 INSTALLED UNKN

002038 FT 2 0 02248 0 00 0019+41

0020/0000 LENGTH(AH 2925 BK 2038)
048 "H 24 "W CON BOX CUL

0010/1894 LEN=0040 INSTALLED UNKN

0010/1345 048 "DIA CIRC CONCR
LEN=0040 INSTALLED UNKN

0010/1103 036 "DIA CIRC CONCR
LEN=0040 INSTALLED UNKN

0010/1075 KAY ST
(TWP)

0010/0794 018 "DIA CIRC CONCR
LEN=0040 INSTALLED UNKN

0010/0431 036 "DIA CIRC CONCR
LEN=0035 INSTALLED UNKN

0010/0170

0010/0101 TO/FROM 0008/0210 SH
(CONN)

000000 FT 2 0 02248 0 00 0000+00
NC SA XONBURG BL
WILLIAM FLYNN HW
(SRO008 SEG 0221/0000)
(SRO008 SEG 0220/0000)

0010/0000 MFC BEGIN = C
LENGTH(AH 2038 BK 0000)

002038 FT

MIDDLE RD
(CNTY)

000000 FT

EXTRACT DATE: 12/21/2020 ROADWAY MANAGEMENT SYSTEM PAGE NUMBER: 556
PRINT DATE: 12/23/2020 SLD COUNTY/SR - ANNUAL PRINT COUNTY: ALLEGHENY
DIR: B TOTAL LEN: 3.871 MI. DIST: 11-1 SR: 1012
LEFT MUN: INDIANA T RIGHT MUN: INDIANA T

020437 FT

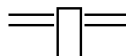

020437 FT SAXONBURG BL
0080/2087 (SR1013 SEG 0140/0404)
024 " DIA CIRC CONCR

DIR: B TOTAL LEN: 3.871 MI. DIST: 11-1 SR: 1012
 LEFT MUN: INDIANA T RIGHT MUN: INDIANA T

Station	Length	Material	Notes
0060/1900	(T613)		
0060/1196	LEN=0040	018 " DIA CIRC CONCR	INSTALLED UNKN
0060/0737	LEN=0070	018 " DIA CIR PLASTIC	INSTALLED UNKN
0060/0720	LEN=0048	018 " DIA CIRC CONCR	INSTALLED UNKN
0060/0266	LEN=0060	024 " DIA CIR PLASTIC	INSTALLED UNKN
012706 FT	2 0 02138 0 02 0135+16	024 " DIA CIRC METAL	
0060/0000	LEN=0100	LENGTH(AH 3434 BK 3242)	INSTALLED UNKN
0050/2626	LEN=0050	018 " DIA CIR PLASTIC	INSTALLED UNKN
0050/2217		NC CHURCH LN	
0050/2190		INDIANA HAMPTON T	
0050/1744	LEN=0040	018 " DIA CIRC METAL	INSTALLED UNKN
0050/1652	LEN=0040	018 " DIA CIR PLASTIC	INSTALLED UNKN
0050/1137	LEN=0040	018 " DIA CIRC CONCR	INSTALLED UNKN
0050/0962	LEN=0040	018 " DIA CIRC CONCR	INSTALLED UNKN
0050/0836	LEN=0099	015 " DIA CIRC CONCR	INSTALLED UNKN
0050/0648	LEN=0040	018 " DIA CIRC CONCR	INSTALLED UNKN
0050/0336	LEN=0040	018 " DIA CIRC CONCR	INSTALLED UNKN
009464 FT	2 0 02138 0 02 0102+59		
0050/0000	LENGTH(AH 3242 BK 2208)		
0040/2208	LEN=0048	018 " DIA CIRC CONCR	INSTALLED UNKN
0040/1343	LEN=0040	018 " DIA CIRC CONCR	INSTALLED UNKN
0040/1169	LEN=0040	018 " DIA CIRC CONCR	INSTALLED UNKN
0040/0281	LEN=0040	018 " DIA CIRC CONCR	INSTALLED UNKN

CEDAR RUN RD
(T653)

DIR: B TOTAL LEN: 3.871 MI. DIST: 11-1 SR: 1012
 LEFT MUN: HAMPTON T RIGHT MUN: HAMPTON T

Location	Distance (FT)	Segment	Details
	007256 FT	0040/0228	SHORT ST (TWP)
		007256 FT	2 0 02138 0 03 0073+00
		0040/0000	LENGTH(AH 2208 BK 1944) 048 " DIA CIR PLASTIC
		0030/1366	LEN=0100 INSTALLED UNKN
HAMPTON COMMUNITY PARK (PARK)	005312 FT	005312 FT	2 0 02138 0 01 0061+07
		0030/0000	LENGTH(AH 1944 BK 2045)
	0020/1525	0020/1120	048 " DIA CIRC METAL LEN=0080 INSTALLED UNKN
HAMPTON HIGH SCHOOL (PRDR)	0020/0516	0020/0740	KENSON DR (T939)
	003267 FT	003267 FT	2 0 02138 0 00 0040+79
		0020/0000	CLAREVILLE DR (T915) LENGTH(AH 2045 BK 3267)
GREENGROVE DR (T929)	0010/2680	0010/2965	024 " DIA CIRC CONCR LEN=0040 INSTALLED UNKN
		0010/2320	KILBERT DR (T973)
		0010/2243	012 " DIA CIRC CONCR LEN=0030 INSTALLED UNKN
BIRCHWOOD LN (T905)	0010/1675	0010/1711	ROSANNA DR (T612)
		0010/1274	018 " DIA CIRC CONCR LEN=0032 INSTALLED UNKN
		0010/0636	BMS EN 02/1012/0010/0620 2 0 02138 0 00 0005+92
		0010/0620	MCCASLIN RUN BMSBG 02/1012/0010/0620
	000000 FT	000000 FT	2 0 02138 0 00 0000+00
		0010/0000	NC MC CULLY RD WILLIAM FLYNN HW (SR0008 SEG 0321/2775) (SR0008 SEG 0320/2665) MFC BEGIN = D LENGTH(AH 3267 BK 0000)

EXTRACT DATE: 12/21/2020 ROADWAY MANAGEMENT SYSTEM PAGE NUMBER: 552
PRINT DATE: 12/23/2020 SLD COUNTY/SR - ANNUAL PRINT COUNTY: ALLEGHENY
DIR: B TOTAL LEN: 1.823 MI. DIST: 11-1 SR: 1011
LEFT MUN: HARMAR T RIGHT MUN: HARMAR T

009627 FT



009627 FT
INTER-AHD GUYS RUN RD
(SR1006 SEG 0120/0000)

DIR: B TOTAL LEN: 1.823 MI. DIST: 11-1 SR: 1011
 LEFT MUN: HARMAR T RIGHT MUN: HARMAR T

007559 FT

005325 FT

			LOCUST HILL RD
	0040/2068	(SR1006	SEG 0120/0000)
		024 "DIA	CIRC CONCR
	0040/1893	LEN=0055	INSTALLED UNKN
		018 "DIA	CIRC PLASTIC
	0040/1500	LEN=0040	INSTALLED UNKN
		018 "DIA	CIRC CONCR
	0040/1229	LEN=0040	INSTALLED UNKN
		018 "DIA	CIRC CONCR
	0040/1162	LEN=0040	INSTALLED UNKN
		018 "DIA	CIRC CONCR
	0040/0859	LEN=0030	INSTALLED UNKN
		018 "DIA	CIRC CONCR
	0040/0683	LEN=0030	INSTALLED UNKN
		018 "DIA	CIRC CONCR
	0040/0543	LEN=0055	INSTALLED UNKN
		018 "DIA	CIRC CONCR
	0040/0189	LEN=0030	INSTALLED UNKN
	007559 FT	1 1 03758	0 00 0073+71
	0040/0000	LENGTH(AH	2068 BK 2234)
		048 "DIA	CIRC CONCR
	0030/2234	LEN=0030	INSTALLED UNKN
	0030/1969	BMSFN 02/1011/0030/1942	
		2 0 02244	0 00 0072+70
		GUY RUN	
	0030/1942	BMSBG 02/1011/0030/1942	
		018 "DIA	CIRC CONCR
	0030/1546	LEN=0030	INSTALLED UNKN
		018 "DIA	CIRC CONCR
	0030/1290	LEN=0030	INSTALLED UNKN
		018 "DIA	CIRC CONCR
	0030/1072	LEN=0030	INSTALLED UNKN
		018 "DIA	CIRC CONCR
	0030/0839	LEN=0030	INSTALLED UNKN
		018 "DIA	CIRC METAL
	0030/0677	LEN=0030	INSTALLED UNKN
		018 "DIA	CIRC METAL
	0030/0655	LEN=0030	INSTALLED UNKN
		018 "DIA	CIRC METAL
	0030/0289	LEN=0030	INSTALLED UNKN
	0030/0017	BMSFN 02/1011/0030/0000	
	005325 FT	2 0 02244	0 00 0053+18
		GUY RUN	
	0030/0000	BMSBG 02/1011/0030/0000	
		LENGTH(AH	2234 BK 2011)
		036 "DIA	CIRC CONCR
	0020/1835	LEN=0030	INSTALLED UNKN
		018 "DIA	CIRC METAL
	0020/1456	LEN=0030	INSTALLED UNKN
		018 "DIA	CIRC CONCR

DIR: B TOTAL LEN: 1.823 MI. DIST: 11-1 SR: 1011
 LEFT MUN: HARMAR T RIGHT MUN: HARMAR T

2 0 02244 0 00 0033+05 003314 FT
 CAMPBELL RUN RD
 (T553) 0020/0000

TERRACE DR
 (TWP) 0010/1438
 WISE HILL RD
 (TWP) 0010/1355

000000 FT

---	0020/1185	LEN=0001	INSTALLED UNKN
---	0020/1006	018 "DIA	CIRC METAL UNKN
---	0020/0464	LEN=0030	INSTALLED UNKN
---	0020/0164	036 "DIA	CIRC CONCR UNKN
---	0020/0164	LEN=0106	INSTALLED UNKN
---	003314 FT	018 "DIA	CIRC CONCR UNKN
---	003314 FT	LEN=0030	INSTALLED UNKN
==	5 0020/0000	LENGTH(AH 2011 BK 3314)	
---	0010/3169	018 "DIA	CIRC CONCR UNKN
[RBR]			
---	0010/2318	BMS EN 02/1011/0010/2295	
[RBR]		2 0 02244 0 00 0022+98	
---	0010/2295	P3	
---		GUYS RUN	
---	0010/1527	BMSBG 02/1011/0010/2295	
---		024 "DIA	CIRC METAL UNKN
---	0010/1438	LEN=0025	INSTALLED UNKN

---	0010/1296	NORTH SHORE R.R. STON OVERPASS IS RR X-ING	
[RBR]			
---	0010/1039	BMS EN 02/1011/0010/1018	
[RBR]		2 0 02244 0 00 0010+10	
---	0010/1018	P3	
---		GUYS RUN	
---	0010/0445	BMSBG 02/1011/0010/1018	
---		RT 0028	SB
---	0010/0378	OP ID 02/0028/0261/2263	
---		RT 0028	NB
---	0010/0227	OP ID 02/0028/0260/2109	
---		018 "DIA	CIRC CONCR UNKN
---	000000 FT	LEN=0072	INSTALLED UNKN
---		2 0 02244 0 00 0000+00	
---		NC GUYS RUN RD	
---		FREEPORT RD	
---		(SR1001 SEG 0220/0425)	
---		(SR1001 SEG 0221/0425)	
---	5 0010/0000	MFC BEGIN = D	
---		LENGTH(AH 3314 BK 0000)	

EXTRACT DATE: 12/21/2020 ROADWAY MANAGEMENT SYSTEM PAGE NUMBER: 549
 PRINT DATE: 12/23/2020 SLD COUNTY/SR - ANNUAL PRINT COUNTY: ALLEGHENY
 DIR: B TOTAL LEN: 2.895 MI. DIST: 11-1 SR: 1010
 LEFT MUN: INDIANA T RIGHT MUN: INDIANA T

015288 FT

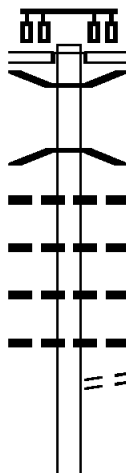

015288 FT
 INTER-AHD HARTS RUN RD
 (SR1006 SEG 0060/0000)
 SAXONBURG BL
 (SR1013 SEG 0080/0000)
 0060/2378
 0060/2345 BMS EN 02/1010/0060/2330
 0 0 00000 0 00 0000+00
 LITTLE PINE
 0060/2330 BMSBG 02/1010/0060/2330
 018 " DIA CIRC CONCR
 0060/1811 LEN=0030 INSTALLED UNKN
 018 " DIA CIRC CONCR
 0060/1608 LEN=0030 INSTALLED UNKN
 018 " DIA CIRC CONCR
 0060/1364 LEN=0030 INSTALLED UNKN
 018 " DIA CIRC CONCR
 0060/1109 LEN=0030 INSTALLED UNKN
 BLACK WALNUT LN
 0060/0977 (PRDR)

018 " DIA CIR PLASTIC

DIR: B TOTAL LEN: 2.895 MI. DIST: 11-1 SR: 1010
 LEFT MUN: INDIANA T RIGHT MUN: INDIANA T

Stationing	Notes	Stationing	Notes
012910 FT	0060/0047 LEN=0030 INSTALLED UNKN	012910 FT	1 1 03757 0 00 0040+43
	INDIANA		HAMPTON T
	5 0060/0000 LENGTH(AH 2378 BK 1949)		018 "DIA CIRC PLASTIC
	0050/1653 LEN=0030 INSTALLED UNKN		024 "DIA CIRC CONCR
	0050/1436 LEN=0035 INSTALLED UNKN		018 "DIA CIRC CONCR
	0050/0636 LEN=0025 INSTALLED UNKN		018 "DIA CIRC CONCR
010961 FT	0050/0216 LEN=0099 INSTALLED UNKN	010961 FT	1 1 03757 0 00 0021+51
	5 0050/0000 LENGTH(AH 1949 BK 2062)		018 "DIA CIRC CONCR
	0040/1912 LEN=0030 INSTALLED UNKN		018 "DIA CIRC CONCR
GREEN VALLEY DR (T930)	0040/1605 ==	0040/1691	LEN=0030 INSTALLED UNKN
	0040/1438		018 "DIA CIRC CONCR
	0040/0625 ==		LEN=0035 INSTALLED UNKN
FARMVIEW DR (T922)	008899 FT	008899 FT	MIDDLE RD (CNTY)
1 1 03757 0 00 0000+00	5 0040/0000		LENGTH(AH 2062 BK 3070)
MIDDLE RD (CNTY)			018 "DIA CIRC CONCR
	0030/3019		LEN=0099 INSTALLED UNKN
	0030/2933		024 "DIA CIRC CONCR
	0030/2399		LEN=0035 INSTALLED UNKN
	0030/2264		018 "DIA CIRC CONCR
			LEN=0035 INSTALLED UNKN
	0030/2200 ==		012 "DIA CIRC CONCR
			LEN=0055 INSTALLED UNKN
	0030/1868		SUNNYFIELD DR (TWP)
	0030/1600		018 "DIA CIRC CONCR
			LEN=0055 INSTALLED UNKN
			018 "DIA CIRC CONCR
			LEN=0060 INSTALLED UNKN
	0030/0945 ==		FERNWOOD LN (TWP)
			060"H 60"W CON BOX CUL

DIR: B TOTAL LEN: 2.895 MI. DIST: 11-1 SR: 1010
 LEFT MUN: HAMPTON T RIGHT MUN: HAMPTON T

1 1 03578 0 00 0058+31 005829 FT
 WOODLAND RD
 (T598)

003566 FT

ROSANNA DR
 (T612)

0010/1870

000000 FT

0030/0296	LEN=0040	INSTALLED UNKN
0030/0170	CLEARVIEW RD	(T357)
005829 FT		
0030/0000	LENGTH(AH 3070 BK 2263)	
0020/2207	030 "DIA CIRC CONCR	INSTALLED UNKN
0020/1563	018 "DIA CIRC CONCR	INSTALLED UNKN
0020/1247	018 "DIA CIRC CONCR	INSTALLED UNKN
0020/0542	018 "DIA CIRC CONCR	INSTALLED UNKN
0020/0213	018 "DIA CIRC CONCR	INSTALLED UNKN
003566 FT	1 1 03578 0 00 0035+81	
0020/0000	048 "DIA CIRC CONCR	INSTALLED UNKN
0010/2928	LENGTH(AH 2263 BK 3566)	
0010/2393	018 "DIA CIRC CONCR	INSTALLED UNKN
0010/1980	018 "DIA CIRC CONCR	INSTALLED UNKN
0010/1334	LEN=0035	INSTALLED UNKN
0010/1032	015 "DIA CIRC CONCR	INSTALLED UNKN
0010/0600	018 "DIA CIRC CONCR	INSTALLED UNKN
0010/0068	LEN=0088	INSTALLED UNKN
0010/0050	BMSSEN 02/1010/0010/0050	
000000 FT	0 0 00000 0 00 0000+00	
	GOURDHEAD RUN	
	BMSBG 02/1010/0010/0050	
	1 1 03578 0 00 0000+00	
	NC HARTS RUN RD	
	WILLIAM FLYNN HW	
	(SR0008 SEG 0311/3045)	
	(SR0008 SEG 0310/3076)	
0010/0000	MFC BEGIN = C	
	LENGTH(AH 3566 BK 0000)	

DIR: B TOTAL LEN: 2.033 MI. DIST: 11-1 SR: 1009
 LEFT MUN: FOX CHAPEL B RIGHT MUN: FOX CHAPEL B

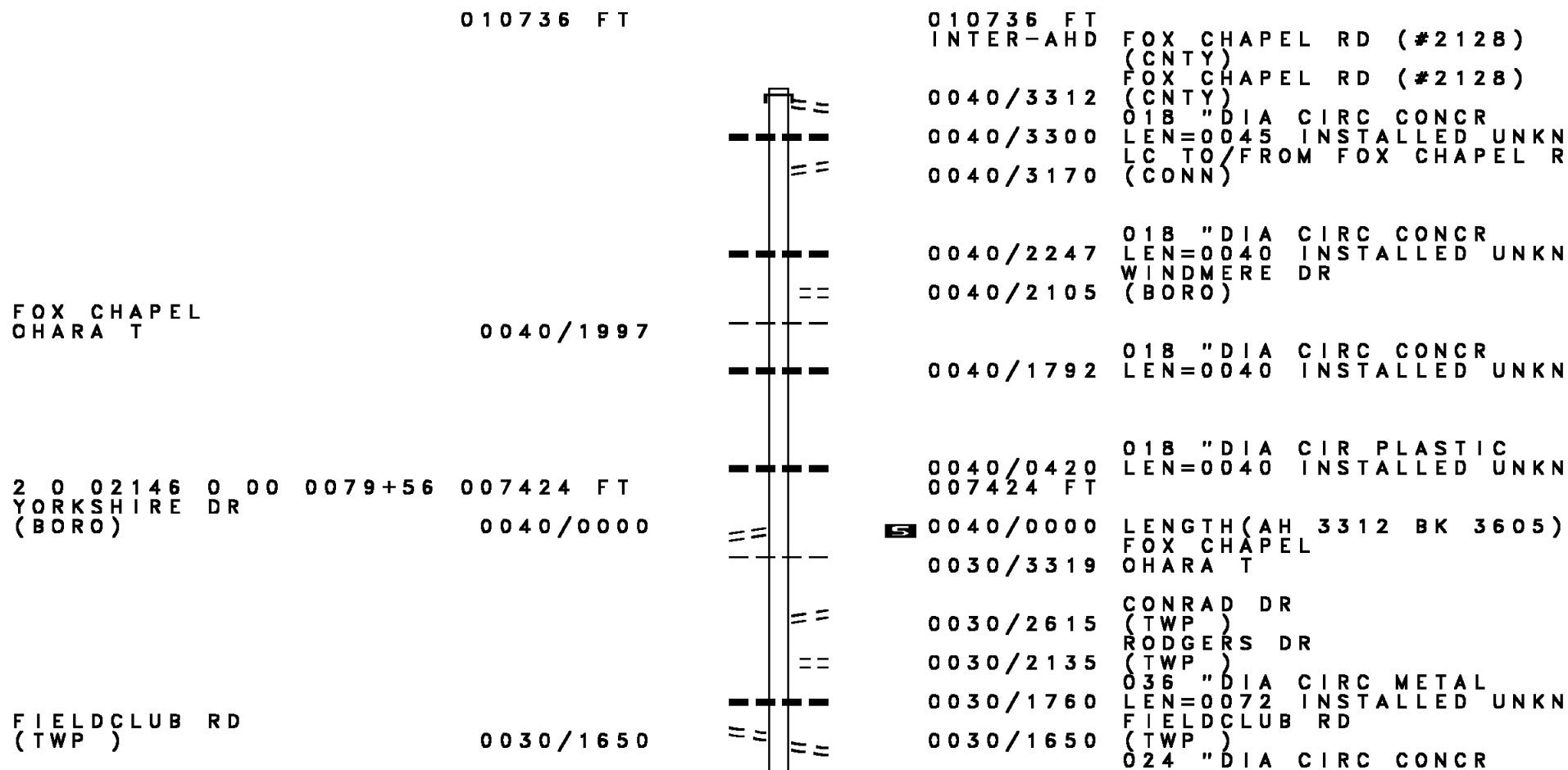

FOX CHAPEL
OHARA T

0040/1997

2 0 02146 0 00 0079+56 007424 FT
YORKSHIRE DR
(BORO)

0040/0000

FIELDCLUB RD
(TWP)

0030/1650

DIR: B TOTAL LEN: 2.033 MI. DIST: 11-1 SR: 1009
 LEFT MUN: OHARA T RIGHT MUN: OHARA T

CABIN LN
(TWP)

0030/0830

FALCONHURST DR
(TWP)
ALMA DR
(TWP)

0020/2770

0020/2465

WHITE GATE RD
(TWP)

0020/1585

CAMBERWELL DR
(TWP)

0020/0810

000782 FT

000000 FT

0030/1178	LEN=0040	INSTALLED UNKN
0030/0973	018 "DIA	CIRC METAL
0030/0895	LEN=0030	INSTALLED UNKN
	ORCHARD HILL DR	(TWP)
0030/0640	018 "DIA	CIRC CONCR
0030/0470	LEN=0072	INSTALLED UNKN
	DRIFTWOOD DR	(TWP)
0030/0270	018 "DIA	CIRC CONCR
003819 FT	LEN=0072	INSTALLED UNKN
	2 0 02146 0 00 0040+00	AQUA DR
		(TWP)
0030/0000	LENGTH(AH 3605 BK 3037)	
0020/2310	024 "DIA	CIR PLASTIC
0020/2240	LEN=0056	INSTALLED UNKN
	LOCUST DR	(TWP)
0020/1935	018 "DIA	CIRC CONCR
	LEN=0030	INSTALLED UNKN
	CORAL DR	(TWP)
0020/1021	018 "DIA	CIRC CONCR
	LEN=0030	INSTALLED UNKN
0020/0749	OP ID RT 28 SB	02/0028/0241/0000
0020/0632	OP ID RT 28 NB	02/0028/0240/0000
000782 FT	2 0 02146 0 00 0007+78	
0020/0000	LENGTH(AH 3037 BK 0782)	
000000 FT	2 0 02146 0 00 0000+00	
	NC POWERS RUN RD	FREEPORT RD
		(SR1001 SEG 0180/0000)
0010/0000	MFC BEGIN = C	LENGTH(AH 0782 BK 0000)

EXTRACT DATE: 12/21/2020 ROADWAY MANAGEMENT SYSTEM PAGE NUMBER: 544
 PRINT DATE: 12/23/2020 SLD COUNTY/SR - ANNUAL PRINT COUNTY: ALLEGHENY
 DIR: B TOTAL LEN: 1.316 MI. DIST: 11-1 SR: 1008
 LEFT MUN: HARMAR T RIGHT MUN: HARMAR T

FROM 1015/0031 SH
 (CONN)

GULF LAB RD ET
 (T595)

006948 FT

0030/2054

0030/1675

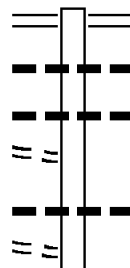

006948 FT RUSSELLTON RD
 0030/2184 (SR1015 SEG 0030/0270)
 018 "DIA CIRC METAL
 0030/2109 LEN=0030 INSTALLED UNKN
 018 "DIA CIRC METAL
 0030/2094 LEN=0001 INSTALLED UNKN
 018 "DIA CIRC METAL
 0030/1694 LEN=0060 INSTALLED UNKN

U PARC ENTRANCE RD
(PRDR)

004764 FT
0030/0000

OLD 910 RD
(T862)

0010/0285
000000 FT

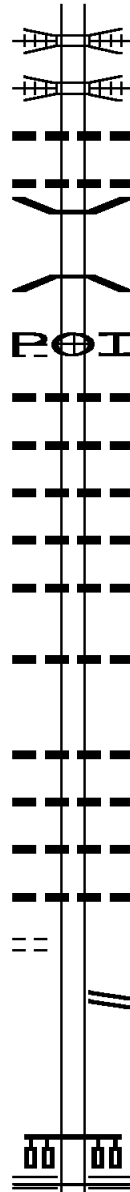

0030/1237	BESSEMER AND LAKE ERIE OVERPASS IS RR X-ING
0030/1136	BESSEMER AND LAKE ERIE OVERPASS IS RR X-ING
0030/0775	018 "DIA CIRC METAL LEN=0030 INSTALLED UNKN 015 "DIA CIRC CONCR
0030/0679	LEN=0050 INSTALLED UNKN
0030/0391	BMSSEN 02/1008/0030/0080 2 0 02215 0 00 0047+44 INTERSTATE 76
0030/0080	BMSBG 02/1008/0030/0080 2 0 02215 0 00 0047+44
0030/0000	(APRA) IT CORPORATION LENGTH(AH 2184 BK 2387) 015 "DIA CIRC METAL
0020/2303	LEN=0035 INSTALLED UNKN 018 "DIA CIRC METAL
0020/1892	LEN=0074 INSTALLED UNKN 018 "DIA CIRC METAL
0020/1419	LEN=0099 INSTALLED UNKN 018 "DIA CIR UNKNOWN
0020/1164	LEN=0099 INSTALLED UNKN 018 "DIA CIRC METAL
0020/0858	LEN=0099 INSTALLED UNKN 018 "DIA CIR UNKNOWN
0020/0036	LEN=0099 INSTALLED UNKN
0020/0000	2 0 02215 0 00 0023+57 LENGTH(AH 2387 BK 2377) 018 "DIA CIRC METAL
0010/1937	LEN=0060 INSTALLED UNKN 018 "DIA CIRC METAL
0010/1486	LEN=0040 INSTALLED UNKN 018 "DIA CIRC METAL
0010/1149	LEN=0050 INSTALLED UNKN 024 "DIA CIRC CONCR
0010/0761	LEN=0060 INSTALLED UNKN
0010/0154	SR 9110 SH (SR9110 SEG 0010/0180)
000000 FT	2 0 02215 0 00 0000+00 NC GU LF LAB RD GIBSONIA RD (SR0910 SEG 0450/0610) (SR0910 SEG 0451/0630)
0010/0000	MFC BEGIN = D LENGTH(AH 2377 BK 0000)

DIR: B TOTAL LEN: .729 MI. DIST: 11-1 SR: 1007
 LEFT MUN: SHALER T RIGHT MUN: SHALER T

Location	Length (FT)	Notes
DORSEYVILLE RD (SR1003 SEG 0080/0000)	003849 FT	DORSEYVILLE RD (SR1003 SEG 0080/0000)
ROBIN DEL DR (TWP)	0020/3412	0020/3185 NC DORSEYVILLE RD 018 "DIA CIRC CONCR LEN=0045 INSTALLED UNKN
ALETA ST (TWP)	0020/2287	0020/2027 018 "DIA CIRC CONCR LEN=0035 INSTALLED UNKN
BETHANY DR (TWP)	0020/1345	
FOUNDRY ST (BORO)	0020/1147	
	0020/0261	
	000437 FT	0020/0225 018 "DIA CIRC CONCR LEN=0040 INSTALLED UNKN
		000437 FT 2 0 02241 0 00 0062+60 NC SHARPSHILL RD SEIFRIED LN (SR1004 SEG 0010/0000) CHARA SHALER T
		0020/0000 LENGTH(AH 3412 BK 0243) 015 "DIA CIR PLASTIC
BERNER ST (BORO)	0014/0095	0014/0095 LEN=0030 INSTALLED UNKN
	000194 FT	000194 FT 2 0 02351 0 00 0021+81 REF-BK RAVINE ST (TBK) (BORO)
		0014/0000 LENGTH(AH 0243 BK 2003)
		000194 FT LENGTH(AH 2003 BK 0194) REF-AHD RAVINE ST (TBK) (BORO)
		0010/0194 SHARPSBURG B
		0010/0167 OP ID 02/0028/0151/0600 RT 0028 NB
		0010/0097 OP ID 02/0028/0150/0470
		000000 FT 2 0 02351 0 00 0000+00 NC RAVINE ST HIGH ST (BORO)
		MFC BEGIN = E
		0010/0000 LENGTH(AH 0194 BK 0000)

037547 FT

037547 FT
 INTER-AHD RICH HILL RD
 (TWP)
 GIBSONIA RD
 (SR0910 SEG 0420/0727)

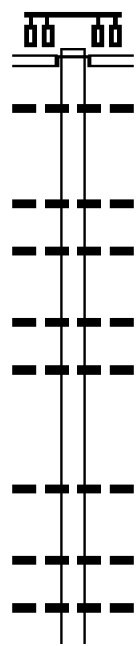

0130/3570 018 " DIA CIRC CONCR
 LEN=0220 INSTALLED UNKN

0130/3060 015 " DIA CIRC CONCR
 LEN=0040 INSTALLED 2002
 015 " DIA CIRC METAL
 LEN=0040 INSTALLED 2002

0130/2100 015 " DIA CIRC CONCR
 LEN=0050 INSTALLED UNKN
 015 " DIA CIRC CONCR
 LEN=0040 INSTALLED UNKN

0130/1700 015 " DIA CIRC CONCR
 LEN=0050 INSTALLED UNKN
 015 " DIA CIRC CONCR
 LEN=0040 INSTALLED UNKN

0130/0850 015 " DIA CIRC CONCR
 LEN=0050 INSTALLED UNKN
 015 " DIA CIRC CONCR
 LEN=0040 INSTALLED UNKN

0130/0795 2 0 02144 0 00 0039+90
 LENGTH(AH 3570 BK 3998)
 018 " DIA CIRC METAL
 LEN=0040 INSTALLED UNKN

033977 FT
 0120/3902 015 " DIA CIRC CONCR
 LEN=0050 INSTALLED UNKN
 015 " DIA CIRC CONCR
 LEN=0035 INSTALLED UNKN
 015 " DIA CIRC CONCR

033977 FT

DIR: B TOTAL LEN: 7.111 MI. DIST: 11-1 SR: 1006
 LEFT MUN: HARMAR T RIGHT MUN: HARMAR T

---	0120/2775	LEN=0035	INSTALLED	UNKN
---	0120/2296	LEN=0030	INSTALLED	UNKN
---	0120/2240	LEN=0006	INSTALLED	UNKN
---	0120/1570	LEN=0040	INSTALLED	UNKN
---	0120/0213	LEN=0040	INSTALLED	UNKN
---	0120/0033	LEN=0050	INSTALLED	UNKN
029979 FT	029979 FT	2 0 02144	0 00 0000+00	
		GUY RUN RD (SR1011 SEG 0040/2068)		
		NC LO CUST HILL RD		
		INTER-BK GUY RUN RD (SR1011 SEG 0040/2068)		
	0120/0000	LENGTH(AH 3998	BK 1515)	
		DREMEL RD (TWP)		
	0110/1270	LEN=0055	INSTALLED	UNKN
	0110/0830	LEN=0055	INSTALLED	UNKN
028464 FT	028464 FT	1 1 03758	0 00 0035+46	
	0110/0000	LENGTH(AH 1515	BK 3168)	
		MEADOWVALE DR (TWP)		
	0100/2985	HARMAR INDIANA T		
	0100/2810	LEN=0050	INSTALLED	UNKN
	0100/2423	LEN=0050	INSTALLED	UNKN
	0100/1512	LEN=0040	INSTALLED	UNKN
	0100/1161	LEN=0040	INSTALLED	UNKN
		(APRA) HARMARVILLE REHA REX NEWTON DR		
	0100/0964	(PRDR)		
	0100/0427	LEN=0040	INSTALLED	UNKN
025296 FT	025296 FT	1 1 03758	0 00 0000+00	
		NC GUY RUN RD		

FOX CHASE DR (PRDR)

029979 FT

0110/1307

028464 FT

025296 FT

POT

DIR: B TOTAL LEN: 7.111 MI. DIST: 11-1 SR: 1006
 LEFT MUN: INDIANA T RIGHT MUN: INDIANA T

Street Name	Segment ID	Start Station	End Station	Notes
				FOX CHAPEL RD (CNTY) INDIANA
	5 0100/0000			FOX CHAPEL B LENGTH(AH 3168 BK 3379)
				012 " DIA CIRC CONCR
	0090/3372			LEN=0050 INSTALLED UNKN
				FOX CHAPEL RD (CNTY)
	0090/3119			018 " DIA CIRC CONCR
				0090/3089 LEN=0035 INSTALLED UNKN
				024 " DIA CIRC CONCR
	0090/2502			LEN=0035 INSTALLED UNKN
OLD PINE LN (PRDR)	0090/2130			
				024 " DIA CIRC METAL
	0090/1822			LEN=0042 INSTALLED UNKN
				SHIRL DR (BORO)
HUMES FARM LN (PRDR)	0090/1775			
				CHAPEL KNOLL DR (PRDR)
	0090/1575			018 " DIA CIRC METAL
				0090/1057 LEN=0040 INSTALLED 2002
OLD MILL RD (T624)	0090/0814			
				OLD MILL RD (T624)
	0090/0735			018 " DIA CIRC METAL
				0090/0668 LEN=0035 INSTALLED UNKN
				036 " DIA CIRC CONCR
	0090/0304			LEN=0050 INSTALLED UNKN
WALNUT RIDGE DR (BORO)	0090/0220			
				018 " DIA CIRC CONCR
	0090/0169			LEN=0040 INSTALLED 2002
				FAWN MEADOW CT (BORO)
	0090/0075			2 0 02284 0 00 0038+47
021917 FT	5 0090/0000			LENGTH(AH 3379 BK 3851)
				012 " DIA CIRC CONCR
	0080/3660			LEN=0040 INSTALLED UNKN
				012 " DIA CIRC CONCR
	0080/3515			LEN=0040 INSTALLED UNKN
				018 " DIA CIRC CONCR
	0080/3417			LEN=0066 INSTALLED UNKN
				DOGWOOD LN (BORO)
	0080/3223			018 " DIA CIRC CONCR

DIR: B TOTAL LEN: 7.111 MI. DIST: 11-1 SR: 1006
 LEFT MUN: INDIANA T RIGHT MUN: INDIANA T

Location	Segment ID	Length	Material	Status
	0080/3038	LEN=0066	INSTALLED	UNKN
	0080/2970	024 "DIA	CIRC CONCR	
	0080/2586	LEN=0050	INSTALLED	UNKN
	0080/2534	LEN=0050	INSTALLED	UNKN
HIGH VIEW AV (T626)	0080/2421			
STROHM DR (PRDR)	0080/1939			
	0080/1121	OAK KNOLL DR (T622)		
	0080/0282	018 "DIA	CIRC CONCR	
2 0 02284 0 00 0000+00	018066 FT	LEN=0035	INSTALLED	UNKN
DORSEYVILLE RD (CNTY)	0080/0000	NC FOX CHAPEL RD		
	0070/1504	LENGTH(AH 3851 BK 1976)		
	0070/0815	018 "DIA	CIRC CONCR	
HODIL TE (T511)	0070/0683	LEN=0040	INSTALLED	UNKN
RAMON DR (T711)	0070/0390			
	0070/0071	012 "DIA	CIRC CONCR	
	0070/0006	024 "DIA	CIRC CONCR	
016090 FT	016090 FT	LEN=0200	INSTALLED	UNKN
	0070/0000	2 0 02283 0 00 0000+00		
	0070/0000	NC DORSEYVILLE RD		
	0060/3090	DORSEYVILLE RD (CNTY)		
	0060/3008	LENGTH(AH 1976 BK 3911)		
	0060/2306	024"H 12"W CON BOX CUL		
MALLARD DR (CNTY)	0060/2055	INDIANA		
		FOX CHAPEL B		
		018 "DIA	CIRC CONCR	
		LEN=0040	INSTALLED	UNKN

DIR: B TOTAL LEN: 7.111 MI. DIST: 11-1 SR: 1006
 LEFT MUN: INDIANA T RIGHT MUN: INDIANA T

1 1 03757 0 00 0063+92 012179 FT
 SAXONBURG BL
 (SR1013 SEG 0080/0000)
 HARTS RUN RD
 (SR1010 SEG 0060/2378) 0060/0000

BIGLER DR
 (TWP) 0040/1460

009670 FT

009670 FT

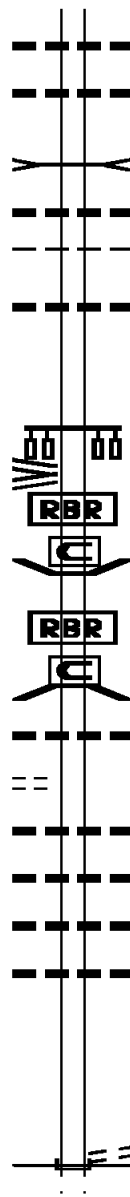

0060/1994 018 " DIA CIRC OTHER
 LEN=0030 INSTALLED UNKN
 0060/1699 018 " DIA CIRC CONCR
 LEN=0035 INSTALLED UNKN
 SMALL RUN
 STRUCTURE LENGTH 8 FT
 0060/1320 BMSID 02/1006/0060/1320
 015 " DIA CIRC CONCR
 0060/1218 LEN=0030 INSTALLED UNKN
 FOX CHAPEL
 0060/1150 INDIANA T
 018 " DIA CIRC METAL
 0060/1010 LEN=0030 INSTALLED UNKN

012179 FT
 NC HARTS RUN RD
 0060/0000 LENGTH(AH 3911 BK 2509)
 BMSEN 02/1006/0040/2405
 0040/2509 2 0 02248 0 00 0157+74
 P3
 BRIDGE CLOSED
 NO UNDERPASS INFORMATION
 0040/1951 BMSBG 02/1006/0040/2405
 018 " DIA CIRC CONCR
 0040/1852 LEN=0060 INSTALLED UNKN

0040/0957 018 " DIA CIRC CONCR
 LEN=0050 INSTALLED UNKN
 0040/0828 018 " DIA CIRC OTHER
 LEN=0040 INSTALLED UNKN
 0040/0409 018 " DIA CIRC METAL
 LEN=0040 INSTALLED UNKN
 0040/0251 018 " DIA CIRC CONCR
 LEN=0035 INSTALLED UNKN
 009670 FT 2 0 02248 0 00 0157+74
 KLEIN RD (TBK)
 (T772)
 NC SA XONBURG BL
 INTER-BK SAXONBURG BL
 (SR1013 SEG 0070/0494)
 MFC BEGIN = C
 0040/0000 LENGTH(AH 2509 BK 0648)
 009670 FT

DIR: B TOTAL LEN: 7.111 MI. DIST: 11-1 SR: 1006
 LEFT MUN: INDIANA T RIGHT MUN: INDIANA T

Stationing	Segment Description	Length	Notes
009651 FT	7038/0000 REF-AHD KLEIN RD (TBK)	009651 FT	LENGTH(AH 0648 BK 0019) BMSSEN 02/1006/0036/0000 (T772)
009651 FT	0036/0000 REF-BK KLEIN RD (TBK)	009651 FT	LENGTH(AH 0019 BK 2640) (T772)
009651 FT	7034/0000 INTER-AHD KLEIN RD (TBK)	009651 FT	LENGTH(AH 2640 BK 2500) (T772)
0030/2308	MIDDLE RD (CNTY)	0030/2308	LENGTH(AH 2500 BK 2308) (T772)
0030/1560	UNKNOWN RD (PRDR)	0030/1560	MIDDLE RD (CNTY)
007343 FT	0030/1400	007343 FT	018 " DIA CIR PLASTIC LEN=0035 INSTALLED UNKN
	0030/1074		018 " DIA CIRC METAL LEN=0030 INSTALLED UNKN
	0030/0707		INDIANA SHALER T
007343 FT	0030/0345	007343 FT	018 " DIA CIR PLASTIC LEN=0030 INSTALLED UNKN
	0030/0000		2 0 02349 0 00 0073+65 PONDEROSA DR (TWP)
0020/2755	LAKESIDE DR (TWP)	0020/2755	LENGTH(AH 2308 BK 3560) 018 " DIA CIRC METAL LEN=0030 INSTALLED UNKN
	0020/2715		018 " DIA CIRC CONCR LEN=0050 INSTALLED UNKN
	0020/1750		DRESSEL RD (TWP)
0020/1380	LAKESIDE DR (TWP)	0020/1380	018 " DIA CIRC CONCR LEN=0025 INSTALLED UNKN
	0020/1240		CLARIDGE DR (TWP)

Stationing	Location	Notes
003783 FT		2 0 02349 0 00 0037+75 ZENO LN (TWP)
0010/3217	MANUEL DR (TWP)	5 0020/0000 LENGTH(AH 3560 BK 3783) 018 " DIA CIR PLASTIC 0010/3280 LEN=0035 INSTALLED UNKN
0010/3000		018 " DIA CIRC CONCR LEN=0025 INSTALLED UNKN LED RD (PRDR)
0010/2928		036 " DIA CIRC CONCR LEN=0025 INSTALLED UNKN
0010/2511	VICTORY DR (TWP)	
0010/2033		COLLEGE PARK RD (TWP)
0010/1279		JO ALYCE DR (TWP)
0010/1272		024 " DIA CIRC CONCR LEN=0025 INSTALLED UNKN
0010/1257		024 " DIA CIRC CONCR LEN=0030 INSTALLED UNKN
0010/1155		024 " DIA CIRC METAL LEN=0030 INSTALLED UNKN
0010/0877		FRANKLYNN DR (TWP)
0010/0867		018 " DIA CIRC CONCR LEN=0025 INSTALLED UNKN
0010/0597		WILLRUTH DR (TWP)
0010/0499	VICTORY RD (TWP)	
0010/0485		BMS EN 02/1006/0010/0342 2 0 02349 0 00 0003+56 PINE CREEK
000000 FT		0010/0369 BMSBG 02/1006/0010/0342 000000 FT 2 0 02349 0 00 0000+00 NC BU RCHFIELD RD WILLIAM FLYNN HW (SRO008 SEG 0290/0000) (SRO008 SEG 0291/0000)
0010/0000		5 0010/0000 MFC BEGIN = D LENGTH(AH 3783 BK 0000)

EXTRACT DATE: 12/21/2020 ROADWAY MANAGEMENT SYSTEM PAGE NUMBER: 534
 PRINT DATE: 12/23/2020 SLD COUNTY/SR - ANNUAL PRINT COUNTY: ALLEGHENY
 DIR: N TOTAL LEN: .775 MI. DIST: 11-1 SR: 1005
 LEFT MUN: OHARA T RIGHT MUN: OHARA T

SR 8082 RAMP 250 RD 003807 FT
 (SR8082 SEG 0250/0000)
 RAMP A FROM SR 0028 NB INTER-AHD
 (SR8050 SEG 0010/1172) 0021/2763

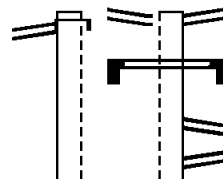

004094 FT RAMP D TO SR 0028 NB SH
 (SR8050 SEG 0750/0000)
 RAMP C TO SR 0028 SB SH
 (SR8050 SEG 0250/0000)
 SIGN: 2 CHORD TRUSS
 0020/2995 BMSID 02/1005/0020/3111
 RAMP G FROM SR 1001 SH
 0020/2844 (SR8082 SEG 0510/0995)
 RAMP F TO SR 1001 SH
 0020/2709 (SR8082 SEG 0500/0000)

DIR: N TOTAL LEN: .775 MI. DIST: 11-1 SR: 1005
 LEFT MUN: OHARA T RIGHT MUN: OHARA T

Stationing	Description	Stationing	Description
009 " DIA CIRC CONCR			
LEN=0020 INSTALLED UNKN	0021/2699		
RAMP K FROM SR 1001 SH			
(SR8082 SEG 0260/0509)	0021/2534		
BMS EN 02/1005/0020/2521	0021/2498	0020/2477	BMS EN 02/1005/0020/2521
2 0 00260 8 00 0033+55			0000000 0 00 0000+00
FREEPORT ROAD SB			FREEPORT ROAD SB
BMSBG 02/1005/0020/2521	0021/2426	0020/2405	BMSBG 02/1005/0020/2521
RAMP X FROM SR 1001 SH			
(SR8082 SEG 0270/0253)	0021/2394		
			RAMP W TO SR 1001 SH
			(SR8082 SEG 0520/0000)
BMS EN 02/1005/0020/0000	0021/2306	0020/2364	BMS EN 02/1005/0020/0000
SIGN: 4 CHORD TRUSS		0020/2306	SIGN: 4 CHORD TRUSS
BMSID 02/1005/0020/2209	0021/2110	0020/2093	BMSID 02/1005/0020/2209
			SIGN: 4 CHORD TRUSS
SIGN: 4 CHORD TRUSS		0020/1241	BMSID 02/1005/0020/1357
BMSID 02/1005/0020/1357	0021/1284		
		0020/0739	OHARA
		0020/0719	SHARPSBURG B
		0020/0241	SHARPSBURG
			ASPINWALL B
			ASPINWALL
SIGN: 4 CHORD TRUSS		0020/0198	SHARPSBURG B
BMSID 02/1005/0020/0314	0021/0211		SIGN: 4 CHORD TRUSS
		0020/0032	BMSID 02/1005/0020/0314
		000968 FT	SHARPSBURG
2 0 02260 8 00 0008+93	001044 FT		PITTSBURGH C
RAMP C TO SR 0008 SH			2 0 02260 8 00 0008+93
(SR8082 SEG 0010/0000)			RAMP D FROM SR 0008 SH
SR 0008			(SR8082 SEG 0750/0623)
BMSBG 02/1005/0020/0000			SR 0008
LENGTH(AH 2763 BK 1044)	0021/0000	0020/0000	BMSBG 02/1005/0020/0000
BMS EN 02/1005/0010/0823	0011/1044	0010/0968	LENGTH(AH 3126 BK 0968)
2 0 02260 4 00 0000+00			BMS EN 02/1005/0010/0823
SR 0008			2 0 02260 4 00 0000+00
BMSBG 02/1005/0010/0823	0011/0928	0010/0852	SR 0008
OHARA			BMSBG 02/1005/0010/0823
PITTSBURGH C	0011/0863		
		0010/0350	018 " DIA CIRC CONCR
2 0 02260 4 00 0000+00	000000 FT	000000 FT	LEN=0099 INSTALLED UNKN
ALLEGHENY RIVER BL			2 0 02260 4 00 0000+00
(SRO008 SEG 0140/1024)			ALLEGHENY RIVER BL
NC HIGHLAND PK BR			(SRO008 SEG 0145/0000)
ALLEGHENY RIVER BL	INTER-BK	INTER-BK	NC HIGHLAND PK BR
(SRO008 SEG 0140/1024)			ALLEGHENY RIVER BL
MFC BEGIN = B			(SRO008 SEG 0145/0000)
LENGTH(AH 1044 BK 0000)	0011/0000	0010/0000	MFC BEGIN = B
			LENGTH(AH 0968 BK 0000)

EXTRACT DATE: 12/21/2020 ROADWAY MANAGEMENT SYSTEM PAGE NUMBER: 532
 PRINT DATE: 12/23/2020 SLD COUNTY/SR - ANNUAL PRINT COUNTY: ALLEGHENY

DIR: B TOTAL LEN: 1.166 MI. DIST: 11-1 SR: 1004
 LEFT MUN: OHARA T RIGHT MUN: OHARA T

KITTANNING PK 006157 FT
 (SR1003 SEG 0030/0000) 0030/2439
 FOR SR 1003 AND 1004
 (CONN) 0030/2363

WINSHELL ST
 (TWP) 0030/2300

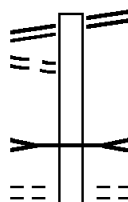

006157 FT KITTANNING PK
 0030/2439 (SR1003 SEG 0030/0000)

0030/2337 TRIBUTARY TO SEITZ RUN
 STRUCTURE LENGTH 8 FT
 BMSID 02/1004/0030/2337
 LOWER RD
 0030/2300 (TWP)

DIR: B TOTAL LEN: 1.166 MI. DIST: 11-1 SR: 1004
 LEFT MUN: OHARA T RIGHT MUN: OHARA T

ALSOP RD
 (TWP)

0030/0555
 003718 FT

ALLEY
 (TWP)

0010/0299

000000 FT

SHARPS HILL RD
 (SR1007 SEG 0020/0000) 0010/0000

---	0030/1809	018 " DIA	CIRC CONCR	
---		LEN=0040	INSTALLED	2002
---	0030/1542	018 " DIA	CIRC CONCR	
---		LEN=0010	INSTALLED	2002
---	0030/1360	018 " DIA	CIRC CONCR	
---		LEN=0030	INSTALLED	UNKN
---	0030/1107	018 " DIA	CIRC CONCR	
---		LEN=0030	INSTALLED	2002
---	0030/0800	018 " DIA	CIRC CONCR	
---		LEN=0035	INSTALLED	2002
==	003718 FT	2 0 02241	0 00 0024+62	
5	0030/0000	LENGTH(AH 2439 BK 2432)		
---	0020/0963	018 " DIA	CIRC CONCR	
---		LEN=0010	INSTALLED	2002
---	0020/0804	018 " DIA	CIRC CONCR	
---		LEN=0035	INSTALLED	2002
---	0020/0655	018 " DIA	CIRC CONCR	
---		LEN=0035	INSTALLED	2002
---	0020/0370	018 " DIA	CIRC CONCR	
---		LEN=0040	INSTALLED	2002
001286 FT	001286 FT	2 0 02241	0 00 0049+35	
		SPRING GROVE AV		
==	5 0020/0000	LENGTH(AH 2432 BK 1286)		
---	0010/1280	018 " DIA	CIRC CONCR	
---		LEN=0040	INSTALLED	2014
		LINWOOD AV		
		(TWP)		
		NC KIRKWOOD DR		
		KIRKWOOD DR		
	0010/0950	(TWP)		
---	0010/0785	018 " DIA	CIRC CONCR	
---		LEN=0020	INSTALLED	UNKN
---	0010/0582	024 " DIA	CIRC CONCR	
---		LEN=0020	INSTALLED	UNKN
		(TWP)		
		018 " DIA CIRC CONCR		
		LEN=0020 INSTALLED UNKN		
		2 0 02241 0 00 0062+60		
		SHARPS HILL RD		
		(SR1007 SEG 0020/0000)		
		NC SE FRIED LN		
		MFC BEGIN = E		
5	0010/0000	LENGTH(AH 1286 BK 0000)		

BUTLER ST 021510 FT
 (SR4019 SEG 0010/0000)
 CRESECNT ST
 (SR4019 SEG 0010/0000)
 (AAR 145711W)#TRKS 01
 TO 0008/0191 SH
 (CONN)
 0 0 00000 0 00 0000+00
 BUTLER ST
 (SR0008 SEG 0201/0000)
 (SR0008 SEG 0200/0000)

MFC BEGIN = C
 LTH AH 000195 BK 000910 0101/0000

SPRUCE ST
 (TWP) 0090/0785

SNYDER ST
 (TWP) 0090/0285

020405 FT

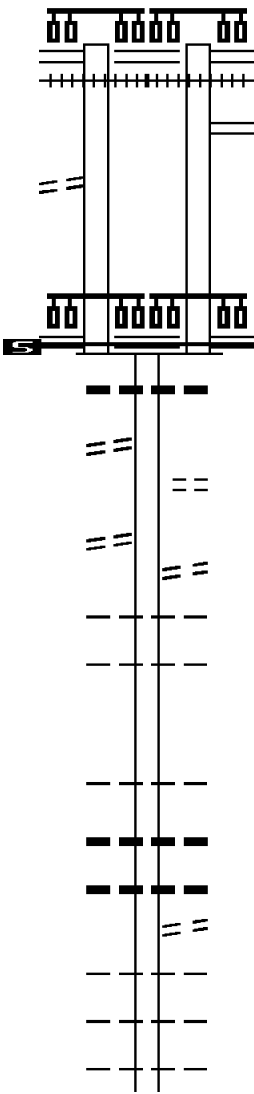

021973 FT BUTLER ST
 (SR4019 SEG 0010/0000)
 CRESENT ST
 (SR4019 SEG 0010/0000)
 (AAR 145711W)#TRKS 01
 BUTLER ST CONNECTOR
 (SR9405 SEG 0010/0198)
 0 0 00000 0 00 0000+00
 WILLIAM FLYNN HW
 (SR0008 SEG 0200/0000)
 (SR0008 SEG 0201/0000)

MFC BEGIN = C
 LENGTH(AH 0195 BK 0910)
 018 "DIA CIRC CONCR
 LEN=0030 INSTALLED UNKN

CATHERINE ST
 (TWP) 0090/0530

GREISMER ST
 (TWP) 0090/0175

ETNA BOROUGH
 SHALER T 0090/0157

SHALER
 ETNA BOROUGH B 0090/0016

1 0 00389 0 01 0009+83
 NC KI TANNING ST
 LENGTH(AH 0910 BK 3709)
 ETNA BOROUGH 0090/0000

SHALER T 0080/3550

018 "DIA CIRC CONCR
 LEN=0099 INSTALLED UNKN
 001 "DIA CIRC CONCR
 LEN=0001 INSTALLED UNKN

LINCOLN ST
 (BORO) 0080/3404

SHALER
 ETNA BOROUGH B 0080/3392

ETNA BOROUGH
 SHALER T 0080/3230

SHALER
 ETNA BOROUGH B 0080/3140

DIR: N TOTAL LEN: 4.162 MI. DIST: 11-1 SR: 1003
 LEFT MUN: SHALER T RIGHT MUN: SHALER T

1 0 00389 0 01 0047+31 016696 FT
 SHARPSHILL RD
 (SR1007 SEG 0020/3412) 0080/0000
 SPARROW LN
 (TWP) 0070/2485

ALSOP RD
 (TWP) 0070/1355

SCHENK TE
 (TWP) 0070/0600

2 0 02241 0 00 0123+05 014023 FT
 CREST DR
 (TWP) 0070/0000

BROOKDALE DR
 (TWP) 0060/2040

FAIRHAVEN DR
 (TWP) 0060/1585

0080/2900	ETNA BOROUGH SHALER T
0080/2642	036 " DIA CIRC CONCR LEN=0035 INSTALLED UNKN
0080/2147	015 " DIA CIRC CONCR LEN=0035 INSTALLED UNKN
0080/1854	015 " DIA CIRC CONCR LEN=0035 INSTALLED UNKN
0080/1400	018 " DIA CIRC CONCR LEN=0001 INSTALLED UNKN
0080/1190	018 " DIA CIRC CONCR LEN=0001 INSTALLED UNKN
0080/0395	BADALI DR (TWP)
0080/0295	THERESA DR (TWP)
017159 FT	SHALER OHARA T
0080/0000	LENGTH(AH 3709 BK 2673)
0070/2335	EMILY DR (TWP)
0070/1392	048 " DIA CIRC METAL LEN=0030 INSTALLED UNKN
0070/1005	COUNTRY CLUB DR (TWP)
014486 FT	
0070/0000	LENGTH(AH 2673 BK 3080)
0060/1860	024 " DIA CIR PLASTIC LEN=0099 INSTALLED UNKN
0060/0900	060 " DIA CIRC CONCR LEN=0072 INSTALLED UNKN 060 " DIA CIRC METAL

DIR: N TOTAL LEN: 4.162 MI. DIST: 11-1 SR: 1003
 LEFT MUN: OHARA T RIGHT MUN: OHARA T

IMPERIAL CT
 (TWP)

0060/0780

010943 FT

KIRKWALL DR
 (TWP)

0050/3025

007207 FT

HIGHMEADOW RD
 (TWP)

0040/0965

0060/0869	LEN=0040	INSTALLED UNKN
0060/0215	VILLAGE DR (TWP)	
011406 FT	2 0 02241 0 00 0153+87	
	NC DO	
	DORSEYVILLE RD	
	DORSEYVILLE RD	
	(CNTY)	
	MFC BEGIN = C	
0060/0000	LENGTH(AH 3080 BK 3736)	
	036 "DIA CIRC CONCR	
0050/3404	LEN=0030	INSTALLED UNKN
	FOX RIDGE FARMS DR	
	(TWP)	
0050/3260	024 "DIA CIRC CONCR	
0050/3231	LEN=0030	INSTALLED UNKN
	018 "DIA CIRC CONCR	
0050/2934	LEN=0030	INSTALLED UNKN
	RAVENCREST RD	
	(TWP)	
0050/2655	018 "DIA CIRC CONCR	
0050/2610	LEN=0030	INSTALLED UNKN
	024 "DIA CIRC CONCR	
0050/2250	LEN=0030	INSTALLED UNKN
	KERRWOOD RD	
	(TWP)	
0050/1860	018 "DIA CIRC CONCR	
0050/1574	LEN=0030	INSTALLED UNKN
	KERR LN	
	(TWP)	
0050/1300	018 "DIA CIRC CONCR	
0050/1052	LEN=0030	INSTALLED UNKN
	018 "DIA CIRC CONCR	
0050/0778	LEN=0035	INSTALLED UNKN
	018 "DIA CIRC CONCR	
0050/0035	LEN=0030	INSTALLED UNKN
007670 FT	1 0 00810 0 00 0076+81	
	MAURERS LN	
	(TWP)	
0050/0000	LENGTH(AH 3736 BK 1513)	
	018 "DIA CIRC CONCR	
0040/1170	LEN=0030	INSTALLED UNKN
	018 "DIA CIRC CONCR	
0040/0944	LEN=0030	INSTALLED UNKN

DIR: N TOTAL LEN: 4.162 MI. DIST: 11-1 SR: 1003
 LEFT MUN: OHARA T RIGHT MUN: OHARA T

COLLINWOOD DR
 (TWP)

0040/0075
 005694 FT

MURRAY ST
 (TWP)
 FOR SR 1003 AND 1004
 (CONN)

0030/0215
 0030/0090

1 0 00810 0 00 0035+44 003055 FT
 KIRKWOOD DR
 (SR1004 SEG 0030/2439) 0030/0000

==	0040/0865	NICHOLAS DR (TWP)
---	0040/0597	048 " DIA CIRC CONCR LEN=0099 INSTALLED UNKN
---	0040/0293	018 " DIA CIRC CONCR LEN=0030 INSTALLED UNKN
---	0040/0133	018 " DIA CIRC CONCR LEN=0030 INSTALLED UNKN
==	006157 FT	1 0 00810 0 00 0061+58 OAKHURST RD (TWP)
---	0040/0000	LENGTH(AH 1513 BK 2639) 024 " DIA CIRC CONCR
---	0030/2530	LEN=0072 INSTALLED UNKN
---	0030/2225	018 " DIA CIRC CONCR LEN=0060 INSTALLED UNKN
==	0030/1585	HARDING RD (TWP)
---	0030/1540	024 " DIA CIRC METAL LEN=0001 INSTALLED UNKN
---	0030/1369	036 " DIA CIRC CONCR LEN=0030 INSTALLED UNKN
==	0030/1258	DIVISION ST (TWP)
---	0030/1117	018 " DIA CIRC CONCR LEN=0030 INSTALLED UNKN
---	0030/0904	078 " DIA CIRC CONCR LEN=0030 INSTALLED UNKN
---	0030/0550	060 " DIA CIRC CONCR LEN=0001 INSTALLED UNKN
==	0030/0485	MARY ST (TWP)
---	0030/0423	018 " DIA CIRC CONCR LEN=0001 INSTALLED UNKN
==	0030/0215	JORDAN AV (TWP)
---	0030/0016	018 " DIA CIRC CONCR LEN=0030 INSTALLED UNKN
---	0030/0014	018 " DIA CIRC CONCR LEN=0030 INSTALLED UNKN
==	0030/0000	NC K I LENGTH(AH 2639 BK 1250)
---	0020/0769	BMS EN 02/1003/0020/0734 1 0 00810 0 00 0030+13

DIR: N TOTAL LEN: 4.162 MI. DIST: 11-1 SR: 1003
 LEFT MUN: OHARA T RIGHT MUN: OHARA T

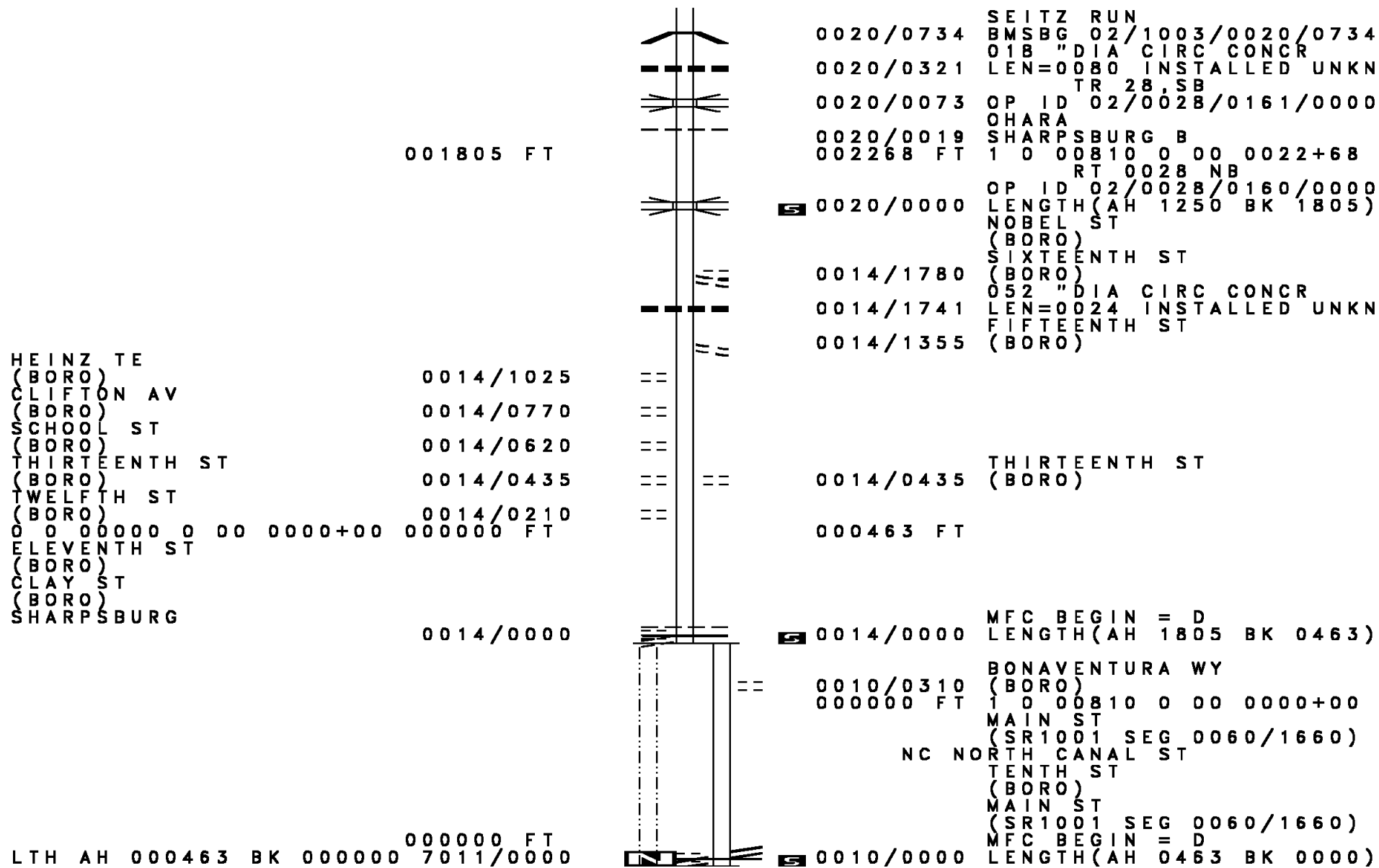

001805 FT

0020/0734 SEITZ RUN
 BMSBG 02/1003/0020/0734
 01B " DIA CIRC CONCR
 0020/0321 LEN=0080 INSTALLED UNKN
 TR 28, SB
 0020/0073 OP ID 02/0028/0161/0000
 OHARA
 0020/0019 SHARPSBURG B
 002268 FT 1 0 00810 0 00 0022+68
 RT 0028 NB
 0020/0000 OP ID 02/0028/0160/0000
 LENGTH(AH 1250 BK 1805)
 NOBEL ST
 (BORO)
 SIXTEENTH ST
 (BORO)
 0014/1780 052 " DIA CIRC CONCR
 0014/1741 LEN=0024 INSTALLED UNKN
 FIFTEENTH ST
 (BORO)
 0014/1355
 THIRTEENTH ST
 (BORO)
 0014/0435
 000463 FT
 MFC BEGIN = D
 0014/0000 LENGTH(AH 1805 BK 0463)
 BONAVENTURA WY
 (BORO)
 0010/0310 1 0 00810 0 00 0000+00
 000000 FT MAIN ST
 (SR1001 SEG 0060/1660)
 NC NORTH CANAL ST
 TENTH ST
 (BORO)
 MAIN ST
 (SR1001 SEG 0060/1660)
 0010/0000 MFC BEGIN = D
 LENGTH(AH 0463 BK 0000)

HEINZ TE
 (BORO) 0014/1025
 CLIFTON AV
 (BORO) 0014/0770
 SCHOOL ST
 (BORO) 0014/0620
 THIRTEENTH ST
 (BORO) 0014/0435
 TWELFTH ST
 (BORO) 0014/0210
 0 0 00000 0 00 0000+00 000000 FT
 ELEVENTH ST
 (BORO)
 CLAY ST
 (BORO)
 SHARPSBURG
 0014/0000

LTH AH 000463 BK 000000 7011/0000

DIR: E TOTAL LEN: .469 MI. DIST: 11-1 SR: 1002
 LEFT MUN: OHARA T RIGHT MUN: OHARA T

SPUR RD (SR9108 SEG 0010/0000) FREEPORT RD (SR1001 SEG 0151/0000) 018 "DIA CIRC CONCR LEN=0099 INSTALLED UNKN	002477 FT INTER-AHD 0021/0697 0021/0685		INTER-AHD FREEPORT RD (SR1001 SEG 0150/0000) FREEPORT RD (SR1001 SEG 0150/0000) 018 "DIA CIRC CONCR LEN=0099 INSTALLED UNKN 018 "DIA CIRC CONCR LEN=0099 INSTALLED UNKN BMSID 02/1002/0020/0000 1 0 00070 3 01 0235+40 SR 9108 BMSBG 02/1002/0020/0000 LENGTH(AH 0697 BK 1780) 018 "DIA CIRC CONCR LEN=0099 INSTALLED UNKN	0020/0777 0020/0554 0020/0195 0020/0155 001576 FT 0020/0000	0021/0155 001780 FT 0021/0000 0011/1778 0011/0916 0011/0893 0011/0595 0011/0465 0011/0200 000000 FT INTER-BK 0011/0000	0010/0856 0010/0731 0010/0484 0010/0231 000000 FT NC FR INTER-BK 0010/0000	TRIB TO ALLG STRUCTURE LENGTH 7 FT BMSID 02/1002/0010/0765 018 "DIA CIRC CONCR LEN=0020 INSTALLED UNKN 018 "DIA CIRC CONCR LEN=0050 INSTALLED UNKN 018 "DIA CIRC CONCR LEN=0040 INSTALLED UNKN 1 0 00070 3 00 0218+65 ALLEGHENY VALLEY EX (SR0028 SEG 0210/0192) FREEPORT RD ALLEGHENY VALLEY EX (SR0028 SEG 0210/0192) MFC BEGIN = C LENGTH(AH 1576 BK 0000)
--	--	--	---	--	---	---	---

AH-BUTLER (10) 119151 FT
 SR 2019 SH REF-AHD *
 (SR2019 SEG 0011/0000) 0511/2863 *
 036 "DIA CIRC CONCR
 LEN=0025 INSTALLED UNKN 0511/2837
 036 "DIA CIRC CONCR
 LEN=0050 INSTALLED UNKN 0511/2290
 MCINTYRE LN
 (TWP) 0511/2252
 048 "DIA CIRC CONCR
 LEN=0099 INSTALLED UNKN 0511/1723
 OLD RD
 (TWP) 0511/1236

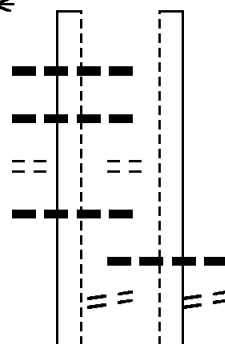

119185 FT AH-BUTLER (10)
 * REF-AHD SR 2019 SH
 0510/2841 (SR2019 SEG 0010/0000)
 0510/2245 MCINTYRE LN
 (TWP)
 0510/1305 018 "DIA CIRC CONCR
 0510/1233 LEN=0099 INSTALLED UNKN
 OLD RD
 (TWP)
 018 "DIA CIRC CONCR

DIR: B TOTAL LEN: 22.573 MI. DIST: 11-1 SR: 1001
 LEFT MUN: HARRISON T RIGHT MUN: HARRISON T

Left Side Description	Left Side Stationing	Left Side Length	Right Side Stationing	Right Side Length	Right Side Description
BAKERSTOWN RD (SR1028 SEG 0290/2829)	0511/0524	116288 FT	0510/0852	LEN=0099	INSTALLED UNKN BAKERSTOWN RD (SR1028 SEG 0290/2829)
1 0 00070 0 02 1429+82			0510/0508	116344 FT	1 0 00070 0 02 1430+47
ROCKY RD (PRDR)			0510/0000		ROCKY RD (PRDR)
LENGTH(AH 2863 BK 3061)	0511/0000		0510/0000		LENGTH(AH 2841 BK 3035)
ALTERMOOR DR (TWP)	0501/0000		0500/0767	LEN=0055	INSTALLED UNKN 018 "DIA CIRC CONCR
1 0 00070 0 02 1400+40		113227 FT	0500/0520	LEN=0062	INSTALLED UNKN 018 "DIA CIRC CONCR
LENGTH(AH 3061 BK 2546)	0501/0000		0500/0000		1 0 00070 0 02 1400+26
OLD RD (TWP)	0491/1850		0490/1860		ALTERMOOR DR (TWP)
HARRISON HILLS PR (PARK)	0491/1494		0490/1499		LENGTH(AH 3035 BK 2544)
HARTFORD DR (TWP)	0491/1275		0490/1430	LEN=0062	INSTALLED UNKN 024 "DIA CIRC CONCR
VETERANS LN (TWP)	0491/0665		0490/1280		HARTFORD DR (TWP)
OAK MANOR RD (SR1032 SEG 0110/3706)	0491/0485		0490/1110	LEN=0062	INSTALLED UNKN 018 "DIA CIRC CONCR
1 0 00070 0 02 1374+97		110681 FT	0490/0660		VETERANS LN (TWP)
EVERGREEN RD (TWP)	0491/0000		0490/0660		OAK MANOR RD (SR1032 SEG 0110/3706)
LENGTH(AH 2546 BK 3765)	0491/0000		0490/0485		HIGHLAND DR (TWP)
HIGHLANDS MALL DR (PRDR)	0481/2634		0480/2890	LEN=0099	INSTALLED UNKN 012 "DIA CIRC CONCR
			0480/2625		HIGHLANDS MALL DR (PRDR)

DIR: B TOTAL LEN: 22.573 MI. DIST: 11-1 SR: 1001
 LEFT MUN: HARRISON T RIGHT MUN: HARRISON T

Segment Description	Segment ID	Start Station	End Station	Length (FT)	Material	Status
LC FROM HIGHLANDS MALL (CONN)	0481/2566	106916	107032	116	010 DIA CIRC CONCR	INSTALLED UNKN
OLD FREEPORT RD (TWP)	0481/2004	106916	107032	116	010 DIA CIRC CONCR	INSTALLED UNKN
BONNIEVIEW DR (TWP)	0481/1545	106916	107032	116	018 DIA CIRC CONCR	INSTALLED UNKN
RAMBLER DR (TWP)	0481/0645	106916	107032	116	018 DIA CIRC CONCR	INSTALLED UNKN
OLIVE AV (TWP)	0481/0000	106916	107032	116	012 DIA CIRC CONCR	INSTALLED UNKN
OLD FREEPORT RD (TWP)	0471/1776	106916	107032	116	018 DIA CIRC CONCR	INSTALLED UNKN
SAXONBURG RD (SR1037 SEG 0010/0000)	0471/1375	106916	107032	116	024 DIA CIRC CONCR	INSTALLED UNKN
LENDEL AV (TWP)	0471/0830	106916	107032	116	018 DIA CIRC CONCR	INSTALLED UNKN
HARRISON AV (TWP)	0471/0765	106916	107032	116	024 DIA CIRC CONCR	INSTALLED UNKN
GORDON ST (TWP)	0471/0335	106916	107032	116	018 DIA CIRC CONCR	INSTALLED UNKN
WASHINGTON ST	0471/0452	106916	107032	116	018 DIA CIRC CONCR	INSTALLED UNKN

DIR: B TOTAL LEN: 22.573 MI. DIST: 11-1 SR: 1001
 LEFT MUN: HARRISON T RIGHT MUN: HARRISON T

Stationing	Description	Stationing	Description
(TWP)	0471/0269	0470/0395	(TWP)
1 0 00070 0 02 1312+35 104415 FT		0470/0123	DAVIS ST
DAVIS ST		(TWP)	
(TWP)		1 0 00070 0 02 1311+38	JEFFERSON AV
LENGTH(AH 2501 BK 3202)	0471/0000	(TWP)	
JEFFERSON AV		5 0470/0000	LENGTH(AH 2634 BK 3105)
(TWP)	0461/3080		
CROSSOVER RD			
(CONN)	0461/2725	0460/2730	CROSSOVER RD
		(CONN)	
		0460/2638	LC FROM PAINTER AV
018 "DIA CIRC CONCR			(CONN)
LEN=0099 INSTALLED UNKN	0461/2585		
CROSSOVER RD			
(CONN)	0461/2581	0460/2567	CROSSOVER RD
		(CONN)	
			PAINTER AV
		0460/2485	(TWP)
		(TWP)	
		0460/2380	COTTAGE AV
036 "DIA CIRC CONCR			(TWP)
LEN=0099 INSTALLED UNKN	0461/2200		018 "DIA CIRC CONCR
			LEN=0099 INSTALLED UNKN
		0460/1915	FROM 1032/0060 SH
024 "DIA CIRC CONCR		(CONN)	
LEN=0099 INSTALLED UNKN	0461/1700		
BURTNER RD			
(SR1032 SEG 0060/0000)			
BURTNER RD		0460/1835	BURTNER RD
(SR1032 SEG 0060/0000)	0461/1690		(SR1032 SEG 0060/0205)
		0460/1488	BURTNER RD
BEACON ST			(SR1032 SEG 0060/0205)
(TWP)			024 "DIA CIRC CONCR
018 "DIA CIRC CONCR	0461/1395		LEN=0026 INSTALLED UNKN
LEN=0040 INSTALLED UNKN	0461/1380		
ALLEY			
(TWP)	0461/1285		
LILAC ST			
(TWP)	0461/1150		
		0460/1106	018 "DIA CIRC CONCR
ROSS ST			LEN=0099 INSTALLED UNKN
(TWP)	0461/1050		ROSS ST
ALLEY			(TWP)
(TWP)	0461/1025		

DIR: B TOTAL LEN: 22.573 MI. DIST: 11-1 SR: 1001
 LEFT MUN: HARRISON T RIGHT MUN: HARRISON T

Street Name	Segment ID	Material	Length	Notes	Segment ID	Material	Length	Notes
MAPLE ST (TWP)	0461/0890							
					0460/0866	BROADVIEW BL (TWP)		
ALLEY (TWP)	0461/0765							
018 "DIA CIRC CONCR								
LEN=0020 INSTALLED UNKN	0461/0675							
POPLAR ST (TWP)	0461/0630							
ALLEY (TWP)	0461/0500							
018 "DIA CIRC CONCR								
LEN=0036 INSTALLED UNKN	0461/0430							
SPRING HILL RD (CNTY)	0461/0354				0460/0355	SPRING HILL RD (CNTY)		
					0460/0014	024 "DIA CIRC CONCR		
1 0 00070 0 02 1280+35 101213 FT					101293 FT	LEN=0030 INSTALLED UNKN		
HARVARD AV (TWP)					0460/0000	1 0 00070 0 02 1280+55		
LENGTH(AH 3202 BK 3262)	0461/0000					HARVARD AV (TWP)		
018 "DIA CIRC CONCR					0460/0000	LENGTH(AH 3105 BK 3261)		
LEN=0048 INSTALLED UNKN	0451/3040							
					0450/3003	036 "DIA CIRC CONCR		
018 "DIA CIRC CONCR						LEN=0099 INSTALLED UNKN		
LEN=0048 INSTALLED UNKN	0451/2815							
PENNSYLVANIA AV (TWP)	0451/2770				0450/2770	PENNSYLVANIA AV (TWP)		
018 "DIA CIRC CONCR								
LEN=0099 INSTALLED UNKN	0451/2445							
PRINCETON AV (TWP)								
JP MARINO BL (TWP)	0451/2270				0450/2260	PRINCETON AV (TWP)		
						JP MARINO BL (TWP)		
018 "DIA CIRC CONCR								
LEN=0099 INSTALLED UNKN	0451/2245							
018 "DIA CIRC CONCR								
LEN=0050 INSTALLED UNKN	0451/1940							
ALLEY (TWP)	0451/1770				0450/1750	ALLEY (TWP)		
DALLAS AV (TWP)	0451/1585				0450/1575	DALLAS AV (TWP)		
DALLAS AV (TWP)	0451/1567				0450/1543	DALLAS AV (TWP)		
FAIRMONT AV (TWP)	0451/1320				0450/1305	FAIRMONT AV (TWP)		

DIR: B TOTAL LEN: 22.573 MI. DIST: 11-1 SR: 1001
 LEFT MUN: HARRISON T RIGHT MUN: HARRISON T

LIBERTY AV (TWP) ALLEY (TWP) LANE AV (TWP) 018 "DIA CIRC CONCR LEN=0050 INSTALLED UNKN	0451/1150 == ==	0451/0998 == ==	0451/0870 == ==	0451/0820 --- ---	0450/1135 (TWP) ALLEY (TWP) LANE AV (TWP) 018 "DIA CIRC CONCR LEN=0099 INSTALLED UNKN	0450/0986 (TWP) 0450/0860 (TWP) 0450/0762	MONTANA AV (TWP) 018 "DIA CIRC CONCR LEN=0050 INSTALLED UNKN	0451/0750 == ==	0451/0385 --- ---	0450/0750 (TWP) 018 "DIA CIRC CONCR LEN=0099 INSTALLED UNKN 018 "DIA CIRC CONCR LEN=0048 INSTALLED UNKN 1 0 00070 0 02 1247+71 097951 FT IDAHO AV (TWP) LENGTH(AH 3262 BK 2750) 036 "DIA CIRC CONCR LEN=0099 INSTALLED UNKN 018 "DIA CIRC CONCR LEN=0040 INSTALLED UNKN	0451/0000 [S] == ==	0451/2625 --- --- 0451/2395 --- --- 0451/2115 --- --- 0451/2075 == ==	0451/2040 --- --- 0451/1830 --- --- 0451/1745 == == 0451/1685 --- --- 0451/1530 == ==	0450/0000 [S] 0450/0000 (TWP) LENGTH(AH 3261 BK 2760) 018 "H 01 "W **UNKNOWN** LEN=0099 INSTALLED UNKN CALIFORNIA AV (BORO) 0450/2164 0440/2073 OREGON AV (BORO) 0440/1745 0440/1580 0440/1515 0440/1470	LIBERTY AV (TWP) ALLEY (TWP) LANE AV (TWP) 018 "DIA CIRC CONCR LEN=0050 INSTALLED UNKN ARGONNE DR (BORO) 018 "DIA CIRC CONCR LEN=0020 INSTALLED UNKN																											
018 "DIA CIRC CONCR LEN=0050 INSTALLED UNKN	0451/0820	0451/0750	0451/0385	0451/0000	0451/2625	0451/2395	0451/2115	0451/2075	0451/2040	0451/1830	0451/1745	0451/1685	0451/1530	0451/1285	0450/0762	0450/0750	0450/0327	0450/0020	098032 FT	0450/0000	0440/2164	0440/2073	0440/1745	0440/1580	0440/1515	0440/1470	0450/1135	0450/0986	0450/0860	0450/0762	0450/0750	0450/0327	0450/0020	098032 FT	0450/0000	0440/2164	0440/2073	0440/1745	0440/1580	0440/1515	0440/1470	LIBERTY AV (TWP) ALLEY (TWP) LANE AV (TWP) 018 "DIA CIRC CONCR LEN=0099 INSTALLED UNKN

DIR: B TOTAL LEN: 22.573 MI. DIST: 11-1 SR: 1001
 LEFT MUN: HARRISON T RIGHT MUN: HARRISON T

018 "DIA CIRC CONCR LEN=0099 INSTALLED UNKN ALABAMA AV (BORO)	0441/0980	---	---	---	0440/0966	012 "DIA CIRC CONCR LEN=0099 INSTALLED UNKN ALABAMA AV (BORO)
018 "DIA CIRC CONCR LEN=0050 INSTALLED UNKN	0441/0700	==	==	==	0440/0685	HARRISON BRACKENRIDGE B
1 0 00070 0 02 1220+15 095201 FT NC FREEPORT RD MILE LOCK LN (BORO)	0441/0305	---	---	---	0440/0033	1 0 00070 0 02 1220+15 NC FREEPORT RD MILE LOCK LN (BORO)
LENGTH(AH 2750 BK 3614)	0441/0000	5==	==	==	5 0440/0000	LENGTH(AH 2760 BK 3594)
018 "DIA CIRC CONCR LEN=0050 INSTALLED UNKN	0431/3175	---	---	---	0430/3013	OHIO ST (BORO)
OHIO ST (BORO)	0431/3036	==	==	==	0430/2846	GEORGIA AV (BORO)
GEORGIA AV (BORO)	0431/2868	==	==	==	0430/2474	PENN ST (BORO)
018 "DIA CIRC CONCR LEN=0050 INSTALLED UNKN	0431/2790	---	---	---	0430/2060	MORGAN ST (BORO)
018 "DIA CIRC CONCR LEN=0050 INSTALLED UNKN	0431/2510	---	---	---	0430/1765	UNNAMED AL (BORO)
PENN ST (BORO)	0431/2495	==	==	==	0430/1425	CARLISLE ST (BORO)
018 "DIA CIRC CONCR LEN=0099 INSTALLED UNKN	0431/2265	---	---	---	0430/1080	EMERSON ST (BORO)
MORGAN ST (BORO)	0431/2084	==	==	==	0430/0753	018 "DIA CIRC CONCR LEN=0040 INSTALLED UNKN PROSPECT ST (BORO)
ALLEY (BORO)	0431/1788	==	==	==	0430/0725	018 "DIA CIRC CONCR LEN=0099 INSTALLED UNKN NORWOOD DR (BORO)
CARLISLE ST (BORO)	0431/1449	==	==	==	0430/0235	CEMETERY LN (BORO)
EMERSON ST (BORO)	0431/0753	==	==	==	0430/0040	0430/0036
PROSPECT ST (BORO)	0431/0725	---	---	---		
HARRISON BRACKENRIDGE B						
NORWOOD DR (BORO)						
CEMETERY LN (BORO)						

DIR: B TOTAL LEN: 22.573 MI. DIST: 11-1 SR: 1001
 LEFT MUN: BRACKENRIDGE B RIGHT MUN: BRACKENRIDGE B

Stationing	Description	Stationing	Description
1 0 00070 0 02 1184+39 091587 FT		091678 FT	1 0 00070 0 02 1184+39
MFC BEGIN = C			MFC BEGIN = C
LENGTH(AH 3614 BK 0628) 0431/0000		0430/0000	LENGTH(AH 3594 BK 0628)
			HORNER ST
		0420/0545	(BORO)
		0420/0355	SYCAMORE AL
		0420/0230	(BORO)
		0420/0190	018" DIA CIRC CONCR
090959 FT		091050 FT	LEN=0030 INSTALLED UNKN
			LAUREL LN
			(BORO)
			1 0 00070 0 02 1178+37
			ORMOND ST
			(BORO)
			BRACKENRIDGE
		0420/0000	TARENTUM B
		0410/2120	LENGTH(AH 0628 BK 2394)
COE ST (BORO)	0410/2062		FENTZELL ST
			(BORO)
			SUMMIT ST
CEDAR AV (BORO)	0410/1800	0410/1945	(BORO)
			WILLS AL
		0410/1775	(BORO)
		0410/1460	GARFIELD ST
		0410/1172	(BORO)
		0410/1000	PORTER ST
			012" DIA CIR UNKNOWN
			LEN=0236 INSTALLED UNKN
			CORBET ST
		0410/0980	(BORO)
		0410/0845	LAWTON ST
LAWTON ST (BORO)	0410/0797		(BORO)
		0410/0714	COAL AL
		0410/0578	(BORO)
		0410/0437	DICKEY ST
		0410/0335	(BORO)
		0410/0286	JACKS AL
			(BORO)
			018" DIA CIRC CONCR
			LEN=0030 INSTALLED UNKN
			LOCK ST
			(BORO)

DIR: B TOTAL LEN: 22.573 MI. DIST: 11-1 SR: 1001
 LEFT MUN: TARENTUM B RIGHT MUN: TARENTUM B

TO 0366/0013 SH
 (CONN)

1 0 00070 0 02 1154+09
 ROSS ST
 (SR0366 SEG 0022/0000)
 (SR0366 SEG 0023/0000)

0410/0145

088565 FT

0410/0000
 088565 FT

FROM 0366/0022 SH
 (CONN)
 MILL ST
 (BORO)

0400/0465

087978 FT

EAST ST
 (BORO)

0390/1085

086793 FT

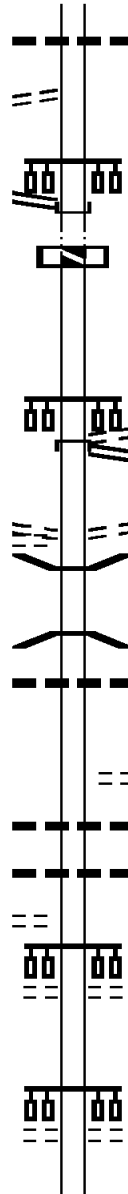

0410/0160 024 " DIA CIR UNKNOWN
 LEN=0040 INSTALLED UNKN

NC TENTH AV

088656 FT
 INTER-BK

5 0410/0000 (SR0366 SEG 0023/0000)
 088656 FT LTH AH 002394 BK 000100
 7402/0000 LTH AH 000100 BK 000587
 INTER-AHD ROSS ST
 (SR0366 SEG 0032/0000)
 SEVENTH AV
 (BORO)

0400/0587 ROSS ST
 (SR0366 SEG 0033/0000)
 (SR0366 SEG 0032/0000)

0400/0465 TO 0366/0032 SH
 0400/0334 (CONN)
 BMS EN 02/1001/0400/0294
 1 0 00070 0 02 1141+88

0400/0294 BULL CREEK
 BMSBG 02/1001/0400/0294
 018 " DIA CIRC CONCR
 0400/0160 LEN=0030 INSTALLED UNKN
 088069 FT 1 0 00070 0 02 1138+63
 LARUSSE BL
 (BORO)

5 0400/0000 LENGTH(AH 0587 BK 1185)
 0390/1140 099 " DIA CIR UNKNOWN
 INSTALLED UNKN
 0390/1128 018 " DIA CIRC CONCR
 LEN=0040 INSTALLED UNKN

CENTER ST
 (BORO)

0390/0610

086884 FT 1 0 00070 0 02 1126+70
 WESTERN ST
 (BORO)

5 0390/0000 LENGTH(AH 1185 BK 2537)
 GRANTHAM ST

EXTRACT DATE: 12/21/2020
PRINT DATE: 12/23/2020

ROADWAY MANAGEMENT SYSTEM
SLD COUNTY/SR - ANNUAL PRINT

PAGE NUMBER: 515
COUNTY: ALLEGHENY

DIR: B TOTAL LEN: 22.573 MI.
LEFT MUN: TARENTUM B

DIST: 11-1 SR: 1001
RIGHT MUN: TARENTUM B

CRYSTAL VIEW DR
(TWP)

084256 FT
0380/0000

BAILEYS RUN RD
(CNTY)

081594 FT
0360/1925

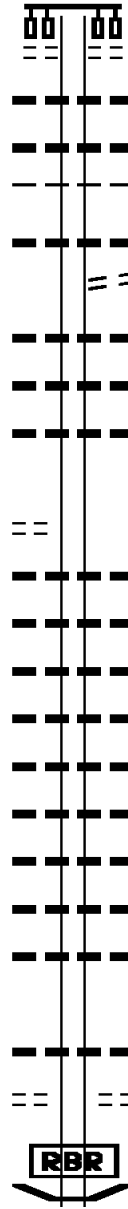

Station	Length	Material	Status	Notes
0380/1800		(BORO)		
0380/1575	LEN=0030	01B " DIA	CIRC CONCR	INSTALLED UNKN
0380/1550	LEN=0030	01B " DIA	CIRC CONCR	INSTALLED UNKN
0380/1362		TARENTUM EAST DEER T		
0380/1300	LEN=0030	01B " DIA	CIRC CONCR	INSTALLED UNKN
0380/1250		SIXTH AV (BORO)		
0380/1180	LEN=0030	01B " DIA	CIRC CONCR	INSTALLED UNKN
0380/0940	LEN=0030	01B " DIA	CIRC CONCR	INSTALLED UNKN
0380/0710	LEN=0030	01B " DIA	CIRC CONCR	INSTALLED UNKN
084347 FT	1 0 00070	0 02 1100+64		
0380/0000	NC SEVENTH AV	LENGTH(AH 2537 BK 2662)		
0370/2551	LEN=0030	01B " DIA	CIRC CONCR	INSTALLED UNKN
0370/2385	LEN=0030	01B " DIA	CIRC CONCR	INSTALLED UNKN
0370/2100	LEN=0030	01B " DIA	CIRC CONCR	INSTALLED UNKN
0370/1880	LEN=0030	01B " DIA	CIRC CONCR	INSTALLED UNKN
0370/1625	LEN=0030	01B " DIA	CIRC CONCR	INSTALLED UNKN
0370/1085	LEN=0030	01B " DIA	CIRC CONCR	INSTALLED UNKN
0370/0860	LEN=0030	01B " DIA	CIRC CONCR	INSTALLED UNKN
0370/0460	LEN=0030	01B " DIA	CIRC CONCR	INSTALLED UNKN
0370/0160	LEN=0050	01B " DIA	CIRC CONCR	INSTALLED UNKN
081685 FT	1 0 00070	0 02 1074+92		
0370/0000	LENGTH(AH 2662 BK 2556)			
0360/2515	LEN=0030	01B " DIA	CIRC CONCR	INSTALLED UNKN
0360/1925		FERRY ST (TWP)		
0360/1586		BMS EN 02/1001/0360/1567		

DIR: B TOTAL LEN: 22.573 MI. DIST: 11-1 SR: 1001
 LEFT MUN: EAST DEER T RIGHT MUN: EAST DEER T

CALLENDAR ST
 (TWP)

0360/1490

BARTSCH ST
 (TWP)

0360/1214

1 0 00070 0 02 1048+63 079038 FT
 CRAWFORD RUN RD (TBK)
 (CNTY) 0360/0000

MURRAY HILL RD
 (TWP)
 KELLAR AL
 (TWP)
 FOURTH ST
 (TWP)

0350/2370

0350/1990

0350/1864

EDNA ST
 (TWP)

0350/1005

THIRD ST

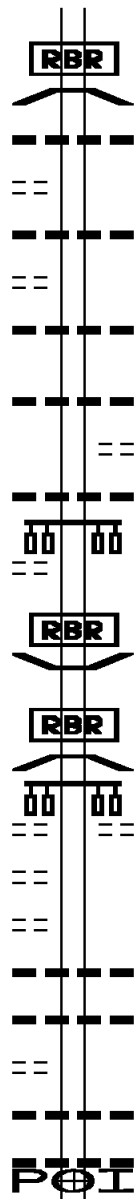

1 0 00070 0 02 1064+98
 P3
 BAILEYS RUN
 0360/1567 BMSBG 02/1001/0360/1567
 018 "DIA CIRC CONCR
 0360/1523 LEN=0030 INSTALLED UNKN
 018 "DIA CIRC CONCR
 0360/1275 LEN=0030 INSTALLED UNKN
 024 "DIA CIRC CONCR
 0360/1196 LEN=0040 INSTALLED UNKN
 024 "DIA CIRC CONCR
 0360/0450 LEN=0030 INSTALLED UNKN
 ROWE ST
 (TWP)
 0360/0430 018 "DIA CIRC CONCR
 0360/0100 LEN=0030 INSTALLED UNKN
 079129 FT
 0360/0000 LENGTH(AH 2556 BK 2806)
 RBR
 0350/2554 BMSBG 02/1001/0350/2537
 1 0 00070 0 02 1046+51
 P3
 CRAWFORD RUN
 0350/2537 BMSBG 02/1001/0350/2537
 FRONT ST
 (TWP)
 0350/2370
 0350/1590 018 "DIA CIRC CONCR
 LEN=0030 INSTALLED UNKN
 0350/1330 018 "DIA CIRC CONCR
 LEN=0030 INSTALLED UNKN
 0350/1000 018 "DIA CIRC CONCR
 LEN=0099 INSTALLED UNKN
 0350/0985 018 "DIA CIRC CONCR
 LEN=0030 INSTALLED UNKN
 (APRA) AIR PRODUCTS CO

EXTRACT DATE: 12/21/2020
PRINT DATE: 12/23/2020

ROADWAY MANAGEMENT SYSTEM
SLD COUNTY/SR - ANNUAL PRINT

PAGE NUMBER: 513
COUNTY: ALLEGHENY

DIR: B TOTAL LEN: 22.573 MI.
LEFT MUN: EAST DEER T

DIST: 11-1 SR: 1001
RIGHT MUN: EAST DEER T

(TWP)

0350/0735

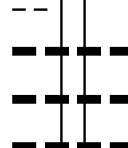

0350/0735

018 " DIA CIRC CONCR
LEN=0030 INSTALLED UNKN
018 " DIA CIRC CONCR
LEN=0030 INSTALLED UNKN
018 " DIA CIRC CONCR
LEN=0030 INSTALLED UNKN

1 0 00070 0 02 1020+78 076232 FT
SECOND ST
(TWP)

0350/0000

==

5

0350/0000

LENGTH(AH 2806 BK 3483)
099"H 18"W **UNKNOWN**
LEN=0099 INSTALLED UNKN
018 " DIA CIRC CONCR
LEN=0030 INSTALLED UNKN

FIRST ST
(TWP)

0340/2860

==

0340/2819

018 " DIA CIRC CONCR
LEN=0030 INSTALLED UNKN
099"H 18"W **UNKNOWN**
LEN=0099 INSTALLED UNKN
018 " DIA CIRC CONCR
LEN=0030 INSTALLED UNKN
018 " DIA CIRC CONCR
LEN=0030 INSTALLED UNKN

ALLEY
(TWP)

0340/2407

==

0340/2234

018 " DIA CIRC CONCR
LEN=0030 INSTALLED UNKN
024 " DIA CIRC CONCR
LEN=0030 INSTALLED UNKN
018 " DIA CIRC CONCR
LEN=0030 INSTALLED UNKN
024 " DIA CIRC CONCR
LEN=0030 INSTALLED UNKN
018 " DIA CIRC CONCR
LEN=0030 INSTALLED UNKN

072749 FT

0340/0365

018 " DIA CIRC CONCR
LEN=0030 INSTALLED UNKN
018 " DIA CIRC CONCR
LEN=0030 INSTALLED UNKN

0340/0139

5

0340/0000

1 0 00070 0 02 0991+22
LENGTH(AH 3483 BK 0748)
024 " DIA CIRC CONCR
LEN=0050 INSTALLED UNKN
SPUR
(SR9 109 SEG 0010/1030)
MFC BEGIN = C
024 " DIA CIRC CONCR

0330/0540

0330/0517

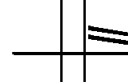

DIR: B TOTAL LEN: 22.573 MI. DIST: 11-1 SR: 1001
 LEFT MUN: EAST DEER T RIGHT MUN: EAST DEER T

Stationing	Description	Material	Length	Status
072001 FT	REF-BK	0330/0357	LEN=0040	INSTALLED UNKN
072001 FT	REF-AHD	072092 FT 7324/0000	1 0 00070 0 02 0978+78	INSTALLED UNKN
0320/3122	INTER-BK	0320/2884	LEN=0040	INSTALLED UNKN
0320/2633	MFC BEGIN	0320/2633	LEN=0036	INSTALLED UNKN
0320/2560	" DIA	0320/1975	LEN=0099	INSTALLED UNKN
0320/1601	" DIA	0320/1251	LEN=0724	INSTALLED UNKN
0320/1025	" DIA	0320/1025	LEN=0226	INSTALLED UNKN
0320/0811	" DIA	0320/0811	LEN=0314	INSTALLED UNKN
0320/0613	" DIA	0320/0613	LEN=0036	INSTALLED UNKN
068879 FT	REF-BK	068970 FT	1 0 00070 0 02 0947+76	INSTALLED UNKN
0310/1240	REF-AHD	0310/1240	LEN=0040	INSTALLED UNKN
067014 FT	REF-BK	067105 FT	1 0 00070 0 02 0929+66	INSTALLED UNKN
0300/0775	REF-AHD	0300/0775	LEN=0040	INSTALLED UNKN

RIDDLE RUN RD
 (SR1021 SEG 0010/0000) 0300/0775

RIDDLE RUN

EXTRACT DATE: 12/21/2020
PRINT DATE: 12/23/2020

ROADWAY MANAGEMENT SYSTEM
SLD COUNTY/SR - ANNUAL PRINT

PAGE NUMBER: 511
COUNTY: ALLEGHENY

DIR: B TOTAL LEN: 22.573 MI.
LEFT MUN: SPRINGDALE T

DIST: 11-1 SR: 1001
RIGHT MUN: SPRINGDALE T

			STRUCTURE	LENGTH	8 FT
	064684 FT		BMSID 02/1001/0300/0514		
			1 0 00070 0 02 0902+43		
			NC FR		
			EREPORT RD		
			SPRINGDALE		
			SPRINGDALE B		
			LENGTH(AH 2330 BK 2591)		
			LINCOLN AV		
			(BORO)		
			LC FOR LINCOLN AV		
			(CONN)		
			(APRA) SPRINGDALE INDUS		
			BUTLER ST		
			(BORO)		
			BORO AL		
			(BORO)		
			HARTREY ST		
			(BORO)		
ORCHARD ST (BORO)	0290/1260				
			HOEVELER ST		
MOYHEND ST (BORO)	0290/0945		(BORO)		
			WALTER LN		
ALLEY (BORO)	0290/0605		(BORO)		
SCHOOL ST (BORO)	0290/0410				
			018 " DIA CIRC CONCR		
			LEN=0099 INSTALLED UNKN		
			RUTH ST		
			(BORO)		
	062093 FT		1 0 00070 0 02 0879+91		
			CENTER ST		
			(BORO)		
			LENGTH(AH 2591 BK 2596)		
			JAMES ST		
			(BORO)		
NORTH AV (BORO)	0280/2045				
			OAK ST		
			(BORO)		
MURTLAND AV (BORO)	0280/1680				
			(APRA) LAMPUS BLOCK CO		
			COLFAX ST		
			(BORO)		

EXTRACT DATE: 12/21/2020
PRINT DATE: 12/23/2020

ROADWAY MANAGEMENT SYSTEM
SLD COUNTY/SR - ANNUAL PRINT

PAGE NUMBER: 510
COUNTY: ALLEGHENY

DIR: B TOTAL LEN: 22.573 MI.
LEFT MUN: SPRINGDALE B

DIST: 11-1 SR: 1001
RIGHT MUN: SPRINGDALE B

ROSA ST
(BORO)

0280/0600
059497 FT

WASHINGTON ST
(BORO)

0270/2020

DUQUESNE CT
(BORO)

0270/1390

BORO RD
(BORO)

0270/1230

MURRAYHILL AV
(BORO)

0270/0575

ATLANTIC AV
(BORO)

0270/0295

056910 FT

HIGHLAND AV



0280/1245

059588 FT 1 0 00070 0 02 0853+88
PORTER ST
(BORO)

5 0280/0000 LENGTH(AH 2596 BK 2587)

0270/1564 INACTIVE PRIVATE PROPER
OVERPASS IS RR X-ING
(APRA) ORION POWER PLAN
ORION POWER PLANT RD

0270/1520 (PRDR)
018 " DIA CIRC CONCR
0270/1398 LEN=0040 INSTALLED UNKN

0270/1265 024"H 18"W BOX CULVERT
LEN=0099 INSTALLED UNKN

0270/1096 BMS EN 02/1001/0270/1058
024"H 24"W CON BOX CUL
0270/1080 LEN=0048 INSTALLED UNKN
1 0 00070 0 02 0838+72

0270/1072 SHOOPS RUN
BMSBG 02/1001/0270/1058
DUQUESNE AV
(BORO)

0270/0850 SPRINGDALE
CHESWICK B
0270/0575 SHADY AV
(BORO)

0270/0482 024"H 08"W BOX CULVERT
LEN=0099 INSTALLED UNKN

0270/0275 ATLANTIC AV
(BORO)
057001 FT 1 0 00070 0 02 0828+93
ALLEGHENY AV
(BORO)

5 0270/0000 LENGTH(AH 2587 BK 2753)
HIGHLAND AV
(BORO)

0260/2420

EXTRACT DATE: 12/21/2020
PRINT DATE: 12/23/2020

ROADWAY MANAGEMENT SYSTEM
SLD COUNTY/SR - ANNUAL PRINT

PAGE NUMBER: 509
COUNTY: ALLEGHENY

DIR: B TOTAL LEN: 22.573 MI.
LEFT MUN: CHESWICK B

DIST: 11-1 SR: 1001
RIGHT MUN: CHESWICK B

Left Side	Right Side
(BORO) 0260/2330	0260/2330
COOLIDGE AV (BORO) 0260/1730	MACLEAN AV (BORO) 0260/1900
HILL AV (BORO) 0260/1415	
PILLOW AV (SR1017 SEG 0010/0000) 0260/0950	018 " DIA CIR PLASTIC LEN=0040 INSTALLED UNKN
ELIZABETH ST (BORO) 0260/0720	0260/0950
	018 " DIA CIR PLASTIC LEN=0040 INSTALLED UNKN
	BLOCKDALE ST (BORO) 0260/0145
054157 FT	024 " DIA CIRC CONCR LEN=0040 INSTALLED UNKN
CHESWICK AV (BORO) 0260/0000	054248 FT 1 0 00070 0 02 0799+34 NC PI
COUCH AL (TWP) 0254/1745	TTTSBURGH ST CHESWICK HARMAR T
WILSON AV (T708) 0254/1545	5 0260/0000 LENGTH(AH 2753 BK 2093) 024 " DIA CIRC CONCR
ORR AV (T792) 0254/0905	0254/2055 LEN=0099 INSTALLED UNKN
SCHOOL AV (T790) 0254/0660	0254/1745 (APRA) CUMMINS DIESEL
JEFFERSON AV (T788) 0254/0330	0254/1547 018 " DIA CIRC CONCR
1 0 00070 0 01 0762+99 052064 FT	LEN=0040 INSTALLED UNKN
HERRON AV (T786) 0254/0000	052155 FT
POPLAR AL (TWP) 0250/1635	5 0254/0000 LENGTH(AH 2093 BK 1819)
PEARL AV (SR1015 SEG 0010/0000) 0250/1506	0250/1599 018 " DIA CIRC CONCR
OAK ST (TWP) 0250/1347	LEN=0040 INSTALLED UNKN
ACME AV	0250/1506

DIR: B TOTAL LEN: 22.573 MI. DIST: 11-1 SR: 1001
 LEFT MUN: HARMAR T RIGHT MUN: HARMAR T

(TWP)	0250/1190	==			
PINE AL		---		0250/1109	018 "DIA CIRC CONCR LEN=0030 INSTALLED UNKN
(TWP)	0250/1031	==			
	050245 FT			0250/0030	BESSEMER AND LAKE ERIE OVERPASS IS RR X-ING
				050336 FT	1 0 00070 0 01 0762+99
				0250/0000	MFC BEGIN = B LENGTH(AH 1819 BK 2358)
				0240/2295	HARBOR VIEW DR (PRDR)
TURNPIKE RAMP RD	0241/2029	==			
(TNPK)					
PA TPK (1-76) EB					
OP ID 02/7076/9900/4800	0241/1985			0240/1918	OP ID PA TPK (1-76) EB 02/7076/9900/4800
PA TPK (1-76) WB					
OP ID 02/7076/9900/4801	0241/1911			0240/1835	OP ID 02/7076/9900/4801 DENNY ESTATES RD
DENNY ESTATES RD					
(TWP)	0241/1858	==		0240/1782	(TWP)
				0240/1360	018 "DIA CIRC CONCR LEN=0099 INSTALLED UNKN
RAMP G					
OP ID 02/7076/9900/4782	0241/1423			0240/1353	OP ID 02/7076/9900/4782 RAMP G
018 "DIA CIRC CONCR					
LEN=0099 INSTALLED UNKN	0241/1417				
PA TPK (RAMP F)					
OP ID 02/7076/9900/4781	0241/1379			0240/1309	OP ID PA TPK (RAMP F) 02/7076/9900/4781 TURNPIKE RAMP RD
				0240/0917	(TNPK)
018 "DIA CIRC CONCR					
LEN=0099 INSTALLED UNKN	0241/0895				
TURNPIKE RAMP RD					
(TNPK)	0241/0607				
				0240/0480	TURNPIKE RAMP RD (TNPK)
018 "DIA CIRC CONCR					
LEN=0099 INSTALLED UNKN	0241/0107				
1 0 00070 0 01 0733+43	047833 FT			047978 FT	1 0 00070 0 01 0736+50
LENGTH(AH 2412 BK 2694)	0241/0000			0240/0000	LENGTH(AH 2358 BK 2760)
EAST ALPHA DR					EAST ALPHA DR
(T860)					(T860)
	0231/2505	==		0230/2495	

EXTRACT DATE: 12/21/2020
PRINT DATE: 12/23/2020

ROADWAY MANAGEMENT SYSTEM
SLD COUNTY/SR - ANNUAL PRINT

PAGE NUMBER: 507
COUNTY: ALLEGHENY

DIR: B TOTAL LEN: 22.573 MI.
LEFT MUN: HARMAR T

DIST: 11-1 SR: 1001
RIGHT MUN: HARMAR T

Stationing	Description	Stationing	Description
0231/1270	(TWP)	0230/1260	(TWP)
018 "DIA CIRC CONCR LEN=0099 INSTALLED UNKN	0231/0523		
018 "DIA CIRC CONCR LEN=0099 INSTALLED UNKN	0231/0426		
TO 0910/0451 SH (CONN)	0231/0175		
1 0 00070 0 01 0710+14	045139 FT	045218 FT	1 0 00070 0 01 0710+14
WERNER CAMP RD		WERNER CAMP RD	
(TWP)		(TWP)	
GIBSONIA RD		GIBSONIA RD	
{SR0910 SEG 0450/1401}		{SR0910 SEG 0450/1401}	
{SR0910 SEG 0451/1411}		{SR0910 SEG 0451/1411}	
LENGTH(AH 2694 BK 2414)	0231/0000	0230/0000	LENGTH(AH 2760 BK 2376)
FROM 0910/0450 SH (CONN)	0221/2286		
BMSEN 02/1001/0220/1890	0221/2046	0220/2036	BMSEN 02/1001/0220/1890
1 0 00070 0 01 0705+08		1 0 00070 0 01 0705+08	
DEER CREEK		DEER CREEK	
BMSBG 02/1001/0220/1890	0221/1900	0220/1890	BMSBG 02/1001/0220/1890
		0220/1871	018 "DIA CIRC CONCR LEN=0099 INSTALLED UNKN
WENZEL DR		0220/1690	WENZEL DR
(TWP)	0221/1701	(TWP)	
		0220/1216	018 "DIA CIRC CONCR LEN=0020 INSTALLED UNKN
		0220/0888	018 "DIA CIRC CONCR LEN=0035 INSTALLED UNKN
018 "DIA CIRC CONCR LEN=0099 INSTALLED UNKN	0221/0570		
		0220/0556	018 "DIA CIRC CONCR LEN=0035 INSTALLED UNKN
GUYS RUN RD		GUYS RUN RD	
(SR1011 SEG 0010/0000)	0221/0425	0220/0425	(SR1011 SEG 0010/0000)
		0220/0203	018 "DIA CIRC CONCR LEN=0099 INSTALLED UNKN
018 "DIA CIRC CONCR LEN=0099 INSTALLED UNKN	0221/0180		
		0220/0131	018 "DIA CIRC CONCR LEN=0099 INSTALLED UNKN
1 0 00070 0 01 0686+17	042725 FT	042842 FT	1 0 00070 0 01 0686+39
MFC BEGIN = B		MFC BEGIN = B	
LENGTH(AH 2414 BK 1965)	0221/0000	0220/0000	LENGTH(AH 2376 BK 1965)
		0210/1646	BMSEN 02/1001/0210/1695
			1 0 00070 0 01 0677+25
		0210/1561	BARGE BASIN
			BMSBG 02/1001/0210/1695

DIR: B TOTAL LEN: 22.573 MI. DIST: 11-1 SR: 1001
 LEFT MUN: HARMAR T RIGHT MUN: HARMAR T

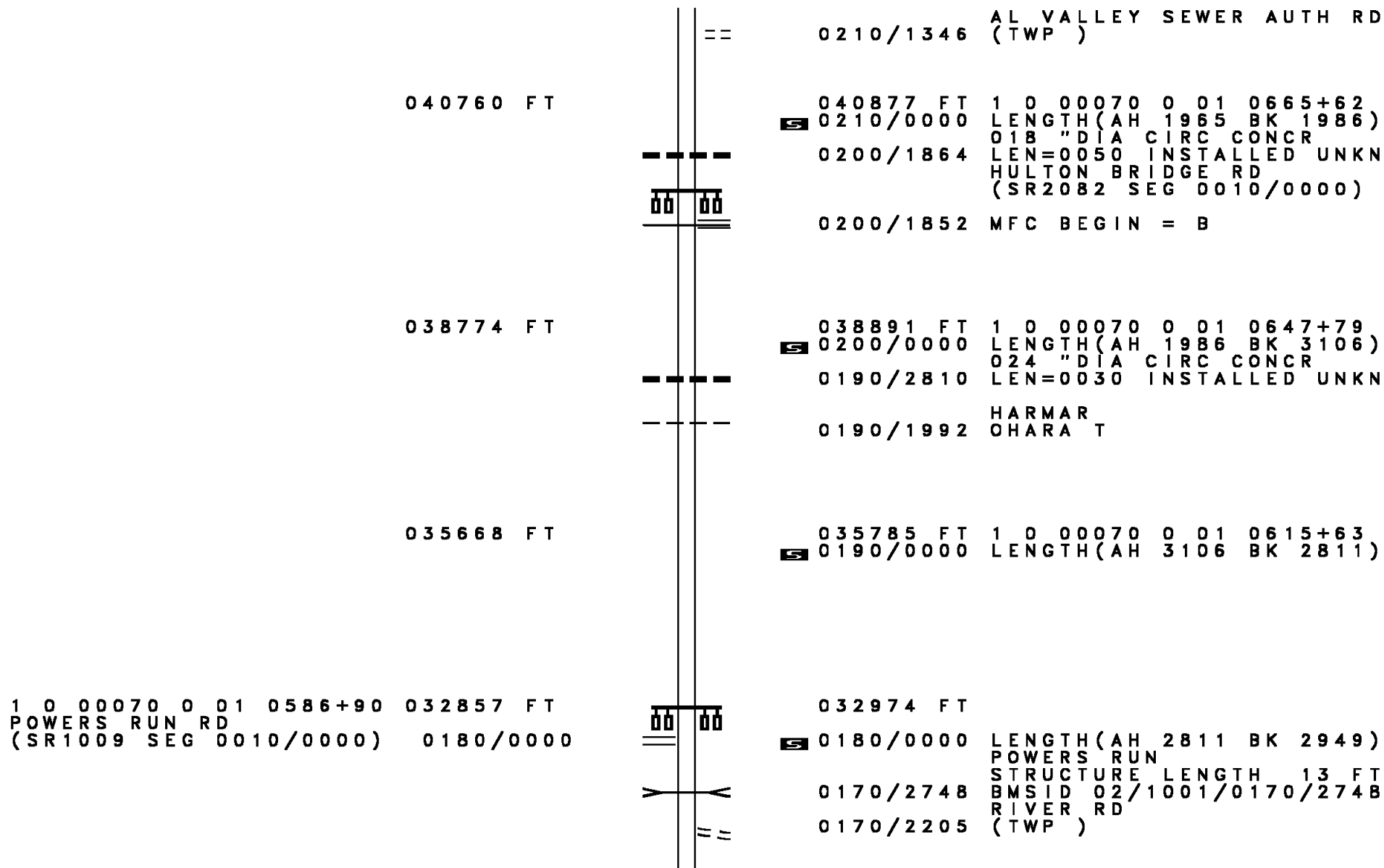

1 0 00070 0 01 0586+90 032857 FT
 POWERS RUN RD
 (SR1009 SEG 0010/0000) 0180/0000

DIR: B TOTAL LEN: 22.573 MI. DIST: 11-1 SR: 1001
 LEFT MUN: OHARA T RIGHT MUN: OHARA T

Stationing	Description	Notes
01 0563+06 029908 FT	CLIFTON AV (TWP)	0170/0000
	KIRK AV (TWP)	0160/1865
	SUN OIL COMPANY RD (PRDR)	0160/1756
		0160/1740
		0160/1480
		0160/1155
		0160/1110
		0160/1100
		0160/1046
027678 FT		0160/0545
		027795 FT
		0160/0000
	CABLE AV (BORO)	0154/2248
	WOODLAND RD (BORO)	0154/2135
	MCKINLEY AV (BORO)	0154/1650
		0154/1315
		0154/1250
	NORTH AV (BORO)	0154/1135
		0154/0955

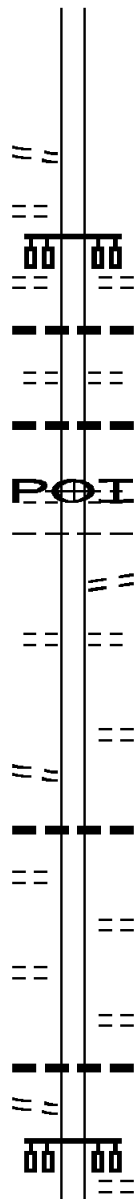

030025 FT
 0170/0000 LENGTH(AH 2949 BK 2230)
 CAR WASH RD (PRDR)
 0160/1756
 0160/1740 01B "DIA CIRC CONCR LEN=0025 INSTALLED UNKN
 BOYD AV (BORO)
 0160/1480 01B "DIA CIRC CONCR LEN=0025 INSTALLED UNKN
 (APRA) BLAWNEX IND COMM
 LEWIS AV (BORO)
 OHARA
 0160/1100 BLAWNEX B LC TO LEWIS AV (CONN)
 HUMBOLDT ST (BORO)
 0160/0000 01 0535+47 JACKSON ST (BORO) LENGTH(AH 2230 BK 2448)
 0154/2160 024 "DIA CIRC CONCR LEN=0030 INSTALLED UNKN
 MAPLE AV (BORO)
 0154/1705
 OAK ST (BORO)
 0154/1315 01B "DIA CIR UNKNOWN LEN=0099 INSTALLED UNKN
 BLAW AV (BORO)

DIR: B TOTAL LEN: 22.573 MI. DIST: 11-1 SR: 1001
 LEFT MUN: BLAWNOX B RIGHT MUN: BLAWNOX B

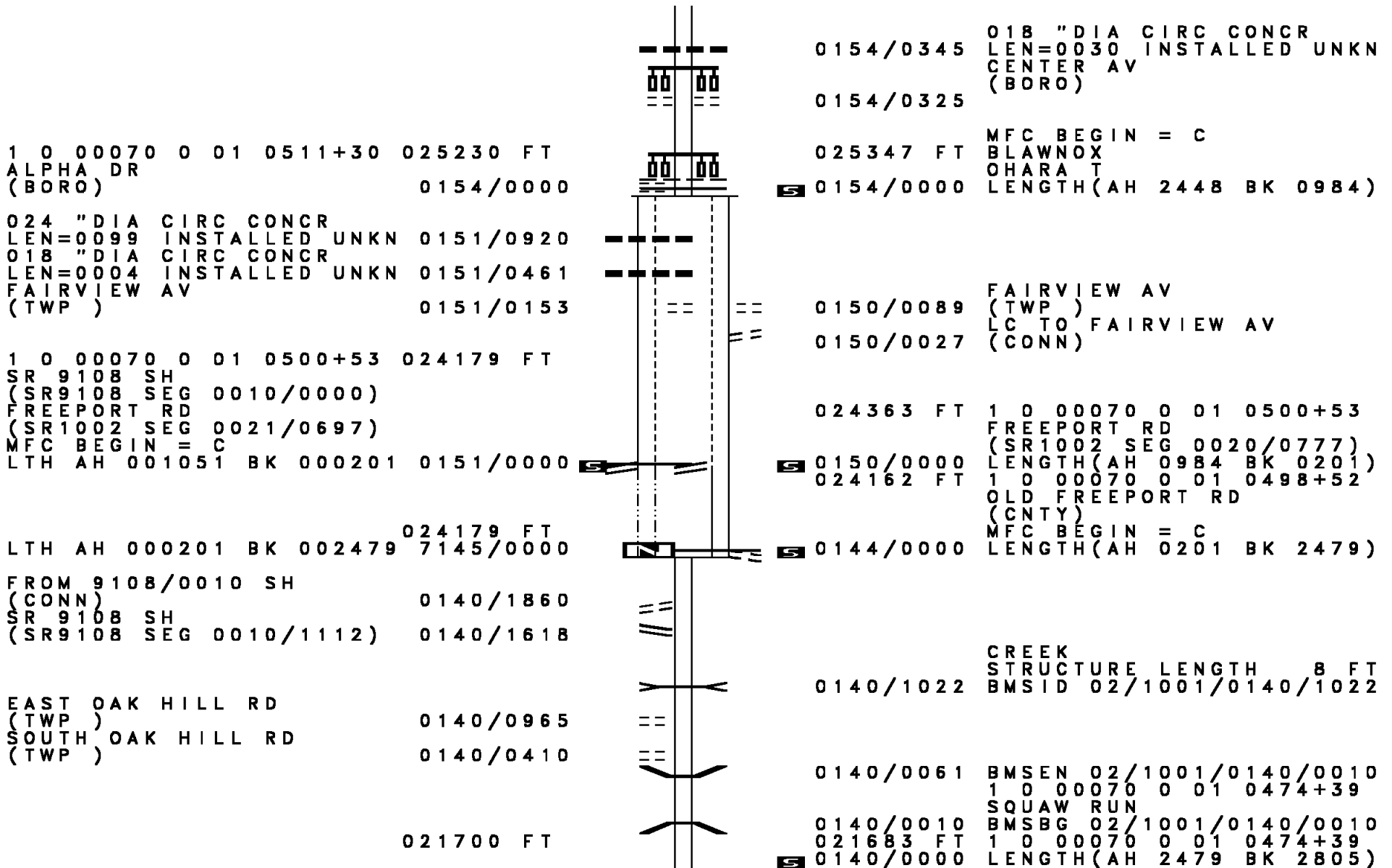

DIR: B TOTAL LEN: 22.573 MI. DIST: 11-1 SR: 1001
 LEFT MUN: OHARA T RIGHT MUN: OHARA T

FOX CHAPEL RD
(CNTY)

0130/1510

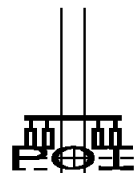

0130/1510

(APRA) FOX CHAPEL YATCH
 OLD FREEPORT RD
 (CNTY)

0130/1320

024 " DIA CIRC CONCR
 LEN=0040 INSTALLED UNKN
 WATER WORKS MALL RAMP R
 (SR8054 SEG 0030/0601)

0130/1050

018 " DIA CIRC CONCR
 LEN=0040 INSTALLED UNKN
 OHARA
 PITTSBURGH C

WATERWORKS MALL ENT RD
(PRDR)

0130/0420



0130/0481

0130/0420

018 " DIA CIRC CONCR
 LEN=0030 INSTALLED UNKN
 1 0 00070 0 01 0445+91
 LENGTH(AH 2805 BK 2689)
 BMSSEN 02/1001/0120/2622
 1 0 00070 0 01 0445+75
 PRIVATE RD

018895 FT

0130/0210

018878 FT

0130/0000

0120/2660

BMSBG 02/1001/0120/2622
 018 " DIA CIRC CONCR
 LEN=0099 INSTALLED UNKN

0120/2644

0120/2572

0120/2429

0120/2038

0120/1765

0120/1600

012 " DIA CIRC CONCR
 LEN=0130 INSTALLED UNKN
 018 " DIA CIRC CONCR
 LEN=0099 INSTALLED UNKN
 018 " DIA CIRC CONCR
 LEN=0040 INSTALLED UNKN
 020 " DIA CIRC CONCR
 LEN=0100 INSTALLED UNKN

WATERWORKS MALL ENT RD
(PRDR)

0120/1532



0120/1532

012 " DIA CIRC CONCR
 LEN=0100 INSTALLED UNKN
 WATER TREATMENT DR
 (CITY)

0120/1324

0120/1083

0120/1071

WATERWORKS MALL ENT RD
(PRDR)

0120/1010



0120/1010

(APRA) WATERWORKS MALL
 012 " DIA CIRC CONCR
 LEN=0080 INSTALLED UNKN

ST MARGARET DR
(CITY)

0120/0615



0120/0800

0120/0615

EXTRACT DATE: 12/21/2020
PRINT DATE: 12/23/2020

ROADWAY MANAGEMENT SYSTEM
SLD COUNTY/SR - ANNUAL PRINT

PAGE NUMBER: 502
COUNTY: ALLEGHENY

DIR: B TOTAL LEN: 22.573 MI.
LEFT MUN: PITTSBURGH C

DIST: 11-1 SR: 1001
RIGHT MUN: PITTSBURGH C

1 0 00070 0 01 0420+07 016206 FT
DELAFIELD AV
(CITY)
LEXINGTON RD
(CITY)

VIRGINIA AV
(BORO)
EMERSON AV
(BORO)
BRILLIANT AV
(BORO)

EASTERN AV
(BORO)
CENTER AV
(BORO)

WESTERN AV
(BORO)

RAMP G RD
(SR8082 SEG 0510/0000)

RAMP F RD
(SR8082 SEG 0500/0932)

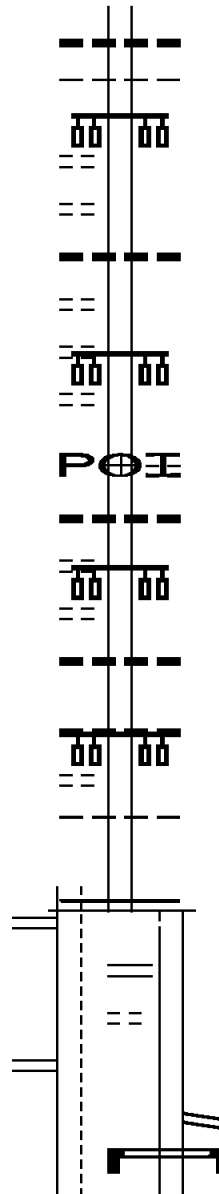

0120/0460 012 "DIA CIR PLASTIC
LEN=0099 INSTALLED UNKN
PITTSBURGH
ASPINWALL B
0120/0020
016189 FT
0120/0000 LENGTH(AH 2689 BK 3380)
0110/3120
0110/2884 024 "DIA CIR UNKNOWN
LEN=0099 INSTALLED UNKN
0110/2339
0110/2189 (APRA) ASPINWALL MARINA
WATERWORKS DR
(BORO)
018 "DIA CIRC CONCR
LEN=0030 INSTALLED UNKN
0110/1639
0110/1054
0110/1039 018"H 36"W CON BOX CUL
LEN=0030 INSTALLED UNKN
0110/0424 018"H 36"W CON BOX CUL
LEN=0030 INSTALLED UNKN
0110/0414
0110/0390 ASPINWALL
CHARA T
1 0 00070 0 01 0389+29
MFC BEGIN = C
012809 FT
0110/0000 LENGTH(AH 3380 BK 0975)
0100/0975 RAMP G RD
(SR8082 SEG 0510/0000)
FROM 8082/0500 SH
(CONN)
0100/0965
0100/0951 RAMP W RD
(SR8082 SEG 0520/0544)
SIGN: CANTILEVER
0100/0894 BMSID 02/1001/0100/0894
024 "DIA CIRC CONCR

DIR: B TOTAL LEN: 22.573 MI. DIST: 11-1 SR: 1001
 LEFT MUN: OHARA T RIGHT MUN: OHARA T

HIGHLAND PARK BRID
 OP ID 02/1005/0020/2521 0101/0345
 RAMP K RD
 (SR8082 SEG 0260/0000) 0101/0125

1 0 00070 0 01 0375+38 011834 FT
 RAMP FR HIGHLAND PK BG
 (SR8082 SEG 0250/0510)
 NC FREEPORT RD
 MFC BEGIN = C
 LENGTH(AH 0992 BK 0843) 0101/0000

TWENTYTHIRD ST
 (BORO) 010991 FT
 OHARA
 SHARPSBURG B 0090/0000
 TWENTYSECOND ST
 (BORO) 0080/1810
 TWENTYFIRST ST
 (BORO) 0080/1665

NINETEENTH ST

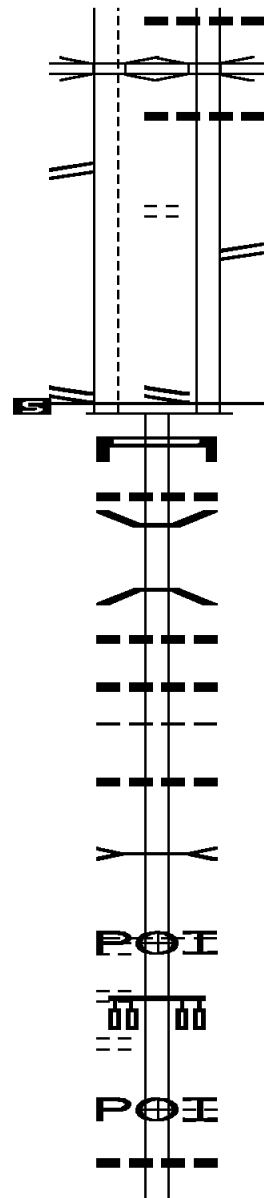

0100/0610 LEN=0030 INSTALLED UNKN
 HIGHLAND PARK BRID
 0100/0331 OP ID 02/1005/0020/2521
 018 "DIA CIRC CONCR
 0100/0285 LEN=0099 INSTALLED UNKN
 FROM 8082/0250 SH
 (CONN)
 RAMP X RD
 0100/0081 (SR8082 SEG 0270/0000)
 0100/0055 1 0 00070 0 01 0375+38
 011834 FT RAMP FR HIGHLAND PK BG
 (SR8082 SEG 0250/0510)
 NC FR FREEPORT RD
 MFC BEGIN = C
 0100/0000 LENGTH(AH 0975 BK 0843)
 SIGN: CANTILEVER
 0090/0820 BMSID 02/1001/0090/0820
 012 "DIA CIRC METAL
 0090/0769 LEN=0070 INSTALLED 2018
 0090/0733 BMSSEN 02/1001/0090/0648
 1 0 00070 0 01 0373+47
 NORFOLK SOUTHERN RAI RR
 0090/0648 BMSBG 02/1001/0090/0648
 012 "DIA CIRC CONCR
 0090/0586 LEN=0041 INSTALLED 2018
 012 "DIA CIRC CONCR
 0090/0436 LEN=0033 INSTALLED 2018
 OHARA
 SHARPSBURG B
 0090/0334 018 "DIA CIRC CONCR
 0090/0280 LEN=0040 INSTALLED UNKN
 GUYASUTA RUN
 STRUCTURE LENGTH 8 FT
 0090/0026 BMSID 02/1001/0090/0045
 010991 FT 1 0 00070 0 01 0367+46
 (APRA) PGH METAL PROCES
 0090/0000 LENGTH(AH 0843 BK 2066)
 0080/1665 (APRA) AZCON SCRAP CORP
 NINETEENTH ST
 (BORO)
 0080/1200 099 "DIA CIRC CONCR
 0080/1030 LEN=0030 INSTALLED UNKN

DIR: B TOTAL LEN: 22.573 MI. DIST: 11-1 SR: 1001
 LEFT MUN: SHARPSBURG B RIGHT MUN: SHARPSBURG B

Location / Segment	Stationing	Length (FT)	Notes / Structures
(BORO)	0080/1025		
1 0 00070 0 01 0346+95	008925	008925 FT	
EIGHTEENTH ST (BORO)	0080/0000		0080/0000 LENGTH(AH 2066 BK 2488)
SIXTEENTH ST (BORO)	0070/1488		
	0070/1465		012"H 12"W CON BOX CUL LEN=0099 INSTALLED UNKN
	0070/1454		16TH ST CRK STRUCTURE LENGTH 17 FT BMSID 02/1001/0070/1440
FIFTEENTH ST (BORO)	0070/1125		
FOURTEENTH ST (BORO)	0070/0860		
MULBERRY ST (BORO)	0070/0695		0070/0700 018 "DIA CIR PLASTIC LEN=0099 INSTALLED UNKN
BENSON WY (BORO)	0070/0180		
1 0 00070 0 01 0322+56	006437	006437 FT	
TWELFTH ST (BORO)	0070/0000		0070/0305 THIRTEENTH ST (BORO)
FREEPORT RD (BORO)	0060/1919		006437 FT
	0060/1662		0070/0000 LENGTH(AH 2488 BK 2267)
NORTH CANAL ST (SR1003 SEG 0010/0000)	0060/1660		012"H 24"W CON BOX CUL LEN=0099 INSTALLED UNKN
TENTH ST (BORO)	0060/1516		
CHURCH ST (BORO)	0060/1355		
NINTH ST (BORO)	0060/1130		
EIGHTH ST (BORO)	0060/1130		0060/1130 ALI ST (BORO)
	0060/1104		0060/1104 SEVENTH ST (BORO)
SIXTH ST			0060/0945 NC MAIN ST S MAIN ST

DIR: B TOTAL LEN: 22.573 MI. DIST: 11-1 SR: 1001
 LEFT MUN: SHARPSBURG B RIGHT MUN: SHARPSBURG B

Station	Description	Station	Description
(BORO) 0060/0730	==	0060/0730	(BORO) FIFTH ST
	==	0060/0590	(BORO) PRAGER ST
GARNIER ST (BORO) 0060/0225	==	0060/0290	(BORO)
	---	0060/0222	024" DIA CIRC CONCR
POWERS ST (BORO) 004170 FT	---	004170 FT	LEN=0099 INSTALLED UNKN
SR 9107 SH (SR9107 SEG 0010/0000) 0060/0000	==	004170 FT	1 0 00070 0 01 0299+36
	==	0060/0000	NC NORTH MAIN ST
	==	0040/1732	LENGTH(AH 2267 BK 1861)
	==	0040/1500	SR 8 NB
	==		OP ID 02/0008/0180/2416
	==		BRIDGE ST
	==		(SR8042 SEG 0022/1045)
	==		BRIDGE ST
	==		(SR8042 SEG 0280/0000)
	==		NC N MAIN ST
	==	0040/1465	FR 28 N TO MAIN RAMP T
	==		(SR8042 SEG 0250/0697)
	==	0040/1377	ALLEGHENY VAL EXPY
	==		OP ID 02/0028/0140/0000
	==	0040/1288	SR 8 SB
	==		OP ID 02/0008/0181/2418
	==	0040/1260	TR 28 S.B.
	==		OP ID 02/0028/0141/0000
	==	0040/1224	SHARPSBURG
	==		ETNA BOROUGH B
SR 9107 SH (SR9107 SEG 0010/0435) 0040/1210	==	0040/1178	BMS EN 02/1001/0040/1080
	==		TO 8042/0520 SH
	==	0040/1140	(CONN)
	==		RAMP 8042 NB
	==	0040/1092	OP ID 02/8042/0260/0409
	==		1 0 00070 0 01 0293+17
	==		PINE CREEK
	==	0040/1080	BMSBG 02/1001/0040/1080
	==		FR 1001 TO 28 S RAMP U
	==	0040/1023	(SR8042 SEG 0520/0000)
	==		RAMP B SB
	==	0040/0995	OP ID 02/8042/0510/0056
	==	0040/0948	(AAR 145707G) #TRKS 02
	==		SYCAMORE ST
	==	0040/0882	(BORO)
	==		024"H 24"W CON BOX CUL
	==	0040/0705	LEN=0025 INSTALLED UNKN

DIR: B TOTAL LEN: 22.573 MI. DIST: 11-1 SR: 1001
 LEFT MUN: ETNA BOROUGH B RIGHT MUN: ETNA BOROUGH B

STREET NAME	STREET ID	STREET TYPE	START POINT	END POINT	LENGTH	REMARKS
BRIDGE ST (BORO)	0040/0642					(APRA) TIPPINS MACHINE CHERRY AV
GARDEN ST (BORO)	0040/0467					(BORO) NC BRIDGE ST
UNION ST (BORO)	0040/0165					CHERRY ST (BORO)
1 0 00070 0 01 0282+24	002309 FT					0040/0240 (BORO)
BUTLER ST (SR4019 SEG 0004/0000)	0040/0000					002309 FT NC FREEPORT ST
ELK ST (BORO)	0030/0210					5 0040/0000 LENGTH (AH 1861 BK 0586) PRAGER ST (BORO)
						0030/0490 (BORO)
						0030/0400 (BORO) WINSCHEL ST
						VFW WAY (BORO)
	001723 FT					0030/0105 (BORO)
						099 " DIA CIRC CONCR LEN=0099 INSTALLED UNKN
						0030/0011 1 0 00070 0 01 0275+03 CENTER ST (BORO)
						5 0030/0000 LENGTH (AH 0586 BK 1723) 018 " DIA CIRC CONCR
PROSPECT ST (BORO)	0010/1501					0010/1599 LEN=0099 INSTALLED UNKN
						ISABELLA ST (BORO)
						0010/1270 (BORO)
						018 " DIA CIRC CONCR LEN=0099 INSTALLED UNKN
WASHINGTON ST (BORO)	0010/0765					
ANN ST (BORO)	0010/0295					
						RT 0028 SB
						0010/0228 OP ID 02/0028/0121/1214 018 " DIA CIRC CONCR
						0010/0164 LEN=0060 INSTALLED UNKN 024 " DIA CIRC CONCR
						0010/0074 LEN=0024 INSTALLED UNKN NC BU
						INTER-BK FR 28 N TO ETNA RAMP RD 000000 FT (SR8048 SEG 0010/0610) MFC BEGIN = C
1 0 00070 0 01 0248+91	000000 FT					5 0010/0000 LENGTH (AH 1723 BK 0000)
FR ETNA TO 2B S RAMP RD (SR8048 SEG 0020/0000)	0010/0000					

EXTRACT DATE: 12/21/2020 ROADWAY MANAGEMENT SYSTEM PAGE NUMBER: 497
 PRINT DATE: 12/23/2020 SLD COUNTY/SR - ANNUAL PRINT COUNTY: ALLEGHENY
 DIR: B TOTAL LEN: .116 MI. DIST: 11-1 SR: 980
 LEFT MUN: NORTH FAYETTE T RIGHT MUN: NORTH FAYETTE T

000613 FT

000613 FT
 INTER-AHD SR 3071 SH TO SR22W
 (SR3071 SEG 0010/0000)
 RAMP D RD
 (SR8024 SEG 0010/0579)
 STEUBENVILLE PK
 (SR3121 SEG 0010/0000)
 0010/0613
 000000 FT 2 0 02183 0 00 0000+00
 NC ROBINSON HW
 * REF-BK ROBINSON HW
 (SR0980 SEG 0330/2414)
 MFC BEGIN = C
 BK-WASHINGTON (62)
 0010/0000 LENGTH(AH 0613 BK 0000)

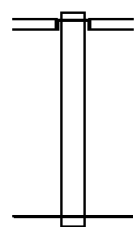

000000 FT

EXTRACT DATE: 12/21/2020 ROADWAY MANAGEMENT SYSTEM PAGE NUMBER: 496
PRINT DATE: 12/23/2020 SLD COUNTY/SR - ANNUAL PRINT COUNTY: ALLEGHENY
DIR: B TOTAL LEN: 9.702 MI. DIST: 11-1 SR: 978
LEFT MUN: NORTH FAYETTE T RIGHT MUN: NORTH FAYETTE T

EXTRACT DATE: 12/21/2020
PRINT DATE: 12/23/2020

ROADWAY MANAGEMENT SYSTEM
SLD COUNTY/SR - ANNUAL PRINT

PAGE NUMBER: 495
COUNTY: ALLEGHENY

DIR: B TOTAL LEN: 9.702 MI.
LEFT MUN: NORTH FAYETTE T

DIST: 11-1 SR: 978
RIGHT MUN: NORTH FAYETTE T

TO 8028/0020 SH
(CONN)

0240/0356

050676 FT

HIGH TECH DR
(TWP)

0230/0575

INTERNATIONAL DR
(TWP)

0230/0100
048292 FT

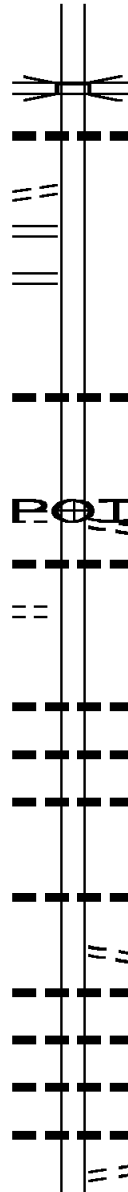

INTER-AHD LINCOLN HW
(SR0030 SEG 0160/0998)
RT 0022 EB
0240/0553 OP ID 02/0022/0060/0771
036 " DIA CIRC CONCR
0240/0445 LEN=0088 INSTALLED UNKN
RAMP O RD
(SR8028 SEG 0020/0000)
RAMP N RD
(SR8028 SEG 0010/1084)
2 0 02015 0 00 0101+42
0240/0000 LENGTH(AH 0553 BK 2384)
012 " DIA CIRC CONCR
0230/1611 LEN=0040 INSTALLED 2002
(APRA) IMPERIAL AGGREGA
IMPERIAL AGGREGATES RD
(PRDR)
060 " DIA CIRC METAL
0230/0260 LEN=0099 INSTALLED UNKN
2 0 02015 0 00 0077+66
0230/0000 LENGTH(AH 2384 BK 3483)
018 " DIA CIRC CONCR
0220/3330 LEN=0040 INSTALLED 2002
048 " DIA CIRC METAL
0220/2897 LEN=0065 INSTALLED UNKN
018 " DIA CIRC CONCR
0220/2612 LEN=0099 INSTALLED UNKN
036 " DIA CIRC CONCR
0220/1619 LEN=0045 INSTALLED UNKN
OAKRIDGE HEIGHTS DR
(TWP)
0220/1596 018 " DIA CIRC CONCR
0220/1297 LEN=0045 INSTALLED UNKN
018 " DIA CIRC CONCR
0220/0894 LEN=0050 INSTALLED UNKN
018 " DIA CIRC CONCR
0220/0791 LEN=0099 INSTALLED UNKN
018 " DIA CIRC CONCR
0220/0563 LEN=0099 INSTALLED UNKN
OAKRIDGE HEIGHTS DR
(TWP)
0220/0081

EXTRACT DATE: 12/21/2020
PRINT DATE: 12/23/2020

ROADWAY MANAGEMENT SYSTEM
SLD COUNTY/SR - ANNUAL PRINT

PAGE NUMBER: 494
COUNTY: ALLEGHENY

DIR: B TOTAL LEN: 9.702 MI.
LEFT MUN: NORTH FAYETTE T

DIST: 11-1 SR: 978
RIGHT MUN: NORTH FAYETTE T

Stationing	Notes	Stationing	Notes
044809 FT		0220/0010	BMSEN 02/0978/0220/0000
		044809 FT	2 0 02015 0 00 0043+10
			ROBINSON RUN
		5 0220/0000	BMSBG 02/0978/0220/0000
			LENGTH(AH 3483 BK 1839)
		0210/1402	018 "DIA CIRC CONCR
			LEN=0040 INSTALLED UNKN
		0210/1310	LC FOR LUTZ RD
			(CONN)
		0210/1282	018 "DIA CIRC CONCR
			LEN=0040 INSTALLED UNKN
		0210/0865	LUTZ RD
			(T340)
		0210/0682	018 "DIA CIRC CONCR
			LEN=0035 INSTALLED UNKN
STONEBRIDGE MANOR DR (PRDR)		0210/0218	(APRA) STONEBRIDGE MANO
0210/0218	POE		ALBERT LN
			(TWP)
		0210/0090	018 "DIA CIRC CONCR
			LEN=0035 INSTALLED UNKN
		0210/0007	018 "DIA CIRC CONCR
			LEN=0040 INSTALLED UNKN
042970 FT		042970 FT	2 0 02015 0 00 0025+16
		5 0210/0000	LENGTH(AH 1839 BK 2475)
			018 "DIA CIRC CONCR
		0200/2203	LEN=0045 INSTALLED UNKN
			018 "DIA CIR PLASTIC
		0200/1200	LEN=0040 INSTALLED UNKN
			015 "DIA CIR PLASTIC
		0200/0310	LEN=0040 INSTALLED UNKN
		0200/0113	BMSEN 02/0978/0200/0078
			2 0 02015 0 00 0000+72
			N. BR. ROBINS.
		0200/0078	BMSBG 02/0978/0200/0078
		040495 FT	OLD NORTH BRANCH RD
			(TB08)
		5 0200/0000	LENGTH(AH 2475 BK 0438)
		040057 FT	
			NC BA TEMAN RD
		5 0190/0000	LENGTH(AH 0438 BK 2445)
			MILLER DR
		0180/2002	(PRDR)
			018 "DIA CIRC CONCR
		0180/1614	LEN=0099 INSTALLED UNKN
			018 "DIA CIR PLASTIC
		0180/1448	LEN=0035 INSTALLED 2002
			012 "DIA CIRC CONCR

EXTRACT DATE: 12/21/2020
PRINT DATE: 12/23/2020

ROADWAY MANAGEMENT SYSTEM
SLD COUNTY/SR - ANNUAL PRINT

PAGE NUMBER: 493
COUNTY: ALLEGHENY

DIR: B TOTAL LEN: 9.702 MI.
LEFT MUN: NORTH FAYETTE T

DIST: 11-1 SR: 978
RIGHT MUN: NORTH FAYETTE T

Stationing	Right of Way	Structure	Material	Status
0180/1066	0180/1066	LEN=0045	INSTALLED	UNKN
0180/0771	0180/0771	LEN=0050	INSTALLED	UNKN
0180/0619	0180/0619	LEN=0099	INSTALLED	UNKN
0180/0336	0180/0336	LEN=0099	INSTALLED	UNKN
0180/0140	0180/0140	BMSSEN 02/0978/0180/0074		
0180/0074	0180/0074	BMSBG 02/0978/0180/0074		
0180/0043	0180/0043	LEN=0060	INSTALLED	UNKN
037612 FT	037612 FT	1 0 00680 0 00 0193+46		
0180/0000	0180/0000	NC N LENGTH(AH 2445 BK 2375)		
0170/2182	0170/2182	LEN=0099	INSTALLED	UNKN
0170/0720	0170/0720	LEN=0060	INSTALLED	UNKN
0170/0528	0170/0528	LEN=0055	INSTALLED	UNKN
0170/0164	0170/0164	LEN=0060	INSTALLED	UNKN
035237 FT	035237 FT	1 0 00681 0 01 0309+62		
0170/0000	0170/0000	LENGTH(AH 2375 BK 1999)		
0160/1823	0160/1823	MCKEE ELEMENTARY SCHOOL		
0160/1240	0160/1240	LEN=0030	INSTALLED	UNKN
0160/1230	0160/1230	012 "DIA CIRC CONCR		
0160/1156	0160/1156	LEN=0040	INSTALLED	UNKN
0160/0021	0160/0021	BMSSEN 02/0978/0160/0000		
033238 FT	033238 FT	1 0 00681 0 00 0286+97		
0160/0000	0160/0000	BR. N. BR. ROBI BMSBG 02/0978/0160/0000		
0160/0000	0160/0000	LENGTH(AH 1999 BK 3286)		
0160/0000	0160/0000	MCKEE RD (SR3103 SEG 0010/0000)		
0160/0000	0160/0000	NC OAKDALE RD		

PRION DR

DIR: B TOTAL LEN: 9.702 MI. DIST: 11-1 SR: 978
 LEFT MUN: NORTH FAYETTE T RIGHT MUN: NORTH FAYETTE T

ROAD NAME	START	END	STATUS	DETAILS
(PRDR) UNKNOWN RD (TWP)	0150/2757	0150/2630	==	
		0150/2583	---	036" DIA CIRC CONCR LEN=0060 INSTALLED UNKN GAMBLE RD
		0150/2480	==	(T362)
		0150/2079	---	030" DIA CIRC CONCR LEN=0050 INSTALLED UNKN MOLINARO CR
		0150/2026	==	(PRDR)
OAKDALE BORO PK RD (T853)	0150/1905	0150/1328	==	ROSE CT (PRDR)
		0150/1059	---	NORTH FAYETTE OAKDALE B
		0150/0865	---	018" DIA CIRC CONCR LEN=0099 INSTALLED UNKN
		0150/0555	---	018" DIA CIRC CONCR LEN=0075 INSTALLED UNKN
CLINTON AV ET (BORO)	0150/0260	0150/0175	==	CLEF DR (BORO)
		0150/0153	---	BMSSEN 02/0978/0150/0037 1 0 00681 0 00 0254+26 BR. ROBSN. RUN
	029952 FT	0150/0037	---	BMSBG 02/0978/0150/0037 1 0 00681 0 00 0253+89
MAPLE AV (BORO)	0150/0000	0150/0000	==	VILLAGE: NORTH FAYETTE LENGTH(AH 3286 BK 1408)
		0140/0807	---	018" DIA CIRC CONCR LEN=0045 INSTALLED UNKN
		0140/0555	---	024" DIA CIRC CONCR LEN=0030 INSTALLED UNKN
		0140/0456	---	024" DIA CIRC CONCR LEN=0060 INSTALLED UNKN
ROBINSON ST (BORO)	0140/0420	0140/0130	==	018" DIA CIRC CONCR LEN=0025 INSTALLED UNKN
	028544 FT	028544 FT	---	1 0 00681 0 00 0240+12 FIRST ST (BORO)
		0140/0000	==	LENGTH(AH 1408 BK 0647)
		0130/0624	---	012"H 12"W ELLIP CONC LEN=0099 INSTALLED UNKN
NOBLESTOWN RD			---	

DIR: B TOTAL LEN: 9.702 MI. DIST: 11-1 SR: 978
 LEFT MUN: OAKDALE B RIGHT MUN: OAKDALE B

(SR3048 SEG 0070/0000) 0130/0521

NC CLINTON AV
 018 "DIA CIRC CONCR
 0130/0443 LEN=0035 INSTALLED UNKN
 NC STATE ST
 STATE ST
 STATE ST
 (SR3048 SEG 0060/1215)
 0130/0332 BMSSEN 02/0978/0130/0171
 0130/0250 1 0 00681 0 00 0235+42
 ROBINSON RUN
 0130/0195 BMSBG 02/0978/0130/0171

WILLOW AV
 (BORO) 0130/0145
 027897 FT

CENTER AV
 (BORO) 0120/0505
 027125 FT

LC TO SHADY LN
 (CONN) 0110/2446
 SHADY LN
 (TWP) 0110/2373

VISTA ST
 (TWP) 0110/2026

CEMETERY ENT RD
 (PRDR) 0110/0580

1 0 00681 0 00 0191+47 023666 FT
 MARSHALL RD
 (TWP) 0110/0000
 SR 9104 SH

027897 FT 1 0 00681 0 00 0234+25
 0130/0000 LENGTH(AH 0647 BK 0772)
 SEMINARY AV
 (CNTY) 0120/0715
 027125 FT 1 0 00681 0 00 0226+19
 VILLAGE: OAKDALE B
 018 "DIA CIRC CONCR
 LEN=0040 INSTALLED 2002
 OAKDALE
 SOUTH FAYETTE T
 0120/0000 LENGTH(AH 0772 BK 3459)
 024 "DIA CIRC CONCR
 0110/2925 LEN=0099 INSTALLED UNKN
 ADULLAM DR
 (TWP) 0110/2590
 0110/2149 018 "DIA CIRC METAL
 LEN=0099 INSTALLED UNKN
 0110/1152 024 "DIA CIRC CONCR
 LEN=0099 INSTALLED UNKN
 018 "DIA CIR PLASTIC
 0110/0913 LEN=0055 INSTALLED UNKN
 0110/0566 018 "DIA CIRC CONCR
 LEN=0099 INSTALLED UNKN
 023666 FT
 0110/0000 LENGTH(AH 3459 BK 2780)
 SR 9104 SH

DIR: B TOTAL LEN: 9.702 MI. DIST: 11-1 SR: 978
 LEFT MUN: SOUTH FAYETTE T RIGHT MUN: SOUTH FAYETTE T

(SR9104 SEG 0010/0000)	0100/2414	0100/2414	(SR9104 SEG 0020/0240) BATTLE RIDGE RD (SR3024 SEG 0060/0000) NC UNION AV
SR 9104 SH (SR9104 SEG 0010/0274)	0100/2004	0100/2035	012 "DIA CIRC CONCR LEN=0099 INSTALLED UNKN
		0100/1355	036 "DIA CIRC CONCR LEN=0099 INSTALLED UNKN
		0100/0021	012 "DIA CIRC CONCR LEN=0099 INSTALLED UNKN
1 0 00681 0 00 0164+44 020886 FT ROBINSON RUN RD (SR3024 SEG 0050/1624) FOR SR 0978 AND 3024 (CONN)	0100/0000 0090/2628	0100/0000	LENGTH(AH 2780 BK 3014)
		0090/0893	024 "DIA CIRC CONCR LEN=0099 INSTALLED UNKN
	017872 FT	017872 FT	1 0 00681 0 00 0134+59 LENGTH(AH 3014 BK 3014)
		0080/2801	018 "DIA CIRC CONCR LEN=0099 INSTALLED 2002
		0080/1894	018 "DIA CIRC CONCR LEN=0039 INSTALLED 2002
		0080/1590	018 "DIA CIRC CONCR LEN=0035 INSTALLED 2002
		0080/1251	018 "DIA CIRC CONCR LEN=0035 INSTALLED UNKN
	014858 FT	0080/0183	018 "DIA CIR PLASTIC LEN=0050 INSTALLED UNKN
		014858 FT	1 0 00681 0 00 0104+45 LENGTH(AH 3014 BK 2905)

DIR: B TOTAL LEN: 9.702 MI. DIST: 11-1 SR: 978
 LEFT MUN: SOUTH FAYETTE T RIGHT MUN: SOUTH FAYETTE T

STERLING DR
(TWP)

0070/0441
011953 FT

MOHAWK RD
(TWP)

0060/0801

009185 FT

006866 FT

004376 FT

==	0070/1353	WALNUT RIDGE DR (TWP)
---	0070/0712	018 " DIA CIRC CONCR LEN=0040 INSTALLED 2002
==	011953 FT	1 0 00681 0 00 0075+40
	5 0070/0000	LENGTH(AH 2905 BK 2768)
==	0060/0735	024 " DIA CIRC CONCR LEN=0099 INSTALLED UNKN
	009185 FT	1 0 00681 0 00 0048+26
	5 0060/0000	LENGTH(AH 2768 BK 2319)
---	0050/1564	018 " DIA CIRC CONCR LEN=0040 INSTALLED 2002
---	0050/1218	018 " DIA CIRC CONCR LEN=0099 INSTALLED 2002
---	0050/0948	018 " DIA CIRC CONCR LEN=0050 INSTALLED UNKN
---	0050/0077	018 " DIA CIRC CONCR LEN=0040 INSTALLED UNKN
	006866 FT	1 0 00681 0 00 0025+07
	5 0050/0000	LENGTH(AH 2319 BK 2490)
---	0040/1430	018 " DIA CIRC CONCR LEN=0099 INSTALLED 2002
---	0040/1110	024 " DIA CIRC CONCR LEN=0040 INSTALLED 2002
---	0040/0568	BMSSEN 02/0978/0040/0509 1 0 00681 0 00 0005+26
	0040/0542	DOLPHIN RUN BMSBG 02/0978/0040/0509
	004376 FT	1 0 00681 0 00 0000+00
		MILLERS RUN RD (SR3026 SEG 0010/0000)
	NC BA	TTLE RIDGE RD
	5 0040/0000	LENGTH(AH 2490 BK 1703)
	0030/1608	BMSSEN 02/0978/0030/1586 1 0 00545 0 01 0088+90

DIR: B TOTAL LEN: 9.702 MI. DIST: 11-1 SR: 978
 LEFT MUN: SOUTH FAYETTE T RIGHT MUN: SOUTH FAYETTE T

MOHAWK RD
 (TWP)

0030/1555

SENEX EXPLOSIVE CO
 (PRDR)

0020/0922

1 0 00545 0 00 0051+53 000442 FT
 MILLERS RUN RD
 (SR3001 SEG 0030/0386)

0020/0000

000000 FT

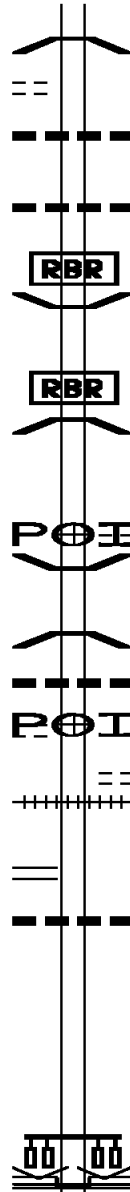

0030/1586 DOLPHIN RUN
 BMSBG 02/0978/0030/1586

0030/1211 024 " DIA CIRC CONCR
 LEN=0122 INSTALLED 2002

0030/0534 024"H 24"W **UNKNOWN**
 LEN=0030 INSTALLED UNKN

0030/0016 BMSEN 02/0978/0030/0000
 002673 FT 1 0 00545 0 01 0073+15
 P3

0030/0000 BMSBG 02/0978/0030/0000
 LENGTH(AH 1703 BK 2231)

0020/1321 (APRA) HOWARD CONCRETE
 0020/1110 MCCLANE ST
 (TWP)
 BMSEN 02/0978/0020/1069
 1 0 00545 0 01 0061+70

0020/1099 SMALL STREAM
 BMSBG 02/0978/0020/1069

0020/1005 024 " DIA CIRC METAL
 LEN=0050 INSTALLED UNKN

0020/0922 (APRA) SENEX EXPLOSIVE
 LEE ST
 (TWP)
 (AAR 472841T)#TRKS 01

0020/0620
 0020/0288
 000442 FT

0020/0000 LENGTH(AH 2231 BK 0442)
 018 " DIA CIRC CONCR
 LEN=0060 INSTALLED UNKN

0010/0170 1 0 01138 1 00 0000+00
 000000 FT VILLAGE: SOUTH FAYETTE
 NC MI MILLERS RUN RD
 SR 0050 SH
 (SR0050 SEG 0031/0000)
 (SR0050 SEG 0030/0000)

INTER-BK PARKS RD
 (TWP)
 MFC BEGIN = C

0010/0000 LENGTH(AH 0442 BK 0000)

WERNER CAMP RD 101657 FT
 (TWP) INTER-AHD
 FREEPORT RD
 (SR1001 SEG 0230/0000)
 (SR1001 SEG 0231/0000) 0451/1411
 018 " DIA CIRC CONCR
 LEN=0099 INSTALLED UNKN 0451/1340

 FROM 1001/0231 SH
 (CONN) 0451/1258

 ANCHOR DR
 (PRDR)

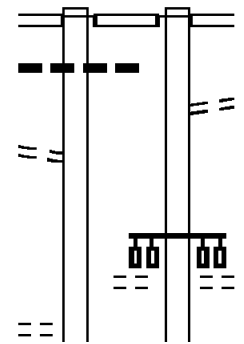

101631 FT
 INTER-AHD WERNER CAMP RD
 (TWP)
 FREEPORT RD
 (SR1001 SEG 0230/0000)
 (SR1001 SEG 0231/0000) 0450/1401

 TO 1001/0221 SH
 (CONN) 0450/1245

 ANCHOR DR
 (PRDR)
 MARINER CT
 (TWP)
 0450/0983

DIR: E TOTAL LEN: 19.253 MI. DIST: 11-1 SR: 910
 LEFT MUN: HARMAR T RIGHT MUN: HARMAR T

MARINER CT
 (TWP)

CONN TO GULF LAB RD (SR9110 SEG 0010/0000)	0451/0995	0451/0790	
018 "DIA CIRC CONCR LEN=0035 INSTALLED UNKN	0451/0665		0450/0688 RAMP A RD (SR8058 SEG 0010/0497)
FROM 8058/0010 SH (CONN) GULF LAB RD (SR1008 SEG 0010/0000)	0451/0630		0450/0625 GULF LAB RD (SR1008 SEG 0010/0000)
RAMP B RD (SR8058 SEG 0750/0000)	0451/0367		
018 "DIA CIRC CONCR LEN=0099 INSTALLED UNKN	0451/0099		0450/0365 018 "DIA CIRC CONCR LEN=0080 INSTALLED UNKN TO 8058/0750 SH
RT 0028 NB OP ID 02/0028/0270/1046	0451/0085		0450/0299 (CONN)
018 "DIA CIRC CONCR LEN=0030 INSTALLED UNKN	0451/0021		0450/0088 RT 0028 NB OP ID 02/0028/0270/1046 018 "DIA CIRC CONCR LEN=0048 INSTALLED UNKN
1 0 00679 0 00 0030+50 100246 FT SR 0028 SB OP ID 02/0028/0271/1085 LENGTH(AH 1411 BK 1749)	0451/0000		0450/0083 100230 FT 1 0 00679 0 00 0013+73 SR 0028 SB OP ID 02/0028/0271/1085 LENGTH(AH 1401 BK 1813)
			0444/1766 036 "DIA CIRC CONCR LEN=0099 INSTALLED UNKN
			0444/1575 018 "DIA CIRC CONCR LEN=0060 INSTALLED UNKN
			0444/1381 018 "DIA CIRC CONCR LEN=0060 INSTALLED UNKN
			0444/1186 018 "DIA CIRC CONCR LEN=0060 INSTALLED UNKN
			0444/0984 018 "DIA CIRC CONCR LEN=0060 INSTALLED UNKN
			0444/0801 018 "DIA CIRC CONCR LEN=0060 INSTALLED UNKN
			0444/0663 018 "DIA CIRC CONCR LEN=0035 INSTALLED UNKN

DIR: E TOTAL LEN: 19.253 MI. DIST: 11-1 SR: 910
 LEFT MUN: HARMAR T RIGHT MUN: HARMAR T

SIGN: 4 CHORD TRUSS
 BMSID 02/0910/0444/0335 0445/0351
 TO 8058/0512 SH
 (CONN) 0445/0233
 018 "DIA CIRC CONCR
 LEN=0040 INSTALLED UNKN 0445/0178

HARMAR INT/RAMP C RD
 (SR8058 SEG 0512/0000)
 1 0 00679 0 00 0030+50 0445/0040
 HARMAR INT/RAMP D RD 098497 FT
 (SR8058 SEG 0502/0666)

MFC BEGIN = B
 LENGTH(AH 1749 BK 2370) 0445/0000
 FROM 8058/0502 SH
 (CONN) 0441/2270

BMS EN 02/0910/0440/1505 0441/1814
 0 0 00000 0 00 0000+00
 DEER CREEK
 BMSBG 02/0910/0440/1505 0441/1590
 018 "DIA CIRC CONCR
 LEN=0099 INSTALLED UNKN 0441/1446

018 "DIA CIRC CONCR
 LEN=0050 INSTALLED UNKN 0441/1088

018 "DIA CIRC CONCR
 LEN=0099 INSTALLED UNKN 0441/0693
 018 "DIA CIRC CONCR
 LEN=0099 INSTALLED UNKN 0441/0386
 0 0 00000 0 00 0000+00 096127 FT
 MFC BEGIN = C
 LENGTH(AH 2370 BK 0629) 0441/0000

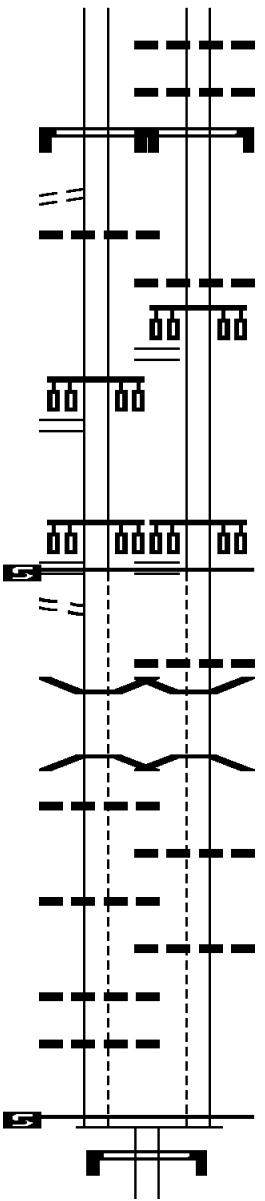

0444/0576 018 "DIA CIRC CONCR
 LEN=0060 INSTALLED UNKN
 0444/0371 018 "DIA CIRC CONCR
 LEN=0060 INSTALLED UNKN
 SIGN: 4 CHORD TRUSS
 BMSID 02/0910/0444/0335

0444/0134 018 "DIA CIRC CONCR
 LEN=0060 INSTALLED UNKN
 HARMAR INT/RAMP C RD
 (SR8058 SEG 0512/0000)
 0444/0046

098417 FT 1 0 00679 0 00 0013+73
 HARMAR INT/RAMP D RD
 (SR8058 SEG 0502/0666)

0444/0000 MFC BEGIN = B
 LENGTH(AH 1813 BK 2290)

0440/1927 018 "DIA CIRC CONCR
 LEN=0099 INSTALLED UNKN
 0440/1729 BMS EN 02/0910/0440/1505
 0 0 00000 0 00 0000+00
 DEER CREEK
 0440/1505 BMSBG 02/0910/0440/1505

0440/1340 018 "DIA CIRC CONCR
 LEN=0030 INSTALLED UNKN

0440/1017 018 "DIA CIRC CONCR
 LEN=0030 INSTALLED UNKN

096127 FT 1 0 00679 0 00 0046+44
 MFC BEGIN = C
 LENGTH(AH 2290 BK 0629)
 SIGN STRUCTURE
 0430/0621 BMSID 02/0910/0330/0621
 018 "DIA CIRC CONCR

DIR: E TOTAL LEN: 19.253 MI. DIST: 11-1 SR: 910
 LEFT MUN: HARMAR T RIGHT MUN: HARMAR T

Stationing	Notes	Material	Length	Status
095498 FT		0430/0045	LEN=0100	INSTALLED UNKN
		095498 FT	1 0 00679 0 00 0060+66	
		0430/0000	LENGTH(AH 0629 BK 1293)	
			024 "DIA CIRC CONCR	
		0420/0882	LEN=0035	INSTALLED UNKN
LC TO RICH HILL RD (CONN)	0420/0846			
RICH HILL RD (T662)	0420/0727			
	094205 FT			
		094205 FT	1 0 00679 0 00 0066+39	
		0420/0000	LENGTH(AH 1293 BK 3545)	
			018 "DIA CIRC CONCR	
		0410/2737	LEN=0080	INSTALLED UNKN
				LOCUST HILL RD (SR1006 SEG 0130/3570)
		0410/1170	018 "DIA CIRC CONCR	LEN=0070 INSTALLED UNKN
		0410/0432	018 "DIA CIRC CONCR	LEN=0070 INSTALLED UNKN
		0410/0062	(APRA) AMERICAN EQUIPME	
		0410/0034	024 "DIA CIRC METAL	LEN=0070 INSTALLED UNKN
		090660 FT	1 0 00679 0 00 0108+92	
910 COMMERCE PARK RD (PRDR)	0410/0000			
		0410/0000	LENGTH(AH 3545 BK 2620)	
			018 "DIA CIRC CONCR	
		0400/2295	LEN=0099	INSTALLED UNKN
		0400/2000	024 "DIA CIRC CONCR	LEN=0070 INSTALLED UNKN
		0400/1850	024 "DIA CIRC CONCR	LEN=0070 INSTALLED UNKN
TOWNSHIP RD (TWP)	0400/1750			
		0400/1434	024 "DIA CIRC CONCR	LEN=0070 INSTALLED UNKN
		0400/1025	018 "DIA CIRC CONCR	LEN=0099 INSTALLED UNKN
WASHINGTON DR (T503)	0400/0920			
LINCOLN DR (T501)	0400/0470			
		0400/0800		HARMAR INDIANA T

DIR: E TOTAL LEN: 19.253 MI. DIST: 11-1 SR: 910
 LEFT MUN: INDIANA T RIGHT MUN: INDIANA T

Location	Segment	Length	Notes
WASHINGTON DR (TWP)	0400/0365	==	
GRANT DR (T505)	0400/0255	==	
SHAFT ST (T507)	088040 FT	==	
	0400/0000	==	088040 FT 1 0 00679 0 00 0135+19 NC SR 910 SH LENGTH(AH 2620 BK 2163) INDIANOLA DR
	0390/1767	==	SHORT ST (T502)
	0390/1245	==	(T509)
	0390/0925	---	018 "DIA CIRC CONCR LEN=0048 INSTALLED UNKN
	0390/0770	---	018 "DIA CIRC CONCR LEN=0048 INSTALLED UNKN
BAYER DR (TWP)	0390/0600	==	
	0390/0576	---	015 "DIA CIRC CONCR LEN=0223 INSTALLED UNKN
	0390/0383	---	BMSSEN 02/0910/0390/0341 1 0 00679 0 00 0151+94 RAWLINS RUN
	0390/0362	---	BMSBG 02/0910/0390/0341 INDIANOLA RD (SR1036 SEG 0060/1742) REPUBLIC AV
	0390/0315	==	(TWP)
MCCLELLAN RD (T587)	085877 FT	==	1 0 00679 0 00 0156+57 (APRA) ALLEGHENY STEEL
	0390/0000	POI	0390/0000 LENGTH(AH 2163 BK 3224) 018 "DIA CIRC CONCR
	0380/3168	---	LEN=0060 INSTALLED UNKN
	0380/2725	---	018 "DIA CIRC CONCR LEN=0060 INSTALLED UNKN
	0380/2148	---	018 "DIA CIRC CONCR LEN=0060 INSTALLED UNKN
	0380/1872	---	018 "DIA CIRC CONCR LEN=0060 INSTALLED UNKN
BUCKEYE TERMINAL LLC (TWP)	0380/1361	==	
	0380/0801	---	018 "DIA CIRC METAL LEN=0020 INSTALLED UNKN
	082653 FT	==	082653 FT 1 0 00679 0 00 0188+84 BLUE RUN RD (T611)
	0380/0000	---	0380/0000 LENGTH(AH 3224 BK 1689) BMSSEN 02/0910/0370/1174 0 0 00000 0 00 0000+00 PA 0076 TURNPIKE
	0370/1418	---	

DIR: E TOTAL LEN: 19.253 MI. DIST: 11-1 SR: 910
 LEFT MUN: INDIANA T RIGHT MUN: INDIANA T

Stationing / Description	Structure / Details	Stationing / Description	Structure / Details
		0370/1174	BMSBG 02/0910/0370/1174
080964 FT		080964 FT	1 0 00679 0 00 0205+18 BLUE RUN STRUCTURE LENGTH 18 FT BMSID 02/0910/0370/0000 LENGTH(AH 1689 BK 1913)
		0370/0000	024 " DIA CIRC CONCR LEN=0060 INSTALLED UNKN
COVE RUN RD (TWP)	0360/1006	0360/1012	018 " DIA CIRC CONCR LEN=0099 INSTALLED UNKN
1 0 00679 0 00 0224+76	079051 FT	0360/0133	079051 FT
COVE RUN RD ET (T773)	0360/0000	0360/0000	LENGTH(AH 1913 BK 2713) TURNPIKE ACCESS RD (PRDR)
		0350/2181	BMSEN 02/7076/9900/4359
		0350/1781	1 0 00679 0 00 0252+28 PA TPK 1-76 BMSBG 02/7076/9900/4359 LAKEWOOD DR
		0350/1589	(PRDR)
		0350/1490	018 " DIA CIRC CONCR LEN=0060 INSTALLED UNKN
		0350/1297	036 " DIA CIRC CONCR LEN=0060 INSTALLED UNKN
		0350/0553	076338 FT
HILLTOP DR (T771)	0350/0276	0350/0000	LENGTH(AH 2713 BK 1120) 018 " DIA CIRC CONCR LEN=0099 INSTALLED UNKN
1 0 00679 0 00 0252+28	076338 FT	0340/1065	018 " DIA CIRC CONCR LEN=0048 INSTALLED UNKN
LC FOR HILLTOP DR (CONN)	0350/0000	0340/0470	075218 FT
		075218 FT	1 0 00679 0 00 0263+36 SAXONBURG BL (SR1013 SEG 0150/1155)
TO 1013/0150 SH (CONN)	0340/0075	0340/0000	LENGTH(AH 1120 BK 2413) 018 " DIA CIRC CONCR
	075218 FT		

DIR: E TOTAL LEN: 19.253 MI. DIST: 11-1 SR: 910
 LEFT MUN: INDIANA T RIGHT MUN: INDIANA T

HAWKINS PRECAST CON RD
 (PRDR)

0330/0247
 072805 FT

MYERS LN
 (PRDR)

0320/1700

069265 FT

068093 FT

0330/2020	LEN=0048	INSTALLED UNKN
	015 "DIA	CIRC CONCR
0330/1901	LEN=0035	INSTALLED UNKN
	MELLOW LN	
0330/1706	(PRDR)	
	018 "DIA	CIRC CONCR
0330/1575	LEN=0048	INSTALLED UNKN
	018 "DIA	CIRC CONCR
0330/0907	LEN=0040	INSTALLED UNKN
	(APRA) HAWKINS PRECAST	
	CEDAR RUN RD	
0330/0247	(T653)	
0330/0031	BMSSEN 02/0910/0330/0000	
072805 FT	2 0 02157 0 00 0029+96	
	CEDAR RUN	
0330/0000	BMSBG 02/0910/0330/0000	
	LENGTH(AH 2413 BK 3540)	
	018 "DIA	CIRC CONCR
0320/2953	LEN=0010	INSTALLED UNKN
0320/2918	BMSSEN 02/7076/9900/4265	
	018 "DIA	CIRC CONCR
0320/2525	LEN=0048	INSTALLED UNKN
	2 0 02157 0 01 0061+14	
	PA TPK I-76	
0320/2367	BMSBG 02/7076/9900/4265	
	018 "DIA	CIRC CONCR
0320/2340	LEN=0048	INSTALLED UNKN
	018 "DIA	CIRC CONCR
0320/2075	LEN=0045	INSTALLED UNKN
	018 "DIA	CIRC CONCR
0320/1932	LEN=0050	INSTALLED UNKN
	018 "DIA	CIRC METAL
0320/1210	LEN=0040	INSTALLED UNKN
	2 0 02157 0 01 0061+14	
	INDIANA	
	WEST DEER T	
0320/0000	LENGTH(AH 3540 BK 1172)	
	04B "DIA	CIRC METAL
0310/0350	LEN=0060	INSTALLED UNKN
068093 FT	2 0 02157 0 01 0073+15	
	CEDAR RIDGE RD	
	(SR1020 SEG 0040/3667)	

EXTRACT DATE: 12/21/2020
PRINT DATE: 12/23/2020

ROADWAY MANAGEMENT SYSTEM
SLD COUNTY/SR - ANNUAL PRINT

PAGE NUMBER: 480
COUNTY: ALLEGHENY

DIR: E TOTAL LEN: 19.253 MI.
LEFT MUN: WEST DEER T

DIST: 11-1 SR: 910
RIGHT MUN: WEST DEER T

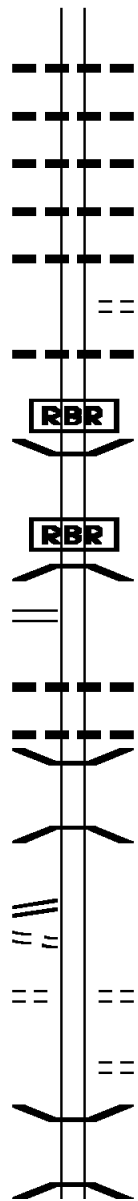

5 0310/0000	LENGTH(AH 1172 BK 2763)
	024 "DIA CIRC CONCR
0300/2274	LEN=0068 INSTALLED UNKN
	018 "DIA CIRC CONCR
0300/1780	LEN=0048 INSTALLED UNKN
	018 "DIA CIRC CONCR
0300/1545	LEN=0048 INSTALLED UNKN
	018 "DIA CIRC CONCR
0300/1160	LEN=0048 INSTALLED UNKN
	018 "DIA CIRC CONCR
0300/0820	LEN=0048 INSTALLED UNKN
	QSI LN
	(PRDR)
0300/0642	018 "DIA CIRC CONCR
0300/0500	LEN=0048 INSTALLED UNKN
	0300/0075 BMSEN 02/0910/0300/0000
	2 0 02157 0 01 0100+19
	P3
	DEER CREEK
	BMSBG 02/0910/0300/0000
5 0300/0000	LENGTH(AH 2763 BK 1894)
	018 "DIA CIRC METAL
0290/0997	LEN=0048 INSTALLED UNKN
	018 "DIA CIRC CONCR
0290/0625	LEN=0040 INSTALLED UNKN
0290/0122	BMSEN 02/0910/0290/0118
	2 0 02157 0 01 0122+25
	BR. DEER CR.
0290/0100	BMSBG 02/0910/0290/0118
063436 FT	
5 0290/0000	LENGTH(AH 1894 BK 2265)
	CAITLIN DR
0280/1830	(PRDR)
	COMMERCE DR
0280/1204	(TWP)
0280/0552	BMSEN 02/0910/0280/0512
	2 0 02148 0 00 0026+54
	DEER CREEK
0280/0512	BMSBG 02/0910/0280/0512

065330 FT

CAMPBELL RD
(SR1020 SEG 0050/0000) 0290/1615

2 0 02157 0 01 0122+25 063436 FT
MOUNTAIN VIEW RD
(SR1024 SEG 0010/0000) 0290/0000
MOUNTAIN VIEW RD
(T670) 0280/1885
CHRISTONIA RD
(T678) 0280/1830

DIR: E TOTAL LEN: 19.253 MI. DIST: 11-1 SR: 910
 LEFT MUN: WEST DEER T RIGHT MUN: WEST DEER T

Stationing	Structure / Notes	Stationing	Structure / Notes
	0280/0480 072"H 72"W CONC STRUCT LEN=0048 INSTALLED UNKN LC FOR MARTIN RD		
061171 FT	0280/0255 (CONN) 061171 FT 2 0 02148 0 00 0020+29 0280/0000 LENGTH(AH 2265 BK 1754) MARTIN RD		
	0270/1644 (T678) FRONTIER DR		
	0270/1534 (TWP) 018 " DIA CIRC CONCR		
	0270/1498 LEN=0048 INSTALLED UNKN		
	0270/0669 BMS EN 02/0910/0270/0621 2 0 02148 0 00 0003+59 DEER CREEK		
	0270/0621 BMSBG 02/0910/0270/0621 096"H 72"W CONC STRUCT		
2 0 02148 0 00 0003+59 OAK RD (SR1022 SEG 0010/0000)	0270/0590 LEN=0048 INSTALLED UNKN 059417 FT		
	0270/0000 LENGTH(AH 1754 BK 1266) 018 " DIA CIRC CONCR		
MIDDLE RD ET (CNTY)	0260/1250 LEN=0048 INSTALLED UNKN		
	0260/0908		
	0260/0848 BMS EN 02/0910/0260/0825 2 0 02150 0 01 0104+17 DEER CREEK		
	0260/0800 BMSBG 02/0910/0260/0825		
058151 FT	058151 FT 2 0 02150 0 01 0104+17 MIDDLE RD (CNTY)		
	0260/0000 LENGTH(AH 1266 BK 2409)		
	0250/1350 018 " DIA CIRC CONCR LEN=0070 INSTALLED UNKN		
	0250/1065 018 " DIA CIRC CONCR LEN=0050 INSTALLED UNKN		
055742 FT	055742 FT 2 0 02150 0 01 0081+55 018 " DIA CIRC CONCR		
	0250/0000 LEN=0048 INSTALLED UNKN LENGTH(AH 2409 BK 3777)		
	0240/3176 018 " DIA CIRC CONCR LEN=0025 INSTALLED UNKN		

DIR: E TOTAL LEN: 19.253 MI. DIST: 11-1 SR: 910
 LEFT MUN: RICHLAND T RIGHT MUN: RICHLAND T

Stationing	Distance	Notes	Material	Length	Notes
	0230/1100		018" DIA CIRC CONCR	LEN=0048	INSTALLED UNKN
	0230/0155		018" DIA CIRC CONCR	LEN=0048	INSTALLED UNKN
2 0 02150 0 00 0004+30 048283 FT	048283 FT				
CLENDENNING RD (T707)	0230/0000		018" DIA CIRC CONCR	LEN=0040	INSTALLED UNKN
	0210/0936		018" DIA CIRC CONCR	LEN=0040	INSTALLED UNKN
COMM CENTER DR (TWP)	0210/0550		018" DIA CIRC CONCR	LEN=0040	INSTALLED UNKN
	0210/0515		018" DIA CIRC CONCR	LEN=0040	INSTALLED UNKN
	0210/0221		018" DIA CIRC CONCR	LEN=0040	INSTALLED UNKN
	0210/0193		018" DIA CIRC CONCR	LEN=0040	INSTALLED UNKN
	0210/0146		018" DIA CIRC CONCR	LEN=0040	INSTALLED UNKN
047247 FT	0210/0099		018" DIA CIRC CONCR	LEN=0040	INSTALLED UNKN
	0210/0000		018" DIA CIRC CONCR	LEN=0040	INSTALLED UNKN
	0200/0647		018" DIA CIRC CONCR	LEN=0040	INSTALLED UNKN
045862 FT	0200/0198		018" DIA CIRC CONCR	LEN=0040	INSTALLED UNKN
	0200/0000		018" DIA CIRC CONCR	LEN=0040	INSTALLED UNKN
BENEDICK RD (T826)	0190/2230		018" DIA CIRC CONCR	LEN=0050	INSTALLED UNKN
	0190/1865		018" DIA CIRC CONCR	LEN=0040	INSTALLED UNKN
	0190/1760		018" DIA CIRC CONCR	LEN=0040	INSTALLED UNKN
	0190/1584		018" DIA CIRC CONCR	LEN=0040	INSTALLED UNKN
	0190/1551		018" DIA CIRC CONCR	LEN=0040	INSTALLED UNKN
FISHER RD (TWP)	0190/1245		018" DIA CIRC CONCR	LEN=0048	INSTALLED UNKN

DIR: E TOTAL LEN: 19.253 MI. DIST: 11-1 SR: 910
 LEFT MUN: RICHLAND T RIGHT MUN: RICHLAND T

Stationing	Notes	Stationing	Notes
043555 FT		043555 FT	1 1 03581 0 00 0000+00 EWALT RD (T842)
FISHER RD (T795)	0180/2409	0190/0000	LENGTH(AH 2307 BK 2455)
		0180/2409	LC TO EWALT RD (CONN)
MERIDIAN RD (CNTY)	0180/1757	0180/2357	RICHLAND RD (T602)
		0180/2078	
FAIRFIELD DR (T749)	0180/0885	0180/1757	018 "DIA CIRC CONCR LEN=0050 INSTALLED UNKN
		0180/1745	
BAUER DR (T620)	0180/0340	0180/0795	018 "DIA CIRC CONCR LEN=0030 INSTALLED UNKN
		0180/0345	018 "DIA CIRC CONCR LEN=0030 INSTALLED UNKN
	041100 FT	0180/0095	018 "DIA CIRC CONCR LEN=0048 INSTALLED UNKN
		041100 FT	2 0 02324 0 00 0134+43
		0180/0000	LENGTH(AH 2455 BK 2607) ANDERSON RD
		0170/2145	(T609)
		0170/2060	018 "DIA CIR PLASTIC LEN=0048 INSTALLED UNKN
		0170/1643	018 "DIA CIRC CONCR LEN=0048 INSTALLED UNKN
LC FOR DICKEY RD (CONN)	0170/0917		
DICKEY RD (T709)	0170/0791		
		0170/0620	018 "DIA CIRC CONCR LEN=0048 INSTALLED UNKN
RICHLAND AV (T686)	0170/0228		
	038493 FT	038493 FT	2 0 02324 0 00 0108+22 GIBSON RD (T794)
		0170/0000	LENGTH(AH 2607 BK 1059)

DIR: E TOTAL LEN: 19.253 MI. DIST: 11-1 SR: 910
 LEFT MUN: RICHLAND T RIGHT MUN: RICHLAND T

ROAD NAME	START	END	LENGTH	STRUCTURE	DETAILS
GRUBBS RD (T584)	0160/0876	0160/0850	037434 FT	WILLOW RUN	STRUCTURE LENGTH 13 FT BMSID 02/0910/0160/0850 (AAR 145729G)#TRKS 01
LAKESIDE DR (T796)	0160/0000	0160/0000			2 0 02324 0 00 0097+54 018 "DIA CIRC CONCR LEN=0070 INSTALLED UNKN HARDT RD (SR4065 SEG 0050/3034)
CLEARVIEW RD (T727)	0150/2725	0150/1130			048 "DIA CIRC CONCR LEN=0080 INSTALLED UNKN
WOODLAND RD (TWP)	0150/1380	0150/0470			018 "DIA CIRC CONCR LEN=0048 INSTALLED UNKN
MONTOUR RD (T576)	0150/0000	0150/0042	033680 FT		018 "DIA CIRC CONCR LEN=0048 INSTALLED UNKN
	0150/0000	0140/1378	032267 FT		LENGTH(AH 3754 BK 1413) BMSEN 02/0910/0140/1182 2 0 02324 0 00 0050+60 PA 0076 TURNPIKE
		0140/1182			BMSBG 02/0910/0140/1182 TURNPIKE ACCESS RD
		0140/1045			(PRDR)
		0140/0498			BMSEN 02/0910/0140/0460 2 0 02324 0 00 0050+60
		0140/0460			MONTOUR RUN
		0140/0350			BMSBG 02/0910/0140/0460 MONTOUR RD
		0130/3366			(T928)
					2 0 02324 0 00 0045+33 LENGTH(AH 1413 BK 3530)
					018 "DIA CIRC CONCR LEN=0048 INSTALLED UNKN
					018 "DIA CIRC CONCR

DIR: E TOTAL LEN: 19.253 MI. DIST: 11-1 SR: 910
 LEFT MUN: RICHLAND T RIGHT MUN: RICHLAND T

0130/3091	LEN=0048	INSTALLED UNKN
0130/2881	RICHLAND PINE T	
0130/2803	018 "DIA CIRC CONCR	INSTALLED UNKN
0130/2445	018 "DIA CIRC CONCR	INSTALLED UNKN
0130/1940	018 "DIA CIRC CONCR	INSTALLED UNKN
0130/1700	015 "DIA CIRC CONCR	INSTALLED UNKN
0130/1411	018 "DIA CIRC CONCR	INSTALLED UNKN
0130/1090	018 "DIA CIRC CONCR	INSTALLED UNKN
0130/0690	KARRINGTON DR (TWP)	
0130/0650	018 "DIA CIRC CONCR	INSTALLED UNKN
0130/0331	018 "DIA CIRC CONCR	INSTALLED UNKN
0130/0034	018 "DIA CIRC CONCR	INSTALLED UNKN
0130/0000	LENGTH(AH 3530 BK 1052)	
0120/0555	018 "DIA CIRC CONCR	INSTALLED UNKN
0120/0119	FROM 4031/0120 SH (CONN)	
0120/0000	2 0 02324 0 00 0000+00 (SR4031 SEG 0130/0000)	
0110/2200	015 "DIA CIRC METAL	INSTALLED UNKN
025231 FT	IRWIN RD (T556)	
0110/0000	LENGTH(AH 2454 BK 1541)	
0100/1268	018 "DIA CIRC METAL	INSTALLED UNKN

2 0 02324 0 00 0010+68 028737 FT
 DENNIS DR (T912)
 OLD STATE RD (T574)
 0130/0000
 0120/0571

2 0 02106 0 00 0135+28 025231 FT
 OLD RD (TWP)
 0110/0000

DIR: E TOTAL LEN: 19.253 MI. DIST: 11-1 SR: 910
 LEFT MUN: PINE T RIGHT MUN: PINE T

WHITE PINE DR
 (TWP)

0100/0400
 023690 FT

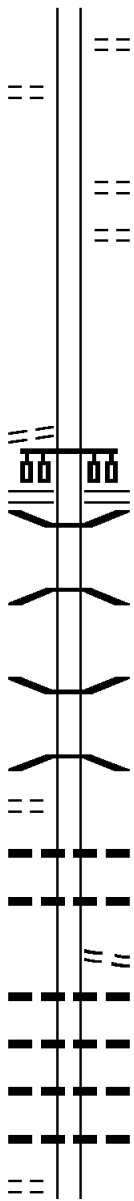

0100/0690 PARKVIEW DR
 (TWP)
 023690 FT 2 0 02106 0 00 0120+08
 0100/0000 LENGTH(AH 1541 BK 3542)
 SALEM LN
 0090/3380 (TWP)
 HEIGHTS DR
 0090/2991 (TWP)

TO 4063/0010 SH
 (CONN)

0090/0883

0090/0788 PEARCE MILL RD
 0090/0418 (SR4063 SEG 0010/3075)
 BMS EN 02/0910/0090/0360
 2 0 02106 0 00 0083+42
 NORTH FORK OF PINE CR.
 0090/0360 BMSBG 02/0910/0090/0360
 020148 FT 2 0 02106 0 00 0083+42
 0090/0000 LENGTH(AH 3542 BK 3460)
 0080/2819 BMS EN 02/0910/0080/2839
 2 0 02106 0 00 0049+99
 BR. PINE CRK
 0080/2798 BMSBG 02/0910/0080/2839

LYNDHURST CR
 (T550)

0080/2409

0080/2395 018 " DIA CIRC CONCR
 LEN=0048 INSTALLED UNKN
 0080/1900 018 " DIA CIRC CONCR
 LEN=0048 INSTALLED UNKN
 REYNOLDS RD
 0080/1386 (CNTY)
 0080/1380 015 " DIA CIRC CONCR
 LEN=0040 INSTALLED UNKN
 0080/1275 018 " DIA CIRC CONCR
 LEN=0040 INSTALLED UNKN
 0080/0785 018 " DIA CIRC CONCR
 LEN=0099 INSTALLED UNKN
 0080/0438 018 " DIA CIRC CONCR
 LEN=0048 INSTALLED UNKN

HILL RD
 (TWP)

0080/0246

DIR: E TOTAL LEN: 19.253 MI. DIST: 11-1 SR: 910
 LEFT MUN: PINE T RIGHT MUN: PINE T

Stationing	Length	Notes	Material	Status
016688 FT	0080/0035	018" DIA	CIRC CONCR	INSTALLED UNKN
	016688 FT	2 0 02106	0 00 0049+99	
	0080/0000	LENGTH(AH 3460 BK 2861)		
	0070/2200	018" DIA	CIRC CONCR	INSTALLED UNKN
	0070/1840	018" DIA	CIRC CONCR	INSTALLED UNKN
	0070/0925	018" DIA	CIRC CONCR	INSTALLED UNKN
	0070/0695	018" DIA	CIRC CONCR	INSTALLED UNKN
VILLAGE CLUB DR (TWP)	0070/0409	0070/0202	024" DIA	CIRC METAL INSTALLED UNKN
	013827 FT	0070/0035	018" DIA	CIRC CONCR INSTALLED 2000
		013827 FT	2 0 02106	0 00 0019+24
		NC SA LEM HOLLOW RD		
		0070/0000	LENGTH(AH 2861 BK 2053)	
		0060/1602	018" DIA	CIRC CONCR INSTALLED UNKN
NORTH CHAPEL DR (SR4073 SEG 0010/0000)	0060/1130	0060/1103	036" DIA	CIRC CONCR INSTALLED UNKN
		0060/1103	LEN=0099	INSTALLED UNKN
		0060/0723	SOUTH CHAPEL DR (T502)	
		0060/0330	OP ID 02/0019/0610/1799	
		0060/0290	018" DIA	CIRC CONCR INSTALLED UNKN
		0060/0197	018" DIA	CIRC CONCR INSTALLED UNKN
		0060/0060	018" DIA	CIRC CONCR INSTALLED UNKN
		NC WE XFORD RD		
2 0 02106 0 00 0000+00	011774 FT	011774 FT	SOUTH CHURCH RD (T835)	
NORTH CHURCH RD (T835)	0060/0000	0060/0000	LENGTH(AH 2053 BK 2447)	
		0050/2425	018" DIA	CIRC CONCR INSTALLED UNKN
		0050/1950	LIMERICK RD (T514)	
			018" DIA	CIRC CONCR

DIR: E TOTAL LEN: 19.253 MI. DIST: 11-1 SR: 910
 LEFT MUN: MARSHALL T RIGHT MUN: MARSHALL T

HIGHPOINT DR
 (T858)

0030/0340

003719 FT

2 0 02323 0 00 0104+45 001377 FT

MINGO RD
 (SR4051 SEG 0010/0000)
 MARSHALL
 FRANKLIN PARK B

0020/0000

018 "DIA CIRC CONCR
 LEN=0035 INSTALLED UNKN 0011/1305
 DEVINE DR
 (TWP) 0011/1149

024 "DIA CIRC CONCR
 LEN=0035 INSTALLED UNKN 0011/0390
 VIP DR
 (TWP)
 BRANDT SCHOOL RD
 (CNTY)

0011/0280

2 0 02323 0 00 0093+74 000000 FT

NC WEXFORD BAYNE RD
 RAMP D RD
 (SR8023 SEG 0750/0000)
 RAMP C RD
 (SR8023 SEG 0010/1115)
 BAYNE WEXFORD RD
 (SR4042 SEG 0041/1740)

INTER-BK

MFC BEGIN = C
 LENGTH(AH 1377 BK 0000) 0011/0000

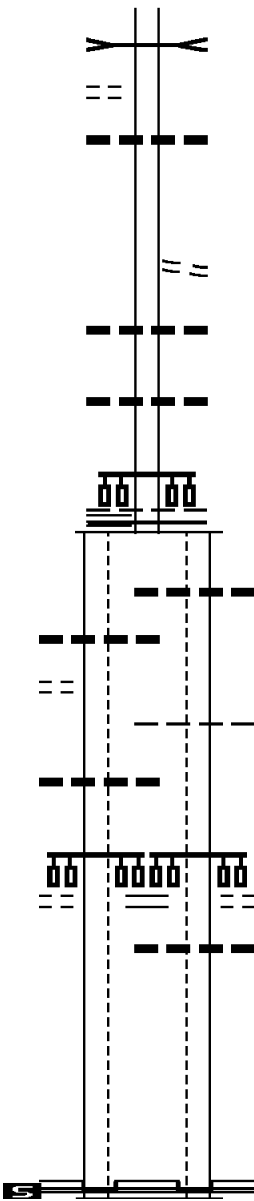

0030/0922 STRUCTURE LENGTH 10 FT
 BMSID 02/0910/0030/0922

0030/0148 024 "DIA CIRC CONCR
 LEN=0048 INSTALLED UNKN
 003719 FT 2 0 02323 0 00 0135+25
 0030/0000 LENGTH(AH 3805 BK 2342)

0020/1540 DAVIDFORD DR
 (TWP)

0020/0935 018 "DIA CIRC CONCR
 LEN=0048 INSTALLED UNKN

0020/0220 018 "DIA CIRC CONCR
 LEN=0035 INSTALLED UNKN
 001377 FT

0020/0000 MFC BEGIN = C
 LENGTH(AH 2342 BK 1377)

0010/1320 018 "DIA CIRC CONCR
 LEN=0040 INSTALLED UNKN

0010/0985 MARSHALL
 FRANKLIN PARK B

VIP DR
 (TWP)
 BRANDT SCHOOL RD
 (CNTY)

0010/0285 018 "DIA CIRC CONCR
 LEN=0072 INSTALLED UNKN
 000000 FT 2 0 02323 0 00 0093+74
 NC WEXFORD BAYNE RD

RAMP D RD
 (SR8023 SEG 0750/0000)
 RAMP C RD
 (SR8023 SEG 0010/1115)
 BAYNE WEXFORD RD
 (SR4042 SEG 0040/1750)
 MFC BEGIN = C
 LENGTH(AH 1377 BK 0000) 0010/0000

000611 FT

000000 FT

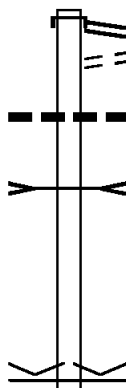

000611 FT INTER-AHD RAINBOW RUN RD
 (SR0136 SEG 0070/0000)
 RAINBOW RUN RD
 0010/0611 (SR0136 SEG 0070/0000)
 FOR SR 0136 AND 0906
 0010/0326 (CONN)
 009 " DIA CIRC CONCR
 0010/0300 LEN=0099 INSTALLED UNKN
 BECKETS RUN
 STRUCTURE LENGTH 14 FT
 0010/0088 BMSID 02/0906/0010/0088
 000000 FT 1 0 00181 7 00 0000+00
 VILLAGE: FORWARD TWP
 NC MO NONGAHELA RD
 * REF-BK SCHOONMAKER AV
 (SR0906 SEG 0180/3319)
 MFC BEGIN = C
 BK-WESTMORELAND (64)
 0010/0000 LENGTH(AH 0611 BK 0000)

EXTRACT DATE: 12/21/2020 ROADWAY MANAGEMENT SYSTEM PAGE NUMBER: 468
 PRINT DATE: 12/23/2020 SLD COUNTY/SR - ANNUAL PRINT COUNTY: ALLEGHENY
 DIR: B TOTAL LEN: 14.214 MI. DIST: 11-1 SR: 885
 LEFT MUN: PITTSBURGH C RIGHT MUN: PITTSBURGH C

074446 FT
 BL OF ALLIES INTER-AHD
 (SR2208 SEG 0020/1509) 0351/2149
 BMS EN 02/0885/0351/1750 0351/1870
 018 "DIA CIRC CONCR
 LEN=0020 INSTALLED UNKN 0351/1830
 1 0 00120 0 01 0073+27

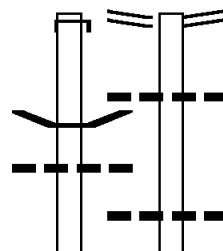

075051 FT RAMP K CROSSTOWN BL INT
 (SR8002 SEG 0280/0000)
 RAMP G CROSSTOWN BL INT
 (SR8002 SEG 0260/0000)
 0350/2406
 0350/1787 018 "DIA CIRC CONCR
 LEN=0024 INSTALLED UNKN
 0350/1668 018 "DIA CIRC CONCR
 LEN=0024 INSTALLED UNKN

EXTRACT DATE: 12/21/2020
PRINT DATE: 12/23/2020

ROADWAY MANAGEMENT SYSTEM
SLD COUNTY/SR - ANNUAL PRINT

PAGE NUMBER: 467
COUNTY: ALLEGHENY

DIR: B TOTAL LEN: 14.214 MI.
LEFT MUN: PITTSBURGH C

DIST: 11-1 SR: 885
RIGHT MUN: PITTSBURGH C

NO UNDERPASS INFORMATIO
BMSBG 02/0885/0351/1750 0351/1750
SIGN: 3 CHORD TRUSS
BMSID 02/0885/0350/1320 0351/1351

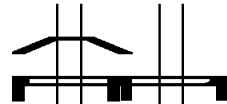

SIGN: 3 CHORD TRUSS
BMSID 02/0885/0350/1320
012"H 24"W CON BOX CUL
LEN=0024 INSTALLED UNKN
012"H 24"W CON BOX CUL
LEN=0024 INSTALLED UNKN
018 "DIA CIRC CONCR
LEN=0024 INSTALLED UNKN
PEDESTRIAN
OP ID 02/0885/0350/0626 0351/0745

PEDESTRIAN
OP ID 02/0885/0350/0626 0351/0745
012"H 24"W CON BOX CUL
LEN=0024 INSTALLED UNKN 0351/0645
018"H 18"W ELLIP CONC
LEN=0024 INSTALLED UNKN 0351/0360

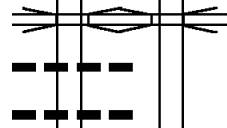

BMSEN 02/0885/0351/0001 0351/0336
1 0 00376 0 04 0812+82 072297 FT
NO UNDERPASS INFORMATIO
BMSBG 02/0885/0351/0001
LENGTH(AH 2149 BK 3153) 0351/0000

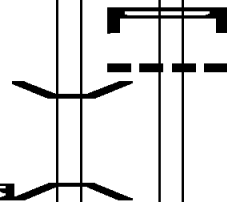

SIGN: CANTILEVER
BMSID 02/0885/0350/0353
018 "DIA CIRC CONCR
LEN=0024 INSTALLED UNKN
072645 FT 1 0 00120 0 01 0061+88
0350/0000 LENGTH(AH 2406 BK 2933)
018 "DIA CIRC CONCR
LEN=0024 INSTALLED UNKN

018 "DIA CIRC CONCR
LEN=0024 INSTALLED UNKN 0341/2903
012 "DIA CIRC CONCR
LEN=0024 INSTALLED UNKN 0341/2654

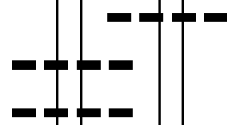

018"H 36"W CON BOX CUL
LEN=0024 INSTALLED UNKN 0341/2210
BMSEN 02/0885/0341/1412 0341/2199

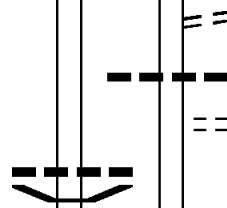

BLUFF ST
(CITY)
018 "DIA CIRC CONCR
LEN=0024 INSTALLED UNKN
MARION ST
(CITY)

018 "DIA CIRC CONCR
LEN=0024 INSTALLED UNKN 0341/1847



VAN BRAAM ST
(CITY)

0 0 00000 0 00 0000+00
NO UNDERPASS INFORMATIO
BMSBG 02/0885/0341/1412 0341/1412
BMSEN 02/0885/0341/0890 0341/1247

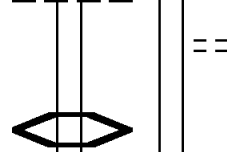

MILTENBERGER ST
(CITY)

DIR: B TOTAL LEN: 14.214 MI. DIST: 11-1 SR: 885
 LEFT MUN: PITTSBURGH C RIGHT MUN: PITTSBURGH C

Item ID	Description	Stationing	Notes
012	"DIA CIRC CONCR LEN=0024 INSTALLED UNKN	0341/1015	---
		== 0340/1010	GIST ST (CITY)
0 0 00000 0 00 0000+00	NO UNDERPASS INFORMATIO		
BMSBG 02/0885/0341/0890		0341/0890	---
		== 0340/0505	JUMONVILLE ST (CITY)
		0340/0275	036"H 36"W CON BOX CUL LEN=0024 INSTALLED UNKN
RETAINING WALL			
BMSID 02/0885/0341/0265		0341/0265	---
BMSEN 02/0885/0341/0001		0341/0203	---
1 0 00120 0 01 0079+39	069144 FT		
NO UNDERPASS INFORMATIO			
BMSBG 02/0885/0341/0001		0341/0000	---
LENGTH(AH 3153 BK 2859)		0340/0000	069712 FT 1 0 00120 0 01 0079+39 LENGTH(AH 2933 BK 3272)
		0330/3000	018 "DIA CIRC CONCR
		0330/2907	LEN=0024 INSTALLED UNKN
		0330/2800	018 "DIA CIRC CONCR LEN=0024 INSTALLED UNKN
018 "DIA CIRC CONCR			
LEN=0024 INSTALLED UNKN		0331/2737	---
		0330/2719	RAMP R FROM PY EAST WB (SR8004 SEG 0500/1162)
BMSEN 02/0885/0331/1302		0331/2589	---
SIGN: 4 CHORD TRUSS			
BMSID 02/0885/0331/2425		0331/2521	---
RAMP TO SR 0376 E			
(SR8004 SEG 0760/0000)		0331/2443	---
		0330/2362	BL OF ALLIES TO PY WEST (SR8004 SEG 0260/0000)
SR 2085			
OP ID 02/2085/0010/2248		0331/2343	SR 2085 OP ID 02/2085/0010/2248
1 0 00120 0 01 0113+14			
FORBES AVE.			
BMSBG 02/0885/0331/1302		0331/1286	---
		0330/1824	018 "DIA CIRC CONCR LEN=0024 INSTALLED UNKN
		0330/1680	SIGN: CANTILEVER BMSID 02/0885/0330/1653
		0330/1640	024 "DIA CIRC CONCR LEN=0099 INSTALLED UNKN
		0330/1525	024 "DIA CIRC CONCR LEN=0099 INSTALLED UNKN
		0330/1350	018 "DIA CIRC CONCR LEN=0024 INSTALLED UNKN
			RAMP B RD

DIR: B TOTAL LEN: 14.214 MI. DIST: 11-1 SR: 885
 LEFT MUN: PITTSBURGH C RIGHT MUN: PITTSBURGH C

Segment ID	Description	Start Station	End Station	Notes
0330/1055	(SR8119 SEG 0250/0574)			
BMSID 02/0885/0331/1026	SIGN: CANTILEVER	0331/1026		
0330/0950	018 "DIA CIRC CONCR LEN=0024 INSTALLED UNKN			
0331/0850	018 "DIA CIRC CONCR LEN=0009 INSTALLED UNKN			
0331/0838	RAMP A RD (SR8119 SEG 0010/0000)			
0330/0750	018 "DIA CIRC CONCR LEN=0024 INSTALLED UNKN SIGN: CANTILEVER			
0330/0630	BMSID 02/0885/0330/0630			
0330/0347	BMSID 02/0885/0330/0630 BMSEN 02/0885/0330/0048			
0331/0358	BMSEN 02/0885/0330/0048			
0331/0106	018 "DIA CIRC CONCR LEN=0036 INSTALLED UNKN			
0331/0048	1 0 00376 0 04 0813+80 SR 2108 EB FORBES AVE			
0331/0048	BMSBG 02/0885/0330/0048			
0331/0000	1 0 00376 0 04 0813+80 066285 FT LENGTH(AH 2859 BK 0869)			
0321/0764	018 "DIA CIRC CONCR LEN=0099 INSTALLED UNKN			
0320/0707	018 "DIA CIRC CONCR LEN=0099 INSTALLED UNKN			
0320/0540	018 "DIA CIRC CONCR LEN=0099 INSTALLED UNKN			
0320/0450	MCDEVITT PL (CITY)			
0321/0490	HAMLET ST (CITY)			
0321/0404	HAMLET ST (CITY)			
0320/0393	LC TO MCDEVITT ST (CONN)			
0320/0375	HAMLET ST (CITY)			
0321/0380	HAMLET ST (CITY)			
0321/0230	CRAFT PL (CITY)			
0320/0195	CRAFT PL (CITY)			
065599 FT	1 0 00376 0 04 0803+11 CRAFT AV (CITY)			
0321/0000	CRAFT AV (CITY)			
0320/0000	CRAFT AV (CITY)			
0321/0000	LENGTH(AH 0869 BK 1445)			
NIAGARA ST	NIAGARA ST			

DIR: B TOTAL LEN: 14.214 MI. DIST: 11-1 SR: 885
 LEFT MUN: PITTSBURGH C RIGHT MUN: PITTSBURGH C

(CITY)	0311/0845		0310/0870	(CITY)
HALKET ST			HALKET ST	(CITY)
(CITY)			(CITY)	
ZULEMA ST			ZULEMA ST	(CITY)
(CITY)	0311/0560		(CITY)	
SIGN: CANTILEVER				
BMSID 02/0885/0311/0300	0311/0300			
1 0 00376 0 04 0788+18	063971 FT		064081 FT	1 0 00376 0 04 0788+18
BATES ST			BATES ST	(CITY)
(CITY)			(CITY)	
NC BL OF THE ALLIES			NC BL OF THE ALLIES	
BL OF THE ALLIES			BL OF THE ALLIES	(CITY)
(CITY)			(CITY)	
MFC BEGIN = B			MFC BEGIN = B	
LENGTH(AH 1445 BK 1706)	0311/0000		0310/0000	LENGTH(AH 1518 BK 1706)
RAMP D RD			0300/0722	099 "DIA CIRC CONCR
(SR8006 SEG 0250/0314)	0300/0553			LEN=0080 INSTALLED UNKN
HODGE ST			0300/0363	BATES ST INT/RAMP A RD
(CITY)	0300/0250			(SR8006 SEG 0500/0535)
			0300/0260	RAMP B RD
				(SR8006 SEG 0750/0000)
			0300/0198	TO 8006/0750 SH
				(CONN)
			0300/0183	SR 0376 EB
				OP ID 02/0376/0724/1534
				GAP TRAIL
			0300/0087	OP ID 02/0885/0300/0087
			062265 FT	1 0 00376 0 04 0772+14
				(APRA) ALLEGHENY ASPHAL
SECOND AV				NC BA
(CITY)				TES ST
TECHNOLOGY DR				MFC BEGIN = B
(CITY)	0300/0000			LENGTH(AH 1706 BK 2463)
099 "DIA CIR UNKNOWN				
LEN=0099 INSTALLED UNKN	0291/2368			
PEDESTRIAN				
OP ID 02/0885/0290/1877	0291/1881		0290/1880	OP ID PEDESTRIAN
HOT METAL ST				02/0885/0290/1877
(CITY)				
	0291/1844		0290/1865	HOT METAL ST
				(CITY)
024 "DIA CIRC CONCR				
LEN=0025 INSTALLED UNKN	0291/1547			018 "DIA CIRC CONCR

DIR: B TOTAL LEN: 14.214 MI. DIST: 11-1 SR: 885
 LEFT MUN: PITTSBURGH C RIGHT MUN: PITTSBURGH C

PARKING LOT
(PRDR)

0291/1353

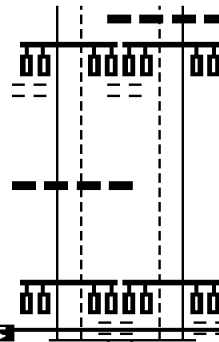

0290/1555 LEN=0050 INSTALLED UNKN
 PARKING LOT
(PRDR)

0290/1363

018 "DIA CIRC CONCR
 LEN=0025 INSTALLED UNKN 0291/0211
 1 0 00376 0 04 0740+26 059830 FT
 SWINEBURNE ST
 (CITY)

059912 FT 1 0 00376 0 04 0740+15
 SWINEBURNE ST
 (CITY)

MFC BEGIN = B
 LENGTH(AH 2435 BK 2423) 0291/0000

0290/0000 MFC BEGIN = B
 LENGTH(AH 2463 BK 2423)
 018"H 20"W CON BOX CUL

SECOND AV
(CITY)

0280/2020

0280/2337 LEN=0099 INSTALLED UNKN

NC SECOND AV

0280/1934 OP ID 02/0885/0280/1934
 PARKING LOT
 CSX RAIL TRANSPORTATION
 0280/1821 OVERPASS IS RR X-ING
 SALINE ST
 (CITY)

0280/1755 GREENFIELD AV
 (CITY)

057407 FT

057489 FT 1 0 00376 0 04 0722+65
 0280/0000 LENGTH(AH 2423 BK 3620)

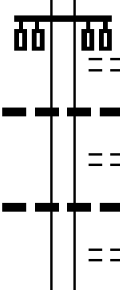

0270/1810 MOBILE ST
 (CITY)
 0270/1269 099"H 00"W **UNKNOWN**
 LEN=0099 INSTALLED UNKN
 TULLYMET ST
 (CITY)
 0270/1245 099"H 09"W **UNKNOWN**
 LEN=0099 INSTALLED UNKN
 BERWICK ST
 (CITY)
 0270/0690 MINDEN ST

DIR: B TOTAL LEN: 14.214 MI. DIST: 11-1 SR: 885
 LEFT MUN: PITTSBURGH C RIGHT MUN: PITTSBURGH C

Stationing	Structure	Notes
053787 FT	0270/0440	(CITY) 099"H 00"W **UNKNOWN** LEN=0099 INSTALLED UNKN 053869 FT 1 0 00376 0 04 0686+30 (APRA) HAZELWOOD AV NC IRVINE ST HAZELWOOD AV (CITY)
052964 FT	0270/0000	LENGTH(AH 3620 BK 0823) 024 "DIA CIRC CONCR 0260/0345 LEN=0099 INSTALLED UNKN FLOWERS AV (CITY)
	0260/0315	1 0 00376 0 04 0678+02 053046 FT GLEN CALADH ST (CITY)
	0260/0000	LENGTH(AH 0823 BK 3900) 018 "DIA CIRC CONCR 0250/3841 LEN=0099 INSTALLED UNKN 018 "DIA CIRC CONCR 0250/3827 LEN=0099 INSTALLED UNKN TECUMSEH ST (CITY)
	0250/3682	TIPTON ST (CITY)
	0250/3427	018 "DIA CIRC CONCR 0250/3424 LEN=0099 INSTALLED UNKN ELIZABETH ST (CITY)
DYKE ST (CITY)	0250/3142	JOHNSTON AV (CITY)
	0250/2767	018 "DIA CIRC CONCR 0250/2696 LEN=0099 INSTALLED UNKN 018 "DIA CIRC CONCR 0250/2474 LEN=0099 INSTALLED UNKN WINSTON ST (CITY)
MELANCHTON ST (CITY)	0250/1950	018 "DIA CIRC CONCR LEN=0099 INSTALLED UNKN
	0250/1872	MANSION ST (CITY)

DIR: B TOTAL LEN: 14.214 MI. DIST: 11-1 SR: 885
 LEFT MUN: PITTSBURGH C RIGHT MUN: PITTSBURGH C

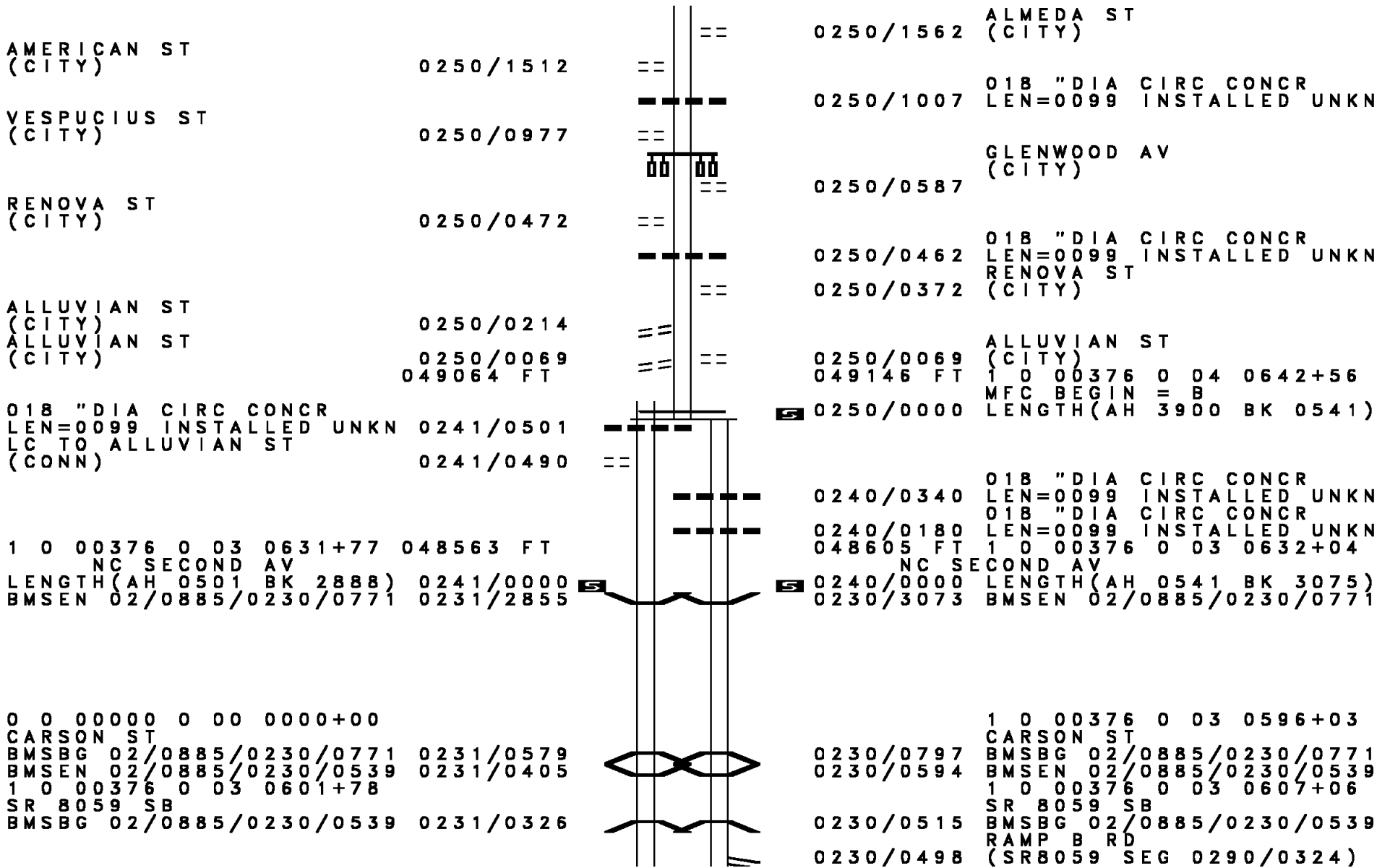

EXTRACT DATE: 12/21/2020
PRINT DATE: 12/23/2020

ROADWAY MANAGEMENT SYSTEM
SLD COUNTY/SR - ANNUAL PRINT

PAGE NUMBER: 460
COUNTY: ALLEGHENY

DIR: B TOTAL LEN: 14.214 MI.
LEFT MUN: PITTSBURGH C

DIST: 11-1 SR: 885
RIGHT MUN: PITTSBURGH C

Station	Description	Length	Notes
0230/0205	SIGN: 4 CHORD TRUSS BMSID 02/0885/0230/0205 EIGHTH ST (SR0837 SEG 0431/1099)		
0231/0159	018 "DIA CIRC CONCR LEN=0099 INSTALLED UNKN	0099	
0231/0035	SIGN: 4 CHORD TRUSS BMSID 02/0885/0230/0205	0035	
045675 FT	1 0 00376 0 03 0601+78	045675	
0231/0000	RAMP A/SR 837 TO 885 SB (SR8059 SEG 0522/0820) 018 "DIA CIRC CONCR LEN=0099 INSTALLED UNKN LENGTH(AH 2888 BK 1951)	0000	
0230/0059	BMSEN 02/0885/0230/0000	0059	
045530 FT	1 0 00376 0 03 0601+75	045530	
0230/0000	RAMP 8059 SB BMSBG 02/0885/0230/0000 LENGTH(AH 3075 BK 2044) RAMP D RD (SR8059 SEG 0262/0607) RAMP FR 885 NB TO 837 S (SR8059 SEG 0252/0000) 018 "DIA CIRC CONCR LEN=0099 INSTALLED UNKN SIGN: 2 CHORD TRUSS BMSID 02/0885/0220/1405	0000	
0220/2001		2001	
0220/1621		1621	
0220/1600		1600	
0220/1530		1530	
0221/1489	RAMP E RD (SR8059 SEG 0512/0000)	1489	
0221/1369	SIGN: CANTILEVER BMSID 02/0885/0221/1423	1369	
0221/1330	RAMP C RD (SR8059 SEG 0280/0920)	1330	
0220/1318	GLASS RUN RD (SR3098 SEG 0080/0400) (SR3098 SEG 0081/0405)	1318	
0221/1239	GLASS RUN STRUCTURE LENGTH 16 FT BMSID 02/0885/0221/1293	1239	
0221/1170	BMSEN 02/0885/0221/1106	1170	
0221/1038	1 0 00376 0 03 0583+03 SR 3098 EB BMSBG 02/0885/0221/1106	1038	
0221/0922	RAMP F RD (SR8059 SEG 0502/0428)	0922	
0220/0143	1 0 00376 0 03 0583+03	0143	
043486 FT	043486 FT	043486	
0220/0000	LENGTH(AH 1951 BK 1160) RAMP G RD (SR8061 SEG 0500/0000)	0000	
0211/0890		0890	
0210/0850	018 "DIA CIRC CONCR LEN=0099 INSTALLED UNKN	0850	

EXTRACT DATE: 12/21/2020
PRINT DATE: 12/23/2020

ROADWAY MANAGEMENT SYSTEM
SLD COUNTY/SR - ANNUAL PRINT

PAGE NUMBER: 459
COUNTY: ALLEGHENY

DIR: B TOTAL LEN: 14.214 MI.
LEFT MUN: PITTSBURGH C

DIST: 11-1 SR: 885
RIGHT MUN: PITTSBURGH C

BMS EN 02/0885/0210/0000 0211/0502
1 0 00376 0 03 0572+17 042564 FT
RAMP ST.
BMSBG 02/0885/0210/0000
LENGTH(AH 1160 BK 0493) 0211/0000

RAMP H RD
(SR8061 SEG 0250/0760) 0201/0160

1 0 00376 0 03 0566+93 042071 FT
HILLBURN ST
(CITY)
DOERRVILLE AV
(CITY)
MFC BEGIN = B
LENGTH(AH 0493 BK 1920) 0201/0000

040151 FT

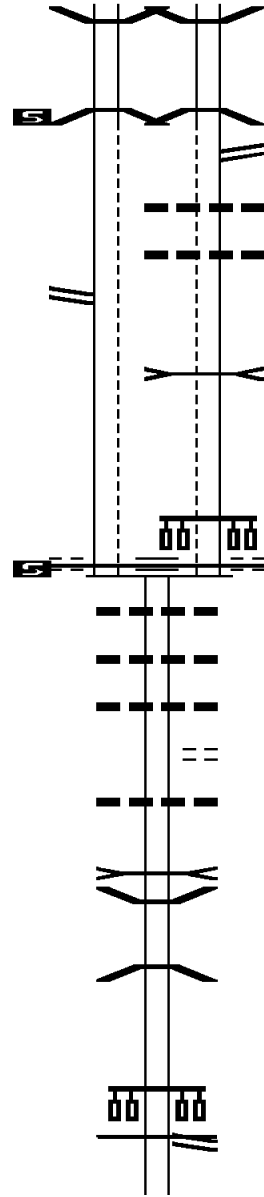

0210/0502
042554 FT

0210/0000

0200/0445

0200/0287

0200/0127

0200/0034

042045 FT

0200/0000

0190/1845

0190/1555

0190/1245

0190/0890

0190/0780

0190/0385

0190/0010

0190/0001

040125 FT

NC MI

0190/0000

BMS EN 02/0885/0210/0000
1 0 00376 0 03 0572+17

RAMP ST.
BMSBG 02/0885/0210/0000
LENGTH(AH 0932 BK 0509)

RAMP J RD
(SR8061 SEG 0010/0000)
018 "DIA CIRC CONCR
LEN=0099 INSTALLED UNKN
018 "DIA CIRC CONCR
LEN=0099 INSTALLED UNKN

BRANCH OF STREETS RUN

STRUCTURE LENGTH 12 FT

BMSID 02/0885/0200/0034

1 0 00376 0 03 0566+93

HILLBURN ST

(CITY)

DOERRVILLE AV

(CITY)

MFC BEGIN = B

LENGTH(AH 0509 BK 1920)

018 "DIA CIRC CONCR

LEN=0060 INSTALLED UNKN

099 "DIA CIR UNKNOWN

LEN=0035 INSTALLED UNKN

099 "DIA CIR UNKNOWN

LEN=0035 INSTALLED UNKN

SLATE ST

(CITY)

099 "DIA CIR UNKNOWN

LEN=0035 INSTALLED UNKN

BRANCH OF STREETS RUN

STRUCTURE LENGTH 14 FT

BMSID 02/0885/0190/0385

BMS EN 02/0885/0190/0001

1 0 00376 0 03 0548+03

BRANCH OF STREETS RUN

BMSBG 02/0885/0190/0001

1 0 00376 0 03 0548+03

MIFFLIN RD

(SR2045 SEG 0100/2370)

MFC BEGIN = B

LENGTH(AH 1920 BK 1683)

BRANCH OF STREETS RUN

STRUCTURE LENGTH 10 FT

EXTRACT DATE: 12/21/2020
PRINT DATE: 12/23/2020

ROADWAY MANAGEMENT SYSTEM
SLD COUNTY/SR - ANNUAL PRINT

PAGE NUMBER: 458
COUNTY: ALLEGHENY

DIR: B TOTAL LEN: 14.214 MI.
LEFT MUN: PITTSBURGH C

DIST: 11-1 SR: 885
RIGHT MUN: PITTSBURGH C

Location	Segment ID	Length (FT)	Structure	Material	Notes
	0180/1597		BMSID 02/0885/0180/1597	009" DIA CIRC CONCR	
	0180/1190		LEN=0099	INSTALLED UNKN	
038468 FT	038442 FT		1 0 00376 0 03 0530+87	099" DIA CIRC CONCR	
	0180/0000		LEN=0080	INSTALLED UNKN	
	0170/1741		LENGTH(AH 1683 BK 1838)	PITTSBURGH	
	0170/0994		WEST MIFFLIN B	BRANCH OF STREETS RUN	
MILLER RD (BORO)	0170/0640		STRUCTURE LENGTH 15 FT	BMSID 02/0885/0170/0994	
	0170/0597		024" DIA CIRC CONCR	LEN=0099	INSTALLED UNKN
	0170/0183		018" DIA CIRC CONCR	LEN=0099	INSTALLED UNKN
036630 FT	0170/0032		018" DIA CIRC CONCR	LEN=0099	INSTALLED UNKN
	036604 FT		1 0 00376 0 03 0511+23	MAIN ENTRANCE DR	
	0170/0000		LENGTH(AH 1838 BK 3754)	018" DIA CIRC CONCR	
	0160/3455		LEN=0080	INSTALLED UNKN	
	0160/2840		018" DIA CIRC CONCR	LEN=0099	INSTALLED UNKN
IRWIN RUN RD (BORO)	0160/2813		IRWIN RUN RD (BORO)		
	0160/2652				
	0160/1097		024" DIA CIRC CONCR	LEN=0099	INSTALLED UNKN
	0160/0488		(APRA) SAFETY KLEEN NOBLE DR (BORO)		
			(APRA) TRUMBULL & PJ DI TRUMBULL & PJ DICK CORP		

EXTRACT DATE: 12/21/2020
PRINT DATE: 12/23/2020

ROADWAY MANAGEMENT SYSTEM
SLD COUNTY/SR - ANNUAL PRINT

PAGE NUMBER: 457
COUNTY: ALLEGHENY

DIR: B TOTAL LEN: 14.214 MI.
LEFT MUN: WEST MIFFLIN B

DIST: 11-1 SR: 885
RIGHT MUN: WEST MIFFLIN B

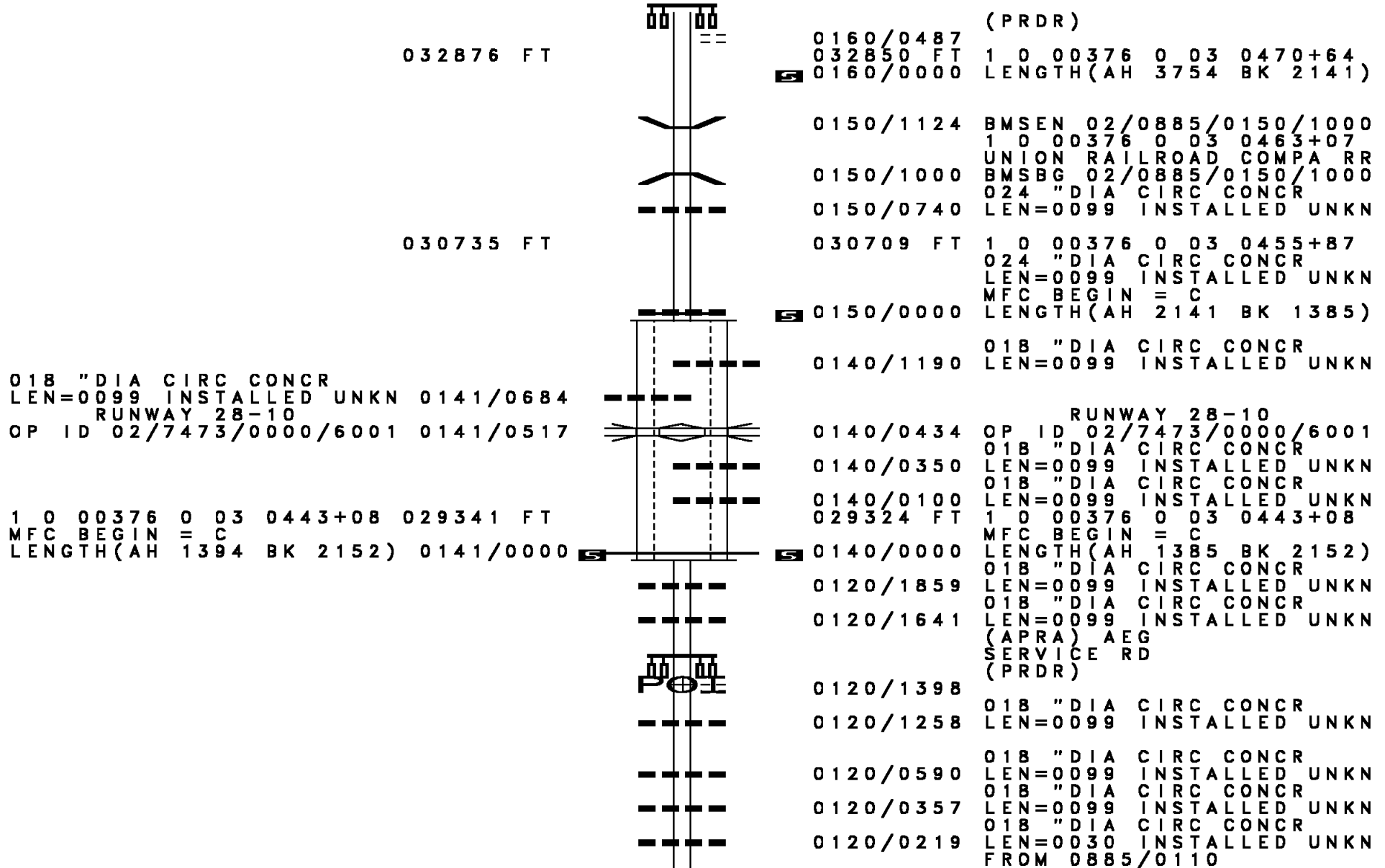

DIR: B TOTAL LEN: 14.214 MI. DIST: 11-1 SR: 885
 LEFT MUN: WEST MIFFLIN B RIGHT MUN: WEST MIFFLIN B

TO 2040/0111 SH
 (CONN)
 1 0 00376 0 03 0415+79 027189 FT
 LEBANON CHURCH RD
 (SR2040 SEG 0111/1939)
 (SR2040 SEG 0110/1955)
 MALL ENT
 (PRDR)
 0120/0000

TO 0885/0101 SH
 (CONN)
 0111/0120
 2 0 02292 0 00 0065+25 025571 FT
 NC LEBANON CHURCH RD
 LEBANON CHURCH RD
 (SR2040 SEG 0130/0000)
 (SR2040 SEG 0131/0000)
 MFC BEGIN = B
 LENGTH(AH 1618 BK 3152)
 FROM 0885/0111 SH
 (CONN)
 0111/0000
 0101/3005

MOUNTAIN VIEW DRIVE
 (PRDR)
 OLD ELIZABETH RD
 (BORO)
 0101/1650

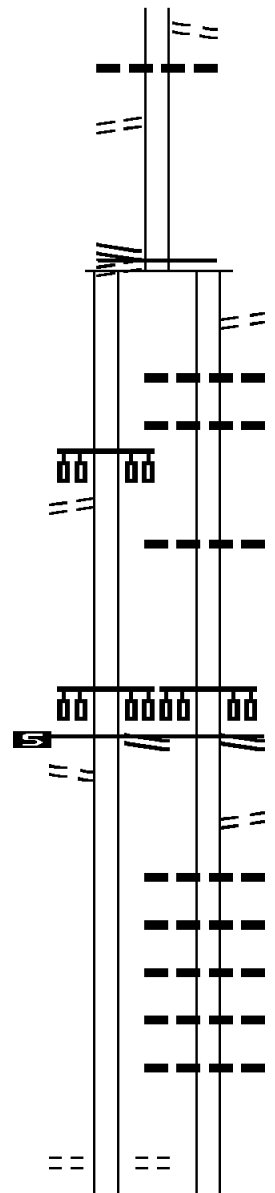

0120/0185 (CONN)
 018" DIA CIRC CONCR
 0120/0160 LEN=0099 INSTALLED UNKN
 027172 FT
 NC LEBANON RD
 MFC BEGIN = C
 0120/0000 LENGTH(AH 2152 BK 1643)
 TO 0885/0120 SH
 (CONN)
 018" DIA CIRC CONCR
 0110/1455 LEN=0030 INSTALLED UNKN
 018" DIA CIRC CONCR
 0110/1020 LEN=0099 INSTALLED UNKN
 0110/0690
 018"H 18"W CON BOX CUL
 0110/0080 LEN=0099 INSTALLED UNKN
 025529 FT 2 0 02292 0 00 0065+25
 NC LEBANON CHURCH RD
 LEBANON CHURCH RD
 (SR2040 SEG 0130/0000)
 (SR2040 SEG 0131/0000)
 MFC BEGIN = B
 LENGTH(AH 1643 BK 3139)
 0110/0000
 TO 2040/0130 SH
 (CONN)
 024" DIA CIRC CONCR
 0100/3015 LEN=0099 INSTALLED UNKN
 018" DIA CIRC CONCR
 0100/2699 LEN=0099 INSTALLED UNKN
 018" DIA CIRC CONCR
 0100/2493 LEN=0030 INSTALLED UNKN
 018" DIA CIRC CONCR
 0100/2260 LEN=0030 INSTALLED UNKN
 018" DIA CIRC CONCR
 0100/2080 LEN=0030 INSTALLED UNKN
 018" DIA CIRC CONCR
 0100/1872 LEN=0030 INSTALLED UNKN

MOUNTAIN VIEW DRIVE

DIR: B TOTAL LEN: 14.214 MI. DIST: 11-1 SR: 885
 LEFT MUN: WEST MIFFLIN B RIGHT MUN: WEST MIFFLIN B

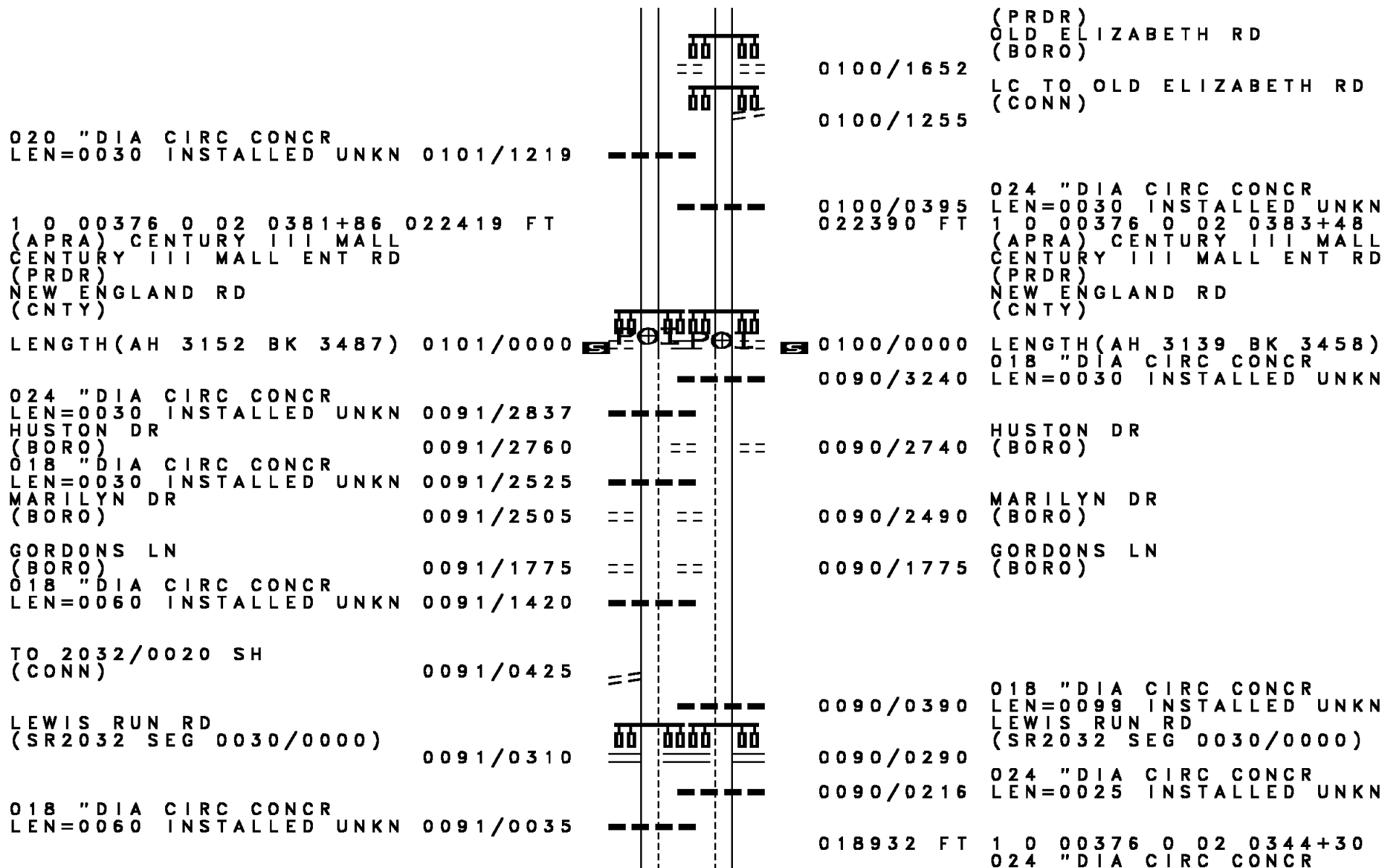

DIR: B TOTAL LEN: 14.214 MI. DIST: 11-1 SR: 885
 LEFT MUN: WEST MIFFLIN B RIGHT MUN: WEST MIFFLIN B

1 0 00376 0 02 0344+30 018932 FT
 COLLEGE DR
 (CNTY)

LEN=0025 INSTALLED UNKN
 COLLEGE DR
 (CNTY)

MFC BEGIN = C
 LENGTH(AH 3487 BK 3257) 0091/0000



0090/0000

MFC BEGIN = C
 LENGTH(AH 3458 BK 3257)
 018 "DIA CIRC CONCR
 LEN=0050 INSTALLED UNKN
 018 "DIA CIRC CONCR
 LEN=0050 INSTALLED UNKN
 018 "DIA CIRC CONCR
 LEN=0030 INSTALLED UNKN

SPARTZ RD
 (BORO) 0080/1785

0080/1787

WEST MIFFLIN
 JEFFERSON HILLS B

015675 FT

0080/0180
 015675 FT
 0080/0000

018 "DIA CIRC CONCR
 LEN=0099 INSTALLED UNKN
 018 "DIA CIRC CONCR
 LEN=0050 INSTALLED UNKN
 018 "DIA CIRC CONCR
 LEN=0099 INSTALLED UNKN
 1 0 00376 0 02 0320+07
 LENGTH(AH 3257 BK 2804)
 FRONTIER DR
 (BORO)

COAL VALLEY RD
 (CNTY) 0070/1990

0070/2075

012 "DIA CIRC CONCR
 LEN=0036 INSTALLED UNKN

BAKER DR
 (BORO) 0070/1755
 ANDREW ACRES
 (T885) 0070/1195

0070/1810

COAL VALLEY RD
 (CNTY)

1 0 00376 0 02 0294+00 012871 FT
 WRAY LARGE RD
 (BORO) 0070/0000

012871 FT

018 "DIA CIRC CONCR
 LEN=0030 INSTALLED UNKN

0070/0000 LENGTH(AH 2804 BK 2881)

DIR: B TOTAL LEN: 14.214 MI. DIST: 11-1 SR: 885
 LEFT MUN: JEFFERSON HILLS B RIGHT MUN: JEFFERSON HILLS B

Location	Segment	Length	Material	Status
WRAY DR (BORO)	0060/1285	0060	018" DIA CIRC CONCR	INSTALLED UNKN
	0060/1105	0060	018" DIA CIRC CONCR	INSTALLED UNKN
	0060/1095	0060	018" DIA CIRC CONCR	INSTALLED UNKN
	0060/0884	0060	018" DIA CIRC CONCR	INSTALLED UNKN
	0060/0460	0060	018" DIA CIRC CONCR	INSTALLED UNKN
	0060/0070	0060	018" DIA CIRC CONCR	INSTALLED UNKN
	009990 FT	009990	1 0 00376 0 02 0262+55	
		0060/0000	LENGTH(AH 2881 BK 1040)	
		0050/0475	018" DIA CIRC CONCR	INSTALLED UNKN
		0050/0297	018" DIA CIRC CONCR	INSTALLED UNKN
FOR SR 0885 AND 2030 (CONN)	0050/0012	0050	018" DIA CIRC CONCR	INSTALLED UNKN
1 0 00376 0 02 0252+15	008950 FT	008950		
PAYNE HILL RD (SR2030 SEG 0020/2567)	0050/0000	0050	LENGTH(AH 1040 BK 3253)	
	0040/2945	0040	018" DIA CIRC CONCR	INSTALLED UNKN
	0040/2580	0040	018" DIA CIRC CONCR	INSTALLED UNKN
	0040/2510	0040	MILLER RD (SR2030 SEG 0030/0000)	
	0040/2085	0040	018" DIA CIRC CONCR	INSTALLED UNKN
	0040/1285	0040	012" DIA CIRC CONCR	INSTALLED UNKN
SUNSET RD (BORO)	0040/1185	0040	018" DIA CIRC CONCR	INSTALLED UNKN
	0040/0075	0040	018" DIA CIRC CONCR	INSTALLED UNKN
005697 FT	005697 FT	005697	1 0 00376 0 02 0216+66	
	0040/0000	0040	WALL RD (SR2036 SEG 0010/0000)	
	0030/2358	0030	LENGTH(AH 3253 BK 3196)	
	0030/2000	0030	018" DIA CIRC CONCR	INSTALLED UNKN
			018" DIA CIRC CONCR	INSTALLED UNKN

DIR: B TOTAL LEN: 14.214 MI. DIST: 11-1 SR: 885
 LEFT MUN: JEFFERSON HILLS B RIGHT MUN: JEFFERSON HILLS B

Segment	Start Station	End Station	Length	Material	Status
1 0 00376 0 02 0184+10 LC TO RAVENSBURG RD (CONN) RAVENSBURG RD (CITY)	0030/1577	0030/1420	0099	018" DIA CIRC CONCR	INSTALLED UNKN
	0030/1420	0030/1220	0099	018" DIA CIRC CONCR	INSTALLED UNKN
	0030/1220	0030/0660	0099	024" DIA CIRC CONCR	INSTALLED UNKN
	0030/0660	0030/0390	0099	018" DIA CIRC CONCR	INSTALLED UNKN
	0030/0390	002501 FT	0099	018" DIA CIRC METAL	INSTALLED UNKN
	002501 FT	0030/0000	0099	JEFFERSON HILLS	
	0030/0000	0020/1035	0000	CLAIRTON C	
	0020/1035	0020/1010	0020	LENGTH(AH 3196 BK 1136)	
	0020/1010	0020/0966	0036	008" DIA CIR PLASTIC	INSTALLED UNKN
	0020/0966	0020/0904	0099	024" DIA CIRC CONCR	INSTALLED UNKN
LC FROM CITY RD (CONN)	0020/0904	0020/0860	0030	010" DIA CIRC CONCR	INSTALLED UNKN
	0020/0860	0020/0816	0099	018" DIA CIRC CONCR	INSTALLED UNKN
WALNUT AV (CITY)	0020/0816	0020/0770	0099	018" DIA CIRC CONCR	INSTALLED UNKN
	0020/0770	0020/0640	0099	010" DIA CIRC CONCR	INSTALLED UNKN
	0020/0640	0020/0615	0025	018" DIA CIRC CONCR	INSTALLED UNKN
	0020/0615	0020/0602	0013	THORNBERRY WY	
	0020/0602	0020/0455	0099	(CITY)	
	0020/0455	0020/0335	0099	018" DIA CIRC CONCR	INSTALLED UNKN
	0020/0335	0020/0300	0030	SEVENTH ST	
	0020/0300	0020/0275	0025	(CITY)	
	0020/0275	0020/0210	0099	018" DIA CIRC CONCR	INSTALLED UNKN
	0020/0210	0020/0150	0099	024" DIA CIRC CONCR	INSTALLED UNKN
0020/0150	0020/0134	0016	SIXTH ST		
0020/0134		0099	(CITY)		
		0099	018" DIA CIRC CONCR	INSTALLED UNKN	
		0099	024" DIA CIRC CONCR	INSTALLED UNKN	

DIR: B TOTAL LEN: 14.214 MI. DIST: 11-1 SR: 885
 LEFT MUN: CLAIRTON C RIGHT MUN: CLAIRTON C

Stationing	Segment Description	Material / Notes
001365 FT	0020/0023	LEN=0030 INSTALLED UNKN
	001365 FT	1 0 00376 0 02 0173+00 CHESTNUT WY (CITY)
	0020/0000	LENGTH(AH 1136 BK 1365) 018 "DIA CIR PLASTIC
	0010/1260	LEN=0024 INSTALLED UNKN 018 "DIA CIRC CONCR
	0010/1240	LEN=0099 INSTALLED UNKN FIFTH ST (CITY)
	0010/1220	018 "DIA CIR PLASTIC
	0010/1098	LEN=0024 INSTALLED UNKN 018 "DIA CIRC CONCR
	0010/1076	LEN=0099 INSTALLED UNKN
BEECH WY (CITY)	0010/1065	
	0010/0958	018 "DIA CIR PLASTIC LEN=0024 INSTALLED UNKN
	0010/0944	018 "DIA CIRC CONCR LEN=0099 INSTALLED UNKN
	0010/0915	FOURTH ST (CITY)
	0010/0789	018 "DIA CIR PLASTIC LEN=0024 INSTALLED UNKN
	0010/0771	018 "DIA CIRC CONCR LEN=0099 INSTALLED UNKN
MAPLE ST (CITY)	0010/0760	
THIRD ST (CITY)	0010/0605	
CHERRY WY (CITY)	0010/0455	
	0010/0334	024 "DIA CIRC CONCR LEN=0099 INSTALLED UNKN
GLENN ST (CITY)	0010/0330	
	0010/0180	RANKIN ST (CITY) 018 "DIA CIRC CONCR
	0010/0020	LEN=0024 INSTALLED UNKN
000000 FT	000000 FT	1 0 00376 0 02 0159+26 NC WA LNUT AV STATE ST (SR0837 SEG 0120/1300)
	INTER-BK	WALNUT AV (CITY)
	0010/0000	MFC BEGIN = C LENGTH(AH 1365 BK 0000)

EXTRACT DATE: 12/21/2020 ROADWAY MANAGEMENT SYSTEM PAGE NUMBER: 450
 PRINT DATE: 12/23/2020 SLD COUNTY/SR - ANNUAL PRINT COUNTY: ALLEGHENY

DIR: B TOTAL LEN: 24.216 MI. DIST: 11-1 SR: 837
 LEFT MUN: PITTSBURGH C RIGHT MUN: PITTSBURGH C

LTH AH 001415 BK 000050 127406 FT
 SR 0051 SH 7601/0000
 (SR0051 SEG 0440/1780) INTER-AHD
 SR 0051 SH
 (SR0051 SEG 0440/1780) 0597/0050

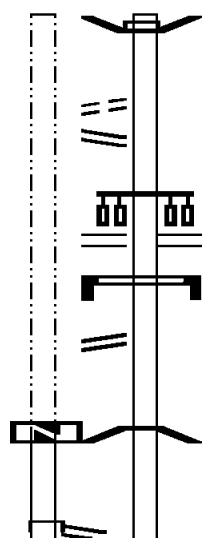

127860 FT BMSID 02/0837/0600/0000
 INTER-AHD WEST CARSON ST
 0600/0604 (SR0051 SEG 0450/0000)
 0600/0584 FOR SR 0051N TO 0051S
 (CONN)
 0600/0455 SR 0051 SH
 (SR0051 SEG 0441/1455)
 WEST END BR
 (SR0019 SEG 0281/0000)
 (SR0019 SEG 0280/0000)
 0600/0310 SIGN: 4 CHORD TRUSS
 0600/0251 BMSID 02/0837/0600/0245
 SR 0051 SH
 0600/0177 (SR0051 SEG 0440/1903)
 127256 FT 1 0 00076 0 00 0000+00
 WEST CARSON ST
 BMSBG 02/0837/0600/0000
 0600/0000 LENGTH(AH 0604 BK 0110)

DIR: B TOTAL LEN: 24.216 MI. DIST: 11-1 SR: 837
 LEFT MUN: PITTSBURGH C RIGHT MUN: PITTSBURGH C

Stationing	Description	Length	Material	Notes
0 0 00000 0 00 0000+00	MFC BEGIN = B	127356 FT		
0597/0000	LENGTH(AH 0050 BK 0485)	0597/0000		
126871 FT				
0591/3175	015 "DIA CIRC CONCR	0591/3175	LEN=0070	INSTALLED UNKN
0591/3077	WEST CARSON ST	0591/3077	(SR3106 SEG 0010/1582)	
0591/3050	MUSK WAY	0591/3050	(CITY)	
0591/2663	015 "DIA CIRC CONCR	0591/2663	LEN=0070	INSTALLED UNKN
0591/2423	018 "DIA CIRC CONCR	0591/2423	LEN=0099	INSTALLED UNKN
0591/1989	015 "DIA CIRC CONCR	0591/1989	LEN=0025	INSTALLED UNKN
0591/1930	GATEWAY VIEW PL ENT RD	0591/1930	(PRDR)	
0591/1779	015 "DIA CIRC CONCR	0591/1779	LEN=0025	INSTALLED UNKN
0591/1368	015 "DIA CIRC CONCR	0591/1368	LEN=0025	INSTALLED UNKN
0591/1090	WEST ACCESS RD	0591/1090	(PRDR)	
0591/0973	015 "DIA CIRC CONCR	0591/0973	LEN=0070	INSTALLED UNKN
0591/0589	PEDESTRIAN	0591/0589	OP ID 02/0837/0590/0612	
0591/0559	015 "DIA CIRC CONCR	0591/0559	LEN=0070	INSTALLED UNKN
127146 FT				
0596/0000	018 "DIA CIRC CONCR	0596/0000	LEN=0040	INSTALLED UNKN
0594/0085	018 "DIA CIRC CONCR	0594/0085	LEN=0040	INSTALLED UNKN
126661 FT				
0594/0000	018 "DIA CIRC CONCR	0594/0000	LEN=0040	INSTALLED UNKN
0590/3099	SIGN: CANTILEVER	0590/3099	BMSID 02/0837/0590/3119	
0590/3075	WEST CARSON ST	0590/3075	(SR3106 SEG 0011/1686)	
0590/2842	MUSK WAY	0590/2842	(CITY)	
0590/2602	018 "DIA CIRC CONCR	0590/2602	LEN=0050	INSTALLED UNKN
0590/2178	018 "DIA CIRC CONCR	0590/2178	LEN=0050	INSTALLED UNKN
0590/1941	GATEWAY VIEW PL ENT RD	0590/1941	(PRDR)	
0590/1570	024 "DIA CIRC CONCR	0590/1570	LEN=0055	INSTALLED UNKN
0590/1108	WEST ACCESS RD	0590/1108	(PRDR)	
0590/0612	PEDESTRIAN	0590/0612	OP ID 02/0837/0590/0612	

EXTRACT DATE: 12/21/2020
PRINT DATE: 12/23/2020

ROADWAY MANAGEMENT SYSTEM
SLD COUNTY/SR - ANNUAL PRINT

PAGE NUMBER: 447
COUNTY: ALLEGHENY

DIR: B TOTAL LEN: 24.216 MI.
LEFT MUN: PITTSBURGH C

DIST: 11-1 SR: 837
RIGHT MUN: PITTSBURGH C

Station	Description	Length (AH/BK)	Material	Station	Description	Length (AH/BK)	Material
120760 FT 1 0 00736 0 04 1058+10	NC WEST CARSON ST			120760 FT 1 0 00736 0 04 1058+10	NC WEST CARSON ST		
STATION SQ ENT RD				STATION SQ ENT RD			
(PRDR)				(PRDR)			
LENGTH(AH 2665 BK 1051)	0581/0000	5	5	LENGTH(AH 2646 BK 1060)	0580/0000	5	5
LEN=0099	INSTALLED UNKN	0571/1050		LEN=0099	INSTALLED UNKN	0571/1050	
018 "DIA CIRC CONCR				018 "DIA CIRC CONCR			
LEN=0064	INSTALLED UNKN	0571/1017		LEN=0064	INSTALLED UNKN	0571/1017	
018 "DIA CIRC CONCR				018 "DIA CIRC CONCR			
LEN=0045	INSTALLED UNKN	0571/0918		LEN=0045	INSTALLED UNKN	0571/0918	
030 "DIA CIRC CONCR				030 "DIA CIRC CONCR			
LEN=0040	INSTALLED UNKN	0571/0818		LEN=0040	INSTALLED UNKN	0571/0818	
018 "DIA CIRC CONCR				018 "DIA CIRC CONCR			
LEN=0099	INSTALLED UNKN	0571/0770		LEN=0099	INSTALLED UNKN	0571/0770	
018 "DIA CIRC CONCR				018 "DIA CIRC CONCR			
LEN=0040	INSTALLED UNKN	0571/0719		LEN=0040	INSTALLED UNKN	0571/0719	
024 "DIA CIRC CONCR				024 "DIA CIRC CONCR			
LEN=0045	INSTALLED UNKN	0571/0617		LEN=0045	INSTALLED UNKN	0571/0617	
(APRA) STATION SQUARE				(APRA) STATION SQUARE			
COMMERCE DR				COMMERCE DR			
(PRDR)				(PRDR)			
0571/0601				0571/0601			
018 "DIA CIRC CONCR				018 "DIA CIRC CONCR			
LEN=0040	INSTALLED UNKN	0571/0519		LEN=0040	INSTALLED UNKN	0571/0519	
018 "DIA CIRC CONCR				018 "DIA CIRC CONCR			
LEN=0045	INSTALLED UNKN	0571/0419		LEN=0045	INSTALLED UNKN	0571/0419	
018 "DIA CIRC CONCR				018 "DIA CIRC CONCR			
LEN=0064	INSTALLED UNKN	0571/0044		LEN=0064	INSTALLED UNKN	0571/0044	
1 0 00736 0 04 1058+10 119898 FT				1 0 00736 0 04 1058+10 119898 FT			
WABASH TN HOV				WABASH TN HOV			
(GOVT)				(GOVT)			
LENGTH(AH 1051 BK 1313)	0571/0000	5	5	LENGTH(AH 1060 BK 1344)	0571/0000	5	5
018 "DIA CIRC CONCR				018 "DIA CIRC CONCR			

DIR: B TOTAL LEN: 24.216 MI. DIST: 11-1 SR: 837
 LEFT MUN: PITTSBURGH C RIGHT MUN: PITTSBURGH C

Segment ID	Description	Length (ft)	Material	Status	Stationing
0561/1037	020 "DIA CIRC CONCR	0045	020 "DIA CIRC CONCR	INSTALLED UNKN	1033+55
0561/1004	PAT BUSWAY RD (CNTY) SMITHFIELD ST (SR3027 SEG 0010/0000) (SR3027 SEG 0011/0000)	0040	020 "DIA CIRC CONCR	INSTALLED UNKN	1032+20
0561/0931	PAT BUSWAY RD (CNTY) SMITHFIELD ST (SR3027 SEG 0010/0000) (SR3027 SEG 0011/0000)	0040	020 "DIA CIRC CONCR	INSTALLED UNKN	1032+20
0561/0670	020 "DIA CIRC CONCR	0030	020 "DIA CIRC CONCR	INSTALLED UNKN	1032+20
0561/0390	024 "DIA CIRC CONCR	0050	020 "DIA CIRC CONCR	INSTALLED UNKN	1032+20
0561/0360	024 "DIA CIRC CONCR	0030	020 "DIA CIRC CONCR	INSTALLED UNKN	1032+20
0560/0945	PAT BUSWAY RD (CNTY) SMITHFIELD ST (SR3027 SEG 0010/0000) (SR3027 SEG 0011/0000)	0040	020 "DIA CIRC CONCR	INSTALLED UNKN	1032+20
0560/0670	018 "DIA CIRC CONCR	0045	020 "DIA CIRC CONCR	INSTALLED UNKN	1032+20
0560/0390	020 "DIA CIRC CONCR	0040	020 "DIA CIRC CONCR	INSTALLED UNKN	1032+20
0560/0345	018 "DIA CIRC CONCR PAT BUSWAY RD (CNTY) STATION SQ ENTR RD (PRDR) ARLINGTON AV (CITY)	0040	020 "DIA CIRC CONCR	INSTALLED UNKN	1032+20
0560/0187	PAT BUSWAY RD (CNTY) STATION SQ ENT RD (PRDR) ARLINGTON AV (CITY)	0040	020 "DIA CIRC CONCR	INSTALLED UNKN	1032+20
0561/0153	PAT BUSWAY RD (CNTY) STATION SQ ENT RD (PRDR) ARLINGTON AV (CITY)	0040	020 "DIA CIRC CONCR	INSTALLED UNKN	1032+20
0560/0065	018 "DIA CIRC CONCR	0030	020 "DIA CIRC CONCR	INSTALLED UNKN	1032+20
0561/0000	1 0 00736 0 04 1033+55 118585 FT	118585	020 "DIA CIRC CONCR	INSTALLED UNKN	1032+20
0560/0000	1 0 00736 0 04 1032+20 118356 FT	118356	020 "DIA CIRC CONCR	INSTALLED UNKN	1032+20

EXTRACT DATE: 12/21/2020
PRINT DATE: 12/23/2020

ROADWAY MANAGEMENT SYSTEM
SLD COUNTY/SR - ANNUAL PRINT

PAGE NUMBER: 445
COUNTY: ALLEGHENY

DIR: B TOTAL LEN: 24.216 MI.
LEFT MUN: PITTSBURGH C

DIST: 11-1 SR: 837
RIGHT MUN: PITTSBURGH C

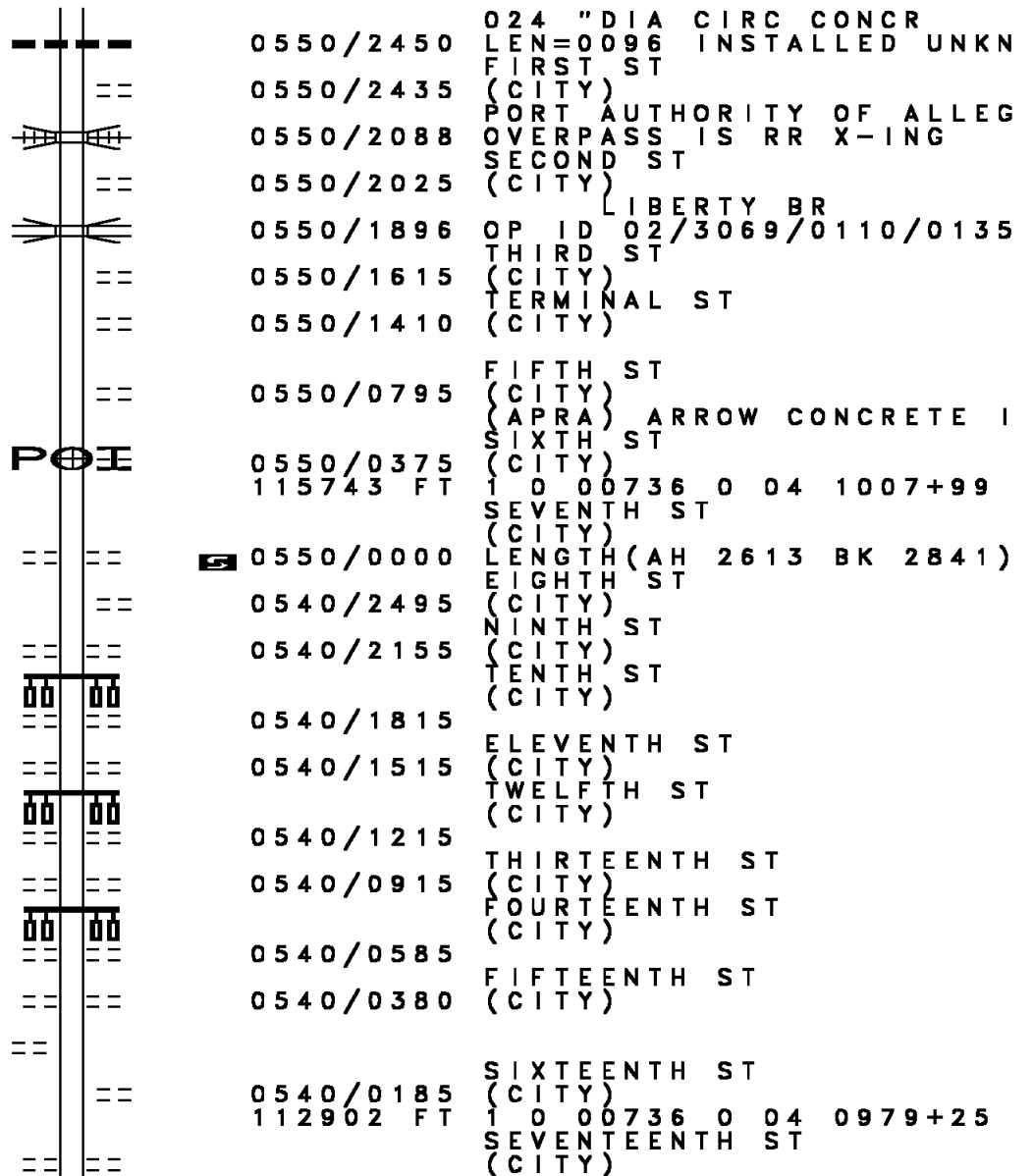

115972 FT

SIXTEENTH ST
(CITY)

0540/0215

113131 FT

DIR: B TOTAL LEN: 24.216 MI.
 LEFT MUN: PITTSBURGH C

DIST: 11-1 SR: 837
 RIGHT MUN: PITTSBURGH C

111061 FT

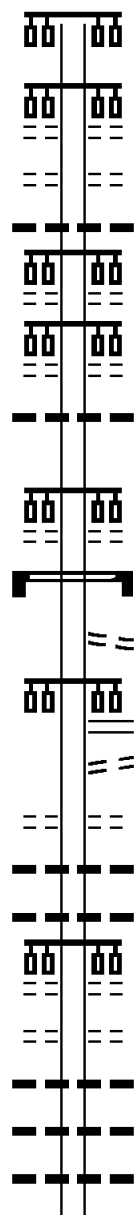

0540/0000	LENGTH(AH 2841 BK 2070) EIGHTEENTH ST (CITY)
0530/1650	NINETEENTH ST (CITY)
0530/1250	095 " DIA CIRC CONCR LEN=0050 INSTALLED UNKN TWENTIETH ST (CITY)
0530/0871	TWENTYFIRST ST (CITY)
0530/0830	TWENTYFIRST ST (CITY)
0530/0450	018 " DIA CIRC CONCR LEN=0070 INSTALLED UNKN 1 0 00736 0 04 0958+53 TWENTYSECOND ST (CITY)
0530/0400	110832 FT
0530/0000	LENGTH(AH 2070 BK 2012) SIGN STRUCTURE
0520/2012	BMSID 02/0837/0520/2012 FROM 2085/0011 SH (CONN)
0520/2011	BIRMINGHAM BR {SR2085 SEG 0010/0000} {SR2085 SEG 0011/0000}
0520/1892	TO 2085/0010 SH (CONN)
0520/1770	TWENTYTHIRD ST (CITY)
0520/1735	018 " DIA CIRC CONCR LEN=0099 INSTALLED UNKN
0520/1720	018 " DIA CIRC CONCR LEN=0099 INSTALLED UNKN
0520/1647	TWENTYFOURTH ST (CITY)
0520/1210	TWENTYFIFTH ST (CITY)
0520/0810	024 " DIA CIRC CONCR LEN=0099 INSTALLED UNKN
0520/0728	024 " DIA CIRC CONCR LEN=0099 INSTALLED UNKN
0520/0653	024 " DIA CIRC CONCR LEN=0099 INSTALLED UNKN
0520/0523	024 " DIA CIRC CONCR LEN=0099 INSTALLED UNKN

DIR: B TOTAL LEN: 24.216 MI. DIST: 11-1 SR: 837
 LEFT MUN: PITTSBURGH C RIGHT MUN: PITTSBURGH C

109049 FT

108108 FT

0520/0453	LEN=0099	INSTALLED	UNKN
TWENTYSIXTH ST (CITY)			
0520/0390	024 " DIA	CIRC	CONCR
0520/0305	LEN=0099	INSTALLED	UNKN
0520/0218	024 " DIA	CIRC	CONCR
0520/0158	LEN=0099	INSTALLED	UNKN
0520/0060	018 " DIA	CIRC	CONCR
108820 FT	LEN=0040	INSTALLED	UNKN
018 " DIA CIRC CONCR			
LEN=0099 INSTALLED UNKN			
1 0 00736 0 04 0936+67			
TWENTYSEVENTH ST (CITY)			
0520/0000	LENGTH(AH 2012 BK 0941)		
0510/0929	018 " DIA	CIRC	CONCR
0510/0693	LEN=0099	INSTALLED	UNKN
0510/0610	024 " DIA	CIRC	CONCR
	LEN=0040	INSTALLED	UNKN
	024 " DIA	CIRC	CONCR
	LEN=0610	INSTALLED	UNKN
	024 " DIA	CIRC	CONCR
	LEN=0040	INSTALLED	UNKN
	TWENTYEIGHTH ST (CITY)		
0510/0451	024 " DIA	CIRC	CONCR
0510/0265	LEN=0035	INSTALLED	UNKN
0510/0159	020 " DIA	CIRC	CONCR
0510/0085	LEN=0030	INSTALLED	UNKN
	024 " DIA	CIRC	CONCR
	LEN=0035	INSTALLED	UNKN
	020 " DIA	CIRC	CONCR
	LEN=0033	INSTALLED	UNKN
107879 FT	1 0 00736 0 04 0919+63		
HOT METAL BRIDGE ST (CITY)			
0510/0000	MFC BEGIN = B		
	LENGTH(AH 0941 BK 2206)		
0504/2163	024 " DIA	CIRC	CONCR
0504/2086	LEN=0035	INSTALLED	UNKN
	020 " DIA	CIRC	CONCR
	LEN=0030	INSTALLED	UNKN
0504/1980	018 " DIA	CIRC	CONCR
	LEN=0020	INSTALLED	UNKN

DIR: B TOTAL LEN: 24.216 MI. DIST: 11-1 SR: 837
 LEFT MUN: PITTSBURGH C RIGHT MUN: PITTSBURGH C

Location	Segment ID	Start	End	Material	Length	Status	Notes
TWENTYNINTH ST (CITY)	0505/1911	==	---	020 " DIA		CIRC CONCR	
		---	---	LEN=0040		INSTALLED UNKN	
		---	---	024 " DIA		CIRC CONCR	
		---	---	LEN=0040		INSTALLED UNKN	
		---	---	024 " DIA		CIRC CONCR	
		---	---	LEN=0040		INSTALLED UNKN	
		---	---	020 " DIA		CIRC CONCR	
		---	---	LEN=0040		INSTALLED UNKN	
		---	---	020 " DIA		CIRC CONCR	
		---	---	LEN=0020		INSTALLED UNKN	
LC TO SARAH ST (CONN)	0505/1368	==	---				
		---	---	024 " DIA		CIRC CONCR	
SARAH ST (CITY)	0505/1284	==	==				
		==	==	LEN=0040		INSTALLED UNKN	
LC FROM SARAH ST (CONN)	0505/1102	==	---				
		---	---	024 " DIA		CIRC CONCR	
WAREHOUSE ENT RD (PRDR)	0505/0680	==	==				
		==	==	LEN=0030		INSTALLED UNKN	
		==	==	024 " DIA		CIRC CONCR	
		==	==	LEN=0015		INSTALLED UNKN	
		==	==	024 " DIA		CIRC CONCR	
	0504/0937	---	---	LEN=0030		INSTALLED UNKN	
	0504/0892	---	---	024 " DIA		CIRC CONCR	
	0504/0826	---	---	LEN=0030		INSTALLED UNKN	
	0504/0750	---	---	020 " DIA		CIRC CONCR	
		---	---	LEN=0030		INSTALLED UNKN	
	0504/0669	---	---				
	0504/0638	---	---	020 " DIA		CIRC CONCR	
	0504/0636	---	---	LEN=0030		INSTALLED UNKN	
	0504/0502	---	---	024 " DIA		CIRC CONCR	
	0504/0439	---	---	LEN=0030		INSTALLED UNKN	
		---	---	024 " DIA		CIRC CONCR	
		---	---	LEN=0020		INSTALLED UNKN	

DIR: B TOTAL LEN: 24.216 MI. DIST: 11-1 SR: 837
 LEFT MUN: PITTSBURGH C RIGHT MUN: PITTSBURGH C

THIRTYTHIRD ST
 (CITY)

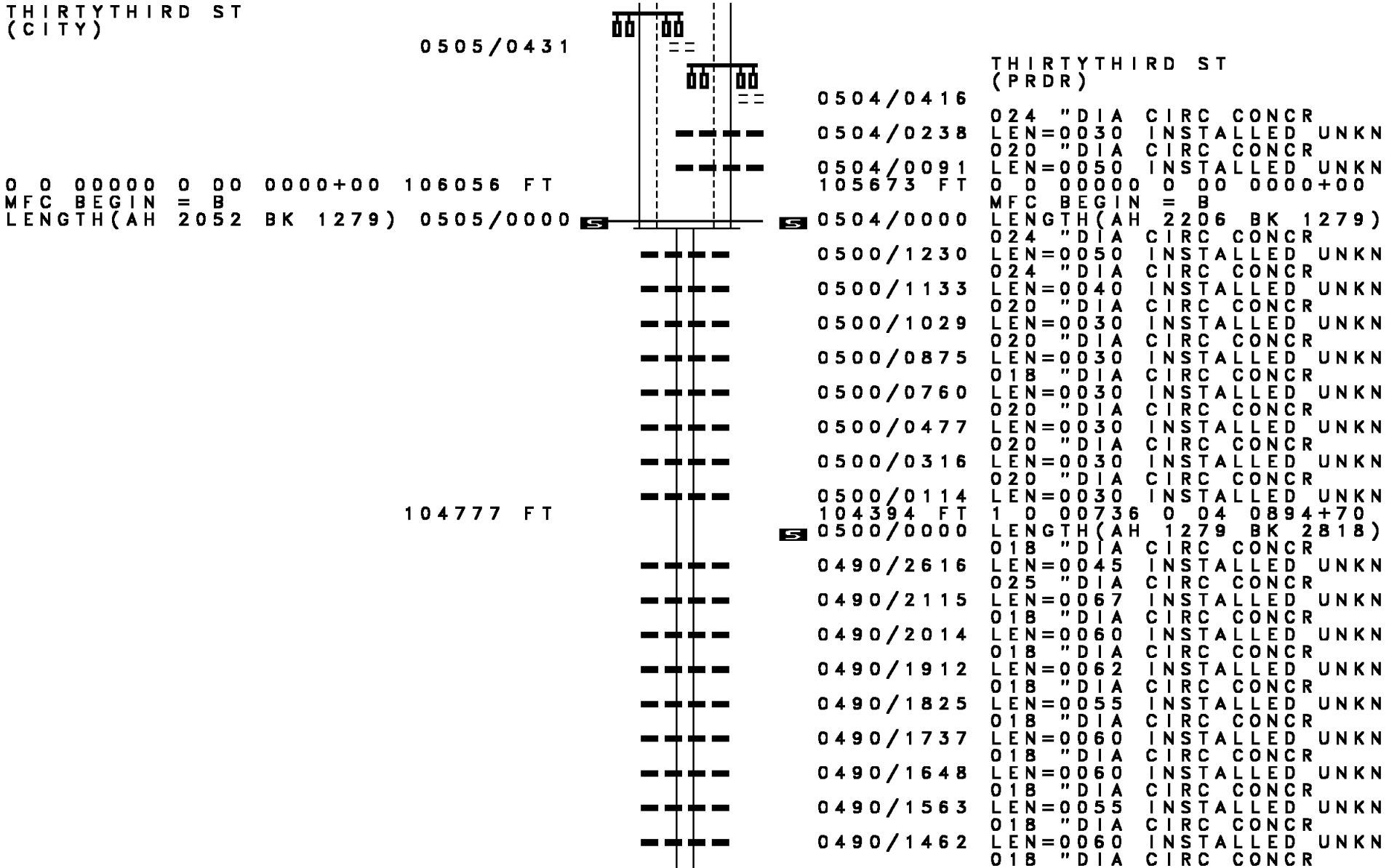

DIR: B TOTAL LEN: 24.216 MI. DIST: 11-1 SR: 837
 LEFT MUN: PITTSBURGH C RIGHT MUN: PITTSBURGH C

0490/1343	LEN=0050	INSTALLED UNKN
	018 "DIA	CIRC CONCR
0490/0946	LEN=0060	INSTALLED UNKN
	012 "DIA	CIRC CONCR
0490/0160	LEN=0040	INSTALLED UNKN
	PITTSBURGH	
0490/0018	BALDWIN B	
0490/0017	BMSEN 02/0837/0490/0010	
	101576 FT	BECKS RUN
	BMSBG 02/0837/0490/0010	
0490/0000	LENGTH(AH 2818 BK 3036)	
0480/2067	018 "DIA	CIRC CONCR
	LEN=0154	INSTALLED UNKN
0480/1913	024 "DIA	CIRC CONCR
	LEN=0040	INSTALLED UNKN
0480/1690	024 "DIA	CIRC CONCR
	LEN=0040	INSTALLED UNKN
0480/1668	018 "DIA	CIRC CONCR
	LEN=0120	INSTALLED UNKN
0480/0844	018 "DIA	CIRC CONCR
	LEN=0045	INSTALLED UNKN
0480/0624	030 "DIA	CIRC CONCR
	LEN=0060	INSTALLED UNKN
0480/0277	030 "DIA	CIRC CONCR
	LEN=0040	INSTALLED UNKN
098540 FT	1 0 00736 0 04 0835+39	
0480/0000	LENGTH(AH 3036 BK 3024)	
0470/3017	018 "DIA	CIRC CONCR
	LEN=0040	INSTALLED UNKN
0470/2710	018 "DIA	CIRC CONCR
	LEN=0040	INSTALLED UNKN
0470/2367	018 "DIA	CIRC CONCR
	LEN=0040	INSTALLED UNKN
0470/2090	018 "DIA	CIRC CONCR
	LEN=0040	INSTALLED UNKN
0470/1391	018 "DIA	CIRC CONCR
	LEN=0040	INSTALLED UNKN
0470/1291	018 "DIA	CIRC CONCR
	LEN=0035	INSTALLED UNKN
0470/0940	024 "DIA	CIRC CONCR
	LEN=0040	INSTALLED UNKN
0470/0502	024 "DIA	CIRC CONCR
	LEN=0040	INSTALLED UNKN
	018 "DIA	CIRC CONCR

1 0 00736 0 04 0863+70 101959 FT
 BECKS RUN RD
 (CNTY) 0490/0000

098923 FT

DIR: B TOTAL LEN: 24.216 MI. DIST: 11-1 SR: 837
 LEFT MUN: BALDWIN B RIGHT MUN: BALDWIN B

095899 FT

0470/0346 LEN=0030 INSTALLED UNKN
 095516 FT 1 0 00736 0 04 0805+15
 0470/0000 LENGTH(AH 3024 BK 2783)
 018 "DIA CIRC CONCR
 0460/2260 LEN=0040 INSTALLED UNKN
 036 "DIA CIRC METAL
 0460/1722 LEN=0045 INSTALLED UNKN
 018 "DIA CIRC CONCR
 0460/1482 LEN=0040 INSTALLED UNKN
 018 "DIA CIRC CONCR
 0460/1367 LEN=0045 INSTALLED UNKN

0460/0740 018 "DIA CIRC CONCR
 LEN=0045 INSTALLED UNKN
 018 "DIA CIRC METAL
 0460/0634 LEN=0048 INSTALLED UNKN

BALDWIN
 0460/0624 PITTSBURGH C
 018 "DIA CIRC CONCR
 0460/0534 LEN=0048 INSTALLED UNKN
 018 "DIA CIRC CONCR

093116 FT

0460/0431 LEN=0048 INSTALLED UNKN
 092733 FT 1 0 00736 0 03 0774+21
 MFC BEGIN = B
 0460/0000 LENGTH(AH 2783 BK 0546)

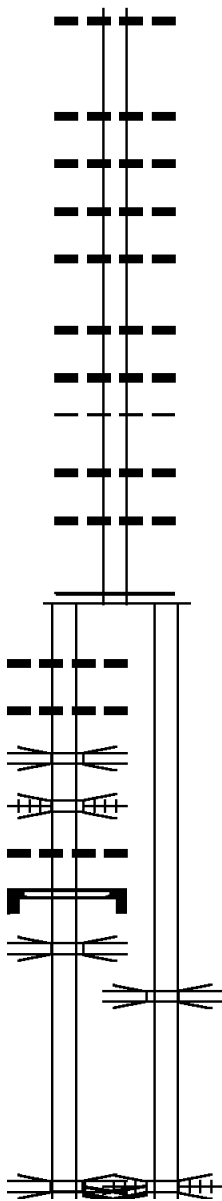

012 "DIA CIRC CONCR
 LEN=0040 INSTALLED UNKN 0453/0820
 012 "DIA CIRC CONCR
 LEN=0040 INSTALLED UNKN 0453/0590
 SR885
 OP ID 02/0885/0230/0771 0453/0550
 NORFOLK SOUTHERN
 OVERPASS IS RR X-ING 0453/0476
 012 "DIA CIRC CONCR
 LEN=0040 INSTALLED UNKN 0453/0425
 SIGN: 2 CHORD TRUSS
 BMSID 02/0837/0453/0190 0453/0210
 RAMP A (8059 SB)
 OP ID 02/8059/0522/0000 0453/0085

1 0 00736 0 03 0764+59 092166 FT
 RAMP D RD
 (SR8059 SEG 0262/0000)
 RAMP B (8059 NB)
 OP ID 02/8059/0290/0000
 NC EAST CARSON ST
 RAMP C RD INTER-BK
 (SR8059 SEG 0280/0000)

SR885
 0452/0120 OP ID 02/0885/0230/0771
 092187 FT 0 0 00000 0 00 0000+00
 RAMP FR 885 NB TO 837 N
 (SR8059 SEG 0252/1230)
 NORFOLK SOUTHERN
 OVERPASS IS RR X-ING
 NC EAST CARSON ST

DIR: B TOTAL LEN: 24.216 MI. DIST: 11-1 SR: 837
 LEFT MUN: PITTSBURGH C RIGHT MUN: PITTSBURGH C

LTH AH 000950 BK 000100 0453/0000 092166 FT 0452/0000 LENGTH(AH 0546 BK 1045)

LTH AH 000100 BK 001099 7441/0000
 LEBANON RD INTER-AHD
 (SR0885 SEG 0230/0205)
 LEBANON RD
 (SR0885 SEG 0230/0205) 0431/1099
 SIGN: 4 CHORD TRUSS
 BMSID 02/0885/0230/0205 0431/1080
 BMSEN 02/0837/0431/0000 0431/0819

PITTSBURGH
 WEST HOMESTEAD B 0431/0513
 1 0 00736 0 03 0760+40 091067 FT
 RAMP 8059 NB
 BMSBG 02/0837/0431/0000
 MFC BEGIN = B
 LENGTH(AH 1099 BK 0624) 0431/0000

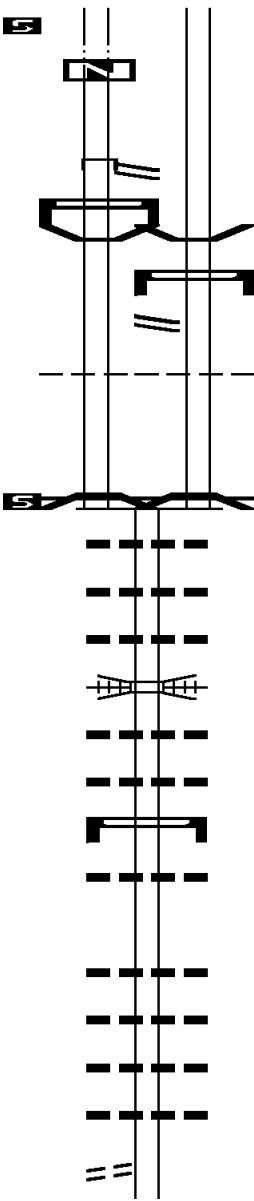

0430/0739 BMSEN 02/0837/0430/0000
 SIGN: CANTILEVER
 0430/0574 BMSID 02/0837/0430/0555
 RAMP A/SR 837 TO 885 SB
 0430/0545 (SR8059 SEG 0522/0000)
 PITTSBURGH

WEST HOMESTEAD B
 1 0 00736 0 03 0757+80
 BALDWIN ROAD LOCAL
 BMSBG 02/0837/0430/0000
 MFC BEGIN = B
 LENGTH(AH 1045 BK 0624)

0420/0471 018 "DIA CIRC CONCR
 LEN=0064 INSTALLED UNKN
 0420/0300 018 "DIA CIRC CONCR
 LEN=0064 INSTALLED UNKN
 0420/0278 018 "DIA CIRC CONCR
 LEN=0064 INSTALLED UNKN
 0420/0256 CSX RAIL TRANSPORTATION
 OVERPASS IS RR X-ING
 0420/0151 018 "DIA CIRC CONCR
 LEN=0064 INSTALLED UNKN
 0420/0145 018 "DIA CIRC CONCR
 LEN=0064 INSTALLED UNKN
 SIGN: 4 CHORD TRUSS
 0420/0110 BMSID 02/0837/0420/0110
 018 "DIA CIRC CONCR
 0420/0027 018 "DIA CIRC CONCR
 LEN=0064 INSTALLED UNKN
 090518 FT 1 0 00736 0 03 0752+93
 0420/0000 LENGTH(AH 0624 BK 1710)
 024 "DIA CIRC CONCR
 0410/1464 018 "DIA CIRC CONCR
 LEN=0058 INSTALLED UNKN
 0410/1262 018 "DIA CIRC CONCR
 LEN=0058 INSTALLED UNKN
 0410/1242 018 "DIA CIRC CONCR
 LEN=0058 INSTALLED UNKN
 0410/1121 018 "DIA CIRC CONCR
 LEN=0058 INSTALLED UNKN

090443 FT

EIGHTH AV
 (CITY)

0410/0575

018 "DIA CIRC CONCR

DIR: B TOTAL LEN: 24.216 MI. DIST: 11-1 SR: 837
 LEFT MUN: WEST HOMESTEAD B RIGHT MUN: WEST HOMESTEAD B

Street Name	Segment ID	Length (FT)	Material	Status
	0410/0155	0058	LEN=0058	INSTALLED UNKN
	088808 FT	1 0 00736	0 03 0735+41	
	NC W	EIGHTH AV		
	0410/0000	LEN=0000	(AH 1710 BK 3019)	
	0400/2900	LEN=0040	024 " DIA CIRC CONCR	INSTALLED UNKN
	0400/2740	LEN=0099	018 " DIA CIRC CONCR	INSTALLED UNKN
	0400/2700	LEN=0040	018 " DIA CIRC CONCR	INSTALLED UNKN
PARRY ST (BORO)	0400/2687	==		
			(APRA) WHEMCO PLANT	
			018 " DIA CIRC CONCR	
			LEN=0099	INSTALLED UNKN
			MESTA ST	
	0400/2054	==	(PRDR)	
	0400/1821	==	018 " DIA CIRC CONCR	INSTALLED UNKN
	0400/1567	==	018 " DIA CIRC CONCR	INSTALLED UNKN
EVANS ST (BORO)	0400/1525	==		
	0400/1493	==	018 " DIA CIRC CONCR	INSTALLED UNKN
	0400/1265	==	LEN=0099	INSTALLED UNKN
			018 " DIA CIRC CONCR	INSTALLED UNKN
MCDONALD ST (BORO)	0400/0999	==		
	0400/0962	==	LEN=0045	INSTALLED UNKN
	0400/0957	==	018 " DIA CIRC CONCR	INSTALLED UNKN
	0400/0774	==	LEN=0060	INSTALLED UNKN
	0400/0409	==	018 " DIA CIRC CONCR	INSTALLED UNKN
			LEN=0080	INSTALLED UNKN
			018 " DIA CIRC CONCR	INSTALLED UNKN
			LEN=0080	INSTALLED UNKN
			036 " DIA CIRC CONCR	INSTALLED UNKN
			(APRA) PARK CORP OLD J&LC FROM SEVENTH AV	
	0400/0325	==	(CONN)	
	0400/0245	==	W SEVENTH AV	
EIGHTH AV (BORO)	0400/0195	==		
	0400/0184	==	(BORO)	
	0400/0195	==	018 " DIA CIRC CONCR	INSTALLED UNKN
	0400/0184	==	LEN=0080	INSTALLED UNKN
	0400/0150	==	018 " DIA CIRC CONCR	INSTALLED UNKN
			LEN=0060	INSTALLED UNKN
			018 " DIA CIRC CONCR	INSTALLED UNKN

DIR: B TOTAL LEN: 24.216 MI.
 LEFT MUN: WEST HOMESTEAD B

DIST: 11-1 SR: 837
 RIGHT MUN: WEST HOMESTEAD B

SARAH ST
 (BORO)

085714 FT
 0400/0000

1 0 00736 0 03 0688+06 084011 FT
 WEST ST
 (BORO) 0390/0000

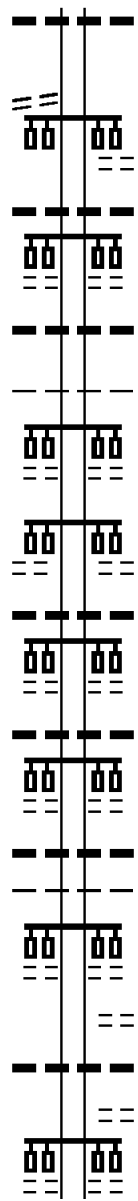

0400/0050 LEN=0040 INSTALLED UNKN
 085789 FT 1 0 00736 0 03 0704+97
 NC SEVENTH AV
 S 0400/0000 LENGTH(AH 3019 BK 1703)
 HOWARD ST
 (BORO)
 0390/1580 018 "DIA CIRC CONCR
 0390/1193 LEN=1094 INSTALLED UNKN
 NEEL ST
 (BORO)
 0390/1180 018 "DIA CIRC CONCR
 0390/1159 LEN=0066 INSTALLED UNKN
 WEST HOMESTEAD
 0390/0416 HOMESTEAD B
 HAYS ST
 (BORO)
 0390/0415 HOMESTEAD GRAYS BR
 084086 FT (CNTY)
 S 0390/0000 LENGTH(AH 1703 BK 2890)
 0380/2865 018 "DIA CIRC CONCR
 LEN=0030 INSTALLED UNKN
 AMITY ST
 (BORO)
 0380/2350 008 "DIA CIR PLASTIC
 0380/1846 LEN=0099 INSTALLED UNKN
 ANN ST
 (BORO)
 0380/1820 012 "DIA CIRC CONCR
 0380/1804 LEN=0040 INSTALLED UNKN
 HOMESTEAD
 0380/1215 MUNHALL B
 MCCLURE ST
 (BORO)
 0380/1203 STONE WAY
 (BORO)
 0380/1105 018"H 18"W CAST IRON
 0380/0968 LEN=0074 INSTALLED UNKN
 TAMMANY WAY
 (BORO)
 0380/0800 DICKSON ST
 (BORO)
 0380/0634

DIR: B TOTAL LEN: 24.216 MI. DIST: 11-1 SR: 837
 LEFT MUN: MUNHALL B RIGHT MUN: MUNHALL B

Location / Segment	Segment ID	Length / Notes	Material / Details
BROOK WAY (BORO)	0380/0411	081121 FT	
LIBRARY PL (BORO)	0380/0000		HEISEL ST (BORO) 018" DIA CIRC CONCR LEN=0001 INSTALLED UNKN LC FROM WILLIAM MARKS W (CONN)
ANDREW ST (BORO)	0370/1505		081196 FT NC EIGHTH AV WILLIAM MARKS WY (PRDR)
MARTHA ST (BORO)	0370/1055		0380/0000 LENGTH(AH 2890 BK 2080) LC TO WILLIAM MARKS WAY (CONN)
GRANT ST (BORO)	0370/0823		0370/1964 018" DIA CIRC CONCR LEN=0062 INSTALLED UNKN
HARRISON ST (BORO)	0370/0590	079041 FT	WILLIAM MARKS DR (PRDR)
MUNN ST (BORO)	0370/0000		0370/0823 018" DIA CIRC CONCR LEN=0005 INSTALLED UNKN
RAVINE ST (BORO)	0360/3079		0360/3185 018" DIA CIRC CONCR LEN=0030 INSTALLED UNKN
WHITAKER WAY (SR2049 SEG 0050/2188)	0360/2771		0360/2864 018" DIA CIRC CONCR LEN=0030 INSTALLED UNKN
WHITAKER WAY (BORO)	0360/2465		0360/2771
HILLTOP AV (BORO)	0360/1983		0360/2104 HOMESTEAD RN STRUCTURE LENGTH 23 FT BMSID 02/0837/0360/2104
			WATERFRONT DR (BORO)
			0360/1506 018" DIA CIRC CONCR LEN=0100 INSTALLED UNKN
			0360/1092

DIR: B TOTAL LEN: 24.216 MI. DIST: 11-1 SR: 837
 LEFT MUN: MUNHALL B RIGHT MUN: MUNHALL B

1 0 00736 0 03 0603+93 075782 FT
 RAMP FROM RANKIN BR
 (SR9111 SEG 0020/0806) 0360/0000

012 "DIA CIRC CONCR
 LEN=0040 INSTALLED UNKN 0351/1204

012 "DIA CIRC CONCR
 LEN=0040 INSTALLED UNKN 0351/1001
 012 "DIA CIRC CONCR
 LEN=0040 INSTALLED UNKN 0351/0756

RANKIN BR
 (CNTY)
 0351/0539

018 "DIA CIRC CONCR
 LEN=0028 INSTALLED UNKN 0351/0476

012 "DIA CIRC CONCR
 LEN=0040 INSTALLED UNKN 0351/0230

1 0 00736 0 02 0591+51 074428 FT
 018 "DIA CIRC CONCR
 LEN=0076 INSTALLED UNKN
 NC EIGHTH AV
 LENGTH(AH 1354 BK 2368) 0351/0000

MIFFLIN AV
 (SR2098 SEG 0010/1670) 0341/1770
 WHITAKER

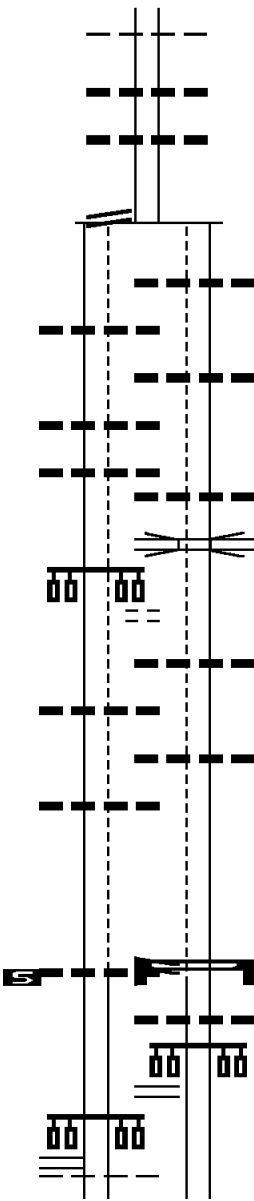

0360/0965 MUNHALL
 WHITAKER B
 018 "DIA CIRC CONCR
 0360/0440 LEN=0040 INSTALLED UNKN
 024 "DIA CIRC CONCR
 0360/0158 LEN=0099 INSTALLED UNKN
 075857 FT
 0360/0000 LENGTH(AH 3259 BK 1375)
 0350/1270 018 "DIA CIRC CONCR
 LEN=0064 INSTALLED UNKN
 0350/1038 018 "DIA CIRC CONCR
 LEN=0064 INSTALLED UNKN
 0350/0755 018 "DIA CIRC CONCR
 LEN=0064 INSTALLED UNKN
 BRADDOCK AVE
 0350/0545 OP ID 02/7456/0000/2347
 0350/0493 018 "DIA CIRC CONCR
 LEN=0064 INSTALLED UNKN
 0350/0265 018 "DIA CIRC CONCR
 LEN=0064 INSTALLED UNKN
 074482 FT 1 0 00736 0 02 0589+01
 SIGN: CANTILEVER
 BMSID 02/0837/0350/0000
 NC E I GHTH AV
 RAMP TO RANKIN BR
 (SR9111 SEG 0010/0000)
 LENGTH(AH 1375 BK 2363)
 0350/0000 024 "DIA CIRC CONCR
 0340/2063 LEN=0040 INSTALLED UNKN
 MIFFLIN AV
 (SR2098 SEG 0010/1670)
 0340/1745

DIR: B TOTAL LEN: 24.216 MI. DIST: 11-1 SR: 837
 LEFT MUN: WHITAKER B RIGHT MUN: WHITAKER B

Stationing	Description	Length	Material	Status
0341/1629	WEST MIFFLIN B			
0341/1318	018 "DIA CIRC CONCR LEN=0076 INSTALLED UNKN			
0340/1585	018 "DIA CIRC CONCR LEN=0090 INSTALLED UNKN			
0340/1051	018 "DIA CIRC CONCR LEN=0090 INSTALLED UNKN			
0340/0447	018 "DIA CIRC CONCR LEN=0090 INSTALLED UNKN			
0340/0259	018 "DIA CIRC CONCR LEN=0090 INSTALLED UNKN			
072119 FT	1 0 00736 0 02 0565+13 WHITAKER			
0340/0000	1 0 00736 0 02 0564+89 072060 FT LENGTH(AH 2368 BK 2268) 0341/0000 018 "DIA CIRC CONCR LEN=0099 INSTALLED UNKN 0331/1748 018 "DIA CIRC CONCR LEN=1280 INSTALLED UNKN 0331/1379			
0330/1103	018 "DIA CIRC CONCR LEN=0068 INSTALLED UNKN			
0330/1100	018 "DIA CIRC CONCR LEN=0040 INSTALLED UNKN			
0330/0067	018 "DIA CIRC CONCR LEN=0068 INSTALLED UNKN			
0330/0000	1 0 00736 0 02 0542+40 069792 FT LENGTH(AH 2268 BK 1739) 0331/0000			
0320/1634	018 "DIA CIRC CONCR LEN=0070 INSTALLED UNKN			
0320/1132	018 "DIA CIRC CONCR LEN=0070 INSTALLED UNKN			
0320/0635	GLENN ST (BORO)			
0321/0635	018 "DIA CIRC CONCR LEN=0099 INSTALLED UNKN 0321/0460			
0321/0405	VALEVIEW DR (BORO)			
0320/0410	VALEVIEW DR (BORO)			
0320/0380	018 "DIA CIRC CONCR LEN=0090 INSTALLED UNKN			
068120 FT	1 0 00736 0 02 0525+27 068053 FT NC KENNYWOOD BL			
0321/0000	GLENCAIRN ST (BORO) LENGTH(AH 1739 BK 2903) 0321/0000			
0320/0000	KENNYWOOD PARK ENT RD GLENCAIRN ST (BORO) LENGTH(AH 1752 BK 2877)			

DIR: B TOTAL LEN: 24.216 MI. DIST: 11-1 SR: 837
 LEFT MUN: WEST MIFFLIN B RIGHT MUN: WEST MIFFLIN B

Item Description	Stationing	Notes	Stationing	Item Description
(PRDR)	0311/2850			
018 "DIA CIRC METAL LEN=0006 INSTALLED UNKN KENNYWOOD PARK ENT RD (PRDR)	0311/2202		0310/2525	018 "DIA CIRC CONCR LEN=0099 INSTALLED UNKN KENNYWOOD PARK ENT RD (PRDR)
018 "DIA CIRC CONCR LEN=0024 INSTALLED UNKN	0311/2175		0310/2150	
0311/1956			0310/1918	018 "DIA CIRC CONCR LEN=0068 INSTALLED UNKN KENNYWOOD PARK ENT RD (PRDR)
KENNYWOOD PARK ENT RD (PRDR)	0311/1670		0310/1645	DRAINAGE STRUCTURE LENGTH 21 FT
DRAINAGE STRUCTURE LENGTH 21 FT BMSID 02/0837/0310/1382	0311/1418		0310/1382	BMSID 02/0837/0310/1382 KENNYWOOD PARK ENT RD (PRDR)
KENNYWOOD PARK ENT RD (PRDR)	0311/1205		0310/1190	018 "DIA CIRC CONCR LEN=0099 INSTALLED UNKN
018 "DIA CIRC CONCR LEN=0024 INSTALLED UNKN	0311/1002			
001 "DIA CIRC CONCR LEN=0099 INSTALLED UNKN (APRA) KENNYWOOD PRK TR HOFFMAN BL (BORO)	0311/0782			(APRA) KENNYWOOD PRK TR HOFFMAN BL (BORO)
BMSEN 02/0837/0310/0102	0311/0745		0310/0740	
WEST MIFFLIN	0311/0689		0310/0681	BMSEN 02/0837/0310/0102 WEST MIFFLIN
DUQUESNE C	0311/0666		0310/0674	DUQUESNE C
1 0 00736 0 02 0497+37 CREEK			0310/0102	1 0 00736 0 02 0497+37 CREEK
BMSBG 02/0837/0310/0102	0311/0110			BMSBG 02/0837/0310/0102
018 "DIA CIRC CONCR LEN=0024 INSTALLED UNKN	0311/0041			
1 0 00736 0 02 0496+32 065150 FT HERMAN AV (BORO)			065243 FT	1 0 00736 0 02 0496+35 HERMAN AV (BORO)
LENGTH(AH 2903 BK 2429)	0311/0000		0310/0000	LENGTH(AH 2877 BK 2466)
MILLER AV (CITY)	0301/2230		0300/2256	MILLER AV (CITY)
018 "DIA CIRC CONCR LEN=0024 INSTALLED UNKN	0301/2190			
018 "DIA CIRC CONCR LEN=0024 INSTALLED UNKN	0301/2000		0300/2206	018 "DIA CIRC CONCR LEN=0068 INSTALLED UNKN
				018 "DIA CIRC CONCR

DIR: B TOTAL LEN: 24.216 MI. DIST: 11-1 SR: 837
 LEFT MUN: DUQUESNE C RIGHT MUN: DUQUESNE C

Street Name	Stationing	Material	Length	Notes	Stationing	Material	Length	Notes
HARDEN AV (CITY)	0301/1950	018 "DIA CIRC CONCR	LEN=0024	INSTALLED UNKN	0300/2007	018 "DIA CIRC CONCR	LEN=0068	INSTALLED UNKN
	0301/1756	018 "DIA CIRC CONCR	LEN=0024	INSTALLED UNKN	0300/1975	018 "DIA CIRC CONCR	LEN=0068	INSTALLED UNKN
	0301/1643	018 "DIA CIRC CONCR	LEN=0024	INSTALLED UNKN	0300/1759	018 "DIA CIRC CONCR	LEN=0068	INSTALLED UNKN
COMMONWEALTH AV (SR2044 SEG 0070/2947)	0301/1535	018 "DIA CIRC CONCR	LEN=0024	INSTALLED UNKN	0300/1575	018 "DIA CIRC CONCR	LEN=0068	INSTALLED UNKN
	0301/1179	018 "DIA CIRC CONCR	LEN=0024	INSTALLED UNKN	0300/1540	018 "DIA CIRC CONCR	LEN=0068	INSTALLED UNKN
FAIRMONT AV (CITY)	0301/1125	018 "DIA CIRC CONCR	LEN=0024	INSTALLED UNKN	0300/1165	018 "DIA CIRC CONCR	LEN=0068	INSTALLED UNKN
	0301/0876	018 "DIA CIRC CONCR	LEN=0024	INSTALLED UNKN	0300/1130	018 "DIA CIRC CONCR	LEN=0068	INSTALLED UNKN
	0301/0575	018 "DIA CIRC CONCR	LEN=0024	INSTALLED UNKN	0300/0865	018 "DIA CIRC CONCR	LEN=0068	INSTALLED UNKN
(APRA) UNION RR CO OAKMONT AV (CITY)	0301/0525	018 "DIA CIRC CONCR	LEN=0024	INSTALLED UNKN	0300/0566	018 "DIA CIRC CONCR	LEN=0068	INSTALLED UNKN
UNION RR CO DR (PRDR)	0301/0276	018 "DIA CIRC CONCR	LEN=0024	INSTALLED UNKN	0300/0530	018 "DIA CIRC CONCR	LEN=0068	INSTALLED UNKN
	0301/0018	018 "DIA CIRC CONCR	LEN=0024	INSTALLED UNKN	0300/0264	018 "DIA CIRC CONCR	LEN=0068	INSTALLED UNKN
1 0 00736 0 02 0471+88 062721 FT	0301/0000	018 "DIA CIRC CONCR	LEN=0058	INSTALLED UNKN	062777 FT	1 0 00736 0 02 0473+17		
LENGTH(AH 2429 BK 1267)	0291/1165	018 "DIA CIRC CONCR	LEN=0058	INSTALLED UNKN	0300/0000	LENGTH(AH 2466 BK 1274)		
OVERLAND AV (CITY)	0291/1140	018 "DIA CIRC CONCR	LEN=0058	INSTALLED UNKN	0290/1092	OVERLAND AV (CITY)		
	0291/1003	018 "DIA CIRC CONCR	LEN=0058	INSTALLED UNKN	0290/1058	018 "DIA CIRC CONCR	LEN=0058	INSTALLED UNKN
BMS EN 02/0837/0290/0233	0291/0968	018 "DIA CIRC CONCR	LEN=0058	INSTALLED UNKN	0290/1027	BMS EN 02/0837/0290/0233		

DIR: B TOTAL LEN: 24.216 MI. DIST: 11-1 SR: 837
 LEFT MUN: DUQUESNE C RIGHT MUN: DUQUESNE C

GRANT AV
 (CITY)
 EAST GRANT AV
 (PRDR)

0281/0278

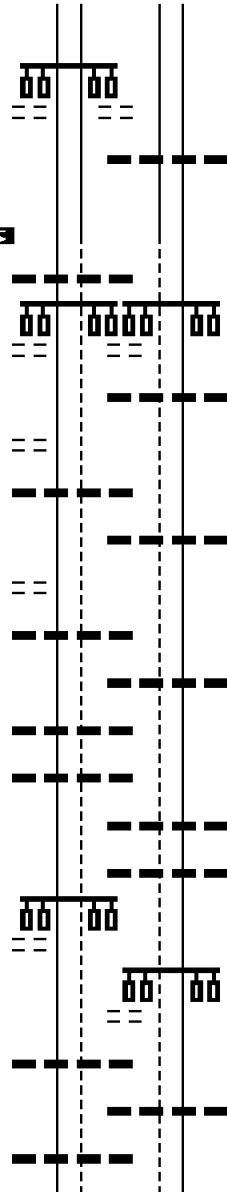

0280/0081 018 "DIA CIRC CONCR
 LEN=0070 INSTALLED UNKN
 058825 FT 1 0 00736 0 02 0433+50
 NC DUQUESNE BL
 0280/0000 LENGTH(AH 2678 BK 3266)

1 0 00736 0 02 0434+36 058992 FT
 LENGTH(AH 2462 BK 3447) 0281/0000
 018 "DIA CIRC CONCR
 LEN=0099 INSTALLED UNKN 0271/3406
 LIBRARY PL
 (CITY)

0271/2975

LIBRARY PL
 (CITY)
 0270/3015
 018 "DIA CIRC CONCR
 LEN=0099 INSTALLED UNKN

WHITFIELD AV
 (CITY)
 018 "DIA CIRC CONCR
 LEN=0005 INSTALLED UNKN 0271/2717
 0271/2602

0270/2573 018 "DIA CIRC CONCR
 LEN=0072 INSTALLED UNKN

CAMP AV
 (CITY)
 018 "DIA CIRC CONCR
 LEN=0400 INSTALLED UNKN 0271/2025
 0271/2020

0270/1835 018 "DIA CIRC CONCR
 LEN=0072 INSTALLED UNKN

018 "H 18" W CON BOX CUL
 LEN=0400 INSTALLED UNKN 0271/1740
 018 "DIA CIRC CONCR
 LEN=0099 INSTALLED UNKN 0271/1560

0270/1530 018 "DIA CIRC CONCR
 LEN=0099 INSTALLED UNKN
 0270/1378 018 "DIA CIRC CONCR
 LEN=0072 INSTALLED UNKN

WYLIE AV
 (CITY)
 0271/1305

WYLIE AV AV
 (CITY)
 0270/1332

018 "DIA CIRC CONCR
 LEN=0005 INSTALLED UNKN 0271/1253

0270/1250 018 "DIA CIRC CONCR
 LEN=0040 INSTALLED UNKN

018 "DIA CIRC CONCR
 LEN=0099 INSTALLED UNKN 0271/1186

024 "DIA CIRC CONCR

DIR: B TOTAL LEN: 24.216 MI. DIST: 11-1 SR: 837
 LEFT MUN: DUQUESNE C RIGHT MUN: DUQUESNE C

Stationing / Description	Stationing / Description	Stationing / Description	Stationing / Description
024 "DIA CIRC CONCR LEN=0026 INSTALLED UNKN 0271/0545	0270/0919 LEN=0306 INSTALLED UNKN	018 "DIA CIRC CONCR LEN=0040 INSTALLED UNKN	0270/0500
018 "DIA CIRC CONCR LEN=0005 INSTALLED UNKN 0271/0245	0270/0140 (SR8057 SEG 0272/2839)	837 N TO 837 N RAMP RD (SR8057 SEG 0272/2839)	055559 FT
1 0 00736 0 01 0405+30 055545 FT NC DUQUESNE BL CENTER ST (CITY) LINDEN ST (CITY)	1 0 00736 0 01 0403+52 CENTER ST (CITY) LINDEN ST (CITY)		
DRAVOSBURG RD (SR2114 SEG 0031/1440) MFC BEGIN = B LTH AH 003447 BK 003095 0271/0000 055545 FT LTH AH 003095 BK 002884 7261/0000	INTER-BK INTER-BK DRAVOSBURG RD (SR2114 SEG 0030/1304) MFC BEGIN = B LTH AH 003266 BK 002859		
WEST MIFFLIN B 0250/2884	0270/0000 055559 FT 7260/0000 INTER-AHD	LTH AH 002859 BK 002884 FR 837 NB TO CENTER AV (SR8057 SEG 0272/0000)	WEST MIFFLIN B
	0250/2884		
	0250/2123	036 "DIA CIRC CONCR LEN=0020 INSTALLED UNKN	
	0250/1886	036 "DIA CIRC CONCR LEN=0020 INSTALLED UNKN	
	0250/1186	036 "DIA CIRC CONCR LEN=0020 INSTALLED UNKN	
	0250/0967	036 "DIA CIRC CONCR LEN=0020 INSTALLED UNKN	
	0250/0820	036 "DIA CIRC CONCR LEN=0020 INSTALLED UNKN	
	0250/0618	036 "DIA CIRC CONCR LEN=0020 INSTALLED UNKN	
	0250/0310	036 "DIA CIRC CONCR LEN=0020 INSTALLED UNKN	
052661 FT	052675 FT	1 0 00736 0 01 0345+08 NC DRAVOSBURG RD	
	0250/0000	LENGTH(AH 2884 BK 3009)	
	0240/2871	036 "DIA CIRC CONCR LEN=0020 INSTALLED UNKN	
	0240/2680	024 "DIA CIRC CONCR LEN=0080 INSTALLED UNKN	
	0240/2499	036 "DIA CIRC CONCR LEN=0025 INSTALLED UNKN	

DIR: B TOTAL LEN: 24.216 MI. DIST: 11-1 SR: 837
 LEFT MUN: WEST MIFFLIN B RIGHT MUN: WEST MIFFLIN B

---	0240/2272	036 " DIA	CIRC CONCR
---		LEN=0020	INSTALLED UNKN
---	0240/2026	036 " DIA	CIRC CONCR
---		LEN=0030	INSTALLED UNKN
---	0240/1766	036 " DIA	CIRC CONCR
---		LEN=0020	INSTALLED UNKN
---	0240/1440	01B " DIA	CIRC CONCR
---		LEN=0080	INSTALLED UNKN
---	0240/1325	04B " DIA	CIRC CONCR
---		LEN=0025	INSTALLED UNKN
---	0240/0299	036 " DIA	CIRC CONCR
---		LEN=0020	INSTALLED UNKN
049652 FT	049666 FT	1 0 00736	0 01 0314+99
		NC DU	QUESNE BL
	5 0240/0000	LENGTH(AH	3009 BK 2553)
---	0230/2051	018 " DIA	CIRC METAL
---		LEN=0040	INSTALLED 2002
---	0230/1547	018 " DIA	CIRC METAL
---		LEN=0040	INSTALLED 2002
---	0230/1150	018 " DIA	CIRC CONCR
---		LEN=0040	INSTALLED 2002
---	0230/0700	018 " DIA	CIRC CONCR
---		LEN=0040	INSTALLED 2002
---	0230/0494	018 " DIA	CIRC CONCR
---		LEN=0030	INSTALLED 2002
047099 FT	0230/0302	WEST MIFFLIN	
	047113 FT	DRAVOSBURG B	
		1 0 00736	0 01 0289+21
		(AAR 507698M)	#TRKS 02
+++++	5 0230/0000	LENGTH(AH	2553 BK 2220)
		(APRA)	BOSWELL OIL CO
		KINDER-MORGAN INC	
		(PRDR)	
POE	0220/1515		
---	0220/0474	018 " DIA	CIRC CONCR
---		LEN=0052	INSTALLED UNKN
044879 FT	044893 FT	1 0 00736	0 01 0267+12
		NC WA	ASHINGTON ST
	5 0220/0000	LENGTH(AH	2220 BK 2542)
MCCLURE ST	0210/1940		
(CITY)			
==			
---	0210/1375	018 " DIA	CIRC CONCR
---		LEN=0040	INSTALLED 2002
---	0210/1094	018 " DIA	CIRC CONCR
---		LEN=0040	INSTALLED 2002

EXTRACT DATE: 12/21/2020
PRINT DATE: 12/23/2020

ROADWAY MANAGEMENT SYSTEM
SLD COUNTY/SR - ANNUAL PRINT

PAGE NUMBER: 426
COUNTY: ALLEGHENY

DIR: B TOTAL LEN: 24.216 MI.
LEFT MUN: DRAVOSBURG B

DIST: 11-1 SR: 837
RIGHT MUN: DRAVOSBURG B

Station	Description	Material	Length
0210/0647	018" DIA CIRC CONCR	LEN=0046	INSTALLED UNKN
0210/0545	036" DIA CIRC CONCR	LEN=0046	INSTALLED UNKN
042337 FT	PGH MCKPT BV		
0210/0535	OP ID 02/7423/2288/2394		
042351 FT	1 0 00736 0 01 0241+47		
0210/0000	018"H 00"W MULT CONCR	LEN=0032	INSTALLED UNKN
POE	LENGTH(AH 2542 BK 3058)		
0200/2887	(APRA) A CRANE RENTAL L		
	(PRDR)		
0200/2181	CENTURY HEAVY HAULING		
	(PRDR)		
0200/2141	018" DIA CIRC CONCR	LEN=0039	INSTALLED UNKN
ELIZABETH ST (CNTY)			
0200/2095			
0200/2089	BMS EN 02/0837/0200/2061		
	1 0 00736 0 01 0231+32		
	CREEK		
0200/2072	BMSBG 02/0837/0200/2061		
0200/2000	018" DIA CIRC CONCR	LEN=0051	INSTALLED UNKN
0200/1849	018" DIA CIRC CONCR	LEN=0050	INSTALLED UNKN
PLANT ENT RD (PRDR)			
0200/1086			
	DRAVOSBURG WEST MIFFLIN B		
0200/0024	018" DIA CIRC CONCR	LEN=0040	INSTALLED UNKN
039293 FT			
1 0 00736 0 01 0210+64 039279 FT			
LEBANON SCHOOL RD (SR2034 SEG 0030/0893)			
0200/0000	LENGTH(AH 3058 BK 3539)		
0190/2712	018" DIA CIRC CONCR	LEN=0060	INSTALLED UNKN
0190/2106	018" DIA CIRC CONCR	LEN=0040	INSTALLED 2002

DIR: B TOTAL LEN: 24.216 MI. DIST: 11-1 SR: 837
 LEFT MUN: CLAIRTON C RIGHT MUN: CLAIRTON C

Stationing	Description	Stationing	Description
030146 FT		030160 FT	1 0 00736 0 01 0119+21
			NC NORTH STATE ST
		0170/0000	LENGTH(AH 2143 BK 1517)
			010 "DIA CIRC CONCR
		0160/1496	LEN=0050 INSTALLED UNKN
			012 "DIA CIRC CONCR
		0160/1300	LEN=0060 INSTALLED UNKN
			018 "DIA CIRC CONCR
		0160/1167	LEN=0060 INSTALLED UNKN
LINCOLN WAY (CITY)	0160/1136		
			018 "DIA CIRC CONCR
		0160/0789	LEN=0050 INSTALLED 2002
			018 "DIA CIRC CONCR
CONNECTICUT AV (CITY)	0160/0525	0160/0581	LEN=0050 INSTALLED 2002
NEW YORK AV (CITY)	0160/0348	0160/0367	018 "DIA CIRC CONCR LEN=0050 INSTALLED UNKN
1 0 00736 0 01 0111+46 028629 FT		0160/0333	018 "DIA CIRC CONCR LEN=0050 INSTALLED UNKN
NEW JERSEY AV (CITY)	0160/0000	028643 FT	
		0160/0000	MFC BEGIN = B LENGTH(AH 1517 BK 0930)
018"H 18"W BOX CULVERT LEN=0099 INSTALLED UNKN	0151/0878	0150/0878	018 "DIA CIRC CONCR LEN=0092 INSTALLED UNKN
SIGN: CANTILEVER			
BMSID 02/0837/0151/0710	0151/0710		
		0150/0643	018 "DIA CIRC CONCR LEN=0098 INSTALLED UNKN
			FROM 2038/0010 SH
CARNEGIE AV (CITY)		0150/0445	(CONN) CARNEGIE AV
CLAIRTON-GLASSPORT BR (SR2038 SEG 0010/0000)			(CITY) CLAIRTON-GLASSPORT BR
	0151/0365	0150/0360	(SR2038 SEG 0010/0000)
036 "DIA CIRC CONCR LEN=0060 INSTALLED UNKN	0151/0305		
		0150/0245	TO 2038/0010 SH (CONN)
			SIGN: CANTILEVER
		0150/0140	BMSID 02/0837/0150/0140
			018 "DIA CIRC CONCR
		0150/0070	LEN=0036 INSTALLED UNKN

EXTRACT DATE: 12/21/2020
PRINT DATE: 12/23/2020

ROADWAY MANAGEMENT SYSTEM
SLD COUNTY/SR - ANNUAL PRINT

PAGE NUMBER: 422
COUNTY: ALLEGHENY

DIR: B TOTAL LEN: 24.216 MI.
LEFT MUN: CLAIRTON C

DIST: 11-1 SR: 837
RIGHT MUN: CLAIRTON C

US STEEL CLAIRTON WKS
(CITY)

0110/1915

MULBERRY AV
(CITY)

0110/0365

1 0 00376 0 01 0110+85 022400 FT
BOUNDARY AV
(CITY)

0110/0000

FRANCIS AV
(CITY)

0100/1590

BROAD AV

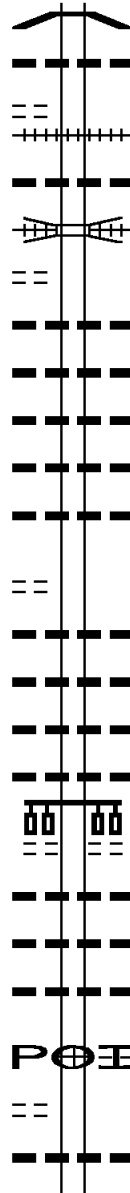

0110/2319 BMSBG 02/0837/0110/2306
024 "DIA CIRC CONCR
0110/2250 LEN=0040 INSTALLED UNKN
0110/1482 (AAR 472960C) #TRKS 01
018 "DIA CIRC CONCR
0110/0922 LEN=0112 INSTALLED UNKN
UNION & PENNSYLVANIA &
0110/0834 OVERPASS IS RR X-ING
0110/0294 018 "DIA CIRC CONCR
LEN=0020 INSTALLED UNKN
0110/0252 018 "DIA CIRC CONCR
LEN=0020 INSTALLED UNKN
0110/0233 018 "DIA CIRC CONCR
LEN=0015 INSTALLED UNKN
0110/0126 018 "DIA CIRC CONCR
LEN=0020 INSTALLED UNKN
0110/0045 012 "DIA CIRC CONCR
LEN=0099 INSTALLED UNKN
022400 FT
0110/0000 LENGTH(AH 3525 BK 2827)
018 "DIA CIRC CONCR
0100/2812 LEN=0010 INSTALLED 2002
012 "DIA CIRC CONCR
0100/2800 LEN=0040 INSTALLED UNKN
012 "DIA CIRC CONCR
0100/2600 LEN=0040 INSTALLED UNKN
018 "DIA CIRC CONCR
0100/2486 LEN=0034 INSTALLED UNKN
MAPLE AV
(CITY)
0100/2315 018 "DIA CIRC CONCR
LEN=0020 INSTALLED UNKN
0100/2306 018 "DIA CIRC CONCR
LEN=0114 INSTALLED UNKN
0100/2143 018 "DIA CIRC CONCR
LEN=0114 INSTALLED UNKN
0100/2121 (APRA) US STEEL CLAIRTO
FRANCIS AV
(CITY)
0100/1660 018 "DIA CIRC CONCR
LEN=0114 INSTALLED UNKN
0100/1437 018 "DIA CIRC CONCR
LEN=0114 INSTALLED UNKN

DIR: B TOTAL LEN: 24.216 MI. DIST: 11-1 SR: 837
 LEFT MUN: CLAIRTON C RIGHT MUN: CLAIRTON C

(CITY)	0100/1375	==							
		---		0100/1275	012 " DIA	CIRC CONCR			
		---			LEN=0099	INSTALLED	UNKN		
SHAW AV		==							
(CITY)	0100/0915	---							
PARK AV		==							
(CITY)	0100/0590	---							
		---		0100/0218	018 " DIA	CIRC CONCR			
		---			LEN=0119	INSTALLED	UNKN		
		---		0100/0053	018 " DIA	CIRC CONCR			
		---		019573 FT	LEN=0030	INSTALLED	UNKN		
1 0 00376 0 01 0081+61 019573 FT									
ST CLAIR ST									
(SR2028 SEG 0090/2021) 0100/0000									
				5 0100/0000	LENGTH(AH 2827 BK 2820)				
					024 " DIA	CIRC CONCR			
				0090/2479	LEN=0099	INSTALLED	UNKN		
					024 " DIA	CIRC METAL			
				0090/2179	LEN=0099	INSTALLED	UNKN		
					024 " DIA	CIRC CONCR			
				0090/1423	LEN=0099	INSTALLED	UNKN		
					018 " DIA	CIRC CONCR			
				0090/1167	LEN=0055	INSTALLED	UNKN		
					018 " DIA	CIRC CONCR			
				0090/0328	LEN=0060	INSTALLED	UNKN		
016753 FT				016753 FT	1 0 00376 0 00 0053+17				
					NC ST				
					CLAIRTON				
					JEFFERSON HILLS B				
				5 0090/0000	LENGTH(AH 2820 BK 3552)				
					015 " DIA	CIRC CONCR			
				0080/3502	LEN=0099	INSTALLED	UNKN		
					018 " DIA	CIRC CONCR			
				0080/3283	LEN=0099	INSTALLED	UNKN		
					018 " DIA	CIRC CONCR			
				0080/2984	LEN=0099	INSTALLED	UNKN		
					018 " DIA	CIRC CONCR			
				0080/2697	LEN=0099	INSTALLED	UNKN		
					036 " DIA	CIRC CONCR			
				0080/2338	LEN=0070	INSTALLED	UNKN		
					018 " DIA	CIRC CONCR			
				0080/1625	LEN=0050	INSTALLED	UNKN		
DUQUESNE LIGHT DISPOSAL									
(PRDR) 0080/1405		==							
		---		0080/1123	018 " DIA	CIRC CONCR			
		---			LEN=0050	INSTALLED	2002		
		---			018 " DIA	CIRC CONCR			
		---		0080/0895	LEN=0100	INSTALLED	UNKN		

DIR: B TOTAL LEN: 24.216 MI. DIST: 11-1 SR: 837
 LEFT MUN: JEFFERSON HILLS B RIGHT MUN: JEFFERSON HILLS B

Stationing	Description	Material	Length	Status
0080/0565	018" DIA	CIRC CONCR	LEN=0045	INSTALLED UNKN
0080/0400	018" DIA	CIRC CONCR	LEN=0060	INSTALLED UNKN
013201 FT	1 0 00376	0 00 0017+17		
0080/0000	JEFFERSON HILLS WEST ELIZABETH B			
0070/1839	LENGTH(AH 3552 BK 1839)	024" DIA	CIRC CONCR	INSTALLED UNKN
0070/1560	018" DIA	CIRC CONCR	LEN=0099	INSTALLED UNKN
0070/1517	SR 51 N TO SR 837 RAMP (SR8073 SEG 0750/0771)	018" DIA	CIRC CONCR	LEN=0099 INSTALLED UNKN
0070/1197	WEST ELIZABETH	012" DIA	CIRC CONCR	LEN=0099 INSTALLED UNKN
0070/0975	JEFFERSON HILLS B	024" DIA	CIRC CONCR	LEN=0099 INSTALLED UNKN
0070/0922	012" DIA	CIRC CONCR	LEN=0099	INSTALLED UNKN
0070/0757	024" DIA	CIRC CONCR	LEN=0040	INSTALLED UNKN
0070/0690	SR 51 ELIZABETH BR	OP ID 02/0051/0110/1552		
0070/0602	RAMP E 8073 NB	OP ID 02/8073/0532/0040		
0070/0479	024" H 36" W CON BOX CUL	LEN=0278	INSTALLED UNKN	
0070/0467	018" DIA	CIRC CONCR	LEN=0057	INSTALLED UNKN
SR 837 TO SR 51 N RAMP (SR8073 SEG 0542/0000)	0070/0348			
0070/0341	SR 51 S TO SR 837 RAMP (SR8073 SEG 0510/0174)	018" DIA	CIRC CONCR	LEN=0040 INSTALLED UNKN
0070/0308	018" DIA	CIRC CONCR	LEN=0057	INSTALLED UNKN
0070/0070	1 0 00376	0 00 0000+00		
011362 FT	NC DR			
0070/0000	RAVOSBURG RD	LENGTH(AH 1839 BK 0646)		
0060/0464	RAMP FR 837N TO 51S (SR8073 SEG 0522/0000)			
0060/0435	MFC BEGIN = B			
0060/0262	RAMP F 8037 SB	OP ID 02/8073/0502/0053		
0060/0218	018" DIA	CIRC CONCR	LEN=0119	INSTALLED UNKN
	018" DIA	CIRC CONCR		

EXTRACT DATE: 12/21/2020
PRINT DATE: 12/23/2020

ROADWAY MANAGEMENT SYSTEM
SLD COUNTY/SR - ANNUAL PRINT

PAGE NUMBER: 419
COUNTY: ALLEGHENY

DIR: B TOTAL LEN: 24.216 MI.
LEFT MUN: JEFFERSON HILLS B

DIST: 11-1 SR: 837
RIGHT MUN: JEFFERSON HILLS B

Stationing	Notes	Stationing	Notes
010716 FT		0060/0119	LEN=0099 INSTALLED UNKN
		010716 FT	1 0 00736 0 00 0106+40
			SR 0051 SB
			OP ID 02/0051/0121/0210
			JEFFERSON HILLS
			WEST ELIZABETH B
		0060/0000	LENGTH(AH 0646 BK 1107)
			022"H 12"W CON BOX CUL
		0050/0716	LEN=0099 INSTALLED UNKN
			WASHINGTON ST
		0050/0685	(TWP)
			018"H 24"W CON BOX CUL
		0050/0663	LEN=0099 INSTALLED UNKN
			018"H 24"W CON BOX CUL
		0050/0653	LEN=0099 INSTALLED UNKN
			BORDER ST
		0050/0460	(TWP)
			018"H 24"W CON BOX CUL
		0050/0218	LEN=0099 INSTALLED UNKN
			018"H 18"W CON BOX CUL
		0050/0021	LEN=0040 INSTALLED UNKN
009609 FT		009609 FT	1 0 00736 0 00 0095+00
			LINCOLN ST
			(TWP)
		0050/0000	LENGTH(AH 1107 BK 0738)
			018"H 24"W CON BOX CUL
		0040/0480	LEN=0040 INSTALLED 2002
			GRANT ST
		0040/0205	(TWP)
			018"H 24"W CON BOX CUL
		0040/0183	LEN=0040 INSTALLED UNKN
008871 FT		008871 FT	1 0 00736 0 00 0087+61
			ROBINSON ST
			(TWP)
		0040/0000	LENGTH(AH 0738 BK 3284)
			WEST ELIZABETH
			JEFFERSON HILLS B
BURNETT ST (BORO)		0030/2147	NC FIFTH ST
VIOLA ST (BORO)			072"H 00"W MULT METAL
		0030/2090	LEN=0065 INSTALLED UNKN
			MADISON ST
		0030/1985	(BORO)
			018" DIA CIRC CONCR
			LEN=0045 INSTALLED UNKN
MADISON ST (TWP)		0030/1740	EASTMAN CO RD
			(BORO)

EXTRACT DATE: 12/21/2020 ROADWAY MANAGEMENT SYSTEM PAGE NUMBER: 417
PRINT DATE: 12/23/2020 SLD COUNTY/SR - ANNUAL PRINT COUNTY: ALLEGHENY
DIR: B TOTAL LEN: 2.106 MI. DIST: 11-1 SR: 791
LEFT MUN: PENN HILLS T RIGHT MUN: PENN HILLS T

FRANKSTOWN RD

011026 FT

011119 FT FRANKSTOWN RD

EXTRACT DATE: 12/21/2020
PRINT DATE: 12/23/2020

ROADWAY MANAGEMENT SYSTEM
SLD COUNTY/SR - ANNUAL PRINT

PAGE NUMBER: 416
COUNTY: ALLEGHENY

DIR: B TOTAL LEN: 2.106 MI.
LEFT MUN: PENN HILLS T

DIST: 11-1 SR: 791
RIGHT MUN: PENN HILLS T

(SR0400 SEG 0260/0000)

0061/0738

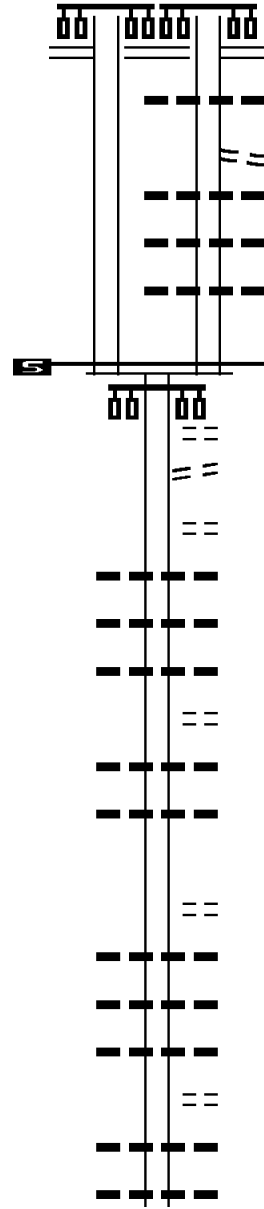

0 0 00000 0 00 0000+00 010288 FT
MFC BEGIN = B
LENGTH(AH 0738 BK 2150) 0061/0000

008138 FT

0060/0738

0060/0622

0060/0369

0060/0330

0060/0137

0060/0058

010381 FT

0060/0000

0050/2150

0050/2045

0050/1805

0050/1680

0050/1480

0050/1060

0050/0805

0050/0790

0050/0490

008231 FT

0050/0000

0040/2640

0040/2300

0040/2155

0040/1740

0040/1400

0040/1220

(SR0400 SEG 0260/0000)

024 "DIA CIRC CONCR
LEN=0099 INSTALLED UNKN
UNIVERSAL RD

(CNTY)
018 "DIA CIRC CONCR
LEN=0099 INSTALLED UNKN

018 "DIA CIRC CONCR
LEN=0099 INSTALLED UNKN
018 "DIA CIRC CONCR
LEN=0060 INSTALLED UNKN

0 0 00000 0 00 0000+00
MFC BEGIN = B
LENGTH(AH 0738 BK 2150)

LC FROM UNIVERSAL RD
(CONN)

LC TO UNIVERSAL RD
(CONN)
RODILIN DR
(TWP)

018 "DIA CIRC CONCR
LEN=0040 INSTALLED UNKN
018 "DIA CIRC CONCR
LEN=0040 INSTALLED UNKN

018 "DIA CIRC CONCR
LEN=0040 INSTALLED UNKN
MORLOW DR
(TWP)

018 "DIA CIRC CONCR
LEN=0099 INSTALLED UNKN
018 "DIA CIRC CONCR
LEN=0099 INSTALLED UNKN

1 0 00395 0 02 0162+77
MORROW DR
(TWP)

LENGTH(AH 2150 BK 2672)
018 "DIA CIRC CONCR
LEN=0045 INSTALLED UNKN

018 "DIA CIRC CONCR
LEN=0028 INSTALLED UNKN
018 "DIA CIRC CONCR
LEN=0099 INSTALLED UNKN

STONELEDGE DR
(TWP)

018 "DIA CIRC CONCR
LEN=0028 INSTALLED UNKN
036 "DIA CIRC CONCR
LEN=0035 INSTALLED UNKN

DIR: B TOTAL LEN: 2.106 MI. DIST: 11-1 SR: 791
 LEFT MUN: PENN HILLS T RIGHT MUN: PENN HILLS T

1 0 00395 0 02 0136+16 005466 FT
 DUFF RD
 (TWP)

HOOVER RD
 (TWP)

PURITY RD
 (TWP)

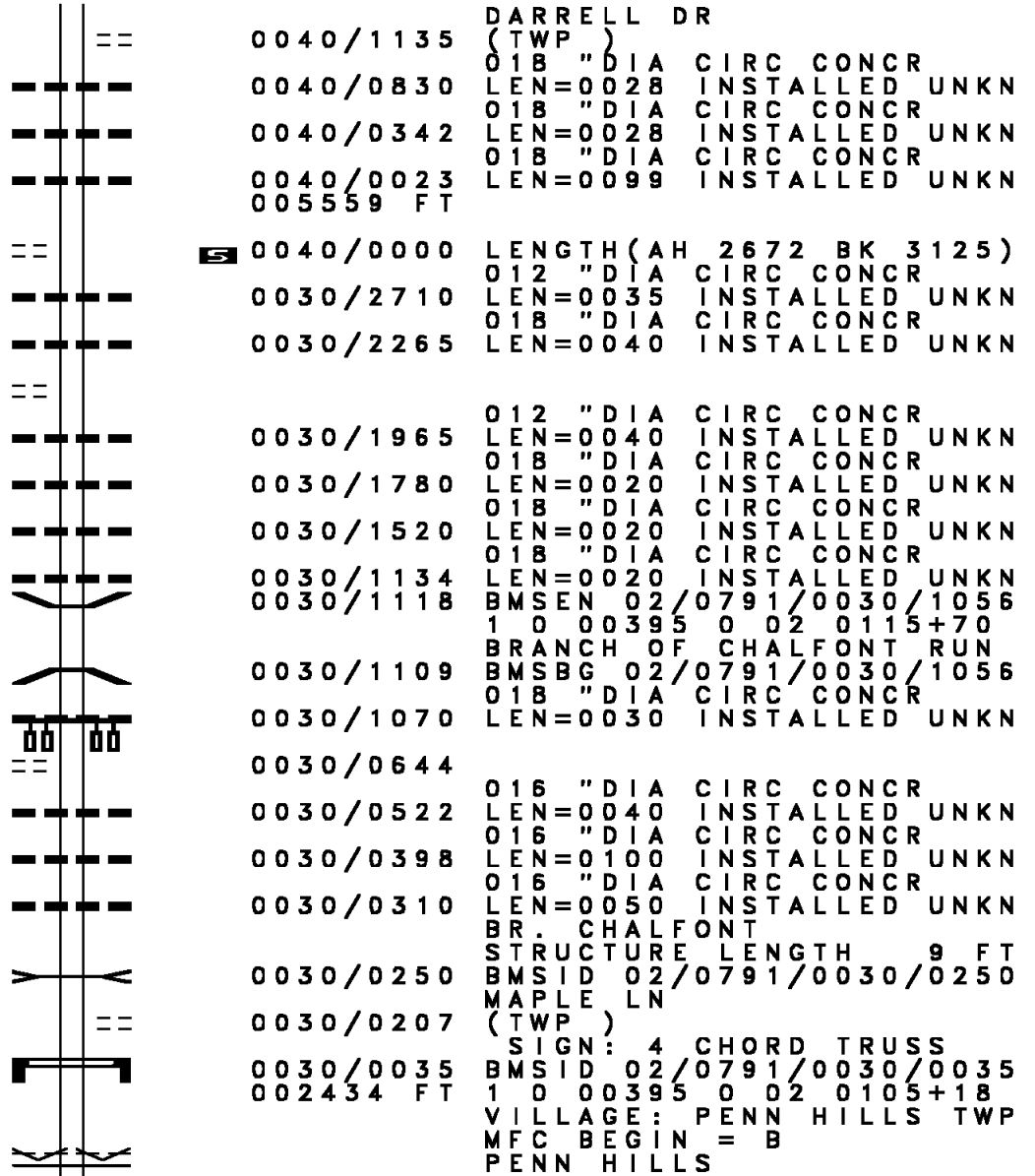

002341 FT

DIR: B TOTAL LEN: 2.106 MI. DIST: 11-1 SR: 791
 LEFT MUN: PENN HILLS T RIGHT MUN: PENN HILLS T

RAMP C RD
 (SR8020 SEG 0250/0000) 0021/1595

SIGN: 4 CHORD TRUSS
 BMSID 02/0791/0021/0700 0021/0700
 PENN LINC.PY
 OP ID 02/0376/0800/2406 0021/0605

RAMP D RD
 (SR8020 SEG 0750/0000) 0021/0580

018 "DIA CIRC CONCR
 LEN=0099 INSTALLED UNKN 0021/0050

1 0 00395 0 02 0088+87 000725 FT
 MFC BEGIN = B
 LENGTH(AH 1616 BK 0725) 0021/0000

TO 2048/0011 SH
 (CONN)

0010/0095
 000000 FT

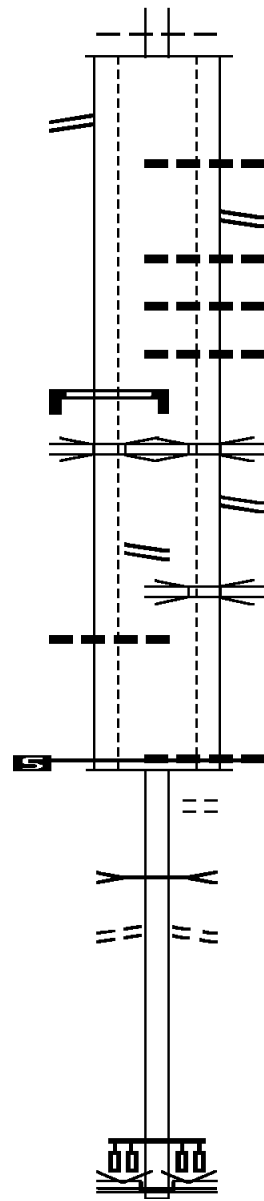

0030/0000 CHURCHILL B
 LENGTH(AH 3125 BK 1709)

0020/1540 018 "DIA CIRC CONCR
 LEN=0099 INSTALLED UNKN
 RAMP F RD
 (SR8020 SEG 0500/0817)

0020/1305 018 "DIA CIRC CONCR
 LEN=0099 INSTALLED UNKN

0020/1270 018 "DIA CIRC CONCR
 LEN=0060 INSTALLED UNKN

0020/0860 018 "DIA CIRC CONCR
 LEN=0048 INSTALLED UNKN

0020/0830

0020/0677 OP ID 02/0376/0800/2406
 PENN LINC.PY
 RAMP E RD
 (SR8020 SEG 0760/1129)

0020/0635

0020/0525 OP ID 02/8020/0750/0112
 RAMP D 8020 EB

000725 FT 1 0 00395 0 02 0088+87
 018 "DIA CIRC CONCR
 LEN=0036 INSTALLED UNKN
 MFC BEGIN = B

0020/0000 LENGTH(AH 1709 BK 0725)
 MCCRADY RD
 (BORO)
 CHALFONT RUN
 STRUCTURE LENGTH 16 FT
 BMSID 02/0791/0010/0231
 FROM 2048/0015 SH
 (CONN)

0010/0430

0010/0284

0010/0095
 000000 FT

1 0 00395 0 02 0081+28
 VILLAGE: CHURCHILL B
 NC RD
 DI RD
 WILLIAM PENN HW
 (SR2048 SEG 0014/0000)
 (SR2048 SEG 0015/0000)

INTER-BK NOTTINGHAM DR
 (BORO)
 MFC BEGIN = B

0010/0000 LENGTH(AH 0725 BK 0000)

EXTRACT DATE: 12/21/2020 ROADWAY MANAGEMENT SYSTEM PAGE NUMBER: 413
PRINT DATE: 12/23/2020 SLD COUNTY/SR - ANNUAL PRINT COUNTY: ALLEGHENY
DIR: N TOTAL LEN: 1.575 MI. DIST: 11-1 SR: 579
LEFT MUN: PITTSBURGH C RIGHT MUN: PITTSBURGH C

SR 0279 SH 008194 FT
(SR0279 SEG 0017/1838) INTER-AHD

SR 0279 SH 008314 FT
(SR0279 SEG 0016/1746) INTER-AHD

SR 0279 SH
SR 0279 SH

☐ ☐

DIR: N TOTAL LEN: 1.575 MI. DIST: 11-1 SR: 579
 LEFT MUN: PITTSBURGH C RIGHT MUN: PITTSBURGH C

SR	SEG	START	END	DESCRIPTION	SR	SEG	START	END	DESCRIPTION
(SR0279	SEG 0017/1838)	0011/3240			0010/3175	(SR0279	SEG 0016/1746)		
SIGN: 4	CHORD TRUSS								
BMSID	02/0279/0017/1253	0011/2700							
OP ID	02/0279/0016/1235	0011/2670			0010/2629	OP ID	02/0279/0016/1235		
	NORTH AVE						NORTH AVE		
	TRIPOLI ST						TRIPOLI ST		
OP ID	02/0279/0016/0998	0011/2470			0010/2390	OP ID	02/0279/0016/0998		
BMSEN	02/0579/0011/0000	0011/1891			0010/1838	BMSEN	02/0579/0010/0000		
						SIGN: CANTILEVER			
					0010/1814	BMSID	02/0579/0010/1862		
SIGN: CANTILEVER									
BMSID	02/0579/0011/1025	0011/1025							
RETAINING WALL						RETAINING WALL			
BMSID	02/0579/0011/1540	0011/0831			0010/0832	BMSID	02/0579/0010/1585		
RETAINING WALL						RETAINING WALL			
BMSID	02/0579/0011/1860	0011/0663			0010/0731	BMSID	02/0579/0010/1910		
						RAMP H RD			
					0010/0410	(SR8121	SEG 0752/0000)		
RAMP G RD									
(SR8121	SEG 0532/1128)	0011/0405							
RETAINING WALL						RETAINING WALL			
BMSID	02/0579/0011/1920	0011/0040			0010/0032	BMSID	02/0579/0010/1890		
0 0 00000 0 00 0000+00	004954 FT				005139 FT	0 0 00000 0 00 0000+00			
E. OHIO ST.						EAST OHIO ST			
BMSBG	02/0579/0011/0000					BMSBG	02/0579/0010/0000		
MILEPOST	001.00					MILEPOST	001.00		
LENGTH(AH 3240 BK 2639)		0011/0000			0010/0000	LENGTH(AH 3175 BK 2614)			
						SIGN: 3 CHORD TRUSS			
BMSEN	02/0579/0004/1532	0005/2639			0004/2582	BMSID	02/0579/0004/2582		
SIGN: CANTILEVER						BMSEN	02/0579/0004/1532		
BMSID	02/0579/0005/2614	0005/2614							
SIGN: 4 CHORD TRUSS									
BMSID	02/0579/0005/1875	0005/1875							
1 0 00000 0 00 0000+00						1 0 00000 0 00 0000+00			
BMSEN	02/0579/0005/0000					BMSEN	02/0579/0004/0000		
ALLEGHENY RIVER						ALLEGHENY RIVER			
BMSBG	02/0579/0004/1532	0005/1589			0004/1532	BMSBG	02/0579/0004/1532		
						SIGN: CANTILEVER			
					0004/1421	BMSID	02/0579/0004/1421		
SIGN: 4 CHORD TRUSS									
BMSID	02/0579/0005/1055	0005/1055							
RAMP J RD						RAMP B RD			
(SR8078	SEG 0500/0000)	0005/0515				(SR8078	SEG 0010/1118)		
						0 0 00000 0 00 0000+00			
0 0 00000 0 00 0000+00	002315 FT				0004/0480	0 0 00000 0 00 0000+00			
PAT E BSWY					002525 FT	PAT E BSWY			

EXTRACT DATE: 12/21/2020
PRINT DATE: 12/23/2020

ROADWAY MANAGEMENT SYSTEM
SLD COUNTY/SR - ANNUAL PRINT

PAGE NUMBER: 411
COUNTY: ALLEGHENY

DIR: N TOTAL LEN: 1.575 MI.
LEFT MUN: PITTSBURGH C

DIST: 11-1 SR: 579
RIGHT MUN: PITTSBURGH C

BMSBG 02/0579/0005/0000
LENGTH(AH 2639 BK 2315) 0005/0000

BIGELOW BLVD
OP ID 02/0400/0005/1346 0003/2260
RAMP F 8078 SB
OP ID 02/8078/0514/0018 0003/1665
RAMP 520 RD
(SR8078 SEG 0520/0581) 0003/1420

BMSEN 02/0579/0003/1060 0003/1178
SR 0400 EB
OP ID 02/0400/0004/0288 0003/1110
1 0 01026 0 00 0009+64
WEBSTER AVE
OP ID 02/2146/0010/0000

RAMP D
BMSBG 02/0579/0003/1060 0003/1060
RAMP F RD
(SR8078 SEG 0514/1226) 0003/0800
SIGN: 4 CHORD TRUSS
BMSID 02/0579/0003/0779 0003/0779
CENTRE AVE
OP ID 02/2144/0010/0000 0003/0675

SIGN: 4 CHORD TRUSS
BMSID 02/0579/0003/0311 0003/0311

BMSEN 02/0579/0003/0000 0003/0211
1 0 01026 0 00 0000+00 000000 FT
RAMP H RD
(SR8002 SEG 0250/0000)
RAMP J RD
(SR8002 SEG 0270/0000) REF-BK *

5TH AVE
BMSBG 02/0579/0003/0000
MFC BEGIN = A
MILEPOST 000.00
LENGTH(AH 2315 BK 0000) 0003/0000

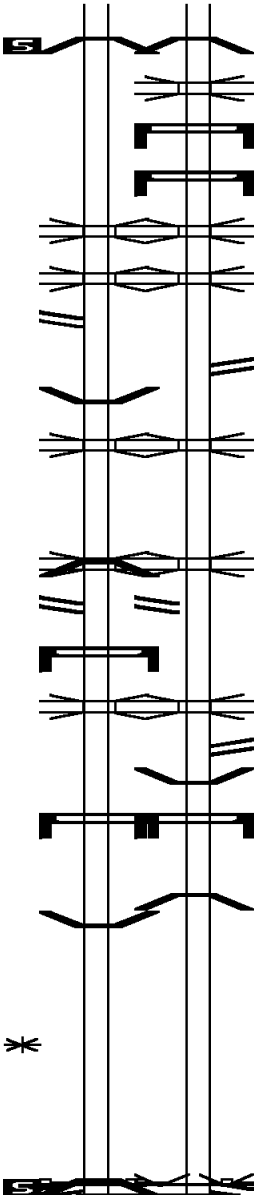

0004/0000 BMSBG 02/0579/0004/0000
LENGTH(AH 2614 BK 2525)

OP ID 02/0400/0005/1346 0002/2260
RAMP F 8078 SB
OP ID 02/8078/0514/0018 0002/1665
RAMP 520 RD
(SR8078 SEG 0520/0581) 0002/1420

RAMP K RD
(SR8078 SEG 0020/0000) 0002/1470
SR 0400 EB
OP ID 02/0400/0004/0288 0002/1225

WEBSTER AVE
OP ID 02/2146/0010/0000 0002/1175
RAMP D RD
(SR8078 SEG 0262/0000) 0002/0865

CENTRE AVE
OP ID 02/2144/0010/0000 0002/0780
RAMP M RD
(SR8002 SEG 0300/0000) 0002/0525
BMSEN 02/0579/0002/0250 0002/0392
SIGN: 4 CHORD TRUSS
BMSID 02/0579/0003/0311 0002/0363
1 0 01026 0 00 0000+00
FIFTH AVE LOCAL
BMSBG 02/0579/0002/0250 0002/0250

000000 FT 1 0 01026 0 00 0000+00
VILLAGE: PITTSBURGH C
NC CR ROSSTOWN BL
RAMP L RD
(SR8002 SEG 0290/0836) * REF-BK
RAMP K RD
(SR8002 SEG 0280/1056)
MFC BEGIN = A
MILEPOST 000.00
LENGTH(AH 2525 BK 0000) 0002/0000

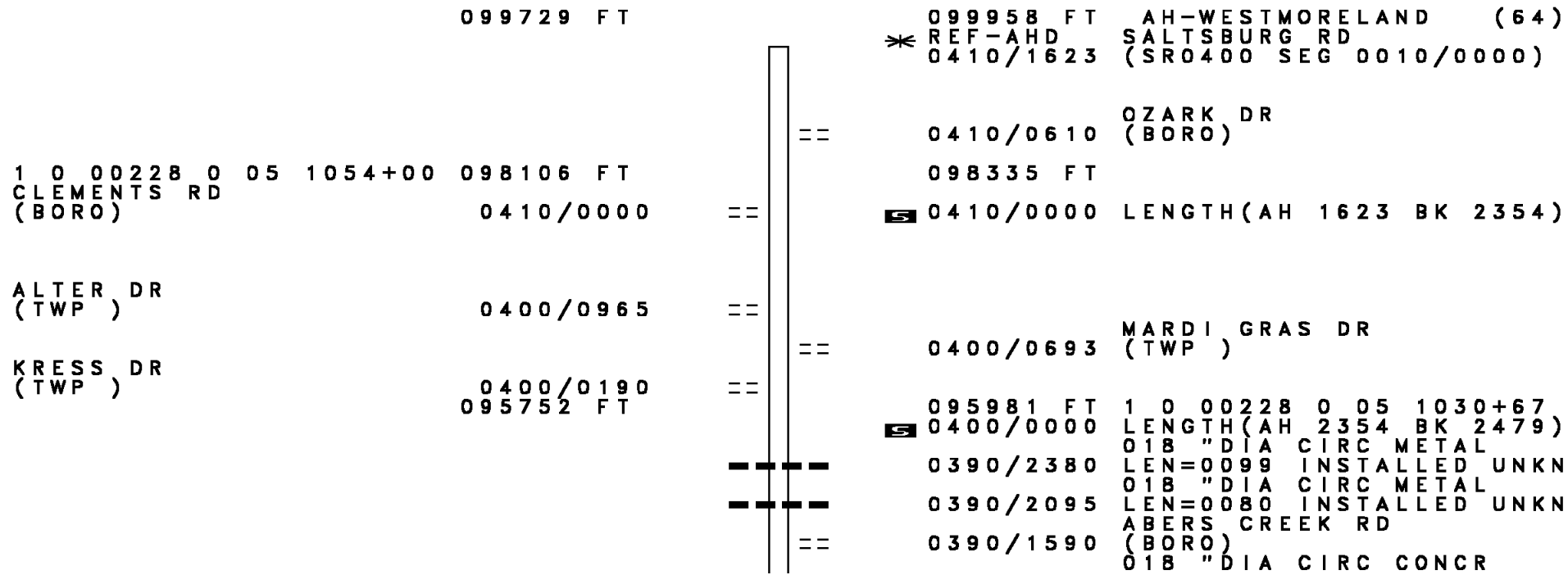

DIR: E TOTAL LEN: 18.931 MI. DIST: 11-1 SR: 400
 LEFT MUN: PLUM BOROUGH B RIGHT MUN: PLUM BOROUGH B

MARIAH DR
 (BORO)

0390/0170
 093273 FT

1 0 00228 0 05 0971+63 089839 FT
 FIRWOOD DR
 (BORO)

0380/0000

BOYCE PARK DR
 (BORO)

0370/0195
 086299 FT

---	0390/1526	LEN=0050	INSTALLED	UNKN
---	0390/0915	018 " DIA	CIRC METAL	
==	0390/0730	LEN=0080	INSTALLED	UNKN
		YORIO DR		
		(TWP)		
==	093502 FT	1 0 00228 0 05	1005+90	
		OBLOCK RD		
		(BORO)		
==	0390/0000	LENGTH(AH 2479 BK 3434)		
---	0380/3434	018 " DIA	CIRC METAL	
---	0380/2850	LEN=0036	INSTALLED	UNKN
		018 " DIA	CIRC METAL	
---	0380/2130	LEN=0080	INSTALLED	UNKN
---	0380/1945	018 " DIA	CIRC METAL	
---	0380/1375	LEN=0080	INSTALLED	UNKN
		036 " DIA	CIRC METAL	
		LEN=0050	INSTALLED	UNKN
==	0380/0906	CHAVELLE CT		
		(BORO)		
	090068 FT			
==	0380/0000	LENGTH(AH 3434 BK 3540)		
---	0370/2450	018 " DIA	CIRC CONCR	
==	0370/2420	LEN=0099	INSTALLED	UNKN
		NEW TEXAS RD		
		(SR2075 SEG 0070/0000)		
---	0370/1445	018 " DIA	CIRC CONCR	
---	0370/0959	LEN=0050	INSTALLED	UNKN
---	0370/0870	018 " DIA	CIR PLASTIC	
		LEN=0050	INSTALLED	UNKN
		018 " DIA	CIRC CONCR	
		LEN=0050	INSTALLED	UNKN
==	086528 FT	1 0 00228 0 05	0936+39	
	0370/0000	LENGTH(AH 3540 BK 3532)		

EXTRACT DATE: 12/21/2020
PRINT DATE: 12/23/2020

ROADWAY MANAGEMENT SYSTEM
SLD COUNTY/SR - ANNUAL PRINT

PAGE NUMBER: 408
COUNTY: ALLEGHENY

DIR: E TOTAL LEN: 18.931 MI.
LEFT MUN: PLUM BOROUGH B

DIST: 11-1 SR: 400
RIGHT MUN: PLUM BOROUGH B

Station	Description	Notes
0360/2550	018 " DIA CIRC CONCR	LEN=0100 INSTALLED UNKN
0360/2429	018 " DIA CIRC CONCR	LEN=0099 INSTALLED UNKN
0360/1670	CENTER HILL RD	(BORO)
0360/0755	024 " DIA CIRC CONCR	LEN=0040 INSTALLED UNKN
0360/0235	018 " DIA CIRC CONCR	LEN=0050 INSTALLED UNKN
0360/0012	BMSSEN 02/0400/0360/0000	1 0 00228 0 05 0900+35
082996 FT	PLUM CREEK	
0360/0000	BMSBG 02/0400/0360/0000	LENGTH(AH 3532 BK 3162)
0350/3095	018 " DIA CIRC CONCR	LEN=2996 INSTALLED UNKN
0350/2820	CENTER NEW TEXAS RD	(BORO)
0350/2480	UNITY TRESTLE RD	(CNTY)
0350/2370	018 " DIA CIRC CONCR	LEN=0050 INSTALLED UNKN
0350/2365	UNITY TRESTLE RD	(CNTY)
0350/2205	BMSSEN 02/0400/0350/2218	1 0 00228 0 05 0868+78
0350/2185	PLUM CREEK	
0350/2185	BMSBG 02/0400/0350/2218	PIERSON RUN RD
0350/2135	(CNTY)	
0350/1915	018 " DIA CIRC CONCR	LEN=0050 INSTALLED UNKN
0350/1890	CENTER RD	(CNTY)
0350/0900	018 " DIA CIRC CONCR	LEN=0099 INSTALLED UNKN
079605 FT		
079834 FT	1 0 00228 0 05 0868+78	
0350/0000	LENGTH(AH 3162 BK 3365)	
0340/3331	BMSSEN 02/7076/9900/5366	1 0 00228 0 05 0835+16

EXTRACT DATE: 12/21/2020
PRINT DATE: 12/23/2020

ROADWAY MANAGEMENT SYSTEM
SLD COUNTY/SR - ANNUAL PRINT

PAGE NUMBER: 407
COUNTY: ALLEGHENY

DIR: E TOTAL LEN: 18.931 MI.
LEFT MUN: PLUM BOROUGH B

DIST: 11-1 SR: 400
RIGHT MUN: PLUM BOROUGH B

Address	Distance	Notes
PLUM AQUA CLUB DR (PRDR)	0340/3150	BRIDGE CLOSED I-76 BMSBG 02/7076/9900/5366
REGENCY DR (BORO)	0340/2140	(APRA) MILLS ASSOCIATES DAVIDSON RD (BORO)
MILLERS LN (BORO)	0340/1590	WILLOW VILLAGE DR (BORO)
1 0 00228 0 05 0835+16 076240 FT CRESTVIEW DR (BORO)	0340/0000	076469 FT 0340/0000 LENGTH(AH 3365 BK 2935) PLUM BOROUGH PENN HILLS T REITER RD 0330/2734 (SR2106 SEG 0010/2863) 0330/2285 018 "DIA CIRC CONCR LEN=0050 INSTALLED UNKN 0330/2216
LAVENDER HEIGHTS CT (TWP)	0330/1262	FORD AV (TWP)
TWIN OAK DR (TWP)	0330/0610	UNIVERSAL RD (CNTY)
073305 FT	0330/0760	018 "DIA CIRC CONCR LEN=0050 INSTALLED UNKN
	0330/0560	018 "DIA CIRC CONCR LEN=0050 INSTALLED UNKN
	073534 FT	1 0 00228 0 05 0806+51
	0330/0000	0330/0000 LENGTH(AH 2935 BK 3725)
	0320/2960	018 "DIA CIRC CONCR LEN=0040 INSTALLED UNKN
	0320/2655	COLONIAL VILLAGE DR (TWP)

DIR: E TOTAL LEN: 18.931 MI. DIST: 11-1 SR: 400
 LEFT MUN: PENN HILLS T RIGHT MUN: PENN HILLS T

Street Name	Segment ID	Length (FT)	Material	Status
ALCOMA DR (TWP)	0320/2584		018 "DIA CIRC CONCR	INSTALLED UNKN
	0320/2295		018 "DIA CIRC CONCR	INSTALLED UNKN
ALCOMA DR (TWP)	0320/2250		018 "DIA CIRC CONCR	INSTALLED UNKN
	0320/1835		018 "DIA CIRC CONCR	INSTALLED UNKN
ALCOMA DR (TWP)	0320/0957		018 "DIA CIRC CONCR	INSTALLED UNKN
	0320/0873		018 "DIA CIRC CONCR	INSTALLED UNKN
ALCOMA DR (TWP)	0320/0430	069580 FT		
ALCOMA DR (TWP)	069809 FT		1 0 00228 0 05 0768+73	
	0320/0000		LENGTH(AH 3725 BK 3924)	
ALCOMA DR (TWP)	0310/3815		018 "DIA CIRC CONCR	INSTALLED UNKN
	0310/3410		018 "DIA CIRC CONCR	INSTALLED UNKN
ALCOMA DR (TWP)	0310/2770			
STOTLERS LN (TWP)	0310/2705		018 "DIA CIRC CONCR	INSTALLED UNKN
TURNER DR (TWP)	0310/2660			
ALCOMA BL (TWP)	0310/2545			
ALCOMA BL (TWP)	0310/1610		018 "DIA CIRC CONCR	INSTALLED UNKN
ALCOMA BL (TWP)	0310/1580			
ALCOMA BL (TWP)	0310/0471	065656 FT	018 "DIA CIRC CONCR	INSTALLED UNKN
ALCOMA BL (TWP)	065885 FT		1 0 00228 0 05 0729+47	
ALCOMA BL (TWP)	0310/0000		STOTLERS LN (SR2067 SEG 0030/3540)	
ALCOMA BL (TWP)	0310/0000		LENGTH(AH 3924 BK 3003)	
ALCOMA BL (TWP)			018 "DIA CIRC CONCR	

DIR: E TOTAL LEN: 18.931 MI. DIST: 11-1 SR: 400
 LEFT MUN: PENN HILLS T RIGHT MUN: PENN HILLS T

ROAD NAME	SEG	START	END	LEN	FT	STATUS	DETAILS
		0300/1910		LEN=0099		INSTALLED UNKN	
		0300/1500		LEN=0050		INSTALLED UNKN	018 "DIA CIRC CONCR
		0300/1465		(TWP)			ASTER ST
LEECHBURG RD	(SR2058 SEG 0140/0000)	0300/0505					
MCGREGOR DR	(TWP)	0300/0475					
1 0 00228 0 05 0699+35		062653			FT		
HULTON RD	(SR2078 SEG 0010/0000)	0300/0360		LEN=0050		INSTALLED UNKN	018 "DIA CIRC CONCR
SALTSBURG RD	(SR2058 SEG 0130/0539)	0300/0000					
		062882			FT		
							NC SALTSBURG RD
		0300/0000		LENGTH(AH 3003 BK 2662)			
		0290/2540		(TWP)			PETERMAN LN
		0290/1765					HELTZELL ST
		0290/0770					CRESTVIEW DR
CRESTVIEW DR	(TWP)	0290/0715					
		0290/0600					LIBERTO DR
		060220			FT		
		0290/0000		LENGTH(AH 2662 BK 2030)			
		0280/1970		LEN=0024		INSTALLED UNKN	018 "DIA CIRC CONCR
CEMETERY ENT RD	(PRDR)	0280/1640					
		0280/1200		LEN=0099		INSTALLED UNKN	018 "DIA CIRC CONCR
GLENFIELD DR	(TWP)	0280/0995					
		0280/0780		LEN=0040		INSTALLED UNKN	018 "DIA CIRC CONCR
SPRING GROVE RD	(TWP)	0280/0680					SHENANDOAH DR
1 0 00228 0 05 0652+57		057961			FT		
CRESCENT HILLS RD		058190			FT		

DIR: E TOTAL LEN: 18.931 MI. DIST: 11-1 SR: 400
 LEFT MUN: PENN HILLS T RIGHT MUN: PENN HILLS T

(TWP) 0280/0000

1 0 00228 0 05 0627+95 055495 FT
 LIME HOLLOW RD
 (SR2064 SEG 0040/0974) 0270/0000

054600 FT

HIGHPOINT DR
 (TWP) 0250/0450

0280/0000	LENGTH(AH 2030 BK 2466)
0270/2215	018 " DIA CIRC CONCR
0270/1665	LEN=0040 INSTALLED UNKN
0270/1340	ORCHARD DR
0270/0580	(TWP)
0270/0460	PARKRIDGE DR
0270/0250	(TWP)
055724 FT	MARYMOUNT DR
0270/0000	(TWP)
0260/0530	HARVARD DR
054829 FT	(TWP)
0260/0000	018 " DIA CIRC CONCR
0250/2560	LEN=0050 INSTALLED UNKN
0250/1805	1 0 00228 0 05 0618+95
0250/1450	RODI RD
0250/1280	(SR0791 SEG 0060/0738)
0250/1040	LENGTH(AH 0895 BK 3431)
0250/1000	DUFF RD
0250/0760	(TWP)
0250/0510	EVERNIA DR
0250/0310	(TWP)
0250/0280	LONG RD
	(SR2059 SEG 0030/3125)
	018 " DIA CIRC CONCR
	LEN=0050 INSTALLED UNKN
	BANYON DR
	(TWP)
	018 " DIA CIRC CONCR
	LEN=0099 INSTALLED UNKN
	018 " DIA CIRC CONCR
	LEN=0050 INSTALLED UNKN
	018 " DIA CIRC CONCR
	LEN=0060 INSTALLED UNKN
	JANICE DR
	(TWP)
	018 " DIA CIRC CONCR
	LEN=0036 INSTALLED UNKN

DIR: E TOTAL LEN: 18.931 MI. DIST: 11-1 SR: 400
 LEFT MUN: PENN HILLS T RIGHT MUN: PENN HILLS T

Location / Segment	Start Station	End Station	Length (FT)	Notes / Details
	051169		FT	
		051398	FT	1 0 00228 0 05 0584+82 HIGHLAND DR (TWP)
		0250/0000		LENGTH(AH 3431 BK 2222) 018 " DIA CIRC CONCR
		0240/2169		LEN=0050 INSTALLED UNKN 018 " DIA CIRC CONCR
		0240/1944		LEN=0050 INSTALLED UNKN
WILSON DR (TWP)	0240/1842			
ERHARDT DR (TWP)	0240/1341			
		0240/1215		018 " DIA CIRC CONCR LEN=0075 INSTALLED UNKN
		0240/1040		018 " DIA CIRC CONCR LEN=0050 INSTALLED UNKN
		0240/0580		018 " DIA CIRC CONCR LEN=0040 INSTALLED UNKN
VANCE ST (TWP)	0240/0333			
	048947		FT	
		0240/0225		018 " DIA CIRC CONCR LEN=0060 INSTALLED UNKN
		049176	FT	1 0 00228 0 05 0562+37 RITZLAND RD (TWP)
		0240/0000		LENGTH(AH 2222 BK 1425) 018 " DIA CIRC CONCR
		0230/1004		LEN=0050 INSTALLED UNKN
TO 0130/0122 SH (CONN)	0230/0579			
		0230/0500		PENNOAK DR (TWP) BEULAH RD (SR0130 SEG 0132/0000)
COAL HOLLOW RD (SR0130 SEG 0132/0000)	0230/0385			
	047522		FT	
		0230/0385		LAKETON RD (CNTY) LC TO LAKETON RD (CONN)
		0230/0200		1 0 00228 0 05 0548+15 NELBON AV (TWP)
		0230/0000		LENGTH(AH 1425 BK 2080) 018 " DIA CIRC CONCR
		0220/2010		LEN=0036 INSTALLED UNKN 018 " DIA CIRC CONCR
		0220/1805		LEN=0040 INSTALLED UNKN 018 " DIA CIRC CONCR
		0220/1610		LEN=0036 INSTALLED UNKN

DIR: E TOTAL LEN: 18.931 MI. DIST: 11-1 SR: 400
 LEFT MUN: PENN HILLS T RIGHT MUN: PENN HILLS T

Street Name	Segment	Length (FT)	Notes
DUFFIELD AV	0220/0835		(TWP)
	0220/0535		(TWP)
CRABHOLLOW RD	0220/0345		018 " DIA CIRC CONCR LEN=0036 INSTALLED UNKN
	0220/0205		018 " DIA CIRC CONCR LEN=0060 INSTALLED UNKN
	045442 FT	045671 FT	1 0 00228 0 05 0527+45 CURTIS ST
	0220/0000		(TWP) LENGTH(AH 2080 BK 1935) 018 " DIA CIRC CONCR
	0210/1763		LEN=0050 INSTALLED UNKN
MCCUTCHEON LN (TWP)	0210/0950		018 " DIA CIRC METAL LEN=0050 INSTALLED UNKN
	0210/0805		ORIN ST (TWP)
	0210/0775		
BON AIR RD (TWP)	0210/0510		018 " DIA CIRC CONCR LEN=0040 INSTALLED UNKN
	0210/0115		EVALINE ST (TWP)
	043507 FT	043736 FT	
1 0 00228 0 05 0508+06	0210/0000		(TWP) LENGTH(AH 1935 BK 0941) 018 " DIA CIRC CONCR
	0200/0595		LEN=0040 INSTALLED UNKN HOWARD ST
TREMONT ST (TWP)	0200/0560		(TWP)
	0200/0415		018 " DIA CIRC CONCR LEN=0040 INSTALLED UNKN
1 0 00228 0 05 0498+58	0200/0240		HENDERSON ST (TWP)
	0200/0200		012 " DIA CIRC CONCR LEN=0050 INSTALLED UNKN
	042566 FT	042795 FT	018 " DIA CIRC CONCR LEN=0040 INSTALLED UNKN
CHAMPA ST (TWP)	0200/0000		(TWP) LENGTH(AH 0941 BK 1064) LAVERN ST
	0190/0970		(TWP)
	0190/0955		018 " DIA CIRC CONCR LEN=0050 INSTALLED UNKN
	0190/0670		
			018 " DIA CIRC CONCR

DIR: E TOTAL LEN: 18.931 MI. DIST: 11-1 SR: 400
 LEFT MUN: PENN HILLS T RIGHT MUN: PENN HILLS T

Location / Segment	Stationing	Length	Notes
CLINTON DR (TWP)	0190/0400		
HOCHBERG RD (TWP)	0190/0205	041502 FT	
			0190/0618 LEN=0050 INSTALLED UNKN
			SAMPSON ST (TWP)
			0190/0460
			041731 FT 1 0 00228 0 04 0488+15
			PALM AV (TWP)
			MFC BEGIN = B
			0190/0000 LENGTH(AH 1064 BK 1304)
CONESTOGA RD (TWP)	0181/1190		0180/1190 CONESTOGA RD (TWP)
GRAHAM BL (TWP)	0181/0940		GRAHAM BL ET (TWP)
			0180/0935 GRAHAM BL (TWP)
			LC TO GRAHAM BL (CONN)
			0180/0755
			0180/0075 018 "DIA CIRC CONCR
			LEN=0100 INSTALLED UNKN
1 0 00228 0 04 0474+76 040217 FT			040427 FT 1 0 00228 0 04 0474+76
VERONA RD (SR2058 SEG 0050/0000)			VERONA RD (SR2058 SEG 0050/0000)
ROBINSON BL (SR2058 SEG 0050/0000)			ROBINSON BL (SR2058 SEG 0050/0000)
LENGTH(AH 1285 BK 1531)	0181/0000		0180/0000 LENGTH(AH 1304 BK 1533)
OVERBROOK RD (TWP)	0171/1176		0170/1188 OVERBROOK RD (TWP)
			0170/0769 PENN HILLS (CITY)
EASTWOOD RD (CITY)			PITTSBURGH C (CITY)
EASTHILLS DR (CITY)			EASTWOOD RD (CITY)
			EASTHILLS DR (CITY)
1 0 00228 0 04 0449+04 038686 FT	0171/0426		0170/0418 038894 FT 1 0 00228 0 04 0451+12
TEXAS ST (CITY)			TEXAS ST (CITY)
LENGTH(AH 1531 BK 2250)	0171/0000		0170/0000 LENGTH(AH 1533 BK 2244)
EYMARD ST (CITY)	0163/1781		EYMARD ST (CITY)
WOODS AV (CITY)	0163/1476		WOODS AV (CITY)
			0162/1797
			0162/1482

DIR: E TOTAL LEN: 18.931 MI. DIST: 11-1 SR: 400
 LEFT MUN: PITTSBURGH C RIGHT MUN: PITTSBURGH C

Location / Description	Segment ID	Length (FT)	Material / Notes
MADONNA ST (CITY)	0162/1008	0050	018 "DIA CIRC CONCR INSTALLED UNKN
WILKINSBURG AV (CITY)	0162/0939		MADONNA ST (CITY)
	0163/0667		WILKINSBURG AV (CITY)
PENN HILLS PITTSBURGH C	0162/0657		PITTSBURGH PENN HILLS T
	0163/0641		NC FRANKSTOWN RD PENN HILLS PITTSBURGH C
018 "DIA CIRC CONCR LEN=0050 INSTALLED UNKN	0163/0320	036436	036650 FT 0 0 00000 0 00 0000+00
STANDARD AV (CITY)			STANDARD AV (CITY)
MFC BEGIN = B LTH AH 002250 BK 001215	0162/0000	2244	MFC BEGIN = B LENGTH(AH 2244 BK 1215)
	0160/1157		EXLEY WY (CITY)
FRANKSTOWN AV (CITY)	0160/0386		
	035221	FT	DORNBUSH ST (CITY)
	0160/0329	035435	1 0 00228 0 04 0424+45
TOKAY ST (CITY)			TOKAY ST (CITY)
CONEMAUGH ST (CITY)	0160/0000		NC FRANKSTOWN AV
LC FROM CONEMAUGH ST (CONN)	0150/1150		LENGTH(AH 1215 BK 1400)
	0150/1030		
	0150/0745		018 "DIA CIRC CONCR INSTALLED UNKN
WHEELER ST (CITY)	0150/0396		BATIVA ST (CITY)
	0150/0175		TYSON WY (CITY)
	0150/0040	034035	018 "DIA CIRC CONCR INSTALLED UNKN
	033821	FT	1 0 00228 0 04 0410+87

DIR: E TOTAL LEN: 18.931 MI. DIST: 11-1 SR: 400
 LEFT MUN: PITTSBURGH C RIGHT MUN: PITTSBURGH C

032441 FT

LC TO MURTLAND AV
 (CONN)

0130/0040
 028486 FT

FRANKSTOWN AV
 (CITY)

0130/0000

		OAKWOOD ST (CITY)
5	0150/0000	LENGTH(AH 1400 BK 1380) HALE ST (CITY)
	0140/1040	
	0140/0725	NEUMAN WY (CITY)
		BRUSHTON AV (CITY)
	0140/0560	
	0140/0395	DURANGO WY (CITY)
	032655 FT	1 0 00228 0 04 0397+14 BRADDOCK AV (CITY)
5	0140/0000	LENGTH(AH 1380 BK 3955) COLLIER ST (CITY)
	0130/3420	
		STERRETT ST (CITY)
	0130/2765	
	0130/2295	ZENITH WY (CITY)
		HOMEWOOD AV (CITY)
	0130/2145	
	0130/1985	NADIR WY (CITY)
	0130/1645	BENNETT PL (CITY)
		LANG AV (CITY)
	0130/1490	
		MURTLAND ST (CITY)
	0130/0740	
	0130/0063	018 "DIA CONC LEN=0050 INSTALLED UNKN
	028700 FT	1 0 00228 0 04 0357+50 NC BENNETT ST
		MFC BEGIN = B
5	0130/0000	LENGTH(AH 3955 BK 2652)

SIMONTON ST
(CITY)

0120/1400

025834 FT

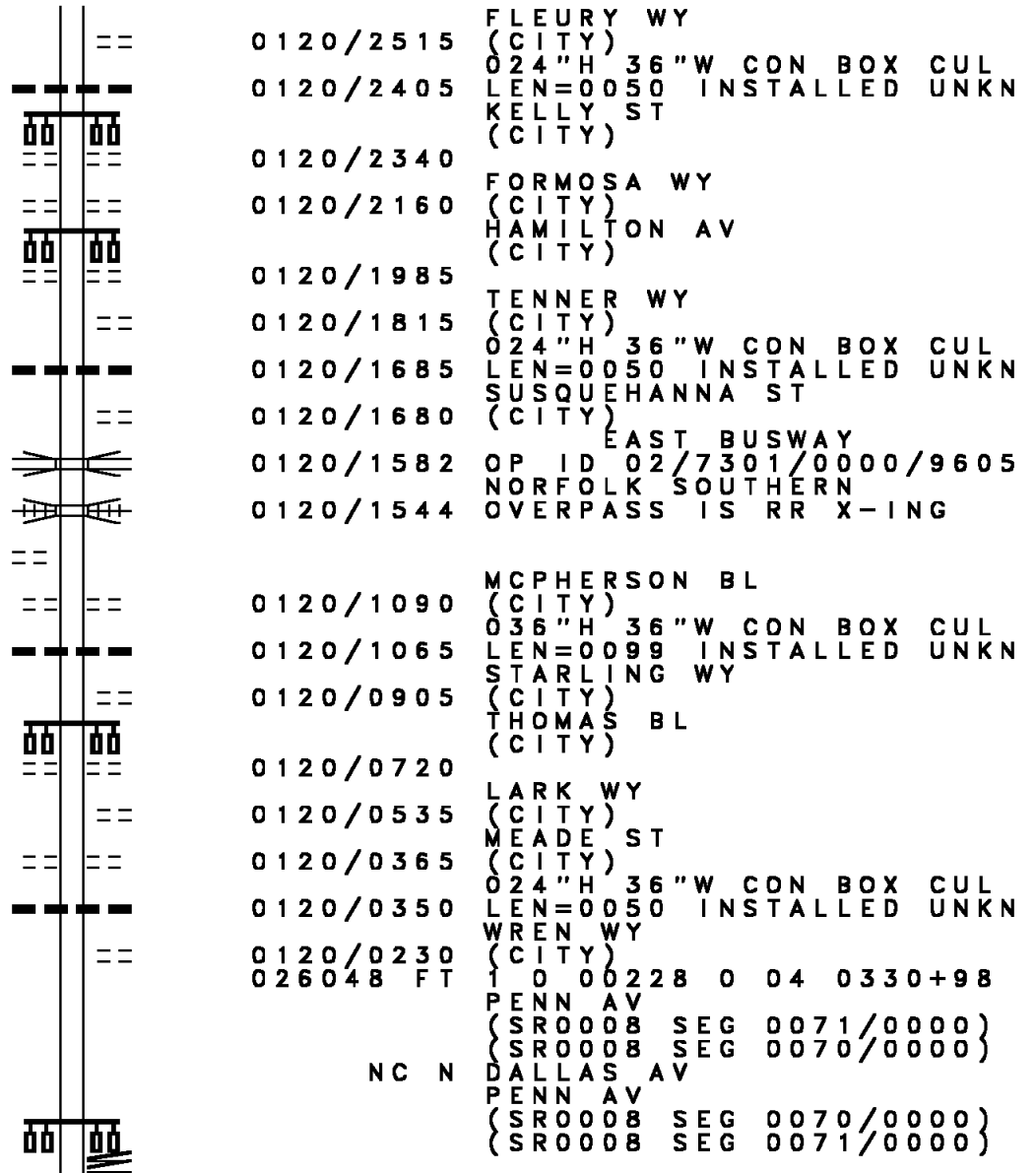

0120/2515 FLEURY WY
(CITY)
024"H 36"W CON BOX CUL
0120/2405 LEN=0050 INSTALLED UNKN
KELLY ST
(CITY)
0120/2340 FORMOSA WY
(CITY)
0120/2160 HAMILTON AV
(CITY)
0120/1985 TENNER WY
(CITY)
0120/1815 024"H 36"W CON BOX CUL
0120/1685 LEN=0050 INSTALLED UNKN
SUSQUEHANNA ST
(CITY)
0120/1680 EAST BUSWAY
0120/1582 OP ID 02/7301/0000/9605
NORFOLK SOUTHERN
0120/1544 OVERPASS IS RR X-ING
MCPHERSON BL
(CITY)
0120/1090 036"H 36"W CON BOX CUL
0120/1065 LEN=0099 INSTALLED UNKN
STARLING WY
(CITY)
0120/0905 THOMAS BL
(CITY)
0120/0720 LARK WY
(CITY)
0120/0535 MEADE ST
(CITY)
0120/0365 024"H 36"W CON BOX CUL
0120/0350 LEN=0050 INSTALLED UNKN
WREN WY
(CITY)
0120/0230 1 0 00228 0 04 0330+98
026048 FT
PENN AV
(SRO008 SEG 0071/0000)
(SRO008 SEG 0070/0000)
NC N DALLAS AV
PENN AV
(SRO008 SEG 0070/0000)
(SRO008 SEG 0071/0000)

EXTRACT DATE: 12/21/2020
PRINT DATE: 12/23/2020

ROADWAY MANAGEMENT SYSTEM
SLD COUNTY/SR - ANNUAL PRINT

PAGE NUMBER: 397
COUNTY: ALLEGHENY

DIR: E TOTAL LEN: 18.931 MI.
LEFT MUN: PITTSBURGH C

DIST: 11-1 SR: 400
RIGHT MUN: PITTSBURGH C

LTH AH 001422 BK 001135 025834 FT
PENN AV 7107/0000
(SR0008 SEG 0081/0000) INTER-AHD
FIFTH AV
(SR0008 SEG 0080/0000)
(SR0008 SEG 0081/0000)

FIFTH AV
(CITY) 0097/1135

1 0 00228 0 04 0289+69 024699 FT
PUTNAM ST
(GOVT)
LENGTH(AH 1135 BK 2635) 0097/0000

018 "DIA CIRC CONCR
LEN=0060 INSTALLED UNKN 0091/1970
(APRA) BAKERY SQUARE
LIBERTY BL
(CITY)
FLORENCE REIZENSTEIN HS
(PRDR)

018 "DIA CIRC CONCR
LEN=0001 INSTALLED UNKN 0091/1895
VILLAGE OF EAST SIDE PZ 0091/1773
(PRDR)

018 "DIA CIRC CONCR
LEN=0060 INSTALLED UNKN 0091/1455
018 "DIA CIRC CONCR
LEN=0050 INSTALLED UNKN 0091/1186
018 "DIA CIRC CONCR
LEN=0060 INSTALLED UNKN 0091/1140
018 "DIA CIRC CONCR
LEN=0060 INSTALLED UNKN 0091/0840

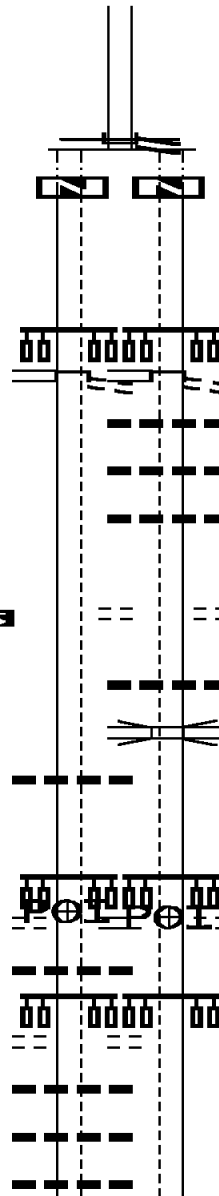

0120/0000
026048 FT
7100/0000
INTER-AHD

INTER-BK

0096/1121
0096/0569
0096/0300
0096/0051
024927 FT

0096/0000
0090/2017
0090/2000

0090/1876
0090/1432

SOUTH DALLAS AV
(SR2108 SEG 0150/1995)
PENN AV
(SR0008 SEG 0070/0000)
MFC BEGIN = C
LTH AH 002652 BK 001511
LTH AH 001511 BK 001121
PENN AV
(SR0008 SEG 0080/0000)
FIFTH AV
(SR0008 SEG 0080/0000)
(SR0008 SEG 0081/0000)

FIFTH AV
(CITY)
018 "DIA CIR PLASTIC
LEN=0024 INSTALLED UNKN
018 "DIA CIR PLASTIC
LEN=0024 INSTALLED UNKN
015 "DIA CIRC CONCR
LEN=0099 INSTALLED UNKN
0 0 00000 0 00 0000+00
PUTNAM ST
(GOVT)
LENGTH(AH 1121 BK 2649)

018 "DIA CIR UNKNOWN
LEN=0099 INSTALLED UNKN
OP ID 02/0400/0090/2000

(APRA) BAKERY SQUARE
LIBERTY BL
(CITY)
FLORENCE REIZENSTEIN HS
(PRDR)

VILLAGE OF EAST SIDE PL
(PRDR)

EXTRACT DATE: 12/21/2020
PRINT DATE: 12/23/2020

ROADWAY MANAGEMENT SYSTEM
SLD COUNTY/SR - ANNUAL PRINT

PAGE NUMBER: 396
COUNTY: ALLEGHENY

DIR: E TOTAL LEN: 18.931 MI.
LEFT MUN: PITTSBURGH C

DIST: 11-1 SR: 400
RIGHT MUN: PITTSBURGH C

SHADY AV
(CITY)
BMS EN 02/7301/0000/9002 0091/0650
LEN=0050 INSTALLED UNKN 0091/0601
0 0 00000 0 00 0000+00 0091/0600
NORFOLK SOUTHERN RAI RR
BMSBG 02/7301/0000/9002 0091/0475
SPIRIT ST
(CITY) 0091/0340
1 0 00228 0 03 0297+15 022064 FT
CENTRE AV
(TBC)
NC PENN AV
PENN AVE
(CITY)
MFC BEGIN = B
LTH AH 002635 BK 000835 0091/0000
SHERIDAN SQ
(CITY) 0082/0346
HIGHLAND AV
(CITY) 0082/0140
021229 FT
LTH AH 000955 BK 001552 021229 FT
7073/0000
BAUM BL INTER-AHD
(CITY)
CENTRE AV
(CITY)
S EUCLID AV
(CITY)
LC FROM S EUCLID AV
(CONN) 0071/1552
0071/1456

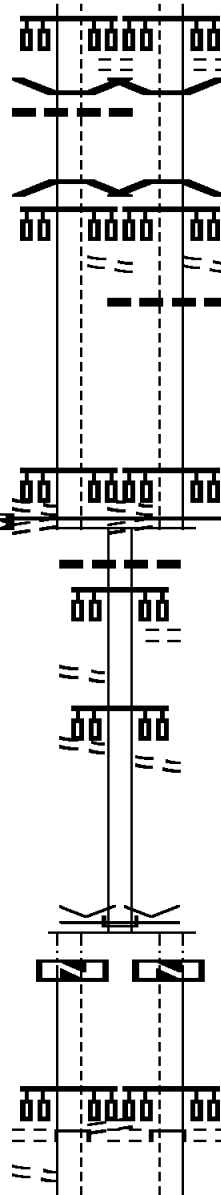

SHADY AV
(CITY)
0090/0618
0090/0549 BMS EN 02/7301/0000/9002
1 0 00228 0 03 0297+15
NORFOLK SOUTHERN RAI RR
BMSBG 02/7301/0000/9002
0090/0423
SPIRIT ST
(CITY) 0090/0298
036"H 01"W ELLIP CONC
LEN=0024 INSTALLED UNKN
022278 FT 1 0 00228 0 03 0297+15
CENTRE AV
(TBC)
NC PENN AV
PENN AVE
(CITY)
MFC BEGIN = B
LENGTH(AH 2649 BK 0835)
018 " DIA CIRC OTHER
LEN=0001 INSTALLED UNKN
ANNIE PL
(CITY)
0082/0499
0082/0474
HIGHLAND AV
(CITY) 0082/0140
021443 FT 1 0 00228 3 00 0000+00
VILLAGE: PITTSBURGH C
NC CENTRE AV
INTER-BK
(CITY)
MFC BEGIN = B
LTH AH 000835 BK 001449
0082/0000
021443 FT
7072/0000
LTH AH 001449 BK 001548
INTER-AHD
BAUM BL
(CITY)
S EUCLID AV
(CITY)
CENTRE AV
(CITY)
0070/1548

EXTRACT DATE: 12/21/2020
PRINT DATE: 12/23/2020

ROADWAY MANAGEMENT SYSTEM
SLD COUNTY/SR - ANNUAL PRINT

PAGE NUMBER: 395
COUNTY: ALLEGHENY

DIR: E TOTAL LEN: 18.931 MI.
LEFT MUN: PITTSBURGH C

DIST: 11-1 SR: 400
RIGHT MUN: PITTSBURGH C

Stationing	Material	Notes	Left Side	Right Side
018 "DIA CIRC CONCR LEN=0050 INSTALLED UNKN 0071/1355			---	---
018 "DIA CIRC CONCR LEN=0050 INSTALLED UNKN 0071/1100			---	---
ST CLAIR ST (CITY) 0071/1055			" "	" "
STAMAR WY (CITY) 0071/0880			" "	" "
AMBER ST (CITY) 0071/0795			" "	" "
018 "DIA CIRC CONCR LEN=0050 INSTALLED UNKN 0071/0560			---	---
RAVOUX WY (CITY) 0071/0470			" "	" "
NEGLEY AV (CITY) 0071/0230			" "	" "
1 0 00228 0 03 0237+36 019677 FT				
ROUP AV (CITY) 0071/0000			" "	" "
LENGTH(AH 1552 BK 2477)				
DAPPER WY (CITY) 0061/2315			" "	" "
FAIRMOUNT ST (CITY) 0061/2126			" "	" "
GRAHAM ST (CITY) 0061/1800			" "	" "
GRAHAM ST (CITY) 0061/1723			" "	" "
VINTAGE WY (CITY) 0061/1513			" "	" "
AIKEN AV (CITY) 0061/1315			" "	" "
AIKEN AV (CITY)			" "	" "
ATLANTIC AV (CITY)			" "	" "
LIBERTY AV (CITY)			" "	" "
LIBERTY AV (CITY)			" "	" "
ST CLAIR ST (CITY) 0070/1050				" "
STAMAR WY (CITY) 0070/0870				" "
AMBER ST (CITY) 0070/0796				" "
018 "DIA CIRC CONCR LEN=0100 INSTALLED UNKN 0070/0700				---
RAVOUX WY (CITY) 0070/0466				" "
NEGLEY AV (CITY) 0070/0222			" "	" "
NEGLEY AV (CITY) 0070/0221			" "	" "
1 0 00228 0 03 0237+36 019895 FT				
ROUP AV (CITY) 0070/0000			" "	" "
LENGTH(AH 1548 BK 2484)				
DAPPER WY (CITY) 0060/2297			" "	" "
FAIRMOUNT ST (CITY) 0060/2130			" "	" "
GRAHAM ST (CITY) 0060/1780			" "	" "
GRAHAM ST (CITY) 0060/1722			" "	" "
VINTAGE WY (CITY) 0060/1500			" "	" "
AIKEN AV (CITY) 0060/1290			" "	" "
AIKEN AV (CITY)			" "	" "
ATLANTIC AV (CITY)			" "	" "
LIBERTY AV (CITY)			" "	" "
LIBERTY AV (CITY)			" "	" "

EXTRACT DATE: 12/21/2020
PRINT DATE: 12/23/2020

ROADWAY MANAGEMENT SYSTEM
SLD COUNTY/SR - ANNUAL PRINT

PAGE NUMBER: 394
COUNTY: ALLEGHENY

DIR: E TOTAL LEN: 18.931 MI.
LEFT MUN: PITTSBURGH C

DIST: 11-1 SR: 400
RIGHT MUN: PITTSBURGH C

Address	Stationing	Notes	Stationing	Address
POWHATTAN ST (CITY)	0061/0975		0060/0965	POWHATTAN ST (CITY)
CYPRESS ST (CITY)	0061/0630		0060/0625	CYPRESS ST (CITY)
CYPRESS ST (CITY)				CYPRESS ST (CITY)
WOODWORTH ST (CITY)	0061/0285		0060/0280	WOODWORTH ST (CITY)
LENGTH(AH 2477 BK 3005)	0061/0000		0060/0000	LENGTH(AH 2484 BK 2985)
BMSBG 02/7301/0000/3008	0051/2919		0050/2924	BMSBG 02/7301/0000/3008
018 "DIA CIRC CONCR				024 "DIA CIRC CONCR
LEN=0050 INSTALLED UNKN	0051/2825		0050/2735	LEN=0050 INSTALLED UNKN
NORFOLK SOUTHERN RAI RR				1 0 00228 0 03 0189+56
BMSBG 02/7301/0000/3008	0051/2549		0050/2554	NORFOLK SOUTHERN RAI RR
MOREWOOD AV (CITY)				BMSBG 02/7301/0000/3008
018 "DIA CIRC CONCR				MOREWOOD AV (CITY)
LEN=0050 INSTALLED UNKN	0051/2316		0050/2300	
BROUGHTN ST (CITY)	0051/2280			BROUGHTON ST (CITY)
MILLVALE AV (CITY)	0051/1885		0050/1885	MILLVALE AV (CITY)
	0051/1585		0050/1580	
ENFIELD ST (CITY)				018 "DIA CIRC METAL
BMSBG 02/0400/0050/0673	0051/1075		0050/1110	LEN=0050 INSTALLED UNKN
1 0 00228 0 03 0189+56	0051/0958		0050/1075	ENFIELD ST (CITY)
PAT BUSWAY			0050/0955	BMSBG 02/0400/0050/0673
BMSBG 02/0400/0050/0673	0051/0648		0050/0645	1 0 00228 0 03 0182+81
MELWOOD AV (CITY)				PAT BUSWAY
MELWOOD AV (CITY)				BMSBG 02/0400/0050/0673
	0051/0394		0050/0390	MELWOOD AV (CITY)
	0051/0374			MELWOOD AV (CITY)
GOLD WY (CITY)				GOLD WY (CITY)
GOLD WY (CITY)				GOLD WY (CITY)
GOLD WY (CITY)	0051/0200		0050/0195	GOLD WY (CITY)

DIR: E TOTAL LEN: 18.931 MI. DIST: 11-1 SR: 400
 LEFT MUN: PITTSBURGH C RIGHT MUN: PITTSBURGH C

Stationing	Description	Notes	Stationing	Description	Notes
0 0 00000 0 00 0000+00 014195 FT	CRAIG ST (CITY)		014426 FT 1 0 00228 0 03 0182+81	CRAIG ST (CITY)	
NC BAUM BL			NC BAUM BL		
LENGTH(AH 3005 BK 2783) 0051/0000			LENGTH(AH 2985 BK 2737) 0050/0000		
			036 "DIA CIRC CONCR		
			LEN=0024 INSTALLED UNKN		
BIGELOW BL (CITY)	0031/1615		BIGELOW BL (CITY)		
			NC CRAIG ST		
SIGN: CANTILEVER			0030/1506		
BMSID 02/0400/0031/1025	0031/1025		0030/1080		
036 "DIA CIRC METAL			018 "DIA CIRC CONCR		
LEN=0099 INSTALLED UNKN	0031/0810		LEN=0099 INSTALLED UNKN		
LC FROM LIBERTY AV (CONN)	0031/0800				
LC TO LIBERTY AV (CONN)			BLESSING ST (CITY)		
BLOOMFIELD BR (CITY)	0031/0700		BLOOMFIELD BR (CITY)		
LC TO BLOOMFIELD BR (CONN)					
PEDESTRIAN			PEDESTRIAN		
OP ID 02/0400/0030/0550	0031/0565		OP ID 02/0400/0030/0550		
			SIGN STRUCTURE		
			BMSID 02/0400/0030/0038		
			018 "DIA CIRC CONCR		
			LEN=0099 INSTALLED UNKN		
1 0 00228 0 02 0154+68 011412 FT			0030/0155		
LENGTH(AH 2783 BK 2001) 0031/0000			011689 FT		
			0030/0000		
			LENGTH(AH 2737 BK 2061)		
			LC TO CONN RD (CITY)		
PEDESTRIAN WALKWAY			PEDESTRIAN WALKWAY		
OP ID 02/0400/0020/1785	0021/1728		OP ID 02/0400/0020/1785		
			SIGN: STRUC MOUNTED		
FINLAND ST (CITY)	0021/1703		BMSID 02/0400/0020/1795		
			SIGN: CANTILEVER		
			BMSID 02/0400/0020/0955		
			018 "DIA CIRC CONCR		
HANCOCK ST (CITY)	0021/0415		LEN=0050 INSTALLED UNKN		

DIR: E TOTAL LEN: 18.931 MI. DIST: 11-1 SR: 400
LEFT MUN: PITTSBURGH C RIGHT MUN: PITTSBURGH C

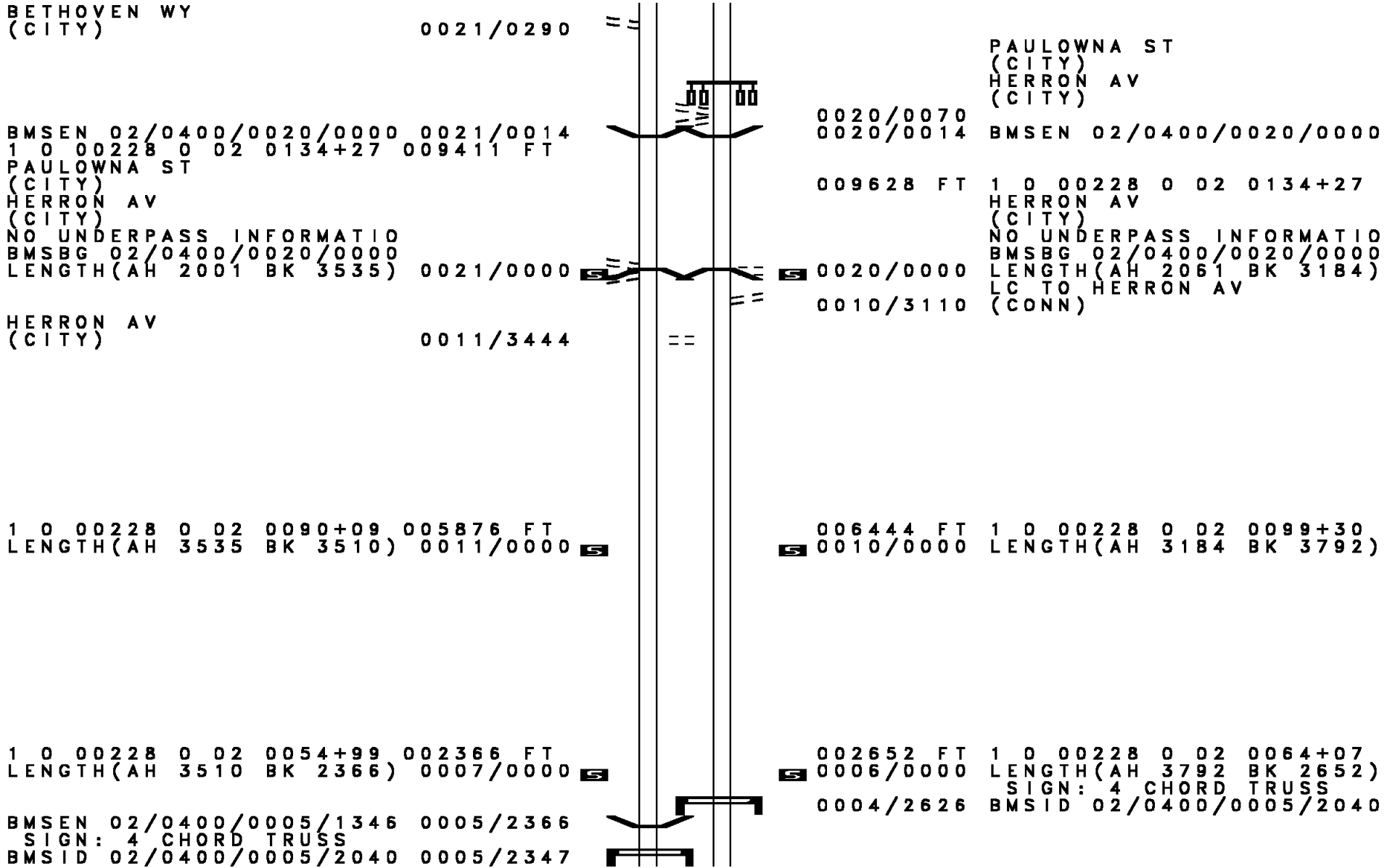

EXTRACT DATE: 12/21/2020 ROADWAY MANAGEMENT SYSTEM PAGE NUMBER: 390
 PRINT DATE: 12/23/2020 SLD COUNTY/SR - ANNUAL PRINT COUNTY: ALLEGHENY
 DIR: E TOTAL LEN: 35.461 MI. DIST: 11-1 SR: 376
 LEFT MUN: MONROEVILLE B RIGHT MUN: MONROEVILLE B

SIGN: 4 CHORD TRUSS
 BMSID 02/2048/0120/0596 186763 FT
 PENN LINCOLN PY INTER-AHD
 (SR0022 SEG 0251/0000)
 WILLIAM PENN HW
 (SR2048 SEG 0121/0760) 0845/0334

 0 0 00000 0 00 0000+00 186429 FT
 LENGTH(AH 0334 BK 2784) 0845/0000

 TURNPIKE RAMP RD
 (TNPK) 0841/2261

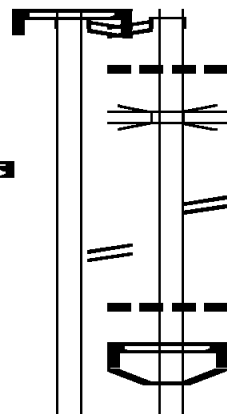

187235 FT
 INTER-AHD
 0844/0798
 0844/0250
 0844/0241
 186437 FT
 0844/0000
 0840/2511

 0840/2286
 0840/2205
 0840/1977

 PENN LINCOLN PY
 (SR0022 SEG 0250/0000)
 WILLIAM PENN HW
 (SR2048 SEG 0120/0600)
 018"H 18"W ELLIP CONC
 LEN=0024 INSTALLED UNKN
 I-76
 OP ID 02/7076/9900/5635
 0 0 00000 0 00 0000+00
 LENGTH(AH 0798 BK 2640)
 TURNPIKE RAMP RD
 (TNPK)

 018 " DIA CIRC CONCR
 LEN=0099 INSTALLED UNKN
 SIGN: 4 CHORD TRUSS
 BMSID 02/0376/0840/2205
 BMSSEN 02/0376/0840/1706
 0 0 00000 0 0 0000+00

EXTRACT DATE: 12/21/2020
PRINT DATE: 12/23/2020

ROADWAY MANAGEMENT SYSTEM
SLD COUNTY/SR - ANNUAL PRINT

PAGE NUMBER: 389
COUNTY: ALLEGHENY

DIR: E TOTAL LEN: 35.461 MI.
LEFT MUN: MONROEVILLE B

DIST: 11-1 SR: 376
RIGHT MUN: MONROEVILLE B

RAMP L RD
(SR8022 SEG 0260/0739) 0841/1334

BMSID 02/0376/0841/0913 0841/0913
0 00000 0 0 0000+00
SR 2057 NB
BMSBG 02/0376/0841/0913 0841/0808

RAMP J RD
(SR8022 SEG 0250/0451) 0841/0321
SIGN: 4 CHORD TRUSS
BMSID 02/0376/0840/0184 0841/0191
0 0 00000 0 00 0000+00 183645 FT
MILEPOST 084.00
LENGTH(AH 2784 BK 2694) 0841/0000

018 "DIA CIRC CONCR
LEN=0099 INSTALLED UNKN 0835/2060
LEAK RUN
STRUCTURE LENGTH 10 FT
BMSID 02/0376/0835/1945 0835/1935
012 "DIA CIRC CONCR
LEN=0030 INSTALLED UNKN 0835/1828

018 "DIA CIRC CONCR
LEN=0099 INSTALLED UNKN 0835/1539

BMSID 02/0376/0834/0952 0835/1217
018 "DIA CIRC CONCR
LEN=0099 INSTALLED UNKN 0835/1007
0 00000 0 0 0000+00
OLD WM.PENN
BMSBG 02/0376/0834/0952 0835/0996

018 "DIA CIRC CONCR
LEN=0099 INSTALLED UNKN 0835/0253
0 0 00000 0 00 0000+00 180951 FT
LENGTH(AH 2694 BK 2661) 0835/0000

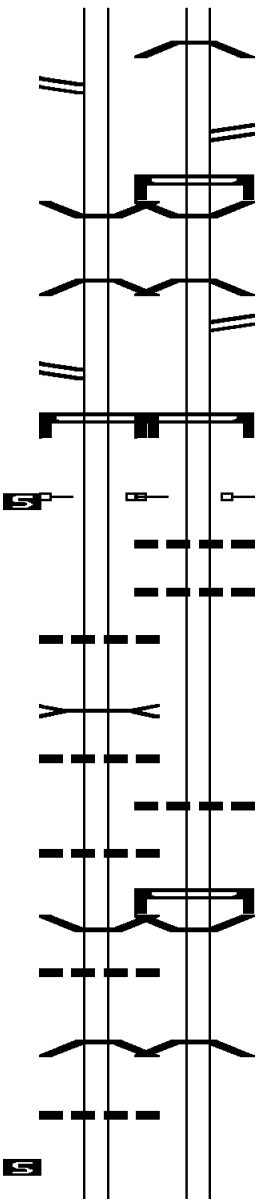

0840/1706 SR 2048 WB
BMSBG 02/0376/0840/1706

0840/1336 RAMP M RD
(SR8022 SEG 0020/0000)
SIGN: 4 CHORD TRUSS

0840/1278 BMSID 02/0376/0840/1278
0840/0988 BMSID 02/0376/0840/0872
0 00000 0 0 0000+00

0840/0872 SR 2057 NB
BMSBG 02/0376/0840/0872
0840/0495 RAMP K RD
(SR8022 SEG 0010/0000)

0840/0184 SIGN: 4 CHORD TRUSS
BMSID 02/0376/0840/0184
0 0 00000 0 00 0000+00
183797 FT MILEPOST 084.00

0840/0000 LENGTH(AH 2640 BK 2640)
018 "DIA CIRC CONCR

0834/2578 LEN=0099 INSTALLED UNKN
024"H 24"W CON BOX CUL
0834/2045 LEN=0024 INSTALLED UNKN

0834/1756 018 "DIA CIRC CONCR
LEN=0099 INSTALLED UNKN

0834/1383 SIGN: CANTILEVER
BMSID 02/0376/0834/1383
0834/1173 BMSID 02/0376/0834/0952

0834/0952 0 00000 0 0 0000+00
OLD WM.PENN
BMSBG 02/0376/0834/0952

181157 FT 0 0 00000 0 00 0000+00
0834/0000 LENGTH(AH 2640 BK 2640)
018 "DIA CIRC CONCR

EXTRACT DATE: 12/21/2020
PRINT DATE: 12/23/2020

ROADWAY MANAGEMENT SYSTEM
SLD COUNTY/SR - ANNUAL PRINT

PAGE NUMBER: 388
COUNTY: ALLEGHENY

DIR: E TOTAL LEN: 35.461 MI.
LEFT MUN: MONROEVILLE B

DIST: 11-1 SR: 376
RIGHT MUN: MONROEVILLE B

Item ID	Description	Stationing	Length	Material	Status
018 "DIA CIRC CONCR		0831/2431	0.099	INSTALLED	UNKN
OP ID 02/2099/0010/0000	GARDEN CITY	0831/2272			
024 "DIA CIRC CONCR		0831/1500	0.060	INSTALLED	UNKN
024 "DIA CIRC CONCR		0831/1200	0.060	INSTALLED	UNKN
BMSEN 02/0376/0830/0726		0831/0930			
0 00000 0 0 0000+00	OLD W. PENN HIGHWAY	0831/0706			
BMSBG 02/0376/0830/0726		0831/0436			
018 "DIA CIRC CONCR		0831/0168	0.168	INSTALLED	UNKN
0 0 00000 0 00 0000+00	178290 FT				
MILEPOST 083.00					
LENGTH(AH 2661 BK 2641)		0831/0000			
018 "DIA CIRC CONCR		0825/2514	0.099	INSTALLED	UNKN
0830/2614			0.099	INSTALLED	UNKN
018 "DIA CIRC CONCR			0.099	INSTALLED	UNKN
0830/2427			0.099	INSTALLED	UNKN
OP ID 02/2099/0010/0000	GARDEN CITY	0830/2242			
SIGN: STRUC MOUNTED					
BMSID 02/2099/0010/0010		0830/2214			
024"H 24"W CON BOX CUL					
018 "DIA CIRC CONCR		0830/2150	0.050	INSTALLED	UNKN
018 "DIA CIRC CONCR		0830/2128	0.099	INSTALLED	UNKN
018 "DIA CIRC CONCR		0830/1828	0.099	INSTALLED	UNKN
024"H 24"W CON BOX CUL					
018 "DIA CIRC CONCR		0830/1789	0.060	INSTALLED	UNKN
018 "DIA CIRC CONCR		0830/1584	0.099	INSTALLED	UNKN
024"H 24"W CON BOX CUL					
018 "DIA CIRC CONCR		0830/1494	0.060	INSTALLED	UNKN
018 "DIA CIRC CONCR		0830/1235	0.099	INSTALLED	UNKN
024"H 24"W CON BOX CUL					
018 "DIA CIRC CONCR		0830/1195	0.040	INSTALLED	UNKN
BMSEN 02/0376/0830/0726		0830/0950			
024"H 24"W CON BOX CUL					
0 00000 0 0 0000+00	OLD W. PENN HIGHWAY				
BMSBG 02/0376/0830/0726		0830/0726			
024"H 24"W CON BOX CUL					
018 "DIA CIRC CONCR		0830/0400	0.060	INSTALLED	UNKN
024"H 24"W CON BOX CUL					
018 "DIA CIRC CONCR		0830/0133	0.060	INSTALLED	UNKN
0 0 00000 0 00 0000+00	178517 FT				
MILEPOST 083.00					
LENGTH(AH 2640 BK 2641)		0830/0000			
024"H 24"W CON BOX CUL					
018 "DIA CIRC CONCR		0824/2442	0.160	INSTALLED	UNKN

DIR: E TOTAL LEN: 35.461 MI. DIST: 11-1 SR: 376
 LEFT MUN: MONROEVILLE B RIGHT MUN: MONROEVILLE B

018 "DIA CIRC CONCR LEN=0099 INSTALLED UNKN	0825/2252	0824/2263	018 "DIA CIRC CONCR LEN=0012 INSTALLED UNKN
		0824/2219	024"H 24"W CON BOX CUL LEN=0070 INSTALLED UNKN
		0824/1922	018 "DIA CIRC CONCR LEN=0030 INSTALLED UNKN
018 "DIA CIRC CONCR LEN=0099 INSTALLED UNKN	0825/1700	0824/1891	024"H 24"W CON BOX CUL LEN=0036 INSTALLED UNKN
		0824/1674	018 "DIA CIRC CONCR LEN=0048 INSTALLED UNKN
		0824/1651	024"H 24"W CON BOX CUL LEN=0060 INSTALLED UNKN
018 "DIA CIRC CONCR LEN=0099 INSTALLED UNKN	0825/1359	0824/1374	018 "DIA CIRC CONCR LEN=0048 INSTALLED UNKN
		0824/1326	024"H 24"W CON BOX CUL LEN=0060 INSTALLED UNKN
		0824/1057	024"H 24"W CON BOX CUL LEN=0060 INSTALLED UNKN
		0824/1055	018 "DIA CIRC CONCR LEN=0002 INSTALLED UNKN
		0824/0773	018 "DIA CIRC CONCR LEN=0060 INSTALLED UNKN
		0824/0470	024"H 24"W ELLIP CONC LEN=0036 INSTALLED UNKN
0 0 00000 0 00 0000+00 175649 FT LENGTH(AH 2641 BK 2613)	0825/0000	0824/0207	024"H 24"W ELLIP CONC LEN=0050 INSTALLED UNKN
		175876 FT	0 0 00000 0 00 0000+00
		0824/0000	LENGTH(AH 2641 BK 2640)
		0820/2629	018 "DIA CIRC CONCR LEN=0011 INSTALLED UNKN
		0820/2600	024"H 24"W CON BOX CUL LEN=0036 INSTALLED UNKN
		0820/2252	024"H 24"W ELLIP CONC LEN=0036 INSTALLED UNKN
		0820/2239	018 "DIA CIRC CONCR LEN=0013 INSTALLED UNKN
		0820/1955	024"H 24"W CON BOX CUL LEN=0048 INSTALLED UNKN
		0820/1937	018 "DIA CIRC CONCR LEN=0018 INSTALLED UNKN
018 "DIA CIRC CONCR LEN=0099 INSTALLED UNKN	0821/1531		
MONROEVILLE			MONROEVILLE
PENN HILLS T	0821/1444	0820/1480	PENN HILLS T

EXTRACT DATE: 12/21/2020
PRINT DATE: 12/23/2020

ROADWAY MANAGEMENT SYSTEM
SLD COUNTY/SR - ANNUAL PRINT

PAGE NUMBER: 386
COUNTY: ALLEGHENY

DIR: E TOTAL LEN: 35.461 MI.
LEFT MUN: MONROEVILLE B

DIST: 11-1 SR: 376
RIGHT MUN: MONROEVILLE B

Item Description	Stationing	Structure/Feature	Material	Length	Notes
018 "DIA CIRC CONCR LEN=0099 INSTALLED UNKN	0821/1176	--- ---	CON	0036	BOX CUL
BMSID 02/0376/0820/0342	0821/1050	~ ~	CON	0036	BOX CUL
0 00000 0 0 0000+00 THOMPSON RUN ROAD	0821/0344	~ ~	CON	0036	BOX CUL
BMSBG 02/0376/0820/0342	0821/0344	~ ~	CON	0036	BOX CUL
BR. THOMPSON STRUCTURE LENGTH 10 FT	0821/0084	> <	CON	0036	BOX CUL
BMSID 02/0376/0820/0080	0821/0084	> <	CON	0036	BOX CUL
0 0 00000 0 00 0000+00 173036 FT MILEPOST 082.00	0821/0000	--- ---	CON	0036	BOX CUL
LENGTH(AH 2613 BK 2640)	0821/0000	--- ---	CON	0036	BOX CUL
018 "DIA CIRC CONCR LEN=0060 INSTALLED UNKN	0815/1994	--- ---	CON	0036	BOX CUL
0814/1946	0814/1946	--- ---	CON	0036	BOX CUL
0814/1266	0814/1266	--- ---	CON	0036	BOX CUL
0814/0980	0814/0980	--- ---	CON	0036	BOX CUL
0814/0695	0814/0695	--- ---	CON	0036	BOX CUL
0814/0690	0814/0690	--- ---	CON	0036	BOX CUL
018 "DIA CIRC CONCR LEN=0099 INSTALLED UNKN	0815/0402	--- ---	CON	0036	BOX CUL
0814/0390	0814/0390	--- ---	CON	0036	BOX CUL
018 "DIA CIRC CONCR LEN=0020 INSTALLED UNKN	0815/0132	--- ---	CON	0036	BOX CUL
0814/0370	0814/0370	--- ---	CON	0036	BOX CUL
0814/0114	0814/0114	--- ---	CON	0036	BOX CUL
0814/0090	0814/0090	--- ---	CON	0036	BOX CUL
0 0 00000 0 00 0000+00 170396 FT LENGTH(AH 2640 BK 2630)	0815/0000	--- ---	CON	0036	BOX CUL
0814/0000	0814/0000	--- ---	CON	0036	BOX CUL

DIR: E TOTAL LEN: 35.461 MI. DIST: 11-1 SR: 376
 LEFT MUN: PENN HILLS T RIGHT MUN: PENN HILLS T

Item ID	Description	Stationing	Material	Length	Notes
018	"DIA CIRC CONCR	0811/2052	LEN=0065	INSTALLED UNKN	0810/2360
OP ID	JEFF HTS RD 02/2092/0010/0000	0811/1342			0810/1338
018	"DIA CIRC CONCR	0811/0939	LEN=0099	INSTALLED UNKN	0810/0910
018	"DIA CIRC CONCR	0811/0686	LEN=0099	INSTALLED UNKN	0810/0658
PENN HILLS WILKINS T		0811/0162			0810/0388
018	"DIA CIRC CONCR	0811/0030	LEN=0036	INSTALLED UNKN	0810/0060
		167982 FT	0 0 00000 0 00 0000+00		
0 0 00000 0 00 0000+00	167766 FT		024"H 24"W CON BOX CUL		
LENGTH(AH 2630 BK 2578)	0811/0000		LEN=0036 INSTALLED UNKN		
BMSEN 02/0376/0804/1997	0805/2562		MILEPOST 081.00		
0 00000 0 0 0000+00			LENGTH(AH 2614 BK 2552)		
SUNSET DRIVE			BMSEN 02/0376/0804/1997		
BMSBG 02/0376/0804/1997	0805/2016		0 00000 0 0 0000+00		
			SUNSET DRIVE		
			BMSBG 02/0376/0804/1997		
024	"DIA CIRC CONCR	0805/1460	LEN=0099	INSTALLED UNKN	0804/1997
			024"H 24"W CON BOX CUL		
			LEN=0036 INSTALLED UNKN		
			018 "DIA CIRC CONCR		
			LEN=0024 INSTALLED UNKN		
			024"H 24"W CON BOX CUL		
			LEN=0036 INSTALLED UNKN		
			018 "DIA CIRC CONCR		
			LEN=0024 INSTALLED UNKN		
			0804/1514		
			024"H 24"W CON BOX CUL		
			LEN=0036 INSTALLED UNKN		
			018 "DIA CIRC CONCR		
			LEN=0024 INSTALLED UNKN		
			0804/1280		
			024"H 24"W CON BOX CUL		
			LEN=0036 INSTALLED UNKN		
			018 "DIA CIRC CONCR		
			LEN=0024 INSTALLED UNKN		
			0804/1211		
			WILKINS		
			CHURCHILL B		
			RAMP D RD		
			(SR8020 SEG 0750/1483)		
			0804/1187		
			0804/1056		

DIR: E TOTAL LEN: 35.461 MI. DIST: 11-1 SR: 376
 LEFT MUN: CHURCHILL B RIGHT MUN: CHURCHILL B

Item Description	Stationing	Item Description	Stationing
018 "DIA CIRC CONCR LEN=0036 INSTALLED UNKN	0805/0950	024 "DIA CAST IRON LEN=0036 INSTALLED UNKN	0804/0985
DMS SIGN STRUCTURE BMSID 02/0376/0804/0813	0805/0830	018 "DIA CIRC CONCR LEN=0024 INSTALLED UNKN	0804/0905
RAMP F RD (SR8020 SEG 0500/0000)	0805/0507	DMS SIGN STRUCTURE BMSID 02/0376/0804/0813	0804/0813
024 "DIA CIRC CONCR LEN=0070 INSTALLED UNKN	0805/0367	024 "DIA CIRC CONCR LEN=0024 INSTALLED UNKN	0804/0612
0 0 00000 0 00 0000+00 165188 FT		RAMP E RD (SR8020 SEG 0760/0000)	0804/0575
LENGTH(AH 2578 BK 2679) 0805/0000		018 "DIA CIRC CONCR LEN=0036 INSTALLED UNKN	0804/0390
BMSEN 02/0376/0800/2406 0801/2678		018 "DIA CIRC CONCR LEN=0024 INSTALLED UNKN	0804/0289
0 00000 0 0 0000+00		RWIS SITE/AT CHURCHILL	0804/0085
LR 395 NB/SB		0 0 00000 0 00 0000+00	
BMSBG 02/0376/0800/2406 0801/2346		LENGTH(AH 2552 BK 2753)	
BR CHALFONT STRUCTURE LENGTH 16 FT		BMSEN 02/0376/0800/2406	0800/2738
BMSID 02/0376/0800/2345 0801/2326		0 00000 0 0 0000+00	
RAMP C RD (SR8020 SEG 0250/1284)	0801/1889	LR 395 NB/SB	
CHALFONT RUN STRUCTURE LENGTH 16 FT		BMSBG 02/0376/0800/2406	0800/2406
BMSID 02/0376/0800/1443 0801/1450		024 "DIA CAST IRON LEN=0036 INSTALLED UNKN	0800/2385
BMSEN 02/0376/0800/0915 0801/0947		BR CHALFONT STRUCTURE LENGTH 16 FT	
0 00000 0 0 0000+00		BMSID 02/0376/0800/2345	0800/2345
SR 0022 TO 376 WB		018 "DIA CIRC CONCR LEN=0036 INSTALLED UNKN	0800/1580
BMSBG 02/0376/0800/0915 0801/0869		CHALFONT RUN STRUCTURE LENGTH 16 FT	
012 "DIA CIR PLASTIC LEN=0288 INSTALLED UNKN	0801/0733	BMSID 02/0376/0800/1443	0800/1443
RAMP A RD (SR8018 SEG 0510/0277)	0801/0092	BMSEN 02/0376/0800/0915	0800/0993
0 0 00000 0 00 0000+00 162509 FT		0 00000 0 0 0000+00	
		SR 0022 TO 376 WB	
		BMSBG 02/0376/0800/0915	0800/0915
		018 "DIA CIRC CONCR LEN=0036 INSTALLED UNKN	0800/0549
		048 "DIA CIRC CONCR LEN=0024 INSTALLED UNKN	0800/0092
		0 0 00000 0 00 0000+00	

DIR: E TOTAL LEN: 35.461 MI. DIST: 11-1 SR: 376
 LEFT MUN: CHURCHILL B RIGHT MUN: CHURCHILL B

Stationing	Description	Stationing	Description
0 0 00000 0 00 0000+00 157114 FT	BMSID 02/0376/0791/0384 0791/0384 018 "DIA CIRC CONCR LEN=0040 INSTALLED UNKN 0791/0371	0790/0309 157396 FT	018 "DIA CIRC CONCR LEN=0099 INSTALLED UNKN
LENGTH(AH 2736 BK 2640) 0791/0000	RAMP S RD (SR8014 SEG 0500/0766) 0785/2328	0790/0000	0 0 00000 0 00 0000+00 MILEPOST 079.00 LENGTH(AH 2641 BK 2274)
SR 2097	OP ID 02/2097/0010/0000 0785/1481	0784/1328	RAMP R RD (SR8014 SEG 0010/0000) SR 2097
		0784/1118	OP ID 02/2097/0010/0000
0 0 00000 0 00 0000+00 154474 FT	CHURCHILL WILKINSBURG B LENGTH(AH 2640 BK 2358) 0785/0000	0784/0408	012 "DIA CIRC CONCR LEN=0030 INSTALLED UNKN CHURCHILL WILKINSBURG B
		0784/0148	
		155122 FT	0 0 00000 0 00 0000+00
		0784/0000	LENGTH(AH 2274 BK 2649) SIGN: CANTILEVER
		0780/2504	BMSID 02/0376/0780/2504
		0780/2446	024 "DIA CIRC CONCR LEN=0099 INSTALLED UNKN
		0780/2211	024 "DIA CIRC CONCR LEN=0099 INSTALLED UNKN
		0780/1964	020 "DIA CIRC CONCR LEN=0099 INSTALLED UNKN
		0780/1736	018 "DIA CIRC CONCR LEN=0099 INSTALLED UNKN
RAMP G RD (SR8012 SEG 0500/0000) 0781/1778		0780/0939	RAMP D RD (SR8012 SEG 0280/3298)
SIGN: CANTILEVER		0780/0721	BMSEN 02/0376/0780/0641
BMSID 02/0376/0781/0200 0781/0976		0780/0641	0 0 00000 0 0 0000+00
BMSEN 02/0376/0780/0641 0781/0837		0780/0641	RAMP G 8012 WB
0 0 00000 0 0 0000+00		0780/0369	BMSBG 02/0376/0780/0641
RAMP G 8012 WB			WILKINSBURG BRADDOCK HILLS B
BMSBG 02/0376/0780/0641 0781/0757			
018 "DIA CIRC CONCR			

DIR: E TOTAL LEN: 35.461 MI. DIST: 11-1 SR: 376
 LEFT MUN: WILKINSBURG B RIGHT MUN: WILKINSBURG B

Segment Description	Start Station	End Station	Notes
LEN=0036 INSTALLED UNKN WILKINSBURG BRADDOCK HILLS B	0781/0256	0781/0236	
SIGN: 4 CHORD TRUSS BMSID 02/0376/0780/0031 0 0 00000 0 00 0000+00 152116 FT LENGTH(AH 2358 BK 2848)	0781/0101	0781/0000	
BMSEN 02/0376/0774/2858 0 0 00000 0 0 0000+00 RAMP A 8012 WB BMSBG 02/0376/0774/2858 BMSEN 02/0376/0774/2445 MILEPOST 078.00	0775/2848	0775/2791 0775/2676 0775/2544	
0 0 00000 0 0 0000+00 ARDMORE BLVD BMSBG 02/0376/0774/2445	0775/2386		
SIGN: 4 CHORD TRUSS BMSID 02/0376/0774/2076	0775/2026		
RAMP A RD (SR8012 SEG 0250/0461)	0775/1704		
BRADDOCK HILLS EDGEWOOD B SR 8012 (RAMP D) E OP ID 02/8012/0280/0516	0775/1513 0775/1464		
RAMP C RD (SR8012 SEG 0270/1614)	0775/0875		
EDGEWOOD BRADDOCK HILLS B	0775/0237		
	0780/0155		RAMP F RD (SR8012 SEG 0760/0000) SIGN: 4 CHORD TRUSS BMSID 02/0376/0780/0031 0 0 00000 0 00 0000+00 LENGTH(AH 2649 BK 2968) 0 0 00000 0 0 0000+00 RAMP A 8012 WB BMSBG 02/0376/0774/2858 BMSEN 02/0376/0774/2858
	0780/0031		
	0780/0000		
	0774/2858		
	0774/2915		
	0774/2735		BMSEN 02/0376/0774/2445 MILEPOST 078.00 0 0 00000 0 0 0000+00 ARDMORE BLVD BMSBG 02/0376/0774/2445 018 "DIA CIRC CONCR LEN=0099 INSTALLED UNKN RAMP B RD (SR8012 SEG 0010/0000) SIGN: 4 CHORD TRUSS BMSID 02/0376/0774/2076 036 "DIA CIRC CONCR LEN=0099 INSTALLED UNKN
	0774/2544		
	0774/2445		
	0774/2444		
	0774/2171		
	0774/2076		
	0774/1772		
	0774/1532		SR 8012 (RAMP D) E OP ID 02/8012/0280/0516 BRADDOCK HILLS EDGEWOOD B
	0774/1472		
	0774/0944		036 "DIA CIRC CONCR LEN=0099 INSTALLED UNKN
	0774/0279		EDGEWOOD BRADDOCK HILLS B 048 "DIA CIRC CONCR LEN=0099 INSTALLED UNKN 018 "DIA CIRC CONCR LEN=0036 INSTALLED UNKN
	0774/0250		
	0774/0175		

DIR: E TOTAL LEN: 35.461 MI. DIST: 11-1 SR: 376
 LEFT MUN: PITTSBURGH C RIGHT MUN: PITTSBURGH C

018 "DIA CIRC CONCR LEN=0036 INSTALLED UNKN	0765/1080	0764/1135	018 "DIA CIRC CONCR LEN=0036 INSTALLED UNKN
PITTSBURGH SWISSVALE B	0765/0844	0764/1050	RAMP G RD (SR8010 SEG 0750/0408)
BMSEN 02/0376/0764/0513	0765/0677	0764/0728 0764/0714	018 "DIA CIRC CONCR LEN=0036 INSTALLED UNKN BMSEN 02/0376/0764/0513 EDGEWOOD
0 00000 0 0 0000+00 BRADDOCK AVE LOCAL SWISSVALE PITTSBURGH C	0765/0476 0765/0379	0764/0605 0764/0513	SWISSVALE B 0 00000 0 0 0000+00 BRADDOCK AVE LOCAL BMSBG 02/0376/0764/0513
BMSEN 02/0376/0764/0000	0765/0174	0764/0260 0764/0174	RAMP X RD (SR8010 SEG 0030/0220) BMSEN 02/0376/0764/0000 SWISSVALE
0 00000 0 0 0000+00 144031 FT RAMP B 8010 EB BMSBG 02/0376/0764/0000 LENGTH(AH 2810 BK 2642) BRADDOCK AV INT/RAMP E (SR8010 SEG 0540/1527)	0765/0000 0761/2407	0764/0140 144225 FT 0764/0000	PITTSBURGH C 0 00000 0 0 0000+00 RAMP B 8010 EB BMSBG 02/0376/0764/0000 LENGTH(AH 2640 BK 2646)
RAMP F RD (SR8010 SEG 0250/0936)	0761/2385	0760/2391	018 "DIA CIRC CONCR LEN=0036 INSTALLED UNKN
		0760/2118	018 "DIA CIRC CONCR LEN=0036 INSTALLED UNKN
		0760/1864	018 "DIA CIR PLASTIC LEN=0036 INSTALLED UNKN
		0760/1791	RAMP A RD (SR8010 SEG 0010/0000)
		0760/0961	048 "DIA CIRC CONCR LEN=0040 INSTALLED UNKN
		0760/0668	024 "DIA CIRC CONCR LEN=0030 INSTALLED UNKN
		0760/0368	024 "DIA CIRC CONCR LEN=0030 INSTALLED UNKN
SIGN: CANTILEVER BMSID 02/0376/0761/0264	0761/0264	0760/0122	MILEPOST 076.00 018 "DIA CIRC CONCR

DIR: E TOTAL LEN: 35.461 MI. DIST: 11-1 SR: 376
 LEFT MUN: PITTSBURGH C RIGHT MUN: PITTSBURGH C

Stationing	Length	Material	Notes	Stationing	Length	Material	Notes
0 0 00000 0 00 0000+00	141389 FT			0760/0038	LEN=0099	INSTALLED UNKN	
MILEPOST 076.00				141579 FT	0 0 00000 0 00 0000+00		
LENGTH(AH 2642 BK 1560)	0761/0000			0760/0000	LENGTH(AH 2646 BK 1561)		
					024 "DIA CIRC CONCR		
SIGN: CANTILEVER				0754/1283	LEN=0030	INSTALLED UNKN	
BMSID 02/0376/0755/0910	0755/0910			0754/0863	BMSEN 02/0376/0754/0000		
BMSEN 02/0376/0754/0000	0755/0863			140018 FT	0 00000 0 0 0000+00		
					018 "DIA CIR UNKNOWN		
0 00000 0 0 0000+00	139829 FT				LEN=0036	INSTALLED UNKN	
COMMERCIAL STREET					COMMERCIAL STREET		
BMSBG 02/0376/0754/0000				0754/0000	BMSBG 02/0376/0754/0000		
LENGTH(AH 1560 BK 1059)	0755/0000				LENGTH(AH 1561 BK 1081)		
					SIGN: 4 CHORD TRUSS		
SIGN: 4 CHORD TRUSS				0750/0938	BMSID 02/0376/0750/0938		
BMSID 02/0376/0750/0938	0751/0927						
				0750/0781	018 "DIA CIRC CONCR		
					LEN=0036	INSTALLED UNKN	
				0750/0763	024 "DIA CIRC CONCR		
					LEN=0099	INSTALLED UNKN	
				0750/0484	024 "DIA CIRC CONCR		
					LEN=0030	INSTALLED UNKN	
				0750/0480	018 "DIA CIRC CONCR		
					LEN=0036	INSTALLED UNKN	
				0750/0280	SERVICE ENT RD		
					(GOVT)		
018 "DIA CIRC CONCR							
LEN=0099	INSTALLED UNKN	0751/0277		0750/0265	024 "DIA CIRC CONCR		
					LEN=0030	INSTALLED UNKN	
				0750/0102	024 "DIA CIRC CONCR		
					LEN=0030	INSTALLED UNKN	
0 0 00000 0 00 0000+00	138770 FT			138937 FT	0 0 00000 0 00 0000+00		
LENGTH(AH 1059 BK 5293)	0751/0000			NC PENN LINCOLN PY	LENGTH(AH 1081 BK 5297)		
NC PENN LINCOLN PY				0750/0000			
MILEPOST 075.00	0745/2640			0744/2640			MILEPOST 075.00

DIR: E TOTAL LEN: 35.461 MI. DIST: 11-1 SR: 376
 LEFT MUN: PITTSBURGH C RIGHT MUN: PITTSBURGH C

Item ID	Description	Stationing	Structure	Material	Status
SIGN: 4 CHORD TRUSS					
BMSID 02/0376/0740/1365		0741/1337	0740/1550	036 " DIA CIRC CONCR	LEN=0099 INSTALLED UNKN
			0740/1365	SIGN: 4 CHORD TRUSS	
			0740/1085	BMSID 02/0376/0740/1365	LEN=0024 INSTALLED UNKN
			0740/0734	024"H 24"W CON BOX CUL	LEN=0024 INSTALLED UNKN
RAMP A RD (SR8008 SEG 0250/1553)		0741/0586			
OP ID 02/7301/0000/3932	GREENFIELD ROAD	0741/0453	0740/0566	024"H 24"W CON BOX CUL	LEN=0024 INSTALLED UNKN
			0740/0460	OP ID 02/7301/0000/3932	SIGN: CANTILEVER
			0740/0222	BMSID 02/0376/0740/0222	036 " DIA CIRC CONCR
			0740/0050	LEN=0099 INSTALLED UNKN	
			0740/0024	018 " DIA CIRC CONCR	LEN=0024 INSTALLED UNKN
0 0 00000 0 00 0000+00	MILEPOST 074.00	130855 FT	131000 FT	0 0 00000 0 00 0000+00	MILEPOST 074.00
LENGTH(AH 2622 BK 2301)		0741/0000	0740/0000	LENGTH(AH 2640 BK 2301)	
024 " DIA CIRC CONCR					
LEN=0099 INSTALLED UNKN		0735/1918			
018 " DIA CIRC CONCR					
LEN=0099 INSTALLED UNKN		0735/1745			
SIGN: CANTILEVER					
BMSID 02/0376/0735/1736		0735/1736			
018 " DIA CIRC CONCR					
LEN=0099 INSTALLED UNKN		0735/1673			
BMSEN 02/0376/0734/1185		0735/1632			
0 00000 0 0 0000+00					
SALINE STREET					
BMSBG 02/0376/0734/1185		0735/1160			
018 " DIA CIRC CONCR					
LEN=0099 INSTALLED UNKN		0734/1734			
BMSEN 02/0376/0734/1185		0734/1657			
0 00000 0 0 0000+00					
SALINE STREET					
BMSBG 02/0376/0734/1185		0734/1185			
018 " DIA CIRC CONCR					
LEN=0099 INSTALLED UNKN		0734/1161			
018 " DIA CIRC CONCR					
LEN=0099 INSTALLED UNKN		0735/0816			
018 " DIA CIRC CONCR					
LEN=0024 INSTALLED UNKN		0735/0738			
018 " DIA CIRC CONCR					
LEN=0099 INSTALLED UNKN		0735/0602			
018 " DIA CIRC CONCR					
LEN=0024 INSTALLED UNKN		0735/0553			
018 " DIA CIRC CONCR					
LEN=0099 INSTALLED UNKN		0734/0600			

DIR: E TOTAL LEN: 35.461 MI. DIST: 11-1 SR: 376
 LEFT MUN: PITTSBURGH C RIGHT MUN: PITTSBURGH C

Item	Description	Stationing	Length	Material	Notes
LEN=0099	INSTALLED UNKN	0735/0420			
018	"DIA CIRC CONCR				
LEN=0024	INSTALLED UNKN	0735/0388			
036	"DIA CIRC CONCR				
LEN=0024	INSTALLED UNKN	0735/0207			
DMS	SIGN STRUCTURE				
BMSID	02/0376/0734/0153	0734/0153			DMS SIGN STRUCTURE
0 0	00000 0 00 0000+00	128554	FT		
OP ID	02/0376/0735/0000		128699	FT	
LENGTH(AH	2301 BK 2934)	0735/0000			
BMSID	02/0376/0730/1965	0731/2934			
0 0	00000 0 00 0000+00				
SWINEBURN/	FRAZIER STRE				
BMSBG	02/0376/0730/1965	0731/1919			
SIGN:	CANTILEVER				
BMSID	02/0376/0731/1878	0731/1878			
018	"DIA CIRC CONCR				
LEN=0024	INSTALLED UNKN	0730/1688			
018	"DIA CIRC CONCR				
LEN=0024	INSTALLED UNKN	0730/1440			
020	"DIA CIRC CONCR				
LEN=0099	INSTALLED UNKN	0730/1263			
018	"DIA CIRC CONCR				
LEN=0024	INSTALLED UNKN	0730/1215			
020	"DIA CIRC CONCR				
LEN=0099	INSTALLED UNKN	0730/1037			
018	"DIA CIRC CONCR				
LEN=0024	INSTALLED UNKN	0730/1001			
018	"DIA CIRC CONCR				
LEN=0024	INSTALLED UNKN	0730/0790			
018	"H 18" W ELLIP CONC				
LEN=0024	INSTALLED UNKN	0730/0594			
036	"DIA CIRC CONCR				
LEN=0024	INSTALLED UNKN	0730/0122			
0 0	00000 0 00 0000+00	125620	FT		
MILEPOST	073.00				
LENGTH(AH	2934 BK 2661)	0731/0000			
016	"H 16" W ELLIP CONC				
LEN=0024	INSTALLED UNKN	0724/2595			
RAMP	B RD				
(SR8006	SEG 0750/0869)	0724/2572			
024	"H 24" W CON BOX CUL				
LEN=0024	INSTALLED UNKN	0725/2599			
018	"DIA CIRC CONCR				
LEN=0024	INSTALLED UNKN	0725/2504			
SIGN:	4 CHORD TRUSS				
BMSID	02/0376/0724/2350	0725/2381			
SIGN:	4 CHORD TRUSS				
BMSID	02/0376/0724/2350	0724/2350			

DIR: E TOTAL LEN: 35.461 MI. DIST: 11-1 SR: 376
 LEFT MUN: PITTSBURGH C RIGHT MUN: PITTSBURGH C

Item ID	Description	Stationing	Material/Type	Length	Notes
BMS EN	02/0376/0721/0143	0721/0203			
OP ID	RAMP F-EXIT 02/8065/0010/0000	0721/0172			
	0 00000 0 0 0000+00				
BMS BG	02/0376/0721/0143	0721/0146			
024 "H	24 "W CON BOX CUL				
LEN=00	24 INSTALLED UNKN	0721/0128			
SR	2085				
OP ID	02/2085/0010/2248	0721/0069			
018 "DIA	CIRC CONCR				
LEN=00	24 INSTALLED UNKN	0721/0057			
0 0 00000	0 00 0000+00	120284 FT			
LENGTH(AH	2675 BK 2633)	0721/0000			
OP ID	RAMP E-ENTR. 02/8065/0250/0000	0715/2623			
024 "DIA	CIRC CONCR	0715/2496			
LEN=00	24 INSTALLED UNKN	0715/2378			
018 "DIA	CIRC CONCR	0715/2319			
LEN=00	24 INSTALLED UNKN	0715/2261			
018 "DIA	CIRC CONCR	0715/2158			
LEN=00	24 INSTALLED UNKN	0715/2137			
024 "DIA	CIRC CONCR	0715/2000			
LEN=00	24 INSTALLED UNKN				
OP ID	RAMP U RD (SR8004 SEG 0260/0677)	0715/2158			
024 "DIA	CIRC CONCR	0715/2137			
LEN=00	24 INSTALLED UNKN	0715/2000			
024 "DIA	CIRC CONCR				
LEN=00	24 INSTALLED UNKN				
018 "DIA	CIRC CONCR	0715/1858			
LEN=00	24 INSTALLED UNKN	0715/1720			
024 "DIA	CIRC CONCR	0715/1582			
LEN=00	24 INSTALLED UNKN	0715/1435			
024 "DIA	CIRC METAL	0715/1310			
LEN=00	24 INSTALLED UNKN				
018 "DIA	CIRC METAL				
LEN=00	24 INSTALLED UNKN				
RETAINING	WALL				
BMS ID	02/0376/0715/1244	0715/1244			
024 "DIA	CIRC METAL				
0720/0103	OP ID RAMP F-EXIT 02/8065/0010/0000				
	0 00000 0 0 0000+00				
0720/0079	BMS BG 02/0376/0720/0079				
0720/0053	RAMP V RD (SR8004 SEG 0750/0000)				
0720/0060	OP ID SR 2085 02/2085/0010/2248				
120438 FT	0 0 00000 0 00 0000+00				
0720/0000	MILEPOST 072.00 LENGTH(AH 2640 BK 2239)				
0714/2225	OP ID RAMP E-ENTR. 02/8065/0250/0000				
0714/2143	SIGN: 4 CHORD TRUSS BMS ID 02/0376/0714/2143				
0714/1927	SIGN: CANTILEVER BMS ID 02/0376/0714/1927				

DIR: E TOTAL LEN: 35.461 MI. DIST: 11-1 SR: 376
 LEFT MUN: PITTSBURGH C RIGHT MUN: PITTSBURGH C

LEN=0024	INSTALLED	UNKN	0715/1130	---						
024	"DIA	CIRC	METAL	---						
LEN=0024	INSTALLED	UNKN	0715/0985	---						
018	"DIA	CIRC	CONCR	---						
LEN=0024	INSTALLED	UNKN	0715/0835	---						
018	"DIA	CIRC	CONCR	---						
LEN=0024	INSTALLED	UNKN	0715/0688	---						
SIGN: CANTILEVER										
BMSID	02/0376/0715/0685	0715/0685		---		0714/0725	BMSID	02/0376/0714/0725		
018	"DIA	CIRC	CONCR	---						
LEN=0024	INSTALLED	UNKN	0715/0530	---						
018	"DIA	CIRC	CONCR	---						
LEN=0024	INSTALLED	UNKN	0715/0315	---						
024	"DIA	CIRC	CONCR	---						
LEN=0024	INSTALLED	UNKN	0715/0138	---						
0 0 00000	0 00 0000+00	117651	FT							
SIGN: CANTILEVER										
BMSID	02/0376/0715/0000			---		118199	FT	0 0 00000	0 00 0000+00	
LENGTH(AH	2633	BK	2608)	0715/0000	---	0714/0000	LENGTH(AH	2239	BK	3059)
					---	0710/2872	BMSEN	02/0376/0710/2109		
					---		DMS	SIGN	STRUCTURE	
					---	0710/2628	BMSID	02/0376/0704/2571		
					---		SIGN:	CANTILEVER		
					---	0710/2567	BMSID	02/0376/0710/2567		
					---		018	"DIA	CIRC	CONCR
					---	0710/2344	LEN=0024	INSTALLED	UNKN	
					---		0 00000	0 0 0000+00		
					---		SECOND	AVE		
BMSEN	02/0376/0711/1750	0711/1750		---		0710/2109	BMSBG	02/0376/0710/2109		
SIGN: CANTILEVER										
BMSID	02/0376/0711/1685	0711/1685		---						
				---		0710/1845	008	"DIA	CIRC	CONCR
				---			LEN=0024	INSTALLED	UNKN	
				---		0710/1683	036	"DIA	CIRC	CONCR
				---			LEN=0024	INSTALLED	UNKN	
				---		0710/1527	036	"DIA	CIRC	CONCR
				---			LEN=0024	INSTALLED	UNKN	
				---		0710/1390	018	"DIA	CIRC	CONCR
				---			LEN=0024	INSTALLED	UNKN	
				---		0710/1254	018	"DIA	CIRC	CONCR
				---			LEN=0024	INSTALLED	UNKN	
				---		0710/1151	018	"DIA	CIRC	CONCR
				---			LEN=0024	INSTALLED	UNKN	
018	"DIA	CIRC	CONCR	---						
LEN=0024	INSTALLED	UNKN	0711/0705	---						
SIGN: 4 CHORD TRUSS										
BMSID	02/0376/0711/0699	0711/0699		---		0710/1084	SIGN:	CANTILEVER		
				---			BMSID	02/0376/0710/1084		
				---		0710/1054	018	"DIA	CIRC	CONCR
				---			LEN=0024	INSTALLED	UNKN	
				---			018	"DIA	CIRC	CONCR

DIR: E TOTAL LEN: 35.461 MI. DIST: 11-1 SR: 376
 LEFT MUN: PITTSBURGH C RIGHT MUN: PITTSBURGH C

Segment / Description	Stationing	Length	Material / Notes
	0710/0985	LEN=0024	INSTALLED UNKN
	0710/0807	LEN=0024	018 "DIA CIRC CONCR INSTALLED UNKN
RAMP M RD (SR8096 SEG 0500/0000)	0711/0688		
	0710/0683	LEN=0024	016 "DIA CIRC CONCR INSTALLED UNKN
	0710/0603		SO TENTH ST OP ID 02/7301/0000/2391
	0710/0568	LEN=0024	018 "DIA CIRC CONCR INSTALLED UNKN
SIGN: CANTILEVER BMSID 02/0376/0711/0000	0711/0562		
	0710/0452	LEN=0024	018"H 18"W ELLIP CONCR INSTALLED UNKN
	0710/0333	LEN=0024	018"H 18"W ELLIP CONCR INSTALLED UNKN
024 "DIA CIRC CONCR LEN=0024 INSTALLED UNKN	0711/0277		
	0710/0214	LEN=0024	024"H 24"W CON BOX CUL INSTALLED UNKN
024 "DIA CIRC CONCR LEN=0024 INSTALLED UNKN	0711/0095		
	0710/0088	LEN=0024	018 "DIA CIRC CONCR INSTALLED UNKN
0 00000 0 0 0000+00 115043 FT SECOND AVE BMSBG 02/0376/0711/1750 MILEPOST 071.00 LENGTH(AH 2608 BK 2668)	0711/0000		
	0710/0000	LEN=0024	115140 FT 0 0 00000 0 00 0000+00 MILEPOST 071.00 LENGTH(AH 3059 BK 2640) 018 "DIA CIRC CONCR INSTALLED UNKN
	0704/2564	LEN=0024	018 "DIA CIRC CONCR INSTALLED UNKN
	0704/2440	LEN=0024	018 "DIA CIRC CONCR INSTALLED UNKN
024 "DIA CIRC CONCR LEN=0024 INSTALLED UNKN	0705/2464		
	0704/2310	LEN=0024	024 "DIA CIRC CONCR INSTALLED UNKN
	0704/2235		SIGN: CANTILEVER BMSID 02/0376/0704/2235
	0704/2183	LEN=0024	018 "DIA CIRC CONCR INSTALLED UNKN
	0704/2058	LEN=0024	036 "DIA CIRC CONCR INSTALLED UNKN
018 "DIA CIRC CONCR LEN=0024 INSTALLED UNKN	0705/2052		
	0704/1892	LEN=0024	018 "DIA CIRC CONCR INSTALLED UNKN
	0704/1522		RAMP A RD (SR8041 SEG 0250/4795)

EXTRACT DATE: 12/21/2020
PRINT DATE: 12/23/2020

ROADWAY MANAGEMENT SYSTEM
SLD COUNTY/SR - ANNUAL PRINT

PAGE NUMBER: 366
COUNTY: ALLEGHENY

DIR: E TOTAL LEN: 35.461 MI.
LEFT MUN: PITTSBURGH C

DIST: 11-1 SR: 376
RIGHT MUN: PITTSBURGH C

Stationing	Structure	Stationing	Structure
0685/1459	NORFOLK SOUTHERN OVERPASS IS RR X-ING	0684/1556	BMSID 02/0376/0684/1551
		0684/1525	NORFOLK SOUTHERN OVERPASS IS RR X-ING
		0684/1440	018 "DIA CIRC CONCR LEN=0099 INSTALLED UNKN SIGN: TRUSS MUL SPA
0685/0835	SIGN: TRUSS MUL SPA BMSID 02/0376/0684/0876	0684/0876	BMSID 02/0376/0684/0876 BANKSVILLE RD (SR0019 SEG 0210/1861)
		0684/0593	012 "DIA CIRC CONCR LEN=0030 INSTALLED UNKN SIGN: 4 CHORD TRUSS
0681/2657	0 0 00000 0 00 0000+00 101846 FT LENGTH(AH 2640 BK 2657)	0684/0071	BMSID 02/0376/0684/0020
		0684/0000	0 0 00000 0 00 0000+00 LENGTH(AH 2645 BK 2637)
0681/2347	BANKSVILLE INT/RMP 250 (SR8075 SEG 0250/0000)	0680/2553	TRUCK ESCAPE RAMP RD (SR9301 SEG 0010/0000)
0681/2040	BMSEN 02/0376/0680/1910 0 00000 0 0 0000+00	0680/2095	BMSEN 02/0376/0680/1910 018 "DIA CIRC CONCR LEN=0099 INSTALLED UNKN 0 00000 0 0 0000+00
0681/1855	SR 0019 BANKSVILLE ROAD BMSBG 02/0376/0680/1910	0680/1910	SR 0019 BANKSVILLE ROAD BMSBG 02/0376/0680/1910
0681/1787	RAMP M RD (SR8075 SEG 0260/0293)	0680/1668	024 "DIA CIRC CONCR LEN=0030 INSTALLED UNKN
		0680/1393	018 "DIA CIRC CONCR LEN=0030 INSTALLED UNKN
		0680/1119	018 "DIA CIRC CONCR LEN=0030 INSTALLED UNKN
0681/0582	SIGN: 4 CHORD TRUSS BMSID 02/0376/0680/0619	0680/0916	018 "DIA CIRC CONCR LEN=0030 INSTALLED UNKN SIGN: 4 CHORD TRUSS
		0680/0619	BMSID 02/0376/0680/0619 018 "DIA CIRC CONCR LEN=0099 INSTALLED UNKN
		0680/0574	018 "DIA CIRC CONCR LEN=0030 INSTALLED UNKN
		0680/0562	018 "DIA CIRC CONCR LEN=0030 INSTALLED UNKN
		0680/0280	018 "DIA CIRC CONCR LEN=0099 INSTALLED UNKN
099189 FT	0 0 00000 0 00 0000+00	0680/0278	018 "DIA CIRC CONCR LEN=0030 INSTALLED UNKN
		099282 FT	0 0 00000 0 00 0000+00
0681/0000	MILEPOST 068.00 LENGTH(AH 2657 BK 2617)	0680/0000	0 0 00000 0 00 0000+00 MILEPOST 068.00 LENGTH(AH 2637 BK 2639) RAMP RD

DIR: E TOTAL LEN: 35.461 MI. DIST: 11-1 SR: 376
 LEFT MUN: PITTSBURGH C RIGHT MUN: PITTSBURGH C

Structure ID	Description	Stationing	Notes
0674/2118	(SR8091 SEG 0250/1904)		
0674/2049	018 "DIA CIRC CONCR LEN=0099 INSTALLED UNKN		
0674/2024	018 "DIA CIRC CONCR LEN=0030 INSTALLED UNKN		
0674/1923	SIGN: 4 CHORD TRUSS BMSID 02/0376/0674/1923		
0674/1744	018 "DIA CIRC CONCR LEN=0099 INSTALLED UNKN		
0675/1413	RAMP RD (SR8091 SEG 0500/0000)		
0675/1376	018 "DIA CIRC CONCR LEN=0100 INSTALLED UNKN		
0675/1252	SR 8091 P WAY CNT OP ID 02/8091/0250/0940		
0675/0944	DMS SIGN STRUCTURE BMSID 02/0376/0674/0946		
0675/0943	PITTSBURGH GREENTREE B		
0674/0980	018 "DIA CIRC CONCR LEN=0099 INSTALLED UNKN		
0674/0877	DMS SIGN STRUCTURE BMSID 02/0376/0674/0946		
0674/0674	PITTSBURGH GREENTREE B		
0674/0419	018 "DIA CIRC CONCR LEN=0099 INSTALLED UNKN		
096572 FT	096643 FT		
0675/0000	0 0 00000 0 00 0000+00 LENGTH(AH 2617 BK 2659)		
0671/2555	SIGN: 4 CHORD TRUSS BMSID 02/0376/0670/2548		
0670/2548	0 0 00000 0 00 0000+00 LENGTH(AH 2639 BK 2657)		
0670/1936	SIGN: 4 CHORD TRUSS BMSID 02/0376/0670/2548		
0671/1807	RAMP A RD (SR8035 SEG 0750/0578)		
0670/1546	024 "DIA CIRC CONCR LEN=0099 INSTALLED UNKN		
0671/1508	SR 0121 NB OP ID 02/0121/0080/0866		
0670/1493	024 "DIA CIRC CONCR LEN=0099 INSTALLED UNKN		
0670/1346	024 "DIA CIRC CONCR LEN=0099 INSTALLED UNKN		
0671/1259	SIGN: CANTILEVER BMSID 02/8035/0260/0000		
0671/1202	RAMP F RD (SR8035 SEG 0270/0000)		
0670/1153	024 "DIA CIRC CONCR LEN=0099 INSTALLED UNKN		
0670/0937	RAMP C RD (SR8035 SEG 0020/0000)		

EXTRACT DATE: 12/21/2020
PRINT DATE: 12/23/2020

ROADWAY MANAGEMENT SYSTEM
SLD COUNTY/SR - ANNUAL PRINT

PAGE NUMBER: 364
COUNTY: ALLEGHENY

DIR: E TOTAL LEN: 35.461 MI.
LEFT MUN: GREENTREE B

DIST: 11-1 SR: 376
RIGHT MUN: GREENTREE B

SIGN: 4 CHORD TRUSS
BMSID 02/0376/0670/0803 0671/0807
BMSEN 02/0376/0670/0490 0671/0613
018 "DIA CIRC CONCR
LEN=0025 INSTALLED UNKN 0671/0499
0 00000 0 0 0000+00
POPLAR AVE LOCAL
BMSBG 02/0376/0670/0490 0671/0498

RAMP E RD
(SR8035 SEG 0250/0413) 0671/0208
0 0 00000 0 00 0000+00 093913 FT
MILEPOST 067.00
LENGTH(AH 2659 BK 2641) 0671/0000
SIGN: 4 CHORD TRUSS
BMSID 02/0376/0664/2501 0665/2494

0 0 00000 0 00 0000+00 091272 FT
LENGTH(AH 2641 BK 2636) 0665/0000

DMS SIGN STRUCTURE
BMSID 02/0376/0660/1145 0661/1143

0 0 00000 0 00 0000+00 088636 FT
MILEPOST 066.00
LENGTH(AH 2636 BK 2571) 0661/0000

GREENTREE
SCOTT T 0655/1762

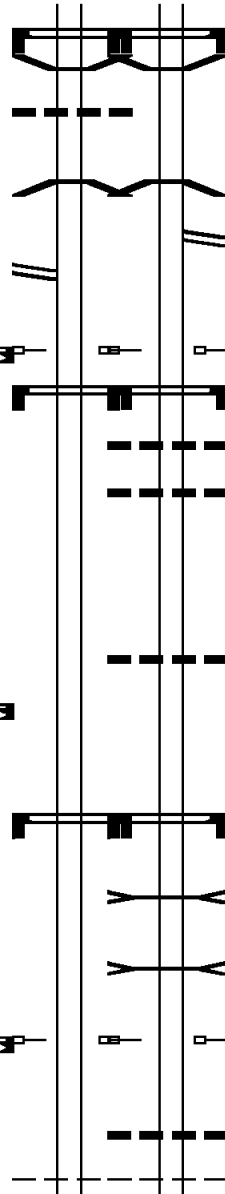

SIGN: 4 CHORD TRUSS
BMSID 02/0376/0670/0803 0670/0803
BMSEN 02/0376/0670/0490 0670/0605
0 00000 0 0 0000+00
POPLAR AVE LOCAL
BMSBG 02/0376/0670/0490
RAMP K RD
(SR8035 SEG 0010/0526)

0 0 00000 0 00 0000+00
MILEPOST 067.00
LENGTH(AH 2657 BK 2641) 0670/0000
SIGN: 4 CHORD TRUSS
BMSID 02/0376/0664/2501 0664/2501
024 "DIA CIRC CONCR
LEN=0099 INSTALLED UNKN
024 "DIA CIRC CONCR
LEN=0099 INSTALLED UNKN

024 "DIA CIRC CONCR
LEN=0099 INSTALLED UNKN
0 0 00000 0 00 0000+00
LENGTH(AH 2641 BK 2636) 0664/0000

DMS SIGN STRUCTURE
BMSID 02/0376/0660/1145 0660/1145

BR.WHISKY R.
STRUCTURE LENGTH 14 FT
BMSID 02/0376/0660/0890 0660/0890
WHISKEY RUN
STRUCTURE LENGTH 16 FT
BMSID 02/0376/0660/0411 0660/0411
0 0 00000 0 00 0000+00
MILEPOST 066.00
LENGTH(AH 2636 BK 2623) 0660/0000

018 "DIA CIRC CONCR
LEN=0040 INSTALLED UNKN
GREENTREE
SCOTT T 0654/1689
0654/1662

DIR: E TOTAL LEN: 35.461 MI. DIST: 11-1 SR: 376
 LEFT MUN: GREENTREE B RIGHT MUN: GREENTREE B

Structure Description	Structure Length	BMSID	SR	Segment	Notes
BR. WHISKY R. STRUCTURE LENGTH 14 FT	14 FT	02/0376/0660/0890	0655	1682	
SCOTT GREENTREE B WHISKEY RUN STRUCTURE LENGTH 16 FT	16 FT	02/0376/0660/0411	0655	1214	
BMSEN 02/0376/0654/0281 NORFOLK SOUTHERN OVERPASS IS RR X-ING	0 0000 0 0 0000+00	0655/0916	0654	0930	018 "DIA CIRC CONCR LEN=0040 INSTALLED UNKN
BELL RD BMSBG 02/0376/0654/0281 SIGN: CANTILEVER		0655/0294	0654	0281	018 "DIA CIRC CONCR LEN=0030 INSTALLED UNKN
BMSID 02/0376/0655/0118 GREENTREE SCOTT T RAMP A RD (SR8033 SEG 0500/0000)	0 0 0000 0 00 0000+00	0655/0070	086086	FT	0 0 0000 0 00 0000+00
LENGTH(AH 2571 BK 2652)	086065 FT	0655/0000	0654	0000	LEN=0099 INSTALLED UNKN
RAMP D RD (SR8033 SEG 0760/0909)		0651/2358	0650	2381	RAMP B RD (SR8033 SEG 0750/1451)
OP ID 02/8033/0760/0105 BMSEN 02/0376/0650/1095		0651/2013	0650	2027	OP ID 02/8033/0760/0105
		0651/1863	0650	1860	BMSEN 02/0376/0650/1095
SCOTT CARNEGIE B RAMP A BMSBG 02/0376/0650/1095	0 0 0000 0 0 0000+00	0651/1098	0650	1845	RAMP C RD (SR8033 SEG 0010/0000)
			0650	1733	SIGN: CANTILEVER
			0650	1399	BMSID 02/0376/0650/1733
			0650	1095	SCOTT CARNEGIE B 0 0 0000 0 0 0000+00
			0650	0990	RAMP A BMSBG 02/0376/0650/1095
			0650	0711	018 "DIA CIRC CONCR LEN=0030 INSTALLED UNKN
SIGN: 4 CHORD TRUSS BMSID 02/0376/0650/0606		0651/0610	0650	0606	018 "DIA CIRC CONCR LEN=0030 INSTALLED UNKN
BMSEN 02/0376/0650/0000	0 0 0000 0 0 0000+00	0651/0560	0650	0560	SIGN: 4 CHORD TRUSS BMSID 02/0376/0650/0606
			0650	0560	BMSEN 02/0376/0650/0000 0 0 0000 0 0 0000+00

EXTRACT DATE: 12/21/2020
PRINT DATE: 12/23/2020

ROADWAY MANAGEMENT SYSTEM
SLD COUNTY/SR - ANNUAL PRINT

PAGE NUMBER: 361
COUNTY: ALLEGHENY

DIR: E TOTAL LEN: 35.461 MI.
LEFT MUN: ROSSLYN FARMS B

DIST: 11-1 SR: 376
RIGHT MUN: ROSSLYN FARMS B

Station	Description	Station	Description
0640/1003	018 " DIA CIRC CONCR LEN=0099 INSTALLED UNKN	0640/1002	018 " DIA CIRC CONCR LEN=0099 INSTALLED UNKN
0641/1015	ROSSLYN FARMS ROBINSON T	0640/0887	ROSSLYN FARMS ROBINSON T
078143 FT		078179 FT	
0 0 00000 0 00 0000+00		0 0 00000 0 00 0000+00	
ROBINSON		ROBINSON	
COLLIER T		COLLIER T	
MILEPOST 064.00		MILEPOST 064.00	
LENGTH(AH 2640 BK 2625)		LENGTH(AH 2640 BK 2619)	
0641/0000		0640/0000	
BMS EN 02/0376/0634/1908		0634/2553	(SR8009 SEG 0010/1378)
SR 8009 SB (RAMP B)		0634/2031	BMS EN 02/0376/0634/1908
OP ID 02/8009/0760/1868		0634/1936	OP ID 02/8009/0760/1868
0 0 00000 0 0 0000+00		0 0 00000 0 0 0000+00	
CAMPBELLS RD COUNTY		CAMPBELLS RD COUNTY	
BMSBG 02/0376/0634/1908		0634/1908	BMSBG 02/0376/0634/1908
CAMPBELLS		CAMPBELLS	
STRUCTURE LENGTH 22 FT		STRUCTURE LENGTH 22 FT	
BMSID 02/0376/0634/1715		0634/1715	BMSID 02/0376/0634/1715
RAMP E RD			
(SR8009 SEG 0750/1022)			
0635/2019		0634/1007	SR 0079 NB OP ID 02/0079/0580/0774
SR 0079 NB		0634/0898	SR 0079 SB OP ID 02/0079/0581/0857
OP ID 02/0079/0580/0774		0634/0760	ROBINSON COLLIER T
SR 0079 SB		0634/0638	RAMP D RD (SR8009 SEG 0270/1230)
OP ID 02/0079/0581/0857		0634/0562	OP ID 02/8009/0260/0293
RAMP G 8009 376 EB		0634/0210	SIGN: CANTILEVER BMSID 02/0376/0634/0210
OP ID 02/8009/0260/0293		075560 FT	0 0 00000 0 00 0000+00
0 0 00000 0 00 0000+00		0634/0000	LENGTH(AH 2619 BK 2619)
LENGTH(AH 2625 BK 2640)			
PITTSBURGH INT/RAMP H R			
(SR8009 SEG 0510/1417)			
0631/2401			
SIGN: 4 CHORD TRUSS			
BMSID 02/0376/0630/1668		0630/1646	RAMP C RD (SR8009 SEG 0250/0000)
		0630/1609	SIGN: 4 CHORD TRUSS BMSID 02/0376/0630/1668

DIR: E TOTAL LEN: 35.461 MI. DIST: 11-1 SR: 376
LEFT MUN: COLLIER T RIGHT MUN: COLLIER T

SIGN: 4 CHORD TRUSS
BMSID 02/0376/0630/0500 0631/0500
018 "DIA CIRC CONCR
LEN=0050 INSTALLED UNKN 0631/0291

0 0 00000 0 00 0000+00 072878 FT
MILEPOST 063.00
LENGTH(AH 2640 BK 2612) 0631/0000
COLLIER
ROBINSON T 0625/2358
ROBINSON
COLLIER T 0625/1803
SIGN: 4 CHORD TRUSS
BMSID 02/0376/0624/1700 0625/1700

SIGN: CANTILEVER
BMSID 02/0376/0625/1000 0625/1066
018 "DIA CIRC CONCR
LEN=0050 INSTALLED UNKN 0625/0406
018 "DIA CIRC CONCR
LEN=0040 INSTALLED UNKN 0625/0176
0 0 00000 0 00 0000+00 070266 FT
LENGTH(AH 2612 BK 2606) 0625/0000

018 "DIA CIRC CONCR
LEN=0050 INSTALLED 2008 0621/2333
SIGN: CANTILEVER
BMSID 02/0376/0621/2000 0621/2301

SIGN: 4 CHORD TRUSS
BMSID 02/0376/0620/1372 0621/1372

012 "DIA CIRC CONCR
LEN=0040 INSTALLED UNKN 0621/1051

CAMPBELLS RUN INT/RP C
(SRB038 SEG 0500/0000) 0621/0796
BMSEN 02/0376/0620/0203 0621/0302
0 00000 0 0 0000+00
SR 3041 MCMICHAEL ROAD
BMSBG 02/0376/0620/0203 0621/0195

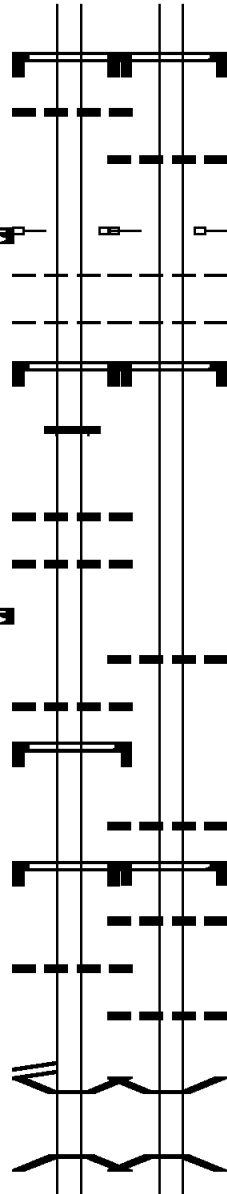

SIGN: 4 CHORD TRUSS
BMSID 02/0376/0630/0500 0630/0500

018 "DIA CIRC CONCR
LEN=0099 INSTALLED UNKN
0 0 00000 0 00 0000+00
MILEPOST 063.00
LENGTH(AH 2619 BK 2640)
COLLIER
ROBINSON T 0624/2447
ROBINSON
COLLIER T 0624/1892
SIGN: 4 CHORD TRUSS
BMSID 02/0376/0624/1700 0624/1700

0 0 00000 0 00 0000+00
LENGTH(AH 2640 BK 2619)
018 "DIA CIRC CONCR
LEN=0030 INSTALLED UNKN
0620/2372

024 "DIA CIRC CONCR
LEN=0030 INSTALLED UNKN
SIGN: 4 CHORD TRUSS
BMSID 02/0376/0620/1372 0620/1372
018 "DIA CIR PLASTIC
LEN=0200 INSTALLED UNKN
0620/1270

018 "DIA CIRC CONCR
LEN=0030 INSTALLED UNKN
0620/0842

BMSEN 02/0376/0620/0203 0620/0310
0 00000 0 0 0000+00
SR 3041 MCMICHAEL ROAD
BMSBG 02/0376/0620/0203 0620/0203
012 "DIA CIRC CONCR

DIR: E TOTAL LEN: 35.461 MI. DIST: 11-1 SR: 376
LEFT MUN: COLLIER T RIGHT MUN: COLLIER T

Stationing	Length	Material	Status	Stationing	Length	Material	Status
0620/0179	0099	INSTALLED	UNKN	0620/0179	0099	INSTALLED	UNKN
0620/0000	0621/0000	0620/0000		0620/0000	0621/0000	0620/0000	
0614/2613		0614/2613		0614/2613		0614/2613	
0615/2546		0615/2546		0614/2485		0614/2485	
0615/2247		0615/2247		0614/2472		0614/2472	
0615/1994		0615/1994		0614/2001		0614/2001	
0615/1743		0615/1743		0614/1756		0614/1756	
0615/0562		0615/0562		0614/1437		0614/1437	
0615/0107		0615/0107		0614/0541		0614/0541	
0611/2478		0611/2478		0614/0372		0614/0372	
0611/2196		0611/2196		0614/0105		0614/0105	
0611/2187		0611/2187		065042 FT		065042 FT	
0611/1841		0611/1841		0614/0000		0614/0000	
				0610/2174		0610/2174	
				0610/2168		0610/2168	

DIR: E TOTAL LEN: 35.461 MI. DIST: 11-1 SR: 376
 LEFT MUN: ROBINSON T RIGHT MUN: ROBINSON T

Stationing	Structure / Feature	Material / Length	Notes
0610/1623		LEN=0030	INSTALLED UNKN
0610/0728	RAMP D RD (SR8090 SEG 0750/1380)		
0611/0468	RAMP A RD (SR8090 SEG 0512/0388)		
0610/0437		018 "DIA CIRC CONCR LEN=0040	INSTALLED UNKN
0610/0037		016 "DIA CIRC CONCR LEN=0040	INSTALLED UNKN
062402 FT		0 0 00000 0 00 0000+00	062378 FT
0611/0000		0 0 00000 0 00 0000+00	MILEPOST 061.00
0611/0000		LENGTH(AH 2640 BK 2640)	0611/0000
0604/2352		018 "DIA CIRC CONCR LEN=0030	INSTALLED UNKN
0605/2221	SIGN: CANTILEVER BMSID 02/0376/0605/2221		
0605/2143	RIDGE RD OP ID 02/3145/0010/0537		
0604/2134		018 "DIA CIRC CONCR LEN=0030	INSTALLED UNKN
0605/1790		018 "DIA CIRC CONCR LEN=0030	INSTALLED UNKN
0605/1374		018 "DIA CIRC CONCR LEN=0099	INSTALLED UNKN
0604/1733		018 "DIA CIRC CONCR LEN=0030	INSTALLED UNKN
0604/1420		018 "DIA CIRC CONCR LEN=0030	INSTALLED UNKN
0604/1212	RAMP C RD (SR8090 SEG 0010/0000)		
0605/1051		018 "DIA CIRC CONCR LEN=0050	INSTALLED UNKN
0604/1107		018 "DIA CIRC CONCR LEN=0050	INSTALLED UNKN
0605/0726	SIGN: 4 CHORD TRUSS BMSID 02/0376/0604/0726		
0604/0797		018 "DIA CIRC CONCR LEN=0030	INSTALLED UNKN
0604/0726		SIGN: 4 CHORD TRUSS BMSID 02/0376/0604/0726	
0604/0489		018 "DIA CIRC CONCR LEN=0134	INSTALLED UNKN
0605/0378	RAMP E RD (SR8036 SEG 0500/0000)		
0604/0179		018 "DIA CIRC CONCR LEN=0030	INSTALLED UNKN
0605/0040		018 "DIA CIRC CONCR LEN=0099	INSTALLED UNKN
059738 FT		0 0 00000 0 00 0000+00	059762 FT
0605/0000		0 0 00000 0 00 0000+00	LENGTH(AH 2640 BK 2640)
0605/0000		LENGTH(AH 2640 BK 2611)	0605/0000
0604/0000		018 "DIA CIRC CONCR LEN=0030	INSTALLED UNKN

DIR: E TOTAL LEN: 35.461 MI. DIST: 11-1 SR: 376
LEFT MUN: ROBINSON T RIGHT MUN: ROBINSON T

018 "DIA CIRC CONCR LEN=0050 INSTALLED UNKN 0601/2480		0600/2491 LEN=0035 INSTALLED UNKN
018 "DIA CIRC CONCR LEN=0040 INSTALLED UNKN 0601/2222		
018 "DIA CIRC CONCR LEN=0050 INSTALLED UNKN 0601/1591		0600/2012 SIGN: CANTILEVER BMSID 02/0376/0600/2012
018 "DIA CIRC CONCR LEN=0070 INSTALLED UNKN 0601/1347		
		016 "DIA CIRC CONCR LEN=0040 INSTALLED UNKN
		RAMP F RD 0600/1072 (SR8036 SEG 0750/1335)
		RAMP B RD 0600/0392 (SR8036 SEG 0760/0000)
SIGN: 2 CHORD TRUSS BMSID 02/0376/0600/0400 0601/0319		0600/0325 SIGN: 2 CHORD TRUSS BMSID 02/0376/0600/0400
		016 "DIA CIRC CONCR LEN=0030 INSTALLED UNKN
RT 0022 EB OP ID 02/0022/0140/1291 0601/0055		RT 0022 EB 0600/0054 OP ID 02/0022/0140/1291
0 0 0000 0 00 0000+00 057127 FT		057122 FT 0 0 0000 0 00 0000+00
MILEPOST 060.00		MILEPOST 060.00
LENGTH(AH 2611 BK 2696) 0601/0000		0600/0000 LENGTH(AH 2640 BK 2614)
NC PENN LINCOLN PY		
SIGN: 2 CHORD TRUSS BMSID 02/0376/0594/2576 0595/2576		SIGN: 2 CHORD TRUSS BMSID 02/0376/0594/2576
RAMP C RD (SR8036 SEG 0260/0000) 0595/2451		NC PENN LINCOLN PY
RAMP G RD (SR8036 SEG 0250/0903) 0595/2155		
		RAMP H RD (SR8036 SEG 0010/0000)
		ROBINSON
		NORTH FAYETTE T
SIGN: 4 CHORD TRUSS BMSID 02/0376/0594/1591 0595/1661		0594/1950
018 "DIA CIRC CONCR LEN=0050 INSTALLED UNKN 0595/1557		0594/1856
ROBINSON		0594/1591
NORTH FAYETTE T		018 "DIA CIRC CONCR LEN=0080 INSTALLED UNKN
SIGN: 4 CHORD TRUSS BMSID 02/0376/0594/1000 0595/0990		SIGN: 4 CHORD TRUSS BMSID 02/0376/0594/1591
RAMP A RD		
		SIGN: 4 CHORD TRUSS BMSID 02/0376/0594/1000

DIR: E TOTAL LEN: 35.461 MI. DIST: 11-1 SR: 376
 LEFT MUN: NORTH FAYETTE T RIGHT MUN: NORTH FAYETTE T

Segment ID	Description	Start Station	End Station	Notes
(SR8044 SEG 0500/0000)		0595/0676		
018 "DIA CIRC CONCR				
LEN=0065	INSTALLED UNKN	0595/0623		
SIGN: STRUC MOUNTED				
BMSID 02/3144/0020/0034		0595/0069		
SR 3144 EB ROBINSO				
OP ID 02/3144/0020/0024		0595/0032		
0 0 00000 0 00 0000+00		054431 FT		
LENGTH(AH 2696 BK 2620)		0595/0000		
RAMP B RD				
(SR8044 SEG 0250/1004)		0591/1610		
0 0 00000 0 00 0000+00		054508 FT		
LENGTH(AH 2614 BK 2640)		0594/0000		
RAMP D RD				
(SR8044 SEG 0020/0644)		0590/2490		
RAMP C RD				
(SR8044 SEG 0010/0000)		0590/1787		
SIGN: CANTILEVER				
BMSID 02/0376/0590/0939		0590/0939		
018 "DIA CIRC CONCR				
LEN=0099	INSTALLED UNKN	0590/0883		
DMS SIGN STRUCTURE				
BMSID 02/0376/0590/0271		0591/0276		
0 0 00000 0 00 0000+00		051811 FT		
MILEPOST 059.00				
LENGTH(AH 2620 BK 2593)		0591/0000		
SIGN: 4 CHORD TRUSS				
BMSID 02/0376/0584/2073		0585/2043		
0 0 00000 0 00 0000+00		051868 FT		
LENGTH(AH 2640 BK 2623)		0590/0000		
SIGN: 4 CHORD TRUSS				
BMSID 02/0376/0584/2073		0584/2073		
018 "DIA CIRC CONCR				
LEN=0040	INSTALLED UNKN	0584/1260		
SIGN: 4 CHORD TRUSS				
BMSID 02/0376/0584/1128		0585/1118		
016 "DIA CIRC CONCR				
LEN=0035	INSTALLED UNKN	0584/0569		
BMSEN 02/0376/0584/0097		0585/0428		
NORTH FAYETTE				
MOON T		0585/0232		
0 0 00000 0 00 0000+00		0584/0097		
CLIFF MINE ROAD				
BMSBG 02/0376/0584/0097		0585/0124		
018 "DIA CIRC CONCR				
LEN=0099	INSTALLED UNKN	0585/0070		
0 0 00000 0 00 0000+00		0584/0056		
CLIFF MINE ROAD				
BMSBG 02/0376/0584/0097		0584/0097		
NORTH FAYETTE				
MOON T				
018 "DIA CIRC CONCR				
LEN=0030	INSTALLED UNKN	0584/0056		
MONTOUR INT RAMP D RD				

DIR: E TOTAL LEN: 35.461 MI. DIST: 11-1 SR: 376
 LEFT MUN: MOON T RIGHT MUN: MOON T

Stationing	Description	Stationing	Description
(SR8074 SEG 0274/0000) 0585/0047		049245 FT 0 0 00000 0 00 0000+00	
0 0 00000 0 00 0000+00 049218 FT		5 0584/0000 LENGTH(AH 2623 BK 2640)	
LENGTH(AH 2593 BK 2619) 0585/0000			
MONTOUR INT RAMP B RD			
(SR8074 SEG 0254/0805) 0581/2317			
018 "DIA CIRC CONCR			
LEN=0065 INSTALLED UNKN 0581/2037			
		018 "DIA CIRC CONCR	
		LEN=0030 INSTALLED UNKN	
		RAMP A SPUR AND C RD	
018 "DIA CIRC CONCR		0580/2023	
LEN=0099 INSTALLED UNKN 0581/1722		0580/1969	(SR8074 SEG 0020/0454)
		018 "DIA CIRC CONCR	
		LEN=0040 INSTALLED UNKN	
		RAMP A RD	
018 "DIA CIRC CONCR		0580/1703	
LEN=0099 INSTALLED UNKN 0581/1445		0580/1691	(SR8074 SEG 0010/0000)
		018 "DIA CIRC CONCR	
		LEN=0040 INSTALLED UNKN	
		SIGN: 4 CHORD TRUSS	
SIGN: 4 CHORD TRUSS		0580/1430	
BMSID 02/0376/0580/1307 0581/1307		0580/1307	BMSID 02/0376/0580/1307
		018 "DIA CIRC CONCR	
		LEN=0040 INSTALLED UNKN	
		018 "DIA CIRC CONCR	
		LEN=0075 INSTALLED UNKN	
		018 "DIA CIRC CONCR	
		LEN=0030 INSTALLED UNKN	
018 "DIA CIRC CONCR			
LEN=0099 INSTALLED UNKN 0581/0759			
SIGN: 4 CHORD TRUSS			
BMSID 02/0376/0580/0504 0581/0504		0580/0504	SIGN: 4 CHORD TRUSS
			BMSID 02/0376/0580/0504
		018 "DIA CIRC CONCR	
		LEN=0030 INSTALLED UNKN	
0 0 00000 0 00 0000+00 046599 FT		0580/0379	
MILEPOST 058.00		046605 FT	0 0 00000 0 00 0000+00
LENGTH(AH 2619 BK 2725) 0581/0000		5 0580/0000	MILEPOST 058.00
			LENGTH(AH 2640 BK 2640)
			018 "DIA CIRC CONCR
			LEN=0100 INSTALLED UNKN
			SIGN: 4 CHORD TRUSS
SIGN: 4 CHORD TRUSS		0574/2635	
BMSID 02/0376/0574/2441 0575/2532		0574/2441	BMSID 02/0376/0574/2441
			BUSINESS 60 SH
		0574/2256	(SR3160 SEG 0132/2390)
BUSINESS 60 SH			
(SR3160 SEG 0133/2785) 0575/2165			
018 "DIA CIRC CONCR			
LEN=0045 INSTALLED UNKN 0575/2143			
012 "DIA CIRC CONCR			
LEN=0099 INSTALLED UNKN 0575/2004			

DIR: E TOTAL LEN: 35.461 MI. DIST: 11-1 SR: 376
 LEFT MUN: MOON T RIGHT MUN: MOON T

Structure ID	Description	Length (FT)	Stationing	Notes
0574/1860	018" DIA CIRC CONCR LEN=0060 INSTALLED UNKN			
0574/1141	BR. MCCLARENS STRUCTURE LENGTH 12 FT BMSID 02/0376/0574/1141 BUSINESS 376	12		
0575/1077	OP ID 02/3160/0132/0858			
0575/1031	SR 8110 (RAMP WS-C)			
0574/1138	OP ID 02/3160/0132/0858			
0575/0698	OP ID 02/8110/0250/2010			
0574/0593	SR 8110 (RAMP WS-C) OP ID 02/8110/0250/2010			
0575/0447	MCCLARENS RU STRUCTURE LENGTH 14 FT BMSID 02/0376/0574/0581	14		
0574/0581	BMSID 02/0376/0574/0581			
043874 FT	0 0 00000 0 00 0000+00			
043965 FT	0 0 00000 0 00 0000+00			
0575/0000	LENGTH(AH 2725 BK 2591)			
0574/0000	FR SR 3160 RAMP RD (SR8110 SEG 0500/1191)			
0571/2538				
0570/1143	TO SR 3160 RAMP RD (SR8110 SEG 0250/0000)			
0570/0012	SIGN: 4 CHORD TRUSS BMSID 02/0376/0570/0012			
041325 FT	0 0 00000 0 00 0000+00			
0571/0000	LENGTH(AH 2591 BK 2740)			
0570/0000	MILEPOST 057.00 LENGTH(AH 2640 BK 2640)			
0565/2125	018" DIA CIRC CONCR LEN=0065 INSTALLED UNKN			
0564/1550	018" DIA CIRC CONCR LEN=0070 INSTALLED UNKN			
0565/1538	018" DIA CIRC CONCR LEN=0640 INSTALLED UNKN			
0564/0914	018" DIA CIRC CONCR LEN=0070 INSTALLED UNKN			
0565/0565	RAMP TO MCCLAREN RD (SR8128 SEG 0500/0000)			
0565/0080	018" DIA CIRC CONCR LEN=0065 INSTALLED UNKN			
038543 FT	0 0 00000 0 00 0000+00			
0565/0000	LENGTH(AH 2740 BK 2674)			
0564/0000	038685 FT 0 0 00000 0 00 0000+00			
0560/2208	LENGTH(AH 2640 BK 2640) RAMP FROM MCCLAREN RD (SR8128 SEG 0020/1629)			

DIR: E TOTAL LEN: 35.461 MI. DIST: 11-1 SR: 376
 LEFT MUN: MOON T RIGHT MUN: MOON T

018 "DIA CIRC CONCR LEN=0040 INSTALLED UNKN 0551/0804	---	0550/1160 LEN=0040 INSTALLED UNKN
018 "DIA CIRC CONCR LEN=0099 INSTALLED UNKN 0551/0407	---	
0 0 00000 0 00 0000+00 030766 FT MILEPOST 055.00		030765 FT 0 0 00000 0 00 0000+00 MILEPOST 055.00
LENGTH(AH 2496 BK 2640) 0551/0000	5	5 0550/0000 LENGTH(AH 2640 BK 2640) 018 "DIA CIRC CONCR LEN=0070 INSTALLED UNKN
018 "DIA CIRC METAL LEN=0040 INSTALLED UNKN 0545/2301	---	0544/2640
018 "DIA CIRC METAL LEN=0040 INSTALLED UNKN 0545/1876	---	
018 "DIA CIRC METAL LEN=0040 INSTALLED UNKN 0545/1528	---	
SIGN: 4 CHORD TRUSS BMSID 02/0376/0545/0763 0545/0763	┌───┐	
0 0 00000 0 00 0000+00 028126 FT LENGTH(AH 2640 BK 2640) 0545/0000	5	5 0544/0435 018 "DIA CIRC CONCR LEN=0070 INSTALLED UNKN 028125 FT 0 0 00000 0 00 0000+00 5 0544/0000 LENGTH(AH 2640 BK 2640)
018 "DIA CIRC METAL LEN=0040 INSTALLED UNKN 0541/1937	---	
	---	0540/1588 018 "DIA CIRC CONCR LEN=0070 INSTALLED UNKN
	---	0540/1137 018 "DIA CIRC CONCR LEN=0070 INSTALLED UNKN
	---	0540/0534 018 "DIA CIRC CONCR LEN=0060 INSTALLED UNKN
SIGN: 4 CHORD TRUSS BMSID 02/0376/0541/0476 0541/0476	┌───┐	
DRAINAGE STRUCTURE LENGTH 16 FT BMSID 02/0376/0540/0403 0541/0399	┌───┐	DRAINAGE STRUCTURE LENGTH 16 FT BMSID 02/0376/0540/0403
018 "DIA CIRC METAL LEN=0040 INSTALLED UNKN 0541/0305	---	
018 "DIA CIRC METAL LEN=0040 INSTALLED UNKN 0541/0005	---	
0 0 00000 0 00 0000+00 025486 FT MILEPOST 054.00		025485 FT 0 0 00000 0 00 0000+00 MILEPOST 054.00
LENGTH(AH 2640 BK 2640) 0541/0000	5	5 0540/0000 LENGTH(AH 2640 BK 2640)
SIGN: 4 CHORD TRUSS BMSID 02/0376/0535/1503 0535/1503	┌───┐	

DIR: E TOTAL LEN: 35.461 MI. DIST: 11-1 SR: 376
 LEFT MUN: MOON T RIGHT MUN: MOON T

SIGN: 4 CHORD TRUSS
 BMSID 02/0376/0535/0723 0535/0723
 TURNPIKE RAMP RD TOLL 5
 (TNPK) 0535/0399

0 0 00000 0 00 0000+00 022846 FT
 LENGTH(AH 2640 BK 2640) 0535/0000

SR 8111 (RAMP MT-
 OP ID 02/8111/0010/2439 0531/2048

018 "DIA CIRC METAL
 LEN=0099 INSTALLED UNKN 0531/1956
 TURNPIKE RAMP RD TOLL 5
 (TNPK) 0531/1588

012 "DIA CIRC CONCR
 LEN=0099 INSTALLED UNKN 0531/1340

PA TPK (I-576)
 OP ID 02/7576/9900/0009 0531/1125

PA TPK (I-576)
 OP ID 02/7576/9900/0010 0531/1046

SR 8111 (RAMP MT-C
 OP ID 02/8111/0260/0738 0531/0717

PA TPK (RAMP D)
 OP ID 02/7576/9900/0012 0531/0608

0 0 00000 0 00 0000+00 020206 FT
 MILEPOST 053.00

LENGTH(AH 2640 BK 2640) 0531/0000
 FR MIDFIELD TERM RMP RD

(SR8111 SEG 0250/0840) 0525/2481
 AIRPORT INT/ RP 0500 RD

(SR8111 SEG 0500/0000) 0525/2367

SIGN: CANTILEVER
 BMSID 02/0376/0525/1256 0525/1256

SIGN: 4 CHORD TRUSS
 BMSID 02/0376/0525/0364 0525/0364

0534/0839 TURNPIKE RAMP RD TOLL 5
 (TNPK)

0534/0210 018 "DIA CIRC METAL
 022845 FT LEN=0110 INSTALLED UNKN
 0534/0000 0 0 00000 0 00 0000+00
 LENGTH(AH 2640 BK 2640)
 FR MIDFIELD TERM RMP RD

0530/2081 (SR8111 SEG 0260/2190)
 SR 8111 (RAMP MT-
 0530/1972 OP ID 02/8111/0010/2439

0530/1957 018 "DIA CIRC CONCR
 LEN=0060 INSTALLED UNKN

0530/1111 OP ID PA TPK (I-576)
 02/7576/9900/0009

0530/1028 OP ID PA TPK (I-576)
 02/7576/9900/0010

0530/0809 OP ID SR 8111 (RAMP MT-C
 02/8111/0260/0738

0530/0637 OP ID PA TPK (RAMP D)
 02/7576/9900/0012

020205 FT 0 0 00000 0 00 0000+00
 MILEPOST 053.00

0530/0000 LENGTH(AH 2640 BK 2640)

0524/2104 TO MIDFIELD TERM RMP RD
 (SR8111 SEG 0010/0000)

0524/1647 SIGN: 4 CHORD TRUSS
 BMSID 02/0376/0524/1689

0524/0604 SIGN: 4 CHORD TRUSS
 BMSID 02/0376/0524/0654

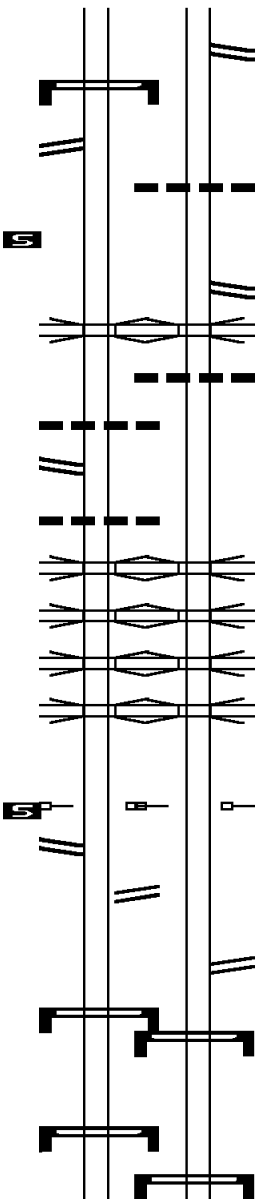

DIR: E TOTAL LEN: 35.461 MI. DIST: 11-1 SR: 376
LEFT MUN: MOON T RIGHT MUN: MOON T

0 0 00000 0 00 0000+00 017566 FT		0524/0528	018 "DIA CIRC CONCR
LENGTH(AH 2640 BK 2531) 0525/0000		017565 FT	LEN=0070 INSTALLED UNKN
		0524/0000	0 0 00000 0 00 0000+00
			LENGTH(AH 2640 BK 2640)
		0520/2500	SIGN: 4 CHORD TRUSS
			BMSID 02/0376/0520/2050
		0520/2346	016 "DIA CIRC CONCR
			LEN=0040 INSTALLED UNKN
RAMP G RD			
(SR8112 SEG 0500/0000) 0521/2165			
018 "DIA CIRC CONCR			
LEN=0050 INSTALLED UNKN 0521/1847			
SR 3089 MOON CLINT			
OP ID 02/3089/0082/1452 0521/1234			
		0520/1274	SR 3089 MOON CLINT
			OP ID 02/3089/0082/1452
		0520/0838	RAMP FROM CLINTON RD
			(SR8112 SEG 0020/1268)
		0520/0035	018 "DIA CIRC CONCR
			LEN=0055 INSTALLED UNKN
RAMP I RD			
(SR8112 SEG 0250/1279) 0521/0021			
0 0 00000 0 00 0000+00 015035 FT			
MILEPOST 052.00			
LENGTH(AH 2531 BK 2668) 0521/0000		014925 FT	0 0 00000 0 00 0000+00
			MILEPOST 052.00
		0520/0000	LENGTH(AH 2640 BK 2723)
			CONNECTOR RD
		0514/2641	(SR9460 SEG 0010/3779)
SIGN: 4 CHORD TRUSS			
BMSID 02/0376/0515/2000 0515/2000			
		0514/1803	SIGN: 4 CHORD TRUSS
			BMSID 02/0376/0514/1900
SIGN: 4 CHORD TRUSS			
BMSID 02/0376/0515/0877 0515/0877			
MOON			
FINDLAY T 0515/0516			
RAREDON RUN			
STRUCTURE LENGTH 8 FT			
BMSID 02/0376/0510/1223 0515/0357			
		0514/0178	018 "DIA CIRC CONCR
			LEN=0070 INSTALLED UNKN
		0514/0144	MOON
		012202 FT	FINDLAY T
		0514/0000	0 0 00000 0 00 0000+00
			LENGTH(AH 2723 BK 2556)
		0510/2424	018 "DIA CIRC CONCR
			LEN=0050 INSTALLED UNKN
SIGN: 4 CHORD TRUSS			

DIR: E TOTAL LEN: 35.461 MI. DIST: 11-1 SR: 376
 LEFT MUN: FINDLAY T RIGHT MUN: FINDLAY T

BMSID 02/0376/0511/2200 0511/2200
 RAMP TO FLAUGHERTY RUN
 (SR8113 SEG 0500/0000) 0511/2138

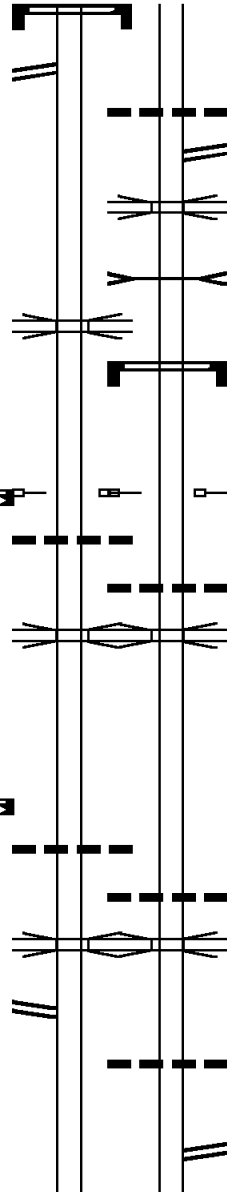

RAMP FR-A
 OP ID 02/8113/0510/2040 0511/1182

0 0 00000 0 00 0000+00 009811 FT
 MILEPOST 051.00
 LENGTH(AH 2556 BK 2621) 0511/0000
 018 "DIA CIRC METAL
 LEN=0045 INSTALLED UNKN 0505/2475

SR 3088 HOOKSTOWN
 OP ID 02/3088/0032/0000 0505/1948

0 0 00000 0 00 0000+00 007190 FT
 LENGTH(AH 2621 BK 2677) 0505/0000
 018 "DIA CIRC CONCR
 LEN=0099 INSTALLED UNKN 0501/2540

RAMP FR-E
 OP ID 02/3160/0012/1527 0501/2521

BUSINESS 60
 (SR3160 SEG 0013/0000) 0501/1787

NC AIRPORT PY

0510/1934 018 "DIA CIRC CONCR
 LEN=0050 INSTALLED UNKN
 CONNECTOR RD
 0510/1430 (SR9460 SEG 0010/0000)
 RAMP FR-A
 0510/1268 OP ID 02/8113/0510/2040
 RAREDON RUN
 STRUCTURE LENGTH 8 FT
 0510/1205 BMSID 02/0376/0510/1223

SIGN: 4 CHORD TRUSS
 0510/1159 BMSID 02/0376/0510/1050

009646 FT 0 0 00000 0 00 0000+00
 MILEPOST 051.00
 0510/0000 LENGTH(AH 2556 BK 2640)

0504/2480 016 "DIA CIRC CONCR
 LEN=0050 INSTALLED UNKN
 SR 3088 HOOKSTOWN
 0504/1975 OP ID 02/3088/0032/0000

007006 FT 0 0 00000 0 00 0000+00
 0504/0000 LENGTH(AH 2640 BK 2640)

0500/2463 018 "DIA CIRC CONCR
 LEN=0060 INSTALLED UNKN
 RAMP FR-E
 0500/2338 OP ID 02/3160/0012/1527

0500/1723 016 "DIA CIRC CONCR
 LEN=0040 INSTALLED UNKN

NC AIRPORT PY
 BUSINESS 60
 0500/0903 (SR3160 SEG 0012/0000)

DIR: E TOTAL LEN: 35.461 MI. DIST: 11-1 SR: 376
 LEFT MUN: FINDLAY T RIGHT MUN: FINDLAY T

0 0 00000 0 00 0000+00 004513 FT
 MILEPOST 050.00
 LENGTH(AH 2677 BK 2640) 0501/0000
 SIGN: CANTILEVER
 BMSID 02/0376/0495/2400 0495/2532
 SIGN: CANTILEVER
 BMSID 02/0376/0495/2401 0495/2401

FINDLAY
 MOON T 0495/1700
 SR 3084 ECOMONY GR
 OP ID 02/3084/0020/1034 0495/1548

018 "DIA CIRC CONCR
 LEN=0145 INSTALLED UNKN 0495/1100

018 "DIA CIRC CONCR
 LEN=0085 INSTALLED 2018 0495/0862

024 "DIA CIRC METAL
 LEN=0071 INSTALLED 2018 0495/0522

0 0 00000 0 00 0000+00 001873 FT
 LENGTH(AH 2640 BK 1873) 0495/0000

CROSSOVER RD
 (CONN) 0493/0222

0 0 00000 0 00 0000+00 000000 FT
 NC BEAVER VALLEY EX REF-BK *
 BEAVER VALLEY EX (SRO376 SEG 0491/0928)
 MFC BEGIN = A
 LENGTH(AH 1873 BK 0000) 0493/0000

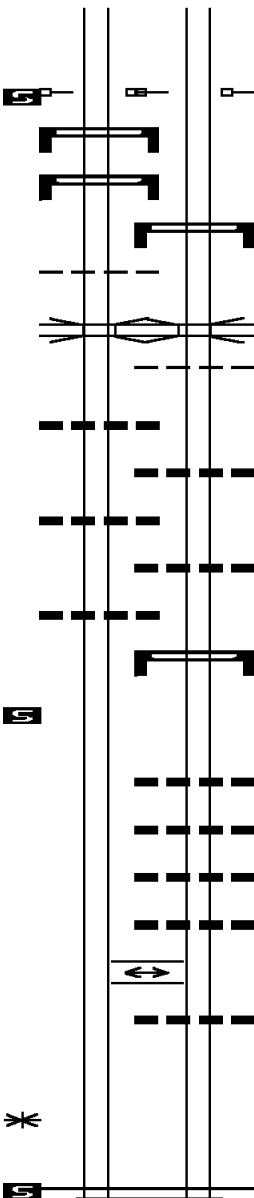

004366 FT 0 0 00000 0 00 0000+00
 MILEPOST 050.00
 LENGTH(AH 2640 BK 2640) 0500/0000

0494/2077 SIGN: 4 CHORD TRUSS
 BMSID 02/0376/0494/2077

SR 3084 ECOMONY GR
 OP ID 02/3084/0020/1034 0494/1510
 FINDLAY
 MOON T 0494/1482

0494/0976 018 "DIA CIRC CONCR
 LEN=0060 INSTALLED UNKN

0494/0640 018 "DIA CIRC CONCR
 LEN=0050 INSTALLED UNKN

0494/0398 SIGN: 4 CHORD TRUSS
 BMSID 02/0376/0494/0398
 001726 FT 0 0 00000 0 00 0000+00
 LENGTH(AH 2640 BK 1726) 0494/0000

0492/1103 018 "DIA CIRC CONCR
 LEN=0050 INSTALLED UNKN

0492/0812 018 "DIA CIRC CONCR
 LEN=0050 INSTALLED UNKN

0492/0556 040 "DIA CIRC CONCR
 LEN=0099 INSTALLED UNKN

0492/0330 018 "DIA CIRC CONCR
 LEN=0110 INSTALLED UNKN

0492/0067 CROSSOVER RD
 (CONN)

0492/0031 018 "DIA CIRC CONCR
 LEN=0120 INSTALLED UNKN

000000 FT 0 0 00000 0 00 0000+00
 NC BEAVER VALLEY EX * REF-BK
 BEAVER VALLEY EX (SRO376 SEG 0490/0914)

MFC BEGIN = A
 BK-BEAVER (04)

LENGTH(AH 1726 BK 0000) 0492/0000

AH-WESTMORELAND (64) 010132 FT
 LEECHBURG RD
 (CITY)
 FREEPORT RD
 (CITY)

STEVENSON BL INTER-BK
 (SR0366 SEG 0012/0000) 0043/2959
 024 "DIA CIRC CONCR
 LEN=0060 INSTALLED UNKN 0043/2520
 CARL AV
 (BORO) 0043/2470

RIVERVIEW PLAZA RD
 (PRDR)
 CALDWELL AV
 (BORO) 0043/1663
 024 "DIA CIRC CONCR
 LEN=0060 INSTALLED UNKN 0043/1470

RIVERVIEW PLAZA RD
 (PRDR) 0043/0629
 012 "DIA CIRC CONCR
 LEN=0060 INSTALLED UNKN 0043/0084
 0 0 00000 0 00 0000+00 007173 FT
 NC STEVENSON BL
 LENGTH(AH 2959 BK 2941) 0043/0000
 BMSN 02/0366/0032/0975 0033/2692

010156 FT
 INTER-AHD STEVENSON BL
 (SR0366 SEG 0012/0000)
 LEECHBURG RD
 (CITY)
 FREEPORT RD
 (CITY)

0042/3171

0042/2684 CARL AV
 (BORO)

RIVERVIEW PLAZA RD
 (PRDR)
 CALDWELL AV
 (BORO) 0042/1887

RIVERVIEW PLAZA RD
 (PRDR) 0042/0837

006985 FT 2 0 64268 0 00 0158+67
 NC STEVENSON BL
 0042/0000 LENGTH(AH 3171 BK 2799)
 0032/2760 BMSN 02/0366/0032/0975

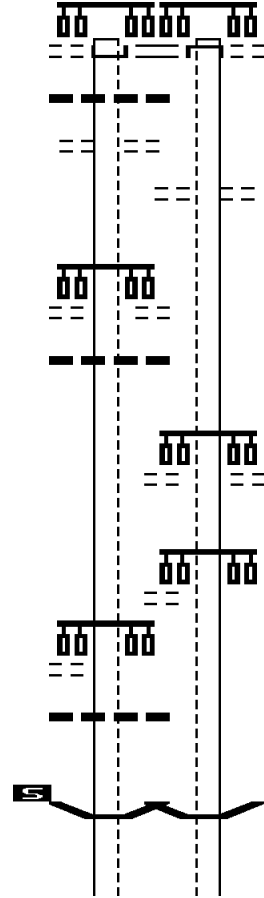

EXTRACT DATE: 12/21/2020
PRINT DATE: 12/23/2020

ROADWAY MANAGEMENT SYSTEM
SLD COUNTY/SR - ANNUAL PRINT

PAGE NUMBER: 346
COUNTY: ALLEGHENY

DIR: E TOTAL LEN: 1.923 MI.
LEFT MUN: TARENTUM B

DIST: 11-1 SR: 366
RIGHT MUN: TARENTUM B

0 0 00000 0 00 0000+00
RAMP D
BMSBG 02/0366/0032/0975 0033/0908
BMSSEN 02/0366/0033/0890 0033/0885

SIGN: CANTILEVER
BMSID 02/0366/0033/0540 0033/0850

RAMP FR FIRST AV
(SR8088 SEG 0020/0686) 0033/0449
0 0 00000 0 00 0000+00
FOURTH AVE
BMSBG 02/0366/0033/0890 0033/0273
LC FROM SIXTH AV
(CONN)
SIXTH AV
(BORO) 0033/0230
024 "DIA CIRC CONCR
LEN=0050 INSTALLED UNKN 0033/0121

1 1 09801 0 00 0000+00 004232 FT
NC TARENTUM BR
SEVENTH AV
(BORO)
SEVENTH AV
(SR1001 SEG 0400/0587)

LENGTH(AH 2941 BK 0918) 0033/0000
024 "DIA CIRC CONCR
LEN=0080 INSTALLED UNKN 0023/0824

024 "DIA CIRC CONCR
LEN=0099 INSTALLED UNKN 0023/0715
EIGHTH AV
(BORO) 0023/0670
024 "DIA CIRC CONCR
LEN=0060 INSTALLED UNKN 0023/0613
NINTH AV
(BORO)
NINTH AV
(BORO) 0023/0430

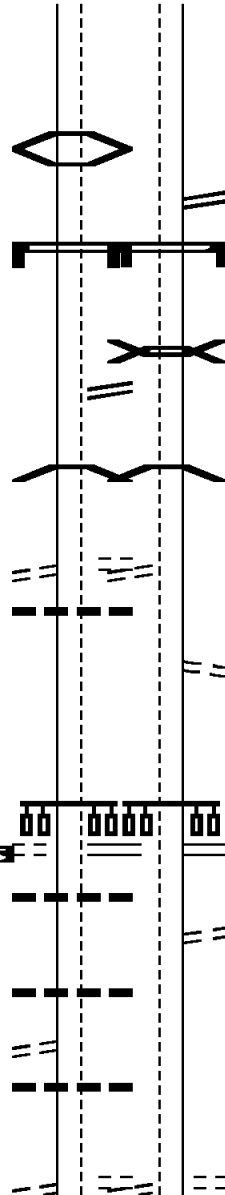

0032/0502 RAMP TO FIRST AV
(SR8088 SEG 0010/0000)
SIGN: 2 CHORD TRUSS
0032/0485 BMSID 02/0366/0032/0485
0 0 00000 0 00 0000+00
BMSSEN 02/0366/0032/0400
RAMP D
0032/0976 BMSBG 02/0366/0032/0975
0 0 00000 0 00 0000+00
RAMP D
0032/0400 BMSBG 02/0366/0032/0400
LC FROM SIXTH AV
(CONN) 0032/0263
FROM 1001/0400 SH
(CONN) 0032/0095
004186 FT 1 1 09801 0 00 0000+00
NC TA RENTUM BR
SEVENTH AV
(BORO)
SEVENTH AV
(SR1001 SEG 0400/0587)
0032/0000 LENGTH(AH 2799 BK 0906)
TO 1001/0400 SH
(CONN) 0022/0806
NINTH AV
(BORO)
NINTH AV
(BORO) 0022/0420

DIR: E TOTAL LEN: 1.923 MI. DIST: 11-1 SR: 366
 LEFT MUN: TARENTUM B RIGHT MUN: TARENTUM B

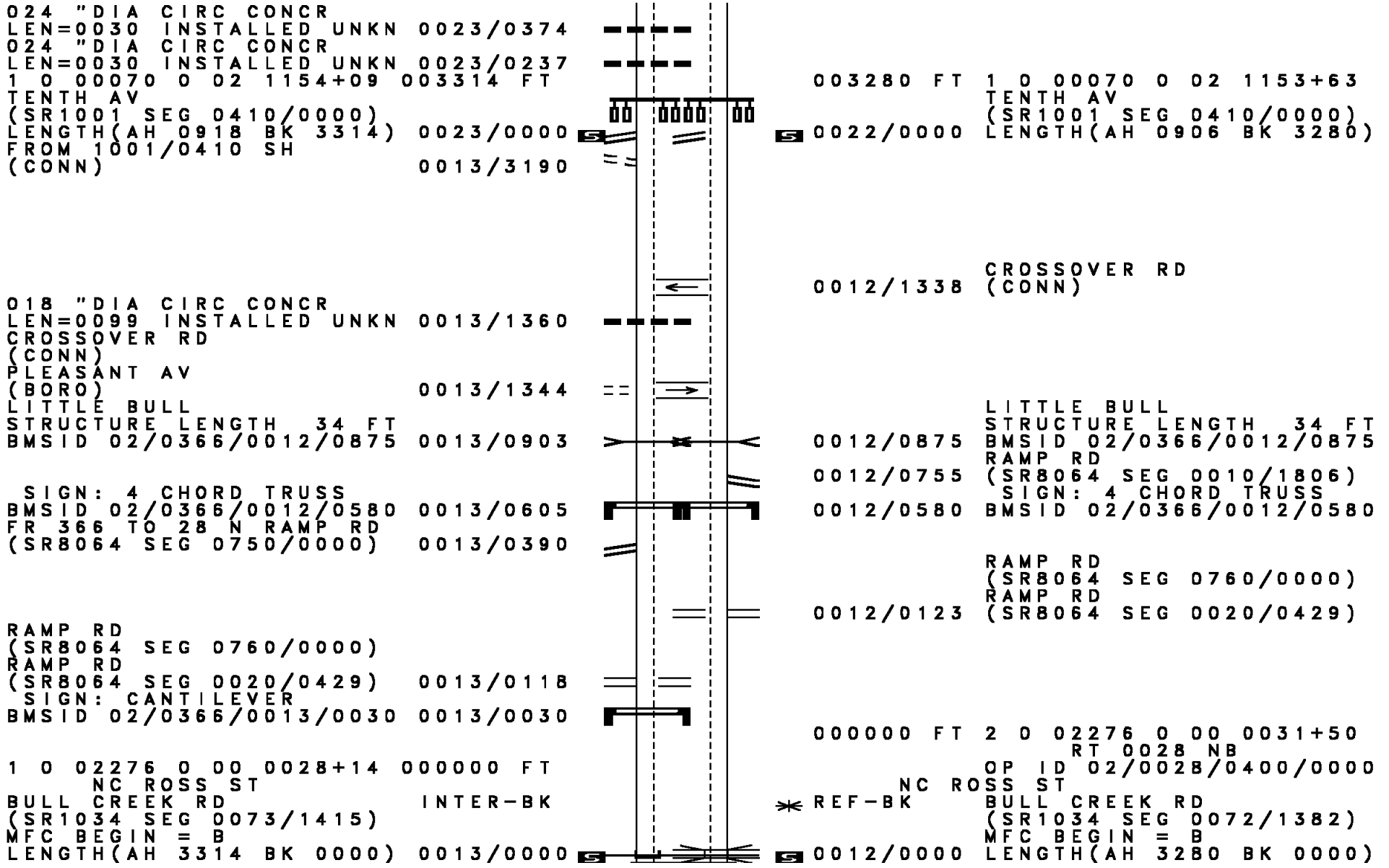

EXTRACT DATE: 12/21/2020 ROADWAY MANAGEMENT SYSTEM PAGE NUMBER: 344
 PRINT DATE: 12/23/2020 SLD COUNTY/SR - ANNUAL PRINT COUNTY: ALLEGHENY
 DIR: E TOTAL LEN: 4.515 MI. DIST: 11-1 SR: 286
 LEFT MUN: PLUM BOROUGH B RIGHT MUN: PLUM BOROUGH B

023141 FT

* 023841 FT AH-WESTMORELAND (64)
 REF-AHD GOLDEN MILE HW
 0090/0919 (SR0286 SEG 0010/0000)

022222 FT

022922 FT 2 0 02143 0 00 0116+45
 0090/0000 LENGTH(AH 0919 BK 3459)
 HUMMS RUN



EXTRACT DATE: 12/21/2020
PRINT DATE: 12/23/2020

ROADWAY MANAGEMENT SYSTEM
SLD COUNTY/SR - ANNUAL PRINT

PAGE NUMBER: 343
COUNTY: ALLEGHENY

DIR: E TOTAL LEN: 4.515 MI.
LEFT MUN: PLUM BOROUGH B

DIST: 11-1 SR: 286
RIGHT MUN: PLUM BOROUGH B

HIALEAH DR
(BORO)

0080/3360

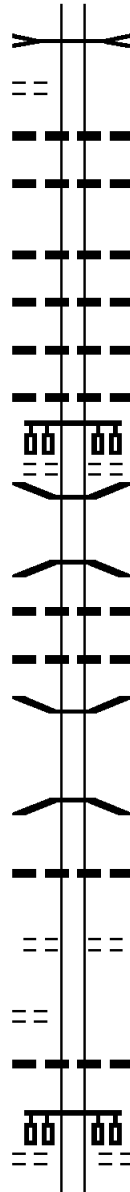

0080/3422 STRUCTURE LENGTH 14 FT
BMSID 02/0286/0080/3412

0080/3040 018 " DIA CIRC CONCR
LEN=0040 INSTALLED 2002
0080/2708 024 " DIA CIRC CONCR
LEN=0060 INSTALLED UNKN

0080/2060 018 " DIA CIRC CONCR
LEN=0048 INSTALLED UNKN
0080/1885 018 " DIA CIRC CONCR
LEN=0045 INSTALLED 2002
0080/1737 018 " DIA CIRC CONCR
LEN=0060 INSTALLED 2002
0080/1322 018 " DIA CIRC CONCR
LEN=0030 INSTALLED 2002

HOLIDAY PARK DR
(BORO)

0080/1270
0080/1044 BMSEN 02/0286/0080/1030
0 0 00000 0 00 0000+00
HUMMS RUN

0080/1030 BMSBG 02/0286/0080/1030
018 " DIA CIRC CONCR
0080/0928 LEN=0099 INSTALLED UNKN
018 " DIA CIRC CONCR
0080/0688 LEN=0040 INSTALLED UNKN

018763 FT

0080/0028 BMSEN 02/0286/0080/0000
019463 FT 2 0 02143 0 00 0082+37
HUMMS RUN

0080/0000 BMSBG 02/0286/0080/0000
LENGTH(AH 3459 BK 3067)

0070/2425 018 " DIA CIRC CONCR
LEN=0099 INSTALLED UNKN

0070/1735 DUANE DR
(BORO)

OLD ABERS CREEK RD
(BORO)

0070/0849

0070/0325 018 " DIA CIRC CONCR
LEN=0020 INSTALLED 2002
SANDUNE DR

2 0 02143 0 00 0048+18 015696 FT
PRESQUE ISLE DR
(BORO)

0070/0000

0070/0000 LENGTH(AH 3067 BK 1830)
018 " DIA CIRC CONCR

EXTRACT DATE: 12/21/2020
PRINT DATE: 12/23/2020

ROADWAY MANAGEMENT SYSTEM
SLD COUNTY/SR - ANNUAL PRINT

PAGE NUMBER: 342
COUNTY: ALLEGHENY

DIR: E TOTAL LEN: 4.515 MI.
LEFT MUN: PLUM BOROUGH B

DIST: 11-1 SR: 286
RIGHT MUN: PLUM BOROUGH B

PINE VALLEY DR
(BORO)

013866 FT

0050/1701

010471 FT

---	0060/1610	LEN=0020	INSTALLED	2002
---	0060/0507	024 "DIA	CIRC CONCR	
---		LEN=0045	INSTALLED	2002
---	0060/0322	036 "DIA	CIRC CONCR	
---		LEN=0045	INSTALLED	2002
---	0060/0032	BMSSEN 02/0286/0060/0000		
---	014566 FT	2 0 02143 0 00 0034+16		
---		HUMMS RUN		
---	0060/0000	BMSBG 02/0286/0060/0000		
---		LENGTH(AH 1830 BK 3395)		
---		KANE RD		
---		(BORO)		
---	0050/2980	018 "DIA	CIRC CONCR	
---	0050/2600	LEN=0036	INSTALLED	UNKN
---	0050/2340	018 "DIA	CIRC CONCR	
---		LEN=0036	INSTALLED	UNKN
---	0050/2115	018 "DIA	CIRC CONCR	
---		LEN=0005	INSTALLED	2002
---	0050/1890	018 "DIA	CIRC CONCR	
---		LEN=0036	INSTALLED	UNKN
---	0050/1701	018 "DIA	CIRC CONCR	
---	0050/1655	LEN=0036	INSTALLED	UNKN
---	0050/1470	024 "DIA	CIRC CONCR	
---		LEN=0036	INSTALLED	UNKN
---	0050/1450	018 "DIA	CIRC CONCR	
---		LEN=0050	INSTALLED	2002
---	0050/1273	024 "DIA	CIRC CONCR	
---		LEN=0036	INSTALLED	UNKN
---	0050/0836	BMSSEN 02/0286/0050/0802		
---		2 0 02143 0 00 0007+98		
---	0050/0802	ABERS CREEK		
---		BMSBG 02/0286/0050/0802		
---	0050/0125	018 "DIA	CIRC CONCR	
---		LEN=0040	INSTALLED	2002
---	011171 FT	2 0 02143 0 00 0000+00		
---		NEW TEXAS RD		
---		(SR2075 SEG 0030/0000)		
---	0050/0000	LENGTH(AH 3395 BK 1834)		
---	0040/1471	024 "DIA	CIRC CONCR	
---		LEN=0020	INSTALLED	2002
---		018 "DIA	CIRC CONCR	

EXTRACT DATE: 12/21/2020
PRINT DATE: 12/23/2020

ROADWAY MANAGEMENT SYSTEM
SLD COUNTY/SR - ANNUAL PRINT

PAGE NUMBER: 341
COUNTY: ALLEGHENY

DIR: E TOTAL LEN: 4.515 MI.
LEFT MUN: PLUM BOROUGH B

DIST: 11-1 SR: 286
RIGHT MUN: PLUM BOROUGH B

Street Name	Segment ID	Length (FT)	Material	Year
008637 FT	0040/0341	0020	INSTALLED	2002
	0040/0115	0025	INSTALLED	2002
	009337 FT	2 0 02134 0 00 0092+75	OLD FRANKSTOWN RD (SR2066 SEG 0110/0000)	
RICKENBAKER DR (PRDR)	0030/1424	1424	PHILIPS DR (PRDR)	
	0030/1116	1116	036 " DIA CIRC CONCR	2002
	0030/1115	1115	036 " DIA CIRC CONCR	2002
FITZSIMMON'S LN (BORO)	0030/0520	0520	018 " DIA CIRC CONCR	2002
	0030/0475	0475	FITZSIMMON'S LN (BORO)	
	005880 FT	006580 FT	015 " DIA CIRC CONCR	2002
005880 FT	0030/0000	0000	LENGTH(AH 2757 BK 3778)	
	0020/3275	3275	024 " DIA CIR PLASTIC	UNKN
	0020/3037	3037	018 " DIA CIRC CONCR	UNKN
	0020/2971	2971	LEN=0036 INSTALLED	UNKN
	0020/2804	2804	024 " DIA CIRC CONCR	UNKN
	0020/2567	2567	LEN=0050 INSTALLED	UNKN
	0020/2567	2567	018 " DIA CIRC CONCR	UNKN
OLD ABERS CRK RD (BORO)	0020/1735	1735	LEN=0036 INSTALLED	UNKN
	0020/1171	1171	018 " DIA CIRC CONCR	UNKN

DIR: E TOTAL LEN: 4.515 MI. DIST: 11-1 SR: 286
LEFT MUN: MONROEVILLE B RIGHT MUN: MONROEVILLE B

2 0 02134 0 00 0045+20 002102 FT
PARK AND RIDE
(BORO) 0020/0000

ALPINE VILLAGE DR
(SR2129 SEG 0010/0182) 0011/0589

ABERS CREEK
STRUCTURE LENGTH 39 FT
BMSID 02/0286/0010/0510 0011/0466

0 0 00000 0 00 0000+00 000611 FT
LENGTH(AH 1491 BK 0611) 0011/0000

018 "DIA CIRC CONCR
LEN=0040 INSTALLED UNKN 0005/0386

ACCESS RD
(TWP) 0005/0185
2 0 02134 2 01 0000+00 000000 FT
NEW WM PENN HW
(SR0022 SEG 0271/1942)
NC GOLDEN MILE HW
NEW WM PENN HW INTER-BK
(SR0022 SEG 0271/1942)
MFC BEGIN = B
LENGTH(AH 0611 BK 0000) 0005/0000

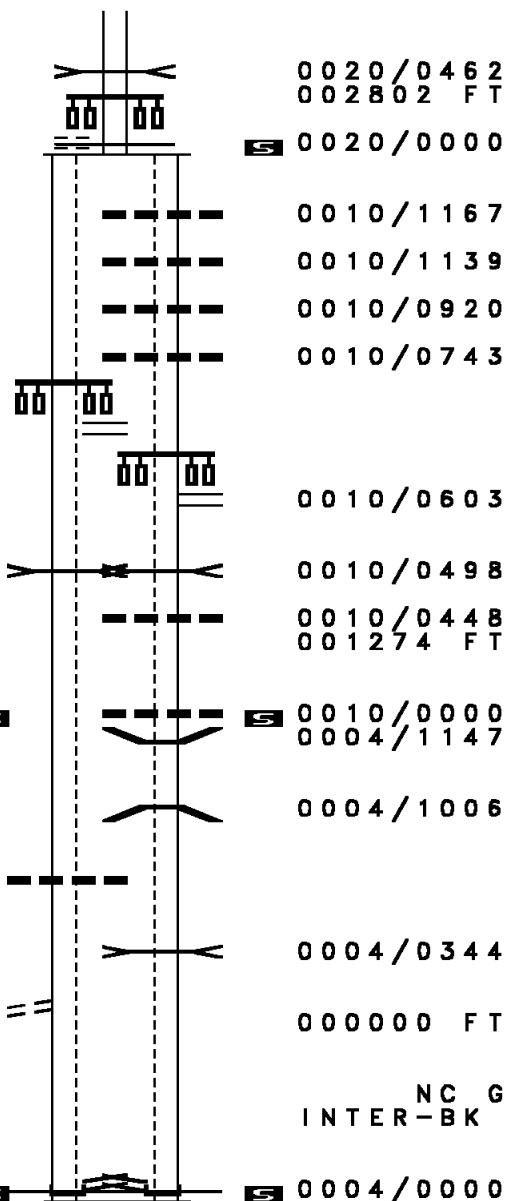

ABERS CREEK
STRUCTURE LENGTH 36 FT
BMSID 02/0286/0020/0462

MFC BEGIN = B
LENGTH(AH 3778 BK 1528)

018 "DIA CIRC CONCR
LEN=0025 INSTALLED UNKN
018 "DIA CIRC CONCR
LEN=0050 INSTALLED UNKN
018 "DIA CIRC CONCR
LEN=0025 INSTALLED 2002
018 "DIA CIRC CONCR
LEN=0025 INSTALLED 2002

ALPINE VILLAGE DR
(SR2129 SEG 0010/0182) 0010/0603

ABERS CREEK
STRUCTURE LENGTH 39 FT
BMSID 02/0286/0010/0510 0010/0498
018 "DIA CIRC CONCR
LEN=0099 INSTALLED UNKN
2 0 02134 0 00 0014+28
018 "DIA CIRC CONCR
LEN=0050 INSTALLED 2002
LENGTH(AH 1528 BK 1274)
BMSSEN 02/0286/0004/1006
0 0 00000 0 00 0000+00
SR 0022 EB
BMSBG 02/0286/0004/1006

THOMPSON RUN
STRUCTURE LENGTH 29 FT
BMSID 02/0022/0270/2100

2 0 02134 2 00 0000+00
WM PENN HW
(SR0022 SEG 0270/1859)
LDEN MILE HW
NEW WM PENN HW
(SR0022 SEG 0270/1859)
MFC BEGIN = B
LENGTH(AH 1274 BK 0000)

EXTRACT DATE: 12/21/2020 ROADWAY MANAGEMENT SYSTEM PAGE NUMBER: 339
PRINT DATE: 12/23/2020 SLD COUNTY/SR - ANNUAL PRINT COUNTY: ALLEGHENY

DIR: N TOTAL LEN: 13.299 MI. DIST: 11-1 SR: 279
LEFT MUN: FRANKLIN PARK B RIGHT MUN: FRANKLIN PARK B

RAYMOND P SHAFER HW
(SR0079 SEG 0711/2119)
SR 4011 ROCHESTER
OP ID 02/4011/0210/1415
RAYMOND P SHAFER HW
(SR0079 SEG 0711/2119) 0133/1704
SIGN: 3 CHORD TRUSS
BMSID 02/0079/0711/1815 0133/1368
069944 FT

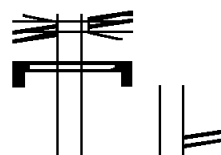

071586 FT RAYMOND P SHAFER HW
(SR0079 SEG 0710/2292)
SR 4011 ROCHESTER

EXTRACT DATE: 12/21/2020
PRINT DATE: 12/23/2020

ROADWAY MANAGEMENT SYSTEM
SLD COUNTY/SR - ANNUAL PRINT

PAGE NUMBER: 337
COUNTY: ALLEGHENY

DIR: N TOTAL LEN: 13.299 MI.
LEFT MUN: FRANKLIN PARK B

DIST: 11-1 SR: 279
RIGHT MUN: FRANKLIN PARK B

Item ID	Material	Length	Stationing	Notes
015	"DIA CIRC CONCR	LEN=0060	INSTALLED UNKN 0117/2025	
018	"DIA CIRC CONCR	LEN=0099	INSTALLED UNKN 0117/0775	
015	"DIA CIRC CONCR	LEN=0060	INSTALLED UNKN 0117/0160	
0 0 00000 0 00 0000+00	060276 FT			
LENGTH(AH 2614 BK 2614)	0117/0000			
0116/2562	018 "DIA CIRC CONCR	LEN=0075	INSTALLED UNKN	
0116/1612	FRANKLIN PARK OHIO T			
0116/0660	018 "DIA CIRC CONCR	LEN=0099	INSTALLED UNKN	
0116/0090	018 "DIA CIRC CONCR	LEN=0099	INSTALLED UNKN	
060722 FT	0 0 00000 0 00 0000+00			
0116/0000	LENGTH(AH 2640 BK 2640)			
0112/2390	018 "DIA CIRC CONCR	LEN=0099	INSTALLED UNKN	
0112/1850	018 "DIA CIRC CONCR	LEN=0099	INSTALLED UNKN	
0112/1410	018 "DIA CIRC CONCR	LEN=0099	INSTALLED UNKN	
0112/0900	018 "DIA CIRC CONCR	LEN=0099	INSTALLED UNKN	
0112/0352	018 "DIA CIR UNKNOWN	LEN=0099	INSTALLED UNKN	
0112/0350	018 "DIA CIRC CONCR	LEN=0099	INSTALLED UNKN	
099	"DIA CIRC CONCR	LEN=0050	INSTALLED UNKN 0113/0340	
0 0 00000 0 00 0000+00	057662 FT			
MILEPOST 011.00				
LENGTH(AH 2614 BK 2609)	0113/0000			
058082 FT	0 0 00000 0 00 0000+00			
0112/0000	MILEPOST 011.00			
0106/2540	LENGTH(AH 2640 BK 2640)			
0106/1835	018 "DIA CIRC CONCR	LEN=0040	INSTALLED UNKN	
0106/1492	018 "DIA CIRC CONCR	LEN=0001	INSTALLED UNKN	
0106/1067	018 "DIA CIRC CONCR	LEN=0045	INSTALLED UNKN	
0106/0807	018 "DIA CIRC CONCR	LEN=0001	INSTALLED UNKN	
	018 "DIA CIRC CONCR			

DIR: N TOTAL LEN: 13.299 MI. DIST: 11-1 SR: 279
 LEFT MUN: OHIO T RIGHT MUN: OHIO T

0 0 00000 0 00 0000+00 055053 FT		0106/0507	LEN=0045	INSTALLED UNKN
LENGTH(AH 2609 BK 2700) 0107/0000		0106/0267	018 "DIA CIRC CONCR	LEN=0045 INSTALLED UNKN
018 "DIA CIRC CONCR		0106/0027	018 "DIA CIRC CONCR	LEN=0001 INSTALLED UNKN
LEN=0001 INSTALLED UNKN 0103/2616		055442 FT	0 0 00000 0 00 0000+00	0106/0000 LENGTH(AH 2640 BK 2640)
BMS EN 02/0279/0103/2399 0103/2399		0102/2372	018 "DIA CIRC CONCR	LEN=0099 INSTALLED UNKN
018 "DIA CIRC CONCR		0102/2315	BMS EN 02/0279/0102/2158	
LEN=0099 INSTALLED UNKN 0103/2286			0 00000 0 0 0000+00	
0 00000 0 0 0000+00			SR 4022 MT NEBO RD	
SR 4022 MT NEBO RD		0102/2158	BMSBG 02/0279/0102/2158	
BMSBG 02/0279/0103/2399 0103/2242		0102/2099	018 "DIA CIRC CONCR	LEN=0099 INSTALLED UNKN
018 "DIA CIRC CONCR				
LEN=0050 INSTALLED UNKN 0103/2142		0102/1780	018 "DIA CIRC CONCR	LEN=0001 INSTALLED UNKN
018 "DIA CIRC CONCR				
LEN=0050 INSTALLED UNKN 0103/1848				
BEAR RUN			BEAR RUN	
STRUCTURE LENGTH 34 FT		0102/1468	STRUCTURE LENGTH 34 FT	
BMSID 02/0279/0102/1468 0103/1572		0102/1380	BMSID 02/0279/0102/1468	
018 "DIA CIRC CONCR			018 "DIA CIRC CONCR	LEN=0001 INSTALLED UNKN
LEN=0099 INSTALLED UNKN 0103/1425				
018 "DIA CIRC CONCR				
LEN=0050 INSTALLED UNKN 0103/0830		0102/0830	018 "DIA CIRC CONCR	LEN=0001 INSTALLED UNKN
018 "DIA CIRC CONCR				
LEN=0050 INSTALLED UNKN 0103/0475		0102/0470	018 "DIA CIRC CONCR	LEN=0001 INSTALLED UNKN
036 "DIA CIRC CONCR				
LEN=0099 INSTALLED UNKN 0103/0130				
0 0 00000 0 00 0000+00 052353 FT		052802 FT	0 0 00000 0 00 0000+00	
LENGTH(AH 2700 BK 2685) 0103/0000		0102/0000	MILEPOST 010.00	
CROSSOVER RD			LENGTH(AH 2640 BK 2640)	
(CONN) 0097/2560		0096/2524	018 "DIA CIRC CONCR	LEN=0050 INSTALLED UNKN
024 "DIA CIRC CONCR		0096/2522	CROSSOVER RD	(CONN)
LEN=0050 INSTALLED UNKN 0097/2210				
			018 "DIA CIRC CONCR	

DIR: N TOTAL LEN: 13.299 MI. DIST: 11-1 SR: 279
 LEFT MUN: OHIO T RIGHT MUN: OHIO T

DMS SIGN STRUCTURE	BMSID	LEN	INSTALLED	UNKN	0096/2122	LEN=0001	INSTALLED	UNKN
018 "DIA CIRC CONCR	02/0279/0097/2010	0097/2088						
018 "DIA CIRC CONCR		0097/1800						
018 "DIA CIRC CONCR		0096/0593						
018 "DIA CIRC CONCR		0096/0155						
000000 000 0000+00 049668 FT		050162 FT						
LENGTH(AH 2685 BK 2609) 0097/0000		0096/0000						
		0092/2384						
018 "DIA CIRC CONCR		0092/1944						
LEN=0099 INSTALLED UNKN 0093/1934								
018 "DIA CIRC CONCR		0092/1564						
LEN=0099 INSTALLED UNKN 0093/1539								
015 "DIA CIRC CONCR		0092/1179						
LEN=0099 INSTALLED UNKN 0093/1182								
024 "DIA CIRC CONCR		0092/0844						
LEN=0099 INSTALLED UNKN 0093/0843								
015 "DIA CIRC CONCR		0092/0449						
LEN=0099 INSTALLED UNKN 0093/0047								
000000 000 0000+00 047059 FT		047522 FT						
MILEPOST 009.00		0092/0000						
LENGTH(AH 2609 BK 2612) 0093/0000								
015 "DIA CIRC CONCR		0086/2640						
LEN=0099 INSTALLED UNKN 0087/2351								
048 "DIA CIRC CONCR		0086/2220						
LEN=0060 INSTALLED UNKN 0087/1862								
OHIO		0086/1825						
ROSS T		0086/1639						
		0087/1323						

DIR: N TOTAL LEN: 13.299 MI. DIST: 11-1 SR: 279
 LEFT MUN: ROSS T RIGHT MUN: ROSS T

Item Description	Item ID	Item Length	Item Material	Item Status	Item Notes
BMSBG 02/0279/0077/1752	0077/1593				
018 "DIA CIRC CONCR					
LEN=0099	INSTALLED UNKN	0077/1493			
018 "DIA CIRC CONCR					
LEN=0001	INSTALLED UNKN	0077/1208			
018 "DIA CIRC CONCR					
LEN=0099	INSTALLED UNKN	0077/0378			
018 "DIA CIRC CONCR					
LEN=0099	INSTALLED UNKN	0077/0068			
0 0 00000 0 00 0000+00	039109 FT				
LENGTH(AH 2636 BK 2585)	0077/0000				
018 "DIA CIRC CONCR					
LEN=0001	INSTALLED UNKN	0073/1965			
UNION AVE					
OP ID 02/4012/0060/1190	0073/1456				
RAMP RD					
(SR8104 SEG 0500/0000)	0073/0771				
0 0 00000 0 00 0000+00	036524 FT				
MILEPOST 007.00					
LENGTH(AH 2585 BK 2731)	0073/0000				
DMS SIGN STRUCTURE					
BMSID 02/0279/0067/2664	0067/2664				
018 "DIA CIRC CONCR					
LEN=0001	INSTALLED UNKN	0067/2540			
RAMP RD					
(SR8104 SEG 0250/1585)	0067/2164				
018 "DIA CIRC CONCR					
LEN=0001	INSTALLED UNKN	0067/1285			
CORNELL AVE					
0076/1613	BMSBG 02/0279/0076/1613				
0076/1094	018 "DIA CIRC CONCR				
	LEN=1094	INSTALLED UNKN			
0076/0692	018 "DIA CIRC CONCR				
	LEN=0099	INSTALLED UNKN			
0076/0374	018 "DIA CIRC CONCR				
	LEN=0374	INSTALLED UNKN			
0076/0355	RAMP RD				
	(SR8104 SEG 0750/1299)				
039602 FT	0 0 00000 0 00 0000+00				
0076/0000	LENGTH(AH 2640 BK 2640)				
	018 "DIA CIRC CONCR				
	LEN=0040	INSTALLED UNKN			
0072/2330					
UNION AVE					
OP ID 02/4012/0060/1190	0072/1560				
0072/0166	018 "DIA CIRC CONCR				
	LEN=0040	INSTALLED UNKN			
036962 FT	0 0 00000 0 00 0000+00				
	MILEPOST 007.00				
0072/0000	LENGTH(AH 2640 BK 2640)				
	RAMP RD				
	(SR8104 SEG 0010/0000)				
0066/2587					
0066/2218	018 "DIA CIRC CONCR				
	LEN=0055	INSTALLED UNKN			
CORNELL AVE					

DIR: N TOTAL LEN: 13.299 MI. DIST: 11-1 SR: 279
LEFT MUN: PITTSBURGH C RIGHT MUN: PITTSBURGH C

Stationing	Description	Material	Status	Stationing	Description	Material	Status
0057/0815	TO SR 19 RAMP C RD			0056/0779	FR SR 19 RAMP B RD		
(SR8103 SEG 0500/0000)				(SR8103 SEG 0750/1160)			
018 "DIA CIRC CONCR							
LEN=0001 INSTALLED UNKN	0057/0327						
024 "DIA CIRC CONCR							
LEN=0001 INSTALLED UNKN	0057/0244						
SIGN: 4 CHORD TRUSS				0056/0142	HOV LN		
BMSID 02/0279/0057/0046	0057/0046			(SR8103 SEG 0760/0546)			
0 0 00000 0 00 0000+00	028555 FT			0056/0130	018 "DIA CIRC CONCR		
LENGTH(AH 2568 BK 2618)	0057/0000			LEN=0099 INSTALLED UNKN			
				029042 FT			
				0056/0000	LENGTH(AH 2640 BK 2640)		
					LR 246 SP C1		
					OP ID 02/4044/0010/0104		
				0052/2430	RETAINING WALL		
018 "DIA CIRC CONCR				BMSID 02/0279/0052/2100			
LEN=0001 INSTALLED UNKN	0053/2481						
LR 246 SP C1							
OP ID 02/4044/0010/0104	0053/2466						
018 "DIA CIRC CONCR							
LEN=0001 INSTALLED UNKN	0053/2456						
HOV RAMP SPUR RD							
(SR8103 SEG 0260/0000)	0053/2216						
018 "DIA CIRC CONCR							
LEN=0001 INSTALLED UNKN	0053/2020						
				0052/1880	018 "DIA CIRC CONCR		
FROM SR 19 N RAMP A RD				LEN=0080 INSTALLED UNKN			
(SR8103 SEG 0250/0716)	0053/1833						
				0052/1480	018 "DIA CIRC CONCR		
				LEN=1480 INSTALLED UNKN			
				0052/1170	RAMP A RD		
				(SR8103 SEG 0010/0000)			
				0052/0960	018 "DIA CIRC CONCR		
018 "DIA CIRC CONCR				LEN=0080 INSTALLED UNKN			
LEN=0001 INSTALLED UNKN	0053/0606						
				0052/0505	018 "DIA CIRC CONCR		
018 "DIA CIRC CONCR				LEN=0080 INSTALLED UNKN			
LEN=0001 INSTALLED UNKN	0053/0019						
0 0 00000 0 00 0000+00	025937 FT						
MILEPOST 005.00				026402 FT			
LENGTH(AH 2618 BK 2518)	0053/0000			0052/0000	LENGTH(AH 2640 BK 3274)		
SR 0019					SR 0019		

EXTRACT DATE: 12/21/2020
PRINT DATE: 12/23/2020

ROADWAY MANAGEMENT SYSTEM
SLD COUNTY/SR - ANNUAL PRINT

PAGE NUMBER: 330
COUNTY: ALLEGHENY

DIR: N TOTAL LEN: 13.299 MI.
LEFT MUN: PITTSBURGH C

DIST: 11-1 SR: 279
RIGHT MUN: PITTSBURGH C

OP ID 02/0019/0410/1068 0047/2191
SIGN: 4 CHORD TRUSS
BMSID 02/0279/0046/2650 0047/1853

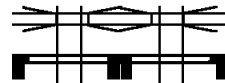

0046/3025 OP ID 02/0019/0410/1068
SIGN: 4 CHORD TRUSS
BMSID 02/0279/0046/2650

018 "DIA CIRC CONCR
LEN=0001 INSTALLED UNKN 0047/1585



0046/2650 015 "DIA CIRC CONCR
LEN=0050 INSTALLED UNKN
0046/2075 015 "DIA CIRC CONCR
LEN=0055 INSTALLED UNKN
0046/1875 015 "DIA CIRC CONCR
LEN=0050 INSTALLED UNKN
0046/1680 015 "DIA CIRC CONCR
LEN=0050 INSTALLED UNKN

018 "DIA CIRC CONCR
LEN=0001 INSTALLED UNKN 0047/1234
018 "DIA CIRC CONCR
LEN=0001 INSTALLED UNKN 0047/0896

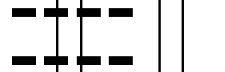

0046/1480 015 "DIA CIRC CONCR
LEN=0055 INSTALLED UNKN
0046/1275 015 "DIA CIRC CONCR
LEN=0050 INSTALLED UNKN

BMS EN 02/0279/0047/0000 0047/0795
018 "DIA CIRC CONCR
LEN=0001 INSTALLED UNKN 0047/0491
SIGN: CANTILEVER
BMSID 02/0279/0047/0234 0047/0234
018 "DIA CIRC CONCR
LEN=0001 INSTALLED UNKN 0047/0091
0 00000 0 0 0000+00 023419 FT
RAMP 8102 SB TO SR 279
BMSBG 02/0279/0047/0000
LENGTH(AH 2518 BK 2631) 0047/0000



0046/0875 018 "DIA CIRC CONCR
LEN=0050 INSTALLED UNKN
0046/0834 BMS EN 02/0279/0046/0000

018 "DIA CIRC CONCR
LEN=0001 INSTALLED UNKN 0043/1877
RAMP J RD
(SR8102 SEG 0500/1406) 0043/1791



023128 FT 0 00000 0 0 0000+00
RAMP J (8102) SB
BMSBG 02/0279/0046/0000
LENGTH(AH 3274 BK 2006)

018 "DIA CIRC CONCR
LEN=0001 INSTALLED UNKN 0043/1645
SIGN: 4 CHORD TRUSS
BMSID 02/0279/0042/1411 0043/1405

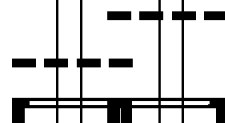

0042/1981 018 "DIA CIRC CONCR
LEN=0050 INSTALLED UNKN

018 "DIA CIRC CONCR
LEN=0001 INSTALLED UNKN 0043/1270

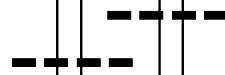

0042/1761 018 "DIA CIRC CONCR
LEN=0050 INSTALLED UNKN

SIGN: 4 CHORD TRUSS
BMSID 02/0279/0042/1411
018 "DIA CIRC CONCR
LEN=0060 INSTALLED UNKN

DIR: N TOTAL LEN: 13.299 MI. DIST: 11-1 SR: 279
 LEFT MUN: PITTSBURGH C RIGHT MUN: PITTSBURGH C

018 "DIA CIRC CONCR LEN=0661 INSTALLED UNKN	0043/0661	---	0042/0940	018 "DIA CIRC CONCR LEN=0099 INSTALLED UNKN
RETAINING WALL BMSID 02/4003/0006/1650 0 0 00000 0 00 0000+00 020788 FT MILEPOST 004.00	0043/0287	≡	0042/0560	018 "DIA CIRC CONCR LEN=0099 INSTALLED UNKN
LENGTH(AH 2631 BK 2620) SIGN: 4 CHORD TRUSS	0043/0000	≡	0042/0385	RAMP RD (SR8102 SEG 0010/0000)
BMSID 02/0279/0036/2449 018 "DIA CIRC CONCR LEN=0001 INSTALLED UNKN	0037/2420	≡	021122 FT	0 0 00000 0 00 0000+00 MILEPOST 004.00
RAMP H RD (SR8101 SEG 0500/0000)	0037/2082	≡	0042/0000	LENGTH(AH 2006 BK 2640) SIGN: 4 CHORD TRUSS
018 "DIA CIRC CONCR LEN=0001 INSTALLED UNKN	0037/2057	≡	0036/2449	BMSID 02/0279/0036/2449
018 "DIA CIRC CONCR LEN=0001 INSTALLED UNKN	0037/1840	≡		
018 "DIA CIRC CONCR LEN=0001 INSTALLED UNKN	0037/1565	≡		
RAMP F RD (SR8101 SEG 0510/0462)	0037/1189	≡		
		---	0036/1016	018 "DIA CIRC CONCR LEN=0060 INSTALLED UNKN
		≡	0036/0901	SIGN: CANTILEVER BMSID 02/0279/0036/0901
		---	0036/0726	018 "DIA CIRC CONCR LEN=0099 INSTALLED UNKN
		≡	0036/0692	EAST STREET OP ID 02/7301/0000/3137
018 "DIA CIRC CONCR LEN=0750 INSTALLED UNKN	0037/0750	---		
EAST STREET OP ID 02/7301/0000/3137	0037/0716	≡		
018 "DIA CIRC CONCR LEN=0001 INSTALLED UNKN	0037/0521	---		
018 "DIA CIRC CONCR LEN=0164 INSTALLED UNKN	0037/0105	---		
0 0 00000 0 00 0000+00 018168 FT LENGTH(AH 2620 BK 2700)	0037/0000	≡	0036/0036	024 "DIA CIRC CONCR LEN=0040 INSTALLED UNKN
018 "DIA CIRC CONCR LEN=0001 INSTALLED UNKN	0033/2570	---	018482 FT	0 0 00000 0 00 0000+00
018 "DIA CIRC CONCR		---	0036/0000	LENGTH(AH 2640 BK 2640)

DIR: N TOTAL LEN: 13.299 MI. DIST: 11-1 SR: 279
 LEFT MUN: PITTSBURGH C RIGHT MUN: PITTSBURGH C

Segment ID	Material	Length	Notes
0033/2280	018 "DIA CIRC CONCR	0001	INSTALLED UNKN
0032/2211	024 "DIA CIRC CONCR	0099	INSTALLED UNKN
0032/2111	018 "DIA CIRC CONCR	0099	INSTALLED UNKN
0033/1907	018 "DIA CIRC CONCR	0001	INSTALLED UNKN
0032/1826	018 "DIA CIRC CONCR	0099	INSTALLED UNKN
0032/1766	SIGN: CANTILEVER		
0032/1766	BMSID 02/0279/0032/1766		
0032/1696	018 "DIA CIRC CONCR	0003	INSTALLED UNKN
0033/1732	018 "DIA CIRC CONCR	0001	INSTALLED UNKN
0032/1526	018 "DIA CIRC CONCR	0060	INSTALLED UNKN
0033/1506	018 "DIA CIRC CONCR	0001	INSTALLED UNKN
0033/1224	018 "DIA CIRC CONCR	0001	INSTALLED UNKN
MILROY ST			
0032/1026	OP ID 02/7301/0000/3136		
0033/1022	024 "DIA CIRC CONCR	0001	INSTALLED UNKN
0033/0932	018 "DIA CIRC CONCR	0001	INSTALLED UNKN
0033/0643	018 "DIA CIRC CONCR	0617	INSTALLED UNKN
RAMP E RD (SRB131 SEG 0750/0469)			
0032/0424	024 "DIA CIRC CONCR	0099	INSTALLED UNKN
0032/0314	024 "DIA CIRC CONCR	0010	INSTALLED UNKN
0032/0244	018 "DIA CIRC CONCR	0099	INSTALLED UNKN
0033/0168	018 "DIA CIRC CONCR	0168	INSTALLED UNKN
0032/0164	018 "DIA CIRC CONCR	0099	INSTALLED UNKN
0032/0084	018 "DIA CIRC CONCR	0099	INSTALLED UNKN
015842 FT	0 0 00000 0 00 0000+00	015468 FT	
NC NORTH HILLS EX			
0033/0000	MILEPOST 003.00		
0032/0000	LENGTH(AH 2700 BK 2644)		
0027/2607	SIGN: 4 CHORD TRUSS		
0026/2623	BMSID 02/0279/0026/2623		
0032/0000	018 "DIA CIRC CONCR		

DIR: N TOTAL LEN: 13.299 MI. DIST: 11-1 SR: 279
 LEFT MUN: PITTSBURGH C RIGHT MUN: PITTSBURGH C

018 "DIA CIRC CONCR LEN=0001 INSTALLED UNKN 0027/2264		0026/2320 LEN=0099 INSTALLED UNKN
		RAMP C RD (SR8131 SEG 0010/0000)
		CHARLES ST
OP ID 02/7301/0000/3109 0027/1901		0026/1919 OP ID 02/7301/0000/3109
018 "DIA CIRC CONCR LEN=0001 INSTALLED UNKN 0027/1850		
SIGN: 4 CHORD TRUSS BMSID 02/0279/0026/1224 0027/1153		
		SIGN: 4 CHORD TRUSS BMSID 02/0279/0026/1224
024 "DIA CIRC CONCR LEN=0099 INSTALLED UNKN 0027/0864		0026/1174
BMSEN 02/0279/0026/0284 0027/0371		0026/0414 BMSEN 02/0279/0026/0284
0 00000 0 0 0000+00		0 00000 0 0 0000+00
SUFFOLK ST LOCAL		SUFFOLK ST LOCAL
BMSBG 02/0279/0026/0284 0027/0241		0026/0284 BMSBG 02/0279/0026/0284
		018 "DIA CIRC CONCR LEN=0055 INSTALLED UNKN
018 "DIA CIRC CONCR LEN=0662 INSTALLED UNKN 0027/0170		
0 0 00000 0 00 0000+00 012824 FT		0026/0057 018 "DIA CIRC CONCR
LENGTH(AH 2644 BK 2602) 0027/0000		LEN=0057 INSTALLED UNKN
		0 0 00000 0 00 0000+00
		013202 FT
		0026/0000 LENGTH(AH 2640 BK 2640)
		015 "DIA CIRC CONCR
018 "DIA CIRC CONCR LEN=0001 INSTALLED UNKN 0023/2398		0022/2466 LEN=0050 INSTALLED UNKN
		STORM SEWER STRUCTURE LENGTH 10 FT
		BMSID 02/0279/0022/2307
SIGN: 4 CHORD TRUSS BMSID 02/0279/0022/2232 0023/2166		0022/2307
018 "DIA CIRC CONCR LEN=0001 INSTALLED UNKN 0023/1904		0022/2240 015 "DIA CIRC CONCR
		LEN=0050 INSTALLED UNKN
		SIGN: 4 CHORD TRUSS BMSID 02/0279/0022/2232
018 "DIA CIRC CONCR LEN=0001 INSTALLED UNKN 0023/1759		
		0022/1806 015 "DIA CIRC CONCR
		LEN=0050 INSTALLED UNKN
		0022/1600 015 "DIA CIRC CONCR
018 "DIA CIRC CONCR		LEN=0050 INSTALLED UNKN

DIR: N TOTAL LEN: 13.299 MI. DIST: 11-1 SR: 279
 LEFT MUN: PITTSBURGH C RIGHT MUN: PITTSBURGH C

Item ID	Description	Length	Material	Status	Stationing	Notes
LEN=0001	INSTALLED UNKN	0023/1569				
018	"DIA CIRC CONCR	LEN=0050	INSTALLED UNKN		0022/1569	015 "DIA CIRC CONCR
LEN=0001	INSTALLED UNKN	0023/1403				
018	"DIA CIRC CONCR	LEN=0099	INSTALLED UNKN			
LEN=0099	INSTALLED UNKN	0023/0897				
018	"DIA CIRC CONCR	LEN=0099	INSTALLED UNKN			
LEN=0099	INSTALLED UNKN	0023/0705				
018	"DIA CIRC CONCR	LEN=0070	INSTALLED UNKN			
LEN=0070	INSTALLED UNKN	0023/0587				
SIGN:	STRUC MOUNTED					
BMSID	02/0279/0023/0586	0023/0586				
	PED. WALKWAY					
OP ID	02/0279/0022/0615	0023/0579			0022/0595	OP ID 02/0279/0022/0615
018	"DIA CIRC CONCR	LEN=0099	INSTALLED UNKN			
LEN=0099	INSTALLED UNKN	0023/0355				
0 0	00000 0 00 0000+00	010222 FT			010562 FT	0 0 00000 0 00 0000+00
	MILEPOST 002.00					MILEPOST 002.00
LENGTH(AH	2602 BK 2739)	0023/0000			0022/0000	LENGTH(AH 2640 BK 2597)
SIGN:	4 CHORD TRUSS					
BMSID	02/0279/0016/2545	0017/2646				
018	"DIA CIRC CONCR	LEN=0001	INSTALLED UNKN		0016/2514	SIGN: 4 CHORD TRUSS
LEN=0001	INSTALLED UNKN	0017/2427				BMSID 02/0279/0016/2545
RAMP F RD	(SR8099 SEG 0500/0000)	0017/2300				
					0016/2082	RAMP S RD
						(SR8099 SEG 0010/0734)
					0016/2035	018 "DIA CIRC CONCR
						LEN=0001 INSTALLED UNKN
					0016/1895	018 "DIA CIRC CONCR
						LEN=0099 INSTALLED UNKN
018	"DIA CIRC CONCR	LEN=0001	INSTALLED UNKN			
LEN=0001	INSTALLED UNKN	0017/1968				
RAMP Q						
OP ID	02/0279/0016/1799					
CROSSTOWN BL	(SR0579 SEG 0011/3240)	0017/1838				
018	"DIA CIRC CONCR	LEN=0001	INSTALLED UNKN			
LEN=0001	INSTALLED UNKN	0017/1761				
					0016/1746	RAMP Q
						OP ID 02/0279/0016/1799
						CROSSTOWN BL
						(SR0579 SEG 0010/3175)
018	"DIA CIRC CONCR	LEN=0001	INSTALLED UNKN			
LEN=0001	INSTALLED UNKN	0017/1716				
					0016/1705	018 "DIA CIRC CONCR
						LEN=0099 INSTALLED UNKN

DIR: N TOTAL LEN: 13.299 MI. DIST: 11-1 SR: 279
 LEFT MUN: PITTSBURGH C RIGHT MUN: PITTSBURGH C

SIGN: 4 CHORD TRUSS
 BMSID 02/0279/0017/1253 0017/1327
 NORTH AVE
 OP ID 02/0279/0016/1235 0017/1271

TRIPOLI ST
 OP ID 02/0279/0016/0998 0017/1069

018 "DIA CIRC CONCR
 LEN=0908 INSTALLED UNKN 0017/0958

018 "DIA CIRC CONCR
 LEN=0608 INSTALLED UNKN 0017/0386

018 "DIA CIRC CONCR
 LEN=0186 INSTALLED UNKN 0017/0286

E. OHIO ST.
 OP ID 02/4084/0060/0035 0017/0153
 018 "DIA CIRC CONCR
 LEN=0099 INSTALLED UNKN 0017/0134

018 "DIA CIRC CONCR
 LEN=0036 INSTALLED UNKN 0017/0036
 0 0 00000 0 00 0000+00 007483 FT
 018 "DIA CIRC CONCR
 LEN=0099 INSTALLED UNKN
 LENGTH(AH 2739 BK 1842) 0017/0000

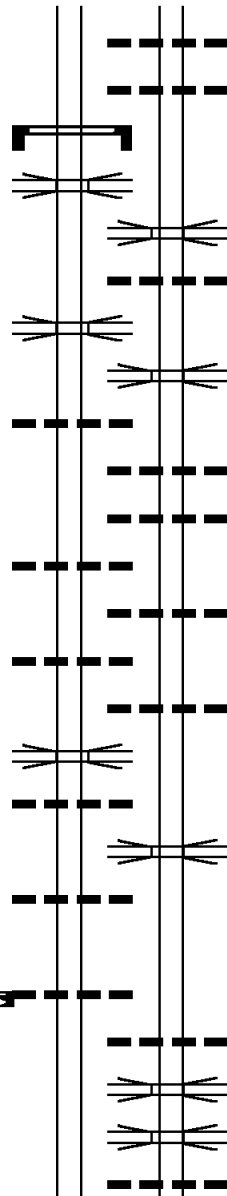

0016/1540 018 "DIA CIRC CONCR
 LEN=0050 INSTALLED UNKN
 0016/1420 018 "DIA CIRC CONCR
 LEN=1420 INSTALLED UNKN
 NORTH AVE
 0016/1196 OP ID 02/0279/0016/1235
 018 "DIA CIRC CONCR
 0016/1155 LEN=1155 INSTALLED UNKN
 TRIPOLI ST
 0016/0959 OP ID 02/0279/0016/0998
 018 "DIA CIRC CONCR
 0016/0930 LEN=0050 INSTALLED UNKN
 018 "DIA CIRC CONCR
 0016/0435 LEN=0050 INSTALLED UNKN
 018 "DIA CIRC CONCR
 0016/0290 LEN=0150 INSTALLED UNKN
 018 "DIA CIRC CONCR
 0016/0235 LEN=0040 INSTALLED UNKN
 E. OHIO ST.
 0016/0053 OP ID 02/4084/0060/0035
 007965 FT 0 0 00000 0 00 0000+00
 0016/0000 LENGTH(AH 2597 BK 2212)
 018 "DIA CIRC CONCR
 0012/2069 LEN=0040 INSTALLED UNKN
 1-579 HOV LN
 0012/2003 OP ID 02/6579/0020/0000
 28 SB TO 279 SB
 0012/1982 OP ID 02/8121/0522/0139
 018 "DIA CIRC CONCR
 0012/1929 LEN=0040 INSTALLED UNKN

EXTRACT DATE: 12/21/2020
PRINT DATE: 12/23/2020

ROADWAY MANAGEMENT SYSTEM
SLD COUNTY/SR - ANNUAL PRINT

PAGE NUMBER: 324
COUNTY: ALLEGHENY

DIR: N TOTAL LEN: 13.299 MI.
LEFT MUN: PITTSBURGH C

DIST: 11-1 SR: 279
RIGHT MUN: PITTSBURGH C

CROSSTOWN BL
OP ID 02/0579/0011/0000 0013/1808
018 "DIA CIRC CONCR
LEN=0001 INSTALLED UNKN 0013/1724

28 SB TO 279 SB
OP ID 02/8121/0522/0139 0013/1635

018 "DIA CIRC CONCR
LEN=0001 INSTALLED UNKN 0013/1520

SIGN: CANTILEVER
BMSID 02/0279/0013/1378 0013/1378
018 "DIA CIRC CONCR
LEN=0001 INSTALLED UNKN 0013/1309

NATIONAL RAILROAD PASSE
OVERPASS IS RR X-ING 0013/0986

FROM 6279/0020
(CONN) 0013/0840
RAMP P RD
(SR8121 SEG 0522/1278) 0013/0805

OTHER
OVERPASS IS RR X-ING 0013/0625

NATIONAL RAILROAD PASSE
OVERPASS IS RR X-ING 0013/0590

0 0 00000 0 00 0000+00 005641 FT
NC EAST STREET VALLEY ET
LENGTH(AH 1842 BK 4449) 0013/0000

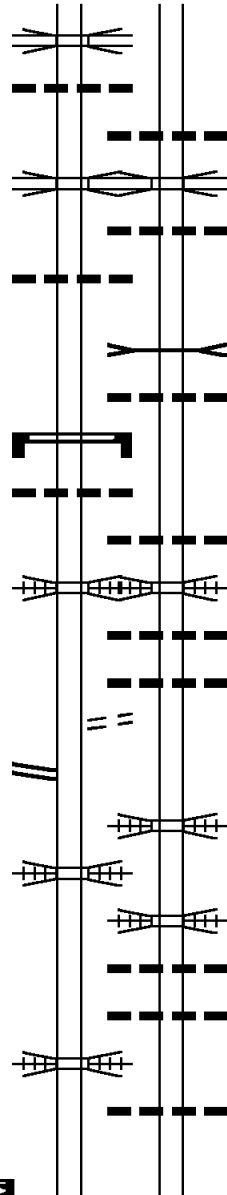

0012/1794 018 "DIA CIRC CONCR
LEN=0099 INSTALLED UNKN
CROSSTOWN BL
OP ID 02/0579/0011/0000
018 "DIA CIRC CONCR
0012/1740
0012/1664 LEN=0040 INSTALLED UNKN

STORM SEWER
STRUCTURE LENGTH 12 FT
BMSID 02/0279/0012/1567
018 "DIA CIRC CONCR
LEN=0099 INSTALLED UNKN
0012/1554
0012/1545

0012/1374 018 "DIA CIRC CONCR
LEN=0099 INSTALLED UNKN
NATIONAL RAILROAD PASSE
OVERPASS IS RR X-ING
0012/1314
018 "DIA CIRC CONCR
LEN=0099 INSTALLED UNKN
018 "DIA CIRC CONCR
LEN=0099 INSTALLED UNKN
0012/1127
0012/1067

0012/0781 OTHER
OVERPASS IS RR X-ING

0012/0754 NATIONAL RAILROAD PASSE
OVERPASS IS RR X-ING
018 "DIA CIRC CONCR
LEN=0040 INSTALLED UNKN
018 "DIA CIRC CONCR
LEN=0099 INSTALLED UNKN
0012/0668
0012/0610

0012/0355 018 "DIA CIRC CONCR
LEN=0040 INSTALLED UNKN
005753 FT 0 0 00000 0 00 0000+00
NC EAST STREET VALLEY ET
LENGTH(AH 2212 BK 4506) 0012/0000

DIR: N TOTAL LEN: 13.299 MI. DIST: 11-1 SR: 279
 LEFT MUN: PITTSBURGH C RIGHT MUN: PITTSBURGH C

SIGN: 4 CHORD TRUSS
 BMSID 02/0279/0009/4446 0009/4446
 BMSEN 02/0279/0009/4448 0009/4419



0008/4506 BMSEN 02/0279/0008/2090

MILEPOST 001.00 0009/4033
 SIGN: 4 CHORD TRUSS
 BMSID 02/0279/0009/3655 0009/3655

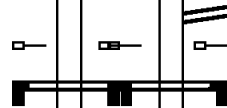

0008/4136 RAMP A RD
 0008/4033 (SRB121 SEG 0012/0000)
 MILEPOST 001.00
 SIGN: 4 CHORD TRUSS
 BMSID 02/0279/0008/3656

RAMP B RD
 (SRB107 SEG 0250/0000) 0009/3048
 SIGN: 4 CHORD TRUSS
 BMSID 02/0279/0009/2841 0009/2841
 RAMP V RD
 (SRB107 SEG 0260/0000) 0009/2598
 0 00000 0 0 0000+00

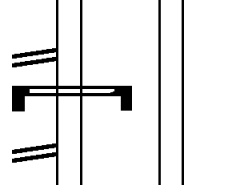

FEDERAL STREET
 BMSBG 02/0279/0009/4448 0009/2587
 BMSEN 02/0279/0009/2586 0009/2586
 SIGN: CANTILEVER
 BMSID 02/0279/0009/2478 0009/2478
 OHIO RIV. BLV
 OP ID 02/0065/0003/0000 0009/2357

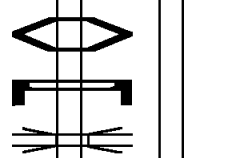

0008/2402 RAMP W RD
 (SRB107 SEG 0010/1327)
 SIGN: CANTILEVER
 BMSID 02/0279/0008/2285
 0 00000 0 0 0000+00
 BMSEN 02/0279/0008/1346
 SR 279 SB
 BMSBG 02/0279/0008/2090

SIGN: CANTILEVER
 BMSID 02/0279/0009/1638 0009/1638
 0 00000 0 0 0000+00
 BMSEN 02/0279/0009/2108
 N. SHORE DR
 BMSBG 02/0279/0009/2586 0009/1272
 I-279 NB
 OP ID 02/0279/0008/0425 0009/1187

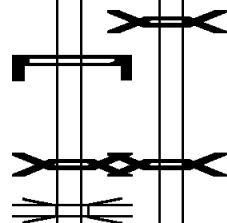

0 00000 0 0 0000+00
 BMSEN 02/0279/0008/0425
 SR 65 SB
 BMSBG 02/0279/0008/1346

OHIO RIVER BL
 (SR0065 SEG 0003/0000) 0009/0804



0008/1373 SIGN: 4 CHORD TRUSS
 BMSID 02/0279/0008/1175
 OHIO RIVER BL
 (SR0065 SEG 0002/0000)

0 00000 0 0 0000+00
 BMSEN 02/0279/0009/0351



0008/0482 SIGN: STRUC MOUNTED
 BMSID 02/0279/0008/0482
 0 00000 0 0 0000+00
 BMSEN 02/0279/0008/0000

DIR: N TOTAL LEN: 13.299 MI. DIST: 11-1 SR: 279
 LEFT MUN: PITTSBURGH C RIGHT MUN: PITTSBURGH C

Segment Description	Stationing	Structure / Notes	Stationing	Segment Description
ALLEGHENY RIVER	BMSBG 02/0279/0009/2108 0009/0351	0008/0452	1-279 SB	BMSBG 02/0279/0008/0425
RAMP K RD (SR8041 SEG 0270/0000)	0009/0264	0008/0405	RAMP G RD (SR8041 SEG 0500/1009)	
0 00000 0 0 0000+00	001192 FT	001247 FT	0 00000 0 0 0000+00	
NC FORT DUQUESNE BR		NC FORT DUQUESNE BR		
SR 8041			SR 8041 RP D	
BMSBG 02/0279/0009/0351		0008/0000	BMSBG 02/0279/0008/0000	
LENGTH(AH 4449 BK 1192)	0009/0000	0008/0000	LENGTH(AH 4506 BK 1247)	
SIGN: 2 CHORD TRUSS				
BMSID 02/0279/0007/0904	0007/0904			
BMSEN 02/0279/0006/0800	0007/0825			
		0006/1003	RAMP C RD (SR8041 SEG 0760/0000)	
		0006/0986	BMSEN 02/0279/0006/0800	
			RAMP B RD (SR8041 SEG 0750/1295)	
RAMP D RD (SR8041 SEG 0510/1506)	0007/0697			
0 00000 0 0 0000+00				
RAMP A RD (SR8041 SEG 0250/0000)				
NO UNDERPASS INFORMATION				
BMSBG 02/0279/0006/0800	0007/0639			
		0006/0800	0 00000 0 0 0000+00	
		0006/0727	NO UNDERPASS INFORMATION	
		0006/0671	BMSBG 02/0279/0006/0800	
			SIGN: 2 CHORD TRUSS	
BMSEN 02/0279/0007/0475	0007/0463		BMSID 02/0279/0006/0727	
			BMSEN 02/0279/0006/0000	
		0006/0321	RAMP N RD (SR8039 SEG 0500/0000)	
		0006/0216	SIGN: 4 CHORD TRUSS	
			BMSID 02/0279/0006/0216	
RAMP Q RD (SR8039 SEG 0520/1101)	0007/0096			
0 00000 0 0 0000+00	000000 FT			
PENN LINCOLN PY		000000 FT	1 0 00392 0 00 0329+03	
(SR0376 SEG 0695/1207)			PENN LINCOLN PY	
RAMP C (FT PITT TO			(SR0376 SEG 0694/1209)	
OP ID 02/0279/0006/0000			NC PENN LINCOLN PY	
NC PENN LINCOLN PY		INTER-BK	PENN LINCOLN PY	
PENN LINCOLN PY	INTER-BK		(SR0376 SEG 0694/1209)	
(SR0376 SEG 0695/1207)			RAMP G (376 WB TO 279 N	
MONONGAHELA			BMSBG 02/0279/0006/0000	
BMSBG 02/0279/0007/0475			MFC BEGIN = A	
MFC BEGIN = A			LENGTH(AH 1247 BK 0000)	
LENGTH(AH 1192 BK 0000)	0007/0000	0006/0000		

034287 FT

034319 FT
 INTER-AHD

1 0 00392 0 00 0329+03 032864 FT
 CONGRESS ST
 (BORO)
 NORTH VERSAILLES
 EAST MCKEESPORT B 0160/0000

018 "DIA CIRC CONCR
 LEN=0001 INSTALLED UNKN 0151/3670
 EAST MCKEESPORT
 NORTH VERSAILLES T 0151/3460

ROBIN ST
 (TWP) 0151/3426

018 "DIA CIRC CONCR
 LEN=0001 INSTALLED UNKN 0151/2928

018 "DIA CIRC CONCR

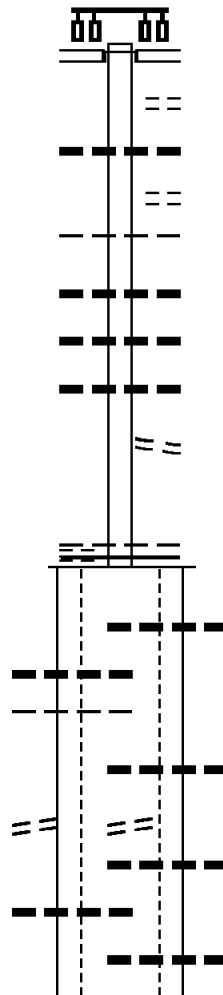

FIFTH AV
 (CNTY)
 LINCOLN HW
 (SR0030 SEG 0301/0000)
 (SR0030 SEG 0300/0000)

0160/1423
 0160/1218
 0160/0791
 0160/0780
 0160/0760
 0160/0595
 0160/0380
 0160/0211
 0160/0165
 032896 FT

LACIVITA WY
 (BORO)
 018 "DIA CIRC CONCR
 LEN=0191 INSTALLED UNKN
 COAL AL
 (BORO)
 EAST MCKEESPORT
 NORTH VERSAILLES T
 018 "DIA CIRC CONCR
 LEN=0191 INSTALLED UNKN
 018 "DIA CIRC CONCR
 LEN=0191 INSTALLED UNKN
 018 "DIA CIRC CONCR
 LEN=0191 INSTALLED UNKN
 OAKDALE RD
 (BORO)

MFC BEGIN = B
 LENGTH(AH 1423 BK 3719)

0150/3698
 0150/3458
 0150/3439
 0150/3150
 0150/2932

018 "DIA CIRC CONCR
 LEN=0001 INSTALLED UNKN

018 "DIA CIRC CONCR
 LEN=0025 INSTALLED UNKN
 ROBIN ST
 (TWP)
 001 "DIA CIRC CONCR
 LEN=0025 INSTALLED UNKN

012 "DIA CIRC CONCR
 LEN=0001 INSTALLED UNKN

DIR: B TOTAL LEN: 6.500 MI. DIST: 11-1 SR: 148
 LEFT MUN: NORTH VERSAILLES T RIGHT MUN: NORTH VERSAILLES T

Item ID	Description	Stationing	Notes
LEN=0001	INSTALLED UNKN	0151/2619	BARRY ST (TWP)
018 "DIA CIRC CONCR	LEN=0001 INSTALLED UNKN	0151/2333	0150/2640 BARRY ST (TWP)
018 "DIA CIRC CONCR	LEN=0001 INSTALLED UNKN	0151/2067	0150/2617 012 "DIA CIRC CONCR LEN=0020 INSTALLED UNKN
018 "DIA CIRC CONCR	LEN=0001 INSTALLED UNKN	0151/1772	0150/2330 018 "DIA CIRC CONCR LEN=0099 INSTALLED UNKN
018 "DIA CIRC CONCR	LEN=0001 INSTALLED UNKN	0151/1381	0150/2050 018 "DIA CIRC CONCR LEN=0099 INSTALLED UNKN
018 "DIA CIRC CONCR	LEN=0001 INSTALLED UNKN	0151/0846	0150/1625 018 "DIA CIRC CONCR LEN=0020 INSTALLED UNKN
SHADY LN (TWP)	0151/0691	0150/0708	018 "DIA CIRC CONCR LEN=0020 INSTALLED UNKN
CROOKED RUN	STRUCTURE LENGTH 14 FT	0151/0248	0150/0273 SHADY LN (TWP) CROOKED RUN STRUCTURE LENGTH 14 FT BMSID 02/0148/0150/0273 CROOKED RUN RD (CNTY)
CROOKED RUN RD (CNTY)	0151/0150	0150/0183	
1 0 00392 0 00 0291+91	029177 FT	0150/0008	018 "DIA CIRC CONCR LEN=0020 INSTALLED UNKN
NAYSMITH RD (TWP)	LENGTH(AH 3687 BK 2944)	0151/0000	1 0 00392 0 00 0290+76 NAYSMITH RD (TWP)
CROOKED RUN	STRUCTURE LENGTH 14 FT	0141/2712	0150/0000 LENGTH(AH 3719 BK 2942)
WASHINGTON RD (SR2039 SEG 0010/0000)	0141/2490	0140/2678	CROOKED RUN STRUCTURE LENGTH 14 FT BMSID 02/0148/0140/2746
018 "DIA CIRC CONCR	LEN=0099 INSTALLED UNKN	0141/1888	WASHINGTON RD (SR2039 SEG 0010/0000)
		0140/1767	012 "DIA CIRC CONCR LEN=0040 INSTALLED UNKN
			012 "DIA CIRC CONCR

EXTRACT DATE: 12/21/2020
PRINT DATE: 12/23/2020

ROADWAY MANAGEMENT SYSTEM
SLD COUNTY/SR - ANNUAL PRINT

PAGE NUMBER: 319
COUNTY: ALLEGHENY

DIR: B TOTAL LEN: 6.500 MI.
LEFT MUN: NORTH VERSAILLES T

DIST: 11-1 SR: 148
RIGHT MUN: NORTH VERSAILLES T

Left Side Description	Left Side Stationing	Right Side Stationing	Right Side Description
		0140/1490	LEN=0040 INSTALLED UNKN
ORLIC LN (TWP)	0141/0236	0140/0235	ORLIC LN (TWP)
1 0 00392 0 00 0262+22 026233 FT		0140/0088	LEN="DIA CIRC CONCR LEN=0040 INSTALLED UNKN
LC TO OLD FIFTH AV (CONN)		026235 FT	1 0 00392 0 00 0262+41
LENGTH(AH 2944 BK 2593)	0141/0000	0140/0000	LC TO OLD FIFTH AV (CONN)
WESTINGHOUSE AV (SR2037 SEG 0020/0000)			LENGTH(AH 2942 BK 2582)
			WESTINGHOUSE AV (SR2037 SEG 0020/0000)
ARCANNIA ST (SR2037 SEG 0020/0000)	0131/2210	0130/2200	ARCANNIA ST (TWP)
WABASH AV (TWP)	0131/2067		
		0130/2035	WABASH AV (TWP)
NORTH VERSAILLES WHITE OAK B	0131/1868	0130/1874	NORTH VERSAILLES WHITE OAK B
		0130/1750	LC TO OLD FIFTH AV (CONN)
AUBERLE ST (TWP)	0131/1741		AUBERLE ST (BORO)
		0130/1533	018 "DIA CIRC CONCR LEN=0040 INSTALLED UNKN
BMSSEN 02/0148/0130/1425	0131/1418	0130/1453	BMSSEN 02/0148/0130/1425
1 0 00392 0 00 0250+69			1 0 00392 0 00 0250+69
CROOKED RUN			CROOKED RUN
BMSBG 02/0148/0130/1425	0131/1390	0130/1425	BMSBG 02/0148/0130/1425
STERLING ST (BORO)	0131/1188	0130/1165	STERLING ST (BORO)
018 "DIA CIRC CONCR LEN=0001 INSTALLED UNKN	0131/1175		
		0130/0762	018 "DIA CIRC CONCR LEN=0040 INSTALLED UNKN
WHITE OAK MCKEESPORT C	0131/0738	0130/0732	WHITE OAK MCKEESPORT C
GAS ST (CITY)	0131/0555	0130/0545	GAS ST (CITY)
		0130/0524	018 "DIA CIRC CONCR LEN=0040 INSTALLED UNKN
		0130/0339	MCKEESPORT WHITE OAK B
BMSSEN 02/0148/0130/0288	0131/0320	0130/0314	BMSSEN 02/0148/0130/0288

EXTRACT DATE: 12/21/2020
PRINT DATE: 12/23/2020

ROADWAY MANAGEMENT SYSTEM
SLD COUNTY/SR - ANNUAL PRINT

PAGE NUMBER: 318
COUNTY: ALLEGHENY

DIR: B TOTAL LEN: 6.500 MI.
LEFT MUN: WHITE OAK B

DIST: 11-1 SR: 148
RIGHT MUN: WHITE OAK B

1 0 00392 0 00 0239+47
CROOKED RUN
BMSBG 02/0148/0130/0288 0131/0294

1 0 00392 0 00 0234+50 023640 FT
PENNA AV
(SR2037 SEG 0010/3544)
MFC BEGIN = B
LENGTH(AH 2593 BK 1493) 0131/0000

CITY AL
(CITY) 0120/0160

022147 FT

ORANGE AL
(CITY) 0111/1880
UPMC MCKEESPORT ENT RD

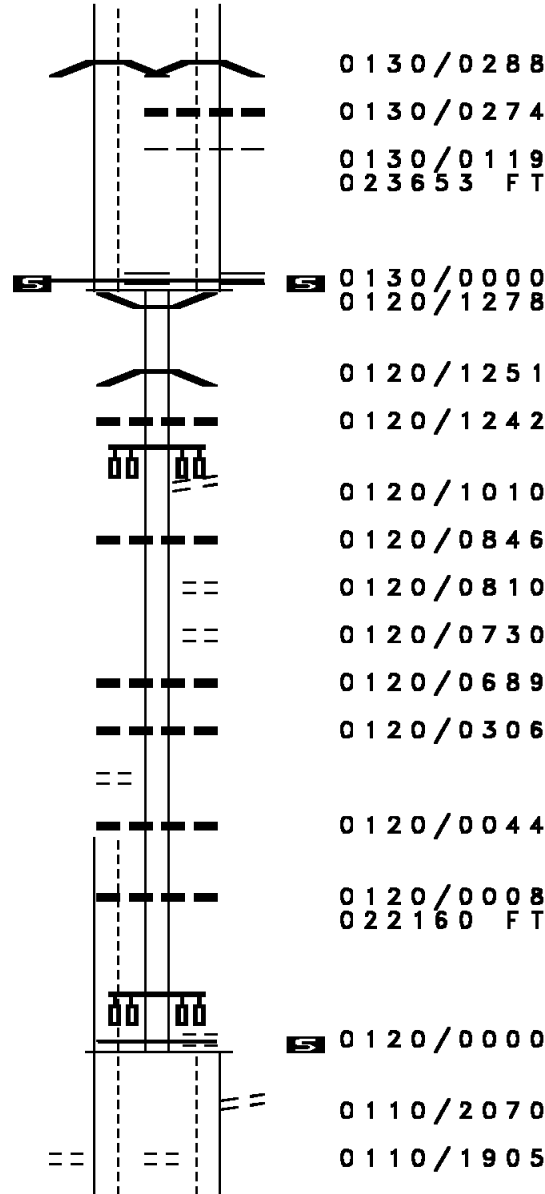

1 0 00392 0 00 0239+47
CROOKED RUN
BMSBG 02/0148/0130/0288
018 "DIA CIRC CONCR
LEN=0040 INSTALLED UNKN
WHITE OAK

MCKEESPORT C
1 0 00392 0 00 0234+50
PENNA AV
(SR2037 SEG 0010/3544)
MFC BEGIN = B
LENGTH(AH 2582 BK 1493)
BMSBG 02/0148/0120/1251

1 0 00392 0 00 0234+09
CROOKED RUN
BMSBG 02/0148/0120/1251
012 "DIA CIRC CONCR
LEN=0040 INSTALLED UNKN
LINCOLN WY
(CNTY)

012 "DIA CIRC CONCR
LEN=0035 INSTALLED UNKN
FAWCETT ST
(CITY)
CITY AL
(CITY)

018 "DIA CIRC CONCR
LEN=0035 INSTALLED UNKN
018 "DIA CIRC METAL
LEN=0099 INSTALLED UNKN

012 "DIA CIRC CONCR
LEN=0099 INSTALLED UNKN

018 "DIA CIRC METAL
LEN=0035 INSTALLED UNKN
1 0 00392 0 00 0221+49
HARTMAN ST
(CNTY)

MFC BEGIN = B
LENGTH(AH 1493 BK 2162)

LC TO EDEN PARK BL
(CONN)
ORANGE AL
(CITY)
UPMC MCKEESPORT ENT RD

EXTRACT DATE: 12/21/2020
PRINT DATE: 12/23/2020

ROADWAY MANAGEMENT SYSTEM
SLD COUNTY/SR - ANNUAL PRINT

PAGE NUMBER: 317
COUNTY: ALLEGHENY

DIR: B TOTAL LEN: 6.500 MI.
LEFT MUN: MCKEESPORT C

DIST: 11-1 SR: 148
RIGHT MUN: MCKEESPORT C

PRDR	DESCRIPTION	START	END	TYPE	PRDR	DESCRIPTION	START	END	TYPE
	0111/1627	==	==	==		0110/1639			(PRDR)
018 "DIA CIRC CONCR	LEN=0099 INSTALLED UNKN	0111/1621	---	---					ELM ST
ELM ST	(CITY)		==	==					(CITY)
SYLVAN AL	0111/1275	==	==	==		0110/1310			SYLVAN AL
(CITY)	0111/1135	==	==	==		0110/1175			(CITY)
KISER ST	0111/0780	==	==	==		0110/0770			KISER ST
(CITY)						0110/0730			SR 2114 SH
						0110/0692			(SR 2114 SEG 0011/0000)
018 "DIA CIRC METAL	LEN=0020 INSTALLED UNKN	0111/0583	---	---					018 "DIA CIRC CONCR
SR 2114 SH	(SR 2114 SEG 0010/0000)	0111/0566	==	==					LEN=0001 INSTALLED UNKN
1 0 00392 0 00 0199+75 019974 FT						019998 FT	1 0 00392 0 00 0200+29		
SR 2114 SH	OP ID 02/2114/0011/0785	0111/0000	==	==		0110/0000	SR 2114 SH		OP ID 02/2114/0011/0785
LENGTH(AH 2173 BK 1089)			==	==		0100/1021			LENGTH(AH 2162 BK 1164)
						0100/0930			018"H 12"W **UNKNOWN**
QUARRY AL	0101/0855	==	==	==		0100/0880			LEN=0001 INSTALLED UNKN
(CITY)						0100/0829			QUARRY AL
CLIFF ST	0101/0830	==	==	==					(CITY)
(CITY)									CLIFF ST
									(CITY)
RAMP F 8086 NB	OP ID 02/8086/0010/0383	0101/0762	==	==		0100/0783	RAMP F 8086 NB		OP ID 02/8086/0010/0383
018 "DIA CIRC CONCR	LEN=0040 INSTALLED UNKN	0101/0565	---	---					PIRL ST
PIRL ST	0101/0420	==	==	==		0100/0450			(CITY)
(CITY)						0100/0245			CLIFF ST
CLIFF ST	0101/0205	==	==	==		018834 FT			(CITY)
(CITY)	1 0 00392 0 00 0190+98 018885 FT								1 0 00392 0 00 0188+55
RAMP H FR DUQ/MCKEESPT	(SR 8086 SEG 0250/0775)	0101/0000	==	==		0100/0000			RAMP F TO BOWMAN AV
LENGTH(AH 1089 BK 0780)									(SR 8086 SEG 0010/0000)
						0090/0556			LENGTH(AH 1164 BK 0705)
SIGN: CANTILEVER	BMSID 02/0148/0091/0503	0091/0503	==	==					SIGN: CANTILEVER
									BMSID 02/0148/0090/0556

EXTRACT DATE: 12/21/2020
PRINT DATE: 12/23/2020

ROADWAY MANAGEMENT SYSTEM
SLD COUNTY/SR - ANNUAL PRINT

PAGE NUMBER: 316
COUNTY: ALLEGHENY

DIR: B TOTAL LEN: 6.500 MI.
LEFT MUN: MCKEESPORT C

DIST: 11-1 SR: 148
RIGHT MUN: MCKEESPORT C

Station	Length	Notes	Station	Length	Notes
1 0 00392 0 00 0182+08 018105 FT NC FIFTH AV FIFTH AV (CITY) LENGTH(AH 0780 BK 0899) 0091/0000	0090/0060 018129 FT	012 " DIA CIRC CONCR LEN=0048 INSTALLED UNKN 1 0 00392 0 00 0181+90 NC FIFTH AV FIFTH AV (CITY) LENGTH(AH 0705 BK 0912) LC TO FIFTH AV (CONN)			
1 0 00392 0 00 0172+00 017206 FT EVANS ST (CITY) LENGTH(AH 0899 BK 3943) 0081/0000 WHITE ST (CITY) (APRA) FORMER US STEEL CENTER ST (CITY) HOUSERMAN AL (CITY) MARTIN ST (CITY) COURSIN ST (CITY)	0090/0000 0080/0670 017217 FT	1 0 00392 0 00 0172+31 EVANS ST (CITY) LENGTH(AH 0912 BK 3954) WHITE ST (CITY) (APRA) FORMER US STEEL CENTER ST (CITY) HOUSERMAN AL (CITY) MARTIN ST (CITY) COURSIN ST (CITY)			
HUEY ST (CITY)	0071/3455 0071/3325 0071/3125 0071/2635 0071/2350	0070/3440 0070/3315 0070/3115 0070/2625 0070/2345	HUEY ST (CITY) SHERIDAN ST (CITY)		
SHERIDAN ST (CITY)	0071/1520	0070/1510	SHERIDAN ST (CITY)		
SINCLAIR ST (CITY)	0071/1245	0070/1242	SINCLAIR ST (CITY)		
(APRA) RIVER PLACE IND LOCUST ST (CITY)	0071/0815	0070/0800	(APRA) QUALITY CHECK ME LOCUST ST (CITY)		
WORK ST (CITY)	0071/0530	0070/0520	TUBE ST (CITY)		
1 0 00392 0 00 0132+50 013263 FT WALNUT ST (CITY)	0071/0185 013263 FT	0070/0180 013263 FT	1 0 00392 0 00 0132+59 WALNUT ST (CITY)		

DIR: B TOTAL LEN: 6.500 MI. DIST: 11-1 SR: 148
 LEFT MUN: MCKEESPORT C RIGHT MUN: MCKEESPORT C

NC LYSLE BL

LYSLE BL
 (SR2094 SEG 0010/1882)
 (SR2094 SEG 0011/1873)
 MFC BEGIN = B
 LENGTH(AH 3943 BK 2015) 0071/0000

HABER AL (CITY) 0060/1610
 SEVENTH AV (CITY) 0060/1070
 EIGHTH AV (CITY) 0060/0710
 SCHOOL AL (CITY) 0060/0530

011248 FT

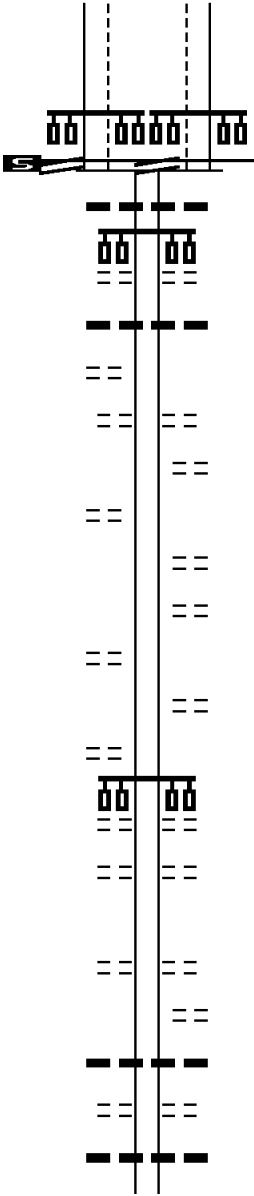

NC LYSLE BL

LYSLE BL
 (SR2094 SEG 0011/1873)
 (SR2094 SEG 0010/1882)
 MFC BEGIN = B
 LENGTH(AH 3954 BK 2015) 0070/0000
 018 "DIA CIRC CONCR
 LEN=0099 INSTALLED UNKN
 FIFTH AV (CITY)
 024 "DIA CIRC CONCR
 LEN=0099 INSTALLED UNKN
 SIXTH ST (CITY)
 SHAW AV (CITY)
 OLIVE ST (CITY)
 WILKINS AL (CITY)
 PENNEY ST (CITY)
 NINTH ST (CITY)
 SPRING ST (CITY)
 1 0 00392 0 00 0112+81
 TENTH ST (CITY)
 LENGTH(AH 2015 BK 2050) 0060/0000
 WHIGHAM ST (CITY)
 012 "DIA CIR UNKNOWN
 LEN=0099 INSTALLED UNKN
 ELEVENTH ST (CITY)
 012 "DIA CIR UNKNOWN
 LEN=0099 INSTALLED UNKN
 TWELFTH ST

DIR: B TOTAL LEN: 6.500 MI. DIST: 11-1 SR: 148
 LEFT MUN: MCKEESPORT C RIGHT MUN: MCKEESPORT C

FIFTEENTH ST
 (SR2096 SEG 0010/0000)
 FROM 2096/0010 SH
 (CONN)

IOWA ST
 (PRDR)

CITY AL
 (CITY)

CITY AL
 (CITY)

Stationing	Notes	Stationing	Notes
		0050/1120	(CITY)
			THIRTEENTH ST
009198 FT		0050/0595	(CITY)
		009198 FT	1 0 00392 0 00 0093+53
		0050/0000	LENGTH(AH 2050 BK 2576)
		0040/2120	MFC BEGIN = C
0040/2097		0040/2097	
0040/2007			
		0040/1996	018 " DIA CIRC CONCR LEN=0040 INSTALLED UNKN
		0040/1571	018 " DIA CIRC CONCR LEN=0099 INSTALLED UNKN
006622 FT		006622 FT	1 0 00392 0 00 0066+21
		0040/0000	LENGTH(AH 2576 BK 2843)
			012 "H 00 "W MULT METAL
		0030/2248	LEN=0035 INSTALLED UNKN
0030/2220		0030/2220	
		0030/1935	STEEL AL (CITY)
		0030/1805	VOLK AL (CITY)
		0030/1680	TWENTYFOURTH ST (CITY)
		0030/1677	012 " DIA CIR PLASTIC LEN=0040 INSTALLED UNKN
0030/1390		0030/1390	(APRA) CPI INDUSTRIAL S TWENTYFIFTH ST (CITY)
		0030/1068	012 " DIA CIRC METAL LEN=0099 INSTALLED UNKN
		0030/1040	TWENTYSIXTH ST (CITY)
0030/1030		0030/0695	TWENTYSEVENTH ST (CITY)
			(APRA) MAGIC CREATIONS
			TWENTYEIGHTH ST (CITY)
003779 FT		0030/0350	
		003779 FT	1 0 00392 0 00 0037+76
			TWENTYNINTH ST

EXTRACT DATE: 12/21/2020
PRINT DATE: 12/23/2020

ROADWAY MANAGEMENT SYSTEM
SLD COUNTY/SR - ANNUAL PRINT

PAGE NUMBER: 313
COUNTY: ALLEGHENY

DIR: B TOTAL LEN: 6.500 MI.
LEFT MUN: MCKEESPORT C

DIST: 11-1 SR: 148
RIGHT MUN: MCKEESPORT C

1 0 00392 0 00 0005+35 001416 FT
RETAIL DR
(CITY)

WILL ST
(CITY)

000000 FT

==	0030/0000	(CITY)
---	0020/2040	LENGTH(AH 2843 BK 2363) 018 "DIA CIRC CONCR LEN=0001 INSTALLED UNKN THIRTIETH ST (CITY)
00 00	0020/2015	018 "DIA CIRC CONCR LEN=0099 INSTALLED UNKN THIRTYFIRST ST (CITY)
---	0020/1981	THIRTYSECOND ST (CITY)
==	0020/1665	THIRTYTHIRD ST (CITY)
==	0020/1390	THIRTYFOURTH ST (CITY)
==	0020/1125	THIRTYFIFTH ST (CITY)
==	0020/0850	018 "DIA CIRC CONCR LEN=0099 INSTALLED UNKN THIRTSIXTH ST (CITY)
---	0020/0505	018 "DIA CIRC CONCR LEN=0015 INSTALLED UNKN EDEN PARK BL (CNTY)
==	0020/0322	0020/0235
---	0020/0175	0020/0000
00 00	0010/1287	LENGTH(AH 2363 BK 1416) 018 "DIA CIRC CONCR LEN=0099 INSTALLED UNKN
---	0010/0855	(APRA) RITE AID PHARMAC 018 "DIA CIRC CONCR LEN=0050 INSTALLED UNKN HILLVIEW ST (CITY)
==	0010/0482	FROM 0048/0171 SH (CONN)
==	0010/0440	018 "DIA CIRC CONCR LEN=0076 INSTALLED UNKN 1 0 00392 0 00 0000+00 NC WA
---	0010/0190	LNUT ST LONG RUN RD (SRO048 SEG 0171/0000) (SRO048 SEG 0170/0000)
---	0010/0175	INTER-BK WALNUT ST (SRO048 SEG 0170/0000) MFC BEGIN = B
---	0010/0000	LENGTH(AH 1416 BK 0000)

EXTRACT DATE: 12/21/2020 ROADWAY MANAGEMENT SYSTEM PAGE NUMBER: 312
PRINT DATE: 12/23/2020 SLD COUNTY/SR - ANNUAL PRINT COUNTY: ALLEGHENY

DIR: B TOTAL LEN: 6.239 MI. DIST: 11-1 SR: 136
LEFT MUN: ELIZABETH T RIGHT MUN: ELIZABETH T

SKILLET HILL RD (TBK)
(TWP)

032940 FT

0130/1434

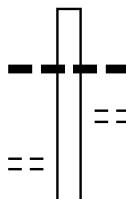

* 032940 FT AH-WESTMORELAND (64)
REF-AHD WEST NEWTON RD
0130/1664 (SR0136 SEG 0010/0000)
0130/1575 018 " DIA CIRC CONCR
LEN=0035 INSTALLED UNKN
ROCKWOOD RD
0130/1525 (TWP)

018 " DIA CIRC CONCR

DIR: B TOTAL LEN: 6.239 MI. DIST: 11-1 SR: 136
 LEFT MUN: ELIZABETH T RIGHT MUN: ELIZABETH T

KNOTTY PINE MOB PRK RD
 (PRDR) 0130/0345
 KNOTTY PINE MOB PRK RD
 (PRDR) 0130/0185
 031276 FT

LONG HOLLOW RD
 (SR2017 SEG 0010/0000) 0120/2310

027563 FT

0130/1417	LEN=0035	INSTALLED UNKN
0130/1234	LEN=0035	INSTALLED UNKN
0130/0766	LEN=0035	INSTALLED UNKN
0130/0518	LEN=0035	INSTALLED UNKN
0130/0345	(APRA)	KNOTTY PINE MOBI
0130/0185	(APRA)	KNOTTY PINE MOBI
031276 FT	1 0 00181 0 01 0318+89	BR GILLSP RN
	STRUCTURE LENGTH	12 FT
	BMSID 02/0136/0130/0000	LENGTH(AH 1664 BK 3713)
0130/0000	LEN=0035	INSTALLED UNKN
0120/3373	LEN=0035	INSTALLED UNKN
0120/2738	LEN=0035	INSTALLED UNKN
0120/2400	LEN=0050	INSTALLED UNKN
0120/2185	P3	BMSEN 02/0136/0120/2172
0120/2172	1 0 00181 0 01 0281+59	BRANCH OF GILLESPIE RUN
	BMSBG 02/0136/0120/2172	018 "DIA CIRC CONCR
0120/1974	LEN=0035	INSTALLED UNKN
0120/1613	LEN=0035	INSTALLED UNKN
0120/1317	LEN=0035	INSTALLED UNKN
0120/0726	LEN=0099	INSTALLED UNKN
0120/0312	LEN=0035	INSTALLED UNKN
027563 FT	1 0 00181 0 01 0281+59	018 "DIA CIRC CONCR
0120/0000	LEN=0035	INSTALLED UNKN
0110/2579	LEN=0035	INSTALLED UNKN
0110/2358	LEN=0035	INSTALLED UNKN
0110/2038	LEN=0035	INSTALLED UNKN

DIR: B TOTAL LEN: 6.239 MI. DIST: 11-1 SR: 136
 LEFT MUN: ELIZABETH T RIGHT MUN: ELIZABETH T

MUNIR DR
 (PRDR)

0110/0890

024887 FT

022770 FT

0110/1810	012 " DIA CIRC CONCR LEN=0035 INSTALLED UNKN
0110/1430	099"H 18"W UNKN STRUCT LEN=0099 INSTALLED UNKN
0110/1046	018 " DIA CIR PLASTIC LEN=0035 INSTALLED 1997
0110/0378	ELIZABETH FORWARD T NC WEST NEWTON RD RAMP D RD (SR8051 SEG 0750/0000) RAMP A RD (SR8051 SEG 0010/0506)
0110/0320	(SR8051 SEG 0010/0506)
0110/0243	BMS EN 02/0136/0110/0092 1 0 00181 0 01 0258+32 SR 0051 NB
0110/0092	BMS BG 02/0136/0110/0092 1 0 00181 0 01 0257+40
024887 FT	RAMP C RD (SR8051 SEG 0500/0430) RAMP B RD (SR8051 SEG 0250/0000)
0110/0000	LENGTH(AH 2676 BK 2117)
0100/0925	RODNEY LN (T640)
0100/0904	012 " DIA CIRC METAL LEN=0035 INSTALLED UNKN
0100/0571	018 " DIA CIRC METAL LEN=0035 INSTALLED UNKN
022770 FT	1 0 00181 0 01 0236+61
0100/0000	LENGTH(AH 2117 BK 3605)
0090/3581	012 " DIA CIRC CONCR LEN=0099 INSTALLED UNKN
0090/3200	018 " DIA CIRC METAL LEN=0035 INSTALLED UNKN
0090/2969	018 " DIA CIRC METAL LEN=0035 INSTALLED UNKN
0090/2507	018 " DIA CIRC CONCR LEN=0045 INSTALLED UNKN
0090/2287	012 " DIA CIRC METAL LEN=0035 INSTALLED UNKN
0090/1882	018 " DIA CIRC METAL LEN=0035 INSTALLED UNKN
0090/1621	012 " DIA CIRC METAL LEN=0035 INSTALLED UNKN
	099"H 18"W UNKN STRUCT

EXTRACT DATE: 12/21/2020
PRINT DATE: 12/23/2020

ROADWAY MANAGEMENT SYSTEM
SLD COUNTY/SR - ANNUAL PRINT

PAGE NUMBER: 308
COUNTY: ALLEGHENY

DIR: B TOTAL LEN: 6.239 MI.
LEFT MUN: FORWARD T

DIST: 11-1 SR: 136
RIGHT MUN: FORWARD T

Stationing	Notes	Length	Material	Status
0070/0311		LEN=0035		INSTALLED UNKN
0070/0289		FOR SR 0136 AND 0906		
014696 FT		(CONN)		
014696 FT		1 0 00181 0 00 0153+36		
		MONONGAHELA RD		
		(SR0906 SEG 0010/0611)		
0070/0000		LENGTH(AH 1303 BK 1841)		
0060/1710		018 "DIA CIRC CONCR		INSTALLED UNKN
0060/1210		JOHN ST		
0060/1151		(T409)		
0060/0860		012 "DIA CIRC CONCR		INSTALLED UNKN
0060/0501		LEN=0035		INSTALLED UNKN
0060/0223		012 "DIA CIRC CONCR		INSTALLED UNKN
012855 FT		012 "DIA CIRC CONCR		INSTALLED UNKN
012855 FT		018 "DIA CIRC CONCR		INSTALLED UNKN
0060/0000		LEN=0040		INSTALLED UNKN
		1 0 00181 0 00 0134+74		
		LENGTH(AH 1841 BK 3453)		
0050/3037		012 "DIA CIRC CONCR		INSTALLED UNKN
0050/2827		012 "DIA CIRC CONCR		INSTALLED UNKN
0050/2733		012 "DIA CIRC CONCR		INSTALLED UNKN
0050/2324		018 "DIA CIRC CONCR		INSTALLED UNKN
0050/1962		LEN=0035		INSTALLED UNKN
0050/1874		012 "DIA CIRC CONCR		INSTALLED UNKN
0050/1874		LEN=0035		INSTALLED UNKN
SUNNYSIDE HOLLOW RD (SR2009 SEG 0010/0000)		0050/1415		
		0050/1319	BMS EN 02/0136/0050/1300	
			1 0 00181 0 00 0114+25	
			SUNFISH RUN	
		0050/1300	BMSBG 02/0136/0050/1300	
			012 "DIA CIRC CONCR	
MC KEEVER ST (T407)		0050/1143	LEN=0099	INSTALLED UNKN
		0050/0895		
		0050/0872	018 "DIA CIRC CONCR	INSTALLED UNKN
			LEN=0035	
		0050/0244	012 "DIA CIRC CONCR	INSTALLED UNKN
			LEN=0035	

DIR: B TOTAL LEN: 6.239 MI. DIST: 11-1 SR: 136
 LEFT MUN: FORWARD T RIGHT MUN: FORWARD T

Stationing	Structure	Material	Status
009402 FT	0050/0021	036"H 48"W CONC STRUCT	LEN=0099 INSTALLED UNKN
	009402 FT	1 0 00181 0 00 0100+19	
		P3	
		MONONGAHELA RVR - TRIB	
		STRUCTURE LENGTH 6 FT	
		BMSID 02/0136/0050/0000	
		LENGTH(AH 3453 BK 3242)	
		012 "DIA CIRC CONCR	
		LEN=0099 INSTALLED UNKN	
		GALLATIN RD	
		(T404)	
		018 "DIA CIRC CONCR	
		LEN=0099 INSTALLED UNKN	
ROSTOSKY RIDGE RD (T610)	0040/1525		
		BMSID 02/0136/0040/1477	
		1 0 00181 0 00 0073+23	
		PERRY MILL R	
		BMSBG 02/0136/0040/1477	
		(APRA) INDUSTRIAL DR	
		INDUSTRIAL DR	
		(PRDR)	
		072"H 72"W CONC STRUCT	
		LEN=0035 INSTALLED UNKN	
		018 "DIA CIRC CONCR	
		LEN=0035 INSTALLED UNKN	
		018 "DIA CIRC CONCR	
		LEN=0035 INSTALLED UNKN	
		018 "DIA CIRC CONCR	
		LEN=0035 INSTALLED UNKN	
		1 0 00181 0 00 0073+23	
		LENGTH(AH 3242 BK 3481)	
		018 "DIA CIRC CONCR	
		LEN=0099 INSTALLED UNKN	
		BOAT CLUB RD	
		(T401)	
		012 "DIA CIRC CONCR	
		LEN=0099 INSTALLED UNKN	
		CAFFARI DR	
		(PRDR)	
		012 "DIA CIRC CONCR	
		LEN=0099 INSTALLED UNKN	
		LOCUST AV	
		(T402)	
		012 "DIA CIRC CONCR	
		LEN=0035 INSTALLED UNKN	
		LOCUST AV	
		(T402)	

DIR: B TOTAL LEN: 6.239 MI. DIST: 11-1 SR: 136
 LEFT MUN: FORWARD T RIGHT MUN: FORWARD T

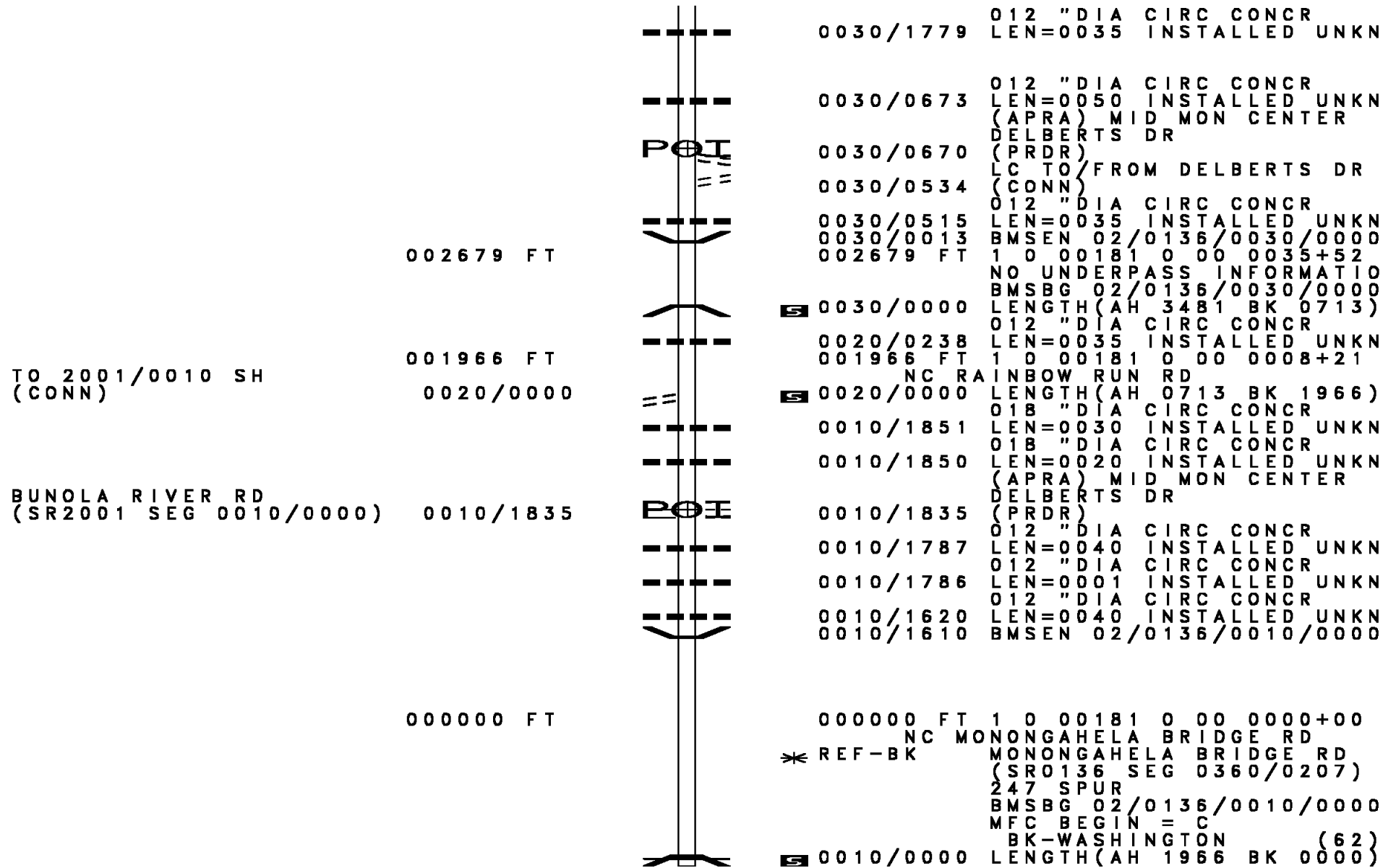

TO 2001/0010 SH
 (CONN)

BUNOLA RIVER RD
 (SR2001 SEG 0010/0000) 0010/1835

002679 FT

001966 FT
 0020/0000

000000 FT

0030/1779 012 " DIA CIRC CONCR
 LEN=0035 INSTALLED UNKN

0030/0673 012 " DIA CIRC CONCR
 LEN=0050 INSTALLED UNKN
 (APRA) MID MON CENTER
 DELBERTS DR

0030/0670 (PRDR)
 LC TO/FROM DELBERTS DR
 (CONN)

0030/0534 012 " DIA CIRC CONCR
 LEN=0035 INSTALLED UNKN

0030/0515 012 " DIA CIRC CONCR
 LEN=0035 INSTALLED UNKN

0030/0013 BMSSEN 02/0136/0030/0000
 002679 FT 1 0 00181 0 00 0035+52
 NO UNDERPASS INFORMATION
 BMSBG 02/0136/0030/0000

0030/0000 LENGTH(AH 3481 BK 0713)

0020/0238 012 " DIA CIRC CONCR
 LEN=0035 INSTALLED UNKN

001966 FT 1 0 00181 0 00 0008+21
 NC RA INBOW RUN RD

0020/0000 LENGTH(AH 0713 BK 1966)
 018 " DIA CIRC CONCR

0010/1851 012 " DIA CIRC CONCR
 LEN=0030 INSTALLED UNKN

0010/1850 018 " DIA CIRC CONCR
 LEN=0020 INSTALLED UNKN
 (APRA) MID MON CENTER
 DELBERTS DR

0010/1835 (PRDR)
 012 " DIA CIRC CONCR
 LEN=0040 INSTALLED UNKN

0010/1787 012 " DIA CIRC CONCR
 LEN=0001 INSTALLED UNKN

0010/1786 012 " DIA CIRC CONCR
 LEN=0040 INSTALLED UNKN

0010/1620 BMSSEN 02/0136/0010/0000
 0010/1610

000000 FT 1 0 00181 0 00 0000+00
 NC MO MONONGAHELA BRIDGE RD
 * REF-BK MONONGAHELA BRIDGE RD
 (SR0136 SEG 0360/0207)
 247 SPUR
 BMSBG 02/0136/0010/0000
 MFC BEGIN = C
 BK-WASHINGTON (62)

0010/0000 LENGTH(AH 1966 BK 0000)

EXTRACT DATE: 12/21/2020
PRINT DATE: 12/23/2020

ROADWAY MANAGEMENT SYSTEM
SLD COUNTY/SR - ANNUAL PRINT

PAGE NUMBER: 304
COUNTY: ALLEGHENY

DIR: B TOTAL LEN: 13.640 MI.
LEFT MUN: MONROEVILLE B

DIST: 11-1 SR: 130
RIGHT MUN: MONROEVILLE B

Location	Segment ID	Length	Notes
	0332/0000	2770	MFC BEGIN = C LENGTH(AH 2770 BK 2351) 018 " DIA CIRC CONCR
	0322/2310	0040	LEN=0040 INSTALLED UNKN BR TURTLE CK
	0322/2245	15	STRUCTURE LENGTH 15 FT BMSID 02/0130/0322/2245
	0322/2054	0065	012 " DIA CIRC CONCR LEN=0065 INSTALLED UNKN
JEWEL WAY (TWP)	0322/1286		
	0322/1183		MONROEVILLE PITCAIRN B
HILLSIDE AV (TWP)	0322/0150		
MCGINNIS AV (TWP)	0322/0120		
	065298 FT		
BRINTON AV (TWP)	0322/0000		
	0312/2797		065319 FT 1 0 00639 0 01 0238+58 VILLAGE: MONROEVILLE B NC FIFTH ST LENGTH(AH 2351 BK 2868) 018 " DIA CIRC CONCR
HIGHLAND AV (TWP)	0312/2695		0312/2797 LEN=1947 INSTALLED UNKN
	0312/2635		ALLEY (TWP)
	0312/2180		012 " DIA CIRC CONCR LEN=0030 INSTALLED UNKN CENTER AV (TWP)
	0312/2145		
	0312/2130		018 " DIA CIRC CONCR LEN=0040 INSTALLED UNKN 012 " DIA CIRC CONCR
	0312/2000		LEN=0065 INSTALLED UNKN
	0312/1930		BMSSEN 02/0130/0312/1910 0 0 00000 0 00 0000+00 DIRTY COMP R
	0312/1910		0312/1910 BMSBG 02/0130/0312/1910 012 " DIA CIRC CONCR
	0312/1870		LEN=0040 INSTALLED UNKN
WALL AV (TWP)	0312/1485		
	0312/1463		012 " DIA CIRC CONCR LEN=0065 INSTALLED UNKN 012 " DIA CIR PLASTIC

DIR: B TOTAL LEN: 13.640 MI. DIST: 11-1 SR: 130
 LEFT MUN: PITCAIRN B RIGHT MUN: PITCAIRN B

Location / TWP	Segment ID	Length (FT)	Notes / Details
SECOND ST ET (TWP)	0312/0705		0312/0978 LEN=0035 INSTALLED UNKN
	062430 FT	062451 FT	0312/0059 LEN=0060 INSTALLED UNKN 062451 FT 1 0 00639 0 01 0209+75 VILLAGE: PITCAIRN B LENGTH(AH 2868 BK 3915) PITCAIRN MONROEVILLE B
MAWCO DR (TWP)	0302/2675		0302/3891 01B "DIA CIRC CONCR LEN=0060 INSTALLED UNKN
			0302/3017 021 "DIA CIRC CONCR LEN=0099 INSTALLED UNKN
			0302/2381 021 "DIA CIRC CONCR LEN=0055 INSTALLED UNKN
			0302/2347 01B "DIA CIRC CONCR LEN=0050 INSTALLED UNKN
STEELE ST (TWP)	0302/2025		0302/2067
VALLEY RD (TWP)	0302/1710		
WASTE MANAGEMENT FACILI (PRDR)	0302/1467		0302/1540 BRANCH OF TURTLE CREEK STRUCTURE LENGTH 15 FT BMSID 02/0130/0302/1540
			0302/1467 (APRA) WASTE MANAGEMENT 012 "DIA CIRC CONCR
QUARRY RD (TWP)	0302/1050		0302/1159 LEN=1060 INSTALLED UNKN
1 0 00639 0 01 0170+42 THOMAS ST (TWP)	058515 FT	058536 FT	058536 FT
	0302/0000		0302/0000 LENGTH(AH 3915 BK 0508) SPRING HILL BR (TWP)
	058007 FT	058028 FT	0292/0045 1 0 00639 0 00 0152+46 STATE ST (TWP)
			MFC BEGIN = B LENGTH(AH 0508 BK 1355)
			0292/0000
			0282/0981 01B "DIA CIRC CONCR LEN=0060 INSTALLED UNKN

EXTRACT DATE: 12/21/2020
PRINT DATE: 12/23/2020

ROADWAY MANAGEMENT SYSTEM
SLD COUNTY/SR - ANNUAL PRINT

PAGE NUMBER: 302
COUNTY: ALLEGHENY

DIR: B TOTAL LEN: 13.640 MI.
LEFT MUN: MONROEVILLE B

DIST: 11-1 SR: 130
RIGHT MUN: MONROEVILLE B

018 "H 18 "W ELLIP CONC
LEN=0045 INSTALLED UNKN 0283/0283

1 0 00639 0 01 0179+02 056667 FT
VILLAGE: MONROEVILLE B
NC BROADWAY BL
LENGTH(AH 1340 BK 3228) 0283/0000
RAMP D-3 RD
(SR8076 SEG 0500/0000) 0273/3042
018 "DIA CIRC CONCR
LEN=2814 INSTALLED UNKN 0273/2943

BMSEN 02/0130/0272/2650 0273/2683
0 0 00000 0 00 0000+00
PATTON STREET LOCAL
BMSBG 02/0130/0272/2650 0273/2617
MONROEVILLE
WILMERDING B 0273/2102

RAMP D-2 RD
(SR8076 SEG 0250/0553) 0273/2084

1 0 00639 0 00 0119+66 053439 FT
NC WATKINS AV
LENGTH(AH 3228 BK 3165) 0273/0000

012 "DIA CIRC CONCR
LEN=0099 INSTALLED UNKN 0263/1746
018 "DIA CIRC CONCR
LEN=0099 INSTALLED UNKN 0263/1561
WILMERDING

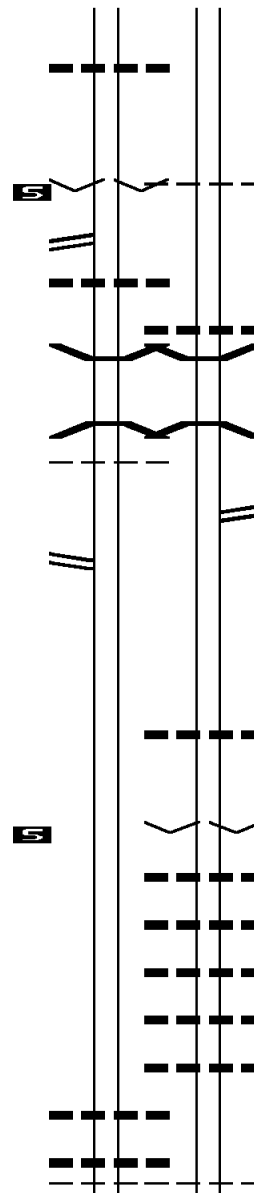

056673 FT 1 0 00639 0 01 0179+02
NC BROADWAY BL
MONROEVILLE
WILMERDING B
0282/0000 LENGTH(AH 1355 BK 3238)

0272/2750 018 "DIA CIRC CONCR
0272/2716 LEN=0100 INSTALLED UNKN
BMSEN 02/0130/0272/2650
0 0 00000 0 00 0000+00
0272/2650 PATTON STREET LOCAL
BMSBG 02/0130/0272/2650

0272/2087 RAMP D-1 RD
(SR8076 SEG 0010/0000)

0272/0084 018 "DIA CIRC CONCR
053435 FT LEN=0099 INSTALLED UNKN
1 0 00639 0 00 0120+08
VILLAGE: WILMERDING B

NC WATKINS AV
0272/0000 LENGTH(AH 3238 BK 3154)

0262/2943 018 "DIA CIRC CONCR
LEN=0099 INSTALLED UNKN

0262/2644 018 "DIA CIRC CONCR
LEN=0099 INSTALLED UNKN

0262/2342 021 "DIA CIRC CONCR
LEN=0099 INSTALLED UNKN

0262/2036 018 "DIA CIRC CONCR
LEN=0099 INSTALLED UNKN

0262/1744 018 "DIA CIRC CONCR
LEN=0099 INSTALLED UNKN

WILMERDING

DIR: B TOTAL LEN: 13.640 MI. DIST: 11-1 SR: 130
 LEFT MUN: WILMERDING B RIGHT MUN: WILMERDING B

Location / Description	Stationing	Material / Notes	Stationing	Location / Description
TURTLE CREEK B	0263/1473	018 "H 01" W UNKN CONC	0262/1323	TURTLE CREEK B
LEN=0099 INSTALLED UNKN	0263/1221			
018 "DIA CIRC CONCR	0263/0966			
LEN=0036 INSTALLED UNKN				
018 "DIA CIRC CONCR	0263/0210			
LEN=0140 INSTALLED UNKN	0263/0000	1 0 00639 0 00 0088+30 050274 FT	050281 FT 1 0 00639 0 00 0089+34	
LENGTH(AH 3165 BK 2500)			0262/0000 LENGTH(AH 3154 BK 2483)	
018 "DIA CIRC CONCR	0253/2175		0252/2152 018 "DIA CIRC CONCR	LEN=0099 INSTALLED UNKN
LEN=0099 INSTALLED UNKN			0252/1947 018 "DIA CIRC CONCR	LEN=0050 INSTALLED UNKN
MONROEVILLE AV (TWP)				
MONROEVILLE AV (TWP)	0253/1850			MONROEVILLE AV (TWP)
				MONROEVILLE AV (TWP)
018 "DIA CIRC CONCR	0253/1539		0252/1801	
LEN=0050 INSTALLED UNKN				
018 "DIA CIRC CONCR	0253/1525			
LEN=0148 INSTALLED UNKN				
GRANT ST (TWP)	0253/1405		0252/1390	GRANT ST (TWP)
				GRANT ST (TWP)
018 "DIA CIRC CONCR	0253/1378		0252/1369	
LEN=0099 INSTALLED UNKN				
CHURCH ST (TWP)	0253/1140			
BMSBEG 02/0130/0252/0940	0253/1025		0252/1005	BMSBEG 02/0130/0252/0940
0 0 00000 0 00 0000+00				0 0 00000 0 00 0000+00
THOMPSON RUN	0253/0960		0252/0940	THOMPSON RUN
BMSBEG 02/0130/0252/0940				BMSBEG 02/0130/0252/0940
THOMPSON ST (TWP)				THOMPSON ST (TWP)
THOMPSON ST (SR2065 SEG 0010/0000)	0253/0915		0252/0890	THOMPSON ST (SR2065 SEG 0010/0000)
018 "DIA CIRC CONCR	0253/0692			
LEN=0045 INSTALLED UNKN				
NEGLEY AV (TWP)	0253/0390		0252/0355	NEGLEY AV (TWP)

DIR: B TOTAL LEN: 13.640 MI. DIST: 11-1 SR: 130
 LEFT MUN: TURTLE CREEK B RIGHT MUN: TURTLE CREEK B

TO 0130/0242 SH
 (CONN)
 1 0 00639 0 00 0063+38 0253/0110
 SHAW ST 047774 FT
 (TWP)
 NC TRI-BORO AV
 BRADDOCK AV
 (SR2037 SEG 0101/3837)
 (SR2037 SEG 0100/3691)
 MFC BEGIN = B
 LENGTH(AH 2500 BK 1603) 0253/0000
 FROM 0130/0253 SH
 (CONN) 0242/1510

MORTIMER AV
 (BORO) 0242/0720
 046171 FT
 045364 FT

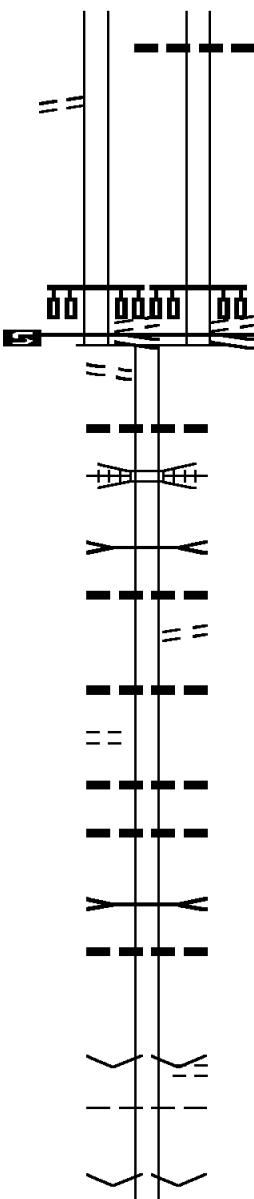

0252/0253 018 "DIA CIRC CONCR
 LEN=0099 INSTALLED UNKN
 047798 FT 1 0 00639 0 00 0063+38
 SHAW ST
 (TWP)
 NC TRI-BORO AV
 BRADDOCK AV
 (SR2037 SEG 0101/3837)
 (SR2037 SEG 0100/3691)
 MFC BEGIN = B
 LENGTH(AH 2483 BK 1603) 0252/0000
 0242/1504 018 "DIA CIRC CONCR
 LEN=1405 INSTALLED UNKN
 UNION & PENNSYLVANIA &
 0242/1455 OVERPASS IS RR X-ING
 SAW MILL RUN
 STRUCTURE LENGTH 10 FT
 0242/1330 BMSID 02/0130/0242/1330
 018 "DIA CIRC CONCR
 0242/1128 LEN=0099 INSTALLED UNKN
 BROWN AV
 (TWP)
 0242/1120 018 "DIA CIRC CONCR
 0242/0925 LEN=0099 INSTALLED UNKN
 0242/0692 018 "DIA CIRC CONCR
 LEN=0099 INSTALLED UNKN
 0242/0672 018 "DIA CIRC CONCR
 LEN=0573 INSTALLED UNKN
 SAW MILL RUN
 STRUCTURE LENGTH 10 FT
 0242/0670 BMSID 02/0130/0242/0670
 018 "DIA CIRC CONCR
 0242/0440 LEN=0030 INSTALLED UNKN
 046195 FT 1 0 00741 0 00 0016+35
 VILLAGE: TURTLE CREEK B
 CEDAR ST
 (TWP)
 S 0242/0000 LENGTH(AH 1603 BK 0807)
 TURTLE CREEK
 0232/0623 WILKINS T
 045388 FT 1 0 00741 0 00 0020+39
 VILLAGE: WILKINS TWP

DIR: B TOTAL LEN: 13.640 MI. DIST: 11-1 SR: 130
 LEFT MUN: WILKINS T RIGHT MUN: WILKINS T

Street Name	Segment ID	Length	Notes
WASHINGTON ST (TWP)	0222/1143		IVY ST (TWP) LENGTH(AH 0807 BK 1294) MOSS ST (TWP)
	0222/0197		BMS EN 02/0130/0222/0180 0 0 0000 0 00 0000+00
	044070 FT	0222/0180	SAW MILL RUN BMSBG 02/0130/0222/0180 1 0 00741 0 00 0037+80
		044094 FT	VILLAGE: WILKINS T 036 "DIA CIRC CONCR LEN=0070 INSTALLED UNKN
STRALEY LN (TWP)	0212/1335		LEN=0070 INSTALLED UNKN LENGTH(AH 1294 BK 2335)
	0212/0705		
	0212/0648		018 "DIA CIRC CONCR LEN=0034 INSTALLED UNKN
	0212/0307		018 "DIA CIRC CONCR LEN=0050 INSTALLED UNKN
BALINT LN (TWP)	041735 FT	0212/0059	024 "DIA CIRC CONCR LEN=0060 INSTALLED UNKN
	0212/0000	041759 FT	1 0 00741 0 00 0060+70
		0212/0000	VILLAGE: WILKINS TWP LENGTH(AH 2335 BK 3257)
		0202/3165	LUCINDA DR (TWP)
RUSSELL LN (TWP)	0202/3107		018 "DIA CIRC CONCR LEN=0099 INSTALLED UNKN
	0202/2997		024 "DIA CIRC CONCR LEN=0099 INSTALLED UNKN
	0202/2562		018 "DIA CIRC CONCR LEN=0099 INSTALLED UNKN
	0202/1920		LC FROM ROLAND RD (CONN)
FREE LN (TWP)	0202/1800		ROLAND RD (TWP)
	0202/1800		
	0202/1750		LC TO ROLAND RD (CONN)
BRIARIDGE DR (TWP)	0202/1800		

DIR: B TOTAL LEN: 13.640 MI. DIST: 11-1 SR: 130
 LEFT MUN: WILKINS T RIGHT MUN: WILKINS T

Street Name	Stationing	Length	Structure	Material	Status
			SAW MILL RUN		
			STRUCTURE LENGTH	16 FT	
			BMSID	02/0130/0202/0665	
			WILKINS		
			CHURCHILL B		
			015" DIA	CIRC CONCR	
			LEN=0099	INSTALLED	UNKN
			KINGSDALE RD		
			(TWP)		
			1 0 00741 0 00 0093+17		
			NC BROWN AV		
			LENGTH(AH 3257 BK 2077)		
WOODLAND HILLS DR (TWP)	0192/1625		THORNBERRY DR		
HOMER DR (TWP)	0192/1325		(TWP)		
			024"H 18"W BOX CULVRT*		
			LEN=0050	INSTALLED	UNKN
			018" DIA	CIRC CONCR	
			LEN=0055	INSTALLED	UNKN
			018" DIA	CIRC CONCR	
			LEN=0050	INSTALLED	UNKN
			018" DIA	CIRC CONCR	
			LEN=0050	INSTALLED	UNKN
			018" DIA	CIRC CONCR	
			LEN=0099	INSTALLED	UNKN
			016" DIA	CIRC CONCR	
			LEN=0099	INSTALLED	UNKN
HAMPSTEAD DR (TWP)	0192/0185				
	036401 FT				
			1 0 00741 0 00 0114+75		
			LENGTH(AH 2077 BK 1751)		
			018" DIA	CIRC CONCR	
			LEN=0036	INSTALLED	UNKN
			018" DIA	CIRC CONCR	
			LEN=0036	INSTALLED	UNKN
			016"H 28"W ELLIP CONC		
			LEN=0099	INSTALLED	UNKN
ROYAL OAK AV (TWP)	0182/0910				
			016" DIA	CIRC CONCR	
			LEN=0099	INSTALLED	UNKN
			LEWIN LN		
			(TWP)		
			018" DIA	CIRC CONCR	
			LEN=0036	INSTALLED	UNKN

DIR: B TOTAL LEN: 13.640 MI. DIST: 11-1 SR: 130
 LEFT MUN: CHURCHILL B RIGHT MUN: CHURCHILL B

					0182/0130	018 "DIA CIRC CONCR LEN=0040 INSTALLED UNKN
	034650 FT				034674 FT	1 0 00741 0 00 0131+35 FENWICK DR (BORO)
OLD BEULAH RD (TWP)	0182/0000				0182/0000	MFC BEGIN = B LENGTH(AH 1751 BK 2546)
015 "DIA CIRC CONCR LEN=0040 INSTALLED UNKN	0173/2025				0172/2041	018 "DIA CIRC CONCR LEN=0099 INSTALLED UNKN
					0172/1658	018 "DIA CIRC CONCR LEN=0060 INSTALLED UNKN
					0172/1050	018 "DIA CIRC CONCR LEN=0099 INSTALLED UNKN
OLD BEULAH RD (BORO)	0173/0425				0172/0442	OLD BEULAH RD (BORO)
TO 2104/0010 SH (CONN)	0173/0326					(APRA) WESTINGHOUSE RES HELLEN DR (PRDR)
(APRA) WESTINGHOUSE RES HELLEN DR (PRDR)						CHURCHILL RD (SR2104 SEG 0010/0000)
CHURCHILL RD (SR2104 SEG 0010/0000)	0173/0220				0172/0230	
FROM 2104/0010 SH (CONN)	0173/0070				032128 FT	1 0 00741 0 00 0156+73 SR 0376 EB
1 0 00741 0 00 0156+73 032106 FT SR 0376 EB						OP ID 02/0376/0790/1628 DRAINAGE
OP ID 02/0376/0790/1628 DRAINAGE						STRUCTURE LENGTH 0 FT BMSID 02/0376/0790/1638
STRUCTURE LENGTH 0 FT BMSID 02/0376/0790/1638	0173/0000				0172/0000	LENGTH(AH 2546 BK 0217)
LENGTH(AH 2544 BK 0195) TO 2110/0040 SH (CONN)	0163/0095				031911 FT	1 0 00741 0 00 0158+76 VILLAGE: CHURCHILL B PENN AV (SR2110 SEG 0040/0000)
1 0 00741 0 00 0158+76 031911 FT PENN AV (SR2110 SEG 0040/0000)						MFC BEGIN = B LENGTH(AH 0217 BK 2300) TO 2110/0031 SH (CONN)
MFC BEGIN = B LENGTH(AH 0195 BK 2300)	0163/0000				0162/0000	
MCCRADY RD					0152/2161	

EXTRACT DATE: 12/21/2020
PRINT DATE: 12/23/2020

ROADWAY MANAGEMENT SYSTEM
SLD COUNTY/SR - ANNUAL PRINT

PAGE NUMBER: 296
COUNTY: ALLEGHENY

DIR: B TOTAL LEN: 13.640 MI.
LEFT MUN: CHURCHILL B

DIST: 11-1 SR: 130
RIGHT MUN: CHURCHILL B

(TWP)

0152/2101



LONG RD
(SR2059 SEG 0010/0000)

0142/1184

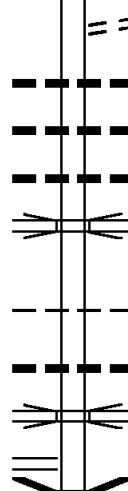

PENNY DR
(TWP)

0142/0775
027899 FT

EMROSE DR
(TWP)

0132/0825

0152/2101

0152/1534

0152/1316

0152/0952

0152/0534

0152/0273

0152/0000

0142/1486

0142/1378

0142/1165

0142/1151

027899 FT

0142/0000

0132/1795

0132/1718

0132/1412

0132/1410

0132/1367

0132/1161

0132/0831

FOREST DR
(TWP)
018 "DIA CIRC CONCR
LEN=0099 INSTALLED UNKN
018 "DIA CIRC PLASTIC
LEN=0099 INSTALLED UNKN
018 "DIA CIRC PLASTIC
LEN=0435 INSTALLED UNKN
PEDESTRIAN
OP ID 02/0130/0152/0345
1 0 00742 0 00 0026+00
CHURCHILL
PENN HILLS T
LENGTH(AH 2300 BK 1712)
018 "DIA CIRC CONCR
LEN=0099 INSTALLED UNKN
PEDESTRIAN
OP ID 02/0130/0142/1415
BMS EN 02/0130/0142/1190
1 0 00742 0 00 0042+55
CHALFONT RUN
BMSBG 02/0130/0142/1190
1 0 00742 0 00 0042+55
012 "DIA CIRC CONCR
LEN=0040 INSTALLED UNKN
LENGTH(AH 1712 BK 2488)
MULBERRY LN
(TWP)
018 "DIA CIRC CONCR
LEN=0099 INSTALLED UNKN
018 "DIA CIRC CONCR
LEN=0099 INSTALLED UNKN
NELBON AV
(TWP)
018 "DIA CIRC CONCR
LEN=0099 INSTALLED UNKN
018 "DIA CIRC CONCR
LEN=0099 INSTALLED UNKN
012 "DIA CIRC CONCR
LEN=0099 INSTALLED UNKN
018 "DIA CIRC CONCR

DIR: B TOTAL LEN: 13.640 MI. DIST: 11-1 SR: 130
 LEFT MUN: PENN HILLS T RIGHT MUN: PENN HILLS T

MELVIN CT
(TWP)

0132/0584

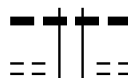

0132/0640 LEN=0099 INSTALLED UNKN
LINDBERG AV

0132/0584 (TWP) 012" DIA CIRC CONCR

025411 FT

0132/0580 LEN=0099 INSTALLED UNKN
025411 FT 1 0 00742 0 00 0067+69

LAKETON RD (CNTY)

NC BEULAH RD FRANKSTOWN RD (SR0400 SEG 0230/0385)

FRANKSTOWN RD (SR0400 SEG 0230/0385) FROM 0400/0230 SH (CONN)

0132/0000



0132/0000 LENGTH(AH 2488 BK 3047)

0122/2862

0122/2317 OLD COAL HOLLOW RD (TWP) 018" DIA CIRC CONCR

CLIFF DR (TWP)

0122/1594

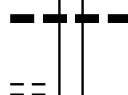

0122/2200 LEN=0099 INSTALLED UNKN



0122/1282 018" DIA CIRC CONCR LEN=0099 INSTALLED UNKN



0122/0675 018" DIA CIRC CONCR LEN=0099 INSTALLED UNKN



0122/0470 018" DIA CIRC CONCR LEN=0028 INSTALLED UNKN



0122/0265 018" DIA CIRC CONCR LEN=0099 INSTALLED UNKN

022364 FT



0122/0180 OLD COAL HOLLOW RD (TWP) 018" DIA CIRC CONCR

022364 FT 2 0 02172 0 00 0030+40 LENGTH(AH 3047 BK 2125)



0112/1872 018" DIA CIRC CONCR LEN=0095 INSTALLED UNKN



0112/1546 018" DIA CIRC CONCR LEN=0095 INSTALLED UNKN



0112/0113 SANDY CREEK STRUCTURE LENGTH 13 FT

020239 FT



0112/0100 BMSID 02/0130/0112/0100 020239 FT 2 0 02172 0 00 0051+90

LIME HOLLOW RD (SR2064 SEG 0010/0000)

0102/0395

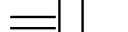

0112/0000 LENGTH(AH 2125 BK 0641)

DIR: B TOTAL LEN: 13.640 MI. DIST: 11-1 SR: 130
 LEFT MUN: PENN HILLS T RIGHT MUN: PENN HILLS T

Stationing / Description	Length (FT)	Material / Notes
019598 FT	0102/0341	018 " DIA CIRC CONCR LEN=0050 INSTALLED UNKN
	019598 FT	2 0 02172 0 00 0058+31
	0102/0000	NC COAL HOLLOW RD LENGTH(AH 0641 BK 0721) SANDY CREEK STRUCTURE LENGTH 14 FT
	0092/0560	BMSID 02/0130/0092/0560 FROM 2058/0080 SH
	0092/0379	(CONN)
	0092/0371	018 " DIA CIR PLASTIC LEN=0040 INSTALLED UNKN VERONA RD (SR2058 SEG 0080/0710)
VERONA RD (SR2058 SEG 0080/0710) FROM 2058/0080 SH (CONN)	0092/0255	
	0092/0050	
018877 FT	0092/0025	BMS EN 02/0130/0092/0000 2 0 02172 0 01 0066+17 SANDY CREEK
	018877 FT	
	0092/0000	BMSBG 02/0130/0092/0000 LENGTH(AH 0721 BK 2190)
	0082/0990	018 " DIA CIR PLASTIC LEN=0048 INSTALLED UNKN
KINCAID DR (PRDR)	0082/0780	(APRA) KINCAID MFG CO 012 " DIA CIRC CONCR
	0082/0740	LEN=0130 INSTALLED UNKN
016687 FT	016687 FT	2 0 02172 0 01 0087+52 VILLAGE: PENN HILLS TWP
	0082/0000	LENGTH(AH 2190 BK 2199) 018 " DIA CIRC CONCR
	0072/2100	LEN=0099 INSTALLED UNKN
	0072/0654	018 " DIA CIRC CONCR LEN=0065 INSTALLED UNKN
	0072/0479	018 " DIA CIRC METAL LEN=0048 INSTALLED UNKN NC SANDY CREEK RD
2 0 02172 0 01 0110+21 ALLEGHENY RIVER BL (SR2073 SEG 0010/0000)	014488 FT	
	0072/0000	LENGTH(AH 2199 BK 2804) 018 " DIA CIRC CONCR
	0062/2664	LEN=0030 INSTALLED UNKN 018 " DIA CIRC CONCR

DIR: B TOTAL LEN: 13.640 MI. DIST: 11-1 SR: 130
 LEFT MUN: PENN HILLS T RIGHT MUN: PENN HILLS T

011684 FT

008927 FT

0062/2246	LEN=0030	INSTALLED UNKN
018 "DIA	CIRC CONCR	
0062/1874	LEN=0030	INSTALLED UNKN
018 "DIA	CIRC CONCR	
0062/1258	LEN=0030	INSTALLED UNKN
018 "DIA	CIRC CONCR	
0062/0873	LEN=0030	INSTALLED UNKN
018 "DIA	CIRC CONCR	
0062/0532	LEN=0030	INSTALLED UNKN
018 "DIA	CIRC CONCR	
0062/0163	LEN=0030	INSTALLED UNKN
011684 FT	2 0 02247	0 00 0231+26
0062/0000	LENGTH(AH 2804 BK 2757)	
099 "DIA	CIR UNKNOWN	
0052/2607	LEN=0030	INSTALLED UNKN
099 "DIA	CIR UNKNOWN	
0052/2347	LEN=0030	INSTALLED UNKN
018 "DIA	CIR UNKNOWN	
0052/1497	LEN=0030	INSTALLED UNKN
018 "DIA	CIR UNKNOWN	
0052/1052	LEN=0300	INSTALLED 199B
018 "DIA	CIR UNKNOWN	
0052/0787	LEN=0030	INSTALLED UNKN
099 "DIA	CIR UNKNOWN	
0052/0455	LEN=0030	INSTALLED UNKN
008927 FT	2 0 02247	0 00 0203+66
099 "DIA	CIR UNKNOWN	
LEN=0030	INSTALLED UNKN	
NADINE RD		
(TWP)		
0052/0000	LENGTH(AH 2757 BK 2387)	
018 "DIA	CIRC CONCR	
0042/2290	LEN=0040	INSTALLED UNKN
018 "DIA	CIRC CONCR	
0042/0340	LEN=0040	INSTALLED UNKN
0042/0312	BMSSEN 02/0130/0042/0165	
0 0 00000	0 00 0000+00	
ABANDONED	PROPERTIES RR	
0042/0250	BMSBG 02/0130/0042/0165	
PENN HILLS		
0042/0221	PITTSBURGH C	
0042/0067	BMSSEN 02/0130/0042/0055	





EXTRACT DATE: 12/21/2020
PRINT DATE: 12/23/2020

ROADWAY MANAGEMENT SYSTEM
SLD COUNTY/SR - ANNUAL PRINT

PAGE NUMBER: 292
COUNTY: ALLEGHENY

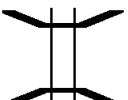
DIR: B TOTAL LEN: 13.640 MI.
LEFT MUN: PITTSBURGH C

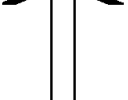
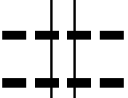
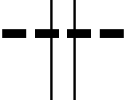
DIST: 11-1 SR: 130
RIGHT MUN: PITTSBURGH C

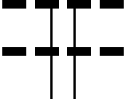
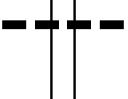
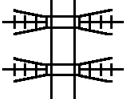
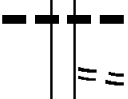
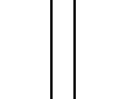
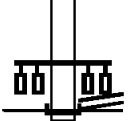
		0042/0057	BMSEN 02/0130/0042/0000 0 0 00000 0 00 0000+00 SHADES RUN
006540 FT		0042/0055 006540 FT	BMSBG 02/0130/0042/0055 2 0 02247 0 00 0181+27 ABANDONED PROPERTIES RR BMSBG 02/0130/0042/0000
		5 0042/0000	LENGTH(AH 2387 BK 3054)
		0032/1426	01B "DIA CIR UNKNOWN LEN=0040 INSTALLED UNKN
		0032/1208	01B "DIA CIR UNKNOWN LEN=0040 INSTALLED UNKN
		0032/0976	01B "DIA CIR UNKNOWN LEN=0040 INSTALLED UNKN
003486 FT		003486 FT	2 0 02268 0 00 0035+64
		5 0032/0000	LENGTH(AH 3054 BK 2524)
		0022/1632	01B "DIA CIR UNKNOWN LEN=0045 INSTALLED UNKN
		0022/1095	01B "DIA CIR UNKNOWN LEN=0035 INSTALLED UNKN
000962 FT		0022/0237 000962 FT	01B "DIA CIR UNKNOWN LEN=0035 INSTALLED UNKN
		5 0022/0000	2 0 02268 0 00 0010+10 LENGTH(AH 2524 BK 0962)
		0012/0770	OTHER OVERPASS IS RR X-ING
		0012/0430	OTHER OVERPASS IS RR X-ING
		0012/0358	01B "DIA CIRC CONCR LEN=0040 INSTALLED UNKN
000000 FT		0012/0190 000000 FT	FROM 0008/0120 SH (CONN) 2 0 02268 0 00 0000+00 WASHINGTON BL (SRO008 SEG 0131/0000) (SRO008 SEG 0130/0000)
			NC ALLEGHENY RIVER BL
		INTER-BK	ALLEGHENY RIVER BL (SRO008 SEG 0131/0000) MFC BEGIN = B
		5 0012/0000	LENGTH(AH 0962 BK 0000)

EXTRACT DATE: 12/21/2020 ROADWAY MANAGEMENT SYSTEM PAGE NUMBER: 291
 PRINT DATE: 12/23/2020 SLD COUNTY/SR - ANNUAL PRINT COUNTY: ALLEGHENY
 DIR: B TOTAL LEN: 4.013 MI. DIST: 11-1 SR: 121
 LEFT MUN: PITTSBURGH C RIGHT MUN: PITTSBURGH C

021188 FT

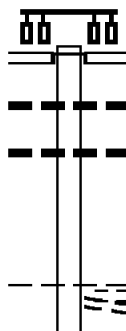

021164 FT
 INTER-AHD POPLAR ST
 (BORO)
 NOBLESTOWN RD
 (SR0050 SEG 0280/0000)
 0100/2811 015 " DIA CIRC CONCR
 0100/2740 LEN=0035 INSTALLED UNKN
 0100/2560 012"H 00"W MULT CONCR
 LEN=0035 INSTALLED UNKN
 KEARNS AV
 (BORO)
 MCKENNA AV
 (BORO)
 PITTSBURGH
 0100/2330 GREENTREE B
 018 " DIA CIRC CONCR

DIR: B TOTAL LEN: 4.013 MI. DIST: 11-1 SR: 121
 LEFT MUN: GREENTREE B RIGHT MUN: GREENTREE B

Location / Segment	Stationing	Length	Notes
TERRACE DR (BORO)	0100/1760	0100/2310	LEN=0030 INSTALLED UNKN
CLEARVIEW DR (BORO)	0100/1330	0100/1525	CHURCHILL RD (BORO)
1 0 00108 1 00 0026+21 MANSFIELD AV (SR3062 SEG 0020/2534) POPLAR ST (BORO)	018377 FT	0100/0375 018353 FT	HECKLER DR (BORO)
FROM 8035/0260 SH (CONN)	0090/0528	0100/0000	NC POPLAR ST RAMP H RD (SR8035 SEG 0260/0309)
	017268 FT	0090/0310 017244 FT	018 " DIA CIRC CONCR LEN=0099 INSTALLED UNKN 1 0 00108 1 00 0038+63 VILLAGE: PITTSBURGH C GREENTREE RD (SR3101 SEG 0010/0000)
RAMP F RD (SR8035 SEG 0270/0792)	0081/1135	0090/0000	NC MANSFIELD AV MFC BEGIN = C LENGTH(AH 1109 BK 1258)
BMSSEN 02/0121/0080/0866	0081/1012	0080/1008	BMSSEN 02/0121/0080/0866
018 " DIA CIR UNKNOWN LEN=0099 INSTALLED UNKN	0081/0875		1 0 00802 0 03 0229+13 SR 0376 EB
1 0 00802 0 03 0229+13 SR 0376 EB	0081/0870	0080/0866	BMSBG 02/0121/0080/0866
BMSBG 02/0121/0080/0866	0081/0829		RAMP C RD (SR8035 SEG 0020/0489)
RAMP C RD (SR8035 SEG 0020/0500)	0081/0829	0080/0821	
FROM 8035/0020 SH (CONN)	0081/0744	0080/0532	RAMP A RD (SR8035 SEG 0750/0000) SIGN: CANTILEVER
		0080/0344	BMSID 02/0121/0080/0281

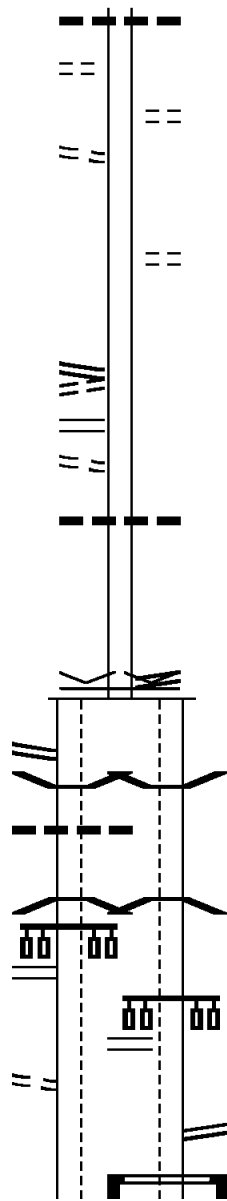

DIR: B TOTAL LEN: 4.013 MI. DIST: 11-1 SR: 121
 LEFT MUN: GREENTREE B RIGHT MUN: GREENTREE B

Street Name (BORO)	Segment ID	Length (FT)	Notes
ROSEBERRY WY (BORO)	0081/0276	015986	LC FROM ROSEBERRY WY (CONN) ROSEBERRY WY (BORO)
MANILLA AV (BORO)	0081/0000	01285	MFC BEGIN = C LENGTH(AH 1285 BK 2792)
WESTERN AV (BORO)	0070/2060	013191	
ORCHARD DR (BORO)	0070/0455	013194	
GREENRIDGE LN (BORO)	0060/3165	013194	
ELMHURST RD (BORO)	0060/2095	0035	POTOMAC AV (CNTY)
CRESTMONT DR (BORO)	0060/1540	0035	018 "DIA CONC CR LCN=0035 INSTALLED UNKN
	0060/1400		BANBURY LN (BORO)
	0060/0840		FOREST DR (BORO)
			MCMONAGLE AV

DIR: B TOTAL LEN: 4.013 MI. DIST: 11-1 SR: 121
 LEFT MUN: GREENTREE B RIGHT MUN: GREENTREE B

Stationing	Description	Stationing	Description
009312 FT		0060/0305 (CNTY)	
		009315 FT	1 0 00802 0 03 0155+66
			VILLAGE: GREENTREE B
			MFC BEGIN = B
			GREENTREE
			SCOTT T
		0060/0000	LENGTH(AH 3879 BK 2704)
ARLA DR (TWP)		ARLA DR (TWP)	
CHATHAM PARK DR (TWP)	0051/2149	CHATHAM PARK DR (TWP)	0050/2295
	0051/2056		0050/2200
RYAN DR (TWP)	0051/1383	RYAN DR (TWP)	0050/1520
GREEN ORCHARD DR (TWP)	0051/1110	GREEN ORCHARD DR (TWP)	0050/1255
			018 "DIA CIRC CONCR
GREEN OAK LN (TWP)	0051/0425	GREEN OAK LN (TWP)	LEN=0099 INSTALLED UNKN
			0050/0585
018 "DIA CIR PLASTIC	0051/0352	015 "DIA CIRC CONCR	LEN=0030 INSTALLED UNKN
LEN=0035 INSTALLED UNKN			0050/0196
018 "DIA CIRC CONCR			LEN=0030 INSTALLED UNKN
LEN=0030 INSTALLED UNKN	0051/0085		006611 FT
1 0 00802 0 02 0124+53	0051/0000	0050/0000	1 0 00802 0 02 0123+71
LENGTH(AH 2572 BK 2772)			LENGTH(AH 2704 BK 2615)
			015 "DIA CIRC CONCR
015 "DIA CIRC CONCR			LEN=0030 INSTALLED UNKN
LEN=0030 INSTALLED UNKN	0041/2500		
GREENVALLEY DR (TWP)		GREENVALLEY DR (TWP)	
FORSYTHE RD (SR3056 SEG 0040/1196)	0041/2435	FORSYTHE RD (SR3056 SEG 0040/1196)	0040/2515
			0040/2431
GREENBRIAR DR (TWP)	0041/2140	GREENBRIAR DR (TWP)	0040/2361
ORCHARD SPRING RD (TWP)	0041/2075	ORCHARD SPRING RD (TWP)	0040/2120
			0040/2079
			012 "DIA CIRC CONCR
			LEN=0099 INSTALLED UNKN
			0040/1665

DIR: B TOTAL LEN: 4.013 MI. DIST: 11-1 SR: 121
 LEFT MUN: SCOTT T RIGHT MUN: SCOTT T

Stationing	Description	Material	Length	Notes
0041/1415	GREENBRIAR DR (TWP)	012 " DIA CIRC CONCR	0099	INSTALLED UNKN
0041/1065	015 " DIA CIRC CONCR LEN=0050 INSTALLED UNKN MARSHALLS ENTRANCE RD (PRDR)	012 " DIA CIRC CONCR	0099	INSTALLED UNKN
0041/0960	MARSHALLS ENTRANCE RD (PRDR)	012 " DIA CIRC CONCR	0070	INSTALLED UNKN
0041/0635	015 " DIA CIRC CONCR LEN=0050 INSTALLED UNKN MARSHALLS ENTRANCE RD (PRDR)	012 " DIA CIRC CONCR	0099	INSTALLED UNKN
0041/0495	MANORVIEW RD (TWP)	015 " DIA CIRC CONCR	0030	INSTALLED UNKN
0041/0187	RAMP B RD (SR9404 SEG 0250/0000)	012 " DIA CIRC CONCR	0099	INSTALLED UNKN
0041/0000	1 0 00802 0 02 0099+40 003968 FT GREENTREE RD (SR3052 SEG 0151/1277) (SR3052 SEG 0150/1368) NC GREENTREE RD	012 " DIA CIRC CONCR	0099	INSTALLED UNKN
0040/0000	LENGTH(AH 2772 BK 0651)	024 " DIA CIRC CONCR	0040	INSTALLED UNKN
003317 FT	2 0 02235 0 01 0006+88 003317 FT ROESSLER RD (TWP) MFC BEGIN = B	012 " DIA CIR PLASTIC	0050	INSTALLED UNKN

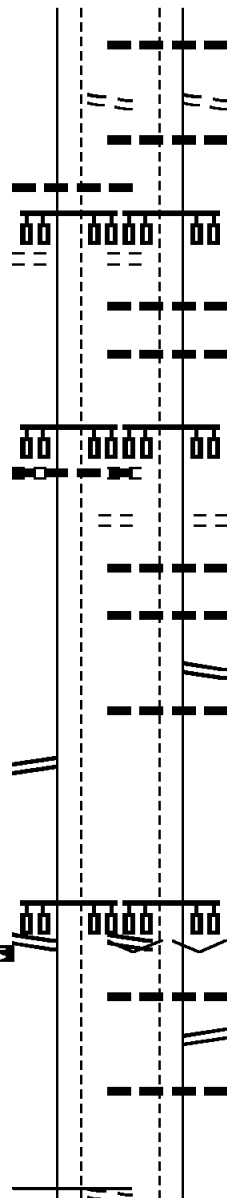

0040/1420
 0040/1400
 0040/1200
 0040/0955
 0040/0904
 0040/0650
 0040/0635
 0040/0500
 0040/0475
 0040/0417
 0040/0261
 0040/0214
 003996 FT
 0040/0000
 0030/0650
 0030/0445
 0030/0306
 003317 FT

012 " DIA CIRC CONCR
 LEN=0099 INSTALLED UNKN
 GREENBRIAR DR (TWP)
 018 " DIA CIRC CONCR
 LEN=0099 INSTALLED UNKN
 MARSHALLS ENTRANCE RD (PRDR)
 012 " DIA CIRC CONCR
 LEN=0070 INSTALLED UNKN
 012 " DIA CIRC CONCR
 LEN=0099 INSTALLED UNKN
 MARSHALLS ENTRANCE RD (PRDR)
 MANORVIEW RD (TWP)
 015 " DIA CIRC CONCR
 LEN=0030 INSTALLED UNKN
 012 " DIA CIRC CONCR
 LEN=0099 INSTALLED UNKN
 RAMP A RD (SR9404 SEG 0010/0347)
 012 " DIA CIRC CONCR
 LEN=0099 INSTALLED UNKN
 1 0 00802 0 02 0099+40
 VILLAGE: SCOTT TWP
 GREENTREE RD (SR3052 SEG 0150/1368)
 (SR3052 SEG 0151/1277)
 NC GREENTREE RD
 LENGTH(AH 2615 BK 0679)
 024 " DIA CIRC CONCR
 LEN=0040 INSTALLED UNKN
 RAMP A RD (SR9404 SEG 0010/0000)
 012 " DIA CIR PLASTIC
 LEN=0050 INSTALLED UNKN
 2 0 02235 0 01 0006+88
 ROESSLER RD

DIR: B TOTAL LEN: 4.013 MI. DIST: 11-1 SR: 121
 LEFT MUN: SCOTT T RIGHT MUN: SCOTT T

Location / Segment	Segment ID	Length (FT)	Notes / Details
SCOTT MT LEBANON T	0031/0000		(TWP) MFC BEGIN = B
	0020/1273		LENGTH(AH 0679 BK 1379) 012 "DIA CIRC CONCR LEN=0099 INSTALLED UNKN
LARCHMONT RD (TWP)	0020/0545		
	0020/0530		018 "DIA CIRC CONCR LEN=0040 INSTALLED UNKN
	0020/0197		012 "DIA CIRC CONCR LEN=0060 INSTALLED UNKN
001938 FT	001938 FT		2 0 02235 0 01 0021+65 VILLAGE: MT. LEBANON T ROBINWOOD DR (TWP)
WILLIAMSBURG RD (TWP)	0010/1520		SCOTT MT LEBANON T
	0010/1800		LENGTH(AH 1379 BK 1938) SCOTT MT LEBANON T
VALLEYVIEW RD (TWP)	0010/0905		MORRISON DR (TWP)
	0010/0833		PARKER DR (TWP)
OSAGE RD (TWP)	0010/0824		
SCRUBGRASS RD (TWP)	0010/0510		
	0010/0305		ARDEN RD (TWP)
	0010/0270		018 "DIA CIRC CONCR LEN=0099 INSTALLED UNKN
ARDEN LN (TWP)	0010/0265		
	0010/0090		018 "DIA CIRC CONCR LEN=0009 INSTALLED UNKN
000000 FT	000000 FT		2 0 02235 0 01 0040+40 VILLAGE: MT. LEBANON T
			NC CO CHHRAN RD BEVERLY RD (SRO019 SEG 0140/0907) COCHRAN RD (SRO019 SEG 0140/0907)
BEVERLY RD (TWP)	0010/0000		MFC BEGIN = B LENGTH(AH 1938 BK 0000)

EXTRACT DATE: 12/21/2020 ROADWAY MANAGEMENT SYSTEM PAGE NUMBER: 285
 PRINT DATE: 12/23/2020 SLD COUNTY/SR - ANNUAL PRINT COUNTY: ALLEGHENY
 DIR: B TOTAL LEN: 8.457 MI. DIST: 11-1 SR: 88
 LEFT MUN: PITTSBURGH C RIGHT MUN: PITTSBURGH C

044655 FT

SAW MILL RUN BL
 (SR0051 SEG 0341/0000)
 (SR0051 SEG 0340/0000) 0170/2302

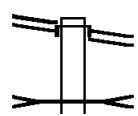

044655 FT
 INTER-AHD SR 9120 CONNECTOR RD
 (SR9120 SEG 0010/0966)
 SAW MILL RUN BL
 (SR0051 SEG 0341/0000)
 (SR0051 SEG 0340/0000)
 WEYMAN RUN
 STRUCTURE LENGTH 24 FT
 BMSID 02/0088/0170/2278

DIR: B TOTAL LEN: 8.457 MI. DIST: 11-1 SR: 88
 LEFT MUN: PITTSBURGH C RIGHT MUN: PITTSBURGH C

Location / Notes	Segment ID	Structure / Details	Length	Status
	0170/2224	SAW MILL RUN STRUCTURE	32 FT	
	0170/2202	BMSID 02/0088/0170/2246 TO 0051/0331 SH (CONN)		
FROM 0051/0341 SH (CONN)	0170/2145	018" DIA CIRC CONCR	LEN=0030	INSTALLED UNKN
	0170/2109			
	0170/2000	018" DIA CIRC CONCR	LEN=0030	INSTALLED UNKN
	0170/1800	018" DIA CIRC CONCR	LEN=0030	INSTALLED UNKN
	0170/1565	018" DIA CIRC CONCR	LEN=0045	INSTALLED UNKN
TARIFF ST (CITY)	0170/1405	010" DIA CIRC CONCR	LEN=0030	INSTALLED UNKN
	0170/1091			
	0170/0925	018" DIA CIRC CONCR	LEN=0030	INSTALLED UNKN
FORUM ST (CITY)	0170/0730	018" DIA CIRC CONCR	LEN=0045	INSTALLED UNKN
	0170/0626			
	0170/0600	018" DIA CIRC CONCR	LEN=0030	INSTALLED UNKN
	0170/0360	018" DIA CIRC CONCR	LEN=0030	INSTALLED UNKN
	0170/0251	018" DIA CIRC CONCR	LEN=0030	INSTALLED UNKN
042353 FT	0170/0038	BMSSEN 02/0088/0170/0001		
	042353 FT	1 0 00247 0 00 0424+17		
	0170/0000	SAW MILL RUN BMSBG 02/0088/0170/0001		
	0160/1585	LENGTH(AH 2302 BK 1771) 018" DIA CIRC CONCR	LEN=0030	INSTALLED UNKN
MCNEILLY RD (CNTY)	0160/1304			
	0160/1280	018"H 24"W ELLIP CONC	LEN=0099	INSTALLED UNKN
	0160/1085	018" DIA CIRC CONCR	LEN=0099	INSTALLED UNKN
	0160/1035	ELWYN AV (CITY)		
	0160/0610	015" DIA CIRC CONCR	LEN=0040	INSTALLED UNKN
	0160/0318	015" DIA CIRC CONCR	LEN=0040	INSTALLED UNKN

DIR: B TOTAL LEN: 8.457 MI. DIST: 11-1 SR: 88
 LEFT MUN: BETHEL PARK B RIGHT MUN: BETHEL PARK B

Location	Segment ID	Length	Material	Status
MILFORD DR (BORO)	0100/2136	0100/2370	018 " DIA CIRC CONCR	INSTALLED UNKN
		0100/1780	LEN=0040 VALLEY DR (BORO)	INSTALLED UNKN
		0100/1776	018 " DIA CIRC CONCR	INSTALLED UNKN
SCHOOL ST (BORO)	0100/1411	0100/1650	LEN=0040	INSTALLED UNKN
		0100/1351	018 " DIA CIRC CONCR	INSTALLED UNKN
MOLLENAUER ST (BORO)	0100/0535	0100/0908	HILLSIDE DR (BORO)	
	026995 FT	0100/0208	018 " DIA CIRC CONCR	INSTALLED UNKN
		026995 FT	1 0 00247 0 00 0269+17	
		0100/0000	WAGNER DR (BORO)	
		0090/3299	LENGTH(AH 2852 BK 3703)	
LORETTA ST (BORO)	0090/2650	0090/2626	012 " DIA CIRC CONCR	INSTALLED UNKN
		0090/2080	LEN=0040 STUART ST (BORO)	
OLD BETHEL CHURCH RD (CNTY)	0090/1950	0090/1950	HORNING RD (BORO)	
		0090/1700	012 " DIA CIRC CONCR	INSTALLED UNKN
BETHEL CHURCH RD (CNTY)	0090/1635	0090/1635	BROUGHTON RD (SR2040 SEG 0010/0000)	
		0090/1555	018 " DIA CIRC CONCR	INSTALLED UNKN
LINDERMER AV (BORO)	0090/1370	0090/1145	LEN=0030	INSTALLED UNKN
		0090/0676	018 " DIA CIRC CONCR	INSTALLED UNKN
			036 " DIA CIRC CONCR	INSTALLED UNKN
			LEN=0141	INSTALLED UNKN
			018 " DIA CIRC CONCR	

EXTRACT DATE: 12/21/2020
PRINT DATE: 12/23/2020

ROADWAY MANAGEMENT SYSTEM
SLD COUNTY/SR - ANNUAL PRINT

PAGE NUMBER: 280
COUNTY: ALLEGHENY

DIR: B TOTAL LEN: 8.457 MI.
LEFT MUN: BETHEL PARK B

DIST: 11-1 SR: 88
RIGHT MUN: BETHEL PARK B

Stationing	Notes	Stationing	Notes
023292 FT		0090/0471	LEN=0030 INSTALLED UNKN
		023292 FT	1 0 00247 0 00 0238+40
		0090/0000	LENGTH(AH 3703 BK 1669) 036 "DIA CIRC CONCR
		0080/1640	LEN=0045 INSTALLED UNKN
		0080/0869	LC FROM BETHEL PARK SC (CONN) BETHEL PARK CTR RD
BRIGHTWOOD RD (CNTY)		0080/0793	(PRDR)
		0080/0785	
		0080/0667	LC TO BETHEL PARK SC RD (CONN)
021623 FT		021623 FT	1 0 00247 0 00 0214+85 PAXTON DR (BORO)
		0080/0000	LENGTH(AH 1669 BK 2413)
		0070/1248	018 "DIA CIRC CONCR LEN=0040 INSTALLED UNKN RHODES AV (TWP)
LYTLE RD (T359)		0070/1235	
		0070/1140	018 "DIA CIRC CONCR LEN=0040 INSTALLED UNKN
		0070/0870	018 "DIA CIRC CONCR LEN=0040 INSTALLED UNKN
		0070/0675	018 "DIA CIRC CONCR LEN=0040 INSTALLED UNKN FROM 3009/0070 SH
		0070/0105	(CONN)
019210 FT		019210 FT	1 0 00247 0 00 0192+00 BAPTIST RD (SR3009 SEG 0070/2690)
		0070/0000	CORRIGAN DR (BORO)
SOUTH PARK RD (SR3009 SEG 0070/2690) FROM 3009/0070 SH (CONN)		0070/0000	LENGTH(AH 2413 BK 3597)
		0060/3475	
		0060/3405	LC TO CORRIGAN DR (CONN)
		0060/3301	018 "DIA CIRC CONCR LEN=0009 INSTALLED UNKN
		0060/3300	018 "DIA CIRC CONCR LEN=0040 INSTALLED UNKN

DIR: B TOTAL LEN: 8.457 MI. DIST: 11-1 SR: 88
 LEFT MUN: BETHEL PARK B RIGHT MUN: BETHEL PARK B

Street Name	Stationing	Segment	Material	Status
BUICK ST (BORO)	0060/2450	0060/2880	012 "DIA CIRC CONCR	INSTALLED UNKN
STUDEBAKER ST (BORO)	0060/1935	0060/2155	018 "DIA CIRC CONCR	INSTALLED UNKN
WOODLAWN AV (BORO)	0060/1170	0060/1620	018 "DIA CIRC CONCR	INSTALLED UNKN
		0060/0950	018 "DIA CIRC CONCR STOLTZ RD (SR3012 SEG 0010/0000)	INSTALLED UNKN
	015613 FT	0060/0187	016 "DIA CIRC CONCR	INSTALLED UNKN
		0060/0000	1 0 00247 0 00 0156+00 LENGTH(AH 3597 BK 2800)	INSTALLED UNKN
		0050/2320	018 "DIA CIRC CONCR	INSTALLED UNKN
		0050/2310	018 "DIA CIRC CONCR	INSTALLED UNKN
		0050/1841	012 "DIA CIRC CONCR	INSTALLED UNKN
		0050/1833	012 "DIA CIRC CONCR	INSTALLED UNKN
BRIGHTWOOD RD (CNTY)	0050/1745	0050/1661	018 "DIA CIRC CONCR	INSTALLED UNKN
		0050/0952	012 "DIA CIRC CONCR	INSTALLED UNKN
		0050/0157	018 "DIA CIRC CONCR	INSTALLED UNKN
SARAH ST (BORO)	0050/0000	0050/0000	1 0 00247 0 00 0128+00 012813 FT LENGTH(AH 2800 BK 2926)	INSTALLED UNKN
		0040/2908	018 "DIA CIRC CONCR	INSTALLED UNKN
LOGAN RD		0040/1863	018 "DIA CIRC CONCR	INSTALLED UNKN

EXTRACT DATE: 12/21/2020
PRINT DATE: 12/23/2020

ROADWAY MANAGEMENT SYSTEM
SLD COUNTY/SR - ANNUAL PRINT

PAGE NUMBER: 278
COUNTY: ALLEGHENY

DIR: B TOTAL LEN: 8.457 MI.
LEFT MUN: BETHEL PARK B

DIST: 11-1 SR: 88
RIGHT MUN: BETHEL PARK B

(SR3010 SEG 0040/2694) 0040/1110

009887 FT

BEAGLE DR
(BORO)

0030/0285

006933 FT

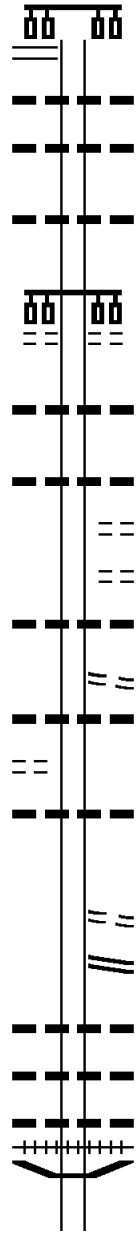

0040/1110 018 " DIA CIRC CONCR
LEN=0036 INSTALLED UNKN
0040/0861 018 " DIA CIRC CONCR
LEN=0036 INSTALLED UNKN
0040/0678 018 " DIA CIRC CONCR
LEN=0036 INSTALLED UNKN
0040/0040 018 " DIA CIRC CONCR
LEN=0036 INSTALLED UNKN
009887 FT 1 0 00247 0 00 0098+54
KINGS SCHOOL RD
(BORO)
5 0040/0000 LENGTH(AH 2926 BK 2954)
0030/2218 012 " DIA CIRC CONCR
LEN=0040 INSTALLED UNKN
0030/1462 012 " DIA CIRC METAL
LEN=0024 INSTALLED UNKN
COLONIAL LN
(BORO)
BETHELMAN AV
0030/1005 (BORO)
0030/0895 008 " DIA CIRC CONCR
LEN=0099 INSTALLED UNKN
LONG AV
(BORO)
0030/0570 012 " DIA CIRC CONCR
LEN=0064 INSTALLED UNKN
0030/0372 (BORO)
0030/0005 060 "H 48 "W CON BOX CUL
LEN=0040 INSTALLED UNKN
006933 FT 1 0 00247 0 00 0069+11
PHILLIPPI AV
(BORO)
5 0030/0000 LENGTH(AH 2954 BK 3153)
BERRYMAN AV
0020/2664 (SR3011 SEG 0040/3376)
0020/2046 018 " DIA CIRC CONCR
LEN=0099 INSTALLED UNKN
0020/1780 018 " DIA CIRC CONCR
LEN=0099 INSTALLED UNKN
012 " DIA CIRC CONCR
LEN=0099 INSTALLED UNKN
0020/1324 (AAR 918760F) #TRKS 02
0020/1026 BMSSEN 02/0088/0020/0622
0020/0650 1 0 00247 0 00 0043+87
BR. PINEY FK.

EXTRACT DATE: 12/21/2020
PRINT DATE: 12/23/2020

ROADWAY MANAGEMENT SYSTEM
SLD COUNTY/SR - ANNUAL PRINT

PAGE NUMBER: 277
COUNTY: ALLEGHENY

DIR: B TOTAL LEN: 8.457 MI.
LEFT MUN: BETHEL PARK B

DIST: 11-1 SR: 88
RIGHT MUN: BETHEL PARK B

CLIFTON RD
(SR3004 SEG 0150/3476) 0020/0340

1 0 00247 0 00 0036+80 003780 FT
CHURCHILL RD
(SR3022 SEG 0010/3044) 0020/0000

ROYAL DR (LINDEN BROOKE
(TWP) 0010/2398

TRAX RD
(TWP) 0010/1745

MONTOUR ST
(T855) 0010/1556

000000 FT

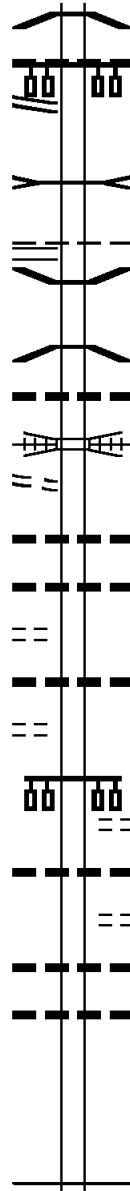

0020/0634 BMSBG 02/0088/0020/0622
024 "DIA CIRC METAL
0020/0399 LEN=0036 INSTALLED UNKN

0020/0340 PINEY FORK CREEK
STRUCTURE LENGTH 24 FT
0020/0292 BMSID 02/0088/0020/0292
003780 FT BETHEL PARK

5 0020/0000 SOUTH PARK T
0010/3224 LENGTH(AH 3153 BK 3780)
BMSEN 02/0088/0010/3215
0 0 00000 0 00 0000+00

0010/3215 SMALL STREAM
BMSBG 02/0088/0010/3215
0010/2945 018 "DIA CIRC CONCR
LEN=0099 INSTALLED UNKN
0010/2479 MONTOUR RAILROAD COMPAN
OVERPASS IS RR X-ING

0010/1980 012 "DIA CIRC CONCR
LEN=0099 INSTALLED UNKN
0010/1758 012 "DIA CIRC CONCR
LEN=0099 INSTALLED UNKN

0010/1617 018 "DIA CIRC CONCR
LEN=0040 INSTALLED UNKN

BROWNSVILLE RD
(CNTY)
0010/0755 018 "DIA CIRC CONCR
0010/0410 LEN=0028 INSTALLED UNKN
VERNA ST

0010/0385 (TWP)
036 "DIA CIRC METAL
0010/0320 LEN=0036 INSTALLED UNKN
036 "DIA CIRC CONCR
0010/0300 LEN=0036 INSTALLED UNKN
000000 FT 1 0 00247 0 00 0000+00

* REF-BK NC LIBRARY RD
FINLEYVILLE LIBRARY RD
(SR0088 SEG 0820/1431)
MFC BEGIN = B
BK-WASHINGTON (62)
5 0010/0000 LENGTH(AH 3780 BK 0000)

EXTRACT DATE: 12/21/2020
PRINT DATE: 12/23/2020

ROADWAY MANAGEMENT SYSTEM
SLD COUNTY/SR - ANNUAL PRINT

PAGE NUMBER: 273
COUNTY: ALLEGHENY

DIR: N TOTAL LEN: 27.879 MI.
LEFT MUN: MARSHALL T

DIST: 11-1 SR: 79
RIGHT MUN: MARSHALL T

1 0 01021 0 00 0743+41
MINGO RD SR 4051
BMSBG 02/0079/0735/2454 0735/2480
E.BR.BIG SEW
STRUCTURE LENGTH 10 FT
BMSID 02/0079/0734/2238 0735/2449

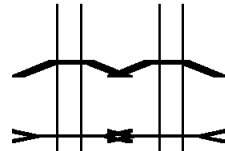

1 0 01021 0 00 0743+41
MINGO RD SR 4051
BMSBG 02/0079/0734/2360
E.BR.BIG SEW
STRUCTURE LENGTH 10 FT
BMSID 02/0079/0734/2238

024 "DIA CIRC CONCR
LEN=0090 INSTALLED UNKN 0735/1428
RAMP B RD
(SR8023 SEG 0500/0000) 0735/1157

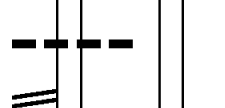

1 0 01021 0 00 0724+47 125714 FT
LENGTH(AH 2650 BK 2640) 0735/0000



SR 4042 WEX BAYNE
OP ID 02/4042/0040/1295 0731/1619



RAMP A RD
(SR8023 SEG 0250/1059) 0731/0481



MARSHALL
FRANKLIN PARK B
1 0 01021 0 00 0698+04 123074 FT
MILEPOST 073.00
LENGTH(AH 2640 BK 2642) 0731/0000

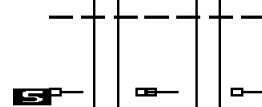

018 "DIA CIRC CONCR
LEN=0070 INSTALLED UNKN 0725/2417



018 "DIA CIRC CONCR
LEN=0070 INSTALLED UNKN 0725/1818



018 "DIA CIRC CONCR
LEN=0070 INSTALLED UNKN 0725/1445
DMS SIGN STRUCTURE

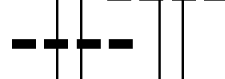

126197 FT
0734/0000

0730/2517

0730/2408

0730/1626

0730/1465

0730/0575

0730/0382
123557 FT

0730/0000

0724/2447

0724/2133

0724/1853

0724/1484

1 0 01021 0 00 0721+46
LENGTH(AH 2640 BK 2640)
RAMP D RD

(SR8023 SEG 0750/0830)
018 "DIA CIRC CONCR
LEN=0050 INSTALLED UNKN

SR 4042 WEX BAYNE
OP ID 02/4042/0040/1295
018 "DIA CIRC CONCR
LEN=0080 INSTALLED UNKN

RAMP C RD
(SR8023 SEG 0010/0000)

MARSHALL
FRANKLIN PARK B
1 0 01021 0 00 0698+28
MILEPOST 073.00

LENGTH(AH 2640 BK 2640)
018 "DIA CIRC CONCR
LEN=0065 INSTALLED UNKN

015 "DIA CIRC CONCR
LEN=0065 INSTALLED UNKN

018 "DIA CIRC CONCR
LEN=0065 INSTALLED UNKN

018 "DIA CIRC CONCR
LEN=0099 INSTALLED UNKN

DIR: N TOTAL LEN: 27.879 MI. DIST: 11-1 SR: 79
 LEFT MUN: FRANKLIN PARK B RIGHT MUN: FRANKLIN PARK B

018 "DIA CIRC CONCR LEN=0045 INSTALLED UNKN 0701/1638	---	---	---	0700/1609	018 "DIA CIRC CONCR LEN=0099 INSTALLED UNKN
018 "DIA CIRC CONCR LEN=0099 INSTALLED UNKN 0701/1330	---	---	---	0700/1315	018 "DIA CIRC CONCR LEN=0099 INSTALLED UNKN
	---	---	---	0700/1030	018 "DIA CIRC CONCR LEN=0099 INSTALLED UNKN
018 "DIA CIRC CONCR LEN=0099 INSTALLED UNKN 0701/1022	---	---	---	0700/0746	018 "DIA CIRC CONCR LEN=0099 INSTALLED UNKN
018 "DIA CIRC CONCR LEN=0099 INSTALLED UNKN 0701/0716	---	---	---		
018 "DIA CIRC CONCR LEN=0099 INSTALLED UNKN 0701/0305	---	---	---	0700/0297	018 "DIA CIRC CONCR LEN=0099 INSTALLED UNKN
1 0 01016 0 00 1075+97 107286 FT				107665 FT	1 0 01016 0 00 1080+76
MILEPOST 070.00					MILEPOST 070.00
LENGTH(AH 2703 BK 2669) 0701/0000	---	---	---	0700/0000	LENGTH(AH 2640 BK 2663)
018 "DIA CIRC CONCR LEN=0099 INSTALLED UNKN 0695/2601	---	---	---		
018 "DIA CIRC CONCR LEN=0050 INSTALLED UNKN 0695/2071	---	---	---		
FRANKLIN PARK				0694/1845	FRANKLIN PARK SEWICKLEY HILLS B
SEWICKLEY HILLS B 0695/1754	---	---	---	0694/1790	018 "DIA CIRC CONCR LEN=0099 INSTALLED UNKN
018 "DIA CIRC CONCR LEN=0099 INSTALLED UNKN 0695/1548	---	---	---	0694/1482	018 "DIA CIRC CONCR LEN=0099 INSTALLED UNKN
018 "DIA CIRC CONCR LEN=0099 INSTALLED UNKN 0695/1094	---	---	---		
018 "DIA CIRC CONCR LEN=0099 INSTALLED UNKN 0695/0635	---	---	---		
018 "DIA CIRC CONCR LEN=0099 INSTALLED UNKN 0695/0132	---	---	---	0694/0110	018 "DIA CIRC CONCR LEN=0099 INSTALLED UNKN
	---	---	---	0694/0091	SEWICKLEY HILLS OHIO T
1 0 01016 0 00 1049+27 104617 FT				105002 FT	1 0 01016 0 00 1052+24
SEWICKLEY HILLS				0694/0000	LENGTH(AH 2663 BK 2640)
OHIO T					
LENGTH(AH 2669 BK 2663) 0695/0000	---	---	---		

DIR: N TOTAL LEN: 27.879 MI. DIST: 11-1 SR: 79
 LEFT MUN: OHIO T RIGHT MUN: OHIO T

OHIO	OHIO
SEWICKLEY HILLS B 0691/1980	SEWICKLEY HILLS B 0690/2201
DMS SIGN STRUCTURE	
BMSID 02/0079/0691/1780 0691/1828	BMSEN 02/0079/0690/0106
BMSEN 02/0079/0691/0194 0691/1762	018 "DIA CIRC CONCR
	LEN=0099 INSTALLED UNKN
1 0 01016 0 00 1034+68	1 0 01016 0 00 1038+60
SR 4043-RED MUD HOLLOW	SR 4043-RED MUD HOLLOW
BMSBG 02/0079/0691/0194 0691/1568	BMSBG 02/0079/0690/0106
	018 "DIA CIRC CONCR
	LEN=0099 INSTALLED UNKN
018 "DIA CIRC CONCR	
LEN=0095 INSTALLED UNKN 0691/1040	
018 "DIA CIRC CONCR	
LEN=0095 INSTALLED UNKN 0691/0752	
	0690/0407 018 "DIA CIRC CONCR
	LEN=0099 INSTALLED UNKN
018 "DIA CIRC CONCR	
LEN=0070 INSTALLED UNKN 0691/0460	
012 "DIA CIRC CONCR	
LEN=0075 INSTALLED UNKN 0691/0310	
KILBUCK RUN	KILBUCK RUN
STRUCTURE LENGTH 12 FT	STRUCTURE LENGTH 12 FT
BMSID 02/0079/0690/1168 0691/0203	BMSID 02/0079/0690/1168
1 0 01016 0 00 1023+33 101954 FT	1 0 01016 0 00 1027+29
MILEPOST 069.00	MILEPOST 069.00
LENGTH(AH 2663 BK 2576) 0691/0000	LENGTH(AH 2640 BK 2640) 0690/0000
	018 "DIA CIRC CONCR
	LEN=0099 INSTALLED UNKN
	018 "DIA CIRC CONCR
	LEN=0099 INSTALLED UNKN
	018 "DIA CIRC CONCR
	LEN=0099 INSTALLED UNKN
018 "DIA CIRC CONCR	
LEN=0120 INSTALLED UNKN 0685/1173	
018 "DIA CIRC CONCR	
LEN=0070 INSTALLED UNKN 0685/0920	
018 "DIA CIRC CONCR	
LEN=0070 INSTALLED UNKN 0685/0675	
	0684/0415 024 "DIA CIRC CONCR
	LEN=0099 INSTALLED UNKN
018 "DIA CIRC CONCR	
LEN=0331 INSTALLED UNKN 0685/0407	
018 "DIA CIRC CONCR	
LEN=0070 INSTALLED UNKN 0685/0165	
1 0 01016 0 00 0998+20 099378 FT	099722 FT 1 0 01016 0 00 1000+67
LENGTH(AH 2576 BK 2614) 0685/0000	LENGTH(AH 2640 BK 2640) 0684/0000
	036 "DIA CIRC CONCR
	LEN=0099 INSTALLED UNKN
	0680/2635

DIR: N TOTAL LEN: 27.879 MI. DIST: 11-1 SR: 79
 LEFT MUN: SEWICKLEY HILLS B RIGHT MUN: SEWICKLEY HILLS B

036 "DIA CIRC CONCR LEN=0070 INSTALLED UNKN 0681/2599 RAMP C RD (SR8021 SEG 0500/0000) 0681/2387		0680/2302 RAMP D RD (SR8021 SEG 0750/0543) 024 "DIA CIRC CONCR LEN=0099 INSTALLED UNKN
024 "DIA CIRC CONCR LEN=0130 INSTALLED UNKN 0681/1755		0680/2260
SR 4022 MT NEBO OP ID 02/4022/0020/0000 0681/1566		0680/1810 018 "DIA CIRC CONCR LEN=0099 INSTALLED UNKN SR 4022 MT NEBO OP ID 02/4022/0020/0000
018 "DIA CIRC CONCR LEN=0050 INSTALLED UNKN 0681/1387		0680/1653
		0680/1419 018 "DIA CIRC CONCR LEN=0099 INSTALLED UNKN
036 "DIA CIRC CONCR LEN=0099 INSTALLED UNKN 0681/0947		0680/1188 018 "DIA CIRC CONCR LEN=0099 INSTALLED UNKN
RAMP A RD (SR8021 SEG 0250/0627) 0681/0784		0680/0960 036 "DIA CIRC CONCR LEN=0099 INSTALLED UNKN
		0680/0809 RAMP B RD (SR8021 SEG 0010/0000) 024 "DIA CIRC CONCR LEN=0099 INSTALLED UNKN
024 "DIA CIRC CONCR LEN=0060 INSTALLED UNKN 0681/0410		0680/0650
KILBUCK RUN STRUCTURE LENGTH 14 FT BMSID 02/0079/0680/0139 0681/0006		0680/0330 024 "DIA CIRC CONCR LEN=0099 INSTALLED UNKN KILBUCK RUN STRUCTURE LENGTH 14 FT BMSID 02/0079/0680/0139
		0680/0139 SEWICKLEY HILLS 0680/0132 OHIO T
018 "DIA CIRC CONCR LEN=0099 INSTALLED UNKN 0681/0001 1 0 01016 0 00 0970+76 096764 FT SEWICKLEY HILLS OHIO T LENGTH(AH 2614 BK 2672) 0681/0000		097082 FT 1 0 01016 0 00 0974+49 MILEPOST 068.00 0680/0000 LENGTH(AH 2640 BK 2640)
036 "DIA CIRC CONCR LEN=0099 INSTALLED UNKN 0675/2071		0674/2000 024 "DIA CIRC CONCR LEN=0099 INSTALLED UNKN

DIR: N TOTAL LEN: 27.879 MI. DIST: 11-1 SR: 79
 LEFT MUN: OHIO T RIGHT MUN: OHIO T

036 "DIA CIRC CONCR	LEN=0099	INSTALLED UNKN	0675/1687	---	---				
036 "DIA CIRC CONCR	LEN=0099	INSTALLED UNKN	0675/1451	---	---				
SIGN: CANTILEVER									
BMSID 02/0079/0675/1046			0675/1100	┌───┐	└───┘				
036 "DIA CIRC CONCR	LEN=0080	INSTALLED UNKN	0675/0993	---	---				
018 "DIA CIRC CONCR	LEN=0070	INSTALLED UNKN	0675/0725	---	---				
						0674/0715	018 "DIA CIRC CONCR	LEN=0099	INSTALLED UNKN
018 "DIA CIRC CONCR	LEN=0099	INSTALLED UNKN	0675/0402	---	---				
036 "DIA CIRC CONCR	LEN=0099	INSTALLED UNKN	0675/0151	---	---				
OHIO						0674/0036	OHIO		
SEWICKLEY HILLS B			0675/0023	---	---		SEWICKLEY HILLS B		
1 0 01016 0 00 0946+42			094092 FT						
SEWICKLEY HILLS									
ALEPPO T									
LENGTH(AH 2672 BK 2612)			0675/0000	┌───┐	└───┘	094442 FT	1 0 01016 0 00 0950+45		
						0674/0000	LENGTH(AH 2640 BK 2640)		
						0670/2640	018 "DIA CIRC CONCR		
						0670/2470	LEN=0099	INSTALLED UNKN	
							036 "DIA CIRC CONCR		
036 "DIA CIRC CONCR	LEN=0099	INSTALLED UNKN	0671/2442	---	---		LEN=0099	INSTALLED UNKN	
						0670/2140	018 "DIA CIRC CONCR		
						0670/1610	LEN=0099	INSTALLED UNKN	
							018 "DIA CIRC CONCR		
018 "DIA CIRC CONCR	LEN=0099	INSTALLED UNKN	0671/1569	---	---		LEN=0099	INSTALLED UNKN	
SIGN: CANTILEVER									
BMSID 02/0079/0671/1351			0671/1442	┌───┐	└───┘				
						0670/1321	036 "DIA CIRC CONCR		
036 "DIA CIRC CONCR	LEN=0070	INSTALLED UNKN	0671/1304	---	---		LEN=0099	INSTALLED UNKN	
018 "DIA CIRC CONCR	LEN=0099	INSTALLED UNKN	0671/1065	---	---				
						0670/0434	036 "DIA CIRC CONCR		
							LEN=0099	INSTALLED UNKN	
024 "DIA CIRC CONCR	LEN=0099	INSTALLED UNKN	0671/0420	---	---				
						0670/0171	018 "DIA CIRC CONCR		
							LEN=0099	INSTALLED UNKN	
							SEWICKLEY HILLS		

DIR: N TOTAL LEN: 27.879 MI. DIST: 11-1 SR: 79
 LEFT MUN: SEWICKLEY HILLS B RIGHT MUN: SEWICKLEY HILLS B

Stationing	Description	Length	Material	Status	Stationing	Description	Length	Material	Status
0917+45	ALEPPO T	091480 FT			0921+45	ALEPPO T	091480 FT		
0671/0000	036 "DIA CIRC CONCR	0671/0000		UNKN	0670/0000	036 "DIA CIRC CONCR	0671/0000		UNKN
0665/2535	018 "DIA CIRC CONCR	0665/2535		UNKN	0664/2521	018 "DIA CIRC CONCR	0665/2535		UNKN
0665/2436	CROSSOVER RD (CONN)	0665/2436			0664/2457	CROSSOVER RD (CONN)	0665/2436		
0665/1876	SIGN: CANTILEVER BMSID 02/0079/0665/1806	0665/1876			0664/2280	018 "DIA CIRC CONCR	0665/1876		UNKN
0665/1839	024 "DIA CIRC CONCR	0665/1839		UNKN	0664/2125	024 "DIA CIRC CONCR	0665/1839		UNKN
0665/1449	024 "DIA CIRC CONCR	0665/1449		UNKN	0664/1780	036 "DIA CIRC CONCR	0665/1449		UNKN
0665/1147	RAMP C RD (SR8019 SEG 0500/0000)	0665/1147			0664/1450	018 "DIA CIRC CONCR	0665/1147		UNKN
0665/0099	018 "DIA CIRC CONCR	0665/0099		UNKN	0664/1093	036 "DIA CIRC CONCR	0665/0099		UNKN
088887 FT	1 0 01016 0 00 0890+94	088887 FT			0664/0695	024 "DIA CIRC CONCR	088887 FT		
0665/0000	018 "DIA CIRC CONCR	0665/0000		UNKN	0664/0511	RAMP D RD (SR8019 SEG 0750/1268)	0665/0000		
0661/2404	018 "DIA CIRC CONCR	0661/2404		UNKN	0664/0310	024 "DIA CIRC CONCR	0661/2404		UNKN
0661/2301	018 "DIA CIRC CONCR	0661/2301		UNKN	0664/0015	018 "DIA CIRC CONCR	0661/2301		UNKN
0661/2207	018 "DIA CIRC CONCR	0661/2207		UNKN	089183 FT	1 0 01016 0 00 0894+77	0661/2207		
0661/2052	018 "DIA CIRC CONCR	0661/2052		UNKN	0664/0000	018 "DIA CIRC CONCR	089183 FT		UNKN
0882+84	1 0 01016 0 00 0882+84	0882+84			0660/2286	036 "DIA CIRC CONCR	0882+84		UNKN
0661/1956	GLENFIELD RD BMSBG 02/0079/0661/0760	0661/1956				018 "DIA CIRC CONCR	0661/1956		UNKN
0661/1841	018 "DIA CIRC CONCR	0661/1841		UNKN	0660/1841	1 0 01016 0 00 0886+35	0661/1841		
						GLENFIELD RD COUNTY			
						BMSBG 02/0079/0660/0615			

DIR: N TOTAL LEN: 27.879 MI. DIST: 11-1 SR: 79
 LEFT MUN: ROBINSON T RIGHT MUN: ROBINSON T

Station	Length (AH/BK)	Material	Notes
0733+89	074082 FT	018 "DIA CIRC CONCR	LEN=0099 INSTALLED UNKN
0733+89	074082 FT	012 "DIA CIRC CONCR	LEN=0080 INSTALLED UNKN
0705+14	070612 FT	018 "DIA CIRC CONCR	LEN=0099 INSTALLED UNKN
0705+14	070612 FT	012 "DIA CIRC CONCR	LEN=0080 INSTALLED UNKN
0678+35	067967 FT	018 "DIA CIRC CONCR	LEN=0099 INSTALLED UNKN
0678+35	067967 FT	012 "DIA CIRC CONCR	LEN=0080 INSTALLED UNKN

DIR: N TOTAL LEN: 27.879 MI. DIST: 11-1 SR: 79
 LEFT MUN: ROBINSON T RIGHT MUN: ROBINSON T

Station	Structure	Material	Length	Notes
0621/1968				
0620/1942		018 " DIA CIRC CONCR	LEN=0099	INSTALLED UNKN
0620/1683		018 " DIA CIRC CONCR	LEN=0099	INSTALLED UNKN
0621/1500	SR 3074 FOREST GRO			
0620/1492		018 " DIA CIRC CONCR	LEN=0099	INSTALLED UNKN
0621/1151				
0621/0815	DMS SIGN STRUCTURE			
0620/0565		018 " DIA CIRC CONCR	LEN=0099	INSTALLED UNKN
0620/0220		018 " DIA CIRC CONCR	LEN=0099	INSTALLED UNKN
065410 FT				
065397 FT				
0621/0000				
0620/0000				
0614/2540		018 " DIA CIRC CONCR	LEN=0099	INSTALLED UNKN
0615/2492				
0615/2192				
0615/0997				
0614/0120		018 " DIA CIRC CONCR	LEN=0099	INSTALLED UNKN
062701 FT				
062746 FT				
0614/0000				
0610/2505		024 " DIA CIRC CONCR	LEN=0099	INSTALLED UNKN
0610/2465		024 " DIA CIRC CONCR	LEN=0099	INSTALLED UNKN
0610/2180	DMS SIGN STRUCTURE			
0611/1936				
0610/1835		024 " DIA CIRC CONCR	LEN=0099	INSTALLED UNKN
0610/1800		036 " DIA CIRC CONCR	LEN=0099	INSTALLED UNKN
		024 " DIA CIRC CONCR	LEN=0099	INSTALLED UNKN

DIR: N TOTAL LEN: 27.879 MI. DIST: 11-1 SR: 79
 LEFT MUN: ROBINSON T RIGHT MUN: ROBINSON T

RAMP D RD (SR8011 SEG 0510/0000) 018 "DIA CIRC CONCR LEN=0070 INSTALLED UNKN	0601/1864	0600/1475	LEN=0099 INSTALLED UNKN
		0600/1234	RAMP B RD (SR8011 SEG 0750/0848)
		0600/1125	018 "DIA CIRC CONCR LEN=0060 INSTALLED UNKN
RAMP C RD (SR8011 SEG 0500/1194) BMSSEN 02/0079/0601/0080 1 0 01016 0 00 0550+80 SR 0060 NB BMSBG 02/0079/0601/0080 SIGN: 4 CHORD TRUSS BMSID 02/0079/0601/0000 1 0 01016 0 00 0550+00 054843 FT MILEPOST 060.00 LENGTH(AH 2634 BK 2621)	0601/1091 0601/0515 0601/0322 0601/0225	0600/0511 0600/0318	BMSSEN 02/0079/0600/0070 1 0 01016 0 00 0551+20 SR 0060 NB BMSBG 02/0079/0600/0070
RAMP E RD (SR8011 SEG 0260/0000) 018 "DIA CIRC CONCR LEN=0070 INSTALLED UNKN	0595/2441 0595/2360	054811 FT 0600/0000	1 0 01016 0 00 0550+50 MILEPOST 060.00 LENGTH(AH 2640 BK 2641)
018 "DIA CIRC CONCR LEN=0075 INSTALLED UNKN	0595/1930	0594/1959	RAMP A RD (SR8011 SEG 0010/0000)
RAMP F RD (SR8011 SEG 0250/1892)	0595/1535	W 0594/1896	RWIS SITE/AT EXIT 60 024 "DIA CIRC CONCR LEN=0099 INSTALLED UNKN
018 "DIA CIRC CONCR LEN=0099 INSTALLED UNKN	0595/0582	0594/1800	018 "DIA CIRC CONCR LEN=0099 INSTALLED UNKN
018 "DIA CIRC CONCR LEN=0050 INSTALLED UNKN	0595/0060	0594/1520	018 "DIA CIRC CONCR LEN=0099 INSTALLED UNKN
1 0 01016 0 00 0523+37 052222 FT LENGTH(AH 2621 BK 2646)	0595/0000	0594/1100	018 "DIA CIRC CONCR LEN=0099 INSTALLED UNKN
018 "DIA CIRC CONCR LEN=0050 INSTALLED UNKN	0591/2330	052170 FT 0594/0000	1 0 01016 0 00 0523+49 LENGTH(AH 2641 BK 2640)
018 "DIA CIRC CONCR LEN=0060 INSTALLED UNKN	0591/1220	0590/1547	036 "DIA CIRC CONCR LEN=0099 INSTALLED UNKN
		0590/1205	024 "DIA CIRC CONCR LEN=0099 INSTALLED UNKN

DIR: N TOTAL LEN: 27.879 MI. DIST: 11-1 SR: 79
 LEFT MUN: ROBINSON T RIGHT MUN: ROBINSON T

Sign	Structure	Length	Station	Notes
SIGN: 2 CHORD TRUSS				
BMSID 02/0079/0591/0668			0591/0696	0590/0813 036 "DIA CIRC CONCR LEN=0099 INSTALLED UNKN
018 "DIA CIRC CONCR				
LEN=0050 INSTALLED UNKN			0591/0530	0590/0532 024 "DIA CIRC CONCR LEN=0099 INSTALLED UNKN
018 "DIA CIRC METAL				
LEN=0060 INSTALLED UNKN			0591/0180	
1 0 01016 0 00 0496+83			049576 FT	049530 FT 1 0 01016 0 00 0497+09
MILEPOST 059.00				MILEPOST 059.00
LENGTH(AH 2646 BK 2704)			0591/0000	0590/0000 LENGTH(AH 2640 BK 2640)
SIGN: 3 CHORD TRUSS				
BMSID 02/0079/0585/0629			0585/0714	0584/0954 PITTSBURGH INT/RAMP G R (SR8009 SEG 0260/3502)
BR.CMBLS.RUN				
STRUCTURE LENGTH 19 FT				
BMSID 02/0079/0584/0118			0585/0219	BR.CMBLS.RUN STRUCTURE LENGTH 19 FT
1 0 01016 0 00 0470+10			046872 FT	BMSID 02/0079/0584/0118 046890 FT
LENGTH(AH 2704 BK 2644)			0585/0000	1 0 01016 0 00 0468+39
				LENGTH(AH 2640 BK 2640)
SIGN: 2 CHORD TRUSS				
BMSID 02/0079/0581/2199			0581/2242	0580/2350 024 "DIA CIRC CONCR LEN=0080 INSTALLED UNKN
PITTSBURGH INT/RAMP H R				
(SR8009 SEG 0510/0000)			0581/2041	0580/2109 RAMP F RD (SR8009 SEG 0770/2177)
				024 "DIA CIRC CONCR
				LEN=0070 INSTALLED UNKN
BMSEN 02/0079/0581/1472			0581/1713	0580/1975 018 "DIA CIRC CONCR
1 0 01016 0 00 0457+99				LEN=0099 INSTALLED UNKN
CAMPBELLS RD COUNTY				BMSEN 02/0079/0580/1553
BMSBG 02/0079/0581/1472			0581/1645	0 0 00000 0 00 0000+00
RAMP G 8009 376 EB			0580/1620	CAMPBELLS RUN RD COUNTY
OP ID 02/8009/0260/0293			0581/1174	BMSBG 02/0079/0580/1553
				RAMP G 8009 376 EB
				OP ID 02/8009/0260/0293
				RAMP E RD
				(SR8009 SEG 0750/0000)
BMSEN 02/0079/0581/0857			0581/1016	SIGN: 3 CHORD TRUSS
1 0 01016 0 00 0450+01				BMSID 02/0079/0580/0870
SR 0376 EB				BMSEN 02/0079/0580/0774
BMSBG 02/0079/0581/0857			0581/0857	1 0 01016 0 00 0450+12
SIGN: 3 CHORD TRUSS				SR 0376 EB
				BMSBG 02/0079/0580/0774

DIR: N TOTAL LEN: 27.879 MI. DIST: 11-1 SR: 79
 LEFT MUN: ROBINSON T RIGHT MUN: ROBINSON T

BMSID	Segment	Start Station	End Station	Length (FT)	Notes
02/0079/0581/0535		0581/0732			
RAMP D RD	(SR8009 SEG 0270/0000)	0581/0515			
1 0 01016 0 00	0444+51	044228	FT		
LENGTH(AH 2644 BK 2484)		0581/0000			
BMSEN 02/0079/0575/2110		0575/2386			
RAMP C RD	(SR8009 SEG 0250/2674)	0575/2305			
1 0 01016 0 00	0438+08				
SR 8009 RAMP B					
BMSBG 02/0079/0575/2110		0575/2094			
					018 "DIA CIRC CONCR LEN=0099 INSTALLED UNKN
					018 "DIA CIRC CONCR LEN=0099 INSTALLED UNKN
					1 0 01016 0 00 0444+18 MILEPOST 058.00 LENGTH(AH 2640 BK 2640) BMSEN 02/0079/0574/2391
					1 0 01016 0 00 0440+06 RAMP B (8009) SB BMSBG 02/0079/0574/2391 SIGN: CANTILEVER
					BMSID 02/0079/0574/2344 RAMP A RD (SR8009 SEG 0010/0000) SIGN: 3 CHORD TRUSS BMSID 02/0079/0574/1600
RAMP B RD	(SR8009 SEG 0760/4227)	0575/0963			
1 0 01016 0 00	0417+56	041744	FT		
LENGTH(AH 2484 BK 2740)		0575/0000			
					SIGN: 3 CHORD TRUSS BMSID 02/0079/0574/0615
CAMPBELLS.RUN	STRUCTURE LENGTH 17 FT				
BMSID 02/0079/0570/2199		0571/2515			
ROBINSON					
COLLIER T		0571/1927			
					024 "DIA CIRC CONCR LEN=0070 INSTALLED UNKN
018 "DIA CIRC CONCR	LEN=0080 INSTALLED UNKN	0571/1640			
					024 "DIA CIRC CONCR LEN=0070 INSTALLED UNKN
SIGN: CANTILEVER					
BMSID 02/0079/0571/0582		0571/1183			
					ROBINSON COLLIER T
024 "DIA CIRC CONCR	LEN=0045 INSTALLED UNKN	0571/0430			

DIR: N TOTAL LEN: 27.879 MI. DIST: 11-1 SR: 79
 LEFT MUN: ROBINSON T RIGHT MUN: ROBINSON T

024 "DIA CIRC CONCR LEN=0085 INSTALLED UNKN	0571/0180	---	0570/0385	024 "DIA CIRC CONCR LEN=0099 INSTALLED UNKN
1 0 01016 0 00 0391+16 039004 FT MILEPOST 057.00 LENGTH(AH 2740 BK 2650)	0571/0000	---	0570/0061	024 "DIA CIRC CONCR LEN=0099 INSTALLED UNKN
CROSSOVER RD (CONN)	0565/2264	↔	0570/0060	024 "DIA CIRC CONCR LEN=0099 INSTALLED UNKN
SIGN: CANTILEVER BMSID 02/0079/0565/2061 0565/2061 BR. ROBINSON STRUCTURE LENGTH 11 FT BMSID 02/0079/0564/1780 0565/1816 SR 3054 COLLIER RD OP ID 02/3054/0080/0760 0565/1398	0564/1989	---	0570/0000	024 "DIA CIRC METAL LEN=0099 INSTALLED UNKN CROSSOVER RD (CONN)
SIGN: CANTILEVER BMSID 02/0079/0565/0258 0565/0191 1 0 01016 0 00 0366+52 036354 FT RAMP D RD (SR8007 SEG 0502/0000) LENGTH(AH 2650 BK 2690) 0565/0000 BMSEN 02/0079/0561/1956 0561/2563	0564/1780	---	0564/2375	018 "DIA CIRC CONCR LEN=0099 INSTALLED UNKN SIGN: 3 CHORD TRUSS BMSID 02/0079/0564/1745 BR. ROBINSON STRUCTURE LENGTH 11 FT BMSID 02/0079/0564/1780 SR 3054 COLLIER RD OP ID 02/3054/0080/0760
1 0 01016 0 00 0359+80 ROBINSON CR. BMSBG 02/0079/0561/1956 0561/1956 018 "DIA CIRC CONCR LEN=0080 INSTALLED UNKN 0561/1785 RAMP C RD (SR8007 SEG 0512/0730) 0561/1776 BMSEN 02/0079/0561/1617 0561/1736 0 0 00000 0 00 0000+00 NOBLESTOWN RD SR 3048 BMSBG 02/0079/0561/1617 0561/1617	0564/1302	---	0564/2248	018 "DIA CIRC PLASTIC LEN=0070 INSTALLED UNKN 018 "DIA CIRC CONCR LEN=0099 INSTALLED UNKN
	0564/1150	---	0564/2025	
	0564/0826	---	0564/1989	
	036334 FT	---	0564/1780	
	0564/0000	---	0564/1780	
	0560/2532	---	0564/1302	
	0560/1946	---	0564/1150	
	0560/1946	---	0564/0826	
	0560/1749	---	0560/2532	
	0560/1630	---	0560/1946	
	0560/1630	---	0560/1749	
	0560/1555	---	0560/1630	
		---	0560/1555	

DIR: N TOTAL LEN: 27.879 MI. DIST: 11-1 SR: 79
 LEFT MUN: COLLIER T RIGHT MUN: COLLIER T

Item ID	Description	Length	Stationing	Material	Notes
024	"DIA CIRC CONCR	LEN=0099	0560/1255	INSTALLED UNKN	RAMP B RD
024	"DIA CIRC CONCR	LEN=0099	0560/1248	INSTALLED UNKN	(SR8007 SEG 0020/0810)
024	"DIA CIRC CONCR	LEN=0099	0560/0952	INSTALLED UNKN	
024	"DIA CIRC CONCR	LEN=0080	0561/0755	INSTALLED UNKN	
018	"DIA CIRC CONCR	LEN=0080	0560/0657	INSTALLED UNKN	RAMP A RD
018	"DIA CIRC CONCR	LEN=0060	0560/0649	INSTALLED UNKN	(SR8007 SEG 0010/0000)
018	"DIA CIRC CONCR	LEN=0099	0560/0375	INSTALLED UNKN	
018	"DIA CIRC CONCR	LEN=0099	0560/0075	INSTALLED UNKN	
1 0 01016 0 00	MILEPOST 056.00		0338+01 033664 FT		
018	"DIA CIRC CONCR	LEN=0099	0560/0000	INSTALLED UNKN	LENGTH(AH 2690 BK 2614)
018	"DIA CIRC CONCR	LEN=0099	0554/2328	INSTALLED UNKN	
018	"DIA CIRC CONCR	LEN=0099	0554/2130	INSTALLED UNKN	
018	"DIA CIRC CONCR	LEN=0100	0555/2096	INSTALLED UNKN	
018	"DIA CIRC CONCR	LEN=0100	0555/1470	INSTALLED UNKN	
024	"DIA CIRC CONCR	LEN=0070	0554/1667	INSTALLED UNKN	SIGN: 3 CHORD TRUSS BMSID 02/0079/0554/1667
024	"DIA CIRC CONCR	LEN=0070	0554/1480	INSTALLED UNKN	
024	"DIA CIRC CONCR	LEN=0070	0554/1029	INSTALLED UNKN	
018	"DIA CIRC CONCR	LEN=0100	0555/1054	INSTALLED UNKN	
018	"DIA CIRC CONCR	LEN=0100	0555/0967	INSTALLED UNKN	
024	"DIA CIRC CONCR	LEN=0070	0554/0833	INSTALLED UNKN	
OP ID 02/3052/0060/2289	SR 3052 HILL TOP R		0555/0761		
024	"DIA CIRC CONCR	LEN=0080	0554/0722	INSTALLED UNKN	OP ID 02/3052/0060/2289
024	"DIA CIRC CONCR	LEN=0080	0554/0647	INSTALLED UNKN	
024	"DIA CIRC CONCR	LEN=0130	0555/0710	INSTALLED UNKN	
024	"DIA CIRC CONCR	LEN=0070	0554/0530	INSTALLED UNKN	DMS SIGN STRUCTURE BMSID 02/0079/0554/0530

COLLIER

DIR: N TOTAL LEN: 27.879 MI. DIST: 11-1 SR: 79
 LEFT MUN: COLLIER T RIGHT MUN: COLLIER T

Station	Description	Length	Material	Notes
031050	SCOTT T	0555/0438	FT	
031054	SCOTT T	0554/0367	FT	
0555/0000	SCOTT T	0554/0000	FT	
0555/0000	SCOTT T	0550/2501	FT	
0551/2044	018 "DIA CIRC CONCR	LEN=0099	INSTALLED UNKN	
0551/1694	018 "DIA CIRC CONCR	LEN=0099	INSTALLED UNKN	
0551/1558	SCOTT COLLIER T			
0551/1234	024 "DIA CIRC CONCR	LEN=0099	INSTALLED UNKN	
0551/0987	018 "DIA CIRC CONCR	LEN=0099	INSTALLED UNKN	
028476	1 0 01016 0 00 0287+54	028476 FT		
0551/0000	LENGTH(AH 2574 BK 2577)	0551/0000		
0545/2576	BMSBG 02/0079/0545/2177	0545/2576		
0545/2161	THOMS RUN RD	0545/2161		
0544/2295	BMSBG 02/0079/0544/2310	0544/2295		
0544/2200	024 "DIA CIRC CONCR	LEN=0099	INSTALLED UNKN	
0544/1690	024 "DIA CIRC CONCR	LEN=0099	INSTALLED UNKN	
0544/1015	024 "DIA CIRC CONCR	LEN=0099	INSTALLED UNKN	
0544/0876	STEEN RD	0544/0876		
0544/0695	024 "DIA CIRC CONCR	LEN=0099	INSTALLED UNKN	
0544/0308	RAMP D RD	0544/0308		
0544/0000	(SR8005 SEG 0750/1520)	0544/0000		
0541/2519	1 0 01016 0 00 0259+76	025899 FT		
0541/2174	LENGTH(AH 2577 BK 2519)	0541/2174		
0541/2064	OFF RAMP 8005 SB	0541/2064		
0540/2202	OFF RAMP 8005 SB	0540/2202		

EXTRACT DATE: 12/21/2020
PRINT DATE: 12/23/2020

ROADWAY MANAGEMENT SYSTEM
SLD COUNTY/SR - ANNUAL PRINT

PAGE NUMBER: 254
COUNTY: ALLEGHENY

DIR: N TOTAL LEN: 27.879 MI.
LEFT MUN: COLLIER T

DIST: 11-1 SR: 79
RIGHT MUN: COLLIER T

Item	Description	Stationing	Notes
RAMP B RD	(SR8005 SEG 0260/0000)	0541/1436	
RAMP A RD	(SR8005 SEG 0250/2935)	0541/0630	
BMSBG 02/0079/0541/0255		0541/0485	
0 0 0000 0 00 0000+00			
CHARTIERS CK			
BMSBG 02/0079/0541/0255		0541/0255	
1 0 01016 0 00 0233+79		023380 FT	
MILEPOST 054.00			
LENGTH(AH 2519 BK 2814)		0541/0000	
018 "DIA CIRC CONCR			
LEN=0150 INSTALLED UNKN		0535/2412	
SR 3031 PRESLEY			
OP ID 02/3031/0020/2416		0535/2023	
024 "DIA CIRC CONCR			
LEN=0060 INSTALLED UNKN		0535/1991	
024 "DIA CIRC CONCR			
LEN=0060 INSTALLED UNKN		0535/1719	
024 "DIA CIRC CONCR			
LEN=0060 INSTALLED UNKN		0535/1362	
024 "DIA CIRC CONCR			
LEN=0060 INSTALLED UNKN		0535/1004	
024 "DIA CIRC CONCR			
LEN=0060 INSTALLED UNKN		0535/0645	
024 "DIA CIRC CONCR			
LEN=0060 INSTALLED UNKN		0535/0342	
SIGN: CANTILEVER			
BMSID 02/0079/0535/0174		0535/0174	
1 0 01016 0 00 0204+92		020566 FT	
LENGTH(AH 2814 BK 2687)		0535/0000	
018 "DIA CIRC CONCR			
LEN=0099 INSTALLED UNKN		0531/2550	
018 "DIA CIRC CONCR			
LEN=0070 INSTALLED UNKN		0531/2176	
		0540/1636	RAMP C RD (SR8005 SEG 0010/0000)
		0540/0498	BMSBG 02/0079/0540/0243 1 0 01016 0 00 0233+10
		0540/0243	CHARTIERS CK BMSBG 02/0079/0540/0243
		023126 FT	1 0 01016 0 00 0231+69
		0540/0000	MILEPOST 054.00 LENGTH(AH 2640 BK 2640)
		0534/2080	024 "DIA CIRC CONCR LEN=0099 INSTALLED UNKN
		0534/1827	SR 3031 PRESLEY OP ID 02/3031/0020/2416
		0534/1690	024 "DIA CIRC CONCR LEN=0099 INSTALLED UNKN
		0534/1440	024 "DIA CIRC CONCR LEN=0099 INSTALLED UNKN
		0534/1100	024 "DIA CIRC CONCR LEN=0099 INSTALLED UNKN
		0534/0760	024 "DIA CIRC CONCR LEN=0099 INSTALLED UNKN
		0534/0420	024 "DIA CIRC CONCR LEN=0099 INSTALLED UNKN
		020486 FT	1 0 01016 0 00 0205+38
		0534/0000	LENGTH(AH 2640 BK 2640)

DIR: N TOTAL LEN: 27.879 MI. DIST: 11-1 SR: 79
 LEFT MUN: COLLIER T RIGHT MUN: COLLIER T

018 "DIA CIRC CONCR LEN=0060 INSTALLED UNKN 0531/1870	0530/2430	024 "DIA CIRC CONCR LEN=0099 INSTALLED UNKN
018 "DIA CIRC CONCR LEN=0060 INSTALLED UNKN 0531/1642	0530/2150	024 "DIA CIRC CONCR LEN=0099 INSTALLED UNKN
018 "DIA CIRC CONCR LEN=0060 INSTALLED UNKN 0531/1272	0530/1815	024 "DIA CIRC CONCR LEN=0099 INSTALLED UNKN
018 "DIA CIRC CONCR LEN=0060 INSTALLED UNKN 0531/0973	0530/1615	018 "DIA CIRC CONCR LEN=0099 INSTALLED UNKN
018 "DIA CIRC CONCR LEN=0060 INSTALLED UNKN 0531/0660	0530/1417	DMS SIGN STRUCTURE BMSID 02/0079/0530/1465
COLLIER BRIDGEVILLE B 0531/0541	0530/1245	024 "DIA CIRC CONCR LEN=0099 INSTALLED UNKN
018 "DIA CIRC CONCR LEN=0060 INSTALLED UNKN 0531/0375	0530/1054	COLLIER BRIDGEVILLE B
1 0 01016 0 00 0179+22 017879 FT	0530/0940	024 "DIA CIRC CONCR LEN=0099 INSTALLED UNKN
018 "DIA CIRC CONCR LEN=0060 INSTALLED UNKN	0530/0630	024 "DIA CIRC METAL LEN=0099 INSTALLED UNKN
MILEPOST 053.00	0530/0345	018 "DIA CIRC CONCR LEN=0099 INSTALLED UNKN
LENGTH(AH 2687 BK 2668) 0531/0000	017846 FT	1 0 01016 0 00 0178+98
018 "DIA CIRC CONCR LEN=0060 INSTALLED UNKN 0525/2387	0530/0000	MILEPOST 053.00
SIGN: 3 CHORD TRUSS	0524/2640	LENGTH(AH 2640 BK 2640)
BMSID 02/0079/0525/1790 0525/1901	0524/1881	018 "DIA CIRC CONCR LEN=0099 INSTALLED UNKN
BMS EN 02/0079/0525/1150 0525/1728	0524/1713	BRIDGEVILLE INT/RAMP E (SR8003 SEG 0750/1922)
1 0 01016 0 00 0163+24	0524/1144	BMS EN 02/0079/0524/1139
CHARTIERS CK		BRIDGEVILLE
		SOUTH FAYETTE T
		1 0 01016 0 00 0157+30
		CHARTIERS CR

DIR: N TOTAL LEN: 27.879 MI. DIST: 11-1 SR: 79
LEFT MUN: BRIDGEVILLE B RIGHT MUN: BRIDGEVILLE B

BMSBG 02/0079/0525/1150	0525/1150		0524/1139	BMSBG 02/0079/0524/1139
018 "DIA CIRC CONCR				
LEN=0040 INSTALLED UNKN	0525/1140			
BRIDGEVILLE				
SOUTH FAYETTE T	0525/1100		0524/1100	018 "DIA CIRC CONCR
BMSBG 02/0079/0525/0486	0525/0673			LEN=0050 INSTALLED UNKN
0 0 0000 0 00 0000+00			0524/0593	BMSBG 02/0079/0524/0409
SR 0050 EB				1 0 01016 0 00 0151+02
BMSBG 02/0079/0525/0486	0525/0486		0524/0409	SR 0050 EB
018 "DIA CIRC CONCR				BMSBG 02/0079/0524/0409
LEN=0040 INSTALLED UNKN	0525/0460			
SIGN: 3 CHORD TRUSS				
BMSID 02/0079/0525/0124	0525/0124			
1 0 01016 0 00 0153+08	015211 FT			
RAMP D RD				
(SR8003 SEG 0260/0000)			015206 FT	1 0 01016 0 00 0151+02
LENGTH(AH 2668 BK 2572)	0525/0000		0524/0000	LENGTH(AH 2640 BK 2640)
024 "DIA CIRC CONCR				
LEN=0099 INSTALLED UNKN	0521/2350			
RAMP C RD				
(SR8003 SEG 0250/1579)	0521/1791		0520/2293	RAMP B RD
018 "DIA CIRC CONCR				(SR8003 SEG 0020/0906)
LEN=0055 INSTALLED UNKN	0521/1730			
RAMP A RD				
018 "DIA CIRC CONCR			0520/1560	(SR8003 SEG 0010/0000)
LEN=0015 INSTALLED UNKN	0521/1430			
018 "DIA CIRC CONCR				
LEN=0070 INSTALLED UNKN	0521/1100		0520/1350	018 "DIA CIRC CONCR
LEN=0065 INSTALLED UNKN				
0521/0802			0520/1020	018 "DIA CIRC CONCR
LEN=0065 INSTALLED UNKN				
0521/0802			0520/0710	018 "DIA CIRC CONCR
LEN=0050 INSTALLED UNKN				
0521/0495				
024 "DIA CIRC CONCR				
LEN=0040 INSTALLED UNKN	0521/0495			
SIGN: 3 CHORD TRUSS				
1 0 01016 0 00 0126+22	012639 FT		0520/0425	BMSID 02/0079/0520/0390
MILEPOST 052.00			012566 FT	1 0 01016 0 00 0127+33
LENGTH(AH 2572 BK 2540)	0521/0000			MILEPOST 052.00
LENGTH(AH 2640 BK 2610)				

DIR: N TOTAL LEN: 27.879 MI. DIST: 11-1 SR: 79
 LEFT MUN: SOUTH FAYETTE T RIGHT MUN: SOUTH FAYETTE T

ID	Material	Length (ft)	Stationing	Notes
1 0 01016	0 00 0073+66	007428	FT	
	MILEPOST	051.00		
018	"DIA CIRC CONCR	LEN=0099	INSTALLED UNKN 0505/2620	
012	"DIA CIRC CONCR	LEN=0099	INSTALLED UNKN 0505/2365	
012	"DIA CIRC CONCR	LEN=0099	INSTALLED UNKN 0505/2083	
OP ID 02/3032/0010/0000	SR 3032 ALPINE RD.			
015	"DIA CIRC CONCR	LEN=0060	INSTALLED UNKN 0505/1688	
018	"DIA CIRC CONCR	LEN=0060	INSTALLED UNKN 0505/1460	
015	"DIA CIRC CONCR	LEN=0060	INSTALLED UNKN 0505/0880	
012	"DIA CIRC CONCR	LEN=0060	INSTALLED UNKN 0505/0795	
012	"DIA CIRC CONCR	LEN=0060	INSTALLED UNKN 0505/0500	
015	"DIA CIRC CONCR	LEN=0060	INSTALLED UNKN 0505/0495	
012	"DIA CIRC CONCR	LEN=0060	INSTALLED UNKN 0505/0388	
018	"DIA CIRC CONCR	LEN=0099	INSTALLED UNKN 0505/0138	
1 0 01016	0 00 0044+09	004711	FT	
	MILEPOST	051.00		
015	"DIA CIRC CONCR	LEN=0045	INSTALLED UNKN 0501/2450	
015	"DIA CIRC CONCR	LEN=0055	INSTALLED UNKN 0501/2100	
REST AREA SB (SR9201 SEG 0010/0000) (APRA) TRUCK STOP/REST				0501/1915
012	"DIA CIRC CONCR	LEN=0050	INSTALLED UNKN 0500/2085	
018	"DIA CIRC CONCR	LEN=0050	INSTALLED UNKN 0500/2430	
018	"DIA CIRC CONCR	LEN=0075	INSTALLED UNKN 0504/0855	
024	"DIA CIRC CONCR	LEN=0075	INSTALLED UNKN 0504/1170	
REST AREA NB (SR9202 SEG 0010/1780)				0504/0655
018	"DIA CIRC CONCR	LEN=0050	INSTALLED UNKN 0504/0460	
004652	FT	1 0 01016	0 00 0046+53	
	LENGTH(AH 2664 BK 2640)			

POT

DIR: N TOTAL LEN: 27.879 MI. DIST: 11-1 SR: 79
 LEFT MUN: SOUTH FAYETTE T RIGHT MUN: SOUTH FAYETTE T

Segment ID	Material	Length	Stationing	Notes
LEN=0080	INSTALLED UNKN	0501/1680		
012 "DIA CIRC CONCR	INSTALLED UNKN	0501/1293		
012 "DIA CIRC CONCR	INSTALLED UNKN	0501/0880		
012 "DIA CIRC CONCR	INSTALLED UNKN	0501/0453		
REST AREA SB		0501/0120		
(SR9201 SEG 0010/1828)		0501/0000		
1 0 01016 0 00 0021+10 002062 FT		0500/0000		
MILEPOST 050.00		0496/1930		
LENGTH(AH 2649 BK 2062)		0496/0954		
015 "DIA CIRC CONCR	INSTALLED UNKN	0497/1958		
012 "DIA CIRC CONCR	INSTALLED UNKN	0497/0947		
012 "DIA CIRC CONCR	INSTALLED UNKN	0497/0711		
018 "DIA CIRC CONCR	INSTALLED UNKN	0497/0391		
SR 3148 CO. LINE		0497/0274		
OP ID 02/3148/0010/0000		0496/0205		
1 0 01016 0 00 0000+00 000000 FT		0496/0000		
NC RAYMOND P SHAFER HW				
SR 0079 SH REF-BK				
(SR0079 SEG 0495/0610)				
MFC BEGIN = A				
LENGTH(AH 2062 BK 0000)				
		0500/1670		018 "DIA CIRC CONCR LEN=0099 INSTALLED UNKN (APRA) TRUCK STOP/REST REST AREA NB (SR9202 SEG 0010/0000)
		0500/1540		
		0500/0748		024 "DIA CIRC CONCR LEN=0060 INSTALLED UNKN 024 "DIA CIRC CONCR LEN=0055 INSTALLED UNKN
		0500/0510		
		0500/0325		024 "DIA CIRC CONCR LEN=0050 INSTALLED UNKN
		002012 FT		1 0 01016 0 00 0020+19 MILEPOST 050.00
		0500/0000		LENGTH(AH 2640 BK 2012) 024 "DIA CIRC CONCR LEN=0050 INSTALLED UNKN
		0496/1930		
		0496/0954		024 "DIA CIRC CONCR LEN=0050 INSTALLED UNKN
		0496/0700		024 "DIA CIRC CONCR LEN=0050 INSTALLED UNKN
		0496/0390		024 "DIA CIRC CONCR LEN=0050 INSTALLED UNKN
		0496/0205		SR 3148 CO. LINE OP ID 02/3148/0010/0000
		000000 FT		1 0 01016 0 00 0000+00 NC RAYMOND P SHAFER HW
		* REF-BK		SR 0079 SH (SR0079 SEG 0494/0660) MFC BEGIN = A BK-WASHINGTON (62)
		0496/0000		LENGTH(AH 2012 BK 0000)

DIR: N TOTAL LEN: 14.791 MI. DIST: 11-1 SR: 65
 LEFT MUN: LEETSDALE B RIGHT MUN: LEETSDALE B

AH-BEAVER (04) 078099 FT
 OHIO RIVER BL REF-AHD *
 (SR0065 SEG 0011/0000) 0271/3036
 BIG SEWICKLEY CREEK
 STRUCTURE LENGTH 40 FT
 BMSID 02/0065/0270/2969 0271/2955
 CROSS ST
 (SR4036 SEG 0010/0000) 0271/2540

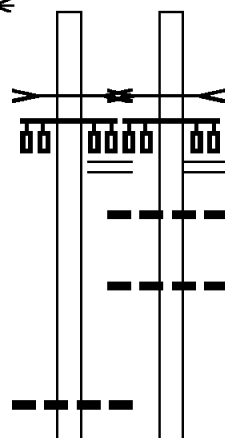

077586 FT
 REF-AHD *
 0270/3028 OHIO RIVER BL
 (SR0065 SEG 0010/0000)
 BIG SEWICKLEY CREEK
 STRUCTURE LENGTH 40 FT
 BMSID 02/0065/0270/2969
 CROSS ST
 (SR4036 SEG 0010/0000)
 018 "DIA CIRC CONCR
 LEN=0040 INSTALLED UNKN
 0270/2969
 0270/2535
 0270/2097
 0270/1396
 018 "DIA CIRC CONCR
 LEN=0034 INSTALLED UNKN

018 "DIA CIRC CONCR
 LEN=0040 INSTALLED UNKN 0271/0080
 1 0 00652 0 03 0746+01 075063 FT

074558 FT 1 0 00652 0 03 0746+01

EXTRACT DATE: 12/21/2020
PRINT DATE: 12/23/2020

ROADWAY MANAGEMENT SYSTEM
SLD COUNTY/SR - ANNUAL PRINT

PAGE NUMBER: 247
COUNTY: ALLEGHENY

DIR: N TOTAL LEN: 14.791 MI.
LEFT MUN: LEETSDALE B

DIST: 11-1 SR: 65
RIGHT MUN: LEETSDALE B

CAVC 203
LENGTH(AH 3036 BK 1798) 0271/0000

FIRST STREET
OP ID 02/7441/0000/1002 0261/0628
LC TO/FROM BROAD ST
(CONN)

1 0 00652 0 03 0728+03 073265 FT
LENGTH(AH 1798 BK 1992) 0261/0000

018 "DIA CIRC CONCR
LEN=0034 INSTALLED UNKN 0251/1583

RAPP ST
(BORO) 0251/1260
012 "DIA CIRC CONCR
LEN=0350 INSTALLED UNKN 0251/1090

012 "DIA CIRC CONCR
LEN=0620 INSTALLED UNKN 0251/0740
018 "DIA CIRC CONCR
LEN=0034 INSTALLED UNKN 0251/0622

MOHAWK AV
(BORO) 0251/0470
SPENCER ST
(BORO) 0251/0260
1 0 00652 0 03 0708+00 071273 FT
FERRY ST
(BORO)

LENGTH(AH 1992 BK 2394) 0251/0000

018 "DIA CIRC CONCR
LEN=0050 INSTALLED UNKN 0241/1601
018 "DIA CIRC CONCR
LEN=0034 INSTALLED UNKN 0241/1600

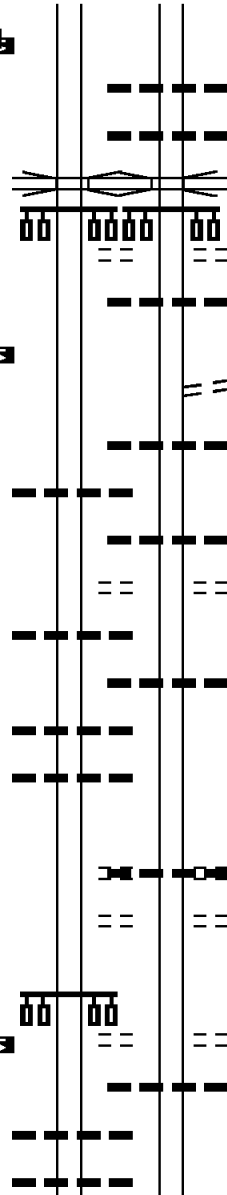

0270/0000

0260/1244

0260/0811

0260/0625

0260/0248

0260/0124

072762 FT
0260/0000

0250/1842

0250/1833

0250/1575

0250/1270

0250/0765

0250/0475

0250/0270

070769 FT

0250/0000

0240/1976

CAVC 203
LENGTH(AH 3028 BK 1796)

018 "DIA CIRC CONCR
LEN=0040 INSTALLED UNKN
018 "DIA CIRC CONCR
LEN=0040 INSTALLED UNKN
FIRST STREET
OP ID 02/7441/0000/1002
LC TO/FROM BROAD ST
(CONN)

012 "DIA CIRC CONCR
LEN=0045 INSTALLED UNKN
1 0 00652 0 03 0727+83
LENGTH(AH 1796 BK 1993)
BROAD ST RAMP

018 "DIA CIRC CONCR
LEN=0034 INSTALLED UNKN

018 "DIA CIRC CONCR
LEN=0040 INSTALLED UNKN
RAPP ST
(BORO)

018 "DIA CIRC CONCR
LEN=0040 INSTALLED UNKN

018 "DIA CIRC CONCR
LEN=0040 INSTALLED UNKN
MOHAWK AV
(BORO)
SPENCER ST
(BORO)

1 0 00652 0 03 0708+09
FERRY ST
(BORO)
LENGTH(AH 1993 BK 2404)
018 "DIA CIRC CONCR
LEN=0050 INSTALLED UNKN

DIR: N TOTAL LEN: 14.791 MI. DIST: 11-1 SR: 65
 LEFT MUN: LEETSDALE B RIGHT MUN: LEETSDALE B

Structure ID	Material	Length (ft)	Stationing	Notes
018	"DIA CIRC CONCR	LEN=0099	0241/0497	QUAKER VILLAGE DR (BORO)
018	"DIA CIRC CONCR	LEN=0045	0231/2617	QUAKER VILLAGE DR (BORO)
018	"DIA CIRC CONCR	LEN=0045	0231/2240	QUAKER VILLAGE DR (BORO)
018	"DIA CIRC CONCR	LEN=0045	0231/1691	QUAKER VILLAGE DR (BORO)
0240/0215	L. SEWICKLEY STRUCTURE	LENGTH 28 FT	0240/0215	L. SEWICKLEY STRUCTURE LENGTH 28 FT
0240/0061	BMSID 02/0065/0240/0061	068365 FT	0240/0061	BMSID 02/0065/0240/0061 068365 FT
0240/0000	LEETSDALE EDGEWORTH B	LENGTH(AH 2394 BK 3690)	0240/0000	LEETSDALE EDGEWORTH B LENGTH(AH 2404 BK 3726)
0230/3068	018 "DIA CIRC CONCR	LEN=0045	0230/3068	018 "DIA CIRC CONCR LEN=0045 INSTALLED UNKN
0230/2056	018 "DIA CIRC CONCR	LEN=0045	0230/2056	018 "DIA CIRC CONCR LEN=0045 INSTALLED UNKN
0230/0000	1 0 00652 0 03 0647+02	065189 FT	0230/0000	1 0 00652 0 03 0646+93 LENGTH(AH 3726 BK 3828) EDGEWORTH LN (BORO)
0220/3050	018 "DIA CIRC CONCR	LEN=0040	0220/3050	018 "DIA CIRC CONCR LEN=0040 INSTALLED UNKN CHESTNUT RD (BORO)
0220/2390	EDGEWORTH COMMONS DR (BORO)		0220/2390	EDGEWORTH COMMONS DR (BORO)
0220/2050	QUAKER RD (BORO)		0220/2050	QUAKER RD (BORO)
0220/1840	ORCHARD PL (BORO)		0220/1840	ORCHARD PL (BORO)
0221/3793	ORCHARD PL (BORO)		0221/3793	ORCHARD PL (BORO)
0221/3000	HAZEL LN (BORO)		0221/3000	HAZEL LN (BORO)

EXTRACT DATE: 12/21/2020
PRINT DATE: 12/23/2020

ROADWAY MANAGEMENT SYSTEM
SLD COUNTY/SR - ANNUAL PRINT

PAGE NUMBER: 245
COUNTY: ALLEGHENY

DIR: N TOTAL LEN: 14.791 MI.
LEFT MUN: EDGEWORTH B

DIST: 11-1 SR: 65
RIGHT MUN: EDGEWORTH B

(BORO)
EDGEWORTH
SEWICKLEY B

0221/1672
0221/1651

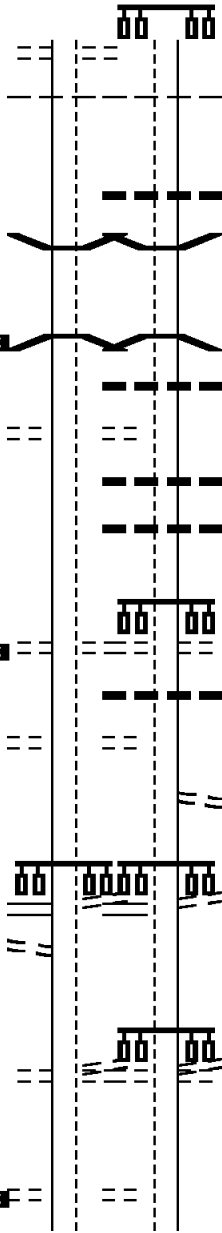

0220/1660
0220/1651

EDGEWORTH
SEWICKLEY B

BMS EN 02/0065/0221/0000 0221/0026
1 0 00652 0 03 0609+05 061392 FT
FERRY ST. LOCAL
BMSBG 02/0065/0221/0000
LENGTH(AH 3797 BK 1465) 0221/0000

WHITE AV
(BORO)

0211/0785

1 0 00652 0 03 0594+69 059927 FT
WALNUT ST
(BORO)
LENGTH(AH 1465 BK 1660) 0211/0000

RIVER AV
(BORO)

0201/1295

BROAD ST
(BORO)
SEWICKLEY BR
(SR4025 SEG 0010/2570)
FROM 4025/0010 SH
(CONN)

0201/1070
0201/0975

BANK ST
(BORO)
CHESTNUT ST
(BORO)

0201/0665

1 0 00652 0 03 0578+18 058267 FT
PINE ST
(BORO)
LENGTH(AH 1660 BK 3403) 0201/0000

0220/0676

018 "DIA CIRC CONCR
LEN=0040 INSTALLED UNKN

0220/0026
060811 FT

BMS EN 02/0065/0221/0000
1 0 00652 0 03 0608+69

0220/0000

BMSBG 02/0065/0221/0000
LENGTH(AH 3828 BK 1377)
018 "DIA CIRC CONCR
LEN=0040 INSTALLED UNKN

0210/1025

WHITE AV
(BORO)

0210/0780

018 "DIA CIRC CONCR
LEN=0040 INSTALLED UNKN

0210/0776

018 "DIA CIRC CONCR
LEN=0040 INSTALLED UNKN

0210/0212
059434 FT

1 0 00652 0 03 0595+00
WALNUT ST
(BORO)

0210/0000

LENGTH(AH 1377 BK 1650)
018 "DIA CIRC CONCR
LEN=0040 INSTALLED UNKN

0200/1297

RIVER AV
(BORO)

0200/1295

LC FROM BROAD ST
(CONN)

0200/1175

BROAD ST
(BORO)

0200/1080

SEWICKLEY BR
(SR4025 SEG 0010/2570)

0200/0650

BANK ST
(BORO)
CHESTNUT ST
(BORO)

057784 FT

1 0 00652 0 03 0579+05
PINE ST
(BORO)

0200/0000

LENGTH(AH 1650 BK 3323)
018 "DIA CIRC CONCR

DIR: N TOTAL LEN: 14.791 MI. DIST: 11-1 SR: 65
 LEFT MUN: SEWICKLEY B RIGHT MUN: SEWICKLEY B

Location	Segment ID	Start Station	End Station	Length (FT)	Material	Notes
GRAHAM ST (BORO)	0191/3040	0190/3258	0190/2955	LEN=0035	INSTALLED UNKN	
DIPPOLD ST (BORO)	0191/2395	0190/2315		LEN=0040	INSTALLED UNKN	
BOUNDARY ST (BORO)	0191/1975	0190/1895		LEN=0040	INSTALLED UNKN	
SEWICKLEY GLEN OSBORNE B	0191/1878	0190/1878		LEN=0096	INSTALLED UNKN	
MCKOWN LN (BORO)	0191/1545	0190/1657		LEN=0121	INSTALLED UNKN	
MCKOWN LN (BORO)	0191/1545	0190/1496		LEN=0120	INSTALLED UNKN	
MCKOWN LN (BORO)	0191/1545	0190/1440		LEN=0096	INSTALLED UNKN	
MCKOWN LN (BORO)	0191/1545	0190/0950		LEN=0118	INSTALLED UNKN	
MCKOWN LN (BORO)	0191/1545	0190/0645		LEN=0117	INSTALLED UNKN	
MCKOWN LN (BORO)	0191/1545	0190/0314		LEN=0116	INSTALLED UNKN	
PARKS RUN STRUCTURE	0191/0030	0190/0030		LEN=0114	INSTALLED UNKN	
PARKS RUN STRUCTURE	0191/0030	0190/0000		LEN=0115	INSTALLED UNKN	
PARKS RUN STRUCTURE	0191/0030	0180/3168		LEN=0040	INSTALLED UNKN	
PARKS RUN STRUCTURE	0191/0030	0180/2914		LEN=0040	INSTALLED UNKN	
PARKS RUN STRUCTURE	0191/0030	0180/2661		LEN=0113	INSTALLED UNKN	
PARKS RUN STRUCTURE	0191/0030	0180/2154		LEN=0113	INSTALLED UNKN	
PARKS RUN STRUCTURE	0191/0030	0180/1900		LEN=0113	INSTALLED UNKN	
PARKS RUN STRUCTURE	0191/0030	0180/1647		LEN=0113	INSTALLED UNKN	
PARKS RUN STRUCTURE	0191/0030	0180/1098		LEN=0113	INSTALLED UNKN	
GLEN OSBORNE HAYSVILLE B	0181/0568	0181/0568		LEN=0034	INSTALLED UNKN	
GLEN OSBORNE HAYSVILLE B	0181/0568	0181/0310		LEN=0034	INSTALLED UNKN	
GLEN OSBORNE HAYSVILLE B	0181/0568	0181/0028		LEN=0034	INSTALLED UNKN	
GLEN OSBORNE HAYSVILLE B	0181/0568	050915 FT		LEN=0034	INSTALLED UNKN	
GLEN OSBORNE HAYSVILLE B	0181/0568	050915 FT		LEN=0034	INSTALLED UNKN	
GLEN OSBORNE HAYSVILLE B	0181/0568	050915 FT		LEN=0034	INSTALLED UNKN	

EXTRACT DATE: 12/21/2020
PRINT DATE: 12/23/2020

ROADWAY MANAGEMENT SYSTEM
SLD COUNTY/SR - ANNUAL PRINT

PAGE NUMBER: 243
COUNTY: ALLEGHENY

DIR: N TOTAL LEN: 14.791 MI.
LEFT MUN: HAYSVILLE B

DIST: 11-1 SR: 65
RIGHT MUN: HAYSVILLE B

BMSID 02/0065/0180/0000
RIVER AV
(BORO)
RIVER AV
(SR4028 SEG 0010/0000)
LENGTH(AH 3472 BK 3209) 0181/0000

HAYSVILLE
GLENFIELD B 0171/0927
1 0 00652 0 03 0477+44 048183 FT
LENGTH(AH 3209 BK 2352) 0171/0000

018 "DIA CIRC CONCR
LEN=0020 INSTALLED UNKN 0161/0500

018 "DIA CIRC CONCR
LEN=0030 INSTALLED UNKN 0161/0235
1 0 00652 0 03 0453+69 045831 FT
LENGTH(AH 2352 BK 1987) 0161/0000

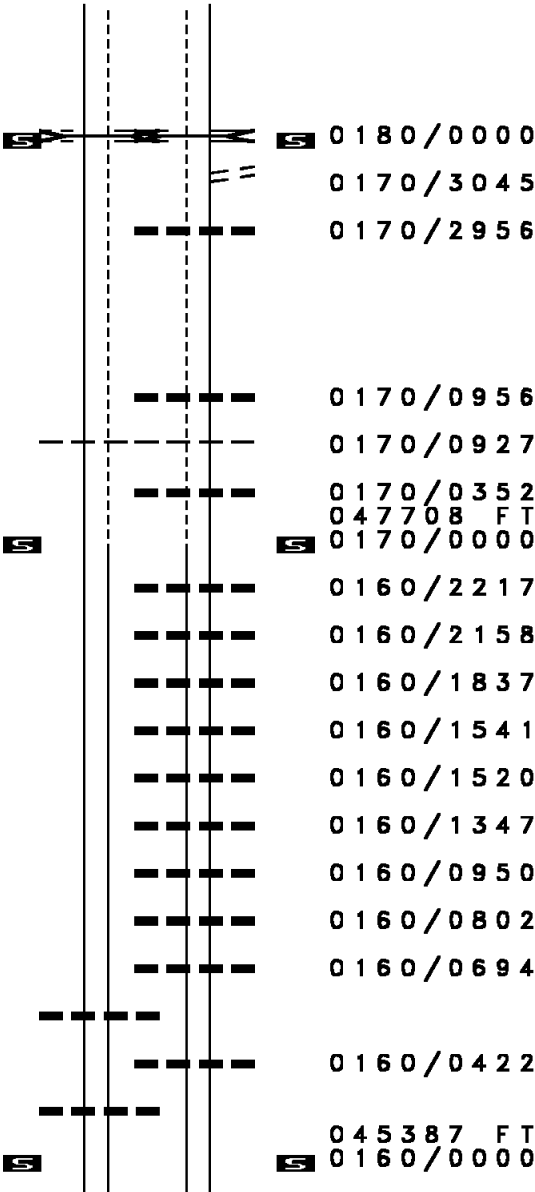

BMSID 02/0065/0180/0000
RIVER AV
(BORO)
RIVER AV
(SR4028 SEG 0010/0000)
LENGTH(AH 3546 BK 3207)
TO 4028/0010 SH
(CONN)
018 "DIA CIRC CONCR
LEN=0200 INSTALLED UNKN

012 "DIA CIRC CONCR
LEN=0084 INSTALLED UNKN
HAYSVILLE
GLENFIELD B
024 "DIA CIRC CONCR
LEN=0045 INSTALLED UNKN
1 0 00652 0 03 0477+43
LENGTH(AH 3207 BK 2321)
018 "DIA CIRC CONCR
LEN=0200 INSTALLED UNKN
018 "DIA CIRC CONCR
LEN=0147 INSTALLED UNKN
018 "DIA CIRC CONCR
LEN=0200 INSTALLED UNKN
018 "DIA CIRC CONCR
LEN=0200 INSTALLED UNKN
018 "DIA CIRC CONCR
LEN=0200 INSTALLED UNKN
018 "DIA CIRC CONCR
LEN=0200 INSTALLED UNKN
018 "DIA CIRC CONCR
LEN=0200 INSTALLED UNKN
018 "DIA CIRC CONCR
LEN=0034 INSTALLED UNKN
018 "DIA CIRC CONCR
LEN=0200 INSTALLED UNKN
018 "DIA CIRC CONCR
LEN=0147 INSTALLED UNKN

018 "DIA CIRC CONCR
LEN=0034 INSTALLED UNKN

045387 FT 1 0 00652 0 03 0453+69
LENGTH(AH 2321 BK 2031)
018 "H 12"W UNKN CONC

DIR: N TOTAL LEN: 14.791 MI. DIST: 11-1 SR: 65
 LEFT MUN: GLENFIELD B RIGHT MUN: GLENFIELD B

Station	Structure	Material	Length	Notes
0140/0660	018" DIA	CIRC CONCR	LEN=0045	INSTALLED UNKN
0140/0460	RAMP FR 65 N TO VIADUCT	(SR8092 SEG 0250/0000)		SIGN: 3 CHORD TRUSS
0140/0370	BMSID 02/0065/0140/0370	018" DIA	CIRC CONCR	
0140/0206	012" DIA	CIRC CONCR	LEN=0045	INSTALLED UNKN
0140/0163	018" DIA	CIRC CONCR	LEN=0045	INSTALLED UNKN
0140/0058	012" DIA	CIRC CONCR	LEN=0045	INSTALLED UNKN
040656 FT	1 0 00652 0 02 0406+74			LENGTH(AH 2700 BK 2144)
0141/0000	012" DIA	CIRC CONCR	LEN=0030	INSTALLED UNKN
0131/1991	012" DIA	CIRC CONCR	LEN=0030	INSTALLED UNKN
0131/1700	012" DIA	CIRC CONCR	LEN=0030	INSTALLED UNKN
0130/1500	018" DIA	CIRC CONCR	LEN=0040	INSTALLED UNKN
0130/1255	018" DIA	CIRC CONCR	LEN=0040	INSTALLED UNKN
0130/0975	012" DIA	CIRC CONCR	LEN=0040	INSTALLED UNKN
0130/0737	012" DIA	CIRC CONCR	LEN=0040	INSTALLED UNKN
0131/0566	012" DIA	CIRC CONCR	LEN=0234	INSTALLED UNKN
0131/0540	012" DIA	CIRC CONCR	LEN=0026	INSTALLED UNKN
0131/0525	TOMS RUN RD	(SR4080 SEG 0050/0531)		GLENFIELD KILBUCK T
0131/0411	012" DIA	CIRC CONCR	LEN=0124	INSTALLED UNKN
0131/0375	012" DIA	CIRC CONCR	LEN=0036	INSTALLED UNKN
0131/0377	TOMS RUN STRUCTURE	LENGTH 21 FT		BMSID 02/0065/0131/0377
0130/0487	018" DIA	CIRC CONCR	LEN=0040	INSTALLED UNKN
0130/0321	012" DIA	CIRC CONCR	LEN=0040	INSTALLED UNKN
0130/0321	TOMS RUN STRUCTURE	LENGTH 21 FT		BMSID 02/0065/0131/0377

DIR: N TOTAL LEN: 14.791 MI. DIST: 11-1 SR: 65
 LEFT MUN: KILBUCK T RIGHT MUN: KILBUCK T

Stationing	Description	Material	Status	Length (AH/BK)	Stationing	Description	Material	Status	Length (AH/BK)
1 0 00652 0 02 0385+06	038512 FT	038951 FT	UNKN	0131/0135	1 0 00652 0 02 0385+54	038512 FT	0385+54	UNKN	0130/0000
LENGTH(AH 2155 BK 3636)				0131/0000	LENGTH(AH 2144 BK 3674)				
018 "DIA CIR PLASTIC					018 "DIA CIR CONC				
LEN=0040			UNKN	0121/3430	LEN=0003			UNKN	
018 "DIA CIR PLASTIC					018 "DIA CIR CONC				
LEN=0030			UNKN	0121/3155	LEN=0040			UNKN	
					018 "DIA CIR CONC				
					LEN=0034			UNKN	
018 "DIA CIR CONC					018 "DIA CIR CONC				
LEN=0158			UNKN	0121/1840	LEN=0034			UNKN	
					018 "DIA CIR CONC				
					LEN=0034			UNKN	
018 "DIA CIR CONC					018 "DIA CIR CONC				
LEN=0157			UNKN	0121/1556	LEN=0050			UNKN	
					KILBUCK				
018 "DIA CIR CONC					EMSWORTH B				
LEN=0156			UNKN	0121/1270	0120/1114				
KILBUCK					EMSWORTH B				
EMSWORTH B				0121/1111					
018 "DIA CIR CONC					018 "DIA CIR CONC				
LEN=0156			UNKN	0121/0996	LEN=0020			UNKN	
					018 "DIA CIR CONC				
					LEN=0040			UNKN	
018 "DIA CIR CONC					018 "DIA CIR CONC				
LEN=0152			UNKN	0121/0805	LEN=0040			UNKN	
					018 "DIA CIR CONC				
					LEN=0040			UNKN	
018 "DIA CIR CONC					018 "DIA CIR CONC				
LEN=0151			UNKN	0121/0277	LEN=0040			UNKN	
					018 "DIA CIR CONC				
					LEN=0040			UNKN	
1 0 00652 0 02 0348+79	034838 FT	035315 FT	UNKN	0121/0000	1 0 00652 0 02 0348+76	034838 FT	0348+76	UNKN	0120/0000
TERRACE AV					LENGTH(AH 3674 BK 2919)				
(BORO)					HAZELWOOD AV				
LENGTH(AH 3636 BK 2927)				0121/0000	(BORO)				
HAZELWOOD AV					0111/2710				
(BORO)					024 "DIA CIR CONC				
024 "DIA CIR CONC				0111/2675	LEN=0025			UNKN	
LEN=0025			UNKN		0110/2700				
					018 "DIA CIR CONC				
					LEN=0040			UNKN	
HUNTINGTON AV					0110/2555				
					HUNTINGTON AV				

EXTRACT DATE: 12/21/2020
PRINT DATE: 12/23/2020

ROADWAY MANAGEMENT SYSTEM
SLD COUNTY/SR - ANNUAL PRINT

PAGE NUMBER: 239
COUNTY: ALLEGHENY

DIR: N TOTAL LEN: 14.791 MI.
LEFT MUN: EMSWORTH B

DIST: 11-1 SR: 65
RIGHT MUN: EMSWORTH B

Stationing	Description	Stationing	Description
(BORO) 0111/2510	WALLISTON AV	0110/2510	(BORO) WALLISTON AV
(BORO) 0111/2465		0110/2460	(BORO)
WALLISTON AV		0110/2428	018 "DIA CIRC CONCR LEN=0040 INSTALLED UNKN
(BORO) 0111/2410		WALLISTON AV	
(BORO) OLIVER AV		(BORO) 0110/2385	(BORO) OLIVER AV
(BORO) GREENWOOD AV		(BORO) 0110/2160	(BORO) GREENWOOD AV
(BORO) 0111/2130		0110/2115	(BORO) ALLEGHENY AV
ALLEGHENY AV			(BORO) ALLEGHENY AV
(BORO) ALLEGHENY AV			(BORO) ALLEGHENY AV
(BORO) 0111/1855		0110/1840	
024 "DIA CIRC CONCR			
LEN=0025 INSTALLED UNKN			
0111/1840			
024 "DIA CIRC CONCR			
LEN=0025 INSTALLED UNKN			
0111/1620			
PENNSYLVANIA AV			
(BORO) 0111/1495		0110/1485	PENNSYLVANIA AV
024 "DIA CIRC CONCR		(BORO)	
LEN=0025 INSTALLED UNKN			
0111/1318			
018 "DIA CIRC CONCR			
LEN=0145 INSTALLED UNKN			
0111/1003			
ORCHARD AV			
(BORO) 0111/0970		0110/0955	ORCHARD AV
MAPLE AV		(BORO)	
(BORO) 0111/0930		0110/0910	MAPLE AV
024 "DIA CIRC CONCR		(BORO)	
LEN=0025 INSTALLED UNKN			
0111/0709			
NORTH AV			
(BORO) 0111/0700		0110/0695	NORTH AV
		(BORO)	
		0110/0520	018 "DIA CIRC CONCR LEN=0200 INSTALLED UNKN
018 "DIA CIRC CONCR			
LEN=0144 INSTALLED UNKN			
0111/0329			
LOCUST ST			
(BORO) 0111/0305		0110/0310	LOCUST AV
018 "DIA CIRC CONCR		(SR4057 SEG 0005/0000)	
LEN=0143 INSTALLED UNKN		0110/0288	LOCUST ST
0111/0033		(BORO)	
1 0 00652 0 02 0319+40 032388 FT			
LOWRY AV		031919 FT	1 0 00652 0 02 0319+40
(BORO)			
CAMP HORNE RD			LOWRY AV
(CNTY)			(BORO)
			CAMP HORNE RD
			(CNTY)

DIR: N TOTAL LEN: 14.791 MI. DIST: 11-1 SR: 65
 LEFT MUN: EMSWORTH B RIGHT MUN: EMSWORTH B

DESCRIPTION	START	END	TYPE	STATUS	DESCRIPTION	START	END	TYPE	STATUS
LENGTH(AH 2927 BK 1379)	0111/0000	5			LENGTH(AH 2919 BK 1203)	5	0110/0000		
024 "DIA CIRC CONCR	0101/1352				018 "DIA CIRC CONCR	0100/1161			
LEN=0142 INSTALLED UNKN					LEN=0040 INSTALLED UNKN				
024 "DIA CIRC CONCR	0101/1268				018 "DIA CIR UNKNOWN	0100/1045			
LEN=0140 INSTALLED UNKN					LEN=0023 INSTALLED 2011				
WILLOW ST					WILLOW ST				
(BORO)					(BORO)				
BMSEN 02/0065/0100/0817	0101/1205				BMSEN 02/0065/0100/0817	0100/1025			
CHARLES ST	0101/1069				CHARLES ST	0100/0920			
(BORO)					(BORO)				
HILAND AV	0101/1055				HILAND AV	0100/0870			
(BORO)					(BORO)				
1 0 00652 0 02 0305+57	0101/0945				1 0 00652 0 02 0315+27				
LOWRIES RUN					LOWRIES RUN				
BMSBG 02/0065/0100/0817	0101/0966				BMSBG 02/0065/0100/0817	0100/0817			
					HILAND AV	0100/0780			
018 "DIA CIRC CONCR	0101/0639				(BORO)				
LEN=0140 INSTALLED UNKN					EMSWORTH AV	0100/0295			
EMSWORTH AV	0101/0490				(BORO)				
(BORO)					MEMORIAL DR	0100/0160			
018 "DIA CIRC CONCR	0101/0344				(BORO)				
LEN=0141 INSTALLED UNKN					MEMORIAL DR	030716 FT			
MEMORIAL DR	0101/0335				LC TO MEMORIAL DR				
(BORO)					(CONN)				
LC TO MEMORIAL DR	0101/0195				LENGTH(AH 1203 BK 2320)	5	0100/0000		
(CONN)					018 "DIA CIR PLASTIC	0090/2290			
1 0 00652 0 02 0305+57	031009 FT				LEN=0040 INSTALLED UNKN	0090/2186			
ATLANTIC AV					ATLANTIC AV				
(BORO)					(BORO)				
LENGTH(AH 1379 BK 2167)	0101/0000	5			DRAINAGE				
					STRUCTURE LENGTH 10 FT				
018 "DIA CIRC CONCR	0091/2019				BMSID 02/0065/0090/1991	0090/1991			
LEN=0150 INSTALLED UNKN					LC TO ATLANTIC AV	0091/1916			
DRAINAGE					(CONN)				
STRUCTURE LENGTH 10 FT					018 "DIA CIRC CONCR	0090/1878			
BMSID 02/0065/0090/1991					LEN=0150 INSTALLED UNKN				
LC TO ATLANTIC AV	0091/1916				HERRON ST				
(CONN)					(BORO)				

DIR: N TOTAL LEN: 14.791 MI. DIST: 11-1 SR: 65
 LEFT MUN: EMSWORTH B RIGHT MUN: EMSWORTH B

Stationing / Description	Material / Notes	Stationing / Description	Material / Notes
EMSWORTH BEN AVON B 018 "DIA CIRC CONCR LEN=0151	INSTALLED UNKN	0091/1651	EMSWORTH BEN AVON B 018 "DIA CIR PLASTIC LEN=0040
018 "DIA CIRC CONCR LEN=0152	INSTALLED UNKN	0091/1068	0090/1599
BMSSEN 02/0065/0090/0745 1 0 00652 0 02 0292+03 FOREST AVE. LOCAL BMSBG 02/0065/0090/0745 018 "DIA CIRC CONCR LEN=0153	INSTALLED UNKN	0091/0903	0090/1500
018 "DIA CIRC CONCR LEN=0153	INSTALLED UNKN	0091/0568	0090/0981
018 "DIA CIRC CONCR LEN=0153	INSTALLED UNKN	0091/0329	0090/0868
LC FROM BRIGHTON RD (CONN)			0090/0805
1 0 00652 0 02 0283+25	028842 FT	0091/0171	0090/0420
BRIGHTON RD (BORO) BELLE RIVIERE CT (BORO) LENGTH(AH 2167 BK 1951)		0091/0000	0090/0160
IRWIN AV (BORO)		0081/1595	028396 FT
DICKSON AV (BORO) 018 "DIA CIRC CONCR LEN=0030	INSTALLED UNKN	0081/0818	1 0 00652 0 02 0283+79
BMSSEN 02/0065/0080/0000		0081/0630	BRIGHTON RD (BORO) BELLE RIVIERE CT (BORO) LENGTH(AH 2320 BK 1969)
1 0 00652 0 02 0264+72	026891 FT		IRWIN AV (BORO)
SPRUCE ST. LOCAL BMSBG 02/0065/0080/0000		0081/0000	DICKSON AV (BORO)
LENGTH(AH 1951 BK 1443)		0081/0000	0080/0950
018 "DIA CIRC CONCR LEN=0030	INSTALLED UNKN	0071/1389	0080/0950
018 "DIA CIRC CONCR LEN=0030	INSTALLED UNKN	0071/1179	0080/0630
LAUREL AV (BORO)		0071/0935	026427 FT
			1 0 00652 0 02 0264+72
			SPRUCE ST. LOCAL BMSBG 02/0065/0080/0000
			LENGTH(AH 1969 BK 1462)
			048 "DIA CIRC CONCR LEN=0025
			INSTALLED UNKN
			LAUREL AV (BORO)

DIR: N TOTAL LEN: 14.791 MI. DIST: 11-1 SR: 65
 LEFT MUN: BEN AVON B RIGHT MUN: BEN AVON B

Left Side Description	Left Side Stationing	Diagram	Right Side Stationing	Right Side Description
MONITOR AV (BORO)				MONITOR AV (BORO)
MONITOR AV (BORO)				MONITOR AV (BORO)
FISK AV (BORO)	0071/0635		0070/0645	FISK AV (BORO)
BEN AVON AVALON B BORO AL (BORO)	0071/0540 0071/0509		0070/0540 0070/0507	BEN AVON AVALON B BORO AL (BORO)
CLEVELAND AV (BORO)	0071/0415 0071/0275		0070/0410 0070/0275	CLEVELAND AV (BORO)
C AL (BORO)	0071/0135		0070/0175	024 "DIA CIRC CONCR LEN=0024 INSTALLED UNKN
1 0 00652 0 02 0248+30 025448 FT HARRISON AV (BORO)	0071/0135		0070/0135	C AL (BORO)
LENGTH(AH 1443 BK 3956)	0071/0000		024965 FT	1 0 00652 0 02 0249+77 HARRISON AV (BORO)
BORO AL (BORO)	0061/3805		0070/0000	LENGTH(AH 1462 BK 3933) BORO AL (BORO)
OHIO ST (BORO)	0061/3670		0060/3805	OHIO ST (BORO)
BMSSEN 02/0065/0060/3108 1 0 00652 0 02 0241+43	0061/3169		0060/3670	BMSSEN 02/0065/0060/3108 1 0 00652 0 02 0241+43
BIRMINGHAM LOCAL BMSBG 02/0065/0060/3108	0061/3123		0060/3154	BIRMINGHAM LOCAL BMSBG 02/0065/0060/3108
LOCUST ST (BORO)	0061/2490		0060/3108	LOCUST ST (BORO)
PROSPECT ST (BORO)	0061/1690		0060/2480	PROSPECT ST (BORO)
018 "DIA CIRC CONCR LEN=0001 INSTALLED 2010	0061/1527		0060/1670	018 "DIA CIRC CONCR LEN=0058 INSTALLED 2010
ELIZABETH AV (BORO)	0061/1430		0060/1545	ELIZABETH AV (BORO)
018 "DIA CIRC CONCR LEN=0044 INSTALLED UNKN	0061/0343		0060/1410	
BMSSEN 02/0065/0060/0000	0061/0225		0060/0338	015 "DIA CIRC CONCR LEN=0044 INSTALLED UNKN
			0060/0225	BMSSEN 02/0065/0060/0000

DIR: N TOTAL LEN: 14.791 MI. DIST: 11-1 SR: 65
 LEFT MUN: AVALON B RIGHT MUN: AVALON B

AVALON BELLEVUE B				AVALON BELLEVUE B			
1 0 00652 0 02 0210+65	0061/0154	021492 FT		0060/0154	021032 FT	1 0 00652 0 02 0210+65	
W. BELLEVUE LOCAL				W. BELLEVUE LOCAL			
BMSBG 02/0065/0060/0000				BMSBG 02/0065/0060/0000		BMSBG 02/0065/0060/0000	
LENGTH(AH 3956 BK 2027)	0061/0000			LENGTH(AH 3933 BK 2027)	0060/0000	LENGTH(AH 3933 BK 2027)	
018 "DIA CIRC CONCR							
LEN=0030 INSTALLED UNKN	0051/2011						
RIVERVIEW AV (SR4012 SEG 0010/0000)				RIVERVIEW AV (SR4012 SEG 0010/0000)			
024 "DIA CIRC CONCR	0051/1250			0050/1215			
LEN=0055 INSTALLED UNKN	0051/0890						
024 "DIA CIRC CONCR							
LEN=0030 INSTALLED UNKN	0051/0691						
BMSEN 02/0065/0050/0000	0051/0300			0050/0300		BMSEN 02/0065/0050/0000	
1 0 00652 0 02 0189+74	019465 FT			019005 FT		1 0 00652 0 02 0189+74	
NO UNDERPASS INFORMATION				NO UNDERPASS INFORMATION			
BMSBG 02/0065/0050/0000				BMSBG 02/0065/0050/0000		BMSBG 02/0065/0050/0000	
LENGTH(AH 2027 BK 3143)	0051/0000			LENGTH(AH 2027 BK 3148)	0050/0000	LENGTH(AH 2027 BK 3148)	
018 "DIA CIRC CONCR							
LEN=0030 INSTALLED UNKN	0041/2928						
018 "DIA CIRC CONCR							
LEN=0030 INSTALLED UNKN	0041/2894						
018 "DIA CIRC CONCR							
LEN=0030 INSTALLED UNKN	0041/2790						
018 "DIA CIRC CONCR							
LEN=0030 INSTALLED UNKN	0041/2655						
018 "DIA CIRC CONCR							
LEN=0030 INSTALLED UNKN	0041/2544						
SHILOH AV (BORO)				SHILOH AV (BORO)			
018 "DIA CIRC CONCR	0041/2485			0040/2485			
LEN=0030 INSTALLED UNKN	0041/2384						
018 "DIA CIRC CONCR							
LEN=0030 INSTALLED UNKN	0041/2076						
GRANT AV (BORO)				GRANT AV (BORO)			
018 "DIA CIRC CONCR	0041/1945			0040/1945			
LEN=0030 INSTALLED UNKN	0041/1914						
018 "DIA CIRC CONCR							
LEN=0030 INSTALLED UNKN	0041/1640						
KENDALL AV (BORO)				KENDALL AV (BORO)			
018 "DIA CIR PLASTIC	0041/1585			0040/1580			
LEN=0030 INSTALLED UNKN	0041/1203						
018 "DIA CIRC CONCR							
LEN=0030 INSTALLED UNKN	0041/0903						

DIR: N TOTAL LEN: 14.791 MI. DIST: 11-1 SR: 65
 LEFT MUN: BELLEVUE B RIGHT MUN: BELLEVUE B

Segment Description	Stationing	Structure	Stationing	Segment Description
BMSEN 02/0065/0040/0000 018 "DIA CIRC CONCR LEN=0030 INSTALLED UNKN BELLEVUE PITTSBURGH C 1 0 00652 0 02 0158+76 016322 FT NO UNDERPASS INFORMATIO BMSBG 02/0065/0040/0000 LENGTH(AH 3143 BK 3725)	0041/0754		0040/0754	BMSEN 02/0065/0040/0000 BELLEVUE PITTSBURGH C 1 0 00652 0 02 0158+76 NO UNDERPASS INFORMATIO BMSBG 02/0065/0040/0000 LENGTH(AH 3148 BK 3763)
MILLERTON AV (CITY)	0031/2485	==	0030/2515	MILLERTON AV (CITY)
BMSEN 02/0065/0030/1555 1 0 00652 0 02 0118+74 NO UNDERPASS INFORMATIO BMSBG 02/0065/0030/1555	0031/1940		0030/2114 0030/1945	BMSEN 02/0065/0030/1555 1 0 00652 0 02 0118+74 NO UNDERPASS INFORMATIO BMSBG 02/0065/0030/1555 LC FR TERMON AV (CONN)
TO 3104/0030 SH (CONN) BRIGHTON HEIGHTS AV (CITY) MCKEES ROCKS BR (SR3104 SEG 0030/3864)	0031/1335	==	0030/1440	BRIGHTON HEIGHTS BL (CITY) MCKEES ROCKS BR (SR3104 SEG 0030/3864)
FROM 3104/0030 SH (CONN)	0031/1225		0030/1235	
	0031/1055	==	0030/1040	LC TO TERMON AV (CONN)
1 0 00652 0 02 0120+03 012597 FT DMS SIGN STRUCTURE BMSID 02/0065/0031/0000 LENGTH(AH 3725 BK 3509)	0031/0000		012094 FT 0030/0000	1 0 00652 0 02 0120+68 LENGTH(AH 3763 BK 3614)
BMSEN 02/0065/0020/1529 0 0 00000 0 00 0000+00 ECKERT STREET BMSBG 02/0065/0020/1529	0021/1920		0020/2320 0020/2039	012 "DIA CIRC CONCR LEN=0030 INSTALLED UNKN BMSEN 02/0065/0020/1529 0 0 00000 0 00 0000+00 ECKERT STREET BMSBG 02/0065/0020/1529
	0021/1410		0020/1529	012 "DIA CIRC CONCR

DIR: N TOTAL LEN: 14.791 MI. DIST: 11-1 SR: 65
 LEFT MUN: PITTSBURGH C RIGHT MUN: PITTSBURGH C

Stationing	Description	Length	Material	Status
0020/0918	018 "DIA CIRC CONCR	LEN=0030	INSTALLED	UNKN
0020/0700	018 "DIA CIRC CONCR	LEN=0075	INSTALLED	UNKN
0021/0296	018 "DIA CIRC CONCR	LEN=0196	INSTALLED	UNKN
0021/0100	018 "DIA CIRC CONCR	LEN=0100	INSTALLED	UNKN
0021/0000	1 0 00652 0 01 0085+05 009088 FT CALIFORNIA AV (SR4265 SEG 0011/2327)	008480 FT	1 0 00652 0 01 0085+05	LENGTH(AH 3614 BK 3628)
0013/3292	RAMP 8043 SB OP ID 02/8043/0250/0000	0013/3292	0012/3380	OP ID 02/8043/0250/0000 CALIFORNIA AV (SR4265 SEG 0010/1939)
0013/3200	018 "DIA CIRC CONCR	LEN=0030	INSTALLED	UNKN
0013/3040	018 "DIA CIRC CONCR	LEN=0202	INSTALLED	UNKN
0013/2838	018 "DIA CIRC CONCR	LEN=0108	INSTALLED	UNKN
0013/2730	018 "DIA CIRC CONCR	LEN=0354	INSTALLED	UNKN
0012/2500	018 "DIA CIRC CONCR	LEN=0100	INSTALLED	UNKN
0013/1778	BMS EN 02/0065/0012/0000	0013/1778	0012/1804	BMS EN 02/0065/0012/0000
			0012/1165	RAMP FR CHATEAU ST (SR8049 SEG 0020/0943)
			0012/0026	1 0 01039 0 00 0967+45 65 SB OFF RP BMSBG 02/0065/0012/0000
005351 FT	RAMP 250 RD (SR8049 SEG 0250/1477)	005351 FT	004852 FT	1 0 00000 0 00 0000+00 INTER-BK OHIO RIVER BL (SR0019 SEG 0290/2811)
0013/0000	OHIO RIVER BL (SR0019 SEG 0291/2684)	0013/0000	0012/0000	LTH AH 003628 BK 000100
005351 FT	65 SB OFF RP	005351 FT	004852 FT	7008/0000
0013/0000	BMSBG 02/0065/0012/0000	0013/0000	7008/0000	LTH AH 000100 BK 002095
002149	LTH AH 000100 BK 002149	002149	INTER-AHD	OHIO RIVER BL (SR0019 SEG 0287/0000)
0005/2149	OHIO RIVER BL (SR0019 SEG 0287/0000)	0005/2149	0004/2095	OP ID 02/0019/0280/1347 SR 19 NB PED. WALKWAY
	SR 19 NB			
	OP ID 02/0019/0280/1347			
	PED. WALKWAY			

DIR: N TOTAL LEN: 14.791 MI. DIST: 11-1 SR: 65
 LEFT MUN: PITTSBURGH C RIGHT MUN: PITTSBURGH C

018 "DIA CIRC CONCR
 LEN=0050 INSTALLED UNKN 0003/2286

DRAINAGE STRUCTURE LENGTH 34 FT
 BMSID 02/0065/0002/2550 0003/2195

018 "DIA CIRC CONCR
 LEN=0050 INSTALLED UNKN 0003/2180

018 "DIA CIRC CONCR
 LEN=0050 INSTALLED UNKN 0003/2075

018 "DIA CIRC CONCR
 LEN=0050 INSTALLED UNKN 0003/1990

SIGN: 4 CHORD TRUSS
 BMSID 02/0065/0003/1958 0003/1928

018 "DIA CIRC CONCR
 LEN=0075 INSTALLED UNKN 0003/1863

018 "DIA CIRC CONCR
 LEN=0050 INSTALLED UNKN 0003/1737

TO SR 279 N RAMP W RD
 (SR8107 SEG 0010/0000)

TO SR 65 S RIDGE AV
 (SR8045 SEG 0750/1990) 0003/1685

018 "DIA CIRC CONCR
 LEN=0050 INSTALLED UNKN 0003/1631

SIGN: CANTILEVER
 BMSID 02/0065/0003/1180 0003/1269

BMSEN 02/0065/0003/0000 0003/1153

SR8045 RAMPA
 OP ID 02/8045/0250/0000 0003/1000

SIGN: CANTILEVER
 BMSID 02/0065/0003/0843 0003/0792

1 0 01039 0 00 0021+05 000000 FT

SR 279 S SH
 (SR0279 SEG 0009/0804)

SR 0279 NB
 OP ID 02/0279/0008/1346

NC OHIO RIVER BL INTER-BK
 SR 279 S SH

(SR0279 SEG 0009/0804)

I-279 SB
 BMSBG 02/0065/0003/0000

MFC BEGIN = B
 LENGTH(AH 3202 BK 0000) 0003/0000

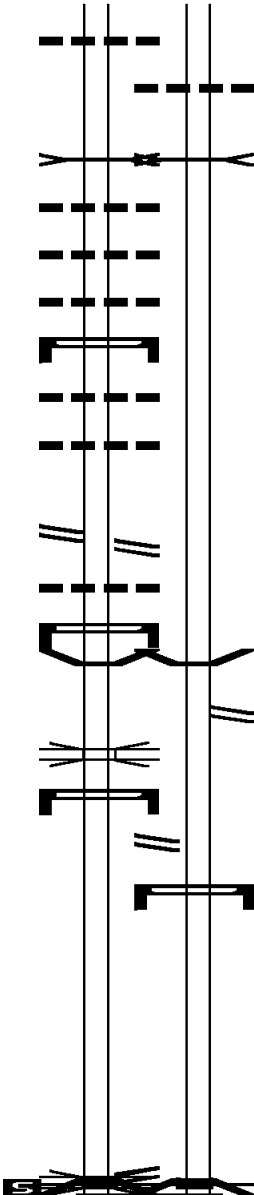

0002/2027 018 "DIA CIRC CONCR
 LEN=0075 INSTALLED UNKN

0002/2022 DRAINAGE STRUCTURE LENGTH 34 FT
 BMSID 02/0065/0002/2550

0002/1293 BMSEN 02/0065/0002/0000

0002/1254 RAMP V RD
 (SR8107 SEG 0260/1522)

0002/0400 RAMP 250 RD
 (SR8045 SEG 0250/0000)

0002/0327 SIGN: 4 CHORD TRUSS
 BMSID 02/0065/0002/0830

000000 FT 1 0 01039 0 00 0021+97

NC OHIO RIVER BL INTER-BK FORT DUQUESNE BR

(SR0279 SEG 0008/1175)

RAMP W - SR 8107

BMSBG 02/0065/0002/0000

MFC BEGIN = B
 LENGTH(AH 2757 BK 0000)

LTH AH 000100 BK 002179 7235/0000
 SR 0022 SH INTER-AHD
 (SR0022 SEG 0140/1449) 0231/2179

TO 8036/0250 SH
 (CONN)

0231/1792

PARK MANOR DR
 (TWP)

0231/1250

024 "DIA CIRC CONCR
 LEN=0099 INSTALLED UNKN 0231/1182

018 "DIA CIRC CONCR
 LEN=0099 INSTALLED UNKN 0231/1040

ROBINSON CT
 (PRDR)

0231/0755

1 0 00257 0 02 0425+44 045137 FT
 (APRA) CASPER COLOSIMO
 CAMPBELLS RUN RD

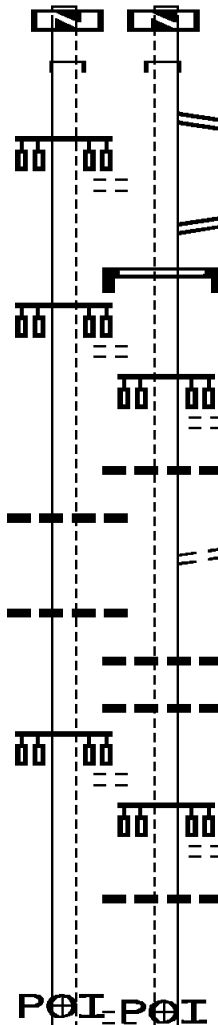

049586 FT
 7234/0000
 INTER-AHD
 0230/2237
 0230/1983

LTH AH 000100 BK 002237
 SR 22 & 30W SH
 (SR0022 SEG 0141/1437)
 RAMP C RD
 (SR8036 SEG 0260/0787)

0230/1710 RAMP G RD
 (SR8036 SEG 0250/0000)
 SIGN: CANTILEVER
 0230/1505 BMSID 02/0060/0230/1505

0230/1252 PARK MANOR DR
 (TWP)
 0230/1227 036 "DIA CIRC CONCR
 LEN=0040 INSTALLED UNKN

0230/1155 LC TO PARK MANOR DR
 (CONN)

0230/0950 018 "DIA CIRC CONCR
 LEN=0040 INSTALLED UNKN
 0230/0915 018 "DIA CIRC CONCR
 LEN=0050 INSTALLED UNKN

0230/0772 ROBINSON CT
 (PRDR)

0230/0685 018 "DIA CIRC CONCR
 LEN=0100 INSTALLED UNKN

047349 FT 1 0 00257 0 02 0425+44
 (APRA) CASPER COLOSIMO
 CAMPBELLS RUN RD
 (CNTY)

DIR: N TOTAL LEN: 9.391 MI. DIST: 11-1 SR: 60
 LEFT MUN: ROBINSON T RIGHT MUN: ROBINSON T

Location / Description	Stationing	Length (FT)	Notes
(CNTY) MFC BEGIN = B	0231/0000		
LENGTH(AH 2179 BK 3466)			
DEVASSIE RD (TWP)	0220/1345		
1 0 00257 0 02 0457+92	041671 FT		
CHURCH HILL RD (T443)	0220/0000		
TWIN CIRCLES MOB HM PRK (PRDR)	0210/1990		
1 0 00257 0 02 0489+03	038564 FT		
TIDBALL RD (T445)	0210/0000		
SUNSET DR (TWP)	0200/1400		
	0230/0000		
	0220/2883		
	0220/2495		
	0220/2440		
	0220/2386		
	0220/1950		
	0220/1420		
	0220/1030		
	0220/0710		
	043883 FT		
	0220/0000		
	0210/3100		
	0210/2376		
	0210/2110		
	0210/1990		
	0210/1569		
	0210/0460		
	0210/0315		
	040776 FT		
	0210/0000		
	0200/1865		

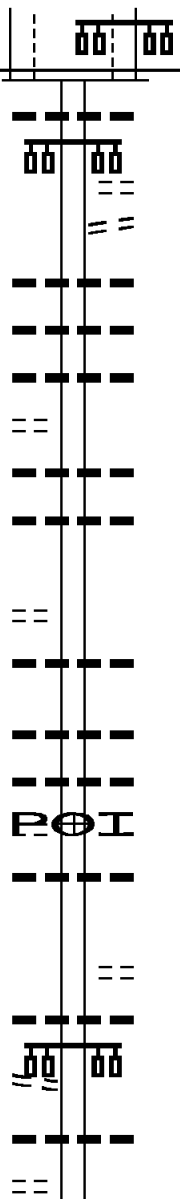

MFC BEGIN = B
 LENGTH(AH 2237 BK 3466)
 018 " DIA CIRC CONCR
 LEN=0100 INSTALLED UNKN
 HIGH TOWER BL
 (TWP)
 LC TO HIGH TOWER BL
 (CONN)
 018 " DIA CIRC CONCR
 LEN=0050 INSTALLED UNKN
 018 " DIA CIRC CONCR
 LEN=0100 INSTALLED UNKN
 018 " DIA CIRC CONCR
 LEN=0048 INSTALLED UNKN
 018 " DIA CIRC CONCR
 LEN=0048 INSTALLED UNKN
 018 " DIA CIRC CONCR
 LEN=0050 INSTALLED UNKN
 LENGTH(AH 3466 BK 3107)
 018 " DIA CIRC CONCR
 LEN=0060 INSTALLED UNKN
 018 " DIA CIRC CONCR
 LEN=0050 INSTALLED UNKN
 036 " DIA CIRC CONCR
 LEN=0099 INSTALLED UNKN
 (APRA) TWIN CIRCLES MOB
 018 " DIA CIRC CONCR
 LEN=0050 INSTALLED UNKN
 WATERFORD DR
 (TWP)
 024 " DIA CIRC CONCR
 LEN=0100 INSTALLED UNKN
 LENGTH(AH 3107 BK 1877)
 018 " DIA CIRC CONCR
 LEN=0100 INSTALLED UNKN

DIR: N TOTAL LEN: 9.391 MI. DIST: 11-1 SR: 60
 LEFT MUN: ROBINSON T RIGHT MUN: ROBINSON T

ROADWAY NAME	START STATION	END STATION	LENGTH (FT)	DESCRIPTION
	0200/0112	038899	036687	018" DIA CIRC CONCR LEN=0100 INSTALLED UNKN 1 0 00257 0 02 0508+02 BEAVER GRADE RD (SR3077 SEG 0010/0000)
	0200/0000			LENGTH(AH 1877 BK 2810)
	0190/1400			018" DIA CIRC METAL LEN=0050 INSTALLED UNKN MOON RUN RD
MOON RUN PARK RD (TWP)	0190/1375			(TWP)
	0190/1260			018" DIA CIRC CONCR LEN=0050 INSTALLED UNKN
	0190/0915			018" DIA CIRC CONCR LEN=0060 INSTALLED UNKN
	0190/0766			018" DIA CIRC CONCR LEN=0050 INSTALLED UNKN
MCCORMICK RD (SR3041 SEG 0080/2765)	036089	0190/0000	033877	1 0 00257 0 02 0535+59 NC ST EUBENVILLE PK LENGTH(AH 2810 BK 2380)
	0180/2122			018" DIA CIRC CONCR LEN=0050 INSTALLED UNKN
	0180/2011			018" DIA CIRC CONCR LEN=0050 INSTALLED UNKN
	0180/1851			018" DIA CIRC CONCR LEN=0050 INSTALLED UNKN
	0180/1664			LC TO OMEGA DR (CONN)
OMEGA DR (PRDR)	0180/1590			0180/1590
	0180/1557			024" DIA CIRC CONCR LEN=0024 INSTALLED UNKN
LC FROM OMEGA DR (CONN)	0180/1525			
VALLEY RD (TWP)	0180/1373			
PLANET WY (TWP)	0180/1350			
	0180/1223			018" DIA CIRC CONCR LEN=0050 INSTALLED UNKN 018" DIA CIRC CONCR

DIR: N TOTAL LEN: 9.391 MI. DIST: 11-1 SR: 60
 LEFT MUN: ROBINSON T RIGHT MUN: ROBINSON T

WINDHAVEN RD
 (TWP)

0180/0825

031497 FT

RAMP F RD
 (SR8011 SEG 0250/0000)
 SIGN: CANTILEVER
 BMSID 02/0060/0151/2960 0151/3071

RAMP E RD
 (SR8011 SEG 0260/1424) 0151/2366

SR 0079 SB
 OP ID 02/0079/0601/0080 0151/1983

SR 0079 NB
 OP ID 02/0079/0600/0070 0151/1879

TO 8011/0750 SH
 (CONN) 0151/1691

RAMP A RD
 (SR8011 SEG 0010/1068)
 0151/1620

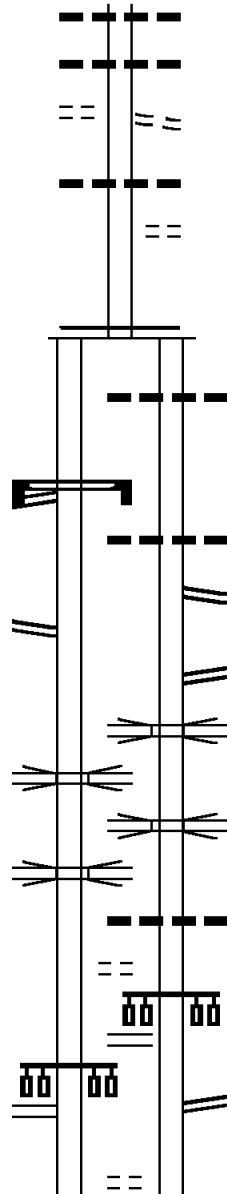

0180/1105 LEN=0050 INSTALLED UNKN
 018 "DIA CIRC CONCR

0180/0866 LEN=0050 INSTALLED UNKN
 MCKEES ROCKS RD

0180/0825 (TWP)

0180/0065 018 "DIA CIRC CONCR
 LEN=0045 INSTALLED UNKN
 OLD STEUBENVILLE PK

0180/0045 (TWP)

033709 FT 1 0 00257 0 02 0551+40
 NC OLD STEUBENVILLE PK

0180/0000 LENGTH(AH 2380 BK 3609)

0150/3404 024 "DIA CIRC CONCR
 LEN=0099 INSTALLED UNKN

0150/3039 024 "DIA CIRC CONCR
 LEN=0036 INSTALLED UNKN
 RAMP D RD

0150/2858 (SR8011 SEG 0510/1637)

0150/2285 RAMP C RD
 (SR8011 SEG 0500/0000)

0150/2006 SR 0079 SB
 OP ID 02/0079/0601/0080

0150/1903 SR 0079 NB
 OP ID 02/0079/0600/0070

0150/1829 027 "DIA CIRC METAL
 LEN=0099 INSTALLED UNKN

0150/1643 RAMP A RD
 (SR8011 SEG 0010/1068)

0150/1620 RAMP B RD
 (SR8011 SEG 0750/0000)

HADDOCK DR
 (TWP)

DIR: N TOTAL LEN: 9.391 MI. DIST: 11-1 SR: 60
 LEFT MUN: ROBINSON T RIGHT MUN: ROBINSON T

LORISH RD
 (TWP)
 HADDOCK DR
 (TWP)

1 0 00257 0 02 0589+75 027886 FT
 MFC BEGIN = B
 LTH AH 003611 BK 002111 0151/0000
 KENNEDY T 0140/2111

1 0 00257 0 03 0620+13 025775 FT
 WINDHAVEN RD
 (T447) 0140/0000

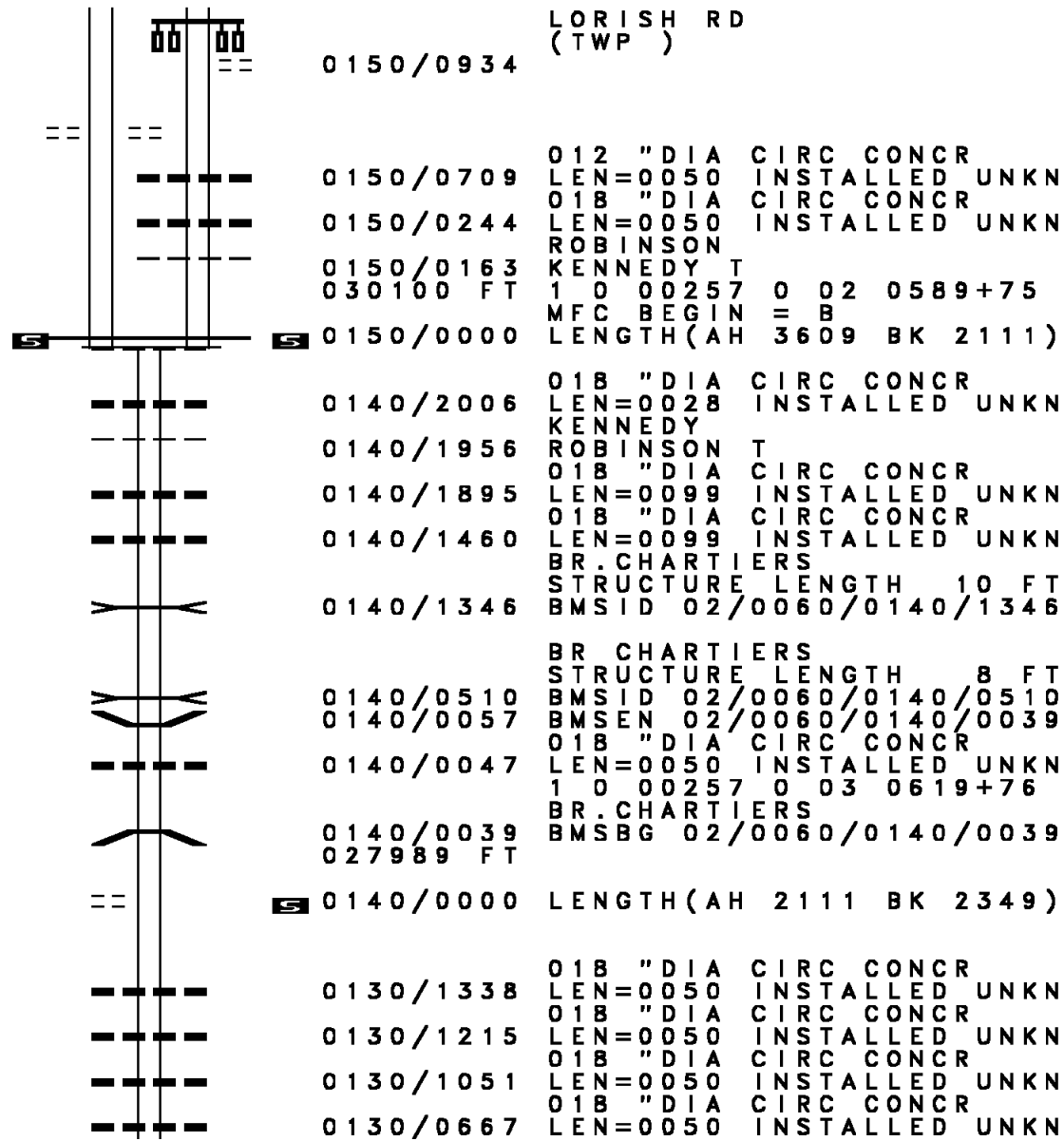

LORISH RD
 (TWP)

0150/0934

0151/0932 ==

0150/0709

012 " DIA CIRC CONCR
 LEN=0050 INSTALLED UNKN
 018 " DIA CIRC CONCR
 LEN=0050 INSTALLED UNKN
 ROBINSON
 KENNEDY T

0150/0244

0150/0163
 030100 FT

1 0 00257 0 02 0589+75
 MFC BEGIN = B
 LENGTH(AH 3609 BK 2111)

0150/0000

018 " DIA CIRC CONCR
 LEN=0028 INSTALLED UNKN
 KENNEDY
 ROBINSON T

0140/2006

0140/1956

0140/1895

0140/1460

018 " DIA CIRC CONCR
 LEN=0099 INSTALLED UNKN
 018 " DIA CIRC CONCR
 LEN=0099 INSTALLED UNKN
 BR. CHARTIERS
 STRUCTURE LENGTH 10 FT
 BMSID 02/0060/0140/1346

0140/1346

0140/0510

0140/0057

0140/0047

0140/0039
 027989 FT

BR CHARTIERS
 STRUCTURE LENGTH 8 FT
 BMSID 02/0060/0140/0510
 BMSSEN 02/0060/0140/0039
 018 " DIA CIRC CONCR
 LEN=0050 INSTALLED UNKN
 1 0 00257 0 03 0619+76
 BR. CHARTIERS
 BMSBG 02/0060/0140/0039

0140/0000

LENGTH(AH 2111 BK 2349)

0130/1338

0130/1215

0130/1051

0130/0667

018 " DIA CIRC CONCR
 LEN=0050 INSTALLED UNKN
 018 " DIA CIRC CONCR
 LEN=0050 INSTALLED UNKN
 018 " DIA CIRC CONCR
 LEN=0050 INSTALLED UNKN
 018 " DIA CIRC CONCR
 LEN=0050 INSTALLED UNKN

DIR: N TOTAL LEN: 9.391 MI. DIST: 11-1 SR: 60
 LEFT MUN: ROBINSON T RIGHT MUN: ROBINSON T

Stationing	Notes	Material	Length	Material	Length
023426 FT		0130/0134	018 " DIA	CIRC CONCR	LEN=0050
		025640 FT	1 0 00257	0 03 0643+85	
		0130/0000	LENGTH(AH 2349 BK 2465)		
		0120/2238	018 " DIA	CIRC CONCR	LEN=0050
		0120/1530	036 " DIA	CIRC CONCR	LEN=0050
		0120/1282	012 " DIA	CIRC CONCR	LEN=0050
		0120/1182	032 " DIA	CIRC CONCR	LEN=0050
		0120/0870	018 " DIA	CIRC CONCR	LEN=0050
		0120/0569	018 " DIA	CIRC CONCR	LEN=0050
		0120/0163	018 " DIA	CIRC CONCR	LEN=0050
020961 FT		023175 FT			
BALDWIN RD (CNTY) CORNELL ST (TWP)		0120/0000	LENGTH(AH 2465 BK 1010)		
		0110/0880	BMS EN 02/0060/0110/0166		
		0110/0451	ROBINSON PITTSBURGH C		
		0110/0195	1 0 00257 0 03 0670+04		
		0110/0073	NAPOR BLVD LOCAL BMSBG 02/0060/0110/0166		
		0110/0040	LC TO WOODMERE AV (CONN)		
019951 FT		022165 FT	WOODMERE AV (CITY)		
			1 0 00257 0 03 0677+06		
			NC ST EUBENVILLE PK		
WOODMERE AV (CITY)		0110/0000	INGRAM AV (CITY)		
		0100/2465	PITTSBURGH CRAFTON B		
CRAFTON BL (BORO)		0100/1865	LENGTH(AH 1010 BK 2656)		
			LC TO INGRAM AV (CONN)		
MCCORMICK AV (BORO)		0100/1385	018 " DIA	CIRC CONCR	LEN=0050
					INSTALLED UNKN

EXTRACT DATE: 12/21/2020
PRINT DATE: 12/23/2020

ROADWAY MANAGEMENT SYSTEM
SLD COUNTY/SR - ANNUAL PRINT

PAGE NUMBER: 224
COUNTY: ALLEGHENY

DIR: N TOTAL LEN: 9.391 MI.
LEFT MUN: CRAFTON B

DIST: 11-1 SR: 60
RIGHT MUN: CRAFTON B

1 0 00257 0 03 0704+83 017295 FT
RICHMOND ST
(BORO) 0100/0000

CRAFTON AV
(BORO) 0090/1555

MILDRED ST
(BORO) 0090/0560

015003 FT

ALICE ST
(BORO) 0080/0920

DIVISION ST
(BORO) 0080/0438

1 0 00257 0 03 0740+25 013780 FT
CRAFTON AV
(BORO)

NOBLE AV
(BORO) 0080/0000

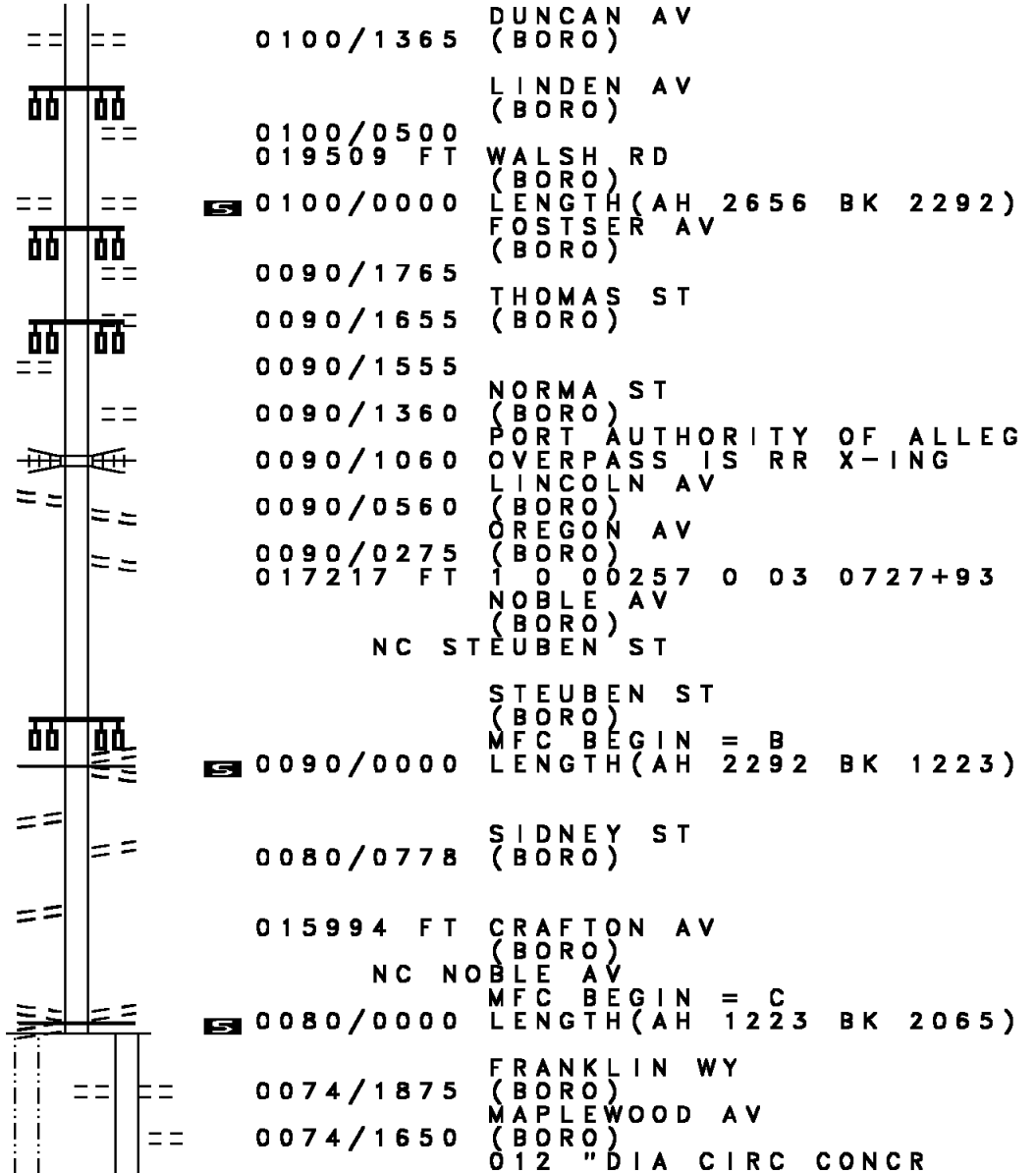

EXTRACT DATE: 12/21/2020
PRINT DATE: 12/23/2020

ROADWAY MANAGEMENT SYSTEM
SLD COUNTY/SR - ANNUAL PRINT

PAGE NUMBER: 223
COUNTY: ALLEGHENY

DIR: N TOTAL LEN: 9.391 MI.
LEFT MUN: CRAFTON B

DIST: 11-1 SR: 60
RIGHT MUN: CRAFTON B

LTH AH 002065 BK 000360 013780 FT
(BORO) 7075/0000
0070/0360

CLEARVIEW ET
(BORO) 0070/0065
013420 FT

0074/1430	LEN=0050	INSTALLED UNKN
0074/1420	HALDANE ST (BORO)	
0074/1390	HALDANE ST (BORO)	
0074/1380	012 " DIA CIRC CONCR LEN=0050	INSTALLED UNKN
0074/1265	ALLEY (BORO)	
0074/1115	WALNUT ST (BORO)	
0074/0965	ALLEY (BORO)	
0074/0840	012 " DIA CIRC CONCR LEN=0050	INSTALLED UNKN
0074/0815	ELMWOOD ST (BORO)	
0074/0570	018 " DIA CIRC CONCR LEN=0050	INSTALLED UNKN
0074/0302	012 " DIA CIRC CONCR LEN=0050	INSTALLED UNKN
013929 FT	1 0 00257 0 03 0761+01	
	CRAFTON BL (BORO)	
	NC DI NSMORE AV	
0074/0000	MFC BEGIN = C LENGTH(AH 2065 BK 0360)	
0070/0170	ALLEY (BORO)	
013569 FT	1 0 00257 0 03 0764+61	
0070/0000	MCMUNN AV (BORO)	
0060/2238	LENGTH(AH 0360 BK 2704) 018 " DIA CIRC CONCR LEN=0050	INSTALLED UNKN
0060/1480	012 " DIA CIRC CONCR LEN=0050	INSTALLED UNKN
0060/1150	012 " DIA CIRC CONCR LEN=0050	INSTALLED UNKN
0060/0820	CRAFTON AV (BORO)	
0060/0751	012 " DIA CIRC CONCR LEN=0050	INSTALLED UNKN
0060/0140	012 " DIA CIRC CONCR LEN=0050	INSTALLED UNKN

DIR: N TOTAL LEN: 9.391 MI. DIST: 11-1 SR: 60
 LEFT MUN: CRAFTON B RIGHT MUN: CRAFTON B

Stationing	Description	Length	Notes
1 0 00257 0 03 0791+69 010716 FT	CROTZER AV (BORO)	0060/0000	
CRAFTON PITTSBURGH C		0050/1040	
NOBLESTOWN RD (SR0050 SEG 0290/2053)	HARTWELL ST (CITY)	009249 FT 0050/0000	
LC TO HARTWELL ST (CONN)	HARTWELL ST (CITY)	0040/2894 0040/2750 0040/2370	
		006006 FT	
	RODGERS AV (BORO)	0060/0105	
	JOSEPHINE ST (BORO)	010865 FT	
	CRAFTON PITTSBURGH C	0060/0000	LENGTH(AH 2704 BK 1467)
	LAWSON AV (CITY)	0050/1281	
	RIDENOUR AV (CITY)	0050/1020	
	ENDERLIN WY (CITY)	0050/0885	
	CUMBERLAND ST (CITY)	0050/0720	
	ATHERLY WY (CITY)	0050/0560	
	STRATMORE ST (CITY)	0050/0555	
	1 0 00257 0 03 0806+15 NC CRAFTON BL	009398 FT	
		0050/0000	LENGTH(AH 1467 BK 3243)
		0040/2876	018 "DIA CIRC CONCR LEN=0050 INSTALLED UNKN
		0040/1955	018 "DIA CIRC CONCR LEN=0050 INSTALLED UNKN
		0040/1905	OBEY ST (CITY)
		0040/0700	018 "DIA CIRC CONCR LEN=0050 INSTALLED UNKN
		0040/0371	018 "DIA CIRC CONCR LEN=0030 INSTALLED UNKN
		006155 FT	1 0 00257 0 03 0838+69 NC NOBLESTOWN RD
		0040/0000	LENGTH(AH 3243 BK 3606)
		0030/3433	018 "DIA CIRC CONCR LEN=0050 INSTALLED UNKN
			018 "DIA CIRC CONCR

EXTRACT DATE: 12/21/2020
PRINT DATE: 12/23/2020

ROADWAY MANAGEMENT SYSTEM
SLD COUNTY/SR - ANNUAL PRINT

PAGE NUMBER: 221
COUNTY: ALLEGHENY

DIR: N TOTAL LEN: 9.391 MI.
LEFT MUN: PITTSBURGH C

DIST: 11-1 SR: 60
RIGHT MUN: PITTSBURGH C

002400 FT

000572 FT

SR 0060 N

0030/3377	LEN=0050	INSTALLED UNKN
018 "DIA	CIRC CONCR	
0030/3106	LEN=0050	INSTALLED UNKN
WEAVER ST		
(CITY)		
0030/2671	018 "DIA	CIRC CONCR
0030/2630	LEN=0050	INSTALLED UNKN
018 "DIA	CIRC CONCR	
0030/2600	LEN=0050	INSTALLED UNKN
018 "DIA	CIRC CONCR	
0030/2245	LEN=0050	INSTALLED UNKN
018 "DIA	CIRC CONCR	
0030/1925	LEN=0050	INSTALLED UNKN
018 "DIA	CIRC CONCR	
0030/1665	LEN=0050	INSTALLED UNKN
018 "DIA	CIRC CONCR	
0030/0990	LEN=0050	INSTALLED UNKN
018 "DIA	CIRC CONCR	
0030/0675	LEN=0050	INSTALLED UNKN
018 "DIA	CIRC CONCR	
0030/0168	LEN=0050	INSTALLED UNKN
002549 FT	1 0 00257 0 03 0875+15	
0030/0000	LENGTH(AH 3606 BK 1828)	
0010/1591	018 "DIA	CIRC CONCR
LEN=0050	INSTALLED UNKN	
WALBRIDGE ST		
(CITY)		
SOUTH MAIN ST		
0010/1554	(CITY)	
WABASH ST		
(CITY)		
0010/1278	ALEXANDER ST	
(CITY)		
0010/1043	SANCTUS ST	
(CITY)		
0010/0691		
0010/0312	BMS EN 02/0060/0010/0702	
1 0 00257 0 03 0898+74		
SAW MILL RUN		
0010/0250	BMSBG 02/0060/0010/0702	
018 "DIA	CIRC CONCR	
0010/0225	LEN=0050	INSTALLED UNKN
000721 FT	1 0 00257 0 03 0898+74	
NC MA	IN ST	
0010/0000	MFC BEGIN = C	
LENGTH(AH 1828 BK 0721)		
SOUTH MAIN ST		

EXTRACT DATE: 12/21/2020
PRINT DATE: 12/23/2020

ROADWAY MANAGEMENT SYSTEM
SLD COUNTY/SR - ANNUAL PRINT

PAGE NUMBER: 220
COUNTY: ALLEGHENY

DIR: N TOTAL LEN: 9.391 MI.
LEFT MUN: PITTSBURGH C

DIST: 11-1 SR: 60
RIGHT MUN: PITTSBURGH C

(SR0060 SEG 0004/0721) 0005/0572

018 "DIA CIRC CONCR
LEN=0050 INSTALLED UNKN 0005/0467
FOR SR 0060N TO 0060S
(CONN) 0005/0465
SIGN: CANTILEVER
BMSID 02/0060/0005/0300 0005/0368

SR 0051 SB
OP ID 02/0051/0441/0373 0005/0334

018 "DIA CIRC CONCR
LEN=0050 INSTALLED UNKN 0005/0160
SR 0019 NB
OP ID 02/0019/0250/0558 0005/0156

1 0 00000 0 00 0000+00 000000 FT
SR 0051 SH
(SR0051 SEG 0440/1465)
NC SOUTH MAIN ST
SR 0051 SH INTER-BK
(SR0051 SEG 0440/1465)
MFC BEGIN = C
LTH AH 000572 BK 000100 0005/0000
000000 FT
LTH AH 000100 BK 000000 7003/0000

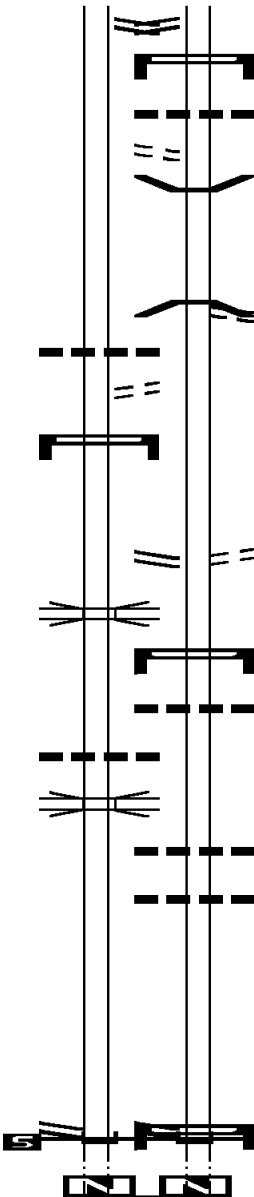

0004/0721 (SR0060 SEG 0005/0572)
SIGN: CANTILEVER
0004/0700 BMSID 02/0060/0004/0700
015 "DIA CIRC CONCR
0004/0678 LEN=0099 INSTALLED UNKN
FOR SR 0060N TO 0060S
0004/0630 (CONN)
0004/0578 BMSEN 02/0060/0004/0480
0 0 00000 0 00 0000+00
LC FROM STEUBEN ST
(CONN)
SAWMILL RUN
0004/0480 BMSBG 02/0060/0004/0480

STEUBEN ST
(CITY)
STEUBEN ST CONN RAMP
(SR9406 SEG 0010/0000)
NC CROSS ST

SIGN: CANTILEVER
0004/0325 BMSID 02/0060/0004/0325
012 "DIA CIRC CONCR
0004/0281 LEN=0099 INSTALLED UNKN

0004/0083 018 "DIA CIRC CONCR
LEN=0050 INSTALLED UNKN
0004/0023 012 "DIA CIRC CONCR
LEN=0099 INSTALLED UNKN
000000 FT 1 0 00257 4 00 0002+60
SIGN: 3 CHORD TRUSS

BMSID 02/0051/0441/0753
SR 0051 SH
(SR0051 SEG 0441/1147)
NC ST STEUBEN ST
INTER-BK SR 0051 SH
(SR0051 SEG 0441/1147)
MFC BEGIN = C
0004/0000 000000 FT
000000 FT
7002/0000 LTH AH 000721 BK 000100
LTH AH 000100 BK 000000

EXTRACT DATE: 12/21/2020 ROADWAY MANAGEMENT SYSTEM PAGE NUMBER: 219
 PRINT DATE: 12/23/2020 SLD COUNTY/SR - ANNUAL PRINT COUNTY: ALLEGHENY
 DIR: N TOTAL LEN: 36.753 MI. DIST: 11-1 SR: 51
 LEFT MUN: CRESCENT T RIGHT MUN: CRESCENT T

193321 FT

HARPER RD
 (SR3096 SEG 0020/2501) 0810/2005

BOCKTOWN RD
 (SR3111 SEG 0010/0702) 0810/1075
 BOCKTOWN RD
 (SR3094 SEG 0040/0676) 0810/0545

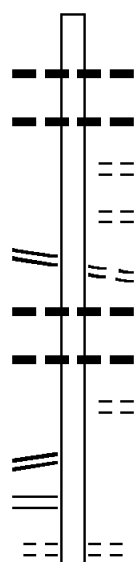

194054 FT AH-BE AVER (04)
 * REF-AHD JORDAN ST BE AVER CO
 0810/3672 (SR0051 SEG 0010/0000)
 0810/3403 01B "DIA CIRC CONCR UNKN
 LEN=0050 INSTALLED UNKN
 0810/3141 01B "DIA CIRC CONCR UNKN
 LEN=0050 INSTALLED UNKN
 JEANETTE AV
 0810/2625 (TWP)
 DIVISION AV
 0810/2315 (TWP)
 PORTER ST
 0810/2005 (TWP)
 01B "DIA CIRC CONCR UNKN
 0810/1618 LEN=0050 INSTALLED UNKN
 01B "DIA CIRC CONCR UNKN
 0810/1464 LEN=0050 INSTALLED UNKN
 MAPLE ST
 0810/1405 (TWP)
 0810/0210 FACTORY ST
 (TWP)

DIR: N TOTAL LEN: 36.753 MI. DIST: 11-1 SR: 51
 LEFT MUN: CRESCENT T RIGHT MUN: CRESCENT T

Stationing	Length	Material	Notes
2 0 02238 0 00 0132+91 189649 FT	0810/0196	018 " DIA	CIRC CONCR
SCHOOL ST (TWP)	190382 FT	LEN=0050	INSTALLED UNKN
	0810/0000	5	LENGTH(AH 3672 BK 3842)
	0800/3822	018 " DIA	CIRC CONCR
	0800/3609	018 " DIA	CIRC CONCR
	0800/3372	018 " DIA	CIRC CONCR
	0800/3150	018 " DIA	CIRC CONCR
UNKNOWN RD (TWP)	0800/2820	LEN=0050	INSTALLED UNKN
	0800/2811	018 " DIA	CIRC CONCR
PROSPECT ST (TWP)	0800/2595	LEN=0050	INSTALLED UNKN
	0800/1688	018 " DIA	CIRC CONCR
	0800/1605	LEN=0050	INSTALLED UNKN
SPRING RUN RD (CNTY)	0800/1535	018 " DIA	CIRC CONCR
	0800/1335	018 " DIA	CIRC CONCR
	0800/1088	018 " DIA	CIRC CONCR
JACKSON ST (TWP)	0800/0925	LEN=0050	INSTALLED UNKN
	0800/0853	018 " DIA	CIRC CONCR
	0800/0360	018 " DIA	CIRC CONCR
185807 FT	186540 FT	2 0 02238 0 00 0094+98	
	0800/0000	018 " DIA	CIRC CONCR
	0790/3188	5	LENGTH(AH 3842 BK 3588)
	0790/2989	012 " DIA	CIRC CONCR
	0790/2685	018 " DIA	CIRC CONCR
	0790/2097	012 " DIA	CIRC CONCR
		018 " DIA	CIRC CONCR

DIR: N TOTAL LEN: 36.753 MI. DIST: 11-1 SR: 51
 LEFT MUN: CRESCENT T RIGHT MUN: CRESCENT T

PURDY RD
(TWP)

0790/1320

FLAUGHERTY RUN RD
(SR3089 SEG 0190/2571)

182219 FT

0790/0000

SHAFER RD
(T363)

0780/0277
178366 FT

CROOKED LN
(TWP)

0770/1013

176645 FT

0790/1629	LEN=0050	018 "DIA	CIRC CONCR	INSTALLED UNKN
0790/1403	LEN=0050	018 "DIA	CIRC CONCR	INSTALLED UNKN
0790/1255	LEN=0050	018 "DIA	CIRC CONCR	INSTALLED UNKN
0790/0906	LEN=0050	018 "DIA	CIRC CONCR	INSTALLED UNKN
0790/0875	LEN=0050	CRESCENT MOON T		
0790/0620	LEN=0050	018 "DIA	CIRC CONCR	INSTALLED UNKN
0790/0345	LEN=0050	018 "DIA	CIRC CONCR	INSTALLED UNKN
0790/0010	LEN=0050	018 "DIA	CIRC CONCR	INSTALLED UNKN
182952 FT	2 0 02238	0 00 0059+58		
NC MC GOVERN BL				
0790/0000	LENGTH(AH	3588 BK 3853)		
0780/3816	BMSBN 02/0051/0780/3736			
	2 0 02238	0 00 0057+59		
	FLAUGHERTY RUN			
0780/3736	BMSBG 02/0051/0780/3736			
0780/3164	LEN=0050	018 "DIA	CIRC CONCR	INSTALLED UNKN
0780/2757	LEN=0080	018 "DIA	CIRC CONCR	INSTALLED UNKN
0780/1858	LEN=0152	018 "DIA	CIRC CONCR	INSTALLED UNKN
0780/0487	LEN=0099	018 "DIA	CIRC CONCR	INSTALLED UNKN
	STAUNTON DR			
	(TWP)			
0780/0277	179099 FT	2 0 02238	0 00 0044+18	
0780/0000	LENGTH(AH	3853 BK 1721)		
177378 FT	2 0 02238	0 00 0010+66		
	MFC BEGIN = B			
0770/0000	LENGTH(AH	1721 BK 0652)		

DIR: N TOTAL LEN: 36.753 MI. DIST: 11-1 SR: 51
 LEFT MUN: MOON T RIGHT MUN: MOON T

Segment ID	Description	Start Station	End Station	Length (FT)	Material	Notes
0731/2051	INSTALLED UNKN					
(APRA)	R.B. & W. COMPAN					(APRA) R.B. & W. COMPAN
VALLEY	AMBULANCE					VALLEY AMBULANCE
(PRDR)						(PRDR)
0731/1805						0730/1792
(APRA)	FAB TEC INDUSTRI					(APRA) FAB TEC INDUSTRI
FAB TEC	INDUSTRIES INC					FAB TEC INDUSTRIES INC
(PRDR)						(PRDR)
0731/1440						0730/1424
018 "DIA	CIRC CONCR					018 "DIA CIRC CONCR
LEN=0099	INSTALLED UNKN					LEN=0099 INSTALLED UNKN
018 "DIA	CIRC CONCR					018 "DIA CIRC CONCR
LEN=0099	INSTALLED UNKN					LEN=0099 INSTALLED UNKN
018 "DIA	CIRC CONCR					018 "DIA CIRC CONCR
LEN=0099	INSTALLED UNKN					LEN=0099 INSTALLED UNKN
018 "DIA	CIRC CONCR					018 "DIA CIRC CONCR
LEN=0080	INSTALLED UNKN					LEN=0080 INSTALLED UNKN
169085 FT						1 0 00076 0 03 0606+58
0731/0000	NC FIFTH AV					0730/0000 NC FIFTH AV
LENGTH(AH 2629 BK 1660)						LENGTH(AH 2008 BK 1639)
TOWNSHIP RD						TOWNSHIP RD
(PRDR)						(PRDR)
0721/1595	CONNECTOR RD					0720/1560 CONNECTOR RD
(CONN)						(CONN)
0721/1400						0720/1392
018 "DIA	CIRC CONCR					
LEN=0099	INSTALLED UNKN					
TO 3087/0040 SH						
(CONN)						
0721/0965						
018 "DIA	CIRC CONCR					
LEN=0099	INSTALLED UNKN					
NC UNIVERSITY BL						
THORN RUN RD						
(SR3087 SEG 0050/0120)						
0721/0790						0720/0720
FROM 3087/0050 SH						
(CONN)						
0721/0635						
THORN HOLLOW DR						
(TWP)						
0721/0565						
BMSEN 02/0051/0721/0328						0720/0191 BMSEN 02/0051/0720/0172
1 0 00076 0 03 0592+86						1 0 00076 3 01 0073+12
THORN RUN						THORN RUN
BMSBG 02/0051/0721/0328						0720/0172 BMSBG 02/0051/0720/0172
MOON						
0721/0269						
CORAOPOLIS B						
018 "H 00" W MULT CONCR						
LEN=0050	INSTALLED UNKN					
0721/0020						
018 "DIA	CIRC CONCR					
LEN=0050	INSTALLED UNKN					
167446 FT						1 0 00076 3 01 0072+84
018 "DIA	CIRC CONCR					

DIR: N TOTAL LEN: 36.753 MI. DIST: 11-1 SR: 51
 LEFT MUN: MOON T RIGHT MUN: MOON T

Stationing	Length	Material	Status	Notes
1 0 00076 0 03 0589+28 166714 FT				
THORN ST (TWP)				LEN=0050 INSTALLED UNKN
LENGTH(AH 1660 BK 1546) 0721/0000				THORN ST (TWP) MOON CORAOPOLIS B
	0720/0000			LENGTH(AH 1639 BK 1517)
	0710/1517			018 "DIA CIRC CONCR
	0710/1320			LEN=0040 INSTALLED UNKN
018 "DIA CIRC CONCR				024 "DIA CIRC CONCR
LEN=0030 INSTALLED UNKN 0711/1240				LEN=0020 INSTALLED UNKN
018 "DIA CIRC CONCR				
LEN=0015 INSTALLED UNKN 0711/1231				
018 "DIA CIRC CONCR				
LEN=0030 INSTALLED UNKN 0711/1100				
018 "DIA CIRC CONCR				
LEN=0015 INSTALLED UNKN 0711/1092				
	0710/1043			018 "DIA CIRC CONCR
	0710/1038			LEN=0020 INSTALLED UNKN
	0710/1025			CHESS ST (BORO)
CHESS ST (BORO)				CHESS ST (BORO)
018 "DIA CIRC CONCR				
LEN=0050 INSTALLED UNKN 0711/0904				
018 "DIA CIRC CONCR				
LEN=0050 INSTALLED UNKN 0711/0751				
	0710/0659			018 "DIA CIRC CONCR
	0710/0460			LEN=0040 INSTALLED UNKN
	0710/0452			LOCUST ST (BORO)
LOCUST ST (BORO)				018 "DIA CIRC CONCR
0711/0480				LEN=0025 INSTALLED UNKN
018 "DIA CIRC CONCR				
LEN=0073 INSTALLED UNKN 0711/0390				
036 "DIA CIRC CONCR				
LEN=0073 INSTALLED UNKN 0711/0362				
036 "DIA CIRC CONCR				
LEN=0050 INSTALLED UNKN 0711/0289				
018 "DIA CIRC CONCR				
LEN=0015 INSTALLED UNKN 0711/0265				
018 "DIA CIRC CONCR				
LEN=0015 INSTALLED UNKN 0711/0156				
018 "DIA CIRC CONCR				
LEN=0015 INSTALLED UNKN 0711/0060				
	165929 FT			
				1 0 00076 3 01 0055+14
				018 "DIA CIRC CONCR
				LEN=0025 INSTALLED UNKN

DIR: N TOTAL LEN: 36.753 MI. DIST: 11-1 SR: 51
 LEFT MUN: CORAOPOLIS B RIGHT MUN: CORAOPOLIS B

Stationing	Material	Length	Status	Notes	Stationing	Material	Length	Status	Notes
1 0 00076 0 03 0571+24 165168 FT									
WATT ST (BORO)									
LENGTH(AH 1546 BK 2834) 0711/0000					0710/0000	LENGTH(AH 1517 BK 2848)			
WOOD ST (BORO)									
024 "DIA CIRC CONCR									
LEN=0099 INSTALLED UNKN									
018 "DIA CIRC CONCR									
LEN=0015 INSTALLED UNKN									
					0700/2318	018 "DIA CIRC CONCR			
						LEN=0020 INSTALLED UNKN			
					0700/2275	018 "DIA CIRC CONCR			
						LEN=0030 INSTALLED UNKN			
018 "DIA CIRC CONCR									
LEN=0015 INSTALLED UNKN									
KENDALL ST (BORO)					0700/2205	KENDALL ST (BORO)			
018 "DIA CIRC CONCR									
LEN=0103 INSTALLED UNKN									
018 "DIA CIRC CONCR									
LEN=0040 INSTALLED UNKN									
018 "DIA CIRC CONCR									
LEN=0030 INSTALLED UNKN									
018 "DIA CIRC CONCR									
LEN=0030 INSTALLED UNKN									
					0700/1817	018 "DIA CIRC CONCR			
						LEN=0020 INSTALLED UNKN			
					0700/1767	018 "DIA CIRC CONCR			
						LEN=0020 INSTALLED UNKN			
MAIN ST (BORO)						MAIN ST (BORO)			
					0700/1705				
018 "DIA CIRC CONCR									
LEN=0027 INSTALLED UNKN									
018 "DIA CIRC CONCR									
LEN=0030 INSTALLED UNKN									
					0700/1395	018 "DIA CIRC CONCR			
						LEN=0020 INSTALLED UNKN			
018 "DIA CIRC CONCR									
LEN=0030 INSTALLED UNKN									
036 "DIA CIRC CONCR									
LEN=0015 INSTALLED UNKN									
WILLOW WY (BORO)					0700/1090	WILLOW WY (BORO)			
						018 "DIA CIRC CONCR			
					0700/1000	LEN=0050 INSTALLED UNKN			
018 "DIA CIRC CONCR									
LEN=0030 INSTALLED UNKN									
MILL ST						MILL ST			

DIR: N TOTAL LEN: 36.753 MI. DIST: 11-1 SR: 51
 LEFT MUN: CORAOPOLIS B RIGHT MUN: CORAOPOLIS B

Station	Description	Material	Length	Notes
0701/0990	(BORO)			
0701/0735	018 "DIA	CIRC CONCR	LEN=0015	INSTALLED UNKN
0701/0620	018 "DIA	CIRC CONCR	LEN=0015	INSTALLED UNKN
0701/0460	MULBERRY ST (BORO)			
0701/0320	018 "DIA	CIRC CONCR	LEN=0099	INSTALLED UNKN
0701/0240	018 "DIA	CIRC CONCR	LEN=0015	INSTALLED UNKN
0701/0220	018 "DIA	CIRC CONCR	LEN=0099	INSTALLED UNKN
0701/0083	018 "DIA	CIRC CONCR	LEN=0099	INSTALLED UNKN
0701/0080	018 "DIA	CIRC CONCR	LEN=0099	INSTALLED UNKN
0701/0025	018 "DIA	CIRC CONCR	LEN=0015	INSTALLED UNKN
0701/0010	018 "DIA	CIRC CONCR	LEN=0099	INSTALLED UNKN
162334 FT	1 0 00076 0 03 0540+97			
0701/0000	BROADWAY ST (BORO)			
0701/0000	LENGTH(AH 2834 BK 2835)			
0691/2628	018 "DIA	CIRC CONCR	LEN=0137	INSTALLED UNKN
0691/2622	018 "DIA	CIRC CONCR	LEN=0286	INSTALLED UNKN
0691/2439	018 "DIA	CIRC CONCR	LEN=0015	INSTALLED UNKN
0691/2439	018 "DIA	CIRC CONCR	LEN=0015	INSTALLED UNKN
0700/0955	(BORO)			
0700/0764	018 "DIA	CIRC CONCR	LEN=0020	INSTALLED UNKN
0700/0497	018 "DIA	CIRC CONCR	LEN=0020	INSTALLED UNKN
0700/0450	MULBERRY ST (BORO)			
0700/0195	LINDEN AL (BORO)			
0700/0090	018 "DIA	CIRC CONCR	LEN=0020	INSTALLED UNKN
0700/0089	018 "DIA	CIRC CONCR	LEN=0004	INSTALLED UNKN
0700/0027	018 "DIA	CIRC CONCR	LEN=0020	INSTALLED UNKN
163081 FT	1 0 00076 3 01 0026+72			
0700/0000	BROADWAY ST (BORO)			
0700/0000	LENGTH(AH 2848 BK 3022)			
0690/2825	ALLEY (BORO)			
0690/2805	018 "DIA	CIRC CONCR	LEN=0025	INSTALLED UNKN

DIR: N TOTAL LEN: 36.753 MI. DIST: 11-1 SR: 51
 LEFT MUN: CORAOPOLIS B RIGHT MUN: CORAOPOLIS B

Segment Description	Stationing	Material / Notes
LEN=0030 INSTALLED UNKN	0691/2432	CHESTNUT ST (BORO)
(SR3079 SEG 0070/0219)	0691/2360	CHESTNUT ST (BORO)
018 "DIA CIRC CONCR	0691/2051	018 "DIA CIRC CONCR
LEN=0030 INSTALLED UNKN	0691/2051	LEN=0020 INSTALLED UNKN
018 "DIA CIRC CONCR	0691/1955	018 "DIA CIRC CONCR
LEN=0110 INSTALLED UNKN	0691/1955	LEN=0020 INSTALLED UNKN
018 "DIA CIRC CONCR	0691/1856	018 "DIA CIRC CONCR
LEN=0099 INSTALLED UNKN	0691/1856	LEN=0020 INSTALLED UNKN
018 "DIA CIRC CONCR	0691/1845	018 "DIA CIRC CONCR
LEN=0099 INSTALLED UNKN	0691/1845	LEN=0020 INSTALLED UNKN
ARCH ST (BORO)	0691/1425	ARCH ST (BORO)
018 "DIA CIRC CONCR	0691/1400	012"H 18"W ELLIP CONC
LEN=0030 INSTALLED UNKN	0691/1400	LEN=0060 INSTALLED UNKN
MCCABE RUN	0691/1375	MCCABE RUN
STRUCTURE LENGTH 10 FT	0691/1375	STRUCTURE LENGTH 14 FT
BMSID 02/0051/0691/1375	0691/1375	BMSID 02/0051/0690/1606
018 "DIA CIRC CONCR	0691/1357	018 "DIA CIRC CONCR
LEN=0035 INSTALLED UNKN	0691/1357	LEN=0020 INSTALLED UNKN
018 "DIA CIRC CONCR	0691/1300	018 "DIA CIRC CONCR
LEN=0015 INSTALLED UNKN	0691/1300	LEN=0020 INSTALLED UNKN
018 "DIA CIRC CONCR	0690/1315	018 "DIA CIRC CONCR
LEN=0035 INSTALLED UNKN	0690/1315	LEN=0025 INSTALLED UNKN
MONTOUR ST (BORO)	0691/1105	MONTOUR ST (BORO)
(SR3081 SEG 0060/0218)	0691/1105	MONTOUR ST (BORO)
018 "DIA CIRC CONCR	0691/1005	018 "DIA CIRC CONCR
LEN=0218 INSTALLED UNKN	0691/1005	LEN=0025 INSTALLED UNKN
018 "DIA CIRC CONCR	0690/1085	018 "DIA CIRC CONCR
LEN=0025 INSTALLED UNKN	0690/1085	LEN=0050 INSTALLED UNKN
018 "DIA CIRC CONCR	0690/1080	018 "DIA CIRC CONCR
LEN=0050 INSTALLED UNKN	0690/1080	LEN=0099 INSTALLED UNKN
018 "DIA CIRC CONCR	0690/0890	018 "DIA CIRC CONCR
LEN=0099 INSTALLED UNKN	0690/0890	LEN=0099 INSTALLED UNKN

DIR: N TOTAL LEN: 36.753 MI. DIST: 11-1 SR: 51
 LEFT MUN: CORAOPOLIS B RIGHT MUN: CORAOPOLIS B

Item Description	Item ID	Item Length	Item Material	Item Status	Item Stationing	Item Notes
LEN=0099 INSTALLED UNKN	0691/0798					
FERREE ST (BORO)	0691/0545					FERREE ST (BORO) CORAOPOLIS BG (CNTY)
036 "DIA CIRC CONCR	0691/0442					
LEN=0015 INSTALLED UNKN	0691/0392					
024 "DIA CIRC CONCR	0691/0380					
LEN=0015 INSTALLED UNKN	0690/0470					BARN ST (BORO)
BARN ST (BORO)	0690/0217					012 "DIA CIRC CONCR
CROSSOVER RD (CONN)	0690/0100					LEN=0099 INSTALLED UNKN
LEG TO STATE AV (BORO)	0691/0160					CROSSOVER RD (CONN)
LEG TO GEORGE ST (BORO)	0691/0050					
018"H 18"W CON BOX CUL	0691/0050					
LEN=0099 INSTALLED UNKN	160059 FT	1 0 00076	3 00	0000+00		
1 0 00076 0 03 0517+11	159499 FT					
STATE AV (BORO)	0691/0000					NC FIFTH AV
NC FIFTH AV	0691/0000					NC FOURTH AV
LENGTH(AH 2835 BK 0394)	0691/0000					LENGTH(AH 3022 BK 0395)
VINE ST (BORO)	0671/0150					VINE ST (BORO)
012 "DIA CIR PLASTIC	0671/0050					012"H 24"W CON BOX CUL
LEN=0050 INSTALLED UNKN	0671/0000					LEN=0035 INSTALLED UNKN
1 0 00076 0 03 0513+44	159105 FT					
MFC BEGIN = B	0671/0000					159664 FT
LENGTH(AH 0394 BK 2830)	0671/0000					1 0 00076 0 03 0513+44
RIDGE AV (BORO)	0660/2135					MFC BEGIN = B
0660/2080	0660/2080					LENGTH(AH 0395 BK 2830)
0660/1819	0660/1819					012 "DIA CIRC CONCR
0660/1693	0660/1693					LEN=0035 INSTALLED UNKN
						018 "DIA CIRC CONCR
						LEN=0050 INSTALLED UNKN
						012 "DIA CIRC CONCR
						LEN=0050 INSTALLED UNKN
						018 "DIA CIRC CONCR
						LEN=0035 INSTALLED UNKN

DIR: N TOTAL LEN: 36.753 MI. DIST: 11-1 SR: 51
 LEFT MUN: CORAOPOLIS B RIGHT MUN: CORAOPOLIS B

Location / Segment	Segment ID	Length (FT)	Notes
ORCHARD ST (BORO)	0660/0780		0660/0840 012" DIA CIRC CONCR LEN=0030 INSTALLED UNKN
ROBERT ST (BORO)	0660/0520		0660/0836 012" DIA CIRC CONCR LEN=0030 INSTALLED UNKN
		156275 FT	0660/0139 012" DIA CIRC CONCR LEN=0050 INSTALLED UNKN
CORNELL ST (BORO)	0660/0000		156834 FT 1 0 00076 0 03 0485+09 NC STATE AV CORAOPOLIS MOON T
CARINA LN (TWP)	0650/0610		0650/0950 LENGTH(AH 2830 BK 1082) MONTOUR RD (TWP)
		155193 FT	0650/0395 BMSBN 02/0051/0650/0000 MOON ROBINSON T
PETRIE RD (SR3083 SEG 0040/3265)	0640/0700		0650/0197 155752 FT 1 0 00076 0 03 0474+50 TWP 142 LOCAL BMSBG 02/0051/0650/0000
		154073 FT	0640/0890 LENGTH(AH 1082 BK 1120) LEWIS AV (TWP) PITTSBURGH AV (TWP)
FROM 3085/0040 SH (CONN)	0631/2261		0640/0100 VILLAGE DR (TWP) 154632 FT 1 0 00076 0 02 0461+73 MFC BEGIN = B
FOREST GROVE RD (SR3085 SEG 0040/2229)	0631/2115		0640/0000 LENGTH(AH 1120 BK 2345)
TO 3085/0040 SH (CONN)	0631/2025		0630/2115 FOREST GROVE RD (SR3085 SEG 0040/2229)
(APRA) LANG MANUFACTURING STATION ST (TWP)	0631/1915		(APRA) LANG MANUFACTURING STATION ST (TWP)
RAMP F RD (SR8013 SEG 0250/0000)	0631/1855		TO 8013/0250 SH (CONN)

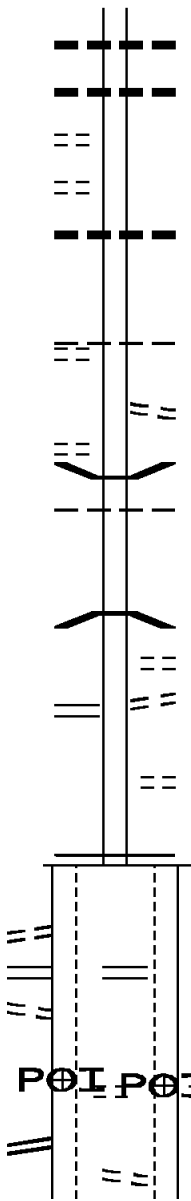

DIR: N TOTAL LEN: 36.753 MI. DIST: 11-1 SR: 51
 LEFT MUN: ROBINSON T RIGHT MUN: ROBINSON T

SR	OP ID	DESCRIPTION	LEN	START	END	SR	OP ID	DESCRIPTION	LEN	START	END
0079 SB	02/0079/0645/1191	018 "DIA CIRC CONCR	0099	0631/1576	0631/1553	0079 SB	02/0079/0645/1191	018 "DIA CIRC CONCR	0099	0630/1615	0630/1586
0079 NB	02/0079/0644/1023	MOON RUN		0631/1271		0079 NB	02/0079/0644/1023	MOON RUN		0630/1302	
		STRUCTURE LENGTH 30 FT						STRUCTURE LENGTH 30 FT			
		BMSID 02/0051/0630/1482		0631/1250				BMSID 02/0051/0630/1482		0630/1280	
		RAMP B RD						RAMP B RD			
		(SR8013 SEG 0020/0000)						(SR8013 SEG 0020/0000)			
		RAMP A RD						RAMP A RD			
		(SR8013 SEG 0010/0990)		0631/0930				(SR8013 SEG 0010/0990)		0630/0970	
		FROM 8013/0010 SH						FROM 8013/0010 SH			
		(CONN)		0631/0842				(CONN)			
		(APRA) TRANSPORT SYSTEM		0631/0254				(APRA) TRANSPORT SYSTEM		0630/0668	
		1 0 00076 0 02 0437+52	151733 FT					1 0 00076 0 02 0437+52	152287 FT	0630/0505	
		MFC BEGIN = B						MFC BEGIN = B		0630/0272	
		LENGTH(AH 2340 BK 2361)		0631/0000				LENGTH(AH 2345 BK 2361)		0630/0155	
										0630/0000	
										0620/1710	
										0620/1310	
										0620/0356	
										0620/0024	
			149372 FT							149926 FT	
										0620/0000	
										0610/2318	
										0610/2186	
										0610/0877	
										0610/0630	
										ROBINSON	
										KENNEDY T	
										012 "DIA CIRC CONCR	
										LEN=0099	INSTALLED UNKN

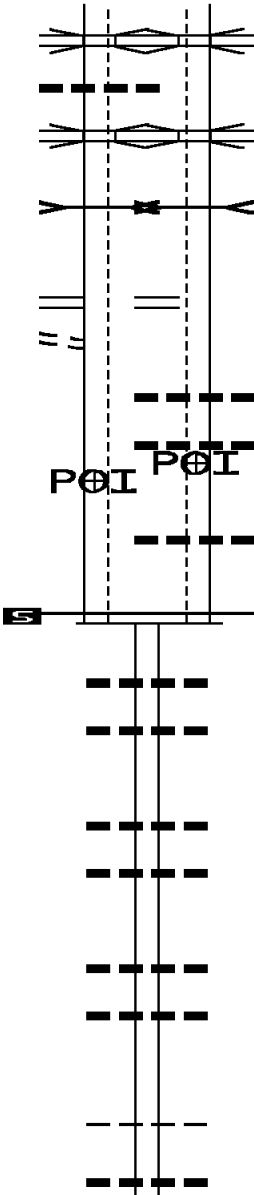

DIR: N TOTAL LEN: 36.753 MI. DIST: 11-1 SR: 51
 LEFT MUN: KENNEDY T RIGHT MUN: KENNEDY T

Stationing	Length (FT)	Segment	Material	Status
0610/0491	012	" DIA	CIRC CONCR	INSTALLED UNKN
0610/0360	012	" DIA	CIRC CONCR	INSTALLED UNKN
147270 FT	1 0 00076	0 02 0386+93		
0610/0000	2656	BK 3586)		
0600/3000	012	" DIA	CIRC CONCR	INSTALLED UNKN
0600/2544	018	" DIA	CIRC CONCR	INSTALLED UNKN
0600/2458	018	" DIA	CIRC CONCR	INSTALLED UNKN
0600/2205	018	" DIA	CIRC CONCR	INSTALLED UNKN
0600/0858		STANFORD CT (TWP)		
0600/0800	012	" DIA	CIRC CONCR	INSTALLED UNKN
0600/0495	012	" DIA	CIRC CONCR	INSTALLED UNKN
0600/0113	012	" DIA	CIRC CONCR	INSTALLED UNKN
0600/0005	012	" DIA	CIRC CONCR	INSTALLED UNKN
143684 FT	1 0 00076	0 02 0354+00		
0600/0000		CORAOPOLIS RD (CNTY)		
0590/1311	018	" DIA	CIRC CONCR	INSTALLED UNKN
0590/0783		STANFORD CT (TWP)		
0590/0037	018	" DIA	CIRC CONCR	INSTALLED UNKN
142271 FT	1 0 00076	0 02 0339+58		
0590/0000		SIPE RD (TWP)		
0590/0000		BRIGHTWOOD DR (TWP)		
139327 FT				
139881 FT	1 0 00076	0 02 0314+29		

DIR: N TOTAL LEN: 36.753 MI. DIST: 11-1 SR: 51
 LEFT MUN: KENNEDY T RIGHT MUN: KENNEDY T

1 0 00076 0 02 0288+52 136652 FT
 EWING RD
 (SR3093 SEG 0030/2561) 0570/0000

133807 FT

WALTHER ST
 (TWP)

0550/0330

Station	Description	Length (ft)	Material	Notes
0580/0000	NC FLEMING PARK RD	2390	BK 2675)	LENGTH(AH 2390 BK 2675)
0570/2370	018" DIA CIRC CONCR	0050	INSTALLED	UNKN
0570/1556	KENNEDY STOWE T			
0570/1547	018" DIA CIRC CONCR	0050	INSTALLED	UNKN
0570/1385	018" DIA CIRC CONCR	0050	INSTALLED	UNKN
0570/1190	018" DIA CIRC CONCR	0099	INSTALLED	UNKN
0570/0338	012" DIA CIRC CONCR	0050	INSTALLED	UNKN
137206 FT				
0570/0000	NC ROBINSON BL	2845	BK 2279)	LENGTH(AH 2675 BK 2845)
0560/1587	018" DIA CIRC CONCR	0060	INSTALLED	UNKN
134361 FT				
0560/0000	NC ROBINSON BL	2845	BK 2279)	LENGTH(AH 2845 BK 2279)
0550/2085	018" DIA CIRC CONCR	0060	INSTALLED	UNKN
0550/1805	018" DIA CIRC CONCR	0060	INSTALLED	UNKN
0550/1370	018" DIA CIRC CONCR	0060	INSTALLED	UNKN
0550/1130	018" DIA CIRC CONCR	0060	INSTALLED	UNKN
0550/1035	018" DIA CIRC CONCR	0060	INSTALLED	UNKN
0550/0310	018" DIA CIRC CONCR	0040	INSTALLED	UNKN
0550/0118	(APRA) TRIAD METALS			
0550/0093	LC FROM FLEMING BR (CONN)			
	BMS EN 02/0051/0550/0050			



DIR: N TOTAL LEN: 36.753 MI. DIST: 11-1 SR: 51
 LEFT MUN: STOWE T RIGHT MUN: STOWE T

Stationing	Distance (FT)	Notes	Material
0550/0090		012" DIA CIRC CONCR LEN=0030 INSTALLED UNKN	CONCR
0550/0050	131528 FT	1 0 00076 0 02 0240+57 NO UNDERPASS INFORMATIO BMSBG 02/0051/0550/0050	CONCR
0550/0000		1 0 00076 0 02 0240+57 FLEMING BR CONN RD (CNTY) LENGTH(AH 2279 BK 1101) LC TO FLEMING BR	CONCR
0540/1010		(CONN)	CONCR
0540/1000		018" DIA CIRC CONCR LEN=0099 INSTALLED UNKN	CONCR
0540/0965		GLENN ST (TWP)	CONCR
0540/0777		012" DIA CIRC CONCR LEN=0678 INSTALLED UNKN	CONCR
0540/0680	130427 FT	FLEMING AV (TWP)	CONCR
0540/0000		1 0 00076 0 01 0225+75 PARKWAY ST (TWP) LENGTH(AH 1101 BK 1556)	CONCR
0530/1520		012" DIA CIRC CONCR LEN=0035 INSTALLED UNKN	CONCR
0530/1130		095"H 94"W **UNKNOWN** LEN=0035 INSTALLED UNKN	CONCR
0530/0825		018" DIA CIRC CONCR LEN=0050 INSTALLED UNKN	CONCR
0530/0510		018" DIA CIRC CONCR LEN=0035 INSTALLED UNKN	CONCR
0530/0335		FLEMING AV (TWP)	CONCR
0530/0177	128871 FT	018" DIA CIRC CONCR LEN=0035 INSTALLED UNKN	CONCR
0530/0000		1 0 00076 0 01 0212+49 ORR ST (TWP)	CONCR
0520/2725		LENGTH(AH 1556 BK 3237) 095"H 94"W **UNKNOWN** LEN=0035 INSTALLED UNKN	CONCR
0520/1820		095"H 94"W **UNKNOWN** LEN=0035 INSTALLED UNKN	CONCR
0520/1450			CONCR
0520/1180			CONCR

018" DIA CIRC CONCR

DIR: N TOTAL LEN: 36.753 MI.
 LEFT MUN: STOWE T

DIST: 11-1 SR: 51
 RIGHT MUN: STOWE T

1 0 00076 0 01 0179+16 125634 FT
 TUNNEL WAY
 (SR3092 SEG 0040/1923) 0520/0000

MCCOY RD
 (CNTY) 0510/2079

RAYMOND ST
 (TWP)
 TO 0051/0510 SH
 (CONN) 0510/1154
 SCHOOL ST
 (TWP) 0510/1143

FROM 0051/0510 SH
 (CONN) 0510/0906

CUTLER ST
 (BORO) 0510/0279
 1 0 00076 0 01 0150+77 122867 FT
 PATTERSON ST
 (BORO) 0510/0000

0520/0620	LEN=0035	INSTALLED UNKN
	MARGARET ST	
0520/0500	(TWP)	
126188 FT		
0520/0000	LENGTH(AH 3237 BK 2767)	
	THOMAS ST	
0510/2625	(TWP)	
0510/2018	STOWE	
	MCKEES ROCKS B	
	012"H 24"W CON BOX CUL	
0510/1984	LEN=0099	INSTALLED UNKN
	012" DIA CIR PLASTIC	
0510/1747	LEN=0040	INSTALLED UNKN
	018" DIA CIR CONCR	
0510/1667	LEN=0040	INSTALLED UNKN
	ADRIAN ST	
0510/1652	(TWP)	
0510/1013	MC KEES ROCKS BR	
	(SR3104 SEG 0011/0000)	
	(SR3104 SEG 0010/0000)	
0510/0853	TO 3104/0010 SH	
	(CONN)	
0510/0578	CHURCHILL ST	
	(BORO)	
0510/0317	095"H 94"W **UNKNOWN**	
	LEN=0090	INSTALLED UNKN
	MICHAEL ST	
	(BORO)	
0510/0279		
123421 FT		
0510/0000	LENGTH(AH 2767 BK 2414)	
	BRADLEY ST	
0500/2215	(BORO)	
	095"H 94"W **UNKNOWN**	
0500/1994	LEN=0099	INSTALLED UNKN
	095"H 94"W **UNKNOWN**	
0500/1943	LEN=0099	INSTALLED UNKN

DIR: N TOTAL LEN: 36.753 MI. DIST: 11-1 SR: 51
 LEFT MUN: MCKEES ROCKS B RIGHT MUN: MCKEES ROCKS B

Location / Description	Stationing	Notes
BOQUET ST (BORO)	0500/0681	0500/1686 JOHN ST (BORO) 095"H 95"W **UNKNOWN** 0500/1372 LEN=0099 INSTALLED UNKN
MARY ST (BORO)	0500/0411	0500/0610 012 "DIA CIRC CONCR LEN=0005 INSTALLED UNKN
CHARTIERS AV (BORO)	0500/0236	0500/0236 NC ISLAND AV
1 0 00076 0 01 0130+10 120453 FT		0500/0222 PITTSBURGH, CHARTIERS & OVERPASS IS RR X-ING 121007 FT
FURNACE ST (BORO)	0500/0000	0500/0000 LENGTH(AH 2414 BK 0726) LOCUST ST (BORO) 018 "DIA CIRC CONCR 0494/0540 LEN=0010 INSTALLED UNKN
MCDONALD WAY (BORO)	0494/0330	0494/0317 018 "DIA CIRC CONCR LEN=0010 INSTALLED UNKN
		0494/0239 018 "DIA CIRC CONCR LEN=0010 INSTALLED UNKN
		0494/0237 018 "DIA CIRC CONCR LEN=0010 INSTALLED UNKN
	119727 FT	0494/0230 BELL AV (BORO) 120281 FT 0 0 00000 0 00 0000+00 NC CHARTIERS AV CHARTIERS AV (BORO)
FURNACE ST (BORO)	0494/0000	0494/0000 MFC BEGIN = B LENGTH(AH 0726 BK 1588)
FROM FURNACE RD (CONN)	0491/1414	0490/1397 TO CHATIERS AV (CONN)
018 "DIA CIRC CONCR LEN=0099 INSTALLED UNKN	0491/1397	
BMSSEN 02/0051/0490/1100	0491/1350	0490/1329 BMSSEN 02/0051/0490/1100
MCKEES ROCKS		MCKEES ROCKS
PITTSBURGH C	0491/1250	0490/1159 PITTSBURGH C
1 0 00076 0 00 0112+23		1 0 00076 0 00 0112+23
CHARTIERS CK		CHARTIERS CK
BMSBG 02/0051/0490/1100	0491/1155	0490/1134 BMSBG 02/0051/0490/1100

DIR: N TOTAL LEN: 36.753 MI. DIST: 11-1 SR: 51
 LEFT MUN: PITTSBURGH C RIGHT MUN: PITTSBURGH C

STREET NAME (CITY)	START POINT	END POINT	DESCRIPTION	STREET NAME (CITY)	START POINT	END POINT	DESCRIPTION
NC LINDEN ST STAFFORD ST (CITY)	0491/1085	0490/1100		STAFFORD ST (CITY) NC LINDEN ST	0490/1100	0490/0576	018 "DIA CIRC CONCR LEN=0010 INSTALLED UNKN
					0490/0576	0490/0358	018 "DIA CIRC CONCR LEN=0010 INSTALLED UNKN
018 "DIA CIRC CONCR LEN=0010 INSTALLED UNKN	0491/0293				0490/0358	0490/0150	018 "DIA CIRC CONCR LEN=0010 INSTALLED UNKN
018 "DIA CIRC CONCR LEN=0010 INSTALLED UNKN	0491/0100				0490/0150	0490/0081	FROM WEST CARSON ST (CONN)
FROM 0051/0480 SH (CONN)	0491/0075				0490/0081	0490/0030	021 "DIA CIRC CONCR LEN=0036 INSTALLED 2016
					0490/0030	0490/0005	021 "DIA CIRC CONCR LEN=0036 INSTALLED 2016
1 0 00076 0 00 0104+24 118132 FT					0490/0005	0490/0000	118693 FT 1 0 00076 0 00 0104+24 WEST CARSON ST (CITY)
WEST CARSON ST (CITY)					0490/0000	0490/0000	WEST CARSON ST (CITY) NC STANHOPE ST
NC STANHOPE ST					0490/0000	0480/2980	MFC BEGIN = B LENGTH(AH 1595 BK 3075) TO 0051/0491 SH (CONN)
MFC BEGIN = B LENGTH(AH 1595 BK 3075) TO 0051/0491 SH (CONN)	0491/0000	0480/2980			0480/2980	0480/2889	021 "DIA CIRC CONCR LEN=0036 INSTALLED 2016
					0480/2889	0480/2829	021 "DIA CIRC CONCR LEN=0036 INSTALLED 2016
SAGAMORE ST (CITY)	0480/2785				0480/2829	0480/2764	021 "DIA CIRC CONCR LEN=0036 INSTALLED 2016
					0480/2764	0480/2404	021 "DIA CIRC CONCR LEN=0036 INSTALLED 2016
TABOR ST (CITY)	0480/2350				0480/2404	0480/2350	021 "DIA CIRC CONCR LEN=0036 INSTALLED 2016
FLORIEN ST (CITY)	0480/2085				0480/2350	0480/1781	021 "DIA CIRC CONCR LEN=0036 INSTALLED 2016
					0480/1781	0480/1461	021 "DIA CIRC CONCR LEN=0036 INSTALLED 2016
FRUSTUM ST (CITY)	0480/1725				0480/1461		
SAGINAW ST (CITY)	0480/1475						

DIR: N TOTAL LEN: 36.753 MI. DIST: 11-1 SR: 51
 LEFT MUN: PITTSBURGH C RIGHT MUN: PITTSBURGH C

STREET NAME (CITY)	START	END	TYPE	LEN	SR	STATUS
SANFORD ST (CITY)	0480/1220	0480/1220	018 " DIA	0035		CIRC CONCR INSTALLED UNKN
EARL ST (CITY)	0480/0960	0480/0955	018 " DIA	0040		CIRC CONCR INSTALLED UNKN
		0480/0941	021 " DIA	0036		CIRC CONCR INSTALLED 2016
		0480/0682	OTHER OVERPASS			IS RR X-ING TRANSPORTATION
		0480/0640	CSX RAIL OVERPASS			IS RR X-ING
		0480/0391	021 " DIA	0036		CIRC CONCR INSTALLED 2016
		0480/0370	018 " DIA	0099		CIRC CONCR INSTALLED UNKN
		0480/0191	021 " DIA	0036		CIRC CONCR INSTALLED 2016
1 0 00076 0 00 0073+73 TELFORD ST (CITY)	115057 FT	115618 FT				
	0480/0000	0470/2586	5 0480/0000	LENGTH (AH 3075 BK 2653)		
		0470/2469		018 " DIA		CIRC CONCR INSTALLED UNKN
		0470/2250		021 " DIA		CIRC CONCR INSTALLED 2016
EDGECLIFF ST (CITY)	0470/2224	0470/2080	021 " DIA	0036		CIRC CONCR INSTALLED 2016
		0470/1979	018 " DIA	0010		CIRC CONCR INSTALLED UNKN
		0470/1734	021 " DIA	0036		CIRC CONCR INSTALLED 2016
		0470/1509	021 " DIA	0036		CIRC CONCR INSTALLED 2016
		0470/1494	018 " DIA	0010		CIRC CONCR INSTALLED UNKN
		0470/1469	021 " DIA	0036		CIRC CONCR INSTALLED 2016
		0470/1414	021 " DIA	0036		CIRC CONCR INSTALLED 2016
		0470/1239	021 " DIA	0036		CIRC CONCR INSTALLED 2016
GLEN MAWR ST (CITY)	0470/0835	0470/0784	021 " DIA	0036		CIRC CONCR INSTALLED 2016
			021 " DIA			CIRC CONCR

DIR: N TOTAL LEN: 36.753 MI. DIST: 11-1 SR: 51
 LEFT MUN: PITTSBURGH C RIGHT MUN: PITTSBURGH C

CASTALIA ST
 (CITY)

0470/0485

1 0 00076 0 00 0047+13 112404 FT
 CORLISS ST
 (CITY)

0470/0000

LC TO BUS EXPRESS LN
 (CONN)

0460/1272

110082 FT

---	0470/0539	LEN=0036	INSTALLED	2016
---	0470/0525	LEN=0010	INSTALLED	UNKN
---	0470/0489	LEN=0036	INSTALLED	2016
==				
---	0470/0204	LEN=0036	INSTALLED	2016
---	112965 FT			
==				
---	0470/0000	LENGTH(AH 2653 BK 2322)		
---	0460/2300	LEN=0099	INSTALLED	UNKN
---	0460/2291	LEN=0036	INSTALLED	2016
---	0460/2180	LEN=0099	INSTALLED	UNKN
---	0460/1970	LEN=0099	INSTALLED	UNKN
---	0460/1946	LEN=0036	INSTALLED	2016
---	0460/1666	LEN=0036	INSTALLED	2016
---	0460/1661	LEN=0010	INSTALLED	UNKN
---	0460/1272	012 "DIA	CIRC	METAL
---	0460/0966	LEN=0036	INSTALLED	2016
---	0460/0675	LEN=0010	INSTALLED	UNKN
---	0460/0631	LEN=0036	INSTALLED	2016
---	0460/0336	LEN=0036	INSTALLED	2016
---	0460/0276	LEN=0010	INSTALLED	UNKN
---	0460/0041	LEN=0036	INSTALLED	2016
---	110643 FT			
---	0460/0000	LENGTH(AH 2322 BK 1830)		
---	0450/1613	LEN=0050	INSTALLED	UNKN
---	0450/1581	LEN=0036	INSTALLED	2016
---	0450/1316	LEN=0001	INSTALLED	2016
---	0450/1173	LEN=0050	INSTALLED	UNKN

DIR: N TOTAL LEN: 36.753 MI. DIST: 11-1 SR: 51
 LEFT MUN: PITTSBURGH C RIGHT MUN: PITTSBURGH C

WEST CARSON ST
 (SR3106 SEG 0011/0000)
 (SR3106 SEG 0010/0000)
 0450/0581
 108252 FT

WEST CARSON ST INTER-AHD
 (SR0837 SEG 0600/0455) 0441/1455
 FOR SR 0051N TO 0051S
 (CONN) 0441/1424
 CSX RAIL TRANSPORTATION
 OVERPASS IS RR X-ING 0441/1340
 CSX RAIL TRANSPORTATION

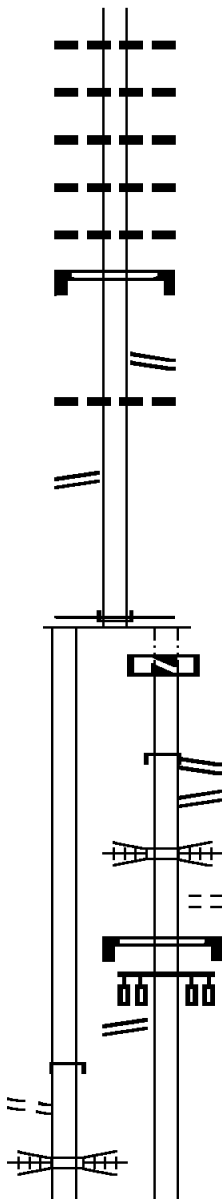

0450/1141 021 " DIA CIRC CONCR
 LEN=0036 INSTALLED 2016
 0450/0986 021 " DIA CIRC CONCR
 LEN=0036 INSTALLED 2016
 0450/0941 021 " DIA CIRC CONCR
 LEN=0036 INSTALLED 2016
 0450/0885 021 " DIA CIRC CONCR
 LEN=0024 INSTALLED 2016
 0450/0756 018 " DIA CIRC CONCR
 LEN=0050 INSTALLED UNKN
 SIGN: CANTILEVER
 0450/0712 BMSID 02/0051/0450/0661
 WEST CARSON ST
 (SR3106 SEG 0010/0000)
 (SR3106 SEG 0011/0000)
 0450/0665 018 " DIA CIRC CONCR
 0450/0618 LEN=0050 INSTALLED UNKN
 108813 FT 1 0 00076 0 00 0009+23
 NC WE WEST CARSON ST
 INTER-BK WEST CARSON ST
 (SR0837 SEG 0600/0604)
 MFC BEGIN = B
 0450/0000 LTH AH 001830 BK 000100
 108813 FT
 7442/0000 LTH AH 000100 BK 001903
 INTER-AHD WEST CARSON ST
 (SR0837 SEG 0600/0177)
 WEST CARSON ST
 (SR0837 SEG 0600/0177)
 0440/1903 WEST CARSON ST
 (SR0837 SEG 0597/0050)
 0440/1780 NORFOLK SOUTHERN
 OVERPASS IS RR X-ING
 GREENLEAF ST
 0440/1707 (CITY)
 SIGN: STRUC MOUNTED
 0440/1630 BMSID 02/0051/0440/1630
 SOUTH MAIN ST
 0440/1465 (SR0060 SEG 0005/0000)

EXTRACT DATE: 12/21/2020
PRINT DATE: 12/23/2020

ROADWAY MANAGEMENT SYSTEM
SLD COUNTY/SR - ANNUAL PRINT

PAGE NUMBER: 198
COUNTY: ALLEGHENY

DIR: N TOTAL LEN: 36.753 MI.
LEFT MUN: PITTSBURGH C

DIST: 11-1 SR: 51
RIGHT MUN: PITTSBURGH C

OVERPASS IS RR X-ING 0441/1307
SIGN: 3 CHORD TRUSS
BMSID 02/0051/0441/0753
STEUBEN ST (SR0060 SEG 0004/0000) 0441/1147
STEUBEN ST CONN RAMP (SR9406 SEG 0010/0239) 0441/1062
SAW MILL RUN STRUCTURE LENGTH 64 FT
BMSID 02/0051/0441/0526 0441/0942
BMSEN 02/0051/0441/0373 0441/0783
O O 00000 0 00 0000+00
SR 0060 SB
BMSBG 02/0051/0441/0373 0441/0600
O O 00000 0 00 0000+00 106797 FT
SAW MILL RUN BL (SR0019 SEG 0245/1302)
NC SR 0051 SH
SAW MILL RUN BL INTER-BK (SR0019 SEG 0245/1302)
LTH AH 001455 BK 000100 0441/0000
106797 FT
LTH AH 000100 BK 000816 7433/0000
BANKSVILLE RD INTER-AHD (SR0019 SEG 0231/0000) 0431/0816
RAMP D RD (SR8037 SEG 0010/0517) 0431/0345
1 0 00247 0 02 0648+61 105981 FT
LENGTH(AH 0816 BK 1924) 0431/0000
LIME ST (CITY) 0421/1880
LEWIS ST (CITY) 0421/1361
018 "DIA CIRC CONCR LEN=0056 INSTALLED UNKN 0421/1305
018 "DIA CIRC CONCR LEN=0056 INSTALLED UNKN 0421/1291
018 "DIA CIRC CONCR LEN=0056 INSTALLED UNKN 0421/1163

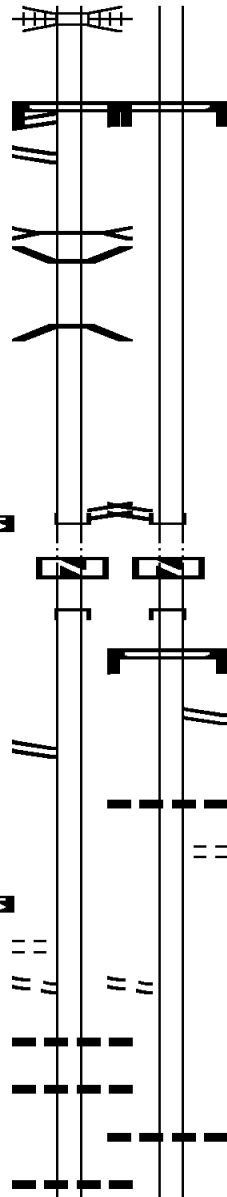

SIGN: CANTILEVER
BMSID 02/0051/0440/0600 0440/1122
106910 FT 0 0 00000 0 00 0000+00
SAW MILL RUN BL (SR0019 SEG 0244/0779)
NC SR 0051 SH
INTER-BK SAW MILL RUN BL (SR0019 SEG 0244/0779)
LTH AH 001903 BK 000100 0440/0000
106910 FT
7432/0000 LTH AH 000100 BK 001039
INTER-AHD BANKSVILLE RD (SR0019 SEG 0230/0000)
SIGN: CANTILEVER
BMSID 02/0051/0430/0940
RAMP B RD (SR8037 SEG 0750/0597) 0430/0940
0430/0669
0430/0230 012 "DIA CIRC CONCR
LEN=0040 INSTALLED UNKN
LIME ST (CITY)
1 0 00247 0 02 0647+04
LENGTH(AH 1039 BK 1695) 0430/0175
105871 FT 0430/0000
LEWIS ST (CITY) 0420/1315
0420/1206 018 "DIA CIRC CONCR
LEN=0050 INSTALLED UNKN

DIR: N TOTAL LEN: 36.753 MI. DIST: 11-1 SR: 51
 LEFT MUN: PITTSBURGH C RIGHT MUN: PITTSBURGH C

Segment Description	Stationing	Length	Material	Status
018 "DIA CIRC CONCR LEN=0056 INSTALLED UNKN	0421/0992			
018 "DIA CIRC CONCR LEN=0050 INSTALLED UNKN	0421/0857			
WOODRUFF JUGHANDLE RD (SR9402 SEG 0010/0000) WOODRUFF JUGHANDLE RD (SR9402 SEG 0010/0305)	0421/0468			
WOODRUFF ST (CITY) 1 0 00247 0 02 0629+75 104057 FT PARKING LOT	0421/0182			
OP ID 02/7301/0000/3933 LENGTH(AH 1924 BK 2542)	0421/0000			
018 "DIA CIRC CONCR LEN=0057 INSTALLED UNKN	0411/2176			
018 "DIA CIRC CONCR LEN=0050 INSTALLED UNKN	0410/1757			
018 "DIA CIRC CONCR LEN=0050 INSTALLED UNKN	0410/1336			
018 "DIA CIRC CONCR LEN=0050 INSTALLED UNKN	0410/0900			
018 "DIA CIRC CONCR LEN=0050 INSTALLED UNKN	0410/0568			
CONNELY RD (PRDR)	0411/0475			
018 "DIA CIRC CONCR LEN=0050 INSTALLED UNKN	0410/0375			
018 "DIA CIRC CONCR LEN=0050 INSTALLED UNKN	0410/0372			
012 "DIA CIRC CONCR LEN=0040 INSTALLED UNKN	0410/0200			
012 "DIA CIRC CONCR LEN=0040 INSTALLED UNKN	0410/0050			
1 0 00247 0 02 0602+41 101515 FT LENGTH(AH 2542 BK 2182)	0411/0000			
012 "DIA CIRC CONCR LEN=0040 INSTALLED UNKN	0400/2240			
018 "DIA CIRC CONCR LEN=0050 INSTALLED UNKN	0400/2015			
018 "DIA CIRC CONCR LEN=0050 INSTALLED UNKN	0420/0990			
018 "DIA CIRC CONCR LEN=0040 INSTALLED UNKN	0420/0863			
018 "DIA CIRC CONCR LEN=0050 INSTALLED UNKN	0420/0558			
WOODRUFF JUGHANDLE RD (SR9402 SEG 0010/0305)	0420/0170			
WOODRUFF ST (CITY) 1 0 00247 0 02 0629+75 104176 FT PARKING LOT	0420/0000			
OP ID 02/7301/0000/3933 LENGTH(AH 1695 BK 2366)	0410/2196			
018 "DIA CIRC CONCR LEN=0050 INSTALLED UNKN	0410/2196			

EXTRACT DATE: 12/21/2020
PRINT DATE: 12/23/2020

ROADWAY MANAGEMENT SYSTEM
SLD COUNTY/SR - ANNUAL PRINT

PAGE NUMBER: 195
COUNTY: ALLEGHENY

DIR: N TOTAL LEN: 36.753 MI.
LEFT MUN: PITTSBURGH C

DIST: 11-1 SR: 51
RIGHT MUN: PITTSBURGH C

(SR8151 SEG 0510/0555) 0397/0245
BMSEN 02/0051/0396/0000 0397/0188
0 0 00000 0 00 0000+00 098644 FT
RAMP C (8151 SB)
BMSBG 02/0051/0396/0000
LENGTH(AH 0689 BK 1370) 0397/0000

LIBERTY TN INT/RMP B RD
(SR8151 SEG 0250/0445) 0387/0852
SIGN: 4 CHORD TRUSS
BMSID 02/0051/0386/0830 0387/0832
SAW MILL RUN
STRUCTURE LENGTH 58 FT
BMSID 02/0051/0386/0860 0387/0792

0 0 00000 0 00 0000+00 097274 FT
BAUSMAN ST
(CITY)

LENGTH(AH 1370 BK 3669) 0387/0000
018 "DIA CIRC CONCR
LEN=0050 INSTALLED UNKN 0381/3566
TIMBERLAND AV
(CITY) 0381/3545

018 "DIA CIRC CONCR
LEN=0190 INSTALLED UNKN 0381/3405

018 "DIA CIRC CONCR
LEN=0190 INSTALLED UNKN 0381/3125
018 "DIA CIRC CONCR
LEN=0099 INSTALLED UNKN 0381/2530

018 "DIA CIRC CONCR
LEN=0190 INSTALLED UNKN 0381/2315
ENSIGN AV
(CITY) 0381/1760
012 "H 18" W ELLIP CONC
LEN=0190 INSTALLED UNKN 0381/1750

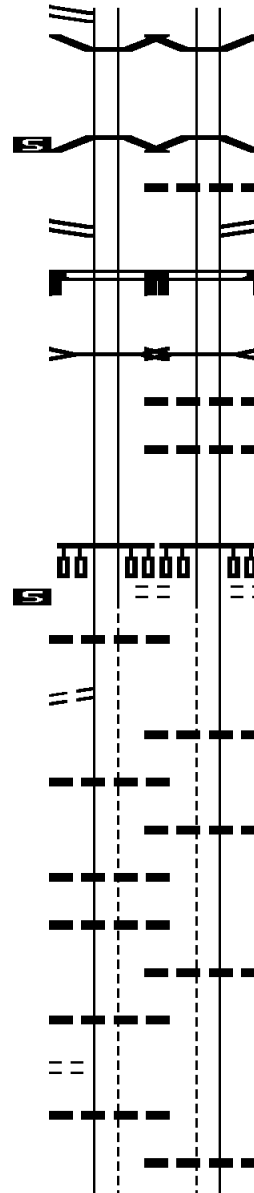

0396/0188
098788 FT

0396/0000

0386/1140

0386/0905

0386/0862

0386/0860

0386/0700

0386/0660

097383 FT

0386/0000

0380/3440

0380/3151

0380/2350

0380/1515

BMSEN 02/0051/0396/0000
0 0 00000 0 00 0000+00

0396/0000
LENGTH(AH 0725 BK 1405)

012 "DIA CIRC CONCR
LEN=0099 INSTALLED UNKN

LIBERTY TN INT/RMP A RD
(SR8151 SEG 0010/0000)

BMSID 02/0051/0386/0830
SAW MILL RUN

STRUCTURE LENGTH 58 FT
BMSID 02/0051/0386/0860

012 "DIA CIRC CONCR
LEN=0040 INSTALLED UNKN

012 "DIA CIRC CONCR
LEN=0290 INSTALLED UNKN

0 0 00000 0 00 0000+00

LENGTH(AH 1405 BK 3669)

012 "DIA CIRC CONCR
LEN=0156 INSTALLED UNKN

024 "DIA CIRC CONCR
LEN=0050 INSTALLED UNKN

012 "DIA CIR PLASTIC
LEN=0340 INSTALLED UNKN

018 "DIA CIRC CONCR
LEN=0050 INSTALLED UNKN
018 "DIA CIRC CONCR

EXTRACT DATE: 12/21/2020
PRINT DATE: 12/23/2020

ROADWAY MANAGEMENT SYSTEM
SLD COUNTY/SR - ANNUAL PRINT

PAGE NUMBER: 194
COUNTY: ALLEGHENY

DIR: N TOTAL LEN: 36.753 MI.
LEFT MUN: PITTSBURGH C

DIST: 11-1 SR: 51
RIGHT MUN: PITTSBURGH C

1 0 00247 0 01 0523+13 093605 FT
EDGEBROOK AV
(CITY)

LENGTH(AH 3669 BK 2263) 0381/0000

BMS EN 02/0051/0370/1907 0371/1987
1 0 00247 0 01 0519+72
SAW MILL RUN
BMSBG 02/0051/0370/1907 0371/1937

018 "DIA CIRC CONCR
LEN=0050 INSTALLED UNKN 0371/1550
GOFF ST
(CITY) 0371/1345

018 "DIA CIRC CONCR
LEN=0050 INSTALLED UNKN 0371/1240
LEVEL WAY
(CITY) 0371/1196

MOREDALE ST
(CITY) 0371/0865
018 "DIA CIRC CONCR
LEN=0050 INSTALLED UNKN 0371/0790

018 "DIA CIRC CONCR
LEN=0099 INSTALLED UNKN 0371/0541
1 0 00247 0 01 0502+35 091342 FT
WHITED ST
(CITY)

COLERAIN ST
(CITY)
LENGTH(AH 2263 BK 0722) 0371/0000

018 "DIA CIRC CONCR
LEN=0050 INSTALLED UNKN 0361/0650
OP ID 02/7301/0000/9203 0361/0576
BMS EN 02/0051/0360/0568 0361/0563

1 0 00247 0 01 0499+16
SAW MILL RUN
BMSBG 02/0051/0360/0568 0361/0503

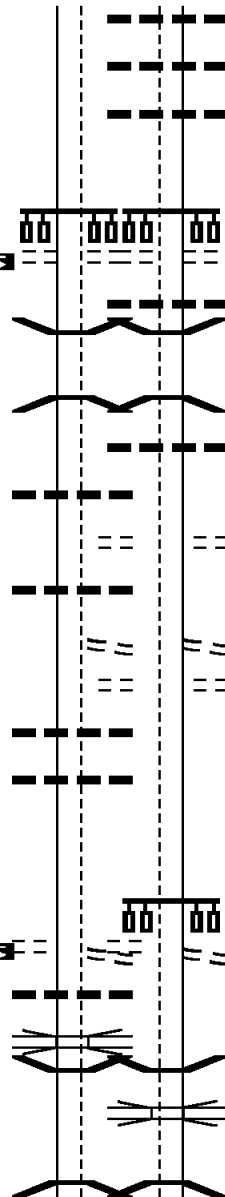

0380/1169 LEN=0050 INSTALLED UNKN
018 "DIA CIRC CONCR
0380/0933 LEN=0050 INSTALLED UNKN
018 "DIA CIRC CONCR
0380/0780 LEN=0050 INSTALLED UNKN

093714 FT 1 0 00247 0 01 0523+13
EDGEBROOK AV
(CITY)

0380/0000 LENGTH(AH 3669 BK 2267)
018 "DIA CIRC CONCR
LEN=0050 INSTALLED UNKN
0370/2240 BMS EN 02/0051/0370/1907
0370/1957 1 0 00247 0 01 0519+72
SAW MILL RUN

0370/1907 BMSBG 02/0051/0370/1907
012 "DIA CIRC CONCR
0370/1550 LEN=0099 INSTALLED UNKN

0370/1340 GOFF ST
(CITY)

0370/1140 LEVEL WAY
(CITY)
0370/0870 MOREDALE ST
(CITY)

091447 FT 1 0 00247 0 01 0502+39
WHITED ST
(CITY)

COLERAIN ST
(CITY)
LENGTH(AH 2267 BK 0739)

0370/0000
0361/0650

0360/0701 BMS EN 02/0051/0360/0568
0360/0656 OP ID 02/7301/0000/9203
1 0 00247 0 01 0499+16
SAW MILL RUN

0360/0641 BMSBG 02/0051/0360/0568

DIR: N TOTAL LEN: 36.753 MI. DIST: 11-1 SR: 51
 LEFT MUN: PITTSBURGH C RIGHT MUN: PITTSBURGH C

NOBLES LN (CITY)	0361/0324	==	==	0360/0345	NOBLES LN (CITY)
018 "DIA CIRC CONCR LEN=0050 INSTALLED UNKN	0361/0320	---	---		
018 "DIA CIRC CONCR LEN=0050 INSTALLED UNKN	0361/0110	---	---		
1 0 00247 0 01 0492+54 090620 FT ANSONIA PL (CITY)				090708 FT	1 0 00247 0 01 0492+44 ANSONIA PL (CITY)
LENGTH(AH 0722 BK 3003)	0361/0000	5=	==	5 0360/0000	LENGTH(AH 0739 BK 3049)
018 "DIA CIRC CONCR LEN=0050 INSTALLED UNKN	0351/3003	---	---	0350/3049	018 "DIA CIRC CONCR LEN=0050 INSTALLED UNKN
				0350/2700	012 "DIA CIRC CONCR LEN=0040 INSTALLED UNKN
MIDWOOD AV (CITY)					MIDWOOD AV (CITY)
	0351/2445	00	00000	0350/2520	
018 "DIA CIRC CONCR LEN=0050 INSTALLED UNKN	0351/2020	---	---		
018 "DIA CIRC CONCR LEN=0050 INSTALLED UNKN	0351/1850	---	---		
018 "DIA CIRC CONCR LEN=0050 INSTALLED UNKN	0351/1620	---	---		
ENGLERT ST (CITY)					ENGLERT ST (CITY)
	0351/0545	00	00000	0350/0630	
1 0 00247 0 01 0463+24 087617 FT LENGTH(AH 3003 BK 1692)	0351/0000	5=	==	5 087659 FT	1 0 00247 0 01 0462+52
LEN=0050 INSTALLED UNKN	0341/1692	---	---	0350/0000	LENGTH(AH 3049 BK 1641)
018 "DIA CIRC CONCR LEN=0050 INSTALLED UNKN	0341/1440	---	---		
OVERBROOK BL (CITY)					OVERBROOK BL (CITY)
	0341/1075	00	00000	0340/1055	
018 "DIA CIRC CONCR LEN=0098 INSTALLED UNKN	0341/1002	---	---		
MAYTIDE ST (CITY)					MAYTIDE ST (CITY)
	0341/0965	00	00000	0340/0930	
				0340/0775	018 "DIA CIRC CONCR LEN=0050 INSTALLED UNKN
SAINT NORBERT ST (CITY)				0340/0680	SAINT NORBERT ST (CITY)
	0341/0705	---	---		
018 "DIA CIRC CONCR LEN=0095 INSTALLED UNKN	0341/0655	---	---		018 "DIA CIRC CONCR

DIR: N TOTAL LEN: 36.753 MI. DIST: 11-1 SR: 51
 LEFT MUN: PITTSBURGH C RIGHT MUN: PITTSBURGH C

Street Name / Segment	Stationing	Structure / Notes	Stationing	Structure / Notes
UNDERWOOD ST (CITY)	0341/0510	== ==	0340/0600	LEN=0050 INSTALLED UNKN
			0340/0490	UNDERWOOD ST (CITY)
GLENBURY ST (CITY)			0340/0450	018 "DIA CIRC CONCR
TO 0088/0170 SH (CONN)	0341/0110	== ==		LEN=0050 INSTALLED UNKN
1 0 00247 0 00 0447+61	085925 FT		0340/0080	GLENBURY ST (CITY)
SR 9120 CONNECTOR RD (SR9120 SEG 0010/0966)			086018 FT	FROM 9120/0010 SH (CONN)
LIBRARY RD (SR0088 SEG 0170/2302)				1 0 00247 0 00 0447+61
LENGTH(AH 1692 BK 1710)	0341/0000	== ==		SR 9120 CONNECTOR RD (SR9120 SEG 0010/0966)
FROM 0088/0170 SH (CONN)			0340/0000	LIBRARY RD (SR0088 SEG 0170/2302)
HILLVIEW ST (CITY)	0331/1600	== ==		LENGTH(AH 1641 BK 1698)
			0330/1687	018 "DIA CIRC CONCR
				LEN=0050 INSTALLED UNKN
			0330/1489	018 "DIA CIRC CONCR
			0330/1364	LEN=0050 INSTALLED UNKN
				BMSSEN 02/0051/0330/1324
				1 0 00330 0 06 0798+69
			0330/1324	WEYMAN RUN
				BMSBG 02/0051/0330/1324
			0330/1291	018 "DIA CIRC CONCR
018 "DIA CIRC CONCR	0331/1245	== ==		LEN=0050 INSTALLED UNKN
LEN=0095 INSTALLED UNKN				
			0330/1157	018 "DIA CIRC CONCR
018 "DIA CIRC CONCR	0331/1025	== ==		LEN=0050 INSTALLED UNKN
LEN=0095 INSTALLED UNKN				
			0330/0817	SR 9120 CONNECTOR RD (SR9120 SEG 0010/0000)
FAIRHAVEN RD (SR9115 SEG 0010/0000)	0331/0678			
BMSSEN 02/0051/0330/0395	0331/0367		0330/0415	BMSSEN 02/0051/0330/0395
1 0 00330 0 06 0785+92				1 0 00330 0 06 0785+92
WEYMAN RUN			0330/0373	WEYMAN RUN
BMSBG 02/0051/0330/0395	0331/0325			BMSBG 02/0051/0330/0395
STEWART AV (SR3035 SEG 0030/1136)				STEWART AV (SR3035 SEG 0030/1136)
	0331/0117		0330/0165	
1 0 00330 0 06 0785+92	084215 FT		084320 FT	1 0 00330 0 06 0785+92
WEYMAN RUN				WEYMAN RUN
STRUCTURE LENGTH 16 FT				STRUCTURE LENGTH 16 FT

EXTRACT DATE: 12/21/2020
PRINT DATE: 12/23/2020

ROADWAY MANAGEMENT SYSTEM
SLD COUNTY/SR - ANNUAL PRINT

PAGE NUMBER: 191
COUNTY: ALLEGHENY

DIR: N TOTAL LEN: 36.753 MI.
LEFT MUN: PITTSBURGH C

DIST: 11-1 SR: 51
RIGHT MUN: PITTSBURGH C

BMSID	02/0051/0330/0000	0331/0000		0330/0000	BMSID	02/0051/0330/0000
LENGTH(AH 1710 BK 2141)					LENGTH(AH 1698 BK 2115)	
PITTSBURGH					018 "DIA CIRC CONCR	LEN=0050 INSTALLED UNKN
WHITEHALL B	0321/1750			0320/2040	PITTSBURGH	WHITEHALL B
018 "DIA CIRC CONCR						
LEN=0095 INSTALLED UNKN	0321/1720					
STEWART AV						STEWART AV
(BORO)	0321/1315			0320/1352	(BORO)	
018 "DIA CIRC CONCR						
LEN=0095 INSTALLED UNKN	0321/1230					018 "DIA CIRC CONCR
018 "DIA CIRC CONCR						LEN=0050 INSTALLED UNKN
LEN=0095 INSTALLED UNKN	0321/0925					
						018 "DIA CIRC CONCR
018 "DIA CIRC CONCR				0320/0689	LEN=0050 INSTALLED UNKN	
LEN=0095 INSTALLED UNKN	0321/0610					018 "DIA CIRC CONCR
						LEN=0050 INSTALLED UNKN
081 "DIA CIRC CONCR						
LEN=0095 INSTALLED UNKN	0321/0270			0320/0375		
WHITEHALL						WHITEHALL
BRENTWOOD B	0321/0040			0320/0040		BRENTWOOD B
018 "DIA CIRC CONCR						
LEN=0099 INSTALLED UNKN	0321/0030					
1 0 00330 0 06 0764+21 082074 FT						082205 FT 1 0 00330 0 06 0764+56
NC SAW MILL RUN BL						NC SAW MILL RUN BL
LENGTH(AH 2141 BK 2618)	0321/0000			0320/0000		LENGTH(AH 2115 BK 2654)
018 "DIA CIRC CONCR						
LEN=0095 INSTALLED UNKN	0311/2571					
018 "DIA CIRC CONCR						
LEN=0095 INSTALLED UNKN	0311/2231					
018 "DIA CIRC CONCR						
LEN=0095 INSTALLED UNKN	0311/1943					
GREENLEE RD						
(BORO)						
	0311/1915			0310/1955		GREENLEE RD
						(BORO)
GREENLEE RD						GREENLEE RD
(BORO)	0311/1825			0310/1855		(BORO)
018 "DIA CIRC CONCR						
LEN=0040 INSTALLED UNKN	0311/1377					
1 0 00330 0 06 0738+46 079456 FT				079551 FT		1 0 00330 0 06 0738+46
MARYLEA RD						MARYLEA AV
(BORO)						(BORO)
DELCO RD						DELCO RD

EXTRACT DATE: 12/21/2020
PRINT DATE: 12/23/2020

ROADWAY MANAGEMENT SYSTEM
SLD COUNTY/SR - ANNUAL PRINT

PAGE NUMBER: 190
COUNTY: ALLEGHENY

DIR: N TOTAL LEN: 36.753 MI.
LEFT MUN: BRENTWOOD B

DIST: 11-1 SR: 51
RIGHT MUN: BRENTWOOD B

(BORO)

LENGTH(AH 2618 BK 3628) 0311/0000
018 "DIA CIRC CONCR
LEN=0185 INSTALLED UNKN 0301/3535

018 "DIA CIRC CONCR
LEN=0185 INSTALLED UNKN 0301/3340

018 "DIA CIRC CONCR
LEN=0185 INSTALLED UNKN 0301/3077
018 "DIA CIRC CONCR
LEN=0050 INSTALLED UNKN 0301/2825
TOWN SQUARE WY

(BORO)

018 "DIA CIRC CONCR
LEN=0050 INSTALLED UNKN 0301/2744
018 "DIA CIRC CONCR
LEN=0099 INSTALLED UNKN 0301/2575
018 "DIA CIRC CONCR
LEN=0099 INSTALLED UNKN 0301/2340
OLD CLAIRTON RD
(BORO)
0301/2125

BROWNSVILLE RD
(BORO)
BROWNSVILLE RD
(BORO)

0301/0990

018 "DIA CIRC CONCR
LEN=0050 INSTALLED UNKN 0301/0410
BRENTWOOD
WHITEHALL B
018 "DIA CIRC CONCR
LEN=0050 INSTALLED UNKN 0301/0371
1 0 00330 0 06 0702+21 075828 FT
STILLEY RD
(SR3046 SEG 0010/0000)
LENGTH(AH 3628 BK 3701) 0301/0000

024 "DIA CIRC CONCR

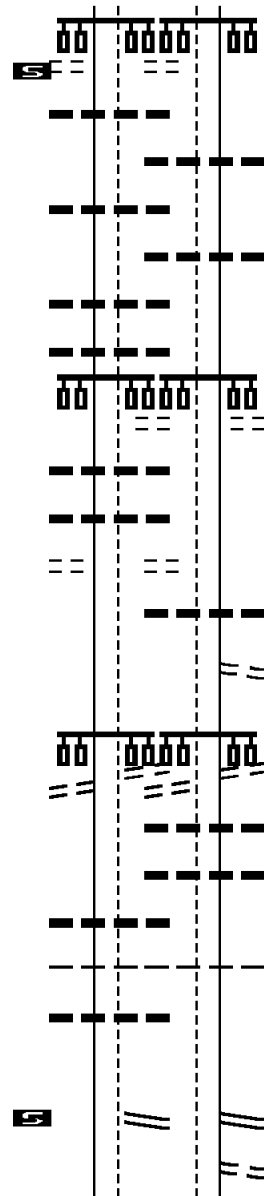

(BORO)

0310/0000 LENGTH(AH 2654 BK 3616)

0300/3406 018 "DIA CIRC CONCR
LEN=0075 INSTALLED UNKN

0300/3147 018 "DIA CIRC CONCR
LEN=0070 INSTALLED UNKN

TOWN SQUARE WY
(BORO)

0300/2714

0300/2110 OLD CLAIRTON RD
(BORO)
0300/1662 018 "DIA CIRC CONCR
LEN=0065 INSTALLED UNKN
LC TO BROWNSVILLE RD
(CONN)

0300/1109

BROWNSVILLE RD
(BORO)
BROWNSVILLE RD
(BORO)

0300/1023

0300/0542 018 "DIA CIRC CONCR
LEN=0050 INSTALLED UNKN
0300/0430 018 "DIA CIRC CONCR
LEN=0070 INSTALLED UNKN

BRENTWOOD
WHITEHALL B

0300/0262

075935 FT 1 0 00330 0 06 0702+11

0300/0000 (SR3046 SEG 0010/0000)
LENGTH(AH 3616 BK 3672)
0290/3490 OLD CLAIRTON RD
(BORO)

DIR: N TOTAL LEN: 36.753 MI. DIST: 11-1 SR: 51
 LEFT MUN: WHITEHALL B RIGHT MUN: WHITEHALL B

Segment ID	Description	Start Station	End Station	Length (ft)	Material	Notes
0291/3455	018 "DIA CIRC CONCR	0291/3455	0291/3229	226	018 "DIA CIRC CONCR	
0291/3229	018 "DIA CIRC CONCR	0291/3229	0291/3005	224	018 "DIA CIRC CONCR	
0291/3005	018 "DIA CIRC CONCR	0291/3005	0291/2636	369	018 "DIA CIRC CONCR	
0291/2636	018 "DIA CIRC CONCR	0291/2636	0291/2118	518	018 "DIA CIRC CONCR	
0291/2118	018 "DIA CIRC CONCR	0291/2118	0291/2070	48	018 "DIA CIRC CONCR	
0291/2070	018 "DIA CIRC CONCR	0291/2070	0291/1890	180	018 "DIA CIRC CONCR	
0291/1890	GLEN ELM DR (BORO)	0291/1890	0291/1855	35	GLEN ELM DR (BORO)	
0291/1855	018 "DIA CIRC CONCR	0291/1855	0291/1842	13	018 "DIA CIRC CONCR	
0291/1842	018 "DIA CIRC CONCR	0291/1842	0291/1411	431	018 "DIA CIRC CONCR	
0291/1411	018 "DIA CIRC CONCR	0291/1411	0291/1394	17	018 "DIA CIRC CONCR	
0291/1394	BEALL DR (BORO)	0291/1394	0291/1398	4	BEALL DR (BORO)	
0291/1398	018 "DIA CIRC CONCR	0291/1398	0291/1121	277	018 "DIA CIRC CONCR	
0291/1121	018 "DIA CIRC CONCR	0291/1121	0291/0678	443	018 "DIA CIRC CONCR	
0291/0678	018 "DIA CIRC CONCR	0291/0678	0291/0380	298	018 "DIA CIRC CONCR	
0291/0380	018 "DIA CIRC CONCR	0291/0380	0291/0320	60	018 "DIA CIRC CONCR	
0291/0320	BOROUGH PARK DR (BORO)	0291/0320	0291/0065	255	BOROUGH PARK DR (BORO)	
0291/0065	1 0 00330 0 06 0667+53 072127 FT	0291/0065	0290/0065	0	1 0 00330 0 06 0665+25	
0290/0065	NURNBERGER DR (BORO)	0290/0065	0290/0000	65	NURNBERGER DR (BORO)	
0290/0000	LENGTH(AH 3701 BK 2695)	0290/0000	0280/2411	5701	LENGTH(AH 3672 BK 2653)	
0280/2411	CLAIRTON AV (BORO)	0280/2411	0280/2130	281	CLAIRTON AV (BORO)	
0280/2130	BR STREETS R	0280/2130	0280/1838	292	BR STREETS R	
0280/1838	STRUCTURE LENGTH 12 FT	0280/1838			STRUCTURE LENGTH 12 FT	
	BMSID 02/0051/0280/2130				BMSID 02/0051/0280/2130	
	MAXWELL DR (BORO)				MAXWELL DR (BORO)	
	018 "DIA CIRC CONCR				018 "DIA CIRC CONCR	
	LEN=0050 INSTALLED UNKN				LEN=0050 INSTALLED UNKN	

DIR: N TOTAL LEN: 36.753 MI. DIST: 11-1 SR: 51
 LEFT MUN: WHITEHALL B RIGHT MUN: WHITEHALL B

Item Description	Stationing	Notes
018 "DIA CIRC CONCR LEN=0050 INSTALLED UNKN	0281/1360	
018 "DIA CIRC CONCR LEN=0050 INSTALLED UNKN	0281/1085	
018 "DIA CIRC CONCR LEN=0040 INSTALLED UNKN	0281/0330	
STREETS RUN RD (SR2046 SEG 0030/0000)		WHITEHALL BALDWIN B
STREETS RUN RD (SR2046 SEG 0030/0000)	0281/0295	STREETS RUN RD (SR2046 SEG 0030/0000)
1 0 00330 0 06 0638+26 069432 FT LEECH DR (BORO) WHITEHALL BALDWIN B LENGTH(AH 2695 BK 3067)	0281/0000	STREETS RUN RD (SR2046 SEG 0030/0000)
BRENTVIEW RD (BORO)	0271/2493	069610 FT 1 0 00330 0 06 0638+30 0280/0000 LENGTH(AH 2653 BK 3117) READSHAW WY (BORO) BRENTVIEW RD (BORO)
GRACE ST (BORO)	0271/2320	0270/3064
018 "DIA CIRC CONCR LEN=0050 INSTALLED UNKN	0271/1950	0270/2495
IRWIN DR (BORO)	0271/1875	0270/2340
018 "DIA CIRC CONCR LEN=0050 INSTALLED UNKN	0271/1730	IRWIN DR (BORO)
FIDELITY DR (BORO)	0271/1510	015 "DIA CIRC CONCR LEN=0050 INSTALLED UNKN
018 "DIA CIRC CONCR LEN=0050 INSTALLED UNKN	0271/1440	FIDELITY DR (BORO) DRAINAGE STRUCTURE LENGTH 29 FT BMSID 02/0051/0270/1451
CSX RAIL TRANSPORTATION OVERPASS IS RR X-ING	0271/1190	0270/1451
RAMP CC RD (SR8084 SEG 0500/0000)	0271/0830	0270/1188 CSX RAIL TRANSPORTATION OVERPASS IS RR X-ING

DIR: N TOTAL LEN: 36.753 MI. DIST: 11-1 SR: 51
 LEFT MUN: BALDWIN B RIGHT MUN: BALDWIN B

RAMP C RD
 (SR8084 SEG 0510/0361) 0271/0780
 018 "DIA CIRC CONCR
 LEN=0050 INSTALLED UNKN 0271/0695

BALDWIN
 PLEASANT HILLS B 0271/0640
 BMSEN 02/0051/0270/0445 0271/0512
 1 0 00330 0 06 0612+17
 SR 2040 LEBANON CHURCH
 BMSBG 02/0051/0270/0445 0271/0440

018 "DIA CIRC CONCR
 LEN=0050 INSTALLED UNKN 0271/0265
 RAMP DD RD
 (SR8084 SEG 0260/0000) 0271/0205
 RAMP D RD
 (SR8084 SEG 0250/0397) 0271/0140

018 "DIA CIRC CONCR
 LEN=0050 INSTALLED UNKN 0271/0005
 1 0 00330 0 05 0562+45 066365 FT
 OLD CLAIRTON RD
 (CNTY)
 OLD LEBANON CHURCH RD
 (CNTY)

LENGTH(AH 3067 BK 2747) 0271/0000
 018 "DIA CIRC CONCR
 LEN=0050 INSTALLED UNKN 0261/2700

PLEASANT HILLS BL
 (BORO) 0261/1790
 018 "DIA CIRC CONCR
 LEN=0050 INSTALLED UNKN 0261/1440
 GLENBURN DR
 (BORO) 0261/1415

018 "DIA CIRC CONCR
 LEN=0050 INSTALLED UNKN 0261/1380
 018 "DIA CIRC CONCR
 LEN=0050 INSTALLED UNKN 0261/0800

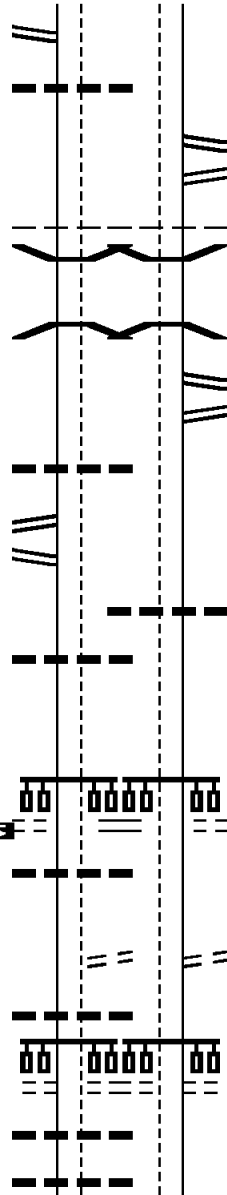

0270/0690 RAMP B RD
 (SR8084 SEG 0750/0382)
 0270/0650 RAMP BB RD
 (SR8084 SEG 0760/0000)
 BALDWIN
 PLEASANT HILLS B
 BMSEN 02/0051/0270/0445
 1 0 00330 0 06 0612+17
 SR 2040 LEBANON CHURCH
 BMSBG 02/0051/0270/0445
 RAMP A RD
 (SR8084 SEG 0020/0329)
 RAMP AA RD
 (SR8084 SEG 0010/0000)

0270/0090 018 "DIA CIRC CONCR
 LEN=0060 INSTALLED UNKN
 066493 FT 1 0 00330 0 05 0562+45
 OLD CLAIRTON RD
 (CNTY)
 OLD LEBANON CHURCH RD
 (CNTY)

0270/0000 LENGTH(AH 3117 BK 2618)

0260/1655 PLEASANT HILLS BL
 (BORO)

0260/1261 GLENBURN DR
 (BORO)

DIR: N TOTAL LEN: 36.753 MI. DIST: 11-1 SR: 51
 LEFT MUN: PLEASANT HILLS B RIGHT MUN: PLEASANT HILLS B

LINE NO	DESCRIPTION	STATUS	START STATION	END STATION	LENGTH (FT)	START STATION	END STATION	LENGTH (FT)
018	"DIA CIRC CONCR	UNKN	0261/0510	0261/0390	110	0260/0000	0260/0000	0
018	"DIA CIRC CONCR	UNKN	0261/0390	0261/0210	180	0260/0000	0260/0000	0
018	"DIA CIRC CONCR	UNKN	0261/0210	0261/0000	210	0260/0000	0260/0000	0
1 0 00330 0 05 0536+04 063618 FT LENGTH(AH 2747 BK 2696) 0261/0000 5 063875 FT 1 0 00330 0 05 0536+14 PLEASANT HILLS BL 0251/2589 5 0260/0000 LENGTH(AH 2618 BK 2857)								
018	"DIA CIRC CONCR	UNKN	0251/2230	0251/2080	150	0250/1560	0250/1560	0
018	"DIA CIRC CONCR	UNKN	0251/2080	0251/1900	180	0250/1560	0250/1560	0
018	"DIA CIRC CONCR	UNKN	0251/1900	0251/1520	380	0250/1560	0250/1560	0
CENTURY III MALL ENT RD (PRDR) 00 0000 00								
018	"DIA CIRC CONCR	UNKN	0251/1410	0251/1269	141	0250/1560	0250/1560	0
018	"DIA CIRC CONCR	UNKN	0251/1269	0251/1230	39	0250/1560	0250/1560	0
018	"DIA CIRC CONCR	UNKN	0251/1230	0251/1130	100	0250/1560	0250/1560	0
018	"DIA CIRC CONCR	UNKN	0251/0950	0251/0950	0	0250/1005	0250/1005	0
018 "DIA CIRC CONCR LEN=0050 INSTALLED UNKN								
018	"DIA CIRC CONCR	UNKN	0251/0795	0251/0795	0	0250/0939	0250/0939	0
018 "DIA CIRC CONCR LEN=0050 INSTALLED UNKN								
018	"DIA CIRC CONCR	UNKN	0251/0770	0251/0770	0	0250/0805	0250/0805	0
CENTURY III MALL DR (PRDR) 00 0000 00								
018	"DIA CIRC CONCR	UNKN	0251/0630	0251/0450	180	0250/0805	0250/0805	0
018	"DIA CIRC CONCR	UNKN	0251/0450	0251/0010	440	0250/0805	0250/0805	0
018	"DIA CIRC CONCR	UNKN	0251/0010	0251/0010	0	061018 FT	061018 FT	0
1 0 00330 0 05 0508+73 060922 FT (APRA) CENTURY III MALL FRED FIORE DR (BORO) CENTURY III MALL DR (PRDR)								
061018 FT 1 0 00330 0 05 0508+64 (APRA) CENTURY III MALL FRED FIORE DR (BORO) CENTURY III MALL DR (PRDR)								

POI POI

DIR: N TOTAL LEN: 36.753 MI. DIST: 11-1 SR: 51
 LEFT MUN: PLEASANT HILLS B RIGHT MUN: PLEASANT HILLS B

Item Description	Stationing	Material	Length	Notes
018 "DIA CIRC CONCR	0251/0000	0250/0000	0250	LENGTH(AH 2696 BK 2291)
LEN=0230 INSTALLED UNKN	0241/1900			
018 "DIA CIRC CONCR	0241/1385	0240/1385	0050	LENGTH(AH 2857 BK 2206)
LEN=0060 INSTALLED UNKN	0241/1154			
SOUTHLAND MALL ENTR (PRDR)	0241/1095			
018 "DIA CIRC CONCR	0241/1095	0240/1056	0050	LENGTH(AH 2857 BK 2206)
LEN=0050 INSTALLED UNKN	0241/0925			
SOUTHLAND MALL ENTR (PRDR)	0241/0775			
018 "DIA CIRC CONCR	0241/0775	0240/0657	0050	LENGTH(AH 2857 BK 2206)
LEN=0050 INSTALLED UNKN	0241/0625			
018 "DIA CIRC CONCR	0241/0277	0240/0317	0040	LENGTH(AH 2857 BK 2206)
LEN=0040 INSTALLED UNKN	0241/0000			
1 0 00330 0 05 0485+40 058631 FT	0241/0000	058812 FT	0240/0000	LENGTH(AH 2206 BK 1930)
018 "DIA CIRC CONCR	0231/1845	0230/1900	0010	LENGTH(AH 2206 BK 1930)
LEN=0050 INSTALLED UNKN	0231/1678			
BRUCETON RD (BORO)	0231/1675			
018 "DIA CIRC CONCR	0231/1675	0230/1678	0010	LENGTH(AH 2206 BK 1930)
LEN=0050 INSTALLED UNKN	0231/1612			
018 "DIA CIRC CONCR	0231/1612	0230/1615	0010	LENGTH(AH 2206 BK 1930)
LEN=0175 INSTALLED UNKN	0231/1070			
1 0 00330 0 05 0466+57 056748 FT	0231/0000	056882 FT	0230/0000	LENGTH(AH 1930 BK 2171)
018 "DIA CIRC CONCR	0221/2215	0220/1693	0010	LENGTH(AH 1930 BK 2171)
LEN=0015 INSTALLED UNKN	0221/2195			
018 "DIA CIRC CONCR	0221/2195			
LEN=0015 INSTALLED UNKN	0221/1625			

DIR: N TOTAL LEN: 36.753 MI. DIST: 11-1 SR: 51
 LEFT MUN: PLEASANT HILLS B RIGHT MUN: PLEASANT HILLS B

Segment Description	Stationing	Material / Notes
BMSEN 02/0051/0220/1065 1 0 00330 0 05 0455+46 LEWIS RUN	0221/1122	0220/1124 0220/1093
BMSBG 02/0051/0220/1065	0221/1094	0220/1065
LINDSEY SNYDER RD (BORO)		0220/1050
LEWIS RUN RD (SR2032 SEG 0010/0000)	0221/1049	0220/1047
FROM LINDSEY SNYDER RD (BORO)	0221/0956	0220/0975
BMSEN 02/0051/0220/0325 1 0 00330 0 05 0448+31 LEWIS RUN	0221/0432	0220/0864
BMSBG 02/0051/0220/0325	0221/0406	0220/0745
018 "DIA CIRC CONCR LEN=0050 INSTALLED UNKN	0221/0137	0220/0613
1 0 00330 0 05 0444+33 054533 FT LENGTH(AH 2215 BK 2804)	0221/0000	0220/0484
018 "DIA CIRC CONCR LEN=0045 INSTALLED UNKN	0211/2705	0220/0351
018 "DIA CIRC CONCR LEN=0045 INSTALLED UNKN	0211/2540	0220/0325
PLEASANT HILLS JEFFERSON HILLS B	0211/2491	0210/2575
036 "DIA CIRC CONCR LEN=0045 INSTALLED UNKN	0211/2380	0210/2534
018 "DIA CIRC CONCR LEN=0140 INSTALLED UNKN	0211/2105	
018 "DIA CIRC CONCR LEN=0135 INSTALLED UNKN	0211/1835	0210/2004
018 "DIA CIRC CONCR LEN=0010 INSTALLED UNKN		018 "DIA CIRC CONCR LEN=0010 INSTALLED UNKN

EXTRACT DATE: 12/21/2020
PRINT DATE: 12/23/2020

ROADWAY MANAGEMENT SYSTEM
SLD COUNTY/SR - ANNUAL PRINT

PAGE NUMBER: 183
COUNTY: ALLEGHENY

DIR: N TOTAL LEN: 36.753 MI.
LEFT MUN: JEFFERSON HILLS B

DIST: 11-1 SR: 51
RIGHT MUN: JEFFERSON HILLS B

Item ID	Description	Material	Length	Stationing	Notes
LEN=0135	INSTALLED UNKN			0211/1712	
018 "DIA	CIRC CONCR				
LEN=0050	INSTALLED UNKN			0211/1590	
018 "DIA	CIRC CONCR				
LEN=0050	INSTALLED UNKN			0210/1518	018 "DIA CIRC CONCR LEN=0010 INSTALLED UNKN
018 "DIA	CIRC CONCR				
LEN=0050	INSTALLED UNKN			0211/1468	
018 "DIA	CIRC CONCR				
LEN=0045	INSTALLED UNKN			0211/1340	
018 "DIA	CIRC CONCR				
LEN=0045	INSTALLED UNKN			0211/1220	
018 "DIA	CIRC CONCR				
LEN=0045	INSTALLED UNKN			0211/0885	
COAL VALLEY RD (CNTY)					COAL VALLEY RD (CNTY)
COAL VALLEY RD (CNTY)					COAL VALLEY RD (CNTY)
BMSEN 02/0051/0210/0628				0211/0825	0210/0866
1 0 00330 0 05 0421+74				0211/0579	0210/0657
LEWIS RUN					BMSEN 02/0051/0210/0628
BMSBG 02/0051/0210/0628				0211/0550	1 0 00330 0 05 0421+74
LEWIS RUN RD					LEWIS RUN
(BORO)				0211/0225	BMSBG 02/0051/0210/0628
018 "DIA	CIRC CONCR				LEWIS RUN RD (BORO)
LEN=0045	INSTALLED UNKN			0211/0222	
BMSEN 02/0051/0210/0000				0211/0030	0210/0030
1 0 00330 0 05 0415+88				051729 FT	051780 FT
LEWIS RUN					BMSEN 02/0051/0210/0000
BMSBG 02/0051/0210/0000					1 0 00330 0 05 0415+88
LENGTH(AH 2804 BK 1728)				0211/0000	LEWIS RUN
018 "DIA	CIRC CONCR				BMSBG 02/0051/0210/0000
LEN=0050	INSTALLED UNKN			0201/1658	LENGTH(AH 2931 BK 1704)
ELLIOT DR					
(BORO)				0201/1640	ELLIOT DR (BORO)
018 "DIA	CIRC CONCR				
LEN=0050	INSTALLED UNKN			0201/1550	
ELLIOT DR					
(BORO)				0201/1455	ELLIOT DR (BORO)
LEWIS RUN					LEWIS RUN
STRUCTURE LENGTH 23 FT					STRUCTURE LENGTH 23 FT
BMSID 02/0051/0200/1015				0201/0990	BMSID 02/0051/0200/1015
018 "DIA	CIRC CONCR				0200/1041
LEN=0045	INSTALLED UNKN				0200/0735
018 "DIA	CIRC CONCR				
LEN=0045	INSTALLED UNKN				0200/0557
030 "DIA	CIRC CONCR				
LEN=0045	INSTALLED UNKN				0200/0375
018 "DIA	CIRC CONCR				
LEN=0050	INSTALLED UNKN			0201/0360	

EXTRACT DATE: 12/21/2020
PRINT DATE: 12/23/2020

ROADWAY MANAGEMENT SYSTEM
SLD COUNTY/SR - ANNUAL PRINT

PAGE NUMBER: 182
COUNTY: ALLEGHENY

DIR: N TOTAL LEN: 36.753 MI.
LEFT MUN: JEFFERSON HILLS B

DIST: 11-1 SR: 51
RIGHT MUN: JEFFERSON HILLS B

Stationing	Structure	Length	Material	Notes
0200/0196	018 "DIA CIRC CONCR	LEN=0045	INSTALLED UNKN	
0200/0080	018 "DIA CIRC CONCR	LEN=0045	INSTALLED UNKN	
0201/0010	018 "DIA CIRC CONCR	LEN=0099	INSTALLED UNKN	
0201/0000	0500076 FT	050001 FT		
0200/0000	018 "DIA CIRC CONCR	LEN=0005	INSTALLED UNKN	
0190/1070	018 "DIA CIRC CONCR	LEN=0005	INSTALLED UNKN	
0190/0633	018 "DIA CIRC CONCR	LEN=0050	INSTALLED UNKN	
0190/0530	018 "DIA CIRC CONCR	LEN=0050	INSTALLED UNKN	
0191/0490	LEWIS RUN	048732 FT		
0191/0000	036 "DIA CIRC CONCR	LEN=0059	INSTALLED UNKN	
0181/2725	018 "DIA CIRC CONCR	LEN=0066	INSTALLED UNKN	
0181/2520	018 "DIA CIRC CONCR	LEN=0059	INSTALLED UNKN	
0181/2335	LEWIS RUN	0181/2231		
0181/2231	018 "DIA CIRC CONCR	LEN=0059	INSTALLED UNKN	
0181/0140	018 "DIA CIRC CONCR	LEN=0059	INSTALLED UNKN	
0181/0018	018 "DIA CIRC CONCR	LEN=0059	INSTALLED UNKN	
0171/1650	018 "DIA CIRC CONCR	LEN=0059	INSTALLED UNKN	
0180/0930	018 "DIA CIRC CONCR	LEN=0050	INSTALLED UNKN	
0180/0571	018 "DIA CIRC CONCR	LEN=0050	INSTALLED UNKN	
0180/0240	012 "DIA CIRC CONCR	LEN=0040	INSTALLED UNKN	
0180/0055	012 "DIA CIRC CONCR	LEN=0040	INSTALLED UNKN	
0180/0000	045856 FT	0180/0000		

WRAY-LARGE RD

EXTRACT DATE: 12/21/2020
PRINT DATE: 12/23/2020

ROADWAY MANAGEMENT SYSTEM
SLD COUNTY/SR - ANNUAL PRINT

PAGE NUMBER: 181
COUNTY: ALLEGHENY

DIR: N TOTAL LEN: 36.753 MI.
LEFT MUN: JEFFERSON HILLS B

DIST: 11-1 SR: 51
RIGHT MUN: JEFFERSON HILLS B

(BORO)		0171/1589	==	==	0170/1638 (BORO)	
BMSSEN 02/0051/0170/1422		0171/1424			0170/1445 BMSSEN 02/0051/0170/1422	
SIGN: CANTILEVER						
BMSID 02/0051/0171/1440		0171/1409				
1 0 00330 0 05 0351+56						0 0 00000 0 00 0000+00
LEWIS RUN						LEWIS RUN
BMSBG 02/0051/0170/1422		0171/1397			0170/1418 BMSBG 02/0051/0170/1422	
LEWIS RUN						LEWIS RUN
STRUCTURE LENGTH 28 FT						STRUCTURE LENGTH 28 FT
BMSID 02/0051/0170/0784		0171/0927			0170/0920 BMSID 02/0051/0170/0784	
TURNPIKE RAMP RD TOLL 4						TURNPIKE RAMP RD TOLL 4
(TNPK)		0171/0560				(TNPK)
TURNPIKE RAMP RD TOLL 4						TURNPIKE RAMP RD TOLL 4
(TNPK)						(TNPK)
JEFFERSON BL						JEFFERSON BL
(TNPK)						(TNPK)
		0171/0029			0170/0030	
1 0 00330 0 05 0337+05		043891 FT			043941 FT	1 0 00330 0 05 0337+05
TURNPIKE RAMP RD TOLL 4						TURNPIKE RAMP RD TOLL 4
(TNPK)						(TNPK)
JEFFERSON BL						JEFFERSON BL
(TNPK)						(TNPK)
LENGTH(AH 1659 BK 2837)		0171/0000			0170/0000	LENGTH(AH 1915 BK 2852)
PA TPK (TOLL 43)					NC CLAIRTON BL	PA TPK (TOLL 43)
OP ID 02/7043/9900/5332		0161/2805			0160/2806	OP ID 02/7043/9900/5332
					0160/2789	TURNPIKE RAMP RD TOLL 4
						(CONN)
NC CLAIRTON BL						
RETAINING WALL						
BMSID 02/0051/0161/2413		0161/2413			0160/2413	036 "DIA CIRC CONCR
						LEN=0050 INSTALLED UNKN
018 "DIA CIRC CONCR						
LEN=0050 INSTALLED UNKN		0161/2300			0160/2168	018 "DIA CIRC CONCR
						LEN=0050 INSTALLED UNKN
018 "DIA CIRC CONCR						
LEN=0099 INSTALLED UNKN		0161/1990			0160/1922	018 "DIA CIRC CONCR
						LEN=0050 INSTALLED UNKN
OLD CLAIRTON RD						OLD CLAIRTON RD
(CNTY)						(CNTY)
		0161/1873			0160/1895	
LEWIS RUN						
STRUCTURE LENGTH 33 FT						
BMSID 02/0051/0161/1640		0161/1592				
018 "DIA CIRC CONCR						
LEN=0099 INSTALLED UNKN		0161/1520				

DIR: N TOTAL LEN: 36.753 MI. DIST: 11-1 SR: 51
 LEFT MUN: JEFFERSON HILLS B RIGHT MUN: JEFFERSON HILLS B

Item ID	Description	Stationing	Notes
018 "DIA CIRC CONCR	LEN=0099 INSTALLED UNKN	0161/1330	
018 "DIA CIRC CONCR	LEN=0050 INSTALLED UNKN	0161/1160	
018 "DIA CIRC CONCR	LEN=0099 INSTALLED UNKN	0161/0920	
RETAINING WALL	BMSID 02/0051/0161/0838	0161/0838	(APRA) DICK CORP DICK CORP DR (BORO) PETERS CREEK RD (BORO)
BMSEN 02/0051/0160/0705	0161/0823	0161/0757	
018 "DIA CIRC CONCR	LEN=0050 INSTALLED UNKN	0161/0733	
1 0 00330 0 05 0315+95	PETERS CREEK		
BMSBG 02/0051/0160/0705	0161/0668		
OP ID 02/7043/9900/5291	0161/0423		
(AAR 472956M)#TRKS 02	0161/0324		
018 "DIA CIRC CONCR	LEN=0103 INSTALLED UNKN	0161/0290	
BRICKYARD RD	0161/0254		
OP ID 02/7043/9900/5287	0161/0164		
1 0 00330 0 05 0311+55	041054 FT		
WORTHINGTON AV			
(CNTY)			
LENGTH(AH 2837 BK 2609)	0161/0000		
018 "DIA CIRC CONCR	LEN=0050 INSTALLED UNKN	0151/2609	
018 "DIA CIRC CONCR	LEN=0123 INSTALLED UNKN	0151/2377	
024 "DIA CIRC CONCR	LEN=0100 INSTALLED UNKN	0151/1504	
0160/1516	018 "DIA CIRC CONCR		
0160/1413	LEN=0050 INSTALLED UNKN		
0160/1102	018 "DIA CIRC CONCR		
0160/0853	LEN=0050 INSTALLED UNKN		
0160/0794	018 "DIA CIRC CONCR		
0160/0705	LEN=0050 INSTALLED UNKN		
0160/0485	018 "DIA CIRC CONCR		
0160/0354	LEN=0050 INSTALLED UNKN		
0160/0287	018 "DIA CIRC CONCR		
0160/0203	LEN=0050 INSTALLED UNKN		
0160/0168	018 "DIA CIRC CONCR		
041089 FT	LEN=0050 INSTALLED UNKN		
0160/0000	018 "DIA CIRC CONCR		
0150/2595	LEN=0050 INSTALLED UNKN		

DIR: N TOTAL LEN: 36.753 MI. DIST: 11-1 SR: 51
 LEFT MUN: JEFFERSON HILLS B RIGHT MUN: JEFFERSON HILLS B

Item ID	Description	Material	Length (ft)	Stationing	Notes
018	" DIA CIRC CONCR	LEN=0050	0150/1378	INSTALLED UNKN	
018	" DIA CIRC CONCR	LEN=0050	0150/1148	INSTALLED UNKN	
018	" DIA CIRC CONCR	LEN=0050	0150/0835	INSTALLED UNKN	
018	" DIA CIRC CONCR	LEN=0050	0150/0620	INSTALLED UNKN	
024	" DIA CIRC CONCR	LEN=0075	0151/0530	INSTALLED UNKN	
018	" DIA CIRC CONCR	LEN=0011	0151/0520	INSTALLED UNKN	
SCOTIA HOLLOW RD (BORO)					
LENGTH(AH 2609 BK 2000) 0151/0000					
LC FR SCOTIA HOLLOW RD (CONN) 0141/1848					
018	" DIA CIRC CONCR	LEN=0059	0141/1742	INSTALLED UNKN	
018	" DIA CIRC CONCR	LEN=0060	0141/1288	INSTALLED UNKN	
018	" DIA CIRC CONCR	LEN=0011	0141/1227	INSTALLED UNKN	
038394 FT 1 0 00330 0 05 0284+00					
0150/0000 LENGTH(AH 2695 BK 1884)					
018	" DIA CIRC CONCR	LEN=0050	0140/1115	INSTALLED UNKN	
018	" DIA CIRC CONCR	LEN=0011	0141/0985	INSTALLED UNKN	
018	" DIA CIRC CONCR	LEN=0244	0141/0983	INSTALLED UNKN	
(APRA) MACSON ENT					
MACSON DR (PRDR) 0141/0977					
018	" DIA CIRC CONCR	LEN=0030	0141/0734	INSTALLED UNKN	
0140/0825 018 " DIA CIRC CONCR					
LEN=0050 INSTALLED UNKN					
CENTURY DR (TWP)					
018	" DIA CIRC CONCR	LEN=0050	0140/0320	INSTALLED UNKN	
018	" DIA CIRC CONCR	LEN=0050	0140/0290	INSTALLED UNKN	
SIGN: CANTILEVER					
BMSID 02/0051/0141/0235 0141/0235					
1 0 00330 0 05 0263+32 036445 FT					
KNIGHT ROAD					
OP ID 02/2028/0050/0000					
LENGTH(AH 2000 BK 3582) 0141/0000					
036510 FT 1 0 00330 0 05 0263+32					
KNIGHT ROAD					
OP ID 02/2028/0050/0000					
LENGTH(AH 1884 BK 3655)					
018 " DIA CIRC CONCR					

DIR: N TOTAL LEN: 36.753 MI. DIST: 11-1 SR: 51
 LEFT MUN: JEFFERSON HILLS B RIGHT MUN: JEFFERSON HILLS B

018 "DIA CIRC CONCR LEN=0055 INSTALLED UNKN FR 51S TO SR 2028 RAMP (SR8077 SEG 0262/0000)	0131/3330	0130/3345	LEN=0050	INSTALLED UNKN
024 "DIA CIRC CONCR LEN=0030 INSTALLED UNKN TO 51S FR SR 2028 RAMP (SR8077 SEG 0252/0767)	0131/3030	0130/3040	012 "DIA CIRC CONCR LEN=0050	INSTALLED UNKN
018 "DIA CIRC CONCR LEN=0060 INSTALLED UNKN	0131/2710	0130/2825	SR 2028 TO SR 51N RAMP (SR8077 SEG 0020/1105)	
018 "DIA CIRC CONCR LEN=0055 INSTALLED UNKN	0131/2630	0130/2750	SR 51N TO SR 2028 RAMP (SR8077 SEG 0010/0000)	
018 "DIA CIRC CONCR LEN=0060 INSTALLED UNKN	0131/2300			
018 "DIA CIRC CONCR LEN=0099 INSTALLED UNKN	0131/1991			
018 "DIA CIRC CONCR LEN=0065 INSTALLED UNKN	0131/1670			
018 "DIA CIRC CONCR LEN=0099 INSTALLED UNKN	0131/1462			
018 "DIA CIRC CONCR LEN=0065 INSTALLED UNKN	0131/1312			
018 "DIA CIRC CONCR LEN=0055 INSTALLED UNKN	0131/1046			
018 "DIA CIRC CONCR LEN=0066 INSTALLED UNKN	0131/0835			
018 "DIA CIRC CONCR LEN=0099 INSTALLED UNKN	0131/0578			
018 "DIA CIRC CONCR LEN=0056 INSTALLED UNKN	0131/0382			
018 "DIA CIRC CONCR LEN=0099 INSTALLED UNKN	0131/0015			
1 0 00330 0 05 0229+64 032863 FT JEFFERSON HILLS WEST ELIZABETH B LENGTH(AH 3582 BK 1512)	0131/0000	032855 FT	1 0 00330 0 05 0229+64 HIGH RD (BORO)	
SIGN: 2 CHORD TRUSS BMSID 02/0051/0121/0445 0121/0445 BMS EN 02/0051/0121/0210 0121/0318		0130/0000	LENGTH(AH 3655 BK 1360)	
		0120/1050	018 "DIA CIRC CONCR LEN=0050	INSTALLED UNKN
		0120/0670	018 "DIA CIRC CONCR LEN=0070	INSTALLED UNKN

DIR: N TOTAL LEN: 36.753 MI. DIST: 11-1 SR: 51
 LEFT MUN: WEST ELIZABETH B RIGHT MUN: WEST ELIZABETH B

1 0 00330 0 04 0225+08
 SR 0837 NB SB
 BMSBG 02/0051/0121/0210 0121/0228

1 0 00330 0 04 0211+71 031351 FT
 CIRCLE SR 51N TO SR 51
 (SR8073 SEG 0502/0159)
 LENGTH(AH 1512 BK 0897) 0121/0000
 LEN=0065 INSTALLED UNKN 0115/0896

RAMP FR 837N TO SR 51 S
 (SR8073 SEG 0522/0084) 0115/0615

SIGN: 4 CHORD TRUSS
 BMSID 02/0051/0115/0510 0115/0510

RAMP FR 51S TO SR 837 S
 (SR8073 SEG 0510/0000) 0115/0325
 018 "DIA CIRC CONCR
 LEN=0050 INSTALLED UNKN 0115/0193

018 "DIA CIRC CONCR
 LEN=0050 INSTALLED UNKN 0115/0065
 1 0 00330 0 04 0203+96 030454 FT
 SIGN: 2 CHORD TRUSS
 BMSID 02/0051/0115/0000
 LENGTH(AH 0897 BK 2001) 0115/0000
 SR 51S TO 51N CIRCLE RD
 (SR8073 SEG 0532/0000) 0111/1926
 BMSEN 02/0051/0111/1559 0111/1917

BMSEN 02/0051/0110/0000 0111/1502
 1 0 00330 0 04 0184+69
 LOCAL ROAD
 BMSBG 02/0051/0111/1559 0111/1475

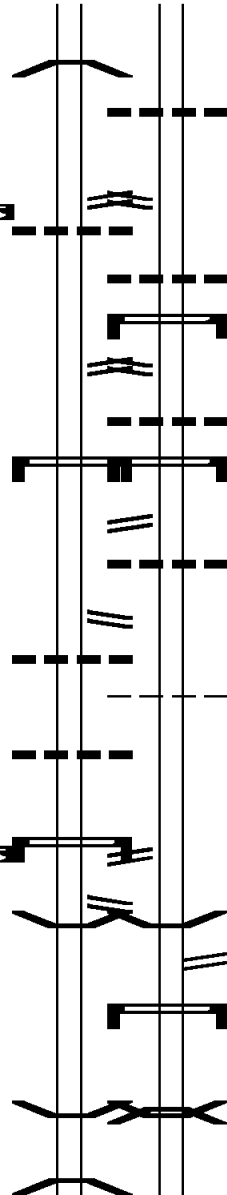

0120/0162 030 "DIA CIRC CONCR
 031495 FT LEN=0060 INSTALLED UNKN
 1 0 00330 0 04 0211+71
 SR 51N TO 51S CIRCLE RD
 (SR8073 SEG 0502/0000)
 LENGTH(AH 1360 BK 1001) 0120/0000

0114/0973 018 "DIA CIRC CONCR
 LEN=0050 INSTALLED UNKN
 SIGN: CANTILEVER
 BMSID 02/0051/0114/0923
 RAMP FR 51N TO 837S SH
 (SR8073 SEG 0512/0000) 0114/0923
 018 "DIA CIRC CONCR
 LEN=0050 INSTALLED UNKN
 SIGN: 4 CHORD TRUSS
 BMSID 02/0051/0114/0570
 SR 837 TO SR 51N RAMP R
 (SR8073 SEG 0542/0180) 0114/0755
 012 "DIA CIRC CONCR
 LEN=0060 INSTALLED UNKN 0114/0632

0114/0570
 0114/0460
 0114/0436

0114/0175 JEFFERSON HILLS
 WEST ELIZABETH B

030494 FT 1 0 00330 0 04 0203+96
 SR 51S TO 51N CIRCLE RD
 (SR8073 SEG 0532/0084)
 LENGTH(AH 1001 BK 2040) 0114/0000

0110/1990 BMSEN 02/0051/0110/1552
 SR 51N TO SR 8073 RAMP
 (SR8073 SEG 0750/0000)
 SIGN: 4 CHORD TRUSS
 BMSID 02/0051/0110/1680
 1 0 00330 0 04 0184+69
 BMSEN 02/0051/0110/0000
 SR 837
 BMSBG 02/0051/0110/1552 0110/1695

0110/1680
 0110/1502

DIR: N TOTAL LEN: 36.753 MI. DIST: 11-1 SR: 51
 LEFT MUN: WEST ELIZABETH B RIGHT MUN: WEST ELIZABETH B

WEST ELIZABETH ELIZABETH B	0111/0622	0110/0622	WEST ELIZABETH ELIZABETH B
1 0 00330 0 04 0184+69 028453 FT		028454 FT	1 0 00330 0 04 0184+69
SR 2001 (SECOND ST.)		NC SR 0051 SH	SR 2001 (SECOND ST.)
BMSBG 02/0051/0110/0000		BMSBG 02/0051/0110/0000	BMSBG 02/0051/0110/0000
LENGTH(AH 2001 BK 1756)	0111/0000	0110/0000	LENGTH(AH 2040 BK 1695)
018 "DIA CIRC CONCR		0100/1535	(SR8073 SEG 0020/0620)
LEN=0050 INSTALLED UNKN	0101/1500		
SIGN: CANTILEVER			
BMSID 02/0051/0101/1526	0101/1446		
RAMP FR SR 51 S TO 3RD		0100/1335	RAMP FR SR 51 N TO 3RD
(SR8073 SEG 0260/0000)	0101/1326		(SR8073 SEG 0010/0000)
018 "DIA CIRC CONCR			
LEN=0020 INSTALLED UNKN	0101/1212		
RAMP FR 3RD ST TO SR51			
(SR8073 SEG 0250/0251)	0101/1107		
018 "DIA CIRC CONCR		0100/1090	018 "DIA CIRC CONCR
LEN=0050 INSTALLED UNKN	0101/0905		LEN=0040 INSTALLED UNKN
018 "DIA CIRC CONCR			
LEN=0050 INSTALLED UNKN	0101/0670		
018 "DIA CIRC CONCR		0100/0534	018 "DIA CIRC CONCR
LEN=0050 INSTALLED UNKN	0101/0445		LEN=0040 INSTALLED UNKN
ELIZABETH			
FORWARD T	0101/0328		ELIZABETH
018 "DIA CIRC CONCR		0100/0328	FORWARD T
LEN=0050 INSTALLED UNKN	0101/0303		
018 "DIA CIRC CONCR			
LEN=0030 INSTALLED UNKN	0101/0167		
1 0 00330 0 03 0168+50 026697 FT		026759 FT	1 0 00330 0 03 0168+50
018 "DIA CIRC CONCR			PENNEMAN AV
LEN=0050 INSTALLED UNKN			(BORO)
LENGTH(AH 1756 BK 2046)	0101/0000	0100/0000	LENGTH(AH 1695 BK 2150)
018 "DIA CIRC CONCR			
LEN=0040 INSTALLED UNKN	0091/1800		
018 "DIA CIRC CONCR			
LEN=0100 INSTALLED UNKN	0091/1260		
BMSEN 02/0051/0090/0844	0091/0817	0090/0880	BMSEN 02/0051/0090/0844

DIR: N TOTAL LEN: 36.753 MI. DIST: 11-1 SR: 51
 LEFT MUN: FORWARD T RIGHT MUN: FORWARD T

Stationing	Description	Length	Material	Notes
0147+00	FALLEN TIMBER RUN	0091/0781	012 "DIA CIRC CONCR	LEN=0001 INSTALLED UNKN
0147+00	FALLEN TIMBER RUN	0091/0844	018 "DIA CIRC CONCR	LEN=0040 INSTALLED UNKN
0147+00	WEIGLES HILL RD (TBK)	0091/0000	018 "DIA CIRC CONCR	LEN=0040 INSTALLED UNKN
0146+00	FALLEN TIMBER RUN	0081/2721	018 "DIA CIRC CONCR	LEN=0040 INSTALLED UNKN
0146+00	FALLEN TIMBER RUN	0081/2692	018 "DIA CIRC CONCR	LEN=0040 INSTALLED UNKN
0146+00	FALLEN TIMBER RUN	0081/2668	018 "DIA CIRC CONCR	LEN=0040 INSTALLED UNKN
0146+00	FALLEN TIMBER RUN	0081/2067	018 "DIA CIRC CONCR	LEN=0040 INSTALLED UNKN
0146+00	FALLEN TIMBER RUN	0081/2024	018 "DIA CIRC CONCR	LEN=0040 INSTALLED UNKN
0146+00	FALLEN TIMBER RUN	0081/1921	018 "DIA CIRC CONCR	LEN=0040 INSTALLED UNKN
0146+00	FALLEN TIMBER RUN	0081/1330	018 "DIA CIRC CONCR	LEN=0040 INSTALLED UNKN
0146+00	FALLEN TIMBER RUN	0081/1102	018 "DIA CIRC CONCR	LEN=0040 INSTALLED UNKN
0122+50	PENN VISTA ST	0081/0000	018 "DIA CIRC CONCR	LEN=0040 INSTALLED UNKN

DIR: N TOTAL LEN: 36.753 MI. DIST: 11-1 SR: 51
 LEFT MUN: FORWARD T RIGHT MUN: FORWARD T

					0070/2926	LEN=0040	INSTALLED UNKN
						018 "DIA	CIRC CONCR
					0070/2458	LEN=0040	INSTALLED UNKN
018 "DIA	CIRC	CONCR					
LEN=0666	INSTALLED	UNKN	0071/2190				
018 "DIA	CIRC	CONCR					
LEN=0265	INSTALLED	UNKN	0071/1925				
018 "DIA	CIRC	CONCR					
LEN=0255	INSTALLED	UNKN	0071/1670				
012 "DIA	CIRC	CONCR					
LEN=0100	INSTALLED	UNKN	0071/1590				
018 "DIA	CIRC	CONCR					
LEN=0109	INSTALLED	UNKN	0071/1018				
					0070/1050		FIRDEN RD (TWP)
012 "DIA	CIRC	CONCR					
LEN=0001	INSTALLED	UNKN	0071/0746				
012 "DIA	CIRC	CONCR					
LEN=0001	INSTALLED	UNKN	0071/0566				
LC TO ROBERTS HOLLOW RD							
(CONN)			0071/0495				
012 "DIA	CIRC	CONCR					
LEN=0001	INSTALLED	UNKN	0071/0456				
					0070/0503	018 "DIA	CIRC CONCR
FALLENTIMBER						LEN=0040	INSTALLED UNKN
STRUCTURE LENGTH 21 FT						FALLENTIMBER	
BMSID 02/0051/0070/0168			0071/0178		0070/0231	STRUCTURE LENGTH 21 FT	
1 0 00330 0 01 0092+50			018870 FT		018835 FT	BMSID 02/0051/0070/0168	
ROBERTS HOLLOW RD						1 0 00330 0 01 0092+50	
(CNTY)						ROBERTS HOLLOW RD	
						(CNTY)	
LENGTH(AH 3014 BK 3305)			0071/0000		0070/0000	LENGTH(AH 2980 BK 3249)	
						018 "DIA	CIRC CONCR
					0060/3043	LEN=0146	INSTALLED UNKN
						FORWARD	
					0060/2923	ELIZABETH T	
						ELIZABETH	
					0060/2723	FORWARD T	
018 "DIA	CIRC	CONCR					
LEN=0040	INSTALLED	UNKN	0061/3018				
FORWARD							
ELIZABETH T			0061/2923		0060/2523	FORWARD	
018 "DIA	CIRC	CONCR				ELIZABETH T	
LEN=0099	INSTALLED	UNKN	0061/2811				
					0060/1999	018 "DIA	CIRC CONCR
ELIZABETH						LEN=0021	INSTALLED UNKN
FORWARD T			0061/2723		0060/1623	ELIZABETH	
						FORWARD T	

DIR: N TOTAL LEN: 36.753 MI. DIST: 11-1 SR: 51
 LEFT MUN: ELIZABETH T RIGHT MUN: ELIZABETH T

018 "DIA CIRC CONCR LEN=0099 INSTALLED UNKN 0061/2000	---				
018 "DIA CIRC CONCR LEN=0040 INSTALLED UNKN 0061/1745	---				
BR. FALLENTIM STRUCTURE LENGTH 9 FT BMSID 02/0051/0060/0985 0061/1078	>-----<		0060/1026	BR. FALLENTIM STRUCTURE LENGTH 9 FT BMSID 02/0051/0060/0985	
018 "DIA CIRC CONCR LEN=0080 INSTALLED UNKN 0061/1045	---				
018 "DIA CIRC CONCR LEN=0040 INSTALLED UNKN 0061/0725	---		0060/0737	018 "DIA CIRC CONCR LEN=0040 INSTALLED UNKN	
018 "DIA CIRC CONCR LEN=0040 INSTALLED UNKN 0061/0462	---				
018 "DIA CIRC CONCR LEN=0030 INSTALLED UNKN 0061/0370	---		0060/0393	018 "DIA CIRC CONCR LEN=0040 INSTALLED UNKN	
1 0 00330 0 01 0048+85 015565 FT MENTOR RD (SR2011 SEG 0070/1850) FORWARD ELIZABETH T LENGTH(AH 3305 BK 1572) 0061/0000	-----		015586 FT	1 0 00330 0 01 0048+85 FORWARD ELIZABETH T LENGTH(AH 3249 BK 1561)	
LEN=0040 INSTALLED UNKN 0051/1572	-----		0060/0000		
BR. FALLENTIM STRUCTURE LENGTH 10 FT BMSID 02/0051/0050/1509 0051/1479	>-----<		0050/1485	BR. FALLENTIM STRUCTURE LENGTH 10 FT BMSID 02/0051/0050/1509	
012 "DIA CIRC CONCR LEN=0328 INSTALLED UNKN 0051/1344	---		0050/1434	018 "DIA CIRC CONCR LEN=0040 INSTALLED UNKN	
	---		0050/1200	018 "DIA CIRC CONCR LEN=0050 INSTALLED UNKN	
	---		0050/0920	018 "DIA CIRC CONCR LEN=0050 INSTALLED UNKN	
	---		0050/0612	018 "DIA CIRC CONCR LEN=0050 INSTALLED UNKN	
	---		0050/0598	018 "DIA CIRC CONCR LEN=0050 INSTALLED UNKN	
018 "DIA CIRC CONCR LEN=0040 INSTALLED UNKN 0051/0354	---				
	---		0050/0263	018 "DIA CIRC CONCR LEN=0050 INSTALLED UNKN	
	---		0050/0248	018 "DIA CIRC CONCR LEN=0350 INSTALLED UNKN	
ELIZABETH FORWARD T 0051/0130	---		0050/0130	ELIZABETH FORWARD T	

EXTRACT DATE: 12/21/2020
PRINT DATE: 12/23/2020

ROADWAY MANAGEMENT SYSTEM
SLD COUNTY/SR - ANNUAL PRINT

PAGE NUMBER: 172
COUNTY: ALLEGHENY

DIR: N TOTAL LEN: 36.753 MI.
LEFT MUN: ELIZABETH T

DIST: 11-1 SR: 51
RIGHT MUN: ELIZABETH T

1 0 00330 0 00 0034+00 013993 FT
HUTCHINSON RD
(TWP)
ROUND HILL ET
(CNTY)
LENGTH(AH 1572 BK 3378) 0051/0000

018 "DIA CIRC CONCR
LEN=0040 INSTALLED UNKN 0041/3094

018 "DIA CIRC CONCR
LEN=0290 INSTALLED UNKN 0041/2823
018 "DIA CIRC CONCR
LEN=0012 INSTALLED UNKN 0041/2523

012 "DIA CIRC CONCR
LEN=0263 INSTALLED UNKN 0041/2143
012 "DIA CIRC CONCR
LEN=0284 INSTALLED UNKN 0041/1880
018 "DIA CIRC CONCR
LEN=0050 INSTALLED UNKN 0041/1811
018 "DIA CIRC CONCR
LEN=0040 INSTALLED UNKN 0041/1596

018 "DIA CIRC CONCR
LEN=0040 INSTALLED UNKN 0041/0677

012 "DIA CIRC CONCR
LEN=0099 INSTALLED UNKN 0041/0367

1 0 00330 0 00 0000+00 010615 FT
PAYDAYS DR
(T611)
SCENERY DR
(SR0048 SEG 0010/0000)

LENGTH(AH 3378 BK 3271) 0041/0000

018 "DIA CIRC CONCR

014025 FT 1 0 00330 0 00 0034+00
HUTCHINSON RD
(T313)
ROUND HILL ET
(CNTY)
LENGTH(AH 1561 BK 3420)
018 "DIA CIRC CONCR
LEN=0040 INSTALLED UNKN

0040/3405

018 "DIA CIRC CONCR
LEN=0040 INSTALLED UNKN
018 "DIA CIRC CONCR
LEN=0040 INSTALLED UNKN

0040/3052
0040/3037

018 "DIA CIRC CONCR
LEN=0040 INSTALLED UNKN

018 "DIA CIRC CONCR
LEN=0040 INSTALLED UNKN

018 "DIA CIRC CONCR
LEN=0040 INSTALLED UNKN

018 "DIA CIRC CONCR
LEN=0040 INSTALLED UNKN

1 0 00330 0 00 0000+00
PAYDAY DR
(T611)
SCENERY DR
(SR0048 SEG 0010/0000)

010605 FT LENGTH(AH 3420 BK 3087)
TO 0048/0010 SH
(CONN)
0030/2953

DIR: N TOTAL LEN: 36.753 MI. DIST: 11-1 SR: 51
 LEFT MUN: FORWARD T RIGHT MUN: FORWARD T

Stationing	Description	Material	Length	Notes
0031/2445	INSTALLED UNKN		0031/2445	
0031/1746	018 "DIA CIRC CONCR INSTALLED UNKN		0031/1746	
0031/1390	GUFFEY RD (T311)		0031/1390	
0031/0927	KIMBERLY LN (TWP)		0031/0927	
0031/0000	1 0 00288 0 00 0087+10 LENGTH(AH 3271 BK 2682)		0031/0000	
0025/2021	UNKNOWN RD (TWP)		0025/2021	
0025/1920	012 "DIA CIRC CONCR INSTALLED UNKN		0025/1920	
0025/1276	012 "DIA CIRC CONCR INSTALLED UNKN		0025/1276	
0025/1009	012 "DIA CIRC CONCR INSTALLED UNKN		0025/1009	
0025/0000	1 0 00288 0 00 0046+60 (APRA) ELIZABETH EQ SER TORRENCE RD (T638) TUNNEL HOLLOW RD (T305) LENGTH(AH 2682 BK 1388)		0025/0000	
0024/1915	018 "DIA CIRC CONCR INSTALLED UNKN		0024/1915	
0024/1534	018 "DIA CIRC CONCR INSTALLED UNKN		0024/1534	
0024/0948	018 "DIA CIRC CONCR INSTALLED UNKN		0024/0948	
0024/0388	018 "DIA CIRC CONCR INSTALLED UNKN		0024/0388	
0024/0000	1 0 00288 0 00 0046+60 (APRA) ELIZABETH EQ SER TORRENCE RD (T638) TUNNEL HOLLOW RD (T305) LENGTH(AH 2848 BK 1408)		0024/0000	
0020/1124	015 "DIA CIRC CONCR INSTALLED UNKN		0020/1124	
0020/0883	012 "DIA CIRC CONCR INSTALLED UNKN		0020/0883	
0020/0747	015 "DIA CIRC CONCR INSTALLED UNKN		0020/0747	
0021/0649	018 "DIA CIRC CONCR INSTALLED UNKN		0021/0649	
0020/0530	RAMP D RD (SR8051 SEG 0750/0524)		0020/0530	

DIR: N TOTAL LEN: 36.753 MI. DIST: 11-1 SR: 51
 LEFT MUN: FORWARD T RIGHT MUN: FORWARD T

Stationing	Description	Material	Length	Notes
0021/0450	RAMP C RD (SR8051 SEG 0500/0000)	015 "DIA CIRC CONCR	0021/0423	INSTALLED UNKN
0020/0157		018 "DIA CIRC CONCR	0020/0157	LEN=0040 INSTALLED UNKN
003274 FT	1 0 00288 0 00 0032+56	018 "DIA CIRC CONCR	003262 FT	1 0 00288 0 00 0032+56
0021/0000	OP ID 02/0136/0110/0092	SR 0136 EB WB	0020/0000	OP ID 02/0136/0110/0092
0014/1885		015 "DIA CIRC CONCR	0014/1885	LEN=0050 INSTALLED UNKN
0014/1883		018 "DIA CIRC CONCR	0014/1883	LEN=0040 INSTALLED UNKN
0014/1632	RAMP A RD (SR8051 SEG 0010/0000)		0014/1632	
0014/1162		018 "DIA CIRC CONCR	0014/1162	LEN=0304 INSTALLED UNKN
0014/0907		018 "DIA CIRC CONCR	0014/0907	LEN=0040 INSTALLED UNKN
0014/0625		018 "DIA CIRC CONCR	0014/0625	LEN=0050 INSTALLED UNKN
0014/0340		018 "DIA CIRC CONCR	0014/0340	LEN=0050 INSTALLED UNKN
0014/0087	FROM AIRPORT RD (CONN)		0014/0087	
0015/1620	RAMP B RD (SR8051 SEG 0250/0494)		0014/0040	RODNEY LN (T640)
0011+50	1 0 00288 0 00 0011+50	NC HA	001122 FT	1 0 00288 0 00 0011+50
0015/0000	AIRPORT DR (T578)		0014/0000	LENGTH(AH 2140 BK 1122)
0010/0762		018 "DIA CIRC CONCR	0010/0762	LEN=0040 INSTALLED UNKN
0010/0411		018 "DIA CIRC CONCR	0010/0411	LEN=0318 INSTALLED UNKN
0010/0093		018 "DIA CIRC CONCR	0010/0093	LEN=0093 INSTALLED UNKN
000000 FT	1 0 00288 0 00 0000+00	NC CL	000000 FT	1 0 00288 0 00 0000+00
REF-BK	SR 0051 SH (SR0051 SEG 0151/2943)		* REF-BK	SR 0051 SH (SR0051 SEG 0150/3070)
0011/0000	MFC BEGIN = B		0010/0000	MFC BEGIN = B
	BK-WESTMORELAND (64)			BK-WESTMORELAND (64)
	LENGTH(AH 1122 BK 0000)			LENGTH(AH 1122 BK 0000)

EXTRACT DATE: 12/21/2020 ROADWAY MANAGEMENT SYSTEM PAGE NUMBER: 169
PRINT DATE: 12/23/2020 SLD COUNTY/SR - ANNUAL PRINT COUNTY: ALLEGHENY
DIR: E TOTAL LEN: 12.039 MI. DIST: 11-1 SR: 50
LEFT MUN: PITTSBURGH C RIGHT MUN: PITTSBURGH C

CRAFTON BL 063564 FT
(SR0060 SEG 0050/0000) 0290/2053

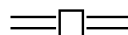

063323 FT NOBLESTOWN RD
0290/2053 (SR0060 SEG 0050/0000)

DIR: E TOTAL LEN: 12.039 MI. DIST: 11-1 SR: 50
 LEFT MUN: PITTSBURGH C RIGHT MUN: PITTSBURGH C

Location	Segment	Length	Notes
BARR AV (CITY)	0290/1350	==	
BARTOW ST (CITY)	0290/1189	==	
		==	0290/1108 BARTOW ST (CITY)
		==	QUEENSBURY RD (CITY)
HARRIS AV (CITY)	0290/0280	==	DENNISONVIEW ST (CITY)
		==	COLESCOTT ST (CITY)
		==	WARRIORS RD (CITY)
		==	GUYLAND ST (CITY)
	061511 FT		0290/0001 (CITY)
			061270 FT 1 0 00108 0 01 0550+93
			5 0290/0000 LENGTH(AH 2053 BK 2380)
MANLEY ST (CITY)	0280/1310	==	
			POPLAR ST (SR0121 SEG 0100/2811)
1 0 00108 0 01 0526+82	059131 FT		058890 FT PITTSBURGH
POPLAR ST (CITY)	0280/0000	==	5 0280/0000 GREENTREE B LENGTH(AH 2380 BK 1066)
	058065 FT		057824 FT 1 0 00108 0 01 0516+55
BALDWICK RD (CITY)	0270/0000	==	SCHOOL ST (BORO)
		==	5 0270/0000 LENGTH(AH 1066 BK 2591)
		==	0260/1384 LC FROM HOLIDAY DR (CONN)
		==	0260/1317 HOLIDAY DR (CITY)
		==	0260/1256 LC TO HOLIDAY DR (CONN)
			0260/0460 018 "DIA CIRC CONCR LEN=0040 INSTALLED UNKN

DIR: E TOTAL LEN: 12.039 MI. DIST: 11-1 SR: 50
 LEFT MUN: PITTSBURGH C RIGHT MUN: SCOTT T

Location / Description	Stationing	Length (FT)	Notes / Details
	055474	FT	
DURBIN ST (CITY)	0250/2329		
ANGENA DR (CITY)	0250/2150		
MORANGE RD (CITY)	0250/1250		
	052519	FT	
	0240/0000		
ALTER ST (TWP) PITTSBURGH SCOTT T	0230/1764		
E KICHENER WY (TWP) DUNCAN WY (TWP)	0230/1362		
	0230/1275		
	0230/1255		
	0250/0182		
	0250/0000		
	0240/2365		
	0240/2085		
	0240/1581		
	0240/1158		
	049674	FT	
	0240/0000		
	0230/1486		
	0230/1484		
	0230/1275		
	0230/1255		
	055233	FT	
	0260/0000		
	0250/2895		
	0250/1195		
	0250/0182		
	052278	FT	
	0250/0000		
	0240/2365		
	0240/2085		
	0240/1581		
	0240/1158		
	049674	FT	
	0240/0000		
	0230/1486		
	0230/1484		
	0230/1275		
	0230/1255		
	055233	FT	
	0260/0000		
	0250/2895		
	0250/1195		
	0250/0182		
	052278	FT	
	0250/0000		
	0240/2365		
	0240/2085		
	0240/1581		
	0240/1158		
	049674	FT	
	0240/0000		
	0230/1486		
	0230/1484		
	0230/1275		
	0230/1255		
	055233	FT	
	0260/0000		
	0250/2895		
	0250/1195		
	0250/0182		
	052278	FT	
	0250/0000		
	0240/2365		
	0240/2085		
	0240/1581		
	0240/1158		
	049674	FT	
	0240/0000		
	0230/1486		
	0230/1484		
	0230/1275		
	0230/1255		
	055233	FT	
	0260/0000		
	0250/2895		
	0250/1195		
	0250/0182		
	052278	FT	
	0250/0000		
	0240/2365		
	0240/2085		
	0240/1581		
	0240/1158		
	049674	FT	
	0240/0000		
	0230/1486		
	0230/1484		
	0230/1275		
	0230/1255		
	055233	FT	
	0260/0000		
	0250/2895		
	0250/1195		
	0250/0182		
	052278	FT	
	0250/0000		
	0240/2365		
	0240/2085		
	0240/1581		
	0240/1158		
	049674	FT	
	0240/0000		
	0230/1486		
	0230/1484		
	0230/1275		
	0230/1255		
	055233	FT	
	0260/0000		
	0250/2895		
	0250/1195		
	0250/0182		
	052278	FT	
	0250/0000		
	0240/2365		
	0240/2085		
	0240/1581		
	0240/1158		
	049674	FT	
	0240/0000		
	0230/1486		
	0230/1484		
	0230/1275		
	0230/1255		
	055233	FT	
	0260/0000		
	0250/2895		
	0250/1195		
	0250/0182		
	052278	FT	
	0250/0000		
	0240/2365		
	0240/2085		
	0240/1581		
	0240/1158		
	049674	FT	
	0240/0000		
	0230/1486		
	0230/1484		
	0230/1275		
	0230/1255		
	055233	FT	
	0260/0000		
	0250/2895		
	0250/1195		
	0250/0182		
	052278	FT	
	0250/0000		
	0240/2365		
	0240/2085		
	0240/1581		
	0240/1158		
	049674	FT	
	0240/0000		
	0230/1486		
	0230/1484		
	0230/1275		
	0230/1255		
	055233	FT	
	0260/0000		
	0250/2895		
	0250/1195		
	0250/0182		
	052278	FT	
	0250/0000		
	0240/2365		
	0240/2085		
	0240/1581		
	0240/1158		
	049674	FT	
	0240/0000		
	0230/1486		
	0230/1484		
	0230/1275		
	0230/1255		
	055233	FT	
	0260/0000		
	0250/2895		
	0250/1195		
	0250/0182		
	052278	FT	
	0250/0000		
	0240/2365		
	0240/2085		
	0240/1581		
	0240/1158		
	049674	FT	
	0240/0000		
	0230/1486		
	0230/1484		
	0230/1275		
	0230/1255		
	055233	FT	
	0260/0000		
	0250/2895		
	0250/1195		
	0250/0182		
	052278	FT	
	0250/0000		
	0240/2365		
	0240/2085		
	0240/1581		
	0240/1158		
	049674	FT	
	0240/0000		
	0230/1486		
	0230/1484		
	0230/1275		
	0230/1255		
	055233	FT	
	0260/0000		
	0250/2895		
	0250/1195		
	0250/0182		
	052278	FT	
	0250/0000		
	0240/2365		
	0240/2085		
	0240/1581		
	0240/1158		
	049674	FT	
	0240/0000		
	0230/1486		
	0230/1484		
	0230/1275		
	0230/1255		
	055233	FT	
	0260/0000		
	0250/2895		
	0250/1195		
	0250/0182		
	052278	FT	
	0250/0000		
	0240/2365		
	0240/2085		
	0240/1581		
	0240/1158		
	049674	FT	
	0240/0000		
	0230/1486		
	0230/1484		
	0230/1275		
	0230/1255		
	055233	FT	
	0260/0000		
	0250/2895		
	0250/1195		
	0250/0182		
	052278	FT	
	0250/0000		
	0240/2365		
	0240/2085		
	0240/1581		
	0240/1158		
	049674	FT	
	0240/0000		
	0230/1486		
	0230/1484		
	0230/1275		
	0230/1255		
	055233	FT	
	0260/0000		
	0250/2895		
	0250/1195		
	0250/0182		
	052278	FT	
	0250/0000		
	0240/2365		
	0240/2085		
	0240/1581		
	0240/1158		
	049674	FT	
	0240/0000		
	0230/1486		
	0230/1484		
	0230/1275		
	0230/1255		
	055233	FT	
	0260/0000		
	0250/2895		
	0250/1195		
	0250/0182		
	052278	FT	
	0250/0000		
	0240/2365		
	0240/2085		
	0240/1581		
	0240/1158		
	049674	FT	
	0240/0000		
	0230/1486		
	0230/1484		
	0230/1275		
	0230/1255		
	055233	FT	
	0260/0000		
	0250/2895		
	0250/1195		
	0250/0182		
	052278	FT	
	0250/0000		
	0240/2365		
	0240/2085		
	0240/1581		
	0240/1158		
	049674	FT	
	0240/0000		
	0230/1486		
	0230/1484		
	0230/1275		
	0230/1255		
	055233	FT	
	0260/0000		
	0250/2895		
	0250/1195		
	0250/0182		
	052278	FT	
	0250/0000		
	0240/2365		
	0240/2085		
	0240/1581		
	0240/1158		
	049674	FT	
	0240/0000		
	0230/1486		
	0230/1484		
	0230/1275		

DIR: E TOTAL LEN: 12.039 MI. DIST: 11-1 SR: 50
 LEFT MUN: SCOTT T RIGHT MUN: SCOTT T

Street Name	Segment ID	Length (FT)	Notes
IDLEWOOD AV (TWP)	0230/0684		0230/0698 LEN=0040 INSTALLED UNKN
			NORTHSIDE AV (TWP) 012 "DIA CIRC CONCR
BELL AV (TWP)	0230/0195		0230/0314 LEN=0024 INSTALLED UNKN
	047932 FT		PENN LINC PW 0230/0151 OP ID 02/0376/0650/1095 047691 FT 1 0 00108 0 01 0414+50 RAMP E WB
JANE ST (TWP)			OP ID 02/8033/0500/1248 NC NO BLESTOWN RD 5 0230/0000 LENGTH(AH 1983 BK 1589) 012 "DIA CIRC CONCR
	0220/1335		0220/1524 LEN=0099 INSTALLED UNKN
			0220/1410 SCOTT CARNEGIE B
			012 "DIA CIRC CONCR 0220/1068 LEN=0040 INSTALLED UNKN
CHESTNUT ST (SR3048 SEG 0250/0362)	0220/0421		ANTHONY ST 0220/0779 (TWP)
	046343 FT		HAYS ST 0220/0599 (TWP) CHESTNUT ST (SR3056 SEG 0010/0000)
MAIN ST (BORO) LC FROM SCHOOL ST (CONN)	0220/0000		0220/0421 SANSBURY AV (BORO)
	0212/1900		0220/0147 (BORO) 046102 FT 1 0 00108 0 01 0398+70 NC MA IN ST 5 0220/0000 MFC BEGIN = C LENGTH(AH 1589 BK 2102)
SCHOOL ST (BORO)	0212/1545		0212/1900 WILLIAM WY (BORO)
			0212/1660 LYDIA ST (SR3058 SEG 0011/0000)
			0212/1425 ACADEMY ST (SR3097 SEG 0010/0000)
			0212/0857 012 "DIA CIRC CONCR LEN=0239 INSTALLED UNKN
			0212/0690 TRIMBLE ST (BORO) LINCOLN AV

DIR: E TOTAL LEN: 12.039 MI. DIST: 11-1 SR: 50
 LEFT MUN: CARNEGIE B RIGHT MUN: CARNEGIE B

Street Name	Segment ID	Length (FT)	Notes
CHRISTY AV (BORO)	0212/0240	044241	0212/0360 (BORO)
CAPITAL DR (BORO)	0210/1925		044000 FT 0 0 00000 0 00 0000+00 ROWLAND AV (BORO) 5 0212/0000 LENGTH(AH 2102 BK 2160)
LEE ST (BORO)	0210/1175		0210/1880 KNOX AV (BORO) 012 " DIA CIRC CONCR 0210/1709 LEN=0040 INSTALLED UNKN FEDERAL AV (BORO)
OSAGE WAY (BORO)	0210/0950		0210/1680 CALIFORNIA AV (BORO) 0210/1560 FRANKLIN AV (BORO) 0210/1425 012 " DIA CIRC CONCR 0210/1424 LEN=0040 INSTALLED UNKN
MARSHALL AV (BORO)	0210/0715		0210/1160 012 " DIA CIRC CONCR LEN=0040 INSTALLED UNKN
	042081	041469	0210/0870 COOK ST (BORO) 0210/0714 012 " DIA CIRC CONCR LEN=0040 INSTALLED UNKN ROSS AV (BORO) 0210/0595 012 " DIA CIRC CONCR LEN=0040 INSTALLED UNKN BODEN AV (TWP) 0210/0492 CARNEGIE SCOTT T 0210/0465 012 " DIA CIRC CONCR LEN=0090 INSTALLED UNKN 041840 FT 1 0 00108 0 01 0360+52 5 0210/0000 LENGTH(AH 2160 BK 0612) 041228 FT 1 0 00108 0 01 0348+79 HOPE ST (TWP)

DIR: E TOTAL LEN: 12.039 MI. DIST: 11-1 SR: 50
 LEFT MUN: SCOTT T RIGHT MUN: SCOTT T

Stationing / Description	Stationing / Description	Stationing / Description
HOPE WY (TWP) 0200/0000		0200/0000 MFC BEGIN = B LENGTH(AH 0612 BK 1429)
018 "DIA CIRC CONCR LEN=0060 INSTALLED UNKN 0191/1436		0190/1172 015 "DIA CIRC CONCR LEN=0020 INSTALLED UNKN
018 "DIA CIRC CONCR LEN=0050 INSTALLED UNKN 0191/1215 LC TO CAROTHERS AV (CONN) 0191/0910		0190/0813 BMSEN 02/0050/0190/0775 CAROTHERS AV (CNTY) HOPE HOLLOW RD (CNTY)
BMSEN 02/0050/0190/0775 0191/0851 CAROTHERS AV (CNTY) HOPE HOLLOW RD (CNTY)		0190/0810
1 0 00108 0 00 0343+49 PITTSBURGH AND OHIO RR BMSBG 02/0050/0190/0775 0191/0813		1 0 00108 0 00 0343+49 PITTSBURGH AND OHIO RR BMSBG 02/0050/0190/0775 0190/0775
LC FROM CAROTHERS AV (CONN) 0191/0740		
015 "DIA CIRC CONCR LEN=0050 INSTALLED UNKN 0191/0650		0190/0612 018 "DIA CIRC CONCR LEN=0030 INSTALLED UNKN
015 "DIA CIRC CONCR LEN=0060 INSTALLED UNKN 0191/0532 BMSEN 02/0050/0191/0154 0191/0501		0190/0535 BMSEN 02/0050/0190/0090 018 "DIA CIRC CONCR LEN=0050 INSTALLED UNKN GEORGES RUN STRUCTURE LENGTH 12 FT BMSID 02/0050/0190/0435
SCOTT HEIDELBERG B 0191/0322		0190/0427
1 0 00108 0 00 0337+06 CHARTIERS CK BMSBG 02/0050/0191/0154 0191/0154		0190/0414
015 "DIA CIRC CONCR		0190/0285 SCOTT HEIDELBERG B 1 0 00108 0 00 0336+54 CHARTIERS CK BMSBG 02/0050/0190/0090 018 "DIA CIRC CONCR LEN=0045 INSTALLED UNKN LC FROM FIRST ST (CONN) 0190/0075

DIR: E TOTAL LEN: 12.039 MI. DIST: 11-1 SR: 50
 LEFT MUN: HEIDELBERG B RIGHT MUN: HEIDELBERG B

LEN=0040 INSTALLED UNKN 0191/0055
 1 0 00108 0 00 0333+48 040003 FT
 (APRA) HEIDELBERG METAL
 NC WASHINGTON AV
 FIRST ST
 (BORO)

MFC BEGIN = B
 LENGTH(AH 1466 BK 2127) 0191/0000

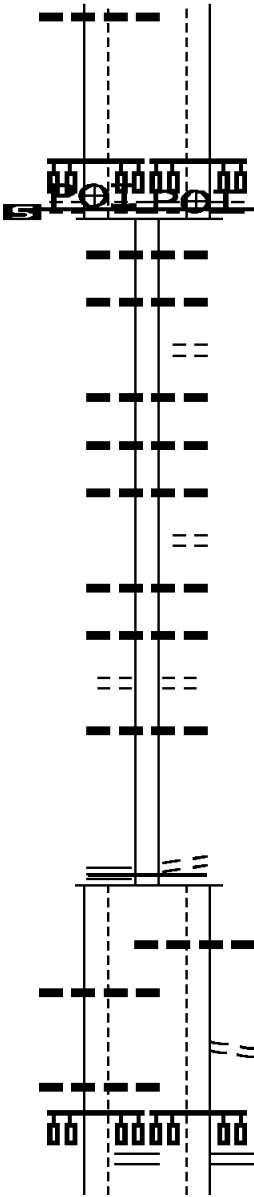

039799 FT 1 0 00108 0 00 0333+74
 (APRA) HEIDELBERG METAL
 NC WASHINGTON AV
 FIRST ST
 (BORO)

MFC BEGIN = B
 LENGTH(AH 1429 BK 2127)

015 "DIA CIRC CONCR
 0180/2075 LEN=0050 INSTALLED UNKN
 012 "DIA CIRC CONCR
 0180/1829 LEN=0045 INSTALLED UNKN
 SECOND ST
 (BORO)
 012 "DIA CIRC CONCR
 0180/1530 LEN=0045 INSTALLED UNKN
 012 "DIA CIRC CONCR
 0180/1507 LEN=0045 INSTALLED UNKN
 012 "DIA CIRC CONCR
 0180/1292 LEN=0045 INSTALLED UNKN
 024 "DIA CIRC CONCR
 0180/1010 LEN=0099 INSTALLED UNKN
 THIRD ST
 (BORO)
 018 "DIA CIRC CONCR
 0180/0980 LEN=0045 INSTALLED UNKN
 018 "DIA CIRC CONCR
 0180/0726 LEN=0050 INSTALLED UNKN
 FOURTH ST
 (BORO)
 012 "DIA CIRC CONCR
 0180/0507 LEN=0045 INSTALLED UNKN
 012 "DIA CIRC CONCR
 0180/0480 LEN=0045 INSTALLED UNKN
 018 "DIA CIRC CONCR
 0180/0240 LEN=0045 INSTALLED UNKN
 037672 FT 1 0 00108 0 00 0314+24
 COLLIER AV
 (BORO)

037876 FT

COLLIER AV
 (SR3052 SEG 0070/2151) 0180/0000

018 "DIA CIRC CONCR
 LEN=0060 INSTALLED UNKN 0171/2353

018 "DIA CIRC CONCR
 LEN=0050 INSTALLED UNKN 0171/2102
 GREENTREE RD
 (SR3052 SEG 0080/0000) 0171/2055

NC EAST RAILROAD ST
 MFC BEGIN = B
 LENGTH(AH 2127 BK 2391)

012 "DIA CIRC CONCR
 0170/2361 LEN=0099 INSTALLED UNKN

0170/2130 FROM 3052/0080 SH
 (CONN)

0170/2025 GREENTREE RD
 (SR3052 SEG 0080/0000)
 TO 3052/0080 SH

EXTRACT DATE: 12/21/2020
PRINT DATE: 12/23/2020

ROADWAY MANAGEMENT SYSTEM
SLD COUNTY/SR - ANNUAL PRINT

PAGE NUMBER: 162
COUNTY: ALLEGHENY

DIR: E TOTAL LEN: 12.039 MI.
LEFT MUN: HEIDELBERG B

DIST: 11-1 SR: 50
RIGHT MUN: HEIDELBERG B

BR. CHARTIERS
STRUCTURE LENGTH 10 FT
BMSID 02/0050/0170/1739 0171/1938
HEIDELBERG
SCOTT T 0171/1753

LC TO RACEWAY PLAZA DR
(CONN) 0171/1553
(APRA) RACEWAY PLAZA
RACEWAY PLAZA DR
(PRDR) 0171/1462

LC FROM RACEWAY PLAZA D
(CONN) 0171/1390
012 "DIA CIRC CONCR
LEN=0045 INSTALLED UNKN 0171/0902
018 "DIA CIRC CONCR
LEN=0045 INSTALLED UNKN 0171/0680
SCOTT
COLLIER T 0171/0614
012 "DIA CIRC CONCR
LEN=0045 INSTALLED UNKN 0171/0509

(APRA) DUQ LT WOODVLL S
DUQ LT WDVLL SBSTATION
(PRDR) 0171/0375
012 "DIA CIRC CONCR
LEN=0045 INSTALLED UNKN 0171/0307
LC TO COLLIER TOWN SQ
(CONN) 0171/0087
1 0 00108 0 00 0290+25 035463 FT
COLLIER TOWN SQUARE DR
(PRDR)

LENGTH(AH 2413 BK 2620) 0171/0000

012 "DIA CIRC CONCR
LEN=0099 INSTALLED UNKN 0161/2574
LC FROM COLLIER SQ
(CONN) 0161/2563

THOMS RUN RD

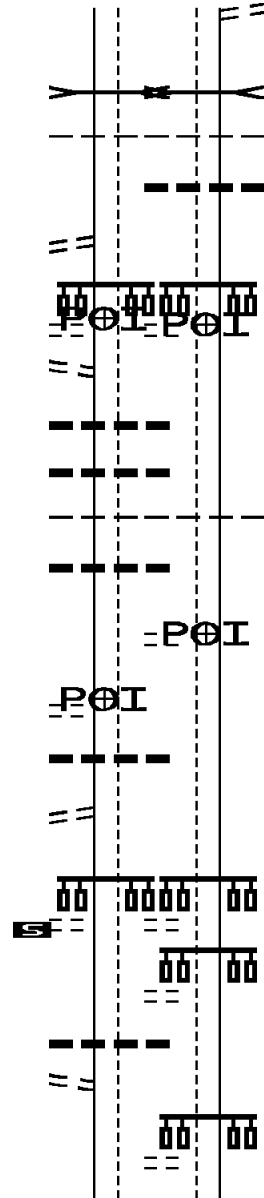

0170/1945 (CONN)
BR. CHARTIERS
STRUCTURE LENGTH 10 FT
BMSID 02/0050/0170/1739 0170/1926
HEIDELBERG
SCOTT T 0170/1849
012 "DIA CIRC CONCR
LEN=0020 INSTALLED UNKN 0170/1613

(APRA) RACEWAY PLAZA
RACEWAY PLAZA DR
(PRDR) 0170/1456

SCOTT
COLLIER T 0170/0639

(APRA) DUQ LT WOODVLL S
DUQ LT WDVLL SBSTATION
(PRDR) 0170/0329

035281 FT 1 0 00108 0 00 0292+10
COLLIER TOWN SQUARE
(PRDR)

LENGTH(AH 2391 BK 2472) 0170/0000
COLLIER TOWN SQUARE
(PRDR)

0160/2472

THOMS RUN RD
(CNTY)

0160/1959

DIR: E TOTAL LEN: 12.039 MI. DIST: 11-1 SR: 50
 LEFT MUN: COLLIER T RIGHT MUN: COLLIER T

Segment Description	Stationing	Notes	Segment Description	Stationing	Notes
(SR8005 SEG 0010/1615)	0151/1565				
012 "DIA CIRC CONCR					
LEN=0060 INSTALLED UNKN	0151/1356				
MURRAY AV					
(TWP)	0151/1175				
			0150/1190		MURRAY AV
					(TWP)
			0150/0935		012 "DIA CIRC CONCR
					LEN=0099 INSTALLED UNKN
VANADIUM RD					VANADIUM RD
(CNTY)	0151/0605				(CNTY)
			0150/0605		
STAFFORD AV					STAFFORD AV
(TWP)	0151/0250				(TWP)
1 0 00108 0 00 0233+00	029916 FT		0150/0255		1 0 00108 0 00 0234+47
BERAM AV			029711 FT		BERAM AV
(TWP)					(TWP)
LENGTH(AH 2927 BK 2584)	0151/0000				LENGTH(AH 3098 BK 2576)
			0150/0000		LANDGRAF AV
					(TWP)
			0140/2291		
LANDGRAF AV					
(TWP)	0141/2298				
GREAT SOUTHERN SHPPG CT					GREAT SOUTHERN SHPPG CT
(PRDR)	0141/2094				(PRDR)
			0140/2077		
					018 "DIA CIRC CONCR
			0140/1997		LEN=0099 INSTALLED 2011
018 "DIA CIRC CONCR					
LEN=0060 INSTALLED UNKN	0141/1965				
					012 "DIA CIRC CONCR
					LEN=0099 INSTALLED UNKN
					012 "DIA CIRC CONCR
					LEN=0099 INSTALLED UNKN
					COMMERCIAL DR
					(PRDR)
					012 "DIA CIRC CONCR
					LEN=0099 INSTALLED UNKN
(APRA) KIRWAN HTS IND M					(APRA) KIRWAN HTS IND M
MAYER ST					MAYER ST
(TWP)					(TWP)
	0141/0838				
COMMERCIAL DR					0140/0800
(PRDR)	0141/0826				
					012 "DIA CIRC CONCR
					LEN=0099 INSTALLED UNKN
012 "DIA CIRC CONCR					
LEN=0150 INSTALLED UNKN	0141/0540				
LC TO CHARTIER VL SHP C					
(CONN)	0141/0491				
CHARTIERS VALLEY SHPPG					CHARTIERS VALLEY SHPPG

EXTRACT DATE: 12/21/2020
PRINT DATE: 12/23/2020

ROADWAY MANAGEMENT SYSTEM
SLD COUNTY/SR - ANNUAL PRINT

PAGE NUMBER: 158
COUNTY: ALLEGHENY

DIR: E TOTAL LEN: 12.039 MI.
LEFT MUN: BRIDGEVILLE B

DIST: 11-1 SR: 50
RIGHT MUN: BRIDGEVILLE B

HICKMAN ST
(BORO)

0120/1006

CHURCH ST
(BORO)

0120/0408

FOR SR 0050W TO 0050W
(CONN)

0120/0110
023367 FT

FOR SR 0050W TO 0050W
(CONN)

0101/1109

RAMP A RD
(SR8003 SEG 0010/1200)
RAMP E RD
(SR8003 SEG 0750/0000)

0101/0839
0101/0803

SR 0079 NB
OP ID 02/0079/0524/0409 0101/0128

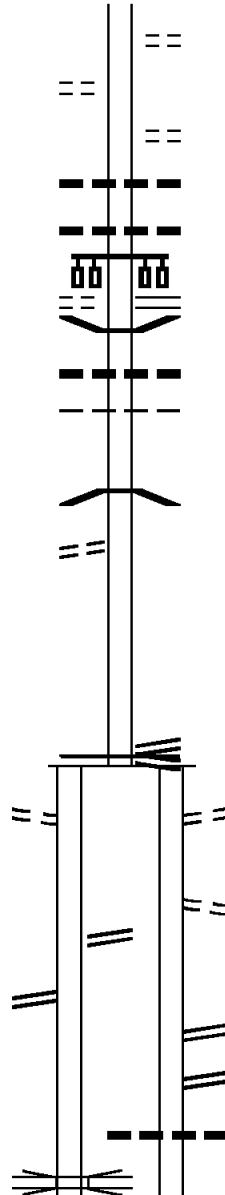

0120/1242 BANK ST ET
(BORO)

0120/0946 JAMES ST
(BORO)

0120/0740 018 " DIA CIRC CONCR
LEN=0099 INSTALLED UNKN

0120/0477 015 " DIA CIRC CONCR
LEN=0099 INSTALLED UNKN

0120/0408 CHARTIERS ST
(SR3034 SEG 0010/0000)

0120/0360 BMS EN 02/0050/0120/0227
018 " DIA CIRC CONCR

0120/0325 LEN=0099 INSTALLED UNKN

0120/0295 BRIDGEVILLE
SOUTH FAYETTE T

0120/0227 1 0 00108 0 00 0171+11
CHARTIERS CK
BMSBG 02/0050/0120/0227

023170 FT 1 0 00108 0 00 0168+84
WASHINGTON PK
(SR3003 SEG 0061/0771)

NC WA WASHINGTON AV
WASHINGTON PK
(SR3003 SEG 0061/0747)
(SR3003 SEG 0060/0747)

0120/0000 MFC BEGIN = B
LENGTH(AH 2195 BK 1235)

0100/1128 TO 3003/0061 SH
(CONN)

0100/0928 FROM 8003/0010 SH
(CONN)

0100/0791 RAMP A RD
(SR8003 SEG 0010/1200)

0100/0725 RAMP B RD
(SR8003 SEG 0020/0000)

0100/0435 024 " DIA CIRC CONCR
LEN=0100 INSTALLED UNKN

EXTRACT DATE: 12/21/2020
PRINT DATE: 12/23/2020

ROADWAY MANAGEMENT SYSTEM
SLD COUNTY/SR - ANNUAL PRINT

PAGE NUMBER: 157
COUNTY: ALLEGHENY

DIR: E TOTAL LEN: 12.039 MI.
LEFT MUN: SOUTH FAYETTE T

DIST: 11-1 SR: 50
RIGHT MUN: SOUTH FAYETTE T

Station	Description	Length	Notes
0100/0128	SR 0079 NB OP ID 02/0079/0524/0409	021935 FT	
0101/0000	SR 0079 SB OP ID 02/0079/0525/0486 LENGTH(AH 1265 BK 2365)	0100/0000	
0091/2235	012 "DIA CIRC CONCR LEN=0030 INSTALLED UNKN	0091/2235	
0091/2188	RAMP C RD (SR8003 SEG 0250/0000) RAMP D RD (SR8003 SEG 0260/1295)	0091/2188	
0091/1860	012 "DIA CIRC CONCR LEN=0030 INSTALLED UNKN	0091/1860	
0091/1797	(APRA) MALACH STEEL CO HICKORY GRADE RD (TWP)	0091/1797	
0091/1429	LC TO NEWBURY DR (CONN) NEWBURY DR (TWP) TODD A MILLER DR (TWP)	0091/1429	
0091/1312		0091/1312	
0091/0672	028 "DIA CIRC CONCR LEN=0060 INSTALLED 2016	0091/0672	
0090/2229	036 "DIA CIRC CONCR LEN=0080 INSTALLED UNKN	0090/2229	
0090/2180		0090/2180	
0090/2135	RAMP C RD (SR8003 SEG 0250/0000) RAMP D RD (SR8003 SEG 0260/1295)	0090/2135	
0090/2072	012 "DIA CIRC CONCR LEN=0024 INSTALLED UNKN TO 8003/0250 SH	0090/2072	
0090/1939	(CONN)	0090/1939	
0090/1748	(APRA) MALACH STEEL CO HICKORY GRADE RD (TWP)	0090/1748	
0090/1359	LC FROM TODD A MILLER D (CONN) NEWBURY DR (TWP) TODD A MILLER DR (TWP)	0090/1359	
0090/1242		0090/1242	
0090/1241	036 "DIA CIRC CONCR LEN=0099 INSTALLED UNKN	0090/1241	
0090/0667	018 "DIA CIRC CONCR LEN=0070 INSTALLED UNKN 018 "DIA CIRC CONCR	0090/0667	

DIR: E TOTAL LEN: 12.039 MI. DIST: 11-1 SR: 50
 LEFT MUN: SOUTH FAYETTE T RIGHT MUN: SOUTH FAYETTE T

012 "DIA CIRC CONCR LEN=0099 INSTALLED UNKN 021 "DIA CIRC CONCR LEN=0004 INSTALLED 2016 TO 3026/0060 SH (CONN) 021 "DIA CIRC CONCR LEN=0004 INSTALLED 2016	0091/0435 0091/0432 0091/0254 0091/0242		0090/0440 LEN=0065 INSTALLED UNKN
012 "DIA CIRC CONCR LEN=0045 INSTALLED UNKN	0091/0185		0090/0237 021 "DIA CIRC CONCR LEN=0004 INSTALLED 2016
021 "DIA CIRC CONCR LEN=0050 INSTALLED 2016	0091/0092		0090/0097 024 "DIA CIRC CONCR LEN=0060 INSTALLED UNKN
1 0 00545 0 01 0219+86 019737 FT MILLERS RUN RD (SR3026 SEG 0060/2077)			0090/0040 018 "DIA CIRC CONCR LEN=0065 INSTALLED UNKN 1 0 00545 0 01 0219+86 MILLERS RUN RD (SR3026 SEG 0060/2077)
LENGTH(AH 2365 BK 1921) 021 "DIA CIRC CONCR LEN=0100 INSTALLED 2016 018 "DIA CIRC CONCR LEN=0099 INSTALLED UNKN FROM 3026/0060 SH (CONN)	0091/0000 0081/1852 0081/1822 0081/1762		0090/0000 LENGTH(AH 2304 BK 1875)
021 "DIA CIRC CONCR LEN=0004 INSTALLED 2016 021 "DIA CIRC CONCR LEN=0060 INSTALLED 2016	0081/1361 0081/1341		0080/1675 018 "DIA CIRC CONCR LEN=0080 INSTALLED UNKN 0080/1383 018 "DIA CIRC CONCR LEN=0065 INSTALLED UNKN
015 "DIA CIRC CONCR LEN=0050 INSTALLED UNKN	0081/1329		0080/1336 021 "DIA CIRC CONCR LEN=0004 INSTALLED 2016
021 "DIA CIRC CONCR LEN=0004 INSTALLED 2016	0081/0971		0080/1316 021 "DIA CIRC CONCR LEN=0055 INSTALLED 2016 099 "DIA CIRC CONCR LEN=0065 INSTALLED UNKN 0080/1053
			0080/0966 021 "DIA CIRC CONCR LEN=0004 INSTALLED 2016

DIR: E TOTAL LEN: 12.039 MI. DIST: 11-1 SR: 50
 LEFT MUN: SOUTH FAYETTE T RIGHT MUN: SOUTH FAYETTE T

021 "DIA CIRC CONCR LEN=0004 INSTALLED 2016	0041/2289	---	---	0040/2744	021 "DIA CIRC CONCR LEN=0004 INSTALLED 2016
021 "DIA CIRC CONCR LEN=0004 INSTALLED 2016	0041/2049	---	---	0040/2284	021 "DIA CIRC CONCR LEN=0004 INSTALLED 2016
021 "DIA CIRC CONCR LEN=0004 INSTALLED 2016	0041/1519	---	---	0040/2044	021 "DIA CIRC CONCR LEN=0001 INSTALLED 2016
021 "DIA CIRC CONCR LEN=0004 INSTALLED 2016	0041/1089	---	---	0040/1529	021 "DIA CIRC CONCR LEN=0004 INSTALLED 2016
021 "DIA CIRC CONCR LEN=0008 INSTALLED 2016	0041/0649	---	---	0040/1514	021 "DIA CIRC CONCR LEN=0004 INSTALLED 2016
021 "DIA CIRC CONCR LEN=0008 INSTALLED 2016	0041/0194	---	---	0040/1463	024 "DIA CIRC CONCR LEN=0150 INSTALLED UNKN
1 0 01138 0 00 0064+68 006523 FT LENGTH(AH 3392 BK 2139) 0041/0000		---	---	0040/1084	021 "DIA CIRC CONCR LEN=0008 INSTALLED 2016
021 "DIA CIRC CONCR LEN=0008 INSTALLED 2016	0031/1819	---	---	0040/1024	018 "DIA CIRC CONCR LEN=0099 INSTALLED UNKN
021 "DIA CIRC CONCR LEN=0008 INSTALLED 2016	0031/1434	---	---	0040/0644	021 "DIA CIRC CONCR LEN=0008 INSTALLED 2016
		---	---	0040/0580	048 "DIA CIRC CONCR LEN=0060 INSTALLED UNKN
		---	---	0040/0189	021 "DIA CIRC CONCR LEN=0008 INSTALLED 2016
		---	---	0040/0136	018 "DIA CIRC CONCR LEN=0050 INSTALLED UNKN
		---	---	006401 FT	1 0 01138 0 00 0065+44
		---	---	0040/0000	LENGTH(AH 3420 BK 2070)
021 "DIA CIRC CONCR LEN=0008 INSTALLED 2016	0031/1819	---	---	0030/1814	021 "DIA CIRC CONCR LEN=0008 INSTALLED 2016
021 "DIA CIRC CONCR LEN=0008 INSTALLED 2016	0031/1434	---	---	0030/1782	012 "DIA CIRC CONCR LEN=0065 INSTALLED UNKN
		---	---	0030/1429	021 "DIA CIRC CONCR LEN=0008 INSTALLED 2016
		---	---	0030/1404	012 "DIA CIRC CONCR LEN=0055 INSTALLED UNKN

DIR: E TOTAL LEN: 12.039 MI. DIST: 11-1 SR: 50
 LEFT MUN: SOUTH FAYETTE T RIGHT MUN: SOUTH FAYETTE T

Item ID	Description	Length	Material	Status	Year	Stationing	Notes
0021/0951	MILLERS RUN	46 FT	CONCR	INSTALLED	2016	0021/0951	
0021/0708	MILLERS RUN	46 FT	CONCR	INSTALLED	2016	0021/0708	
0021/0485	021 "DIA CIRC CONCR			INSTALLED	2016	0021/0485	
0021/0075	021 "DIA CIRC CONCR			INSTALLED	2016	0021/0075	
0020/0070	021 "DIA CIRC CONCR			INSTALLED	2016	0020/0070	
0020/0000	1 0 01138 0 00 0020+28	2307 FT				0020/0000	
0011/1650	021 "DIA CIRC CONCR			INSTALLED	2016	0011/1650	
0011/1220	012 "DIA CIRC CONCR			INSTALLED	UNKN	0011/1220	
0011/1200	021 "DIA CIRC CONCR			INSTALLED	2016	0011/1200	
0011/1164	012 "DIA CIRC CONCR			INSTALLED	UNKN	0011/1164	
0011/0850	027 "DIA CIRC CONCR			INSTALLED	2016	0011/0850	
0011/0500	027 "DIA CIRC CONCR			INSTALLED	2016	0011/0500	
0011/0220	027 "DIA CIRC CONCR			INSTALLED	2016	0011/0220	
0011/0000	1 0 01138 0 00 0000+00	000000 FT				0011/0000	
0020/0735	MILLERS RUN	46 FT	CONCR	INSTALLED	2016	0020/0735	
0020/0635	018 "DIA CIRC CONCR			INSTALLED	UNKN	0020/0635	
0020/0070	021 "DIA CIRC CONCR			INSTALLED	2016	0020/0070	
0020/0000	1 0 01138 0 00 0020+82	2306 FT				0020/0000	
0010/1795	021 "DIA CIRC CONCR			INSTALLED	2016	0010/1795	
0010/1645	021 "DIA CIRC CONCR			INSTALLED	2016	0010/1645	
0010/1198	018 "DIA CIRC CONCR			INSTALLED	UNKN	0010/1198	
0010/1195	021 "DIA CIRC CONCR			INSTALLED	2016	0010/1195	
0011/1164	012 "DIA CIRC CONCR			INSTALLED	UNKN	0011/1164	
0011/0850	027 "DIA CIRC CONCR			INSTALLED	2016	0011/0850	
0011/0500	027 "DIA CIRC CONCR			INSTALLED	2016	0011/0500	
0010/0845	027 "DIA CIRC CONCR			INSTALLED	2016	0010/0845	
0010/0495	027 "DIA CIRC CONCR			INSTALLED	2016	0010/0495	
0010/0493	024 "DIA CIRC CONCR			INSTALLED	UNKN	0010/0493	
0010/0215	027 "DIA CIRC CONCR			INSTALLED	2016	0010/0215	
0010/0000	1 0 01138 0 00 0000+00	000000 FT				0010/0000	
0010/0000	NC SR 0050 SH					0010/0000	
0010/0000	BISHOP HICKORY RD					0010/0000	
0010/0000	(SR0050 SEG 0391/1630)					0010/0000	
0010/0000	MFC BEGIN = B					0010/0000	
0010/0000	BK-WASHINGTON					0010/0000	
0010/0000	LENGTH(AH 2025 BK 0000)					0010/0000	

EXTRACT DATE: 12/21/2020 ROADWAY MANAGEMENT SYSTEM PAGE NUMBER: 149
 PRINT DATE: 12/23/2020 SLD COUNTY/SR - ANNUAL PRINT COUNTY: ALLEGHENY
 DIR: B TOTAL LEN: 18.919 MI. DIST: 11-1 SR: 48
 LEFT MUN: MONROEVILLE B RIGHT MUN: MONROEVILLE B

HAYMAKER RD		099892 FT		099851 FT	HAYMAKER RD
(SR2057 SEG 0011/0000)		INTER-AHD		INTER-AHD	(SR2057 SEG 0010/0000)
WILLIAM PENN HW					WILLIAM PENN HW
(SR2048 SEG 0110/0000)					(SR2048 SEG 0111/0000)
(SR2048 SEG 0111/0000)					(SR2048 SEG 0110/0000)
		0401/2769		0400/2733	

DIR: B TOTAL LEN: 18.919 MI. DIST: 11-1 SR: 48
 LEFT MUN: MONROEVILLE B RIGHT MUN: MONROEVILLE B

FROM	TO	DESCRIPTION	LEN	STATUS
2048/0100 SH (CONN)	0401/2638			
LC TO UPMC EAST DR (CONN)	0401/1811			
HOLIDAY LN (BORO)	0401/1722			
018 "DIA CIRC CONCR LEN=0099 INSTALLED UNKN	0401/1712			
UPMC EAST DR (PRDR)	0401/1701			
LC FROM UPMC DR EAST (CONN)	0401/1593			
018 "DIA CIRC CONCR LEN=0099 INSTALLED UNKN	0401/0915			
DAUGHERTY DR (BORO)	0401/0539			
DAUGHERTY DR (BORO)	0401/0530			
2 0 02105 0 00 0000+00 097123 FT NORTHERN PK {SR2054 SEG 0020/0000} {SR2054 SEG 0021/0000}	097123 FT			
NORTHERN PK {SR2054 SEG 0020/0000} {SR2054 SEG 0021/0000}	0401/0000			
015 "DIA CIRC CONCR LEN=0099 INSTALLED UNKN	0381/0955			
MOSSIDE VILLAGE ENT (PRDR)	0381/0817			
0400/2610 (CONN)	0400/2610			
012 "DIA CIRC CONCR LEN=0020 INSTALLED UNKN	0400/1767			
HOLIDAY LN (BORO)	0400/1720			
UPMC EAST DR (PRDR)	0400/1704			
012 "DIA CIRC CONCR LEN=0050 INSTALLED UNKN	0400/1700			
018 "DIA CIRC CONCR LEN=0099 INSTALLED UNKN	0400/0966			
DAUGHERTY DR (BORO)	0400/0565			
018 "DIA CIRC CONCR LEN=0050 INSTALLED UNKN	0400/0508			
018 "DIA CIRC CONCR LEN=0099 INSTALLED UNKN	0400/0037			
2 0 02105 0 00 0000+00 097118 FT NORTHERN PK {SR2054 SEG 0021/0000} {SR2054 SEG 0020/0000}	097118 FT			
NORTHERN PK {SR2054 SEG 0020/0000} {SR2054 SEG 0021/0000}	0400/0000			
TO 2054/0020 SH (CONN)	0380/1035			
MOSSIDE VILLAGE ENT (PRDR)	0380/0826			

DIR: B TOTAL LEN: 18.919 MI. DIST: 11-1 SR: 48
 LEFT MUN: MONROEVILLE B RIGHT MUN: MONROEVILLE B

Stationing	Length	Material	Status
0350/1979	LEN=0060	018" DIA CIRC CONCR	INSTALLED UNKN
0350/1351	LEN=0060	024" DIA CIRC CONCR	INSTALLED UNKN
0350/0931	LEN=0060	018" DIA CIRC CONCR	INSTALLED UNKN
0350/0490	LEN=0060	018" DIA CIRC CONCR	INSTALLED UNKN
087177 FT	087157 FT	2 0 0225 1 0 00 0173+16	
0350/0000	LENGTH(AH 3856 BK 3761)	024" DIA CIRC CONCR	INSTALLED 2002
0340/3536	LEN=0099	018" DIA CIRC CONCR	INSTALLED UNKN
0340/2944	LEN=0060	018" DIA CIRC CONCR	INSTALLED UNKN
0340/2185		HILLSIDE AV (BORO)	
0340/0851	LEN=0060	018" DIA CIRC CONCR	INSTALLED UNKN
0340/0030	LEN=0060	018" DIA CIRC CONCR	INSTALLED UNKN
083416 FT	083396 FT	2 0 0225 1 0 00 0135+41	
0340/0000	LENGTH(AH 3761 BK 1107)	018" DIA CIRC CONCR	INSTALLED UNKN
0330/0697	LEN=0050	018" DIA CIRC CONCR	INSTALLED UNKN
0330/0309	LEN=0099	018" DIA CIRC CONCR	INSTALLED UNKN
0330/0205	LEN=0099	018" DIA CIRC CONCR	INSTALLED UNKN
0330/0110	LEN=0099	018" DIA CIRC CONCR	INSTALLED UNKN
082309 FT	082289 FT	2 0 0225 1 0 00 0124+13	
		BROADWAY BL (SR0130 SEG 0332/0000)	
MONROEVILLE NORTH VERSAILLES T	0330/0000	MFC BEGIN = B	
	0330/0000	LENGTH(AH 1107 BK 2304)	
	0320/1836	018" DIA CIRC CONCR	INSTALLED UNKN
	0320/1685	018" DIA CIRC CONCR	INSTALLED UNKN
024"H 28"W ELLIP CONC	LEN=0099		INSTALLED UNKN
0321/1702			

EXTRACT DATE: 12/21/2020
PRINT DATE: 12/23/2020

ROADWAY MANAGEMENT SYSTEM
SLD COUNTY/SR - ANNUAL PRINT

PAGE NUMBER: 145
COUNTY: ALLEGHENY

DIR: B TOTAL LEN: 18.919 MI.
LEFT MUN: MONROEVILLE B

DIST: 11-1 SR: 48
RIGHT MUN: MONROEVILLE B

BMS EN 02/0048/0321/0001 0321/1350
0 0 00000 0 00 0000+00
TURTLE CREEK
BMSBG 02/0048/0321/0001 0321/0841
018 "DIA CIRC CONCR
LEN=0099 INSTALLED UNKN 0321/0793

DRAINAGE
STRUCTURE LENGTH 32 FT
BMSID 02/0048/0320/0218 0321/0231
0 0 00000 0 00 0000+00 079997 FT
WALL AV
(CNTY)
MFC BEGIN = B
LENGTH(AH 2312 BK 2163) 0321/0000

CENTRALIA AV
(TWP) 0310/1515
GRAHAM ST
(TWP) 0310/1233

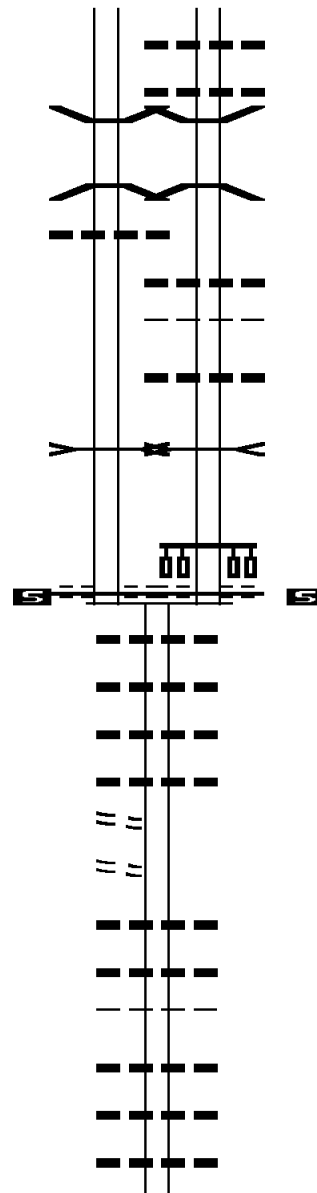

0320/1533 018 "DIA CIRC CONCR
LEN=0099 INSTALLED UNKN
0320/1350 018 "DIA CIRC CONCR
LEN=0099 INSTALLED UNKN
0320/1311 BMS EN 02/0048/0320/0001
2 0 02251 0 00 0107+74
TURTLE CREEK
0320/0802 BMSBG 02/0048/0320/0001
018 "DIA CIRC CONCR
LEN=0099 INSTALLED UNKN
MONROEVILLE
0320/0682 NORTH VERSAILLES T
018 "DIA CIRC CONCR
LEN=0099 INSTALLED UNKN
0320/0545 DRAINAGE
STRUCTURE LENGTH 32 FT
0320/0218 BMSID 02/0048/0320/0218
079985 FT 2 0 02251 0 00 0107+74
WALL AV
(CNTY)
0320/0000 MFC BEGIN = B
LENGTH(AH 2304 BK 2163)
0310/2057 024 "DIA CIRC CONCR
LEN=0040 INSTALLED UNKN
0310/1925 018 "DIA CIRC CONCR
LEN=0035 INSTALLED UNKN
0310/1775 018 "DIA CIRC CONCR
LEN=0035 INSTALLED UNKN
0310/1640 015 "DIA CIRC CONCR
LEN=0035 INSTALLED UNKN
0310/0980 018 "DIA CIRC CONCR
LEN=0045 INSTALLED UNKN
0310/0910 018 "DIA CIRC METAL
LEN=0040 INSTALLED UNKN
NORTH VERSAILLES
0310/0814 WALL BOROUGH B
0310/0787 018 "DIA CIRC METAL
LEN=0040 INSTALLED UNKN
0310/0685 018 "DIA CIRC METAL
LEN=0040 INSTALLED UNKN
0310/0586 018 "DIA CIRC METAL
LEN=0040 INSTALLED UNKN
018 "DIA CIRC CONCR

DIR: B TOTAL LEN: 18.919 MI. DIST: 11-1 SR: 48
 LEFT MUN: WALL BOROUGH B RIGHT MUN: WALL BOROUGH B

Stationing	Length	Description	Material	Status
2 0 02251 0 00 0075+05 077834 FT	0310/0130	ROSS ST ET (BORO)	018" DIA CIRC CONC	INSTALLED UNKN
	077822 FT			
	0310/0000		LENGTH(AH 2163 BK 3086)	
			024" DIA CIRC CONC	INSTALLED UNKN
SIGNAL HILL DR (PRDR)	0300/2915		018" DIA CIRC CONC	INSTALLED UNKN
	0300/2401	POI	(APRA) CORNERSTONE T V	
	0300/2280		018" DIA CIRC CONC	INSTALLED UNKN
	0300/2243		024" DIA CIRC CONC	INSTALLED UNKN
	0300/2118		018" DIA CIRC CONC	INSTALLED UNKN
	0300/2018		024" DIA CIRC CONC	INSTALLED UNKN
	0300/1918	WALL BOROUGH	018" DIA CIRC CONC	INSTALLED UNKN
	0300/1917	NORTH VERSAILLES T	015" DIA CIRC CONC	INSTALLED UNKN
	0300/1817		015" DIA CIRC CONC	INSTALLED UNKN
	0300/1718		015" DIA CIRC CONC	INSTALLED UNKN
	0300/1620		015" DIA CIRC CONC	INSTALLED UNKN
	0300/1520		015" DIA CIRC CONC	INSTALLED UNKN
	0300/0980		018" DIA CIRC CONC	INSTALLED UNKN
	0300/0817		024" DIA CIRC CONC	INSTALLED UNKN
	0300/0310		018" DIA CIRC CONC	INSTALLED UNKN
074748 FT	074736 FT		018" DIA CIRC CONC	INSTALLED UNKN
	0300/0000		LENGTH(AH 3086 BK 1417)	
	0290/1295		018" DIA CIRC CONC	INSTALLED UNKN
	0290/1093		018" DIA CIRC CONC	INSTALLED UNKN
	0290/0764		018" DIA CIRC CONC	INSTALLED UNKN
	0290/0182		018" DIA CIRC CONC	INSTALLED UNKN
2 0 02251 0 00 0030+00 073331 FT	073319 FT	NASER RD (TWP)	018" DIA CIRC CONC	INSTALLED UNKN
	0290/0000		LENGTH(AH 1417 BK 3435)	
	0280/2988		024" DIA CIRC CONC	INSTALLED UNKN
			024" DIA CIRC CONC	INSTALLED UNKN

DIR: B TOTAL LEN: 18.919 MI. DIST: 11-1 SR: 48
 LEFT MUN: NORTH VERSAILLES T RIGHT MUN: NORTH VERSAILLES T

ALDI DR
(TWP)

0280/0759

069896 FT

EAST ALLEGHENY SCHOOL D
(PRDR)

0270/0272
067755 FT

BIROS MOBILE HOME PARK
(PRDR)

0260/1261

---	0280/2624	LEN=0040	INSTALLED UNKN
---	0280/1117	024 " DIA CIRC CONCR LEN=1018	INSTALLED UNKN
==	0280/0759		
---	0280/0048	018 " DIA CIRC CONCR LEN=0050	INSTALLED UNKN
---	069884 FT	2 0 02251 0 00 0000+00	
---		NC MO	
---		SSIDE BL	
---		LINCOLN HW	
---		(SR0030 SEG 0341/0000)	
---		(SR0030 SEG 0340/0000)	
==	0280/0000	LENGTH(AH 3435 BK 2141)	
---		PRESTON RD	
==	0270/1950		
---	0270/1840	018 " DIA CIRC CONCR LEN=0040	INSTALLED 2002
---	0270/1636	018 " DIA CIRC CONCR LEN=0099	INSTALLED UNKN

==	067743 FT	1 0 00377 0 00 0125+01	
---		BR JACKS RUN	
---		STRUCTURE LENGTH 9 FT	
---		BMSID 02/0048/0270/0000	
==	0270/0000	LENGTH(AH 2141 BK 2966)	
---	0260/2612	018 " DIA CIRC CONCR LEN=0040	INSTALLED UNKN
---	0260/2137	018 " DIA CIRC CONCR LEN=0040	INSTALLED UNKN
---	0260/1797	NORTH VERSAILLES WHITE OAK B	
---	0260/1785	018 " DIA CIRC CONCR LEN=0040	INSTALLED UNKN
---	0260/1552	012 " DIA CIRC CONCR LEN=0050	INSTALLED UNKN

==	0260/0981	036 "H 24 "W CON BOX CUL LEN=0099	INSTALLED UNKN
---	0260/0925	MCKEESPORT SPORTSMENS E (T387)	

EXTRACT DATE: 12/21/2020
PRINT DATE: 12/23/2020

ROADWAY MANAGEMENT SYSTEM
SLD COUNTY/SR - ANNUAL PRINT

PAGE NUMBER: 142
COUNTY: ALLEGHENY

DIR: B TOTAL LEN: 18.919 MI.
LEFT MUN: WHITE OAK B

DIST: 11-1 SR: 48
RIGHT MUN: WHITE OAK B

Stationing	Length	Material	Status
0260/0750	0099	018" DIA CONC	INSTALLED UNKN
0260/0026	0040	018" DIA CONC	INSTALLED UNKN
064777 FT	1000377	000095+35	
0260/0000	2966	018" DIA CONC	INSTALLED UNKN
0250/3599	0060	024" DIA CONC	INSTALLED UNKN
0250/3182	0060	012" DIA CONC	INSTALLED UNKN
0250/2712	0070	024" DIA CONC	INSTALLED UNKN
0250/2480	0040	012" DIA CONC	INSTALLED UNKN
0250/2273	0048	018" DIA CONC	INSTALLED UNKN
0250/2069	0050	018" DIA CONC	INSTALLED UNKN
0250/1586	0060	018" DIA CONC	INSTALLED UNKN
0250/1230	0048	018" DIA CONC	INSTALLED UNKN
0250/1014	0050	018" DIA CONC	INSTALLED UNKN
0250/0750	0060	015" DIA CONC	INSTALLED UNKN
0250/0492	0070	015" DIA CONC	INSTALLED UNKN
0250/0078	0050	015" DIA CONC	INSTALLED UNKN
060974 FT	1000377	000057+75	
0250/0000	3815	024" DIA CONC	INSTALLED UNKN
0240/1601	0099	015" DIA CONC	INSTALLED UNKN
0240/1375	0050	015" DIA CONC	INSTALLED UNKN
0240/1069	0050	015" DIA CONC	INSTALLED UNKN
0240/0757	0050	015" DIA CONC	INSTALLED UNKN
0240/0110	0048	0240/0000	
058848 FT	1000377	000036+46	
		BR. JACKS RUN	
		BMSBG 02/0048/0240/0000	

MCKEE RD
(SR2035 SEG 0010/0000) 0240/0110
058848 FT

EXTRACT DATE: 12/21/2020
PRINT DATE: 12/23/2020

ROADWAY MANAGEMENT SYSTEM
SLD COUNTY/SR - ANNUAL PRINT

PAGE NUMBER: 141
COUNTY: ALLEGHENY

DIR: B TOTAL LEN: 18.919 MI.
LEFT MUN: WHITE OAK B

DIST: 11-1 SR: 48
RIGHT MUN: WHITE OAK B

1 0 00377 0 00 0002+76 055806 FT
RAINBOW SHOPPING CTR EN
(PRDR) 0230/0000

TO 2031/0040 SH
(CONN)

0220/0149
055209 FT

FROM 2031/0040 SH
(CONN)
OLIVER DR
(BORO)

0211/2086
0211/1930

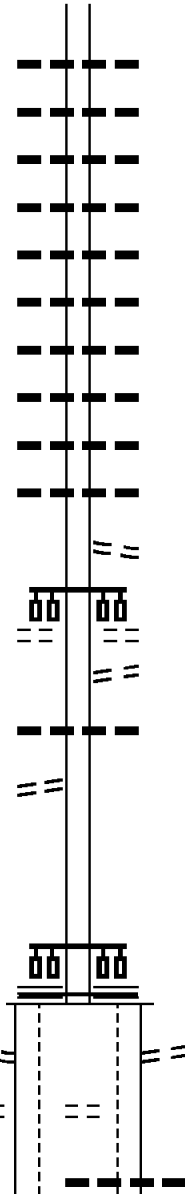

5 0240/0000 LENGTH(AH 2126 BK 3042)
015 "DIA CIRC CONCR
0230/2990 LEN=0050 INSTALLED UNKN
014 "DIA CIRC CONCR
0230/2609 LEN=0099 INSTALLED UNKN
024 "DIA CIRC CONCR
0230/2420 LEN=0099 INSTALLED UNKN
018 "DIA CIRC CONCR
0230/2251 LEN=0050 INSTALLED UNKN
015 "DIA CIRC CONCR
0230/1902 LEN=0055 INSTALLED UNKN
018 "DIA CIRC CONCR
0230/1589 LEN=0045 INSTALLED UNKN
015 "DIA CIRC CONCR
0230/1285 LEN=0040 INSTALLED UNKN
015 "DIA CIRC CONCR
0230/0963 LEN=0040 INSTALLED UNKN
015 "DIA CIRC CONCR
0230/0487 LEN=0040 INSTALLED UNKN
015 "DIA CIRC CONCR
0230/0089 LEN=0050 INSTALLED 2002
LC FR OAK PARK MALL
0230/0080 (CONN)
OAK PARK MALL ENT
055794 FT (PRDR)

5 0230/0000 LENGTH(AH 3042 BK 0597)
LC TO OAK PARK MALL
0220/0490 (CONN)
018 "DIA CIRC CONCR
0220/0317 LEN=0040 INSTALLED UNKN

055197 FT 1 0 00377 0 00 0000+00
NC J A CKS RUN RD
LINCOLN WY
(SR2031 SEG 0040/0232)
LINCOLN WY
(SR2031 SEG 0040/0232)

5 0220/0000 MFC BEGIN = B
LENGTH(AH 0597 BK 2187)
TO 2031/0040 SH
0210/2060 (CONN)
OLIVER DR
0210/1925 (BORO)

018 "DIA CIRC CONCR
0210/1250 LEN=0040 INSTALLED UNKN

DIR: B TOTAL LEN: 18.919 MI. DIST: 11-1 SR: 48
 LEFT MUN: MCKEESPORT C RIGHT MUN: MCKEESPORT C

012 "DIA CIRC CONCR LEN=0011 INSTALLED UNKN	0181/1543	---	---	0180/1670	012 "DIA CIRC CONCR LEN=0048 INSTALLED UNKN
015 "DIA CIRC CONCR LEN=0030 INSTALLED UNKN	2002 0173/1732	---	---	0180/1174	015 "DIA CIRC CONCR LEN=0040 INSTALLED UNKN
018 "DIA CIRC CONCR LEN=0050 INSTALLED UNKN	0173/1612	---	---		
095 "DIA CIRC CONCR LEN=0095 INSTALLED UNKN	0173/1099	---	---		
024 "DIA CIRC CONCR LEN=0099 INSTALLED UNKN	0173/0841	---	---		
0 0 00000 0 00 0000+00 OLYMPIA SHOPPING CTR EN (PRDR)	044978 FT			044933 FT	0 0 00000 0 00 0000+00 OLYMPIA SHOPPING CTR EN (PRDR)
LENGTH(AH 1794 BK 2176)	0173/0000	5	==	5	0172/0000 LENGTH(AH 1941 BK 2131)
MAPLEWOOD ST (CITY)	0171/1200	==	==	0170/1190	MAPLEWOOD ST (CITY)
ELIZABETH ST (CITY)	0171/0455	==	==	0170/0455	ELIZABETH ST (CITY)
TO 0148/0010 SH (CONN)	0171/0170	==	==	0170/0195	FROM 0048/0150 SH (CONN)
012 "DIA CIRC CONCR LEN=0050 INSTALLED UNKN	0171/0058	---	---		
1 0 00288 0 00 0535+03 WALNUT ST (SR0148 SEG 0010/0000)	042802 FT			042802 FT	1 0 00288 0 00 0535+03 WALNUT ST (SR0148 SEG 0010/0000)
NC LONG RUN RD MFC BEGIN = B					NC LONG RUN RD MFC BEGIN = B
LENGTH(AH 2176 BK 1360)	0171/0000	5	==	5	0170/0000 LENGTH(AH 2131 BK 1360) LONG RUN STRUCTURE LENGTH 25 FT
				0150/1290	BMSID 02/0048/0150/1320 TO 0048/0170 SH
				0150/1180	(CONN)
				0150/0709	012 "DIA CIRC CONCR LEN=0024 INSTALLED UNKN

DIR: B TOTAL LEN: 18.919 MI. DIST: 11-1 SR: 48
 LEFT MUN: MCKEESPORT C RIGHT MUN: MCKEESPORT C

Street Name	Stationing	Notes	Material	Length	Status
LINCOLN ST (BORO)	0150/0400				
	0150/0415		MCKEESPORT VERSAILLES B		
	0150/0350		018" DIA CIRC CONCR	LEN=0095	INSTALLED UNKN
	0150/0215		OLYMPIA SHOPPING CTR EN (PRDR)		
1 0 00288 0 00 0520+74 041442 FT	041442 FT				
JEFFERSON ST (BORO)	0150/0000				
	0150/0000		LENGTH(AH 1360 BK 2302)		
	0140/2287		012" DIA CIRC CONCR	LEN=0040	INSTALLED UNKN
GRANT ST (BORO)	0140/1910				
	0140/1882		012" DIA CIRC CONCR	LEN=0040	INSTALLED UNKN
	0140/1623		012" DIA CIRC CONCR (APRA) TYGART IND	LEN=0095	INSTALLED UNKN
	0140/1600	POT	JUNIPER ST (BORO)		
	0140/1599		012" DIA CIR PLASTIC	LEN=0012	INSTALLED UNKN
	0140/1196		012" DIA CIR PLASTIC	LEN=0015	INSTALLED UNKN
LARCH ST (BORO)	0140/1185		012" DIA CIRC CONCR	LEN=0012	INSTALLED UNKN
	0140/1065		012" DIA CIRC CONCR	LEN=0095	INSTALLED UNKN
	0140/0887		012"H 12"W BOX CULVERT	LEN=0011	INSTALLED UNKN
WAMPLER ST (BORO)	0140/0825				
CONN RD (BORO)	0140/0620		WORTHINGTON ST (BORO)		
	0140/0592		012" DIA CIR PLASTIC	LEN=0099	INSTALLED UNKN
WORTHINGTON ST (BORO)	0140/0540				
	0140/0308		012" DIA CIRC CONCR	LEN=0012	INSTALLED UNKN
	0140/0290		HIGH ST (BORO)		
HIGH ST (BORO)	0140/0235				
	0140/0007		018" DIA CIR PLASTIC	LEN=0095	INSTALLED UNKN

DIR: B TOTAL LEN: 18.919 MI. DIST: 11-1 SR: 48
 LEFT MUN: VERSAILLES B RIGHT MUN: VERSAILLES B

Stationing	Notes	Stationing	Notes
039140 FT		039140 FT	1 0 00288 0 00 0497+56 CENTER ST (SR2118 SEG 0010/0000) LENGTH(AH 2302 BK 2358)
CENTER ST (BORO)	0130/2190	0140/0000	
		0130/2145	012 " DIA CIRC CONCR LEN=0095 INSTALLED UNKN
		0130/1954	018 " DIA CIRC CONCR LEN=0095 INSTALLED UNKN
THIRD ST (BORO)	0130/1940	0130/1940	CHESTNUT ST (BORO)
		0130/1870	012 " DIA CIR PLASTIC LEN=0095 INSTALLED UNKN
KENNEDY AV (BORO)	0130/1645	0130/1790	LEMON AL (BORO)
		0130/1645	LINDEN ST (BORO)
		0130/1385	BMSBG 02/0048/0130/0203 VERSAILLES
		0130/0805	ELIZABETH T
		0130/0203	1 0 00288 0 00 0479+25 RAILROAD ST
	036782 FT	036782 FT	BMSBG 02/0048/0130/0203 1 0 00288 0 00 0474+71 NC WA
			LNUT ST (CNTY)
			SMITHFIELD ST (CNTY)
SMITHFIELD ST (SR2018 SEG 0040/2807)	0130/0000	0130/0000	RENZIE ST (SR2017 SEG 0200/3168) LENGTH(AH 2358 BK 2867)
DONNER ST (TWP)	0120/2460		
		0120/2335	018 " DIA CIRC CONCR LEN=0099 INSTALLED UNKN
		0120/1939	018 " DIA CIRC CONCR LEN=0072 INSTALLED UNKN
		0120/1652	012 " DIA CIRC CONCR LEN=0099 INSTALLED UNKN
		0120/1328	012 " DIA CIRC CONCR LEN=0030 INSTALLED UNKN
		0120/1160	PITT ST (TWP)
		0120/1110	PITT ST (TWP)
		0120/0875	018 " DIA CIRC CONCR LEN=0060 INSTALLED UNKN
			012 " DIA CIRC CONCR

EXTRACT DATE: 12/21/2020
PRINT DATE: 12/23/2020

ROADWAY MANAGEMENT SYSTEM
SLD COUNTY/SR - ANNUAL PRINT

PAGE NUMBER: 136
COUNTY: ALLEGHENY

DIR: B TOTAL LEN: 18.919 MI.
LEFT MUN: ELIZABETH T

DIST: 11-1 SR: 48
RIGHT MUN: ELIZABETH T

FEY RD
(TWP)

033915 FT

0110/2546

030079 FT

0120/0768	LEN=0030	INSTALLED	UNKN
0120/0000	LEN=0065	INSTALLED	UNKN
0110/3453	LEN=0030	INSTALLED	UNKN
0110/3242	LEN=0030	INSTALLED	UNKN
0110/3064	LEN=0030	INSTALLED	UNKN
0110/2754	LEN=0030	INSTALLED	UNKN
0110/2479	LEN=0030	INSTALLED	UNKN
0110/2308	LEN=0099	INSTALLED	UNKN
0110/1634	LEN=0042	INSTALLED	2019
0110/1412	LEN=0050	INSTALLED	UNKN
0110/0832	LEN=0035	INSTALLED	UNKN
0110/0678	LEN=0040	INSTALLED	UNKN
0110/0523	LEN=0040	INSTALLED	UNKN
0110/0232	LEN=0046	INSTALLED	2019
0100/3680	LEN=0046	INSTALLED	2019
0100/2833	LEN=0099	INSTALLED	UNKN

DIR: B TOTAL LEN: 18.919 MI. DIST: 11-1 SR: 48
 LEFT MUN: LINCOLN B RIGHT MUN: LINCOLN B

Left Side	Right Side	Notes
	0100/2805	MANSFIELD RD (BORO)
	0100/2170	LINCOLN ELIZABETH T
FINNEY RD (SR2025 SEG 0010/0000) 0100/2110	0100/2040	WYLIE RUN STRUCTURE LENGTH 10 FT BMSID 02/0048/0100/2040 072"H 72"W ELLIP CONC
	0100/2036	LEN=0032 INSTALLED UNKN
	0100/1479	012" DIA CIRC CONCR
	0100/1150	LEN=0030 INSTALLED UNKN
		018" DIA CIRC CONCR
		LEN=0040 INSTALLED UNKN
1 0 00288 0 00 0370+05 026374 FT VALLEY VIEW DR (TWP) 0100/0000	026374 FT	
	0100/0000	LENGTH(AH 3705 BK 3735) HILLVIEW DR (TWP)
	0090/3626	HILLVIEW RD (TWP)
LOVEDALE RD (SR2010 SEG 0040/2971) 0090/2725	0090/2638	036" DIA CIRC CONCR
	0090/2630	LEN=0055 INSTALLED UNKN
	0090/2620	036" DIA CIRC METAL BROADLAWN DR (CNTY)
ENTERPRISE ST (TWP) 0090/0818	0090/0434	015" DIA CIRC CONCR
		LEN=0045 INSTALLED UNKN
GIBSON RD (TWP) 0090/0250 022639 FT	022639 FT	1 0 00288 0 00 0333+00 GIBSON DR (TWP)
	0090/0000	LENGTH(AH 3735 BK 3233) 012"H 12"W CON BOX CUL
	0080/3233	LEN=0035 INSTALLED UNKN

DIR: B TOTAL LEN: 18.919 MI. DIST: 11-1 SR: 48
 LEFT MUN: ELIZABETH T RIGHT MUN: ELIZABETH T

0080/2935	018 " DIA CIRC CONCR LEN=0040 INSTALLED 2002
0080/2730	ROCK RUN RD (CNTY)
0080/1790	SIMPSON HOWELL RD (TWP)
0080/1650	LC TO SIMPSON RD (CONN)
019406 FT	019406 FT 1 0 00288 0 00 0300+28 CIRCLE DR (TWP)
0080/0000	NC BOSTON HOLLOW RD LENGTH(AH 3233 BK 3383) 018 " DIA CIRC CONCR
0070/3310	LEN=0037 INSTALLED 2019
0070/2444	018 " DIA CIRC CONCR LEN=0040 INSTALLED UNKN
0070/1471	018 " DIA CIR PLASTIC LEN=0010 INSTALLED 1999
0070/1445	CIRCLE DR (TWP)
0070/0244	018 " DIA CIRC METAL LEN=0160 INSTALLED UNKN
016023 FT	016023 FT
0070/0000	LENGTH(AH 3383 BK 2607) 015 " DIA CIRC CONCR
0060/2540	LEN=0040 INSTALLED UNKN
0060/2390	018 " DIA CIRC METAL LEN=0055 INSTALLED UNKN
0060/1778	012 " DIA CIRC METAL LEN=0035 INSTALLED UNKN
0060/1309	012 " DIA CIRC CONCR LEN=0099 INSTALLED UNKN
0060/1071	015 " DIA CIRC CONCR LEN=0030 INSTALLED UNKN
	015 " DIA CIRC CONCR

019406 FT

MILL HILL RD
 (SR2008 SEG 0020/2080) 0070/1445

1 0 00288 0 00 0266+33 016023 FT
 COWAN DR
 (TWP) 0070/0000

DIR: B TOTAL LEN: 18.919 MI. DIST: 11-1 SR: 48
 LEFT MUN: ELIZABETH T RIGHT MUN: ELIZABETH T

Stationing	Length	Notes	Material	Status
	0060/0895		LEN=0030	INSTALLED UNKN
	0060/0237		015 "DIA CIRC CONCR	
	013416 FT		LEN=0040	INSTALLED UNKN
1 0 00288 0 00 0240+38	013416 FT			
HAPPY HOLLOW RD				
(TWP)	0060/0000			
	0060/0000	LENGTH(AH 2607 BK 2186)		
	0050/1589	018 "DIA CIRC METAL		INSTALLED 2002
GROUSE DR				
(TWP)	0050/0860			
	0050/0787	015 "DIA CIRC CONCR		INSTALLED UNKN
GROUSE DR				
(TWP)	0050/0270			
	011230 FT			
	011230 FT	1 0 00288 0 00 0218+37		
		PEAIRS RD		
		(TWP)		
	0050/0000	LENGTH(AH 2186 BK 2084)		
	0040/0940	018 "DIA CIRC CONCR		INSTALLED UNKN
1 0 00288 0 00 0197+66	009146 FT			
WEIGLES HILL RD (TBK)				
(TWP)	0040/0000			
	0040/0000	LENGTH(AH 2084 BK 2289)		
	0030/2203	018 "DIA CIRC CONCR		INSTALLED UNKN
LC TO WEIGLES HILL RD				
(CONN)	0030/2035			
BUS DEPOT RD				
(PRDR)	0030/1605			
	0030/1605	(APRA) ELIZABETH/FORWAR		
	0030/1544	024 "DIA CIRC CONCR		INSTALLED UNKN
	0030/0859	015 "DIA CIRC CONCR		INSTALLED UNKN
	0030/0535	015 "DIA CIRC CONCR		INSTALLED UNKN
	006857 FT	LEN=0040		INSTALLED UNKN
	006857 FT	1 0 00288 0 00 0174+74		
		PARKSIDE DR		
		(TWP)		
	0030/0000	LENGTH(AH 2289 BK 3676)		
	0020/3479	015 "DIA CIRC CONCR		INSTALLED UNKN

EXTRACT DATE: 12/21/2020
PRINT DATE: 12/23/2020

ROADWAY MANAGEMENT SYSTEM
SLD COUNTY/SR - ANNUAL PRINT

PAGE NUMBER: 132
COUNTY: ALLEGHENY

DIR: B TOTAL LEN: 18.919 MI.
LEFT MUN: ELIZABETH T

DIST: 11-1 SR: 48
RIGHT MUN: ELIZABETH T

1 0 00288 0 00 0137+21 003181 FT
ROUND HILL ET
(CNTY) 0020/0000

000000 FT

0020/2281	048 " DIA CIRC METAL LEN=0060 INSTALLED UNKN
0020/2134	015 " DIA CIRC CONCR LEN=0045 INSTALLED UNKN
0020/1354	015 " DIA CIRC CONCR LEN=0045 INSTALLED UNKN
0020/1335	ROUND HILL CHURCH RD (TWP)
0020/0900	015 " DIA CIRC CONCR LEN=0035 INSTALLED UNKN
0020/0622	015 " DIA CIRC CONCR LEN=0035 INSTALLED UNKN
0020/0322	018 " DIA CIRC CONCR LEN=0035 INSTALLED UNKN
003181 FT	ROUND HILL RD (CNTY) ELIZABETH FORWARD T
0020/0000	LENGTH(AH 3676 BK 3181)
0010/2426	018 " DIA CIRC CONCR LEN=0028 INSTALLED 2018
0010/2407	016 " DIA CIRC CONCR LEN=0040 INSTALLED UNKN
0010/2376	DOUGLASS RUN STRUCTURE LENGTH 11 FT BMSID 02/0048/0010/2376
0010/2318	018 " DIA CIRC CONCR LEN=0028 INSTALLED 2018
0010/1736	012 " DIA CIRC METAL LEN=0050 INSTALLED UNKN
0010/0490	LC FROM SCENERY DR (CONN)
0010/0325	LC TO SCENERY DR (CONN)
0010/0131	FROM 0051/0030 SH (CONN)
000000 FT	1 0 00288 0 00 0106+02 NC SCENERY DR HAYDEN BL (SRO051 SEG 0040/0000)
INTER-BK	PAYDAYS DR (TWP)
0010/0000	MFC BEGIN = B LENGTH(AH 3181 BK 0000)

EXTRACT DATE: 12/21/2020 ROADWAY MANAGEMENT SYSTEM PAGE NUMBER: 131
PRINT DATE: 12/23/2020 SLD COUNTY/SR - ANNUAL PRINT COUNTY: ALLEGHENY

DIR: B TOTAL LEN: 15.024 MI. DIST: 11-1 SR: 30
LEFT MUN: NORTH VERSAILLES T RIGHT MUN: NORTH VERSAILLES T

AH-WESTMORELAND (64) 079327 FT		079244 FT	
LINCOLN HW REF-AHD *		REF-AHD *	LINCOLN HW
(SR0030 SEG 0011/0000) 0341/2448		0340/2437	(SR0030 SEG 0010/0000)
018 "DIA CIRC CONCR		0340/2290	015 "DIA CIRC CONCR
LEN=0099 INSTALLED UNKN 0341/2300	==	0340/1750	LEN=0040 INSTALLED UNKN
TRACY DR			TRACY DR
(BORO) 0341/1760			(BORO)
REISS LN			REISS LN

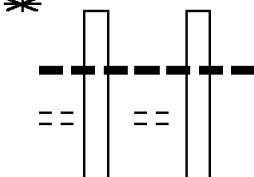

DIR: B TOTAL LEN: 15.024 MI. DIST: 11-1 SR: 30
 LEFT MUN: NORTH VERSAILLES T RIGHT MUN: NORTH VERSAILLES T

Stationing	Description	Stationing	Description
(BORO) 0341/1145		0340/1145 (BORO)	
018 "DIA CIRC CONCR		018 "DIA CIRC CONCR	
LEN=0099 INSTALLED UNKN 0341/0314		LEN=0099 INSTALLED UNKN	
1 0 00120 0 01 0831+41 076879 FT		076807 FT 1 0 00120 0 01 0831+41	
MOSSIDE BL		MOSSIDE BL	
(SRO048 SEG 0280/0000)		(SRO048 SEG 0280/0000)	
JACKS RUN RD		JACKS RUN RD	
(SRO048 SEG 0280/0000)		(SRO048 SEG 0280/0000)	
LENGTH(AH 2448 BK 2035) 0341/0000		LENGTH(AH 2437 BK 1997) 0340/0000	
018 "DIA CIRC CONCR		015 "DIA CIRC CONCR	
LEN=0099 INSTALLED UNKN 0331/1868		LEN=0045 INSTALLED UNKN	
018 "DIA CIRC CONCR			
LEN=0099 INSTALLED UNKN 0331/1535			
DIX DR		DIX DR	
(BORO) 0331/1160		(BORO) 0330/1150	
BACH DR		BACH DR	
(BORO) 0331/0565		(BORO) 0330/0555	
1 0 00120 0 01 0811+15 074844 FT		074810 FT 1 0 00120 0 01 0811+33	
N VERSAILLES PLAZA		N VERSAILLES PLAZA	
(PRDR)		(PRDR)	
LUEHM AV		LUEHM AV	
(BORO)		(BORO)	
LENGTH(AH 2035 BK 2951) 0331/0000		LENGTH(AH 1997 BK 2945) 0330/0000	
018 "DIA CIRC CONCR		018 "DIA CIRC CONCR	
LEN=0099 INSTALLED UNKN 0321/2332		LEN=0040 INSTALLED UNKN	
DENNING WY		018 "DIA CIRC CONCR	
(BORO) 0321/2115		LEN=0040 INSTALLED UNKN	
018 "DIA CIRC CONCR		DENNING WY	
LEN=0099 INSTALLED UNKN 0321/1980		(BORO) 0320/2095	
NASER RD		NASER RD	
(BORO) 0321/1237		(BORO) 0320/1195	
MCKEE RD		MCKEE RD	
(SR2035 SEG 0040/3558) 0321/0905		(SR2035 SEG 0040/3558) 0320/0895	
1 0 00120 0 01 0781+65 071893 FT		071865 FT 1 0 00120 0 01 0781+88	
LENGTH(AH 2951 BK 3735) 0321/0000		LENGTH(AH 2945 BK 3751) 0320/0000	
		UNKNOWN RD	

DIR: B TOTAL LEN: 15.024 MI. DIST: 11-1 SR: 30
 LEFT MUN: NORTH VERSAILLES T RIGHT MUN: NORTH VERSAILLES T

Segment ID	Description	Start Station	End Station	Material	Length	Status	Notes
095	"DIA CIRC CONCR LEN=0999 INSTALLED UNKN ST JOE CEMETERY RD (PRDR) BROAD ST (SR2031 SEG 0110/3474)	0311/3250	0311/3190	CONCRETE	60	Installed	ST JOE CEMETERY RD (PRDR) BROAD ST (SR2031 SEG 0110/3474)
024	"DIA CIRC CONCR LEN=0030 INSTALLED UNKN	0311/3065	0310/3096	CONCRETE	30	Installed	018 "DIA CIRC CONCR LEN=0060 INSTALLED UNKN
018	"H 01" W ELLIP CONC LEN=0036 INSTALLED UNKN	0311/2860	0310/2877	CONCRETE	36	Installed	018 "DIA CIRC CONCR LEN=0040 INSTALLED UNKN
024	"DIA CIRC CONCR LEN=0099 INSTALLED UNKN	0311/2300	0310/2255	CONCRETE	99	Installed	JACOB ST (BORO)
018	"DIA CIRC CONCR LEN=0999 INSTALLED UNKN	0311/2232	0310/2220	CONCRETE	99	Installed	018 "DIA CIRC CONCR LEN=0040 INSTALLED UNKN
018	"DIA CIRC CONCR LEN=0048 INSTALLED UNKN	0311/1910	0310/1889	CONCRETE	48	Installed	018 "DIA CIRC CONCR LEN=0050 INSTALLED UNKN
ISAAC ST (BORO)		0311/1745	0310/1740	CONCRETE	5	Installed	ISAAC ST (BORO)
JACKMAN ST (BORO)		0311/1385	0310/1380	CONCRETE	5	Installed	JACKMAN ST (BORO)
TAYLOR ST (BORO)		0311/1025	0310/1053	CONCRETE	28	Installed	018 "DIA CIRC CONCR LEN=0060 INSTALLED UNKN
TAYLOR ST (BORO)		0311/0885	0310/1025	CONCRETE	60	Installed	TAYLOR ST (BORO)
EDWARD ST (BORO)		0311/0625	0310/0926	CONCRETE	301	Installed	018 "DIA CIRC CONCR LEN=0040 INSTALLED UNKN
018 "DIA CIRC CONCR LEN=0099 INSTALLED UNKN		0311/0600	0310/0880	CONCRETE	280	Installed	TAYLOR ST (BORO)
018 "DIA CIRC CONCR LEN=0099 INSTALLED UNKN		0311/0340	0310/0625	CONCRETE	285	Installed	EDWARD ST (BORO)
ELIZABETH ST (BORO)		0311/0300	0310/0335	CONCRETE	35	Installed	018 "DIA CIRC CONCR LEN=0045 INSTALLED UNKN
			0310/0300	CONCRETE	35	Installed	ELIZABETH ST (BORO)

DIR: B TOTAL LEN: 15.024 MI. DIST: 11-1 SR: 30
 LEFT MUN: NORTH VERSAILLES T RIGHT MUN: NORTH VERSAILLES T

Stationing	Length	Material	Notes
1 0 00120 0 01 0744+31	068158 FT		
THIRD ST (BORO)			
LENGTH(AH 3735 BK 1497)	0311/0000		
PARK AV (TWP)			
	0301/1100		
NORTH VERSAILLES EAST MCKEESPORT B GRAHAM AV (BORO)			
	0301/0913		
	0301/0865		
THOMAS AV (BORO)			
MCCLURE AV (BORO)			
018 "DIA CIRC METAL LENO=0175 INSTALLED UNKN	0301/0375		
MCCLURE AV (BORO)			
	0301/0255		
1 0 00120 0 01 0729+31	066661 FT		
FIFTH AV (CNTY)			
FIFTH AV (SR0148 SEG 0160/1423)			
LENGTH(AH 1497 BK 1853)	0301/0000		
BROADWAY AV (BORO)			
	0291/1680		
LARGO ST (BORO)			
ICE PLANT HILL (CNTY)			
024 "DIA CIRC CONCR	0291/1505		
068114 FT			
THIRD ST (BORO)			
LENGTH(AH 3751 BK 1516)	0310/0000		
018 "DIA CIRC CONCR LENO=0040 INSTALLED UNKN	0300/1485		
PARK AV (TWP)			
	0300/1110		
NORTH VERSAILLES EAST MCKEESPORT B GRAHAM AV (BORO)			
	0300/0894		
	0300/0875		
018 "DIA CIRC CONCR LENO=0060 INSTALLED UNKN	0300/0634		
THOMAS AV (BORO)			
MCCLURE AV (BORO)			
	0300/0585		
	0300/0400		
018 "DIA CIRC CONCR LENO=0999 INSTALLED UNKN	0300/0324		
MCCLURE AV (BORO)			
1 0 00120 0 01 0729+31	066598 FT		
FIFTH AV (CNTY)			
FIFTH AV (SR0148 SEG 0160/1423)			
LENGTH(AH 1516 BK 1796)	0300/0000		
018 "DIA CIRC CONCR LENO=0999 INSTALLED UNKN	0290/1757		
018 "DIA CIRC CONCR LENO=0050 INSTALLED UNKN	0290/1634		
BROADWAY AV (BORO)			
	0290/1628		
018 "DIA CIRC CONCR LENO=0999 INSTALLED UNKN	0290/1506		
LARGO ST (BORO)			
ICE PLANT HILL (CNTY)			
	0290/1484		

DIR: B TOTAL LEN: 15.024 MI. DIST: 11-1 SR: 30
 LEFT MUN: EAST MCKEESPORT B RIGHT MUN: EAST MCKEESPORT B

Segment Description	Stationing	Material / Length	Notes
LEN=0999 INSTALLED UNKN	0291/1442		
SANTOS AV (BORO)	0291/1411	0290/1439	018 "DIA CIRC CONCR LEN=0070 INSTALLED UNKN
HILDA AV (BORO)		0290/1419	SANTOS AV (BORO)
GREENSBURG PK (CNTY)	0291/0995	0290/1164	018 "DIA CIRC CONCR LEN=0050 INSTALLED UNKN
EAST MCKEESPORT NORTH VERSAILLES T	0291/0556	0290/0973	HILDA AV (BORO)
GREENSBURG PK (CNTY)	0291/0306	0290/0536	GREENSBURG PK (CNTY)
1 0 00120 0 01 0710+93 064808 FT		0290/0529	EAST MCKEESPORT NORTH VERSAILLES T
OP ID 02/2087/0010/0001		0290/0245	018 "DIA CIRC CONCR LEN=0050 INSTALLED UNKN
LENGTH(AH 1853 BK 2622)	0291/0000	0290/0245	GREENSBURG PK (CNTY)
018 "DIA CIRC CONCR		064802 FT	1 0 00120 0 01 0710+93
LEN=0060 INSTALLED UNKN	0281/2554	0290/0000	OP ID 02/2087/0010/0001
			LENGTH(AH 1796 BK 2847)
018 "DIA CIRC CONCR			
LEN=0060 INSTALLED UNKN	0281/2331	0280/2753	018 "DIA CIRC METAL LEN=0095 INSTALLED UNKN
HIGHWOOD RD (BORO)	0281/2183	0280/2632	018 "DIA CIRC CONCR LEN=0055 INSTALLED UNKN
095 "DIA CIRC CONCR			HIGHWOOD RD (BORO)
LEN=0999 INSTALLED UNKN	0281/1785		
MARYLAND AV (BORO)	0281/1725	0280/1929	MARYLAND AV (BORO)
		0280/1795	LC TO MARYLAND AV (CONN)
024 "DIA CIRC CONCR			
LEN=0999 INSTALLED UNKN	0281/1583		
024 "DIA CIRC CONCR			
LEN=0099 INSTALLED UNKN	0281/1314		
018 "DIA CIRC CONCR		0280/1400	018 "DIA CIRC CONCR LEN=0030 INSTALLED UNKN
LEN=0099 INSTALLED UNKN	0281/1210		
		0280/1373	FROM 2068/0010 SH (CONN)
NAVY MARINE CORP WY (SR2068 SEG 0011/1385)			NAVY MARINE CORP WY (SR2068 SEG 0011/1385)
(SR2068 SEG 0010/1418)			(SR2068 SEG 0010/1418)
	0281/1080	0280/1269	

DIR: B TOTAL LEN: 15.024 MI. DIST: 11-1 SR: 30
 LEFT MUN: NORTH VERSAILLES T RIGHT MUN: NORTH VERSAILLES T

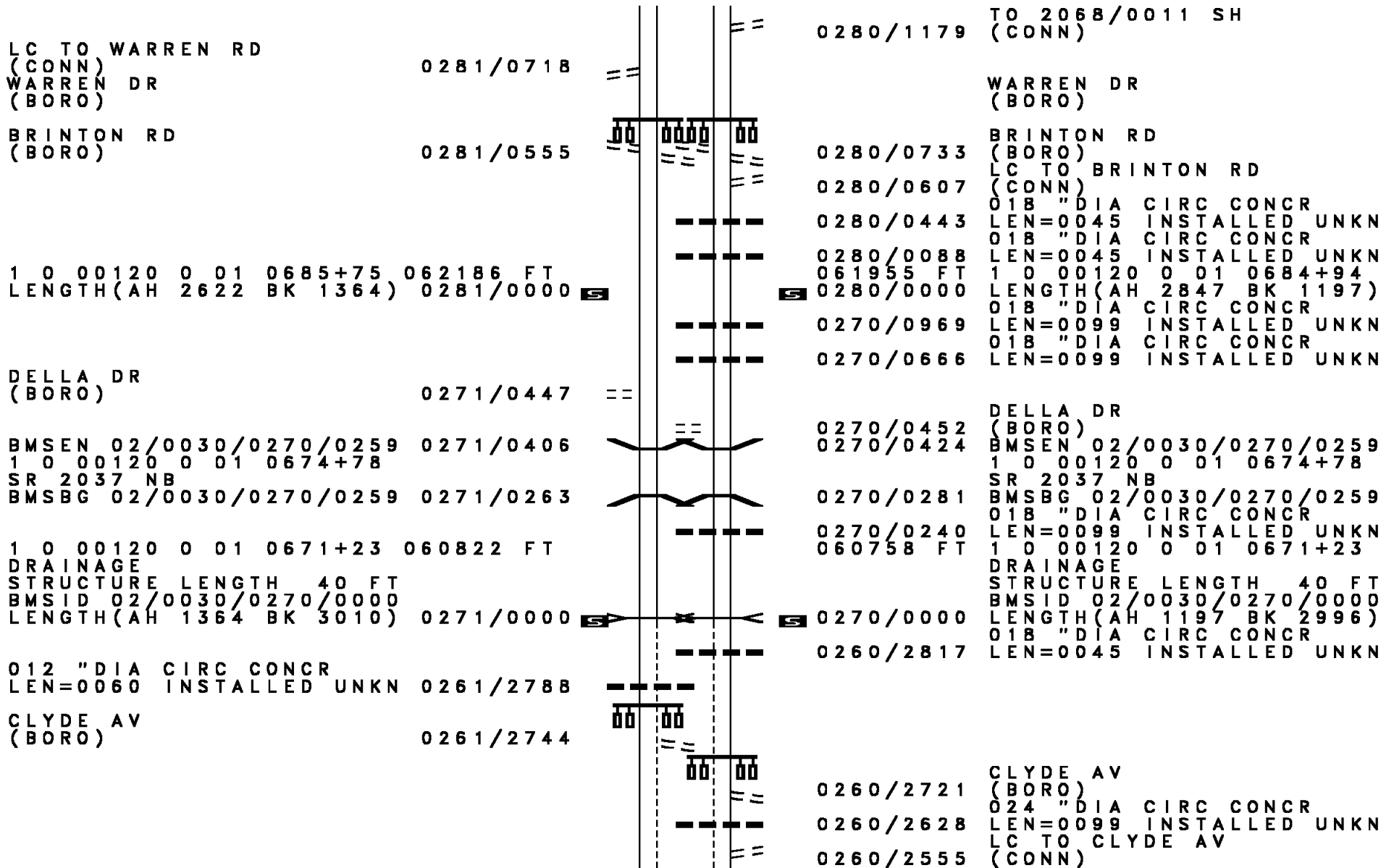

LC TO WARREN RD
 (CONN)
 WARREN DR
 (BORO)

0281/0718

BRINTON RD
 (BORO)

0281/0555

1 0 00120 0 01 0685+75 062186 FT
 LENGTH(AH 2622 BK 1364)

0281/0000

DELLA DR
 (BORO)

0271/0447

BMSID 02/0030/0270/0259 0271/0406
 1 0 00120 0 01 0674+78
 SR 2037 NB
 BMSBG 02/0030/0270/0259 0271/0263

1 0 00120 0 01 0671+23 060822 FT
 DRAINAGE
 STRUCTURE LENGTH 40 FT
 BMSID 02/0030/0270/0000
 LENGTH(AH 1364 BK 3010)

0271/0000

012 "DIA CIRC CONCR
 LEN=0060 INSTALLED UNKN

0261/2788

CLYDE AV
 (BORO)

0261/2744

0280/1179 TO 2068/0011 SH
 (CONN)

WARREN DR
 (BORO)

BRINTON RD
 (BORO)

0280/0733

0280/0607

0280/0443

0280/0088

061955 FT
 0280/0000

0270/0969

0270/0666

LC TO BRINTON RD
 (CONN)

018 "DIA CIRC CONCR
 LEN=0045 INSTALLED UNKN
 018 "DIA CIRC CONCR
 LEN=0045 INSTALLED UNKN
 1 0 00120 0 01 0684+94
 LENGTH(AH 2847 BK 1197)
 018 "DIA CIRC CONCR
 LEN=0099 INSTALLED UNKN
 018 "DIA CIRC CONCR
 LEN=0099 INSTALLED UNKN

DELLA DR
 (BORO)

0270/0452

0270/0424

0270/0281

0270/0240

060758 FT

0270/0000

0260/2817

BMSID 02/0030/0270/0259
 1 0 00120 0 01 0674+78
 SR 2037 NB
 BMSBG 02/0030/0270/0259
 018 "DIA CIRC CONCR
 LEN=0099 INSTALLED UNKN
 1 0 00120 0 01 0671+23
 DRAINAGE
 STRUCTURE LENGTH 40 FT
 BMSID 02/0030/0270/0000
 LENGTH(AH 1197 BK 2996)
 018 "DIA CIRC CONCR
 LEN=0045 INSTALLED UNKN

CLYDE AV
 (BORO)

0260/2721

0260/2628

0260/2555

024 "DIA CIRC CONCR
 LEN=0099 INSTALLED UNKN
 LC TO CLYDE AV
 (CONN)

DIR: B TOTAL LEN: 15.024 MI. DIST: 11-1 SR: 30
 LEFT MUN: NORTH VERSAILLES T RIGHT MUN: NORTH VERSAILLES T

018 "DIA CIRC CONCR LEN=0099 INSTALLED UNKN	0261/2213	---	0260/2257	018 "DIA CIRC CONCR LEN=0040 INSTALLED UNKN
018 "DIA CIRC CONCR LEN=0048 INSTALLED UNKN	0261/1935	---	0260/1979	018 "DIA CIRC CONCR LEN=0040 INSTALLED UNKN
018 "DIA CIRC METAL LEN=0099 INSTALLED UNKN	0261/1592	---	0260/1524	BMSEN 02/0030/0260/0000
BMSEN 02/0030/0260/0000	0261/1524	---		
NORTH VERSAILLES EAST PITTSBURGH B	0261/0338	---	0260/0465	NORTH VERSAILLES EAST PITTSBURGH B
1 0 00120 0 01 0641+22	057812 FT	---	057762 FT	1 0 00120 0 01 0641+22
1074 SPUR 1		---		1074 SPUR 1
BMSBG 02/0030/0260/0000		---		BMSBG 02/0030/0260/0000
LENGTH(AH 3010 BK 0815)	0261/0000	---	0260/0000	LENGTH(AH 2996 BK 0854)
(SR8124 SEG 0250/0000)	0251/0673	---		
BMSEN 02/0030/0250/0254	0251/0299	---	0250/0312	BMSEN 02/0030/0250/0254
1 0 00120 0 01 0634+78		---		1 0 00120 0 01 0634+78
BESSEMER AVE LOCAL		---		BESSEMER AVE LOCAL
BMSBG 02/0030/0250/0254	0251/0241	---	0250/0254	BMSBG 02/0030/0250/0254
012 "DIA CIRC CONCR LEN=0099 INSTALLED UNKN	0251/0007	---		
1 0 00120 0 01 0631+97	056997 FT	---	056908 FT	1 0 00120 0 01 0632+37
CENTER ST		---		CENTER ST
(SR2051 SEG 0010/0000)		---		(SR2051 SEG 0010/0000)
LENGTH(AH 0815 BK 1731)	0251/0000	---	0250/0000	LENGTH(AH 0854 BK 1707)
012 "DIA CIRC METAL LEN=0048 INSTALLED UNKN	0241/1107	---		
1 0 00120 0 01 0614+29	055266 FT	---	0240/0580	018 "DIA CIRC CONCR LEN=0045 INSTALLED UNKN
LENGTH(AH 1731 BK 2663)	0241/0000	---	055201 FT	1 0 00120 0 01 0614+88
		---	0240/0000	LENGTH(AH 1707 BK 2647)
EAST PITTSBURGH NORTH BRADDOCK B	0231/2035	---	0230/2041	EAST PITTSBURGH NORTH BRADDOCK B
		---	0230/1732	018 "DIA CIRC METAL LEN=0018 INSTALLED UNKN
		---	0230/1136	018 "DIA CIRC CONCR LEN=0999 INSTALLED UNKN
018 "DIA CIRC CONCR LEN=0050 INSTALLED UNKN	0231/1121	---		

DIR: B TOTAL LEN: 15.024 MI. DIST: 11-1 SR: 30
 LEFT MUN: NORTH BRADDOCK B RIGHT MUN: NORTH BRADDOCK B

BMS EN 02/0030/0231/0001	0231/0462		0230/0364	BMS EN 02/0030/0230/0001
0 0 00000 0 00 0000+00				0 0 00000 0 00 0000+00
ELECTRIC AVENUE				ELECTRIC AVENUE
BMSBG 02/0030/0231/0001	0231/0163		0230/0071	BMSBG 02/0030/0230/0001
024 "DIA CIRC CONCR				
LEN=0999 INSTALLED UNKN	0231/0073			
1 0 00120 0 01 0588+88	052603 FT		052554 FT	1 0 00120 0 01 0588+41
LENGTH(AH 2663 BK 3306)	0231/0000		0230/0000	LENGTH(AH 2647 BK 3327)
				018 "DIA CIRC CONCR
			0220/2799	LEN=0099 INSTALLED UNKN
NORTH BRADDOCK			0220/2730	NORTH BRADDOCK
CHALFANT B	0221/2947			CHALFANT B
018 "DIA CIRC CONCR				
LEN=0999 INSTALLED UNKN	0221/2690			
ELECTRIC AV				
(SR2112 SEG 0011/0000)	0221/2650			
			0220/2633	ELECTRIC AV
018 "DIA CIRC CONCR				(SR2112 SEG 0010/0000)
LEN=0999 INSTALLED UNKN	0221/2395			
018 "DIA CIRC METAL				
LEN=0048 INSTALLED UNKN	0221/2355			
			0220/2348	012 "DIA CIRC CONCR
				LEN=0099 INSTALLED UNKN
018 "DIA CIRC METAL				
LEN=0999 INSTALLED UNKN	0221/2283			
CHALFANT				
FOREST HILLS B	0221/2231		0220/2253	CHALFANT
018 "DIA CIRC CONCR				FOREST HILLS B
LEN=0999 INSTALLED UNKN	0221/2052			
			0220/2102	SIGN: 2 CHORD TRUSS
FOREST HILLS				BMSID 02/0030/0220/2102
NORTH BRADDOCK B	0221/1928		0220/2056	FOREST HILLS
				NORTH BRADDOCK B
			0220/2028	024 "DIA CIRC CONCR
018 "DIA CIRC CONCR				LEN=0099 INSTALLED UNKN
LEN=0099 INSTALLED UNKN	0221/1920			
FALLS RUN				
STRUCTURE LENGTH 10 FT				
BMSID 02/0030/0220/1532	0221/1532		0220/1532	FALLS RUN
				STRUCTURE LENGTH 10 FT
			0220/1367	BMSID 02/0030/0220/1532
				SIGN: CANTILEVER
018 "DIA CIRC CONCR				BMSID 02/0030/0220/1367
LEN=0099 INSTALLED UNKN	0221/1342			
			0220/1310	018 "DIA CIRC CONCR
				LEN=0180 INSTALLED UNKN
			0220/1183	018 "DIA CIRC CONCR
				LEN=0099 INSTALLED UNKN

DIR: B TOTAL LEN: 15.024 MI. DIST: 11-1 SR: 30
 LEFT MUN: FOREST HILLS B RIGHT MUN: FOREST HILLS B

Stationing	Description	Length	Notes
1 0 00120 0 01 0541+65 047932 FT	LENOX AV (BORO)		
018 "DIA CIRC CONCR	LEN=0035 INSTALLED UNKN	0201/2870	
018 "DIA CIRC CONCR	LEN=0035 INSTALLED UNKN	0201/2584	
MARION AV (BORO)			
BERKLEY AV (BORO)			
SIGN: SHAPE OR TUBE	BMSID 02/0030/0201/2008	0201/2039	
018 "DIA CIRC CONCR	LEN=0099 INSTALLED UNKN	0201/1985	
BR.FALLS RUN STRUCTURE LENGTH 12 FT	BMSID 02/0030/0200/1876	0201/1904	
FILMORE RD (BORO)		0201/1856	
018 "DIA CIRC CONCR	LEN=0125 INSTALLED UNKN	0201/1795	
018 "DIA CIRC CONCR	LEN=0036 INSTALLED UNKN	0201/1331	
CENTURION DR (BORO)			
FAIRFAX RD (BORO)		0201/0678	
1 0 00120 0 01 0513+27 045007 FT	FALLS RUN STRUCTURE LENGTH 14 FT	BMSID 02/0030/0200/0000	0201/0000
024 "DIA CIRC CONCR	LEN=0999 INSTALLED UNKN	0190/2534	
(BORO) SUMNER AV (BORO) KENMORE AV (BORO)			
0210/0000	LENGTH(AH 1112 BK 3057)		
0200/2489	018 "DIA CIRC CONCR LEN=0999 INSTALLED UNKN		
0200/2065	MARION AV (BORO) BERKLEY AV (BORO)		
0200/1945	SIGN: SHAPE OR TUBE BMSID 02/0030/0200/1945		
0200/1876	BR.FALLS RUN STRUCTURE LENGTH 12 FT BMSID 02/0030/0200/1876		
0200/1750	FILMORE RD (BORO)		
0200/1748	018 "DIA CIR PLASTIC LEN=0099 INSTALLED UNKN		
0200/1303	018 "DIA CIRC CONCR LEN=0999 INSTALLED UNKN		
0200/0595	CENTURION DR (BORO) FAIRFAX RD (BORO)		
0200/0582	018 "DIA CIRC CONCR LEN=0099 INSTALLED UNKN		
045058 FT	1 0 00120 0 01 0513+37		
0200/0000	FALLS RUN STRUCTURE LENGTH 14 FT BMSID 02/0030/0200/0000		
0200/0000	LENGTH(AH 3057 BK 2766)		
0190/2534	024 "DIA CIRC CONCR LEN=0999 INSTALLED UNKN		

EXTRACT DATE: 12/21/2020
PRINT DATE: 12/23/2020

ROADWAY MANAGEMENT SYSTEM
SLD COUNTY/SR - ANNUAL PRINT

PAGE NUMBER: 121
COUNTY: ALLEGHENY

DIR: B TOTAL LEN: 15.024 MI.
LEFT MUN: FOREST HILLS B

DIST: 11-1 SR: 30
RIGHT MUN: FOREST HILLS B

P3
FALLS RUN
STRUCTURE LENGTH 13 FT
BMSID 02/0030/0190/1870 0191/1802
BRADDOCK RD
(CNTY)

NEWPORT RD
(BORO)
BMSEN 02/0030/0190/0770 0191/0995
1 0 00120 0 01 0492+64
FALLS RUN
BMSBG 02/0030/0190/0770 0191/0753
018 "DIA CIRC CONCR
LEN=0045 INSTALLED UNKN 0191/0711
CROSSOVER RD
(CONN) 0191/0485

CROSSOVER RD
(CONN) 0191/0358
018 "DIA CIRC CONCR
LEN=0036 INSTALLED UNKN 0191/0024
1 0 00120 0 01 0485+26 042242 FT
LENGTH(AH 2765 BK 2315) 0191/0000

LAFAYETTE RD
(BORO) 0181/1810

LC TO MORROW RD
(CONN) 0181/0785
MORROW RD
(BORO)
DIGITAL PL
(PRDR)

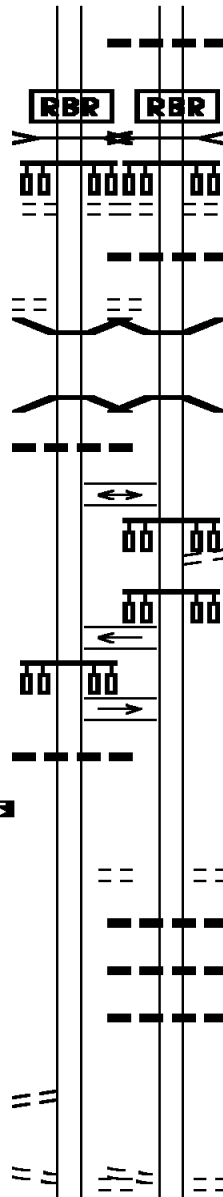

0190/2018 024 "DIA CIRC CONCR
LEN=0005 INSTALLED UNKN

P3
FALLS RUN
STRUCTURE LENGTH 13 FT
BMSID 02/0030/0190/1870 0190/1870
BRADDOCK RD
(CNTY)

0190/1715 018 "DIA CIRC CONCR
LEN=0999 INSTALLED UNKN
NEWPORT RD
(BORO)
BMSEN 02/0030/0190/0770 0190/0960
1 0 00120 0 01 0485+03
FALLS RUN
BMSBG 02/0030/0190/0770 0190/0719
0190/0701

0190/0410 CROSSOVER RD
(CONN)
BEVINGTON RD
(BORO)

0190/0370 CROSSOVER RD
(CONN)

0190/0340

042292 FT 1 0 00120 0 01 0485+03
5 0190/0000 LENGTH(AH 2766 BK 2355)

0180/1755 LAFAYETTE RD
(BORO)
0180/1653 018 "DIA CIRC CONCR
LEN=0070 INSTALLED UNKN
0180/1652 018 "DIA CIRC CONCR
LEN=0070 INSTALLED UNKN
0180/1380 018 "DIA CIRC CONCR
LEN=0070 INSTALLED UNKN

MORROW RD
(BORO)
DIGITAL PL
(PRDR)

DIR: B TOTAL LEN: 15.024 MI. DIST: 11-1 SR: 30
 LEFT MUN: FOREST HILLS B RIGHT MUN: FOREST HILLS B

Left Side Description	Left Side Stationing	Right Side Description	Right Side Stationing
FOREST HILLS	0181/0695	0180/0680	FOREST HILLS
WILKINSBURG B	0181/0558	0180/0136	WILKINSBURG B
SIGN: CANTILEVER			
BMSID 02/0030/0181/0515	0181/0515		
RAMP A RD			
(SR8012 SEG 0750/0000)	0181/0405		
SIGN: CANTILEVER			
BMSID 02/0030/0181/0364	0181/0364		
1 0 00120 0 01 0461+95	039927 FT	039937 FT	1 0 00120 0 01 0461+95
RAMP D 8012 EB TO			RAMP D 8012 EB TO
OP ID 02/8012/0280/1906			OP ID 02/8012/0280/1906
NC LINCOLN HW			NC LINCOLN HW
LENGTH(AH 2315 BK 0578)	0181/0000	0180/0000	LENGTH(AH 2355 BK 0588)
RAMP F RD			RAMP B RD
(SR8012 SEG 0760/0719)	0171/0255	0170/0460	(SR8012 SEG 0010/0603)
1 0 00120 0 01 0456+05	039349 FT	039349 FT	1 0 00120 0 01 0456+05
PARKWAY EAST			PARKWAY EAST
OP ID 02/0376/0774/2445			OP ID 02/0376/0774/2445
NC ARDMORE BL			NC ARDMORE BL
ARDMORE BL	REF-BK	* REF-BK	ARDMORE BL
(SR0008 SEG 0010/0000)			(SR0008 SEG 0011/0000)
MFC BEGIN = B			MFC BEGIN = B
LTH AH 000578 BK 000100	0171/0000	0170/0000	LTH AH 000588 BK 000100
	039349 FT	039349 FT	
			7164/0000
			INTER-AHD
NORTH FAYETTE T	0160/0998	0160/0998	NORTH FAYETTE T
FROM 8028/0500 SH			RAMP L RD
(CONN)	0160/0660	0160/0854	(SR8028 SEG 0500/0639)
STEUBEN ST		0160/0755	(TO 22 W) RAMP K RD
(T439)	0160/0505		(SR8028 SEG 0250/0000)
TO 3066/0010 SH			018 " DIA CIRC CONCR
(CONN)	0160/0164	0160/0565	LEN=0099 INSTALLED UNKN
2 0 02015 0 00 0118+29	038351 FT	0160/0505	STEUBEN ST
STEUBENVILLE PK		0160/0370	(T439)
			018 " DIA CIRC CONCR
			LEN=0099 INSTALLED UNKN
		038351 FT	OLD STEUBENVILLE PK
			(TWP)

DIR: B TOTAL LEN: 15.024 MI.
 LEFT MUN: NORTH FAYETTE T

DIST: 11-1 SR: 30
 RIGHT MUN: NORTH FAYETTE T

(SR3066 SEG 0010/0000) 0160/0000
 FROM 3066/0010 SH
 (CONN) 0150/0535

CHIRI LN
 (TWP) 0150/0074
 037653 FT

SEDLOCK LN
 (TWP) 0140/1771

LC TO CHURCH RD
 (CONN) 0140/0834
 CHURCH RD
 (TWP) 0140/0461
 CHURCH RD
 (TWP) 0140/0347

PATTERSON AV
 (TWP) 0130/1085

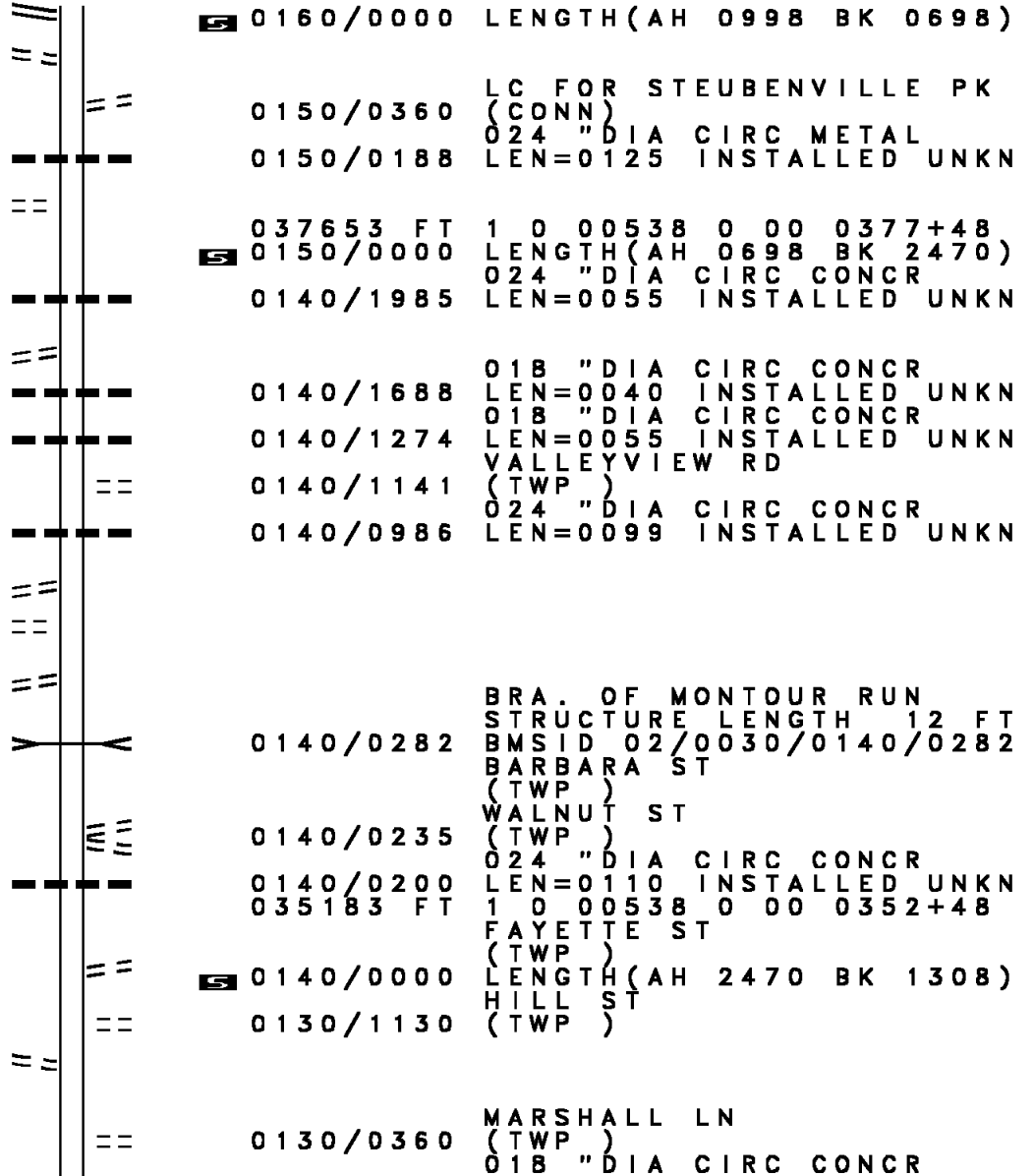

EXTRACT DATE: 12/21/2020
PRINT DATE: 12/23/2020

ROADWAY MANAGEMENT SYSTEM
SLD COUNTY/SR - ANNUAL PRINT

PAGE NUMBER: 118
COUNTY: ALLEGHENY

DIR: B TOTAL LEN: 15.024 MI.
LEFT MUN: NORTH FAYETTE T

DIST: 11-1 SR: 30
RIGHT MUN: NORTH FAYETTE T

Stationing	Distance	Notes
0130/0300	LEN=0055	INSTALLED UNKN
0130/0285		NORTH STAR RD (T435)
0130/0100	LEN=0075	INSTALLED UNKN
033875 FT	1 0 00538 0 00	0339+44
0130/0000		MONTOUR RAILROAD COMPAN OVERPASS IS RR X-ING LENGTH(AH 1308 BK 2397)
0120/2315	BMSEN 02/0030/0120/2263	1 0 00538 0 00 0338+30 P3
0120/2263		SOUTH FORK MOUNTOUR RUN BMSBG 02/0030/0120/2263 SANTIAGO RD (TBK) (TWP)
0120/1885		NORTH FAYETTE FINDLAY T
0120/1845	LEN=0084	INSTALLED UNKN
0120/1730	LEN=0050	INSTALLED UNKN
0120/1565	LEN=0070	INSTALLED UNKN
0120/1255		
0120/1030		
0120/0950	LEN=0099	INSTALLED UNKN
0120/0046	LEN=0099	INSTALLED UNKN
031478 FT	1 0 00538 0 00	0315+65
0120/0000		IMP/BURGETTSTOWN RD (CNTY) LENGTH(AH 2397 BK 3091)
0110/3052	LEN=0070	INSTALLED UNKN
0110/2293	LEN=0060	INSTALLED UNKN
0110/1907	LEN=0060	INSTALLED UNKN

SANTIAGO RD (T437)

MAIN ST (TWP)
GREGG LN (TWP)

1 0 00538 0 00 0284+47 028387 FT
 ROBINSON RD
 (PRDR) 0110/0000

024490 FT

021772 FT

PA TPK (1-576), WB
 OP ID 02/7576/9900/0143 0091/0632
 PA TPK (1-576 EB)
 OP ID 02/7576/9900/0142 0091/0533

TURNPIKE RAMP RD TOLL 5

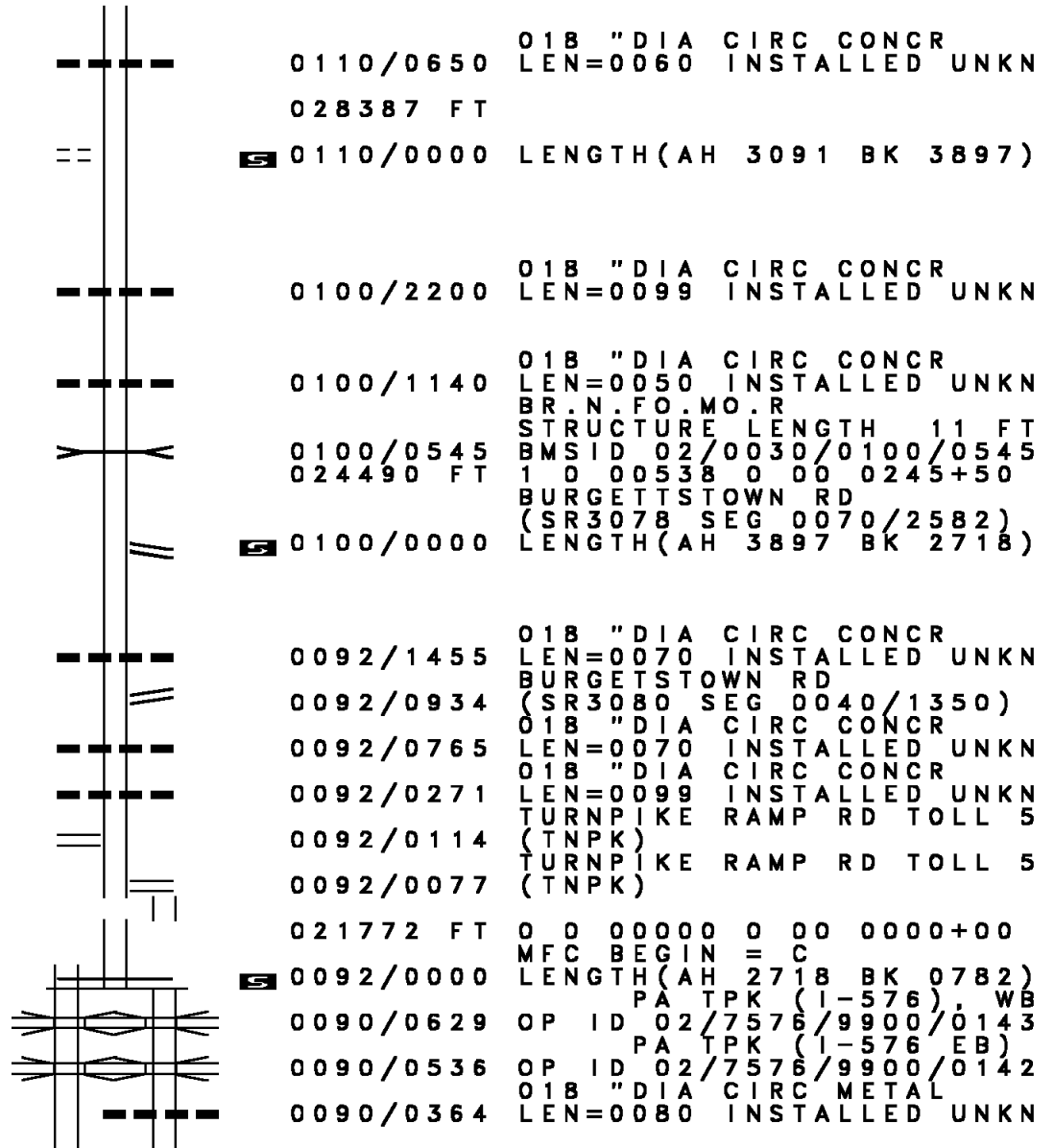

DIR: B TOTAL LEN: 15.024 MI. DIST: 11-1 SR: 30
 LEFT MUN: FINDLAY T RIGHT MUN: FINDLAY T

Stationing	Description	Length	Notes
0 0 00000 0 00 0000+00	TURNPIKE RAMP RD TOLL 5 (TNPK)	020990 FT	0091/0334
0 0 00000 0 00 0000+00	TURNPIKE RAMP RD TOLL 5 (TNPK)	020990 FT	0091/0302
0 0 00000 0 00 0000+00	MFC BEGIN = C LENGTH(AH 0782 BK 1955)	0091/0000	0090/0302
0 0 00000 0 00 0000+00	POINT PARK RD (TWP)	0080/1875	0090/0000
0 0 00000 0 00 0000+00		019035 FT	0080/0000
0 0 00000 0 00 0000+00		0070/1886	0070/1886
0 0 00000 0 00 0000+00		0070/0990	0070/0990
0 0 00000 0 00 0000+00		0070/0225	0070/0225
1 0 00538 0 00 0169+44	CRESCENT DR (T458)	017005 FT	0070/0000
0 0 00000 0 00 0000+00		0060/2500	0060/2500
0 0 00000 0 00 0000+00	PRIORITY EQ RENTAL DR (PRDR)	0060/1803	0060/1803
0 0 00000 0 00 0000+00		0060/1679	0060/1679
0 0 00000 0 00 0000+00		0060/1676	0060/1676
0 0 00000 0 00 0000+00		0060/1550	0060/1550
0 0 00000 0 00 0000+00	CRESCENT DR (T457)	0060/0525	0060/0525
0 0 00000 0 00 0000+00		0060/0125	0060/0125
1 0 00538 0 00 0144+15	CLINTON RD (SR3089 SEG 0070/0000)	014471 FT	014471 FT
0 0 00000 0 00 0000+00		0060/0000	0060/0000

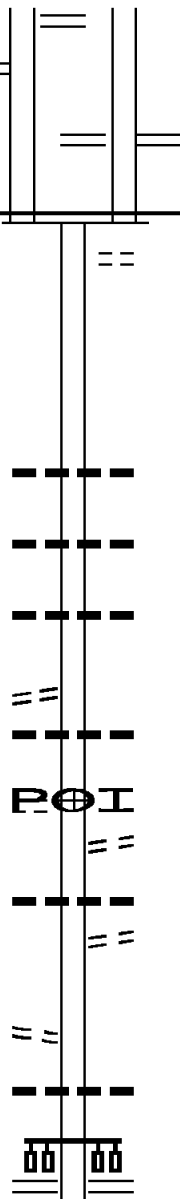

TURNPIKE RAMP RD TOLL 5 (TNPK)
 TURNPIKE RAMP RD TOLL 5 (TNPK)
 1 0 00538 0 00 0210+58 MFC BEGIN = C LENGTH(AH 0782 BK 1955)
 1 0 00538 0 00 0189+74 LENGTH(AH 1955 BK 2030)
 012 "DIA CIRC CONCR LEN=0060 INSTALLED UNKN
 018 "DIA CIRC CONCR LEN=0065 INSTALLED UNKN
 018 "DIA CIRC CONCR LEN=0055 INSTALLED UNKN
 LENGTH(AH 2030 BK 2534)
 018 "DIA CIRC CONCR LEN=0045 INSTALLED UNKN
 (APRA) PRIORITY EQ RENT PHYLLIS DR (TWP)
 024 "DIA CIRC CONCR LEN=0040 INSTALLED UNKN WILSON LN (PRDR)
 024 "DIA CIRC CONCR LEN=0040 INSTALLED UNKN WASHINGTON RD (SR3089 SEG 0070/0000)
 LENGTH(AH 2534 BK 3630)

DIR: B TOTAL LEN: 15.024 MI. DIST: 11-1 SR: 30
 LEFT MUN: FINDLAY T RIGHT MUN: FINDLAY T

FROM (CONN)	0050/3472	==	0050/3146	MUNICIPAL DR (TWP)
		==	0050/2816	018 " DIA CIRC CONCR LEN=0040 INSTALLED UNKN
MATCHETTE RD (T316)	0050/2785	POI	0050/2785	(APRA) PRECISION KIDD PARKVIEW DR
		==	0050/2225	(TWP)
		==	0050/2152	018 " DIA CIRC CONCR LEN=0099 INSTALLED UNKN
		==	0050/2115	RIZOR LN (TWP)
CAMP MEETING RD (T314)	0050/1450	==	0050/1403	021 " DIA CIRC CONCR LEN=0002 INSTALLED UNKN
		==	0050/1365	CLINTON PARK DR (T847)
		==	0050/1154	018 " DIA CIRC CONCR LEN=0036 INSTALLED UNKN
POPLAR DR (T318)	0050/0870	==	0050/0845	POPLAR DR (CNTY)
	010841 FT		010841 FT	1 0 00538 0 00 0108+00 MOODY RD (T306)
		==	0050/0000	LENGTH(AH 3630 BK 3865)
		==	0040/3230	MOODY LN (T851)
MANSE DR (TWP)	0040/3017	==	0040/1173	018 " DIA CIRC CONCR LEN=0048 INSTALLED UNKN
		==	0040/0322	012 " DIA CIRC CONCR LEN=0099 INSTALLED UNKN
FERGUSON RD (T503)	0040/0216 006976 FT	==	006976 FT	1 0 00538 0 00 0069+24

DIR: B TOTAL LEN: 15.024 MI. DIST: 11-1 SR: 30
 LEFT MUN: FINDLAY T RIGHT MUN: FINDLAY T

Stationing	Segment	Description	Material	Status
004574 FT	0040/0000	COMBS RD	LENGTH(AH 3865 BK 2402)	
	0030/2363	(T505)		
	0030/0735	018 " DIA CIRC CONCR	LEN=0050	INSTALLED UNKN
	0030/0465	012 " DIA CIRC CONCR	LEN=0050	INSTALLED UNKN
	0030/0420	018 " DIA CIRC CONCR	LEN=0099	INSTALLED UNKN
	004574 FT	1 0 00538 0 00 0045+29		
		COMBS RD		
		(T505)		
	0030/0000	POTATO GARDEN RUN RD	LENGTH(AH 2402 BK 2999)	
	0020/2366	(SR3071 SEG 0100/0000)		
	0020/2054	018 " DIA CIRC CONCR	LEN=0099	INSTALLED UNKN
	0020/1675	WINTER TR	(T304)	
	0020/1650	018 " DIA CIRC CONCR	LEN=0099	INSTALLED UNKN
		HEBRON RD		
		(T302)		
	0020/0075	1 0 00538 0 00 0017+71		
	001575 FT	CLINTON FRANKFORT RD		
		(SR3082 SEG 0010/3512)		
	0020/0000	LENGTH(AH 2999 BK 1575)		
	0010/1389	024 " DIA CIRC CONCR	LEN=0048	INSTALLED UNKN
	0010/0993	018 " DIA CIRC CONCR	LEN=0048	INSTALLED UNKN
	0010/0664	036 " DIA CIRC CONCR	LEN=0056	INSTALLED UNKN
	000000 FT	1 0 00538 0 00 0000+00		
		NC LINCOLN HW		
	* REF-BK	LINCOLN HW		
		(SR0030 SEG 0220/1824)		
		MFC BEGIN = C		
		BK-BEAVER (04)		
	0010/0000	LENGTH(AH 1575 BK 0000)		

EXTRACT DATE: 12/21/2020 ROADWAY MANAGEMENT SYSTEM PAGE NUMBER: 113
PRINT DATE: 12/23/2020 SLD COUNTY/SR - ANNUAL PRINT COUNTY: ALLEGHENY
DIR: N TOTAL LEN: 24.087 MI. DIST: 11-1 SR: 28
LEFT MUN: HARRISON T RIGHT MUN: HARRISON T

AH-BUTLER (10) 126959 FT
ALLEGHENY VALLEY EX REF-AHD

127178 FT
REF-AHD ALLEGHENY VALLEY EX

DIR: N TOTAL LEN: 24.087 MI. DIST: 11-1 SR: 28
 LEFT MUN: HARRISON T RIGHT MUN: HARRISON T

Stationing	Description	Length	Notes
0491/1333	RAMP K RD		
0491/1307	(SR8129 SEG 0500/0000)		
0491/1300	016 "DIA CIRC CONCR		
0491/0564	BMSBG 02/0028/0491/0344		
0491/0344	018 "DIA CIRC CONCR		
0491/0302	LEN=0030 INSTALLED UNKN		
0491/0000	1 0 01037 0 01 0835+80 125626 FT		
0491/0000	LENGTH(AH 1333 BK 1551)		
0481/1151	RAMP I RD		
0481/1050	(SR8129 SEG 0250/0748)		
0481/0280	018 "DIA CIRC CONCR		
0481/0000	LEN=0099 INSTALLED UNKN		
0481/0000	1 0 01037 0 01 0820+29 124075 FT		
0481/0000	LENGTH(AH 1551 BK 2650)		
0471/2400	018 "DIA CIRC CONCR		
0471/1998	LEN=0099 INSTALLED UNKN		
0471/1508	018 "DIA CIRC CONCR		
0471/1125	LEN=0099 INSTALLED UNKN		
0471/0727	018 "DIA CIRC CONCR		
0471/0000	LEN=0099 INSTALLED UNKN		
0470/0269	CROSSOVER RD		
0470/0240	(CONN)		
0470/0000	012 "DIA CIRC CONCR		
0470/0000	LEN=0099 INSTALLED UNKN		
0470/0000	1 0 01037 0 01 0791+28		
0470/0000	LENGTH(AH 2650 BK 3682)		
0461/3150	024 "DIA CIRC CONCR		
0461/2767	LEN=0048 INSTALLED UNKN		
0461/2757	FAWN HARRISON T		
0460/2696	BMSBG 02/0028/0461/2413		
0490/1351	(SR0028 SEG 0010/0000)		
0490/0603	BMSBG 02/0028/0490/0373		
0490/0373	018 "DIA CIRC CONCR		
0490/0000	LEN=0030 INSTALLED UNKN		
0490/0000	1 0 01037 0 01 0835+23		
0490/0000	LENGTH(AH 1351 BK 1836)		
0480/1320	RAMP J RD		
0480/0000	(SR8129 SEG 0010/0000)		
0480/0000	1 0 01037 0 01 0816+87		
0480/0000	LENGTH(AH 1836 BK 2660)		
0460/2380	BMSBG 02/0028/0460/2380		

DIR: N TOTAL LEN: 24.087 MI. DIST: 11-1 SR: 28
 LEFT MUN: FAWN T RIGHT MUN: FAWN T

Station	Material	Length	Notes	Station	Material	Length	Notes
1 0 01037 0 01 0780+27				0460/2660	FAWN HARRISON T		
LR 02222				W 0460/2505	RWIS SITE/AT TARENTUM		
BMSBG 02/0028/0461/2413	0461/2392				1 0 01037 0 01 0756+75		
018 "DIA CIRC CONCR					LR 02222		
LEN=0030	INSTALLED UNKN	0461/2356	---	0460/2357	BMSBG 02/0028/0460/2380		
018 "DIA CIRC CONCR							
LEN=0099	INSTALLED UNKN	0461/1723	---				
018 "DIA CIRC CONCR							
LEN=0099	INSTALLED UNKN	0461/1420	---				
018 "DIA CIRC CONCR							
LEN=0099	INSTALLED UNKN	0461/1024	---				
018 "DIA CIRC CONCR							
LEN=0099	INSTALLED UNKN	0461/0355	---				
099 "H 00 "W **UNKNOWN**							
LEN=0048	INSTALLED UNKN	0461/0034	---				
1 0 01037 0 01 0756+58	117743 FT						
LENGTH(AH 3682 BK 3146)	0461/0000		5	117867 FT	1 0 01037 0 01 0756+75		
018 "DIA CIRC CONCR				5 0460/0000	LENGTH(AH 3464 BK 3072)		
LEN=0099	INSTALLED UNKN	0451/2869	---				
018 "DIA CIRC CONCR							
LEN=0099	INSTALLED UNKN	0451/2435	---				
099 "DIA CIRC CONCR							
LEN=0099	INSTALLED UNKN	0451/1936	---				
018 "DIA CIRC CONCR							
LEN=0099	INSTALLED UNKN	0451/1590	---				
099 "H 00 "W **UNKNOWN**							
LEN=0099	INSTALLED UNKN	0451/1540	---				
099 "H 00 "W **UNKNOWN**							
LEN=0099	INSTALLED UNKN	0451/1101	---				
018 "DIA CIRC CONCR							
LEN=0040	INSTALLED UNKN	0451/0764	---				
018 "DIA CIRC CONCR							
LEN=0099	INSTALLED UNKN	0451/0441	---				
1 0 01037 0 01 0725+13	114597 FT						
LENGTH(AH 3146 BK 2657)	0451/0000		5	114795 FT	1 0 01037 0 01 0725+78		
018 "DIA CIRC CONCR				5 0450/0000	LENGTH(AH 3072 BK 2430)		
LEN=0099	INSTALLED UNKN	0443/2183	---				
018 "DIA CIRC CONCR							
LEN=0099	INSTALLED UNKN	0443/1769	---				
018 "DIA CIRC CONCR							
LEN=0099	INSTALLED UNKN	0443/1242	---				
018 "DIA CIRC CONCR							
LEN=0099	INSTALLED UNKN	0443/0775	---				
018 "DIA CIRC CONCR							
LEN=0099	INSTALLED UNKN	0443/0321	---				

DIR: N TOTAL LEN: 24.087 MI. DIST: 11-1 SR: 28
 LEFT MUN: HARRISON T RIGHT MUN: HARRISON T

Station	Description	Length (AH/BK)	Material	Status	Station	Description	Length (AH/BK)	Material	Status
1 0 01037 0 01 0697+90	111940 FT				1 0 01037 0 01 0700+18	112365 FT			
LENGTH(AH 2657 BK 3246)	0443/0000				LENGTH(AH 2430 BK 3531)	0440/0000			
RAMP F RD					RAMP H RD				
(SR8066 SEG 0500/0000)	0433/3187				(SR8066 SEG 0750/1160)	0430/3239			
018 "DIA CIRC CONCR									
LEN=0099 INSTALLED UNKN	0433/2987								
018 "DIA CIRC CONCR									
LEN=0099 INSTALLED UNKN	0433/2644								
018 "DIA CIRC CONCR									
LEN=0099 INSTALLED UNKN	0433/2155								
BMS EN 02/0028/0433/1947	0433/2100				0430/2121	BMS EN 02/0028/0430/1987			
1 0 01037 0 01 0685+70					1 0 01037 0 01 0677+38				
BURTNER RD SR 1032 WB					BURTNER ROAD SR 1032 WB				
BMSBG 02/0028/0433/1947	0433/1947				0430/1968	BMSBG 02/0028/0430/1987			
018 "DIA CIRC CONCR									
LEN=0030 INSTALLED UNKN	0433/1933								
018 "DIA CIRC CONCR									
LEN=0099 INSTALLED UNKN	0433/1344								
018 "DIA CIRC CONCR									
LEN=0099 INSTALLED UNKN	0433/1343								
RAMP E RD									
(SR8066 SEG 0250/0831)	0433/1155				0430/1285	RAMP G RD			
LITTLE BULL						(SR8066 SEG 0010/0000)			
STRUCTURE LENGTH 12 FT					0430/1136	LITTLE BULL			
BMSID 02/0028/0430/1159	0433/1119					STRUCTURE LENGTH 12 FT			
018 "DIA CIRC CONCR						BMSID 02/0028/0430/1159			
LEN=0050 INSTALLED UNKN	0433/0793								
018 "DIA CIRC CONCR									
LEN=0050 INSTALLED UNKN	0433/0478								
018 "DIA CIRC CONCR									
LEN=0099 INSTALLED UNKN	0433/0442								
036 "DIA CIRC CONCR									
LEN=0050 INSTALLED UNKN	0433/0154								
1 0 01037 0 01 0665+38	108694 FT								
HARRISON									
EAST DEER T									
LENGTH(AH 3246 BK 2436)	0433/0000				108834 FT	1 0 01037 0 01 0665+98			
					0430/0000	LENGTH(AH 3531 BK 3948)			
						018 "DIA CIRC CONCR			
					0420/3790	LEN=0099 INSTALLED UNKN			
						018 "DIA CIRC CONCR			
					0420/3565	LEN=0099 INSTALLED UNKN			
						018 "DIA CIRC CONCR			
					0420/3340	LEN=0099 INSTALLED UNKN			
						018 "DIA CIRC CONCR			
					0420/3140	LEN=0099 INSTALLED UNKN			
						018 "DIA CIRC CONCR			
					0420/2845	LEN=0099 INSTALLED UNKN			
						024 "DIA CIRC CONCR			
					0420/2591	LEN=0099 INSTALLED UNKN			

018 "DIA CIRC CONCR

DIR: N TOTAL LEN: 24.087 MI. DIST: 11-1 SR: 28
LEFT MUN: EAST DEER T RIGHT MUN: EAST DEER T

LEN=0099	INSTALLED UNKN	0425/2436	---	---	---	0430/1950	012 "DIA	CIRC CONCR	LEN=0099	INSTALLED UNKN
						0420/2290	018 "DIA	CIRC CONCR	LEN=0099	INSTALLED UNKN
018 "DIA	CIRC CONCR	LEN=0099	INSTALLED UNKN	0425/1826	---					
						0420/1621	012 "DIA	CIRC CONCR	LEN=0099	INSTALLED UNKN
018 "DIA	CIRC CONCR	LEN=0099	INSTALLED UNKN	0425/1361	---					
						0420/1342	012 "DIA	CIRC CONCR	LEN=0099	INSTALLED UNKN
						0420/1119	012 "DIA	CIRC CONCR	LEN=0099	INSTALLED UNKN
018 "DIA	CIRC CONCR	LEN=0099	INSTALLED UNKN	0425/0755	---					
						0430/0085	015 "DIA	CIRC CONCR	LEN=0099	INSTALLED UNKN
018 "DIA	CIRC CONCR	LEN=0099	INSTALLED UNKN	0425/0112	---					
						104886 FT	1 0 01037	0 00 0625+19		
1 0 01037	0 01 0641+02	106258 FT					HARRISON			
LENGTH(AH 2436	BK 3833)	0425/0000	5			5	0420/0000	EAST DEER T		
018 "DIA	CIRC CONCR	LEN=0099	INSTALLED UNKN	0417/3465	---			LENGTH(AH 3948	BK 2682)	
018 "DIA	CIRC CONCR	LEN=0045	INSTALLED UNKN	0417/2835	---					
018 "DIA	CIRC CONCR	LEN=0099	INSTALLED UNKN	0417/1915	---					
						0410/1660	018 "DIA	CIRC CONCR	LEN=0099	INSTALLED UNKN
018 "DIA	CIRC CONCR	LEN=0099	INSTALLED UNKN	0417/1318	---					
						0410/1122	018 "DIA	CIRC CONCR	LEN=0099	INSTALLED UNKN
018 "DIA	CIRC CONCR	LEN=0099	INSTALLED UNKN	0417/0785	---					
						0410/0650	018 "DIA	CIRC CONCR	LEN=0099	INSTALLED UNKN
018 "DIA	CIRC CONCR	LEN=0035	INSTALLED UNKN	0417/0320	---					
1 0 01037	0 01 0602+45	102425 FT								
LENGTH(AH 3833	BK 1422)	0417/0000	5			5	0410/0000	102204 FT	1 0 01037	0 00 0598+62
SR 8064	SH							LENGTH(AH 2682	BK 1093)	
(SR8064	SEG 0500/0000)	0407/1335	---							

DIR: N TOTAL LEN: 24.087 MI. DIST: 11-1 SR: 28
 LEFT MUN: EAST DEER T RIGHT MUN: EAST DEER T

Stationing	Description	Material	Length	Notes
0374/1940			LEN=0099	INSTALLED UNKN
RAMP B RD				
(SR8062 SEG 0500/0710)			0375/0260	
1 0 01037 0 01 0486+19			090746 FT	
LENGTH(AH 3800 BK 1652)			0375/0000	
018 "DIA CIRC CONCR				
LEN=0065			INSTALLED UNKN	0371/1354
BMSEN 02/0028/0371/0878			0371/1318	
1 0 01037 0 00 0479+63				
BAILEYS ROAD COUNTY				
BMSBG 02/0028/0371/0878			0371/0878	
018 "DIA CIRC CONCR				
LEN=0080			INSTALLED UNKN	0371/0764
018 "DIA CIRC CONCR				
LEN=0099			INSTALLED UNKN	0371/0020
1 0 01037 0 00 0470+94			089094 FT	
LENGTH(AH 1652 BK 1562)			0371/0000	
018 "DIA CIRC CONCR				
LEN=0099			INSTALLED UNKN	0361/1100
018 "DIA CIRC CONCR				
LEN=0060			INSTALLED UNKN	0361/0551
BMSEN 02/0028/0361/0208			0361/0534	
1 0 01037 0 00 0457+31				
CRAWFORD RUN ROAD				
BMSBG 02/0028/0361/0208			0361/0208	
1 0 01037 0 00 0455+23			087532 FT	
LENGTH(AH 1562 BK 2327)			0361/0000	
087862 FT				
1 0 01037 0 00 0455+59				
CRAWFORD RUN ROAD				
BMSBG 02/0028/0360/0000			0360/0000	
LENGTH(AH 1598 BK 2456)				
0350/1209				RETAINING WALL
0350/1044				BMSID 02/8062/0010/0150
				RAMP A RD
				(SR8062 SEG 0010/0000)
1 0 01037 0 00 0430+21			085205 FT	
LENGTH(AH 2327 BK 2280)			0351/0000	
085406 FT				
1 0 01037 0 00 0430+71				
LENGTH(AH 2456 BK 2392)			0350/0000	

DIR: N TOTAL LEN: 24.087 MI. DIST: 11-1 SR: 28
 LEFT MUN: EAST DEER T RIGHT MUN: EAST DEER T

024 "DIA CIRC CONCR LEN=0070 INSTALLED UNKN CROSSOVER RD (CONN)	0341/2092	---	---	0340/1945 CROSSOVER RD (CONN)
	0341/1882	---	---	099 "DIA CIRC CONCR LEN=0099 INSTALLED UNKN
EAST DEER FRAZER T	0341/1239	---	---	EAST DEER FRAZER T
018 "DIA CIRC CONCR LEN=0070 INSTALLED UNKN	0341/1180	---	---	0340/1573
	0341/0501	---	---	0340/1301
018 "DIA CIRC CONCR LEN=0070 INSTALLED UNKN	0341/0501	---	---	099 "DIA CIRC METAL LEN=0099 INSTALLED UNKN
	0341/0256	---	---	012 "DIA CIRC METAL LEN=0099 INSTALLED UNKN
018 "DIA CIRC CONCR LEN=0070 INSTALLED UNKN	0341/0256	---	---	
OP ID 02/1019/0060/0149	0341/0064	---	---	
1 0 01037 0 00 0407+41 082925 FT LENGTH(AH 2280 BK 2825)	0341/0000	---	---	083014 FT 1 0 01037 0 00 0406+79 BUTLER LOGAN OP ID 02/1019/0060/0149
018 "DIA CIRC CONCR LEN=0060 INSTALLED UNKN	0331/2651	---	---	0340/0000 LENGTH(AH 2392 BK 2691)
018 "DIA CIRC CONCR LEN=0060 INSTALLED UNKN	0331/2410	---	---	
RAMP D RD (SR8114 SEG 0500/0000)	0331/1537	---	---	
018 "DIA CIRC CONCR LEN=0070 INSTALLED UNKN	0331/1027	---	---	
018 "DIA CIRC CONCR LEN=0060 INSTALLED UNKN	0331/0756	---	---	
OP ID 02/1049/0010/0830	0331/0616	---	---	0330/0522 PGH MILLS BD OP ID 02/1049/0010/0830
018 "DIA CIRC CONCR LEN=0060 INSTALLED UNKN	0331/0500	---	---	
	0331/0180	---	---	0330/0369 RAMP A RD (SR8114 SEG 0020/0780)
018 "DIA CIRC CONCR LEN=0070 INSTALLED UNKN	0331/0180	---	---	
1 0 01037 0 00 0379+16 080100 FT LENGTH(AH 2825 BK 2852)	0331/0000	---	---	080323 FT 1 0 01037 0 00 0379+86 0330/0000 LENGTH(AH 2691 BK 2957)
018 "DIA CIRC CONCR LEN=0070 INSTALLED UNKN	0321/2594	---	---	
RAMP C RD (SR8114 SEG 0250/0916)	0321/2570	---	---	
018 "DIA CIRC CONCR		---	---	

DIR: N TOTAL LEN: 24.087 MI. DIST: 11-1 SR: 28
 LEFT MUN: FRAZER T RIGHT MUN: FRAZER T

Item ID	Description	Stationing	Structure	Notes
LEN=0065	INSTALLED UNKN	0321/2501		
0320/2000	018 " DIA CIRC CONCR			LEN=0099 INSTALLED UNKN
0320/1906	018 " DIA CIRC CONCR			LEN=0055 INSTALLED UNKN
0320/1780	RAMP B RD			(SR8114 SEG 0010/0000)
018 " DIA CIRC CONCR				
LEN=0060	INSTALLED UNKN	0321/1585		
0320/1323	SIGN: CANTILEVER			BMSID 02/0028/0320/1323
0320/1140	018 " DIA CIRC CONCR			LEN=0099 INSTALLED UNKN
018 " DIA CIRC CONCR				
LEN=0060	INSTALLED UNKN	0321/1055		
FRAZER				
SPRINGDALE T		0321/0960		
0320/0978	FRAZER			SPRINGDALE T
0320/0876	018 " DIA CIRC CONCR			LEN=0046 INSTALLED UNKN
0320/0689	018 " DIA CIRC CONCR			LEN=0100 INSTALLED UNKN
018 " DIA CIRC CONCR				
LEN=0060	INSTALLED UNKN	0321/0545		
077366 FT	1 0 01037 0 00 0352+07			
1 0 01037 0 00 0352+25 077248 FT				
LENGTH(AH 2852 BK 2989)		0321/0000		
018 " DIA CIRC CONCR				
LEN=0060	INSTALLED UNKN	0311/2763		
018 " DIA CIRC CONCR				
LEN=0060	INSTALLED UNKN	0311/2528		
018 " DIA CIRC CONCR				
LEN=0055	INSTALLED UNKN	0311/2349		
YUTES RUN				
STRUCTURE LENGTH 9 FT				
BMSID 02/0028/0310/2048		0311/2120		
BMSSEN 02/0028/0311/1744		0311/1878		
1 0 01037 0 00 0339+97				
SR 1017				
BMSBG 02/0028/0311/1744		0311/1764		
018 " DIA CIRC CONCR				
LEN=0055	INSTALLED UNKN	0311/1496		
018 " DIA CIRC CONCR				
LEN=0055	INSTALLED UNKN	0311/1242		
0310/1965	YUTES RUN			
0310/1565	STRUCTURE LENGTH 9 FT			
	BMSID 02/0028/0310/2048			
	BMSSEN 02/0028/0310/1477			
	1 0 01037 0 00 0323+77			
	SR 1017			
	BMSBG 02/0028/0310/1477			
	015 " DIA CIRC CONCR			
	LEN=0099			INSTALLED UNKN
0310/1417				
0310/1150	024 " DIA CIRC CONCR			LEN=0100 INSTALLED UNKN
018 " DIA CIRC CONCR				
LEN=0055	INSTALLED UNKN	0311/0997		

DIR: N TOTAL LEN: 24.087 MI. DIST: 11-1 SR: 28
 LEFT MUN: SPRINGDALE T RIGHT MUN: SPRINGDALE T

018 "DIA CIRC CONCR LEN=0070 INSTALLED UNKN RAMP M RD (SR8060 SEG 0500/0000) 018 "DIA CIRC CONCR LEN=0100 INSTALLED UNKN	0311/0476 0311/0355 0311/0273		0310/0650	015 "DIA CIRC CONCR LEN=0100 INSTALLED UNKN
036 "DIA CIRC CONCR LEN=0050 INSTALLED UNKN 1 0 01037 0 00 0322+12 074259 FT SPRINGDALE HARMAR T LENGTH(AH 2989 BK 3131)	0311/0060		0310/0264	RAMP K RD (SR8060 SEG 0750/0370)
018 "DIA CIRC CONCR LEN=0045 INSTALLED UNKN SR 1014 EB OP ID 02/1014/0020/0399	0301/2939 0301/2809		074663 FT 0310/0000	1 0 01037 0 00 0323+77 LENGTH(AH 2703 BK 3471) RAMP J RD (SR8060 SEG 0760/0000) SPRINGDALE HARMAR T
018 "DIA CIRC CONCR LEN=0050 INSTALLED UNKN 018 "DIA CIRC CONCR LEN=0060 INSTALLED UNKN	0301/2703 0301/2469		0300/3170	
018 "DIA CIRC CONCR LEN=0060 INSTALLED UNKN 036 "DIA CIRC CONCR LEN=0050 INSTALLED UNKN 018 "DIA CIRC CONCR LEN=0060 INSTALLED UNKN 018 "DIA CIRC CONCR LEN=0070 INSTALLED UNKN	0301/2215 0301/2000 0301/1938 0301/1702		0300/2859 0300/2740	SR 1014 EB OP ID 02/1014/0020/0399 018 "DIA CIRC CONCR LEN=0099 INSTALLED UNKN
RAMP L RD (SR8060 SEG 0250/1423)	0301/1285		0300/2355	SIGN: 3 CHORD TRUSS BMSID 02/0028/0300/2355
			0300/1523	018 "DIA CIRC CONCR LEN=0099 INSTALLED UNKN
			0300/1265	018 "DIA CIRC CONCR LEN=0099 INSTALLED UNKN
			0300/0152	024 "DIA CIRC CONCR LEN=0099 INSTALLED UNKN

DIR: N TOTAL LEN: 24.087 MI. DIST: 11-1 SR: 28
 LEFT MUN: HARMAR T RIGHT MUN: HARMAR T

Stationing	Length	Material	Notes
0290+92 071128 FT	0300/0082	018 "DIA CIRC CONCR	LEN=0099 INSTALLED UNKN
SR 1015	071192 FT	018 "DIA CIRC CONCR	LEN=0099 INSTALLED UNKN
OP ID 02/1015/0030/1307			
LENGTH(AH 3131 BK 3025) 0301/0000	0300/0000	018 "DIA CIRC CONCR	LEN=0099 INSTALLED UNKN
0291/2340	0290/2221	018 "DIA CIRC CONCR	LEN=0048 INSTALLED UNKN
0291/1976	0290/1868	012 "DIA CIRC CONCR	LEN=0048 INSTALLED UNKN
		024 "DIA CIRC CONCR	LEN=0099 INSTALLED UNKN
BESSEMER AND LAKE ERIE OVERPASS IS RR X-ING	0290/1857	BESSEMER AND LAKE ERIE OVERPASS IS RR X-ING	
	0290/1780	024 "DIA CIRC CONCR	LEN=0099 INSTALLED UNKN
	0290/1682	018 "DIA CIRC CONCR	LEN=0099 INSTALLED UNKN
	0290/1345	018 "DIA CIRC CONCR	LEN=0099 INSTALLED UNKN
BMSSEN 02/0028/0291/1327 0291/1499	0290/1299	BMSSEN 02/0028/0290/1112	
1 0 01037 0 00 0273+52		1 0 01037 0 00 0271+18	
PA TURNPIKE 0076		PA TURNPIKE 0076	
BMSBG 02/0028/0291/1327 0291/1303	0290/1112	BMSBG 02/0028/0290/1112	
0260+25 068103 FT	068361 FT	018 "DIA CIRC CONCR	LEN=0099 INSTALLED UNKN
LENGTH(AH 3025 BK 1755) 0291/0000	0290/0000	018 "DIA CIRC CONCR	LEN=0099 INSTALLED UNKN
0242+93 066348 FT	066707 FT	024 "DIA CIRC CONCR	LEN=0099 INSTALLED UNKN
LENGTH(AH 1755 BK 3420) 0281/0000	0280/0000	024 "DIA CIRC CONCR	LEN=0099 INSTALLED UNKN
0271/3035	0270/3268	024 "DIA CIRC CONCR	LEN=0099 INSTALLED UNKN
	0270/3020	024 "DIA CIRC CONCR	LEN=0099 INSTALLED UNKN
RAMP D RD (SR8058 SEG 0502/0000)			
	0270/2772	024 "DIA CIRC CONCR	LEN=0099 INSTALLED UNKN
	0270/2525	024 "DIA CIRC CONCR	LEN=0099 INSTALLED UNKN
RAMP C RD (SR8058 SEG 0512/0614) 018 "DIA CIRC CONCR			

DIR: N TOTAL LEN: 24.087 MI. DIST: 11-1 SR: 28
 LEFT MUN: HARMAR T RIGHT MUN: HARMAR T

Segment ID	Material	Length (ft)	Stationing	Notes
LEN=0099	INSTALLED UNKN		0271/2275	
0270/2007	RAMP B RD			(SR8058 SEG 0750/1023)
BMSEN 02/0028/0271/1085	BMSEN 02/0028/0270/1046	0271/1275	0270/1236	1 0 01037 0 00 0219+89
SR 910 EB	SR 910 EB			
BMSBG 02/0028/0271/1085	BMSBG 02/0028/0270/1046	0271/1085	0270/1046	012 "DIA CIRC CONCR
			0270/1040	LEN=0099 INSTALLED UNKN
018 "DIA CIRC CONCR				
LEN=0099	INSTALLED UNKN		0271/0783	
118 "DIA CIRC CONCR				
LEN=0040	INSTALLED UNKN		0271/0514	
BMSEN 02/0028/0271/0000	BMSEN 02/0028/0270/0000	0271/0176	0270/0176	1 0 01037 0 00 0208+95 062928 FT
DEER CREEK	DEER CREEK			
BMSBG 02/0028/0271/0000	BMSBG 02/0028/0270/0000		0270/0000	LENGTH(AH 3420 BK 2879)
018 "DIA CIRC CONCR				LEN=0040 INSTALLED UNKN 0261/2870
BMSEN 02/0028/0261/2263	BMSEN 02/0028/0260/2109	0261/1572	0260/2230	1 0 01037 0 00 0194+58
SR 1011 GUYS RUN RD	SR 1011 GUYS RUN RD			
BMSBG 02/0028/0261/2263	BMSBG 02/0028/0260/2109	0261/1429	0260/2087	
BMSEN 02/0028/0261/1084	BMSEN 02/0028/0260/0801	0261/1233	0260/1872	
				1 0 01037 0 00 0169+38
SERVICE ROAD	SERVICE ROAD			
BMSBG 02/0028/0261/1084	BMSBG 02/0028/0260/0801	0261/0241	0260/0785	024 "DIA CIRC CONCR
			0260/0240	LEN=0099 INSTALLED UNKN
018 "DIA CIRC CONCR				
LEN=0040	INSTALLED UNKN		0261/0081	
1 0 01037 0 00 0169+56	036 "DIA CIRC CONCR	060049 FT	0260/0013	LEN=0099 INSTALLED UNKN
LENGTH(AH 2879 BK 3798)	1 0 01037 0 00 0169+38	0261/0000	059503 FT	
024 "DIA CIRC CONCR	LENGTH(AH 3540 BK 3793)		0260/0000	
LEN=0040				
024 "DIA CIRC CONCR				
LEN=0040	INSTALLED UNKN		0251/3611	
024 "DIA CIRC CONCR				
LEN=0040	INSTALLED UNKN		0251/3363	
024 "DIA CIRC METAL				
LEN=0040	INSTALLED UNKN		0251/3103	
024 "DIA CIRC METAL				

DIR: N TOTAL LEN: 24.087 MI. DIST: 11-1 SR: 28
 LEFT MUN: HARMAR T RIGHT MUN: HARMAR T

LEN=0040	INSTALLED	UNKN	0251/2856	---	---				
024 "DIA	CIRC CONCR			---	---				
LEN=0040	INSTALLED	UNKN	0251/2336	---	---				
024 "DIA	CIRC CONCR			---	---				
LEN=0040	INSTALLED	UNKN	0251/2088	---	---				
024 "DIA	CIRC CONCR			---	---				
LEN=0040	INSTALLED	UNKN	0251/1838	---	---				
024 "DIA	CIRC CONCR			---	---				
LEN=0040	INSTALLED	UNKN	0251/1578	---	---				
024 "DIA	CIRC CONCR			---	---				
LEN=0040	INSTALLED	UNKN	0251/1337	---	---				
024 "DIA	CIRC CONCR			---	---				
LEN=0040	INSTALLED	UNKN	0251/1083	---	---				
018 "DIA	CIRC CONCR			---	---				
LEN=0040	INSTALLED	UNKN	0251/0855	---	---				
024 "DIA	CIRC CONCR			---	---				
LEN=0040	INSTALLED	UNKN	0251/0654	---	---				
HARMAR									
OHARA T			0251/0481	---	---	0250/0616	HARMAR	OHARA T	
024 "DIA	CIRC CONCR			---	---				
LEN=0040	INSTALLED	UNKN	0251/0405	---	---				
024 "DIA	CIRC CONCR			---	---				
LEN=0040	INSTALLED	UNKN	0251/0164	---	---				
1 0 01037	0 00 0132+80	056251 FT				055710 FT	1 0 01037	0 00 0131+45	
LENGTH(AH	3798 BK	4558)	0251/0000	---	---	0250/0000	LENGTH(AH	3793 BK	3979)
018 "DIA	CIRC CONCR			---	---				
LEN=0045	INSTALLED	UNKN	0241/4208	---	---				
036 "DIA	CIRC CONCR			---	---				
LEN=0050	INSTALLED	UNKN	0241/4180	---	---				
018 "DIA	CIRC CONCR			---	---				
LEN=0050	INSTALLED	UNKN	0241/3960	---	---				
018 "DIA	CIRC CONCR			---	---				
LEN=0050	INSTALLED	UNKN	0241/3931	---	---				
				---	---	0240/3863	018 "DIA	CIRC CONCR	
				---	---		LEN=0050	INSTALLED	UNKN
				---	---	0240/3353	012 "DIA	CIRC CONCR	
				---	---		LEN=0099	INSTALLED	UNKN
				---	---	0240/3138	018 "DIA	CIRC CONCR	
				---	---		LEN=0050	INSTALLED	UNKN
				---	---	0240/3080	012 "DIA	CIRC CONCR	
				---	---		LEN=0099	INSTALLED	UNKN
				---	---	0240/2860	018 "DIA	CIRC CONCR	
				---	---		LEN=0050	INSTALLED	UNKN
				---	---	0240/2590	018 "DIA	CIRC CONCR	
				---	---		LEN=0050	INSTALLED	UNKN
018 "DIA	CIRC CONCR			---	---				
LEN=0055	INSTALLED	UNKN	0241/2385	---	---				
				---	---	0240/2342	018 "DIA	CIRC CONCR	
				---	---		LEN=0050	INSTALLED	UNKN
018 "DIA	CIRC CONCR			---	---				

DIR: N TOTAL LEN: 24.087 MI. DIST: 11-1 SR: 28
LEFT MUN: OHARA T RIGHT MUN: OHARA T

LEN=0045	INSTALLED	UNKN	0241/2249	-----	0240/2093	018 "DIA	CIRC	CONCR	LEN=0050	INSTALLED	UNKN
				-----	0240/2040	018 "DIA	CIRC	CONCR	LEN=0040	INSTALLED	UNKN
				-----	0240/1840	018 "DIA	CIRC	CONCR	LEN=0050	INSTALLED	UNKN
015 "DIA	CIRC	CONCR		-----							
LEN=0055	INSTALLED	UNKN	0241/1633	-----	0240/1590	018 "DIA	CIRC	CONCR	LEN=0050	INSTALLED	UNKN
				-----	0240/1340	018 "DIA	CIRC	CONCR	LEN=0050	INSTALLED	UNKN
				-----	0240/1142	018 "DIA	CIRC	CONCR	LEN=0050	INSTALLED	UNKN
				-----	0240/0544	012 "DIA	CIRC	CONCR	LEN=0099	INSTALLED	UNKN
BMS EN 02/0028/0241/0000			0241/0182	-----	0240/0242	BMS EN 02/0028/0240/0000					
1 0 01037 0 00 0096+58			051693 FT	-----	051731 FT	1 0 01037 0 00 0093+77					
SR 1009				-----		SR 1009					
BMSBG 02/0028/0241/0000				-----	0240/0000	BMSBG 02/0028/0240/0000					
LENGTH(AH 4558 BK 3039)			0241/0000	-----		LENGTH(AH 3979 BK 2803)					
018 "DIA	CIRC	CONCR		-----							
LEN=0040	INSTALLED	UNKN	0231/2650	-----							
018 "DIA	CIRC	CONCR		-----							
LEN=0040	INSTALLED	UNKN	0231/2200	-----							

				-----	0230/0820	012 "DIA	CIRC	CONCR	LEN=0099	INSTALLED	UNKN
024 "DIA	CIRC	CONCR		-----							
LEN=0040	INSTALLED	UNKN	0231/0725	-----	0230/0585	012 "DIA	CIRC	CONCR	LEN=0099	INSTALLED	UNKN

018 "DIA	CIRC	CONCR		-----							
LEN=0040	INSTALLED	UNKN	0231/0460	-----							
018 "DIA	CIRC	CONCR		-----							
LEN=0050	INSTALLED	UNKN	0231/0221	-----							
018 "DIA	CIRC	CONCR		-----							
LEN=0040	INSTALLED	UNKN	0231/0210	-----							
1 0 01037 0 00 0066+29			048654 FT	-----	048928 FT	1 0 01037 0 00 0067+25					
LENGTH(AH 3039 BK 2998)			0231/0000	-----	0230/0000	LENGTH(AH 2803 BK 3168)					
				-----		RAMP D RD					
				-----	0220/3078	(SR8056 SEG 0750/0439)					
RAMP C RD				-----							
(SR8056 SEG 0500/0000)			0221/2893	-----	0220/2642	BMS EN 02/0028/0220/2488					
BMS EN 02/0028/0221/2358			0221/2564	-----		1 0 01037 0 00 0034+05					
1 0 01037 0 00 0059+84				-----		TWP RD. 505					
TWP RD. 505				-----							

DIR: N TOTAL LEN: 24.087 MI. DIST: 11-1 SR: 28
 LEFT MUN: OHARA T RIGHT MUN: OHARA T

Segment ID	Description	Length	Status	Stationing	Notes
BMSBG 02/0028/0221/2358		0221/2377			
RAMP B RD (SR8056 SEG 0250/0830)		0221/1454			
018 "DIA CIRC CONCR		LEN=0050	INSTALLED UNKN	0221/1452	
018 "DIA CIRC CONCR		LEN=0055	INSTALLED UNKN	0221/0083	
1 0 01037 0 00 0036+19	ALPHA DRIVE	045656 FT			
OP ID 02/1018/0010/0000		LENGTH(AH 2998 BK 3399)		0221/0000	
018 "DIA CIRC CONCR		LEN=0099	INSTALLED UNKN	0211/3195	
018 "DIA CIRC CONCR		LEN=0099	INSTALLED UNKN	0211/2950	
018 "DIA CIRC CONCR		LEN=0099	INSTALLED UNKN	0211/2697	
018 "DIA CIRC CONCR		LEN=0050	INSTALLED UNKN	0210/2860	
018 "DIA CIRC CONCR		LEN=0050	INSTALLED UNKN	0210/2607	
018 "DIA CIRC CONCR		LEN=0099	INSTALLED UNKN	0210/2357	
018 "DIA CIRC CONCR		LEN=0099	INSTALLED UNKN	0211/1830	
012 "DIA CIRC CONCR		LEN=0099	INSTALLED UNKN	0211/0645	
015 "DIA CIRC CONCR		LEN=0099	INSTALLED UNKN	0211/0426	
TRIB TO ALLG STRUCTURE LENGTH 7 FT				0211/0290	
BMSID 02/1002/0010/0765				0210/0566	
015 "DIA CIRC CONCR		LEN=0099	INSTALLED UNKN	0211/0141	
0220/2467	BMSBG 02/0028/0220/2488				
0220/1960	RAMP A RD (SR8056 SEG 0010/0000)				
0220/0784	024 "DIA CIRC CONCR	LEN=0048	INSTALLED UNKN		
0220/0075	012 "DIA CIRC CONCR	LEN=0099	INSTALLED UNKN		
045760 FT	1 0 01037 0 00 0034+05				
0220/0000	ALPHA DRIVE				
0220/0000	OP ID 02/1018/0010/0000	LENGTH(AH 3168 BK 3557)			
0210/0915	048 "DIA CIRC CONCR	LEN=0045	INSTALLED UNKN		
0210/0786	SB RAMP OP ID 02/1002/0011/0595				
0210/0566	TRIB TO ALLG STRUCTURE LENGTH 7 FT				
0210/0192	BMSID 02/1002/0010/0765				
	FREEPORT RD (SR1002 SEG 0010/0000)				

EXTRACT DATE: 12/21/2020
PRINT DATE: 12/23/2020

ROADWAY MANAGEMENT SYSTEM
SLD COUNTY/SR - ANNUAL PRINT

PAGE NUMBER: 97
COUNTY: ALLEGHENY

DIR: N TOTAL LEN: 24.087 MI.
LEFT MUN: PITTSBURGH C

DIST: 11-1 SR: 28
RIGHT MUN: PITTSBURGH C

Segment ID	Start Station	End Station	Description	Material	Length (FT)
0190/0630			RAMP L RD	LEN=0040	INSTALLED UNKN
0190/0438			(SR8052 SEG 0750/0755)		
0190/0380			018 "DIA CIRC CONCR	LEN=0040	INSTALLED UNKN
0190/0337			RAMP K RD	(SR8052 SEG 0760/0000)	
BMS EN 02/0028/0191/0000	0191/0314		PITTSBURGH ASPINWALL B		
1 0 00070 3 00 0166+22	036779		DELAFIELD RD LOCAL		FT
BMSBG 02/0028/0191/0000	0191/0000		LENGTH(AH 2797 BK 2713)		
018 "DIA CIRC CONCR	0181/2635		LEN=0099		INSTALLED UNKN
018 "DIA CIRC CONCR	0181/2425		LEN=0099		INSTALLED UNKN
018 "DIA CIRC CONCR	0181/2085		LEN=0099		INSTALLED UNKN
RAMP J RD	0181/2080		(SR8052 SEG 0250/0301)		
ASPINWALL	0181/1778		OHARA T		
018 "DIA CIRC CONCR	0181/1485		LEN=0099		INSTALLED UNKN
OHARA	0181/1467		ASPINWALL B		
018 "DIA CIRC CONCR	0181/1302		LEN=0099		INSTALLED UNKN
BMS EN 02/0028/0181/1015	0181/1073		0 0 00000 0 00 0000+00		
CENTER AVE. LOCAL	0181/1015				
BMSBG 02/0028/0181/1015	0181/1015				
0180/0000	0180/3383		015 "DIA CIRC CONCR	LEN=0040	INSTALLED UNKN
0180/3070			0 0 00000 0 00 0000+00		
0180/2386			DELAFIELD RD LOCAL		
0180/2352			BMSBG 02/0028/0180/3070		
0180/2336			ASPINWALL		
0180/2075			OHARA T		
0180/1889			024 "DIA CIRC CONCR	LEN=0040	INSTALLED UNKN
0180/1844			099"H 00"W **UNKNOWN**	LEN=0099	INSTALLED UNKN
0180/1837			OHARA		
0180/1392			ASPINWALL B		
0180/1334			024"H 24"W CON BOX CUL	LEN=0040	INSTALLED UNKN
			024 "DIA CIRC METAL	LEN=0040	INSTALLED UNKN
			024 "DIA CIRC CONCR	LEN=0099	INSTALLED UNKN
			BMS EN 02/0028/0180/1373		
			1 0 00070 3 00 0129+08		
			CENTER AVE. LOCAL		
			BMSBG 02/0028/0180/1373		

DIR: N TOTAL LEN: 24.087 MI. DIST: 11-1 SR: 28
 LEFT MUN: ASPINWALL B RIGHT MUN: ASPINWALL B

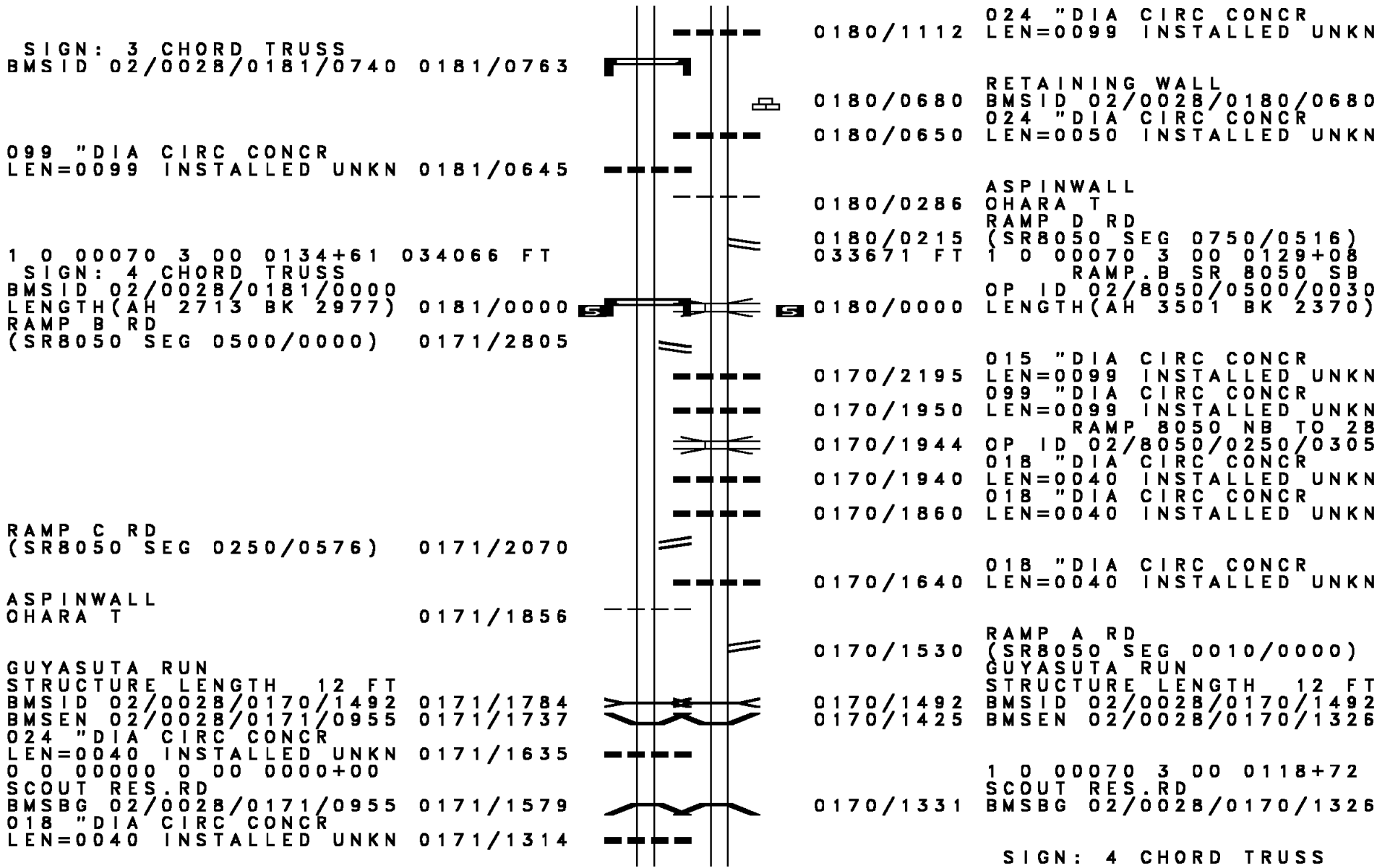

SIGN: 4 CHORD TRUSS

DIR: N TOTAL LEN: 24.087 MI. DIST: 11-1 SR: 28
 LEFT MUN: OHARA T RIGHT MUN: OHARA T

018 "DIA CIRC CONCR LEN=0040 INSTALLED UNKN 0171/1090		0170/1145 BMSID 02/0028/0170/1145
018 "DIA CIRC CONCR LEN=0040 INSTALLED UNKN 0171/0800		0170/1035 018 "DIA CIRC CONCR LEN=0040 INSTALLED UNKN
018 "DIA CIRC CONCR LEN=0040 INSTALLED UNKN 0171/0235		0170/0736 018 "DIA CIRC CONCR LEN=0040 INSTALLED UNKN
1 0 00070 3 00 0105+02 031089 FT LENGTH(AH 2977 BK 2440) 0171/0000		0170/0442 018 "DIA CIRC CONCR LEN=0040 INSTALLED UNKN
		031301 FT 1 0 00070 3 00 0105+46 LENGTH(AH 2370 BK 2696)
		0160/1640 018 "DIA CIRC CONCR LEN=0040 INSTALLED UNKN
SIGN: 2 CHORD TRUSS BMSID 02/0028/0161/2175 0161/2175		0160/0945 SIGN: 2 CHORD TRUSS BMSID 02/0028/0160/0945
024 "DIA CIRC CONCR LEN=0099 INSTALLED UNKN 0161/2105		
018 "DIA CIRC CONCR LEN=0099 INSTALLED UNKN 0161/1857		
018 "DIA CIRC CONCR LEN=0099 INSTALLED UNKN 0161/1354		
018 "DIA CIRC CONCR LEN=0099 INSTALLED UNKN 0161/1110		
018 "DIA CIRC CONCR LEN=0099 INSTALLED UNKN 0161/0860		0160/0840 018 "DIA CIRC CONCR LEN=0040 INSTALLED UNKN
024 "DIA CIRC CONCR LEN=0099 INSTALLED UNKN 0161/0606		
BMSEN 02/0028/0161/0000 0161/0570		0160/0530 018 "DIA CIRC CONCR LEN=0099 INSTALLED UNKN
OHARA		0160/0522 BMSEN 02/0028/0160/0000
SHARPSBURG B 0161/0049		OHARA
1 0 00070 3 00 0081+67 028649 FT		SHARPSBURG B
NC ALLEGHENY VALLEY EX		1 0 00070 3 00 0078+41
KITTANNING P		NC ALLEGHENY VALLEY EX
BMSBG 02/0028/0161/0000		SR 1003
LENGTH(AH 2440 BK 3304) 0161/0000		BMSBG 02/0028/0160/0000
		LENGTH(AH 2696 BK 3193)
018 "DIA CIRC CONCR LEN=0099 INSTALLED UNKN 0151/3135		0150/2975 018 "DIA CIRC CONCR LEN=0040 INSTALLED UNKN

DIR: N TOTAL LEN: 24.087 MI. DIST: 11-1 SR: 28
 LEFT MUN: SHARPSBURG B RIGHT MUN: SHARPSBURG B

018 "DIA CIRC CONCR LEN=0099 INSTALLED UNKN 0151/2842	0150/2730	018 "DIA CIRC CONCR LEN=0099 INSTALLED UNKN
036 "DIA CIRC CONCR LEN=0099 INSTALLED UNKN 0151/2531	0150/2425	018 "DIA CIRC CONCR LEN=0099 INSTALLED UNKN
018 "DIA CIRC CONCR LEN=0099 INSTALLED UNKN 0151/2317	0150/2125	018 "DIA CIRC CONCR LEN=0099 INSTALLED UNKN
SIGN: 3 CHORD TRUSS BMSID 02/0028/0151/2130 0151/2185	0150/1838	SIGN: 2 CHORD TRUSS BMSID 02/0028/0150/1785
018 "DIA CIRC CONCR LEN=0099 INSTALLED UNKN 0151/2059		
018 "DIA CIRC CONCR LEN=0099 INSTALLED UNKN 0151/1586		
018 "DIA CIRC CONCR LEN=0099 INSTALLED UNKN 0151/1285	0150/1380	018 "DIA CIRC CONCR LEN=0040 INSTALLED UNKN
	0150/1125	018 "DIA CIRC CONCR LEN=0040 INSTALLED UNKN
BMSEN 02/0028/0151/0600 0151/0777	0150/0880	018 "DIA CIRC CONCR LEN=0040 INSTALLED UNKN
0 0 00000 0 00 0000+00	0150/0646	BMSEN 02/0028/0150/0470
RAVINE STREET		0 0 00000 0 00 0000+00
BMSBG 02/0028/0151/0600 0151/0621	0150/0525	RAVINE ST. SR 1007
		BMSBG 02/0028/0150/0470
1 0 00070 3 00 0048+75 025345 FT	025412 FT	1 0 00070 3 00 0047+05
SR 8042 SH		SR 8042 SH
(SR8042 SEG 0752/0000)		(SR8042 SEG 0762/0821)
NC SR 0028 SH		NC SR 0028 SH
LENGTH(AH 3304 BK 1102) 0151/0000	0150/0000	LENGTH(AH 3193 BK 1043)
BMSEN 02/0028/0141/0000 0141/1046	0140/0876	BMSEN 02/0028/0140/0000
SHARPSBURG		SHARPSBURG
ETNA BOROUGH B		ETNA BOROUGH B
1 0 00070 3 00 0037+51 024243 FT	0140/0465	1 0 00070 3 00 0035+99
N MAIN ST	024369 FT	NORTH MAIN STREET
BMSBG 02/0028/0141/0000		BMSBG 02/0028/0140/0000
LENGTH(AH 1102 BK 1567) 0141/0000	0140/0000	LENGTH(AH 1043 BK 1715)
		SR 8042 SH
030 "DIA CIRC METAL LEN=0100 INSTALLED 2008 0131/1294	0130/1460	(SR8042 SEG 0260/0000)
	0130/1312	RAMP T RD (SR8042 SEG 0250/0000)

DIR: N TOTAL LEN: 24.087 MI. DIST: 11-1 SR: 28
 LEFT MUN: ETNA BOROUGH B RIGHT MUN: ETNA BOROUGH B

SR 8042 SH
 (SR8042 SEG 0510/1086) 0131/1198

BMS EN 02/0028/0131/1093 0131/0924
 1 0 00070 3 00 0016+77
 CSX RR
 BMSBG 02/0028/0131/1093 0131/0663

1 0 00070 3 00 0016+77 022676 FT
 LENGTH(AH 1567 BK 2343) 0131/0000
 BMS EN 02/0028/0121/1214 0121/2025
 1 0 00070 3 00 0011+05
 SR 1001 BUTLER ST
 BMSBG 02/0028/0121/1214 0121/1633

015 "DIA CIRC CONCR
 LEN=0050 INSTALLED 2009 0121/0940
 SR 8048 SH
 (SR8048 SEG 0020/0360) 0121/0808
 024 "DIA CIRC CONCR
 LEN=0050 INSTALLED 2009 0121/0713
 018 "H 18 "W UNKN CONC
 LEN=0050 INSTALLED 2009 0121/0600
 SIGN: CANTILEVER
 BMSID 02/0028/0121/0570 0121/0513
 024 "DIA CIRC CONCR
 LEN=0050 INSTALLED 2009 0121/0383
 018 "DIA CIRC CONCR
 LEN=0050 INSTALLED 2009 0121/0150

1 0 00070 3 00 0000+00 020333 FT
 NC ETNA BP
 LENGTH(AH 2343 BK 0772) 0121/0000
 018 "DIA CIRC CONCR
 LEN=0099 INSTALLED 2009 0111/0770
 RETAINING WALL
 BMSID 02/0028/0121/1215 0111/0675
 ETNA BOROUGH
 SHALER T 0111/0528
 RETAINING WALL
 BMSID 02/0028/0121/0770 0111/0447
 018 "DIA CIRC CONCR
 LEN=0050 INSTALLED 2009 0111/0423

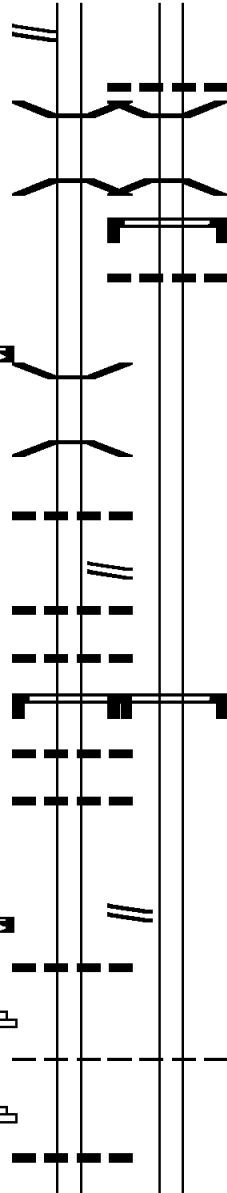

0130/0970 01B "DIA CIRC CONCR
 0130/0950 LEN=0099 INSTALLED 2008
 BMS EN 02/0028/0130/0857
 1 0 00070 3 00 0027+19
 CSX RR
 BMSBG 02/0028/0130/0857
 SIGN: 2 CHORD TRUSS
 BMSID 02/0028/0130/1155
 01B "DIA CIRC CONCR
 0130/0667
 0130/0632 LEN=0040 INSTALLED UNKN
 022654 FT 1 0 00070 3 00 0020+44
 0130/0000 LENGTH(AH 1715 BK 1705)

0120/0500 SIGN: CANTILEVER
 BMSID 02/0028/0120/0500

020949 FT 1 0 00070 3 00 0000+00
 NC ETNA BP
 SR 8048 SH
 (SR8048 SEG 0010/0000)
 0120/0000 LENGTH(AH 1705 BK 0574)

0110/0528 ETNA BOROUGH
 SHALER T

SIGN: 3 CHORD TRUSS

DIR: N TOTAL LEN: 24.087 MI. DIST: 11-1 SR: 28
 LEFT MUN: SHALER T RIGHT MUN: SHALER T

Item ID	Description	Material	Year	Stationing	Length	Notes
0110/0347	BMSID	02/0028/0110/0390				
018	"DIA CIRC CONCR	INSTALLED	2009	0111/0253		
LEN=0099						
018	"DIA CIRC CONCR	INSTALLED	2009	0111/0051		
LEN=0050						
1 0 00070	0 01 0246+18	019561 FT				
LENGTH(AH 0772 BK 1622)		0111/0000				
020375 FT	1 0 00070	0 01 0241+74				
0110/0000	LENGTH(AH 0574 BK 2232)					
018	"DIA CIRC CONCR	INSTALLED	UNKN			
LEN=0099						
024	"DIA CIRC CONCR	INSTALLED	UNKN			
LEN=0099						
012	"DIA CIRC CONCR	INSTALLED	UNKN			
LEN=0099						
0100/1516						
RETAINING WALL						
BMSID 02/0028/0101/1346		0101/1346				
018	"DIA CIRC CONCR	INSTALLED	2009	0101/1266		
LEN=0050						
018	"DIA CIRC CONCR	INSTALLED	2009	0101/1029		
LEN=0050						
0100/1327	SIGN: CANTILEVER	BMSID 02/0028/0100/1345				
024	"DIA CIRC CONCR	INSTALLED	2009	0101/0784		
LEN=0050						
018	"DIA CIRC CONCR	INSTALLED	2009	0101/0544		
LEN=0050						
018	"DIA CIRC CONCR	INSTALLED	2009	0101/0463		
LEN=0050						
0100/0884	030"H 30"W CON BOX CUL	LEN=0099	INSTALLED	UNKN		
0100/0642	018 "DIA CIRC CONCR	LEN=0099	INSTALLED	UNKN		
0100/0396	018 "DIA CIRC CONCR	LEN=0099	INSTALLED	UNKN		
018	"DIA CIRC CONCR	INSTALLED	2009	0101/0375		
LEN=0050						
018	"DIA CIRC CONCR	INSTALLED	2009	0101/0209		
LEN=0050						
0100/0170	018 "DIA CIRC CONCR	LEN=0035	INSTALLED	UNKN		
018	"DIA CIRC CONCR	LEN=0024	INSTALLED	UNKN		
0100/0074	018 "DIA CIRC CONCR	LEN=0024	INSTALLED	UNKN		
018143 FT	1 0 00070	0 01 0220+35				
0100/0000	LENGTH(AH 2232 BK 2886)					
0090/2682	018 "DIA CIRC CONCR	LEN=0099	INSTALLED	UNKN		
018	"DIA CIRC CONCR	INSTALLED	2009	0091/2343		
LEN=0050						
0090/2343	018"H 18"W UNKN CONC	LEN=0050	INSTALLED	2009		
	018 "DIA CIRC CONCR					

DIR: N TOTAL LEN: 24.087 MI. DIST: 11-1 SR: 28
 LEFT MUN: SHALER T RIGHT MUN: SHALER T

Item Description	Year	Stationing	Length	Material	Status	Notes
018 "DIA CIRC CONCR	2009	0091/2023	0099	INSTALLED	UNKN	
018 "H 18" W UNKN CONC	2009	0090/2308	0050	INSTALLED	UNKN	
018 "DIA CIRC CONCR	2009	0090/1976	0099	INSTALLED	UNKN	
018 "H 18" W UNKN CONC	2009	0090/1923	0050	INSTALLED	UNKN	
018 "DIA CIRC CONCR	2009	0090/1681	0099	INSTALLED	UNKN	
SIGN: CANTILEVER						
BMSID 02/002B/0091/1450	2009	0091/1450				
012 "DIA CIRC CONCR	2008	0090/1566	0070	INSTALLED	UNKN	
012 "DIA CIRC CONCR	2008	0090/1536	0015	INSTALLED	UNKN	
012 "DIA CIRC CONCR	2008	0090/1494	0020	INSTALLED	UNKN	
012 "DIA CIRC CONCR	2008	0090/1493	0020	INSTALLED	UNKN	
012 "DIA CIRC CONCR	2008	0090/1487	0050	INSTALLED	UNKN	
012 "DIA CIRC CONCR	2008	0090/1282	0064	INSTALLED	UNKN	
012 "DIA CIRC CONCR	2008	0090/1278	0020	INSTALLED	UNKN	
018 "DIA CIRC CONCR	2009	0091/1101	0050	INSTALLED	UNKN	
018 "H 18" W UNKN CONC	2009	0090/1233	0050	INSTALLED	UNKN	
012 "DIA CIRC CONCR	2008	0090/1214	0064	INSTALLED	UNKN	
012 "DIA CIRC CONCR	2008	0090/1133	0020	INSTALLED	UNKN	
012 "DIA CIRC CONCR	2008	0090/1111	0035	INSTALLED	UNKN	
012 "DIA CIRC CONCR	2008	0090/1108	0040	INSTALLED	UNKN	
012 "DIA CIRC CONCR	2008	0090/1088	0030	INSTALLED	UNKN	
012 "DIA CIRC CONCR	2008	0090/1079	0035	INSTALLED	UNKN	
018 "DIA CIRC CONCR	2011	0091/0854	0050	INSTALLED	UNKN	
018 "DIA CIRC CONCR	2009	0091/0747	0050	INSTALLED	UNKN	
018 "H 18" W UNKN CONC	2009	0090/0854	0050	INSTALLED	UNKN	
012 "DIA CIRC CONCR						

DIR: N TOTAL LEN: 24.087 MI. DIST: 11-1 SR: 28
 LEFT MUN: SHALER T RIGHT MUN: SHALER T

					0090/0821	LEN=0020	INSTALLED	2008	
						012 "DIA	CIRC CONCR		
					0090/0819	LEN=0020	INSTALLED	2008	
018 "DIA	CIRC CONCR								
LEN=0050	INSTALLED	2009	0091/0647						
018 "DIA	CIRC CONCR								
LEN=0050	INSTALLED	2009	0091/0578						
018 "DIA	CIRC CONCR								
LEN=0050	INSTALLED	2009	0091/0443						
					0090/0578	018"H 18"W UNKN CONC			
						LEN=0050	INSTALLED	2009	
018 "DIA	CIRC CONCR								
LEN=0050	INSTALLED	2009	0091/0323						
018 "DIA	CIRC CONCR								
LEN=0100	INSTALLED	2009	0091/0223						
SIGN:	CANTILEVER								
BMSID 02/0028/0091/0131	0091/0131				0090/0296	SIGN: CANTILEVER			
RETAINING WALL						BMSID 02/0028/0090/0316			
BMSID 02/0028/0091/0124	0091/0124								
018 "DIA	CIRC CONCR								
LEN=0099	INSTALLED	2009	0091/0123		0090/0123	018"H 18"W UNKN CONC			
1 0 00070 0 01 0193+56	015181 FT					LEN=0100	INSTALLED	2009	
LENGTH(AH 2758 BK 1838)	0091/0000				015257 FT	1 0 00070 0 01 0192+36			
RAMP E RD					0090/0000	LENGTH(AH 2886 BK 1887)			
(SR8046 SEG 0500/0000)	0081/1740								
SHALER									
MILLVALE B	0081/1452								
					0080/1626	SHALER			
					0080/1278	MILLVALE B			
						BMSEN 02/0028/0081/0940			
						1 0 00070 0 01 0183+25			
						RAMP A (8046) NORTH			
					0080/1218	BMSBG 02/0028/0081/0940			
					0080/1195	RAMP B RD			
						(SR8046 SEG 0250/0622)			
012 "DIA	CIRC CONCR								
LEN=0030	INSTALLED	2008	0081/1399						
					0080/1103	015 "DIA CIRC CONCR			
						LEN=0040	INSTALLED	2008	
012 "DIA	CIRC CONCR								
LEN=0060	INSTALLED	2008	0081/1339						
					0080/1086	GIRTY RUN			
						STRUCTURE LENGTH 25 FT			
					0080/1050	BMSID 02/0028/0080/1086			
						015 "DIA CIRC CONCR			
						LEN=0123	INSTALLED	2008	
012 "DIA	CIRC CONCR								
LEN=0287	INSTALLED	2008	0081/1052						
BMSEN 02/0028/0081/0940	0081/1038				0080/0792	BMSEN 02/0028/0080/0981			
0 0 00000 0 00 0000+00						0 0 00000 0 00 0000+00			
RAMP A (8046) NORTH						RAMP B (8046)			
BMSBG 02/0028/0081/0940	0081/0978				0080/0760	BMSBG 02/0028/0080/0981			

DIR: N TOTAL LEN: 24.087 MI. DIST: 11-1 SR: 28
 LEFT MUN: MILLVALE B RIGHT MUN: MILLVALE B

Item ID	Description	Length	Material	Year	Stationing	Notes
LEN=0020	INSTALLED	2008	0071/0490			
0070/0473	OP ID	02/2124/0010/0255			40TH STREET	
0070/0421	SIGN: CANTILEVER					
0070/0258	BMSID 02/0028/0070/0341					
	048 "DIA CIRC OTHER					
	LEN=0005	INSTALLED	2008			
018 "DIA CIRC CONCR						
LEN=0020	INSTALLED	2008	0071/0234			
012242 FT	1 0 00070 0 01 0163+59					
	RAMP P					
	(SR8120 SEG 0010/0000)					
0070/0000	LENGTH(AH 1128 BK 1556)					
1 0 00070 0 01 0164+22	012691 FT					
LENGTH(AH 0652 BK 1920)	0071/0000					
018 "DIA CIRC CONCR						
LEN=0020	INSTALLED	2008	0061/1878			
018 "DIA CIRC CONCR						
LEN=0015	INSTALLED	2008	0061/1876			
048 "DIA CAST IRON						
LEN=0020	INSTALLED	2008	0061/1625			
018 "DIA CIRC CONCR						
LEN=0020	INSTALLED	2008	0061/1624			
RAMP Q						
(SR8120 SEG 0250/0342)	0061/1554					
0060/1421	018 "DIA CIRC CONCR					
	LEN=0005	INSTALLED	2008			
018 "DIA CIRC CONCR						
LEN=0015	INSTALLED	2008	0061/1257			
018 "DIA CIRC CONCR						
LEN=0020	INSTALLED	2008	0061/1256			
0060/1245	018 "DIA CIRC CONCR					
	LEN=0005	INSTALLED	2008			
018 "DIA CIRC CONCR						
LEN=0020	INSTALLED	2008	0061/1078			
0060/1015	018 "DIA CIRC CONCR					
	LEN=0005	INSTALLED	2008			
018 "DIA CIRC CONCR						
LEN=0020	INSTALLED	2008	0061/0856			
SIGN: 4 CHORD TRUSS						
BMSID 02/0028/0061/0695	0061/0737					
0060/0842	SIGN: 4 CHORD TRUSS					
	BMSID 02/0028/0061/0695					
0060/0804	018 "DIA CIRC CONCR					
	LEN=0005	INSTALLED	2008			
018 "DIA CIRC CONCR						
LEN=0020	INSTALLED	2008	0061/0644			
0060/0500	036 "DIA CIRC OTHER					
	LEN=0150	INSTALLED	2008			
0060/0216	018 "DIA CIRC CONCR					
	LEN=0015	INSTALLED	2008			
0060/0209	SIGN: 4 CHORD TRUSS					
	BMSID 02/0028/0061/0064					
SIGN: 4 CHORD TRUSS						
BMSID 02/0028/0061/0064	0061/0099					
018 "DIA CIRC CONCR						

DIR: N TOTAL LEN: 24.087 MI. DIST: 11-1 SR: 28
 LEFT MUN: MILLVALE B RIGHT MUN: MILLVALE B

Segment ID	Material	Length (ft)	Start Station	End Station	Notes
LEN=0020	INSTALLED	2008	0061/0033		
024 "DIA	CIRC CONCR	LEN=0200	INSTALLED	2008	
1 0 00070	0 01 0145+28	010771	FT		
018 "DIA	CIRC CONCR	LEN=0035	INSTALLED	2008	
MILLVALE					
PITTSBURGH C					
LENGTH(AH 1920	BK 2373)	0061/0000			
018 "DIA	CIRC CONCR	LEN=0020	INSTALLED	2008	
024 "DIA	CIRC CONCR	LEN=0019	INSTALLED	2008	
018 "DIA	CIRC CONCR	LEN=0069	INSTALLED	2008	
018 "DIA	CIRC CONCR	LEN=0020	INSTALLED	2008	
018 "DIA	CIRC CONCR	LEN=0020	INSTALLED	2008	
024 "DIA	CIRC CONCR	LEN=0004	INSTALLED	2013	
024 "DIA	CIRC CONCR	LEN=0031	INSTALLED	2013	
018 "DIA	CIRC CONCR	LEN=0133	INSTALLED	2008	
018 "DIA	CIRC CONCR	LEN=0015	INSTALLED	2008	
018 "DIA	CIRC CONCR	LEN=0015	INSTALLED	2008	
024 "DIA	CIRC CONCR	LEN=0002	INSTALLED	2013	
024 "DIA	CIRC CONCR	LEN=0038	INSTALLED	2013	
018 "DIA	CIRC CONCR	LEN=0010	INSTALLED	2008	
018 "DIA	CIRC CONCR	LEN=0015	INSTALLED	2008	
015 "DIA	CIRC CONCR	LEN=0190	INSTALLED	2008	
015 "DIA	CIRC CONCR	LEN=0190	INSTALLED	2008	
015 "DIA	CIRC CONCR	LEN=0190	INSTALLED	2008	
015 "DIA	CIRC CONCR	LEN=0190	INSTALLED	2008	
0060/0024		010686	FT		
018 "DIA	CIRC CONCR	LEN=0070	0 01 0148+44		
018 "DIA	CIRC CONCR	LEN=0035	INSTALLED	2008	
MILLVALE					
PITTSBURGH C					
LENGTH(AH 1556	BK 2226)	0060/0000			
018 "DIA	CIRC CONCR	LEN=0030	INSTALLED	2008	
0050/1895					
018 "DIA	CIRC CONCR	LEN=0030	INSTALLED	2008	
0050/1676					
018 "DIA	CIRC CONCR	LEN=0030	INSTALLED	2008	
0050/1555					
018 "DIA	CIRC CONCR	LEN=0025	INSTALLED	2008	
0050/1166					
018 "DIA	CIRC CONCR	LEN=0025	INSTALLED	2008	

DIR: N TOTAL LEN: 24.087 MI. DIST: 11-1 SR: 28
 LEFT MUN: PITTSBURGH C RIGHT MUN: PITTSBURGH C

LEN=0199	INSTALLED	2008	0051/1150	----	0050/1003	018 "DIA	CIRC	CONCR	
				----		LEN=0050	INSTALLED	2008	
				----	0050/0977	018 "DIA	CIRC	CONCR	
				----		LEN=0030	INSTALLED	2008	
018 "DIA	CIRC	CONCR							
LEN=0190	INSTALLED	2008	0051/0960	----					
018 "DIA	CIRC	CONCR							
LEN=0015	INSTALLED	2008	0051/0954	----					
024 "DIA	CIRC	CONCR							
LEN=0009	INSTALLED	2013	0051/0878	----					
RAMP C									
(SRB125	SEG	0500/0000)	0051/0840	====	0050/0840	018 "DIA	CIRC	CONCR	
018 "DIA	CIRC	CONCR				LEN=0020	INSTALLED	2008	
LEN=0020	INSTALLED	2008	0051/0837	----					
					0050/0836	018 "DIA	CIRC	CONCR	
						LEN=0005	INSTALLED	2008	
030 "DIA	CIRC	CONCR							
LEN=0024	INSTALLED	2013	0051/0778	----					
					0050/0742	RAMP D			
						(SRB125	SEG	0750/0602)	
036 "DIA	CIRC	CONCR				036 "DIA	CIRC	CONCR	
LEN=0005	INSTALLED	2013	0051/0736	----	0050/0736	LEN=0046	INSTALLED	2013	
						018 "DIA	CIRC	CONCR	
					0050/0623	LEN=0020	INSTALLED	2008	
						018 "DIA	CIRC	CONCR	
					0050/0589	LEN=0020	INSTALLED	2008	
018 "DIA	CIRC	CONCR							
LEN=0020	INSTALLED	2008	0051/0578	----					
					0050/0534	024 "DIA	CIRC	CONCR	
						LEN=0023	INSTALLED	2013	
024 "DIA	CIRC	CONCR							
LEN=0027	INSTALLED	2013	0051/0519	----					
					0050/0382	018 "DIA	CIRC	CONCR	
						LEN=0020	INSTALLED	2008	
018 "DIA	CIRC	CONCR							
LEN=0020	INSTALLED	2008	0051/0370	----					
					0050/0364	018 "DIA	CIRC	CONCR	
						LEN=0020	INSTALLED	2008	
						024 "DIA	CIRC	CONCR	
					0050/0343	LEN=0023	INSTALLED	2013	
024 "DIA	CIRC	CONCR							
LEN=0023	INSTALLED	2013	0051/0331	----					
					0050/0114	030 "DIA	CIRC	CONCR	
						LEN=0023	INSTALLED	2013	
						018 "DIA	CIRC	CONCR	
					0050/0100	LEN=0015	INSTALLED	2008	
						018 "DIA	CIRC	CONCR	
					0050/0099	LEN=0121	INSTALLED	2008	
						018 "DIA	CIRC	CONCR	
					0050/0094	LEN=0010	INSTALLED	2008	
036 "DIA	CIRC	CONCR							

DIR: N TOTAL LEN: 24.087 MI. DIST: 11-1 SR: 28
 LEFT MUN: PITTSBURGH C RIGHT MUN: PITTSBURGH C

LEN=0026	INSTALLED	2013	0051/0093	---					
018 "DIA	CIRC	CONCR		---					
LEN=0020	INSTALLED	2008	0051/0091	---					
024 "DIA	CIRC	CONCR		---					
LEN=0026	INSTALLED	2013	0051/0035	---					
1 0 00070	0 01	0124+07	008398 FT						
31ST.BRIDGE									
OP ID 02/2122/0010/0025									
LENGTH(AH 2373 BK 1631)			0051/0000	5					
024 "DIA	CIRC	CONCR		---					
LEN=0027	INSTALLED	2013	0041/1604	---					
024 "DIA	CIRC	CONCR		---					
LEN=0028	INSTALLED	2013	0050/0049	---					
008460 FT	1 0	00070	0 01						
31ST.BRIDGE									
OP ID 02/2122/0010/0025									
LENGTH(AH 2226 BK 1645)									
024 "DIA	CIRC	CONCR		---					
LEN=0023	INSTALLED	2013	0040/1632	---					
SIGN: STRUC MOUNTED									
BMSID 02/2122/0010/0035									
024 "DIA	CIRC	CONCR		---					
LEN=0027	INSTALLED	2013	0040/1603	---					
018 "DIA	CIRC	CONCR		---					
LEN=0010	INSTALLED	2008	0040/1521	---					
018 "DIA	CIRC	CONCR		---					
LEN=0020	INSTALLED	2008	0041/1482	---					
018 "DIA	CIRC	CONCR		---					
LEN=0020	INSTALLED	2008	0041/1330	---					
024 "DIA	CIRC	CONCR		---					
LEN=0003	INSTALLED	2013	0040/1256	---					
036 "DIA	CIRC	CONCR		---					
LEN=0024	INSTALLED	2013	0040/1255	---					
036 "DIA	CIRC	CONCR		---					
LEN=0003	INSTALLED	2013	0040/1148	---					
RAMP F									
(SR8125 SEG 0250/0540)			0041/1139						
036 "DIA	CIRC	CONCR		---					
LEN=0021	INSTALLED	2013	0041/1116	---					
024 "DIA	CIRC	CONCR		---					
LEN=0003	INSTALLED	2013	0041/1102	---					
024 "DIA	CIRC	CONCR		---					
LEN=0026	INSTALLED	2013	0041/1061	---					
024 "DIA	CIRC	CONCR		---					
LEN=0005	INSTALLED	2013	0040/0919	---					
RAMP E									
(SR8125 SEG 0010/0000)			0040/1095						
024 "DIA	CIRC	CONCR		---					
LEN=0005	INSTALLED	2013	0040/0758	---					
024 "DIA	CIRC	CONCR		---					
LEN=0005	INSTALLED	2013	0040/0758	---					

DIR: N TOTAL LEN: 24.087 MI. DIST: 11-1 SR: 28
 LEFT MUN: PITTSBURGH C RIGHT MUN: PITTSBURGH C

010 "DIA CAST IRON					0030/2412	LEN=0003	INSTALLED	2013	
LEN=0010	INSTALLED	2013	0031/2577	---					
024 "DIA CIRC CONCR				---					
LEN=0026	INSTALLED	2013	0031/2575	---					
024 "DIA CIRC CONCR				---					
LEN=0007	INSTALLED	2013	0031/2574	---					
024 "DIA CIRC CONCR				---					
LEN=0002	INSTALLED	2013	0031/2501	---					
024 "DIA CIRC CONCR				---					
LEN=0010	INSTALLED	2013	0031/2500	---					
SIGN: 4 CHORD TRUSS					SIGN: 4 CHORD TRUSS				
BMSID 02/0028/0030/1159	0031/1332			---	0030/1159	BMSID 02/0028/0030/1159			
PED WALKWAY					PED WALKWAY				
OP ID 02/0028/0020/1915	0031/0150			---					
1 0 00070 0 01 0079+83	003760 FT			---					
RAMP K RD				---					
(SR8121 SEG 0502/0000)				---					
NC EAST OHIO ST				---					
LENGTH(AH 3007 BK 1883)	0031/0000			---	003937 FT	1 0 00070 0 01 0079+83			
				---	0030/0000	NC EAST OHIO ST			
				---		LENGTH(AH 2878 BK 1958)			
				---		PED WALKWAY			
				---	0020/1915	OP ID 02/0028/0020/1915			
				---		RAMP J-E RD			
				---	0020/1665	(SR8121 SEG 0512/0778)			
SIGN: 4 CHORD TRUSS					SIGN: 4 CHORD TRUSS				
BMSID 02/0028/0021/1385	0021/1413			---					
RETAINING WALL				---					
BMSID 02/8121/0502/0170	0021/1390			---	0020/1338	RETAINING WALL			
SR 8108 RAMP J				---		BMSID 02/0028/0020/1338			
OP ID 02/8121/0512/0225	0021/1357			---	0020/1300	SR 8108 RAMP J			
CHESTNUT ST				---		OP ID 02/8121/0512/0225			
OP ID 02/7301/0000/3131	0021/0986			---	0020/0908	CHESTNUT ST			
				---		OP ID 02/7301/0000/3131			
				---	0020/0740	RAMP H RD			
				---		(SR8121 SEG 0752/1102)			
RETAINING WALL					RETAINING WALL				
BMSID 02/0028/0021/0733	0021/0733			---					
SIGN: 3 CHORD TRUSS				---					
BMSID 02/0028/0021/0618	0021/0618			---					
RAMP G RD				---					
(SR8121 SEG 0532/0000)	0021/0543			---					

BMSEN 02/0028/0021/0170	0021/0301			---	0020/0500	RETAINING WALL			
0 0 00000 0 00 0000+00				---		BMSID 02/0028/0020/0500			
RAMP 8108 MADISON AVE				---					
BMSBG 02/0028/0021/0170	0021/0209			---					

EXTRACT DATE: 12/21/2020 ROADWAY MANAGEMENT SYSTEM PAGE NUMBER: 81
PRINT DATE: 12/23/2020 SLD COUNTY/SR - ANNUAL PRINT COUNTY: ALLEGHENY
DIR: E TOTAL LEN: 10.282 MI. DIST: 11-1 SR: 22
LEFT MUN: MONROEVILLE B RIGHT MUN: MONROEVILLE B

AH-WESTMORELAND (64) 054287 FT
WILLIAM PENN HW INTER-AHD
(SR0022 SEG 0011/0000)



054273 FT
INTER-AHD WILLIAM PENN HW
(SR0022 SEG 0010/0000)

EXTRACT DATE: 12/21/2020
PRINT DATE: 12/23/2020

ROADWAY MANAGEMENT SYSTEM
SLD COUNTY/SR - ANNUAL PRINT

PAGE NUMBER: 80
COUNTY: ALLEGHENY

DIR: E TOTAL LEN: 10.282 MI.
LEFT MUN: MONROEVILLE B

DIST: 11-1 SR: 22
RIGHT MUN: MONROEVILLE B

OLD WILLIAM PENN HW
(BORO)

PLAZA DR
(BORO)

0291/2080

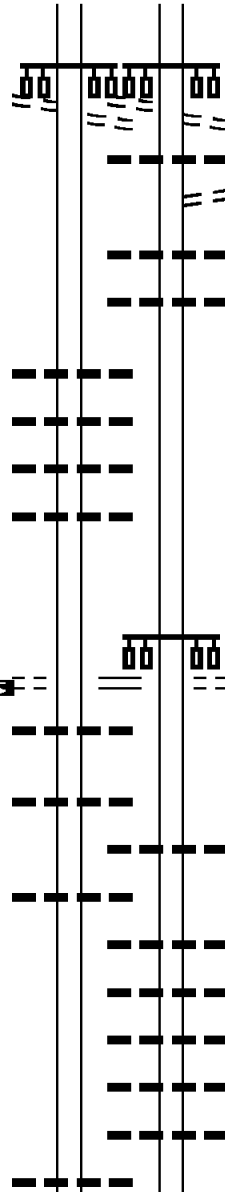

012 "DIA CIRC CONCR
LEN=0030 INSTALLED UNKN 0291/1035
018 "DIA CIRC CONCR
LEN=0040 INSTALLED UNKN 0291/0628
018 "DIA CIRC CONCR
LEN=0040 INSTALLED UNKN 0291/0316
018 "DIA CIRC CONCR
LEN=0040 INSTALLED UNKN 0291/0106

1 0 00187 0 01 0508+35 052207 FT
MC CLURE RD
(BORO)
CAVITT RD
(BORO)

LENGTH(AH 2080 BK 2200) 0291/0000
012 "DIA CIRC CONCR
LEN=0035 INSTALLED UNKN 0283/2155

024 "DIA CIRC CONCR
LEN=0035 INSTALLED UNKN 0283/1550

018 "DIA CIRC CONCR
LEN=0040 INSTALLED UNKN 0283/1346

012 "DIA CIRC CONCR
LEN=0030 INSTALLED UNKN 0283/0091

OLD WM PENN HW
(BORO)

PLAZA DR
(BORO)

0290/2050

0290/1972

0290/1865

0290/1820

0290/1676

018 "DIA CIRC CONCR
LEN=0050 INSTALLED UNKN
LC TO PLAZA DR
(CONN)
018 "DIA CIRC CONCR
LEN=0070 INSTALLED UNKN
012 "DIA CIRC CONCR
LEN=0075 INSTALLED UNKN

052223 FT 1 0 00187 0 01 0506+87

MC CLURE RD
(BORO)
CAVITT RD
(BORO)

LENGTH(AH 2050 BK 2173) 0290/0000

0282/1367 024 "DIA CIRC CONCR
LEN=0050 INSTALLED UNKN

0282/1210 024 "DIA CIRC CONCR
LEN=0050 INSTALLED UNKN

0282/0939 018 "DIA CIRC CONCR
LEN=0050 INSTALLED UNKN

0282/0650 012 "DIA CIRC METAL
LEN=0050 INSTALLED UNKN

0282/0350 012 "DIA CIRC METAL
LEN=0040 INSTALLED UNKN

0282/0100 012 "DIA CIRC CONCR
LEN=0040 INSTALLED UNKN

EXTRACT DATE: 12/21/2020
PRINT DATE: 12/23/2020

ROADWAY MANAGEMENT SYSTEM
SLD COUNTY/SR - ANNUAL PRINT

PAGE NUMBER: 77
COUNTY: ALLEGHENY

DIR: E TOTAL LEN: 10.282 MI.
LEFT MUN: MONROEVILLE B

DIST: 11-1 SR: 22
RIGHT MUN: MONROEVILLE B

LC TO OLD WM PENN HW
(CONN) 0261/0160

1 0 00187 0 01 0409+12 042283 FT
OLD WILLIAM PENN HW
(BORO)

LTH AH 003087 BK 003680 0261/0000

018 "DIA CIRC CONCR
LEN=0030 INSTALLED UNKN 0251/3600

THOMPSON RUN
STRUCTURE LENGTH 16 FT

BMSID 02/0022/0250/3482 0251/3472

018 "DIA CIRC CONCR
LEN=0030 INSTALLED UNKN 0251/3350

024 "DIA CIRC CONCR
LEN=0099 INSTALLED UNKN 0251/3125

012 "DIA CIRC CONCR
LEN=0099 INSTALLED UNKN 0251/2900

SIGN: CANTILEVER
BMSID 02/0022/0251/2785 0251/2785

018 "DIA CIRC CONCR
LEN=0050 INSTALLED UNKN 0251/2284

012 "DIA CIRC CONCR
LEN=0035 INSTALLED UNKN 0251/2145

012 "DIA CIRC CONCR
LEN=0040 INSTALLED UNKN 0251/1805

CAR DEALERSHIP
(PRDR)

CAR DEALERSHIP
(PRDR)

CAR DEALERSHIP
(PRDR)

012 "DIA CIRC CONCR
LEN=0040 INSTALLED UNKN 0251/1500

SIGN: CANTILEVER
BMSID 02/0022/0251/1262 0251/1262

OP ID 1-76
02/7076/9900/5635 0251/0574

012 "DIA CIRC CONCR
LEN=0040 INSTALLED UNKN 0251/0073

TURNPIKE RAMP RD
(TNPK)

0250/0001
038619 FT 1 0 00187 0 01 0372+42

NC NEW WM PENN HW
PENN LINCOLN PY
(SRO376 SEG 0845/0334)

WILLIAM PENN HW
INTER-BK

0250/0605 OP ID 1-76
02/7076/9900/5635

012 "DIA CIRC CONCR
LEN=0040 INSTALLED UNKN

TURNPIKE RAMP RD
(TNPK)

0250/0001
038619 FT 1 0 00187 0 01 0372+42

NC NEW WM PENN HW
PENN LINCOLN PY
(SRO376 SEG 0844/0798)

WILLIAM PENN HW
INTER-BK

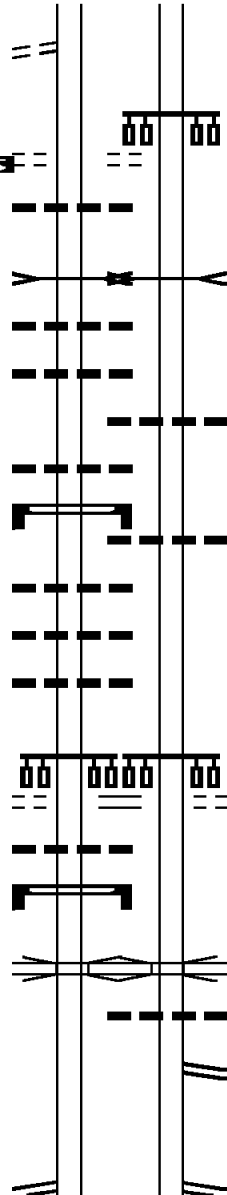

042269 FT 1 0 00187 0 01 0408+92
OLD WILLIAM PENN HW
(BORO)

0260/0000 LTH AH 003040 BK 003650

THOMPSON RUN
STRUCTURE LENGTH 16 FT

0250/3452 BMSID 02/0022/0250/3482

0250/3082 012 "DIA CIRC CONCR
LEN=0080 INSTALLED UNKN

0250/2762 012 "DIA CIRC CONCR
LEN=0050 INSTALLED UNKN

CAR DEALERSHIP
(PRDR)
CAR DEALERSHIP
(PRDR)
CAR DEALERSHIP
(PRDR)

0250/1604

0250/0605 OP ID 1-76
02/7076/9900/5635

012 "DIA CIRC CONCR
LEN=0040 INSTALLED UNKN

TURNPIKE RAMP RD
(TNPK)

0250/0001
038619 FT 1 0 00187 0 01 0372+42

NC NEW WM PENN HW
PENN LINCOLN PY
(SRO376 SEG 0844/0798)

WILLIAM PENN HW
INTER-BK

DIR: E TOTAL LEN: 10.282 MI. DIST: 11-1 SR: 22
 LEFT MUN: ROBINSON T RIGHT MUN: ROBINSON T

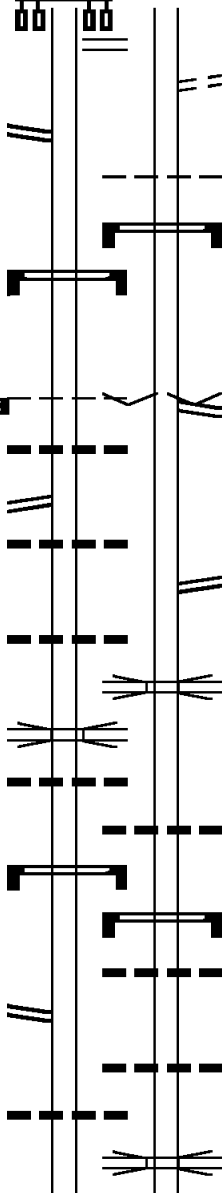
(SR8036 SEG 0750/0000)	0141/0901		0140/0755 TO 8036/0750 SH (CONN)
RAMP H RD (SR8036 SEG 0010/0928)	0141/0511		ROBINSON NORTH FAYETTE T SIGN: 4 CHORD TRUSS BMSID 02/0022/0140/0270
SIGN: 4 CHORD TRUSS BMSID 02/0022/0140/0270	0141/0250		037170 FT 1 0 00257 0 02 0386+64 VILLAGE: ROBINSON TWP STEUBENVILLE PK (SR3066 SEG 0090/0870)
1 0 00257 0 02 0386+64 037166 FT ROBINSON NORTH FAYETTE T LENGTH(AH 1437 BK 3942)	0141/0000		0140/0000 LENGTH(AH 1449 BK 3578)
018 "DIA CIRC CONCR LEN=0045 INSTALLED UNKN	0131/3716		
RAMP V RD (SR8034 SEG 0500/0000)	0131/3412		
018 "DIA CIRC CONCR LEN=0030 INSTALLED UNKN	0131/3382		
018 "DIA CIRC CONCR LEN=0039 INSTALLED UNKN	0131/3061		0130/2628 RAMP X RD (SR8034 SEG 0750/0000)
MONTOUR CHURCH ROA OP ID 02/3086/0010/0001	0131/2893		0130/2511 OP ID 02/3086/0010/0001
018 "DIA CIRC CONCR LEN=0045 INSTALLED UNKN	0131/2724		
SIGN: 2 CHORD TRUSS BMSID 02/0022/0130/2195	0131/2600		0130/2280 018 "DIA CIRC CONCR LEN=0050 INSTALLED UNKN
RAMP U RD (SR8034 SEG 0250/0596)	0131/2357		0130/2195 SIGN: 2 CHORD TRUSS BMSID 02/0022/0130/2195
018 "DIA CIRC CONCR LEN=0050 INSTALLED UNKN	0131/1905		0130/2011 018 "DIA CIRC CONCR LEN=0099 INSTALLED UNKN
			0130/1724 018 "DIA CIRC CONCR LEN=0099 INSTALLED UNKN
STUEBEN PIKE			0130/1289 OP ID 02/3066/0080/0000

DIR: E TOTAL LEN: 10.282 MI. DIST: 11-1 SR: 22
 LEFT MUN: NORTH FAYETTE T RIGHT MUN: NORTH FAYETTE T

Item Description	Item ID	Item Length	Item Material	Item Status
RAMP R RD (SR8030 SEG 0510/0000)	0091/2602			
012 "DIA CIRC CONCR	0091/2436			
LEN=0050 INSTALLED UNKN	0091/2398			
012 "DIA CIRC CONCR	0091/2398			
LEN=0050 INSTALLED UNKN				
RAMP Q RD (SR8030 SEG 0500/0746)	0091/2207			
BMS EN 02/0022/0090/1802	0091/2055			
1 0 00257 3 00 0252+88	0091/2055			
SR 3063 OAKDALE RD.	0091/1889			
BMSBG 02/0022/0090/1802	0091/1889			
012 "DIA CIRC CONCR	0091/1552			
LEN=0050 INSTALLED UNKN	0091/1552			
018 "DIA CIRC CONCR	0091/1253			
LEN=0050 INSTALLED UNKN	0091/1253			
012 "DIA CIRC CONCR	0091/0953			
LEN=0050 INSTALLED UNKN	0091/0953			
012 "DIA CIRC CONCR	0091/0645			
LEN=0050 INSTALLED UNKN	0091/0645			
018 "DIA CIRC CONCR	0090/0555			
LEN=0020 INSTALLED UNKN	0090/0533			
018 "DIA CIRC CONCR	0090/0533			
LEN=0060 INSTALLED UNKN	0090/0228			
018 "DIA CIRC CONCR	0090/0228			
LEN=0099 INSTALLED UNKN	0090/0000			
1 0 00257 3 00 0233+80 023410 FT	0090/0000			
LENGTH(AH 3114 BK 2677)	0090/0000			
018 "DIA CIRC CONCR	0080/2092			
LEN=0099 INSTALLED UNKN	0080/2092			
012 "DIA CIRC CONCR	0081/1905			
LEN=0050 INSTALLED UNKN	0081/1905			
018 "DIA CIRC CONCR	0080/1776			
LEN=0055 INSTALLED UNKN	0080/1776			
024 "DIA CIRC CONCR				

DIR: E TOTAL LEN: 10.282 MI. DIST: 11-1 SR: 22
 LEFT MUN: NORTH FAYETTE T RIGHT MUN: NORTH FAYETTE T

LEN=0099	INSTALLED UNKN	0081/1605	---	---	---	0080/1463	018 "DIA CIRC CONCR	LEN=0060	INSTALLED UNKN
012 "DIA CIRC CONCR									
LEN=1195	INSTALLED UNKN	0081/1294	---	---		0080/1168	018 "DIA CIRC CONCR	LEN=0099	INSTALLED UNKN
						0080/0965	MILEPOST	017.00	
						0080/0917	018 "DIA CIRC CONCR	LEN=0100	INSTALLED UNKN
018 "DIA CIRC CONCR									
LEN=0045	INSTALLED UNKN	0081/0660	---	---		0080/0553	036 "DIA CIRC CONCR	LEN=0099	INSTALLED UNKN
018 "DIA CIRC CONCR									
LEN=0055	INSTALLED UNKN	0081/0327	---	---		0080/0253	018 "DIA CIRC CONCR	LEN=0099	INSTALLED UNKN
1 0 00257 3 00 0207+73 020733 FT						021111 FT	1 0 00257 3 00 0210+08		
CAVC							CAVC		
LENGTH(AH 2677 BK 1681)		0081/0000	---	---		0080/0000	LENGTH(AH 2437 BK 1984)		
						0070/1194	018 "DIA CIRC CONCR	LEN=0099	INSTALLED UNKN
						0070/0819	018 "DIA CIRC CONCR	LEN=0099	INSTALLED UNKN
012 "DIA CIRC CONCR									
LEN=0050	INSTALLED UNKN	0071/0589	---	---					
018 "DIA CIRC CONCR									
LEN=0060	INSTALLED UNKN	0071/0224	---	---		019127 FT	1 0 00257 3 00 0190+92		
1 0 00257 3 00 0190+92						0070/0000	LENGTH(AH 1984 BK 2307)		
019052 FT							012 "DIA CIRC CONCR		
LENGTH(AH 1681 BK 2322)		0071/0000	---	---		0060/2041	LEN=0040	INSTALLED UNKN	
024 "DIA CIRC CONCR									
LEN=0050	INSTALLED UNKN	0061/1973	---	---		0060/1725	012 "DIA CIRC CONCR	LEN=0120	INSTALLED UNKN
(TO 30 W) RAMP L RD									
(SR8028 SEG 0500/0000)		0061/1456	---	---		0060/1254	018 "DIA CIRC CONCR	LEN=0050	INSTALLED UNKN
						0060/0933	BMSSEN 02/0022/0060/0771		
BMSSEN 02/0022/0060/0771							1 0 00257 3 00 0164+82		
1 0 00257 3 00 0168+22							SR 0978		
SR 0978						0060/0773	BMSBG 02/0022/0060/0771		
BMSBG 02/0022/0060/0771		0061/0819	---	---		0060/0694	018 "DIA CIRC CONCR	LEN=0080	INSTALLED UNKN
							(FR 30E/978S) RAMP O RD		
						0060/0535	(SR8028 SEG 0020/0811)		

DIR: E TOTAL LEN: 10.282 MI. DIST: 11-1 SR: 22
 LEFT MUN: NORTH FAYETTE T RIGHT MUN: NORTH FAYETTE T

012 "DIA CIRC CONCR LEN=0500 INSTALLED UNKN 0041/2156	0040/2207	LEN=0045	INSTALLED UNKN
012 "DIA CIRC CONCR LEN=0045 INSTALLED UNKN 0041/1961	0040/2127		MILEPOST 015.00
012 "DIA CIRC CONCR LEN=0050 INSTALLED UNKN 0041/1339			
RAMP F RD (SR8026 SEG 0500/0000) 0041/1023	0040/1038	012 "DIA CIRC CONCR LEN=0050	INSTALLED UNKN
018 "DIA CIRC CONCR LEN=0040 INSTALLED UNKN 0041/0866			
	0040/0683	RAMP G RD (SR8026 SEG 0760/0784)	
	0040/0295	RAMP H RD (SR8026 SEG 0750/0000)	
018 "DIA CIRC CONCR LEN=0040 INSTALLED UNKN 0041/0082			
012 "DIA CIRC CONCR LEN=0100 INSTALLED UNKN 0041/0058			
1 0 00257 3 00 0093+62 009379 FT	009391 FT	1 0 00257 3 00 0093+62	
VILLAGE: N. FAYETTE TWP KELSO ROAD		VILLAGE: N. FAYETTE TWP KELSO ROAD	
OP ID 02/3051/0050/0296 LENGTH(AH 3634 BK 3396) 0041/0000	0040/0000	OP ID 02/3051/0050/0296 LENGTH(AH 3663 BK 3233)	
012 "DIA CIRC CONCR LEN=0100 INSTALLED UNKN 0031/3101			
RAMP E RD (SR8026 SEG 0250/0595) 0031/2788	0030/2920	012 "DIA CIRC CONCR LEN=0040	INSTALLED UNKN
	0030/2358	012 "DIA CIRC CONCR LEN=0050	INSTALLED UNKN
	0030/2112	012 "DIA CIRC CONCR LEN=0050	INSTALLED UNKN
	0030/2043	012 "DIA CIRC CONCR LEN=0050	INSTALLED UNKN
	0030/1530	018 "DIA CIRC CONCR LEN=0050	INSTALLED UNKN
	0030/0520	018 "DIA CIRC CONCR LEN=0050	INSTALLED UNKN
	0030/0284		MILEPOST 014.00
	0030/0085	018 "DIA CIRC CONCR LEN=0050	INSTALLED UNKN
	006158 FT	1 0 00257 3 00 0062+67	

DIR: E TOTAL LEN: 10.282 MI. DIST: 11-1 SR: 22
 LEFT MUN: NORTH FAYETTE T RIGHT MUN: NORTH FAYETTE T

1 0 00257 3 00 0062+67 005983 FT VILLAGE: N. FAYETTE TWP
 LENGTH(AH 3396 BK 2764) 0031/0000 0030/0000 LENGTH(AH 3233 BK 2972)

BMS EN 02/0022/0020/0000 0021/0441 0020/0436 BMS EN 02/0022/0020/0000
 1 0 00257 3 00 0031+82 1 0 00257 3 00 0031+82
 OLD STEUBENVILLE PIKE L OLD STEUBENVILLE PIKE L
 BMSBG 02/0022/0020/0000 0021/0205 0020/0200 BMSBG 02/0022/0020/0000
 1 0 00257 3 00 0033+00 003219 FT 003186 FT 1 0 00257 3 00 0033+00
 LENGTH(AH 2764 BK 3219) 0021/0000 0020/0000 LENGTH(AH 2972 BK 3186)
 018 "DIA CIRC CONCR
 LEN=0150 INSTALLED UNKN 0011/2902
 018 "DIA CIRC CONCR
 LEN=0050 INSTALLED UNKN 0011/2628

024 "DIA CIRC CONCR
 LEN=0050 INSTALLED UNKN 0011/1193
 BMS EN 02/0022/0010/0659 0011/0910 0010/2013
 1 0 00257 3 00 0006+31 0010/1715
 SR 3071 (SR8024 SEG 0750/0508)
 BMSBG 02/0022/0010/0659 0011/0650 0010/1443
 SIGN: 2 CHORD TRUSS 012 "DIA CIRC CONCR
 BMSID 02/0022/0010/0614 0011/0591 0010/0614 LEN=0040 INSTALLED UNKN

NORTH FAYETTE MILEPOST 013.00
 FINDLAY T 0011/0456 BMS EN 02/0022/0010/0659
 RAMP B RD 0010/0423 1 0 00257 3 00 0006+31
 (SR8024 SEG 0250/0000) 0011/0255 SR 3071
 BMSBG 02/0022/0010/0659
 SIGN: 2 CHORD TRUSS

1 0 00257 3 00 0000+00 000000 FT 000000 FT 1 0 00257 3 00 0000+00
 NC SR INTER-BK VILLAGE: N. FAYETTE TWP
 SR 22 SH WASHINGTON CO REF-BK (SR8024 SEG 0010/0000)
 (SR0022 SEG 0261/3110) SR 0022 SH SR 0022 SH
 MFC BEGIN = B (SR0022 SEG 0260/3069)
 BK-WASHINGTON (62)
 LENGTH(AH 3219 BK 0000) 0011/0000 0010/0000 LENGTH(AH 3186 BK 0000)

DIR: N TOTAL LEN: 29.135 MI. DIST: 11-1 SR: 19
 LEFT MUN: MARSHALL T RIGHT MUN: MARSHALL T

AH-BUTLER (10) 153206 FT PERRY HW BUTLER CO REF-AHD * (SR0019 SEG 0011/0000) 0681/3516 024 "DIA CIRC CONCR LEN=0070 INSTALLED UNKN 0681/3230 EMERYVILLE DR (T877) FREEPORT RD (SR4054 SEG 0010/0000) 0681/3165		* 153835 FT REF-AHD PERRY HW BUTLER CO 0680/3452 (SR0019 SEG 0010/0000) EMERYVILLE DR (T877) FREEPORT RD (SR4054 SEG 0010/0000) 0680/3090 018 "DIA CIRC CONCR LEN=0020 INSTALLED UNKN 0680/2845 RAMP W RD (SR8027 SEG 0010/3259) 0680/1515 018 "DIA CIRC CONCR LEN=0020 INSTALLED UNKN 0680/1119 (APRA) THORN HILL IND P THORN HILL RD (CNTY) 0680/0800 BR BRUSH CR STRUCTURE LENGTH 14 FT BMSID 02/0019/0680/0605 0680/0605 018 "DIA CIRC CONCR LEN=0010 INSTALLED UNKN 0681/0484
--	--	--

DIR: N TOTAL LEN: 29.135 MI. DIST: 11-1 SR: 19
 LEFT MUN: MARSHALL T RIGHT MUN: MARSHALL T

018 "DIA CIRC CONCR LEN=0010 INSTALLED UNKN 0681/0320	---	0680/0260	018 "DIA CIRC CONCR LEN=0020 INSTALLED UNKN
018 "DIA CIRC CONCR LEN=0010 INSTALLED UNKN 0681/0044	---	0680/0002 150383 FT	018 "DIA CIRC CONCR LEN=0020 INSTALLED UNKN 1 0 00246 0 04 1000+32
1 0 00246 0 04 0998+88 149690 FT LENGTH(AH 3516 BK 3517) 0681/0000	---	0680/0000	018 "DIA CIRC CONCR LEN=0020 INSTALLED UNKN LENGTH(AH 3452 BK 3223)
018 "DIA CIRC CONCR LEN=0030 INSTALLED UNKN 0671/3042	---	0670/2890	018 "DIA CIRC CONCR LEN=0020 INSTALLED UNKN
SIGN: 3 CHORD TRUSS BMSID 02/0019/0670/2401 0671/2792	---	0670/2536	018 "DIA CIRC CONCR LEN=0020 INSTALLED UNKN SIGN: 3 CHORD TRUSS
018 "DIA CIRC CONCR LEN=0030 INSTALLED UNKN 0671/2676	---	0670/2421	BMSID 02/0019/0670/2401
OP ID 02/7076/9900/2972 0671/2600	---	0670/2167	OP ID 02/7076/9900/2972 018 "DIA CIRC CONCR LEN=0020 INSTALLED UNKN
RAMP V RD (SR8027 SEG 0250/0000) 0671/2029	---	0670/2041	
018 "DIA CIRC CONCR LEN=0030 INSTALLED UNKN 0671/2000	---	0670/1847	018 "DIA CIRC CONCR LEN=0020 INSTALLED UNKN
018 "DIA CIRC CONCR LEN=0030 INSTALLED UNKN 0671/1653	---	0670/1522	018 "DIA CIRC CONCR LEN=0020 INSTALLED UNKN
LR 1021 - I-79 SB OP ID 02/0079/0761/1834 0671/1046	---	0670/1044	018 "DIA CIRC CONCR LEN=0020 INSTALLED UNKN LR 1021 - I-79 SB
018 "DIA CIRC CONCR LEN=0030 INSTALLED UNKN 0671/0844	---	0670/0961	OP ID 02/0079/0761/1834 018 "DIA CIRC CONCR LEN=0020 INSTALLED UNKN
BRUSH CREEK STRUCTURE LENGTH 16 FT BMSID 02/0019/0670/0480 0671/0798	---	0670/0721	SR 0079 NB OP ID 02/0079/0760/1607
SR 0079 NB OP ID 02/0079/0760/1607 0671/0707	---	0670/0582	BRUSH CREEK STRUCTURE LENGTH 16 FT
	---	0670/0535	BMSID 02/0019/0670/0480

DIR: N TOTAL LEN: 29.135 MI. DIST: 11-1 SR: 19
 LEFT MUN: MARSHALL T RIGHT MUN: MARSHALL T

Stationing	Description	Length	Material	Notes
0671/0200	018 "DIA CIRC CONCR LEN=0030 INSTALLED UNKN			
0671/0000	1 0 00246 0 04 0968+28 146173 FT LENGTH(AH 3517 BK 2133)	146173	CONCR	
0661/1930	018 "DIA CIRC CONCR LEN=0030 INSTALLED UNKN			
0661/1556	018 "DIA CIRC CONCR LEN=0030 INSTALLED UNKN			
0661/1498	TO 4052/0091 SH (CONN)			
0661/1368	018 "DIA CIRC CONCR LEN=0099 INSTALLED UNKN			
0661/1365	018 "DIA CIRC CONCR LEN=0030 INSTALLED UNKN			
0661/1273	WARRENDALE BAYNE RD (SR4052 SEG 0100/0000)			
0661/0816	018 "DIA CIRC CONCR LEN=0030 INSTALLED UNKN			
0661/0667	018 "DIA CIRC CONCR LEN=0030 INSTALLED UNKN			
0661/0613	018 "DIA CIRC CONCR LEN=0030 INSTALLED UNKN			
0661/0256	018 "DIA CIRC CONCR LEN=0099 INSTALLED UNKN			
0661/0017	018 "DIA CIRC CONCR LEN=0030 INSTALLED UNKN			
0661/0000	1 0 00246 0 04 0945+52 144040 FT LENGTH(AH 2133 BK 1923)	144040	CONCR	
0651/1922	018 "DIA CIRC CONCR LEN=0143 INSTALLED UNKN			
0651/1235	018 "DIA CIRC CONCR LEN=0070 INSTALLED UNKN			
0651/1232	HARMONY RD (T388)			
0671/0322	NORTHGATE DR (PRDR)			
0671/0313	UNKNOWN RD (TWP)			
0670/0035	018 "DIA CIRC CONCR LEN=0020 INSTALLED UNKN			
0670/0000	1 0 00246 0 04 0968+28 LENGTH(AH 3223 BK 2259)	147160	CONCR	
0660/1040	WARRENDALE BAYNE RD (SR4052 SEG 0100/0000)			
0660/0846	TO 4052/0100 SH (CONN)			
0660/0105	018 "DIA CIRC CONCR LEN=0020 INSTALLED UNKN			
0660/0000	1 0 00246 0 04 0944+75 LENGTH(AH 2259 BK 2238)	144901	CONCR	
0650/1915	018 "DIA CIRC CONCR LEN=0020 INSTALLED UNKN			
0650/1405	HARMONY RD (T388)			

DIR: N TOTAL LEN: 29.135 MI. DIST: 11-1 SR: 19
 LEFT MUN: MARSHALL T RIGHT MUN: MARSHALL T

Stationing	Description	Stationing	Description
0651/1031	LEN=0099 INSTALLED UNKN	0651/1031	LEN=0099 INSTALLED UNKN
0651/0765	018 "DIA CIRC CONCR LEN=0070 INSTALLED UNKN	0651/0765	018 "DIA CIRC CONCR LEN=0070 INSTALLED UNKN
0651/0651	BR. BRUSH CR. STRUCTURE LENGTH 17 FT BMSID 02/0019/0650/0841	0651/0651	BR. BRUSH CR. STRUCTURE LENGTH 17 FT BMSID 02/0019/0650/0841
0651/0461	018 "DIA CIRC CONCR LEN=0030 INSTALLED UNKN	0651/0461	018 "DIA CIRC CONCR LEN=0030 INSTALLED UNKN
0651/0275	SHENOT RD (TWP) NORTHGATE DR (TWP)	0651/0275	SHENOT RD (TWP) NORTHGATE DR (T482)
0651/0105	142117 FT 018 "DIA CIRC CONCR LEN=0143 INSTALLED UNKN LENGTH(AH 1923 BK 2865)	0651/0105	142663 FT 018 "DIA CIRC CONCR LEN=0020 INSTALLED UNKN
0641/2641	018 "DIA CIRC CONCR LEN=0050 INSTALLED UNKN	0641/2641	018 "DIA CIRC CONCR LEN=0050 INSTALLED UNKN
0641/2291	018 "DIA CIRC CONCR LEN=0099 INSTALLED UNKN	0641/2291	018 "DIA CIRC CONCR LEN=0099 INSTALLED UNKN
0641/1928	018 "DIA CIRC CONCR LEN=0070 INSTALLED UNKN	0641/1928	018 "DIA CIRC CONCR LEN=0070 INSTALLED UNKN
0641/1700	018 "DIA CIRC CONCR LEN=0099 INSTALLED UNKN	0641/1700	018 "DIA CIRC CONCR LEN=0099 INSTALLED UNKN
0641/1690	018 "DIA CIRC CONCR LEN=0050 INSTALLED UNKN	0641/1690	018 "DIA CIRC CONCR LEN=0050 INSTALLED UNKN
0641/1337	018 "DIA CIRC CONCR LEN=0099 INSTALLED UNKN	0641/1337	018 "DIA CIRC CONCR LEN=0060 INSTALLED UNKN
0641/1400	018 "DIA CIRC CONCR LEN=1301 INSTALLED UNKN	0641/1400	018 "DIA CIRC CONCR LEN=1301 INSTALLED UNKN
0641/1040	018 "DIA CIRC CONCR LEN=0099 INSTALLED UNKN	0641/1040	018 "DIA CIRC CONCR LEN=0099 INSTALLED UNKN
0641/0635	ROWAN RD (T834)	0641/0635	ROWAN RD (T834)
0640/0761	018 "DIA CIRC CONCR	0640/0761	018 "DIA CIRC CONCR

DIR: N TOTAL LEN: 29.135 MI. DIST: 11-1 SR: 19
 LEFT MUN: MARSHALL T RIGHT MUN: MARSHALL T

Segment ID	Description	Stationing	Length	Material	Status
018	"DIA CIRC CONCR	0640/0617	LEN=0518	INSTALLED	UNKN
018	"DIA CIRC CONCR	0641/0520	LEN=0050	INSTALLED	UNKN
018	"DIA CIRC CONCR	0640/0482	LEN=0099	INSTALLED	UNKN
018	"DIA CIRC CONCR	0641/0280	LEN=0050	INSTALLED	UNKN
1 0 00246 0 04	MARSHALL PINE T	0893+22	139252 FT		
1 0 00246 0 04	MARSHALL PINE T	0894+04	139763 FT		
5	GATEWAY AV (T400)	0641/0000	LEN=2865	INSTALLED	UNKN
5	GATEWAY AV (T400)	0640/0000	LEN=2900	INSTALLED	UNKN
018	"DIA CIRC CONCR	0634/2321	LEN=0099	INSTALLED	UNKN
018	"DIA CIRC CONCR	0634/1825	LEN=0050	INSTALLED	UNKN
018	"DIA CIRC CONCR	0634/1739	LEN=0099	INSTALLED	UNKN
018	"DIA CIRC CONCR	0635/1669	LEN=0099	INSTALLED	UNKN
BRADFORD RD (T400)	BRADFORD DR (TWP)	0634/1610	LEN=1511	INSTALLED	UNKN
00	0000	00	0635/1490		
018	"DIA CIRC CONCR	0634/1496	LEN=0099	INSTALLED	UNKN
018	"DIA CIRC CONCR	0634/1345	LEN=0099	INSTALLED	UNKN
018	"DIA CIRC CONCR	0635/1366	LEN=0010	INSTALLED	UNKN
UNKNOWN RD (TWP)	STONEWOOD DR (TWP)	0634/1090	LEN=0040	INSTALLED	UNKN
018	"DIA CIRC CONCR	0634/0928	LEN=0099	INSTALLED	UNKN
018	"DIA CIRC CONCR	0635/1200	LEN=0010	INSTALLED	UNKN
018	"DIA CIRC CONCR	0635/1068	LEN=0070	INSTALLED	UNKN
018	"DIA CIRC CONCR	0635/1025	LEN=0070	INSTALLED	UNKN
018	"DIA CIRC CONCR	0634/0739	LEN=0351	INSTALLED	UNKN
018	"DIA CIRC CONCR	0634/0430	LEN=0309	INSTALLED	UNKN
018	"DIA CIRC CONCR	0634/0204	LEN=0099	INSTALLED	UNKN
018	"DIA CIRC CONCR	0634/0135	LEN=0099	INSTALLED	UNKN

DIR: N TOTAL LEN: 29.135 MI. DIST: 11-1 SR: 19
 LEFT MUN: PINE T RIGHT MUN: PINE T

WALLACE RD (SR4068 SEG 0012/0000) (SR4068 SEG 0013/0000)					WALLACE RD (SR4068 SEG 0012/0000) (SR4068 SEG 0013/0000)
	0621/1660			0620/1013	
018 "DIA CIRC CONCR LEN=0010 INSTALLED UNKN	0621/1574				
018 "DIA CIRC CONCR LEN=0050 INSTALLED UNKN	0621/1418				
018 "DIA CIRC CONCR LEN=0050 INSTALLED UNKN	0621/1118				
018 "DIA CIRC CONCR LEN=0005 INSTALLED UNKN	0621/0822				
				0620/0633	018 "DIA CIRC CONCR LEN=0099 INSTALLED UNKN
1 0 00246 0 04 0831+73 132502 FT MANOR RD (T697) NORTH CHAPEL RD (SR4073 SEG 0010/1532) NORTH CHURCH RD (T835)					
LENGTH(AH 2686 BK 2925)	0621/0000			133822 FT 0620/0000	1 0 00246 0 04 0834+74 LENGTH(AH 2491 BK 3623)
					MANOR RD (T697) NORTH CHAPEL DR (SR4073 SEG 0010/1498) NORTH CHURCH RD (T835)
018 "DIA CIRC CONCR LEN=0034 INSTALLED 2012	0611/2859			0610/2946	
018 "DIA CIRC CONCR LEN=0050 INSTALLED 2012	0611/2113			0610/2698	TO 4073/0010 (CONN)
018 "DIA CIRC CONCR LEN=0017 INSTALLED UNKN	0611/1965				
BMS EN 02/0019/0610/1799	0611/1896			0610/1945	BMS EN 02/0019/0610/1799
				0610/1799	0 0 00000 0 00 0000+00 SR 0910 BMSBG 02/0019/0610/1799
0 0 00000 0 00 0000+00 SR 0910 BMSBG 02/0019/0610/1799	0611/1750				
				0610/1570	018 "DIA CIRC CONCR LEN=0031 INSTALLED 2012

DIR: N TOTAL LEN: 29.135 MI. DIST: 11-1 SR: 19
 LEFT MUN: PINE T RIGHT MUN: PINE T

Segment Description	Stationing	Material / Notes	Length (FT)	Stationing	Material / Notes
LC TO SOUTH CHURCH RD (CONN)	0611/1161				
SOUTH CHURCH RD (T835)	0611/1020				
BONNIEVIEW DR (T513)	0611/0620				BONNIEVIEW DR (T513)
018 "DIA CIRC CONCR	0611/0591			0610/0625	
LEN=0028 INSTALLED 2011					
1 0 00246 0 04 0799+16	129577 FT		130199 FT		1 0 00246 0 04 0799+42
BROWN RD (T691)					BROWN RD (T691)
LENGTH(AH 2925 BK 3398)	0611/0000			0610/0000	LENGTH(AH 3623 BK 3340)
FIELDVIEW DR (TWP)	0601/2970			0600/2875	FIELDVIEW DR (TWP)
018 "DIA CIRC CONCR	0601/2536				
LEN=0030 INSTALLED 2011					
PRIVATE DR (PRDR)					PRIVATE DR (PRDR)
0601/2344				0600/2276	
018 "DIA CIRC CONCR	0601/2228				
LEN=0005 INSTALLED 2011					
MAPLE DR (T513)	0601/1970			0600/1905	MAPLE DR (T911)
LAKE DR (TWP)	0601/1653			0600/1595	LAKE DR (TWP)
036 "DIA CIRC CONCR	0601/1278				
LEN=0050 INSTALLED 2011					
BROOKTREE RD (TWP)					BROOKTREE RD (TWP)
BROOKER RD (TWP)					BROOKER DR (TWP)
0601/1200				0600/1150	
018 "DIA CIRC CONCR	0601/0912				
LEN=0049 INSTALLED 2011					
ASPEN RD (TWP)	0601/0559			0600/0505	ASPEN RD (TWP)
018 "DIA CIRC CONCR	0601/0538				
LEN=0035 INSTALLED 2011					
018 "DIA CIRC CONCR	0601/0103				
LEN=0005 INSTALLED 2011					
018 "DIA CIRC CONCR	0601/0094				
LEN=0010 INSTALLED UNKN					
1 0 00246 0 04 0765+38	126179 FT		126859 FT		1 0 00246 0 04 0765+63
PINE MCCANDLESS T					PINE MCCANDLESS T
LENGTH(AH 3398 BK 2653)	0601/0000			0600/0000	LENGTH(AH 3340 BK 2560)

DIR: N TOTAL LEN: 29.135 MI. DIST: 11-1 SR: 19
 LEFT MUN: MCCANDLESS T RIGHT MUN: MCCANDLESS T

Item ID	Description	Length	Material	Status	Year	Stationing	Notes
018	"DIA CIRC CONCR	0033	INSTALLED	2012	0591/2642		
N MEADOWS DR (TWP)							
		0591/2528				0590/2406	N MEADOWS DR (TWP) WEXFORD PLAZA DR (TWP)
018	"DIA CIRC CONCR	0010	INSTALLED	2012	0591/2500		
018	"DIA CIRC CONCR	0031	INSTALLED	2011	0591/2171		
018	"DIA CIRC CONCR	0010	INSTALLED	UNKN	0591/1853		
REICHOLD RD (TWP)							
RICHARD RD (SR4053 SEG 0010/0000)							
		0591/1618				0590/1481	REICHOLD RD (TWP) RICHARD RD (SR4053 SEG 0010/0000)
WELLER DR (TWP)							
		0591/1146				0590/1005	WELLER DR (TWP)
018	"DIA CIRC CONCR	0030	INSTALLED	2011	0591/1065		
018	"DIA CIRC CONCR	0010	INSTALLED	UNKN	0591/1046		
LITTLE MEADOW RD (TWP)							
		0591/0782				0590/0876	018"H 18"W **UNKNOWN** LEN=0099 INSTALLED 2012
018	"DIA CIRC CONCR	0034	INSTALLED	2011	0591/0309		
018	"DIA CIRC CONCR	0010	INSTALLED	UNKN	0591/0286		
ALBERMARLE RD (TWP)							
		0591/0125				0590/0123	018 "DIA CIRC CONCR LEN=0028 INSTALLED 2012 1 0 00246 0 04 0741+24 ALBERMARLE RD (TWP)
1 0 00246 0 04 0739+59	123526 FT	0591/0000				0590/0000	LENGTH(AH 2560 BK 2950)
018	"DIA CIRC CONCR	0010	INSTALLED	UNKN	0581/2512		
EINHOUSE DR (TWP)							
		0581/2460				0580/2575	EINHOUSE DR (TWP)
LC TO N ALLEGHENY HS (CONN)							
		0581/2327				0580/2405	N ALLEGHENY HS ENT/EX (TWP)
N ALLEGHENY HS ENT/EX (TWP)							
		0581/2285					
LC FR ALLEG SCHOOL RD (CONN)							
		0581/2195					

DIR: N TOTAL LEN: 29.135 MI. DIST: 11-1 SR: 19
 LEFT MUN: MCCANDLESS T RIGHT MUN: MCCANDLESS T

MCKNIGHT RD (SR4003 SEG 0161/2268) MFC BEGIN = B	0571/0255		0570/0240 118470 FT	018 "DIA CIRC CONCR LEN=0010 INSTALLED UNKN 1 0 00246 0 04 0684+87 MCKNIGHT RD (SR4003 SEG 0160/1470) MFC BEGIN = B
1 0 00246 0 04 0684+47 117879 FT LENGTH(AH 2928 BK 1635)	0571/0000		0570/0000	LENGTH(AH 2879 BK 1593) 018 "DIA CIRC CONCR LEN=0020 INSTALLED UNKN 018 "DIA CIRC CONCR LEN=0020 INSTALLED UNKN
MCKNIGHT RD OP ID 02/4003/0161/0599 0561/0363 1 0 00246 0 04 0666+33 116244 FT PINE CREEK RD (SR4086 SEG 0040/0000)	0561/0363		0560/0320 116877 FT	MCKNIGHT RD OP ID 02/4003/0161/0599 1 0 00246 0 04 0666+33 PINE CREEK RD (SR4086 SEG 0040/0000)
PINE CREEK RD (SR4086 SEG 0040/0000) LENGTH(AH 1635 BK 2693)	0561/0000		0560/0000	PINE CREEK RD (SR4086 SEG 0040/0000) LENGTH(AH 1593 BK 2693) TO 4086/0040 SH (CONN)
PINE CREEK STRUCTURE LENGTH 26 FT BMSID 02/0019/0550/2307	0551/2351		0550/2363	PINE CREEK STRUCTURE LENGTH 26 FT BMSID 02/0019/0550/2307 018 "DIA CIRC CONCR LEN=0010 INSTALLED UNKN
018 "DIA CIR PLASTIC LEN=0010 INSTALLED UNKN	0551/2346		0550/2337	
018 "DIA CIRC CONCR LEN=0206 INSTALLED UNKN	0551/1962		0550/2334	
018 "DIA CIRC CONCR LEN=0030 INSTALLED UNKN	0551/1760			
018 "DIA CIRC CONCR LEN=0030 INSTALLED UNKN	0551/1475			
018 "DIA CIRC CONCR LEN=0030 INSTALLED UNKN	0551/1130			
STOCKPILE #17 (GOVT)	0551/1010		0550/1040	STOCKPILE #17 (GOVT)
018 "DIA CIRC CONCR LEN=0030 INSTALLED UNKN	0551/0376			
018 "DIA CIRC CONCR LEN=0030 INSTALLED UNKN	0551/0060			
1 0 00246 0 04 0639+35 113551 FT W INGOMAR RD (SR4070 SEG 0030/0000)			114184 FT	1 0 00246 0 04 0639+35 W INGOMAR RD (SR4070 SEG 0030/0000)

EXTRACT DATE: 12/21/2020
PRINT DATE: 12/23/2020

ROADWAY MANAGEMENT SYSTEM
SLD COUNTY/SR - ANNUAL PRINT

PAGE NUMBER: 56
COUNTY: ALLEGHENY

DIR: N TOTAL LEN: 29.135 MI.
LEFT MUN: MCCANDLESS T

DIST: 11-1 SR: 19
RIGHT MUN: MCCANDLESS T

Left Side Description	Left Side Stationing	Right Side Description	Right Side Stationing
INGOMAR RD (SR4070 SEG 0030/0000)		INGOMAR RD (SR4070 SEG 0030/0000)	
LENGTH(AH 2693 BK 3354)	0551/0000	LENGTH(AH 2693 BK 3184)	0550/0000
018 "DIA CIRC CONCR LEN=0010 INSTALLED UNKN	0541/3300	CRESTMONT RD (TWP) 018 "DIA CIRC CONCR LEN=0314 INSTALLED UNKN	0540/2805
CRESTMONT RD (TWP)	0541/2985		0540/2800
018 "DIA CIRC CONCR LEN=0010 INSTALLED UNKN	0541/2950	PINE RD (TWP)	0540/2650
PINE RD (TWP)	0541/2835	OLD PERRY HW (TWP)	0540/2544
OLD PERRY HW (TWP)	0541/2710		
018 "DIA CIRC CONCR LEN=0305 INSTALLED UNKN	0541/1615	ARCADIA DR (TWP)	0540/0860
ARCADIA DR (TWP)	0541/1045	ARCADIA DR (TWP)	0540/0820
018 "DIA CIRC CONCR LEN=0010 INSTALLED UNKN	0541/1028		
ARCADIA DR (TWP)	0541/1010		
018 "DIA CIRC CONCR LEN=0010 INSTALLED UNKN	0541/0367		
GUENEVERE DR (TWP)	0541/0185		
1 0 00246 0 04 0604+82 110197 FT		111000 FT	1 0 00246 0 04 0607+30
OLD PERRY HW (TWP)		GUENEVERE DR (TWP)	
LENGTH(AH 3354 BK 2956)	0541/0000	LENGTH(AH 3184 BK 3649)	0540/0000
		OLD PERRY HW (TWP)	0530/3425
018 "DIA CIRC CONCR LEN=0010 INSTALLED UNKN	0531/2927	PERRYVISTA AV (TWP)	0530/3255
PERRYVISTA AV (TWP)	0531/2765	CUMBERLAND RD (SR4024 SEG 0010/0000)	0530/3110
CUMBERLAND RD (SR4024 SEG 0010/0000)	0531/2620	MOHICAN AV (TWP)	0530/2955
MOHICAN AV (TWP)	0531/2460	OLD PERRY HW (TWP)	0530/2777
OLD PERRY HW (TWP)	0531/2258		
018 "DIA CIRC CONCR LEN=0241 INSTALLED UNKN	0531/2024		

EXTRACT DATE: 12/21/2020
PRINT DATE: 12/23/2020

ROADWAY MANAGEMENT SYSTEM
SLD COUNTY/SR - ANNUAL PRINT

PAGE NUMBER: 55
COUNTY: ALLEGHENY

DIR: N TOTAL LEN: 29.135 MI.
LEFT MUN: MCCANDLESS T

DIST: 11-1 SR: 19
RIGHT MUN: MCCANDLESS T

Stationing	Notes	Stationing	Notes
0531/1783	018 "DIA CIRC CONCR LEN=0010 INSTALLED UNKN HILLVUE LN (TWP)	0530/2150	HILLVUE LN (TWP)
0531/1660		0530/1962	018 "DIA CIRC CONCR LEN=0030 INSTALLED UNKN OLD PERRY HW (TWP)
0531/1265	OLD PERRY HW (TWP)	0530/1745	018 "DIA CIRC CONCR LEN=0050 INSTALLED UNKN MEMORIAL DR (TWP)
0531/1191	MEMORIAL DR (TWP)	0530/1680	018 "DIA CIRC CONCR LEN=0010 INSTALLED UNKN
0531/0927	018 "DIA CIRC CONCR LEN=0010 INSTALLED UNKN MEMORIAL DR (TWP)	0530/1520	018 "DIA CIRC CONCR LEN=0010 INSTALLED UNKN
0531/0484	NINETEEN NORTH DR (TWP)	0530/0987	MEMORIAL DR (TWP)
10002460040576+18107241 FT		0530/0500	NINETEEN NORTH DR (TWP)
0531/0000	OLD PERRY HW (TWP)	0530/0000	OLD PERRY HW (TWP)
0521/2150	LENGTH(AH 2956 BK 2637) PRESCOTT DR (TWP)	0520/2508	10002460040575+47 PRESCOTT DR (TWP)
0521/1388	LENGTH(AH 2956 BK 2637) PRESCOTT DR (TWP)	0520/2505	018 "DIA CIRC CONCR LEN=0010 INSTALLED UNKN LC TO PRESCOTT DR (CONN)
0521/1230	018 "DIA CIRC CONCR LEN=0010 INSTALLED UNKN OLD PERRY HW (TWP)	0520/1685	018 "DIA CIRC CONCR LEN=0010 INSTALLED UNKN GLORIA ST (TWP)
0521/0995	GLORIA ST (TWP)	0520/1460	OLD PERRY HW (TWP)
0521/0669	MONTCLAIR AV (TWP)		GLORIA ST (TWP)
	018 "DIA CIRC CONCR LEN=0659 INSTALLED UNKN W FAIRVIEW AV (TWP)		MONTCLAIR AV (TWP)
	FAIRVIEW AV		W FAIRVIEW AV (TWP)
			FAIRVIEW AV

DIR: N TOTAL LEN: 29.135 MI. DIST: 11-1 SR: 19
 LEFT MUN: MCCANDLESS T RIGHT MUN: MCCANDLESS T

Stationing	Description	Stationing	Description
(TWP) 0521/0450		0520/0925	(TWP)
		0520/0553	018 " DIA CIRC CONCR LEN=0010 INSTALLED UNKN W SANDLE AV (TWP) E SANDLE AV (TWP)
018 " DIA CIRC CONCR LEN=0010 INSTALLED UNKN 0521/0091		0520/0470	(TWP)
1 0 00246 0 04 0547+90 104604 FT		0520/0059	018 " DIA CIRC CONCR LEN=0010 INSTALLED UNKN 104730 FT 1 0 00246 0 04 0547+29 PERRYMONT RD (SR4056 SEG 0010/0000)
W SANDLE AV (TWP) E SANDLE DR (TWP) LENGTH(AH 2637 BK 3159) 0521/0000		0520/0000	LENGTH(AH 2621 BK 2583)
018 " DIA CIRC CONCR LEN=0020 INSTALLED UNKN 0511/3119			
PERRYMONT RD (SR4056 SEG 0010/0000)			
0511/2670			
018 " DIA CIRC CONCR LEN=0170 INSTALLED UNKN 0511/2632			
ROLSHOUSE RD (TWP)			
0511/2631		0510/2520	ROLSHOUSE RD (TWP)
		0510/2401	099 " DIA CIRC CONCR LEN=0099 INSTALLED UNKN
018 " DIA CIRC CONCR LEN=0020 INSTALLED UNKN 0511/2496			
MANOR RD (TWP)		0510/1820	MANOR RD (TWP)
0511/1922		0510/1740	BIRCH AV (TWP)
BIRCH AV (TWP)			
018 " DIA CIRC CONCR LEN=0303 INSTALLED UNKN 0511/1452		0510/1345	LINCOLN AV (TWP)
LINCOLN AV (TWP)			
0511/1451			
018 " DIA CIRC CONCR LEN=0084 INSTALLED UNKN 0511/1368		0510/1171	MCCANDLESS ROSS T WASHINGTON BL (TWP)
MCCANDLESS ROSS T WASHINGTON BL (TWP)		0510/1155	OLD PERRY HW (TWP)
0511/1300		0510/0940	LEE AV (TWP)
0511/1252		0510/0905	LEE AV (TWP)
0511/1085			
0511/1007			

DIR: N TOTAL LEN: 29.135 MI. DIST: 11-1 SR: 19
 LEFT MUN: ROSS T RIGHT MUN: ROSS T

018 "DIA CIRC CONCR LEN=0724 INSTALLED UNKN OLD PERRY HW (TWP) TRION RD (TWP)	0511/0724	---	---	---	0510/0355	OLD PERRY HW (TWP) TRION RD (TWP)
OAK RIDGE RD (TWP)	0511/0434	==	==	==	0510/0305	OAK RIDGE RD (TWP)
1 0 00246 0 04 0518+70 101445 FT ROSS PINE T LENGTH(AH 3159 BK 2775)	0511/0000	---	---	---	102147 FT 0510/0000	1 0 00246 0 04 0519+59 LENGTH(AH 2583 BK 2878) TRION RD (TWP)
TRION RD (TWP)	0501/2537	==	==	==	0500/2532	
LC TO TRION RD (CONN)	0501/2332	==	==	==		
THON DR (TWP)	0501/1935	==	==	==	0500/1918	THON DR (TWP)
		---	---	---	0500/1882	018 "DIA CIRC CONCR LEN=0050 INSTALLED UNKN
PINE ROSS T GLENVUE DR (TWP)	0501/1496	---	---	---	0500/1494	GLENVUE DR (TWP)
	0501/1468	==	==	==	0500/1343	018 "DIA CIRC CONCR LEN=0010 INSTALLED UNKN
LOMBARDY DR (TWP)		---	---	---		LOMBARDY DR (TWP)
SEWICKLEY OAKMONT RD (SR4022 SEG 0150/2360)	0501/1275	==	==	==	0500/1265	SEWICKLEY OAKMONT RD (SR4022 SEG 0150/2360)
GRAHAM RD (TWP)		---	---	---		GRAHAM RD (TWP)
THREE DEGREE RD (CNTY)	0501/1055	==	==	==	0500/1025	THREE DEGREE RD (CNTY)
018 "DIA CIRC CONCR LEN=0020 INSTALLED UNKN REEL AV (TWP)	0501/0900	---	---	---	0500/0781	REEL AV (TWP)
024 "DIA CIRC CONCR LEN=0040 INSTALLED UNKN	0501/0772	---	---	---		
018 "DIA CIRC CONCR LEN=0020 INSTALLED UNKN	0501/0438	---	---	---		
DECKER LN (TWP)	0501/0351	==	==	==	0500/0351	DECKER LN (TWP)
GRAHAM RD (TWP)	0501/0085	==	==	==	0500/0055	GRAHAM RD (TWP)
1 0 00246 0 04 0488+27 098670 FT						

DIR: N TOTAL LEN: 29.135 MI. DIST: 11-1 SR: 19
 LEFT MUN: ROSS T RIGHT MUN: ROSS T

Station	Notes	Station	Notes
018 "DIA CIRC CONCR LEN=0020 INSTALLED UNKN MFC BEGIN = C LTH AH 002775 BK 002335	0501/0000	099269 FT 1 0 00246 0 04 0490+34 MFC BEGIN = C LENGTH(AH 2878 BK 2335) JACKSON ST (TWP)	0500/0000
LINDLEY LN (TWP)	0490/2029	0490/2073 0490/2029 CELMAR DR (TWP)	
		0490/1823 0490/1642 0490/1618 0490/1571 0490/1312	018 "DIA CIRC CONCR LEN=0030 INSTALLED UNKN 024 "DIA CIRC CONCR LEN=0010 INSTALLED UNKN MALVERN ST (TWP) GOOD LN (TWP)
ATLANTIC AV (TWP)	0490/0787	0490/0717 0490/0694 0490/0367	018 "DIA CIRC CONCR LEN=0010 INSTALLED UNKN 018 "DIA CIRC CONCR LEN=0010 INSTALLED UNKN 018 "DIA CIRC CONCR LEN=0010 INSTALLED UNKN
ATLANTIC AV (TWP)	0490/0246 096335 FT	096934 FT 1 0 00246 0 04 0465+69 0490/0000 SCHARS LN (TWP)	0465+69 LENGTH(AH 2335 BK 2898)
DEIMLING RD (TWP)	0480/2600	0480/2771	
HIGHLAND VALLEY DR (TWP)	0480/1728	0480/1600 0480/1250	018 "DIA CIRC CONCR LEN=0020 INSTALLED UNKN 018 "DIA CIRC CONCR LEN=0020 INSTALLED UNKN THOMPSON DR (TWP)
PERRY LN (TWP)	0480/0830	0480/0830	
HARDING RD (TWP)	0480/0475		024 "DIA CIRC CONCR

DIR: N TOTAL LEN: 29.135 MI. DIST: 11-1 SR: 19
 LEFT MUN: ROSS T RIGHT MUN: ROSS T

Stationing	Notes	Material	Quantity	Unit	Notes
093437 FT		0480/0464	LEN=0020	INSTALLED	UNKN
		094036 FT	1 0 00246	0 04	0438+54
		0480/0000	LENGTH(AH 2898 BK 1996)		
			024 " DIA	CIRC	CONCR
		0470/1900	LEN=0020	INSTALLED	UNKN
			HARDEN DR		
		0470/1770	(TWP)		
			018 " DIA	CIRC	CONCR
		0470/1715	LEN=0020	INSTALLED	UNKN
			ROCHESTER RD		
			(SR4011 SEG 0080/0000)		
WELLINGTON DR (TWP)		0470/1305			
		0470/0805			
		0470/0607			
			ROSS		
			WEST VIEW B		
		0470/0605			
			SCHWITTER AV		
			(BORO)		
		091441 FT			
		092040 FT	1 0 00246	0 04	0418+55
			HIGHLAND AV		
			(BORO)		
HIGHLAND AV (SR4012 SEG 0090/2940)		0470/0000	LENGTH(AH 1996 BK 2386)		
			018 " DIA	CIRC	CONCR
		0460/2040	LEN=0020	INSTALLED	UNKN
CHALFONTE AV (BORO)		0460/2005			
			CHALFONTE AV		
			(BORO)		
		0460/1745	LEN=0020	INSTALLED	UNKN
			018 " DIA	CIRC	CONCR
		0460/1310	LEN=0020	INSTALLED	UNKN
			018 " DIA	CIRC	CONCR
		0460/1300	LEN=0020	INSTALLED	UNKN
			018 " DIA	CIRC	CONCR
		0460/1020	LEN=0020	INSTALLED	UNKN
			018 " DIA	CIRC	CONCR
		0460/0955	LEN=0020	INSTALLED	UNKN
			018 " DIA	CIRC	METAL
		0460/0730	LEN=0020	INSTALLED	UNKN
			NC PERRY HW		
			CENTER AV		
			(BORO)		
LC TO WEST VIEW PARK DR (CONN)		0460/0695			
		0460/0470	018 " DIA	CIRC	CONCR
			LEN=0020	INSTALLED	UNKN
WEST VIEW PARK DR					

EXTRACT DATE: 12/21/2020
PRINT DATE: 12/23/2020

ROADWAY MANAGEMENT SYSTEM
SLD COUNTY/SR - ANNUAL PRINT

PAGE NUMBER: 50
COUNTY: ALLEGHENY

DIR: N TOTAL LEN: 29.135 MI.
LEFT MUN: WEST VIEW B

DIST: 11-1 SR: 19
RIGHT MUN: WEST VIEW B

(BORO)
ALLEY
(BORO)

0460/0465
0460/0240
089055 FT

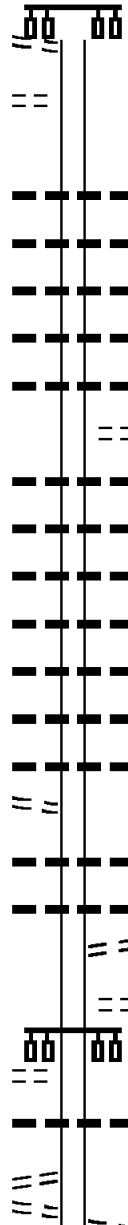

0460/0465
089654 FT 1 0 00246 0 04 0394+16
018 "DIA CIRC CONCR
LEN=0020 INSTALLED UNKN
LENGTH(AH 2386 BK 3357)
S 0460/0000 018 "H 00" W MULT CONCR
0450/2996 LEN=0020 INSTALLED UNKN
018 "DIA CIRC CONCR
0450/2995 LEN=0020 INSTALLED UNKN
018 "DIA CIRC CONCR
0450/2760 LEN=0020 INSTALLED UNKN
018 "DIA CIRC CONCR
0450/2608 LEN=0020 INSTALLED UNKN
TOWNSHIP RD
0450/2362 (BORO)
018 "DIA CIRC CONCR
0450/2255 LEN=0353 INSTALLED UNKN
018 "DIA CIRC CONCR
0450/2025 LEN=0040 INSTALLED UNKN
018 "DIA CIRC CONCR
0450/1588 LEN=0030 INSTALLED UNKN
018 "DIA CIRC CONCR
0450/1365 LEN=0020 INSTALLED UNKN
018 "DIA CIRC CONCR
0450/1005 LEN=0040 INSTALLED UNKN
018 "DIA CIRC CONCR
0450/0902 LEN=0040 INSTALLED UNKN
018 "DIA CIRC CONCR
0450/0805 LEN=0050 INSTALLED UNKN
018 "DIA CIRC CONCR
0450/0664 LEN=0050 INSTALLED UNKN
018 "DIA CIRC CONCR
0450/0341 LEN=0080 INSTALLED UNKN
RIDGEWOOD AV
0450/0294 (BORO)
PARK AV
0450/0095 (BORO)
086297 FT
S 0450/0000 LENGTH(AH 3357 BK 1641)
018 "DIA CIR PLASTIC
0440/1221 LEN=0071 INSTALLED UNKN
PERRYSVILLE RD
0440/0610 (BORO)

PARK RD
(BORO)

0450/0715

1 0 00246 0 02 0360+90 085698 FT
BELLEVUE RD
(BORO) 0450/0000

PERRYSVILLE RD
(BORO)
PERRYSVILLE RD
(BORO)

0440/1140
0440/0610

DIR: N TOTAL LEN: 29.135 MI. DIST: 11-1 SR: 19
 LEFT MUN: WEST VIEW B RIGHT MUN: WEST VIEW B

WEST VIEW
 ROSS T

0440/0601
 084057 FT

HOV LN TO/FR NORTHSORE
 (SR6279 SEG 0090/3095) 0430/1755
 FROM 6279/0090 SH
 (CONN) 0430/1678

081568 FT

STOCKPILE #19
 (GOVT) 0430/0000
 TO 4044/0010 SH
 (CONN) 0420/2005

SR 4044 SH
 (SR4044 SEG 0010/0678) 0420/1895

079175 FT

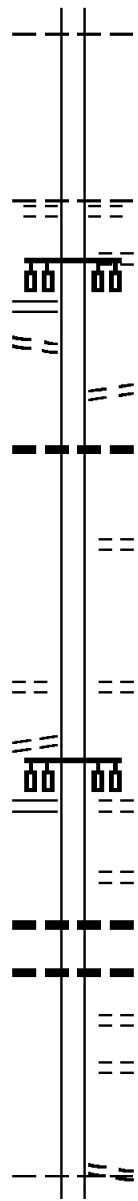

084656 FT 1 0 00246 0 02 0344+60
 WINTER AV
 (BORO)
 WEST VIEW
 ROSS T
 0440/0000 LENGTH(AH 1641 BK 2489)
 CENTER AV
 (TWP)
 0430/2170
 0430/1755
 OLD PERRY HW
 (TWP)
 0430/1615
 018 " DIA CIRC CONCR
 0430/1600 LEN=0050 INSTALLED UNKN
 CLARWIN AV
 (TWP)
 0430/0675
 082167 FT 1 0 00246 0 02 0319+68
 NC PERRYVILLE AV
 HANWAY AV
 (TWP)
 0430/0000 LENGTH(AH 2489 BK 2393)
 CEMETERY LN
 (CNTY)
 0420/1895
 PAT TRANSIT ENTR/EXIT
 (CNTY)
 0420/1050
 024 " DIA CIRC CONCR
 0420/1030 LEN=0050 INSTALLED UNKN
 024 " DIA CIRC CONCR
 0420/0551 LEN=0050 INSTALLED UNKN
 PAT TRANSIT ENTR/EXIT
 (CNTY)
 0420/0515
 WEST VIEW AV
 (TWP)
 0420/0390
 079774 FT 1 0 00246 0 02 0294+52
 0420/0000 LENGTH(AH 2393 BK 1928)
 LC FROM IVORY AV
 (CONN)
 0410/1540
 ROSS

DIR: N TOTAL LEN: 29.135 MI.
 LEFT MUN: ROSS T

DIST: 11-1 SR: 19
 RIGHT MUN: ROSS T

CONNIE DR
 (CITY)
 LC FROM CONNIE DR
 (CONN)

0410/0790
 0410/0715

077247 FT

PERRY VIEW AV
 (CITY)

0400/1185

BASCOM ST
 (CITY)
 VINCETON ST
 (CITY)
 PORTMAN AV
 (CITY)

0400/0800
 0400/0495
 075680 FT

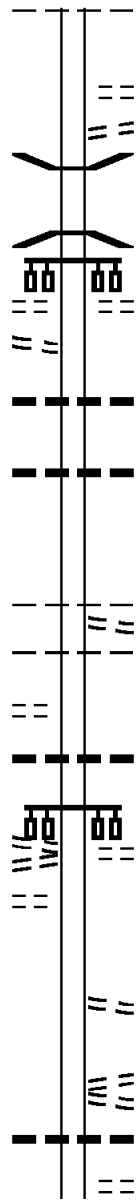

0410/1495 PITTSBURGH C
 NC PERRY HW
 IVORY AV
 (CNTY)
 LC TO IVORY AV
 (CONN)
 0410/1471
 0410/1410
 0410/1282 BMSSEN 02/0019/0410/1068
 1 0 00246 0 00 0287+97
 SR 6279 HOV
 0410/1068 BMSBG 02/0019/0410/1068
 PHIPPS ST
 (CITY)
 0410/0790
 0410/0790
 0410/0625 018 "DIA CIRC CONCR
 LEN=0030 INSTALLED UNKN
 0410/0020 018 "DIA CIRC CONCR
 LEN=0030 INSTALLED UNKN
 077846 FT 1 0 00246 0 02 0276+00
 BLUEBELLE ST
 (CITY)
 PITTSBURGH
 ROSS T
 0410/0000 LENGTH(AH 1928 BK 1567)
 ROSS
 0400/1246 PITTSBURGH C
 0400/0870 024 "DIA CIRC CONCR
 LEN=0050 INSTALLED UNKN
 VINCETON ST
 (CITY)
 0400/0800
 076279 FT 1 0 00246 0 02 0260+78
 WALDORF ST
 (CITY)
 0400/0000 LENGTH(AH 1567 BK 2650)
 FRANKLIN RD
 (CITY)
 BONVUE ST
 (CITY)
 0390/2155
 0390/1967 018 "DIA CIRC CONCR
 LEN=0030 INSTALLED UNKN
 BAYTREE ST
 (CITY)

DIR: N TOTAL LEN: 29.135 MI. DIST: 11-1 SR: 19
 LEFT MUN: PITTSBURGH C RIGHT MUN: PITTSBURGH C

Left Side Street	Left Side ID	Right Side Street	Right Side ID	Notes
MAIRDALE AV (CITY)	0390/1890	EAST ST (CITY)	0390/1890	
HEMPHILL ST (CITY)	0390/1635			
DE FOE ST (CITY)	0390/0935			
SEMICIR ST (CITY)	0390/0810	GOULD AV (CITY)	0390/0885	
		RICHEY AV (CITY)	0390/0635	
		DUNLAP ST (CITY)	0390/0380	
073030 FT		1 0 00246 0 02 0234+12 CHERRYFIELD ST (CITY)	073629 FT	
		LENGTH(AH 2650 BK 2716)	0390/0000	
RIVERVIEW AV (CITY)	0380/2318	VENTURE ST (CITY)		
		WATSON BL (CITY)	0380/2050	
		024 " DIA CIRC CONCR LEN=0020 INSTALLED UNKN	0380/2019	
		CHEMUNG ST (CITY)	0380/1820	
070314 FT		1 0 00246 0 02 0207+03 DELAWARE ST (CITY)	070913 FT	
		LENGTH(AH 2716 BK 1829)	0380/0000	
		018 " DIA CIRC ALUMIN LEN=0099 INSTALLED UNKN	0370/1807	
		WATSON BL (CITY)	0370/1385	
MARSHALL RD (CITY)	0370/1280	018 " DIA CIRC CONCR LEN=0030 INSTALLED UNKN	0370/0555	
		MILROY ST (CITY)	0370/0325	

DIR: N TOTAL LEN: 29.135 MI. DIST: 11-1 SR: 19
 LEFT MUN: PITTSBURGH C RIGHT MUN: PITTSBURGH C

Segment Description	Segment ID	Length (FT)	Notes
LC TO BRIGHTON RD (CONN)	0350/0107	063066	
BRIGHTON RD (CITY)	0350/0000		
STAYTON ST (CITY)	0340/1295		
NEW HAMPSHIRE DR (CITY)	0340/0455		
SORRELL ST (CITY)	0340/0142		
MARSHALL AV (SR0019 SEG 0330/0786)	0340/0000	061483	
MCCOOK ST (CITY)	0330/0475		
MANNHEIM ST (CITY)	0330/0341		
ATMORE ST (CITY)	0330/0185		
TO 4265/0010 SH (CONN)	0330/0145	060697	
TWAIN ST (CITY)	0350/0920		
024" DIA CIRC CONCR	0350/0176		LEN=0083 INSTALLED UNKN
BRIGHTON RD (CITY)	063665		
LC TO BRIGHTON RD (CONN)	0350/0000		LENGTH(AH 3326 BK 1583)
RIDGE LAND DR (CITY)	0340/1505		
RIDGE LAND DR (CITY)	0340/1140		
018" DIA CIRC CONCR	0340/0725		LEN=0020 INSTALLED UNKN
RIDGE LAND DR (CITY)	0340/0690		
018" DIA CIRC CONCR	0340/0138		LEN=0038 INSTALLED UNKN
018" DIA CIRC CONCR	0340/0100		LEN=0030 INSTALLED UNKN
INTER-BK RAMP RD	0340/0000		LENGTH(AH 1583 BK 0786)
INTER-AHD MARSHALL AV (SR0019 SEG 0340/0000)	0340/0000		
RAMP RD (SR8049 SEG 0030/2091)	0330/0786		
FROM 8049/0750 SH (CONN)	0330/0145		
MARSHALL AV (SR4265 SEG 0010/0000)	061296		
CALIFORNIA AV (SR4265 SEG 0011/0000)			

EXTRACT DATE: 12/21/2020
PRINT DATE: 12/23/2020

ROADWAY MANAGEMENT SYSTEM
SLD COUNTY/SR - ANNUAL PRINT

PAGE NUMBER: 44
COUNTY: ALLEGHENY

DIR: N TOTAL LEN: 29.135 MI.
LEFT MUN: PITTSBURGH C

DIST: 11-1 SR: 19
RIGHT MUN: PITTSBURGH C

060697 FT
7293/0000
LTH AH 000100 BK 002684
RAMP FR CALIFORNIA AV
(SR8049 SEG 0250/1477)
OHIO RIVER BL
(SR0065 SEG 0013/0000) 0291/2684
BMSEN 02/0019/0290/2068 0291/2168
0 00000 0 0 0000+00
BEAVER AVE LOCAL
BMSBG 02/0019/0290/2068 0291/1968

SIGN: 4 CHORD TRUSS
BMSID 02/0019/0291/1677 0291/1653
DRAINAGE
STRUCTURE LENGTH 28 FT
BMSID 02/0019/0291/1282 0291/1282
RETAINING WALL
BMSID 02/0019/0291/0755 0291/0755
SIGN: 4 CHORD TRUSS
BMSID 02/8055/0510/0400 0291/0260
0 0 00000 0 00 0000+00 058013 FT
SR 65/19 SB TO SR 19 SH
(SR8055 SEG 0510/0000)
LENGTH(AH 2684 BK 0950) 0291/0000
BMSID 02/8055/0510/0260 0287/0950
RETAINING WALL BEGIN
BMSID 02/8055/0510/0260 0287/0650
SIGN: CANTILEVER
BMSID 02/0019/0287/0635 0287/0635
SIGN: 4 CHORD TRUSS
BMSID 02/0019/0287/0300 0287/0300
SR 19 S TO REEDSDALE ST
(SR8055 SEG 0520/0000) 0287/0050
0 0 00000 0 00 0000+00 057063 FT
SR 19 NB
OP ID 02/0019/0280/1347
NC OH IO RIVER BL
OHIO RIVER BL
(SR0065 SEG 0005/2149) INTER-BK
LTH AH 000950 BK 000100 0287/0000
057063 FT
LTH AH 000100 BK 002184 7285/0000
BMSEN 02/0019/0280/1347
WESTERN AV INTER-AHD
(TBC)

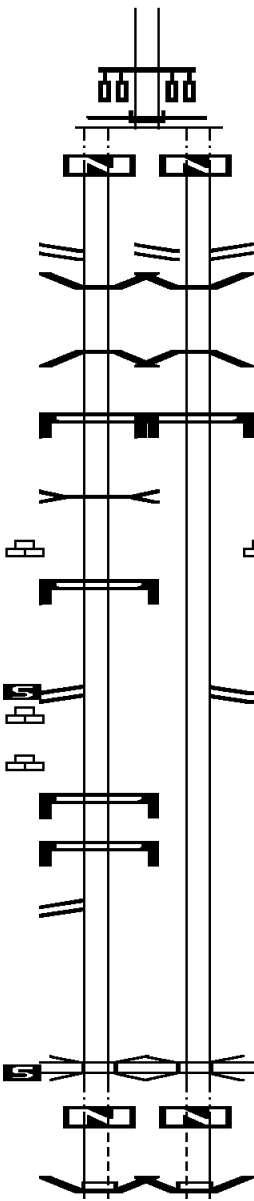

INTER-BK RAMP RD
(SR8049 SEG 0250/0000)
MFC BEGIN = C
LTH AH 000786 BK 000100
0330/0000
061296 FT
7292/0000
LTH AH 000100 BK 002811
FR SR 19 N TO MARSHALL
(SR8049 SEG 0010/0000)
OHIO RIVER BL
(SR0065 SEG 0012/0000)
BMSEN 02/0019/0290/2068
0 00000 0 0 0000+00
BEAVER AVE LOCAL
BMSBG 02/0019/0290/2068

SIGN: CANTILEVER
BMSID 02/0019/0290/1381

RETAINING WALL
BMSID 02/0019/0290/0834
0290/0834
058485 FT
0 0 00000 0 00 0000+00
CHATEAU ST
(SR8055 SEG 0750/0680)
LENGTH(AH 2811 BK 0752)
0290/0000
057733 FT 0 0 00000 0 00 0000+00
SR 19 NB
OP ID 02/0019/0280/1347
NC OH IO RIVER BL
OHIO RIVER BL
(SR0065 SEG 0004/2095)
LTH AH 000752 BK 000100
LTH AH 000100 BK 002200
BMSEN 02/0019/0280/1347
WESTERN AV
(TBC)
INTER-BK
0286/0000
057733 FT
7284/0000
INTER-AHD

DIR: N TOTAL LEN: 29.135 MI. DIST: 11-1 SR: 19
 LEFT MUN: PITTSBURGH C RIGHT MUN: PITTSBURGH C

Left Side Description	Left Side Stationing	Right Side Stationing	Right Side Description
CHATEAU ST (SR8055 SEG 0750/0000) RAMP RD (SR8055 SEG 0010/0438)	0281/2184	0280/2200	FROM WEST END BR TO 19 (SR8055 SEG 0750/0000) 65 NB TO WEST END BR (SR8055 SEG 0010/0438)
SIGN: 4 CHORD TRUSS BMSID 02/0019/0280/2005	0281/1975	0280/1982	SIGN: 4 CHORD TRUSS BMSID 02/0019/0280/2005
RAMP RD (SR8055 SEG 0510/1061)	0281/1675	0280/1784	RAMP RD (SR8055 SEG 0250/0000)
SIGN: 4 CHORD TRUSS BMSID 02/0019/0280/1705	0281/1665	0280/1682	SIGN: 4 CHORD TRUSS BMSID 02/0019/0280/1705
0 0 00000 0 00 0000+00			0 0 00000 0 00 0000+00
RAMP H BMSBG 02/0019/0280/1347	0281/1381	0280/1397	RAMP H BMSBG 02/0019/0280/1347
BMSSEN 02/0019/0280/0126	0281/1336	0280/1347	BMSSEN 02/0019/0280/0126
SIGN: 4 CHORD TRUSS BMSID 02/0019/0280/0995	0281/0965	0280/0995	SIGN: 4 CHORD TRUSS BMSID 02/0019/0280/0995
SIGN: 3 CHORD TRUSS BMSID 02/0019/0280/0382	0281/0398	0280/0417	SIGN: 3 CHORD TRUSS BMSID 02/0019/0280/0382
0 0 00000 0 00 0000+00			0 0 00000 0 00 0000+00
OHIO RIVER BMSBG 02/0019/0280/0126	0281/0115	0280/0126	OHIO RIVER BMSBG 02/0019/0280/0126
1 0 00076 4 00 0000+00	054879 FT	055533 FT	1 0 00076 4 00 0000+00
NC WEST END BR CARSON ST (SR0837 SEG 0600/0310)			NC WEST END BR CARSON ST (SR0837 SEG 0600/0310)
LENGTH(AH 2184 BK 1047) BMSSEN 02/0060/0004/0100	0281/0000	0280/0000	LENGTH(AH 2200 BK 1052) BMSSEN 02/0019/0250/1013
1 0 00257 4 00 0003+84	0251/1021	0250/1022	0 0 00000 0 00 0000+00
SAW MILL RUN BMSBG 02/0060/0004/0100	0251/0986	0250/0998	NO UNDERPASS INFORMATION BMSBG 02/0019/0250/1013
		0250/0953	024 "DIA CIRC CONCR LEN=0035 INSTALLED UNKN
		0250/0948	SIGN: STRUC MOUNTED BMSID 02/0019/0250/0948
018 "DIA CIRC CONCR LEN=0050 INSTALLED UNKN	0251/0930		
NORFOLK SOUTHERN OVERPASS IS RR X-ING	0251/0923	0250/0938	NORFOLK SOUTHERN OVERPASS IS RR X-ING
		0250/0860	024 "DIA CIRC CONCR LEN=0035 INSTALLED UNKN
018 "DIA CIRC CONCR LEN=0050 INSTALLED UNKN	0251/0828		
		0250/0659	024 "DIA CIRC CONCR LEN=0035 INSTALLED UNKN
BMSSEN 02/0019/0250/0558	0251/0615	0250/0642	BMSSEN 02/0019/0250/0558
018 "DIA CIRC CONCR			

DIR: N TOTAL LEN: 29.135 MI. DIST: 11-1 SR: 19
 LEFT MUN: PITTSBURGH C RIGHT MUN: PITTSBURGH C

Item ID	Description	Stationing	Length	Material	Notes
LEN=0099	INSTALLED UNKN	0251/0603			
0 0 00000	0 00 0000+00				
SR 60 SB					
BMSBG 02/0019/0250/0558		0251/0424			
SIGN: 3 CHORD TRUSS					
BMSID 02/0019/0246/0000		0251/0279			
1 0 00257	4 00 0002+60	053832 FT			
LENGTH(AH 1047 BK 1707)		0251/0000			
SR 0051 SH					
(SRO051 SEG 0441/0000)		0245/1302			
018 "DIA CIRC CONCR					
LEN=0050	INSTALLED UNKN	0245/1085			
SIGN: 3 CHORD TRUSS					
BMSID 02/0019/0244/0372		0245/0397			
1 0 00247	0 02 0693+32	052125 FT			
LENGTH(AH 1707 BK 2041)		0245/0000			
SIGN: CENTER MOUNTD					
BMSID 02/0019/0241/1458		0241/1458			
018 "DIA CIRC CONCR					
LEN=0099	INSTALLED UNKN	0241/1092			
024 "DIA CIRC CONCR					
LEN=0040	INSTALLED UNKN	0240/1119			
024 "DIA CIRC CONCR					
LEN=0020	INSTALLED UNKN	0240/1082			
018 "DIA CIRC CONCR					
LEN=0020	INSTALLED UNKN	0240/0841			
024 "DIA CIRC CONCR					
LEN=0020	INSTALLED UNKN	0240/0710			
SIGN: CANTILEVER					
BMSID 02/0019/0234/0000		0240/0406			
1 0 00247	0 02 0673+09	050084 FT			
SIGN: CANTILEVER					
BMSID 02/0019/0241/0000		050866 FT			
LENGTH(AH 2041 BK 1368)		0241/0000			
018 "DIA CIRC CONCR					
LEN=0099	INSTALLED UNKN	0231/1301			
SHALER STREET					
OP ID 02/3110/0010/0001		0231/1202			
WABASH ST					
(CITY)		0231/1110			
024 "DIA CIRC CONCR					
LEN=0020	INSTALLED UNKN	0230/1347			
SHALER STREET					
OP ID 02/3110/0010/0001		0230/1220			

DIR: N TOTAL LEN: 29.135 MI. DIST: 11-1 SR: 19
 LEFT MUN: PITTSBURGH C RIGHT MUN: PITTSBURGH C

Item ID	Description	Stationing	Notes
WABASH ST (CITY)		0231/0970	
SIGN: CANTILEVER			
BMSID 02/0019/0231/0734		0231/0734	0230/0907 018" DIA CIRC CONCR LEN=0020 INSTALLED UNKN
SIGN: 4 CHORD TRUSS			
BMSID 02/0019/0231/0656		0231/0656	0230/0732 018" DIA CIRC CONCR LEN=0020 INSTALLED UNKN
TO SR 376 RAMP C RD			
(SR8037 SEG 0260/0000)		0231/0600	
RAMP A 8037 SB			
OP ID 02/8037/0250/0053		0231/0456	
BMSID 02/0019/0231/0000		0231/0183	
1 0 00247 0 02 0657+02		048716 FT	
NC SAW MILL RUN BL			
SAW MILL RUN BL		INTER-BK	
(SR0051 SEG 0431/0816)			
SR 0376 EB			
BMSBG 02/0019/0231/0000		0231/0000	
LTH AH 001368 BK 000100		048716 FT	
LTH AH 000100 BK 001211		7221/0000	
SAWMILL RUN INT/RAMP C		INTER-AHD	
(SR8037 SEG 0260/2617)		0211/1211	
TO SR 376 RAMP RD			
(SR8075 SEG 0260/0000)		0211/1100	
018" DIA CIRC CONCR			
LEN=0099 INSTALLED UNKN		0211/1032	
SR 0376 EB			
OP ID 02/0376/0680/1910		0211/0880	
RAMP E RD			
(SR8075 SEG 0010/0000)		0211/0778	
036" DIA CIRC CONCR			
			0230/0430 TO SR 279S RAMP A RD (SR8037 SEG 0250/0000)
			SIGN: 4 CHORD TRUSS
		0230/0333	BMSID 02/0019/0230/0333
		0230/0220	BMSID 02/0019/0230/0000
		049461 FT	1 0 00247 0 02 0657+02
			NC SAW MILL RUN BL
			INTER-BK
			SAW MILL RUN BL
			(SR0051 SEG 0430/1039)
			SR 0376 EB
			BMSBG 02/0019/0230/0000
			LTH AH 001405 BK 000100
			LTH AH 000100 BK 001861
			PENN LINCOLN PY
			(SR0376 SEG 0684/0876)
			PENN LINCOLN PY
			(SR0376 SEG 0684/0876)
			SAW MILL RUN
			STRUCTURE LENGTH 16 FT
			BMSID 02/0019/0210/1521
			RAMP E RD
			(SR8075 SEG 0010/0677)
			0210/1861
			0210/1360
			0210/1190
			0210/0875 018" DIA CIRC CONCR LEN=0070 INSTALLED UNKN
			RAMP E 8075 NB
			OP ID 02/8075/0010/0189
			SIGN: 4 CHORD TRUSS
			BMSID 02/0019/0210/0706

DIR: N TOTAL LEN: 29.135 MI. DIST: 11-1 SR: 19
 LEFT MUN: PITTSBURGH C RIGHT MUN: PITTSBURGH C

Item Description	Stationing	Length	Notes
018 "DIA CIRC CONCR LEN=0099 INSTALLED UNKN CRANE AV (CNTY)	0191/1200		
018 "DIA CIRC CONCR LEN=0060 INSTALLED UNKN	0191/1125 0191/1038		
018 "DIA CIRC CONCR LEN=0010 INSTALLED UNKN L SAW MIL RN STRUCTURE LENGTH 15 FT BMSID 02/0019/0191/0700	0191/0702 0191/0700		
018 "DIA CIRC CONCR LEN=0010 INSTALLED UNKN	0191/0401		
018 "DIA CIRC CONCR LEN=0010 INSTALLED UNKN OLD BANKSVILLE RD (CITY)	0191/0132 0191/0085		
2 0 02269 0 00 0066+56 043963 FT LENGTH(AH 1979 BK 2140)	0191/0000	044034 FT	
018 "DIA CIRC CONCR LEN=0050 INSTALLED UNKN	0190/1420		
018 "DIA CIRC CONCR LEN=0030 INSTALLED UNKN	0190/0913		
018 "DIA CIRC CONCR LEN=0025 INSTALLED UNKN	0190/0517		
018 "DIA CIRC CONCR LEN=0050 INSTALLED UNKN	0190/0260		
018 "DIA CIRC CONCR LEN=0025 INSTALLED UNKN	0190/0000		
018 "DIA CIRC CONCR LEN=0050 INSTALLED UNKN	0180/1917		
018 "DIA CIRC CONCR LEN=0025 INSTALLED UNKN	0180/1627		
018 "DIA CIRC CONCR LEN=0002 INSTALLED UNKN	0180/1626		
018 "DIA CIRC CONCR LEN=0025 INSTALLED UNKN	0180/1600		
018 "DIA CIRC CONCR LEN=0025 INSTALLED UNKN	0180/1249		
018 "DIA CIRC CONCR LEN=0040 INSTALLED UNKN L SAW MILL STRUCTURE LENGTH 12 FT BMSID 02/0019/0180/0909	0181/1016 0181/0883		
018 "DIA CIRC CONCR LEN=0020 INSTALLED UNKN CHAPPEL AV	0181/0835 0181/0820		
			018 "DIA CIRC CONCR LEN=0050 INSTALLED UNKN CRANE AV (CNTY)
			018 "DIA CIRC CONCR LEN=0030 INSTALLED UNKN L SAW MIL RN STRUCTURE LENGTH 15 FT BMSID 02/0019/0191/0700
			018 "DIA CIRC CONCR LEN=0025 INSTALLED UNKN GOLDSTROM AV (CITY) LENGTH(AH 1829 BK 2249)
			018 "DIA CIRC CONCR LEN=0025 INSTALLED UNKN L SAW MILL STRUCTURE LENGTH 12 FT BMSID 02/0019/0180/0909 COAST AV (CITY)
			CHAPPEL AV

DIR: N TOTAL LEN: 29.135 MI. DIST: 11-1 SR: 19
 LEFT MUN: PITTSBURGH C RIGHT MUN: PITTSBURGH C

(CITY)	0181/0790	==	==	0180/0815	(CITY)
018 "DIA CIRC CONCR LEN=0020 INSTALLED UNKN	0181/0769	---	---	0180/0800	018 "DIA CIRC CONCR LEN=0010 INSTALLED UNKN
018 "DIA CIRC CONCR LEN=0020 INSTALLED UNKN	0181/0738	---	---	0180/0500	018 "DIA CIRC CONCR LEN=0025 INSTALLED UNKN
018 "DIA CIRC CONCR LEN=0030 INSTALLED UNKN	0181/0488	---	---	0180/0326	018 "DIA CIRC CONCR LEN=0025 INSTALLED UNKN
018 "DIA CIRC CONCR LEN=0030 INSTALLED UNKN	0181/0276	---	---	0180/0320	018 "DIA CIRC CONCR LEN=0025 INSTALLED UNKN
2 0 02269 0 00 0044+90 041823 FT OLD BANKSVILLE AV (CITY)	0181/0000	---	---	0180/0025	018 "DIA CIRC CONCR LEN=0025 INSTALLED UNKN
LENGTH(AH 2140 BK 2555) 018 "DIA CIRC CONCR LEN=0010 INSTALLED UNKN	0171/2540	---	---	041785 FT	2 0 02269 0 00 0044+54
L.SAW MILL STRUCTURE LENGTH 17 FT BMSID 02/0019/0171/2440	0171/2471	>	<	0180/0000	LENGTH(AH 2249 BK 2536)
CARNAHAN RD (CITY)	0171/2295	==	==	0170/2505	L.SAW MILL STRUCTURE LENGTH 17 FT BMSID 02/0019/0171/2440
WENZELL AV (CITY)	0171/1941	---	---	0170/2265	WENZELL AV (CITY)
036 "DIA CIRC CONCR LEN=0010 INSTALLED UNKN	0171/1636	---	---	0170/2091	018 "DIA CIRC CONCR LEN=0005 INSTALLED UNKN
036 "DIA CIRC CONCR LEN=0010 INSTALLED UNKN	0171/1418	---	---	0170/2090	018 "DIA CIRC CONCR LEN=0050 INSTALLED UNKN
018 "DIA CIRC CONCR LEN=0020 INSTALLED UNKN	0171/1000	---	---	0170/1917	048 "DIA CIRC CONCR LEN=0050 INSTALLED UNKN
018 "DIA CIRC CONCR LEN=0030 INSTALLED UNKN		---	---	0170/1608	018 "DIA CIRC CONCR LEN=0050 INSTALLED UNKN
					018 "DIA CIRC CONCR

DIR: N TOTAL LEN: 29.135 MI. DIST: 11-1 SR: 19
 LEFT MUN: PITTSBURGH C RIGHT MUN: PITTSBURGH C

Stationing	Material	Length	Notes
0170/0988	018 "DIA CIRC CONCR	LEN=0010	INSTALLED UNKN
0171/0830	018 "DIA CIRC CONCR	LEN=0099	INSTALLED UNKN
0170/0823	018 "DIA CIRC CONCR	LEN=0005	INSTALLED UNKN
0171/0560	018 "DIA CIRC CONCR	LEN=0040	INSTALLED UNKN
0170/0559	018 "DIA CIRC CONCR	LEN=0060	INSTALLED UNKN
0171/0078	018 "DIA CIRC CONCR	LEN=0040	INSTALLED UNKN
0170/0050	018 "DIA CIRC CONCR	LEN=0010	INSTALLED UNKN
039249 FT	2 0 02269 0 00 0019+70	039268 FT	LITTLE SAW MILL RUN STRUCTURE LENGTH 11 FT BMSID 02/0019/0170/0000 POTOMAC AV (CNTY)
0171/0000	LENGTH(AH 2555 BK 1671)	0171/0000	LENGTH(AH 2536 BK 1844)
0160/1790	020 "DIA CIRC CONCR	LEN=0010	INSTALLED UNKN
0160/1586	024 "DIA CIRC CONCR	LEN=0010	INSTALLED UNKN
0160/1463	024 "DIA CIRC CONCR	LEN=0010	INSTALLED UNKN
0160/1399	036 "DIA CIRC CONCR	LEN=0010	INSTALLED UNKN
0161/1254	018 "DIA CIRC CONCR	LEN=0010	INSTALLED UNKN
0161/1188	018 "DIA CIRC CONCR	LEN=0010	INSTALLED UNKN
0160/1030	018 "DIA CIRC CONCR	LEN=0010	INSTALLED UNKN
0160/0834	018 "DIA CIRC CONCR	LEN=0070	INSTALLED UNKN
0161/0625	018 "DIA CIRC CONCR	LEN=0010	INSTALLED UNKN
0160/0545	018 "DIA CIRC CONCR	LEN=0070	INSTALLED UNKN
0161/0334	018 "DIA CIRC CONCR	LEN=0050	INSTALLED UNKN
0160/0150	MCMONAGLE AV (CNTY)	0160/0150	
0161/0120	018 "DIA CIRC CONCR	LEN=0025	INSTALLED UNKN
037405 FT	2 0 02269 0 00 0000+00	037597 FT	NC BANKSVILLE RD

EXTRACT DATE: 12/21/2020
PRINT DATE: 12/23/2020

ROADWAY MANAGEMENT SYSTEM
SLD COUNTY/SR - ANNUAL PRINT

PAGE NUMBER: 36
COUNTY: ALLEGHENY

DIR: N TOTAL LEN: 29.135 MI.
LEFT MUN: PITTSBURGH C

DIST: 11-1 SR: 19
RIGHT MUN: PITTSBURGH C

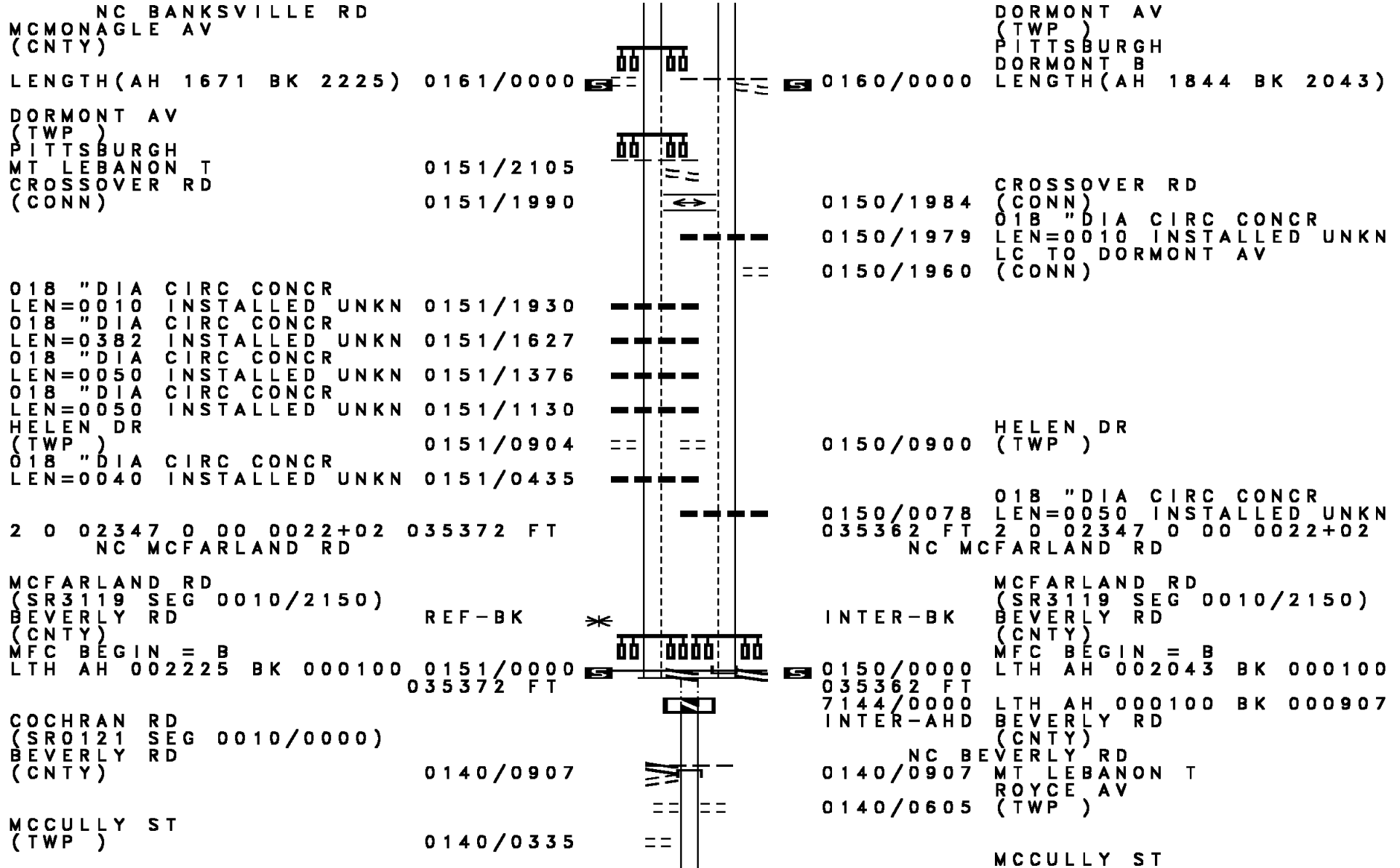

DIR: N TOTAL LEN: 29.135 MI. DIST: 11-1 SR: 19
 LEFT MUN: MT LEBANON T RIGHT MUN: MT LEBANON T

BEAVER PL
(TWP)

0140/0185
034465 FT

BOWER AL
(TWP)

0130/2870

SERPENTINE DR
(TWP)

0130/1915

ATLANTA DR
(TWP)

0130/0790

==	0140/0305 (TWP)
==	034455 FT 2 0 02235 0 01 0049+09 BOWER HILL RD (TWP)
==	0140/0000 LENGTH(AH 0907 BK 3020) 018 "DIA CIRC CONCR
==	0130/3005 LEN=0099 INSTALLED UNKN
==	NAVATO PL (TWP)
==	0130/2690 018 "DIA CIRC CONCR
==	0130/2644 LEN=0040 INSTALLED UNKN LANDSDALE PL (TWP)
==	0130/2445 018 "DIA CIRC CONCR
==	0130/2254 LEN=0030 INSTALLED UNKN ALTOONA PL (TWP)
==	0130/2210 018 "DIA CIRC CONCR
==	0130/2047 LEN=0030 INSTALLED UNKN
==	ACADEMY AV (TWP)
==	0130/1605 018 "DIA CIRC CONCR
==	0130/1370 LEN=0030 INSTALLED UNKN CEDAR BL (TWP)
==	0130/1255 018 "DIA CIRC CONCR
==	0130/1160 LEN=0030 INSTALLED UNKN ATLANTA DR (TWP)
==	0130/0920 018 "DIA CIRC CONCR
==	0130/0866 LEN=0030 INSTALLED UNKN
==	BAYWOOD AV (TWP)
==	0130/0585 018 "DIA CIRC CONCR
==	0130/0539 LEN=0035 INSTALLED UNKN MAGNOLIA PL (TWP)
==	0130/0265 018 "DIA CIRC CONCR

DIR: N TOTAL LEN: 29.135 MI. DIST: 11-1 SR: 19
 LEFT MUN: MT LEBANON T RIGHT MUN: MT LEBANON T

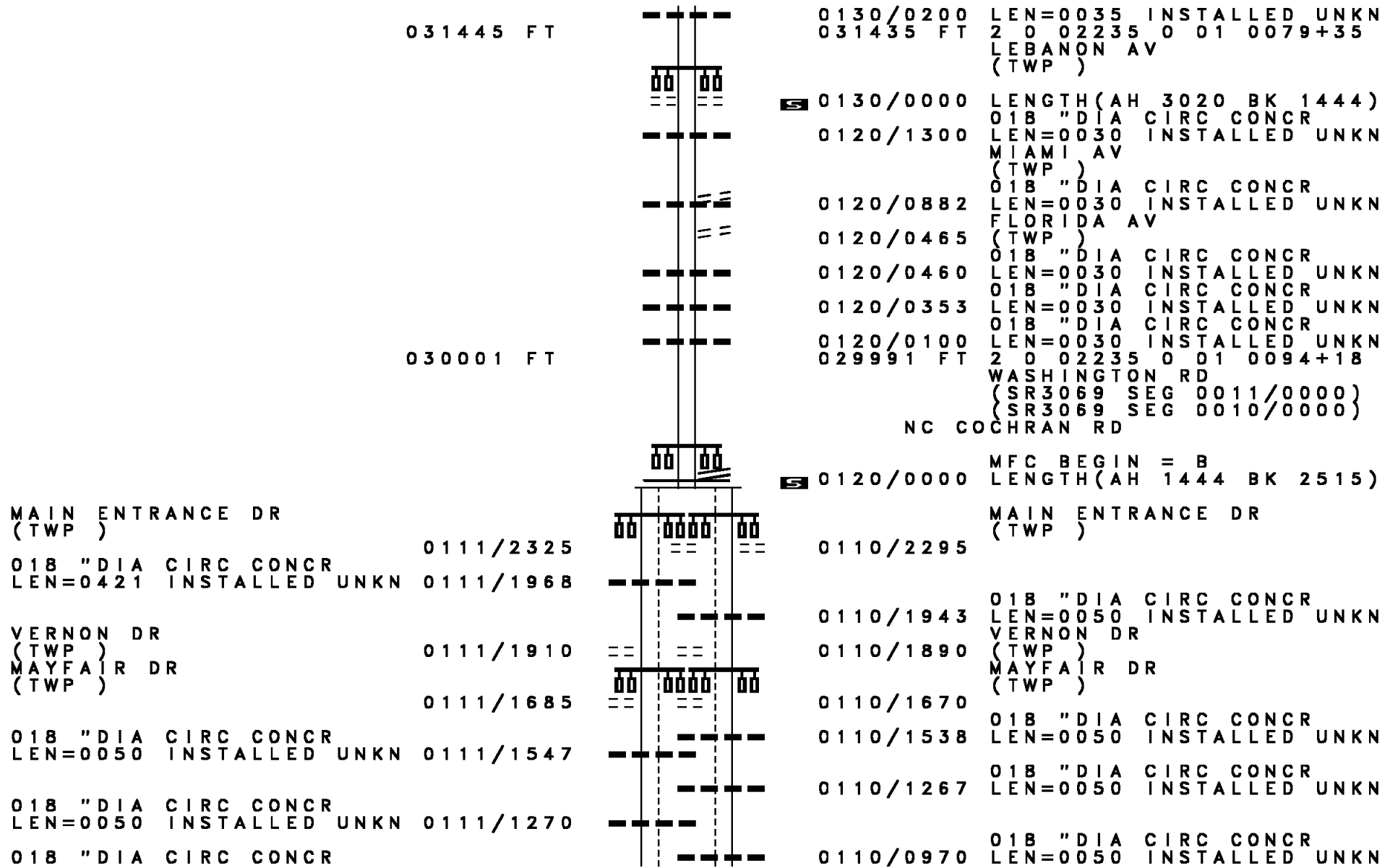

031445 FT

0130/0200 LEN=0035 INSTALLED UNKN
 031435 FT 2 0 02235 0 01 0079+35
 LEBANON AV
 (TWP)

0130/0000 LENGTH(AH 3020 BK 1444)
 0120/1300 018 "DIA CIRC CONCR
 LEN=0030 INSTALLED UNKN
 MIAMI AV
 (TWP)

0120/0882 018 "DIA CIRC CONCR
 LEN=0030 INSTALLED UNKN
 FLORIDA AV
 (TWP)

0120/0465 018 "DIA CIRC CONCR
 LEN=0030 INSTALLED UNKN

0120/0353 018 "DIA CIRC CONCR
 LEN=0030 INSTALLED UNKN

030001 FT

0120/0100 018 "DIA CIRC CONCR
 LEN=0030 INSTALLED UNKN
 029991 FT 2 0 02235 0 01 0094+18
 WASHINGTON RD
 (SR3069 SEG 0011/0000)
 (SR3069 SEG 0010/0000)
 NC CO CHRAN RD

0120/0000 MFC BEGIN = B
 LENGTH(AH 1444 BK 2515)

MAIN ENTRANCE DR
 (TWP) 0111/2325
 018 "DIA CIRC CONCR
 LEN=0421 INSTALLED UNKN 0111/1968

0110/2295
 MAIN ENTRANCE DR
 (TWP)

VERNON DR
 (TWP) 0111/1910
 MAYFAIR DR
 (TWP) 0111/1685

0110/1943 018 "DIA CIRC CONCR
 LEN=0050 INSTALLED UNKN
 VERNON DR
 (TWP)
 0110/1890 MAYFAIR DR
 (TWP)

018 "DIA CIRC CONCR
 LEN=0050 INSTALLED UNKN 0111/1547

0110/1670 018 "DIA CIRC CONCR
 LEN=0050 INSTALLED UNKN

018 "DIA CIRC CONCR
 LEN=0050 INSTALLED UNKN 0111/1270

0110/1538 018 "DIA CIRC CONCR
 LEN=0050 INSTALLED UNKN

018 "DIA CIRC CONCR

0110/1267 018 "DIA CIRC CONCR
 LEN=0050 INSTALLED UNKN
 0110/0970 018 "DIA CIRC CONCR
 LEN=0050 INSTALLED UNKN

EXTRACT DATE: 12/21/2020
PRINT DATE: 12/23/2020

ROADWAY MANAGEMENT SYSTEM
SLD COUNTY/SR - ANNUAL PRINT

PAGE NUMBER: 33
COUNTY: ALLEGHENY

DIR: N TOTAL LEN: 29.135 MI.
LEFT MUN: MT LEBANON T

DIST: 11-1 SR: 19
RIGHT MUN: MT LEBANON T

Left Side Description	Left Side ID	Right Side Description	Right Side ID
LEN=0050 INSTALLED UNKN PARK ENTRANCE DR (TWP)	0111/0979	PARK ENTRANCE DR (TWP)	0110/0830
	0111/0840	018 "DIA CIRC CONCR LEN=0050 INSTALLED UNKN	0110/0764
018 "DIA CIRC CONCR LEN=0050 INSTALLED UNKN BEADLING RD (TWP)	0111/0769	BEADLING RD (TWP)	0110/0535
	0111/0545	018 "DIA CIRC CONCR LEN=0050 INSTALLED UNKN	0110/0500
1 0 00806 0 02 0156+75 027484 FT WOODHAVEN DR (TWP)		1 0 00806 0 02 0156+51 WOODHAVEN DR (TWP)	027476 FT
CRESTVUE MANOR DR (TWP)		CRESTVUE MANOR DR (TWP)	
LENGTH(AH 2517 BK 3036) LONGUEVUE DR (TWP)	0111/0000	LENGTH(AH 2515 BK 3073) LONGUEVUE DR (TWP)	0110/0000
	0101/2972	018 "DIA CIRC CONCR LEN=0050 INSTALLED UNKN	0100/3010
ROCKLYNN PL (TWP)	0101/2780	ROCKLYNN PL (TWP)	0100/2855
018 "DIA CIRC CONCR LEN=0050 INSTALLED UNKN	0101/2760		0100/2820
SUNNYHILL DR (TWP)		SUNNYHILL DR (TWP)	
ST CLAIR DR (TWP)		ST CLAIR DR (TWP)	
	0101/2302		0100/2345
STANDISH BL (TWP)	0101/2058	STANDISH BL (TWP)	0100/2110
LC TO STANDISH BL (CONN)	0101/1824	LC TO STANDISH BL (CONN)	0100/1865
		FROM 3042/0010 SH (CONN)	0100/1780
MT LEBANON BL (SR3042 SEG 0010/0000)	0101/1623	MT LEBANON BL (SR3042 SEG 0010/0000)	0100/1660
		018 "DIA CIRC CONCR LEN=0050 INSTALLED UNKN	0100/1593
		TO 3042/0010 SH (CONN)	0100/1565
		018 "DIA CIRC CONCR LEN=0050 INSTALLED UNKN	0100/1329
TERRACE DR (TWP)	0101/1272	TERRACE DR (TWP)	0100/1290

DIR: N TOTAL LEN: 29.135 MI. DIST: 11-1 SR: 19
 LEFT MUN: MT LEBANON T RIGHT MUN: MT LEBANON T

Item Description	Segment ID	Length	Material	Status	Notes
018 "DIA CIRC CONCR LEN=0050 INSTALLED UNKN	0101/0540				
018 "DIA CIRC CONCR LEN=0050 INSTALLED UNKN	0101/0161				
1 0 00806 0 02 0125+56 024448 FT LENGTH(AH 3036 BK 3795)	0101/0000	5			
ORDALE BL (TWP)	0091/3265				
TO 3038/0031 SH (CONN) PAINTERS RUN STRUCTURE LENGTH 8 FT BMSID 02/0019/0090/2324	0091/2319 0091/2275				
018 "DIA CIRC CONCR LEN=0010 INSTALLED UNKN	0091/2270				
GILKESON RD (SR3038 SEG 0030/3011) CONNOR RD (SR3038 SEG 0031/3073) FROM 3038/0030 SH (CONN)	0091/2143 0091/2046				
018 "DIA CIRC CONCR LEN=0010 INSTALLED UNKN	0091/1888				
018 "DIA CIRC CONCR LEN=0050 INSTALLED UNKN	0091/1589				
HIGHLAND RD (TWP)	0091/1493				
ABBEVILLE RD (TWP)	0091/1065				
018 "DIA CIRC CONCR LEN=0099 INSTALLED UNKN	0091/0930				
0100/0170					
024403 FT 0100/0000	5				
0090/3639					
0090/3213					
0090/2324					
0090/2290					
0090/2210					
0090/2130					
0090/1984					
0090/1025					
0090/0930					
0090/0700					
0090/0471					
0090/0033					
018 "DIA CIRC CONCR LEN=0050 INSTALLED UNKN					
018 "DIA CIRC CONCR LEN=0050 INSTALLED UNKN					
018 "DIA CIRC CONCR LEN=0050 INSTALLED UNKN					
018 "DIA CIRC CONCR LEN=0050 INSTALLED UNKN					
018 "DIA CIRC CONCR LEN=0025 INSTALLED UNKN					

DIR: N TOTAL LEN: 29.135 MI. DIST: 11-1 SR: 19
 LEFT MUN: MT LEBANON T RIGHT MUN: MT LEBANON T

Stationing	Description	Length	Notes
020629 FT	MT LEBANON BETHEL PARK B	0090/0000	
0084/1240	018 "DIA CIRC CONCR	LEN=0020	INSTALLED UNKN
0084/1030	LC FROM HIGHLAND RD		(CONN)
0085/0932	HIGHLAND RD (TWP)		
0084/0940	HIGHLAND RD (TWP)		
0084/0850	018 "DIA CIRC CONCR	LEN=0020	INSTALLED UNKN
0084/0571	018 "DIA CIRC CONCR	LEN=0020	INSTALLED UNKN
0084/0350	018 "DIA CIRC CONCR	LEN=0020	INSTALLED UNKN
0085/0157	BETHEL PARK UPPER ST CLAIR T	0084/0194	
0084/0100	LC FROM FORT COUCH RD		(CONN)
019279 FT	FORT COUCH RD	0072+81	
0085/0000	FORT COUCH RD (SR3036 SEG 0030/2783)	0084/0000	
0080/2359	018 "DIA CIRC CONCR	LEN=0261	INSTALLED UNKN
0081/2427	018 "DIA CIRC CONCR	LEN=0010	INSTALLED UNKN
0081/2405	FROM 3036/0030 SH		(CONN)
0081/1921	LC TO CONSOL COAL CO RD		(CONN)
0081/1847	CONSOL COAL CO RD (PRDR)		
0081/1781	HILLS MALL ENT EXIT RD (PRDR)		
0080/1743	CONSOL COAL CO RD (PRDR)		
0080/1252	CONCOURSE DR (PRDR)		
0080/1252	018 "DIA CIRC CONCR	LEN=0154	INSTALLED UNKN

DIR: N TOTAL LEN: 29.135 MI. DIST: 11-1 SR: 19
 LEFT MUN: UPPER ST CLAIR T RIGHT MUN: UPPER ST CLAIR T

018 "DIA CIRC CONCR LEN=0010 INSTALLED UNKN 0071/0596	0070/0837	LEN=0025	INSTALLED UNKN
018 "DIA CIRC CONCR LEN=0010 INSTALLED UNKN 0071/0341	0070/0536	018 "DIA CIRC CONCR LEN=0025	INSTALLED UNKN
018 "DIA CIRC CONCR LEN=0050 INSTALLED UNKN 0071/0017	0070/0230	018 "DIA CIRC CONCR LEN=0025	INSTALLED UNKN
1 0 00806 0 00 0010+80 013383 FT LENGTH(AH 3379 BK 1173) 0071/0000	013435 FT 0070/0000	1 0 00806 0 00 0011+98 LENGTH(AH 3406 BK 1250)	018 "DIA CIRC CONCR LEN=0050 INSTALLED UNKN
018 "DIA CIRC CONCR LEN=0010 INSTALLED UNKN 0061/0939	0060/0982	018 "DIA CIRC CONCR LEN=0050	INSTALLED UNKN
018 "DIA CIRC CONCR LEN=0010 INSTALLED UNKN 0061/0433	0060/0626	018 "DIA CIRC CONCR LEN=0050	INSTALLED UNKN
018 "DIA CIRC CONCR LEN=0010 INSTALLED UNKN 0061/0159	0060/0386	018 "DIA CIRC CONCR LEN=0086	INSTALLED UNKN
BMS EN 02/0019/0060/0000 0061/0077 2 0 02057 0 00 0122+47 012210 FT SR 3004 MCMURRAY RD BMSBG 02/0019/0060/0000 LENGTH(AH 1173 BK 2393) 0061/0000	0060/0280 0060/0210	(SR8047 SEG 0750/0416) RAMP RD (SR8047 SEG 0760/0000)	018 "DIA CIRC CONCR LEN=0050 INSTALLED UNKN
RAMP RD (SR8047 SEG 0260/0000) 0051/2195 RAMP RD (SR8047 SEG 0250/0478) 0051/2115	0060/0078 0060/0077 012185 FT 0060/0000	018 "DIA CIRC CONCR LEN=0050 INSTALLED UNKN BMS EN 02/0019/0060/0000 2 0 02057 0 00 0122+47 SR 3004 MCMURRAY RD BMSBG 02/0019/0060/0000 LENGTH(AH 1250 BK 2377)	018 "DIA CIRC CONCR LEN=0070 INSTALLED UNKN
018 "DIA CIRC CONCR LEN=0010 INSTALLED UNKN 0051/1188	0050/1482	018 "DIA CIRC CONCR LEN=0070	INSTALLED UNKN
018 "DIA CIRC CONCR	0050/1283	018 "DIA CIRC CONCR LEN=0199	INSTALLED UNKN
	0050/1084		

EXTRACT DATE: 12/21/2020
PRINT DATE: 12/23/2020

ROADWAY MANAGEMENT SYSTEM
SLD COUNTY/SR - ANNUAL PRINT

PAGE NUMBER: 28
COUNTY: ALLEGHENY

DIR: N TOTAL LEN: 29.135 MI.
LEFT MUN: UPPER ST CLAIR T

DIST: 11-1 SR: 19
RIGHT MUN: UPPER ST CLAIR T

Item Description	Stationing	Length	Material	Notes
LEN=0050 INSTALLED UNKN	0051/0882			
LAMBETH DR (TWP)	0051/0589			
2 0 02057 0 00 0098+75	009817 FT			
COUNTRY CLUB				
OP ID 02/3002/0010/0000				
LENGTH(AH 2393 BK 3131)	0051/0000			
SOUTHERN HILANDS DR (TWP)	0041/2797			
SOUTHERN HILANDS DR (TWP)	0041/2755			
018 "DIA CIRC CONCR	0041/2716			
LEN=0050 INSTALLED UNKN				
018 "H 18"W CON BOX CUL				
LEN=0010 INSTALLED UNKN	0041/1815			
OLD WASHINGTON RD (TWP)				
OLD WASHINGTON RD (TWP)	0041/1310			
024 "DIA CIRC CONCR				
LEN=0010 INSTALLED UNKN	0041/0282			
2 0 02057 0 00 0067+87	006686 FT			
LENGTH(AH 3131 BK 2594)	0041/0000			
018 "DIA CIRC CONCR				
LEN=0010 INSTALLED UNKN	0031/2198			
018 "DIA CIRC CONCR				
LEN=0050 INSTALLED UNKN	0031/1970			
CHAPEL WOOD DR (TWP)	0031/1658			
018 "DIA CIRC CONCR				
LEN=00287 INSTALLED UNKN	0050/0626			
LAMBETH DR (TWP)				
2 0 02057 0 00 0098+75	009808 FT			
COUNTRY CLUB				
OP ID 02/3002/0010/0000				
LENGTH(AH 2377 BK 3158)	0050/0000			
SOUTHERN HILANDS DR (TWP)	0040/2780			
025 "DIA CIRC CONCR				
LEN=0060 INSTALLED UNKN	0040/2085			
018 "DIA CIRC CONCR				
LEN=0060 INSTALLED UNKN	0040/1830			
018 "DIA CIRC CONCR				
LEN=0030 INSTALLED UNKN	0040/1245			
OLD WASHINGTON RD (TWP)				
OLD WASHINGTON RD (TWP)	0040/1235			
022 "DIA CIRC CONCR				
LEN=0070 INSTALLED UNKN	0040/0873			
018 "DIA CIRC CONCR				
LEN=0070 INSTALLED UNKN	0040/0312			
018 "DIA CIRC CONCR				
LEN=0070 INSTALLED UNKN	0040/0090			
2 0 02057 0 00 0067+72	006650 FT			
LENGTH(AH 3158 BK 2690)	0040/0000			
012 "DIA CIR PLASTIC				
LEN=0030 INSTALLED UNKN	0030/2417			
CHAPEL WOOD DR (TWP)				
018 "DIA CIRC CONCR				
LEN=0030 INSTALLED UNKN	0030/1839			
018 "DIA CIRC CONCR				
LEN=0070 INSTALLED UNKN	0030/1569			
018 "DIA CIRC CONCR				
LEN=0070 INSTALLED UNKN	0030/1273			

DIR: N TOTAL LEN: 29.135 MI. DIST: 11-1 SR: 19
 LEFT MUN: UPPER ST CLAIR T RIGHT MUN: UPPER ST CLAIR T

Stationing	Description	Length	Material	Status	Notes
0030+00	018 "DIA CIRC CONCR	0070	CONCR	INSTALLED	UNKN
0039+60	018 "DIA CIRC CONCR	0070	CONCR	INSTALLED	UNKN
0041+40	018 "DIA CIRC CONCR	0031	CONCR	INSTALLED	UNKN
0041+96	018 "DIA CIRC CONCR	0031	CONCR	INSTALLED	UNKN
0021+76	018 "DIA CIRC CONCR	0021	CONCR	INSTALLED	UNKN
0021+76	024 "DIA CIRC CONCR	0035	CONCR	INSTALLED	UNKN
0021+1437	018 "DIA CIRC CONCR	0021	CONCR	INSTALLED	UNKN
0021+1021	018 "DIA CIRC CONCR	0021	CONCR	INSTALLED	UNKN
0021+1012	036 "DIA CIRC CONCR	0050	CONCR	INSTALLED	UNKN
0021+0839	018 "DIA CIRC CONCR	0050	CONCR	INSTALLED	UNKN
0021+0392	018 "DIA CIRC CONCR	0050	CONCR	INSTALLED	UNKN
0021+76	018 "DIA CIRC CONCR	0021	CONCR	INSTALLED	UNKN
0021+76	024 "DIA CIRC CONCR	0035	CONCR	INSTALLED	UNKN
0011+1945	018 "DIA CIRC CONCR	0011	CONCR	INSTALLED	UNKN
0011+1843	018 "DIA CIRC CONCR	0050	CONCR	INSTALLED	UNKN
0011+0683	018 "DIA CIRC CONCR	0011	CONCR	INSTALLED	UNKN
0011+0461	018 "DIA CIRC CONCR	0011	CONCR	INSTALLED	UNKN
0011+0355	018 "DIA CIRC CONCR	0011	CONCR	INSTALLED	UNKN
0011+0322	018 "DIA CIRC CONCR	0011	CONCR	INSTALLED	UNKN
0011+0251	018 "DIA CIRC CONCR	0011	CONCR	INSTALLED	UNKN
0011+0050	018 "DIA CIRC CONCR	0011	CONCR	INSTALLED	UNKN
0000+00	018 "DIA CIRC CONCR	0000	CONCR	INSTALLED	UNKN
0011+0000	018 "DIA CIRC CONCR	0011	CONCR	INSTALLED	UNKN
0010+1033	018 "DIA CIRC METAL	0060	METAL	INSTALLED	UNKN
0010+0510	018 "DIA CIRC METAL	0060	METAL	INSTALLED	UNKN
0010+0328	018 "DIA CIRC METAL	0060	METAL	INSTALLED	UNKN
0010+0283	018 "DIA CIRC METAL	0060	METAL	INSTALLED	UNKN
0000+00	018 "DIA CIRC METAL	0060	METAL	INSTALLED	UNKN
0010+0000	018 "DIA CIRC METAL	0060	METAL	INSTALLED	UNKN

EXTRACT DATE: 12/21/2020 ROADWAY MANAGEMENT SYSTEM PAGE NUMBER: 26
 PRINT DATE: 12/23/2020 SLD COUNTY/SR - ANNUAL PRINT COUNTY: ALLEGHENY
 DIR: N TOTAL LEN: 20.630 MI. DIST: 11-1 SR: 8
 LEFT MUN: RICHLAND T RIGHT MUN: RICHLAND T

AH-BUTLER	(10)	108819	FT		
WILLIAM FLYNN HW		REF-AHD	*		
(SR0008 SEG 0011/0000)		0461/1775			
012 "DIA	CIRC	CONCR			
LEN=0099	INSTALLED	UNKN	0461/1333	---	---
018 "DIA	CIRC	CONCR			
LEN=0099	INSTALLED	UNKN	0461/1089	---	---
024 "DIA	CIRC	CONCR			
LEN=0050	INSTALLED	UNKN	0461/0651	---	---
BURKS LN					
(TWP)		0461/0588	==		==

		108927	FT		
*	REF-AHD	WILLIAM FLYNN HW			
	0460/1875	(SR0008 SEG 0010/0000)			
		BURKS LN			
	0460/0465	(TWP)			

EXTRACT DATE: 12/21/2020
PRINT DATE: 12/23/2020

ROADWAY MANAGEMENT SYSTEM
SLD COUNTY/SR - ANNUAL PRINT

PAGE NUMBER: 25
COUNTY: ALLEGHENY

DIR: N TOTAL LEN: 20.630 MI.
LEFT MUN: RICHLAND T

DIST: 11-1 SR: 8
RIGHT MUN: RICHLAND T

BR. GLADE RUN
STRUCTURE LENGTH 14 FT
BMSID 02/0008/0460/0385 0461/0363

1 0 00072 0 02 0685+55 107044 FT
LENGTH(AH 1775 BK 3399) 0461/0000

GLASGOW RD
(T729) 0451/3030

024 "DIA CIRC CONCR
LEN=0048 INSTALLED UNKN 0451/2783

018 "DIA CIRC CONCR
LEN=0050 INSTALLED UNKN 0451/2599

018 "DIA CIRC CONCR
LEN=0050 INSTALLED UNKN 0451/2386

CUNNINGHAM RD
(TWP)

SANDY HILL RD
(T729) 0451/2003

018 "DIA CIRC CONCR
LEN=0048 INSTALLED UNKN 0451/1529

012 "DIA CIRC CONCR
LEN=0099 INSTALLED UNKN 0451/1207

HECKERT RD
(T760) 0451/1103

018 "DIA CIRC CONCR
LEN=0099 INSTALLED UNKN 0451/0849

018 "DIA CIRC CONCR
LEN=0099 INSTALLED UNKN 0451/0709

012 "DIA CIRC CONCR
LEN=0099 INSTALLED UNKN 0451/0464

018 "DIA CIRC CONCR
LEN=0099 INSTALLED UNKN 0451/0289

1 0 00072 0 02 0655+06 103645 FT
LENGTH(AH 3399 BK 2924) 0451/0000

WILLOW CREEK DR
(TWP) 0441/2300

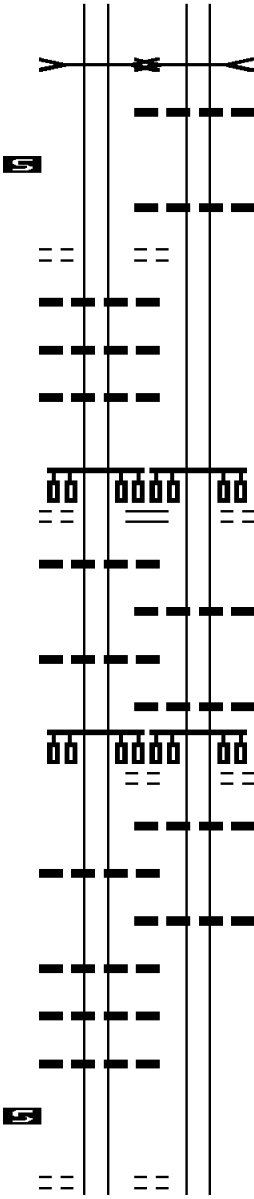

BR. GLADE RUN
STRUCTURE LENGTH 14 FT
BMSID 02/0008/0460/0385

1 0 00072 0 02 0685+35
LENGTH(AH 1875 BK 3430)

GLASGOW RD
(T729)

018 "DIA CIRC CONCR
LEN=0005 INSTALLED UNKN

024 "DIA CIRC CONCR
LEN=0180 INSTALLED UNKN

CUNNINGHAM RD
(TWP)

SANDY HILL RD
(T729)

018 "DIA CIRC CONCR
LEN=0060 INSTALLED UNKN

018 "DIA CIRC CONCR
LEN=0040 INSTALLED UNKN

018 "DIA CIRC CONCR
LEN=0040 INSTALLED UNKN

018 "DIA CIRC CONCR
LEN=0040 INSTALLED UNKN

1 0 00072 0 02 0653+70
LENGTH(AH 3430 BK 2921)

WILLOW CREEK DR
(TWP)

DIR: N TOTAL LEN: 20.630 MI. DIST: 11-1 SR: 8
 LEFT MUN: RICHLAND T RIGHT MUN: RICHLAND T

012 "H 24 "W CON BOX CUL LEN=0099 INSTALLED UNKN 0441/2271	---		
018 "DIA CIRC CONCR LEN=0048 INSTALLED UNKN 0441/1946	---		
(APRA) SHAULL EQUIPMENT SHAULL EQUIPMENT CO RD (PRDR) 0441/1865	POI-POI	0440/1865	(APRA) SHAULL EQUIPMENT SHAULL EQUIPMENT CO RD
LEGION DR (T836) 0441/1635	== ==	0440/1635	(PRDR) LEGION DR (T836)
024 "H 18 "W CON BOX CUL LEN=0090 INSTALLED UNKN 0441/1332	---		
018 "DIA CIRC CONCR LEN=0099 INSTALLED UNKN 0441/1165	---		
018 "DIA CIRC CONCR LEN=0048 INSTALLED UNKN 0441/0966	---		
RAMP X RD (SR8040 SEG 0500/0000) 0441/0335	==		
		0440/0380	RAMP B RD (SR8040 SEG 0750/0360)
018 "DIA CIRC CONCR LEN=0099 INSTALLED UNKN 0441/0308	---		
DEER CREEK STRUCTURE LENGTH 8 FT BMSID 02/0008/0440/0217 0441/0165	==	0440/0217	DEER CREEK STRUCTURE LENGTH 8 FT BMSID 02/0008/0440/0217
BMSEN 02/0008/0440/0000 0441/0050	==	0440/0050	BMSEN 02/0008/0440/0000
1 0 00072 0 02 0622+30 100721 FT		100701 FT	1 0 00072 0 02 0622+30
SR 4068 RED BELT BMSBG 02/0008/0440/0000	==	0440/0000	SR 4068 RED BELT BMSBG 02/0008/0440/0000
LENGTH(AH 2924 BK 2275) 0441/0000	==	0440/0000	LENGTH(AH 2921 BK 2292)
RAMP R RD (SR8040 SEG 0250/0264) 0431/2115	==		
		0430/2240	015 "DIA CIRC CONCR LEN=0060 INSTALLED UNKN
024 "DIA CIRC CONCR LEN=0099 INSTALLED UNKN 0431/1976	---		
024 "DIA CIRC CONCR LEN=0099 INSTALLED UNKN 0431/1439	---		
HECKERT RD (T760) 0431/1404	== ==	0430/1405	HECKERT RD (T760)
ST GEORGE DR (TWP) 0431/1333	== ==	0430/1357	ST GEORGE DR (TWP)
		0430/1300	LC TO HECKERT RD (CONN)
018 "DIA CIRC CONCR LEN=0099 INSTALLED UNKN 0431/1261	---		
036 "H 18 "W CON BOX CUL LEN=0099 INSTALLED UNKN 0431/0986	---		

DIR: N TOTAL LEN: 20.630 MI. DIST: 11-1 SR: 8
 LEFT MUN: RICHLAND T RIGHT MUN: RICHLAND T

018 "DIA CIRC CONCR LEN=0048 INSTALLED UNKN 0431/0651	---	---	==	0430/0200	LEE RD (TWP)
018 "DIA CIRC CONCR LEN=0048 INSTALLED UNKN 0431/0423	---	---		098409 FT	1 0 00072 0 02 0597+57 DICKEY RD (T709)
1 0 00072 0 02 0597+60 098446 FT DICKEY RD (T709)				0430/0000	LENGTH(AH 2292 BK 2601)
LENGTH(AH 2275 BK 2679) 0431/0000	5	==	==	5	
036 "DIA CIRC CONCR LEN=0036 INSTALLED UNKN 0421/2545	---	---			
048 "DIA CIRC CONCR LEN=0040 INSTALLED UNKN 0421/2528	---	---			
018 "DIA CIRC CONCR LEN=0040 INSTALLED UNKN 0421/2241	---	---			
GRANDVIEW CROSSING (CONN) 0421/1839			==		
GRANDVIEW CROSSING (TWP)					GRANDVIEW CROSSING (TWP)
GRANDVIEW DR (TWP)	00	0000	00		GRANDVIEW DR (TWP)
GRANDVIEW CROSSING (CONN) 0421/1744	==	==	==	0420/1674	
0421/1672	==				
018 "DIA CIRC CONCR LEN=0025 INSTALLED UNKN 0421/1333	---	---		0420/1280	015 "DIA CIRC CONCR LEN=0040 INSTALLED UNKN
COMMUNITY CENTER DR (T760) 0421/1199			==		
018 "DIA CIRC CONCR LEN=0099 INSTALLED UNKN 0421/0958	---	---		0420/1053	COMMUNITY CENTER DR (T760)
018 "DIA CIRC CONCR LEN=0015 INSTALLED UNKN 0421/0615	---	---		0420/0899	003"H 12"W CON BOX CUL LEN=0060 INSTALLED UNKN
018 "DIA CIRC CONCR LEN=0050 INSTALLED UNKN 0421/0332	---	---			
1 0 00072 0 02 0573+41 095767 FT LENGTH(AH 2679 BK 2189) 0421/0000	5		5	095808 FT	1 0 00072 0 02 0572+76 LENGTH(AH 2601 BK 2134)
LC TO NORTHTOWN SQ (CONN) 0411/2075			==	0420/0000	
NORTHTOWN SQ (PRDR)	00	0000	00		018 "DIA CIRC CONCR LEN=0048 INSTALLED UNKN NORTHTOWN SQ (PRDR)
0411/1990	==	==		0410/1874	
				0410/1857	

DIR: N TOTAL LEN: 20.630 MI. DIST: 11-1 SR: 8
 LEFT MUN: RICHLAND T RIGHT MUN: RICHLAND T

Segment Description	Stationing	Notes	Stationing	Notes
LC FROM NORTHTOWN SQ (CONN)	0411/1948	==		
		---	0410/1600	018 "DIA CIRC CONCR LEN=0048 INSTALLED UNKN
		---	0410/1368	018 "DIA CIRC CONCR LEN=0040 INSTALLED UNKN
		[RBR] [RBR]		
BMS EN 02/0008/0410/1108 1 0 00072 0 02 0563+04 P3	0411/1262		0410/1133	BMS EN 02/0008/0410/1108 1 0 00072 0 02 0563+04 P3
WEST BRANCH DEER CREEK BMSBG 02/0008/0410/1108 GIBSONIA RD (SR0910 SEG 0210/0000)	0411/1237	[RBR] [RBR]	0410/1108	WEST BRANCH DEER CREEK BMSBG 02/0008/0410/1108 GIBSONIA RD (SR0910 SEG 0210/0000)
GIBSONIA RD (SR0910 SEG 0210/0000)	0411/1196	00 0000 00	0410/1032	GIBSONIA RD (SR0910 SEG 0210/0000)
018 "DIA CIRC CONCR LEN=0996 INSTALLED UNKN	0411/1095	---		
018 "DIA CIRC CONCR LEN=0099 INSTALLED UNKN	0411/0642	---		
		---	0410/0481	018 "DIA CIRC CONCR LEN=0050 INSTALLED UNKN
WESTLAND DR (T788)	0411/0460	==	0410/0322	WESTLAND DR (T788)
1 0 00072 0 02 0546+14 093578 FT COMMUNITY CENTER DR (T760)				
LENGTH(AH 2189 BK 2274)	0411/0000	==	093674 FT	1 0 00072 0 02 0550+87
		[S]	0410/0000	LENGTH(AH 2134 BK 2408) COMMUNITY CENTER DR (T760)
			0400/2275	(T760)
		---	0400/2250	018 "DIA CIRC CONCR LEN=0050 INSTALLED UNKN
		---	0400/1955	018 "DIA CIRC CONCR LEN=0060 INSTALLED UNKN
		---	0400/1670	018 "DIA CIRC CONCR LEN=0060 INSTALLED UNKN
		---	0400/1485	018 "DIA CIRC CONCR LEN=0099 INSTALLED UNKN
		---	0400/1190	018 "DIA CIRC CONCR LEN=0099 INSTALLED UNKN
WESTLAND DR (T786)	0401/1045	==	0400/1040	WESTLAND DR (T786)
APPLEWOOD DR (T610)	0401/0920	==	0400/0915	APPLEWOOD DR (T610)
		==		018 "DIA CIRC CONCR

DIR: N TOTAL LEN: 20.630 MI. DIST: 11-1 SR: 8
 LEFT MUN: RICHLAND T RIGHT MUN: RICHLAND T

Stationing	Length	Material	Status	Notes
1 0 00072 0 02 0528+01 091304 FT				EWALT RD (T788)
0400/0880	LEN=0099		INSTALLED UNKN	
091266 FT				1 0 00072 0 02 0528+14 EWALT RD (T788)
0401/0000	LEN=0099	CIRC CONCR	INSTALLED UNKN	0400/0000 LENGTH(AH 2408 BK 2048)
0391/1938				
0391/1821				0390/1510 COOK RD (T760)
0391/1612				
0391/1371				
0391/1357				
0391/1040				0390/0735 018 "DIA CIRC CONCR LEN=0099 INSTALLED UNKN
0391/0630				
0391/0485				
0391/0387				
089218 FT				1 0 00072 0 02 0505+15 MALL ENTRANCE RD (PRDR)
0391/0306				0390/0000 LENGTH(AH 2048 BK 2479)
0380/2440				018 "DIA CIRC METAL LEN=0099 INSTALLED UNKN
0380/2300				018 "DIA CIRC CONCR LEN=0099 INSTALLED UNKN
0380/2295				COOK RD (TWP)
0499+67 088950 FT				PIONEER RD (TWP)
0391/0000				0380/2170 PIONEER RD (TWP)
0381/2073				(APRA) PENN AGH TRUCK S PENN AGH TRUCK STOP RD (PRDR)
0381/1910				0380/2089 PENN AGH TRUCK STOP RD (PRDR)
0381/1680				012 "DIA CIRC CONCR LEN=0099 INSTALLED UNKN
				VISTA VUE DR (T441)
				0380/1670 VISTA VUE DR (T441)

DIR: N TOTAL LEN: 20.630 MI. DIST: 11-1 SR: 8
 LEFT MUN: RICHLAND T RIGHT MUN: RICHLAND T

Location / Segment	Stationing	Length (AH / BK)	Notes
RANALLI DR (T444)	0381/1230		0380/1420 018" DIA CIRC CONCR LEN=0099 INSTALLED UNKN
			RANALLI DR (T444)
			0380/1220 024" DIA CIRC CONCR LEN=0099 INSTALLED UNKN
RICHLAND HAMPTON T	0381/0446		0380/1050 018" DIA CIRC CONCR LEN=0099 INSTALLED UNKN
			0380/0621 RICHLAND HAMPTON T
			0380/0555 018" DIA CIRC CONCR LEN=0099 INSTALLED UNKN
			0380/0330 018" DIA CIRC CONCR LEN=0099 INSTALLED UNKN
1 0 00072 0 02 0482+54 086767 FT EAST HARDIES RD (SR4067 SEG 0080/0000)			0380/0330 086739 FT
LENGTH(AH 2183 BK 1783)	0381/0000		0380/0000 LENGTH(AH 2479 BK 1785)
			TURNPIKE RAMP RD (TNPK)
			0370/1145 018" DIA CIRC CONCR LEN=0099 INSTALLED UNKN
TPK RAMP AB			0370/1000 OP ID 02/7076/9900/3903
OP ID 02/7076/9900/3903	0371/0894		0370/0909 018" DIA CIRC CONCR LEN=0100 INSTALLED UNKN
			0370/0900 024" DIA CIRC CONCR LEN=0060 INSTALLED UNKN
TURNPIKE RAMP RD (TNPK)	0371/0666		0370/0735 TURNPIKE RAMP RD (TNPK)
TURNPIKE RAMP RD (TNPK)	0371/0555		0370/0570 018" DIA CIRC CONCR LEN=0060 INSTALLED UNKN
			0370/0205 BMSSEN 02/7076/9900/3910
BMSSEN 02/7076/9900/3910	0371/0121		0370/0121 1 0 00072 0 02 0465+36 084984 FT
1 0 00072 0 02 0465+36 084984 FT			084954 FT
I-76			I-76
BMSBG 02/7076/9900/3910			BMSBG 02/7076/9900/3910
LENGTH(AH 1783 BK 3071)	0371/0000		0370/0000 LENGTH(AH 1785 BK 3067)
			0360/2436 010" DIA CIRC CONCR LEN=0099 INSTALLED UNKN
			0360/2308 018" DIA CIRC CONCR LEN=0099 INSTALLED UNKN
BARDONNER RD (T600)	0361/1800		0360/1810 BARDONNER RD (T600)
			018" DIA CIRC CONCR

DIR: N TOTAL LEN: 20.630 MI. DIST: 11-1 SR: 8
 LEFT MUN: HAMPTON T RIGHT MUN: HAMPTON T

Structure ID	Description	Length	Material	Status	Year
0360/1691	BARDONNER RD ET (T677)	0361/1655	018" DIA CIRC CONCR	INSTALLED	2009
0360/1660	BR. CROUSE STRUCTURE LENGTH 10 FT BMSID 02/0008/0360/1428	0361/1436	018" DIA CIRC CONCR	INSTALLED	2009
0360/1292	MALL ENTRANCE RD (PRDR)	0361/0610	018" DIA CIRC CONCR	INSTALLED	2009
0360/0530	MALL ENTRANCE RD (PRDR)	0360/0530	018" DIA CIRC CONCR	INSTALLED	2009
0360/0000	1 0 00072 0 02 0433+58 081913 FT GRANDVIEW DR (T927) LENGTH(AH 3071 BK 2195) MCNEAL RD (T992)	0361/0000	018" DIA CIRC CONCR	INSTALLED	2009
0350/1820	MCNEAL RD (T992)	0351/1820	018" DIA CIRC CONCR	INSTALLED	2009
0350/1613	018" DIA CIRC CONCR LEN=0040 INSTALLED UNKN	0351/1613	018" DIA CIRC CONCR	INSTALLED	2009
0350/1065	WOODLAND CR (T979)	0351/1044	018" DIA CIRC CONCR	INSTALLED	2009
0350/0900	018" H 12" W ELLIP CONC LEN=0099 INSTALLED UNKN	0351/0900	018" DIA CIRC CONCR	INSTALLED	2009
0350/0582	018" DIA CIRC CONCR LEN=0040 INSTALLED UNKN	0351/0170	018" DIA CIRC CONCR	INSTALLED	2009
079679 FT	1 0 00072 0 02 0411+59 079718 FT PIONEER RD (T760) LENGTH(AH 2195 BK 3061)	0351/0000	018" DIA CIRC CONCR	INSTALLED	2009
0350/0000	018" DIA CIRC CONCR LEN=0099 INSTALLED UNKN	0341/2880	018" DIA CIRC CONCR	INSTALLED	2009
0340/2198	018" DIA CIRC CONCR LEN=0099 INSTALLED UNKN	0341/2200	018" DIA CIRC CONCR	INSTALLED	2009
0340/1840	OXFORD BLVD (PRDR) TALLEY CAVEY RD (T970)	0341/1840	018" DIA CIRC CONCR	INSTALLED	2009
0340/1765	LC FROM HAMPTON SHOPPE (CONN)	0341/1765	018" DIA CIRC CONCR	INSTALLED	2009

018" DIA CIRC CONCR

DIR: N TOTAL LEN: 20.630 MI. DIST: 11-1 SR: 8
 LEFT MUN: HAMPTON T RIGHT MUN: HAMPTON T

Segment ID	Description	Stationing	Length	Material	Status	Notes
0340/1745			LEN=0040	018" DIA CIRC CONCR	INSTALLED UNKN	
0340/1710			LEN=0040	018" DIA CIRC CONCR	INSTALLED UNKN	
0341/1625	BELLA VISTA DR (T578)					
0340/1573			LEN=0040	018" DIA CIRC CONCR	INSTALLED UNKN	
0341/1480	WILDWOOD RD ET (SR4070 SEG 0140/0000)					
0340/1505	WILDWOOD RD (SR4070 SEG 0140/0000)		LEN=0040	024" DIA CIRC CONCR	INSTALLED UNKN	
0340/1313			LEN=0040	018" DIA CIRC CONCR	INSTALLED UNKN	
0340/1110			LEN=0050	018" DIA CIRC CONCR	INSTALLED UNKN	
0340/0990			LEN=0040	015" DIA CIRC CONCR	INSTALLED UNKN	
0340/0903			LEN=0022	018" DIA CIRC CONCR	INSTALLED UNKN	
0340/0670			LEN=0099		INSTALLED UNKN	
076637 FT	ANDERSON DR (T900)		076657 FT			
0341/0000	LENGTH(AH 3061 BK 2615)					
0340/0000	LENGTH(AH 3042 BK 2611)					
0331/2009	012"H 18"W ELLIP CONC		LEN=0040		INSTALLED UNKN	
0331/1842	MT ROYAL BL (SR4019 SEG 0150/3001)					
0331/1219	018" DIA CIRC CONCR		LEN=0050		INSTALLED UNKN	
0331/0391	018" DIA CIRC CONCR		LEN=0091		INSTALLED UNKN	
0331/0108	018" DIA CIRC CONCR		LEN=0099		INSTALLED UNKN	
074026 FT	CRAIGHEAD RD (T995)		074042 FT			
0331/0000	LENGTH(AH 2615 BK 3338)					
0330/0000	LENGTH(AH 2611 BK 3330)					
0321/3154	018" DIA CIRC CONCR		LEN=0050		INSTALLED UNKN	
0321/3098	CRAIGHEAD RD (T995)					
0321/2885	018" DIA CIRC CONCR		LEN=0135		INSTALLED UNKN	
0321/2775	MCCULLY RD (SR1012 SEG 0010/0000)					
0320/2995	CRAIGHEAD RD (T995)					
0320/2665	MCCULLY RD (SR1012 SEG 0010/0000)					

DIR: N TOTAL LEN: 20.630 MI. DIST: 11-1 SR: 8
 LEFT MUN: HAMPTON T RIGHT MUN: HAMPTON T

018 "DIA CIRC CONCR LEN=0099 INSTALLED UNKN	0321/2750	---	---			
018 "DIA CIRC CONCR LEN=0099 INSTALLED UNKN	0321/1410	---	---			
018 "DIA CIRC CONCR LEN=0050 INSTALLED UNKN	0321/1090	---	---			
018 "DIA CIRC CONCR LEN=0099 INSTALLED UNKN	0321/0880	---	---			
HILLCREST FARM RD (PRDR)	0321/0091		==			
1 0 00072 0 02 0323+78 070704 FT LENGTH(AH 3338 BK 3527)	0321/0000	5	==	5	070696 FT 1 0 00072 0 02 0322+08 HILLCREST FARM RD (PRDR)	
018 "DIA CIRC CONCR LEN=0099 INSTALLED UNKN	0311/3286	---	---			
HARTS RUN RD (SR1010 SEG 0010/0000)	0311/3045	00	0000	00	0310/3100	018 "DIA CIRC CONCR LEN=0050 INSTALLED UNKN HARTS RUN RD (SR1010 SEG 0010/0000)
015 "DIA CIRC CONCR LEN=0099 INSTALLED UNKN	0311/2958	---	---		0310/3076	
018 "DIA CIRC CONCR LEN=0099 INSTALLED UNKN	0311/2791	---	---		0310/2780	018 "DIA CIRC CONCR LEN=0040 INSTALLED UNKN
048 "DIA CIRC CONCR LEN=0099 INSTALLED UNKN	0311/2443	---	---		0310/2608	018 "DIA CIRC CONCR LEN=0040 INSTALLED UNKN
OLD ROUTE 8 RD (T996)	0311/2373	==	==		0310/2353	OLD ROUTE 8 RD (T996)
015 "DIA CIRC CONCR LEN=0099 INSTALLED UNKN	0311/2217	---	---			
018 "DIA CIRC CONCR LEN=0099 INSTALLED UNKN	0311/1970	---	---			
024 "DIA CIRC CONCR LEN=0099 INSTALLED UNKN	0311/1657	---	---			
018 "DIA CIRC CONCR LEN=0099 INSTALLED UNKN	0311/1416	---	---			
CLEARVIEW RD (T357)	0311/1150		==	==	0310/1110	CLEARVIEW RD (T357)
024 "DIA CIRC CONCR LEN=0099 INSTALLED UNKN	0311/1124	---	---			
BMSEN 02/0008/0310/0745	0311/0787				0310/0791	BMSEN 02/0008/0310/0745

DIR: N TOTAL LEN: 20.630 MI. DIST: 11-1 SR: 8
 LEFT MUN: HAMPTON T RIGHT MUN: HAMPTON T

Stationing	Description	Length	Material	Notes
0294+02	GOURDHEAD RN			
0310/0741	BMSBG 02/0008/0310/0745	0311/0741		
0286+76	OLD ROUTE 8 RD (T996)	067177 FT		
0311/0000	LENGTH(AH 3527 BK 2992)	0311/0000		
0301/2440	024 "DIA CIRC CONCR LEN=0040 INSTALLED UNKN	0301/2440		
0301/2135	024 "DIA CIRC CONCR LEN=0099 INSTALLED UNKN	0301/2135		
0301/2023	021 "DIA CIRC CONCR LEN=0067 INSTALLED 2016	0301/2023		
0301/1986	024 "DIA CIRC CONCR LEN=0099 INSTALLED UNKN	0301/1986		
0301/1915	DUNCAN AV (CNTY)	0301/1915		
0301/1455	MURRAY AV (TWP)	0301/1455		
0301/1425	NAYLOR AV (TWP)	0301/1425		
0301/1205	CLEVELAND ST (TWP)	0301/1205		
0301/1176	BMSEN 02/0008/0300/1095	0301/1176		
0267+67	PINE CREEK			
0301/1085	BMSBG 02/0008/0300/1095	0301/1085		
0301/0630	018 "DIA CIRC CONCR LEN=0099 INSTALLED UNKN	0301/0630		
0301/0035	(APRA) ALLISON PARK IND INDUSTRIAL DR (PRDR)	0301/0035		
0255+41	HAMPTON	064185 FT		
0301/0000	SHALER T LENGTH(AH 2992 BK 3297)	0301/0000		
0294+02	GOURDHEAD RN			
0310/0745	BMSBG 02/0008/0310/0745	0311/0741		
0310/0456	018"H 36"W CON BOX CUL LEN=0099 INSTALLED UNKN	0310/0456		
0310/0238	015 "DIA CIRC CONCR LEN=0099 INSTALLED UNKN	0310/0238		
0286+57	OLD ROUTE 8 RD (T996)	067126 FT		
0310/0000	LENGTH(AH 3570 BK 2991)	0310/0000		
0300/2570	010 "DIA CIRC CONCR LEN=0099 INSTALLED UNKN	0300/2570		
0300/2154	018 "DIA CIRC CONCR LEN=0060 INSTALLED UNKN	0300/2154		
0300/2020	021 "DIA CIRC CONCR LEN=0067 INSTALLED 2016	0300/2020		
0300/2015	015 "DIA CIRC CONCR LEN=0060 INSTALLED UNKN	0300/2015		
0300/1915	DUNCAN AV (CNTY)	0300/1915		
0300/1460	MURRAY AV (TWP)	0300/1460		
0300/1430	NAYLOR AV (TWP)	0300/1430		
0300/1230	CLEVELAND ST (TWP)	0300/1230		
0300/1186	BMSEN 02/0008/0300/1095	0300/1186		
0267+67	PINE CREEK			
0300/1095	BMSBG 02/0008/0300/1095	0300/1095		
0300/0035	(APRA) ALLISON PARK IND INDUSTRIAL DR (PRDR)	0300/0035		
0257+10	HAMPTON	064135 FT		
0300/0000	SHALER T LENGTH(AH 2991 BK 3338)	0300/0000		

DIR: N TOTAL LEN: 20.630 MI. DIST: 11-1 SR: 8
 LEFT MUN: SHALER T RIGHT MUN: SHALER T

Item Description	Stationing	Length	Material	Status
018 "DIA CIRC CONCR	0281/1096	LEN=0123	INSTALLED UNKN	
BUTLER PLANK RD (SR4060 SEG 0030/3013)	0281/0515			
018 "DIA CIRC CONCR	0281/0273	LEN=0030	INSTALLED UNKN	
BMSBN 02/0008/0280/0000 1 0 00072 0 02 0189+10 057414 FT PINE CREEK	0281/0057	057400 FT		
BMSBG 02/0008/0280/0000 LENGTH(AH 3474 BK 1977)	0281/0000			
018 "DIA CIRC CONCR	0271/1964	LEN=0040	INSTALLED UNKN	
024 "DIA CIRC CONCR	0271/0492	LEN=0099	INSTALLED UNKN	
1 0 00072 0 02 0169+55 055437 FT (APRA) V B FABRICATING SPENCER LN ET (TWP)		055416 FT		
LENGTH(AH 1977 BK 2082)	0271/0000			
024 "DIA CIRC CONCR	0261/2000	LEN=0099	INSTALLED UNKN	
SPENCER LN (TWP)	0261/1125			
0280/1187		LEN=0040	INSTALLED UNKN	
0280/0944		LEN=0040	INSTALLED UNKN	
0280/0548		LEN=0050	INSTALLED UNKN	
0280/0305		LEN=0055	INSTALLED UNKN	
0280/0220		LEN=0057	INSTALLED UNKN	
0280/0057		LEN=0000	INSTALLED UNKN	
0270/1130		LEN=0055	INSTALLED UNKN	
0270/0840		LEN=0048	INSTALLED UNKN	
0270/0610		LEN=0048	INSTALLED UNKN	
0270/0335		LEN=0099	INSTALLED UNKN	
0270/0065		LEN=0040	INSTALLED UNKN	
0270/0019		LEN=0019	INSTALLED UNKN	
0270/0000		LEN=0000	INSTALLED UNKN	
0260/1062		LEN=0062	INSTALLED UNKN	

DIR: N TOTAL LEN: 20.630 MI. DIST: 11-1 SR: 8
 LEFT MUN: SHALER T RIGHT MUN: SHALER T

PINE CREEK				PINE CREEK			
BMSBG 02/0008/0240/0248	0241/0403	0240/0356	BMSBG 02/0008/0240/0248	0240/0356	0240/0356	BMSBG 02/0008/0240/0248	0240/0356
1 0 00072 0 02 0100+45	048563 FT	048694 FT	1 0 00072 0 02 0101+58	048694 FT	048694 FT	1 0 00072 0 02 0101+58	048694 FT
LENGTH(AH 1789 BK 2893)	0241/0000	0240/0000	LENGTH(AH 2034 BK 2981)	0240/0000	0240/0000	LENGTH(AH 2034 BK 2981)	0240/0000
		0230/2370	018 "DIA CIRC CONCR			018 "DIA CIRC CONCR	
		0230/2168	LEN=0060 INSTALLED UNKN			LEN=0060 INSTALLED UNKN	
		0230/2156	018 "DIA CIRC CONCR			018 "DIA CIRC CONCR	
		0230/1800	LEN=0060 INSTALLED UNKN			LEN=0060 INSTALLED UNKN	
			018 "DIA CIRC CONCR			018 "DIA CIRC CONCR	
		0230/0928	LEN=0099 INSTALLED UNKN			LEN=0099 INSTALLED UNKN	
OLD BUTLER PLANK RD	0231/0755	0230/0765	036 "DIA CIRC CONCR			036 "DIA CIRC CONCR	
(TWP)			LEN=0099 INSTALLED UNKN			LEN=0099 INSTALLED UNKN	
018 "DIA CIRC CONCR	0231/0525		OLD BUTLER PLANK RD			OLD BUTLER PLANK RD	
LEN=0099 INSTALLED UNKN			(TWP)			(TWP)	
		0230/0513	018 "DIA CIRC CONCR			018 "DIA CIRC CONCR	
		0230/0470	LEN=0230 INSTALLED UNKN			LEN=0230 INSTALLED UNKN	
PENNVIEW ST	0231/0475		PENNVIEW ST			PENNVIEW ST	
(TWP)			(TWP)			(TWP)	
018 "DIA CIRC CONCR	0231/0305						
LEN=0099 INSTALLED UNKN							
		0230/0250	018 "DIA CIRC CONCR			018 "DIA CIRC CONCR	
			LEN=0050 INSTALLED UNKN			LEN=0050 INSTALLED UNKN	
		0230/0070	018 "DIA CIRC CONCR			018 "DIA CIRC CONCR	
		045713 FT	LEN=0070 INSTALLED UNKN			LEN=0070 INSTALLED UNKN	
1 0 00072 0 02 0071+96	045670 FT	045713 FT	1 0 00072 0 02 0072+09			1 0 00072 0 02 0072+09	
NC WILLIAM FLINN HW		NC WILLIAM FLINN HW	LENGTH(AH 2981 BK 0956)			LENGTH(AH 2981 BK 0956)	
LENGTH(AH 2893 BK 0958)	0231/0000	0230/0000	018 "DIA CIRC CONCR			018 "DIA CIRC CONCR	
		0220/0810	LEN=0035 INSTALLED UNKN			LEN=0035 INSTALLED UNKN	
018 "DIA CIRC CONCR	0221/0792						
LEN=0040 INSTALLED UNKN							
SHOP & SAVE LOT	0221/0577		SHOP & SAVE LOT			SHOP & SAVE LOT	
(PRDR)			(PRDR)			(PRDR)	
		0220/0576					
018 "DIA CIRC CONCR	0221/0065						
LEN=0099 INSTALLED UNKN							
1 0 00072 0 02 0062+50	044712 FT	044757 FT	1 0 00072 0 02 0062+24			1 0 00072 0 02 0062+24	
SAXONBURG BL		SAXONBURG BL	SAXONBURG BL			SAXONBURG BL	
(SR1013 SEG 0010/0000)		(SR1013 SEG 0010/0000)	(SR1013 SEG 0010/0000)			(SR1013 SEG 0010/0000)	
		0220/0000					
LENGTH(AH 0958 BK 1488)	0221/0000	0220/0000	LENGTH(AH 0956 BK 1924)			LENGTH(AH 0956 BK 1924)	

DIR: N TOTAL LEN: 20.630 MI. DIST: 11-1 SR: 8
 LEFT MUN: SHALER T RIGHT MUN: SHALER T

Segment Description	Stationing	Notes	Stationing	Notes
018 "DIA CIRC CONCR LEN=0099 INSTALLED UNKN	0211/1424		0210/1885	TO 1013/0010 SH (CONN)
BMSBG 02/0008/0210/0974 1 0 00072 0 02 0059+31 PINE CREEK	0211/1265		0210/1753	BMSBG 02/0008/0210/0974 1 0 00072 0 02 0059+31 PINE CREEK
BMSBG 02/0008/0210/0974 BMSEN 02/0008/0210/0471 1 0 00072 0 02 0054+26 PINE CREEK	0211/1198 0211/0802		0210/1686 0210/1294	BMSBG 02/0008/0210/0974 BMSEN 02/0008/0210/0471 1 0 00072 0 02 0059+31 PINE CREEK
BMSBG 02/0008/0210/0471 024 "DIA CIRC CONCR LEN=0030 INSTALLED UNKN	0211/0691 0211/0397		0210/1183	BMSBG 02/0008/0210/0471
CHARLES ST (TWP)	0211/0241		0210/0851	024 "DIA CIRC CONCR LEN=0060 INSTALLED UNKN CHARLES ST
			0210/0698	(TWP)
			0210/0590	018 "DIA CIRC CONCR LEN=0099 INSTALLED UNKN
			0210/0269	018 "DIA CIRC CONCR LEN=0050 INSTALLED UNKN
			0210/0138	SHALER ETNA BOROUGH B
1 0 00072 0 02 0049+66 043224 FT LENGTH(AH 1488 BK 2454) SHALER	0211/0000		0210/0081	018 "DIA CIRC CONCR LEN=0050 INSTALLED UNKN
ETNA BOROUGH B	0201/2362		042833 FT 1 0 00072 0 02 0049+66 0210/0000	LENGTH(AH 1924 BK 2000)
018 "DIA CIRC CONCR LEN=0099 INSTALLED UNKN	0201/1753			
018 "DIA CIRC CONCR LEN=0338 INSTALLED UNKN	0201/0937			
CATHERINE ST (BORO) GRANT AV (SR4017 SEG 0004/0000)	0201/0800		0200/0757	CATHERINE ST (BORO) GRANT AV (SR4017 SEG 0004/0000)
018 "DIA CIRC CONCR LEN=0080 INSTALLED UNKN	0201/0437		0200/0500	018 "DIA CIRC CONCR LEN=0050 INSTALLED UNKN
SR 9405 SH (SR9405 SEG 0010/0000)	0201/0391		0200/0425	018 "DIA CIRC CONCR LEN=0050 INSTALLED UNKN
				018 "DIA CIRC CONCR

DIR: N TOTAL LEN: 20.630 MI. DIST: 11-1 SR: 8
 LEFT MUN: ETNA BOROUGH B RIGHT MUN: ETNA BOROUGH B

1 0 00072 0 00 0023+58 040770 FT
 KITTANNING ST
 (SR1003 SEG 0101/0000)
 (SR1003 SEG 0100/0000)

LENGTH(AH 2454 BK 2443) 0201/0000
 FROM 1003/0101 SH 0191/2343
 (CONN)
 SIGN: 2 CHORD TRUSS
 BMSID 02/0008/0191/1750 0191/1750

SIGN: 2 CHORD TRUSS
 BMSID 02/0008/0191/0944 0191/0944

1 0 00072 3 00 0013+50 038327 FT
 RAMP RD
 (SR8042 SEG 0510/0000)
 NC BUTLER ST
 LENGTH(AH 2443 BK 3296) 0191/0000
 SIGN: 2 CHORD TRUSS
 BMSID 02/0008/0181/3250 0181/3283
 RAMP RD
 (SR8042 SEG 0762/0000) 0181/3242

RAMP 8042 NB
 OP ID 02/8042/0260/0409 0181/3117
 BMSEN 02/0008/0181/2418 0181/3116
 TR 28 S.B.
 OP ID 02/0028/0141/0000 0181/2804
 ALLEGHENY VAL EXPY
 OP ID 02/0028/0140/0000 0181/2686
 RAMP X RD
 (SR8042 SEG 0270/0000) 0181/2500

2 0 02260 5 00 0022+90
 TR28N OFF RP
 BMSBG 02/0008/0181/2418 0181/2418
 BMSEN 02/0008/0180/0048 0181/2176

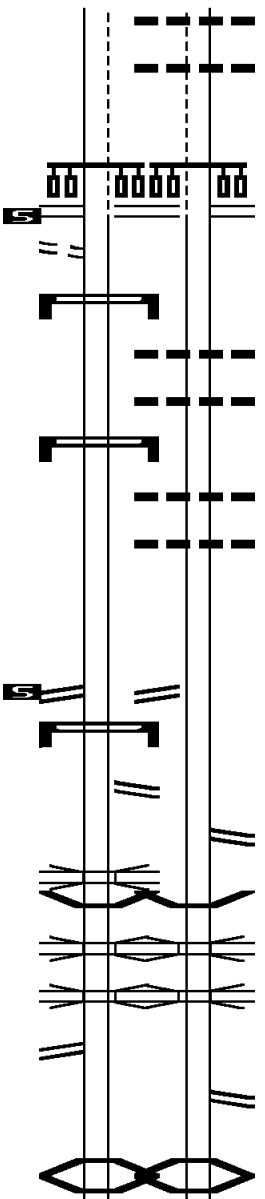

0200/0280 LEN=0082 INSTALLED UNKN
 018 "DIA CIRC CONCR
 0200/0198 LEN=0026 INSTALLED UNKN
 040833 FT 1 0 00072 0 00 0023+58
 KITTANNING ST
 (SR1003 SEG 0101/0000)
 (SR1003 SEG 0100/0000)

0200/0000 LENGTH(AH 2000 BK 2515)
 0190/1562 024 "DIA CIRC CONCR
 LEN=0040 INSTALLED UNKN
 0190/1095 036 "DIA CIRC CONCR
 LEN=0040 INSTALLED UNKN

0190/0867 018 "DIA CIRC CONCR
 LEN=0030 INSTALLED UNKN
 0190/0630 018 "DIA CIRC CONCR
 LEN=0040 INSTALLED UNKN

038318 FT 1 0 00072 3 00 0010+14
 RAMP RD
 (SR8042 SEG 0260/0949)
 NC BUTLER ST
 LENGTH(AH 2515 BK 3304)

0190/0000 RAMP RD
 (SR8042 SEG 0752/0642)

0180/3214 BMSEN 02/0008/0180/2416
 TR 28 S.B.

0180/2839 OP ID 02/0028/0141/0000

0180/2717 OP ID 02/0028/0140/0000

0180/2505 RAMP Y RD
 (SR8042 SEG 0012/0414)
 2 0 02260 5 00 0022+94
 OLD RT 28

0180/2442 BMSBG 02/0008/0180/2416

0180/2154 BMSEN 02/0008/0180/0048

DIR: N TOTAL LEN: 20.630 MI. DIST: 11-1 SR: 8
 LEFT MUN: PITTSBURGH C RIGHT MUN: PITTSBURGH C

BAKER ST (CITY)	0150/0000		0150/0000	MFC BEGIN = B LENGTH(AH 2806 BK 1137)
BMS EN 02/0008/0144/0896 0 0 0000 0 00 0000+00 NO UNDERPASS INFORMATIO BMSBG 02/0008/0144/0896	0145/1037		0144/1037	BMS EN 02/0008/0144/0896 2 0 02260 0 00 0253+51 NO UNDERPASS INFORMATIO BMSBG 02/0008/0144/0896
	0145/0818		0144/0818	NC BUTLER ST ONE WILD PL (CITY)
NC BUTLER ST SIGN: CANTILEVER BMSID 02/0008/0140/1928	0145/0490		0144/0557	
0 0 00000 0 00 0000+00 028921 FT HIGHLAND PK BR (SR1005 SEG 0010/0000) HIGHLAND PARK BR (SR1005 SEG 0010/0000) MFC BEGIN = B LENGTH(AH 1137 BK 1827)	0145/0000		0144/0079	095"H 95"W **UNKNOWN** LEN=0079 INSTALLED UNKN
	0145/0000		028904 FT	0 0 00000 0 00 0000+00 MFC BEGIN = B LENGTH(AH 1137 BK 1827)
	0140/1024		0144/0000	RAMP C RD (SR8082 SEG 0010/0715) 018"H 18"W **UNKNOWN** LEN=0060 INSTALLED UNKN 018"H 18"W **UNKNOWN** LEN=0099 INSTALLED UNKN 018"H 09"W **UNKNOWN** LEN=0060 INSTALLED UNKN
HIGHLAND PARK BR (SR1005 SEG 0011/0000)	0140/1024		0140/1649	SR 1005 NB (RAMP E OP ID 02/1005/0010/0823 018 "DIA CIRC CONCR LEN=0040 INSTALLED UNKN
	0140/1024		0140/1254	RAMP D RD (SR8082 SEG 0750/0000) SIGN: CANTILEVER
	0140/0839		0140/1253	BMSID 02/0008/0140/0423 2 0 02260 0 00 0253+51 MFC BEGIN = B LENGTH(AH 1827 BK 0740)
	0140/0389		0140/1060	
	027094 FT		0140/0243	
	0131/0580		027077 FT	
018 "DIA CIRC CONCR LEN=0099 INSTALLED UNKN TO 0008/0121 SH (CONN)	0131/0165		0140/0000	
018 "DIA CIRC CONCR LEN=0050 INSTALLED UNKN 2 0 02260 0 00 0264+50 026339 FT NC ALLEGHENY RIVER BL	0131/0155		026337 FT	2 0 02260 0 00 0264+50 NC ALLEGHENY RIVER BL

DIR: N TOTAL LEN: 20.630 MI. DIST: 11-1 SR: 8
 LEFT MUN: PITTSBURGH C RIGHT MUN: PITTSBURGH C

Left Side Description	Left Side Stationing	Right Side Stationing	Right Side Description
ALLEGHENY RIVER BL (SR0130 SEG 0012/0000) LENGTH(AH 0755 BK 3105) FROM 0008/0131 SH (CONN)	0131/0000 0121/2951	0130/0000 0120/2879	ALLEGHENY RIVER BL (SR0130 SEG 0012/0000) LENGTH(AH 0740 BK 3100) TO 0130/0012 SH (CONN) DRAINAGE STRUCTURE LENGTH 7 FT BMSID 02/0008/0120/2308 018 "DIA CAST IRON LEN=0030 INSTALLED UNKN
024 "DIA CIRC METAL LEN=0048 INSTALLED UNKN	0121/1955	0120/1957	018 "DIA CIRC CONCR LEN=0055 INSTALLED UNKN
024 "DIA CIRC METAL LEN=0048 INSTALLED UNKN	0121/1375	0120/1820	018 "DIA CIRC CONCR LEN=0040 INSTALLED UNKN
DRIVER EXAM CTR (GOVT)	0121/0630	0120/0630	DRIVER EXAM CTR (GOVT)
2 0 02337 0 00 0086+94 LENGTH(AH 3105 BK 0973) (APRA) SHUMAN CENTER VA DRIVER EXAM STATION DR (GOVT) HIGHLAND DR (LEECH FARM (CITY)	023234 FT 0121/0000	0120/0050 023237 FT 0120/0000	018 "DIA CIRC CONCR LEN=0040 INSTALLED UNKN 2 0 02337 0 00 0086+56 LENGTH(AH 3100 BK 1065) (APRA) SHUMAN CENTER VA HACP POLICE HDQTRS (GOVT) HIGHLAND DR (LEECH FARM (CITY)
HACP POLICE HDQTRS (GOVT)	0111/0432 0111/0231	0110/0510	
2 0 02337 0 00 0078+59 LENGTH(AH 0973 BK 1851) 036"H 24"W UNKN METAL LEN=0048 INSTALLED UNKN 024 "DIA CIRC METAL LEN=0048 INSTALLED UNKN POLICE FIRE CTR EXIT (CITY)	022261 FT 0111/0000 0101/1830 0101/1545 0101/1185	0110/0062 022172 FT 0110/0000	018 "DIA CIRC CONCR LEN=0040 INSTALLED UNKN 2 0 02337 0 00 0075+36 LENGTH(AH 1065 BK 1794)
NEGLEY RUN BL (CITY)	0101/0835	0100/1204 0100/0920 0100/0854	POLICE FIRE CTR EXIT (CITY) 015 "DIA CIRC CONCR LEN=0099 INSTALLED UNKN NEGLEY RUN BL (CITY)

DIR: N TOTAL LEN: 20.630 MI. DIST: 11-1 SR: 8
 LEFT MUN: PITTSBURGH C RIGHT MUN: PITTSBURGH C

Stationing	Structure	Stationing	Structure
2 0 02337 0 00 0058+67 020410 FT		0100/0590	018" DIA CIRC CONCR
LENGTH(AH 1851 BK 3791) 0101/0000			LEN=0491 INSTALLED UNKN
LARIMER AVE		0100/0265	018" DIA CIRC CONCR
OP ID 02/7301/0000/3047 0091/3570			LEN=0265 INSTALLED UNKN
		020378 FT	2 0 02337 0 00 0058+16
		0100/0000	LENGTH(AH 1794 BK 3766)
			LARIMER AVE
		0090/3545	OP ID 02/7301/0000/3047
LINCOLN AVE			LINCOLN AVE
OP ID 02/7301/0000/3048 0091/1602		0090/1602	OP ID 02/7301/0000/3048
SILVER LAKE DR			SILVER LAKE DR
(CITY)		0090/1485	(CITY)
SHETLAND ST			SHETLAND ST
(CITY)		0090/0470	(CITY)
HUDSON PL			HUDSON PL
(PRDR)		0090/0335	(PRDR)
2 0 02337 0 00 0020+89 016619 FT			
FRANKSTOWN AV		016612 FT	2 0 02337 0 00 0020+89
(CITY)			NC WASHINGTON BL
NC WASHINGTON BL			FRANKSTOWN AV
FRANKSTOWN AV			(CITY)
(CITY)			
LENGTH(AH 3791 BK 2089) 0091/0000		0090/0000	LENGTH(AH 3766 BK 2107)
			018"H 24"W CON BOX CUL
		0080/2043	LEN=0010 INSTALLED UNKN
TRANSIT WAY			TRANSIT WAY
(CITY)		0080/1950	(CITY)
KELLY ST			KELLY ST
(CITY)		0080/1870	(CITY)
FORMOSA WAY			FORMOSA WAY
(CITY)		0080/1690	(CITY)
HAMILTON AV			HAMILTON AV
(CITY)			(CITY)
		0080/1516	NORFOLK SOUTHERN
NORFOLK SOUTHERN			OVERPASS IS RR X-ING
OVERPASS IS RR X-ING		0080/1317	NATIONAL RAILROAD PASSE
NATIONAL RAILROAD PASSE			OVERPASS IS RR X-ING
OVERPASS IS RR X-ING		0080/1258	NORFOLK SOUTHERN
NORFOLK SOUTHERN			OVERPASS IS RR X-ING
OVERPASS IS RR X-ING		0080/1197	OVERPASS IS RR X-ING
OVERPASS IS RR X-ING			SIMONTON ST
SIMONTON ST		0080/1140	(CITY)
(CITY)			

EXTRACT DATE: 12/21/2020
PRINT DATE: 12/23/2020

ROADWAY MANAGEMENT SYSTEM
SLD COUNTY/SR - ANNUAL PRINT

PAGE NUMBER: 5
COUNTY: ALLEGHENY

DIR: N TOTAL LEN: 20.630 MI.
LEFT MUN: PITTSBURGH C

DIST: 11-1 SR: 8
RIGHT MUN: PITTSBURGH C

Stationing	Description	Stationing	Description
0081/0820	MCPHERSON BL (CITY)	0080/0825	MCPHERSON BL (CITY)
012"H 36"W UNKN CONC LEN=0099 INSTALLED UNKN			
0081/0745	THOMAS BL (CITY)	0080/0435	THOMAS BL (CITY)
0081/0435	JUNE WY (CITY)	0080/0215	JUNE WY (CITY)
0081/0220	2 0 02337 0 00 0000+00 014530 FT	0080/0215	2 0 02337 0 00 0000+00 014505 FT
014530 FT	PENN AV (SR0400 SEG 0097/1135) (SR0400 SEG 0096/1121) NC FIFTH AV	014505 FT	PENN AV (SR0400 SEG 0096/1121) (SR0400 SEG 0097/1135) NC FIFTH AV
	FIFTH AV (CITY)		FIFTH AV (CITY)
0081/0000	LENGTH(AH 2089 BK 1515)	0080/0000	LENGTH(AH 2107 BK 1507)
0071/1400	LC FROM FIFTH AV (CONN)	0070/1438	012"DIA CIR PLASTIC LEN=0099 INSTALLED UNKN
0071/1315	024"DIA CIRC CONCR LEN=0040 INSTALLED UNKN	0070/1110	018"DIA CIRC METAL LEN=0040 INSTALLED UNKN
0071/1085	012"DIA CIRC CONCR LEN=0005 INSTALLED UNKN	0070/1070	POINT BREEZE PL (CITY)
0071/1075	POINT BREEZE PL (CITY)	0070/0740	LINDEN AV (CITY)
0071/0745	LINDEN AV (CITY)	0070/0720	018"H 48"W CON BOX CUL LEN=0050 INSTALLED UNKN
0071/0709	024"H 36"W CON BOX CUL LEN=0040 INSTALLED UNKN	0070/0050	015"H 36"W CON BOX CUL LEN=0015 INSTALLED UNKN
0071/0044	015"H 24"W CON BOX CUL LEN=0040 INSTALLED UNKN	012998 FT	1 0 00228 0 04 0330+98
013015 FT	0 0 00000 0 00 0000+00 013015 FT		SOUTH DALLAS AV (SR2108 SEG 0150/1995) NORTH DALLAS AV (SR0400 SEG 0120/0000)
013015 FT	SOUTH DALLAS AV (SR2108 SEG 0150/1995) NORTH DALLAS AV (SR0400 SEG 0120/0000)		
0071/0000	LENGTH(AH 1515 BK 2086)	0070/0000	LENGTH(AH 1507 BK 2084) 018"H 36"W CON BOX CUL

DIR: N TOTAL LEN: 20.630 MI. DIST: 11-1 SR: 8
 LEFT MUN: PITTSBURGH C RIGHT MUN: PITTSBURGH C

STREET	OFFICIAL ID	STATUS	LENGTH	DESCRIPTION	OFFICIAL ID	STATUS	LENGTH	DESCRIPTION
MURTLAND ST (CITY)	0065/1520	==	0064/1790	LEN=0050 INSTALLED UNKN	0064/1790	LEN=0050	INSTALLED UNKN	018"H 36"W CON BOX CUL
MURTLAND ST (CITY)	0065/1355	==	0064/1585	LEN=0050 INSTALLED UNKN	0064/1585	LEN=0050	INSTALLED UNKN	MURTLAND ST (CITY)
018"H 48"W CON BOX CUL LEN=0010 INSTALLED UNKN	0065/1050	---	0064/1360	(CITY)	0064/1360	(CITY)		MURTLAND ST (CITY)
LANG AV (CITY)	0065/0740	==	0064/0735	LANG AV (CITY)	0064/0735			
OSAGE LN (CITY)	0065/0355	==	0064/0355	OSAGE LN (CITY)	0064/0355			
024"H 24"W CON BOX CUL LEN=0048 INSTALLED UNKN	0065/0271	---	0064/0295	018"H 36"W CON BOX CUL LEN=0050 INSTALLED UNKN	0064/0295			
018"H 36"W CON BOX CUL LEN=0015 INSTALLED UNKN	0065/0020	---	0064/0040	018"H 36"W CON BOX CUL LEN=0030 INSTALLED UNKN	0064/0040			
1 0 00120 0 01 0352+43 010929 FT HOMWOOD AV (CITY)			010914 FT	1 0 00120 0 01 0346+15 HOMWOOD AV (CITY)				
LENGTH(AH 2086 BK 2324) LEXINGTON ST (CITY)	0065/0000	==	0064/0000	LENGTH(AH 2084 BK 2321) LEXINGTON ST (CITY)	0064/0000			
LEXINGTON AV (CITY)	0061/1841	==	0060/1841	LEXINGTON AV (CITY)	0060/1841			
018"H 48"W CON BOX CUL LEN=0099 INSTALLED UNKN	0061/1603	---	0060/1781	LEXINGTON AV (CITY)	0060/1781			
CARNEGIE PL (CITY)	0061/1376	==	0060/1556	018"H 36"W CON BOX CUL LEN=0050 INSTALLED UNKN	0060/1556			
PENFIELD CT (CITY)	0061/1136	==	0060/1376	CARNEGIE PL (CITY)	0060/1376			
018"H 36"W CON BOX CUL LEN=0099 INSTALLED UNKN	0061/1089	---	0060/1136	PENFIELD CT (CITY)	0060/1136			
RICHLAND LN (PRDR)	0061/0886	==	0060/0921	012 " DIA CIRC CONCR LEN=0036 INSTALLED UNKN	0060/0921			
			0060/0886	RICHLAND LN (PRDR)	0060/0886			
			0060/0831	095"H 95"W **UNKNOWN** LEN=0050 INSTALLED UNKN	0060/0831			
			0060/0481	012"H 36"W CON BOX CUL LEN=0025 INSTALLED UNKN	0060/0481			

EXTRACT DATE: 12/21/2020
PRINT DATE: 12/23/2020

ROADWAY MANAGEMENT SYSTEM
SLD COUNTY/SR - ANNUAL PRINT

PAGE NUMBER: 3
COUNTY: ALLEGHENY

DIR: N TOTAL LEN: 20.630 MI.
LEFT MUN: PITTSBURGH C

DIST: 11-1 SR: 8
RIGHT MUN: PITTSBURGH C

BRADDOCK AV
(CITY)

0061/0451



0060/0451

BRADDOCK AV
(CITY)

EAST END AV
(BORO)

0061/0092

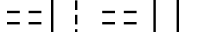

0060/0154

012"H 12"W **UNKNOWN**
LEN=0099 INSTALLED UNKN
EAST END AV
(BORO)

012"H 60"W CON BOX CUL
LEN=0015 INSTALLED UNKN
1 0 00120 0 01 0371+16 008605 FT

BRUSHTON AV
(BORO)

0061/0000

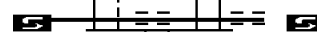

008593 FT

1 0 00120 0 01 0370+59

MFC BEGIN = B
LENGTH(AH 2324 BK 2714)

PEEBLES ST
(BORO)

0050/2435

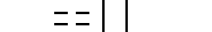

0060/0000

BRUSHTON AV
(BORO)
MFC BEGIN = B
LENGTH(AH 2321 BK 2714)
PITTSBURGH
WILKINSBURG B

0050/2563

WEST ST
(BORO)

0050/1460



0050/2050

018" DIA CIRC CONCR
LEN=0025 INSTALLED UNKN
TRENTON AV
(BORO)

PENNWOOD AV
(BORO)

0050/1030



0050/1985

BMS EN 02/0008/0050/1716
1 0 00120 0 01 0379+46
DAULS RUN

0050/1729

SAWYER WY

0050/1716

BMS BG 02/0008/0050/1716
012"H 12"W **UNKNOWN**
LEN=0020 INSTALLED UNKN
095"H 95"W **UNKNOWN**
LEN=0099 INSTALLED UNKN

0050/1695

0050/1687

0050/1460

012"H 12"W **UNKNOWN**
LEN=0050 INSTALLED UNKN
024" DIA CIRC CONCR
LEN=0099 INSTALLED UNKN

0050/1425

0050/1060

0050/0964

NATIONAL RAILROAD PASSE
OVERPASS IS RR X-ING
018" DIA CIRC CONCR
LEN=0099 INSTALLED UNKN

0050/0963

0050/0914

PORT AUTHORITY BUS
OP ID 02/0008/0050/0914
PAT BSWY9608

0050/0831

0050/0778

OP ID 02/7478/0000/9608
PITT ST
(BORO)

DIR: N TOTAL LEN: 20.630 MI. DIST: 11-1 SR: 8
 LEFT MUN: WILKINSBURG B RIGHT MUN: WILKINSBURG B

Segment Description	Segment ID	Length (FT)	Notes
(BORO)	0050/0727		
LC TO SAWYER WY	0050/0650		
(CONN)	0050/0650		
	0050/0340	005891 FT	HAY ST (BORO)
	0050/0000		WOOD ST (BORO)
	0040/1615		LENGTH(AH 2714 BK 1637) 012"H 12"W **UNKNOWN**
	0040/1613		LEN=0050 INSTALLED UNKN 095"H 95"W **UNKNOWN**
	0040/1270		LEN=0099 INSTALLED UNKN ALLEY (BORO)
	0040/1100		018 "DIA CIRC CONCR LEN=0099 INSTALLED UNKN
	0040/0830		018 "DIA CIRC CONCR LEN=0030 INSTALLED UNKN
	0040/0782		CENTER ST (BORO)
	0040/0415	004254 FT	MILL ST (BORO)
	0040/0000		1 0 00120 0 01 0413+86 COAL ST (BORO)
	0040/0000		LENGTH(AH 1637 BK 2258) SWISSVALE AV (SR2058 SEG 0011/0000) (SR2058 SEG 0010/0000)
SWISSVALE AV (BORO)	0030/1760		015 "DIA CIRC CONCR LEN=0030 INSTALLED UNKN
STONER WAY (BORO)	0030/1470		
	0030/1365		MONTIER ST (BORO)
	0030/1130		PENN AV (SR2110 SEG 0010/0000)
ROSS AV (BORO)	0030/1055		
SOUTH AV (BORO)	0030/0455		
	0030/0040		NC PENN AV 012 "DIA CIRC CONCR LEN=0080 INSTALLED UNKN

EXTRACT DATE: 12/21/2020
PRINT DATE: 12/23/2020

ROADWAY MANAGEMENT SYSTEM
SLD COUNTY/SR - ANNUAL PRINT

PAGE NUMBER: 1
COUNTY: ALLEGHENY

DIR: N TOTAL LEN: 20.630 MI.
LEFT MUN: WILKINSBURG B

DIST: 11-1 SR: 8
RIGHT MUN: WILKINSBURG B

FRANKLIN AV
(BORO)

0030/0011
001996 FT

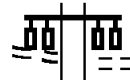

0030/0011
001984 FT

FRANKLIN AV
(BORO)

0030/0000

1 0 00120 0 01 0431+92
MFC BEGIN = B
LENGTH(AH 2258 BK 1984)

(BORO)
FRANKLIN AV
(BORO)

0011/1995

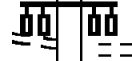

018 "DIA CIRC CONCR
LEN=0099 INSTALLED UNKN 0011/1977

0010/1975

012 "DIA CIRC CONCR
LEN=0100 INSTALLED UNKN

018 "DIA CIRC CONCR
LEN=0099 INSTALLED UNKN 0011/1871



HAZEL WAY
(BORO) 0011/1865

0010/1864

HAZEL WAY
(BORO)

012 "DIA CIRC CONCR
LEN=0099 INSTALLED UNKN 0011/1589



REBECCA AV
(BORO) 0011/1578

0010/1554

REBECCA AV
(BORO)

MARLBORO AV
(BORO) 0011/0920



BRINTON RD
(SR2120 SEG 0020/1810) 0011/0840

0010/0920

012 "DIA CIRC CONCR
LEN=0060 INSTALLED UNKN
MARLBORO AV
(BORO)
BRINTON RD
(SR2120 SEG 0020/1810)

SIGN: CANTILEVER
BMSID 02/0008/0011/0840 0011/0785



RAMP C RD
(SR8012 SEG 0270/0000) 0011/0317

0010/0460

CHANNEL 4 TV ENT
(PRDR)

RAMP A (B012) WB T
OP ID 02/8012/0750/1423 0011/0317



0010/0413

018 "DIA CIRC CONCR
LEN=0280 INSTALLED UNKN
RAMP A (B012) WB T

1 0 00120 0 01 0456+05 000000 FT

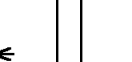

NC ARDMORE BL
LINCOLN HW
(SRO030 SEG 0170/0000) REF-BK

0010/0130

018 "DIA CIRC CONCR
LEN=0350 INSTALLED UNKN

MFC BEGIN = B
LENGTH(AH 1996 BK 0000) 0011/0000

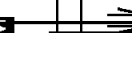

000000 FT

1 0 00120 0 01 0456+05
PARKWAY EAST

NC ARDMORE BL

OP ID 02/0376/0774/2445
LINCOLN HW

REF-BK

(SRO030 SEG 0171/0000)

0010/0000

MFC BEGIN = B
LENGTH(AH 1984 BK 0000)