

Differential Pressure and
Pressure Transmitters

EJ□110□, EJ□120□,
EJ□130□, EJ□310□,
EJ□430□, and EJ□440□

DPharp **EJX**[®]

DPharp **EJA**[®]

IM 01C25B01-01E

vigilantplant[®]

DPharp
FOR THE DIGITAL WORLD

Differential Pressure and Pressure Transmitters

EJ□110□, EJ□120□, EJ□130□,
EJ□310□, EJ□430□, and EJ□440□

IM 01C25B01-01E 15th Edition

Contents

1.	Introduction.....	1-1
	■ Regarding This Manual.....	1-1
	1.1 Safe Use of This Product	1-2
	1.2 Warranty.....	1-3
	1.3 ATEX Documentation	1-4
2.	Handling Cautions.....	2-1
	2.1 Model and Specifications Check.....	2-1
	2.2 Unpacking.....	2-1
	2.3 Storage	2-1
	2.4 Selecting the Installation Location	2-2
	2.5 Pressure Connection.....	2-2
	2.6 Waterproofing of Cable Conduit Connections	2-2
	2.7 Restrictions on Use of Radio Transceivers	2-2
	2.8 Insulation Resistance and Dielectric Strength Test.....	2-2
	2.9 Installation of an Explosion-Protected Instrument.....	2-3
	2.9.1 FM Approval.....	2-4
	2.9.2 CSA Certification.....	2-6
	2.9.3 ATEX Certification.....	2-8
	2.9.4 IECEx Certification.....	2-12
	2.10 EMC Conformity Standards.....	2-14
	2.11 Pressure Equipment Directive (PED)	2-14
	2.12 Safety Requirement Standards	2-15
3.	Component Names	3-1
4.	Installation.....	4-1
	4.1 Precautions	4-1
	4.2 Mounting	4-1
	4.3 Changing the Process Connection.....	4-2
	4.4 Swapping the High/Low-pressure Side Connection.....	4-3
	4.4.1 Rotating Pressure-detector Section 180°	4-3
	4.4.2 Using the Communicator	4-3
	4.5 Rotating Transmitter Section.....	4-4
	4.6 Changing the Direction of Integral Indicator	4-4

5.	Installing Impulse Piping	5-1
5.1	Impulse Piping Installation Precautions	5-1
5.1.1	Connecting Impulse Piping to a Transmitter	5-1
5.1.2	Routing the Impulse Piping	5-3
5.2	Impulse Piping Connection Examples	5-4
6.	Wiring	6-1
6.1	Wiring Precautions	6-1
6.2	Selecting the Wiring Materials	6-1
6.3	Connections of External Wiring to Terminal Box	6-1
6.3.1	Power Supply Wiring Connection	6-1
6.3.2	External Indicator Connection	6-2
6.3.3	Communicator Connection	6-2
6.3.4	Check Meter Connection	6-2
6.3.5	Status Output Connection	6-3
6.4	Wiring	6-3
6.4.1	Loop Configuration	6-3
6.4.2	Wiring Installation	6-4
6.5	Grounding	6-5
6.6	Power Supply Voltage and Load Resistance	6-5
7.	Operation	7-1
7.1	Preparation for Starting Operation	7-1
7.2	Zero Point Adjustment	7-3
7.2.1	Adjusting Zero Point for Differential Pressure Transmitters	7-3
7.2.2	Adjusting Zero Point for Gauge/Absolute Pressure Transmitters	7-3
7.3	Starting Operation	7-4
7.4	Shutting Down the Transmitter	7-4
7.5	Venting or Draining Transmitter Pressure-detector Section	7-5
7.5.1	Draining Condensate	7-5
7.5.2	Venting Gas	7-5
7.6	Local Parameter Setting	7-5
7.6.1	Local Parameter Setting (LPS) Overview	7-6
7.6.2	Activating Local Parameter Setting	7-7
7.6.3	Parameter Setting Review	7-7
7.6.4	Tag Number Configuration	7-8
7.6.5	Pressure Unit Configuration	7-8
7.6.6	Pressure LRV/URV Configuration	7-8
7.6.7	Damping Time Constant Configuration	7-9
7.6.8	Output Mode Configuration	7-9
7.6.9	Display Out 1 Configuration	7-9
7.6.10	Re-range by applying actual pressure (LRV/URV)	7-9
7.6.11	Save or Cancel	7-10
7.6.12	Abort Configuration	7-10

	7.6.12.1	Abort Configuration (Menu)	7-10
	7.6.12.2	Abort Configuration (Parameter)	7-10
	7.6.13	Local Parameter Setting Lock	7-10
	7.6.14	Others	7-10
8.	Maintenance		8-1
	8.1	Overview	8-1
	8.2	Calibration Instruments Selection	8-1
	8.3	Calibration	8-1
	8.4	Disassembly and Reassembly	8-3
	8.4.1	Replacing the Integral Indicator	8-3
	8.4.2	Replacing the CPU Board Assembly	8-4
	8.4.3	Cleaning and Replacing the Capsule Assembly	8-4
	8.4.4	Replacing the Process Connector Gaskets	8-6
	8.5	Troubleshooting	8-6
	8.5.1	Basic Troubleshooting	8-6
	8.5.2	Troubleshooting Flowcharts	8-7
	8.5.3	Alarms and Countermeasures	8-9
9.	General Specifications		9-1
	9.1	Standard Specifications	9-1
	9.2	Model and Suffix Codes	9-6
	9.3	Optional Specifications	9-19
	9.4	Dimensions	9-22

Revision Information

When using the Transmitters in a Safety Instrumented Systems(SIS) application, refer to Appendix A in either IM 01C25T01-06EN for the HART protocol or IM 01C25T03-01E for the BRAIN protocol.

1. Introduction

Thank you for purchasing the DPharp Differential Pressure and pressure transmitter.

Your transmitter was precisely calibrated at the factory before shipment. To ensure both safety and efficiency, please read this manual carefully before you operate the instrument.



NOTE

This manual describes the hardware configurations of the transmitters listed in below. For information on the software configuration and operation, please refer to either IM 01C25T03-01E for the BRAIN communication type, or IM 01C25T01-06EN for the HART communication type.

For FOUNDATION Fieldbus protocol type, please refer to IM 01C25T02-01E.

For PROFIBUS PA protocol type, please refer to IM 01C25T04-01EN.

Model	Style code
EJX110A	S3
EJX120A	S1
EJX130A	S2
EJX310A	S2
EJX430A	S2
EJX440A	S2
EJA110E	S1
EJA120E	S1
EJA130E	S1
EJA310E	S1
EJA430E	S1
EJA440E	S1

To ensure correct use of this instrument, read both the hardware and software manuals thoroughly before use.



WARNING

When using the transmitters in a Safety Instrumented Systems (SIS) application, refer to Appendix 1 in either IM 01C25T01-06EN for the HART protocol or IM 01C25T03-01E for the BRAIN protocol. The instructions and procedures in this section must be strictly followed in order to maintain the transmitter for this safety level.



NOTE

When describing the model name like EJ□110□, it shows the applicability for both EJX110A and EJA110E. The same representations are used for the other models, too.



NOTE

Unless otherwise stated, the illustrations in this manual are of the EJ□110□ differential pressure transmitter. Users of the other models should bear in mind that certain features of their instrument will differ from those shown in the illustrations of the EJ□110□.

■ Regarding This Manual

- This manual should be provided to the end user.
- The contents of this manual are subject to change without prior notice.
- All rights reserved. No part of this manual may be reproduced in any form without Yokogawa's written permission.
- Yokogawa makes no warranty of any kind with regard to this manual, including, but not limited to, implied warranty of merchantability and fitness for a particular purpose.
- If any question arises or errors are found, or if any information is missing from this manual, please inform the nearest Yokogawa sales office.
- The specifications covered by this manual are limited to those for the standard type under the specified model number break-down and do not cover custom-made instruments.
- Please note that changes in the specifications, construction, or component parts of the instrument may not immediately be reflected in this manual at the time of change, provided that postponement of revisions will not cause difficulty to the user from a functional or performance standpoint.

- Yokogawa assumes no responsibilities for this product except as stated in the warranty.
- If the customer or any third party is harmed by the use of this product, Yokogawa assumes no responsibility for any such harm owing to any defects in the product which were not predictable, or for any indirect damages.
- The following safety symbols are used in this manual:



WARNING

Indicates a potentially hazardous situation which, if not avoided, could result in death or serious injury.



CAUTION

Indicates a potentially hazardous situation which, if not avoided, may result in minor or moderate injury. It may also be used to alert against unsafe practices.



IMPORTANT

Indicates that operating the hardware or software in this manner may damage it or lead to system failure.



NOTE

Draws attention to information essential for understanding the operation and features.

— Direct current

⊥ Functional grounding terminal

⚠ Caution

This symbol indicates that the operator must refer to an explanation in the user’s manual in order to avoid the risk of injury or death of personnel or damage to the instrument.

1.1 Safe Use of This Product

For the safety of the operator and to protect the instrument and the system, please be sure to follow this manual’s safety instructions when handling this instrument. If these instructions are not heeded, the protection provided by this instrument may be impaired. In this case, Yokogawa cannot guarantee that the instrument can be safely operated. Please pay special attention to the following points:

(a) Installation

- This instrument may only be installed by an engineer or technician who has an expert knowledge of this device. Operators are not allowed to carry out installation unless they meet this condition.
- With high process temperatures, care must be taken not to burn yourself by touching the instrument or its casing.
- Never loosen the process connector nuts when the instrument is installed in a process. This can lead to a sudden, explosive release of process fluids.
- When draining condensate from the pressure detector section, take appropriate precautions to prevent the inhalation of harmful vapors and the contact of toxic process fluids with the skin or eyes.
- When removing the instrument from a hazardous process, avoid contact with the fluid and the interior of the meter.
- All installation shall comply with local installation requirements and the local electrical code.

(b) Wiring

- The instrument must be installed by an engineer or technician who has an expert knowledge of this instrument. Operators are not permitted to carry out wiring unless they meet this condition.
- Before connecting the power cables, please confirm that there is no current flowing through the cables and that the power supply to the instrument is switched off.

(c) Operation

- Wait 5 min. after the power is turned off, before opening the covers.

(d) Maintenance

- Please carry out only the maintenance procedures described in this manual. If you require further assistance, please contact the nearest Yokogawa office.
- Care should be taken to prevent the build up of dust or other materials on the display glass and the name plate. To clean these surfaces, use a soft, dry cloth.

(e) Explosion Protected Type Instrument

- Users of explosion proof instruments should refer first to section 2.9 (Installation of an Explosion Protected Instrument) of this manual.
- The use of this instrument is restricted to those who have received appropriate training in the device.
- Take care not to create sparks when accessing the instrument or peripheral devices in a hazardous location.

(f) Modification

- Yokogawa will not be liable for malfunctions or damage resulting from any modification made to this instrument by the customer.

1.2 Warranty

- The warranty shall cover the period noted on the quotation presented to the purchaser at the time of purchase. Problems occurring during the warranty period shall basically be repaired free of charge.
- If any problems are experienced with this instrument, the customer should contact the Yokogawa representative from which this instrument was purchased or the nearest Yokogawa office.
- If a problem arises with this instrument, please inform us of the nature of the problem and the circumstances under which it developed, including the model specification and serial number. Any diagrams, data and other information you can include in your communication will also be helpful.
- The party responsible for the cost of fixing the problem shall be determined by Yokogawa following an investigation conducted by Yokogawa.
- The purchaser shall bear the responsibility for repair costs, even during the warranty period, if the malfunction is due to:
 - Improper and/or inadequate maintenance by the purchaser.
 - Malfunction or damage due to a failure to handle, use, or store the instrument in accordance with the design specifications.
 - Use of the product in question in a location not conforming to the standards specified by Yokogawa, or due to improper maintenance of the installation location.
 - Failure or damage due to modification or repair by any party except Yokogawa or an approved representative of Yokogawa.
 - Malfunction or damage from improper relocation of the product in question after delivery.
 - Reason of force majeure such as fires, earthquakes, storms/floods, thunder/lightening, or other natural disasters, or disturbances, riots, warfare, or radioactive contamination.

1.3 ATEX Documentation

This is only applicable to the countries in European Union.

<p>GB All instruction manuals for ATEX Ex related products are available in English, German and French. Should you require Ex related instructions in your local language, you are to contact your nearest Yokogawa office or representative.</p>	<p>SK Všetky návody na obsluhu pre prístroje s ATEX Ex sú k dispozícii v jazyku anglickom, nemeckom a francúzskom. V prípade potreby návodu pre Ex-prístroje vo Vašom národnom jazyku, skontaktujte prosím miestnu kanceláriu firmy Yokogawa.</p>
<p>DK Alle brugervejledninger for produkter relateret til ATEX Ex er tilgængelige på engelsk, tysk og fransk. Skulle De ønske yderligere oplysninger om håndtering af Ex produkter på eget sprog, kan De rette henvendelse herom til den nærmeste Yokogawa afdeling eller forhandler.</p>	<p>CZ Všechny uživatelské příručky pro výrobky, na něž se vztahuje nevybušné schválení ATEX Ex, jsou dostupné v angličtině, němčině a francouzštině. Požadujete-li pokyny týkající se výrobků s nevybušným schválením ve vašem lokálním jazyku, kontaktujte prosím vaši nejbližší reprezentativní kancelář Yokogawa.</p>
<p>I Tutti i manuali operativi di prodotti ATEX contrassegnati con Ex sono disponibili in inglese, tedesco e francese. Se si desidera ricevere i manuali operativi di prodotti Ex in lingua locale, mettersi in contatto con l'ufficio Yokogawa più vicino o con un rappresentante.</p>	<p>LT Visos gaminių ATEX Ex kategorijos Eksploatavimo instrukcijos teikiama anglų, vokiečių ir prancūzų kalbomis. Norėdami gauti prietaisų Ex dokumentaciją kitomis kalbomis susisieki su artimiausiu bendrovės "Yokogawa" biuru arba atstovu.</p>
<p>E Todos los manuales de instrucciones para los productos antiexplosivos de ATEX están disponibles en inglés, alemán y francés. Si desea solicitar las instrucciones de estos artículos antiexplosivos en su idioma local, deberá ponerse en contacto con la oficina o el representante de Yokogawa más cercano.</p>	<p>LV Visas ATEX Ex kategorijas izstrādājumu Lietošanas instrukcijas tiek piegādātas angļu, vācu un franču valodās. Ja vēlaties saņemt Ex ierīšu dokumentāciju citā valodā, Jums ir jāsazinās ar firmas Jokogava (Yokogawa) tuvāko ofisu vai pārstāvi.</p>
<p>NL Alle handleidingen voor producten die te maken hebben met ATEX explosiebeveiliging (Ex) zijn verkrijgbaar in het Engels, Duits en Frans. Neem, indien u aanwijzingen op het gebied van explosiebeveiliging nodig hebt in uw eigen taal, contact op met de dichtstbijzijnde vestiging van Yokogawa of met een vertegenwoordiger.</p>	<p>EST Kõik ATEX Ex toodete kasutamishendid on esitatud inglise, saksa ja prantsuse keeles. Ex seadmete muukeelse dokumentatsiooni saamiseks pöörduge lähima lokagava (Yokogawa) kontori või esindaja poole.</p>
<p>SF Kaikkien ATEX Ex -tyyppisten tuotteiden käyttöohjeet ovat saatavilla englannin-, saksan- ja ranskankielisinä. Mikäli tarvitsette Ex -tyyppisten tuotteiden ohjeita omalla paikallisella kielellänne, ottakaa yhteyttä lähimpään Yokogawa-toimistoon tai -edustajaan.</p>	<p>PL Wszystkie instrukcje obsługi dla urządzeń w wykonaniu przeciwwybuchowym Ex, zgodnych z wymaganiami ATEX, dostępne są w języku angielskim, niemieckim i francuskim. Jeżeli wymagana jest instrukcja obsługi w Państwa lokalnym języku, prosimy o kontakt z najbliższym biurem Yokogawy.</p>
<p>P Todos os manuais de instruções referentes aos produtos Ex da ATEX estão disponíveis em Inglês, Alemão e Francês. Se necessitar de instruções na sua língua relacionadas com produtos Ex, deverá entrar em contacto com a delegação mais próxima ou com um representante da Yokogawa.</p>	<p>SLO Vsi predpisi in navodila za ATEX Ex sorodni pridelki so pri roki v angleščini, nemščini ter francoščini. Če so Ex sorodna navodila potrebna v vašem tujejnem jeziku, kontaktirajte vaš najbližji Yokogawa office ili predstavnika.</p>
<p>F Tous les manuels d'instruction des produits ATEX Ex sont disponibles en langue anglaise, allemande et française. Si vous nécessitez des instructions relatives aux produits Ex dans votre langue, veuillez bien contacter votre représentant Yokogawa le plus proche.</p>	<p>H Az ATEX Ex műszerek gépkönyveit angol, német és francia nyelven adjuk ki. Amennyiben helyi nyelven kéri az Ex eszközök leírásait, kérjük keressék fel a legközelebbi Yokogawa irodát, vagy képviselőt.</p>
<p>D Alle Betriebsanleitungen für ATEX Ex bezogene Produkte stehen in den Sprachen Englisch, Deutsch und Französisch zur Verfügung. Sollten Sie die Betriebsanleitungen für Ex-Produkte in Ihrer Landessprache benötigen, setzen Sie sich bitte mit Ihrem örtlichen Yokogawa-Vertreter in Verbindung.</p>	<p>BG Всички упътвания за продукти от серията ATEX Ex се предлагат на английски, немски и френски език. Ако се нуждаете от упътвания за продукти от серията Ex на родния ви език, се свържете с най-близкия офис или представителство на фирма Yokogawa.</p>
<p>S Alla instruktionsböcker för ATEX Ex (explosionssäkra) produkter är tillgängliga på engelska, tyska och franska. Om Ni behöver instruktioner för dessa explosionssäkra produkter på annat språk, skall Ni kontakta närmaste Yokogawakontor eller representant.</p>	<p>RO Toate manualele de instructiuni pentru produsele ATEX Ex sunt in limba engleza, germana si franceza. In cazul in care doriti instructiunile in limba locala, trebuie sa contactati cel mai apropiat birou sau reprezentant Yokogawa.</p>
<p>GR Όλα τα εγχειρίδια λειτουργίας των προϊόντων με ATEX Ex διατίθενται στα Αγγλικά, Γερμανικά και Γαλλικά. Σε περίπτωση που χρειάζεστε οδηγίες σχετικά με Ex στην τοπική γλώσσα παρακαλούμε επικοινωνήστε με το πλησιέστερο γραφείο της Yokogawa ή αντιπρόσωπο της.</p>	<p>M Il-manwali kollha ta' l-istruzzjonijiet għal prodotti marbuta ma' ATEX Ex huma disponibbli bi-Ingliż, bi-Ġermaniż u bi-Franċiż. Jekk tkun teħtieġ struzzjonijiet marbuta ma' Ex fil-lingwa lokali tiegħek, għandek tikkuntattja lill-eqreb rappreżentant jew ufficiju ta' Yokogawa.</p>

2. Handling Cautions

This chapter provides important information on how to handle the transmitter. Read this carefully before using the transmitter.

The transmitters are thoroughly tested at the factory before shipment. When taking delivery of an instrument, visually check them to make sure that no damage occurred during shipment.

Also check that all transmitter mounting hardware shown in figure 2.1 is included. If the transmitter is ordered without the mounting bracket and the process connector, the transmitter mounting hardware will not be included. After checking the transmitter, carefully repack it in its box and keep it there until you are ready to install it.

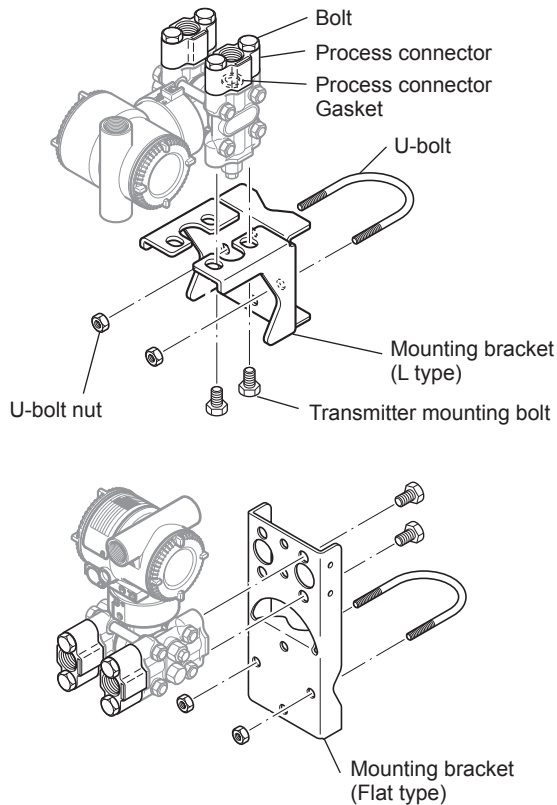

Figure 2.1 Transmitter Mounting Hardware

F0201.ai

2.1 Model and Specifications Check

The model name and specifications are written on the name plate attached to the case.

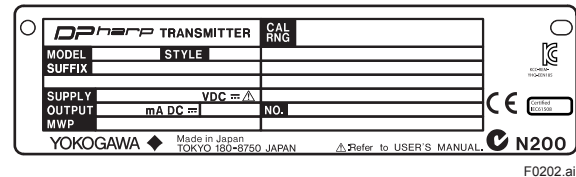

Figure 2.2 Name Plate (EJX110A)

F0202.ai

2.2 Unpacking

Keep the transmitter in its original packaging to prevent it from being damaged during shipment. Do not unpack the transmitter until it reaches the installation site.

2.3 Storage

The following precautions must be observed when storing the instrument, especially for a long period.

- (a) Select a storage area which meets the following conditions:
 - It is not exposed to rain or subject to water seepage/leaks.
 - Vibration and shock are kept to a minimum.
 - It has an ambient temperature and relative humidity within the following ranges.

Ambient temperature:

- 40* to 85°C without integral indicator
- 30* to 80°C with integral indicator
- * –15°C when /HE is specified.

Relative humidity:

0% to 100% R.H.

Preferred temperature and humidity:

approx. 25°C and 65% R.H.

- (b) When storing the transmitter, repack it carefully in the packaging that it was originally shipped with.
- (c) If the transmitter has been used, thoroughly clean the chambers inside the cover flanges, so that there is no process fluid remaining inside. Before placing it in storage, also make sure that the pressure-detector is securely connected to the transmitter section.

2.4 Selecting the Installation Location

The transmitter is designed to withstand severe environmental conditions. However, to ensure that it will provide years of stable and accurate performance, take the following precautions when selecting the installation location.

- (a) **Ambient Temperature**
Avoid locations subject to wide temperature variations or a significant temperature gradient. If the location is exposed to radiant heat from plant equipment, provide adequate thermal insulation and/or ventilation.
- (b) **Ambient Atmosphere**
Do not install the transmitter in a corrosive atmosphere. If this cannot be avoided, there must be adequate ventilation as well as measures to prevent the leaking of rain water and the presence of standing water in the conduits.
- (c) **Shock and Vibration**
Although the transmitter is designed to be relatively resistant to shock and vibration, an installation site should be selected where this is kept to a minimum.
- (d) **Installation of Explosion-protected Transmitters**
An explosion-protected transmitter is certified for installation in a hazardous area containing specific gas types. See subsection 2.9 "Installation of an Explosion-Protected Transmitters."

2.5 Pressure Connection



WARNING

- Never loosen the process connector bolts when an instrument is installed in a process. The device is under pressure, and a loss of seal can result in a sudden and uncontrolled release of process fluid.
- When draining toxic process fluids that have condensed inside the pressure detector, take appropriate steps to prevent the contact of such fluids with the skin or eyes and the inhalation of vapors from these fluids.

The following precautions must be observed in order to safely operate the transmitter under pressure.

- (a) Make sure that all the process connector bolts are tightened firmly.
- (b) Make sure that there are no leaks in the impulse piping.
- (c) Never apply a pressure higher than the specified maximum working pressure.

2.6 Waterproofing of Cable Conduit Connections

Apply a non-hardening sealant to the threads to waterproof the transmitter cable conduit connections. (See figure 6.8, 6.9 and 6.10.)

2.7 Restrictions on Use of Radio Transceivers



IMPORTANT

Although the transmitter has been designed to resist high frequency electrical noise, if a radio transceiver is used near the transmitter or its external wiring, the transmitter may be affected by high frequency noise pickup. To test this, start out from a distance of several meters and slowly approach the transmitter with the transceiver while observing the measurement loop for noise effects. Thereafter use the transceiver outside the range where the noise effects were first observed.

2.8 Insulation Resistance and Dielectric Strength Test

Since the transmitter has undergone insulation resistance and dielectric strength tests at the factory before shipment, normally these tests are not required. If the need arises to conduct these tests, heed the following:

- (a) Do not perform such tests more frequently than is absolutely necessary. Even test voltages that do not cause visible damage to the insulation may degrade the insulation and reduce safety margins.

- (b) Never apply a voltage exceeding 500 V DC (100 V DC with an internal lightning protector) for the insulation resistance test, nor a voltage exceeding 500 V AC (100 V AC with an internal lightning protector) for the dielectric strength test.
- (c) Before conducting these tests, disconnect all signal lines from the transmitter terminals. The procedure for conducting these tests is as follows:

• Insulation Resistance Test

- 1) Short-circuit the + and – SUPPLY terminals in the terminal box. In case of 1 to 5 V output, short-circuit the SUPPLY+, SUPPLY – and A (VOUT +) terminals.
- 2) Turn OFF the insulation tester. Then connect the insulation tester plus (+) lead wire to the shorted SUPPLY terminals and the minus (–) leadwire to the grounding terminal.
- 3) Turn ON the insulation tester power and measure the insulation resistance. The voltage should be applied as briefly as possible to verify that the insulation resistance is at least 20 MΩ.
- 4) After completing the test and being very careful not to touch exposed conductors disconnect the insulation tester and connect a 100 kΩ resistor between the grounding terminal and the short-circuiting SUPPLY terminals. Leave this resistor connected at least one second to discharge any static potential. Do not touch the terminals while it is discharging.

• Dielectric Strength Test

- 1) Short-circuit the + and – SUPPLY terminals in the terminal box. In case of 1 to 5 V output, short-circuit the SUPPLY+, SUPPLY – and A (VOUT +) terminals.
- 2) Turn OFF the dielectric strength tester. Then connect the tester between the shorted SUPPLY terminals and the grounding terminal. Be sure to connect the grounding lead of the dielectric strength tester to the ground terminal.
- 3) Set the current limit on the dielectric strength tester to 10 mA, then turn ON the power and gradually increase the test voltage from '0' to the specified voltage.
- 4) When the specified voltage is reached, hold it for one minute.
- 5) After completing this test, slowly decrease the voltage to avoid any voltage surges.

2.9 Installation of an Explosion-Protected Instrument



NOTE

For FOUNDATION Fieldbus explosion protected type, please refer to IM 01C22T02-01E.
For PROFIBUS PA explosion protected type, please refer to IM 01C25T04-01EN.

If a customer makes a repair or modification to an intrinsically safe or explosionproof instrument and the instrument is not restored to its original condition, its intrinsically safe or explosionproof construction may be compromised and the instrument may be hazardous to operate. Please contact Yokogawa before making any repair or modification to an instrument.



CAUTION

This instrument has been tested and certified as being intrinsically safe or explosionproof. Please note that severe restrictions apply to this instrument's construction, installation, external wiring, maintenance and repair. A failure to abide by these restrictions could make the instrument a hazard to operate.



WARNING

Maintaining the safety of explosionproof equipment requires great care during mounting, wiring, and piping. Safety requirements also place restrictions on maintenance and repair. Please read the following sections very carefully.



WARNING

The range setting switch must not be used in a hazardous area.



IMPORTANT

For combined approval types
Once a device of multiple approval type is installed, it should not be re-installed using any other approval types. Apply a permanent mark in the check box of the selected approval type on the certification label on the transmitter to distinguish it from unused approval types.



IMPORTANT

All the blind plugs which accompany the EJX/EJA-E transmitters upon shipment from the factory are certified by the applicable agency in combination with those transmitters. The plugs which are marked with the symbols “◇ Ex” on their surfaces are certified only in combination with the EJX/EJA-E series transmitters.

2.9.1 FM Approval

a. FM Intrinsically Safe Type

Caution for FM intrinsically safe type. (Following contents refer “DOC. No. IFM022-A12”)

- Note 1. Model EJX/EJA-E Series Differential, gauge and absolute pressure transmitters with optional code /FS1 are applicable for use in hazardous locations.
- Applicable Standard: FM3600, FM3610, FM3611, FM3810
 - Intrinsically Safe for Class I, Division 1, Groups A, B, C & D. Class II, Division 1, Groups E, F & G and Class III, Division 1, Class I, Zone 0 in Hazardous Locations, AEx ia IIC
 - Nonincendive for Class I, Division 2, Groups A, B, C & D. Class II, Division 2, Groups F & G, Class I, Zone 2, Groups IIC, in Hazardous Locations.
 - Outdoor hazardous locations, NEMA TYPE 4X.
 - Temperature Class: T4
 - Ambient temperature: -60 to 60°C

Note 2. Entity Parameters

- Intrinsically Safe Apparatus Parameters [Groups A, B, C, D, E, F and G]
 $V_{max} = 30\text{ V}$ $C_i = 6\text{ nF}$
 $I_{max} = 200\text{ mA}$ $L_i = 0\text{ }\mu\text{H}$
 $P_{max} = 1\text{ W}$

- * Associated Apparatus Parameters (FM approved barriers)
 $V_{oc} \leq 30\text{ V}$ $C_a > 6\text{ nF}$
 $I_{sc} \leq 200\text{ mA}$ $L_a > 0\text{ }\mu\text{H}$
 $P_{max} \leq 1\text{ W}$

- Intrinsically Safe Apparatus Parameters [Groups C, D, E, F and G]
 $V_{max} = 30\text{ V}$ $C_i = 6\text{ nF}$
 $I_{max} = 225\text{ mA}$ $L_i = 0\text{ }\mu\text{H}$
 $P_{max} = 1\text{ W}$

- * Associated Apparatus Parameters (FM approved barriers)
 $V_{oc} \leq 30\text{ V}$ $C_a > 6\text{ nF}$
 $I_{sc} \leq 225\text{ mA}$ $L_a > 0\text{ }\mu\text{H}$
 $P_{max} \leq 1\text{ W}$

- Entity Installation Requirements
 $V_{max} \geq V_{oc}$ or U_o or V_t , $I_{max} \geq I_{sc}$ or I_o or I_t ,
 P_{max} (or P_o) $\leq P_i$, C_a or $C_o \geq C_i + C_{cable}$,
 L_a or $L_o \geq L_i + L_{cable}$

Note 3. Installation

- Barrier must be installed in an enclosure that meets the requirements of ANSI/ISA S82.01.
- Control equipment connected to barrier must not use or generate more than 250 V rms or V dc.
- Installation should be in accordance with ANSI/ISA RP12.6 “Installation of Intrinsically Safe Systems for Hazardous (Classified) Locations” and the National Electric Code (ANSI/NFPA 70).
- The configuration of associated apparatus must be FMRC Approved.
- Dust-tight conduit seal must be used when installed in a Class II, III, Group E, F and G environments.
- Associated apparatus manufacturer’s installation drawing must be followed when installing this apparatus.
- The maximum power delivered from the barrier must not exceed 1 W.
- Note a warning label worded “SUBSTITUTION OF COMPONENTS MAY IMPAIR INTRINSIC SAFETY,” and “INSTALL IN ACCORDANCE WITH DOC. No. IFM022-A12”

Note 4. Maintenance and Repair

- The instrument modification or parts replacement by other than authorized representative of Yokogawa Electric Corporation is prohibited and will void Factory Mutual Intrinsically safe and Nonincendive Approval.

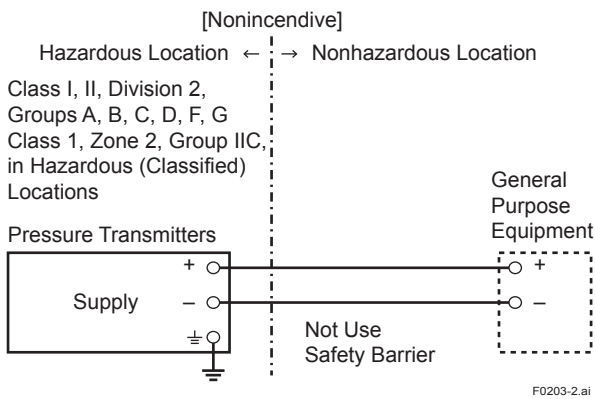
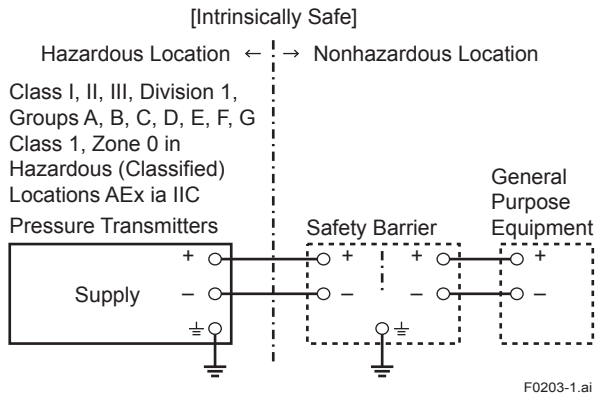

- Output signal: 4 to 20 mA
15 mA (FOUNDATION Fieldbus and PROFIBUS PA type)
1 to 5 V (Low Power type)

Note 2. Wiring

- All wiring shall comply with National Electrical Code ANSI/NFPA70 and Local Electrical Codes.
- When installed in Division 1, "FACTORY SEALED, CONDUIT SEAL NOT REQUIRED."
- Wiring connection for output signal code Q (Low Power type) shall follow the diagram below.

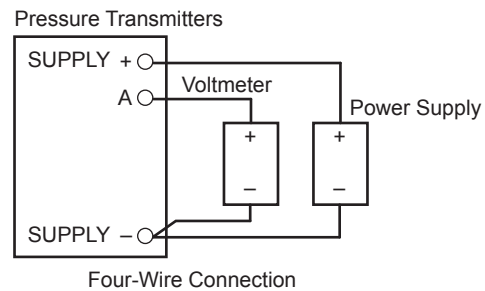
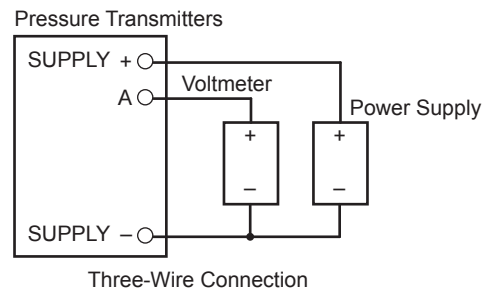

b. FM Explosionproof Type

Caution for FM explosionproof type.

Note 1. Model EJX/EJA-E Series pressure transmitters with optional code /FF1 or /V1F are applicable for use in hazardous locations.

- Applicable Standard: FM3600, FM3615, FM3810, ANSI/NEMA 250
- Explosionproof for Class I, Division 1, Groups B, C and D.
- Dust-ignitionproof for Class II/III, Division 1, Groups E, F and G.
- Enclosure rating: NEMA TYPE 4X.
- Temperature Class: T6
- Ambient Temperature: -40 to 60°C
- Supply Voltage: 42 V dc max.
32 V dc max. (FOUNDATION Fieldbus and PROFIBUS PA type)
9 to 28 V dc, 27 mW (Low Power type)

Note 3. Operation

- Keep the "WARNING" nameplate attached to the transmitter.
WARNING: OPEN CIRCUIT BEFORE REMOVING COVER. FACTORY SEALED, CONDUIT SEAL NOT REQUIRED. INSTALL IN ACCORDANCE WITH THE USERS MANUAL IM 01C25.
- Take care not to generate mechanical sparking when accessing to the instrument and peripheral devices in a hazardous location.

Note 4. Maintenance and Repair

- The instrument modification or parts replacement by other than authorized representative of Yokogawa Electric Corporation is prohibited and will void Factory Mutual Explosionproof Approval.

c. FM Intrinsically Safe Type/FM Explosionproof Type

Model EJX/EJA-E Series pressure transmitters with optional code /FU1 or /V1U1 can be selected the type of protection (FM Intrinsically Safe or FM Explosionproof) for use in hazardous locations.

Note 1. For the installation of this transmitter, once a particular type of protection is selected, any other type of protection cannot be used. The installation must be in accordance with the description about the type of protection in this instruction manual.

Note 2. In order to avoid confusion, unnecessary marking is crossed out on the label other than the selected type of protection when the transmitter is installed.

2.9.2 CSA Certification

a. CSA Intrinsically Safe Type

Caution for CSA Intrinsically safe and nonincendive type. (Following contents refer to "DOC No. ICS013-A13")

Note 1. Model EJX/EJA-E Series differential, gauge, and absolute pressure transmitters with optional code /CS1 are applicable for use in hazardous locations

Certificate: 1606623

[For CSA C22.2]

- Applicable Standard: C22.2 No.0, C22.2 No.0.4, C22.2 No.25, C22.2 No.94, C22.2 No.157, C22.2 No.213, C22.2 No.61010-1, C22.2 No.60079-0
- Intrinsically Safe for Class I, Division 1, Groups A, B, C & D, Class II, Division 1, Groups E, F & G, Class III, Division 1
- Nonincendive for Class I, Division 2, Groups A, B, C & D, Class II, Division 2, Groups F & G, Class III, Division 1
- Enclosure: NEMA TYPE 4X
- Temp. Code: T4
- Amb. Temp.: -50* to 60°C
* -15°C when /HE is specified.
- Process Temperature: 120°C max.

[For CSA E60079]

- Applicable Standard: CAN/CSA E60079-11, CAN/CSA E60079-15, IEC 60529:2001
- Ex ia IIC T4, Ex nL IIC T4
- Ambient Temperature: -50* to 60°C
* -15°C when /HE is specified.
- Max. Process Temp.: 120°C
- Enclosure: IP66/IP67

Note 2. Entity Parameters

- Intrinsically safe ratings are as follows:
Maximum Input Voltage (Vmax/Ui) = 30 V
Maximum Input Current (Imax/Ii) = 200 mA
Maximum Input Power (Pmax/Pi) = 0.9 W
Maximum Internal Capacitance (Ci) = 10 nF
Maximum Internal Inductance (Li) = 0 μH
- Type "n" or Nonincendive ratings are as follows:
Maximum Input Voltage (Vmax/Ui) = 30 V
Maximum Internal Capacitance (Ci) = 10 nF
Maximum Internal Inductance (Li) = 0 μH
- Installation Requirements
Uo ≤ Ui, Io ≤ Ii, Po ≤ Pi,
Co ≥ Ci + Ccable, Lo ≥ Li + Lcable
Voc ≤ Vmax, Isc ≤ Imax,
Ca ≥ Ci + Ccable, La ≥ Li + Lcable
Uo, Io, Po, Co, Lo, Voc, Isc, Ca and La are parameters of barrier.

Note 3. Installation

- In any safety barrier used output current must be limited by a resistor 'R' such that Io=Uo/R or Isc=Voc/R.
- The safety barrier must be CSA certified.
- Input voltage of the safety barrier must be less than 250 Vrms/Vdc.
- Installation should be in accordance with Canadian Electrical Code Part I and Local Electrical Code.
- Dust-tight conduit seal must be used when installed in Class II and III environments.
- The instrument modification or parts replacement by other than authorized representative of Yokogawa Electric Corporation and Yokogawa Corporation of America is prohibited and will void Canadian Standards Intrinsically safe and nonincendive Certification.

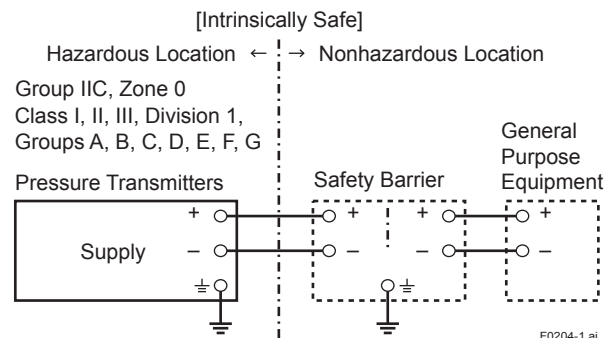

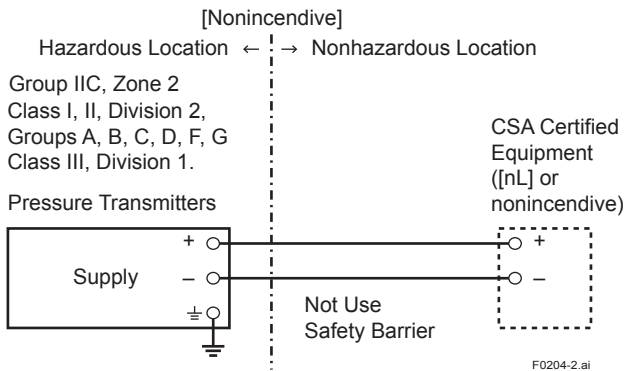

b. CSA Explosionproof Type

Caution for CSA explosionproof type.

Note 1. Model EJX/EJA-E Series pressure transmitters with optional code /CF1 or /V1F are applicable for use in hazardous locations:

- Certificate: 2014354
- Applicable Standard: C22.2 No.0, C22.2 No.0.4, C22.2 No.0.5, C22.2 No.25, C22.2 No.30, C22.2 No.94, C22.2 No.61010-1, C22.2 No.60079-0, C22.2 No.60079-1
- Explosion-proof for Class I, Groups B, C and D.
- Dustignition-proof for Class II/III, Groups E, F and G.
- Enclosure: NEMA TYPE 4X
- Temperature Code: T6...T4
- Ex d IIC T6...T4
- Enclosure: IP66/IP67
- Maximum Process Temperature: 120°C (T4), 100°C (T5), 85°C (T6)
- Ambient Temperature: -50* to 75°C (T4), -50* to 80°C (T5), -50* to 75°C (T6)
* -15°C when /HE is specified.
- Supply Voltage: 42 V dc max.
32 V dc max. (FOUNDATION Fieldbus and PROFIBUS PA type)
9 to 28 V dc, 27 mW (Low Power type)
- Output Signal: 4 to 20 mA dc
15 mA (FOUNDATION Fieldbus and PROFIBUS PA type)
1 to 5 V (Low Power type)

Note 2. Wiring

- All wiring shall comply with Canadian Electrical Code Part I and Local Electrical Codes.
- In hazardous location, wiring shall be in conduit as shown in the figure.
- WARNING: A SEAL SHALL BE INSTALLED WITHIN 50cm OF THE ENCLOSURE. UN SCELLEMENT DOIT ÊTRE INSTALLÉ À MOINS DE 50cm DU BOÎTIER.
- WARNING: WHEN INSTALLED IN CL.I, DIV 2, SEAL NOT REQUIRED. UNE FOIS INSTALLÉ DANS CL I, DIV 2, AUCUN JOINT N'EST REQUIS.

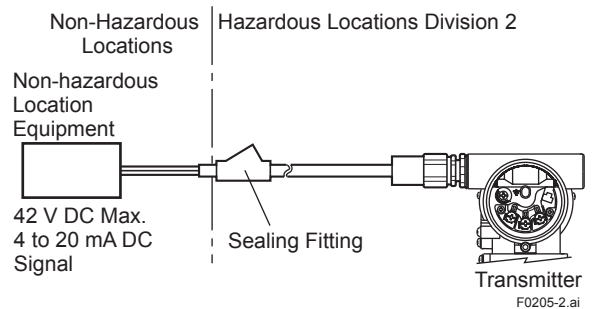
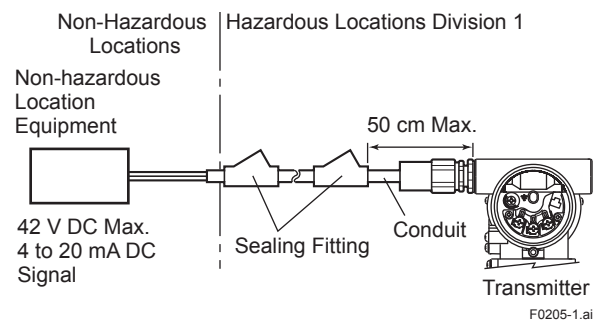

- All wiring shall comply with local installation requirements and local electrical code.
- In hazardous locations, the cable entry devices shall be of a certified flameproof type, suitable for the conditions of use and correctly installed.
- Unused apertures shall be closed with suitable flameproof certified blanking elements. (The plug attached is flameproof certified.)
- Wiring connection for output signal code Q (Low Power type) shall follow the diagram below.

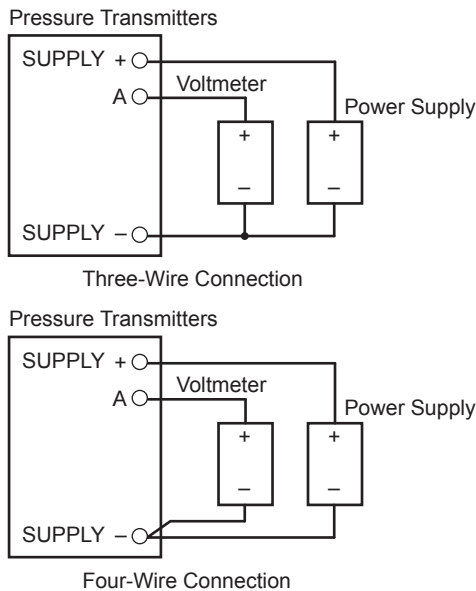

Note 3. Operation

- **WARNING:**
AFTER DE-ENERGIZING, DELAY 5 MINUTES BEFORE OPENING.
APRÉS POWER-OFF, ATTENDRE 5 MINUTES AVANT D'OUVRIR.
- **WARNING:**
WHEN AMBIENT TEMPERATURE $\geq 65^{\circ}\text{C}$,
USE THE HEAT-RESISTING CABLES $\geq 90^{\circ}\text{C}$.
QUAND LA TEMPÉRATURE AMBIANTE $\geq 65^{\circ}\text{C}$, UTILISEZ DES CÂBLES
RÉSISTANTES Á LA CHALEUR $\geq 90^{\circ}\text{C}$.
- Take care not to generate mechanical sparking when accessing to the instrument and peripheral devices in a hazardous location.

Note 4. Maintenance and Repair

- The instrument modification or parts replacement by other than authorized representative of Yokogawa Electric Corporation and Yokogawa Corporation of America is prohibited and will void Canadian Standards Explosionproof Certification.

c CSA Intrinsically Safe Type/CSA Explosionproof Type

Model EJX/EJA-E Series pressure transmitters with optional code /CU1 or /V1U1 can be selected the type of protection (CSA Intrinsically Safe or CSA Explosionproof) for use in hazardous locations.

Note 1. For the installation of this transmitter, once a particular type of protection is selected, any other type of protection cannot be used. The installation must be in accordance with the description about the type of protection in this instruction manual.

Note 2. In order to avoid confusion, unnecessary marking is crossed out on the label other than the selected type of protection when the transmitter is installed.

2.9.3 ATEX Certification

(1) Technical Data

a. ATEX Intrinsically Safe Ex ia

Caution for ATEX Intrinsically safe type.

Note 1. Model EJX/EJA-E Series pressure transmitters with optional code /KS21 for potentially explosive atmospheres:

- No. DEKRA 11ATEX0228 X
- Applicable Standard:
EN 60079-0:2009, EN 60079-11:2007,
EN 60079-26:2007, EN 61241-11:2006
- Type of Protection and Marking code:
Ex ia IIC T4 Ga
Ex ia IIIC T85 °C T100 °C T120 °C Db
- Group: II
- Category: 1G, 2D
- Ambient Temperature for EPL Ga:
-50 to 60°C
- Ambient Temperature for EPL Db:
-30* to 60°C
* -15°C when /HE is specified.
- Process Temperature (Tp.): 120°C max.
- Maximum Surface Temperature for EPL Db:
T85°C (Tp.: 80°C)
T100°C (Tp.: 100°C)
T120°C (Tp.: 120°C)
- Enclosure: IP66 / IP67

Note 2 Electrical Data

- In type of explosion protection intrinsic safety Ex ia IIC or Ex ia IIIC, only for connection to a certified intrinsically safe circuit with following maximum values:
Ui = 30 V
Ii = 200 mA
Pi = 0.9 W
(Linear Source)
Maximum internal capacitance; Ci = 27.6 nF
Maximum internal inductance; Li = 0 µH

Note 3. Installation

- Refer to the control drawing. All wiring shall comply with local installation requirements.

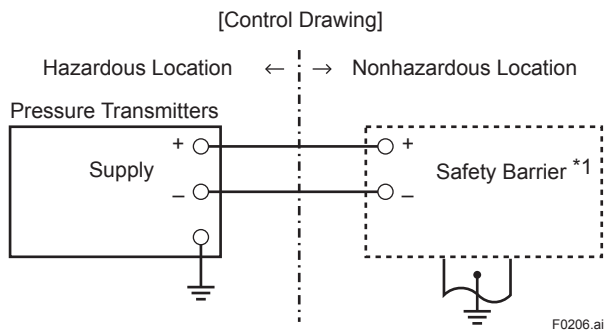

*1: In any safety barriers used the output current must be limited by a resistor "R" such that $I_o = U_z/R$.

Note 4. Maintenance and Repair

- The instrument modification or parts replacement by other than authorized representative of Yokogawa Electric Corporation is prohibited and will void DEKRA Intrinsically safe Certification.

Note 5. Special Conditions for Safe Use



WARNING

- In the case where the enclosure of the Pressure Transmitter is made of aluminium, if it is mounted in an area where the use of category 1 G apparatus is required, it must be installed such, that, even in the event of rare incidents, ignition sources due to impact and friction sparks are excluded.
- Electrostatic charge may cause an explosion hazard. Avoid any actions that cause the generation of electrostatic charge, such as rubbing with a dry cloth on coating face of the product.
- In case of the enclosure of the Pressure Transmitter with paint layers, if it is mounted in an area where the use of category 2D apparatus is required, it shall be installed in such a way that the risk from electrostatic discharges and propagating brush discharges caused by rapid flow of dust is avoided.
- To satisfy IP66 or IP67, apply waterproof glands to the electrical connection port.
- When the lightning protector option is specified, the apparatus is not capable of withstanding the 500V insulation test required by EN60079-11. This must be taken into account when installing the apparatus.

b. ATEX Flameproof Type

Caution for ATEX flameproof type.

Note 1. Model EJX/EJA-E Series pressure transmitters with optional code /KF22 or /V1F for potentially explosive atmospheres:

- No. KEMA 07ATEX0109 X
- Applicable Standard: EN 60079-0:2009, EN 60079-1:2007, EN 60079-31:2009
- Type of Protection and Marking Code: Ex d IIC T6...T4 Gb, Ex tb IIIC T85°C Db
- Group: II
- Category: 2G, 2D
- Enclosure: IP66 / IP67
- Temperature Class for gas-proof: T6, T5, and T4
- Ambient Temperature for gas-proof: -50 to 75°C (T6), -50 to 80°C (T5), and -50 to 75°C (T4)
- Maximum Process Temperature (Tp.) for gas-proof: 85°C (T6), 100°C (T5), and 120°C (T4)
- Maximum Surface Temperature for dust-proof: T85°C (Tamb.: -30* to 75°C, Tp.: 85°C)
* -15°C when /HE is specified.

Note 2. Electrical Data

- Supply voltage: 42 V dc max. 32 V dc max. (FOUNDATION Fieldbus and PROFIBUS PA type)
9 to 28 V dc, 27 mW (Low Power type)
- Output signal: 4 to 20 mA
15 mA (FOUNDATION Fieldbus and PROFIBUS PA type)
1 to 5 V (Low Power type)

Note 3. Installation

- All wiring shall comply with local installation requirement.
- Cable glands, adapters and/or blanking elements with a suitable IP rating shall be of Ex d IIC/Ex tb IIIC certified by ATEX and shall be installed so as to maintain the specific degree of protection (IP Code) of the equipment.
- Wiring connection for output signal code Q (Low Power type) shall follow the diagram below.

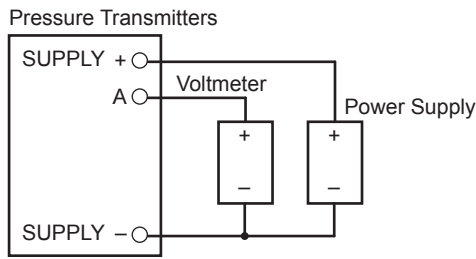

Three-Wire Connection

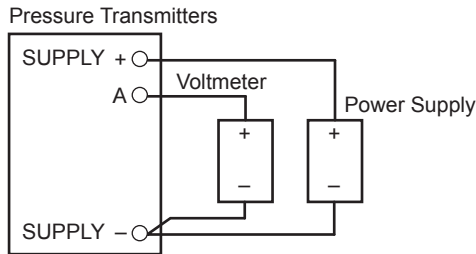

Four-Wire Connection

F0213.ai

Note 4. Operation

WARNING: AFTER DE-ENERGIZING, DELAY 5 MINUTES BEFORE OPENING. WHEN THE AMBIENT TEMP. $\geq 65^{\circ}\text{C}$, USE HEAT-RESISTING CABLE AND CABLE GLAND $\geq 90^{\circ}\text{C}$.

- Take care not to generate mechanical sparking when accessing to the instrument and peripheral devices in a hazardous location.

Note 5. Special Conditions for Safe Use



WARNING

- Electrostatic charge may cause an explosion hazard. Avoid any actions that cause the generation of electrostatic charge, such as rubbing with a dry cloth on coating face of the product.
- In the case where the enclosure of the Pressure Transmitter is made of aluminium, if it is mounted in an area where the use of category 2D apparatus is required, it shall be installed in such a way that the risk from electrostatic discharges and propagating brush discharges caused by rapid flow of dust is avoided.
- The instrument modification or parts replacement by other than an authorized Representative of Yokogawa Electric Corporation is prohibited and will void the certification.

c. ATEX Intrinsically Safe Type/ATEX Flameproof Type

Model EJX/EJA-E Series pressure transmitters with optional code /KU22 or /V1U1 can be selected the type of protection ATEX Flameproof, Intrinsically Safe. Ex ia, or Ex ic for use in hazardous area.

Note 1. For the installation of this transmitter, once a particular type of protection is selected, any other type of protection cannot be used. The installation must be in accordance with the description about the type of protection in this user's manual.

Note 2. For combined approval types Once a device of multiple approval type is installed, it should not be re-installed using any other approval types. Apply a permanent mark in the check box of the selected approval type on the certification label on the transmitter to distinguish it from unused approval types.

• ATEX Intrinsically Safe Ex ic

Caution for ATEX intrinsically safe Ex ic

- Applicable Standard: EN 60079-0:2009/EN 60079-0:2012, EN 60079-11:2012
- Type of Protection and Marking Code: Ex ic IIC T4 Gc
- Ambient Temperature: -30°C to $+60^{\circ}\text{C}$
* -15°C when /HE is specified.
- Ambient Humidity: 0 to 100% (No condensation)
- Maximum Process Temperature: 120°C
- IP Code: IP66
- Ambient pollution degree: 2
- Overvoltage category: I

Note 1. Electrical Data

$U_i = 30\text{ V}$
 $C_i = 27.6\text{ nF}$
 $L_i = 0\text{ }\mu\text{H}$

Note 2. Installation

- All wiring shall comply with local installation requirements. (refer to the control drawing)
- Cable glands, adapters and/or blanking elements shall be of Ex "n", Ex "e" or Ex "d" and shall be installed so as to maintain the specified degree of protection (IP Code) of the transmitters.

Note 3. Maintenance and Repair

- The instrument modification or parts replacement by other than authorized representative of Yokogawa Electric Corporation is prohibited and will void ATEX intrinsically safe.

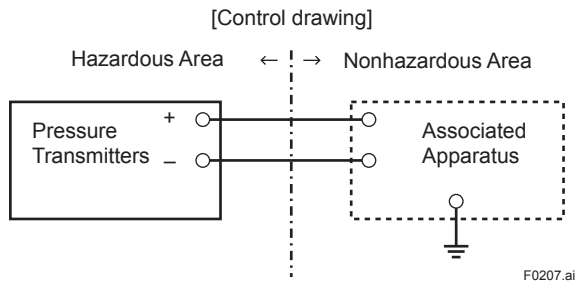

Note 4. Specific Conditions of Use

WARNING

- Electrostatic charge may cause an explosion hazard. Avoid any actions that cause the generation of electrostatic charge, such as rubbing with a dry cloth on coating face of the product.
- When the lightning protector option is specified, the apparatus is not capable of withstanding the 500V insulation test required by EN60079-11. This must be taken into account when installing the apparatus.

(2) Electrical Connection

A mark indicating the electrical connection type is stamped near the electrical connection port. These marks are as followed.

Screw Size	Marking
ISO M20 × 1.5 female	⚠ M
ANSI 1/2 NPT female	⚠ N or ⚠ W

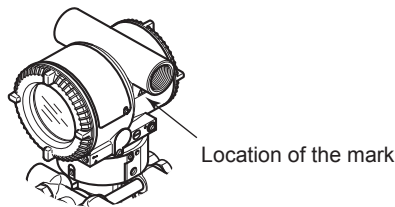

(3) Installation

WARNING

- All wiring shall comply with local installation requirements and the local electrical code.
- There is no need for conduit seal in Division 1 and Division 2 hazardous locations because this product is sealed at the factory.

(4) Operation

WARNING

- OPEN CIRCUIT BEFORE REMOVING COVER. INSTALL IN ACCORDANCE WITH THIS USER'S MANUAL
- Take care not to generate mechanical sparking when access to the instrument and peripheral devices in a hazardous location.

(5) Maintenance and Repair

WARNING

The instrument modification or parts replacement by other than an authorized Representative of Yokogawa Electric Corporation is prohibited and will void the certification.

(6) Name Plate

● Name plate

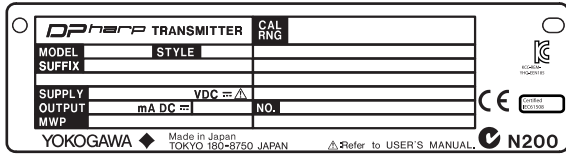

● Tag plate for flameproof type

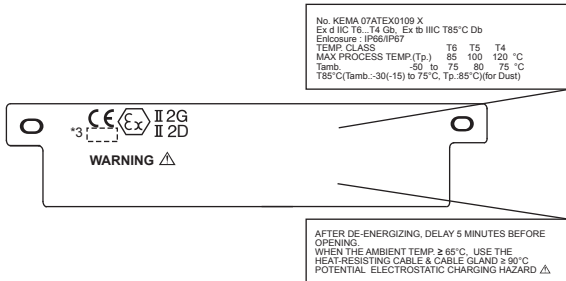

● Tag plate for intrinsically safe type

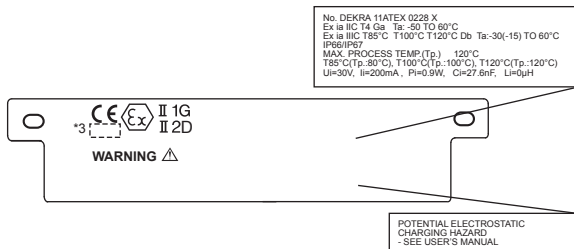

● Tag plate for intrinsically safe Ex ic

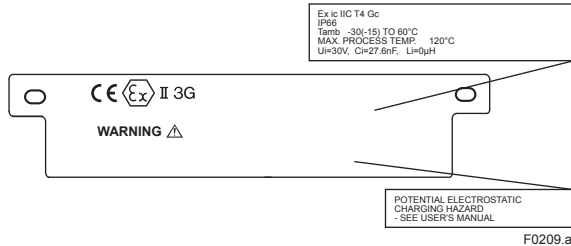

MODEL: Specified model code.
 STYLE: Style code.
 SUFFIX: Specified suffix code.
 SUPPLY: Supply voltage.
 OUTPUT: Output signal.
 MWP: Maximum working pressure.
 CAL RNG: Specified calibration range.
 NO.: Serial number and year of production*1.
 TOKYO 180-8750 JAPAN:
 The manufacturer name and the address*2.

*1: The first digit in the three numbers next to the nine letters of the serial number appearing after "NO." on the nameplate indicates the year of production. The following is an example of a serial number for a product that was produced in 2010:

91K819857 032

The year 2010

*2: "180-8750" is a zip code which represents the following address.

2-9-32 Nakacho, Musashino-shi, Tokyo Japan

*3: The identification number of Notified Body.

2.9.4 IECEx Certification

Model EJX Series pressure transmitters with optional code /SU2 can be selected the type of protection (IECEx Intrinsically Safe/type n or flameproof) for use in hazardous locations.

Note 1. For the installation of this transmitter, once a particular type of protection is selected, any other type of protection cannot be used. The installation must be in accordance with the description about the type of protection in this instruction manual.

Note 2. In order to avoid confusion, unnecessary marking is crossed out on the label other than the selected type of protection when the transmitter is installed.

a. IECEx Intrinsically Safe Type / type n

Caution for IECEx Intrinsically safe and type n.

Note 1. Model EJX Series differential, gauge, and absolute pressure transmitters with optional code /SU2 are applicable for use in hazardous locations

- No. IECEx CSA 05.0005
- Applicable Standard: IEC 60079-0:2000, IEC 60079-11:1999, IEC 60079-15:2001
- Ex ia IIC T4, Ex nL IIC T4
- Ambient Temperature: -50 to 60°C
- Max. Process Temp.: 120°C
- Enclosure: IP66/IP67

Note 2. Entity Parameters

- Intrinsically safe ratings are as follows:
 Maximum Input Voltage (Vmax/Ui) = 30 V
 Maximum Input Current (Imax/Ii) = 200 mA
 Maximum Input Power (Pmax/Pi) = 0.9 W
 Maximum Internal Capacitance (Ci) = 10 nF
 Maximum Internal Inductance (Li) = 0 µH
- Type "n" ratings are as follows:
 Maximum Input Voltage (Vmax/Ui) = 30 V
 Maximum Internal Capacitance (Ci) = 10 nF
 Maximum Internal Inductance (Li) = 0 µH
- Installation Requirements
 $U_o \leq U_i, I_o \leq I_i, P_o \leq P_i,$
 $C_o \geq C_i + C_{cable}, L_o \geq L_i + L_{cable}$
 $V_{oc} \leq V_{max}, I_{sc} \leq I_{max},$
 $C_a \geq C_i + C_{cable}, L_a \geq L_i + L_{cable}$
 $U_o, I_o, P_o, C_o, L_o, V_{oc}, I_{sc}, C_a$ and L_a are parameters of barrier.

Note 3. Installation

- In any safety barrier used output current must be limited by a resistor 'R' such that $I_o = U_o/R$.
- The safety barrier must be IECEx certified.
- Input voltage of the safety barrier must be less than 250 Vrms/Vdc.
- The instrument modification or parts replacement by other than authorized representative of Yokogawa Electric Corporation and will void IECEx Intrinsically safe and type n certification.

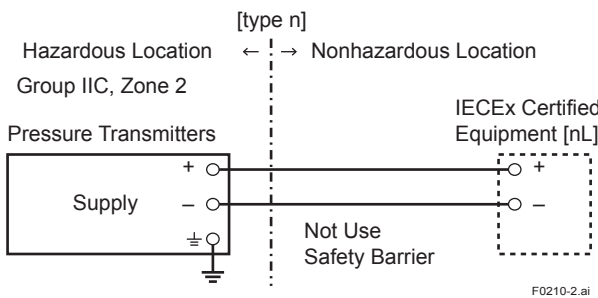
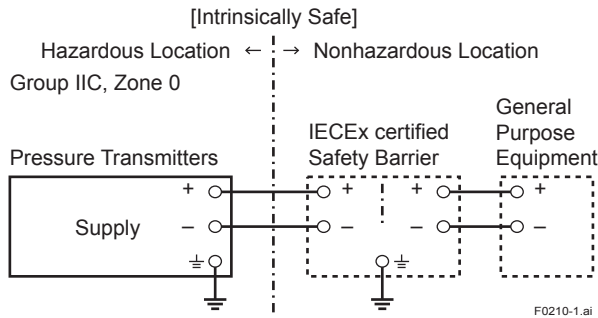

b. IECEx Flameproof Type

Caution for IECEx flameproof type.

Note 1. Model EJX/EJA-E Series pressure transmitters with optional code /SF2, /SU2, or /V1F are applicable for use in hazardous locations:

- No. IECEx CSA 07.0008
- Applicable Standard: IEC60079-0:2011, IEC60079-1:2007-4
- Flameproof for Zone 1, Ex d IIC T6...T4 Gb
- Enclosure: IP66/IP67
- Maximum Process Temperature: 120°C (T4), 100°C (T5), 85°C (T6)
- Ambient Temperature: -50 to 75°C (T4), -50 to 80°C (T5), -50 to 75°C (T6)
- Supply Voltage: 42 V dc max. 32 V dc max. (FOUNDATION Fieldbus and PROFIBUS PA type) 9 to 28 V dc, 27 mW (Low Power type)

- Output Signal: 4 to 20 mA dc 15 mA (FOUNDATION Fieldbus and PROFIBUS PA type) 1 to 5 V (Low Power type)

Note 2. Wiring

- In hazardous locations, the cable entry devices shall be of a certified flameproof type, suitable for the conditions of use and correctly installed.
- Unused apertures shall be closed with suitable flameproof certified blanking elements.
- Wiring connection for output signal code Q (Low Power type) shall follow the diagram below.

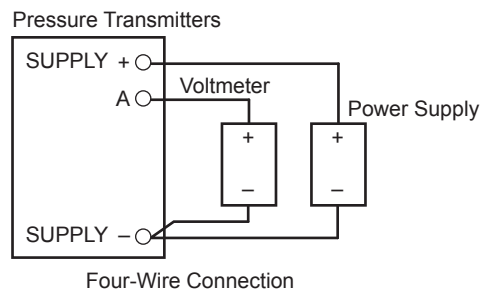
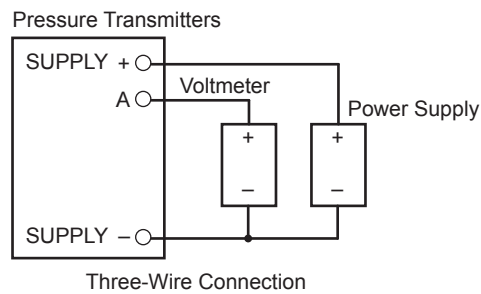

Note 3. Operation

- WARNING: AFTER DE-ENERGIZING, DELAY 5 MINUTES BEFORE OPENING.
- WARNING: WHEN THE AMBIENT TEMP. ≥ 65°C, USE HEAT-RESISTING CABLE AND CABLE GLAND ≥ 90°C.
- Take care not to generate mechanical sparking when accessing to the instrument and peripheral devices in a hazardous location.
- Electrostatic charge may cause an explosion hazard. Avoid any actions that cause the generation of electrostatic charge, such as rubbing with a dry cloth on coating face of the product.

Note 4. Maintenance and Repair

- The instrument modification or parts replacement by other than authorized representative of Yokogawa Electric Corporation is prohibited and will void IECEx Certification.
- Electrical Connection
A mark indicating the electrical connection type is stamped near the electrical connection port. These marks are as followed.

Screw Size	Marking
ISO M20 × 1.5 female	△ M
ANSI 1/2 NPT female	△ N or △ W

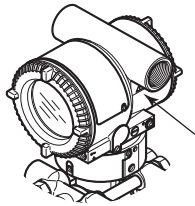

Location of the mark

F0215.ai

2.10 EMC Conformity Standards

- EN61326-1 Class A, Table2 (For use in industrial locations)
- EN61326-2-3
- EN61326-2-5 (for PROFIBUS only)



CAUTION

To meet EMC regulations, Yokogawa recommends that customers run signal wiring through metal conduits or use shielded twisted-pair cabling when installing EJX/EJA-E series transmitters in a plant.

2.11 Pressure Equipment Directive (PED)

(1) General

- EJX/EJA-E Series pressure transmitters are categorized as piping under the pressure accessories section of directive 97/23/EC, which corresponds to Article 3, Paragraph 3 of PED, denoted as Sound Engineering Practice (SEP).

- EJX110A-□MS, EJX110A-□HS, EJX110A-□VS, EJ□130□, EJ□440□, and EJA110E with /HG can be used above 200 bar and therefore considered as a part of a pressure retaining vessel where category III, Module H applies. These models with option code /PE3 conform to that category.

(2) Technical Data

- Models without /PE3
Article 3, Paragraph 3 of PED, denoted as Sound Engineering Practice (SEP).
- Models with /PE3
Module: H
Type of Equipment: Pressure Accessory-Vessel
Type of fluid: Liquid and Gas
Group of fluid: 1 and 2

Model	Capsule code	PS*1 (bar)	V(L)	PS.V (bar.L)	Category*2
EJA110E	M, H, V	160	0.01	1.6	Article 3, Paragraph 3 (SEP)
EJ□110□	F, L				
EJX110A	M, H, V	250	0.01	2.5	
EJA110E with code /HG					
EJ□110□ with code /PE3	M, H, V	250	0.01	2.5	III
EJ□130□	M, H	500	0.01	5.0	Article 3, Paragraph 3 (SEP)
EJ□130□ with code /PE3	M, H	500	0.01	5.0	III
EJ□310□	L, M, A, B	160	0.01	1.6	Article 3, Paragraph 3 (SEP)
EJ□430□	H, A, B	160	0.01	1.6	Article 3, Paragraph 3 (SEP)
EJ□440□	C, D	500	0.1	5.0	Article 3, Paragraph 3 (SEP)
EJ□440□ with code /PE3	C, D	500	0.1	5.0	III

*1: PS is maximum pressure for vessel itself based on Pressure Equipment Directive 97/23/EC. Refer to General Specification for maximum working pressure of a transmitter.

*2: Referred to Table 1 covered by ANNEX II of EC Directive on Pressure Equipment Directive 97/23/EC

(3) Operation**CAUTION**

- The temperature and pressure of fluid should be maintained at levels that are consistent with normal operating conditions.
- The ambient temperature should be maintained at a level that is consistent with normal operating conditions.
- Please take care to prevent water hammer and the like from inducing excessive pressures in pipes and valves. If phenomena are likely, install a safety valve or take some other appropriate measure to prevent pressure from exceeding PS.
- Take appropriate measures at the device or system level to protect transmitters if they are to be operated near an external heat source.

2.12 Safety Requirement Standards

Applicable standard: EN61010-1,
EN61010-2-30

(1) Pollution Degree 2

"Pollution degree" describes the degree to which a solid, liquid, or gas which deteriorates dielectric strength or surface resistivity is adhering. " 2 " applies to normal indoor atmosphere. Normally, only non-conductive pollution occurs. Occasionally, however, temporary conductivity caused by condensation must be expected.

(2) Installation Category I

"Overvoltage category (Installation category)" describes a number which defines a transient overvoltage condition. It implies the regulation for impulse withstand voltage. " I " applies to electrical equipment which is supplied from the circuit when appropriate transient overvoltage control means (interfaces) are provided.

(3) Altitude of installation site:

Max. 2,000 m above sea level

(4) Indoor/Outdoor use

3. Component Names

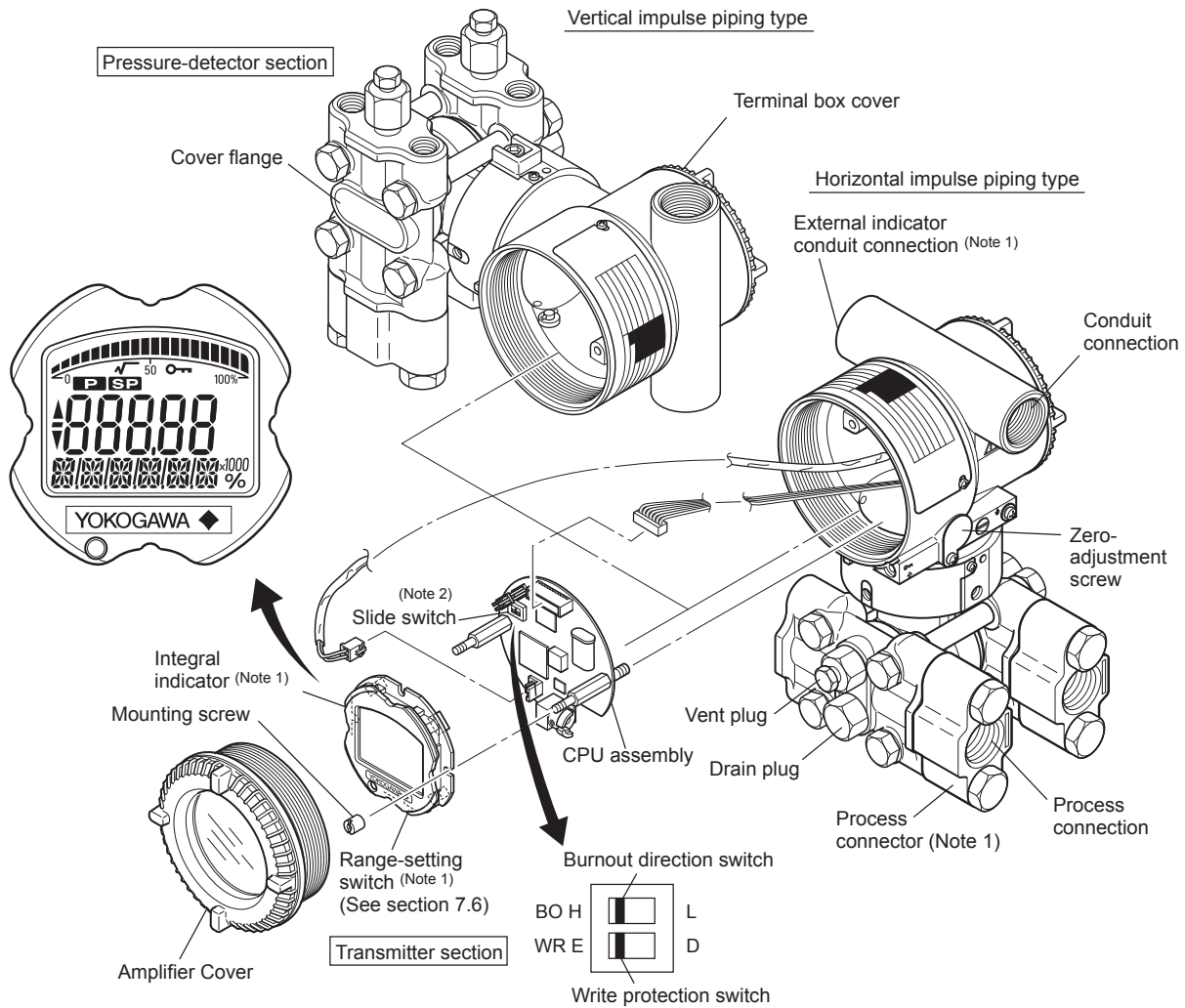

Burnout direction switch (BO)				Hardware write protection switch (WR)				
Burnout Direction Switch Position	H	L	E	D	H	L	E	D
Burnout Direction	HIGH		LOW		NO (Write enabled)		YES (Write disabled)	

Note 1: See subsection 9.2, "Model and Suffix Codes," for details. A process connector will not be applied for lower side of EJ□310□, EJ□430□, and EJ□440□.

Note 2: Applicable for BRAIN/HART communication type. Set the switches as shown in the figure above to set the burn-out direction and write protection. The Burnout switch is set to the H side for delivery (unless option code /C1 or /C2 is specified in the order), and the hardware write protection switch is set to E side. The setting of the switches can be confirmed via communication. An external zero adjustment screw can only be disabled by communication. To disable the screw, set a parameter before activating the hardware write protect function. See each communication manual.

Figure 3.1 Component Names

Table 3.1 Display Symbol

Display Symbol	Meaning of Display Symbol
√	Display mode is 'square root'. (Display is not lit when 'linear' mode.)
▲	The output signal being zero-adjusted is increasing. Besides, this symbol lights when local parameter setting is in progress.
▼	The output signal being zero-adjusted is decreasing. Besides, this symbol lights when local parameter setting is in progress.
Ⓚ	Write protect function is enabled.

F0302.ai

4. Installation

4.1 Precautions

Before installing the transmitter, read the cautionary notes in section 2.4, "Selecting the Installation Location." For additional information on the ambient conditions allowed at the installation location, refer to subsection 9.1 "Standard Specifications."



IMPORTANT

- When welding piping during construction, take care not to allow welding currents to flow through the transmitter.
- Do not step on this instrument after installation.
- For the EJ□430□ and EJ□440□, the atmospheric opening is located on the low pressure side cover flange. The opening must not face upward. See section 9.4, "Dimensions," for the location of the opening.

4.2 Mounting

- The transmitter is shipped with the process connection, according to the ordering specifications. To change the orientation of the process connections, refer to section 4.3.
- With differential pressure transmitters, the distance between the impulse piping connection ports is usually 54 mm (figure 4.1). By changing the orientation of the process connector, the dimension can be changed to 51 mm or 57 mm.
- The transmitter can be mounted on a nominal 50 mm (2-inch) pipe using the mounting bracket supplied, as shown in figure 4.2 and 4.3. The transmitter can be mounted on either a horizontal or a vertical pipe.
- When mounting the bracket on the transmitter, tighten the (four) bolts that hold the transmitter with a torque of approximately 39 N·m {4kgf·m}.

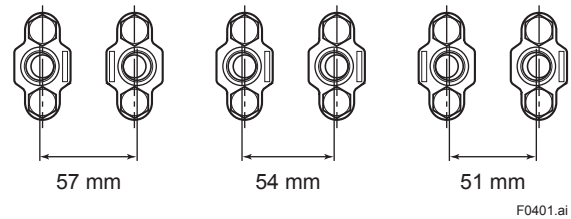
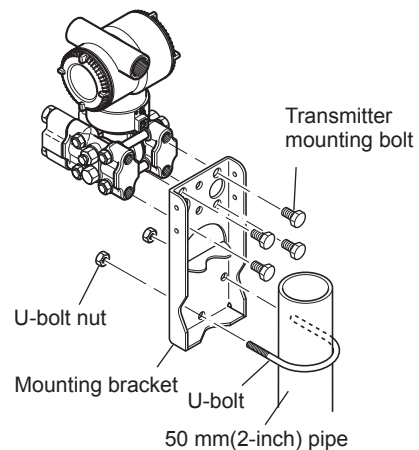

Figure 4.1 Process Connector Impulse Piping Connection Distances for Differential Pressure Transmitters

Figure 4.1 and 4.2 shows the mounting of the transmitter for horizontal piping and vertical piping with using the mounting bracket. The transmitters with the installation code -U (Universal flange) can be used for either type of mounting.

Vertical pipe mounting



Horizontal pipe mounting

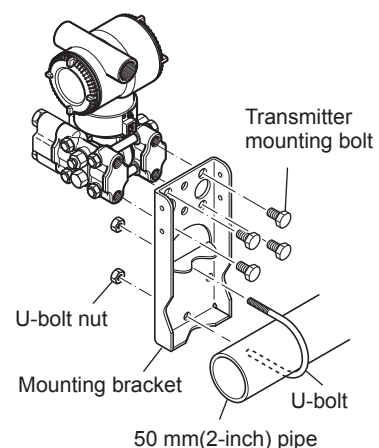
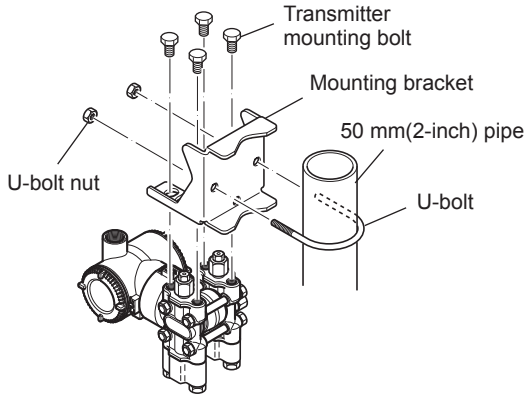

Figure 4.2 Transmitter Mounting (Horizontal Impulse Piping Type)

F0402.ai

Vertical pipe mounting
(Process connector downside)



Vertical pipe mounting
(Process connector upside)

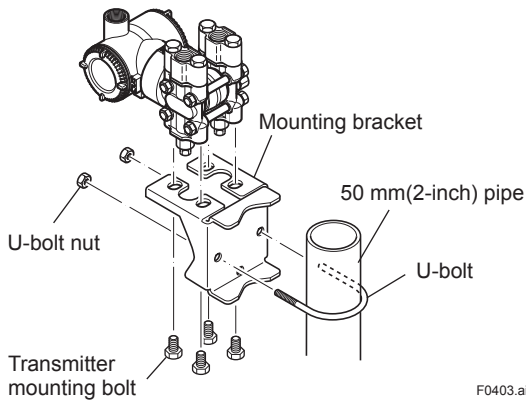

F0403.ai

Figure 4.3 Transmitter Mounting (Vertical Impulse Piping Type)

4.3 Changing the Process Connection

The transmitter is shipped with the process connection specified at the time of ordering. To change the process connection, the drain (vent) plug must be repositioned.

To reposition a drain (vent) plug, use a wrench to slowly and gently unscrew it. Then, remove and remount it on the opposite side. Wrap sealing tape around the drain (vent) plug threads (*1 in the figure below), and apply a lubricant to the threads of the drain (vent) screw(s) (*2 below). To tighten the drain (vent) plugs, apply a torque of 34 to 39 N·m (3.5 to 4 kgf·m). Process connector bolts are to be tightened uniformly to a torque shown in table 4.1.

Table 4.1 Torque

Model	EJ□110□ EJ□120□ EJ□130□ EJ□310□ EJ□430□	EJ□440□	
		C capsule	D capsule
Torque(N·m) {kgf·m}	39 to 49 {4 to 5}	49 to 59 {5 to 6}	

Vertical impulse piping type

Horizontal impulse piping type

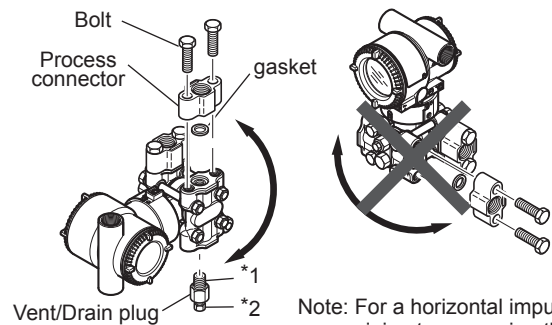

Note: For a horizontal impulse piping type, moving the process connectors from the front side to the back cannot be made.

F0404.ai

Figure 4.4 Changing Process Connection

4.4 Swapping the High/Low-pressure Side Connection



IMPORTANT

This section is applicable only for EJ□110□, EJ□120□, and EJ□130□ differential transmitters, and not applicable for gauge or absolute pressure transmitters.

4.4.1 Rotating Pressure-detector Section 180°

This procedure can be applied only to a transmitter with a vertical impulse piping type.

The procedure below can be used to turn the pressure detector assembly 180°. Perform this operation in a maintenance shop with the necessary tools laid out and ready for use, and then install the transmitter in the field after making the change.

- 1) Use an Allen wrench (JIS B4648, nominal 2.5 mm) to remove the two setscrews at the joint between the pressure-detector section and transmitter section.
- 2) Leaving the transmitter section in position, rotate the pressure-detector section 180°.
- 3) Tighten the two setscrews to fix the pressure-detector section and transmitter section together (at a torque of 1.5 N·m).

Reposition the process connector and drain (vent) plugs to the opposite side as described in subsection 4.3.

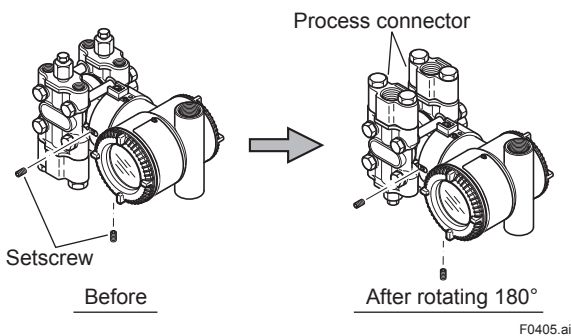

Figure 4.5 Before and After Modification

4.4.2 Using the Communicator

This method is applicable only to the Model EJ□110□, EJ□120□, and EJ□130□.

With a communicator, you can change which process connection is used as the high-pressure side without mechanically rotating the pressure-detector section 180 as described in subsection 4.4.1. To change, call parameter 'D15: H/L SWAP' for BRAIN Communication or 'H/L swap' for HART Communication and select REVERSE (right side: low pressure; left side: high pressure) or select NORMAL to change back to normal (right side: high pressure; left side: low pressure).

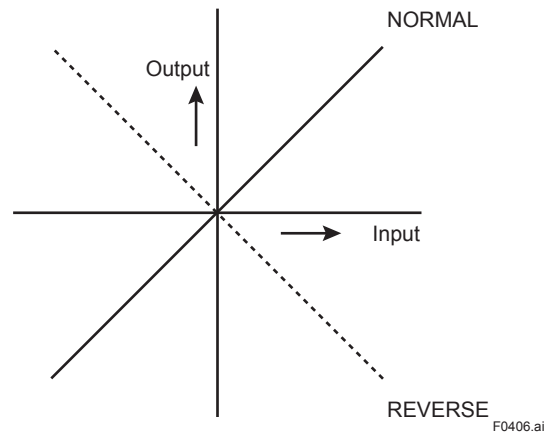

Figure 4.6 Input/Output Relationship



IMPORTANT

Since the H/L label plate on the capsule assembly will remain unchanged, use this function only when you cannot switch the impulse piping. If the 'H/L SWAP' parameter setting is changed, the input/output relationship is reversed as shown in figure 4.6; be sure this is understood by all.

4.5 Rotating Transmitter Section

The transmitter section can be rotated approximately 360° (180° to either direction or 360° to one direction from the original position at shipment, depending on the configuration of the instrument.) It can be fixed at any angle within above range.

- 1) Remove the two setscrews that fasten the transmitter section and capsule assembly, using the Allen wrench.
- 2) Rotate the transmitter section slowly and stop it at designated position.
- 3) Tighten the two setscrews to a torque of 1.5 N·m.



IMPORTANT

Do not rotate the transmitter section more than the above limit.

Vertical impulse piping type

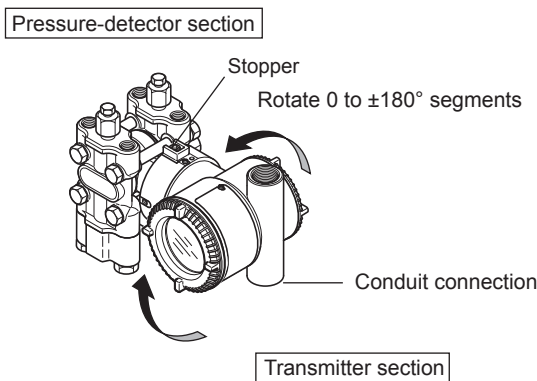

Horizontal impulse piping type

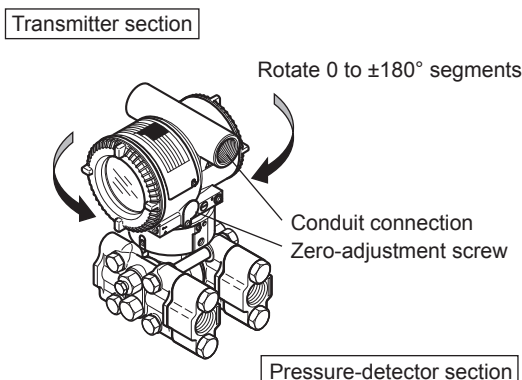

F0407.ai

Figure 4.7 Rotating Transmitter Section (Left Side High Pressure Type)

4.6 Changing the Direction of Integral Indicator



IMPORTANT

Always turn OFF power, release pressure and remove a transmitter to non-hazardous area before disassembling and reassembling an indicator.

An integral indicator can be installed in the following three directions. Follow the instructions in section 8.4 for removing and attaching the integral indicator.

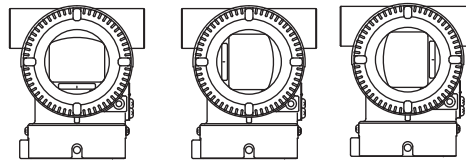

F0408.ai

Figure 4.8 Integral Indicator Direction

5. Installing Impulse Piping

5.1 Impulse Piping Installation Precautions

The impulse piping that connects the process outputs to the transmitter must convey the process pressure accurately. If, for example, gas collects in a liquid-filled impulse line, or the drain for a gas-filled impulse line becomes plugged, it will not convey the pressure accurately. Since this will cause errors in the measurement output, select the proper piping method for the process fluid (gas, liquid, or steam). Pay careful attention to the following points when routing the impulse piping and connecting the impulse piping to a transmitter.

5.1.1 Connecting Impulse Piping to a Transmitter

(1) Check the High and Low Pressure Connections on the Transmitter (Figure 5.1)

Symbols “H” and “L” have been placed on the capsule assembly to indicate high and low pressure side. With differential pressure transmitters, connect the high pressure side impulse line to the “H” side, and the low pressure side impulse line to the “L” side.

With gauge/absolute pressure transmitters, connect the impulse line to the ‘H’ side.

Differential Pressure Transmitter

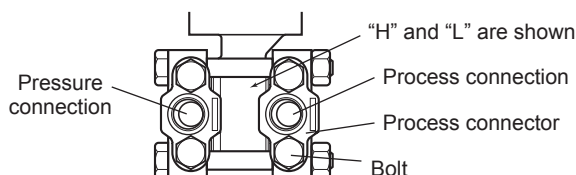

Gauge/Absolute Pressure Transmitters

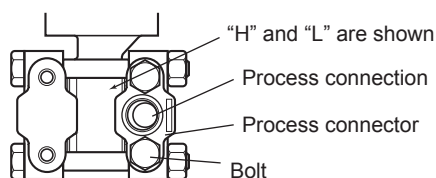

F0501.ai

Figure 5.1 “H” and “L” Symbols on a Capsule Assembly

(2) Changing the Process Connector Piping Connections (Figure 4.1) (for differential pressure transmitters)

The impulse piping connection distances can be changed between 51 mm, 54 mm and 57 mm by changing the orientation of the process connectors. This is convenient for aligning an impulse line with a process connectors.

(3) Tightening the Process Connector Mounting Bolts

After connecting an impulse line, tighten the process connector mounting bolts uniformly.

(4) Removing the Impulse Piping Connecting Port Dustproof Cap

The impulse piping connecting port on the transmitter is covered with a plastic cap to keep out dust. This cap must be removed before connecting the line. (Be careful not to damage the threads when removing this cap. Never insert a screwdriver or other tool between the cap and port threads to remove the cap.)

(5) Connecting the Transmitter and 3-Valve Manifold (for differential pressure transmitters)

A 3-valve manifold consists of two stop valves to block process pressure and an equalizing valve to equalize the pressures on the high and low pressure sides of the transmitter. Such a manifold makes it easier to disconnect the transmitter from the impulse piping, and is convenient when adjusting the transmitter zero point.

There are two 3-valve manifold types: the pipe-mounting type and the direct-mounting type; care should be taken with respect to the following points when connecting the manifold to the transmitter.

■ **Pipe-Mounting Type 3-Valve Manifold (Figure 5.2)**

- 1) Screw nipples into the connection ports on the transmitter side of the 3-valve manifold, and into the impulse piping connecting ports on the process connectors. (To maintain proper sealing, wind sealing tape around the nipple threads.)
- 2) Mount the 3-valve manifold on the 50 mm (2-inch) pipe by fastening a U-bolt to its mounting bracket. Tighten the U-bolt nuts only lightly at this time.
- 3) Install the pipe assemblies between the 3-valve manifold and the process connectors and lightly tighten the ball head lock nuts. (The ball-shaped ends of the pipes must be handled carefully, since they will not seal properly if the ball surface is scratched or otherwise damaged.)
- 4) Now tighten the nuts and bolts securely in the following sequence:
 Process connector bolts → transmitter-end ball head lock nuts → 3-valve manifold ball head lock nuts → 3-valve manifold mounting bracket U-bolt nuts

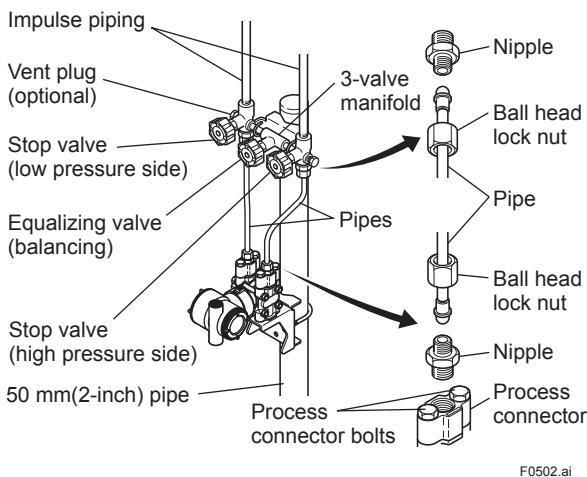

Figure 5.2 3-Valve Manifold (Pipe-Mounting Type)

■ **Direct-Mounting Type 3-Valve Manifold (Figure 5.3)**

- 1) Mount the 3-valve manifold on the transmitter. (When mounting, use the two gaskets and the four bolts provided with the 3-valve manifold. Tighten the bolts evenly.)
- 2) Mount the process connectors and gaskets on the top of the 3-valve manifold (the side on which the impulse piping will be connected).

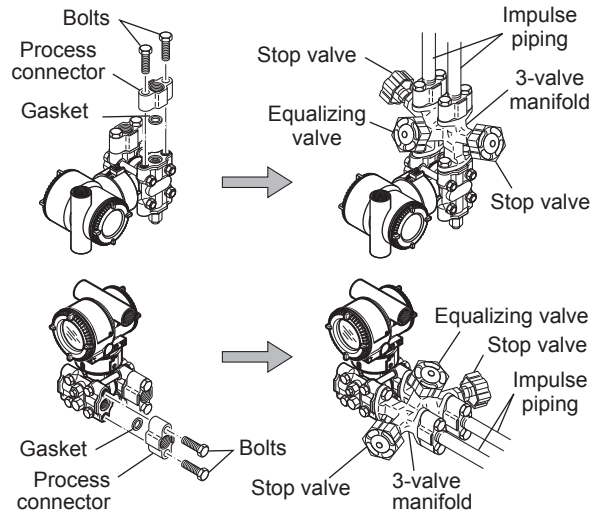

Figure 5.3 3-Valve Manifold (Direct-Mounting Type)



NOTE

After completing the connection of the transmitter and 3-valve manifold, be sure to CLOSE the low pressure and high pressure stop valves, OPEN the equalizing valve, and leave the manifold with the equalizing valve OPEN. You must do this in order to avoid overloading the transmitter from either the high or the low pressure side when beginning operation. This instruction must also be followed as part of the startup procedure (chapter 7.)

5.1.2 Routing the Impulse Piping

(1) Process Pressure Tap Angles

If condensate, gas, sediment or other extraneous material in the process piping gets into the impulse piping, pressure measurement errors may result. To prevent such problems, the process pressure taps must be angled as shown in figure 5.4 according to the kind of fluid being measured.



NOTE

- If the process fluid is a gas, the taps must be vertical or within 45° either side of vertical.
- If the process fluid is a liquid, the taps must be horizontal or below horizontal, but not more than 45° below horizontal.
- If the process fluid is steam or other condensing vapor, the taps must be horizontal or above horizontal, but not more than 45° above horizontal.

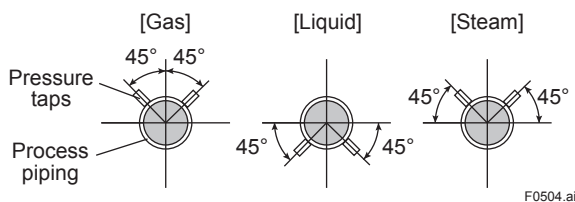

Figure 5.4 Process Pressure Tap Angle (For Horizontal Piping)

(2) Position of Process Pressure Taps and Transmitter

If condensate (or gas) accumulates in the impulse piping, it should be removed periodically by opening the drain (or vent) plugs. However, this will generate a transient disturbance in the pressure measurement, and therefore it is necessary to position the taps and route the impulse piping so that any extraneous liquid or gas generated in the leadlines returns naturally to the process piping.

- If the process fluid is a gas, then as a rule the transmitter must be located higher than the process pressure taps.
- If the process fluid is a liquid or steam, then as a rule the transmitter must be located lower than the process pressure taps.

(3) Impulse Piping Slope

The impulse piping must be routed with only an upward or downward slope. Even for horizontal routing, the impulse piping should have a slope of at least 1/10 to prevent condensate (or gases) from accumulating in the pipes.

(4) Temperature Difference Between Impulse Lines (for differential pressure transmitters)

If there is a temperature difference between the high and low impulse lines, the density difference of the fluids in the two lines will cause an error in the measurement pressure. When measuring flow, impulse lines must be routed together so that there is no temperature difference between them.

(5) Condensate Pots for Steam Flow Measurement (for differential pressure transmitters)

If the liquid in the impulse piping repeatedly condenses or vaporizes as a result of changes in the ambient or process temperature, this will cause a difference in the fluid head between the high pressure and low pressure sides. To prevent measurement errors due to these head differences, condensate pots are used when measuring steam flow.

(6) Preventing Wind Speed Effects in Very Low Differential Pressure Measurement (for differential pressure transmitters)



IMPORTANT

When using a differential pressure transmitter to measure very low pressures (draft pressure), the low pressure connection port is left open to atmospheric pressure (the reference pressure). Any wind around the differential pressure transmitter will therefore cause errors in the measurement. To prevent this, it will be necessary either to enclose the transmitter in a box, or to connect an impulse line to the low pressure side and insert its end into a wind-excluding pot (cylindrical with a base plate).

(7) Preventing Freezing

If there is any risk that the process fluid in the impulse piping or transmitter could freeze, use a steam jacket or heater to maintain the temperature of the fluid.



NOTE

After completing the connections, close the valves on the process pressure taps (main valves), the valves at the transmitter (stop valves), and the impulse piping drain valves, so that condensate, sediment, dust and other extraneous material cannot enter the impulse piping.

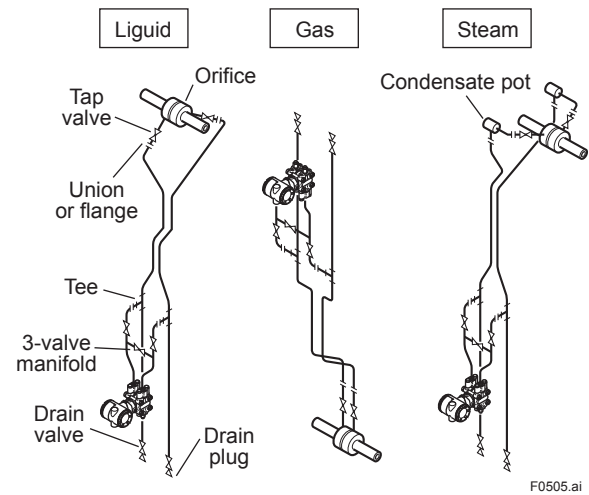

Figure 5.5 Impulse Piping Connection Examples for Differential Pressure Transmitters

5.2 Impulse Piping Connection Examples

Figure 5.5 and 5.6 show examples of typical impulse piping connections. Before connecting the transmitter to the process, study the transmitter installation location, the process piping layout, and the characteristics of the process fluid (corrosiveness, toxicity, flammability, etc.), in order to make appropriate changes and additions to the connection configurations.

Note the following points when referring to these piping examples.

- The high pressure connecting port on the transmitter is shown on the right (as viewed from the front).
- The transmitter impulse piping connection is shown for a vertical impulse piping connection configuration in which the direction of connection is either upwards or downwards.
- If the impulse line is long, bracing or supports should be provided to prevent vibration.
- The impulse piping material used must be compatible with the process pressure, temperature, and other conditions.
- A variety of process pressure tap valves (main valves) are available according to the type of connection (flanged, screwed, welded), construction (globe, gate, or ball valve), temperature and pressure. Select the type of valve most appropriate for the application.

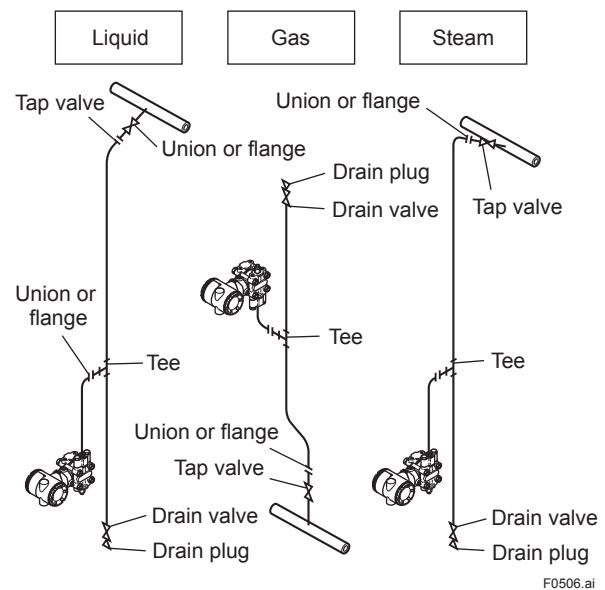

Figure 5.6 Impulse Piping Connection Examples for Gauge/absolute Pressure Transmitters

6. Wiring

6.1 Wiring Precautions



IMPORTANT

- Lay wiring as far as possible from electrical noise sources such as large capacity transformers, motors, and power supplies.
- Remove the electrical connection dust cap before wiring.
- All threaded parts must be treated with waterproofing sealant. (A non-hardening silicone group sealant is recommended.)
- To prevent noise pickup, do not pass signal and power cables through the same ducts.
- Explosion-protected instruments must be wired in accordance with specific requirements (and, in certain countries, legal regulations) in order to preserve the effectiveness of their explosion-protected features.
- The terminal box cover is locked by an Allen head bolt (a shrouding bolt) on ATEX flameproof type transmitters. When the shrouding bolt is driven clockwise using an Allen wrench, it goes in. The cover lock can then be released and the cover can be opened by hand. See subsection 8.4 “Disassembly and Reassembly” for details.
- Plug and seal an unused conduit connection.

6.2 Selecting the Wiring Materials

- Use stranded leadwires or cables which are the same as or better than 600 V grade PVC insulated wire (JIS C3307) or its equivalent.
- Use shielded wires in areas that are susceptible to electrical noise.
- In areas with higher or lower ambient temperatures, use appropriate wires or cables.
- In environment where oils, solvents, corrosive gases or liquids may be present, use wires or cables that are resistant to such substances.
- It is recommended that crimp-on solderless terminal lugs (for 4 mm screws) with insulating sleeves be used for leadwire ends.

6.3 Connections of External Wiring to Terminal Box

• Terminal Configuration

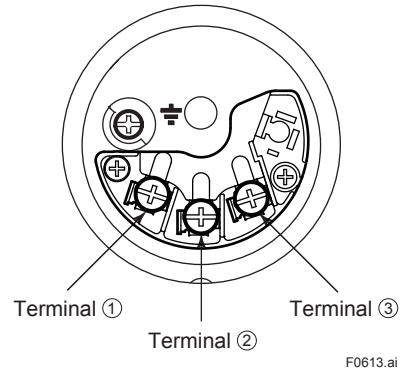

F0613.ai

• Terminal Wiring for 4 to 20 mA output, FOUNDATION Fieldbus type, and PROFIBUS PA type.

SUPPLY	+	①	Power supply and output terminals
	-	②	
CHECK	+	③	External indicator (ammeter) terminals ^{*1,2}
or	-	②	
ALARM	+	③	Status contact output terminals ² (when /AL is specified)
	-	②	
			⏏ Ground terminal

*1: When using an external indicator or check meter, the internal resistance must be 10 Ω or less. A check meter or indicator cannot be connected when /AL option is specified.

*2: Not available for FOUNDATION Fieldbus and PROFIBUS PA communication types.

• Terminal Wiring for 1 to 5 V output

SUPPLY	+	①	Power supply terminals
	-	②	
VOUT	+	③	1 to 5 V DC with HART communication terminals
	-	②	
			⏏ Ground terminal

F0614.ai

Figure 6.1 Terminal

6.3.1 Power Supply Wiring Connection



IMPORTANT

Connecting with the commercial AC power supply will damage the device. Be sure to use the DC power supply in the predetermined range.

Connect the power supply wiring to the SUPPLY + and – terminals. When /AL is specified, also refer to subsection 6.3.5.

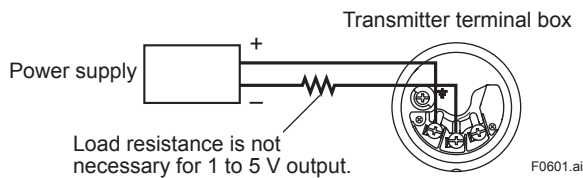

Figure 6.2 Power Supply Wiring Connection

6.3.2 External Indicator Connection

Available only for 4 to 20mA output type and when /AL is not specified.

Connect wiring for external indicators to the CHECK (+) and SUPPLY – terminals.

(Note) Use an external indicator whose internal resistance is 10 Ω or less.

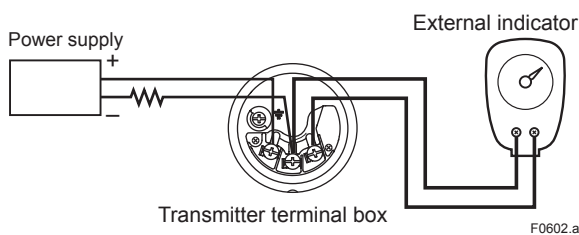

Figure 6.3 External Indicator Connection

6.3.3 Communicator Connection

- 4 to 20 mA output, BRAIN / HART



IMPORTANT

Analog output may change temporarily in connecting with BRAIN terminal due to an initial current flowed to it. To prevent communication signal affecting the upper system, it is recommended to install a low-pass filter (approximately 0.1s)

Connect the BT200 or HART Communicator to the SUPPLY + and – terminals. (Use hooks.)

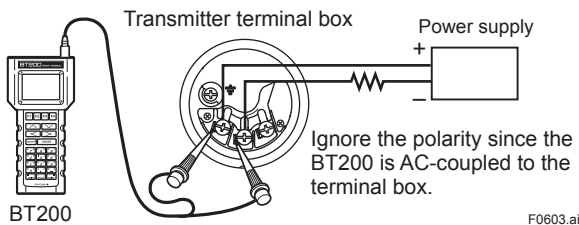

Figure 6.4 BT200 Connection

- 1 to 5 V output, HART
Connect the HART communicator or configuration tool to the SUPPLY - and VOUT (+) terminals. (Use hooks.)

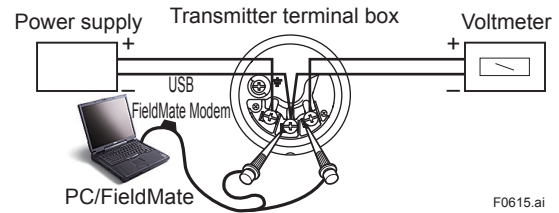

Figure 6.5 Four wire connection

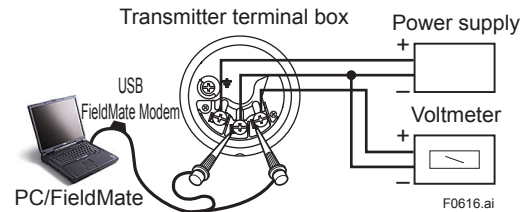

Figure 6.6 Three wire connection

6.3.4 Check Meter Connection

Available only for 4 to 20mA output type and when /AL is not specified.

Connect the check meter to the CHECK (+) and SUPPLY – terminals. (Use hooks.)

- A 4 to 20 mA DC output signal from the CHECK (+) and SUPPLY – terminals.

(Note) Use a check meter whose internal resistance is 10 Ω or less.

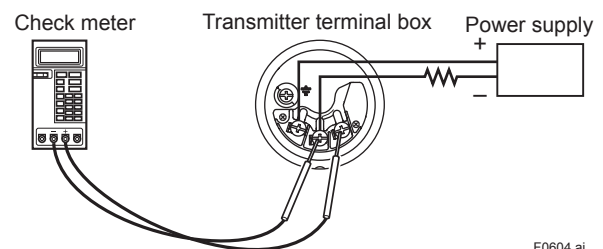

Figure 6.7 Check Meter Connection

6.3.5 Status Output Connection

When option code /AL is specified, connect the external wiring as shown in Figure 6.5.

To configure and activate the process alarm function and status output, it is necessary to set some parameters. Refer to each communication manual for procedures.

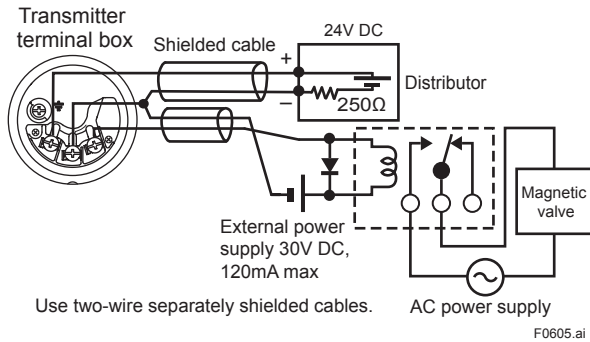

Figure 6.8 Status Output Connection

6.4 Wiring

6.4.1 Loop Configuration

Since the DPharp uses a two-wire transmission system for 4 to 20 mA output, signal wiring is also used as power wiring.

DC power is required for the transmitter loop. The transmitter and distributor are connected as shown below.

For details of the power supply voltage and load resistance, see section 6.6; for communications line requirements, see section 9.1.

For 1 to 5 V output, three or four wire system is used. See (3).

(1) 4 to 20 mA output, General-use Type and Flameproof Type

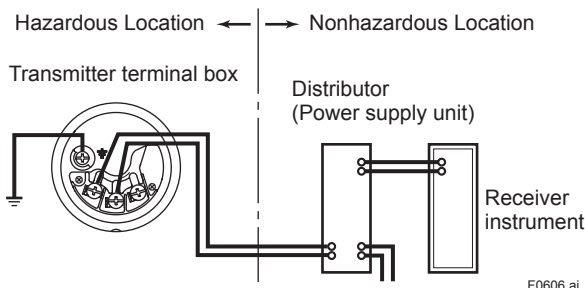

Figure 6.9 Connection between Transmitter and Distributor

(2) 4 to 20 mA output, Intrinsically Safe Type

With the intrinsically safe type, a safety barrier must be included in the loop.

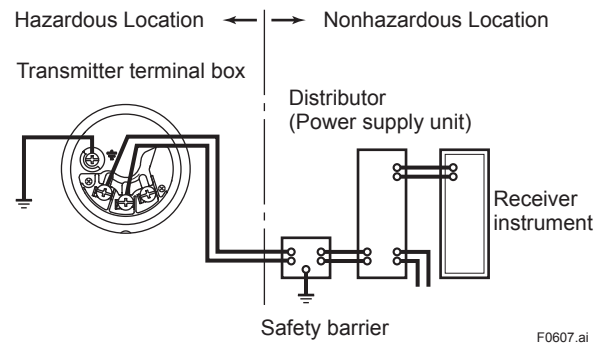

Figure 6.10 Connection between Transmitter and Distributor

(3) 1 to 5 V output

Either three or four wire system is used.

Power supply line and 1 to 5 V signal line commonly use the SUPPLY - terminal.



NOTE

With three wire connection, the cable length may affect the measurement accuracy of the output signal.

In either three-wire or four-wire connection, recommended wiring distance is 200 m or less, and the use of shielded cable is recommended.

■ Three wire connection

For three wire system, a negative wiring shall be commonly used for power supply and signal line.

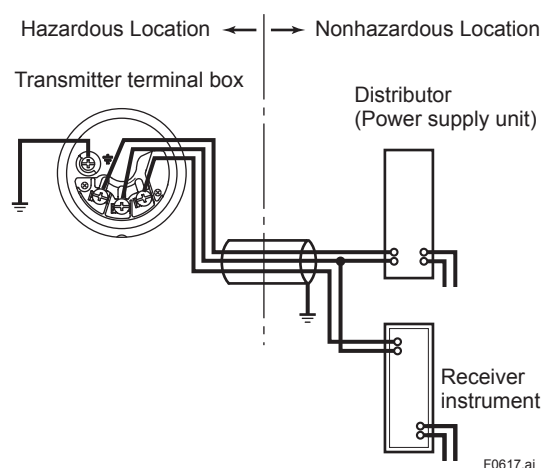

Figure 6.11 Connection between Transmitter, Distributor and Receiver

- Four wire connection
Fasten the negative side wiring of both power supply and signal line to the SUPPLY - terminal.

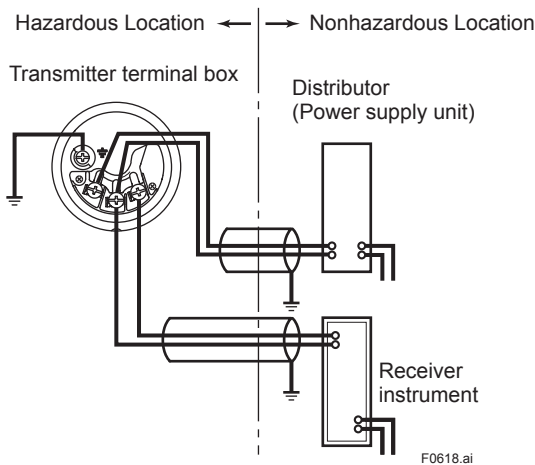

Figure 6.12 Connection between Transmitter, Distributer and Receiver

6.4.2 Wiring Installation

(1) General-use Type and Intrinsically Safe Type

With the cable wiring, use a metallic conduit or waterproof glands.

- Apply a non-hardening sealant to the terminal box connection port and to the threads on the flexible metal conduit for waterproofing.

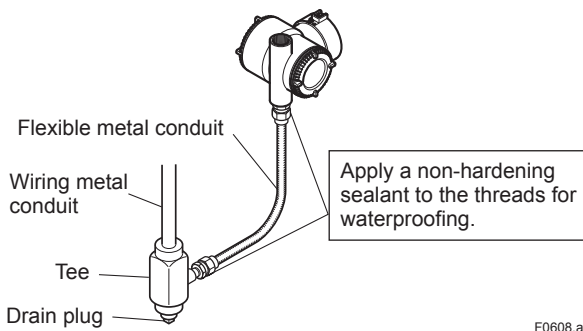

Figure 6.13 Typical Wiring Using Flexible Metal Conduit

(2) Flameproof Type

Wire cables through a flameproof packing adapter, or use a flameproof metal conduit.

- Wiring cable through flameproof packing adapter.
 - Apply a non-hardening sealant to the terminal box connection port and to the threads on the flameproof packing adapter for waterproofing.

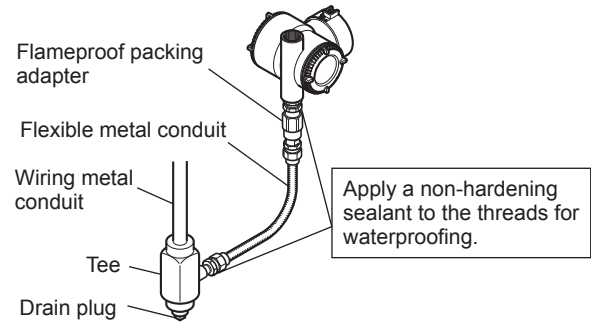

Figure 6.14 Typical Cable Wiring Using Flameproof Packing Adapter

- Flameproof metal conduit wiring

- A seal fitting must be installed near the terminal box connection port for a sealed construction.
- Apply a non-hardening sealant to the threads of the terminal box connection port, flexible metal conduit and seal fitting for waterproofing.

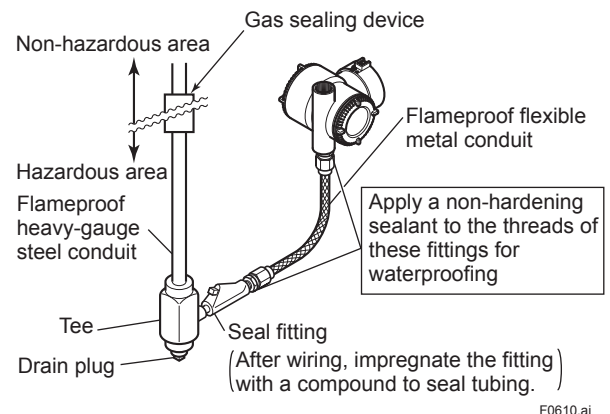

Figure 6.15 Typical Wiring Using Flameproof Metal Conduit

6.5 Grounding

Grounding is always required for the proper operation of transmitters. Follow the domestic electrical requirements as regulated in each country. For a transmitter with a built-in lightning protector, grounding should satisfy ground resistance of 10Ω or less.

Ground terminals are located on the inside and outside of the terminal box. Either of these terminals may be used.

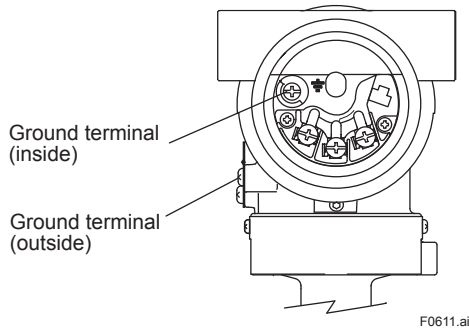

Figure 6.16 Ground Terminals

6.6 Power Supply Voltage and Load Resistance

For 4 to 20 mA output only.

When configuring the loop, make sure that the external load resistance is within the range in the figure below.

(Note) In case of an intrinsically safe transmitter, external load resistance includes safety barrier resistance.

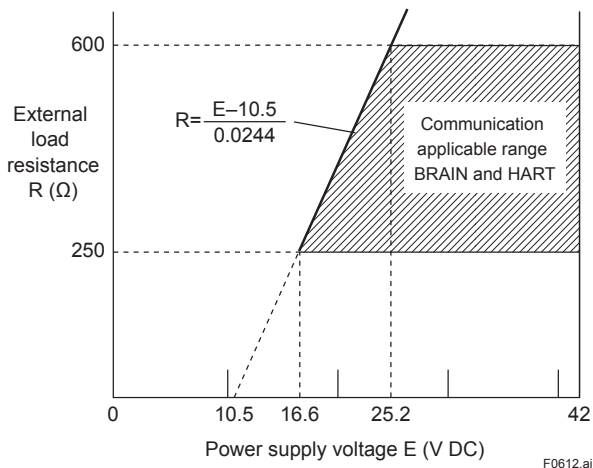

Figure 6.17 Relationship between Power Supply Voltage and External Load Resistance

7. Operation

7.1 Preparation for Starting Operation

This section describes the operation procedure for the EJ□110□, EJ□120□ and EJ□130□ as shown in figure 7.1a (vertical impulse piping type, high-pressure connection: right side) when measuring the liquid flow rate, and EJ□430□, EJ□440□ and EJ□310□ as shown in figure 7.1b when measuring pressure.



NOTE

Check that the process pressure tap valves, drain valves, and 3-valve manifold stop valves on both the low pressure and high pressure sides are closed, and that the 3-valve manifold equalizing valve is opened.

- (a) Follow the procedures below to introduce process pressure into the impulse piping and transmitter.

■ Differential Pressure Transmitters

- 1) Open the low pressure and high pressure tap valves to fill the impulse piping with process liquid.
- 2) Slowly open the high pressure stop valve to fill the transmitter pressure-detector section with process liquid.
- 3) Close the high pressure stop valve.
- 4) Gradually open the low pressure stop valve and completely fill the transmitter pressure-detector section with process liquid.
- 5) Close the low pressure stop valve.
- 6) Gradually open the high pressure stop valve. At this time, equal pressure is applied to the low and high pressure sides of the transmitter.
- 7) Check that there are no liquid leaks in the impulse piping, 3-valve manifold, transmitter, or other components.

■ Gauge/Absolute Pressure Transmitters

- 1) Open the tap valve (main valve) to fill the impulse piping with process fluid.
- 2) Gradually open the stop valve to introduce process fluid into the transmitter pressure-detector section.
- 3) Confirm that there is no pressure leak in the impulse piping, transmitter, or other components.

Venting Gas from the Transmitter Pressure-detector Section

- Since the piping in the example of figure 7.1 is constructed to be self-venting, no venting operation is required. If it is not possible to make the piping self-venting, refer to subsection 7.5 for instructions. Leave the equalizing valve open even after venting gas.
- (b) Turn ON power and connect the communicator. Open the terminal box cover, and connect the communicator to the SUPPLY + and – terminals.
 - (c) Using the communicator, confirm that the transmitter is operating properly. Check parameter values or change the setpoints as necessary. See IM 01C25T03-01E (BRAIN communication) or IM 01C25T01-06EN (HART communication) for communicator operation. If the transmitter is equipped with an integral indicator, its indication can be used to confirm that the transmitter is operating properly.

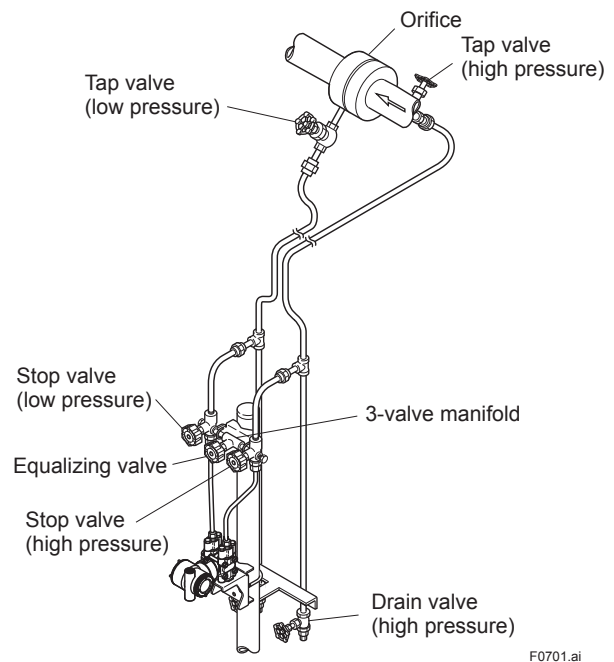

F0701.ai

Figure 7.1a Liquid Flow Measurement

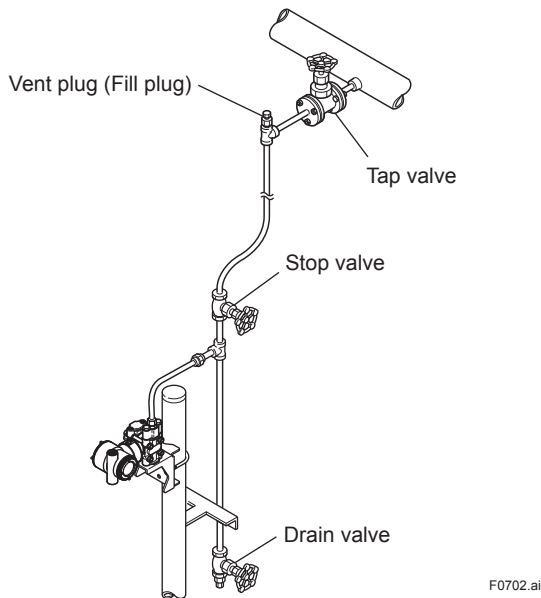

Figure 7.1b Liquid Pressure Measurement

■ **Confirming that Transmitter is Operating Properly**

Using the BT200



IMPORTANT

- Analog output may change temporally in connecting with BRAIN terminal due to an initial current flowed to it. To prevent communication signal affecting the upper system, it is recommended to install a low-pass filter (approximately 0.1s).
- Communication signal is superimposed on analog output signal. It is recommended to set a low-pass filter (approximately 0.1s) to the receiver in order to reduce the output effect from communication signal. Before online-communication, confirm that communication signal does not give effect on the upper system.

- If the wiring system is faulty, 'communication error' appears on the display.
- If the transmitter is faulty, 'SELF CHECK ERROR' appears on the display.

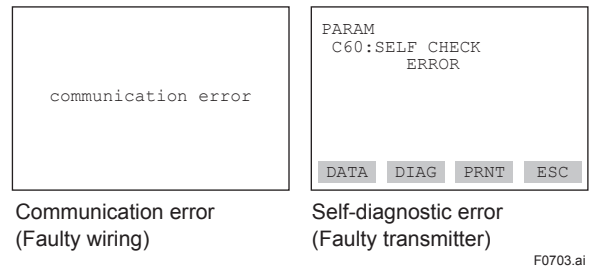

Figure 7.2 BT200 Display

Using the integral indicator

- If the wiring system is faulty, the display stays blank.
- If the transmitter is faulty, an error code is displayed.



Self-diagnostic error on the integral indicator (Faulty transmitter)

F0704.ai

Figure 7.3 Integral Indicator with Error Code



NOTE

If any of the above errors are indicated on the display of the integral indicator or the communicator, refer to subsection 8.5.3 for the corrective action.

■ **Verify and Change Transmitter Parameter Setting and Values**

The parameters related to the following items are set at factory as specified in order.

- Calibration range
- Integral indicator display
- Output mode
- Software damping (optional)

Other parameters like following are shipped with the default setting.

- Low-cut
- Process alarm setting
- Static pressure range
- Signal characterizer
- Write protection

To confirm or change the values, see IM 01C25T01-06EN or 01C25T03-01E.

7.2 Zero Point Adjustment

After completing preparations for operating the transmitter, adjust the zero point.

Zero point adjustment can be done by turning the transmitter's zero-adjustment screw or by using the communicator. This section describes the procedure for the zero-adjustment screw. For the communicator procedure, see the communication manual.



IMPORTANT

Do not turn off the power to the transmitter immediately after performing a zero point adjustment. Powering off within 30 seconds of performing this procedure will return the zero point to its previous setting.



NOTE

Before performing this adjustment, make sure that the external zero adjustment function has NOT been disabled by a parameter setting.

To check the output signal, use a digital multimeter, calibrator, or communicator.

7.2.1 Adjusting Zero Point for Differential Pressure Transmitters

Before adjusting zero point, make sure that the equalizing valve is open.

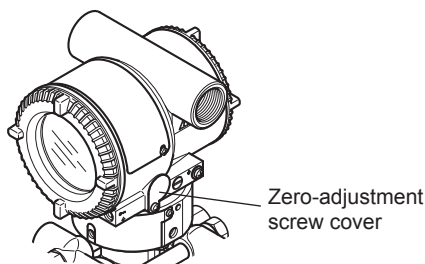

F0705.ai

Figure 7.4 External Zero Adjustment Screw

The zero-adjustment screw is located inside the cover.

Use a slotted screwdriver to turn the zero-adjustment screw. Equalize the transmitter, then turn the screw clockwise to increase the output or counterclockwise to decrease the output. The zero point adjustment can be made with a resolution of 0.01% of the setting range. The degree of zero adjustments varies with the screw turning speed; turn the screw slowly to make a fine adjustment, quickly to make a rough adjustment.

When using differential pressure transmitters for level measurement and if you cannot obtain the lower range value from the actual measurement value of 0%, refer to subsection 7.2.2(2).

7.2.2 Adjusting Zero Point for Gauge/Absolute Pressure Transmitters

(1) When you can obtain the Low Range Value from the actual measured value of 0% (0 kPa, atmospheric pressure);

For pressure measurement using gauge pressure transmitters, follow the steps below before performing zero point adjustment.

- 1) Close the tap valve (main valve).
- 2) Loosen the fill plug so that the pressure applied to the transmitter is only the head of the seal liquid.
- 3) Adjust the zero point at this status.
- 4) After the adjustment, close the fill plug and then gradually open the tap valve.

Use a slotted screwdriver to turn the zero-adjustment screw. Turn the screw clockwise to increase the output or counterclockwise to decrease the output. The zero point adjustment can be made with a resolution of 0.01% of the setting range. Since the degree of the zero adjustment varies with the screw turning speed, turn the screw slowly to make a fine adjustment and quickly to make a rough adjustment.

(2) When you cannot obtain the Low Range Value from the actual measured value of 0%;

Adjust the transmitter output to the actual measured value obtained by a digital manometer or a glass gauge.

[Example]

The measuring range of 50 to 250 kPa; the actual measured value of 130 kPa.

$$\text{Actual measured value} = \frac{130-50}{250-50} \times 100 = 40.0\% \\ (=10.4\text{mA})$$

Turn the screw to match the output signal to the actual measured value.

7.3 Starting Operation

After completing the zero point adjustment, follow the procedures below to start operation. Steps 1) and 2) are specific to the differential pressure transmitters.

- 1) Close the equalizing valve.
- 2) Gradually open the low pressure stop valve. This places the transmitter in an operational condition.
- 3) Confirm the operating status. If the output signal exhibits wide fluctuations (hunting) due to periodic variation in the process pressure, use the communicator to dampen the transmitter output signal. Confirm the hunting using a receiving instrument or the integral indicator, and set the optimum damping time constant.
- 4) After confirming the operating status, perform the following.



IMPORTANT

- Remove the communicator from the terminal box, and confirm that none of the terminal screws are loose.
- Close the terminal box cover and the amplifier cover. Screw each cover in tightly until it will not turn further.
- There are two covers that must be locked on the ATEX Flameproof type transmitters. An Allen head bolt (shrouding bolt) under the edge of each cover is used to lock the cover. When the shrouding bolt is driven counterclockwise with an Allen wrench, the bolt rotates upward and locks the cover. (See section 8.4.) After locking the covers, confirm that they are secure and cannot be opened by hand. Tighten the zero-adjustment cover mounting screw to secure the cover.
- Tighten the zero-adjustment cover mounting screw to secure the cover.

7.4 Shutting Down the Transmitter

Shut down the transmitter as follows. Steps 2) and 3) are specific to the differential pressure transmitters.

- 1) Turn off the power.
- 2) Close the low pressure stop valve.
- 3) Open the equalizing valve.
- 4) Close the high pressure stop valve.
- 5) Close the high pressure and low pressure tap valves.



NOTE

- Whenever shutting down the transmitter for a long period, remove any process fluid that is in the transmitter pressure-detector section.
- The equalizing valve must be left OPEN.

7.5 Venting or Draining Transmitter Pressure-detector Section

Since this transmitter is designed to be self-draining and self-venting with vertical impulse piping connections, neither draining nor venting will be required if the impulse piping is configured appropriately for self-draining or self-venting operation.

If condensate (or gas) collects in the transmitter pressure-detector section, the measured pressure may be in error. If it is not possible to configure the piping for self-draining (or self-venting) operation, you will need to loosen the drain (vent) screw on the transmitter to completely drain (vent) any stagnated liquid (gas.)

However, since draining condensate or bleeding off gas disturbs the pressure measurement, this should not be done when the loop is in operation.

WARNING

Since the accumulated liquid (or gas) may be toxic or otherwise harmful, take appropriate care to avoid contact with the body, or inhalation of vapors.

7.5.1 Draining Condensate

- 1) Gradually open the drain screw or drain plug and drain the transmitter pressure-detector section. (See figure 7.5.)
- 2) When all accumulated liquid is completely removed, close the drain screw or drain plug.
- 3) Tighten the drain screw to a torque of 10 N·m, and the drain plug to a torque of 34 to 39 N·m.

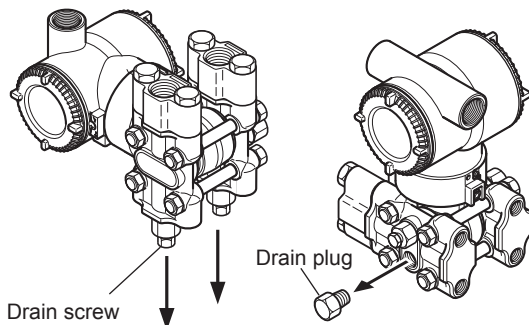

When you loosen the drain screw or drain plug, the accumulated liquid will be expelled in the direction of the arrow.

F0706.ai

Figure 7.5 Draining the Transmitter

7.5.2 Venting Gas

- 1) Gradually open the vent screw to vent gas from the transmitter pressure-detector section. (See figure 7.6.)
- 2) When the transmitter is completely vented, close the vent screw.
- 3) Tighten the vent screw to a torque of 10 N·m.

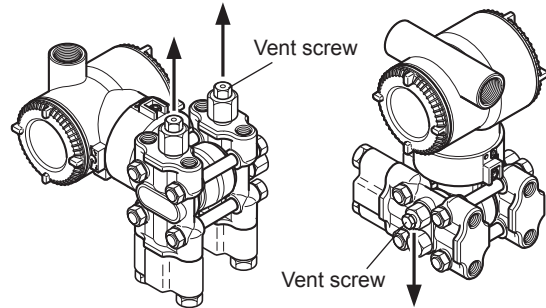

When you loosen the vent screw, the gas escapes in the direction of the arrow.

F0707.ai

Figure 7.6 Venting the Transmitter

7.6 Local Parameter Setting

WARNING

The local push button on the integral indicator must not be used in a hazardous area. When it is necessary to use the push button, operate it in a non-hazardous location.

IMPORTANT

- Do not turn off the power to the transmitter immediately after performing parameter setting. Powering off within 30 seconds of performing this procedure will return the parameter to its previous setting.
- The parameter of Ext SW must be "Enabled" to perform this configuration. See the user's manual IM 01C25T (HART/BRAIN) for the setting procedure.
- The Local Parameter Setting function is available with HART or BRAIN communication type. LCD update will be slower at low ambient temperature, and it is recommended to use LPS function at temperatures above -10 degrees C.

7.6.1 Local Parameter Setting (LPS) Overview

Parameter configuration by the external adjustment screw and push button (integral indicator code E) offers easy and quick setup for parameters of Tag number, Unit, LRV, URV, Damping, Output mode (linear/square root), Display out 1, and Re-range by applying actual pressure (LRV/URV). There is no effect on measurement signal (analog output or communication signal) when Local Parameter Setting is carried out.

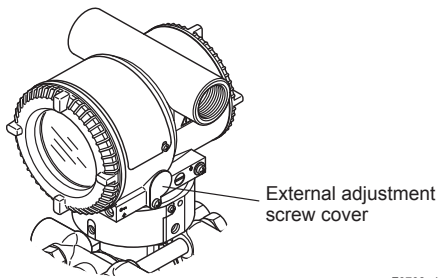

F0708.ai

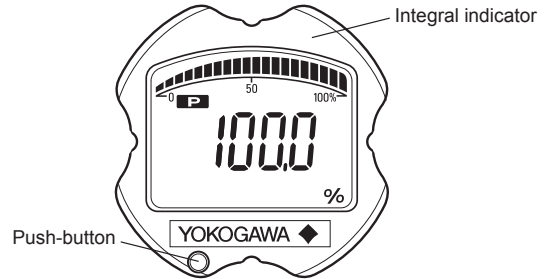

F0709.ai

Figure 7.7 External Adjustment Screw

Figure 7.8 Range-Setting Switch (push button)

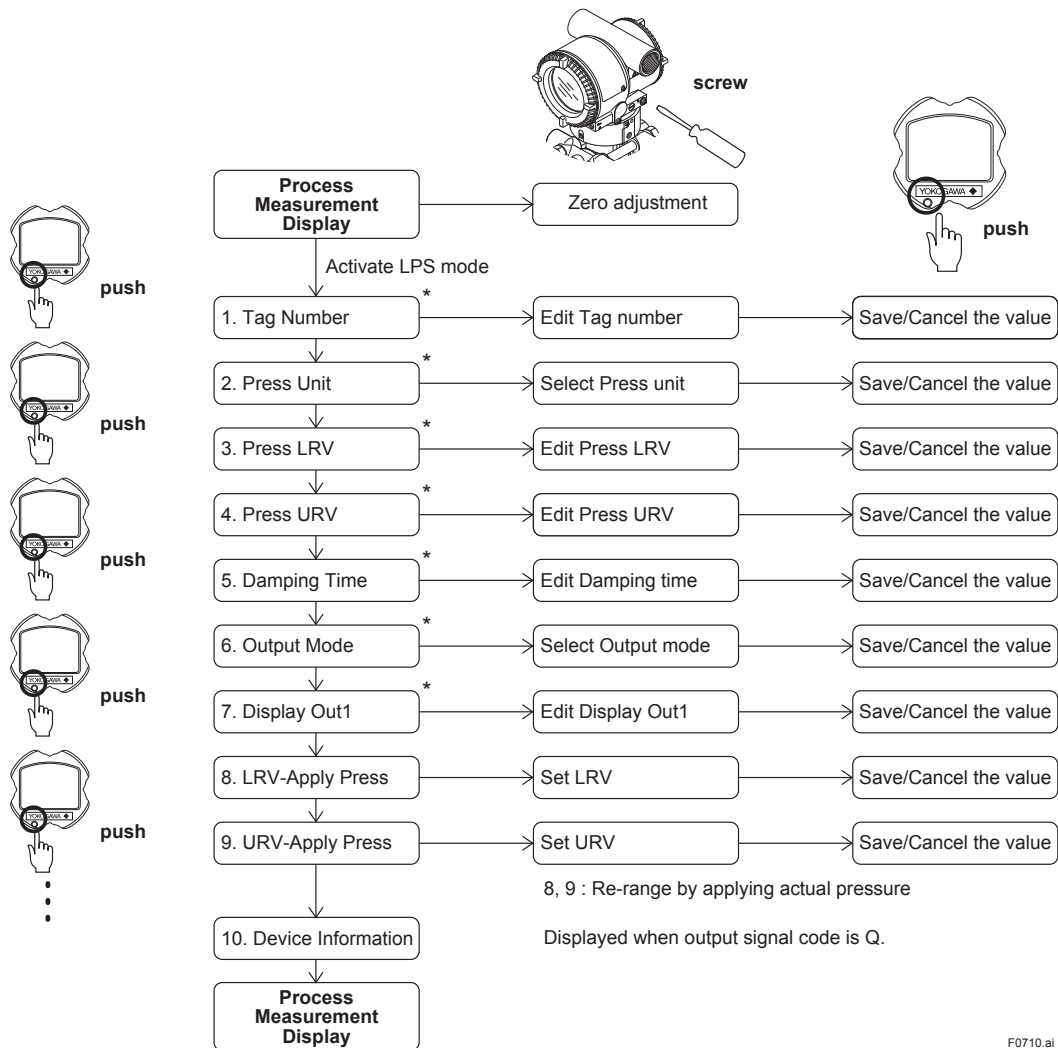

F0710.ai

*: Note that the above 1 to 7 parameter configurations are available with the software revision (SOFT REV)2.03 or later. Software revision can be checked via a field communicator (HART/BRAIN) or DTM. Please refer to IM 01C25T01 for HART parameter "Software rev" and IM 01C25T03 for BRAIN "SOFT REV".

Figure 7.9

7.6.2 Activating Local Parameter Setting

Press the push button on the integral indicator to activate the Local Parameter Setting mode. The transmitter will exit automatically from the Local Parameter Setting mode if no operation is carried out for 10 minutes.

7.6.3 Parameter Setting Review

Current setting value for the below parameters are shown sequentially by each press of the push button.

Tag number, Unit, LRV, URV, Damping, Output mode (linear/square root), Display out 1.

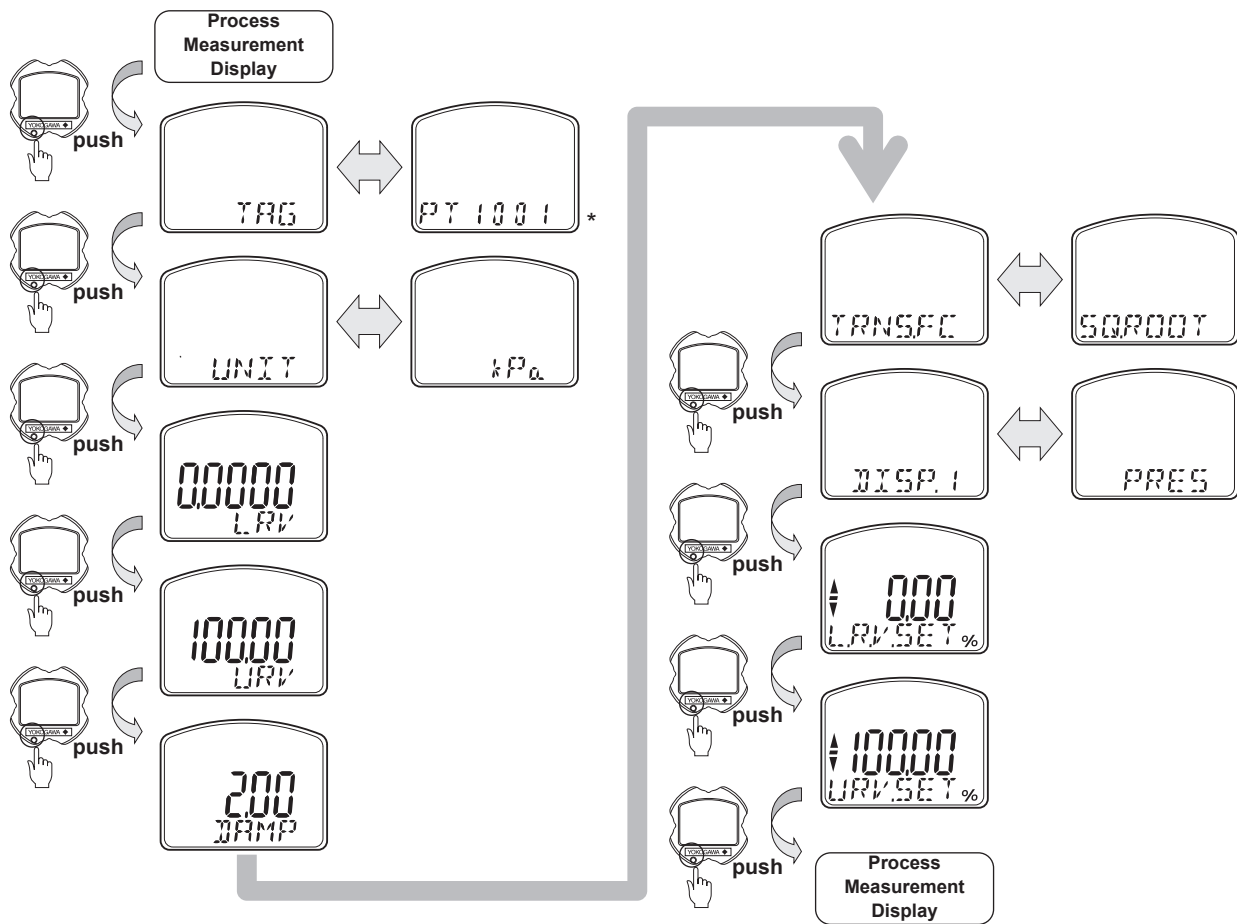

F0711.ai

*: Up to 6 characters are shown in the bottom line. To review after the 7th character, turn the external adjustment screw and press the push button six times or more.

To configure each parameter value, turn the external adjustment screw on each parameter screen after activating the Local Parameter Setting mode.

To cancel the Local Parameter Setting configuration, please refer to 7.6.11 Save or Cancel and 7.6.12 Abort Configuration.

7.6.4 Tag Number Configuration

Tag Number is edited by turning the external adjustment screw. Up to 8 alphanumeric characters for HART or 16 alphanumeric characters for BRAIN can be set.

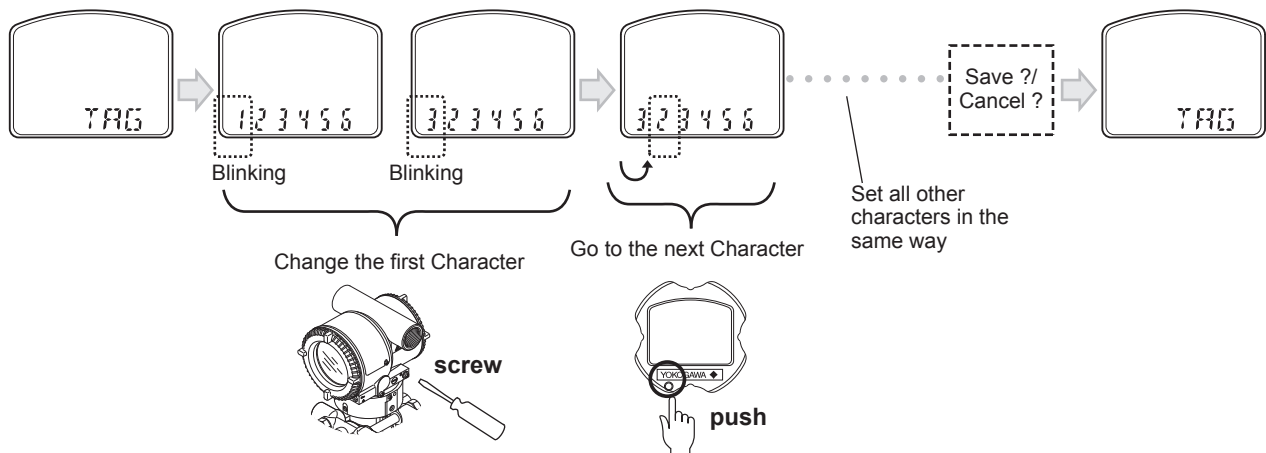

F0712.ai

7.6.5 Pressure Unit Configuration

Pressure unit for the below table can be changed as below. By turning the external adjustment screw, user can scroll between the various available pressure units.

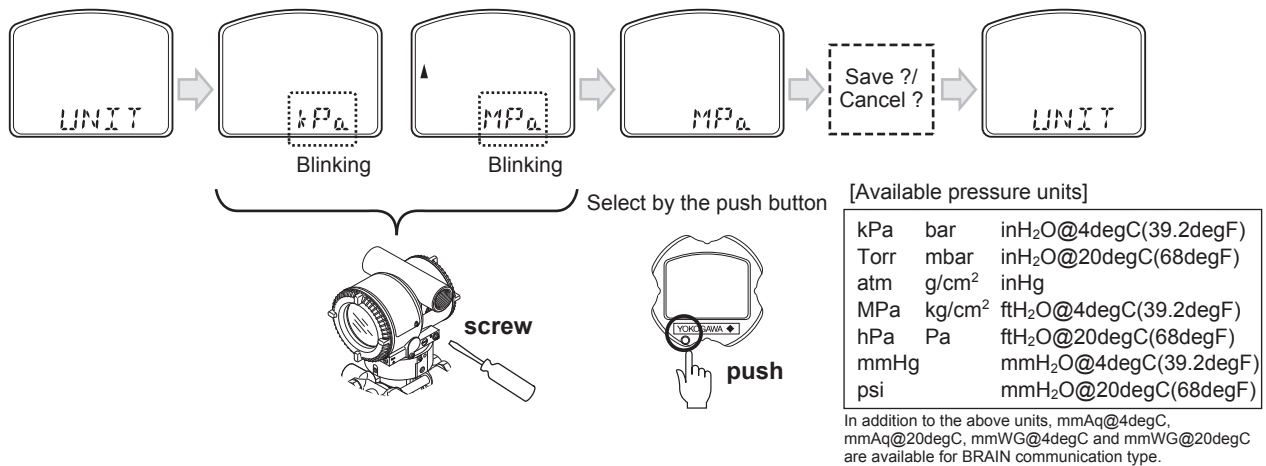

F0713.ai

7.6.6 Pressure LRV/URV Configuration

Pressure LRV and URV can be set. The number for each digit is changed by turning the external adjustment screw and set by pressing the push button. Please refer to 7.6.7 Damping Time Constant Configuration for how to change the numerical value. When the setting is out of the limit, an alarm will be generated.

7.6.7 Damping Time Constant Configuration

The damping time constant for the amplifier assembly can be set. Quick Response Parameter is automatically set to ON when the damping time constant is set to less than 0.5 seconds. Damping time constant is rounded off to two decimal places.

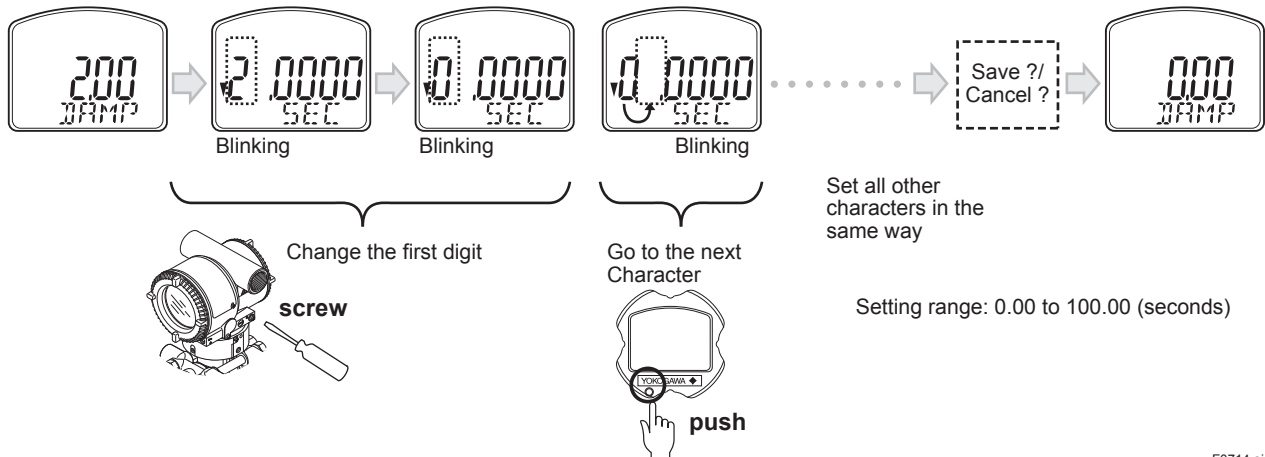

F0714.ai

7.6.8 Output Mode Configuration

Pressure Output Mode (Linear or Sq root) can be selected by turning the external adjustment screw. Please refer to 7.6.5 Pressure Unit Configuration for how to select and set the enumerated value.

7.6.9 Display Out 1 Configuration

Display Out1 can be selected by turning the external adjustment screw. Please refer to 7.6.5 Pressure Unit Configuration for how to select and set the enumerated value.

7.6.10 Re-range by applying actual pressure (LRV/URV).

This feature allows the lower and upper range values to be setup with the actual input applied.

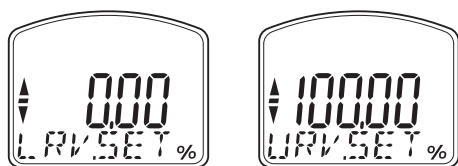

F0715.ai

Follow the procedure below to change the LRV and URV settings.

[Example]

Rerange LRV to 0 and URV to 3 MPa.

- 1) Connect the transmitter and apparatus as shown in Figure 8.1 and warm it up for at least five minutes.

- 2) Press the push-button. The integral indicator then displays “LRV.SET.”
- 3) Apply a pressure of 0 kPa (atmospheric pressure) to the transmitter. (Note 1)
- 4) Turn the external adjustment screw in the desired direction. The integral indicator displays the output signal in %. (Note 2)
- 5) Adjust the output signal to 0% (1 V DC) by rotating the external adjustment screw. Press the push button to save the value. Doing so completes the LRV setting. (Note 3)
- 6) Press the push-button. The integral indicator then displays “URV.SET.”
- 7) Apply a pressure of 3 MPa to the transmitter. (Note 1)
- 8) Turn the external adjustment screw in the desired direction. The integral indicator displays the output signal in %. (Note 2)
- 9) Adjust the output signal to 100% (5 V DC) by rotating the external adjustment screw. Press the button to save the value. Doing so completes the URV setting.
- 10) Press the push-button. The transmitter then switches back to the normal operation mode with the measurement range of 0 to 3 MPa.

Note 1: Wait until the pressure inside the pressure-detector section has stabilized before proceeding to the next step.

Note 2: If the pressure applied to the transmitter exceeds the previous LRV (or URV), the integral indicator may display error number “AL.30” (In this case, the output signal percent and “AL.30” are displayed alternately every two seconds). Although “AL.30” is displayed, you may proceed to the next step. However, should any other error number be displayed, take the

appropriate measure in reference to , “Errors and Countermeasures” in each communication manual.

Note 3 : Changing the lower range value (LRV) also automatically changes the upper range value (URV), keeping the span constant. New URV=previous URV+(new LRV–previous LRV)

7.6.11 Save or Cancel

At the end of each parameter setting, select “Save” or “Cancel” by the external adjustment screw and press the push button to save or cancel the configuration.

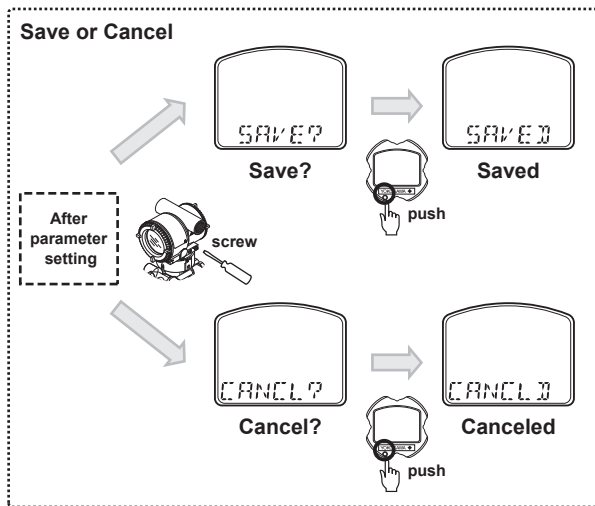

F0716.ai

7.6.12 Abort Configuration

7.6.12.1 Abort Configuration (Menu)

Hold down the push button for over 2 seconds to exit the Local Parameter Setting mode.

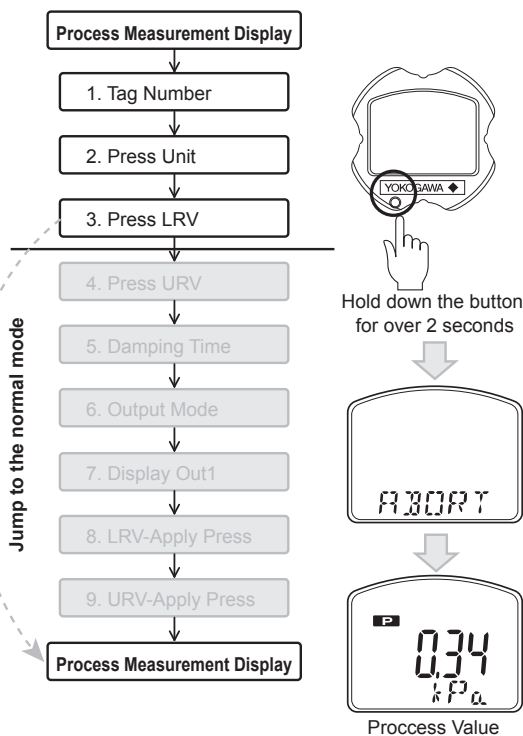

F0717.ai

7.6.12.2 Abort Configuration (Parameter)

To exit the configuration while editing the value, hold down the button for over 2 seconds and select “Save” or “Cancel”.

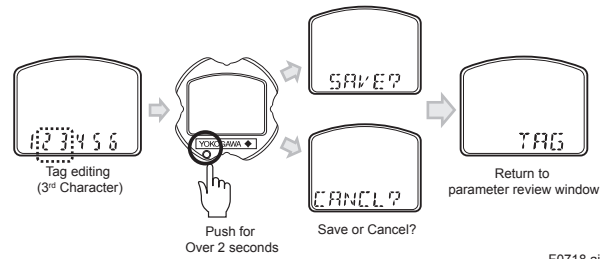

F0718.ai

7.6.13 Local Parameter Setting Lock

To disable parameter changes by the Local Parameter Setting there are three different ways.

	Locked features
Communication Parameter Ext SW =disable (EXT ZERO ADJ = disable)	<ul style="list-style-type: none"> External Zero Adjustment Local Parameter Setting
Communication Parameter Write Protect = On (WRT PROTECT = Yes)	<ul style="list-style-type: none"> Local Parameter Setting All Communication Parameters *
Hardware write protection switch on CPU assembly = D (Disable)	<ul style="list-style-type: none"> Local Parameter Setting All Communication Parameters *

*External Zero Adjustment is unlocked.

The above parameter setting is carried out by using field communicator or DTM. See the user’s manual IM 01C25T (HART/BRAIN) for the setting procedure.

Reviewing local parameter setting by push button on the integral indicator is available at any time even when the Local Parameter Setting is locked.

7.6.14 Others

- Difference between BRAIN and HART

	HART	BRAIN
Tag Number	Up to 8 characters can be set	Up to 16 characters can be set
Output Mode (Linear/Sq root)	“TRNS.FC” shown on the integral indicator	“OUT.MOD” shown on the integral indicator

- The degree of adjustment depends on the speed of turning the adjustment screw. Turn the screw slowly for fine tuning and turn the screw fast for quick tuning.

8. Maintenance

8.1 Overview



WARNING

Since the accumulated process fluid may be toxic or otherwise harmful, take appropriate care to avoid contact with the body or inhalation of vapors when draining condensate or venting gas from the transmitter pressure-detector section and even after dismounting the instrument from the process line for maintenance.

Maintenance of the transmitter is easy due to its modular construction. This chapter describes the procedures for calibration, adjustment, and the disassembly and reassembly procedures required for component replacement.

Transmitters are precision instruments. Please carefully and thoroughly read the following sections for information on how to properly handle them while performing maintenance.



IMPORTANT

- As a rule, maintenance of this transmitter should be done in a shop that has all the necessary tools.
- The CPU assembly contains sensitive parts that can be damaged by static electricity. Take precautions such as using a grounded wrist strap when handling electronic parts or touching the board circuit patterns. Also be sure to place the removed CPU assembly into a bag with an antistatic coating.

8.2 Calibration Instruments Selection

Table 8.1 lists the instruments that can be used to calibrate a transmitter. When selecting an instrument, consider the required accuracy level. Exercise care when handling these instruments to ensure they maintain the specified accuracy.

8.3 Calibration

Use the procedure below to check instrument operation and accuracy during periodic maintenance or troubleshooting.

- 1) Connect the instruments as shown in figure 8.1 and warm up the instruments for at least five minutes (ten minutes for EJ□310□.)



IMPORTANT

- To adjust the transmitter for highest accuracy, make adjustments with the power supply voltage and load resistance including leadwire resistances set close to the conditions under which the transmitter is installed.
 - If the measurement range 0% point is 0 kPa or shifted in the positive direction (suppressed zero), the reference pressure should be applied as shown in the figure. If the measurement range 0% point is shifted in the negative direction (elevated zero), the reference pressure should be applied using a vacuum pump.
- 2) Apply reference pressures of 0%, 50%, and 100% of the measurement range to the transmitter. Calculate the errors (differences between digital voltmeter readings and reference pressures) as the pressure is increased from 0% to 100% and is decreased from 100% to 0%, and confirm that the errors are within the required accuracy.

Table 8.1 Instruments Required for Calibration

Name	Yokogawa-recommended Instrument	Remarks
Power supply	Model SDBT or SDBS distributor	4 to 20 mA DC signal
Load resistor	Model 2792 standard resistor [250 Ω ±0.005%, 3 W] Load adjustment resistor [100 Ω ±1%, 1 W]	
Voltmeter	Model 2501 A digital multimeter Accuracy (10V DC range): ±(0.002% of rdg + 1 dgt)	
Digital manometer	Model MT220 precision digital manometer 1) For 10 kPa class Accuracy: ±(0.015% of rdg + 0.015% of F.S.) for 0 to 10 kPa ±(0.2% of rdg + 0.1% of F.S.) for -10 to 0 kPa 2) For 130 kPa class Accuracy: ±0.02% of rdg for 25 to 130 kPa ±5digits for 0 to 25 kPa ±(0.2% of rdg + 0.1% of F.S.) for -80 to 0 kPa 3) For 700 kPa class Accuracy: ±(0.02% of rdg + 3digits) for 100 to 700 kPa ±5 digits for 0 to 100 kPa ±(0.2% of rdg + 0.1% of F.S.) for -80 to 0 kPa 4) For 3000 kPa class Accuracy: ±(0.02% of rdg + 10 digits) for 0 to 3000 kPa ±(0.2% of rdg + 0.1% of F.S.) for -80 to 0 kPa 5) For 130 kPa abs class Accuracy: ±(0.03% of rdg + 6 digits) for 0 to 130 kPa abs	Select a manometer having a pressure range close to that of the transmitter.
Pressure generator	Model 7674 pneumatic pressure standard for 200 kPa {2 kgf/cm ² }, 25 kPa {2500 mmH ₂ O} Accuracy: ±0.05% of F.S.	Requires air pressure supply.
	Dead weight gauge tester 25 kPa {2500 mmH ₂ O} Accuracy: ±0.03% of setting	Select the one having a pressure range close to that of the transmitter.
Pressure source	Model 6919 pressure regulator (pressure pump) Pressure range: 0 to 133 kPa {1000 mmHg}	Prepare the vacuum pump for negative pressure ranges.

Note: The above table contains the instruments capable of performing calibration to the 0.2% level. Since special maintenance and management procedures involving traceability of each instrument to higher-level standards are required for calibration to the 0.1% or higher level, there may be difficulties in calibration to this level in the field. For calibration to the 0.1% level, contact Yokogawa representatives from which the instrument was purchased or the nearest Yokogawa office.

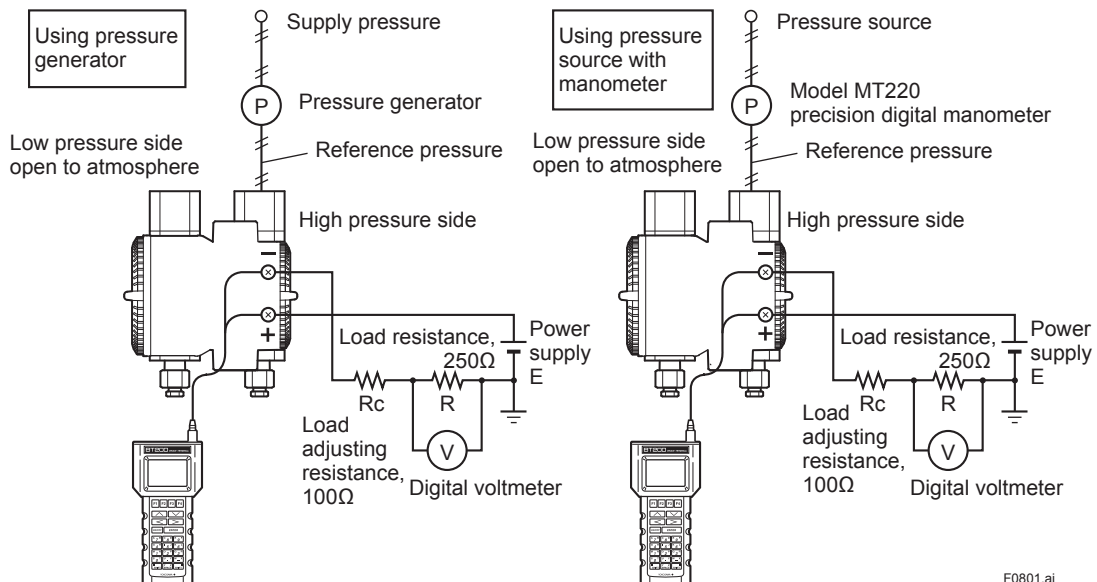

Figure 8.1 Instrument Connections (EJX110A, 4 to 20mA output)

8.4 Disassembly and Reassembly

This section describes procedures for disassembly and reassembly for maintenance and component replacement.

Always turn OFF power and shut off and release pressures before disassembly. Use proper tools for all operations. Table 8.2 shows the tools required.

Table 8.2 Tools for Disassembly and Reassembly

Tool	Quantity	Remarks
Phillips screwdriver	1	JIS B4633, No. 2
Slotted screwdriver	1	
Allen wrenches	3	JIS B4648 One each, nominal 3, 4 and 2.5 mm Allen wrenches
Wrench	1	Width across flats, 17 mm
Torque wrench	1	
Adjustable wrench	1	
Socket wrench	1	Width across flats, 16 mm
Socket driver	1	Width across flats, 5.5 mm
Tweezers	1	

CAUTION

Precautions for ATEX Flameproof Type Transmitters

- Flameproof type transmitters must be, as a rule, removed to a non-hazardous area for maintenance and be disassembled and reassembled to the original state.
- On the flameproof type transmitters the two covers are locked, each by an Allen head bolt (shrouding bolt). When a shrouding bolt is driven clockwise by an Allen wrench, it is going in and cover lock is released, and then the cover can be opened. When a cover is closed it should be locked by a shrouding bolt without fail. Tighten the shrouding bolt to a torque of 0.7 N·m.

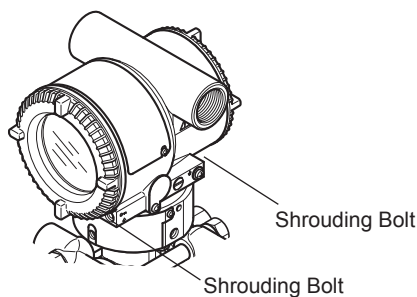

Figure 8.2 Shrouding Bolts

F0802.ai

8.4.1 Replacing the Integral Indicator

CAUTION

Cautions for Flameproof Type Transmitters

Users are prohibited by law from modifying the construction of a flameproof type transmitter. This would invalidate the agency approval for the use of the transmitter in a rated area. It follows that the user is prohibited from using a flameproof type transmitter with its integral indicator removed, or from adding an integral indicator to a transmitter. If such modification is absolutely required, contact Yokogawa.

This subsection describes the procedure for replacing an integral indicator. (See figure 8.3)

■ Removing the Integral Indicator

- 1) Remove the cover.
- 2) While supporting the integral indicator with one hand, loosen its two mounting screws.
- 3) Dismount the LCD board assembly from the CPU assembly.

When doing this, carefully pull the LCD board assembly straight forward so as not to damage the connector pins between it and the CPU assembly.

■ Attaching the Integral Indicator

- 1) Align both the LCD board assembly and CPU assembly connectors and engage them.
- 2) Insert and tighten the two mounting screws.
- 3) Replace the cover.

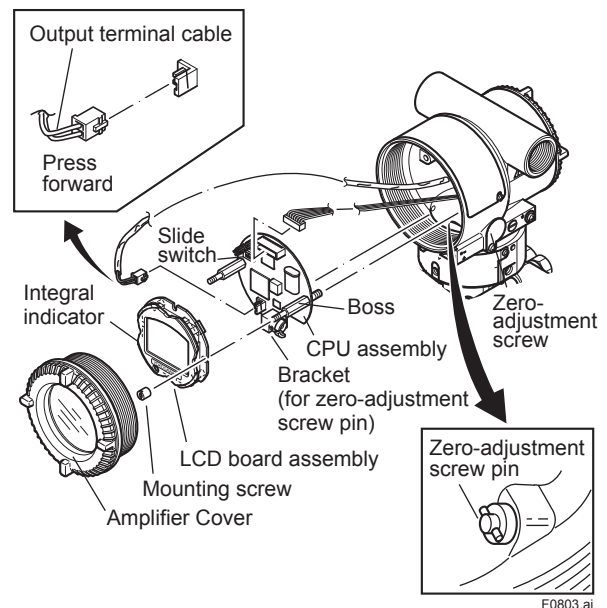

F0803.ai

Figure 8.3 Removing and Attaching LCD Board Assembly and CPU Assembly

8.4.2 Replacing the CPU Board Assembly

This subsection describes the procedure for replacing the CPU assembly. (See figure 8.3)

■ Removing the CPU Assembly

- 1) Remove the cover. If an integral indicator is mounted, refer to subsection 8.4.1 and remove the indicator.
- 2) Turn the zero-adjustment screw to the position (where the screw head slot is horizontal) as shown in figure 8.3.
- 3) Disconnect the output terminal cable (cable with brown connector at the end). When doing this, lightly press the side of the CPU assembly connector and pull the cable connector to disengage.
- 4) Use a socket driver (width across flats, 5.5mm) to loosen the two bosses.
- 5) Carefully pull the CPU assembly straight forward to remove it.
- 6) Disconnect the flat cable (cable with white connector at the end) that connects the CPU assembly and the capsule.



NOTE

Be careful not to apply excessive force to the CPU assembly when removing it.

■ Mounting the CPU Assembly

- 1) Connect the flat cable (with white connector) between the CPU assembly and the capsule.
- 2) Connect the output terminal cable (with brown connector).



NOTE

Make certain that the cables do not get pinched between the case and the edge of the CPU assembly.

- 3) Align and engage the zero-adjustment screw pin with the groove on the bracket on the CPU assembly. Then insert the CPU board assembly straight onto the post in the amplifier case.
- 4) Tighten the two bosses. If the transmitter is equipped with an integral indicator, refer to subsection 8.4.1 to mount the indicator.



NOTE

Confirm that the zero-adjustment screw pin is placed properly in the groove on the bracket prior to tightening the two bosses. If it is not, the zero-adjustment mechanism will be damaged.

- 5) Replace the cover.

8.4.3 Cleaning and Replacing the Capsule Assembly

This subsection describes the procedures for cleaning and replacing the capsule assembly. (See figure 8.4.)



CAUTION

Cautions for Flameproof Type Transmitters

Users are prohibited by law from modifying the construction of a flameproof type transmitter. If you wish to replace the capsule assembly with one of a different measurement range, contact Yokogawa.

The user is permitted, however, to replace a capsule assembly with another of the same measurement range. When doing so, be sure to observe the following.

- The replacement capsule assembly must have the same part number as the one being replaced.
- The section connecting the transmitter and capsule assembly is a critical element in preservation of flameproof performance, and must be checked to verify that it is free of dents, scratches, and other defects.
- After completing maintenance, be sure to securely tighten the setscrews that fasten the transmitter section and pressure-detector section together.

■ **Removing the Capsule Assembly**



IMPORTANT

Exercise care as follows when cleaning the capsule assembly.

- Handle the capsule assembly with care, and be especially careful not to damage or distort the diaphragms that contact the process fluid.
- Do not use a chlorinated or acidic solution for cleaning.
- Rinse thoroughly with clean water after cleaning.

- 1) Remove the CPU assembly as shown in subsection 8.4.2.
- 2) Remove the two setscrews that connect the transmitter section and pressure-detector section.
- 3) Remove the hexagon-head screw and the stopper.
- 4) Separate the transmitter section and pressure-detector section.
- 5) Remove the nuts from the four flange bolts.
- 6) While supporting the capsule assembly with one hand, remove the cover flange.
- 7) Remove the capsule assembly.
- 8) Clean the capsule assembly or replace with a new one.

■ **Reassembling the Capsule Assembly**

- 1) Insert the capsule assembly between the flange bolts, paying close attention to the relative positions of the H (high pressure side) and L (low pressure side) marks on the capsule assembly.
Replace the two capsule gaskets with new gaskets.
- 2) Install the cover flange on the high pressure side, and use a torque wrench to tighten the four nuts uniformly to a torque shown below.

Model	EJ□110□, EJ□310□, EJ□430□		EJ□120□
	Wetted parts material code		
	S	H, M, T, A, D, B	
Torque(N·m) {kgf·m}	17* {1.7}	40 {4.1}	40 {4.1}

*: 40 for measurement span code F.

Model	EJ□130□		EJ□440□	
	Bolts & nuts material code			
	G, C	J	G, C	J
Torque(N·m) {kgf·m}	90 {9.2}	110 {11.2}	70 {7.1}	100 {10.2}

- 3) After the pressure-detector section has been reassembled, a leak test must be performed to verify that there are no pressure leaks.
- 4) Reattach the transmitter section to the pressure-detector section.
Reattach the stopper with the hexagon-head screw.
- 5) Tighten the two setscrews. (Tighten the screws to a torque of 1.5 N·m)
- 6) Install the CPU assembly according to subsection 8.4.2.
- 7) After completing reassembly, adjust the zero point and recheck the parameters.

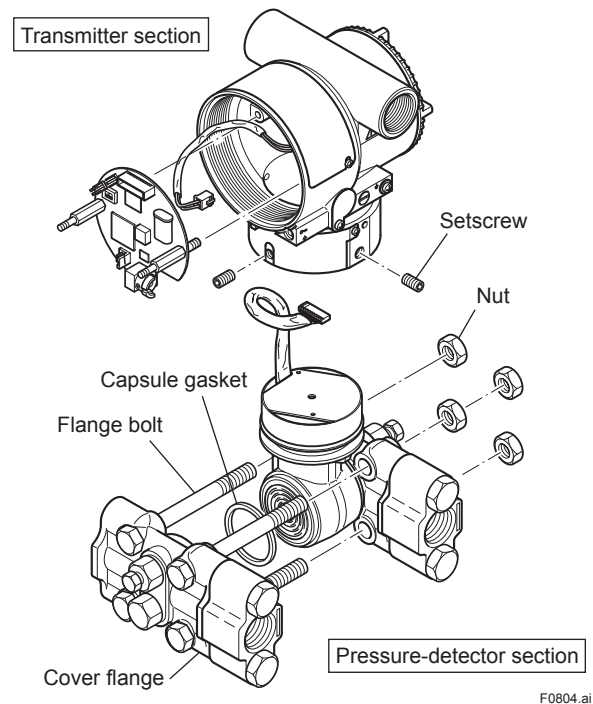

Figure 8.4 Removing and Mounting the Pressure-detector Section



IMPORTANT

If you remove the vent/drain plugs when disassembling EJ□130□ and EJ□440□ transmitters, install the plugs again before reassembling the cover flanges with the capsule assembly.

8.4.4 Replacing the Process Connector Gaskets

This subsection describes process connector gasket replacement. (See figure 8.5.)

- (a) Loosen the two bolts, and remove the process connectors.
- (b) Replace the process connector gaskets.
- (c) Remount the process connectors. Tighten the bolts securely and uniformly to a torque shown below, and verify that there are no pressure leaks.

Model	EJ□110□ EJ□120□ EJ□130□ EJ□310□ EJ□430□	EJ□440□	
		C capsule	D capsule
Torque(N·m) {kgf·m}	39 to 49 {4 to 5}	49 to 59 {5 to 6}	

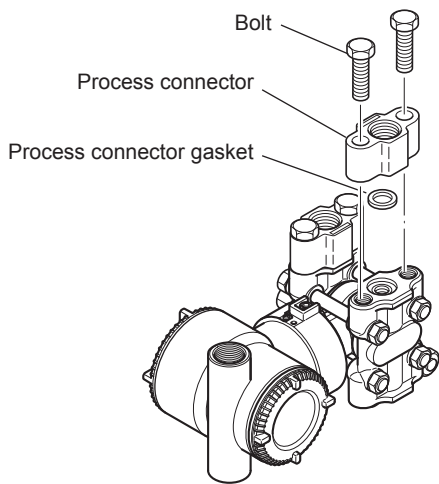

F0805.ai

Figure 8.5 Removing and Mounting the Process Connector

8.5 Troubleshooting

If any abnormality appears in the measured values, use the troubleshooting flow chart below to isolate and remedy the problem. Since some problems have complex causes, these flow charts may not identify all. If you have difficulty isolating or correcting a problem, contact Yokogawa service personnel.

8.5.1 Basic Troubleshooting

First determine whether the process variable is actually abnormal or a problem exists in the measurement system.

If the problem is in the measurement system, isolate the problem and decide what corrective action to take.

This transmitter is equipped with a self-diagnostic function which will be useful in troubleshooting, and the transmitter equipped with an integral indicator will show an alarm code as a result of self-diagnosis.

See subsection 8.5.3 for the list of alarms. See also each communication manual.

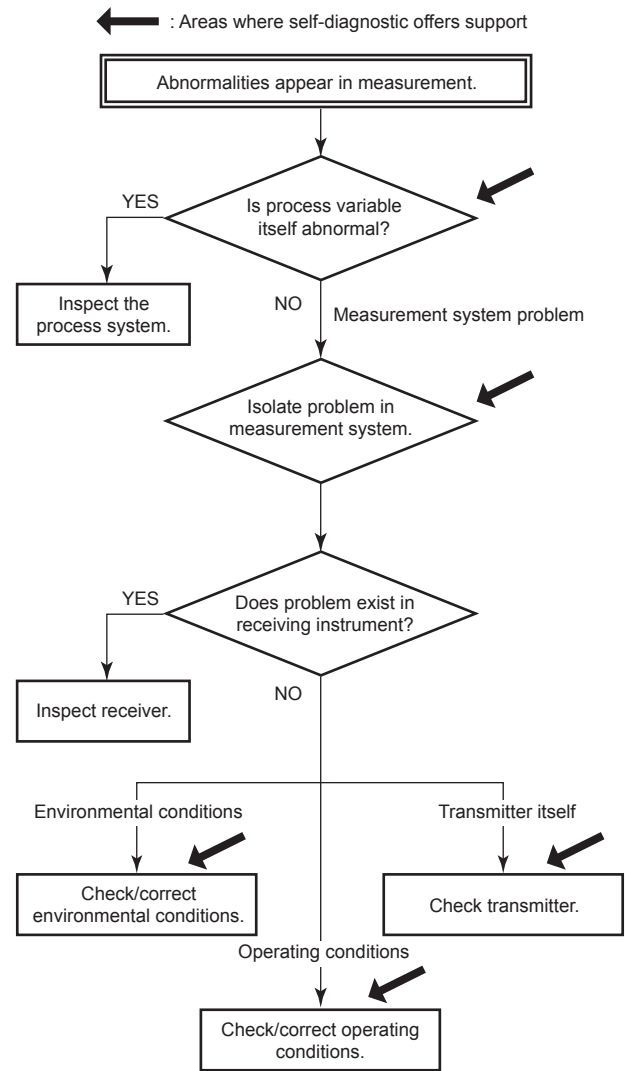

F0806.ai

Figure 8.6 Basic Flow and Self-Diagnostics

8.5.2 Troubleshooting Flowcharts

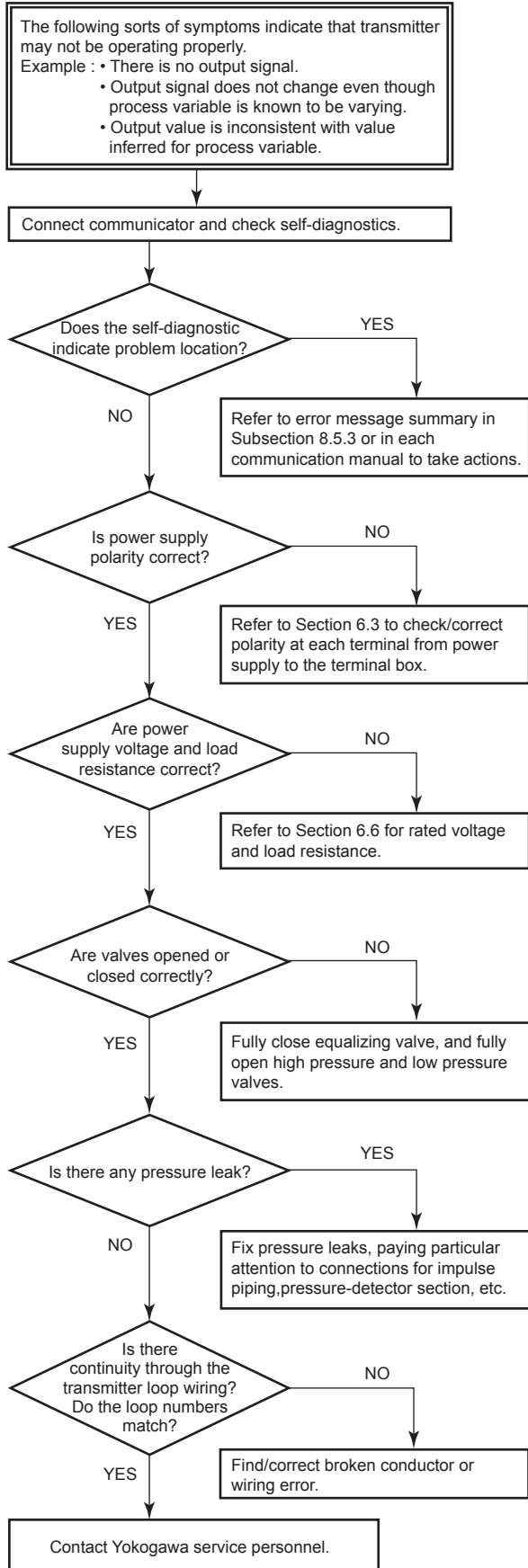

F0807.ai

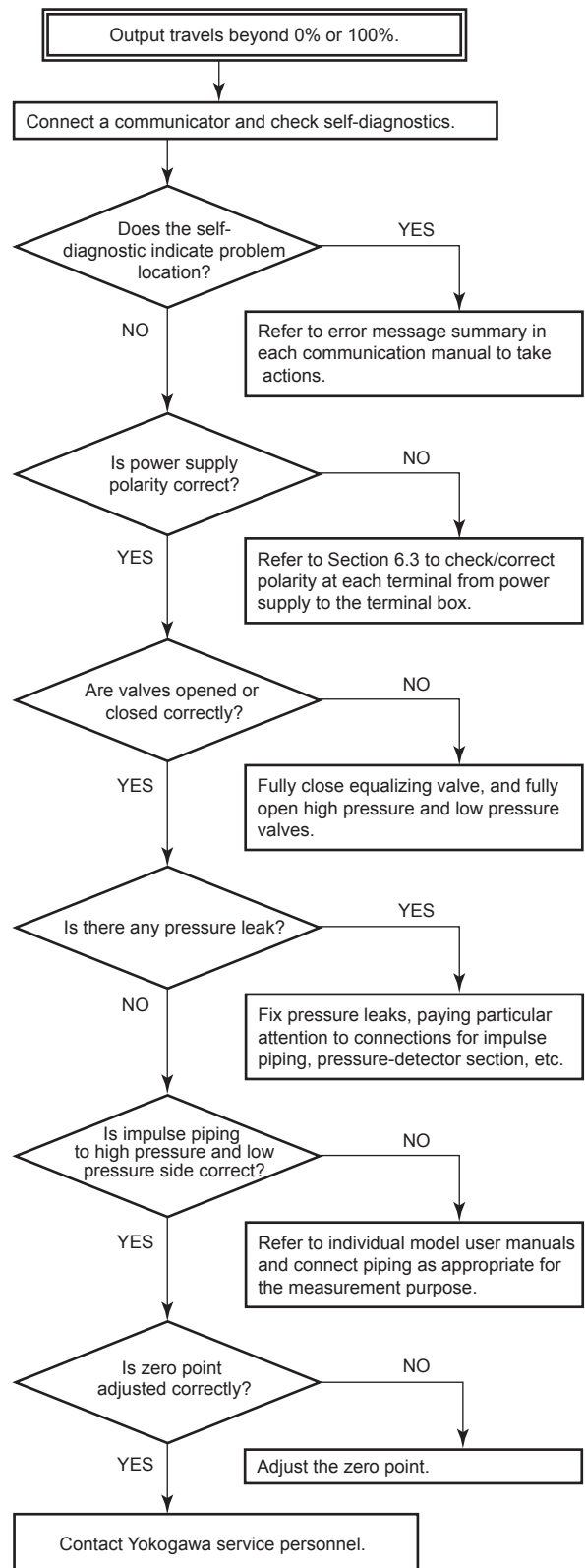

F0808.ai

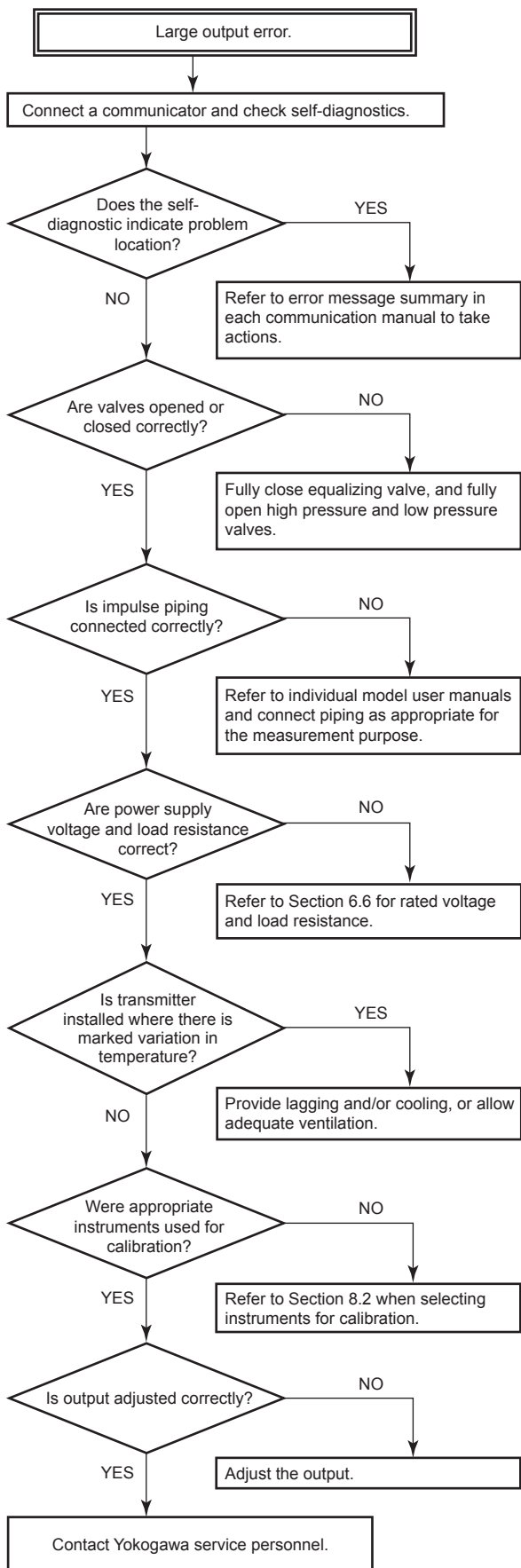

F0809.ai

8.5.3 Alarms and Countermeasures

Table 8.3 Alarm Message Summary

Indicator	Cause	Output Operation during Error	Countermeasure
None			
AL. 01 CAP. ERR	Sensor problem. Capsule temperature sensor problem. Capsule EEPROM problem.	Outputs the signal (Hold, High, or Low) set with parameter.	Replace capsule when error keeps appearing even after restart.
AL. 02 AMP. ERR	Amplifier temperature sensor problem. Amplifier EEPROM problem. Amplifier problem.	Outputs the signal (Hold, High, or Low) set with parameter.	Replace amplifier.
AL. 10 PRESS	Input is outside measurement range limit of capsule.	Outputs high range limit value or low range limit value.	Check input or replace capsule when necessary. Use heat insulation or make lagging to keep temperature within range.
AL. 11 ST. PRSS	Static pressure exceeds limit.	Continues to operate and output.	
AL. 12 CAP. TMP	Capsule temperature is outside range (-50 to 130°C).		
AL. 13 AMP. TMP	Amplifier temperature is outside range (-50 to 95°C)		
AL. 30 RANGE	Output is outside upper or lower range limit value.	Outputs high range limit value or low range limit value.	Check input and range setting, and change them as needed.
AL. 31 SP. RNG	Static pressure exceeds specified range.	Continues to operate and output.	Check input.
AL. 35 *1 P. HI	Input pressure exceeds specified threshold.		
AL. 36 *1 P. LO			
AL. 37 *1 SP. HI	Input static pressure exceeds specified threshold.		
AL. 38 *1 SP. LO			
AL. 39 *1 TMP. HI	Detected temperature exceeds specified threshold.		
AL. 40 *1 TMP. LO			
AL. 50 P. LRV	Specified value is outside of setting range.	Holds output immediately before error occurred.	Check setting and change them as needed.
AL. 51 P. URV			
AL. 52 P. SPN			
AL. 53 P. ADJ		Continues to operate and output.	Check input.
AL. 54 SP. RNG		Continues to operate and output holding static pressure in %.	Check setting and change them as needed.
AL. 55 SP. ADJ		Continues to operate and output.	Check input.
AL. 60 SC. CFG		Specified values or settings to define signal characterizer function do not satisfy the condition.	
AL. 79 OV. DISP	Displayed value exceeds limit.		

*1: These alarms may appear only when process alarm function is activated.

9. General Specifications

9.1 Standard Specifications

Refer to IM 01C25T02-01E for FOUNDATION
 Fieldbus communication type and IM 01C25T04-
 01EN for PROFIBUS PA communication type for
 the items marked with “◇”.

● Performance Specifications

See General Specifications sheet of each model.

● Functional Specifications

Span & Range Limits

EJX110A

Measurement Span/Range	kPa	inH ₂ O(/D1)	mbar(/D3)	mmH ₂ O(/D4)	
F*	Span	0.1 to 5	0.4 to 20	1 to 50	10 to 500
	Range	-5 to 5	-20 to 20	-50 to 50	-500 to 500
L*	Span	0.1 to 10	0.4 to 40	1 to 100	10 to 1000
	Range	-10 to 10	-40 to 40	-100 to 100	-1000 to 1000
M	Span	0.5 to 100	2 to 400	5 to 1000	50 to 10000
	Range	-100 to 100	-400 to 400	-1000 to 1000	-10000 to 10000
H	Span	2.5 to 500	10 to 2000	25 to 5000	0.025 to 5 kgf/cm ²
	Range	-500 to 500	-2000 to 2000	-5000 to 5000	-5 to 5 kgf/cm ²
V	Span	0.07 to 14 MPa	10 to 2000 psi	0.7 to 140 bar	0.7 to 140 kgf/cm ²
	Range	-0.5 to 14 MPa	-71 to 2000 psi	-5 to 140 bar	-5 to 140 kgf/cm ²

*: F capsule is applicable for wetted parts material code S.
 L capsule is applicable for wetted parts material code other than S.

EJX120A

Measurement Span/Range	kPa	inH ₂ O(/D1)	mbar(/D3)	mmH ₂ O(/D4)	
E	Span	0.025 to 1	0.1 to 4	0.25 to 10	2.5 to 100
	Range	-1 to 1	-4 to 4	-10 to 10	-100 to 100

EJX130A

Measurement Span/Range	kPa	inH ₂ O(/D1)	mbar(/D3)	mmH ₂ O(/D4)	
M	Span	1 to 100	4 to 400	10 to 1000	100 to 10000
	Range	-100 to 100	-400 to 400	-1000 to 1000	-10000 to 10000
H	Span	5 to 500	20 to 2000	50 to 5000	0.05 to 5 kgf/cm ²
	Range	-500 to 500	-2000 to 2000	-5000 to 5000	-5 to 5 kgf/cm ²

EJX310A

Measurement Span/Range	kPa abs	psi abs (/D1)	mbar abs (/D3)	mmHg abs (/D4)	
L	Span	0.5 to 10	0.15 to 2.95 inHg	5 to 100	3.8 to 75
	Range	0 to 10	0 to 2.95 inHg	0 to 100	0 to 75
M	Span	1.3 to 130	0.39 to 38 inHg	13 to 1300	9.8 to 970
	Range	0 to 130	0 to 38 inHg	0 to 1300	0 to 970
A	Span	0.0175 to 3.5 MPa	2.5 to 500	0.175 to 35 bar	0.175 to 35 kgf/cm ²
	Range	0 to 3.5 MPa	0 to 500	0 to 35 bar	0 to 35 kgf/cm ²
B	Span	0.08 to 16 MPa	12 to 2300	0.8 to 160 bar	0.8 to 160 kgf/cm ²
	Range	0 to 16 MPa	0 to 2300	0 to 160 bar	0 to 160 kgf/cm ²

EJX430A

Measurement Span/Range	MPa	psi (/D1)	bar(/D3)	kgf/cm ² (/D4)	
H	Span	2.5 to 500 kPa	10 to 2000 inH ₂ O	0.025 to 5	0.025 to 5
	Range	-100 to 500 kPa	-400 to 2000 inH ₂ O	-1 to 5	-1 to 5
A	Span	0.0175 to 3.5	2.5 to 500	0.175 to 35	0.175 to 35
	Range	-0.1 to 3.5	-15 to 500	-1 to 35	-1 to 35
B	Span	0.08 to 16	12 to 2300	0.8 to 160	0.8 to 160
	Range	-0.1 to 16	-14.7 to 2300	-1 to 160	-1 to 160

EJX440A

Measurement Span/Range	MPa	psi (/D1)	bar(/D3)	kgf/cm ² (/D4)	
C	Span	0.25 to 32	36 to 4500	2.5 to 320	2.5 to 320
	Range	-0.1 to 32	-14.5 to 4500	-1 to 320	-1 to 320
D	Span	0.25 to 50	36 to 7200	2.5 to 500	2.5 to 500
	Range	-0.1 to 50	-14.5 to 7200	-1 to 500	-1 to 500

EJA110E

Measurement Span/Range	kPa	inH ₂ O(/D1)	mbar(/D3)	mmH ₂ O(/D4)	
F*	Span	0.5 to 5	2.0 to 20	5 to 50	50 to 500
	Range	-5 to 5	-20 to 20	-50 to 50	-500 to 500
L*	Span	0.5 to 10	2.0 to 40	5 to 100	50 to 1000
	Range	-10 to 10	-40 to 40	-100 to 100	-1000 to 1000
M	Span	1 to 100	4 to 400	10 to 1000	100 to 10000
	Range	-100 to 100	-400 to 400	-1000 to 1000	-10000 to 10000
H	Span	5 to 500	20 to 2000	50 to 5000	0.05 to 5 kgf/cm ²
	Range	-500 to 500	-2000 to 2000	-5000 to 5000	-5 to 5 kgf/cm ²
V	Span	0.14 to 14 MPa	20 to 2000 psi	1.4 to 140 bar	1.4 to 140 kgf/cm ²
	Range	-0.5 to 14 MPa	-71 to 2000 psi	-5 to 140 bar	-5 to 140 kgf/cm ²

*: F capsule is applicable for wetted parts material code S.
 L capsule is applicable for wetted parts material code other than S.

EJA120E

Measurement Span/Range		kPa	inH ₂ O(/D1)	mbar(/D3)	mmH ₂ O(/D4)
E	Span	0.1 to 1	0.4 to 4	1 to 10	10 to 100
	Range	-1 to 1	-4 to 4	-10 to 10	-100 to 100

EJA130E

Measurement Span/Range		kPa	inH ₂ O(/D1)	mbar(/D3)	mmH ₂ O(/D4)
M	Span	1 to 100	4 to 400	10 to 1000	100 to 10000
	Range	-100 to 100	-400 to 400	-1000 to 1000	-10000 to 10000
H	Span	5 to 500	20 to 2000	50 to 5000	0.05 to 5 kgf/cm ²
	Range	-500 to 500	-2000 to 2000	-5000 to 5000	-5 to 5 kgf/cm ²

EJA310E

Measurement Span/Range		kPa abs	psi abs (/D1)	mbar abs (/D3)	mmHg abs (/D4)
L	Span	0.67 to 10	0.2 to 2.95 inHg	6.7 to 100	5 to 75
	Range	0 to 10	0 to 2.95 inHg	0 to 100	0 to 75
M	Span	1.3 to 130	0.39 to 38 inHg	13 to 1300	9.8 to 970
	Range	0 to 130	0 to 38 inHg	0 to 1300	0 to 970
A	Span	0.03 to 3.5 MPa	4.3 to 500	0.3 to 35 bar	0.3 to 35 kgf/cm ²
	Range	0 to 3.5 MPa	0 to 500	0 to 35 bar	0 to 35 kgf/cm ²
B	Span	0.14 to 16 MPa	20 to 2300	1.4 to 160 bar	1.4 to 160 kgf/cm ²
	Range	0 to 16 MPa	0 to 2300	0 to 160 bar	0 to 160 kgf/cm ²

EJA430E

Measurement Span/Range		MPa	psi (/D1)	bar(/D3)	kgf/cm ² (/D4)
H	Span	5 to 500 kPa	20 to 2000 inH ₂ O	0.05 to 5	0.05 to 5
	Range	-100 to 500 kPa	-400 to 2000 inH ₂ O	-1 to 5	-1 to 5
A	Span	0.03 to 3.5	4.3 to 500	0.3 to 35	0.3 to 35
	Range	-0.1 to 3.5	-14.5 to 500	-1 to 35	-1 to 35
B	Span	0.14 to 16	20 to 2300	1.4 to 160	1.4 to 160
	Range	-0.1 to 16	-14.5 to 2300	-1 to 160	-1 to 160

EJA440E

Measurement Span/Range		MPa	psi (/D1)	bar(/D3)	kgf/cm ² (/D4)
C	Span	5 to 32	720 to 4500	50 to 320	50 to 320
	Range	-0.1 to 32	-14.5 to 4500	-1 to 320	-1 to 320
D	Span	5 to 50	720 to 7200	50 to 500	50 to 500
	Range	-0.1 to 50	-14.5 to 7200	-1 to 500	-1 to 500

Output “◇”

For 4 to 20 mA output

(Output signal code D, E and J)

Two wire 4 to 20 mA DC output with digital communications, linear or square root programmable. BRAIN or HART FSK protocol are superimposed on the 4 to 20 mA signal. Output range: 3.6 mA to 21.6 mA. Output limits conform to NAMUR NE43 can be pre-set by option C2 or C3.

For 1 to 5 V output (Output signal code Q)

Three or four wire low power 1 to 5 V DC output with HART, linear or square root programmable. HART protocol is superimposed on the 1 to 5 V DC signal.

Output range: 0.9 V to 5.4 V DC

Failure Alarm “◇”

For 4 to 20 mA output

(Output signal code D, E and J)

Analog output status at CPU failure and hardware error;

Up-scale: 110%, 21.6 mA DC or more (standard)

Down-scale: -5%, 3.2 mA DC or less

For 1 to 5 V output (Output signal code Q)

Analog output status at CPU failure and hardware error;

Up-scale: 110%, 5.4 V DC or more (standard)

Down-scale: -5%, 0.8 V DC or less

Damping Time Constant (1st order)

Amplifier damping time constant is adjustable from 0 to 100.00 seconds and added to response time.

Note: For BRAIN protocol type, when amplifier damping is set to less than 0.5 seconds, communication may occasionally be unavailable during the operation, especially while output changes dynamically. The default setting of damping ensures stable communication.

Update Period “◇”

Differential Pressure: 45 ms

Static Pressure: 360 ms

Zero Adjustment Limits

Zero can be fully elevated or suppressed, within the lower and upper range limits of the capsule.

External Zero Adjustment “◇”

External Zero is continuously adjustable with 0.01% incremental resolution of span. Re-range can be done locally using the digital indicator with range-setting switch.

Integral Indicator (LCD display)

5-digit Numerical Display, 6-digit Unit Display and Bar graph.

The indicator is configurable to display one or up to four of the following variables periodically.; Differential pressure in %, Scaled Differential pressure, Differential Pressure in Engineering unit, Static Pressure in Engineering unit. See “Setting When Shipped” for factory setting.

Local Parameter Setting (Output signal code D, J and Q)

Parameter configuration by the external zero adjustment screw and push button (Integral indicator code E) offers easy and quick setup for parameters of Tag number, Unit, LRV, URV, Damping, Output mode (linear/square root), Display out 1, and Re-range by applying actual pressure (LRV/URV).

Burst Pressure Limits

- [EJ□110□, EJ□310□, EJ□430□]
69 MPa (10000 psi)
- [EJ□130□, EJ□440□]
132 MPa (19100 psi)

● **Normal Operating Condition**
(Selected features may affect limits.)

Ambient Temperature Limits

- 40 to 85°C (-40 to 185°F)
- 30 to 80°C (-22 to 176°F) with LCD display
- 25 to 80°C (-40 to 176°F) for EJ□120□

Process Temperature Limits

- 40 to 120°C (-40 to 248°F)
- 25 to 80°C (-40 to 176°F) for EJ□120□
- 40 to 100°C (-40 to 212°F) for EJ□310□
L capsule

Ambient Humidity Limits

0 to 100% RH

Working Pressure Limits (Silicone oil)

EJ□120□ -50 to 50 kPa

Maximum Pressure Limits

EJX110A

Capsule	Pressure
F, L	16 MPa (2300 psi)
M, H, V	25 MPa (3600 psi)*

* 16 MPa for wetted parts material code H, M, T, A, D, and B.

EJA110E

Capsule	Pressure
F, L, M, H, V	16 MPa (2300 psi)*

* 25 MPa (3600 psi) when /HG is specified.

EJ□130□

Capsule	Pressure
M, H	32 MPa (4500 psi)

EJ□310□

Capsule	Pressure
L	10 kPa abs (2.95 inHg abs)
M	130 kPa abs (38 inHg abs)
A	3.5 MPa abs (500 psia)
B	16 MPa abs (2300 psia)

EJ□430□

Capsule	Pressure
H	500 kPa (2000 inH ₂ O)
A	3.5 MPa (500 psi)
B	16 MPa (2300 psi)

EJ□440□

Capsule	Pressure
C	32 MPa (4500 psi)
D	50 MPa (7200 psi)

Minimum Pressure Limit

See graph below

EJ□110□, EJ□130□, EJ□430□, EJ□440□

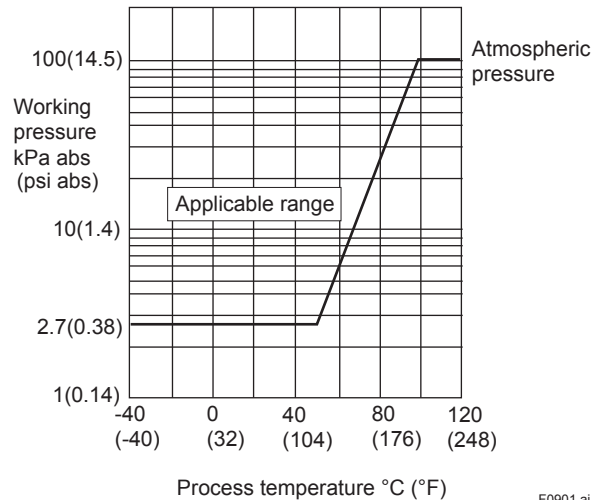

F0901.ai

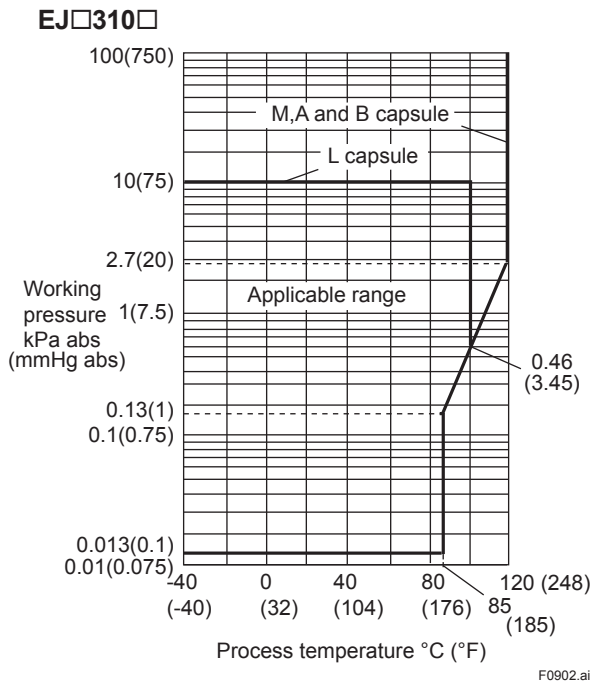

Figure 9.1 Working Pressure and Process Temperature

Maximum Over Pressure

EJ□310□

Capsule	Pressure
L, M	500 kPa abs (72 psia)
A	16 MPa abs (2300 psia)
B	25 MPa abs (3600 psia)

EJ□430□

Capsule	Pressure
H, A	16 MPa (2300 psi)
B	25 MPa (3600 psi)*

* 24 MPa for wetted parts material code H, M, T, A, D, and B.

EJ□440□

Capsule	Pressure
C	48 MPa (6750 psi)
D	75 MPa (10800 psi)*

* 60 MPa (8700 psi) for EJA440E.

Supply & Load Requirements “◇” (For output signal code D, E, and J. Optional features or approval codes may affect electrical requirements.)

With 24 V DC supply, up to a 550 Ω load can be used. See graph below.

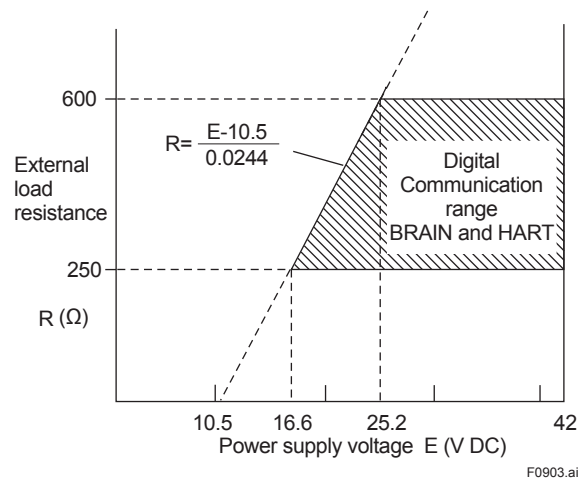

Figure 9.2 Relationship Between Power Supply Voltage and External Load Resistance

Supply Voltage

For 4 to 20 mA output

(Output signal code D, E and J)

10.5 to 42 V DC for general use and flameproof type.

10.5 to 32 V DC for lightning protector (Option code /A).

10.5 to 30 V DC for intrinsically safe, type n or non-incendive type.

Minimum voltage limited at 16.6 V DC for digital communications, BRAIN and HART

For 1 to 5 V output (Output signal code Q)

Power supply :

9 to 28 V DC for general use and flame proof type.

Power Consumption :

0.96 mA to 3 mA, 27 mW

Load for 4 to 20 mA output

(Output signal code D, E and J)

0 to 1290 Ω for operation

250 to 600 Ω for digital communication

Output Load for 1 to 5 V output

(Output signal code Q)

1 MΩ or greater (meter input impedance)

Communication Requirements “◇”

(Safety approvals may affect electrical requirements.)

BRAIN

Communication Distance

Up to 2 km (1.25 miles) when using CEV polyethylene-insulated PVC-sheathed cables. Communication distance varies depending on type of cable used.

Load Capacitance

0.22 µF or less

Load Inductance

3.3 mH or less

Input Impedance of communicating device

10 kΩ or more at 2.4 kHz.

HART

Communication Distance

Up to 1.5 km (1 mile) when using multiple twisted pair cables. Communication distance varies depending on type of cable used.

EMC Conformity Standards

EN61326-1 Class A, Table2 (For use in industrial locations)

EN61326-2-3

EN61326-2-5 (for PROFIBUS only)

Performance Specifications under EMI

Differential pressure: Output shift is specified within ±1% of 1/20 Max span.

Static pressure: Output shift is specified within ±2% of 1MPa span.

● **Physical Specifications**

Wetted Parts Materials

Diaphragm, Cover Flange, Process Connector, Capsule Gasket, and Vent/Drain Plug

Refer to “Model and Suffix Code.”

Process Connector Gasket/o-ring

[EJ□110□, EJ□120□, EJ□430□, EJ□310□]

PTFE Teflon

Fluorinated rubber for Option code /N2 and /N3

[EJ□130□]

Fluorinated rubber (O-ring)

[EJ□440□]

Fluorinated rubber (O-ring) for C capsule

Glass reinforced Teflon (gasket) for D capsule

Non-wetted Parts Materials

Bolting

ASTM-B7 carbon steel, 316L SST stainless steel, or ASTM grade 660 stainless steel

Housing

Low copper cast aluminum alloy with polyurethane paint or ASTM CF-8M stainless steel

Degrees of Protection

IP66/IP67, NEMA TYPE 4X

Cover O-rings

Buna-N, fluoro-rubber (option)

Nameplate and tag

316SST (including /N4 wired tag)

Fill Fluid

Silicone, Fluorinated oil (option)

Weight

[Installation code 7, 8, and 9 and wetted parts material code S for EJ□110□, EJ□310□, and EJ□430□ (Except for measurement span code F)]

2.8 kg (6.2 lb) without integral indicator, mounting bracket, and process connector.

[Installation code 7, 8, and 9 for EJ□120□]

3.7 kg (8.2 lb) without integral indicator, mounting bracket, and process connector.

[Installation code 7, 8, and 9 for EJ□130□]

6.8 kg (14.3 lb) without integral indicator, mounting bracket, and process connector.

[Installation code 7, 8, and 9 for EJ□440□]

4.9 kg (10.8 lb) without integral indicator, mounting bracket, and process connector.

Add 1.5 kg(3.3lb) for amplifier housing code 2.

Connections

Refer to “Model and Suffix Code.”

Process Connection of Cover Flange (models except for EJ□440□-□D): IEC61518

9.2 Model and Suffix Codes

Model EJX110A

Model	Suffix Codes	Description
EJX110A	Differential pressure transmitter
Output signal	-D -E -J -F -G	4 to 20 mA DC with digital communication (BRAIN protocol) 4 to 20 mA DC with digital communication (HART protocol) 4 to 20 mA DC with digital communication (HART 5/HART 7 protocol) Digital communication (FOUNDATION Fieldbus protocol, refer to IM 01C25T02-01E) Digital communication (PROFIBUS PA protocol, refer to IM 01C25T04-01EN)
Measurement span (capsule)	F L M H V	0.1 to 5 kPa (0.4 to 20 inH ₂ O) (For Wetted parts material code S) 0.1 to 10 kPa (0.4 to 40 inH ₂ O) (For Wetted parts material code M, H, T, A, D and B) 0.5 to 100 kPa (2 to 400 inH ₂ O) 2.5 to 500 kPa (10 to 2000 inH ₂ O) 0.07 to 14 MPa (10 to 2000 psi)
Wetted parts material *1	<input type="checkbox"/>	Refer to Table. 1 Wetted Parts Materials on Page 9-18.
Process connections	0 1 2 3 4 ▶ 5	without process connector (Rc1/4 female on the cover flanges) with Rc1/4 female process connector with Rc1/2 female process connector with 1/4 NPT female process connector with 1/2 NPT female process connector without process connector (1/4 NPT female on the cover flanges)
Bolts and nuts material	J G C	ASTM-B7 carbon steel 316L SST stainless steel ASTM grade 660 stainless steel
Installation	-2 -3 -6 -7 -8 ▶ -9 -B -U	Vertical piping, right side high pressure, and process connection upside Vertical piping, right side high pressure, and process connection downside Vertical piping, left side high pressure, and process connection upside Vertical piping, left side high pressure, and process connection downside Horizontal piping and right side high pressure Horizontal piping and left side high pressure Bottom Process Connection, left side high pressure Universal flange
Amplifier housing	1 2 3	Cast aluminum alloy ASTM CF-8M stainless steel Cast aluminum alloy with corrosion resistance properties
Electrical connection	▶ 0 2 4 5 7 9 A C D	G1/2 female, one electrical connection without blind plugs 1/2 NPT female, two electrical connections without blind plugs M20 female, two electrical connections without blind plugs G1/2 female, two electrical connections and a blind plug 1/2 NPT female, two electrical connections and a blind plug M20 female, two electrical connections and a blind plug G1/2 female, two electrical connections and a 316 SST blind plug 1/2 NPT female, two electrical connections and a 316 SST blind plug M20 female, two electrical connections and a 316 SST blind plug
Integral indicator	▶ D E N	Digital indicator Digital indicator with the range setting switch (push button) None
Mounting bracket	▶ B D G J K M N	304 SST 2-inch pipe mounting, flat type (for horizontal piping) 304 SST 2-inch pipe mounting, L type (for vertical piping) 304 SST 2-inch pipe mounting (for bottom process connection type) 316 SST 2-inch pipe mounting, flat type (for horizontal piping) 316 SST 2-inch pipe mounting, L type (for vertical piping) 316 SST 2-inch pipe mounting (for bottom process connection type) None
Optional codes		/ <input type="checkbox"/> Optional specification

The “▶” marks indicate the most typical selection for each specification.

*1: Users must consider the characteristics of selected wetted parts material and influence of process fluids. Specifying inappropriate materials has the potential to cause serious damage to human body and plant facilities resulted from an unexpected leak of the corrosive process fluids.

Model EJX120A

Model	Suffix Codes	Description
EJX120A	Differential pressure transmitter
Output signal	-D -E -J -F -G	4 to 20 mA DC with digital communication (BRAIN protocol) 4 to 20 mA DC with digital communication (HART protocol) 4 to 20 mA DC with digital communication (HART 5/HART 7 protocol) Digital communication (FOUNDATION Fieldbus protocol, refer to IM 01C25T02-01E) Digital communication (PROFIBUS PA protocol, refer to IM 01C25T04-01EN)
Measurement span (capsule)	E.....	0.025 to 1 kPa (0.1 to 4 inH ₂ O)
Wetted parts material *1	S.....	Refer to Table. 1 Wetted Parts Materials on Page 9-18
Process connections	0 1 2 3 4 5	without process connector (Rc1/4 female on the cover flanges) with Rc1/4 female process connector with Rc1/2 female process connector with 1/4 NPT female process connector with 1/2 NPT female process connector without process connector (1/4 NPT female on the cover flanges)
Bolts and nuts material	J G C	ASTM-B7 carbon steel 316L SST stainless steel ASTM grade 660 stainless steel
Installation	-2 -3 -6 -7 -8 -9 -U	Vertical piping, right side high pressure, and process connection upside Vertical piping, right side high pressure, and process connection downside Vertical piping, left side high pressure, and process connection upside Vertical piping, left side high pressure, and process connection downside Horizontal piping and right side high pressure Horizontal piping and left side high pressure Universal flange
Amplifier housing	1 2 3	Cast aluminum alloy ASTM CF-8M stainless steel Cast aluminum alloy with corrosion resistance properties
Electrical connection	0 2 4 5 7 9 A C D	G1/2 female, one electrical connection without blind plugs 1/2 NPT female, two electrical connections without blind plugs M20 female, two electrical connections without blind plugs G1/2 female, two electrical connections and a blind plug 1/2 NPT female, two electrical connections and a blind plug M20 female, two electrical connections and a blind plug G1/2 female, two electrical connections and a 316 SST blind plug 1/2 NPT female, two electrical connections and a 316 SST blind plug M20 female, two electrical connections and a 316 SST blind plug
Integral indicator	D E N	Digital indicator Digital indicator with the range setting switch (push button) None
Mounting bracket	B D G J K N	304 SST 2-inch pipe mounting, flat type (for horizontal piping) 304 SST 2-inch pipe mounting, L type (for vertical piping) 304 SST 2-inch pipe mounting (for bottom process connection type) 316 SST 2-inch pipe mounting, flat type (for horizontal piping) 316 SST 2-inch pipe mounting, L type (for vertical piping) None
Optional codes		/ <input type="checkbox"/> Optional specification

The "▶" marks indicate the most typical selection for each specification.

*1: Users must consider the characteristics of selected wetted parts material and influence of process fluids. Specifying inappropriate materials has the potential to cause serious damage to human body and plant facilities resulted from an unexpected leak of the corrosive process fluids.

Model EJX130A

Model	Suffix Codes	Description
EJX130A	Differential pressure transmitter
Output signal	-D -E -J -F -G	4 to 20 mA DC with digital communication (BRAIN protocol) 4 to 20 mA DC with digital communication (HART protocol) 4 to 20 mA DC with digital communication (HART 5/HART 7 protocol) Digital communication (FOUNDATION Fieldbus protocol, refer to IM 01C25T02-01E) Digital communication (PROFIBUS PA protocol, refer to IM 01C25T04-01EN)
Measurement span (capsule)	M H.....	1 to 100 kPa (4 to 400 inH ₂ O) 5 to 500 kPa (20 to 2000 inH ₂ O)
Wetted parts material *1	S.....	Refer to Table. 2 Wetted Parts Materials on Page 9-18
Process connections ▶	3..... 4..... 5.....	with 1/4 NPT female process connector *2 with 1/2 NPT female process connector *2 without process connector (1/4 NPT female on the cover flanges)
Bolts and nuts material	J G C.....	ASTM-B7 carbon steel 316L SST stainless steel ASTM grade 660 stainless steel
Installation ▶	-2 -3 -6 -7 -8 -9 -U	Vertical piping, right side high pressure, and process connection upside Vertical piping, right side high pressure, and process connection downside Vertical piping, left side high pressure, and process connection upside Vertical piping, left side high pressure, and process connection downside Horizontal piping and right side high pressure Horizontal piping and left side high pressure Universal flange
Amplifier housing	1 2 3.....	Cast aluminum alloy ASTM CF-8M stainless steel Cast aluminum alloy with corrosion resistance properties
Electrical connection ▶	0 2 4 5 7 9 A..... C..... D.....	G1/2 female, one electrical connection without blind plugs 1/2 NPT female, two electrical connections without blind plugs M20 female, two electrical connections without blind plugs G1/2 female, two electrical connections and a blind plug 1/2 NPT female, two electrical connections and a blind plug M20 female, two electrical connections and a blind plug G1/2 female, two electrical connections and a 316 SST blind plug 1/2 NPT female, two electrical connections and a 316 SST blind plug M20 female, two electrical connections and a 316 SST blind plug
Integral indicator ▶	D..... E..... N.....	Digital indicator Digital indicator with the range setting switch (push button) None
Mounting bracket ▶	B..... D..... J..... K..... N.....	304 SST 2-inch pipe mounting, flat type (for horizontal piping) 304 SST 2-inch pipe mounting, L type (for vertical piping) 316 SST 2-inch pipe mounting, flat type (for horizontal piping) 316 SST 2-inch pipe mounting, L type (for vertical piping) None
Optional codes		/ <input type="checkbox"/> Optional specification

The “▶” marks indicate the most typical selection for each specification.

*1: Users must consider the characteristics of selected wetted parts material and influence of process fluids. Specifying inappropriate materials has the potential to cause serious damage to human body and plant facilities resulted from an unexpected leak of the corrosive process fluids.

*2: Lower limit of ambient and process temperature is -15°C.

Model EJX310A

Model	Suffix Codes	Description
EJX310A	Absolute pressure transmitter
Output signal	-D -E -J -F -G	4 to 20 mA DC with digital communication (BRAIN protocol) 4 to 20 mA DC with digital communication (HART protocol) 4 to 20 mA DC with digital communication (HART 5/HART 7 protocol) Digital communication (FOUNDATION Fieldbus protocol, refer to IM 01C25T02-01E) Digital communication (PROFIBUS PA protocol, refer to IM 01C25T04-01EN)
Measurement span (capsule)	L M A B	0.5 to 10 kPa abs (0.15 to 2.95 inHg abs) 1.3 to 130 kPa abs (0.39 to 38 inHg abs) 0.0175 to 3.5 MPa abs (2.5 to 500 psia) 0.08 to 16 MPa abs (12 to 2300 psia)
Wetted parts material *1	S	Refer to Table. 1 Wetted Parts Materials on Page 9-18.
Process connections	0 1 2 3 4 ▶ 5	without process connector (Rc1/4 female on the cover flanges) with Rc1/4 female process connector with Rc1/2 female process connector with 1/4 NPT female process connector with 1/2 NPT female process connector without process connector (1/4 NPT female on the cover flanges)
Bolts and nuts material	J G C	ASTM-B7 carbon steel 316L SST stainless steel ASTM grade 660 stainless steel
Installation	-2 -3 -6 -7 -8 ▶ -9 -B -U	Vertical piping, right side high pressure, and process connection upside Vertical piping, right side high pressure, and process connection downside Vertical piping, left side high pressure, and process connection upside Vertical piping, left side high pressure, and process connection downside Horizontal piping and right side high pressure Horizontal piping and left side high pressure Bottom process connection, left side high pressure Universal flange
Amplifier housing	1 2 3	Cast aluminum alloy ASTM CF-8M stainless steel Cast aluminum alloy with corrosion resistance properties
Electrical connection	▶ 0 2 4 5 7 9 A C D	G1/2 female, one electrical connection without blind plugs 1/2 NPT female, two electrical connections without blind plugs M20 female, two electrical connections without blind plugs G1/2 female, two electrical connections and a blind plug 1/2 NPT female, two electrical connections and a blind plug M20 female, two electrical connections and a blind plug G1/2 female, two electrical connections and a 316 SST blind plug 1/2 NPT female, two electrical connections and a 316 SST blind plug M20 female, two electrical connections and a 316 SST blind plug
Integral indicator	▶ D E N	Digital indicator Digital indicator with the range setting switch (push button) None
Mounting bracket	▶ B D G J K M N	304 SST 2-inch pipe mounting, flat type (for horizontal piping) 304 SST 2-inch pipe mounting, L type (for vertical piping) 304 SST 2-inch pipe mounting (for bottom process connection type) 316 SST 2-inch pipe mounting, flat type (for horizontal piping) 316 SST 2-inch pipe mounting, L type (for vertical piping) 316 SST 2-inch pipe mounting (for bottom process connection type) None
Optional codes		/ <input type="checkbox"/> Optional specification

The "▶" marks indicate the most typical selection for each specification.

*1: Users must consider the characteristics of selected wetted parts material and influence of process fluids. Specifying inappropriate materials has the potential to cause serious damage to human body and plant facilities resulted from an unexpected leak of the corrosive process fluids.

Model EJX430A

Model	Suffix Codes	Description
EJX430A	Gauge pressure transmitter
Output signal	-D -E -J -F -G	4 to 20 mA DC with digital communication (BRAIN protocol) 4 to 20 mA DC with digital communication (HART protocol) 4 to 20 mA DC with digital communication (HART 5/HART 7 protocol) Digital communication (FOUNDATION Fieldbus protocol, refer to IM 01C25T02-01E) Digital communication (PROFIBUS PA protocol, refer to IM 01C25T04-01EN)
Measurement span (capsule)	H..... A..... B.....	2.5 to 500 kPa (10 to 2000 inH ₂ O) 0.0175 to 3.5 MPa (2.5 to 500 psi) 0.08 to 16 MPa (12 to 2300 psi)
Wetted parts material *1	<input type="checkbox"/>	Refer to Table. 1 Wetted Parts Materials on Page 9-18
Process connections	0 1 2 3 4 ▶ 5	without process connector (Rc1/4 female on the cover flanges) with Rc1/4 female process connector with Rc1/2 female process connector with 1/4 NPT female process connector with 1/2 NPT female process connector without process connector (1/4 NPT female on the cover flanges)
Bolts and nuts material	J..... G..... C.....	ASTM-B7 carbon steel 316L SST stainless steel ASTM grade 660 stainless steel
Installation	-2 -3 -6 -7 -8 ▶ -9 -B -U	Vertical piping, right side high pressure, and process connection upside Vertical piping, right side high pressure, and process connection downside Vertical piping, left side high pressure, and process connection upside Vertical piping, left side high pressure, and process connection downside Horizontal piping and right side high pressure Horizontal piping and left side high pressure Bottom Process Connection, left side high pressure Universal flange
Amplifier housing	1 2 3	Cast aluminum alloy ASTM CF-8M stainless steel Cast aluminum alloy with corrosion resistance properties
Electrical connection	▶ 0 2 4 5 7 9 A..... C..... D.....	G1/2 female, one electrical connection without blind plugs 1/2 NPT female, two electrical connections without blind plugs M20 female, two electrical connections without blind plugs G1/2 female, two electrical connections and a blind plug 1/2 NPT female, two electrical connections and a blind plug M20 female, two electrical connections and a blind plug G1/2 female, two electrical connections and a 316 SST blind plug 1/2 NPT female, two electrical connections and a 316 SST blind plug M20 female, two electrical connections and a 316 SST blind plug
Integral indicator	▶ D..... E..... N.....	Digital indicator Digital indicator with the range setting switch (push button) None
Mounting bracket	▶ B..... D..... G..... J..... K..... M..... N.....	304 SST 2-inch pipe mounting, flat type (for horizontal piping) 304 SST 2-inch pipe mounting, L type (for vertical piping) 304 SST 2-inch pipe mounting (for bottom process connection type) 316 SST 2-inch pipe mounting, flat type (for horizontal piping) 316 SST 2-inch pipe mounting, L type (for vertical piping) 316 SST 2-inch pipe mounting (for bottom process connection type) None
Optional codes		/ <input type="checkbox"/> Optional specification

The "▶" marks indicate the most typical selection for each specification.

*1: Users must consider the characteristics of selected wetted parts material and influence of process fluids. Specifying inappropriate materials has the potential to cause serious damage to human body and plant facilities resulted from an unexpected leak of the corrosive process fluids.

Model EJX440A

Model	Suffix Codes	Description
EJX440A	Gauge pressure transmitter
Output signal	-D -E -J -F -G	4 to 20 mA DC with digital communication (BRAIN protocol) 4 to 20 mA DC with digital communication (HART protocol) 4 to 20 mA DC with digital communication (HART 5/HART 7 protocol) Digital communication (FOUNDATION Fieldbus protocol, refer to IM 01C25T02-01E) Digital communication (PROFIBUS PA protocol, refer to IM 01C25T04-01EN)
Measurement span (capsule)	C..... D.....	0.25 to 32 MPa (36 to 4500 psi) 0.25 to 50 MPa (36 to 7200 psi)
Wetted parts material *1	S.....	Refer to Table. 3 Wetted Parts Materials on Page 9-18.
Process connections ▶	3..... 4..... 5.....	with 1/4 NPT female process connector *2*3 with 1/2 NPT female process connector *2*3 without process connector (1/4 NPT female on the cover flanges)
Bolts and nuts material	J..... G..... C.....	ASTM-B7 carbon steel 316L SST stainless steel ASTM grade 660 stainless steel
Installation ▶	-2 -3 -6 -7 -8 -9 -U	Vertical piping, right side high pressure, and process connection upside Vertical piping, right side high pressure, and process connection downside Vertical piping, left side high pressure, and process connection upside Vertical piping, left side high pressure, and process connection downside Horizontal piping and right side high pressure Horizontal piping and left side high pressure Universal flange
Amplifier housing	1..... 2..... 3.....	Cast aluminum alloy ASTM CF-8M stainless steel Cast aluminum alloy with corrosion resistance properties
Electrical connection ▶	0..... 2..... 4..... 5..... 7..... 9..... A..... C..... D.....	G1/2 female, one electrical connection without blind plugs 1/2 NPT female, two electrical connections without blind plugs M20 female, two electrical connections without blind plugs G1/2 female, two electrical connections and a blind plug 1/2 NPT female, two electrical connections and a blind plug M20 female, two electrical connections and a blind plug G1/2 female, two electrical connections and a 316 SST blind plug 1/2 NPT female, two electrical connections and a 316 SST blind plug M20 female, two electrical connections and a 316 SST blind plug
Integral indicator ▶	D..... E..... N.....	Digital indicator Digital indicator with the range setting switch (push button) None
Mounting bracket ▶	B..... D..... J..... K..... N.....	304 SST 2-inch pipe mounting, flat type (for horizontal piping) 304 SST 2-inch pipe mounting, L type (for vertical piping) 316 SST 2-inch pipe mounting, flat type (for horizontal piping) 316 SST 2-inch pipe mounting, L type (for vertical piping) (None)
Optional codes		/ <input type="checkbox"/> Optional specification

The "▶" marks indicate the most typical selection for each specification.

- *1: Users must consider the characteristics of selected wetted parts material and influence of process fluids. Specifying inappropriate materials has the potential to cause serious damage to human body and plant facilities resulted from an unexpected leak of the corrosive process fluids.
- *2: Lower limit of ambient and process temperature is -15°C for capsule code C.
- *3: Specify the process connections code 3 or 4, when using the process connector for D capsule. Without the process connector, use the 1/4 NPT male piping to directly connect to the cover flange.

Model EJA110E

Model	Suffix Codes	Description
EJA110E	Differential pressure transmitter
Output signal	-D	4 to 20 mA DC with digital communication (BRAIN protocol)
	-J	4 to 20 mA DC with digital communication (HART 5/HART 7 protocol)
	-F	Digital communication (FOUNDATION Fieldbus protocol, refer to IM 01C25T02-01E)
	-G	Digital communication (PROFIBUS PA protocol, refer to IM 01C25T04-01EN)
	-Q	Low Power, 1 to 5 V DC with digital communication (HART 7 protocol)
Measurement span (capsule)	F	0.5 to 5 kPa (2.0 to 20 inH ₂ O) (For Wetted parts material code S)
	L	0.5 to 10 kPa (2.0 to 40 inH ₂ O) (For Wetted parts material code M, H, T, A, D and B)
	M	1 to 100 kPa (4 to 400 inH ₂ O)
	H	5 to 500 kPa (20 to 2000 inH ₂ O)
	V	0.14 to 14 MPa (20 to 2000 psi)
Wetted parts material *1	<input type="checkbox"/>	Refer to Table.1 Wetted Parts Material on Page 9-18
Process connections	0	without process connector (Rc1/4 female on the cover flanges)
	1	with Rc1/4 female process connector
	2	with Rc1/2 female process connector
	3	with 1/4 NPT female process connector
	4	with 1/2 NPT female process connector
	5	without process connector (1/4 NPT female on the cover flanges)
Bolts and nuts materia	J	B7 carbon steel
	G	316L SST
	C	660 SST
Installation	-2	Vertical piping, right side high pressure, and process connection upside
	-3	Vertical piping, right side high pressure, and process connection downside
	-6	Vertical piping, left side high pressure, and process connection upside
	-7	Vertical piping, left side high pressure, and process connection downside
	-8	Horizontal piping and right side high pressure
	-9	Horizontal piping and left side high pressure
	-B	Bottom Process Connection, left side high pressure
	-U	Universal flange
Amplifier housing	1	Cast aluminum alloy
	3	Cast aluminum alloy with corrosion resistance properties
	2	ASTM CF-8M stainless steel
Electrical connection	0	G1/2 female, one electrical connection without blind plugs
	2	1/2 NPT female, two electrical connections without blind plugs
	4	M20 female, two electrical connections without blind plugs
	5	G1/2 female, two electrical connections and a blind plug
	7	1/2 NPT female, two electrical connections and a blind plug
	9	M20 female, two electrical connections and a blind plug
	A	G1/2 female, two electrical connections and a SUS316 blind plug
	C	1/2 NPT female, two electrical connections and a SUS316 blind plug
	D	M20 female, two electrical connections and a SUS316 blind plug
Integral indicator	D	Digital indicator
	E	Digital indicator with the range setting switch (push button)
	N	None
Mounting bracket	B	304 SST 2-inch pipe mounting, flat type (for horizontal piping)
	D	304 SST 2-inch pipe mounting, L type (for vertical piping)
	J	316 SST 2-inch pipe mounting, flat type (for horizontal piping)
	K	316 SST 2-inch pipe mounting, L type (for vertical piping)
	M	316 SST 2-inch pipe mounting (for bottom process connection type)
	N	None
Optional Codes	<input type="checkbox"/>	/ <input type="checkbox"/> Optional specification

The "▶" marks indicate the most typical selection for each specification.

*1: Users must consider the characteristics of selected wetted parts material and influence of process fluids. Specifying inappropriate materials has the potential to cause serious damage to human body and plant facilities resulted from an unexpected leak of the corrosive process fluids.

Model EJA120E

Model	Suffix Codes	Description
EJA120E	Differential pressure transmitter
Output signal	-D	4 to 20 mA DC with digital communication (BRAIN protocol)
	-J	4 to 20 mA DC with digital communication (HART 5/HART 7 protocol)
	-F	Digital communication (FOUNDATION Fieldbus protocol, refer to IM 01C25T02-01E)
	-G	Digital communication (PROFIBUS PA protocol, refer to IM 01C25T04-01EN)
	-Q	Low Power, 1 to 5 V DC with digital communication (HART 7 protocol)
Measurement span (capsule)	E	0.1 to 1 kPa (0.4 to 4 inH ₂ O)
Wetted parts material *1	<input type="checkbox"/>	Refer to Table.1 Wetted Parts Material on Page 9-18
Process connections	0	without process connector (Rc1/4 female on the cover flanges)
	1	with Rc1/4 female process connector
	2	with Rc1/2 female process connector
	3	with 1/4 NPT female process connector
	4	with 1/2 NPT female process connector
	5	without process connector (1/4 NPT female on the cover flanges)
Bolts and nuts materia	J	B7 carbon steel
	G	316L SST
	C	660 SST
Installation	-2	Vertical piping, right side high pressure, and process connection upside
	-3	Vertical piping, right side high pressure, and process connection downside
	-6	Vertical piping, left side high pressure, and process connection upside
	-7	Vertical piping, left side high pressure, and process connection downside
	-8	Horizontal piping and right side high pressure
	-9	Horizontal piping and left side high pressure
Amplifier housing	1	Cast aluminum alloy
	3	Cast aluminum alloy with corrosion resistance properties
	2	ASTM CF-8M stainless steel
Electrical connection	0	G1/2 female, one electrical connection without blind plugs
	2	1/2 NPT female, two electrical connections without blind plugs
	4	M20 female, two electrical connections without blind plugs
	5	G1/2 female, two electrical connections and a blind plug
	7	1/2 NPT female, two electrical connections and a blind plug
	9	M20 female, two electrical connections and a blind plug
	A	G1/2 female, two electrical connections and a SUS316 blind plug
	C	1/2 NPT female, two electrical connections and a SUS316 blind plug
Integral indicator	D	Digital indicator
	E	Digital indicator with the range setting switch (push button)
	N	None
Mounting bracket	B	304 SST 2-inch pipe mounting, flat type (for horizontal piping)
	D	304 SST 2-inch pipe mounting, L type (for vertical piping)
	J	316 SST 2-inch pipe mounting, flat type (for horizontal piping)
	K	316 SST 2-inch pipe mounting, L type (for vertical piping)
	N	None
Optional Codes	<input type="checkbox"/>	/ <input type="checkbox"/> Optional specification

The "▶" marks indicate the most typical selection for each specification.

*1: Users must consider the characteristics of selected wetted parts material and influence of process fluids. Specifying inappropriate materials has the potential to cause serious damage to human body and plant facilities resulted from an unexpected leak of the corrosive process fluids.

Model EJA130E

Model	Suffix Codes	Description
EJA130E	Differential pressure transmitter
Output signal	-D	4 to 20 mA DC with digital communication (BRAIN protocol)
	-J	4 to 20 mA DC with digital communication (HART 5/HART 7 protocol)
	-F	Digital communication (FOUNDATION Fieldbus protocol, refer to IM 01C25T02-01E)
	-G	Digital communication (PROFIBUS PA protocol, refer to IM 01C25T04-01EN)
	-Q	Low Power, 1 to 5 V DC with digital communication (HART 7 protocol)
Measurement span (capsule)	M	1 to 100 kPa (4 to 400 inH ₂ O)
	H	5 to 500 kPa (20 to 2000 inH ₂ O)
Wetted parts material *1	S	Refer to Table.1 Wetted Parts Material on Page 9-18
Process connections	3	with 1/4 NPT female process connector*2
	4	with 1/2 NPT female process connector*2
	5	without process connector (1/4 NPT female on the cover flanges)
Bolts and nuts materia	J	B7 carbon steel
	G	316L SST
	C	660 SST
Installation	-2	Vertical piping, right side high pressure, and process connection upside
	-3	Vertical piping, right side high pressure, and process connection downside
	-6	Vertical piping, left side high pressure, and process connection upside
	-7	Vertical piping, left side high pressure, and process connection downside
	-8	Horizontal piping and right side high pressure
	-9	Horizontal piping and left side high pressure
	-U	Universal flange
Amplifier housing	1	Cast aluminum alloy
	3	Cast aluminum alloy with corrosion resistance properties
	2	ASTM CF-8M stainless steel
Electrical connection	0	G1/2 female, one electrical connection without blind plugs
	2	1/2 NPT female, two electrical connections without blind plugs
	4	M20 female, two electrical connections without blind plugs
	5	G1/2 female, two electrical connections and a blind plug
	7	1/2 NPT female, two electrical connections and a blind plug
	9	M20 female, two electrical connections and a blind plug
	A	G1/2 female, two electrical connections and a SUS316 blind plug
	C	1/2 NPT female, two electrical connections and a SUS316 blind plug
	D	M20 female, two electrical connections and a SUS316 blind plug
Integral indicator	D	Digital indicator
	E	Digital indicator with the range setting switch (push button)
	N	None
Mounting bracket	B	304 SST 2-inch pipe mounting, flat type (for horizontal piping)
	D	304 SST 2-inch pipe mounting, L type (for vertical piping)
	J	316 SST 2-inch pipe mounting, flat type (for horizontal piping)
	K	316 SST 2-inch pipe mounting, L type (for vertical piping)
	N	None
Optional Codes		/ <input type="checkbox"/> Optional specification

The "▶" marks indicate the most typical selection for each specification.

*1: Users must consider the characteristics of selected wetted parts material and influence of process fluids. Specifying inappropriate materials has the potential to cause serious damage to human body and plant facilities resulted from an unexpected leak of the corrosive process fluids.

*2: Lower limit of ambient and process temperature is -15°C.

Model EJA310E

Model	Suffix Codes	Description
EJA310E	Absolute pressure transmitter
Output signal	-D -J -F -G -Q	4 to 20 mA DC with digital communication (BRAIN protocol) 4 to 20 mA DC with digital communication (HART 5/HART 7 protocol) Digital communication (FOUNDATION Fieldbus protocol, refer to IM 01C25T02-01E) Digital communication (PROFIBUS PA protocol, refer to IM 01C25T04-01EN) Low Power, 1 to 5 V DC with digital communication (HART 7 protocol)
Measurement span (capsule)	L M A B	0.67 to 10 kPa abs (0.2 to 2.95 inHg abs) 1.3 to 130 kPa abs (0.39 to 38 inHg abs) 0.03 to 3.5 MPa abs (4.3 to 500 psia) 0.14 to 16 MPa abs (20 to 2300 psia)
Wetted parts material *1	S	Refer to Table.1 Wetted Parts Material on Page 9-18
Process connections	0 1 2 3 4 5	without process connector (Rc1/4 female on the cover flanges) with Rc1/4 female process connector with Rc1/2 female process connector with 1/4 NPT female process connector with 1/2 NPT female process connector without process connector (1/4 NPT female on the cover flanges)
Bolts and nuts materia	J G C	B7 carbon steel 316L SST 660 SST
Installation	-2 -3 -6 -7 -8 -9 -B -U	Vertical piping, right side high pressure, and process connection upside Vertical piping, right side high pressure, and process connection downside Vertical piping, left side high pressure, and process connection upside Vertical piping, left side high pressure, and process connection downside Horizontal piping and right side high pressure Horizontal piping and left side high pressure Bottom Process Connection, left side high pressure: Universal flange
Amplifier housing	1 3 2	Cast aluminum alloy Cast aluminum alloy with corrosion resistance properties ASTM CF-8M stainless steel
Electrical connection	0 2 4 5 7 9 A C D	G1/2 female, one electrical connection without blind plugs 1/2 NPT female, two electrical connections without blind plugs M20 female, two electrical connections without blind plugs G1/2 female, two electrical connections and a blind plug 1/2 NPT female, two electrical connections and a blind plug M20 female, two electrical connections and a blind plug G1/2 female, two electrical connections and a 316 SST blind plug 1/2 NPT female, two electrical connections and a 316 SST blind plug M20 female, two electrical connections and a 316 SST blind plug
Integral indicator	D E N	Digital indicator Digital indicator with the range setting switch (push button) (None)
Mounting bracket	B D J K M N	304 SST 2-inch pipe mounting, flat type (for horizontal piping) 304 SST 2-inch pipe mounting, L type (for vertical piping) 316 SST 2-inch pipe mounting, flat type (for horizontal piping) 316 SST 2-inch pipe mounting, L type (for vertical piping) 316 SST 2-inch pipe mounting (for bottom process connection type) (None)
Optional Codes		/ <input type="checkbox"/> Optional specification

The "▶" marks indicate the most typical selection for each specification.

*1: Users must consider the characteristics of selected wetted parts material and influence of process fluids. Specifying inappropriate materials has the potential to cause serious damage to human body and plant facilities resulted from an unexpected leak of the corrosive process fluids.

Model EJA430E

Model	Suffix Codes	Description
EJA430E	Gauge pressure transmitter
Output signal	-D -J -F -G -Q	4 to 20 mA DC with digital communication (BRAIN protocol) 4 to 20 mA DC with digital communication (HART 5/HART 7 protocol) Digital communication (FOUNDATION Fieldbus protocol, refer to IM 01C25T02-01E) Digital communication (PROFIBUS PA protocol, refer to IM 01C25T04-01EN) Low Power, 1 to 5 V DC with digital communication (HART 7 protocol)
Measurement span (capsule)	H A B	5 to 500 kPa (20 to 2000 inH ₂ O) 0.03 to 3.5 MPa (4.3 to 500 psi) 0.14 to 16 MPa (20 to 2300 psi)
Wetted parts material *1	<input type="checkbox"/>	Refer to Table.1 Wetted Parts Material on Page 9-18
Process connections	0 1 2 3 4 5	without process connector (Rc1/4 female on the cover flanges) with Rc1/4 female process connector with Rc1/2 female process connector with 1/4 NPT female process connector with 1/2 NPT female process connector without process connector (1/4 NPT female on the cover flanges)
Bolts and nuts materia	J G C	B7 carbon steel 316L SST 660 SST
Installation	-2 -3 -6 -7 -8 -9 -B -U	Vertical piping, right side high pressure, and process connection upside Vertical piping, right side high pressure, and process connection downside Vertical piping, left side high pressure, and process connection upside Vertical piping, left side high pressure, and process connection downside Horizontal piping and right side high pressure Horizontal piping and left side high pressure Bottom Process Connection, left side high pressure Universal flange
Amplifier housing	1 3 2	Cast aluminum alloy Cast aluminum alloy with corrosion resistance properties ASTM CF-8M stainless steel
Electrical connection	0 2 4 5 7 9 A C D	G1/2 female, one electrical connection without blind plugs 1/2 NPT female, two electrical connections without blind plugs M20 female, two electrical connections without blind plugs G1/2 female, two electrical connections and a blind plug 1/2 NPT female, two electrical connections and a blind plug M20 female, two electrical connections and a blind plug G1/2 female, two electrical connections and a 316 SST blind plug 1/2 NPT female, two electrical connections and a 316 SST blind plug M20 female, two electrical connections and a 316 SST blind plug
Integral indicator	D E N	Digital indicator Digital indicator with the range setting switch (push button) (None)
Mounting bracket	B D J K M N	304 SST 2-inch pipe mounting, flat type (for horizontal piping) 304 SST 2-inch pipe mounting, L type (for vertical piping) 316 SST 2-inch pipe mounting, flat type (for horizontal piping) 316 SST 2-inch pipe mounting, L type (for vertical piping) 316 SST 2-inch pipe mounting (for bottom process connection type) (None)
Optional Codes		/ <input type="checkbox"/> Optional specification

The "▶" marks indicate the most typical selection for each specification.

*1: Users must consider the characteristics of selected wetted parts material and influence of process fluids. Specifying inappropriate materials has the potential to cause serious damage to human body and plant facilities resulted from an unexpected leak of the corrosive process fluids.

Model EJA440E

Model	Suffix Codes	Description
EJA440E	Gauge pressure transmitter
Output signal	-D	4 to 20 mA DC with digital communication (BRAIN protocol)
	-J	4 to 20 mA DC with digital communication (HART 5/HART 7 protocol)*1
	-F	Digital communication (FOUNDATION Fieldbus protocol, refer to IM 01C25T02-01E)
	-G	Digital communication (PROFIBUS PA protocol, refer to IM 01C25T04-01EN)
	-Q	Low Power, 1 to 5 V DC with digital communication (HART 7 protocol)
Measurement span (capsule)	C	5 to 32 MPa (720 to 4500 psi)
	D	5 to 50 MPa (720 to 7200 psi)
Wetted parts material *1	S	Refer to Table.1 Wetted Parts Material on Page 9-18
Process connections	3	with 1/4 NPT female process connector*2*3
	4	with 1/2 NPT female process connector*2*3
	5	without process connector (1/4 NPT female on the cover flanges)
Bolts and nuts materia	J	B7 carbon steel
	G	316L SST
	C	660 SST
Installation	-2	Vertical piping, right side high pressure, and process connection upside
	-3	Vertical piping, right side high pressure, and process connection downside
	-6	Vertical piping, left side high pressure, and process connection upside
	-7	Vertical piping, left side high pressure, and process connection downside
	-8	Horizontal piping and right side high pressure
	-9	Horizontal piping and left side high pressure
Amplifier housing	1	Cast aluminum alloy
	3	Cast aluminum alloy with corrosion resistance properties
	2	ASTM CF-8M stainless steel
Electrical connection	0	G1/2 female, one electrical connection without blind plugs
	2	1/2 NPT female, two electrical connections without blind plugs
	4	M20 female, two electrical connections without blind plugs
	5	G1/2 female, two electrical connections and a blind plug
	7	1/2 NPT female, two electrical connections and a blind plug
	9	M20 female, two electrical connections and a blind plug
	A	G1/2 female, two electrical connections and a 316 SST blind plug
Integral indicator	D	Digital indicator
	E	Digital indicator with the range setting switch (push button)
	N	(None)
Mounting bracket	B	304 SST 2-inch pipe mounting, flat type (for horizontal piping)
	D	304 SST 2-inch pipe mounting, L type (for vertical piping)
	J	316 SST 2-inch pipe mounting, flat type (for horizontal piping)
	K	316 SST 2-inch pipe mounting, L type (for vertical piping)
	N	(None)
Optional Codes		/ <input type="checkbox"/> Optional specification

The "▶" marks indicate the most typical selection for each specification.

- *1: Users must consider the characteristics of selected wetted parts material and influence of process fluids. Specifying inappropriate materials has the potential to cause serious damage to human body and plant facilities resulted from an unexpected leak of the corrosive process fluids.
- *2: Specify the process connections code 3 or 4, when using the process connector for D capsule. Without the process connector, use the 1/4 NPT male piping to directly connect to the cover flange.
- *3: Lower limit of ambient and process temperature is -15°C for capsule code C.

Table. 1 Wetted Parts Materials for EJ□110□, EJ□120□, EJ□310□, and EJ□430□

Wetted parts material code	Cover flange and process connector	Capsule	Capsule gasket	Vent/Drain plug
S #	ASTM CF-8M	Hastelloy C-276 (Diaphragm) F316L SST, 316L SST (Others)	Teflon-coated 316L SST PTFE for EJX120A	316 SST
H	ASTM CF-8M	Hastelloy C-276	PTFE (Teflon)	316 SST
M	ASTM CF-8M	Monel	PTFE (Teflon)	316 SST
T	ASTM CF-8M	Tantalum	PTFE (Teflon)	316 SST
A	Hastelloy C-276 equivalent	Hastelloy C-276	PTFE (Teflon)	Hastelloy C-276
D	Hastelloy C-276 equivalent	Tantalum	PTFE (Teflon)	Hastelloy C-276
B	Monel equivalent	Monel	PTFE (Teflon)	Monel

The '#' marks indicate the construction materials conform to NACE material recommendations per MR01-75. For the use of 316 SST material, there may be certain limitations for pressure and temperature. Please refer to NACE standards for details.

Table. 2 Wetted Parts Materials for EJ□130□

Wetted parts material code	Cover flange	process connector	Capsule	Capsule gasket	Vent/Drain plug
S #	F316 SST	ASTM CF-8M *1	Hastelloy C-276*2 (Diaphragm) F316L SST, 316L SST (Others)	Teflon-coated 316L SST	316 SST

*1: Cast version of 316 SST. Equivalent to SCS14A.

*2: Hastelloy C-276 or ASTM N10276.

The '#' marks indicate the construction materials conform to NACE material recommendations per MR01-75. For the use of 316 SST material, there may be certain limitations for pressure and temperature. Please refer to NACE standards for details.

Table. 3 Wetted Parts Materials for EJ□440□

Wetted parts material code	Cover flange	process connector	Capsule	Capsule gasket	Vent/Drain plug
S #	F316 SST	ASTM CF-8M *1 (C-capsule) F316L SST (D-capsule)	Hastelloy C-276 *2 (Diaphragm) F316L SST, 316L SST (Others)	Teflon-coated 316L SST	316 SST

*1: Cast version of 316 SST. Equivalent to SCS14A.

*2: Hastelloy C-276 or ASTM N10276.

The '#' marks indicate the construction materials conform to NACE material recommendations per MR01-75. For the use of 316 SST material, there may be certain limitations for pressure and temperature. Please refer to NACE standards for details.

9.3 Optional Specifications

Item		Description	Code
Factory Mutual (FM)		FM Explosionproof *1 Explosionproof for Class I, Division 1, Groups B, C and D Dust-ignitionproof for Class II/III, Division 1, Groups E, F and G Hazardous (classified) locations, indoors and outdoors (NEMA 4X)	FF1
		FM Intrinsically safe *1*3 Intrinsically Safe for Class I, Division 1, Groups A, B, C and D, Class II, Division 1, Groups E, F and G and Class III, Division 1 Hazardous Locations. Nonincendive for Class I, Division 2, Groups A, B, C and D, Class II, Division 2, Groups F and G, Hazardous Locations.	FS1
		Combined FF1 and FS1 *1*3	FU1
ATEX		ATEX Flameproof *1 II 2G, 2D Ex d IIC T6...T4 Gb, Ex tb IIIC T85°C Db Special fastener: ClassA2-50(A4-50) or more	KF22
		ATEX Intrinsically safe Ex ia *1*3 II 1G, 2D Ex ia IIC T4 Ga, Ex ia IIIC T85°C T100°C T120°C Db	KS21
		Combined KF22, KS21 and ATEX Intrinsically safe Ex ic *1*3 Ex ic: II 3G Ex ic IIC T4 Gc	KU22
Canadian Standards Association (CSA)		CSA Explosionproof *1 Explosionproof for Class I, Groups B, C and D Dustignitionproof for Class II/III, Groups E, F and G Enclosure TYPE 4X, Temp.Code:T6...T4 Ex d IIC T6...T4 Enclosure IP66/IP67 Process Sealing Certification Dual Seal Certified by CSA to the requirement of ANSI/ISA 12.27.01 No additional sealing required Primary seal failure annunciation: at the zero adjustment screw	CF1
		CSA Intrinsically safe *1 *3 [For CSA C22.2] Intrinsically safe for Class I, Division 1, Groups A, B, C and D, Class II, Division 1, Groups E, F and G, Class III, Division 1 Nonincendive for Class I, Division 2, Groups A, B, C and D, Class II, Division 2, Groups F and G, Class III, Division 1 [For CSA E60079] Ex ia IIC T4, Ex nL IIC T4 Process Sealing Certification Dual Seal Certified by CSA to the requirement of ANSI/ISA 12.27.01 No additional sealing required Primary seal failure annunciation: at the zero adjustment screw	CS1
		Combined CF1 and CS1 *1*3	CU1
IECEX		IECEX flameproof *1 Flameproof for Zone1, Ex d IIC T6...T4 Gb Special fastener: ClassA2-50(A4-50) or more	SF2
		IECEX Intrinsically safe, type n and flameproof *1*3 Intrinsically safe and type n Ex ia IIC T4, Ex nL IIC T4 Flameproof Flameproof for Zone1, Ex d IIC T6...T4 Gb Special fastener: ClassA2-50(A4-50) or more	SU2
Combination of Approval		Combination of KU22, FU1 and CU1	V1U1
Painting	Color change	Terminal cover only	P□
		Both sides of amplifier covers, Munsell 7.5 R4/14	PR
	Coating change	Anti-corrosion coating	X2
316 SST exterior parts		316 SST name plate, tag plate and zero adjustment screw	HC
Fluoro-rubber O-ring		All O-rings of amplifier housing. Lower limit of ambient temperature: -15°C(5°F)	HE
Lightning protector		Transmitter power supply voltage: 10.5 to 32 V DC (10.5 to 30 V DC for intrinsically safe type.) Allowable current: Max. 6000 A (1×40 μs), Repeating 1000 A (1×40 μs) 100 times Applicable Standards: IEC 61000-4-4, IEC 61000-4-5	A
Status output *11		Transistor output (sink type) Contact rating: 10.5 to 30 VDC, 120 mA DC(max) Low level: 0 to 2 VDC	AL

Item	Description	Code	
Oil-prohibited use *4	Degrease cleansing treatment.	K1	
	Degrease cleansing treatment and with fluorinated oilfilled capsule. Operating temperature -20 to 80°C (-4 to 176°F)	K2	
Oil-prohibited use with dehydrating treatment *4	Degrease cleansing treatment and dehydrating treatment.	K5	
	Degrease cleansing treatment and dehydrating treatment with fluorinated oilfilled capsule. Operating temperature -20 to 80°C (-4 to 176°F)	K6	
Capsule fill fluid	Fluorinated oil filled in capsule Operating temperature -20 to 80°C (-4 to 176°F)	K3	
Calibration units *5	P calibration (psi unit)	(See Table for Span and Range Limits.)	D1
	bar calibration (bar unit)		D3
	M calibration (kgf/cm ² unit)		D4
Long vent *6	Total length: 119 mm (standard: 34 mm); Total length when combining with Optional code K1, K2, K5, and K6: 130 mm. Material: 316SST.	U1	
Gold-plated capsule gasket *13	Gold-plated 316L SST capsule gasket. No PTFE is used for wetted parts.	GS	
Gold-plated diaphragm *14	Surface of isolating diaphragm is gold plated, effective for hydrogen permeation.	A1	
130 Pa abs calibration *12	Minimum input puresure at calibration testing: 130 Pa abs (1 mmHg abs)	S1	
Output limits and failure operation *7	Failure alarm down-scale: Output status at CPU failure and hardware error is -5%, 3.2 mA DC or less. *30	C1	
	NAMUR NE43 Compliant Output signal limits: 3.8 mA to 20.5 mA *31	Failure alarm down-scale: Output status at CPU failure and hardware error is -5%, 3.2 mA DC or less.	C2
		Failure alarm up-scale: Output status at CPU failure and hardware error is 110%, 21.6 mA or more.	C3
Body option *8	Without drain and vent plugs	N1	
	N1 and Process connection, based on IEC61518 with female thread on both sides of cover flange, with blind kidney flanges on back.	N2	
	N2 and Material certificate for cover flange, diaphragm, capsule body, and blind kidney flange	N3	
Stainless steel tag plate	304SST tag plate wired onto transmitter	N4	
Data configuration at factory *9	Data configuration for HART communication type	Software damping, Descriptor, Message	CA
	Data configuration for BRAIN communication type	Software damping	CB
European Pressure Directive *10	PED 97/23/EC Category: III, Module: H, Type of Equipment; Pressure Accessory-Vessel, Type of Fluid; Liquid and gas, Group of Fluid: 1 and 2 Lower limit of Process and Ambient temperature for EJX110A : -29°C	PE3	
Advanced diagnostics *27	Multi-sensing process monitoring • Impulse line blockage detection *28 • Heat trace monitoring	DG6	
Material certificate *15	Cover flange *16	M01	
	Cover flange, Process connector *17	M11	
Pressure test/ Leak test certificate	Test Pressure: 16 MPa (2300 psi) *18	Nitrogen(N ₂) Gas *25 Retention time: one minute	T12
	Test Pressure: 25 MPa (3600 psi) *19		T13
	Test Pressure: 3.5 MPa (500 psi) *20		T01
	Test Pressure: 500 kPa (2000 inH ₂ O) *21		T11
	Test Pressure: 50 kPa (200 inH ₂ O) *22	T04	
	Test Pressure: 32 MPa (4500 psi) *23	Nitrogen(N ₂) Gas or water *26 Retention time: one minute	T09
	Test Pressure: 50 MPa (7200 psi) *24		T08
High accuracy type	High accuracy	HAC	
High pressure-proof structure	Maximum working pressure for differential pressure measurement: 25MPa*29	HG	

Contact Yokogawa representative for the codes indicated as '-'.
 *1: Applicable for Electrical connection code 2, 4, 7, and 9.
 *2: Applicable for Electrical connection code 2 and 7.
 *3: Not applicable for option code /AL.
 *4: Applicable for Wetted parts material code S, H, M, and T.
 *5: The unit of MWP (Max. working pressure) on the name plate of the housing is the same unit as specified by Option code D1, D3, and D4.

- *6: Applicable for vertical impulse piping type (Installation code 7) and Wetted parts material code S, H, M, and T.
- *7: Applicable for output signal code D, E and J. The hardware error indicates faulty amplifier or capsule.
- *8: Applicable for Wetted parts material code S, H, M, and T; Process connection code 3, 4, and 5; Installation code 9; and Mounting bracket code N. Process connection faces on the other side of zero adjustment screw.
- *9: Also see 'Ordering Instructions'.
- *10: Applicable for M, H and V capsules of EJX110A with wetted parts material code S, and all the ranges of EJ□130□ and EJ□440□. Applicable also for EJA110E with option code /HG.
- *11: Not applicable for output signal code F.
- *12: Applicable only for EJ□310□ M and A capsules whose upper range value is set as smaller than 53.3 kPa abs.
- *13: Applicable for wetted parts material code S; process connection code 0 and 5; and installation code 8 and 9. Not applicable for option code U1, N2, N3 and M11. Not applicable for EJ□120□.
- *14: Applicable for wetted parts material code S.
- *15: Material traceability certification, per EN 10204 3.1B.
- *16: Applicable for Process connections code 0 and 5.
- *17: Applicable for Process connections code 1, 2, 3, and 4.
- *18: Applicable for EJA110E, Capsule code F and L of EJX110A, Capsule code B of EJ□430□ and EJX310A, and all the capsules of EJX110A with wetted parts material code H, M, T, A, D, and B.
- *19: Applicable for Capsule code M, H and V of EJX110A with wetted parts material code S.
- *20: Applicable for Capsule code A of EJ□430□ and EJ□310□.
- *21: Applicable for Capsule code H of EJ□430□.
- *22: Applicable for EJ□120□ and Capsule code L and M of EJ□310□.
- *23: Applicable for EJ□130□ and Capsule code C of EJ□440□.
- *24: Applicable for Capsule code D of EJ□440□.
- *25: Pure nitrogen gas is used for oil-prohibited use (Option code K1, K2, K5, and K6).
- *26: Pure nitrogen gas or pure water is used for oil-prohibited use (Option code K1, K2, K5, and K6).
- *27: Applicable only for output signal code E and J.
- *28: The change of pressure fluctuation is monitored and then detects the impulse line blockage. See TI 01C25A31-01E for detailed technical information required for using this function. The detection is for one side only.
- *29: Applicable for EJA110E, Measurement span code M, H, and, V; and wetted parts material code S. The URL of static pressure range is also extended to 25 MPa.
- *30: Output status at CPU failure and hardware error is -5%, 0.8V DC or less for output signal code Q.
- *31: The 1 to 5 V voltage output corresponding to 4 to 20 mA current output is applied to output signal code Q which is non-compliant to NAMUR NE43.

9.4 Dimensions

Model EJ□110□

Unit: mm (approx. inch)

• Vertical Impulse Piping Type

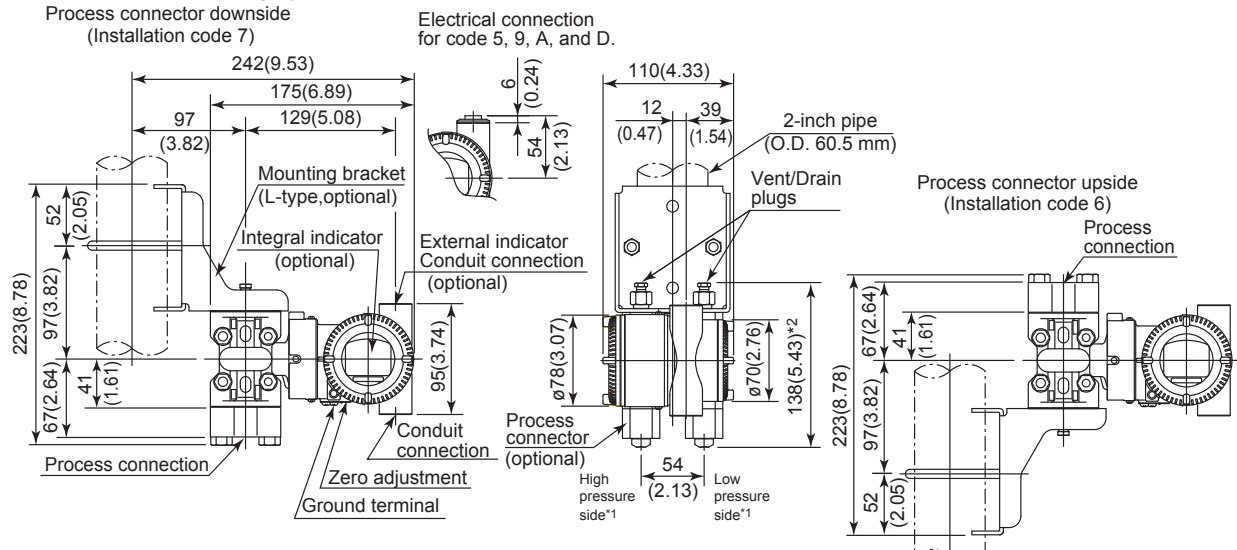

• Horizontal Impulse Piping Type (Installation code 9)

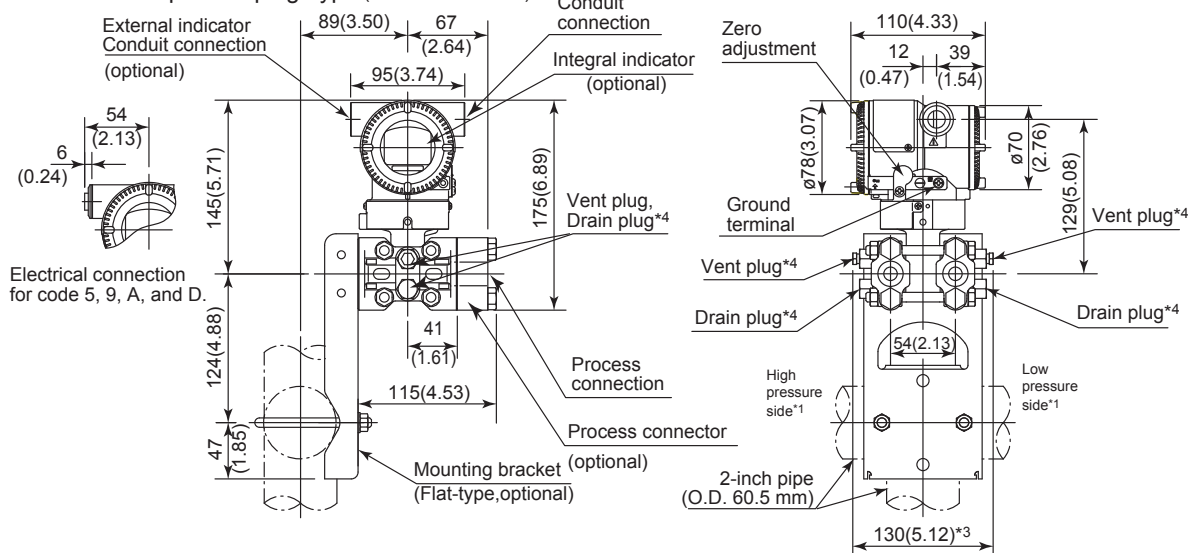

*1: When Installation code 2, 3, or 8 is selected, high and low pressure side on the above figure are reversed. (i.e. High pressure side is on the right side.)

*2: When Option code K1, K2, K5, or K6 is selected, add 15 mm(0.59 inch) to the value in the figure.

*3: When Option code K1, K2, K5, or K6 is selected, add 30 mm(1.18 inch) to the value in the figure.

*4: Not available when option code GS is specified.

F0904.ai

Unit: mm (approx. inch)

● Vertical Impulse Piping Type

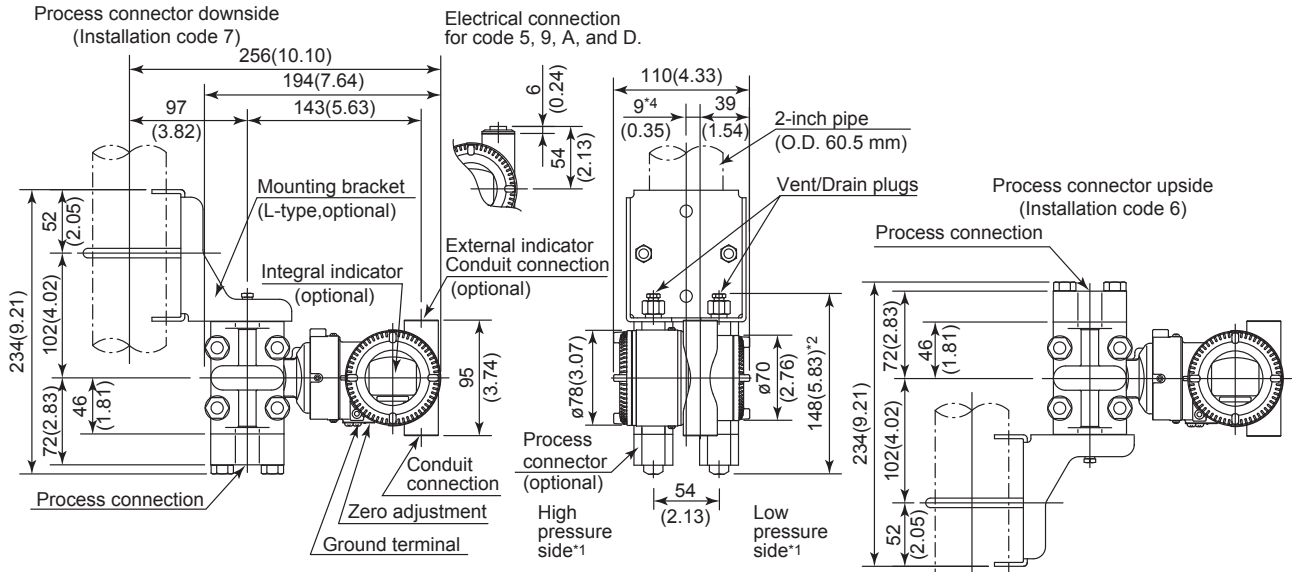

● Horizontal Impulse Piping Type (Installation code 9)

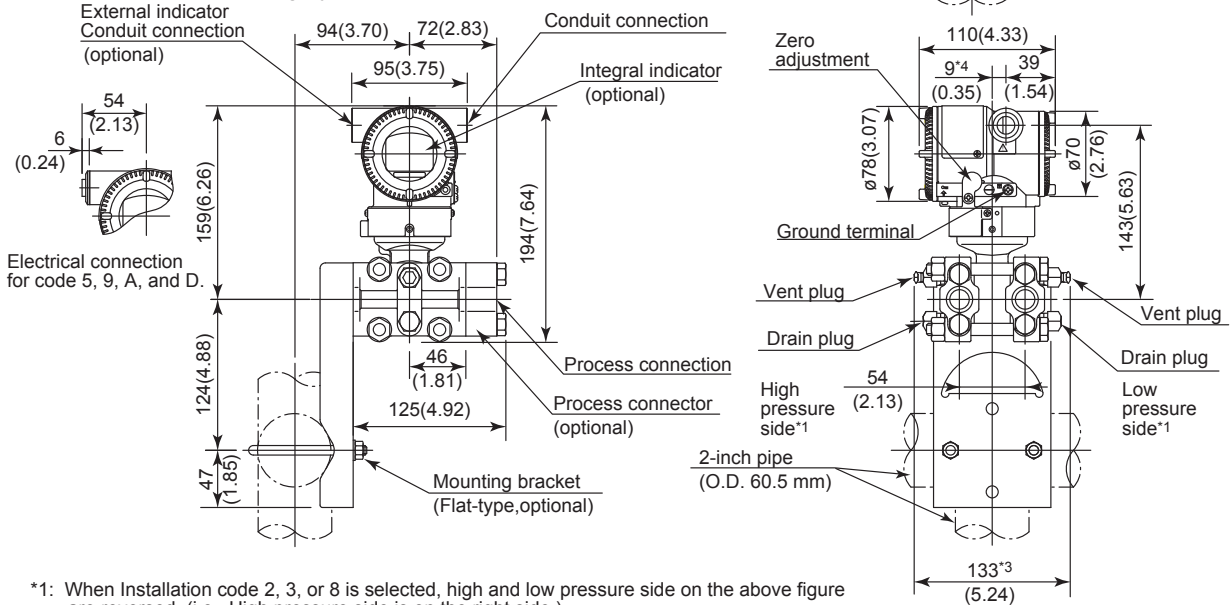

*1: When Installation code 2, 3, or 8 is selected, high and low pressure side on the above figure are reversed. (i.e. High pressure side is on the right side.)

*2: When Option code K1, K2, K5, or K6 is selected, add 15 mm(0.59 inch) to the value in the figure.

*3: When Option code K1, K2, K5, or K6 is selected, add 30 mm(1.18 inch) to the value in the figure.

*4: 15 mm(0.59 inch) for right side high pressure.

F0905.ai

Unit: mm (approx. inch)

● Bottom Process Connection (Installation code -B)

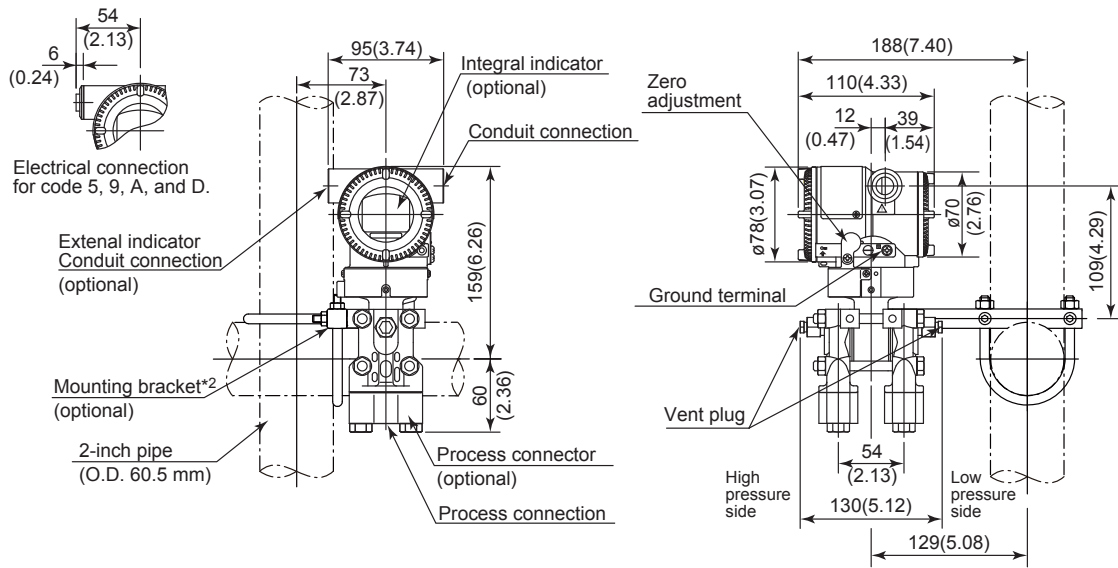

F0906.ai

● Universal Flange (Installation code -U), Measurement Span code M, H and V

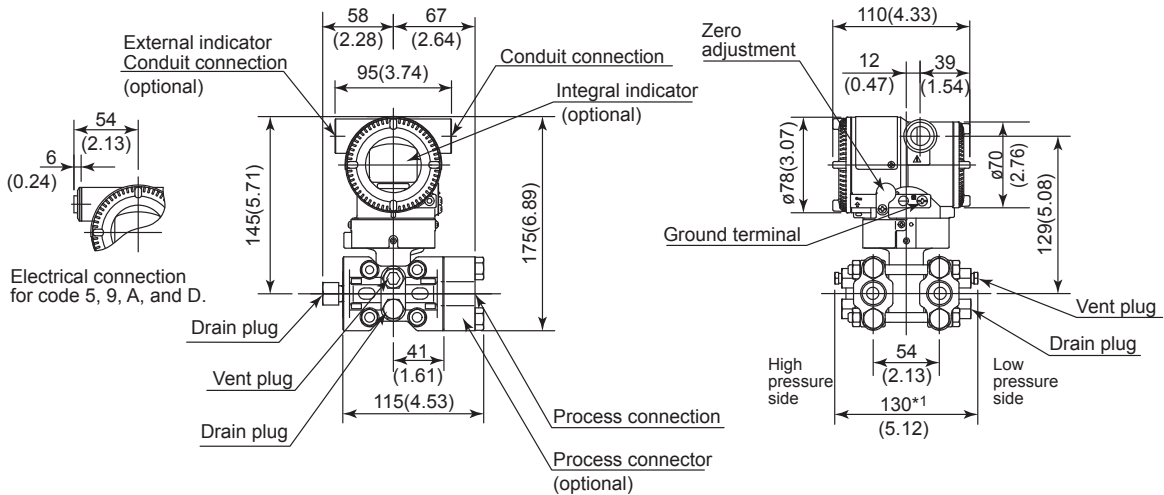

● Universal Flange (Installation code -U), Measurement Span code F

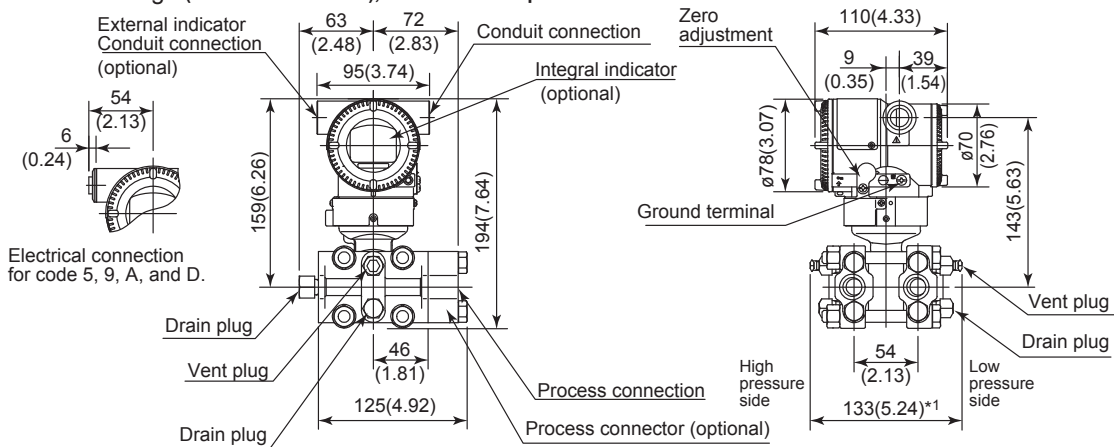

*1: When Option code K1, K2, K5, or K6 is selected, add 30 mm (1.18 inch) to the value.

*2: A transmitter with SST housing is not applicable for mounting to horizontal 2-inch pipe.

F0907.ai

Model EJ□120□

Unit: mm (approx. inch)

● Vertical Impulse Piping Type

Process connector downside
(Installation code 7)

Electrical connection
for code 5, 9, A, and D.

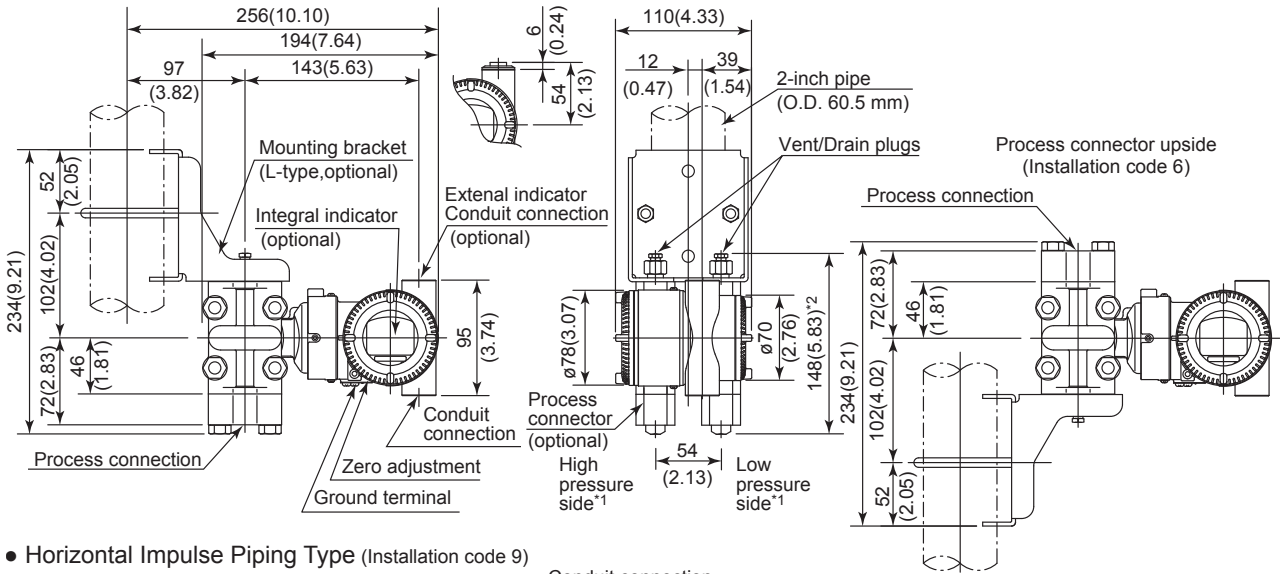

● Horizontal Impulse Piping Type (Installation code 9)

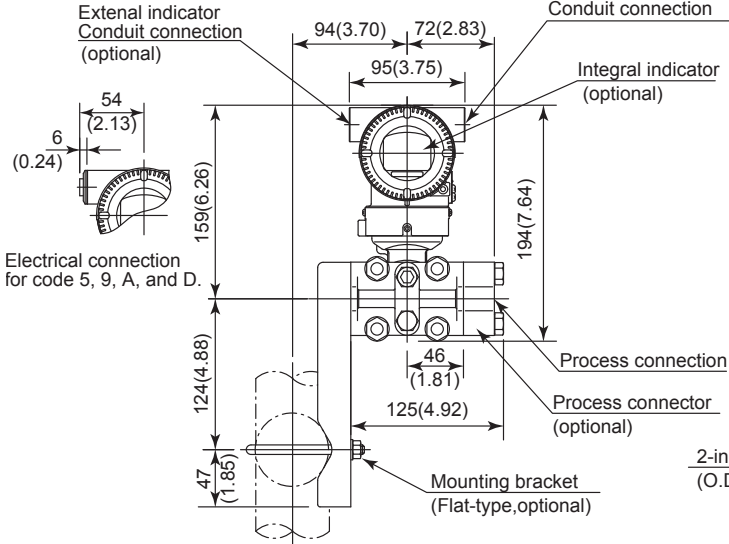

*1: When Installation code 2, 3, or 8 is selected, high and low pressure side on the above figure are reversed. (i.e. High pressure side is on the right side.)

*2: When Option code K1, K2, K5, or K6 is selected, add 15 mm(0.59 inch) to the value in the figure.

*3: When Option code K1, K2, K5, or K6 is selected, add 30 mm(1.18 inch) to the value in the figure.

F0908.ai

Unit: mm (approx. inch)

● Universal Flange (Installation code -U)

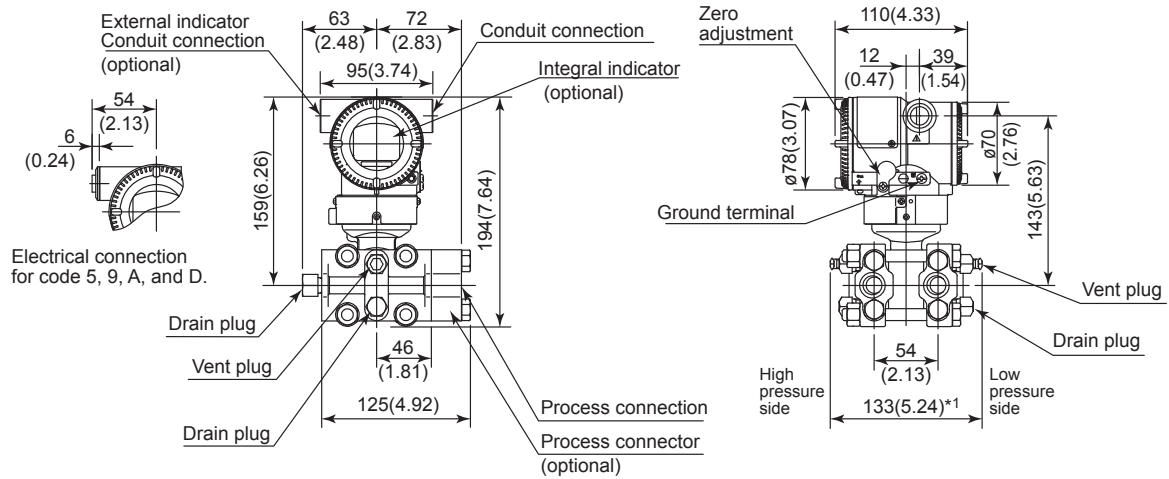

*1: When Option code K1, K2, K5, or K6 is selected, add 30 mm (1.18 inch) to the value.

F0909.ai

Model EJ□130□

Unit: mm (approx. inch)

• Vertical Impulse Piping Type

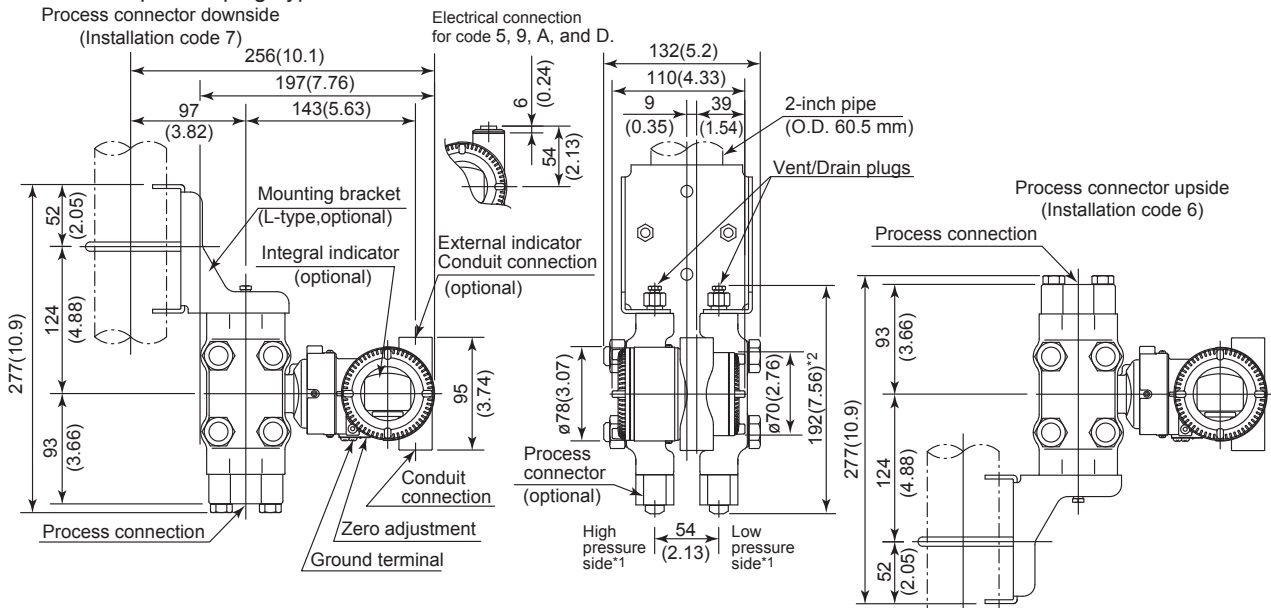

• Horizontal Impulse Piping Type (Installation code 9)

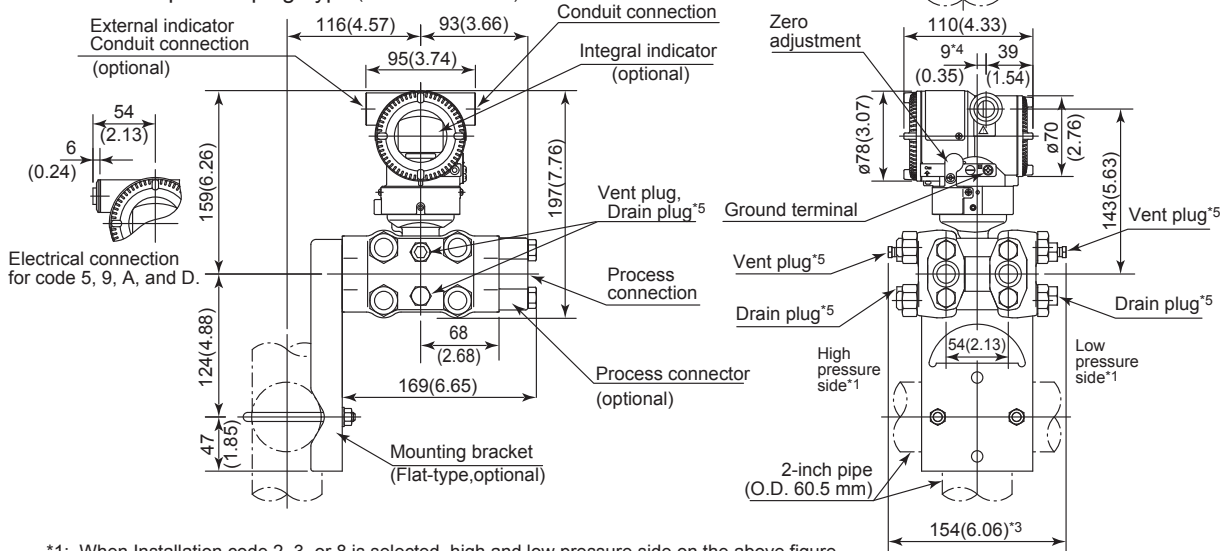

*1: When Installation code 2, 3, or 8 is selected, high and low pressure side on the above figure are reversed. (i.e. High pressure side is on the right side.)

*2: When Option code K1, K2, K5, or K6 is selected, add 15 mm(0.59 inch) to the value in the figure.

*3: When Option code K1, K2, K5, or K6 is selected, add 30 mm(1.18 inch) to the value in the figure.

*4: 15 mm(0.59 inch) for right side high pressure.

*5: Not available when Option code GS is specified.

F0910.ai

Unit: mm (approx. inch)

● Universal Flange (Installation code -U)

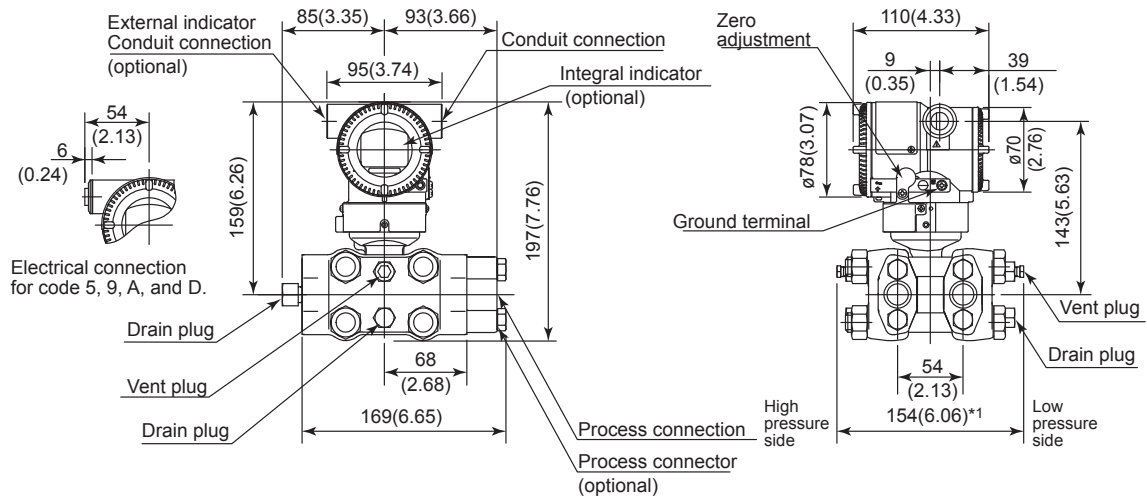

*1: When Option code K1, K2, K5, or K6 is selected, add 30 mm(1.18 inch) to the value.

F0911.ai

Model EJ□310□

Unit: mm (approx. inch)

• Vertical Impulse Piping Type

Process connector downside
(Installation code 7)

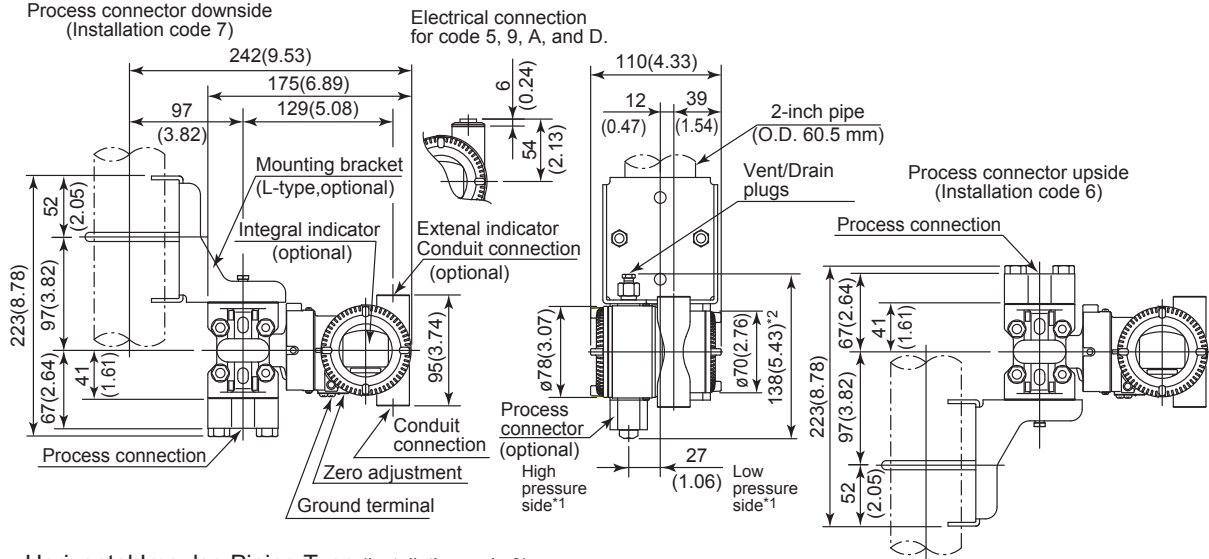

• Horizontal Impulse Piping Type (Installation code 9)

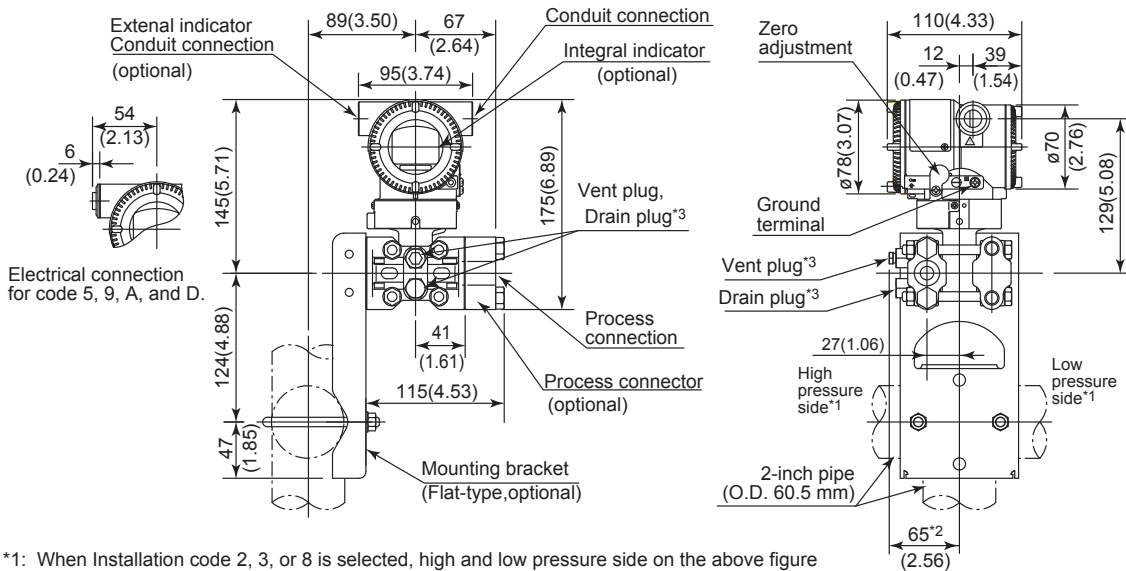

*1: When Installation code 2, 3, or 8 is selected, high and low pressure side on the above figure are reversed. (i.e. High pressure side is on the right side.)

*2: When Option code K1, K2, K5, or K6 is selected, add 15 mm(0.59 inch) to the value in the figure.

*3: Not available when Option code GS is specified.

F0912.ai

Unit: mm (approx. inch)

• Bottom Process Connection (Installation code -B)

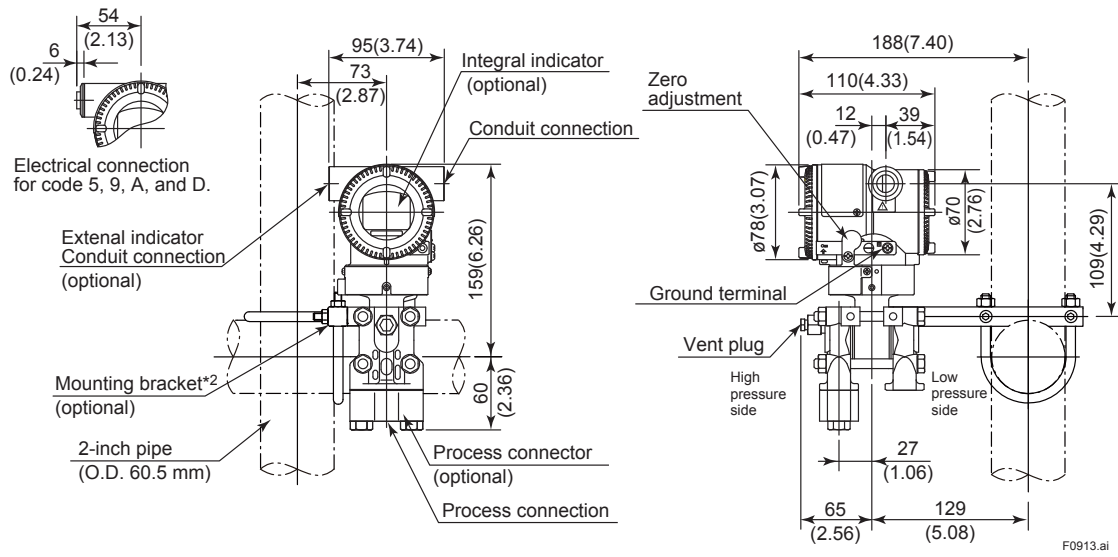

• Universal Flange (Installation code -U)

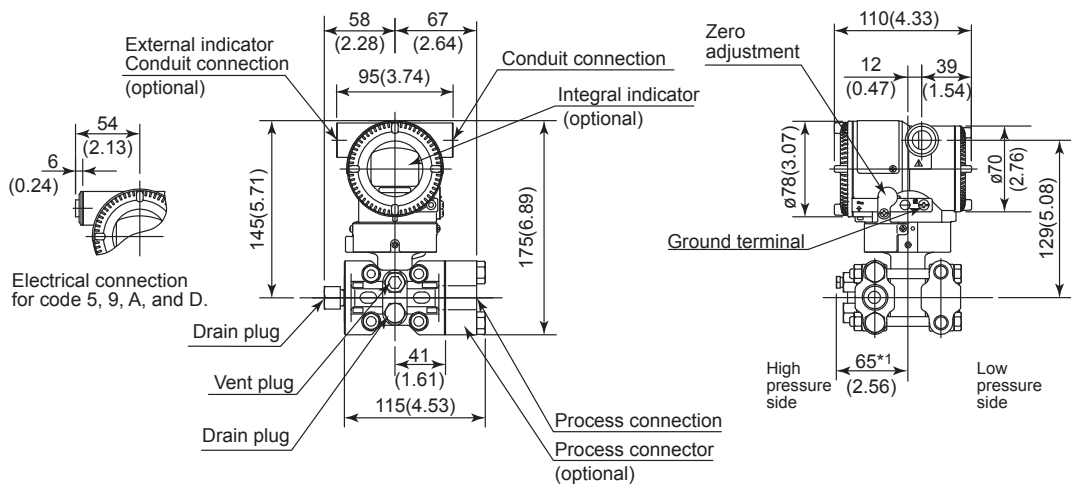

*1: When Option code K1, K2, K5, or K6 is selected, add 15 mm(0.59 inch) to the value.

*2: A transmitter with SST housing is not applicable for mounting to horizontal 2-inch pipe.

Model EJ□430□

Unit: mm (approx. inch)

• Vertical Impulse Piping Type

Process connector downside
(Installation code 7)

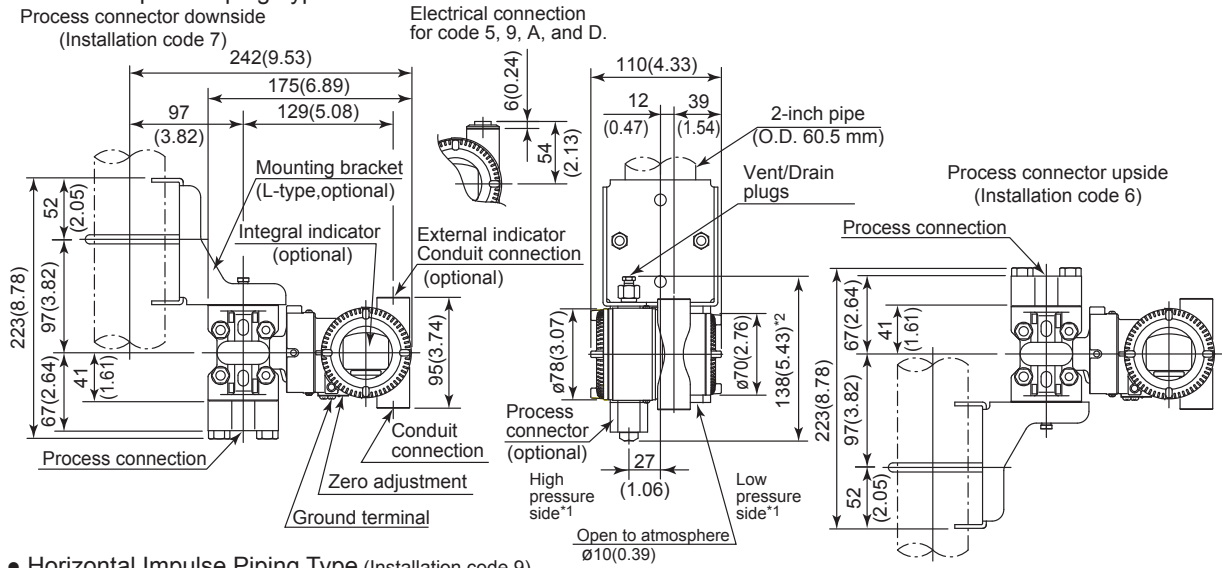

Electrical connection
for code 5, 9, A, and D.

• Horizontal Impulse Piping Type (Installation code 9)

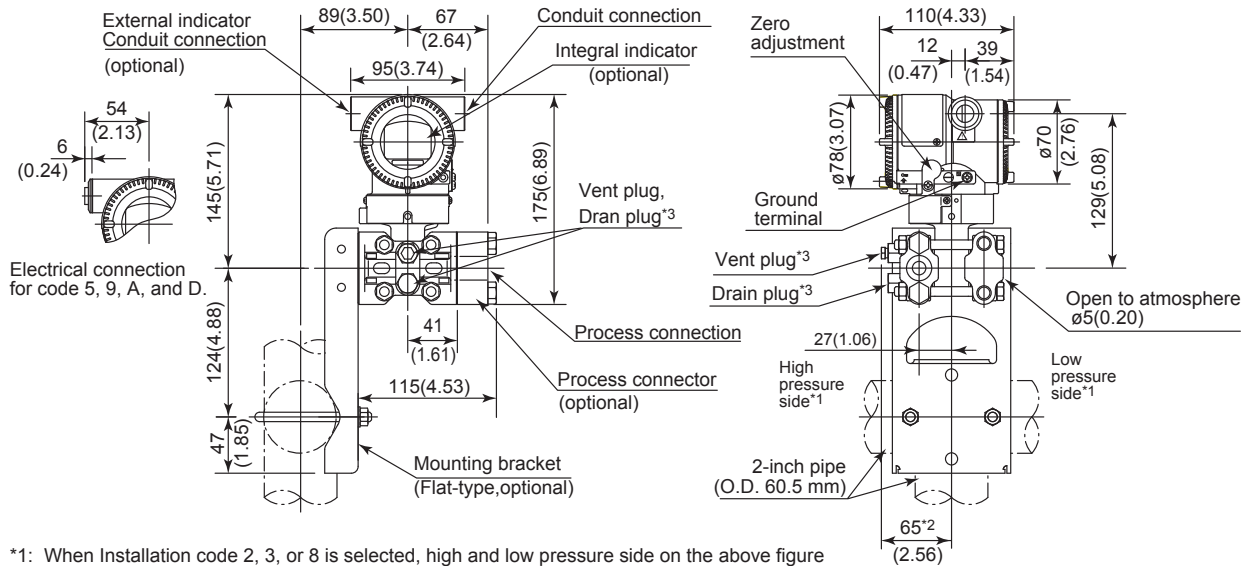

*1: When Installation code 2, 3, or 8 is selected, high and low pressure side on the above figure are reversed. (i.e. High pressure side is on the right side.)

*2: When option code K1, K2, K5, or K6 is selected, add 15 mm(0.59 inch) to the value in the figure.

*3: Not available when option code GS is specified.

F0915.ai

Unit: mm (approx. inch)

● Vertical Impulse Piping Type

Process connector downside
(Installation code 7)

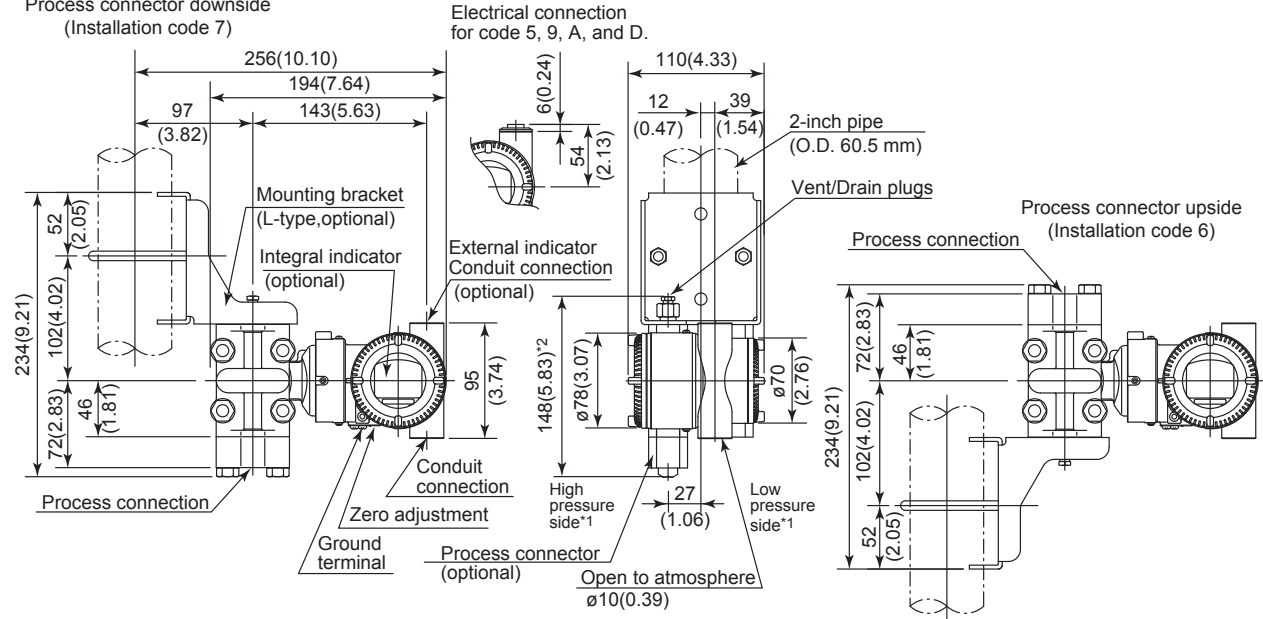

● Horizontal Impulse Piping Type (Installation code 9)

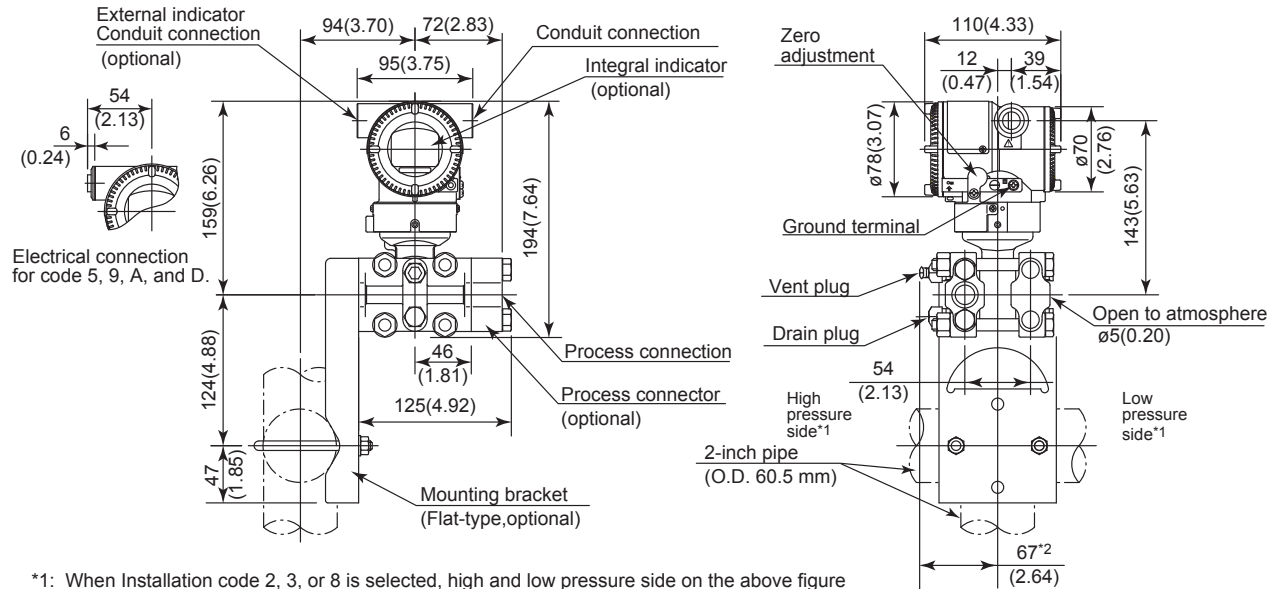

*1: When Installation code 2, 3, or 8 is selected, high and low pressure side on the above figure are reversed. (i.e. High pressure side is on the right side.)

*2: When Option code K1, K2, K5, or K6 is selected, add 15 mm(0.59 inch) to the value in the figure.

F0916.ai

Unit: mm (approx. inch)

• Bottom Process Connection (Installation code -B)

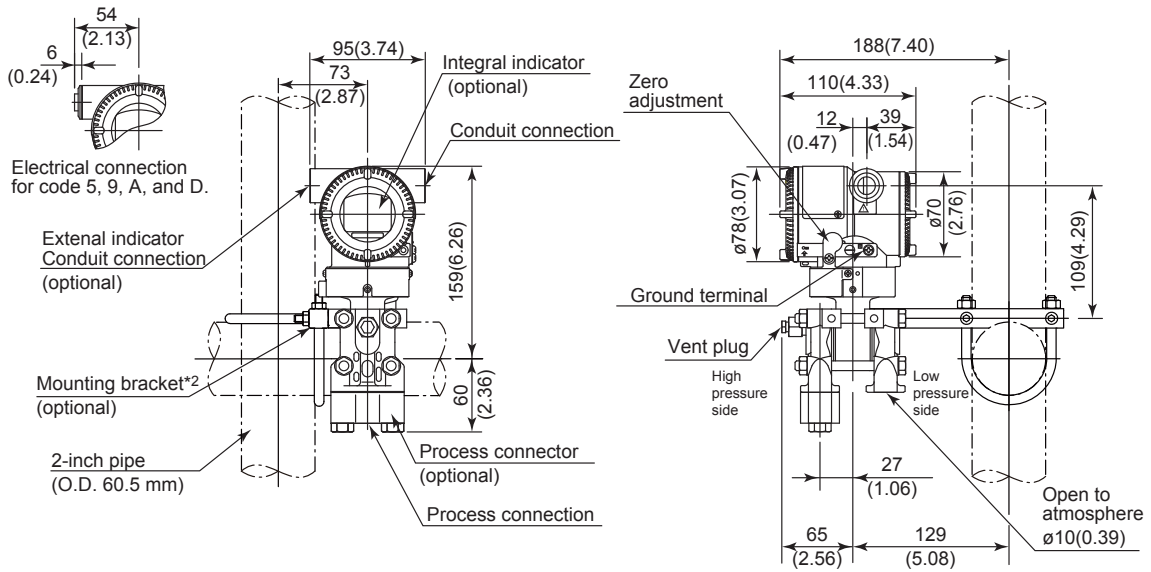

F0917.ai

• Universal Flange (Installation code -U)

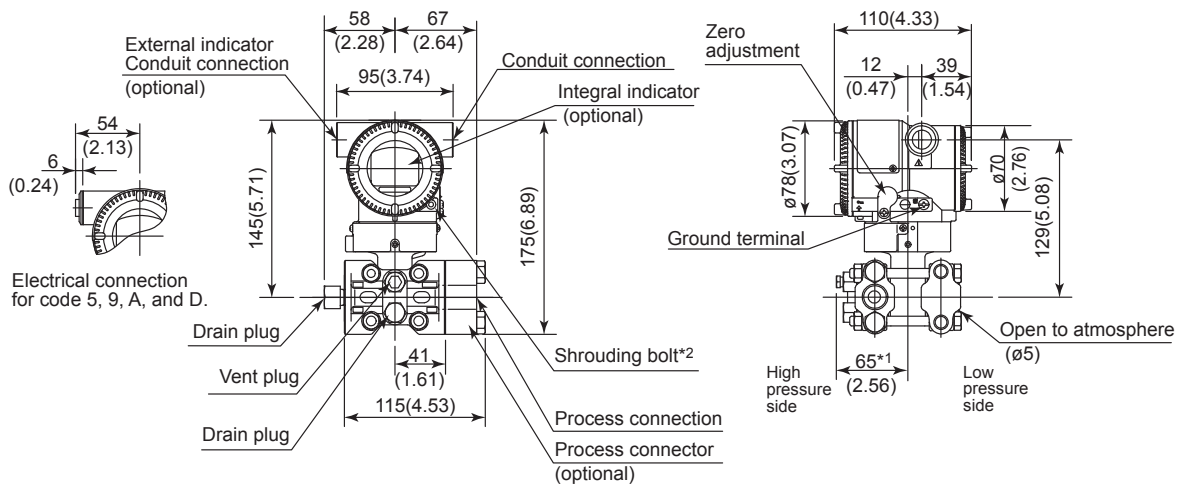

*1: When Option code K1, K2, K5, or K6 is selected, add 15 mm (0.59 inch) to the value.

*2: A transmitter with SST housing is not applicable for mounting to horizontal 2-inch pipe.

F0918.ai

Model EJ□440□

Unit: mm (approx. inch)

• Vertical Impulse Piping Type

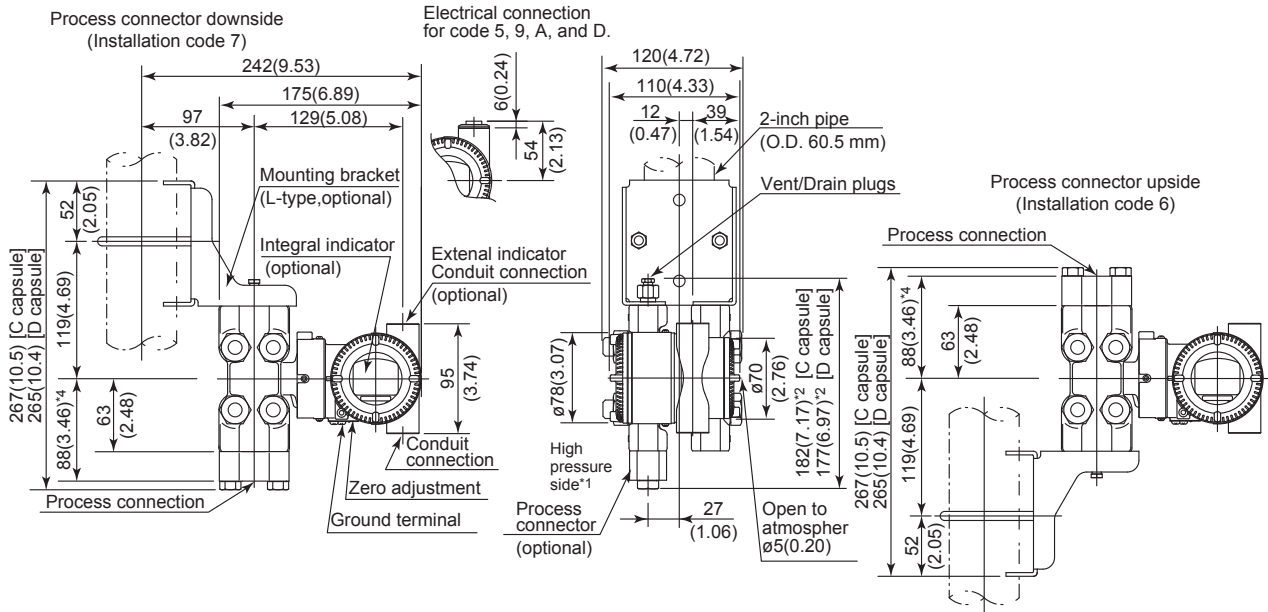

• Horizontal Impulse Piping Type (Installation code 9)

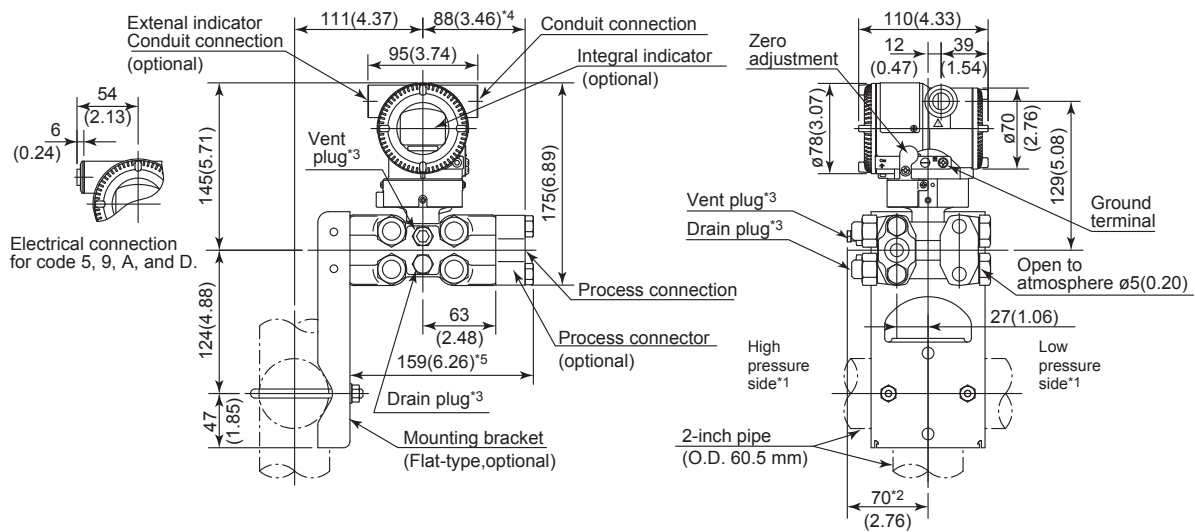

*1: When Installation code 2, 3, or 8 is selected, high and low pressure side on the above figure are reversed. (i.e. High pressure side is on the right side.)

*2: When Option code K1, K2, K5, or K6 is selected, add 15 mm(0.59 inch) to the value in the figure.

*3: Not available when Option code GS is specified.

*4: 87 mm(3.43 inch) for capsule code D.

*5: 157 mm(6.18 inch) for capsule code D.

F0919.ai

Unit: mm (approx. inch)

● Universal Flange (Installation code -U)

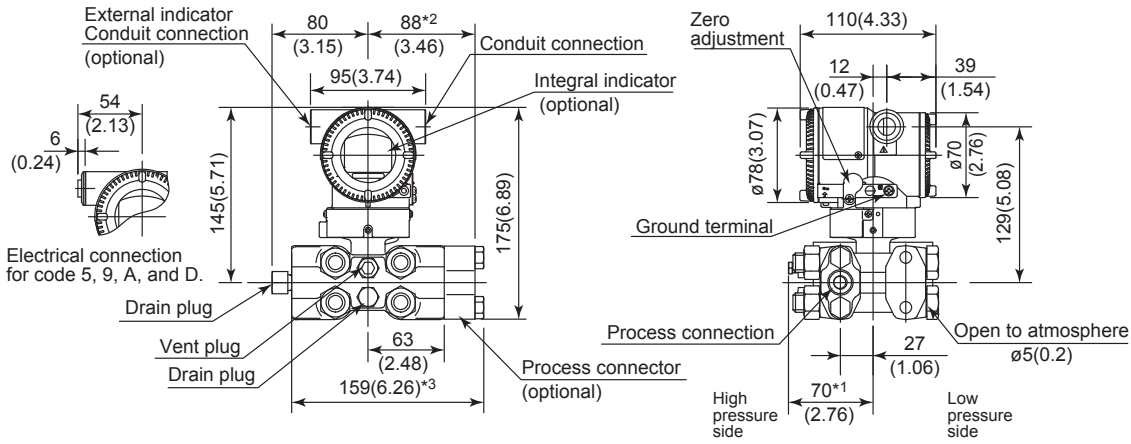

- *1: When Option code K1, K2, K5, or K6 is selected, add 15 mm(0.59 inch) to the value.
- *2: 87(3.43) for D capsule.
- *3: 157(6.18) for D capsule.

F0920.ai

● Terminal Configuration

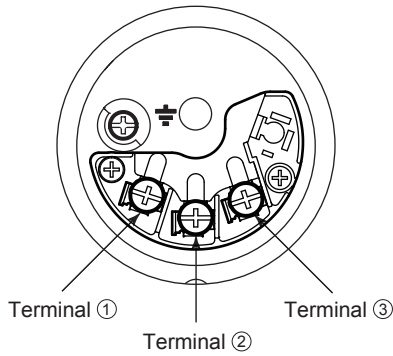

● Terminal Wiring for 4 to 20 mA output, FOUNDATION Fieldbus type, and PROFIBUS PA type.

SUPPLY	+	①	Power supply and output terminals
	-	②	
CHECK	+	③	External indicator (ammeter) terminals ^{*1,2}
or	-	②	
ALARM	+	③	Status contact output terminals ^{*2}
	-	②	
			⏏ Ground terminal

- *1: When using an external indicator or check meter, the internal resistance must be 10 Ω or less. A check meter or indicator cannot be connected when /AL option is specified.
- *2: Not available for FOUNDATION Fieldbus and PROFIBUS PA communication types.

● Terminal Wiring for 1 to 5 V output

SUPPLY	+	①	Power supply terminals
	-	②	
VOUT	+	③	1 to 5 V DC with HART communication terminals
	-	②	
			⏏ Ground terminal

F0921.ai

Revision Information

- Title : Differential Pressure and Pressure Transmitters
EJ□110□, EJ□120□, EJ□130□, EJ□310□, EJ□430□, and EJ□440□
- Manual No. : IM 01C25B01-01E

Edition	Date	Page	Revised Item
1st	Mar. 2004	—	New publication
2nd	Apr. 2004	—	Revise words and phrases.
		2-6	2.9.3 • Correct Ambient temperature –60 → –50
		4-4	4.5 • Change the description of rotation angle.
		8-3	8.4 • Add Allen wrench nominal 3mm to Table 8.4.1.
3rd	Feb. 2005	—	Re-number figure and table title.
		i	Add subsection 6.3.5.
		ii	Add note for Safety Transmitter.
		1-1	1. • Add note for Fieldbus communication type.
		1-3	1.1 • Add (f) Modification.
		2-3	2.9 • Add NOTE for fieldbus communication type.
		2-5	2.9.2 • Modify descriptions and instructions for CSA certification
		2-7	2.9.3 • Correct number in Note 4. 10 MINUTES → 5 MINUTES
		2-8	• Delete WARNING on non-incendive power supply.
			• Correct number for Electrical data Ci. 6 nF → 10 nF
		3-1	3. • Correct label of the switch in the figure. N → E, Y → D
			• Add descriptions in Note 2.
		4-3	4.4.1 • Add description about process connector in 3).
		4-4	4.6 • Add section 4.6.
		6-1	6.3.1, 6.3.2 • Add limitation/note when /AL is specified.
		6-2	6.3.4 • Add limitation when /AL is specified.
		6-2	6.3.5 • Add subsection 6.3.5.
		7-3	7.2.1 • Add descriptions about zero adjustment.
		9-1, 9-2	9.1 • Add notes for FOUNDATION fieldbus communication type.
	• Add capsule code H.		
9-4, 9-5	9.2 • Add output signal code -F and capsule code H.		
9-6	9.3 • Add CSA approvals and note *2 and *3		
9-8	9.4 • Add note *3.		
9-10	9.4 • Add notes for /AL and FOUNDATION Fieldbus.		
4th	Sep. 2005	1-1	1. • Add model names to the manual coverage.
		2-3 to 2-8	2. • Add applicable standard and certificate number for each approval.
		2-11	2.10 • Change australian reference standard.
		2-11	2.11 • Add descriptions for PED.
		2-12	2.11 • Add section 2.12.
		4-1	4.1 • Add model name.
		4-2	4.3 • Add table 4.1.
		8-5	8.4.3 • Add table for torque.
			Add notes for reassembling EJX130A and EJX440A.
		9-1 to 9-18	8.4.4 • Add table for torque.
	9. • Add specifications, codes, and dimensions for EJX130A, EJX310A and EJX440A.		
5th	July 2006	2-8-	2.9.3 • Change applicable standards for ATEX type n.—
6th	Nov. 2007	1-1	1. • Add model code table.
		2-3	2.9 • Add note for EJX130A.
		9-10	9.3 • Add note for EJX130A.
		9-15	9.4 • Modify dimensions of EJX130A.
		A-1	APPENDIX 1. Add "EJX130A ADDITIONAL INFORMATION."

Edition	Date	Page	Revised Item
7th	Feb. 2008	— General 1-1 2-1 2-5 2-6 2-7 2-8 2-9 2-10 9-1 to 9-3 9-5 to 9-10 9-11 9-12 9-14 to 9-20 —	Change of the style code, add EJX120A. • Change the figure of amplifier housing. • Add style code table. • Update the Figure 2.2. • Add code /V1U. • Revise information for CSA Explosionproof type. • Add code /V1U. • Revise information for KEMA flameproof type. Add code /V1U. • Revise Figure in (2) Electrical connection and (6) Nameplate. • Revise information for IECEx flameproof type. • Add information for EJX120A. • Add new suffix codes for 316 SST blind plugs and brackets. Add EJX120A. • Remove /KF2 and /KU2. Add /KF21, /KU21, /SF2 and /V1U. • Add /HC. • Revise external dimensions. Add EJX120A. • Remove Appendix 1 'Additional Information for EJX130A.'
8th	June 2008	2-6 2-8 2-11 4-1 8-5 9-1 to 9-27 9-10	2.9.2 2.9.3 2.11 4.2 8.4.3 9. 9.3 • Correct certification number. • Revise applicable standards for ATEX Type n. • Add EJX110A V capsule, wetted parts material code S and EJX310A L capsule. • Add information of Universal flange. • Add wetted parts material code in the torque table. • Add EJX110A V capsule, EJX110A/EJX430A wetted parts material code H, M, T, A, D, and B, EJX310A L capsule and option code /S1, and universal flange. • Add statement of sealing certification for CSA approval.
9th	Aug. 2009	2-1 2-11 9-4 to 9-9 9-11 to 9-12 9-13 to 9-26	2.1 2.10 2.11 9.2 9.3 9.4 • Replace a name plate. • Revise standards. • Revise information of PED. • Modify descriptions of materials. • Add /GS, /A1, and /DG6. • Correct errors. Add note for /GS.
10th	Apr. 2010	2-4 to 2-11 8-1 9-4 9-12	2.9 8.3 9.1 9.3 • Add limitation of ambient temperature for /HE. • Add description for warm up time. • Add O-ring material. • Add /HE.
11th	Mar. 2012	2-3 9-4 9-5 to 9-10	2.9 9.1 9.2 • Add note for blind plugs. • Change description for a plate material. • Add amplifier housing code 3.
12th	June 2012	— 1-1 2.3 to 2.12 2-7 to 2-10 8-5 9.1 to end	• Add EJA-E series. Add measurement span code F for EJX110A. • Add Note. Add model name of EJA-E series. • Delete /V1U. • Delete /KS2, /KF21, and /KU21. Add /KS21, /KF22, and /KU22. • Add note for measurement span code F. • Add information for EJA-E series. Add output signal code –J and measurement span code F.
13th	June 2013	— 2-3 2-6, 2-7 2-8 to 2-11 2-13 9-3 9-6 to 9-17 9-19 to 9-20 9-22 to 9-35	Add note for PROFIBUS PA communication type. Add note for multiple approval type. 2.9.2 2.9.3 2.11 9.1 9.2 9.3 9.4 • Correct CSA applicable standards. • Replace ATEX type n by ATEX Intrinsically safe Ex ic. • Add note for CE marking notified body number. • Add EJA110E with /HG. • Add MWP for EJA110E with /HG. • Add PROFIBUS PA communication type. • Add process connection code 2, 3 and 6. • Replace ATEX type n by ATEX Intrinsically safe Ex ic. • Add /V1U1. Add /HG. • Add process connection codes 2, 3 and 6. Correct drawing of EJ□430□ universal flange type. Add note for shrouding bolt.

Edition	Date	Page	Revised Item
14th	June 2014	1-2 2-6 2-13 6-1 to 6-4 6-1 6-2, 7-2 7-5 to 7-10 9-18 9-22 to 9-35 9-35	1. • Add note for symbols. 2.9.2 • Revise category for CSA Nonincendive. 2.12 • Update safety requirement standard. 6. • Revise drawings and symbols for terminal. 6.3.1 • Add note for power supply. Add note for BRAIN communication. 7.6 • Add local parameter setting function. 9.2 • Revise wetted parts material for capsule. 9.4 • Revise a part of dimension for horizontal piping use. • Change terminal drawing.
15th	Oct. 2014	2-2 2-5 2-7, 2-8 2-9 to 2-11 2-13 2-14 6-1 6-2 6-3 6-5 7-6 7-7 7-8 7-9 8-9 9-2 to 9-4 9-5 9-12 to 9-17 9-19 9-35	2.8 • Add information for 1 to 5 V output. 2.9.1 • Add information for 1 to 5 V output. 2.9.2 • Add information for 1 to 5 V output. 2.9.3 • Add information for 1 to 5 V output. 2.9.4 • Add EPL code. Revise applicable standard. Add information for 1 to 5 V output. Add note for electro static charge. Add electrical connection. 2.10 • Add standard for PROFIBUS. 6.3 • Add Figure 6.1 Terminal. 6.3.3 • Add information for 1 to 5 V output. 6.4 • Add information for 1 to 5 V output. 6.6 • Add applicability. 7.6.1 • Add "10.Device information" in Figure 7.9. 7.6.3 • Add note in the figure. 7.6 • Add 7.6.6 Pressure LRV/URV Configuration. 7.6 • Add 7.6.8 Output Mode Configuration and 7.6.9 Display Out 1 Configuration. 8.5.3 • Correct AL31 output operation. 9.1 • Add information for 1 to 5 V output. • Add EMC standard for PROFIBUS and EMI specification. 9.2 • Add output signal code Q 9.3 • Revise the description for SU2 and SF2. 9.4 • Add information for 1 to 5 V output.