

# Uninterruptible Power Supply User Manual



## SDU DC UPS B-Series

SOLAHD™



---

# Contents

<b>Safety Instructions</b> .....	<b>1</b>	<b>Storage</b> .....	<b>19</b>
<b>Introduction</b> .....	<b>2</b>	Extended Storage .....	19
<b>Preinstallation</b> .....	<b>2</b>	<b>Technical Support</b> .....	<b>20</b>
<b>Receiving</b> .....	<b>2</b>	<b>Warranty</b> .....	<b>20</b>
What's Included .....	2	Warranty Information.....	20
Battery Options .....	3	Product Literature .....	20
Optional Accessories .....	3		
<b>Product Description</b> .....	<b>3</b>		
<b>Installation</b> .....	<b>4</b>		
Location .....	4		
DIN Rail Mounting .....	4		
Removing the Unit from the DIN Rail .....	4		
Optional Chassis Mounting .....	5		
Connecting the Unit - Wiring Diagrams .....	8		
SDU DC UPS B-Series with SDU 24-BATB .....	8		
SDU DC UPS B-Series with SDU 24-BATEM .....	9		
Charging the Battery .....	9		
<b>Operation</b> .....	<b>10</b>		
Turning ON the UPS (Normal Mode) .....	10		
Turning OFF the UPS .....	10		
Remote ON/OFF .....	10		
Self-Testing.....	10		
<b>LED Status</b> .....	<b>11</b>		
<b>Contact Relay Truth Table</b> .....	<b>12</b>		
<b>UPS Battery</b> .....	<b>13</b>		
Battery Types.....	13		
Batteries for SDU-24 BATB .....	13		
Batteries for SDU-24 BATEM .....	13		
<b>Battery Backup Times</b> .....	<b>14</b>		
SDU 10-24B with SDU 24-BATB.....	14		
SDU 20-24B with SDU 24-BATB.....	14		
SDU 10-24B with SDU 24-BATEM.....	14		
SDU 20-24B with SDU 24-BATEM.....	14		
<b>Specifications</b> .....	<b>15</b>		
Power Module Specifications .....	15		
Battery Module Specifications .....	17		
<b>Troubleshooting</b> .....	<b>18</b>		
Troubleshooting .....	18		

---

# Safety Instructions

**PLEASE READ AND FOLLOW THESE INSTRUCTIONS!**

This manual contains important safety instructions that must be followed during the installation and operation of the DC UPS. Follow all warnings on the unit, in this manual and on the safety instruction sheet.

## **WARNING - Explosion Hazard, Risk of Electric Shock and Energy Hazard**

This device receives input power from multiple sources. Disconnect the DC UPS input from the AC to DC power supply connection and the DC Battery Modules before wiring. Follow all local, National Electrical Code® (NEC®) and CEC wiring and installation codes

**Wiring/Torque Specifications: Use only 90°C rated solid or stranded copper wire**

Terminals	Gauge Size	Torque
Input/Output	10-14 AWG (5.3-2.1mm <sup>2</sup> )	4.4-6.5lb-inch (50-73 N-cm)
Remote On/Off Connections (1-9)	16-24 AWG (1.3-0.2mm <sup>2</sup> )	N/A
Contact Terminal Connections (10-11)	16-24 AWG (1.3-0.2mm <sup>2</sup> )	N/A

- Remote On/Off and Contact Terminal connections: Connect only to Class 2 or LPS circuit.
- Battery Connection: Use only the SOLA cable provided with unit or SOLA type SDU 24EXTBC6

## **CAUTION - Risk of electric shock and personal injury**

Do not remove the cover, as the unit has no user-serviceable parts inside.

### **GENERAL INSTALLATION SAFETY PRECAUTIONS:**

- This product is for indoor use only in a Pollution Degree II environment, Overvoltage Category II system.
- Device provides Double Insulation based on 100 V maximum working voltage according to IEC61010-1.
- To prevent the risk of fire or electric shock, install the DC UPS in a temperature and humidity controlled ventilated enclosure, free of conductive contaminants, moisture, flammable liquids, gases, and corrosive substances. Do not install or operate the DC UPS in or near water.
- Do not place the DC UPS under direct sunlight or close to heat-emitting sources.
- To allow proper ventilation of the DC UPS, do not block or cover the top and bottom sides of the unit. Do not insert any objects into the ventilation holes or other openings of the DC UPS. Keep all vents free of dust accumulation that could restrict airflow.
- Do not place the DC UPS on an unstable cart, stand, or table. Ensure that it is properly installed on the DIN rail.

---

## GENERAL OPERATING SAFETY PRECAUTIONS:

### RATINGS:

Model	SDU 10-24B	SDU 20-24B
Nominal Input Voltage /Current	24Vdc, 12A	24Vdc, 22A
Nominal Output Voltage/ Current/Power	24Vdc, 10A, 240W	24Vdc, 20A, 480W
Contact Relay	50Vdc, 0.2A	50Vdc, 0.2A
Ambient	Ordinary Location: -15C to +50C	Ordinary Location: -15C to +50C

The following documents contain important safety instructions that must be followed during the installation and operation of the DC UPS. Follow all warnings mentioned in the documents.

Document	Part No./ Rev/ Year
Safety Instruction Sheet – SDU 10-24B, SDU 20-24B DC Uninterruptible Power Supplies	A272-367 Rev.0 8/2021
Safety Instruction Sheet – SDU 24-BATB DC Uninterruptible Power Supply Battery Module	A272-368 Rev.0 8/2021
Safety Instruction Sheet – SDU-BATEM DC Uninterruptible Power Supply Battery Module	A272-369 Rev.0 8/2021

## Introduction

Congratulations on your choice of the SDU DC B Series Uninterruptible Power System (UPS). The SDU DC is an advanced 24 Vdc UPS that combines an industry leading design, unique installation options, and a wide operational temperature range (see “Specifications”).

The SDU DC is a powerful microprocessor-controlled UPS which provides protection from power interruptions and is the ideal power backup solution for your critically connected loads.

## Preinstallation

### Receiving

Inspect the UPS upon receipt. Damage that may have occurred in transit is not covered under the warranty. If shipping damage is present, contact your local carrier and SolaHD distributor immediately.

### What's Included

- SDU 10-24B or SDU 20-24B
- Safety Instruction Sheet
- Remote On/Off Bypass Jumper

## Battery Options

Two battery modules are available:

- SDU 24-BATB: 24 V DIN rail/panel mount battery module (cable included).  
**NOTE:** Up to 4 SDU 24-BATB modules can be connected to the UPS.
- SDU 24-BATEM: 24 V external mount battery module (cable included).  
**NOTE:** Only 1 SDU 24-BATEM module can be connected to the UPS.  
**NOTE:** A combination of both modules cannot be used with the UPS.

## Optional Accessories

- SDU 24EXTBC6: 1ft (30.5cm) battery module cable.
- SDU 24-DB9: Interface kit to convert relay contact signals to DB9 signals.
- SDU-PMBRK: Chassis mounting brackets to secure the UPS to the wall, back of the panel, or enclosure.

# Product Description

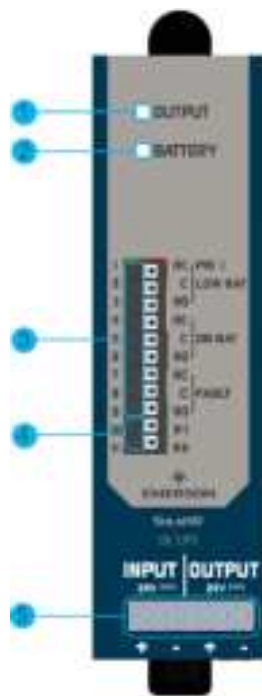

Figure 1

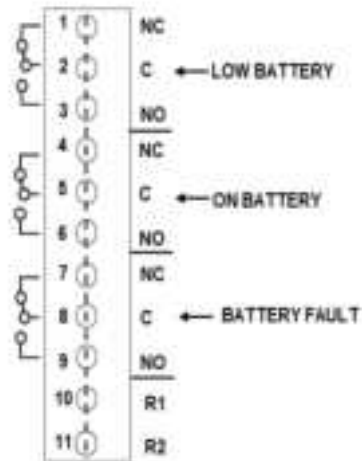

Figure 2

1. Output LED: Indicates the output status of the DC UPS. See Table 1.
2. Battery LED: Indicates the status of the battery module connected to the DC UPS. See Table 1.
3. Contact Relay Terminals: The control module incorporates dry relay contacts for remote signaling of the UPS and battery module status.
4. Remote ON/OFF Terminals (R1 and R2): Turns the unit ON/OFF.
5. DC Input/Output Screw Terminal Connections: IP20 rated input and output screw terminals.

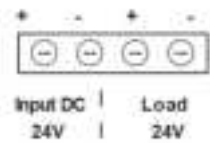

Figure 3

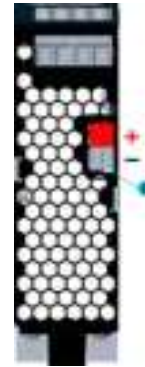

Figure 4

6. Polarized Terminal Connections for the Battery (+ Red color; - Black color).

# Installation

## Location

Install the power module and battery module in a protected area with adequate airflow and free of excessive dust. Do not operate the UPS outdoors.

## DIN Rail Mounting

1. Tilt and place the unit onto the DIN rail.
2. Push the unit downward until it stops.
3. Push at the lower front edge to lock. Ensure that the retainer has locked.

## Removing the Unit from the DIN Rail

Push the button and swing the bottom out and up.

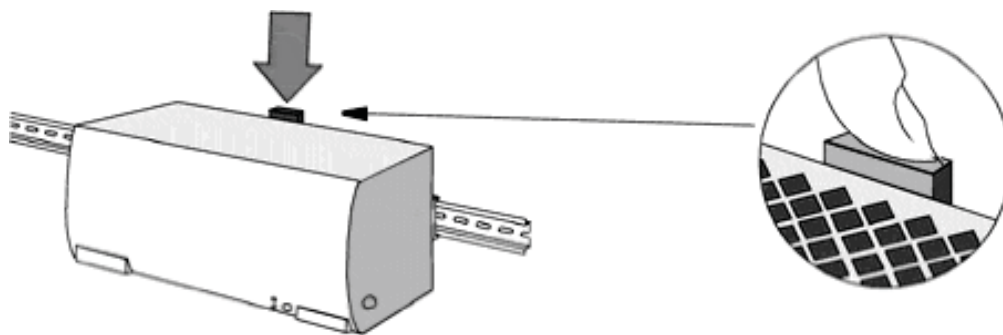
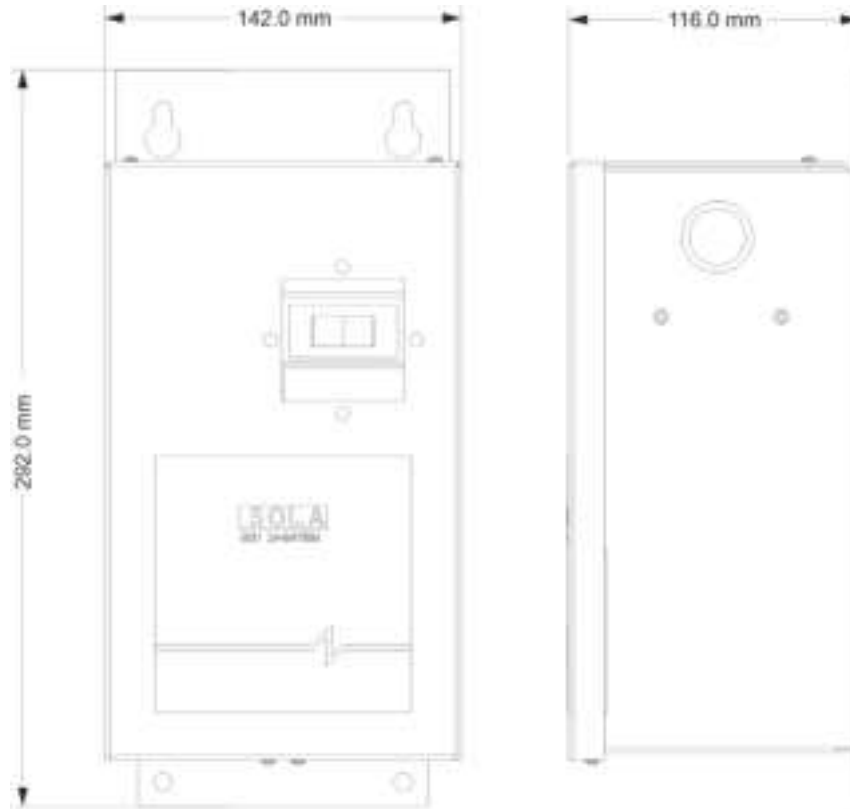

Figure 5

## Optional Chassis Mounting

Optional chassis mounting brackets (P/N: SDU-PMBRK) are sold separately. Please refer to the installation instructions supplied with the brackets.

**NOTE:** If you will be shipping the UPS already mounted, we recommend using the chassis mounting brackets (P/N: SDU-PMBRK) to secure the UPS.



Parting Number	Dimensions - Inches (mm)		
	H	W	D
SDU-26-NA175M	11.50 (292.0)	5.60 (142.0)	4.50 (116.0)

Figure 6

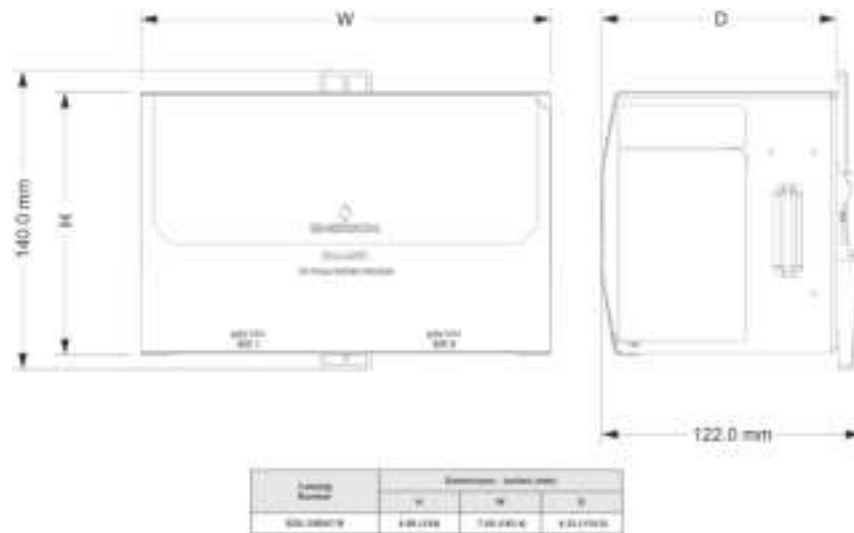

Figure 7

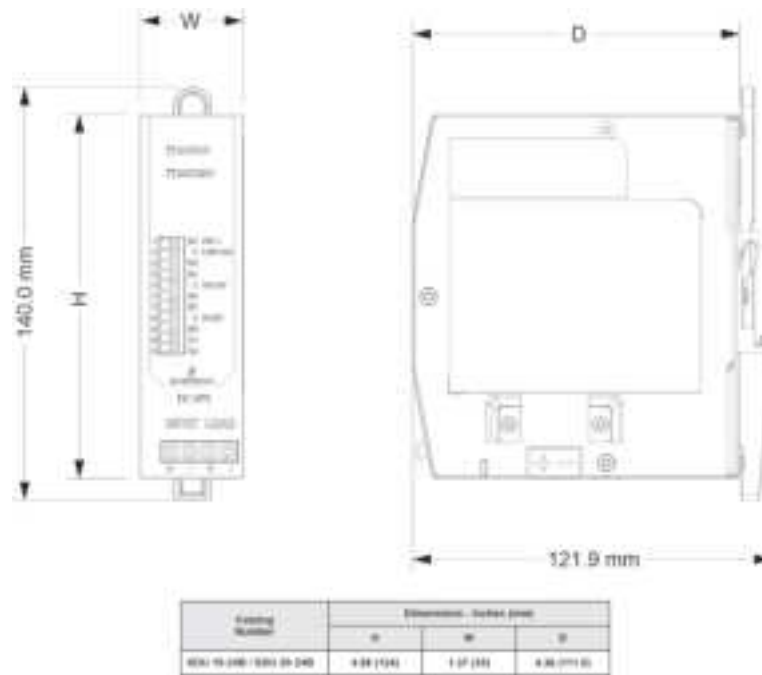

Figure 8

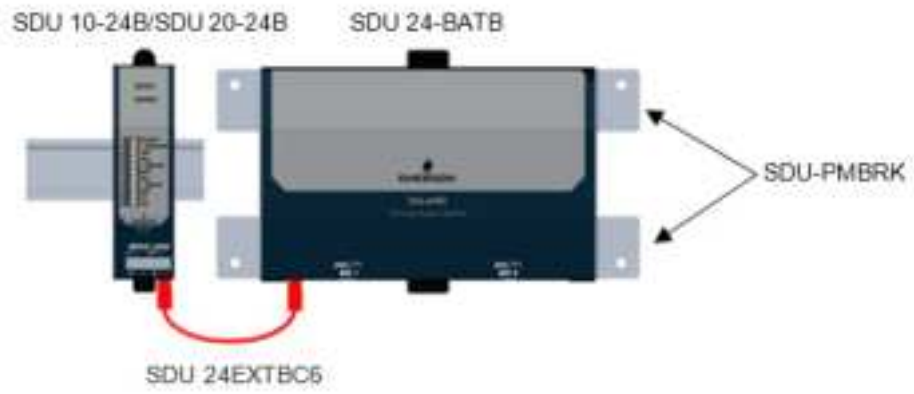

Figure 9

---

## Connecting the Unit - Wiring Diagrams

### SDU DC UPS B-Series with SDU 24-BATB

#### **⚠ WARNING - Risk of electric shock!**

Disconnect the DC input's AC supply connection before wiring. Operate the UPS only from a properly grounded (earthed) DC supply. To reduce the risk of electric shock, do not remove the cover. For service, contact a qualified technician.

---

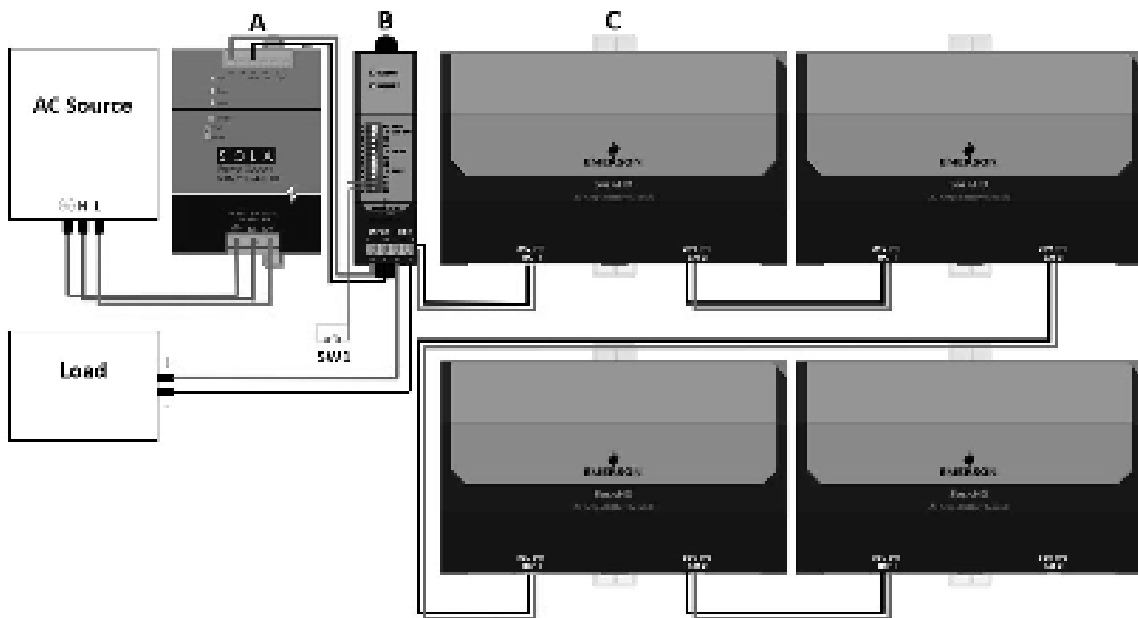

Figure 10

#### Connections:

1. Use the polarized cable to connect the power module to the battery module.
2. Connect the power module dc input connector to the 24 Vdc input power source.
3. Hardwire the load to the power module output terminal connector.

---

## SDU DC UPS B-Series with SDU 24-BATEM

### **⚠ WARNING - Risk of electric shock!**

Disconnect the DC input's AC supply connection before wiring. Operate the UPS only from a properly grounded (earthed) DC supply. To reduce the risk of electric shock, do not remove the cover. For service, contact a qualified technician.

---

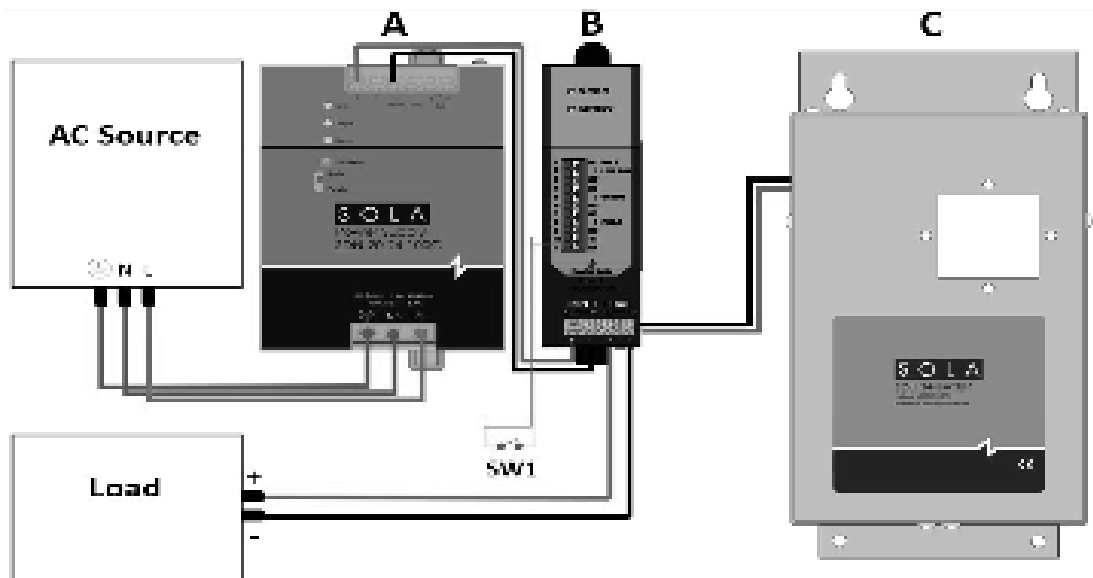

Figure 11

#### **Connections:**

1. Use the polarized cable to connect the power module to the battery module.
2. Connect the power module dc input connector to the 24 Vdc input power source.
3. Hardwire the load to the power module output terminal connector.

#### **Charging the Battery**

---

# Operation

## Turning ON the UPS (Normal Mode)

1. Ensure that the DC input supply is de-energized prior to wiring the DC UPS system.
2. Ensure that the Battery Module meets the charge schedule.
3. Ensure that the Remote ON/OFF toggle switch for R1 and R2 is open (if using Remote ON/OFF Bypass Jumper, make sure it is disconnected).
4. Connect the DC input to the DC UPS module; connect the Battery Module to the UPS module; then, connect the load to the UPS module.
5. Energize the DC input supply.
6. Enable the DC UPS by shorting R1 and R2 through the Remote ON/OFF toggle switch (if not using toggle switch, insert the Remote ON/OFF Bypass Jumper).
7. This will start the UPS in Normal Mode.

**Note:** If the DC input supply is not present, the DC UPS will enable Battery Mode. The load will be powered by the battery module until reaching cutoff voltage (21.6V). Please ensure switch is OFF or ON/OFF Bypass Jumper is removed when UPS is not in use to prevent draining of the battery.

## Turning OFF the UPS

1. Disable the DC UPS by disconnecting R1 and R2 through turning off the Remote ON/OFF toggle switch (if not using a toggle switch, remove the Remote ON/OFF Bypass Jumper).
2. De-energize the DC input supply.
3. Disconnect the DC input supply, Battery Module, and the load.

## Remote ON/OFF

Turns UPS output on when terminals R1 and R2 are shorted.

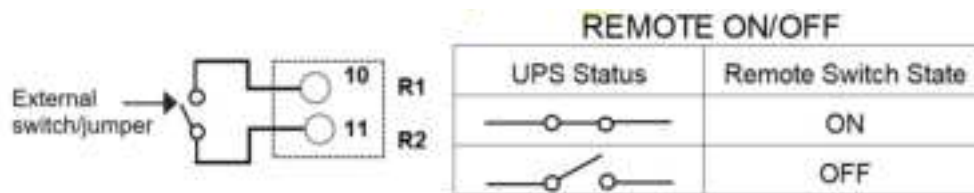

Figure 12

**NOTE:** The Remote ON/OFF is connected to the DC UPS internal signal ground and it should be isolated from the chassis ground potentials that may cause unit malfunction or damage. Isolate the Remote Sense wiring away from high current, high voltage, and high frequency components to prevent any magnetically coupled noise on the Remote ON/OFF connections.

## Self-Testing

The DC UPS employs an Automatic Self-Test feature. This feature checks the Battery Module's health and serves as indicator if the battery is still in good condition. The first Self-Testing will be activated 5 hours after commissioning. The subsequent Self-Testing will happen every 1 month thereafter. If the Battery Health fails the Self-Test, the Battery LED will display Solid Red.

# LED Status

Table 1

Operating MODE		LED Signal
	<b>Load Condition / Control Module Status</b>	<b>Output LED</b>
<b>NORMAL (input present)</b>	Load Within Range (100% < I <sub>out</sub> < 120%)	Steady Green
	Overload (125% – 150% for >4s) Power Boost	Green Flashing (0.25s ON : 0.25s OFF)
	Overcurrent and Short Circuit Protection	Red Flashing (1s ON : 1s OFF)
	Overtemperature Protection	Steady Red
<b>BATTERY (Input loss)</b>	Battery Mode & Load Within Range	Green Flashing (0.5s ON: 0.5s OFF)
	Overtemperature Protection	Steady Red
	<b>Battery Condition</b>	<b>Battery LED</b>
<b>NORMAL (input present)</b>	Battery Full	Steady Green
	Battery Charging / <50% Capacity	Green Flashing (0.25s ON : 0.25s OFF)
	Battery Charging / >50% Capacity	Green Flashing (1s ON : 1s OFF)
<b>BATTERY (Input loss)</b>	Battery Mode & Load Within Range	OFF
	Overtemperature Protection	OFF
<b>BATTERY FAULT</b>	Shorted Battery, Battery Overvoltage, reverse polarity, end of life or no battery.	Steady Red

# Contact Relay Truth Table

*Table 2*

UPS Status	Low Battery		On Battery		Battery Fault	
	Pin 1-2	Pin 2-3	Pin 4-5	Pin 5-6	Pin 7-8	Pin 8-9
	N.C.	N.O.	N.C.	N.O.	N.C.	N.O.
<b>Normal mode</b>	O	X	O	X	O	X
<b>Battery mode (30-100% SOC)</b>	O	X	X	O	O	X
<b>Battery mode - Low Battery (20-30% SOC)</b>	X	O	X	O	O	X
<b>Battery fault</b>	I	I	I	I	X	O

**Legend:**

- X – Contact close
- O – Contact open
- I - Indeterminate
- N.C. - Normally close
- N.O. - Normally open

---

# UPS Battery

## CAUTION

- Do not attempt to open the DC UPS or replace the batteries inside the battery module.
- Call SolaHD Technical Support for further instructions.
- Do not mount the DC UPS or the Battery Module in an upside-down orientation.

### Battery Types

Table 3		
Batteries for SDU-24 BATB		
Manufacturer	Type	Rating
CSB	HRL 1225W	12 V dc, 5.0 Ah
Taiwan Yuasa Battery Co. Ltd.	NPX25	

Table 4		
Batteries for SDU-24 BATEM		
Manufacturer	Type	Rating
CSB	GP1272	12 V dc, 7.2 Ah

### Recharging the Battery

Locate the recharge label on the box containing the product. The label will indicate the last recharge date. Please refer to the label for the next recharge due date.

If the product is due for recharge, please follow the wiring diagram Figure 10 to recharge the SDU 24-BATB. Please allow 8 hours to fully recharge a battery.

Once the battery is recharged, please create a LOG and track the due dates to properly maintain the charge.

# Battery Backup Times

*Table 5*

<b>SDU 10-24B with SDU 24-BATB</b>					
<b>Load</b>	<b>20% (2 A)</b>	<b>40% (4 A)</b>	<b>60% (6 A)</b>	<b>80% (8 A)</b>	<b>100% (10 A)</b>
<b>1 unit</b>	113	45	30	21	14
<b>2 units</b>	247	114	74	48	38
<b>3 units</b>	396	178	117	80	58
<b>4 units</b>	531	233	148	111	81

*Table 6*

<b>SDU 20-24B with SDU 24-BATB</b>					
<b>Load</b>	<b>20% (4 A)</b>	<b>40% (8 A)</b>	<b>60% (12 A)</b>	<b>80% (16 A)</b>	<b>100% (20 A)</b>
<b>1 unit</b>	46	21	10	6	4
<b>2 units</b>	116	50	28	17	10
<b>3 units</b>	178	80	46	31	20
<b>4 units</b>	237	113	65	43	31

*Table 7*

<b>SDU 10-24B with SDU 24-BATEM</b>					
<b>Load</b>	<b>20% (2 A)</b>	<b>40% (4 A)</b>	<b>60% (6 A)</b>	<b>80% (8 A)</b>	<b>100% (10 A)</b>
<b>1 unit</b>	135	52	28	19	14

*Table 8*

<b>SDU 20-24B with SDU 24-BATEM</b>					
<b>Load</b>	<b>20% (4 A)</b>	<b>40% (8 A)</b>	<b>60% (12 A)</b>	<b>80% (16 A)</b>	<b>100% (20 A)</b>
<b>1 unit</b>	48	17	9	6	4

**NOTE:** Run times are based on new, fully charged battery module at a temperature of 25°C (77°F) with purely resistive DC UPS load. Run times listed above may vary due to manufacturing variances of the individual batteries.

# Specifications

Table 9		
Power Module Specifications		
Parameter	Catalog Number	
	SDU 10-24B	SDU 20-24B
Nominal Input Voltage	24 V dc	
Efficiency (Normal Mode) - Battery Fully Charged	>95%	>95%
Efficiency (BATTERY Mode) - Battery Fully Charged	>93%	>93%
INPUT		
Nominal Input Voltage	24V	
Input Voltage Range	22.1 – 28.6 V dc	
OUTPUT		
Nominal Output Voltage	24 V dc	
Output Voltage Range	Ubat range: 22.1 – 28.6 Vdc maximum Worst case: Ubat - 0.4 V DC = Uout	
Output Ripple(Normal Mode) Fully Charged	Uin Ripple = Uout Ripple	
Rated Output Current	10 A	20 A
Rated Output Power	240W	480 A
PROTECTION		
Input Current Protection (Normal Mode)	Internally Fused 30A 32VDC	
Peak current capability (Normal Mode)	Power boost (allows for 150% of rated load) for > 4 seconds	
Reverse Polarity, input voltage	UPS goes to battery mode	
Reverse Polarity, battery input	UPS does not turn on	
Output Short Circuit	UPS shutdown, Auto-recovery	
Battery Over Voltage Protection	Charging stops at 28V, Auto-recovery	
Input Protection	Allowable Input range is 21.6V min and 28.6V max. or else UPS goes to Battery Mode	
Back EMF Immunity, output	< 35 V Max No damage, Auto-recovery	
Overtemperature Protections	Unit shutdown, Auto-recovery	
WEIGHT & DIMENSIONS		
Net Weight	0.88 lb. (0.4 kg)	
H x W x D	4.88 in. x 1.37 in. x 4.80 in. (124 mm x 35 mm x 121.9 mm)	

Table 9		
Power Module Specifications		
Parameter	Catalog Number	
	SDU 10-24B	SDU 20-24B
<b>ENVIRONMENT</b>		
Audible Noise	<40 dBA (1 m) distance	
Operating Temperature	-15°C to +50°C	
Storage Temperature	-40°C to +85°C	
Humidity	0 to 95%, non-condensing	
Pollution	Degree 2	
Maximum Elevation	3000m max	
Shock	According to IEC60068-2-27	
Vibration	According to IEC60068-2-6; DNVGL-CG-0339 Section 3	
<b>GENERAL</b>		
MTBF	>1,000,000 hours; Telcordia SR-332 @ 40C	
Life Expectancy	>15 yrs. 50% load at 40C >15 yrs. 100% load at 25C	
<b>INSTALLATION</b>		
Power Input/Output Terminals (Screw Type)	Connector size range: 16-10 AWG (1.5-6 mm <sup>2</sup> ) for solid/stranded conductors. Screw Torque: 4.4 -6.5 lb-in (50-73 N-cm)	
Battery Terminals	Polarized Terminal Connections for the Battery (+Red color, - Black color)  <b>NOTE:</b> The maximum length of the connection between the power module and battery module is 6 ft. (1.85m).	
Relay Contact Terminals	Use connector size range: 24 – 16 AWG (0.34 – 4mm <sup>2</sup> )	
Mounting	Use DIN TS35/7.5 or TS35/15 rail system. Apply to both thin and thick DIN Rail (1.0 and 1.5mm), optional screw mounting set SDU-PMBRK.	
<b>SAFETY APPROVALS</b>		
SDU DC UPS System*	cULus Listed: UL/CSA 61010-1, UL/CSA 61010-2-201 cRUus: UL Recognized Component UL/CSA 62368-1, UL/CSA 60950-1 CE LVD / UKCA EE (Safety) Regulations 2016 –IEC/EN 62368-1, IEC/EN 61010-1, IEC/EN 61010-2-201 (CB Certified IEC/EN 60950-1) CE EMC/ UKCA - EN 62040-2 Category C2, EN 55032, EN 55011, EN 55024, EN 55035, EN 61000-6-1, EN 61000-6-2, EN 61000-6-3, EN 61000-6-4, EN 61326-1, EN61000-3-2, EN 61000-3-3, IEC/EN 61000-4 Series	
*The SDU DC UPS system includes a power module (SDU 10-24B or SDU 20-24B) and a battery module (SDU 24-BATB or SDU 24-BATEM).		

Table 10

<b>Battery Module Specifications</b>		
<b>Parameter</b>	<b>Catalog Number</b>	
	<b>SDU 24-BATB</b>	<b>SDU 24-BATEM</b>
Nominal Voltage	24 V dc	
Protection	Fuse: 30 A	Circuit Breaker: 24 V, 25 A
Charging Current	1.2 A	
Battery Type	Sealed, maintenance-free lead acid batteries	
Enclosure Type	IP20	NEMA 1
Terminal Connector Type	Polarized power pole connectors	
Operating Temperature	-15°C to +50°C	
Storage Temperature	-15°C to +40°C	
Humidity	95%, non-condensing	
Typical Recharge Time (to 90% of full capacity)	SDU 24-BATB: 6 hours for 2 battery modules; 3 hours for each additional battery module SDU 24-BATEM: 8 hours for 1 battery module	
Backup Times	See Tables 5–8	
Weight	11.46 lb. (5.2 kg)	16 lb. (7.26 kg)
Enclosure Dimensions	7.57 in. x 4.85 in. x 4.33 in. (192.4 mm x 123.3 mm x 110 mm)	11.50 in. x 5.57 in. x 4.57 in. (292 mm x 142 mm x 116 mm)
Mounting	Simple snap-on system for DIN rail TS35/7.5 or TS35/15 or optional chassis mounting brackets (P/N: SDU-PMBRK)	Chassis mounting brackets (P/N: SDU-PMBRK)
Accessories	1 ft (30.5cm) polarized battery cable	6 ft (180cm) polarized battery cable
*The SDU DC UPS B-Series system includes a power module (SDU 10-24B or SDU 20-24B) and a battery module (SDU 24-BATB or SDU 24-BATEM).		

# Troubleshooting

Table 11

<b>Troubleshooting</b>		
<b>Problem</b>	<b>Probable Cause</b>	<b>Required Action</b>
UPS has no output	Remote ON/OFF terminals (R1 and R2) are not short circuited.	Insert REMOTE ON/OFF BYPASS jumper to short circuit the terminals.
	Input DC voltage is not within the acceptable range of 22.1V – 28.6V and the battery is drained.	Check the DC input voltage. If the input is within the range, check the input fuse.
	Load is short circuited	Remove the load.
	Other failure.	Contact Technical Support.
UPS cannot turn ON at Normal Mode	Loose input DC voltage power connection.	Tighten the dc input power connection.
	Input DC voltage is not within the acceptable range of 22.1V – 28.6V.	Adjust dc input voltage
	Other failure.	Contact Technical Support.
UPS cannot turn ON at Battery Mode	Battery is Drained or not connected	Connect or recharge battery.
Backup time is too short	Battery is not fully charged.	Recharge the UPS for at least three (3) hours.
	Battery has low capacity due to deterioration	Replace the battery
	Other failure.	Contact Technical Support.
Display Steady Red at Battery LED	Battery is drained	Recharge the battery for at least three (3) hours.
	Battery is disconnected.	Check battery connections.
	Other battery failure.	Replace the battery.
SOLAHD Technical Support (USE STANDARD VERBIAGE)		
For further assistance, please contact SolaHD Technical Support at 1.800.377.4384/1.847.268.6651 or by e-mail at <a href="mailto:solahd.technicalservices@emerson.com">solahd.technicalservices@emerson.com</a> .		

---

# Storage

## Extended Storage

- Store the UPS covered and upright in a cool, dry location with the battery fully charged.
- Remove the REMOTE ON/OFF Bypass Jumper (or turn remote ON/OFF Switch to OFF position). Remove any accessories in the accessory slot and disconnect any cables connected to the computer interface port to avoid unnecessary draining of the battery.
- During extended storage in environments where the ambient temperature is -15°C to +30°C (+5°F to +86°F), charge the UPS battery every 4 months.
- During extended storage in environments where the ambient temperature is +30°C to +45°C (+86°F to +113°F), charge the UPS battery every three (3) months.

---

The information in this manual is provided as a guide for installation, operation, and maintenance. It does not affect or exceed our obligations under the Terms and Conditions of Sale.

Note that unit specifications are subject to change without notice.

## Technical Support

Website: [www.solahd.com](http://www.solahd.com)

Technical Support E-Mail: [solahd.technicalservices@emerson.com](mailto:solahd.technicalservices@emerson.com)

Toll-Free: (800) 377-4384

USA: (847) 268-6651

## Warranty

### Warranty Information

Please refer to the “Terms & Conditions of Sale” at <https://www.appleton.emerson.com/documents/appleton-grp-llc-terms-of-sale-policies-procedures-en-us-7444090.pdf>

### Product Literature

For additional product literature, including French and Spanish manuals, please visit [www.solahd.com](http://www.solahd.com).

While every precaution has been taken to ensure accuracy and completeness in this manual, Appleton Grp LLC d/b/a Appleton Group assumes no responsibility, and disclaims all liability for damages resulting from use of this information or for any errors or omissions.

The Emerson logo is a trademark and service mark of Emerson Electric Co.  
Appleton Grp LLC d/b/a Appleton Group. SolaHD is a registered trademark of Appleton Grp LLC.  
All other marks are the property of their respective owners. © 2021 Emerson Electric Co. All rights reserved.

**United States  
(Headquarters)**

Appleton Grp LLC  
9377 W. Higgins Road  
Rosemont, IL 60018  
United States  
T +1 800 621 1506

**Australia Sales Office**

Bayswater, Victoria  
T +61 3 9721 0348

**Korea Sales Office**

Seoul  
T +82 2 3483 1555

**Europe**

ATX SAS  
Espace Industriel Nord  
35, rue André Durouchez,  
CS 98017  
80084 Amiens Cedex 2  
France  
T +33 3 2254 1390

**China Sales Office**

Shanghai  
T +86 21 3338 7000

**Canada**

EGS Electrical Group Canada  
Ltd.  
99 Union Street  
Elmira ON, N3B 3L7  
Canada  
T +1 888 765 2226

**Middle East Sales Office**

Dammam, Saudi Arabia  
T +966 13 510 3702

**Asia Pacific**

EGS Private Ltd.  
Block 4008, Ang Mo Kio  
Ave 10,  
#04-16 TechPlace 1,  
Singapore 569625  
T +65 6556 1100

**Chile Sales Office**

Las Condes  
T +56 2928 4819

**Latin America**

EGS Comercializadora  
Mexico S de RL de CV  
Calle 10 N°145 Piso 3  
Col. San Pedro de los Pinos  
Del. Álvaro Obregon  
Ciudad de México. 01180  
T +52 55 5809 5049

**India Sales Office**

Chennai  
T +91 44 3919 7300