

This Guide to Quantities is only applicable to Data Sheets E120.2 and E130.2.

### Specification for Individual Panels

	<b>Weatherfold 4s 50</b>	<b>Weatherfold 4s 100</b>
Track System	E120	E120
Refer to Data Sheet		
Max Panel Height	3000mm	3300mm
Max Panel Weight	50kg	75/100kg
Max Panel Width	1000mm	1000mm
Min Panel Thickness	35mm	35mm
Max Number of Panels	8 each direction	8 each direction

#### 2 Panel Unit

	<b>Quantities</b>	<b>Product Codes</b>	
Track	1	180A-A20	350-A20
Pivot Set	1	BWS1-100H	BWS1-100H
Hinge Handle Set	1	BW3-100H	BW3-100H
End Hanger Set	1	BWS2-50SH	BWS2-100SH
Flush Bolt Top	1	456*	456*
Flush Bolt Bottom	1	456E*	456E*
Channel	1	94PPA-A20	94PPA-A20

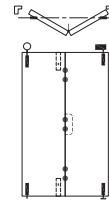

#### 3 Panel Unit

	<b>Quantities</b>	<b>Product Codes</b>	
Track	1	180A-A30	350-A30
Pivot Set	1	BWS1-100H	BWS1-100H
Offset Hinge Handle Set	1	BW7-100H	BW7-100H
Intermediate Hanger Set	1	BWS4-50SH	BWS4-100SH
Flush Bolt Top	1	456*	456*
Flush Bolt Bottom	1	456E*	456E*
Channel	1	94PPA-A30	94PPA-A30

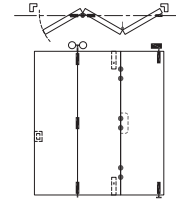

#### 4 Panel Unit

	<b>Quantities</b>	<b>Product Codes</b>	
Track	1	180A-A40	350-A40
Pivot Set	1	BWS1-100H	BWS1-100H
Offset Hinge Handle Set	2	BW7-100H	BW7-100H
Intermediate Hanger Set	1	BWS4-50SH	BWS4-100SH
End Hanger Set	1	BWS2-50SH	BWS2-100SH
Flush Bolt Top	2	456*	456*
Flush Bolt Bottom	2	456E*	456E*
Channel	1	94PPA-A40	94PPA-A40

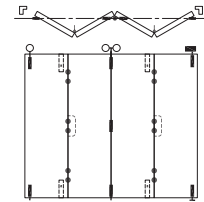

#### 4 Panel Unit 'Floating'

	<b>Quantities</b>	<b>Product Codes</b>	
Track	1	180A-A40	350-A40
Offset Hinge Handle Set	2	BW7-100H	BW7-100H
Intermediate Hanger Set	1	BWS4-50SH	BWS4-100SH
End Hanger Set	2	BWS2-50SH	BWS2-100SH
Flush Bolt Top	2	456*	456*
Flush Bolt Bottom	2	456E*	456E*
Channel	1	94PPA-A40	94PPA-A40

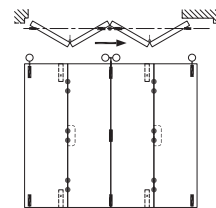

#### 2+2 Panel Unit

	<b>Quantities</b>	<b>Product Codes</b>	
Track	1	180A-A40	350-A40
Pivot Set	2	BWS1-100H	BWS1-100H
Hinge Handle Set	2	BW3-100H	BW3-100H
Hanger Set - Meeting	1	BWS8-50S	BWS8-100S
Flush Bolt Top	2	456*	456*
Flush Bolt Bottom	2	456E*	456E*
Channel	1	94PPA-A40	94PPA-A40

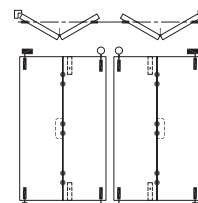

### 5 Panel Unit

	Quantities	Weatherfold 4s 50 Product Codes	Weatherfold 4s 100 Product Codes
Track	1	180A-A60	350-A60
Pivot Set	1	BWS1-100H	BWS1-100H
Offset Hinge Handle Set	1	BW7-100H	BW7-100H
Intermediate Hanger Set	2	BWS4-50SH	BWS4-100SH
Hinge Handle Set	1	BW3-100H	BW3-100H
Flush Bolt Top	2	456*	456*
Flush Bolt Bottom	2	456E*	456E*
Channel	1	94PPA-A60	94PPA-A60

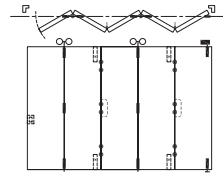

### 6 Panel Unit

	Quantities	Weatherfold 4s 50 Product Codes	Weatherfold 4s 100 Product Codes
Track	1	180A-A60	350-A60
Pivot Set	1	BWS1-100H	BWS1-100H
Offset Hinge Handle Set	2	BW7-100H	BW7-100H
Intermediate Hanger Set	2	BWS4-50SH	BWS4-100SH
Hinge Handle Set	1	BW3-100H	BW3-100H
End Hanger Set	1	BWS2-50SH	BWS2-100SH
Flush Bolt Top	3	456*	456*
Flush Bolt Bottom	3	456E*	456E*
Channel	1	94PPA-A60	94PPA-A60

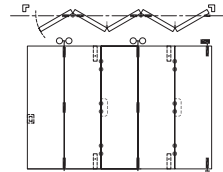

### 6 Panel Unit 'Floating'

	Quantities	Weatherfold 4s 50 Product Codes	Weatherfold 4s 100 Product Codes
Track	1	180A-A60	350-A60
Offset Hinge Handle Set	2	BW7-100H	BW7-100H
Intermediate Hanger Set	2	BWS4-50SH	BWS4-100SH
Intermediate Hinge Set	1	BW3-100H	BW3-100H
End Hanger Set	2	BWS2-50SH	BWS2-100SH
Flush Bolt Top	3	456*	456*
Flush Bolt Bottom	3	456E*	456E*
Channel	1	94PPA-A60	94PPA-A60

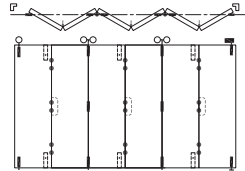

\*Note, for aluminium systems refer to data sheet E130. On 2+2 units replace BWS8-50 or BWS8-100 with quantity 2 BWS2-50F or BWS2-100F respectively.

Replace 456 and 456RE flush bolts with 512 and 512E respectively. Alternatively top and bottom flush bolts can be replaced with dual point lock 286 in timber and aluminium.

### Application

For residential and commercial folding systems where weatherproofing of the opening is required.

This section covers Weatherfold 4s 50 & 100 hardware suitable for non mortice timber applications.

For extra corrosion resistance, Weatherfold 4s is supplied with precision stainless steel bearings. Hangers are cast 316 marine stainless steel.

### Panel Specification

Track System:	Weatherfold 4s 50	Weatherfold 4s 100
Max Panel Height	3000mm	3300mm
Max Panel Weight	50kg	100kg
Max Panel Width	1000mm	1000mm
Panel Thickness	35mm	35mm
Max Number of Panels	8 each direction	8 each direction

### Hardware Specification

Track:	180A	350
Material	Clear Anodised	
Standard Lengths	2000mm, 3000mm, 4000mm, 5000mm and 6000mm	

#### Hanger Sets:

Intermediate Hanger Set:	BWS4-50SH	BWS4-100SH
End Hanger Set:	BWS2-50SH	BWS2-100SH
Meeting Door Hanger Set - Rebate (includes 2 hangers)	BWS8-50	BWS8-100

#### Pivot Set:

BWS1-100H	BWS1-100H
-----------	-----------

#### Jamb Pivot:

BW189H	BW189H
--------	--------

#### Hinge Sets:

Hinge Handle Set	BW3-100H	BW3-100H
Offset Hinge Handle Set	BW7-100H	BW7-100H
Hinge Set	BW5-100H	BW5-100H
Offset Hinge Set	BW6-100H	BW6-100H

#### Channels:

Polypropylene	94P	94P
Polyprop Plus Support	94PPA	94PPA
Aluminium	94A	94A
Standard lengths	2000mm, 3000mm, 4000mm, 5000mm and 6000mm	

#### Accessories:

Lock Body - 35mm back set	286T/35	286T/35
Lock Body Dual Access - 35mm back set	286TD/35	286TD/35
Lock Body - 45mm back set	286T/45	286T/45
Lock Body Dual Access - 45mm back set	286TD/45	286TD/45
Non Locking Handle	286N	286N
Locking Handle 38-44mm panel	286L-30	286L-30
Locking Handle 44mm+ panel	286L-40	286L-40
Locking Handle Dual Access (Rod pack dependant on panel)	286DL	286DL
Flush Bolt - 190mm	456	456
Flush Bolt - 450mm	456L	456L
Security Aligner	199SS	199SS
Frame Seal	AQ21	AQ21
Door Seal	AQ63	AQ63
Track Seal	PS13B	PS13B

#### Finish options

Dual Point Lock: (SS) Satin Stainless, (SN) Satin Nickel, (PBK) Powdercoat Black  
 Hardware: (SS) Satin Stainless, (PS) Polished Stainless, (PB) PVD Brass, (PR) PVD Black.  
 Flush bolts: (SN) Satin Nickel, (PVDB) PVD Brass, (PVDR) PVD Black.

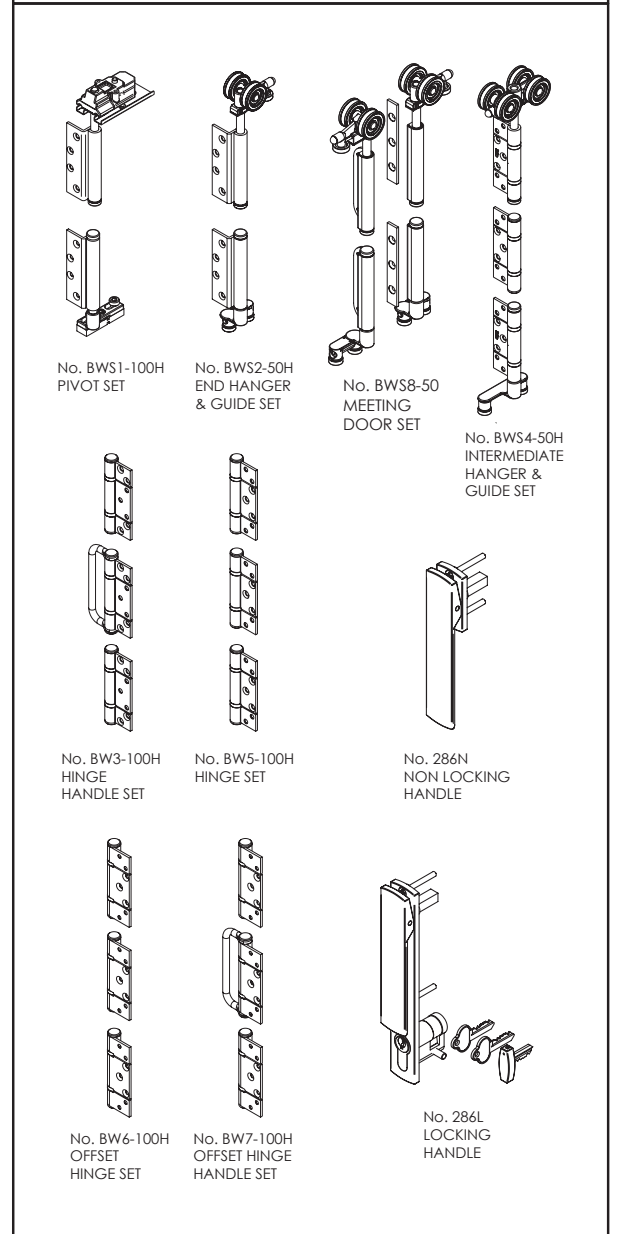

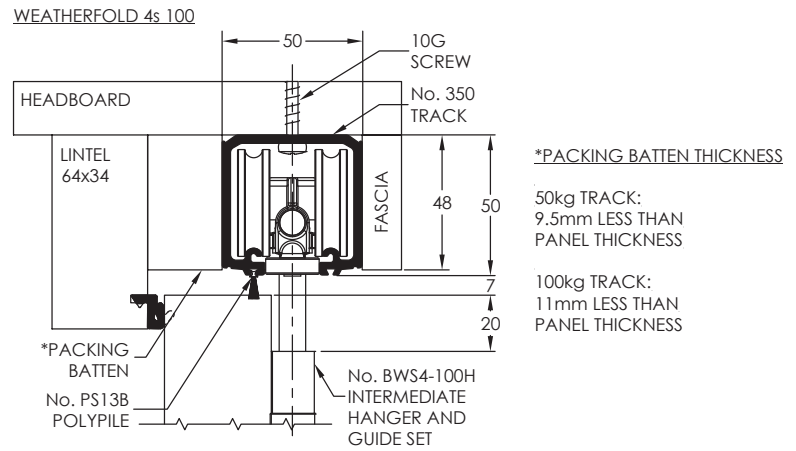
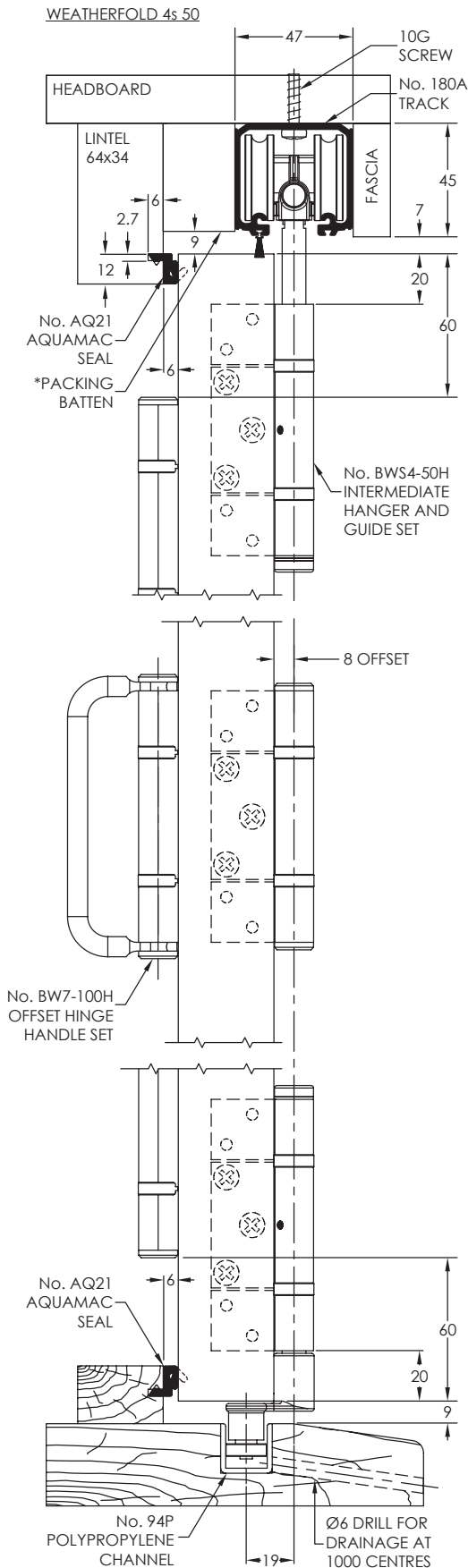

\*PACKING BATTEN THICKNESS

50kg TRACK:  
9.5mm LESS THAN  
PANEL THICKNESS

100kg TRACK:  
11mm LESS THAN  
PANEL THICKNESS

**4+0 PANEL OUTWARD OPENING SYSTEM - CLOSED**  
(SHOWN WITHOUT TRACK OR HEAD SECTION)

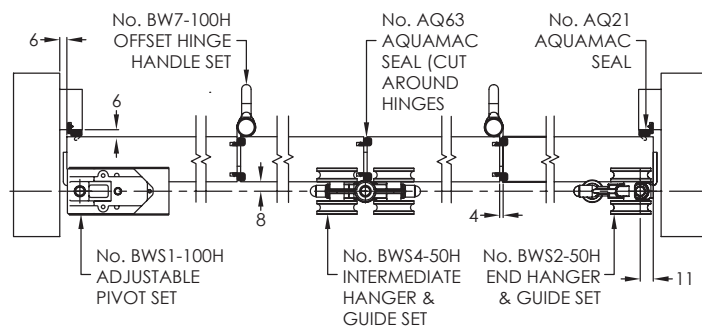

**4+0 PANEL OUTWARD OPENING SYSTEM - OPEN**  
(SHOWN WITHOUT HEAD SECTION)

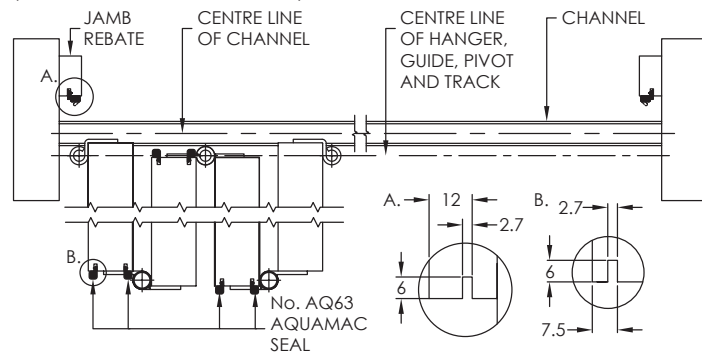

**4+0 PANEL OUTWARD OPENING SYSTEM - CLOSED**  
(TYPICAL OUTSIDE ELEVATION)

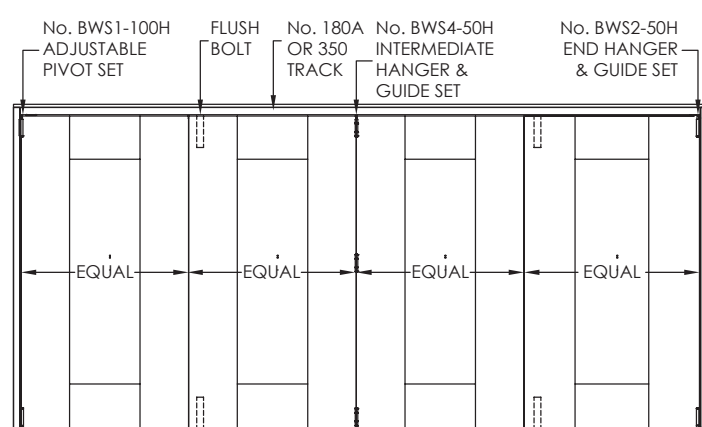

### Application

For residential and commercial folding systems where weatherproofing of the opening is required.

This section covers Weatherfold 4s 50 & 100 hardware suitable for non mortice aluminium applications.

For extra corrosion resistance, Weatherfold 4s is supplied with precision stainless steel bearings. Hangers are cast 316 marine stainless steel.

### Panel Specification

Track System:	Weatherfold 4s 50	Weatherfold 4s 100
Max Panel Height	3000mm	3300mm
Max Panel Weight	50kg	100kg
Max Panel Width	1000mm	1000mm
Panel Thickness	35mm	35mm
Max Number of Panels	8 each direction	8 each direction

### Hardware Specification

Track:	180A	350
Material	Clear Anodised	
Standard Lengths	2000mm, 3000mm, 4000mm, 5000mm and 6000mm	

Hanger Sets:		
Intermediate Hanger Set:	BWS4-50SH	BWS4-100SH
End Hanger Set:		
Face Fix	BWS2-50SF	BWS2-100SF
Edge Fix	BWS2-50SH	BWS2-100SH

Pivot Set:		
Face Fix	BWS1-100F	BWS1-100F
Edge Fix	BWS1-100H	BWS1-100H

Jamb Pivot:	BW189H	BW189H
-------------	--------	--------

Hinge Sets:		
Hinge Handle Set	BW3-100H	BW3-100H
Offset Hinge Handle Set	BW7-100H	BW7-100H
Hinge Set	BW5-100H	BW5-100H
Offset Hinge Set	BW6-100H	BW6-100H

Channels:		
Polypropylene	94P	94P
Polyprop Plus Support	94PPA	94PPA
Aluminium	94A	94A
Standard lengths	2000mm, 3000mm, 4000mm, 5000mm and 6000mm	

Accessories:		
Lever Furniture	288	288
Lock Body Dual Access	286AD	286AD
Lock Body	286A	286A
Non Locking Handle	286N	286N
Locking Handle	286L-40	286L-40
Locking Handle Dual Access (Rod pack dependant on panel)	286DL	286DL
Flush Bolt - 400mm	512-400	512-400
Flush Bolt - 600mm	512-600	512-600
Flush Bolt - 900mm	512-900	512-900

**Finish options**  
 Dual Point Lock: (SS) Satin Stainless, (SN) Satin Nickel, (PBK) Powdercoat Black  
 Hardware: (SS) Satin Stainless  
 Flush bolts: (SS) Satin Stainless

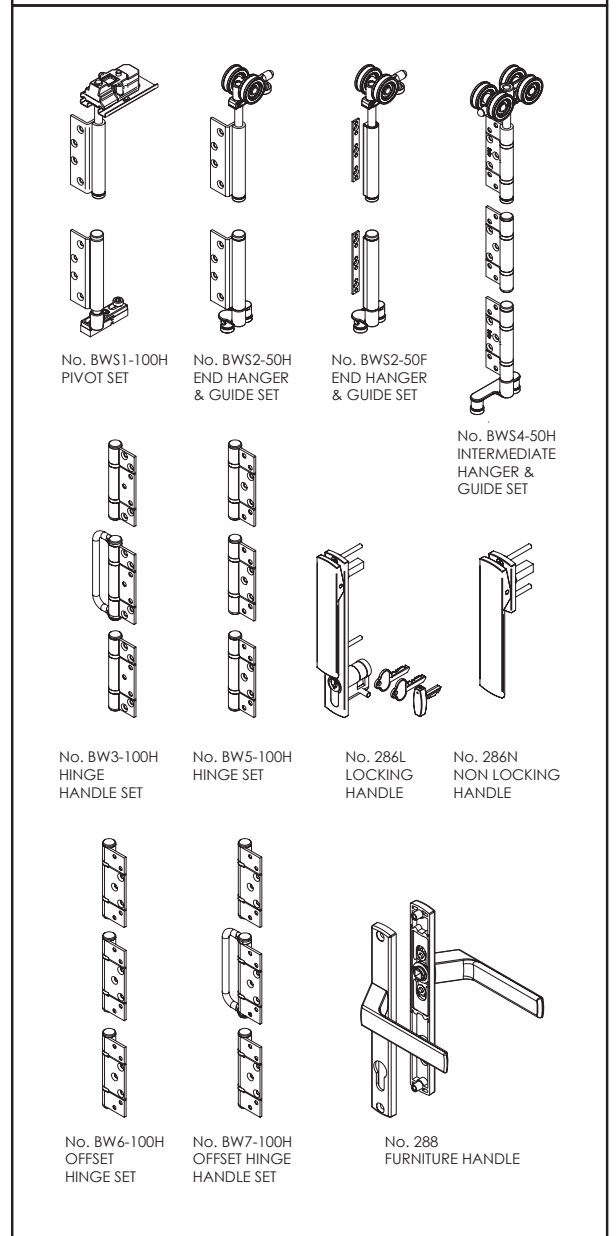
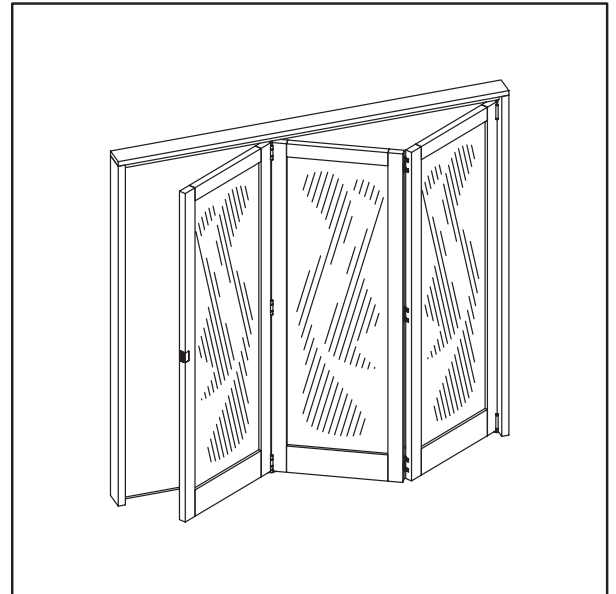

WEATHERFOLD 4s 50

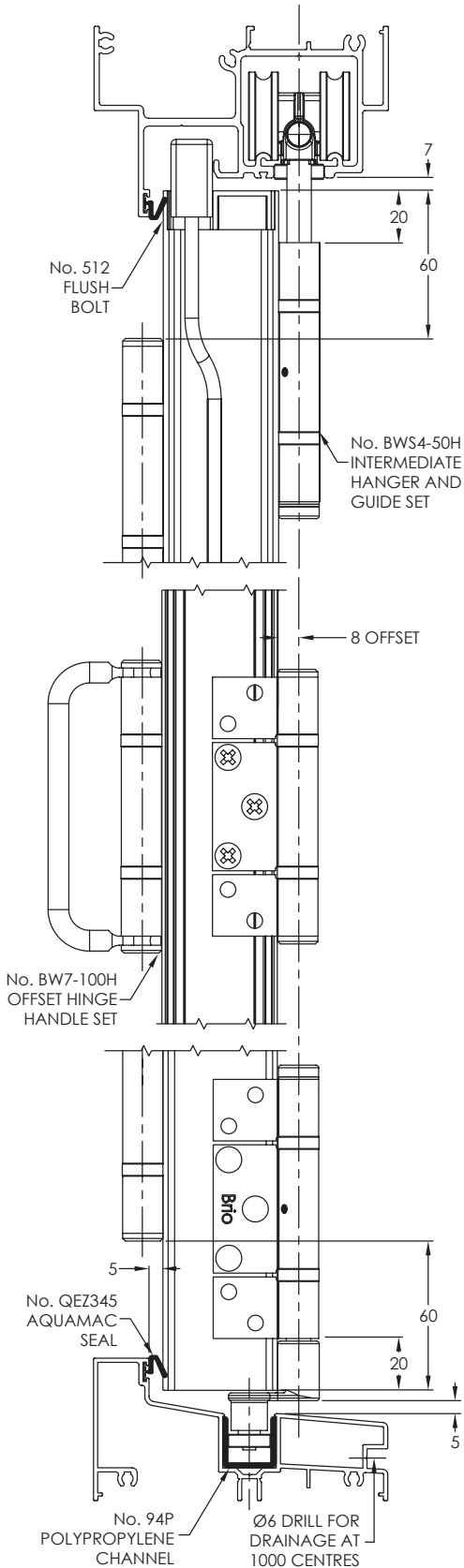

WEATHERFOLD 4s 100

