

# BUOYANCY COMPENSATOR OWNER'S MANUAL

---

## WARNING

---

**IMPROPER USE OR MISUSE OF THIS BUOYANCY COMPENSATOR, OR ANY DIVING EQUIPMENT, COULD RESULT IN SERIOUS INJURY OR DEATH.**

Do not use this Buoyancy Compensator (BC) until you have carefully and completely read, understood and followed all instructions and safety precautions found in this manual, all inserts that accompanied this manual, and all tags and markings found on the Buoyancy Compensator.

Proper training in swimming, scuba diving, buoyancy control, and emergency buoyancy skills is required to safely use this product. A Buoyancy Compensator is not a substitute for these skills. The user must have successfully completed a course of training in SCUBA diving, buoyancy control, and emergency buoyancy skills. This instruction should be from a certified SCUBA instructor of a recognized educational organization, such as YMCA, NASDS, PADI, NAUI, SSI, BSAC, CMAS or FIPS, etc.

Retain this manual for your reference.

Review this manual periodically and prior to diving.

If you have any questions or are unclear about any instructions, call **SCUBAPRO®** Service or contact any service center listed inside.

---

The following Norms are compulsory by law in Europe and are the only world wide official requirements for B.C.'s . SCUBAPRO® has been the first and only manufacturer to obtain these certifications:

- **EN 12628** for CBRD (Combined Buoyancy Rescue Device) that provides divers with a device for controlling buoyancy that also guarantees a head up position of the wearer at the surface.
  - **EN 1809: 1997** for B.C. (Buoyancy Compensator) that provides divers with a device for controlling buoyancy, but does not guarantee a head up position of the wearer at the surface.
  - **EN 250: 2000** for body harness that provides divers with a device for fixing the tank to the body : it has not to be used deeper than 50 m (164 feet).
- Each B.C model has an indication of the relevant EU certificate obtained.
- 



---

## WARNING

---

**FAILURE TO READ, UNDERSTAND, AND FOLLOW THE PRECAUTIONS LISTED BELOW COULD RESULT IN SERIOUS INJURY OR DEATH**

**THIS IS NOT A LIFE JACKET.** Emergency face up flotation may not be provided for all wearers and in all conditions (*except for the Master Jacket*)

This B.C. is not a breathing device

**Always perform a pre-dive and post-dive inspection of the B.C.**

---

## IMPORTANT

---

Before use, the SCUBAPRO® Buoyancy Compensators must be matched to one of the following inflation mechanisms.

- **A.I.R. 2 (Alternate Inflation Regulator 2 style or SCUBAPRO® equivalent).**  
Attaches to the tank/regulator system for push-button buoyancy control and acts as an alternate regulator for emergency breathing, eliminating the need for an “Octopus” regulator. When used with a Pony Bottle and separate regulator first stage (such as a MK20), this system functions as an independent air supply. The A.I.R. 2 may also be used for manual deflation and oral inflation of the jacket.
- **B.P.I. (Balanced Power Inflator)**  
Provides push-button buoyancy control when attached to existing tank/regulator systems and may also be used for manual deflation and oral inflation of the jacket. Your SCUBAPRO® Dealer will assist you in choosing and assembling your personal buoyancy control system.
- **I.P.I. (Integrated Power Inflator)**  
Directly connected to the B.C. bag, it allows to inflate your B.C. by using air from your SCUBA cylinder.

---

Your **SCUBAPRO®** dealer will assist you in choosing and assembling your personal buoyancy control system.

TABLE OF CONTENTS

1	General Information .....	I - 4
2	Initial Set Up .....	I - 5
3	Set Up for Double Scuba Cylinders .....	I - 8
4	Ballasting System .....	I - 8
5	Valve Set Up and Operation .....	I - 12
6	BC Harness Adjustment General Features .....	I - 17
7	BC Examination and Procedures .....	I - 18
8	Storage .....	I - 19
9	General Specifications .....	I - 20
10	Master Jacket .....	I - 21
11	Glide Line .....	I - 24
12	Glide 2000 BW .....	I - 26
13	Glide 3000 I.P.I. ....	I - 28
14	Glide 1000 .....	I - 30
15	Glide 500 .....	I - 31
16	Glide 3D PRO .....	I - 32
17	Glide 3D CLUB .....	I - 34
18	Glide STAR .....	I - 34
19	Glide Tek (Basic / Pro) - Ladyhawk - Knighthawk	I - 36

## **1. GENERAL INFORMATION**

### **Primary purpose of the Buoyancy Compensator**

The primary purpose of a Buoyancy Compensator is to make you more comfortable by enabling you to maintain neutral buoyancy at depth.

You are neutrally buoyant when you maintain a specific depth without expending significant physical effort to prevent an ascent or descent from that depth.

Inventor and leader in the development of Stabilizing Jackets, SCUBAPRO® offers a complete range of these items, specifically designed :

- *Stabilizing Jacket*
- *Adjustable Jacket*
- *Back flotation Jacket*

All these models have been provided with inflating, deflating and draining valve system and designed to make surface swimming easier.

### **Back Packs (two sizes)/Back Plate**

The materials used for the bag (single or double) even tough, could be not strong enough in certain extreme conditions (for example jumping into water from height) : for this reason Scubapro® invented and improved in the years, the “sandwich” system that encloses, with two metal screws, the bag between two semirigid plates (back pack and back plate).

### **Soft Padding**

All the main internal surfaces of the Jackets, where there is more compression on the body (such as shoulder lobes, back pack, cummerbunds, etc.) are soft padded.

### **Cummerbunds**

This accessory is designed to hold tight but to be comfortable at the same time: for these reasons it is anatomically designed with a semirigid panel outside, and a soft padding inside, just in contact with the diver's body. The length is easily adjustable, at the moment, without any tool.

---

## **ATTENTION**

**Do not use your BC as an assist or “lift bag” for bringing objects to the surface. These objects may be lost during the ascent, creating a sudden increase in buoyancy and loss of buoyancy control.**

---

## 2. INITIAL SET UP

### Low Pressure (LP) hose

Connect the low pressure (LP) hose of the Power Inflation Valve or A.I.R. 2 to an unused LP port of the first stage, **that must have the same thread (fig. 1)**.

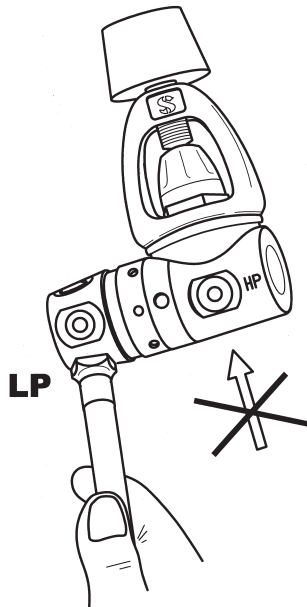

Fig. 1

---

### ATTENTION

Do not attach a L.P. hose to a Scuba regulator high pressure (HP) port or to an air supply with pressure in excess of 200 psi (13.8 bar). This may result in damage or explosive failure of the Inflation Valve or Low pressure Hose, which could result in injury or death.

---

## **SUPER CINCH Q.A. (QUICK ADJUST.) CYLINDER STRAP SET UP AND ATTACHMENT (SINGLE CYLINDER)**

The SCUBAPRO® Super Cinch Q.A. cylinder strap allows you to easily fasten your BC to any single SCUBA cylinder.

Set up for a single SCUBA cylinder can be accomplished following these steps :

- 1) Wet the webbing of the Super Cinch Q.A. cylinder strap prior to tightening. Wrap the Super Cinch Q.A. ( $W_1$ ) strap (fig. 2 – 1) around the SCUBA cylinder and insert the end of the stainless steel buckle (B) into the trapezoidal “D” ring ( $DR_1$ ) (fig 2 – 1). Position the SCUBA cylinder so that the cavity (S) of the back plate corresponds to the cylinder shoulder (fig. 2 – 2) with the lever (B) close to the back pack (BP) (fig. 2 – 3).

The cylinder locator strap (L ) (fig. 2 – 2), on the top of the back plate, encircling the valve neck of the cylinder, prevents the back pack strap assy from sliding down, while connecting and tightening the Super Cinch Q.A. Once correctly adjusted, it helps to easily and consistently find the correct position.

- 2) Close the buckle (C) (fig. 2 – 3). If the webbing strap is too tight to close or too loose to grab the SCUBA cylinder, open the velcro fastener on the webbing and readjust the length of the Super Cinch Q.A. ( $W_1$ ) webbing (fig. 2 – 1). For extra safety look, slide the loop (SL) (fig. 2 – 1) around the webbing end (T). With SCUBA cylinder in place, lift the assembly by the back pack handle and shake firmly to check for secure fastening. Try to move the backpack up and down on the SCUBA cylinder. If there is movement, the band is not tight enough.

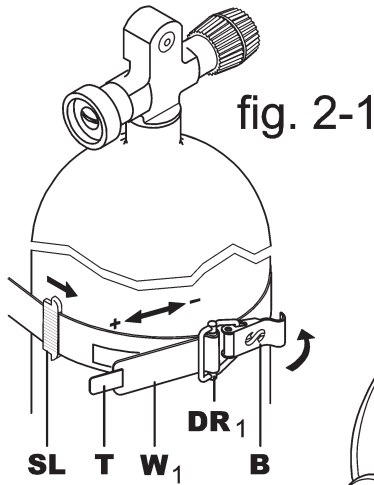

fig. 2-1

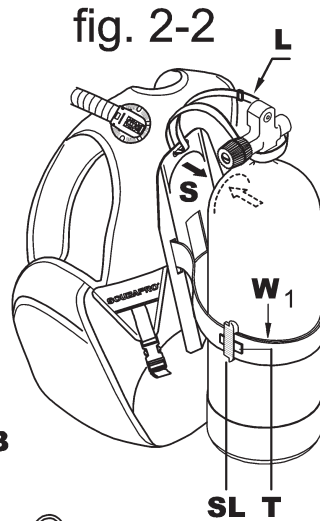

fig. 2-2

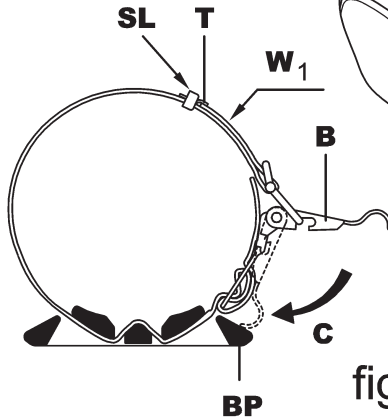

fig. 2-3

### WARNING

Soak the webbing of the SCUBA air cylinder strap and then tighten prior to each use of the BC. Webbing may stretch when initially exposed to water. Failure to soak the webbing may allow the cylinder strap to loosen around the SCUBA air cylinder. This could result in injury or death.

### 3. SET UP FOR DOUBLE SCUBA CYLINDERS (P/N 20.040.000).

SCUBAPRO® offers the only system to connect two tanks with an adjustable belt system, that allows to easily fasten and remove your BC from the double tanks.  
(fig.3)

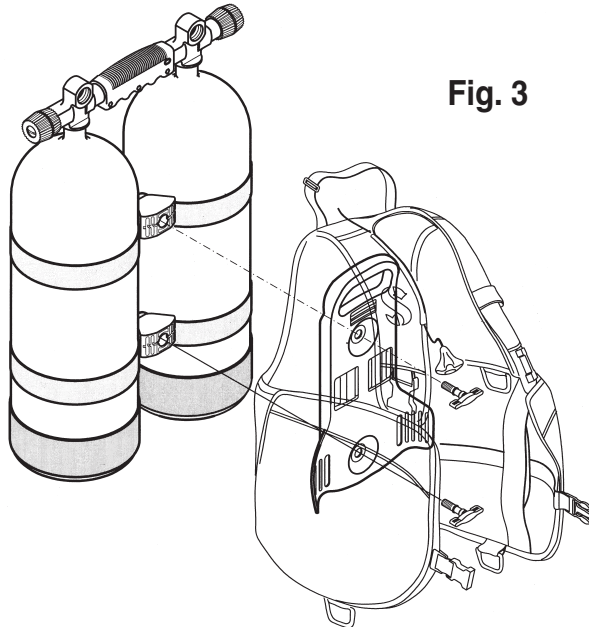

### 4. BALLASTING SYSTEM

The total weight must be calculated and tested in order to maintain a neutral buoyancy since you change depth during the dive, by simply adding or releasing the correct amount of air. For this reason each B.C. (model and size) has a different lifting capacity (referred to fresh water) marked on the model itself, to address the users to a correct choice, and to prevent an excess of weight.

The SCUBAPRO® B.C. has been designed for three ballasting systems, based on the use of the 'Ecoweight' (soft sealed weight, patented by Scubapro®) developed to improve comfort, to reduce wear of the pockets and to protect the ambient as well.

#### 1. Standard Weight Belt

It is the traditional harness weight belt, separate from the BC.



## 2. Counter Weight Pockets

Surface and submerged flotation attitude can be adjusted with your BC with the back counter weight pocket system. Addition of weight in the counter weight pockets may also assist in reducing any forward pitching that may be encountered with back inflation “wings”.

Each pocket can accept up to a 5.5 lb. (2.5 Kg.) SCUBAPRO® Ecoweight (fig. 4 - E).

The weight pockets are standard on Glide 2000/3000/Glide Star/Glide 3D Pro (fig. 4-1 - CP<sub>1</sub>) and, as optional, can be placed on either side of the Supercinch cylinder strap (fig. 4-2 - CW) on Glide Tek.

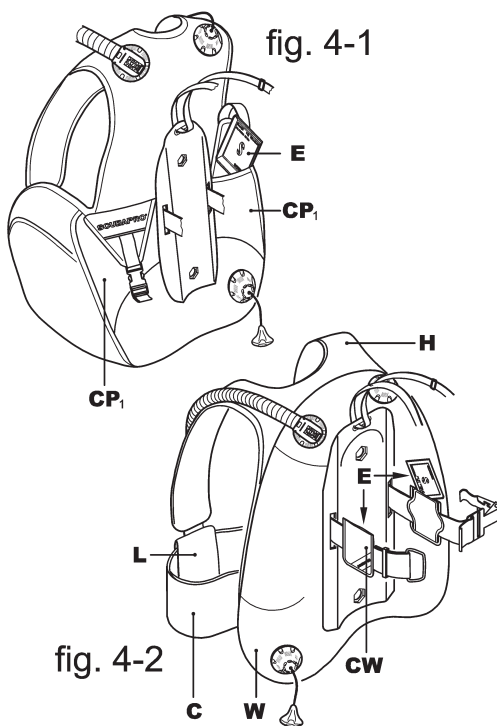

### WARNING

Counter weights are not designed to be released in an emergency. Failure to create adequate positive buoyancy in an emergency situation may result in injury or death. The user of the BC must configure the entire diving system in a manner that provides the means for rapidly and easily creating positive buoyancy as an aid for emergency ascent.

### 3. Removable Buckle Weight Pocket System (BW) (Patented) (used on some models only) (fig. 5 – RP<sub>1</sub> – RP<sub>2</sub>)

These removable pockets accept up to 11 lb (5 Kg) Ecoweight in the size "L" and up to 5.5 lb (2.5 Kg) in the "S" size (see assy procedure, fig. 5<sub>1</sub> - 5<sub>2</sub> - 5<sub>3</sub> - 5<sub>4</sub>)

They are inserted in the B.C. compartments (fig. 5<sub>5</sub> - 5<sub>6</sub>) held in position by the buckle (B fig. 5<sub>7</sub>) with the strap pulled by the "D" ring (P): in case of need, by disengaging the buckle (B) (fig. 5<sub>8</sub> - 5<sub>9</sub>) it is possible whether to release the weights for emergency or, simply, to transfer the weight pocket to the boat, at the end of the dive .

If the removable weight pocket would not be used, it should be possible to hide the male buckle (B<sub>M</sub>) and its strap into the B.C. pocket loop (L) (fig. 5<sub>10</sub> - 5<sub>11</sub>), so they would not hang down.

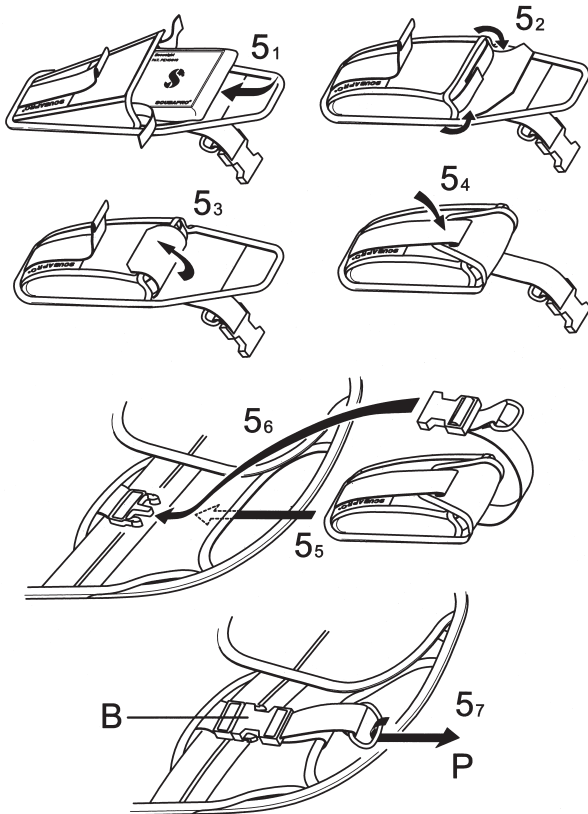

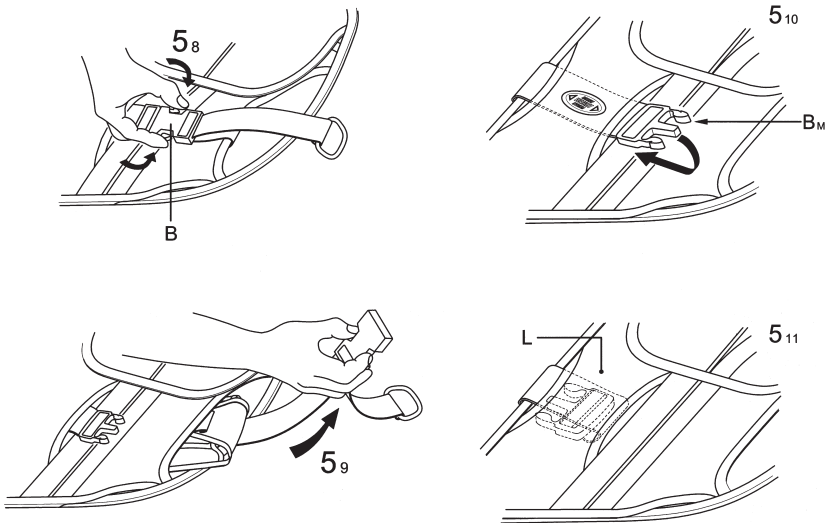

---

### ATTENTION

The Ecoweight (fig. 5<sub>1</sub>) and Removable Pocket (fig. 5<sub>4</sub>) must be perfectly secured with the buckles fully and correctly engaged (fig. 5<sub>7</sub>) : the loss of the pocket during diving causes positive buoyancy and uncontrolled ascent that could result in injury or death.

---

## 5. VALVE SET UP AND OPERATION

### Connecting the B.P.I., A.I.R. 2, or I.P.I.

The Power Inflation Valve allows you to inflate your BC using air from your SCUBA cylinder. Its LP hose, threaded on a LP port of the first stage regulator, is connected to the Power Inflation Valve by the Quick Disconnect Coupling that works with the air on or off.

To attach the Quick Disconnect Coupling (fig. 6 - C) :

1. Make sure that both fittings are free of contamination prior to mating them together.
2. Pull back the collar of the Quick Disconnect Coupling, while pushing the hose firmly onto the fitting plug found on the power inflation valve.
3. Release the collar when the coupling is fully seated on the plug. Pull gently but firmly on the hose to check for a secure connection.
4. To disconnect, pull the Quick Disconnect Coupling collar back and disengage the LP hose from the plug.

Fig. 6

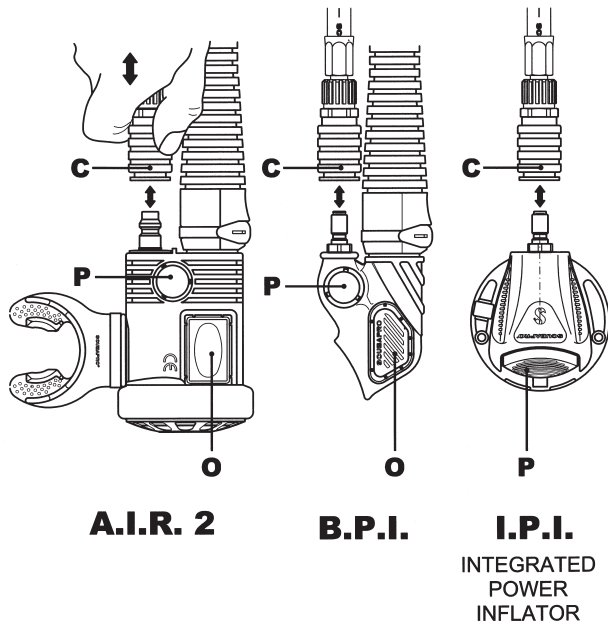

---

## WARNING

**Never breathe from the BC.** Your BC may contain gas residue, liquid, or contamination that may result in injury or death if inhaled.

**Keep water out of the inflatable aircell of the BC.** Repeated use of the oral valve or the Overpressure Valve may allow water inside the BC, reducing the amount of buoyancy provided by the BC. This could result in injury or death. Drain all water out of the BC prior to every use.

---

### **Inflating the BC with the Power Inflation Valve (on BPI, AIR 2 and I.P.I.).**

To inflate the BC, press the Power Inflation Valve Button (fig. 6-P). Air should enter the BC. For better control during inflation use short bursts of air by repeatedly pressing and releasing the PIV button.

### **Inflating the BC with the Oral Valve (on BPI and/or AIR 2)**

The Oral Valve is typically found on the end of the airway. It allows you to inflate your BC with your exhaled breath. Use of this valve for inflation is recommended on the surface, or on land prior to diving. It may be used when you cannot, or do not wish to add air to the BC with the Power Inflation Valve (fig. 6 - O).

1. First exhale a small amount of air into the mouthpiece of the valve to purge any water that may be trapped there.
2. With the same breath, continue to exhale while deeply depressing the Oral Inflation Valve Button (fig. 6 - O).
3. Release the Oral Valve Button when you inhale fresh air.
4. Repeat steps 2 and 3 until the desired amount of buoyancy is reached.

fig. 7

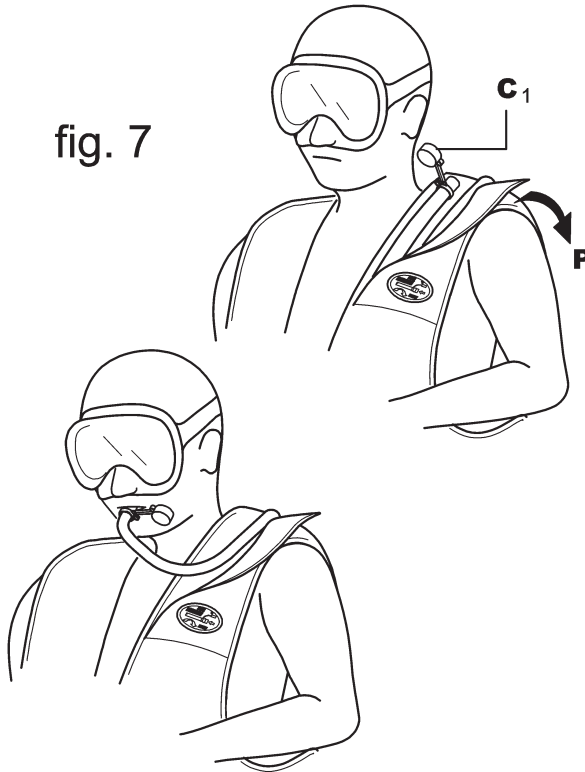

**Inflating the B.C. with the oral inflator tube.**

1. Open the shoulder pad (fig. 7 – P)
2. Remove the valve cap (fig. 7 – C<sub>1</sub>)
3. Exhale into the inlet port until the desired amount of buoyancy is reached.
4. Put the cap on.
5. Replace the bent tube assy and close the pad.

## Deflating the BC with the Manual Dump Valve

Stop and assume an upright position in the water. When in position, open the Manual Dump Valve by gently pulling downward on the Oral Valve/Power Inflation Valve Assembly (fig. 8 - A). It is not necessary to use excessive pressure to pull on the hose assembly. Valve travel is limited and pulling harder will not increase the air flow. To close the Manual Dump Valve, stop pulling downward, and release.

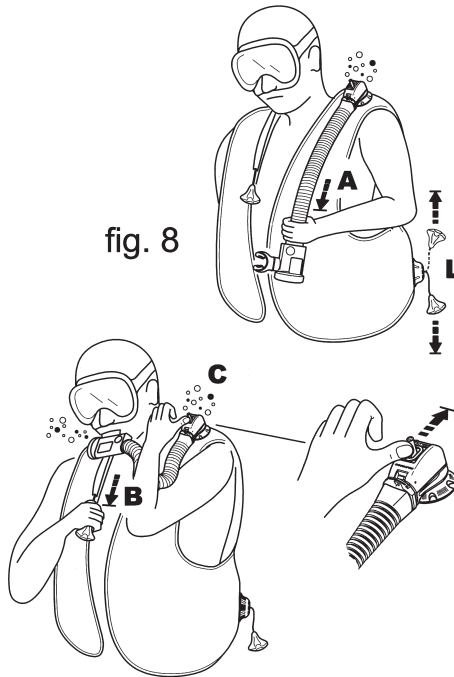

---

### WARNING

**Keep sand and other contamination out of the Oral Valve mouthpiece and valve button.** Under certain conditions, contamination can cause the valve to not close completely. If this occurs while diving, shake the valve while depressing it several times. If the valve leaks or remains inoperable, terminate the dive. Diving with a leaking Buoyancy Compensator or with valves that do not operate properly may result in a loss of buoyancy control that could result in injury or death.

---

## **Deflating the BC with the Oral Valve (BPI and /or AIR 2 only)**

Assume a head up position in the water. Raise the Oral Valve above and in front of your face. (This insures the Oral valve will be positioned above the air bubble in the BC.). Depress the Oral Valve button and visually confirm that air is escaping from the mouthpiece. For best control, let air out in a series of short, measured amounts while observing the effects on your buoyancy.

---

### **IMPORTANT**

- When breathing from an Air 2 equipped BC, the recommended valve for dumping air is the shoulder Dump Valve (fig. 8 - B), located on the right shoulder, of the BC, or the push pin (fig.8 - C) on top.
  - The SCUBAPRO® Dual Manual Dump Valve (Patent) has a safety hand pin on the top (fig. 8 - C) that, by pushing it upward, releases air in case of failure of the Manual Dump System (broken cable, pin, etc.) or while breathing from an Air 2.
  - If the BC model does not have a right shoulder Dump valve or the push pin, then the Air 2 may require removal from the mouth to actuate the Manual Dump Valve (fig. 8 - A).
  - With all deflation methods, hold the valve open no longer than needed. This helps prevent excess water from entering the BC.
  - Do not depress the Oral Valve button when activating the Manual Dump valve, as water may enter the BC through the Oral Valve mouthpiece.
- 

## **Over Pressure Valve Operation**

The Over Pressure Valve prevents over-inflation of the BC. If the internal pressure exceeds the spring pressure in the Over Pressure Valve, the valve automatically opens and releases air to prevent damage to the BC. The valve will automatically close when the internal pressure goes below the spring pressure in the Over pressure Valve.

## **Shoulder Valves**

SCUBAPRO® Buoyancy Compensators have over pressure valves on either one or both shoulders that act also as dump valves. The dump valve on the left shoulder is always present and is activated either by : a) pulling gently on the hose assembly (fig. 8 - A) or b) pushing on the rod that protrudes out of the valve casing (fig. 8 - C) (Patented) : this system could be useful also to purge air of another diver having problems (panic, beginner diver, unconsciousness, etc.). The valve on the right shoulder, if present, is activated by pulling gently on the knob which is connected via a lanyard to the valve itself (fig. 8 - B). To operate either style of dump valve, orient the valve to a position higher than the air bubble in the BC. Activate the dump valve until the desired amount of buoyancy is reached. Stop pulling/pushing to close the valve (fig. 8 - B)



## Lower Dump Valve (fig. 8 - L)

An over Pressure Valve located at the lower rear of the BC is equipped with lanyard and pull knob. This lower Dump Valve can be manually activated when the Diver operates them in a horizontal or head down orientation in the water, positioning them at the highest point of the air bubble.

## 6. BC HARNESS ADJUSTMENT - GENERAL FEATURES

SCUBAPRO® manufactures Buoyancy Compensator jackets with many different adjustments and features. Adjustments and features specific to the model that you have purchased are typically included with this manual on a separate insert.

---

### WARNING

**Adjust the BC so that it does not restrict your breathing when fully inflated.** Restriction of normal breathing while wearing your BC could result in injury or death. Before each use, check all bands, straps, quick-connect clips, and/or cummerbund for proper adjustment to the user.

---

### Waist and Front Closures

Waist closures may use a web and cam buckle system, Adjustable Front Closure Buckle with a "squeeze to release" feature, or may use a touch fastener closure on a cummerbund. Touch fastener closures are fastened by placing the hook and loop panels on top of each other and applying moderate pressure. Waist closures may need to be adjusted at depth if a neoprene suit is worn by the diver (fig. 11).

### Adjustable shoulder BCs

Shoulder straps are adjustable on your BC. These straps adjust by a length of webbing passing through a locking feature on a quick release buckle. Tighten buckles by grasping the free end of the adjustment webbing and pulling firmly downward. Lift the front of the buckle upwards while wearing the BC to loosen (fig. 11).

A quick release feature may also be incorporated into the buckle. Check for two tabs on either side of the buckle that may be squeezed to separate the buckle halves.

Front and shoulder closures on the BC are used to keep it in a low drag configuration.

## 7. BC EXAMINATION AND PROCEDURES

Pre-dive, dive and post-dive BC examination helps to identify equipment problems before unsafe conditions exist, preventing diving accidents. All equipment must be regularly inspected by an authorized SCUBA equipment repair facility.

---

### WARNING

**DO NOT DIVE with a BC that does not pass any of the Pre-Dive, Dive or Post-Dive inspection points and tests.** Loss of buoyancy control or air holding integrity could occur, resulting in serious injury or death.

---

#### Pre-Dive Visual Inspection and Valve Test:

- 1) **Examine** the entire BC for cuts, punctures, frayed seams, excessive abrasion, loose/missing hardware and other damage of any kind.
- 2) **Inspect** the Oral Valve, Power Inflation Valve, Manual Dump Valve and Over Pressure Valve(s) for cracks, damage, or contamination.
- 3) **Operate** the Power Inflation Valve (with the LP hose attached and charged with air pressure), Oral Valve, manual Dump Valve and Over Pressure Valve, checking for proper operation and resealing. If the OP Valve has a Pull Dump, test it by pulling on the cord.
- 4) **Inflate** the BC through the Oral Valve until it is firm. Listen and check for leaks. Let the BC stand inflated for 30 minutes or more, then check the BC for loss of air.
- 5) **Soak** the cylinder band(s) and fit the BC to a SCUBA cylinder, pull up on the BC while attached on the SCUBA cylinder, checking that the BC will not slip while diving.
- 6) While wearing the BC, **adjust** the straps and other attachments on the BC for a comfortable fit that does not restrict breathing. Make these adjustments with the BC inflated and while wearing the exposure suit you intend to dive with.
- 7) **Check** quick release weight pockets or systems that retain weight (if your BC is equipped with them). Make sure that their retention systems are fully engaged and attached : they have to be released, and the weight removed from your equipment, quickly.
- 8) **Cross check** all valves' operation and visually inspect your BC with your dive partner before each dive, prior to entering the water.

---

### WARNING

**DO NOT DIVE with a BC that is damaged, leaks air, or does not function properly.** Terminate any dive as safely and quickly as possible if the BC becomes damaged, leaks air, or does not function properly.

---

## Post-Dive : BC Cleaning and examination and Storage

With proper care and service, your BC should provide years of enjoyment. Maintenance and care procedures must be observed and are as follows:

- 1) **Rinse the BC** thoroughly inside and out with fresh water after every use (do not use any aggressive solvent and/or cleansing liquid).
  - Fill the BC Inner Bladder, approximately  $\frac{1}{4}$  full with clean fresh water through the Oral valve.
  - Orally inflate the BC and shake to distribute water inside of the BC.
  - Hold the BC upside down, depress the Oral Valve Button, and allow all water and air to drain from the Oral Valve mouthpiece.
  - Repeat one or two more times.
  - Rinse the entire BC with fresh water by dipping in a tub or spraying with a hose.
  - Rinse all valves (OI/DV, PIV, MDV, OP) to make sure all sand and other debris is removed.
  
- 2) **Dry the BC** ; if hanging, make sure it is not in direct sunlight. Dry completely if storing, slightly inflated.

---

### IMPORTANT

Avoid prolonged or repeated exposure to chlorinated water, such as in swimming pools. Wash your BC immediately after any use in chlorinated water. Chlorinated water can oxidize fabrics and materials on your BC, thereby shortening their life, and cause colors (especially neon) to fade. Damage and fading from prolonged exposure to chlorinated water is specifically not covered under warranty.

---

## 8. STORAGE

Store your BC, after it has fully dried, by partially inflating and then placing it in a cool, dark, dry, location : ultraviolet rays will shorten the life of the fabric and cause colors to fade. Slightly grease (with SCUBAPRO® Lubricant Grease), the AIR 2 and BPI couplings.

## Inspection and Service Interval

Your BC should be inspected and maintained at an Authorized Service Center at least once a year, more often if you dive frequently. Any damage caused due to failure to properly maintain the BC is not covered by the warranty.

## 9. GENERAL SPECIFICATIONS

### Shelf Life

Shelf life is seven years for a new, unused jacket when deflated and stored in a sealed container or bag at typical room temperature, with no exposure to UV.

### Operating temperature range

Air	-4° to 122°F	-20° to +50°C
Water	28° to 104°F	-2° to +40°C

---

### WARNING

**Special instruction in cold water diving methods, and the specific use of this product in cold water, is required prior to cold water diving (temperatures below 10°C/50° F).** This instruction is beyond the scope of this manual.

---

### Low pressure Hose / Pneumatic Inflation Valve

LP hose and Pneumatic Inflation Valve operating pressure	95 – 200 psi (6.5 – 13.8 bar)
Low Pressure Hose Fitting threads	3/8 – 24 UNF
O-Rings - Seals	EPDM – Buna/Nitrile - Silicone

---

### WARNING

**This product is designed to use air or nitrogen/oxygen mixtures containing up to 40% oxygen.** Use of gas mixtures with increased oxygen, or the addition of helium or other substances, may cause corrosion, deterioration, premature aging or component failure of metal and rubber parts. These actions may result in loss of buoyancy control or air holding integrity of the BC, resulting in injury or death. Non-standard gas mixtures may also present a risk of fire or explosion. Use only nitrogen/oxygen mixtures containing up to 40% oxygen.

---

**10 MASTER JACKET** (certified as CBRD-EN 12628, that includes also the EN 1809 norms, that means it can be used as buoyancy compensator underwater as well as Life Jacket on the boat).

The original design of this legendary model has been developed since 1978 : it was the first diving Jacket ever produced and the project was so good that up until today, it is, practically, unchanged.

Master Jacket is quite different from all other models on the market due to its “three dimensional balance” buoyancy control : regardless of the sequence of movements or in what position the movement begins underwater , the internal air bubble cannot cause rotational movements, which would destabilize the diver (fig. 9 - A).

This outcome is owed to the peculiar internal bag design, that uses three interconnecting circles or passageways, permitting the air bubble an unobstructed circulation (fig. 9 - A<sub>1</sub>). If the ring is interrupted (fig. 9 - B), a rotation of the ring 9 itself, which would bring one of the ends (E or E<sub>1</sub>) to the highest point (where the bubble (O) resides), would cause the rotation to stop. If the ring is not interrupted, however, the rotation can continue until it reaches the most stable configuration. This guarantees not only an unparalleled level of comfort during diving, but also a “face-up” position of the diver

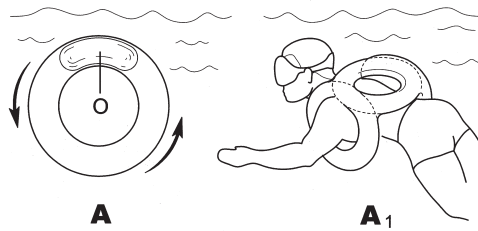
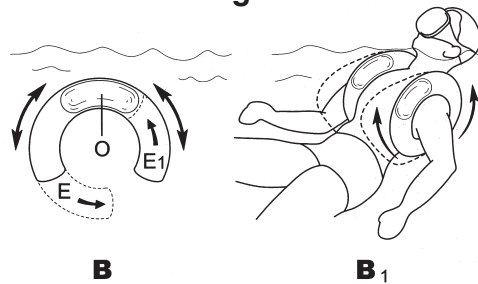

Fig. 9



on the surface, even in case of unconsciousness, providing thus an inherent level of safety. For this main reason, the Master Jacket has been tested and certified as the unique worldwide CBRD (Combined Buoyancy Rescue Device) : this means that the Jacket can be used as buoyancy compensator underwater as well as a Life Jacket on the boat !

Other skilful technical solutions and quality materials support the basic safety concept : the Master Jacket infact consists of two bags : an internal bag that holds the air bubble, made of polyurethane/polyether, radio frequency welded , and an external bag made of tough polyester fabric, sewn with thick polyester thread, that guarantees mechanical and abrasion resistance.

The webbing system is conceived for the maximum safety too: infact there are adjustable shoulder belts with 50 mm. (2") metal buckles, easy to adjust even with thick gloves, to hold tight the diver, even jumping into the water from many meters ! The chest straps are elastic to prevent squeezing of the lungs, if the bag is over inflated. Fotoluminescent patches complete the safety features.

In the right epaulette there is an elastic loop ( fig. 10 - L), to hold a blinking light during the night dive (such as SCUBAPRO® Safety Light or Strobe Light).

Back pack, back plate, soft padding cummerbund and Supercinch Q.A. are described in the Manual (paragraph 1/2).

All valves, inflator and tank band assy, are described in the manual (paragr. 5/6).

In addition, the Master Jacket has the possibility to apply a Pony Bottle System and/or CO<sub>2</sub> detonator ( both of them are optional) that fit on special pockets (fig. 10 PB / CO<sub>2</sub>) so that they do not hang out.

Heavy duty AISI 316 stainless steel "D" rings allow to hook up heavy accessories.

Performances (printed in the patches stitched besides the back pack) are listed below:

Sizes	Weight (in air) (Kgf)	Max Lifting Buoyancy (N*)	Max size of bottle (l)
Small	3.120	200	10 + 10
Medium	3.430	220	10 + 10
Large	3.520	230	10 + 10
XLarge	3.650	250	10 + 10
XXLarge	3.720	250	10 + 10



\*N=Newton

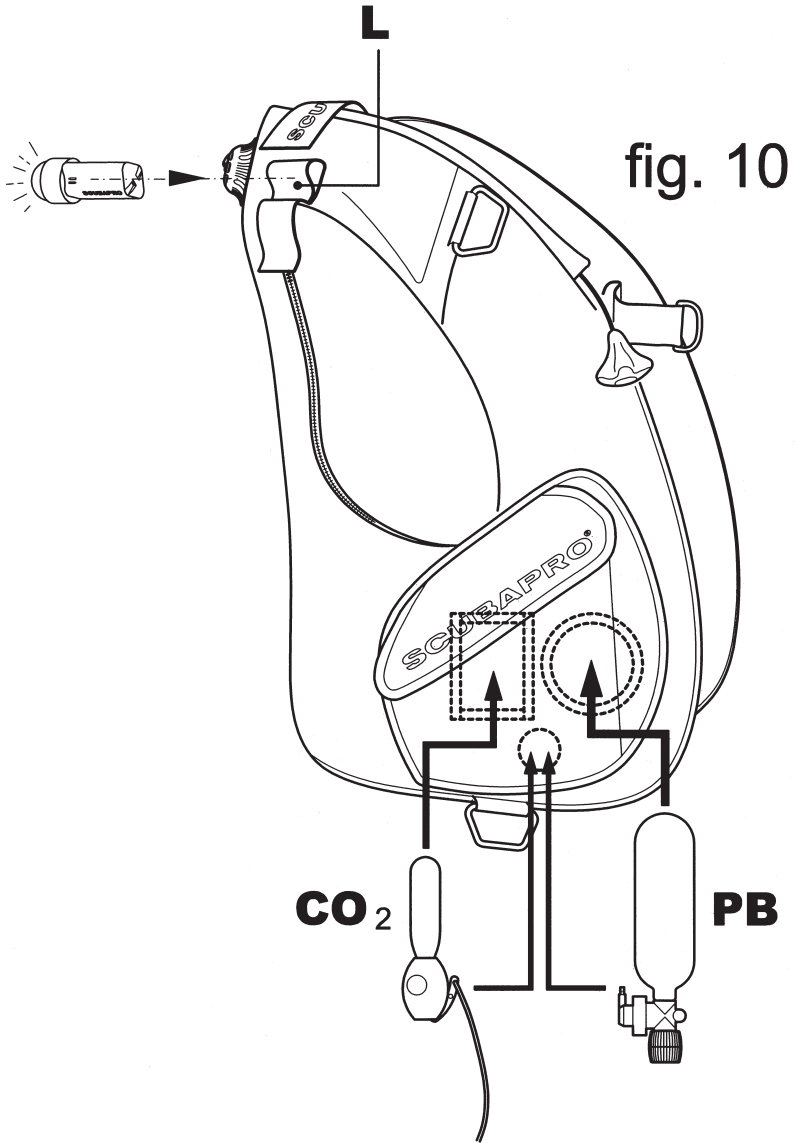

## **11 GLIDE LINE** (all Glide's are EN 1809 and EN 250 – 2000 certified)

This is a family of Jackets which has in common the cut and a worldwide patented feature that reduces the drag, and risk to be entangled, underwater : all webbing ends, after the adjustment, can pass inside through the belt connection loops or can be placed in specific pockets (Patented), so that they don't float around during the dive (fig. 11 - L/P)

This family consists of a scale of the models that differ from each other for their accessories.

### **Main accessories :**

1. Belt connection loop (Patented) (fig. 11 – L)
2. Replaceable nylon “D” rings (fig. 11 – D)
3. 40 mm Stainless steel “D” rings plates (fig. 11 DP)
4. Rotating shoulder buckles (fig. 11 – RB)
5. Color coordination pad , to easily individuate the size even from far (fig. 12 – CC), as follows :
  - (purple as XXS size;
  - pink as XS size;
  - green as S size;
  - blue as M size;
  - yellow as L size;
  - orange as XL size;
  - dark gray as XXL size)
6. Pockets with zippers
7. Carbon Accents



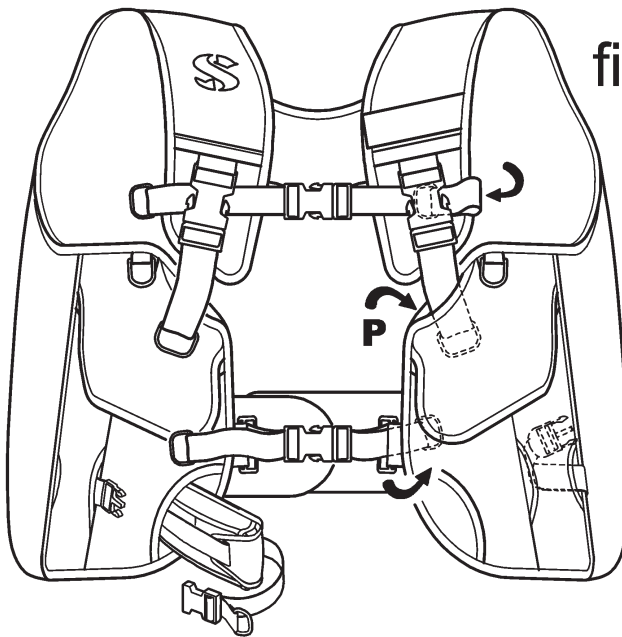
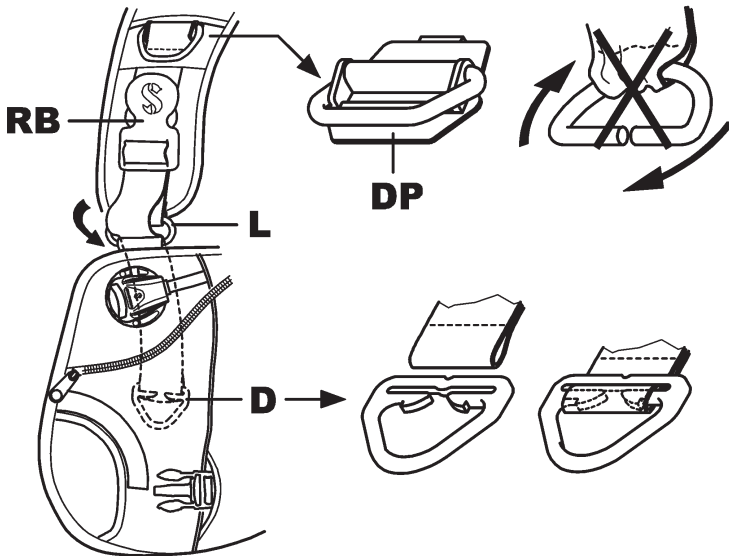

fig. 11

## 12 GLIDE 2000 BW

This is a single bag adjustable B.C.

The material is a 420 denier nylon, polyurethane coated, radio frequency welded.

The shoulder lobes and pockets are made of heavy polyester fabric and threads with a built in soft neck collar (fig. 12 - NC).

It has all features and accessories described at paragraph 11. GLIDE LINE (from 1 to 6, except 4)

The other features are: the Integrated Weight System (paragraph 4 - fig. 5) and two back extra pockets (fig. 12 - CP) to hold counterweights (fig. 4 - paragraph 4), small Marker Buoy or other accessories.

To highlight the "Glide" concept, also the shoulder buckles are protected with a fabric patch (fig. 12 - F). The chest strap is elastic to prevent squeezing of the lungs, if the bag is over inflated : the « D » rings can be placed under the above patch (fig. 12 - F). All main buckles are 50 mm. (2") for easy handling even with thick gloves.

In the right epaulette (fig. 12 - L) there is an elastic loop, to possibly hold a blinking light during the night dive (such as the SCUBAPRO® Safety Light or Strobe Light)

The Glide 2000 BW has the pockets with the integrated weight system (Fig 5, paragr. 4). Bright reflecting stripes and patches are placed in the visible positions, for safety. Internal welded cross walls limit the volume expansion and create a contoured shape around the diver's body.

Back packs, back plate, soft padding, cummerbund system and Supercinch Q.A. are the ones described in the Manual ( paragr. 1/2).

The valves and tank band assy are described in the manual (paragr. 5/6).

Performance (printed in the patches stitched besides the back pack) are listed below:

Sizes	Weight (in air) (Kgf)	Max Lifting Buoyancy (N*)	Max size of bottle (l)	Color Coord.
XXSmall	2.900	110	7	purple
XSmall	3.050	113	10	neon pink
Small	3.195	152	15	neon green
Medium	3.465	170	15	blue
Large	3.585	187	15	neon yellow
XLarge	3.660	213	15	neon orange
XXLarge	3.680	230	15	dark grey



\*N=Newton

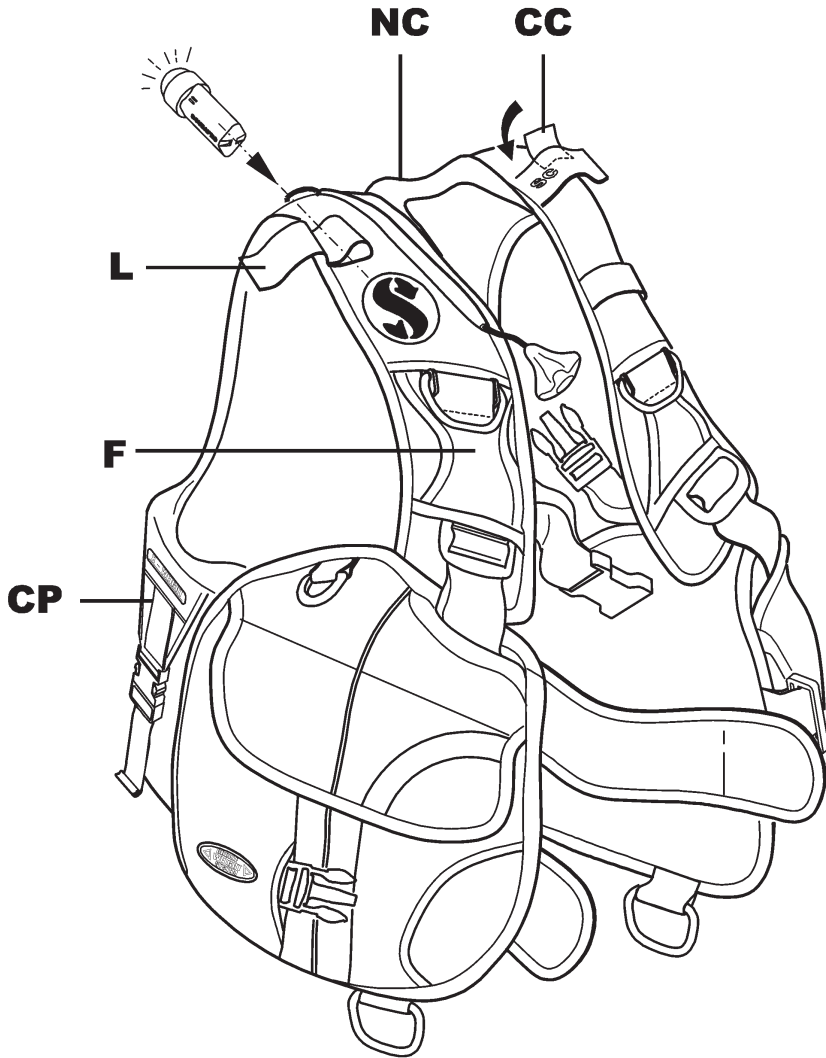

fig. 12

### 13. GLIDE 3000 I.P.I.

This Front Adjustable, single bag BC, has all common features described on the above paragraph 12. Glide 2000 and the accessories described at paragraph 11. GLIDE LINE (from 1 to 7; except 4) and the following specific ones :

- the new IPI (Integrated Power Inflation) (fig.13 – IPI) that means no pull dump, corrugated hose/BPI system : the left shoulder/lobe side is free from any hose hanging around (the IPI / LP hose passes under the arm), and an oral inflator tube is hidden with a pad fixed with velcro (fig. 13 - OI).
- The second unique feature is that, thanks to the modularity of the valves, it is possible to come back to the corrugate, BPI system, by simply plugging the IPI hole with the specific plug/ring (fig. 13 – PR) and connecting the corrugated hose/elbow on the left shoulder, in place of the said oral inflator connection.
- The integrated weight system is the one with the standard buckle pockets (fig.5 – paragraph 4) combined with two back pockets for counter weights (paragraph 4) (fig. 13 – CP).
- Soft neck (fig. 13 - NC).

Back packs, back plate, soft padding, cummerbund system and Supercinch Q.A. are the ones described in the Manual (paragraphs 1 / 2))

The valves and tank band assy are described in the manual (paragraph 5 – 6).

#### Technical specifications:

Sizes	Weight (in air) (Kgf)	Max Lifting Buoyancy (N*)	Max size of bottle (l)	Color Coord.
XXSmall	—	—	—	purple
XSmall	2.800	115	10	neon pink
Small	2.910	150	15	neon green
Medium	3.160	157	15	blue
Large	3.242	180	15	neon yellow
XLarge	3.300	202	15	neon orange
XXLarge	—	—	—	dark grey



\*N=Newton

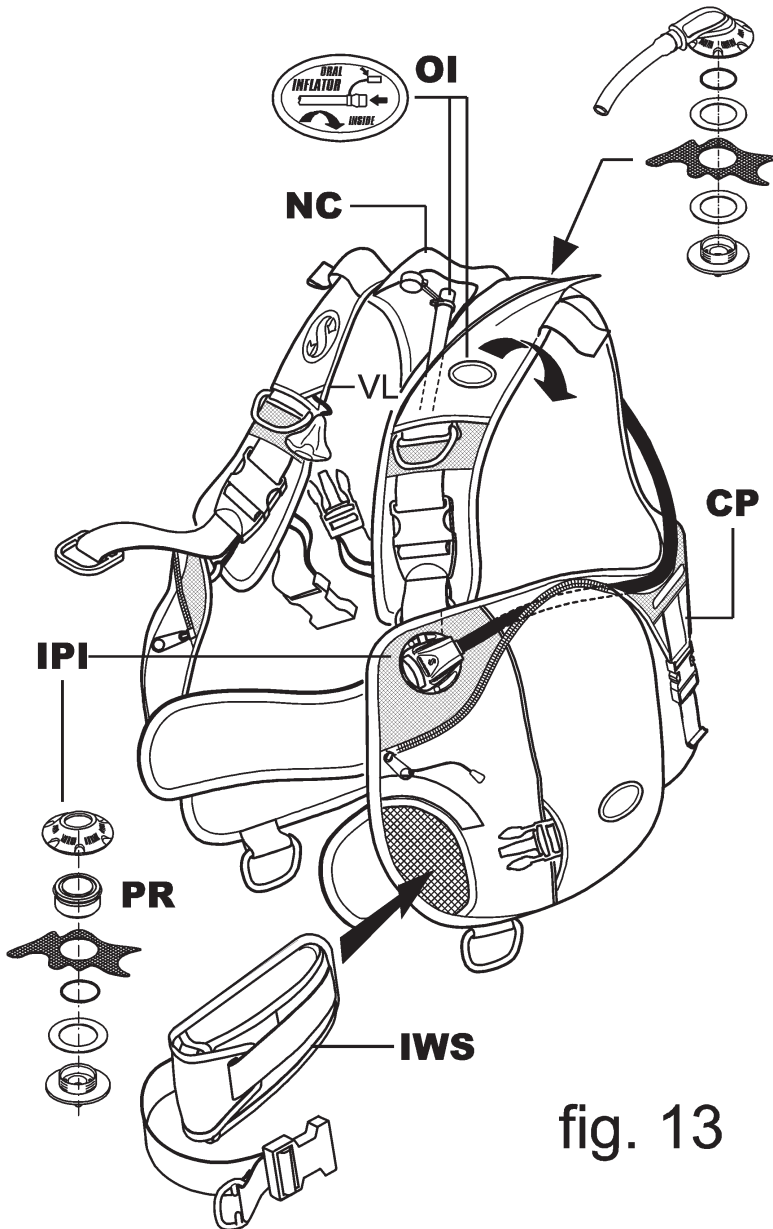

fig. 13

## 14 GLIDE 1000

This is a single bag adjustable B.C.

The material is a 420 denier nylon, polyurethane coated, radio frequency welded. Shoulder lobes and pockets are made of heavy polyester fabric.

Features and accessories are described at paragraph 11. GLIDE LINE (from 1 to 7, except 4, 6).

N. 2 stainless steel « D » rings allow to hook heavy accessories.

Bright stripes and a reflecting patch are placed in the visible positions, for safety.

Internal welded cross walls limit the volume expansion and create a contoured shape around the diver's body.

Back packs, back plate, soft padding, cummerbund system and Supercinch Q.A. are the ones described in the Manual (paragr. 1/2).

In the right epaulette (fig. 12 - L) there is an elastic loop, to possibly hold a blinking light during the night dive (such as the SCUBAPRO® Flashlight or Strobe Light)

The valves and tank band assy are described in the manual (paragr. 5/6).

Performance (printed in the patches stitched besides the back pack) are listed below:

Sizes	Weight (in air) (Kgf)	Max Lifting Buoyancy (N*)	Max size of bottle (l)	Color Coord.
XXSmall	2.210	110	7	purple
XSmall	2.320	113	10	neon pink
Small	2.430	152	15	neon green
Medium	2.540	170	15	blue
Large	2.640	187	15	neon yellow
XLarge	2.680	213	15	neon orange
XXLarge	2.760	230	15	dark grey



\*N=Newton

## 15 GLIDE 500

This is the simplest single bag, adjustable B.C. of the Glide family. The material is a 420 denier nylon, polyurethane coated, radio frequency welded. Shoulder lobes and pockets are made of heavy polyester fabric and mesh. Reflecting patches are placed in the visible positions, for safety.

Back packs, back plate, soft padding, cummerbund system and Supercinch Q.A. are the ones described in the manual (paragr. 1/2).

The valves and tank band assy are described in the manual (paragr. 5/6). Performance (printed in the patches stitched besides the back pack) are listed below:

Sizes	Weight (in air) (Kgf)	Max Lifting Buoyancy (N <sup>t</sup> )	Max size of bottle (l)	Color Coord.
XXSmall	2.140	110	7	purple
XSmall	2.200	113	10	neon pink
Small	2.250	152	15	neon green
Medium	2.330	170	15	blue
Large	2.430	187	15	neon yellow
XLarge	2.460	213	15	neon orange
XXLarge	2.490	230	15	dark grey



\*N=Newton

## 16 GLIDE 3D PRO

This model is the compendium of years of SCUBAPRO® experience on the matter. It is based on the legendary Master Jacket (paragr. 10) which comes from a project developed since 1978, combined with the new features (Patented) of the Glide family.

Infact like the Master Jacket, it has the “3 dimensional buoyancy control” (see Master Jacket - fig. 9) that guarantees not only an unparalleled level of comfort during diving, but also a “face up” position of the diver on the surface even in case of unconsciousness, thus providing an inherent level of safety. Internal welded cross walls limit the volume expansion and create a contoured shape around the diver's body.

The material specifications are the ones described in the Glide Line: it is single bag jacket made of a 420 denier nylon, polyurethane coated, radio frequency welded.

The basic bag is completed and reinforced with heavy polyester fabric and threads with a built in soft neck collar (fig. 14 - NC).

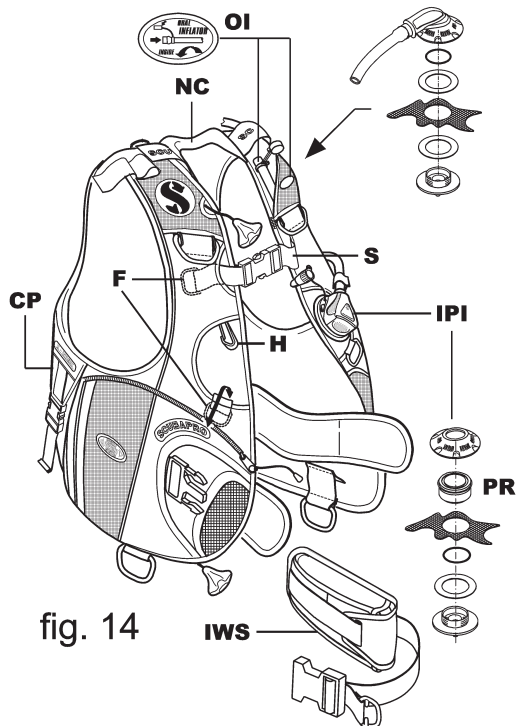

fig. 14



Features and accessories are described at the paragraph 11. GLIDE LINE (from 1 to 7, except 1,4).

Another feature is the inflating system that does not use the traditional bulky and delicate corrugated hose, but the new I.P.I. inlet valve (fig. 6 & 14 - IPI). As it is swiveling, it allows to place the LP hose and coupling (the same of BPI) in the preferred position : below the left arm (fig. 14 – L<sub>A</sub>) held by a logo and/or in the traditional position, passing through the shoulder lobe (fig. 14 – L<sub>B</sub>).

Another feature is the new (Patented) integrated weight system (see BC Manual, paragraph 4 – fig. 5) and two back extra pockets (fig. 14 – CP) to hold counterweights, small Marker Buoy or other accessories.

To highlight the “Glide” concept, all belts and rings can be “hidden” (fig. 14 - F) if not used, in order to reduce drag and risk to be entangled. The chest strap (fig. 14 - S) is elastic to prevent squeezing of the lungs, if the bag is over inflated. Stainless steel “D” rings allow to hook heavy accessories.

Under the right epaulette (fig. 14 - L) there is an elastic loop, to possibly hold a blinking light during night dives (such as SCUBAPRO® Strobe or Safety Light).

It has a swivel hook (fig. 14 - H) to fix any accessory, particularly SCUBAPRO® Navigation Board (optional) with or without Compass.

Back packs, back plate, soft padding, cummerbund system and Supercinch Q.A. are the ones described in the Manual (paragr. 1/2).

The valves and tank band assy are described in the manual (paragr. 5 - 6).

Performance (printed in the patches stitched besides the back pack) are listed below:

Sizes	Weight (in air) (Kgf)	Max Lifting Buoyancy (N*)	Max size of bottle (l)	Color Coord.
XSmall	—	—	—	—
Small	2.780	145	15	neon green
Medium	2.980	171	15	blue
Large	3.020	195	15	neon yellow
XLarge	3.020	203	15	neon orange
XXLarge	—	—	—	—



\*N=Newton

## 17 GLIDE 3D CLUB

This is the simplified version (configuration) of the Glide 3 D Pro, with the traditional inflation system (corrugated hose, BPI and/or AIR2) (paragraph 5).

It has the “3 dimensional buoyancy control” (see paragraph Master Jacket – fig. 9) that guarantees not only an unparalleled level of comfort during diving, but also a “face up” position of the diver on the surface even in case of unconsciousness, thus providing an inherent level of safety. Internal welded cross walls limit the volume expansion and create a contoured shape around the diver's body.

Features and accessories are described at the paragraph 11. GLIDE LINE (from 1 to 7, except 1, 4).

It is single bag jacket made of a 420 denier nylon, polyurethane coated, radio frequency welded, completed with heavy polyester fabric and threads.

To highlight the “Glide” concept, all belts and rings can be “hidden” (fig. 14 – F) if not used, in order to reduce drag and risk to be entangled.

Back packs, back plate, soft padding, cummerbund system and Supercinch Q.A. are the ones described in the Manual (paragraph 1/2)

The valves and tank band assy are described in the manual (paragraph 5/6).

Performance (printed in the patches stitched besides the back pack) are listed below:

Sizes	Weight (in air) (Kgf)	Max Lifting Buoyancy (N*)	Max size of bottle (l)	Color Coord.
XSmall	—	—	—	—
Small	2.090	140	15	neon green
Medium	2.230	153	15	blue
Large	2.270	170	15	neon yellow
XLarge	2.270	180	15	neon orange
XXLarge	—	—	—	—



\*N=Newton

## 18 GLIDE STAR

This new adjustable single bag B.C. has most Glide 2000 BW common features and other specific new ones :

- Design.** The front part (shoulder lobes, pockets) has been designed to be as more compact as possible .
- Lifting capacity.** The new bag has the back position semiexpandable (fig. 15 - SB) to get more lifting capacity, and retractable, by means of two elastic straps (fig. 15 - ES) and, being positioned between bottle and back of the diver, in normal use, it does not create any extra drag.

**3. Other features :**

- a) All new features described on the paragraph 11. GLIDE LINE (from 1 to 7)
- b) The integrated weight system (paragr. 4 – fig. 5) (fig. 15 – IWS).
- c) Soft neck (fig. 15 - NC).

Back packs, back plate, soft padding, cummerbund system and Supercinch Q.A. are the ones described in the Manual (paragraphs 1/2.)

The valves and tank band assy are described in the manual (paragraph 5/6).

Performance (printed in the patches stitched besides the back pack) are listed below:

Sizes	Weight (in air) (Kgf)	Max Lifting Buoyancy (N*)	Max size of bottle (l)	Color Coord.
XSmall	2.900	120	10	neon pink
Small	3.050	122	15	neon green
Medium	3.180	130	15	blue
Large	3.330	153	15	neon yellow
XLarge	3.500	170	15	neon orange
XXLarge	—	—	—	—



\*N=Newton

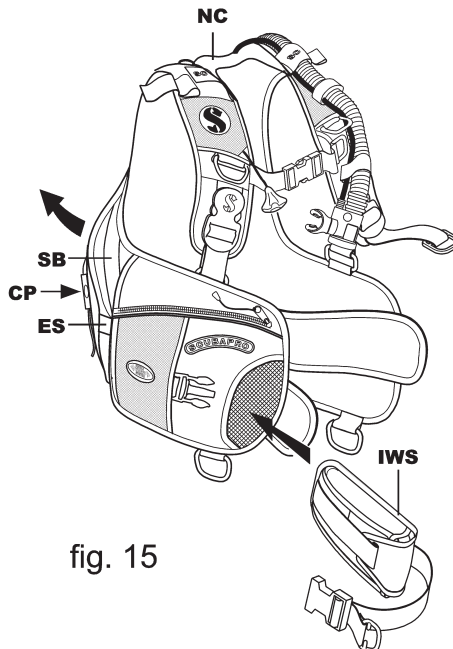

fig. 15

## 19 GLIDE TEK ( BASIC / PRO ) - LADYHAWK - KNIGHTHAWK

This is a back floatation BC that consists of a single bag WING (fig.16 – W), an independent harness (fig.16 – H) and an adjustable cummerbund (fig. 16 – C) system.

The system is modular so, to the GLIDE TEK Basic model it is possible to apply the optional weight pockets both on the back (paragraph 4, fig. 4 - CW) and, on the cummerbund, by using the integrated weight system pockets (paragraph 4 – fig. 5 & fig. 16 – IWS)).

The main positive feature of this model is that it leaves the diver's chest and arms free, so it is ideal for any kind of underwater work.

In addition, when the bag is empty or slightly inflated, it causes less drag because it is kept slim and profiled by the elastic bands.

- GLIDE TEK back floatation bags. It comes in two different capacities : small (13 lt) used on S/XS/XXS sizes and large (18 lt) used on M/L/XL/XXL sizes, but they are both interchangeable and applicable also to all Scubapro B.C.'s. . In order to allow the bag top to follow the shoulder shape, when inflated, there are plastic discs that create a bending line on this area.
- The connections to the back pack/harness of the two above bags are exactly the same, so both ones can be used on all Glide Tek sizes, in case of specific need.
- The GLIDE TEK Basic model (P/N 21.320.X00) has only two loops (fig.16 – CL) to connect the shoulder lobes to the cummerbund. The Pro model (P/N 21.324.X00) has pockets (fig. 16 – BW) with standard integrated weight system (fig.16 – IWS) : both pockets will come in 2 sizes.

The material used are the toughest both for Wing bag (420 denier nylon, PU coated) and for the harness (heavy polyester fabric), soft padded inside.

- Ladyhawk and Knighthawk bag: see table pag. I-37.

All valves and tank band assy are described in the Manual (paragraph 5/6).

Performance (printed in the patches stitched besides the back pack) are listed below:

### GLIDE TEK BASIC:

Sizes	Weight (in air) (Kgf)	Max Lifting Buoyancy (N*)	Max size of bottle (l)	Color Coord.
Small	2.190	140	15	neon green
Medium	2.380	190	15	blue
Large	2.460	190	15	neon yellow



### GLIDE TEK PRO:

Sizes	Weight (in air) (Kgf)	Max Lifting Buoyancy (N*)	Max size of bottle (l)	Color Coord.
Small	2.700	140	15	neon green
Medium	3.160	190	15	blue
Large	3.280	190	15	neon yellow



\*N=Newton

**LADYHAWK:**

Sizes	Weight (in air) (Kgf)	Max Lifting Buoyancy (N*)	Max size of bottle (l)	Color Coord.
Small	2.970	150	18	black
Medium	3.030	150	18	black
Med/Large	3.070	150	18	black
Large	3.120	150	18	black



**KNIGHTHAWK:**

Sizes	Weight (in air) (Kgf)	Max Lifting Buoyancy (N*)	Max size of bottle (l)	Color Coord.
Small	2.970	150	18	black
Medium	3.480	200	18	black
Large	3.600	200	18	black
X Large	3.670	200	18	black
XX Large	3.770	200	18	black



\*N=Newton

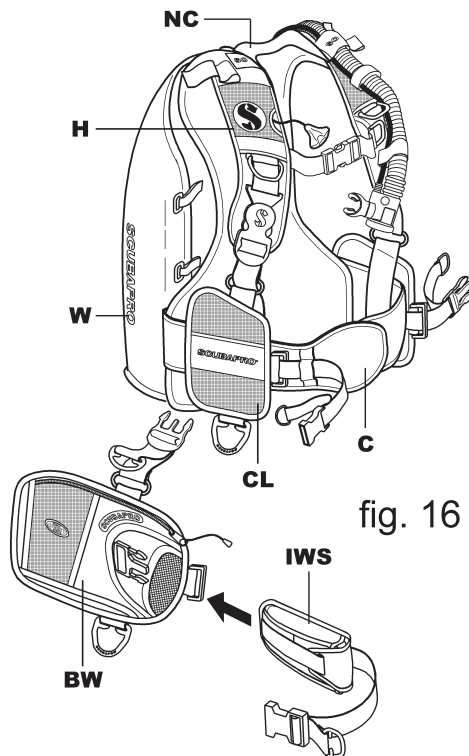

fig. 16



