

EX4550 Switch Hardware Guide

Published
2020-12-15

Juniper Networks, Inc.
1133 Innovation Way
Sunnyvale, California 94089
USA
408-745-2000
www.juniper.net

Juniper Networks, the Juniper Networks logo, Juniper, and Junos are registered trademarks of Juniper Networks, Inc. in the United States and other countries. All other trademarks, service marks, registered marks, or registered service marks are the property of their respective owners.

Juniper Networks assumes no responsibility for any inaccuracies in this document. Juniper Networks reserves the right to change, modify, transfer, or otherwise revise this publication without notice.

EX4550 Switch Hardware Guide

Copyright © 2020 Juniper Networks, Inc. All rights reserved.

The information in this document is current as of the date on the title page.

YEAR 2000 NOTICE

Juniper Networks hardware and software products are Year 2000 compliant. Junos OS has no known time-related limitations through the year 2038. However, the NTP application is known to have some difficulty in the year 2036.

END USER LICENSE AGREEMENT

The Juniper Networks product that is the subject of this technical documentation consists of (or is intended for use with) Juniper Networks software. Use of such software is subject to the terms and conditions of the End User License Agreement (“EULA”) posted at <https://support.juniper.net/support/eula/>. By downloading, installing or using such software, you agree to the terms and conditions of that EULA.

Table of Contents

About the Documentation | xi

Documentation and Release Notes | xi

Using the Examples in This Manual | xi

Merging a Full Example | xii

Merging a Snippet | xiii

Documentation Conventions | xiii

Documentation Feedback | xvi

Requesting Technical Support | xvi

Self-Help Online Tools and Resources | xvii

Creating a Service Request with JTAC | xvii

1

Overview

EX4550 System Overview | 19

EX4550 Switches Hardware Overview | 19

Benefits of the EX4550 Switch | 20

Software | 20

EX4550 Switches First View | 20

Optional Modules | 22

Virtual Chassis | 23

Power Supplies | 24

Fan Modules | 24

Components on the EX4550 Switch | 25

EX4550 Switch Models | 27

Identifying EX4550 Switch Models | 30

EX4550 Switch Hardware and CLI Terminology Mapping | 31

EX4550 Chassis | 35

Chassis Physical Specifications for EX4550 Switches | 35

Field-Replaceable Units in EX4550 Switches | 36

LCD Panel in EX4550 Switches | 37

LCD Panel Modes | 38

LCD Panel Menus | 39

Expansion Modules in EX4550 Switches | 43

Virtual Chassis Module in EX4550 Switches | 47

Chassis Status LEDs in EX4550 Switches | 49

Management Port LEDs in EX4550 Switches | 50

Network Port and Expansion Module Port LEDs in EX4550 Switches | 51

Cooling System and Airflow in an EX4550 Switch | 55

Fan Modules | 55

Airflow Direction in EX4550 Switches | 56

Back-to-Front Airflow | 57

Front-to-Back Airflow | 58

Do Not Install Components with Different Airflow in the Switch | 59

Positioning the Switch | 59

Fan Module Status | 59

EX4550 Power System | 60

AC Power Supply in EX4550 Switches | 61

AC Power Supply LEDs in EX4550 Switches | 63

AC Power Supply Specifications for EX4550 Switches | 64

AC Power Cord Specifications for an EX4550 Switch | 65

DC Power Supply in EX4550 Switches | 67

DC Power Supply LEDs in EX4550 Switches | 69

DC Power Supply Specifications for EX4550 Switches | 71

Site Planning, Preparation, and Specifications

Site Preparation Checklist for EX4550 Switches | 73

EX4550 Site Guidelines and Requirements | 74

Environmental Requirements and Specifications for EX Series Switches | 75

General Site Guidelines | 80

Site Electrical Wiring Guidelines | 80

Rack Requirements | 81

Cabinet Requirements | 82

Clearance Requirements for Airflow and Hardware Maintenance for EX4550 Switches | 83

EX4550 Network Cable and Transceiver Planning | 85

Pluggable Transceivers Supported on EX4550 Switches | 86

SFP+ Direct Attach Copper Cables for EX Series Switches | 87

Cable Specifications | 87

List of DAC Cables Supported on EX Series Switches | 88

Standards Supported by These Cables | 88

QSFP+ Direct Attach Copper Cables for EX Series Switches | 89

Cable Specifications | 89

DAC Cables Supported on EX3400, EX4300, EX4550, EX4600, EX9251, and EX9253 Switches | 90

Understanding EX Series Switches Fiber-Optic Cable Signal Loss, Attenuation, and Dispersion | 90

Signal Loss in Multimode and Single-Mode Fiber-Optic Cable | 91

Attenuation and Dispersion in Fiber-Optic Cable | 91

Calculating the Fiber-Optic Cable Power Budget for EX Series Devices | 92

Calculating the Fiber-Optic Cable Power Margin for EX Series Devices | 92

EX4550 Management Cable Specifications and Pinouts | 94

Management Cable Specifications | 95

Console Port Connector Pinout Information | 95

Mini-USB Port Pinout Specifications | 96

USB Port Specifications for an EX Series Switch | 97

RJ-45 Management Port Connector Pinout Information | 97

RJ-45 Port, SFP Port, SFP+ Port, QSFP+ Port, and QSFP28 Port Connector Pinout Information | 98

RJ-45 to DB-9 Serial Port Adapter Pinout Information | 103

Virtual Chassis Port Connector Pinout Information for EX4550 Switches | 104

EX4550 Virtual Chassis | 107

Understanding EX4200, EX4500, and EX4550 Virtual Chassis Hardware Configurations | 108

Ports Used to Interconnect Virtual Chassis Members | 108

Number of Switches, Required Software Releases, and Member Roles That You Configure in the Virtual Chassis | 109

Virtual Chassis Module | 110

Switch Role and Member ID on the LCD Panel | 111

Planning EX4200, EX4500, and EX4550 Virtual Chassis | 111

Virtual Chassis Cabling Configuration Examples for EX4550 Switches | 114

3

Initial Installation and Configuration

Unpacking and Mounting the EX4550 | 120

Unpacking an EX4550 Switch | 120

Parts Inventory (Packing List) for an EX4550 Switch | 121

Register Products—Mandatory to Validate SLAs | 122

Installing and Connecting an EX4550 Switch | 123

Mounting an EX4550 Switch | 124

Mounting an EX4550 Switch on Two Posts in a Rack or Cabinet | 124

Mounting an EX4550 Switch on Four Posts in a Rack or Cabinet | 127

Mounting an EX4550 Switch in a Recessed Position in a Rack or Cabinet | 131

Connecting the EX4550 to Power | 131

Connect Earth Ground to an EX Series Switch | 132

Parts and Tools Required for Connecting an EX Series Switch to Earth Ground | 132

Special Instructions to Follow Before Connecting Earth Ground to an EX Series Switch | 137

Connecting Earth Ground to an EX Series Switch | 138

Connecting AC Power to an EX4550 Switch | 139

Connecting DC Power to an EX4550 Switch | 142

Connecting the EX4550 to Network | 146

Connect a Fiber-Optic Cable | 146

Install a Transceiver | 147

Connecting the EX4550 to External Devices | 150

- Connect a Device to a Network for Out-of-Band Management | 151
- Connect a Device to a Management Console Using an RJ-45 Connector | 151
- Connect an EX Series Switch to a Management Console Using the Mini-USB Type-B Console Port | 153

Configuring Junos OS on the EX4550 | 154

- EX4550 Default Configuration | 155
- Connecting and Configuring an EX Series Switch (CLI Procedure) | 168
- Connecting and Configuring an EX Series Switch (J-Web Procedure) | 171
- Configuring the LCD Panel on EX Series Switches (CLI Procedure) | 175
 - Disabling or Enabling Menus and Menu Options on the LCD Panel | 176
 - Configuring a Custom Display Message | 177

Dashboard for EX Series Switches | 178

- Graphical Chassis Viewer | 179
- System Information Panel | 181
- Health Status Panel | 184
- Capacity Utilization Panel | 188
- Alarms Panel | 189
- File System Usage | 189
- Chassis Viewer | 189

4

Maintaining Components

Maintaining the EX4550 Cooling System | 208

- Removing a Fan Module from an EX4550 Switch | 208
- Installing a Fan Module in an EX4550 Switch | 209

Maintaining the EX4550 Power System | 210

- Removing an AC Power Supply from an EX4550 Switch | 211
- Installing an AC Power Supply in an EX4550 Switch | 212
- Removing a DC Power Supply from an EX4550 Switch | 214
- Installing a DC Power Supply in an EX4550 Switch | 215

Maintaining Expansion Module in an EX4550 Switch | 217

- Removing an Expansion Module from an EX4550 Switch | 217
- Installing an Expansion Module in an EX4550 Switch | 219

Maintaining EX4550 Virtual Chassis Module | 222

Removing a Virtual Chassis Module from an EX4550 Switch | 222

Installing a Virtual Chassis Module in an EX4550 Switch | 223

Maintaining EX4550 Virtual Chassis Cable | 225

Disconnecting a Virtual Chassis Cable from an EX4550 Switch | 225

Connecting a Virtual Chassis Cable to an EX4550 Switch | 227

Maintain Transceivers | 228

Remove a Transceiver | 228

Remove a QSFP28 Transceiver | 231

Install a Transceiver | 233

Install a QSFP28 Transceiver | 235

Maintain Fiber-Optic Cables | 237

Connect a Fiber-Optic Cable | 237

Disconnect a Fiber-Optic Cable | 238

How to Handle Fiber-Optic Cables | 239

5

Troubleshooting Hardware

Troubleshooting the EX4550 Components | 242

Understand Alarm Types and Severity Levels on EX Series Switches | 242

Chassis Component Alarm Conditions on EX4550 Switches | 244

Check Active Alarms with the J-Web Interface | 250

Monitor System Log Messages | 252

Troubleshoot Temperature Alarms in EX Series Switches | 256

6

Contacting Customer Support and Returning the Chassis or Components

Returning an EX4550 Chassis or Components | 263

Returning an EX4550 Switch or Component for Repair or Replacement | 263

Locating the Serial Number on an EX4550 Switch or Component | 264

Listing the Switch and Components Details with the CLI | 264

Locating the Chassis Serial Number ID Label on an EX4550 Switch | 265

- Locating the Serial Number ID Labels on FRUs in an EX4550 Switch | 265
- Contact Customer Support to Obtain Return Material Authorization | 268
- Packing an EX4550 Switch or Component for Shipping | 269
 - Packing an EX4550 Switch for Shipping | 269
 - Packing EX4550 Switch Components for Shipping | 271

Safety and Compliance Information

General Safety Guidelines and Warnings | 274

Definitions of Safety Warning Levels | 275

Qualified Personnel Warning | 278

Warning Statement for Norway and Sweden | 279

Fire Safety Requirements | 279

- Fire Suppression | 279
- Fire Suppression Equipment | 279

Installation Instructions Warning | 281

Chassis and Component Lifting Guidelines | 281

Restricted Access Warning | 283

Ramp Warning | 285

Rack-Mounting and Cabinet-Mounting Warnings | 286

Grounded Equipment Warning | 292

Radiation from Open Port Apertures Warning | 293

Laser and LED Safety Guidelines and Warnings | 294

- General Laser Safety Guidelines | 294
- Class 1 Laser Product Warning | 295
- Class 1 LED Product Warning | 296
- Laser Beam Warning | 297

Maintenance and Operational Safety Guidelines and Warnings | 297

- Battery Handling Warning | 299
- Jewelry Removal Warning | 300

Lightning Activity Warning | 302

Operating Temperature Warning | 303

Product Disposal Warning | 305

General Electrical Safety Guidelines and Warnings | 306

Action to Take After an Electrical Accident | 307

Prevention of Electrostatic Discharge Damage | 308

AC Power Electrical Safety Guidelines | 309

AC Power Disconnection Warning | 311

DC Power Electrical Safety Guidelines | 312

DC Power Disconnection Warning | 313

DC Power Grounding Requirements and Warning | 315

DC Power Wiring Sequence Warning | 317

DC Power Wiring Terminations Warning | 320

Multiple Power Supplies Disconnection Warning | 323

TN Power Warning | 324

Agency Approvals for EX Series Switches | 324

Compliance Statements for EMC Requirements for EX Series Switches | 325

Canada | 326

Taiwan | 327

European Community | 327

Israel | 327

Japan | 327

Korea | 328

United States | 328

FCC Part 15 Statement | 328

Nonregulatory Environmental Standards | 329

Compliance Statements for Acoustic Noise for EX Series Switches | 330

Statements of Volatility for Juniper Network Devices | 330

About the Documentation

IN THIS SECTION

- Documentation and Release Notes | xi
- Using the Examples in This Manual | xi
- Documentation Conventions | xiii
- Documentation Feedback | xvi
- Requesting Technical Support | xvi

Use this guide to install hardware and perform initial software configuration, routine maintenance, and troubleshooting for the EX4550 switch. After completing the installation and basic configuration procedures covered in this guide, refer to the Junos OS documentation for information about further software configuration.

Documentation and Release Notes

To obtain the most current version of all Juniper Networks[®] technical documentation, see the product documentation page on the Juniper Networks website at <https://www.juniper.net/documentation/>.

If the information in the latest release notes differs from the information in the documentation, follow the product Release Notes.

Juniper Networks Books publishes books by Juniper Networks engineers and subject matter experts. These books go beyond the technical documentation to explore the nuances of network architecture, deployment, and administration. The current list can be viewed at <https://www.juniper.net/books>.

Using the Examples in This Manual

If you want to use the examples in this manual, you can use the **load merge** or the **load merge relative** command. These commands cause the software to merge the incoming configuration into the current candidate configuration. The example does not become active until you commit the candidate configuration.

If the example configuration contains the top level of the hierarchy (or multiple hierarchies), the example is a *full example*. In this case, use the **load merge** command.

If the example configuration does not start at the top level of the hierarchy, the example is a *snippet*. In this case, use the **load merge relative** command. These procedures are described in the following sections.

Merging a Full Example

To merge a full example, follow these steps:

1. From the HTML or PDF version of the manual, copy a configuration example into a text file, save the file with a name, and copy the file to a directory on your routing platform.

For example, copy the following configuration to a file and name the file **ex-script.conf**. Copy the **ex-script.conf** file to the **/var/tmp** directory on your routing platform.

```
system {
  scripts {
    commit {
      file ex-script.xsl;
    }
  }
}
interfaces {
  fxp0 {
    disable;
    unit 0 {
      family inet {
        address 10.0.0.1/24;
      }
    }
  }
}
```

2. Merge the contents of the file into your routing platform configuration by issuing the **load merge** configuration mode command:

```
[edit]
user@host# load merge /var/tmp/ex-script.conf
load complete
```

Merging a Snippet

To merge a snippet, follow these steps:

1. From the HTML or PDF version of the manual, copy a configuration snippet into a text file, save the file with a name, and copy the file to a directory on your routing platform.

For example, copy the following snippet to a file and name the file **ex-script-snippet.conf**. Copy the **ex-script-snippet.conf** file to the **/var/tmp** directory on your routing platform.

```
commit {  
  file ex-script-snippet.xml; }  
}
```

2. Move to the hierarchy level that is relevant for this snippet by issuing the following configuration mode command:

```
[edit]  
user@host# edit system scripts  
[edit system scripts]
```

3. Merge the contents of the file into your routing platform configuration by issuing the **load merge relative** configuration mode command:

```
[edit system scripts]  
user@host# load merge relative /var/tmp/ex-script-snippet.conf  
load complete
```

For more information about the **load** command, see [CLI Explorer](#).

Documentation Conventions

[Table 1](#) on [page xiv](#) defines notice icons used in this guide.

Table 1: Notice Icons







Icon	Meaning	Description
	Informational note	Indicates important features or instructions.
	Caution	Indicates a situation that might result in loss of data or hardware damage.
	Warning	Alerts you to the risk of personal injury or death.
	Laser warning	Alerts you to the risk of personal injury from a laser.
	Tip	Indicates helpful information.
	Best practice	Alerts you to a recommended use or implementation.

Table 2 on page xiv defines the text and syntax conventions used in this guide.

Table 2: Text and Syntax Conventions

Convention	Description	Examples
Bold text like this	Represents text that you type.	To enter configuration mode, type the configure command: user@host> configure
Fixed-width text like this	Represents output that appears on the terminal screen.	user@host> show chassis alarms No alarms currently active
<i>Italic text like this</i>	<ul style="list-style-type: none"> Introduces or emphasizes important new terms. Identifies guide names. Identifies RFC and Internet draft titles. 	<ul style="list-style-type: none"> A policy <i>term</i> is a named structure that defines match conditions and actions. <i>Junos OS CLI User Guide</i> RFC 1997, <i>BGP Communities Attribute</i>

Table 2: Text and Syntax Conventions (*continued*)

Convention	Description	Examples
<i>Italic text like this</i>	Represents variables (options for which you substitute a value) in commands or configuration statements.	Configure the machine's domain name: [edit] root@# set system domain-name <i>domain-name</i>
Text like this	Represents names of configuration statements, commands, files, and directories; configuration hierarchy levels; or labels on routing platform components.	<ul style="list-style-type: none"> To configure a stub area, include the stub statement at the [edit protocols ospf area area-id] hierarchy level. The console port is labeled CONSOLE.
< > (angle brackets)	Encloses optional keywords or variables.	stub <default-metric <i>metric</i>>;
(pipe symbol)	Indicates a choice between the mutually exclusive keywords or variables on either side of the symbol. The set of choices is often enclosed in parentheses for clarity.	broadcast multicast (<i>string1</i> <i>string2</i> <i>string3</i>)
# (pound sign)	Indicates a comment specified on the same line as the configuration statement to which it applies.	rsvp { # Required for dynamic MPLS only
[] (square brackets)	Encloses a variable for which you can substitute one or more values.	community name members [<i>community-ids</i>]
Indentation and braces ({ })	Identifies a level in the configuration hierarchy.	[edit] routing-options { static { route default { nexthop <i>address</i> ; retain; } } }
;(semicolon)	Identifies a leaf statement at a configuration hierarchy level.	

GUI Conventions

Table 2: Text and Syntax Conventions (*continued*)

Convention	Description	Examples
Bold text like this	Represents graphical user interface (GUI) items you click or select.	<ul style="list-style-type: none"> In the Logical Interfaces box, select All Interfaces. To cancel the configuration, click Cancel.
> (bold right angle bracket)	Separates levels in a hierarchy of menu selections.	In the configuration editor hierarchy, select Protocols>Ospf .

Documentation Feedback

We encourage you to provide feedback so that we can improve our documentation. You can use either of the following methods:

- Online feedback system—Click TechLibrary Feedback, on the lower right of any page on the [Juniper Networks TechLibrary](#) site, and do one of the following:

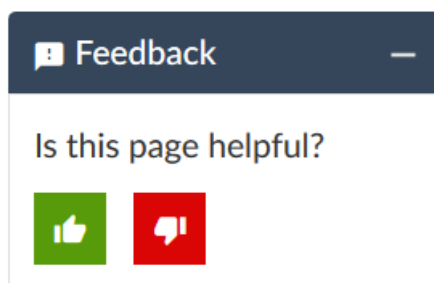

- Click the thumbs-up icon if the information on the page was helpful to you.
- Click the thumbs-down icon if the information on the page was not helpful to you or if you have suggestions for improvement, and use the pop-up form to provide feedback.
- E-mail—Send your comments to techpubs-comments@juniper.net. Include the document or topic name, URL or page number, and software version (if applicable).

Requesting Technical Support

Technical product support is available through the Juniper Networks Technical Assistance Center (JTAC). If you are a customer with an active Juniper Care or Partner Support Services support contract, or are

covered under warranty, and need post-sales technical support, you can access our tools and resources online or open a case with JTAC.

- JTAC policies—For a complete understanding of our JTAC procedures and policies, review the *JTAC User Guide* located at <https://www.juniper.net/us/en/local/pdf/resource-guides/7100059-en.pdf>.
- Product warranties—For product warranty information, visit <https://www.juniper.net/support/warranty/>.
- JTAC hours of operation—The JTAC centers have resources available 24 hours a day, 7 days a week, 365 days a year.

Self-Help Online Tools and Resources

For quick and easy problem resolution, Juniper Networks has designed an online self-service portal called the Customer Support Center (CSC) that provides you with the following features:

- Find CSC offerings: <https://www.juniper.net/customers/support/>
- Search for known bugs: <https://prsearch.juniper.net/>
- Find product documentation: <https://www.juniper.net/documentation/>
- Find solutions and answer questions using our Knowledge Base: <https://kb.juniper.net/>
- Download the latest versions of software and review release notes: <https://www.juniper.net/customers/csc/software/>
- Search technical bulletins for relevant hardware and software notifications: <https://kb.juniper.net/InfoCenter/>
- Join and participate in the Juniper Networks Community Forum: <https://www.juniper.net/company/communities/>
- Create a service request online: <https://myjuniper.juniper.net>

To verify service entitlement by product serial number, use our Serial Number Entitlement (SNE) Tool: <https://entitlementsearch.juniper.net/entitlementsearch/>

Creating a Service Request with JTAC

You can create a service request with JTAC on the Web or by telephone.

- Visit <https://myjuniper.juniper.net>.
- Call 1-888-314-JTAC (1-888-314-5822 toll-free in the USA, Canada, and Mexico).

For international or direct-dial options in countries without toll-free numbers, see <https://support.juniper.net/support/requesting-support/>.

1

CHAPTER

Overview

EX4550 System Overview | **19**

EX4550 Chassis | **35**

Cooling System and Airflow in an EX4550 Switch | **55**

EX4550 Power System | **60**

EX4550 System Overview

IN THIS SECTION

- [EX4550 Switches Hardware Overview | 19](#)
- [EX4550 Switch Models | 27](#)
- [Identifying EX4550 Switch Models | 30](#)
- [EX4550 Switch Hardware and CLI Terminology Mapping | 31](#)

EX4550 Switches Hardware Overview

IN THIS SECTION

- [Benefits of the EX4550 Switch | 20](#)
- [Software | 20](#)
- [EX4550 Switches First View | 20](#)
- [Optional Modules | 22](#)
- [Virtual Chassis | 23](#)
- [Power Supplies | 24](#)
- [Fan Modules | 24](#)
- [Components on the EX4550 Switch | 25](#)

Juniper Networks EX4550 Ethernet Switches provide high-density 10-gigabit ports for aggregation layers and data center top-of-rack deployments, and provide options for data center optimized airflow (hot aisle/cold aisle). EX4550 switches have a base port density of 32 fixed 10-Gigabit SFP+ or 10-Gigabit Ethernet BASE-T (10GBASE-T) ports that you can scale up to 48 ports by installing the optional expansion modules. You can configure EX4550 switches in a Virtual Chassis, or in a mixed Virtual Chassis with Juniper Networks EX4200 Ethernet Switches or Juniper Networks EX4500 Ethernet Switches or both, in a total of up to 10 members.

You can expand the number of ports on an EX4550 switch by installing up to two optional expansion modules in the module slots on either side of the chassis.

The optional modules for an EX4550 switch are:

- 8-port 10-Gigabit SFP+ expansion module—Provides eight ports for eight 1-gigabit small form-factor pluggable (SFP) transceivers or eight 10-gigabit small form-factor pluggable (SFP+) transceivers. You can install a total of eight SFP and SFP+ transceivers in any combination in these eight ports.
- 8-port 10GBASE-T expansion module—Provides eight ports for 100-Megabit Ethernet BASE-T, 1-Gigabit Ethernet BASE-T, or 10-Gigabit Ethernet BASE-T RJ-45 connectors.
- 2-port 40-Gigabit QSFP+ expansion module—Provides two ports for 40-gigabit quad small form-factor pluggable (QSFP+) transceivers.
- 128-Gigabit Virtual Chassis module—Provides two dedicated Virtual Chassis ports (VCPs) for connecting the switch in a Virtual Chassis. You can also connect Virtual Chassis members using the SFP+ network ports, SFP+ expansion module ports, 10GBASE-T network ports, 10GBASE-T expansion module ports, and QSFP+ expansion module ports configured as VCPs.

You can manage EX4550 switches by using the same interfaces that you use for managing other devices running Juniper Networks Junos operating system (Junos OS)—the CLI, the J-Web graphical interface, and Junos Space.

Benefits of the EX4550 Switch

Compact solution—The EX4550 switch supports up to 48 10-Gigabit Ethernet ports in a 1 rack unit (1 U) chassis.

Support for Virtual Chassis—EX4550 switches support Virtual Chassis technology. You can interconnect up to 10 EX4200 switches, EX4500 switches, or EX4550 switches to form a Virtual Chassis.

Energy efficiency—The 10-Gigabit Ethernet fiber ports consume less than five watts and the 10-Gigabit Ethernet copper ports consume less than nine watts, thereby offering a low power solution for top-of-rack, end-of-row, and aggregation deployments.

Software

Juniper Networks EX Series Ethernet Switches run Junos OS, which provides Layer 2 and Layer 3 switching, routing, and security services. The same Junos OS code base that runs on EX Series switches also runs on all Juniper Networks M Series, MX Series, and T Series routers, and SRX Series Services Gateways. For information about installing software for your switch, see [Software Installation](#).

EX4550 Switches First View

EX4550 switches provide connectivity for high-density 10-Gigabit Ethernet data center top-of-rack, enterprise, and campus aggregation and core deployments. EX4550 switches can be used in large branch offices, campus wiring closets, and data centers where they can be positioned as the top device in a rack to provide connectivity for all devices in the rack.

EX4550 switches are available in two base switches—a 32-port SFP+ based switch (EX4550-32F), which provides 32 fixed 10-Gigabit SFP+ ports in which you can install 1-gigabit SFP or 10-gigabit SFP+ transceivers and a 32-port 10GBASE-T based switch (EX4550-32T), which provides 32 fixed 10-Gigabit Ethernet BASE-T ports in which you can install 100-Megabit, 1-Gigabit, or 10-Gigabit BASE-T connectors. See “EX4550 Switch Models” on page 27.

EX4550 switches have different airflow directions in the chassis. EX4550 switches provide two module slots, each of which can house any one of the following optional modules:

- 8-port 10-Gigabit SFP+ expansion module
- 8-port 10GBASE-T expansion module
- 2-port 40-Gigabit QSFP+ expansion module
- 128-Gigabit Virtual Chassis module

Figure 1 on page 21 shows the front panel of an EX4550-32F switch.

Figure 1: Front Panel of an EX4550-32F Switch

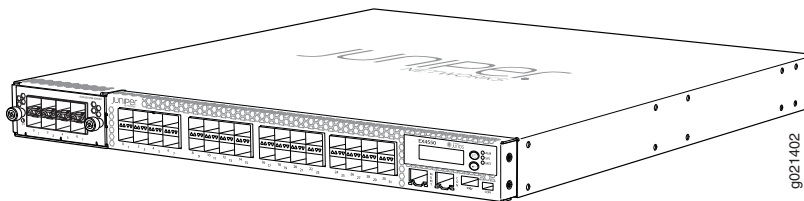

Figure 2 on page 21 shows the front panel of an EX4550-32T switch.

Figure 2: Front Panel of an EX4550-32T Switch

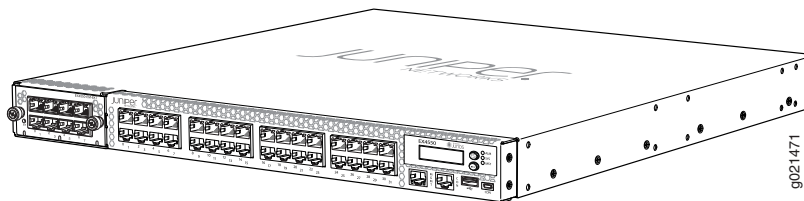
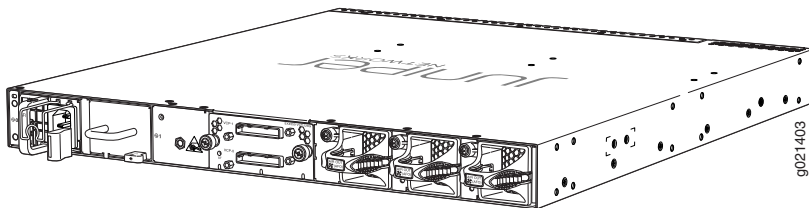

Figure 3 on page 22 shows the rear panel of an EX4550 switch with power supplies and fan modules installed.

Figure 3: Rear Panel of an EX4550 Switch



To provide carrier-class reliability, EX4550 switches include:

- Dual redundant, load-sharing power supplies that are hot-insertable and hot-removable field-replaceable units.
- Three fan modules, which are field-replaceable units (FRUs).
- Redundant Routing Engines in a Virtual Chassis configuration. This redundancy enables graceful Routing Engine switchover (GRES).
- Junos OS with its modular design that enables failed system processes to gracefully restart.

Optional Modules

EX4550 switches support four types of optional modules: an 8-port 10-Gigabit Ethernet SFP+ expansion module, an 8-port 10GBASE-T expansion module, a 2-port 40-Gigabit Ethernet QSFP+ expansion module, and a 128-Gigabit Virtual Chassis module. You can install up to two modules, in any combination of these modules, one in each of the module slots. There is one module slot on the front panel and one on the rear panel of the switch.

[Table 3 on page 22](#) shows the module model numbers, names of the optional modules with a short description, and the Junos OS release in which each module was released.

Table 3: Optional Modules in EX4550 Switches

Model Number	Module Name	Description	First Junos OS Release
EX4550-EM-8XSFP	8-port 10-Gigabit SFP+ expansion module	An SFP+ expansion module can house up to eight 10-gigabit SFP+ transceivers or 1-gigabit SFP transceivers or a combination of SFP+ and SFP transceivers. You can use the ports on this expansion module to connect the switch to other devices. You can also configure these ports as VCPs and use them to connect the EX4550 switch with EX4200, EX4500, or EX4550 switches to form a Virtual Chassis.	12.2R1

Table 3: Optional Modules in EX4550 Switches (continued)

Model Number	Module Name	Description	First Junos OS Release
EX4550-EM-8XT	8-port 10GBASE-T expansion module	A 10GBASE-T expansion module can house up to eight 100-Megabit, 1-Gigabit, or 10-Gigabit Ethernet BASE-T connectors. You can use the ports on this expansion module to connect the switch to other devices. You can also configure these ports as VCPs and use them to interconnect EX4550 switches to form a Virtual Chassis.	12.2R4
EX4550-EM-2QSFP	2-port 40-Gigabit QSFP+ expansion module	A QSFP+ expansion module has two ports, each of which can house a 40-Gigabit QSFP+ connector. You can also configure these ports as VCPs and use them to interconnect EX4550 switches to form a Virtual Chassis.	13.2X50-D10 NOTE: Starting with Release 13.2X50-D15, you can configure QSFP+ as VCPs.
EX4550-VC-128G	128-Gigabit Virtual Chassis module	You can install the 128-Gigabit Virtual Chassis module in the EX4550 switch to connect the switch to other switches in a Virtual Chassis configuration. The Virtual Chassis module has two dedicated VCPs, using which you can connect the EX4550 switch with EX4200, EX4500, or EX4550 switches to form a Virtual Chassis.	12.2R1

Virtual Chassis

You can interconnect the EX4550 switch with EX4200, EX4500, or EX4550 switches to form a Virtual Chassis. You can operate these interconnected switches as a single, logical device with a single IP address.

You can interconnect a maximum of 10 EX4550 switches to form a Virtual Chassis composed exclusively of EX4550 switches. You can interconnect EX4200 switches or EX4500 switches or both with EX4550 switches to form a mixed Virtual Chassis that has a maximum of 10 switches. See [“Understanding EX4200, EX4500, and EX4550 Virtual Chassis Hardware Configurations” on page 108](#).

You can use the following ports to connect an EX4550 switch in a Virtual Chassis:

- Dedicated VCPs on the Virtual Chassis module installed in the switch
- SFP+ network ports and SFP+ expansion module ports configured as VCPs

- 10GBASE-T Ethernet network ports or 10GBASE-T expansion module ports configured as VCPs
- QSFP+ expansion module ports configured as VCPs

NOTE: You can use the 10GBASE-T Ethernet network ports, 10GBASE-T expansion module ports, and QSFP+ expansion module ports configured as VCPs to interconnect only EX4550 switches in a Virtual Chassis. These ports cannot be used to connect an EX4550 switch with an EX4200 switch or an EX4500 switch in a Virtual Chassis.

NOTE: Installing the Virtual Chassis module is not mandatory for using an EX4550 switch in a Virtual Chassis configuration.

For information about understanding and configuring Virtual Chassis, see [EX2200](#), [EX3300](#), [EX4200](#), [EX4500](#) and [EX4550 Virtual Chassis](#).

Power Supplies

EX4550 switches support AC or DC power supplies with different airflow directions. Power supplies for the EX4550 switch are hot-removable and hot-insertable FRUs. All the EX4550 switch models, except the EX4550-32F-S switches are shipped with one power supply pre-installed in the rear panel of the switches. EX4550-32F-S switches are not shipped with pre-installed power supplies; you must order them separately.

You can install a second AC or DC power supply in the EX4550 switches. See “[AC Power Supply in EX4550 Switches](#)” on page 61 and “[DC Power Supply in EX4550 Switches](#)” on page 67

Each power supply has a label—**AFI** or **AFO**—on the faceplate of the power supply that indicates the direction of airflow. **AFI** labels indicate back-to-front airflow whereas **AFO** labels indicate front-to-back airflow. See “[Cooling System and Airflow in an EX4550 Switch](#)” on page 55.



CAUTION: Do not mix:

- AC and DC power supplies in the same chassis.
- Power supplies with different airflow labels (**AFI** and **AFO**) in the same chassis.

Fan Modules

Fan modules for the EX4550 switches are hot-insertable and hot-removable field-replaceable units (FRUs).

All the EX4550 switch models, except the EX4550-32F-S switches are shipped with three fan modules pre-installed in the rear panel of the switches. EX4550-32F-S switches are not shipped with pre-installed fan modules; you must order them separately.

Two variants of fan modules are available, each with a different airflow direction—back-to-front airflow, indicated by the label **AIR IN (AFI)** and front-to-back airflow, indicated by the label **AIR OUT (AFO)**. See “Cooling System and Airflow in an EX4550 Switch” on page 55.

 **CAUTION:** Do not mix fan modules with different airflow labels (**AIR IN (AFI)** and **AIR OUT (AFO)**) in the same chassis.

Components on the EX4550 Switch

Figure 4 on page 25 shows the components on the front panel of an EX4550-32F switch (with the module slot cover panel installed).

Figure 4: Components on the Front Panel of an EX4550-32F Switch

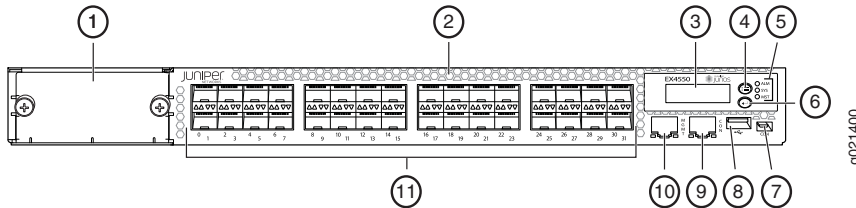

1—Module slot cover panel	7—Mini-USB console port
2—Air vents	8—USB port
3—LCD panel	9—RJ-45 console port
4—LCD panel Menu button	10—Management port
5—Chassis status LEDs	11—SFP+ network ports
6—LCD panel Enter button	

Figure 5 on page 26 shows the components on the front panel of an EX4550-32T switch (with the module slot cover panel installed).

Figure 5: Components on the Front Panel of an EX4550-32T Switch

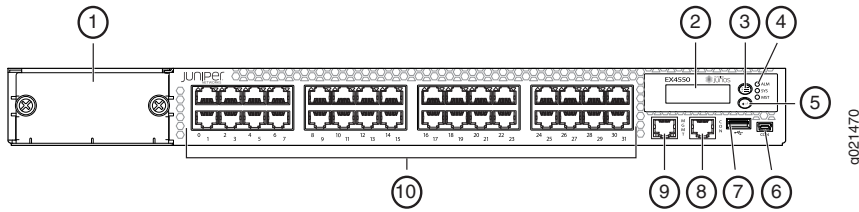

1—Module slot cover panel	6—Mini-USB console port
2—LCD panel	7—USB port
3—LCD panel Menu button	8—RJ-45 console port
4—Chassis status LEDs	9—Management port
5—LCD panel Enter button	10—Ethernet network ports

Figure 6 on page 26 shows the components on the rear panel of an EX4550 switch (with the module slot cover panel, an AC power supply, and three fan modules installed).

Figure 6: Components on the Rear Panel of an EX4550 Switch

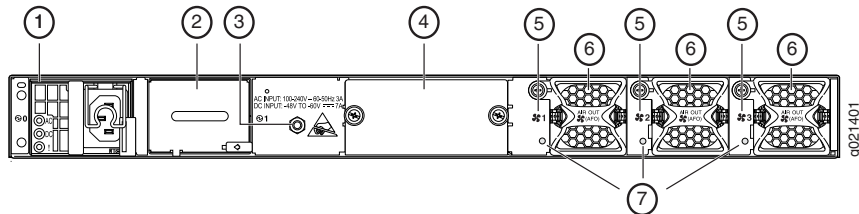

1—An AC power supply (in power supply slot 0)	5—Fan module slot labels
2—Power supply cover panel (in power supply slot 1)	6—Fan modules
3—ESD point	7—Fan status LEDs
4—Module slot cover panel	

NOTE: The protective earthing terminal is located on the left side of the chassis. See [“Connect Earth Ground to an EX Series Switch”](#) on page 132.

SEE ALSO

| [Understanding EX Series Virtual Chassis](#)

EX4550 Switch Models

Table 4 on page 27 lists the available EX4550 switches.

Table 4: EX4550 Switch Model Number, Shipped Components, and Supported Junos OS Release

Model Number	Number and Types of Ports	Direction of Airflow	Fan Modules	Power Supply	First Junos OS Release
EX4550-32F-AFI	32-port 10-Gigabit SFP+	Back-to-front—air intake to cool the chassis is through the vents on the rear panel of the chassis, and hot air exhausts through the vents on the front panel of the chassis.	Three fan modules; each with an AIR IN (AFI) label	One AC power supply (with power cord) with an AFI label on its handle	12.2R1
EX4550-32F-AFO	32-port 10-Gigabit SFP+	Front-to-back—air intake to cool the chassis is through the vents on the front panel of the chassis, and hot air exhausts through the vents on the rear panel of the chassis.	Three fan modules; each with an AIR OUT (AFO) label	One AC power supply (with power cord) with an AFO label on its handle	12.2R1
EX4550-32F-DC-AFI	32-port 10-Gigabit SFP+	Back-to-front—air intake to cool the chassis is through the vents on the rear panel of the chassis, and hot air exhausts through the vents on the front panel of the chassis.	Three fan modules; each with an AIR IN (AFI) label	One DC power supply with an AFI label on its handle	12.2R1

Table 4: EX4550 Switch Model Number, Shipped Components, and Supported Junos OS Release (continued)

Model Number	Number and Types of Ports	Direction of Airflow	Fan Modules	Power Supply	First Junos OS Release
EX4550-32F-DC-AFO	32-port 10-Gigabit SFP+	Front-to-back—air intake to cool the chassis is through the vents on the front panel of the chassis, and hot air exhausts through the vents on the rear panel of the chassis.	Three fan modules; each with an AIR OUT (AFO) label	One DC power supply with an AFO label on its handle	12.2R1
EX4550-32F-S	32-port 10-Gigabit SFP+	-	Fan modules for this model are not shipped by default; you must separately order either three AIR OUT (AFO) labelled or three AIR IN (AFI) labelled fan modules.	Power supplies for this model are not shipped by default; you must separately order either AC power supplies or DC power supplies.	12.3R5
EX4550-32T-AFI	32-port 10-Gigabit BASE-T	Back-to-front—air intake to cool the chassis is through the vents on the rear panel of the chassis, and hot air exhausts through the vents on the front panel of the chassis.	Three fan modules; each with an AIR IN (AFI) label	One AC power supply (with power cord) with an AFI label on its handle	12.2R4

Table 4: EX4550 Switch Model Number, Shipped Components, and Supported Junos OS Release (continued)

Model Number	Number and Types of Ports	Direction of Airflow	Fan Modules	Power Supply	First Junos OS Release
EX4550-32T-AFO	32-port 10-Gigabit BASE-T	Front-to-back—air intake to cool the chassis is through the vents on the front panel of the chassis, and hot air exhausts through the vents on the rear panel of the chassis.	Three fan modules; each with an AIR OUT (AFO) label	One AC power supply (with power cord) with an AFO label on its handle	12.2R4
EX4550-32T-DC-AFI	32-port 10-Gigabit BASE-T	Back-to-front—air intake to cool the chassis is through the vents on the rear panel of the chassis, and hot air exhausts through the vents on the front panel of the chassis.	Three fan modules; each with an AIR IN (AFI) label	One DC power supply with an AFI label on its handle	12.2R4
EX4550-32T-DC-AFO	32-port 10-Gigabit BASE-T	Front-to-back—air intake to cool the chassis is through the vents on the front panel of the chassis, and hot air exhausts through the vents on the rear panel of the chassis.	Three fan modules; each with an AIR OUT (AFO) label	One DC power supply with an AFO label on its handle	12.2R4

NOTE: The optional modules, the Virtual Chassis cable, the Virtual Chassis cable connector retainers, and transceivers are not part of the EX4550 switch shipping configuration. If you want to purchase any of these components, power supplies, or fan modules for your switch, you must order them separately.

Identifying EX4550 Switch Models

Purpose

Identify the model number of your EX4550 switch.

Action

Check the value of the FRU Model Number field in the Routing Engine section in the output of the **show chassis hardware extensive** CLI command.

```
user@switch> show chassis hardware extensive
```

```

. . . .
Routing Engine 0 REV 03   750-039067   LX0212079218   EX4550-32F
  Jedec Code:   0x7fb0           EEPROM Version: 0x02
  P/N:         750-039067       S/N:           LX0212079218
  Assembly ID: 0x0b39           Assembly Version: 03.03
  Date:        03-03-2012       Assembly Flags: 0x00
  Version:     REV 03
  ID: EX4550-32F               FRU Model Number: EX4550-32F-AFO
. . .

```

The model number of your switch is one of the following:

- EX4550-32F-AFI
- EX4550-32F-AFO
- EX4550-32F-DC-AFI
- EX4550-32F-DC-AFO
- EX4550-32T-AFI
- EX4550-32T-AFO
- EX4550-32T-DC-AFI
- EX4550-32T-DC-AFO

Meaning

In EX4550 switch model numbers:

- The 32F or 32T in the model number indicates:
 - 32F—The switch has 32 1G/10G SFP+ Ethernet network ports.
 - 32T—The switch has 32 100M/1G/10G BASE-T Ethernet network ports.
- AFI or AFO in the model number indicates:

- AFI indicates that the switch is shipped with three fan modules, each bearing an **AIR IN (AFI)** label and a power supply bearing an **AFI** label.
- AFO indicates that the switch is shipped with three fan modules, each bearing an **AIR OUT (AFO)** label and a power supply bearing an **AFO** label.

The labels on the fan modules and power supplies indicate the direction of airflow in the switch. **AFI** and **AIR IN (AFI)** labels indicate back-to-front airflow, and **AFO** and **AIR OUT (AFO)** labels indicate front-to-back airflow.

- The DC in the model number indicates that the switch works on DC power supply. Switches that do not have DC in their model numbers work on AC power supply.

EX4550 Switch Hardware and CLI Terminology Mapping

This topic describes the hardware terms used in EX4550 switch documentation and the corresponding terms used in the Junos OS CLI. See [Table 5 on page 31](#).

Table 5: CLI Equivalents of Terms Used in the Documentation for EX4550 Switches

Hardware Item (CLI)	Description (CLI)	Value (CLI)	Item in Documentation	Additional Information
Chassis	One of the following: <ul style="list-style-type: none"> • EX4550-32F • EX4550-32T 	-	Switch chassis	“Chassis Physical Specifications for EX4550 Switches” on page 35
Routing Engine (n)	One of the following: <ul style="list-style-type: none"> • EX4550-32F • EX4550-32T 	n is a value in the range 0 through 9. <ul style="list-style-type: none"> • On a standalone switch, the default value is 0. • On a Virtual Chassis configuration, the values correspond to the member ID assigned to the switches configured in the primary role and the backup role in the Virtual Chassis. 	Routing Engine	-

Table 5: CLI Equivalents of Terms Used in the Documentation for EX4550 Switches (continued)

Hardware Item (CLI)	Description (CLI)	Value (CLI)	Item in Documentation	Additional Information
FPC (n)	Abbreviated name of the Flexible PIC Concentrator (FPC) One of the following: <ul style="list-style-type: none"> • EX4550-32F • EX4550-32T 	n is a value in the range 0 through 9.		<i>Understanding Interface Naming Conventions</i>
		On a standalone switch, the default value is 0.	The switch does not have actual FPCs. In this case, FPC refers to the switch itself.	
		On a Virtual Chassis configuration, the values correspond to the assigned member ID of switches in the Virtual Chassis.	In this case, the FPC number refers to the member ID assigned to the switch.	

Table 5: CLI Equivalents of Terms Used in the Documentation for EX4550 Switches (continued)

Hardware Item (CLI)	Description (CLI)	Value (CLI)	Item in Documentation	Additional Information
PIC (n)	Abbreviated name of the Physical Interface Card (PIC)	n is a value in the range 0 through 2.	The switch does not have actual PIC devices; see entries for PIC 0 through PIC 2 for the equivalent item on the switch.	<i>Understanding Interface Naming Conventions</i>
	One of the following: <ul style="list-style-type: none"> • 32x 1G/10G SFP/SFP+ • 32x 100M/1G/10G BASE-T 	PIC 0	Built-in network ports on the switch.	"EX4550 Switches Hardware Overview" on page 19
	One of the following: <ul style="list-style-type: none"> • 8x 1G/10G SFP/SFP+ • 8x 100M/1G/10G BASE-T • 2x40GE QSFP+ • 2x 32GE Virtual Chassis 	PIC 1	The expansion module or the Virtual Chassis module installed in the module slot on the front panel of the switch.	<ul style="list-style-type: none"> • Expansion Modules in EX4550 Switches on page 43 • Virtual Chassis Module in EX4550 Switches on page 47
		PIC 2	The expansion module or the Virtual Chassis module installed in the module slot on the rear panel of the switch.	<ul style="list-style-type: none"> • Expansion Modules in EX4550 Switches on page 43 • Virtual Chassis Module in EX4550 Switches on page 47

Table 5: CLI Equivalents of Terms Used in the Documentation for EX4550 Switches (continued)

Hardware Item (CLI)	Description (CLI)	Value (CLI)	Item in Documentation	Additional Information
	One of the following: <ul style="list-style-type: none"> • 8x 1G/10G SFP/SFP+ • 8x 100M/1G/10G BASE-T • 2x40GE QSFP+ • 2x 32GE Virtual Chassis 			
Xcvr (n)	Abbreviated name of the transceiver	n is a value equivalent to the number of the port in which the transceiver is installed	Optical transceivers	“Pluggable Transceivers Supported on EX4550 Switches” on page 86
Power supply (n)	One of the following: <ul style="list-style-type: none"> • JPSU-650W -AC-AFO • JPSU-650W -AC-AFI • JPSU-650W -DC-AFO • JPSU-650W -DC-AFI 	n has a value 0 or 1, corresponding to the power supply slot number. CAUTION: Do not mix: <ul style="list-style-type: none"> • AC and DC power supplies in the same chassis • Power supplies with different airflow labels (AFI and AFO) in the same chassis 	AC power supply or DC power supply.	<ul style="list-style-type: none"> • AC Power Supply in EX4550 Switches on page 61 • DC Power Supply in EX4550 Switches on page 67

Table 5: CLI Equivalents of Terms Used in the Documentation for EX4550 Switches (*continued*)

Hardware Item (CLI)	Description (CLI)	Value (CLI)	Item in Documentation	Additional Information
Fan tray	One of the following: <ul style="list-style-type: none"> • Fan module, Airflow In (AFI) • Fan module, Airflow Out (AFO) 		Fan module NOTE: The EX4550 switch has three fan modules, which are collectively referred to as <i>fan tray</i> in the CLI.	“Cooling System and Airflow in an EX4550 Switch” on page 55

EX4550 Chassis

IN THIS SECTION

- [Chassis Physical Specifications for EX4550 Switches | 35](#)
- [Field-Replaceable Units in EX4550 Switches | 36](#)
- [LCD Panel in EX4550 Switches | 37](#)
- [Expansion Modules in EX4550 Switches | 43](#)
- [Virtual Chassis Module in EX4550 Switches | 47](#)
- [Chassis Status LEDs in EX4550 Switches | 49](#)
- [Management Port LEDs in EX4550 Switches | 50](#)
- [Network Port and Expansion Module Port LEDs in EX4550 Switches | 51](#)

Chassis Physical Specifications for EX4550 Switches

The EX4550 switch chassis is a rigid sheet-metal structure that houses all components of the switch. [Table 6 on page 36](#) summarizes the physical specifications of the EX4550 switch chassis.

Table 6: Physical Specifications of the EX4550 Switch Chassis

Description	Value
Chassis height	1.72 in. (4.37 cm)
Chassis width	<ul style="list-style-type: none"> • 17.35 in. (44.07 cm) • The outer edges of the front mount brackets extend the width to 19 in. (48.3 cm).
Chassis depth	<ul style="list-style-type: none"> • 18.50 in. (46.99 cm)
Weight	<ul style="list-style-type: none"> • EX4550 switch with 1 AC power supply: 19.4 lb (8.8 kg) • EX4550 switch with 1 DC power supply: 19.4 lb (8.8 kg) • AC power supply: 2.4 lb (1.1 kg) • DC power supply: 2.4 lb (1.1 kg) • SFP+ expansion module: 0.74 lb (0.34 kg) • 10GBASE-T expansion module: 0.9 lb (0.41 kg) • QSFP+ expansion module port: 0.61 lb (0.28 kg) • Virtual Chassis module: 0.66 lb (0.3 kg)

You can mount an EX4550 switch on a standard 19-in. two-post rack. You can also mount the switch on a standard 19-in. four-post rack or in a standard 19-in. enclosed cabinet.

SEE ALSO

[Installing and Connecting an EX4550 Switch](#) | 123

Field-Replaceable Units in EX4550 Switches

Field-replaceable units (FRUs) are components that you can replace at your site. The FRUs in EX4550 switches are hot-removable and hot-insertable: You can remove and replace them without powering off the switch. EX4550 switches support the following FRUs:

- Power supplies
- Fan modules
- Expansion modules
- Virtual Chassis module
- Transceivers

NOTE: The EX4550-32F switch model ships with one power supply (AC or DC) and three fan modules preinstalled and the EX4550-32F-S switch model is shipped without any power supply or fan modules preinstalled; you must order them separately. The optional modules, the Virtual Chassis cable, the Virtual Chassis cable connector retainers, and transceivers are not part of the EX4550 switch shipping configuration. If you want to purchase any of these components, power supplies, or fan modules for your switch, you must order them separately.

NOTE: If you have a Juniper J-Care service contract, register any addition, change, or upgrade of hardware components at <https://www.juniper.net/customers/support/tools/updateinstallbase/> . Failure to do so can result in significant delays if you need replacement parts. This note does not apply if you replace existing components with the same type of component.

LCD Panel in EX4550 Switches

IN THIS SECTION

- LCD Panel Modes | 38
- LCD Panel Menus | 39

The LCD panel of the EX4550 switch shows two lines of text, each that can contain a maximum of 16 characters. The LCD panel displays a variety of information about the switch and also provides a menu to perform basic operations such as initial setup and reboot.

There are two navigation buttons—Menu and Enter—to the right of the LCD panel.

See [Figure 7 on page 38](#).

Figure 7: LCD Panel in EX4550 Switches

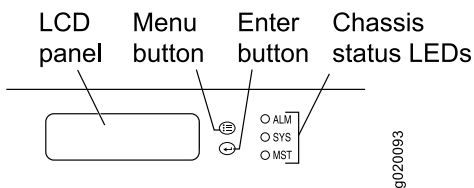

The first line of text on the LCD panel displays basic information about the switch and the second line of text displays information about the mode selected on the LCD panel. You can configure the second line of the text for the LCD panel to display a custom message. If the LCD panel is configured to display a custom message, the Menu button and the Enter button are disabled. See [“Configuring the LCD Panel on EX Series Switches \(CLI Procedure\)” on page 175.](#)

The LCD panel has a backlight. If the LCD panel is idle for 60 seconds, the backlight turns off. You can turn on the backlight by pressing the Menu or Enter button once. After turning on the backlight, you can toggle between the LCD panel menus by pressing the Menu button and navigate through the menu options by pressing the Enter button.

NOTE: The chassis viewer in the J-Web interface also displays the LCD panel. From the J-Web interface, you can view real-time status information in the LCD panel. See [“Dashboard for EX Series Switches” on page 178.](#)

LCD Panel Modes

The LCD panel operates in four modes: boot, idle, status, and maintenance.

The first line of text on the LCD panel displays the slot number, the role of the switch, and hostname in all the modes.

For a standalone EX4550 switch, the slot number is always **00**, and the role is always **RE**.

In an EX4550 switch that is a member of a Virtual Chassis, the first line of the LCD panel always displays:

- The slot number (the member ID for the Virtual Chassis member)
- Role of the switch in the Virtual Chassis (**RE** for primary, **BK** for backup, and **LC** for linecard member)
- Hostname

The LCD panel operates in boot mode during switch reboot. In the boot mode, the second line of the LCD panel displays the key milestones in the switch boot process. The boot mode does not have any menu options. After the boot process is complete, the LCD panel automatically reverts to the Idle (**IDLE**) menu.

In idle mode, the second line of text on the LCD panel displays the mode of the network ports' Status LED and the number of chassis alarms. The number of alarms is updated every second.

In status mode, the second line displays:

- Status of the Virtual Chassis port (VCP)
- Status of the power supplies
- Status of the fan modules and the chassis temperature
- Version of Junos OS for EX Series switches loaded on the switch

In maintenance mode, the second line displays one of the following options, which you can use to configure and troubleshoot the switch:

- System halt
- System reboot
- Load rescue
- Request VC port
- Factory default
- EZSetup

LCD Panel Menus

The LCD panel has three menus: Idle, Status, and Maintenance. You can toggle between the LCD panel menus by pressing the Menu button and navigate through the menu options by pressing the Enter button.

[Table 7 on page 39](#) describes the LCD panel menu options.

Table 7: LCD Panel Menu Options in EX4550 Switches

Menu Label	Description
IDLE	<p>In the Idle menu:</p> <ul style="list-style-type: none"> • Press Enter to cycle through the Status LED modes, which are port status indicators: <ul style="list-style-type: none"> • ADM (administrative status) • DPX (duplex) • SPD (speed) <p>See “Network Port and Expansion Module Port LEDs in EX4550 Switches” on page 51 for information about the Status LED modes.</p> • Press Menu to exit the Idle menu and go to the Status menu.

Table 7: LCD Panel Menu Options in EX4550 Switches (*continued*)

Menu Label	Description
STATUS	<p>In the Status menu, press Menu to cycle through the following information:</p> <ul style="list-style-type: none"> ● VCPs status: Up or Down <ul style="list-style-type: none"> Display the status of VCPs on the Virtual Chassis module installed on the front panel followed by the status of VCPs on the Virtual Chassis module installed on the rear panel of the switch. ● Power supply status: OK, Failed, or Absent. ● Fan status and Temperature status. <ul style="list-style-type: none"> ● Fan status: OK, Failed, or Absent ● Temp status: OK, High, or Shutdown ● Junos OS version for EX Series switches loaded on the switch. ● EXIT STAT MENU? <ul style="list-style-type: none"> Choose one of the following: <ul style="list-style-type: none"> ● Press Enter to exit the Status menu and go to the Maintenance Menu. ● Press Menu to display the status of the VCPs again. <p>You can disable the Status menu or the options in the Status menu in the LCD panel. See “Configuring the LCD Panel on EX Series Switches (CLI Procedure)” on page 175.</p>

Table 7: LCD Panel Menu Options in EX4550 Switches (*continued*)

Menu Label	Description
MAINT (Maintenance Menu)	

Table 7: LCD Panel Menu Options in EX4550 Switches (*continued*)

Menu Label	Description
	<p>The Maintenance menu has the following options to configure and troubleshoot the switch:</p> <ul style="list-style-type: none"> ● SYSTEM HALT?—Choose one of the following: <ul style="list-style-type: none"> ● Press Enter to halt the switch. Press Enter again to confirm the halt. ● Press Menu to go to the next option in the Maintenance menu. ● SYSTEM REBOOT?—Choose one of the following: <ul style="list-style-type: none"> ● Press Enter to reboot the switch. Press Enter again to confirm the reboot. ● Press Menu to go to the next option in the Maintenance menu. ● LOAD RESCUE?—Choose one of the following: <ul style="list-style-type: none"> ● Press Enter to roll back the switch to the previous valid configuration. Press Enter again to confirm the rollback. ● Press Menu to go to the next option in the Maintenance menu. ● REQUEST VC PORT?—Choose one of the following: <ul style="list-style-type: none"> ● Press the Enter button to configure an expansion module port or a network port to be a VCP or to delete a VCP from the switch configuration (when you delete the VCP, the port is reset to an expansion module port or network port). ● Press the Menu button to go to the next option in the Maintenance menu. ● FACTORY DEFAULT?—Choose one of the following: <ul style="list-style-type: none"> ● Press Enter to restore the switch to the factory default configuration. Press Enter again to confirm the restoration. The LCD panel flashes a success or failure message, after which it displays the Idle menu. ● Press Menu to go to the next option in the Maintenance menu. ● ENTER EZSETUP?—Choose one of the following: <ul style="list-style-type: none"> ● Press Enter to launch EZSetup. Press Enter again to confirm the launch. EZSetup configures DHCP and enables the J-Web user interface on the switch. The LCD panel flashes a success or failure message for approximately 10 seconds, after which it displays the Idle menu. <p>NOTE: You can use EZSetup only on a standalone switch that is in the factory default configuration.</p> <p>For information about EZSetup, see “Connecting and Configuring an EX Series Switch (J-Web Procedure)” on page 171.</p> <ul style="list-style-type: none"> ● Press Menu to go to the next option in the Maintenance menu. ● EXIT MAINT MENU?—Choose one of the following: <ul style="list-style-type: none"> ● Press Enter to exit the Maintenance menu. ● Press Menu to return to the SYSTEM HALT? option.

Table 7: LCD Panel Menu Options in EX4550 Switches (*continued*)

Menu Label	Description
	You can disable the Maintenance menu or the options in the Maintenance menu in the LCD panel. See “Configuring the LCD Panel on EX Series Switches (CLI Procedure)” on page 175.

SEE ALSO

| [Configuring the LCD Panel on EX Series Switches \(CLI Procedure\)](#) | 175

Expansion Modules in EX4550 Switches

EX4550 switches support three optional expansion modules—an 8-port 10-Gigabit SFP+ expansion module, an 8-port 10GBASE-T expansion module, and a 2-port 40-Gigabit QSFP+ expansion module. Expansion modules are hot-insertable and hot-removable field replaceable units (FRUs).

[Table 8 on page 43](#) lists the names of the expansion modules and the model numbers, a short description of the modules, and the first Junos OS release each module supports.

Table 8: Expansion Modules in EX4550 Switches

Uplink Module Name	Model Number	Description	First Junos OS Release
8-port SFP+ expansion module	EX4550-EM-8XSFP	An SFP+ expansion module can house up to eight 10-gigabit SFP+ transceivers or these 1-gigabit SFP transceivers or in any combination of SFP and SFP+ transceivers. You can use the ports on the expansion module to connect the switch to other devices. You can also configure these ports as Virtual Chassis ports (VCPs) and use them to connect the switch in a Virtual Chassis configuration.	12.2R1
8-port 10GBASE-T expansion module	EX4550-EM-8XT	A 10GBASE-T expansion module can house up to eight 100-Megabit, 1-Gigabit, or 10-Gigabit BASE-T Ethernet connectors. You can use the ports on the expansion module to connect the switch to other devices. You can also configure these ports as VCPs and use them to interconnect EX4550 switches in a Virtual Chassis configuration.	12.2R4

Table 8: Expansion Modules in EX4550 Switches (*continued*)

Uplink Module Name	Model Number	Description	First Junos OS Release
2-port 40-Gigabit QSFP+ expansion module	EX4550-EM-2QSFP	A QSFP+ expansion module can house up to two 40-Gigabit QSFP+ transceivers. You can use the ports on the expansion module to connect the switch to other devices. You can also configure these ports as Virtual Chassis ports (VCPs) and use them to interconnect EX4550 switches in a Virtual Chassis configuration.	13.2X50-D10 NOTE: Starting with Release 13.2X50-D15, you can configure QSFP+ ports as VCPs.

NOTE: Expansion modules and transceivers are not part of the EX4550 switch shipping configuration. You must order them separately.

You can install up to two expansion modules in an EX4550 switch—one in each of the module slots on the front panel and the rear panel of the switch. By installing an expansion module, you add more ports to your switch, thereby increasing the port density of the switch. You can also use the ports on the expansion module to connect the switch to core devices or to connect an access switch to a distribution switch. Besides, you can configure these ports as Virtual Chassis ports (VCPs) and use them to connect the switch in a Virtual Chassis configuration.

Figure 8 on page 44 shows the SFP+ expansion module.

Figure 8: 8-Port SFP+ Expansion Module

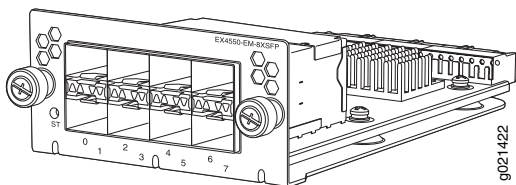

The SFP+ expansion module can operate either in 10-gigabit or in 1-gigabit mode. The operating mode for an SFP+ expansion module is shown in the output of the **show chassis pic fpc-slot slot number pic-slot slot number** command.

Figure 9 on page 45 shows the 10GBASE-T expansion module.

Figure 9: 8-Port 10GBASE-T Expansion Module

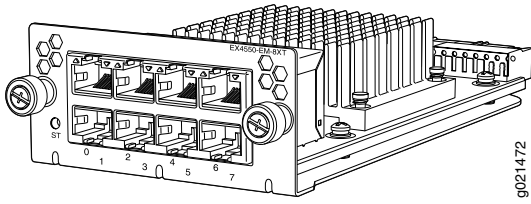
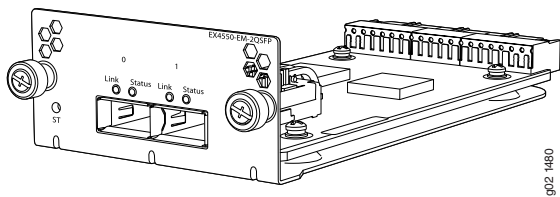

Figure 10 on page 45 shows the QSFP+ expansion module.

Figure 10: 2-Port QSFP+ Expansion Module



NOTE: When you install an expansion module in the switch or replace an expansion module with another expansion module, the switch detects the ports on the expansion module. The switch creates the required interfaces when transceivers are installed in these ports.

Each expansion module has an LED on the faceplate (labeled **ST**). It indicates the status of the expansion module.

Figure 11 on page 45 shows the location of LEDs on the SFP+ expansion module.

Figure 11: LEDs on an SFP+ Expansion Module

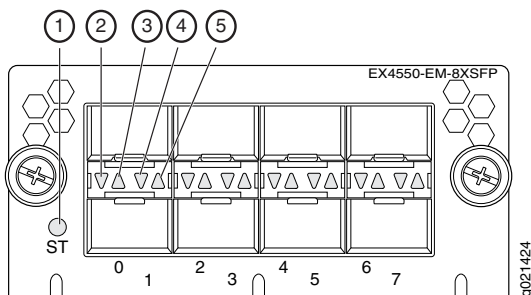

1—Status LED of the expansion module	4—Status lower port
2—Link/Activity lower port	5—Status upper port
3—Link/Activity upper port	

Figure 12 on page 46 shows the location of LEDs on the 10GBASE-T expansion module.

Figure 12: LEDs on a 10GBASE-T Expansion Module

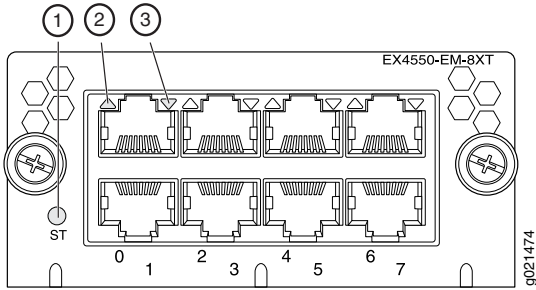

1–Status LED of the expansion module	3–Link/Activity lower port
2–Link/Activity upper port	

Figure 13 on page 46 shows the location of LEDs on the QSFP+ expansion module.

Figure 13: LEDs on a QSFP+ Expansion Module

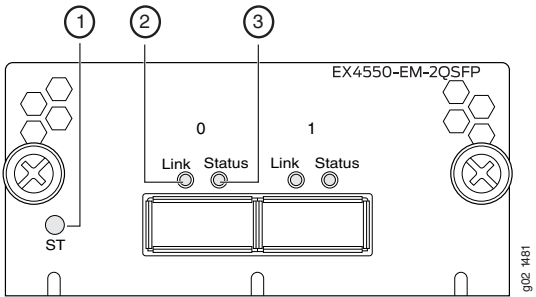

1–Status LED of the expansion module	3–Port's Status LED
2–Port's Link/Activity LED	

Each SFP+ expansion module port and QSFP+ expansion module port has a pair of LEDs that indicate the link activity and status of the port and each 10GBASE-T expansion module port has an LED that indicates the link activity of the port.

Table 9 on page 46 describes the Status LED on the expansion modules.

Table 9: Expansion Module Status LED

LED	State	Description
ST	Unlit	<ul style="list-style-type: none"> The expansion module is offline. The chassis is powered off.
	Green	<ul style="list-style-type: none"> The expansion module is online and functioning normally.

See “[Network Port and Expansion Module Port LEDs in EX4550 Switches](#)” on page 51 for details about the status and link activity LEDs.

SFP+ expansion modules and QSFP+ expansion modules are shipped with dust covers preinstalled in the ports.

SEE ALSO

[SFP+ Direct Attach Copper Cables for EX Series Switches](#) | 87

[Installing an Expansion Module in an EX4550 Switch](#) | 219

[Interfaces Overview for Switches](#)

Virtual Chassis Module in EX4550 Switches

EX4550 switches support an optional 128-Gigabit Virtual Chassis module. The Virtual Chassis module is a hot-insertable and hot-removable field replaceable unit (FRU). You can install Virtual Chassis modules in the module slots on the front panel and the rear panel of an EX4550 switch chassis.

The Virtual Chassis module has two dedicated Virtual Chassis ports (VCPs), using which you can interconnect the EX4550 switch to an EX4200, EX4500, or EX4550 switch in a Virtual Chassis configuration.

[Figure 14 on page 47](#) shows the Virtual Chassis module.

Figure 14: Virtual Chassis Module

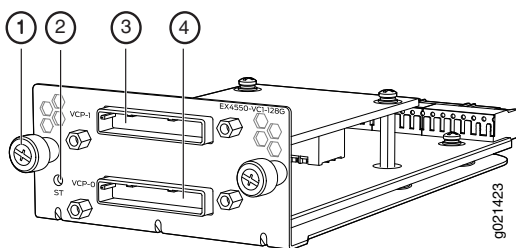

1—Captive screw

2—Status LED of Virtual Chassis module

3—Virtual Chassis Port 1 (**VCP-1**)

4—Virtual Chassis Port 0 (**VCP-0**)

VCPs of the Virtual Chassis module installed in the module slot on the front panel of the chassis are displayed as **VCP-1/0** and **VCP-1/1** in the CLI. VCPs of the Virtual Chassis module installed in the module slot on the rear panel of the chassis are displayed as **VCP-2/0** and **VCP-2/1** in the CLI. A **255** appears in the interface name if this dedicated VCP is part of a link aggregation group (LAG) bundle; for instance, a display of **VCP-255/1/0** indicates that **VCP-1/0** is part of a LAG.

NOTE: Installing the Virtual Chassis module is not mandatory for using an EX4550 switch in a Virtual Chassis configuration. You can also interconnect EX4550 switches or connect EX4550 switches to EX4200 switches and EX4500 switches through SFP+ expansion module ports or SFP+ network ports configured as VCPs to form a Virtual Chassis. You can also configure 10GBASE-T network ports, 10GBASE-T expansion module ports, or QSFP+ expansion module ports as VCPs to interconnect EX4550 switches in a Virtual Chassis.

NOTE: Virtual Chassis module, Virtual Chassis cables, and Virtual Chassis cable connector retainers are not part of the EX4550 switch shipping configuration. If you want to purchase these, you must order them separately.

The Virtual Chassis module supports the following Virtual Chassis cables:

- EX-CBL-VCP-50CM
- EX-CBL-VCP-1M
- EX-CBL-VCP-3M
- EX-CBL-VCP-5M

The Virtual Chassis module has an LED (labeled **ST**) on the left side of its faceplate. It indicates the status of the Virtual Chassis module. See [Figure 15 on page 48](#).

Figure 15: Virtual Chassis Module LED

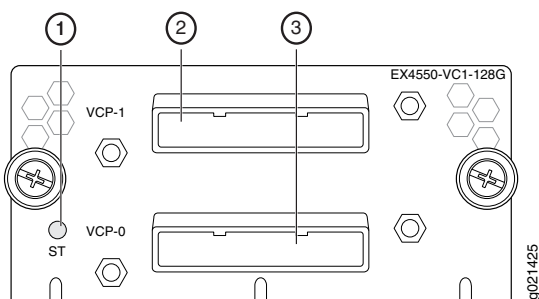

1—Status LED of Virtual Chassis module

3—Virtual Chassis Port 0 (**VCP-0**)

2—Virtual Chassis Port 1 (**VCP-1**)

[Table 10 on page 49](#) describes the Status LED on the Virtual Chassis module in an EX4550 switch.

Table 10: Virtual Chassis Module LED

LED	State	Description
ST	Green	The Virtual Chassis module is functioning normally.
	Unlit	One of the following: <ul style="list-style-type: none"> The Virtual Chassis module is not functioning normally. The switch has been powered off.

The Virtual Chassis module has two captive screws on the faceplate that secure the module to the switch chassis. To remove or replace the Virtual Chassis module, follow the instructions in [“Removing a Virtual Chassis Module from an EX4550 Switch” on page 222](#).

SEE ALSO

| [Installing a Virtual Chassis Module in an EX4550 Switch | 223](#)

Chassis Status LEDs in EX4550 Switches

The front panel of an EX4550 switch has three chassis status LEDs (labeled **ALM**, **SYS**, and **MST**) on the far right side of the panel, next to the Menu and Enter buttons (see [Figure 16 on page 49](#)).

Figure 16: Chassis Status LEDs in an EX4550 Switch

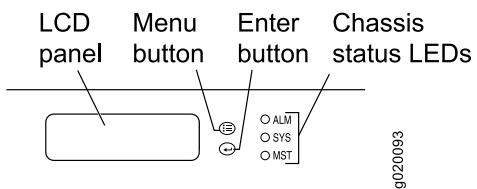

[Table 11 on page 50](#) describes the chassis status LEDs in an EX4550 switch, their colors and states, and the status they indicate. You can view the colors of the three LEDs remotely through the CLI by issuing the operational mode command **show chassis led**.

Table 11: Chassis Status LEDs in an EX4550 Switch

LED Label	Color	State and Description
ALM (Alarm)	Unlit	There is no alarm or the switch is halted.
	Red	There is a major alarm.
	Yellow	There is a minor alarm.
SYS (System)	Green	<ul style="list-style-type: none"> On steadily—Junos OS for EX Series switches has been loaded on the switch. Blinking—The switch is booting. Off—The switch is powered off or is halted.
MST (Primary)	Green	<p>In a standalone EX4550 switch:</p> <ul style="list-style-type: none"> On steadily—The switch is functioning normally as primary. Off—The switch is powered off or is halted. <p>In a Virtual Chassis configuration:</p> <ul style="list-style-type: none"> On steadily—The switch is the primary in the Virtual Chassis configuration. Blinking—The switch is the backup in the Virtual Chassis configuration. Off—The switch is a linecard member in the Virtual Chassis configuration or is halted.

A major alarm (red) indicates a critical error condition that requires immediate action.

A minor alarm (yellow) indicates a noncritical condition that requires monitoring or maintenance. A minor alarm that is left unchecked might cause interruption in service or performance degradation.

All three LEDs can be lit simultaneously.

SEE ALSO

[Check Active Alarms with the J-Web Interface | 250](#)

[Understand Alarm Types and Severity Levels on EX Series Switches | 242](#)

Management Port LEDs in EX4550 Switches

The management port, which is on the front panel of an EX4550 switch, has two LEDs that indicate link activity and status of the management port (see [Figure 17 on page 51](#)).

Figure 17: LEDs on the Management Port on an EX4550 Switch

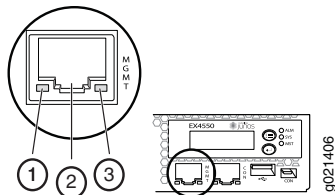

1—Link/Activity LED

3—Status LED

2—Management port

Table 12 on page 51 describes the Link/Activity LED.

Table 12: Link/Activity LED on the Management Port on an EX4550 Switch

LED	Color	State and Description
Link/Activity	Green	<ul style="list-style-type: none"> • Blinking—The port and the link are active, and there is link activity. • On steadily—The port and the link are active, but there is no link activity. • Off—The port is not active.

Table 13 on page 51 describes the Status LED.

Table 13: Status LED on the Management Port on an EX4550 Switch

LED	Color	State and Description
Status	Green	Indicates the speed. The speed indications are: <ul style="list-style-type: none"> • One blink per second—10 Mbps • Two blinks per second—100 Mbps • Three blinks per second—1000 Mbps

SEE ALSO

[Connect a Device to a Network for Out-of-Band Management](#) | 151

Network Port and Expansion Module Port LEDs in EX4550 Switches

The figures in this topic show the LEDs on the 10-Gigabit SFP+ network and expansion module ports, 10GBASE-T Ethernet network and expansion module ports, and QSFP+ expansion module ports.

Figure 18 on page 52 shows the LEDs on the SFP+ network ports and SFP+ expansion module ports of an EX4550 switch.

Figure 18: SFP+ Network Port and SFP+ Expansion Module Port LEDs

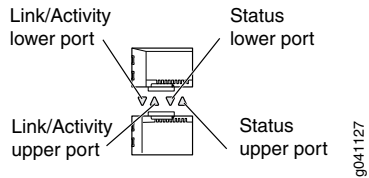

Each SFP+ network port and SFP+ expansion module port has two LEDs that indicate link activity and status of the network ports and the expansion module ports. Each LED is shaped to point toward the port for which it displays link activity and status.

Figure 19 on page 52 shows the LEDs on the 10GBASE-T Ethernet network ports and the 10GBASE-T expansion module ports of an EX4550 switch.

Figure 19: 10GBASE-T Ethernet Network Port and 10GBASE-T Expansion Module Port LEDs

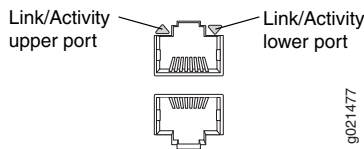

Each 10GBASE-T Ethernet network port and 10GBASE-T expansion module port has an LED that indicate the link activity of the port. Each LED is shaped to point toward the port for which it displays the link activity.

Figure 20 on page 52 shows the LEDs on the QSFP+ expansion module ports of an EX4550 switch.

Figure 20: QSFP+ Expansion Module Port LEDs

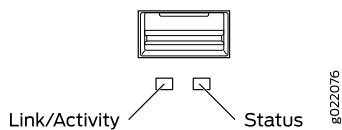

Each QSFP+ expansion module port has two LEDs that indicate link activity and status of the expansion module ports.

The following tables in this topic describes the behavior of link activity and status LEDs of network ports and expansion module ports in EX4550 switches:

- [Table 14 on page 53](#) describes the Link/Activity LED.

- [Table 15 on page 54](#) describes the Status LED on SFP+ network ports and SFP+ expansion module ports.
- [Table 16 on page 54](#) describes the Status LED on QSFP+ expansion module ports.

Table 14: Link/Activity LED on Network Ports and Expansion Module Ports

LED	Color	State and Description
Link/Activity	Green	<ul style="list-style-type: none"> • Blinking—The port and the link are active, and there is link activity. • On steadily—The port and the link are active, but there is no link activity. • Off—The port is not active.

NOTE: You must configure medium-dependent interface (MDI) properties for a 10-gigabit Ethernet interface on 10GBASE-T network ports and 10GBASE-T expansion module ports to ensure that both sides of the link are compatible. For information about MDI properties, see *mdi-mode*.

NOTE: To configure 100-Mbps speed for an interface on a 10GBASE-T port, you must disable the **auto-negotiation** mode and set the **speed** to **100m** for the interface. Such 10GBASE-T ports cannot read 10-gigabit interfaces and 1-gigabit interfaces until you manually reset **auto-negotiation** and **speed** of the port to *auto*.

The LEDs labeled Status in [Figure 18 on page 52](#) indicate the status of one of the three port parameters. The port parameters are administrative status, duplex mode, and speed.

[Table 15 on page 54](#) describes the Status LED on SFP+ network ports and SFP+ expansion module ports in EX4550 switches. From the Idle menu of the LCD panel, use the Enter button on the LCD panel to toggle between the ADM, DPX, and SPD indicators.

Table 15: Status LED on SFP+ Network Ports and Expansion Module Ports

LED	LCD Indicator	State and Description
Status	LED: ADM	<p>Indicates the administrative status (enabled or disabled).</p> <p>The status indicators are:</p> <ul style="list-style-type: none"> • Green—Port is administratively enabled. • Unlit—Port is administratively disabled.
	LED: DPX	<p>Indicates the duplex mode.</p> <p>The status indicators for network ports on the front panel are:</p> <ul style="list-style-type: none"> • Green—Port is set to full-duplex mode. • Unlit—Port is set to half-duplex mode. <p>The expansion module ports are always set to full-duplex mode; therefore, this LED is always lit green on an expansion module.</p>
	LED: SPD	<p>Indicates the speed.</p> <p>The speed indicators are:</p> <ul style="list-style-type: none"> • Blinking green—1 Gbps • Steadily green—10 Gbps

The LEDs labeled Status in [Figure 20 on page 52](#) indicate the status of the QSFP+ port. [Table 16 on page 54](#) describes the Status LED of QSFP+ expansion module ports in EX4550 switches.

Table 16: Status LED on QSFP+ Expansion Module Ports

LED	LED Color	State and Description
Status	Green	<p>Indicates the status (enable or disable) of the port:</p> <ul style="list-style-type: none"> • Green—The port is up. • Unlit—The port is down.

Cooling System and Airflow in an EX4550 Switch

IN THIS SECTION

- Fan Modules | 55
- Airflow Direction in EX4550 Switches | 56
- Back-to-Front Airflow | 57
- Front-to-Back Airflow | 58
- Do Not Install Components with Different Airflow in the Switch | 59
- Positioning the Switch | 59
- Fan Module Status | 59

The cooling system in an EX4550 switch consists of three fan modules and a single fan in each power supply. EX4550 switches provide back-to-front airflow (air comes in from the back of the switch) or front-to-back (air exhausts through the back of the switch) airflow depending on the fan modules and power supplies installed in the switch.

Fan Modules

Fan modules for the EX4550 switches are hot-insertable and hot-removable field-replaceable units (FRUs).

All the EX4550 switch models, except the EX4550-32F-S switches are shipped with three fan modules pre-installed in the rear panel of the switch. EX4550-32F-S switches are not shipped with pre-installed fan modules; you must order them separately.

Each switch can accommodate three fan modules in the fan module slots on the rear panel of the switch. The fan module slots are numbered 1 through 3 from left to right. Each slot has a fan icon next to it.

[Figure 21 on page 56](#) shows a fan module used in an EX4550 switch.

Figure 21: Fan Module Used in an EX4550 Switch

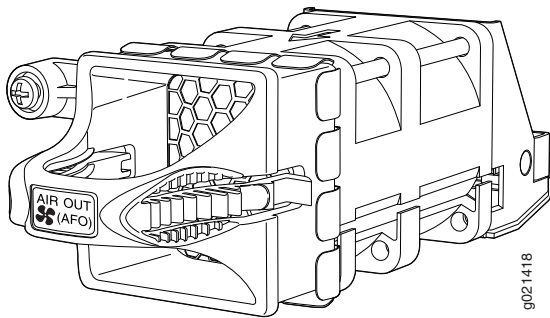

You remove and replace a fan module from the rear panel of the chassis. The switch continues to operate for a limited period of time (30 seconds) during the replacement of the fan module without thermal shutdown.

NOTE: All three fan modules must be installed for optimal functioning of the switch.

Two variants of fan modules are available, each with a different airflow direction—back-to-front airflow, indicated by the label **AIR IN (AFI)**, or front-to-back, indicated by the label **AIR OUT (AFO)**.

[Table 17 on page 56](#) lists the available fan module model numbers and the direction of airflow in them.

Table 17: Fan Modules in EX4550 Switches

Model Number	Label on the Fan Module	Direction of Airflow in the Fan Module
EX4550-FAN-AFI	AIR IN (AFI)	Back-to-front—air comes in from the back of the switch.
EX4550-FAN-AFO	AIR OUT (AFO)	Front-to-back—air exhausts from the back of the switch.

Airflow Direction in EX4550 Switches

[Table 18 on page 57](#) shows the direction of airflow in EX4550 switches as shipped. All the EX4550 switches except the EX4550-32F-S switches have the fan modules and power supplies preinstalled on the rear panel of the switches. Power supplies and fan modules for the EX4550-32F-S switch are not shipped by default; you must order them separately.

Table 18: Airflow Direction in EX4550 Switches

Model Number	Fan Modules and Power Supply	Direction of Airflow
<ul style="list-style-type: none"> EX4550-32F-AFI EX4550-32T-AFI 	The switch ships with three fan modules, each bearing a label AIR IN (AFI) , and an AC power supply bearing a label AFI .	Back-to-front—air intake to cool the chassis is through the vents on the rear panel of the chassis, and hot air exhausts through the vents on the front panel of the chassis.
<ul style="list-style-type: none"> EX4550-32F-AFO EX4550-32T-AFO 	The switch ships with three fan modules, each bearing a label AIR OUT (AFO) , and an AC power supply bearing a label AFO .	Front-to-back—air intake to cool the chassis is through the vents on the front panel of the chassis, and hot air exhausts through the vents on the rear panel of the chassis.
<ul style="list-style-type: none"> EX4550-32F-DC-AFI EX4550-32T-DC-AFI 	The switch ships with three fan modules, each bearing a label AIR IN (AFI) and a DC power supply bearing a label AFI .	Back-to-front—air intake to cool the chassis is through the vents on the rear panel of the chassis, and hot air exhausts through the vents on the front panel of the chassis.
<ul style="list-style-type: none"> EX4550-32F-DC-AFO EX4550-32T-DC-AFO 	The switch ships with three fan modules, each bearing a label AIR OUT (AFO) and a DC power supply bearing a label AFO .	Front-to-back—air intake to cool the chassis is through the vents on the front panel of the chassis, and hot air exhausts through the vents on the rear panel of the chassis.

**CAUTION:**

Do not mix:

- AC and DC power supplies in the same chassis.
- Power supplies (**AFI** or **AFO**) and fan modules (**AIR IN (AFI)** or **AIR OUT (AFO)**) with different airflow labels in the same chassis.

Back-to-Front Airflow

In the EX4550 switches that have back-to-front airflow, the air intake to cool the chassis is through the vents on the rear panel, and hot air exhausts through the vents on the front panel of the switch. See [Figure 22 on page 58](#).

Figure 22: Back-to-Front Airflow Through the EX4550 Switch Chassis

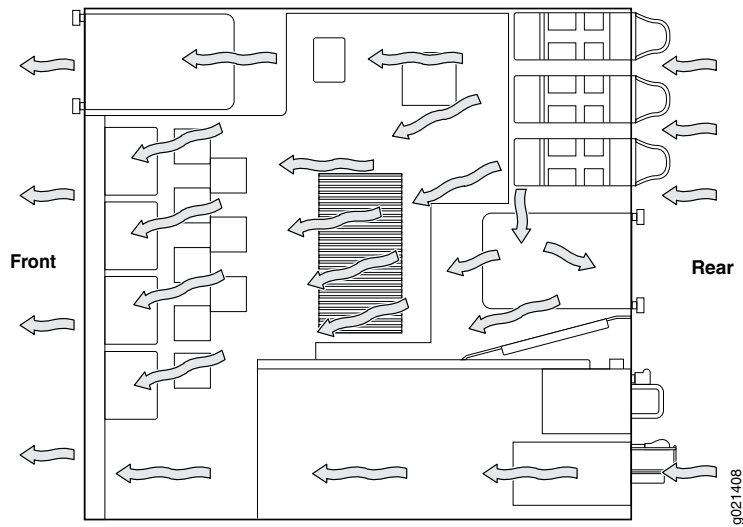

You must install only power supplies that have **AFI** labels in switches in which the fan modules have **AIR IN (AFI)** labels.

Front-to-Back Airflow

In the EX4550 switches that have front-to-back airflow, the air intake to cool the chassis is through the vents on the front panel of the switch, and hot air exhausts through the vents on the rear panel. See [Figure 23 on page 58](#).

Figure 23: Front-to-Back Airflow Through the EX4550 Switch Chassis

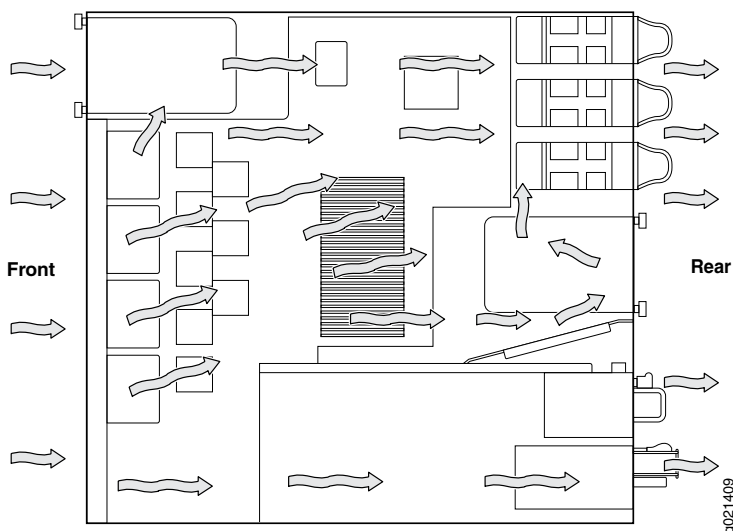

You must install only power supplies that have **AFO** labels in switches in which the fan modules have **AIR OUT (AFO)** labels.

Do Not Install Components with Different Airflow in the Switch

Do not mix power supplies with different airflow labels (**AFI** and **AFO**) and fan modules with different airflow labels (**AIR IN (AFI)** and **AIR OUT (AFO)**) in the same chassis. If the fan modules have **AIR IN (AFI)** labels, the power supplies must have **AFI** labels; if the fan modules have **AIR OUT (AFO)** labels, the power supplies must have **AFO** labels.

Mixing components with different airflows in the same chassis hampers the performance of the cooling system of the switch and leads to overheating of the chassis.



CAUTION: The system raises an alarm if a fan module fails or if the ambient temperature inside the chassis rises above the acceptable range. If the temperature inside the chassis rises above the threshold temperature, the system shuts down automatically.

Positioning the Switch

In front-to-back airflow, indicated by the label **AIR OUT (AFO)** on the fan modules and the label **AFO** on the power supplies, hot air exhausts through the vents on the rear panel of the switch. In back-to-front airflow, indicated by the label **AIR IN (AFI)** on the fan modules and the label **AFI** on the power supplies, hot air exhausts through the vents on the front panel of the switch.

In data center deployments, position the switch in such a manner that the **AFI** and **AIR IN (AFI)** labels on switch components are next to the cold aisle, and **AFO** and **AIR OUT (AFO)** labels on switch components are next to the hot aisle.

Fan Module Status

Each switch has a Status LED (labeled **ST**) for each fan module on the left side of the corresponding fan module slot. It indicates the status of the fan module. [Table 19 on page 60](#) describes the Status LED on a fan module in an EX4550 switch.

Table 19: Fan Module LED

LED	State	Description
ST	Green	The fan module is functioning normally.
	Unlit	Indicates one of the following: <ul style="list-style-type: none"> • The fan module is not installed. • The fan module is not functioning normally.

Under normal operating conditions, the fan modules operate at a moderate speed. Temperature sensors in the chassis monitor the temperature within the chassis.

The system raises an alarm if a fan module fails or if the ambient temperature inside the chassis rises above the acceptable range. If the temperature inside the chassis rises above the threshold temperature, the system shuts down automatically.

You can check the status of fans and the chassis temperature from the Environment Status option in the Status menu on the LCD panel. See [“LCD Panel in EX4550 Switches” on page 37](#).

RELATED DOCUMENTATION

| [Removing a Fan Module from an EX4550 Switch | 208](#)

EX4550 Power System

IN THIS SECTION

- [AC Power Supply in EX4550 Switches | 61](#)
- [AC Power Supply LEDs in EX4550 Switches | 63](#)
- [AC Power Supply Specifications for EX4550 Switches | 64](#)
- [AC Power Cord Specifications for an EX4550 Switch | 65](#)
- [DC Power Supply in EX4550 Switches | 67](#)
- [DC Power Supply LEDs in EX4550 Switches | 69](#)
- [DC Power Supply Specifications for EX4550 Switches | 71](#)

AC Power Supply in EX4550 Switches

The AC power supply in EX4550 switches is a hot-insertable and hot-removable field-replaceable unit (FRU): You can install it without powering off the switch or disrupting the switching function.

All the EX4550 switches that are powered by AC power supplies, except the EX4550-32F-S switches are shipped with one AC power supply pre-installed in the rear panel of the switches. EX4550-32F-S switches are not shipped with pre-installed power supplies; you must order them separately.

This topic describes the AC power supplies.

The AC power supply in EX4550 switches gives an output of 650 W and supports both low line voltage (100–120 VAC) and high line voltage (200–240 VAC). [Figure 24 on page 61](#) shows an AC power supply for an EX4550 switch.

Figure 24: AC Power Supply for an EX4550 Switch

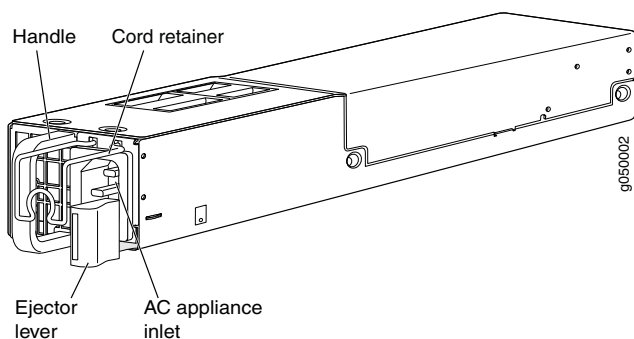

The AC power supply in EX4550 switches is a hot-insertable and hot-removable field-replaceable unit (FRU): You can install it without powering off the switch or disrupting the switching function.

Two variants of AC power supplies are available, each with a different airflow:

- Back-to-front airflow, indicated by **AFI** label
- Front-to-back airflow, indicated by **AFO** label

Each power supply has a label **AFI** or **AFO** and an arrow on the handle that depicts the direction of airflow (see [Figure 25 on page 62](#)).

[Table 20 on page 62](#) shows the AC power supply model numbers and the direction of airflow in them.

Table 20: Airflow Direction in AC Power Supply for EX4550 Switches

Model Number	Label on Power Supply	Direction of Airflow
JPSU-650W-AC-AFI	AFI	Back-to-front—air intake to cool the chassis is through the vents on the rear panel of the chassis, and hot air exhausts through the vents on the front panel of the chassis.
JPSU-650W-AC-AFO	AFO	Front-to-back—air intake to cool the chassis is through the vents on the front panel of the chassis, and hot air exhausts through the vents on the rear panel of the chassis.

Figure 25: Label Identifying the Airflow Direction in an AC Power Supply

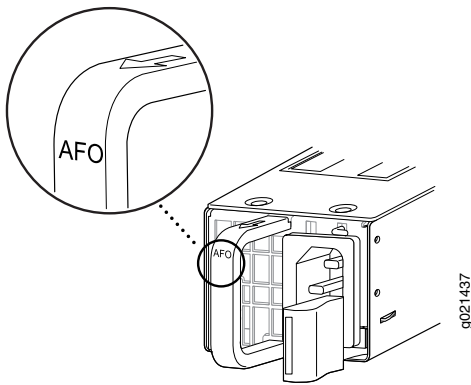
**CAUTION:** Do not mix:

- AC and DC power supplies in the same chassis.
- Power supplies with different airflow labels (**AFI** and **AFO**) in the same chassis.

To avoid electrical injury while installing or removing AC power supplies, carefully follow instructions in [“Installing an AC Power Supply in an EX4550 Switch” on page 212](#) and [“Removing an AC Power Supply from an EX4550 Switch” on page 211](#).

SEE ALSO

| [Connecting AC Power to an EX4550 Switch](#) | 139

AC Power Supply LEDs in EX4550 Switches

Figure 26 on page 63 shows the location of the LEDs on an AC power supply for an EX4550 switch.

Figure 26: AC Power Supply LEDs in an EX4550 Switch

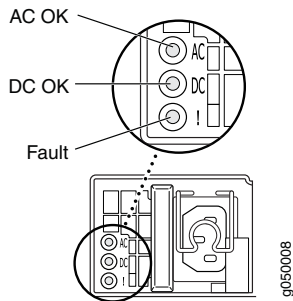

Table 21 on page 63 describes the AC power supply LEDs.

Table 21: AC Power Supply LEDs in EX4550 Switches

LED	Color	State	Description
AC (AC OK)	Unlit	Off	Indicates one of the following: <ul style="list-style-type: none"> • Power supply is disconnected from AC power feed. • AC power input voltage is not within normal operating range. • No AC power input.
	Green	On steadily	Power supply is functioning normally.
DC (DC OK)	Unlit	Off	Indicates one of the following: <ul style="list-style-type: none"> • The power supply is disconnected from the power feed. • The power supply is not delivering power correctly.
	Green	On steadily	The power supply is functioning correctly.
! (Fault)	Yellow	On steadily	The power supply has failed and must be replaced.

NOTE: If the **AC** LED and the **DC** LED are unlit, either the AC power cord is not installed properly or the power supply fuse has failed.

If the **AC** LED is lit and the **DC** LED is unlit, the AC power supply is installed properly, but the power supply has an internal failure.

AC Power Supply Specifications for EX4550 Switches

Table 22 on page 64 lists the power supply specifications for an AC power supply used in an EX4550 switch.

Table 22: AC Power Supply Specifications for an EX4550 Switch

Item	Specification
AC input voltage	Operating range: <ul style="list-style-type: none"> • Low-voltage line—100–120 VAC • High-voltage line—200–240 VAC
AC input line frequency	50–60 Hz
AC input current rating	<ul style="list-style-type: none"> • Low-voltage line—7.8 A • High-voltage line—3.8 A
AC output power	<ul style="list-style-type: none"> • Low-voltage line—650 W • High-voltage line—650 W
Maximum System Power Requirement for EX4550-32F switches with two EX4550-EM-8XT expansion modules installed	336 W
System Thermal Output of EX4550-32F switches with two EX4550-EM-8XT expansion modules installed = (Maximum System Power Requirement) * 3.41 NOTE: 1 W = 3.41 BTU/Hour	1146 BTU/Hour
Maximum System Power Requirement for EX4550-32T switches with two EX4550-EM-8XT expansion modules installed	403 W
System Thermal Output of EX4550-32T switches with two EX4550-EM-8XT expansion modules installed = (Maximum System Power Requirement) * 3.41 NOTE: 1 W = 3.41 BTU/Hour	1375 BTU/Hour
Power required by each fan module	<ul style="list-style-type: none"> • When operating in normal speed—4.8 W • When operating in high speed—16.8 W

AC Power Cord Specifications for an EX4550 Switch

A detachable AC power cord is supplied with the AC power supplies. The coupler is type C13 as described by International Electrotechnical Commission (IEC) standard 60320. The plug end of the power cord fits into the power source outlet that is standard for your geographical location.

NOTE: In North America, AC power cords must not exceed 4.5 meters (approximately 14.75 feet) in length, to comply with National Electrical Code (NEC) Sections 400-8 (NFPA 75, 5-2.2) and 210-52 and Canadian Electrical Code (CEC) Section 4-010(3). The cord supplied with the switch is in compliance.

Table 23 on page 65 lists AC power cord specifications provided for each country or region.

Table 23: AC Power Cord Specifications for an EX4550 Switch

Country/Region	Electrical Specifications	Plug Standards	Juniper Model number	Graphic
Argentina	250 VAC, 10 A, 50 Hz	IRAM 2073 Type RA/3	CBL-EX-PWR-C13-AR	No graphic available
Australia	250 VAC, 10 A, 50 Hz	AS/NZS 3112 Type SAA/3	CBL-EX-PWR-C13-AU	 8021262
Brazil	250 VAC, 10 A, 50 Hz	NBR 14136 Type BR/3	CBL-EX-PWR-C13-BR	No graphic available
China	250 VAC, 10 A, 50 Hz	GB 1002-1996 Type PRC/3	CBL-EX-PWR-C13-CH	 8021263
Europe (except Italy, Switzerland, and United Kingdom)	250 VAC, 10 A, 50 Hz	CEE (7) VII Type VIIG	CBL-EX-PWR-C13-EU	 8021264
India	250 VAC, 10 A, 50 Hz	IS 1293 Type IND/3	CBL-EX-PWR-C13-IN	No graphic available

Table 23: AC Power Cord Specifications for an EX4550 Switch (continued)



Country/Region	Electrical Specifications	Plug Standards	Juniper Model number	Graphic
Israel	250 VAC, 10 A, 50 Hz	SI 32/1971 Type IL/3G	CBL-EX-PWR-C13-IL	
Italy	250 VAC, 10 A, 50 Hz	CEI 23-16 Type I/3G	CBL-EX-PWR-C13-IT	
Japan	125 VAC, 12 A, 50 Hz or 60 Hz	SS-00259 Type VCTF	CBL-EX-PWR-C13-JP	
Korea	250 VAC, 10 A, 50 Hz or 60 Hz	CEE (7) VII Type VIIGK	CBL-EX-PWR-C13-KR	
North America	125 VAC, 13 A, 60 Hz	NEMA 5-15 Type N5-15	CBL-EX-PWR-C13-US	
South Africa	250 VAC, 10 A, 50 Hz	SABS 164/1:1992 Type ZA/13	CBL-EX-PWR-C13-SA	
Switzerland	250 VAC, 10 A, 50 Hz	SEV 6534-2 Type 12G	CBL-EX-PWR-C13-SZ	No graphic available

Table 23: AC Power Cord Specifications for an EX4550 Switch (*continued*)

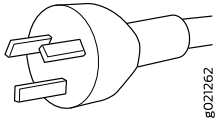
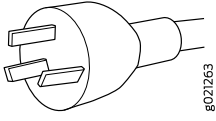
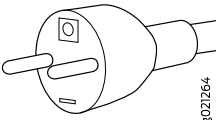
Country/Region	Electrical Specifications	Plug Standards	Juniper Model number	Graphic
Taiwan	125 VAC, 10 A, 50 Hz	NEMA 5-15P Type N5-15P	CBL-EX-PWR-C13-TW	 6021288
United Kingdom	250 VAC, 10 A, 50 Hz	BS 1363/A Type BS89/13	CBL-EX-PWR-C13-UK	 6021271

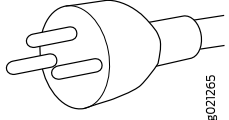
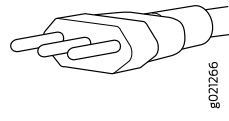
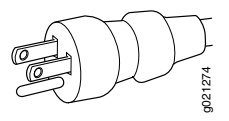
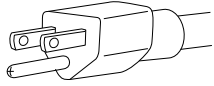

CAUTION: The AC power cord for the EX4550 switch is intended for use with this switch only. Do not use the cord with any other product.



CAUTION: Power cords must not block access to switch components.

DC Power Supply in EX4550 Switches

The DC power supply in EX4550 switches is a hot-insertable and hot-removable field-replaceable unit (FRU): You can install it without powering off the switch or disrupting the switching function.

All the EX4550 switches that are powered by DC power supplies, except the EX4550-32F-S switches are shipped with one DC power supply pre-installed in the rear panel of the switches. EX4550-32F-S switches are not shipped with pre-installed power supplies; you must order them separately.

This topic describes the DC power supplies used in EX4550 switches.

The DC power supply gives an output power of 650 W. [Figure 27 on page 68](#) shows a DC power supply for an EX4550 switch.

NOTE: The **V+** terminals are shunted internally together, as are the **V-** terminals. The same polarity terminal can be wired together from the same source to provide an additional current path in a higher power chassis. Each power supply must be connected to a single source only.

Figure 27: DC Power Supply for an EX4550 Switch

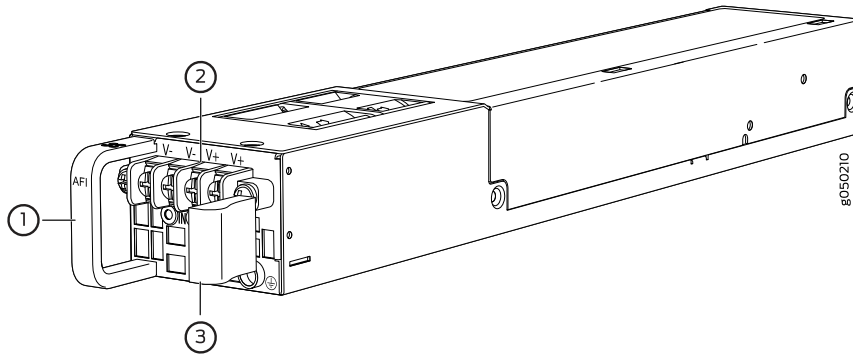

1—Handle

3—Ejector lever

2—Terminal block

The DC power supply in EX4550 switches is a hot-insertable and hot-removable field-replaceable unit (FRU): You can install it without powering off the switch or disrupting the switching function.

Two variants of DC power supplies are available, each with a different airflow:

- Back-to-front airflow, indicated by **AFI** label
- Front-to-back airflow, indicated by **AFO** label

Each power supply has a label **AFI** or **AFO** and an arrow on the handle that depicts the direction of airflow (see [Figure 28 on page 69](#)).

[Table 24 on page 68](#) shows the DC power supply model numbers and the direction of airflow in them.

Table 24: Airflow Direction in DC Power Supply Used in EX4550 Switches

Model Number	Label on Power Supply	Direction of Airflow
JPSU-650W-DC-AFI	AFI	Back-to-front—air intake to cool the chassis is through the vents on the rear panel of the chassis, and hot air exhausts through the vents on the front panel of the chassis.
JPSU-650W-DC-AFO	AFO	Front-to-back—air intake to cool the chassis is through the vents on the front panel of the chassis, and hot air exhausts through the vents on the rear panel of the chassis.

Figure 28: Label Identifying the Airflow Direction in a DC Power Supply

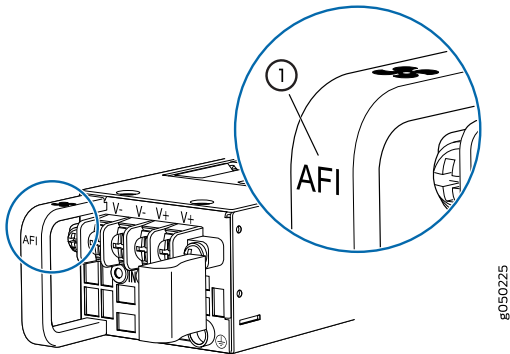

CAUTION: Do not mix:

- AC and DC power supplies in the same chassis.
- Power supplies with different airflow labels (**AFI** and **AFO**) in the same chassis.

To avoid electrical injury, carefully follow instructions in [“Installing a DC Power Supply in an EX4550 Switch”](#) on page 215 and [“Removing a DC Power Supply from an EX4550 Switch”](#) on page 214.

DC Power Supply LEDs in EX4550 Switches

[Figure 29 on page 70](#) shows the location of the LEDs on a DC power supply for an EX4550 switch.

Figure 29: DC Power Supply Faceplate on an EX4550 Switch

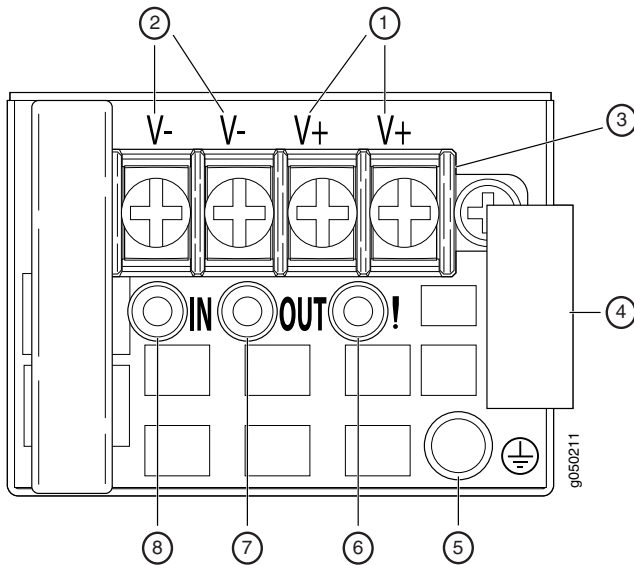

1–V+ input terminals	5–ESD grounding point
2–V- input terminals	6–! (Fault) LED
3–Terminal block	7–OUT (Output) LED
4–Ejector lever	8–IN (Input) LED

Table 25 on page 70 describes the LEDs on the DC power supplies.

Table 25: DC Power Supply LEDs on an EX4550 Switch

Name	Color	State	Description
IN	Unlit	Off	Indicates one of the following: <ul style="list-style-type: none"> Power supply is disconnected from DC power feed. DC power input voltage is not within normal operating range. No DC power input.
	Green	On steadily	The power supply is receiving power.
OUT	Unlit	Off	Indicates one of the following: <ul style="list-style-type: none"> The power supply is disconnected from the power feed. The power supply is not delivering power correctly.
	Green	On steadily	The power supply is functioning correctly.
! (Fault)	Yellow	On steadily	The power supply has failed and must be replaced.

DC Power Supply Specifications for EX4550 Switches

Table 26 on page 71 lists the power supply specifications for a DC power supply used in an EX4550 switch.

Table 26: DC Power Supply Specifications for an EX4550 Switch

Item	Specifications
DC input voltage	<ul style="list-style-type: none">• Minimum operating voltage: -36 VDC• Nominal operating voltage: -48 VDC• Operating voltage range: -36 VDC through -72 VDC
DC input current rating	7 A maximum at nominal operating voltage (-48 VDC)
Output power	650 W

2

CHAPTER

Site Planning, Preparation, and Specifications

Site Preparation Checklist for EX4550 Switches | **73**

EX4550 Site Guidelines and Requirements | **74**

EX4550 Network Cable and Transceiver Planning | **85**

EX4550 Management Cable Specifications and Pinouts | **94**

EX4550 Virtual Chassis | **107**

Site Preparation Checklist for EX4550 Switches

The checklist in [Table 27 on page 73](#) summarizes the tasks you need to perform when preparing a site for EX4550 switch installation.

Table 27: Site Preparation Checklist

Item or Task	For More Information	Performed by	Date
Environment			
Verify that environmental factors such as temperature and humidity do not exceed switch tolerances.	"Environmental Requirements and Specifications for EX Series Switches" on page 75		
Power			
Measure the distance between external power sources and the switch installation site.			
Locate sites for connection of system grounding.			
Calculate the power consumption and requirements.	<ul style="list-style-type: none"> • AC Power Supply Specifications for EX4550 Switches on page 64 • DC Power Supply Specifications for EX4550 Switches on page 71 		
Hardware Configuration			
Choose the switches you want to install.	"EX4550 Switches Hardware Overview" on page 19		
Rack or Cabinet			
Verify that your rack or cabinet meets the minimum requirements for the installation of the switch.	<ul style="list-style-type: none"> • Rack Requirements on page 81 • Cabinet Requirements on page 82 		
Plan rack or cabinet location, including required space clearances.	"Clearance Requirements for Airflow and Hardware Maintenance for EX4550 Switches" on page 83		

Table 27: Site Preparation Checklist (continued)

Item or Task	For More Information	Performed by	Date
Secure the rack or cabinet to the floor and building structure.			
Cables			
Acquire cables and connectors: <ul style="list-style-type: none"> • Determine the number of cables needed based on your planned configuration. • Review the maximum distance allowed for each cable. Choose the length of cable based on the distance between the hardware components being connected. 			
Plan the cable routing and management.			

RELATED DOCUMENTATION

[General Safety Guidelines and Warnings | 274](#)

[General Site Guidelines | 80](#)

[Installing and Connecting an EX4550 Switch | 123](#)

EX4550 Site Guidelines and Requirements

IN THIS SECTION

- [Environmental Requirements and Specifications for EX Series Switches | 75](#)
- [General Site Guidelines | 80](#)
- [Site Electrical Wiring Guidelines | 80](#)
- [Rack Requirements | 81](#)
- [Cabinet Requirements | 82](#)
- [Clearance Requirements for Airflow and Hardware Maintenance for EX4550 Switches | 83](#)

Environmental Requirements and Specifications for EX Series Switches

The switch must be installed in a rack or cabinet housed in a dry, clean, well-ventilated, and temperature-controlled environment.

Ensure that these environmental guidelines are followed:

- The site must be as dust-free as possible, because dust can clog air intake vents and filters, reducing the efficiency of the switch cooling system.
- Maintain ambient airflow for normal switch operation. If the airflow is blocked or restricted, or if the intake air is too warm, the switch might overheat, leading to the switch temperature monitor shutting down the switch to protect the hardware components.

Table 28 on page 75 provides the required environmental conditions for normal switch operation.

Table 28: EX Series Switch Environmental Tolerances

Switch or device	Environment Tolerance			
	Altitude	Relative Humidity	Temperature	Seismic
EX2200-C	No performance degradation up to 5,000 feet (1524 meters)	Normal operation ensured in the relative humidity range 10% through 85% (noncondensing)	Normal operation ensured in the temperature range 32° F (0° C) through 104° F (40° C) at altitudes up to 5,000 ft (1,524 m). For information about extended temperature SFP transceivers supported on EX2200 switches, see <i>Pluggable Transceivers Supported on EX2200 Switches</i> .	Complies with Zone 4 earthquake requirements as per GR-63, Issue 4.
EX2200 (except EX2200-C switches)	No performance degradation up to 10,000 feet (3048 meters)	Normal operation ensured in the relative humidity range 10% through 85% (noncondensing)	Normal operation ensured in the temperature range 32° F (0° C) through 113° F (45° C)	Complies with Zone 4 earthquake requirements as per GR-63, Issue 4.
EX2300-C	No performance degradation up to 5,000 feet (1524 meters)	Normal operation ensured in the relative humidity range 10% through 85% (noncondensing)	Normal operation ensured in the temperature range 32° F (0° C) through 104° F (40° C)	Complies with Zone 4 earthquake requirements as per GR-63, Issue 4.

Table 28: EX Series Switch Environmental Tolerances (continued)

Switch or device	Environment Tolerance			
	Altitude	Relative Humidity	Temperature	Seismic
EX2300 (except EX2300-C switches)	No performance degradation up to 13,000 feet (3962 meters) at 104° F (40° C) as per GR-63	Normal operation ensured in the relative humidity range 10% through 85% (noncondensing)	Normal operation ensured in the temperature range 32° F (0° C) through 113° F (45° C)	Complies with Zone 4 earthquake requirements as per GR-63, Issue 4.
EX3200	No performance degradation up to 10,000 feet (3048 meters)	Normal operation ensured in the relative humidity range 10% through 85% (noncondensing)	Normal operation ensured in the temperature range 32° F (0° C) through 113° F (45° C)	Complies with Zone 4 earthquake requirements as per GR-63, Issue 4.
EX3300	No performance degradation up to 10,000 feet (3048 meters)	Normal operation ensured in the relative humidity range 10% through 85% (noncondensing)	Normal operation ensured in the temperature range 32° F (0° C) through 113° F (45° C)	Complies with Zone 4 earthquake requirements as per GR-63, Issue 4.
EX3400	No performance degradation up to 10,000 feet (3048 meters)	Normal operation ensured in the relative humidity range 10% through 85% (noncondensing)	Normal operation ensured in the temperature range 32° F (0° C) through 113° F (45° C)	Complies with Zone 4 earthquake requirements as per GR-63, Issue 4.
EX4200	No performance degradation up to 10,000 feet (3048 meters)	Normal operation ensured in the relative humidity range 10% through 85% (noncondensing)	Normal operation ensured in the temperature range 32° F (0° C) through 113° F (45° C)	Complies with Zone 4 earthquake requirements as per GR-63, Issue 4.

Table 28: EX Series Switch Environmental Tolerances (continued)

Switch or device	Environment Tolerance			
	Altitude	Relative Humidity	Temperature	Seismic
EX4300 The maximum thermal output for EX4300-48T is 423 BTU/hour and for EX4300-48P is 5844 BTU/hour.	EX4300 switches except the EX4300-48MP model— No performance degradation up to 10,000 feet (3048 meters) EX4300-48MP model— No performance degradation up to 6,000 feet (1829 meters)	EX4300 switches except the EX4300-48MP model— Normal operation ensured in the relative humidity range 10% through 85% (noncondensing) EX4300-48MP model— Normal operation ensured in the relative humidity range 5% through 90% (noncondensing)	Normal operation ensured in the temperature range 32° F (0° C) through 113° F (45° C)	Complies with Zone 4 earthquake requirements as per GR-63, Issue 4.
EX4500	No performance degradation up to 10,000 feet (3048 meters)	Normal operation ensured in the relative humidity range 10% through 85% (noncondensing)	Normal operation ensured in the temperature range 32° F (0° C) through 113° F (45° C)	Complies with Zone 4 earthquake requirements as per GR-63, Issue 4.
EX4550	No performance degradation up to 10,000 feet (3048 meters)	Normal operation ensured in the relative humidity range 10% through 85% (noncondensing)	<ul style="list-style-type: none"> • EX4550-32F switches— Normal operation ensured in the temperature range 32° F (0° C) through 113° F (45° C) • EX4550-32T switches— Normal operation is ensured in the temperature range 32° F through 104° F (40° C) 	Complies with Zone 4 earthquake requirements as per GR-63, Issue 4.

Table 28: EX Series Switch Environmental Tolerances (continued)

Switch or device	Environment Tolerance			
	Altitude	Relative Humidity	Temperature	Seismic
EX4600	No performance degradation to 6,562 feet (2000 meters)	<p>Normal operation ensured in the relative humidity range 5% through 90%, noncondensing</p> <ul style="list-style-type: none"> Short-term operation ensured in the relative humidity range 5% through 93%, noncondensing <p>NOTE: As defined in NEBS GR-63-CORE, Issue 4, short-term events can be up to 96 hours in duration but not more than 15 days per year.</p>	<ul style="list-style-type: none"> Normal operation ensured in the temperature range 32° F (0° C) through 113° F (45° C) Nonoperating storage temperature in shipping container: - 40° F (-40° C) through 158° F (70° C) 	Complies with Zone 4 earthquake requirements per NEBS GR-63-CORE, Issue 4.
EX4650	No performance degradation to 6,000 feet (1829 meters)	Normal operation ensured in the relative humidity range 10% through 85% (condensing)	Normal operation is ensured in the temperature range 32° F (0° C) through 104° F (40° C)	Complies with Zone 4 earthquake requirements as per GR-63, Issue 4.
EX6210	No performance degradation up to 10,000 feet (3048 meters)	Normal operation ensured in the relative humidity range 10% through 85% (noncondensing)	Normal operation is ensured in the temperature range 32° F (0° C) through 104° F (40° C)	Complies with Zone 4 earthquake requirements as per GR-63, Issue 4.
EX8208	No performance degradation up to 10,000 feet (3048 meters)	Normal operation ensured in the relative humidity range 10% through 85% (noncondensing)	Normal operation is ensured in the temperature range 32° F (0° C) through 104° F (40° C)	Complies with Zone 4 earthquake requirements as per GR-63, Issue 4.
EX8216	No performance degradation up to 10,000 feet (3048 meters)	Normal operation ensured in the relative humidity range 10% through 85% (noncondensing)	Normal operation is ensured in the temperature range 32° F (0° C) through 104° F (40° C)	Complies with Zone 4 earthquake requirements as per GR-63, Issue 4.

Table 28: EX Series Switch Environmental Tolerances (continued)

Switch or device	Environment Tolerance			
	Altitude	Relative Humidity	Temperature	Seismic
EX9204	No performance degradation up to 10,000 feet (3048 meters)	Normal operation ensured in the relative humidity range 5% through 90% (noncondensing)	Normal operation is ensured in the temperature range 32° F (0° C) through 104° F (40° C) Nonoperating storage temperature in shipping container: - 40° F (-40° C) to 158° F (70° C)	Complies with Zone 4 earthquake requirements as per GR-63.
EX9208	No performance degradation up to 10,000 feet (3048 meters)	Normal operation ensured in the relative humidity range 5% through 90% (noncondensing)	Normal operation is ensured in the temperature range 32° F (0° C) through 104° F (40° C) Nonoperating storage temperature in shipping container: - 40° F (-40° C) to 158° F (70° C)	Complies with Zone 4 earthquake requirements as per GR-63.
EX9214	No performance degradation up to 10,000 feet (3048 meters)	Normal operation ensured in the relative humidity range 5% through 90% (noncondensing)	Normal operation is ensured in the temperature range 32° F (0° C) through 104° F (40° C) Nonoperating storage temperature in shipping container: - 40° F (-40° C) through 158° F (70° C)	Complies with Zone 4 earthquake requirements as per GR-63.
EX9251 The maximum thermal output is 1705 BTU/hour (500 W).	No performance degradation up to 10,000 ft (3048 m)	Normal operation ensured in relative humidity range of 5% to 90%, noncondensing	Normal operation ensured in temperature range of 32° F (0° C) to 104° F (40° C) Nonoperating storage temperature in shipping container: - 40° F (-40° C) to 158° F (70° C)	Complies with Telcordia Technologies Zone 4 earthquake requirements

Table 28: EX Series Switch Environmental Tolerances (*continued*)

Switch or device	Environment Tolerance			
	Altitude	Relative Humidity	Temperature	Seismic
XRE200	No performance degradation up to 10,000 feet (3048 meters)	Normal operation ensured in the relative humidity range 10% through 85% (noncondensing)	Normal operation ensured in the temperature range 41° F (5° C) through 104° F (40° C)	Complies with Zone 4 earthquake requirements as per GR-63, Issue 4.

NOTE: Install EX Series switches only in restricted areas, such as dedicated equipment rooms and equipment closets, in accordance with Articles 110- 16, 110- 17, and 110- 18 of the National Electrical Code, ANSI/NFPA 70.

General Site Guidelines

Efficient device operation requires proper site planning and maintenance and proper layout of the equipment, rack or cabinet (if used), and wiring closet.

To plan and create an acceptable operating environment for your device and prevent environmentally caused equipment failures:

- Keep the area around the chassis free from dust and conductive material, such as metal flakes.
- Follow prescribed airflow guidelines to ensure that the cooling system functions properly and that exhaust from other equipment does not blow into the intake vents of the device.
- Follow the prescribed electrostatic discharge (ESD) prevention procedures to prevent damaging the equipment. Static discharge can cause components to fail completely or intermittently over time.
- Install the device in a secure area, so that only authorized personnel can access the device.

Site Electrical Wiring Guidelines

Table 29 on page 81 describes the factors you must consider while planning the electrical wiring at your site.



WARNING: You must provide a properly grounded and shielded environment and use electrical surge-suppression devices.

Avertissement Vous devez établir un environnement protégé et convenablement mis à la terre et utiliser des dispositifs de parasurtension.

Table 29: Site Electrical Wiring Guidelines

Site Wiring Factor	Guidelines
Signaling limitations	<p>If your site experiences any of the following problems, consult experts in electrical surge suppression and shielding:</p> <ul style="list-style-type: none"> • Improperly installed wires cause radio frequency interference (RFI). • Damage from lightning strikes occurs when wires exceed recommended distances or pass between buildings. • Electromagnetic pulses (EMPs) caused by lightning damage unshielded conductors and electronic devices.
Radio frequency interference	<p>To reduce or eliminate RFI from your site wiring, do the following:</p> <ul style="list-style-type: none"> • Use a twisted-pair cable with a good distribution of grounding conductors. • If you must exceed the recommended distances, use a high-quality twisted-pair cable with one ground conductor for each data signal when applicable.
Electromagnetic compatibility	<p>If your site is susceptible to problems with electromagnetic compatibility (EMC), particularly from lightning or radio transmitters, seek expert advice.</p> <p>Some of the problems caused by strong sources of electromagnetic interference (EMI) are:</p> <ul style="list-style-type: none"> • Destruction of the signal drivers and receivers in the device • Electrical hazards as a result of power surges conducted over the lines into the equipment

Rack Requirements

You can mount the device on two-post racks or four-post racks.

Rack requirements consist of:

- Rack type
- Mounting bracket hole spacing

- Rack size and strength
- Rack connection to the building structure

Table 30 on page 82 provides the rack requirements and specifications.

Table 30: Rack Requirements and Specifications

Rack Requirement	Guidelines
Rack type	<p>You can mount the device on a rack that provides bracket holes or hole patterns spaced at 1-U (1.75 in. or 4.45 cm) increments and meets the size and strength requirements to support the weight.</p> <p>A U is the standard rack unit defined by the Electronic Components Industry Association (http://www.ecianow.org).</p>
Mounting bracket hole spacing	The holes in the mounting brackets are spaced at 1-U (1.75 in. or 4.45 cm), so that the device can be mounted in any rack that provides holes spaced at that distance.
Rack size and strength	<ul style="list-style-type: none"> • Ensure that the rack complies with the size and strength standards of a 19-in. rack as defined by the Electronic Components Industry Association (http://www.ecianow.org). • Ensure that the rack rails are spaced widely enough to accommodate the external dimensions of the device chassis. The outer edges of the front mounting brackets extend the width of the chassis to 19 in. (48.2 cm). • The rack must be strong enough to support the weight of the device. • Ensure that the spacing of rails and adjacent racks provides for proper clearance around the device and rack.
Rack connection to building structure	<ul style="list-style-type: none"> • Secure the rack to the building structure. • If your geographical area is earthquake-prone, secure the rack to the floor. • Secure the rack to the ceiling brackets as well as wall or floor brackets for maximum stability.

SEE ALSO

| [Rack-Mounting and Cabinet-Mounting Warnings](#) | 286

Cabinet Requirements

You can mount the device in a cabinet that contains a 19-in. rack.

Cabinet requirements consist of:

- Cabinet size
- Clearance requirements
- Cabinet airflow requirements

Table 31 on page 83 provides the cabinet requirements and specifications.

Table 31: Cabinet Requirements and Specifications

Cabinet Requirement	Guidelines
Cabinet size	<ul style="list-style-type: none"> • The minimum cabinet size is 36 in. (91.4 cm) depth. Large cabinets improve airflow and reduce chances of overheating.
Cabinet clearance	<ul style="list-style-type: none"> • The outer edges of the front mounting brackets extend the width of the chassis to 19 in. (48.2 cm). • The minimum total clearance inside the cabinet is 30.7 in. (78 cm) between the inside of the front door and the inside of the rear door.
Cabinet airflow requirements	<p>When you mount the device in a cabinet, ensure that ventilation through the cabinet is sufficient to prevent overheating.</p> <ul style="list-style-type: none"> • Ensure adequate cool air supply to dissipate the thermal output of the device or devices. • Ensure that the hot air exhaust of the chassis exits the cabinet without recirculating into the device. An open cabinet (without a top or doors) that employs hot air exhaust extraction from the top ensures the best airflow through the chassis. If the cabinet contains a top or doors, perforations in these elements assist with removing the hot air exhaust. • Install the device in the cabinet in a way that maximizes the open space on the side of the chassis that has the hot air exhaust. • Route and dress all cables to minimize the blockage of airflow to and from the chassis. • Ensure that the spacing of rails and adjacent cabinets is such that there is proper clearance around the device and cabinet. • A cabinet larger than the minimum required provides better airflow and reduces the chance of overheating.

Clearance Requirements for Airflow and Hardware Maintenance for EX4550 Switches

When planning the site for installing an EX4550 switch, you must allow sufficient clearance around the switch.

Follow these clearance requirements:

- For the cooling system to function properly, the airflow around the chassis must be unrestricted. See [Figure 30 on page 84](#) and [Figure 31 on page 84](#).

Figure 30: Back-to-Front Airflow

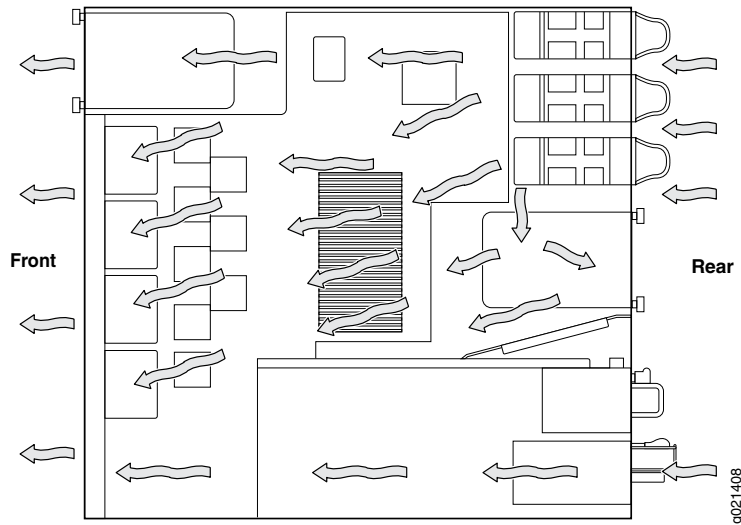
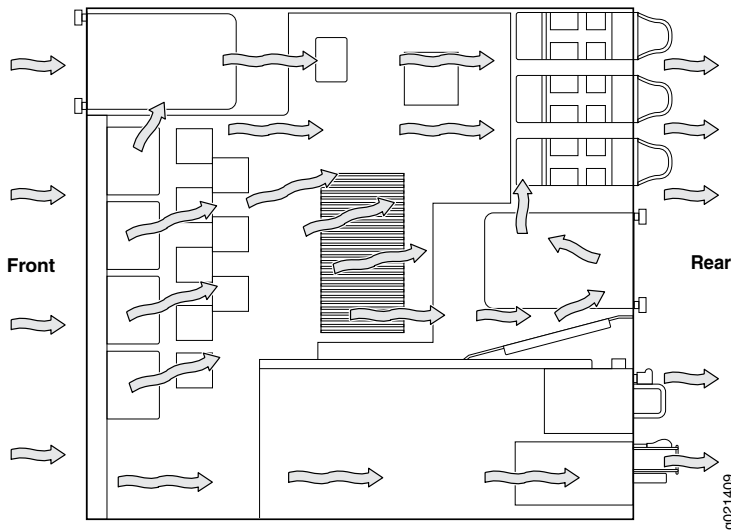
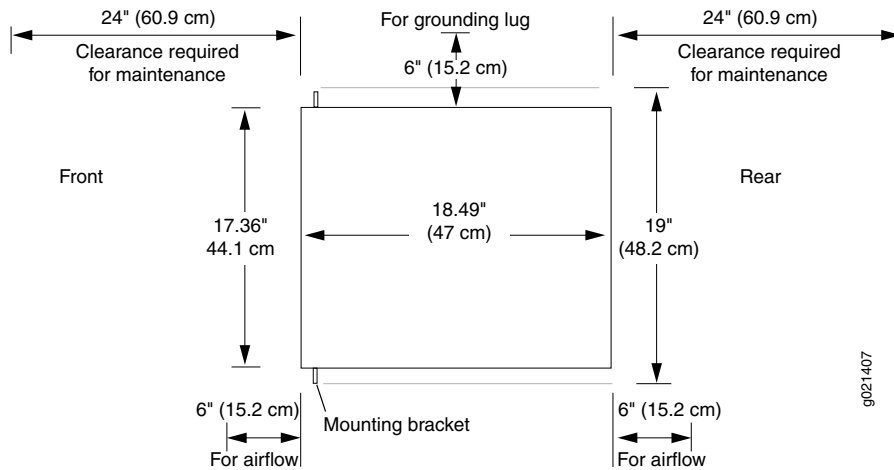

Figure 31: Front-to-Back Airflow



- If you are mounting the switch on a rack or cabinet along with other equipment, ensure that the exhaust from other equipment does not blow into the intake vents of the chassis.
- Leave at least 6 in. (15.2 cm) clearance on the front and the back of the chassis for airflow.
- Leave at least 6 in. (15.2 cm) clearance on the left of the chassis for installing the grounding lug.
- Leave at least 24 in. (61 cm) clearance on front and of the switch for service personnel to remove and install hardware components. See [Figure 32 on page 85](#).

Figure 32: Clearance Requirements for Airflow and Hardware Maintenance for an EX4550 Switch Chassis



SEE ALSO

[Chassis Physical Specifications for EX4550 Switches | 35](#)

[Rack-Mounting and Cabinet-Mounting Warnings | 286](#)

[Cooling System and Airflow in an EX4550 Switch | 55](#)

EX4550 Network Cable and Transceiver Planning

IN THIS SECTION

- [Pluggable Transceivers Supported on EX4550 Switches | 86](#)
- [SFP+ Direct Attach Copper Cables for EX Series Switches | 87](#)
- [QSFP+ Direct Attach Copper Cables for EX Series Switches | 89](#)
- [Understanding EX Series Switches Fiber-Optic Cable Signal Loss, Attenuation, and Dispersion | 90](#)
- [Calculating the Fiber-Optic Cable Power Budget for EX Series Devices | 92](#)
- [Calculating the Fiber-Optic Cable Power Margin for EX Series Devices | 92](#)

Pluggable Transceivers Supported on EX4550 Switches

Uplink module ports on EX4550 switches support SFP, SFP+, and QSFP+ transceivers. You can find the list of transceivers supported on EX4550 switches and information about those transceivers at the [Hardware Compatibility Tool page for EX4550](#).

NOTE: We recommend that you use only optical transceivers and optical connectors purchased from Juniper Networks with your Juniper Networks device.



CAUTION: If you face a problem running a Juniper Networks device that uses a third-party optic or cable, the Juniper Networks Technical Assistance Center (JTAC) can help you diagnose the source of the problem. Your JTAC engineer might recommend that you check the third-party optic or cable and potentially replace it with an equivalent Juniper Networks optic or cable that is qualified for the device.

The SFP, SFP+, and QSFP+ transceivers installed in EX4550 switches support digital optical monitoring (DOM): You can view the diagnostic details for these transceivers by issuing the operational mode CLI command **show interfaces diagnostics optics**.

NOTE: The transceivers support DOM even if they are installed in the expansion module ports or SFP+ network ports configured as Virtual Chassis ports (VCPs).

SEE ALSO

| [Install a Transceiver](#) | 147

SFP+ Direct Attach Copper Cables for EX Series Switches

IN THIS SECTION

- [Cable Specifications | 87](#)
- [List of DAC Cables Supported on EX Series Switches | 88](#)
- [Standards Supported by These Cables | 88](#)

Small form-factor pluggable plus transceiver (SFP+) direct attach copper (DAC) cables, also known as Twinax cables, are suitable for in-rack connections between servers and switches. They are suitable for short distances, making them ideal for highly cost-effective networking connectivity within a rack and between adjacent racks.

NOTE: We recommend that you use only SFP+ DAC cables purchased from Juniper Networks with your Juniper Networks device.



CAUTION: If you face a problem running a Juniper Networks device that uses a third-party optic or cable, the Juniper Networks Technical Assistance Center (JTAC) can help you diagnose the source of the problem. Your JTAC engineer might recommend that you check the third-party optic or cable and potentially replace it with an equivalent Juniper Networks optic or cable that is qualified for the device.

Cable Specifications

EX Series switches support SFP+ passive DAC cables. The passive Twinax cable is a straight cable with no active electronic components. EX Series switches support 1 m, 3 m, 5 m, and 7 m long SFP+ passive DAC cables. See [Figure 33 on page 88](#).

Figure 33: SFP+ Direct Attach Copper Cables for EX Series Switches

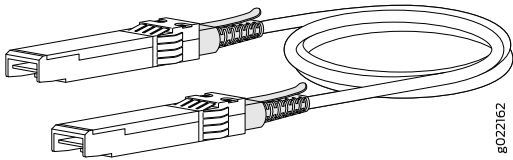

The cables are hot-removable and hot-insertable: You can remove and replace them without powering off the switch or disrupting switch functions. A cable comprises a low-voltage cable assembly that connects directly into two 10-Gigabit Ethernet ports, one at each end of the cable. The cables use high-performance integrated duplex serial data links for bidirectional communication and are designed for data rates of up to 10 Gbps.

List of DAC Cables Supported on EX Series Switches

For the list of DAC cables supported on EX Series switches and the specifications of these cables, see:

- EX2300—[Hardware Compatibility Tool page for EX2300](#)
- EX3200—[Hardware Compatibility Tool page for EX3200](#)
- EX3300—[Hardware Compatibility Tool page for EX3300](#)
- EX3400—[Hardware Compatibility Tool page for EX3400](#)
- EX4200—[Hardware Compatibility Tool page for EX4200](#)
- EX4300—[Hardware Compatibility Tool page for EX4300](#)
- EX4500—[Hardware Compatibility Tool page for EX4500](#)
- EX4550—[Hardware Compatibility Tool page for EX4550](#)
- EX4600—[Hardware Compatibility Tool page for EX4600](#)
- EX8208—[Hardware Compatibility Tool page for EX8208](#)
- EX8216—[Hardware Compatibility Tool page for EX8216](#)
- EX9251—[Hardware Compatibility Tool page for EX9251](#)
- EX9253—[Hardware Compatibility Tool page for EX9253](#)

Standards Supported by These Cables

The cables comply with the following standards:

- SFP mechanical standard SFF-843— see <ftp://ftp.seagate.com/sff/SFF-8431.PDF>.
- Electrical interface standard SFF-8432— see <ftp://ftp.seagate.com/sff/SFF-8432.PDF>.

- SFP+ Multi-Source Alliance (MSA) standards

QSFP+ Direct Attach Copper Cables for EX Series Switches

IN THIS SECTION

- Cable Specifications | 89
- DAC Cables Supported on EX3400, EX4300, EX4550, EX4600, EX9251, and EX9253 Switches | 90

Quad small form-factor pluggable plus (QSFP+) direct attach copper (DAC) cables are suitable for in-rack connections between QSFP+ ports on EX3400, EX4300, EX4550, EX4600, EX9251, and EX9253 switches. They are suitable for short distances, making them ideal for highly cost-effective networking connectivity within a rack and between adjacent racks.

NOTE: We recommend that you use only QSFP+ DAC cables purchased from Juniper Networks with your Juniper Networks device.



CAUTION: If you face a problem running a Juniper Networks device that uses a third-party optic or cable, the Juniper Networks Technical Assistance Center (JTAC) can help you diagnose the source of the problem. Your JTAC engineer might recommend that you check the third-party optic or cable and potentially replace it with an equivalent Juniper Networks optic or cable that is qualified for the device.

Cable Specifications

QSFP+ passive DAC cables are hot-removable and hot-insertable. A cable consists of a cable assembly that connects directly into two QSFP+ modules, one at each end of the cable. The cables use integrated duplex serial data links for bidirectional communication and are designed for data rates up to 40 Gbps. Passive DAC cables have no signal amplification built into the cable assembly. See [Figure 34 on page 90](#).

Figure 34: QSFP+ Direct Attach Copper Cables

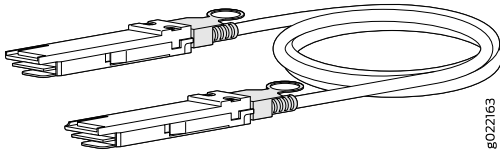

DAC Cables Supported on EX3400, EX4300, EX4550, EX4600, EX9251, and EX9253 Switches

For the list of DAC cables supported on EX3400, EX4300, EX4550, EX4600, EX9251, and EX9253 switches and the specifications of these cables, see:

- EX3400—[Hardware Compatibility Tool page for EX3400](#)
- EX4300—[Hardware Compatibility Tool page for EX4300](#)
- EX4550—[Hardware Compatibility Tool page for EX4550](#)
- EX4600—[Hardware Compatibility Tool page for EX4600](#)
- EX9251—[Hardware Compatibility Tool page for EX9251](#)
- EX9253—[Hardware Compatibility Tool page for EX9253](#)

Understanding EX Series Switches Fiber-Optic Cable Signal Loss, Attenuation, and Dispersion

IN THIS SECTION

- [Signal Loss in Multimode and Single-Mode Fiber-Optic Cable | 91](#)
- [Attenuation and Dispersion in Fiber-Optic Cable | 91](#)

To determine the power budget and power margin needed for fiber-optic connections, you need to understand how signal loss, attenuation, and dispersion affect transmission. EX Series switches use various types of network cable, including multimode and single-mode fiber-optic cable.

Signal Loss in Multimode and Single-Mode Fiber-Optic Cable

Multimode fiber is large enough in diameter to allow rays of light to reflect internally (bounce off the walls of the fiber). Interfaces with multimode optics typically use LEDs as light sources. However, LEDs are not coherent light sources. They spray varying wavelengths of light into the multimode fiber, which reflects the light at different angles. Light rays travel in jagged lines through a multimode fiber, causing signal dispersion. When light traveling in the fiber core radiates into the fiber cladding (layers of lower refractive index material in close contact with a core material of higher refractive index), higher-order mode loss (HOL) occurs. Together, these factors reduce the transmission distance of multimode fiber compared to that of single-mode fiber.

Single-mode fiber is so small in diameter that rays of light reflect internally through one layer only. Interfaces with single-mode optics use lasers as light sources. Lasers generate a single wavelength of light, which travels in a straight line through the single-mode fiber. Compared to multimode fiber, single-mode fiber has a higher bandwidth and can carry signals for longer distances. It is consequently more expensive.

Exceeding the maximum transmission distances can result in significant signal loss, which causes unreliable transmission.

Attenuation and Dispersion in Fiber-Optic Cable

An optical data link functions correctly provided that modulated light reaching the receiver has enough power to be demodulated correctly. *Attenuation* is the reduction in strength of the light signal during transmission. Passive media components such as cables, cable splices, and connectors cause attenuation. Although attenuation is significantly lower for optical fiber than for other media, it still occurs in both multimode and single-mode transmission. An efficient optical data link must transmit enough light to overcome attenuation.

Dispersion is the spreading of the signal over time. The following two types of dispersion can affect signal transmission through an optical data link:

- Chromatic dispersion, which is the spreading of the signal over time caused by the different speeds of light rays.
- Modal dispersion, which is the spreading of the signal over time caused by the different propagation modes in the fiber.

For multimode transmission, modal dispersion, rather than chromatic dispersion or attenuation, usually limits the maximum bit rate and link length. For single-mode transmission, modal dispersion is not a factor. However, at higher bit rates and over longer distances, chromatic dispersion limits the maximum link length.

An efficient optical data link must have enough light to exceed the minimum power that the receiver requires to operate within its specifications. In addition, the total dispersion must be within the limits specified for the type of link in Telcordia Technologies document GR-253-CORE (Section 4.3) and International Telecommunications Union (ITU) document G.957.

When chromatic dispersion is at the maximum allowed, its effect can be considered as a power penalty in the power budget. The optical power budget must allow for the sum of component attenuation, power penalties (including those from dispersion), and a safety margin for unexpected losses.

Calculating the Fiber-Optic Cable Power Budget for EX Series Devices

To ensure that fiber-optic connections have sufficient power for correct operation, calculate the link's power budget when planning fiber-optic cable layout and distances to ensure that fiber-optic connections have sufficient power for correct operation. The power budget is the maximum amount of power the link can transmit. When you calculate the power budget, you use a worst-case analysis to provide a margin of error, even though all the parts of an actual system do not operate at the worst-case levels.

To calculate the worst-case estimate for fiber-optic cable power budget (P_B) for the link:

1. Determine values for the link's minimum transmitter power (P_T) and minimum receiver sensitivity (P_R). For example, here, (P_T) and (P_R) are measured in decibels, and decibels are referred to one milliwatt (dBm).

$$P_T = -15 \text{ dBm}$$

$$P_R = -28 \text{ dBm}$$

NOTE: See the specifications for your transmitter and receiver to find the minimum transmitter power and minimum receiver sensitivity.

2. Calculate the power budget (P_B) by subtracting (P_R) from (P_T):

$$-15 \text{ dBm} - (-28 \text{ dBm}) = 13 \text{ dBm}$$

Calculating the Fiber-Optic Cable Power Margin for EX Series Devices

Calculate the link's power margin when planning fiber-optic cable layout and distances to ensure that fiber-optic connections have sufficient signal power to overcome system losses and still satisfy the minimum

input requirements of the receiver for the required performance level. The power margin (P_M) is the amount of power available after attenuation or link loss (LL) has been subtracted from the power budget (P_B).

When you calculate the power margin, you use a worst-case analysis to provide a margin of error, even though all the parts of an actual system do not operate at worst-case levels. A power margin (P_M) greater than zero indicates that the power budget is sufficient to operate the receiver and that it does not exceed the maximum receiver input power. This means the link will work. A (P_M) that is zero or negative indicates insufficient power to operate the receiver. See the specification for your receiver to find the maximum receiver input power.

Before calculating the power margin:

- Calculate the power budget (see “[Calculating the Fiber-Optic Cable Power Budget for EX Series Devices](#)” on page 92).

To calculate the worst-case estimate for the power margin (P_M) for the link:

1. Determine the maximum value for link loss (LL) by adding estimated values for applicable link-loss factors—for example, use the sample values for various factors as provided in [Table 32 on page 93](#) (here, the link is 2 km long and multimode, and the (P_B) is 13 dBm):

Table 32: Estimated Values for Factors Causing Link Loss

Link-Loss Factor	Estimated Link-Loss Value	Sample (LL) Calculation Values
Higher-order mode losses (HOL)	<ul style="list-style-type: none"> • Multimode—0.5 dBm • Single mode—None 	<ul style="list-style-type: none"> • 0.5 dBm • 0 dBm
Modal and chromatic dispersion	<ul style="list-style-type: none"> • Multimode—None, if product of bandwidth and distance is less than 500 MHz/km • Single mode—None 	<ul style="list-style-type: none"> • 0 dBm • 0 dBm
Connector	0.5 dBm	This example assumes 5 connectors. Loss for 5 connectors: (5) * (0.5 dBm) = 2.5 dBm
Splice	0.5 dBm	This example assumes 2 splices. Loss for two splices: (2) * (0.5 dBm) = 1 dBm
Fiber attenuation	<ul style="list-style-type: none"> • Multimode—1 dBm/km • Single mode—0.5 dBm/km 	This example assumes the link is 2 km long. Fiber attenuation for 2 km: <ul style="list-style-type: none"> • (2 km) * (1.0 dBm/km) = 2 dBm • (2 km) * (0.5 dBm/km) = 1 dBm

Table 32: Estimated Values for Factors Causing Link Loss (*continued*)

Link-Loss Factor	Estimated Link-Loss Value	Sample (LL) Calculation Values
Clock Recovery Module (CRM)	1 dBm	1 dBm

NOTE: For information about the actual amount of signal loss caused by equipment and other factors, see your vendor documentation for that equipment.

2. Calculate the (P_M) by subtracting (LL) from (P_B):

$$P_B - LL = P_M$$

$$(13 \text{ dBm}) - (0.5 \text{ dBm [HOL]}) - ((5) * (0.5 \text{ dBm})) - ((2) * (0.5 \text{ dBm})) - ((2 \text{ km}) * (1.0 \text{ dBm/km})) - (1 \text{ dB [CRM]}) = P_M$$

$$13 \text{ dBm} - 0.5 \text{ dBm} - 2.5 \text{ dBm} - 1 \text{ dBm} - 2 \text{ dBm} - 1 \text{ dBm} = P_M$$

$$P_M = 6 \text{ dBm}$$

The calculated power margin is greater than zero, indicating that the link has sufficient power for transmission. Also, the power margin value does not exceed the maximum receiver input power. Refer to the specification for your receiver to find the maximum receiver input power.

EX4550 Management Cable Specifications and Pinouts

IN THIS SECTION

- [Management Cable Specifications | 95](#)
- [Console Port Connector Pinout Information | 95](#)
- [Mini-USB Port Pinout Specifications | 96](#)
- [USB Port Specifications for an EX Series Switch | 97](#)
- [RJ-45 Management Port Connector Pinout Information | 97](#)
- [RJ-45 Port, SFP Port, SFP+ Port, QSFP+ Port, and QSFP28 Port Connector Pinout Information | 98](#)
- [RJ-45 to DB-9 Serial Port Adapter Pinout Information | 103](#)
- [Virtual Chassis Port Connector Pinout Information for EX4550 Switches | 104](#)

Management Cable Specifications

Table 33 on page 95 lists the specifications for the cables that connect the console and management ports to management devices.

Table 33: Specifications of Cables to Connect to Management Devices

Ports	Cable Specifications	Receptacle	Additional Information
RJ-45 Console port	CAT5e UTP (unshielded twisted pair) cable	RJ-45	“Connect a Device to a Management Console Using an RJ-45 Connector” on page 151
Management Ethernet port	Ethernet cable with an RJ-45 connector	RJ-45	“Connect a Device to a Network for Out-of-Band Management” on page 151
Mini-USB Type-B Console port	Mini-USB cable with standard-A and Mini-USB Type-B (5-pin) connector	Mini-USB	

Console Port Connector Pinout Information

The console port on a Juniper Networks device is an RS-232 serial interface that uses an RJ-45 connector to connect to a console management device. The default baud rate for the console port is 9600 baud.

Table 34 on page 95 provides the pinout information for the RJ-45 console connector.

NOTE: If your laptop or desktop PC does not have a DB-9 plug connector pin and you want to connect your laptop or desktop PC directly to a device, use a combination of the RJ-45 to DB-9 socket adapter and a USB to DB-9 plug adapter. You must provide the USB to DB-9 plug adapter.

Table 34: Console Port Connector Pinout Information

Pin	Signal	Description
1	RTS Output	Request to send
2	DTR Output	Data terminal ready

Table 34: Console Port Connector Pinout Information (*continued*)

Pin	Signal	Description
3	TxD Output	Transmit data
4	Signal Ground	Signal ground
5	Signal Ground	Signal ground
6	RxD Input	Receive data
7	CD Input	Data carrier detect
8	NC	CTS Input

Mini-USB Port Pinout Specifications

If your management host (laptop or PC) does not have a DB-9 plug connector pin or an RJ-45 connector pin but has a USB port, you can connect your management host to the Mini-USB Type-B console port by using a cable that has a standard Type-A USB connector on one end and a Mini-USB Type-B (5-pin) connector on the other end.

The Mini-USB Type-B console port uses a Mini-USB Type-B connector to connect to a console management device. The default baud rate for the console port is 9600 baud.

[Table 35 on page 96](#) provides the pinout information of the Mini-USB Type-B console port.

Table 35: Mini-USB Type-B Console Port Pinout Information

Pin	Signal	Description
1	VCC	+5 VDC
2	D-	Data -
3	D+	Data +
X	N/C	Could be not connected (N/C), connected to ground (GND), or used as an attached device presence indicator
4	GND	Ground

USB Port Specifications for an EX Series Switch

The following Juniper Networks USB flash drives have been tested and are officially supported for the USB port on all EX Series switches:

- RE-USB-1G-S
- RE-USB-2G-S
- RE-USB-4G-S



CAUTION: Any USB memory product not listed as supported for EX Series switches has not been tested by Juniper Networks. The use of any unsupported USB memory product could expose your EX Series switch to unpredictable behavior. Juniper Networks Technical Assistance Center (JTAC) can provide only limited support for issues related to unsupported hardware. We strongly recommend that you use only supported USB flash drives.

All USB flash drives used on EX Series switches must have the following features:

- USB 2.0 or later.
- Formatted with a FAT or MS-DOS file system.
- If the switch is running Junos OS Release 9.5 or earlier, the formatting method must use a primary boot record. Microsoft Windows formatting, by default, does not use a primary boot record. See the documentation for your USB flash drive for information about how your USB flash drive is formatted.

RJ-45 Management Port Connector Pinout Information

[Table 36 on page 97](#) provides the pinout information for the RJ-45 connector for the management port on Juniper Networks devices.

Table 36: RJ-45 Management Port Connector Pinout Information

Pin	Signal	Description
1	TRP1+	Transmit/receive data pair 1
2	TRP1–	Transmit/receive data pair 1
3	TRP2+	Transmit/receive data pair 2

Table 36: RJ-45 Management Port Connector Pinout Information (continued)

Pin	Signal	Description
4	TRP3+	Transmit/receive data pair 3
5	TRP3–	Transmit/receive data pair 3
6	TRP2–	Transmit/receive data pair 2
7	TRP4+	Transmit/receive data pair 4
8	TRP4–	Transmit/receive data pair 4

RJ-45 Port, SFP Port, SFP+ Port, QSFP+ Port, and QSFP28 Port Connector Pinout Information

The tables in this topic describe the connector pinout information for the RJ-45, QSFP+, QSFP28, SFP+, and SFP ports.

- [Table 37 on page 98](#)—10/100/1000BASE-T Ethernet network port connector pinout information
- [Table 38 on page 99](#)—SFP network port connector pinout information
- [Table 39 on page 100](#)—SFP+ network port connector pinout information
- [Table 40 on page 101](#)—QSFP+ and QSFP28 network module ports connector pinout information

Table 37: 10/100/1000BASE-T Ethernet Network Port Connector Pinout Information

Pin	Signal	Description
1	TRP1+	Transmit/receive data pair 1 Negative Vport (in PoE models)
2	TRP1-	Transmit/receive data pair 1 Negative Vport (in PoE models)
3	TRP2+	Transmit/receive data pair 2 Positive Vport (in PoE models)
4	TRP3+	Transmit/receive data pair 3

Table 37: 10/100/1000BASE-T Ethernet Network Port Connector Pinout Information (continued)

Pin	Signal	Description
5	TRP3-	Transmit/receive data pair 3
6	TRP2-	Transmit/receive data pair 2 Positive Vport (in PoE models)
7	TRP4+	Transmit/receive data pair 4
8	TRP4-	Transmit/receive data pair 4

Table 38: SFP Network Port Connector Pinout Information

Pin	Signal	Description
1	VeeT	Module transmitter ground
2	TX_Fault	Module transmitter fault
3	TX_Disable	Transmitter disabled
4	SDA	2-wire serial interface data line
5	SCL-	2-wire serial interface clock
6	MOD_ABS	Module absent
7	RS	Rate select
8	RX_LOS	Receiver loss of signal indication
9	VeeR	Module receiver ground
10	VeeR	Module receiver ground
11	VeeR	Module receiver ground
12	RD-	Receiver inverted data output
13	RD+	Receiver noninverted data output
14	VeeR	Module receiver ground

Table 38: SFP Network Port Connector Pinout Information (continued)

Pin	Signal	Description
15	VccR	Module receiver 3.3 V supply
16	VccT	Module transmitter 3.3 V supply
17	VeeT	Module transmitter ground
18	TD+	Transmitter noninverted data input
19	TD-	Transmitter inverted data input
20	VeeT	Module transmitter ground

Table 39: SFP+ Network Port Connector Pinout Information

Pin	Signal	Description
1	VeeT	Module transmitter ground
2	TX_Fault	Module transmitter fault
3	TX_Disable	Transmitter disabled
4	SDA	2-wire serial interface data line
5	SCL-	2-wire serial interface clock
6	MOD_ABS	Module absent
7	RS0	Rate select 0, optionally controls SFP+ module receiver
8	RX_LOS	Receiver loss of signal indication
9	RS1	Rate select 1, optionally controls SFP+ transmitter
10	VeeR	Module receiver ground
11	VeeR	Module receiver ground
12	RD-	Receiver inverted data output
13	RD+	Receiver noninverted data output

Table 39: SFP+ Network Port Connector Pinout Information (*continued*)

Pin	Signal	Description
14	VeeR	Module receiver ground
15	VccR	Module receiver 3.3-V supply
16	VccT	Module transmitter 3.3-V supply
17	VeeT	Module transmitter ground
18	TD+	Transmitter noninverted data input
19	TD-	Transmitter inverted data input
20	VeeT	Module transmitter ground

Table 40: QSFP+ and QSFP28 Network Port Connector Pinout Information

Pin	Signal
1	GND
2	TX2n
3	TX2p
4	GND
5	TX4n
6	TX4p
7	GND
8	ModSelL
9	LPMode_Reset
10	VccRx
11	SCL
12	SDA

Table 40: QSFP+ and QSFP28 Network Port Connector Pinout Information (continued)

Pin	Signal
13	GND
14	RX3p
15	RX3n
16	GND
17	RX1p
18	RX1n
19	GND
20	GND
21	RX2n
22	RX2p
23	GND
24	RX4n
25	RX4p
26	GND
27	ModPrsL
28	IntL
29	VccTx
30	Vcc1
31	Reserved
32	GND
33	TX3p

Table 40: QSFP+ and QSFP28 Network Port Connector Pinout Information (*continued*)

Pin	Signal
34	TX3n
35	GND
36	TX1p
37	TX1n
38	GND

RJ-45 to DB-9 Serial Port Adapter Pinout Information

The console port is an RS-232 serial interface that uses an RJ-45 connector to connect to a management device such as a laptop or a desktop PC. If your laptop or desktop PC does not have a DB-9 plug connector pin and you want to connect your laptop or desktop PC to the device, use a combination of the RJ-45 to DB-9 socket adapter along with a USB to DB-9 plug adapter.

[Table 41 on page 103](#) provides the pinout information for the RJ-45 to DB-9 serial port adapter.

Table 41: RJ-45 to DB-9 Serial Port Adapter Pinout Information

RJ-45 Pin	Signal	DB-9 Pin	Signal
1	RTS	8	CTS
2	DTR	6	DSR
3	TxD	2	RxD
4	GND	5	GND
6	RxD	3	TxD
7	DSR	4	DTR
8	CTS	7	RTS

Virtual Chassis Port Connector Pinout Information for EX4550 Switches

EX4550 switches use a 68-pin connector cable to interconnect switches to form a Virtual Chassis. [Table 42 on page 104](#) provides connector pinout information for the Virtual Chassis ports (VCPs).

Table 42: Virtual Chassis Ports (VCPs) Connector Pinout Information

Pin Number	Pin Name
A1	GND
A2	P1TXP0
A3	P1TXN0
A4	GND
A5	P1TXP1
A6	P1TXN1
A7	GND
A8	P1TXP2
A9	P1TXN2
A10	GND
A11	P1TXP3
A12	P1TXN3
A13	GND
A14	N/C
A15	N/C
A16	GND
A17	N/C
A18	N/C

Table 42: Virtual Chassis Ports (VCPs) Connector Pinout Information (continued)

Pin Number	Pin Name
A19	N/C
A20	N/C
A21	N/C
A22	GND
A23	P2TXP0
A24	P2TXN0
A25	GND
A26	P2TXP1
A27	P2TXN1
A28	GND
A29	P2TXP2
A30	P2TXN2
A31	GND
A32	P2TXP3
A33	P2TXN3
A34	GND
B1	GND
B2	P1RXP0
B3	P1RXN0
B4	GND
B5	P1RXP1

Table 42: Virtual Chassis Ports (VCPs) Connector Pinout Information (continued)

Pin Number	Pin Name
B6	P1RXN1
B7	GND
B8	P1RXP2
B9	P1RXN2
B10	GND
B11	P1RXP3
B12	P1RXN3
B13	GND
B14	N/C
B15	N/C
B16	N/C
B17	N/C
B18	N/C
B19	N/C
B20	N/C
B21	N/C
B22	GND
B23	P2RXP0
B24	P2RXN0
B25	GND
B26	P2RXP1

Table 42: Virtual Chassis Ports (VCPs) Connector Pinout Information (*continued*)

Pin Number	Pin Name
B27	P2RXN1
B28	GND
B29	P2RXP2
B30	P2RXN2
B31	GND
B32	P2RXP3
B33	P2RXN3
B34	GND

SEE ALSO

[Planning EX4200, EX4500, and EX4550 Virtual Chassis | 111](#)

[Understanding EX Series Virtual Chassis](#)

[Understanding Virtual Chassis Components](#)

[Connecting a Virtual Chassis Cable to an EX4550 Switch | 227](#)

EX4550 Virtual Chassis

IN THIS SECTION

- [Understanding EX4200, EX4500, and EX4550 Virtual Chassis Hardware Configurations | 108](#)
- [Planning EX4200, EX4500, and EX4550 Virtual Chassis | 111](#)
- [Virtual Chassis Cabling Configuration Examples for EX4550 Switches | 114](#)

Understanding EX4200, EX4500, and EX4550 Virtual Chassis Hardware Configurations

IN THIS SECTION

- [Ports Used to Interconnect Virtual Chassis Members | 108](#)
- [Number of Switches, Required Software Releases, and Member Roles That You Configure in the Virtual Chassis | 109](#)
- [Virtual Chassis Module | 110](#)
- [Switch Role and Member ID on the LCD Panel | 111](#)

You can interconnect EX4200 switches together to form a Virtual Chassis composed exclusively of EX4200 switches. You can interconnect EX4500 switches together to form a Virtual Chassis composed exclusively of EX4500 switches. You can interconnect EX4550 switches together to form a Virtual Chassis composed exclusively of EX4550 switches. You can also interconnect EX4200 switches with EX4500 switches or with EX4550 switches or with both switches to form a mixed Virtual Chassis.

Ports Used to Interconnect Virtual Chassis Members

You can use the following ports to connect Virtual Chassis members:

- On EX4200 switches:
 - The dedicated Virtual Chassis ports (VCPs) on each switch
 - SFP, SFP+, or XFP uplink module ports configured as VCPs
 - SFP network ports on EX4200-24F switches configured as VCPs
- On EX4500 switches:
 - The dedicated VCPs on the Virtual Chassis module
 - SFP+ network ports configured as VCPs
 - SFP+ uplink module ports configured as VCPs
- On EX4550 switches:
 - The dedicated VCPs on the Virtual Chassis module
 - SFP+ network ports configured as VCPs
 - SFP+ expansion module ports configured as VCPs

- 10GBASE-T network ports configured as VCPs
- 10GBASE-T expansion module ports configured as VCPs
- 40G QSFP+ expansion module ports configured as VCPs

NOTE: You can use the 10GBASE-T Ethernet network ports, 10GBASE-T expansion module ports, and QSFP+ expansion module ports configured as VCPs to interconnect only EX4550 switches in a Virtual Chassis. These ports cannot be used to connect an EX4550 switch with an EX4200 switch or an EX4500 switch in a Virtual Chassis.

Number of Switches, Required Software Releases, and Member Roles That You Configure in the Virtual Chassis

A Virtual Chassis must have one member designated as the primary switch and one member designated as the backup switch. All other switches in the configuration are designated as being in the linecard role. You manage Virtual Chassis operation through the primary switch.

The number of switches that you can configure in a Virtual Chassis and the role that can be assigned to each switch in a Virtual Chassis depend on the Juniper Networks Junos operating system (Junos OS) release that is running on the switches.

See the following tables:

- [Table 43 on page 109](#)—EX4200 Virtual Chassis
- [Table 44 on page 109](#)—EX4500 Virtual Chassis
- [Table 45 on page 110](#)—EX4550 Virtual Chassis
- [Table 46 on page 110](#)—Mixed EX4200, EX4500, and EX4550 Virtual Chassis

Table 43: Number of Switches and Switch Roles for an EX4200 Virtual Chassis, per Junos OS Release

Junos OS Release	Number of Switches	Role
9.0 or later	Up to 10 EX4200 switches	There must be a primary and a backup; the remaining switches must be in the linecard role.

Table 44: Number of Switches and Switch Roles for an EX4500 Virtual Chassis, per Junos OS Release

Junos OS Release	Number of Switches	Role
11.1–11.3	Up to 2 EX4500 switches	There must be a primary and a backup.

Table 44: Number of Switches and Switch Roles for an EX4500 Virtual Chassis, per Junos OS Release (continued)

Junos OS Release	Number of Switches	Role
11.4 or later	Up to 10 EX4500 switches	There must be a primary and a backup; the remaining switches must be in the linecard role.

Table 45: Number of Switches and Switch Roles for an EX4550 Virtual Chassis, per Junos OS Release

Junos OS Release	Number of Switches	Role
12.2 or later	Up to 10 EX4550 switches	There must be a primary and a backup; the remaining switches must be in the linecard role.

Table 46: Number of Switches and Switch Roles for a Mixed EX4200, EX4500, and EX4550 Virtual Chassis, per Junos OS Release

Junos OS Release	Number of Switches	Role
11.1	Up to 2 EX4500 switches and up to 8 EX4200 switches	EX4500 switches must be in the primary and backup roles and EX4200 switches in the linecard role.
11.2, 11.3	Up to 2 EX4500 switches and up to 8 EX4200 switches	Primary and backup must be of the same switch type—either both EX4200 or both EX4500 switches. The remaining switches must be in the linecard role.
11.4 or later	Up to 10 total of both EX4200 and EX4500 switches	Any switch type in any role. There must be a primary and a backup and the remaining switches must be in the linecard role.
12.2 or later	Up to 10 total of EX4200, EX4500, and EX4550 switches	Any switch type in any role. There must be a primary and a backup and the remaining switches must be in the linecard role.

Virtual Chassis Module

Virtual Chassis modules are available for EX4500 and EX4550 switches. However, installing a Virtual Chassis module is not mandatory for using these switches in a Virtual Chassis configuration.

NOTE: On EX4500 switches that are running Junos OS releases earlier than Release 11.4R1, you must install a Virtual Chassis module for using the switch in a Virtual Chassis configuration. Starting with Release 11.4R1, you can use uplink port connections to interconnect EX4500 member switches into a Virtual Chassis.

Switch Role and Member ID on the LCD Panel

For each switch in the Virtual Chassis, the LCD panel of the switch displays:

- Role of the switch—**RE** for primary, **BK** for backup, and **LC** for linecard member
- Member ID for the Virtual Chassis member—A number in the range 0 through 9

SEE ALSO

Understanding Virtual Chassis Components

Understanding EX Series Virtual Chassis

Planning EX4200, EX4500, and EX4550 Virtual Chassis

Before interconnecting EX4200, EX4500, and EX4550 switches in a Virtual Chassis configuration:

- Verify that the rack in which you will install the switches meets the requirements described in “[Rack Requirements](#)” on [page 81](#). You can mount the switches in a Virtual Chassis on a single rack or on multiple racks.
- Verify that the installation site meets the power requirements of the switches in a Virtual Chassis.
- Verify that you have installed a Virtual Chassis module in an EX4500 switch running Junos OS releases earlier than Release 11.4R1. The Virtual Chassis module must be installed in an EX4500 switch to form a Virtual Chassis.

[Table 47 on page 112](#) describes the Virtual Chassis components and the Junos OS release running on switches that you need to consider when you plan your EX4200, EX4500, and EX4550 Virtual Chassis configuration.

Table 47: Virtual Chassis Components to Consider When Planning an EX4200, EX4500, and EX4550 Virtual Chassis

Virtual Chassis Components	Junos OS Release Running on the Member Switches	Virtual Chassis Details
EX4200 switches only	Junos OS Release 9.0 and later	You can interconnect two to ten EX4200 switches to form a Virtual Chassis composed exclusively of EX4200 switches.
EX4500 switches only	Junos OS Releases 11.1, 11.2, and 11.3	You can interconnect two EX4500 switches into a Virtual Chassis composed exclusively of EX4500 switches.
	Junos OS Release 11.4 or later	You can interconnect up to ten EX4500 switches into a Virtual Chassis composed exclusively of EX4500 switches.
EX4550 switches only	Junos OS Release 12.2 or later	You can interconnect up to ten EX4550 switches into a Virtual Chassis composed exclusively of EX4550 switches.
EX4200, EX4500, and EX4550 switches	Junos OS Release 11.1	You can interconnect up to two EX4500 switches and up to eight EX4200 switches into a mixed Virtual Chassis. EX4500 switches must always be configured in the primary and backup roles.
	Junos OS Releases 11.2 and 11.3	You can interconnect up to two EX4500 switches and up to eight EX4200 switches into a mixed Virtual Chassis. The same type of switch must act in the primary and backup roles.
	Junos OS Release 11.4 or later	You can interconnect up to ten total EX4200 and EX4500 switches into a mixed Virtual Chassis . Any switch can be configured in any role in any configuration.
	Junos OS Release 12.2 or later	You can interconnect up to ten total EX4200, EX4500, and EX4550 switches into a mixed Virtual Chassis. Any switch can be configured in any role in any configuration.

Table 48 on page 113 describes the cabling requirements for a Virtual Chassis.

Table 48: Cabling Requirements for a Virtual Chassis

Distance Between Virtual Chassis Members	Virtual Chassis Cable Lengths Supported	Details
Up to 0.5 m	0.5 m	<p>You can interconnect EX4200, EX4500, and EX4550 switches into a Virtual Chassis through Virtual Chassis ports (VCPs) using the 0.5-meter Virtual Chassis cable.</p> <ul style="list-style-type: none"> • This Virtual Chassis cable is supplied with an EX4200 switch. • You must order this cable separately for EX4500 and EX4550 switches, including EX4500 switches that are shipped with a preinstalled Virtual Chassis module.
0.5 m through 5 m	1 m, 3 m, and 5 m	<p>You must order these cables separately for EX4200, EX4500, and EX4550 switches, including EX4500 switches that are shipped with a preinstalled Virtual Chassis module.</p>
Greater than 5 m	-	<ul style="list-style-type: none"> • To interconnect EX4200 switches that are installed farther apart than 5 m, you must configure the SFP, SFP+, or XFP uplink module ports or the SFP network ports in the EX4200-24F switch as VCPs and use them to interconnect the switches. • To interconnect EX4500 switches that are installed farther apart than 5 m, you must configure either the uplink module ports or the SFP+ network ports as VCPs and use them to interconnect the switches. • To interconnect EX4550 switches that are installed farther apart than 5 m, you must configure either the expansion module ports or the network ports as VCPs and use them to interconnect the switches.

NOTE: With separately ordered Virtual Chassis cables, you can use the cable connector retainers provided with the original cable; you can also use separately ordered Virtual Chassis cable connector retainers.

Virtual Chassis Cabling Configuration Examples for EX4550 Switches

You can install EX4550 switches on a single rack or in multiple racks, or in different wiring closets, and interconnect them to form a Virtual Chassis.

You form an EX4550 Virtual Chassis by using dedicated Virtual Chassis ports (VCPs) or expansion module ports configured as Virtual Chassis ports (VCPs).

You can use ports on the following to connect an EX4550 switch in a Virtual Chassis:

- SFP+ network ports and 10GBASE-T Ethernet network ports
- 8-port 10GBASE-T expansion module
- 8-port 10-Gigabit SFP+ expansion module
- 2-port 40-Gigabit QSFP+ expansion module
- 128-Gigabit Virtual Chassis module

The physical location of the switches in a Virtual Chassis is restricted only by the maximum length supported for cables to connect the VCPs.

The following illustrations show various Virtual Chassis cabling configuration examples.

NOTE: For increased availability and redundancy, we recommend that you always configure your Virtual Chassis in a ring topology.

[Figure 35 on page 115](#) and [Figure 36 on page 115](#) shows five EX4550 switches stacked vertically in a rack and interconnected in a ring topology using Virtual Chassis module and using four short Virtual Chassis cables and one long Virtual Chassis cable.

Figure 35: EX4550 Switches Mounted on a Single Rack and Connected in a Ring Topology Using Virtual Chassis Module and Using Short and Long Cables: Example 1

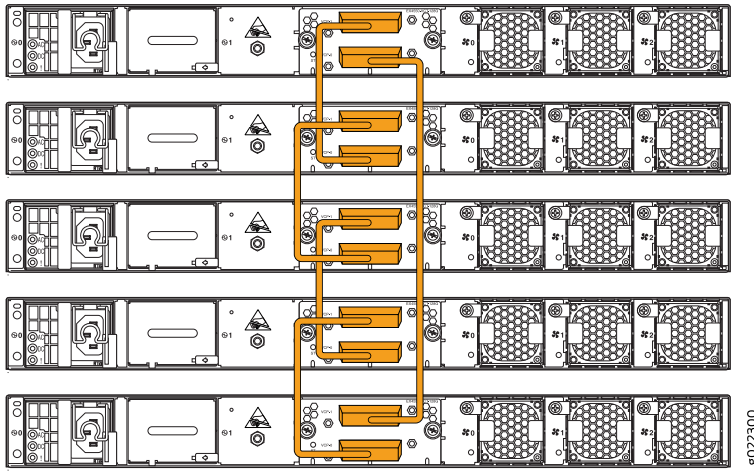

Figure 36: EX4550 Switches Mounted on a Single Rack and Connected in a Ring Topology Using Virtual Chassis Module and Using Short and Long Cables: Example 2

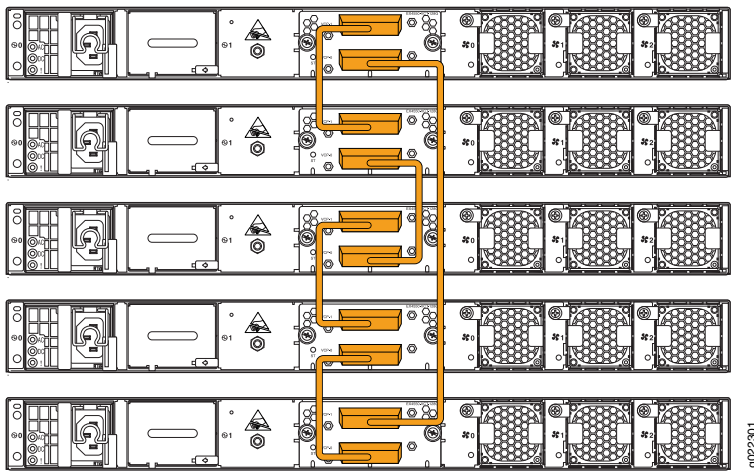
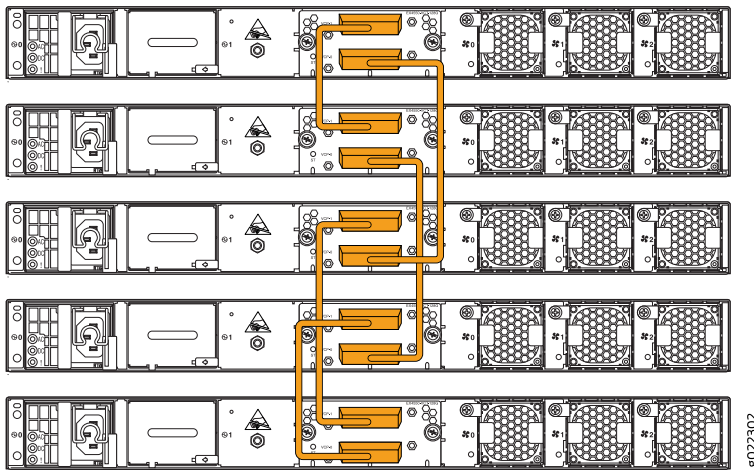

Figure 37 on page 116 shows five EX4550 switches stacked vertically in a rack and interconnected in a ring topology using Virtual Chassis module and using short-length and medium-length Virtual Chassis cables.

Figure 37: EX4550 Switches Mounted on a Single Rack and Connected in a Ring Topology Using Virtual Chassis Module and Using Short and Medium Cables



[Figure 38 on page 116](#) and [Figure 39 on page 116](#) shows five EX4550 switches mounted on the top rows of adjacent racks and interconnected in a ring topology using Virtual Chassis module and using medium-length and long-length Virtual Chassis cables.

Figure 38: EX4550 Switches Mounted on Adjacent Racks and Connected in a Ring Topology Using Virtual Chassis Module and Using Medium and Long Cables: Example 1

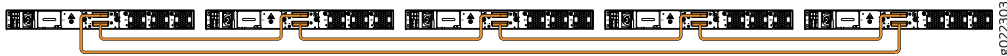

Figure 39: EX4550 Switches Mounted on Adjacent Racks and Connected in a Ring Topology Using Virtual Chassis Module and Using Medium and Long Cables: Example 2



[Figure 40 on page 117](#) and [Figure 41 on page 117](#) shows five EX4550 switches stacked vertically in a rack and interconnected in a ring topology using 8-port 10GBASE-T expansion module and using four short cables and one long cable.

Figure 40: EX4550 Switches Mounted on a Single Rack and Connected in a Ring Topology Using 8-port 10GBASE-T Expansion Module and Using Short and Long Cables: Example 1



Figure 41: EX4550 Switches Mounted on a Single Rack and Connected in a Ring Topology Using 8-port 10GBASE-T Expansion Module and Using Short and Long Cables: Example 2

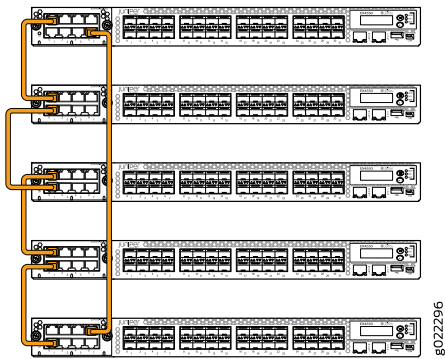

Figure 42 on page 118 shows five EX4550 switches stacked vertically in a rack and interconnected in a ring topology using 8-port 10GBASE-T expansion module and using short-length and medium-length cables.

Figure 42: EX4550 Switches Mounted on a Single Rack and Connected in a Ring Topology Using 8-port 10GBASE-T Expansion Module and Using Short and Medium Cables

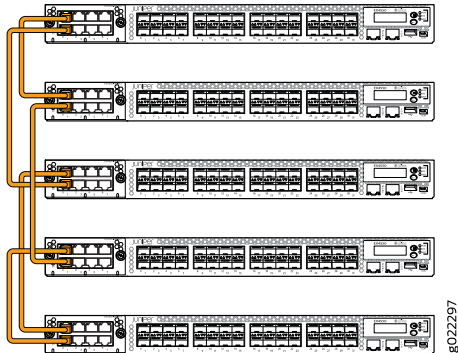

Figure 43 on page 118 and Figure 44 on page 118 show five EX4550 switches mounted on the top rows of adjacent racks and interconnected in a ring topology using 8-port 10GBASE-T expansion module and using medium-length and long-length cables.

Figure 43: EX4550 Switches Mounted on Adjacent Racks and Connected in a Ring Topology Using 8-port 10GBASE-T Expansion Module and Using Medium and Long Cables: Example 1

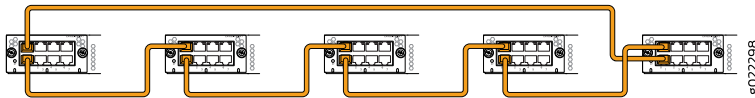
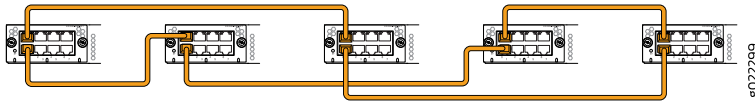

Figure 44: EX4550 Switches Mounted on Adjacent Racks and Connected in a Ring Topology Using 8-port 10GBASE-T Expansion Module and Using Medium and Long Cables: Example 2



NOTE: The interconnections using SFP+ network ports, 10GBASE-T Ethernet network ports, 8-port 10-Gigabit SFP+ expansion module, and 2-port 40-Gigabit QSFP+ expansion module are similar to the interconnections using 8-port 10GBASE-T expansion module.

SEE ALSO

| *Understanding Virtual Chassis Components*

3

CHAPTER

Initial Installation and Configuration

Unpacking and Mounting the EX4550 | **120**

Connecting the EX4550 to Power | **131**

Connecting the EX4550 to Network | **146**

Connecting the EX4550 to External Devices | **150**

Configuring Junos OS on the EX4550 | **154**

Dashboard for EX Series Switches | **178**

Unpacking and Mounting the EX4550

IN THIS SECTION

- Unpacking an EX4550 Switch | 120
- Parts Inventory (Packing List) for an EX4550 Switch | 121
- Register Products—Mandatory to Validate SLAs | 122
- Installing and Connecting an EX4550 Switch | 123
- Mounting an EX4550 Switch | 124
- Mounting an EX4550 Switch on Two Posts in a Rack or Cabinet | 124
- Mounting an EX4550 Switch on Four Posts in a Rack or Cabinet | 127
- Mounting an EX4550 Switch in a Recessed Position in a Rack or Cabinet | 131

Unpacking an EX4550 Switch

The EX4550 switches are shipped in a cardboard carton, secured with foam packing material. The carton has an accessory compartment.



CAUTION: EX4550 switches are maximally protected inside the shipping carton. Do not unpack the switches until you are ready to begin installation.

To unpack the switch:

1. Open the carton.
2. Pull out the packing material holding the switch in place.
3. Verify the parts received against the inventory on the label (packing list) attached to the carton. See [“Parts Inventory \(Packing List\) for an EX4550 Switch” on page 121.](#)
4. Save the shipping carton and packing materials in case you need to move or ship the switch later.

Parts Inventory (Packing List) for an EX4550 Switch

The switch shipment includes a packing list. Check the parts you receive with the switch against the items on the packing list. The packing list specifies the part number and provides a description of each part in your order. The parts shipped depend on the model number of the switch you order. See “EX4550 Switch Models” on page 27 for more information.

If any part on the packing list is missing, contact your customer service representative or contact Juniper customer care from within the U.S. or Canada by telephone at 1-888-314-5822. For international-dial or direct-dial options in countries without toll-free numbers, see <https://www.juniper.net/support/requesting-support.html>.

Table 49 on page 121 lists the parts and their quantities as in the standard packing list for an EX4550 switch.

Table 49: Inventory of Components Provided with an EX4550 Switch

Component		Quantity
Switch		1
Fan modules	EX4550-32F switches	3 preinstalled
	EX4550-32F-S switches	Fan modules for this model are not shipped by default; you must separately order either three AIR OUT (AFO) labelled or three AIR IN (AFI) labelled fan modules.
Power supply	EX4550-32F switches	1 (AC or DC) preinstalled
	EX4550-32F-S switches	Power supplies for this model are not shipped by default; you must separately order either AC power supplies or DC power supplies.
AC power cord with retainer clip appropriate for your geographical location (only for switches with AC power supply)	EX4550-32F switches	1
	EX4550-32F-S switches	AC power cord with retainer clip for this model is not shipped by default; you must order it separately.
Cover panels for slots without installed components (preinstalled)		<ul style="list-style-type: none"> • Power supply cover panel: 1 • Module slot cover panels: 2
Dust covers for ports (only for an EX4550-32F switch)		32
Mounting brackets		2

Table 49: Inventory of Components Provided with an EX4550 Switch (continued)

Component	Quantity
Mounting screws	8
Rubber feet	4
RJ-45 cable and RJ-45 to DB-9 serial port adapter	1
Documentation Roadmap	1
Juniper Networks Product Warranty	1
End User License Agreement	1

NOTE: You must provide mounting screws that are appropriate for your rack to mount the chassis on a rack or a cabinet.

Register Products—Mandatory to Validate SLAs

Register all new Juniper Networks hardware products and changes to an existing installed product using the Juniper Networks website to activate your hardware replacement service-level agreements (SLAs).



CAUTION: Register product serial numbers on the Juniper Networks website and update the installation base data if there is any addition or change to the installation base or if the installation base is moved. Juniper Networks will not be held accountable for not meeting the hardware replacement service-level agreement for products that do not have registered serial numbers or accurate installation base data.

Register your product(s) at <https://tools.juniper.net/svcreg/SRegSerialNum.jsp>.

Update your installation base at

<https://www.juniper.net/customers/csc/management/updateinstallbase.jsp>.

Installing and Connecting an EX4550 Switch

To install and connect an EX4550 switch:

1. Follow instructions in [“Unpacking an EX4550 Switch” on page 120](#).
2. Install a power supply if it is not preinstalled: see
 - [Installing an AC Power Supply in an EX4550 Switch on page 212](#)
 - [Installing a DC Power Supply in an EX4550 Switch on page 215](#)
3. Install a fan module if it is not preinstalled; see [“Installing a Fan Module in an EX4550 Switch” on page 209](#).
4. Mount the switch by following instructions appropriate for your site:
 - [“Mounting an EX4550 Switch on Two Posts in a Rack or Cabinet” on page 124](#) (using the mounting brackets provided)
 - [“Mounting an EX4550 Switch on Four Posts in a Rack or Cabinet” on page 127](#) (using the separately orderable four-post rack-mount kit)
5. Follow instructions in [“Connect Earth Ground to an EX Series Switch” on page 132](#).
6. Follow instructions for connecting power as appropriate for your site:
 - [Connecting AC Power to an EX4550 Switch on page 139](#)
 - [Connecting DC Power to an EX4550 Switch on page 142](#)
7. Register your product by following instructions in [“Register Products—Mandatory to Validate SLAs” on page 122](#).
8. Perform initial configuration of the switch by following the instructions in [“Connecting and Configuring an EX Series Switch \(CLI Procedure\)” on page 168](#) or [“Connecting and Configuring an EX Series Switch \(J-Web Procedure\)” on page 171](#).
9. Set the switch’s management options by following the instructions:
 - [Connect a Device to a Network for Out-of-Band Management on page 151](#)
 - [Connect a Device to a Management Console Using an RJ-45 Connector on page 151](#)
 - [Connect an EX Series Switch to a Management Console Using the Mini-USB Type-B Console Port on page 153](#)

SEE ALSO

[Rack Requirements | 81](#)

[Cabinet Requirements | 82](#)

[Clearance Requirements for Airflow and Hardware Maintenance for EX4550 Switches | 83](#)

Mounting an EX4550 Switch

You can mount an EX4550 switch:

- Flush with the rack front on two posts of a 19-in. two-post or four-post rack or cabinet by using the mounting brackets provided with the switch.
- Flush with the rack front on four posts of a 19-in. four-post rack or cabinet by using the separately orderable four-post rack-mount kit.
- In a position recessed 2 in. (5 cm) from the front of a 19-in. two-post or four-post rack or cabinet by using the separately orderable four-post rack-mount kit.

The holes in the mounting brackets are placed at 1 U (1.75 in. or 4.45 cm) apart so that the switch can be mounted in any rack or cabinet that provides holes spaced at that distance.

See the Related Documentation for detailed descriptions of the various rack or cabinet mounting options.

Mounting an EX4550 Switch on Two Posts in a Rack or Cabinet

You can mount an EX4550 switch on two posts in a 19-in. rack or cabinet (either a two-post or a four-post rack or cabinet) by using the mounting brackets provided with the switch. (The remainder of this topic uses *rack* to mean *rack or cabinet*.)

You can mount the switch on four posts in a four-post rack by using the mounting brackets provided with the separately orderable four-post rack-mount kit. See [“Mounting an EX4550 Switch on Four Posts in a Rack or Cabinet” on page 127](#).

NOTE: If you need to mount the switch in a recessed position on two posts of either a two-post rack or a four-post rack, you can use the 2-in.-recess front mount brackets provided in the separately orderable four-post rack-mount kit.

Before mounting the switch on two posts in a rack:

- Verify that the site meets the requirements described in [“Site Preparation Checklist for EX4550 Switches” on page 73](#).
- Place the rack in its permanent location, allowing adequate clearance for airflow and maintenance, and secure it to the building structure.
- Read [“General Safety Guidelines and Warnings” on page 274](#), with particular attention to [“Chassis and Component Lifting Guidelines” on page 281](#).
- Remove the switch from the shipping carton (see [“Unpacking an EX4550 Switch” on page 120](#)).

Ensure that you have the following parts and tools available:

- Phillips (+) screwdriver, number 2
- 2 mounting brackets and 8 mounting screws (provided in the accessory box shipped with the switch)
- Screws to secure the chassis to the rack (not provided)
- 2-in.-recess front mount brackets if you will mount the switch in a recessed position (brackets are part of the separately orderable four-post rack-mount kit).
- Cover panels for module slots (provided in the accessory box shipped with the switch)
- Dust covers for ports (provided in the accessory box shipped with the EX4550-32F switches)

NOTE: One person must be available to lift the switch while another secures the switch to the rack.



CAUTION: If you are mounting multiple switches on a rack, mount a switch in the bottom of the rack first and proceed to mount the rest of the switches from bottom to top.

To mount the switch on two posts in a rack:

1. Place the switch on a flat, stable surface.
2. Place the mounting brackets along the side panels of the switch chassis, aligning them with the rear panel, the front panel, or with the center of the side panels depending on how you want to mount the switch. See [Figure 45 on page 126](#).

Figure 45: Attaching the Mounting Bracket to the Side Panel of the Switch

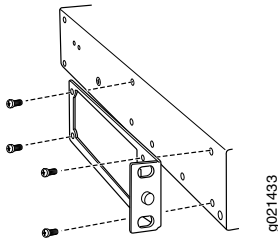

NOTE: If you need to mount the switch in a recessed position, use the 2-in.-recess front mount brackets from the separately orderable four-post rack-mount kit.

3. Align the bottom holes in the mounting brackets with holes on the side panels of the switch chassis.
4. Insert mounting screws into the aligned holes. Tighten the screws by using the Phillips (+) screwdriver.
5. Ensure that the other holes in the mounting brackets are aligned with the holes in the side panels. Insert a screw in each hole and tighten the screws.
6. Have one person grasp both sides of the switch, lift the switch, and position it in the rack, aligning the mounting bracket holes with the threaded holes in the rack or cabinet rail. Align the bottom hole in both the mounting brackets with a hole in each rack rail, making sure the chassis is level. See [Figure 46 on page 126](#).

Figure 46: Mounting the Switch on Two Posts in a Rack

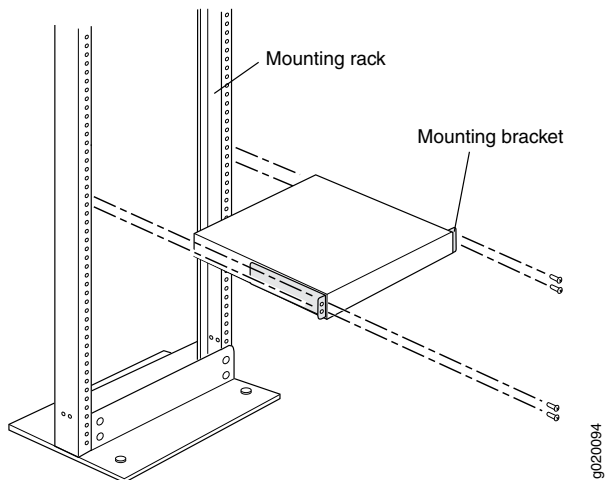

7. Have a second person secure the switch to the rack by using the appropriate screws. Tighten the screws using the appropriate screwdrivers.
8. Ensure that the switch chassis is level by verifying that all screws on one side of the rack are aligned with the screws on the other side.

NOTE: We recommend that you install cover panels in unused module slots and dust covers in unused SFP/SFP+ ports.

SEE ALSO

[Connecting AC Power to an EX4550 Switch | 139](#)

[Connecting DC Power to an EX4550 Switch | 142](#)

[Connecting and Configuring an EX Series Switch \(CLI Procedure\) | 168](#)

[Connecting and Configuring an EX Series Switch \(J-Web Procedure\) | 171](#)

[Rack-Mounting and Cabinet-Mounting Warnings | 286](#)

Mounting an EX4550 Switch on Four Posts in a Rack or Cabinet

You can mount an EX4550 switch on four posts in a 19-in. rack or cabinet by using the separately orderable four-post rack-mount kit. (The remainder of this topic uses *rack* to mean *rack or cabinet*.)

You can mount the switch on two posts in either a two-post rack or a four-post rack by using the mounting brackets provided with the switch. See “[Mounting an EX4550 Switch on Two Posts in a Rack or Cabinet](#)” on page 124.

NOTE: If you need to mount the switch in a recessed position on either a two-post rack or a four-post rack, you can use the 2-in.-recess front mount brackets provided in the separately orderable four-post rack-mount kit.

NOTE:

To ensure that the protective earthing terminal is accessible through the opening in the rear mounting-blade:

- Ensure that the rack is 27.5 in. (70 cm) through 30.5 in. (77.5 cm) deep if you are mounting the switch flush with the rack front on four posts of a rack.
- Ensure that the rack is 29.5 in. (75 cm) through 32.5 in. (82.5 cm) deep if you will mount the switch 2 in. recessed from the rack front.

Before mounting the switch on four posts in a rack:

- Verify that the site meets the requirements described in [“Site Preparation Checklist for EX4550 Switches” on page 73](#).
- Place the rack in its permanent location, allowing adequate clearance for airflow and maintenance, and secure it to the building structure.
- Read [“General Safety Guidelines and Warnings” on page 274](#), with particular attention to [“Chassis and Component Lifting Guidelines” on page 281](#).
- Remove the switch from the shipping carton (see [“Unpacking an EX4550 Switch” on page 120](#)).

Ensure that you have the following parts and tools available:

- Phillips (+) screwdriver, number 2
- 6 4-40 flat-head Phillips mounting screws (provided with the four-post rack-mount kit)
- 12 4x6-mm Phillips flat-head mounting screws (provided with the four-post rack-mount kit)
- One pair each of flush or 2-in.-recess front mount brackets (provided with the four-post rack-mount kit)
- One pair of side mounting-rails (provided with the four-post rack-mount kit)
- One pair of rear mounting-blades (provided)
- Screws to secure the chassis and the rear mounting-blades to the rack (not provided)
- Cover panels for module slots
- Dust covers for ports (provided in the accessory box shipped with the EX4550-32F switches)

NOTE: One person must be available to lift the switch while another secures it to the rack.



CAUTION: If you are mounting multiple units on a rack, mount the heaviest unit at the bottom of the rack and mount the other units from the bottom of the rack to the top in decreasing order of the weight of the units.

To mount the switch on four posts in a rack:

1. Attach the front mount brackets (either the flush or the 2-in.-recess brackets) to the side mounting-rails using the six 4-40 flat-head Phillips mounting screws. See [Figure 47 on page 129](#). Tighten the screws by using the Phillips (+) screwdriver.

Figure 47: Attaching the Front Mount Bracket to the Side Mounting-Rail

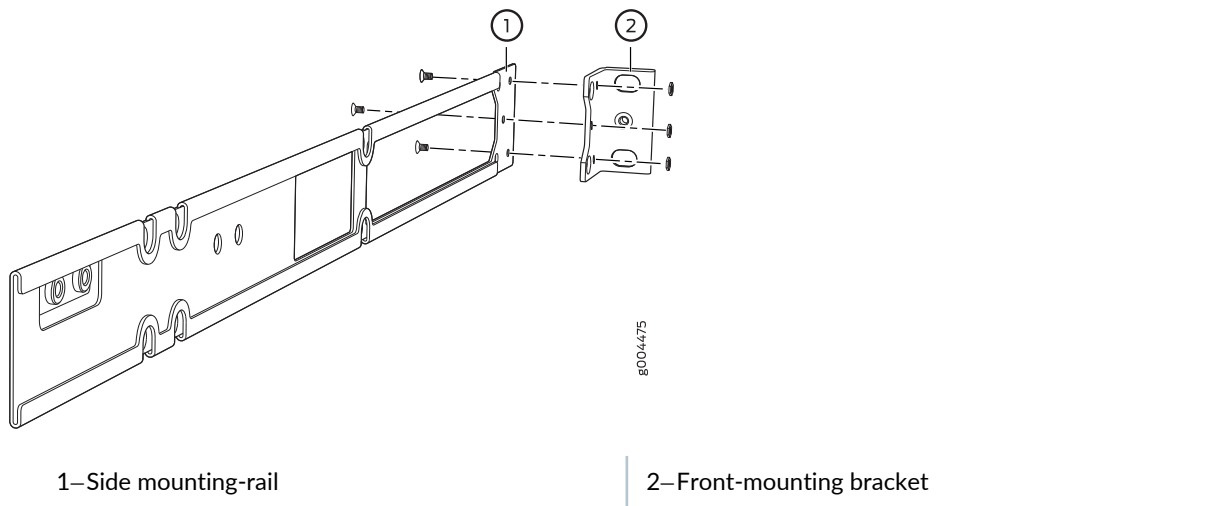

2. Place the switch on a flat, stable surface.
3. Align the side mounting-rails along the side panels of the switch chassis. Align the two holes in the rear of the side mounting-rails with the two holes on the rear of the side panel.
4. Insert 4x6-mm Phillips flat-head mounting screws into the two aligned holes and tighten the screws. Ensure that the remaining four holes in the side mounting-rails are aligned with the four holes in the side panel. See [Figure 48 on page 130](#).

Figure 48: Attaching the Side Mounting-Rail to the Switch Chassis

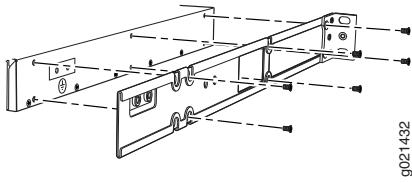

5. Insert the 4x6-mm Phillips flat-head mounting screws into the remaining four holes in the side mounting-rails and tighten the screws by using the Phillips (+) screwdriver.
6. Have one person grasp both sides of the switch, lift the switch, and position it in the rack, aligning the side mounting-rail holes with the threaded holes in the front post of the rack. Align the bottom hole in both the front-mounting brackets with a hole in each rack rail, making sure the chassis is level. See [Figure 49 on page 130](#).

Figure 49: Mounting the Switch to the Front Posts in a Rack

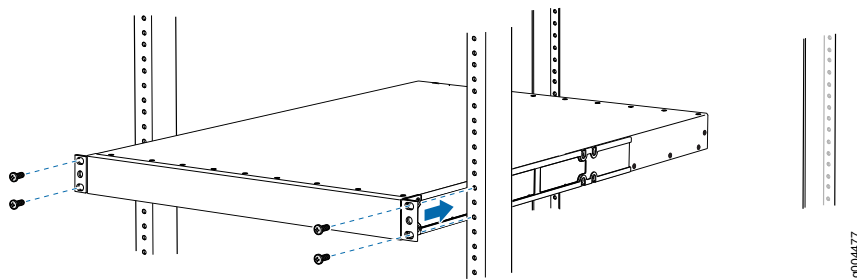

7. Have a second person secure the front mount brackets to the rack by using the appropriate screws for your rack.
8. Slide the rear mounting-blades into the side mounting-rails. See [Figure 50 on page 130](#).

Figure 50: Sliding the Rear Mounting-Blade into the Side Mounting-Rail

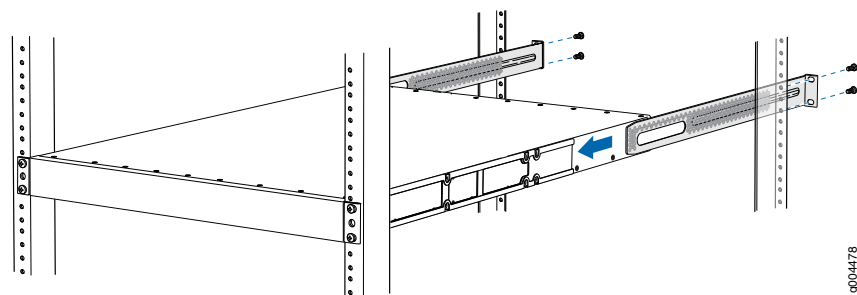

9. Attach the rear mounting-blades to the rear post by using the appropriate screws for your rack. Tighten the screws.
10. Ensure that the switch chassis is level by verifying that all the screws on the front of the rack are aligned with the screws at the back of the rack.

NOTE: We recommend that you use cover panels in unused module slots and dust covers in any unused SFP/SFP+ ports.

Mounting an EX4550 Switch in a Recessed Position in a Rack or Cabinet

You can mount an EX4550 switch in a recessed position on two posts of either a two-post rack or a four-post rack such that the switch is recessed inside the rack from the rack front by 2 inches. To mount the switch in a recessed position, use the front mount brackets provided in the separately orderable four-post rack-mount kit.

Reasons to mount the switch in a recessed position include:

- You are mounting the switch in a cabinet and the cabinet doors do not close completely unless the switch is recessed.
- The switch you are mounting has an expansion module with transceivers installed in it—the transceivers in the expansion module ports protrude from the front of the switch.

To mount the switch in a recessed position on four posts, follow the instructions in [“Mounting an EX4550 Switch on Two Posts in a Rack or Cabinet” on page 124](#) or [“Mounting an EX4550 Switch on Four Posts in a Rack or Cabinet” on page 127](#).

Connecting the EX4550 to Power

IN THIS SECTION

- [Connect Earth Ground to an EX Series Switch | 132](#)
- [Connecting AC Power to an EX4550 Switch | 139](#)
- [Connecting DC Power to an EX4550 Switch | 142](#)

Connect Earth Ground to an EX Series Switch

IN THIS SECTION

- [Parts and Tools Required for Connecting an EX Series Switch to Earth Ground | 132](#)
- [Special Instructions to Follow Before Connecting Earth Ground to an EX Series Switch | 137](#)
- [Connecting Earth Ground to an EX Series Switch | 138](#)

To ensure proper operation and to meet safety and electromagnetic interference (EMI) requirements, you must connect an EX Series switch to earth ground before you connect power to the switch. You must use the protective earthing terminal on the switch chassis to connect the switch to earth ground (see [Figure 52 on page 139](#)).

You must install the EX Series switch in a restricted-access location and ensure that the chassis is always properly grounded. EX Series switches have a two-hole protective grounding terminal provided on the chassis. See [Table 50 on page 133](#) for the location of the earthing terminals on various EX Series switches. We recommend that you use the protective grounding terminal as the preferred method for grounding the chassis regardless of the power supply configuration. However, if additional grounding methods are available, you can also use those methods. For example, you can use the grounding wire in the power cord of an AC power supply or use the grounding terminal or lug on a DC power supply. This system was tested to meet or exceed all applicable EMC regulatory requirements with the two-hole protective grounding terminal connected correctly.

Ensure that a licensed electrician has attached an appropriate grounding lug to the grounding cable you supply. Using a grounding cable with an incorrectly attached lug can damage the switch.

Parts and Tools Required for Connecting an EX Series Switch to Earth Ground

Before you begin connecting an EX Series switch to earth ground, ensure you have the parts and tools required for your switch.

[Table 50 on page 133](#) lists the earthing terminal location, grounding cable and lug specifications, and parts needed for connecting an EX Series switch to earth ground.

Table 50: Parts Required for Connecting an EX Series Switch to Earth Ground

Switch	Earthing Terminal Location	Grounding Cable Requirements	Grounding Lug Specifications	Screws and Washers	Additional Information
EX2200	Rear panel of the chassis	14 AWG (2 mm ²), minimum 90° C wire, or as permitted by the local code	Panduit LCC10-14BWL or equivalent— not provided	<ul style="list-style-type: none"> • Two 10-32 x .25 in. screws with #10 split-lock washer— not provided • Two #10 flat washers—not provided 	
EX2300-C	Rear panel of the chassis	14 AWG (2 mm ²), minimum 90° C wire, or as permitted by the local code	Panduit LCC10-14AW-L or equivalent— not provided	<ul style="list-style-type: none"> • Two 10-32 x .25 in. screws with #10 split-lock washer— not provided • Two #10 flat washers—not provided 	

Table 50: Parts Required for Connecting an EX Series Switch to Earth Ground (continued)

Switch	Earthing Terminal Location	Grounding Cable Requirements	Grounding Lug Specifications	Screws and Washers	Additional Information
EX2300	Rear panel of the chassis	<ul style="list-style-type: none"> EX2300 switches except EX2300-24MP and EX2300-48MP models—14 AWG (2 mm²), minimum 90°C wire, or as permitted by the local code EX2300-24MP and EX2300-48MP models—14-10 AWG STR (2.5-6 mm²), 12-10 AWG SOL (4-6 mm²) minimum 90°C wire, or as permitted by the local code—not provided 	<ul style="list-style-type: none"> EX2300 switches except EX2300-24MP and EX2300-48MP models—Panduit LCC10-14AW-L or equivalent—not provided EX2300-24MP and EX2300-48MP models—Panduit LCA10-10L or equivalent—not provided 	<ul style="list-style-type: none"> EX2300 switches except EX2300-24MP and EX2300-48MP models <ul style="list-style-type: none"> Two 10-32 x .25 in. screws with #10 split-lock washer—not provided Two #10 flat washers—not provided EX2300-24MP and EX2300-48MP models <ul style="list-style-type: none"> One Pan Phillips M 4 x 6 mm Nickel plated screw—provided 	
EX3200, EX3300, and EX3400	Rear panel of the chassis	14 AWG (2 mm ²), minimum 90° C wire, or as permitted by the local code	Panduit LCC10-14BWL or equivalent—not provided	<ul style="list-style-type: none"> Two 10-32 x .25 in. screws with #10 split-lock washer—not provided Two #10 flat washers—not provided 	For EX3200 Switches, see “Special Instructions to Follow Before Connecting Earth Ground to an EX Series Switch” on page 137.

Table 50: Parts Required for Connecting an EX Series Switch to Earth Ground (continued)

Switch	Earthing Terminal Location	Grounding Cable Requirements	Grounding Lug Specifications	Screws and Washers	Additional Information
EX4200, EX4500, and EX4550	Left side of the chassis	14 AWG (2 mm ²), minimum 90° C wire, or as permitted by the local code	Panduit LCC10-14BWL or equivalent— not provided	<ul style="list-style-type: none"> • Two 10-32 x .25 in. screws with #10 split-lock washer— not provided • Two #10 flat washers— not provided 	See “Special Instructions to Follow Before Connecting Earth Ground to an EX Series Switch” on page 137.
EX6210	Rear panel of the chassis (on lower left side)	The grounding cable must be the same gauge as the power feed cables and as permitted by the local code.	Panduit LCD2-14A-Q or equivalent —provided	<ul style="list-style-type: none"> • Two ¼ -20 x 0.5 in. screws with #¼” split-washer —provided • Two #¼” flat washers— provided 	
EX8208	Left side of the chassis	6 AWG (13.3 mm ²), minimum 90° C wire, or as permitted by the local code	Panduit LCD2-14A-Q or equivalent —provided	<ul style="list-style-type: none"> • Two ¼ -20 x 0.5 in. screws with #¼” split-washer —provided • Two #¼” flat washers— provided 	

Table 50: Parts Required for Connecting an EX Series Switch to Earth Ground (continued)

Switch	Earthing Terminal Location	Grounding Cable Requirements	Grounding Lug Specifications	Screws and Washers	Additional Information
EX8216	<p>Two earthing terminals:</p> <ul style="list-style-type: none"> • Left side of the chassis • Rear panel of the chassis <p>NOTE: You must use only one of the two protective earthing terminals.</p>	2 AWG (33.6 mm ²), minimum 90° C wire, or as permitted by the local code	Panduit LCD2-14A-Q or equivalent—provided	<ul style="list-style-type: none"> • Two ¼ -20 x 0.5 in. screws with #¼" split-washer—provided • Two #¼" flat washers—provided 	
EX9204, EX9208, and EX9214	Rear panel of the chassis	One 6 AWG (13.3 mm ²), minimum 90° C wire, or one that complies with the local code	Thomas& Betts LCN6-14 or equivalent—provided	<ul style="list-style-type: none"> • Two ¼ -20 x 0.5 in. screws with #¼" split-washer—provided • Two #¼" flat washers—provided 	See Grounding Cable and Lug Specifications for EX9200 Switches.
EX9251	Rear panel of the chassis	12 AWG (2.5 mm ²), minimum 90° C wire, or one that complies with the local code— not provided	Panduit LCD10-10A-L or equivalent— not provided	Two 10-32 screws— provided	See Grounding Cable and Lug Specifications for EX9200 Switches.

Table 50: Parts Required for Connecting an EX Series Switch to Earth Ground (*continued*)

Switch	Earthing Terminal Location	Grounding Cable Requirements	Grounding Lug Specifications	Screws and Washers	Additional Information
EX9253	Right side of the chassis	14-10 AWG (2-5.3 mm ²), minimum 90° C wire, or one that complies with the local code— not provided	Panduit LCD10-14B-L or equivalent— provided	Two M5 Pan Head screws— provided	

Tools required for connecting an EX Series switch to earth ground:

- An electrostatic discharge grounding strap (provided)
- A Phillips (+) number 2 screwdriver to tighten the screws.

An AC-powered EX Series switch gains additional grounding when you plug the power supply in the switch into a grounded AC power outlet by using an AC power cord appropriate for your geographical location.

Special Instructions to Follow Before Connecting Earth Ground to an EX Series Switch

[Table 51 on page 137](#) lists the special instructions that you might need to follow before connecting earth ground to a switch.

Table 51: Special Instructions to Follow Before Connecting Earth Ground to an EX Series Switch

Switch	Special Instructions
EX3200 and EX4200	Some early variants of EX3200 and EX4200 switches for which the Juniper Networks model number on the label next to the protective earthing terminal is from 750-021xxx through 750-030xxx require 10-24x.25 in. screws.

Table 51: Special Instructions to Follow Before Connecting Earth Ground to an EX Series Switch (continued)

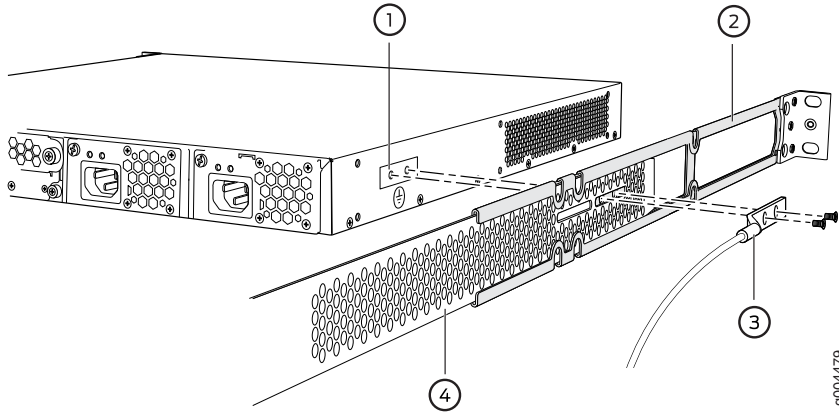
Switch	Special Instructions
EX4200, EX4500, and EX4550	<p data-bbox="467 331 1450 401">If you plan to mount your switch on four posts of a rack or cabinet, mount your switch in the rack or cabinet before attaching the grounding lug to the switch.</p> <p data-bbox="467 432 1450 611">NOTE: The protective earthing terminal on switches mounted on four posts of a rack is accessible through the slot on the left rear bracket only if the rack is 27.5 in. (69.85 cm) through 30.5 in. (77.47 cm) deep for a switch mounted flush with the rack front and 29.5 in. (74.93 cm) through 32.5 in. (82.55 cm) deep for a switch mounted 2 in. (5.08 cm) recessed from the rack front. See Figure 51 on page 138.</p> <p data-bbox="467 663 1435 737">Figure 51: Connecting the Grounding Lug to a Switch Mounted on Four Posts of a Rack</p>  <p data-bbox="483 1220 813 1251">1–Protective earthing terminal</p> <p data-bbox="483 1272 716 1304">2–Side mounting-rail</p> <p data-bbox="971 1220 1159 1251">3–Grounding lug</p> <p data-bbox="971 1272 1230 1304">4–Rear mounting-blade</p> <p data-bbox="467 1339 1450 1444">NOTE: The brackets must be attached to the chassis before the grounding lug is attached. (The brackets are shown pulled away from the chassis so that the protective earthing terminal is seen.)</p>

Connecting Earth Ground to an EX Series Switch

To connect earth ground to an EX Series switch:

1. Verify that a licensed electrician has attached the cable lug to the grounding cable.
2. Connect one end of the grounding cable to a proper earth ground, such as the rack in which the switch is mounted.

3. Attach an ESD grounding strap to your bare wrist, and connect the strap to the ESD grounding point on the switch.
4. Place the grounding lug attached to the grounding cable over the protective earthing terminal. See [Figure 52 on page 139](#).

Figure 52: Connecting a Grounding Cable to an EX Series Switch

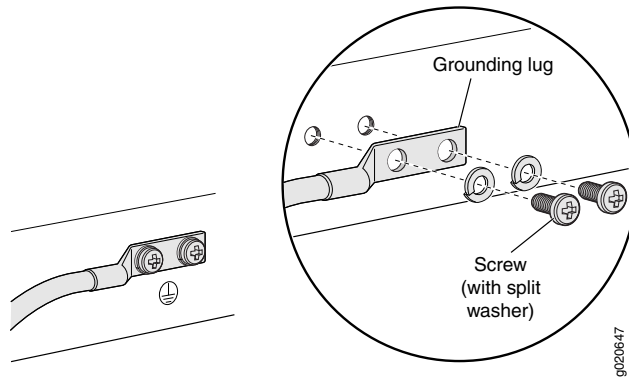

5. Secure the grounding lug to the protective earthing terminal with the washers and screws.
6. Dress the grounding cable and ensure that it does not touch or block access to other switch components and that it does not drape where people could trip over it.

SEE ALSO

[General Safety Guidelines and Warnings | 274](#)

[Grounded Equipment Warning | 292](#)

Connecting AC Power to an EX4550 Switch

The power supply in an EX4550 switch is a hot-removable and hot-insertable field-replaceable unit (FRU): You can remove and replace it without powering off the switch or disrupting switch functions.

Ensure that you have a power cord appropriate for your geographical location available to connect AC power to an EX4550 switch.

Before you begin connecting AC power to an EX4550 switch:

- Ensure that you have taken the necessary precautions to prevent electrostatic discharge (ESD) damage (see [“Prevention of Electrostatic Discharge Damage” on page 308](#)).
- Ensure that you have connected the device chassis to earth ground, if required by your site guidelines or installation. A ground connection to the protective earthing terminal is not required for an AC-powered switch. The AC power cords provide adequate grounding when you connect the power supply in the switch to a grounded AC power outlet by using the AC power cord appropriate for your geographical location (see [“AC Power Cord Specifications for an EX4550 Switch” on page 65](#)).



CAUTION: For installations that require a separate grounding conductor to the chassis, have a licensed electrician complete this connection before you connect the switch to power. For instructions on connecting earth ground, see [“Connect Earth Ground to an EX Series Switch” on page 132](#).

- Install the power supply in the chassis. For instructions on installing a power supply in an EX4550 switch, see [“Installing an AC Power Supply in an EX4550 Switch” on page 212](#).

NOTE: Each power supply must be connected to a dedicated power source outlet.

To connect AC power to an EX4550 switch:

1. Attach the grounding strap to your bare wrist and to a site ESD point.
2. Ensure that the power supplies are fully inserted in the chassis and the latches are secure. If only one power supply is installed, ensure that a blank cover panel is installed over the second power supply slot.
3. Locate the power cord or cords shipped with the switch; the cords have plugs appropriate for your geographical location. See [“AC Power Cord Specifications for an EX4550 Switch” on page 65](#).



WARNING: Ensure that the power cord does not block access to switch components or drape where people can trip on it.

4. Insert the coupler end of the power cord into the AC power cord inlet on the AC power supply faceplate.
5. Push the power cord retainer onto the power cord (see [Figure 53 on page 141](#)).

Figure 53: Connecting an AC Power Cord to an AC Power Supply in an EX4550 Switch

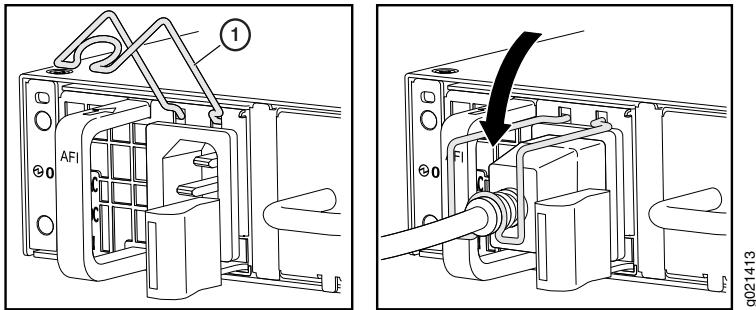

1—Power cord retainer clip

6. If the AC power source outlet has a power switch, set it to the off (O) position.
7. Insert the power cord plug into an AC power source outlet.
8. If the AC power source outlet has a power switch, set it to the on (I) position.
9. Repeat these steps for the second AC power supply, if one is installed.
10. Verify that the **AC** and **DC** LEDs on each power supply are lit green.

If the fault status (!) LED is lit yellow, remove power from the power supply, and replace the power supply (see [“Removing an AC Power Supply from an EX4550 Switch” on page 211](#)). Do not remove the power supply until you have a replacement power supply ready: the power supplies or a blank cover panel must be installed in the switch to ensure proper airflow.



CAUTION: We recommend that you install either a replacement power supply or a cover panel in the empty power supply slot to avoid chassis overheating and dust accumulation.

SEE ALSO

[AC Power Supply in EX4550 Switches | 61](#)

Connecting DC Power to an EX4550 Switch

The power supply in an EX4550 switch is a hot-removable and hot-insertable field-replaceable unit (FRU): You can remove and replace it without powering off the switch or disrupting switch functions.

Before you begin connecting DC power to an EX4550 switch:

- Ensure that you have taken the necessary precautions to prevent electrostatic discharge (ESD) damage (see [“Prevention of Electrostatic Discharge Damage” on page 308](#)).
- Ensure that you have connected the switch chassis to earth ground.



CAUTION: Ensure that you install the power supply module first and then install the DC input wire, before closing input breaker ON.



CAUTION: Before you connect power to the device, a licensed electrician must attach a cable lug to the grounding and power cables that you supply. A cable with an incorrectly attached lug can damage the device (for example, by causing a short circuit).

To meet safety and electromagnetic interference (EMI) requirements and to ensure proper operation, you must connect the chassis to earth ground before you connect it to power. For installations that require a separate grounding conductor to the chassis, use the protective earthing terminal on the switch chassis to connect to the earth ground. For instructions on connecting earth ground, see [“Connect Earth Ground to an EX Series Switch” on page 132](#).

- Install the power supply in the chassis. For instructions on installing a DC power supply in an EX4550 switch, see [“Installing a DC Power Supply in an EX4550 Switch” on page 215](#).

Ensure that you have the following parts and tools available:

- DC power source cables (14–16 AWG) with ring lug (Molex 190700069 or equivalent) (not provided)
- Phillips (+) screwdriver, number 2 (not provided)
- Multimeter (not provided)

To connect DC power to an EX4550 switch:

1. Attach the grounding strap to your bare wrist and to a site ESD point.
2. Verify that the DC power cables are correctly labeled before making connections to the power supply. In a typical power distribution scheme where the return is connected to chassis ground at the battery plant, you can use a multimeter to verify the resistance of the -48V and RTN DC cables to chassis ground:
 - The cable with very low resistance (indicating a closed circuit) to chassis ground is positive (+) and will be installed on the V+ (return) DC power input terminal.
 - The cable with very high resistance (indicating an open circuit) to chassis ground is negative (-) and will be installed on the V- (input) DC power input terminal.



CAUTION: You must ensure that power connections maintain the proper polarity. The power source cables might be labeled (+) and (-) to indicate their polarity. There is no standard color coding for DC power cables. The color coding used by the external DC power source at your site determines the color coding for the leads on the power cables that attach to the DC power input terminals on each power supply.

3. Ensure that the input circuit breaker is open so that the voltage across the DC power source cable leads is 0 V and that the cable leads will not become active while you are connecting DC power.

NOTE: The V+ terminals are referred to as +RTN and V- terminals are referred to as -48 V in “[DC Power Wiring Sequence Warning](#)” on page 317 and “[DC Power Electrical Safety Guidelines](#)” on page 312.

4. Ensure that the power supplies are fully inserted in the chassis.
5. Remove the terminal block cover. The terminal block cover is a piece of clear plastic that snaps into place over the terminal block.
6. Remove the screws on the terminals using the screwdriver. Save the screws.



WARNING: Ensure that the power cables do not block access to switch components or drape where people can trip on them.

NOTE: To supply sufficient power, terminate the DC input wiring on a facility DC source that is capable of supplying a minimum of 20 A at -48 VDC.

7. Connect each power supply to the power source. Secure power source cables to the power supplies by screwing the ring lugs attached to the cables to the appropriate terminals by using the screw from the terminals (see [Figure 54 on page 145](#) and [Figure 55 on page 145](#)).

NOTE: The DC power supply has four input terminals labeled **V+**, **V+**, **V-**, and **V-** for connecting DC power source cables labeled positive (+) and negative (-). The **V+** terminals are shunted internally together, as are the **V-** terminals to provide parallel current path. The same polarity input terminals can be connected with the same source to provide an additional current path in a higher power chassis. Each power supply must be connected to a single source only.

- a. Secure the ring lug of the positive (+) DC power source cable to the V+ terminal on the DC power supply.
- b. Secure the ring lug of the negative (-) DC power source cable to the V- terminal on the DC power supply.
- c. Tighten the screws on the power supply terminals until snug using the screwdriver. Do not overtighten—apply between 5 in-lb (0.56 Nm) and 6 in-lb (0.68 Nm) of torque to the screws.

Figure 54: DC Power Supply Faceplate for an EX4550 Switch

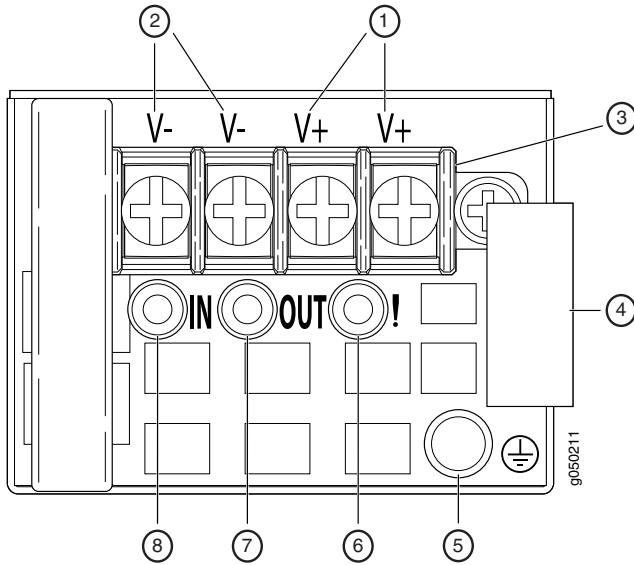

1–V+ input terminals	5–ESD grounding point
2–V- input terminals	6–Fault LED
3–Terminal block	7–Output LED
4–Ejector lever	8–Input LED

Figure 55: Securing Ring Lugs to the Terminals on the DC Power Supply

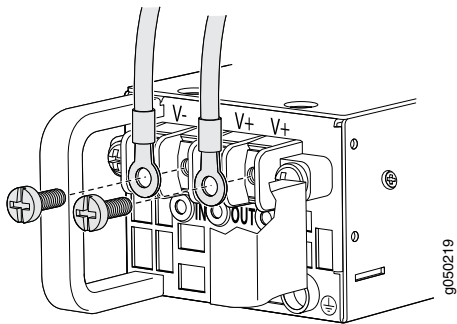

8. Replace the terminal block cover.

9. Close the input circuit breaker.

NOTE: The device powers on as soon as power is provided to the power supply. There is no power switch on the device.

10. Verify that the **IN** and **OUT** LEDs on the power supply are lit green and are on steadily.

SEE ALSO

| [DC Power Supply in EX4550 Switches](#) | 67

Connecting the EX4550 to Network

IN THIS SECTION

- [Connect a Fiber-Optic Cable](#) | 146
- [Install a Transceiver](#) | 147

Connect a Fiber-Optic Cable

Before you connect a fiber-optic cable to an optical transceiver installed in a device, ensure that you have taken the necessary precautions for safe handling of lasers (see [“Laser and LED Safety Guidelines and Warnings”](#) on page 294).

To connect a fiber-optic cable to an optical transceiver installed in a device:



WARNING: Do not look directly into a fiber-optic transceiver or into the ends of fiber-optic cables. Fiber-optic transceivers and fiber-optic cables connected to transceivers emit laser light that can damage your eyes.

1. If the fiber-optic cable connector is covered with a rubber safety cap, remove the cap. Save the cap.
2. Remove the rubber safety cap from the optical transceiver. Save the cap.
3. Insert the cable connector into the optical transceiver (see [Figure 56 on page 147](#)).

Figure 56: Connect a Fiber-Optic Cable to an Optical Transceiver Installed in a Device

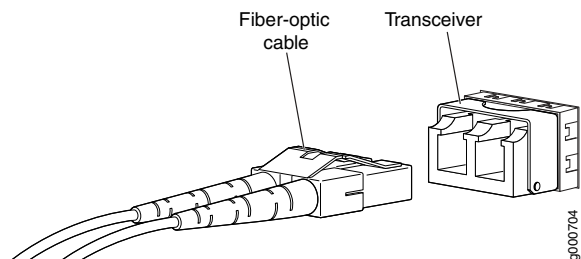

4. Secure the cables so that they do not support their own weight. Place excess cable out of the way in a neatly coiled loop. Placing fasteners on a loop helps cables maintain their shape.



CAUTION: Do not bend fiber-optic cables beyond their minimum bend radius. An arc smaller than a few inches in diameter can damage the cables and cause problems that are difficult to diagnose.

Do not let fiber-optic cables hang free from the connector. Do not allow fastened loops of cables to dangle, which stresses the cables at the fastening point.

Install a Transceiver

The transceivers for Juniper Networks devices are hot-removable and hot-insertable field-replaceable units (FRUs): You can remove and replace them without powering off the device or disrupting the device functions.

NOTE: After you insert a transceiver or after you change the media-type configuration, wait for 6 seconds for the interface to display operational commands.

NOTE: We recommend that you use only optical transceivers and optical connectors purchased from Juniper Networks with your Juniper Networks device.



CAUTION: If you face a problem running a Juniper Networks device that uses a third-party optic or cable, the Juniper Networks Technical Assistance Center (JTAC) can help you diagnose the source of the problem. Your JTAC engineer might recommend that you check the third-party optic or cable and potentially replace it with an equivalent Juniper Networks optic or cable that is qualified for the device.

Before you install a transceiver in a device, ensure that you have taken the necessary precautions for safe handling of lasers (see [“Laser and LED Safety Guidelines and Warnings” on page 294](#)).

Ensure that you have a rubber safety cap available to cover the transceiver.

[Figure 57 on page 150](#) shows how to install a QSFP+ transceiver. The procedure is the same for all types of transceivers except the QSFP28 and CFP transceivers.

To install a transceiver:



CAUTION: To prevent electrostatic discharge (ESD) damage to the transceiver, do not touch the connector pins at the end of the transceiver.

1. Wrap and fasten one end of the ESD wrist strap around your bare wrist, and connect the other end of the strap to the ESD point on the switch.
2. Remove the transceiver from its bag.
3. Check to see whether the transceiver is covered with a rubber safety cap. If it is not, cover the transceiver with a rubber safety cap.



WARNING: Do not leave a fiber-optic transceiver uncovered except when inserting or removing a cable. The rubber safety cap keeps the port clean and prevents accidental exposure to laser light.

4. If the port in which you want to install the transceiver is covered with a dust cover, remove the dust cover and save it in case you need to cover the port later. If you are hot-swapping a transceiver, wait for at least 10 seconds after removing the transceiver from the port before installing a new transceiver.
5. Using both hands, carefully place the transceiver in the empty port. The connectors must face the chassis.



CAUTION: Before you slide the transceiver into the port, ensure that the transceiver is aligned correctly. Misalignment might cause the pins to bend, making the transceiver unusable.

6. Slide the transceiver in gently until it is fully seated. If you are installing a CFP transceiver, tighten the captive screws on the transceiver by using your fingers.
7. Remove the rubber safety cap from the transceiver and the end of the cable, and insert the cable into the transceiver.



WARNING: Do not look directly into a fiber-optic transceiver or into the ends of fiber-optic cables. Fiber-optic transceivers and fiber-optic cable connected to a transceiver emit laser light that can damage your eyes.



CAUTION: Do not leave a fiber-optic transceiver uncovered except when inserting or removing cable. The safety cap keeps the port clean and prevents accidental exposure to laser light.

8. If there is a cable management system, arrange the cable in the cable management system to prevent the cable from dislodging or developing stress points. Secure the cable so that it does not support its own weight as it hangs to the floor. Place excess cable out of the way in a neatly coiled loop in the cable management system. Placing fasteners on the loop helps to maintain its shape.



CAUTION: Do not let fiber-optic cable hang free from the connector. Do not allow fastened loops of cable to dangle, which stresses the cable at the fastening point.



CAUTION: Avoid bending fiber-optic cable beyond its minimum bend radius. An arc smaller than a few inches in diameter can damage the cable and cause problems that are difficult to diagnose.

Figure 57: Install a Transceiver

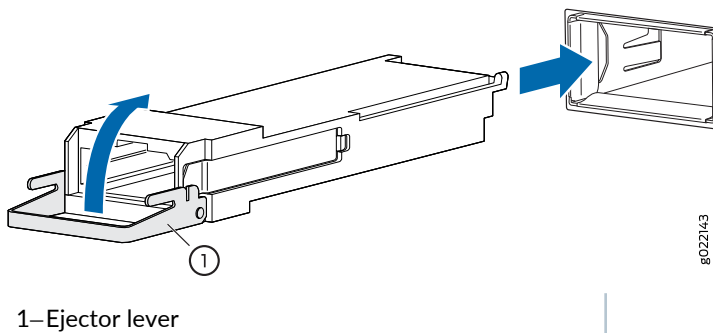

Connecting the EX4550 to External Devices

IN THIS SECTION

- [Connect a Device to a Network for Out-of-Band Management | 151](#)
- [Connect a Device to a Management Console Using an RJ-45 Connector | 151](#)
- [Connect an EX Series Switch to a Management Console Using the Mini-USB Type-B Console Port | 153](#)

Connect a Device to a Network for Out-of-Band Management

You can monitor and manage these devices by using a dedicated management channel. Each device has a management port to which you can connect an Ethernet cable with an RJ-45 connector. Use the management port to connect the device to the management device.

Ensure that you have an Ethernet cable that has an RJ-45 connector at either end. [Figure 58 on page 151](#) shows the RJ-45 connector of the Ethernet cable supplied with the device.

Figure 58: RJ-45 Connector on an Ethernet Cable

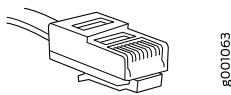

To connect a device to a network for out-of-band management (see [Figure 59 on page 151](#)):

1. Connect one end of the Ethernet cable to the management port on the device.
2. Connect the other end of the Ethernet cable to the management device.

Figure 59: Connect a Device to a Network for Out-of-Band Management

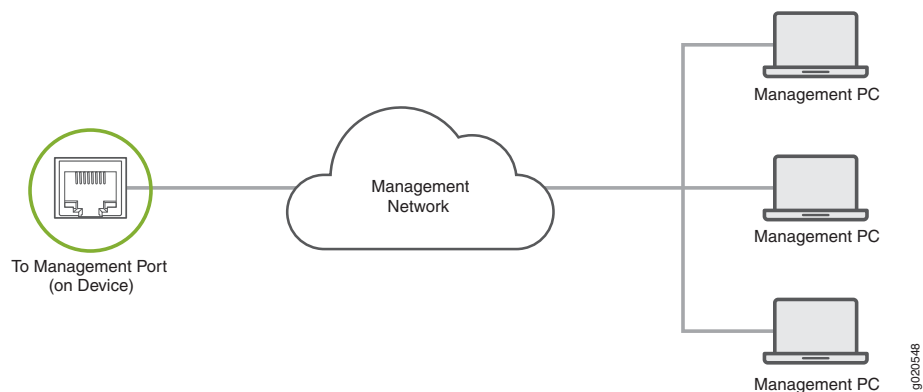

Connect a Device to a Management Console Using an RJ-45 Connector

You can configure and manage devices using a dedicated management channel. Each device has a console port which you can connect to using an Ethernet cable with an RJ-45 connector. Use the console port to connect the device to the console server or management console. The console port accepts a cable that has an RJ-45 connector.

Ensure that you have an Ethernet cable that has an RJ-45 connector at either end. One such cable and an RJ-45 to DB-9 serial port adapter are supplied with the device.

Figure 60 on page 152 shows the RJ-45 connector of the Ethernet cable.

Figure 60: RJ-45 Connector on an Ethernet Cable

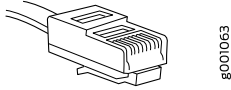

NOTE: If your laptop or desktop PC does not have a DB-9 plug connector pin and you want to connect your laptop or desktop PC directly to the device, use a combination of the RJ-45 to DB-9 socket adapter supplied with the device and a USB to DB-9 plug adapter. You must provide the USB to DB-9 plug adapter.

To connect the device to a management console (see Figure 61 on page 152 and Figure 62 on page 152):

1. Connect one end of the Ethernet cable to the console port (labeled **CON**, **CONSOLE**, or **CON1**) on the device.
2. Connect the other end of the Ethernet cable to the console server (see Figure 61 on page 152) or management console (see Figure 62 on page 152).

Figure 61: Connect a Device to a Management Console Through a Console Server

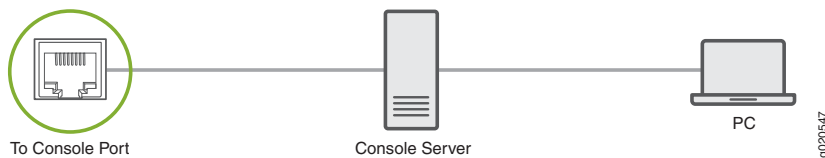
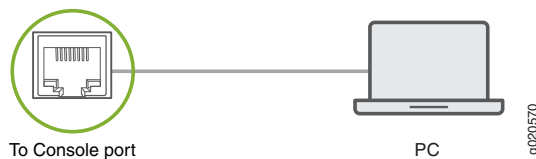

Figure 62: Connect a Device Directly to a Management Console



Connect an EX Series Switch to a Management Console Using the Mini-USB Type-B Console Port

EX2200-C, EX2300, EX2300-C, EX3400, EX4300, and EX4550 switches, except EX2300-24MP and EX2300-48MP models, have two console ports: an RJ-45 console port that accepts a cable with an RJ-45 connector and a Mini-USB Type-B console port that accepts a cable with a Mini-USB Type-B plug (5-pin) connector. You can configure and manage the switch using the RJ-45 console port or the Mini-USB Type-B console port. On EX2200-C and EX4550 switches, only one console port is active at a time and the console input is active only on that port. On EX2300, EX2300-C, EX3400, and EX4300 switches, both the RJ-45 console port and the Mini-USB Type-B console port can be active at the same time.

NOTE: EX2300-24MP and EX2300-48MP models only have an RJ-45 console port.

By default, the RJ-45 console port is the active port. If your laptop or PC does not have a DB-9 plug connector pin or RJ-45 connector pin, you can connect your laptop or PC directly to the switch using a mini-USB cable that has a Standard-A USB connector on one end and a Mini-USB Type-B (5-pin) connector on the other end. You must first configure the Mini-USB Type-B console port as the active port before you can use it to connect to the switch.

This topic describes the procedure to connect EX2200-C, EX2300, EX2300-C, EX3400, EX4300, and EX4550 switches to the management console using the Mini-USB Type-B console port.

For information about configuring and managing an EX Series switch using the RJ-45 console port, see [“Connect a Device to a Management Console Using an RJ-45 Connector” on page 151](#).

Before You Begin

Before you connect the switch using the Mini-USB Type-B console port:

- Ensure that the USB to Serial driver is installed on the host machine.
- Ensure that the HyperTerminal properties of the console server or laptop are set as follows:
 - Baud rate—9600
 - Flow control—None
 - Data—8
 - Parity—None
 - Stop bits—1
 - DCD state—Disregard

You will need the following parts and tools:

- One mini-USB cable with Standard-A and Mini-USB Type-B (5-pin) connectors (not provided)

To connect the switch to the console using the Mini-USB Type-B console port:

1. Connect the host machine to the device directly using the active console port or remotely using the management interface. To connect using the active console port, which is the RJ-45 console port by default, see [“Connect a Device to a Management Console Using an RJ-45 Connector” on page 151](#).
2. Connect the Standard-A connector of the mini-USB cable to the host machine (PC or laptop).
3. Connect the Mini-USB Type-B (5-pin) connector of the mini-USB cable to the Mini-USB Type-B console port (labeled **CON**) on the switch.
4. By default, the RJ-45 port is set as an active console port and the Mini-USB Type-B port is the passive console port. Set the Mini-USB Type-B console port as the active console port using the **port-type** command. See *Configuring the Console Port Type (CLI Procedure)*.
5. Reboot the switch. The boot log appears on the activated console.

After the connection is established, the Mini-USB Type-B becomes the active console port. The host machine connected to the Mini-USB Type-B console port displays log messages and you can control switch functionality through it. On EX2300, EX2300-C, EX3400, and EX4300 switches, both the Mini-USB Type-B and RJ-45 console ports are now active. On EX2200-C and EX4550 switches, the Mini-USB Type-B console port is active and the RJ-45 console port is passive.

Configuring Junos OS on the EX4550

IN THIS SECTION

- [EX4550 Default Configuration | 155](#)
- [Connecting and Configuring an EX Series Switch \(CLI Procedure\) | 168](#)
- [Connecting and Configuring an EX Series Switch \(J-Web Procedure\) | 171](#)
- [Configuring the LCD Panel on EX Series Switches \(CLI Procedure\) | 175](#)

EX4550 Default Configuration

Each EX Series switch is programmed with a factory default configuration that contains the values set for each configuration parameter when the switch is shipped. The default configuration file sets values for system parameters such as **syslog** and **commit**, configures Ethernet switching on all interfaces, enables IGMP snooping, and enables the LLDP and RSTP protocols.

The following default configuration file is for an EX4550-32F switch. The default configuration file of an EX4550-32T switch does not include interfaces ge-0/0/0 through ge-0/0/31.

NOTE: Interfaces ge-0/0/0 through ge-0/0/31 and xe-0/0/0 through xe-0/0/31 are network port interfaces. Interfaces ge-0/1/0 through ge-0/1/7, xe-0/1/0 through xe-0/1/7, ge-0/2/0 through ge-0/2/7, and xe-0/2/0 through xe-0/2/7 are expansion module port interfaces. Interfaces et-0/1/0, et-0/1/1, et-0/2/0, and et-0/2/1 are QSFP+ expansion module port interfaces.

When you commit changes to the configuration, a new configuration file is created, which becomes the active configuration. You can always revert to the factory default configuration. See *Reverting to the Default Factory Configuration for the EX Series Switch*.

```

system {
  syslog {
    user * {
      any emergency;
    }
    file messages {
      any notice;
      authorization info;
    }
    file interactive-commands {
      interactive-commands any;
    }
  }
  commit {
    factory-settings {
      reset-chassis-lcd-menu;
      reset-virtual-chassis-configuration;
    }
  }
}
interfaces {

```

```
ge-0/0/0 {
  unit 0 {
    family ethernet-switching;
  }
}
xe-0/0/0 {
  unit 0 {
    family ethernet-switching;
  }
}
ge-0/0/1 {
  unit 0 {
    family ethernet-switching;
  }
}
xe-0/0/1 {
  unit 0 {
    family ethernet-switching;
  }
}
ge-0/0/2 {
  unit 0 {
    family ethernet-switching;
  }
}
xe-0/0/2 {
  unit 0 {
    family ethernet-switching;
  }
}
ge-0/0/3 {
  unit 0 {
    family ethernet-switching;
  }
}
xe-0/0/3 {
  unit 0 {
    family ethernet-switching;
  }
}
ge-0/0/4 {
  unit 0 {
    family ethernet-switching;
  }
}
```

```
}
xe-0/0/4 {
  unit 0 {
    family ethernet-switching;
  }
}
ge-0/0/5 {
  unit 0 {
    family ethernet-switching;
  }
}
xe-0/0/5 {
  unit 0 {
    family ethernet-switching;
  }
}
ge-0/0/6 {
  unit 0 {
    family ethernet-switching;
  }
}
xe-0/0/6 {
  unit 0 {
    family ethernet-switching;
  }
}
ge-0/0/7 {
  unit 0 {
    family ethernet-switching;
  }
}
xe-0/0/7 {
  unit 0 {
    family ethernet-switching;
  }
}
ge-0/0/8 {
  unit 0 {
    family ethernet-switching;
  }
}
xe-0/0/8 {
  unit 0 {
    family ethernet-switching;
  }
}
```

```
    }  
  }  
  ge-0/0/9 {  
    unit 0 {  
      family ethernet-switching;  
    }  
  }  
  xe-0/0/9 {  
    unit 0 {  
      family ethernet-switching;  
    }  
  }  
  ge-0/0/10 {  
    unit 0 {  
      family ethernet-switching;  
    }  
  }  
  xe-0/0/10 {  
    unit 0 {  
      family ethernet-switching;  
    }  
  }  
  ge-0/0/11 {  
    unit 0 {  
      family ethernet-switching;  
    }  
  }  
  xe-0/0/11 {  
    unit 0 {  
      family ethernet-switching;  
    }  
  }  
  ge-0/0/12 {  
    unit 0 {  
      family ethernet-switching;  
    }  
  }  
  xe-0/0/12 {  
    unit 0 {  
      family ethernet-switching;  
    }  
  }  
  ge-0/0/13 {  
    unit 0 {
```

```
        family ethernet-switching;
    }
}
xe-0/0/13 {
    unit 0 {
        family ethernet-switching;
    }
}
ge-0/0/14 {
    unit 0 {
        family ethernet-switching;
    }
}
xe-0/0/14 {
    unit 0 {
        family ethernet-switching;
    }
}
ge-0/0/15 {
    unit 0 {
        family ethernet-switching;
    }
}
xe-0/0/15 {
    unit 0 {
        family ethernet-switching;
    }
}
ge-0/0/16 {
    unit 0 {
        family ethernet-switching;
    }
}
xe-0/0/16 {
    unit 0 {
        family ethernet-switching;
    }
}
ge-0/0/17 {
    unit 0 {
        family ethernet-switching;
    }
}
xe-0/0/17 {
```

```
    unit 0 {
      family ethernet-switching;
    }
  }
  ge-0/0/18 {
    unit 0 {
      family ethernet-switching;
    }
  }
  xe-0/0/18 {
    unit 0 {
      family ethernet-switching;
    }
  }
  ge-0/0/19 {
    unit 0 {
      family ethernet-switching;
    }
  }
  xe-0/0/19 {
    unit 0 {
      family ethernet-switching;
    }
  }
  ge-0/0/20 {
    unit 0 {
      family ethernet-switching;
    }
  }
  xe-0/0/20 {
    unit 0 {
      family ethernet-switching;
    }
  }
  ge-0/0/21 {
    unit 0 {
      family ethernet-switching;
    }
  }
  xe-0/0/21 {
    unit 0 {
      family ethernet-switching;
    }
  }
}
```



```
ge-0/0/22 {
  unit 0 {
    family ethernet-switching;
  }
}
xe-0/0/22 {
  unit 0 {
    family ethernet-switching;
  }
}
ge-0/0/23 {
  unit 0 {
    family ethernet-switching;
  }
}
xe-0/0/23 {
  unit 0 {
    family ethernet-switching;
  }
}
ge-0/0/24 {
  unit 0 {
    family ethernet-switching;
  }
}
xe-0/0/24 {
  unit 0 {
    family ethernet-switching;
  }
}
ge-0/0/25 {
  unit 0 {
    family ethernet-switching;
  }
}
xe-0/0/25 {
  unit 0 {
    family ethernet-switching;
  }
}
ge-0/0/26 {
  unit 0 {
    family ethernet-switching;
  }
}
```

```
}
xe-0/0/26 {
  unit 0 {
    family ethernet-switching;
  }
}
ge-0/0/27 {
  unit 0 {
    family ethernet-switching;
  }
}
xe-0/0/27 {
  unit 0 {
    family ethernet-switching;
  }
}
ge-0/0/28 {
  unit 0 {
    family ethernet-switching;
  }
}
xe-0/0/28 {
  unit 0 {
    family ethernet-switching;
  }
}
ge-0/0/29 {
  unit 0 {
    family ethernet-switching;
  }
}
xe-0/0/29 {
  unit 0 {
    family ethernet-switching;
  }
}
ge-0/0/30 {
  unit 0 {
    family ethernet-switching;
  }
}
xe-0/0/30 {
  unit 0 {
    family ethernet-switching;
  }
}
```

```
    }  
  }  
  ge-0/0/31 {  
    unit 0 {  
      family ethernet-switching;  
    }  
  }  
  xe-0/0/31 {  
    unit 0 {  
      family ethernet-switching;  
    }  
  }  
  et-0/1/0 {  
    unit 0 {  
      family ethernet-switching;  
    }  
  }  
  ge-0/1/0 {  
    unit 0 {  
      family ethernet-switching;  
    }  
  }  
  xe-0/1/0 {  
    unit 0 {  
      family ethernet-switching;  
    }  
  }  
  et-0/1/1 {  
    unit 0 {  
      family ethernet-switching;  
    }  
  }  
  ge-0/1/1 {  
    unit 0 {  
      family ethernet-switching;  
    }  
  }  
  xe-0/1/1 {  
    unit 0 {  
      family ethernet-switching;  
    }  
  }  
  ge-0/1/2 {  
    unit 0 {
```

```
        family ethernet-switching;
    }
}
xe-0/1/2 {
    unit 0 {
        family ethernet-switching;
    }
}
ge-0/1/3 {
    unit 0 {
        family ethernet-switching;
    }
}
xe-0/1/3 {
    unit 0 {
        family ethernet-switching;
    }
}
ge-0/1/4 {
    unit 0 {
        family ethernet-switching;
    }
}
xe-0/1/4 {
    unit 0 {
        family ethernet-switching;
    }
}
ge-0/1/5 {
    unit 0 {
        family ethernet-switching;
    }
}
xe-0/1/5 {
    unit 0 {
        family ethernet-switching;
    }
}
ge-0/1/6 {
    unit 0 {
        family ethernet-switching;
    }
}
xe-0/1/6 {
```

```
    unit 0 {
      family ethernet-switching;
    }
  }
  ge-0/1/7 {
    unit 0 {
      family ethernet-switching;
    }
  }
  xe-0/1/7 {
    unit 0 {
      family ethernet-switching;
    }
  }
  et-0/2/0 {
    unit 0 {
      family ethernet-switching;
    }
  }
  ge-0/2/0 {
    unit 0 {
      family ethernet-switching;
    }
  }
  xe-0/2/0 {
    unit 0 {
      family ethernet-switching;
    }
  }
  et-0/2/1 {
    unit 0 {
      family ethernet-switching;
    }
  }
  ge-0/2/1 {
    unit 0 {
      family ethernet-switching;
    }
  }
  xe-0/2/1 {
    unit 0 {
      family ethernet-switching;
    }
  }
}
```

```
ge-0/2/2 {
  unit 0 {
    family ethernet-switching;
  }
}
xe-0/2/2 {
  unit 0 {
    family ethernet-switching;
  }
}
ge-0/2/3 {
  unit 0 {
    family ethernet-switching;
  }
}
xe-0/2/3 {
  unit 0 {
    family ethernet-switching;
  }
}
ge-0/2/4 {
  unit 0 {
    family ethernet-switching;
  }
}
xe-0/2/4 {
  unit 0 {
    family ethernet-switching;
  }
}
ge-0/2/5 {
  unit 0 {
    family ethernet-switching;
  }
}
xe-0/2/5 {
  unit 0 {
    family ethernet-switching;
  }
}
ge-0/2/6 {
  unit 0 {
    family ethernet-switching;
  }
}
```

```
}
xe-0/2/6 {
  unit 0 {
    family ethernet-switching;
  }
}
ge-0/2/7 {
  unit 0 {
    family ethernet-switching;
  }
}
xe-0/2/7 {
  unit 0 {
    family ethernet-switching;
  }
}
}
protocols {
  igmp-snooping {
    vlan all;
  }
  rstp;
  lldp {
    interface all;
  }
  lldp-med {
    interface all;
  }
}
ethernet-switching-options {
  storm-control {
    interface all;
  }
}
}
```

SEE ALSO

| *Interfaces Overview for Switches*

Connecting and Configuring an EX Series Switch (CLI Procedure)

There are two ways to connect and configure an EX Series switch: one method is through the console by using the CLI and the other is by using the J-Web interface.

NOTE: EX2200-24T-4G-DC switches do not support switch connection and configuration through the J-Web interface.

This topic describes the CLI procedure.

NOTE: To run the **ezsetup** script, the switch must have the factory-default configuration as the active configuration. If you have configured anything on the switch and want to run **ezsetup**, revert to the factory-default configuration. See *Reverting to the Default Factory Configuration for the EX Series Switch*.

Using the CLI, set the following parameter values in the console server or PC:

- Baud rate—9600
- Flow control—None
- Data—8
- Parity—None
- Stop bits—1
- DCD state—Disregard

To connect and configure the switch from the console by using the CLI:

1. Connect the console port to a laptop or PC by using the RJ-45 to DB-9 serial port adapter. An Ethernet cable that has an RJ-45 connector at either end and an RJ-45 to DB-9 serial port adapter are supplied with the switch. If your laptop doesn't have a serial port, use a serial to USB adapter.

For the location of the console port on different EX Series switches:

- See *EX2200 Switches Hardware Overview*.
- See *EX2300 Switches Hardware Overview*.
- See *Rear Panel of an EX3200 Switch*.
- See *Rear Panel of an EX3300 Switch*.
- See *Rear Panel of an EX3400 Switch*.
- See *Rear Panel of an EX4200 Switch*.
- See *EX4300 Switches Hardware Overview*
- See *Front Panel of an EX4500 Switch*.
- See [“EX4550 Switches Hardware Overview” on page 19](#)
- See *Switch Fabric and Routing Engine (SRE) Module in an EX6200 Switch*.
- See *Switch Fabric and Routing Engine (SRE) Module in an EX8208 Switch*.
- See *Routing Engine (RE) Module in an EX8216 Switch*.

NOTE: In EX2200-C, EX2300, EX3400, EX4300, and EX4550 switches, you can also use the Mini-USB Type-B console port to connect to a laptop or PC. See [“Connect an EX Series Switch to a Management Console Using the Mini-USB Type-B Console Port” on page 153](#).

2. At the Junos OS shell prompt **root%**, type **ezsetup**.
3. Enter the hostname. This is optional.
4. Enter the root password you want to use for the device. Reenter the root password when prompted.

5. Enable services such as SSH and Telnet.

NOTE: You will not be able to log in to the switch as the **root** user through Telnet. Root login is allowed only through SSH.

- The default option for SSH is **yes**. Select this to enable SSH.
- The default option for Telnet is **no**. Change this to **yes** to enable Telnet.

6. Use the Management Options page to select the management scenario:

NOTE: On EX2300 and EX3400 switches, you cannot create a new VLAN for management. On EX4500, EX6200, and EX8200 switches, only the out-of-band management option is available.

- *Configure in-band management.* In in-band management, you configure a network interface or an uplink module (expansion module) interface as the management interface and connect it to the management device.
In this scenario, you have the following two options:
 - Use the automatically created VLAN *default* for management—Select this option to configure all data interfaces as members of the default VLAN. Specify the management IP address and the default gateway.
 - Create a new VLAN for management—Select this option to create a management VLAN. Specify the VLAN name, VLAN ID, management IP address, and default gateway. Select the ports that must be part of this VLAN.
- *Configure out-of-band management*—Configure the management port. In out-of-band management, you use a dedicated management channel (**MGMT** port) to connect to the management device. Specify the IP address and gateway of the management interface. Use this IP address to connect to the switch.

7. Specify the SNMP read community, location, and contact to configure SNMP parameters. These parameters are optional.
8. Specify the system date and time. Select the time zone from the list. These options are optional.

9. The configured parameters are displayed. Enter **yes** to commit the configuration. The configuration is committed as the active configuration for the switch.
10. (For EX4500 switches only) Enter the operational mode command **request chassis pic-mode intraconnect** to set the PIC mode to intraconnect.

You can now log in with the CLI or the J-Web interface to continue configuring the switch. If you use the J-Web interface to continue configuring the switch, the Web session is redirected to the new management IP address. If the connection cannot be made, the J-Web interface displays instructions for starting a J-Web session.

SEE ALSO

[Connecting and Configuring an EX Series Switch \(J-Web Procedure\) | 171](#)

[Installing and Connecting an EX2200 Switch](#)

[Installing and Connecting an EX2300 Switch](#)

[Installing and Connecting an EX3200 Switch](#)

[Installing and Connecting an EX3300 Switch](#)

[Installing and Connecting an EX3400 Switch](#)

[Installing and Connecting an EX4200 Switch](#)

[Installing and Connecting an EX4300 Switch](#)

[Installing and Connecting an EX4550 Switch | 123](#)

[Installing and Connecting an EX4500 Switch](#)

[Installing and Connecting an EX6210 Switch](#)

[Installing and Connecting an EX8208 Switch](#)

[Installing and Connecting an EX8216 Switch](#)

Connecting and Configuring an EX Series Switch (J-Web Procedure)

There are two ways to connect and configure an EX Series switch: one method is through the console by using the CLI and the other is by using the J-Web interface.

Starting in Junos OS Release 19.2R1, J-Web supports EX4650 switches.

NOTE: You cannot connect to and perform initial configuration of EX2200-24T-4G-DC, EX4300-48MP, EX4300-48MP-S switches, and EX4600 switches using EZSetup procedure from the J-Web interface. For EX2200-24T-4G-DC switches, you must use EZSetup from the switch console. For EX4300-48MP, EX4300-48MP-S, and EX4600 switches, you must use the CLI procedure through the switch console.

This topic describes the J-Web procedure.

NOTE: Before you begin the configuration, enable a DHCP client on the management PC that you will connect to the switch so that the PC can obtain an IP address dynamically.

NOTE: Read the following steps before you begin the configuration. You must complete the initial configuration by using EZSetup within 10 minutes. The switch exits EZSetup after 10 minutes and reverts to the factory default configuration, and the PC loses connectivity to the switch.

- EX2200 and EX2200-C switch—The LEDs on the network ports on the front panel blink when the switch is in the initial setup mode.
- EX3200, EX3300, EX4200, EX4300 switches except EX4300-48MP and EX4300-48MP-S switches, EX4500, EX4550, EX6200, or EX8200 switch—The LCD panel displays a count-down timer when the switch is in initial setup mode.

NOTE: There is no LCD panel on EX4300-48MP and EX4300-48MP-S switches.

To connect and configure the switch by using the J-Web interface:

1. Transition the switch into initial setup mode:

- EX2200 and EX2200-C switch—Press the mode button located on the lower right corner of the front panel for 10 seconds.
- EX3200, EX3300, EX4200, EX4300 switches except EX4300-48MP and EX4300-48MP-S switches, EX4500, EX4550, EX6200, or EX8200 switch—Use the **Menu** and **Enter** buttons located to the right of the LCD panel (see [Figure 63 on page 173](#) or [Figure 64 on page 173](#)):

Figure 63: LCD Panel in an EX3200, EX4200, EX4500, EX4550, or EX8200 Switch

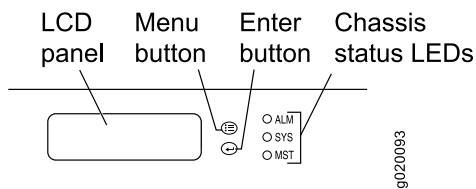
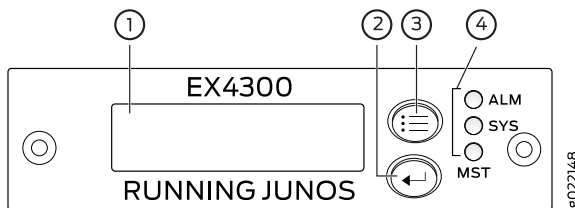

Figure 64: LCD Panel in an EX4300 Switches Except EX4300-48MP and EX4300-48MP-S Switches



1—LCD panel

2—LCD panel Enter button

3—LCD panel Menu button

4—Chassis status LEDs

1. Press the **Menu** button until you see **MAINTENANCE MENU**. Then press the **Enter** button.
 2. Press **Menu** until you see **ENTER EZSetup**. Then press **Enter**.
If EZSetup does not appear as an option in the menu, select **Factory Default** to return the switch to the factory default configuration. EZSetup is displayed in the menu of standalone switches only when a switch is set to the factory default configuration.
 3. Press **Enter** to confirm setup and continue with EZSetup.
2. Connect the Ethernet cable from the Ethernet port on the PC to the switch.
- EX2200, EX3200, or EX4200 switch—Connect the cable to port 0 (ge-0/0/0) on the front panel of the switch.
 - EX3300 switch—Connect the cable to the port labeled **MGMT** on the rear panel of the switch.
 - EX4300 switches except EX4300-48MP and EX4300-48MP-S switches—Connect the cable to the port labeled **MGMT** on the rear panel of the switch.

- EX4500 or EX4550 switch—Connect the cable to the port labeled **MGMT** on the front panel (LCD panel side) of the switch.
- EX4650 switches—Connect the cable to the port labeled **CON** on the rear panel of the switch.
- EX6200 switch—Connect the cable to one of the ports labeled **MGMT** on the Switch Fabric and Routing Engine (SRE) module in slot 4 or 5 in an EX6210 switch.
- EX8200 switch—Connect the cable to the port labeled **MGMT** on the Switch Fabric and Routing Engine (SRE) module in slot SRE0 in an EX8208 switch or on the Routing Engine (RE) module in slot RE0 in an EX8216 switch.

These ports are configured as the DHCP server with the default IP address, 192.168.1.1. The switch can assign an IP address to the management PC in the IP address range 192.168.1.2 through 192.168.1.253.

3. From the PC, open a Web browser, type **http://192.168.1.1** in the address field, and press **Enter**.
4. On the J-Web login page, type **root** as the username, leave the password field blank, and click **Login**.
5. On the Introduction page, click **Next**.
6. On the Basic Settings page, modify the hostname, the root password, and date and time settings:
 - Enter the hostname. This is optional.
 - Enter a password and reenter the password.
 - Specify the time zone.
 - Synchronize the date and time settings of the switch with the management PC or set them manually by selecting the appropriate option button. This is optional.

Click **Next**.

7. Use the Management Options page to select the management scenario:

NOTE: On EX2300 and EX3400 switches, you cannot create a new VLAN for management.

On EX4500, EX6210, and EX8200 switches, only the out-of-band management option is available.

- *Configure in-band management.* In in-band management, you configure a network interface or an uplink module (expansion module) interface as the management interface and connect it to the management device.

In this scenario, you have the following two options:

- Use the automatically created VLAN *default* for management—Select this option to configure all data interfaces as members of the default VLAN. Specify the management IP address and the default gateway.
 - Create a new VLAN for management—Select this option to create a management VLAN. Specify the VLAN name, VLAN ID, management IP address, and default gateway. Select the ports that must be part of this VLAN.
 - *Configure out-of-band management*—Configure the management port. In out-of-band management, you use a dedicated management channel (**MGMT** port) to connect to the management device. Specify the IP address and gateway of the management interface. Use this IP address to connect to the switch.
8. Click **Next**.
 9. On the Manage Access page, you can select options to enable Telnet, SSH, and SNMP services. For SNMP, you can configure the read community, location, and contact.
 10. Click **Next**. The Summary screen displays the configured settings.
 11. Click **Finish**. The configuration is committed as the active switch configuration.

NOTE: After the configuration is committed, the connectivity between the PC and the switch might be lost. To renew the connection, release and renew the IP address by executing the appropriate commands on the management PC or by removing and reinserting the Ethernet cable.

12. (For EX4500 switches only) In the CLI, enter the **request chassis pic-mode intraconnect** operational mode command to set the PIC mode to intraconnect.

You can now log in by using the CLI or the J-Web interface to continue configuring the switch.

If you use the J-Web interface to continue configuring the switch, the Web session is redirected to the new management IP address. If the connection cannot be made, the J-Web interface displays instructions for starting a J-Web session.

Configuring the LCD Panel on EX Series Switches (CLI Procedure)

This topic applies to hardware devices in the EX Series product family, which includes switches and the XRE200 External Routing Engine, that support the LCD panel interface.

The LCD panel on the front panel of EX Series switches displays a variety of information about the switch in the Status menu and provides the Maintenance menu to enable you to perform basic operations such as initial setup and reboot. You can disable these menus or individual menu options if you do not want switch users to use them. You can also set a custom message that will be displayed on the panel.

- [Disabling or Enabling Menus and Menu Options on the LCD Panel | 176](#)
- [Configuring a Custom Display Message | 177](#)

Disabling or Enabling Menus and Menu Options on the LCD Panel

By default, the Maintenance menu, the Status menu, and the options in those menus in the LCD panel are enabled. Users can configure and troubleshoot the switch by using the Maintenance menu and view certain details about the switch by using the Status menu.

If you do not want users to be able to use those menus or some of the menu options, you can disable the menus or individual menu options. You can reenable the menus or menu options.

Issue the **show chassis lcd menu** operational mode command to see the menus or menu options that are currently enabled.

NOTE: On some platforms, you must specify an FPC slot number in these commands. See the *lcd-menu* statement for details.

To disable a menu:

```
[edit]
```

```
user@switch# set chassis lcd-menu menu-item menu-name disable
```

To enable a menu:

```
[edit]
```

```
user@switch# delete chassis lcd-menu menu-item menu-name disable
```

To disable a menu option:

```
[edit]
```

```
user@switch# set chassis lcd-menu menu-item menu-option disable
```

To enable a menu option:

```
[edit]
```

```
user@switch# delete chassis lcd-menu menu-item menu-option disable
```

Configuring a Custom Display Message

You can configure the second line of the LCD to display a custom message temporarily for 5 minutes or permanently.

To display a custom message temporarily:

- On an EX3200 switch, a standalone EX3300 switch, a standalone EX4200 switch, a standalone EX4300 switch except EX4300-48MP and EX4300-48MP-S switches, a standalone EX4500 switch, a standalone EX4550 switch, an EX6200 switch, an EX8200 switch, or an XRE200 External Routing Engine:

```
user@switch> set chassis display message message
```

- On an EX3300, EX4200, EX4300, EX4500, or EX4550 switch in a Virtual Chassis configuration:

```
user@switch> set chassis display message message fpc-slot slot-number
```

To display a custom message permanently:

- On an EX3200 switch, a standalone EX3300 switch, a standalone EX4200 switch, a standalone EX4300 switch except EX4300-48MP and EX4300-48MP-S switches, a standalone EX4500 switch, a standalone EX4550 switch, an EX6200 switch, an EX8200 switch, or an XRE200 External Routing Engine:

```
user@switch> set chassis display message message permanent
```

- On an EX3300, EX4200, EX4300 except EX4300-48MP and EX4300-48MP-S, EX4500, or EX4550 switch in a Virtual Chassis configuration:

```
user@switch> set chassis display message message fpc-slot slot-number permanent
```

NOTE: The buttons on the LCD panel are disabled when the LCD is configured to display a custom message.

To disable the display of the custom message:

```
user@switch> clear chassis display message
```

You can view the custom message by issuing the **show chassis lcd** command.

Dashboard for EX Series Switches

IN THIS SECTION

- [Graphical Chassis Viewer | 179](#)
- [System Information Panel | 181](#)
- [Health Status Panel | 184](#)
- [Capacity Utilization Panel | 188](#)
- [Alarms Panel | 189](#)
- [File System Usage | 189](#)
- [Chassis Viewer | 189](#)

NOTE: This topic applies only to the J-Web Application package.

When you log in to the J-Web user interface, the dashboard for the Juniper Networks EX Series Ethernet Switches appears. Use the dashboard to view system information.

The Update Available window appears if there is a latest update of the J-Web Application package available on the Juniper Networks server. This window is enabled by the auto update feature of J-Web.

NOTE:

- The Update Available window will *not* appear when you log in, if you have not selected the **Check for updates automatically on every login** in the *Update Preference* section in the **Maintain > Update J-Web** side pane. By default, the *Check for update automatically on every login* is selected.
- If you choose *Update Later*, you can update to the latest J-Web Application package by clicking the orange icon next to *Update Available* on the top pane of the J-Web interface or through **Maintain > Update J-Web**.

The dashboard comprises a graphical chassis viewer and four panels.

Graphical Chassis Viewer

The Dashboard panel displays a graphical view of the chassis of a switch. In a Virtual Chassis, it displays a graphical view of each member switch.

In a Virtual Chassis, the default values are shown on the Dashboard panel when no chassis image is clicked. The panel displays the value for a switch if you click its image.

NOTE:

- If the member switch is not present, inactive, or not provisioned, you cannot expand the member switch image.

In J-Web Application package Release 14.1X53-A2, you can form a Virtual Chassis using EX4600 and EX4300 switches. When in a mixed Virtual Chassis consisting of EX4600 switches and EX4300 switches, the EX4600 switches can be the primary, backup, or in the linecard role, while the EX4300 switches must be in the linecard role.

- Starting in J-Web Application Package Release 19.2A1, J-Web supports EX4650 switches.

NOTE: For EX4650 switches, chassis viewer supports only the standalone view and does not support the Virtual Chassis configuration.

Table 52 on page 179 lists the details that are displayed on each member switch.

Table 52: Details of a Virtual Chassis Member Switch

Details	Example
Model number of the member switch	EX3300
Assigned ID that applies to the entire Virtual Chassis configuration	ID 2 NOTE: If the member switch is not provisioned, the serial number of the switch is displayed instead of its ID.
Role of the member switch	Master Possible roles are: Master, Backup, or Linecard
Status of the member switch	Prsnt Possible statuses are: Prsnt, NotPrsnt, Inactive, or Unprvsnd

The status of the member switch is displayed on the image of the switch. If the member switch appears dimmed, it means the switch is not present, is inactive, or is not provisioned in the Virtual Chassis. If the member switch does not appear dimmed, it means the switch is present and is active.

Table 53 on page 180 describes the possible status of a member switch.

Table 53: Status of a Member Switch in a Virtual Chassis

If the member switch is	It appears as	It means the member switch
Present	Prsnt	Has established physical and logical connections with Virtual Chassis member switches.
Not present	dimmed and NotPrsnt	Has been disconnected from the existing Virtual Chassis.
Inactive	dimmed and Inactive	Has established physical connections, but is unable to establish logical connections.
Not provisioned	dimmed and Unprvsnd	Cannot synchronize with the existing preprovisioned Virtual Chassis.

Click **Rear View** for a graphical view of the rear panel of the switch.

Click **Preferences** to choose which panels must be displayed and set the refresh interval for chassis viewer information. Click **OK** to save your changes and return to the dashboard or click **Cancel** to return to the dashboard without saving changes.

NOTE: You can drag the various panels to different locations in the J-Web window.

System Information Panel

Table 54: System Information

Field	Description
System name	<p>Indicates the local name of the EX Series switch. The local name of the EX Series switches changes when an individual image is clicked.</p> <p>For EX4650 switches, indicates the host name of the switch. Specific host name of the EX4650 switch is displayed when you click on the individual line card.</p>
Device model	<p>Indicates the model of the EX Series switch. In a Virtual Chassis configuration, to indicate the model of a switch, click the image of that switch.</p> <p>NOTE: In a Virtual Chassis setup for an EX6210, EX8208, or EX8216 switch, the Device model field displays details of the primary Routing Engine. To view details of a member, select it.</p> <p>By default, the EX4650 switches show the model of the primary switch. When you click on the image, the model of the switch is displayed.</p>

Table 54: System Information (*continued*)

Field	Description
Inventory details	

Table 54: System Information (continued)

Field	Description
	<p data-bbox="854 338 1101 365">Indicates the following:</p> <ul data-bbox="854 401 1453 1885" style="list-style-type: none"> <li data-bbox="854 401 1453 646">• For EX3200 switches; and for EX2200, EX2200-C, EX3300, EX4200, EX4300, EX4500, EX4550, and EX4600 switches that are not configured as Virtual Chassis, the value displayed in Inventory details field is always 1 FPC. FPC is a legacy term for a slot in a large Juniper Networks chassis; which simply refers to the standalone switch. <li data-bbox="854 667 1453 800">• For EX2200 and EX2200-C switches configured as a Virtual Chassis, the value displayed in the Inventory details field is 1–4 FPC, with the number corresponding to the number of member switches. <li data-bbox="854 821 1453 953">• For EX3300 switches configured as a Virtual Chassis, the value displayed in the Inventory details field is 1–6 FPC, with the number corresponding to the number of member switches. <p data-bbox="878 989 1453 1087">NOTE: For Junos OS Release 14.1X53-D10 and later, EX3300 switches configured as a Virtual Chassis display the value 1–10 FPC in the Inventory details field.</p> <ul data-bbox="854 1123 1453 1885" style="list-style-type: none"> <li data-bbox="854 1123 1453 1255">• For EX4200, EX4500, EX4550, and EX4600 switches configured as a Virtual Chassis, the value displayed in the Inventory details field is 1–10 FPC, with the number corresponding to the number of member switches. <li data-bbox="854 1276 1453 1339">• For EX4650 switches, the value displayed in Inventory details field is equal to the number of FPCs. <li data-bbox="854 1360 1453 1493">• For EX6210 switches, the values displayed in the Inventory details field are 1–2 CB and 1–9 FPC. CB, or Control Board, refers to the SRE module. FPC refers to line cards and the FPC within the CB. <li data-bbox="854 1514 1453 1646">• For an EX8208 switch, the values displayed in Inventory details field are 1–3 CB and 0–8 FPC. CB, or Control Board, refers to SRE and SF modules. FPC refers to line cards. <li data-bbox="854 1667 1453 1766">• For EX8216 switches, the values displayed in Inventory details field are 1–2 CB and 0–16 FPC. CB, or Control Board, refers to RE modules and FPC refers to line cards. <li data-bbox="854 1787 1453 1885">• For an XRE200 External Routing Engine in an EX8200 Virtual Chassis, the value displayed in Inventory details is 1 XRE. XRE refers to RE modules. For XRE200

Table 54: System Information (continued)

Field	Description
	External Routing Engines configured as a Virtual Chassis, the values displayed in Inventory details are 1–2 XRE and 0–4 LCC, where LCC refers to the EX8200 line card chassis.
Junos image	Indicates the version of the Junos OS image. In a Virtual Chassis configuration, the Junos OS image of the primary switch is displayed by default. To display the Junos OS image of a specific switch, click the image of that switch. NOTE: For EX4650 switches, the Junos OS image of the primary is displayed by default. To display the Junos OS image of a specific switch, click the image of that switch.
Boot image	Indicates the version of the boot image that is used. In a Virtual Chassis configuration, the boot image of the primary switch is displayed by default. To display the boot image of a specific switch, click the image of that switch. NOTE: For EX4650 switches, the boot image of the primary switch is displayed by default. To display the boot image of a specific switch, click the image of that switch.
Device uptime	Indicates the time since the last reboot. In a Virtual Chassis configuration, to display the uptime of the specific switch, click the image of that switch. NOTE: For EX4650 switches, click the image of the switch to display the uptime.
Last configured time	Indicates the time when the switch was last configured.

Health Status Panel

Table 55: Health Status

Field	Description
EX2200, EX2200-C, EX3200, EX3300, EX4200, and EX4300 Switches	

Table 55: Health Status (continued)

Field	Description
Memory util.	<p>Indicates the memory used in the Routing Engine. In a Virtual Chassis configuration, the memory utilization value of the primary Routing Engine is displayed.</p> <p>NOTE: In EX4300 and EX4600 Virtual Chassis, to display the Routing Engine memory utilization of the primary or backup, click the respective image. J-Web is supported on EX4600 switches only in J-Web Application package Release 14.1X53-A2.</p>
Flash	<p>Indicates the usage and capacity of internal flash memory and any external USB flash drive.</p> <p>NOTE: In EX4300 Virtual Chassis, the flash memory utilization of the primary switch is displayed by default. To display the flash memory utilization along with the internal and external flash memory utilization details for each switch or line card, mouse over individual switch or line card images.</p> <p>In EX4600 Virtual Chassis, to display the flash memory utilization along with the internal and external flash memory utilization details of each switch or line card mouse over the green-colored indicator.</p>
Temp.	<p>Indicates the chassis temperature status. Temperatures are listed in Celsius and the corresponding Fahrenheit values.</p> <p>NOTE: The Temp field is unavailable for a standalone EX2200-C switch.</p> <p>The Temp field is dynamically available for an EX2200 Virtual Chassis switch based on the model of the member clicked.</p> <p>NOTE: In EX4300 Virtual Chassis, the temperature of the primary Routing Engine is displayed by default. To display the temperature of the Routing Engine of any switch, click the image of that switch.</p> <p>In EX4600 Virtual Chassis, to display the temperature of the Routing Engine of each switch, mouse over the green-colored indicator.</p>
CPU load	<p>Indicates the average CPU usage over 15 minutes. In a Virtual Chassis configuration, on loading the primary or backup switch, the CPU load for that switch's Routing Engine is displayed by default. To display the CPU load for a specific switch's Routing Engine, click the image of that switch.</p>

Table 55: Health Status (continued)

Field	Description
Fan status	<p>Indicates the status of the fans in the fan tray. The possible values are OK, Failed, and Absent. In a Virtual Chassis configuration, the fan status of the primary switch is displayed by default. To display the fan status for any switch , click the image of that switch.</p> <p>NOTE: The Fan status field is unavailable for a standalone EX2200-C switch.</p> <p>The Fan status field is dynamically available for an EX2200 Virtual Chassis switch based on the model of the member clicked.</p> <p>In EX4600 Virtual Chassis, mouse over the fan icon to display the fan status of all the switches.</p>
EX4500 and EX4550 Switches	
Memory util.	Indicates the memory used in the Routing Engine. In a Virtual Chassis configuration, the memory utilization value of the primary Routing Engine is displayed.
Flash	Indicates the usage and capacity of internal flash memory and any external USB flash drive.
Temp.	<p>Indicates the chassis temperature status. Temperatures in the dashboard are listed in Celsius and the corresponding Fahrenheit values.</p> <p>NOTE: The Temp field is unavailable for an EX4500 switch.</p>
CPU load	Indicates the average CPU usage over 15 minutes.
Fan status	Indicates the status of the fans in the fan tray. The possible values are OK , Failed , and Absent . This field also indicates the direction of airflow of the fan tray. The possible values are Front to back and Back to front .
EX4650 Switches	
Fan status	<p>Indicates the status of the fans in the fan tray. The possible values are OK, Failed, and Absent.</p> <p>NOTE: The fans are located on the side panel of the chassis.</p>
Temp.	Indicates temperature of the sensor near to Routing Engine.
Memory util.	Indicates the memory used in the Routing Engine.
CPU load	Indicates the average CPU usage over 15 minutes.
EX6210 Switches	

Table 55: Health Status (continued)

Field	Description
Memory util.	Indicates the memory used in the primary Routing Engine. Click the backup Routing Engine to view the memory used in the backup Routing Engine.
CPU load	Indicates the average CPU usage over 15 minutes.
Flash	Indicates the usage and capacity of internal flash memory and any external USB flash drive.
Fan status	Indicates the status of the fans in the fan tray. The possible values are OK , Failed , and Absent .
EX8208 Switches	
Memory util.	Indicates the memory used in the external Routing Engine. In an EX8200 Virtual Chassis, the memory utilization value of the XRE200 External Routing Engine in the primary role is displayed. Click the XRE200 External Routing Engine in the backup role to view the memory used in the backup external Routing Engine.
CPU load	Indicates the average CPU usage over 15 minutes.
Flash	Indicates the usage and capacity of internal flash memory and any external USB flash drive.
EX8216 Switches	
Memory util.	Indicates the memory used in the external Routing Engine. In an EX8200 Virtual Chassis, the memory utilization value of the XRE200 External Routing Engine in the primary role is displayed. Click the XRE200 External Routing Engine in the backup role to view the memory used in the backup external Routing Engine.
CPU load	Indicates the average CPU usage over 15 minutes.
Flash	Indicates the usage and capacity of internal flash memory and any external USB flash drive.
XRE200 External Routing Engines	
Memory util.	Indicates the memory used in the external Routing Engine. In an EX8200 Virtual Chassis, the memory utilization value of the XRE200 External Routing Engine in the primary role is displayed. Click the backup XRE200 External Routing Engine to view the memory used in backup external Routing Engine.
CPU load	Indicates the average CPU usage over 15 minutes.
Flash	Indicates the usage and capacity of internal flash memory and any external USB flash drive.

Table 55: Health Status (*continued*)

Field	Description
Fan Status	Indicates the status of the fans in the fan tray. The possible values are OK , Failed , and Absent .

Capacity Utilization Panel

Table 56: Capacity Utilization

Field	Description
Number of active ports	Indicates the number of active ports in the switch. Configured Virtual Chassis ports (VCPs) are considered as active ports.
Total number of ports	Indicates the number of ports in the switch. NOTE: In EX3300 and EX4600 Virtual Chassis, the total number of ports of all of the switches is displayed. NOTE: For EX4650 switches, on loading the switch, the consolidated values for all the FPCs are displayed by default.
Used-up MAC-Table entries	Indicates the number of MAC table entries.
Supported MAC-Table entries	Indicates the maximum number of MAC table entries permitted. NOTE: For EX4650 switches, the supported maximum number of MAC table entries are 288000.
Number of VLANs configured	Indicates the number of VLANs configured. NOTE: Only tagged VLANs are counted.
Number of VLANs supported	Indicates the maximum number of VLANs supported. NOTE: For EX4650 switches, the supported maximum number of VLANs are 4094.

Alarms Panel

Displays information about the last five alarms raised in the system. For example, if there are 5 major alarms, then details of all 5 major alarms are displayed. If there are 4 major alarms and 3 minor alarms, then details of the 4 major alarms and 1 minor alarm are displayed. Major alarms are displayed in red and minor alarms are displayed in yellow.

In an EX8200 Virtual Chassis, the top 5 alarms for the primary external Routing Engine are displayed by default. If you select an EX8200 member switch of the Virtual Chassis, the top 5 alarms for that member switch are displayed.

File System Usage

To display the file system storage details of a switch in the backup or line card role, click the image of that switch.

For EX4650 switches, the directory, space used, and the file type details are displayed. By default, primary switch file system storage details are displayed. When you click the image, line card switch file system storage details are displayed.

Chassis Viewer

Click the **Rear View** button to see the back of the chassis image. Click the **Front View** button to see the front of the chassis image. In a Virtual Chassis configuration, the **Rear View** button is disabled if the switch is not selected.

NOTE: For EX4650 switches, chassis viewer supports only the standalone view and does not support Virtual Chassis configuration.

- [Table 57 on page 190](#)—Describes the chassis viewer for EX2200 switches.
- [Table 58 on page 190](#)—Describes the chassis viewer for EX2200-C switches.
- [Table 59 on page 191](#)—Describes the chassis viewer for EX3200, EX3300, and EX4200 switches.
- [Table 60 on page 193](#)—Describes the chassis viewer for EX4300 switches.
- [Table 61 on page 195](#)—Describes the chassis viewer for EX4500 switches.
- [Table 62 on page 196](#)—Describes the chassis viewer for EX4550 switches.

- [Table 63 on page 198](#)—Describes the chassis viewer for EX4600 switches.
- [Table 64 on page 199](#)—Describes the chassis viewer for EX4650 switches.
- [Table 65 on page 200](#)—Describes the chassis viewer for EX6210 switches.
- [Table 66 on page 201](#)—Describes the chassis viewer for EX8208 switches.
- [Table 67 on page 202](#)—Describes the chassis viewer for EX8216 switches.
- [Table 68 on page 204](#)—Describes the chassis viewer for the XRE200 External Routing Engines.

Table 57: Chassis Viewer for EX2200 Switches

Field	Description
Front View	
Interface status	<p>In the image, the following colors denote the interface status:</p> <ul style="list-style-type: none"> • Green—Interface is up and operational. • Yellow—Interface is up but is nonoperational. • Gray—Interface is down and nonoperational. <p>Mouse over the interface (port) to view more information.</p>
Rear View	
Management (me0) port	The management port is used to connect the switch to a management device for out-of-band management.
Console port	The console port is used to connect the switch to a management console or to a console server. (You might do this for initial switch configuration.)
USB port	<p>Indicates the USB port for the switch.</p> <p>NOTE: We recommend that you use USB flash drives purchased from Juniper Networks for your EX Series switch.</p>
Fan tray	Mouse over the fan tray icon to display name, status, and description information.
Power supply	Mouse over the power outlet icon to display name, status, and description information.

Table 58: Chassis Viewer for EX2200-C Switches

Field	Description
Front View	

Table 58: Chassis Viewer for EX2200-C Switches (*continued*)

Field	Description
Interface status	<p>In the image, the following colors denote the interface status:</p> <ul style="list-style-type: none"> • Green—Interface is up and operational. • Yellow—Interface is up but is nonoperational. • Gray—Interface is down and nonoperational. <p>Mouse over the interface (port) to view more information.</p>
Management (me0) port	The management port is used to connect the switch to a management device for out-of-band management.
Console port	The console port is used to connect the switch to a management console or to a console server. (You might do this for initial switch configuration.)
USB port	<p>Indicates the USB port for the switch.</p> <p>NOTE: We recommend that you use USB flash drives purchased from Juniper Networks for your EX Series switch.</p>
Rear View	
Power supply	Mouse over the power outlet icon to display name, status, and description information.

Table 59: Chassis Viewer for EX3200, EX3300, and EX4200 Switches

Field	Description
Front View	

Table 59: Chassis Viewer for EX3200, EX3300, and EX4200 Switches (continued)

Field	Description
Interface status	<p>In the image, the following colors denote the interface status:</p> <ul style="list-style-type: none"> • Green—Interface is up and operational. • Yellow—Interface is up but is nonoperational. • Gray—Interface is down and nonoperational. <p>Mouse over the interface (port) to view more information.</p> <p>For a Virtual Chassis configuration, select the switch to view the interface status.</p> <p>If an SFP+ uplink module is installed in the switch, mouse over the port icon to display whether the module is configured to operate in 1-gigabit mode or in 10-gigabit mode. If the module is configured to operate in 1-gigabit mode, the tool tip information is displayed for all 4 ports. If the module is configured to operate in 10-gigabit mode, the tool tip information is displayed only for 2 ports.</p> <p>On an EX3300 switch with the 4x GE/XE SFP+ module, mouse over the port icon to display whether the module is configured to operate in 1-gigabit mode or 10-gigabit mode.</p> <p>For SFP, SFP+, and XFP ports, the interfaces appear dimmed if no transceiver is inserted. The chassis viewer displays Transceiver not plugged-in when you mouse over the port icon.</p>
LCD panel	LCD panel configured for the LEDs on the ports. Mouse over the icon to view the current character display.

Rear View of the EX3200 Switch

Management (me0) port	The management port is used to connect the switch to a management device for out-of-band management.
Console port	The console port is used to connect the switch to a management console or to a console server. (You might do this for initial switch configuration.)
USB port	Indicates the USB port for the switch. NOTE: We recommend that you use USB flash drives purchased from Juniper Networks for your EX Series switch.
Fan tray	Mouse over the fan tray icon to display name, status, and description information.
Power supply	Mouse over the power supply icon to display name, status, and description information.

Rear View of the EX3300 and EX4200 Switch

Table 59: Chassis Viewer for EX3200, EX3300, and EX4200 Switches (continued)

Field	Description
Fan tray	Mouse over the fan tray icon to display name, status, and description information. For a Virtual Chassis, the status of the fans of the selected member switch is displayed.
Virtual Chassis port	Displayed only when EX4200 switches are configured as a Virtual Chassis. The following colors denote the Virtual Chassis port (VCP) status: <ul style="list-style-type: none"> • Green—VCP is up and operational. • Yellow—VCP is up but is nonoperational. • Gray—VCP is down and nonoperational.
USB port	Indicates the USB port for the switch. NOTE: We recommend that you use USB flash drives purchased from Juniper Networks for your EX Series switch.
Management (me0) port	The management port is used to connect the switch to a management device for out-of-band management.
Console port	The console port is used to connect the switch to a management console or to a console server. (You might do this for initial switch configuration.)
Power supplies	Mouse over the power supply icons to display name, status, and description information.

Table 60: Chassis Viewer for EX4300 Switches

Field	Description
Front View	
Interface status	In the image, the colors listed below denote the interface status for both copper and fiber media type of ports: <ul style="list-style-type: none"> • Green—Interface is up and operational. • Yellow—Interface is up but is nonoperational. • Gray—Interface is down and nonoperational. Mouse over the interface (port) to view more information.
LCD panel	LCD panel configured for the LEDs on the ports. Mouse over the icon to view the current character display.
Mini USB console	The mini console port is used to connect the switch to the management console.

Table 60: Chassis Viewer for EX4300 Switches (continued)

Field	Description
PIC 2 slot	<p>You can install an uplink module in the PIC 2 slot. Mouse over the ports in the module to view the details of the ports in module.</p> <p>24-port and 48-port EX4300 switches support the 4-port 10-Gigabit SFP+ uplink module.</p> <p>EX4300-32F switches support the 2-port 40-Gigabit QSFP+ uplink module and the 8-port 10-Gigabit SFP+ uplink module.</p> <p>When you install a transceiver in the port, the following colors denote the interface status:</p> <ul style="list-style-type: none"> • Green—Interface is up and operational. • Yellow—Interface is up but is not operational. • Gray—Interface is down and not operational.

NOTE: In EX4300 switches the LEDs are seen in the front panel, these are not active.

Rear View of the EX4300 Switch

Management port	The management port is used to connect the switch to a management device for out-of-band management.
Console port	The Console port (RJ-45) is used to connect the switch to a management console or to a console server.
USB port	<p>Indicates the USB port for the switch.</p> <p>NOTE: We recommend that you use USB flash drives purchased from Juniper Networks for your EX Series switch.</p>
Fan tray	Mouse over the fan tray icons to display name, status, and description information.
Power supplies	Mouse over the power supply icons to display name, status, and description information.

Table 60: Chassis Viewer for EX4300 Switches (*continued*)

Field	Description
PIC 1 slot	<p>The rear panel of a 24-port and a 48-port EX4300 switch has four (built-in) 40-Gigabit QSFP+ ports, and the rear panel of an EX4300-32F switch has two (built-in) 40-Gigabit QSFP+ ports, in which you can install QSFP+ transceivers. Mouse over the ports to view the details of the ports.</p> <p>After you install a transceiver in the port, the following colors denote the interface status:</p> <ul style="list-style-type: none"> • Green—Interface is up and operational. • Yellow—Interface is up but is not operational. • Gray—Interface is down and not operational. <p>For QSFP+ ports, the interfaces appear dimmed if no transceiver is inserted. The chassis viewer displays Transceiver not plugged in when you mouse over the port.</p> <p>When a QSFP+ port is configured as a Virtual Chassis Port (VCP), the following colors denote the VCP status:</p> <ul style="list-style-type: none"> • Green—VCP is up and operational. • Yellow—VCP is up but is not operational. • Gray—VCP is down and not operational.

Table 61: Chassis Viewer for EX4500 Switches

Field	Description
Front View	
Interface status	<p>In the image, the colors listed below denote the interface status:</p> <ul style="list-style-type: none"> • Green—Interface is up and operational. • Yellow—Interface is up but is nonoperational. • Gray—Interface is down and nonoperational. <p>Mouse over the interface (port) to view more information.</p> <p>For a Virtual Chassis configuration, select the switch to view the interface status.</p> <p>If an SFP+ uplink module is installed in the switch, mouse over the interface (ports) on the module for more information.</p> <p>For SFP and SFP+ ports, the interfaces appear dimmed if no transceiver is inserted. The chassis viewer displays Transceiver not plugged-in when you mouse over the port icon.</p>
LCD panel	LCD panel configured for the LEDs on the ports. Mouse over the icon to view the current character display.

Table 61: Chassis Viewer for EX4500 Switches (*continued*)

Field	Description
Console port	The console port is used to connect the switch to a management console or to a console server.
Management (me0) port	The management port is used to connect the switch to a management device for out-of-band management. Use this port for initial switch configuration.
USB port	Indicates the USB port for the switch. NOTE: We recommend that you use USB flash drives purchased from Juniper Networks for your EX Series switch.

Rear View of the EX4500 Switch

Fan tray	Mouse over the fan tray icon to display status of the fans and airflow direction information. For a Virtual Chassis, the status of the fans of the selected member switch is displayed.
Virtual Chassis port	Displayed only when switches are configured as a Virtual Chassis. The colors listed below denote the Virtual Chassis port (VCP) status: <ul style="list-style-type: none"> • Green—VCP is up and operational. • Yellow—VCP is up but is nonoperational. • Gray—VCP is down and nonoperational.
Power supplies	Mouse over the power supply icons to display name, status, and description information.
Intraconnect module	Mouse over the module to display details of the intraconnect module. The intraconnect module helps the switch achieve line rate on all its ports.
Virtual Chassis module	Mouse over to display details of the switches in the Virtual Chassis configuration.

Table 62: Chassis Viewer for EX4550 Switches

Field	Description
Front View	

Table 62: Chassis Viewer for EX4550 Switches (*continued*)

Field	Description
Interface status	<p>In the image, the colors listed below denote the interface status:</p> <ul style="list-style-type: none"> • Green—Interface is up and operational. • Yellow—Interface is up but is nonoperational. • Gray—Interface is down and nonoperational. <p>Mouse over the interface (port) to view more information.</p> <p>For a Virtual Chassis configuration, select the switch to view the interface status.</p> <p>If an expansion module or a Virtual Chassis module is installed in the switch, mouse over the interface (ports) on the module for more information.</p> <p>On an EX4550-32F switch, for SFP and SFP+ ports, the interfaces appear dimmed if no transceiver is inserted. The chassis viewer displays Transceiver (1G/10G) not plugged in when you mouse over the port icon.</p>
LCD panel	LCD panel configured for the LEDs on the ports. Mouse over the icon to view the current character display.
Console port	The console port is used to connect the switch to a management console or to a console server.
Mini Console port	The mini console port is used to connect the switch to the management console.
Management (me0) port	The management port is used to connect the switch to a management device for out-of-band management. Use this port for initial switch configuration.
PIC1 slot	You can insert an uplink module or a Virtual Chassis module in the PIC1 slot. Mouse over to display the details of the module inserted (uplink or Virtual Chassis).
USB port	<p>Indicates the USB port for the switch.</p> <p>NOTE: We recommend that you use USB flash drives purchased from Juniper Networks for your EX Series switch.</p>
Rear View of the EX4550 Switch	
Fan tray	Mouse over the fan tray icon to display the status of the fans and airflow direction information. For a Virtual Chassis, the status of the fans of the selected member switch is displayed.

Table 62: Chassis Viewer for EX4550 Switches (*continued*)

Field	Description
Virtual Chassis port	<p>Displayed only when switches are configured as a Virtual Chassis. In the image, the colors listed below denote the Virtual Chassis port (VCP) status:</p> <ul style="list-style-type: none"> ● Green—VCP is up and operational. ● Yellow—VCP is up but is nonoperational. ● Gray—VCP is down and nonoperational.
Power supplies	Mouse over the power supply icons to display name, status, and description information.
PIC2 slot	You can insert an uplink module or a Virtual Chassis module into the PIC2 slot. Mouse over to display the details of the module inserted (uplink or Virtual Chassis).

Table 63: Chassis Viewer for EX4600 Switches

Field	Description
Front View	
NOTE: J-Web is supported on EX4600 switches only in J-Web Application package Release 14.1X53-A2.	
Interface status	<p>In the image, the colors listed below denote the interface status for both copper and fiber media type of ports:</p> <ul style="list-style-type: none"> ● Green—Interface is up and operational. ● Yellow—Interface is up but is nonoperational. ● Gray—Interface is down and nonoperational. <p>Mouse over the interface (port) to view more information.</p>
PIC 1 and PIC 2 slots	<p>You can install an expansion module in the PIC 1 and PIC 2 slots. If you have installed an expansion module, mouse over the ports in the module to view the details of the ports in module.</p> <p>When you install a transceiver in the port, the following colors denote the interface status:</p> <ul style="list-style-type: none"> ● Green—Interface is up and operational. ● Yellow—Interface is up but is not operational. ● Gray—Interface is down and not operational.

Table 63: Chassis Viewer for EX4600 Switches (*continued*)

Field	Description
-------	-------------

NOTE:

- In EX4600 switches the LEDs are seen in the front panel; these are not active.
- In EX4600 switches there is no LCD panel.

Rear View of the EX4600 Switch

Management port	The management ports (RJ-45 and SFP) is used to connect the switch to a management device for out-of-band management.
Console port	The Console port (RJ-45) is used to connect the switch to a management console or to a console server.
USB port	Indicates the USB port for the switch. NOTE: We recommend that you use USB flash drives purchased from Juniper Networks for your EX Series switch.
Fan tray	Mouse over the fan tray icons to display name, status, and description information.
Power supplies	Mouse over the power supply icons to display name, status, and description information.

Table 64: Chassis Viewer for EX4650 Switches

Field	Description
-------	-------------

Front View

SFP28 and QSFP28 Ports	Displays 48 small form-factor pluggable (SFP28) ports and eight 100-Gbps quad small form-factor pluggable (QSFP28) ports. Mouse over the interface (port) to view more information.
------------------------	--

Rear View

Management port	The management port (em0) is used to connect the switch to a management device for out-of-band management.
Virtual Chassis ports	Not supported.
Console port	The Console port (RJ-45) is used to connect the switch to a management console or to a console server.

Table 64: Chassis Viewer for EX4650 Switches (continued)

Field	Description
USB port	Indicates the USB port for the switch. NOTE: We recommend that you use USB flash drives purchased from Juniper Networks for your EX Series switch.
Fan Tray	Mouse over the fan tray icons to display name, status, and description information.
Power supply	Mouse over the power supply icon to display name, status, and description information.

Table 65: Chassis Viewer for EX6210 Switches

Field	Description
Front View	
Temperature	Mouse over the temperature icon to display the temperature of the CB or line card.
Interface status	<p>Select the CB or line card.</p> <p>In the image, the colors listed below denote the interface status:</p> <ul style="list-style-type: none"> • Green—Interface is up and operational. • Yellow—Interface is up but is nonoperational. • Gray—Interface is down and nonoperational. <p>Mouse over the interface (port) to view more information.</p> <p>You can view status for the following ports on the SRE module:</p> <ul style="list-style-type: none"> • USB port—Indicates the USB port for the switch. NOTE: We recommend that you use USB flash drives purchased from Juniper Networks for your EX Series switch. • Management (me0) port—The management port is used to connect the switch to a management device for out-of-band management. There are 2 management ports: fiber and copper. The same status is displayed for both the me0 ports. • Console port—The console port is used to connect the switch to a management console or to a console server. (You might do this for initial switch configuration.) <p>CBs support 4 SFP+ uplink ports. Mouse over the interface on the CB for more information.</p> <p>For SFP and SFP+ ports, the interfaces appear dimmed if no transceiver is inserted. The chassis viewer displays Transceiver not plugged-in when you mouse over the port icon.</p>

Table 65: Chassis Viewer for EX6210 Switches (*continued*)

Field	Description
Power supplies	Mouse over the power supply icons to display name, status, and description information.
LCD panel	LCD panel configured for the LEDs on the ports. Mouse over the icon to view the current character display of the primary Routing Engine. The EX6210 switch has 2 LCD panels, one for each Routing Engine. The backup Routing Engine LCD displays Backup .

Rear View of the EX6210 Switch

Fan tray	Mouse over the fan tray icon to display information regarding the cooling fans.
----------	---

Table 66: Chassis Viewer for EX8208 Switches

Field	Description
Front View	
Interface status	<p>In the image, click any line card, SRE module, or SF module to view the front view of the selected component. In the image, the colors listed below denote the interface status:</p> <ul style="list-style-type: none"> • Green—Interface is up and operational. • Yellow—Interface is up but is nonoperational. • Gray—Interface is down and nonoperational. <p>Mouse over the interface (port) to view more information.</p> <p>You can view status for the following ports on the SRE module:</p> <ul style="list-style-type: none"> • USB port—Indicates the USB port for the switch. <p>NOTE: We recommend that you use USB flash drives purchased from Juniper Networks for your EX Series switch.</p> <ul style="list-style-type: none"> • Auxiliary port—This port is unavailable. • Management (me0) port—The management port is used to connect the switch to a management device for out-of-band management. • Console port—The console port is used to connect the switch to a management console or to a console server. (You might do this for initial switch configuration.) <p>Because the SF module has no ports, no status information is displayed.</p>

Table 66: Chassis Viewer for EX8208 Switches (continued)

Field	Description
Slot numbers	Slots on the switch are labeled, from the top of the switch down: <ul style="list-style-type: none"> • 0-3 (line cards) • SRE0, SF, SRE1 (SRE and SF modules) • 4-7 (line cards)
Temperature	The active slots contain a gray temperature icon. Mouse over the icon to display temperature information for the slot.
Fan status	Mouse over the fan tray icon to display name, status, and description information.
Power supplies	Mouse over the power supply icons to display name, status, and description information.
LCD panel	LCD panel configured for the LEDs on the ports. Mouse over the icon to view the current character display.
Rear View	The EX8208 switch does not have any components on the rear of the chassis.

Table 67: Chassis Viewer for EX8216 Switches

Field	Description
Front View	

Table 67: Chassis Viewer for EX8216 Switches (continued)

Field	Description
Interface status	<p>In the image, click any line card or RE module to display the front view of the selected component. In the image, the colors listed below denote the interface status:</p> <ul style="list-style-type: none"> ● Green—Interface is up and operational. ● Yellow—Interface is up but is nonoperational. ● Gray—Interface is down and nonoperational. <p>Mouse over the interface (port) to view more information.</p> <p>You can view status for the following ports on the RE module:</p> <ul style="list-style-type: none"> ● USB port—Indicates the USB port for the switch. <p>NOTE: We recommend that you use USB flash drives purchased from Juniper Networks for your EX Series switch.</p> <ul style="list-style-type: none"> ● Auxiliary port—This port is unavailable. ● Management (me0) port—The management port is used to connect the switch to a management device for out-of-band management. ● Console port—The console port is used to connect the switch to a management console or to a console server. (You might do this for initial switch configuration.)
Slot numbers	<p>Slots on the switch are labeled, from the top of the switch down:</p> <ul style="list-style-type: none"> ● RE0 (RE module) ● RE1 (RE module) ● 0–15 (line cards)
Temperature	<p>The active slots contain a gray temperature icon. Mouse over the icon to display temperature information for the slot.</p>
Fan status	<p>Mouse over the fan tray icon to display consolidated information about the fans.</p>
Power supplies	<p>Mouse over the power supply icons to display name, status, and description information.</p>
LCD panel	<p>LCD panel configured for the LEDs on the ports. Mouse over the icon to view the current character display.</p>
Rear View	
SF modules	<p>Mouse over the SF module icons in their respective slots to display information. Slots are numbered SF7–SF0, from left to right.</p>

Table 68: Chassis Viewer for XRE200 External Routing Engines

Field	Description
Front View	
Interface status	<p>In the image, the colors listed below denote the interface status:</p> <ul style="list-style-type: none"> • Green—Interface is up and operational. • Yellow—Interface is up but is nonoperational. • Gray—Interface is down and nonoperational. <p>Mouse over the interface (port) to view more information.</p> <p>For a Virtual Chassis configuration, select the switch to view the interface status.</p>
Console port	The console port is used to connect the switch to a management console or to a console server.
Management (me0) port	The management port is used to connect the switch to a management device for out-of-band management. Use this port for initial switch configuration.
Virtual Chassis port	<p>In the image, the colors listed below denote the Virtual Chassis port (VCP) status:</p> <ul style="list-style-type: none"> • Green—VCP is up and operational. • Yellow—VCP is up but is nonoperational. • Gray—VCP is down and nonoperational. <p>Mouse over the interface (port) to view more information.</p>
LCD panel	LCD panel configured for the LEDs on the ports. Mouse over the icon to view the current character display.
Temperature	The active slots contain a gray temperature icon. Mouse over the icon to display temperature information for the slot.
USB port	<p>Indicates the USB port for the switch.</p> <p>NOTE: We recommend that you use USB flash drives purchased from Juniper Networks for your EX Series switch.</p>
PIC1 slot	You can install a Virtual Chassis module in the PIC1 slot. Mouse over the Virtual Chassis ports to display the port status details.
PIC2 slot	You can install a Virtual Chassis module in the PIC2 slot. Mouse over the Virtual Chassis ports to display the port status details.

Table 68: Chassis Viewer for XRE200 External Routing Engines (*continued*)

Field	Description
Rear View of the XRE200 External Routing Engine	
Fan modules	Mouse over the fan modules to display status of the fans and airflow direction information. For a Virtual Chassis, the status of the fans of the selected member switch is displayed.
Power supplies	Mouse over the power supply icons to display name, status, and description information.

Release History Table

Release	Description
19.2A1	Starting in J-Web Application Package Release 19.2A1, J-Web supports EX4650 switches.
14.1X53-D10	For Junos OS Release 14.1X53-D10 and later, EX3300 switches configured as a Virtual Chassis display the value 1-10 FPC in the Inventory details field.
14.1X53-A2	In J-Web Application package Release 14.1X53-A2, you can form a Virtual Chassis using EX4600 and EX4300 switches.
14.1X53-A2	J-Web is supported on EX4600 switches only in J-Web Application package Release 14.1X53-A2.

RELATED DOCUMENTATION

J-Web User Interface for EX Series Switches Overview

EX2200 Switches Hardware Overview

EX2300 Switches Hardware Overview

EX3200 Switches Hardware Overview

EX3300 Switches Hardware Overview

EX4200 Switches Hardware Overview

EX4300 Switches Hardware Overview

EX4500 Switches Hardware Overview

EX6210 Switch Hardware Overview

EX8208 Switch Hardware Overview

EX8216 Switch Hardware Overview

[Check Active Alarms with the J-Web Interface | 250](#)

XRE200 External Routing Engine Hardware Guide

4

CHAPTER

Maintaining Components

Maintaining the EX4550 Cooling System | **208**

Maintaining the EX4550 Power System | **210**

Maintaining Expansion Module in an EX4550 Switch | **217**

Maintaining EX4550 Virtual Chassis Module | **222**

Maintaining EX4550 Virtual Chassis Cable | **225**

Maintain Transceivers | **228**

Maintain Fiber-Optic Cables | **237**

Maintaining the EX4550 Cooling System

IN THIS SECTION

- [Removing a Fan Module from an EX4550 Switch | 208](#)
- [Installing a Fan Module in an EX4550 Switch | 209](#)

Removing a Fan Module from an EX4550 Switch

The fan module is a hot-removable and hot-insertable field-replaceable unit (FRU) installed in the rear panel of the switch: You can remove and replace it without powering off the switch or disrupting switch functions.

Ensure that you have the following parts and tools available:

- Phillips (+) screwdriver, number 2
- An antistatic bag or an antistatic mat
- A replacement fan module

To remove a fan module from the switch (see [Figure 65 on page 209](#)):

1. Place the antistatic bag or the antistatic mat on a flat, stable surface.
2. Loosen the screw securing the fan module by using the screwdriver.



WARNING: To avoid injury, do not touch the fan with your hands or any tools as you slide the fan module out of the chassis—the fan might still be running.

3. Grasp the handle on the fan module and compress the release clip on both sides of the handle firmly to release the fan.
4. Pull the handle firmly to slide the fan module out of the chassis.

5. Place the fan module in the antistatic bag or on the antistatic mat placed on a flat, stable surface.
6. Install the replacement fan.

Figure 65: Removing a Fan Module from an EX4550 Switch

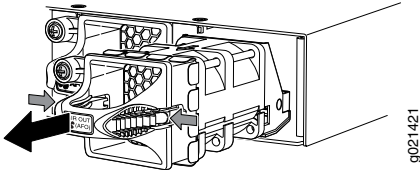

NOTE: All three fan modules must be installed and operational for optimal functioning of the switch.

SEE ALSO

[Cooling System and Airflow in an EX4550 Switch | 55](#)

Installing a Fan Module in an EX4550 Switch

Each fan module is a hot-removable and hot-insertable field-replaceable unit (FRU) installed in the rear panel of the switch: You can remove and replace it without powering off the switch or disrupting switch functions.

Before you install a fan module in the switch:

- Ensure you understand how to prevent electrostatic discharge (ESD) damage. See [“Prevention of Electrostatic Discharge Damage” on page 308](#).
- Ensure that you have the correct fan module. The label **AIR IN (AFI)** or **AIR OUT (AFO)** on the fan module must match the label **AFI** or **AFO** on the installed power supply.

Ensure that you have the following parts and tools available to install a fan module in the switch chassis:

- ESD grounding strap
- Phillips (+) screwdriver, number 2

To install a fan module in the switch (see [Figure 66 on page 210](#)):

1. Attach the ESD grounding strap to your bare wrist, and connect the strap to the ESD point on the chassis.
2. Remove the fan module from its bag.
3. Hold the handle of the fan module with one hand and support the weight of the module with the other hand. Place the fan module in the fan module slot on the rear panel of the switch and slide it in until it is fully seated.
4. Tighten the screw on the fan module by using the screwdriver.

Figure 66: Installing a Fan Module in an EX4550 Switch

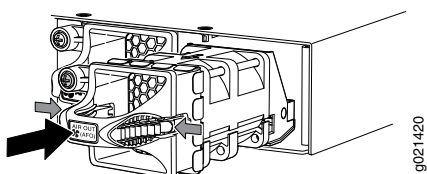

NOTE: If you have a Juniper J-Care service contract, register any addition, change, or upgrade of hardware components at <https://www.juniper.net/customers/support/tools/updateinstallbase/> . Failure to do so can result in significant delays if you need replacement parts. This note does not apply if you replace existing components with the same type of component.

Maintaining the EX4550 Power System

IN THIS SECTION

- [Removing an AC Power Supply from an EX4550 Switch | 211](#)
- [Installing an AC Power Supply in an EX4550 Switch | 212](#)
- [Removing a DC Power Supply from an EX4550 Switch | 214](#)
- [Installing a DC Power Supply in an EX4550 Switch | 215](#)

Removing an AC Power Supply from an EX4550 Switch

The power supplies in EX4550 switches are hot-removable and hot-insertable field-replaceable units (FRUs) installed in the rear panel of the switch: You can remove and replace them without powering off the switch or disrupting switch functions.

Before you remove a power supply from an EX4550 switch, ensure that you have taken the necessary precautions to prevent electrostatic discharge (ESD) damage (see [“Prevention of Electrostatic Discharge Damage” on page 308](#)).

Ensure that you have the following parts and tools available to remove a power supply from an EX4550 switch:

- ESD grounding strap
- Antistatic bag or an antistatic mat
- Replacement power supply or a cover panel for the power supply slot



CAUTION: We recommend that you install either a replacement power supply or a cover panel in the empty power supply slot to avoid chassis overheating and dust accumulation.

To remove a power supply from an EX4550 switch (see [Figure 67 on page 212](#)):

1. Place the antistatic bag or the antistatic mat on a flat, stable surface.
2. Attach the ESD grounding strap to your bare wrist, and connect the strap to the ESD point on the chassis.
3. If the AC power source outlet has a power switch, set it to the off (O) position.
4. Gently pull out the plug end of the power cord connected to the power source outlet.
5. Remove the power cord from the power supply faceplate by detaching the power cord retainer and gently pulling out the socket end of the power cord connected to the power supply faceplate.
6. Slide the ejector lever toward the left until the power supply is unseated.
7. Grasp the power supply handle and pull firmly to slide the power supply halfway out of the chassis.
8. Place one hand under the power supply to support it and slide it completely out of the chassis. Take care not to touch power supply components, pins, leads, or solder connections.

9. Place the power supply in the antistatic bag or on the antistatic mat placed on a flat, stable surface.
10. If you are not replacing the power supply, install the cover panel over the slot.

Figure 67: Removing an AC Power Supply from an EX4550 Switch

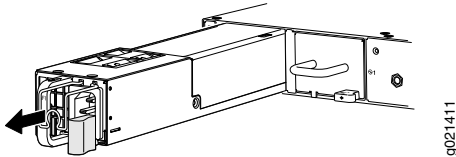

SEE ALSO

[AC Power Supply in EX4550 Switches](#) | 61

Installing an AC Power Supply in an EX4550 Switch

The AC power supply in EX4550 switches is a hot-removable and hot-insertable field-replaceable unit (FRU) installed in the rear panel of the switch: You can remove and replace it without powering off the switch or disrupting switch functions.

Before you install an AC power supply in the switch:

- Ensure you understand how to prevent electrostatic discharge (ESD) damage. See [“Prevention of Electrostatic Discharge Damage”](#) on page 308.

Ensure that you have the following parts and tools available to install the power supply:

- ESD grounding strap



CAUTION:

Do not mix:

- AC and DC power supplies in the same chassis.
- Power supplies (**AFI** or **AFO**) and fan modules (**AIR IN (AFI)** or **AIR OUT (AFO)**) with different airflow labels in the same chassis.

NOTE: Each power supply must be connected to a dedicated power source outlet.

To install an AC power supply in the switch (see [Figure 68 on page 213](#)):

1. Ensure that you have the correct power supply. The label **AFI** or **AFO** on the power supply must match the label **AIR IN (AFI)** or **AIR OUT (AFO)** on the installed fan module.
2. Attach the ESD grounding strap to your bare wrist, and connect the strap to the ESD point on the chassis.
3. If the power supply slot has a cover panel on it, with one hand slide the ejector lever toward the left until it stops and using the other hand pull the handle of the cover panel outward to remove it. Save the cover panel for later use.
4. Taking care not to touch power supply pins, leads, or solder connections, remove the power supply from the bag.
5. Using both hands, place the power supply in the power supply slot on the rear panel of the switch and slide it in until it is fully seated and the ejector lever fits into place. You will hear a distinct click when the power supply is fully seated in the chassis.

Figure 68: Installing an AC Power Supply in an EX4550 Switch

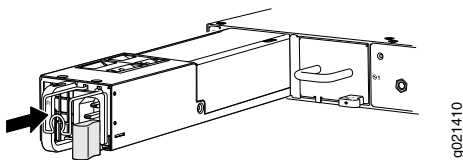

NOTE: If you have a Juniper J-Care service contract, register any addition, change, or upgrade of hardware components at <https://www.juniper.net/customers/support/tools/updateinstallbase/> . Failure to do so can result in significant delays if you need replacement parts. This note does not apply if you replace existing components with the same type of component.

SEE ALSO

Removing a DC Power Supply from an EX4550 Switch

The power supply in EX4550 switches is a hot-removable and hot-insertable field-replaceable unit (FRU) installed in the rear panel of the switch: You can remove and replace it without powering off the switch or disrupting switch functions.

Before you begin removing a power supply from the switch:

- Ensure you understand how to prevent electrostatic discharge (ESD) damage. See [“Prevention of Electrostatic Discharge Damage” on page 308](#).

Ensure that you have the following parts and tools available to remove the power supply from the switch chassis:

- ESD grounding strap
- Phillips (+) screwdriver, number 2
- An antistatic bag or an antistatic mat
- Replacement power supply or a cover panel for the power supply slot



CAUTION: We recommend that you install either a replacement power supply or a cover panel in the empty power supply slot to avoid chassis overheating and dust accumulation.

To remove a power supply from the switch (see [Figure 69 on page 215](#)):

1. Place the antistatic bag or the antistatic mat on a flat, stable surface.
2. Attach the ESD grounding strap to your bare wrist, and connect the strap to the ESD point on the chassis.
3. Make sure that the voltage across the DC power source cables leads is 0 V and that there is no chance that the cables might become active during the removal process.
4. Remove the plastic cover from the input terminals by sliding the cover either to the left or right.
5. Unscrew the locking screws counterclockwise by using the screwdriver.

6. Remove the cable lugs from the input DC terminals.
7. Slide the ejector lever toward the left until the power supply is unseated.
8. Grasp the power supply handle and pull firmly to slide the power supply halfway out of the chassis.
9. Taking care not to touch power supply pins, leads, or solder connections, place one hand under the power supply to support it. Grasp the power supply handle with your other hand and pull the power supply completely out of the chassis.
10. Place the power supply in the antistatic bag or on the antistatic mat placed on a flat, stable surface.
11. If you are not replacing the power supply, install the cover panel over the slot.

Figure 69: Removing a DC Power Supply from an EX4550 Switch

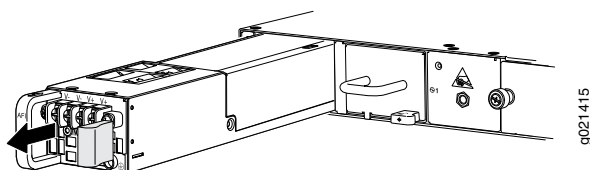

SEE ALSO

[DC Power Supply in EX4550 Switches](#) | 67

Installing a DC Power Supply in an EX4550 Switch

The DC power supply in EX4550 switches is a hot-removable and hot-insertable field-replaceable unit (FRU) installed in the rear panel of the switch: You can remove and replace it without powering off the switch or disrupting switch functions.

Before you install a DC power supply in the switch:

- Ensure you understand how to prevent electrostatic discharge (ESD) damage. See [“Prevention of Electrostatic Discharge Damage”](#) on page 308.

Ensure that you have the following parts and tools available to install a DC power supply in the switch chassis:

- ESD grounding strap



CAUTION:

Do not mix:

- AC and DC power supplies in the same chassis.
- Power supplies (**AFI** or **AFO**) and fan modules (**AIR IN (AFI)** or **AIR OUT (AFO)**) with different airflow labels in the same chassis.

NOTE: Each power supply must be connected to a dedicated power source outlet.

To install a DC power supply in the switch (see [Figure 70 on page 216](#)):

1. Ensure that you have the correct power supply. The label **AFI** or **AFO** on the power supply must match the label **AIR IN (AFI)** or **AIR OUT (AFO)** on the installed fan module.
2. Attach the ESD grounding strap to your bare wrist, and connect the strap to the ESD point on the chassis.
3. If the power supply slot has a cover panel on it, with one hand slide the ejector lever toward the left until it stops and using the other hand pull the handle of the cover panel outward to remove it. Save the cover panel for later use.
4. Taking care not to touch power supply pins, leads, or solder connections, remove the power supply from the bag.
5. Using both hands, place the power supply in the power supply slot on the rear panel of the switch and slide it in until it is fully seated and the ejector lever fits into place. You will hear a distinct click when the power supply is fully seated in the chassis.

Figure 70: Installing a DC Power Supply in an EX4550 Switch

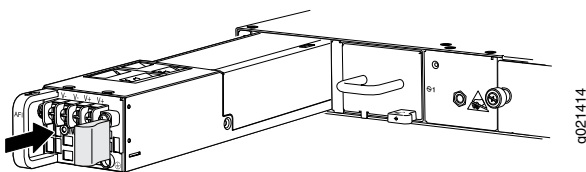

NOTE: If you have a Juniper J-Care service contract, register any addition, change, or upgrade of hardware components at <https://www.juniper.net/customers/support/tools/updateinstallbase/> . Failure to do so can result in significant delays if you need replacement parts. This note does not apply if you replace existing components with the same type of component.

SEE ALSO

[Connecting DC Power to an EX4550 Switch | 142](#)

[DC Power Supply in EX4550 Switches | 67](#)

Maintaining Expansion Module in an EX4550 Switch

IN THIS SECTION

- [Removing an Expansion Module from an EX4550 Switch | 217](#)
- [Installing an Expansion Module in an EX4550 Switch | 219](#)

Removing an Expansion Module from an EX4550 Switch

The expansion modules in EX4550 switches are hot-removable and hot-insertable field-replaceable units (FRUs): You can remove and replace them without powering off the switch or disrupting switch functions.

Before you begin removing an expansion module from the switch:

- Ensure that you have taken the necessary precautions to prevent electrostatic discharge (ESD) damage (see [“Prevention of Electrostatic Discharge Damage” on page 308](#)).
- If there are any transceivers installed in the expansion module, remove them before you remove the expansion module. For instructions on removing transceivers, see [“Remove a Transceiver” on page 228](#).

Ensure that you have the following parts and tools available:

- ESD grounding strap
- Phillips screwdriver, number 2
- A replacement optional module or cover panel
- An antistatic bag or antistatic mat



CAUTION: We recommend that you install either a replacement optional module or a cover panel in the empty module slot to avoid chassis overheating and dust accumulation.

To remove an expansion module from the switch (see [Figure 71 on page 219](#), [Figure 72 on page 219](#), and [Figure 73 on page 219](#)):

1. Attach the ESD grounding strap to your bare wrist, and connect the strap to the ESD point on the chassis.
2. Unscrew both captive screws on the faceplate of the expansion module by using your fingers. If you are unable to unscrew the captive screws by using your fingers, use the screwdriver.
3. Hold both the captive screws and gently pull the expansion module outward and out of the module slot.
4. Place the expansion module in an antistatic bag or on an antistatic mat placed on a flat, stable surface.
5. If you are not replacing the expansion module with an optional module, install the cover panel over the slot.

NOTE: After you have removed an expansion module, wait for at least 5 seconds before you install an expansion module. If you do not wait for at least 5 seconds, the interfaces on the expansion module might not come up.

[Figure 71 on page 219](#) shows removing an SFP+ expansion module from the front panel of an EX4550-32F switch.

Figure 71: Removing an SFP+ Expansion Module from an EX4550-32F Switch

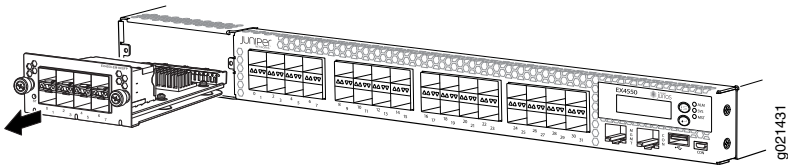

Figure 72 on page 219 shows removing a 10GBASE-T expansion module from the front panel of an EX4550-32T switch.

Figure 72: Removing a 10GBASE-T Expansion Module from an EX4550-32T Switch

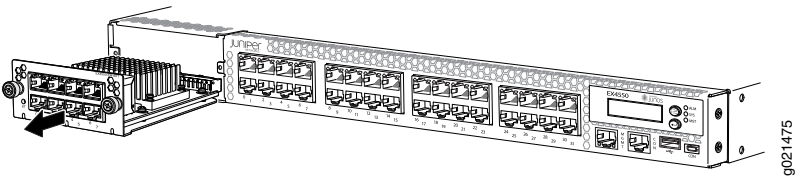
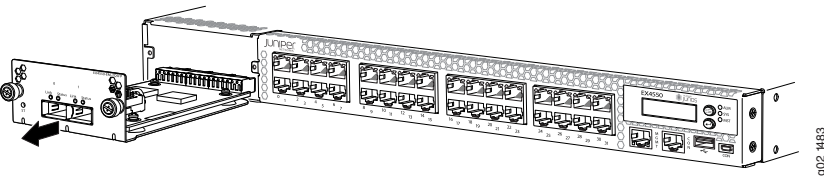

Figure 73 on page 219 shows removing a QSFP+ expansion module from the front panel of an EX4550-32T switch.

Figure 73: Removing a QSFP+ Expansion Module from an EX4550-32T Switch



Installing an Expansion Module in an EX4550 Switch

The 8-port SFP+ expansion module, the 8-port 10GBASE-T expansion module, and the 2-port QSFP+ expansion module in EX4550 switches are hot-removable and hot-insertable field-replaceable units (FRUs): You can remove and replace these modules without powering off the switch or disrupting switch functions.

You can install up to two expansion modules in the module slots; one each on the front panel and the rear panel of an EX4550 switch chassis.

NOTE: When an expansion module is installed in the switch or an existing expansion module is replaced with another expansion module, the switch detects the ports on the expansion module. The switch creates the required interfaces when transceivers are installed in these ports.

Before you begin installing an expansion module in the switch, ensure that you have taken the necessary precautions to prevent electrostatic discharge (ESD) damage (see [“Prevention of Electrostatic Discharge Damage” on page 308](#)).

Ensure that you have the following parts and tools available:

- ESD grounding strap. If a grounding strap is not available, follow the alternative grounding method described in Step 1 of the following procedure.
- Phillips (+) screwdriver, number 2

To install an expansion module in an EX4550 switch (see [Figure 74 on page 221](#), [Figure 75 on page 221](#), and [Figure 76 on page 221](#)):

1. Attach the ESD grounding strap to your bare wrist, and connect the strap to the ESD point on the chassis.

If a grounding strap is not available, hold the expansion module in its antistatic bag in one hand and touch the exposed metallic part of the switch with the other hand to ground yourself and the component.
2. If the module slot has a cover panel on it, remove the cover panel by using the screwdriver and save it for later use.
3. Taking care not to touch module components, pins, leads, or solder connections, remove the expansion module from its bag.
4. Loosen the captive screws on the front faceplate of the expansion module by using your fingers. If you are unable to loosen the captive screws by using your fingers, use the screwdriver.
5. Using both hands, place the expansion module in the empty slot and slide it in gently until it is fully seated.

NOTE: After you have removed an expansion module, wait for at least 5 seconds before you install an expansion module. If you do not wait for at least 5 seconds, the interfaces on the expansion module might not come up.

6. Tighten the captive screws by using your fingers or the screwdriver. When the status (ST) LED turns green, the expansion module is ready for use.

Figure 74 on page 221 shows how to install an SFP+ expansion module on the front panel of an EX4550-32F switch.

Figure 74: Installing an SFP+ Expansion Module in an EX4550-32F Switch

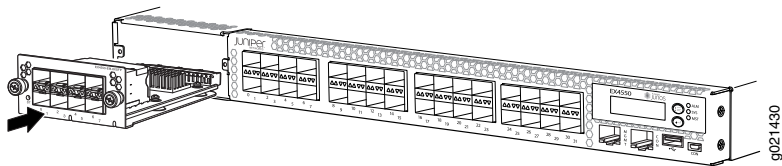

Figure 75 on page 221 shows how to install a 10GBASE-T expansion module on the front panel of an EX4550-32T switch.

Figure 75: Installing a 10GBASE-T Expansion Module in an EX4550-32T Switch

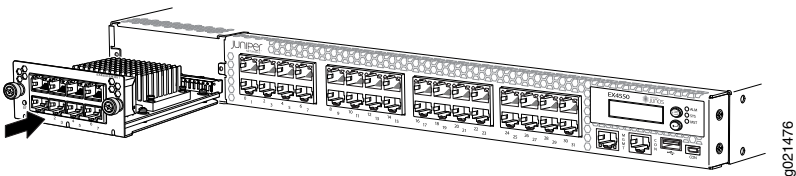
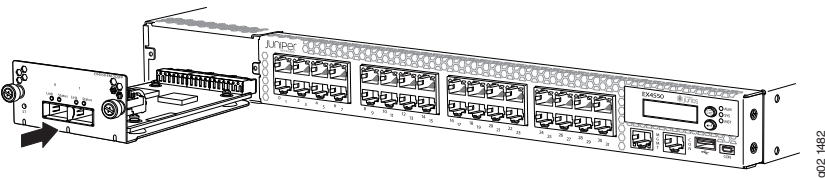

Figure 76 on page 221 shows how to install a QSFP+ expansion module on the front panel of an EX4550-32T switch.

Figure 76: Installing a QSFP+ Expansion Module in an EX4550-32T Switch



NOTE: If you have a Juniper J-Care service contract, register any addition, change, or upgrade of hardware components at <https://www.juniper.net/customers/support/tools/updateinstallbase/> . Failure to do so can result in significant delays if you need replacement parts. This note does not apply if you replace existing components with the same type of component.

Maintaining EX4550 Virtual Chassis Module

IN THIS SECTION

- [Removing a Virtual Chassis Module from an EX4550 Switch | 222](#)
- [Installing a Virtual Chassis Module in an EX4550 Switch | 223](#)

Removing a Virtual Chassis Module from an EX4550 Switch

The Virtual Chassis module in EX4550 switches is a hot-removable and hot-insertable field-replaceable unit (FRU): You can remove and replace it without powering off the switch or disrupting switch functions. The Virtual Chassis module is installed in the module slots on the front panel and the rear panel of an EX4550 switch chassis.

Use the procedure described in this topic to remove the module from the switch chassis.

Before you begin removing the Virtual Chassis module from the switch:

- Ensure that you have taken the necessary precautions to prevent electrostatic discharge (ESD) damage (see [“Prevention of Electrostatic Discharge Damage” on page 308](#)).

Ensure that you have the following parts and tools available:

- ESD grounding strap
- Phillips screwdriver, number 2
- A replacement optional module or cover panel
- An antistatic bag or antistatic mat

To remove the Virtual Chassis module from the switch (see [Figure 77 on page 223](#)):

1. Attach the ESD grounding strap to your bare wrist, and connect the strap to the ESD point on the chassis.
2. Unscrew both captive screws on the faceplate of the Virtual Chassis module by using your fingers. If you are unable to unscrew the captive screws by using your fingers, use the screwdriver.
3. Hold both the captive screws and gently pull the Virtual Chassis module out of the module slot.
4. Place the Virtual Chassis module in an antistatic bag or on an antistatic mat placed on a flat, stable surface.
5. If you are not replacing the Virtual Chassis module with an optional module, install the cover panel over the slot.

Figure 77: Removing the Virtual Chassis Module from an EX4550 Switch

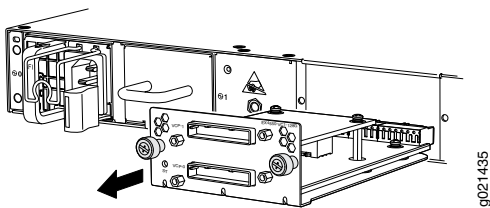

NOTE: If you have a Juniper J-Care service contract, register any addition, change, or upgrade of hardware components at <https://www.juniper.net/customers/support/tools/updateinstallbase/> . Failure to do so can result in significant delays if you need replacement parts. This note does not apply if you replace existing components with the same type of component.

Installing a Virtual Chassis Module in an EX4550 Switch

You can install the Virtual Chassis module in either of the two module slots; one each on the front panel and the rear panel of the switch. Use the procedure described in this topic to install the Virtual Chassis module.

Before you begin installing the Virtual Chassis module in the switch:

- Ensure that you have taken the necessary precautions to prevent electrostatic discharge (ESD) damage (see [“Prevention of Electrostatic Discharge Damage”](#) on page 308).

Ensure that you have the following parts and tools available:

- ESD grounding strap
- Phillips (+) screwdriver, number 2

To install a Virtual Chassis module in the switch (see [Figure 78](#) on page 225):

1. Attach the ESD grounding strap to your bare wrist, and connect the strap to the ESD point on the chassis.
2. Taking care not to touch module components, pins, leads, or solder connections, remove the Virtual Chassis module from its bag.
3. If the module slot has a cover panel on it, remove the cover panel by using the screwdriver and save it for later use.
4. Loosen the captive screws on the front faceplate of the Virtual Chassis module by using your fingers. If you are unable to loosen the captive screws by using your fingers, use the screwdriver.
5. Using both hands, place the Virtual Chassis module in the empty slot and slide it in until it is fully seated.



CAUTION: Before you slide the Virtual Chassis module into the slot on the switch chassis, ensure that the module is aligned correctly. Misalignment might cause the pins to bend, making the module unusable.

6. Tighten the captive screws by using your fingers or the screwdriver.
7. Connect power to the switch. See [“Connecting AC Power to an EX4550 Switch”](#) on page 139 or [“Connecting DC Power to an EX4550 Switch”](#) on page 142.

When the status (**ST**) LED on the Virtual Chassis module turns green, the module is ready for use.

Figure 78: Installing the Virtual Chassis Module in an EX4550 Switch

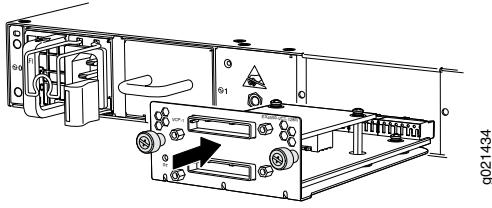

NOTE: If you have a Juniper J-Care service contract, register any addition, change, or upgrade of hardware components at <https://www.juniper.net/customers/support/tools/updateinstallbase/> . Failure to do so can result in significant delays if you need replacement parts. This note does not apply if you replace existing components with the same type of component.

Maintaining EX4550 Virtual Chassis Cable

IN THIS SECTION

- [Disconnecting a Virtual Chassis Cable from an EX4550 Switch | 225](#)
- [Connecting a Virtual Chassis Cable to an EX4550 Switch | 227](#)

Disconnecting a Virtual Chassis Cable from an EX4550 Switch

Use the procedure described in this topic to disconnect a Virtual Chassis cable from the dedicated Virtual Chassis port (VCP) on a Virtual Chassis module.

Ensure that you have the following parts and tools available:

- Phillips (+) screwdriver, number 2

To disconnect a Virtual Chassis cable from a dedicated VCP on an EX4550 switch (see [Figure 79 on page 226](#)):

1. Loosen the screws on the cable connector retainer by using the screwdriver.
2. Slide the cable connector retainer back.
3. Gently pull the release pull tab on the Virtual Chassis cable connector to release the lock holding the Virtual Chassis cable connector in the Virtual Chassis port.
4. Gently pull the Virtual Chassis cable connector out of the Virtual Chassis port.

Figure 79: Disconnecting a Virtual Chassis Cable from a Dedicated VCP on a Virtual Chassis Module

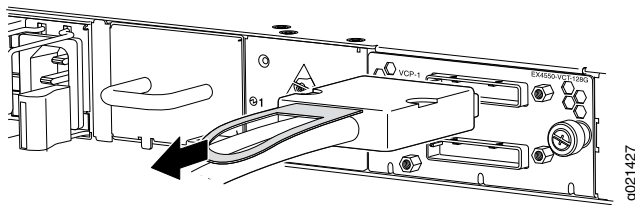

NOTE: With separately ordered Virtual Chassis cables, you can use the cable connector retainers provided with the original cable; you can also use separately ordered Virtual Chassis cable connector retainers.

SEE ALSO

[Virtual Chassis Port Connector Pinout Information for EX4550 Switches](#) | 104

Connecting a Virtual Chassis Cable to an EX4550 Switch

The Virtual Chassis module has two dedicated Virtual Chassis ports (VCPs) that can be used to interconnect the EX4550 switch with EX4200, EX4500, or EX4550 switches to form a Virtual Chassis. You can install the Virtual Chassis module in either of the two module slots: one each on the front panel and the rear panel of the switch. Use the procedure described in this topic to connect a Virtual Chassis cable to a dedicated VCP on a Virtual Chassis module.

Ensure that you have the following parts and tools available:

- Phillips (+) screwdriver, number 2

NOTE: Virtual Chassis cables and Virtual Chassis cable connector retainers are not part of the EX4550 switch's shipping configuration. If you want to purchase these, you must order them separately.

To connect a Virtual Chassis cable to a dedicated VCP on an EX4550 switch (see [Figure 80 on page 227](#)):

1. Taking care not to touch module components, pins, leads, or solder connections, remove the Virtual Chassis cable from its bag.
2. Using both hands, place the Virtual Chassis cable connector in the empty VCP and slide it in gently until it is fully seated.
3. Slide the cable connector retainer over the Virtual Chassis cable connector.
4. Tighten the screws on the cable connector retainer by using the screwdriver.

Figure 80: Connecting a Virtual Chassis Cable to a Dedicated VCP on a Virtual Chassis Module

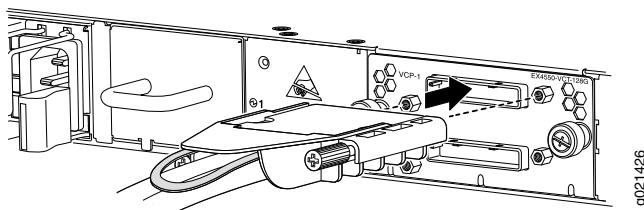

SEE ALSO

[Understanding EX4200, EX4500, and EX4550 Virtual Chassis Hardware Configurations](#) | 108

Maintain Transceivers

IN THIS SECTION

- Remove a Transceiver | 228
- Remove a QSFP28 Transceiver | 231
- Install a Transceiver | 233
- Install a QSFP28 Transceiver | 235

Remove a Transceiver

The transceivers for Juniper Networks devices are hot-removable and hot-insertable field-replaceable units (FRUs): You can remove and replace them without powering off the device or disrupting device functions.

NOTE: After you remove a transceiver or when you change the media-type configuration, wait for 6 seconds for the interface to display the operational commands.

Before you remove a transceiver from a device, ensure that you have taken the necessary precautions for the safe handling of lasers (see “[Laser and LED Safety Guidelines and Warnings](#)” on page 294).

Ensure that you have the following parts and tools available:

- An antistatic bag or an antistatic mat
- Rubber safety caps to cover the transceiver and fiber-optic cable connector
- A dust cover to cover the port or a replacement transceiver

[Figure 81 on page 230](#) shows how to remove a QSFP+ transceiver. The procedure is the same for all types of transceivers except the QSFP28 and CFP transceivers.

To remove a transceiver from a device:

1. Place the antistatic bag or antistatic mat on a flat, stable surface.
2. Wrap and fasten one end of the ESD wrist strap around your bare wrist, and connect the other end of the strap to the ESD point on the switch.
3. Label the cable connected to the transceiver so that you can reconnect it correctly.



WARNING: Do not look directly into a fiber-optic transceiver or into the ends of fiber-optic cables. Fiber-optic transceivers and fiber-optic cables connected to transceivers emit laser light that can damage your eyes.



WARNING: Do not leave a fiber-optic transceiver uncovered except when inserting or removing a cable. The rubber safety cap keeps the port clean and prevents accidental exposure to laser light.



CAUTION: Do not bend fiber-optic cables beyond their minimum bend radius. An arc smaller than a few inches in diameter can damage the cables and cause problems that are difficult to diagnose.

4. Remove the cable connected to the transceiver (see [“Disconnect a Fiber-Optic Cable”](#) on page 238). Cover the transceiver and the end of each fiber-optic cable connector with a rubber safety cap immediately after disconnecting the fiber-optic cables.
5. If there is a cable management system, arrange the cable in the cable management system to prevent it from dislodging or developing stress points. Secure the cable so that it does not support its own weight as it hangs to the floor. Place excess cable out of the way in a neatly coiled loop in the cable management system. Placing fasteners on the loop helps to maintain its shape.



CAUTION: Do not bend the fiber-optic cable beyond its minimum bend radius. An arc smaller than a few inches in diameter can damage the cable and cause problems that are difficult to diagnose.

6. To remove an SFP, SFP+, XFP, or a QSFP+ transceiver:
 - a. By using your fingers, pull open the ejector lever on the transceiver to unlock the transceiver.



CAUTION: Before removing the transceiver, make sure that you open the ejector lever completely until you hear it click. This prevents damage to the transceiver.

- b. Grasp the transceiver ejector lever and gently slide the transceiver approximately 0.5 in. (1.3 cm) straight out of the port.



CAUTION: To prevent ESD damage to the transceiver, do not touch the connector pins at the end of the transceiver.

Figure 81: Remove a QSFP+ Transceiver

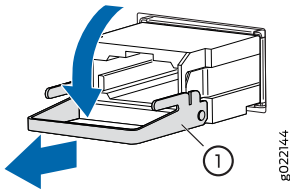

1-Ejector lever

To remove a CFP transceiver:

- a. Loosen the screws on the transceiver by using your fingers.
- b. Grasp the screws on the transceiver and gently slide the transceiver approximately 0.5 in. (1.3 cm) straight out of the port.



CAUTION: To prevent ESD damage to the transceiver, do not touch the connector pins at the end of the transceiver.

7. By using your fingers, grasp the body of the transceiver and pull it straight out of the port.

8. Place the transceiver in the antistatic bag or on the antistatic mat placed on a flat, stable surface.
9. Place the dust cover over the empty port or install the replacement transceiver.

Remove a QSFP28 Transceiver

The transceivers for Juniper Networks devices are hot-removable and hot-insertable field-replaceable units (FRUs). You can remove and replace them without powering off the device or disrupting the device functions.

NOTE: After you insert a transceiver or after you change the media-type configuration, wait for 6 seconds for the interface to display operational commands.

NOTE: We recommend that you use only optical transceivers and optical connectors purchased from Juniper Networks with your Juniper Networks device.

Before you remove a transceiver from a device, ensure that you have taken the necessary precautions for safe handling of lasers (see [“Laser and LED Safety Guidelines and Warnings”](#) on page 294).

Ensure that you have the following parts and tools available:

- An antistatic bag or an antistatic mat
- Rubber safety caps to cover the transceiver and fiber-optic cable connector
- A dust cover to cover the port or a replacement transceiver

To remove a QSFP28 transceiver (see [Figure 82 on page 232](#)):

1. Place an antistatic bag or antistatic mat on a flat, stable surface to receive the QSFP28 transceiver. Have a rubber safety cap ready for the QSFP28 transceiver and the cable.
2. Wrap and fasten one end of an ESD wrist strap around your bare wrist, and connect the other end of the strap to the ESD point on the switch.
3. Label the cable connected to the QSFP28 transceiver so that you can later reconnect it to the correct QSFP28 transceiver.

4. Disconnect the cable from the transceiver. Immediately cover the transceiver and the end of the cable with a rubber safety cap.



CAUTION: Do not leave a fiber-optic transceiver uncovered except when inserting or removing a cable. The safety cap keeps the port clean and prevents accidental exposure to laser light.

5. If there is a cable management system, arrange the cable in the cable management system to prevent it from dislodging or developing stress points. Secure the cable so that it does not support its own weight as it hangs to the floor. Place excess cable out of the way in a neatly coiled loop in the cable management system. Placing fasteners on the loop helps to maintain its shape.



CAUTION: Do not bend the fiber-optic cable beyond its minimum bend radius. An arc smaller than a few inches in diameter can damage the cable and cause problems that are difficult to diagnose.

Figure 82: Remove a QSFP28 Transceiver

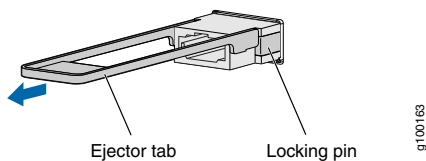

6. Pull the ejector tab straight back. The locking pins on the transceiver automatically release the transceiver.
7. Place the transceiver on the antistatic mat or in the antistatic bag.
8. Place the dust cover over the empty port or install the replacement transceiver.

Install a Transceiver

The transceivers for Juniper Networks devices are hot-removable and hot-insertable field-replaceable units (FRUs): You can remove and replace them without powering off the device or disrupting the device functions.

NOTE: After you insert a transceiver or after you change the media-type configuration, wait for 6 seconds for the interface to display operational commands.

NOTE: We recommend that you use only optical transceivers and optical connectors purchased from Juniper Networks with your Juniper Networks device.



CAUTION: If you face a problem running a Juniper Networks device that uses a third-party optic or cable, the Juniper Networks Technical Assistance Center (JTAC) can help you diagnose the source of the problem. Your JTAC engineer might recommend that you check the third-party optic or cable and potentially replace it with an equivalent Juniper Networks optic or cable that is qualified for the device.

Before you install a transceiver in a device, ensure that you have taken the necessary precautions for safe handling of lasers (see [“Laser and LED Safety Guidelines and Warnings” on page 294](#)).

Ensure that you have a rubber safety cap available to cover the transceiver.

[Figure 57 on page 150](#) shows how to install a QSFP+ transceiver. The procedure is the same for all types of transceivers except the QSFP28 and CFP transceivers.

To install a transceiver:



CAUTION: To prevent electrostatic discharge (ESD) damage to the transceiver, do not touch the connector pins at the end of the transceiver.

1. Wrap and fasten one end of the ESD wrist strap around your bare wrist, and connect the other end of the strap to the ESD point on the switch.
2. Remove the transceiver from its bag.

3. Check to see whether the transceiver is covered with a rubber safety cap. If it is not, cover the transceiver with a rubber safety cap.



WARNING: Do not leave a fiber-optic transceiver uncovered except when inserting or removing a cable. The rubber safety cap keeps the port clean and prevents accidental exposure to laser light.

4. If the port in which you want to install the transceiver is covered with a dust cover, remove the dust cover and save it in case you need to cover the port later. If you are hot-swapping a transceiver, wait for at least 10 seconds after removing the transceiver from the port before installing a new transceiver.
5. Using both hands, carefully place the transceiver in the empty port. The connectors must face the chassis.



CAUTION: Before you slide the transceiver into the port, ensure that the transceiver is aligned correctly. Misalignment might cause the pins to bend, making the transceiver unusable.

6. Slide the transceiver in gently until it is fully seated. If you are installing a CFP transceiver, tighten the captive screws on the transceiver by using your fingers.
7. Remove the rubber safety cap from the transceiver and the end of the cable, and insert the cable into the transceiver.



WARNING: Do not look directly into a fiber-optic transceiver or into the ends of fiber-optic cables. Fiber-optic transceivers and fiber-optic cable connected to a transceiver emit laser light that can damage your eyes.



CAUTION: Do not leave a fiber-optic transceiver uncovered except when inserting or removing cable. The safety cap keeps the port clean and prevents accidental exposure to laser light.

8. If there is a cable management system, arrange the cable in the cable management system to prevent the cable from dislodging or developing stress points. Secure the cable so that it does not support its

own weight as it hangs to the floor. Place excess cable out of the way in a neatly coiled loop in the cable management system. Placing fasteners on the loop helps to maintain its shape.



CAUTION: Do not let fiber-optic cable hang free from the connector. Do not allow fastened loops of cable to dangle, which stresses the cable at the fastening point.



CAUTION: Avoid bending fiber-optic cable beyond its minimum bend radius. An arc smaller than a few inches in diameter can damage the cable and cause problems that are difficult to diagnose.

Figure 83: Install a Transceiver

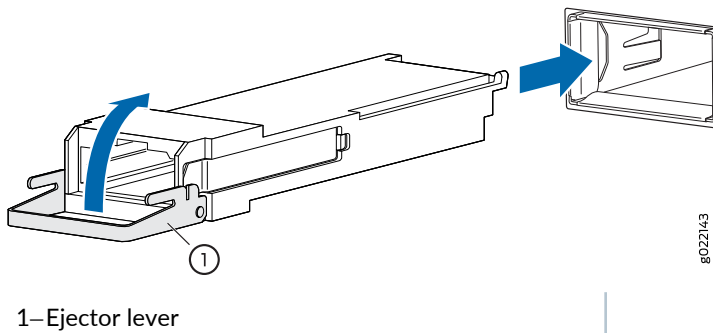

Install a QSFP28 Transceiver

The transceivers for Juniper Networks devices are hot-removable and hot-insertable field-replaceable units (FRUs): You can remove and replace them without powering off the device or disrupting the device functions.

NOTE: After you insert a transceiver or after you change the media-type configuration, wait for 6 seconds for the interface to display operational commands.

NOTE: We recommend that you use only optical transceivers and optical connectors purchased from Juniper Networks with your Juniper Networks device.



CAUTION: If you face a problem running a Juniper Networks device that uses a third-party optic or cable, the Juniper Networks Technical Assistance Center (JTAC) can help you diagnose the source of the problem. Your JTAC engineer might recommend that you check the third-party optic or cable and potentially replace it with an equivalent Juniper Networks optic or cable that is qualified for the device.

Before you install a transceiver in a device, ensure that you have taken the necessary precautions for safe handling of lasers (see [“Laser and LED Safety Guidelines and Warnings”](#) on page 294).

Ensure that you have a rubber safety cap available to cover the transceiver.

To install a QSFP28 transceiver (see [Figure 84](#) on page 236):

1. Wrap and fasten one end of the ESD wrist strap around your bare wrist, and connect the other end of the strap to the ESD point on the switch.
2. Verify that a rubber safety cap covers the QSFP28 transceiver.
3. Orient the transceiver in front of the port so that the QSFP28 connector faces the appropriate direction.

Figure 84: Install a QSFP28 Transceiver

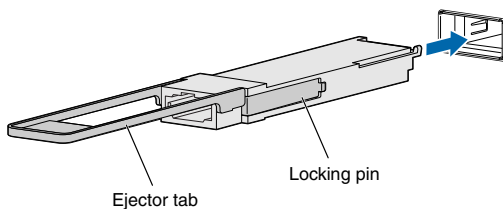

4. Slide the transceiver into the slot until the locking pins lock in place. If there is resistance, remove the transceiver and flip it so that the connector faces the other direction.
5. Remove the rubber safety cap from the transceiver and the end of the cable, and insert the cable into the transceiver.



WARNING: Do not look directly into a fiber-optic transceiver or into the ends of fiber-optic cables. Fiber-optic transceivers and fiber-optic cable connected to a transceiver emit laser light that can damage your eyes.



CAUTION: Do not leave a fiber-optic transceiver uncovered except when inserting or removing cable. The safety cap keeps the port clean and prevents accidental exposure to laser light.

6. If there is a cable management system, arrange the cable in the cable management system to prevent the cable from dislodging or developing stress points. Secure the cable so that it does not support its own weight as it hangs to the floor. Place excess cable out of the way in a neatly coiled loop in the cable management system. Placing fasteners on the loop helps to maintain its shape.



CAUTION: Do not let fiber-optic cable hang free from the connector. Do not allow fastened loops of cable to dangle, which stresses the cable at the fastening point.



CAUTION: Avoid bending fiber-optic cable beyond its minimum bend radius. An arc smaller than a few inches in diameter can damage the cable and cause problems that are difficult to diagnose.

Maintain Fiber-Optic Cables

IN THIS SECTION

- [Connect a Fiber-Optic Cable | 237](#)
- [Disconnect a Fiber-Optic Cable | 238](#)
- [How to Handle Fiber-Optic Cables | 239](#)

Connect a Fiber-Optic Cable

Before you connect a fiber-optic cable to an optical transceiver installed in a device, ensure that you have taken the necessary precautions for safe handling of lasers (see [“Laser and LED Safety Guidelines and Warnings” on page 294](#)).

To connect a fiber-optic cable to an optical transceiver installed in a device:



WARNING: Do not look directly into a fiber-optic transceiver or into the ends of fiber-optic cables. Fiber-optic transceivers and fiber-optic cables connected to transceivers emit laser light that can damage your eyes.

1. If the fiber-optic cable connector is covered with a rubber safety cap, remove the cap. Save the cap.
2. Remove the rubber safety cap from the optical transceiver. Save the cap.
3. Insert the cable connector into the optical transceiver (see [Figure 56 on page 147](#)).

Figure 85: Connect a Fiber-Optic Cable to an Optical Transceiver Installed in a Device

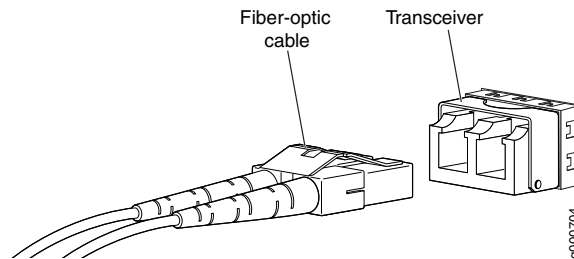

4. Secure the cables so that they do not support their own weight. Place excess cable out of the way in a neatly coiled loop. Placing fasteners on a loop helps cables maintain their shape.



CAUTION: Do not bend fiber-optic cables beyond their minimum bend radius. An arc smaller than a few inches in diameter can damage the cables and cause problems that are difficult to diagnose.

Do not let fiber-optic cables hang free from the connector. Do not allow fastened loops of cables to dangle, which stresses the cables at the fastening point.

Disconnect a Fiber-Optic Cable

Juniper Networks devices have optical transceivers to which you can connect fiber-optic cables.

Before you disconnect a fiber-optic cable from an optical transceiver, ensure that you have taken the necessary precautions for safe handling of lasers. See [“Laser and LED Safety Guidelines and Warnings” on page 294](#).

Ensure that you have the following parts and tools available:

- A rubber safety cap to cover the transceiver
- A rubber safety cap to cover the fiber-optic cable connector

To disconnect a fiber-optic cable from an optical transceiver installed in the device:

1. Disable the port in which the transceiver is installed by issuing the following command:

```
[edit interfaces]  
user@device# set interface-name disable
```



WARNING: Do not look directly into a fiber-optic transceiver or into the ends of fiber-optic cables. Fiber-optic transceivers and fiber-optic cables connected to transceivers emit laser light that can damage your eyes.

2. Carefully unplug the fiber-optic cable connector from the transceiver.
3. Cover the transceiver with a rubber safety cap.



WARNING: Do not leave a fiber-optic transceiver uncovered except when inserting or removing a cable. The rubber safety cap keeps the port clean and prevents accidental exposure to laser light.

4. Cover the fiber-optic cable connector with the rubber safety cap.

How to Handle Fiber-Optic Cables

Fiber-optic cables connect to optical transceivers that are installed in Juniper Networks devices.

To maintain fiber-optic cables:

- When you unplug a fiber-optic cable from a transceiver, place rubber safety caps over the transceiver and on the end of the cable.
- Anchor fiber-optic cables to prevent stress on the connectors. When attaching a fiber-optic cable to a transceiver, be sure to secure the fiber-optic cable so that it does not support its own weight as it hangs to the floor. Never let a fiber-optic cable hang free from the connector.
- Avoid bending fiber-optic cables beyond their minimum bend radius. Bending fiber-optic cables into arcs smaller than a few inches in diameter can damage the cables and cause problems that are difficult to diagnose.
- Frequent plugging and unplugging of fiber-optic cables in and out of optical instruments can damage the instruments, which are expensive to repair. Attach a short fiber extension to the optical equipment. Any wear and tear due to frequent plugging and unplugging is then absorbed by the short fiber extension, which is easier and less expensive to replace than the instruments.
- Keep fiber-optic cable connections clean. Microdeposits of oil and dust in the canal of the transceiver or cable connector can cause loss of light, reduction in signal power, and possibly intermittent problems with the optical connection.
 - To clean the transceiver canal, use an appropriate fiber-cleaning device such as RIFOCS Fiber Optic Adaptor Cleaning Wands (part number 946). Follow the instructions in the cleaning kit you use.
 - After cleaning the transceiver, make sure that the connector tip of the fiber-optic cable is clean. Use only an approved alcohol-free fiber-optic cable cleaning kit such as the Opptex Cletop-S Fiber Cleaner. Follow the instructions in the cleaning kit you use.

5

CHAPTER

Troubleshooting Hardware

Troubleshooting the EX4550 Components | 242

Troubleshooting the EX4550 Components

IN THIS SECTION

- [Understand Alarm Types and Severity Levels on EX Series Switches | 242](#)
- [Chassis Component Alarm Conditions on EX4550 Switches | 244](#)
- [Check Active Alarms with the J-Web Interface | 250](#)
- [Monitor System Log Messages | 252](#)
- [Troubleshoot Temperature Alarms in EX Series Switches | 256](#)

Understand Alarm Types and Severity Levels on EX Series Switches

NOTE: This topic applies only to the J-Web Application package.

Alarms alert you to conditions that might prevent normal operation of the switch. Before monitoring alarms on a Juniper Networks EX Series Ethernet switch, become familiar with the terms defined in [Table 69 on page 242](#).

Table 69: Alarm Terms

Term	Definition
alarm	Signal alerting you to conditions that might prevent normal operation. On a switch, the alarm signal is the ALM LED lit on the front of the chassis.
alarm condition	Failure event that triggers an alarm.
alarm severity	Seriousness of the alarm. If the Alarm (ALM) LED is red, this indicates a major alarm. If the Alarm LED is yellow or amber, this indicates a minor alarm. If the Alarm LED is unlit, there is no alarm or the switch is halted.
chassis alarm	Preset alarm triggered by a physical condition on the switch such as a power supply failure, excessive component temperature, or media failure.

Table 69: Alarm Terms (*continued*)

Term	Definition
system alarm	Preset alarm triggered by a missing rescue configuration or failure to install a license for a licensed software feature. NOTE: On EX6200 switches, a system alarm can be triggered by an internal link error.

Alarm Types

The switch supports these alarms:

- Chassis alarms indicate a failure on the switch or one of its components. Chassis alarms are preset and cannot be modified.
- System alarms indicate a missing rescue configuration. System alarms are preset and cannot be modified, although you can configure them to appear automatically in the J-Web interface display or the CLI display.

Alarm Severity Levels

Alarms on switches have two severity levels:

- Major (red)—Indicates a critical situation on the switch that has resulted from one of the following conditions. A red alarm condition requires immediate action.
 - One or more hardware components have failed.
 - One or more hardware components have exceeded temperature thresholds.
 - An alarm condition configured on an interface has triggered a critical warning.
- Minor (yellow or amber)—Indicates a noncritical condition on the switch that, if left unchecked, might cause an interruption in service or degradation in performance. A yellow or amber alarm condition requires monitoring or maintenance.

A missing rescue configuration generates a yellow or amber system alarm.

SEE ALSO

[Dashboard for EX Series Switches | 178](#)

Chassis Component Alarm Conditions on EX4550 Switches

This topic describes the chassis component alarm conditions on EX4550 switches.

Table 70 on page 244 lists the alarms that the chassis components can generate on EX4550 switches, their severity levels, and the actions you can take to respond to them.

Table 70: Chassis Component Alarm Conditions on EX4550 Switches

Chassis Component	Alarm Condition	Alarm Severity	Remedy
Power supplies	A power supply has been removed from the chassis.	Minor (yellow)	Install a power supply into the empty slot.
	An unknown power supply is installed.	Minor (yellow)	Install a power supply recommended by Juniper Networks.
	The power supply is offline or the power supply output has failed.	Major (red)	Open a support case using the Case Manager link at https://www.juniper.net/support/ or call 1-888-314-5822 (toll-free within the United States and Canada) or 1-408-745-9500 (from outside the United States).

Table 70: Chassis Component Alarm Conditions on EX4550 Switches (*continued*)

Chassis Component	Alarm Condition	Alarm Severity	Remedy
Fan module	Fan module is not installed.	Major (red)	Install the fan module.
	Fan failure-i2c read failure.	Major (red)	<ul style="list-style-type: none"> • Check the fan. • Replace the faulty fan module. • If the above two checks show no problems, open a support case using the Case Manager link at https://www.juniper.net/support/ or call 1-888-314-5822 (toll-free within the United States and Canada) or 1-408-745-9500 (from outside the United States).
	One fan in the chassis is not spinning or is spinning below the required speed.	Major (red)	<ul style="list-style-type: none"> • Check the fan. • Replace the faulty fan module. • If the above two checks show no problems, open a support case using the Case Manager link at https://www.juniper.net/support/ or call 1-888-314-5822 (toll-free within the United States and Canada) or 1-408-745-9500 (from outside the United States).
	Mix of fan modules with different airflow directions.	Major (red)	

Table 70: Chassis Component Alarm Conditions on EX4550 Switches (continued)

Chassis Component	Alarm Condition	Alarm Severity	Remedy
			<p>Open a support case using the Case Manager link at https://www.juniper.net/support/ or call 1-888-314-5822 (toll-free within the United States and Canada) or 1-408-745-9500 (from outside the United States).</p>
	<p>Mix of fan modules and power supplies with different airflow directions.</p>	<p>Major (red)</p>	<p>Open a support case using the Case Manager link at https://www.juniper.net/support/ or call 1-888-314-5822 (toll-free within the United States and Canada) or 1-408-745-9500 (from outside the United States).</p>

Table 70: Chassis Component Alarm Conditions on EX4550 Switches (*continued*)

Chassis Component	Alarm Condition	Alarm Severity	Remedy
Temperature	The temperature inside the chassis reaches the red alarm limit.	Major (red)	<ul style="list-style-type: none"> • Check the fan. • Open a support case using the Case Manager link at https://www.juniper.net/support/ or call 1-888-314-5822 (toll-free within the United States and Canada) or 1-408-745-9500 (from outside the United States).
	The temperature inside the chassis reaches the yellow alarm limit.	Minor (yellow)	<ul style="list-style-type: none"> • Check the fan. • Open a support case using the Case Manager link at https://www.juniper.net/support/ or call 1-888-314-5822 (toll-free within the United States and Canada) or 1-408-745-9500 (from outside the United States).
	The temperature sensor has failed.	Major (red)	Open a support case using the Case Manager link at https://www.juniper.net/support/ or call 1-888-314-5822 (toll-free within the United States and Canada) or 1-408-745-9500 (from outside the United States).

Table 70: Chassis Component Alarm Conditions on EX4550 Switches (continued)

Chassis Component	Alarm Condition	Alarm Severity	Remedy
Media	Device booted from backup root.	Minor (yellow)	Open a support case using the Case Manager link at https://www.juniper.net/support/ or call 1-888-314-5822 (toll-free within the United States and Canada) or 1-408-745-9500 (from outside the United States).
	<code>/var</code> or <code>/config</code> full (only 10% free).	Major (red)	Open a support case using the Case Manager link at https://www.juniper.net/support/ or call 1-888-314-5822 (toll-free within the United States and Canada) or 1-408-745-9500 (from outside the United States).
	<code>/var</code> or <code>/config</code> full (only 25% free).	Minor (yellow)	Open a support case using the Case Manager link at https://www.juniper.net/support/ or call 1-888-314-5822 (toll-free within the United States and Canada) or 1-408-745-9500 (from outside the United States).
	Upgrade bank is empty or corrupted.	Major (red)	Open a support case using the Case Manager link at https://www.juniper.net/support/ or call 1-888-314-5822 (toll-free within the United States and Canada) or 1-408-745-9500 (from outside the United States).
	Firmware version is not the latest.	Minor (yellow)	

Table 70: Chassis Component Alarm Conditions on EX4550 Switches (continued)

Chassis Component	Alarm Condition	Alarm Severity	Remedy
			Open a support case using the Case Manager link at https://www.juniper.net/support/ or call 1-888-314-5822 (toll-free within the United States and Canada) or 1-408-745-9500 (from outside the United States).
	Single-bit ECC error detected.	Major (red)	Open a support case using the Case Manager link at https://www.juniper.net/support/ or call 1-888-314-5822 (toll-free within the United States and Canada) or 1-408-745-9500 (from outside the United States).
Management Ethernet interface	Management Ethernet link is down.	Major (red)	<ul style="list-style-type: none"> • Check whether a cable is connected to the management Ethernet interface, or whether the cable is defective. Replace the cable if required. • If you are unable to resolve the problem, open a support case using the Case Manager link at https://www.juniper.net/support/ or call 1-888-314-5822 (toll-free within the United States and Canada) or 1-408-745-9500 (from outside the United States).

Table 70: Chassis Component Alarm Conditions on EX4550 Switches (*continued*)

Chassis Component	Alarm Condition	Alarm Severity	Remedy
Routing Engine	/var partition usage is high.	Minor (yellow)	Clean up the system file storage space on the switch. For more information, see <i>Freeing Up System Storage Space</i> .
	/var partition is full.	Major (red)	Clean up the system file storage space on the switch. For more information, see <i>Freeing Up System Storage Space</i> .
	Rescue configuration is not set.	Minor (yellow)	Use the request system configuration rescue save command to set the rescue configuration.
	Feature usage requires a license or the license for the feature usage has expired.	Minor (yellow)	Install the required license for the feature specified in the alarm. For more information, see <i>Understanding Software Licenses for EX Series Switches</i> .

SEE ALSO

| [Chassis Status LEDs in EX4550 Switches](#) | 49

Check Active Alarms with the J-Web Interface

Purpose

NOTE: This topic applies only to the J-Web Application package.

Use the monitoring functionality to view alarm information for the EX Series switches including alarm type, alarm severity, and a brief description for each active alarm on the switching platform.

Action

To view the active alarms:

1. Select **Monitor > Events and Alarms > View Alarms** in the J-Web interface.
2. Select an alarm filter based on alarm type, severity, description, and date range.
3. Click **Go**.

All the alarms matching the filter are displayed.

NOTE: When the switch is reset, the active alarms are displayed.

Meaning

[Table 71 on page 251](#) lists the alarm output fields.

Table 71: Summary of Key Alarm Output Fields

Field	Values
Type	Category of the alarm: <ul style="list-style-type: none"> • Chassis—Indicates an alarm condition on the chassis (typically an environmental alarm such as one related to temperature). • System—Indicates an alarm condition in the system.
Severity	Alarm severity—either major (red) or minor (yellow or amber).
Description	Brief synopsis of the alarm.
Time	Date and time when the failure was detected.

SEE ALSO

[Monitor System Log Messages | 252](#)

[Dashboard for EX Series Switches | 178](#)

[Understand Alarm Types and Severity Levels on EX Series Switches | 242](#)

Monitor System Log Messages

Purpose

NOTE: This topic applies only to the J-Web Application package.

Use the monitoring functionality to filter and view system log messages for EX Series switches.

Action

To view events in the J-Web interface, select **Monitor > Events and Alarms > View Events**.

Apply a filter or a combination of filters to view messages. You can use filters to display relevant events. [Table 72 on page 252](#) describes the different filters, their functions, and the associated actions.

To view events in the CLI, enter the following command:

show log

Table 72: Filtering System Log Messages

Field	Function	Your Action
System Log File	<p>Specifies the name of a system log file for which you want to display the recorded events.</p> <p>Lists the names of all the system log files that you configure.</p> <p>By default, a log file, messages, is included in the /var/log/ directory.</p>	<p>To specify events recorded in a particular file, select the system log filename from the list— for example, messages.</p> <p>Select Include archived files to include archived files in the search.</p>
Process	<p>Specifies the name of the process generating the events you want to display.</p> <p>To view all the processes running on your system, enter the CLI command show system processes.</p> <p>For more information about processes, see the Junos OS Installation and Upgrade Guide.</p>	<p>To specify events generated by a process, type the name of the process.</p> <p>For example, type mgd to list all messages generated by the management process.</p>

Table 72: Filtering System Log Messages (*continued*)

Field	Function	Your Action
Date From To	<p>Specifies the time period in which the events you want displayed are generated.</p> <p>Displays a calendar that allows you to select the year, month, day, and time. It also allows you to select the local time.</p> <p>By default, the messages generated during the last one hour are displayed. End Time shows the current time and Start Time shows the time one hour before End Time.</p>	<p>To specify the time period:</p> <ul style="list-style-type: none"> ● Click the Calendar icon and select the year, month, and date— for example, 02/10/2007. ● Click the Calendar icon and select the year, month, and date— for example, 02/10/2007. ● Click to select the time in hours, minutes, and seconds.
Event ID	<p>Specifies the event ID for which you want to display the messages.</p> <p>Allows you to type part of the ID and completes the remainder automatically.</p> <p>An event ID, also known as a system log message code, uniquely identifies a system log message. It begins with a prefix that indicates the generating software process or library.</p>	<p>To specify events with a specific ID, type the partial or complete ID— for example, TFTPD_AF_ERR.</p>
Description	<p>Specifies text from the description of events that you want to display.</p> <p>Allows you to use regular expressions to match text from the event description.</p> <p>NOTE: Regular expression matching is case-sensitive.</p>	<p>To specify events with a specific description, type a text string from the description with regular expression.</p> <p>For example, type ^Initial* to display all messages with lines beginning with the term <i>Initial</i>.</p>
Search	<p>Applies the specified filter and displays the matching messages.</p>	<p>To apply the filter and display messages, click Search.</p>
Reset	<p>Resets all the fields in the Events Filter box.</p>	<p>To reset the field values that are listed in the Events Filter box, click Reset.</p>

Table 72: Filtering System Log Messages (continued)

Field	Function	Your Action
<p>Generate Raw Report</p> <p>NOTE:</p> <ul style="list-style-type: none"> Starting in Junos OS Release 14.1X53, a Raw Report can be generated from the log messages being loaded in the Events Detail table. The Generate Raw Report button is enabled after the event log messages start loading in the Events Detail table. After the log messages are completely loaded in the Events Detail table, Generate Raw Report changes to Generate Report. 	<p>Generates a list of event log messages in nontabular format.</p>	<p>To generate a raw report:</p> <ol style="list-style-type: none"> Click Generate Raw Report. The <i>Opening filteredEvents.html</i> window appears. Select Open with to open the HTML file or select Save File to save the file. Click OK.
<p>Generate Report</p> <p>NOTE: Starting in Junos OS Release 14.1X53, a Formatted Report can be generated from event log messages being loaded in an Events Detail table. The Generate Report button appears only after event log messages are completely loaded in the Events Detail table. The Generate Raw Report button is displayed while event log messages are being loaded.</p>	<p>Generates a list of event log messages in tabular format, which shows system details, events filter criteria, and event details.</p>	<p>To generate a formatted report:</p> <ol style="list-style-type: none"> Click Generate Report. The <i>Opening Report.html</i> window appears. Select Open with to open the HTML file or select Save File to save the file. Click OK.

Meaning

Table 73 on page 255 describes the Event Summary fields.

NOTE: By default, the View Events page in the J-Web interface displays the most recent 25 events, with severity levels highlighted in different colors. After you specify the filters, Event Summary displays the events matching the specified filters. Click the **First**, **Next**, **Prev**, and **Last** links to navigate through messages.

Table 73: Viewing System Log Messages

Field	Function	Additional Information
Process	Displays the name and ID of the process that generated the system log message.	The information displayed in this field is different for messages generated on the local Routing Engine than for messages generated on another Routing Engine (on a system with two Routing Engines installed and operational). Messages from the other Routing Engine also include the identifiers re0 and re1 that identify the Routing Engine.
Severity	<p>Severity level of a message is indicated by different colors.</p> <ul style="list-style-type: none"> ● Unknown—Gray—Indicates no severity level is specified. ● Debug/Info/Notice—Green—Indicates conditions that are not errors but are of interest or might warrant special handling. ● Warning—Yellow or Amber—Indicates conditions that warrant monitoring. ● Error—Blue—Indicates standard error conditions that generally have less serious consequences than errors in the emergency, alert, and critical levels. ● Critical—Pink—Indicates critical conditions, such as hard-drive errors. ● Alert—Orange—Indicates conditions that require immediate correction, such as a corrupted system database. ● Emergency—Red—Indicates system panic or other conditions that cause the switch to stop functioning. 	A severity level indicates how seriously the triggering event affects switch functions. When you configure a location for logging a facility, you also specify a severity level for the facility. Only messages from the facility that are rated at that level or higher are logged to the specified file.

Table 73: Viewing System Log Messages (continued)

Field	Function	Additional Information
Event ID	<p>Displays a code that uniquely identifies the message.</p> <p>The prefix on each code identifies the message source, and the rest of the code indicates the specific event or error.</p>	<p>The event ID begins with a prefix that indicates the generating software process.</p> <p>Some processes on a switch do not use codes. This field might be blank in a message generated from such a process.</p> <p>An event can belong to one of the following type categories:</p> <ul style="list-style-type: none"> • Error—Indicates an error or failure condition that might require corrective action. • Event—Indicates a condition or occurrence that does not generally require corrective action.
Event Description	Displays a more detailed explanation of the message.	
Time	Displays the time at which the message was logged.	

SEE ALSO

[Check Active Alarms with the J-Web Interface | 250](#)

[Understand Alarm Types and Severity Levels on EX Series Switches | 242](#)

Troubleshoot Temperature Alarms in EX Series Switches

Problem

Description: EX Series switches generate a temperature alarm **FPC 0 EX-PFE1 Temp Too Hot**.

Cause

Temperature sensors in the chassis monitor the temperature of the chassis. The switch raises an alarm if a fan fails or if the temperature of the chassis exceeds permissible levels.

Solution

When the switch raises a temperature alarm such as the **FPC 0 EX-PFE1 Temp Too Hot** alarm, use the **show chassis environment** and the **show chassis temperature-thresholds** commands to identify the condition that triggered the alarm.



CAUTION: To prevent the switch from overheating, do not operate it in an area that exceeds the maximum recommended ambient temperature. To prevent airflow restriction, allow at least 6 inches (15.2 cm) of clearance around the ventilation openings.

1. Connect to the switch by using Telnet and issue the **show chassis environment** command. This command displays environmental information about the switch chassis, including the temperature, and information about the fans, power supplies, and Routing Engines. Following is a sample output on an EX9208 switch. The output is similar on other EX Series switches.

```
user@switch> show chassis environment
```

Class	Item	Status	Measurement
Temp	PEM 0	OK	40 degrees C / 104 degrees F
	PEM 1	OK	40 degrees C / 104 degrees F
	PEM 2	Absent	
	PEM 3	Absent	
	Routing Engine 0	OK	37 degrees C / 98 degrees F
	Routing Engine 0 CPU	OK	35 degrees C / 95 degrees F
	Routing Engine 1	Absent	
	Routing Engine 1 CPU	Absent	
	CB 0 Intake	OK	36 degrees C / 96 degrees F
	CB 0 Exhaust A	OK	34 degrees C / 93 degrees F
	CB 0 Exhaust B	OK	40 degrees C / 104 degrees F
	CB 0 ACBC	OK	39 degrees C / 102 degrees F
	CB 0 XF A	OK	46 degrees C / 114 degrees F
	CB 0 XF B	OK	45 degrees C / 113 degrees F
	CB 1 Intake	Absent	
	CB 1 Exhaust A	Absent	
	CB 1 Exhaust B	Absent	
	CB 1 ACBC	Absent	
	CB 1 XF A	Absent	
	CB 1 XF B	Absent	
	FPC 3 Intake	OK	48 degrees C / 118 degrees F
	FPC 3 Exhaust A	OK	46 degrees C / 114 degrees F
	FPC 3 Exhaust B	OK	51 degrees C / 123 degrees F
	FPC 3 XL TSen	OK	67 degrees C / 152 degrees F
	FPC 3 XL Chip	OK	58 degrees C / 136 degrees F
	FPC 3 XL_XR0 TSen	OK	67 degrees C / 152 degrees F
	FPC 3 XL_XR0 Chip	OK	51 degrees C / 123 degrees F
	FPC 3 XL_XR1 TSen	OK	67 degrees C / 152 degrees F
	FPC 3 XL_XR1 Chip	OK	63 degrees C / 145 degrees F

FPC 3 XQ TSen	OK	67 degrees C / 152 degrees F
FPC 3 XQ Chip	OK	63 degrees C / 145 degrees F
FPC 3 XQ_XR0 TSen	OK	67 degrees C / 152 degrees F
FPC 3 XQ_XR0 Chip	OK	68 degrees C / 154 degrees F
FPC 3 XM TSen	OK	67 degrees C / 152 degrees F
FPC 3 XM Chip	OK	76 degrees C / 168 degrees F
FPC 3 XF TSen	OK	67 degrees C / 152 degrees F
FPC 3 XF Chip	OK	75 degrees C / 167 degrees F
FPC 3 PLX PCIe Switch TSe	OK	51 degrees C / 123 degrees F
FPC 3 PLX PCIe Switch Chi	OK	54 degrees C / 129 degrees F
FPC 3 Aloha FPGA 0 TSen	OK	51 degrees C / 123 degrees F
FPC 3 Aloha FPGA 0 Chip	OK	70 degrees C / 158 degrees F
FPC 3 Aloha FPGA 1 TSen	OK	51 degrees C / 123 degrees F
FPC 3 Aloha FPGA 1 Chip	OK	75 degrees C / 167 degrees F
FPC 5 Intake	Testing	
FPC 5 Exhaust A	Testing	
FPC 5 Exhaust B	Testing	
Fans Top Rear Fan	OK	Spinning at intermediate-speed
Bottom Rear Fan	OK	Spinning at intermediate-speed
Top Middle Fan	OK	Spinning at intermediate-speed
Bottom Middle Fan	OK	Spinning at intermediate-speed
Top Front Fan	OK	Spinning at intermediate-speed
Bottom Front Fan	OK	Spinning at intermediate-speed

Table 74 on page 258 lists the output fields for the **show chassis environment** command. Output fields are listed in the approximate order in which they appear.

Table 74: show chassis environment Output Fields

Field Name	Field Description
Class	Information about the category or class of chassis component: <ul style="list-style-type: none"> • Temp: Temperature of air flowing through the chassis in degrees Celsius (°C) and degrees Fahrenheit (°F). • Fans: Information about the status of fans and blowers.
Item	Information about the chassis components: Flexible PIC Concentrators (FPCs)—that is, the line cards—, Control Boards (CBs), Routing Engines (REs), Power Entry Modules (PEMs)—that is, the power supplies.

Table 74: show chassis environment Output Fields (continued)

Field Name	Field Description
Status	Status of the specified chassis component. For example, if Class is Fans , the fan status can be: <ul style="list-style-type: none"> • OK: The fans are operational. • Testing: The fans are being tested during initial power-on. • Failed: The fans have failed or the fans are not spinning. • Absent: The fan tray is not installed.
Measurement	Depends on the Class. For example, if Class is Temp , indicates the temperature in degrees Celsius (°C) and degrees Fahrenheit (°F). If the Class is Fans , indicates actual fan RPM.

2. Issue the command **show chassis temperature-thresholds**. This command displays the chassis temperature threshold settings. Following is a sample output on an EX9208 switch. The output is similar on other EX Series switches.

```
user@ host> show chassis temperature-thresholds
```

Item	Fan speed (degrees C)		Yellow alarm (degrees C)		Red alarm (degrees C)		Fire Shutdown (degrees C)
	Normal	High	Normal	Bad fan	Normal	Bad fan	Normal
Chassis default	48	54	65	55	80	65	100
Routing Engine 0	70	80	95	95	110	110	112
FPC 3	55	60	75	65	105	80	110
FPC 5	55	60	75	65	90	80	95

Table 75 on page 259 lists the output fields for the **show chassis temperature-thresholds** command. Output fields are listed in the approximate order in which they appear.

Table 75: show chassis temperature-thresholds Output Fields

Field Name	Field Description
Item	Chassis component. You can configure for the threshold information for components such as the chassis. Information is displayed in the output. By default, information is displayed only for the chassis and the Routing Engines.
Fan speed	Temperature thresholds, in degrees Celsius, for the fans to operate at normal and at high speed. <ul style="list-style-type: none"> • Normal—The temperature threshold at which the fans operate at normal speed and when all the fans are operational. • High—The temperature threshold at which the fans operate at high speed or when a fan has failed. <p>NOTE: An alarm is not triggered until the temperature exceeds the threshold settings for a yellow or red alarm.</p>

Table 75: show chassis temperature-thresholds Output Fields (*continued*)

Field Name	Field Description
Yellow or amber alarm	Temperature threshold, in degrees Celsius, that trigger a yellow or amber alarm. <ul style="list-style-type: none"> • Normal—The temperature threshold that must be exceeded on the component to trigger a yellow or amber alarm. • Bad fan—The temperature threshold that must be exceeded on the component to trigger a yellow or amber alarm.
Red alarm	Temperature threshold, in degrees Celsius, that trigger a red alarm. <ul style="list-style-type: none"> • Normal—The temperature threshold that must be exceeded on the component to trigger a red alarm. • Bad fan—The temperature threshold that must be exceeded on the component to trigger a red alarm.
Fire Shutdown	Temperature threshold, in degrees Celsius, for the switch to shut down.

When a temperature alarm is triggered, you can identify the condition that triggered it by running the **show chassis environment** command to display the chassis temperature values for each component and comparing those with the temperature threshold values, which you can display by running the **show chassis temperature-thresholds** command.

For example, for **FPC 3**:

- If the temperature of **FPC 3** exceeds 55° C, the output indicates that the fans are operating at a high speed (no alarm is triggered).
- If the temperature of **FPC 3** exceeds 65° C, a yellow alarm is triggered to indicate that one or more fans have failed.
- If the temperature of **FPC 3** exceeds 75° C, a yellow alarm is triggered to indicate that the temperature threshold limit is exceeded.
- If the temperature of **FPC 3** exceeds 80° C, a red alarm is triggered to indicate that one or more fans have failed.
- If the temperature of **FPC 3** exceeds 105° C, a red alarm is triggered to indicate that the temperature threshold limit is exceeded.
- If the temperature of **FPC 3** exceeds 110° C, the switch is powered off.

[Table 76 on page 260](#) lists the possible causes for the switch to generate a temperature alarm and the respective remedies.

Table 76: Causes and Remedies for Temperature Alarms

Cause	Remedy
Ambient temperature is above threshold temperature.	Ensure that the ambient temperature is within the threshold temperature limit. See “Environmental Requirements and Specifications for EX Series Switches” on page 75 .

Table 76: Causes and Remedies for Temperature Alarms (continued)

Cause	Remedy
Fan module or fan tray has failed.	<ul style="list-style-type: none">• Check the fan.• Replace the faulty fan module or fan tray.• If the above two checks show no problems, open a support case using the Case Manager link at https://www.juniper.net/support/ or call 1-888-314-5822 (toll-free within the United States and Canada) or 1-408-745-9500 (from outside the United States).
Restricted airflow through the switch due to insufficient clearance around the installed switch.	Ensure that there is sufficient clearance around the installed switch. See the following topics to understand the clearance requirements of various EX Series switches.



CHAPTER

Contacting Customer Support and Returning the Chassis or Components

[Returning an EX4550 Chassis or Components](#) | **263**

Returning an EX4550 Chassis or Components

IN THIS SECTION

- [Returning an EX4550 Switch or Component for Repair or Replacement | 263](#)
- [Locating the Serial Number on an EX4550 Switch or Component | 264](#)
- [Contact Customer Support to Obtain Return Material Authorization | 268](#)
- [Packing an EX4550 Switch or Component for Shipping | 269](#)

Returning an EX4550 Switch or Component for Repair or Replacement

If you need to return an EX4550 switch or hardware component to Juniper Networks for repair or replacement, follow this procedure:

1. Determine the serial number of the component. For instructions, see [“Locating the Serial Number on an EX4550 Switch or Component” on page 264](#).
2. Obtain an Return Materials Authorization (RMA) number from JTAC as described in [“Contact Customer Support to Obtain Return Material Authorization” on page 268](#).

NOTE: Do not return any component to Juniper Networks unless you have first obtained an RMA number. Juniper Networks reserves the right to refuse shipments that do not have an RMA. Refused shipments are returned to the customer through collect freight.

3. Pack the switch or component for shipping as described in [“Packing an EX4550 Switch or Component for Shipping” on page 269](#).

For more information about return and repair policies, see the customer support page at <https://www.juniper.net/support/guidelines.html> .

Locating the Serial Number on an EX4550 Switch or Component

IN THIS SECTION

- [Listing the Switch and Components Details with the CLI | 264](#)
- [Locating the Chassis Serial Number ID Label on an EX4550 Switch | 265](#)
- [Locating the Serial Number ID Labels on FRUs in an EX4550 Switch | 265](#)

If you are returning a switch or hardware component to Juniper Networks for repair or replacement, you must locate the serial number of the switch or component. You must provide the serial number to the Juniper Networks Technical Assistance Center (JTAC) when you contact them to obtain Return Materials Authorization (RMA).

If the switch is operational and you can access the CLI, you can list serial numbers for the switch and for some components with a CLI command. If you do not have access to the CLI or if the serial number for the component does not appear in the command output, you can locate the serial number ID label on the physical switch or component.

NOTE: If you want to find the serial number on the physical switch component, you will need to remove the component from the switch chassis, for which you must have the required parts and tools available. See *Installing and Removing EX4550 Switch Hardware Components*.

Listing the Switch and Components Details with the CLI

To list the switch and switch components and their serial numbers, enter the following CLI command:

```
show chassis hardware
```

The following output lists the switch components and serial numbers for an EX4550-32F-AFO switch:

```
user@switch> show chassis hardware
```

```
Hardware inventory:
Item           Version  Part number  Serial number  Description
Chassis                LX0212079218  EX4550-32F
Routing Engine 0 REV 03  750-039067  LX0212079218  EX4550-32F
```



```

FPC 0          REV 03   750-039067   LX0212079218   EX4550-32F
  CPU          BUILTIN   BUILTIN         FPC CPU
  PIC 0        BUILTIN   BUILTIN         32x 1G/10G SFP/SFP+
    Xcvr 0     REV 01   740-030658   AD0946A01K0    SFP+-10G-USR
    Xcvr 1     REV 01   740-030658   AD1146A05M3    SFP+-10G-USR
    Xcvr 2     REV 01   740-030658   AD0946A01UD    SFP+-10G-USR
    Xcvr 22    REV 01   740-011613   E08E03397      SFP-SX
  PIC 1        REV 02   711-039080   LV0212130022   8x 1G/10G SFP/SFP+
    Xcvr 2     REV 01   740-011613   E08J02549      SFP-SX
    Xcvr 3     REV 01   740-011613   E08E03374      SFP-SX
    Xcvr 4     REV 02   740-011613   AM0943SEKHV    SFP-SX
    Xcvr 5     REV 01   740-011613   E08C02015      SFP-SX
  PIC 2        REV 02   711-039072   LM0212069201   2x 32GE Virtual Chassis
module
  Power Supply 0 Rev 01   740-041741   VJ00228        JPSU-650W-AC-AFO
  Fan Tray
(AFO)

```

For information about the **show chassis hardware** command, see *show chassis hardware*.

Locating the Chassis Serial Number ID Label on an EX4550 Switch

The serial number ID label is located on the rear panel of an EX4550 switch. See [Figure 86 on page 265](#).

Figure 86: Location of the Serial Number ID Label on an EX4550 Switch

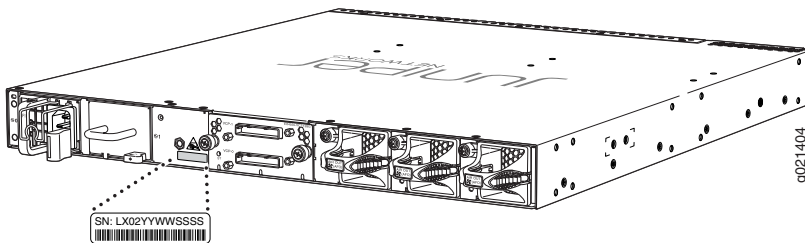

Locating the Serial Number ID Labels on FRUs in an EX4550 Switch

The power supplies, fan modules, expansion modules, and the Virtual Chassis module installed in EX4550 switches are field-replaceable units (FRUs).

For each of these FRUs, you must remove the FRU from the switch chassis to see the FRU's serial number ID label.

- **Power supply**—The serial number ID label is on the top of the power supply. [Figure 87 on page 266](#) shows the location of the serial number ID label on an AC power supply and [Figure 88 on page 266](#) shows the location of the serial number ID label on a DC power supply. See [“Removing an AC Power Supply from an EX4550 Switch” on page 211](#) or [“Removing a DC Power Supply from an EX4550 Switch” on page 214](#).

Figure 87: Location of the Serial Number ID Label on an AC Power Supply Used in an EX4550 Switch

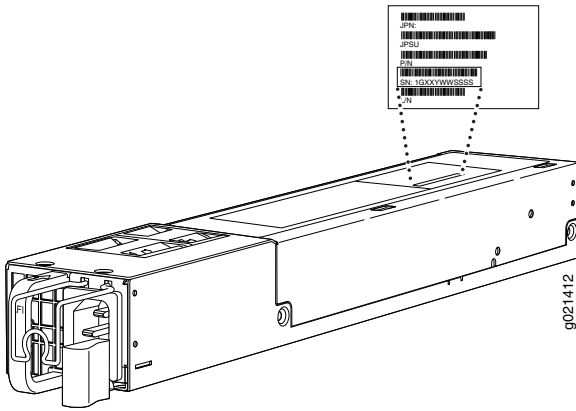
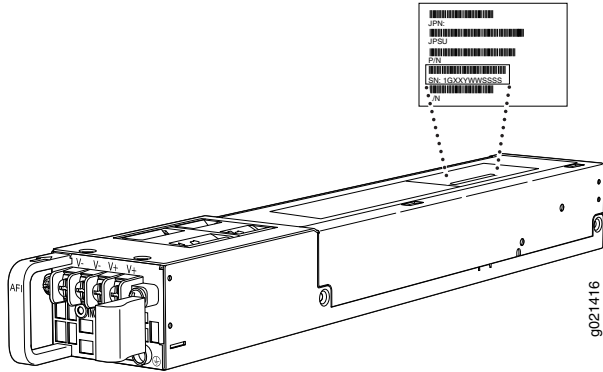
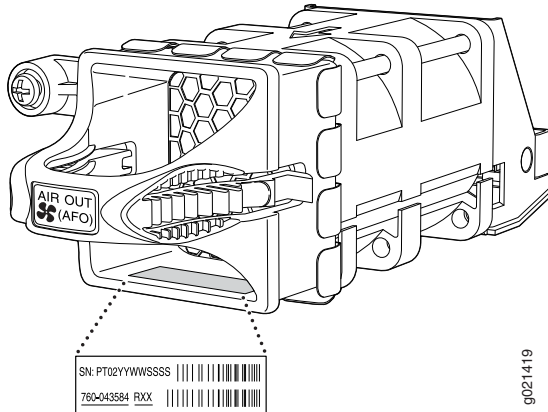

Figure 88: Location of the Serial Number ID Label on a DC Power Supply Used in an EX4550 Switch



- **Fan module**—The serial number ID label is on the front bottom lip of the fan module. [Figure 89 on page 267](#) shows the location of the serial number ID label. See [“Removing a Fan Module from an EX4550 Switch” on page 208](#).

Figure 89: Location of the Serial Number ID Label on a Fan Module Used in an EX4550 Switch



- **Expansion module**—The serial number ID label is on the circuit board. [Figure 90 on page 267](#) and [Figure 91 on page 267](#) show the location of the serial number ID label.

Figure 90: Location of the Serial Number ID Label on a SFP+ Expansion Module Used in an EX4550 Switch

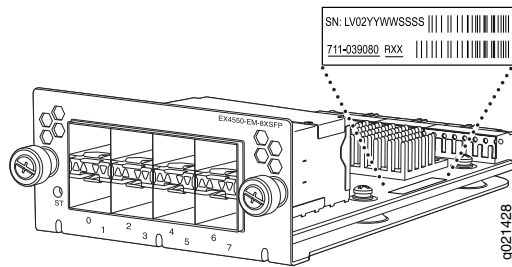
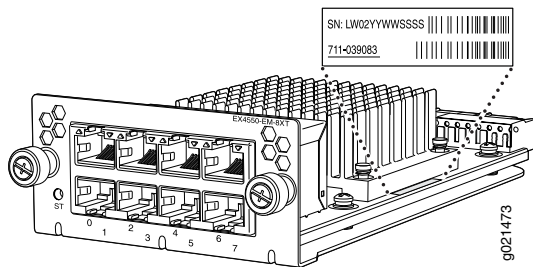
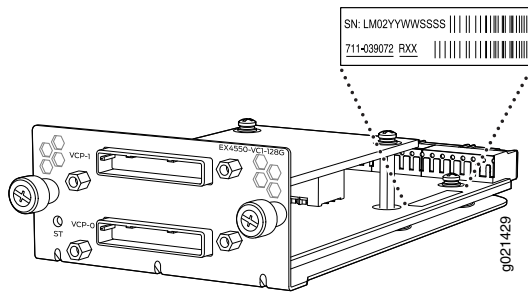

Figure 91: Location of the Serial Number ID Label on a 10GBASE-T Expansion Module Used in an EX4550 Switch



- **Virtual Chassis module**—The serial number ID label is on the circuit board. [Figure 92 on page 268](#) shows the location of the serial number ID label. See [“Removing a Virtual Chassis Module from an EX4550 Switch” on page 222](#).

Figure 92: Location of the Serial Number ID Label on a Virtual Chassis Module Used in an EX4550 Switch



Contact Customer Support to Obtain Return Material Authorization

If you are returning a device or hardware component to Juniper Networks for repair or replacement, obtain a Return Material Authorization (RMA) number from Juniper Networks Technical Assistance Center (JTAC).

After locating the serial number of the device or hardware component you want to return, open a service request with Juniper Networks Technical Assistance Center (JTAC) on the Web or by telephone.

Before you request an RMA number from JTAC, be prepared to provide the following information:

- Your existing service request number, if you have one
- Serial number of the component
- Your name, organization name, telephone number, fax number, and shipping address
- Details of the failure or problem
- Type of activity being performed on the device when the problem occurred
- Configuration data displayed by one or more **show** commands

You can contact JTAC 24 hours a day, seven days a week on the Web or by telephone:

- Service Request Manager: <https://support.juniper.net/support>
- Telephone: +1-888-314-JTAC (+1-888-314-5822), toll free in U.S., Canada, and Mexico

NOTE: For international or direct-dial options in countries without toll free numbers, see <https://support.juniper.net/support>

If you are contacting JTAC by telephone, enter your 12-digit service request number followed by the pound (#) key for an existing case, or press the star (*) key to be routed to the next available support engineer.

The support representative validates your request and issues an RMA number for return of the component.

Packing an EX4550 Switch or Component for Shipping

If you are returning an EX4550 switch or component to Juniper Networks for repair or replacement, pack the item as described in this topic.

Before you begin packing the switch or component, ensure you have:

- Followed all the steps listed in [“Contact Customer Support to Obtain Return Material Authorization” on page 268](#).
 - Retrieved the original shipping carton and packing materials. Contact your JTAC representative if you do not have these materials, to learn about approved packing materials. See [“Contact Customer Support to Obtain Return Material Authorization” on page 268](#).
 - Ensure you understand how to prevent electrostatic discharge (ESD) damage. See [“Prevention of Electrostatic Discharge Damage” on page 308](#).
1. [Packing an EX4550 Switch for Shipping | 269](#)
 2. [Packing EX4550 Switch Components for Shipping | 271](#)

Packing an EX4550 Switch for Shipping

If you need to transport the switch to another location or return the switch to Juniper Networks, you need to pack the switch securely in its original packaging to prevent damage during transportation.

Before you pack the switch:

1. On the console or other management device connected to the switch, enter the CLI operational mode and issue the following command to shut down the switch software:

```
user@switch> request system halt
```

Wait until a message appears on the console confirming that the operating system has halted.

2. Disconnect power from the switch by performing one of the following:
 - If the power source outlet has a power switch, set it to the off (O) position.
 - If the power source outlet does not have a power switch, gently pull out the plug end of the power cord connected to the power source outlet.

3. Remove the cables that connect the switch to all external devices. See [“Disconnect a Fiber-Optic Cable” on page 238](#).
4. Remove all optical transceivers installed in the switch. See [“Remove a Transceiver” on page 228](#).

Ensure that you have the following parts and tools available to pack the switch:

- Phillips (+) screwdriver, number 2
- The original switch packing material (cardboard box, accessory box and its contents, and foam padding)
- ESD grounding strap
- Antistatic bag



CAUTION: Do not pack the switch in anything except its original container or the switch might be damaged in transit.

To pack the switch:

1. If the switch is installed in a rack or cabinet, have one person support the weight of the switch while another person unscrews and removes the mounting screws.
2. Remove the switch from the rack or cabinet and place the switch on a flat, stable surface.
3. Use the Phillips (+) screwdriver, number 2 to remove the rack-mounting brackets from the switch chassis.
4. Place the switch in an antistatic bag.
5. Place the bottom portion of the packaging foam in the shipping carton.
6. Place the switch inside the cavity in the bottom packaging foam.
7. Place the top portion of the packaging foam on top of the switch.
8. If you are returning accessories or field-replaceable units (FRUs) with the switch, pack them as instructed in [“Packing EX4550 Switch Components for Shipping” on page 271](#).
9. Place the accessory box vertically by the rear end of the chassis in the shipping carton.

10. Close the top of the cardboard shipping box and seal it with packing tape.
11. Write the RMA number on the exterior of the box to ensure proper tracking.

Packing EX4550 Switch Components for Shipping

To pack the switch components, follow the instructions here.

Ensure that you have the following parts and tools available:

- Antistatic bag, one for each component
- ESD grounding strap



CAUTION: Do not stack switch components. Return individual components in separate boxes if they do not fit together on one level in the shipping box.

To pack the switch components:

- Place individual components in antistatic bags.
- Use the original packing materials if they are available. If the original packing materials are not available, ensure the component is adequately packed to prevent damage during transit. The packing material you use must be able to support the weight of the component.
- Ensure that the components are adequately protected by wrapping them well with packing materials. Pack the component in an oversized box (if the original box is not available) with extra packing material around the unit so that the component is prevented from moving around inside the box.
- Securely tape the box closed.
- Write the RMA number on the exterior of the box to ensure proper tracking.

7

CHAPTER

Safety and Compliance Information

General Safety Guidelines and Warnings | **274**

Definitions of Safety Warning Levels | **275**

Qualified Personnel Warning | **278**

Warning Statement for Norway and Sweden | **279**

Fire Safety Requirements | **279**

Installation Instructions Warning | **281**

Chassis and Component Lifting Guidelines | **281**

Restricted Access Warning | **283**

Ramp Warning | **285**

Rack-Mounting and Cabinet-Mounting Warnings | **286**

Grounded Equipment Warning | **292**

Radiation from Open Port Apertures Warning | **293**

Laser and LED Safety Guidelines and Warnings | **294**

Maintenance and Operational Safety Guidelines and Warnings | **297**

General Electrical Safety Guidelines and Warnings | **306**

Action to Take After an Electrical Accident | **307**

Prevention of Electrostatic Discharge Damage | **308**

AC Power Electrical Safety Guidelines | **309**

AC Power Disconnection Warning | **311**

DC Power Electrical Safety Guidelines | **312**

DC Power Disconnection Warning | **313**

DC Power Grounding Requirements and Warning | **315**

DC Power Wiring Sequence Warning | **317**

DC Power Wiring Terminations Warning | **320**

Multiple Power Supplies Disconnection Warning | **323**

TN Power Warning | **324**

Agency Approvals for EX Series Switches | **324**

Compliance Statements for EMC Requirements for EX Series Switches | **325**

Compliance Statements for Acoustic Noise for EX Series Switches | **330**

Statements of Volatility for Juniper Network Devices | **330**

General Safety Guidelines and Warnings

The following guidelines help ensure your safety and protect the device from damage. The list of guidelines might not address all potentially hazardous situations in your working environment, so be alert and exercise good judgment at all times.

- Perform only the procedures explicitly described in the hardware documentation for this device. Make sure that only authorized service personnel perform other system services.
- Keep the area around the device clear and free from dust before, during, and after installation.
- Keep tools away from areas where people could trip over them while walking.
- Do not wear loose clothing or jewelry, such as rings, bracelets, or chains, which could become caught in the device.
- Wear safety glasses if you are working under any conditions that could be hazardous to your eyes.
- Do not perform any actions that create a potential hazard to people or make the equipment unsafe.
- Never attempt to lift an object that is too heavy for one person to handle.
- Never install or manipulate wiring during electrical storms.
- Never install electrical jacks in wet locations unless the jacks are specifically designed for wet environments.
- Operate the device only when it is properly grounded.
- Follow the instructions in this guide to properly ground the device to earth.
- Replace fuses only with fuses of the same type and rating.
- Do not open or remove chassis covers or sheet-metal parts unless instructions are provided in the hardware documentation for this device. Such an action could cause severe electrical shock.
- Do not push or force any objects through any opening in the chassis frame. Such an action could result in electrical shock or fire.
- Avoid spilling liquid onto the chassis or onto any device component. Such an action could cause electrical shock or damage the device.
- Avoid touching uninsulated electrical wires or terminals that have not been disconnected from their power source. Such an action could cause electrical shock.
- Some parts of the chassis, including AC and DC power supply surfaces, power supply unit handles, SFB card handles, and fan tray handles might become hot. The following label provides the warning of the hot surfaces on the chassis:



- Always ensure that all modules, power supplies, and cover panels are fully inserted and that the installation screws are fully tightened.

Definitions of Safety Warning Levels

The documentation uses the following levels of safety warnings (there are two *Warning* formats):

NOTE: You might find this information helpful in a particular situation, or you might overlook this important information if it was not highlighted in a Note.



CAUTION: You need to observe the specified guidelines to prevent minor injury or discomfort to you or severe damage to the device.

Attention Veillez à respecter les consignes indiquées pour éviter toute incommodité ou blessure légère, voire des dégâts graves pour l'appareil.



WARNING: This symbol alerts you to the risk of personal injury from a laser.

Avertissement Ce symbole signale un risque de blessure provoquée par rayon laser.



WARNING: This symbol means danger. You are in a situation that could cause bodily injury. Before you work on any equipment, be aware of the hazards involved with electrical circuitry and be familiar with standard practices for preventing accidents.

Waarschuwing Dit waarschuwingssymbool betekent gevaar. U verkeert in een situatie die lichamelijk letsel kan veroorzaken. Voordat u aan enige apparatuur gaat werken, dient u zich bewust te zijn van de bij elektrische schakelingen betrokken risico's en dient u op de hoogte te zijn van standaard maatregelen om ongelukken te voorkomen.

Varoitus Tämä varoitusmerkki merkitsee vaaraa. Olet tilanteessa, joka voi johtaa ruumiinvammaan. Ennen kuin työskentelet minkään laitteiston parissa, ota selvää sähkökytkentöihin liittyvistä vaaroista ja tavanomaisista onnettomuuksien ehkäisykeinoista.

Avertissement Ce symbole d'avertissement indique un danger. Vous vous trouvez dans une situation pouvant causer des blessures ou des dommages corporels. Avant de travailler sur un équipement, soyez conscient des dangers posés par les circuits électriques et familiarisez-vous avec les procédures couramment utilisées pour éviter les accidents.

Warnung Dieses Warnsymbol bedeutet Gefahr. Sie befinden sich in einer Situation, die zu einer Körperverletzung führen könnte. Bevor Sie mit der Arbeit an irgendeinem Gerät beginnen, seien Sie sich der mit elektrischen Stromkreisen verbundenen Gefahren und der Standardpraktiken zur Vermeidung von Unfällen bewußt.

Avvertenza Questo simbolo di avvertenza indica un pericolo. La situazione potrebbe causare infortuni alle persone. Prima di lavorare su qualsiasi apparecchiatura, occorre conoscere i pericoli relativi ai circuiti elettrici ed essere al corrente delle pratiche standard per la prevenzione di incidenti.

Advarsel Dette varselsymbolet betyr fare. Du befinner deg i en situasjon som kan føre til personskade. Før du utfører arbeid på utstyr, må du være oppmerksom på de faremomentene som elektriske kretser innebærer, samt gjøre deg kjent med vanlig praksis når det gjelder å unngå ulykker.

Aviso Este símbolo de aviso indica perigo. Encontra-se numa situação que lhe poderá causar danos físicos. Antes de começar a trabalhar com qualquer equipamento, familiarize-se com os perigos relacionados com circuitos eléctricos, e com quaisquer práticas comuns que possam prevenir possíveis acidentes.

¡Atención! Este símbolo de aviso significa peligro. Existe riesgo para su integridad física. Antes de manipular cualquier equipo, considerar los riesgos que entraña la corriente eléctrica y familiarizarse con los procedimientos estándar de prevención de accidentes.

Varning! Denna varningssymbol signalerar fara. Du befinner dig i en situation som kan leda till personskada. Innan du utför arbete på någon utrustning måste du vara medveten om farorna med elkretsar och känna till vanligt förfarande för att förebygga skador.

Qualified Personnel Warning



WARNING: Only trained and qualified personnel should install or replace the device.

Waarschuwing Installatie en reparaties mogen uitsluitend door getraind en bevoegd personeel uitgevoerd worden.

Varoitus Ainoastaan koulutettu ja pätevä henkilökunta saa asentaa tai vaihtaa tämän laitteen.

Avertissement Tout installation ou remplacement de l'appareil doit être réalisé par du personnel qualifié et compétent.

Warnung Gerät nur von geschultem, qualifiziertem Personal installieren oder auswechseln lassen.

Avvertenza Solo personale addestrato e qualificato deve essere autorizzato ad installare o sostituire questo apparecchio.

Advarsel Kun kvalifisert personell med riktig opplæring bør montere eller bytte ut dette utstyret.

Aviso Este equipamento deverá ser instalado ou substituído apenas por pessoal devidamente treinado e qualificado.

¡Atención! Estos equipos deben ser instalados y reemplazados exclusivamente por personal técnico adecuadamente preparado y capacitado.

Varning! Denna utrustning ska endast installeras och bytas ut av utbildad och kvalificerad personal.

Warning Statement for Norway and Sweden



WARNING: The equipment must be connected to an earthed mains socket-outlet.

Advarsel Apparatet skal kobles til en jordet stikkontakt.

Varning! Apparatet skall anslutas till jordat nätuttag.

Fire Safety Requirements

In the event of a fire emergency, the safety of people is the primary concern. You should establish procedures for protecting people in the event of a fire emergency, provide safety training, and properly provision fire-control equipment and fire extinguishers.

In addition, you should establish procedures to protect your equipment in the event of a fire emergency. Juniper Networks products should be installed in an environment suitable for electronic equipment. We recommend that fire suppression equipment be available in the event of a fire in the vicinity of the equipment and that all local fire, safety, and electrical codes and ordinances be observed when you install and operate your equipment.

Fire Suppression

In the event of an electrical hazard or an electrical fire, you should first turn power off to the equipment at the source. Then use a Type C fire extinguisher, which uses noncorrosive fire retardants, to extinguish the fire.

Fire Suppression Equipment

Type C fire extinguishers, which use noncorrosive fire retardants such as carbon dioxide and Halotron™, are most effective for suppressing electrical fires. Type C fire extinguishers displace oxygen from the point of combustion to eliminate the fire. For extinguishing fire on or around equipment that draws air from the environment for cooling, you should use this type of inert oxygen displacement extinguisher instead of an extinguisher that leaves residues on equipment.

Do not use multipurpose Type ABC chemical fire extinguishers (dry chemical fire extinguishers). The primary ingredient in these fire extinguishers is monoammonium phosphate, which is very sticky and difficult to clean. In addition, in the presence of minute amounts of moisture, monoammonium phosphate can become highly corrosive and corrodes most metals.

Any equipment in a room in which a chemical fire extinguisher has been discharged is subject to premature failure and unreliable operation. The equipment is considered to be irreparably damaged.

NOTE: To keep warranties effective, do not use a dry chemical fire extinguisher to control a fire at or near a Juniper Networks device. If a dry chemical fire extinguisher is used, the unit is no longer eligible for coverage under a service agreement.

We recommend that you dispose of any irreparably damaged equipment in an environmentally responsible manner.

Installation Instructions Warning



WARNING: Read the installation instructions before you connect the device to a power source.

Waarschuwing Raadpleeg de installatie-aanwijzingen voordat u het systeem met de voeding verbindt.

Varoitus Lue asennusohjeet ennen järjestelmän yhdistämistä virtälähteeseen.

Avertissement Avant de brancher le système sur la source d'alimentation, consulter les directives d'installation.

Warnung Lesen Sie die Installationsanweisungen, bevor Sie das System an die Stromquelle anschließen.

Avvertenza Consultare le istruzioni di installazione prima di collegare il sistema all'alimentatore.

Advarsel Les installasjonsinstruksjonene før systemet kobles til strømkilden.

Aviso Leia as instruções de instalação antes de ligar o sistema à sua fonte de energia.

¡Atención! Ver las instrucciones de instalación antes de conectar el sistema a la red de alimentación.

Varning! Läs installationsanvisningarna innan du kopplar systemet till dess strömförsörjningsenhet.

Chassis and Component Lifting Guidelines

- Before moving the device to a site, ensure that the site meets the power, environmental, and clearance requirements.
- Before lifting or moving the device, disconnect all external cables and wires.
- As when lifting any heavy object, ensure that most of the weight is borne by your legs rather than your back. Keep your knees bent and your back relatively straight. Do not twist your body as you lift. Balance the load evenly and be sure that your footing is firm.
- Use the following lifting guidelines to lift devices and components:

- Up to 39.7 lbs (18 kg): One person.
- 39.7 lbs (18 kg) to 70.5 lbs (32 kg): Two or more people.
- 70.5 lbs (32 kg) to 121.2 lbs (55 kg): Three or more people.
- Above 121.2 lbs (55 kg): Material handling systems (such as levers, slings, lifts and so on) must be used. When this is not practical, specially trained persons or systems must be used (riggers or movers).

Restricted Access Warning



WARNING: This unit is intended for installation in restricted access areas. A restricted access area is an area to which access can be gained only by service personnel through the use of a special tool, lock and key, or other means of security, and which is controlled by the authority responsible for the location.

Waarschuwing Dit toestel is bedoeld voor installatie op plaatsen met beperkte toegang. Een plaats met beperkte toegang is een plaats waar toegang slechts door servicepersoneel verkregen kan worden door middel van een speciaal instrument, een slot en sleutel, of een ander veiligheidsmiddel, en welke beheerd wordt door de overheidsinstantie die verantwoordelijk is voor de locatie.

Varoitus Tämä laite on tarkoitettu asennettavaksi paikkaan, johon pääsy on rajoitettua. Paikka, johon pääsy on rajoitettua, tarkoittaa paikkaa, johon vain huoltohenkilöstö pääsee jonkin erikoistyökalun, lukkoon sopivan avaimen tai jonkin muun turvalaitteen avulla ja joka on paikasta vastuussa olevien toimivaltaisten henkilöiden valvoma.

Avertissement Cet appareil est à installer dans des zones d'accès réservé. Ces dernières sont des zones auxquelles seul le personnel de service peut accéder en utilisant un outil spécial, un mécanisme de verrouillage et une clé, ou tout autre moyen de sécurité. L'accès aux zones de sécurité est sous le contrôle de l'autorité responsable de l'emplacement.

Warnung Diese Einheit ist zur Installation in Bereichen mit beschränktem Zutritt vorgesehen. Ein Bereich mit beschränktem Zutritt ist ein Bereich, zu dem nur Wartungspersonal mit einem Spezialwerkzeugs, Schloß und Schlüssel oder anderer Sicherheitsvorkehrungen Zugang hat, und der von dem für die Anlage zuständigen Gremium kontrolliert wird.

Avvertenza Questa unità deve essere installata in un'area ad accesso limitato. Un'area ad accesso limitato è un'area accessibile solo a personale di assistenza tramite un'attrezzo speciale, lucchetto, o altri dispositivi di sicurezza, ed è controllata dall'autorità responsabile della zona.

Advarsel Denne enheten er laget for installasjon i områder med begrenset adgang. Et område med begrenset adgang gir kun adgang til servicepersonale som bruker et spesielt verktøy, lås og nøkkel, eller en annen sikkerhetsanordning, og det kontrolleres av den autoriteten som er ansvarlig for området.

Aviso Esta unidade foi concebida para instalação em áreas de acesso restrito. Uma área de acesso restrito é uma área à qual apenas tem acesso o pessoal de serviço autorizado, que possui uma ferramenta, chave e fechadura especial, ou qualquer outra forma de segurança. Esta área é controlada pela autoridade responsável pelo local.

¡Atención! Esta unidad ha sido diseñada para instalarse en áreas de acceso restringido. Área de acceso restringido significa un área a la que solamente tiene acceso el personal de servicio mediante la utilización de una herramienta especial, cerradura con llave, o algún otro medio de seguridad, y que está bajo el control de la autoridad responsable del local.

Varning! Denna enhet är avsedd för installation i områden med begränsat tillträde. Ett område med begränsat tillträde får endast tillträdas av servicepersonal med ett speciellt verktyg, lås och nyckel, eller annan säkerhetsanordning, och kontrolleras av den auktoritet som ansvarar för området.

Ramp Warning



WARNING: When installing the device, do not use a ramp inclined at more than 10 degrees.

Waarschuwing Gebruik een oprijplaat niet onder een hoek van meer dan 10 graden.

Varoitus Älä käytä sellaista kaltevaa pintaa, jonka kaltevuus ylittää 10 astetta.

Avertissement Ne pas utiliser une rampe dont l'inclinaison est supérieure à 10 degrés.

Warnung Keine Rampen mit einer Neigung von mehr als 10 Grad verwenden.

Avvertenza Non usare una rampa con pendenza superiore a 10 gradi.

Advarsel Bruk aldri en rampe som heller mer enn 10 grader.

Aviso Não utilize uma rampa com uma inclinação superior a 10 graus.

¡Atención! No usar una rampa inclinada más de 10 grados

Varning! Använd inte ramp med en lutning på mer än 10 grader.

Rack-Mounting and Cabinet-Mounting Warnings

Ensure that the rack or cabinet in which the device is installed is evenly and securely supported. Uneven mechanical loading could lead to a hazardous condition.



WARNING: To prevent bodily injury when mounting or servicing the device in a rack, take the following precautions to ensure that the system remains stable. The following directives help maintain your safety:

- The device must be installed in a rack that is secured to the building structure.
- The device should be mounted at the bottom of the rack if it is the only unit in the rack.
- When mounting the device on a partially filled rack, load the rack from the bottom to the top with the heaviest component at the bottom of the rack.
- If the rack is provided with stabilizing equipment, install the stabilizers before mounting or servicing the device in the rack.

Waarschuwing Om lichamelijk letsel te voorkomen wanneer u dit toestel in een rek monteert of het daar een servicebeurt geeft, moet u speciale voorzorgsmaatregelen nemen om ervoor te zorgen dat het toestel stabiel blijft. De onderstaande richtlijnen worden verstrekt om uw veiligheid te verzekeren:

- De Juniper Networks switch moet in een stellage worden geïnstalleerd die aan een bouwsel is verankerd.
- Dit toestel dient onderaan in het rek gemonteerd te worden als het toestel het enige in het rek is.
- Wanneer u dit toestel in een gedeeltelijk gevuld rek monteert, dient u het rek van onderen naar boven te laden met het zwaarste onderdeel onderaan in het rek.
- Als het rek voorzien is van stabiliseringshulpmiddelen, dient u de stabilisatoren te monteren voordat u het toestel in het rek monteert of het daar een servicebeurt geeft.

Varoitus Kun laite asetetaan telineeseen tai huolletaan sen ollessa telineessä, on noudatettava erityisiä varotoimia järjestelmän vakavuuden säilyttämiseksi, jotta vältetään loukkaantumiselta. Noudata seuraavia turvallisuusohjeita:

- Juniper Networks switch on asennettava telineeseen, joka on kiinnitetty rakennukseen.
- Jos telineessä ei ole muita laitteita, aseta laite telineen alaosaan.
- Jos laite asetetaan osaksi täytettyyn telineeseen, aloita kuormittaminen sen alaosasta kaikkein raskaimmalla esineellä ja siirry sitten sen yläosaan.
- Jos telinettä varten on vakaimet, asenna ne ennen laitteen asettamista telineeseen tai sen huoltamista siinä.

Avertissement Pour éviter toute blessure corporelle pendant les opérations de montage ou de réparation de cette unité en casier, il convient de prendre des précautions spéciales afin de maintenir la stabilité du système. Les directives ci-dessous sont destinées à assurer la protection du personnel:

- Le rack sur lequel est monté le Juniper Networks switch doit être fixé à la structure du bâtiment.
- Si cette unité constitue la seule unité montée en casier, elle doit être placée dans le bas.
- Si cette unité est montée dans un casier partiellement rempli, charger le casier de bas en haut en plaçant l'élément le plus lourd dans le bas.
- Si le casier est équipé de dispositifs stabilisateurs, installer les stabilisateurs avant de monter ou de réparer l'unité en casier.

Warnung Zur Vermeidung von Körperverletzung beim Anbringen oder Warten dieser Einheit in einem Gestell müssen Sie besondere Vorkehrungen treffen, um sicherzustellen, daß das System stabil bleibt. Die folgenden Richtlinien sollen zur Gewährleistung Ihrer Sicherheit dienen:

- Der Juniper Networks switch muß in einem Gestell installiert werden, das in der Gebäudestruktur verankert ist.
- Wenn diese Einheit die einzige im Gestell ist, sollte sie unten im Gestell angebracht werden.
- Bei Anbringung dieser Einheit in einem zum Teil gefüllten Gestell ist das Gestell von unten nach oben zu laden, wobei das schwerste Bauteil unten im Gestell anzubringen ist.
- Wird das Gestell mit Stabilisierungszubehör geliefert, sind zuerst die Stabilisatoren zu installieren, bevor Sie die Einheit im Gestell anbringen oder sie warten.

Avvertenza Per evitare infortuni fisici durante il montaggio o la manutenzione di questa unità in un supporto, occorre osservare speciali precauzioni per garantire che il sistema rimanga stabile. Le seguenti direttive vengono fornite per garantire la sicurezza personale:

- Il Juniper Networks switch deve essere installato in un telaio, il quale deve essere fissato alla struttura dell'edificio.
- Questa unità deve venire montata sul fondo del supporto, se si tratta dell'unica unità da montare nel supporto.
- Quando questa unità viene montata in un supporto parzialmente pieno, caricare il supporto dal basso all'alto, con il componente più pesante sistemato sul fondo del supporto.
- Se il supporto è dotato di dispositivi stabilizzanti, installare tali dispositivi prima di montare o di procedere alla manutenzione dell'unità nel supporto.

Advarsel Unngå fysiske skader under montering eller reparasjonsarbeid på denne enheten når den befinner seg i et kabinett. Vær nøye med at systemet er stabilt. Følgende retningslinjer er gitt for å verne om sikkerheten:

- Juniper Networks switch må installeres i et stativ som er forankret til bygningsstrukturen.
- Denne enheten bør monteres nederst i kabinettet hvis dette er den eneste enheten i kabinettet.
- Ved montering av denne enheten i et kabinett som er delvis fylt, skal kabinettet lastes fra bunnen og opp med den tyngste komponenten nederst i kabinettet.
- Hvis kabinettet er utstyrt med stabiliseringsutstyr, skal stabilisatorene installeres før montering eller utføring av reparasjonsarbeid på enheten i kabinettet.

Aviso Para se prevenir contra danos corporais ao montar ou reparar esta unidade numa estante, deverá tomar precauções especiais para se certificar de que o sistema possui um suporte estável. As seguintes directrizes ajudá-lo-ão a efectuar o seu trabalho com segurança:

- O Juniper Networks switch deverá ser instalado numa prateleira fixa à estrutura do edifício.
- Esta unidade deverá ser montada na parte inferior da estante, caso seja esta a única unidade a ser montada.
- Ao montar esta unidade numa estante parcialmente ocupada, coloque os itens mais pesados na parte inferior da estante, arrumando-os de baixo para cima.
- Se a estante possuir um dispositivo de estabilização, instale-o antes de montar ou reparar a unidade.

¡Atención! Para evitar lesiones durante el montaje de este equipo sobre un bastidor, oerriormente durante su mantenimiento, se debe poner mucho cuidado en que el sistema quede bien estable. Para garantizar su seguridad, proceda según las siguientes instrucciones:

- El Juniper Networks switch debe instalarse en un bastidor fijado a la estructura del edificio.
- Colocar el equipo en la parte inferior del bastidor, cuando sea la única unidad en el mismo.
- Cuando este equipo se vaya a instalar en un bastidor parcialmente ocupado, comenzar la instalación desde la parte inferior hacia la superior colocando el equipo más pesado en la parte inferior.
- Si el bastidor dispone de dispositivos estabilizadores, instalar éstos antes de montar o proceder al mantenimiento del equipo instalado en el bastidor.

Warning! För att undvika kroppsskada när du installerar eller utför underhållsarbete på denna enhet på en ställning måste du vidta särskilda försiktighetsåtgärder för att försäkra dig om att systemet står stadigt. Följande riktlinjer ges för att trygga din säkerhet:

- Juniper Networks switch måste installeras i en ställning som är förankrad i byggnadens struktur.
- Om denna enhet är den enda enheten på ställningen skall den installeras längst ned på ställningen.
- Om denna enhet installeras på en delvis fylld ställning skall ställningen fyllas nedifrån och upp, med de tyngsta enheterna längst ned på ställningen.
- Om ställningen är försedd med stabiliseringsdon skall dessa monteras fast innan enheten installeras eller underhålls på ställningen.

Grounded Equipment Warning



WARNING: This device must be properly grounded at all times. Follow the instructions in this guide to properly ground the device to earth.

Waarschuwing Dit apparaat moet altijd goed geaard zijn. Volg de instructies in deze gids om het apparaat goed te aarden.

Varoitus Laitteen on oltava pysyvästi maadoitettu. Maadoita laite asianmukaisesti noudattamalla tämän oppaan ohjeita.

Avertissement L'appareil doit être correctement mis à la terre à tout moment. Suivez les instructions de ce guide pour correctement mettre l'appareil à la terre.

Warnung Das Gerät muss immer ordnungsgemäß geerdet sein. Befolgen Sie die Anweisungen in dieser Anleitung, um das Gerät ordnungsgemäß zu erden.

Avvertenza Questo dispositivo deve sempre disporre di una connessione a massa. Seguire le istruzioni indicate in questa guida per connettere correttamente il dispositivo a massa.

Advarsel Denne enheten på jordes skikkelig hele tiden. Følg instruksjonene i denne veiledningen for å jorde enheten.

Aviso Este equipamento deverá estar ligado à terra. Siga las instrucciones en esta guía para conectar correctamente este dispositivo a tierra.

¡Atención! Este dispositivo debe estar correctamente conectado a tierra en todo momento. Siga las instrucciones en esta guía para conectar correctamente este dispositivo a tierra.

Warning! Den här enheten måste vara ordentligt jordad. Följ instruktionerna i den här guiden för att jorda enheten ordentligt.

Radiation from Open Port Apertures Warning



WARNING: Because invisible radiation might be emitted from the aperture of the port when no fiber cable is connected, avoid exposure to radiation and do not stare into open apertures.

Waarschuwing Aangezien onzichtbare straling vanuit de opening van de poort kan komen als er geen fiberkabel aangesloten is, dient blootstelling aan straling en het kijken in open openingen vermeden te worden.

Varoitus Koska portin aukosta voi emittoitua näkymätöntä säteilyä, kun kuitukaapelia ei ole kytkettynä, vältä säteilylle altistumista äläkä katso avoimiin aukkoihin.

Avertissement Des radiations invisibles à l'il nu pouvant traverser l'ouverture du port lorsqu'aucun câble en fibre optique n'y est connecté, il est recommandé de ne pas regarder fixement l'intérieur de ces ouvertures.

Warnung Aus der Port-Öffnung können unsichtbare Strahlen emittieren, wenn kein Glasfaserkabel angeschlossen ist. Vermeiden Sie es, sich den Strahlungen auszusetzen, und starren Sie nicht in die Öffnungen!

Avvertenza Quando i cavi in fibra non sono inseriti, radiazioni invisibili possono essere emesse attraverso l'apertura della porta. Evitate di esporvi alle radiazioni e non guardate direttamente nelle aperture.

Advarsel Unngå utsettelse for stråling, og stirr ikke inn i åpninger som er åpne, fordi usynlig stråling kan emitteres fra portens åpning når det ikke er tilkoblet en fiberkabel.

Aviso Dada a possibilidade de emissão de radiação invisível através do orifício da via de acesso, quando esta não tiver nenhum cabo de fibra conectado, deverá evitar a exposição à radiação e não deverá olhar fixamente para orifícios que se encontrarem a descoberto.

¡Atención! Debido a que la apertura del puerto puede emitir radiación invisible cuando no existe un cable de fibra conectado, evite mirar directamente a las aperturas para no exponerse a la radiación.

Warning! Osynlig stråling kan avges från en portöppning utan ansluten fiberkabel och du bör därför undvika att bli utsatt för stråling genom att inte stirra in i oskyddade öppningar.

Laser and LED Safety Guidelines and Warnings

IN THIS SECTION

- [General Laser Safety Guidelines | 294](#)
- [Class 1 Laser Product Warning | 295](#)
- [Class 1 LED Product Warning | 296](#)
- [Laser Beam Warning | 297](#)

Juniper Networks devices are equipped with laser transmitters, which are considered a Class 1 Laser Product by the U.S. Food and Drug Administration and are evaluated as a Class 1 Laser Product per EN 60825-1 requirements.

Observe the following guidelines and warnings:

General Laser Safety Guidelines

When working around ports that support optical transceivers, observe the following safety guidelines to prevent eye injury:

- Do not look into unterminated ports or at fibers that connect to unknown sources.
- Do not examine unterminated optical ports with optical instruments.
- Avoid direct exposure to the beam.



WARNING: Unterminated optical connectors can emit invisible laser radiation. The lens in the human eye focuses all the laser power on the retina, so focusing the eye directly on a laser source—even a low-power laser—could permanently damage the eye.

Avertissement Les connecteurs à fibre optique sans terminaison peuvent émettre un rayonnement laser invisible. Le cristallin de l'œil humain faisant converger toute la puissance du laser sur la rétine, toute focalisation directe de l'œil sur une source laser, —même de faible puissance—, peut entraîner des lésions oculaires irréversibles.

Class 1 Laser Product Warning



WARNING: Class 1 laser product.

Waarschuwing Klasse-1 laser produkt.

Varoitus Luokan 1 lasertuote.

Avertissement Produit laser de classe I.

Warnung Laserprodukt der Klasse 1.

Avvertenza Prodotto laser di Classe 1.

Advarsel Laserprodukt av klasse 1.

Aviso Produto laser de classe 1.

¡Atención! Producto láser Clase I.

Varning! Laserprodukt av klass 1.

Class 1 LED Product Warning



WARNING: Class 1 LED product.

Waarschuwing Klasse 1 LED-product.

Varoitus Luokan 1 valodiodituote.

Avertissement Alarme de produit LED Class I.

Warnung Class 1 LED-Produktwarnung.

Avvertenza Avvertenza prodotto LED di Classe 1.

Advarsel LED-produkt i klasse 1.

Aviso Produto de classe 1 com LED.

¡Atención! Aviso sobre producto LED de Clase 1.

Varning! Lysdiodprodukt av klass 1.

Laser Beam Warning



WARNING: Do not stare into the laser beam or view it directly with optical instruments.

Waarschuwing Niet in de straal staren of hem rechtstreeks bekijken met optische instrumenten.

Varoitus Älä katso säteeseen äläkä tarkastele sitä suoraan optisen laitteen avulla.

Avertissement Ne pas fixer le faisceau des yeux, ni l'observer directement à l'aide d'instruments optiques.

Warnung Nicht direkt in den Strahl blicken und ihn nicht direkt mit optischen Geräten prüfen.

Avvertenza Non fissare il raggio con gli occhi né usare strumenti ottici per osservarlo direttamente.

Advarsel Stirr eller se ikke direkte p strlen med optiske instrumenter.

Aviso Não olhe fixamente para o raio, nem olhe para ele directamente com instrumentos ópticos.

¡Atención! No mirar fijamente el haz ni observarlo directamente con instrumentos ópticos.

Warning! Rikta inte blicken in mot strålen och titta inte direkt på den genom optiska instrument.

Maintenance and Operational Safety Guidelines and Warnings

IN THIS SECTION

- [Battery Handling Warning | 299](#)
- [Jewelry Removal Warning | 300](#)
- [Lightning Activity Warning | 302](#)

- Operating Temperature Warning | 303
- Product Disposal Warning | 305

While performing the maintenance activities for devices, observe the following guidelines and warnings:

Battery Handling Warning



WARNING: Replacing a battery incorrectly might result in an explosion. Replace a battery only with the same or equivalent type recommended by the manufacturer. Dispose of used batteries according to the manufacturer's instructions.

Waarschuwing Er is ontplofingsgevaar als de batterij verkeerd vervangen wordt. Vervang de batterij slechts met hetzelfde of een equivalent type dat door de fabrikant aanbevolen is. Gebruikte batterijen dienen overeenkomstig fabrieksvoorschriften weggeworpen te worden.

Varoitus Räjähdyksen vaara, jos akku on vaihdettu väärään akkuun. Käytä vaihtamiseen ainoastaan saman- tai vastaaventyypistä akkua, joka on valmistajan suosittelema. Hävitä käytetyt akut valmistajan ohjeiden mukaan.

Avertissement Danger d'explosion si la pile n'est pas remplacée correctement. Ne la remplacer que par une pile de type semblable ou équivalent, recommandée par le fabricant. Jeter les piles usagées conformément aux instructions du fabricant.

Warnung Bei Einsetzen einer falschen Batterie besteht Explosionsgefahr. Ersetzen Sie die Batterie nur durch den gleichen oder vom Hersteller empfohlenen Batterietyp. Entsorgen Sie die benutzten Batterien nach den Anweisungen des Herstellers.

Advarsel Det kan være fare for eksplosjon hvis batteriet skiftes på feil måte. Skift kun med samme eller tilsvarende type som er anbefalt av produsenten. Kasser brukte batterier i henhold til produsentens instruksjoner.

Avvertenza Pericolo di esplosione se la batteria non è installata correttamente. Sostituire solo con una di tipo uguale o equivalente, consigliata dal produttore. Eliminare le batterie usate secondo le istruzioni del produttore.

Aviso Existe perigo de explosão se a bateria for substituída incorrectamente. Substitua a bateria por uma bateria igual ou de um tipo equivalente recomendado pelo fabricante. Destrua as baterias usadas conforme as instruções do fabricante.

¡Atención! Existe peligro de explosión si la batería se reemplaza de manera incorrecta. Reemplazar la batería EXclusivamente con el mismo tipo o el equivalente recomendado por el fabricante. Desechar las baterías gastadas según las instrucciones del fabricante.

Warning! Explosionsfara vid felaktigt batteribyte. Ersätt endast batteriet med samma batterityp som rekommenderas av tillverkaren eller motsvarande. Följ tillverkarens anvisningar vid kassering av använda batterier.

Jewelry Removal Warning



WARNING: Before working on equipment that is connected to power lines, remove jewelry, including rings, necklaces, and watches. Metal objects heat up when connected to power and ground and can cause serious burns or can be welded to the terminals.

Waarschuwing Alvorens aan apparatuur te werken die met elektrische leidingen is verbonden, sieraden (inclusief ringen, kettingen en horloges) verwijderen. Metalen voorwerpen worden warm wanneer ze met stroom en aarde zijn verbonden, en kunnen ernstige brandwonden veroorzaken of het metalen voorwerp aan de aansluitklemmen lassen.

Varoitus Ennen kuin työskentelet voimavirtajohtoihin kytkettyjen laitteiden parissa, ota pois kaikki korut (sormukset, kaulakorut ja kellot mukaan lukien). Metalliesineet kuumentuvat, kun ne ovat yhteydessä sähkövirran ja maan kanssa, ja ne voivat aiheuttaa vakavia palovammoja tai hitsata metalliesineet kiinni liitännänpoihin.

Avertissement Avant d'accéder à cet équipement connecté aux lignes électriques, ôter tout bijou (anneaux, colliers et montres compris). Lorsqu'ils sont branchés à l'alimentation et reliés à la terre, les objets métalliques chauffent, ce qui peut provoquer des blessures graves ou souder l'objet métallique aux bornes.

Warnung Vor der Arbeit an Geräten, die an das Netz angeschlossen sind, jeglichen Schmuck (einschließlich Ringe, Ketten und Uhren) abnehmen. Metallgegenstände erhitzen sich, wenn sie an das Netz und die Erde angeschlossen werden, und können schwere Verbrennungen verursachen oder an die Anschlußklemmen angeschweißt werden.

Avvertenza Prima di intervenire su apparecchiature collegate alle linee di alimentazione, togliersi qualsiasi monile (inclusi anelli, collane, braccialetti ed orologi). Gli oggetti metallici si riscaldano quando sono collegati tra punti di alimentazione e massa: possono causare ustioni gravi oppure il metallo può saldarsi ai terminali.

Advarsel Fjern alle smykker (inkludert ringer, halskjeder og klokker) før du skal arbeide på utstyr som er koblet til kraftledninger. Metallgjenstander som er koblet til kraftledninger og jord blir svært varme og kan forårsake alvorlige brannskader eller smelte fast til polene.

Aviso Antes de trabalhar em equipamento que esteja ligado a linhas de corrente, retire todas as jóias que estiver a usar (incluindo anéis, fios e relógios). Os objectos metálicos aquecerão em contacto com a corrente e em contacto com a ligação à terra, podendo causar queimaduras graves ou ficarem soldados aos terminais.

¡Atención! Antes de operar sobre equipos conectados a líneas de alimentación, quitarse las joyas (incluidos anillos, collares y relojes). Los objetos de metal se calientan cuando

se conectan a la alimentación y a tierra, lo que puede ocasionar quemaduras graves o que los objetos metálicos queden soldados a los bornes.

Warning! Tag av alla smycken (inklusive ringar, halsband och armbandsur) innan du arbetar på utrustning som är kopplad till kraftledning. Metallobjekt hettas upp när de kopplas ihop med ström och jord och kan förorsaka allvarliga brännskador; metallobjekt kan också sammansvetsas med kontakterna.

Lightning Activity Warning



WARNING: Do not work on the system or connect or disconnect cables during periods of lightning activity.

Waarschuwing Tijdens onweer dat gepaard gaat met bliksem, dient u niet aan het systeem te werken of kabels aan te sluiten of te ontkoppelen.

Varoitus Älä työskentele järjestelmän parissa äläkä yhdistä tai irrota kaapeleita ukkosilmalla.

Avertissement Ne pas travailler sur le système ni brancher ou débrancher les câbles pendant un orage.

Warnung Arbeiten Sie nicht am System und schließen Sie keine Kabel an bzw. trennen Sie keine ab, wenn es gewittert.

Avvertenza Non lavorare sul sistema o collegare oppure scollegare i cavi durante un temporale con fulmini.

Advarsel Utfør aldri arbeid på systemet, eller koble kabler til eller fra systemet når det tordner eller lyner.

Aviso Não trabalhe no sistema ou ligue e desligue cabos durante períodos de mau tempo (trovoada).

¡Atención! No operar el sistema ni conectar o desconectar cables durante el transcurso de descargas eléctricas en la atmósfera.

Warning! Vid åska skall du aldrig utföra arbete på systemet eller ansluta eller koppla loss kablar.

Operating Temperature Warning



WARNING: To prevent the device from overheating, do not operate it in an area that exceeds the maximum recommended ambient temperature. To prevent airflow restriction, allow at least 6 in. (15.2 cm) of clearance around the ventilation openings.

Waarschuwing Om te voorkomen dat welke switch van de Juniper Networks router dan ook oververhit raakt, dient u deze niet te bedienen op een plaats waar de maximale aanbevolen omgevingstemperatuur van 40° C wordt overschreden. Om te voorkomen dat de luchtstroom wordt beperkt, dient er minstens 15,2 cm speling rond de ventilatie-openingen te zijn.

Varoitus Ettei Juniper Networks switch-sarjan reititin ylikuumentuusi, sitä ei saa käyttää tilassa, jonka lämpötila ylittää korkeimman suositellun ympäristölämpötilan 40° C. Ettei ilmanvaihto estyisi, tuuletusaukkojen ympärille on jätettävä ainakin 15,2 cm tilaa.

Avertissement Pour éviter toute surchauffe des routeurs de la gamme Juniper Networks switch, ne l'utilisez pas dans une zone où la température ambiante est supérieure à 40° C. Pour permettre un flot d'air constant, dégagez un espace d'au moins 15,2 cm autour des ouvertures de ventilations.

Warnung Um einen Router der switch vor Überhitzung zu schützen, darf dieser nicht in einer Gegend betrieben werden, in der die Umgebungstemperatur das empfohlene Maximum von 40° C überschreitet. Um Lüftungsverschluß zu verhindern, achten Sie darauf, daß mindestens 15,2 cm lichter Raum um die Lüftungsöffnungen herum frei bleibt.

Avvertenza Per evitare il surriscaldamento dei switch, non adoperateli in un locale che ecceda la temperatura ambientale massima di 40° C. Per evitare che la circolazione dell'aria sia impedita, lasciate uno spazio di almeno 15.2 cm di fronte alle aperture delle ventole.

Advarsel Unngå overoppheting av eventuelle rutere i Juniper Networks switch Disse skal ikke brukes på steder der den anbefalte maksimale omgivelsestemperaturen overstiger 40° C (104° F). Sørg for at klaringen rundt lufteåpningene er minst 15,2 cm (6 tommer) for å forhindre nedsatt luftsirkulasjon.

Aviso Para evitar o sobreaquecimento do encaminhador Juniper Networks switch, não utilize este equipamento numa área que exceda a temperatura máxima recomendada de 40° C. Para evitar a restrição à circulação de ar, deixe pelo menos um espaço de 15,2 cm à volta das aberturas de ventilação.

¡Atención! Para impedir que un encaminhador de la serie Juniper Networks switch se recaliente, no lo haga funcionar en un área en la que se supere la temperatura ambiente máxima recomendada de 40° C. Para impedir la restricción de la entrada de aire, deje un espacio mínimo de 15,2 cm alrededor de las aberturas para ventilación.

Warning! Förhindra att en Juniper Networks switch överhettas genom att inte använda den i ett område där den maximalt rekommenderade omgivningstemperaturen på 40° C överskrids. Förhindra att luftcirkulationen inskränks genom att se till att det finns fritt utrymme på minst 15,2 cm omkring ventilationsöppningarna.

Product Disposal Warning



WARNING: Disposal of this device must be handled according to all national laws and regulations.

Waarschuwing Dit produkt dient volgens alle landelijke wetten en voorschriften te worden afgedankt.

Varoitus Tämän tuotteen lopullisesta hävittämisestä tulee huolehtia kaikkia valtakunnallisia lakeja ja säännöksiä noudattaen.

Avertissement La mise au rebut définitive de ce produit doit être effectuée conformément à toutes les lois et réglementations en vigueur.

Warnung Dieses Produkt muß den geltenden Gesetzen und Vorschriften entsprechend entsorgt werden.

Avvertenza L'eliminazione finale di questo prodotto deve essere eseguita osservando le normative italiane vigenti in materia

Advarsel Endelig disponering av dette produktet må skje i henhold til nasjonale lover og forskrifter.

Aviso A descartagem final deste produto deverá ser efectuada de acordo com os regulamentos e a legislação nacional.

¡Atención! El desecho final de este producto debe realizarse según todas las leyes y regulaciones nacionales

Warning! Slutlig kassering av denna produkt bör skötas i enlighet med landets alla lagar och föreskrifter.

General Electrical Safety Guidelines and Warnings



WARNING: Certain ports on the device are designed for use as intrabuilding (within-the-building) interfaces only (Type 2 or Type 4 ports as described in GR-1089-CORE) and require isolation from the exposed outside plant (OSP) cabling. To comply with NEBS requirements and protect against lightning surges and commercial power disturbances, the intrabuilding ports *must not* be metallicity connected to interfaces that connect to the OSP or its wiring. The intrabuilding ports on the device are suitable for connection to intrabuilding or unexposed wiring or cabling only. The addition of primary protectors is not sufficient protection for connecting these interfaces metallicity to OSP wiring.

Avertissement Certains ports de l'appareil sont destinés à un usage en intérieur uniquement (ports Type 2 ou Type 4 tels que décrits dans le document GR-1089-CORE) et doivent être isolés du câblage de l'installation extérieure exposée. Pour respecter les exigences NEBS et assurer une protection contre la foudre et les perturbations de tension secteur, les ports pour intérieur *ne doivent pas* être raccordés physiquement aux interfaces prévues pour la connexion à l'installation extérieure ou à son câblage. Les ports pour intérieur de l'appareil sont réservés au raccordement de câbles pour intérieur ou non exposés uniquement. L'ajout de protections ne constitue pas une précaution suffisante pour raccorder physiquement ces interfaces au câblage de l'installation extérieure.



CAUTION: Before removing or installing components of a device, connect an electrostatic discharge (ESD) grounding strap to an ESD point and wrap and fasten the other end of the strap around your bare wrist. Failure to use an ESD grounding strap could result in damage to the device.

Attention Avant de retirer ou d'installer des composants d'un appareil, raccordez un bracelet antistatique à un point de décharge électrostatique et fixez le bracelet à votre poignet nu. L'absence de port d'un bracelet antistatique pourrait provoquer des dégâts sur l'appareil.

- Install the device in compliance with the following local, national, and international electrical codes:
 - United States—National Fire Protection Association (NFPA 70), United States National Electrical Code.
 - Other countries—International Electromechanical Commission (IEC) 60364, Part 1 through Part 7.
 - Evaluated to the TN power system.

- Canada—Canadian Electrical Code, Part 1, CSA C22.1.
- Suitable for installation in Information Technology Rooms in accordance with Article 645 of the National Electrical Code and NFPA 75.

Peut être installé dans des salles de matériel de traitement de l'information conformément à l'article 645 du National Electrical Code et à la NFPA 75.

- Locate the emergency power-off switch for the room in which you are working so that if an electrical accident occurs, you can quickly turn off the power.
- Make sure that grounding surfaces are cleaned and brought to a bright finish before grounding connections are made.
- Do not work alone if potentially hazardous conditions exist anywhere in your workspace.
- Never assume that power is disconnected from a circuit. Always check the circuit before starting to work.
- Carefully look for possible hazards in your work area, such as moist floors, ungrounded power extension cords, and missing safety grounds.
- Operate the device within marked electrical ratings and product usage instructions.
- To ensure that the device and peripheral equipment function safely and correctly, use the cables and connectors specified for the attached peripheral equipment, and make certain they are in good condition.

You can remove and replace many device components without powering off or disconnecting power to the device, as detailed elsewhere in the hardware documentation for this device. Never install equipment that appears to be damaged.

Action to Take After an Electrical Accident

If an electrical accident results in an injury, take the following actions in this order:

1. Use caution. Be aware of potentially hazardous conditions that could cause further injury.
2. Disconnect power from the device.
3. If possible, send another person to get medical aid. Otherwise, assess the condition of the victim, then call for help.

Prevention of Electrostatic Discharge Damage

Device components that are shipped in antistatic bags are sensitive to damage from static electricity. Some components can be impaired by voltages as low as 30 V. You can easily generate potentially damaging static voltages whenever you handle plastic or foam packing material or if you move components across plastic or carpets. Observe the following guidelines to minimize the potential for electrostatic discharge (ESD) damage, which can cause intermittent or complete component failures:

- Always use an ESD wrist strap when you are handling components that are subject to ESD damage, and make sure that it is in direct contact with your skin.

If a grounding strap is not available, hold the component in its antistatic bag (see [Figure 93 on page 309](#)) in one hand and touch the exposed, bare metal of the device with the other hand immediately before inserting the component into the device.



WARNING: For safety, periodically check the resistance value of the ESD grounding strap. The measurement must be in the range 1 through 10 Mohms.

Avertissement Par mesure de sécurité, vérifiez régulièrement la résistance du bracelet antistatique. Cette valeur doit être comprise entre 1 et 10 mégohms (Mohms).

- When handling any component that is subject to ESD damage and that is removed from the device, make sure the equipment end of your ESD wrist strap is attached to the ESD point on the chassis.

If no grounding strap is available, touch the exposed, bare metal of the device to ground yourself before handling the component.

- Avoid contact between the component that is subject to ESD damage and your clothing. ESD voltages emitted from clothing can damage components.
- When removing or installing a component that is subject to ESD damage, always place it component-side up on an antistatic surface, in an antistatic card rack, or in an antistatic bag (see [Figure 93 on page 309](#)). If you are returning a component, place it in an antistatic bag before packing it.

Figure 93: Placing a Component into an Antistatic Bag

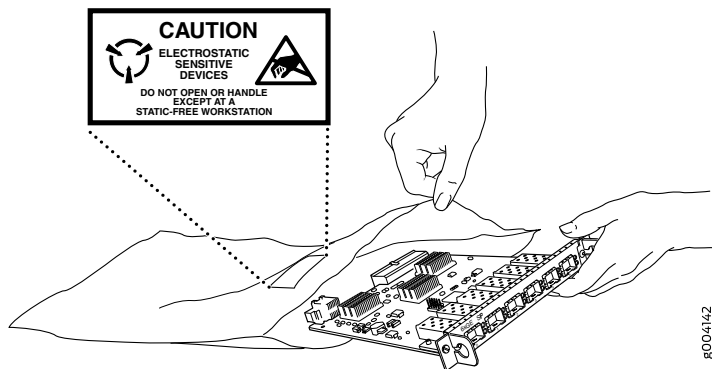

CAUTION: ANSI/TIA/EIA-568 cables such as Category 5e and Category 6 can get electrostatically charged. To dissipate this charge, always ground the cables to a suitable and safe earth ground before connecting them to the system.

Attention Les câbles ANSI/TIA/EIA-568, par exemple Cat 5e et Cat 6, peuvent emmagasiner des charges électrostatiques. Pour évacuer ces charges, reliez toujours les câbles à une prise de terre adaptée avant de les raccorder au système.

AC Power Electrical Safety Guidelines

The following electrical safety guidelines apply to AC-powered devices:

- Note the following warnings printed on the device:

“CAUTION: THIS UNIT HAS MORE THAN ONE POWER SUPPLY CORD. DISCONNECT ALL POWER SUPPLY CORDS BEFORE SERVICING TO AVOID ELECTRIC SHOCK.”

“ATTENTION: CET APPAREIL COMPORTE PLUS D'UN CORDON D'ALIMENTATION. AFIN DE PRÉVENIR LES CHOCS ÉLECTRIQUES, DÉBRANCHER TOUT CORDON D'ALIMENTATION AVANT DE FAIRE LE DÉPANNAGE.”

- AC-powered devices are shipped with a three-wire electrical cord with a grounding-type plug that fits only a grounding-type power outlet. Do not circumvent this safety feature. Equipment grounding must comply with local and national electrical codes.
- You must provide an external certified circuit breaker (2-pole circuit breaker or 4-pole circuit breaker based on your device) rated minimum 20 A in the building installation.

- The power cord serves as the main disconnecting device for the AC-powered device. The socket outlet must be near the AC-powered device and be easily accessible.
- For devices that have more than one power supply connection, you must ensure that all power connections are fully disconnected so that power to the device is completely removed to prevent electric shock. To disconnect power, unplug all power cords (one for each power supply).

Power Cable Warning (Japanese)

WARNING: The attached power cable is only for this product. Do not use the cable for another product.

注意

附属の電源コードセットはこの製品専用です。
他の電気機器には使用しないでください。

9017253

AC Power Disconnection Warning



WARNING: Before working on the device or near power supplies, unplug all the power cords from an AC-powered device.

Waarschuwing Voordat u aan een frame of in de nabijheid van voedingen werkt, dient u bij wisselstroom toestellen de stekker van het netsnoer uit het stopcontact te halen.

Varoitus Kytke irti vaihtovirtalaitteiden virtajohto, ennen kuin teet mitään asennuspohjalle tai työskentelet virtalähteiden läheisyydessä.

Avertissement Avant de travailler sur un châssis ou à proximité d'une alimentation électrique, débrancher le cordon d'alimentation des unités en courant alternatif.

Warnung Bevor Sie an einem Chassis oder in der Nähe von Netzgeräten arbeiten, ziehen Sie bei Wechselstromeinheiten das Netzkabel ab bzw.

Avvertenza Prima di lavorare su un telaio o intorno ad alimentatori, scollegare il cavo di alimentazione sulle unità CA.

Advarsel Før det utføres arbeid på kabinettet eller det arbeides i nærheten av strømforsyningsenheter, skal strømledningen trekkes ut på vekselstrømsenheter.

Aviso Antes de trabalhar num chassis, ou antes de trabalhar perto de unidades de fornecimento de energia, desligue o cabo de alimentação nas unidades de corrente alternada.

¡Atención! Antes de manipular el chasis de un equipo o trabajar cerca de una fuente de alimentación, desenchufar el cable de alimentación en los equipos de corriente alterna (CA).

Warning! Innan du arbetar med ett chassi eller nära strömförsörjningsenheter skall du för växelströmsenheter dra ur nätsladden.

DC Power Electrical Safety Guidelines

- A DC-powered device is equipped with a DC terminal block that is rated for the power requirements of a maximally configured device.
- For permanently connected equipment, a readily accessible disconnect device shall be incorporated external to the equipment.
- For pluggable equipment, the socket-outlet shall be installed near the equipment and shall be easily accessible.
- Be sure to connect the ground wire or conduit to a solid central office earth ground.
- A closed loop ring is recommended for terminating the ground conductor at the ground stud.
- Run two wires from the circuit breaker box to a source of 48 VDC.
- A DC-powered device that is equipped with a DC terminal block is intended only for installation in a restricted-access location. In the United States, a restricted-access area is one in accordance with Articles 110-16, 110-17, and 110-18 of the National Electrical Code ANSI/NFPA 70.

NOTE: Primary overcurrent protection is provided by the building circuit breaker. This breaker must protect against excess currents, short circuits, and earth grounding faults in accordance with NEC ANSI/NFPA 70.

- Ensure that the polarity of the DC input wiring is correct. Under certain conditions, connections with reversed polarity might trip the primary circuit breaker or damage the equipment.
- The marked input voltage of -48 VDC for a DC-powered device is the nominal voltage associated with the battery circuit, and any higher voltages are only to be associated with float voltages for the charging function.
- Because the device is a positive ground system, you must connect the positive lead to the terminal labeled **RTN**, the negative lead to the terminal labeled -48 VDC, and the earth ground to the device grounding points.

DC Power Disconnection Warning



WARNING: Before performing any of the DC power procedures, ensure that power is removed from the DC circuit. To ensure that all power is off, locate the circuit breaker on the panel board that services the DC circuit, switch the circuit breaker to the OFF position, and tape the device handle of the circuit breaker in the OFF position.

Waarschuwing Voordat u een van de onderstaande procedures uitvoert, dient u te controleren of de stroom naar het gelijkstroom circuit uitgeschakeld is. Om u ervan te verzekeren dat alle stroom UIT is geschakeld, kiest u op het schakelbord de stroomverbreker die het gelijkstroom circuit bedient, draait de stroomverbreker naar de UIT positie en plakt de schakelaarhendel van de stroomverbreker met plakband in de UIT positie vast.

Varoitus Varmista, että tasavirtapiirissä ei ole virtaa ennen seuraavien toimenpiteiden suorittamista. Varmistaaksesi, että virta on KATKAISTU täysin, paikanna tasavirrasta huolehtivassa kojetaulussa sijaitseva suojakytkin, käännä suojakytkin KATKAISTU-asentoon ja teippaa suojakytkimen varsi niin, että se pysyy KATKAISTU-asennossa.

Avertissement Avant de pratiquer l'une quelconque des procédures ci-dessous, vérifier que le circuit en courant continu n'est plus sous tension. Pour en être sûr, localiser le disjoncteur situé sur le panneau de service du circuit en courant continu, placer le disjoncteur en position fermée (OFF) et, à l'aide d'un ruban adhésif, bloquer la poignée du disjoncteur en position OFF.

Warnung Vor Ausführung der folgenden Vorgänge ist sicherzustellen, daß die Gleichstromschaltung keinen Strom erhält. Um sicherzustellen, daß sämtlicher Strom abgestellt ist, machen Sie auf der Schalttafel den Unterbrecher für die Gleichstromschaltung ausfindig, stellen Sie den Unterbrecher auf AUS, und kleben Sie den Schaltergriff des Unterbrechers mit Klebeband in der AUS-Stellung fest.

Avvertenza Prima di svolgere una qualsiasi delle procedure seguenti, verificare che il circuito CC non sia alimentato. Per verificare che tutta l'alimentazione sia scollegata (OFF), individuare l'interruttore automatico sul quadro strumenti che alimenta il circuito CC, mettere l'interruttore in posizione OFF e fissarlo con nastro adesivo in tale posizione.

Advarsel Før noen av disse prosedyrene utføres, kontroller at strømmen er frakoblet likestrømkretsen. Sørg for at all strøm er slått AV. Dette gjøres ved å lokalisere strømbryteren på brytertavlen som betjener likestrømkretsen, slå strømbryteren AV og teipe bryterhåndtaket på strømbryteren i AV-stilling.

Aviso Antes de executar um dos seguintes procedimentos, certifique-se que desligou a fonte de alimentação de energia do circuito de corrente contínua. Para se assegurar

que toda a corrente foi DESLIGADA, localize o disjuntor no painel que serve o circuito de corrente contínua e coloque-o na posição OFF (Desligado), segurando nessa posição a manivela do interruptor do disjuntor com fita isoladora.

¡Atención! Antes de proceder con los siguientes pasos, comprobar que la alimentación del circuito de corriente continua (CC) esté cortada (OFF). Para asegurarse de que toda la alimentación esté cortada (OFF), localizar el interruptor automático en el panel que alimenta al circuito de corriente continua, cambiar el interruptor automático a la posición de Apagado (OFF), y sujetar con cinta la palanca del interruptor automático en posición de Apagado (OFF).

Warning! Innan du utför någon av följande procedurer måste du kontrollera att strömförsörjningen till likströmskretsen är bruten. Kontrollera att all strömförsörjning är BRUTEN genom att slå AV det överspänningsskydd som skyddar likströmskretsen och tejpa fast överspänningsskyddets omkopplare i FRÅN-läget.

DC Power Grounding Requirements and Warning

An insulated grounding conductor that is identical in size to the grounded and ungrounded branch circuit supply conductors but is identifiable by green and yellow stripes is installed as part of the branch circuit that supplies the device. The grounding conductor is a separately derived system at the supply transformer or motor generator set.



WARNING: When you install the device, the ground connection must always be made first and disconnected last.

Waarschuwing Bij de installatie van het toestel moet de aardverbinding altijd het eerste worden gemaakt en het laatste worden losgemaakt.

Varoitus Laitetta asennettaessa on maahan yhdistäminen aina tehtävä ensiksi ja maadoituksen irti kytkeminen viimeiseksi.

Avertissement Lors de l'installation de l'appareil, la mise à la terre doit toujours être connectée en premier et déconnectée en dernier.

Warnung Der Erdanschluß muß bei der Installation der Einheit immer zuerst hergestellt und zuletzt abgetrennt werden.

Avvertenza In fase di installazione dell'unità, eseguire sempre per primo il collegamento a massa e disconnetterlo per ultimo.

Advarsel Når enheten installeres, må jordledningen alltid tilkobles først og frakobles sist.

Aviso Ao instalar a unidade, a ligação à terra deverá ser sempre a primeira a ser ligada, e a última a ser desligada.

¡Atención! Al instalar el equipo, conectar la tierra la primera y desconectarla la última.

Warning! Vid installation av enheten måste jordledningen alltid anslutas först och kopplas bort sist.

DC Power Wiring Sequence Warning



WARNING: Wire the DC power supply using the appropriate lugs. When connecting power, the proper wiring sequence is ground to ground, +RTN to +RTN, then -48 V to -48 V. When disconnecting power, the proper wiring sequence is -48 V to -48 V, +RTN to +RTN, then ground to ground. Note that the ground wire must always be connected first and disconnected last.

Waarschuwing De juiste bedradingsvolgorde verbonden is aarde naar aarde, +RTN naar +RTN, en -48 V naar -48 V. De juiste bedradingsvolgorde losgemaakt is en -48 naar -48 V, +RTN naar +RTN, aarde naar aarde.

Varoitus Oikea yhdistettävä kytkentäjäjestys on maajohto maajohtoon, +RTN varten +RTN, -48 V varten -48 V. Oikea irrotettava kytkentäjäjestys on -48 V varten -48 V, +RTN varten +RTN, maajohto maajohtoon.

Avertissement Câblez l'alimentation d'alimentation CC En utilisant les crochets appropriés à l'extrémité de câblage. En reliant la puissance, l'ordre approprié de câblage est rectifié pour rectifier, +RTN à +RTN, puis -48 V à -48 V. En débranchant la puissance, l'ordre approprié de câblage est -48 V à -48 V, +RTN à +RTN, a alors rectifié pour rectifier. Notez que le fil de masse devrait toujours être relié d'abord et débranché pour la dernière fois. Notez que le fil de masse devrait toujours être relié d'abord et débranché pour la dernière fois.

Warnung Die Stromzufuhr ist nur mit geeigneten Ringösen an das DC Netzteil anzuschliessen. Die richtige Anschlusssequenz ist: Erdanschluss zu Erdanschluss, +RTN zu +RTN und dann -48V zu -48V. Die richtige Sequenz zum Abtrennen der Stromversorgung ist -48V zu -48V, +RTN zu +RTN und dann Erdanschluss zu Erdanschluss. Es ist zu beachten dass der Erdanschluss immer zuerst angeschlossen und als letztes abgetrennt wird.

Avvertenza Mostra la morsettiera dell alimentatore CC. Cablare l'alimentatore CC usando i connettori adatti all'estremità del cablaggio, come illustrato. La corretta sequenza di cablaggio è da massa a massa, da positivo a positivo (da linea ad L) e da negativo a negativo (da neutro a N). Tenere presente che il filo di massa deve sempre venire collegato per primo e scollegato per ultimo.

Advarsel Riktig tilkoples tilkoplingssekvens er jord til jord, +RTN til +RTN, -48 V til -48 V. Riktig frakoples tilkoplingssekvens er -48 V til -48 V, +RTN til +RTN, jord til jord.

Aviso Ate con alambre la fuente de potencia cc Usando los terminales apropiados en el extremo del cableado. Al conectar potencia, la secuencia apropiada del cableado se muele para moler, +RTN a +RTN, entonces -48 V a -48 V. Al desconectar potencia, la secuencia apropiada del cableado es -48 V a -48 V, +RTN a +RTN, entonces molió

para moler. Observe que el alambre de tierra se debe conectar siempre primero y desconectar por último. Observe que el alambre de tierra se debe conectar siempre primero y desconectar por último.

¡Atención! Wire a fonte de alimentação de DC Usando os talões apropriados nan EXTremidade da fiação. Ao conectar a potência, a seqüência apropriada da fiação é moída para moer, +RTN a +RTN, então -48 V a -48 V. Ao desconectar a potência, a seqüência apropriada da fiação é -48 V a -48 V, +RTN a +RTN, moeu então para moer. Anote que o fio à terra deve sempre ser conectado primeiramente e desconectado por último. Anote que o fio à terra deve sempre ser conectado primeiramente e desconectado por último.

Varning! Korrekt kopplingssekvens ar jord till jord, +RTN till +RTN, -48 V till -48 V. Korrekt kopplas kopplingssekvens ar -48 V till -48 V, +RTN till +RTN, jord till jord.

DC Power Wiring Terminations Warning



WARNING: When stranded wiring is required, use approved wiring terminations, such as closed-loop or spade-type with upturned lugs. These terminations must be the appropriate size for the wires and must clamp both the insulation and conductor.

Waarschuwing Wanneer geslagen bedrading vereist is, dient u bedrading te gebruiken die voorzien is van goedgekeurde aansluitingspunten, zoals het gesloten-lus type of het grijperschop type waarbij de aansluitpunten omhoog wijzen. Deze aansluitpunten dienen de juiste maat voor de draden te hebben en dienen zowel de isolatie als de geleider vast te klemmen.

Varoitus Jos säikeellinen johdin on tarpeen, käytä hyväksyttyä johdinliitääntä, esimerkiksi suljettua silmukkaa tai kourumaista liitääntä, jossa on ylöspäin käännetyt kiinnityskorvat. Tällaisten liitääntöjen tulee olla kooltaan johtimiin sopivia ja niiden tulee puristaa yhteen sekä eristeen että johdinosan.

Avertissement Quand des fils torsadés sont nécessaires, utiliser des douilles terminales homologuées telles que celles à circuit fermé ou du type à plage ouverte avec cosses rebroussées. Ces douilles terminales doivent être de la taille qui convient aux fils et doivent être refermées sur la gaine isolante et sur le conducteur.

Warnung Wenn Litzenverdrahtung erforderlich ist, sind zugelassene Verdrahtungsabschlüsse, z.B. für einen geschlossenen Regelkreis oder gabelförmig, mit nach oben gerichteten Kabelschuhen zu verwenden. Diese Abschlüsse sollten die angemessene Größe für die Drähte haben und sowohl die Isolierung als auch den Leiter festklemmen.

Avvertenza Quando occorre usare trecce, usare connettori omologati, come quelli a occhiello o a forcella con linguette rivolte verso l'alto. I connettori devono avere la misura adatta per il cablaggio e devono serrare sia l'isolante che il conduttore.

Advarsel Hvis det er nødvendig med flertrådede ledninger, brukes godkjente ledningsavslutninger, som for eksempel lukket sløyfe eller spadetype med oppoverbøyde kabelsko. Disse avslutningene skal ha riktig størrelse i forhold til ledningene, og skal klemme sammen både isolasjonen og lederen.

Aviso Quando forem requeridas montagens de instalação eléctrica de cabo torcido, use terminações de cabo aprovadas, tais como, terminações de cabo em circuito fechado e planas com terminais de orelha voltados para cima. Estas terminações de cabo deverão ser do tamanho apropriado para os respectivos cabos, e deverão prender simultaneamente o isolamento e o fio condutor.

¡Atención! Cuando se necesite hilo trenzado, utilizar terminales para cables homologados, tales como las de tipo "bucle cerrado" o "espada", con las lengüetas de

conexión vueltas hacia arriba. Estos terminales deberán ser del tamaño apropiado para los cables que se utilicen, y tendrán que sujetar tanto el aislante como el conductor.

Varning! När flertrådiga ledningar krävs måste godkända ledningskontakter användas, t.ex. kabelsko av sluten eller öppen typ med uppåtvänd tapp. Storleken på dessa kontakter måste vara avpassad till ledningarna och måste kunna hålla både isoleringen och ledaren fastklämda.

Multiple Power Supplies Disconnection Warning



WARNING: The network device has more than one power supply connection. All connections must be removed completely to remove power from the unit completely.

Waarschuwing Deze eenheid heeft meer dan één stroomtoevoerverbinding; alle verbindingen moeten volledig worden verwijderd om de stroom van deze eenheid volledig te verwijderen.

Varoitus Tässä laitteessa on useampia virtalähdekytkentöjä. Kaikki kytkennät on irrotettava kokonaan, jotta virta poistettaisiin täysin laitteesta.

Avertissement Cette unité est équipée de plusieurs raccordements d'alimentation. Pour supprimer tout courant électrique de l'unité, tous les cordons d'alimentation doivent être débranchés.

Warnung Diese Einheit verfügt über mehr als einen Stromanschluß; um Strom gänzlich von der Einheit fernzuhalten, müssen alle Stromzufuhren abgetrennt sein.

Avvertenza Questa unità ha più di una connessione per alimentatore elettrico; tutte le connessioni devono essere completamente rimosse per togliere l'elettricità dall'unità.

Advarsel Denne enheten har mer enn én strømtilkobling. Alle tilkoblinger må kobles helt fra for å eliminere strøm fra enheten.

Aviso Este dispositivo possui mais do que uma conexão de fonte de alimentação de energia; para poder remover a fonte de alimentação de energia, deverão ser desconectadas todas as conexões existentes.

¡Atención! Esta unidad tiene más de una conexión de suministros de alimentación; para eliminar la alimentación por completo, deben desconectarse completamente todas las conexiones.

Warning! Denna enhet har mer än en strömförsörjningsanslutning; alla anslutningar måste vara helt avlägsnade innan strömtillförseln till enheten är fullständigt bruten.

TN Power Warning



WARNING: The device is designed to work with a TN power system.

Waarschuwing Het apparaat is ontworpen om te functioneren met TN energiesystemen.

Varoitus Koje on suunniteltu toimimaan TN-sähkövoimajärjestelmien yhteydessä.

Avertissement Ce dispositif a été conçu pour fonctionner avec des systèmes d'alimentation TN.

Warnung Das Gerät ist für die Verwendung mit TN-Stromsystemen ausgelegt.

Avvertenza Il dispositivo è stato progettato per l'uso con sistemi di alimentazione TN.

Advarsel Utstyret er utfomet til bruk med TN-strømsystemer.

Aviso O dispositivo foi criado para operar com sistemas de corrente TN.

¡Atención! El equipo está diseñado para trabajar con sistemas de alimentación tipo TN.

Varning! Enheten är konstruerad för användning tillsammans med elkraftssystem av TN-typ.

Agency Approvals for EX Series Switches

This topic applies to hardware devices in the EX Series product family, which includes EX Series switches, the EX Series Redundant Power System (RPS), and the XRE200 External Routing Engine.

These hardware devices comply with the following standards:

- Safety
 - CAN/CSA-C22.2 No. 60950-1 Information Technology Equipment
 - UL 60950-1 Information Technology Equipment
 - EN 60950-1 Information Technology Equipment
 - IEC 60950-1 Information Technology Equipment
 - EN 60825-1 Safety of Laser Products - Part 1: Equipment classification and requirements

- EMC
 - FCC 47CFR Part 15 Class A (USA)
 - EN 55022 Class A Emissions (Europe)
 - ICES-003 Class A
 - VCCI Class A (Japan)
 - AS/NZS CISPR 22 Class A (Australia/New Zealand)
 - CISPR 22 Class A
 - EN 55024
 - EN 300386
 - EN 61000-3-2 Power Line Harmonics
 - EN 61000-3-3 Voltage Fluctuations and Flicker
 - EN 61000-4-2 ESD
 - EN 61000-4-3 Radiated Immunity
 - EN 61000-4-4 EFT
 - EN 61000-4-5 Surge
 - EN 61000-4-6 Low Frequency Common Immunity
 - EN 61000-4-11 Voltage Dips and Sags

Compliance Statements for EMC Requirements for EX Series Switches

IN THIS SECTION

- [Canada | 326](#)
- [Taiwan | 327](#)
- [European Community | 327](#)
- [Israel | 327](#)
- [Japan | 327](#)
- [Korea | 328](#)

- United States | 328
- FCC Part 15 Statement | 328
- Nonregulatory Environmental Standards | 329

This topic applies to hardware devices in the EX Series product family, which includes EX Series switches, the EX Series Redundant Power System (RPS), and the XRE200 External Routing Engine.

This topic describes the EMC requirements for these hardware devices.

Canada

This Class A digital apparatus complies with Canadian ICES-003.

Cet appareil numérique de la classe A est conforme à la norme NMB-003 du Canada.

The Industry Canada label identifies certified equipment. This certification means that the equipment meets certain telecommunications network protective, operational, and safety requirements. Industry Canada does not guarantee the equipment will operate to the users' satisfaction.

Before installing this equipment, users should ensure that it is permissible to connect the equipment to the facilities of the local telecommunications company. The equipment must also be installed using an acceptable method of connection. In some cases, the inside wiring associated with a single line individual service can be extended by means of a certified connector assembly. The customer should be aware that compliance with the above conditions might not prevent degradation of service in some situations.

Repairs to certified equipment should be made by an authorized Canadian maintenance facility designated by the supplier. Any repairs or alterations made by the user to this equipment, or equipment malfunctions, might give the telecommunications company cause to request the user to disconnect the equipment.



CAUTION: Users should not attempt to make electrical ground connections by themselves, but should contact the appropriate inspection authority or an electrician, as appropriate.

Users should ensure for their own protection that the electrical ground connections of the power utility, telephone lines, and internal metallic water pipe system, if present, are connected together. This precaution might be particularly important in rural areas.

Taiwan

此為甲類資訊技術設備。於一般家居環境使用時，本設備可能導致射頻干擾，用戶請採取相應措施。

The preceding translates as follows:

This is a Class A device. In a domestic environment, this device might cause radio interference, in which case the user needs to take adequate measures.

European Community

This is a Class A device. In a domestic environment this device might cause radio interference, in which case the user needs to take adequate measures.

Israel

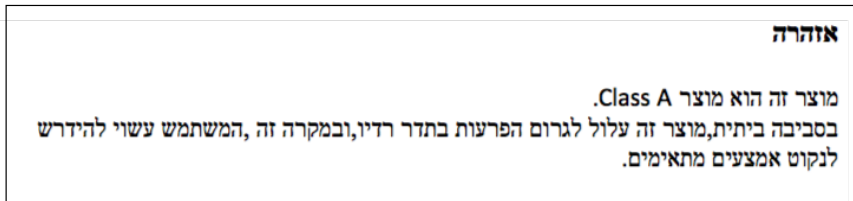

The preceding translates as follows:

Warning: This product is Class A. In residential environments, the product may cause radio interference, and in such a situation, the user may be required to take adequate measures.

Japan

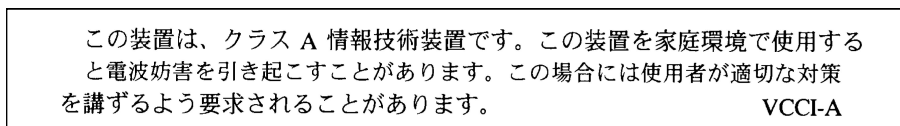

The preceding translates as follows:

This is a Class A device. In a domestic environment this device might cause radio interference, in which case the user needs to take adequate measures.

VCCI-A

Korea

이 기기는 업무용(A급) 전자파적합기기로서 판매자 또는 사용자는 이 점을 주의하시기 바라며, 가정외의 지역에서 사용하는 것을 목적으로 합니다.

Korean Class A Warning 9040913

The preceding translates as follows:

This equipment is Industrial (Class A) electromagnetic wave suitability equipment and seller or user should take notice of it, and this equipment is to be used in the places except for home

United States

The device has been tested and found to comply with the limits for a Class A digital device, pursuant to Part 15 of the FCC Rules. These limits are designed to provide reasonable protection against harmful interference when the equipment is operated in a commercial environment. This equipment generates, uses, and can radiate radio frequency energy and, if not installed and used in accordance with the instruction manual, might cause harmful interference to radio communications. Operation of this equipment in a residential area is likely to cause harmful interference, in which case users need to correct the interference at their own expense.

FCC Part 15 Statement

This equipment has been tested and found to comply with the limits for a Class A digital device pursuant to Part 15 of the FCC Rules. These limits are designed to provide reasonable protection against harmful interference in a residential installation. This equipment generates, uses, and can radiate radio frequency energy and, if not installed and used in accordance with the instructions, might cause harmful interference to radio communications. However, there is no guarantee that interference will not occur in a particular installation.

If this equipment does cause harmful interference to radio or television reception, which can be determined by turning the equipment off and on, the user is encouraged to try and correct the interference by one or more of the following measures:

- Reorient or relocate the receiving antenna.
- Increase the separation between the equipment and the receiver.
- Connect the equipment into an outlet on a circuit different from that to which the receiver is connected.
- Consult the dealer or an experienced radio or TV technician for help.

Nonregulatory Environmental Standards

NEBS compliance—These EX Series switches are Network Equipment Building System (NEBS) compliant:

- EX2200-24T and EX2200-48T
- EX3200-24T, EX3200-48T
- EX3300-24T, EX3300-48T
- EX4200-24T, EX4200-24F, EX4200-24F-S, EX4200-48T and EX4200-48T-S
- EX4300-24T, EX4300-24T-S, EX4300-24P, EX4300-24P-S, EX4300-32F, EX4300-32F-S, EX4300-48T, EX4300-48T-AFI, EX4300-48T-S, EX4300-48P, and EX4300-48P-S
- All EX4500 switches with AC power supplies
- EX4550-32T-AFO, EX4550-32T-AFI, EX4550-32F-AFO, EX4550-32F-AFI, and EX4550-32F-S
- EX4600-40F and EX4600-40F-S
- All EX6200 switches

NOTE: For the EX6200-48P line cards, the intrabuilding ports must use shielded intrabuilding cabling or wiring that is grounded at both ends.

- All EX8200 switches
- EX9251
- EX9253

These switches meet the following NEBS compliance standards:

- SR-3580 NEBS Criteria Levels (Level 4 Compliance)
- GR-1089-CORE: EMC and Electrical Safety for Network Telecommunications Equipment

- GR-63-CORE: NEBS, Physical Protection
 - The equipment is suitable for installation as part of the Common Bonding Network (CBN).
 - The equipment is suitable for installation in locations where the National Electrical Code (NEC) applies.
 - The battery return connection is to be treated as an Isolated DC return (DC-I), as defined in GR-1089-CORE.
 - You must provision a readily accessible device outside of the equipment to disconnect power. The device must also be rated based on local electrical code practice.

Compliance Statements for Acoustic Noise for EX Series Switches

This topic applies to hardware devices in the EX Series product family, which includes EX Series switches, the EX Series Redundant Power System (RPS), and the XRE200 External Routing Engine.

Maschinenlärminformations-Verordnung - 3. GPSGV, der höchste Schalldruckpegel beträgt 70 dB(A) oder weniger gemäss EN ISO 7779

Translation: The emitted sound pressure is below 70 dB(A) per EN ISO 7779.

Statements of Volatility for Juniper Network Devices

A *statement of volatility (SoV)*—sometimes known as *letter of volatility (LoV)*—identifies the volatile and non-volatile storage components in Juniper Networks devices, and describes how to remove non-volatile storage components from the device.

NOTE: Individual FRUs do not have separate SoV or LoV documents. They are covered in the SoV or LoV of the Juniper Networks device in which they are installed.

NOTE: Statements of volatility are not available for all Juniper Networks devices.

CTP Series:

- CTP150
- CTP2000

EX Series:

- EX2200 and EX2200-C
- EX2300-24P, EX2300-24T, and EX2300-24T-DC
- EX2300-48P and EX2300-48T
- EX2300-C
- EX3300
- EX3400-24P, EX3400-24T, EX3400-24T-DC
- EX3400-48P, EX3400-48T, EX3400-48T-AFI
- EX4200
- EX4300
- EX4300-48MP
- EX4500
- EX4550
- EX4600
- EX8200
- XRE200 External Routing Engine

LN Series:

- LN1000-CC

MX Series:

- M7i
- M7i Compact Forwarding Engine Board (CFEB)
- M40e and M10i
- M320
- MX5, MX10, MX40, and MX80
- MX104
- MX204
- MX240, MX480, and MX960

- MX10003
- RE-A-2000 Route Engine
- RE-S-X6-64G Routing Engine

QFX Series:

- QFX3008-I
- QFX3100
- QFX3500
- QFX3600
- QFX5100-24Q
- QFX5100-48S
- QFX5100-48T
- QFX5110-32Q
- QFX5110-48S
- QFX5200
- QFX5200-32C
- QFX10008 and QFX10016

SRX Series:

- SRX100
- SRX110
- SRX210B
- SRX210H-POE
- SRX210H-P-MGW
- SRX220
- SRX240H
- SRX240H-POE
- SRX300
- SRX320
- SRX340 and SRX345
- SRX550
- SRX650

- SRX1400
- SRX1500
- SRX3400 and SRX3600
- SRX5400, SRX5600, and SRX5800
- SRX-MP-1SERIAL
- SSG-520M

T Series:

- RE-A-2000 Route Engine