

INSTRUCTIONS
FOR USE

A-dec 511

DENTAL CHAIR



 a dec[®]

Copyright

© 2020 A-dec Inc. All rights reserved.

A-dec Inc. makes no warranty of any kind with regard to this material, including, but not limited to, the implied warranties of merchantability and fitness for a particular purpose. A-dec Inc. shall not be held liable for any errors contained herein or any consequential or other damages concerning the furnishing, performance or use of this material. The information in this document is subject to change without notice. If you find any problems in the documentation, please report them to us in writing. A-dec Inc. does not warrant that this document is error-free.

No part of this document may be copied, reproduced, altered, or transmitted in any form or by any means, electronic or mechanical, including photocopying, recording, or by any information storage and retrieval system, without prior written permission from A-dec Inc.

Trademarks and Additional Intellectual Property Rights

A-dec, the A-dec logo, A-dec Inspire, Cascade, Century Plus, Continental, Decade, ICX, ICV, Performer, Preference, Preference Collection, Preference ICC, Radius, and reliablecreativesolutions are trademarks of A-dec Inc. and are registered in the United States and other countries. A-dec 500, A-dec 400, A-dec 300, A-dec 200, and EasyFlex are also trademarks of A-dec Inc. None of the trademarks or trade names in this document may be reproduced, copied, or manipulated in any manner without the express, written approval of the trademark owner.

Certain touchpad symbols and icons are proprietary to A-dec Inc. Any use of these symbols or icons, in whole or in part, without the express written consent of A-dec Inc., is strictly prohibited.

Regulatory Information and Warranty

For required regulatory information and the A-dec warranty, see the *Regulatory Information, Specifications, and Warranty* document (p/n 86.0221.00) available in the Resource Center at www.a-dec.com.

Product Service

Product service is available through your local authorized A-dec dealer. To locate an authorized dealer, or for additional service information, visit www.a-dec.com or contact A-dec at 1.800.547.1883 in the USA and Canada or 1.503.538.7478 worldwide.

Product Models and Versions Covered in This Document

Model	Version	Description
511	B	Dental Chair

Content Map

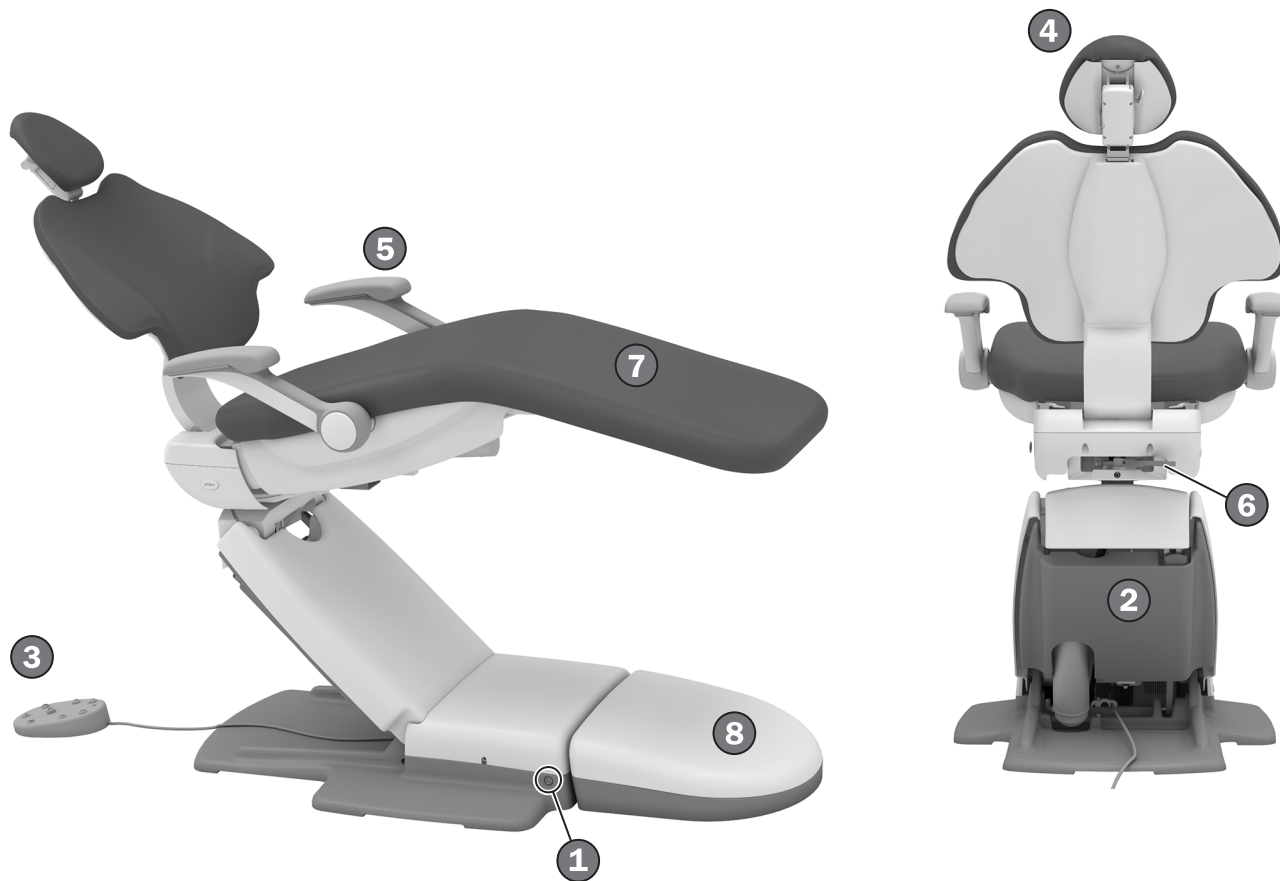

Features/Topics

1	Power Button	2
2	Chair Stop Plate	3
3	Footswitch/Chair Controls	4
4	Headrest	7
5	Armrests	6
6	Chair Swivel Brake	9
7	Upholstery Care	10
8	Utilities	11
	Specifications	12

Operate / Adjust

Turn On/Turn Off the Power

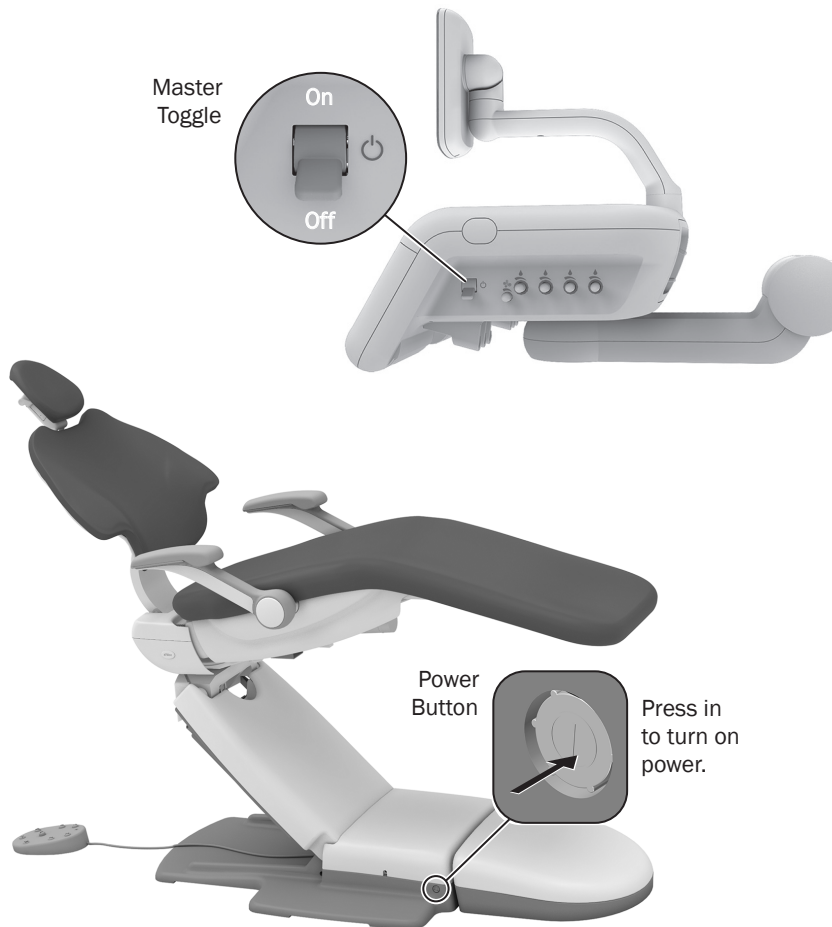

Chairs with Delivery and Support Systems

If you have a chair with an attached system, use the master toggle to turn on the power, water, and air. The master toggle is normally located on the delivery system, but may instead be located on the support center or floor box on chairs without a delivery system.

If there is no power to the system, verify that the power button on the chair is pressed in. This button must be on in order for the master toggle to control system power.

Chair-Only Configurations

If you have a chair-only configuration, press the power button on the chair to turn on or turn off the power.

When to Turn Off the Power

To save energy and reduce the chance of air leaks, press the power button to turn off power at the end of the day and before longer periods of non-use.

Chair Safety Features



A-dec dental chairs and systems include safety features (like the chair stop plate) that may stop or prevent the chair from moving. This may occur due to any of the following:

- There's an obstruction under the chair or attached module.
- The foot control disc or lever is pressed.
- A handpiece isn't properly seated in its holder.

If the Chair Stops Unexpectedly or Won't Move

Check for and correct any of the conditions listed above. If an obstruction is blocking chair movement, use the touchpad or footswitch to raise the chair, then remove the obstruction.

Position the Chair with Manual Controls

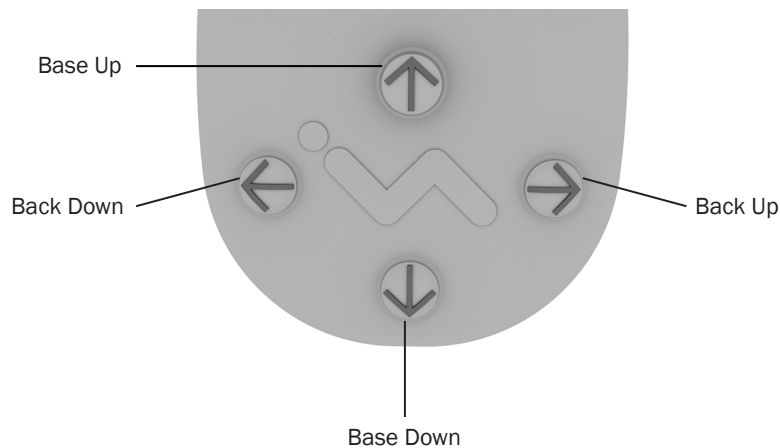
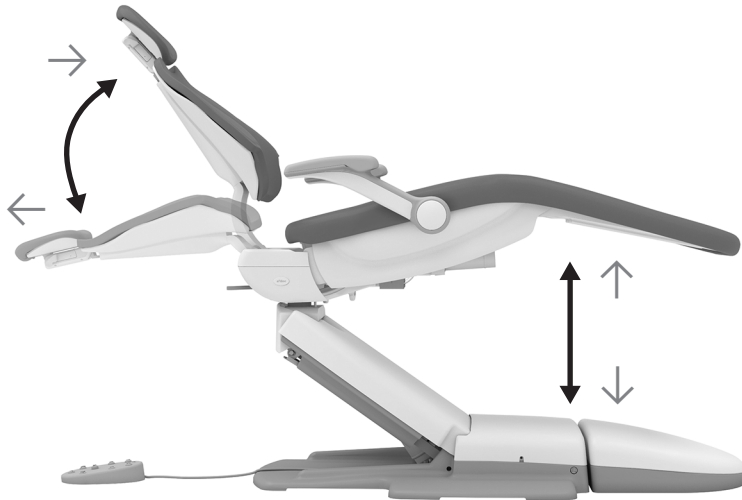

IMPORTANT The A-dec touchpad and footswitch move the chair in the same manner. See your delivery system Instructions for Use for detailed information about your touchpad controls.



WARNING Ensure that the patient is positioned safely before using the manual or preset chair controls. Never leave the patient unattended while the chair is in motion. Always take extra care with small children and patients with limited mobility.

To stop the chair at any point during preset movement, press any chair positioning button on the footswitch or touchpad.



NOTE If you would like to adjust the maximum height of your chair, contact your local authorized A-dec dealer.

Icon/Function	Actions/Options
↑ Base Up	Press and hold ↑ to raise the chair base.
↓ Base Down	Press and hold ↓ to lower the chair base.
→ Back Up	Press and hold → to raise the chair back.
← Back Down	Press and hold ← to lower the chair back.

Position the Chair with Preset Controls

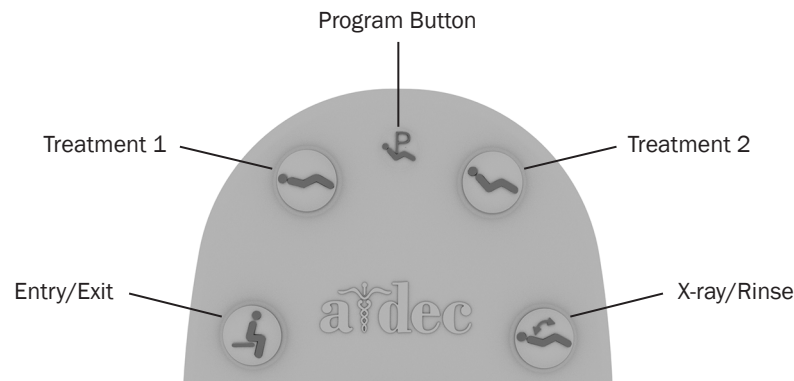

Icon	Preset Name	Factory Setting
	Entry/Exit	Positions the chair for patient entry/exit.
	Treatment 1	Positions the chair base and back down.
	Treatment 2	Positions the chair base down and the back partially up.
	X-Ray/Rinse	Moves the chair to either x-ray or rinse position. A second press moves the chair to the previous position.

Press , , , or to move the chair to a preset position. See the table (below left) for factory settings.

Customize the Chair Preset Positions

To customize chair presets , , and :

1. Position the chair as desired.
2. Press and hold until you hear one beep, which indicates program mode is on.
3. Within five seconds, press the chair preset icon you want assigned to this new chair position (e.g., press). Three beeps indicate that your new setting is saved.

Customize the X-Ray/Rinse Chair Preset

The factory preset moves the chair and patient into an upright position for x-rays or cuspidor access. A second press of returns the chair to the previous position.

You can also set to function as a customized chair preset position. To change its function:

1. Press and at the same time and hold for three seconds.
 - One beep indicates is set as another customizable chair preset button.
 - Three beeps indicate that is set as the x-ray/rinse factory preset (which toggles between the x-ray/rinse position and the previous chair position).
2. If you set as another customizable chair preset and want to assign a different chair position, follow the steps outlined above in “Customize the Chair Preset Positions.”

Prepare the Chair for the Patient

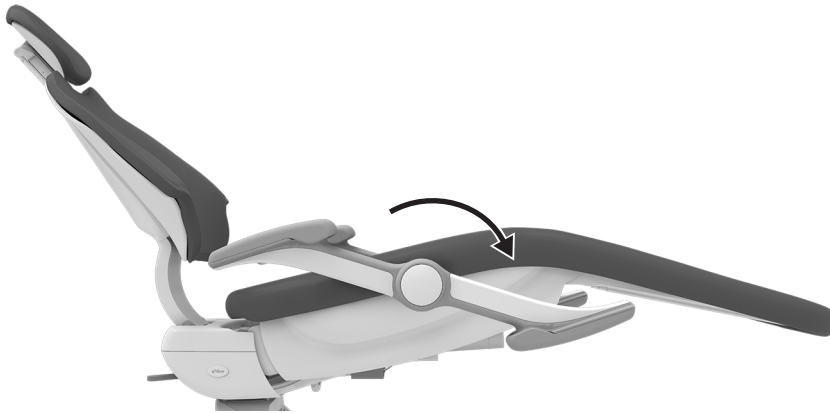

Position the Armrests



WARNING Do not allow patients to drop their arms behind the armrests or under the backrest, or injury may occur when the chair moves.

Move the armrest out of the way to allow for easy patient entry/exit and improved operator access when working direct. Simply push or pull the armrest into position.

Encourage a Proper Seating Position

To properly seat patients in the chair, ask them to sit as far back in the seat as possible. This ensures the best alignment with the lumbar support and comfort for the patient.

For optimal comfort, patients can place their forearms on the armrests or keep their arms comfortably folded on their lap.



TIP Before the patient sits down in the chair, leave the headrest at a higher position. This will encourage the patient to sit all the way back in the chair. Adjust the headrest once the patient is seated to improve patient comfort and operator access to the oral cavity.



TIP For patients who require additional support to exit the chair, leave the armrests in the back position.

Position the Headrest

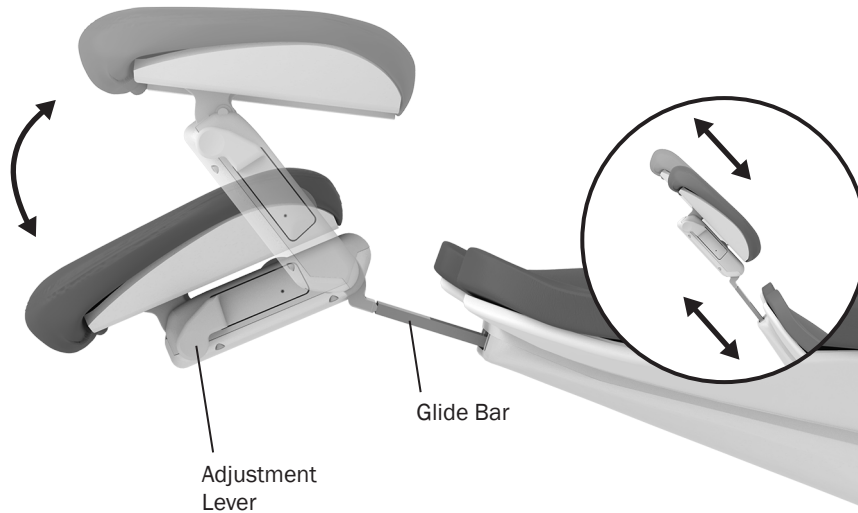

The dual-articulating gliding headrest includes several features you can use to improve access to the oral cavity and increase patient comfort.

Use the glide bar to accommodate a variety of patient heights. Simply pull up or push down on the headrest until it is in the desired position. The gliding headrest cushion provides additional height adjustment.



WARNING If the glide bar has exceeded its maximum recommended working height, a warning line will be visible on the patient's side of the glide bar. Do not use the headrest in a position where this warning line is visible.

You can easily adjust the headrest angle using one hand. Press the adjustment lever to position the headrest. Release, and the headrest holds its position.

Position the Headrest for Wheelchairs



To position the headrest for wheelchairs:

1. Remove the headrest from the dental chair.
2. Rotate the headrest 180° and slide the glide bar into the backrest until it stops.
3. Swivel the dental chair, if necessary, and position the backrest to its full upright position.
4. Position the wheelchair and the dental chair back to back.
5. Move the dental chair up or down, as needed, to adjust the headrest height.
6. Lock the wheelchair wheels.

Adjust the Headrest Glide Bar Tension

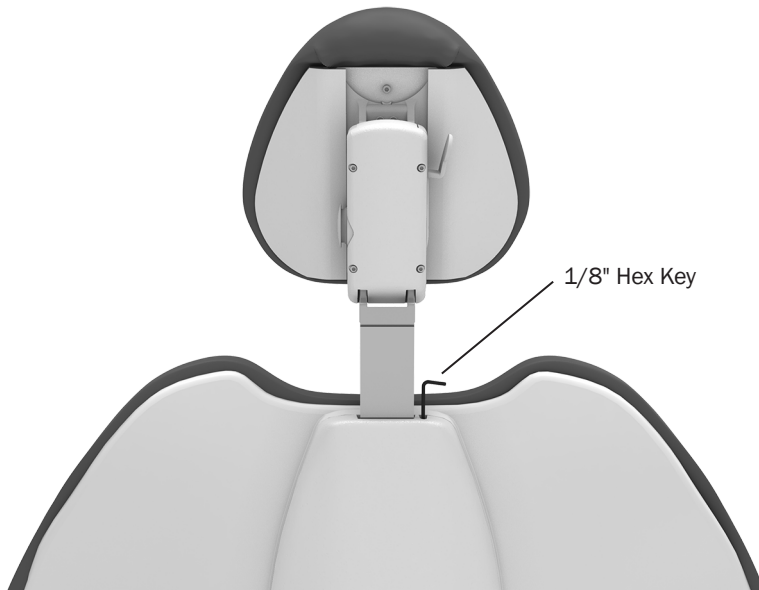

If the headrest drifts downward, or if it is difficult to move up or down, the glide bar tension needs adjustment.

To adjust the tension, use a 1/8" hex key. Turn the adjustment screw clockwise to increase tension.

Operate the Chair Swivel Brake

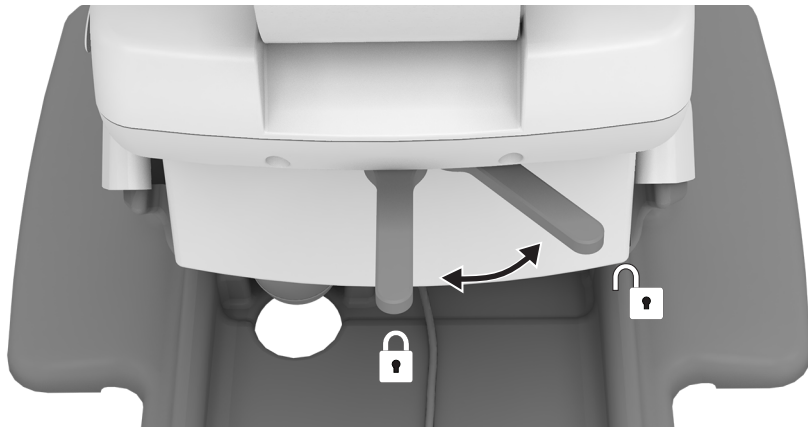

The chair can rotate to any position within 30° either side of center. The chair swivel brake restricts rotation of the chair to keep the chair from moving during a procedure.

To release the swivel brake, pull the brake lever to the right. To engage the brake, pull the brake lever firmly to the left.

Adjust the Chair Swivel Brake Tension

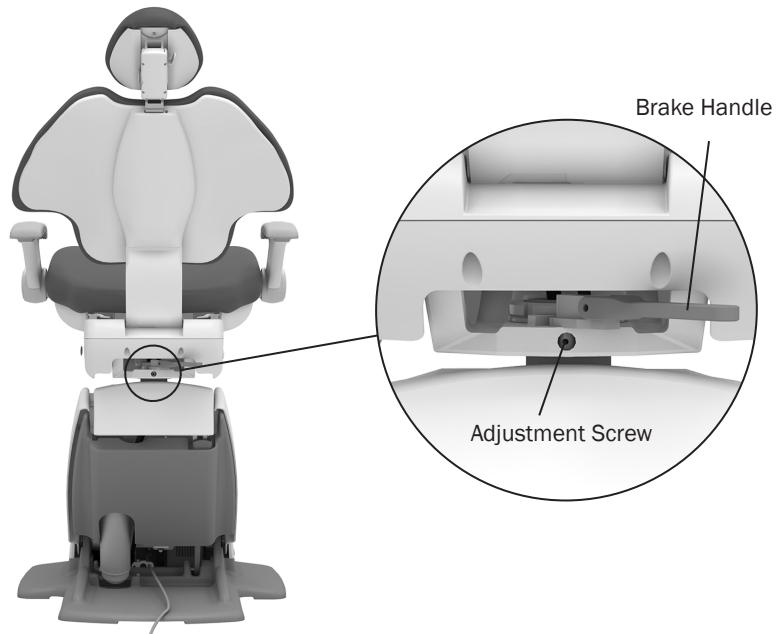

If the chair swivels left or right with the brake engaged, or is difficult to move with the brake disengaged, adjust the swivel brake tension. Properly tensioned, the brake handle should be in the middle when it is fully engaged. To make the adjustment:

1. Move the brake handle to the right.
2. If the chair includes a back mount module, swivel the chair to access the adjustment screw.
3. Use a 7/64" hex key and turn the tension adjustment screw clockwise to increase brake friction or counterclockwise to decrease brake friction. Only a small adjustment is needed to significantly increase or decrease tension.

Clean / Maintain

Protect with Barriers

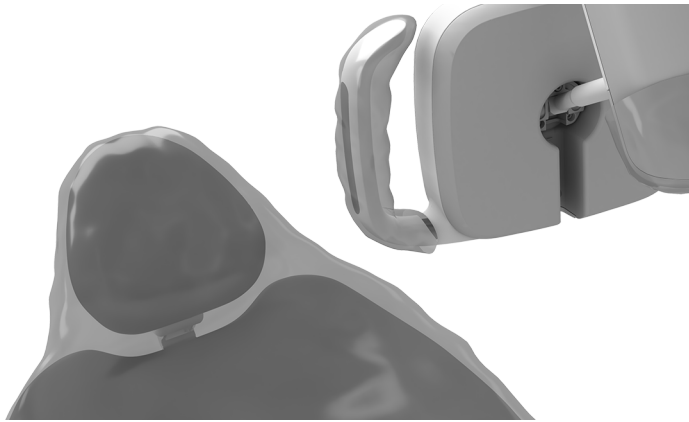

NOTE For proper use and disposal of barriers, see the instructions provided by the barrier manufacturer.

A-dec recommends barrier protection for all applicable touch and transfer surfaces. Touch surfaces are areas that come into contact with hands and become potential cross-contamination points during dental procedures. Transfer surfaces are areas that come into contact with instruments and other inanimate objects.

In the USA, barriers must be produced under the Current Good Manufacturing Practice (CGMP) as specified by the U.S. Food and Drug Administration (USFDA). For regions outside the USA, refer to the medical device regulations specific to your location.



IMPORTANT For recommendations on cleaning and chemical disinfection of touch and transfer surfaces (where barrier protection is not applicable or when barriers are compromised), please see the *A-dec Equipment Asepsis Guide* (p/n 85.0696.00).

Extend the Life of the Upholstery



CAUTION Do not use household bleach (sodium hypochlorite) or other products containing chlorine, isopropyl alcohol (greater than 25 percent by volume), or hydrogen peroxide to clean or disinfect the upholstery. It can cause rapid deterioration and damage the product.

To preserve the quality of your A-dec upholstery, use barrier covers instead of relying on chemicals. Barriers significantly extend the life of the upholstery and will help preserve its luxurious look and soft feel. To clean the upholstery, use a solution of mild dishwashing liquid and water. Use surface disinfectants only when the barriers have been compromised or there is visible spatter on the upholstery. For more information, see the *Upholstery Maintenance Guide* (p/n 86.0501.00) available in the Resource Center at www.a-dec.com.

Access the Utilities

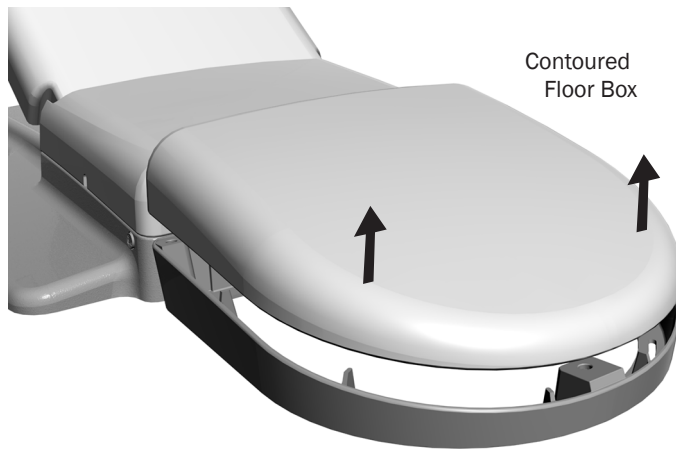

CAUTION When removing or replacing covers, take care not to damage any wiring or tubing. Verify that the covers are secure after replacing them.

The chair utilities are located in the contoured floor box under your chair and typically include the electrical outlet, as well as the system hookups for air, water, and vacuum. To access, lift the cover up and off the floor box frame. For maintenance, contact your local authorized A-dec dealer.

Specifications



Maximum Chair Capacity

Patient Load: 500 lb (227 kg)



IMPORTANT For chair accessory load capacity, electrical specifications, identification of symbols, and other regulatory requirements, see the *Regulatory Information, Specifications, and Warranty* document (p/n 86.0221.00) available in the Resource Center at www.a-dec.com.



NOTE Specifications are subject to change without notice. Requirements may vary depending on your location. For more information, contact your authorized A-dec dealer.



 **A-dec Headquarters**

2601 Crestview Drive
Newberg, Oregon 97132
United States
Tel: 1.800.547.1883 within USA/CAN
Tel: +1.503.538.7478 outside USA/CAN
www.a-dec.com

A-dec Australia

Unit 8
5-9 Ricketty Street
Mascot, NSW 2020
Australia
Tel: 1.800.225.010 within AUS
Tel: +61.(0).2.8332.4000 outside AUS

A-dec China

A-dec (Hangzhou) Dental Equipment Co., Ltd.
528 Shunfeng Road
Qianjiang Economic Development Zone
Hangzhou 311100, Zhejiang, China
Tel: 400.600.5434 within China
Tel: +86.571.89026088 outside China

A-dec United Kingdom

Austin House
11 Liberty Way
Nuneaton, Warwickshire CV11 6RZ
England
Tel: 0800.ADEC.UK (2332.85) within UK
Tel: +44.(0).24.7635.0901 outside UK



86.0761.00 Rev D
Date of Issue 2020-02-12
Copyright 2020 A-dec Inc.
All rights reserved.