

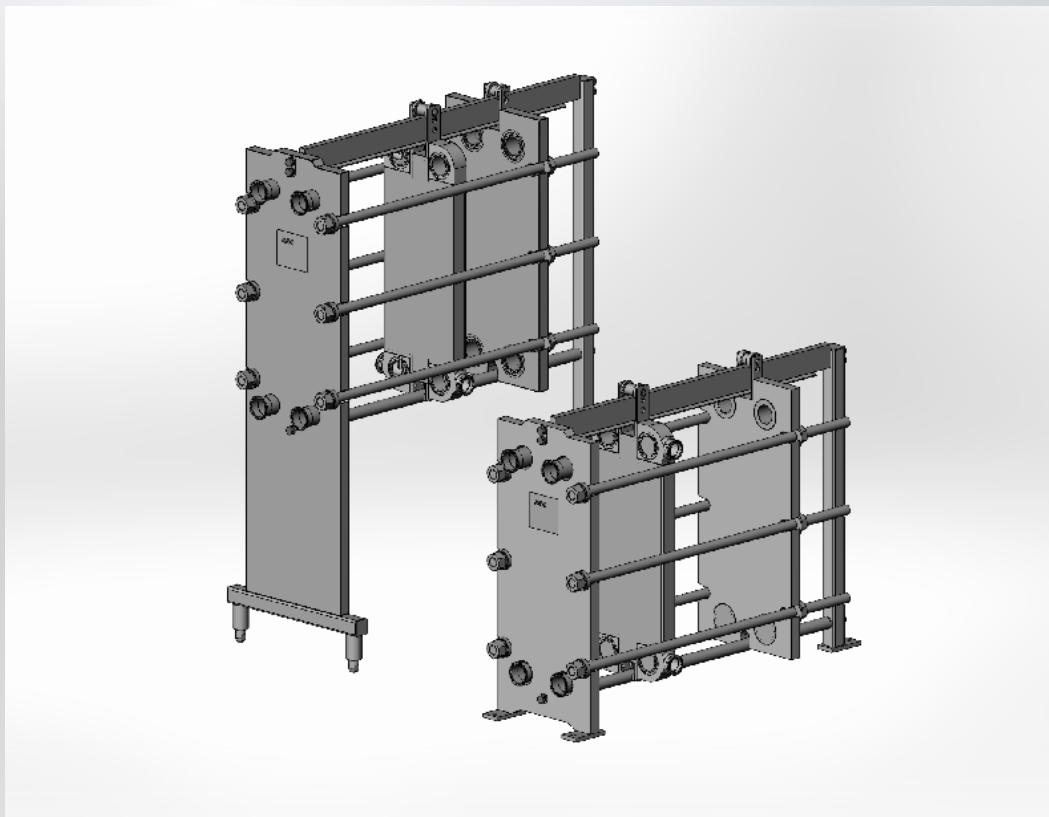

AGC Model Pro2

Operation and Maintenance Manual



proflow^{sanitary}
SERIES

Eastern (Main) +1 703-257-1660 • Western +1 503-774-7342 • Central Sales +1 847-301-6890

Table of Contents

Scope:	1
Receiving and Inspection:	1
Drawing Package:	2
Frame Placement:	3
Frame Connections:	5
Normal Operation:	6
Opening the Heat Exchanger:	8
Operator Maintenance:	8
Model Features:	8
Parts List:	10
Pro2-SH Frame Components.....	11
Pro2-S Frame Components	12
Pro2-F/I Frame Components.....	13
Pro2-DFH Frame Components	14
Pro2-DF Frame Components.....	15
Pro2 Rail Size Chart.....	16
Pro2-I Tiebolt Assembly	17
Pro2-S/SH Tiebolt Assembly.....	18
Pro2-F/DF/DFH Tiebolt Assembly.....	19
Pro2 Terminal Assembly	20
Pro2 Plate and Frame Gaskets.....	21

Western

3109 NE 230th Avenue
Fairview, OR 97024
+1.503.774.7342
+1.800.715.8820
FAX +1.503.774.2550

Central

8400 Lakeview Parkway
Suite 700
Pleasant Prairie, WI 53158
+1.847.301.6890
+1.888.489.8820

Eastern

10129 Piper Lane
Bristow, VA 20136
+1.703.257.1660
+1.800.825.8820
FAX +1.703.330.7940

www.agcheattransfer.com

Revised 07/01/2020

Scope:

This manual is a supplement to the AGC Heat Transfer ProFlow plate heat exchanger manual. We recommend you read the ProFlow manual first because it will provide you with a basic understanding of plate heat exchangers and define the technical terms used in this manual. The information provided within this manual describes the installation, operation, and maintenance of the AGC Heat Transfer Pro2 tiebolt style heat exchangers. Currently 6 (six) different models of the Pro2 tiebolt heat exchangers are available and this manual covers all 6.

Please read this manual carefully before installing your heat exchanger. Pay particular attention to the safety instructions and the initial startup procedures. Failure to follow all safety recommendations could result in injury to the operator or cause damage to the heat exchanger.

Receiving and Inspection:

Each AGC heat exchanger is assembled and fully tested at the factory prior to shipping. Once the unit has successfully passed all tests it is prepared for shipping. Every AGC heat exchanger is thoroughly inspected to ensure it is in perfect condition before leaving the factory. Upon arrival, carefully inspect your new heat exchanger for any damage that may have occurred during shipping. If the press was damaged during shipping be sure to annotate the damage on the shipping documents and report the damage to AGC immediately. To aid you in describing where the damage may have occurred figure one shows the major components of a typical tiebolt style frame.

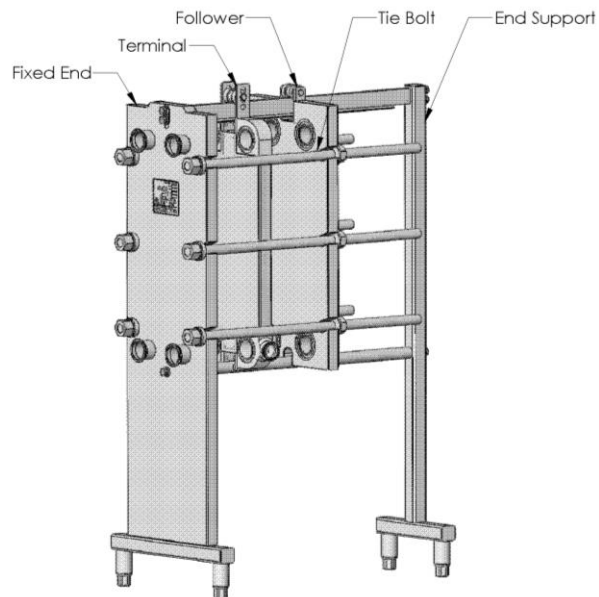

Figure 1
Major Frame Components

Typically, tiebolt style frames are shipped on a skid with the plates installed. Because the press can weigh several hundred pounds, only qualified forklift drivers should lift and position it. High leg frames such as the Pro2-SH and Pro2-DFH can be top heavy and could tip if not handled properly.

Drawing Package:

Every frame is shipped with a drawing package. This drawing package contains important information that is specific to your heat exchanger. If you cannot find the drawing package, contact AGC Heat Transfer or your local AGC distributor to obtain a replacement prior to installing the heat exchanger.

The drawing package is a collection of several important documents related explicitly to your heat exchanger. The first of these is the streaming diagram. Two copies of the streaming diagram are provided with every new heat exchanger. One copy has been laminated and is intended to be used by production and maintenance personnel when servicing the heat exchanger. The other copy should be kept on file in a safe place in the event the production copy is lost or damaged. The streaming diagram (also referred to as the drawing) describes all the characteristics of the heat exchanger. Figure 2 shows a typical two page streaming diagram.

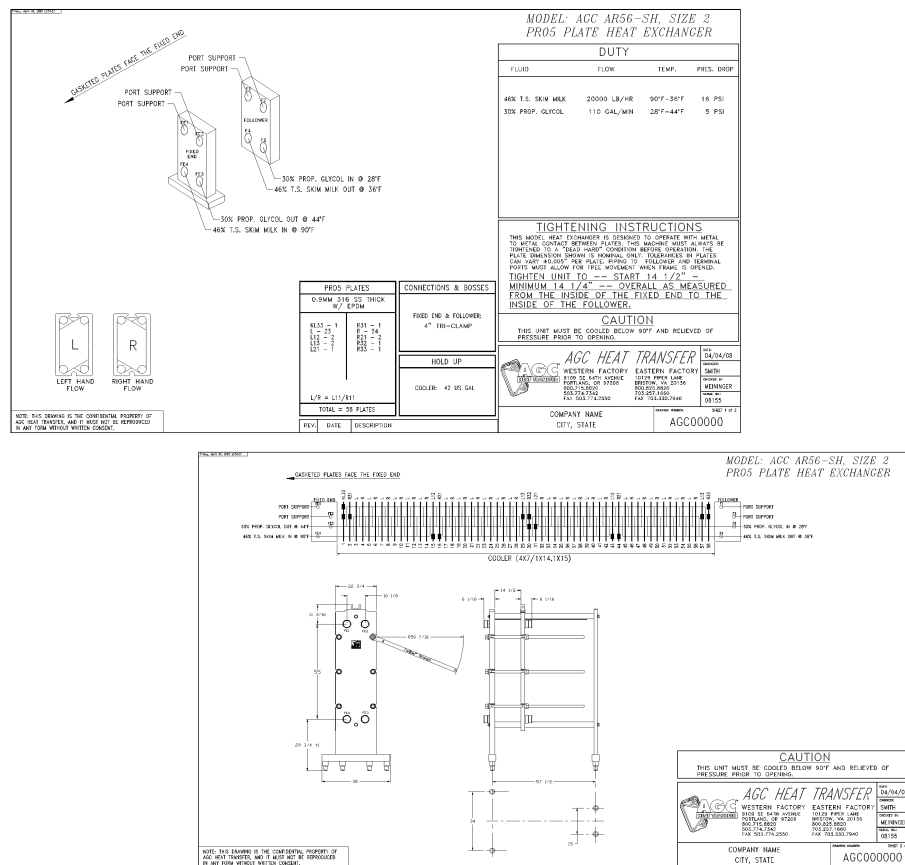

**Figure 2
Typical Streaming Diagram**

Page one shows the unit serial number, the duty, plate type, plate count, gasket type, connection type, connection size, and the tightening dimension. If the heat exchanger has been re-streamed, a revision block will also be included.

Page two of the drawing shows how the fluids pass through the heat exchanger. If the unit is small, such as the unit in figure two, a front and side view of the heat exchanger will be shown on page two. For larger units the front and side views are shown on page three or page four.

The second document in the drawing package is a plate punching diagram. This diagram will help you identify the configuration of each plate either by the number stamped at the top of the plate or by the ports that have been opened. The ProFlow manual describes how these different types of plates are used.

The final document in the drawing package is the ProFlow manual. The ProFlow manual has information about the AGC Heat Transfer product line and a more in-depth discussion about plate heat exchangers in general.

Frame Placement:

The Pro2 frame should be located on a firm flat surface capable of supporting the press and all of its contents when full. If possible the frame should remain strapped to the shipping skid until it is near its final location. Once the press is positioned cut the metal bands holding it to the shipping skid and, using an appropriately sized lifting strap, carefully lift the press off the skid. The top rail can be used as a lifting point. Never lift the press by the tiebolts. These bolts are in slots and are not designed to support the weight of the frame for lifting. When locating the heat exchanger, ensure that adequate space is left around the frame for maintenance and plate installation/removal. Also include enough space to allow the AGC Fat Boy™ wrench to fully swing. See figure 3.

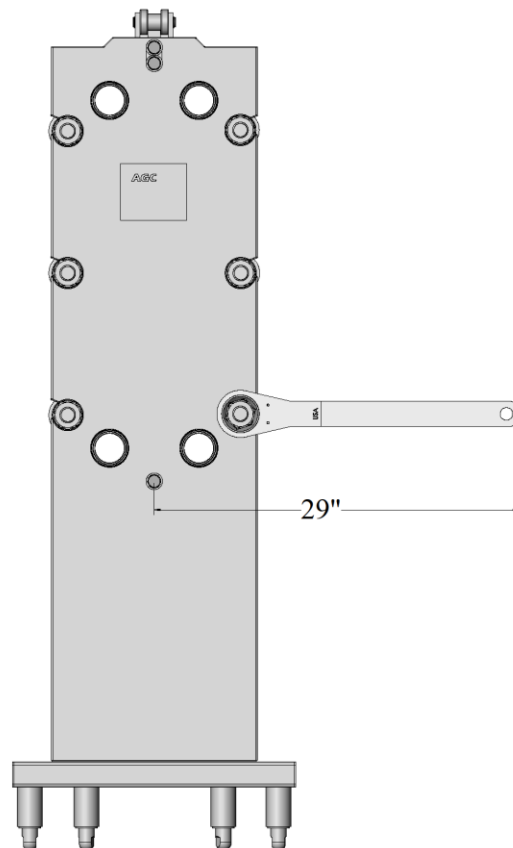

Figure 3
Wrench Space Requirement

The Pro2-SH, Pro2-S, Pro2-DFH and Pro2-DF are equipped with adjustable ball feet. These feet are adjusted by turning the base clockwise to lower and counterclockwise to raise the press. The ball feet should be adjusted so the ports are level from side to side. Figure 4 shows a spirit level placed across the ports to establish level.

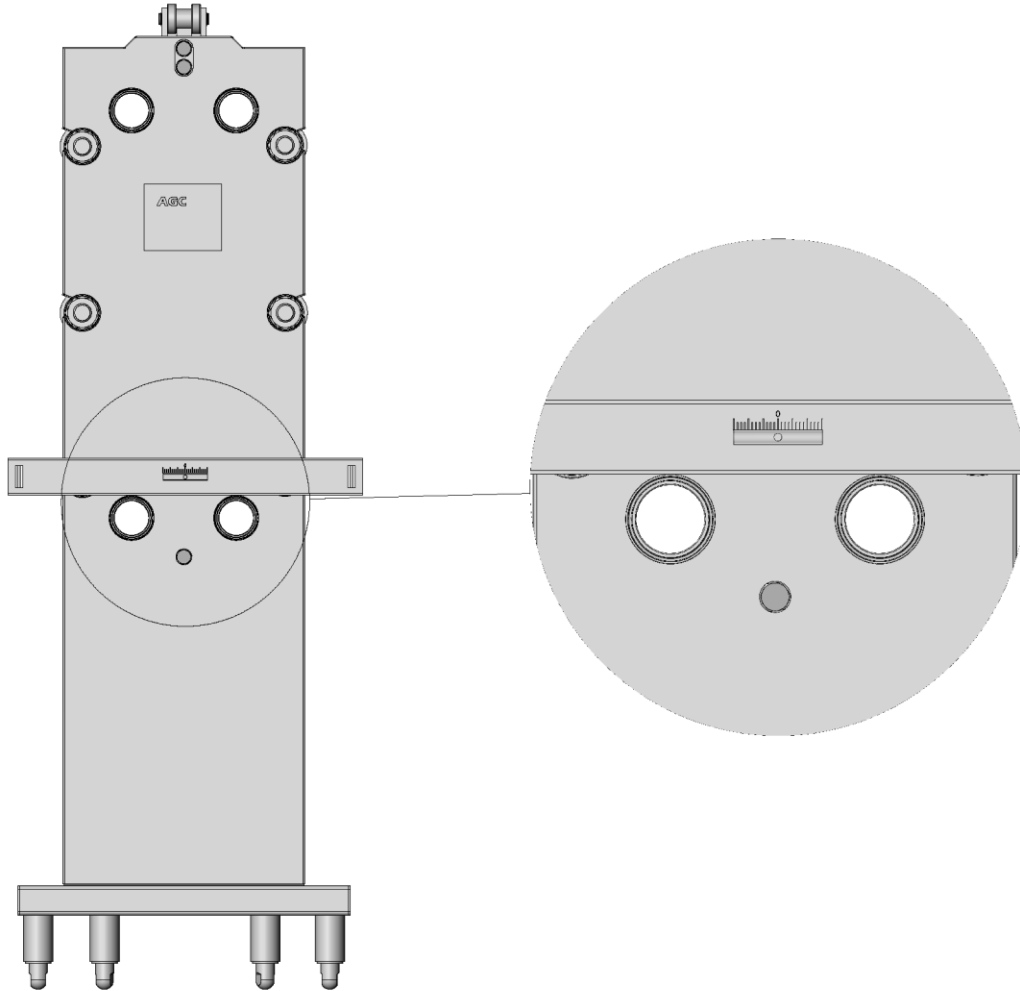

Figure 4
Port Leveling

Once the ports are level the heat exchanger should be adjusted so it will drain properly. This is done by adjusting the ball feet to establish a slope from end to end. Figure 5 shows a press adjusted to drain forward to the fixed end. Consult your onsite Plant Engineer or Project Manager to determine how much slope and which direction (toward the fixed end or follower) is appropriate for your installation.

The Pro2-I and Pro2-F frames are built with flat foot pads that are designed to be bolted to the floor. Therefore, no provisions for leveling are designed into the frame. These frames can be leveled by adding an appropriate amount of filler material under each foot pad as required.

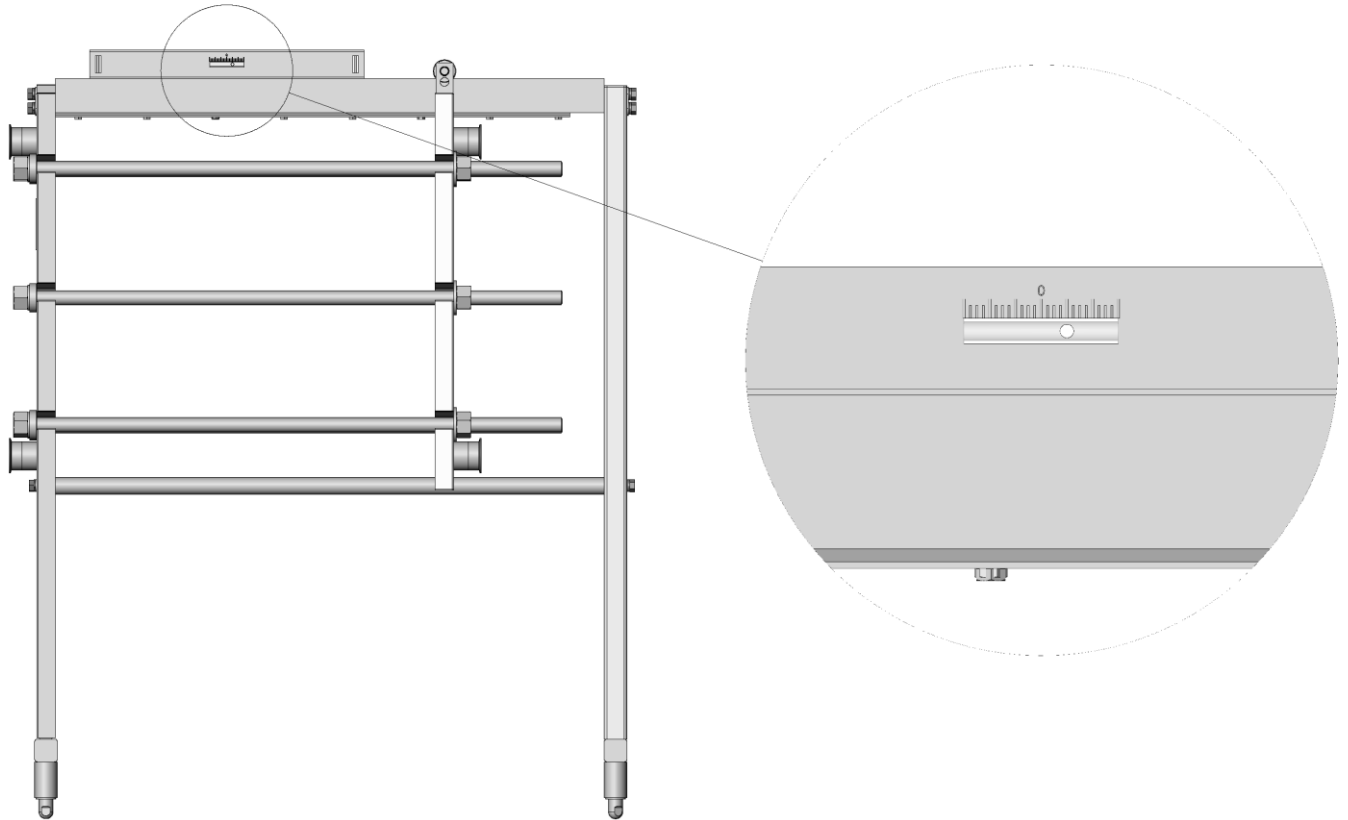

Figure 5
Frame Adjusted to Drain to Fixed End

Frame Connections:

Careful planning during the installation of your new heat exchanger will help ensure years of trouble free operation. All piping connections should be well supported and carefully aligned with the ports on the heat exchanger. Misaligned pipes or pipes that are not properly supported can lead to connection failures or cracks in the welded joints. When laying out a new installation, include enough breaks in the piping so service and maintenance can be completed easily. The piping connected to the follower should be configured with joints that are easy to remove so the follower can be fully retracted. This will provide enough space for clear inspection of the heat exchanger plates. The streaming diagram will show where all external connections should be made. Figure 6 shows page one of a typical streaming diagram for a multi section heat exchanger.

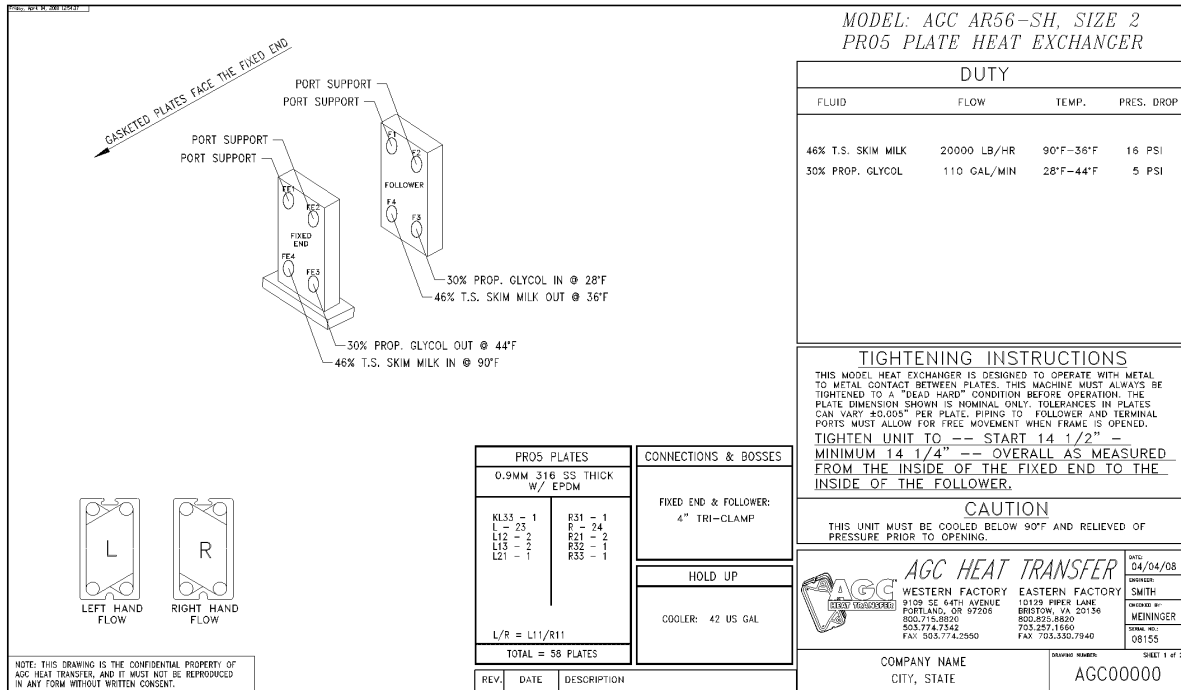

Figure 6
Typical Streaming Diagram

Notice that all ports have labels that clearly state what is to be connected to each one.

Normal Operation:

The Pro2 series heat exchangers are tiebolt style frames. This means the press is closed by using 6 tiebolts to compress the plates. It is important for each tiebolt to take an equal share of the load. After your heat exchanger is in place you should check the compressed dimension. The dimension for your heat exchanger is listed on the first page of your streaming diagram. Figure 7 shows where the tightening dimension is located on the drawing.

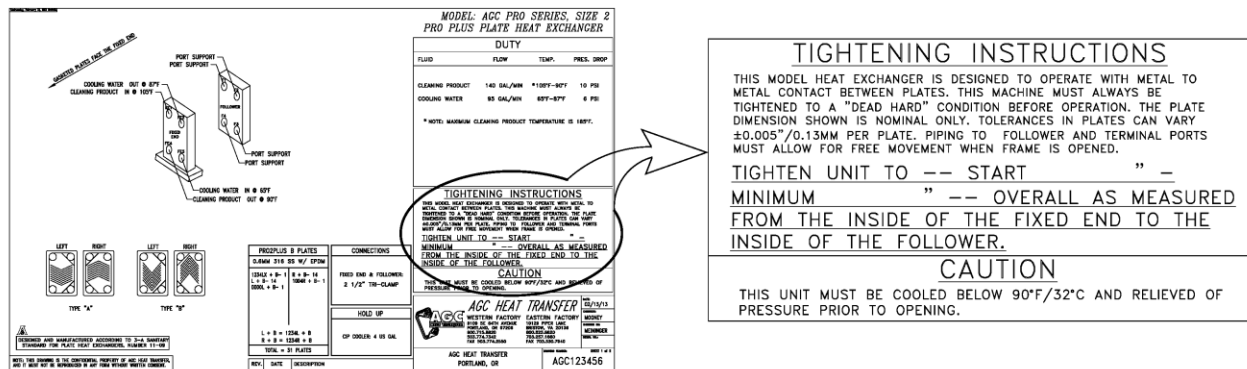

Figure 7
Tightening Instructions

Most new plate packs will seal at the start dimension. As the plates and gaskets wear it may be necessary to compress or close the press slightly more. You should never exceed the minimum dimension shown on the streaming diagram. If your press is closed to the minimum dimension and leaks are noticed contact AGC Heat Transfer for technical assistance. Closing the press beyond the minimum dimension could cause permanent damage to the plates, frame, or both. When measuring the compressed dimension it is a good practice to take the measurement in several locations on the inside of the fixed end and follower as shown in figure 8.

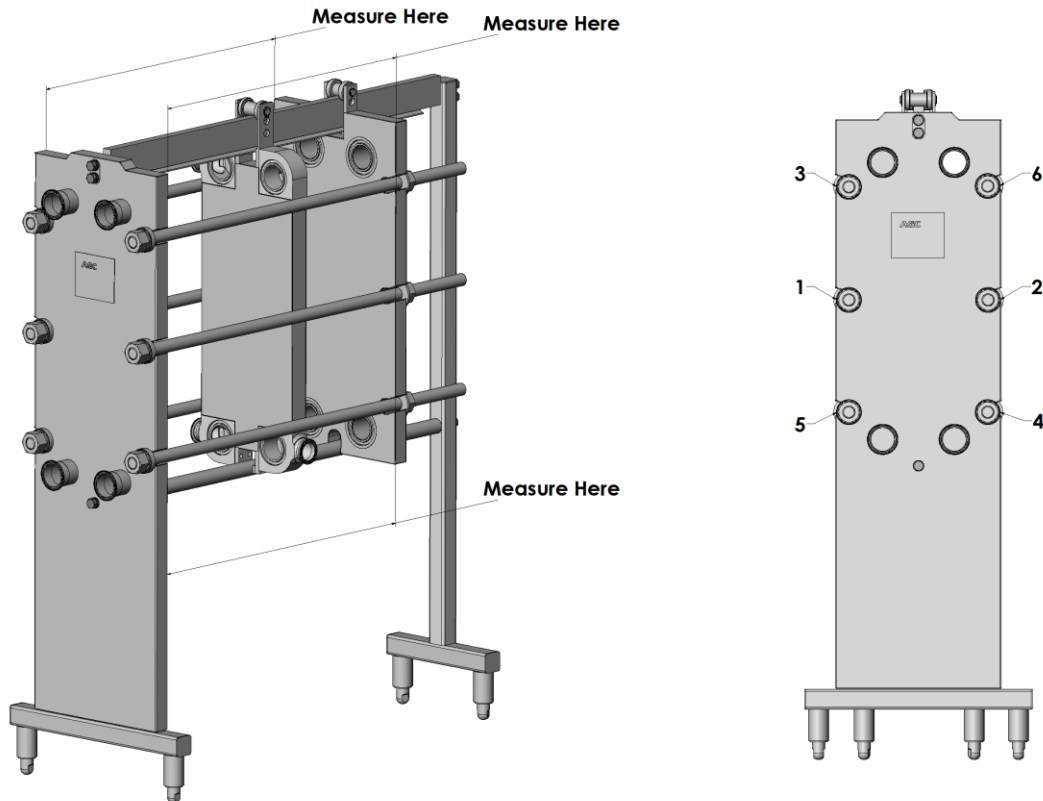

Figure 8
Tightening Location and Sequence

Measure top and bottom as well as front and back. The heat exchanger is designed to operate at its top efficiency when it is closed to a metal to metal condition. This means the rubber plate gaskets are fully compressed and the plates contact points are fully engaged with each adjacent plate. In this condition, the plate gap is uniform and the plates are fully supported. To maintain this condition all tiebolts should be tightened equally and in sequence. Following the sequence shown in figure 8, tighten each tiebolt in small increments so the follower remains parallel to the fixed end. As the press approaches the start dimension smaller increments at each bolt will make for easier closing.

After the press is closed and all connections are made to the heat exchanger the unit is ready to be pressure checked. Consult the onsite plant engineer or project manager for the correct procedure on pressure testing the press.

Opening the Heat Exchanger:

Before opening this or any other heat exchanger you must verify the temperature in the unit is below 90° F and that the unit has been relieved of all internal pressure. Failure to follow this safety warning could result in serious injury to the operator or damage to the plates and gaskets. All pipes/connections should be disconnected from the heat exchanger before the tiebolts are loosened.

Prior to opening the press, inspect the tiebolts to ensure they are free from dirt or excessive dust and that grease is on each one. Opening or closing the tiebolts without lubrication may cause serious permanent damage to the tiebolt. As with closing, when opening a Pro2 frame it is important for the follower to remain parallel with the fixed end. Small increments on each bolt will make the process easier and prevent damage to the press or any of its parts. The tiebolts should be loosened using the same sequence as for tightening. See figure 8 for the bolt sequence. As previously stated, the closer the unit is to the minimum dimension the more torque will be required on the Fat Boy™ wrench so small increments at each bolt will make opening easier and will prevent overloading one bolt. Once the plates are completely uncompressed, the tiebolts can be lifted from their slots. Handle the tiebolts with care so the threads are not damaged. The follower can now be moved back toward the end support and the plates can be inspected or removed.

Operator Maintenance:

All AGC Heat Transfer heat exchangers are designed to require minimal operator maintenance. As long as the unit is operated within the pressure and temperature limits the only maintenance required is routine cleaning, lubrication and inspection. We recommend the unit be leak checked annually using the PlateCheck™ field service provided by AGC Heat Transfer. This service is performed onsite by factory trained service engineers. The PlateCheck™ service provides a thorough inspection of all parts of the heat exchanger. After the service is completed, a detailed written report is provided on the condition of the heat exchanger. This preventative maintenance service greatly reduces unscheduled down time by keeping the heat exchanger in peak operating condition.

Model Features:

The Pro2 tiebolt frame is offered in 6 different models. Figure 9 shows each of the models. Regardless of the model chosen, each Pro2 frame will accept the AGC Pro2 heat exchanger plate and one or more AGC terminal(s). Additionally, all AGC heat exchangers can be fitted with special removable port nozzles. This feature is particularly useful in applications where the product erodes the stainless steel nozzles.

The Pro2-S and Pro2-SH are stainless steel clad frames. Both models conform to the current 3A sanitary standards. The factory installs ports at all eight locations (4 on the fixed end and 4 on the follower) on both models of these frames. The un-used ports are capped using sanitary caps and clamps. This makes it very easy to expand the heat exchanger in the field to increase capacity or to add other processes to the frame. The major difference between the –S

and –SH frames is the height of the port centers. The –SH frame is the high leg version. Both frames are equipped with adjustable ball feet.

The Pro2-F and Pro2-I are powder coated mild steel frames. These frames are designed to be bolted to the factory floor or other support structure. They utilize the Pro2 heat exchanger plate and can be configured to have any of the eight available ports used. Typically these models are shipped from the factory with ports installed at the active ports only. The un-used ports are blanked using a stainless steel blanking disk. The major difference between the –F and –I models is the tiebolt material. The –F frame has stainless steel tiebolts with a silicon-bronze nut. The –I frame has galvanized tiebolts with a stainless steel nut. Additional connecting ports can be ordered from the AGC factory if the frame needs to be expanded or restreamed. New port nozzles may require some welding onsite depending on the connections.

The Pro2-DF and Pro2-DFH are a lower cost alternative to the –S and –SH frames. These frames have adjustable ball feet and a stainless steel leg base, but the main body of the frame is powder coated mild steel. The tiebolts are stainless steel with silicon-bronze nuts. If these frames are ordered with sanitary connections they will comply with the current 3A guidelines for sanitary dairy equipment.

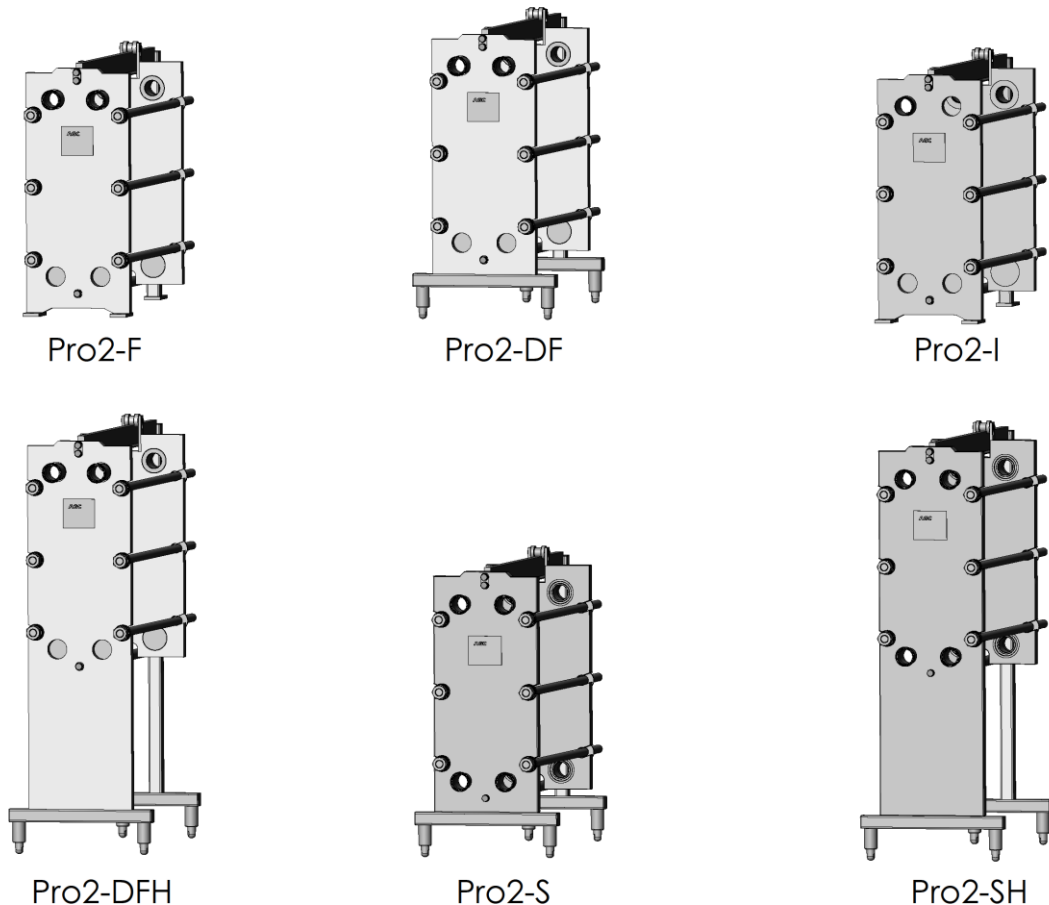

Figure 9
Pro2 Tiebolt Frame Assemblies

Parts List:

Replacement parts for any AGC Pro2 frame can be ordered from AGC Heat Transfer or from your local AGC Distributor. Most parts are in stock and can be shipped within 24 hours from the time we receive your order. Some parts have been revised so it is important to have your unit model and serial number available when placing an order for spare or replacement parts. All models of the Pro2 heat exchangers have some parts that are common as well as model specific parts. The following parts diagrams are separated by model when appropriate. Most of the field replaceable parts are listed in this manual. If the part you need is not listed on the following pages contact your local AGC distributor or the AGC Heat Transfer Factory.

Contact information is provided below or visit our website for more information:

Western

3109 NE 230th Avenue
Fairview, OR 97024
+1.503.774.7342
+1.800.715.8820
FAX +1.503.774.2550

Central

8400 Lakeview Parkway
Suite 700
Pleasant Prairie, WI 53158
+1.847.301.6890
+1.888.489.8820

Eastern

10129 Piper Lane
Bristow, VA 20136
+1.703.257.1660
+1.800.825.8820
FAX +1.703.330.7940

www.AGCHeatTransfer.com

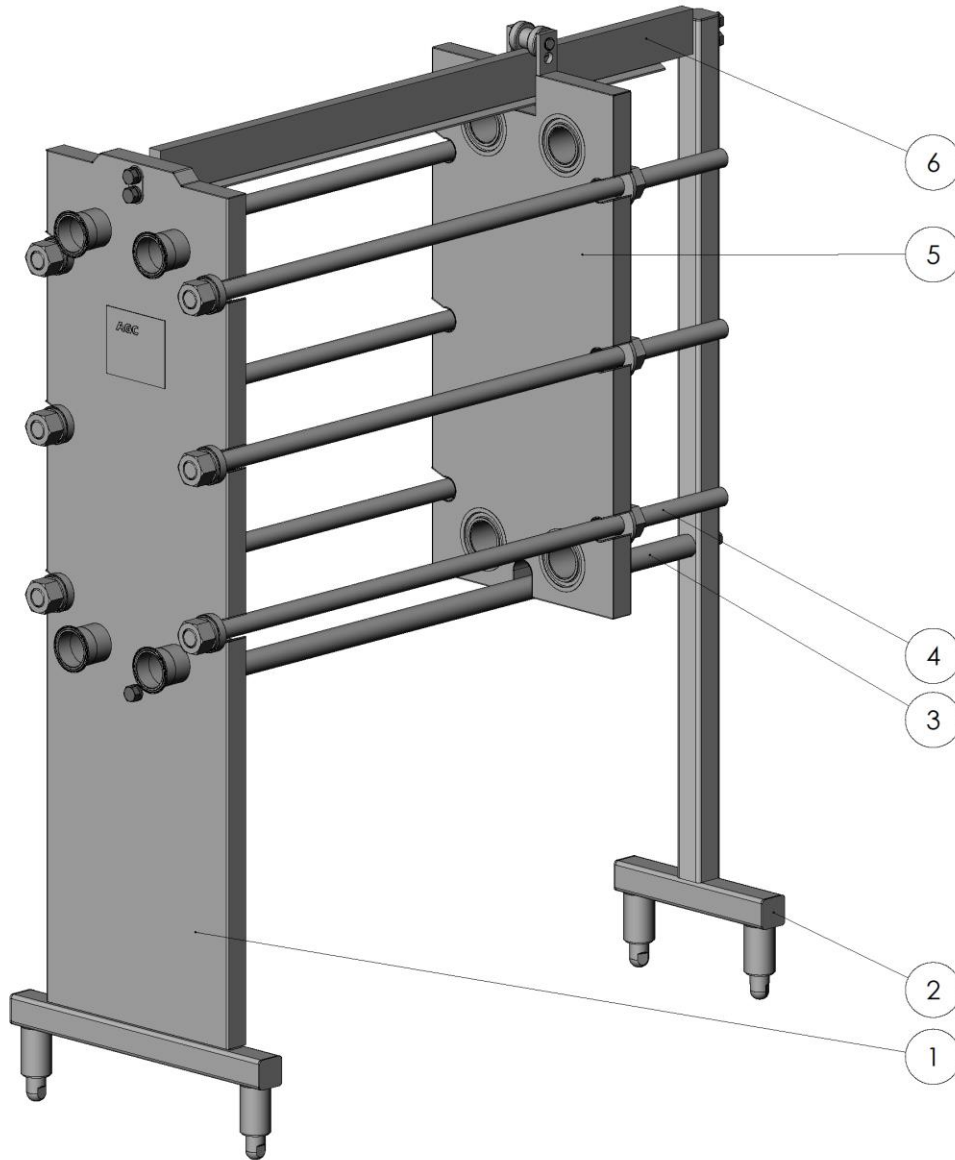

Item Number	Pro2-SH Quantity	Part Number	Description
1	1	11024104	Pro2-SH Fixed End
2	1	11024073	Pro2-SH End Support
3	1	See Chart Page 16	Pro2 Bottom Rail
4	6	See Chart Page 18	Pro2-SH Tie Bolt
5	1	11024114	Pro2-S/SH Follower
6	1	See Chart Page 16	Pro2 Upper Rail

Pro2-SH Frame Components

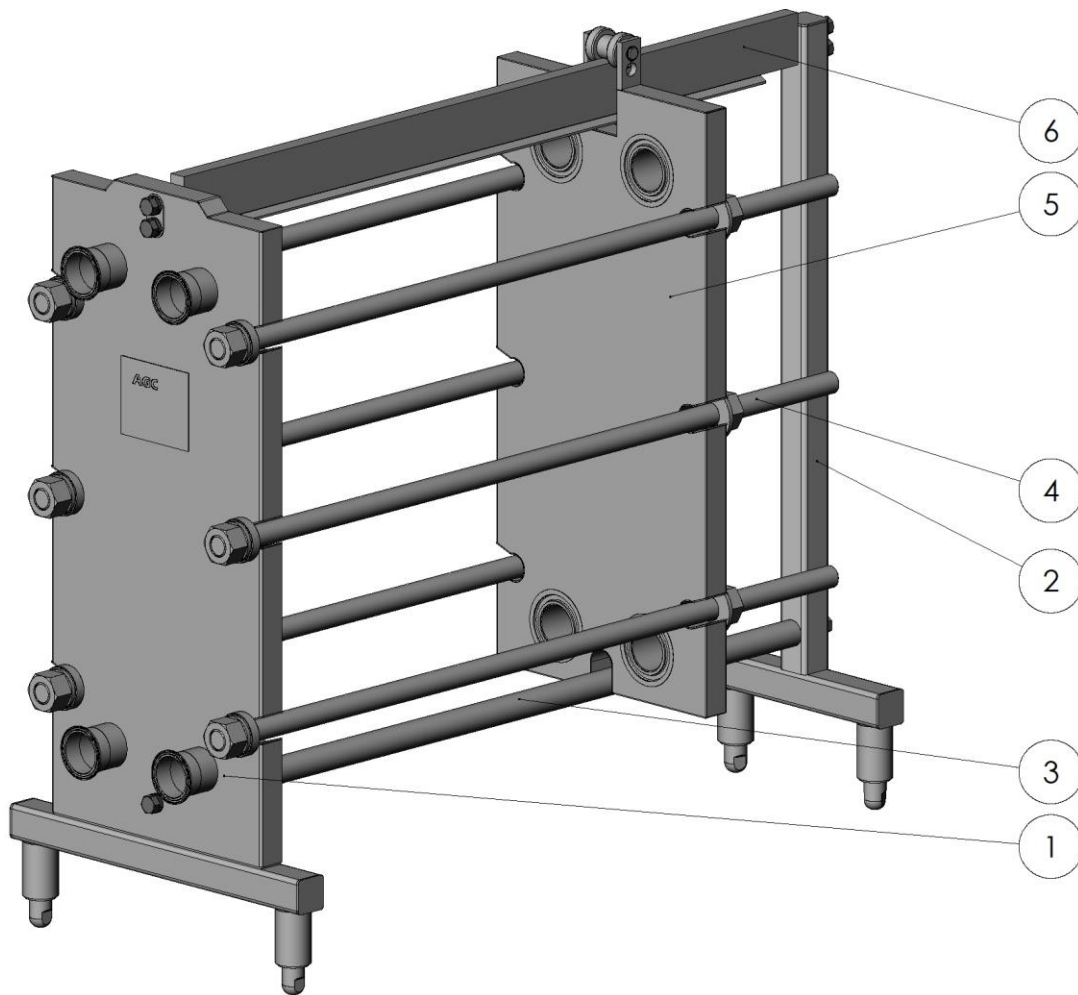

Item Number	Pro2-S Quantity	Part Number	Description
1	1	11024007	Pro2-S Fixed End
2	1	11024017	Pro2-S End Support
3	1	See Chart Page 16	Pro2 Bottom Rail
4	6	See Chart Page 18	Pro2-S Tie Bolt
5	1	11024114	Pro2-S/SH Follower
6	1	See Chart Page 16	Pro2 Upper Rail

Pro2-S Frame Components

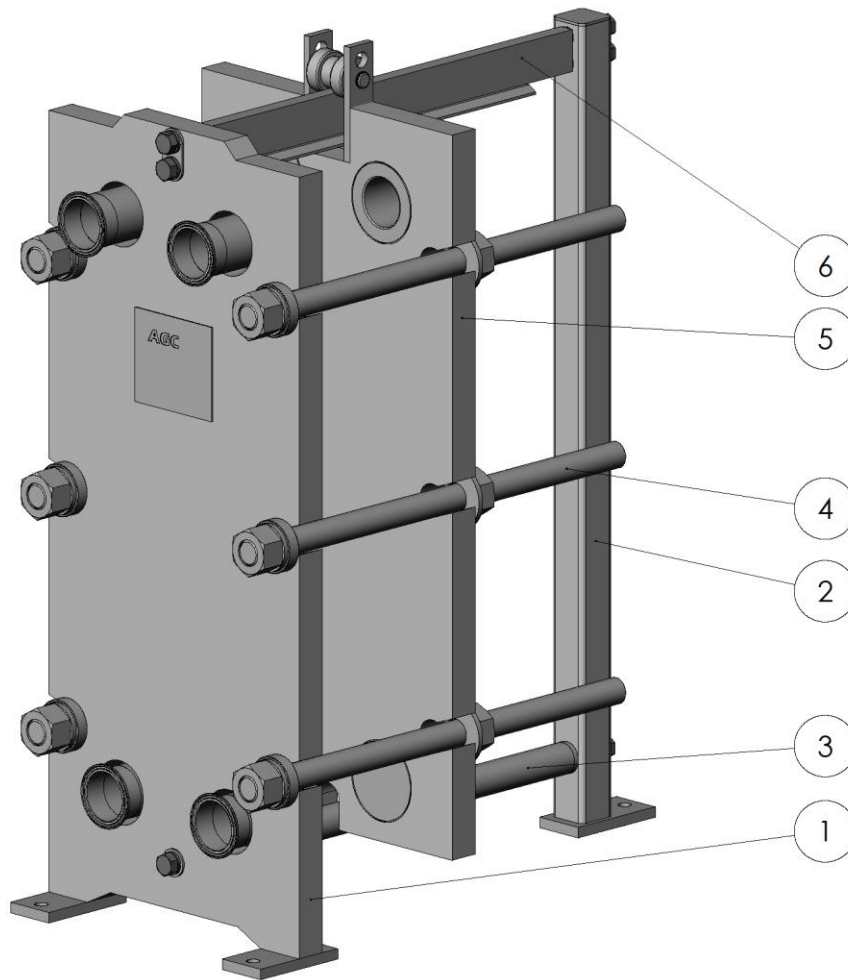

Item Number	Pro2-I/F Quantity	Part Number	Description
1	1	11024000	Pro2-I/F Fixed End
2	1	11024071	Pro2-I/F End Support
3	1	See Chart Page 16	Pro2 Bottom Rail
4	6	See Chart Page 17	Pro2-I Tie Bolt
5	1	11024114	Pro2-I/F Follower
6	1	See Chart Page 16	Pro2 Upper Rail

Pro2-F/I Frame Components

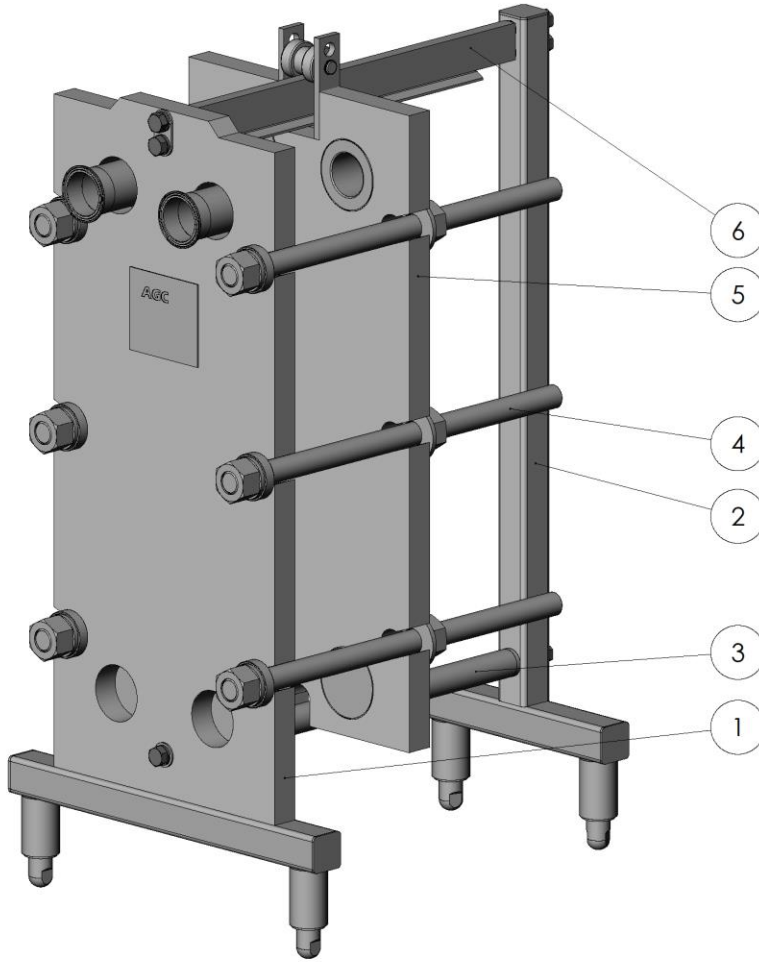

Item Number	Pro2-DF Quantity	Part Number	Description
1	1	11025100	Pro2-DF Fixed End
2	1	11024072	Pro2-DF End Support
3	1	See Chart Page 16	Pro2 Bottom Rail
4	6	See Chart Page 19	Pro2-F Tie Bolt
5	1	11024014	Pro2-I/F/DF Follower
6	1	See Chart Page 16	Pro2 Upper Rail

Pro2-DF Frame Components

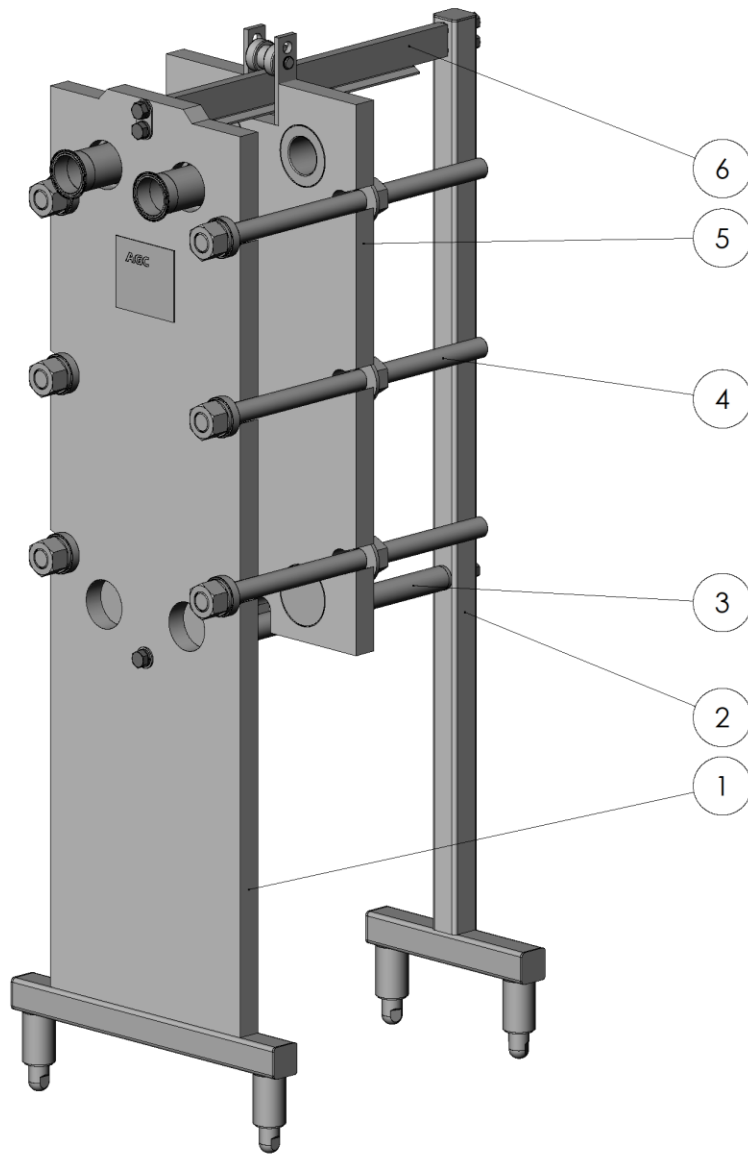

Item Number	Pro2-DFH Quantity	Part Number	Description
1	1	11025120	Pro2-DFH Fixed End
2	1	11025110	Pro2-DFH End Support
3	1	See Chart Page 16	Pro2 Bottom Rail
4	6	See Chart Page 19	Pro2-F Tie Bolt
5	1	11024014	Pro2-I/F/DF Follower
6	1	See Chart Page 16	Pro2 Upper Rail

Pro2-DFH Frame Components

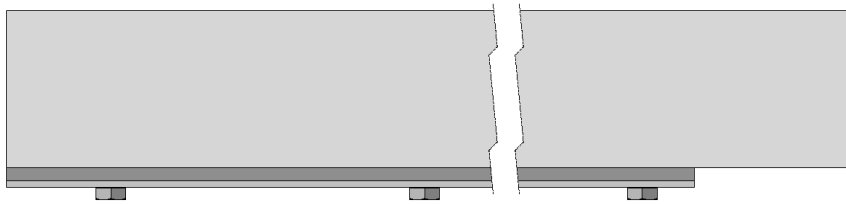

Pro2 High Capacity Top Rail

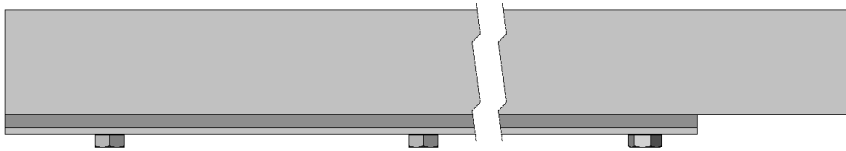
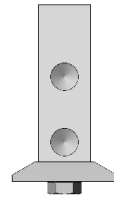

Pro2 Standard Top Rail

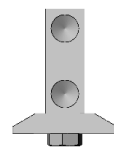

Pro2 Bottom Rail



Rail Size	Rail Length	Bottom Rail	Upper Rail Assembly
Pro2 Size 1	12	11024083	11024035
Pro2 Size 2	24	11024084	11024036
Pro2 Size 3	36	11024085	11024037
Pro2 Size 4	48	11024086	11024094
Pro2 Size 5	60	11024087	11024095
Pro2 Size 6	72	11024088	11024096

***Note:** All rails shipped without bolts and washers unless specifically ordered
 Size 4, 5, and 6 upper rails are high capacity and require high capacity rollers for follower
 and any terminals.

Pro2 Rail Size Chart
 (All Pro2 Tiebolt Frame Models)

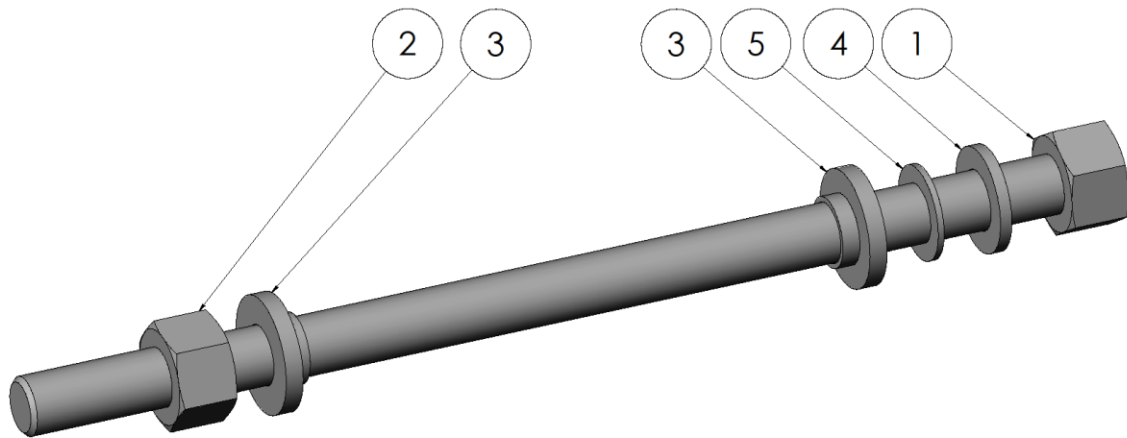

Item Number	Pro2-I Tiebolt Quantity	Part Number	Description
1	1	See Chart	Tiebolt Base
2	1	DG114C	Hex Nut
3	2	11012377	Tiebolt Bushing
4	1	11013002	Tiebolt Retaining Cap
5	1	EW203202	Thrust Bearing

Pro2-I Tiebolt Assembly Size Chart			
Tiebolt Size	Overall Length	Tiebolt Part Number	Assembly Part Number
Pro2-I Size 1	12 inches	11015144	11025027
Pro2-I Size 2	24 inches	11015145	11025028
Pro2-I Size 3	36 inches	11015146	11025029
Pro2-I Size 4	48 inches	11015147	11025030
Pro2-I Size 5	60 inches	11015164	11025049
Pro2-I Size 6	72 inches	11015165	11025050

Pro2-I Tiebolt Assembly

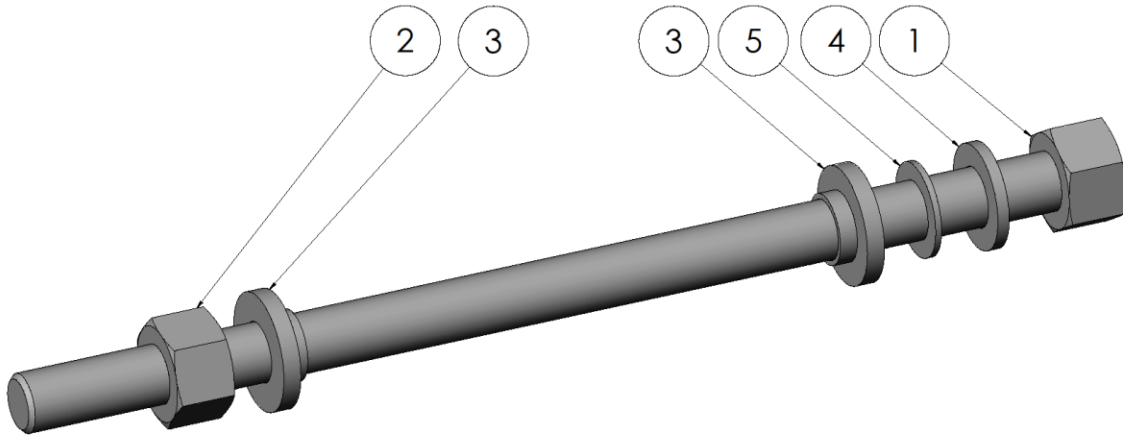

Item Number	Pro2-S/SH Tiebolt Quantity	Part Number	Description
1	1	See Chart	Tiebolt Base
2	1	SG114C	Hex Nut
3	2	11012377	Tiebolt Bushing
4	1	11013002	Tiebolt Retaining Cap
5	1	EW203202	Thrust Bearing

Pro2-S/SH Tiebolt Assembly Size Chart			
Tiebolt Size	Overall Length	Tiebolt Part Number	Assembly Part Number
Pro2-S/SH Size 1	12 inches	11015137	11025019
Pro2-S/SH Size 2	24 inches	11015138	11025020
Pro2-S/SH Size 3	36 inches	11015139	11025021
Pro2-S/SH Size 4	48 inches	11015140	11025022
Pro2-S/SH Size 5	60 inches	11015162	11025046
Pro2-S/SH Size 6	72 inches	11015163	11025047

Pro2-S/SH Tiebolt Assembly

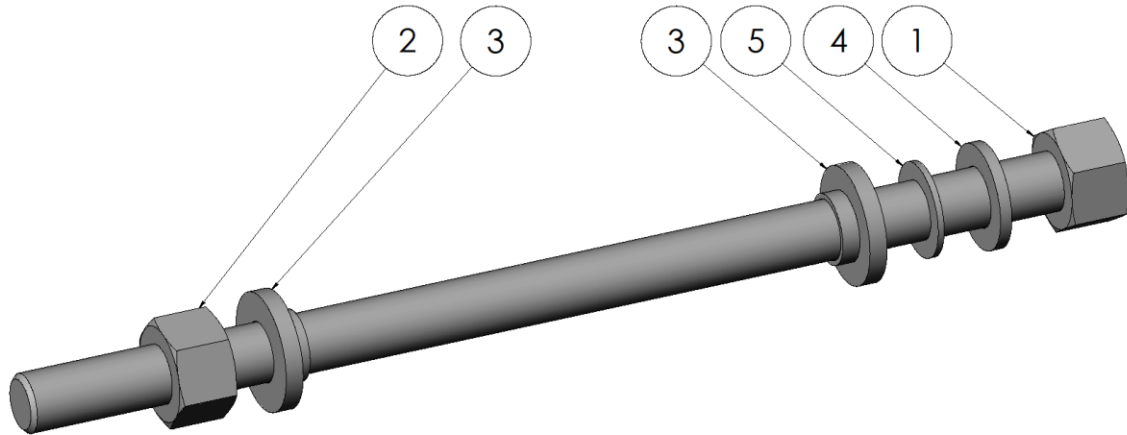

Item Number	Pro2-F/DF/DFH Tiebolt Quantity	Part Number	Description
1	1	See Chart	Tiebolt Base
2	1	SG114C	Hex Nut
3	2	11012377	Tiebolt Bushing
4	1	11013002	Tiebolt Retaining Cap
5	1	EW203202	Thrust Bearing

Pro2-F/DF/DFH Tiebolt Assembly Size Chart			
Tiebolt Size	Overall Length	Tiebolt Part Number	Assembly Part Number
Pro2-F/DF/DFH Size 1	12 inches	11015137	11026100
Pro2-F/DF/DFH Size 2	24 inches	11015138	11026101
Pro2-F/DF/DFH Size 3	36 inches	11015139	11026102
Pro2-F/DF/DFH Size 4	48 inches	11015140	11026103
Pro2-F/DF/DFH Size 5	60 inches	11015162	11026104
Pro2-F/DF/DFH Size 6	72 inches	11015163	11025045

Pro2-F/DF/DFH Tiebolt Assembly

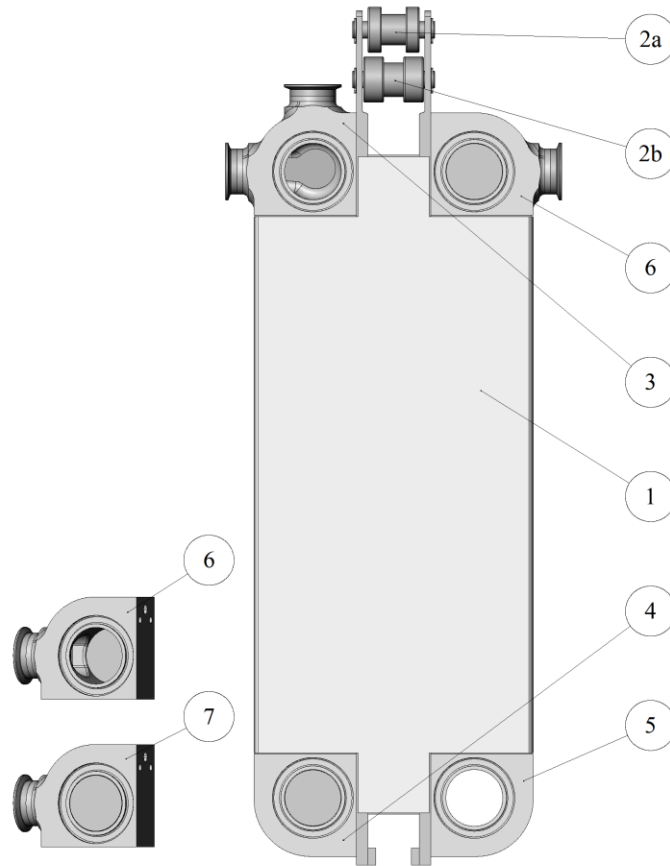

Item Number	Quantity	Part Number	Description
1	1	11024019	Pro2 Terminal Assembly without Bosses
2a	1	11110750	Pro2 Terminal Roller Assembly (Standard Rail)
2b	1	11110432	Pro2 Terminal Roller Assembly (High Capacity)
3	1	11024054	Pro2 Double Port Boss
4	1	11024069	Pro2 Blank Port Boss
5	1	11024051	Pro2 Thru Port Boss
6	1	11024054	Pro2 Single Port Boss (V Configuration)
7	1	11024063	Pro2 Single Port Boss (X Configuration)

Note: Frame Size 4 and larger will require a high capacity roller. Frame size 1, 2, and 3 use standard rail roller.

Pro2 Terminal Assembly
(All Pro2 Tiebolt Frames)

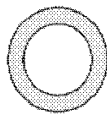
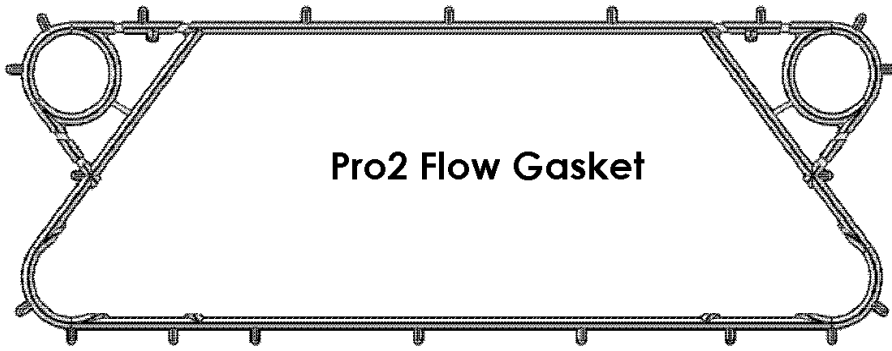

**Die Cut Pro2
Port Gasket**

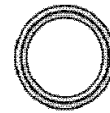

**Molded Pro2
Port Gasket**

Description	Part Number	Frame Application
Pro2 Flow Gasket EPDM	AGPRO201E	All Pro 2 Frames
Pro2 Flow Gasket NBR	AGPRO201N	All Pro2 Frames
Pro2 End Gasket EPDM	AGPRO202E	All Pro2 Frames
Pro2 End Gasket NBR	AGPRO202N	All Pro2 Frames
Pro2 Die Cut Port Gasket EPDM	11018581	Pro2-F/I/DFH/DF
Pro2 Die Cut Port Gasket NBR	11018575	Pro2-F/I/DFH/DF
Pro2 Molded Port Gasket EPDM	AGPRO203E	Pro2-S/SH and Pro2 Terminal
Pro2 Molded Port Gasket NBR	AGPRO203N	Pro2-S/SH and Pro2 Terminal

Pro2 Plate and Frame Gaskets

AGC NEW UNITS

Proflow™ Sanitary Frames

- Manufactured by AGC in USA
- Over 40 frame models to choose from
- Built to 3A standards



Heavy Duty — AR51-M
Expandable Version



HYDRAULIC END OPTION
easy open and close — proven design



Tie Bar Frames



PRO31
Hydraulic Frame

AGC REPLACEMENT PLATES

Latest technology at competitive prices



Pro5

Pro5Plus™

Pro3

ProHX

Pro2

Up to
26%
Pressure drop
reduction

Energy
& Space
Savings
Version

Plate Pack Upgrades —
Upgrade your existing APV Plate Pack.
Plate in stock ready for shipment!



AGC Snap-in Gasket

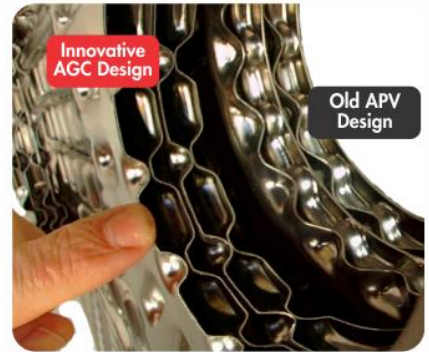

Innovative
AGC Design

Old APV
Design

Reduced Restriction Inlet —
just one of many improvements

sanitary™
proflow
SERIES



AGC GASKETS & SERVICE

Regasketing services for every
make and model — **OEM quality**



PlateCheck

Meets
3A accepted
practices for
testing

Field Leak Check Service

- The only all-inclusive Field Leak Check Service
- Most units can be checked in 2 to 4 hours
- Our method checks ALL the plates in the unit as well as gaskets, frame condition and CIP response as recommended by 3A accepted practices for testing HTST & HHST systems

Field Leak Check is fast and easy

Gaskets for all Makes & Models

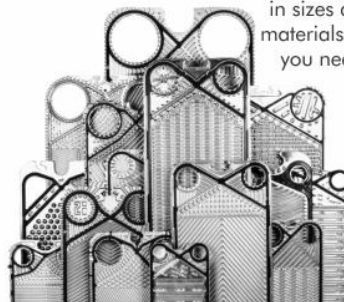

A wide variety
of gaskets/plates
in sizes and
materials that
you need



Gaskets and spares
IN STOCK!





sanitary™
proflow
S E R I E S



"Building the best, servicing the rest"™

AGC Heat Transfer, Inc. is the leading supplier of sanitary plate heat exchangers in North America, manufacturing plate heat exchangers specifically designed for sanitary applications. AGC offers complete heat exchangers services including new frames as well as upgrade plate packs, gaskets and spares that fit other brands. Frames available are tie-bolt, twin spindle and hydraulic (automatic) closure. AGC offers Platecheck™ Field Leak Testing of plate heat exchangers that meets the 3-A sanitary standard.

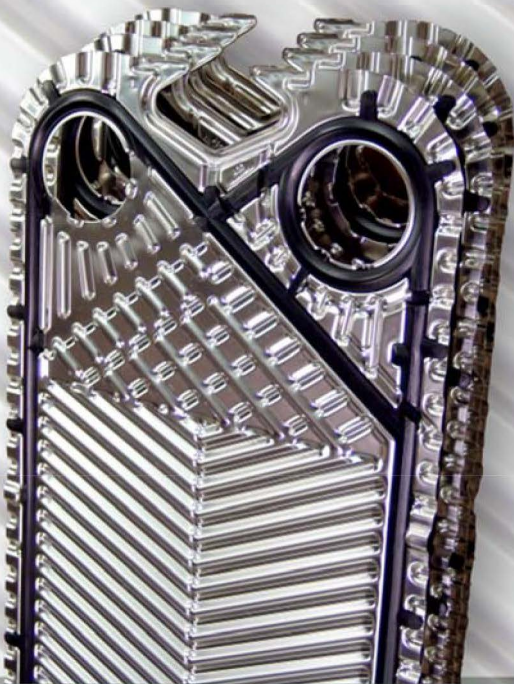

Western

3109 NE 230th Avenue
Fairview, OR 97024
+1.503.774.7342
+1.800.715.8820
FAX +1.503.774.2550

Central

8400 Lakeview Parkway
Suite 700
Pleasant Prairie, WI 53158
+1.847.301.6890
+1.888.489.8820

Eastern

10129 Piper Lane
Bristow, VA 20136
+1.703.257.1660
+1.800.825.8820
FAX +1.703.330.7940