



USER GUIDE

SMCE21011

**EliteConnect™
802.11 a/b/g/n Access Point**



EliteConnect™ SMCE21011 User Guide

SMC®

Networks

20 Mason
Irvine, CA 92618
Phone: (949) 679-8000

May 2009
Pub. # 149100000016A
E052009-CS-R01

Information furnished by SMC Networks, Inc. (SMC) is believed to be accurate and reliable. However, no responsibility is assumed by SMC for its use, nor for any infringements of patents or other rights of third parties which may result from its use. No license is granted by implication or otherwise under any patent or patent rights of SMC. SMC reserves the right to change specifications at any time without notice.

Copyright © 2009 by

SMC Networks, Inc.

20 Mason

Irvine, CA 92618

All rights reserved

Trademarks:

SMC is a registered trademark; and EZ Switch, TigerStack, TigerSwitch, and TigerAccess are trademarks of SMC Networks, Inc. Other product and company names are trademarks or registered trademarks of their respective holders.

WARRANTY AND PRODUCT REGISTRATION

To register SMC products and to review the detailed warranty statement, please refer to the Support Section of the SMC Website at <http://www.smc.com>.

COMPLIANCES

FEDERAL COMMUNICATION COMMISSION INTERFERENCE STATEMENT

This equipment has been tested and found to comply with the limits for a Class B digital device, pursuant to Part 15 of the FCC Rules. These limits are designed to provide reasonable protection against harmful interference in a residential installation. This equipment generates, uses and can radiate radio frequency energy and, if not installed and used in accordance with the instructions, may cause harmful interference to radio communications. However, there is no guarantee that interference will not occur in a particular installation. If this equipment does cause harmful interference to radio or television reception, which can be determined by turning the equipment off and on, the user is encouraged to try to correct the interference by one of the following measures:

- ◆ Reorient or relocate the receiving antenna
- ◆ Increase the separation between the equipment and receiver
- ◆ Connect the equipment into an outlet on a circuit different from that to which the receiver is connected
- ◆ Consult the dealer or an experienced radio/TV technician for help

This device complies with Part 15 of the FCC Rules. Operation is subject to the following two conditions: (1) This device may not cause harmful interference, and (2) this device must accept any interference received, including interference that may cause undesired operation.

FCC Caution: Any changes or modifications not expressly approved by the party responsible for compliance could void the user's authority to operate this equipment.

For product available in the USA/Canada market, only channel 1~11 can be operated. Selection of other channels is not possible.

This device and its antenna(s) must not be co-located or operation in conjunction with any other antenna or transmitter.

This device is going to be operated in 5.15~5.25GHz frequency range, it is restricted in indoor environment only.

**IMPORTANT NOTE:
FCC RADIATION EXPOSURE STATEMENT**

This equipment complies with FCC radiation exposure limits set forth for an uncontrolled environment. This equipment should be installed and operated with minimum distance 20 cm between the radiator & your body.

IC STATEMENT :

This Class B digital apparatus complies with Canadian ICES-003.

Operation is subject to the following two conditions: (1) this device may not cause interference, and (2) this device must accept any interference, including interference that may cause undesired operation of the device.

Cet appareil numérique de la classe B conforme á la norme NMB-003 du Canada.

To reduce potential radio interference to other users, the antenna type and its gain should be so chosen that the equivalent isotropically radiated power (e.i.r.p) is not more than that permitted for successful communication.

This device has been designed to operate with the antennas listed below, and having a maximum gain of 5 dB. Antennas not included in this list or having a gain greater than 5 dB are strictly prohibited for use with this device. The required antenna impedance is 50 ohms.

The device could automatically discontinue transmission in case of absence of information to transmit, or operational failure. Note that this is not intended to prohibit transmission of control or signaling information or the use of repetitive codes where required by the technology.

The device for the band 5150-5250 MHz is only for indoor usage to reduce potential for harmful interference to co-channel mobile satellite systems.

The maximum antenna gain permitted (for devices in the band 5725-5825 MHz) to comply with the e.i.r.p. limits specified for point-to-point and non point-to-point operation as appropriate, as stated in section A9.2(3).

The maximum antenna gain permitted (for devices in the bands 5250-5350 MHz and 5470-5725 MHz) to comply with the e.i.r.p. limit.

High-power radars are allocated as primary users (meaning they have priority) of the bands 5250-5350 MHz and 5650-5850 MHz and these radars could cause interference and/or damage to LE-LAN devices.

**IMPORTANT NOTE:
IC RADIATION EXPOSURE STATEMENT:**

This equipment complies with IC RSS-102 radiation exposure limits set forth for an uncontrolled environment. This equipment should be installed and operated with minimum distance 20 cm between the radiator & your body.

AUSTRALIA/NEW ZEALAND AS/NZS 4771



ACN 066 352010

TAIWAN NCC

根據交通部低功率管理辦法規定：

第十二條 經型式認證合格之低功率射頻電機，非經許可，公司、商號或使用者均不得擅自變更頻率、加大功率或變更原設計之特性及功能。

第十四條 低功率射頻電機之使用不得影響飛航安全及干擾合法通信；經發現有干擾現象時，應立即停用，並改善至無干擾時方得繼續使用。前項合法通信，指依電信法規定作業之無線電通信。低功率射頻電機須忍受合法通信或工業、科學及醫療用電波輻射性電機設備之干擾。

EC CONFORMANCE DECLARATION

Marking by the above symbol indicates compliance with the Essential Requirements of the R&TTE Directive of the European Union (1999/5/EC). This equipment meets the following conformance standards:

- ◆ EN 60950-1 (IEC 60950-1) - Product Safety
- ◆ EN 301 893 - Technical requirements for 5 GHz radio equipment
- ◆ EN 300 328 - Technical requirements for 2.4 GHz radio equipment
- ◆ EN 301 489-1 / EN 301 489-17 - EMC requirements for radio equipment

This device is intended for use in the following European Community and EFTA countries:

- | | | | | |
|-----------------|-------------|---------------|------------------|---------------|
| ◆ Austria | ◆ Belgium | ◆ Cyprus | ◆ Czech Republic | ◆ Denmark |
| ◆ Estonia | ◆ Finland | ◆ France | ◆ Germany | ◆ Greece |
| ◆ Hungary | ◆ Iceland | ◆ Ireland | ◆ Italy | ◆ Latvia |
| ◆ Liechtenstein | ◆ Lithuania | ◆ Luxembourg | ◆ Malta | ◆ Netherlands |
| ◆ Norway | ◆ Poland | ◆ Portugal | ◆ Slovakia | ◆ Slovenia |
| ◆ Spain | ◆ Sweden | ◆ Switzerland | ◆ United Kingdom | ◆ |

Requirements for indoor vs. outdoor operation, license requirements and allowed channels of operation apply in some countries as described below:

- ◆ In Italy the end-user must apply for a license from the national spectrum authority to operate this device outdoors.
- ◆ In Belgium outdoor operation is only permitted using the 2.46 - 2.4835 GHz band: Channel 13.
- ◆ In France outdoor operation is only permitted using the 2.4 - 2.454 GHz band: Channels 1 - 7.



NOTE: The user must use the configuration utility provided with this product to ensure the channels of operation are in conformance with the spectrum usage rules for European Community countries as described below.

- ◆ This device requires that the user or installer properly enter the current country of operation in the command line interface as described in the user guide, before operating this device.
- ◆ This device will automatically limit the allowable channels determined by the current country of operation. Incorrectly entering the country of operation may result in illegal operation and may cause harmful interference to other systems. The user is obligated to ensure the device is operating according to the channel limitations, indoor/outdoor restrictions and license requirements for each European Community country as described in this document.
- ◆ This device employs a radar detection feature required for European Community operation in the 5 GHz band. This feature is automatically enabled when the country of operation is correctly configured for any European Community country. The presence of nearby radar operation may result in temporary interruption of operation of this device. The radar detection feature will automatically restart operation on a channel free of radar.
- ◆ The 5 GHz Turbo Mode feature is not allowed for operation in any European Community country. The current setting for this feature is found in the 5 GHz 802.11a Radio Settings Window as described in the user guide.
- ◆ The 5 GHz radio's Auto Channel Select setting described in the user guide must always remain enabled to ensure that automatic 5 GHz channel selection complies with European requirements. The current setting for this feature is found in the 5 GHz 802.11a Radio Settings Window as described in the user guide.
- ◆ This device is restricted to indoor use when operated in the European Community using the 5.15 - 5.35 GHz band: Channels 36, 40, 44, 48, 52, 56, 60, 64. See table below for allowed 5 GHz channels by country.
- ◆ This device may be operated indoors or outdoors in all countries of the European Community using the 2.4 GHz band: Channels 1 - 13, except where noted below.
 - In Italy the end-user must apply for a license from the national spectrum authority to operate this device outdoors.
 - In Belgium outdoor operation is only permitted using the 2.46 - 2.4835 GHz band: Channel 13.
 - In France outdoor operation is only permitted using the 2.4 - 2.454 GHz band: Channels 1 - 7.

OPERATION USING 5 GHz CHANNELS IN THE EUROPEAN COMMUNITY

The user/installer must use the provided configuration utility to check the current channel of operation and make necessary configuration changes to ensure operation occurs in conformance with European National spectrum usage laws as described below and elsewhere in this document.

Allowed Frequency Bands	Allowed Channel Numbers	Countries
5.15 - 5.25 GHz*	36, 40, 44, 48	Austria, Belgium
5.15 - 5.35 GHz*	36, 40, 44, 48, 52, 56, 60, 64	France, Switzerland, Liechtenstein
5.15 - 5.35* & 5.470 - 5.725 GHz	36, 40, 44, 48, 52, 56, 60, 64, 100, 104, 108, 112, 116, 120, 124, 128, 132, 136, 140	Denmark, Finland, Germany, Iceland, Ireland, Italy, Luxembourg, Netherlands, Norway, Portugal, Spain, Sweden, U.K.
5 GHz Operation Not Allowed	None	Greece

* Outdoor operation is not allowed using 5.15-5.35 GHz bands (Channels 36 - 64).

DECLARATION OF CONFORMITY IN LANGUAGES OF THE EUROPEAN COMMUNITY

Czech Česky	SMC tímto prohlašuje, že tento Radio LAN je ve shodě se základními požadavky a dalšími příslušnými ustanoveními směrnice 1999/5/ES.
Estonian Eesti	Käesolevaga kinnitab SMC seadme Radio LAN device vastavust direktiivi 1999/5/EÜ põhinõuetele ja nimetatud direktiivist tulenevatele teistele asjakohastele sätetele.
English	Hereby, SMC, declares that this Radio LAN device is in compliance with the essential requirements and other relevant provisions of Directive 1999/5/EC.
Finnish Suomi	Valmistaja SMC vakuuttaa täten että Radio LAN device tyyppinen laite on direktiivin 1999/5/EY oleellisten vaatimusten ja sitä koskevien direktiivin muiden ehtojen mukainen.
Dutch Nederlands	Hierbij verklaart SMC dat het toestel Radio LAN device in overeenstemming is met de essentiële eisen en de andere relevante bepalingen van richtlijn 1999/5/EG Bij deze SMC dat deze Radio LAN device voldoet aan de essentiële eisen en aan de overige relevante bepalingen van Richtlijn 1999/5/EC.
French Français	Par la présente SMC déclare que l'appareil Radio LAN device est conforme aux exigences essentielles et aux autres dispositions pertinentes de la directive 1999/5/CE
Swedish Svenska	Härmed intygar SMC att denna Radio LAN device står i överensstämmelse med de väsentliga egenskapskrav och övriga relevanta bestämmelser som framgår av direktiv 1999/5/EG.
Danish Dansk	Undertegnede SMC erklærer herved, at følgende udstyr Radio LAN device overholder de væsentlige krav og øvrige relevante krav i direktiv 1999/5/EF
German Deutsch	Hiermit erklärt SMC, dass sich dieser/diese/dieses Radio LAN device in Übereinstimmung mit den grundlegenden Anforderungen und den anderen relevanten Vorschriften der Richtlinie 1999/5/EG befindet". (BMW) Hiermit erklärt SMC die Übereinstimmung des Gerätes Radio LAN device mit den grundlegenden Anforderungen und den anderen relevanten Festlegungen der Richtlinie 1999/5/EG. (Wien)
Greek Ελληνική	με την παρούσα SMC δηλώνει ότι radio LAN device συμμορφώνεται προς τις ουσιαστικές απαιτήσεις και τις λοιπές σχετικές διατάξεις της οδηγίας 1999/5/εκ.

Hungarian <i>Magyar</i>	Alulírott, SMC nyilatkozom, hogy a Radio LAN device megfelel a vonatkozó alapvető követelményeknek és az 1999/5/EC irányelv egyéb előírásainak.
Italian Italiano	Con la presente SMC dichiara che questo Radio LAN device è conforme ai requisiti essenziali ed alle altre disposizioni pertinenti stabilite dalla direttiva 1999/5/CE.
Latvian Latviski	Ar šo SMC deklarē, ka Radio LAN atbilst Direktīvas 1999/5/EK būtiskajām prasībām un citiem ar to saistītajiem noteikumiem.
Lithuanian Lietuvių	Šiuo SMC deklaruoja, kad šis Radio LAN atitinka esminius reikalavimus ir kitas 1999/5/EB Direktyvos nuostatas.
Maltese Malti	Hawnhekk, SMC, jiddikjara li dan Radio LAN jikkonforma mal-ftigijiet essenzjali u ma pprova jidher li hemm fid-Direttiva 1999/5/EC.
Spanish Español	Por medio de la presente SMC declara que el Radio LAN device cumple con los requisitos esenciales y cualesquiera otras disposiciones aplicables o exigibles de la Directiva 1999/5/CE
Polish Polski	Niniejszym SMC oświadcza, że Radio LAN jest zgodny z zasadniczymi wymogami oraz pozostałymi stosownymi postanowieniami Dyrektywy 1999/5/EC.
Portuguese Português	SMC declara que este Radio LAN device está conforme com os requisitos essenciais e outras disposições da Directiva 1999/5/CE.
Slovak Slovensky	SMC týmto vyhlasuje, že Radio LAN spĺňa základné požiadavky a všetky príslušné ustanovenia Smernice 1999/5/ES.
Slovenian Slovensko	SMC izjavlja, da je ta radio LAN device v skladu z bistvenimi zahtevami in ostalimi relevantnimi določili direktive 1999/5/ES.

ABOUT THIS GUIDE

PURPOSE This guide gives specific information on how to install the 11n wireless access point and its physical and performance related characteristics. It also gives information on how to operate and use the management functions of the access point.

AUDIENCE This guide is intended for use by network administrators who are responsible for installing, operating, and maintaining network equipment; consequently, it assumes a basic working knowledge of LANs (Local Area Networks), the Internet Protocol (IP), and Simple Network Management Protocol (SNMP).

CONVENTIONS The following conventions are used throughout this guide to show information:



NOTE: Emphasizes important information or calls your attention to related features or instructions.



CAUTION: Alerts you to a potential hazard that could cause loss of data, or damage the system or equipment.



WARNING: Alerts you to a potential hazard that could cause personal injury.

RELATED PUBLICATIONS As part of the access point's software, there is an online web-based help that describes all management related features.

REVISION HISTORY This section summarizes the changes in each revision of this guide.

MAY 2009 REVISION

This is the first revision of this guide. It is valid for software version 1.1.0.12.

CONTENTS

WARRANTY AND PRODUCT REGISTRATION	4
COMPLIANCES	5
ABOUT THIS GUIDE	11
CONTENTS	12
FIGURES	17
TABLES	20
INDEX OF CLI COMMANDS	23

SECTION I	GETTING STARTED	26
	1 INTRODUCTION	27
	Key Hardware Features	27
	Description of Capabilities	27
	Package Contents	28
	Hardware Description	29
	Antennas	30
	External Antenna Connectors	30
	LED Indicators	32
	Console Port	33
	Ethernet Port	33
	Power Connector	33
	Reset Button	33
	2 NETWORK TOPOLOGIES	34
	Interference Issues	34
	Infrastructure Wireless LAN	34
	Infrastructure Wireless LAN for Roaming Wireless PCs	35
	Infrastructure Wireless Bridge	36

3	INSTALLING THE ACCESS POINT	38
	Location Selection	38
	Mounting on a Horizontal Surface	39
	Mounting on a Wall	40
	Connecting and Powering On	41
4	INITIAL CONFIGURATION	42
	Connecting to the Login Page	42
	Home Page and Main Menu	43
	Common Web Page Buttons	44
	Quick Start	45
	Step 1	45
	Step 2	46
	Step 3	48
	Main Menu Items	49
<hr/>		
SECTION II	WEB CONFIGURATION	50
5	SYSTEM SETTINGS	51
	Administration Settings	52
	IP Address	53
	RADIUS Settings	54
	Primary and Secondary RADIUS Server Setup	54
	RADIUS Accounting	55
	System Time	56
	SNTP Server Settings	57
	Time Zone Setting	57
	Daylight Saving Settings	57
	SpectraLink Voice Priority	58
	VLAN Configuration	58
	System Logs	60
	Quick Start Wizard	61
6	MANAGEMENT SETTINGS	62
	Remote Management Settings	62
	Access Limitation	64
	Simple Network Management Protocol	65

SNMP Basic Settings	65
SNMP Trap Settings	67
View Access Control Model	68
SNMPv3 Users	69
SNMPv3 Targets	70
SNMPv3 Notification Filters	71
7 ADVANCED SETTINGS	73
Local Bridge Filter	73
Link Layer Discovery Protocol	74
Access Control Lists	76
Source Address Settings	76
Destination Address Settings	77
Ethernet Type	78
8 WIRELESS SETTINGS	79
Spanning Tree Protocol (STP)	79
Bridge	80
Ethernet Interface	81
Wireless Interface	81
Authentication	82
Local MAC Authentication	82
RADIUS MAC Authentication	84
Interface Mode	85
Radio Settings	86
Virtual Access Points (VAPs)	89
VAP Basic Settings	90
WDS-STA Mode	91
Wireless Security Settings	92
Wired Equivalent Privacy (WEP)	94
Quality of Service (QoS)	95
9 MAINTENANCE SETTINGS	100
Upgrading Firmware	100
Running Configuration	103
Resetting the Access Point	104
10 STATUS INFORMATION	105
AP Status	105

AP System Configuration	105
AP Wireless Configuration	107
Station Status	107
Event Logs	108

SECTION III	COMMAND LINE INTERFACE	110
11	USING THE COMMAND LINE INTERFACE	112
	Console Connection	112
	Telnet Connection	113
	Entering Commands	114
	Keywords and Arguments	114
	Minimum Abbreviation	114
	Command Completion	114
	Getting Help on Commands	114
	Showing Commands	114
	Negating the Effect of Commands	115
	Using Command History	115
	Understanding Command Modes	115
	Exec Commands	116
	Configuration Commands	116
	Command Line Processing	117
12	GENERAL COMMANDS	118
13	SYSTEM MANAGEMENT COMMANDS	122
14	SYSTEM LOGGING COMMANDS	137
15	SYSTEM CLOCK COMMANDS	141
16	DHCP RELAY COMMANDS	146
17	SNMP COMMANDS	148
18	FLASH/FILE COMMANDS	162
19	RADIUS CLIENT COMMANDS	165
20	802.1X AUTHENTICATION COMMANDS	171
21	MAC ADDRESS AUTHENTICATION COMMANDS	173

22	FILTERING COMMANDS	177
23	SPANNING TREE COMMANDS	182
24	WDS BRIDGE COMMANDS	193
25	ETHERNET INTERFACE COMMANDS	195
26	WIRELESS INTERFACE COMMANDS	200
27	WIRELESS SECURITY COMMANDS	214
28	LINK LAYER DISCOVERY COMMANDS	224
29	VLAN COMMANDS	228
30	WMM COMMANDS	231
<hr/>		
SECTION IV	APPENDICES	236
A	TROUBLESHOOTING	237
	Diagnosing LED Indicators	237
	Before Contacting Technical Support	237
B	WDS SETUP EXAMPLES	240
	Basic WDS Link Between Two APs	241
	WDS Links Between Three or More APs	246
C	HARDWARE SPECIFICATIONS	249
D	CABLES AND PINOUTS	252
	Twisted-Pair Cable Assignments	252
	10/100BASE-TX Pin Assignments	252
	Straight-Through Wiring	253
	Crossover Wiring	254
	1000BASE-T Pin Assignments	254
	Console Port Pin Assignments	256
	GLOSSARY	257
	INDEX	261

FIGURES

Figure 1: Top Panel	29
Figure 2: Rear Panel	29
Figure 3: Ports	30
Figure 4: External Antenna Connectors	31
Figure 5: Screw-off External Antenna Connector - Close Up	31
Figure 6: LEDs	32
Figure 7: Infrastructure Wireless LAN	35
Figure 8: Infrastructure Wireless LAN for Roaming Wireless PCs	36
Figure 9: Bridging Mode	37
Figure 10: Attach Feet	39
Figure 11: Wall Mounting	40
Figure 12: Login Page	42
Figure 13: Home Page	43
Figure 14: Set Configuration Changes	44
Figure 15: Help Menu	44
Figure 16: Quick Start - Step 1	45
Figure 17: Quick Start - Step 2	46
Figure 18: Quick Start - Step 3	48
Figure 19: Administration	52
Figure 20: IP Configuration	53
Figure 21: RADIUS Settings	55
Figure 22: SNTP Settings	56
Figure 23: SVP Settings	58
Figure 24: Setting the VLAN Identity	59
Figure 25: System Log Settings	60
Figure 26: Remote Management	63
Figure 27: Access Limitation	64
Figure 28: SNMP Basic Settings	66
Figure 29: SNMP Trap Settings	67
Figure 30: SNMP VACM	68
Figure 31: Configuring SNMPv3 Users	69

Figure 32: SNMPv3 Targets	71
Figure 33: SNMP Notification Filter	71
Figure 34: Local Bridge Filter	73
Figure 35: LLDP Settings	74
Figure 36: Source ACLs	76
Figure 37: Destination ACLs	77
Figure 38: Ethernet Type Filter	78
Figure 39: Spanning Tree Protocol	80
Figure 40: Local Authentication	83
Figure 41: RADIUS Authentication	84
Figure 42: Interface Mode	85
Figure 43: Radio Settings	86
Figure 44: VAP Settings	89
Figure 45: VAP Basic Settings	90
Figure 46: WDS-STA Mode	91
Figure 47: Configuring VAPs - Common Settings	92
Figure 48: WEP Configuration	94
Figure 49: WMM Backoff Wait Times	97
Figure 50: QoS	97
Figure 51: Firmware	101
Figure 52: Running Configuration File	103
Figure 53: Resetting the Access Point	104
Figure 54: AP System Configuration	105
Figure 55: AP Wireless Configuration	107
Figure 56: Station Status	107
Figure 57: Event Logs	108
Figure 58: Basic WDS Link Between Two APs	241
Figure 59: WDS Example — Access Point A VAP Setting	242
Figure 60: WDS Example — Access Point A VAP Details	242
Figure 61: WDS Example — Access Point A WDS-AP VAP Setting	243
Figure 62: WDS Example — Access Point A VAP SSID and MAC	243
Figure 63: WDS Example — Access Point B VAP Details	244
Figure 64: WDS Example — Access Point B WDS-STA VAP Setting	244
Figure 65: WDS Example — Access Point A Station Status	245
Figure 66: WDS Links Between Three or More APs	246
Figure 67: RJ-45 Connector	252

Figure 68: Straight Through Wiring	253
Figure 69: Crossover Wiring	254
Figure 70: RJ-45 Console	256

TABLES

Table 1: Key Hardware Features	27
Table 2: LED Behavior	32
Table 3: Logging Levels	61
Table 4: WMM Access Categories	96
Table 5: Command Modes	116
Table 6: Keystroke Commands	117
Table 7: General Commands	118
Table 8: System Management Commands	122
Table 9: Country Codes	123
Table 10: System Management Commands	137
Table 11: Logging Levels	139
Table 12: System Clock Commands	141
Table 13: DHCP Relay Commands	146
Table 14: SNMP Commands	148
Table 15: Flash/File Commands	162
Table 16: RADIUS Client Commands	165
Table 17: 802.1x Authentication	171
Table 18: MAC Address Authentication	173
Table 19: Filtering Commands	177
Table 20: Spanning Tree Commands	182
Table 21: WDS Bridge Commands	193
Table 22: Ethernet Interface Commands	195
Table 23: Wireless Interface Commands	200
Table 24: Wireless Security Commands	214
Table 25: Link Layer Discovery Commands	224
Table 26: VLAN Commands	228
Table 27: WMM Commands	231
Table 28: AP Parameters	233
Table 29: BSS Parameters	233
Table 30: LED Indicators	237
Table 31: 10/100BASE-TX MDI and MDI-X Port Pinouts	253

Table 32: 1000BASE-T MDI and MDI-X Port Pinouts	255
Table 33: Console Port Pinouts	256

INDEX OF CLI COMMANDS

NUMERICS

802.1x enable 171
802.1x session-timeout 172

A

address filter default 173
address filter delete 174
address filter entry 174
a-mpdu 201
a-msdu 202
apmgmtui ssh enable 125
apmgmtip 130
apmgmtui http port 127
apmgmtui http server 127
apmgmtui http session-timeout 128
apmgmtui https port 128
apmgmtui https server 129
apmgmtui snmp 130
apmgmtui ssh port 126
apmgmtui telnet-server enable 126
assoc-timeout-interval 210
auth 214
auth-timeout-interval 210

B

beacon-interval 207
bridge stp br-conf forwarding-delay 183
bridge stp br-conf hello-time 184
bridge stp br-conf max-age 184
bridge stp br-conf priority 185
bridge stp port-conf interface 185
bridge stp service 183
bridge-link path-cost 186
bridge-link port-priority 186

C

channel 202
cipher-suite 219
cli-session-timeout 119
closed-system 209
configure 118
copy 163
country 123

D

dhcp-relay server 146
dns 196
dtim-period 207
dual-image 162

E

encryption 216
end 119
exit 119

F

filter acl-destination-address 179
filter acl-source-address 178
filter ap-manage 178
filter ethernet-type enabled 179
filter ethernet-type protocol 180
filter local-bridge 177

I

interface ethernet 195
interface wireless 201
interface-radio-mode 204
ip address 196
ip dhcp 197

K

key 217

L

lldp service 224
lldp transmit delay-to-local-change 226
lldp transmit interval 225
lldp transmit re-init-delay 226
lldp-transmit hold-multiplier 225
logging clear 139
logging console 138
logging host 138
logging level 139
logging on 137

M

mac-authentication server 175
 mac-authentication session-timeout 175
 make-radius-effective 169
 make-rf-setting-effective 205
 make-security-effective 221
 management-vlanid 229

P

password 125
 path-cost (STP Interface) 187
 ping 120
 pmksa-lifetime 221
 port-priority (STP Interface) 188
 preamble 205
 prompt 124

R

radius-server accounting address 167
 radius-server accounting key 168
 radius-server accounting port 168
 radius-server accounting timeout-interim 169
 radius-server address 166
 radius-server enable 165
 radius-server key 167
 radius-server port 166
 reset 121
 rts-threshold 208

S

short-guard-interval 206
 show apmanagement 131
 show authentication 176
 show bridge br-conf 189
 show bridge forward address 191
 show bridge port-conf interface 189
 show bridge status 190
 show bridge stp 188
 show config 132
 show dual-image 164
 show event-log 140
 show filters 181
 show interface ethernet 198
 show interface wireless 211
 show line 121
 show lldp 227
 show logging 140
 show radius 170
 show snmp 159
 show snmp filter 159
 show snmp target 158
 show snmp users 158
 show snmp vacm group 160
 show snmp vacm view 160

show snmp 144
 show station 213
 show system 131
 show version 132
 show wds wireless 194
 shutdown 198
 shutdown 211
 snmp-server community 149
 snmp-server contact 149
 snmp-server enable server 150
 snmp-server filter 157
 snmp-server host 151
 snmp-server location 150
 snmp-server target 156
 snmp-server trap 152
 snmp-server user 155
 snmp-server vacm group 154
 snmp-server vacm view 153
 snmp-server date-time 142
 snmp-server daylight-saving 143
 snmp-server enabled 142
 snmp-server ip 141
 snmp-server timezone 144
 ssid 209
 system name 124

T

transmit-key 218
 transmit-power 204

V

vap 201
 vap (STP Interface) 187
 vlan 228
 vlan-id 230

W

wds ap 193
 wds sta 193
 wmm 231
 wmm-acknowledge-policy 232
 wmmparam 232
 wpa-pre-shared-key 220

SECTION I

GETTING STARTED

This section provides an overview of the access point, and introduces some basic concepts about wireless networking. It also describes the basic settings required to access the management interface.

This section includes these chapters:

- ◆ [“Introduction” on page 27](#)
- ◆ [“Network Topologies” on page 34](#)
- ◆ [“Installing the Access Point” on page 38](#)
- ◆ [“Initial Configuration” on page 42](#)

The EliteConnect™ SMCE21011 is an IEEE 802.11n access point (AP) that meets draft 2.0 standards. It is fully interoperable with older 802.11a/b/g standards, providing a transparent, wireless high speed data communication between the wired LAN and fixed or mobile devices. The unit includes three detachable dual-band 2.4/5 GHz antennas with the option to attach alternative antennas that can extend or shape the network coverage area.

KEY HARDWARE FEATURES

The following table describes the main hardware features of the AP.

Table 1: Key Hardware Features

Feature	Description
Antennas	Three detachable dual-band 2.4/5 GHz MIMO antennas.
LAN Port	One 1000BASE-T RJ-45 port that supports a Power over Ethernet (PoE) connection to power the device.
Console Port	Console connection through an RJ-45 port with included RS-232 serial cable.
Reset Button	For resetting the unit and restoring factory defaults.
LEDs	Provides LED indicators for system status, wireless radio status, and LAN port status.
Power	Power over Ethernet (PoE) support through the RJ-45 Ethernet port, or from an external AC power adapter.
Mounting Options	Can be mounted on a wall, or on any horizontal surface such as a desktop or shelf.

DESCRIPTION OF CAPABILITIES

The SMCE21011 supports up to eight Virtual Access Point (VAP) interfaces, which allow traffic to be separated for different user groups within the same AP service area. The VAPs can support up to a total of 64 wireless clients, whereby the clients associate with each VAP in the same way as they would with physically separate access points. This means that each VAP can be configured with its own Service Set Identification (SSID), security settings, VLAN assignments, and other parameters, allowing the AP to serve a diverse range of client needs in an area from a single unit.

In addition, the access point offers full network management capabilities through an easy to configure web interface, a command line interface for initial configuration and troubleshooting, and support for Simple Network Management tools.

The SMCE21011 utilises MIMO technology and Spatial Multiplexing to achieve the highest possible data rate and throughput on the 802.11n frequency. The unit's PoE RJ-45 port provides a 1 Gbps full-duplex link to a wired LAN.

PACKAGE CONTENTS

The EliteConnect™ SMCE21011 package includes:

- ◆ 11n Access Point (SMCE21011)
- ◆ RJ-45 to RS-232 console cable
- ◆ AC power adapter
- ◆ Four rubber feet
- ◆ User Guide CD

Inform your dealer if there are any incorrect, missing or damaged parts. If possible, retain the carton, including the original packing materials. Use them again to repack the product in case there is a need to return it.

HARDWARE DESCRIPTION

Figure 1: Top Panel

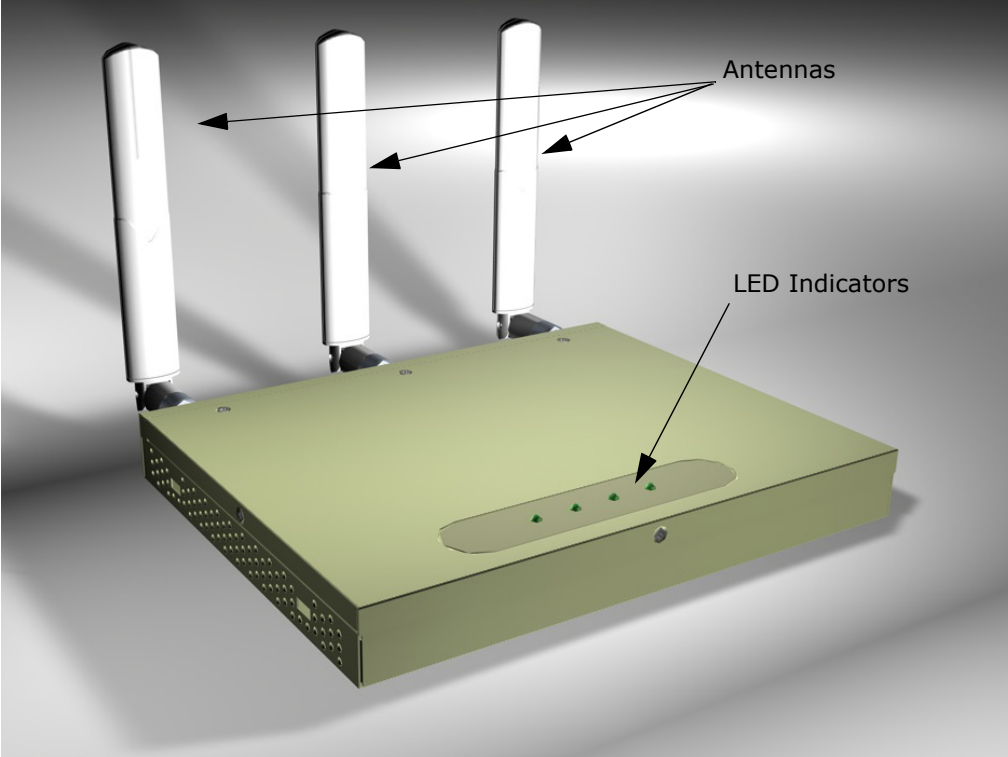

Figure 2: Rear Panel

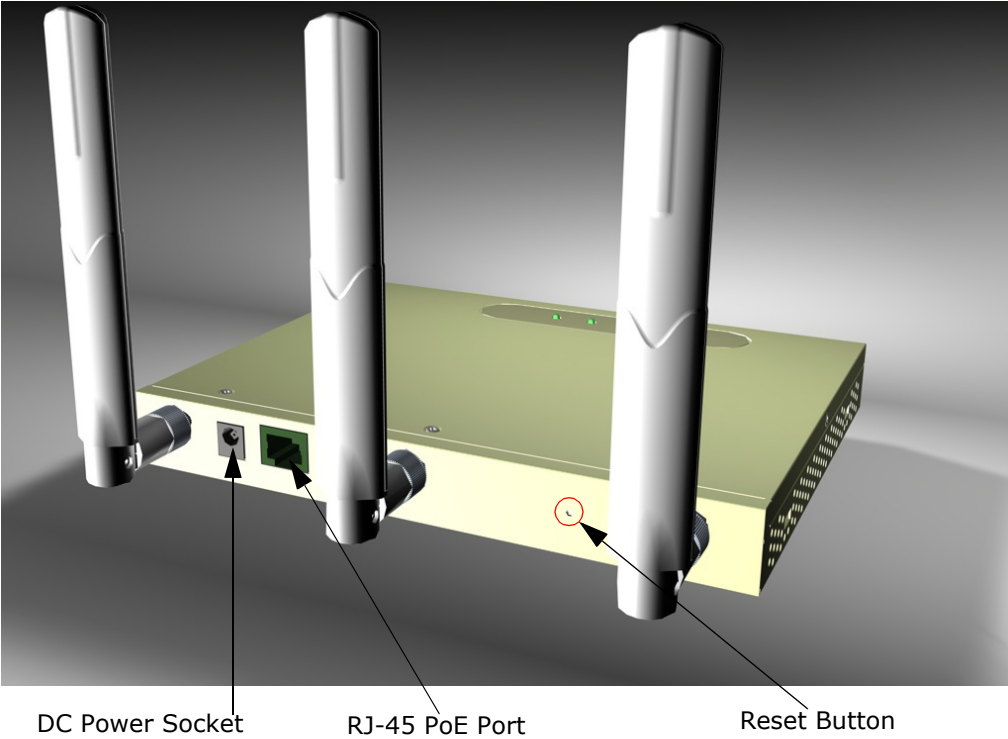
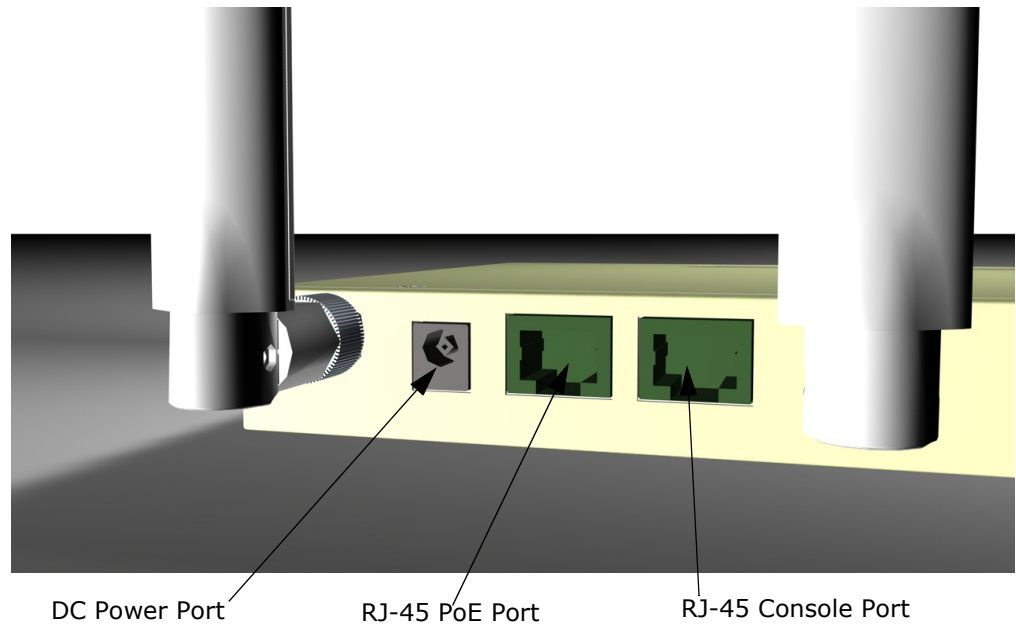

Figure 3: Ports



ANTENNAS The access point includes three integrated external MIMO (multiple-input and multiple-output) antennas. MIMO uses multiple antennas for transmitting and receiving radio signals to improve data throughput and link range.

Each antenna transmits the outgoing signal as a toroidal sphere (doughnut shaped), with the coverage extending most in a direction perpendicular to the antenna. Therefore, the antennas should be adjusted to an angle that provides the appropriate coverage for the service area.

EXTERNAL ANTENNA CONNECTORS The antennas supplied with the AP screw off in a clockwise manner and can be replaced with alternative antennas that can extend or shape the coverage area.

Figure 4: External Antenna Connectors

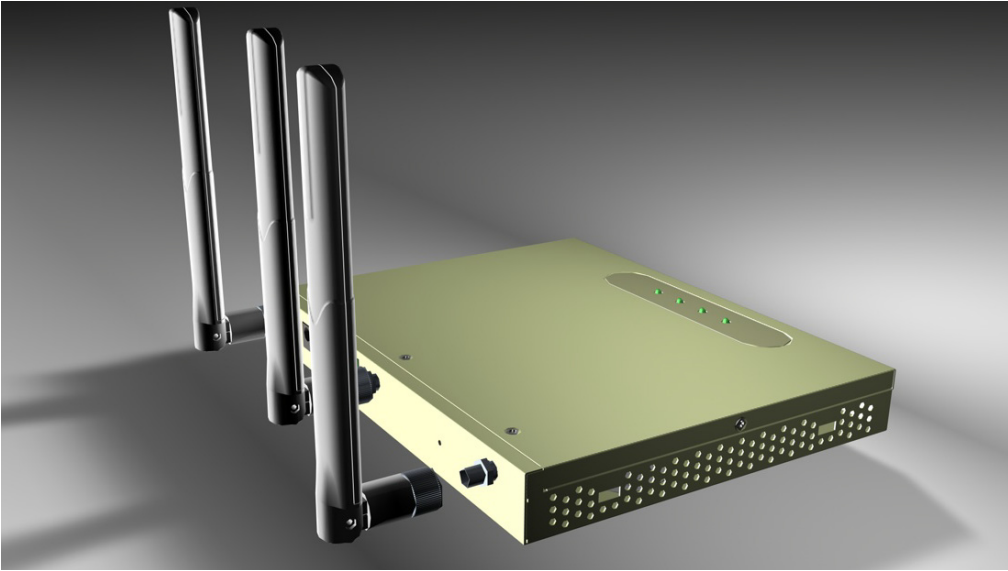
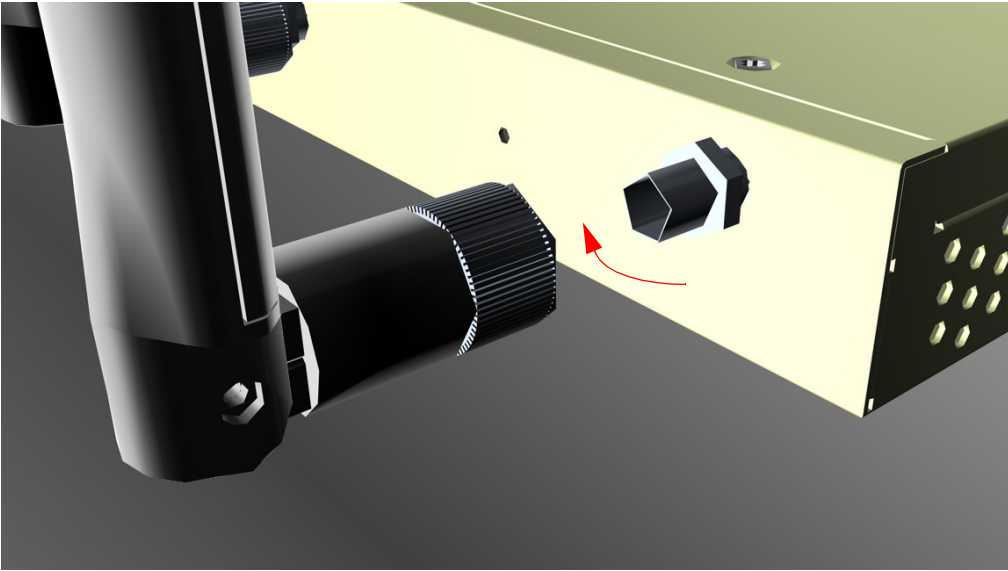

Figure 5: Screw-off External Antenna Connector - Close Up



LED INDICATORS The access point includes four status LED indicators, as described in the following figure and table.

Figure 6: LEDs

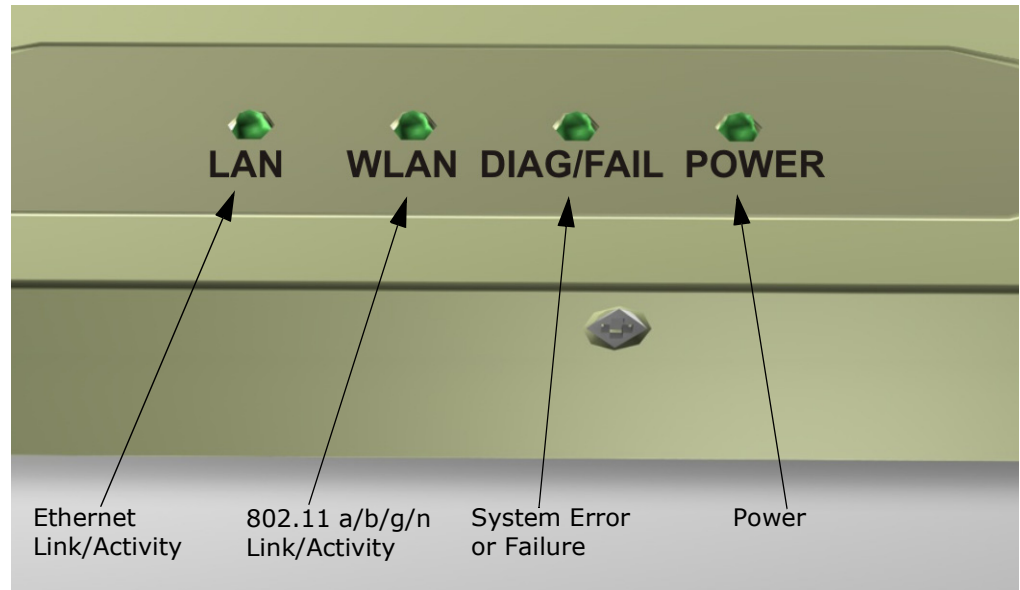

Table 2: LED Behavior

LED	Status	Description
LAN	Off	Ethernet RJ-45 has no valid link.
	Blue	Ethernet RJ-45 has a 1000 Mbps link. Blinking indicates network activity.
	Green	Ethernet RJ-45 has a 100 Mbps link. Blinking indicates network activity.
	Amber	Ethernet RJ-45 has a 10 Mbps link. Blinking indicates network activity.
WLAN	Off	The AP radio is disabled.
	Green	The radio is operating at 5 GHz (802.11a/n). Blinking indicates network activity.
	Yellow	The radio is operating at 2.4 GHz (802.11b/g/n). Blinking indicates network activity.
Diag/Fail	Off	The AP is operating normally.
	Red	The AP has detected a fault.
	Blinking	The system is initializing.
Power	Off	The AP has no power.
	Yellow	The AP is receiving power.

CONSOLE PORT This port is used to connect a console device to the access point through a serial cable. The console device can be a PC or workstation running a VT-100 terminal emulator, or a VT-100 terminal. A crossover RJ-45 to DB-9 cable is supplied with the unit for connecting to the console port.

ETHERNET PORT The access point has one 1000BASE-T RJ-45 port that can be attached directly to 10BASE-T/100BASE-TX/1000BASE-TX LAN segments.

This port supports automatic MDI/MDI-X operation, so you can use straight-through cables for all network connections to PCs, switches, or hubs.

The access point appears as an Ethernet node and performs a bridging function by moving packets from the wired LAN to remote workstations on the wireless infrastructure.



NOTE: The RJ-45 port also supports Power over Ethernet (PoE) based on the IEEE 802.3af standard. Refer to the description for the "Power Connector" for information on supplying power to the access point's network port from a network device, such as a switch or power injector, that provides Power over Ethernet (PoE).

POWER CONNECTOR The access point does not have a power switch. It is powered on when connected to the AC power adapter, and the power adapter is connected to a power source. The power adapter automatically adjusts to any voltage between 100~240 volts at 50 or 60 Hz, and supplies 12 volts DC power to the unit. No voltage range settings are required.

The access point may also receive Power over Ethernet (PoE) from a switch or other network device that supplies power over the network cable based on the IEEE 802.3af standard.



NOTE: The access point supports both endspan and midspan PoE.

If the access point is connected to a PoE source device and also connected to a local power source through the AC power adapter, AC power will be disabled.

RESET BUTTON This button can be used to restart the AP.

Wireless networks support a standalone configuration as well as an integrated configuration with 10/100/1000 Mbps Ethernet LANs. The SMCE21011 also provides bridging services that can be configured independently on any of the virtual AP (VAP) interfaces.

Access points can be deployed to support wireless clients and connect wired LANs in the following configurations:

- ◆ Infrastructure for wireless LANs
- ◆ Infrastructure wireless LAN for roaming wireless PCs
- ◆ Infrastructure wireless bridge to connect wired LANs

INTERFERENCE ISSUES

The 802.11b, 802.11g and 802.11n frequency band operating at 2.4 GHz can easily encounter interference from other 2.4 GHz devices, such as other 802.11b/g/n wireless devices, cordless phones and microwave ovens. If you experience poor wireless LAN performance, try the following measures:

- ◆ Limit any possible sources of radio interference within the service area
- ◆ Increase the distance between neighboring access points
- ◆ Decrease the signal strength of neighboring access points
- ◆ Increase the channel separation of neighboring access points (e.g. up to 3 channels of separation for 802.11b, or up to 4 channels for 802.11a, or up to 5 channels for 802.11g)

INFRASTRUCTURE WIRELESS LAN

The access point also provides access to a wired LAN for wireless workstations. An integrated wired/wireless LAN is called an Infrastructure configuration. A Basic Service Set (BSS) consists of a group of wireless PC users, and an access point that is directly connected to the wired LAN. Each wireless PC in this BSS can talk to any computer in its wireless group via a radio link, or access other computers or network resources in the wired LAN infrastructure via the access point.

The infrastructure configuration extends the accessibility of wireless PCs to the wired LAN.

A wireless infrastructure can be used for access to a central database, or for connection between mobile workers, as shown in the following figure.

Figure 7: Infrastructure Wireless LAN

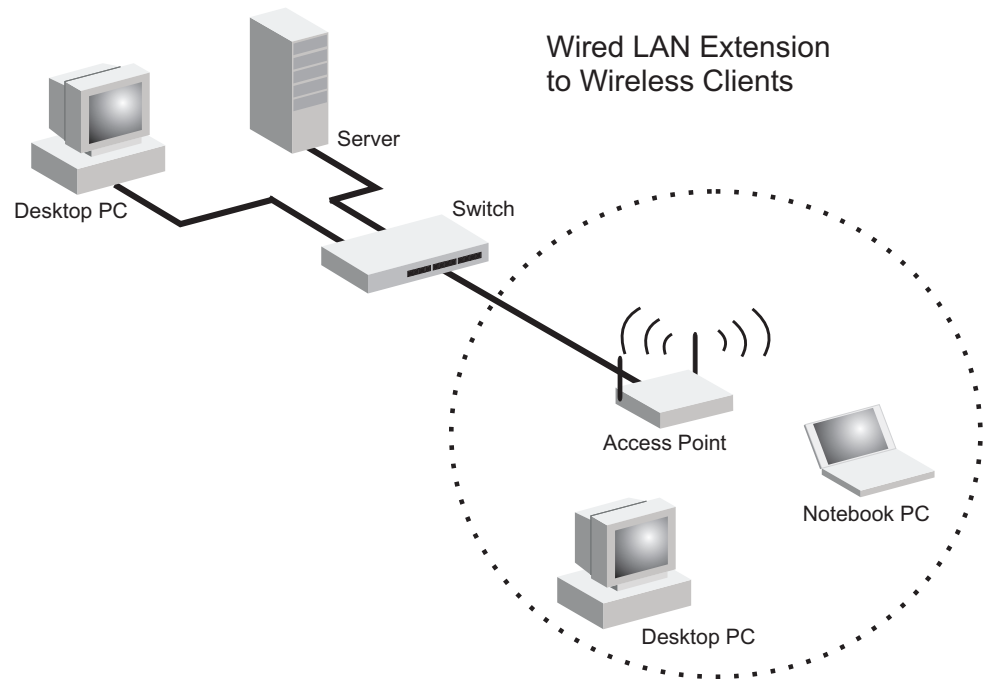

INFRASTRUCTURE WIRELESS LAN FOR ROAMING WIRELESS PCs

The Basic Service Set (BSS) defines the communications domain for each access point and its associated wireless clients. The BSS ID is a 48-bit binary number based on the access point's wireless MAC address, and is set automatically and transparently as clients associate with the access point. The BSS ID is used in frames sent between the access point and its clients to identify traffic in the service area.

The BSS ID is only set by the access point, never by its clients. The clients only need to set the Service Set Identifier (SSID) that identifies the service set provided by one or more access points. The SSID can be manually configured by the clients, can be detected in an access point's beacon, or can be obtained by querying for the identity of the nearest access point. For clients that do not need to roam, set the SSID for the wireless card to that used by the access point to which you want to connect.

A wireless infrastructure can also support roaming for mobile workers. More than one access point can be configured to create an Extended Service Set (ESS). By placing the access points so that a continuous coverage area is created, wireless users within this ESS can roam freely. All

wireless network cards and adapters and wireless access points within a specific ESS must be configured with the same SSID.

Figure 8: Infrastructure Wireless LAN for Roaming Wireless PCs

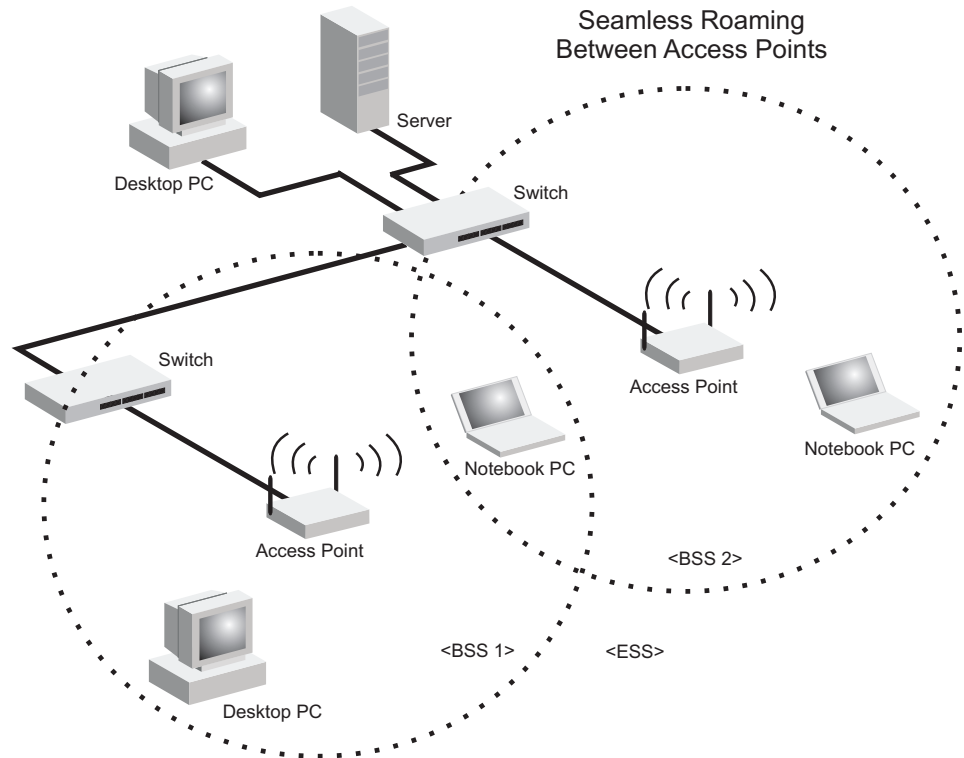

INFRASTRUCTURE WIRELESS BRIDGE

The IEEE 802.11 standard defines a Wireless Distribution System (WDS) for bridge connections between BSS areas (access points). The access point uses WDS to forward traffic on links between units.

The access point supports WDS bridge links that are independently configurable on each VAP. There are two WDS modes; WDS-AP and WDS-STA. Otherwise, VAPs operate in a normal AP mode.

- ◆ **AP Mode:** The VAP provides services to clients as a normal access point.
- ◆ **WDS-AP Mode:** The VAP operates as an access point in WDS mode, which accepts connections from client stations in WDS-STA mode.
- ◆ **WDS-STA Mode:** The VAP operates as a client station in WDS mode, which connects to an access point VAP in WDS-AP mode. The user needs to specify the MAC address of the VAP in WDS-AP mode to which it intends to connect.

Figure 9: Bridging Mode

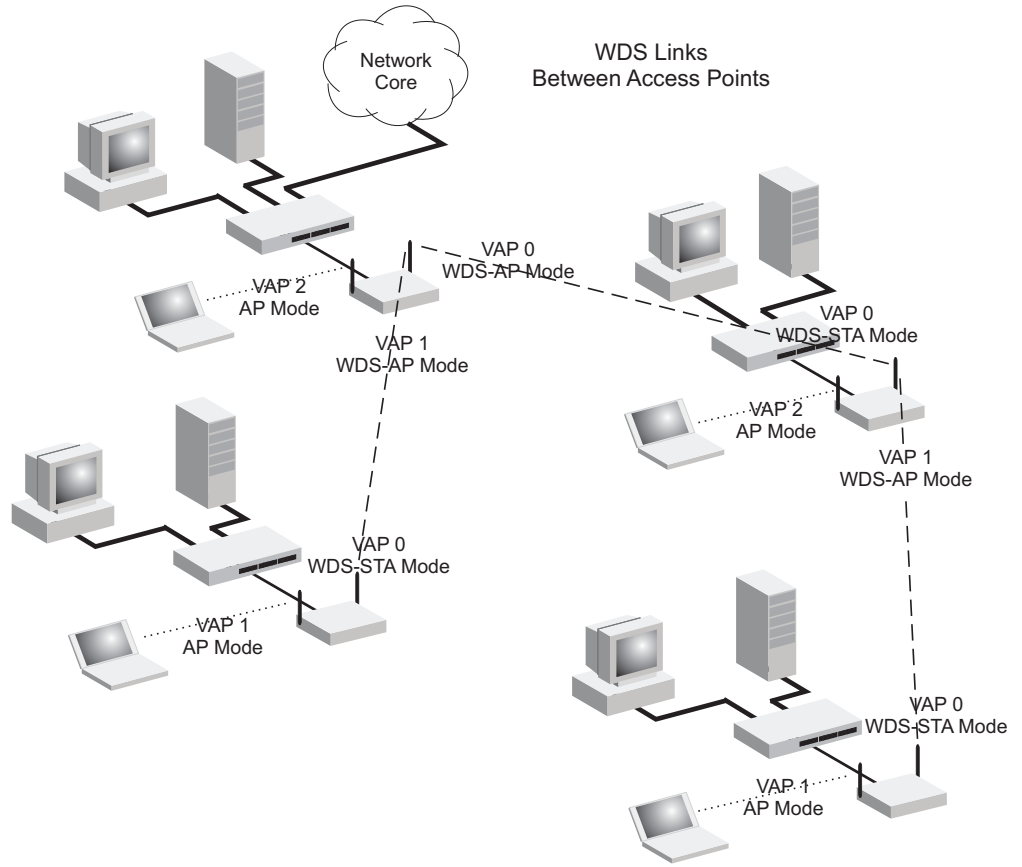

3

INSTALLING THE ACCESS POINT

This chapter describes how to install the access point.

LOCATION SELECTION

Choose a proper place for the access point. In general, the best location is at the center of your wireless coverage area, within line of sight of all wireless devices. Try to place the access point in a position that can best cover its service area. For optimum performance, consider these guidelines:

- ◆ Mount the access point as high as possible above any obstructions in the coverage area.
- ◆ Avoid mounting next to or near building support columns or other obstructions that may cause reduced signal or null zones in parts of the coverage area.
- ◆ Mount away from any signal absorbing or reflecting structures (such as those containing metal).

The access point can be mounted on any horizontal surface, or a wall.

MOUNTING ON A HORIZONTAL SURFACE

To keep the access point from sliding on the surface, attach the four rubber feet provided in the accessory kit to the marked circles on the bottom of the access point.

Figure 10: Attach Feet

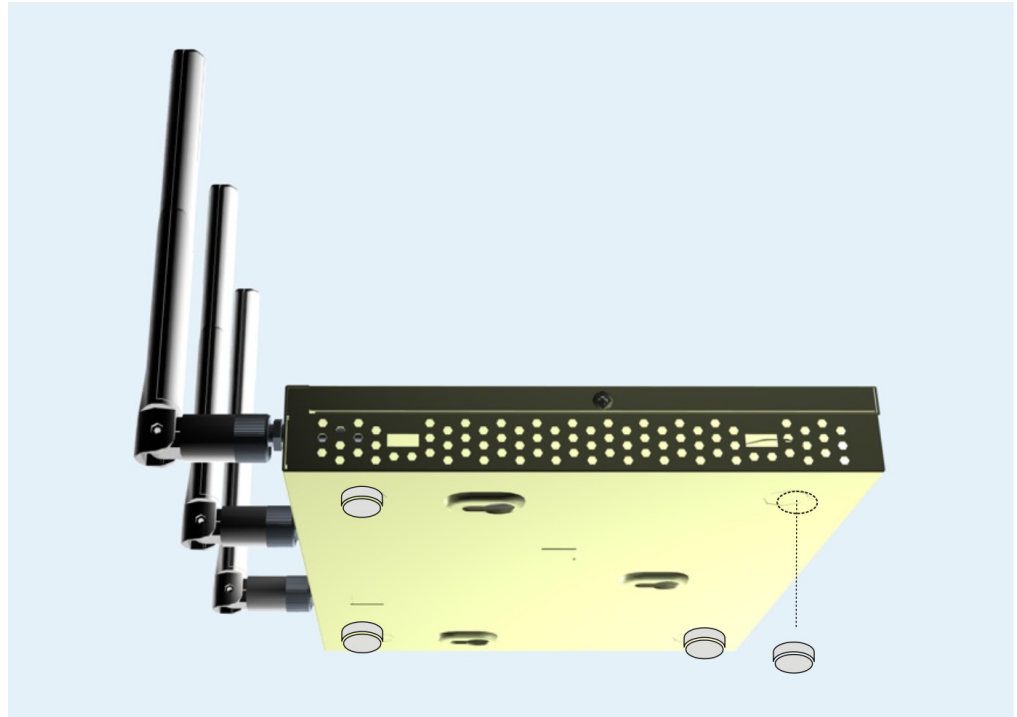

MOUNTING ON A WALL

To mount on a wall follow the instructions below.

Figure 11: Wall Mounting

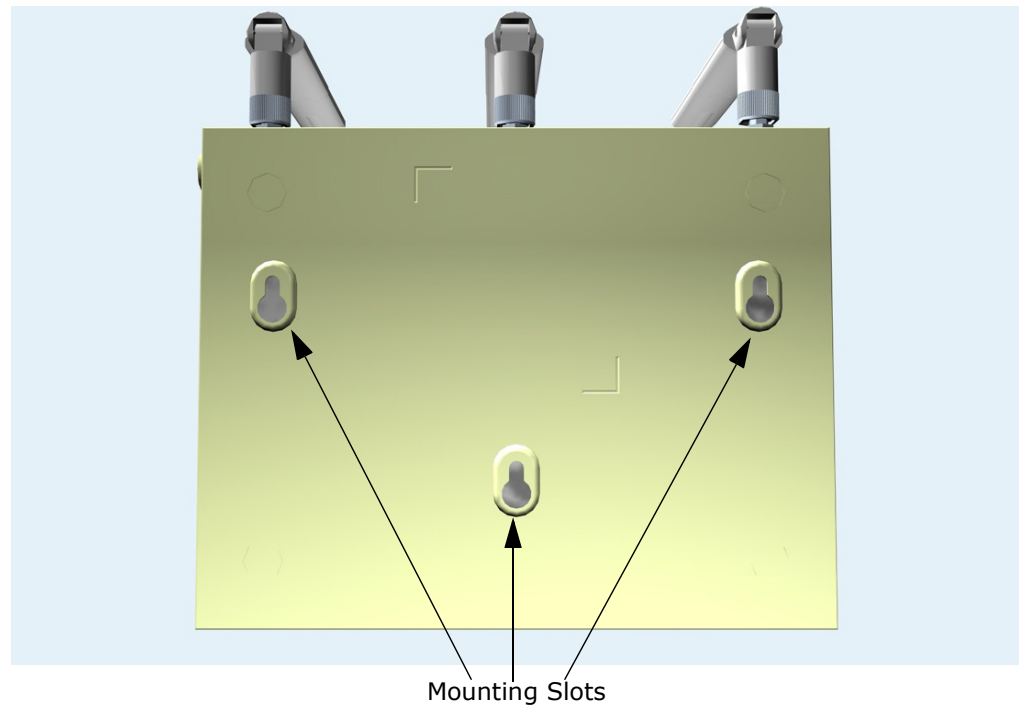

The access point should be mounted only to a wall or wood surface that is at least 1/2-inch plywood or its equivalent. To mount the access point on a wall, always use its wall-mounting bracket. The access point must be mounted with the RJ-45 cable connector oriented upwards to ensure proper operation.

1. Mark the position of the three screw holes on the wall. For concrete or brick walls, you will need to drill holes and insert wall plugs for the screws.
2. Insert the included 20-mm M4 tap screws into the holes, leaving about 2-3 mm clearance from the wall.
3. Line up the three mounting points on the AP with the screws in the wall, then slide the AP down onto the screws until it is in a secured position.

CONNECTING AND POWERING ON

Connect the power adapter to the access point, and the power cord to an AC power outlet.

Otherwise, the access point can derive its operating power directly from the RJ-45 port when connected to a device that provides IEEE 802.3af compliant Power over Ethernet (PoE).



CAUTION: Use ONLY the power adapter supplied with this access point. Otherwise, the product may be damaged.



NOTE: If the access point is connected to both a PoE source device and an AC power source, AC will be disabled.

- 1. Observe the Self Test** – When you power on the access point, verify that the Power indicator turns on, and that the other indicators start functioning as described under [“LED Indicators” on page 32](#).

If the red DIAG/FAIL LED does not turn off, the self test has not completed correctly. Refer to [“Troubleshooting” on page 237](#).

- 2. Connect the Ethernet Cable** – The access point can be connected to a 10/100/1000 Mbps Ethernet through a network device such as a hub or a switch. Connect your network to the RJ-45 port on the back panel with Category 5E or better UTP Ethernet cable. When the access point and the connected device are powered on, the Ethernet Link LED should turn on indicating a valid network connection.



NOTE: The RJ-45 port on the access point supports automatic MDI/MDI-X operation, so you can use straight-through cables for all network connections to PCs, switches, or hubs.

- 3. Position the Antennas** – Each antenna emits a radiation pattern that is toroidal (doughnut shaped), with the coverage extending most in the direction perpendicular to the antenna. Therefore, the antennas should be oriented so that the radio coverage pattern fills the intended horizontal space. Also, the antennas should both be positioned along the same axes, providing the same coverage area. For example, if the access point is mounted on a horizontal surface, all antennas should be positioned pointing vertically up to provide optimum coverage.
- 4. (Optional) Connect the Console Port** – Connect the RJ-45 console cable (included with access point) to the RS-232 console port for accessing the command-line interface. You can manage the access point using the console port, the web interface, or SNMP management software.

The SMCE21011 offers a user-friendly web-based management interface for the configuration of all the unit's features. Any PC directly attached to the unit can access the management interface using a web browser, such as Internet Explorer (version 6.0 or above) or Firefox (version 2.0 or above).

CONNECTING TO THE LOGIN PAGE

It is recommended to make initial configuration changes by connecting a PC directly to the SMCE21011's LAN port. The SMCE21011 has a default IP address of 192.168.2.1 and a subnet mask of 255.255.255.0. You must set your PC IP address to be on the same subnet as the SMCE21011 (that is, the PC and SMCE21011 addresses must both start 192.168.2.x).

To access the access point management interface, follow these steps:

1. Use your web browser to connect to the management interface using the default IP address of 192.168.2.1.
2. Log into the interface by entering the default username "admin" and password also "smcadmin," then click Login.



NOTE: It is strongly recommended to change the default user name and password the first time you access the web interface. For information on changing user names and passwords, See ["Administration Settings" on page 52.](#)

Figure 12: Login Page

A screenshot of a web-based login page. The page has a dark blue header. Below the header, there are two input fields: one labeled 'USERNAME' and one labeled 'PASSWORD'. Below these fields are two buttons: a green 'Login' button and a green 'Cancel' button.

HOME PAGE AND MAIN MENU

After logging in to the web interface, the Home page displays. The Home page shows some basic settings for the AP, including Country Code and the management access password.

Figure 13: Home Page

The web interface Main Menu menu provides access to all the configuration settings available for the access point.

The following items are displayed on this page:

- ◆ **System Name** – An alias for the access point, enabling the device to be uniquely identified on the network. (Default: 11n_AP; Range: 1-32 characters)
- ◆ **Username** – The name of the user is fixed as “admin” and is not configurable.
- ◆ **Old Password** – Type your old password. The default password is “smcdamin.”
- ◆ **New Password** – The password for management access. (Length: 5-32 characters, case sensitive)
- ◆ **Confirm New Password** – Enter the password again for verification.
- ◆ **Country Code** – This command configures the access point’s country code, which identifies the country of operation and sets the authorized radio channels.



CAUTION: You must set the country code to the country of operation. Setting the country code restricts operation of the access point to the radio channels and transmit power levels permitted for wireless networks in the specified country.

COMMON WEB PAGE BUTTONS

The list below describes the common buttons found on most web management pages:

- ◆ **Set** – Applies the new parameters and saves them to temporary RAM memory. Also displays a screen to inform you when it has taken affect. Clicking 'OK' returns to the home page. The running configuration will not be saved upon a reboot unless you use the "Save Config" button.

Figure 14: Set Configuration Changes

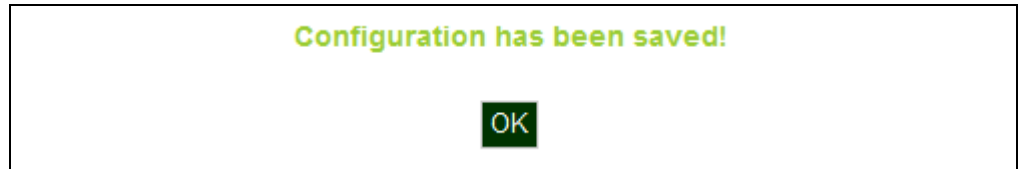

- ◆ **Cancel** – Cancels the newly entered settings and restores the originals.
- ◆ **Help** – Displays the help window.

Figure 15: Help Menu

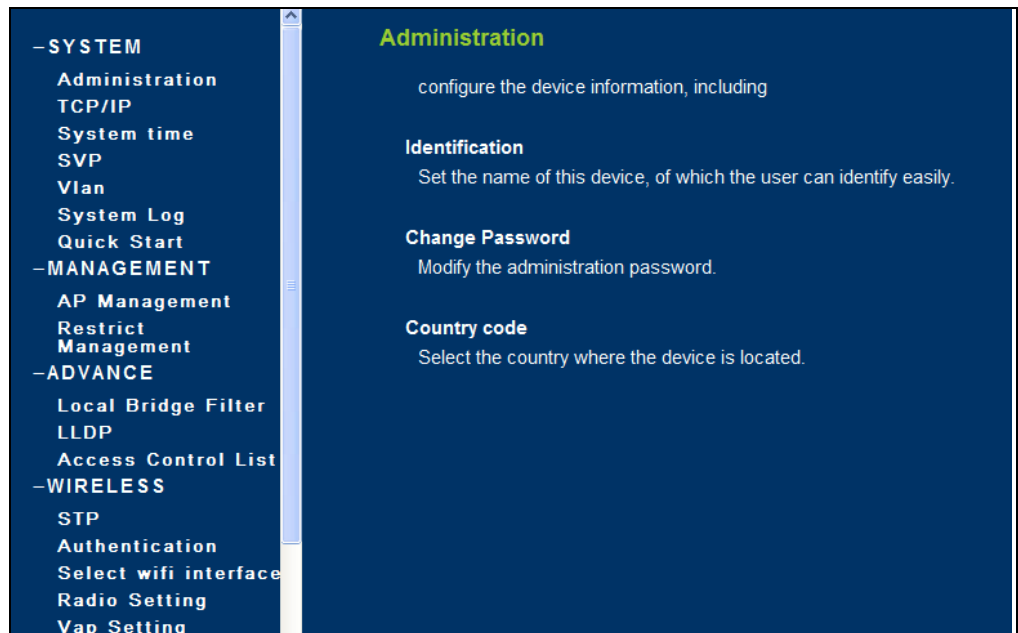

- ◆ **Logout** – Ends the web management session.
- ◆ **Save Config** – Saves the current configuration so that it is retained after a restart.

QUICK START

The Quick Start menu is designed to help you configure the basic settings required to get the access point up and running. Click 'System', followed by 'Quick Start'.

- STEP 1** The first page of the Quick Start configures the system identification, access password, and the Country Code.

Figure 16: Quick Start - Step 1

The screenshot shows the 'Quick Start' configuration page. It is titled 'Quick Start' in green. Under the 'Identification' section, there is a 'System Name' field with the value '11n_AP'. Below this is a note: 'The system name is designed for the user to uniquely identify this device.' The 'Change Password' section includes a 'Username' field with the value 'admin', an empty 'Old Password' field with a note '(If no password, please input "null" string)', and two empty 'New Password' and 'Confirm New Password' fields, both masked with dots. The 'Country Code' section has a dropdown menu showing 'US, United States'. At the bottom are 'Cancel' and 'Next' buttons.

The following items are displayed on the first page of the Quick Start wizard:

IDENTIFICATION

- ◆ **System Name** — The name assigned to the access point. (Default: 11n_AP)

CHANGE PASSWORD

- ◆ **Username** — The name of the user is fixed as "admin" and is not configurable.

- ◆ **Old Password** — If the unit has been configured with a password already, enter that password, otherwise enter the default password “smcdamin.”
- ◆ **New Password** — The password for management access. (Length: 5-32 characters, case sensitive)
- ◆ **Confirm New Password** — Enter the password again for verification.

COUNTRY CODE

- ◆ **Country Code** — Configures the access point’s country code from a drop down menu, which identifies the country of operation and sets the authorized radio channels.



CAUTION: You must set the country code to the country of operation. Setting the country code restricts operation of the access point to the radio channels and transmit power levels permitted for wireless networks in the specified country.

- ◆ **Cancel** — Cancels the newly entered settings and restores the originals.
- ◆ **Next** — Proceeds to the next page.

STEP 2 The Step 2 page of the Quick Start configures IP settings and DHCP client status.

Figure 17: Quick Start - Step 2

The screenshot shows the 'Quick Start' configuration interface. At the top, the title 'Quick Start' is displayed in green. Below it, the 'DHCP Client' section is highlighted. The 'DHCP Status' is set to 'Disable' (indicated by a selected radio button). The 'IP Address' is set to '192.168.1.1', 'Subnet Mask' is '255.255.255.0', and 'Default Gateway' is '192.168.1.254'. The 'Primary DNS Address' and 'Secondary DNS Address' fields are empty. At the bottom, there are three buttons: 'Prev', 'Cancel', and 'Next'.

DHCP Client	
DHCP Status	<input type="radio"/> Enable <input checked="" type="radio"/> Disable
IP Address	192.168.1.1
Subnet Mask	255.255.255.0
Default Gateway	192.168.1.254
Primary DNS Address	
Secondary DNS Address	

Prev Cancel Next

The following items are displayed on this page:

DHCP

- ◆ **DHCP Status** — Enables/disables DHCP on the access point. (Default: disabled)
- ◆ **IP Address** — Specifies an IP address for management of the access point. Valid IP addresses consist of four decimal numbers, 0 to 255, separated by periods. (Default: 192.168.2.1.)
- ◆ **Subnet Mask** — Indicates the local subnet mask. Select the desired mask from the drop down menu. (Default: 255.255.255.0)
- ◆ **Default Gateway** — The default gateway is the IP address of the router for the access point, which is used if the requested destination address is not on the local subnet. (Default: 192.168.2.254)

If you have management stations, DNS, RADIUS, or other network servers located on another subnet, type the IP address of the default gateway router in the text field provided.

- ◆ **Primary and Secondary DNS Address** — The IP address of Domain Name Servers on the network. A DNS maps numerical IP addresses to domain names and can be used to identify network hosts by familiar names instead of the IP addresses. (The default Primary and Secondary DNS addresses are null values.)
- ◆ **Prev** — Returns to the previous screen.
- ◆ **Cancel** — Cancels the newly entered settings and restores the originals.
- ◆ **Next** — Proceeds to the final step in the Quick Start wizard.

STEP 3 The Step 3 page of the Quick Start configures radio interface settings.

Figure 18: Quick Start - Step 3

Quick Start

Interface Setting

WiFi mode 11ng

Basic Setting

SSID SMC_VAP_0

Security

Association Mode Open System

Encryption Method None

Authentication

802.1X Disable Enable

802.1X Reauthentication Refresh Rate 3600 seconds (0 = Disabled)

If 802.1x is enabled, then [RADIUS](#) setup must be completed

Prev Cancel Set

The following items are displayed on this page:

INTERFACE SETTING

- ◆ **WiFi Mode** — Sets the mode of operation of the radio chip to 802.11n/g (2.4 GHz) or 802.11n/a (5 GHz). (Default: 11n/g)

BASIC SETTING

- ◆ **SSID** — Sets the service set identifier for the primary VAP. (Default: vap_a0)

SECURITY

- ◆ **Association Mode** — Selects the security mode for association of other access points and wireless devices to the access point. For more information, see ["Wireless Security Settings" on page 92](#). (Default: Open System; Range: Open System, WPA, WPA-PSK, WPA2, WPA2-PSK, WPA-WPA2-mixed, or WPA-WPA2-PSK-mixed)
- ◆ **Encryption Mode** — The available data encryption methods depend on the selected Association Mode. (Default: None)
 - **None:** Implements no encryption for Open System association.
 - **WEP:** WEP is used as the multicast encryption cipher. You should select WEP only when both WPA and WEP clients are supported.

- **TKIP:** TKIP is used as the multicast encryption cipher.
- **AES-CCMP:** AES-CCMP is used as the multicast encryption cipher. AES-CCMP is the standard encryption cipher required for WPA2.

AUTHENTICATION

- ◆ **802.1x** — Enables 802.1X authentication. (Default: Disabled)
- ◆ **802.1x Reauthentication Refresh Rate** — The time period after which a connected client must be re-authenticated. During the reauthentication process of verifying the client's credentials on the RADIUS server, the client remains connected the network. Only if reauthentication fails is network access blocked. (Default: 3600 seconds; Range: 0-65535 seconds; 0=disabled)



NOTE: When 802.1X is enabled, be sure to configure RADIUS server details. For more information, see ["RADIUS Settings" on page 54](#).

MAIN MENU ITEMS

To configure settings, click the relevant Main Menu item. Each Main Menu item is summarized below with links to the relevant section in this guide where configuration parameters are described in detail:

- ◆ **System** — Configures Management IP, WAN, LAN and QoS settings. See ["System Settings" on page 51](#).
- ◆ **Management** — Configures SNMP, HTTP and Telnet settings. See ["Management Settings" on page 62](#).
- ◆ **Advanced** — Configures LLDP and Access Control Lists. See ["Advanced Settings" on page 73](#).
- ◆ **Wireless** — Configures Wi-Fi access point settings. See ["Wireless Settings" on page 79](#).
- ◆ **Maintenance** — Configures firmware upgrades remote and locally. See ["Maintenance Settings" on page 100](#).
- ◆ **Information** — Displays current system settings. See ["Status Information" on page 105](#).

SECTION II

WEB CONFIGURATION

This section provides details on configuring the access point using the web browser interface.

This section includes these chapters:

- ◆ ["System Settings" on page 51](#)
- ◆ ["Management Settings" on page 62](#)
- ◆ ["Advanced Settings" on page 73](#)
- ◆ ["Wireless Settings" on page 79](#)
- ◆ ["Maintenance Settings" on page 100](#)
- ◆ ["Status Information" on page 105](#)

This chapter describes basic system settings on the access point. It includes the following sections:

- ◆ ["Administration Settings" on page 52](#)
- ◆ ["IP Address" on page 53](#)
- ◆ ["RADIUS Settings" on page 54](#)
- ◆ ["System Time" on page 56](#)
- ◆ ["SpectraLink Voice Priority" on page 58](#)
- ◆ ["VLAN Configuration" on page 58](#)
- ◆ ["System Logs" on page 60](#)
- ◆ ["Quick Start Wizard" on page 61](#)

ADMINISTRATION SETTINGS

The Administration Settings page configures some basic settings for the AP, such as the system identification name, the management access password, and the wireless operation Country Code.

Figure 19: Administration

The screenshot shows the Administration Settings page with the following sections:

- Administration** (Section Header)
- Identification** (Section Header)
 - System Name: 11n_AP
- The system name is designed for the user to uniquely identify this device.
- Change Password** (Section Header)
 - Username: admin
 - Old Password: (If no password, please input "null" string)
 - New Password: [Masked]
 - Confirm New Password: [Masked]
- Country Code** (Section Header)
 - Country Code: US, United States
- Buttons: Set, Cancel, Help

The following items are displayed on this page:

- ◆ **System Name** — An alias for the access point, enabling the device to be uniquely identified on the network. (Default: 11n_AP; Range: 1-32 characters)
- ◆ **Username** — The user name is fixed as “admin” and cannot be configured.
- ◆ **Old Password** — Type your current password.
- ◆ **New Password** — The password for management access. (Length: 5-32 characters, case sensitive)
- ◆ **Confirm New Password** — Enter the password again for verification.
- ◆ **Country Code** — This command configures the access point’s country code, which identifies the country of operation and sets the authorized radio channels.



CAUTION: You must set the country code to the country of operation. Setting the country code restricts operation of the access point to the radio channels and transmit power levels permitted for wireless networks in the specified country.

IP ADDRESS

Configuring the access point with an IP address expands your ability to manage the access point. A number of access point features depend on IP addressing to operate.

You can use the web browser interface to access IP addressing only if the access point already has an IP address that is reachable through your network.

By default, the access point will be not be automatically configured with IP settings from a Dynamic Host Configuration Protocol (DHCP) server. The default IP address is 192.168.2.1, subnet mask 255.255.255.0 and a default gateway of 192.168.2.254.

Figure 20: IP Configuration

DHCP Client	
DHCP Status	<input type="radio"/> Enable <input checked="" type="radio"/> Disable
IP Address	192.168.2.1
Subnet Mask	255.255.255.0
Default Gateway	192.168.2.254
Primary DNS Address	
Secondary DNS Address	

The following items are displayed on this page:

- ◆ **DHCP Status** — Enables/disables DHCP on the access point.
- ◆ **IP Address** — Specifies an IP address for management of the access point. Valid IP addresses consist of four decimal numbers, 0 to 255, separated by periods. (Default: 192.168.2.1.)
- ◆ **Subnet Mask** — Indicates the local subnet mask. Select the desired mask from the drop down menu. (Default: 255.255.255.0)

- ◆ **Default Gateway** — The default gateway is the IP address of the router for the access point, which is used if the requested destination address is not on the local subnet.

If you have management stations, DNS, RADIUS, or other network servers located on another subnet, type the IP address of the default gateway router in the text field provided.

- ◆ **Primary and Secondary DNS Address** — The IP address of Domain Name Servers on the network. A DNS maps numerical IP addresses to domain names and can be used to identify network hosts by familiar names instead of the IP addresses.

If you have one or more DNS servers located on the local network, type the IP addresses in the text fields provided.

After you have network access to the access point, you can use the web browser interface to modify the initial IP configuration, if needed.

If there is no DHCP server on your network, or DHCP fails, the access point will automatically start up with a default IP address of 192.168.2.1

RADIUS SETTINGS

Remote Authentication Dial-in User Service (RADIUS) is an authentication protocol that uses software running on a central server to control access to RADIUS-aware devices on the network. An authentication server contains a database of user credentials for each user that requires access to the network.

PRIMARY AND SECONDARY RADIUS SERVER SETUP

A primary RADIUS server must be specified for the access point to implement IEEE 802.1X network access control and Wi-Fi Protected Access (WPA) wireless security. A secondary RADIUS server may also be specified as a backup should the primary server fail or become inaccessible.

In addition, you can configure a RADIUS Accounting server to receive user-session accounting information from the access point. RADIUS Accounting can be used to provide valuable information on user activity in the network.



This guide assumes that you have already configured RADIUS server(s) to support the access point. Configuration of RADIUS server software is beyond the scope of this guide, refer to the documentation provided with the RADIUS server software.

Figure 21: RADIUS Settings

RADIUS

Primary RADIUS Server Setup

Radius Status	<input type="radio"/> Disable <input checked="" type="radio"/> Enable
IP Address	10.7.16.96
Port (1024-65535)	1812
Key	••••••••

Secondary RADIUS Server Setup

Radius Status	<input type="radio"/> Disable <input checked="" type="radio"/> Enable
IP Address	10.7.16.96
Port (1024-65535)	1812
Key	•••

RADIUS Accounting

Account Status	<input checked="" type="radio"/> Disable <input type="radio"/> Enable
IP Address	10.7.16.96
Port (1024-65535)	1813
Key	••••••••
Interim Update Timeout (60-86400)	300

The following items are displayed on the RADIUS Settings page:

- ◆ **RADIUS Status** — Enables/disables the primary RADIUS server.
- ◆ **IP Address** — Specifies the IP address or host name of the RADIUS server.
- ◆ **Port (1024-65535)** — The UDP port number used by the RADIUS server for authentication messages. (Range: 1024-65535; Default: 1812)
- ◆ **Key** — A shared text string used to encrypt messages between the access point and the RADIUS server. Be sure that the same text string is specified on the RADIUS server. Do not use blank spaces in the string. (Maximum length: 255 characters)

RADIUS ACCOUNTING The following items are displayed on the RADIUS Settings page:

- ◆ **Account Status** — Enables/disables RADIUS accounting.
- ◆ **IP Address** — Specifies the IP address or host name of the RADIUS accounting server.

- ◆ **Port (1024-65535)** — The UDP port number used by the RADIUS accounting server for authentication messages. (Range: 1024-65535; Default: 1813)
- ◆ **Key** — A shared text string used to encrypt messages between the access point and the RADIUS accounting server. Be sure that the same text string is specified on the RADIUS server. Do not use blank spaces in the string. (Maximum length: 255 characters)
- ◆ **Interim Update Timeout (60-86400)** — The interval between transmitting accounting updates to the RADIUS server. (Range: 60-86400; Default: 300 seconds)

SYSTEM TIME

Simple Network Time Protocol (SNTP) allows the access point to set its internal clock based on periodic updates from a time server (SNTP or NTP). Maintaining an accurate time on the access point enables the system log to record meaningful dates and times for event entries. If the clock is not set, the access point will only record the time from the factory default set at the last bootup.

The access point acts as an SNTP client, periodically sending time synchronization requests to specific time servers. You can configure up to two time server IP addresses. The access point will attempt to poll each server in the configured sequence.

Figure 22: SNTP Settings

The screenshot displays the 'System Time' configuration interface. It is divided into three main sections: 'SNTP Server Settings', 'Time Zone Setting', and 'Daylight Saving Settings'.
1. **SNTP Server Settings:** This section includes a 'SNTP Status' toggle set to 'Enable', a 'Primary Server' text field containing '129.6.15.28', and a 'Secondary Server' text field containing '132.163.4.101'.
2. **Time Zone Setting:** This section features a 'Time Zone' dropdown menu currently set to '(GMT+08) Hong Kong, Perth, Singapore, Taipei'.
3. **Daylight Saving Settings:** This section includes a 'Daylight Saving Status' toggle set to 'Disable'.
At the bottom of the configuration area, there are three buttons: 'Set', 'Cancel', and 'Help'.

SNTP SERVER SETTINGS Configures the access point to operate as an SNTP client. When enabled, at least one time server IP address must be specified.

- ◆ **SNTP Status** — Enables/disables SNTP. (Default: enabled)
- ◆ **Primary Server** — The IP address of an SNTP or NTP time server that the access point attempts to poll for a time update.
- ◆ **Secondary Server** — The IP address of a secondary SNTP or NTP time server. The access point first attempts to update the time from the primary server; if this fails it attempts an update from the secondary server.

TIME ZONE SETTING SNTP uses Greenwich Mean Time, or GMT (sometimes referred to as Coordinated Universal Time, or UTC) based on the time at the Earth's prime meridian, zero degrees longitude. To display a time corresponding to your local time, you must indicate the number of hours your time zone is located before (east) or after (west) GMT.

- ◆ **Time Zone** — Select from the scroll down list the locale you are situated most close to, for example for New York, select '(GMT-05) Eastern Time (US & Canada)'.

DAYLIGHT SAVING SETTINGS The access point provides a way to automatically adjust the system clock for Daylight Savings Time changes. To use this feature you must define the month and date to begin and to end the change from standard time. During this period the system clock is set back by one hour.

- ◆ **Daylight Saving Status** — Enables/disables daylight savings time. (Default: disabled)

When enabled, set the month, day, and week to start and stop the daylight savings time.

SPECTRALINK VOICE PRIORITY

SpectraLink Voice Priority (SVP) is a voice priority mechanism for WLANs. SVP is an open, straightforward QoS approach that has been adopted by most leading vendors of WLAN APs. SVP favors isochronous voice packets over asynchronous data packets when contending for the wireless medium and when transmitting packets onto the wired LAN.

Figure 23: SVP Settings

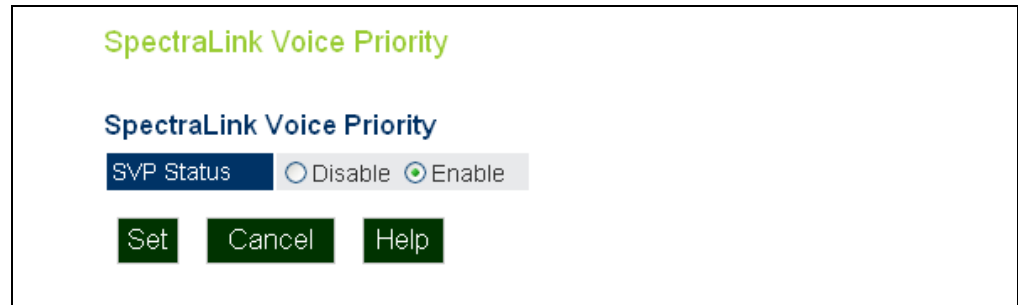

The following items are displayed on this page:

- ◆ **SVP Status** — Enables/disables SVP on the access point.

VLAN CONFIGURATION

VLANs (virtual local area networks) are turned off by default when first installing the access point. If turned on they will automatically tag any packets received by the LAN port before sending them on to the relevant VAP (virtual access point).

The access point can employ VLAN tagging support to control access to network resources and increase security. VLANs separate traffic passing between the access point, associated clients, and the wired network. There can be a default VLAN for each VAP (Virtual Access Point) interface, and a management VLAN for the access point.

Note the following points about the access point's VLAN support:

- ◆ The management VLAN is for managing the access point through remote management tools, such as the web interface, SSH, SNMP, or Telnet. The access point only accepts management traffic that is tagged with the specified management VLAN ID.
- ◆ All wireless clients associated to the access point are assigned to a VLAN. Wireless clients are assigned to the default VLAN for the VAP interface with which they are associated. The access point only allows traffic tagged with default VLAN IDs to access clients associated on each VAP interface.

- ◆ When VLAN support is enabled on the access point, traffic passed to the wired network is tagged with the appropriate VLAN ID, either a VAP default VLAN ID, or the management VLAN ID. Traffic received from the wired network must also be tagged with one of these known VLAN IDs. Received traffic that has an unknown VLAN ID or no VLAN tag is dropped.
- ◆ When VLAN support is disabled, the access point does not tag traffic passed to the wired network and ignores the VLAN tags on any received frames.



NOTE: Before enabling VLAN tagging on the access point, be sure to configure the attached network switch port to support tagged VLAN frames from the access point's management VLAN ID and default VLAN IDs. Otherwise, connectivity to the access point will be lost when you enable the VLAN feature.

Figure 24: Setting the VLAN Identity

The following items are displayed on this page:

- ◆ **VLAN Classification** — Enables/disables VLAN packet tagging. (Default: disabled)
- ◆ **Native VLAN ID(1-4094)** — If enabled the packets received by the LAN port must be tagged within the Management VLAN ID (native VLAN ID). (Range: 1-4094)

SYSTEM LOGS

The access point can be configured to send event and error messages to a System Log Server. The system clock can also be synchronized with a time server, so that all the messages sent to the Syslog server are stamped with the correct time and date.

Figure 25: System Log Settings

System Log

System Log Settings

syslog status Disable Enable

Server 1 Disable Enable

IP 10.7.16.98 UDP Port 514

Server 2 Disable Enable

IP 10.7.13.48 UDP Port 514

Server 3 Disable Enable

Server 4 Disable Enable

Logging Console Disable Enable

Logging Level Debug

Set Cancel Help

The following items are displayed on this page:

- ◆ **Syslog Status** — Enables/disables the logging of error messages. (Default: enabled)
- ◆ **Server 1~4** — Enables the sending of log messages to a Syslog server host. Up to four Syslog servers are supported on the access point. (Default: disabled)
- ◆ **IP** — The IP address or name of a Syslog server. (Server 1 Default: 10.7.16.98; Server 2 Default: 10.7.13.48; Server 3 Default: 10.7.123.123; Server 4 Default: 10.7.13.77)
- ◆ **UDP Port** — The UDP port used by a Syslog server. (Range: 514 or 11024-65535; Server 1~2 Default: 514; Server 3 Default: 6553; Server 4 Default: 5432)
- ◆ **Logging Console** — Enables the logging of error messages to the console. (Default: disabled)

- ◆ **Logging Level** — Sets the minimum severity level for event logging. (Default: Debug)

The system allows you to limit the messages that are logged by specifying a minimum severity level. The following table lists the error message levels from the most severe (Emergency) to least severe (Debug). The message levels that are logged include the specified minimum level up to the Emergency level.

Table 3: Logging Levels

Error Level	Description
Emergency	System unusable
Alerts	Immediate action needed
Critical	Critical conditions (e.g., memory allocation, or free memory error - resource exhausted)
Error	Error conditions (e.g., invalid input, default used)
Warning	Warning conditions (e.g., return false, unexpected return)
Notice	Normal but significant condition, such as cold start
Informational	Informational messages only
Debug	Debugging messages

QUICK START WIZARD

The Quick Start menu item is described in the preceding chapter, see [“Quick Start” on page 45](#).

This chapter describes management access settings on the access point. It includes the following sections:

- ◆ “Remote Management Settings” on page 62
- ◆ “Access Limitation” on page 64
- ◆ “Simple Network Management Protocol” on page 65

REMOTE MANAGEMENT SETTINGS

The Web, Telnet, and SNMP management interfaces are enabled and open to all IP addresses by default. To provide more security for management access to the access point, specific interfaces can be disabled and management restricted to a single IP address or a limited range of IP addresses.

Once you specify an IP address or range of addresses, access to management interfaces is restricted to the specified addresses. If anyone tries to access a management interface from an unauthorized address, the access point will reject the connection.

Telnet is a remote management tool that can be used to configure the access point from anywhere in the network. However, Telnet is not secure from hostile attacks. The Secure Shell (SSH) can act as a secure replacement for Telnet. The SSH protocol uses generated public keys to encrypt all data transfers passing between the access point and SSH-enabled management station clients and ensures that data traveling over the network arrives unaltered. Clients can then securely use the local user name and password for access authentication.

Note that SSH client software needs to be installed on the management station to access the access point for management via the SSH protocol.

Both HTTP and HTTPS service can be enabled independently. If you enable HTTPS, you must indicate this in the URL: `https://device:port_number]`

When you start HTTPS, the connection is established in this way:

- ◆ The client authenticates the server using the server’s digital certificate.
- ◆ The client and server negotiate a set of security protocols to use for the connection.

- ◆ The client and server generate session keys for encrypting and decrypting data.
- ◆ The client and server establish a secure encrypted connection.
- ◆ A padlock icon should appear in the status bar for Internet Explorer.

Figure 26: Remote Management

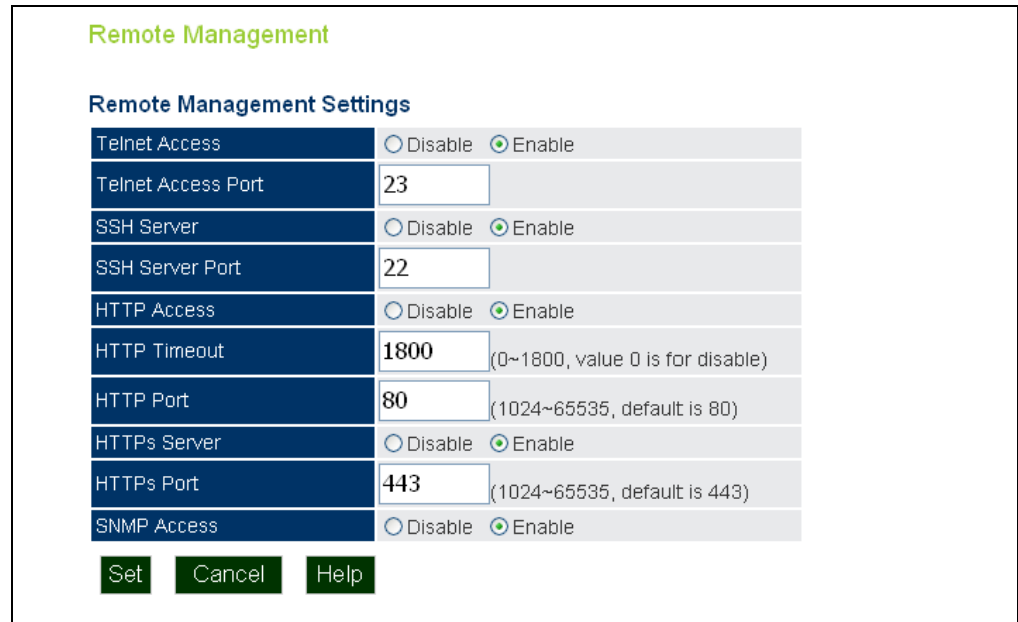

The following items are displayed on Admin Interface page:

- ◆ **Telnet Access** — Enables/disables management access from Telnet interfaces. (Default: enabled)
- ◆ **Telnet Access Port** — Sets the specified Telnet port for communication. (Default: 23)
- ◆ **SSH Server** — Enables/disables management access from SSH Servers. (Default: enabled)
- ◆ **SSH Server Port** — Sets the specified SSH Server port for communication. (Default: 22)
- ◆ **HTTP Access** — Enables/disables management access from any IP address. (Default: enabled)
- ◆ **HTTP Timeout** — Specifies the time after which the HTTP connection will be lost with a period of inactivity. (Default: 1800 seconds; Range: 1-1800 seconds; 0=disabled)
- ◆ **HTTP Port** — Specifies the HTTP port for IP connectivity. (Default: 80; Range 1024-65535)

- ◆ **HTTPS Server** — Enables/disables management access from a HTTPS server. (Default: enabled)
- ◆ **HTTPS Port** — Specifies the HTTPS port for secure IP connectivity. (Default: 443; Range 1024-65535)
- ◆ **SNMP Access** — Enables/disables management access from SNMP interfaces. (Default: enabled)

ACCESS LIMITATION

The Access Limitation page limits management access to the access point from specified IP addresses or wireless clients.

Figure 27: Access Limitation

Access Limitation

IP Management Control

Any IP Allow any IP address to access device

Single IP Specify one IP address to access device

Multiple IP Specify multiple IP address to access device

IP Address

Subnet Mask 255.255.255.255

Restrict Management

Disable Allow AP management via wireless client.

Enable Prevent AP management via wireless client.

The following items are displayed on the Access Limitation page:

IP MANAGEMENT CONTROL

- ◆ **Any IP** — Indicates that any IP address is allowed management access.
- ◆ **Single IP** — Specifies a single IP address that is allowed management access.
- ◆ **Multiple IP** — Specifies an address range as defined by the entered IP address and subnet mask. For example, IP address 192.168.1.6 and subnet mask 255.255.255.0, defines all IP addresses from 192.168.1.1 to 192.168.1.254.
- ◆ **IP Address** — Specifies the IP address.

- ◆ **Subnet Mask** — Specifies the subnet mask in the form 255.255.255.x

RESTRICT MANAGEMENT

- ◆ **Enable/Disable** — Enables/disables management of the device by a wireless client. (Default: disabled)

SIMPLE NETWORK MANAGEMENT PROTOCOL

Simple Network Management Protocol (SNMP) is a communication protocol designed specifically for managing devices on a network. Equipment commonly managed with SNMP includes switches, routers and host computers. SNMP is typically used to configure these devices for proper operation in a network environment, as well as to monitor them to evaluate performance or detect potential problems.

Managed devices supporting SNMP contain software, which runs locally on the device and is referred to as an agent. A defined set of variables, known as managed objects, is maintained by the SNMP agent and used to manage the device. These objects are defined in a Management Information Base (MIB) that provides a standard presentation of the information controlled by the agent. SNMP defines both the format of the MIB specifications and the protocol used to access this information over the network.

The access point includes an onboard agent that supports SNMP versions 1, 2c, and 3 clients. This agent continuously monitors the status of the access point, as well as the traffic passing to and from wireless clients. A network management station can access this information using SNMP management software that is compliant with MIB II. To implement SNMP management, the access point must first have an IP address and subnet mask, configured either manually or dynamically. Access to the onboard agent using SNMP v1 and v2c is controlled by community strings. To communicate with the access point, the management station must first submit a valid community string for authentication.

Access to the access point using SNMP v3 provides additional security features that cover message integrity, authentication, and encryption; as well as controlling notifications that are sent to specified user targets.

SNMP BASIC SETTINGS

The access point SNMP agent must be enabled to function (for versions 1, 2c, and 3 clients). Management access using SNMP v1 and v2c also requires community strings to be configured for authentication. Trap notifications can be enabled and sent to up to four management stations.

Figure 28: SNMP Basic Settings

SNMP Basic Settings

Basic Settings

SNMP	<input type="radio"/> Disable <input checked="" type="radio"/> Enable
System Location	where?
System Contact	who?
Read-Only Community	*****
Read-Write Community	*****

set Help

The following items are displayed on this page:

- ◆ **SNMP** — Enables or disables SNMP management access and also enables the access point to send SNMP traps (notifications). (Default: Disable)
- ◆ **System Location** — A text string that describes the system location. (Maximum length: 255 characters)
- ◆ **System Contact** — A text string that describes the system contact. (Maximum length: 255 characters)
- ◆ **Read-Only Community** — Defines the SNMP community access string that has read-only access. Authorized management stations are only able to retrieve MIB objects. (Maximum length: 23 characters, case sensitive; Default: public)
- ◆ **Read-Write Community** — Defines the SNMP community access string that has read/write access. Authorized management stations are able to both retrieve and modify MIB objects. (Maximum length: 23 characters, case sensitive; Default: private)

SNMP TRAP SETTINGS Traps indicating status changes are issued by the AP to specified trap managers. You must specify trap managers so that key events are reported by the AP to your management station (using network management platforms).

Figure 29: SNMP Trap Settings

SNMP Trap

Create Trap Destination

Trap Destination	Community	Action
<input type="text"/>	<input type="text"/>	<input type="button" value="Add"/>

Trap Destination List

No.	Trap Destination	Community	Action
1	192.168.1.9	*****	<input type="button" value="Delete"/>

Trap Configuration

Trap	Status
sysSystemUp	<input checked="" type="radio"/> Disable <input type="radio"/> Enable
sysSystemDown	<input checked="" type="radio"/> Disable <input type="radio"/> Enable

The following items are displayed on this page:

- ◆ **Trap Destination** — Specifies the recipient of SNMP notifications. Enter the IP address or the host name. (Host Name: 1 to 63 characters, case sensitive)
- ◆ **Community** — The community string sent with the notification operation. (Maximum length: 23 characters, case sensitive; Default: public)
- ◆ **Action** — Adds a new SNMP trap destination to the list.
- ◆ **Trap Destination List** — Lists the configured SNMP trap destinations.
- ◆ **Trap Configuration** — Enables or disables trap status.
 - **sysSystemUp**: The access point is up and running.
 - **sysSystemDown**: The access point is about to shutdown and reboot.
- ◆ **Save Trap Config** — Applies the new parameters and saves them to RAM memory. Also prompts a screen to inform you when it has taken affect. Clicking 'OK' returns to the home page. Changes will not be saved upon a reboot unless the running configuration file is saved.

VIEW ACCESS CONTROL MODEL To configure SNMPv3 management access to the AP, follow these steps:

1. Specify read and write access views for the AP MIB tree.
2. Configure SNMP user groups with the required security model (that is, SNMP v1, v2c, or v3) and security level (authentication and privacy).
3. Assign SNMP users to groups, along with their specific authentication and privacy passwords.

Figure 30: SNMP VACM

View Access Control Model

Create View

View Name	Type	OID	Mask(option)	Action
<input type="text"/>	Included	<input type="text"/>	<input type="text"/>	Add

View List

View	Type	OID	Mask	Action
testview	Included	.1		Delete
	excluded	.1.3.6.1.2.1.2.2.1.1.23		Delete

Create Group

Group Name	Security Level	Read-View	Write-View	Action	Help
<input type="text"/>	noAuthNoPriv	testview	testview	Add	Help

Group List

Group Name	Security Level	Read-View	Write-View	Action
testgroup	noAuthNoPriv	testview	testview	Delete

CREATING VIEWS

SNMPv3 views are used to restrict user access to specified portions of the MIB tree. There are no predefined views by default.

The following items are displayed on the VACM page.

- ◆ **View Name** – The name of the SNMP view. (Range: 1-32 characters)
- ◆ **Type** – Indicates if the object identifier of a branch within the MIB tree is included or excluded from the SNMP view.
- ◆ **OID** – Allows you to configure the object identifiers of branches within the MIB tree. Wild cards can be used to mask a specific portion of the OID string.
- ◆ **Mask (option)** – A hexadecimal value with each bit masking the corresponding ID in the MIB subtree. A “1” in the mask indicates an exact match and a “0” indicates a “wild card.” For example, a mask value of 0xFFBF provides a bit mask “1111 1111 1011 1111.” If applied

to the subtree "1.3.6.1.2.1.2.2.1.1.23," the zero corresponds to the 10th subtree ID. When there are more subtree IDs than bits in the mask, the mask is padded with ones.

- ◆ **View List** – Shows the currently configured object identifiers of branches within the MIB tree that define the SNMP view.

CREATING GROUPS

An SNMPv3 group sets the access policy for its assigned users, restricting them to specific read, write, and notify views. You can create new groups to map a set of SNMP users to SNMP views.

- ◆ **Group Name** – The name of the SNMP group. (Range: 1-32 characters)
- ◆ **Security Level** – The security level used for the group:
 - **noAuthNoPriv** – There is no authentication or encryption used in SNMP communications.
 - **AuthNoPriv** – SNMP communications use authentication, but the data is not encrypted.
 - **AuthPriv** – SNMP communications use both authentication and encryption.
- ◆ **Read View** – The configured view for read access. (Range: 1-32 characters)
- ◆ **Write View** – The configured view for write access. (Range: 1-32 characters)

SNMPv3 USERS The access point allows multiple SNMP v3 users to be configured. Each SNMPv3 user is defined by a unique name. Users must be configured with a specific security level and assigned to a group. The SNMPv3 group restricts users to a specific read, write, or notify view.

Figure 31: Configuring SNMPv3 Users

SNMPv3 User

Create SNMPv3 User

User Name	Group	Auth Type	Auth Passphrase	Priv Type	Priv Passphrase	Action	Help
	testgroup	None		None		Add	Help

SNMPv3 User List

No	User	Group	Auth Type	Auth Passphrase	Priv Type	Priv Passphrase	Action
1	chris	testgroup	None	N/A	None	N/A	Delete

The following items are displayed on this page:

- ◆ **User Name** — The SNMPv3 user name. (32 characters maximum)
- ◆ **Group** — The SNMPv3 group name.
- ◆ **Auth Type** — The authentication type used for the SNMP user; either MD5 or none. When MD5 is selected, enter a password in the corresponding Passphrase field.
- ◆ **Auth Passphrase** — The authentication password or key associated with the authentication and privacy settings. A minimum of eight plain text characters is required.
- ◆ **Priv Type** — The data encryption type used for the SNMP user; either DES or none. When DES is selected, enter a key in the corresponding Passphrase field.
- ◆ **Priv Passphrase** — The password or key associated with the authentication and privacy settings. A minimum of eight plain text characters is required.
- ◆ **Action** — Click the Add button to add a new user to the list. Click the edit button to change details of an existing user. Click the Del button to remove a user from the list.



NOTE: Users must be assigned to groups that have the same security levels. For example, a user who has "Auth Type" and "Priv Type" configured to MD5 and DES respectively (that is, uses both authentication and data encryption) must be assigned to the RWPriv group. If this same user were instead assigned to the read-only (RO) group, the user would not be able to access the database.

SNMPV3 TARGETS An SNMP v3 notification Target ID is specified by the SNMP v3 user, IP address, and UDP port. A user-defined filter can also be assigned to specific targets to limit the notifications received to specific MIB objects. (Note that the filter must first be configured. See ["SNMPv3 Notification Filters" on page 71.](#))

To configure a new notification receiver target, define the parameters and select a filter, if required. Note that the SNMP v3 user name must first be defined (See ["SNMPv3 Users" on page 69.](#))

Figure 32: SNMPv3 Targets

SNMP Target

Create SNMP Target

Target ID	IP Address	UDP Port	SNMP User	Notification Filter	Action	Help
<input type="text"/>	<input type="text"/>	<input type="text"/>	No User ▾	Optional Filter Assignment ▾	Add	Help

SNMP Target List

There is no SNMP target.

The following items are displayed on this page:

- ◆ **Target ID** — A user-defined name that identifies a receiver of notifications. (Maximum length: 32 characters)
- ◆ **IP Address** — Specifies the IP address of the receiving management station.
- ◆ **UDP Port** — The UDP port that is used on the receiving management station for notification messages.
- ◆ **SNMP User** — The defined SNMP v3 user that is to receive notification messages.
- ◆ **Notification Filter** — The name of a user-defined notification filter that is applied to the target.

**SNMPv3
NOTIFICATION FILTERS**

SNMP v3 users can be configured to receive notification messages from the access point. An SNMP Target ID is created that specifies the SNMP v3 user, IP address, and UDP port. A user-defined notification filter can be created so that specific notifications can be prevented from being sent to particular targets.

Figure 33: SNMP Notification Filter

SNMP Notification Filter

Create Notification Filter

Filter ID	Subtree	Type	Action	Help
<input type="text"/>	<input type="text"/>	Excluded ▾	Add	Help

SNMP Notification filter List

The following items are displayed on this page:

- ◆ **Filter ID** — A user-defined name that identifies the filter. (Maximum length: 32 characters)
- ◆ **Subtree** — Specifies MIB subtree to be filtered. The MIB subtree must be defined in the form “.1.3.6.1” and always start with a “.”.
- ◆ **Type** — Indicates if the filter is to “include” or “exclude” the MIB subtree objects from the filter. Note that MIB objects included in the filter are not sent to the receiving target and objects excluded are sent. By default all traps are sent, so you can first use an “include” filter entry for all trap objects. Then use “exclude” entries for the required trap objects to send to the target. Note that the filter entries are applied in the sequence that they are defined.
- ◆ **Action** — Adds the notification filter.

This chapter describes advanced settings on the access point. It includes the following sections:

- ◆ “Local Bridge Filter” on page 73
- ◆ “Link Layer Discovery Protocol” on page 74
- ◆ “Access Control Lists” on page 76

LOCAL BRIDGE FILTER

The access point can employ network traffic frame filtering to control access to network resources and increase security. You can prevent communications between wireless clients and prevent access point management from wireless clients. Also, you can block specific Ethernet traffic from being forwarded by the access point.

The Local Bridge Filter sets the global mode for wireless-to-wireless communications between clients associated to Virtual AP (VAP) interfaces on the access point. (Default: Disabled)

Figure 34: Local Bridge Filter

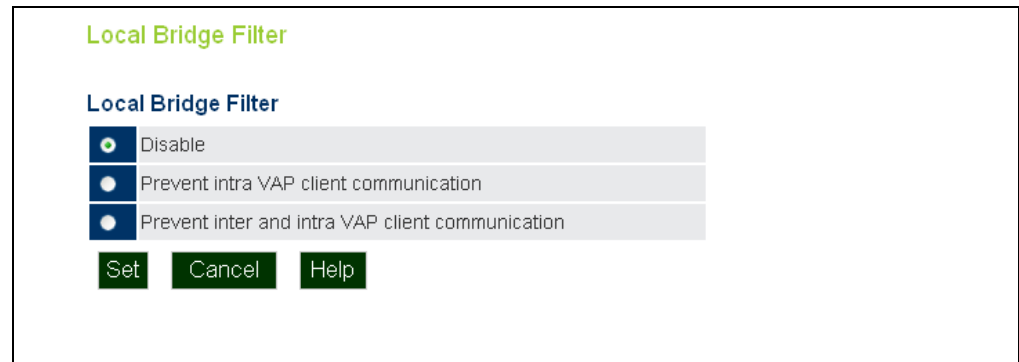

The following items are displayed on this page:

- ◆ **Disabled** — All clients can communicate with each other through the access point.
- ◆ **Prevent Intra VAP client communication** — When enabled, clients associated with a specific VAP interface cannot establish wireless communications with each other. Clients can communicate with clients associated to other VAP interfaces.

- ◆ **Prevent Inter and Intra VAP client communication** — When enabled, clients cannot establish wireless communications with any other client, either those associated to the same VAP interface or any other VAP interface.

LINK LAYER DISCOVERY PROTOCOL

This page allows you to configure the Link Layer Discovery Protocol (LLDP). LLDP allows devices in the local broadcast domain to share information about themselves. LLDP-capable devices periodically transmit information in messages called Type Length Value (TLV) fields to neighbor devices. Advertised information is represented in Type Length Value (TLV) format according to the IEEE 802.1ab standard, and can include details such as device identification, capabilities and configuration settings.

This information can be used by SNMP applications to simplify troubleshooting, enhance network management, and maintain an accurate network topology.

Figure 35: LLDP Settings

Link Layer Discovery Protocol

Link Layer Discovery Protocol : Disable Enable

LLDP Transmitter Parameter

Message Transmission Hold Time	<input type="text" value="4"/>	(2~10, default is 4)
Message Transmission Interval (seconds)	<input type="text" value="30"/>	(5~32768, default is 30)
Reinitial Delay Time (seconds)	<input type="text" value="2"/>	(2~10, default is 2)
Transmission Delay Value (seconds)	<input type="text" value="2"/>	(1~8192, default is 2)

The following items are displayed on this page:

- ◆ **Disable/Enable** — Disables/Enables LLDP on the access point.
- ◆ **Message Transmission Hold Time** — Configures the time-to-live (TTL) value sent in LLDP advertisements as shown in the formula below. (Range: 2-10; Default: 4)

The time-to-live tells the receiving LLDP agent how long to retain all information pertaining to the sending LLDP agent if it does not transmit updates in a timely manner. TTL in seconds is based on the following rule: $(\text{Transmission Interval} * \text{Hold time}) \leq 65536$. Therefore, the default TTL is $4 * 30 = 120$ seconds.

- ◆ **Message Transmission Interval (seconds)** — Configures the periodic transmit interval for LLDP advertisements. (Range: 5-32768 seconds; Default: 30 seconds)

This attribute must comply with the following rule: (Transmission Interval * Hold Time) \leq 65536, and Transmission Interval \geq (4 * Delay Interval)

- ◆ **ReInitial Delay Time (seconds)** — Configures the delay before attempting to re-initialize after LLDP ports are disabled or the link goes down. (Range: 1-10 seconds; Default: 2 seconds)

When LLDP is re-initialized on a port, all information in the remote systems LLDP MIB associated with this port is deleted.

- ◆ **Transmission Delay Value (seconds)** — Configures a delay between the successive transmission of advertisements initiated by a change in local LLDP MIB variables. (Range: 1-8192 seconds; Default: 4 seconds)

The transmit delay is used to prevent a series of successive LLDP transmissions during a short period of rapid changes in local LLDP MIB objects, and to increase the probability that multiple, rather than single changes, are reported in each transmission.

This attribute must comply with the rule: (4 * Delay Interval) \leq Transmission Interval

ACCESS CONTROL LISTS

Access Control Lists allow you to configure a list of wireless client MAC addresses that are not authorized to access the network. A database of MAC addresses can be configured locally on the access point.

SOURCE ADDRESS SETTINGS The ACL Source Address Settings page enables traffic filtering based on the source MAC address in the data frame.

Figure 36: Source ACLs

Access Control List

Source Address Setting

SA Status Enable Disable

MAC Address	Action
<input type="text"/>	<input type="button" value="Add"/>

Source Address List

Number	MAC Address	DELETE
1	<input type="text" value="00:12:34:56:78:9a"/>	<input type="button" value="Delete"/>
2	<input type="text" value="00:11:22:33:44:55"/>	<input type="button" value="Delete"/>

The following items are displayed on this page:

- ◆ **SA Status** — Enables network traffic with specific source MAC addresses to be filtered (dropped) from the access point.
- ◆ **MAC Address** — Specifies a source MAC address to filter, in the form xx.xx.xx.xx.xx.xx, or xx-xx-xx-xx-xx-xx.
- ◆ **Action** — Selecting “Add” adds a new MAC address to the filter list, selecting delete removes the specified MAC address.
- ◆ **Number** — Specifies the number associated with the MAC address.
- ◆ **MAC Address** — Displays the configured source MAC address.

DESTINATION ADDRESS SETTINGS The ACL Destination Address Settings page enables traffic filtering based on the destination MAC address in the data frame.

Figure 37: Destination ACLs

Access Control List

Destination Address Setting

DA Status: Enable Disable

MAC Address	Action
<input type="text"/>	<input type="button" value="Add"/>

Destination Address List

Number	MAC Address	DELETE
1	<input type="text" value="00:12:34:56:78:9a"/>	<input type="button" value="Delete"/>
2	<input type="text" value="00:11:22:33:44:55"/>	<input type="button" value="Delete"/>

The following items are displayed on this page:

- ◆ **DA Status** — Enables network traffic with specific destination MAC addresses to be filtered (dropped) from the access point.
- ◆ **MAC Address** — Specifies a destination MAC address to filter, in the form xx:xx:xx:xx:xx:xx or xx-xx-xx-xx-xx-xx.
- ◆ **Action** — Selecting “Add” adds a new MAC address to the filter list, selecting delete deletes the specified MAC address.
- ◆ **Number** — Specifies the number of the MAC address in the filter table.
- ◆ **MAC Address** — Displays the configured destination MAC address.

ETHERNET TYPE The Ethernet Type Filter controls checks on the Ethernet type of all incoming and outgoing Ethernet packets against the protocol filtering table. (Default: Disabled)

Figure 38: Ethernet Type Filter



The following items are displayed on this page:

- ◆ **Disabled** — Access point does not filter Ethernet protocol types.
- ◆ **Enabled** — Access point filters Ethernet protocol types based on the configuration of protocol types in the filter table. If the status of a protocol is set to "ON," the protocol is filtered from the access point.
- ◆ **Local Management** — Describes the Ethernet filter type.
- ◆ **ISO Designator** — Describes the ISO Designator identifier.
- ◆ **Filter Status** — Turns the filter on or off.

This chapter describes wireless settings on the access point. It includes the following sections:

- ◆ “Spanning Tree Protocol (STP)” on page 79
- ◆ “Authentication” on page 82
- ◆ “Radio Settings” on page 86
- ◆ “Virtual Access Points (VAPs)” on page 89
- ◆ “Quality of Service (QoS)” on page 95

SPANNING TREE PROTOCOL (STP)

The Spanning Tree Protocol (STP) can be used to detect and disable network loops, and to provide backup links between switches, bridges or routers. This allows the wireless bridge to interact with other bridging devices (that is, an STP-compliant switch, bridge or router) in your network to ensure that only one route exists between any two stations on the network, and provide backup links which automatically take over when a primary link goes down.

STP uses a distributed algorithm to select a bridging device (STP-compliant switch, bridge or router) that serves as the root of the spanning tree network. It selects a root port on each bridging device (except for the root device) which incurs the lowest path cost when forwarding a packet from that device to the root device. Then it selects a designated bridging device from each LAN which incurs the lowest path cost when forwarding a packet from that LAN to the root device. All ports connected to designated bridging devices are assigned as designated ports. After determining the lowest cost spanning tree, it enables all root ports and designated ports, and disables all other ports. Network packets are therefore only forwarded between root ports and designated ports, eliminating any possible network loops.

Once a stable network topology has been established, all bridges listen for Hello BPDUs (Bridge Protocol Data Units) transmitted from the root bridge. If a bridge does not get a Hello BPDU after a predefined interval (Maximum Age), the bridge assumes that the link to the root bridge is down. This bridge will then initiate negotiations with other bridges to reconfigure the network to reestablish a valid network topology.

Figure 39: Spanning Tree Protocol

Spanning Tree Protocol

Bridge

Spanning Tree Protocol	<input checked="" type="radio"/> Disable <input type="radio"/> Enable	
Priority	32768	(0-65535)
Max Age	20	(6-40 sec.)
Hello Time	2	(1-10 sec.)
Forwarding Delay	15	(4-30 sec.)

Ethernet Interface

	Link Path Cost	Link Port Priority
Ethernet	4	(1-65535)
	32	(0-63)

Wireless Interface

Index	Link Path Cost	Link Port Priority
Vap 0	19	(1-65535)
Vap 1	19	(1-65535)
Vap 2	19	(1-65535)
Vap 3	19	(1-65535)
Vap 4	19	(1-65535)
Vap 5	19	(1-65535)
Vap 6	19	(1-65535)
Vap 7	19	(1-65535)
Vap 7	19	(1-65535)

BRIDGE Sets STP bridge link parameters.

The following items are displayed on the STP page:

- ◆ **Spanning Tree Protocol** — Enables/disables STP on the AP.
(Default: Enabled)
- ◆ **Priority** — Used in selecting the root device, root port, and designated port. The device with the highest priority becomes the STP root device. However, if all devices have the same priority, the device with the lowest MAC address will then become the root device. (Note that lower numeric values indicate higher priority.)
(Default: 32768; Range: 0-65535)
- ◆ **Max Age** — The maximum time (in seconds) a device can wait without receiving a configuration message before attempting to reconfigure. All device ports (except for designated ports) should receive configuration messages at regular intervals. Any port that ages out STP information (provided in the last configuration message) becomes the designated port for the attached LAN. If it is a root port, a new root port is selected

from among the device ports attached to the network.
(Default: 20 seconds; Range: 6-40 seconds)

Minimum: The higher of 6 or $[2 \times (\text{Hello Time} + 1)]$.
Maximum: The lower of 40 or $[2 \times (\text{Forward Delay} - 1)]$

- ◆ **Hello Time** — Interval (in seconds) at which the root device transmits a configuration message. (Default: 2 seconds; Range: 1-10 seconds)

Minimum: 1
Maximum: The lower of 10 or $[(\text{Max. Message Age} / 2) - 1]$

- ◆ **Forwarding Delay** — The maximum time (in seconds) this device waits before changing states (i.e., discarding to learning to forwarding). This delay is required because every device must receive information about topology changes before it starts to forward frames. In addition, each port needs time to listen for conflicting information that would make it return to a discarding state; otherwise, temporary data loops might result. (Default: 15 seconds; Range: 4-30 seconds)

Minimum: The higher of 4 or $[(\text{Max. Message Age} / 2) + 1]$
Maximum: 30

ETHERNET INTERFACE Sets STP settings for the Ethernet port.

- ◆ **Link Path Cost** — This parameter is used by the STP to determine the best path between devices. Therefore, lower values should be assigned to ports attached to faster media, and higher values assigned to ports with slower media. (Path cost takes precedence over port priority.) (Default: Ethernet interface: 19; Wireless interface: 40; Range: 1-65535)
- ◆ **Link Port Priority** — Defines the priority used for this port in the Spanning Tree Protocol. If the path cost for all ports on a switch are the same, the port with the highest priority (i.e., lowest value) will be configured as an active link in the spanning tree. This makes a port with higher priority less likely to be blocked if the Spanning Tree Protocol is detecting network loops. Where more than one port is assigned the highest priority, the port with lowest numeric identifier will be enabled. (Default: 128; Range: 0-240, in steps of 16)

WIRELESS INTERFACE Sets STP settings for the radio interface.

- ◆ **Index** — Describes the VAP in question.
- ◆ **Link Path Cost** — This parameter is used by the STP to determine the best path between devices. Therefore, lower values should be assigned to ports attached to faster media, and higher values assigned to ports with slower media. (Path cost takes precedence over port priority.) (Default: Ethernet interface: 19; Wireless interface: 40; Range: 1-65535)

- ◆ **Link Port Priority** — Defines the priority used for this port in the Spanning Tree Protocol. If the path cost for all ports on a switch are the same, the port with the highest priority (i.e., lowest value) will be configured as an active link in the spanning tree. This makes a port with higher priority less likely to be blocked if the Spanning Tree Protocol is detecting network loops. Where more than one port is assigned the highest priority, the port with lowest numeric identifier will be enabled. (Default: 128; Range: 0-240, in steps of 16)

AUTHENTICATION

Wireless clients can be authenticated for network access by checking their MAC address against the local database configured on the access point, or by using a database configured on a central RADIUS server. Alternatively, authentication can be implemented using the IEEE 802.1X network access control protocol.

You can configure a list of the MAC addresses for wireless clients that are authorized to access the network. This provides a basic level of authentication for wireless clients attempting to gain access to the network. A database of authorized MAC addresses can be stored locally on the access point or remotely on a central RADIUS server. (Default: Local MAC)

LOCAL MAC AUTHENTICATION

Configures the local MAC authentication database. The MAC database provides a mechanism to take certain actions based on a wireless client's MAC address. The MAC list can be configured to allow or deny network access to specific clients.

Figure 40: Local Authentication

Authentication

MAC Authentication Local MAC ▾

Local MAC Authentication

System Default Deny Allow

MAC Authentication Settings

MAC Address	Permission	Add
<input type="text"/>	<input type="radio"/> Allow <input checked="" type="radio"/> Deny	<input type="button" value="Add"/>

MAC Authentication Table

Number	MAC Address	Permission	DELETE
1	<input type="text" value="00:12:34:56:78:9a"/>	<input type="radio"/> Allow <input checked="" type="radio"/> Deny	<input type="button" value="Delete"/>
2	<input type="text" value="00:12:23:34:45:56"/>	<input type="radio"/> Allow <input checked="" type="radio"/> Deny	<input type="button" value="Delete"/>
3	<input type="text" value="00:11:22:33:44:55"/>	<input type="radio"/> Allow <input checked="" type="radio"/> Deny	<input type="button" value="Delete"/>

The following items are displayed on Authentication page:

MAC Authentication — Selects between, disabled, Local MAC authentication and RADIUS authentication.

- ◆ **Local MAC** — The MAC address of the associating station is compared against the local database stored on the access point. The Local MAC Authentication section enables the local database to be set up.
- ◆ **System Default** — Specifies a default action for all unknown MAC addresses (that is, those not listed in the local MAC database).
 - **Deny:** Blocks access for all MAC addresses except those listed in the local database as "Allow."
 - **Allow:** Permits access for all MAC addresses except those listed in the local database as "Deny."
- ◆ **MAC Authentication Settings** — Enters specified MAC addresses and permissions into the local MAC database.
 - **MAC Address:** Physical address of a client. Enter six pairs of hexadecimal digits separated by hyphens; for example, 00-90-D1-12-AB-89.
 - **Permission:** Select Allow to permit access or Deny to block access.
 - **Add/Delete:** Adds or deletes the specified MAC address and permission setting into or from the local database.

- ◆ **MAC Authentication Table** — Displays current entries in the local MAC database.

RADIUS MAC AUTHENTICATION

The MAC address of the associating station is sent to a configured RADIUS server for authentication. When using a RADIUS authentication server for MAC address authentication, the server must first be configured on the RADIUS page.

Figure 41: RADIUS Authentication

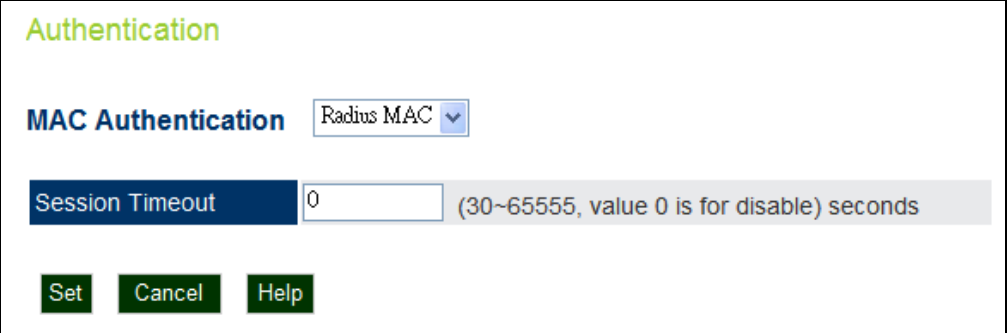

Authentication

MAC Authentication

Session Timeout (30~65555, value 0 is for disable) seconds

The following items are displayed on Authentication page:

MAC Authentication — Selects between, disabled, Local MAC authentication and RADIUS authentication.

- ◆ **RADIUS MAC** — The MAC address of the associating station is compared against the RADIUS server database. The RADIUS MAC Authentication section enables the RADIUS database to be set up.
- ◆ **Session Timeout** — The time period after which a connected client must be re-authenticated. During the re-authentication process of verifying the client's credentials on the RADIUS server, the client remains connected the network. Only if re-authentication fails is network access blocked. (Default: 0 means disabled; Range: 30-65535 seconds)

INTERFACE MODE

The access point can operate in two modes, IEEE 802.11a/n only, or 802.11g/n only. Also note that 802.11g is backward compatible with 802.11b, operating in the 2.4 GHz band. The 802.11a/n mode operates in the 5 GHz band.



NOTE: The SMCE21011 radio can operate in 2.4 GHz mode or 5 GHz mode. It does not operate at 2.4 GHz and 5 GHz modes at the same time. You must first select the basic radio operating mode you want to use for your network.

Figure 42: Interface Mode

The screenshot shows a web interface titled "Interface Mode Selection". Below the title is a section labeled "Select Interface Mode". Inside this section, there is a dropdown menu labeled "Interface0 Mode" with "11ng" selected. Below the dropdown are two buttons: "Set" and "Help".

The following items are displayed on the Interface Mode Selection page:

- ◆ **Interface0 Mode** — Selects the mode of the radio interface:
 - 11ng: All 802.11g and n clients can communicate with the wireless AP/ Router (up to 300 Mbps) using the 2.4 GHz band, but data transmission rates may be slowed to compensate for 802.11g clients.
 - 11na: All 802.11a and n clients can communicate with the wireless AP/ Router (up to 300 Mbps) using the 5 GHz band, but data transmission rates may be slowed to compensate for 802.11a clients.

RADIO SETTINGS

The IEEE 802.11n interfaces include configuration options for radio signal characteristics and wireless security features.

The access point can operate in two modes, mixed 802.11g/n (2.4 GHz), or mixed 802.11a/n (5 GHz). Note that the radio cannot not operate at 2.4 GHz and 5 GHz modes at the same time.

Each radio supports eight virtual access point (VAP) interfaces, referred to as VAP0 ~ VAP7. Each VAP functions as a separate access point, and can be configured with its own Service Set Identification (SSID) and security settings. However, most radio signal parameters apply to all VAP interfaces. The configuration options are nearly identical, and are therefore both covered in this section of the manual. Traffic to specific VAPs can be segregated based on user groups or application traffic. The clients associate with each VAP in the same way as they would with separate physical access points. The access point supports up to a total of 64 wireless clients across all VAP interfaces.

Figure 43: Radio Settings

Radio Settings

High Throughput Mode	HT20
Radio Channel	CH 11
Auto Channel Select	<input checked="" type="radio"/> Disable <input type="radio"/> Enable
Transmit Power	min
Maximum Association Clients	64 Clients
Radio Mode	11n (g compatible)
Preamble Length	Short-or-Long
Beacon Interval (20-1000)	100 TUs
Data Beacon Rate (DTIM) (1-255)	1 Beacons
Fragment Length (256-2346)	2346 Bytes
RTS Threshold (0-2347)	2347 Bytes
Short Guard Interval	<input type="radio"/> Disable <input checked="" type="radio"/> Enable
Aggregate MAC Protocol Data Unit (A-MPDU)	<input type="radio"/> Disable <input checked="" type="radio"/> Enable
A-MPDU Length Limit (1024-65535)	65535 Bytes
Aggregate MAC Service Data Unit (A-MSDU)	<input type="radio"/> Disable <input checked="" type="radio"/> Enable
A-MSDU Length Limit (2290-4096)	4096 Bytes

The following items are displayed on this page:

- ◆ **High Throughput Mode** — The access point provides a channel bandwidth of 20 MHz by default giving an 802.11g connection speed of 54 Mbps and a 802.11n connection speed of up to 108 Mbps, and ensures backward compliance for slower 802.11b devices. Setting the HT Channel Bandwidth to 40 MHz (sometimes referred to as Turbo Mode) increases connection speed for 802.11g and 802.11n to 74 Mbps and 300 Mbps respectively. HT40plus indicates that the secondary channel is above the primary channel. HT40minus indicates that the secondary channel is below the primary channel. (Default: HT20; Range:HT20, HT40PLUS, HT40MINUS)



NOTE: Some 802.11n wireless clients may be capable of transmission rates of up to 600 Mbps, however the access point will only be able to connect to them at a maximum transmission rate of 300 Mbps.

- ◆ **Radio Channel** — The radio channel that the access point uses to communicate with wireless clients. When multiple access points are deployed in the same area, set the channel on neighboring access points at least five channels apart to avoid interference with each other. For example, in 11ng HT20 mode you can deploy up to three access points in the same area using channels 1, 6, 11. Note that wireless clients automatically set the channel to the same as that used by the access point to which it is linked. (The available channels are dependent on the Radio Mode, High Throughput Mode, and Country Code settings.)
- ◆ **Auto Channel Select** — Selecting Auto Select enables the access point to automatically select an unoccupied radio channel.
- ◆ **Transmit Power** — Adjusts the power of the radio signals transmitted from the access point. The higher the transmission power, the farther the transmission range. Power selection is not just a trade off between coverage area and maximum supported clients. You also have to ensure that high-power signals do not interfere with the operation of other radio devices in the service area. (Default: Minimum; Range: min, 12.5%, 25%, 50%, 100%)
- ◆ **Maximum Association Clients** — The total maximum number of clients that may associate with all VAPs is fixed at 64.
- ◆ **Radio Mode** — Defines the radio mode for the VAP interface. (Default: 11n (g compatible); 11ng Mode Options: 11n (b&g compatible), 11n (g compatible), 11n; 11na Mode Options: 11n (a compatible), 11n)



NOTE: Enabling the access point to communicate with 802.11b/g clients in both 802.11b/g/n Mixed and 802.11n modes also requires that HT Operation be set to HT20.

- ◆ **Preamble Length** — The radio preamble (sometimes called a header) is a section of data at the head of a packet that contains information that the wireless device and client devices need when sending and receiving packets. You can set the radio preamble to long or short. A short preamble improves throughput performance, whereas a long preamble is required when legacy wireless devices are part of your network.
- ◆ **Beacon Interval (20-1000)** — The rate at which beacon signals are transmitted from the access point. The beacon signals allow wireless clients to maintain contact with the access point. They may also carry power-management information. (Range: 20-1000 TUs; Default: 100 TUs)
- ◆ **Data Beacon Rate (DTIM) (1-255)** — The rate at which stations in sleep mode must wake up to receive broadcast/multicast transmissions.

Known also as the Delivery Traffic Indication Map (DTIM) interval, it indicates how often the MAC layer forwards broadcast/multicast traffic, which is necessary to wake up stations that are using Power Save mode. The default value of 2 indicates that the access point will save all broadcast/multicast frames for the Basic Service Set (BSS) and forward them after every second beacon. Using smaller DTIM intervals delivers broadcast/multicast frames in a more timely manner, causing stations in Power Save mode to wake up more often and drain power faster. Using higher DTIM values reduces the power used by stations in Power Save mode, but delays the transmission of broadcast/multicast frames. (Range: 1-255 beacons; Default: 1 beacon)

- ◆ **RTS Threshold (0-2345)** — Sets the packet size threshold at which a Request to Send (RTS) signal must be sent to a receiving station prior to the sending station starting communications. The access point sends RTS frames to a receiving station to negotiate the sending of a data frame. After receiving an RTS frame, the station sends a CTS (clear to send) frame to notify the sending station that it can start sending data.

If the RTS threshold is set to 0, the access point always sends RTS signals. If set to 2347, the access point never sends RTS signals. If set to any other value, and the packet size equals or exceeds the RTS threshold, the RTS/CTS (Request to Send / Clear to Send) mechanism will be enabled.

The access points contending for the medium may not be aware of each other. The RTS/CTS mechanism can solve this "Hidden Node Problem." (Range: 0-2345 bytes; Default: 2345 bytes)

- ◆ **Short Guard Interval** — The 802.11n draft specifies two guard intervals: 400ns (short) and 800ns (long). Support of the 400ns GI is optional for transmit and receive. The purpose of a guard interval is to introduce immunity to propagation delays, echoes, and reflections to which digital data is normally very sensitive. Enabling the Short Guard Interval sets it to 400ns. (Default: Disabled)

- ◆ **Aggregate MAC Protocol Data Unit (A-MPDU)** — Enables / disables the sending of this four frame packet header for statistical purposes. (Default: Enabled)
- ◆ **A-MPDU Length Limit (1024-65535)** — Defines the A-MPDU length. (Default: 65535 bytes; Range: 1024-65535 bytes)
- ◆ **Aggregate MAC Service Data Unit (A-MSDU)** — Enables / disables the sending of this four frame packet header for statistical purposes. (Default: Enabled)
- ◆ **A-MSDU Length Limit (2290-4096)** — Defines the A-MSDU length. (Default: 4096 bytes; Range: 2290-4096 bytes)
- ◆ **Set Radio** — Sets all entered parameters.

VIRTUAL ACCESS POINTS (VAPs)

The access point supports up to eight virtual access point (VAP) interfaces numbered 0 to 7. Each VAP functions as a separate access point, and can be configured with its own Service Set Identification (SSID) and security settings. However, most radio signal parameters apply to all eight VAP interfaces.

The VAPs function similar to a VLAN, with each VAP mapped to its own default VLAN ID. Traffic to specific VAPs can be segregated based on user groups or application traffic. All VAPs can support up to a total of 64 wireless clients, whereby the clients associate with each VAP the same way as they would with separate physical access points.



NOTE: The radio channel settings for the access point are limited by local regulations, which determine the number of channels that are available. See [“Operating Channels” on page 250](#) for additional information on the maximum number channels available.

Figure 44: VAP Settings

VAP Setting				
VAP Number	SSID	Enable	Status	Edit setting
VAP 0	SMC_VAP_0	<input checked="" type="checkbox"/>	ap	Edit
VAP 1	SMC_VAP_1	<input type="checkbox"/>	ap	Edit
VAP 2	SMC_VAP_2	<input type="checkbox"/>	ap	Edit
VAP 3	SMC_VAP_3	<input type="checkbox"/>	ap	Edit
VAP 4	SMC_VAP_4	<input type="checkbox"/>	ap	Edit
VAP 5	SMC_VAP_5	<input type="checkbox"/>	ap	Edit
VAP 6	SMC_VAP_6	<input type="checkbox"/>	ap	Edit
VAP 7	SMC_VAP_7	<input type="checkbox"/>	ap	Edit

The following items are displayed on this page:

- ◆ **VAP Number** — The number associated with the VAP, 0-7.
- ◆ **SSID** — The name of the basic service set provided by a VAP interface. Clients that want to connect to the network through the access point must set their SSID to the same as that of an access point VAP interface. (Default: SMC_VAP_# (0 to 7); Range: 1-32 characters)
- ◆ **Enable** — Enables the specified VAP. (Default: Disabled)
- ◆ **Status** — Displays the mode of the VAP. The default is set to "AP," for normal access point services.
- ◆ **Edit Setting** — Click to open the page for configuring the selected VAP.

VAP BASIC SETTINGS Sets the basic operating mode and other settings for the VAP.

Each VAP can operate in one of three modes; normal AP mode, WDS-AP bridge AP mode, or WDS-STA bridge station mode. The default mode is AP for the VAP to support normal access point services.



NOTE: For more information and examples for setting up WDS networks, see ["WDS Setup Examples" on page 240](#).

Note that the Basic Settings are the same for both AP and WDS-AP modes.

Figure 45: VAP Basic Settings

Basic Setting	
Closed System	<input checked="" type="radio"/> Disable <input type="radio"/> Enable
Mode	<input checked="" type="radio"/> AP <input type="radio"/> WDS-AP <input type="radio"/> WDS-STA
Association Timeout Interval	5 (5-60 Mins)
Authentication Timeout Interval	3 (3-60 Mins)
Default VLAN ID	1
DHCP_relay_server	0 . 0 . 0 . 0
SSID	SMC_VAP_0

The following items are displayed on this page:

- ◆ **Closed System** — When enabled, the VAP does not include its SSID in beacon messages. Nor does it respond to probe requests from clients that do not include a fixed SSID. (Default: Disable)

- ◆ **Mode** — Selects the mode in which the VAP will function.
 - **AP Mode:** The VAP provides services to clients as a normal access point.
 - **WDS-AP Mode:** The VAP operates as an access point in WDS mode, which accepts connections from client stations in WDS-STA mode.
 - **WDS-STA Mode:** The VAP operates as a client station in WDS mode, which connects to an access point VAP in WDS-AP mode. The user needs to specify the MAC address of the access point in WDS-AP mode to which it intends to connect.
- ◆ **Association Timeout Interval** — The idle time interval (when no frames are sent) after which a client is disassociated from the VAP interface. (Range: 5-60 minutes; Default: 30 minutes)
- ◆ **Authentication Timeout Interval** — The time within which the client should finish authentication before authentication times out. (Range: 5-60 minutes; Default: 60 minutes)
- ◆ **Default VLAN ID** — The VLAN ID assigned to wireless clients associated to the VAP interface that are not assigned to a specific VLAN by RADIUS server configuration. (Default: 1)
- ◆ **DHCP Relay Server** — The IP address of the DHCP relay server. Dynamic Host Configuration Protocol (DHCP) can dynamically allocate an IP address and other configuration information to network clients that broadcast a request. To receive the broadcast request, the DHCP server would normally have to be on the same subnet as the client. However, when the access point's DHCP relay agent is enabled, received client requests can be forwarded directly by the access point to a known DHCP server on another subnet. Responses from the DHCP server are returned to the access point, which then broadcasts them back to clients. (Default: 0.0.0.0 (disabled))
- ◆ **SSID** — The service set identifier for the VAP.

WDS-STA MODE Describes additional basic VAP settings when functioning in WDS-STA mode.

Figure 46: WDS-STA Mode

Basic Setting	
Mode	<input type="radio"/> AP <input type="radio"/> WDS-AP <input checked="" type="radio"/> WDS-STA
Default VLAN ID	<input type="text" value="1"/>
WDS-AP (Parent) SSID	<input type="text" value="vap_a0"/>
WDS-AP (Parent) MAC	<input type="text" value="10"/> : <input type="text" value="23"/> : <input type="text" value="45"/> : <input type="text" value="87"/> : <input type="text" value="21"/> : <input type="text" value="54"/>

The following items are displayed in the VAP Basic Settings when WDS-AP mode is selected:

- ◆ **WDS-AP (Parent) SSID** — The SSID of the VAP on the connecting access point that is set to WDS-AP mode.
- ◆ **WDS-AP (Parent) MAC** — The MAC address of the VAP on the connecting access point that is set to WDS-AP mode.

WIRELESS SECURITY SETTINGS Describes the wireless security settings for each VAP, including association mode, encryption, and authentication.



NOTE: For VAPs set to WDS-AP or WDS-STA mode, the security options are limited to WPA-PSK and WPA2-PSK only.

Figure 47: Configuring VAPs - Common Settings

Security

Association Mode: Open System

Encryption Method: none

Authentication

802.1X: Disable Enable

802.1X Reauthentication Time: 3600 seconds (0 = Disabled)

If 802.1x is enabled, then [RADIUS](#) setup must be completed

Set Cancel Help

The following items are common to all three modes:

- ◆ **Association Mode** — Defines the mode with which the access point will associate with other clients.
 - **Open System:** The VAP is configured by default as an “open system,” which broadcasts a beacon signal including the configured SSID. Wireless clients with an SSID setting of “any” can read the SSID from the beacon and automatically set their SSID to allow immediate connection.
 - **WPA:** WPA employs a combination of several technologies to provide an enhanced security solution for 802.11 wireless networks.
 - **WPA-PSK:** For enterprise deployment, WPA requires a RADIUS authentication server to be configured on the wired network. However, for small office networks that may not have the resources

to configure and maintain a RADIUS server, WPA provides a simple operating mode that uses just a pre-shared password for network access. The Pre-Shared Key mode uses a common password for user authentication that is manually entered on the access point and all wireless clients. The PSK mode uses the same TKIP packet encryption and key management as WPA in the enterprise, providing a robust and manageable alternative for small networks.

- **WPA2:** WPA2 – WPA was introduced as an interim solution for the vulnerability of WEP pending the ratification of the IEEE 802.11i wireless security standard. In effect, the WPA security features are a subset of the 802.11i standard. WPA2 includes the now ratified 802.11i standard, but also offers backward compatibility with WPA. Therefore, WPA2 includes the same 802.1X and PSK modes of operation and support for TKIP encryption.
 - **WPA2-PSK:** Clients using WPA2 with a Pre-shared Key are accepted for authentication.
 - **WPA-WPA2 Mixed:** Clients using WPA or WPA2 are accepted for authentication.
 - **WPA-WPA2-PSK-mixed:** Clients using WPA or WPA2 with a Pre-shared Key are accepted for authentication.
- ◆ **Encryption Method** — Selects an encryption method for the global key used for multicast and broadcast traffic, which is supported by all wireless clients.
- **WEP:** WEP is used as the multicast encryption cipher. You should select WEP only when both WPA and WEP clients are supported.
 - **TKIP:** TKIP is used as the multicast encryption cipher.
 - **AES-CCMP:** AES-CCMP is used as the multicast encryption cipher. AES-CCMP is the standard encryption cipher required for WPA2.
- ◆ **802.1X** — The access point supports 802.1X authentication only for clients initiating the 802.1X authentication process (i.e., the access point does not initiate 802.1X authentication). For clients initiating 802.1X, only those successfully authenticated are allowed to access the network. For those clients not initiating 802.1X, access to the network is allowed after successful wireless association with the access point. The 802.1X mode allows access for clients not using WPA or WPA2 security.
- ◆ **Pre-Authentication** — When using WPA2 over 802.1X, pre-authentication can be enabled, which allows clients to roam to a new access point and be quickly associated without performing full 802.1X authentication. (Default: Disabled)
- ◆ **802.1x Reauthentication Time** — The time period after which a connected client must be re-authenticated. During the re-authentication process of verifying the client's credentials on the

RADIUS server, the client remains connected the network. Only if re-authentication fails is network access blocked. (Range: 0-65535 seconds; Default: 0 means disabled)

**WIRED EQUIVALENT
PRIVACY (WEP)**

WEP provides a basic level of security, preventing unauthorized access to the network, and encrypting data transmitted between wireless clients and the VAP. WEP uses static shared keys (fixed-length hexadecimal or alphanumeric strings) that are manually distributed to all clients that want to use the network.

WEP is the security protocol initially specified in the IEEE 802.11 standard for wireless communications. Unfortunately, WEP has been found to be seriously flawed and cannot be recommended for a high level of network security. For more robust wireless security, the access point provides Wi-Fi Protected Access (WPA) and WPA2 for improved data encryption and user authentication.

Setting up shared keys enables the basic IEEE 802.11 Wired Equivalent Privacy (WEP) on the access point to prevent unauthorized access to the network.

If you choose to use WEP shared keys instead of an open system, be sure to define at least one static WEP key for user authentication and data encryption. Also, be sure that the WEP shared keys are the same for each client in the wireless network. All clients share the same keys, which are used for user authentication and data encryption. Up to four keys can be specified.

Figure 48: WEP Configuration

Security

Association Mode	Open System ▼
Encryption Method	WEP ▼
Default WEP Key Index	1 ▼

Authentication

802.1X	<input checked="" type="radio"/> Disable <input type="radio"/> Enable
802.1X Reauthentication Time	3600 seconds (0 = Disabled)

If 802.1x is enabled, then [RADIUS](#) setup must be completed

WEP Setting

Index	Key Type	Key length		Key
Key 1	<input type="radio"/> Hex <input checked="" type="radio"/> ASCII	<input checked="" type="radio"/> 64 Bit	<input type="radio"/> 128 Bit	•••••
Key 2	<input type="radio"/> Hex <input checked="" type="radio"/> ASCII	<input checked="" type="radio"/> 64 Bit	<input type="radio"/> 128 Bit	•••••
Key 3	<input type="radio"/> Hex <input checked="" type="radio"/> ASCII	<input checked="" type="radio"/> 64 Bit	<input type="radio"/> 128 Bit	•••••
Key 4	<input type="radio"/> Hex <input checked="" type="radio"/> ASCII	<input checked="" type="radio"/> 64 Bit	<input type="radio"/> 128 Bit	•••••

Set
Cancel
Help

The following items are on this page for WEP configuration:

- ◆ **Default WEP Key Index** – Selects the key number to use for encryption for the VAP interface. If the clients have all four WEP keys configured to the same values, you can change the encryption key to any of the settings without having to update the client keys. (Default: Key 1)
- ◆ **Key Type** – Select the preferred method of entering WEP encryption keys for the VAP, either hexadecimal digits (Hex) or alphanumeric characters (ASCII).
- ◆ **Key Length** – Select 64 Bit or 128 Bit key length. Note that the same size of encryption key must be supported on all wireless clients. (Default: 64 bit)
- ◆ **Key** – Enter up to four WEP encryption keys for the VAP.
 - **Hex:** Enter keys as 10 hexadecimal digits (0-9 and A-F) for 64 bit keys, or 26 hexadecimal digits for 128 bit keys.
 - **ASCII:** Enter keys as 5 alphanumeric characters for 64 bit keys, or 13 alphanumeric characters for 128 bit keys.



NOTE: Key index, type, and length must match that configured on the clients.

QUALITY OF SERVICE (QoS)

Wireless networks offer an equal opportunity for all devices to transmit data from any type of application. Although this is acceptable for most applications, multimedia applications (with audio and video) are particularly sensitive to the delay and throughput variations that result from this “equal opportunity” wireless access method. For multimedia applications to run well over a wireless network, a Quality of Service (QoS) mechanism is required to prioritize traffic types and provide an “enhanced opportunity” wireless access method.

The access point implements QoS using the Wi-Fi Multimedia (WMM) standard. Using WMM, the access point is able to prioritize traffic and optimize performance when multiple applications compete for wireless network bandwidth at the same time. WMM employs techniques that are a subset of the developing IEEE 802.11e QoS standard and it enables the access point to inter operate with both WMM-enabled clients and other devices that may lack any WMM functionality.

Access Categories — WMM defines four access categories (ACs): voice, video, best effort, and background. These categories correspond to traffic priority levels and are mapped to IEEE 802.1D priority tags (see [“WMM Access Categories” on page 96](#)). The direct mapping of the four ACs to

802.1D priorities is specifically intended to facilitate inter operability with other wired network QoS policies. While the four ACs are specified for specific types of traffic, WMM allows the priority levels to be configured to match any network-wide QoS policy. WMM also specifies a protocol that access points can use to communicate the configured traffic priority levels to QoS-enabled wireless clients.

Table 4: WMM Access Categories

Access Category	WMM Designation	Description	802.1D Tags
AC_VO (AC3)	Voice	Highest priority, minimum delay. Time-sensitive data such as VoIP (Voice over IP) calls.	7, 6
AC_VI (AC2)	Video	High priority, minimum delay. Time-sensitive data such as streaming video.	5, 4
AC_BE (AC0)	Best Effort	Normal priority, medium delay and throughput. Data only affected by long delays. Data from applications or devices that lack QoS capabilities.	0, 3
AC_BK (AC1)	Background	Lowest priority. Data with no delay or throughput requirements, such as bulk data transfers.	2, 1

WMM Operation — WMM uses traffic priority based on the four ACs; Voice, Video, Best Effort, and Background. The higher the AC priority, the higher the probability that data is transmitted.

When the access point forwards traffic, WMM adds data packets to four independent transmit queues, one for each AC, depending on the 802.1D priority tag of the packet. Data packets without a priority tag are always added to the Best Effort AC queue. From the four queues, an internal “virtual” collision resolution mechanism first selects data with the highest priority to be granted a transmit opportunity. Then the same collision resolution mechanism is used externally to determine which device has access to the wireless medium.

For each AC queue, the collision resolution mechanism is dependent on two timing parameters:

- ◆ AIFSN (Arbitration Inter-Frame Space Number), a number used to calculate the minimum time between data frames
- ◆ CW (Contention Window), a number used to calculate a random backoff time

After a collision detection, a backoff wait time is calculated. The total wait time is the sum of a minimum wait time (Arbitration Inter-Frame Space, or AIFS) determined from the AIFSN, and a random backoff time calculated from a value selected from zero to the CW. The CW value varies within a configurable range. It starts at CWMin and doubles after every collision up to a maximum value, CWMax. After a successful transmission, the CW value is reset to its CWMin value.

Figure 49: WMM Backoff Wait Times

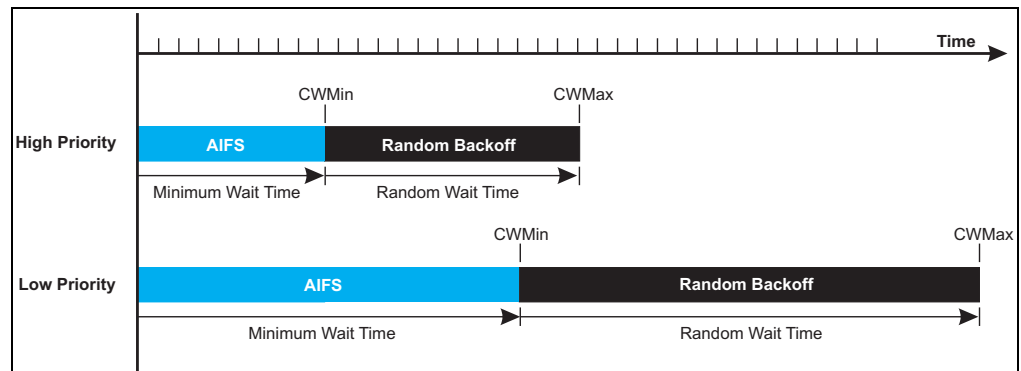

For high-priority traffic, the AIFSN and CW values are smaller. The smaller values equate to less backoff and wait time, and therefore more transmit opportunities.

Figure 50: QoS

Quality of Service (QoS)

WMM : Disable Enable

WMM Acknowledge Policy :

AC0 (Best Effort)	<input checked="" type="radio"/> Acknowledge <input type="radio"/> No Acknowledge
AC1 (Background)	<input checked="" type="radio"/> Acknowledge <input type="radio"/> No Acknowledge
AC2 (Video)	<input checked="" type="radio"/> Acknowledge <input type="radio"/> No Acknowledge
AC3 (Voice)	<input checked="" type="radio"/> Acknowledge <input type="radio"/> No Acknowledge

WMM BSS Parameters :

	AC0 (BestEffort)	AC1(Background)	AC2 (Video)	AC3 (Voice)
CwMin	4	4	3	2
CwMax	10	10	4	3
AIFSN	3	7	2	2
TXOP Limit	0	0	3008	1504
Admission Control	<input checked="" type="radio"/> Disable <input type="radio"/> Enable	<input checked="" type="radio"/> Disable <input type="radio"/> Enable	<input checked="" type="radio"/> Disable <input type="radio"/> Enable	<input checked="" type="radio"/> Disable <input type="radio"/> Enable

WMM AP Parameters :

	AC0 (BestEffort)	AC1 (Background)	AC2 (Video)	AC3 (Voice)
CwMin	4	4	3	2
CwMax	6	10	4	3
AIFSN	3	7	1	1
TXOP Limit	0	0	3008	1504

Set WMM Cancel Help

The following items are displayed on this page:

- ◆ **WMM** — Sets the WMM operational mode on the access point. When enabled, the parameters for each AC queue will be employed on the access point and QoS capabilities are advertised to WMM-enabled clients. (Default: Disabled)
 - **Disable:** WMM is disabled.
 - **Enable:** WMM must be supported on any device trying to associate with the access point. Devices that do not support this feature will not be allowed to associate with the access point.
- ◆ **WMM Acknowledge Policy** — By default, all wireless data transmissions require the sender to wait for an acknowledgement from the receiver. WMM allows the acknowledgement wait time to be turned off for each Access Category (AC) 0-3. Although this increases data throughput, it can also result in a high number of errors when traffic levels are heavy. (Default: Acknowledge)
 - **Acknowledge** — Applies the WMM policy.
 - **No Acknowledge** — Ignores the WMM policy.
- ◆ **WMM BSS Parameters** — These parameters apply to the wireless clients.
- ◆ **WMM AP Parameters** — These parameters apply to the access point.
 - **logCWMin** (Minimum Contention Window): The initial upper limit of the random backoff wait time before wireless medium access can be attempted. The initial wait time is a random value between zero and the CWMin value. Specify the CWMin value in the range 0-15 microseconds. Note that the CWMin value must be equal or less than the CWMax value.
 - **logCWMax** (Maximum Contention Window): The maximum upper limit of the random backoff wait time before wireless medium access can be attempted. The contention window is doubled after each detected collision up to the CWMax value. Specify the CWMax value in the range 0-15 microseconds. Note that the CWMax value must be greater or equal to the CWMin value.
 - **AIFSN** (Arbitration Inter-Frame Space): The minimum amount of wait time before the next data transmission attempt. Specify the AIFS value in the range 0-15 microseconds.
 - **TXOP Limit** (Transmit Opportunity Limit): The maximum time an AC transmit queue has access to the wireless medium. When an AC queue is granted a transmit opportunity, it can transmit data for a time up to the TxOpLimit. This data bursting greatly improves the efficiency for high data-rate traffic. Specify a value in the range 0-65535 microseconds.

- **Admission Control:** The admission control mode for the access category. When enabled, clients are blocked from using the access category. (Default: Disabled)
- ◆ **Set WMM** — Applies the new parameters and saves them to RAM memory. Also prompts a screen to inform you when it has taken affect. Click "OK" to return to the home page. Changes will not be saved upon a reboot unless the running configuration file is saved.

Maintenance settings includes the following sections:

- ◆ [“Upgrading Firmware” on page 100](#)
- ◆ [“Running Configuration” on page 103](#)
- ◆ [“Resetting the Access Point” on page 104](#)

UPGRADING FIRMWARE

You can upgrade new access point software from a local file on the management workstation, or from an FTP or TFTP server. New software may be provided periodically from your distributor.

After upgrading new software, you must reboot the access point to implement the new code. Until a reboot occurs, the access point will continue to run the software it was using before the upgrade started. Also note that new software that is incompatible with the current configuration automatically restores the access point to the factory default settings when first activated after a reboot.

Figure 51: Firmware

Firmware

Firmware Version

Image A	1.1.0.12	Active
Image B	1.1.0.8	Backup

Next Boot Image

Change Next Boot Image A B

Set Next Boot

Local

New firmware file

Start Upgrade

Remote

FTP TFTP

New firmware file

IP Address

Username

Password

Start Upgrade **Help**

It may take several minutes to upgrade the firmware please wait...

The following items are displayed on this page:

- ◆ **Firmware Version** — Displays what version of software is being used as a runtime image - "Active", and what version is a backup image - "Backup". You may specify up to two images.
- ◆ **Next Boot Image** — Specifies what version of firmware will be used as a runtime image upon bootup.
- ◆ **Set Next Boot** — Applies the runtime image setting.
- ◆ **Local** — Downloads an operation code image file from the web management station to the access point using HTTP. Use the Browse button to locate the image file locally on the management station and click Start Upgrade to proceed.
 - **New Firmware File:** Specifies the name of the code file on the server. The new firmware file name should not contain slashes (\ or /), the leading letter of the file name should not be a period (.), and the maximum length for file names is 32 characters for files on the access point. (Valid characters: A-Z, a-z, 0-9, ".", "-", "_")

- ◆ **Remote** — Downloads an operation code image file from a specified remote FTP or TFTP server. After filling in the following fields, click Start Upgrade to proceed.
 - **New Firmware File:** Specifies the name of the code file on the server. The new firmware file name should not contain slashes (\ or /), the leading letter of the file name should not be a period (.), and the maximum length for file names on the FTP/TFTP server is 255 characters or 32 characters for files on the access point. (Valid characters: A-Z, a-z, 0-9, ".", "-", "_")
 - **IP Address:** IP address or host name of FTP or TFTP server.
 - **Username:** The user ID used for login on an FTP server.
 - **Password:** The password used for login on an FTP server.
- ◆ **Start Upgrade** — Commences the upgrade process.

RUNNING CONFIGURATION

A copy of a previous running configuration may be uploaded to the access point as a saved file from a remote location, or the current configuration saved and stored for restoration purposes at a later point. A configuration file may be saved or downloaded to/from a specified remote FTP or TFTP server.

Figure 52: Running Configuration File

Configuration

File Backup/Restore

FTP TFTP
 Export Import

Config file	syscfg	(must be "syscfg")
IP Address		
Username		
Password		

Restore Factory Setting

Runtime Config To Startup Config

The following items are displayed on this page:

- ◆ **File Backup/Restore** — Downloads an operation code image file from a specified remote FTP or TFTP server. After filling in the following fields, click Start Export/Import to proceed.
- ◆ **Export/Import** — Select Export to upload a file to an FTP/TFTP server. Select Import to download a file from an FTP/TFTP server.
- ◆ **Config file** — Specifies the name of the configuration file, which must always be "syscfg." A path on the server can be specified using "/" in the name, providing the path already exists; for example, "myfolder/syscfg." Other than to indicate a path, the file name must not contain any slashes (\ or /), the leading letter cannot be a period (.), and the maximum length for file names on the FTP/TFTP server is 255 characters. (Valid characters: A-Z, a-z, 0-9, ".", "-", "_")

- ◆ **IP Address** — IP address or host name of FTP or TFTP server.
- ◆ **Username** — The user ID used for login on an FTP server.
- ◆ **Password** — The password used for login on an FTP server.
- ◆ **Start Import/Export** — Initiates the selected backup or restore.
- ◆ **Restore Factory Setting** — Click the Restore button to reset the configuration settings for the access point to the factory defaults and reboot the system. Note that all user configured information will be lost. You will have to re-enter the default user name and password to re-gain management access to this device.
- ◆ **Running Config To Startup Config** — Click “Save” to save the running configuration to the startup file.

RESETTING THE ACCESS POINT

The Reset page allows you to reset the access point and save the running configuration before the reboot.

Figure 53: Resetting the Access Point

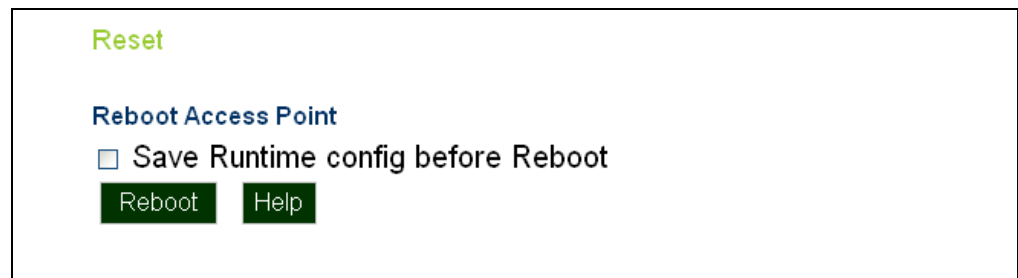

The following items are displayed on this page:

- ◆ **Save Runtime config before Reboot** — Checking this option saves the current running configuration to the startup file.
- ◆ **Reboot** — Click the “Reboot” button to reset the configuration settings for the AP and reboot the system. Note that all unsaved user configured information will be lost.



NOTE: If you have upgraded system software, then you must reboot the access point to implement the new operation code. New software that is incompatible with the current configuration automatically restores the access point to default values when first activated after a reboot.

The Information menu displays information on the current system configuration, the wireless interface, the station status and system logs.

Status Information includes the following sections:

- ◆ “AP Status” on page 105
- ◆ “Station Status” on page 107
- ◆ “Event Logs” on page 108

AP STATUS

The AP Status window displays basic system configuration settings, as well as the settings for the wireless interface.

AP SYSTEM CONFIGURATION

The AP System Configuration table displays the basic system configuration settings

Figure 54: AP System Configuration

AP Status	
AP System Configuration	
Serial Number	A912002340
System Up Time	2:53
Ethernet MAC Address	00:22:2d:4d:7b:80
Radio 0 MAC Address	00:22:2d:4d:7b:81
System Name	11n_AP
System Contact	who?
IP Address	192.168.1.1
IP default-gateway	192.168.1.254
HTTP Server Status	Enable
HTTP Port	80
HTTPs Server Status	Enable
HTTPs Port	443
Software Version	1.1.0.12
Boot Rom Version	v0.1.0
Hardware Version	1.0

The following items are displayed on this page:

- ◆ **Serial Number** — The serial number of the physical access point.
- ◆ **System Up Time** — Length of time the management agent has been up.
- ◆ **Ethernet MAC Address** — The physical layer address for the Ethernet port.
- ◆ **Radio 0 MAC Address** — The physical layer address for the VAP 0 interface.
- ◆ **System Name** — Name assigned to this system.
- ◆ **System Contact** — Administrator responsible for the system.
- ◆ **IP Address** — IP address of the management interface for this device.
- ◆ **IP Default Gateway** — IP address of the gateway router between this device and management stations that exist on other network segments.
- ◆ **HTTP Server Status** — Shows if management access via HTTP is enabled.
- ◆ **HTTP Port** — Shows the TCP port used by the HTTP interface.
- ◆ **HTTPS Server Status** — Shows if management access via HTTPS is enabled.
- ◆ **HTTPS Port** — Shows the TCP port used by the HTTPS interface.
- ◆ **Software Version** — Shows the software version number.
- ◆ **Bootrom Version** — Show the bootrom version number.
- ◆ **Hardware Version** — Shows the hardware version number.

**AP WIRELESS
CONFIGURATION**

The AP Wireless Configuration displays the VAP interface settings.

Figure 55: AP Wireless Configuration

AP Wireless Configuration				
Wireless Interface				
VAP	SSID	Association Mode	802.1X	MAC Address
0	SMC_VAP_0	Open	Disable	00:22:2d:4d:7b:81
1	SMC_VAP_1	Open	Disable	00:22:2d:4d:7b:82
2	SMC_VAP_2	Open	Disable	00:22:2d:4d:7b:83
3	SMC_VAP_3	Open	Disable	00:22:2d:4d:7b:84
4	SMC_VAP_4	Open	Disable	00:22:2d:4d:7b:85
5	SMC_VAP_5	Open	Disable	00:22:2d:4d:7b:86
6	SMC_VAP_6	Open	Disable	00:22:2d:4d:7b:87
7	SMC_VAP_7	Open	Disable	00:22:2d:4d:7b:88

The following items are displayed on this page:

- ◆ **VAP** — Displays the VAP number.
- ◆ **SSID** — The service set identifier for the VAP interface.
- ◆ **Association Mode** — Shows the basic security mode configured for the VAP.
- ◆ **802.1X** — Shows if IEEE 802.1X access control for wireless clients is enabled.

STATION STATUS

The Station Status window shows the wireless clients currently associated with the access point.

Figure 56: Station Status

Station Status	
Wireless Interface	
Station Address	VLAN ID

The following items are displayed on this page:

- ◆ **Station Address** — The MAC address of the wireless client.
- ◆ **VLAN ID** — Displays the VLAN to which the wireless client has been assigned.

EVENT LOGS

The Event Logs window shows the log messages generated by the access point and stored in memory.

Figure 57: Event Logs

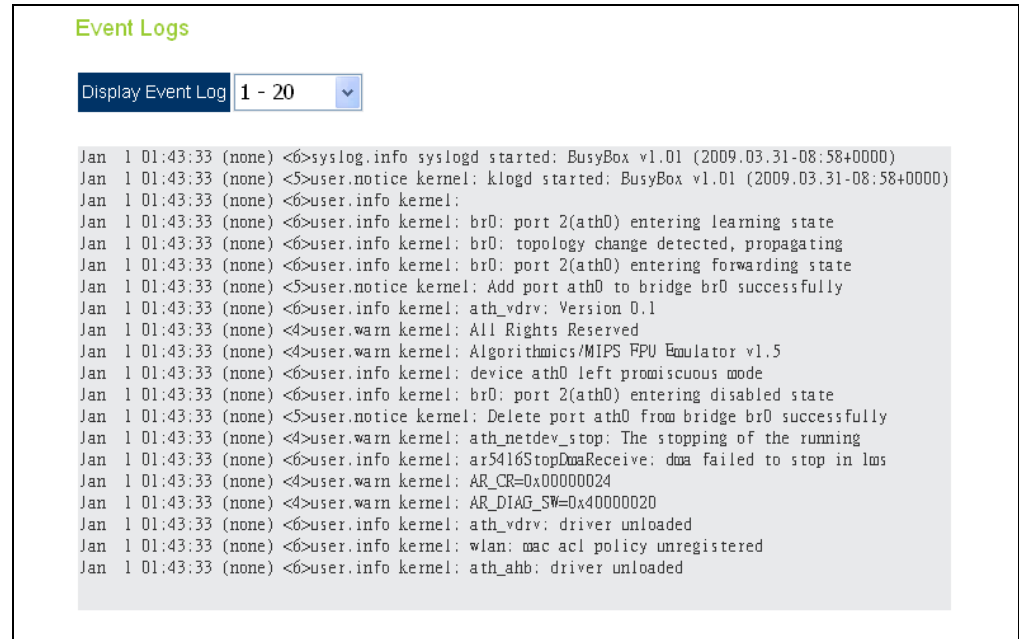

The following items are displayed on this page:

- ◆ **Display Event Log** — Selects the log entries to display. Up to 20 log messages can be displayed at one time.

Each log entry includes the time the log message was generated, the logging level associated with the message, and the text of the log message.

SECTION III

COMMAND LINE INTERFACE

This section provides a detailed description of the Command Line Interface, along with examples for all of the commands.

This section includes these chapters:

- ◆ ["Using the Command Line Interface" on page 112](#)
- ◆ ["General Commands" on page 118](#)
- ◆ ["System Management Commands" on page 122](#)
- ◆ ["System Logging Commands" on page 137](#)
- ◆ ["System Clock Commands" on page 141](#)
- ◆ ["DHCP Relay Commands" on page 146](#)
- ◆ ["SNMP Commands" on page 148](#)
- ◆ ["Flash/File Commands" on page 162](#)
- ◆ ["RADIUS Client Commands" on page 165](#)
- ◆ ["802.1X Authentication Commands" on page 171](#)
- ◆ ["MAC Address Authentication Commands" on page 173](#)
- ◆ ["Filtering Commands" on page 177](#)
- ◆ ["Spanning Tree Commands" on page 182](#)
- ◆ ["WDS Bridge Commands" on page 193](#)
- ◆ ["Ethernet Interface Commands" on page 195](#)
- ◆ ["Wireless Interface Commands" on page 200](#)
- ◆ ["Wireless Security Commands" on page 214](#)
- ◆ ["Link Layer Discovery Commands" on page 224](#)

- ◆ "VLAN Commands" on page 228
- ◆ "WMM Commands" on page 231

USING THE COMMAND LINE INTERFACE

When accessing the management interface for the over a direct connection to the console port, or via a Telnet connection, the access point can be managed by entering command keywords and parameters at the prompt. Using the access point's command-line interface (CLI) is very similar to entering commands on a UNIX system.

CONSOLE CONNECTION

To access the access point through the console port, perform these steps:

At the console prompt, enter the user name and password. (The default user name is "admin" and the default password is "smcadmin") When the user name is entered, the CLI displays the "Enterprise AP#" prompt.

Enter the necessary commands to complete your desired tasks.

When finished, exit the session with the "exit" command.

After connecting to the system through the console port, the login screen displays

EXAMPLE

```
(none) login: accton
Password:
  1 03:47:41 login[2222]: root login on `ttyS0'

Accton#
```



NOTE: Command examples shown later in this chapter abbreviate the console prompt to "AP" for simplicity.

TELNET CONNECTION

Telnet operates over the IP transport protocol. In this environment, your management station and any network device you want to manage over the network must have a valid IP address. Valid IP addresses consist of four numbers, 0 to 255, separated by periods. Each address consists of a network portion and host portion. For example, if the access point cannot acquire an IP address from a DHCP server, the default IP address used by the access point, 192.168.2.1, consists of a network portion (192.168.2) and a host portion (1).

To access the access point through a Telnet session, you must first set the IP address for the access point, and set the default gateway if you are managing the access point from a different IP subnet. For example:

```
AP#configure
AP(config)#interface ethernet
AP(if-ethernet)#ip address 10.1.0.1 255.255.255.0 10.1.0.254
AP(if-ethernet)#
```

If your corporate network is connected to another network outside your office or to the Internet, you need to apply for a registered IP address. However, if you are attached to an isolated network, then you can use any IP address that matches the network segment to which you are attached.

After you configure the access point with an IP address, you can open a Telnet session by performing these steps.

1. From the remote host, enter the Telnet command and the IP address of the device you want to access.
2. At the prompt, enter the user name and system password. The CLI will display the "Enterprise AP#" prompt to show that you are using executive access mode (that is, Exec).
3. Enter the necessary commands to complete your desired tasks.
4. When finished, exit the session with the "quit" or "exit" command.

After entering the Telnet command, the login screen displays:

```
Username: admin
Password:
Enterprise AP#
```



NOTE: You can open up to four sessions to the device through Telnet.

ENTERING COMMANDS

This section describes how to enter CLI commands.

KEYWORDS AND ARGUMENTS A CLI command is a series of keywords and arguments. Keywords identify a command, and arguments specify configuration parameters. For example, in the command “show interfaces ethernet,” **show** and **interfaces** are keywords, and ethernet is an argument that specifies the interface type.

You can enter commands as follows:

- ◆ To enter a simple command, enter the command keyword.
- ◆ To enter commands that require parameters, enter the required parameters after the command keyword. For example, to set a password for the administrator, enter:

```
Enterprise AP(config)#username smith
```

MINIMUM ABBREVIATION The CLI will accept a minimum number of characters that uniquely identify a command. For example, the command “configure” can be entered as **con**. If an entry is ambiguous, the system will prompt for further input.

COMMAND COMPLETION If you terminate input with a Tab key, the CLI will print the remaining characters of a partial keyword up to the point of ambiguity. In the “configure” example, typing **con** followed by a tab will result in printing the command up to “**configure.**”

GETTING HELP ON COMMANDS You can display a brief description of the help system by entering the **help** command. You can also display command syntax by following a command with the “?” character to list keywords or parameters.

SHOWING COMMANDS If you enter a “?” at the command prompt, the system will display the first level of keywords for the current configuration mode (Exec, Global Configuration, or Interface). You can also display a list of valid keywords for a specific command. For example, the command “**show ?**” displays a list of possible show commands:

```
AP: show ?
  APmanagement      Show management AP information.
  authentication     Show Authentication parameters.
  bridge             Show bridge.
  config             Show current configuration.
  event-log          Show event log on console.
  dual-image         Show dual images version.
```

```

filters          Show filters.
interface        Show interface information.
line             TTY line information.
lldp            Show lldp parameters.
logging         Show the logging buffers.
radius          Show radius server.
snmp            Show snmp configuration.
sntp           Show snmp configuration.
station         Show 802.11 station table.
svp            Show SVP.
system         Show system information.
version        Show system version.
wds            Show WDS service.
AP: show

```

The command “**show interface ?**” will display the following information:

```

AP# show interface ?
  ethernet  Show Ethernet interface
  wireless  Show Wireless interface
AP# show interface

```



NOTE: Partial keyword lookup does not work with the show command.

NEGATING THE EFFECT OF COMMANDS

For many configuration commands you can enter the prefix keyword “no” to cancel the effect of a command or reset the configuration to the default value. For example, the **logging** command will log system messages to a host server. To disable logging, specify the **no logging** command. This guide describes the negation effect for all applicable commands.

USING COMMAND HISTORY

The CLI maintains a history of commands that have been entered. You can scroll back through the history of commands by pressing the up arrow key. Any command displayed in the history list can be executed again, or first modified and then executed.

Using the **show history** command displays a longer list of recently executed commands.

UNDERSTANDING COMMAND MODES

The command set is divided into Exec and Configuration classes. Exec commands generally display information on system status or clear statistical counters. Configuration commands, on the other hand, modify interface parameters or enable certain functions. These classes are further divided into different modes. Available commands depend on the selected mode. You can always enter a question mark “?” at the prompt to display a

list of the commands available for the current mode. The command classes and associated modes are displayed in the following table:

Table 5: Command Modes

Class	Mode
Exec	Privileged
Configuration	Global Interface-ethernet Interface-wireless Interface-wireless-vap

EXEC COMMANDS When you open a new console session on an access point, the system enters Exec command mode. Only a limited number of the commands are available in this mode. You can access all other commands only from the configuration mode. To access Exec mode, open a new console session with the user name "admin." The command prompt displays as "Enterprise AP#" for Exec mode.

```
Username: admin
Password: [system login password]
Enterprise AP#
```

CONFIGURATION COMMANDS Configuration commands are used to modify access point settings. These commands modify the running configuration and are saved in memory.

The configuration commands are organized into four different modes:

- ◆ Global Configuration (GC) - These commands modify the system level configuration, and include commands such as **system name** and **password**.
- ◆ Interface-Ethernet Configuration (IC-E) - These commands modify the Ethernet port configuration, and include command such as **dns** and **ip**.
- ◆ Interface-Wireless Configuration (IC-W) - These commands modify the wireless port configuration of global parameters for the radio, and include commands such as **channel** and **beacon-interval**.
- ◆ Interface-Wireless Virtual Access Point Configuration (IC-W-VAP) - These commands modify the wireless port configuration for each VAP, and include commands such as **ssid** and **encryption**.

To enter the Global Configuration mode, enter the command **configure** in Exec mode. The system prompt will change to "Enterprise AP(config)#" which gives you access privilege to all Global Configuration commands.

```
AP#configure
AP(config)#
```

To enter Interface mode, you must enter the **"interface ethernet"** while in Global Configuration mode. The system prompt will change to "AP(if-ethernet)#," or "AP(if-wireless 0)" indicating that you have access privileges to the associated commands. You can use the **exit** command to return to the Exec mode.

```
AP(config)#interface ethernet
AP(if-ethernet)#
```

COMMAND LINE PROCESSING

Commands are not case sensitive. You can abbreviate commands and parameters as long as they contain enough letters to differentiate them from any other currently available commands or parameters. You can use the Tab key to complete partial commands, or enter a partial command followed by the "?" character to display a list of possible matches. You can also use the following editing keystrokes for command-line processing:

Table 6: Keystroke Commands

Keystroke	Function
Ctrl-A	Shifts cursor to start of command line.
Ctrl-B	Shifts cursor to the left one character.
Ctrl-C	Terminates a task and displays the command prompt.
Ctrl-E	Shifts cursor to end of command line.
Ctrl-F	Shifts cursor to the right one character.
Ctrl-K	Deletes from cursor to the end of the command line.
Ctrl-L	Repeats current command line on a new line.
Ctrl-N	Enters the next command line in the history buffer.
Ctrl-P	Shows the last command.
Ctrl-R	Repeats current command line on a new line.
Ctrl-U	Deletes the entire line.
Ctrl-W	Deletes the last word typed.
Esc-B	Moves the cursor backward one word.
Esc-D	Deletes from the cursor to the end of the word.
Esc-F	Moves the cursor forward one word.
Delete key or backspace key	Erases a mistake when entering a command.

This chapter details general commands that apply to the CLI.

Table 7: General Commands

Command	Function	Mode	Page
configure	Activates global configuration mode	Exec	118
end	Returns to previous configuration mode	GC, IC	119
exit	Returns to the previous configuration mode, or exits the CLI	any	119
cli-session-timeout	Sets a timeout for CLI and Telnet sessions	Exec	119
ping	Sends ICMP echo request packets to another node on the network	Exec	120
reset	Restarts the system	Exec	121
show line	Shows the configuration settings for the console port	Exec	121

configure This command activates Global Configuration mode. You must enter this mode to modify most of the settings on the access point. You must also enter Global Configuration mode prior to enabling the context modes for Interface Configuration. See ["Using the Command Line Interface" on page 112](#).

DEFAULT SETTING

None

COMMAND MODE

Exec

EXAMPLE

```
AP#configure
AP(config)#
```

RELATED COMMANDS

[end](#)

end This command returns to the previous configuration mode.

DEFAULT SETTING

None

COMMAND MODE

Global Configuration, Interface Configuration

EXAMPLE

This example shows how to return to the Configuration mode from the Interface Configuration mode:

```
AP(if-ethernet)#end
AP(config)#
```

exit This command returns to the Exec mode or exits the configuration program.

DEFAULT SETTING

None

COMMAND MODE

Any

EXAMPLE

This example shows how to return to the Exec mode from the Interface Configuration mode, and then quit the CLI session:

```
AP(if-ethernet)#exit
AP#exit

(none) login:
```

cli-session-timeout This command enables a timeout for console and Telnet sessions.

SYNTAX

cli-session-timeout <**enable** | **disable** | *value*>

enable - Enables the timeout.

disable - Disables the timeout.

value - Sets a time for the timeout (Range: 60~3600 seconds).

DEFAULT SETTING

120 seconds

COMMAND MODE

Exec

EXAMPLE

The following example disables the CLI timeout.

```
AP(config)# cli-session-timeout disable
AP(config)#
```

ping This command sends ICMP echo request packets to another node on the network.

SYNTAX

ping <host_name | ip_address>

host_name - Alias of the host.

ip_address - IP address of the host.

DEFAULT SETTING

None

COMMAND MODE

Exec

COMMAND USAGE

- ◆ Use the ping command to see if another site on the network can be reached.
- ◆ The following are some results of the ping command:
 - Normal response - The normal response occurs in one to ten seconds, depending on network traffic.
 - Destination does not respond - If the host does not respond, a "timeout" appears in ten seconds.
 - Destination unreachable - The gateway for this destination indicates that the destination is unreachable.
 - Network or host unreachable - The gateway found no corresponding entry in the route table.

EXAMPLE

```
AP#ping 192.168.1.19
192.168.1.19 is alive
AP#
```

reset This command restarts the system or restores the factory default settings.

SYNTAX

reset <**board** | **configuration**>

board - Reboots the system.

configuration - Resets the configuration settings to the factory defaults, and then reboots the system.

DEFAULT SETTING

None

COMMAND MODE

Exec

COMMAND USAGE

When the system is restarted, it will always run the Power-On Self-Test.

EXAMPLE

This example shows how to reset the system:

```
AP#reset board
Please wait a moment...
```

show line This command displays the console port's configuration settings.

COMMAND MODE

Exec

EXAMPLE

The console port settings are fixed at the values shown below.

```
AP#show line
Console Line Information
=====
  databits   : 8
  parity     : none
  speed      : 115200
  stop bits  : 1
=====
AP#
```

These commands are used to configure the password, system logs, browser management options, clock settings, and a variety of other system information.

Table 8: System Management Commands

Command	Function	Mode	Page
country	Sets the access point country code	Exec	123
prompt	Customizes the command line prompt	GC	124
system name	Specifies the host name for the access point	GC	124
password	Specifies the password for management access	GC	125
apmgmtui ssh enable	Enables the Secure Shell server	GC	125
apmgmtui ssh port	Sets the Secure Shell port	GC	126
ip telnet-server enable	Enables the Telnet server	GC	126
apmgmtip	Specifies an IP address or range of addresses allowed access to management interfaces	GC	130
apmgmtui telnet-server	Enables Telnet management access	GC	126
apmgmtui snmp	Enables SNMP management access	GC	130
apmgmtui http port	Specifies the port to be used by the web browser interface	GC	127
apmgmtui http server	Allows the access point to be monitored or configured from a browser	GC	127
apmgmtui http session-timeout	Sets the web interface timeout	GC	128
apmgmtui https port	Specifies the UDP port number used for a secure HTTP connection to the access point's Web interface	GC	128
apmgmtui https server	Enables the secure HTTP server on the access point	GC	129
show apmanagement	Shows the AP management configuration	Exec	131
show system	Displays system information	Exec	131
show version	Displays version information for the system	Exec	132
show config	Displays detailed configuration information for the system	Exec	132

country This command configures the access point's country code, which identifies the country of operation and sets the authorized radio channels.

SYNTAX

country <country_code>

country_code - A two character code that identifies the country of operation. See the following table for a full list of codes.

Table 9: Country Codes

Country	Code	Country	Code	Country	Code	Country	Code
Albania	AL	Dominican Republic	DO	Kuwait	KW	Romania	RO
Algeria	DZ	Ecuador	EC	Latvia	LV	Russia	RU
Argentina	AR	Egypt	EG	Lebanon	LB	Saudi Arabia	SA
Armenia	AM	Estonia	EE	Liechtenstein	LI	Singapore	SG
Australia	AU	Finland	FI	Lithuania	LT	Slovak Republic	SK
Austria	AT	France	FR	Macao	MO	Spain	ES
Azerbaijan	AZ	Georgia	GE	Macedonia	MK	Sweden	SE
Bahrain	BH	Germany	DE	Malaysia	MY	Switzerland	CH
Belarus	BY	Greece	GR	Malta	MT	Syria	SY
Belgium	BE	Guatemala	GT	Mexico	MX	Taiwan	TW
		Honduras	HN	Monaco	MC	Thailand	TH
Belize	BZ	Hong Kong	HK	Morocco	MA	Trinidad & Tobago	TT
Bolivia	BO	Hungary	HU	Netherlands	NL	Tunisia	TN
Brazil	BR	Iceland	IS	New Zealand	NZ	Turkey	TR
Brunei Darussalam	BN	India	IN	Norway	NO	Ukraine	UA
Bulgaria	BG	Indonesia	ID	Qatar	QA	United Arab Emirates	AE
Canada	CA	Iran	IR	Oman	OM	United Kingdom	GB
Chile	CL	Ireland	IE	Pakistan	PK	United States	US
China	CN	Israel	IL	Panama	PA	Uruguay	UY
Colombia	CO	Italy	IT	Peru	PE	Uzbekistan	UZ
Costa Rica	CR	Japan	JP	Philippines	PH	Yemen	YE
Croatia	HR	Jordan	JO	Poland	PL	Venezuela	VE
Cyprus	CY	Kazakhstan	KZ	Portugal	PT	Vietnam	VN
Czech Republic	CZ	North Korea	KP	Puerto Rico	PR	Zimbabwe	ZW
Denmark	DK	Korea Republic	KR	Slovenia	SI		
Elsalvador	SV	Luxembourg	LU	South Africa	ZA		

DEFAULT SETTING

US - for units sold in the United States
 99 (no country set) - for units sold in other countries

COMMAND MODE

Exec

COMMAND USAGE

- ◆ If you purchased an access point outside of the United States, the country code must be set before radio functions are enabled.
- ◆ The available Country Code settings can be displayed by using the **country ?** command.

EXAMPLE

```
AP#country tw
AP#
```

prompt This command customizes the CLI prompt. Use the **no** form to restore the default prompt.

SYNTAX

prompt <*string*>
no prompt

string - Any alphanumeric string to use for the CLI prompt.
 (Maximum length: 32 characters)

DEFAULT SETTING

Enterprise AP

COMMAND MODE

Global Configuration

EXAMPLE

```
AP(config)#prompt RD2
RD2(config)#
```

system name This command specifies or modifies the system name for this device.

SYNTAX

system name <*name*>

name - The name of this host.
 (Maximum length: 32 characters)

DEFAULT SETTING

Enterprise AP

COMMAND MODE

Global Configuration

EXAMPLE

```
AP(config)#system name AP
AP(config)#
```

password After initially logging onto the system, you should set the password. Remember to record it in a safe place.

SYNTAX

password <*password*>

password - Password for management access.
(Length: 5-32 characters, case sensitive)

DEFAULT SETTING

smcadmin

COMMAND MODE

Global Configuration

EXAMPLE

```
AP(config)#password
AP(config)#
```

apmgmtui ssh enable This command enables the Secure Shell server. Use the **no** form to disable the server.

SYNTAX

apmgmtui ssh enable
no apmgmtui ssh-server

DEFAULT SETTING

Enabled

COMMAND MODE

Global Configuration

COMMAND USAGE

- ◆ The access point supports Secure Shell version 2.0 only.

- ◆ After boot up, the SSH server needs about two minutes to generate host encryption keys. The SSH server is disabled while the keys are being generated. The **show system** command displays the status of the SSH server.

EXAMPLE

```
AP(config)# apmgmtui ssh enable
AP(config)#
```

apmgmtui ssh port This command sets the Secure Shell server port.

SYNTAX

apmgmtui ssh port <port-number>

port-number - The UDP port used by the SSH server.
(Range: 1-65535)

DEFAULT SETTING

22

COMMAND MODE

Global Configuration

EXAMPLE

```
AP(config)# apmgmtui ssh port 1124
AP(config)#
```

apmgmtui telnet-server enable This command enables the Telnet server. Use the **no** form to disable the server.

SYNTAX

apmgmtui telnet-server enable
no apmgmtui telnet-server

DEFAULT SETTING

Interface enabled

COMMAND MODE

Global Configuration

EXAMPLE

```
AP(config)# apmgmtui telnet-server enable
AP(config)#
```

apmgmtui http port This command specifies the TCP port number used by the web browser interface. Use the **no** form to use the default port.

SYNTAX

apmgmtui http port <port-number>
no apmgmtui http port

port-number - The TCP port to be used by the browser interface.
 (Range: 80 or 1024-65535)

DEFAULT SETTING

80

COMMAND MODE

Global Configuration

EXAMPLE

```
AP(config)# apmgmtui http port 769
AP(config)
```

RELATED COMMANDS

[apmgmtui http server](#)

apmgmtui http server This command allows this device to be monitored or configured from a web browser. Use the **no** form to disable this function.

SYNTAX

[no] apmgmtui http server

DEFAULT SETTING

Enabled

COMMAND MODE

Global Configuration

EXAMPLE

```
AP(config)# apmgmtui http server
AP(config)#
```

RELATED COMMANDS

[apmgmtui http port](#)

apmgmtui http session-timeout This command sets the web browser timeout limit.

SYNTAX

apmgmtui http session-timeout <seconds>

seconds - The web session timeout. (Range: 0-1800 seconds, 0 means disabled)

DEFAULT SETTING

1800 seconds

COMMAND MODE

Global Configuration

EXAMPLE

```
AP(config)# apmgmtui http session-timeout 0
AP(config)#
```

RELATED COMMANDS

[apmgmtui http server](#)

apmgmtui https port Use this command to specify the UDP port number used for HTTPS/SSL connection to the access point's web interface. Use the **no** form to restore the default port.

SYNTAX

apmgmtui https port <port_number>
no apmgmtui https port

port_number - The UDP port used for HTTPS/SSL.
 (Range: 443, 1024-65535)

DEFAULT SETTING

443

COMMAND MODE

Global Configuration

COMMAND USAGE

- ◆ You cannot configure the HTTP and HTTPS servers to use the same port.
- ◆ To avoid using common reserved TCP port numbers below 1024, the configurable range is restricted to 443 and between 1024 and 65535.
- ◆ If you change the HTTPS port number, clients attempting to connect to the HTTPS server must specify the port number in the URL, in this format: **https://device:port_number**

EXAMPLE

```
AP(config)# apmgmtui https port 1234
AP(config)#
```

apmgmtui https server Use this command to enable the secure hypertext transfer protocol (HTTPS) over the Secure Socket Layer (SSL), providing secure access (that is, an encrypted connection) to the access point's web interface. Use the **no** form to disable this function.

SYNTAX

[no] apmgmtui https server

DEFAULT SETTING

Enabled

COMMAND MODE

Global Configuration

COMMAND USAGE

- ◆ Both HTTP and HTTPS service can be enabled independently.
- ◆ If you enable HTTPS, you must indicate this in the URL:
https://device:port_number]
- ◆ When you start HTTPS, the connection is established in this way:
 - The client authenticates the server using the server's digital certificate.
 - The client and server negotiate a set of security protocols to use for the connection.
 - The client and server generate session keys for encrypting and decrypting data.
 - The client and server establish a secure encrypted connection. A padlock icon should appear in the status bar for Internet Explorer.

EXAMPLE

```
AP(config)# apmgmtui https server
AP(config)#
```

apmgmtui snmp This command enables and disables SNMP management access to the AP.

SYNTAX

apmgmtui snmp [**enable** | **disable**]

enable - Enables SNMP management access.

disable - Disables SNMP management access.

DEFAULT SETTING

Enabled

COMMAND MODE

Global Configuration

EXAMPLE

```
AP(config)# apmgmtui snmp enable
AP(config)#
```

apmgmtip This command specifies the client IP addresses that are allowed management access to the access point through various protocols.



NOTE: Secure Web (HTTPS) connections are not affected by the UI Management or IP Management settings.

SYNTAX

apmgmtip [**multiple** <*ip-address*> <*subnet-mask*> | **single** <*ip-address*> | **any**]

multiple - Adds IP addresses within a specifiable range to the SNMP, web and Telnet groups.

single - Adds an IP address to the SNMP, web and Telnet groups.

any - Allows any IP address access through SNMP, web and Telnet groups.

ip-address - Adds IP addresses to the SNMP, web and Telnet groups.

subnet-mask - Specifies a range of IP addresses allowed management access.

DEFAULT SETTING

All addresses

COMMAND MODE

Global Configuration

COMMAND USAGE

- ◆ If anyone tries to access a management interface on the access point from an invalid address, the unit will reject the connection, enter an event message in the system log, and send a trap message to the trap manager.
- ◆ Management access applies to SNMP, HTTP (web), Telnet, and SSH connections.

EXAMPLE

This example restricts management access to the specified addresses.

```
AP(config)#apmgmtip multiple 192.168.1.50 255.255.255.0
AP(config)#
```

**show
apmanagement**

This command shows the AP management configuration, including the IP addresses of management stations allowed to access the AP, and the protocols that are open to management access.

COMMAND MODE

Exec

EXAMPLE

```
AP#show apmanagement
Management AP Information
=====
AP Management IP Mode: Any IP
Telnet UI: Enable
WEB UI   : Enable
SNMP UI  : Enable
=====
AP#
```

show system This command displays basic system configuration settings.

DEFAULT SETTING

None

COMMAND MODE

Exec

EXAMPLE

```
AP#show system
System Information
=====
Serial Number       : A123456789
System Up time      : 0 days, 4 hours, 33 minutes, 29 seconds
System Name         : 11n_AP
System Location     :
```

```

System Contact      :
System Country Code : US - United States
MAC Address        : 00:22:2d:4d:7b:80
Radio 0 MAC Address : 00:22:2d:4d:7b:81:
IP Address         : 192.168.1.1
Subnet Mask        : 255.255.255.0
Default Gateway    : 192.168.1.254
VLAN Status        : Disable
Management VLAN ID(AP): 1
DHCP Client        : static
HTTP Access        : Enable
HTTP Port          : 80
HTTP Timeout       : 0
HTTPs Access       : Enable
HTTPs Port         : 443
Slot Status        : Dual band(a/g)
Boot Rom Version   : v0.1.0
Software Version   : 1.1.0.8
Hardware Version    : 1.0
SSH Server         : Enable
SSH Server Port    : 22
Telnet Access      : Enable
User Name          : admin
=====
AP#

```

show version This command displays the software version for the system.

COMMAND MODE

Exec

EXAMPLE

```

AP#show version
Boot Rom Version   : v0.1.0
Software Version   : 1.1.0.8
Hardware Version    : 1.0
AP#

```

show config This command displays detailed configuration information for the system.

COMMAND MODE

Exec

EXAMPLE

```

AP#show config

Authentication Information
=====
MAC Authentication Server      : DISABLED
MAC Auth Session Timeout Value : 0 min
802.1x supplicant              : DISABLED
802.1x supplicant user        : EMPTY
802.1x supplicant password    : EMPTY

```

```

Address Filtering                : ALLOWED

System Default : ALLOW addresses not found in filter table.
Filter Table
-----
No Filter Entries.

Bootfile Information
=====
Bootfile : ec-img.bin
=====

Protocol Filter Information
=====
Local Bridge      :DISABLED
AP Management     :ENABLED
Ethernet Type Filter :DISABLED

Enabled Protocol Filters
-----
No protocol filters are enabled
=====

Hardware Version Information
=====
Hardware version R01A
=====

Ethernet Interface Information
=====
IP Address       : 192.168.0.151
Subnet Mask      : 255.255.255.0
Default Gateway  : 192.168.0.1
Primary DNS      : 210.200.211.225
Secondary DNS    : 210.200.211.193
Speed-duplex     : 100Base-TX Full Duplex
Admin status     : Up
Operational status : Up
=====

Wireless Interface 802.11a Information
=====
-----Identification-----
Description      : SMC 802.11a Access Point
SSID             : SMC_A 0
Channel          : 0 (AUTO)
Status           : Disable
-----802.11 Parameters-----
Transmit Power   : 100% (5 dBm)
Data Rate        : 54Mbps
Fragmentation Threshold : 2346 bytes
RTS Threshold    : 2347 bytes
Beacon Interval  : 100 TUs
DTIM Interval    : 1 beacon
Maximum Association : 64 stations
Native VLAN ID   : 1
-----Security-----
Closed System    : DISABLED
Multicast cipher : WEP
Unicast cipher   : TKIP and AES
WPA clients      : REQUIRED
WPA Key Mgmt Mode : PRE SHARED KEY
WPA PSK Key Type : ALPHANUMERIC
Encryption       : DISABLED
Default Transmit Key : 1
Static Keys :

```

```

    Key 1: EMPTY      Key 2: EMPTY      Key 3: EMPTY      Key 4: EMPTY
Key Length :
    Key 1: ZERO       Key 2: ZERO       Key 3: ZERO       Key 4: ZERO
Authentication Type : OPEN
Rogue AP Detection  : Disabled
Rogue AP Scan Interval : 720 minutes
Rogue AP Scan Duration : 350 milliseconds
=====

```

Console Line Information

```

=====
databits   : 8
parity     : none
speed      : 9600
stop bits  : 1
=====

```

Logging Information

```

=====
Syslog State           : Disabled
Logging Console State  : Disabled
Logging Level          : Informational
Logging Facility Type  : 16

```

Servers

```

    1: 0.0.0.0          , UDP Port: 514, State: Disabled
    2: 0.0.0.0          , UDP Port: 514, State: Disabled
    3: 0.0.0.0          , UDP Port: 514, State: Disabled
    4: 0.0.0.0          , UDP Port: 514, State: Disabled
=====

```

Radius Server Information

```

=====
IP           : 0.0.0.0
Port         : 1812
Key          : *****
Retransmit   : 3
Timeout      : 5
Radius MAC format : no-delimiter
Radius VLAN format : HEX
=====

```

Radius Secondary Server Information

```

=====
IP           : 0.0.0.0
Port         : 1812
Key          : *****
Retransmit   : 3
Timeout      : 5
Radius MAC format : no-delimiter
Radius VLAN format : HEX
=====

```

SNMP Information

```

=====
Service State           : Disable
Community (ro)          : *****
Community (rw)          : *****
Location                 :
Contact                  : Contact

```

```

EngineId   :80:00:07:e5:80:00:00:29:f6:00:00:00:0c
EngineBoots:2

```

Trap Destinations:

```

    1: 0.0.0.0, Community: *****, State: Disabled

```

```

2:          0.0.0.0, Community: *****, State: Disabled
3:          0.0.0.0, Community: *****, State: Disabled
4:          0.0.0.0, Community: *****, State: Disabled
  dot11InterfaceAGFail Enabled          dot11InterfaceBFail Enabled
  dot11StationAssociation Enabled        dot11StationAuthentication Enabled
dot11StationReAssociation Enabled        dot11StationRequestFail Enabled
      dot1xAuthFail Enabled              dot1xAuthNotInitiated Enabled
      dot1xAuthSuccess Enabled           dot1xMacAddrAuthFail Enabled
dot1xMacAddrAuthSuccess Enabled         iappContextDataSent Enabled
  iappStationRoamedFrom Enabled         iappStationRoamedTo Enabled
      localMacAddrAuthFail Enabled       localMacAddrAuthSuccess Enabled
      pppLogonFail Enabled                snmpServerFail Enabled
  configFileVersionChanged Enabled      radiusServerChanged Enabled
      systemDown Enabled                  systemUp Enabled

```

```
=====
```

SNTP Information

```

=====
Service State      : Disabled
SNTP (server 1) IP : 137.92.140.80
SNTP (server 2) IP : 192.43.244.18
Current Time       : 00 : 14, Jan 1st, 1970
Time Zone          : -5 (BOGOTA, EASTERN, INDIANA)
Daylight Saving    : Disabled
=====

```

Station Table Information

```
=====
```

```

if-wireless A VAP [0] :
802.11a Channel : Auto

```

```
No 802.11a Channel Stations.
```

```
.
.
.
```

```

if-wireless G VAP [0] :
802.11g Channel : Auto

```

```
No 802.11g Channel Stations.
```

```
.
.
.
```

System Information

```
=====
```

```

Serial Number      :
System Up time     : 0 days, 0 hours, 16 minutes, 51 seconds
System Name       : SMC
System Location    :
System Contact     : Contact
System Country Code : 99 - NO_COUNTRY_SET
MAC Address       : 00-12-CF-05-B7-84
IP Address        : 192.168.0.151
Subnet Mask       : 255.255.255.0
Default Gateway   : 192.168.0.1
VLAN State        : DISABLED
Management VLAN ID(AP): 1
IAPP State        : ENABLED
DHCP Client       : ENABLED
HTTP Server       : ENABLED
HTTP Server Port  : 80
HTTPS Server      : ENABLED
HTTPS Server Port : 443
Slot Status       : Dual band(a/g)

```

```
Boot Rom Version      : v3.0.7
Software Version     : v4.3.2.2
SSH Server           : ENABLED
SSH Server Port      : 22
Telnet Server        : ENABLED
WEB Redirect         : DISABLED
DHCP Relay           : DISABLED
```

=====

Version Information

=====

Version: v4.3.2.2

Date : Dec 20 2005, 18:38:12

=====

AP#



These commands are used to configure system logging on the access point.

Table 10: System Management Commands

Command	Function	Mode	Page
logging on	Controls logging of error messages	GC	137
logging host	Adds a syslog server host IP address that will receive logging messages	GC	138
logging console	Initiates logging of error messages to the console	GC	138
logging level	Defines the minimum severity level for event logging	GC	139
logging clear	Clears all log entries in access point memory	GC	139
show logging	Displays the state of logging	Exec	140
show event-log	Displays all log entries in access point memory	Exec	140

logging on This command controls logging of error messages; i.e., sending debug or error messages to memory. The **no** form disables the logging process.

SYNTAX

[no] logging on

DEFAULT SETTING

Disabled

COMMAND MODE

Global Configuration

COMMAND USAGE

The logging process controls error messages saved to memory. You can use the **logging level** command to control the type of error messages that are stored in memory.

EXAMPLE

```
AP(config)#logging on
AP(config)#
```

logging host This command specifies syslog servers host that will receive logging messages. Use the **no** form to remove syslog server host.

SYNTAX

logging host <1 | 2 | 3 | 4> <*host_name* | *host_ip_address*>
[*udp_port*]

no logging host <1 | 2 | 3 | 4>

1 - First syslog server.

2 - Second syslog server.

3 - Third syslog server.

4 - Fourth syslog server.

host_name - The name of a syslog server. (Range: 1-20 characters)

host_ip_address - The IP address of a syslog server.

udp_port - The UDP port used by the syslog server.

DEFAULT SETTING

None

COMMAND MODE

Global Configuration

EXAMPLE

```
AP(config)#logging host 1 10.1.0.3
AP(config)#
```

logging console This command initiates logging of error messages to the console. Use the **no** form to disable logging to the console.

SYNTAX

[no] logging console

DEFAULT SETTING

Disabled

COMMAND MODE

Global Configuration

EXAMPLE

```
AP(config)#logging console
AP(config)#
```

logging level This command sets the minimum severity level for event logging.

SYNTAX

logging level <Emergency | Alert | Critical | Error | Warning | Notice | Informational | Debug>

DEFAULT SETTING

Informational

COMMAND MODE

Global Configuration

COMMAND USAGE

Messages sent include the selected level down to Emergency level.

Table 11: Logging Levels

Level Argument	Description
Emergency	System unusable
Alert	Immediate action needed
Critical	Critical conditions (e.g., memory allocation, or free memory error - resource exhausted)
Error	Error conditions (e.g., invalid input, default used)
Warning	Warning conditions (e.g., return false, unexpected return)
Notice	Normal but significant condition, such as cold start
Informational	Informational messages only
Debug	Debugging messages

EXAMPLE

```
AP(config)#logging level alert
AP(config)#
```

logging clear This command clears all log messages stored in the access point's memory.

SYNTAX

logging clear

COMMAND MODE

Global Configuration

EXAMPLE

```
AP(config)#logging clear
AP(config)#
```

show logging This command displays the logging configuration.

SYNTAX

show logging

COMMAND MODE

Exec

EXAMPLE

```
AP#show logging

Logging Information
=====
Syslog State           : ENABLE
Logging Console State  : DISABLE
Logging Level         : Debug
Servers
1: 10.7.16.98, UDP Port: 514, State: DISABLE
2: 10.7.13.48, UDP Port: 514, State: DISABLE
3: 10.7.123.123, UDP Port: 65535, State: DISABLE
4: 10.7.13.77, UDP Port: 5432, State: DISABLE
=====
AP#
```

show event-log This command displays log messages stored in the access point's memory.

SYNTAX

show event-log

COMMAND MODE

Exec

EXAMPLE

```
AP#show event-log
Jan  1 05:45:50 (none) <6>user.info kernel: ar5416Reset Setting CFG 0x10a
Jan  1 05:45:50 (none) <6>user.info kernel: Howl Revision ID 0xb9
Jan  1 05:45:50 (none) <6>user.info kernel: ar5416Reset Setting CFG 0x10a
Jan  1 05:45:50 (none) <6>user.info kernel: Howl Revision ID 0xb9
Jan  1 05:45:50 (none) <6>user.info kernel: MBSSID Set bit 22 of AR_STA_ID
0xb8c1817b
Jan  1 05:45:50 (none) <6>user.info kernel: Force rf_pwd_icsyndiv to 2 on 2462
(1 0)

AP#
```

These commands are used to configure SNTP and system clock settings on the access point.

Table 12: System Clock Commands

Command	Function	Mode	Page
sntp-server ip	Specifies one or more time servers	GC	141
sntp-server enabled	Accepts time from the specified time servers	GC	142
sntp-server date-time	Manually sets the system date and time	GC	142
sntp-server daylight-saving	Sets the start and end dates for daylight savings time	GC	143
sntp-server timezone	Sets the time zone for the access point's internal clock	GC	144
show sntp	Shows current SNTP configuration settings	Exec	144

sntp-server ip This command sets the IP address of the servers to which SNTP time requests are issued. Use the this command with no arguments to clear all time servers from the current list.

SYNTAX

sntp-server ip <1 | 2> <ip>

1 - First time server.

2 - Second time server.

ip - IP address of an time server (NTP or SNTP).

DEFAULT SETTING

129.6.15.28

132.163.4.101

COMMAND MODE

Global Configuration

COMMAND USAGE

When SNTP client mode is enabled using the **sntp-server enabled** command, the **sntp-server ip** command specifies the time servers from which the access point polls for time updates. The access point will poll the time servers in the order specified until a response is received.

EXAMPLE

```
AP(config)#ntp-server ip 1 10.1.0.19
AP#
```

RELATED COMMANDS[ntp-server enabled](#)[show ntp](#)

ntp-server enabled This command enables SNTP client requests for time synchronization with NTP or SNTP time servers specified by the **ntp-server ip** command. Use the **no** form to disable SNTP client requests.

SYNTAX**[no] ntp-server enabled****DEFAULT SETTING**

Enabled

COMMAND MODE

Global Configuration

COMMAND USAGE

The time acquired from time servers is used to record accurate dates and times for log events. Without SNTP, the access point only records the time starting from the factory default set at the last bootup (i.e., 00:14:00, January 1, 1970).

EXAMPLE

```
AP(config)#ntp-server enabled
AP(config)#
```

RELATED COMMANDS[ntp-server ip](#)[show ntp](#)

ntp-server date-time This command sets the system clock.

SYNTAX**ntp-server <year> <month> <day> <hour> <minute>***year* - Sets the year. (Range: 1970-2100)*month* - Sets the month. (Range: 1-12)*day* - Sets the day. (Range: 1-31)*hour* - Sets the hour. (Range: 0-23)

minute - Sets the minute. (Range: 0-59)

DEFAULT SETTING

00:14:00, January 1, 1970

COMMAND MODE

Global Configuration

EXAMPLE

This example sets the system clock to 12:10 April 27, 2009.

```
AP(config)# sntp-server date-time 2009 4 27 12 10
AP(config)#
```

RELATED COMMANDS

[sntp-server enabled](#)

sntp-server daylight-saving This command sets the start and end dates for daylight savings time. Use the **no** form to disable daylight savings time.

SYNTAX

sntp-server daylight-saving [**date-week** <*start-month*> <*start-week*> <*start-day*> <*end-month*> <*end-week*> <*end-day*>]

no sntp-server daylight-saving

date-week - The key word to set the date on which to start and end the daylight-saving time.

start-month - Sets the start month. (Range: 1-12)

start-week - Sets the start week. (Range: 1-5)

start-day - Sets the start day. (Range: 0-6, where 0 is Sunday)

end-month - Sets the end month. (Range: 1-12)

end-week - Sets the end week. (Range: 1-5)

end-day - Sets the end day. (Range: 0-6, where 0 is Sunday)

DEFAULT SETTING

Disabled

COMMAND MODE

Global Configuration

COMMAND USAGE

- ◆ The command sets the system clock back one hour during the specified period.
- ◆ Using the command without setting the start and end date enables the daylight-saving feature.

EXAMPLE

This sets daylight savings time to be used from the Sunday in the fourth week of April, to the Sunday in the fourth week of October.

```
AP(config)# sntp-server daylight-saving date-week 4 4 0 10 4 0
AP(config)#
```

**sntp-server
timezone** This command sets the time zone for the access point's internal clock.

SYNTAX

sntp-server timezone <hours>

hours - Number of hours before/after UTC.
(Range: -12 to +12 hours)

DEFAULT SETTING

+08 hours (Hong Kong, Perth, Singapore, Taipei)

COMMAND MODE

Global Configuration

COMMAND USAGE

This command sets the local time zone relative to the Coordinated Universal Time (UTC, formerly Greenwich Mean Time or GMT), based on the earth's prime meridian, zero degrees longitude. To display a time corresponding to your local time, you must indicate the number of hours and minutes your time zone is east (before) or west (after) of UTC.

EXAMPLE

```
AP(config)#sntp-server timezone +8
AP(config)#
```

show sntp This command displays the current time and configuration settings for the SNTP client.

COMMAND MODE

Exec

EXAMPLE

```
AP#show sntp

SNTP Information
=====
Service State      : ENABLED
SNTP (server 1) IP : 129.6.15.28
SNTP (server 2) IP : 132.163.4.101
Current Time       : Mon Apr 27 13:39:23 UTC 2009
```



```
Time Zone          : (GMT+08) Hong Kong, Perth, Singapore, Taipei
Daylight Saving    : DISABLED
Daylight Saving Time : From MAR, Fourth Week, Wednesday To NOV, Last Week,
                    Sunday
=====
```

AP#

Dynamic Host Configuration Protocol (DHCP) can dynamically allocate an IP address and other configuration information to network clients that broadcast a request. To receive the broadcast request, the DHCP server would normally have to be on the same subnet as the client. However, when the access point's DHCP relay agent is enabled, received client requests can be forwarded directly by the access point to a known DHCP server on another subnet. Responses from the DHCP server are returned to the access point, which then broadcasts them back to clients.

Table 13: DHCP Relay Commands

Command	Function	Mode	Page
dhcp-relay server	Sets the DHCP server address and enables the DHCP relay agent	IC-W-VAP	146

dhcp-relay server This command configures the DHCP server address and enables the DHCP relay agent.

SYNTAX

dhcp-relay server <ip_address>

ip_address - IP address of the DHCP server.

DEFAULT SETTING

0.0.0.0 (disabled)

COMMAND MODE

Interface Configuration (Wireless-VAP)

COMMAND USAGE

- ◆ For the DHCP relay agent to function, the DHCP server IP address must be configured. The default IP address "0.0.0.0" disables the DHCP relay agent.
- ◆ To view the DHCP relay status, use the **show interface wireless** command.

EXAMPLE

```
AP(if-wireless 0: VAP[0])# dhcp-relay server 192.168.1.10
AP(if-wireless 0: VAP[0])#
```

RELATED COMMANDS

[show interface wireless](#)

Controls access to this access point from management stations using the Simple Network Management Protocol (SNMP), as well as the hosts that will receive trap messages.

Table 14: SNMP Commands

Command	Function	Mode	Page
snmp-server community	Sets up the community access string to permit access to SNMP commands	GC	149
snmp-server contact	Sets the system contact string	GC	149
snmp-server location	Sets the system location string	GC	150
snmp-server enable server	Enables SNMP service and traps	GC	150
snmp-server host	Specifies the recipient of an SNMP notification operation	GC	151
snmp-server trap	Enables specific SNMP notifications	GC	152
snmp-server vacm view	Configures the VACM view	GC	153
snmp-server vacm group	Configures the VACM group	GC	154
snmp-server user	Sets the name of the SNMP v3 user	GC	155
snmp-server target	Configures SNMP v3 notification targets	GC	156
snmp-server filter	Configures SNMP v3 notification filters	GC	157
show snmp vacm group	Displays the VACM group	Exec	160
show snmp vacm view	Displays VACM views	Exec	160
show snmp users	Displays SNMP v3 user settings	Exec	158
show snmp target	Displays the SNMP v3 notification targets	Exec	158
show snmp filter	Displays the SNMP v3 notification filters	Exec	159
show snmp	Displays the status of SNMP communications	Exec	159

snmp-server community This command defines the community access string for the Simple Network Management Protocol. Use the **no** form to remove the specified community string.

SYNTAX

snmp-server community *string* [**ro** | **rw**]
no snmp-server community *string*

string - Community string that acts like a password and permits access to the SNMP protocol. (Maximum length: 23 characters, case sensitive)

ro - Specifies read-only access. Authorized management stations are only able to retrieve MIB objects.

rw - Specifies read/write access. Authorized management stations are able to both retrieve and modify MIB objects.

DEFAULT SETTING

- ◆ **public** - Read-only access. Authorized management stations are only able to retrieve MIB objects.
- ◆ **private** - Read/write access. Authorized management stations are able to both retrieve and modify MIB objects.

COMMAND MODE

Global Configuration

COMMAND USAGE

If you enter a community string without the **ro** or **rw** option, the default is read only.

EXAMPLE

```
AP(config)#snmp-server community alpha rw
AP(config)#
```

snmp-server contact This command sets the system contact string. Use the **no** form to remove the system contact information.

SYNTAX

snmp-server contact *string*
no snmp-server contact

string - String that describes the system contact. (Maximum length: 255 characters)

DEFAULT SETTING

None

COMMAND MODE
Global Configuration

EXAMPLE

```
AP(config)#snmp-server contact Paul
AP(config)#
```

RELATED COMMANDS
[snmp-server location](#)

snmp-server location This command sets the system location string. Use the **no** form to remove the location string.

SYNTAX

snmp-server location <*text*>
no snmp-server location

text - String that describes the system location.
(Maximum length: 255 characters)

DEFAULT SETTING
None

COMMAND MODE
Global Configuration

EXAMPLE

```
AP(config)#snmp-server location WC-19
AP(config)#
```

RELATED COMMANDS
[snmp-server contact](#)

snmp-server enable server This command enables SNMP management access and also enables this device to send SNMP traps (i.e., notifications). Use the **no** form to disable SNMP service and trap messages.

SYNTAX

[no] snmp-server enable server

DEFAULT SETTING
Enabled

COMMAND MODE
Global Configuration

COMMAND USAGE

- ◆ This command enables both authentication failure notifications and link-up-down notifications.
- ◆ The **snmp-server host** command specifies the host device that will receive SNMP notifications.

EXAMPLE

```
AP(config)#snmp-server enable server
AP(config)#
```

RELATED COMMANDS

[snmp-server host](#)

snmp-server host This command specifies the recipient of an SNMP notification. Use the **no** form to remove the specified host.

SYNTAX

snmp-server host <host_ip_address> <community-string>
no snmp-server host

host_ip_address - IP of the host (the targeted recipient).

community-string - Password-like community string sent with the notification operation. (Maximum length: 23 characters)

DEFAULT SETTING

None

COMMAND MODE

Global Configuration

COMMAND USAGE

- ◆ The **snmp-server host** command is used in conjunction with the **snmp-server enable server** command to enable SNMP notifications. You can configure up to four host IP addresses. A separate **snmp-server host** command must be entered for each host.
- ◆ Although you can set the community string using the **snmp-server host** command by itself, it is recommended that you define this string using the **snmp-server community** command prior to using the **snmp-server host** command.

EXAMPLE

```
AP(config)#snmp-server host 1 10.1.19.23 batman
AP(config)#
```

RELATED COMMANDS

[snmp-server enable server](#)

snmp-server trap This command enables the access point to send specific SNMP traps (i.e., notifications). Use the **no** form to disable specific trap messages.

SYNTAX

snmp-server trap <trap>
no snmp-server trap <trap>

trap - One of the following SNMP trap messages:

dot11InterfaceAGFail - The 802.11a or 802.11g interface has failed.

dot11InterfaceBFail - The 802.11b interface has failed.

dot11StationAssociation - A client station has successfully associated with the access point.

dot11StationAuthentication - A client station has been successfully authenticated.

dot11StationReAssociation - A client station has successfully re-associated with the access point.

dot11StationRequestFail - A client station has failed association, re-association, or authentication.

dot1xAuthFail - A 802.1X client station has failed RADIUS authentication.

dot1xAuthNotInitiated - A client station did not initiate 802.1X authentication.

dot1xAuthSuccess - A 802.1X client station has been successfully authenticated by the RADIUS server.

dot1xMacAddrAuthFail - A client station has failed MAC address authentication with the RADIUS server.

dot1xMacAddrAuthSuccess - A client station has successfully authenticated its MAC address with the RADIUS server.

iappContextDataSent - A client station's Context Data has been sent to another access point with which the station has associated.

iappStationRoamedFrom - A client station has roamed from another access point (identified by its IP address).

iappStationRoamedTo - A client station has roamed to another access point (identified by its IP address).

localMacAddrAuthFail - A client station has failed authentication with the local MAC address database on the access point.

localMacAddrAuthSuccess - A client station has successfully authenticated its MAC address with the local database on the access point.

pppLogonFail - The access point has failed to log onto the PPPoE server using the configured user name and password.

snmpServerFail - The access point has failed to set the time from the configured SNTP server.

sysConfigFileVersionChanged - The access point's configuration file has been changed.

sysRadiusServerChanged - The access point has changed from the primary RADIUS server to the secondary, or from the secondary to the primary.

sysSystemDown - The access point is about to shutdown and reboot.

sysSystemUp - The access point is up and running.

DEFAULT SETTING

All traps enabled

COMMAND MODE

Global Configuration

COMMAND USAGE

This command is used in conjunction with the **snmp-server host** and **snmp-server enable server** commands to enable SNMP notifications.

EXAMPLE

```
AP(config)#no snmp-server trap dot11StationAssociation
AP(config)#
```

snmp-server vacm view This command configures SNMP v3 views. Use the **no** form to delete an SNMP v3 view or remove a subtree from a filter.

SYNTAX

snmp-server vacm view *<name>* [**included** | **excluded**] *<subtree>*
[**mask** *<mask>*]

no snmp-server vacm view *<name>* [**included** | **excluded**]
<subtree>

name - A user-defined name that identifies an SNMP v3 view.
(Maximum length: 32 characters)

include - Defines a filter type that includes objects in the MIB subtree.

exclude - Defines a filter type that excludes objects in the MIB subtree.

subtree - The part of the MIB subtree that is to be filtered.

mask - An optional hexadecimal value bit mask to define objects in the MIB subtree.

DEFAULT SETTING

None

COMMAND MODE

Global Configuration

COMMAND USAGE

- ◆ The access point allows multiple notification filters to be created. Each filter can be defined by up to 20 MIB subtree ID entries.
- ◆ Use the command more than once with the same filter ID to build a filter that includes or excludes multiple MIB objects. Note that the filter entries are applied in the sequence that they are defined.
- ◆ The MIB subtree must be defined in the form “.1.3.6.1” and always start with a “.”.
- ◆ The mask is a hexadecimal value with each bit masking the corresponding ID in the MIB subtree. A “1” in the mask indicates an exact match and a “0” indicates a “wild card.” For example, a mask value of 0xFFBF provides a bit mask “1111 1111 1011 1111.” If applied to the subtree 1.3.6.1.2.1.2.2.1.1.23, the zero corresponds to the 10th subtree ID. When there are more subtree IDs than bits in the mask, the mask is padded with ones.

EXAMPLE

```
AP(config)#snmp-server vacm view testview include .1
AP(config)#snmp-server vacm view testview exclude .1.3.6.1.2.1.2.2.1.1.23
```

snmp-server vacm group This command configures SNMP v3 groups. Use the **no** form to delete an SNMP v3 group.

SYNTAX

snmp-server vacm group <name> {**security-level** <level>}
<read-view> <write-view>

no snmp-server vacm group <name>

name - A user-defined name that identifies an SNMP v3 group.
(Maximum length: 32 characters)

level - The SNMPv3 security level of the group. One of the following:

NoAuthNoPriv - A group using no authentication and no data encryption. Users in this group use no security, either authentication or encryption, in SNMP messages they send to the agent.

AuthNoPriv - A group using authentication, but no data encryption. Users in this group send SNMP messages that use an MD5 key/password for authentication, but not a DES key/password for encryption.

AuthPriv - A group using authentication and data encryption. Users in this group send SNMP messages that use an MD5 key/

password for authentication and a DES key/password for encryption.

read-view - The name of a defined SNMPv3 view for read access.

write-view - The name of a defined SNMPv3 view for write access.

DEFAULT SETTING

None

COMMAND MODE

Global Configuration

COMMAND USAGE

- ◆ The access point allows multiple groups to be created.
- ◆ A group sets the access policy for the assigned users.
- ◆ When authentication is selected, the MD5 algorithm is used as specified in the `snmp-server user` command.
- ◆ When privacy is selected, the DES algorithm is used for data encryption.

EXAMPLE

```
AP(config)#snmp-server vacm group testgroup security-level authpriv rdview
wrview
AP(config)#
```

snmp-server user This command configures the SNMP v3 users that are allowed to manage the access point. Use the **no** form to delete an SNMP v3 user.

SYNTAX

snmp-server user <username> <groupname> {**none** | **md5** <auth-passphrase>} {**none** | **des** <priv-passphrase>}

no snmp-server user <username> <groupname>

username - Name of the user connecting to the SNMP agent.
(Range: 1-32 characters)

groupname - Name of an SNMP group to which the user is assigned.
(Range: 1-32 characters)

none | **md5** - Uses no authentication or MD5 authentication.

auth-passphrase - Authentication password. Enter a minimum of eight characters for the user. (8 – 32 characters)

none | **des** - Uses SNMPv3 with no privacy, or with DES56 encryption.

priv-passphrase - Privacy password. Enter a minimum of eight characters for the user. (8 – 32 characters)

DEFAULT SETTING

None

COMMAND MODE

Global Configuration

COMMAND USAGE

- ◆ Multiple SNMPv3 users can be configured on the access point.
- ◆ Users must be assigned to groups that have the same security levels. If a user who has "AuthPriv" security (uses authentication and encryption) is assigned to a NoAuthNoPriv group, the user will not be able to access the database. An AuthPriv user must be assigned to the group with the AuthPriv security level.

EXAMPLE

```
AP(config)#snmp-server user chris grname md5 passw1 des passw2
AP(config)#
```

snmp-server target This command configures SNMP v3 notification targets. Use the **no** form to delete an SNMP v3 target.

SYNTAX

snmp-server target <target-id> <ip-addr> <sec-name> <port-number> [notification-filter-id]

no snmp-server target <target-id>

target-id - A user-defined name that identifies a receiver of SNMP notifications. (Maximum length: 32 characters)

ip-addr - Specifies the IP address of the management station to receive notifications.

sec-name - The defined SNMP v3 user name that is to receive notifications.

port-number - The UDP port that is used on the receiving management station for notifications.

notification-filter-id - The name of a defined notification filter.

DEFAULT SETTING

None

COMMAND MODE

Global Configuration

COMMAND USAGE

- ◆ The access point supports multiple SNMP v3 target IDs.

- ◆ The SNMP v3 user name that is specified in the target must first be configured using the **snmp-server user** command.

EXAMPLE

```
AP(config)#snmp-server target tarname 192.168.1.33 chris 1234
AP(config)#
```

snmp-server filter This command configures SNMP v3 notification filters. Use the **no** form to delete an SNMP v3 filter or remove a subtree from a filter.

SYNTAX

```
snmp-server filter <filter-id> <include | exclude> <subtree>
no snmp-server filter <filter-id> [subtree]
```

filter-id - A user-defined name that identifies an SNMP v3 notification filter. (Maximum length: 32 characters)

include - Defines a filter type that includes objects in the MIB subtree.

exclude - Defines a filter type that excludes objects in the MIB subtree.

subtree - The part of the MIB subtree that is to be filtered.

DEFAULT SETTING

None

COMMAND MODE

Global Configuration

COMMAND USAGE

- ◆ The access point allows multiple notification filters to be created. Each filter can be defined by up to 20 MIB subtree ID entries.
- ◆ Use the command more than once with the same filter ID to build a filter that includes or excludes multiple MIB objects. Note that the filter entries are applied in the sequence that they are defined.
- ◆ The MIB subtree must be defined in the form ".1.3.6.1" and always start with a ".".

EXAMPLE

```
AP(config)#snmp-server filter trapfilter include .1
AP(config)#snmp-server filter trapfilter exclude .1.3.6.1.2.1.2.2.1.1.23
```

show snmp users This command displays the SNMP v3 users and settings.

SYNTAX

show snmp users

COMMAND MODE

Exec

EXAMPLE

```

AP# show snmp users

User List:
=====
UserName      : chris
GroupName     : testgroup
AuthType      : None
PrivType      : None

UserName      : david
GroupName     : group2
AuthType      : MD5,   Passphrase: *****
PrivType      : DES,   Passphrase: *****

=====
AP#

```

show snmp target This command displays the SNMP v3 notification target settings.

SYNTAX

show snmp target

COMMAND MODE

Exec

EXAMPLE

```

AP# show snmp target

Target List:
=====
Target ID    : christraps
IP Address   : 192.168.1.33
User Name    : chris
UDP Port     : 4321
Filter ID    : Not Defined

=====
AP#

```

show snmp filter This command displays the SNMP v3 notification filter settings.

SYNTAX

show snmp filter [*filter-id*]

filter-id - A user-defined name that identifies an SNMP v3 notification filter. (Maximum length: 32 characters)

COMMAND MODE

Exec

EXAMPLE

```
AP# show snmp filter

Filter List:
=====
Filter: defaultfilter
      Type: Included
      Subtree: .1

      Type: Excluded
      Subtree: .1.3.6.1.2.1.2.2.1.1.23

Filter: testfilter
      Type: Excluded
      Subtree: .13.6.1.2.1.2.2.1.2

=====
AP#
```

show snmp This command displays the SNMP configuration settings.

COMMAND MODE

Exec

EXAMPLE

```
AP# show snmp

SNMP Information
=====
Service State           : Enable
Community (ro)         : *****
Community (rw)         : *****
Location                : where?
Contact                 : who?
=====

Trap Destination List:
=====
Trap Destination: 192.168.1.22, Community : *****
=====

Trap Configuration:
=====
```

```

                                systemUp: Disabled                systemDown: Disabled
=====
AP#

```

show snmp vacm view This command displays the configured SNMP v3 views.

SYNTAX

show snmp vacm view [*view-name*]

view-name - The name of a user-defined SNMPv3 view.

COMMAND MODE

Exec

EXAMPLE

```

AP# sh snmp vacm view
View List:
=====
View Name   : defaultview
  Type      : included
  OID       : .1
  Mask      :

View Name   : testview
  Type      : included
  OID       : .1
  Mask      :

                Type : excluded
                OID  : .13.6.1.2.1.2.2.1.2.1.1
                Mask  :

=====
AP#

```

show snmp vacm group This command displays the configured SNMP v3 groups.

SYNTAX

show snmp vacm group [*group-name*]

group-name - The name of a user-defined SNMPv3 group.

COMMAND MODE

Exec

EXAMPLE

```

AP# sh snmp vacm group

Group List:

```



```
=====
Group Name      : testgroup
Security Level  : NoAuthNoPriv
Read-View       : defaultview
Write-View      : defaultview

Group Name      : group2
Security Level  : AuthPriv
Read-View       : defaultview
Write-View      : defaultview

=====
AP#
```

These commands are used to manage the system code or configuration files.

Table 15: Flash/File Commands

Command	Function	Mode	Page
dual-image	Specifies the file or image used to start up the system	GC	162
copy	Copies a code image or configuration between flash memory and a FTP/TFTP server	Exec	163
show dual-image	Displays the name of the current operation code file that booted the system	Exec	164

dual-image This command specifies the image used to start up the system.

SYNTAX

dual-image boot image [a | b]

- a** - Selects image file A as the startup software.
- b** - Selects image file B as the startup software.

DEFAULT SETTING

None

COMMAND MODE

Exec

COMMAND USAGE

- ◆ The access point supports two software image files (A and B), one of which is set as the boot image, or "Active" file, and the other acts as a "Backup" file.
- ◆ You can upgrade new access point software from a local file on the management workstation, or from an FTP or TFTP server. The new software file replaces the image (A or B) that is not currently set as the boot image.
- ◆ After upgrading new software, you must reboot the access point to implement the new code. Until a reboot occurs, the access point will continue to run the software it was using before the upgrade started. Also note that new software that is incompatible with the current configuration automatically restores the access point to the factory default settings when first activated after a reboot.

EXAMPLE

```
AP# dual-image boot-image A
Change image to A
AP#
```

copy This command copies a boot file, code image, or configuration file between the access point's flash memory and a FTP/TFTP server. When you save the configuration settings to a file on a FTP/TFTP server, that file can later be downloaded to the access point to restore system operation. The success of the file transfer depends on the accessibility of the FTP/TFTP server and the quality of the network connection.

SYNTAX

```
copy {ftp [firmware | config] <file-name> <ip-address> <user-name> <password> | tftp [firmware | config] <file-name> <ip-address>}
```

```
copy config {ftp <file-name> <ip-address> <user-name> <password> | tftp <file-name> <ip-address>}
```

copy running startup

ftp - Keyword that allows you to copy to/from an FTP server.

tftp - Keyword that allows you to copy to/from a TFTP server.

firmware - Keyword that allows you to copy a software image file from an FTP/TFTP server to flash memory.

config - Keyword that allows you to copy a configuration file to/from an FTP/TFTP server.

running startup - Keywords that save the current running configuration to the startup configuration file in flash memory.

file-name - The name of a file to copy.

ip-address - The IP address of an FTP or TFTP server.

user-name - The access user name for the FTP server.

password - The access password for the FTP server.

DEFAULT SETTING

None

COMMAND MODE

Exec

COMMAND USAGE

- ◆ Only a configuration file can be uploaded to an FTP/TFTP server, but every type of file can be downloaded to the access point.
- ◆ The destination file name should not contain slashes (\ or /), the leading letter of the file name should not be a period (.), and the maximum length for file names on the FTP/TFTP server is 255 characters or 32

characters for files on the access point. (Valid characters: A-Z, a-z, 0-9, ".", "-", "_")

- ◆ Due to the size limit of the flash memory, the access point supports only two operation code files.
- ◆ The system configuration file must be named "syscfg" in all copy commands.

EXAMPLE

The following example shows how to upload the configuration settings to a file on the TFTP server:

```
AP# copy config tftp syscfg 192.168.1.19
Backup Config to tftp was successful!!
AP#
```

The following example shows how to download a configuration file:

```
AP# copy tftp config syscfg 192.168.1.19
Restore Config from tftp was successful.
AP#
```

show dual-image This command displays the name of the current operation code file that booted the system and the file saved as a secondary image.

SYNTAX

show dual image

COMMAND MODE

Exec

EXAMPLE

```
AP#show dual-image
  Image      Status      Version
-----
  Image A    (Active)    1.1.0.6
  Image B    (Backup)    1.1.0.1
AP#
```

Remote Authentication Dial-in User Service (RADIUS) is a logon authentication protocol that uses software running on a central server to control access for RADIUS-aware devices to the network. An authentication server contains a database of credentials, such as users names and passwords, for each wireless client that requires access to the access point.

Table 16: RADIUS Client Commands

Command	Function	Mode	Page
radius-server enable	Enables the RADIUS server.	GC	165
radius-server address	Specifies the RADIUS server	GC	166
radius-server port	Sets the RADIUS server network port	GC	166
radius-server key	Sets the RADIUS encryption key	GC	167
radius-server accounting address	Sets the RADIUS server accounting address	GC	167
radius-server accounting port	Sets the RADIUS server accounting port	GC	168
radius-server accounting key	Sets the RADIUS server accounting key	GC	168
radius-server accounting timeout-interim	Sets the interval between transmitting accounting updates to the RADIUS server	GC	169
make-radius-effective	Implements RADIUS command changes made in current CLI session.	GC	169
show radius	Shows the current RADIUS settings	Exec	170

radius-server enable This command enables the RADIUS server.

SYNTAX

radius-server {primary | secondary} enable

primary - Specifies the primary RADIUS server.

secondary - Specifies the secondary RADIUS server.

DEFAULT SETTING

Enabled

COMMAND MODE

Global Configuration

EXAMPLE

```

AP(config)# radius-server primary enable
This setting has not been effective !
If want to take effect, please execute make-radius-effective command !

AP(config)#

```

radius-server address This command specifies the primary and secondary RADIUS server address.

SYNTAX

radius-server {primary | secondary} address <address>

address - IP address of server.

DEFAULT SETTING

10.7.16.96

COMMAND MODE

Global Configuration

EXAMPLE

```

AP(config)# radius-server primary address 192.168.1.9

This setting has not been effective !
If want to take effect, please execute make-radius-effective command !

AP(config)#

```

radius-server port This command sets the RADIUS server network port.

SYNTAX

radius-server {primary | secondary} port <port_number>

port_number - RADIUS server UDP port used for authentication messages. (Range: 1024-65535)

DEFAULT SETTING

1812

COMMAND MODE

Global Configuration

EXAMPLE

```

AP(config)# radius-server primary port 1810

This setting has not been effective !

```

```
If want to take effect, please execute make-radius-effective command !
```

```
AP(config)#
```

radius-server key This command sets the RADIUS encryption key.

SYNTAX

radius-server {**primary** | **secondary**} **key** <*key_string*>

key_string - Encryption key used to authenticate logon access for client. Do not use blank spaces in the string. (Maximum length: 20 characters)

DEFAULT SETTING

DEFAULT

COMMAND MODE

Global Configuration

EXAMPLE

```
AP(config)# radius-server primary key green
```

```
This setting has not been effective !
```

```
If want to take effect, please execute make-radius-effective command !
```

```
AP(config)#
```

radius-server accounting address This command sets the RADIUS Accounting server network IP address.

SYNTAX

radius-server accounting address <*address*>

address - IP address of the RADIUS Accounting server

DEFAULT SETTING

10.7.16.96

COMMAND MODE

Global Configuration

COMMAND USAGE

When the RADIUS Accounting server UDP address is specified, a RADIUS accounting session is automatically started for each user that is successfully authenticated to the access point.

EXAMPLE

```
AP(config)# radius-server accounting address 192.168.1.19
```

```
This setting has not been effective !
If want to take effect, please execute make-radius-effective command !

AP(config)#
```

radius-server accounting port

This command sets the RADIUS Accounting port.

SYNTAX

radius-server accounting port <port>

port - The port used by the RADIUS Accounting server.
(Range: 1024~65535)

DEFAULT SETTING

1813

COMMAND MODE

Global Configuration

COMMAND USAGE

When the RADIUS Accounting server UDP port is specified, a RADIUS accounting session is automatically started for each user that is successfully authenticated to the access point.

EXAMPLE

```
AP(config)# radius-server accounting port 1882

This setting has not been effective !
If want to take effect, please execute make-radius-effective command !

AP(config)#
```

radius-server accounting key

This command sets the RADIUS Accounting key.

SYNTAX

radius-server accounting key <key>

key - The RADIUS Accounting server keyphrase.

DEFAULT SETTING

DEFAULT

COMMAND MODE

Global Configuration

EXAMPLE

```

AP(config)# radius-server accounting key green

This setting has not been effective !
If want to take effect, please execute make-radius-effective command !

AP(config)#

```

**radius-server
accounting
timeout-interim**

This command sets the interval between transmitting accounting updates to the RADIUS server.

SYNTAX

radius-server accounting timeout-interim <number_of_seconds>}

number_of_seconds - Number of seconds the access point waits between transmitting accounting updates. (Range: 60-86400)

DEFAULT SETTING

300

COMMAND MODE

Global Configuration

COMMAND USAGE

The access point sends periodic accounting updates after every interim period until the user logs off and a "stop" message is sent.

EXAMPLE

```

AP(config)# radius-server accounting timeout-interim 600

This setting has not been effective !
If want to take effect, please execute make-radius-effective command !

AP(config)#

```

**make-radius-
effective**

This command implements the RADIUS settings made in the current CLI session.

DEFAULT SETTING

None

COMMAND MODE

Global Configuration

EXAMPLE

```

AP(config)# make-radius-effective

It will take several minutes !

```

```
Please wait a while...
```

```
AP(config)#
```

show radius This command displays the current settings for the RADIUS server.

DEFAULT SETTING

None

COMMAND MODE

Exec

EXAMPLE

```
AP#show radius
```

```
Radius Accounting Information
```

```
=====
IP           : 10.7.16.96
Key          : *****
Port         : 1813
timeout-interim : 300
=====
```

```
Radius Primary Server Information
```

```
=====
Status : ENABLED
IP      : 192.168.1.1
Port    : 1812
Key     : *****
=====
```

```
Radius Secondary Server Information
```

```
=====
Status : ENABLED
IP      : 10.7.16.96
Port    : 1812
Key     : ****
=====
```

```
AP#
```

802.1X AUTHENTICATION COMMANDS

The access point supports IEEE 802.1X access control for wireless clients. This control feature prevents unauthorized access to the network by requiring an 802.1X client application to submit user credentials for authentication. Client authentication is then verified by a RADIUS server using EAP (Extensible Authentication Protocol) before the access point grants client access to the network. The 802.1X EAP packets are also used to pass dynamic unicast session keys and static broadcast keys to wireless clients.

Table 17: 802.1x Authentication

Command	Function	Mode	Page
802.1x enable	Configures 802.1X as enabled or disabled	IC-W-VAP	171
802.1x session-timeout	Sets the timeout after which a connected client must be re-authenticated	IC-W-VAP	172

802.1x enable This command configures 802.1X as enabled for wireless clients. Use the **no** form to disable 802.1X support.

SYNTAX

802.1x enable
no 802.1x

DEFAULT SETTING

Disabled

COMMAND MODE

Interface Configuration (Wireless-VAP)

COMMAND USAGE

- ◆ When 802.1X is disabled, the access point does not support 802.1X authentication for any station. After successful 802.11 association, each client is allowed to access the network.
- ◆ 802.1X does not apply to the 10/100Base-TX port.
- ◆ To display the current 802.1X status, use the **show interface wireless** command.

EXAMPLE

```
AP(if-wireless 0: VAP[0])# 802.1x enable
```

```
This setting has not been effective !
If want to take effect, please execute make-security-effective command !
```

```
AP(if-wireless 0: VAP[0])#
```

RELATED COMMANDS

[show interface wireless](#)

802.1x session-timeout This command sets the time period after which a connected client must be re-authenticated.

SYNTAX

802.1x session-timeout <seconds>

seconds - The number of seconds. (Range: 0-1440)

DEFAULT

600 seconds

COMMAND MODE

Interface Configuration (Wireless-VAP)

EXAMPLE

```
AP(if-wireless 0: VAP[0])# 802.1x session-timeout 600
```

```
This setting has not been effective !
If want to take effect, please execute make-security-effective command !
```

```
AP(if-wireless 0: VAP[0])#
```

MAC ADDRESS AUTHENTICATION COMMANDS

Use these commands to define MAC authentication on the access point. For local MAC authentication, first define the default filtering policy using the address filter default command. Then enter the MAC addresses to be filtered, indicating if they are allowed or denied. For RADIUS MAC authentication, the MAC addresses and filtering policy must be configured on the RADIUS server.

Table 18: MAC Address Authentication

Command	Function	Mode	Page
address filter default	Sets filtering to allow or deny listed addresses	GC	173
address filter entry	Enters a MAC address in the filter table	GC	174
address filter delete	Removes a MAC address from the filter table	GC	174
mac- authentication server	Sets address filtering to be performed with local or remote options	GC	175
mac- authentication session-timeout	Sets the interval at which associated clients will be re-authenticated with the RADIUS server authentication database	GC	175
show authentication	Shows all authentication settings, as well as the address filter table	Exec	176

address filter default

This command sets filtering to allow or deny listed MAC addresses.

SYNTAX

address filter default <allowed | denied>

allowed - Only MAC addresses entered as “denied” in the address filtering table are denied.

denied - Only MAC addresses entered as “allowed” in the address filtering table are allowed.

DEFAULT

Allowed

COMMAND MODE

Global Configuration

EXAMPLE

```
AP(config)#address filter default denied
AP(config)#
```

RELATED COMMANDS
[address filter entry](#)

address filter entry This command enters a MAC address in the filter table.

SYNTAX

address filter entry <allowed | denied> <mac-address>

allowed - Entry is allowed access.

denied - Entry is denied access.

mac-address - Physical address of client. (Enter six pairs of hexadecimal digits separated by hyphens; e.g., 00-90-D1-12-AB-89.)

DEFAULT

None

COMMAND MODE

Global Configuration

COMMAND MODE

- ◆ The access point supports up to 1024 MAC addresses.
- ◆ An entry in the address table may be allowed or denied access depending on the global setting configured for the **address entry default** command.

EXAMPLE

```
AP(config)#address filter entry allowed 00-70-50-cc-99-1a
AP(config)#
```

RELATED COMMANDS

[address filter default](#)

address filter delete This command deletes a MAC address from the filter table.

SYNTAX

address filter delete <allowed | denied> <mac-address>

allowed - Entry is allowed access.

denied - Entry is denied access.

mac-address - Physical address of client. (Enter six pairs of hexadecimal digits separated by hyphens; e.g., 00-90-D1-12-AB-89.)

DEFAULT

None

COMMAND MODE

Global Configuration

EXAMPLE

```
AP(config)#address filter delete allowed 00-70-50-cc-99-1b
AP(config)#
```

mac-authentication server This command sets address filtering to be performed with local or remote options. Use the **no** form to disable MAC address authentication.

SYNTAX

mac-authentication server [local | remote]
no mac-authentication server

local - Authenticate the MAC address of wireless clients with the local authentication database during 802.11 association.

remote - Authenticate the MAC address of wireless clients with the RADIUS server during 802.1X authentication.

DEFAULT

Disabled

COMMAND MODE

Global Configuration

EXAMPLE

```
AP(config)#mac-authentication server remote
AP(config)#
```

RELATED COMMANDS

[address filter entry](#)
[radius-server address](#)

mac-authentication session-timeout This command sets the interval at which associated clients will be re-authenticated with the RADIUS server authentication database. Use the **no** form to disable reauthentication.

SYNTAX

mac-authentication session-timeout <seconds>
no mac-authentication session-timeout

seconds - Re-authentication interval. (Range: 30-65555)

DEFAULT

0 (disabled)

COMMAND MODE

Global Configuration

EXAMPLE

```
AP(config)#mac-authentication session-timeout 300
AP(config)#
```

show authentication This command shows all authentication settings, as well as the address filter table.

COMMAND MODE

Exec

EXAMPLE

```
AP# show authentication

Authentication Information
=====
MAC Authentication Server : Disable
Session Timeout          : Disable

Filter Table (Allow List):
-----

Filter Table (Deny List):
-----
=====

AP#
```

The commands described in this section are used to filter communications between wireless clients, control access to the management interface from wireless clients, and filter traffic using specific Ethernet protocol types.

Table 19: Filtering Commands

Command	Function	Mode	Page
filter local-bridge	Disables communication between wireless clients	GC	177
filter ap-manage	Prevents wireless clients from accessing the management interface	GC	178
filter acl-source-address	Configures ACL filtering based on source MAC addresses	GC	178
filter acl-destination-address	Configures ACL filtering based on destination MAC addresses	GC	179
filter ethernet-type enable	Checks the Ethernet type for all incoming and outgoing Ethernet packets against the protocol filtering table	GC	179
filter ethernet-type protocol	Sets a filter for a specific Ethernet type	GC	180
show filters	Shows the filter configuration	Exec	181

filter local-bridge This command disables communication between wireless clients. Use the **no** form to disable this filtering.

SYNTAX

filter local-bridge <all-VAP | intra-VAP>
no filter local-bridge

all-VAP - When enabled, clients cannot establish wireless communications with any other client, either those associated to the same VAP interface or any other VAP interface.

intra-VAP - When enabled, clients associated with a specific VAP interface cannot establish wireless communications with each other. Clients can communicate with clients associated to other VAP interfaces.

DEFAULT

Disabled

COMMAND MODE

Global Configuration

COMMAND USAGE

This command can disable wireless-to-wireless communications between clients via the access point. However, it does not affect communications between wireless clients and the wired network.

EXAMPLE

```
AP(config)#filter local-bridge all-vap
AP(config)#
```

filter ap-manage This command prevents wireless clients from accessing the management interface on the access point. Use the **no** form to disable this filtering.

SYNTAX

[no] filter ap-manage

DEFAULT

Disabled

COMMAND MODE

Global Configuration

EXAMPLE

```
AP(config)#filter AP-manage
AP(config)#
```

filter acl-source-address This command configures ACL filtering based on source MAC addresses in data frames.

SYNTAX

filter acl-source-address {**enable** | **disable** | **add** <mac-address> | **delete** <mac-address> }

enable - Key word that enables ACL filtering on the access point.

disable - Key word that disables ACL filtering on the access point.

add - Key word that adds a MAC address to the filter table.

delete - Key word that removes a MAC address from the filter table

mac-address - Specifies a MAC address in the form xx-xx-xx-xx-xx-xx.

DEFAULT

Disabled

COMMAND MODE

Global Configuration

COMMAND USAGE

You can add up to 128 MAC addresses to the filtering table.

EXAMPLE

```
AP(config)#filter acl-source-address add 00-12-34-56-78-9a
AP(config)#filter acl-source-address enable
AP(config)#
```

filter acl-destination-address

This command configures ACL filtering based on source MAC addresses in data frames.

SYNTAX

filter acl-destination-address {**enable** | **disable** | **add** <mac-address> | **delete** <mac-address>}

enable - Key word that enables ACL filtering on the access point.

disable - Key word that disables ACL filtering on the access point.

add - Key word that adds a MAC address to the filter table.

delete - Key word that removes a MAC address from the filter table

mac-address - Specifies a MAC address in the form xx-xx-xx-xx-xx-xx.

DEFAULT

Disabled

COMMAND MODE

Global Configuration

EXAMPLE

```
AP(config)#filter acl-destination-address add 00-12-34-56-78-9a
AP(config)#filter acl-destination-address enable
AP(config)#
```

filter ethernet-type enabledThis command checks the Ethernet type on all incoming and outgoing Ethernet packets against the protocol filtering table. Use the **no** form to disable this feature.**SYNTAX**

[**no**] **filter ethernet-type enabled**

DEFAULT

Disabled

COMMAND MODE

Global Configuration

COMMAND USAGE

This command is used in conjunction with the **filter ethernet-type protocol** command to determine which Ethernet protocol types are to be filtered.

EXAMPLE

```
AP(config)#filter ethernet-type enabled
AP(config)#
```

RELATED COMMANDS

[filter ethernet-type protocol](#)

filter ethernet-type protocol

This command sets a filter for a specific Ethernet type. Use the **no** form to disable filtering for a specific Ethernet type.

SYNTAX

[no] filter ethernet-type protocol <protocol>

protocol - An Ethernet protocol type. (Options: ARP, RARP, Berkeley-Trailer-Negotiation, LAN-Test, X25-Level-3, Banyan, CDP, DEC XNS, DEC-MOP-Dump-Load, DEC-MOP, DEC-LAT, Ethertalk, Appletalk-ARP, Novell-IPX(old), Novell-IPX(new), EAPOL, Telxon-TXP, Aironet-DDP, Enet-Config-Test, IP, IPv6, NetBEUI, PPPoE_Discovery, PPPoE_PPP_Session)

DEFAULT

None

COMMAND MODE

Global Configuration

COMMAND USAGE

Use the **filter ethernet-type enable** command to enable filtering for Ethernet types specified in the filtering table, or the **no filter ethernet-type enable** command to disable all filtering based on the filtering table.

EXAMPLE

```
AP(config)#filter ethernet-type protocol ARP
AP(config)#
```

RELATED COMMANDS

[filter ethernet-type enabled](#)

show filters This command shows the filter options and protocol entries in the filter table.

SYNTAX

show filters [**acl-source-address** | **acl-destination-address**]

COMMAND MODE

Exec

EXAMPLE

```

AP#show filters

Protocol Filter Information
=====
Local Bridge           :Traffic among all client STAs blocked
AP Management          :DISABLED
EtherType Filter       :DISABLED

Enabled EtherType Filters
-----
=====

AP#

```

The commands described in this section are used to set the MAC address table aging time and spanning tree parameters for both the Ethernet and wireless interfaces.

Table 20: Spanning Tree Commands

Command	Function	Mode	Page
bridge stp service	Enables the Spanning Tree feature	GC	183
bridge stp br-conf forwarding-delay	Configures the spanning tree bridge forward time	GC	183
bridge stp br-conf hello-time	Configures the spanning tree bridge hello time	GC	184
bridge stp br-conf max-age	Configures the spanning tree bridge maximum age	GC	184
bridge stp br-conf priority	Configures the spanning tree bridge priority	GC	185
bridge stp port-conf interface	Enters STP interface configuration mode	GC	185
bridge-link path-cost	Configures the spanning tree path cost for the Ethernet port	IC-E	186
bridge-link port-priority	Configures the spanning tree priority for the Ethernet port	IC-E	186
vap	Selects the VAP interface in STP interface configuration mode	GC-STP	187
path-cost	Sets the path cost for a VAP interface in STP interface configuration mode	GC-STP	187
port-priority	Sets the port priority for a VAP interface in STP interface configuration mode	GC-STP	188
show bridge stp	Displays the global spanning tree settings	Exec	188
show bridge br-conf	Displays spanning tree settings for specified VLANs	Exec	189
show bridge port-conf	Displays spanning tree settings for specified interfaces	Exec	189
show bridge status	Displays STP bridge status for a specified VLAN or all VLANs	Exec	190
show bridge forward address	Displays STP settings for forwarding MAC addresses on specified interfaces or VLANs	Exec	191

bridge stp service This command enables the Spanning Tree Protocol. Use the **no** form to disable the Spanning Tree Protocol.

SYNTAX

[no] bridge stp service

DEFAULT SETTING

Enabled

COMMAND MODE

Global Configuration

EXAMPLE

This example globally enables the Spanning Tree Protocol.

```
AP(config)#bridge stp service
AP(config)
```

bridge stp br-conf forwarding-delay Use this command to configure the spanning tree bridge forward time globally for the wireless bridge.

SYNTAX

bridge stp br-conf forwarding-delay <seconds>

seconds - Time in seconds. (Range: 4 - 30 seconds)

The minimum value is the higher of 4 or $[(\text{max-age} / 2) + 1]$.

DEFAULT SETTING

15 seconds

COMMAND MODE

Global Configuration

COMMAND USAGE

This command sets the maximum time (in seconds) the root device will wait before changing states (i.e., discarding to learning to forwarding). This delay is required because every device must receive information about topology changes before it starts to forward frames. In addition, each port needs time to listen for conflicting information that would make it return to the discarding state; otherwise, temporary data loops might result.

EXAMPLE

```
AP(config)#bridge stp br-conf forwarding-delay 20
AP(config)#
```

bridge stp br-conf hello-time Use this command to configure the spanning tree bridge hello time globally for the wireless bridge.

SYNTAX

bridge stp br-conf hello-time <*time*>

time - Time in seconds. (Range: 1-10 seconds).

The maximum value is the lower of 10 or $[(\text{max-age} / 2) - 1]$.

DEFAULT SETTING

2 seconds

COMMAND MODE

Global Configuration

COMMAND USAGE

This command sets the time interval (in seconds) at which the root device transmits a configuration message.

EXAMPLE

```
AP(config)#bridge stp br-conf hello-time 5
AP(config)#
```

bridge stp br-conf max-age Use this command to configure the spanning tree bridge maximum age globally for the wireless bridge.

SYNTAX

bridge stp br-conf max-age <*seconds*>

seconds - Time in seconds. (Range: 6-40 seconds)

The minimum value is the higher of 6 or $[2 \times (\text{hello-time} + 1)]$.

The maximum value is the lower of 40 or $[2 \times (\text{forward-time} - 1)]$.

DEFAULT SETTING

20 seconds

COMMAND MODE

Global Configuration

COMMAND USAGE

This command sets the maximum time (in seconds) a device can wait without receiving a configuration message before attempting to reconfigure. All device ports (except for designated ports) should receive configuration messages at regular intervals. Any port that ages out STP information (provided in the last configuration message) becomes the designated port for the attached LAN. If it is a root port, a new root port is selected from among the device ports attached to the network.

EXAMPLE

```
AP(config)#bridge stp max-age 40
AP(config)#
```

bridge stp br-conf priority Use this command to configure the spanning tree priority globally for the wireless bridge.

SYNTAX

bridge stp br-conf priority <priority>

priority - Priority of the bridge. (Range: 0 - 65535)

DEFAULT SETTING

32768

COMMAND MODE

Global Configuration

COMMAND USAGE

Bridge priority is used in selecting the root device, root port, and designated port. The device with the highest priority becomes the STP root device. However, if all devices have the same priority, the device with the lowest MAC address will then become the root device.

EXAMPLE

```
AP(config)#bridge stp br-conf priority 40000
AP(config)#
```

bridge stp port-conf interface This command enters STP interface configuration mode.

SYNTAX

bridge stp port-conf interface {**ethernet** | **wireless** <index>}

index - The wireless interface index number. (Only "0" for this AP.)

DEFAULT SETTING

None

COMMAND MODE

Global Configuration

COMMAND USAGE

Use this command to enter STP interface configuration mode. In this mode STP settings for specific VAP interfaces can be configured.

EXAMPLE

```

AP(config)# bridge stp port-conf interface wireless 0
Enter Wireless configuration commands, one per line.
AP(stp-if-wireless 0)#

```

bridge-link path-cost Use this command to configure the spanning tree path cost for the Ethernet port.

SYNTAX

bridge-link path-cost <cost>

cost - The path cost for the port. (Range: 1-65535)

DEFAULT SETTING

4

COMMAND MODE

Interface Configuration (Ethernet)

COMMAND USAGE

- ◆ This command is used by the Spanning Tree Protocol to determine the best path between devices. Therefore, lower values should be assigned to ports attached to faster media, and higher values assigned to ports with slower media.
- ◆ Path cost takes precedence over port priority.

EXAMPLE

```

AP(if-wireless a)#bridge-link path-cost 1 50
AP(if-wireless a)#

```

bridge-link port-priority Use this command to configure the priority for the Ethernet port.

SYNTAX

bridge-link port-priority <priority>

priority - The priority for a port. (Range: 1-255)

DEFAULT SETTING

32

COMMAND MODE

Interface Configuration (Ethernet)

COMMAND USAGE

- ◆ This command defines the priority for the use of a port in the Spanning Tree Protocol. If the path cost for all ports on a wireless bridge are the same, the port with the highest priority (that is, lowest value) will be configured as an active link in the spanning tree.
- ◆ Where more than one port is assigned the highest priority, the port with lowest numeric identifier will be enabled.

EXAMPLE

```
AP(if-wireless a)#bridge-link port-priority 1 64
AP(if-wireless a)#
```

RELATED COMMANDS

[bridge-link path-cost](#)

vap (STP Interface) This command selects the VAP interface for configuring STP settings.

SYNTAX

vap <vap-index>

vap-index - The index number for the VAP interface. (Range: 0-7)

COMMAND MODE

Global Configuration (STP interface)

EXAMPLE

```
AP(stp-if-wireless 0)# vap 0
AP(stp-if-wireless 0: VAP[0])#
```

path-cost (STP Interface) This command sets the spanning tree path cost for the VAP interface.

SYNTAX

path-cost <cost>

cost - The path cost for the VAP interface. (Range: 1-65535)

COMMAND MODE

Global Configuration (STP interface)

COMMAND USAGE

- ◆ This command is used by the Spanning Tree Protocol to determine the best path between devices. Therefore, lower values should be assigned to interfaces with faster media, and higher values assigned to interfaces with slower media.
- ◆ Path cost takes precedence over port priority.

EXAMPLE

```
AP(stp-if-wireless 0: VAP[0])# path-cost 512
AP(stp-if-wireless 0: VAP[0])#
```

port-priority (STP Interface) This command sets the spanning tree path cost for the VAP interface.

SYNTAX

port-priority <priority>

priority - The priority for the VAP interface. (Range: 0-63)

COMMAND MODE

Global Configuration (STP interface)

COMMAND USAGE

- ◆ This command defines the priority for the use of an interface in the Spanning Tree Protocol. If the path cost for all interfaces on a bridge are the same, the interface with the highest priority (that is, lowest value) will be configured as an active link in the spanning tree.
- ◆ Where more than one interface is assigned the highest priority, the interface with lowest numeric identifier will be enabled.

EXAMPLE

```
AP(stp-if-wireless 0: VAP[0])# port-priority 10
AP(stp-if-wireless 0: VAP[0])#
```

show bridge stp This command displays displays the global spanning tree settings for the bridge.

SYNTAX

show bridge stp

COMMAND MODE

Exec

EXAMPLE

```
AP#show bridge stp

Bridge STP Information
=====
Bridge MAC           : 00:12:CF:A2:54:30
Status               : Disabled
priority             : 32768
Hello Time           : 2 seconds
Maximum Age          : 20 seconds
Forward Delay        : 15 seconds
```

```

=====
AP#

```

show bridge br-conf This command displays spanning tree settings for a specified VLAN.

SYNTAX

show bridge br-conf <all | *vlan-id*>

all - Keyword to show the STP configuration for all VLANs.

vlan-id - Specifies a VLAN ID. (Range: 0-4095)

COMMAND MODE

Exec

EXAMPLE

```

AP# show bridge br-conf all

BR0 configuration
=====
BRIDGE MAC       : 00:12:cf:a2:54:30
Priority         : 32768
Hello Time      : 2
Maximum Age     : 20
Forward Delay   : 0
=====
AP#

```

show bridge port-conf interface This command displays spanning tree settings for specified interfaces.

SYNTAX

show bridge port-conf interface {all | ethernet | wireless *index* <all | vap *vap-index*>}

all - Keyword to display STP settings for all interfaces.

ethernet - Keyword to display STP settings for the Ethernet interface.

wireless - Keyword to display STP settings for the Wireless interface.

vap - Keyword to display STP settings for a specific VAP interface.

COMMAND MODE

Exec

EXAMPLE

```

AP#show bridge port-conf interface all

ETH0 configuration
=====

```

```

Link Port Priority      : 32
Link Path Cost         : 4
=====

ATH0 configuration
=====
Link Port Priority      : 32
Link Path Cost         : 19
=====

ATH1 configuration
=====
Link Port Priority      : 32
Link Path Cost         : 19
=====

ATH2 configuration
=====
Link Port Priority      : 32
Link Path Cost         : 19
=====

ATH3 configuration
=====
Link Port Priority      : 32
Link Path Cost         : 19
=====

ATH4 configuration
=====
Link Port Priority      : 32
Link Path Cost         : 19
=====

ATH5 configuration
=====
Link Port Priority      : 32
Link Path Cost         : 19
=====

ATH6 configuration
=====
Link Port Priority      : 32
Link Path Cost         : 19
=====

ATH7 configuration
=====
Link Port Priority      : 32
Link Path Cost         : 19
=====
AP#

```

show bridge status This command displays STP bridge status for a specified VLAN or all VLANs.

SYNTAX

show bridge status <all | *vlan-id*>

all - Keyword to show the bridge status for all VLANs.

vlan-id - Specifies a VLAN ID. (Range: 0-4095)

COMMAND MODE

Exec

EXAMPLE

```

AP# show bridge status all

br0 status
=====
Bridge ID           : 8000.0012cfa25430
Designated Root ID : 8000.0012cfa25430
Root Port          : 0

ath0 --- port 0x2

Port ID           : 0x8002
Designated Root ID : 8000.0012cfa25430
Designated Bridge ID : 8000.0012cfa25430
Root Port Path Cost : 0
State             : FORWARDING

eth0 --- port 0x1

Port ID           : 0x8001
Designated Root ID : 8000.0012cfa25430
Designated Bridge ID : 8000.0012cfa25430
Root Port Path Cost : 0
State             : DISABLED
=====

AP#

```

show bridge forward address This command displays STP settings for forwarding MAC addresses on specified interfaces or VLANs.

SYNTAX

show bridge forward address {**all** | **mac** <mac-address> | <vlan-id>}

show bridge forward address {**ethernet** | **wireless** <index> **vap** <vap-index>}

all - Show settings for all forwarding MAC addresses.

mac - Show settings for specific forwarding MAC addresses. MAC addresses are specified in the form xx-xx-xx-xx-xx-xx.

ethernet - The Ethernet port interface.

wireless - The wireless port interface.

vap - Wireless VAP interfaces. (Wireless Range: 0; VAP Range: 0-7)

vlan-id - Show settings for forwarding addresses on specific VLANs. (Range: 0-4095)

COMMAND MODE

Exec

EXAMPLE

```
AP# show bridge forward-addr interface wireless 0 vap 0
```

```
MAC ADDRESS                INTERFACE  VLAN   AGE
=====
02:12:cf:a2:54:30          ath0      0      0
=====
AP#
```

The commands described in this section are used to set the operation mode for each access point interface and configure Wireless Distribution System (WDS) forwarding table settings.

Table 21: WDS Bridge Commands

Command	Function	Mode	Page
wds ap	Selects the bridge operation mode for a radio interface	IC-W VAP	193
wds sta	Configures the MAC addresses of the parent bridge node	IC-W VAP	193
show wds wireless	Configures MAC addresses of connected child bridge nodes	Exec	194

wds ap This command enables the bridge operation mode for the radio interface.

SYNTAX

wds ap

DEFAULT SETTING

Disabled

COMMAND MODE

Interface Configuration (Wireless) VAP

EXAMPLE

```
AP(if-wireless 0 [VAP 0])#wds ap
AP(if-wireless 0 [VAP 0])#
```

wds sta This command configures WDS station mode on a VAP interface.

SYNTAX

wds sta ap-ssid <ssid> address <mac-address>

ssid - Severice set identifier. Maximum: 32 characters.

mac-address - The MAC address of the connecting VAP in WDS-AP mode.

DEFAULT SETTING

None

COMMAND MODE

Interface Configuration (Wireless) VAP

COMMAND USAGE

In WDS-STA mode, the VAP operates as a client station in WDS mode, which connects to an access point in WDS-AP mode. The user needs to specify the SSID and MAC address of the VAP to which it intends to connect.

EXAMPLE

```
AP(if-wireless 0 [VAP 0])#wds sta ap-ssid red address 00-11-22-33-44-55
AP(if-wireless 0 [VAP 0])#
```

show wds wireless This command displays the current WDS settings for VAPs.

SYNTAX

show wds wireless <index> vap {all | <vap-index>}

index -The wireless interface index number. (Option: 0)

vap-index - The VAP index number. (Range: 0-7)

COMMAND MODE

Exec

EXAMPLE

```
AP# show wds wireless 0 vap 0
```

```
WDS Status(wireless 0 vap 0)
```

```
=====
```

```
Status: up
```

```
Mode: STA
```

```
AP SSID: red
```

```
AP MAC: 00:11:22:33:44:55
```

```
=====
```

```
AP#
```

The commands described in this section configure connection parameters for the Ethernet port and wireless interface.

Table 22: Ethernet Interface Commands

Command	Function	Mode	Page
interface ethernet	Enters Ethernet interface configuration mode	GC	195
dns	Specifies the primary and secondary name servers	IC-E	196
ip address	Sets the IP address for the Ethernet interface	IC-E	196
ip dhcp	Submits a DHCP request for an IP address	IC-E	197
shutdown	Disables the Ethernet interface	IC-E	198
show interface ethernet	Shows the status for the Ethernet interface	Exec	198

interface ethernet This command enters Ethernet interface configuration mode.

DEFAULT SETTING

None

COMMAND MODE

Global Configuration

EXAMPLE

To specify the 1000BASE-T network interface, enter the following command:

```
AP(config)#interface ethernet
AP(if-ethernet)#
```

dns This command specifies the address for the primary or secondary domain name server to be used for name-to-address resolution.

SYNTAX

dns {**primary-server** | **secondary-server**} <*server-address*>

primary-server - Primary server used for name resolution.

secondary-server - Secondary server used for name resolution.

server-address - IP address of domain-name server.

DEFAULT SETTING

None

COMMAND MODE

Global Configuration

COMMAND USAGE

The primary and secondary name servers are queried in sequence.

EXAMPLE

This example specifies two domain-name servers.

```
AP(if-ethernet)#dns primary-server 192.168.1.55
AP(if-ethernet)#dns secondary-server 10.1.0.55
AP(if-ethernet)#
```

RELATED COMMANDS

[show interface ethernet](#)

ip address This command sets the IP address for the access point. Use the **no** form to restore the default IP address.

SYNTAX

ip address <*ip-address*> <*netmask*> <*gateway*>

no ip address

ip-address - IP address

netmask - Network mask for the associated IP subnet. This mask identifies the host address bits used for routing to specific subnets.

gateway - IP address of the default gateway

DEFAULT SETTING

IP address: 192.168.2.1

Netmask: 255.255.255.0

COMMAND MODE

Interface Configuration (Ethernet)

COMMAND USAGE

- ◆ DHCP is enabled by default. To manually configure a new IP address, you must first disable the DHCP client with the **no ip dhcp** command.
- ◆ You must assign an IP address to this device to gain management access over the network or to connect the access point to existing IP subnets. You can manually configure a specific IP address using this command, or direct the device to obtain an address from a DHCP server using the **ip dhcp** command. Valid IP addresses consist of four numbers, 0 to 255, separated by periods. Anything outside this format will not be accepted by the configuration program.

EXAMPLE

```
AP(config)#interface ethernet
Enter Ethernet configuration commands, one per line.
Enterprise AP(if-ethernet)#ip address 192.168.1.2 255.255.255.0 192.168.1.253
AP(if-ethernet)#
```

RELATED COMMANDS[ip dhcp](#)

ip dhcp This command enables the access point to obtain an IP address from a DHCP server. Use the **no** form to restore the default IP address.

SYNTAX**[no] ip dhcp****DEFAULT SETTING**

Enabled

COMMAND MODE

Interface Configuration (Ethernet)

COMMAND USAGE

- ◆ You must assign an IP address to this device to gain management access over the network or to connect the access point to existing IP subnets. You can manually configure a specific IP address using the **ip address** command, or direct the device to obtain an address from a DHCP server using this command.
- ◆ When you use this command, the access point will begin broadcasting DHCP client requests. The current IP address (i.e., default or manually configured address) will continue to be effective until a DHCP reply is received. Requests will be broadcast periodically by this device in an effort to learn its IP address. (DHCP values can include the IP address, subnet mask, and default gateway.)

EXAMPLE

```

AP(config)#interface ethernet
Enter Ethernet configuration commands, one per line.
AP(if-ethernet)#ip dhcp
AP(if-ethernet)#

```

RELATED COMMANDS[ip address](#)

shutdown This command disables the Ethernet interface. To restart a disabled interface, use the **no** form.

SYNTAX

[no] shutdown

DEFAULT SETTING

Interface enabled

COMMAND MODE

Interface Configuration (Ethernet)

COMMAND USAGE

This command allows you to disable the Ethernet port due to abnormal behavior (e.g., excessive collisions), and reenables it after the problem has been resolved. You may also want to disable the Ethernet port for security reasons.

EXAMPLE

The following example disables the Ethernet port.

```

AP(if-ethernet)#shutdown
AP(if-ethernet)#

```

show interface ethernet This command displays the status for the Ethernet interface.

SYNTAX

show ethernet interface

DEFAULT SETTING

Ethernet interface

COMMAND MODE

Exec

EXAMPLE

```
AP#show interface ethernet
Ethernet Interface Information
=====
IP Address       : 192.168.1.1
Subnet Mask     : 255.255.255.0
Default Gateway : 192.168.1.254
Admin status    : Up
Operational status : Up
=====

AP#
```

The commands described in this section configure connection parameters for the wireless interfaces.

Table 23: Wireless Interface Commands

Command	Function	Mode	Page
interface wireless	Enters wireless interface configuration mode	GC	201
vap	Provides access to the VAP interface configuration mode	IC-W	201
a-mpdu	Sets the Aggregate MAC Protocol Data Unit (A-MPDU)	IC-W	201
a-msdu	Sets the Aggregate MAC Service Data Unit (A-MSDU)	IC-W	202
channel	Configures the radio channel	IC-W	202
transmit-power	Adjusts the power of the radio signals transmitted from the access point	IC-W	204
interface-radio-mode	Forces the operating mode of the 802.11g radio	IC-W	204
make-rf-setting-effective	Implements wireless command changes made in current CLI session	IC-W	205
preamble	Sets the length of the 802.11g signal preamble	IC-W	205
short-guard-interval	Enables the 802.11n short guard interval	IC-W	206
beacon-interval	Configures the rate at which beacon signals are transmitted from the access point	IC-W	207
dtim-period	Configures the rate at which stations in sleep mode must wake up to receive broadcast/multicast transmissions	IC-W	207
rts-threshold	Sets the packet size threshold at which an RTS must be sent to the receiving station prior to the sending station starting communications	IC-W	208
ssid	Configures the service set identifier	IC-W-VAP	209
closed system	Opens access to clients without a pre-configured SSID	IC-W-VAP	209
assoc- timeout-interval	Configures the idle time interval (when no frames are sent) after which a client is disassociated from the VAP interface	IC-W-VAP	210
auth- timeout-value	Configures the time interval after which clients must be re-authenticated	IC-W-VAP	210
shutdown	Disables the wireless interface	IC-W-VAP	211
show interface wireless	Shows the status for the wireless interface	Exec	211
show station	Shows the wireless clients associated with the access point	Exec	213

interface wireless This command enters wireless interface configuration mode.

SYNTAX

interface wireless <*index*>

index - The index of the wireless interface. (Range: 0)

DEFAULT SETTING

None

COMMAND MODE

Global Configuration

EXAMPLE

```
AP(config)# interface wireless 0
Enter Wireless configuration commands, one per line.
AP(if-wireless 0)#
```

vap This command provides access to the VAP (Virtual Access Point) interface configuration mode.

SYNTAX

vap <*vap-index*>

vap-index - The number that identifies the VAP interface.
(Options: 0-7)

DEFAULT SETTING

None

COMMAND MODE

Interface Configuration (Wireless)

EXAMPLE

```
AP(if-wireless 0)#vap 0
AP(if-wireless 0: VAP[0])#
```

a-mpdu This command enables and sets the Aggregate MAC Protocol Data Unit (A-MPDU).

SYNTAX

a-mpdu {**enable** | **disable** | **length** | <*length*>}

enable - Enable A-MPDU.

disable - Disable A-MPDU.

length - 1024-65535 bytes.

DEFAULT SETTING

Disabled

COMMAND MODE

Interface Configuration (Wireless)

EXAMPLE

```
AP(if-wireless 0)#a-mpdu enable
AP(if-wireless 0)#
```

a-msdu This command enables and sets the Aggregate MAC Service Data Unit (A-MSDU).

SYNTAX

a-msdu {**enable** | **disable** | **length** <*length*>}

enable - Enable A-MSDU.

disable - Disable A-MSDU.

length - 1024-65535 bytes.

DEFAULT SETTING

Disabled

COMMAND MODE

Interface Configuration (Wireless)

EXAMPLE

```
AP(if-wireless 0)#a-msdu enable
AP(if-wireless 0)#
```

channel This command configures the radio channel through which the access point communicates with wireless clients.

SYNTAX

channel {**ht20** <*ht20-channel*> | **ht40** <*ht40-channel*> | **auto**}

ht20-channel - The 802.11n 20 MHz channel number:

11ng mode: 01, 02, 03, 04, 05, 06, 07, 08, 09, 10, 11

11na mode: 36, 40, 44, 48, 52, 56, 60, 64, 100, 104, 108, 112, 116, 120, 124, 128, 132, 136, 140, 149, 153, 157, 161, 165

ht40-channel - The 802.11n 40 MHz channel number:

11ng mode: 01Plus, 02Plus, 03Plus, 04Plus, 05Plus, 05Minus, 06Plus, 06Minus, 07Plus, 07Minus, 08Minus, 09Minus, 10Minus, 11Minus

11na mode: 36Plus, 40Minus, 44Plus, 48Minus, 52Plus, 56Minus, 60Plus, 64Minus, 100Plus, 104Minus, 108Plus, 112Minus, 116Plus, 120Minus, 124Plus, 128Minus, 132Plus, 136Minus, 149Plus, 153Minus, 157Plus, 161Minus

auto - Automatically selects an unoccupied channel (if available). Otherwise, the lowest channel is selected.

DEFAULT SETTING

Automatic channel selection

COMMAND MODE

Interface Configuration (Wireless)

COMMAND USAGE

- ◆ The available channel settings are limited by local regulations, which determine the number of channels that are available.
- ◆ The available channels depend on the current radio mode setting, either 11ng (2.4 GHz) or 11na (5 GHz). Use the **interface-radio-mode** command to set the radio mode.
- ◆ The AP provides a channel bandwidth of 40 MHz by default giving an 802.11g connection speed of 108 Mbps (sometimes referred to as Turbo Mode) and a 802.11n connection speed of up to 300 Mbps. Setting the HT Channel Bandwidth to 20 MHz slows connection speed for 802.11g and 802.11n to 54 Mbps and 74 Mbps respectively and ensures backward compliance for slower 802.11b devices.
- ◆ For most wireless adapters, the channel for wireless clients is automatically set to the same as that used by the access point to which it is linked.

EXAMPLE

```
AP(if-wireless 0)# channel ht20 06
```

```
This setting has not been effective !
If want to take effect, please execute make-RF-setting-effective command !
```

```
AP(if-wireless 0)#
```

transmit-power This command adjusts the power of the radio signals transmitted from the access point.

SYNTAX

transmit-power <*signal-strength*>

signal-strength - Signal strength transmitted from the access point.
(Options: full, half, quarter, eighth, min)

DEFAULT SETTING

Full

COMMAND MODE

Interface Configuration (Wireless)

COMMAND USAGE

- ◆ The "min" keyword indicates minimum power.
- ◆ The longer the transmission distance, the higher the transmission power required. But to support the maximum number of users in an area, you must keep the power as low as possible. Power selection is not just a trade off between coverage area and maximum supported clients. You also have to ensure that high strength signals do not interfere with the operation of other radio devices in your area.

EXAMPLE

```
AP(if-wireless g)#transmit-power half
AP(if-wireless g)#
```

interface-radio-mode This command sets the operating mode for the wireless interface.

SYNTAX

interface-radio-mode <**11na** | **11ng**>

11na - n/a mixed mode: Both 802.11a and 802.11n clients can communicate with the access point at 5 GHz.

11ng - n/g mixed mode: Both 802.11b, 802.11g and 802.11n clients can communicate with the access point at 2.4 GHz.

DEFAULT SETTING

11ng mode

COMMAND MODE

Interface Configuration (Wireless)

COMMAND USAGE

Both the 802.11g and 802.11b standards operate within the 2.4 GHz band. If you are operating in 11ng mode, any 802.11b devices in the service area will contribute to the radio frequency noise and affect network performance.

EXAMPLE

```
AP(if-wireless 0)#interface-radio-mode 11na
AP(if-wireless 0)#
```

make-rf-setting-effective This command implements all wireless command changes made in current CLI session.

SYNTAX

make-rf-setting-effective

COMMAND MODE

Interface Configuration (Wireless)

EXAMPLE

```
Accton(if-wireless 0)# make-RF-setting-effective

It will take several minutes !
Please wait a while...

AP(if-wireless 0)#
```

preamble This command sets the length of the signal preamble that is used at the start of a 802.11b/g data transmission.

SYNTAX

preamble [long | short-or-long]

long - Sets the preamble to long (192 microseconds).

short-or-long - Sets the preamble to short if no 802.11b clients are detected (96 microseconds).

DEFAULT SETTING

Short-or-Long

COMMAND MODE

Interface Configuration (Wireless)

COMMAND USAGE

- ◆ Using a short preamble instead of a long preamble can increase data throughput on the access point, but requires that all clients can support a short preamble.
- ◆ Set the preamble to long to ensure the access point can support all 802.11b and 802.11g clients.

EXAMPLE

```
AP(if-wireless 0)# preamble short-or-long

This setting has not been effective !
If want to take effect, please execute make-RF-setting-effective command !

AP(if-wireless 0)#
```

short-guard-interval This command sets the 802.11n guard interval to 400ns (short) or 800ns (long).

SYNTAX

short-guard-interval <enable | disable>

DEFAULT SETTING

Disabled

COMMAND MODE

Interface Configuration (Wireless)

COMMAND USAGE

The 802.11n draft specifies two guard intervals: 400ns (short) and 800ns (long). Support of the 400ns guard interval is optional for transmit and receive. The purpose of a guard interval is to introduce immunity to propagation delays, echoes, and reflections to which digital data is normally very sensitive. Enabling the short guard interval sets it to 400ns.

EXAMPLE

```
AP(if-wireless 0)# short-guard-interval enable

This setting has not been effective !
If want to take effect, please execute make-RF-setting-effective command !

AP(if-wireless 0)#
```

beacon-interval This command configures the rate at which beacon signals are transmitted from the access point.

SYNTAX

beacon-interval <*interval*>

interval - The rate for transmitting beacon signals.
(Range: 20-1000 milliseconds)

DEFAULT SETTING

100

COMMAND MODE

Interface Configuration (Wireless)

COMMAND USAGE

The beacon signals allow wireless clients to maintain contact with the access point. They may also carry power-management information.

EXAMPLE

```
AP(if-wireless 0)# beacon-interval 60

This setting has not been effective !
If want to take effect, please execute make-RF-setting-effective command !

AP(if-wireless 0)#
```

dtim-period This command configures the rate at which stations in sleep mode must wake up to receive broadcast/multicast transmissions.

SYNTAX

dtim-period <*interval*>

interval - Interval between the beacon frames that transmit broadcast or multicast traffic. (Range: 1-255 beacon frames)

DEFAULT SETTING

1

COMMAND MODE

Interface Configuration (Wireless)

COMMAND USAGE

- ◆ The Delivery Traffic Indication Map (DTIM) packet interval value indicates how often the MAC layer forwards broadcast/multicast traffic. This parameter is necessary to wake up stations that are using Power Save mode.
- ◆ The DTIM is the interval between two synchronous frames with broadcast/multicast information. The default value of 1 indicates that

the access point will save all broadcast/multicast frames for the Basic Service Set (BSS) and forward them after every beacon.

- ◆ Using smaller DTIM intervals delivers broadcast/multicast frames in a more timely manner, causing stations in Power Save mode to wake up more often and drain power faster. Using higher DTIM values reduces the power used by stations in Power Save mode, but delays the transmission of broadcast/multicast frames.

EXAMPLE

```
AP(if-wireless 0)# dtim-period 10

This setting has not been effective !
If want to take effect, please execute make-RF-setting-effective command !

AP(if-wireless 0)#
```

rts-threshold This command sets the packet size threshold at which a Request to Send (RTS) signal must be sent to the receiving station prior to the sending station starting communications.

SYNTAX

rts-threshold <threshold>

threshold - Threshold packet size for which to send an RTS.
(Range: 0-2347 bytes)

DEFAULT SETTING

2347

COMMAND MODE

Interface Configuration (Wireless)

COMMAND USAGE

- ◆ If the threshold is set to 0, the access point always sends RTS signals. If set to 2347, the access point never sends RTS signals. If set to any other value, and the packet size equals or exceeds the RTS threshold, the RTS/CTS (Request to Send / Clear to Send) mechanism will be enabled.
- ◆ The access point sends RTS frames to a receiving station to negotiate the sending of a data frame. After receiving an RTS frame, the station sends a CTS frame to notify the sending station that it can start sending data.
- ◆ Access points contending for the wireless medium may not be aware of each other. The RTS/CTS mechanism can solve this "Hidden Node" problem.

EXAMPLE

```

AP(if-wireless 0)# rts-threshold 0

This setting has not been effective !
If want to take effect, please execute make-RF-setting-effective command !

AP(if-wireless 0)#

```

ssid This command configures the service set identifier (SSID) of the VAP.

SYNTAX

ssid <*string*>

string - The name of a basic service set supported by the access point. (Range: 1 - 32 characters)

DEFAULT SETTING

vap_a0 to vap_a7 (for VAPs 0-7)

COMMAND MODE

Interface Configuration (Wireless-VAP)

COMMAND USAGE

Clients that want to connect to the wireless network through an access point must set their SSIDs to the same as that of the access point.

EXAMPLE

```

AP(if-wireless 0: VAP[0])# ssid net-name

This setting has not been effective !
If want to take effect, please execute make-security-effective command !

AP(if-wireless 0: VAP[0])#

```

closed-system This command prohibits access to clients without a pre-configured SSID. Use the **no** form to disable this feature.

SYNTAX

[**no**] **closed-system**

DEFAULT SETTING

Disabled

COMMAND MODE

Interface Configuration (Wireless-VAP)

COMMAND USAGE

When closed system is enabled, the access point will not include its SSID in beacon messages. Nor will it respond to probe requests from clients that do not include a fixed SSID.

EXAMPLE

```
AP(if-wireless g: VAP[0])#closed-system
```

```
This setting has not been effective !
If want to take effect, please execute make-security-effective command !
```

```
AP(if-wireless g)#
```

assoc-timeout-interval This command configures the idle time interval (when no frames are sent) after which the client is disassociated from the VAP interface.

SYNTAX

assoc-timeout-interval <minutes>

minutes - The number of minutes of inactivity before disassociation.
(Range: 5-60 minutes)

DEFAULT SETTING

5 minutes

COMMAND MODE

Interface Configuration (Wireless-VAP)

EXAMPLE

```
AP(if-wireless 0: VAP[0])# assoc-timeout-interval 10
```

```
This setting has not been effective !
If want to take effect, please execute make-security-effective command !
```

```
AP(if-wireless 0: VAP[0])#
```

auth-timeout-interval This command configures the time interval within which clients must complete authentication to the VAP interface.

SYNTAX

auth-timeout-interval <minutes>

minutes - The number of minutes before re-authentication.
(Range: 3-60 minutes)

DEFAULT SETTING

3 minutes

COMMAND MODE

Interface Configuration (Wireless-VAP)

EXAMPLE

```

AP(if-wireless 0: VAP[0])# auth-timeout-interval 10

This setting has not been effective !
If want to take effect, please execute make-security-effective command !

AP(if-wireless 0: VAP[0])#

```

shutdown This command disables the VAP interface. Use the **no** form to restart the interface.

SYNTAX

[no] shutdown

DEFAULT SETTING

Interface enabled

COMMAND MODE

Interface Configuration (Wireless-VAP)

COMMAND USAGE

You must first enable VAP interface 0 before you can enable VAP interfaces 1, 2, 3, 4, 5, 6, or 7.

EXAMPLE

```

AP(if-wireless 0: VAP[0])# shutdown

This setting has not been effective !
If want to take effect, please execute make-security-effective command !

AP(if-wireless 0: VAP[0])#

```

show interface wireless This command displays the status for a specified VAP interface.

SYNTAX

show interface wireless <index> vap <vap-index>

index - The wireless interface slot number. (Range: 0)

vap-index - The number that identifies a VAP interface. (Options: 0-7)

COMMAND MODE

Exec

EXAMPLE

```

AP# show interface wireless 0 vap 0
-----Basic Setting-----
SSID                               : SMC_VAP_0
Interface Radio Mode                : 11ng
Auto Channel Select                 : DISABLE
Channel                             : 11
High Throughput Mode                : HT20
Status                              : ENABLE
VLAN-ID                             : 1
Dhcp-Relay Server Ip                : 0.0.0.0
-----Capacity-----
Maximum Association Client Number    : 64 Clients
-----802.11 Parameters-----
Transmit Power                      : min(3 dBm)
Fragmentation Threshold              : 2346
RTS Threshold                        : 2347
Beacon Interval                     : 100
Authentication Timeout INTERVAL     : 3 Mins
Association Timeout Interval         : 5 Mins
DTIM Interval                        : 1
Short Guard Interval Status          : Enabled
A-MPDU Status                       : Enabled
A-MPDU Length Limit                  : 65535 Bytes
A-MSDU Status                        : Enabled
A-MSDU Length Limit                  : 4096 Bytes

-----Security-----
Closed System                       : DISABLE
WPA Function                         : OPEN-SYSTEM, WPA FUNCTION DISABLE
WPA PSK Key Type                     : ascii
WPA PSK Key                           : 12345678

-----Press any key to continue-----

Default Transmit Key                 : 1
Static WEP Keys
Key 1                               : 12345
Key 2                               : 12345
Key 3                               : 12345
Key 4                               : 12345
Pre-Authentication                   : DISABLE
-----802.1x-----
802.1x                               : DISABLE
802.1x Session Timeout Value         : 3600 min

-----Quality of Service-----
WMM Mode                             : DISABLE

WMM Acknowledge Policy
AC0(Best Effort)                     : NO-Acknowledge
AC1(Background)                     : NO-Acknowledge
AC2(Video)                           : NO-Acknowledge
AC3(Voice)                           : NO-Acknowledge

AP#

```

show station This command shows the wireless clients associated with the access point.

COMMAND MODE

Exec

EXAMPLE

```
AP#show station
```

```
Station Table Information
```

```
=====
```

```
Wireless Interface 0 VAPs List:
```

```
if-wireless 0 VAP [0] :
```

```
if-wireless 0 VAP [1] :
```

```
if-wireless 0 VAP [2] :
```

```
if-wireless 0 VAP [3] :
```

```
if-wireless 0 VAP [4] :
```

```
if-wireless 0 VAP [5] :
```

```
if-wireless 0 VAP [6] :
```

```
if-wireless 0 VAP [7] :
```

```
=====
```

```
AP#
```

The commands described in this section configure parameters for wireless security on the VAP interfaces.

Table 24: Wireless Security Commands

Command	Function	Mode	Page
auth	Defines the 802.11 authentication type allowed by the access point	IC-W-VAP	217
encryption	Defines whether or not WEP encryption is used to provide privacy for wireless communications	IC-W-VAP	216
key	Sets the keys used for WEP encryption	IC-W	217
transmit-key	Sets the index of the key to be used for encrypting data frames sent between the access point and wireless clients	IC-W-VAP	218
cipher-suite	Selects an encryption method for the global key used for multicast and broadcast traffic	IC-W-VAP	219
wpa-pre-shared-key	Defines a WPA preshared-key value	IC-W-VAP	220
pmksa-lifetime	Sets the lifetime PMK security associations	IC-W-VAP	221
make-security-effective	Implements wireless security changes made in current CLI session	IC-W-VAP	221

auth This command configures authentication for the VAP interface.

SYNTAX

auth <open-system | shared-key | wpa | wpa-psk | wpa2 | wpa2-psk | wpa-wpa2-mixed | wpa-wpa2-psk-mixed>

open-system - Accepts the client without verifying its identity using a shared key. "Open" authentication means either there is no encryption (if encryption is disabled) or WEP-only encryption is used (if encryption is enabled).

shared-key - Authentication is based on a WEP shared key that has been distributed to all stations.

wpa - Clients using WPA are accepted for authentication.

wpa-psk - Clients using WPA with a Pre-shared Key are accepted for authentication.

wpa2 - Clients using WPA2 are accepted for authentication.

wpa2-psk - Clients using WPA2 with a Pre-shared Key are accepted for authentication.

wpa-wpa2-mixed - Clients using WPA or WPA2 are accepted for authentication.

wpa-wpa2-psk-mixed - Clients using WPA or WPA2 with a Pre-shared Key are accepted for authentication

DEFAULT SETTING

open-system

COMMAND MODE

Interface Configuration (Wireless-VAP)

COMMAND USAGE

- ◆ The **auth** command automatically configures settings for each authentication type, including encryption, 802.1X, and cipher suite. The command **auth open-system** disables encryption and 802.1X.
- ◆ To use WEP shared-key authentication, set the authentication type to "shared-key" and define at least one static WEP key with the **key** command. Encryption is automatically enabled by the command.
- ◆ To use WEP encryption only (no authentication), set the authentication type to "open-system." Then enable WEP with the **encryption** command, and define at least one static WEP key with the **key** command.
- ◆ When any WPA or WPA2 option is selected, clients are authenticated using 802.1X via a RADIUS server. Each client must be WPA-enabled or support 802.1X client software. The 802.1X settings (see "[802.1X Authentication Commands](#)" on page 171) and RADIUS server details (see "[RADIUS Client Commands](#)" on page 165) must be configured on the access point. A RADIUS server must also be configured and be available in the wired network.
- ◆ If a WPA/WPA2 mode that operates over 802.1X is selected (WPA, WPA2, WPA-WPA2-mixed, or WPA-WPA2-PSK-mixed), the 802.1X settings (see "[802.1X Authentication Commands](#)" on page 171) and RADIUS server details (see "[RADIUS Client Commands](#)" on page 165) must be configured. Be sure you have also configured a RADIUS server on the network before enabling authentication. Also, note that each client has to be WPA-enabled or support 802.1X client software. A RADIUS server must also be configured and be available in the wired network.
- ◆ If a WPA/WPA2 Pre-shared Key mode is selected (WPA-PSK, WPA2-PSK or WPA-WPA2-PSK-mixed), the key must first be generated and distributed to all wireless clients before they can successfully associate with the access point. Use the wpa-preshared-key command to configure the key (see "[key](#)" on page 217 and "[transmit-key](#)" on page 218).
- ◆ WPA2 defines a transitional mode of operation for networks moving from WPA security to WPA2. WPA2 Mixed Mode allows both WPA and WPA2 clients to associate to a common VAP interface. When the

encryption cipher suite is set to TKIP, the unicast encryption cipher (TKIP or AES-CCMP) is negotiated for each client. The access point advertises its supported encryption ciphers in beacon frames and probe responses. WPA and WPA2 clients select the cipher they support and return the choice in the association request to the access point. For mixed-mode operation, the cipher used for broadcast frames is always TKIP. WEP encryption is not allowed.

EXAMPLE

```
AP(if-wireless 0: VAP[0])# auth wpa-psk
AP(if-wireless 0: VAP[0])#
```

RELATED COMMANDS

[encryption](#)
[key](#)

encryption This command enables data encryption for wireless communications. Use the **no** form to disable data encryption.

SYNTAX

[no] encryption

DEFAULT SETTING

disabled

COMMAND MODE

Interface Configuration (Wireless-VAP)

COMMAND USAGE

- ◆ Selecting a security method using the **auth** command, automatically enables data encryption (WEP, TKIP, or AES-CCMP) for the VAP. Only use this command when using WEP encryption with an Open System.
- ◆ Encryption is implemented in this device to prevent unauthorized access to your wireless network. For more secure data transmissions, enable encryption by selecting a security method using the **auth** command, or by using the **encryption** command when using WEP encryption only.
- ◆ The encryption settings must be the same on each client in your wireless network.
- ◆ Note that encryption protects data transmitted between wireless nodes, but does not protect any transmissions over your wired network or over the Internet.

EXAMPLE

```

AP(if-wireless 0: VAP[0])# encryption

This setting has not been effective !
If want to take effect, please execute make-security-effective command !

AP(if-wireless 0: VAP[0])#

```

RELATED COMMANDS**key**

key This command sets the keys used for WEP encryption. Use the **no** form to delete a configured key.

SYNTAX

key {<*index*> <*size*> <*type*> <*value*> | **static** | **dynamic**}

no key <*index*>

index - Key index. (Range: 1-4)

size - Key size. (Options: 64 or 128 bits)

type - Input format. (Options: ASCII, HEX)

value - The key string.

For 64-bit keys, use 5 alphanumeric characters or 10 hexadecimal digits.

For 128-bit keys, use 13 alphanumeric characters or 26 hexadecimal digits.

static - Uses static WEP keys with 802.1X authentication.

dynamic - When using 802.1X authentication, allows WEP keys to be dynamically generated by the RADIUS server.

DEFAULT SETTING

None

COMMAND MODE

Interface Configuration (Wireless-VAP)

COMMAND USAGE

- ◆ To enable WEP, use the **auth shared-key** command to select the "shared key" authentication type, use the **key** command to configure at least one key, and then use the **transmit-key** command to select a key to use.
- ◆ If WEP is enabled, all wireless clients must be configured with the same shared keys to communicate with the VAP.
- ◆ The WEP key index, length and type configured for the VAP must match those configured for clients.

EXAMPLE

```
AP(if-wireless 0: VAP[0])# key 1 64 hex 1234512345
```

```
This setting has not been effective !
If want to take effect, please execute make-security-effective command !
```

```
AP(if-wireless 0: VAP[0])#
```

RELATED COMMANDS[key](#)[encryption](#)[transmit-key](#)

transmit-key This command sets the index of the WEP key to be used for encrypting data frames transmitted from the VAP to wireless clients.

SYNTAX

transmit-key <*index*>

index - Key index. (Range: 1-4)

DEFAULT SETTING

1

COMMAND MODE

Interface Configuration (Wireless-VAP)

COMMAND USAGE

- ◆ If you use WEP key encryption option, the access point uses the transmit key to encrypt multicast and broadcast data signals that it sends to client devices. Other keys can be used for decryption of data from clients.
- ◆ When using dynamic keys with 802.1X, the access point uses a dynamic key to encrypt unicast and broadcast messages to 802.1X-enabled clients. However, because the access point sends the keys during the 802.1X authentication process, these keys do not have to appear in the client's key list.

EXAMPLE

```
AP(if-wireless 0: VAP[0])# transmit-key 1
```

```
This setting has not been effective !
If want to take effect, please execute make-security-effective command !
```

```
AP(if-wireless 0: VAP[0])#
```

cipher-suite This command defines the cipher algorithm used to encrypt the global key for broadcast and multicast traffic when using WPA or WPA2 security.

SYNTAX

multicast-cipher <**aes-ccmp** | **tkip**>

aes-ccmp - Use AES-CCMP encryption for the unicast and multicast cipher.

tkip - Use TKIP encryption for the multicast cipher. TKIP or AES-CCMP can be used for the unicast cipher depending on the capability of the client.

DEFAULT SETTING

None

COMMAND MODE

Interface Configuration (Wireless-VAP)

COMMAND USAGE

- ◆ WPA and WPA2 enable a VAP to support different unicast encryption keys for each client. However, the global encryption key for multicast and broadcast traffic must be the same for all clients.
- ◆ TKIP provides data encryption enhancements including per-packet key hashing (i.e., changing the encryption key on each packet), a message integrity check, an extended initialization vector with sequencing rules, and a re-keying mechanism. Select TKIP if there are clients in the network that are not WPA2 compliant.
- ◆ TKIP defends against attacks on WEP in which the unencrypted initialization vector in encrypted packets is used to calculate the WEP key. TKIP changes the encryption key on each packet, and rotates not just the unicast keys, but the broadcast keys as well. TKIP is a replacement for WEP that removes the predictability that intruders relied on to determine the WEP key.
- ◆ AES-CCMP (Advanced Encryption Standard Counter-Mode/CBCMAC Protocol): WPA2 is backward compatible with WPA, including the same 802.1X and PSK modes of operation and support for TKIP encryption. The main enhancement is its use of AES Counter-Mode encryption with Cipher Block Chaining Message Authentication Code (CBC-MAC) for message integrity. The AES Counter-Mode/CBCMAC Protocol (AES-CCMP) provides extremely robust data confidentiality using a 128-bit key. The AES-CCMP encryption cipher is specified as a standard requirement for WPA2. However, the computational intensive operations of AES-CCMP requires hardware support on client devices. Therefore to implement WPA2 in the network, wireless clients must be upgraded to WPA2-compliant hardware.

EXAMPLE

```
AP(if-wireless 0: VAP[0])# cipher-suite tkip
```

```
This setting has not been effective !
If want to take effect, please execute make-security-effective command !
```

```
AP(if-wireless 0: VAP[0])#
```

wpa-pre-shared-key This command defines a Wi-Fi Protected Access (WPA/WPA2) Pre-shared-key.

SYNTAX

wpa-pre-shared-key <hex | passphrase-key> <value>

hex - Specifies hexadecimal digits as the key input format.

passphrase-key - Specifies an ASCII pass-phrase string as the key input format.

value - The key string. For ASCII input, specify a string between 8 and 63 characters. For HEX input, specify exactly 64 digits.

COMMAND MODE

Interface Configuration (Wireless-VAP)

COMMAND USAGE

- ◆ To support WPA or WPA2 for client authentication, use the **auth** command to specify the authentication type, and use the **wpa-pre-shared-key** command to specify one static key.
- ◆ If WPA or WPA2 is used with pre-shared-key mode, all wireless clients must be configured with the same pre-shared key to communicate with the access point's VAP interface.

EXAMPLE

```
AP(if-wireless 0: VAP[0])# wpa-pre-shared-key passphrase-key agoodsecret
```

```
This setting has not been effective !
If want to take effect, please execute make-security-effective command !
```

```
AP(if-wireless 0: VAP[0])#
```

RELATED COMMANDS

[auth](#)

pmksa-lifetime This command sets the time for aging out cached WPA2 Pairwise Master Key Security Association (PMKSA) information for fast roaming.

SYNTAX

pmksa-lifetime <minutes>

minutes - The time for aging out PMKSA information.
(Range: 0 - 14400 minutes)

DEFAULT SETTING

720 minutes

COMMAND MODE

Interface Configuration (Wireless-VAP)

COMMAND USAGE

- ◆ WPA2 provides fast roaming for authenticated clients by retaining keys and other security information in a cache, so that if a client roams away from an access point and then returns reauthentication is not required.
- ◆ When a WPA2 client is first authenticated, it receives a Pairwise Master Key (PMK) that is used to generate other keys for unicast data encryption. This key and other client information form a Security Association that the access point names and holds in a cache. The lifetime of this security association can be configured with this command. When the lifetime expires, the client security association and keys are deleted from the cache. If the client returns to the access point, it requires full reauthentication.

EXAMPLE

```
AP(if-wireless 0: VAP[0])# pmksa-lifetime 600
```

```
This setting has not been effective !
If want to take effect, please execute make-security-effective command !
```

```
AP(if-wireless 0: VAP[0])#
```

make-security-effective This command implements all wireless security changes made in the current CLI session.

SYNTAX

make-security-effective

DEFAULT SETTING

None

COMMAND MODE

Interface Configuration (Wireless-VAP)

EXAMPLE

```
AP(if-wireless 0: VAP[0])# make-security-effective
```

```
It will take several minutes !  
Please wait a while...
```

```
Args: 1
```

```
lo      no wireless extensions.
```

```
eth0    no wireless extensions.
```

```
br0     no wireless extensions.
```

```
wifi0   no wireless extensions.
```

```
lo      no wireless extensions.
```

```
eth0    no wireless extensions.
```

```
br0     no wireless extensions.
```

```
wifi0   no wireless extensions.
```

```
lo      no wireless extensions.
```

```
eth0    no wireless extensions.
```

```
br0     no wireless extensions.
```

```
wifi0   no wireless extensions.
```

```
lo      no wireless extensions.
```

```
eth0    no wireless extensions.
```

```
br0     no wireless extensions.
```

```
wifi0   no wireless extensions.
```

```
lo      no wireless extensions.
```

```
eth0    no wireless extensions.
```

```
br0     no wireless extensions.
```

```
wifi0   no wireless extensions.
```

```
lo      no wireless extensions.
```

```
eth0    no wireless extensions.
```

```
br0     no wireless extensions.
```

```
wifi0   no wireless extensions.
```

```
lo      no wireless extensions.
```

```
eth0    no wireless extensions.
```

```
br0     no wireless extensions.
```

```
wifi0   no wireless extensions.
```

```
lo          no wireless extensions.

eth0       no wireless extensions.

br0        no wireless extensions.

wifi0      no wireless extensions.

Error for wireless request "Set Fragmentation Threshold" (8B24) :
    SET failed on device ath0 ; Invalid argument.
[: Added ath0 mode master
Created ath0 mode ap for SMC_VAP_0: bad number
ath0 Link encap:Ethernet HWaddr 00:22:2D:4D:7B:81
killall: udhcpc: no process killed
Close vap multi cast when vap mode is wds-sta, but stp is disabled
AP(if-wireless 0: VAP[0])#
```

LLDP allows devices in the local broadcast domain to share information about themselves. LLDP-capable devices periodically transmit information in messages called Type Length Value (TLV) fields to neighbor devices. Advertised information is represented in Type Length Value (TLV) format according to the IEEE 802.1ab standard, and can include details such as device identification, capabilities and configuration settings.

This information can be used by SNMP applications to simplify troubleshooting, enhance network management, and maintain an accurate network topology.

Table 25: Link Layer Discovery Commands

Command	Function	Mode	Page
lldp service	Enables the transmission of LLDP information	GC	224
lldp transmit hold-multiplier	Sets the message transmission hold time	GC	225
lldp transmit interval	Sets the message transmission interval time	GC	225
lldp transmit re-init-delay	Sets the reinitial delay time	GC	226
lldp transmit delay-to-local-change	Sets the transmission delay value	GC	226
show lldp	Shows the current LLDP information	Exec	227

lldp service This command enables LLDP on the access point. Use the **no** form to disable LLDP.

SYNTAX

[no] lldp service

DEFAULT SETTING

Enabled

COMMAND MODE

Global Configuration

EXAMPLE

```
AP(config)# lldp service
AP(config)#
```

lldp-transmit hold-multiplier This command configures the time-to-live (TTL) value sent in LLDP advertisements.

SYNTAX

lldp transmit hold-multiplier <*multiplier*>

multiplier - The hold multiplier number. (Range: 2-10)

DEFAULT SETTING

4

COMMAND MODE

Global Configuration

COMMAND USAGE

- ◆ This command configures the time-to-live (TTL) value sent in LLDP advertisements as shown in the following formula:
(Transmission Interval * Hold time) ≤ 65536
Therefore, the default TTL is 4*30 = 120 seconds.
- ◆ The time-to-live tells the receiving LLDP agent how long to retain all information pertaining to the sending LLDP agent if it does not transmit updates in a timely manner.

EXAMPLE

```
AP(config)# lldp transmit hold-multiplier 6
AP(config)#
```

lldp transmit interval This command configures the periodic transmit interval for LLDP advertisements.

SYNTAX

lldp transmit interval <*interval*>

interval - The time between LLDP advertisements.
(Range: 5-32768 seconds)

DEFAULT SETTING

30 seconds

COMMAND MODE

Global Configuration

COMMAND USAGE

This command configures the periodic transmit interval for LLDP advertisements. This parameter must comply with the following rule: (Transmission Interval * Hold Time) ≤ 65536, and Transmission Interval ≥ (4 * Delay Interval)

EXAMPLE

```
AP(config)# lldp transmit interval 30
AP(config)#
```

lldp transmit re-init-delay This command configures the delay before attempting to re-initialize after LLDP ports are disabled or the link goes down.

SYNTAX

lldp transmit re-init-delay <seconds>

seconds - Time in seconds. (Range: 2 - 10)

DEFAULT SETTING

2 seconds

COMMAND MODE

Global Configuration

COMMAND USAGE

- ◆ This command configures the delay before attempting to re-initialize after LLDP ports are disabled or the link goes down.
- ◆ When LLDP is re-initialized on a port, all information in the remote systems LLDP MIB associated with this port is deleted.

EXAMPLE

```
AP(config)#lldp transmit re-init-delay 10
AP(config)#
```

lldp transmit delay-to-local-change This command configures a delay between the successive transmission of LLDP advertisements initiated by a change in local LLDP MIB variables.

SYNTAX

lldp transmit delay-to-local-change <seconds>

seconds - Time in seconds. (Range: 1-8192 seconds)

DEFAULT SETTING

2 seconds

COMMAND MODE

Global Configuration

COMMAND USAGE

- ◆ The transmit delay is used to prevent a series of successive LLDP transmissions during a short period of rapid changes in local LLDP MIB

objects, and to increase the probability that multiple, rather than single changes, are reported in each transmission.

- ◆ This attribute must comply with the rule: $(4 * \text{Delay Interval}) \leq \text{Transmission Interval}$

EXAMPLE

```
AP(config)# lldp transmit delay-to-local-change 10
txDelay range is 1 to quter of msgTxInterval
AP(config)#
```

show lldp This command displays the current LLDP configuration.

COMMAND MODE

Exec

EXAMPLE

```
AP# show lldp
LLDP Information
=====
Status                               :Enabled
Message Transmission Hold Time       :5
Message Transmission Interval (seconds) :30
Reinitial Delay Time (seconds)      :2
Transmission Delay Value (seconds)   :2
=====
AP#
```

The access point can enable the support of VLAN-tagged traffic passing between wireless clients and the wired network. VLAN IDs can be mapped to specific VAP interfaces, allowing users to remain within the same VLAN as they move around a campus site.



CAUTION: When VLANs are enabled, the access point's Ethernet port drops all received traffic that does not include a VLAN tag. To maintain network connectivity to the access point and wireless clients, be sure that the access point is connected to a device port on a wired network that supports IEEE 802.1Q VLAN tags.

The VLAN commands supported by the access point are listed below.

Table 26: VLAN Commands

Command	Function	Mode	Page
vlan	Enables a single VLAN for all traffic	GC	228
management-vlanid	Configures the management VLAN for the access point	GC	229
vlan-id	Configures the default VLAN for the VAP interface	IC-W-VAP	230

vlan This command enables VLANs for all traffic. Use the **no** form to disable VLANs.

SYNTAX

vlan enabled
no vlan

DEFAULT

Disabled

COMMAND MODE

Global Configuration

COMMAND DESCRIPTION

- ◆ When VLANs are enabled, the access point tags frames received from wireless clients with the VAP's default VLAN ID.

- ◆ Traffic entering the Ethernet port must be tagged with a VLAN ID that matches the access point's management VLAN ID, or with a VLAN tag that matches one of the VAP default VLAN IDs.

EXAMPLE

```
AP(config)# vlan enabled

Warning!  VLAN's status has been changed now !

It will take several seconds !
Please wait a while...

AP(config)#
```

RELATED COMMANDS

[management-vlanid](#)

management-vlanid This command configures the management VLAN ID for the access point.

SYNTAX

management-vlanid <*vlan-id*>

vlan-id - Management VLAN ID. (Range: 1-4094)

DEFAULT SETTING

1

COMMAND MODE

Global Configuration

COMMAND USAGE

The management VLAN is for managing the access point. For example, the access point allows traffic that is tagged with the specified VLAN to manage the access point through remote management, SNMP, Telnet, SSH, etc.

EXAMPLE

```
AP(config)# management-vlanid 3

Warning!  VLAN's structure is re-created now !

It will take several seconds !
Please wait a while...

AP(config)#
```

RELATED COMMANDS

[vlan](#)

vlan-id This command configures the default VLAN ID for the VAP interface.

SYNTAX

vlan-id <*vlan-id*>

vlan-id - Default VLAN ID. (Range: 1-4094)

DEFAULT SETTING

1

COMMAND MODE

Interface Configuration (Wireless-VAP)

COMMAND USAGE

- ◆ To implement the default VLAN ID setting for VAP interface, the access point must enable VLAN support using the **vlan** command.
- ◆ When VLANs are enabled, the access point tags frames received from wireless clients with the default VLAN ID for the VAP interface.

EXAMPLE

```
AP(if-wireless 0: VAP[0])# vlan-ID 6
```

```
This setting has not been effective !  
If want to take effect, please execute make-security-effective command !
```

```
AP(if-wireless 0: VAP[0])#
```

The access point implements QoS using the Wi-Fi Multimedia (WMM) standard. Using WMM, the access point is able to prioritize traffic and optimize performance when multiple applications compete for wireless network bandwidth at the same time. WMM employs techniques that are a subset of the IEEE 802.11e QoS standard and it enables the access point to inter-operate with both WMM-enabled clients and other devices that may lack any WMM functionality.

Table 27: WMM Commands

Command	Function	Mode	Page
wmm	Enables WMM on the access point	IC-W	231
wmm-acknowledge-policy	Allows the acknowledgement wait time to be enabled or disabled for each Access Category (AC)	IC-W	232
wmmparam	Configures detailed WMM parameters that apply to the access point (AP) or the wireless clients (BSS)	IC-W	232

wmm This command enables WMM on the access point. Use the **no** form to disable WMM.

SYNTAX

wmm required
no wmm

required - WMM must be supported on any device trying to associate with the access point. Devices that do not support this feature will not be allowed to associate with the access point.

DEFAULT

Disabled

COMMAND MODE

Interface Configuration (Wireless)

EXAMPLE

```
AP(if-wireless 0)# wmm required
```

```
This setting has not been effective !
If want to take effect, please execute make-RF-setting-effective command !
```

```
AP(if-wireless 0)#
```

wmm-acknowledge-policy This command allows the acknowledgement wait time to be enabled or disabled for each Access Category (AC).

SYNTAX

wmm-acknowledge-policy <ac_number> <ack | noack>

ac_number - Access categories. (Range: 0-3)

ack - Require the sender to wait for an acknowledgement from the receiver.

noack - Does not require the sender to wait for an acknowledgement from the receiver.

DEFAULT

ack

COMMAND MODE

Interface Configuration (Wireless)

COMMAND USAGE

- ◆ WMM defines four access categories (ACs) – voice, video, best effort, and background. These categories correspond to traffic priority levels and are mapped to IEEE 802.1D priority tags. The direct mapping of the four ACs to 802.1D priorities is specifically intended to facilitate interpretability with other wired network QoS policies. While the four ACs are specified for specific types of traffic, WMM allows the priority levels to be configured to match any network-wide QoS policy. WMM also specifies a protocol that access points can use to communicate the configured traffic priority levels to QoS-enabled wireless clients.
- ◆ Although turning off the requirement for the sender to wait for an acknowledgement can increase data throughput, it can also result in a high number of errors when traffic levels are heavy.

EXAMPLE

```
AP(if-wireless 0)# wmm-acknowledge-Policy 0 noAck

This setting has not been effective !
If want to take effect, please execute make-RF-setting-effective command !

AP(if-wireless 0)#
```

wmmparam This command configures detailed WMM parameters that apply to the access point (AP) or the wireless clients (BSS).

SYNTAX

wmmparam <AP | BSS> <ac_number> <LogCwMin> <LogCwMax>
<AIFS> <TxOpLimit> <admission_control>

AP - Access Point

BSS - Wireless client

ac_number - Access categories (ACs) – voice, video, best effort, and background. These categories correspond to traffic priority levels and are mapped to IEEE 802.1D priority tags as shown in [Table 4 on page 96](#). (Range: 0-3)

LogCwMin - Minimum log value of the contention window. This is the initial upper limit of the random backoff wait time before wireless medium access can be attempted. The initial wait time is a random value between zero and the LogCwMin value. Specify the LogCwMin value. Note that the LogCwMin value must be equal or less than the LogCwMax value. (Range: 1-15 microseconds)

LogCwMax - Maximum log value of the contention window. This is the maximum upper limit of the random backoff wait time before wireless medium access can be attempted. The contention window is doubled after each detected collision up to the LogCwMax value. Note that the CWMax value must be greater or equal to the LogCwMin value. (Range: 1-15 microseconds)

AIFS - Arbitrary InterFrame Space specifies the minimum amount of wait time before the next data transmission attempt. (Range: 1-15 microseconds)

TXOPLimit - Transmission Opportunity Limit specifies the maximum time an AC transmit queue has access to the wireless medium. When an AC queue is granted a transmit opportunity, it can transmit data for a time up to the TxOpLimit. This data bursting greatly improves the efficiency for high data-rate traffic. (Range: 0-65535 microseconds)

admission_control - The admission control mode for the access category. When enabled, clients are blocked from using the access category. (Options: 0 to disable, 1 to enable)

DEFAULT**Table 28: AP Parameters**

WMM Parameters	AC0 (Best Effort)	AC1 (Background)	AC2 (Video)	AC3 (Voice)
LogCwMin	4	4	3	2
LogCwMax	10	10	4	3
AIFS	3	7	2	2
TXOP Limit	0	0	94	47
Admission Control	Disabled	Disabled	Disabled	Disabled

Table 29: BSS Parameters

WMM Parameters	AC0 (Best Effort)	AC1 (Background)	AC2 (Video)	AC3 (Voice)
LogCwMin	4	4	3	2
LogCwMax	6	10	4	3

WMM Parameters	AC0 (Best Effort)	AC1 (Background)	AC2 (Video)	AC3 (Voice)
AIFS	3	7	1	1
TXOP Limit	0	0	94	47
Admission Control	Disabled	Disabled	Disabled	Disabled

COMMAND MODE

Interface Configuration (Wireless)

EXAMPLE

```
AP(if-wireless 0)# wmmparam ap 0 5 10 3 64 1
```

```
This setting has not been effective !
If want to take effect, please execute make-RF-setting-effective command !
```

```
AP(if-wireless 0)#
```

SECTION IV

APPENDICES

This section provides additional information and includes these items:

- ◆ [“Troubleshooting” on page 237](#)
- ◆ [“WDS Setup Examples” on page 240](#)
- ◆ [“Hardware Specifications” on page 249](#)
- ◆ [“Cables and Pinouts” on page 252](#)
- ◆ [“Glossary” on page 257](#)
- ◆ [“Index” on page 261](#)

DIAGNOSING LED INDICATORS

Table 30: LED Indicators

Symptom	Action
Power LED is off	<ul style="list-style-type: none"> ◆ The AC power adapter may be disconnected. Check connections between the unit, the power adapter, and the wall outlet. ◆ The PoE cable may be disconnected. Check connections between the unit and the PoE power source.
Diag/Fail LED is red	<ul style="list-style-type: none"> ◆ Reset the unit to try and clear the condition. ◆ If the condition does not clear, contact technical support for assistance.
LAN LED is off (when port connected)	<ul style="list-style-type: none"> ◆ Verify that the unit and attached device are powered on. ◆ Be sure the cable is plugged into both the unit and corresponding device. ◆ Verify that the proper cable type is used and its length does not exceed specified limits. ◆ Check the cable connections for possible defects. Replace the defective cable if necessary.
WLAN LED is off	<ul style="list-style-type: none"> ◆ There is no detected signal from the 802.11a/n or 802.11b/g/n radio. Check the radio settings in the management interface.

BEFORE CONTACTING TECHNICAL SUPPORT

Check the following items before you contact local Technical Support.

1. If wireless clients cannot access the network, check the following:
 - Be sure the access point VAP and the wireless clients are configured with the same Service Set ID (SSID).
 - If authentication or encryption are enabled, ensure that the wireless clients are properly configured with the appropriate authentication or encryption keys.
 - If authentication is being performed through a RADIUS server, ensure that the clients are properly configured on the RADIUS server.

- If authentication is being performed through IEEE 802.1X, be sure the wireless users have installed and properly configured 802.1X client software.
 - If MAC address filtering is enabled, be sure the client's address is included in the local filtering database or on the RADIUS server database.
 - If the wireless clients are roaming between access points, make sure that all the access point VAPs and wireless devices in the Extended Service Set (ESS) are configured to the same SSID and authentication method.
- 2.** If the access point cannot be configured using the Telnet, SSH, a web browser, or SNMP software:
- Be sure to have configured the access point with a valid IP address, subnet mask and default gateway.
 - If VLANs are enabled on the access point, the management station should be configured to send tagged frames with a VLAN ID that matches the access point's management VLAN (default VLAN 1, see ["VLAN Configuration" on page 58](#)). However, to manage the access point from a wireless client, the AP Management Filter should be disabled (see ["Access Limitation" on page 64](#)).
 - Check that you have a valid network connection to the access point and that the Ethernet port or the wireless interface that you are using has not been disabled.
 - If you are connecting to the access point through the wired Ethernet interface, check the network cabling between the management station and the access point. If you are connecting to access point from a wireless client, ensure that you have a valid connection to the access point.
 - If you cannot connect using Telnet, you may have exceeded the maximum number of concurrent Telnet sessions permitted (that is, four sessions). Try connecting again at a later time.
- 3.** If you cannot access the CLI through a serial port connection:
- Be sure you have set the terminal emulator program to VT100 compatible, 8 data bits, 1 stop bit, no parity and 9600 bps.
 - Check that the null-modem serial cable conforms to the pin-out connections provided in ["Console Port Pin Assignments" on page 256](#).
- 4.** If you forgot or lost the password, contact technical support for assistance.

5. If all other recovery measure fail, and the access point is still not functioning properly, take any of these steps:
 - Reset the access point's hardware using the console interface, web interface, or through a power reset.
 - Reset the access point to its default configuration by using the console interface or web interface. Then use the default user name "admin" and password "smcadmin" to access the management interface.

The SMCE21011 can use the IEEE 802.11 Wireless Distribution System (WDS) to set up links between APs independently on any of the unit's eight VAP interfaces. This enables the configuration of multiple links between multiple APs.



NOTE: The SMCE21011 radio can operate in 2.4 GHz mode or 5 GHz mode. It does not operate at 2.4 GHz and 5 GHz at the same time. You must first select the basic radio operating mode you want to use for your WDS network. All AP units in the WDS network must be set to the same radio operating mode and radio channel.

Each VAP interface on the SMCE21011 can be configured to operate in one of the three following WDS modes:

- ◆ **AP Mode:** WDS is disabled. The VAP provides services to clients as a normal access point.
- ◆ **WDS-AP Mode:** The VAP operates as an access point in WDS mode, which accepts connections from client stations in WDS-STA mode.
- ◆ **WDS-STA Mode:** The VAP operates as a client station in WDS mode, which connects to an access point VAP in WDS-AP mode. The user needs to specify the MAC address of the VAP in WDS-AP mode to which it intends to connect.

This appendix provides additional information and examples for setting up WDS links between APs.

BASIC WDS LINK BETWEEN TWO APs

Consider the example illustrated in [Figure 58](#). In this example, an SMCE21011 connected to the main wired LAN needs to connect to another SMCE21011 using a WDS link on VAP interface 0.

Figure 58: Basic WDS Link Between Two APs

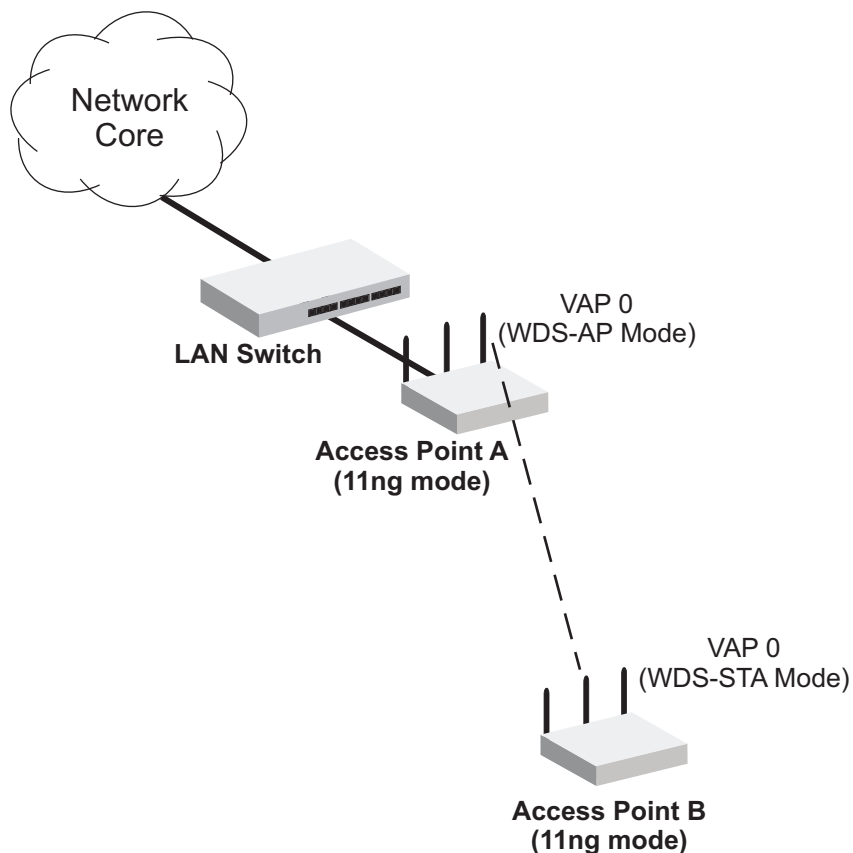

The following two sections show how to configure access point A and access point B to set up a WDS link between them. Follow the steps in each section.

ACCESS POINT A CONFIGURATION

1. Go to the Wireless>VAP Settings page and click Edit to configure VAP 0.

Figure 59: WDS Example — Access Point A VAP Setting

VAP Setting

VAP Number	SSID	Enable	Status	Edit setting
VAP 0	SMC_VAP_0	<input checked="" type="checkbox"/>	ap	Edit
VAP 1	SMC_VAP_1	<input type="checkbox"/>	ap	Edit
VAP 2	SMC_VAP_2	<input type="checkbox"/>	ap	Edit
VAP 3	SMC_VAP_3	<input type="checkbox"/>	ap	Edit
VAP 4	SMC_VAP_4	<input type="checkbox"/>	ap	Edit
VAP 5	SMC_VAP_5	<input type="checkbox"/>	ap	Edit
VAP 6	SMC_VAP_6	<input type="checkbox"/>	ap	Edit
VAP 7	SMC_VAP_7	<input type="checkbox"/>	ap	Edit

Set Cancel Help

- In the VAP Basic Settings, select WDS-AP for the Mode.
- For security on the WDS link, select WPA-PSK or WPA2-PSK, set the encryption type, then enter the security key.
- Click Set to confirm the new settings.

Figure 60: WDS Example — Access Point A VAP Details

Basic Setting

Closed System Disable Enable

Mode AP WDS-AP WDS-STA

Association Timeout Interval (5-60 Mins)

Authentication Timeout Interval (3-60 Mins)

Default VLAN ID

DHCP_relay_server . . .

SSID

Security

Association Mode ▼

Encryption Method ▼

Pre-Shared Key Setting

Key Type Hex Ascii

Key

Set Cancel Help

- On the VAP Setting page, enable VAP 0, and then click Set to implement the new settings.

Figure 61: WDS Example — Access Point A WDS-AP VAP Setting

VAP Setting

VAP Number	SSID	Enable	Status	Edit setting
VAP 0	SMC_VAP_0	<input checked="" type="checkbox"/>	ap-wds	Edit
VAP 1	SMC_VAP_1	<input type="checkbox"/>	ap	Edit
VAP 2	SMC_VAP_2	<input type="checkbox"/>	ap	Edit
VAP 3	SMC_VAP_3	<input type="checkbox"/>	ap	Edit
VAP 4	SMC_VAP_4	<input type="checkbox"/>	ap	Edit
VAP 5	SMC_VAP_5	<input type="checkbox"/>	ap	Edit
VAP 6	SMC_VAP_6	<input type="checkbox"/>	ap	Edit
VAP 7	SMC_VAP_7	<input type="checkbox"/>	ap	Edit

Set Cancel Help

- Click the Save Config button to retain the configuration set up when the AP is restarted.

ACCESS POINT B CONFIGURATION

- Go to the Wireless>VAP Settings page and click Edit to configure VAP 0.
- In the VAP Basic Setting, select WDS-STA for the Mode.
- Enter the SSID and MAC address of VAP 0 on Access point A. The SSIDs and MAC addresses of VAP interfaces are displayed on the Information>AP Status page (see ["AP Wireless Configuration" on page 107](#)).

Figure 62: WDS Example — Access Point A VAP SSID and MAC

AP Wireless Configuration

Wireless Interface

VAP	SSID	Association Mode	802.1X	MAC Address
0	SMC_VAP_0	WPA-PSK	Disable	00:22:2d:4d:7b:71
1	SMC_VAP_1	Open	Disable	00:22:2d:4d:7b:72
2	SMC_VAP_2	Open	Disable	00:22:2d:4d:7b:73
3	SMC_VAP_3	Open	Disable	00:22:2d:4d:7b:74
4	SMC_VAP_4	Open	Disable	00:22:2d:4d:7b:75
5	SMC_VAP_5	Open	Disable	00:22:2d:4d:7b:76
6	SMC_VAP_6	Open	Disable	00:22:2d:4d:7b:77
7	SMC_VAP_7	Open	Disable	00:22:2d:4d:7b:78

- For security on the WDS link, select WPA-PSK or WPA2-PSK, then configure the same encryption type and security key as in the Access Point A configuration.

- Click Set to confirm the new settings.

Figure 63: WDS Example — Access Point B VAP Details

Basic Setting

Mode AP WDS-AP WDS-STA

Default VLAN ID

WDS-AP (Parent) SSID

WDS-AP (Parent) MAC

Security

Association Mode

Encryption Method

Pre-Shared Key Setting

Key Type Hex Ascii

Key

- On the VAP Settings page, enable VAP 0 (if not already enabled) and then click Set to implement the new settings.

Figure 64: WDS Example — Access Point B WDS-STA VAP Setting

VAP Setting

VAP Number	SSID	Enable	Status	Edit setting
VAP 0	SMC_VAP_0	<input checked="" type="checkbox"/>	sta-wds	Edit
VAP 1	SMC_VAP_1	<input type="checkbox"/>	ap	Edit
VAP 2	SMC_VAP_2	<input type="checkbox"/>	ap	Edit
VAP 3	SMC_VAP_3	<input type="checkbox"/>	ap	Edit
VAP 4	SMC_VAP_4	<input type="checkbox"/>	ap	Edit
VAP 5	SMC_VAP_5	<input type="checkbox"/>	ap	Edit
VAP 6	SMC_VAP_6	<input type="checkbox"/>	ap	Edit
VAP 7	SMC_VAP_7	<input type="checkbox"/>	ap	Edit

- Click the Save Config button to retain the configuration set up when the AP is restarted.

CHECKING THE WDS LINK STATUS

When you have configured both access point VAPs, you can check the status of the link from Access Point A.

Go to the Information>Station Status page. For the VAP 0 interface, the Access Point B MAC address displays as a connected station.

Figure 65: WDS Example — Access Point A Station Status



The screenshot shows the 'Station Status' page for the VAP0 interface. It displays a table with two columns: 'Station Address' and 'VLAN ID'. The 'Station Address' column contains the MAC address '00:22:2d:4d:7b:81', and the 'VLAN ID' column contains a hyphen '-'. The interface is titled 'Wireless Interface' and 'VAP0'.

Wireless Interface	
VAP0	
Station Address	VLAN ID
00:22:2d:4d:7b:81	-

WDS LINKS BETWEEN THREE OR MORE APs

Consider the example illustrated in Figure 66. In this example, an SMCE21011 connected to the main wired LAN connects to two other units using a WDS links. One of the connected units also connects to another SMCE21011. In addition, two of the SMCE21011 units support local wireless clients.

Figure 66: WDS Links Between Three or More APs

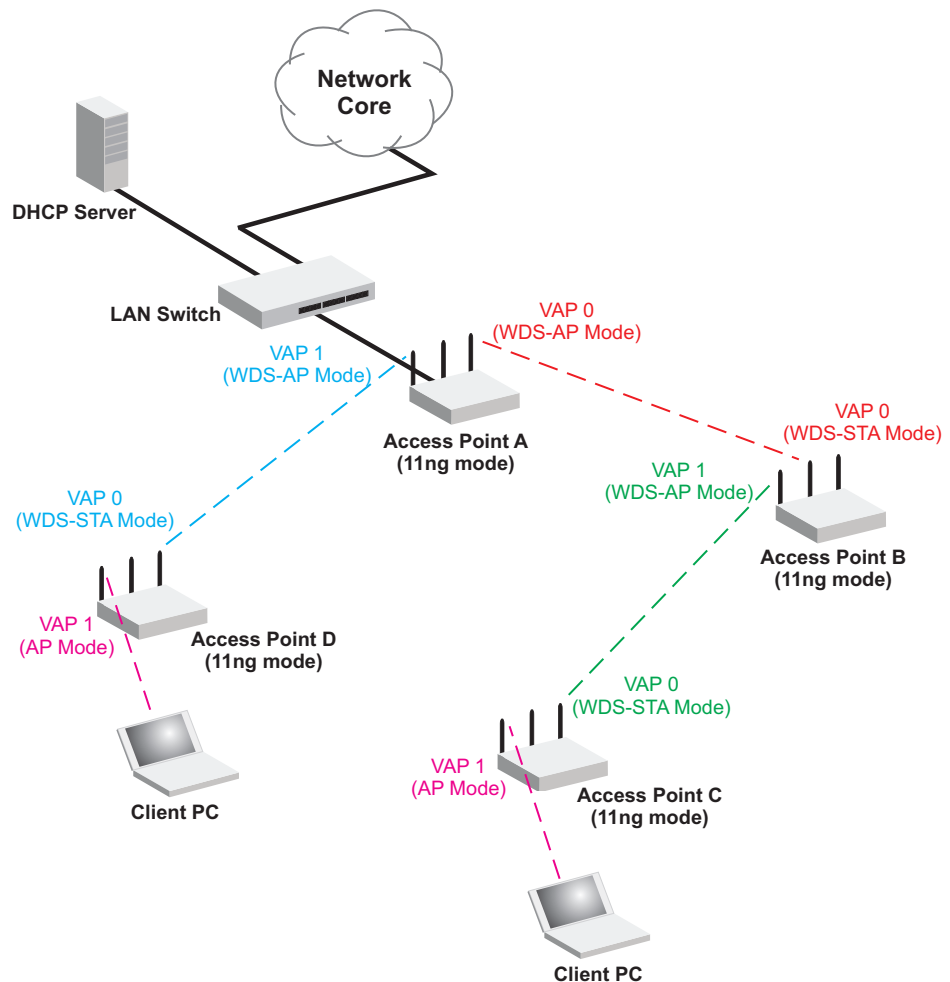

The following sections summarize how to configure access points A, B, C, and D. The detailed set up for WDS links on each AP will be based on the configuration procedure in the two-AP example (page 241).



NOTE: For all APs in the WDS network, go to Advanced Settings>Local Bridge Filter and check that the Local Bridge Filter is disabled. For more information, see "Local Bridge Filter" on page 73.

ACCESS POINT A CONFIGURATION

1. Configure VAP 0 settings:
 - a. Set VAP 0 to WDS-AP mode.
 - b. Set security to WPA-PSK or WPA2-PSK and configure a key.
 - c. Set the SSID and enable the VAP.
2. Configure VAP 1 settings:
 - a. Set VAP 1 to WDS-AP Mode.
 - b. Set security to WPA-PSK or WPA2-PSK and configure a key.
 - c. Set the SSID and enable the VAP.

ACCESS POINT B CONFIGURATION

1. Configure VAP 0 settings:
 - a. Set VAP 0 to WDS-STA mode.
 - b. Configure the WDS Parent SSID and Parent MAC address of VAP 0 on Access point A.
 - c. Set the same security and encryption key as VAP 0 on Access Point A.
 - d. Enable the VAP.
2. Configure VAP 1 settings:
 - a. Set VAP 1 to WDS-AP Mode.
 - b. Set security to WPA-PSK or WPA2-PSK and configure a key.
 - c. Set the SSID and enable the VAP.

ACCESS POINT C CONFIGURATION

1. Configure VAP 0 settings:
 - a. Set VAP 0 to WDS-STA mode.
 - b. Configure the WDS Parent SSID and Parent MAC address of VAP 1 on Access point B.
 - c. Set the same security and encryption key as VAP 1 on Access Point B.
 - d. Enable the VAP.

- 2.** Configure VAP 1 settings:
 - a.** Set VAP 1 to AP Mode.
 - b.** Set the required security for wireless clients.
 - c.** Set the SSID and enable the VAP.

ACCESS POINT D CONFIGURATION

- 1.** Configure VAP 0 settings:
 - a.** Set VAP 0 to WDS-STA mode.
 - b.** Configure the WDS Parent SSID and Parent MAC address of VAP 1 on Access point A.
 - c.** Set the same security and encryption key as VAP 1 on Access Point A.
 - d.** Enable the VAP.
- 2.** Configure VAP 1 settings:
 - a.** Set VAP 1 to AP Mode.
 - b.** Set the required security for wireless clients.
 - c.** Set the SSID and enable the VAP.

WIRELESS TRANSMIT POWER (MAXIMUM) 802.11b/g/n:
802.11b: 21 dBm (typical)
802.11g: 16 dBm
802.11n HT20 (20MHz, MCS): 20.5 dBm
802.11n HT40 (40MHz, MCS): 21 dBm

802.11a/n:
802.11a: 16 dBm
802.11n HT20 (20MHz, MCS): 18 dBm
802.11n HT40 (40 MHz, MCS): 16 dBm

WIRELESS RECEIVE SENSITIVITY (MAXIMUM) 802.11b/g/n:
802.11b: -92 dBm
802.11g: -89 dBm
802.11n HT20 (20MHz, MCS): -87 dBm
802.11n HT40 (40MHz, MCS): -88 dBm

802.11a/n:
802.11a: -88 dBm
802.11n HT20 (20MHz, MCS): -87 dBm
802.11n HT40 (40MHz, MCS): -85 dBm

OPERATING FREQUENCY 802.11g/n:
2.4 ~ 2.4835 GHz (US, Canada)
2.4 ~ 2.4835 GHz (ETSI, Japan)
802.11b:
2.4 ~ 2.4835 GHz (US, Canada)
2.4 ~ 2.4835 GHz (ETSI)
2.4 ~ 2.497 GHz (Japan)
802.11a:
5.15 ~ 5.25 GHz (lower band) US/Canada, Europe, Japan
5.25 ~ 5.35 GHz (middle band) US/Canada, Europe, Japan
5.725 ~ 5.825 GHz (upper band) US/Canada
5.50 ~ 5.70 GHz Europe
4.92 ~ 4.98 GHz Japan
5.04 ~ 5.08 GHz Japan

DATA RATE **802.11b**: 1, 2, 5.5, 11 Mbps per channel
802.11g: 6, 9, 12, 18, 24, 36, 48, 54 Mbps per channel
802.11n: 27, 54, 81, 108, 162, 216, 243, 270, 300 Mbps per channel (40MHz)
802.11a:
Normal Mode: 6, 9, 12, 18, 24, 36, 48, 54 Mbps per channel
Turbo Mode: 12, 18, 24, 36, 48, 54, 96, 108 Mbps per channel

OPERATING CHANNELS **802.11g/n**:
11 channels in base mode (US, Canada)
13 channels (ETSI, Japan)
802.11b:
11 channels in base mode (US, Canada)
13 channels (ETSI)
14 channels (Japan)
802.11a:
US & Canada: 13 (normal mode), 5 (turbo mode)
ETSI: 19 channels (normal mode)
Japan: 15 channels (normal mode)

MODULATION TYPE 802.11g/n: CCK, BPSK, QPSK, OFDM
802.11b: CCK, BPSK, QPSK
802.11a: OFDM

AC POWER ADAPTER Input: 100-240 VAC, 50-60 Hz, 0.65 A maximum
Output: 12 VDC, 2 A maximum

UNIT POWER SUPPLY DC Input: 12 VDC, 2 A maximum
Power Consumption: 5.94 W maximum

LED INDICATORS Power, Diag/Fail (System diagnostic), LAN (Ethernet Link/Activity), WLAN (Wireless Link/Activity)

NETWORK MANAGEMENT Web-browser
Console
Telnet
SSH
SNMP

TEMPERATURE Operating: 0 to 40 °C (32 to 104 °F)
Storage: -20 to 70 °C (32 to 158 °F)

HUMIDITY 15% to 95% (non-condensing)

COMPLIANCES FCC Part 15B Class B
EN 55022B
EN 55024
EN 61000-3-2
EN 61000-3-3

**RADIO SIGNAL
CERTIFICATION** FCC Part 15C 15.247, 15.207 (2.4 GHz)
EN 300 328
EN 301 489-1
EN 301 489-17
IC RSS-210

STANDARDS IEEE 802.11b/g
IEEE 802.11a
IEEE 802.11n draft v2.0
IEEE 802.3-2005

PHYSICAL SIZE 18.8 x 15 x 2.2 cm (7.40 x 5.90 x 0.87 in)

WEIGHT 598 g (21 oz)

TWISTED-PAIR CABLE ASSIGNMENTS

For 10/100BASE-TX connections, a twisted-pair cable must have two pairs of wires. For 1000BASE-T connections the twisted-pair cable must have four pairs of wires. Each wire pair is identified by two different colors. For example, one wire might be green and the other, green with white stripes. Also, an RJ-45 connector must be attached to both ends of the cable.



NOTE: Each wire pair must be attached to the RJ-45 connectors in a specific orientation.



CAUTION: DO NOT plug a phone jack connector into the RJ-45 port. Use only twisted-pair cables with RJ-45 connectors that conform with FCC standards.

The following figure illustrates how the pins on the RJ-45 connector are numbered. Be sure to hold the connectors in the same orientation when attaching the wires to the pins.

Figure 67: RJ-45 Connector

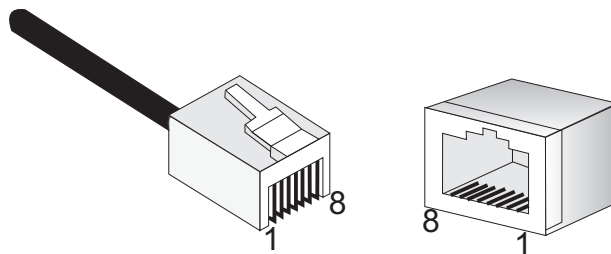

10/100BASE-TX PIN ASSIGNMENTS

Use unshielded twisted-pair (UTP) or shielded twisted-pair (STP) cable for RJ-45 connections: 100-ohm Category 3 or better cable for 10 Mbps connections. Also be sure that the length of any twisted-pair connection does not exceed 100 meters (328 feet).

The RJ-45 port on the access point supports automatic MDI/MDI-X operation, so you can use straight-through or crossover cables for all network connections to PCs, switches, or hubs. In straight-through cable, pins 1, 2, 3, and 6, at one end of the cable, are connected straight through to pins 1, 2, 3, and 6 at the other end of the cable.

Table 31: 10/100BASE-TX MDI and MDI-X Port Pinouts

PIN	MDI Signal Name ^a	MDI-X Signal Name
1	Transmit Data plus (TD+) -48V power (Negative V_{port})	Receive Data plus (RD+) GND (Positive V_{port})
2	Transmit Data minus (TD-) -48V power (Negative V_{port})	Receive Data minus (RD-) GND (Positive V_{port})
3	Receive Data plus (RD+) GND (Positive V_{port})	Transmit Data plus (TD+) -48V power (Negative V_{port})
4	-48V power (Negative V_{port})	GND (Positive V_{port})
5	-48V power (Negative V_{port})	GND (Positive V_{port})
6	Receive Data minus (RD-) GND (Positive V_{port})	Transmit Data minus (TD-) -48V power (Negative V_{port})
7	GND (Positive V_{port})	-48V power (Negative V_{port})
8	GND (Positive V_{port})	-48V power (Negative V_{port})

a. The "+" and "-" signs represent the polarity of the wires that make up each wire pair.

STRAIGHT-THROUGH WIRING

If the twisted-pair cable is to join two ports and only one of the ports has an internal crossover (MDI-X), the two pairs of wires must be straight-through. (When auto-negotiation is enabled for any RJ-45 port on this switch, you can use either straight-through or crossover cable to connect to any device type.)

You must connect all four wire pairs as shown in the following diagram to support Gigabit Ethernet connections.

Figure 68: Straight Through Wiring

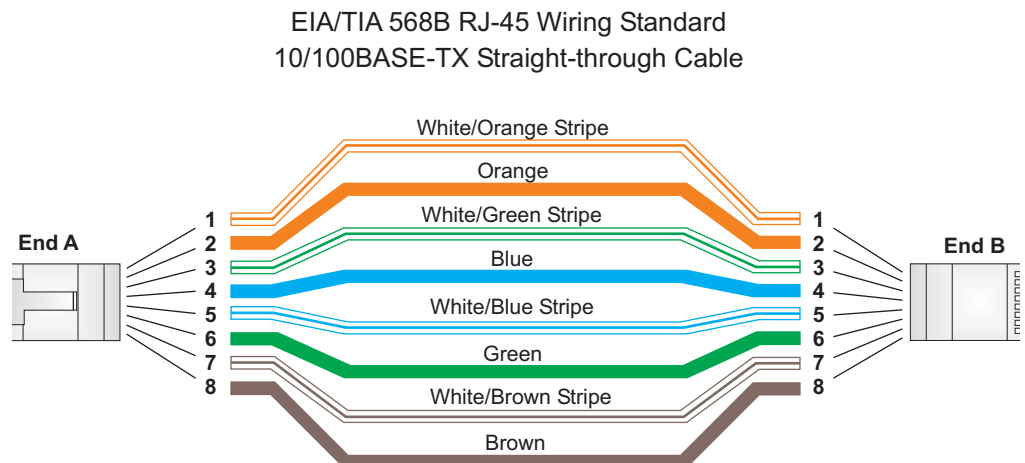

CROSSOVER WIRING If the twisted-pair cable is to join two ports and either both ports are labeled with an "X" (MDI-X) or neither port is labeled with an "X" (MDI), a crossover must be implemented in the wiring. (When auto-negotiation is enabled for any RJ-45 port on this switch, you can use either straight-through or crossover cable to connect to any device type.)

You must connect all four wire pairs as shown in the following diagram to support Gigabit Ethernet connections.

Figure 69: Crossover Wiring

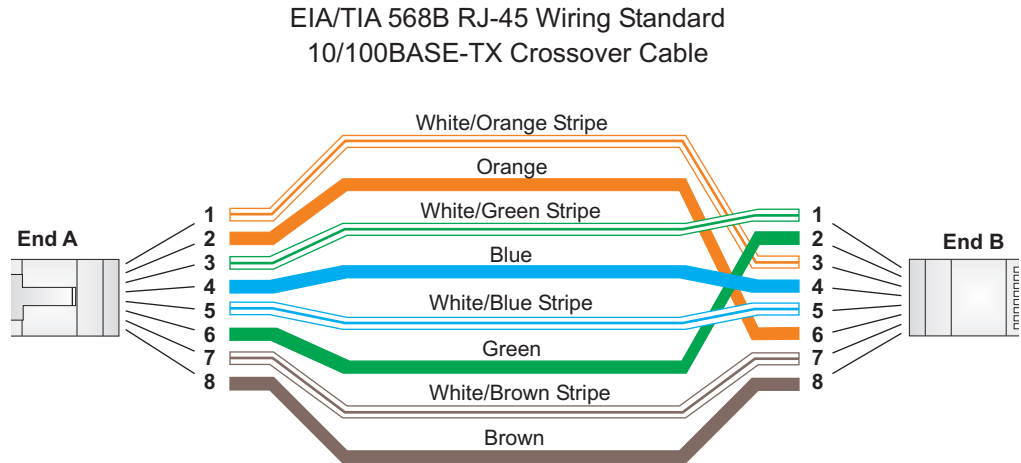

1000BASE-T PIN ASSIGNMENTS All 1000BASE-T ports support automatic MDI/MDI-X operation, so you can use straight-through cables for all network connections to PCs or servers, switches or hubs.

The table below shows the 1000BASE-T MDI and MDI-X port pinouts. These ports require that all four pairs of wires be connected. Note that for 1000BASE-T operation, all four pairs of wires are used for both transmit and receive.

Use 100-ohm Category 5, 5e or 6 unshielded twisted-pair (UTP) or shielded twisted-pair (STP) cable for 1000BASE-T connections. Also be sure that the length of any twisted-pair connection does not exceed 100 meters (328 feet).

Table 32: 1000BASE-T MDI and MDI-X Port Pinouts

Pin	MDI Signal Name	MDI-X Signal Name
1	Bi-directional Pair A Plus (BI_DA+) -48V power (Negative V_{port})	Bi-directional Pair B Plus (BI_DB+) GND (Positive V_{port})
2	Bi-directional Pair A Minus (BI_DA-) -48V power (Negative V_{port})	Bi-directional Pair B Minus (BI_DB-) GND (Positive V_{port})
3	Bi-directional Pair B Plus (BI_DB+) GND (Positive V_{port})	Bi-directional Pair A Plus (BI_DA+) -48V power (Negative V_{port})
4	Bi-directional Pair C Plus (BI_DC+) -48V power (Negative V_{port})	Bi-directional Pair D Plus (BI_DD+) GND (Positive V_{port})
5	Bi-directional Pair C Minus (BI_DC-) -48V power (Negative V_{port})	Bi-directional Pair D Minus (BI_DD-) GND (Positive V_{port})
6	Bi-directional Pair B Minus (BI_DB-) GND (Positive V_{port})	Bi-directional Pair A Minus (BI_DA-) -48V power (Negative V_{port})
7	Bi-directional Pair D Plus (BI_DD+) GND (Positive V_{port})	Bi-directional Pair C Plus (BI_DC+) -48V power (Negative V_{port})
8	Bi-directional Pair D Minus (BI_DD-) GND (Positive V_{port})	Bi-directional Pair C Minus (BI_DC-) -48V power (Negative V_{port})

CABLE TESTING FOR EXISTING CATEGORY 5 CABLE

Installed Category 5 cabling must pass tests for Attenuation, Near-End Crosstalk (NEXT), and Far-End Crosstalk (FEXT). This cable testing information is specified in the ANSI/TIA/EIA-TSB-67 standard. Additionally, cables must also pass test parameters for Return Loss and Equal-Level Far-End Crosstalk (ELFEXT). These tests are specified in the ANSI/TIA/EIA-TSB-95 Bulletin, "The Additional Transmission Performance Guidelines for 100 Ohm 4-Pair Category 5 Cabling."

Note that when testing your cable installation, be sure to include all patch cables between switches and end devices.

ADJUSTING EXISTING CATEGORY 5 CABLING TO RUN 1000BASE-T

If your existing Category 5 installation does not meet one of the test parameters for 1000BASE-T, there are basically three measures that can be applied to try and correct the problem:

1. Replace any Category 5 patch cables with high-performance Category 5e or Category 6 cables.
2. Reduce the number of connectors used in the link.
3. Reconnect some of the connectors in the link.

CONSOLE PORT PIN ASSIGNMENTS

The RJ-45 console port on the front panel of the access point is used to connect to the access point for out-of-band console configuration to a DB-9 connector on a PC. The command-line configuration program can be accessed from a terminal, or a PC running a terminal emulation program. The pin assignments and cable wiring used to connect to the console port are provided in the following table.

Figure 70: RJ-45 Console

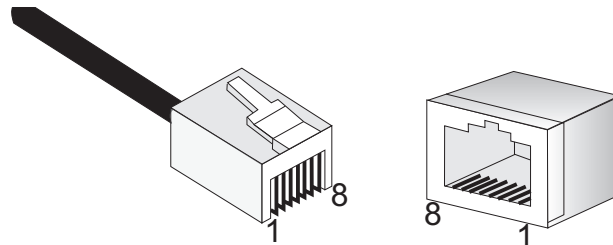

WIRING MAP FOR SERIAL CABLE

Table 33: Console Port Pinouts

RJ-45 Pin	Signal Name	DB-9 Pin
6 RXD	<-----RXD -----	3 TxD
3 TXD	-----TXD ----->	2 RxD
5 SGND	-----SGND -----	5 SGND

GLOSSARY

10BASE-T IEEE 802.3-2005 specification for 10 Mbps Ethernet over two pairs of Category 3 or better UTP cable.

100BASE-TX IEEE 802.3-2005 specification for 100 Mbps Fast Ethernet over two pairs of Category 5 or better UTP cable.

1000BASE-T IEEE 802.3ab specification for 1000 Mbps Gigabit Ethernet over four pairs of Category 5 or better UTP cable.

ACCESS POINT An internetworking device that seamlessly connects wired and wireless networks. Access points attached to a wired network, support the creation of multiple radio cells that enable roaming throughout a facility.

ADVANCED ENCRYPTION STANDARD (AES) An encryption algorithm that implements symmetric key cryptography. AES provides very strong encryption using a completely different ciphering algorithm to TKIP and WEP.

AUTHENTICATION The process to verify the identity of a client requesting network access. IEEE 802.11 specifies two forms of authentication: open system and shared key.

BACKBONE The core infrastructure of a network. The portion of the network that transports information from one central location to another central location where it is unloaded onto a local system.

BEACON A signal periodically transmitted from the access point that is used to identify the service set, and to maintain contact with wireless clients.

BROADCAST KEY Broadcast keys are sent to stations using dynamic keying. Dynamic broadcast key rotation is often used to allow the access point to generate a random group key and periodically update all key-management capable wireless clients.

DYNAMIC HOST CONFIGURATION PROTOCOL (DHCP) Provides a framework for passing configuration information to hosts on a TCP/IP network. DHCP is based on the Bootstrap Protocol (BOOTP), adding the capability of automatic allocation of reusable network addresses and additional configuration options.

ENCRYPTION Data passing between the access point and clients can use encryption to protect from interception and eavesdropping.

ETHERNET A popular local area data communications network, which accepts transmission from computers and terminals.

FILE TRANSFER PROTOCOL (FTP) A TCP/IP protocol used for file transfer.

HYPertext TRANSFER PROTOCOL (HTTP) HTTP is a standard used to transmit and receive all data over the World Wide Web.

IEEE 802.11A A wireless standard that supports high-speed communications in the 5 GHz band using Orthogonal Frequency Division Multiplexing (OFDM). The standard supports data rates of 6, 12, 24, and 54 Mbps.

IEEE 802.11B A wireless standard that supports wireless communications in the 2.4 GHz band using Direct Sequence Spread Spectrum (DSSS). The standard provides for data rates of 1, 2, 5.5, and 11 Mbps.

IEEE 802.11G A wireless standard that supports wireless communications in the 2.4 GHz band using Orthogonal Frequency Division Multiplexing (OFDM). The standard provides for data rates of 6, 9, 12, 18, 24, 36, 48, 54 Mbps. IEEE 802.11g is also backward compatible with IEEE 802.11b.

IEEE 802.11N A wireless standard that supports wireless communications in the 2.4 GHz band using Orthogonal Frequency Division Multiplexing (OFDM). The standard provides for data rates of 27, 54, 81, 108, 162, 216, 243, 270, 300 Mbps. IEEE 802.11n is also backward compatible with IEEE 802.11b/g.

INFRASTRUCTURE An integrated wireless and wired LAN is called an infrastructure configuration.

LOCAL AREA NETWORK (LAN) A group of interconnected computer and support devices.

- MAC ADDRESS** The physical layer address used to uniquely identify network nodes.
- NETWORK TIME PROTOCOL (NTP)** NTP provides the mechanisms to synchronize time across the network. The time servers operate in a hierarchical-master-slave configuration in order to synchronize local clocks within the subnet and to national time standards via wire or radio.
- OPEN SYSTEM** A security option which broadcasts a beacon signal including the access point's configured SSID. Wireless clients can read the SSID from the beacon, and automatically reset their SSID to allow immediate connection to the nearest access point.
- ORTHOGONAL FREQUENCY DIVISION MULTIPLEXING (OFDM)** OFDM allows multiple users to transmit in an allocated band by dividing the bandwidth into many narrow bandwidth carriers.
- SERVICE SET IDENTIFIER (SSID)** An identifier that is attached to packets sent over the wireless LAN and functions as a password for joining a particular radio cell; i.e., Basic Service Set (BSS).
- SESSION KEY** Session keys are unique to each client, and are used to authenticate a client connection, and correlate traffic passing between a specific client and the access point.
- SHARED KEY** A shared key can be used to authenticate each client attached to a wireless network. Shared Key authentication must be used along with the 802.11 Wireless Equivalent Privacy algorithm.
- SIMPLE NETWORK TIME PROTOCOL (SNTP)** SNTP allows a device to set its internal clock based on periodic updates from a Network Time Protocol (NTP) server. Updates can be requested from a specific NTP server, or can be received via broadcasts sent by NTP servers.
- TEMPORAL KEY INTEGRITY PROTOCOL (TKIP)** A data encryption method designed as a replacement for WEP. TKIP avoids the problems of WEP static keys by dynamically changing data encryption keys.
- TRIVIAL FILE TRANSFER PROTOCOL (TFTP)** A TCP/IP protocol commonly used for software downloads.

- VIRTUAL ACCESS POINT (VAP)** Virtual AP technology multiplies the number of Access Points present within the RF footprint of a single physical access device. With Virtual AP technology, WLAN users within the device.s footprint can associate with what appears to be different access points and their associated network services. All the services are delivered using a single radio channel, enabling Virtual AP technology to optimize the use of limited WLAN radio spectrum.
- WI-FI PROTECTED ACCESS** WPA employs 802.1X as its basic framework for user authentication and dynamic key management to provide an enhanced security solution for 802.11 wireless networks.
- WIRED EQUIVALENT PRIVACY (WEP)** WEP is based on the use of security keys and the popular RC4 encryption algorithm. Wireless devices without a valid WEP key will be excluded from network traffic.
- WPA PRE-SHARED KEY (WPA-PSK)** WPA-PSK can be used for small office networks with a limited number of users that may not need a high level of security. WPA-PSK provides a simple security implementation that uses just a pre-shared password for network access.

INDEX

A

- antennas 30
- authentication
 - cipher suite 216
 - closed system 210
 - MAC address 173, 174
 - type 210

B

- beacon
 - interval 207
 - rate 207
- BOOTP 196, 197
- bridge 36

C

- channel 202
- closed system 209
- community name, configuring 149
- community string 149
- configuration settings, saving or restoring 163
- connect console port 41
- connect Ethernet cable 41
- connecting and powering on 41
- console port 33
- country code
 - configuring 123
- CTS 208

D

- device status, displaying 131
- DHCP 196, 197
- DNS 196
- Domain Name Server *See* DNS
- downloading software 163
- DTIM 207

E

- Ethernet port 33
- event logs 140
- external antennas 30

F

- filter 173
 - address 173
 - between wireless clients 177
 - local bridge 177
 - local or remote 175
 - management access 178
 - protocol types 179
 - VLANs 228
- firmware
 - displaying version 132
 - upgrading 163

G

- gateway address 196

H

- hardware capabilities 27
- hardware description 29
- hardware version, displaying 132
- HTTPS 129

I

- IEEE 802.11a 201
 - configuring interface 201
 - radio channel 202
- IEEE 802.11g
 - radio channel 202
- IEEE 802.1x 171
 - configuring 171
- infrastructure wireless LAN 34
- initial configuration 42
- installing the access point 38
- interference issues 34
- introduction 27
- IP address 47, 53
 - BOOTP/DHCP 196, 197
 - configuring 196, 197

K

- key features 27

L

- LED indicators 32

location selection [38](#)

log
 messages [138](#)
 server [138](#)

M

MAC address, authentication [173, 174](#)
 mounting on a horizontal surface [39](#)
 mounting on a wall [40](#)

N

network configuration [34](#)

O

open system [209](#)

P

package contents [28](#)
 password
 configuring [125](#)
 management [125](#)
 port priority
 STA [186](#)
 position antennas [41](#)
 power connector [33](#)

R

radio channel
 802.11a interface [202](#)
 802.11g interface [202](#)
 RADIUS [165](#)
 reset button [33](#)
 roaming [35](#)
 RTS
 threshold [208](#)

S

Secure Socket Layer See [SSL](#)
 self test [41](#)
 shared key [217](#)
 SNMP [148](#)
 community name [149](#)
 community string [149](#)
 enabling traps [150](#)
 trap destination [151](#)
 trap manager [151](#)
 SNMP [141](#)
 enabling client [142](#)
 server [141](#)
 software
 displaying version [132](#)
 downloading [163](#)
 SSID [209](#)

SSL [129](#)

STA
 interface settings [186–??](#)
 path cost [186](#)
 port priority [186](#)
 startup files, setting [162](#)
 station status [213](#)
 status
 displaying device status [131](#)
 displaying station status [213](#)
 subnet mask [47, 53](#)
 system clock, setting [142](#)
 system log
 enabling [137](#)
 server [138](#)
 system software, downloading from server [163](#)

T

time zone [144](#)
 transmit power, configuring [204](#)
 trap destination [151](#)
 trap manager [151](#)

U

upgrading software [163](#)
 user password [125](#)

V

VLAN
 configuration [228](#)

W

WEP
 shared key [217](#)
 WPA
 pre-shared key [220](#)

TECHNICAL SUPPORT

From U.S.A. and Canada (24 hours a day, 7 days a week)
Phn: (800) SMC-4-YOU / (949) 679-8000
Fax: (949) 679-1481

English: Technical Support information available at www.smc.com

English (For Asia Pacific): Technical Support information available at www.smc-asia.com

Deutsch: Technischer Support und weitere Information unter www.smc.com

Español: En www.smc.com Ud. podrá encontrar la información relativa a servicios de soporte técnico

Français: Informations Support Technique sur www.smc.com

Português: Informações sobre Suporte Técnico em www.smc.com

Italiano: Le informazioni di supporto tecnico sono disponibili su www.smc.com

Svenska: Information om Teknisk Support finns tillgängligt på www.smc.com

Nederlands: Technische ondersteuningsinformatie beschikbaar op www.smc.com

Polski: Informacje o wsparciu technicznym są dostępne na www.smc.com

Čeština: Technická podpora je dostupná na www.smc.com

Magyar: Műszaki támogatás információ elérhető -on www.smc.com

简体中文: 技术支持讯息可通过www.smc-prc.com查询

繁體中文: 產品技術支援與服務請上 www.smcnetworks.com.tw

ไทย: สามารถหาข้อมูลทางด้านเทคนิคได้ที่ www.smc-asia.com

한국어: 기술지원 관련 정보는 www.smc-asia.com을 참고하시기 바랍니다

INTERNET

E-mail address: www.smc.com → Support → By email
Driver updates: www.smc.com → Support → Downloads

World Wide Web: <http://www.smc.com/>

SMCE21011