

SAVE VTR 500

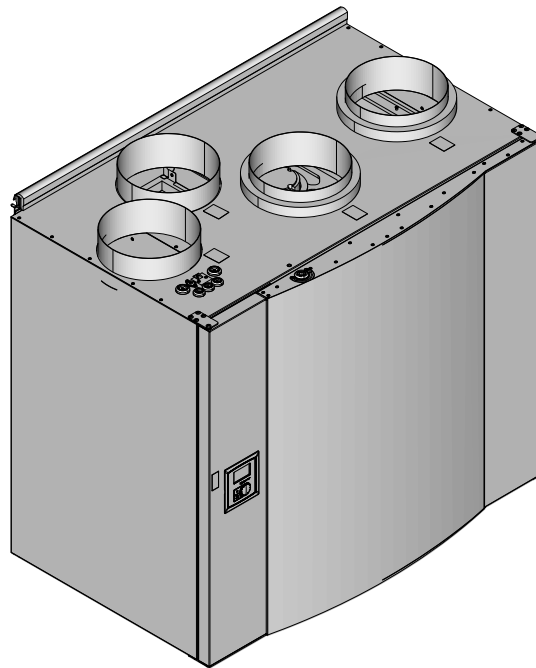

GB User Manual

© 2015 Copyright Systemair AB

Systemair AB can accept no responsibility for possible errors in catalogues, brochures and other printed material. Systemair AB reserves the right to alter its products without notice. This also applies to products already on order provided that such alterations can be made without sub sequential changes being necessary in specifications already agreed.

All rights reserved.

Contents

1 Disposal and recycling	1
2 Warnings	1
3 Product description	1
3.1 Left and Right models	2
4 Configuration	2
4.1 Control panel	2
4.1.1 Display symbols	3
4.2 Setting the temperature	3
4.3 Manual setting of airflow	4
4.4 Programming the Week schedule	5
4.5 Manual and automatic summer mode	6
5 Maintenance of the unit	7
5.1 Warnings	7
5.2 Open the front hatch	7
5.3 Changing filters	8
5.4 Resetting the filter time	9
5.5 Checking and cleaning the heat exchanger	9
5.6 Cleaning the fans	10
5.7 Replacing rotor drive belt	11
5.8 Overheat protection reset button	13
6 Duct system maintenance	14
6.1 Cleaning extract louvres and supply air diffusers	14
6.2 Checking the outdoor air intake	14
6.3 Checking the roof cowl (if fitted)	14
6.4 Checking and cleaning the duct system	14
7 Trouble shooting	15
7.1 Alarm list	15
7.2 Type label	16

1 Disposal and recycling

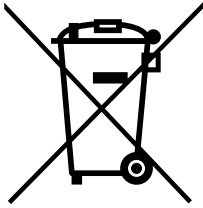

This product are applicable to the WEEE directive. When disposing the unit, follow your local rules and regulations.

This product packing materials are recyclable and can be reused. Do not dispose in household waste.



2 Warnings

The following admonitions will be presented in different sections of the document:

Danger

- Make sure that the mains supply to the unit is disconnected before performing any maintenance or electrical work!
- All electrical connections and maintenance work must be carried out by an authorized installer and in accordance with local rules and regulations.

Warning

- The system should operate continuously, and only be stopped for maintenance/service.
- The installation of the unit and complete ventilation system must be performed by an authorized installer and in accordance with local rules and regulations.
- Beware of sharp edges during mounting and maintenance. Use protective gloves.
- All though the Mains supply to the unit has been disconnected there is still risk for injury due to rotating parts that have not come to a complete standstill.
- Make sure that filters are mounted before starting the unit.
- This product must only be operated by a person which has suitable knowledge or education within this field or carried out with the supervision of a suitably qualified person.

Caution

- Do not connect tumble dryers to the ventilation system.
- Duct connections/duct ends must be covered during storage and installation.

3 Product description

The SAVE VTR 500 is a heat recovery ventilation unit with a built in rotating heat exchanger. The SAVE VTR 500 is suitable for houses with up to 400 m² heated living area. It supplies filtered outdoor air to residential areas and extract air from bathroom, kitchen and wet rooms.

SAVE VTR 500 is equipped with a 1670 W electrical re-heater battery.

3.1 Left and Right models

There are two model options, right (R) and left (L) model. The different models are recognized by the placing of the internal components and the supply air outlet, which is situated on left side of the unit on an (L) unit and on the right hand side on an (R) unit..

Note:

This document describes a left (L) model. The inside of a right (R) model is mirrored.

4 Configuration

4.1 Control panel

Connect the unit electrically to the mains with the enclosed plug and check that it starts up correctly.

The control panel is used to make the necessary adjustments.

An external control panel can be connected on the top of the unit.

The illustration below shows the control panel with a short description.

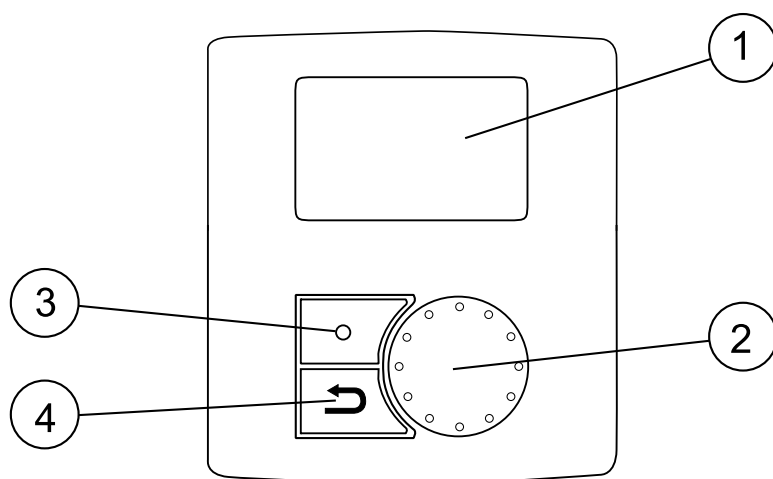

Fig. 1 Control panel

Position	Description	Explanation
1	Display	Shows symbols, menus and settings
2	SELECTION knob	Move through the menu lists or change settings and values by turning the knob left or right
3	ENTER button	ENTER menu choices or settings by pressing the button
4	RETURN button	Step RETURN in the menu levels and to abort an initiated parameter change and restore the original value by pressing the button

4.1.1 Display symbols

Symbol	Description	Explanation
	Temp	<p>Illustrates the current set-point for supply air temperature (from completely empty to filled symbol).</p> <p>Turn the SELECTION knob to choose temperature.</p> <p>Press ENTER to save the setting.</p>
	Airflow	<p>Illustrates the current airflow. The airflow can be set manually in 5 steps: Off, Low, Nom, High and Auto.</p> <p>Turn the SELECTION knob to choose airflow.</p> <p>Press ENTER to save the setting.</p> <div style="display: flex; justify-content: space-around; align-items: center;"> </div> <p style="text-align: center;">A B C D E</p> <p>A. Ventilation off.¹</p> <p>B. Low ventilation: Can be used when leaving the building for a longer period</p> <p>C. Nominal ventilation: Will give required air change under normal conditions.</p> <p>D. Maximum ventilation: To increase the airflow if necessary.</p> <p>E. Auto ventilation: Will regulate after the pre-setting for the demand control settings.</p>
	Service	Press ENTER to access the service menu.
	Alarm	Press ENTER to access the alarm list.

1. The fan can be set to OFF by activating manual fan stop. See service menu description under functions.

Important

It is not recommended to activate manual fan stop (set fan to OFF) in standard households. If manual fan stop is activated, the unit should be provided with dampers in exhaust and fresh air ducts to avoid cold draught and risk of condensation when the unit has been stopped.

4.2 Setting the temperature

The supply air temperature is set manually in steps of 1 K in the main menu display by choosing the temperature symbol.

If an electrical re-heater is installed the temperature setpoints are: 12-22 °C. For installed water re-heater the setpoints are: 12-40 °C.

If the re-heater is deactivated, the temperature steps are:
15-19 °C. Default value: 15.0 °C.

Each temperature step is illustrated by increasing the filling of the temperature symbol and the temperature is shown in the display

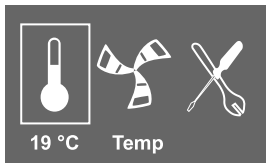

An unfilled temperature symbol will activate manual summer mode. See chapter 4.5

4.3 Manual setting of airflow

It is possible, at any time, to manually set the airflow in the main menu display. By choosing the fan symbol and confirming, it is possible to increase or decrease the airflow in 5 steps: Off, Low, Nom, High and Auto.

By doing so, you override the programmed week schedule for the unit until the end of the present time period in the week program (chapter 4.4).

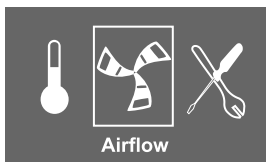

Warning

It is **not** recommended to activate manual fan stop (set fan to OFF) in standard households. If manual fan stop is activated, the unit should be provided with dampers in exhaust and fresh air ducts to avoid cold draught and risk of condensation when the unit has been stopped.

The fan can be set to OFF by activating manual fan stop. See the Installation and Service manual, chapter Service menu overview: *Manual fan stop*.

4.4 Programming the Week schedule

Set the week schedule according to below procedure:

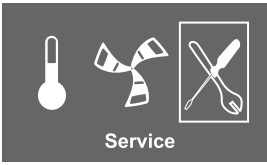
<p>1. Go to the service menu by using the SELECTION knob.</p>	
<p>2. Enter the service level by typing the password, default 1111. Use the SELECTION knob for each digit and confirm with the ENTER button after each set digit and choose "NO" for the system not be locked.</p>	<p>Password Password XXXX Locked YES/NO</p>
<p>3. Go to: Week program</p>	<p>Service Week program</p>
<p>4. Choose Week program again.</p>	<p>Week program Airflow</p>
<p>5. Set week day and time you want the unit to be in ON level. Two periods per day can be programmed. The rest of the time the unit will be in OFF level.</p>	<p>Week program Day: MON Per 1: 07:00 16:00 Per 2: 00:00 00:00</p>
<p>6. Go back to the previous dialogue frame with the RETURN button and go down to Airflow.</p>	<p>Week program Airflow</p>
<p>7. Set which airflow the fan is supposed to be running in the ON level, choose between Low, Nom, High or Auto.</p> <p>Set which airflow the fan is supposed to be running in the OFF level, choose between OFF, Low, Nom or High.</p> <hr/> <p>Note:</p> <p>If an electrical re-heater battery is installed and active and the unit is shut down from the control panel, for example by choosing OFF. When the unit is in OFF level in the week program, the fans will continue to run for 3 minutes, to prevent the heater from triggering the over heat protection sensor, before they stop.</p> <hr/>	<p>Airflow</p> <p>On level: low/nom/high/auto Off level: off/low/nom/high</p>
<p>8. Step back with the RETURN button until you reach the main menu display</p>	

4.5 Manual and automatic summer mode

Manual summer mode occurs if no temperature step is selected. The temperature symbol on the main menu is then completely empty.

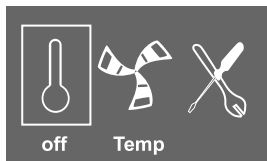

If the electrical re-heater is activated, it will switch off during manual summer mode. Manual summer mode goes automatically to step 1 (setpoint 12 °C) after two minutes if the supply air temperature is +5 °C or below.

If a water heater battery is installed and activated, the manual summer mode goes automatically to step 1 (setpoint 12 °C) if the outdoor air or supply air temperature is +5 °C or below.

The unit will automatically alternate between winter operation with heat recovery and summer operation without heat recovery.

5 Maintenance of the unit

Maintenance of the SAVE VTR 500 should normally be performed 3 - 4 times a year.

5.1 Warnings

Danger

- Make sure that the mains supply to the unit is disconnected before performing any maintenance or electrical work!
- All electrical connections and maintenance work must be carried out by an authorized installer and in accordance with local rules and regulations.

Warning

- The system should operate continuously, and only be stopped for maintenance/service
- Although the mains supply to the unit has been disconnected there is still risk for injury due to rotating parts that have not come to a complete standstill
- Beware of sharp edges during maintenance. Use protective gloves
- Make sure that filters are mounted in their place before running the system
- This product must only be operated by a person which has suitable knowledge or education within this field or carried out with the supervision of a suitably qualified person.

5.2 Open the front hatch

Danger

- Make sure that the Mains supply to the unit is disconnected before performing any maintenance or electrical work!

1. Open the locks on top and at the bottom of the front hatch.

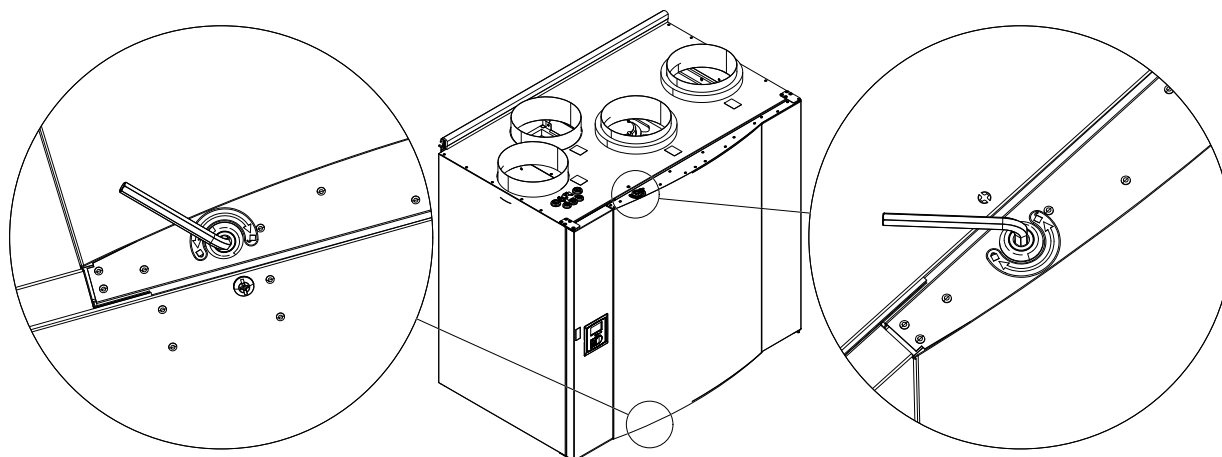

2. Open the hatch.

5.3 Changing filters

Danger

Make sure that the Mains supply to the unit is disconnected before performing any maintenance or electrical work!

The filters are to be changed every 6/9/12/15 months, default value is 12 months. When the filters have been changed the filter timer must be reset. See chapter 5.4.

The factory installed filters are of filter quality F7 for the supply air and G3 for the extract air filter. The filters need to be replaced when polluted. New sets of filters can be acquired from your installer or wholesaler.

Filter quality G3 can be installed for supply air filtering.
The filter type is labelled on the top of the filter.

Caution

If the filter types are changed, the heat recovery system may need re-configuration to function optimally.

If type G3 filters are used instead of F7, the system curve for Supply Fan (SF) must be changed:

For G3 type filter: 11–20, for F7 type filter: 1–10. See Installation and Service Instruction.

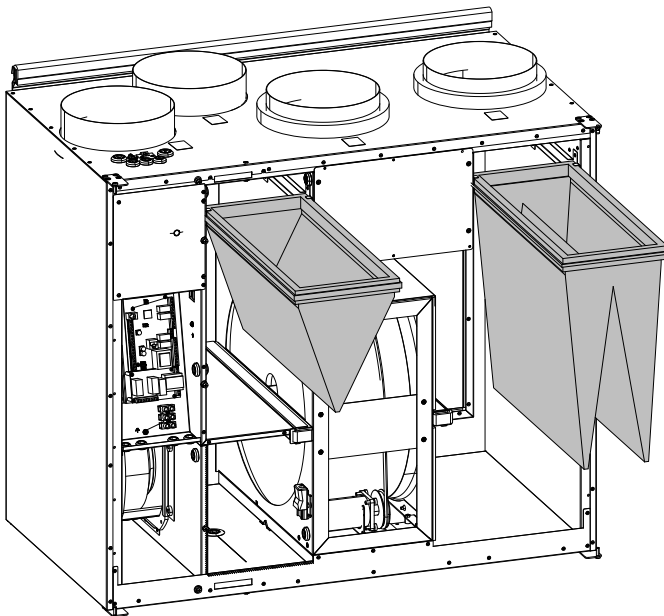



Fig. 2 Extract and supply air filters

1. Stop the unit by disconnecting the mains.
2. Open the front hatch. See chapter 5.2.
3. Pull out the filters towards you. Some force may be needed.
4. Insert the new filters. Make sure that the correct filter types are inserted.
5. Close and lock the front hatch and connect the unit to mains.
6. Reset the filter time. See chapter 5.4.

5.4 Resetting the filter time

<p>1. Go to the service menu by using the selection knob.</p>	 <p>Service</p>
<p>2. Enter the service level by typing the password. Use the SELECTION knob for each digit and confirm with the ENTER button after each set digit and choose "NO" for the system not be locked.</p>	<p>Service ->Password Locked YES/NO</p>
<p>3. Go to: Filter period, press ENTER. Choose: Reset: YES with the SELECTION knob and then ENTER. Change, if necessary, Time to replace X month, to the time of your choice with the SELECTION knob and then press ENTER. Press the RETURN button until you reach the main menu.</p>	<p>Filter period Time to replace: 6/9/12/15 month Reset NO/YES</p>

5.5 Checking and cleaning the heat exchanger

Danger

Make sure that the Mains supply to the unit is disconnected before performing any maintenance or electrical work!

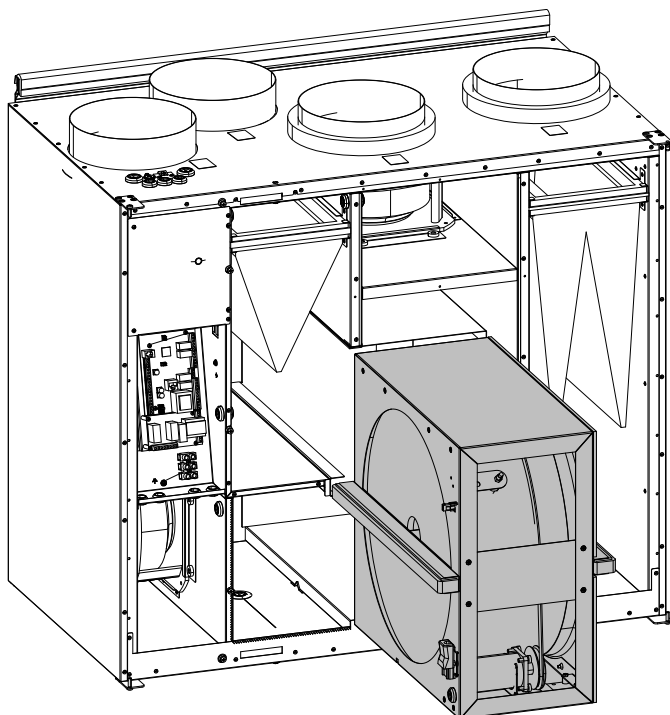

Fig. 3 Heat exchanger

 **Warning**

Risk of personal injury! The heat exchanger weighs about 16 kg. There is a risk that the heat exchanger falls out of the unit.

Make sure that small children are not beneath the unit when the heat exchanger is removed!

Even if the required maintenance is carried out, dust will build up in the exchanger block. It is therefore of vital importance for the upkeep of a high efficiency that the exchanger block is removed from the unit and cleaned periodically as described below. Clean the heat exchanger at least every 3 years or when required.

1. Stop the unit by disconnecting the mains.
2. Open the front hatch. See chapter 5.2.
3. Disconnect the heat exchanger power supply and the rotor sensor. Both cables are found beside the heat exchanger.
- 4.

 **Warning**

Risk of personal injury! The heat exchanger weighs about 16 kg. There is a risk that the heat exchanger falls out of the unit.

Pull out the heat exchanger. Some force may be needed.

5. Clean the rotor.

Wash in hot soapy water. Do not use detergent containing ammonia. Rinse using, for instance, a shower handle or carefully with compressed air.

 **Warning**

Ensure the rotor motor is not exposed to moisture

6. Remount the heat exchanger. Don't forget to reconnect the heat exchanger power and sensor cables.
7. Close and lock the front hatch and connect the unit to mains.

5.6 Cleaning the fans

 **Danger**

- Make sure that the Mains supply to the unit is disconnected before performing any maintenance or electrical work!

The extract air fan is accessed by opening the front hatch. The supply air fan is accessed by opening the side hatch.

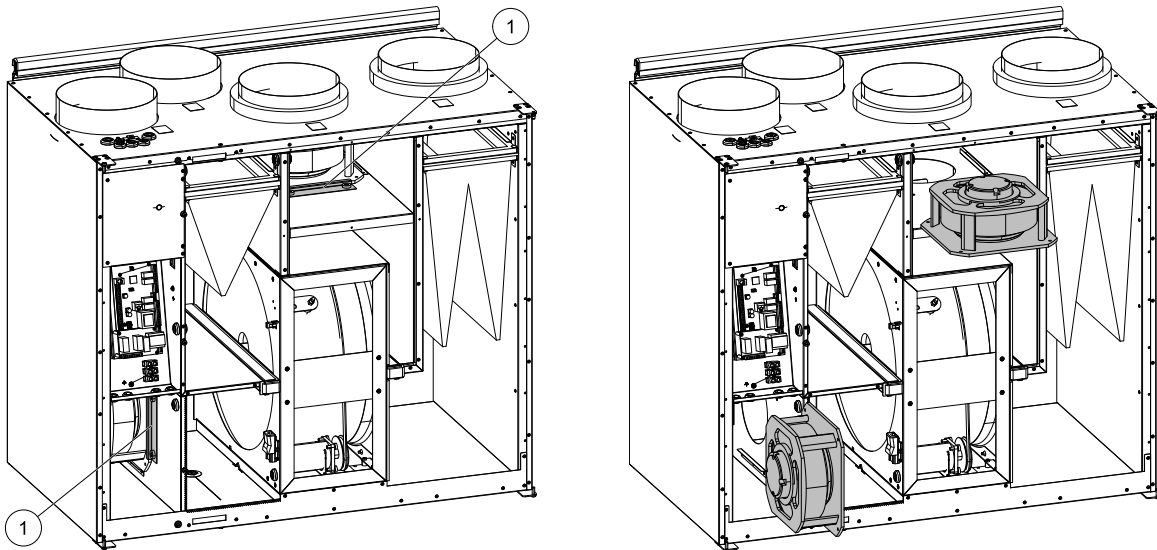

The motor bearings are life time lubricated and maintenance free.

Even if the required maintenance, such as changing of filters is carried out, dust and grease may slowly build up inside the fans. This will reduce the efficiency.

The fans may be cleaned as described below.

1. Stop the unit by disconnecting the mains.
2. Open the front hatch. See chapter 5.2.
3. Loosen the screws securing the side hatch and open it.
4. Disconnect the fan power cables. The cables are found beside the fans.
5. Loosen the screws to the brackets holding the fans (1).
6. Remove the brackets.
7. Pull the fans towards you.
8. Clean the fans with a cloth or a soft brush. Do not use water. White spirit can be used to remove obstinate deposits.
Allow the fans to dry properly before remounting.
9. Remount the fans.
10. Remount and tighten the brackets.
11. Don't forget to reconnect the fan power cables.
12. Close and lock the front and side hatch and connect the unit to mains.

5.7 Replacing rotor drive belt

Danger

- Make sure that the Mains supply to the unit is disconnected before performing any maintenance or electrical work!

If the alarm `ROTOR` is raised the rotor drive belt may be damaged or broken, see chapter 7.1.

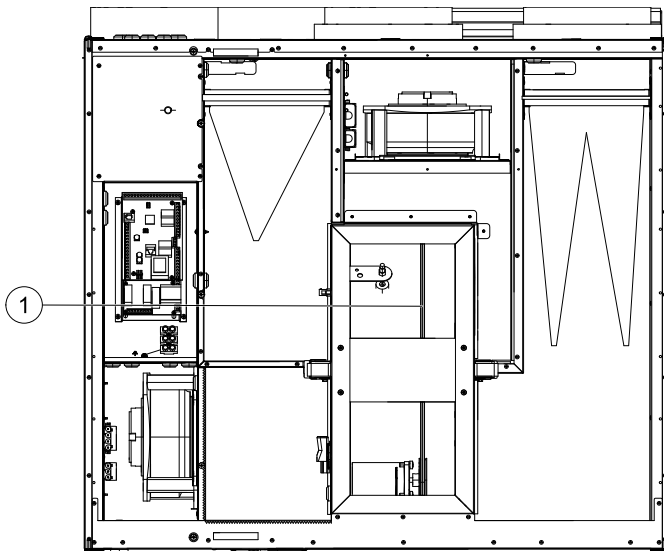

Fig. 4 Rotor drive belt

The rotor drive belt (1) can be acquired from your installer or wholesaler.

The replacement drive belt is adjustable and delivered with a nipple attached in one end.

1. Stop the unit by disconnecting the mains.
2. Open the front hatch. See chapter 5.2.
3. Remove the broken drive belt.
4. Use tape to attach the drive belt to the rotating heat exchanger, and rotate the exchanger by hand to get hold of the drive belt.
5. Remove the tape and put the "empty" end on to the nipple.
6. Press the ends firmly towards each other to secure the nipple.
7. Pull the drive belt on to the belt pulley and rotate the exchanger by hand. Check that the belt pulley rotates.

Note:

If the drive belt slips, the drive belt may be too long and needs to be shortened. Cut the drive belt 5 mm and go to step 6.

8. Close and lock the front hatch and connect the unit to mains.
9. Check that the alarm has ceased on the Control Display.

Note:

If the alarm remains, contact the installer.

5.8 Overheat protection reset button

If the supply air temperature is low, it can indicate that the over heat protection is triggered. The overheat protection can be reset by pressing the reset button (1).

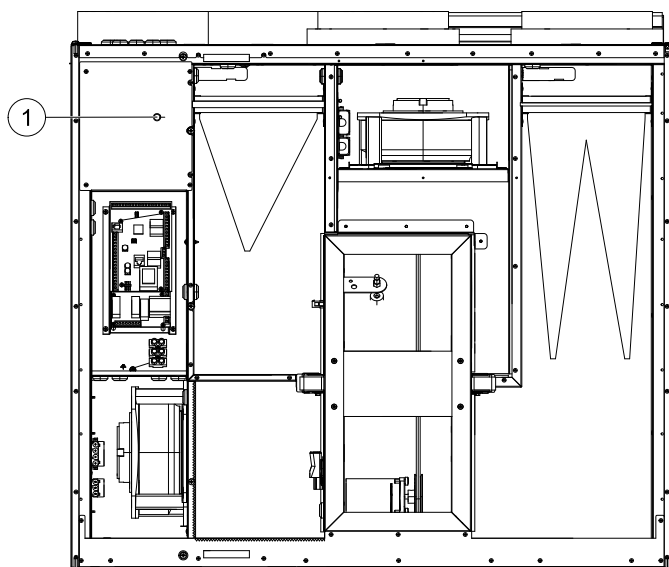

Fig. 5 Overheat protection reset button

1. Stop the unit by disconnecting the mains.
2. Open the front hatch. See chapter 5.2.
3. Loosen the screws securing the side hatch and open it.
4. Press the reset button (1).
5. Close and lock the front and side hatch and connect the unit to mains.

6 Duct system maintenance

6.1 Cleaning extract louvres and supply air diffusers

The system supplies fresh air to your home and extracts the used indoor air via the duct system and diffusers/louvres. Diffusers and louvres are mounted in ceilings/walls in bedrooms, living room, wet rooms, WC etc. Remove diffusers and louvres and wash in hot soapy water as required (diffusers/louvres must not be exchanged). Cleaning of diffusers/louvres can be done as necessary.

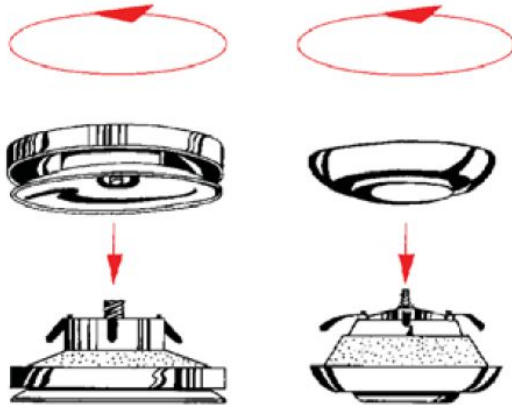

Fig. 6 Diffusers and louvres

6.2 Checking the outdoor air intake

Leaves and pollution could plug up the air intake grille and reduce the capacity. Check the air intake grille, and clean as necessary. It is recommended to do this at least twice a year.

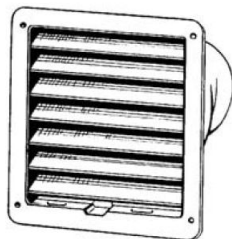

Fig. 7 Intake grille

6.3 Checking the roof cowl (if fitted)

The roof cowl (if fitted) connected to the exhaust air duct needs to be checked at least twice a year and cleaned if necessary.

6.4 Checking and cleaning the duct system

Dust and grease deposits may build up in the duct system, even if required maintenance such as changing of filters is being carried out. This will reduce the efficiency of the installation.

The duct runs should therefore be cleaned/changed when necessary. Steel ducts can be cleaned by pulling a brush soaked in hot soapy water through the duct via diffuser/louvre openings or special inspection hatches in the duct system (if fitted).

It is recommended to do this every 5 years and is normally carried out by authorized companies specialized in this area.

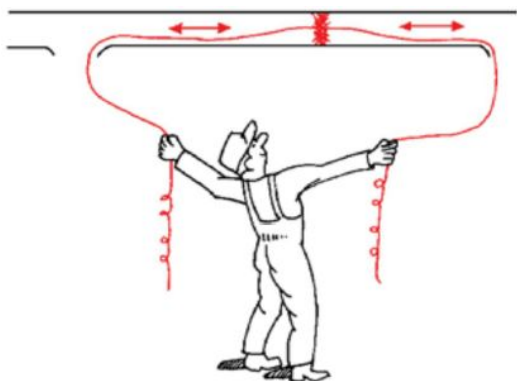

Fig. 8 Cleaning duct system

7 Trouble shooting

A warning triangle with text in the display indicates an alarm. Turn menu selector to the warning triangle and press confirm twice to view the alarm.

Danger

Make sure that the mains supply to the unit is disconnected before performing any maintenance or electrical work on the unit!

7.1 Alarm list

Alarm	Explanation	Do the following
Fan	Indicates error on either supply or extract air fan.	<p>The alarm is displayed in the control panel.</p> <p>Check that quick connectors are connected for the both fans.</p> <p>Contact your installation company or place of purchase.</p>
EMT/Frost	Indicates triggered frost protection (in case of installed water heating battery) or triggered overheat protection (in case of installed electric re-heater battery).	<p>A triggered frost protection alarm results in the following:</p> <ul style="list-style-type: none"> • Both fans stop. • Outdoor and exhaust air dampers closed. • Water valve opens completely (10 V signal goes out to the actuator). <p>The unit will restart once the water temperature reaches +5°C above the set frost protection temperature.</p> <p>A triggered over heat protection (EMT) gives an alarm in the control panel.</p> <p>Reset by pushing the reset button. See chapter 5.8.</p> <p>If the problem continues contact your installation company or place of purchase.</p>

Alarm	Explanation	Do the following
Rot	Indicates a rotor malfunction.	<p>The alarm is displayed in the control panel.</p> <ul style="list-style-type: none"> If the rotating heat exchanger has stopped. Check the rotor belt. See chapter 5.7 If the heat exchanger is still rotating, check that the quick connector for the sensor is connected and that there is an air gap of 5-10mm between the sensor and the magnet. <p>Adjust the gap if necessary.</p> <p>If the alarm persists, the rotor sensor may be faulty.</p> <p>Contact your installation company or place of purchase.</p>
Pb Fail	<p>Error in connection with relay card for the electrical re-heater (if installed and activated).</p> <p>The overheat protection sensor, automatic reset (ET2) may be triggered due to high temperature.</p>	<p>The alarm is displayed in the control panel.</p> <p>The heater will not be activated.</p> <p>For triggered ET2, wait 10–15 min. If the error remains, contact your installation company or place of purchase.</p>
Temp	Malfunction in one or more of the temperature sensors.	<p>The alarm is displayed in the control panel.</p> <p>Contact your installation company or place of purchase.</p>
Filter	Time for filter change.	<p>The alarm is displayed in the control panel.</p> <p>Change filter according to the instructions in the User Manual.</p>
Low SS	Indicates low supply air temperature	<p>The alarm is displayed in the control panel.</p> <p>If water reheater is configured and frost protection have failed, then an extra security function is triggered when supply air temperature is lower than 5 °C and outdoor air temperature is below 0 °C.</p>
RH	Indicates malfunction of internal relative humidity sensor.	<p>The alarm is displayed in the control panel.</p>

7.2 Type label

Before calling your service representative, make a note of the specification and production number from the type label, which can be found on the side of the units, next to the external connections.

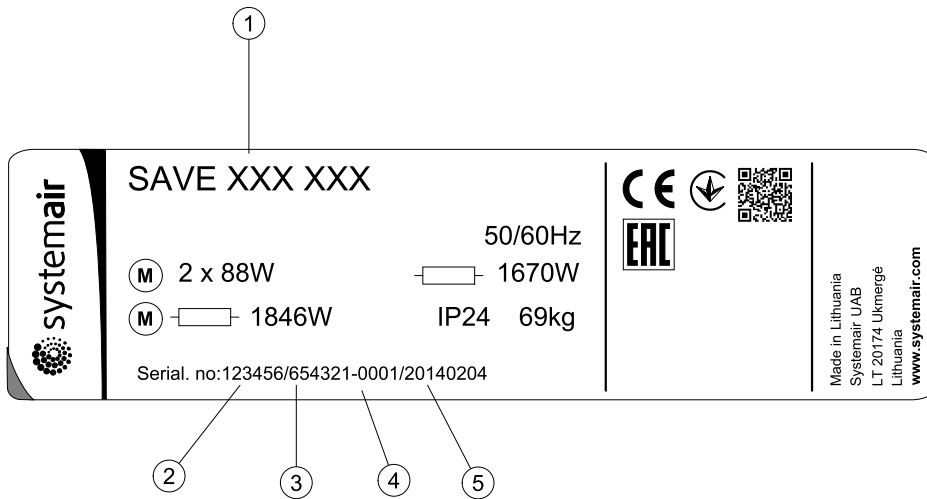

Fig. 9 Type label

Position	Description
1	Product code (product specification)
2	Product item number
3	Production order number
4	Serial number
5	Production date (YY.MM.DD)

Systemair Sverige AB reserves the right to make changes and improvements to the contents of this manual without prior notice.



Systemair UAB
Linių st. 101
LT-20174 Ukmergė, LITHUANIA
Phone +370 340 60165
Fax +370 340 60166
www.systemair.com