

# hy-gain®

## AR-500 Instruction Sheet



**CAUTION:** Read and Adhere to all **IMPORTANT SAFEGUARDS** listed elsewhere in this booklet. Read and observe safety, installation and operating instructions supplied with this unit and with your antenna **BEFORE** installation or operation. Retain this booklet and all instructions for your safety and future reference.

### IMPORTANT SAFEGUARDS

Your antenna rotator unit, consisting of a control and a drive, has been engineered and manufactured to assure your personal safety, but improper installation or abuse of the unit, or the antenna connected to it, can result in potential electrical shock or fire hazards. In order not to defeat the safeguards incorporated in this unit, observe the following basic rules for its installation, use and servicing.

**1. Read Instructions**

All the safety and operating instructions should be read before the product is operated.

**2. Retain Instructions**

The safety and operating instructions should be retained for future reference.

**3. Heed Warnings**

All warnings on the product and in the operating instructions should be adhered to.

**4. Follow Instructions**

All operating instructions should be followed.

**5. Power Lines**

An outside antenna system should not be located in the vicinity of power lines or other electric light or power circuits, or where it can fall into such power lines or circuits. When installing an outside antenna system, extreme care should be taken to keep from touching such power lines or circuits as contact with them might be fatal.

**6. Outdoor Antenna Grounding**

If the drive unit is installed on an outdoor antenna, be sure the antenna system is grounded so as to provide some protection against voltage surges and built-up static charges. Section 810 of the National Electrical Code, ANS/NFPA70, or CSA C22.1 Sections 10, 16, and 54, of the Canadian Electrical Code, provides information with respect to proper grounding of the mast and supporting structure, grounding of the antenna lead-in wire to an antenna discharge unit, size of grounding conductors, location of antenna-discharge unit, connection to grounding electrodes, and requirements for the grounding electrode. See separate enclosed grounding code. See **Fig A**.

### Example of Antenna Grounding

According to the National Electrical Code

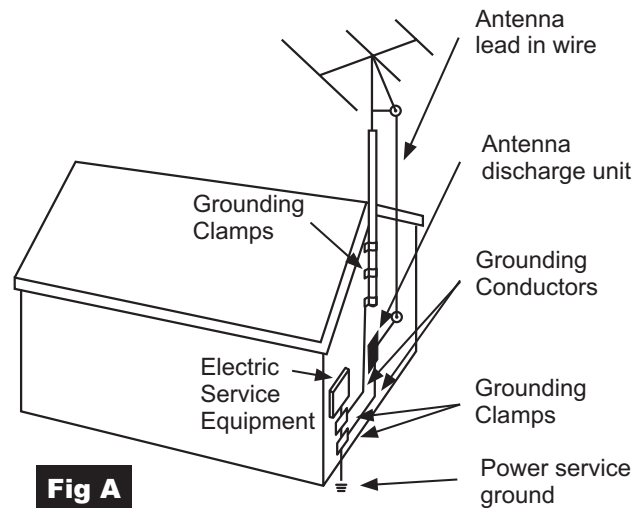

**Fig A**

#### NEC – NATIONAL ELECTRIC CODE

Antenna Discharge Unit is not required if lead-in conductors are enclosed in a continuous metallic shield that is permanently and effectively grounded.

### CONTENTS

- Drive and Controller
- Handheld Unit
- 2 AAA Batteries
- AC Adapter
- Instruction Sheet

## 7. Ventilation

Your control is provided with ventilation openings to allow heat generated during operation to be released. If these openings are blocked, heat build-up can cause failure of the control and external damage. Therefore:

- Never block the ventilation slots by placing it on a bed, sofa, rug, etc.
- Never place in a "built-in" enclosure unless proper ventilation is provided.
- Never cover the openings with cloth or material.
- Never place near or over radiators, heat registers, amplifiers, or other heat sources.

## 8. Grounding or Polarization

Your control may be equipped with a polarized AC line plug (one blade of the plug is wider than the other). This safety feature allows the plug to fit into the power outlet only one way. Should you be unable to insert the plug fully into the outlet, try reversing the plug. Should it still fail to fit, contact your electrician to replace your obsolete outlet. Do not defeat the safety purpose of the polarized plug.

## 9. Power sources

Operate the control only from an A.C. power source as indicated on the bottom of the control. Do not use D.C.

## 10. Overloading

Overloaded AC outlets and extension cords are dangerous, and so are frayed power cords and broken plugs. They may result in a shock or fire hazard. Unplug the control and call your service technician for replacement.

## 11. Power Cord Protection

Do not allow anything to rest on or roll over the power cord, and do not place the control where power cord is subject to traffic or abuse. Pay particular attention to the cord at the plug and the point where it exists from the control unit. This may result in a shock or fire hazard.

## 12. Object and Liquid Entry

All individuals, especially children, should be cautioned about dropping or pushing objects into any openings. Some internal parts carry hazardous voltages and contact can result in electrical shock. Objects dropped into the control may also result in a fire hazard.

## 13. Water and Moisture

Never expose the control to rain or water. If the control becomes damp or wet, or if liquids are spilled into it, unplug the control automatically switches off 5 seconds after it is initially plugged in or after a power glitch. and have it inspected by a service technician before further use. Liquids, rain or excessive moisture may cause electrical shorts which can result in fire or shock hazards. Never operate the control near water, such as a swimming pool, etc. or near a bathtub, sink, laundry tub, or in a wet basement.

## 14. Cleaning

Unplug the control before cleaning. Use a slightly damp (not wet) cloth. Do not use an aerosol directly on the control since it may over spray and cause electrical shock.

## 15. Performance Change

Whenever the unit exhibits distinct change on performance, unplug the control and call your dealer or service technician.

## 16. Servicing

Any attempt to disassemble the control or drive portions of the unit may expose you to high voltage or other hazards. Observe all cautionary labels, warnings and safeguards.

## 17. Damage Requiring Service

If the control has been dropped or the case has been damaged, fire, and shock hazard may exist. Unplug the control and have it checked by a service technician before use.

## 18. Replacement Parts

When replacement parts are required, have the service technician verify that the replacements used have the same safety characteristics as the original parts. Unauthorized substitutions may result in a risk of fire or electric shock, or other risks.

## 19. Safety Check

Upon completion of any service or repairs to the unit, please ask the service technician to perform routine safety checks to determine that the unit is in a safe operating condition.

## 20. Lightning

For added protection of the control during a lightning storm or when control is to be left unattended for an extended period of time, unplug it from the wall outlet and disconnect the rotator cable. This will prevent possible shock, fire hazard and damage to the control due to lightning storms or power line surges.

## 21. Rooftop Installation

Always use extreme caution when installing a rooftop antenna and rotator system to reduce the risk of falls. Wear rubber-soled shoes and use a sturdy ladder. Do not install on a windy day or when the roof is wet or is covered with ice or snow.

## ROTATOR INSTALLATION

1. Determine proper size number of rotator cable from chart. Three conductor cable is suitable, but if four conductor cable is used, connect both conductors 3 and 4 to terminal 3 on the drive and control.

Gage		No. of Conductors	Maximum Length	
AWG	MM		Feet	Meters
22	.6	3	180	55
22	.6	4*	200	61
20	.8	3	280	85
20	.8	4*	310	95
18	1.0	3	445	136
18	1.0	4*	510	155

\*NOTES: Attach 3 and 4 conductors to No. 3 terminals on control and drive.

\*NOTAS: Conecte los conductores 3 y 4 al terminal No. 3 en el control y en la guía.

2. Install drive unit. On new drive units, arrow on mast support should be aligned with arrow shaped mast stop on housing. Install drive unit with arrows pointing south. Using a short piece of mast (3 feet or less), install the antenna to the drive unit aiming the antenna south. When desired channels are close to or on opposite sides of the north end stops, the antenna may be installed pointing north. Note, however, that the antenna will be pointing in the opposite direction from that indicated on the control. An alternative means of setting up is to perform a synchronization of the drive unit using the controller. Then set up the antenna pointing north. Ensure power is disconnected from the controller when making antenna adjustments. See Fig 1 and 2.

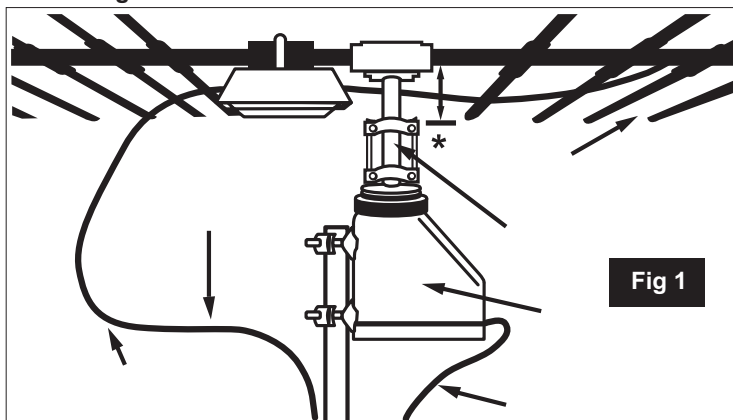

\*Mount antenna as close to rotor as possible. use no more than 3 feet of mast in top of drive unit.

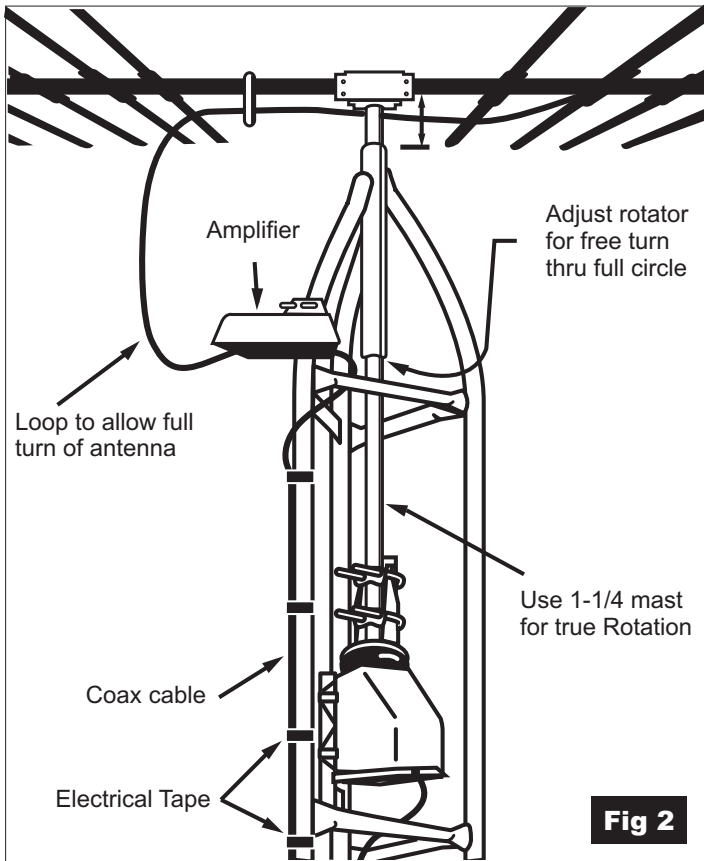

**CAUTION:** Before disconnecting old control box, make note of each wire color and the corresponding terminal connections. To reduce the risk of electric shock, do not remove cover. No user-serviceable parts inside. Refer servicing to qualified service personnel.

## CONTROLLER INSTALLATION

1. Determine the AC supply voltage and frequency in your country. The US, Canada, Japan, Taiwan and South America are generally 120 VAC Hz. Europe, Africa, Australia and Asia (except above mentioned) are generally 230 VAC 50 Hz. Your power company will advise. Ensure the supplied wall plug power supply voltage has the same input voltage as your household supply ( $\pm 10\%$ ). If not, contact your dealer.
2. Plug the power supply into the controller and the household supply. Observe the digital diagnostic display. It should display:
  - **60H** (or 50H in 50 Hz countries)
  - **HH1** (to use with the supplied handheld remote control)
 If the above are not correct refer to **Appendix A** to change.
3. Disconnect the wall plug supply at the wall outlet. Connect the cables between the controller and drive unit. See **Fig B**.
4. Reconnect the AC supply to the controller. After 5 seconds it will switch off. Switch back on by pressing any key on the front panel or handheld remote control. Perform a synchronization by pressing the sync button on the left of the front panel. This takes slightly over one minute. The unit may now be operated from the

front panel using the up and down controls.

### 5. Digital Compass

This feature operates as follows:

The display **000** to **360** degrees where:

- **000** is North (fully CCW viewed by a bird)
- **090** is East
- **180** is South
- **270** is West
- **360** is North (fully CW viewed by a bird)

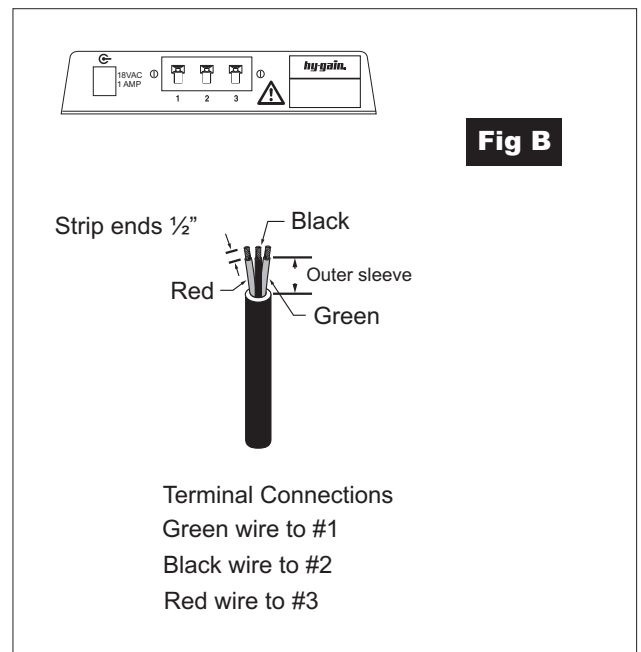
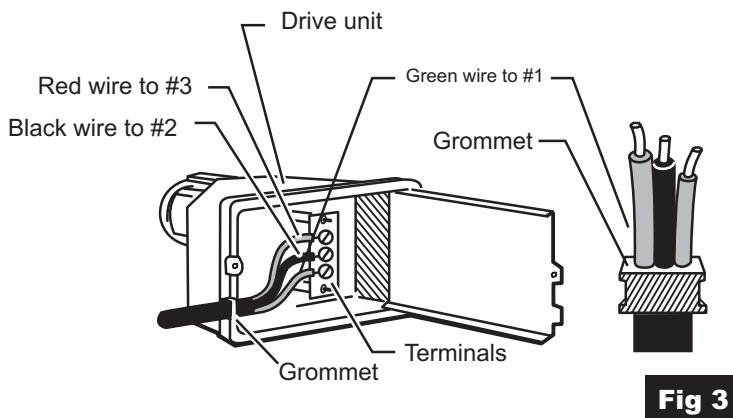

3. Connect rotator cable to drive unit terminal board. See **Fig 3**.  
**CAUTION:** When using jacketed cable, be sure jacket of cable passes thru the grommet to avoid moisture collection in the cable.
4. Attach rotator cable and antenna cable securely to mast or tower, and pass through building to TV or FM set.

**NOTES:** See **Fig A** of the Important Safeguards section regarding grounding of the lead-in cable for lightning protection.

## HANDHELD REMOTE SETUP

1. Install 2 AAA batteries in the handheld remote.
2. Check operation by pressing the **POWER** button and observing the display. If it does not function, check for **HH1** in power up diagnostic display. If the display is **HH2**, refer to **Appendix A** to change.
3. The **UP** and **DOWN** controls will move the antenna position (the same as the front panel controls). Alternately, a location may be accessed directly using a 3 digit compass location. Example, press **090** for East, **225** for South-West, etc.
4. **Programming Preset Locations**  
This is the most popular mode of operation, 69 preset locations (01 to 69) allow location numbers to be the same as TV channel numbers if desired.
  - a. Find best signal using **UP** and **DOWN** controls.
  - b. Decide on a memory location, eg. 27.
  - c. Press **27 UP 27**.  
(Locations 01 to 09, eg. 05 may be programmed by either **05 UP 05** or **5 UP 5**.)
  - d. Location is now memorized.
5. **Accessing a Preset Location**  
As an example, to access location 27, press **27**. Display will flash "**c27**", then show compass bearing while the antenna is moving. It will become steady "**c27**" when it arrives.  
(Locations 01 to 09, eg. 05 may be accessed as either 05 or 5).
6. **Displaying Memory Locations/Status**  
From the handheld remote control, press **99 UP**. Then observe the display. Each programmed location is shown, followed by its digital compass location. Additionally setting of **power frequency**, **handheld**, **autosync** and **timeout** are shown.  
A typical display might be:

<b>60H</b>	60Hz power	<b>c05 270</b>	Compass bearing for c05
<b>HH1</b>	Handheld 1	<b>c11 090</b>	Compass bearing for c11
<b>to on</b>	Timeout on	<b>c17 270</b>	Compass bearing for c17
<b>888</b>	End of diagnostics	<b>35</b>	35 moves before a resync

**Syn on** Autosync on
7. **Deleting Programmed Locations/Reset**  
Press **91 DOWN** from the handheld remote control.  
**CAUTION:** Use this command with care as ALL memory locations will be deleted. This will also set **autosync** off and **timeout** on
8. **Synchronization**  
Press the **SYNC** key on the left of the front panel or **00 Down** from the handheld. A counterclockwise movement is performed to synchronize the control unit with the drive unit for proper operation. Synchronization takes slightly over one minute.  
After severe storms, or an extended period of use, the rotator may appear to position the antenna incorrectly. First try pressing the **SYNC** key to re-synchronize the system. If this fails, the antenna or drive motor may be misaligned on the mast. You may either go to the antenna and re-orient it, or reprogram the control unit to correspond to the new antenna orientation.
9. **Auto Synchronization**  
The unit may be set up program a sync command automatically after 50 pre programmed moves. This feature is switched on (or reset to 50) by pressing **98 UP**. It is switched off by pressing **98 DOWN**. Check to see if active by pressing **99 UP** (Display Status) and observing "**SYn on**" or "**SYn OFF**".
10. **Timeout**  
The unit may be set to switch off after 8 minutes of no activity by pressing **97 UP**. This feature is deactivated by pressing **97 DOWN**. Check to see if **timeout** is active by pressing **99 UP** (Display Status) and observing "**to on**" or "**to OFF**." The unit

## USING THE CONTROLLER WITH A "UNIVERSAL REMOTE CONTROL"

Universal handheld remote controls are popular as they can typically control a TV, a VCR, a cable box and audio components. They are also cheap and ideal replacements for lost and broken units. The rotator controller will respond to commands from universal remote controls configured to control most Pioneer® brand cable converter boxes (HH1 mode) or most Pioneer® brand CD players (HH2 mode). See **Appendix A**. Refer to the instructions supplied with the universal remote control.

**NOTES:** Hy-gain cannot guarantee universal handheld remote control compatibility.

### APPENDIX A (Front Panel Setup Summary)

SET 60 Hz POWER	▲ + ▼	AT POWER UP
SET 50 Hz POWER	▲ + ▼ + SY	AT POWER UP
SET REMOTE HH1	▲ + SY	AT POWER UP
SET REMOTE HH2	▼ + SY	AT POWER UP

Example: To set for 60 Hz power:

- a. Disconnect the power connector at the rear of the unit.
- b. Press and hold **UP** and **DOWN** in together.
- c. Reconnect the power connector at the rear end of the unit.
- d. Release **UP** and **DOWN**

Other functions are set in a similar manner using the following buttons at b and d: 50Hz POWER: **UP**, **DOWN**, and **SYNC** Remote handheld 1 (supplied unit and most Pioneer® cable boxes): **UP** and **SYNC** Remote handheld 2 (most Pioneer® CD players): **DOWN** and **SYNC**. Check settings are correct by removing power for a few seconds, then reconnect power. Display will indicate:

**50H** (or 50H for 50 Hz)

**HH1** (or HH2 for alternate remote)

### APPENDIX B (Handheld Remote Control Command Summary)

SYNC:	00▼
PROGRAM:	#▲ # (# = 01-69)
DISPLAY MEMORIES/STATUS:	99 ▲
AUTOSYNC ON/RESET TO 50:	98 ▲
AUTOSYNC OFF:	98 ▼
TIMEOUT (8 MINUTES) ON:	97 ▲
TIMEOUT OFF:	97 ▼
DELETE MEMORIES/RESET:	91 ▼

### APPENDIX C (Common Problems)

**HANDHELD CONTROL DOES NOT FUNCTION**

Battery bad or set for wrong handheld type (See **Appendix A**).

**UNIVERSAL HANDHELD DOES NOT OPERATE CERTAIN FUNCTIONS** (eg. **UP/DOWN**) If supplied remote control is OK, try all available Pioneer® cable box and Pioneer® CD player codes. Universal remote may not be fully compatible.

**UNIT DOES NOT TRACK CORRECTLY**

Check power frequency 50/60 Hz setting (See **Appendix A**).

**POSITION ACCURACY SEEMS DEGRADED**

Perform **SYNC** function.

**ANTENNA DOES NOT MOVE, BUT CONTROLLER INDICATES MOVEMENT**

Check the wiring between the controller and the drive unit.