

1977

Airstream

Owner's

Manual

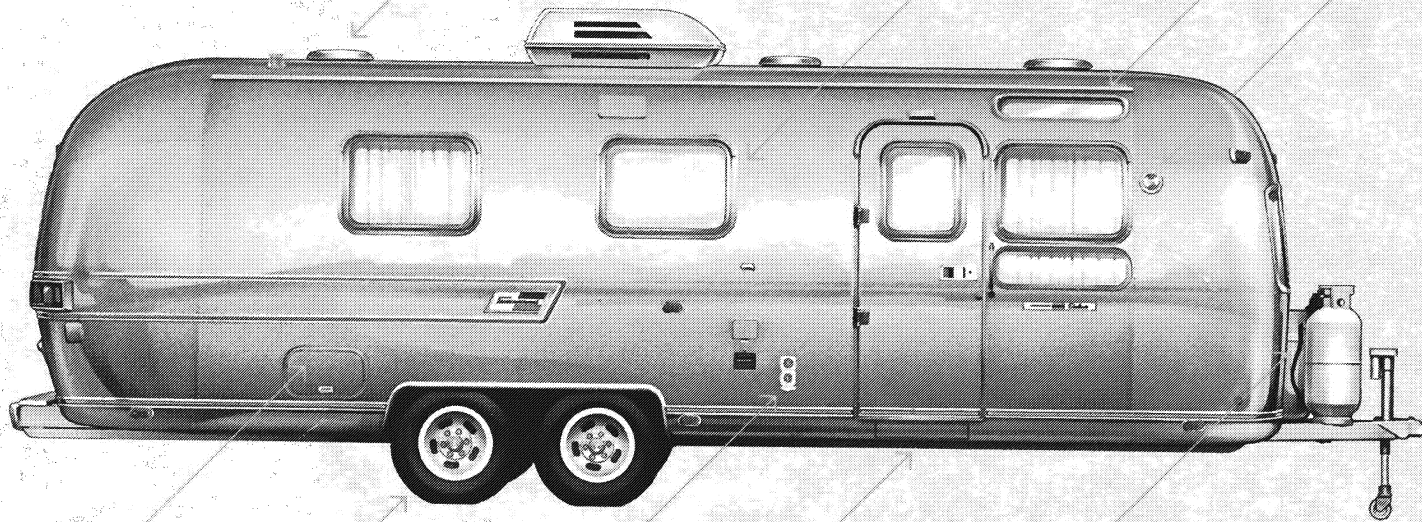

Introduction

An Airstream travel trailer offers you excellence in travel luxury and mobility. This owner's manual is your key to carefree travel fun. It contains information necessary to avoid problems. Consult it when you have a question about your new Airstream. It has been designed to aid you in knowing your trailer better. All information, illustrations and specifications contained in this literature are based on the latest product information available at the time of publication approval. The right is reserved to make changes at any time without notice. Should you trade or sell your Airstream, please leave the manual with the trailer. Go Airstream and make this your year for carefree vacations.

Note: If and when new materials and production techniques are developed which can improve the quality of its product or material substitutions are necessary due to availability, Airstream reserves the right to make such changes.

Contents

Wally Byam Caravans and Clubs	2
Warranty and Service	4
Explanation of Airstream Warranty	6
Certified Service Centers	9
Wally Byam Stores	15
Tow Car Equipment	16
Brakes	17
Loading	20
Tires	30
Hitching Up	33
Towing Tips	36
Overnight Stop	39
Extended Stay	40
Winter Airstreaming	42
Storage and Winterizing	43
Exterior Identifications	44
Exterior	46
Floor Plans	48
Interior	54
L.P.G. System	63
Refrigerator	64
Microwave Oven	66
Range and Oven	68
Furnace	70
Water Heater	72
Water System	73
Drain and Waste System	76
Electrical System	79
Battery	81
Electrical Outlet Locations	82
Electrical Wiring Diagrams	83
Electrical Trouble Shooting	91
Specifications	92
Pre-Travel Check List	94
Lubrication and Maintenance	96
Maintenance Record	97
Index	98

Wally Byam Caravans and Clubs

When you bought your Airstream, you bought a whole new way of life. Airstream owners enjoy endless opportunities for friendship, fun and adventure. You may join every **Airstream Wally Byam Caravan** and **Airstream Company Rally**. We arrange for such rallies each year: one in the North West, South West, North East and South East. You also become eligible to join the **Wally Byam Caravan Club International**, the largest single make trailer club in the world. The **WBCCI** is made up of 26,000 family memberships and 160 local chapters or units throughout the United States, Canada and Mexico. They meet at monthly rallies, or where weather conditions prevent year round rallies, Caravanners come together for pot luck dinners to plan events for the good seasons.

Since the first Wally Byam Caravan in 1951, 110 Airstream Caravans have gone to most parts of the world. Caravans to Canada and Mexico are now so popular that there are six each year. Many a lifelong friendship was started on these trips. Old-timers and new owners share experiences and find a new kind of fellowship, and there is no better way to learn to use your Airstream. Caravanners enjoy many advantages: the security of traveling in a group, planned entertainment and exceptional sightseeing opportunities. The prestige and good will established over many years by our Caravans adds further benefit to Caravanner membership.

The **"Caravanner"** is the Airstream publication and the **"Blue Beret"** is the official



Caravan Club publication. The bi-monthly "Caravanner" is for general distribution to owners and prospective buyers, while the monthly "Blue Beret" is for WBCCI members only.

Several months before a Caravan rolls, the "Caravanner" and the "Blue Beret" publish a description and a registration coupon. Everyone who registers receives a detailed bulletin with complete information on the caravan. When going abroad, all official matters such as insurance, tourist cards and border crossing formalities are handled for you by the Caravan staff. On every Airstream Caravan, the route is carefully planned, and a day by day itinerary, including mail stops, is given to all Caravanners in advance. Our staff also makes all the arrangements for parking, entertainment, tours, etc. well ahead of the



starting date. Airstream Caravan Programs always take caravanners of all ages into account. Airstream provides the Caravan Staff: a leader, a recreation advisor, a service representative and an advance representative. This staff is backed by committees composed of interested Caravan members who assist in the day-to-day operations.

Wally Byam, pioneer trailer traveler, and founder of the Airstream Company, was born on July Fourth and the first **International Rally** was in the form of a huge birthday party for him at Bull Shoals, Arkansas. It was patterned after the International Rallies in Europe which Wally and his wife Stella had attended for many years. Everyone enjoyed this first big rally so much that the club decided to make it an annual event. Since then, International

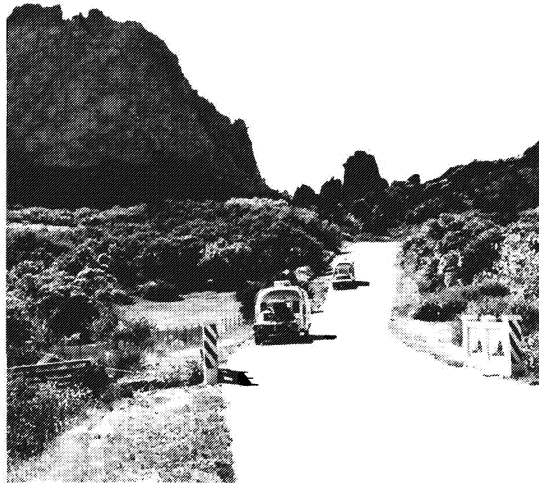

Rallies have grown and grown. Some 4493 Airstream Travel Trailer families recently gathered at Louisville, Kentucky for the 1976 International Rally.

Only Airstream Wally Byam Caravanners and WBCCI members are entitled to have an official **Trailer Number** and be listed in the 1976 **Annual Directory**. This directory contains a schedule of all major WBCCI Rallies and Airstream Wally Byam Caravans and Rallies for the year, and announces the activities of the Ham Radio, C.B. Radio, Square Dance and the many other WBCCI special interest groups.

Along with the fun, Airstream owners recognize the need for better legislation, more and better overnight parking facilities, more sanitary stations and other travel conveniences.



They are alert to adverse bills governing travel trailers and have achieved much through the actions of the strong **WBCCI National Legislative Committee**.

The Way of Life Department, of the Airstream Company dedicates its full time staff to improving the owners' fun and makes use of all the information and experience gained by owners over the years to help develop even better Airstreams and Way of Life programs for the enjoyment of all Airstream owners.

Become part of the Airstream Way of Life. Join our WBCCI activities and we believe you will enrich your life. Owners join through a local unit of WBCCI. All operate autonomously, elect their own officers and fix their own dues. Annual International dues are paid with the unit dues at the time

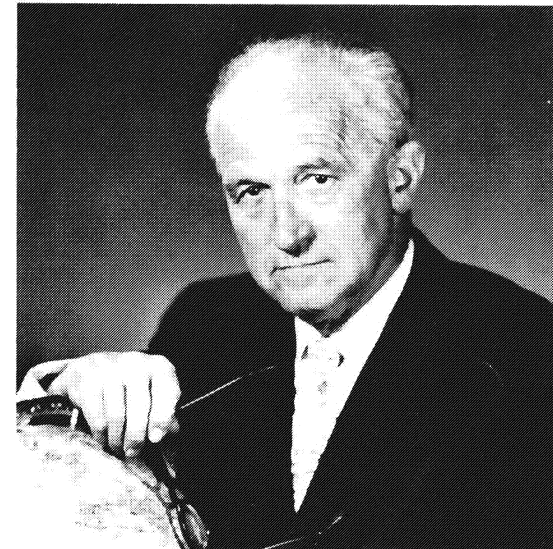

of application. These are at present: International dues, \$7.50 per trailer and unit dues from \$1 to \$10. If you are interested, please write to the following address and we will forward your letter to the unit nearest you:

WBCCI Headquarters Office
15939 Piuma Avenue
Cerritos, California 90701

Warranty and Service

Airstream offers the most complete and explicit warranty in the industry. Your valuable warranty covers every item in your trailer (except tires and battery) against failures resulting from defects in either material or workmanship for two years from date of purchase as the original owner.

Please read the facsimile warranty carefully. As soon as the factory has received your signed check-out and acceptance sheet, a formal warranty is issued to you, together with an owner's identification card. As soon as you receive your warranty, please attach it over the facsimile for safekeeping. **In order to qualify for service without charge under the Airstream Warranty Program, your owner's identification card or authorization for Interim Warranty must be presented to the service representative.**

The Airstream Certified Performance Checkout, or C.P.C., is an exclusive Airstream program. Before leaving the factory, each and every vital part of an Airstream is tested for performance. Each test is signed and certified by an inspector. After the Airstream arrives on your dealer's lot, all of these vital parts and systems are again tested. When you take delivery of your new Airstream, a factory trained trailer expert personally gives you a complete check-out on the trailer.

C.P.C. does not stop here. After you have traveled with your Airstream for 1000 miles (or 60 days, whichever comes first) you can make an appointment with any one of the

170 Airstream dealers or service centers for still another check-out of your trailer. At that time, a specified list of performance checks on your trailer equipment will be conducted and any deficiencies you have experienced since taking delivery will be corrected. Give the C.P.C. card overleaf to the dealer when you take your Airstream for the 1000 mile check.

Please contact your dealer if you need service. Major service under your Airstream Warranty is available through our nationwide network of factory trained specialists at Airstream Certified Dealer Service Centers listed on pages 9-14 of this manual. **All centers operate on an appointment basis for the utmost efficiency.** When you require service from the Airstream factory or a certified service center, please contact the service manager for an appointment, and kindly inform him if you are unable to keep the appointment date or wish to change it.

Airstream factory service may be arranged by contacting the service manager at:

Airstream
15939 Piuma Avenue
Cerritos, California 90701
(213) 860-4411

Airstream
Jackson Center, Ohio 45334
(513) 596-6111



Please place your Registered Warranty over this Facsimile, the folded edge on top. There is a glue strip on the back for this purpose.

AIRSTREAM LIMITED WARRANTY

When you buy a new Airstream Travel Trailer from an authorized dealer, Airstream warrants to you that, except for tires and battery, it will pay for the repair or replacement of any part of your trailer or any component equipment installed by the factory that is defective in material or workmanship. This warranty extends for a period of two (2) years from the date of original purchase.

All that we require is that you use your trailer in a normal manner and properly maintain and service all component parts requiring scheduled maintenance, and that all repairs and replacements be made by an Airstream factory or any Airstream Certified Dealer Service center. Any warranty defect will be corrected without cost upon return of the trailer, or defective part, to an Airstream factory or Airstream Certified Dealer Service center.

All warranties of merchantability and fitness for a particular purpose, whether written or oral, express or implied, shall extend only for a period of two (2) years from the date of original purchase. There are no other warranties which extend beyond those described on the face hereof and expressly excludes conditions resulting from normal wear, accident, abuse, exposure or overload. Some states do not allow limitations on how long an implied warranty lasts, so the above limitation may not apply to you.

For additional information regarding your Airstream Warranty, refer to the materials entitled "Explanation of Airstream Warranty" provided with this warranty.

AIRSTREAM®

Ohio Factory: 177 West Church Street, Jackson Center, Ohio 45334
California Factory: 15939 Piuma Avenue, Cerritos, California 90701

Explanation of Airstream Warranty

The Airstream Warranty applies for a period of two (2) years from the date of original purchase, and the applicable date of all warranties is that indicated on the owner's I.D. card. (Owner's Identification.) Warranty defects (except tires and battery) will be corrected without cost upon the return at the owner's expense of the trailer or defective part to any Airstream factory, Airstream Certified Dealer Service Center, or participating Argosy Certified Dealer Service center.

The Airstream axle is manufactured to a tolerance of 1° camber and 1/8" toe-in. These tolerances will only change if the trailer is subjected to abuse, such as dropping off a sharp berm, striking a curb, or hitting a deep hole in the road. Such damage would be considered as resulting from an accident which risks are not covered under the warranty. Abnormal tire wear and/or wheel alignment resulting from such damage is not covered under the terms of the warranty.

The tire and battery warranties will be handled by their respective service points and according to their written policy.

Caution: Your Airstream is equipped with the all new Excella-Vac brake system which for the first time brings all of the advantages of full disc braking to travel trailers. It is extremely important to note, however, that Excella-Vac uses an entirely different system for controlling brake operation. It is not compatible in any way with the old electric brake

control system. If you do not use the control system designed for use with the Excella-Vac disc brakes, the terms of your Airstream warranty will be voided with respect to any damages incurred as a result of the use of a noncompatible system. In addition, many advantages of the exclusive Airstream disc brakes will be lost if the Excella-Vac control system is not used.

Inasmuch as this warranty covers defective material and/or workmanship, adjustments and checking are excluded. All adjustments are made at the factory prior to shipment, and rechecked by the dealer prior to delivery to the customer. An additional check-up, including adjustments, is given at the 1,000 mile or 60 day inspection. Adjustments thereafter become a customer responsibility.

Each Airstream exterior (not including the underside) is sprayed with a plastic coating material to prevent oxidation. This application is covered by the two year warranty against peeling. Prolonged exposure to salt air or industrial fall-out will permit penetration through the coating material, causing damage to the exterior metal. Since Airstream has no control over these conditions, it is necessary for the owner to wash his trailer as instructed in the Owner's Manual.

Damage to enameled or porcelain surfaces resulting from abrasion or blows is the result of accident or abuse, and is not covered by warranty. Window glass breakage, and what is termed by the automotive

industry as "mysterious explosions," although not covered under this warranty, is covered by the comprehensive clause of most insurance policies.

This warranty does not include failure caused by accident, abuse, normal wear, overload, or any cause not attributable to a defect in original material or workmanship of the trailer or component equipment as installed by the factory.

Exclusions:

1. Normal Wear.

Items such as tires, water heater flints, water purifier packs, curtains, upholstery, floor coverings, window, door and vent seals will show wear or may even wear out within the two year warranty period depending upon the amount of usage, weather, and atmospheric conditions.

2. Accident

We can all recognize damage caused by accident because it is visible, and we strongly urge our dealers and customers to inspect the trailer upon receipt of delivery for any damage caused by accident while being delivered to the dealer, or while it is on the dealer's lot. Damage of this nature becomes the dealer's or customer's responsibility upon acceptance of delivery, unless Airstream is notified and the damage is verified by the person making the delivery.

3. Abuse.

Lack of customer care and/or improper maintenance will result in early failure for

which Airstream cannot be held responsible.

4. Exposure

Not unlike a car, the steel parts of a trailer can and will rust if subjected to prolonged exposure to moisture, salt air, or corrosive air-borne pollutants without repainting. Aluminum oxidizes when unprotected under similar conditions, and refinery chemicals of a sulfurous nature are harmful to finishes if not washed off periodically. Extremely hot or direct sunlight will deteriorate rubber and fade curtains and upholstery. Conditions of this nature, although they may be normal for the area, are beyond Airstream's control and become the responsibility of the owner.

One other type of exposure is that resulting from an accident, rain or plumbing leak. Although it is our obligation to correct a rain or plumbing leak within the terms of the warranty, it is the owner's responsibility to use reasonable, prudent care to minimize foreseeable secondary damage, such as a delaminated floor, stained upholstery, carpeting, drapes, etc.

5. Overload.

Damage due to loading, either beyond capacity or to cause improper towing because of improper balance, is beyond Airstream's responsibility. The Airstream trailer is engineered to properly handle the gross vehicle load rating on the certification label. Load distribution has a

definite effect upon the towing characteristics and attitudes of the trailer. Level hitch installations are a necessity, and very important on a tandem axle trailer. There are limits to the amount of load that can be safely transported depending upon speed and road conditions, and reasonable cause to believe these factors have been exceeded could void the Airstream warranty. For additional information on the loading of your trailer, consult your Owners Manual or gross vehicle weight rating plate.

Airstream will not be responsible for any consequential damages incurred as a result of any warranty defect. Consequential damages include, but are not limited to, travel expenses, gasoline, oil, lodging, meals, telephone tolls, loss of work and loss of use of the trailer. Some states do not allow the exclusion or limitation of incidental or consequential damages, so the above limitation or exclusion may not apply to you.

In the event of a warranty defect, the warranty holder should take corrective action to lessen the damages which might result from such defect. Airstream will not be responsible for resulting damages which could have been avoided.

The full extent of Airstream's warranty is set forth in the "Airstream Limited Warranty" and this "Explanation of Airstream Warranty." Airstream will not be responsible for additional representations or implied warranties made by any of its dealers to the

extent those representations are not a part of, or are contrary to, the terms and conditions of the Airstream Warranty and Explanation of Warranty. This warranty gives you specific legal rights, and you may also have other rights which vary from state to state.

If you believe your trailer needs repairs under the terms of the Airstream warranty, you should contact the Service Manager at any Airstream factory, Airstream Certified Dealer Service center or participating Argosy Certified Dealer Service center. The trailer or defective part must be returned to a factory or authorized service center at the owner's expense.



Insurance

The Exclusive Caravanner Travel Trailer Insurance Plan

A complete comprehensive policy, including these five bonus benefits at no additional cost:

- Collision coverage (low deductible)
- Theft coverage against personal effects
- Personal effects coverage against damage or loss by collision, etc.
- Vacation expense allowance
- Mexico travel coverage (90 days)

And, there are no other deductibles!

Already over 25,000 Airstream owners are benefiting from this program. Fast, efficient claim service, coast to coast. Underwritten by Central National Insurance Company of Omaha, with assets of over \$60 million. This program also includes complete protection against these losses: fire, lightning, explosion, windstorm, hail, landslide, flood, all accessories, vandalism, and many more perils commonly insured by comprehensive coverage.

The New Airstream Owner's Association Accident Insurance Program

A big bonus benefit available only to Airstream owners.

This program includes 24-hour protection for accidental death or dismemberment – anywhere in the world, on or off the job; on business, on vacation – or at home PLUS 2½ times the benefits while on a trip with your Airstream.

No medical statement is required and you will not be bothered by a physical examination or investigation. But you must be an Airstream owner, under age 70. There are 4 specialized plans from which to choose. Here's an example of benefits:

Plan B-1 (While at home) Plan offers the owner and spouse full 24-

hour protection against accidents anywhere in the world, whether on or off the job, on business, pleasure, or vacation. This plan pays \$20,000 and \$10,000 to owner and spouse respectively in event of accidental death or dismemberment, and \$14.00 a day for up to 365 days while in the hospital.

Plan B-1 (While on a trip with an Airstream) Benefits are payable if the accident occurs when the insured is away from his permanent address while on a trip with his Airstream Travel Trailer. Coverage is provided 24-hours a day for all types of accidents during a trip. At this time the accidental death benefit would increase to \$50,000 and \$25,000 respectively. The daily in-hospital allowance would increase to \$35.00 a day for up to 365 days. The annual premium for plan B-1 is only \$89.

For fast efficient service and answers to your specific questions, call **TOLL FREE 800-421-8560**.

Travel carefree. Fill out and mail the following request card today!

Protect your investment.

Please rush information on these exclusive Airstream money-saving programs:

- Caravanner Travel Trailer Insurance Plan.
- Airstream Owner's Association Accident Insurance Program

Name _____

Address _____

City _____ State _____ Zip _____

Business Reply Mail

No postage necessary if mailed in the United States

First Class
Permit No. 36321
Los Angeles, CA

Postage will be paid by

Caravanner Insurance, Inc.
2411 West Third Street
Los Angeles, CA 90057

Certified Service Centers

ALABAMA

Alabama Auto Carriage Inc.
2359 West Fairview
P.O. Box 1695
Montgomery, Alabama 36108
205-262-3563 or 262-3564

R & S Camper Sales
2405 Ardmore Highway
Huntsville, Alabama 35806
205-837-5241

ARKANSAS

Fred and Jack Trailer Sales
10318 New Benton Highway
1-30 West
Little Rock, Arkansas 72209
501-565-0131

ARIZONA

O'Rielly RV Center, Inc.
4780 E. 22nd Street
Tucson, Arizona 85711
602-748-1414

Robert Crist & Company
2025 East Main Street
Mesa, Arizona 85203
602-834-9410

Robert Crist & Company
8833 North Black Canyon Hwy.
Phoenix, Arizona 85021
602-944-2288

CALIFORNIA

Adventure Trailer Center
5810 S. Union Avenue
Bakersfield, California 93307
805-831-5451

Bill Barry Pontiac
2000 East 1st Street
Santa Ana, California 92705
714-558-1000

Caswell's Vacation Vehicles
700 East Foothill Boulevard
Pomona, California 91767
213-331-0163

Coastline Trailer Sales
303 North Ventura Avenue
Ventura, California 93001
805-648-1772

Haller Trailer Sales
15711 South Lakewood Boulevard
Paramount, California 90723
213-634-3553

Holiday Trailer Sales
770 East Baseline
San Bernardino, California 92410
714-889-8918

Manteca Trailer Sales
9862 E. Yosemite Avenue
Manteca, California 95336
209-239-1267

Murray's RV Center
1201 E. Washington
Escondido, California 92025
714-743-2422

Nelson's RV Enterprises, Inc.
28001 Mission Boulevard
Hayward, California 94544
415-582-9433

Pulmobile Trailer Sales
4563 San Fernando Road
Glendale, California 91204
213-241-0310 213-245-6068

Ralph's Trailer Sales and Supply
1025 East Main
El Cajon, California 92021
714-442-4435

Santa Rosa Airstream
3534 Santa Rosa Avenue
Santa Rosa, California 95401
707-525-8330

Toscano Recreation Center
617 W. Pacheco Boulevard
Los Banos, California 93635
209-826-4923

Valley Motors Camperland
2370 S. Broadway
Santa Maria, California 93454
805-925-8617

Valley Trailer Sales, Inc.
1650 El Camino Avenue
Sacramento, California 95815
916-929-2200

Valley Travel Center, Inc.
584 El Camino Real North
Salinas, California 93901
408-499-5438

COLORADO

Chisman Trailer Sales
2500 East Boulder Street
Colorado Springs, Colorado 80909
303-473-7043

Trailerland
8200 W. Colfax Avenue
Denver, Colorado 80215
303-237-9591
Branch: 2515 E. Mulberry Street
Ft. Collins, Colorado 80521
303-493-3676

CONNECTICUT

A-1 Trailer and Motorhome Sales
Route 66 and Jackson Hill Road
Middlefield, Connecticut 06455
203-344-0338 or 344-0339

Camperama of Danbury, Inc.
Mill Plain, Route 6, Btw. Exit 1 & 3, I-84
Danbury, Connecticut 06810
203-743-2726

DELAWARE

Marty's Travel Trailers, Inc.
2343 South DuPont Highway
Dover, Delaware 19901
302-697-3173

FLORIDA

Airstreams by General
5610 Okeechobee Road
West Palm Beach, Florida 33406
305-686-3707 or 584-2888

Airstreams by General
1881 St. Rd. 84
Ft. Lauderdale, Florida 33315
305-525-3374

Bell's Trailer Park and Sales, Inc.
Route 4, Box 382, Highway 90W
Tallahassee, Florida 32310
904-576-2915

Camptown USA, Inc.
23905 SW 132nd Avenue
6 mi. S. of Perrine on US 1 at Princeton
Miami, Florida 33171
305-245-2353

Carpenter's Campers, Inc.
8450 Pensacola Boulevard
US 29 North, Between I-10 & 90
Pensacola, Florida 32504
904-477-6666

Indian River Trailer Sales
5855 US Highway 1 –
Midway between Cocoa
and Titusville
Cocoa, Florida 32922
305-636-1422

Orlando Travel Center
5001 Sand Lake Road
Route 528, 1 mile E. of I-4
Orlando, Florida 32809
305-351-0581

Kropf Eldorado, Inc.
6915 14th Street West
US 41, S.
Bradenton, Florida 33507
813-755-1586

C. J. Stoll, Inc.
5985 34th Street, North
US 19
St. Petersburg, Florida 33714
813-527-2189

GEORGIA

Three-Way Campers, Inc.
1370 North 4 Lane Highway (US 41)
Marietta, Georgia 30062
404-422-9300

IDAHO

Wheels Unlimited
709 N. 5th, P.O. Box 4685
Pocatello, Idaho 83201
208-233-4230

ILLINOIS

Crystal Valley, Inc.
4220 Northwest Highway
US 14 at Route 31
Crystal Lake, Illinois 60014
815-459-6611

Four Winds of America, Inc.
U.S. 51N, RR#1
Maroa, Illinois 61756
217-794-2292

Rocket Trailer Sales
Route 30 and Sixth Avenue
Rock Falls, Illinois 61071
815-625-6245

Wilderness Lake Camp Ground, Inc.
Route #2
Martinsville, Illinois 62442
217-279-3340

Vacationland Trailer Sales
US 30
Shabbona, Illinois 60550
815-824-2063

INDIANA

Berning Trailer Sales, Inc.
5220 New Haven Avenue
Fort Wayne, Indiana 46803
219-749-9415

C & G Recreational Center, Inc.
RR #3, Box 46
North Muncie, Indiana 47302
317-228-1883

Camp-Land, Inc.
US 30, ½ mi. W. of I-65
1 mi. W. of South Lake Mall
Merrillville, Indiana 46410
219-769-8496

Four Seasons Trailer Sales, Corp.
8225 W. Washington Street
Indianapolis, Indiana 46231
317-241-8348

Mid-West Trailer Mart, Inc.
2409 Corydon Pike
New Albany, Indiana 47150
812-945-1173

Travel Center of Elkhart, Inc.
25610 C.R. 4 E.
Elkhart, Indiana 46514
219-264-3161

IOWA

Barrows Camp-O-Rama
1912 Washington Boulevard
Camanche, Iowa 52730
319-259-8921

Ace Fogdall, Inc.
5324 University Avenue
Cedar Falls, Iowa 50613
319-266-4404

Imperial RV Center
1727 Ankeny Road
Ankeny, Iowa 50021
515-964-1424

KANSAS

Scholfield Winnebago, Inc.
11516 East Kellogg
Wichita, Kansas 67207
316-684-0236

KENTUCKY

Crouch Campers & Trailers
5081 Reidland Rd., Route 4
Highway 62-68 S.E.
Paducah, Kentucky 42001
502-898-7373

Murphy Sales Company, Inc.
Winchester Road (US 60W)
Box 404
Mt. Sterling, Kentucky 40353
606-498-1168

LOUISIANA

Camper Village, Inc.
705 Florida Boulevard, S.W.
Denham Springs, Louisiana 70726
504-664-7104

Givens Travel Center
9724 Mansfield Road
Shreveport, Louisiana 71108
318-686-8863

Superior Pontiac GMC, Inc.
200 Wright Avenue
Gretna, Louisiana 70053
504-368-5640

MARYLAND

B & J Trailer Sales
Box 369, US Route 40
Aberdeen, Maryland 21001
301-575-6840

Koons Ford of Annapolis, Inc.
2540 Riva Road
Annapolis, Maryland 21401
301-224-2100

MAINE

Giant Advance Camper Country
765 Center Street
Auburn, Maine 04210
207-783-2291

MASSACHUSETTS

Donahue's Trailer Sales
88 Mountain Road, Box 126
Off Route 128 at Exit 41-S
Burlington, Massachusetts 01803
617-272-9830

Mosher Travel Trailer Center
171 Route 20
Shrewsbury, Massachusetts 01545
617-754-7500 or 865-4294
Service: Central Pike
Sutton, Mass. 617-865-4294

MICHIGAN

Bay Valley RV Center
2717 Delta Road, RR #4
Bay City, Michigan 48706
517-684-0930

Caswell and Company
243 South Dexter
Ionia, Michigan 48846
616-527-3310

Cadillac R.V. Center
2108 North Mitchell
Cadillac, Michigan 49601
616-775-8131

Kolbe Trailer Sales
4401 East Eight Mile Road
Warren, Michigan 48091
313-536-0265 or 754-8310

Moore's Recreation
1222 E. North Territorial Road
Whitmore Lake, Michigan 48189
313-662-4548

*Northwoods
Recreational Vehicle Center*
G-6369 North Dort Highway
Mt. Morris, Michigan 48458
313-686-4330

Vicars Trailer Sales, Inc.
9080 Pelham at Wick
Taylor, Michigan 48180
313-291-9000 or 291-1980

Woodland Travel Center, Inc.
5190 Plainfield Road
Grand Rapids, Michigan 49505
616-363-9038

MINNESOTA

Hart Trailer Sales
Highway 71
Long Prairie, Minnesota 56347
612-732-6106

Minnesota Trailer Sales, Inc.
11350 Highway 65 N.E.
Blaine, Minnesota 55433
612-757-1420

MISSOURI

I-44 Recreational Vehicles, Inc.
Box 93, S. Side Halltown Exit on I-44
14 miles W. of Springfield, Mo.
Halltown, Missouri 65664
417-749-2131

Kansas City Trailer Sales, Inc.
11530 South 71 Highway
Kansas City, Missouri 64137
816-761-3322

Bill Thomas Camper Sales, Inc.
5217 N. Lindbergh Boulevard
Bridgeton, (St. Louis) Missouri 63042
314-731-2217

MONTANA

Big Sky Airstream
1923 Old Hardin Road
Billings, Montana 59101
406-259-5571

Bretz Trailer Sales
1023 Kensington
Missoula, Montana 59801
406-543-5721

Modern Equipment Company, Inc.
4025 10th Avenue, South
Great Falls, Montana 59401
406-761-3520

NEBRASKA

Autosport RV Center
6101 "L" Street
Omaha, Nebraska 68117
402-734-1133

NEVADA

"95" Trailer Sales
4339 N. Rancho Drive
Las Vegas, Nevada 89106
702-645-1122

NEW HAMPSHIRE

Ray's Marina, Inc.
Route #16
Milton, New Hampshire 03851
603-652-4523

NEW JERSEY

Airstream by Angell
Route 78 & 173 Interchange
Box 94
Bloomsbury, New Jersey 08804
201-479-4118

South Jersey Travel Trailer Center, Inc.
Route 47
Delsea Drive
Franklinville, New Jersey 08322
609-694-1700 or 694-1701

NEW MEXICO

Wayne's Recreational Vehicles, Inc.
12020 Central Ave., S.E.
Albuquerque, New Mexico 87123
505-296-0507

NEW YORK

Bailey-Momot, Inc.
Rural Route 1, Box 316
Plattsburgh, New York 12901
518-563-2440 or 563-2441

Ballantyne Trailer City, Inc.
7447 Route 96
Victor, New York 14564
716-924-3264

Ralph Bubbs Sport Center
RD 5
Route 57
Fulton, New York 13069
315-695-5020

Ken's Camper Sales
Noxon Road
Poughkeepsie, New York 12603
914-452-5095

Maroone Family Travel Center, Inc.
2550 Walden Avenue, Exit 52
E from NY Thruway
Buffalo, New York 14225
716-681-1700

Niblack Trailer Sales
691 McLean Avenue
Corner NY Thruway
Yonkers, New York 10704
914-965-5685

O'Malley Enterprises, Inc.
Traffic Circle-Route 9 & 7
P.O. Box 116
Latham, New York 12110
518-785-6654

Walker's Four Seasons
Route 17, Box 265
Big Flats, New York 14814
607-562-8731

NORTH CAROLINA

College Park
4208 New Bern Avenue
Raleigh, North Carolina 27610
919-833-7015

College Park
North Church Street Extension
US 301 and 301A North
Rocky Mount, North Carolina 27801
919-446-7166 or 446-9233

Faires, Inc.
3217 N. Tyron Street
Box 5205, Route 29 and 49
Charlotte, North Carolina 28206
704-333-1195 or 377-1449

Hawley's Cycle & Camping Ctr., Inc.
4784 Raeford Road
Fayetteville, North Carolina 28304
919-425-3145

Out Of Doors Mart, Inc.
Winston-Salem,
Greensboro Highpoint
I-40 at Sandy Ridge Road Exit
Drawer 799
Kernersville, North Carolina 27284
919-993-4518

NORTH DAKOTA

McLaughlin Equipment Co.
320 27th Street, South
Fargo, North Dakota 58102
701-237-6046

OHIO

Avalon Travel Center, Inc.
11761 Portage Road
Canal Fulton, Ohio 44614
216-854-2222

Buckeye Airstream Serv. & Sls., Inc.
Baltimore Road, Box 13
N. of E. I-70 on 310 at Rt. 40
Etna, Ohio 43018
614-861-6389

Executive Travelers
4668 Monroe Street
Toledo, Ohio 43623
419-473-1189

Jerry Greer Airstream Argosy, Inc.
4855 Groveport Road
Columbus, Ohio 43207
614-491-8544

Coachman Camping Center
410 East Sandusky Street
Findlay, Ohio 45840
419-423-1912

H & H Recreational World
P.O. Box 108, N. County Rd. 25A
Piqua, Ohio 45356
513-773-2212

H&H Recreational World
Branch: 5275 N. Dixie Drive
Dayton, Ohio 45414
513-275-3311

Murphy Travel Trailers of Ohio, Inc.
11526 Chester Road
3 doors N. of Windjammer
Cincinnati, Ohio 45246
513-771-5771

Frank B. Ricketts Travel Trailers
P.O. Box 683
I-77 at US 40
Cambridge, Ohio 43725
614-432-4040

OKLAHOMA

Brassfield Mobilhomes
7227 NW 39th Expressway
Bethany, Oklahoma 73008
405-789-4941

Travel Home Sales, Inc.
16015 East Admiral Place
Tulsa, Oklahoma 74138
918-437-0020

OREGON

Cascade Trailer Sales
1876 Highway 99, North
Eugene, Oregon 97402
503-688-8505

Spencer's RV Center
9341 S.E. 82nd Avenue
Portland, Oregon 97266
503-777-1484

PENNSYLVANIA

Farnsworth Camping Center
Route 54
Elysburg, Pennsylvania 17824
717-672-2332

Glasgow Recreational Vehicles, Inc.
1650 Lincoln Way East
Chambersburg, Pennsylvania 17201
717-264-9551

Lo-Jan Travel Center
Route 6, Scranton-Carbondale Hwy.
Scranton, Pennsylvania 18508
717-489-9302

Mellott Brothers
R.D. #2
Willow Street, Pennsylvania 17584
717-464-2311 or 464-2601

Robison Trailer Sales
Route 198 at Blooming Valley
R.D. #3
Meadville, Pennsylvania 16335
814-724-8129

Trav-L-Homes
Lewis Road
Royersford, Pennsylvania 19468
215-948-5111

Turner Airstream Sales
412 Lincoln Highway, W.
Jeannette, Pennsylvania 15644
412-523-6545 or 523-6546

Village Green Trailer Sales Co.
Route 452, Pennell Road
Media, Pennsylvania 19063
215-494-4155 or 494-4035

Wiles Trailer Sales
1030 North Main Street
Route 8 & 422
Butler, Pennsylvania 16001
412-287-4745

Wise Trailer Sales
Division of F.W. Wise Gas Co.
1501 Airstream Way
Clearfield, Pennsylvania 16830
814-765-7801

RHODE ISLAND

Arlington Trailer Sales
966 Quaker Lane, Route 2
Warwick, Rhode Island 02818
401-884-7550

SOUTH CAROLINA

Dixie Lee Trailer Sales
Highways US 1 & 78
P.O. Box 306
Clearwater, South Carolina 29822
803-593-2162

Trail Center of Charleston, Inc.
5728 Dorchester Road
North Charleston, S. Carolina 29405
803-552-4700

Wray Frazier Camping Center
3630 Fernandina Rd., and I-26 West
Columbia, South Carolina 29210
803-798-0450

SOUTH DAKOTA

Eddies Airstream & Winnebago Inn
1002 East Omaha
Rapid City, South Dakota 57701
605-342-3900

Spader Camper Center
5500 North Cliff, Box 963
Sioux Falls, South Dakota 57101
605-339-3230

TENNESSEE

Bobby Jones Trailer Sales
4222 James Road (In Raleigh)
Memphis, Tennessee 38128
901-386-5833

Cullum & Maxey Camping Center
Elzie Miller Road
2 Miles North of Opryland
Donelson (Nashville)
Tennessee 37214
615-889-1600

Jewell's Camping Center
Route 4, Highway 45
Trenton, Tennessee 38382
901-855-9590

Murphy Motor Manors
Murphy Park
3163 Airport Road
Alcoa, Tennessee 37701
615-984-2380

TEXAS

A & A Trailer Sales
118 Arnold Boulevard
Abitene, Texas 79605
915-692-1555

Abbott Trailer Sales
408 Avenue Q
Lubbock, Texas 79401
806-763-4747

Bear Trailer Sales
South of Dallas on I-35
Bear Creek Road Exit
Lancaster, Texas 75146
214-223-6025

Buchanan's Camper & Trailer Sales
4109 Forest Lane
Garland, Texas 75042
214-276-2244 or 276-8542

D & M Trailer Sales, Inc.
3900 I-40 East
Amarillo, Texas 79103
806-374-1211 or 374-3789

Frank Gillman Travel Trailers
7620 Bellaire Blvd.
Houston, Texas 77036
713-771-3611

Land Yacht Trailer Sales, Inc.
4616 Titanic Avenue
El Paso, Texas 79904
915-751-0591

Lloyd's Trailer Sales
350 Twin City Hwy.
Port Neches, Texas 77651
713-727-1666

Otis Thomas Sales, Inc.
2606 Jacksboro Highway
Wichita Falls, Texas 76302
817-767-1234 or 767-0220

South Texas Trailers & Supplies
Highway 77, S., P.O. Box 880
Sinton, Texas 78387
512-364-1118

South Texas Trailer & Supplies
101 Expressway 83
P.O. Box 457
Donna, Texas 78537
512-464-3432

UTAH

Brasher's RV Sales and Service
3371 S. State
Salt Lake City, Utah 84115
801-466-5501

VIRGINIA

Bay Camping, Inc.
3757 Bonney Road
Virginia Beach, Virginia 23452
804-486-1211

James River Camper Sales, Inc.
Box 834, US 460E
Lynchburg, Virginia 24505
804-845-6127 or 846-7444

Koons Pontiac-Oldsmobile, Inc.
7105 Sudley Road
Manassas, Virginia 22110
703-591-4934

Travel Trailers of Va.
2211 South Main Street
P.O. Box 1089
Harrisonburg, Virginia 22801
703-434-9676

WASHINGTON

Central Trailer Exchange
14433 Pacific Highway, South
Seattle, Washington 98168
206-244-9600

Devon Lee Corporation
11257 Kirkland Way, P.O. Box 464
Kirkland, Washington 98033
206-822-2211

Tveten Motor Company
45th and Pacific Avenues
Tacoma, Washington 98408
206-472-1600 or 472-7112

WEST VIRGINIA

Airstream by Stanley
1400 N. Eisenhower Drive
Box 1545
Beckley, West Virginia 25801
304-252-6121

WISCONSIN

Donna Lee, Inc.
DBA Du-B-Do Sales & Service
Route 3, Box 136
Mosinee, Wisconsin 54455
715-457-2406

*Motor Vacation Unlimited
of Wisconsin*
Route 2, Box 201
Edgerton, Wisconsin 53534
608-884-3396

Northside Trailer Sales, Inc.
N56 W13180 Silver Spring Road
1 mi. W. of Hwy 100
on Silver Spring Rd.
Menomonee Falls, Wisconsin 53051
414-781-9646 or 781-9647

Swee Trailer Sales
US 2 and US 51
Hurley, Wisconsin 54534
715-561-4887

WYOMING

Bundy's Marine and Ski
3201 CY Avenue
Casper, Wyoming 82601
307-237-2509

CANADA

Barber Motors, Ltd.
19 2nd Street
Weyburn, Saskatchewan
306-842-5421

Can-Am Trailers Ltd.
Box 370
Hwy 4, ½ mi. N. 401, Exit 19
Lambeth, Ontario NOL 1S0
519-652-3284

Claynor Trailer Sales
20720 42nd Avenue
Langley, B.C.
604-530-0771

Go Camping Limited
Route #4, Highway 7
Brampton, Ontario, L6T 3S1
416-851-2366 or 674-0031

Kanata Equipment Ltd.
Highway 7, Box 190
Stittsville, Ontario
613-836-1421

Maurice Gareau, Inc.
8595 Henri-Bourassa E. Blvd.
Montreal, Quebec
514-321-7933

Pik-A-Dilly Trailer and Marine Sales, Ltd.
34th Street & Victoria Avenue
Brandon, Manitoba R7B 0M0
204-728-8570

Totem Trailer, Ltd.
85 Plains Road, West
Burlington, Ontario
416-632-0703

Travel Trailers Southern
2620A Barlow Trail, N.E.
Calgary, Alberta, T1Y 1A1
403-273-2223

Travel Trailers Western, Ltd.
6006 104th Street
Edmonton, Alberta T2N 2K3
403-434-6555 or 434-6939

Twin City Trailer Sales, Ltd.
Dartmouth Highway, Box 395
Bedford, Halifax Co., Nova Scotia
902-835-3138

Wally Byam Stores

To make trailering more enjoyable, there are Wally Byam Stores established at the majority of Airstream dealers. All Airstream dealers have the opportunity of purchasing for you the necessary equipment which would enable you to enjoy your new Airstream trailer to the utmost. The Wally Byam Stores authorized dealerships stretch from coast to coast, and these dealers stock hundreds of items which are tested and approved by travel experts. Be sure and get a Wally Byam Stores Catalog from your dealer or write to:

Wally Byam Stores

Ohio Building
P.O. Box 128
Sidney, Ohio 45365

The following is a list of equipment we recommend:

1. First Aid Kit
2. Flashlight
3. Emergency Road Warning Triangle
4. Handi-Roll Trailer Tool File – with small hand tools – hammer, pliers, crescent wrench, screwdrivers, electrical tape
5. Crosstype Lug Wrench for Trailer Wheels
6. Pop Rivets (3 sizes)
7. Pop Rivet Gun
8. Battery Booster Cables
9. Tire Gauge (up to 100 pounds P.S.I.)
10. Hitch Ball Lube
11. Small Bi-Directional Spirit Level
12. Heavy-Duty Turn Signal Flasher
13. Four Stabilizing Jacks
14. Leveling Ramps
15. Wheel Chocks

16. Spare Tire and Wheel for Single Axle Trailers
17. One 50 ft and one 25 ft length of $\frac{5}{8}$ " High Pressure Water Hose
18. Y-Connection with Cap
19. 5 Gal. Water Jug
20. Quick Disconnect Garden Hose Coupling
21. One 10 ft or 20 ft Sewer Hose
22. One Thetford Sewer Hose Adapter – Straight or Elbow
23. One Elbow Sewer Hose Outlet
24. Two $2\frac{1}{2}$ " to $3\frac{3}{4}$ " Adjustable Hose Clamps
25. One Thetford Plastic Cap with Hose Drain
26. One $\frac{1}{2}$ Gal. Holding Tank Cleaner and Deodorizer
27. 50 ft Electric Cord #12-3 wire
28. 20 ft Electric Cord #10-3 wire, 30 amp capacity
29. One Service Cord Adapter 30-15 amp
30. Spare 20, 40, and 50 amp Cartridge Fuses
31. Spare Light Bulbs (see page 92 for sizes)
32. Electrical Contact Cleaner (Spra-Kleen)

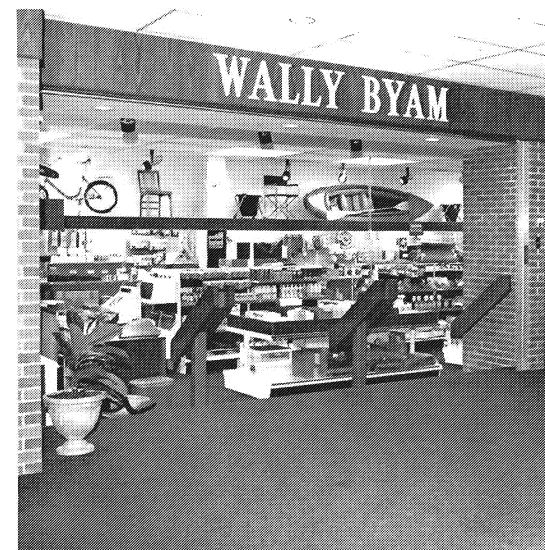

Tow Car Equipment

If you plan to buy a new car to tow your Airstream, we suggest that you include in your purchase the trailer towing options offered by most automobile manufacturers. These include such things as a heavy duty alternator and radiator, heavy duty springs and shock absorbers, automatic transmission cooler, heavy duty fan and flasher unit and others, depending on the make of the vehicle.

Transmissions may be manual or automatic, but an automatic transmission may prolong your car's engine life and generally does a better job of controlling engine loads than the average driver using a manual shift.

Having adequate power is very important when considering the purchase of a new car or the trailer towing capability of your present one. Emission controls that are required by the Federal Government have reduced overall engine power. To determine generally what the tow capability of your car is, divide the total weight of your trailer by the cubic inch displacement of your automobile engine. This ratio should be between 10 and 20 pounds of trailer weight per cubic inch of engine displacement with 15 pounds per cubic inch considered optimal. For example, with a 31' Airstream weighing 6500 pounds totally loaded for travel and a car with 400 cubic inch displacement engine, divide 6500 by 400 giving a value of 16.25 pounds of trailer weight per cubic inch engine displacement. This is very close to the optimal value and the automobile should have adequate

power for towing the trailer. Obviously, total car performance such as maximum speed up grades and acceleration is lessened when towing a trailer. Remember that engine power is only one indication of the car's towing capabilities; the axle ratio and cooling capabilities certainly must be considered. We suggest you review the owner's manual of your present car and discuss your automobile towing capabilities with your Airstream dealer and your automobile dealer.

Inspect your vehicle's hitch regularly for loose bolts or nuts, cracked welds, loose ball mounts, worn parts, etc.

The majority of new trailerists carry more food and other supplies than really needed. Remember that every item you take along is one more thing to stow and adds weight to the total load you must pull. Consolidate items in shelves, lockers, and in the refrigerator. It is better to have one full and one empty locker than two half empty ones. Special care must be taken not to overload the front and rear ends of the trailer.

See tire section for correct tire sizes and pressures for your trailer and load on pages 30-32.

Brakes

The **disc brake system** is operated by 12 volt negative ground current and engine vacuum from your tow vehicle. The brake controller and trailer disc brakes improve brake balance, braking control, reliability, and reduce brake fade from high speed stops or frequent brake application.

Disc brake components consist of a controller, power brake booster, brake release valve, disc brake calipers, and hub and rotor. Tow vehicle's and trailer's vacuum lines, brake hoses and brake lines should be checked periodically for abrasion and signs of leakage at fittings.

The **brake controller** (Fig 1), designed for use with your Excella-Vac disc brake system, must be installed in your tow vehicle for proper brake operation. **It is extremely important to note that Excella-Vac uses an entirely different system for controlling brake operation. It is not compatible in any way with the old electric brake control system. If you do not use the control system designed for use with the Excella-Vac disc brakes, the terms of your Airstream warranty will be voided with respect to any damages incurred as a result of the use of a noncompatible system. In addition, many advantages of the exclusive Airstream disc brakes will be lost if the Excella-Vac control system is not used.** The brake controller is activated automatically when you apply the brakes of the tow vehicle. Trailer brakes may be applied manually, independent from your tow vehicle brake system, by

moving the controller's lever to the right.

A **trailer brake balance lever** located on the top of the controller provides adjustment to balance the trailer brakes with your tow vehicles' brakes without the need for a selective resistor. Balanced brakes provide smooth braking action without premature shredding of tires on either trailer or tow vehicle during heavy braking.

Move the balance lever away from you to increase or toward you to decrease the effectiveness of your trailer brakes. When first installed set the adjustment to the maximum setting, then reduce setting as required to obtain smooth braking.

There are **two indicator lights** on your controller. During brake application, the green light glows indicating normal system operation. The intensity of the green light increases as braking effort increases. A red light will glow if the brake electrical wiring is faulty. Loss of electrical input to your controller will be indicated by neither light glowing when brakes are applied.

Do not use a selective resistor.

A **vacuum line assembly** furnished in your disc brake tow vehicle kit must be installed in your tow vehicle, which provides vacuum to the power brake booster assembly located on your trailer. (See Fig. 2) Vacuum is supplied to the trailer by coupling the trailer vacuum hose to the tow vehicle



Fig 1—Brake Controller

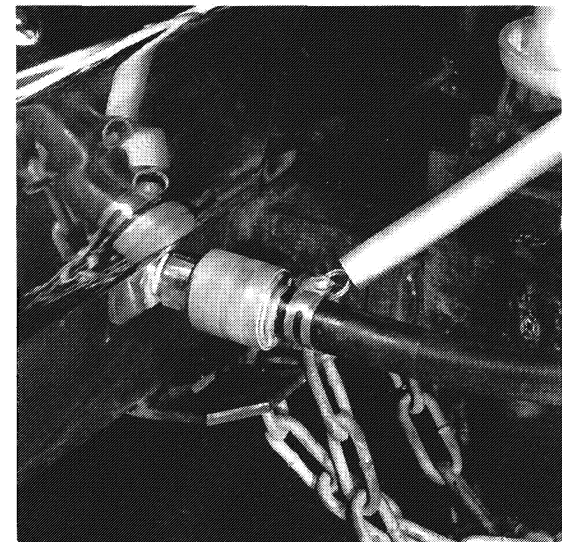

Fig. 2—Trailer Vacuum Hose Connection

vacuum connector. To couple, push knurled coupling sleeve forward, firmly insert trailer's vacuum hose fitting and pull sleeve back. Check for proper locking by firmly pulling trailer's hose fitting.

Important: A coupling plug must be inserted in the tow vehicle's vacuum connector when the trailer is disconnected. Operating your engine without the plug will result in a vacuum leak. This may result in engine misfiring, or inoperative vacuum boosted accessories (brakes, emissions, etc.) Extended operation may cause engine damage. An extra plug is supplied in the kit.

The **power brake actuator** (Fig. 3) located in the trailer tongue (or under the front lounge or optional corner table in some models) supplies hydraulic pressure to the disc brake calipers. The fluid level in the booster's master cylinder should be checked twice a year. If necessary, add fluid to bring level to within ¼ inch of the top of the reservoir. With disc brakes, fluid level can be expected to fall as the brake pads wear. Only brake fluid conforming to DOT 3 should be used. Use only fresh brake fluid that has been in a tightly closed container to avoid contamination from foreign matter or moisture. Periodically check actuator breather. Replace element if dirty.

When the **trailer vacuum hose** (Fig. 4) is disconnected from the tow vehicle, the trailer brakes are automatically applied.



Fig. 3—Power Brake Activator and Breather

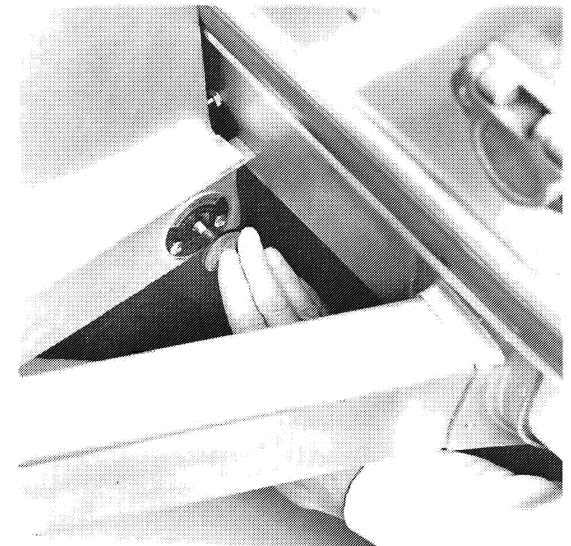

Fig. 5—Brake Release Knob

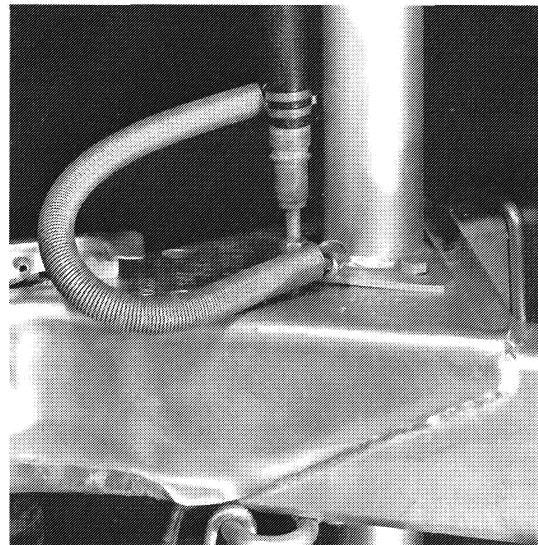

Fig. 4—Trailer Vacuum Hose Storage



Fig. 6—Disc Brake Calipers, Hub and Rotor

X

This provides break-away protection should the trailer break away from the tow vehicle. Brakes engaged by a disconnected supply line can be disengaged by pushing and holding knob (Fig. 5) on brake release valve for 10 seconds. Blocking or chocking wheels is necessary when parking your trailer. **Do not use trailer brakes as parking brakes** by disconnecting the trailer vacuum line.

The self-adjusting **disc brake calipers** (Fig. 6) should be inspected for wear any time the wheels are removed for tire rotation, wheel bearing maintenance, etc. The lining will need replacement if there is evidence of brake fluid leakage or if there is less than $\frac{1}{16}$ " between the liner and liner's steel backing plate. See your Air-stream dealer for all trailer braking service.

The optional **Tru Track Sway Control** is a single package system which momentarily applies the trailer brakes when sway develops as the result of such occurrences as rapid maneuvers to avoid road obstacles, extreme air disturbances and accidental travel on and off the shoulder of the road. Because of its design, it will not react to any normal driving maneuver that is smoothly performed. However, it will interpret any maneuver that jerks the trailer as an indication of sway and the restraint felt from the short brake application will normally alert the driver to steer with greater care.

The green light on your brake controller

will illuminate each time the sway control applies the brakes. It also illuminates when the brakes are applied by the driver in normal braking.

Frequent operation of the Sway Control indicates that the car-trailer combination is basically unstable and prone to excessive sway. The problem should be corrected; check for improper load distribution in the trailer, an inadequate hitch, insufficient or excessive tire pressure, etc.

Important: If at any time the brake controller green light remains on or Sway Control is continually applying trailer brakes, disconnect Sway Control unit at power source and correct problem.

Additional information on the Brake System is available in the Airstream Service Manual.

Loading

For over 40 years, Airstream has been building trailers and has rarely found an instance where people have overloaded their trailer. Because it can happen we are giving you instructions for weighing your trailer. We are also providing you with an alternate method of determining the weight of your trailer without the use of scales. The following weight information and form will help you determine the actual weight of your trailer, with all its options and variable weights, and how much personal cargo weight can be added, staying within the weight ratings of your trailer.

Per Federal regulations, your trailer is placarded on the front roadside area with a gross vehicle weight rating (G.V.W.R.) and a gross axle weight rating (G.A.W.R.). The gross vehicle weight rating is the maximum the trailer can weigh when it is being towed. The gross axle weight rating is the maximum load that can be on each axle when the trailer is being towed.

The **Dura-Torque axle** is designed to last the life of your trailer without service, except for lubrication of the wheel bearings. **Under no circumstances should welding be done on or near the axle.**

The diagram on the following page illustrates the use of scales in determining (1) your trailer's total weight, (2) weight on axle assemblies and (3) weight on tongue.

The allowable personal cargo, and placement within the trailer, may be determined by the following methods.

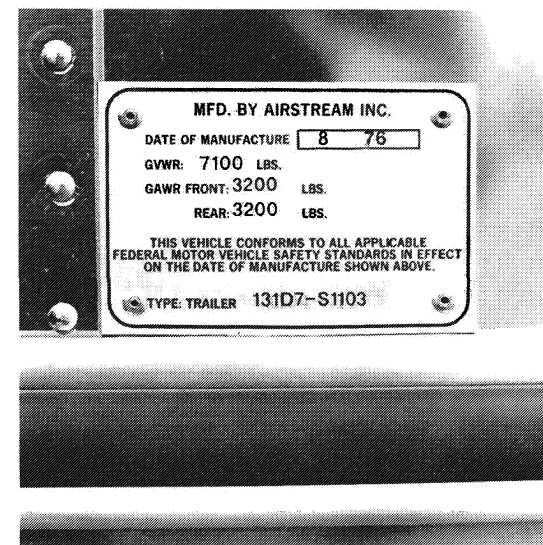

Federal Placard

Before weighing trailer **add all trailer's variable weights** which are full water tank, LPG tanks and water heater.

Note: The variable weights of the main and auxiliary holding tanks are not used because, under typical usage, if the water tank is full, there is storage capacity in the holding tanks. As the water tank is emptied, the holding tanks are filled.

Remove personal cargo which includes food, clothing, kitchen utensils, etc. from trailer. Your trailer is now ready for weighing.

The **trailer's total weight** is determined by placing the trailer, without tow vehicle, on a scale. This weight indicates your trailer's total weight without personal cargo. The allowable personal cargo that you add to your trailer **shall not exceed** the difference

Trailer Weighing

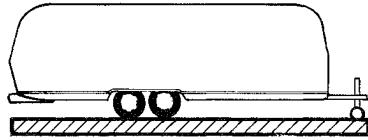

1. **Trailer's Total Weight**
(cannot exceed G.V.W.R.)

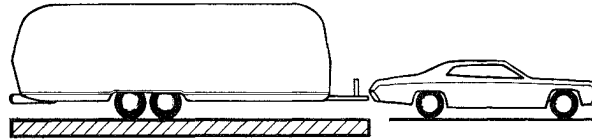

2. **Trailer's Weight
On Axle Assemblies**
(cannot exceed G.A.W.R.)

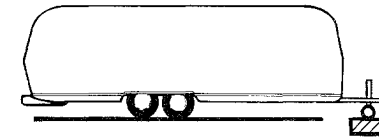

3. **Weight on
Trailer's Tongue**

between the Gross Vehicle Weight Rating (G.V.W.R.) and this weight. Example: if the G.V.W.R. rating on the placard is 7100 lbs and the trailer's total weight is 6100 lbs, your personal cargo may not exceed 1000 lbs (7100 - 6100 = 1000).

The **allowable personal cargo**, determined above, must be distributed in your trailer in such a manner that the **Gross Axle Weight Rating** (G.A.W.R.) is not exceeded.

To determine this, it is necessary to load all of your allowable personal cargo (example above 1000 lbs total) and variable weights. Then hitch trailer to tow vehicle with load equalizing hitch properly adjusted, see the diagram on page 33.

Place trailer on scale with both axles only on scale, see (2). If the weight on the axles

exceeds the axle system G.A.W.R. then some of the personal cargo must be redistributed forward in order to place some of this weight on the tongue.

The **tongue weight** should be between 10%-15% of the trailer's weight **but must not exceed 1,000 lbs**. Some tow vehicle manufacturers may restrict the amount of tongue load to a lower value. To determine tongue load, unhitch tow vehicle and place tongue hitch post on scale, see (3). The trailer must be properly loaded, as determined above, with your allowable personal cargo and variable weights.

A scale which has a lower weight limit than your tongue load, such as a bathroom scale, may be used to check the tongue weight by using the following method (see illustration):

Place a piece of wood of approximately the same thickness as the bathroom scales on the ground in line with the trailer hitch jack as shown. It should be so spaced that a short piece of pipe or other round piece will lay exactly one foot from the center line of the jack extension. Place the scales so that another round piece can be exactly two feet from the center line of the jack extension in the other direction. Place a 4 x 4 on the two round pieces and screw the jack extension down on the top of the 4 x 4 until the tongue of the trailer is supported by it. Multiply the scale reading by three. This will be the tongue weight of your trailer. If you exceed the capacity of the bathroom scales, increase the two foot dimension to three or four or more feet but always multiply the scale reading by the total number of feet between the wood and scales.

Caution: Be sure trailer is level when you read scales.

An alternate method for determining the weight of your trailer, without the use of scales, is by using the following information and form.

Before you fill in the blank form that pertains to your trailer, please read the sample form, page 24, to see what type of information will be needed.

First enter the model length, type of beds, and type of bathroom of your trailer on the first line (i.e. **31 Ft. Twin Rear Bath**).

Column A

Column A represents the Total Maximum Personal Cargo weight that can be added to your trailer. Personal Cargo includes food supplies, clothing, other personal items, etc. Find the Factory Weight of your trailer, Chart A, page 26 and enter it across from ITEM 1 Column A (Factory Weight = weight without options and variable weights (i.e. **5040 lbs**).

Next fill in the total weights of the options and variable weights with which your trailer is equipped. This information is on Charts B, C, or D, pages 27, 28, 29. Add all of the weights together and this total becomes ITEM 2, Column A (i.e. **761 lbs**). Next add ITEM 1 and ITEM 2. This becomes ITEM 4, Column A (i.e. **5801 lbs**). This is the sum total of your trailer's Factory Weight plus the Options and Variable Weights.

Next enter in ITEM 5, Column A (i.e. **7100 lbs**), your trailer's Gross Vehicle Weight Rating (G.V.W.R.). This information is on the placard located on the front road side area of your trailer which corresponds to information on Chart A, page 26. The Gross Vehicle Weight Rating is the maximum the trailer can weigh when it is being towed. Next subtract ITEM 4, Column A from ITEM 5 Column A; this amount indicates the Total Maximum Personal Cargo that can be added to your trailer (i.e. **1299 lbs**). Under no circumstances shall the G.V.W.R. be exceeded.

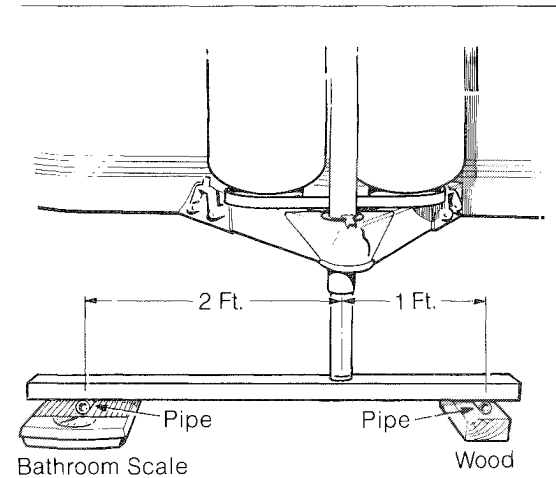

Tongue Weight

Column B

Column B represents the Recommended Personal Cargo that can be added to your trailer's tongue. Find the Factory Tongue Weight of your trailer and enter it in ITEM 1 Column B (Factory Tongue = weight without options and variable weights, (i.e. **630 lbs**). This information is on Chart A Page 26. Column B has + weight and - weight. Due to the location of optional items within the trailer, their weight will either have a + weight or - weight effect on the tongue. If the option is behind the axle system, or rear of trailer, it will tend to have a - weight, or lifting effect on the tongue; if the option is forward of the axle system, or the front of the trailer, it will have a + weight or loading effect on the tongue. Next fill in + weights or - weights of the options and variable weights with which your trailer is equipped, indicated in the

Tongue Weight Columns on Chart B, C or D.

Next total both the + weight (i.e. **215 lbs**) and – weight (i.e. **21 lbs**) columns and find the difference between the two columns; this becomes ITEM 2 Column B (i.e. + **194 lbs**). Next add ITEM 1 Column B and ITEM 2 Column B; this becomes ITEM 4 (i.e. **824 lbs**). This is the total of your trailer's Factory Tongue Weight, plus the weight of the Options and Variable Weights on the tongue. Next enter in ITEM 5 Column B 12½% of your trailer's G.V.W.R. (i.e. **.125 x 7100 = 888**); this information is located on Chart A page 26.

Next subtract ITEM 4 Column B from ITEM 5 Column B and the amount indicates the amount of Recommended Personal Cargo that can be added to your trailer's tongue (i.e. **64 lbs**).

The maximum tongue load must not exceed 1000 pounds. Some tow vehicles may restrict the amount of tongue load to a lower value. The tongue load is a total of the weight in ITEM 4 Column B plus your personal cargo.

Column C

Column C represents the Maximum Personal Cargo that can be added to your trailer's axle system. Find the Factory Axle Weight of your trailer and enter it in ITEM 1 Column C (i.e. **4410 lbs** – Factory axle Weight = weight without options and variable weights). This information is on Chart A page 26. Next fill in the axle system

weights of the options and variable weights with which your trailer is equipped from the Axle System columns on Chart B, C or D pages 27, 28, 29. Add all of the weights together and this total becomes ITEM 2, Column C (i.e. **567 lbs**).

Next calculate 34% of ITEM 5 Column B (i.e. **.34 x 888 = 302**). This becomes ITEM 3 column C and represents the amount of tongue weight that is transferred to the trailer's axle system when properly hitched with a load equalizing hitch assembly. (The remaining 66% is transferred to the tow vehicle.) Next add ITEM 1 Column C, ITEM 2 Column C, and ITEM 3 Column C; this becomes ITEM 4 Column C (i.e. **5279 lbs**). This is the sum total of your trailer's Factory Axle Weight, the weight of the Options and Variable Weights on the axle system, and 34% of the tongue weight. Next enter in ITEM 5 Column C the sum of your trailer's Gross Axle Weight Rating (G.A.W.R. – i.e. **3200 + 3200 = 6400 lbs**).

This information is on the placard on the front roadside area of your trailer which corresponds to information on Chart A page 26.

The Gross Axle Weight Rating is the maximum load that can be carried on the axle system when the trailer is being towed. Next subtract ITEM 4 Column C from ITEM 5 Column C. The remainder is the amount of total Maximum Personal Cargo that can be added to your trailer's axle system (i.e. **1121 lbs**).

Under no circumstances shall the G.A.W.R. be exceeded.

International Option Package

The following items are included in the International Option Package:

Solar Dome

Exterior Trim

Water Purifier with Filter Faucet (page 74)

Automatic Gas Regulator (page 63)

Step Light Assembly

Central Control System (page 56)

Range Exhaust Fan (page 69)

Bath Exhaust Fan

Electronic Digital Clock (page 58)

Twin or Double Bedspreads

Ceiling Fan (page 61)

Combination Sink Cover and Cutting Board

Sample Form

Model: <i>31 FT. TWIN - REAR BATH</i>	Column A		Column B			Column C	
	Maximum Personal Cargo Total (includes axle systems & tongue)		Recommended Personal Cargo on Tongue			Maximum Personal Cargo on Axle System	
Factory Weight (without options and variable weights)	Item 1	<i>5040</i>					
Factory Axle Weight (without options and variable weights)	----->					Item 1	<i>4410</i>
Factory Tongue Weight (without options and variable weights)	----->		Item 1		<i>630</i>		
Options:			+ Weight	- Weight			
Air Conditioner	<i>150</i>		<i>26</i>			<i>124</i>	
Auxiliary Main Step	<i>11</i>		<i>5</i>			<i>6</i>	
B.A.L. Jacks	<i>60</i>		<i>10</i>			<i>50</i>	
Bunk Bed (each)							
Entertainment Group	<i>17</i>		<i>11</i>			<i>6</i>	
L-Front Lounge							
Microwave Oven							
Refrigerator RM-100 (25 Ft. Twin and Double)							
Safety Group	<i>10</i>		<i>2</i>			<i>8</i>	
Space Locker							
Spare Tire Bracket							
Spare Tire							
T.V. Antenna							
Vacuum Cleaner							
Window – Double Pane							
Window – Vista View	<i>34</i>		<i>14</i>			<i>20</i>	
International Package (See page 23)							
Variable Weights:							
Water Heater	<i>50</i>			<i>-21</i>		<i>71</i>	
Water Tank	<i>373</i>		<i>97</i>			<i>276</i>	
L.P.G. (tank and liquid) <i>7 GAL. STEEL TANK</i>	<i>56</i>		<i>50</i>			<i>6</i>	
Item 2 Total	<i>761</i>	<i>761</i>	<i>+ 215</i>	<i>- 21</i>	<i>= 194</i>	<i>567</i>	<i>567</i>
Item 3 34% of Item 5 Column B	----->		----->			----->	
Item 4 Items 1 & 2 Total	<i>5801</i>		Add Items 1 & 2	<i>824</i>	Add Items 1,2,3	<i>5279</i>	
Item 5 G.V.W.R.	<i>7100</i>		Enter 12½% G.V.W.R.	<i>888</i>	G.A.W.R.	<i>6400</i>	
Enter Item 4 and subtract from Item 5	<i>5801</i>			<i>- 824</i>		<i>- 5279</i>	
Maximum Personal Cargo	<i>1299</i>						
Recommended Personal Cargo on Tongue	----->		----->			----->	
					<i>64</i>		
Maximum Personal Cargo on Axle System	----->		----->			----->	
						<i>1121</i>	

Chart A: Weights and Ratings

Model		Gross Vehicle Weight Rating G.V.W.R.	Factory Weight Without Options or Variable Weights	Allowable Additional Total Weight Incl. Personal Cargo	Gross Axle Weight Rating G.A.W.R. (Axle System)	Factory Axle Weight (Axle System)	Allowable Additional Weight (Axle System)	Factory Tongue Weight Without Options or Variable Weights
21 Ft.		4500	3410	1090	4080	2920	1160	490
23 Ft. Single Axle	T	4800	3490	1310	4080	2880	1200	610
	D	4800	3510	1290	4080	2910	1170	600
23 Ft. Tandem Axle	T	5800	3800	2000	5200	3050	2150	750
	D	5800	3850	1950	5200	3105	2095	745
25 Ft.	T	5800	4090	1710	5200	3365	1835	725
	D	5800	4175	1625	5200	3440	1760	735
25 Ft. Caravanner		6200	4435	1625	5600	4024	1576	580
27 Ft. Rear Bath	T	6200	4520	1680	5600	3930	1670	590
	D	6200	4550	1650	5600	3980	1620	570
29 Ft. Rear Bath	T	7100	4830	2270	6400	4225	2175	605
	D	7100	4840	2260	6400	4250	2150	590
29 Ft. Center Bath	T	7100	4790	2310	6400	4070	2330	720
	D	7100	4775	2325	6400	4050	2350	725
31 Ft. Rear Bath	T	7100	5040	2060	6400	4410	1990	630
	D	7100	5070	2030	6400	4450	1950	620
31 Ft. Center Bath	T	7100	5025	2075	6400	4315	2085	710
	D	7100	5005	2095	6400	4290	2110	715

*Allowable additional weight includes all options and accessories, L.P.G., water, waste, food supplies, clothing, other personal cargo, etc.

T—Twin Bed Models
D—Double Bed Models

Chart B: 21, 23 and 25 Ft.

Optional Equipment & Variable Weights	Total Weight	21 Ft.		23 Ft.		23 Ft. Twin		23 Ft. Double		25 Ft. Twin and Double		25 Ft. Caravanner	
		Single Axle	Tongue	Single Axle	Tongue	Axle System	Tongue	Axle System	Tongue	Axle System	Tongue	Axle System	Tongue
Air Conditioner	150	140	10	140	10	178	-28	178	-28	128	12	128	12
Auxiliary Main Step	11	8	3	4	7	8	3	8	3	6	5	6	5
B.A.L. Jacks	60	60	0	46	14	60	0	60	0	48	12	48	12
Bunk Bed	45	46	-1	46	-1	58	-13	58	-13	48	-3	NA	NA
Entertainment Group	17	8	9	3	11	6	11	6	11	6	11	6	11
L-Front Lounge	80	NA	NA	NA	NA	NA	NA	NA	NA	NA	NA	NA	NA
L.P.G. 7 gal. Steel Tanks & Liquid	56	9	47	8	48	8	48	8	48	7	49	7	49
L.P.G. 7½ gal. Alum. Tanks & Liquid	40	6	34	5	35	5	35	5	35	5	35	5	35
L.P.G. 10 gal. Alum. Tanks & Liquid	66	10	56	8	58	8	58	8	58	8	58	8	58
Microwave Oven	70	NA	NA	NA	NA	NA	NA	NA	NA	NA	NA	NA	NA
Refrigerator RM-100	Variable	NA	NA	NA	NA	NA	NA	NA	NA	62	38	NA	NA
Safety Group	10	8	2	8	2	8	2	8	2	8	2	8	2
Space Locker	20	23	-3	20	0	24	-4	24	-6	20	0	20	0
Spare Tire Bracket	9	2	7	2	7	2	7	2	7	2	7	2	7
Spare Tire	60	14	46	14	46	14	46	14	46	14	46	14	46
T.V. Antenna	5	2	3	2	3	2	3	2	3	2	3	2	3
Vacuum Cleaner	15	24	-9	10	-5	26	-11	26	-11	20	-5	20	-5
Water Tank—Liquid Only	373	346	27	244	129	308	64	308	64	300	73	300	73
Water Heater—Liquid Only	50	40	10	76	-26	76	-26	76	-26	63	-13	63	-13
Windows—Double Pane	Variable	17	4	17	4	34	4	34	4	44	4	44	4
Windows—Vista View	Variable	10	6	4	2	8	2	8	2	12	10	12	10

Liquid weights indicate full container.
 NA—Not Available

Chart C: 27, 29 and 31 Ft. Rear Bath

Optional Equipment & Variable Weights	Total Weight	27 Ft. Twin		27 Ft. Double		29 Ft. Twin		29 Ft. Double		31 Ft. Twin		31 Ft. Double	
		Axle System	Tongue	Axle System	Tongue	Axle System	Tongue	Axle System	Tongue	Axle System	Tongue	Axle System	Tongue
Air Conditioner	150	128	21	128	21	120	30	132	18	124	26	124	26
Auxiliary Main Step	11	6	5	6	5	6	5	6	5	6	5	6	5
B.A.L. Jacks	60	46	17	42	17	44	16	44	16	50	10	50	10
Bunk Bed	45	62	-17	62	-17	46	-1	52	-7	50	-5	50	-5
Entertainment Group	17	6	11	6	11	6	11	6	11	6	11	6	11
L-Front Lounge	80	NA	NA	NA	NA	40	40	40	40	40	40	40	40
L.P.G. 7 gal. Steel Tanks & Liquid	56	7	49	7	49	6	50	6	50	6	50	6	50
L.P.G. 7½ gal. Alum. Tanks & Liquid	40	5	35	5	35	5	35	5	35	4	36	4	36
L.P.G. 10 gal. Alum. Tanks & Liquid	66	8	58	8	58	8	58	8	58	7	59	7	59
Microwave Oven	70	66	4	66	4	64	6	62	8	60	10	60	10
Safety Group	10	8	2	8	2	8	2	8	2	8	2	8	2
Space Locker	20	22	-2	NA	NA	22	-2	NA	NA	22	-2	22	-2
Spare Tire Bracket	9	2	7	2	7	2	7	2	7	2	7	2	7
Spare Tire	60	14	46	14	46	14	46	14	46	14	46	14	46
T.V. Antenna	5	2	3	2	3	2	3	2	3	2	3	2	3
Vacuum Cleaner	15	2	13	2	13	2	13	2	13	2	13	2	13
Water Tank—Liquid Only	373	266	109	266	109	290	83	290	83	276	97	276	97
Water Heater—Liquid Only	50	63	-13	63	-13	60	-10	60	-10	71	-21	71	-21
Windows—Double Pane	Variable	44	4	34	4	60	5	60	5	60	5	60	5
Windows—Vista View	Variable	12	10	6	10	20	14	20	14	20	14	20	14
International Package (See page 23.)	88	54	34	54	34	54	34	54	34	54	34	54	34

Liquid weights indicate full container.
 NA—Not Available

Chart D: 29 and 31 Ft. Center Bath

Optional Equipment & Variable Weights	Total Weight	29 Ft. Twin		29 Ft. Double		31 Ft. Twin		31 Ft. Double			
		Axle System	Tongue	Axle System	Tongue	Axle System	Tongue	Axle System	Tongue		
Air Conditioner	150	128	22	128	22	132	18	132	18		
Auxiliary Main Step	11	4	7	4	7	4	7	4	7		
B.A.L. Jacks	60	60	0	60	0	60	0	60	0		
Bunk Bed	45	NA	NA	NA	NA	NA	NA	NA	NA		
Entertainment Group	17	6	11	6	11	6	11	6	11		
L-Front Lounge	80	44	36	44	36	40	40	40	40		
L.P.G. 7 gal. Steel Tanks & Liquid	56	6	50	6	50	6	50	6	50		
L.P.G. 7½ gal. Alum. Tanks & Liquid	40	5	35	5	35	4	36	4	36		
L.P.G. 10 gal. Alum. Tanks & Liquid	66	8	58	8	58	7	59	7	59		
Microwave Oven	NA	NA	NA	NA	NA	NA	NA	NA	NA		
Safety Group	10	8	2	8	2	8	2	8	2		
Space Locker	20	NA	NA	NA	NA	NA	NA	NA	NA		
Spare Tire Bracket	9	2	7	2	7	2	7	2	7		
Spare Tire	60	14	46	14	46	14	46	14	46		
T.V. Antenna	5	2	3	2	3	2	3	2	3		
Vacuum Cleaner	15	14	1	14	1	14	1	14	1		
Water Tank—Liquid Only	373	274	99	274	99	282	91	282	91		
Water Heater—Liquid Only	50	60	-10	60	-10	61	-11	61	-11		
Windows—Double Pane	Variable	60	5	60	5	60	5	60	5		
Windows—Vista View	Variable	54	4	56	4	64	8	64	8		
International Package (See page 23.)	88	54	34	54	34	54	34	54	34		

Liquid weights indicate full container
 NA—Not Available

Tires

Your Airstream is equipped at the factory with name brand trailer tires. Airstream dealers cannot make adjustments to tires. This must be done by a dealer who handles that particular brand. If you ever have tire problems, check the local telephone directory for the nearest dealer.

To get the maximum performance from your tires check the air pressure often, but only when the tires are cool. Never bleed out air immediately after driving. Recommended tire pressures vary with models, tire type and size. For specific pressures refer to the table, page 32.

It is also important to periodically check on the tightness of the lug nuts. They should be tightened to a torque of 90-95-ft.-lbs. on both the steel and forged aluminum wheels. Care should be taken at all times when handling the forged aluminum wheel because of possible damage to its appearance.

In a warm climate, park out of the sun whenever possible. In desert regions use the tire covers to prevent ultra-violet deterioration to tires.

To change a tire with a jack, see the label affixed to the underbelly just to the rear of the wheels. This indicates the proper jack placement. On tandem axle models a flat tire may be changed without the aid of a jack. Drive the unit up a ramp 8" wide, 6" high and about 3 feet long at the base (see photo).



Tire Changing

All tire, wheel, hub and drum assemblies are dynamically balanced at the factory. **Be sure to rebalance the tire, wheel, hub and drum assemblies each time a tire is changed or rotated.**

In an emergency remove the flat tire. The independent suspension of the Dura-Torque Axle allows a four wheel unit to be safely towed on three wheels for a short distance (100 miles maximum) and only at a low speed (30 MPH). Be especially cautious in crossing holes or dips in the road. Under these circumstances, it is good practice to set your rear view mirrors so that you can observe your tires at all times.

Tire Rotation

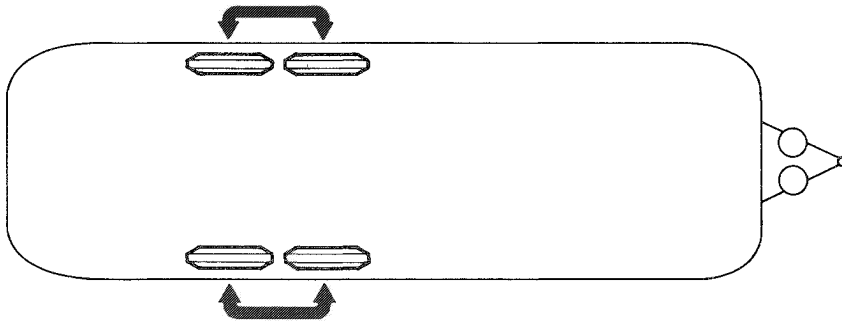

Radial

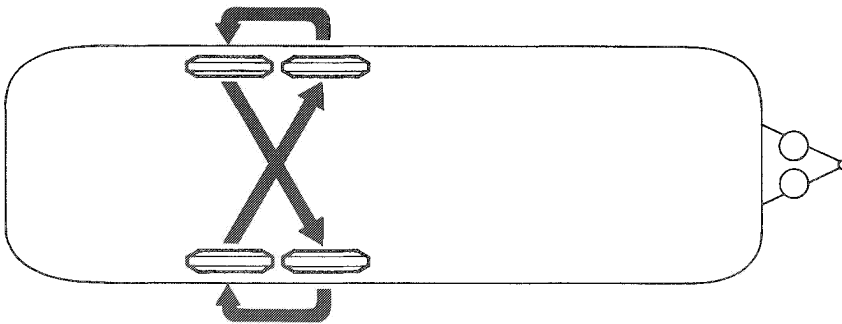

Bias Belted

Tire Inflation Pressure (PSI) Cold Inflation

Model	7.00 x 15 Load Range C	7.00 x 15 Load Range D	7.00 x 15 XC Steel Radial Tires
21 & 23 Ft. Single Axle	N.R.	60 PSI	N.R.
23, 25, 27 Ft. Dual Axle	35 PSI	N.R.	35 PSI
29, 31 Ft. Dual Axle	40 PSI	N.R.	45 PSI

*N.R. Not recommended by tire manufacturer

Tire Load and Inflation Pressure Notes

1. Tire inflation pressure may increase as much as 6 pounds per square inch (PSI) when hot.
2. Cold tire inflation pressure: after vehicle has been inoperative for 3 hours or more, or driven less than 1 mile.

Hitching Up

Hitching up your Airstream trailer is something that will become almost second nature with practice. The following section includes proper hitch load distribution and a procedure for hitching up.

The electric jack is strongly recommended for anyone who, for any reason, should not physically exert himself. Available as a factory option or through the Wally Byam Stores, the electric jack makes hitching and unhitching a much easier operation.

Equalizing Hitch Load Distribution

When a trailer is hitched up properly to a tow vehicle, with a load equalizing hitch, approximately $\frac{1}{3}$ of the trailer's tongue weight will be on the trailer's axles and $\frac{2}{3}$ will be transferred to the tow vehicle. $\frac{1}{3}$ of this weight transfer will be carried by the front wheels and $\frac{1}{3}$ by the rear wheels of the tow vehicle (see diagram). Thus, the tire loading of each wheel on the tow vehicle will be increased by $\frac{1}{6}$ of the trailer's tongue weight. The tire air pressure of the tow vehicle should be increased to compensate for this additional weight. Refer to the vehicle's owners manual for this information.

The tongue weight should be approximately 10% to 15% of the trailer's total weight but **must not exceed 1000 lbs.** and under no condition exceed the hitch rating. Your hitch rating information should be provided to you by your hitch installer.

Equalizing Hitch Load Distribution

Proper Installation

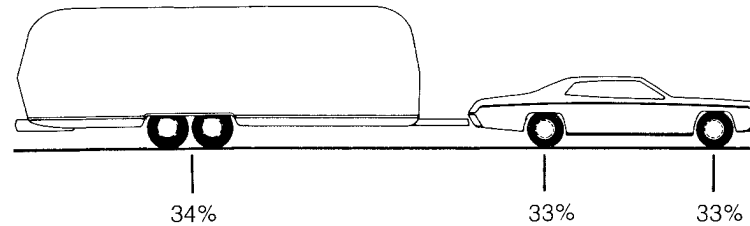

Percentage of Tongue Load distributed to car and/or trailer wheels.

Hitch High

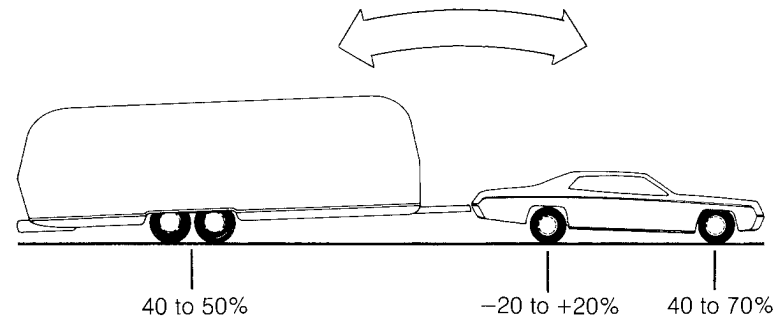

Hitch Low

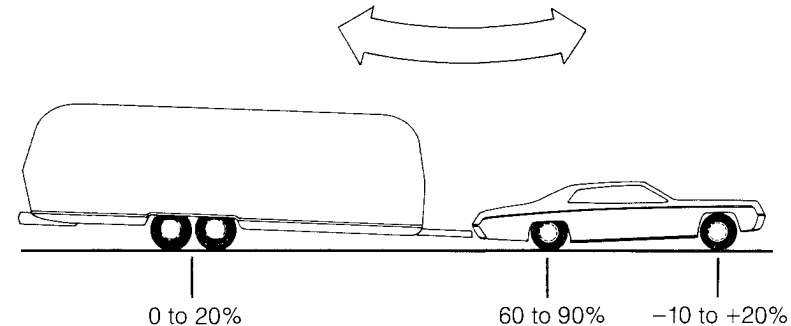

Steps for Hitching Up

Jack up the trailer hitch until there is clearance for the **hitch ball** to slide under, remove safety pin and raise the **locking lever**. Back the car straight back to the hitch. (See Fig. 2.) This can best be accomplished through the use of prearranged hand signals with the help of another person, but if you are hitching up by yourself we recommend the use of a **hook-up view mirror**.

Lower the trailer hitch onto the hitch ball; then close the locking lever and insert safety pin. (See Fig. 3.)

Now raise the trailer and car to the full height of the hitch jack (See Fig. 4) and then attach the **leveling bars**. (See Fig. 5.) Lower the car and trailer. The hitch ball should be level to slightly higher. Readjust leveling bars until this condition is correct. (See Fig. 6.) This will result in the best balance for towing and steering control as the weight equalizing hitch distributes the hitch load. With proper hitch installation and hitching up the bar should have a noticeable amount of deflection or bending. (See Fig. 7.) A little practice with your rig will teach you how far to pull up the bar, and you may wish to mark the chain links that match your rig. Always choose level ground for checking correct hook-up. For further information see manufacturers' literature.

Note: If your car is equipped with adjustable load leveling air shocks, you must load the car first with typical

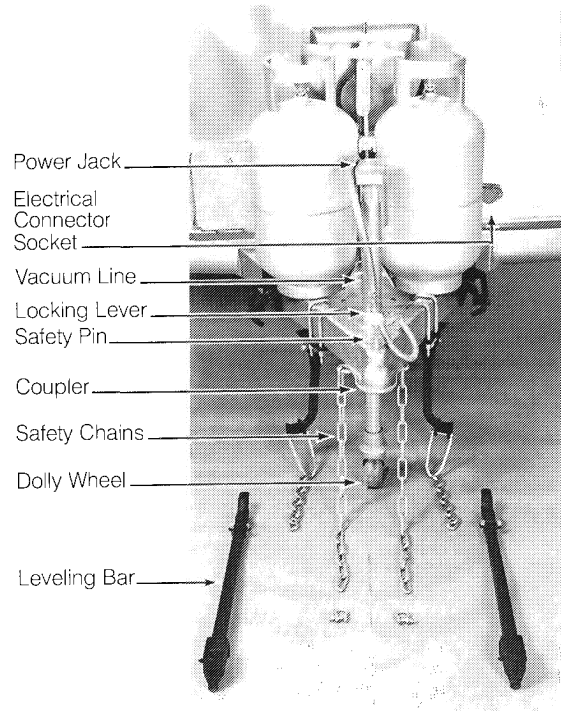

Fig. 1 – Hitching Up Equipment

luggage and passengers and bring it back to level. Then attach the trailer and adjust the load leveling bars. Otherwise the air shocks on your car will overload the rear wheels. Do not use air shocks to level car and trailer after hitching up.

The hitch ball on your car should be installed at a height of 19½" to the top of the hitch ball, measured when the car is loaded. A low hitch ball increases tail-wagging tendencies by lowering the nose of the trailer thus changing the center of support for the trailer and reducing the weight on the front wheels of the car.

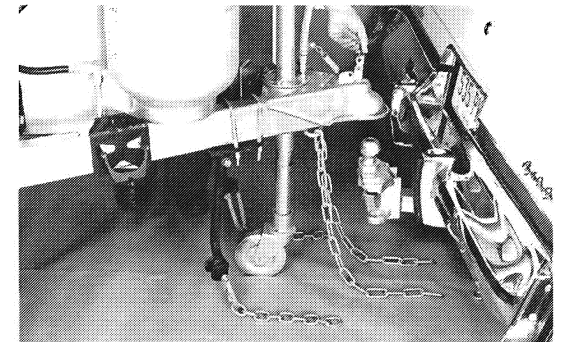

Fig. 2 – Hitching Up

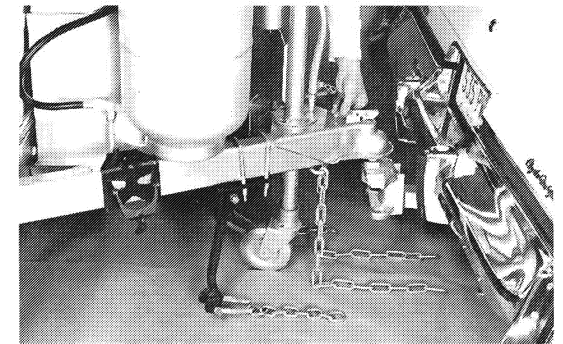

Fig. 3

Plug in the electrical connector cord and check running, directional, and brake lights. The electrical connector cord should be completely removed and stored when not in use. Remove plug from tow vehicle's vacuum coupling and insert trailer's vacuum line plug. (See Fig. 8.) To couple, push knurled coupling sleeve forward, firmly insert trailer's vacuum hose fitting and pull sleeve back. Check for proper locking by firmly pulling trailer's hose fitting. Attach the safety chains to the welded portion of the hitch of the car's frame, but never to the removable ball mount. Cross the safety chains under the hitch.

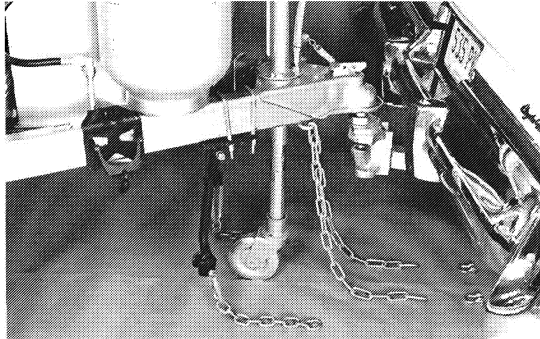

Fig. 4

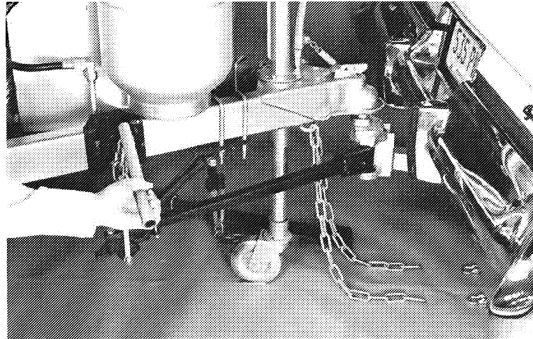

Fig. 6

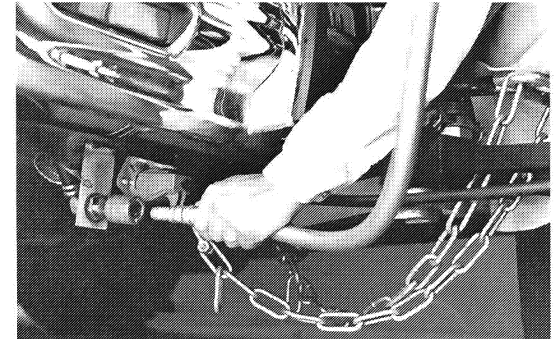

Fig. 8

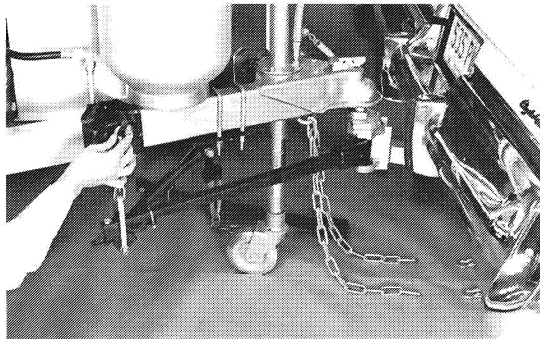

Fig. 5

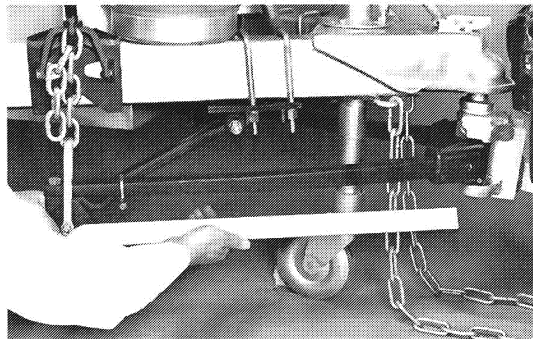

Fig. 7

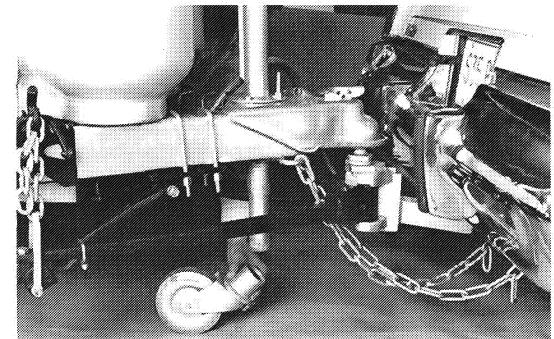

Fig 9

Retract the hitch jack completely for maximum ground clearance. Remove the dolly wheel and jack pad (See Fig. 9), and stow them in the car's trunk, along with leveling jack and other gear used when stopped. Never tow your trailer with the jack down or the dolly wheel on. Check that the fold-away step is up and that the main door is completely closed and locked for towing. If it is not locked the constant vibration of travel may cause it to open with possible damage.

Move the rig ahead about 50 feet and test the trailer brakes, then check the ground for forgotten objects. Regularly check the

condition of your tires, air pressure, and the tightness of the lug bolts. For specific tire pressures refer to page 32.

Towing Tips

We want every Airstream owner to be a safe and courteous driver.

A few hours of towing practice in a large empty supermarket parking lot will make pulling your Airstream over the road much easier. Line out two corners for both left and right turns. You may also use these corners to practice backing and parking. **Observe that the tracks made by the trailer wheels are distinctly different from those made by your car.** Studying this will make it easier for you to correct mistakes. Truck or trailer type fender or door grip rear view mirrors are a must for maximum visibility and in most states they are required by law.

After thoroughly inspecting your hitch, brakes and tires you should be ready to tow. Check traffic, signal that you are about to pull away, and start slowly. Look often in your mirrors, and observe the action of the trailer, then carefully move into the proper lane of traffic. Remember that the trailer wheels will not follow the path of the car's wheels, therefore, **wider turns are necessary when turning to the left or to the right.**

On freeways or expressways try to pick the lane you want, and stay in it. Always maintain plenty of space between you and the car ahead, at least the length of the car plus trailer, for every ten miles per hour. Remember that in order to pass another vehicle, you will need longer to accelerate. You must also allow for the length of the trailer when returning to the right hand lane.

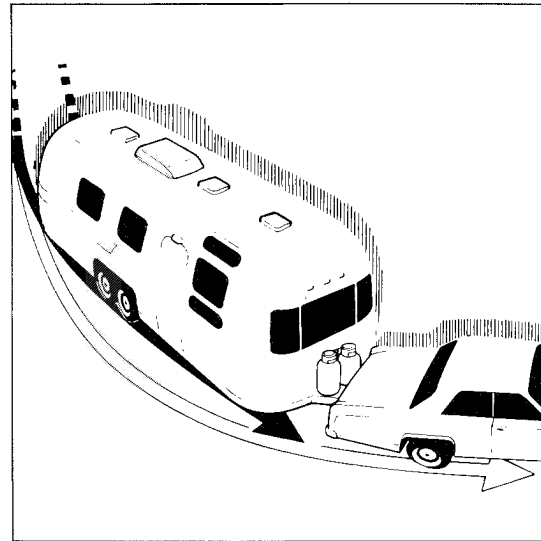

Tracking

On a two lane road, cars will be lining up behind you because you travel at a lower speed. It is both courteous and sensible to signal, pull onto the shoulder, and let them pass. Your Airstream is designed to be towed easily at any legal speed, so if you are not careful you may be inclined to forget it is there.

The **brake controller** is activated when you apply the brakes of the tow vehicle. This sends a modulated electrical signal to the **power brake booster** assembly located in your trailer. Trailer brakes may be applied manually, independent from your tow vehicle brake system, by moving the controller's lever to the right.

Note: The tow vehicle's engine must be warm (near operating temperature) to insure maximum braking.

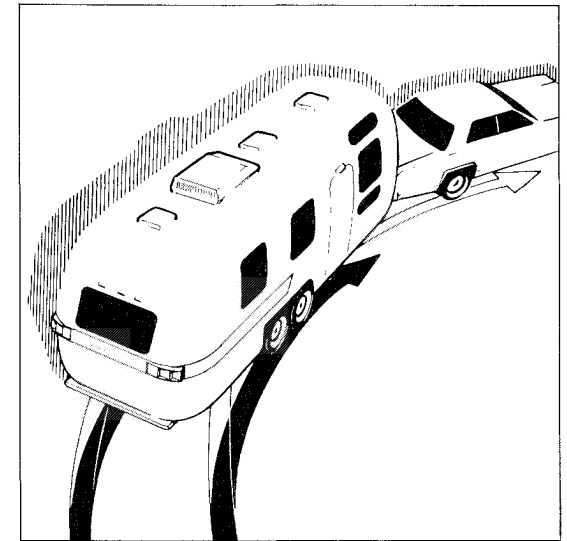

When trailering, you might encounter a temporary cooling system overload during severe conditions – such as hot days when pulling on a long grade, when slowing down after higher-speed driving, or driving long idle periods in traffic jams. If the hot indicator light comes on or the temperature gauge indicates overheat and you have your air conditioning turned on, turn it off. Pull over in a safe place and put on your emergency brake. Don't turn off the engine. Increase the engine idle speed. Lift the engine hood and check for fluid leaks at the radiator hoses, radiator or radiator overflow outlet. Check to see that all drive belts are intact and the fan is turning. If you have a problem, have it fixed at the next opportunity. If there is no problem, light should go off or temperature should come down within one minute. Proceed on the highway a little slower. Ten minutes later

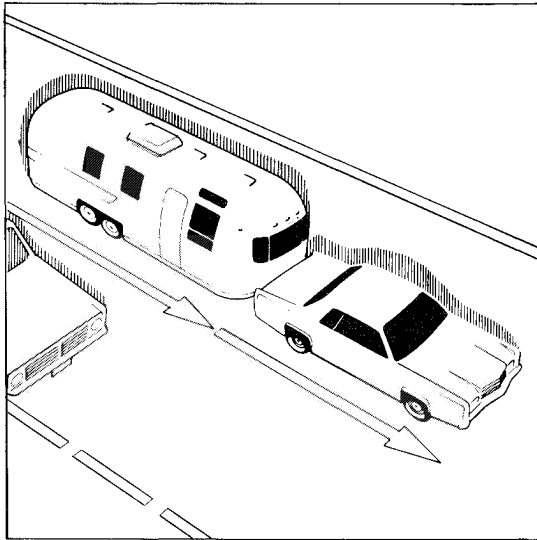

Passing

resume normal driving.

Caution: Never open a radiator cap. when the car is hot! Check the car coolant level when the car is cool.

When going downhill in dry weather, down shift so that engine compression will slow the whole rig down. Take dips and depressions in the road slowly and do not resume normal driving speeds until you are sure that the trailer wheels are clear of the dip.

On slippery pavement do not use engine drag to help slow down as this may cause the rear wheels of the car to skid. On icy pavement drive slowly and if you feel the car is skidding, gently apply the trailer brakes only. This will bring the car and trailer back into a straight line. Chains do

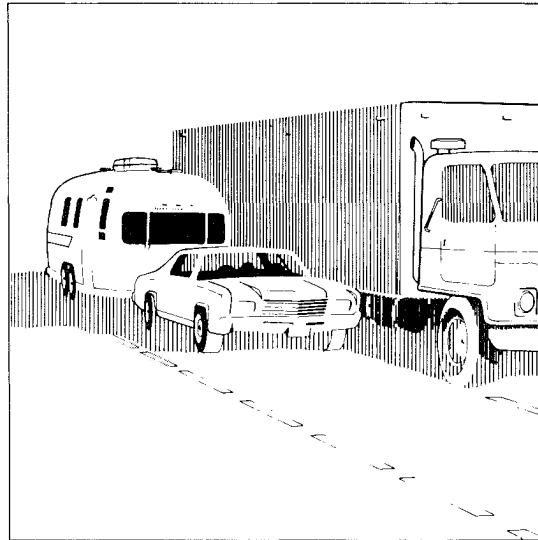

not help trailer wheels.

When driving in mud and sand let the momentum carry the rig through. Apply power gently and use as little as possible. Stay in the tracks of the vehicle ahead and keep the car in the highest possible gear. If you do get stuck it is best to tow out both car and trailer together without unhitching.

If you have to tow long distances over bad roads, the stones and gravel thrown back by your tires will dent and scratch the aluminum finish of your Airstream. To prevent this, use masking tape to secure heavy sheets of cardboard to the lower front end of the trailer.

Despite the best hitch, you will notice that whenever a large bus or truck overtakes your rig the displaced air first pushes the

trailer rear to the right and then affects the front. **Do not apply the brakes.** Maintain your steering in a straight line. Do not try to compensate for sway by turning your steering wheel.

When stopping on a hill or slope, leaving your car in gear is not enough for stand-still-safety. **Chock the trailer wheels** to be double sure. Do not use trailer brakes as parking brakes by disconnecting the trailer vacuum line.

Backing Up

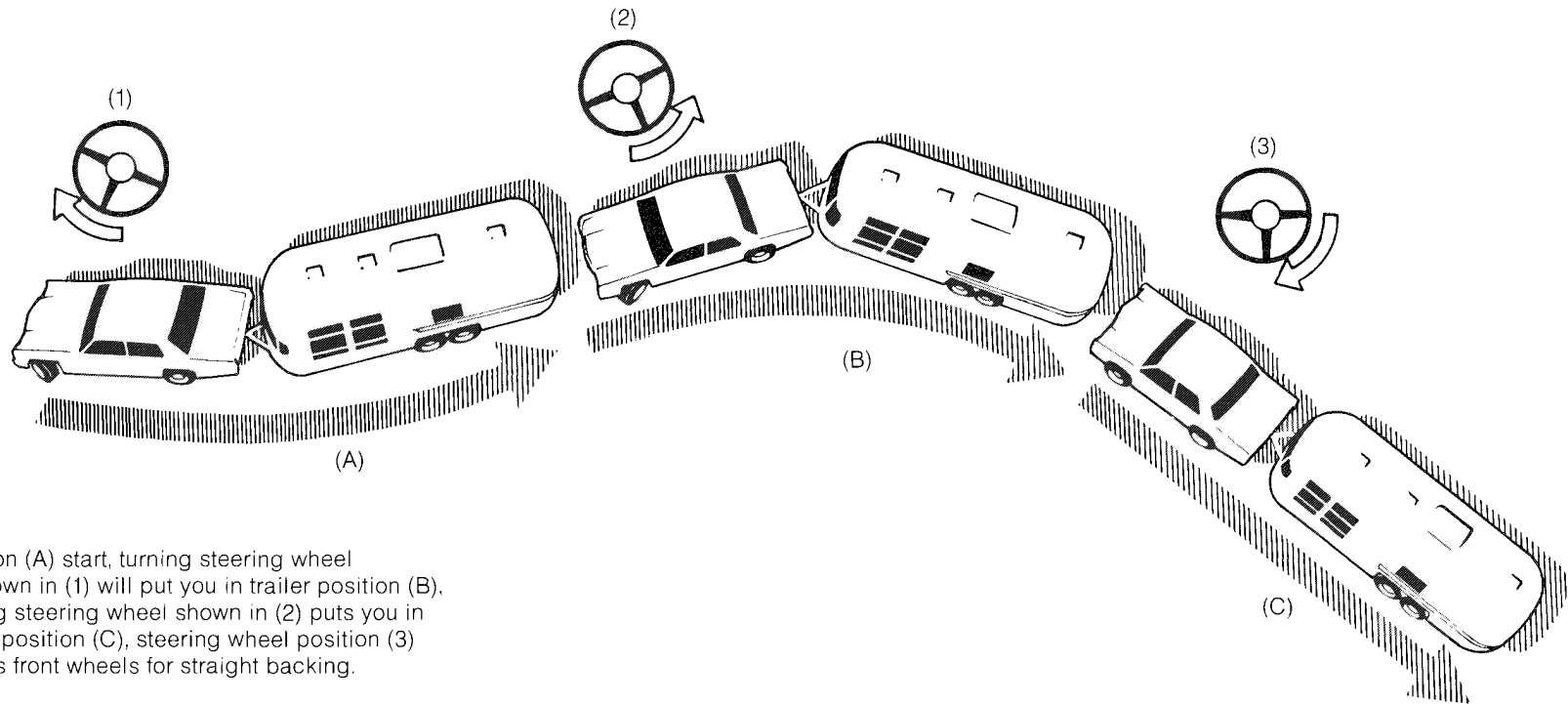

Position (A) start, turning steering wheel as shown in (1) will put you in trailer position (B), turning steering wheel shown in (2) puts you in trailer position (C), steering wheel position (3) returns front wheels for straight backing.



Indicates steering direction

In backing up, the important thing to remember is to **do everything slowly** and to correct immediately if you see the trailer turning the wrong way. Concentrate on the rear of the trailer. With your car and trailer in a straight line, back up slowly and turn the bottom of the steering wheel in the direc-

tion you want the trailer to go. Watch out the window or in the mirror until the rear of the trailer is pointing in the desired direction. Then turn the steering wheel in the opposite direction. Your car will be following the trailer in an arc. Straighten the car and trailer by turning the steering wheel more

sharply, then when they are in line, straighten the steering wheel. **Always try to back to your left because the visibility is much better.** (See illustration.) When you don't make it on the first try it is usually much easier to pull forward to your original position and start over.

Overnight Stop

Airstream owners have parked virtually every place imaginable from filling stations to farm lands. In time you will develop a knack for spotting wonderful little roadside locations by turning off the main highway and exploring.

There are many modern trailer parks including State, County and Federal parks with good facilities, where you may obtain hookups of electrical, water and sewer connections. Directories are published which describe in detail these parks and tell what is available in the way of services and hookups.

On overnight or weekend trips, chances are you will not use up the capacity of the sewage holding tank, deplete the water supply or run down the battery which supplies the 12 volt current.

On a longer trip, when you have stayed where sewer connections and utility hookups were not available, it will be necessary for you to stop from time to time to dispose of the waste in the holding tank and replenish the water supply. Many gas stations (chain and individually owned) have installed **sanitary dumping stations** for just this purpose. Booklets are available which list these dumping stations.

When stopping for the night your Airstream is built to be safely parked in any spot that is relatively level and where the ground is firm. **Your facilities are with you, you are self-contained.** Unless the car is needed for transportation, it is not necessary to

unhitch. Try to pick as level a parking spot as possible. **Stabilizing jacks** or **blocks** probably won't be required for an overnight stay; however if you put the jack pad on the hitch jack and run the hitch jack down to take the weight off the car's springs this will provide some stability. If you must park on a slope, **park facing downhill**; it is easier to level the Airstream this way.

All you need to do to enjoy the self-contained luxury of your Airstream is to:

1. Light the water heater, refrigerator and furnace pilots if required. See pages 63-72 for complete details on LPG system and gas operated appliances.
2. Turn on range gas supply and light the pilot.

Before moving on, check the campsite, both for cleanliness and also to be sure you haven't left anything behind, turn off the gas supply petcock to the range and make sure everything is properly stowed. Use your Pre-Travel Check List on page 94 and you are ready for more travel adventure.



Extended Stay

Making a long trip in your Airstream is not very different from making a weekend excursion. Since everything you need is right at hand you are at home wherever you go. When packing for an extended trip take everything you need, but only what you need.

When you plan to stay in the same place for several days, weeks, or months, you will want your trailer to be as level and steady as possible. Check the attitude of your Airstream with a small spirit level set on the inside work counter or the trailer hitch "A-Frame." (See Fig. 1.) If a correction is necessary then **you must level from side to side first**. This can be done most easily up a small ramp consisting of 2" x 6" boards about four feet long and tapered at both ends. (See Fig. 2.) We do not recommend placing tires in a hole for leveling.

Level from front to rear by disconnecting the hitch from the car, putting the jack pad under the hitch jack and adjusting the jack up or down until you are level. Block or chock the wheels to keep the trailer from rolling. Use **stabilizing jacks** at all four corners as shown in the diagram to the right, to eliminate the natural spring action of the axles. If you have optional **B.A.L. stabilizing jacks** (Fig. 3) use the wrench, located in the hose carrier, to lower the two units on the low side. Bring trailer to a level position side to side. Lower opposite stabilizing units to a firm position.

Note: Whenever the trailer must be lifted with a jack as when changing a tire or leveling on very rough terrain, **always**

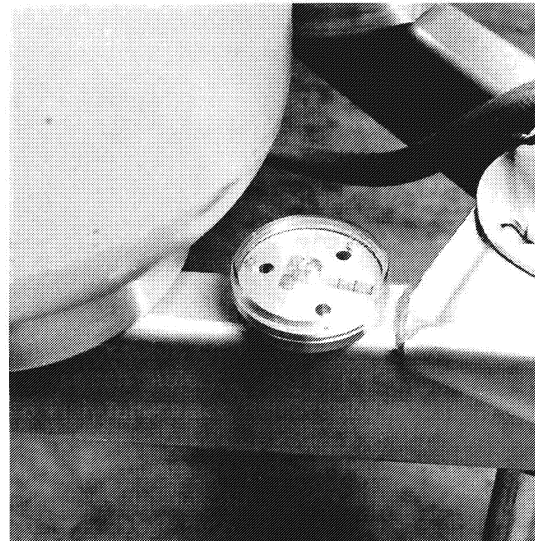
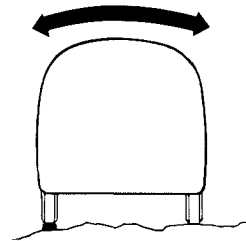

Fig. 1 – Spirit Level



Fig. 2 – Trailer Leveling



1. Level from Side to Side.

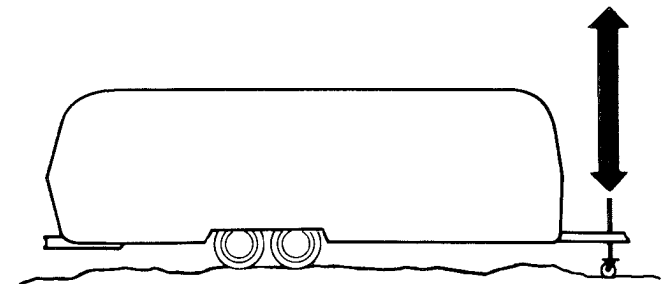

2. Level from Front to Rear.

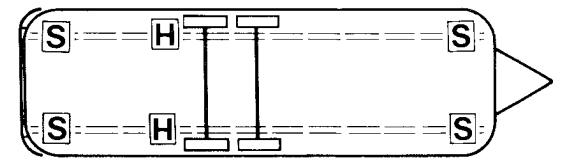
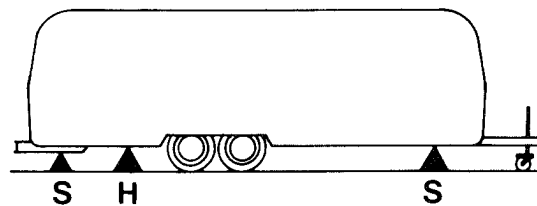

H – Hydraulic Jack Positions
S – B.A.L. Stabilizing Jack

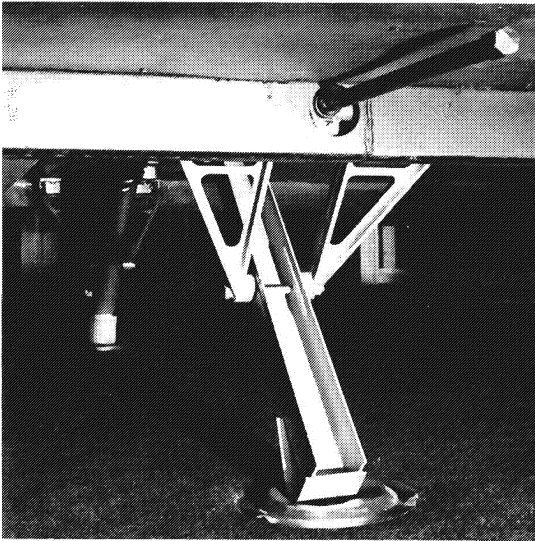

Fig. 3—B.A.L. Stabilizing Jack

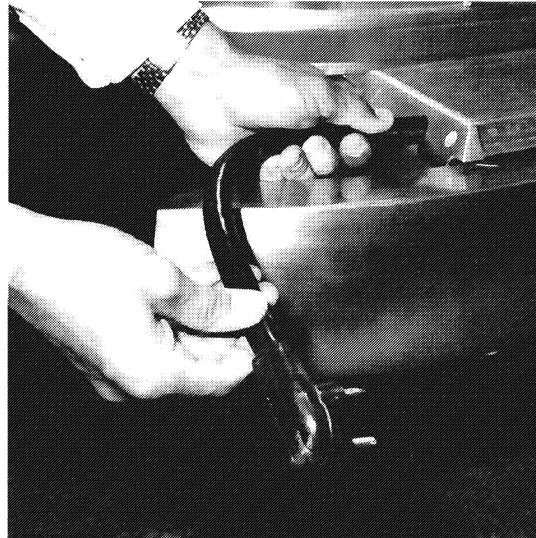

Fig. 5—120 Volt Electrical Cable

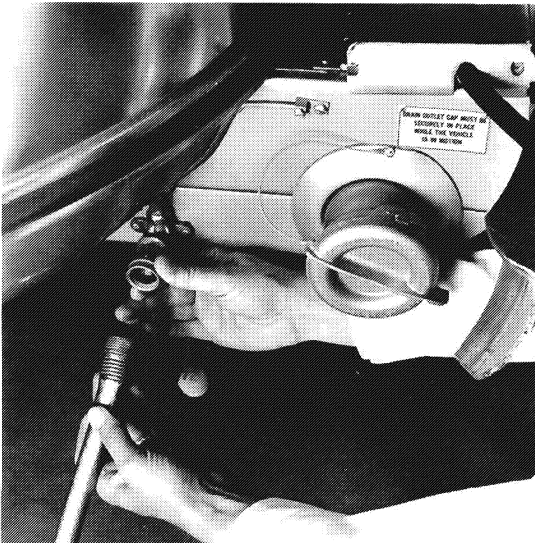

Fig. 4—City Water Hook-Up

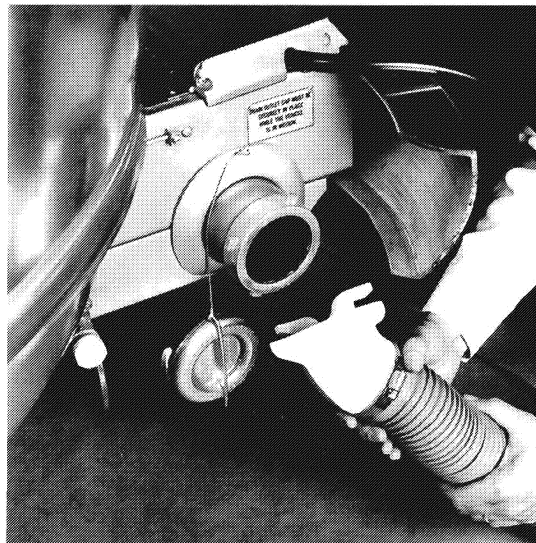

Fig. 6—Waste Drain Hose Hook-Up

place the jack under the main frame rail. A label is provided to indicate the proper position for the jack. **Never use stabilizing jacks to lift the trailer.**

Hook up to water (see Fig. 4) by attaching a ½" minimum high pressure water hose to the city water service.

Plug the **electrical cable** (see Fig. 5), which is stored in the bumper storage compartment into the **city power service**. Be sure you have the wire grounded and have the proper polarity. See page 79 for details.

Hook your **waste drain hose** (see Fig. 6) into the **sewer disposal facility** and attach to the drain outlet in your trailer. For details on this procedure refer to page 76.

Turn on gas supply; light the range and oven pilots, light the water heater, refrigerator and furnace pilots. See pages 63-72 for complete details on L.P.G. system and gas operated appliances.

When you stay for extended periods where electric or water hook-ups are not available, you must make regular checks on the condition of your 12 volt battery and the contents of your water tank. Try to conserve electricity. You can recharge your battery by hooking up the car/trailer electrical connector and running the car engine at a fast idle. 45 minutes per day should provide about 3-4 hours of power. Carry drinking water in a clean bucket to refill your tank. When your waste tank nears capacity, move to a dumping location.

Winter Airstreaming

Traveling in an Airstream during the cold winter months can be one of the most exhilarating experiences in all trailering. When we speak of cold, we are talking about temperatures of zero to -10 degrees. Airstreams properly outfitted with dual-pane windows have been cold-soaked at -20 degrees with no adverse effects and with no real discomfort. Dual-pane side windows which are offered as an option, do not require storm windows. Dual-pane side windows, galley, bathroom and optional window shades improve the efficiency of the heating system.

There are of course certain precautions which must be taken as you would in your own home in low temperatures.

1. There should be heat in the trailer at all times. Some states do not allow L.P.G. to be turned on while moving. Additionally, L.P.G. should be shut off when gasoline is added to the tow vehicle.
2. You must have a plentiful supply of propane gas.
3. If your stay is longer than overnight, then you should endeavor to have 110 V electricity available. The battery (fully charged) will not last more than about 10 hours in zero weather. Of course you can always run your car to recharge the battery and normally the battery will attain sufficient power to run another 3-4 hours by running your engine for approximately 45 minutes to one hour at fast idle. For more detailed information on the battery see page 81.
4. Minimize use of electricity if 110 volt

power source is not available.

5. Your Airstream has forced air heating in the holding tank area. There is also heating around the water tank.
6. In extreme cold conditions and when 120 volt electricity is available, porcelain lamp receptacles, with 75 watt bulbs, and adequate wire guards, over bulbs, may be used. These should be permanently attached to the floor adjacent to the inside wall in the area between the inside wall of the trailer and the storage compartment below the front travel lounge. When lamps are in use this area should be emptied of all other items. This will give a more comfortable feeling to the living room area and will minimize condensation.
7. Leave cabinet doors, bed doors and wardrobe doors slightly open at night to allow circulation of air around all furniture components.
8. For extended stays in cold weather, insulate the water line outside the trailer.

You should remember that low temperatures in combination with high winds cause an equivalent chill temperature much below what your thermometer is reading. For instance, with an outside temperature of zero degrees and the wind velocity of 10 miles per hour, the equivalent chill temperature is minus 20 degrees F.

There is no substitute for common sense in cold weather.



Storage and Winterizing

When storing your trailer for short or long periods use the same precautions as you would in your own home in regard to perishables, ventilation and rain protection. In addition, for prolonged storage periods, flush out all the drain lines and the holding tanks. Also, drain the entire water system including the water heater and the water storage tank. Instructions for draining the water system are explained in the following paragraphs on winterizing.

Twice a year or after a long storage period, we suggest you take your unit in for a check-up and cleaning of the gas operated appliances.

The main consideration in winterizing is to guard against freezing damage to the hot and cold water systems, the waste drain system (including the traps), the waste-holding tanks, the water heater and the battery. To completely winterize your Airstream, follow this procedure:

1. Level the trailer from side to side and front to rear. Open all faucets.
2. Turn the water pump switch to the ON position to expel water from the storage tank.
3. Open all drain valves. On rear bath models, two are located in the rear trunk (roadside). On center bath models, one is located under the bed on the roadside, and three are under the galley sink. On all models one is located on the water heater accessible through the exterior access panel.
4. While the water is draining from the

system, open and flush the toilet flushing valve. Depress hand spray lever while holding the spray head down inside the bowl. Depress hand spray thumb button on the telephone shower head while holding down inside the tub and drain all water from the flexible hose. Unscrew the heads on both spray units and store.

5. After pump has removed all water from the storage tank, turn the pump switch OFF.
6. Remove exhaust hose from water pump.
7. Disconnect the water pump inlet connection, and with check valve removed, turn the pump by hand until all the water is expelled.
8. Lower the front of the trailer as far as the jack will allow until water ceases to drain, then crank the jack up as high as it will go and let any remaining water drain out the rear drain valves.
9. Pour a cup of nontoxic antifreeze into the lavatory, sink, and tub drains to prevent trap freeze-up.
10. Be sure to open the waste-holding tank drain valves and drain and flush the tanks thoroughly. **(This is very important as the sewage in the tanks, if frozen, could seriously damage the tanks.)**
11. Remove the cartridge of the water purifier and leave the purifier valve in the open position.
12. Remove the battery from your Airstream and store in a cool dry place where there is no danger of freezing. It is very important for optimum life of your battery to check it periodically and to keep it fully charged.

13. Remove any items (food, cosmetics, etc.) from trailer interior that might be damaged by freezing — or might damage the trailer if containers break.

For additional winterizing protection add a nontoxic antifreeze (approved for drinking water systems) to the water lines using the following procedure:

1. Reconnect all lines except the hose to the pump inlet port. Close all drain valves (see step No. 3).
2. Attach a length of hose to the pump inlet port. This piece of hose should be long enough for the free end to be inserted into and reach the bottom of the antifreeze container.
3. Dilute the antifreeze solution in accordance with the manufacturer's instructions.
4. Open all water faucets.
5. Insert hose length into the antifreeze container, turn the pump switch on, and run the water pump until the antifreeze solution fills all water lines and the water heater. Flush toilet, work hand spray while holding down in bowl. Work hand shower spray while holding down in tub.
6. Shut off the pump and close all faucets.
7. Disconnect the hose length from pump inlet fitting and reconnect water system inlet line.

Exterior Identifications

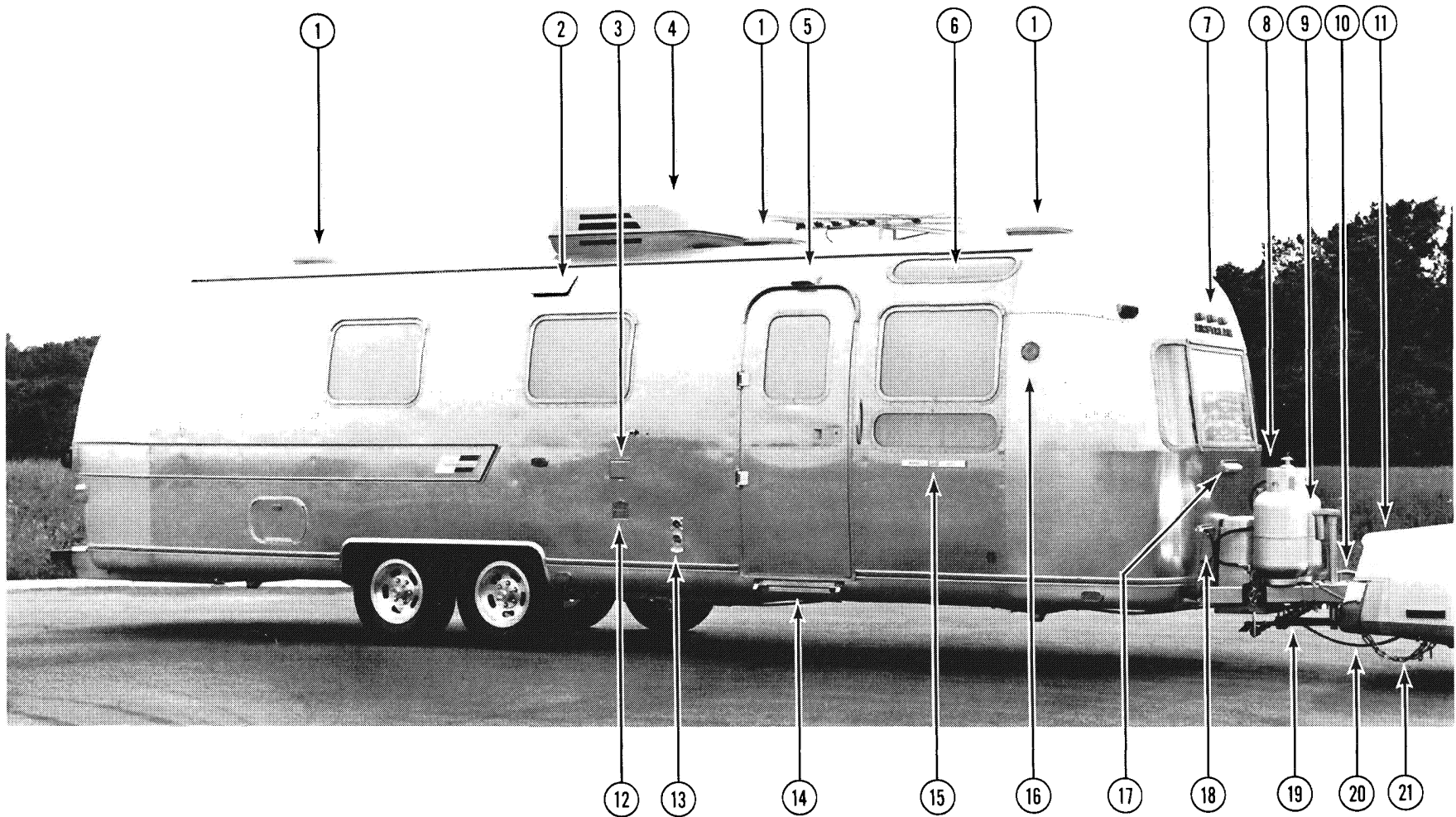

No.	Description	Page No.
1.	Roof vent	.61
2.	Range exhaust vent	.68
3.	120 volt outlet	.79
4.	Air conditioner (optional)	.59
5.	Main door light	.92
6.	Vista view window (optional)	.47
7.	Cluster lights	.92
8.	L.P.G. tanks and regulator	.63
9.	Electric jack	.33
10.	Brake vacuum line	.17
11.	Coupler	.34
12.	Water inlet (tank)	.73
13.	Furnace vent	.70
14.	Main door step	.46
15.	Serial number plate	—
16.	Exterior light	.92
17.	Univolt vent	—
18.	Battery compartment	.81

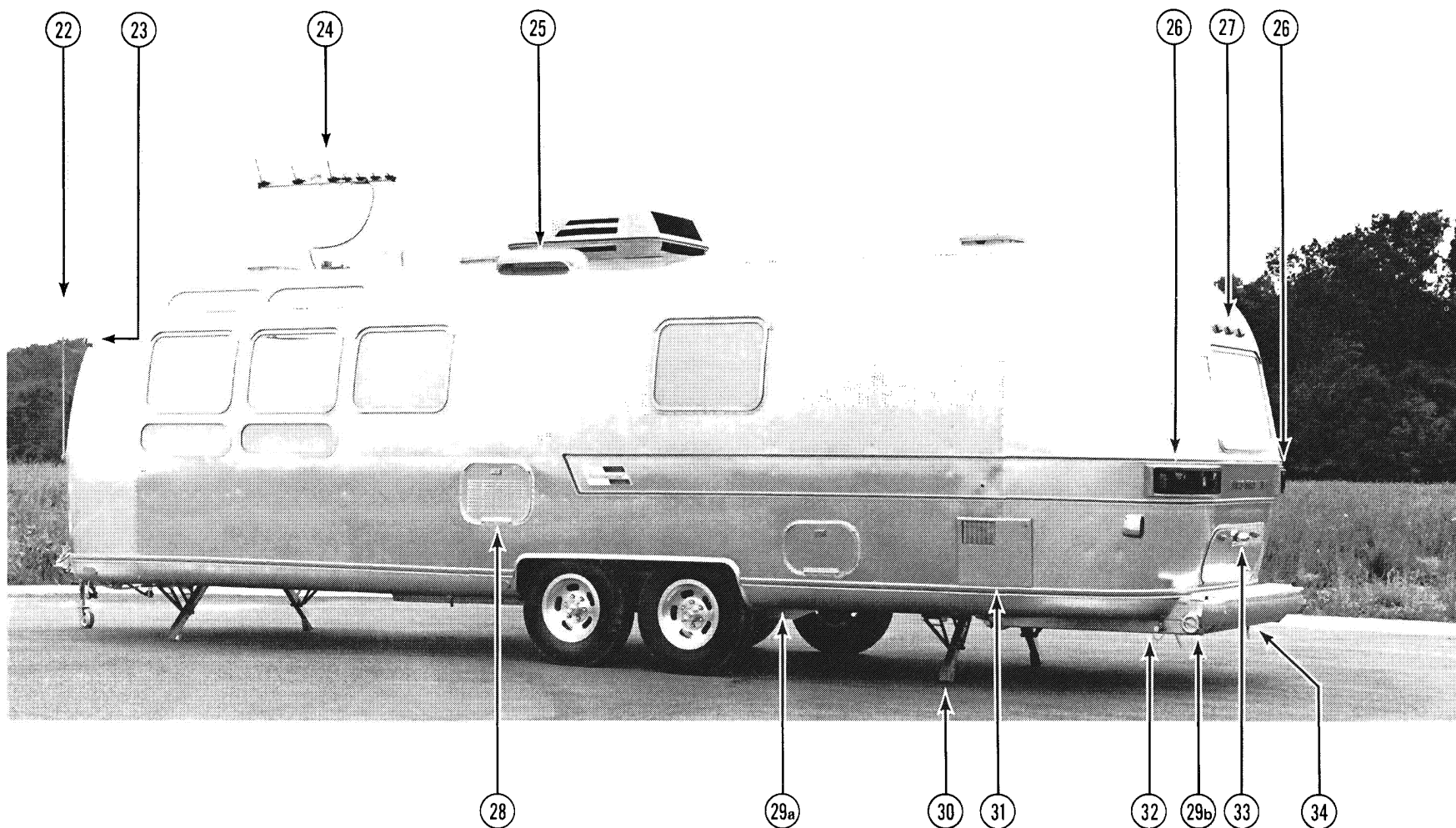

No. Description

Page No.

19. Load equalizing bars34
 20. Electrical connector (towing)34
 21. Safety chains34
 22. Radio antenna (optional)47
 23. Clearance light92
 24. T.V. antenna (optional)47

25. Refrigerator vent36
 26. Stop, tail, turn and backing lights ...92
 27. Cluster lights92
 28. Refrigerator access door64
 29.a. Waste outlet (center bath)76
 29.b. Waste outlet (rear bath)76

30. B.A.L. stabilizing jacks (optional) ...40
 31. Water heater access panel72
 32. Water inlet (city)73
 33. License plate light92
 34. Electrical inlet (city)79

Exterior

The Airstream exterior has been covered by an acrylic lacquer finish providing years of environmental protection. Washing the exterior of your Airstream is similar to washing an automobile. Both have high quality finishes and certain precautions must be taken to protect them. Oil, grease, dust, and dirt may be removed by washing with any mild nonabrasive soap or detergent. Automatic dishwasher detergents and acid etch cleaners are too strong and should never be used. **Always clean your Airstream in the shade or on a cloudy day when the aluminum skin is cool.** Cleaning should be followed by a thorough clean water rinse. Spots and streaks may be prevented by drying the unit with a chamois or a soft cloth.

After cleaning and drying, a good grade of nonabrasive automotive paste or liquid wax will increase the life of the finish, especially in coastal areas where the finish is exposed to salt air or in polluted industrial areas. It will also protect the shell from minor scratches and make subsequent cleaning easier. Wax should normally be applied every three to six months. The first application should not be sooner than 90 days after purchase to allow acrylic finish to cure.

It is important to remove sap, seeds, gum, resin, asphalt, etc., as soon as possible after they appear by washing and re-waxing. Sunlight and time will bake-harden these materials making them almost impossible to remove without heavy buffing. If asphalt remains on the trailer after washing, use a small amount of kerosene on a rag and wipe the spots individually, being

careful not to scratch the aluminum.

For small areas of damage to the acrylic protective coating, or where oxidation is beginning to occur, remove all traces of the acrylic coating with a good grade of lacquer solvent and then thoroughly clean the aluminum with an aluminum cleaner. Re-spray the area with clear acrylic lacquer.

All items needed for these minor repairs to the exterior shell are available at Wally Byam Stores. For extensive refinishing we recommend that you contact an Airstream Service Center or the factory for instructions. To keep your trailer looking new, paint the "A" frame, L.P.G. tanks, and rear frame periodically, by brushing on aluminum lacquer or, if possible, by spraying.

Each time you connect the **7-way electrical connector** check for dirt and corrosion. Keep the contacts clean with "Spray-Kleen."

It is important that the main door be completely closed and locked during towing. If it is not locked the constant vibration of travel may cause it to open with possible damage.

For your security the lock has been designed as a dead bolt. For this reason never try to shut the door when it is locked. The door is properly closed when the handle is firm. If the door is difficult to open, push in to release the latch. When the door swings open it will automatically latch against the side of the trailer.

The **screen door** latches to the main door or operates independently using the same

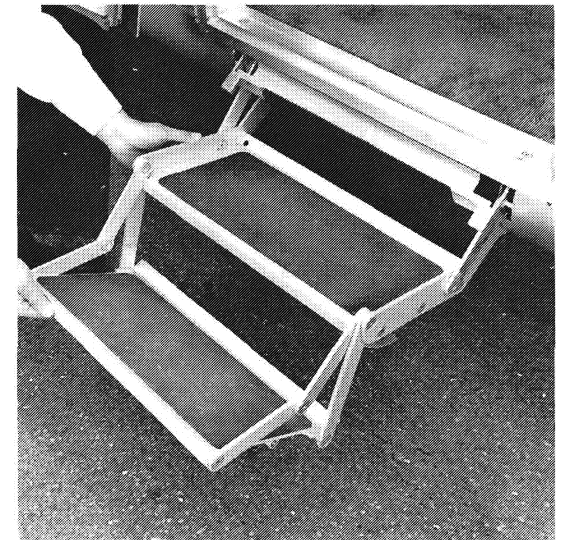

Fig. 1 – Fold-Away Step

type latch that holds the main door open.

To operate the **fold-away step** (see Fig. 1) just press down the latch on either side and the step will automatically drop into position. To stow the step simply lift the front edge and then push it up under the trailer to its stowed position.

The optional **extension step** (see Fig. 1) is permanently attached to the main step and when needed it is simply flipped out.

Never travel with step lowered.

The **exterior windows** in your trailer are of heat strengthened safety plate glass. To open: release the two lever locks at the bottom, pull the two side operator handles toward the center and pull down until the window is in the desired position (see Fig.



Fig. 2 – Window Operation

2) and place the operators into one of the five positioning holes. To close: pull the two side operator handles toward the center and slowly lift.

The optional high strength safety glass **front center window** is cleaned in the same manner that ordinary windows are. Clean the seals with a damp cloth or mild detergent every three to six months taking care not to use strong solvents as they will damage the seals. A coat of natural silicone lubricant applied after the seal has dried will keep it flexible. Spread the lubricant evenly with a brush or finger, working it into the surface. This is a good practice for all rubber seals in your Airstream. For replacement of a damaged window contact an Airstream Service Center or the factory.

The **optional double paned side windows**

include metalized mylar tint. They eliminate the need for storm windows and improve the efficiency of the air conditioning system.

Screens are made of plastic for hard wear and easy maintenance. Clean with a damp cloth. **Note: They will melt at the point of contact if touched by a cigarette.**

Vista view windows are double paned, allow for interior lighting while maintaining privacy and are equipped with integral shades.

Factory recommended awnings give shade during trips and rallies. They are easy to operate and can be installed by your dealer.

The aluminum construction of your trailer creates a radio-shield and you will need outside antennas for good reception. This can be accomplished by a whip radio antenna or T.V. antenna with an auto coupler.

An **auto coupler** (optional) enables you to utilize your T.V. antenna for AM-FM radio reception.

A telescoping whip **radio antenna** (optional) is available for the optional 12-volt AM-FM radio and should be professionally installed next to the front window roadside of your trailer on a swivel mount.

The controls for the optional **T.V. antenna** are in the ceiling directly below the antenna. To raise the antenna, turn hand

crank clockwise until it stops. Then turn on TV set and select channel. While watching picture, reverse the handle approximately ½ turn, push handle up toward the ceiling, hold in that position and rotate antenna. If you hit a stop in rotation before the picture is clear, reverse rotation. You may have to readjust when changing channels. To close, reverse the direction of cranking. Before traveling, check outside that the antenna is folded and pointed straight forward.

Floor Plans

No.	Description	Page No.
1.	Electrical inlet-city	79
2.	Waste outlet	76
3.	Water inlet-city	73
4.	Bed light	60
5.	Water pump	73
6.	Water inlet-tank	73
7.	Water heater	72
8.	Table	56
9.	Front lounge	55
10.	12 volt distribution panel	89
11.	Univolt	79
12.	120 volt circuit breaker panel	80
13.	Toilet	77
14.	Furnace	70
15.	Range and oven	68
16.	Central control panel (optional)	56
17.	Sink	60
18.	Water filter	74
19.	Refrigerator	64
20.	Air conditioner (optional)	59
21.	Stereo AM/FM radio/tape (optional)	58
22.	Battery	81
23.	Clock (optional)	58
24.	Power brake booster	17
25.	L.P.G. tanks and regulator	63
26.	Hitch	33

21 Ft. Double

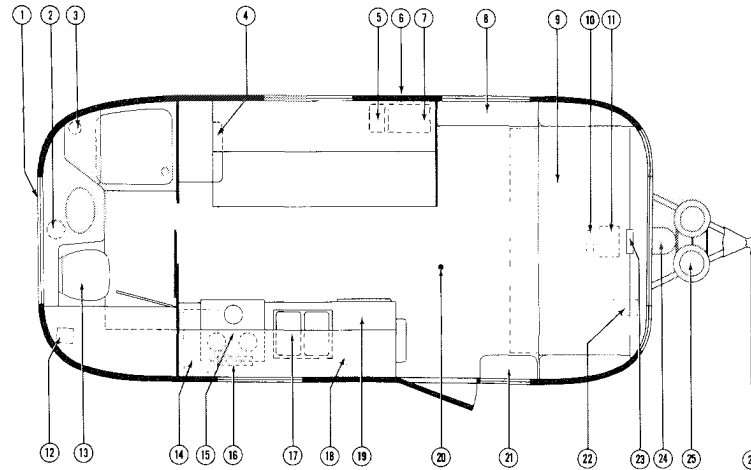

23 Ft. Twin and Double

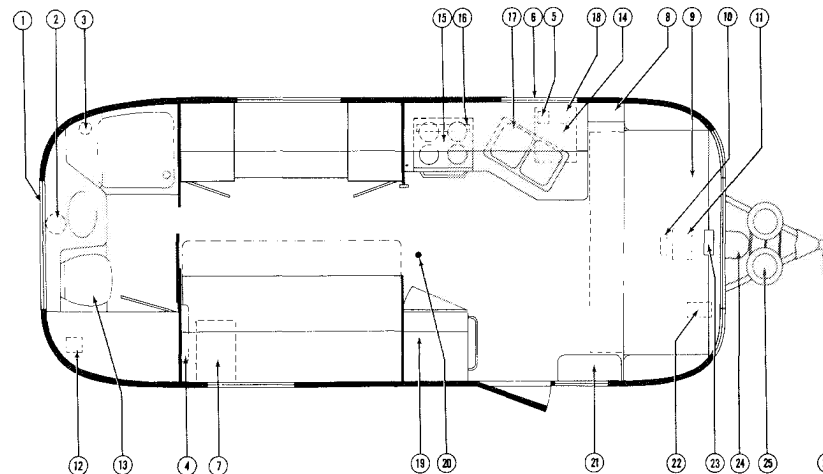

No.	Description	Page No.
1.	Electrical inlet-city	79
2.	Waste outlet	76
3.	Water inlet-city	73
4.	Toilet	77
5.	Bed light	60
6.	Central control panel (optional)	56
7.	Range and oven	68
8.	Water inlet-tank	73
9.	Sink	60
10.	Water pump	73
11.	Furnace	70
12.	Water filter	74
13.	Stereo AM/FM radio/tape (optional)	58
14.	12 volt distribution panel	89
15.	Front lounge	55
16.	Univolt	79
17.	120 volt circuit breaker panel	80
18.	Water heater	72
19.	Air conditioner (optional)	59
20.	Refrigerator	64
21.	Table	56
22.	Battery	81
23.	Clock (optional)	58
24.	Power brake booster	17
25.	L.P.G. tanks and regulator	63
26.	Hitch	33

25 Ft. Twin and Double – Rear Bath

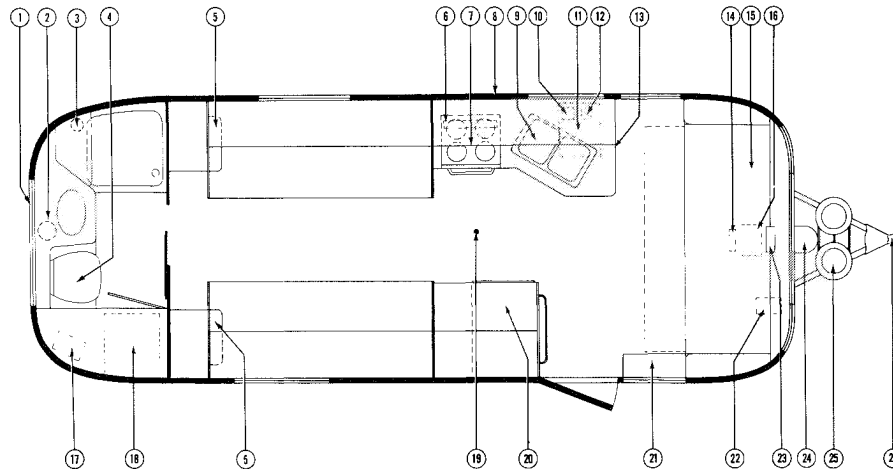

25 Ft. Double – Rear Bath (Caravanner)

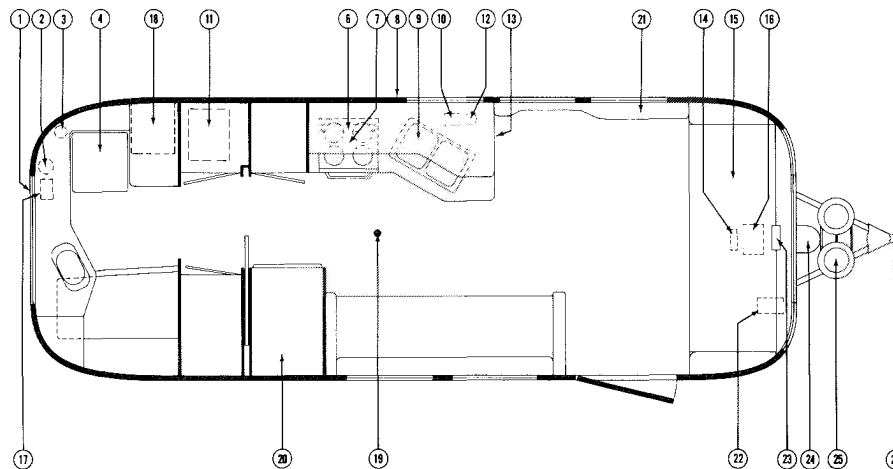

No.	Description	Page No.
1.	Electrical inlet-city	79
2.	Waste outlet	76
3.	Water inlet-city	73
4.	Toilet	77
5.	Water heater	72
6.	Refrigerator	64
7.	Table	56
8.	Front lounge	55
9.	12 volt distribution panel	89
10.	Univolt	79
11.	120 volt circuit breaker panel	80
12.	Bed light	60
13.	Air conditioner (optional)	59
14.	Central control panel (optional)	56
15.	Range & oven	68
16.	Water inlet-tank	73
17.	Sink	60
18.	Water pump	73
19.	Furnace	70
20.	Water filter	74
21.	Stereo AM/FM radio/tape (optional)	58
22.	Battery	81
23.	Clock (optional)	58
24.	Power brake booster	17
25.	L.P.G. tanks and regulator	63
26.	Hitch	33

27 Ft. Twin and Double—Rear Bath

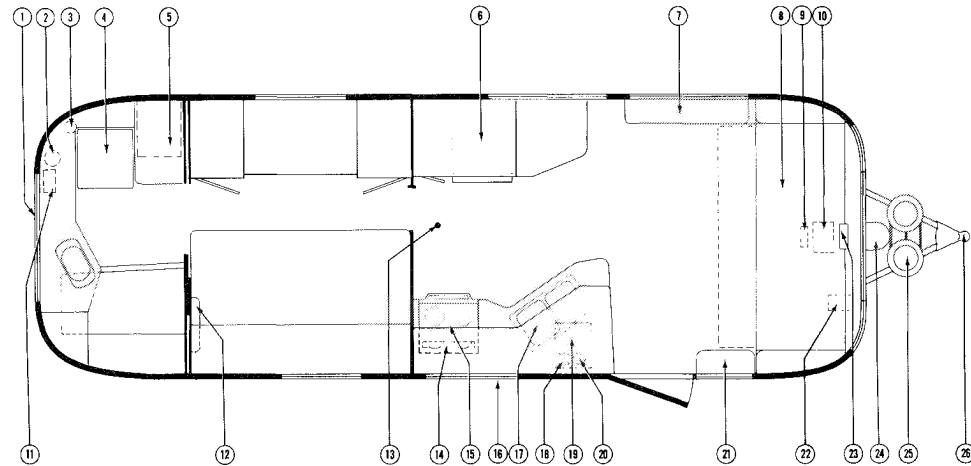

No. Description	Page No.
1. Electrical inlet-city	.79
2. Water inlet-city	.73
3. Bed light	.60
4. 120 volt circuit breaker panel	.80
5. Waste outlet	.76
6. Air conditioner (optional)	.59
7. Refrigerator	.64
8. Table	.56
9. 12 volt distribution panel	.89
10. Front lounge	.55
11. Univolt	.79
12. Water heater	.72
13. Toilet	.77
14. Central control panel (optional)	.56
15. Range and oven	.68
16. Water inlet-tank	.73
17. Sink	.60
18. Water pump	.73
19. Furnace	.70
20. Water Filter	.74
21. Stereo AM/FM radio/tape (optional)	.58
22. Battery	.81
23. Clock (optional)	.58
24. Power brake booster	.17
25. L.P.G. tanks and regulator	.62
26. Hitch	.33

29 Ft. Twin and Double – Center Bath

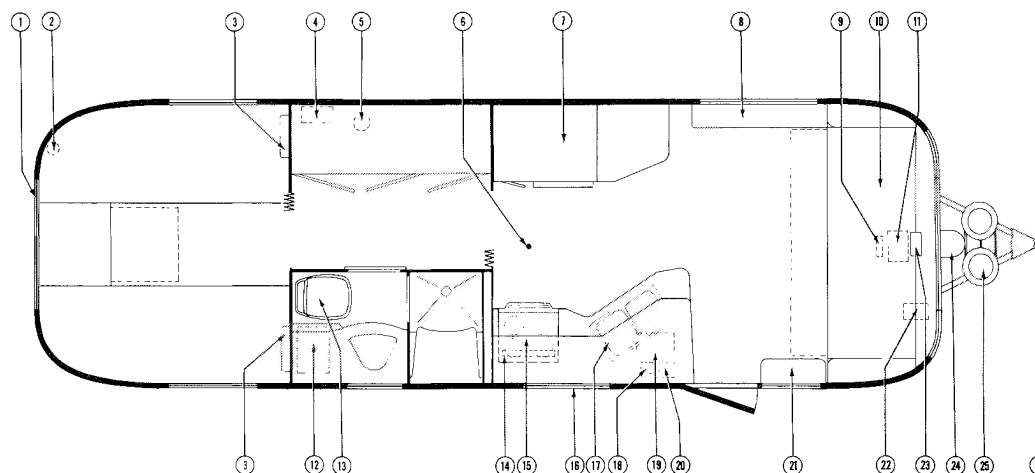

31 Ft. Twin and Double – Center Bath

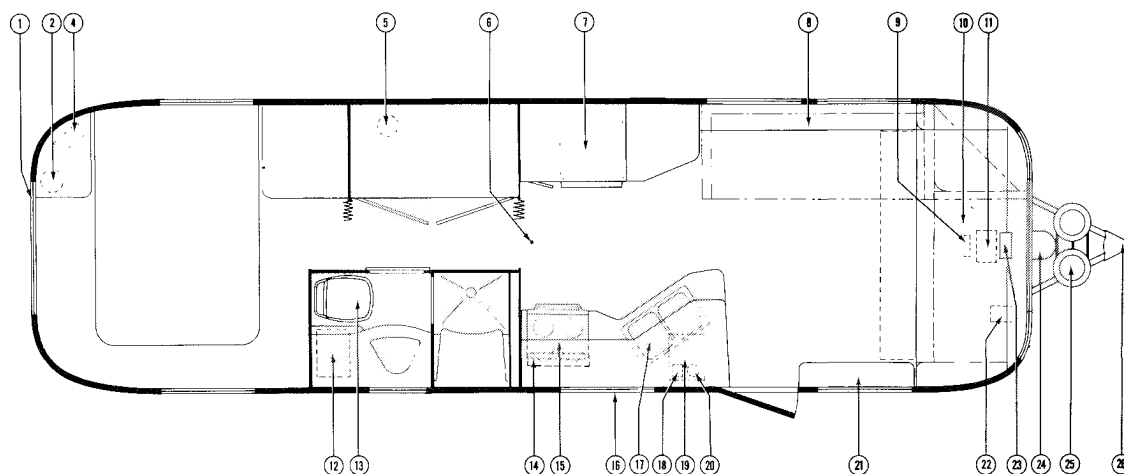

No.	Description	Page No.
1.	Electrical inlet-city	79
2.	Waste outlet	76
3.	Water inlet-city	73
4.	Toilet	77
5.	Water heater	72
6.	Refrigerator	64
7.	Stereo AM/FM radio/tape (optional)	58
8.	12 volt distribution panel	89
9.	Front lounge	55
10.	Univolt	79
11.	120 volt circuit breaker panel	80
12.	Bed light	60
13.	Air conditioner (optional)	59
14.	Central control panel (optional)	56
15.	Range and oven	68
16.	Water inlet-tank	73
17.	Sink	60
18.	Water pump	73
19.	Furnace	70
20.	Water filter	74
21.	Battery	81
22.	Clock (optional)	58
23.	Power brake booster	17
24.	L.P.G. tanks and regulator	63
25.	Hitch	33

29 Ft. Twin and Double – Rear Bath

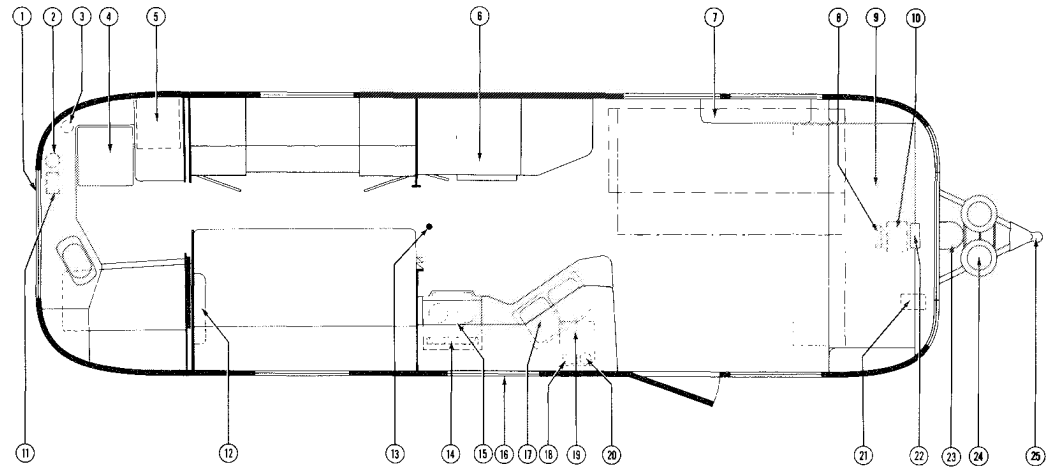

31 Ft. Twin and Double – Rear Bath

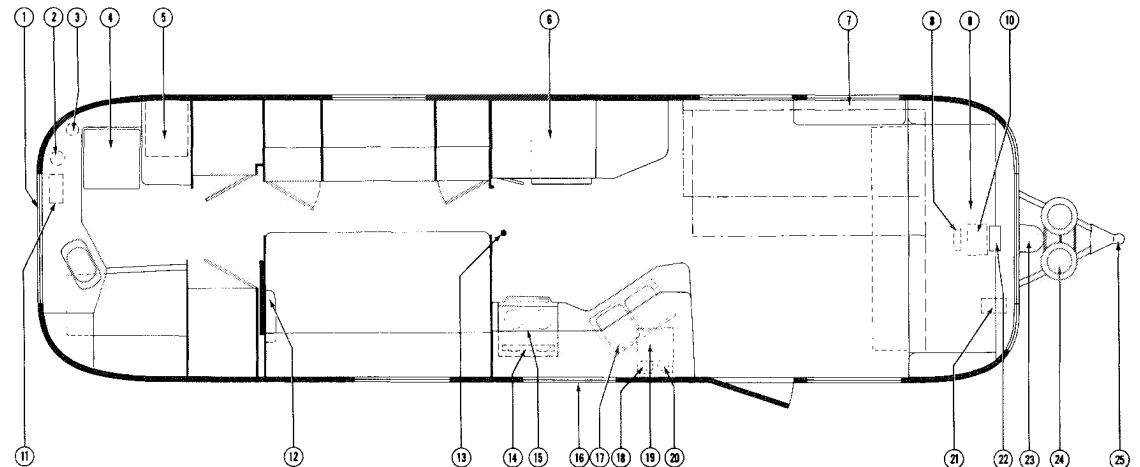

Interior

The Airstream interior has been designed for comfort, convenience, durability and appearance. How you use it and how you take care of it naturally depends on you. However, if you learn how to operate the interior components and take care of them and the trailer properly, this knowledge will add to your pleasure as well as the long life of your trailer.

Drapery, upholstery and mattress covers must be professionally dry cleaned. Frequent vacuum cleaning is recommended.

Your Airstream upholstery is treated with Scotchgard and should repel moisture. Minor spills should be removed by blotting. Avoid rubbing as this will cause a stain to work itself into the fabric.

The cleanability code for the green and gold color schemes is code S. Spot clean, using a mild, water-free solvent or dry cleaning product. Pre-test small area before proceeding.

The rust color scheme requires cleanability code X. Clean this fabric only by vacuuming or light brushing to prevent accumulation of dust or grime. Water-based foam or solvent-based cleaning agents of any kind may cause excessive shrinking, fading or possible pile distortion.

The beige color scheme requires cleanability code W. Spot clean, using the foam only from a water-based

cleaning agent, such as a mild detergent or non-solvent upholstery shampoo product. Apply foam with a soft brush in a circular motion and vacuum when dry. Pre-test small area before proceeding.

We suggest calling a professional furniture cleaner when an overall soiled condition is reached. Any tumble cleaning method can destroy the backing, shrink or otherwise damage upholstery fabric.

Use the following procedure to remove drapery panels for cleaning:

1. Front lounge, both roadside and curbside – unsnap the dot fasteners holding the lower and upper rear corner to the outer wall. Remove the rear most screw holding the lower drapery track to the outer wall. Remove three screws attaching the upper drapery track end cap and remove the cap. Slide drapery panels to the rear until they are completely free of both tracks.
2. Front wrap-around drapes – unsnap dot fastener holding the corners of the curbside and roadside panels to the outer trailer walls. Remove the two rear most screws holding lower tracks to outer trailer wall. Slide the drapery panels to the rear until they are completely free of both upper and lower tracks.
3. Side bedroom windows, both roadside and curbside – using a ¼" size drill bit, drill out the pop rivet holding one of the dot fasteners to the lower drapery track. There are two fasteners, one at

each end of the track, on both the curbside and roadside. Select the end with the most clearance between track end and bulkhead wall. Remove the corresponding screw from the end of the upper track. Remove drapery panels by sliding them clear of both upper and lower track.

After replacing drapes, reinstall dot fasteners using a pop rivet of correct diameter.

The carpet can be cleaned with any good commercial carpet cleaner, or with a detergent and water. **Be careful not to soak the carpet with water, however.**

The counter areas around the sink are of a high-pressure laminate and can be cleaned with soap and water, or you can use a common cleaning solvent on tough spots. Be sure no abrasive cleaner is used as there is the possibility it could scratch the surface. A protective pad should always be placed under hot utensils.

The walls can be cleaned with any vinyl cleaner or with any mild household detergent and water. But, again, no abrasives.

The high-pressure laminate wood of the wardrobes and cabinets may be waxed, if desired, or may be cleaned simply with a damp cloth.

See the bathroom section for cleaning and maintenance suggestions for the ABS plastic surfaces.



Fig. 1 – Lounge Into Bed

To convert the lounge into a bed, lift up the front of the lounge and fold down the seat spacer bar located on the front edge of the bed frame. Lower the lounge to release the latch. Grasp the front edge of the seat and pull lounge assembly out until it stops. Lift the seat again until the lounge back is in a horizontal position. Remove stored bedding. Push release lever to the left and lower the seat to a horizontal position. Make sure that the bolster strip is properly positioned before making bed.

To return bed to lounge position, grasp the front edge of bed and raise until the pivot pins engage to rear half of the bed. Store bedding. Lower the seat to a horizontal position, returning assembly to a lounge position. Lift the front edge of seat and swing seat spacer bar to up position. Lower the seat and push lounge assembly



Fig. 2

toward the wall until locking pins engage.

The **below bed storage** is available on fixed twin and double models for additional storage of bedding and linen or fishing and hunting gear. Both the front lounge and the side roll-out lounge have below bed storage.

A **space locker** attached to the roof lockers is available for additional storage space for bedding, etc. in the bedroom.

All the drawers are removable allowing you storage flexibility and ease of packing and unpacking. Wardrobe catches are self-locking and they may be opened by sliding the touch plate away from the door opening.

When attaching wall hung improvements,

like hooks for clothing, bookshelves and extra towel racks, secure with half-inch No. 8 sheet metal screws  with flat binder heads, make holes in the aluminum inner walls with a small hand drill (No. 30 drill bit).

The **bunk beds** (optional), located in the bedroom, serve as the bolster for the bed when not in use. In order to place bunk into sleeping position:

1. Depress latch located on the center back side of the bolster.
2. With latch depressed pull up on fabric loop located on the center front bottom of bolster. This will allow bolster filler to hinge down.
3. Bring bolster filler up to horizontal position and attach both straps onto bracket on ceiling.

To lower bunk:

1. Release straps.
2. Rotate bolster filler into latched position.
3. Lower bolster down against wall.

Make beds in the usual way, using fitted sheets $\frac{3}{4}$ bed size. The space beneath the cushion is ideal for storing bedding for both front travel lounges and side pull-out beds. an easy method of storing bedding is to remove and store pillows then fold back the ends of the bedding neatly to expose about 2" of the mattress; then starting from the edge furthest from you, roll up the bedding as tightly as possible towards you. Raise the front of the cushion and store the rolled bedding in the space below.

To make fixed twin beds, lift mattress slightly, pull it away from the wall and then tuck bedding along wall. **Note: Please do not launder mattress ticking; it has to be dry cleaned to prevent shrinkage.**

To open the table, lift the table into a horizontal position, (See Fig. 1) depress latch and pull the folding leg down until it locks in position. (See Fig. 2) To extend the table pull out on the latch underneath the table right next to the leg and lift the table and leg slightly off the floor. Now pull the extension frame and leg out as far as they will go. Release the catch on the extension table leaf and rotate it over onto the extended frame. (See Fig. 3.) By raising the leg the entire table can be slid forward and aft for your seating comfort.

To stow simply reverse the procedure and

unlock the leg and drop the table to the wall. Additional storage is provided behind the table compartment.

The **Central Control Panel**, located in the galley roof locker of your unit, contains the necessary instrumentation to monitor your Airstream's systems.

The **panel light** switch lights the gauges.

The **battery condition tester** has a switch which operates a meter indicating: good, fair and low condition. (This meter does not indicate true battery state of charge while you are hooked-up to 120 volt city power. For this reason you should briefly disconnect city power, turn one light on in low position for about 30 seconds and then make this check.) When it shows low condition, you should take every reasonable step to conserve power by using as few lights as possible and switching off appliances. The battery should be charged as soon as practical and with the tow vehicle charging system or connection to 120 volt power.

The **ammeter** indicates whether the trailer battery is being charged. The charging system in your trailer is much like the charging system in your car. The univolt package performs a similar function to the car alternator by constantly recharging your battery as power is used. If the total current draw is greater than the univolt's capacity to recharge, your ammeter will indicate a discharge. In this case, reduce the power usage until the ammeter once again



Fig 1—Table Opening

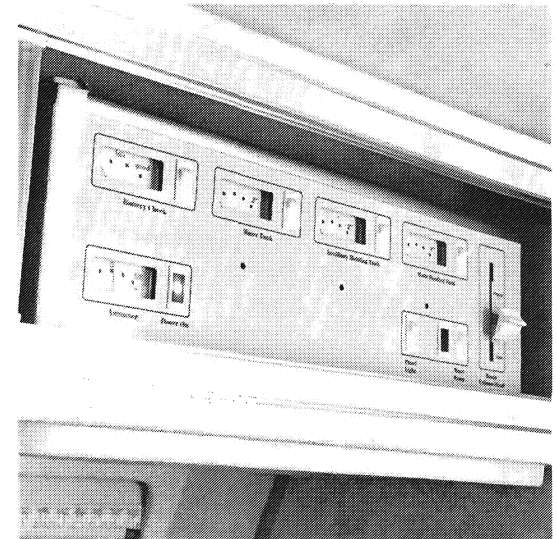

Central Control Panel



Fig. 2



Fig. 3

indicates a charge. If you do not reduce power usage, your battery may become discharged even though the univolt is attempting to keep it charged.

The **water pump switch**, when on, also lights the indicator light. On trailers without a Central Control Panel, this switch is located in the galley area. For a complete discussion of the pump, please refer to page 73.

The **water tank, main holding tank and auxiliary holding tank gauges** indicate the amount of liquid in their respective tanks. Measurements are made by means of a series of electronically controlled probes located at various levels in each tank. Press the appropriate switch and the gauge will indicate in one of the five positions (see diagram).

The needle position may be slightly off the indicated mark due to varying voltage in the Univolt System. With a partially discharged trailer battery, the needle would be to the left of dot. A higher voltage would move the needle to the right of the dot. Under these conditions the correct tank level is indicated by the closest dot.

Before leaving the factory the tank level gauges are calibrated. Periodic recalibration may be necessary due to mineral deposits on tank probes. To recalibrate any of the three tank gauges: fill the tank to its maximum capacity with water. Press switch and align gauge needle to the middle of the F dot by

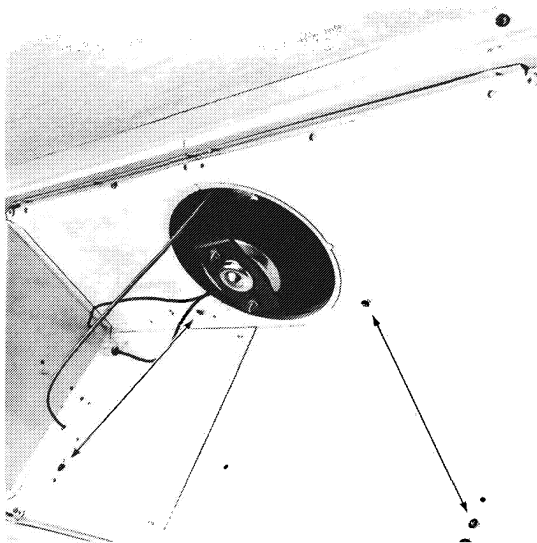

Central Control Panel Removal

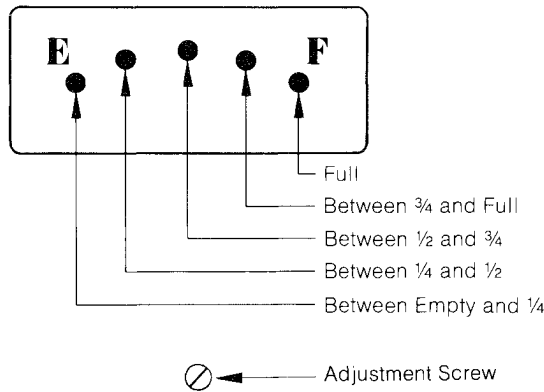

Water Tank and Holding Tank Gauges

turning adjustment screw. This screw is located in a hole directly below meter, and may be turned with a narrow blade screwdriver. Accumulation of oxides, dirt, etc. on the probes may prevent proper alignment of the needle. In this case remove probes from the tank and scrape clean. Apply sealant to thread area only and replace probes. Care must be taken to keep the probes free of sealant.

The **power-on light** will glow automatically when you are hooked up to city power. This light and the polarity warning light are your checks on a proper 120 volt connection.

If the gauges are not working and the panel light does not light, check the fuse to the right of the central control panel. The fuse serves all lights and gauges of the central control panel except the water pump. The water pump has two fuses, one in the central control panel and one at the water pump.

Access to the rear of the Central Control Panel is necessary for replacement of panel light bulbs. To remove Central Control Panel: remove 2 screws that secure the filter to the range exhaust hood housing and drop it out. Remove 2 screws up inside range exhaust hood and remove range exhaust fan knob from lever by pulling straight out on knob. Remove screws on side panel inside roof locker, and pull electrical connector apart.

The optional **electronic digital clock** operates at all times whether you are on self-

contained battery power or hooked up to 120 volt city power.

To operate the clock, push display switch to ON. To set correct time, push set switch to SET MINUTES and then to SET HOURS.

To conserve electricity, the display switch may be turned OFF. (See Fig. 1.) The correct time is held in memory until the display is turned back on. If, when the display is turned back on, the time shown is incorrect, there has likely been a power interruption.

After some time you may experience what appears to be a malfunction in the set switch; that is, the displays may not turn on at all or they may "rapid fire." This is caused by dust on the switch contacts and is easily corrected by moving the switches back and forth 10-20 times.

A Motorola AM-FM stereo radio and combination Motorola Stereo AM-FM radio with 8 track stereo tape player are available. (See Fig. 2.) The "fader" control allows the front speakers to be turned on by themselves, or the rear speakers by themselves, or any combination of front and rear speakers.

To operate the AM-FM Stereo Radio:

1. Switch power on at ON-OFF and VOLUME knob.
2. Slide the AM-FM switch to the left or right to receive band desired.
3. Tune in desired station manually or automatically with pushbutton.
4. Push LOCAL-DISTANT knob in for

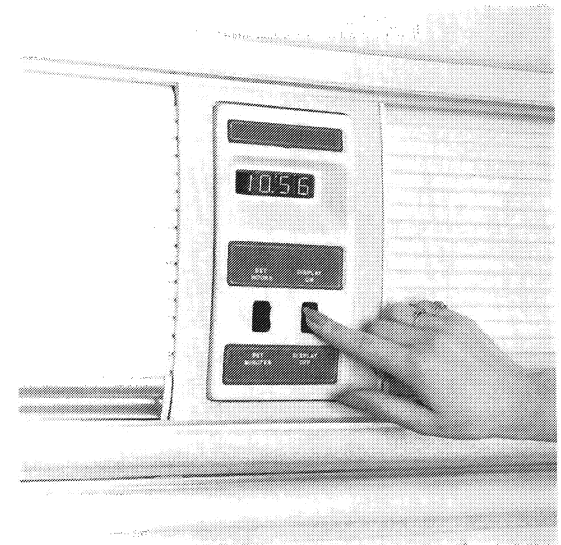

Fig. 1 – Electronic Digital Clock



Fig. 2 – Stereo Tape and AM/FM Radio

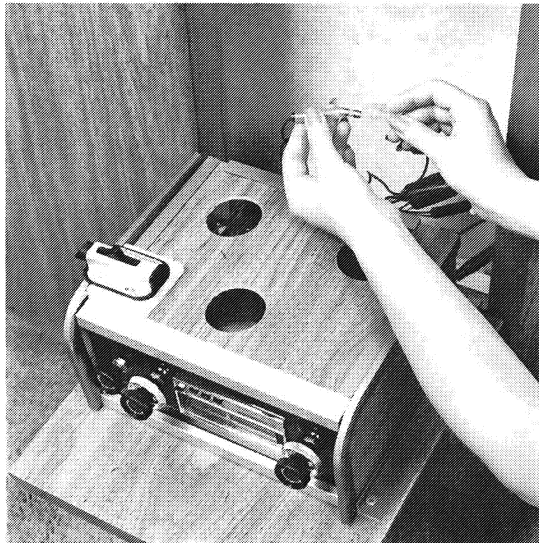

Fig. 3—AM/FM Radio Fuse

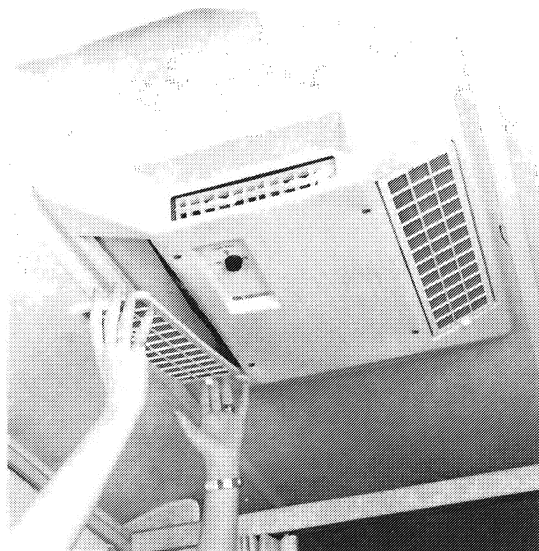

Fig. 4—Air Conditioner Ducts and Filter

- DISTANT and pull out for LOCAL to achieve optimum FM reception.
5. Adjust VOLUME control to desired listening level.
 6. Adjust TONE control for desired bass or treble response.
 7. Adjust FADER control for desired sound level between front and rear speakers.
 8. Adjust BALANCE control for desired balance between left and right channels.
 9. To switch radio off, turn ON-OFF knob to extreme left.

To operate the 8 track stereo tape:

1. Switch power on at SELECT-VOL control.
2. Turn tape player on by inserting the 8 track cartridge into the tape slot; insert cartridge open end first, label side up, until it is firmly seated in mechanism.
3. Adjust VOLUME, TONE, FADER and BALANCE controls.
4. Change programs as desired by pushing SELECT-VOL control. Each time the selector is pushed and released, the next program will play. Programs will play in succession (change automatically), and continuously, if manual SELECT is not pushed. The tape program indicator lights will light, indicating which program is being played.
5. To switch tape player off and radio on, pull cartridge out approximately one inch from its seated position or remove it entirely. Never leave a cartridge in the tape slot when player is not in use.

Store tapes in a cool area with open end down. Protect tapes from dust and direct sunlight.

In time, oxide from recording tape will accumulate on the tape head and capstan shaft which can cause tape hiss and erratic operation. The more often the tape player is used, the more often it should be cleaned.

Clean the head with a cotton swab moistened with isopropyl alcohol. **Do not use carbon tetrachloride.**

To clean the capstan shaft, first turn on the motor by depressing the motor switch (next to the capstan shaft) with the eraser end of a pencil. Use a cotton swab moistened with alcohol on the shaft.

The fuse for the radio, or radio/tape is located behind the unit. To gain access to the fuse, release the latch located on the back of the stereo unit cabinet and let unit hinge down. The fuse is secured with an inline fuse holder. (See Fig. 3.)

The **Armstrong air conditioner** can be used for cooling or heating your trailer or for air circulation only.

To operate for cooling:

1. Close doors, windows and ventilator.
2. Set wall thermostat to "COOL" position and set thermostat indicator to your desired comfort level.
3. Set system switch (located at ceiling cover of air conditioner) to your preferred speed setting

Note: The air conditioner will not operate until speed selection is made. The recommended cooling speeds for various outdoor temperature ranges are:

Hi-Cool	70-120
Med-Cool	60-110
Lo-Cool	50-100

To operate for heating:

1. Set wall thermostat to "HEAT" position and set thermostat indicator to your desired comfort level.
2. Set system switch to your preferred speed setting. We suggest MED or LO speed.

Note: The heater will not operate until speed selection is made.

To use for air circulation, set wall thermostat to "OFF" position and system switch to any of the three speed selections. To shut unit off, set system switch to OFF position.

Shut unit off to clean or replace filters. Clean both filters with vacuum cleaner once a week. Once a month, remove filters and wash in warm soapy water. (See Fig. 4, page 59.)

Stainless steel sinks cannot be harmed by boiling water. However, salt, mustard, mayonnaise and ketchup can cause pitting. Stubborn stains will yield to a paste made of water and slightly abrasive household cleaner. Be sure to work in the direction of the polish-lines on the steel, to keep the original finish. Fingerprints are some-

times a problem. They can be minimized by applying a cleaner that leaves a film of thin wax: simply wipe it on and remove the excess with a dry cloth. After this, fingerprints can be wiped off with a soft dry cloth, or one moistened with a little wax cleaner. The surface should always be washed before wax is applied. Regular cleaning will prevent buildup of scale and film. Ordinary soaps or detergents are best for routine cleaning of the stainless steel sinks. Rinse thoroughly with warm water and wipe dry with a cloth to avoid streaks and spots.

For further information on galley equipment refer to page 64 for the refrigerator and page 68 for the range and oven.

Professional carpet cleaning methods should be used for heavy carpet cleaning. However, you can clean your carpet more frequently with a broom or vacuum cleaner. Consult a professional carpet cleaner for hard to remove stains.

The **vacuum cleaner**, optional, is located in the storage cabinet adjacent to the refrigerator. To start the unit, raise the flap on the outlet and insert the hose with a slight twist. **Make sure the dust bubble is connected to the hose before using.** To stop the unit, simply remove the hose from its outlet. For best performance and your convenience, three disposable filters with instructions are included within the dust bubble.

To open and empty the dust bubble, hold it over a trash container and twist the lower

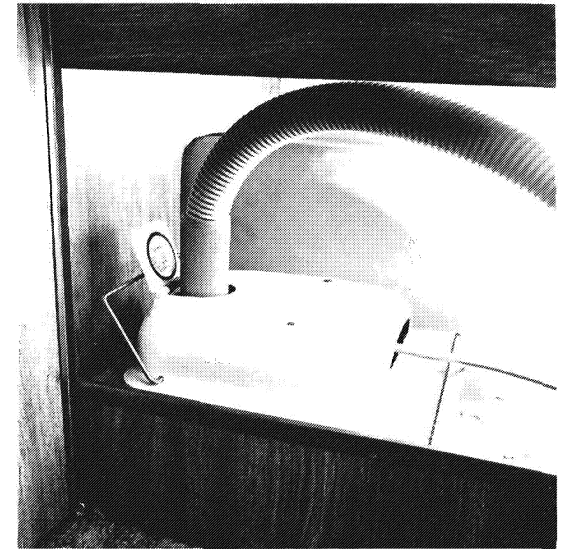

Vacuum Cleaner Hose and Outlet

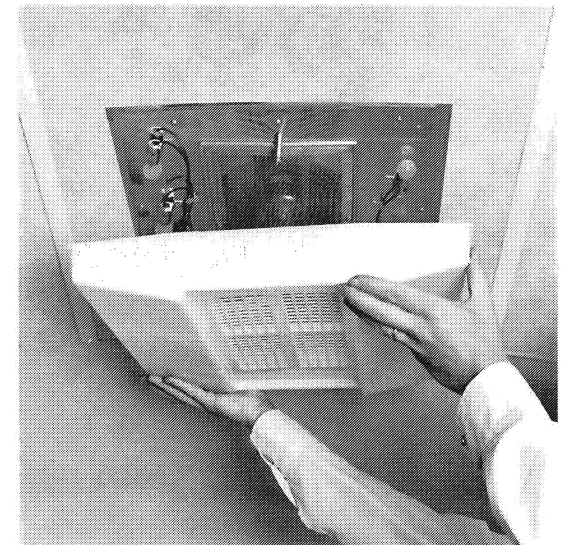

Ceiling Light Fixture

lid carefully. When disposable filters are not used, tap the two halves to release any dirt trapped on the filters. The dust bubble can also be rinsed out after removing both upper and lower filters.

To remove the filters, remove the lid and grasp the large outer red ring in the upper half of the bubble. Pull it gently toward you until free. Lift out the small inner red ring from the center of the bubble. Remove the lid filter ring by pulling gently. To reposition the filters reverse this procedure. When properly positioned, the large outer red ring should rotate freely on the flange.

Bed-lights are operated by a switch on the side of the light. To replace bulbs snap the lens out by squeezing gently the long side of the lens until it drops out of the fixture. Area lights have switches on the rim and their lenses are removed in the same manner.

Ceiling light fixtures are incorporated with the ceiling fresh air vents. To operate the lights turn the forward control knob clockwise; first position 2 lights, second position 4 lights, third position 6 lights, fourth position is off.

To remove the lens and replace the bulbs, pull knob from light switch shaft and remove shaft nut. Remove the screw from the vent control handle and remove handle. This will release the lens. To replace, reverse removal procedure.

The **fresh air vents** are operated by the aft

control handle. Turning clockwise will raise the vent and at the maximum extension, vents with fans will automatically turn on. For maximum air without fan, open until fan starts and back up just enough to turn fan off. Turning counterclockwise will close the vent. Airstream vents are designed to allow air circulation while still keeping out rain and can be used in any weather. Screens should be removed for periodic cleaning.

The optional **NuTone Food Center** allows you to operate several appliances with just one built-in power unit. The food center is equipped with three attachments, mixer, blender, and knife sharpener. Other appliance attachments are available.

Your power unit was oiled at the time of manufacture but a storage period may have permitted oil to drain back into the reservoir. Before using it for the first time, please run the power unit for one to two minutes to insure lubrication...before attaching an appliance. At intervals of from one to two months, depending on the amount of use, a few drops of ordinary household oil should be placed around the motor shaft opening.

The unit will warm up in proportion to the length of time it's run and the load it carries. If you run it unusually long or hard, give it a rest before putting it to work again.

The **mixer** was designed for convenience and efficient operation. The bowl rests on a turntable directly connected to power unit. The motor, not the beater, turns the bowl —

automatically keeps it revolving during mixing, regardless of the consistency of the batter. This feature eliminates hand-turning the bowl. And, while the bowl revolves automatically, the beater turns in the opposite direction. This 'counter-motion' feature helps prevent lumpy, incomplete mixing.

To operate the mixer:

1. Place turntable in position on the power unit.
2. Lock the turntable in place by pressing the locking lever clockwise.
3. Place the mixing bowl on the turntable.
4. Push the beater blade into the beater head. Blade will 'click' when it's locked in position.
5. Insert beater head shaft into center tube of bowl. Place it in one of six positions until it snaps into turntable.
6. Turn dial to desired speed.

Note: To remove beater head, turn counterclockwise, and lift it out of mixing bowl. If the turntable should become locked into power unit and cannot be easily removed, insert beater head and turn it counterclockwise.

The **blender** makes meal preparation and entertaining less work and more fun. It performs, quickly and easily the time-consuming and tiring tasks of grating, chopping, shredding and mincing; it even liquifies solids and blends them to perfection.

To operate the blender:

1. Place blender in position on power unit,

and turn clockwise to lock securely in place. **Never attempt to place blender or any other attachment in position while power unit is running.**

2. Put food in blender. Cover. Turn dial to desired speed. Or...
3. When adding solids, cover, then turn dial to desired speed. Remove insert from lid. Add food through opening while blades are in motion.
4. To remove contents from blender, use a long-handled rubber bottle and jar scraper or a wooden spoon or fork. Don't use a metal spatula or spoon.

The **knife sharpener** will allow you to sharpen your knives in just seconds.

To operate the knife sharpener:

1. Place sharpener in power unit; turn clockwise to lock in position. Be sure sharpening stone is on left as you face the knife sharpener.
2. Turn control dial to speed 3. Be sure knife is clean and dry.
3. Place heel of knife blade into guide slot next to sharpening stone (left or right). Hold knife firmly by the handle and draw it slowly toward you with cutting edge against stone. Allow weight of the knife and the guide slot to apply necessary pressure and positioning.
4. Repeat operation, alternating to left and right side of stone with each stroke, until desired sharpness is obtained.

Don't sharpen knives which have an irregular edge such as serrated, scalloped, fluted, corrugated or hollow edges...and

don't sharpen scissors. **Don't clean sharpener while attached to power unit. Be sure speed control dial is turned 'off' before attaching or removing sharpener.**

The **lavatory bowl, counter top, tub or shower pan** in your Airstream bathroom are made of a special ABS long-wearing, lightweight, high-strength plastic material. **When cleaning, use soap or detergent only – never use scouring powder.** Always re wax the ABS plastic surfaces after each heavy cleaning with a good grade paste wax (without solvents or cleaners). The wax will protect the surfaces from discoloration and stains. When you first purchase your trailer, Airstream recommends that you give all ABS plastic surfaces a heavy coating of paste wax. This will assure easier cleaning and lasting beauty.

The **bathroom exhaust fan** is in the bathroom ceiling and is operated by a switch at the fan.

The **telephone shower head** is designed to give maximum flexibility in usage and provide for water saving techniques when using your trailer on self-containment. It can be held in the hand and moved about the body. Normally the best water conservation procedure is to wet the entire body and then turn the water off with the push button at the shower head. Apply soap, lather thoroughly, then rinse the soap off. On 27, 29 and 31 ft. models, the shower can be turned on and off without disturbing the hot-cold adjustment. The telephone shower head is also used to fill the tub for taking a

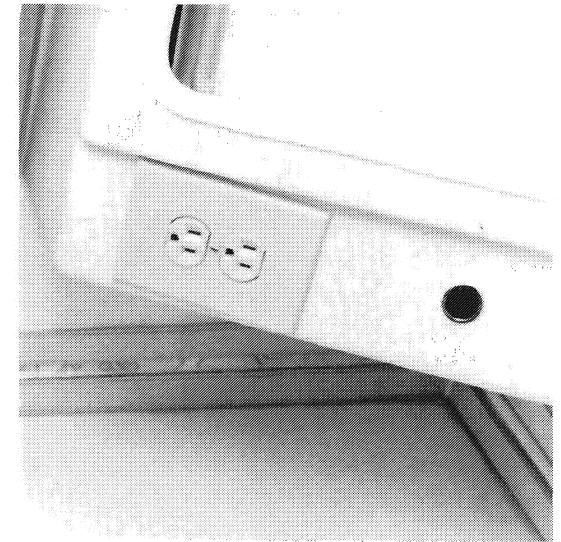

Bathroom 120 and 12 Volt Outlets

bath. When you have finished using the shower be sure to shut the water off at the faucet. The push button is intended as a shower convenience only and should not be used as a water shut-off.

The **120 volt and 12 volt outlets** in the 27, 29 and 31 ft. rear bath models are located on the under surface of the rooflocker near the window. In the 29 and 31 ft. center bath models and 21, 23 and 25 ft. models, the 120 and 12 volt outlets are located behind the mirror.

The **light** in the bathroom is operated by a switch on the light. To change bulbs, squeeze the lens at each end and pop it out.

L.P.G. System

Your Airstream is equipped with two tanks for LPG (Liquid Petroleum Gas). LPG burns with a clean blue flame. There are two basic types of LPG in common usage: **Butane and Propane.** Butane is widely used where temperatures are normally above freezing the year round and Propane is used where subfreezing temperatures are common, since Butane freezes at 32° as compared to -40° for Propane. **All of the orifices in your Airstream LPG appliances are of the universal type which will burn either fuel.**

How long a full tank of gas will last is dependent on usage. In cold weather when you are using the furnace, large amounts of hot water, and are doing extensive cooking, you will naturally use more than you will in warm weather when you may do limited cooking. On the average, with normal cooking and other appliance use, you can probably count on three weeks service from each 28-lb. tank.

27, 29 and 31 ft. models are equipped with an **automatic gas regulator.** Both tanks are connected to this regulator and are turned on. Gas is drawn from only one tank at a time and when the tank being used is depleted the regulator automatically switches to the full tank. An indicator on the regulator points toward the tank being used to give you a visual reminder when one tank is empty. Note: The tank in use is not completely empty until the red warning flag is fully visible in the indicator window. The empty tank can be removed for refilling without disturbing the tank being used.

Simply close the tank valve, disconnect it, have it refilled and reconnect.

The vent at the bottom of the regulator must be kept free of any obstruction. Inspect the vent opening regularly.

To remove the gas tank, disconnect the tubing nut with a wrench and loosen the bar handle which holds the tanks in place. **The tubing nut has a left thread so be sure to always turn it clockwise to loosen and counterclockwise to tighten.** When replacing a tank, connect and tighten the tubing nut before clamping it in place.

If you have allowed both tanks to run out, air may have gotten into the lines. In this event, the air must be forced out through the lines by gas pressure before you will be able to light the pilots. Hold a match to the pilot of the appliance closest to the tanks until it lights and stays lit. Then move to the next closest, etc. For complete appliance operating instructions, refer to pages 64-72.

Close the shutoff valves on the gas tanks if you smell LP-gas, or if appliance pilot light fails to stay on. Contact an LP gas company service man to correct the problem.

Additional information on the LPG system is available in the Airstream Service Manual.

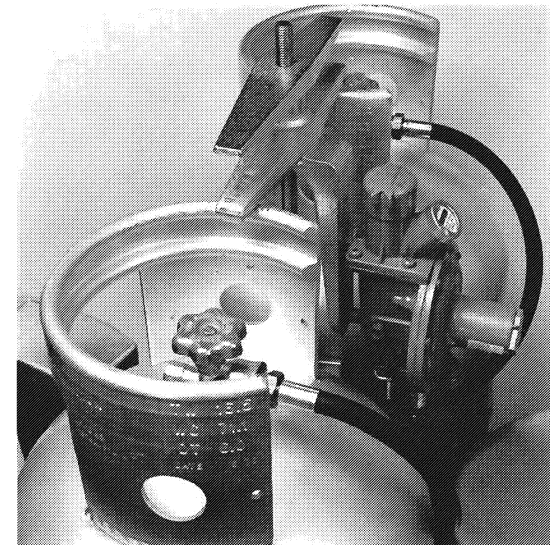

L.P.G. Tanks and Regulator

Refrigerator

Your Airstream is equipped with an **A.G.A. approved Dometic gas-electric refrigerator**. These are the finest refrigerators available for trailer use and will give you many years of faithful service.

For best operation of this refrigerator it is important to level your trailer. Continued off-level operation may permanently damage the cooling unit. When parking try to avoid having a strong wind blowing directly against the vent outlet for most efficient operation.

Controls for both gas and electric operation are located inside the food storage compartment, at the bottom of the unit, and in the outside access compartment. See photo.

For gas operation, follow these instructions (See Fig. 1):

1. Open refrigerator door. All controls for gas operation are located at bottom of unit.
2. To start the refrigerator turn the valve knob (A) to gas position. The gas valve is now open and the electric circuits are not in use. Set thermostat knob (C) to setting No. 4.
3. Pull knob (D) of the automatic pilot, and keep it out for 15 seconds. Press in knob (E) of the piezo lighter. The pressing may have to be repeated.
4. After the burner is lit, which can be seen through reflector window (F), keep the knob (D) pulled outward for an additional 15 seconds.
5. Release the knob (D) and check that the

burner is operating.

If the burner is not operating, repeat the lighting procedure.

After a replacement of a gas bottle or a long shut-off period the gas lines are likely to be filled with air. In such cases the lighting procedure has to be repeated until the air is pushed out of the lines and the gas has reached the burner.

As soon as the required cold temperature inside the cabinet is reached, the thermostat cuts the burner main flame to the by-pass flame sufficient to keep the safety valve open during gas operation. During electric operation the thermostat cycles the flow of the electrical current to maintain the set temperature.

Incorporated in the burner bracket is an automatic flame failure device which allows gas to pass only when the burner is lighted, keeping the thermocouple hot. Should the flame be blown out, the thermocouple will cool and the device will cut off the flow of gas to the burner.

The refrigerator is fitted with a piezo lighter which does not require flint.

For electric operation, follow these instructions.

1. Open refrigerator door and outside access compartment door. Outside access doors are opened by unlocking and turning the handle ¼ turn counterclockwise. Controls for electric operation are lo-

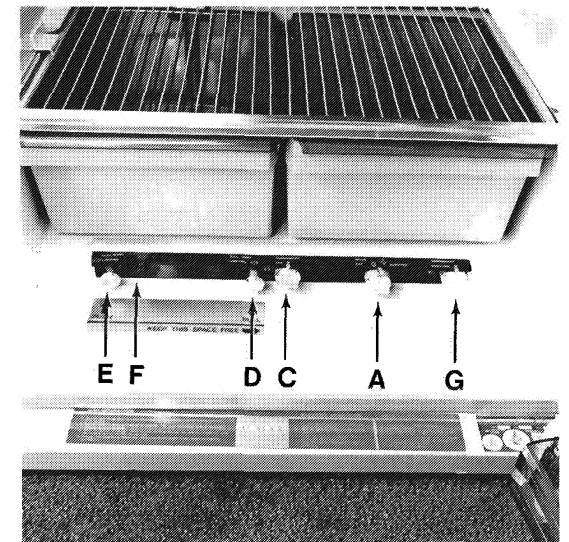

Fig. 1 – Controls Inside Refrigerator

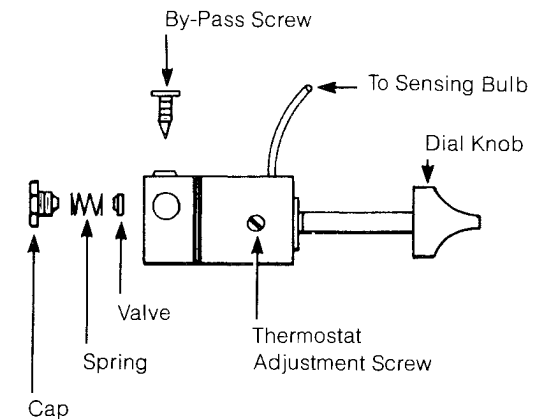

Fig. 2 – Thermostat

- cated in both areas.
2. To start the refrigerator turn the valve knob (A) to the off position.
 3. Plug the electrical cord into the 120 volt outlet located in the refrigerator outside access compartment.
 4. Press knob (A) in, until it stops, then turn to electric position.
 5. Turn the electric thermostat knob (G) to setting No. 4.

For best operation even during extended stays in parks your unit should be periodically run on gas.

The refrigerator has automatic thermostatic control of the temperature in the food storage space. The gas thermostat (C) controls the temperature during gas operation, while the electric thermostat (G) controls the temperature during electric operation. **Be sure to make the temperature setting on the correct thermostat.**

The Dometic R100 model incorporates a unique, **fully automatic defrosting device** for the general food storage compartment, which eliminates the necessity for manual defrosting at frequent intervals normally associated with most conventional refrigerators in the medium size range. Furthermore, the time interval of each defrosting cycle, and the frequency, have been so arranged that during defrosting there is no noticeable effect upon the temperature of the foods stored in the refrigerator, and the frozen food storage conditions can be maintained at all times in the frozen storage compartment.

When cleaning, remove all food and clean the interior and all other plastic parts with warm water, and mild detergents. **Never use abrasive or caustic cleansing powders, polishes, cleaning paste, gasoline, turpentine or other solvent type cleaners.** Use a damp cloth for cleaning and finish with a soft dry cloth.

When the refrigerator is to be out of operation for some time, always leave the door slightly open or place a pie tin of barbecue charcoal on the shelf.

The following are some trouble shooting tips for emergency use only. They relate to gas operation and should normally be done by the dealer.

Problem: Flame goes out. The thermostat is out of adjustment. To adjust it, turn the dial to "zero". If the flame does not go down to the "low" by-pass setting, follow this procedure (See Fig. 2.):

1. Unscrew the large cap screw at the rear of the thermostat and remove the valve. Clean the seat and valve, and replace.
2. If procedure (1) does not correct the problem, adjust the set screw out (in counterclockwise direction) until the flame goes down to the "low" position.

If the flame keeps going out when the dial is turned to (O), remove and clean the by-pass screw which is located as shown in the diagram above.

Problem: Burner does not light. Remove and clean the burner barrel, and/or check

the gas supply.

On gas refrigerators, the flue will require cleaning at least every six months. To do this, it will be necessary to gain access to the back of the cabinet. When cleaning the flue proceed as follows:

Unscrew the burner housing, then lift out the baffle on its support wire from the top of the boiler tube. From the top, clean the baffle, before putting back in place. An obstruction in the flue will reduce or stop flue draft. Flue obstructions will cause odors outside refrigerator, slow freezing and higher cabinet temperatures.

Additional information on the Refrigerator is available in the Airstream Service Manual.

Microwave Oven

The Litton Industries, **portable microwave oven** is available as an option in your Airstream. Airstream dealers cannot service or make adjustments to the oven. This must be done by an authorized Litton Industries service agency. If you ever have problems with the oven check the list of authorized service agents. This list is packed in your microwave oven.

To operate your Litton microwave oven:

1. Depress door release.
2. Place food item inside oven.
3. Set the appropriate Vari-Cook® setting for your food. (See Vari-Cook Cookbook.)
4. Set timer for desired time. (See push-to-turn dial timer.)
5. Close door. Oven will start cooking. (The microwave oven may be opened at any point to check food even if time is left on the dial. The timer will maintain the proper time setting and cooking will commence when door is reclosed.)
6. When the time is up, a bell rings once and the oven shuts off automatically.

Note: The moisture on the inside of your microwave oven is normal and nothing to worry about. It is caused by the steam from the cooking food hitting a cool oven surface. The inside of the door of the microwave oven may seem to ripple when you cook; it is only expanding because of heated air or steam and will return to normal when cool.

Never operate your microwave oven unless the removable shelf is in place. The shelf may be cleaned in the dishwasher.

To operate the push-to-turn dial timer, push knob in and turn clockwise to the desired time. For settings of 15 seconds or less push and turn dial to 1 minute first, then back to the desired time. To decrease time, push knob in and turn counter clockwise. Time can be increased or decreased at any point during the operation of the unit.

Note: It is normal for the timer knob to spin freely when knob is not pushed in.

The **Vari-Cook™** feature of your oven gives you total flexibility of choosing your speed of cooking. The "HIGH" setting provides the greatest cooking speed and settings between "HIGH" and "WARM" provide decreasing amounts of cooking speed.

For further information and microwave cooking recipes, refer to your Vari-Cook® Cookbook.

Note: While your oven is operating in a Vari-Cook selection other than "HIGH" the interior light will vary in intensity and the oven will make a slight humming sound. These are normal occurrences and an indication that oven is operating as designed.

Please read your cooking guide carefully. It will help you learn about your new Litton Electronic Oven quickly.

Your microwave oven is portable and can be removed for use in your home when your trailer is not in use. This can be done

by removing the attachment screw that is located in the top of the cabinet directly below the oven.

IMPORTANT

Safety and Maintenance Instructions

Litton microwave ovens are one of the safest kitchen appliances. Each Litton microwave oven meets all safety standards set by the U.S. Dept. of Health, Education and Welfare. Look for the safety seal and UL tested label on your oven. However, it is important for you as a user to observe certain precautions and care in utilizing your Litton oven for maximum performance and safety. The door on your oven has been carefully designed to contain the microwave energy; therefore, it is important that you observe the following:

1. Do not attempt to operate this oven with the door open since open-door operation can result in harmful exposure to microwave energy. It is important not to defeat or tamper with the safety interlocks.
2. Do not place any object between the oven front face and the door or allow soil or cleaner residue to accumulate on sealing surfaces.
3. Do not operate the oven if it is damaged. It is particularly important that the oven door close properly and that there is no damage to the: a. Door (bent). b. Hinges and latches (broken or loosened). c. Door seals and sealing surfaces.
4. The oven should not be adjusted or repaired by anyone except properly qualified service personnel.

5. Remember that it requires considerable electrical power to operate the microwave oven (15 amps). Operation of other 120 volt appliances should be kept at a minimum when operating the oven.

Your new oven requires very little maintenance except for cleaning. Do not allow grease, soil or splatter to build up on the door seal to the oven cavity. Use only mild detergent, water and a soft cloth to clean the door surface and the interior surfaces. Odors can be eliminated by boiling a solution of one cup of water and several tablespoons of lemon juice in the oven for 5-7 minutes. Litton maintains trained service technicians in all principal metropolitan areas. It is suggested that these authorized service agencies be utilized for proper repair and adjustment of your oven.

The Litton **Micro-Browner® Steak Grill** allows you to brown and sear steaks, hamburgers and chops, fry eggs, grill a cheese sandwich.

Additional information on the Microwave Oven is available in the Airstream Service Manual.

Range and Oven

Your Airstream is equipped with a Magic Chef **gas range and oven**. The following are some hints on how to keep them operating at their best.

Note: The range gas line shut-off valve, located on the lower exterior of the trailer below the range, must be turned off when towing the trailer, when changing the gas tanks, or if the gas supply is turned off for any reason. Be sure oven and top pilot lights have been relighted as soon as range shut-off valve is turned on. If the range has not been operating for a long time, a longer waiting period for ignition of the pilot may be necessary due to air in the gas lines.

To light the pilots:

1. Be sure all valves are in the "OFF" position. The oven thermostat dial should be in the "PILOTS OFF" position.
2. Turn on main gas supply to range.
3. Depress and turn the thermostat dial to the "OFF" position.
4. Lift main cook top panel and light top burner pilot with a match.
5. Open oven door and light pilot with a match. A small flame will be noted at the top of the pilot burner.

The oven thermostat control knob (see Fig. 2) is combined with the constant oven and top burner pilot shut-off. For normal use: turn only between "OFF" and "BROIL." When traveling, turn to "PILOTS OFF." Relight only when you want to use the range, by turning from "PILOTS OFF" to "OFF" and lighting pilots with a match. On

ranges equipped with separate pilot shut-off valve on manifold, the "PILOTS OFF" position on thermostat will turn off oven pilot only.

Range Top Section

The range is equipped with orifices for use with L.P. gas only. The flame will be approximately 1/2 inch long. Do not attempt to adjust gas to burner. The orifices have no readjustment.

Air shutters are provided on the top burners of some models. These shutters consist of sleeves located behind the burner control knobs at the front end of the burner. To adjust, rotate either to the left or right as necessary so that each cone of the flame appears separate and distinct. (See Fig. 4.) Air shutters set too far open will cause the flame to lift away from the burner head and the burner will be difficult to light. If the air shutters are closed too much, the flame will look hazy and the distinct cones will be missing. Burners without air shutters have pre-set air openings and need no adjustment.

The following are possible problems and corrections on burners with air shutters:

- *Problem: Flame lifts off ports—Too much air. Decrease air.
- *Problem: Soot formations—Not enough air. Increase air.
- *Problem: Flame flashes back into air mixture chamber—Too much air in proportion to gas. Slightly decrease air.
- *Problem: Orange flame; caused by small filings in new burners or dust in air—Clean



Fig. 1 – Range and Oven

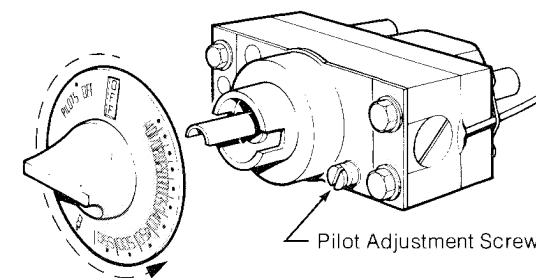

Fig. 2 – Oven Thermostat

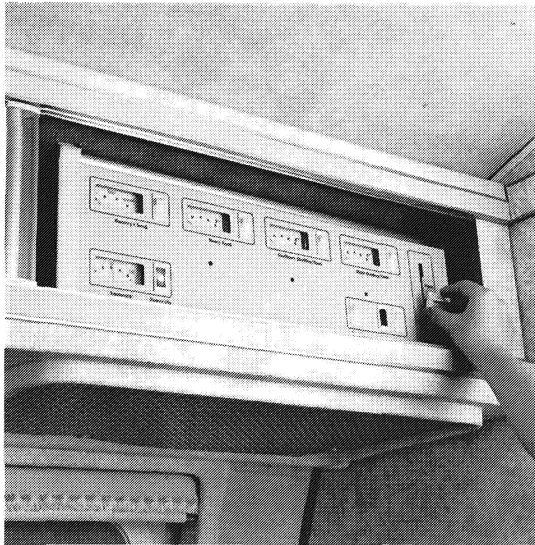

Fig 3—Range Exhaust Hood

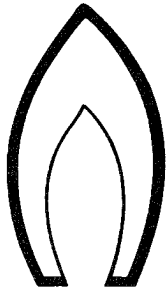

Fig. 4—Separation of Flame into Distinct Cones

burners.

*Problem: Burner fails to light— Usually too much air. Decrease air.

Top burner pilot adjustment:

Adjust top pilot so that tip of flame is just over the edge of inner cone. Top burner pilot adjustment screw can be reached by removing thermostat knob (See Fig. 2.) on ranges equipped with thermostats having top burner pilot shut-off feature. Burners should light within 4 seconds. If lighting is difficult, refer back to the previous step on ranges with air shutters.

Warning: Never allow the top cover to be closed while the range is in operation, as this could extinguish the flame and permit gas to escape into the trailer.

Oven Section

The thermostat on your oven does not have a by-pass setting. It will cycle off and on at all temperature settings except broil. No by-pass adjustment is necessary. There are no oven pilot adjustments on the thermostat. Control has been factory preset for use on L.P. gas. No field adjustment is necessary. The air shutter has been adjusted at the factory, however, it may require additional adjustment when used at high altitudes.

To adjust main oven burner air shutter:

Open air shutter to the full open position where you have a blowing condition. Begin closing the shutter slowly. When you reach the correct adjustment, blowing will stop. Burner should have a sharp blue flame approximately 3 inches long.

Important: Your oven is equipped with a **safety ignition** that requires a minimum of 30 seconds to operate after turning the oven control knob on. The oven pilot may be slow in lighting due to air in the gas lines.

Cleaning Instructions:

1. The main top has been hinged from the back so that it can be raised or removed for cleaning around the top burners.
2. When cleaning the top burner heads, care should be taken that all ports are opened up with a toothpick afterwards.
3. Spill-over or spotting in the oven or broiler are more easily cleaned when removed promptly after they occur.

Never wash porcelain when warm. Never use cleaning powder containing grit or acid. When oven bottom is replaced after cleaning and servicing, be sure that it is locked in place.

The range exhaust hood (see Fig. 3) vents cooking heat and smoke from the trailer. To operate, pull down on lever located on the right hand side of central control panel. This will open the shutter and turn on the switch for the power fan. Clean the filter at least every six months with warm water and detergent. To remove the filter, remove the two screws that secure it to the housing and let it drop out while supporting it with your hand. Keep the vent housing clean of grease and dirt by frequent washing.

Additional information on the Range and Oven is available in the Airstream Service Manual.

Furnace

The Airstream furnace is an American Gas Association approved Suburban unit with an electronic ignition designed specifically for travel trailers. It has a sealed combustion system with a dual blower for maximum air circulation. One blower circulates room air while the other draws in air for combustion. The adjustable louvered heat registers control warm air flow while cold air returns through the galley cabinet toe kick opening.

The heat duct system also circulates warm air around the holding tank, water tank, and one-stop-service center, a vital feature when operating in below freezing weather.

The Suburban furnace is thermostatically controlled. When the thermostat calls for heat, the blower starts and only after it has reached nearly full speed will the burner light. After the temperature set on the thermostat is reached the blower will continue to run for a short time removing most of the remaining heat from the furnace as well as forcing the combustion gases from the heat exchanger. To turn the furnace off for an extended period of time turn the thermostat and the gas valve to their "OFF" positions. The gas shut-off valve is outside the trailer below the furnace. Operating instructions are printed inside the furnace door.

Trouble-free operation of the Suburban furnace will depend on your adherence to recommended operating procedures and precautions. Corrections of possible malfunctions presented here will be helpful in



Furnace Thermostat

an emergency situation, but servicing should be done by a dealer. One note of caution regarding flue gases: they are vented from the furnace to the outside of the trailer through a vent in the outside wall.

Do not in any way obstruct this vent by placing clothing or other flammable material on the vent assembly. Check it often to make certain it does not become clogged.

To start the furnace:

1. Turn main gas valve to full "ON" position.
2. Set thermostat to desired temperature.
3. The main burner will normally light within 3-4 seconds, not exceeding 15 seconds.
4. If burner does not light, set thermostat to "OFF," wait 120 seconds and try again for ignition.
5. If, after three tries, the burner does not light, turn the main gas valve and the

thermostat to their "OFF" positions and determine cause. **Do not attempt to light burner with matches.**

Caution: The air shutter adjustment cover must be tightly secured for proper operation of the heater.

If your fuel supply is depleted the main burner will go into lockout. To reset the lockout, turn gas valve to "OFF" and set thermostat to "OFF." Wait 2 minutes and return to operation.

Adjustment of Main Burner (Primary air): Set the furnace into operation by advancing the thermostat and allow to run until it reaches near-maximum operating temperature. Observe the main burners through the burner observation window. The flame should be without a trace of yellow and be "sitting" on the burner. As the furnace was tested at the factory before shipment, it may be found that the primary air is already in proper adjustment. However, adjustments may vary from one location to another due to differences in elevation and in characteristics of the fuel gases.

If the flame burns yellow or "lifts" off the burner, it needs adjustment. Take out the screws retaining the rectangular cover plate and lift the plate off.

Inside the opening is a threaded rod with the visible end slotted to receive a screwdriver. By turning the rod you will adjust the position of the main burner air shutter. This air shutter should be adjusted to the point

where a slight trace of yellow remains in the tip of the flame. Replace the cover and check that the yellow tips have now disappeared. **Caution: The primary air adjustment cover plate must be in place for proper operation of the furnace.**

Note: If burner is allowed to operate in yellow condition, "soot" will accumulate on vent cap and in radiators. This should not be allowed to occur.

When the humidity is high inside your trailer and you wish to remove moisture, open a roof vent and turn on a vent or open a window slightly for cross ventilation.

Additional information on the Furnace is available in the Airstream Service Manual.

Water Heater

The Atwood-Bowen Gas Water Heater is equipped with a Robertshaw LP gas pressure regulator control with a 100% shut-off safety valve which shuts off the gas supply if the pilot flame is extinguished or the water temperature becomes excessively hot. It is lighted and serviced from the outside through an access panel at the roadside, rear, of the trailer.

Procedure for lighting or relighting:

1. **Be sure the water heater is filled with water.** Open the hot water faucet at the sink and when the water flows, the heater is full.
2. Turn gas supply line valve, on the lower exterior of the trailer below the water heater, to the "ON" position.
3. Turn the gas valve knob (A) to the "OFF" position and the temperature indicator dial (B) to the lowest temperature position.
4. Wait sufficient length of time to allow gas, which may have accumulated in the burner compartment, to escape (approximately five minutes).
5. Turn gas valve knob (A) to "PILOT."
6. Depress and hold the red reset knob (E) and push the lighter (D) in and turn until the pilot flame ignites. This may take several turns of the knob. Or you may light it with a match. **Note: use cigarette lighter flint for flint replacement in pilot lighter.**
7. Keep the reset knob depressed for one-half minute after the pilot flame ignites.
8. Turn the gas cock knob to "ON."
9. Set the temperature indicator dial to the desired water temperature.

10. To shut down the water heater, turn the gas cock knob to the "OFF" position.

Pilot Flame Adjustment

If the pilot flame does not have a small orange tip, the pilot is not getting enough gas. The flame should be about ¼ inch in vertical height when the water in the tank is cold and the burner is off, ¼ to ⅜ inch in horizontal length when the tank is warm.

A large orange flame indicates excessive gas supply, which will result in short pilot life and early replacement. The pilot has been properly adjusted at the factory and should operate with a blue, orange tipped flame enveloping the pilot thermocouple. Removal of the pilot adjustment cap (C) in the lower right corner of the control will reveal the pilot adjustment screw. Turning this screw counter-clockwise reduces the flow of gas to the pilot (blue flame) and clockwise, the gas supply will increase (orange flame). Replace pilot adjustment cap.

Air Shutter Adjustment

All fuels depend upon air (oxygen) to give them proper burning characteristics. A yellow, smoking flame indicates a lack of air and a noisy hard blue flame indicates too much air. The air shutter slides back and forth along the burner tube and is held in place by a small shutter adjustment screw (F). Loosen the screw for adjustment. A good method of adjusting the air shutter is to slide the shutter to the right until yellow tipping occurs on the main burner flame (not the pilot) and then slowly slide the

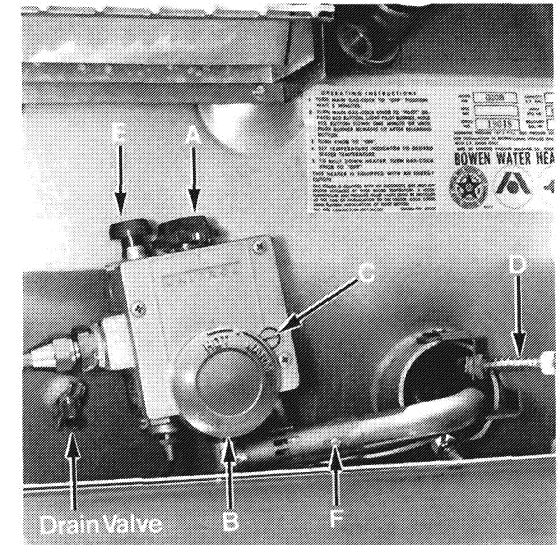

Water Heater Controls and Drain Valve

shutter to the left until all signs of yellow tipping are gone. When proper adjustment has been obtained, tighten the screw holding the air shutter. The outside access door must be kept firmly locked for proper operation.

Additional information on the Water Heater is available in the Airstream Service Manual.

Water System

The Airstream water system provides full service both when the trailer is self-contained or when city water is available. Water heater capacity is 6 gallons. The water tank stores 45 gallons of clean fresh water for all your needs.

When self-contained, the water pump should be turned on. The switch is located on the Central Control Panel in the galley roof locker of your Airstream. The water pump will run whenever a faucet is opened, and will shut off whenever a faucet is closed. It will deliver 3 gallons per minute under constant pressure.

Note: The water pump must be turned off when hooked up to city water supply and when you leave your Airstream unattended.

The **water pump and filter** are under the galley adjacent to the furnace. The filter screen should be cleaned periodically to prevent accumulation of dirt and sand. To remove the screen, disconnect the rubber hoses from both ends, separate the screen housing, remove the screen, clean and replace.

For city water supply, connect a ½" minimum high pressure hose to the water inlet fitting (see Figs. 1 and 2) located under the rear roadside corner of the trailer, just forward of the bumper. Turn the hose on and slowly open an inside faucet until the water flows free of air. The system will now be ready for use. If you are staying for some time where city water is available,

drain the water storage tank. To drain the tank, open a drain valve or faucet and turn the water pump switch on until the tank is empty. Be sure to refill the tank with fresh water before departing. The system has check valves in the water lines to protect the water tank while you are connected to the city water supply.

The water tank is located under the floor just forward of the axle. To fill the water storage tank, open the filler spout (see Fig. 3, page 74) on the exterior wall adjacent to the galley, and fill with a hose or a bucket. Close and lock the spout and the water system is ready to use.

To clean the tank, pour some bicarbonate of soda into the filler spout with several gallons of water and allow to stand for a minimum of four hours. Then flush the tank out by opening a faucet, allowing the water pump to drain the system. Then refill with fresh drinking water. If the water tank must be cleaned further, the following procedure is recommended.

1. Prepare a sodium hypochlorite solution using potable water and household bleach (5¼ or 6%) in the ratio of ¼ cup of bleach to 1 gallon of water. (Common household bleaches are Purex and Chlorox.)
2. Pour 1 gallon of hypochlorite solution for each 15 gallons of capacity into the empty water tank.
3. Add enough fresh drinking water to completely fill the water system.
4. Allow closed system to stand for three hours.

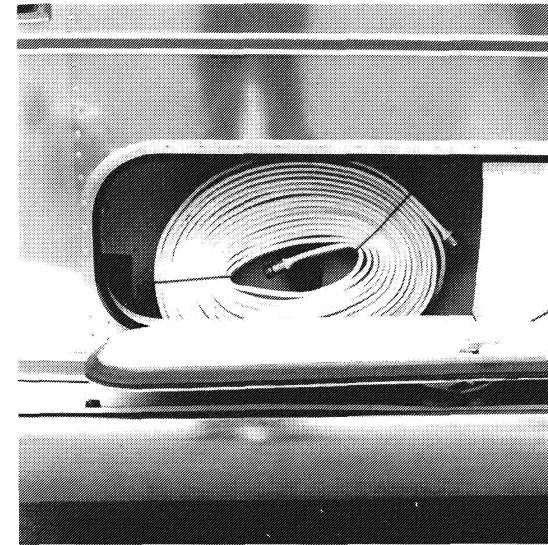

Fig. 1 – Water Hose Storage

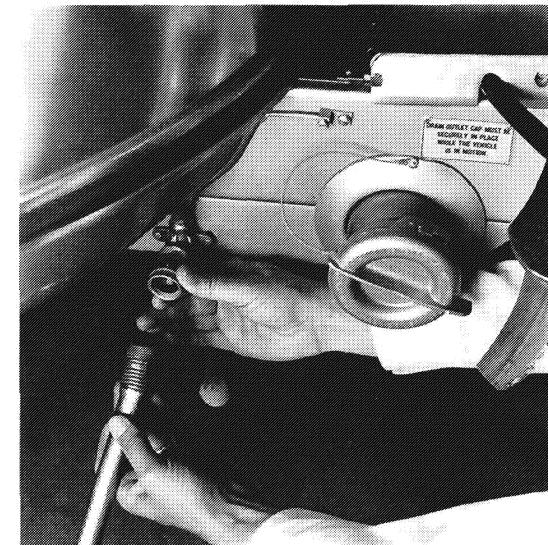

Fig. 2 – City Water Hook-Up

5. Drain the hypochlorite solution from the system and refill with potable water.
6. Excessive hypochlorite taste or odor remaining in the water system is removed by rinsing the system with a vinegar solution mixed in the ratio of 1 quart of vinegar to 5 gallons of water.
7. Drain the system and flush with fresh drinking water.
8. Drain the system and refill with fresh drinking water.

The **Everpure QC2 Water Filter** is located under the galley sink. (See Fig. 4.) It will remove even very fine dirt and colloidal matter, and eliminates most chlorine, phenol, and similar distasteful odors and tastes while delivering sparkling taste-free water for drinking and cooking. The filter is connected to the cold water galley drinking faucet only. The filter will also remove iron and sulphur provided the water supply is chlorinated. Super-chlorination will precipitate the iron and sulphur which will then be removed by the QC2 Filter. To purify any questionable water, fill the Everpure Chlorine Disinfectant Dispenser with liquid bleach and add 1/8 ounce (one teaspoonful) per 10 gallons of water to the water tank (i.e. 4 1/2 teaspoons for a 45 gallon tank). The water will remain sparkling clear even to the end of the filter life, however, as the minute pores slowly fill up with impurities the flow rate will be gradually reduced. When it becomes too slow for convenience, the cartridge can be very simply changed. Follow the instructions on the cartridge. We advise keeping a spare cartridge at all times.



Fig. 3—Water Tank Fill Spout

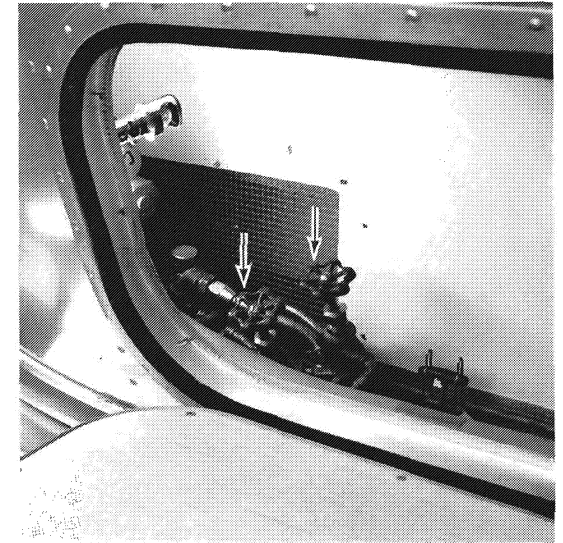

Fig. 5a—Water Drain Valve (Rear Bath)



Fig. 4—Water Pump and Filter

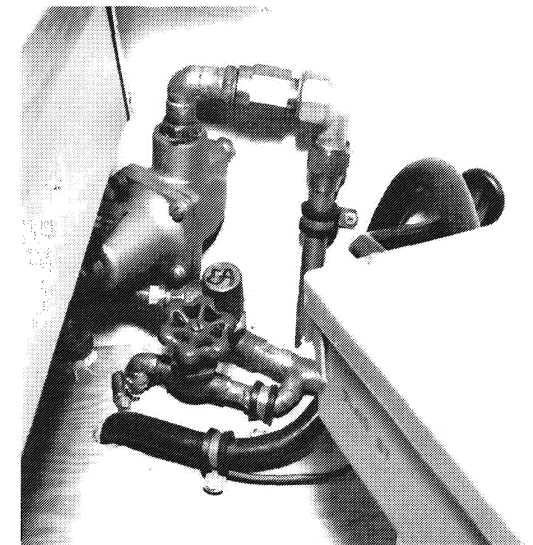
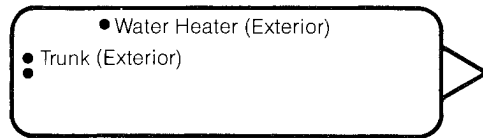
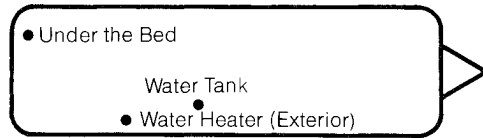

Fig. 5b—Water Drain Valve (Center Bath)



Rear Bath



Center Bath

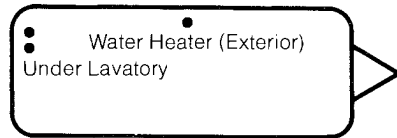

21, 23 and 25 Ft. Twin and Double

• *Drain Valve Locations*

To remove used cartridge:

1. Shut off water by lifting valve handle counterclockwise as far as possible.
2. Turn colored ring all the way to the left. Ring will drop about 5/8".
3. Lift cartridge slightly and turn it further to the left until it can be disengaged.
4. Lower cartridge to disengage it from ring. Discard used cartridge.

To install new cartridge:

1. With colored ring in lowered position (turned all the way to the left), orient lug on cartridge with cutout under label on ring.
2. Insert cartridge straight up into ring as far as it will go. Holding colored ring steady, turn cartridge as far to the right as possible, without forcing.
3. Then turn colored ring far to right to drive cartridge up into head.

4. To lock ring in place and turn water on, move valve handle down. Be sure handle leg engages ring locking-lug.

The **water pressure regulator** (see Figs. 5a and 5b) is on the roadside of the rear trunk in 27, 29 and 31 ft. models rear bath models, below the bed in 29 and 31 ft. center bath models and in the aft roadside wardrobe of 21, 23 and 25 ft. models. It protects the plumbing inside your trailer, regardless of the variation in city water pressures. The pressure at the faucet is kept constant.

The water system has built-in drain valves to protect it from winter freezing. For complete details see Storage and Winterizing, page 43.

Drain and Waste System

Your Airstream has a drain and waste system. The system includes waste holding tanks made from molded plastic, free from corrosion problems, with trouble free dump valves. The **main holding tank** enables you to use the toilet for several days away from disposal facilities. The waste water from the sink, shower, bath and lavatory drains into the **auxiliary holding tank**. Each tank has its own dump valve, however, both tanks drain through a common outlet. Therefore you need to make only one connection when hooking up in a trailer park with sewer facilities.

When the toilet will no longer drain, the main holding tank is full and must be emptied. Watch this closely, because **when the tank is full, sewage cannot be emptied from the toilet bowl.** In models with a central control panel, check the main holding tank gauge. The auxiliary holding tank must be emptied when the gauge on the central control panel indicates full.

On 27, 29 and 31 ft. rear bath models the **dump valves** are located in the rear trunk compartment. The main holding tank dump valve is located on the roadside and the auxiliary holding tank dump valve is located on the curbside. (See Fig. 1.) On 27, 29 and 31 ft. center bath models the dump valves are located on the roadside, just behind the rear wheels, on the main frame rail. The main holding tank dump valve is located forward of the sewage outlet. (See Fig. 2.) On 21, 23 and 25 ft. models the main holding tank dump valve is located in

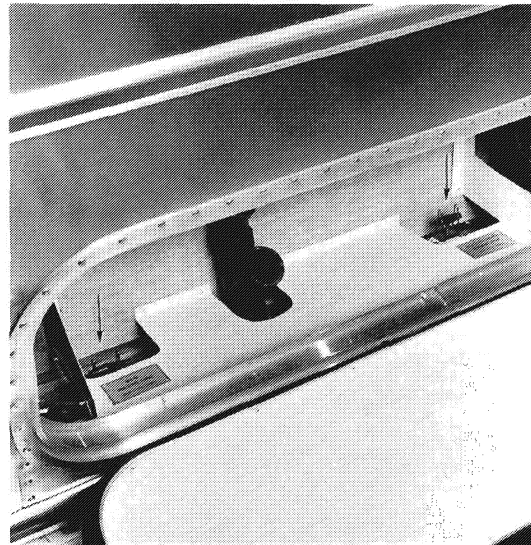

Fig. 1—27, 29 and 31 Ft. Rear Bath Dump Valves

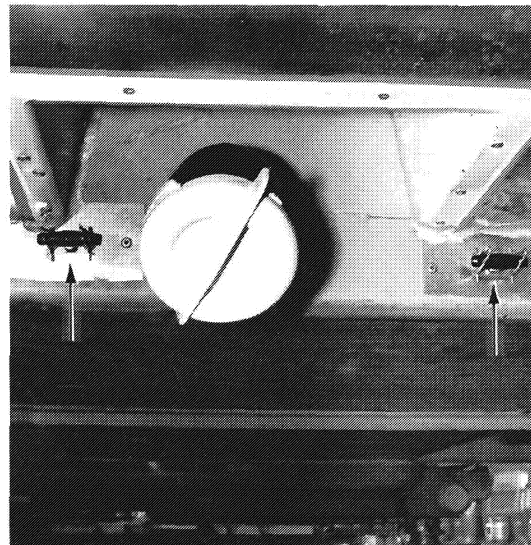

Fig. 2—27, 29 and 31 Ft. Center Bath Dump Valves



Fig. 3—21, 23 and 25 Ft. Dump Valve—Main Holding Tank

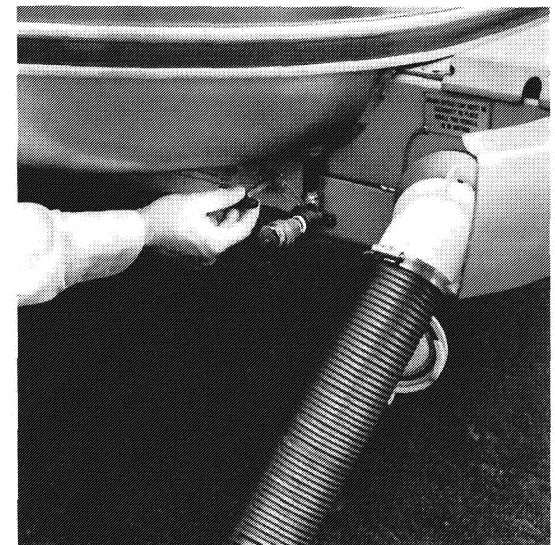

Fig. 4—21, 23 and 25 Ft. Dump Valve—Auxiliary Holding Tank plus Sewage Outlet

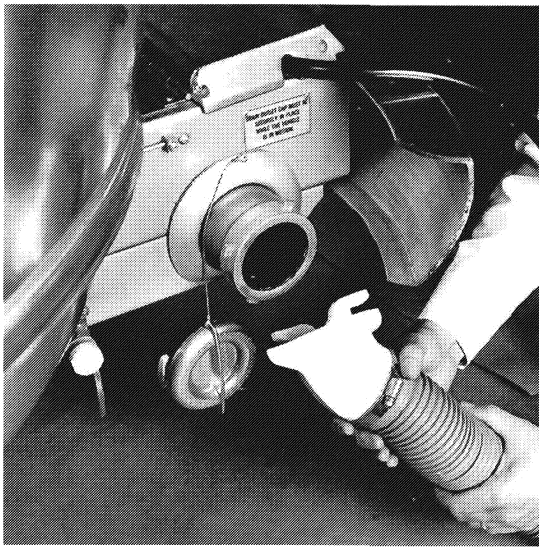

Fig. 5—27, 29 and 31 Ft. Rear Bath Sewage Outlet

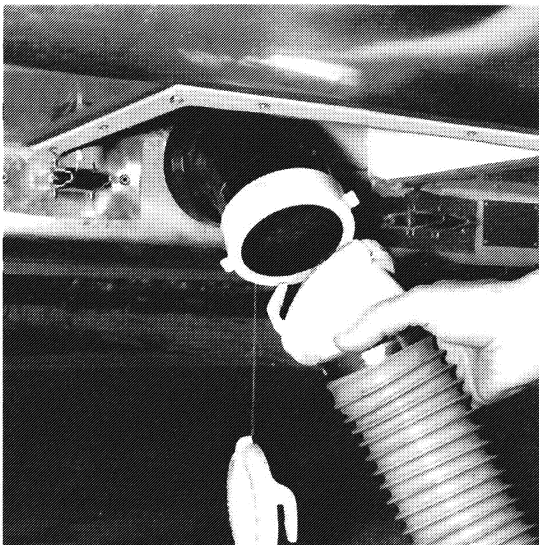

Fig. 6—27, 29 and 31 Ft. Center Bath Sewage Outlet

the rear bumper storage compartment (see Fig. 3), and the auxiliary holding tank dump valve is located next to the sewage outlet on the roadside main frame rail just forward of the bumper. (See Fig. 4.)

To empty one or both tanks attach the sewer hose by pressing the bayonet fitting onto the dump valve outlet and rotate clockwise until it feels solid and secure. (See Figs. 5 and 6.) Attach the outlet end of the hose to the sewage outlet, making sure that the hose is placed so it will drain completely. The dump valves have two wire loops that lock the handle in the closed position. To unlock push outward on the wire loops and they will snap loose, permitting you to open the valve. Pull up the dump valve handle as far as it will go and wait until the tank is drained. When dumping, the main holding tank should be dumped first; then the auxiliary holding tank. This will help to rinse out the sewer line with auxiliary holding tank water.

The main holding tank must be flushed out until all paper and waste material is removed. Close the dump valve and refill the tank with 5 to 10 gallons of clean water and repeat until clean.

On 27, 29 and 31 ft. rear bath models, a convenient fitting for flushing the holding tank is in the center of the rear trunk compartment.

Replace the plug after using the fitting. The sewer hose is stored in the rear bumper compartment. Rinse out the sewer line

before storing.

When in a park and connected to a sewer outlet, keep the main holding tank dump valve closed and empty the tank every few days or whenever it becomes almost full. **Only by sending a large volume of liquid through the main holding tank at a time will toilet paper and other solids completely wash away.**

This practice will avoid the accumulation of solids in the main holding tank which could lead to an unpleasant cleaning job. Should solids accumulate and close the dump valve, fill the tank about half full with water; then tow the trailer for a few miles. The turbulence and surging of the water will usually dissolve the solids into suspension so the tank can be drained. If your trailer is equipped with the auxiliary holding tank, keep the tank valve open when connected to a sewer outlet.

The **Aqua Magic toilet** employs a sliding self-cleaning positive seal blade. Odors cannot escape from the holding tank into the trailer. The unit uses less than 2 quarts of water for automatic flush. A special feature is the second pedal attached to the main foot pedal which, when pressed by itself, allows fresh water through either the fill rim or hand spray without opening the slide valve.

When conserving water, use the hand spray (See Fig. 1, page 78) in the following way:

1. Hold the hand spray in ready position

over bowl.

2. Depress thumb button and step on the foot pedal, which sprays water and dumps the contents at the same time.
3. Spray bowl clean.
4. Release foot pedal, shutting off water flow.
5. If you wish to refill bowl with water for next use, depress small foot pedal till water reaches desired level.

When using automatic flush:

1. Step on main foot pedal, and this will automatically open the slide valve and drop the waste into holding tank.
2. Hold pedal down until water begins to swirl. This fills rim storage and rinses the bowl.
3. Release the foot pedal. This will close the valve blade and stop fresh water from flowing. The bowl will refill automatically.

If you are certain to empty your holding tank every few days, you can use the toilet on automatic flush. It uses very little water and the tank will provide for the requirements of two adults from 2 to 4 days.

Whenever water is scarce, the hand spray flush makes it possible to stay a week or longer in areas where you cannot empty the holding tank. In flushing for urine only, first, wet the bowl with fresh water, and again after use. Starting with a dry bowl takes more water for the final rinse. To flush for urine and solid matter: spray just enough water in the dry bowl to provide for floating the paper and solids. After use, rinse down the sides with the hand spray

and empty the bowl. Hold the slide valve open and spray and rinse the lower surfaces. Even if it appears clean, quickly spray it one more time, then release the pedal and it is ready for the next use.

There are certain items that should never be put into the toilet or tank. Facial and other similar tissues: because they have wet strength and do not dissolve easily. Toilet paper, especially white, dissolves well after a period of traveling.

Use only trailer sewage tank deodorizers. Antifreeze, ammonias, alcohols and acetones may cause damage to the tank, valve parts, tank fittings, and drain hose. For protection against freezing, use recommended fluids (see Winterizing, page 43).

Some state and federal parks prohibit draining sink and bath waters into the ground, although this is done in the wilderness. Your auxiliary holding tank will hold this water until you are at a dump area.

The **auxiliary holding tank should be flushed out periodically** to wash away sediments that may accumulate on the bottom of the tank. To flush, close dump valve, fill tank with water and then release dump valve. This volume of water will wash sediment away.

Additional information on the Drain and Waste System is available in the Airstream Service Manual.



Toilet Hand Spray

Electrical System

The exclusive **Airstream Univolt System** enables you to use the lights and appliances whether operating on self-contained battery power or hooked up to 120 volt city power. This combination unit is designed for protection from damage up to and including a dead short. The 12 volt light bulbs give off the same light as regular household bulbs, so that when operating on self-contained battery power, everything works normally **except the 120 volt convenience outlets and electrical operation of the refrigerator.**

Convenience outlets for 120 volts and 12 volts are located throughout the interior of the trailer, see diagrams page 82.

Exterior outlets for 120 V are located on the curbside exterior wall, aft of the main door. (See Fig. 1)

When operating with city power, make very certain that the service is 120 volt and not 220 volt. Open the bumper storage compartment lid, uncoil only the needed amount of cord and plug it into the city power source. Before closing the lid, carefully place the cord in the opening provided for it on the left side of the lid.

The univolt system has a transformer designed to maintain constant output voltages regardless of the variances that occur in city power systems. The transformer design eliminates the need for complex electronic sensing systems to charge the battery, minimizing the possibility of failures and greatly increasing its overall reliability.

When the three pronged plug can be used, there will be no problem with proper polarity or grounding. In some older parks and other locations where three pronged outlets are not available, **certain precautions to insure proper grounding and polarity must be taken.** These precautions are listed below:

1. Attach the three pronged plug to a two pronged adapter. The third conductor line of this adapter has a short wire lead which must be grounded.
2. For proper grounding connect the short ground lead to a grounded outlet box or to a cold water pipe. When no water pipe is available, drive a metal rod two feet into the ground and attach the ground lug to it thus providing the unit with proper grounding.
3. Check the polarity light located above the water heater access panel in International models and to the roadside of the license plate on Land Yacht models. If it is on, pull the plug, turn it over and reinsert. The light will now be out.

The **polarity warning light** (See Figs. 2 and 3) indicates improper polarity and it should be off when the power supply cable is used with a two pronged adapter. It may occasionally glow when the three wire system is in use, but your trailer is properly grounded, and in this case you may ignore the light.

To operate self-contained, simply disconnect the power supply cable.

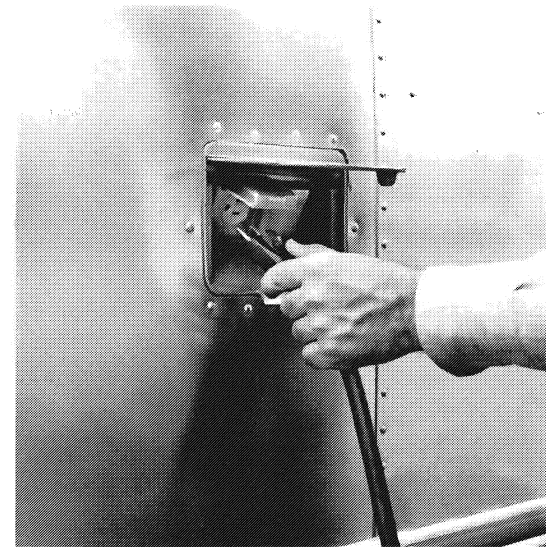

Fig. 1 – 120 Volt Exterior Outlet

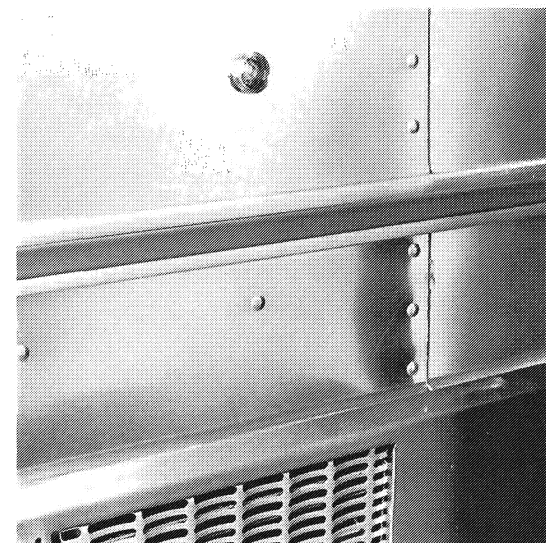

Fig. 2 – 27, 29 and 31 Ft. Polarity Warning Light

When your Airstream is hooked up to 120 volt A.C. the **univolt system automatically charges the trailer battery** and, if it is hooked up, your automobile battery as well. The speed and degree of charge depends on how much power is used for lights and appliances, as only the surplus goes to charging the battery. (Please refer to the specifications section for more information on power consumption.) If you are making an extended stay or storing your Airstream, then you should (if it is available) **keep your trailer hooked up to 120 volt current.**

Whenever possible, use the automatic built-in charger of the univolt system for charging. The charging circuit automatically controls the current, reducing it as the battery increases in charge. At service stations, make certain they give your battery a slow charge because quick charges will drastically shorten the life of the battery as will allowing repeated complete discharges.

The **low voltage fuse panel** is located behind the front lounge on all models.

On 27, 29 and 31 ft. rear bath models the **120 volt circuit breaker panel** is accessible in the bathroom cabinet to the right of the sink. On 27, 29, and 31 ft. center bath models it is located in the rear of the roadside wardrobe. on 21, 23 and 25 ft. models, it is located in the curbside bathroom wardrobe.

In the event of failure of a 120 volt circuit, check your circuit breaker first. While you

are connected to the 120 volt receptacle, the wiring is protected by circuit breakers in the breaker panel providing the polarity and grounding is correct. If a breaker continues to trip after you have reset it several times, your circuit may be overloaded with appliances or there may be a short in the circuit. If lessening the load does not solve the problem consult an Airstream Service Center.

The Univolt System and the Central Control Panel are provided with a series of fuses (see illustrations page 89) for the safety of you and your unit. Trouble with the electrical system is extremely unlikely, but if it should occur we recommend that you contact your nearest Certified Service Center for repairs. We have included a trouble shooting chart to be used in emergencies only. Details of electric motor amperage, light bulb size, and fuse and circuit breaker locations are shown on the chart in the specifications section on pages 92-93.

When being towed, the 12 volt battery in your Airstream is receiving a constant charge from the car's generator or alternator through the **Seven Way Connector**. The charge rate is controlled by your automobile's voltage regulator. It is important to keep the seven way connector clean: one method is to use "Spra-Kleen."

Additional information on the Electrical System is available in the Airstream Service Manual.

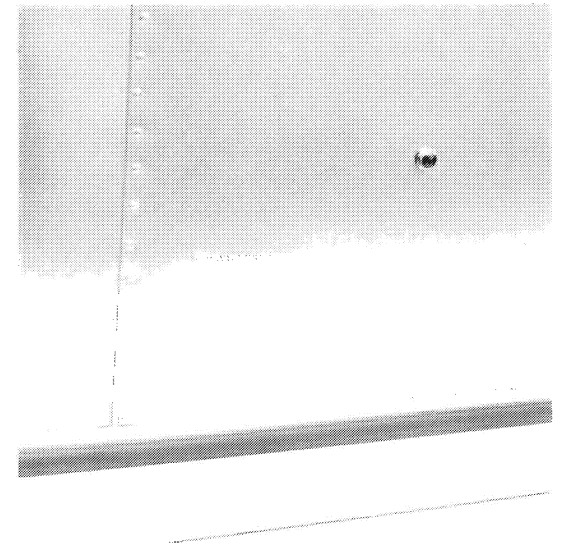

Fig. 3-21, 23 and 25 Ft. Polarity Warning Light

Battery

A normal battery will discharge by itself in 30 to 45 days when not in use, therefore, **it is necessary to periodically check the battery and charge it as is necessary.** We suggest checking the battery at least every two weeks in freezing weather. A fully charged battery will not freeze under any normal circumstances, therefore, it is imperative that you keep your battery charged during the winter. A safe level of charge is a specific gravity reading of 1.225. A fully charged battery has a specific gravity of 1.250 to 1.280. Always use a hydrometer which has a temperature correction scale.

Maintain a clean battery top and check terminals and cables for tightness and cleanliness. A dirty battery will dissipate its charge through surface contamination. Clean battery top with a damp cloth and dry thoroughly.

The terminals should be tight and free of corrosion. To clean terminals, neutralize with a solution of baking soda, rinse in clear water, and dry.

To insure maximum battery capacity on both charge and discharge, the battery terminals and the inside portion of the cable connector should be scraped or brushed until both of these surfaces are shiny bright. The cable connectors should then be reconnected to the battery and tightened. The complete assembly, battery post and cable connector should be coated with a heavy bodied mineral

grease, petroleum grease or a petroleum jel.

Important: Reconnect the battery cables to the correct battery posts. The black cable should be connected to the negative (–) post and the red cable to the (+) post. The polarity of your tow vehicle must also be negative (–) ground since it must always match the trailer. Most tow vehicles are negative grounded, but always check your vehicle owner's manual to be sure.

Add water to cells as necessary. Check the electrolyte level at least once a month. When you are traveling steadily and for an extended period of time, or you are in climates above 90° check the electrolyte level about every two weeks. Do not fill battery above the split ring in filler opening.

Caution: The gases generated within a storage battery cell may be ignited by an open flame or spark in the vicinity of the battery. Do not use a match to provide light for checking the level of the water.

During the winter the battery should be removed from the Airstream and stored in a cool, dry place, where there is no danger of freezing. It should be kept full of water, cleaned and charged monthly. A battery which is allowed to completely lose its charge will never regain its original power, or a full charge.

The battery is located in an exterior curbside compartment. It slides out onto



Battery Cable Quick Disconnects

the opened door for service and removal. For removal it is not necessary to remove cables from battery terminals, just pull quick disconnects apart (see photo).

For battery service or replacement, go to any service station or dealer who sells and services this battery. The battery is rated for 105 amp. hours at 80°F and has a 5 year prorated warranty.

Electrical Outlet Locations

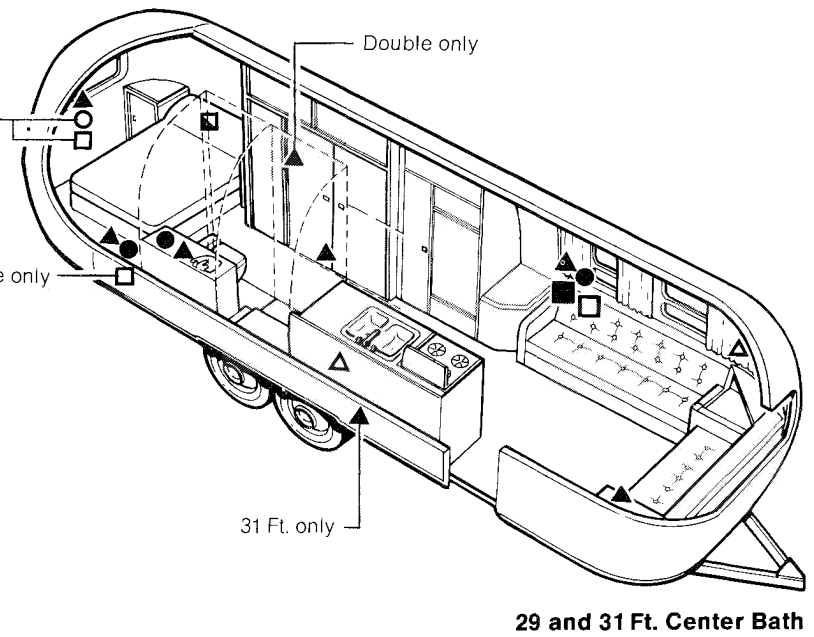
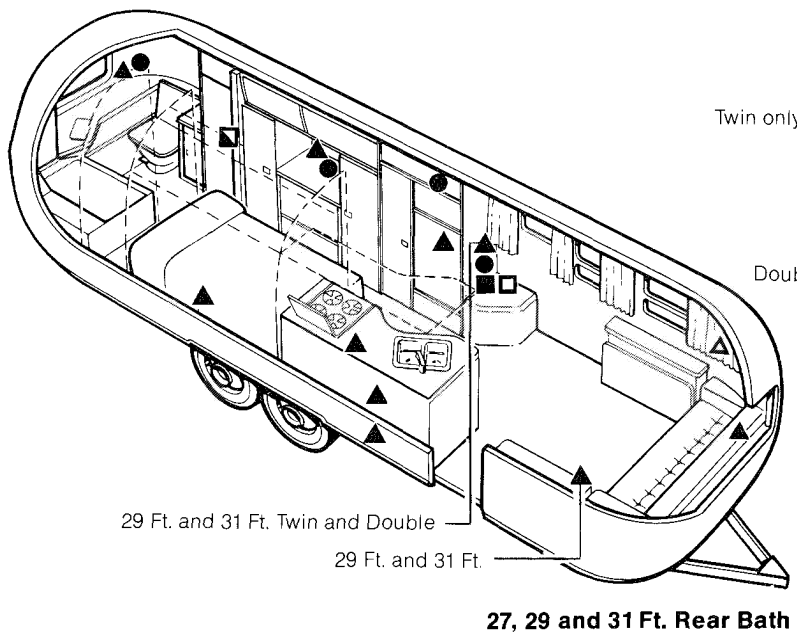
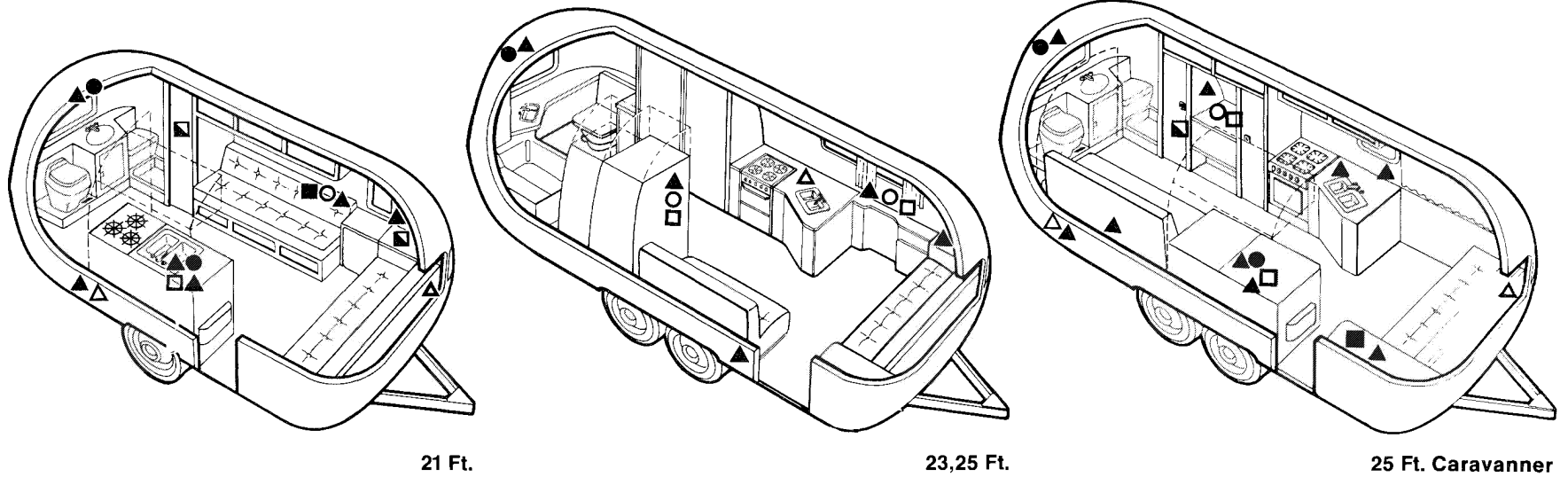

- ▲ 120 V (standard) ▲ 120 V (optional) ■ Telephone Jack (optional) □ T.V. Jack (optional)
- 12 V (optional) ○ 12 V (standard) ◻ Telephone Inlet (optional)

Electrical Wiring Diagrams

120 Volt Distribution System—27, 29 and 31 Ft. Rear Bath

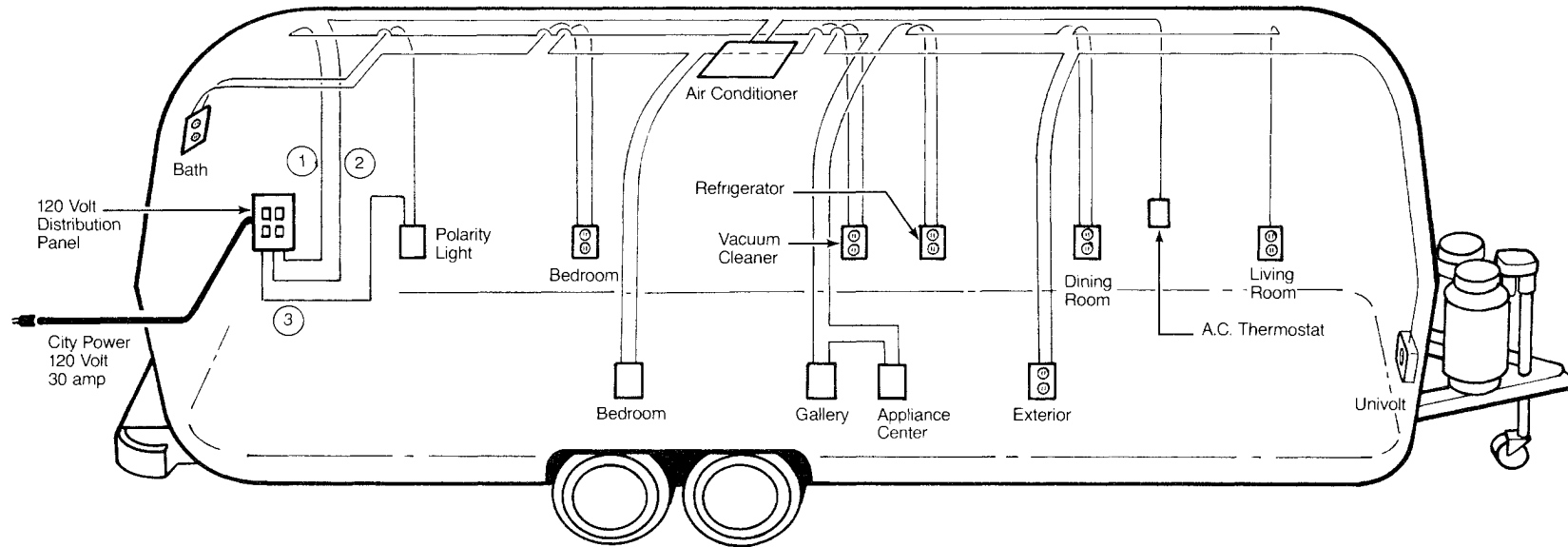

- ① Appliance Circuit 20 amp
- ② Air Conditioner 20 amp
- ③ General Circuit 15 amp

120 Volt Distribution System – 27, 29 and 31 Ft. Center Bath

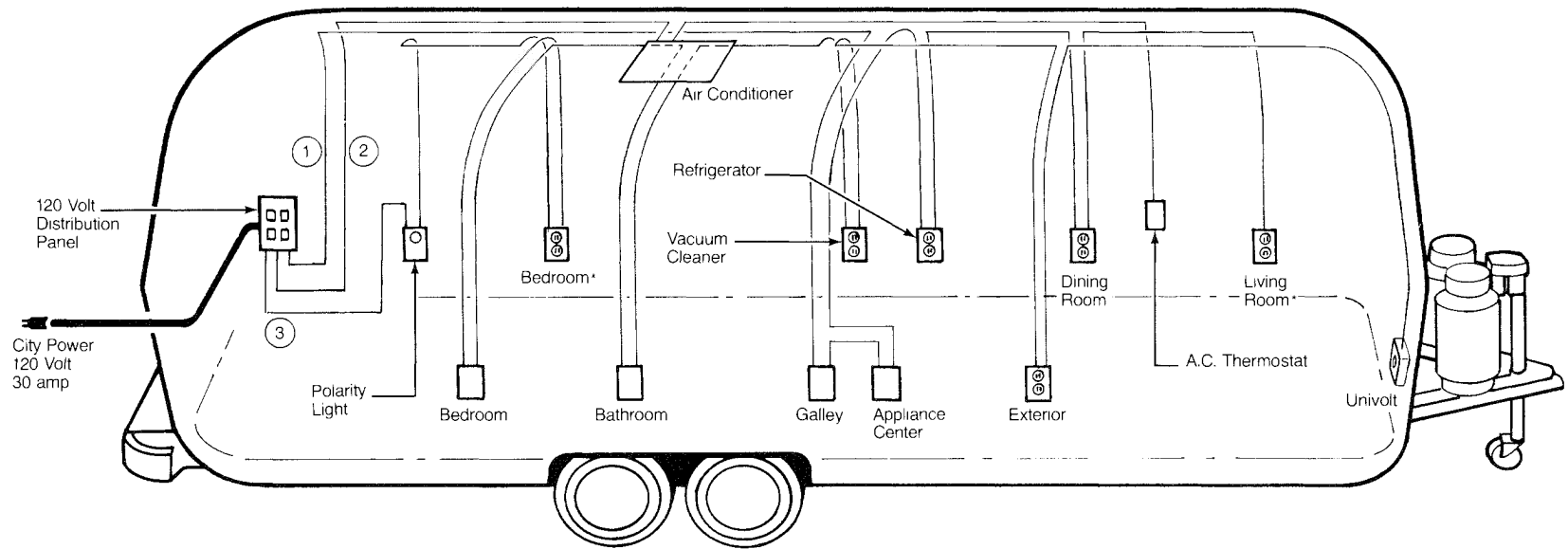

- ① Appliance Circuit 20 amp
- ② Air Conditioner 20 amp
- ③ General Circuit 15 amp

*Location of outlet varies with floor plan.

120 Volt Distribution System – 21, 23 and 25 Ft.

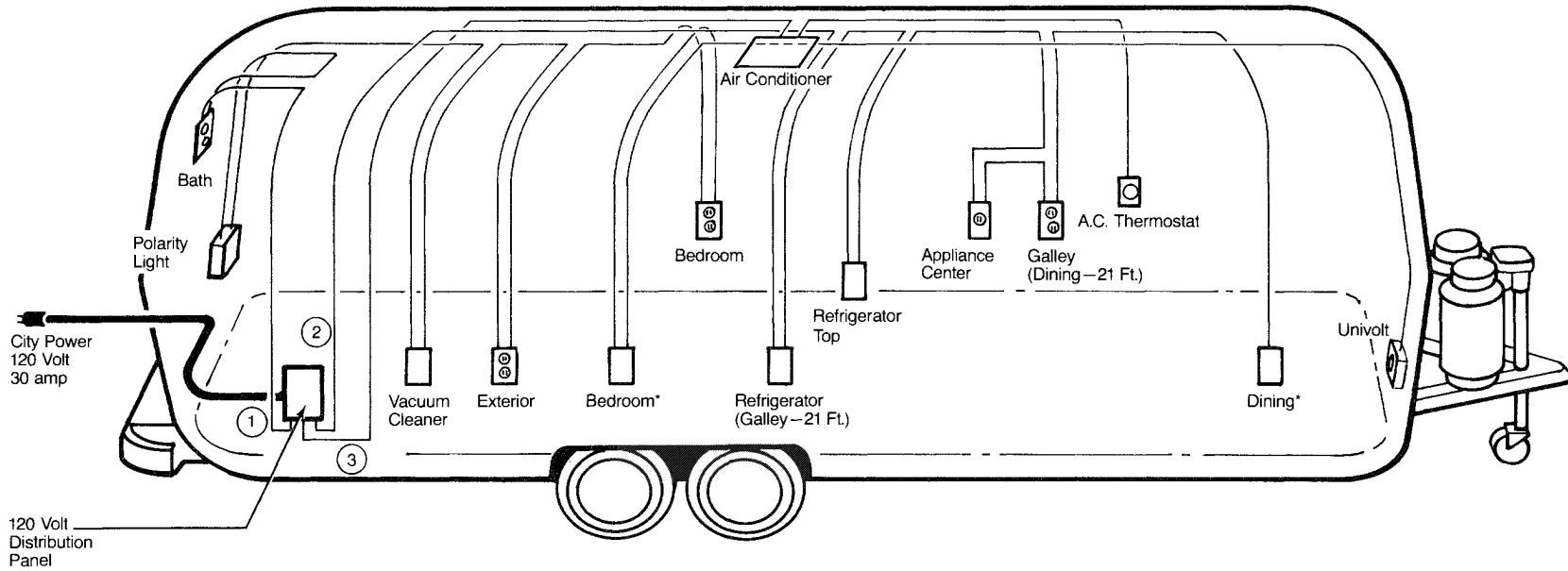

- ① General Circuit 15 amp
- ② Appliance Circuit 20 amp
- ③ Air Conditioner 20 amp

*23 and 25 Ft. only

12 Volt Interior

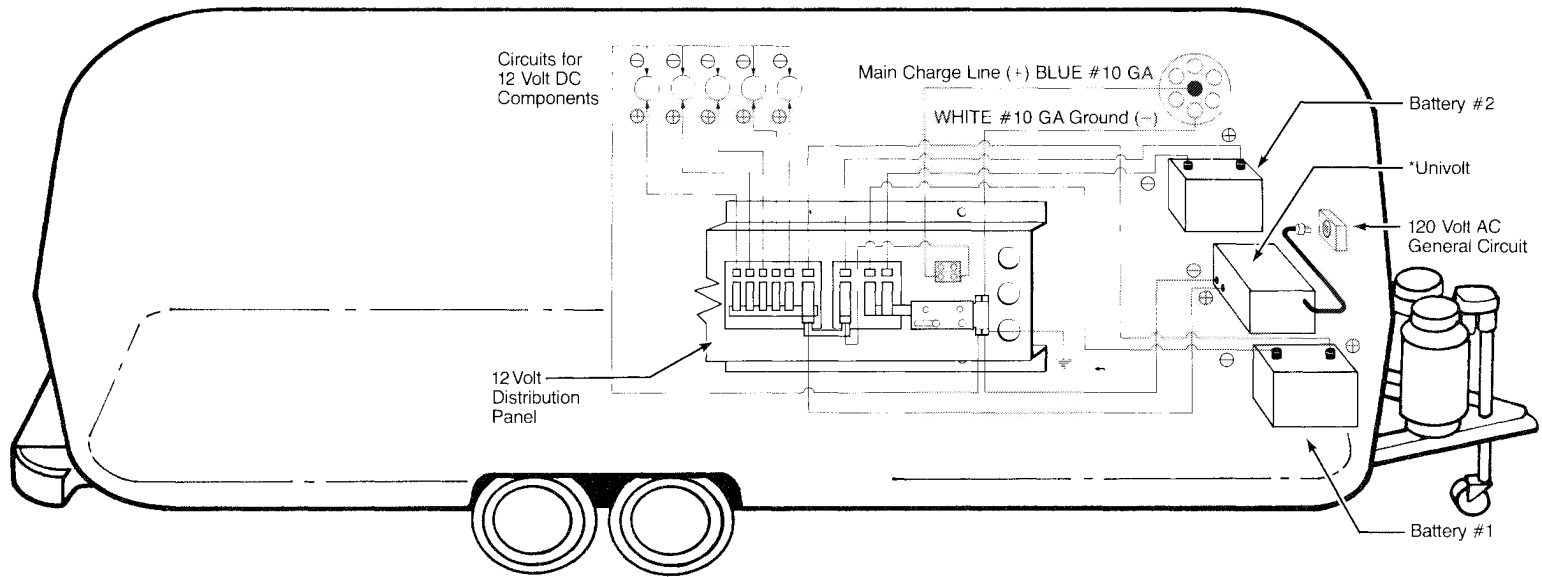

Wiring Color Code
BLUE – Main Charge Line
WHITE – Ground Line

*Univolt converts 120 volts AC to 12 volts DC

Main Charge Circuit and Brake Circuit

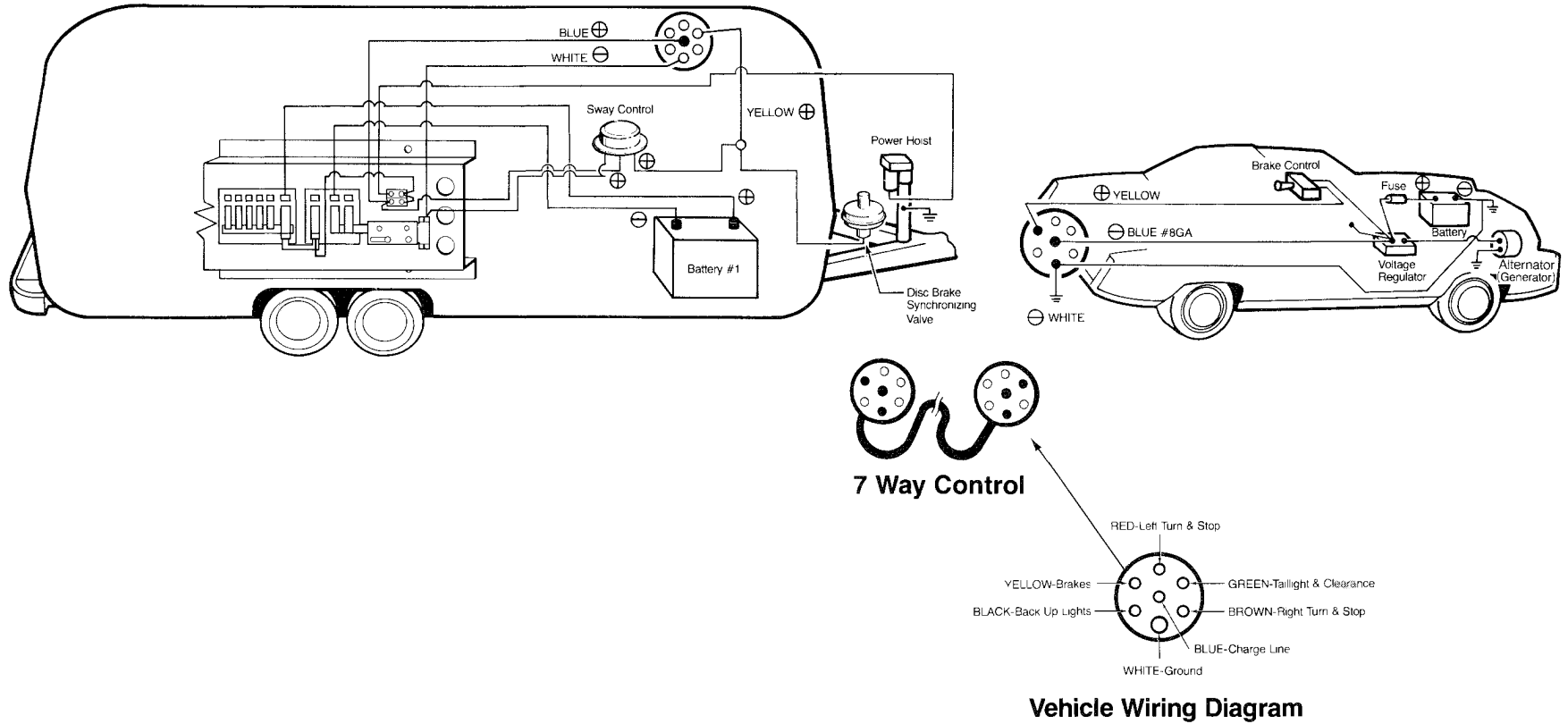

Wiring Color Code

BLUE – Main Charge Line

WHITE – Ground Line

YELLOW – Brake Line

Low Voltage Distribution Panel

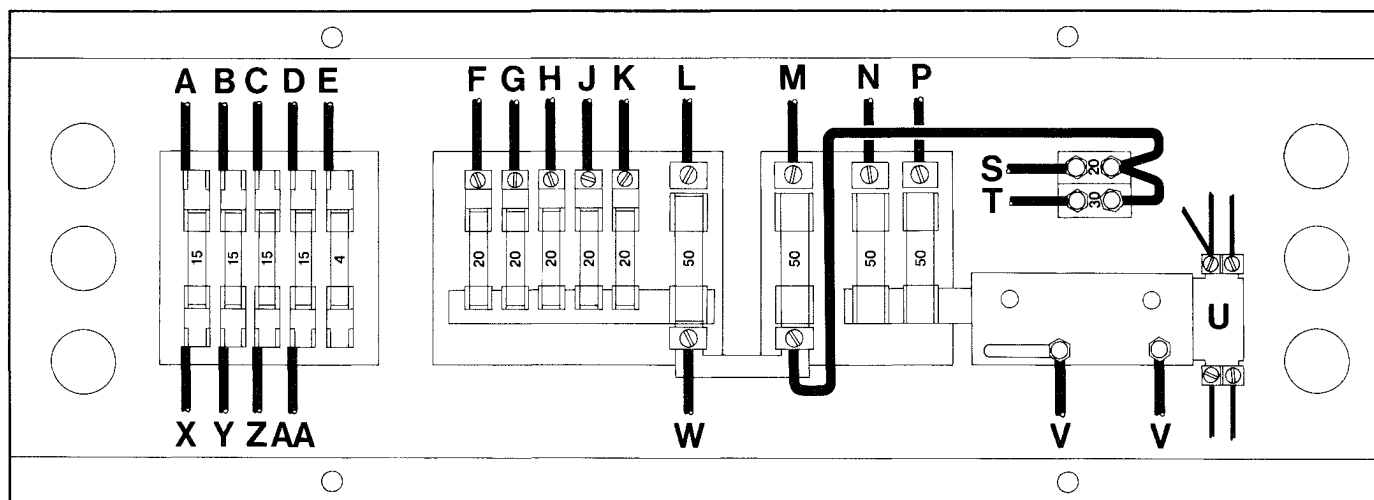

A – Back-Up Light – Black
 B – Right Turn and Stop Light – Brown
 C – Clearance and Taillight – Green
 D – Left Turn and Stop Light – Red
 E – Power-On Light – Gray
 F – Circuit #1 – Purple
 G – Circuit #2 – Yellow
 H – Circuit #3 – Pink
 J – Circuit #4 – Brown
 K – Circuit #5 – Blue

L – Battery #1 (pos)
 M – Battery #2 (pos)
 N – Battery #1 (neg)
 P – Battery #2 (neg)
 S – Hoist – Orange
 T – Main 12 Volt Charge – Blue
 U – All Ground Wires – White
 V – Ammeter – Red and Black
 W – Univolt (pos)
 X – Back-Up Light – Black

Y – Right Turn and Stop Light – Brown
 Z – Clearance and Taillight – Green
 AA – Left Turn and Stop Light – Red

Notes:

1. A, B, C, D, S and T are from 7-Way Plug Harness.
2. F, G, H, J, K, V, X, Y, Z and AA are from Main Wiring Harness.

Central Control Panel

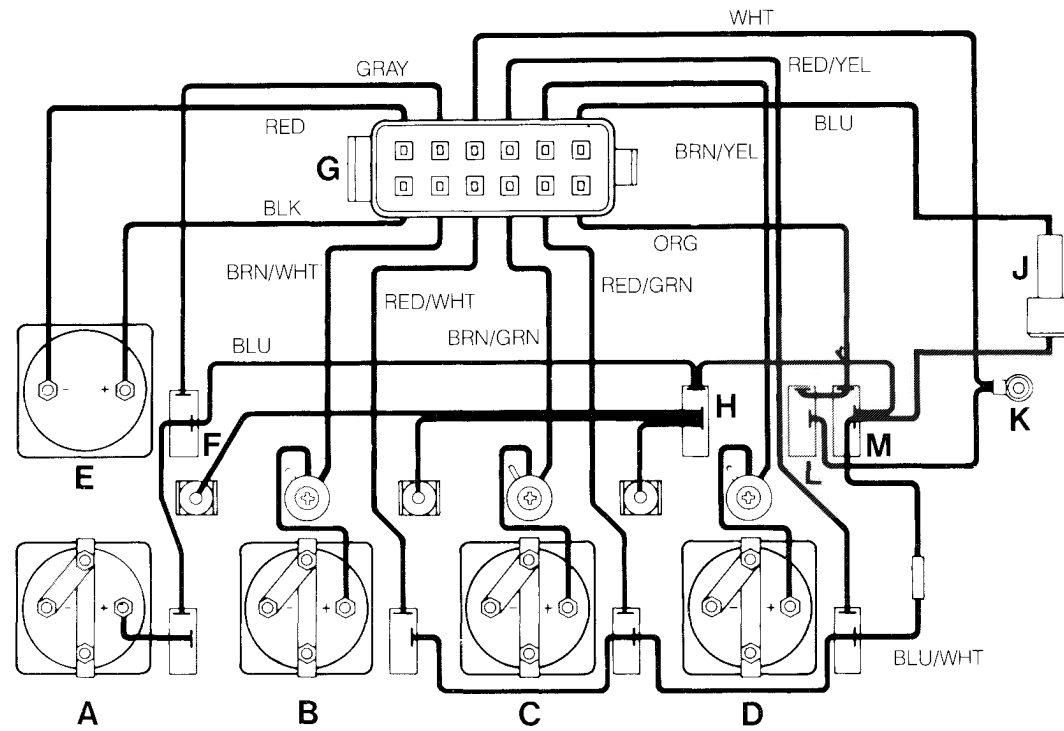

A – Battery
 B – Water Tank
 C – Auxiliary Holding Tank
 D – Main Holding Tank
 E – Ammeter

F – Power On Light
 G – Connector
 H – Panel Light
 J – Fuse
 K – Ground to Panel

L – Panel Light
 M – Water Pump

Electrical Trouble Shooting

Additional electrical trouble shooting information is available in the Airstream Service Manual.

Symptom	Possible Cause	Remedy
No 12-volt power (Lights, appliances do not work)	<ol style="list-style-type: none"> 1. Input line and/or battery not connected 2. Discharged trailer battery 3. Trailer battery on wrong polarity 	<ol style="list-style-type: none"> 1. Make necessary connections 2. Charge battery 3. See Item 7
Blown fuse	<ol style="list-style-type: none"> 4. Overloaded circuit (over 50 amps) 5. Electrical short 6. Shorted battery 7. Battery terminals not properly connected to UNIVOLT + and – terminals 	<ol style="list-style-type: none"> 4. Turn off switches to reduce load. Replace blown fuse in Univolt or next to Univolt. 5. Find blown fuse in Univolt and identify circuit. From wiring diagrams check the circuit for defective wiring, lamps or motors. 6. Replace battery and fuse 7. Make proper connections; replace fuse
Dim lights or sluggish fan motor	<ol style="list-style-type: none"> 8. 25- or 50-cycle power (some foreign countries) 9. Discharged battery (when operating without 120-volt line) 10. Battery is low on water 	<ol style="list-style-type: none"> 8. Use 60-cycle power 9. Charge battery 10. Add distilled water to battery
UNIVOLT will not charge battery	<ol style="list-style-type: none"> 11. Input line not connected 12. Battery not connected (or polarity reversed) 13. Bad battery 14. Too many lights and appliances in use 15. Fuse blown 	<ol style="list-style-type: none"> 11. Connect input line 12. Connect battery to UNIVOLT (Check polarity) 13. Replace battery 14. Reduce electrical load 15. Replace fuse

Specifications

Capacities

Appliance	Capacity
Main Holding Tank – 27, 29 and 31 Ft. Rear Bath	20 gal.
Main Holding Tank – Center Bath	23 gal.
Main Holding Tank – 21, 23 and 25 Ft.	14 gal.
Auxiliary Holding Tank – 27, 29 and 31 Ft. Rear Bath	16 gal.
Auxiliary Holding Tank – Center Bath	13 gal.
Auxiliary Holding Tank – 21, 23 and 25 Ft.	10 gal.
Water Tank	50 gal.
Water Heater	6 gal.

Specifications listed herein are those which are designed to be in your trailer. There may be some small differences in the capacities of individual trailers.

Light and Appliance Amperages

Item	Lamp Number	Amperage
Control Panel Light	53X	.1
Water Pump	—	9.9 max.
Ceiling Fan	—	4.8
Bathroom Exhaust Fan	—	2.0
Range Exhaust Fan	—	2.0
Furnace Fan	—	5.0
Toilet Exhaust Fan	—	2.0
Reading Lights:		
Living Room	1383	1.6 each bulb
Bedroom	1141	1.6 each bulb
Main Door Light	1141	1.6
Exterior Light	1156	
Ceiling Light (6 Bulbs):		
Living Room, Galley	1141F	1.6 each bulb
Bedroom, Bathroom	1141F	1.6 each bulb
Galley and Vanity Lights under Roof Locker	1141	1.6 each bulb
Trunk Lights:		
Service Center, Trunk	67	.6 each bulb
Clearance & Cluster Lights	1895	
Stop & Turn Signal	1156	
Tail Light	1157	
License Plate Light	89	
Backup Lights	1156	
Battery		105 amp hrs. at 80°F.
Fluorescent Lights	F15T8WW	

Fuses and Circuit Breakers

Circuit	Location	Rating
Main Breaker	120 volt panel	30 amp
General Circuit	120 volt panel	15 amp
Appliance Circuit	120 volt panel	20 amp
Air Conditioner	120 volt panel	20 amp
Charge Line from Car	Univolt	AGU 40 amp fuse
Low Voltage Circuits	Univolt	SFE 20 amp fuse
Trailer Battery Fuse (+)	Univolt	AGU 50 amp fuse
Trailer Battery Fuse (-)	Nxt. to Univolt	AGU 50 amp fuse
Power On Circuit	Univolt	SFE 4 amp fuse
Ammeter	Nxt. to Univolt	SFE 4 amp fuse
Central Control Panel	Main Cen. Ctrl. Pnl.	AGC 15 amp fuse
Radio, Radio/Tape	Radio, Radio/Tape	IAG 5 amp fuse
Water Pump	Water Pump	6¼ SLO-BLO

Pre-Travel Check List

Interior

1. Turn off water pump switch.
2. Check battery water level.
3. Close windows and vents.
4. Turn off gas to range & oven.
5. Lock all interior cabinet doors.
6. Lock refrigerator door.
(Seal containers first.)
7. Hold down or stack securely, all loose, hard and sharp objects.
8. Fasten sliding & foldette doors.
9. Drain toilet bowl.
10. Turn off interior lights.
11. Secure and lock the Main door.
12. Pull up step.

Exterior

1. Disconnect and stow:
 - a) electrical hook-up cord.
 - b) sewer-hose hook-up hose (flush out).
 - c) water-hook-up hose.
2. Turn off gas line shut-off valve to appliances.
3. Remove and stow leveling jacks and wheel chocks.
4. Check hitch: it must be properly attached.
5. Check safety chains and breakaway switch cable.
6. Fully retract jack. Remove and stow dolly wheel.
7. Check clearance and stop lights.
8. Check lug nuts. (See page 30)
9. Check tires, for correct pressure.
(See page 32)
10. Check that TV antenna is pointed forward and dipoles closed.
11. Adjust car mirrors.
12. Pull forward some 50 ft., test brakes, and check site for forgotten objects and cleanliness.

Home

1. Leave key with your neighbor.
2. Store valuables and important papers in a safe place.
3. Discontinue newspaper, milk and other deliveries.
4. Ask the Post Office to hold your mail for you.
5. Arrange with the Telephone Company for discontinued or 'Vacation Service.'
6. Arrange care for your pets.
7. Have your lawn, garden and house plants cared for.
8. Lock all windows and doors securely.
Keep shades open for a lived-in look.
9. Cover all food to keep out mice and insects.
10. Eliminate all fire hazards. Place matches in a tin box or glass jar.
11. Store oil, gasoline and other inflammables properly.
12. Destroy all newspapers, magazines and oily rags.
13. Notify police.

Personal

14. Automobile insurance to cover you and your family fully.
15. Avoid cash. Use travelers checks and credit cards.
16. Confirm reservations.
17. Have sunglasses for everyone.
18. Pack cameras and films.
19. Make a check list of clothing for everyone, and toilet articles.

Motoring Essentials

1. Display car and trailer registration properly.
2. Carry driver's license. In Canada you will need a non-resident liability insurance card.
3. In Mexico you must have special auto insurance.
4. Carry an extra set of ignition and trunk keys in a separate pocket, or in your wallet.
5. Keep an operating flashlight with fresh batteries in the glove compartment.
6. Pack the trunk so that you can reach the tools and spare tire without completely unpacking.
7. Keep sharp or hard articles securely packed wherever they may be.
8. Do not pack things in the passenger sitting area, you need maximum space for comfort.
9. Wear easy-wash, drip-dry traveling clothes.
10. Do not make your vacation trips a mileage marathon! Stop and relax frequently.
11. Carry a first aid kit.
12. Carry your pet's dish, food, leash and health and registration papers.

Lubrication and Maintenance

Your Airstream is without a doubt the finest engineered travel trailer ever to be mass-produced. Every design feature and component has been chosen with the thought in mind of giving you thousands of miles of trouble-free operation. By adhering to the following minimum maintenance schedule and the additional exterior and interior maintenance suggestions you will enjoy all

of the pleasure you dream of from your trailer...and more.

Item	Every 1,000 miles or 30 days	Every 5,000 miles or 90 days	Every 10,000 miles or 6 months	Procedure
All Exterior Door Locks	X			Lubricate by shooting in dry graphite.
Axle				None, except wheel bearings.
Battery	X			Check water level – fill with distilled water only.
Brake Fluid		X		Remove reservoir cover. Add Dot 3 fluid.
Brakes			X	Inspect and replace as necessary.
Entrance Door Hinges	X			Lubricate with light household oil.
Hitch Ball Latch	X			Lubricate with engine motor oil.
Hitch Jack	X			Lubricate with light household oil (put oil can spout up under handle and allow oil to run down post).
LPG Hold Down Knob	X			Lubricate with light household oil.
Main Door Step	X			Lubricate moving parts.
Range Exhaust Hood				Clean fan blades and wash filter. See page 69.
Refrigerator Flue Cleaning		X		See page 65.
Roof Vent Elevator Screws	X			Lubricate with light household oil.
Strike Pocket on Main Door	X			Coat with paraffin.
T.V. Antenna	X			Lubricate exterior moving parts with silicon spray or WD 40.
Tires	X			Check for foreign objects. Air pressure – page 32.
Water Pump		X		Check belt for wear and proper tension.
Wheel Bearings			X	Clean, repack, and adjust.
Wheel Lug Nuts		X*		Check for tightness.
Window Seals/Door Seals		X		Clean with mild detergent and coat with "Slipicone."
7-Way Plugs and Receptacle		X		Clean contacts and coat with "SPRA-KLEEN."

Note: If and when new materials and production techniques are developed which can improve the quality of its product, Airstream reserves the right to make such changes.

*Note: On new trailers check lug nuts every 200 miles for the first 1,000 miles.

Index

Air Conditioner	59	Filter (Water)	73	Refrigerator	64	Water Drain Valves	43, 75
Aluminum Shell	46	Flat Tires	30	Registration	4	Water Filter	73
Ammeter	56	Foldaway Step	46	Regulator (LPG).....	63	Water Heater	72
Amperage Chart	92	Gas (LPG) System.....	63	Repair Centers.....	9	Water Inlet	74
Automatic Gas Regulator	63	Gas Tank	63	Removing Moisture.....	71	Water Level Gauge.....	57
Axle	20	Gas Tank	63	Running Gear	16	Water Pump	73
Backing	38	Gauge Recalibration	57	Self-Contained (Drainage)	76	Water Purifier (Filter).....	74
Ball (Hitch)	34	Grounding	79, 81	Self-Contained (Electrical)....	79	Water System	73
Battery	81	Hitch	33	Service Centers.....	9	Weight: HP Ratio	16
Battery Condition Tester	56	Hitch Ball Height	34	Sewer Connection	76	Windows	46
Brake Controller	17	Hitching Up	33	Shower Head	62	Winterizing	43
Brakes	17	Holding Tanks	76	Sink Maintenance	60		
Bulbs (Replacement).....	92	Home Check List	94	Specifications	92		
Bunk Beds	55	Interior Check List.....	94	Stabilizing Jack Positions.....	40		
Capacities	92	Interior Maintenance.....	54	Sway Control	19		
Car Connector	34, 88	Jacking Trailer.....	40	Switches: Lights	60, 62		
Cargo Capacity	20, 34	Lubrication Chart	96	Tank (Sewage).....	76		
Ceiling Fans	61, 62	Leveling	40	Tank (Water)	73		
Ceiling Vents	61	Leveling Bars	34	Telephone Jacks	82		
Central Control Panel.....	56, 90	Light Bulb Replacement ..	61, 92	Telephone Shower Head	62		
Check Lists.....	94	Lights	61	Tires	30		
Circuit Breakers.....	80	L.P.G. System	63	Tire Pressures	32		
City Power	79	Load Chart	24-29	Toilet	77		
Clock.....	58	Loading	16, 20	Towing Tips	36		
Defrosting	65	Microwave Oven	66	Trailer Storage.....	43		
Drainage System	76	Motoring Check List	94	Trouble Shooting			
Dump Valves.....	76	Oven	68	Electrical	91		
Electrical Components.....	79	Oven Cleaning	69	Furnace	70		
Electrical Connector	34, 88	Overheating	36	Range and Oven.....	68		
Electrical Inlet	79	Overnight Stop	39	Refrigerator	64		
Electrical Panels.....	56, 89, 90	Panel Switches.....	56	Water Systems.....	73		
Electrical System	79	Panel Gauges	56	TV Antenna	47		
Electric Jack (Hitch)	34	Pilot Adjustment:		TV Jacks	82		
Equipment List	15	Furnace	70	Univolt	79		
Extended Stay	40	Oven	68	Utility Connection.....	41		
Extension Step	46	Range.....	68	Vacuum Cleaner	60		
Exterior	46	Refrigerator	64	Vents	61		
Factory Service	4	Water Heater	72	Vista View Windows	47		
Fan Switch	61	Personal Check List	94	Warranty	5		
Filter (Air Conditioner)	60	Power On	58	Water Drainage			
Filter (Vacuum Cleaner)	60	Polarity Light.....	79	Procedure.....	43, 73		
		Range.....	68				

Main Charge Circuit and Brake Circuit

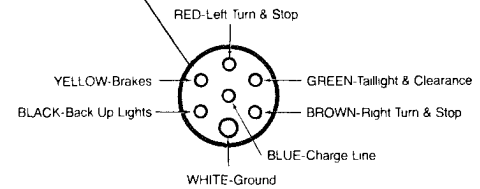
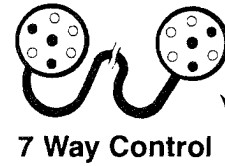
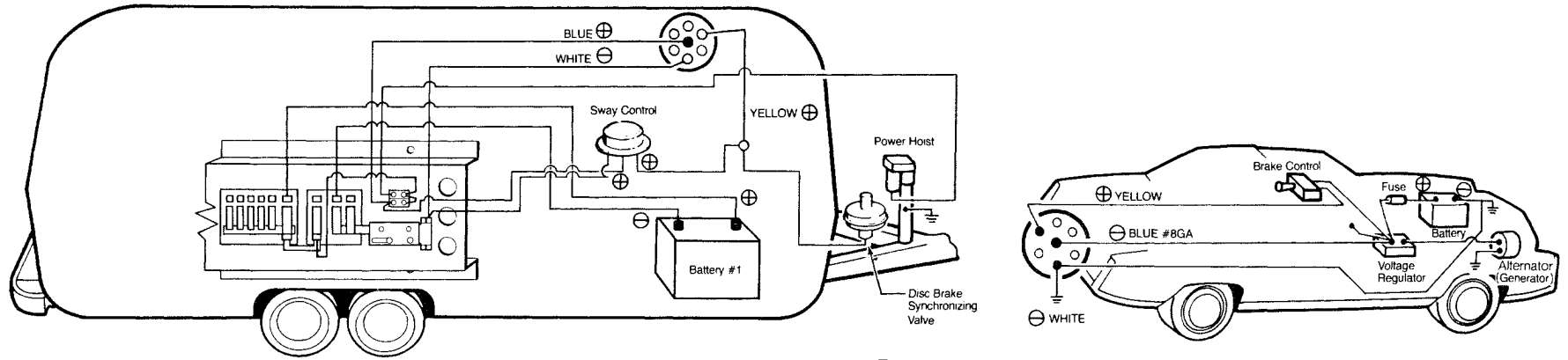

Wiring Color Code

BLUE – Main Charge Line

WHITE – Ground Line

YELLOW – Brake Line

12 Volt Exterior

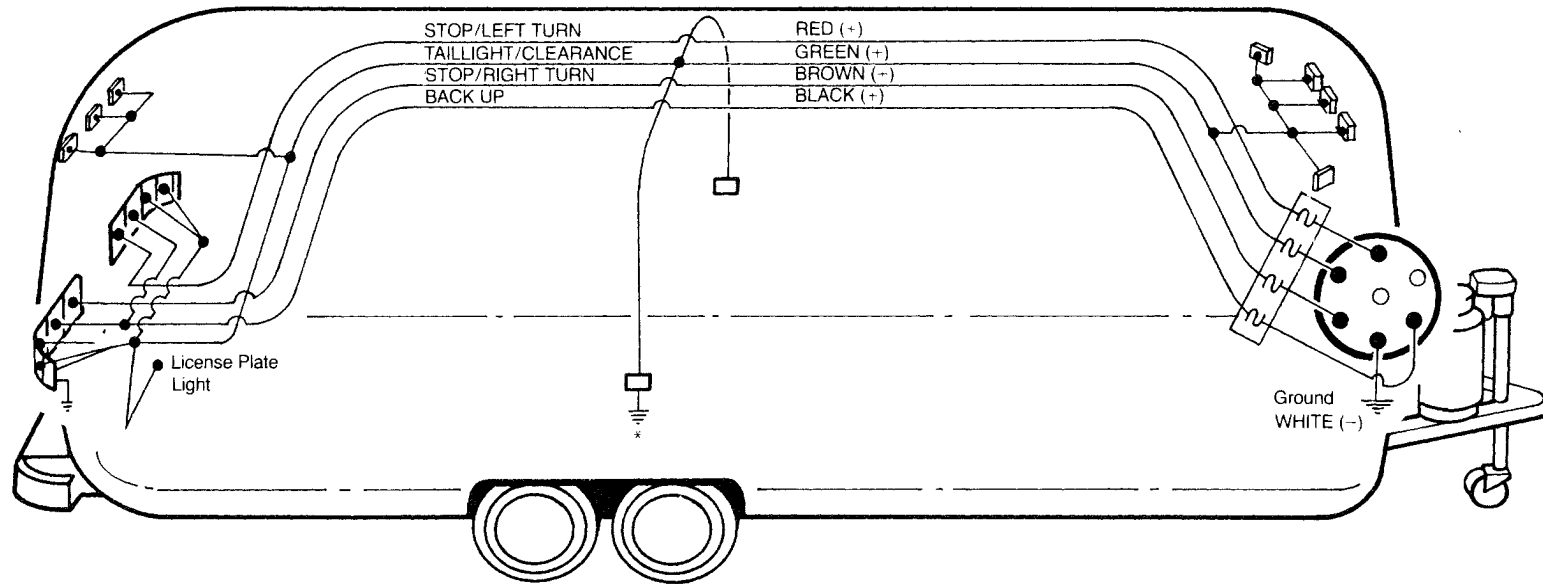

Wiring Color Code

RED – Stop/Left Turn
GREEN – Taillight/Clearance
BROWN – Stop/Right Turn
BLACK – Back Up
WHITE – Ground

*All lamp assemblies are grounded to exterior skin.

