

**BY ORDER OF THE  
SECRETARY OF THE AIR FORCE**

**AIR FORCE MANUAL 11-217, VOLUME 3  
23 FEBRUARY 2009**



*Flying Operations*

**SUPPLEMENTAL FLIGHT INFORMATION**

**COMPLIANCE WITH THIS PUBLICATION IS MANDATORY**

---

**ACCESSIBILITY:** Publications and forms are available on the e-Publishing website at [www.e-Publishing.af.mil](http://www.e-Publishing.af.mil) for downloading or ordering.

**RELEASABILITY:** There are no releasability restrictions on this publication.

---

OPR:HQAFFSA/A3OF

Certified by: HQ USAF/AEO-A (Brig Gen Lyn D. Sherlock)

Supersedes: AFMAN11-217V2, 6 August 1998

Pages: 209

---

This instruction implements AFD 11-2, *Flight Rules and Procedures*, by providing guidance and procedures for standard Air Force instrument flying. Since aircraft flight instrumentation and mission objectives are so varied, this instruction is necessarily general regarding equipment and detailed accomplishment of maneuvers. Individual aircraft flight manuals should provide detailed instructions required for particular aircraft instrumentation or characteristics. This manual, when used with related flight directives and publications, provides adequate guidance for instrument flight under most circumstances, but is not a substitute for sound judgment. Circumstances may require modification of prescribed procedures. Aircrew members charged with the safe operation of United States Air Force aircraft must be knowledgeable of the guidance contained in this manual. This publication applies to Air Force Reserve Command (AFRC) Units and to the Air National Guard (ANG). This publication is applicable to all USAF aircraft, to include Unmanned Aerial Vehicles (UAVs). Ensure that all records created as a result of processes prescribed in this publication are maintained in accordance with AFMAN 33-363, *Management of Records*, and disposed of in accordance with Air Force Records Information Management System (AFRIMS) located at <https://my.af.mil/gcss-af61a/afirms/afirms>. Submit recommended changes or questions about this publication to the Office of Primary Responsibility (OPR) using the AF IMT 847, *Recommendation for Change of Publication*; route AF IMT 847 from the field through the appropriate functional's change of command. Address any questions regarding this manual to HQ Air Force Flight Standards Agency (AFFSA) at [hqaffsa.a3of@tinker.af.mil](mailto:hqaffsa.a3of@tinker.af.mil) or via mail, HQ AFFSA/AJW31AF, Attn: Flight Directives Branch, Building 4 - Room 106, 6500 South MacArthur Blvd, Oklahoma City, OK 73169. POC: Matt Thompson, Major, USAF. The use of the name or mark of any specific manufacturer, commercial product, commodity, or service in this publication does not imply endorsement by the Air Force.

**SUMMARY OF CHANGES**

**General:** Changed formatting to conform to AFI 33-360 guidance. Deleted unused chapters that were transferred to AFMAN 11-217 Volume 1, *INSTRUMENT FLIGHT PROCEDURES*. Some chapters and paragraphs were renumbered as a result. Corrected grammar, spelling, and punctuation along with updated some graphics. The majority of the information in this manual has been completely revised and/or updated. This manual also includes eight new chapters (reference the addition of Chapter 4, REDUCED VERTICAL SEPARATION MINIMUMS (RVSM); Chapter 5, TERRAIN AVOIDANCE WARNING SYSTEM (TAWS); Chapter 6, TRAFFIC COLLISION AVOIDANCE SYSTEM (TCAS); Chapter 7 COMMUNICATION, NAVIGATION, SURVEILLANCE (CNS)/AIR TRAFFIC MANAGEMENT (ATM); Chapter 8, AIRCRAFT INSTRUMENTS; Chapter 9, EXTREME LATITUDE NAVIGATION; Chapter 10, TERMINAL INSTRUMENT PROCEDURES (TERPS); and Chapter 13, OCEANIC NAVIGATION. Therefore, this manual is considered new and should be reviewed in its entirety.

**NOTE:** Where used, “*miles*” means nautical miles unless otherwise specified, and when used in relation to visibility means statute miles.

**NOTE:** “*Course, bearing, azimuth, heading, and wind direction*” information shall always be magnetic unless specifically stated otherwise.

**NOTE:** Since USAF aircraft are comprised of both multi-crew and single pilot configurations; the terms “*aircrew*” and “*pilot*” may be used interchangeably as applicable.

**NOTE:** The reports in this directive are exempt from licensing according to AFI 33-324, *Controlling Internal, Public, and Interagency Air Force Information Collections*.

<b>Chapter 1 GROUND-BASED NAVIGATIONAL AIDS</b>	<b>9</b>
1.1. Non-directional Radio Beacon (NDB).....	9
1.2. VOR System.....	12
1.3. Tactical Air Navigation (TACAN) System.....	15
1.4. Instrument Landing System (ILS).....	18
1.5. Precautions to Prevent Navigation Errors.....	31
1.6. Reporting Malfunctions.....	31
<b>Chapter 2 WAKE TURBULENCE</b>	<b>32</b>
2.2. Introduction to Wake Turbulence.....	32
2.3. Induced Roll and Counter Control.....	32
<b>Figure 2.1. Touchdown and Rotation Points when Following Larger Aircraft...</b>	<b>33</b>
<b>Figure 2.2. Aircraft Generated Vortex Descent Profile.....</b>	<b>34</b>
<b>Figure 2.3. Recommended Flight Path Landing Behind a Larger Aircraft.....</b>	<b>35</b>

<b>Figure 2.4. Recommended Touchdown Point for Parallel Runway Operations..</b>	<b>36</b>
<b>Figure 2.5. Crossing Flight Path Considerations.....</b>	<b>36</b>
<b>Figure 2.6. Landing Behind a Departing Aircraft.....</b>	<b>37</b>
<b>Figure 2.7. Landing Behind a Departing Aircraft – Crossing Runway ..... (Rotation Point Past Intersection)</b>	<b>37</b>
<b>Figure 2.8. Landing Behind a Departing Aircraft – Crossing Runway..... (Rotation Point Prior to Intersection)</b>	<b>37</b>
<b>2.6. Pilot Responsibility.....</b>	<b>38</b>
<b>2.7. ATC Responsibility.....</b>	<b>39</b>
<b>2.8. Special Wake Considerations.....</b>	<b>40</b>
<b>Chapter 3 THE 60-TO-1 RULE AND OTHER AVIATION CALCULATIONS</b>	<b>42</b>
<b>3.1. The 60-to-1 Rule.....</b>	<b>42</b>
<b>3.2. When Do You Use the 60-to-1 Rule?.....</b>	<b>42</b>
<b>3.3. Application of the 60-to-1 Rule.....</b>	<b>42</b>
<b>3.4. Mathematical Derivation of the 60-to-1 Rule.....</b>	<b>43</b>
<b>3.5. Aviation Calculations.....</b>	<b>44</b>
<b>3.6. The Gradient.....</b>	<b>47</b>
<b>3.7. Descent Gradients.....</b>	<b>47</b>
<b>Figure 3.1. STAR for Minneapolis, Minnesota (EAU CLAIRE EIGHT).....</b>	<b>50</b>
<b>3.8. Climb Gradients.....</b>	<b>51</b>
<b>Figure 3.2. Jackson Hole, Teton Two Departure.....</b>	<b>55</b>
<b>3.9. Visual Descent Point (VDP).....</b>	<b>57</b>
<b>Figure 3.3. ILS Runway 16, McChord AFB.....</b>	<b>58</b>
<b>3.10. Calculating a VVI for a Precision Approach.....</b>	<b>61</b>
<b>Figure 3.4. ILS Runway 12, Mountain Home AFB.....</b>	<b>63</b>
<b>3.11. Determining Turn Radius.....</b>	<b>65</b>
<b>Figure 3.5. General Turning Performance (Constant Altitude, Steady Turn).....</b>	<b>67</b>
<b>3.12 Standard and ½ Standard Rate Calculations.....</b>	<b>67</b>
<b>3.13. Arc-to-Radial and Radial-to-Arc Calculations.....</b>	<b>70</b>
<b>3.14. Procedure Turns Calculations (PTs).....</b>	<b>72</b>
<b>Figure 3.6 HI-ILS or LOC Runway 33, Bangor International.....</b>	<b>76</b>
<b>Figure 3.7 Summary of 60-1 Rules and Formulas.....</b>	<b>79</b>
<b>Chapter 4 REDUCED VERTICAL SEPARATION MINIMUMS (RVSM)</b>	<b>83</b>

4.1. RVSM Airspace.....	83
4.2. Access to RVSM Airspace.....	83
4.3. RVSM Aircraft Equipment Requirements.....	84
4.4. Executing an RVSM Flight.....	85
<b>Chapter 5 TERRAIN AVOIDANCE WARNING SYSTEM (TAWS)</b>	<b>88</b>
5.1. Definitions.....	88
5.2. TAWS Equipment (Class A and Class B).....	88
<b>Chapter 6 TRAFFIC COLLISION AVOIDANCE SYSTEM (TCAS)</b>	<b>91</b>
6.1. General Information.....	91
Figure 6.1. Typical TCAS Display.....	91
6.2. TCAS Advisories.....	92
6.3. TCAS Operation.....	92
6.4. Traffic Advisories.....	92
6.5. Resolution Advisories.....	92
Figure 6.2. Example of a Typical EVVI Display with TCAS RA.....	93
6.6. Warning Times.....	93
6.7. Advisory Thresholds.....	93
6.8. Air-Air Coordination of Resolution Advisories.....	94
6.9. General TCAS Operational Procedures.....	94
Table 6.1. Recommended Pitch Change in Response to TCAS RA.....	95
6.10. ATC Considerations.....	96
6.11. Operating Practices.....	97
6.12. Limitations of TCAS.....	98
<b>Chapter 7 COMMUNICATIONS, NAVIGATION, SURVEILLANCE (CNS)/AIR TRAFFIC MANAGEMENT (ATM)</b>	<b>100</b>
7.1. General Overview.....	100
7.2. Communications.....	100
7.3. Navigation.....	102
Figure 7.1 RNAV accuracy vs. RNP containment.....	103
Figure 7.2. Performance-Based Navigation.....	104
Table 7.1. Airspace RNP and RNAV Accuracy Requirements.....	105
7.4. Surveillance.....	107
7.5. CNS/ATM Compliance.....	110

<b>Chapter 8 AIRCRAFT INSTRUMENTS</b>	<b>111</b>
<b>8.1. Pressure Instruments</b>	<b>111</b>
<b>Figure 8.1. Correction for Compressibility on DR Computer</b>	<b>112</b>
<b>Figure 8.2. Altimeters</b>	<b>114</b>
<b>Figure 8.3. Altimeter Settings</b>	<b>116</b>
<b>Figure 8.4. Types of Altitude</b>	<b>117</b>
<b>Figure 8.5. Airspeed Measurement</b>	<b>118</b>
<b>Figure 8.6. Vertical Velocity Indicator</b>	<b>120</b>
<b>8.2. AIMS</b>	<b>120</b>
<b>8.3. Attitude Instruments</b>	<b>122</b>
<b>Figure 8.7. Three-Axis Attitude Director Indicator (ADI)</b>	<b>122</b>
<b>Figure 8.8. Precession of Gyroscope Resulting from Applied Deflective Force</b>	<b>123</b>
<b>Figure 8.9. Turn and Slip Indicators</b>	<b>124</b>
<b>8.4. Heading Systems</b>	<b>124</b>
<b>Figure 8.10. Isogonic Lines</b>	<b>125</b>
<b>Figure 8.11. Northerly and Southerly Turning Error</b>	<b>127</b>
<b>Figure 8.12. Acceleration/Deceleration Error</b>	<b>128</b>
<b>8.5. Angle of Attack System</b>	<b>129</b>
<b>8.6. Radar Altimeters</b>	<b>129</b>
<b>Chapter 9 EXTREME LATITUDE NAVIGATION</b>	<b>130</b>
<b>9.1. Areas of Magnetic Unreliability (AMU)</b>	<b>131</b>
<b>9.2. Boundaries of the AMU</b>	<b>131</b>
<b>Figure 9.1. Heading Indications while Crossing Meridians</b>	<b>131</b>
<b>9.3. Grid Operations</b>	<b>131</b>
<b>9.4. Definition of an Emergency in the AMU</b>	<b>132</b>
<b>9.5. Using the VOR in the AMU</b>	<b>133</b>
<b>9.6. Using an NDB in the AMU</b>	<b>134</b>
<b>Chapter 10 TERMINAL INSTRUMENT PROCEDURES (TERPS)</b>	<b>135</b>
<b>10.1. United States Standard for TERPS</b>	<b>135</b>
<b>10.2. General Criteria and Common Information</b>	<b>135</b>
<b>Figure 10.1. Relationship of OCS and ROC for Level Segment</b>	<b>136</b>
<b>Figure 10.2 Relationship of OCS and ROC for Sloping Segment</b>	<b>136</b>
<b>10.3. Procedure Construction</b>	<b>137</b>

<b>Figure 10.3. Segments of an Approach Procedure.....</b>	<b>137</b>
<b>10.4. Enroute Operations.....</b>	<b>137</b>
<b>10.5. Minimum Safe/Sector Altitudes (MSA) and Emergency Safe Altitudes (ESA).</b>	<b>138</b>
<b>10.6. Initial Approach Segment.....</b>	<b>138</b>
<b>Figure 10.4. Obstacle Clearance.....</b>	<b>139</b>
<b>10.7. Intermediate Approach Segment.....</b>	<b>140</b>
<b>10.8. Final Approach Segment.....</b>	<b>141</b>
<b>Figure 10.5. Standard Visual Area.....</b>	<b>142</b>
<b>Figure 10.6. Straight-in Visual Area.....</b>	<b>142</b>
<b>Figure 10.7. Circling Approach Area Construction.....</b>	<b>144</b>
<b>10.9. Missed Approach Segment.....</b>	<b>145</b>
<b>Figure 10.8. Straight Missed Approach Area.....</b>	<b>146</b>
<b>Figure 10.9. Missed Approach Cross Section.....</b>	<b>147</b>
<b>Figure 10.10. Obstacle Clearance Surface for Missed Approach.....</b>	<b>147</b>
<b>10.10. Holding.....</b>	<b>148</b>
<b>10.11. Summary.....</b>	<b>149</b>
<b>Chapter 11 USING NON-DOD/NACO INSTRUMENT PROCEDURES</b>	<b>150</b>
<b>11.1. Introduction.....</b>	<b>150</b>
<b>11.2. Commercial Products.....</b>	<b>150</b>
<b>11.3. Using FLIP Other Than NGA or NACO.....</b>	<b>150</b>
<b>11.4. Determining Review Status.....</b>	<b>150</b>
<b>Figure 11.1 Example ASRR Instrument Procedure Information.....</b>	<b>151</b>
<b>Figure 11.2. Example ASRR TERPS Review Page.....</b>	<b>152</b>
<b>Figure 11.3. Example ASRR MAJCOM TERPS Review Page.....</b>	<b>153</b>
<b>Chapter 12 NIGHT VISION DEVICES (NVD)</b>	<b>154</b>
<b>12.1. Introduction.....</b>	<b>154</b>
<b>12.2. Dark Adaptation.....</b>	<b>154</b>
<b>12.3. Spatial Orientation and NVGs.....</b>	<b>154</b>
<b>12.4. The Night Environment.....</b>	<b>155</b>
<b>Figure 12.1. The Electromagnetic Spectrum.....</b>	<b>155</b>
<b>12.5. Sources of Illumination.....</b>	<b>156</b>
<b>12.6. Night Vision Goggle Characteristics.....</b>	<b>157</b>
<b>Figure 12.2. NVG Components and the Image Intensification Process.....</b>	<b>158</b>

12.7. NVG Characteristics.....	159
12.8. NVG Limitations.....	159
12.9. Avoiding Depth and Distance Problems.....	160
Figure 12.3. Basic Night Vision Goggle Components.....	161
Figure 12.4. ANV- 20/20 Visual Acuity Box Image.....	162
Figure 12.5. NVG Image Defects.....	164
12.10. Factors Affecting NVG Operations.....	164
12.11. Night Operations with NVGs.....	167
12.12. NVG Misperceptions and Illusions.....	169
12.13. Emergency Situations.....	170
12.14. Spatial Disorientation.....	171
12.15. Overconfidence in NVG's.....	172
12.16. Other Night Vision Device Systems.....	172
Table 12.1. NVG and FLIR Comparisons.....	172
Chapter 13 OCEANIC NAVIGATION	173
13.1. Introduction.....	173
Table 13.1. Useful Oceanic Travel Planning Website Resources.....	173
13.2. Oceanic Flight.....	174
Figure 13.1. Example of NAT Track Message.....	176
13.3. Oceanic Navigational Errors.....	177
13.4. Oceanic Checklist.....	177
Figure 13.2. Sample Oceanic Checklist.....	177
13.5. Flight Planning.....	180
Figure 13.3. Equal Time Point (ETP) Calculation.....	180
13.6. Review Coast-Out Positional Accuracy.....	181
Figure 13.4. Example – Use of Master CFP Symbols.....	183
13.7. Taxi and Prior to Take-Off.....	184
13.8. Climb Out.....	184
13.9. Prior to Oceanic Entry.....	184
Figure 13.5. Suggested re-clearance checklist.....	185
13.10. After Oceanic Entry.....	186
13.11. Approaching Waypoints.....	187
13.12. Overhead Waypoints.....	187

<b>13.13. 10-Minute Plot.....</b>	<b>187</b>
<b>13.14. Mid-Point.....</b>	<b>188</b>
<b>13.15. Coast In.....</b>	<b>188</b>
<b>13.16. Descent.....</b>	<b>188</b>
<b>13.17. Destination/Block-In.....</b>	<b>188</b>
<b>13.18. Information Collection, Records, and Forms:.....</b>	<b>189</b>
<b>Attachment 1 GLOSSARY OF REFERENCES AND SUPPORTING INFORMATION</b>	<b>190</b>



## Chapter 1

### Ground-Based Navigational Aids

#### 1.1. Non-Directional Radio Beacon (NDB)

1.1.1. Introduction. The NDB is still an important navigational aid (NAVAID) used in the US and around the world. In fact, at numerous airports, the NDB may provide the only form of navigation. Although less precise than other NAVAIDs providing non-precision approach course guidance, the NDB still provides a safe means of descent and a way to locate an airport in marginal VFR or IFR conditions.

1.1.2. Usability. The low and medium frequency radio signals are not limited to Line Of Sight (LOS) reception like VHF signals are. For this reason, if the transmitting power is high enough, the NDB signal may be usable at low altitudes and/or at long distances from the station.

1.1.3. Frequency Range. Since ranges of the NDB can vary significantly, knowing which type or “class” of NDB you are using is very important (refer to paragraph 1.1.6). The 190 to 535 kHz frequency range is assigned to NDBs, while the 540 to 1650 kHz range is reserved for commercial amplitude modulation (AM) broadcast stations. Although commercial stations may be picked up by your receiver; they are not flight-checked and thus, not intended for navigational use.

1.1.4. Airway Designation. Although not used in the airway system in the continental US (CONUS), NDBs are still used in parts of the world to define enroute airways as part of the airspace structure. When designated in the FLIP, the NDB is often referred to in terms of its signal output which is the low and medium frequency band width (or simply as LF/MF NAVAIDS).

1.1.5. Automatic Direction Finding (ADF) Equipment.

1.1.5.1. Depending on the type of ADF equipment installed on your aircraft, you may be able to receive frequencies between 100 and 1,750 kilohertz (kHz). The ADF uses two antennas (“loop” and “sense”) to automatically determine the direction of the strongest signal strength being transmitted by the ground station (NDB).

1.1.5.2. Through the use of a bearing pointer, the result is then displayed to the pilot as a bearing from the aircraft to the station in relation to aircraft heading. The angular difference between the bearing pointer and the aircraft’s magnetic heading is referred to as the “relative bearing” to the station. If this information is then combined with a rotating compass card that automatically aligns with the aircraft’s heading (as it is on USAF aircraft); a magnetic bearing (or course) “to” or “from” the station is provided, similar in operating principle to VOR or TACAN RMI procedures.

1.1.6. Classes of NDBs. The IFR En Route Supplement (IFR Supp) lists the class, location, and frequencies of individual NDBs. In the legend of the IFR Supp, it also lists the power output and ranges associated with each NDB class. NDBs are grouped into four classes based on their

individual power output and associated range capability.

1.1.6.1. HH class beacons transmit with approximately 2,000 watts of power and have a range of at least 75 nautical miles (nm). They are normally used for long over-water routes.

1.1.6.2. H class beacons have a power output of from 50 to 1,999 watts and a range of 50 nm.

1.1.6.3. MH class beacons are the most common type used in the US. They have a power output of less than 50 watts and a range of 25 nm.

1.1.6.4. The fourth class of NDB is the compass locator. The compass locator normally has a power output equal to or less than 25 watts and a range of 15 nm. Compass locators are a part of the Instrument Landing System (ILS) and are usually collocated with the outer markers (OM) and/or middle markers (MM) and referred to as a Locator Outer Marker (LOM) and Locator Middle Marker (LMM) respectively (reference paragraph 1.1.7.1.2). At locations where 400 watt radio beacons are used in conjunction with the OM, the aircrew may be able to obtain aural weather information in the form of Transcribed Weather Broadcast (TWEB).

#### 1.1.7. NDB Identification.

1.1.7.1. The NDB transmits a signal with an audible Morse code identifier. Some NDBs may also carry voice transmissions (weather, etc.) which override the identifying code. Those without voice capability will have a "W" (without voice) included at the end of the class designator listed in the Flight Information Publications (FLIP). Facilities without voice capability are also indicated by the frequency being underlined on government charts.

1.1.7.1.1. When using the NDB as the primary source of navigation, it is important to tune and identify the station carefully. Since frequency congestion in combination with minimal frequency protection may occur in certain parts of the world, aircrews should exercise extreme caution when using the NDB or L/MF NAVAIDS. Consult the appropriate Area Planning series FLIP for additional information.

1.1.7.1.2. If the NDB is a LOM, the identifier is the first two letters of the associated ILS identifier. Likewise, if the NDB is a LMM, then the identifier is the last two letters of the ILS identifier. For example, if the localizer identifier is I-SFO, the LOM identifier is SF. For a LMM, the identifier would be FO.

#### 1.1.8. Automatic Direction Finding Errors.

1.1.8.1. ADF receivers are subject to errors that could affect the accuracy of the bearing received. Even when the ground facility has been positively identified and the set has been tuned accurately, under some circumstances, the bearings received may still not be correct. Some of the more common errors are described below.

1.1.8.1.1. Thunderstorm Effect. Radio waves are distorted by the electrical disturbances caused by thunderstorms. Due to this effect, the pilot may experience erratic fluctuations of the bearing pointer in the direction of the thunderstorm. There may even be cases when the bearing pointer may home to the thunderstorm.

1.1.8.1.2. Night Effect. This effect is caused by the ionosphere reflecting radio waves. The effect is most noticeable when the height of the ionosphere is changing at sunrise and sunset. The interference from the bouncing radio waves may cause the bearing pointer to fluctuate. The amount of interference depends largely on the frequency used and the type of antenna. *The* maximum night effect is on commercial broadcast stations operating near 1,000 kHz. Generally, the interference is slight within 30 miles of the station and becomes more pronounced as the distance from the station increases. Night effect can be reduced by increasing altitude, flying closer to the station, or tuning a station of a lower frequency or stronger signal. If the needle is fluctuating due to night effect, it may be necessary to interpolate the average of the fluctuations. Diligence must be exercised when using the NDB at night due to the possibility of receiving signals from another station on the same frequency as the one you intend to use.

1.1.8.1.3. Bank Error. This error is most predominant when the aircraft is at altitude close to the station. While the aircraft is banking, a slight error is introduced since the bearing pointer points down towards the station. The error is greatest when the aircraft is heading directly towards or away from the station when the bank is applied and at a pitch angle other than straight and level flight. Depending on the amount of bank (and pitch) used, this error may provide erroneous bearing indications when flying an NDB approach.

1.1.8.1.4. Precipitation Static. When the ADF is used as a low frequency receiver, precipitation static may make the reception noisy. This type of static can be reduced by putting static dischargers on the trailing edges of the wing. Areas of ice crystals may also cause the bearing pointer to fluctuate excessively or give erroneous indications.

1.1.8.1.5. Shoreline Effect. This error occurs when radio waves change direction crossing the shore line. It is possible to have errors of 40° in bearing. The maximum error is found when the bearing to or from the station is less than 30° to the shoreline.

1.1.8.1.6. Mountain Effect. Mountains reflect radio waves, creating fluctuations of the bearing pointer. Sometimes the radio waves can be split or bent in the area of mountains, so be cautious when taking a bearing fix in mountainous regions.

### **1.1.9. ADF Navigation.**

1.1.9.1. Navigating directly to or from the station or intercepting an inbound or outbound course is the same as those listed in RMI navigation techniques and procedures outlined in AFMAN 11-217 Vol 1. Remember, all the ADF does is point to the station, the bearing to or from the station is the heading that corresponds with either the head or the tail of the bearing pointer respectively. Failing to correct for winds will result in an aircraft “homing” to the station. Where a published NDB bearing is used to define an intersection on an aeronautical chart, it is always the bearing TO the NDB. On an approach procedure where an inbound and outbound bearing may be flown (e.g. procedure turn), both are published.

1.1.9.2. Although the procedures and techniques in using an ADF to navigate are essentially the same as those used in VOR and/or TACAN RMI procedures, there is a slight difference in how the displayed information is derived. An ADF is only capable of determining a relative bearing to the station; the ADF needle must be combined with a functioning compass card to display

magnetic bearing. Conversely, A VOR receiver is only capable of determining a magnetic bearing/radial to the station; the VOR needle must be combined with a functioning compass card to display relative bearing. In the event of a compass card malfunction, an ADF needle should indicate correct relative bearing but a false magnetic bearing. The opposite is true for a VOR needle, it would indicate a correct magnetic bearing but false relative bearing. In either case, it is very important that the pilot/crew carefully discern what information is being displayed prior to using it to maintain or enhance situational awareness.

## **1.2. VOR System.**

1.2.1. Introduction. Although other systems are rapidly being incorporated, the VOR remains the primary NAVAID used to form airways and specified courses in both the low and high IFR en route airspace structure within the National Airspace System (NAS). It is important to understand that the VOR only provides the pilot/crew with azimuth information. Although technically a separate component, many VORs are collocated with a DME transmitter. Depending on the type of VOR receiver installed, under the frequency pairing plan, it is usually transparent to the crew that the VOR and DME are completely separate components since distance to a particular station is often automatically displayed in conjunction with azimuth information when a VOR frequency is selected. Since transmitting equipment is in the VHF (very high frequency) band width, VOR signals are relatively free of atmospheric disturbances; however, reception is limited to line-of-sight (LOS); therefore, the usable range suitable for navigation will vary according to the altitude of the aircraft, terrain, and the class of the VOR station.

1.2.2. Transmission Principle. The transmission principle of the VOR is based on creating a phase difference between two signals. One of the signals, the reference phase, is omnidirectional, and radiates from the station in a circular pattern. The phase of this signal is constant through 360°. The other signal, the variable phase, rotates uniformly at 1,800 RPM and its phase changes 1° for each degree change in azimuth around the VOR. Except when located in the extreme latitudes (see 9.4.1), the majority of VORs use magnetic north as the baseline for measuring the phase relationship between the reference and variable phase signals. At magnetic north, the signals are exactly in phase; but a phase difference exists at any other point around the station. This phase difference provides the magnetic bearing to the VOR or radial emanating from the station. Depending on your aircraft instrumentation, this information can be displayed as either a magnetic bearing TO or FROM the VOR station or the aircraft's position in relation to a selected radial.

1.2.3. TO and FROM Indications. VOR radials are identified by their magnetic bearing FROM the station. The TO/FROM indicator displays whether the course selected, if properly intercepted will take the aircraft TO or FROM the station. It is important to understand that aircraft heading has no effect on the TO/FROM indication. For example, when the aircraft's position is located North of the line between 090° and 270°, if the pilot sets 180° in the course selector window, regardless of aircraft heading, a TO indication will appear in the TO/FROM window. If the aircraft is South of the line between 090° and 270° and the pilot sets 180° in the course select window, regardless of heading, a FROM indication will be displayed. Should the aircraft be located along a radial that is approximately 90 degrees offset from the one selected in

the course window, the signals may become ambiguous and result in a fluctuating TO/FROM indication. Using the previous example, the TO/FROM indicator would normally begin to fluctuate if the aircraft's location was close to the 090° and 270° line.

#### 1.2.4. VOR Radio Class Codes and Standard Service Volume.

1.2.4.1. Normal usable altitude and range limitations for various classes of VOR stations, based on interference-free signal reception, are specified in the Flight Information Publications (FLIP) and the AIM, Chapter 1. Stations are classified as Low (L), High **Altitude (HA)**, and **Terminal** type of VORs. The frequencies of most (L) and (HA) class VORs are in the 112.0 to 118.0 MHz range. Most (T) class VORs have a frequency range between 108.0 and 112.0 MHz.

1.2.4.1.1. L Class VORs: Normally usable from 1,000 feet AGL up to and including 18,000 feet AGL at radial distances out to 40 nm.

1.2.4.1.2. HA Class VORs: Between 1,000 feet AGL up to and including 14,500 feet, out to a distance of 40 nm; between 14,500 feet and 60,000 feet, usable to 100 nm; between 18,000 and 45,000 feet AGL, usable range increases to 130 nm.

1.2.4.1.3. T Class VORs: Normally usable only within 25 nm between 1,000 feet AGL up to 12,000 feet AGL.

1.2.4.1.3.1. Terminal class (T) VORs are usually associated with an airfield and thus not normally part of the IFR en route structure.

1.2.5. Usable Service Volume. In some cases the usable range of a VOR may be different from the standard service volume. The service volume may be either expanded or restricted depending on operational needs or other constraints (e.g. terrain, obstacles, etc). If a service volume is restricted, the station's broadcast area will be noted in the civilian Airport/Facility Directory, IFR En route Supplement, and/or Notice to Airmen (NOTAM).

1.2.6. Voice Communications. In addition to the voice communication capabilities outlined in AFMAN 11-217 Volume 1, many VORs are able to broadcast weather information (e.g. ATIS, TWEB, etc).

#### 1.2.7. Errors Associated with VORs.

1.2.7.1. VOR energy will reflect from some features of the Earth's surface. This results in an effect known as "scalloping" which can be indicated on your aircraft instrumentation by either a smooth, rhythmic deviation or a rough, irregular deviation, normally for short time intervals. The effects will look similar to those effects experienced when an aircraft is approaching station passage.

1.2.7.2. With a failed compass card, a VOR RMI needle will continue to display the correct magnetic course indications; however, it will not give a correct relative bearing (see 1.1.9.2. for additional information regarding how derived information is displayed). Since a relative bearing is not displayed, a pilot/crew should exercise extreme caution when attempting to navigate using VOR/TACAN needles on instruments with failed compass cards.

1.2.7.3. VOR ground stations are calibrated to account for magnetic variation in reference to magnetic North. Since magnetic variation drifts (or changes) over time, the VOR stations alignment in relation to magnetic North will also change. Therefore, any difference between current and actual variation is translated to the aircraft using the VOR for navigation. When the magnetic variation at the VOR is 6 degrees out of tolerance, the station will be re-calibrated. The current magnetic variation settings for individual VORs are listed in the FLIP IFR Enroute Supplement.

#### 1.2.8. VOR Receiver Testing.

1.2.8.1. VOR Test Facility (VOT) Check. A VOT is a low-power (2 watt) VHF omni-test transmitter which permits the ground checking of aircraft VOR equipment without reference to a check radial. VOT emits an omni-directional magnetic North (360°) radial, plus an aural identification consisting of a series of dots or a continuous tone. It is monitored to a tolerance of  $\pm 1^\circ$ .

1.2.8.1.1. Aircraft equipment properly tuned to a VOT should have the CDI centered and the bearing pointer reading  $0^\circ$  with a FROM indication or  $180^\circ$  with a TO indication. The allowable tolerance is  $\pm 4^\circ$ . If the VOR receiver operates an RMI, the needle should normally rotate to indicate  $180^\circ$  or  $360^\circ$ .

1.2.8.1.2. LOS reference to the VOT should normally be established prior to use because any intervening structure may induce a shielding effect and reduce signal strength.

1.2.8.1.3. Some VOT installations may also carry automatic terminal information service (ATIS) data.

1.2.8.1.4. The airborne use of a VOT is permitted, but is strictly limited to those areas and altitudes specifically authorized in the Airport/Facility Directory or appropriate supplement.

1.2.8.2. Designated Ground Checkpoint. At certain airports, a circle is painted on the pavement, usually on the ramp or at the run-up area. The course TO and FROM a designated VOR will be indicated. To use a designated ground checkpoint, park on the painted circle (aircraft orientation does not matter). Then verify the indicated bearing to the VOR on the RMI and center the needle in the HSI instruments. Both should read within  $4^\circ$  of the specified course TO or FROM the VOR. A check of the DME against the published distance from the station to the checkpoint can also be made. It should be within  $\frac{1}{2}$  mile or 3% of the total distance (whichever is greater). Designated ground checkpoints are listed in the Federal Aviation Administration (FAA) Airport/Facility Directory.

1.2.8.3. Airborne Checkpoint. Airborne checkpoints consist of certified radials that should be received over specific points or landmarks while airborne in the immediate vicinity of the airport. The course selector window should read within  $6^\circ$  of the specified radial. Locations of airborne checkpoints can be found in the civilian Airport/Facility Directory and in FLIP Area Planning.

1.2.8.4. Dual VOR Check. You may test two VOR instruments against each other, either RMI or HSI by tuning both to the same VOR and comparing the indications. They should read within

4° of each other. The dual VOR check is the least desirable since it might “pass” two wildly inaccurate instruments as long as they have similar errors. For example, if one instrument reads +7° and the other +10°, they pass. The dual VOR check will also fail two instruments that individually would pass a test. For example, if the VOT check shows one instrument + 3° and the other -3°, they are both good VOR instruments, but will fail the dual VOR check since they are 6° apart.

1.2.8.5. Self-Test. Many aircraft have VORs with a self-test function that provides an operational test of the system. The aircraft flight manual will discuss the specific procedures for your aircraft. The self-test does not, however, test the aircraft antennas. If the self-test checks within your aircraft’s flight manual tolerances and you can receive the identification from the station, it is not necessary to test the VOR at a ground check point.

### 1.3. Tactical Air Navigation (TACAN) System.

1.3.1. Introduction. Due to the unique requirements associated with military operations, the TACAN was developed to augment other forms of civilian navigational systems. The TACAN is an Ultra High Frequency (UHF) omni-directional NAVAID which provides continuous azimuth information in degrees from the station and slant range distance information up to 200 nm from the station. Like the VOR, the receipt of a TACAN signal is dependent on LOS (line-of-sight) principle. Therefore, aircraft altitude, distance from station, terrain and obstructions are principle factors that affect TACAN navigation.

1.3.2. Equipment and Transmission Principles. The TACAN operates in the UHF band and has a total of 126 channels operating between 1,025 to 1,150 MHz. DME-associated frequencies are in the 962 to 1024 MHz and 1151 to 1213 MHz ranges. Channels are spaced at 1 MHz intervals in these bands. The TACAN set may also have an X or Y setting to double the frequencies available. A difference in microsecond pulse length is the only difference in the X and Y settings. These settings are normally used in a dense signal **environment where it is possible to** have duplicate frequency interference. The TACAN frequency published can be assumed to be X unless the letter Y appears in parenthesis after the TACAN frequency.

1.3.3. Ground Equipment. The TACAN consists of a rotating type antenna for transmitting bearing information and a receiver-transmitter (transponder) for transmitting distance information. Permanent TACAN ground stations are usually dual-transmitter equipped (one operating and other on standby) and are fully monitored installations. These automatically switch to the standby transmitter when a malfunction occurs. Newer NAVAIDS may have only one transmitter due to improved reliability of modern solid-state technology. Mobile TACANs still use dual transmitters.

1.3.3.1. Use the TACAN only if it is providing both bearing and DME information in conjunction with a proper IDENT. Engineering features in the design of TACANs require that both the bearing and DME function together for proper operation. Receipt of only bearing or only DME without the other indicates a malfunctioning TACAN station; therefore, the information received should not be relied upon. Since bearing and DME are integral; even with proper identification, receipt of one without the other not only indicates a malfunctioning TACAN, it also signifies the built in error detection system has failed to automatically deactivate

the TACAN. The monitoring system is designed to detect radial shift errors in excess of  $\pm 1^\circ$  from the design reference point. The system also continuously monitors the NAVAID equipment to detect power fluctuations, inaccurate signals, etc., and should automatically notify the appropriate ATC responsible for the NAVAID's proper operation should a malfunction occur. If using a TACAN for primary navigation, and reception is suspect or bearing and/or distance breaks lock in flight, you should retune and identify the selected NAVAID, switch to an alternate NAVAID, verify your position with other sources of navigation data, and check on the status of the ground equipment by querying ATC.

1.3.4. TACAN Identification. TACAN stations transmit an aural IDENT through international Morse code every 30 seconds. There is only one transmitter for bearing, DME information, and station identification. For this reason, the station identification is designed to operate less than continuously, and the aircraft equipment has an installed memory system (approximately 3 seconds), which provides bearing and DME information while the signals are off the air during an identification.

1.3.5. Theory of Operation.

1.3.5.1. The operating principle of the TACAN system is based on phase comparison of radio signals for bearing information. It can be defined as the measurement of the time interval between receptions from two separate signals.

1.3.5.2. Two basic signals are produced by the rotation of the inner and outer reflectors of the central antenna. A 15 Hz signal is produced once during each rotation of the inner reflector. A 135 Hz signal is produced nine times with each rotation of the outer reflector. When the radio wave's maximum (lobe) of the 15 Hz signal passes through Magnetic East, a separate omni-directional signal is transmitted. This is the main reference signal. When each of the nine lobes of the 135 Hz signal passes through magnetic east, nine additional omni-directional signals are transmitted and designated auxiliary reference signals (one of **which is paired with the main** reference signal). These reference signals create nine separate 40 degree sectors within the 360 degree azimuth (reference 1.3.11.1 for azimuth lock on error indications).

1.3.6. Measuring Aircraft Bearing. To determine the aircraft's position from the station (bearing TO the station), a phase signal is electronically measured. This is done between the main reference signal and 15 Hz signal. This time interval is converted to an angle, which isolates one of the nine 40° segments. The time interval between the reception of the auxiliary reference signal and the maximum of the 135 Hz signal is then measured within that segment. This angular difference is finally converted into degrees magnetic and displayed on the TACAN bearing pointer. For practical purposes, there are 360 radials which are read off the "tail" of the bearing pointer. As previously mentioned, TACAN navigation is dependent on LOS operation between the NAVAID and the aircraft's receiver antenna. Temporary disruption of the TACAN signals can occur in flight when the aircraft fuselage, gear, external stores, terrain, a wingman or other obstruction gets between the ground station and the aircraft antenna. Receipt of a signal is also not available during the TACAN station's identification transmission. To combat these affects, a 3-second memory circuit within the receiver maintains the last bearing when there is a loss of signal reception.



1.3.7. Determining Distance. TACAN DME is measured by calculating the elapsed time between transmission of interrogating pulses of the airborne set and reception of corresponding reply pulses from the ground station. The aircraft transmitter initiates the interrogation process by sending out a distance pulse signal. Receipt of this signal by the ground station receiver activates its transmitter to reply in turn with a distance pulse signal. These pulses require 12 microseconds round-trip travel time per nautical mile (nm) of distance from the ground beacon. Since a large number of aircraft could be interrogating the same beacon, the airborne set must sort out only the pulses that correspond to its own interrogations. Interrogation pulses are transmitted on an irregular random basis by the airborne set, which then “searches” for replies synchronized to its own interrogations. If the signals are interrupted, a memory circuit maintains the indication on the range indicator for approximately 10 seconds to prevent the search operation from recurring. This range is accurate to within  $\pm 600$  feet plus 0.02 percent (0.02% equals 240 feet at 200 nm) of the distance being measured. Although the TACAN can handle an unlimited number of bearing interrogations, the ground equipment responsible for providing DME is only capable of responding to 100 simultaneous interrogations before saturation occurs. When more than 100 DME interrogations are received, the TACAN is designed to automatically disregard the weaker signals.

1.3.8. The Cone of Silence. There is cone-shaped volume of airspace above the NAVAID within which the CDI will fluctuate and bearing information becomes unreliable. It is commonly referred to as the “cone of confusion.” Although distance information is still received, it is providing vertical range versus an indication of horizontal distance. When an aircraft enters the “cone of silence,” the DME equipment will approximate aircraft altitude (or vertical distance over station) in miles with the expected distance to horizontally transgress the zone being twice this measured distance. For example, an aircraft at 12000 feet will indicate 2 DME with loss of bearing information for a horizontal distance of 4 NM. For this reason, a TACAN station is not suitable as a holding fix or High Altitude Initial Approach Fix (IAF).

1.3.9. Station Passage. As the aircraft enters the “cone of silence” the bearing pointer will break lock and begin to rotate. The track indicator and TO/FROM indicator may also reflect the bearing pointer movement. If installed, the course warning flag will appear. The range indicator will continue to decrease until the aircraft is over the station; then it will begin to increase as the aircraft passes the station. As the aircraft leaves the “cone of silence,” the bearing pointer will stabilize and the track indicator will resume its normal indication. Station passage is determined when the range indicator stops decreasing. Aircrews can anticipate when station passage will likely occur since the DME will normally approximate aircraft altitude above the station in miles. For example, the range indicator in an aircraft at 30,000 feet above a station will normally stop decreasing at approximately 5 nm. Lateral displacement from a course that passes directly over the station may affect these approximations; therefore, regardless of aircraft altitude, consider station passage to have occurred when the TACAN DME stops decreasing.

1.3.10. Usable Range. Although the operational principles are different, TACANs are also listed according to the same standard service volumes (SSVs) that categorize other ground based NAVAIDs (refer to para 1.2.4.1) and approximate the same level of operational performance. Since the bearing and distance information is subject to LOS restrictions, at low altitudes, the curvature of the earth, terrain, and buildings can restrict the distance from which the TACAN signal is received from a ground station. Even though TACANs are rated according to the SSV

classification system, due to design features, receipt of bearing and distance information may be acquired outside the standard parameters.

1.3.11. TACAN Characteristics and Errors. Since TACAN bearing and distance signals are subject to LOS restrictions, the rotating bearing pointer and DME indicator may break lock if these signals are obstructed beyond a certain length of time. Aircraft receiver memory circuits prevent unlocking when signals are obstructed for short periods (10 seconds for DME and 3 seconds for bearing indications). Should a break lock occur, the equipment will stay unlocked until the obstruction is removed and/or the bearing and DME reacquired. Extended maneuvering that causes the TACAN antenna to be obstructed from clear signal acquisition with the ground station for more than 3 to 10 seconds may cause a break lock condition.

1.3.11.1. Azimuth Error Lock On. The construction of the TACAN ground antenna (one main and eight auxiliary reference pulses), makes it possible to have 40° azimuth error lock on. When the airborne receiver is working correctly, these pulses lock onto the airborne equipment with the main reference at 90°. When the airborne receiver is weak, the main reference pulse may “slide over,” miss the 90° slot, and lock on at one of the auxiliary positions. When this occurs, azimuth indications will be 40° (or some multiple of 40°) in error. Should this happen, re-channeling the receiver to deliberately make it unlock may help re-acquire the TACAN signals and display proper instrument indications for your aircraft position in relation to the ground station. To confirm suspected TACAN errors, if available, use other navigational or geographical references to fix your position. False or incorrect lock-on indications in the aircraft can also be caused by misalignment or excessive wear of the internal components of the receiver. The wear of these components or other misalignment can cause the wrong TACAN transmitter being tuned in, or miss it entirely, resulting in a constant unlock. Should this occur, re-channeling from the selected channel number and back (preferably from the opposite direction to the original setting) will sometimes correct the error.

1.3.11.2. Co-channel Interference. Co-channel interference occurs when an aircraft is in a position to receive TACAN signals from more than one ground station which utilizes the same frequency. Since it is not possible for individual TACAN receivers to accept information from more than one input source, when the aircraft is in a position to potentially receive two TACANs, it is possible for your aircraft equipment to select and display unintended navigational data. The only way to positively identify which TACAN you are using for navigation is through its Morse code identification. Co-channel interference is not a malfunction of either air or ground equipment, it is a result of ground equipment location in relation to aircraft position.

1.3.12. TACAN Approaches. To use the aircraft's TACAN receiver to fly an approach, the term “TACAN” or “TAC” must be published in the instrument procedures title (e.g., VOR or TACAN RWY 18 or VORTAC RWY 36 – both examples stipulate that the approach may be flown using either the VOR or TACAN equipment on the aircraft). Even if the NAVAID providing navigational guidance is a VORTAC, if the approach is listed as a VOR and there is no mention of TACAN in the approach name, the aircraft's TACAN equipment cannot be used to fly the approach.

#### **1.4. Instrument Landing System (ILS).**

1.4.1. Introduction. The precision ILS consists of three separate components that, when combined, form the system required to provide guidance, range, and visual information to the aircrew. Electronic lateral and vertical guidance is provided by the localizer and glideslope transmitter while range information may be provided in the form of associated marker beacons, compass locators, precision radar, and/or DME (or a combination thereof). Visual information is supplied by the approach light system (ALS, see 1.4.3.7), runway lights and at some locations, touchdown and centerline lights. The electronic components of the system (localizer and glideslope) are internally monitored and should automatically switch to a standby localizer or glideslope transmitter in the event a malfunction is detected in the primary system.

1.4.1.1. NOTE: Compass locators may be substituted for the outer marker (OM) and middle marker (MM). DME, crossing radial, or radar, when specified in the IAP, may be substituted for the OM.

#### 1.4.2. ILS Categories.

1.4.2.1. The ILS is classified by category according to both the ground and aircraft performance capabilities. The lowest minimums with all required ground and airborne system components operative are listed below. Reference the inoperative components section on the approach plate to adjust landing minimums (if required).

1.4.2.1.1. Category I ILS equipment provides guidance information down to a Decision Height (DH) of not less than 200 feet and a visibility of ½ statute mile or Runway Visual Range (RVR) of 2,400 feet.

1.4.2.1.1.1. NOTE: With touchdown zone and centerline lighting, the visibility may be reduced to 1800 RVR.

1.4.2.1.2. Category II ILS offer lower minimums with improved equipment (airborne and ground) and an aircrew certification process to enable the use of a DH not less than 100 feet and an RVR not less than 1,200 feet.

1.4.2.1.3. Category III ILS have three separate levels (a, b, and c). These approaches may have DH below 100 feet or no DH published at all along with varying visibility requirements.

1.4.2.1.3.1. Category IIIa ILS provides for an approach that has a DH lower than 100 feet or has no published DH and requires a RVR of at least 700 feet (the pilot is usually required to see the runway to land).

1.4.2.1.3.2. Category IIIb ILS provides for an approach with DH below 50 feet or has no published DH with a RVR requirement of not less than 150 feet (the pilot is usually not required to see the runway to land).

1.4.2.1.3.3. Category IIIc ILS is essentially a zero/zero approach with no DH or RVR requirement.

#### 1.4.3. Components.

1.4.3.1. Localizer Transmitter. The localizer transmitter provides lateral guidance and is usually located at the departure end of the runway so that it transmits its course signal along the extended runway centerline.

1.4.3.2. Glideslope Transmitter. The glideslope transmitter normally sits about 1,000 feet from the runway threshold so the Threshold Crossing Height (TCH) of a 3-degree glideslope is between 30 and 50 feet. Not taking into account the final flare, if an aircraft is on the glideslope and does not alter its descent angle after passing the runway threshold, it would touch down abeam the glideslope antenna.

1.4.3.2.1. NOTE: The TCH is the altitude the aircraft receiver antenna crosses the threshold. Depending on the location of the receiver antenna, aircraft type, pitch attitude and aircraft position in relation to the glideslope, it is critical that the aircrew understand that the aircraft's landing gear may cross the threshold at a significantly lower altitude when compared to what is displayed on the aircraft's altimeter or radar altimeter.

1.4.3.3. Outer Marker. If an OM is installed, it is normally located approximately 5 nm from the runway threshold and usually coincides with the point at which an aircraft on the localizer at the glideslope intercept altitude will intercept the glideslope.

1.4.3.4. Middle Marker. If a MM is installed, it is approximately ½ mile from the threshold and defines the point where an airplane on the glideslope reaches the Category I ILS DH.

1.4.3.5. Inner Marker (IM). An Inner Marker (IM) is located at the Category II ILS DH.

1.4.3.6. Compass Locator. There may be a low-power NDB, known as a compass locator, at the OM or MM position. A low power NDB is either a LOM or LMM (refer to paragraph 1.1.6.4). Where NDBs are utilized to define either the LOM and LMM position, they are designed to operate in conjunction with the marker beacon equipment onboard your aircraft.

1.4.3.7. Approach Lighting System (ALS). An ALS is part of the ILS and aids the aircrew in transitioning from instrument to visual conditions. The ALS comes in a variety of lighting configurations depending on the instrument approach serving the runway. For precision approaches, the ALS will normally extend 2400-3000 feet (approximately ½ mile) from the landing threshold. Of note, at some military airfields, the normal ALS requirements for a precision approach have been waived and may be as short as 2000 feet. In contrast, for non-precision approaches, the ALS may only extend 1400-1500 feet (approximately ¼ mile) into the approach area. For a complete description of different ALS systems, including diagrams, refer to the Flight Information Handbook, the AIM, or the legend at the front of an Instrument Approach Procedures (IAP) booklet.

1.4.4. Localizer Transmitter.

1.4.4.1. The localizer transmitter is normally located about 1,000 feet beyond the departure end of the ILS runway. ILS localizer transmitters use the odd-decimal VHF frequencies from 108.10 to 111.95 (for example, 108.7). The antenna is normally positioned in line with the runway centerline and radiates a 90-cycle and 150-cycle signal patterns on opposite sides of the extended runway centerline. The 150-cycle signal is on the right when looking at the runway from the

OM; and the 90-cycle signal is on the left. The course is formed along the extended runway centerline (toward OM) where the signals overlap and are of equal strength. This course is referred to as the front course.

1.4.4.1.1. **WARNING:** Since the same localizer frequency may be used for both landing directions to the runway, it is critical to identify the localizer using Morse code to prevent flying the wrong localizer course.

1.4.4.1.2. **NOTE:** Some aircraft's ILS equipment may not be capable of receiving the .05 MHz frequency even though the VOR equipment will receive this signal. In this case, the aircrew will be unable to receive the ILS signal and cannot fly the ILS approach. These .05 MHz frequencies are designed to eliminate a single frequency used for ILS equipment at both ends of a runway at locations where frequency congestion is a concern.

1.4.4.2. **Morse Code and Communication Capabilities.** The Morse Code identifier for an ILS normally consists of four letters, the first of which is always an "I." There are instances where the localizer associated with an ILS may have only three letters (e.g. Canadian instrument procedures). At some locations, ATC may also have voice capability on these frequencies. An underlined frequency indicates the transmitter has no voice capability. Localizer frequencies are received by the same equipment as VOR signals; therefore, although different internal circuitry is used to decode the course signal and the sensitivity varies between the two, the course deviation indicator (CDI) reacts to them similarly.

1.4.4.3. **Localizer Width.** Depending on the distance of the transmitter from the landing threshold, the localizer course width may vary from 3° to 6°. The exact width is chosen to produce a signal ± 350 feet either side of centerline at the threshold. Since the localizer is approximately four times more sensitive than a VOR signal, a full scale CDI deflection indicates 1.5° to 3° off course. On an instrument where two dots corresponds to full scale deflection, a CDI off course indication of one dot represents approximately 800 feet displacement from centerline at the OM and approximately 250 feet at the MM (based on a localizer width of 5°, a runway length of 8,000 feet, and touchdown point 1,000 feet from threshold).

1.4.4.4. **Localizer Alignment.** The localizer is normally aligned with the extended runway centerline; however, it may be offset up to 3 degrees. If the approach course alignment exceeds 3 degrees, then the instrument approach will be published as an LDA (refer to paragraph 1.4.15).

1.4.4.5. **Back Course Localizer.** Most localizer transmitters also provide a signal pattern around the runway so course signals also overlap in the opposite direction forming a back course. Every localizer antenna puts out a back course signal unless it is shielded. A back course localizer has an on-course zone which is monitored and flight checked to wider tolerances than the inbound (front) course associated with the ILS. It will normally vary between 3° to 6° wide depending on the particular installation.

1.4.4.5.1. **Back-course localizer IAPs** are often published for civilian airfields and, on occasion, military airfields.

1.4.4.5.2. **NOTE:** Disregard all glideslope signal indications when making a back course approach unless a usable published glideslope is specified for that approach.

1.4.4.5.3. Back Course Localizer CDI Indications. When flying inbound on the back course, the CDI is not directional unless the published front course for the ILS is placed in the course select window of an HSI. The course arrow will be at the bottom of the HSI. Back course approaches are flown using techniques similar to those for localizer approaches. Since the localizer antenna will normally be on the approach end of the runway, the CDI will be more sensitive than a front course localizer as you approach the runway. Unless your aircraft is equipped with reverse sensing capability, the command bars of a flight director may not provide directional information or function properly without the correct back course flight guidance mode selected. Consult your aircraft flight manual for system specific guidance.

#### 1.4.5. Caution Regarding the Use of Localizers.

1.4.5.1. Localizers are subject to reflection from terrain, buildings, vehicles, and aircraft (on the ground or in the air). These reflections may cause scalloping and/or roughness in the course deviation indicator and course bending. Scalloping indications are defined by a smooth rhythmic deviation of the localizer course. Rough or ragged indications are defined by irregular or erratic course deviations. When experiencing scalloping or irregular course deviations during an approach, depending on the severity, the aircrew may elect to “average out” the deviations to maintain a flyable course; however, any irregular indication received on your aircraft instruments while in IMC conditions during an approach should be a cause for concern. Under these circumstances, unless visual references associated with an instrument approach are present, serious consideration should be given to executing a missed approach. A bend in the course is not noticeable from the cockpit since the indications will appear normal. The ILS localizer and glideslope signal may receive reflective interference when vehicles or aircraft are operated near the localizer or glideslope antennas. To protect signal integrity, navigational reception, and prevent distortion, at many airfields, an ILS critical area is established.

#### 1.4.5.2. ILS Critical Area.

1.4.5.2.1. Localizer Critical Area. When reported conditions are less than 800-foot ceiling and/or visibility is less than 2 statute miles, ATC will not authorize aircraft or vehicles to operate inside the critical area while an aircraft is between the ILS final approach fix (OM or fix used in lieu of the OM) and the airport. Operations inside the critical area may be allowed if:

1.4.5.2.1.1. The aircraft on the approach has reported the airfield in sight and is circling or side-stepping to land on a runway other than the ILS runway.

1.4.5.2.1.2. A preceding aircraft on take-off or missed approach to the same or adjacent RWY will pass through the area.

1.4.5.2.1.3. A preceding aircraft on the same or adjacent RWY will pass through the area while landing or exiting the RWY.

1.4.5.2.2. In addition, when the reported ceiling is less than 200 feet or reported visibility less than ½ mile (RVR 2000), all vehicle and aircraft are restricted from proceeding beyond the instrument hold line (no exceptions) while an aircraft flying an ILS approach is inside the middle marker.

1.4.5.2.3. Glideslope Critical Area. When the reported ceiling is less than 800 feet or visibility is less than two miles, ATC will not authorize vehicle or aircraft operations in or over the critical area. Operation inside the critical area may be authorized if:

1.4.5.2.3.1. The arriving aircraft has reported the runway in sight or is circling to land on another runway.

1.4.5.2.4. Additional Considerations.

1.4.5.2.4.1. If an arriving aircraft advises the tower that an AUTOLAND or COUPLED approach will be flown, an advisory will be given when another vehicle or aircraft is in or over the critical area while inside the ILS MM or 1 nm from touchdown if there is no MM.

1.4.5.2.4.2. Aircraft holding below 5,000 feet between the OM and the airport may cause localizer signal variations for aircraft conducting ILS approaches. To prevent this, holding in this area is not authorized when the ceiling is less than 800 feet and/or the visibility less than 2 statute miles.

1.4.5.2.4.3. Critical areas are not monitored at uncontrolled airfields and aircrews must be aware that vehicles and aircraft not subject to ATC may cause interference with the localizer and glide slope signals being received. Also, when the weather at controlled airfields is at/or above 800 feet and/or 2 statute miles, protective measures are not required and may not be implemented. Aircraft conducting AUTOLAND or COUPLED approaches should monitor aircraft equipment closely since signal interference may cause abrupt and/or excessive deviations in the aircraft flight path or cause an unintended go-around command input.

1.4.5.3. Limits. Flight inspection aircraft regularly confirm the coverage and validity of ILS localizer signals within 35° either side of a front course approach path to a distance of 10 nm and through 10° either side of a front course approach path to a distance of 18 nm. A ground monitoring system continuously evaluates the signal integrity and strength within the defined parameters and should automatically switch to the secondary system or shut down the primary if a malfunction is detected.

1.4.5.3.1. NOTE: Unless a higher services volume is indicated, the integrity of the signal received cannot be guaranteed beyond the standard limits. When operating outside the standard parameters and receiving ILS signals (course and/or glideslope), the aircrew should be aware that erratic indications are possible.

1.4.5.4. False Courses or Low Clearances. It has been found that terrain or failure of certain electronic elements within the localizer antennae may cause false courses or low clearances within 35° of the front or back course centerline of a localizer without being detected by the localizer monitoring system or onboard navigational equipment (see note).

1.4.5.4.1. CAUTION: Due to this potential, aircrews should confirm the localizer on-course indication by referring to aircraft heading and utilizing other navigational resources (such as an ADF bearing from the LOM) before commencing final descent. Any abnormal indications experienced within 35° of the published front or back course centerline of an ILS localizer should be reported to the appropriate ATC facility.

1.4.5.4.2. NOTE: A low clearance is a less than full scale deflection of the CDI at a position where a full scale deflection should be displayed.

#### 1.4.6. Glideslope Transmitter.

1.4.6.1. General Description. The glideslope transmitter is located approximately 750 to 1,250 feet down the runway from the approach end and 250 to 650 feet from the centerline. Like the localizer transmitter, 90 and 150 Hertz (Hz) signal patterns are transmitted to form a glideslope. The 150 Hz signal is below the glideslope; the 90 Hz signal is above it. The area of equal strength forms the glideslope. These signals transmit out the front course with the glideslope angle normally set to between  $2\frac{1}{2}^{\circ}$  to  $3^{\circ}$ . This angle usually approximates intersecting the MM and OM (where installed) at 200 feet and 1,400 feet above the runway elevation respectively along the extended glide slope. The glideslope envelope extends  $0.7^{\circ}$  above and below this angle. With the aircraft established on course, the glideslope has a usable range of 10 nm (measured from the glideslope antenna) unless an expanded service volume is established. Due to glide path signal reflection and disturbances close to the ground (between 18 and 27 feet AGL), a reliable glide path may not be received below these levels. Because of this limitation, the aircrew should be aware that, unless certified as a CAT III ILS, the glideslope should not be expected to provide complete guidance to a touchdown point on the runway.

1.4.6.2. Glideslope Frequencies. Glideslope transmitters operate in the 329.15 and 335.0 MHz UHF frequency band and are paired to specific localizer frequencies. In most aircraft, the glideslope receiver is automatically tuned when the localizer frequency is selected. Since glideslope transmitters do not emit identification signals, on-board instrument warning flags are the only means of determining the validity of glideslope signals.

1.4.6.3. Glide Path Errors. The ultra-high frequency (UHF) glide path signal is subject to reflection from surface irregularities, vegetation, and other aircraft. The impact to the radio signal caused by aircraft near the landing runway is the reason for the additional hold-short line protecting the ILS critical area during poor weather. All procedures are flight checked to ensure the procedure is flyable and any course irregularities like bends are within tolerance. Pilots are unlikely to perceive any course irregularities on a published approach, but if a notable course irregularity occurs, sufficient to cause the autopilot to decouple, the pilot should report the issue to the airfield manager. An insidious error without an off flag glideslope warning occurs when the pilot intercepts what is referred as the “false” glideslope. If a pilot intercepts a glideslope inside the FAF (between the FAF and the runway) it is possible to intercept a “false” glideslope. This is another reason for pilots to crosscheck their control/performance instrumentation. Pilots flying a “false” glide path will notice an unusually steep approach with a much lower power setting and a much higher than expected VVI. ILS approaches are evaluated by flight check aircrew on a periodic basis to ensure users on the localizer course will receive a full fly-down indication prior to a false glideslope. Additionally, false glide slope signals may also be received during a back course localizer approach which may cause the glideslope warning flag (normally in view) to disappear and give the impression that reliable glideslope is being displayed. When flying a back course localizer, unless the glideslope’s use is specified on the IAP, consider any glide slope indications to be erroneous.



1.4.7. ILS DME. In most cases, ILS DME is also provided. If provided, the DME is usually automatically paired with the LOC frequency and displayed when LOC frequency is selected. If your DME is manually tuned, you will have to set it to the ILS DME frequency. The DME provided may or may not be the distance to touch down depending on the location of the transmitter. The pilot/crew can increase their situational awareness by comparing the published DME at key points along the approach with the distance remaining to the runway provided on the instrument approach plate.

1.4.8. Marker Beacons. Marker beacons are very low-powered 75 MHz transmitters located along ILS final to “mark” a specific position along the approach course. Normally, two marker beacons are used for this purpose, and are depicted on the terminal chart by the letters OM and MM. An additional beacon called an IM may also be installed for Category II and Category III ILS procedures. The beacons are identified in the aircraft visually (marker beacon light) and/or aurally depending on your aircraft’s avionics equipment. The reception area of the aural signal is larger than the visual signal. Marker beacons are not installed for navigation purposes, but indicate a specific point on the localizer course to provide distance information of aircraft position in relation to the runway.

1.4.8.1. Outer Marker (OM). The OM normally is located 4 to 7 nm from the end of the runway and is identified aurally by the receipt of continuous low pitched (400 Hz) Morse code “dashes.” Depending on your aircraft’s equipment, passing over the OM is also signified by actuation of the blue marker beacon light. Normal width of this signal is 1,350 feet to 2,650 feet, which means the light will flash for 7 to 13 seconds at 120 knots groundspeed (GS). The published altitude at the OM is what the altimeter should indicate when the aircraft is over the marker and on the glideslope; however, there are no specific limits. The OM altitude may also be the procedure turn or glideslope interception altitude.

1.4.8.2. Middle Marker (MM). The MM is located approximately 3,500 feet from the runway and is identified by alternating dots and dashes. The aural signal is comparatively high pitched (1,300 Hz) and is easily distinguished from the OM signal. The MM actuates an amber marker beacon light. The normal width of this signal is 675 to 1,325 feet, which means the light will flash for 3 to 7 seconds at 120 knots GS. Category I published minimums are normally reached at or near the MM whereby if an aircraft is on glideslope, it will be at an altitude of approximately 200 feet above the elevation of the touchdown zone. The MM may not be used as the sole method of identifying the MAP.

1.4.8.3. Inner Marker (IM). The IM is normally associated with and considered an integral part of Category II and Category III ILSs. Receipt of the IM should coincide with the aircraft arriving at a designated point that corresponds to the DH on the glideslope for a Category II ILS and will mark the approximate position of an aircraft as it progresses along a CAT III ILS. The IM is modulated at 3000 Hz and identified with continuous dots keyed at the rate of six dots per second. The normal width of this signal is between 340 to 660 feet, which means the light will flash for 2 to 3 seconds at 120 knots GS.

1.4.8.4. Back Marker (BM). A BM is located on a back course 3 to 5 nm from the runway threshold and is identified by an aural tone of 6 dots per second. It modulates at an audio frequency of 400 Hz per second (low pitched) and actuates the blue marker beacon light. At

some locations the BM may be supplanted by a “fix” intersection composed of the localizer course and a radial from a VOR or a bearing from a non-directional beacon. Where installed, the BM is used to mark the FAF on a published back course localizer approach.

1.4.9. Compass Locators. If the instrument approach design utilizes a compass locator, it is usually installed to coincide with either the middle or outer marker beacon sites (MM and OM, see 1.4.8.1 and 1.4.8.2). They can be an integral part of the instrument approach procedure or used as an additional aid to navigation. Compass locators are low powered, non-directional radio beacons operating between 200 and 415 KHz with a reliable reception range of at least 15 nm. However, higher powered, low-frequency non-directional radio beacons may be collocated with the marker beacons and used as compass locators. These generally carry TWEB information (also see 1.1.6.4 and 1.1.7.2).

#### 1.4.10. Flying an ILS.

1.4.10.1. Aircraft control. When flying an ILS approach the most common tendency is to “fly” the CDI and GSI and neglect to incorporate a continual crosscheck of the control/performance instruments. Immediate and smooth corrections should be made on the control instruments based on aircraft and flight path performance indications. The importance of precise aircraft control cannot be over emphasized. If a flight director is inoperative or unavailable, assessing the affects of winds and determining a heading that compensates for drift will help significantly in maintaining the inbound course. Small heading corrections to maintain track are important during the final approach stage. Make these corrections with reference to the aircraft heading indicator or compass because the CDI or GSI gives may only the aircraft position relative to the inbound track or glide slope. “Chasing the CDI or GSI” is a sign of poor basic instrument flying. If the aircraft drifts off the localizer, causing the CDI to move away from the center, make a correction towards the CDI using the aircraft compass/heading indicator to regain the localizer. Then select a new heading that accounts for wind drift.

1.4.10.2. Radar Vectors. When being radar vectored to an ILS final, retain radar service until established at a point where you can transition to the published procedure. According to Order 7110.65, Air Traffic Control, the controller is required to provide vector headings to within 30° of the localizer course, at least 2 nm from the glideslope intercept point, and at an altitude below the glideslope (see 1.4.6.3 for potential glide path errors). When the controller issues the final vector, altitude, and clearance for the approach, you should know your position in relation to the airfield. If the aircraft is at a range beyond the coverage of the approach chart, maintain the last assigned ATC altitude until established on a published segment of the approach. “Published segment” means the course, radial, localizer, as appropriate, and the altitude for that segment of the approach. You must be complying with both published course guidance and altitudes to be established on a published segment of the approach. The localizer course may be flown outside of the 18 nm flight-check distance if the instrument procedure depicts a greater distance or radar service is provided. If the controller clears you to intercept a localizer course, regardless of the distance from the antenna, radar service is being provided and you are expected to intercept the localizer. Query the controller if you have any doubt concerning position or altitude clearance. It is always highly recommended that you use radar monitoring service when available as an additional source of information.

1.4.10.3. Intercepting the Localizer. Before localizer interception, set the published front course in the course selector window so that the aircraft heading/localizer relationship is displayed on the CDI. The transition may require a large turn onto the localizer course; for example, a teardrop penetration or procedure turn. If the CDI indicates full scale deflection (course deviation  $2\frac{1}{2}^{\circ}$  or greater) during the latter portion of the turn, roll out with an intercept angle that will ensure localizer interception prior to the glideslope intercept point. Normally a  $30^{\circ}$  to  $45^{\circ}$  intercept is sufficient; however, groundspeed, wind drift, distance from the localizer course, and FAF location may require another intercept angle. Descent to the next lower altitude published on the IAP should only be initiated IAW the “established on course” guidance found in Chapter 11 of 11-217V1.

1.4.10.4. Course Deviation Indicator. Maintain the published track, ATC assigned heading, or course reversal turn until first movement of the CDI whereby you can adjust your intercept bank angle and heading depending upon the rate of CDI movement. Rate of CDI movement may also help estimate the force and direction of the winds and aid in establishing an initial wind drift heading to maintain course. Further adjustment to wind drift corrected headings will need to be made to maintain course as the approach progresses. Heading corrections should be sufficient to stop the CDI movement and return the aircraft to course. After returning to course, apply the drift correction necessary to keep the CDI centered. Except during high crosswind situations, an accepted technique is to limit heading corrections to within 5 degrees of the inbound course. As the aircraft continues inbound, smaller and smaller heading changes should be required to maintain course and adjust for wind drift. During high cross wind landings, establishing a calculated wind drift heading and then varying aircraft heading no more than 5 degrees from this reference heading is also a good technique. Maintain the glideslope interception altitude, configure the aircraft for landing, and establish the final approach airspeed before reaching the GSI point. Do not descend below glideslope interception altitude if the CDI indicates full scale deflection.

1.4.10.5. Glideslope Indicator (GSI). As the GSI moves downward from its upper limits, prepare to intercept the glideslope. Slightly before the GSI reaches the center position, establish a pitch attitude on the attitude indicator and a power setting that will result in the vertical velocity and airspeed required to maintain the glide path. The amount of pitch change required will depend on the difference between the pitch angle required to maintain level flight and calculated pitch based on the glideslope angle (gradient). VVI required is dependent upon the aircraft groundspeed and pitch change made in reference to level flight (see Chapter 3, this manual, regarding 60 to 1 calculations). One technique that may be used when intercepting the glideslope (if the final approach airspeed and configuration have been established) is to change the pitch attitude on the attitude indicator the same number of degrees as the glideslope angle, normally  $2\frac{1}{2}^{\circ}$  to  $3^{\circ}$ .

1.4.10.6. Pitch corrections. Once you are established on the glideslope (GS), reference your vertical velocity indicator to determine if your calculated pitch change, power setting, and VVI is working. Should a minor deviation from the GS occur, an accepted technique is to make small coordinated pitch and power changes that result in a vertical velocity change of less than 200 to 300 ft/min. As the aircraft nears re-intercepting the glide path, readjust your pitch and power setting to reacquire the GS and establish a new descent rate. To correct for minor deviations from the GS, the pitch change made should result in vertical velocity changes of less than 300

ft/min. To achieve these corrections, a 1° to 2° pitch change on the attitude indicator coupled with a small addition or reduction of power is usually sufficient to achieve the desired vertical velocity change of 200 to 300 ft/min. This glide path control technique works for most aircraft since it is applicable for approach groundspeeds between 120 and 180 knots. Since the size of the course and glideslope envelope narrows progressively throughout the approach, the degree of pitch and bank corrections should also be gradually reduced as the distance to touchdown decreases.

1.4.10.7. Decision Height (DH). This is one of the most critical parts of an ILS approach since the pilot is required to make coordinated corrections (if required) to maintain course, glide path, and airspeed while preparing to either continue or abandon the approach. Upon arrival at the DH, if sufficient visual references are acquired (see AFMAN 11-217, Volume 1, Chapter 14), the pilot can elect to continue the approach and/or land if in a safe position to do so. If a missed approach (MA) is required due to lack of visual references, it is important that you execute the procedure at the DH. This is because obstacle clearance cannot be assured if you initiate the MA below DH. This may be particularly hazardous if you are operating a performance limited aircraft. If the MA is initiated at DH, obstacle clearance takes into account the momentary dip below DH during the go-around maneuver to accommodate for the downward vector an aircraft has when flying a constant rate descent (associated with a precision approaches). Also, it is critical to remember that the CAT I DH is based solely on your barometric altimeter and not the radar altimeter since the radar altimeter normally indicates the height of the terrain over which the aircraft is currently flying and not necessarily the HAT listed on the approach plate. Initiate the missed approach at DH if visual reference with the runway environment is insufficient to complete the landing, when instructed by the controlling agency, or when a safe landing is not possible. If the course warning flag is displayed during the final approach, initiate the missed approach procedure. If the glideslope warning flag is displayed, the approach may be flown no lower than the published localizer-only altitude or, if not published, no lower than circling minimum altitude for the aircraft category.

1.4.11. Use of Flight Directors During ILS Approaches. In addition to the information displayed by a course and glideslope indicator, the flight director provides computed pitch and bank steering commands for intercepting the localizer course and glideslope to fly the final approach. This section will give you a basic understanding of flight director functions during ILS approaches; your aircraft flight manual will give specific guidance on the operation of your flight director equipment. Two modes of operation, intercept and final approach, may be used during an ILS approach. These two modes are referred to by various names, ILS, localizer, ILS approach, etc.

1.4.11.1. Intercept Mode. The intercept mode is used for initial intercept of the localizer. When this mode is selected, the bank guidance is displayed. Flying the bank guidance should intercept the published localizer front course. The bank guidance may command up to a 45° angle of intercept to the localizer front course without regard to the location of the glideslope intercept (GSI) point. Some flight directors do not correct bank steering commands for wind drift in this mode, in which case the intercept may have to be made disregarding the bank steering commands. Before following the intercept mode commands, aircraft intercept heading should be within 90° or less of the front course to ensure a turn in the shorter direction. The aircraft must be

positioned by use of other NAVAIDs or radar vectors to ensure localizer course interception prior to the GSI.

1.4.11.2. Final approach mode. The final approach mode is usually selected (manually or automatically) when the aircraft is established inbound on the localizer course. Restrictions for manual selection of the final approach may vary with flight directors. Some systems allow intercepts up to 90° while others may restrict operators to less than 15° of intercept and CDI within one dot of center. See your aircraft flight manual for specific operating instructions for your aircraft. When the final approach mode is selected, both pitch and bank guidance may be displayed. With automatic glideslope switching, the pitch guidance will not appear until near glideslope. Normally, bank steering commands are automatically corrected for wind drift in this mode.

1.4.12. Front Course Approach. This approach is performed by maneuvering the aircraft as depicted in reference to the published terminal IAP or through the receipt of radar vectors to intercept the localizer course inbound. The pilot should analyze the entire approach procedure, landing environment, missed approach procedure as well as descent and missed approach climb gradient restrictions before beginning the approach (preferably during pre-mission planning if able). Tune and identify the ILS as soon as practical during the transition. Set the published localizer front course in the course selector window. Position the flight director switches for localizer interception. The bank guidance will come into view. Use all available NAVAIDs (NDB or TACAN for example), to remain aware of your aircraft's position relative to the localizer and glideslope intercept point.

1.4.12.1. Transitioning to the Localizer. When the aircraft is properly positioned and its heading is within flight manual tolerances, bank the aircraft to center the CDI. Depending on your aircraft's avionics and flight director system, the final approach mode is usually selected either when established on a base leg or when the final course is intercepted. Most systems will provide a bank steering signal that is corrected for wind drift thereby decreasing the pilot's workload in flying the approach and enable some of their attention to be focused elsewhere if needed.

1.4.12.2. Intercepting the Glideslope. Disregard the pitch steering command and maintain glideslope interception altitude, published or assigned, until reaching the GSI point. Establish the aircraft final approach configuration and airspeed in accordance with the aircraft flight manual. Do not descend below glideslope interception altitude if the CDI indicates full scale deflection. The GSI will move from the upper limits of the glideslope deviation scale toward center as the aircraft approaches the glideslope intercept point. When the GSI approaches an on-glideslope indication, adjust aircraft pitch to follow the steering command. Control pitch and power to maintain final approach airspeed. Call the controlling agency at the FAF (OM, compass locator, DME, radar, etc.) according to position reports required by the Flight Information Handbook (FIH). During the remainder of the approach, control aircraft pitch and bank attitude to follow the steering commands. Monitor flight path and aircraft performance instruments to ensure that the desired flight path is being flown and aircraft performance is within acceptable limits. A common and dangerous error when flying an ILS with the flight director is the over reliance on the steering bars. It is important to cross check the information provided by the steering bars with the other navigational instrumentation (raw data) and aircraft performance instruments.

Failure of the flight director computer may not be accompanied by the appearance of warning flags. Steering commands should always be correlated with flight path raw data (CDI and GSI) and aircraft performance instruments.

1.4.13. Localizer Approaches. Localizer-only approaches are planned and flown as non-precision approaches. If the approach is based on timing, it's important that the aircraft is configured and on final approach speed prior to the FAF and the timing is commenced at the FAF. There are also localizer-only approaches that use DME as the missed approach point (MAP). Execute a missed approach when you have reached the MAP (timing or DME) and the runway environment is not in sight or a safe landing is not possible.

1.4.14. Localizer Back Course Approach. This is a non-precision approach since glideslope information is usually not provided (see 1.4.6.3). To maintain the proper aircraft heading/localizer course relationship, set the published front course in the course selector window. When inbound on the back course, the course arrow will point to the bottom of the HSI. The CDI will now be directional. Back course approaches are flown using techniques similar to those for localizer approaches. Since the localizer antenna will normally be on the approach end of the runway, the CDI will be more sensitive than a front course localizer as you approach the runway. Unless the flight director has a back course localizer mode, it should not be used since steering information is reversed.

1.4.15. Localizer-type Directional Aid (LDA). This is of comparable use and accuracy to a localizer, but is not part of a complete ILS system. The LDA course usually provides a more precise approach course than a simplified directional facility (SDF) does (see paragraph 1.4.16 for more information on SDF).

1.4.15.1. Approach Alignment. The most important factor to remember about the LDA is that it does not line up with the runway. It is just localizer (or ILS) that is offset more than 3°. Straight-in minimums may be published if the LDA alignment with the runway does not exceed 30°. Circling minimums are published when this alignment exceeds 30°. Although rare, there are LDAs that do include a glideslope. They contain a bold typed note signifying the presence of a usable glideslope.

1.4.15.2. International Civil Aviation Organization (ICAO) LDA. You may see ICAO approaches that list the approach as an "IGS," an Instrument Guidance System. Essentially, this is the ICAO version of the US LDA and uses the same procedures and data.

1.4.16. Simplified Directional Facility (SDF). This facility provides a final approach course similar to that of the ILS localizer and the LDA; however, A SDF approach will not have glideslope capability.

1.4.16.1. Frequencies. The SDF transmits signals within the 108.10 to 111.95 MHz frequency range.

1.4.16.2. Approaches. The approach techniques and procedures used on an SDF instrument approach are essentially the same as those used on a normal localizer approach. However, the SDF course may not be aligned with the runway and the course is normally wider. These factors result in a less precise approach. The SDF signal width is fixed at either 6° or 12° as necessary

to provide for maximum flyability and optimum course quality. Usable off-course indications are limited to 35° on either side of the course centerline. Any instrument indications received beyond this 35° limit must be disregarded.

1.4.16.3. Approach Alignment. The SDF antenna may be offset from the runway centerline. For this reason, you must refer to the IAP chart to see at what angle the final approach course will bring you into the runway. Normally this angle is not more than 3°; but because the approach course begins at the SDF antenna, an approach continued beyond the runway threshold will lead your aircraft to an offset position, not to the runway centerline.

1.4.16.4. Identifier. Identification of the SDF is accomplished by the three-letter Morse Code identifier found on the IAP chart.

### **1.5. Precautions to Prevent Navigation Errors.**

1.5.1. To prevent navigational errors, it is critical to ensure that the NAVAID providing primary course guidance is properly identified. This is accomplished by continuously monitoring a station's identification (IDENT) either through a visual display or by listening to the aural Morse code at a sufficient volume to detect a malfunction should one occur (refer to AFMAN 11-217 Volume 1, Chapter 7).

1.5.2. In addition to using the primary NAVAID, aircrew should increase their situational awareness by using all available navigational sources to confirm their aircraft's position relative to heading, desired location, ETA, and terrain.

1.5.3. Check NOTAMs and FLIP before flight for possible malfunctions or limitations on NAVAIDs to be used.

1.5.4. Discontinue use of any suspect NAVAID and, if necessary, confirm aircraft position with radar or other equipment.

### **1.6. Reporting Malfunctions.**

1.6.1. Since most NAVAIDs are designed with automatic back-up capabilities and/or monitored by ATC; NAVAID anomalies are normally transparent to aircrews when operating in the national airspace system (NAS). Despite these features, both the ground and space-based NAVAIDS do experience malfunctions that may make them unreliable for use. When a NAVAID signal is suspect (e.g., error message, "red" flag, lack of IDENT) and the instrument indications are not the result of internal aircraft instrumentation problems (e.g., wrong frequency or NAV source tuned) or aircraft positioning (e.g., beyond NAVAID service volume); aircrews should report anomalies to the nearest ATC facility. Upon receipt of a reported problem, ATC will normally ask a second aircraft to confirm NAVAID reception difficulties and/or contact the facility responsible for monitoring the NAVAID to determine status and ensure back-up system (if capable) is activated. This status and actions taken (if any) will normally be reported back to the aircrew.

## Chapter 2

### WAKE TURBULENCE

2.1. Purpose. This chapter is intended to increase an aircrew's awareness of potential hazards associated with aircraft wake turbulence and generated disturbances associated with ground operations. Following the initial discussions, techniques are provided in graphical format that are designed to help mitigate the adverse effects of wake turbulence. The information in this chapter was extracted from the FAA's Advisory Circular (AC) 90-23F, Aircraft Wake Turbulence, the Aeronautical Information Manual (AIM), and Order 7110.65R, Air Traffic Control.

#### 2.2. Introduction to Wake Turbulence.

2.2.1. Vortex Generation. Lift is generated by the creation of a pressure differential over the wing surfaces. The lowest pressure occurs over the upper wing surface and the highest pressure occurs under the wing. This pressure differential triggers the rollup of the airflow aft of the wing resulting in swirling air masses trailing downstream of the wingtips. After the rollup is completed, the wake consists of two counter-rotating cylindrical vortices.

2.2.2. In-flight Hazard. Every aircraft in flight generates wake turbulence. This disturbance is caused by a pair of counter-rotating vortices trailing from the wing tips. The vortices generated by other aircraft (especially aircraft larger than your own) can create serious problems and in some cases, impose rolling moments exceeding the control authority of your aircraft. Additionally, the turbulence generated within the vortices, if encountered at close range, not only has the potential to cause a serious aircraft upset, but could damage your aircraft and/or inflict personal injury to the occupants within. Therefore, it is important to imagine the location of the vortices generated by other aircraft and adjust your flight path accordingly.

2.2.3. Vortex Strength. The strength of a vortex is governed by the weight, speed, and shape of the wing of the generating aircraft. The vortex characteristics of an aircraft will also change when moving the flaps or other wing configuring devices. Since weight is the primary factor regarding vortex strength, as aircraft weight increase, vortex strength increases proportionately. Peak vortex tangential speeds of nearly 300 feet per second (approximately 200 MPH) have been recorded. The greatest vortex strength occurs when the generating aircraft is HEAVY, CLEAN, and SLOW.

#### 2.3. Induced Roll and Counter Control.

2.3.1. Induced Roll. While it is possible for a wake vortex encounter to cause catastrophic in-flight structural damage, the most common hazard is the induced rolling moment that exceeds the roll control capability of the aircraft you are flying. During flight tests, the capability of an aircraft to counteract the roll imposed by the wake vortex of the preceding aircraft primarily depends on the wing span and counter control responsiveness of the encountering aircraft.



2.3.2. Counter Control. Counter control is usually more effective and the induced roll reduced in cases where the wing span and ailerons of the encountering aircraft are extended beyond the rotational flow field of the vortex. Aircraft with short wing spans (relative to the vortex generating aircraft) will usually find it more difficult to counter the imposed roll produced by vortex flow. Therefore, pilots flying aircraft with short wing spans, regardless of their individual performance capabilities, must be particularly cognizant of and respect the strength of the wake vortices produced by much larger and heavier aircraft.

2.3.3. Vortex Behavior. Trailing vortices have certain behavioral characteristics that can help pilots visualize the wake location and thereby take the necessary precautions to avoid them. Since vortices are the by-product of lift, they are generated from the moment an aircraft rotates for take-off until touchdown at the end of a flight. Thus, prior to conducting a takeoff or landing, pilots should note the rotation or touchdown point of the preceding aircraft (see figure 2.1). The vortex circulation is outward, upward, and around the wing tips when viewed from either ahead or behind the aircraft. Tests with large aircraft have shown the vortices remain spaced

**Figure 2.1. Touchdown and Rotation Points when Following Larger Aircraft.**

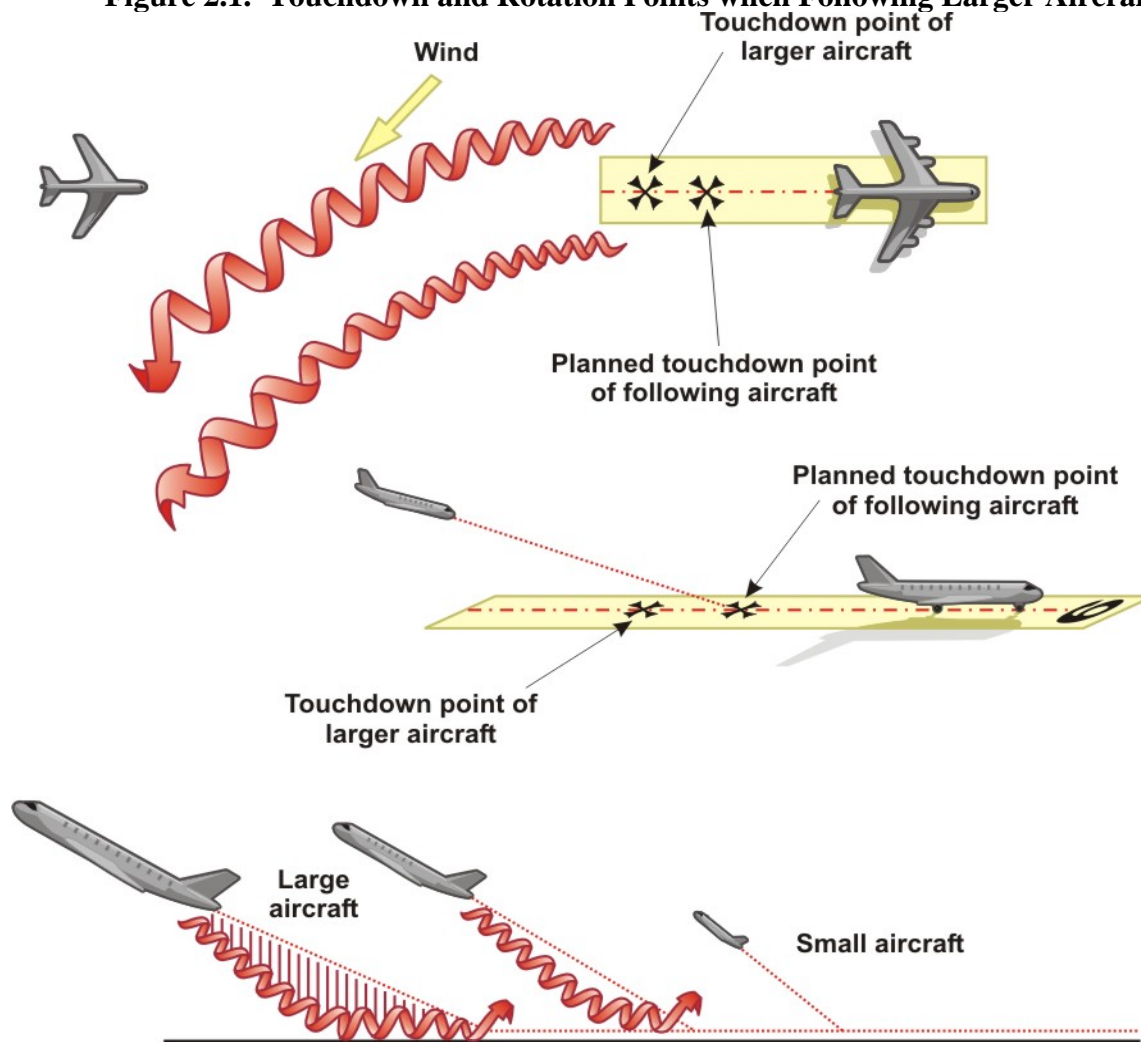

a bit less than a wing span apart drifting with the wind at altitudes greater than a wing span from the ground. Therefore, if you encounter turbulence that is being generated by the preceding aircraft, a slight change of altitude and/or lateral position (preferably upwind) will normally provide a flight path clear of the turbulence.

2.3.4. Flight tests show that vortices from large (transport category) aircraft during climb-out, cruise, and descent sink at a rate of several hundred ft/min. The vortex strength and sink rate diminishes with time and distance. Atmospheric turbulence will also hasten the breakup of aircraft generated disturbances. Therefore, you should fly at or above the preceding aircraft's flight path, altering course as necessary to avoid the area behind and below the generating aircraft. As a general rule, vertical separation of 1,000 feet may be considered safe (see figure 2.2).

**Figure 2.2. Aircraft Generated Vortex Descent Profile.**

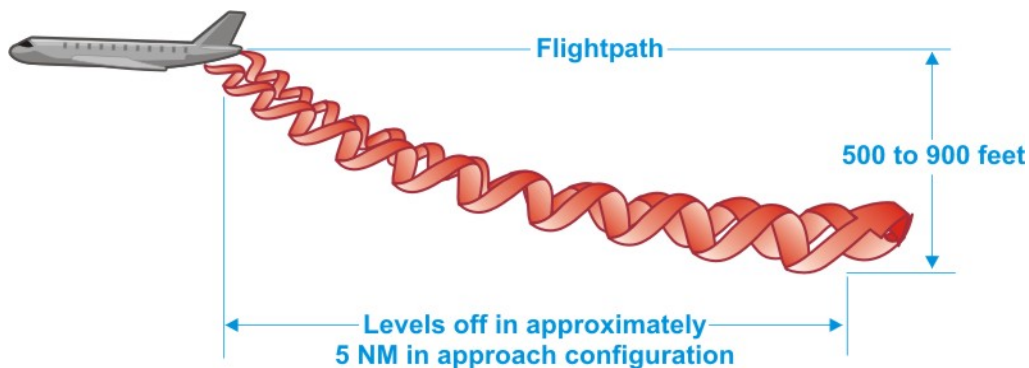

2.3.4.1. When the vortices of a larger aircraft sink close to the ground (within 100 to 200 feet), they tend to move laterally over the ground at a speed of 2 to 3 knots.

2.3.4.2. A crosswind will decrease the lateral movement of the upwind vortex and increase the movement of the downwind vortex. Thus, a light wind with a cross-runway component of 1 to 5 knots (depending on conditions) can result in the upwind vortex remaining in the touchdown zone and hasten the drift of the downwind vortex toward another runway. Similarly, a tailwind condition can move the vortices of the preceding aircraft forward into the touchdown zone. Pilots should therefore be alert to larger aircraft upwind from their approach and takeoff flight paths.

2.3.4.2.1. **CAUTION:** The light quartering tailwind requires maximum caution regarding the effects of wake turbulence.

2.4. Operational Problem Areas. Wake turbulence may cause aircraft upsets similar to traversing an area of turbulence with the severity of the encounter dependent on the direction of the encounter, weight of the generating aircraft, size of the encountering aircraft, distance from the generating aircraft, and point of vortex encounter. The possibility of an induced roll

increases when the encountering aircraft's heading is generally aligned with or parallel to the flight path of the generating aircraft.

2.4.1. Pilots should be particularly alert in calm wind conditions and maneuvering situations in the vicinity of the airport where the vortices could:

2.4.1.1. Remain in the touchdown area.

2.4.1.2. Drift from aircraft operating on a nearby runway.

2.4.1.3. Sink into the takeoff or landing path from a crossing runway.

2.4.1.4. Sink into the traffic patterns from other airport operations.

2.4.1.5. Sink into the flight path of aircraft operating VFR.

2.4.2. Pilots of all aircraft should attempt to visualize the location of the vortex trail behind a larger aircraft and exercise wake turbulence avoidance procedures to achieve safe operation. It is equally important that pilots of larger aircraft plan or adjust their flight paths, whenever possible, to minimize vortex exposure to other aircraft.

2.5. Vortex Avoidance Procedures. Under certain conditions, air traffic controllers apply procedures for separating aircraft operating under IFR. The controllers will also provide precautionary wake turbulence information to VFR aircraft which in the tower's opinion may be adversely affected by the vortices generated by a larger aircraft. ATC will give the position, altitude and direction of flight of larger aircraft followed by the phrase "CAUTION—WAKE TURBULENCE." Whether or not a warning is given, pilots are expected to adjust their flight path(s) to avoid serious wake encounters. Vortex avoidance procedures are recommended for the following situations:

2.5.1. Landing Behind a Larger Aircraft. When landing behind a larger aircraft on the same runway; stay at or above the larger aircraft's final approach flight path; note the touchdown point and then, if safety permits, land beyond it (see figure 2.3).

**Figure 2.3. Recommended Flight Path Landing Behind a Larger Aircraft.**

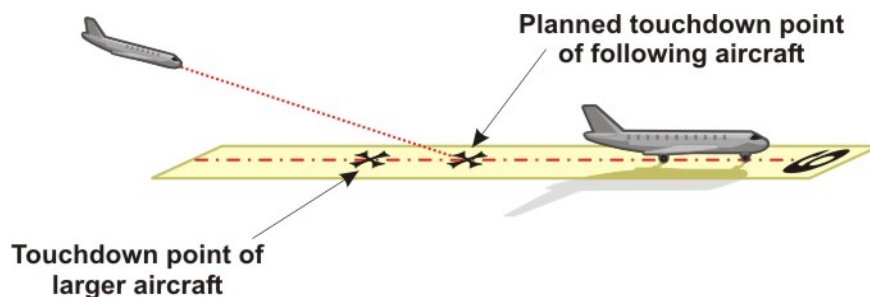

2.5.1.1. CAUTION: Avoid the area below and behind the preceding aircraft especially at low altitude where even a momentary wake encounter could be catastrophic.

2.5.2. Parallel Runway Considerations. When landing behind and offset from a larger aircraft landing on a parallel runway separated by less than 2,500 feet, consider the possibility of the vortices drifting onto your runway. Stay at or above the larger aircraft's final approach flight path; note its touchdown point and, if safety permits, land beyond it (see figure 2.4).

**Figure 2.4. Recommended Touchdown Point for Parallel Runway Operations.**

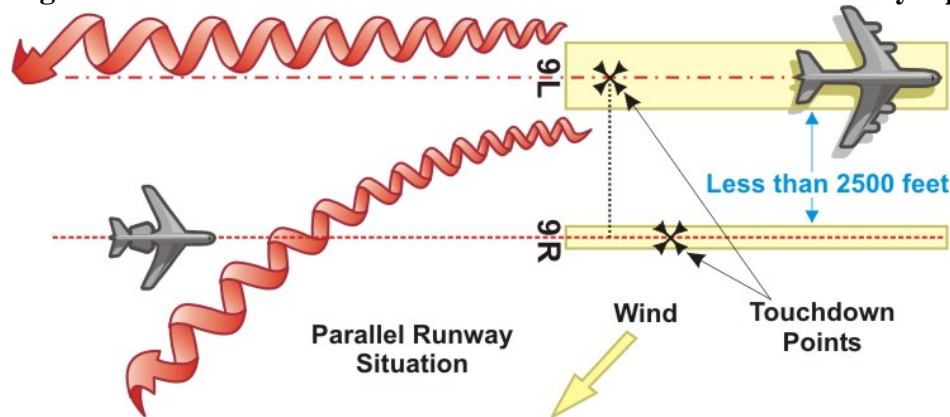

2.5.2.1. Crossing Flight Paths. When landing behind a larger aircraft on a crossing runway; cross above the larger aircraft's flight path (see figure 2.5).

**Figure 2.5. Crossing Flight Path Considerations.**

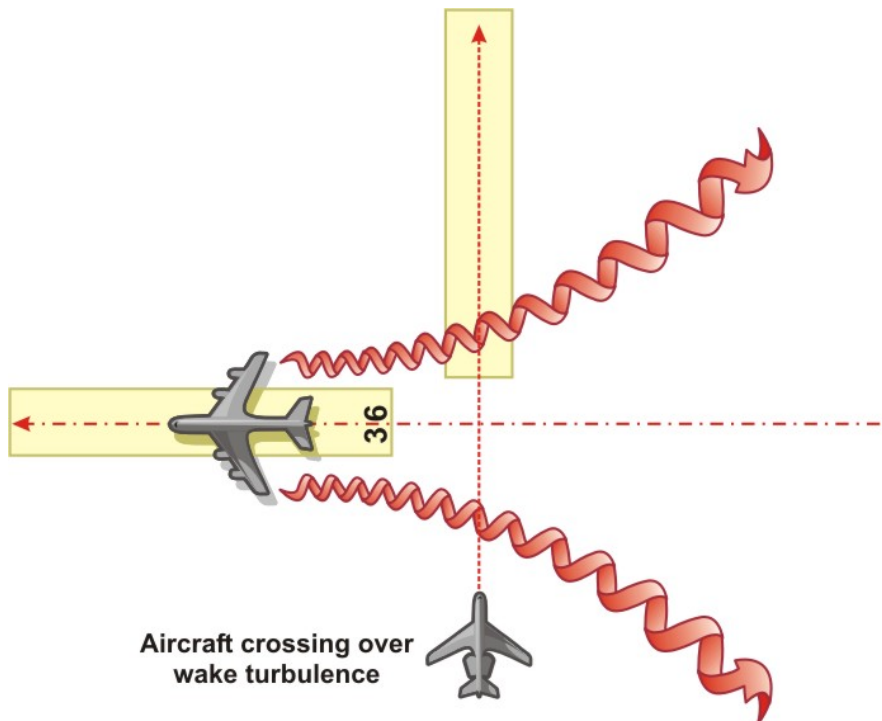

2.5.3. Landing Behind Departing Aircraft – Same Runway. When landing behind a departing larger aircraft on the same runway: note larger aircraft's rotation point and land well prior to rotation point (see figure 2.6).

**Figure 2.6. Landing Behind a Departing Aircraft**

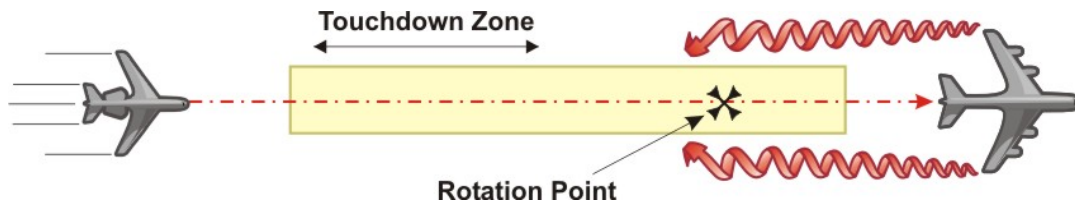

2.5.4. **Landing Behind Departing Aircraft – Crossing Runway.** When landing behind a departing larger aircraft on a crossing runway; note larger aircraft's rotation point. If the aircraft rotated past the intersection of the two runways, continue the approach and land prior to the intersection (see figure 2.7). If the aircraft rotated prior to the intersection, consider abandoning the approach unless able to land well before reaching the intersection (see figure 2.8).

**Figure 2.7. Landing Behind a Departing Aircraft – Crossing Runway (Rotation Point Past Intersection)**

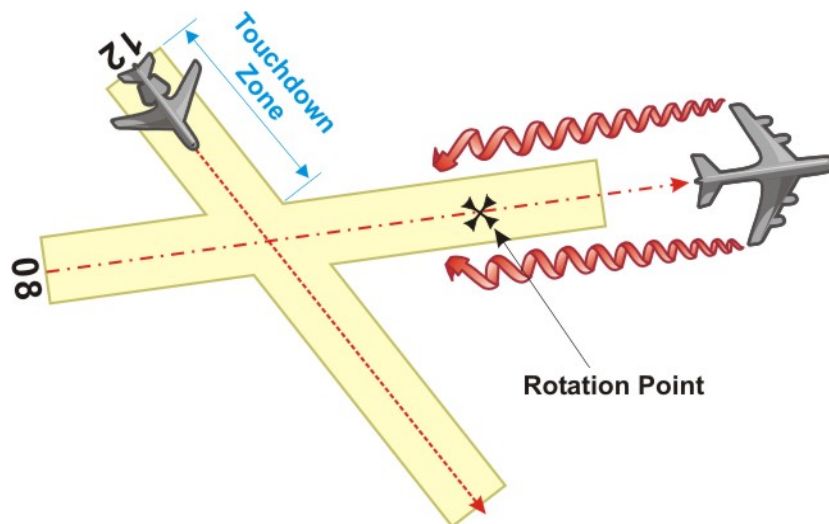

**Figure 2.8. Landing Behind a Departing Aircraft – Crossing Runway (Rotation Point Prior to Intersection)**

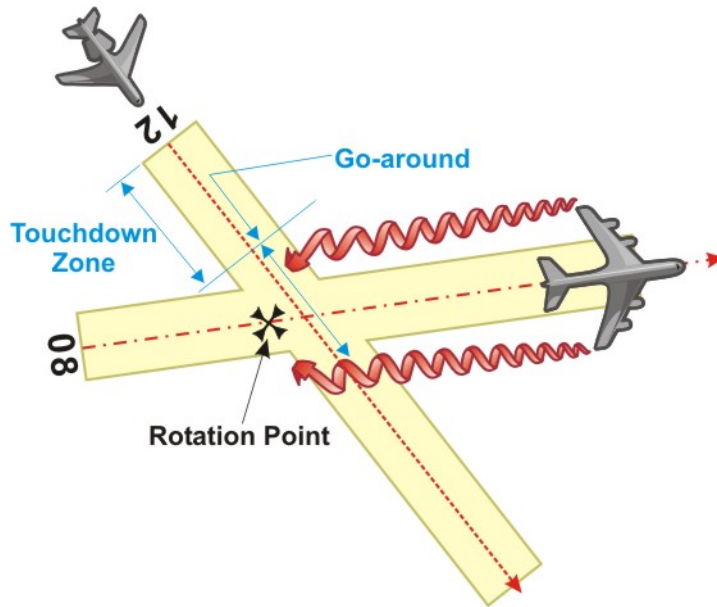

**2.5.5. Departing Behind a Large Aircraft.** When departing behind a larger aircraft; note the other aircraft's rotation point and, if able, rotate your aircraft prior to that point. Then, climb above the larger aircraft's climb path until turning clear of the larger aircraft's wake (see figure 2.1). Continue to avoid subsequent headings which will cross below and behind a larger aircraft. If unable, consider waiting 2 minutes to allow the wake induced vortices to dissipate.

2.5.5.1. When departing from a runway that intersects another, be alert for adjacent large aircraft operations, particularly upwind of your runway, and avoid headings which will cross below a larger aircraft's flight path.

2.5.5.2. Because vortices settle and move laterally near the ground, the vortex hazard may exist along the runway and in your flight path after a larger aircraft has executed a low approach, missed approach or a touch-and-go landing, particular in light quartering wind conditions. In these cases, it is highly recommended that you wait at least 2 minutes before your takeoff or landing.

**2.5.6. Flying Behind a Larger Aircraft.** When operating VFR, avoid flight below and behind a larger aircraft's flight path. If a larger aircraft is observed above on the same track (meeting or overtaking), adjust your position laterally, preferably upwind. If operating IFR, consider contacting ATC to request and offset to avoid potential wake turbulence.

## **2.6. Pilot Responsibility.**

2.6.1. Government and industry groups are making concerted efforts to minimize the hazards of trailing vortices. However, whether operating VFR or IFR, pilots should make every effort to reduce the hazards associated with vortex encounters. Vortex visualization and avoidance procedures should be exercised by an aircrew using the same degree of concern as collision avoidance.

2.6.2. Pilots are reminded that when flying behind all aircraft, acceptance of instructions from ATC in the following situations is an acknowledgement that the pilot will ensure safe takeoff and landing intervals and accepts responsibility for providing their own wake turbulence separation:

2.6.2.1. Traffic information.

2.6.2.2. Instructions to follow an aircraft

2.6.2.3. The acceptance of a visual approach clearance.

## **2.7. ATC Responsibility.**

2.7.1. For operations conducted behind heavy aircraft, ATC will specify the word “heavy” when this information is known. Pilots of heavy aircraft should always use the word “heavy” in radio communications.

2.7.2. For aircraft departing behind heavy aircraft, ATC is required to use at least a 2 minute separation interval unless a pilot has initiated a request to deviate from the 2 minute interval and accepts responsibility for maneuvering their aircraft so as to avoid the wake turbulence hazard.

2.7.3. Required ATC Separation Behind Heavy Jets and B-757. Because of the possible effects of wake turbulence, ATC is required to apply no less than specified minimum separation for aircraft operating behind a heavy jet/B757 and in certain instances, behind large non-heavy aircraft at the same altitude or when less than 1,000 feet of vertical separation will occur:

2.7.3.1. Heavy jet behind heavy jet – 4 nm.

2.7.3.2. Large/Heavy aircraft behind B757 – 4 nm.

2.7.3.3. Small aircraft behind B-757 – 5 nm.

2.7.3.4. Small/large aircraft behind heavy jet – 5 nm.

2.7.4. Required ATC Separation for Small Aircraft. The following separation, measured at the time the preceding aircraft is over the landing threshold, is provided to small aircraft:

2.7.4.1. Small aircraft landing behind heavy jet – 6 miles.

2.7.4.2. Small aircraft landing behind a B-757 – 5 miles.

2.7.4.3. Small aircraft landing behind large aircraft – 4 miles.

2.7.5. Required ATC Wake Turbulence Take-Off Separation: Aircraft will be separated by 2 minutes or the appropriate 4 or 5 mile radar separation applied when taking off behind a heavy jet/B-757 when departing:

2.7.5.1. From the same threshold.

2.7.5.2. On a crossing runway and projected flight paths will cross.

2.7.5.3. From the threshold of a parallel runway when staggered ahead of that of the adjacent runway by less than 500 feet and when the runways are separated by less than 2,500 feet.

2.7.6. Required Separation Behind Larger Aircraft. A three minute interval will be provided when a small aircraft will takeoff:

2.7.6.1. From an intersection on the same runway (same or opposite direction) behind a departing large aircraft.

2.7.6.2. In the opposite direction on the same runway behind a large aircraft takeoff or low/missed approach.

2.7.6.2.1. NOTE: This 3 minute interval may be waived upon specific pilot request when operating behind a large aircraft.

2.7.6.3. A 3 minute interval will be provided for all aircraft taking off when the operations are as described above, the preceding aircraft is a heavy jet/B-757, and the operations are on either the same runway or parallel runways separated by less than 2,500 feet.

2.7.6.3.1. NOTE: When operations are conducted behind a heavy jet /B-757, ATC may not reduce or waive the required 3 minute interval.

2.7.6.4. When departing, pilots have the option of requesting timing versus horizontal spacing when utilizing wake turbulence avoidance procedures (2 minutes instead of 4 or 5 miles). This request should be made as soon as practical with ATC before taxiing onto the runway.

2.7.6.5. Controllers may anticipate separation and do not need to withhold a takeoff clearance for an aircraft departing behind a large/heavy aircraft if there is reasonable assurance the required separation will exist when the departing aircraft starts takeoff roll.

## **2.8. Special Wake Considerations.**

2.8.1. Ground Hazards. During ground operations and during takeoff, jet engine blast (thrust stream turbulence) at high power settings may cause damage and/or loss of directional control to aircraft that are taxiing or parked, particularly if encountered at close range. Aircrew that are taking-off or landing should exercise extreme caution when an aircraft is conducting high power engine runs in close proximity to the runway and jet/prop exhaust is crossing the arrival or departure flight path. Exhaust velocity versus distance studies at various thrust levels show a need for light aircraft to maintain adequate separation behind large turbojet aircraft. Due to the possible engine exhaust velocities generated by larger jet aircraft during ground operations and/or initial takeoff roll, lighter aircraft awaiting takeoff should maintain separation by holding well back. If holding well back is not possible, offset laterally and/or position the aircraft to parallel any possible jet engine blast effects. Pilots of larger aircraft should be particularly



careful to consider the effects their jet blast will have on other aircraft, vehicles, and/or maintenance equipment during ground operations.

2.8.2. Helicopters. In a slow hover taxi or stationary hover near the surface, helicopter main rotor(s) generate downwash producing high velocity outwash vortices to a distance that equates to approximately three times the diameter of the rotor. When rotor downwash hits the surface, the resulting outwash vortices have behavioral characteristics similar to wing tip vortices produced by fixed wing aircraft. However, the vortex circulation is outward, upward, around, and away from the main rotor(s) in all directions. Pilots of small aircraft should avoid operating within three rotor diameters of any helicopter in a slow hover taxi or stationary hover. In forward flight, departing or landing helicopters produce a pair of strong, high speed trailing vortices similar to wing tip vortices of larger fixed wing aircraft. Pilots of small aircraft should use caution when operating behind or crossing behind landing and departing helicopters.

## Chapter 3

### THE 60-TO-1 RULE AND OTHER AVIATION CALCULATIONS

**3.1. The 60-to-1 Rule.** The 60-to-1 rule, along with the other mathematical formulas, provides the professional aviator a set of predetermined calculations that enhance situational awareness and precision while flying. The formulas are applicable in both the vertical and horizontal plane, making them usable during all phases of flight. The 60-to-1 rule is a technique for establishing pitch changes and lead points that aid you, for example, in determining course intercepts, arc intercepts, enroute descent points, visual descent points, an expected rate of climb or descent, etc... These calculations are valid as long as the pilot maintains (as closely as possible) a constant airspeed, bank, or pitch depending on the application used. Listed below are some reasons why learning and using the 60-to-1 rule and other aviation calculations presented in this chapter is worthwhile:

3.1.1. It allows you to compute the pitch changes necessary to establish proper attitude using the control and performance concept (establish pitch, trim, cross-check, and adjust) during flight.

3.1.2. Since applied calculations normally result in more precise flying, fewer and smaller changes are required thus reducing your workload and increasing your ability to devote more cognitive efforts towards other areas critical to the flight or mission.

3.1.3. When you fly the aircraft more precisely, fewer and smaller changes are required. This equates to the aircraft being flown more economically.

**3.2. When Do You Use the 60-to-1 Rule?** The following are some examples of the types of aviation problems that can be readily solved by applying the 60-to-1 rule:

3.2.1. You're in level flight and flying 400 KTAS airspeed and you want to establish a rate of climb or descent of 1,000 feet/min. What pitch change will give you the desired rate of climb or descent?

3.2.2. You're at 80 DME, at Flight Level 310 inbound to XYZ VORTAC, and ATC gives you instructions to cross the VORTAC at 5,000 feet at "pilot's discretion." When should you start your descent and what pitch change should you make?

3.2.3. You're departing an airfield with a climb gradient requirement and would like to increase your situational awareness by determining what the associated VVI to expect?

3.2.4. You're climbing at 3,000 ft/min at 250 KIAS. What pitch change will be necessary to level your aircraft at FL 350?

**3.3. Application of the 60-to-1 Rule.** The 60-to-1 rule should be used in flight as needed; however, you may find it advantageous to perform some of the more complex calculations during the preflight planning process. As a professional aviator, you can use the 60-to-1 calculations to determine your aircraft's general performance figures that can (as long as the

same parameters are used) be applied as “standard.” To expand on this concept, if your particular aircraft is normally flown in the low altitude instrument environment at 180 KTAS, then your “standard” speed (converted to nm/min) is 3 nm/min. As long as a constant airspeed is maintained, the aircraft’s turn radius becomes a “standard” 1 nm, etc. Since this figure becomes the known “standard,” it can make using the other formulas even easier.

3.3.1. **NOTE:** Although the 60-to-1 rule follows a standard set of physical properties and normally applies to most aircraft; it is important to understand that it only provides approximations based on general principles. It does not replace the more specific performance data derived from an aircraft’s technical order (TO). The performance data taken from the TO always takes precedence.

### 3.4. Mathematical Derivation of the 60-to-1 Rule.

3.4.1. Since the circumference of a circle is based on a known formula, we can mathematically determine that 1 degree of arc at a distance of 60 nm from a ground based station is approximately 1 nm in length. Let’s relate this to a VORTAC station. We know that the formula for the circumference of a circle ( $C = 2\pi r$ ).  $C$  = the circumference,  $\pi = 3.142$  and  $r$  = the radius; therefore, we can calculate the circumference for a 60 nm circle around the VORTAC is:

3.4.1.1. Calculation:  $C = 2 \times 3.142 \times 60\text{nm}$

$$C = 377.04 \text{ nm (for a 60 nm radius circle)}$$

3.4.2. By knowing the circumference (at a 60 nm radius), we are further able to determine the length (in nm) of each individual degree of arc. This is computed by simply dividing the circumference by the number of degrees in a circle, or  $360^\circ$ .

3.4.2.1. Calculation:  $X = C \div 360^\circ$

$$X = 377.04 \text{ nm} \div 360^\circ = 1.0472 \text{ nm}$$

3.4.2.2. Therefore,  $1^\circ$  approximates 1 nm at a radius (or distance) of 60 nm.

3.4.3. Because 1 nm = 6,076 feet or approximately 6,000 feet, we can say that:  $1^\circ = 1 \text{ nm}$  at 60 nm. Therefore, if you fly  $1^\circ$  off your assigned heading, after 60 nm, you will be 1 nm off course.

3.4.4. This knowledge can further be used in a formula that equates nautical miles off course (NMOC) or degrees off course (DOC) in relation to distance flown (DF):

3.4.4.1.  $\text{NMOC} \div \text{DF} = \text{DOC} \div 60^\circ$

3.4.5. For example, if you deviate from your required heading to maintain a course by  $3^\circ$  and you fly for 40 nm, the aircraft will be 2 nm off the original course. Where the  $\text{DOC} = 3^\circ$  and  $\text{DF} = 40 \text{ nm}$ , after applying basic algebra and solving the above equation for NMOC, the solution is:

3.4.5.1.  $\text{NMOC} = 3^\circ \times 40 \text{ nm} \div 60^\circ = 2 \text{ nm}$

3.4.6. This relationship does not only exist in the horizontal plane, but is also applicable in the vertical plane. If a 1° pitch change is made, after traveling 60 nm; the aircraft will have a net altitude change of 6000 ft (or 1 nm). Simple division then allows us to determine the altitude change that will occur per nautical mile. This relationship is represented in the following formula:

$$3.4.6.1. \text{ Formula: } 1^\circ = \frac{6000 \text{ ft}}{60 \text{ nm}} = \frac{100 \text{ ft}}{1 \text{ nm}}$$

3.4.7. Therefore, a 1° pitch change equates to a 100 foot altitude change per nautical mile flown. Subsequently, a 2° pitch change equals 200 ft/nm gradient, a 3° pitch change equals 300 ft/nm (normal glideslope), etc... This relationship is also referred to as the climb or descent gradient and becomes the basis for many of the calculations utilized in the vertical plane (see paragraph 3.6).

3.4.8. It is important to understand that when varying the pitch of the aircraft using a conventional ADI, the pilot is attempting to change the glide path angle (gradient) the aircraft will fly. Since an aircraft's angle of attack (AOA) is the difference between pitch and flight path angle, unless a constant airspeed is maintained, the actual gradient flown will not equal the one calculated or desired (e.g. a constant altitude can be maintained as airspeed decreases by increasing the aircraft AOA with pitch and the application of power while airspeed is allowed to decay).

3.4.8.1. NOTE: Aircraft equipped with a Head-Up Display (HUD) are able to display a flight path marker (FPM), also referred to as a velocity vector (VV). The FPM or VV displays pitch compensated for angle of attack (including drift and yaw) and allows the pilot to make a more precise glide path (gradient change) compared to aircraft equipped with conventional performance instruments (ADI, VVI, and airspeed indicator) which can only provide an approximate flight path (gradient) change. Therefore, if available, aircraft with properly certified and endorsed HUDs should use the FPM or VV when applying the applicable 60-to-1 techniques provided in this chapter.

### 3.5. Aviation Calculations.

3.5.1. Determining an Aircraft's Rate of Travel. To increase the accuracy of the calculations and make the 60-to-1 formula applicable at all altitudes, the formulas presented in this text are based on either True Airspeed (TAS) or True Mach Number (TMN). These figures are then converted to rate of travel in nautical miles per minute for use in the individual calculations. Although TAS and TMN are used within the text, it does not negate the pilot or crew from using an Indicated Airspeed or Mach Number (IAS or IMN) if this instrumentation is the only one available in their particular aircraft and time does not permit converting to TAS or TMN. Although large inaccuracies will normally result if IAS or IMN is used in the 60-to-1 at the higher altitudes, in the low altitude structure, particular when maneuvering the aircraft while conducting instrument approaches, the errors are normally negligible between indicated and true airspeeds and thus interchangeable and slightly easier to use. For this chapter on the 60-to-1 "rule," for simplification, we have assumed that IAS equals Calibrated Airspeed (CAS).

3.5.1.1. NOTE: Should your aircraft have a large installation error correction between IAS and CAS for a particular phase of flight, it is highly recommended applying this correction to IAS before converting IAS or CAS to TAS prior to using the formulas in this chapter

3.5.1.2. By using a simple conversion factor, we can convert TAS from nautical miles per hour (nm/hr) into nautical miles per minute (nm/min):

3.5.1.2.1. Formula:  $TAS = \frac{nm}{hr} \times \frac{1 hr}{60 min}$

3.5.1.2.2. Formula (condensed):  $TAS \div 60 = nm/min$

3.5.1.3. Example: If an aircraft has a TAS of 420 nm/hr, if we divide by 60, it is also traveling at a rate of 7 nm/min.

3.5.1.3.1.  $TAS \text{ (in nm/min)} = 420 \div 60 = 7 \text{ nm/min}$

3.4.1.4. Although your Mach number as it equates to TAS will vary with temperature, a reasonably accurate relationship exists between them as listed below:

3.5.1.4.1. <u>TAS</u>	=	<u>nm/min</u>	=	<u>TMN</u>
300		5		.5
360		6		.6
420		7		.7
480		8		.8

3.5.1.5. Therefore; by comparing the TMN to rate of travel in nm/min, the following calculation can be deduced:

3.5.1.5.1. Formula:  $TMN \times 10 = TAS \text{ in nm/min}$

3.5.1.6. Example: If an aircraft is traveling at .5 Mach, then the resultant rate of travel is approximately 5 nm/min.

3.5.1.7. If the aircraft is not equipped with TAS or Mach instrumentation, an approximate TAS can be computed from IAS. Since TAS increases at a rate of approximately 2 percent per 1,000 feet altitude increase for a given IAS, the following formula can be used:

3.5.1.7.1.  $TAS = [IAS \times (2\% \text{ per } 1,000 \text{ feet})] + IAS$

3.5.1.8. Example: If an aircraft has an indicated airspeed of 250 knots at 10,000 feet, the resultant TAS is 300 knots TAS.

3.5.1.8.1. Calculation:  $TAS = [250 \times (2\% \times 10)] + 250$   
 $TAS = (250 \times .20) + 250$

$$\text{TAS} = 50 + 250 = 300 \text{ knots}$$

3.5.1.9. Using the airspeed ratios presented in paragraph 3.5.1.3.1; a TAS of 300 knots also equates to 5 nm/min.

3.5.1.10. Another formula used to estimate TAS is to divide your altitude (converted to a flight level) by two and then add result to your IAS. Using the previous example: The aircraft is flying at 10,000 feet (equates to FL 100) and indicating 250 knots. The TAS can be calculated as follows:

$$3.5.1.10.1. \text{TAS} = (\text{FL} \div 2) + \text{IAS}$$

$$\text{TAS} = (100 \div 2) + 250$$

$$\text{TAS} = 50 + 250$$

$$\text{TAS} = 300$$

3.5.1.11. NOTE: The formulas used to convert TAS and TMN (or groundspeed) into a rate of travel in nautical miles per minute (nm/min) form the basis for other useful calculations applicable in the flying environment, such as rate of descent (VVI) and turn radius (TR).

3.5.2. Determining a VVI. Since we are able to determine the altitude gained or lost over a given distance (or gradient), for each degree of pitch change, if we then correlate this information with the aircraft's speed (rate of travel), we can calculate a VVI. Referencing paragraph 3.4.6, it was determined that one degree of pitch change approximates 100 ft/nm (gradient). Therefore, based on the amount of pitch change or gradient (in ft/nm) and aircraft speed, we can further calculate a VVI using the following formula (s):

$$3.5.2.1. \text{Formula (a): } \text{VVI} = \text{nm/min} \times \text{pitch change} \times 100 \text{ ft/nm}$$

$$3.5.2.2. \text{Formula (b): } \text{VVI} = \text{nm/min} \times \text{gradient (in ft/nm)}$$

3.5.3. Example #1: An aircraft is holding a positive (nose up) 1° pitch on the attitude indicator to maintain level flight and has a TAS of 300 knots or an TMN of .5 Mach (both equate to 5 nm/min). If you adjust the pitch by 3° from the level flight attitude (to either 4° nose up or 2° nose down) and adjust power/thrust to maintain your TAS or Mach, the resultant VVI will equal a rate of ascent or descent of 1500 ft/min.

$$3.5.3.1. \text{VVI} = 5 \text{ nm/min} \times 3^\circ \times 100 \text{ ft/nm}$$

$$\text{VVI} = 1500 \text{ ft/min}$$

3.5.4. Example #2: An aircraft is traveling at .6 Mach and makes a 1° pitch change (from level flight). Since 0.6 Mach equates to 6 nm/min (see 3.4.1.2), we can calculate the VVI as follows:

$$3.5.4.1. \text{VVI} = 6 \text{ nm/min} \times 1^\circ \times 100 \text{ ft/nm}$$

$$\text{VVI} = 600 \text{ ft/min}$$

3.5.5. Example #3: An aircraft is traveling at 150 KTAS (approximates 2.5 nm/min) in level flight and makes a 2° pitch change, if the aircraft speed remains constant, the resultant VVI will roughly equate to 500 ft/nm.

$$3.5.5.1. \text{VVI} = 2.5 \text{ nm/min} \times 2^\circ \times 100 \text{ ft/nm}$$

$$\text{VVI} = 500 \text{ ft/min}$$

3.5.6. Example #4: You are planning to take-off from an airfield with a required departure climb gradient of 330 feet per nm. See paragraph 3.8.3.

**3.6. The Gradient.** Whether climbing or descending, the gradient (or angle) the pilot chooses to fly is usually predicated on one of the following three circumstances. First, the gradient can be calculated individually by the pilot/crew based on the desired altitude to be gained or lost over a known distance. Second, the gradient can be mandated by ATC (e.g., crossing altitude restriction). Finally, it may be required by a published instrument procedure (e.g., SID, ODP, STAR, or IAP). As stated earlier, the pilot controls the gradient flown by making positive or negative pitch changes (normally in reference to the pitch attitude that maintained level flight at a particular altitude). Therefore a 3° pitch change from level flight will yield a 300 feet per nautical mile gradient, a 400 feet per nautical mile climb or descent gradient will result from a 4° change or vice versa. The VVI associated with the pitch change (or chosen gradient) is dependent on the aircraft's speed (TAS or TMN) converted to nm/min. To obtain even more accurate calculations, use groundspeed whenever practical since it adjusts the aircraft's speed to account for winds.

### 3.7. Descent Gradients.

3.7.1. Preplanned Descents (Altitude vs. Distance).

3.7.1.1. Example #1: You are cruising at 30,000 feet MSL and would like to estimate the pitch change (or gradient) required to descend to the approximate FAF altitude, 3,000 feet MSL. The DME from the destination is currently reading around 90 nm. With the given information, the descent gradient (DG) is approximately 300 feet per nautical mile which equates to a pitch change of around 3° (from level flight reference pitch).

3.7.1.1.1.  $\text{DG} = \text{Total Altitude (to lose or gain)} \div \text{Distance}$

$$\text{DG} = (30,000 \text{ ft} - 3,000 \text{ ft}) \div 90 \text{ nm}$$

$$\text{DG} = 27,000 \div 90 \text{ nm}$$

$$\text{DG} = 300 \text{ ft/nm (or } 3^\circ)$$

3.7.1.2. As previously shown (see 3.4.6), the resultant gradient is also equivalent to the required pitch change from level flight; therefore a 300 ft/nm gradient also equates to a 3° pitch change.

3.7.1.3. Additionally, you may desire to utilize a predetermined descent gradient. By using basic algebra and solving for “distance” in the equation above, you can determine at what distance from a predetermined point, usually an airfield, upon which to start an enroute descent. Although the final descent from cruise altitude to the final approach fix altitude is normally divided by a variety of level-offs, calculating a predetermined point upon which to start an enroute descent and then updating throughout the arrival phase should increase your situational awareness. This application is very useful when cleared “pilot’s discretion” from the cruise altitude to a lower one by ATC.

3.7.1.4. Example #2: An aircraft is level at 30,000 feet, 130 miles from the airfield and given an initial clearance to descend “at pilot’s discretion” to 6,000 feet. Since a 300 ft/nm ratio or 3° descent profile is quite common, the pilot/crew can determine the distance from the airport upon which to initiate the descent by using the following formula:

3.7.1.4.1. Distance = Altitude (to lose or gain) ÷ Descent Gradient (DG)

$$\text{Distance} = (30,000 \text{ feet} - 6,000 \text{ ft}) \div 300 \text{ ft/nm}$$

$$\text{Distance} = 24,000 \text{ feet} \div 300 \text{ ft/nm}$$

$$\text{Distance} = 80 \text{ nm}$$

3.7.1.5. Therefore, based on the current set of known information, the pilot/crew would wait until instrument indications indicated the aircraft was 80 nm from the field and then start their descent. As a technique, depending on the type of approach planned and where the IAF or FAF was located in relation to the descent point, the pilot/crew may want to add or subtract 5 or 10 miles from the calculated figure to account for the additional distance needed to fly the IAP. Another factor that should be accounted for in descent planning includes the affects of an average headwind or tailwind component during the descent.

3.7.2. ATC Crossing Restriction.

3.7.2.1. Example #3: An aircraft is heading southbound on the 360 degree radial and established at FL 270. ATC directs the pilot to cross 10 nm north of the ABC VORTAC at 12,000 feet. Referencing the DME, the pilot determines the aircraft is approximately 35 miles from the ABC VORTAC. The same 60-1 formula used in “Example 1” applies.

3.7.2.1.1. DG = Total Altitude (to lose or gain) ÷ Distance

$$DG = (27,000 \text{ feet} - 12,000 \text{ feet}) \div (35 \text{ nm} - 10 \text{ nm})$$

$$DG = 15,000 \text{ feet} \div 25 \text{ nm}$$

$$DG = 600 \text{ ft/nm}$$

3.7.2.2. Therefore, to lose 15,000 feet in 25 nm will require a 600 ft/nm gradient and also equates to a 6° pitch change (from level flight). After calculating the required gradient/pitch change, the approximate VVI to expect can also be determined. The VVI required during the



descent will depend on the aircraft's speed (in TAS, TMN, or groundspeed converted to nm/min) experienced during the descent (or climb). Normally, if you base your VVI calculation (as in the example above) on the initial speed (TAS) at the higher altitude, you will reach the lower altitude prior to the crossing restriction fix. Because TAS increases for a constant IAS while climbing, the reverse is not true. If you use the aircraft's initial speed to calculate a VVI when vacating a lower altitude and climbing to a relatively higher one, you will reach the higher altitude at a point beyond that which was desired (see 3.8.2).

3.7.2.2.1. **NOTE:** When traversing through large altitude changes (whether climbing or descending); utilizing an average TAS will increase the accuracy of VVI calculations.

3.7.3. Gradient Determined from a Published Procedure. During the arrival phase, there are many applications that may require you to calculate a descent gradient (e.g., while flying a STAR) or where you may desire to calculate one to increase your situational awareness as the instrument approach progress.

3.7.3.1. Example #4: You are flying a jet enroute to Minneapolis via the EAU CLAIRE EIGHT ARRIVAL, GREEN BAY TRANSITION (see figure 3.1.) Your aircraft is currently established on the 278° radial at FL 240 flying westbound having just passed the GRB VORTAC. In order to plan the descent profile, ATC is queried. ATC informs the pilot/crew to expect a descent upon reaching the EAU VORTAC and cross the TWINZ intersection as depicted on the STAR. Although ATC may assign a different altitude, for planning purposes (and for this example), a descent gradient (pitch change) is calculated predicated on the published crossing altitude, 11,000 feet.

Figure 3.1. STAR for Minneapolis, Minnesota (EAU CLAIRE EIGHT).

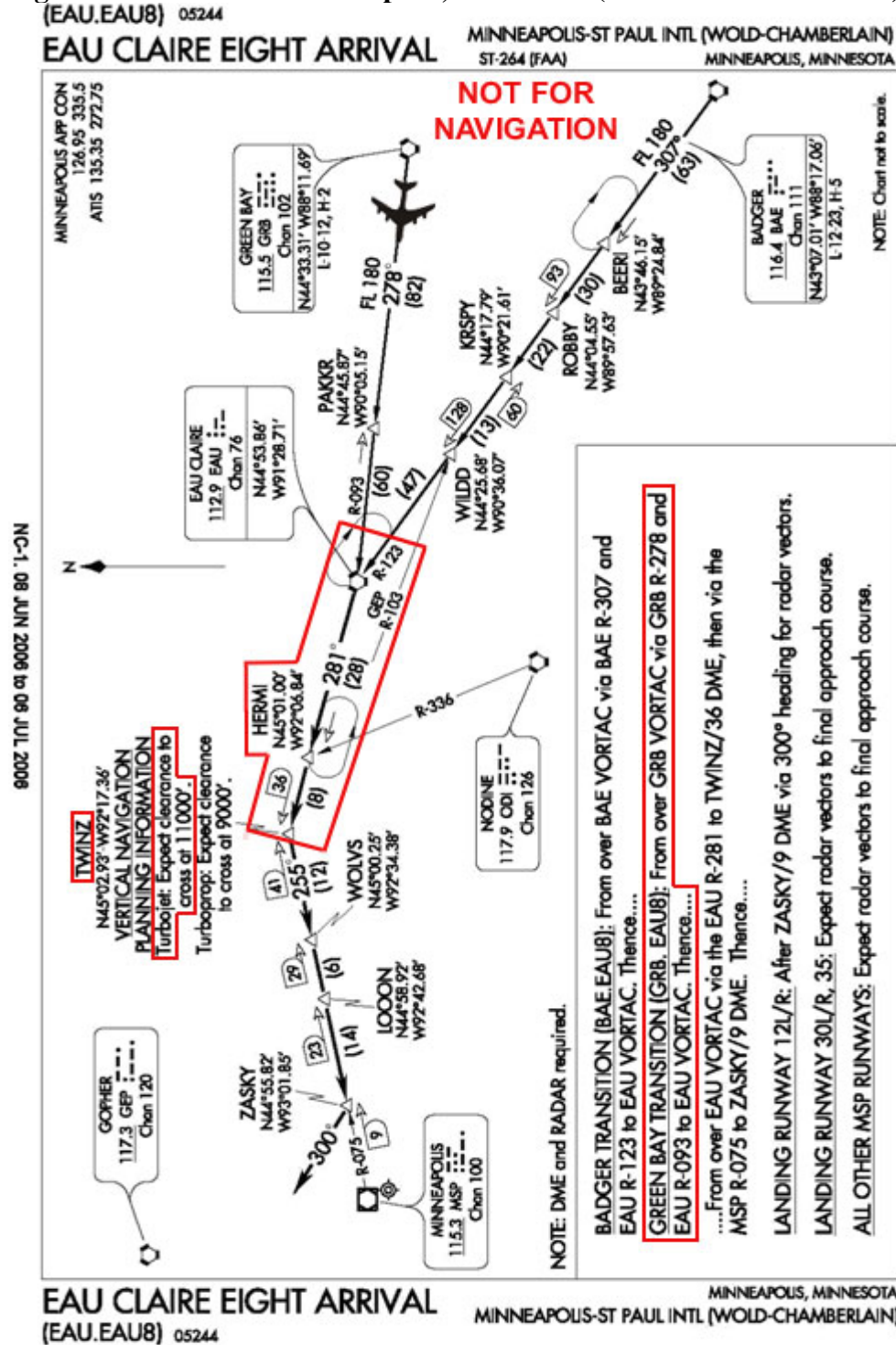

3.7.3.2. Although the scenario is slightly different from the two previous examples, the application of the formula is the same. You must descend from your current altitude to a predetermined crossing altitude in a certain amount of distance. The calculated descent **gradient**

also corresponds to a required pitch change. Here are the calculations based on the information given and taken from the STAR (see Figure 3.1.):

3.7.3.2.1.  $DG = \text{Total Altitude (to lose or gain)} \div \text{Distance}$

$$DG = (24,000 \text{ feet} - 11,000 \text{ feet}) \div 36 \text{ nm}$$

$$DG = 13,000 \text{ feet} \div 36 \text{ nm}$$

$$DG = 361 \text{ feet/nm}$$

3.7.3.3. Therefore, you should plan to lose 13,000 feet in 36 nm (the total distance from EAU VORTAC to the TWINZ intersection) which equates to a 361 ft/nm descent gradient. It also equals a 3.6° (use 4° for 60-to-1 purposes) pitch change from level flight.

3.7.4. Affect of Maintaining a Constant IAS During a Descent. If you elect to fly a constant IAS throughout the descent, which is a common practice (and often recommended by the MDS performance manual), then the corresponding TAS will decrease as the aircraft descends. Since the VVI calculation is predicated on the aircrafts speed, it too will decrease if a constant pitch is held. Therefore, if you calculate and hold a VVI, particularly one predicated on a groundspeed, versus maintaining a set pitch, the aircraft will reach the descent altitude at a point prior to the fix. Since crossing the fix at the designated altitude is required, calculating and holding a VVI that will enable the aircraft to descend to and reach the required altitude may work to your benefit in this particular situation. If the situation was reversed and a climb gradient was based on meeting a higher crossing fix altitude, a calculated VVI may not work since TAS as it relates to a constant IAS increases with altitude. This concept is expanded upon in the discussion on climb gradients in the following section.

3.7.4.1. NOTE: The most important part of the equation (which remains constant no matter what speed the aircraft is flying) is the gradient. The pilot/crew must descend at the calculated gradient in order to reach the desired descent point, mandated ATC crossing altitude restriction or gradient published within an instrument procedure.

**3.8. Climb Gradients.** The formulas used to compute climb gradients (CG) and the factors affecting the calculations are the same as those utilized in determining descent gradients.

3.8.1. ATC Crossing Restriction.

3.8.1.1. Example #1: An aircraft is maintaining 250 KIAS in straight and level flight at 2,000 ft MSL with a positive 3° pitch attitude. ATC instructs the aircraft to “climb and maintain FL 200, cross the ABC VORTAC at 12,000.” DME indicates the aircraft is 50 nm from the ABC VORTAC. Here are the calculations:

3.8.1.1.1.  $CG = \text{Total Altitude (to lose or gain)} \div \text{Distance}$

$$CG = (12,000 \text{ ft} - 2,000 \text{ ft}) \div 50 \text{ nm}$$

$$CG = 10,000 \text{ ft} \div 50 \text{ nm}$$

CG = 200 ft/nm (or 2°)

3.8.1.2. Therefore, based on this information, a positive 2° pitch change (or more) is required. Since the aircraft already had a pitch attitude of 3°, with an additional 2° change, the pilot must set and hold a new pitch attitude of 5° (or more) to meet the crossing restriction.

### 3.8.2. Affects of Changing TAS on VVI When Climbing.

3.8.2.1. If you maintain an IAS throughout the climb, which is a common practice (and often recommended by the MDS performance manual or regulatory procedure), then your TAS will increase as the aircraft ascends in altitude. Since the nm/min calculation utilized in the 60-1 formulas are predicated on TAS, it will similarly affect the VVI. Simply put, as your aircraft's TAS (and rate of travel in nm/min) increases, a larger VVI is required to maintain the integrity of the calculation. Therefore, if you calculate and set a VVI based on initial TAS instead of holding the calculated pitch attitude and do not account for the TAS changes as your aircraft climbs, you will arrive at the crossing fix altitude at a point beyond that which was desired.

3.8.2.2. To prevent this, it is advisable that you set the required pitch; then adjust thrust to maintain the airspeed recommended by the performance manual or accepted practice (e.g., accelerating to and maintaining 250 KIAS until 10,000 ft MSL).

3.8.2.3. Based on general aircraft performance characteristics (independent of aircraft type), you will spend roughly half of your time ascending two-thirds of the total altitude to be gained. The remaining time is spent climbing the final one-third of altitude to level off. Conversely, it takes an aircraft about one-third the time to climb one-half the altitude to be gained and the other two-thirds of the time climbing the other half. Since TAS increases with altitude, if we apply this concept to a VVI calculation, we have to compensate for the extended period of time the aircraft will spend at the associated higher true airspeeds. Therefore, should you wish to calculate a required VVI for a climb; there are two recommended techniques:

3.8.2.4. Technique #1: Since you will spend approximately half the time traversing the final one third of your altitude to be gained, it makes sense to compensate for this in the VVI calculation. Therefore, a good approximation for the average TAS to use in is the one that would be two-thirds of the total altitude traversed added to the altitude you started the climb from. Since TAS increases approximately 2% per 1,000 feet, if we use the information from the example in paragraph 3.8.1.1, the formula and subsequent calculations are:

3.8.2.4.1.  $TAS = IAS + 2\% [2/3 (\text{altitude traversed}) + \text{initial altitude}]$

$$TAS = 250 + 0.02 [2/3 (12,000 \text{ ft} - 2000 \text{ ft}) + 2,000 \text{ ft}]$$

$$TAS = 250 + 0.02 [2/3(10,000 \text{ ft}) + 2,000 \text{ ft}]$$

$$TAS = 250 + 0.02 [6,670 \text{ ft} + 2,000 \text{ ft}]$$

$$TAS = 250 + 0.02 [8,670] \dots \text{for simplification, use 9,000 ft}$$

$$TAS = 250 + 180$$

$$TAS = 430$$

3.8.2.5. To convert the result into nm/min, we further divide by 60 to obtain an average airspeed of 7.2 nm/min or for the purposes of this discussion, use 7 nm/min.

3.8.2.6. Utilizing the formula referenced in paragraph 3.5.2 and the expected TAS in nm/min (at two-thirds of the altitude to be gained), we can calculate a VVI that should allow the pilot to meet the crossing restriction.

3.8.2.6.1.  $VVI = \text{nm/min} \times \text{pitch change (or gradient)} \times 100 \text{ ft/nm}$

$$VVI = 7 \text{ nm/min} \times 2^\circ \times 100 \text{ ft/nm}$$

$$VVI = 7 \text{ nm/min} \times 200 \text{ ft/nm}$$

$$VVI = 1400 \text{ ft/min}$$

3.8.2.7. Technique #2: To virtually guarantee that you will arrive at the desired altitude at or before the crossing restriction, the most conservative approach is to simply use the approximate TAS (converted to nm/min) at the level off altitude. This should yield a VVI greater than required; that if maintained, will allow you to meet your altitude restriction with some margin for error provided (e.g., variable winds aloft, non-standard temperatures at altitude).

3.8.2.8. Using the level off altitude of 12,000 feet and airspeed of 250 KIAS from the same example (paragraph 3.8.1.1), the TAS (converted to nm/min) and VVI computations would be:

3.8.2.8.1.  $TAS = IAS + (2\% \times \text{altitude})$

$$TAS = 250 + (0.02 \times 12,000 \text{ feet})$$

$$TAS = 250 + 240$$

$$TAS = 490 \text{ (for simplification, use 500 KTAS)}$$

3.8.2.9. Again, we divide 500 KTAS by 60 to obtain a rate of travel of 8.3 nm/min (for simplification we can use 8.5). Using the same VVI formula from above (see 3.8.2.6.1), the calculation to determine the rate of climb needed is as follows:

3.8.2.9.1  $VVI = \text{nm/min} \times \text{pitch change (or gradient)} \times 100 \text{ ft/nm}$

$$VVI = 8.5 \text{ nm/min} \times 2^\circ \times 100 \text{ ft/nm}$$

$$VVI = 1700 \text{ ft/min}$$

3.8.2.9.2. **NOTE:** TAS and TMN are used for “air mass” determinations and do not account for the affect of wind on the aircraft’s ground track. To further increase accuracy of the calculations, it is highly encouraged that you use your aircraft’s groundspeed (converted to nm/min) whenever possible. Groundspeed is TAS or TMN corrected for wind.

3.8.2.10. To prove the theory mentioned in paragraph 3.8.2.1, if you did not calculate an average TAS or (converted to nm/min) but instead only used the TAS for the initial part of the climb to determine a VVI and then held it, it is very unlikely you would meet the crossing restriction. Based on the TAS at 2,000 feet, the pilot/crew would have calculated an initial rate of travel at

4.8 nm/min (for simplification we'll use 5.0) upon which a 2° pitch change would yield a rate of climb of 1000 ft/min. If 1,000 ft/min rate of climb were held and 250 KIAS maintained while pitch was allowed to vary, since TAS increases with altitude, the aircraft would actually not maintain a rate of travel of 5 nm/min but would average almost 7 nm/min (see 3.8.2.3).

3.8.2.11. Using the known conditions and basic algebra we can determine that it will take the aircraft a fraction over 7 minutes to travel 50 nm at the actual rate of 7 nm/min. Therefore; if a climb rate of 1,000 ft/min were held for 7 minutes, the aircraft will climb 7,000 feet. If we add this 7,000 foot increment to the initial altitude of 2,000 feet, the aircraft would be approximately at 9,000 feet or 3,000 feet below the required crossing altitude. To climb the additional 3,000 feet at 1,000 ft/min would take another 3 minutes and at the average rate of 7 nm/min, the pilot would not reach the required altitude until 21 nm beyond the fix.

### 3.8.3. Determining Climb Gradient from a Published Procedure.

3.8.3.1. Example #2: You are planning to depart RWY 19 at Jackson Hole (KJAC), Wyoming. Referring to the TETON TWO DEPARTURE (figure 3.2.) and noting the TAKE OFF MINIMUMS, a 330 feet/nm climb gradient is required to 11,400 feet. The total amount of feet the aircraft must climb at 330 feet/nm is determined by subtracting the departure end of the runway (DER) crossing height elevation from the required climb to altitude. In this case, you are departing a civilian field which has a DER crossing restriction of 35'; therefore, the calculations would require you to add 35 feet to the DER elevation and then subtract this figure from 11,400. Therefore, the total feet the aircraft must climb ( $11,400 - 6413 + 35$ ) is 5022 feet. For the purpose of this example we'll use 5000 feet. In addition, although the best climb speed for your particular aircraft can be found in the applicable aircraft performance manual, for simplification, we'll utilize 250 KIAS. Since the climb gradient is already given (330 ft/nm) and the total altitude that must be gained (5,000 feet) has been calculated, an approximate VVI can be determined to increase your situational awareness as your climb progresses. In order to calculate a VVI to meet the climb restriction, as stated previously, you need to determine what the average TAS the aircraft will experience during the climb.

Figure 3.2. Jackson Hole, Teton Two Departure  
 (TETON2.KICNE) 04162 SL-504 (FAA) JACKSON HOLE (JAC) JACKSON, WYOMING

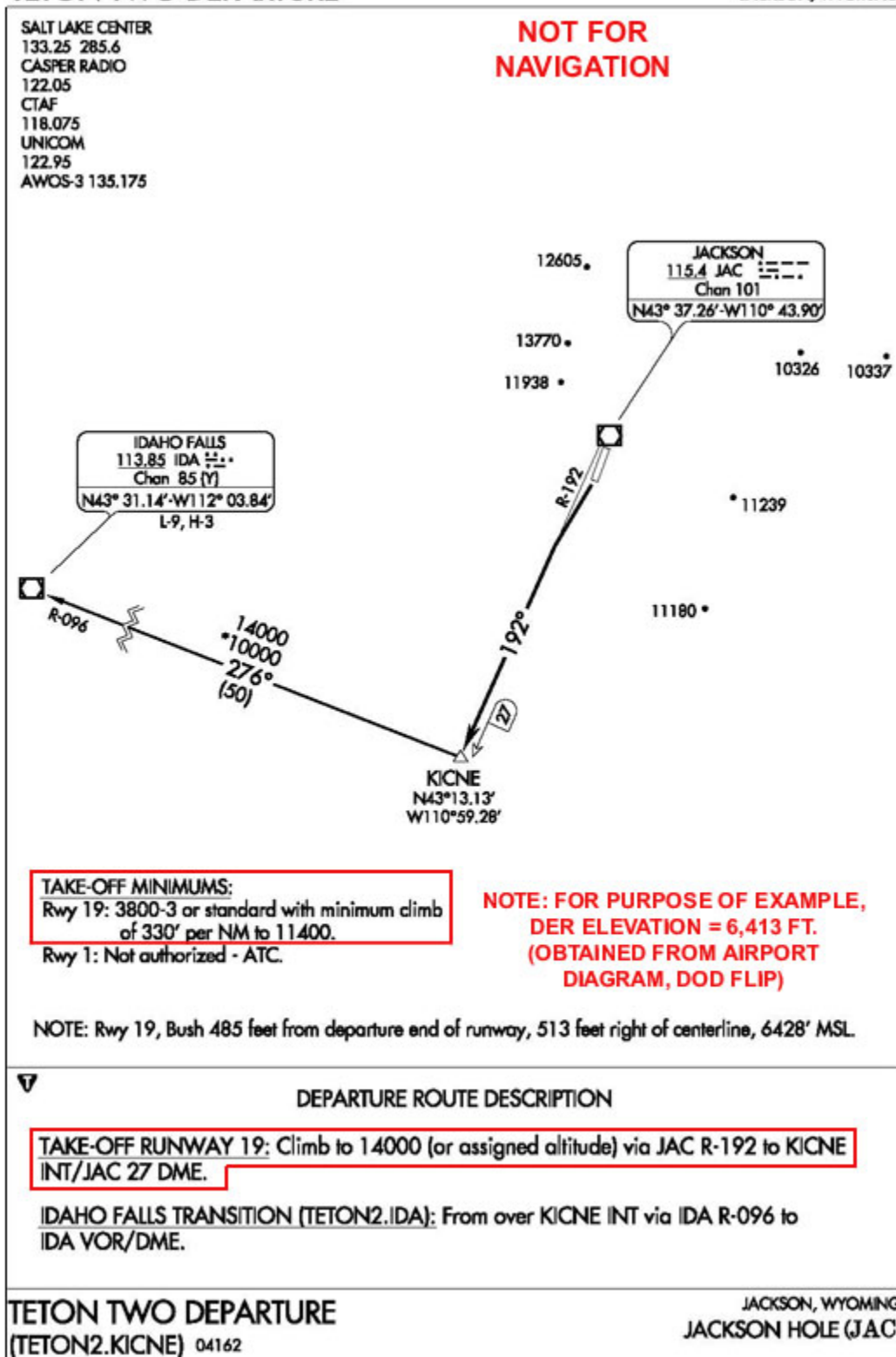

3.8.3.2. After determining an average TAS, a VVI can then be calculated and used to increase your situational awareness as to whether the aircraft's performance is meeting the **required** climb gradient. For the purpose of this example, we'll assume the aircraft accelerates to and uses 250 KIAS for the climb. The following calculations will guide you through the process.

3.8.3.2.1. To determine TAS (in nm/min) at DER (6400 feet) at 250 KIAS:

$$\text{TAS} = \text{IAS} + (2\% \text{ per } 1,000 \text{ feet})$$

$$\text{TAS} = 250 + (0.02 \times 6.4 \times 250)$$

$$\text{TAS} = 250 + 32$$

$$\text{TAS} = 282$$

3.8.3.2.2. To determine TAS at 11,400 feet:

$$\text{TAS} = \text{IAS} + (2\% \text{ per } 1,000 \text{ feet})$$

$$\text{TAS} = 250 + (0.02 \times 11.4 \times 250)$$

$$\text{TAS} = 250 + 57$$

$$\text{TAS} = 307.$$

3.8.3.2.3. By adding these two airspeeds together and then dividing by two, the average TAS for the climb is 295 knots. By further dividing this figure by 60, we obtain a rate of travel of 4.9 nm/min (see paragraph 3.5.1).

3.8.3.3. Utilizing the formula referenced in 3.5.2 and the average TAS in nm/min, we can then calculate an approximate VVI that will allow for the pilot to meet the climb gradient (CG) crossing restriction.

3.8.3.3.1.  $\text{VVI} = \text{nm/min} \times \text{required gradient}$

$$\text{VVI} = 4.9 \text{ nm/min} \times 330 \text{ ft/nm}$$

$$\text{VVI} = 1617 \text{ ft/min (or higher, } \approx 1650 \text{) required to meet CG.}$$

3.8.3.3.2. NOTE: Since the aircraft will be accelerating and reconfiguring during the initial phase of the departure, your tech order calculations should take these factors into account and take precedence. The 60-to-1 calculations are used only as an approximation tool to confirm and add additional insights and situational awareness to the data extracted from your specific aircraft's performance manual.

3.8.3.4. As mentioned earlier, to increase the accuracy of the calculations and actually validate the climb gradient required against aircraft performance, an adjustment for winds needs to be applied. Using the information from Example #2, an average TAS during the climb was determined to be 295 knots. Referencing the forecasted airport weather and appropriate winds



aloft chart, an approximate groundspeed can be calculated by applying the average winds experienced throughout the climb. For the purpose of this example, we'll assume the take-off winds for RWY 19 at KJAC are forecasted to be 210° at 9 knots and the winds aloft information at 9,000 and 12,000 feet were 240° at 21 knots and 270° at 30 knots respectively.

3.8.3.5. By adding the individual wind direction information and speed information and then dividing by three, the average climb winds experienced would be approximately 240° at 20 knots.

3.8.3.6. The SID at Jackson Hole requires the crew to intercept and track the 192 degree radial after departing RWY 19 which is approximately aligned with runway heading. Therefore the difference between the departure track heading and average wind direction would be 50 degrees. Using a standard headwind/crosswind chart, the pilot/crew can then calculate an approximate headwind component of 13 knots experienced during the climb.

3.8.3.7. To calculate an approximate groundspeed, the pilot/crew would then subtract the headwind component (13 knots) from the average TAS (295 knots). The average groundspeed would then be 282 knots which equates to an average rate of travel of 4.7 nm/min (see 3.5.1).

3.8.3.8. Inserting this figure into the VVI calculation (refer to paragraph 3.5.2) would give you a slightly lower VVI of approximately 1550 ft/min (versus  $\approx$  1650 ft/min) required.

3.8.3.8.1. **NOTE:** With the performance benefit a headwind provides, you may elect to add an additional safety layer within your calculations and not use it. It is; however, highly recommended that you always take into account the effects of tail winds since they can adversely affect the aircraft's ability to meet a specified climb gradient.

3.8.3.8.2. **NOTE:** As with any mathematical formula, the gradient equation and its associated formulas can be manipulated to solve for any variable desired.

### 3.9. Visual Descent Point (VDP).

3.9.1. Calculating a VDP. The first step in calculating a VDP is to find the distance the VDP is located from the end of the threshold by dividing the Height Above Touchdown (HAT) listed in the minimums section of the IAP by the desired descent gradient. Although some aircraft may utilize a different descent gradient due to operational purposes, most use a 3° glide path for landing which equates to 300 ft per nm. Next, you will need to add the calculated VDP distance to the DME associated with the RWY threshold. This will give you the DME for the VDP. In some cases, depending on the position of the DME source in relation to the RWY, you may need to actually subtract the VDP distance from the RWY threshold DME. This is because the VDP calculation is predicated on the distance in miles from the end of the RWY, not the DME source.

3.9.1.1. Formula:  $VDP = HAT \div \text{Gradient (normally 300 ft/nm)}$ .

3.9.1.2. For practical purposes, you can use:  $VDP = HAT \div 300$ .

3.9.1.3. Example. You are planning to fly the localizer portion of the ILS RWY 16 at McChord AFB (KTCM). Referencing the landing minimums section of figure 3.3, the HAT for the S-LOC 16 is listed as 494 ft. The VDP calculation would be as follows:

3.9.1.3.1. Formula:  $VDP = HAT \div 300$

$$VDP = 494 \div 300$$

$$VDP = 1.65 \text{ (or } \approx 1.7 \text{ nm from RWY)}$$

3.9.1.4. From the profile or the airport diagram section, you can determine the RWY is 4.8 nm from the FAF. Since the FAF is at 5 DME and the RWY is 4.8 miles away, the DME at the approach threshold is the difference between these two figures or 0.2 DME.

3.9.1.5. Therefore, the DME for the VDP can be determined by adding the calculated VDP distance (from the end of the RWY) to the DME associated with the RWY threshold. In this example, the approximate DME associated with the VDP would be 1.9 DME (1.7 + 0.2).

**Figure 3.3. ILS Runway 16, McChord AFB**

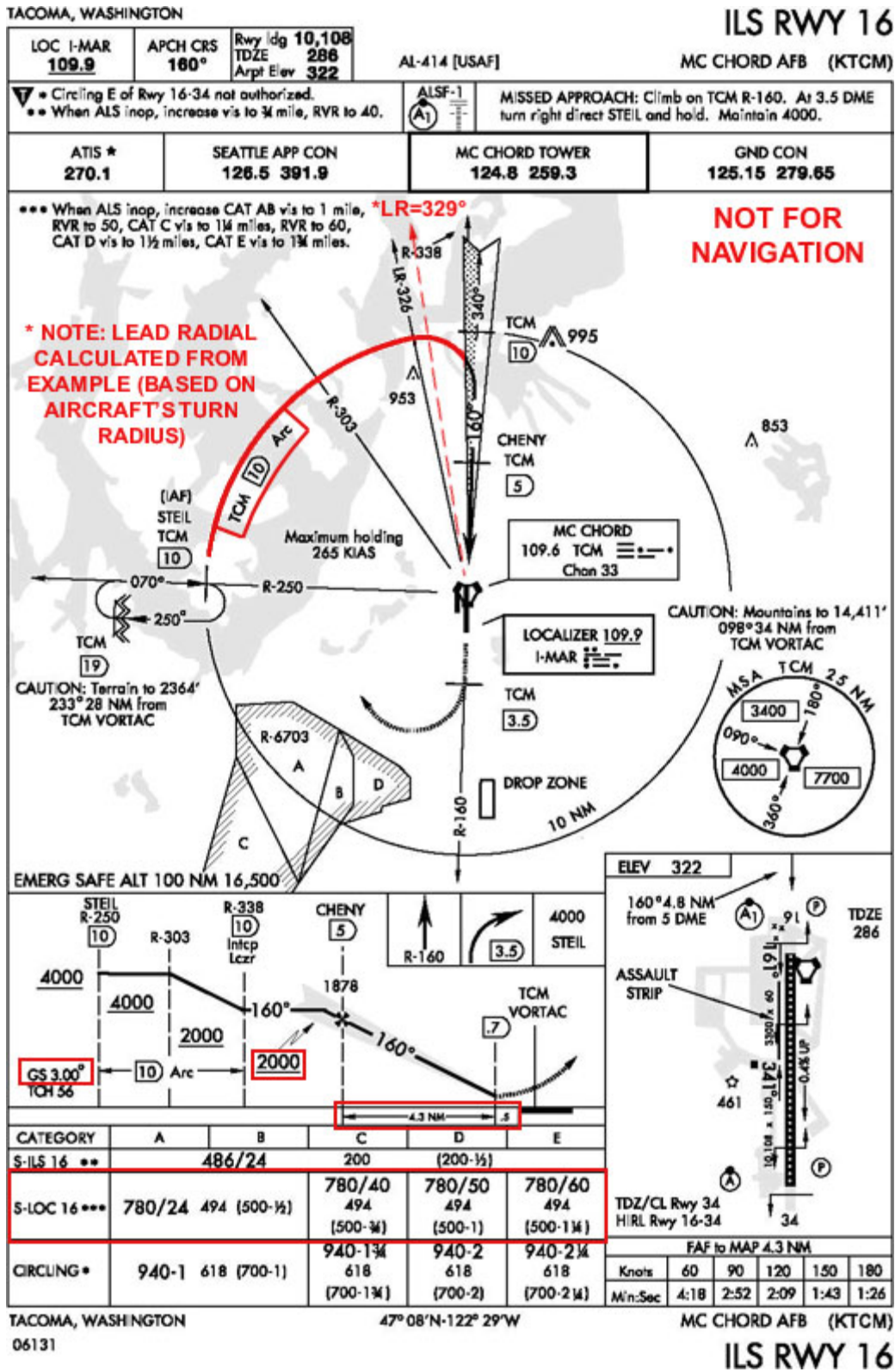

3.9.2. Calculations to reach the MDA at the VDP.

3.9.2.1. Referencing figure 3.3, as a technique, you can also compute a descent gradient, target

VVI, and pitch change needed to descend from the FAF altitude to reach the MDA at the VDP. This is explained in the following calculations.

3.9.2.2. First, determine the distance that the aircraft will travel from the FAF DME to the calculated VDP DME.

3.9.2.2.1. Descent Distance = FAF DME - VDP DME

$$\text{Descent Distance} = 5.0 \text{ DME} - 1.9 \text{ DME} = 3.1 \text{ nm}$$

3.9.2.3. Then, calculate the altitude to lose from the FAF altitude to the MDA.

3.9.2.3.1. Altitude to lose = FAF altitude – MDA altitude

$$\text{Altitude to lose} = 2000 \text{ feet} - 780 \text{ feet} = 1220 \text{ feet}$$

3.9.2.4. Once the distance and altitude difference is known, a descent gradient (DG) can be calculated.

3.9.2.4.1.  $\text{DG} = \text{Altitude to lose} \div \text{distance}$

$$\text{DG} = 1220 \text{ feet} \div 3.1 \text{ nm} = 394 \text{ ft/nm (or approximately 400 ft/nm)}.$$

3.9.2.4.2. Referencing paragraph 3.4.6, 400 ft/nm also equates to a pitch change of 4° from level flight.

3.9.2.4.3. If you flew the approach at 150 KTAS which approximates 2.5 nm/min rate of travel, then a corresponding VVI can be calculated at 1,000 ft/min.

3.9.2.4.4. By determining a descent gradient, pitch change, and target VVI, you can reach the MDA at the VDP. With a slight pitch adjustment, you can then pick up a normal 3° glide path (or aim point for landing).

3.9.2.5. To summarize this portion of the example, with the calculated information, you can depart the FAF at 150 KTAS (2.5 nm/min), adjust your pitch from level flight by 4° and descend along a 400 ft/nm gradient to reach the MDA at the VDP. If the aircraft maintains these parameters, at each mile inside the FAF, the aircraft should lose 400 ft of altitude.

3.9.2.5.1. NOTE: Published VDP's may be absent from an instrument approach procedure (IAP) for a couple of reasons. First, there was a period of time when the FAA and DoD TERPS simply did not emphasize publishing VDP's, so they were not added to the IAPs. TERPS procedures (ref AFMAN 11-226) may also dictate the exclusion of a VDP if an obstacle exists inside the visual segment and penetrates either the 34:1 or 20:1 plane. Therefore, you should exercise caution when departing an MDA without a published VDP, particularly during periods of reduced visibility or at night. See 11-217 Vol 1, Chapter 15, Visual Glide Slope Indicators (VGSI) for more information on obstacles that penetrate the 20:1 surface.

3.9.2.5.1. In the TERPS design criteria for a non-precision approach, protected airspace requirements and obstacle clearance is predicated on the aircraft leveling off at the MDA and executing a go-around from the MDA if the runway environment is not acquired and a safe landing cannot be made. Unlike a “go-around” or “missed approach” executed from a precision approach, no account for obstacle clearance is made for a “momentary dip” below the MDA on a non-precision approach. Without proper planning, an undesired “momentary dip” below the MDA could occur during a constant rate descent is made to the VDP. Pilots and aircrew should be aware of this and adjust accordingly so as to not go below the MDA should it appear that a missed approach may be likely based on weather conditions (e.g. reported weather is at/or near minimums) and/or other factors.

### **3.10. Calculating a VVI for a Precision Approach.**

3.10.1. The glide path published for an approach will be the same for every aircraft. Therefore, a pitch change from level flight equal to the published glide path can be made on the attitude indicator when intercepting the glide path. The speed at which the approach is flown has no effect upon the amount of pitch change required when intercepting the glide path. Airspeed only affects the time required to fly the final approach segment and the rate of descent (VVI). Prior to intercepting the glide path, to increase your situational awareness during this critical phase of flight, you should compute a target VVI. When the aircraft has intercepted and is stabilized on the glide path, you can crosscheck the actual VVI against the target VVI you computed. The difference between the two should be relatively close. If not, it provides an indication that something could be affecting the safety of the approach (e.g., wind shear) and further investigation or a missed approach may be warranted.

3.10.2. Referencing paragraph 3.5.2, an expected VVI can be easily computed based on your planned approach airspeed (TAS or TMN) converted to nm/min. To further increase the accuracy of the final descent approach planning, it is highly recommended that you adjust for a headwind/tailwind component and use a groundspeed when computing an expected VVI.

3.10.2.1. NOTE: A rate of descent table (based on groundspeed and angle of descent) is published at the back of the instrument approach plate booklet.

3.10.3. Although the descent angle for a precision glide path listed on the instrument approach plate (IAP) may vary, the majority are designed to provide a 3° glide path (or 300 ft/nm gradient).

3.10.4. Example #1: A pilot/crew is flying an aircraft with a malfunction that requires a “no flap” precision approach to be flown to the ILS RWY 16 at McChord AFB (KTCM), see figure 3.3. Due to the higher speeds flown for “no flap” approaches, an approach speed of .3 Mach (TMN) is planned. Referencing the profile view, the IAP indicates there is a standard 3° glide path associated with the ILS. In order to calculate an expected VVI on final approach, the pilot/crew must first convert the TMN to nm/min for use in the 60-to-1 formulas. Converting TMN (and TAS) to nm/min whereby a VVI can then be determined is discussed in paragraphs 3.5.1 and 3.5.2 respectively. Here are the computations for this example:

- 3.10.1.1. Aircraft speed in nm/min = TMN  $\times$  10  
 Aircraft speed in nm/min = 0.3 TMN  $\times$  10

$$\text{Aircraft speed in nm/min} = 3$$

3.10.5. VVI can be determined using the glide path angle as presented in Formula (a) or by using the gradient as demonstrated in Formula (b). Here are the calculations for each:

- 3.10.5.1. Formula (a): VVI = angle  $\times$  nm/min  $\times$  100  
 VVI = 3 $^{\circ}$   $\times$  3 nm/min  $\times$  100

$$\text{VVI} = 900 \text{ ft/min}$$

- 3.10.5.2. Formula (b): VVI = gradient  $\times$  nm/min

$$\text{VVI} = 300 \text{ ft/nm} \times 3 \text{ nm/min}$$

$$\text{VVI} = 900 \text{ ft/min}$$

3.10.6. Example #2: You are planning to fly the ILS RWY 12 at Mountain Home AFB (KMUO), refer to figure 3.4. The final approach speed is approximately 120 KTAS. Again, you must first convert the KTAS to nm/min in order to calculate the expected VVI. Notice, this particular precision approach is set to 2.5 $^{\circ}$  versus the standard 3 $^{\circ}$  glide path.

- 3.10.6.1. Aircraft speed in nm/min = TAS  $\div$  60

$$\text{Aircraft speed in nm/min} = 120 \text{ KTAS} \div 60$$

$$\text{Aircraft speed} = 2 \text{ nm/min}$$

3.10.7. VVI can then be determined using the angle of descent or gradient (b) as calculated below:

- 3.10.7.1. Formula (a): VVI = angle  $\times$  nm/min  $\times$  100

$$\text{VVI} = 2.5^{\circ} \times 2 \text{ nm/min} \times 100$$

$$\text{VVI} = 500 \text{ ft/min}$$

- 3.10.7.2. Formula (b): VVI = gradient  $\times$  nm/min

$$\text{VVI} = 250 \text{ ft/nm} \times 2 \text{ nm/min}$$

$$\text{VVI} = 500 \text{ ft/min}$$

3.10.8. Additional formulas have developed over the years that have also proven beneficial, particularly when time available to conduct approach planning is limited. The following approximate the VVI required for a 3 $^{\circ}$  and 2.5 $^{\circ}$  glide path.

- 3.10.8.1. VVI for 3 $^{\circ}$  = TAS  $\times$  10  $\div$  2

3.10.8.2.  $VVI \text{ for } 2.5^\circ = (TAS \times 10 \div 2) - 100$

3.10.8.2.1 NOTE: TAS is used for “air mass” determinations and do not account for the affect of wind on the aircraft’s ground track. To increase the accuracy of the calculations, the pilot/crew should determine their rate of travel in relationship with the earth’s surface and use a groundspeed (converted to nm/min) if able. Groundspeed is TAS corrected for a headwind/tailwind component.

**Figure 3.4. ILS Runway 12, Mountain Home AFB**

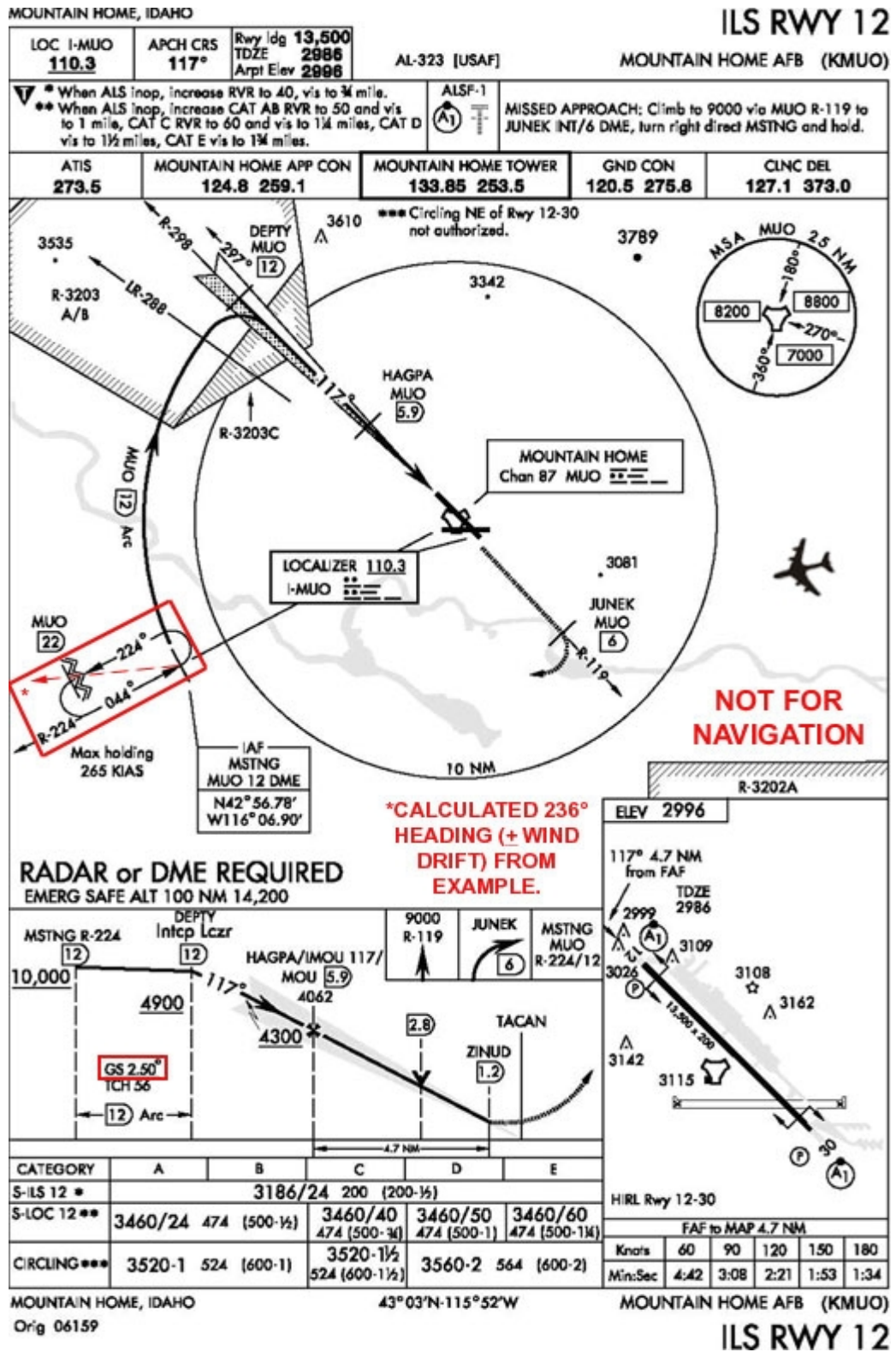



### 3.11. Determining Turn Radius.

3.11.1. Overview. When an aircraft is flown in a steady, coordinated turn at a specific angle of bank (AOB) and velocity, the turn rate and turn radius is fixed and independent of aircraft type. Although turn radius (TR) formulas are not specifically derived from the 60-to-1 relationship, they are very useful when used in conjunction with the other calculations provided in this chapter.

3.11.1.1. NOTE: As an aid, an aircrew may calculate the TR for their particular aircraft at the various altitudes and airspeeds that are flown regularly since these figures usually remain relatively constant.

3.11.2. Relationship between AOB and TAS. An aircraft's turn radius is dependent on TAS and angle of bank. For a constant angle of bank in a level turn, if the TAS increases, the turn radius also increases. If the TAS is kept constant, as the angle of bank increases in a level turn, the turn radius decreases. In order to develop a technique for determining your TR, one of the two elements in the equation, either angle of bank or TAS, must be kept constant. Since most instrument procedures are based on the pilot/crew using 30° of bank through the initial phases of the procedure, the majority of the calculations presented are based on this fact. However, it does not preclude utilizing a constant TAS and calculating a desired bank angle for the set speed (e.g., standard rate and ½ standard rate turns).

3.11.2.1. NOTE: To increase accuracy, it is recommended that the pilot/crew add or subtract the wind component from the TAS or True Mach Number (TMN) and use a groundspeed (converted to nm/min) when determining the various formulas presented in the section. It not only increases the accuracy of your calculations but will also help ensure the aircraft stays within the confines of protected airspace (e.g., when performing a procedure turn course reversal maneuver).

3.11.3. Turn Radius Calculation. The following two relationships provide the distance required to turn an aircraft 90° using 30° of bank. This distance is the aircraft's approximate turn radius. These formulas are particularly useful when determining lead turn points when planning to perform a radial-to-arc or arc-to-radial portion of an instrument procedure.

3.11.3.1. Formula 1:  $TR = (TAS \div 60) - 2$  or  $(TMN \times 10) - 2$

3.11.3.2. Formula 2:  $TR = (TAS \div 60)^2 \div 10$  or  $(TMN)^2 \times 10$

3.11.3.3. Example. An aircraft is flying at 240 knots TAS with a corresponding indicated Mach # of 0.4 (TMN). Based on this information, the aircraft's approximate TR at 30° angle of bank can be calculated directly from the TMN or after the TAS is converted to the aircraft's rate of travel in nm/min.

3.11.3.4. Formula 1:  $TR = (TAS \div 60) - 2$  (or)  $TR = (TMN \times 10) - 2$   
 $TR = (240 \div 60) - 2$   $TR = (0.4 \times 10) - 2$   
 $TR = 4 - 2$   $TR = 4 - 2$

$$TR = 2 \text{ nm}$$

$$TR = 2 \text{ nm}$$

3.11.3.5. Formula 2:  $TR = (TAS \div 60)^2 \div 10$  (or)  $TR = (TMN)^2 \times 10$   
 $TR = (240 \div 60)^2 \div 10$        $TR = (0.4)^2 \times 10$   
 $TR = (4)^2 \div 10$        $TR = 0.16 \times 10$   
 $TR = 16 \div 10$        $TR = 1.6 \text{ nm}$   
 $TR = 1.6 \text{ nm}$

3.11.3.6. As you can see, depending on which formula is used, slight variances are possible. The final TR calculations; however, are close enough and will enable the pilot to fly a more precise IAP whether Formula 1 or Formula 2 is used.

3.11.4. Turning Performance Chart. The actual turn performance curve (dashed line) is derived from the General Turning Performance Chart (reference Figure 3.5). Depending on which type airspeed presentation is available and/or which method is easier to use normally determines which formula is used. As you can see, when the results are compared against each other, a ½ nm difference is noted. This is because accuracy is slightly improved when Formula 2 (refer to 3.11.4.2.) is used since the results closely mirror the actual turning performance line. In fact, except at the upper speed regimes, when Formula 1 is used, the largest variation from actual data is approximately 0.5 nm. Above the Mach .8 (480 KTAS) airspeed regime, the difference becomes quite large; however, few aircraft accomplish instrument procedures at this speed. Even though slightly less accurate, the benefit of using Formula 1 is that it provides a small margin of increased safety during maneuvering. The calculations provide for more TR than is actually required which the pilot can compensate for by decreasing the angle of bank. When using Formula 2, unless all factors affecting the turn are taken into account (e.g., winds) and the turn started at the correct point, the potential exists for you to overshoot the desired course/arc or exceed protected airspace. Additionally, it may tempt you to bank the aircraft beyond the accepted 30° limit in IMC and expose you to the possibility of becoming spatially disoriented (which increases as the angle of bank increases). Considering these factors, it is usually better to allow for additional TR than not enough.

Figure 3.5. General Turning Performance (Constant Altitude, Steady Turn)

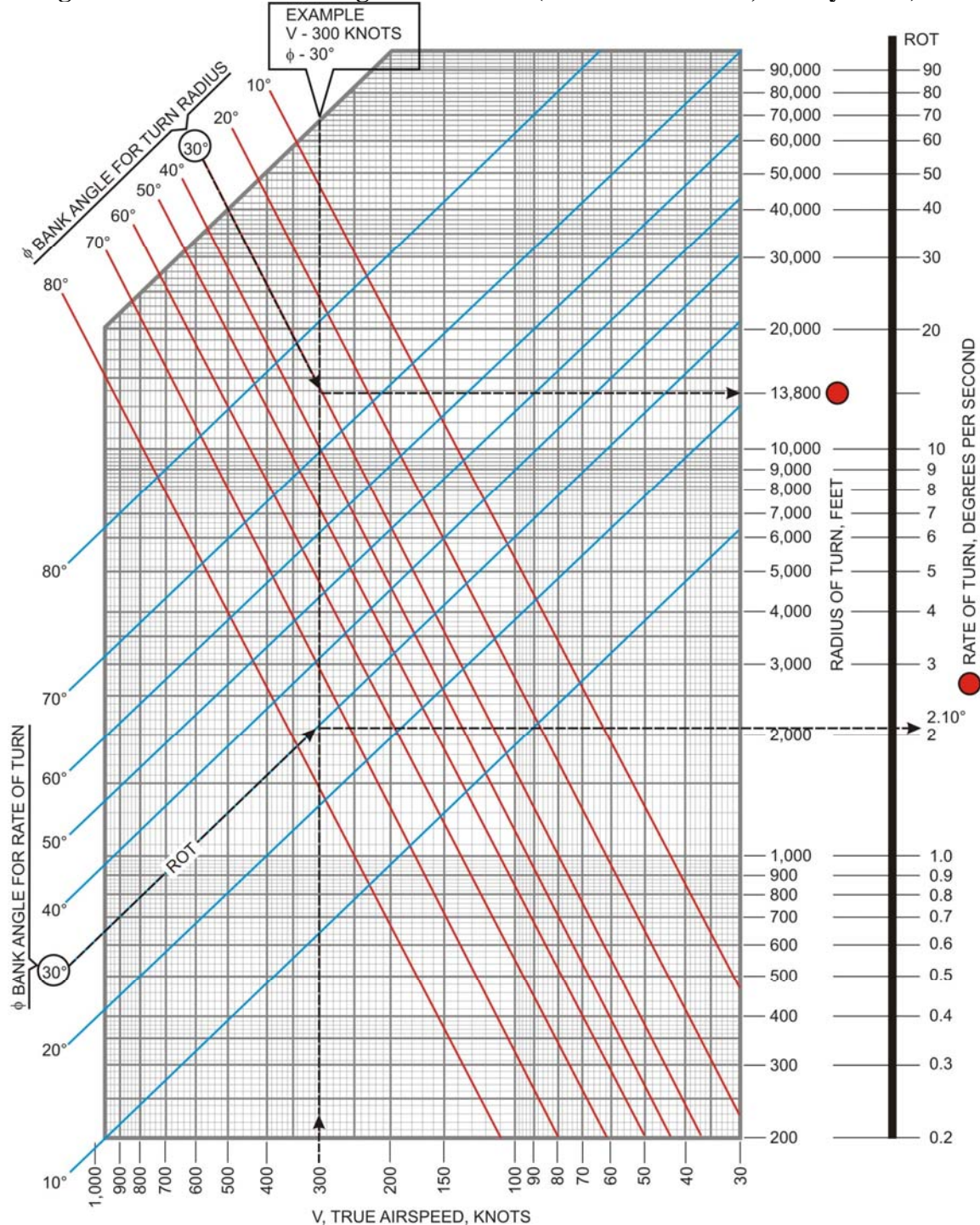

3.12 Standard and 1/2 Standard Rate Calculations.

3.12.1. Determining Lead Points - Standard and 1/2 Standard Rate Turns. The previous techniques work well for computing radial-to-arc and arc-to-radial turns using 30° of bank;

however, they do not necessarily translate into standard rate turn calculations. To determine the aircraft's approximate turn radius (TR) for a standard rate turn (SRT) or ½ standard rate turn (½ SRT); the following formulas have proven useful.

3.12.1.1. TR for SRT = .5% of KTAS (or GS).

3.12.1.2. TR for ½ SRT = 1% of KTAS (or GS).

3.12.1.3. Example: You are flying at 200 KTAS, using the formulas above, the SRT and ½ SRT are determined as follows:

3.12.1.3.1. TR for SRT = .5% × 200 KTAS.

$$\text{TR for SRT} = 0.005 \times 200$$

$$\text{TR} = 1 \text{ nm}$$

3.12.1.3.2 TR for ½ SRT = 1% × 200 KTAS

$$\text{TR for } \frac{1}{2} \text{ SRT} = 0.01 \times 200 \text{ KTAS}$$

$$\text{TR for } \frac{1}{2} \text{ SRT} = 2 \text{ nm}$$

3.12.1.4. Therefore, for an aircraft flying 200 KTAS, the radius for a standard rate turn and ½ standard rate turn would be 1 nm and 2 nm respectively.

3.12.2. Determining Bank Angles - Standard and ½ Standard Rate Turn. While we are discussing standard rate and ½ standard rate turns, the following calculations have proven useful in determining approximate bank angles ( $\Delta$ ) associated with each maneuver.

3.12.2.1. Bank  $\Delta$  for SRT = (TAS ÷ 10) + 7.

3.12.2.2. Bank  $\Delta$  for ½ SRT = (TAS ÷ 20) + 7.

3.12.2.3. For precision or non-precision radar approaches, the controller expects the pilot to make the transition to final using a bank that allows the aircraft to approximate a standard rate turn. After established on final segment of the approach, no more than ½ SRT should be used.

3.12.2.4. Example: You are maneuvering your aircraft in the radar pattern in preparation for a radar approach. You are currently flying at 180 KTAS but will subsequently slow to 120 KTAS on the final approach segment after configuring the aircraft. The calculation for a SRT at 180 KTAS is as follows:

3.12.2.4.1 SRT Bank  $\Delta$  = (180 ÷ 10) + 7.

$$\text{SRT Bank } \Delta = 18 + 7$$

$$\text{SRT Bank } \Delta = 25^\circ$$

3.12.2.5. After configuring the aircraft and slowing to 120 KTAS on the final approach segment of the procedure, smaller heading changes are required and the bank angle should normally not exceed that required to make a  $\frac{1}{2}$  standard rate turn. Therefore, based on 120 KTAS, the calculations for the  $\frac{1}{2}$  SRT is as follows:

$$3.12.2.5.1. \frac{1}{2} \text{ SRT Bank } \Delta = 120/20 + 7$$

$$\frac{1}{2} \text{ SRT Bank } \Delta = 6 + 7$$

$$\frac{1}{2} \text{ SRT Bank } \Delta = 13^\circ$$

3.12.3. Turn Relationships for Turns Greater than  $90^\circ$ . The turn radius discussion outlined in paragraph 3.11.3 is based upon making a  $90^\circ$  turn when flying a radial-to-arc or arc-to-radial turn intercept. However, you may experience situations requiring a turn that is more than  $90^\circ$  or less than  $90^\circ$ . The following chart allows you to determine the approximate offset or lead distance required based on a fraction of what would be required for a  $90^\circ$  turn. Simply put, you must determine your  $90^\circ$  turn radius, then apply a fractional percentage of this figure to determine the required offset or lead distance to make a turn that is greater than or less than  $90^\circ$ . The following relationships should help in determining a more accurate lead point:

Degrees to Turn	Fraction of $90^\circ$ Turn
180	2
150	1 $\frac{5}{6}$
135	1 $\frac{2}{3}$
120	1 $\frac{1}{2}$
90	1
60	$\frac{1}{2}$
45	$\frac{1}{3}$
30	$\frac{1}{6}$

3.12.3.1 The items in **BOLD** refer to degrees of turn that are commonly used.

3.12.3.2. Example: If your mission profile dictates making a  $180^\circ$  turn, you must offset your desired course twice the distance required to make a  $90^\circ$  turn. For  $60^\circ$  of turn (intercept), you need to apply one-half the computed lead point. Based on a 3 nm TR computed in example 3.11.2.2 (Formula 1), the following offset/lead points can be determined from the chart above.

$$3.12.3.2.1. \text{ } 180^\circ \text{ turn} = 2 \times 3 \text{ nm} = 6 \text{ nm lead/offset}$$

$$150^\circ \text{ turn} = 1 \frac{5}{6} \times 3 = 5 \frac{1}{2} \text{ nm lead/offset}$$

$$135^\circ \text{ turn} = 1 \frac{2}{3} \times 3 = 5 \text{ nm lead/offset}$$

$$120^\circ \text{ turn} = 1 \frac{1}{2} \times 3 = 4 \frac{1}{2} \text{ nm lead/offset}$$

$$90^\circ \text{ turn} = 1 \times 3 = 3 \text{ nm lead/offset}$$

$$60^\circ \text{ turn} = \frac{1}{2} \times 3 = 1.5 \text{ nm lead/offset}$$

$$45^\circ \text{ turn} = \frac{1}{3} \times 3 = 1 \text{ nm lead/offset}$$

$$30^\circ \text{ turn} = \frac{1}{6} \times 3 = \frac{1}{2} \text{ nm lead/offset}$$

3.12.3.3. Of the fractional formulas listed, you may want to consider committing the relationships corresponding to 180°, 120°, 90°, and 60° to memory since they provide the majority of the TR's you will encounter during instrument flight. When making intercepts requiring less than 60° of turn, your lead point is usually small enough that it is normally not worth calculating.

### 3.13. Arc-to-Radial and Radial-to-Arc Calculations.

3.13.1 Computing a Lead DME (turning to intercept an arc). Computing the aircraft's turn radius for a 90° turn to intercept an arc using 30° of bank is relatively simple. While established on a particular radial (either tracking inbound or outbound from the NAVAID), you will add or subtract the TR (see 3.11.3.) from the DME associated with the arc. Formula:

3.13.1.1. Lead Point DME = Desired Arc DME ± TR.

3.13.1.2. Example: You are established in holding as depicted and planning on flying the ILS RWY 16 at McChord AFB (reference figure 3.3) via the STEIL IAF. For the purpose of this example, you are holding at 5000 feet MSL and indicating 200 KIAS which will be maintained until configuring prior to reaching the FAF. Since TAS increases approximately 2% per 1,000 feet, after converting IAS to TAS, the calculations below will be predicated on 220 KTAS. Therefore, you need to determine a lead point (DME) upon which to initiate the turn to intercept the 10 DME arc (based off of the TCM VORTAC). Here are the no-wind calculations:

3.13.1.3. Lead Point (LP) DME = Desired Arc DME ± TR

$$LP \text{ DME} = 10 \text{ DME} + TR$$

$$LP \text{ DME} = 10 \text{ DME} + [(220 \div 60) - 2]$$

$$LP \text{ DME} = 10 \text{ DME} + (3.7 - 2)$$

$$LP \text{ DME} = 10 \text{ DME} + 1.7 \text{ DME}$$

$$LP \text{ DME} = 11.7 \text{ DME}$$

3.13.1.4. Therefore, after you have received clearance for the approach, when tracking inbound on the 070° course (250° radial) to the TCM VORTAC, upon reaching 11.7 DME, the calculated LP, you should commence a left turn to intercept the 10 DME arc.

3.13.1.4.1 NOTE: The formula is predicated on knowing the aircraft's turn radius which is based on the aircraft's speed in nm/min. Although accuracy will vary slightly, for the purpose of

60-to-1 calculations, the formula works regardless of whether nm/min was determined using TAS or TMN (see 3.5.1.1 and 3.5.1.4).

3.13.1.4.2. NOTE: TAS is used for “air mass” determinations and does not account for the affect of wind on the aircraft’s ground track. To increase accuracy, you should, if able, use a groundspeed (converted to nm/min). This is accomplished by adjusting your TAS to account for the headwind or tailwind component.

3.13.2. Maintaining The Arc. As stated in 11-217 Vol 1, Chapter 7; there are two techniques you can use to maintain an arc. You can use either a series of straight legs or maintain a constant bank angle ( $\Delta$ ). To determine the approximate bank angle to maintain an arc, the following formula may be utilized:

3.13.2.1. Required Bank  $\Delta$  (to maintain arc) =  $(30 \div \text{Arc DME}) \times \text{TR}$

3.13.2.2. Based on the example used in paragraph 3.13.2, if you intercept the 10 DME arc (as depicted) and maintain a relatively constant 220 KTAS during your approach until configuring just prior to the FAF, then you would need to hold approximately  $5^\circ$  of bank to maintain the arc. Here are the calculations:

3.13.2.3. Required Arc Bank  $\Delta$  =  $(30 \div \text{Arc DME}) \times \text{TR}$

$$\text{Required Arc Bank } \Delta = (30 \div 10) \times \text{TR (in nm/min)}$$

$$\text{Required Arc Bank } \Delta = 3 \times 1.7 = 5.1^\circ \text{ (or approximately } 5^\circ)$$

3.13.2.4 NOTE: Calculating and using a constant bank on an arc may be required when flying relatively “tight” arcs, for example, 6 DME arc or less; however, the pilot must be aware that doing so may increase the exposure to developing spatial disorientation (the leans).

3.13.3. Computing a Lead Radial (turning from an arc onto a radial). The following provides a discussion on how to compute a lead radial upon which you can use to intercept an inbound course from an arc. The formulas you use to determine a lead radial to start an arc-to-radial turn are based on the original 60-to-1 calculation. Referencing paragraph 3.4.1, we know that  $1^\circ$  (or radial) equals 1 nm at 60 nm. Using the 60-to-1 formula, if an aircraft is established on the 60 nm (DME) arc and you wanted to intercept an inbound (our outbound radial); then you should initiate the turn  $1^\circ$  (or 1 radial) prior to the desired radial. If the aircraft’s turn radius is 4 nm, then you would need to lead the turn by  $4^\circ$  (or 4 radials) prior. Since virtually all arc-to-radial intercepts occur closer (e.g., 10, 15, 20 DME arc) to the NAVAID, you can easily determine the lead radial upon which to start your turn based on a simple relationship to the original 60-to-1 formula. The relationship enables you to determine the number of radials per nm at a certain distance from the NAVAID (other than 60 nm). Then, based on this figure and the aircraft’s turn radius (refer to paragraph 3.11.1), you can calculate the lead radial needed to turn from the arc to the desired radial. The following formula relationships simplify this discussion.

3.13.3.1. The number of radials per nm at a certain distance (arc DME) from a NAVAID is equal to 60 divided by the arc DME. The formula is written as:

3.13.3.1.1. Radials per nm =  $60 \div \text{DME (arc)}$

3.13.3.2. To determine a lead radial; you then multiply the radials per nm by the aircraft's TR. The formula is written as:

3.13.3.2.1 Lead radial = radials per nm  $\times$  aircraft's TR

3.13.3.3. Example: You are planning on flying localizer portion of the ILS RWY 16 at McChord AFB (reference figure 3.3) via the STEIL IAF and will therefore intercept the inbound course from the 10 DME arc (based off of TCM VORTAC). The turn is initially based on the TCM 338° radial, then once established in the turn, the primary NAVAID providing lateral guidance will become the localizer. For the purpose of this example, you'll maintain 220 KTAS until slowing to configure prior to the FAF. Here are the calculations to determine which radial indication you should use to initiate your turn to intercept the inbound course:

3.13.3.3.1. Radials per nm =  $60 \div \text{DME (arc)}$

$$\text{Radials per nm} = 60 \div 10$$

$$\text{Radials per nm} = 6$$

3.13.3.3.2. Lead radial = radial per nm  $\times$  aircraft TR

$$\text{Lead radial} = 6 \times \text{aircraft TR}$$

$$\text{Lead radial} = 6 \times 1.7$$

$$\text{Lead radial} = 10.2 \text{ (approximately 10 radials)}$$

3.13.3.4 Therefore, if the computed aircraft's turn radius is 1.7 nm, the lead radial upon which you should initiate their turn upon reaching the TCM 328° radial (or 10 radials prior to the TCM 338° radial) in order to intercept the 160° inbound localizer course at KTCM.

3.13.3.5. NOTE: When TERPS publishes a lead radial on an instrument procedure that includes an arc, it is normally based on a TAS of 240 knots and can allow for 2 or 1 nm of turn. Since it is unknown which turning distance the TERPS specialist used and your aircraft's turn radius will vary depending on your airspeed (or groundspeed), it is highly recommended that you calculate your own lead radial.

### **3.14. Procedure Turns Calculations (PTs).**

3.14.1. Overview. The following formulas are designed to aid the pilot/crew in determining the expected distance that is utilized when executing either the 45/180, 80/260, or teardrop portion of a procedure turn course reversal. More importantly, the calculations are designed to help the pilot stay within the required TERPS protected airspace. To reemphasize the information stated in 11-217 Vol 1, paragraph 13.4.1, in order to not exceed protected airspace, based on airspeed flown, it is critical you take into consideration factors affecting the aircraft's turn performance



(e.g., winds, TAS, bank angle). A procedure turn should have a “remain within” distance of either 10 or 15 nm annotated on the profile view of the instrument approach procedure.

3.14.1.1. NOTE: TAS is used for “air mass” determinations and does not account for the affect of wind on the aircraft’s ground track. To increase accuracy of the procedure turn calculations and more importantly, stay within the confines of protected airspace, the pilot/crew should determine their rate of travel in relationship with the earth’s surface by using a groundspeed. This is accomplished by adjusting TAS to account for the headwind or tailwind component.

3.14.2. 45/180 Course Reversal Maneuver Distance. The following formula provides a good estimate to determine the distance that will be utilized (no wind) while flying a 45/180 course reversal maneuver.

3.14.2.1. 45/180 Maneuver Distance =  $(3 \times TR) + 2$

3.14.2.2. For example, a pilot/crew plans to fly a 45/180 procedure turn course reversal at 180 KTAS. In order to complete the calculation, the crew must first convert their rate of travel (TAS or TMN) into nm/min; then compute their TR. Since 180 KTAS equates to 3 nm per min (refer to 3.5.1.2.1), this in turn gives a TR of 1 nm (refer to 3.9.1.3). Here is the calculation:

3.14.2.3. 45/180 Maneuver Distance =  $(3 \times TR) + 2$  nm

45/180 Maneuver Distance =  $(3 \times 1 \text{ nm}) + 2 \text{ nm}$

45/180 Maneuver Distance =  $3\text{nm} + 2 \text{ nm}$

45/180 Maneuver Distance =  $5 \text{ nm}$

3.14.2.4. Based on this information, the distance require to perform the maneuver would be approximately 5 nm (not corrected for winds).

3.14.2.5. Therefore, if the course reversal is flown at 180 KTAS, 5 nm of the “remain within” distance will be dedicated towards executing the 45°/180° maneuver. If the annotated “remain within” distance is 10 nm, the pilot/crew must begin the 45/180 no later than 5 nm from the procedure turn fix (no wind) to stay within protected airspace.

3.14.3. 80/260 Course Reversal Maneuver Distance. The following formula provides a good estimate to determine the required distance needed for the 80/260 course reversal procedure turn maneuver:

3.14.3.1. 80/260 Maneuver Distance =  $3 \times TR$

3.14.3.2. Based on the information provided in the example above (refer to paragraph 3.11.2), if the pilot/crew elected to perform an 80/260 course reversal, approximately 3 nm of the “remain within” distance would be devoted to performing the maneuver. Here are the calculations:

3.14.3.3. 80/260 Maneuver Distance =  $3 \times TR$

80/260 Maneuver Distance =  $3 \times 1 \text{ nm}$

80/260 Maneuver Distance = 3 nm

3.14.3.4. Therefore, based on the information given, 3 nm of the “remain within” distance will be used to perform the 80/260 maneuver. If the “remain within” distance was annotated as 10 nm, the pilot/crew should go outbound no farther than 7 nm from the procedure turn fix before starting the 80/260 maneuver (no wind).

3.14.4. Teardrop, Determining Outbound Distance. In order to determine the required outbound distance (OD) you should fly when executing a teardrop approach and then turn to intercept an inbound course using 30° angle of bank requires the use of the following formula.

3.14.4.1.  $OD = 60 \times \text{turn diameter} \div \text{degrees between radials}$

3.14.4.2. Since the turn diameter is twice the turn radius (TR), the formula can be further be simplified as follows:

3.14.4.3.  $OD = 60 \times (2 \times TR) \div \text{degrees between radials}$

$OD = 120 \times TR \div \text{degrees between radials}$

3.14.4.4. Example: You are planning to fly a teardrop with a calculated average TAS of 180 KTAS (equates to an approximate TR of 1 nm). A review of the IAP indicates that the outbound radial is 045° with an inbound course (195°) corresponding to the 015° radial. Based on the information given, the outbound distance the pilot is required to fly (no wind) would be calculated as follows:

3.14.4.5.  $OD = 120 \times TR \div \text{degrees between radials}$

$OD = 120 \times 1 \text{ nm} \div (045 \text{ radial} - 015 \text{ radial})$

$OD = 120 \div 30$

$OD = 4 \text{ nm}$

3.14.4.6. Therefore, you would proceed outbound on the 045° radial for 4 nm to acquire the proper spacing and then execute a 30° bank turn and roll out on the 015° radial (195° course to the station) at 180 KTAS. Since the aircraft had a 1 nm turn radius, the total distance required to execute the teardrop maneuver would be 5 nm [4 nm + 1 nm (used to complete the first 90° of the turn)].

3.14.4.7. NOTE: In order to ensure the aircraft stays within protected airspace, it is highly recommended that the pilot/crew account for any known winds and use a groundspeed when determining procedure turn calculations. Also, the distance used when performing any procedure turn maneuver can be reduced by using a slower TAS (or groundspeed).

3.14.5. Determining Teardrop Bank Angle ( $\Delta$ ) Required. If the teardrop approach has a required or “hard” turn point, you may want to consider calculating a constant bank angle that would enable you to roll out on the inbound course. To determine a constant bank angle under these circumstances, the pilot/crew must first determine the distance the aircraft will travel between the two radials used in the teardrop procedure.

$$3.14.5.1 \text{ Distance between radials} = \frac{[\text{Radial (a)} - \text{Radial (b)}]}{60} \times \text{DME}$$

3.14.5.2. Once the distance between radials is known, the bank angle that will enable the pilot/crew to roll out on the inbound course (no wind) can be determined by inserting the result into the following formula:

$$3.14.5.3 \text{ Bank angle required} = \text{TR} \times 60 \div \text{distance between radials}$$

3.14.5.3.1. NOTE: The teardrop bank angle calculation works equally as well when rate of travel in nm/min and subsequently TR is determined from a TMN (refer to paragraph 3.9.1.3). Depending on which method is used, TAS versus TMN, the resulting bank angle required will vary within a few degrees.

3.14.5.4. Example: You are planning to fly the HI-ILS or LOC RWY 33 at Bangor International (KBGR) and will maintain an average 210 KTAS for the teardrop portion of the maneuver. Referencing figure 3.6, the teardrop turn is initiated from the BGR 177° radial at 22 DME with the desire to roll out on the 153° radial (closely aligned with the localizer 333° inbound course). Based on the aircraft’s speed and information taken from the IAP, you can determine the approximate bank angle to maintain during the turn using the following two formulas:

$$3.14.5.4.1. \text{ Distance between radials} = \frac{[\text{Radial (a)} - \text{Radial (b)}]}{60} \times \text{DME}$$

$$\text{Distance between radials} = (177^\circ - 153^\circ \text{ radial}) \times 22 \text{ DME} \div 60$$

$$\text{Distance between radials} = (24) \times 22 \text{ DME} \div 60$$

$$\text{Distance between radials} = 8.8 \text{ nm} (\approx 9 \text{ nm})$$

3.14.5.5. As previously discussed, this figure is then inserted into the bank angle ( $\Delta$ ) formula. The aircraft’s turn radius (TR) is calculated using the formula in paragraph 3.11.3. Based on the aircraft’s average TAS of 210 knots, it is therefore determined to have a TR of 1.5 miles.

$$3.14.5.5.1. \text{ Bank } \Delta \text{ required} = \text{TR} \times 60 \div \text{distance between radials}$$

$$\text{Bank } \Delta \text{ required} = 1.5 \text{ nm} \times 60 \div 9 \text{ nm}$$

$$\text{Bank } \Delta \text{ required} = 10^\circ$$

3.14.5.6. Therefore, upon reaching 22 DME, if you establish approximately 10° of bank during the turn, the aircraft should roll out on the 153° radial (or the 333° course inbound).

3.14.5.6.1. **NOTE:** This example does not take into account the affects of winds. To increase accuracy of the calculations, the pilot/crew should determine, if able, their rate of travel in relationship with the earth's surface and use an average groundspeed (converted to nm/min). Groundspeed is TAS corrected for wind.

**Figure 3.6 HI-ILS or LOC Runway 33, Bangor International**

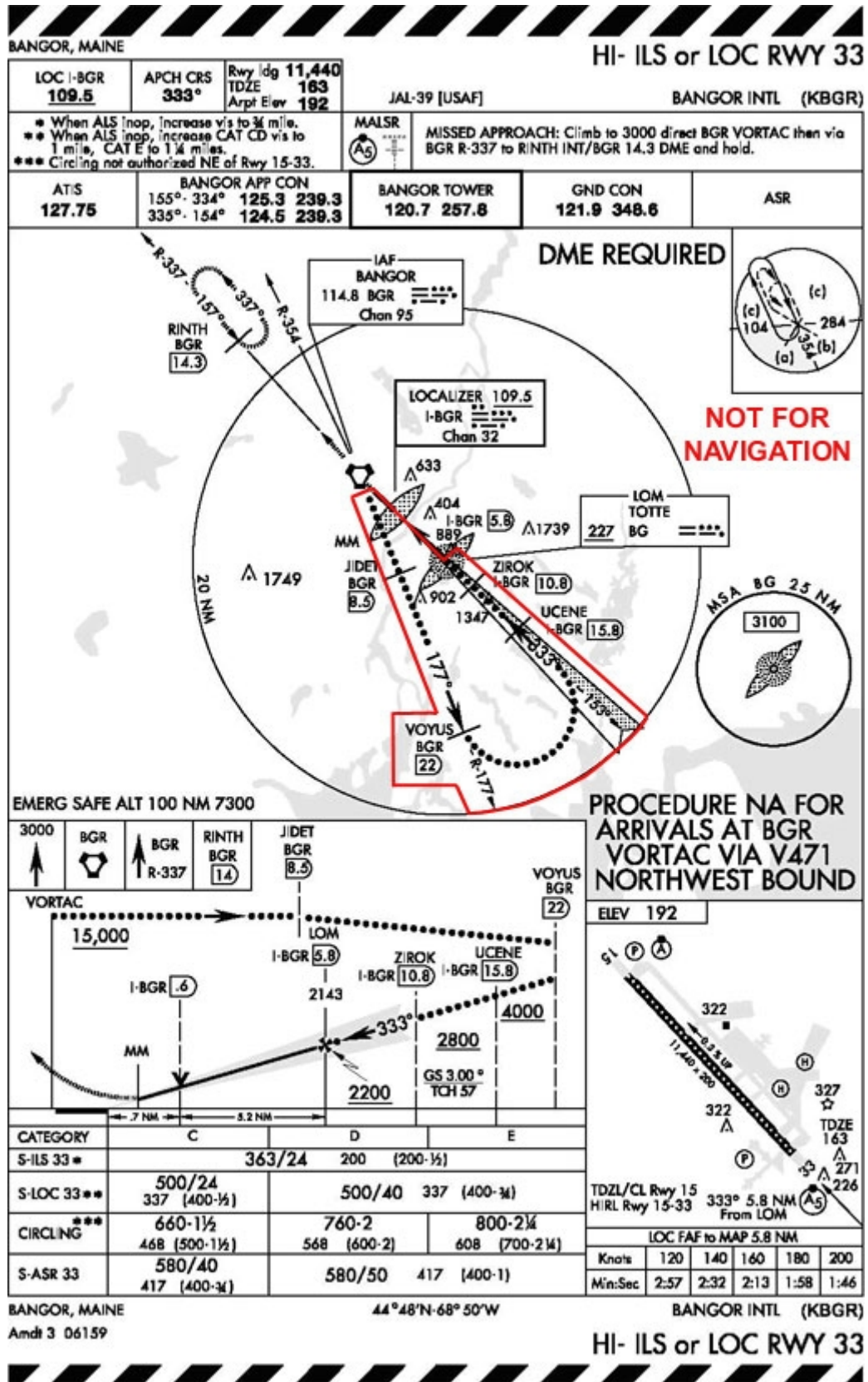

3.14.6. Teardrop Offset. The teardrop offset angle calculation enables the pilot/crew to achieve

required spacing that should allow them to make a standard 30° bank turn back to an inbound course. The calculation works for either a procedure turn course reversal maneuver or may also be used in holding. Since the calculation is predicated on using all available airspace, it is usually more advantageous to utilize the 45/180 and 80/260 course reversal formulas mentioned in the previous discussion when executing a procedure turn and reserve the teardrop offset calculation to holding applications. This is because holding pattern airspace is not only larger but will usually not expose the crew to the same dangers associated with obstacle clearance if inadvertently exceeded.

3.14.6.1. NOTE: Since the formula is predicated on using all available airspace, it is highly recommended that TAS be compensated for winds and groundspeed utilized in the calculation. This will not only increase the accuracy of the calculation, but more importantly, help the pilot/crew stay within protected airspace.

3.14.6.2 When the calculation is used to determine an offset angle for a holding pattern, the “leg length” used in the formula will be based on the distance displayed on the chart, instrument approach plate (IAP), or from timing (e.g., rate of travel for 1 or 1 ½ min will equal a certain distance).

3.14.6.3. For the procedure turn (PT) calculation, to determine the “leg length” distance that should be inserted into the formula, the pilot/crew should subtract the aircraft’s TR from the “remain within” distance.

3.14.6.4. Given a known TAS (or preferably a groundspeed) converted to nm/min and “leg length” distance, the pilot/crew can determine an offset angle (or radial) by using the following formula:

3.14.6.4.1. Degree offset =  $60 \times \text{turn diameter} \div \text{leg length}$

3.14.6.5. Since the turn diameter is twice the turn radius (TR), the formula can be further be simplified as follows:

3.14.6.5.1. Degrees offset =  $60 \times (2 \times \text{TR}) \div \text{leg length}$

Degree offset =  $120 \times \text{TR} \div \text{leg length}$

3.14.6.6. Example: Referencing figure 3.4, you are traveling westbound from the east and planning to fly the full procedure ILS RWY 12 at Mountain Home AFB (KMUO) via the “Mustang” IAF (MUO 224° radial, 12 DME). After receiving clearance to enter holding, you determine that you are conveniently aligned to execute a teardrop upon reaching the fix. The aircraft’s current rate of travel is 180 KTAS. Referring to the IAP, the charted “leg length” is 10 nm (22 DME – 12 DME). After determining the aircraft’s turn radius for 180 KTAS (refer to paragraph 3.11.1.), based on the information given, the calculations to determine an offset angle that will enable a 30° bank turn back to the inbound course is as follows:

3.14.6.6.1. Degree offset =  $120 \times \text{TR} \div \text{leg length}$

Degree offset =  $120 \times 1 \text{ nm} \div 10 \text{ nm}$

Degree offset = 12°

**Figure 3.7 Summary of 60-1 Rules and Formulas**

**CLIMBS AND DESCENTS**

<b>The 60:1 Rule:</b>	1° = 1 NM at 60 NM	1° = 100 FT at 1 NM
<b>Climb and Descent Gradients:</b> Required gradient (FT/NM) = $\frac{\text{altitude to lose (or gain)}}{\text{distance to travel}}$	Pitch change = $\frac{\text{gradient}}{100}$	(1° pitch change = 100 FT/NM)
<b>VVI:</b>	VVI = Gradient (or pitch X 100) X TAS in minutes	
VVI for a 3° glideslope = $\left(\frac{\text{GndSpd X 10}}{2}\right)$	VVI for a 2.5° glideslope = $\left(\frac{\text{GndSpd X 10}}{2}\right) - 100$	
<b>Determine TAS and NM/MIN:</b> TAS = IMN X 600	TAS = IAS + $\frac{\text{FL}}{2}$	TAS = IAS + $\left(\frac{5\text{kt}}{1000}\right)$ <i>Note: works well for the 200-300 knot range</i>
NM/MIN = IMN X 10	TAS = 2% of IAS per 1000'	NM/MIN = $\left(\frac{\text{TAS}}{60}\right)$
<b>Steps to Determine Required Pitch and VVI (Winded Application). Mathematical steps:</b>		
Required gradient:	Gradient = $\frac{\text{Alt to lose}}{\text{Dist to travel}}$	
Required VVI with wind:	VVI = $\frac{\text{gradient X groundspeed (NM/MIN)}}{\text{required VVI}}$	
Required pitch change:	Pitch change = $\frac{\text{required VVI}}{\text{TAS (in NM/MIN)}}$	
<b>NOTE: For practical applications, each 60 KTS of wind will change pitch 1°.</b>		

**TURNS**

Turn Radius (TR)		Turn Diameter (TD) = 2 X TR	
<b>Distance to turn 90° using 30° of bank:</b> TR = NM/MIN - 2		or	TR = (IMN X 10) - 2
TR = $\frac{(\text{NM/MIN})^2}{10}$		or	TR = IMN <sup>2</sup> X 10
<b>Distance to turn 90° using SRTs and 1/2 SRTs:</b> SRT = .5% of TAS (or groundspeed)		1/2 SRT = 1% of TAS (or groundspeed)	
<b>Bank for Rate Turns:</b> Bank for SRT = $\left(\frac{\text{TAS}}{10}\right) + 7$		Bank for 1/2 SRT = $\left(\frac{\text{TAS}}{20}\right) + 7$	
<b>Lead Point for Radial to an Arc or 90° Intercept of an Arc:</b> Lead point in DME = Desired Arc ± TR			
<b>Lead Point for Arc to Radial or 90° Intercept of a Radial:</b> Lead point (in degrees) = $\left(\frac{60}{\text{Arc}}\right) \times \text{TR (in NM)}$ or $\left(\frac{60}{\text{DME}}\right) \times \text{TR (in NM)}$			
<b>For Turns Less or More Than 90°, Use The Following: (These cover most situations):</b>			
<b>Degrees to Turn</b>	<b>Fraction of 90° Turn</b>	<b>Degrees to Turn</b>	<b>Fraction of 90° Turn</b>
180° - 2		90° - 1	
150° - 1 5/6		60° - 1/2	
135° - 1 2/3		45° - 1/3	
120° - 1 1/2		30° - 1/6	
<b>Bank Angle Required to Maintain an Arc:</b> Required bank angle = $\left(\frac{30}{\text{Arc}}\right) \times \text{TR}$ (Use IMN squared for TR to obtain best results)			
or Required Bank angle = $\left(\frac{\text{Radial Lead Point}}{2}\right)$			

**Figure 3.7 (continued)**



### HOLDING

<b>Teardrop Holding Calculations:</b>	
Offset in degrees = $\frac{TD \times 60}{\text{outbound distance}}$	or $\frac{TR \times 120}{\text{outbound distance}}$
<b>Timing:</b>	$\leq 14,000 = 1+00$ $> 14,000 = 1+30$
<b>Outbound Correction for Inbound:</b>	
$1+00 \text{ Correction} = \left( \frac{3600}{\text{inbound time}} \right) = \text{outbound time}$	$1+30 \text{ Correction} = \left( \frac{8100}{\text{inbound time}} \right) = \text{outbound time}$
<b>Double Drift:</b>	
Into wind turn = $30^\circ$ bank - $1^\circ$ for every deg of drift Inbound to fix = <b>course heading <math>\pm</math> drift</b>	Other Turn = $30^\circ$ bank Outbound leg = <b>outbound heading <math>\pm</math> ( drift X 2 )</b> <b>Hold double drift for same amount of time as the <math>180^\circ</math> turn</b>
<b>Drift calculation:</b> Drift = $\frac{\text{Crosswind Component}}{\text{NM/MIN of TAS}}$	<b><math>180^\circ</math> turn = <math>\frac{1\% \text{ TAS}}{2}</math></b> Ex. $240 \text{ TAS} = 2.4 / 2 = 1.2 \text{ Min} = 1+12$
<b>Triple drift:</b> Into Wind Turn = $30^\circ$ bank Inbound to fix = <b>Course heading <math>\pm</math> drift</b>	Other Turn = $30^\circ$ bank Outbound leg = <b>outbound heading <math>\pm</math> ( drift X 3 )</b> <b>Hold triple drift for same amount of time as the <math>180^\circ</math> turn</b>
<b>Drift Calculation:</b> Drift = $\frac{\text{Crosswind component}}{\text{NM/MIN of TAS}}$	<b><math>180^\circ</math> turn = <math>\frac{1\% \text{ TAS}}{2}</math></b> Ex. $240 \text{ TAS} = 2.4 / 2 = 1.2 \text{ Min} = 1+12$

### APPROACH

<b>Teardrop Penetration Calculation:</b>	
Determine <b>outbound distance</b> for $30^\circ$ bank turn:	
Outbound distance = $\left( \frac{TD \times 60}{\text{Degrees between radials}} \right)$	Outbound distance = $\left( \frac{TR \times 120}{\text{Degrees between radials}} \right)$
Determine <b>bank angle</b> required for teardrop penetration ( When $30^\circ$ bank will not work):	
$\frac{TR \times 60}{\text{Distance between Radials in NM}}$	
<b>Procedure Turn Calculations:</b>	
45/180 Maneuver distance = $(3 \times TR) + 2$	80/260 Maneuver distance = $3 \times TR$
<p style="text-align: center;"><math>(3 \times TR) + 2</math>  ----Remain within distance----- </p>	<p style="text-align: center;"><math>3 \times TR</math>  ---Remain within distance--- </p>
<b>VDP Calculation:</b>	
VDP ( in NM ) From the <i>end of the runway</i> = $\frac{\text{HAT}}{\text{Gradient ( normally 300 )}}$	
VDP ( in timing ) From the <i>FAF</i> = $( \text{FAF to End of runway Distance (NM)} ) - \frac{\text{HAT}}{\text{Gradient ( normally 300 )}} = \text{FAF to VDP Dist}$	
$\frac{\text{Timing to MAP ( From timing box )}}{\text{NM from FAF to MAP}} = \text{Seconds per Mile}$ or $\frac{60}{\text{TAS} / 60} = \text{Seconds per Mile}$	
$( \text{Seconds per Mile} ) \times \text{FAF to VDP Dist (NM)} = \text{Time ( in Seconds )}$	

Figure 3.7 (continued)

**CIRCLE**

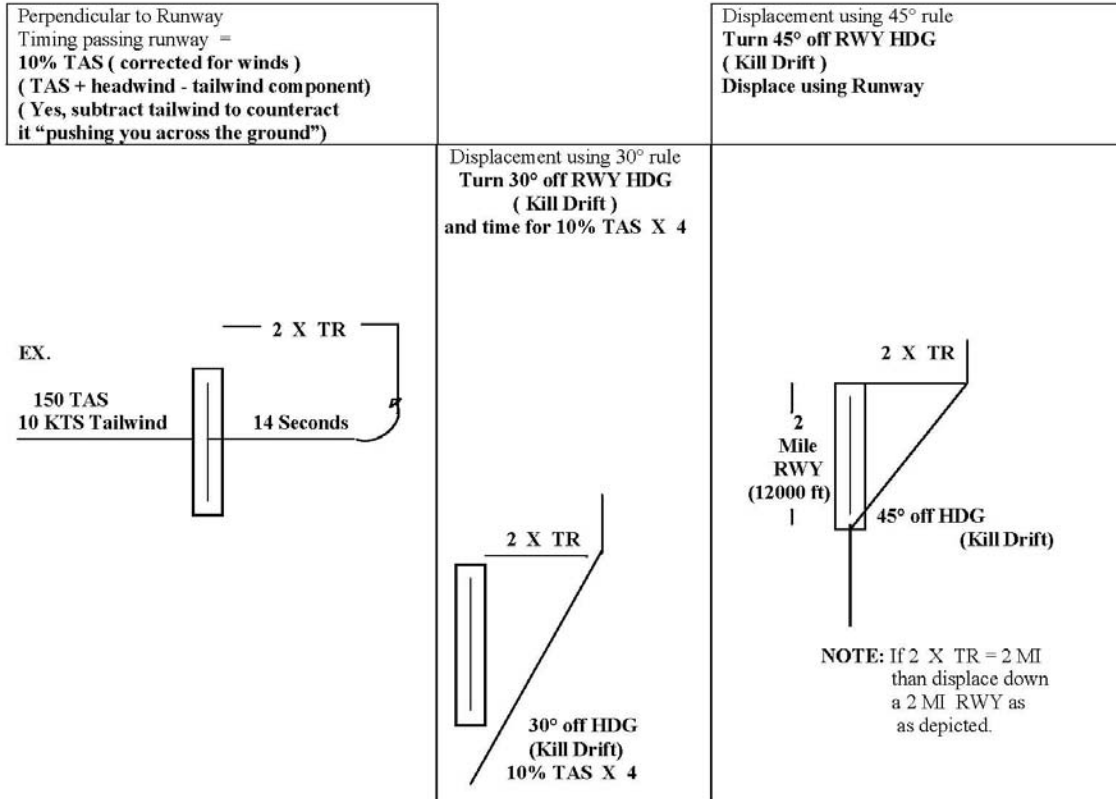

## Chapter 4

### REDUCED VERTICAL SEPARATION MINIMUMS (RVSM)

#### 4.1. RVSM Airspace.

4.1.1. RVSM is a program that enables vertical separation to be reduced from 2,000 feet to 1,000 feet between properly equipped aircraft and appropriately trained aircrew operating from FL 290 to FL 410. Historically, the vertical separation provided to aircraft operating above FL 290 was 2,000 ft. This was due to barometric altimeter inaccuracies at higher altitudes. However, advances in altimeter technology, autopilot capabilities, and altitude deviation warning systems have enabled aviation authorities around the world to safely decrease separation minimums to 1,000 feet (airspace dependent) as long as the aircraft is outfitted with certain avionics capabilities (see paragraph 4.2). Currently within domestic (U.S.) airspace, the RVSM flight levels are between FL 290 and FL 410 with the following orientation based on direction of flight:

4.1.1.1. Magnetic Course 000-179° = Odd Flight Levels

4.1.1.2. Magnetic Course 180-359° = Even Flight Levels

4.1.2. RVSM airspace has been implemented in various regions worldwide. Normal RVSM altitudes include FL 290–410, but altitudes may vary. Therefore, you should consult the appropriate AP Series FLIP to determine the specific regional altitudes and operational rules before operating in RVSM airspace.

4.1.3. The benefits of RVSM include allowing aircraft to fly more optimum altitudes and routes, increased fuel and time savings, increased enroute airspace capacity, and greater air traffic control flexibility.

#### 4.2. Access to RVSM Airspace.

4.2.1. In order for aircrews to fly in RVSM airspace, the aircraft must be properly certified and approved by the lead command. An ATC clearance may be obtained which allows the entrance of a non-RVSM approved aircraft into RVSM airspace.

4.2.2. The FAA has currently authorized DOD non-RVSM compliant aircraft access to RVSM airspace if traffic conditions and controller work load permit. When a non-compliant RVSM aircraft is operating in RVSM airspace, the vertical separation standard applied between the aircraft and others will be 2,000 feet.

4.2.2.1. NOTE: Pilots and crews that are operating in RVSM airspace in a non-RVSM compliant aircraft (whether due to certification or component failure) will state “negative RVSM” upon initial contact with each frequency change.

4.2.2.2. NOTE: Procedures for non-RVSM aircraft to gain access to RVSM airspace, or climb to/descend from altitudes above RVSM airspace, vary by region. Consult FLIP to determine flight plan designation and access requirements.

**4.3. RVSM Aircraft Equipment Requirements.** Aircraft must have certain equipment prior to obtaining certification/approval to operate in RVSM airspace. The following equipment must meet specific tolerances and be functional prior to conducting flight in RVSM airspace:

4.3.1. Two independent altitude measurement systems. Each system should be composed of the following elements:

4.3.1.1. A cross-coupled static source/system with proper ice protection feature (if located in an area subject to ice accumulation).

4.3.1.2. Equipment capable of measuring and displaying pressure altitude to the flight crew (altimeter).

4.3.1.3. Equipment able to convert the displayed pressure altitude into a digitally coded signal for automatic altitude reporting purposes.

4.3.1.4. A static source error correction (if needed to meet the specified performance requirements to operate in RVSM airspace).

4.3.1.5. Equipment that provides reference signals for automatic control and alerting when aircraft is approaching, level, or vacating a selected altitude.

4.3.1.6. An automatic altitude control system (autopilot).

4.3.1.7. An altitude alert system. An altitude deviation warning system should signal an alert to the pilot/crew when a certain deviation from selected altitude is experienced.

4.3.1.8. At least one altitude reporting transponder. If the aircraft has only one altitude reporting transponder, it should have the capability of operating from either independent altitude measurement system.

4.3.1.9. Although a traffic collision avoidance system (TCAS) is not required to operate in RVSM airspace, if the aircraft is equipped with TCAS II, in order to conduct flight in RVSM airspace, it must be modified with, meet, or exceed TCAS II Version 7.0.

4.3.2. Should any of the required equipment needed to operate in RVSM airspace fail, either prior to or while operating in RVSM airspace, notify the controlling agency as soon as possible. Examples of equipment failure that should be reported to ATC either before or after entering RVSM airspace include the following:

4.3.2.1. Failure of the automatic altitude control system (autopilot)

4.3.2.2. Loss of required redundancy capability of the dual independent pressure altitude measuring systems.

4.3.3. Access into or continued flight in RVSM airspace may or may not be granted by the controlling agency based on the level of degradation, ATC traffic considerations, or specific contingency procedures associated with the RVSM airspace (refer to FLIP for regional specific guidance).

#### **4.4. Executing an RVSM Flight.**

4.4.1. Flight Planning. While planning a flight that will operate in RVSM airspace, the flight crew and mission planners (if applicable) should pay particular attention to conditions that may affect operation in RVSM airspace. These include, but may not be limited to:

4.4.1.1. Consulting regional or area specific FLIP regarding guidance and contingency procedures while operating in RVSM airspace.

4.4.1.2. Verifying the aircraft has been certified/approved for RVSM operations and required equipment is operating normally (see paragraph 4.3).

4.4.1.3. If the aircraft is not RVSM-approved or the required equipment not operating within designed specifications, the flight crew must comply with applicable procedures for a non-RVSM capable aircraft and file using the appropriate non-RVSM suffix code.

4.4.1.4. To meet mission requirements, the FAA may be contacted prior to an aircraft's departure (1-4 hours in advance) to receive a conditional or tentative approval for a non-compliant aircraft to operate in domestic RVSM airspace. The FAA facility to be contacted and the method used depends on the number of the "centers" the flight will traverse in RVSM airspace:

4.4.1.4.1. Two hours or less prior to departure: The Traffic Management Unit (TMU) should be contacted at the Air Route Traffic Control Center's (ARTCC) airspace office where the departure airport is located. Contact information can be found at the following link:

[http://www.faa.gov/about/office\\_org/headquarters\\_offices/ato/service\\_units/enroute/rvsm/](http://www.faa.gov/about/office_org/headquarters_offices/ato/service_units/enroute/rvsm/)

4.4.1.4.2. Three or more hours from departure: The FAA has set up a specific website (DOD Priority Mission Site) where military units can enter specific information. It is located at the following link:

<https://www.fly.faa.gov/rvsm/rvsmSignIn.html> (note the https)

4.4.1.5. Annotate on the FAA, ICAO, or military flight plan the appropriate suffix code indicating that the aircraft is approved for RVSM operations.

4.4.1.5.1. NOTE: Only RVSM-approved aircraft with required equipment may use an aircraft equipment suffix indicating RVSM capability. Refer to FLIP General Planning for RVSM flight plan equipment suffix guidance.

4.4.1.6. Obtain reported and forecast weather conditions, particularly areas of turbulence, on the route of flight that may affect RVSM operations.

4.4.1.6.1. NOTE: For information regarding domestic, oceanic, and international RVSM airspace, requirements, and procedures; pilots, crews, and mission planners can access an FAA RVSM website at:

[http://www.faa.gov/about/office\\_org/headquarters\\_offices/ato/service\\_units/enroute/rvsm/](http://www.faa.gov/about/office_org/headquarters_offices/ato/service_units/enroute/rvsm/)

4.4.2. Preflight Actions. The following preflight actions should be accomplished prior to flight in RVSM airspace:

4.4.2.1. Review maintenance forms to ascertain the condition of equipment required for flight in RVSM airspace. Equipment required for flight in RVSM airspace should be operational and any malfunction resolved.

4.4.2.2. During the external inspection of the aircraft, particular attention should be paid to the condition of static sources and the condition of the fuselage skin in the vicinity of each static source and any other component that may affect altimeter accuracy

4.4.2.3. Before takeoff, the aircraft altimeters should be set to the local altimeter setting and should display a known elevation (e.g., field elevation) within the limits specified in aircraft flight manuals. The difference between the known elevation and the elevation displayed on the altimeters should not exceed 75 ft. Both altimeters should also agree within limits as specified in the aircraft flight manual between each other.

4.4.3. Inflight Actions. During flight in RVSM airspace:

4.4.3.1. Flight crews should understand and use proper pilot/controller phraseology while operating in RVSM airspace. Refer to FLIP Area Planning documents for proper RVSM phraseology.

4.4.3.2. Flight crews should ensure aircraft equipment required for operations continue to function normally. Any malfunction or failure that potentially degrades the aircraft's ability to operate safely and meet RVSM requirements should be reported to ATC or appropriate controlling agency.

4.4.3.3. All primary and standby altimeters (if installed) should be promptly set to 29.92 in. Hg when passing the transition altitude and rechecked for proper setting when reaching assigned flight level (FL).

4.4.3.4. In level cruise it is essential that the aircraft is flown at the assigned FL. Except in contingency or emergency situations, the aircraft should not intentionally depart from assigned FL without a positive clearance from ATC or controlling agency.

4.4.3.5. When climbing or descending between assigned FL(s) in RVSM airspace, the aircraft should not be allowed to overshoot or undershoot the cleared FL by more than 150 ft. It is recommended that the level off be accomplished using the altitude capture feature of the automatic altitude-control system, if installed.

4.4.3.6. When entering or changing flight levels within RVSM airspace, vertical speeds should be limited to 1000 feet per minute or less. This helps ensure the aircraft does not overshoot or undershoot the assigned FL by more than 150 feet and reduce the likelihood of inadvertent TCAS resolution advisories occurring.

4.4.3.7. An automatic altitude-control system (autopilot) should be operative and engaged during level cruise, except when circumstances such as re-trimming the aircraft or encountering turbulence require disengagement.

4.4.3.8. At intervals of approximately one hour, it is recommended that the pilot/crew crosscheck the altitude displayed on both primary altimeters and the stand-by altimeter (if installed). The two primary altimeters should agree within 200 ft (60 m) or a lesser value if specified in the aircraft flight manual. (Failure to meet this condition requires the altimetry system be reported as defective and ATC or controlling agency notified). The difference between the primary and stand-by altimeters should be noted for use in contingency situations.

4.4.3.9. Normally, the altimetry system being used to control the aircraft should be selected to provide the input to the altitude-reporting transponder transmitting information to ATC. If the pilot is notified by ATC of an altitude deviation error that exceeds 300 ft, the pilot should take action to return to assigned FL as quickly as possible or resolve the issue.

4.4.3.10. The pilot/crew should notify ATC of contingencies (aircraft system failures, weather conditions) that affect the ability to maintain the assigned FL (within  $\pm 200$  feet or greater) and coordinate a plan of action. Contingency procedures for specific regions and areas are located in FLIP Area Planning documents.

4.4.3.11. Pilots should be aware of the potential for wake turbulence encounters while operating in RVSM airspace, particularly:

4.4.3.11.1. In the vicinity of aircraft climbing or descending through their altitude.

4.4.3.11.2. Approximately 12-15 miles after passing 1,000 feet below opposite direction traffic.

4.4.3.11.3. Approximately 12-15 miles behind and 1,000 below same-direction traffic.

4.4.3.11.3.1. NOTE: Regions may implement use of track-offset procedures to mitigate the effect of wake turbulence and reduce the likelihood of operational errors in RVSM airspace. Specific offset procedures are located in FLIP Area Planning documents.

## Chapter 5

### TERRAIN AVOIDANCE WARNING SYSTEM (TAWS)

#### 5.1. Definitions.

5.1.1. Controlled Flight Into Terrain (CFIT). The term CFIT defines an accident in which a fully qualified pilot or certificated crew inadvertently flies a properly working airplane into the ground, water, or an obstacle with no apparent awareness by the pilots. TAWS is designed to increase situational awareness (particularly during IMC or night conditions) by providing sufficient information and alert notification to detect a potentially hazardous terrain situation. With its enhanced design parameters, TAWS should permit the pilot/crew to take the action necessary to prevent a CFIT event.

5.1.2. Ground Proximity Warning System (GPWS). GPWS was the first generation of ground proximity warning. The traditional GPWS was unable to predict accurately what was ahead of the aircraft since the system only took real time vertical measurements of the terrain directly beneath the aircraft. It did have some limited predictive capabilities based on trend information since the computer kept a track of how quickly the terrain was rising in relation to the aircraft's profile (climbing, level, or descending). Therefore, it was able to warn the aircrew under some, but not all, circumstances since it could not detect steep gradients in terrain (sheer cliff or extremely steep slope) in a timely fashion. Still, by monitoring the aircraft's height in relation to the ground through a radio altimeter and providing basic trend information, the original GPWS significantly reduced CFIT accidents.

5.1.3. Enhanced Ground Proximity Warning System (EGPWS). EGPWS expands on the technology provided by the original or traditional GPWS by incorporating additional terrain alerting features. To provide the aircrew with additional positional awareness, EGPWS may also include a visual display of the aircraft's position in relation to surrounding terrain to. This is accomplished by adding a terrain database for special reference.

5.1.4. Terrain Avoidance Warning System (TAWS). TAWS improves on existing GPWS systems by using position data from a navigation system (e.g. GPS, INS), a digital terrain database, forward looking terrain avoidance capability, and continued operation in the landing configuration. These features provide the aircrew earlier aural and visual warnings of an impending or potential terrain conflict and make a smoother corrective action. Most modern multi function displays have capabilities to interface and display terrain information overlaid with the aircraft's geographical position along with other types of useful data.

5.1.4.1. NOTE: Air Force flight crews should ascertain the regional area of coverage their specific TAWS database covers, particularly when flying internationally.

#### 5.2. TAWS Equipment (Class A and Class B).



5.2.1. **Class A TAWS.** TAWS is divided into two different classes. Of the two, Class A is the more advanced version. Class A TAWS equipment, as a minimum, will provide alerts for the following circumstances:

5.2.1.1. Reduced required terrain clearance.

5.2.1.2. Imminent terrain impact.

5.2.1.3. Premature descent.

5.2.1.4. Excessive rates of descent.

5.2.1.5. Excessive closure rate to terrain.

5.2.1.6. Negative climb rate or altitude loss after take-off.

5.2.1.7. Flight into terrain when not in landing configuration.

5.2.1.8. Excessive downward deviation from an ILS glideslope.

5.2.1.9. Descent of the airplane to 500 feet above the terrain or nearest runway elevation.

5.2.1.10. Voice callout “Five Hundred” during a non-precision approach.

5.2.1.11. Class A TAWS installations must provide a terrain awareness display that shows either the surrounding terrain or obstacles relative to the airplane, or both.

5.2.1.12. Class A systems require input from a 2500 ft. radio altimeter.

5.2.2. **Class B TAWS.** Class B TAWS equipment, as a minimum, will provide alerts for the following circumstances:

5.2.2.1. Reduced required terrain clearance.

5.2.2.2. Imminent terrain impact and premature descent.

5.2.2.3. Excessive rates of descent.

5.2.2.4. Negative climb rate or altitude loss after take-off.

5.2.2.5. Descent of the airplane to 500 feet above the terrain or nearest runway elevation.

5.2.2.6. Voice callout “Five Hundred” during a non-precision approach.

5.2.2.7. Class B TAWS installation may provide a terrain awareness display that shows either the surrounding terrain or obstacles relative to the airplane, or both.

5.2.3. Terrain Awareness Display (TAD). These functions use aircraft geographic position, aircraft altitude, and an internal terrain database to predict potential conflicts between the aircraft flight path and terrain, and to provide graphic displays of the conflicting terrain. The TAD of Class A TAWS displays an image of surrounding terrain in varying density dot patterns of green, yellow and red. The display is generated from the aircraft altitude compared to terrain data in the EGPWS computer. With terrain data available, these dot patterns represent specific terrain separation with respect to the aircraft.

## Chapter 6

### TRAFFIC COLLISION AVOIDANCE SYSTEM (TCAS)

**6.1. General Information.** The objective of TCAS is to provide collision avoidance information. This is achieved primarily through the use of a display medium that provides an overview of squawking aircraft in the general proximity (based on range selection and capabilities). Should an aircraft become a perceived threat, a traffic advisory (TA) is issued whereby the crew is intended to visually acquire and avoid the intruding aircraft. If the aircraft is not visually acquired and the threat increases, a resolution advisory (RA) is then issued directing the pilot to immediately maneuver the aircraft to avoid the potential collision. Figure 6.1 represents a standard TCAS display with the basic color-coding you could expect to see between the various traffic and threat indications. Additional data may be provided as well. This may include but is not limited trend information such as whether traffic is climbing or descending and relative height of traffic (whether above or below) to your aircrafts present altitude. TCAS was designed to reduce the risk of midair collision in the existing conventional air traffic control system while minimizing unwanted alarms in encounters for which the collision risk does not warrant an escape maneuver. TCAS is not dependent upon any ground-based systems, but does need transponder information to operate. TCAS is the U. S. version of ACAS, which is the ICAO accepted name for Airborne Collision Avoidance System (ACAS). TCAS II, version 7 is the same as ACAS II and is the latest version of TCAS software. Although not intended for aircraft that fly in tight formation packages (e.g. fighter-type), it is beneficial for pilots of these types of aircraft to have an understanding of how TCAS works. Doing so may help prevent inadvertently causing a resolution advisory (RA) on another aircraft.

**Figure 6.1. Typical TCAS Display**

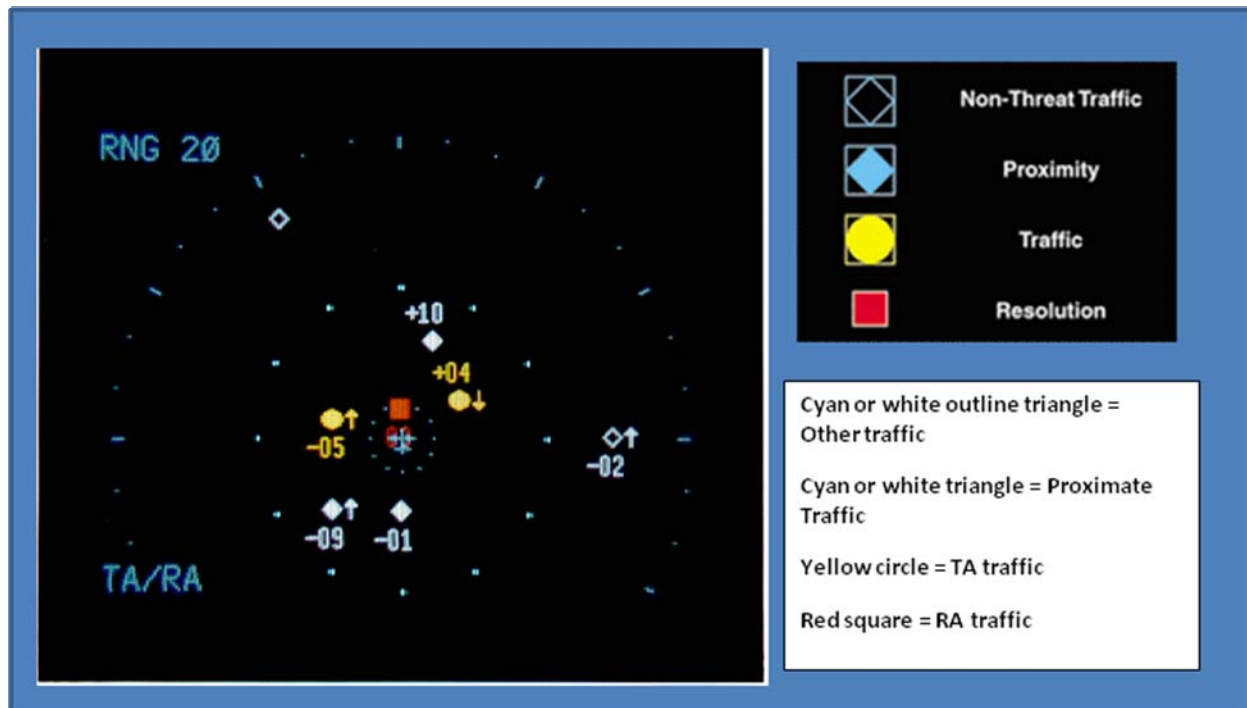

**6.2. TCAS Advisories.** TCAS is capable of providing two classes of advisories. RAs either direct vertical maneuvers, or impose restrictions that are predicted on increasing or maintaining the existing vertical separation from threatening aircraft. TAs indicate the approximate positions of potential threats (e.g., aircraft that may later cause RAs to be displayed). Remember, TCAS RAs only offer vertical solutions and will not give a horizontal escape maneuver. It is also important to understand that while pilots are expected to maneuver their aircraft in response to an RA, they are not expected to do so based on a TA.

**6.3. TCAS Operation.** When airborne, TCAS equipment periodically transmits interrogation signals. These interrogations are replied to by transponders installed on nearby aircraft. The required nominal tracking range is 14 NM. TCAS surveillance range will be reduced in geographic areas with a large number of ground interrogators and/or TCAS equipped aircraft. A minimum surveillance range of 4.5 NM is guaranteed for TCAS aircraft that are airborne. A Mode C transponder replies with its altitude. A Mode S transponder replies with its altitude and unique aircraft address. The TCAS equipment computes the range of the intruding aircraft by using the round-trip time between the transmission of the interrogation and the receipt of the reply. Altitude information, whether the aircraft is climbing or descending, range, closure rate, acceleration and bearing are estimated from the reply information. This data is then processed to determine whether the intruding aircraft is a threat.

#### **6.4. Traffic Advisories.**

6.4.1. TAs alert the flight crew to a potential threat aircraft which may or may not become an impending RA. A TA indicates the general position of a potential threat relative to their aircraft. The general position will normally include some or all of the following; range, range rate, altitude, altitude rate, and bearing of the intruding aircraft relative to their own aircraft. The information conveyed in TAs is intended to assist the flight crew in sighting nearby traffic. TAs without altitude information also guard against non-altitude reporting, transponder-equipped aircraft. However, this type of TA is much more difficult to visually acquire since altitude information is not displayed to the pilot/crew. TAs can be issued against any transponder-equipped aircraft even if the aircraft does not have altitude-reporting capability.

6.4.2. Azimuth resolution accuracy using TCAS equipment is nominal at best. Worst-case azimuth accuracy within  $\pm 10^\circ$ , elevation is  $\pm 9^\circ$  with a peak of  $\pm 27^\circ$ . From  $10^\circ$  to  $20^\circ$  of elevation, the worst-case azimuth accuracy degrades to  $\pm 15^\circ$  with a peak of  $\pm 45^\circ$ . The TCAS is designed to alert the crew to aircraft deemed a potential threat. The pilot/crew is responsible to exercise the appropriate scan techniques to visually acquire the aircraft.

#### **6.5. Resolution Advisories.**

6.5.1. If the threat detection logic in the TCAS computer determines that an encounter with a nearby aircraft could soon lead to a near-collision or collision, the computer threat resolution logic determines an appropriate vertical maneuver that will ensure the safe vertical separation from conflicting aircraft. The selected maneuver ensures adequate vertical separation within constraints imposed by the climb rate capability and proximity to the ground of the TCAS aircraft. The aural advisory given may also be used in conjunction with a electronic vertical

velocity indicator (EVVI) whereby the pilot is provided a rate of climb, either positive or negative, that needs to be complied with to ensure separation (see figure 6.2).

6.5.2. The RAs provided to the pilot/crew can be divided into two categories: corrective advisories, which instruct the pilot to deviate from the current flight path (e.g., “CLIMB” when the aircraft is in level flight); and preventive advisories, which advise the pilot to maintain or avoid certain vertical speeds (e.g., “DON’T CLIMB” when the aircraft is in level flight).

6.5.2.1. NOTE: RAs can be issued only in the vertical plane and only against aircraft that are reporting altitude.

**Figure 6.2. Example of a Typical EVVI Display with TCAS RA**

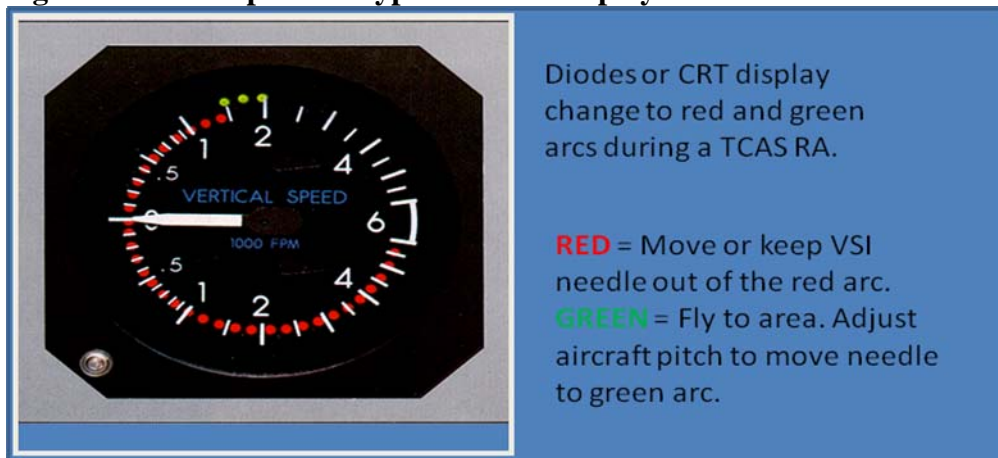

**6.6. Warning Times.** TCAS advisories are typically based on time to Closest Point of Approach (CPA). The time must be short and vertical separation must be small, or projected to be small, before an advisory can be issued. The separation standards provided by air traffic services are different from those against which TCAS issues alerts. In encounters with a slow closure rate, TCAS advisories will be issued based on distance. Thresholds for issuing a TA or RA vary with altitude. The thresholds are larger at higher altitudes. RAs are chosen to provide the desired vertical miss distance at CPA. As a result, RAs can instruct a climb or descent through the intruder aircraft’s altitude. In any potential collision, the TCAS equipment generates an RA nominally 15 to 35 seconds before the CPA of the aircraft. The TCAS equipment may generate a TA up to 20 seconds in advance of an RA.

**6.7. Advisory Thresholds.** The following are the criteria that a TCAS uses for issuing TAs and RAs.

6.7.1. The TA altitude threshold is an 850-foot bubble below FL420 and a 1,200-foot bubble above FL420.

6.7.2. When the vertical miss distance is projected to penetrate the bubble, an RA requiring a change to the existing vertical speed will be issued. The TCAS desired separation varies from 300 feet at low altitude to a maximum of 700 feet above FL300.

6.7.3. When the vertical miss distance is projected to be just outside the bubble, an RA that does not require a change to the existing vertical speed will be issued. This separation varies from 600 to 800 ft.

6.7.4. RA fixed range thresholds vary between 0.2 NM at low altitude and 1.1 NM at high altitude. These fixed range thresholds are used to issue RAs in encounters with slow closure rates.

## **6.8. Air-Air Coordination of Resolution Advisories.**

6.8.1. When the pilot of a TCAS aircraft receives an RA and maneuvers as advised, the TCAS aircraft will normally be able to avoid the intruding aircraft provided the intruder does not accelerate or maneuver so as to defeat the RA response of the TCAS aircraft.

6.8.2. If the intruding aircraft is equipped with TCAS II, a coordination procedure is performed via the air-to-air Mode S data link in order to ensure that the TCAS RAs are compatible.

6.8.3 Failure to respond to an RA negates the collision protection provided by the TCAS. By not taking the appropriate action indicated with a RA, the flight crew effectively takes responsibility for achieving safe separation. In TCAS-TCAS encounters, failure to comply with an RA also degrades the ability of the other aircraft's TCAS equipment to successfully calculate a separation solution.

6.8.4. TCAS provides RAs against aircraft equipped with altitude reporting Mode A/C or Mode S transponders. Aircraft operating a transponder without altitude encoding will only generate a TA. Aircraft not equipped with or not operating Mode A/C or Mode S transponders cannot be tracked by TCAS. Therefore, see and avoid is always warranted to avoid collisions with other aircraft.

**6.9. General TCAS Operational Procedures.** The TCAS system is intended to assist pilots/crews in the avoidance of potential collisions and in the active search for, and visual acquisition of, potentially conflicting traffic. For TCAS to work as designed, immediate and correct crew response to TCAS advisories is essential. Delayed flight crew response to an RA or reluctance to maneuver the aircraft in response to an RA can significantly decrease or negate the protection afforded by TCAS. Therefore, a clear understanding among flight crews of their respective responsibilities when a TCAS advisory occurs is required. Flight crews are expected to respond to TCAS indications in accordance with the following guidelines:

6.9.1. Respond to TAs by attempting to establish visual contact with the intruder aircraft and other aircraft that may be in the vicinity. Coordinate to the degree possible with other crew members to assist in searching for traffic. Do not deviate from an assigned clearance based only on TA information. For any traffic that is acquired visually, continue to maintain safe separation in accordance with current regulations and good operating practices. Pilots should not make horizontal maneuvers based solely on information shown on the traffic display. Slight adjustments in vertical speed while climbing or descending, or slight adjustments in airspeed while still complying with the ATC clearance are acceptable.

6.9.2. When an RA occurs, it is very important that the PF (Pilot Flying) respond immediately by looking at the RA displays and maneuver as indicated, unless doing so would jeopardize the safe operation of the flight. The pilot's instinctive reaction should always be to respond to RAs in the direction and to the degree displayed, without delay.

6.9.3. If a decision is made not to respond to an RA, the flight crew negates the safety benefits provided by their TCAS. A decision to not respond also decreases the safety benefits to all other aircraft involved in the encounter and results in the flight crew taking responsibility for maintaining safe separation.

6.9.3.1. WARNING: Disregarding or maneuvering in such a manner that is not in compliance with a commanded RA could result in a collision with the intruder aircraft.

6.9.4. The following considerations should be taken into account:

6.9.4.1. TCAS does not alter or diminish the pilot's basic authority and responsibility to ensure safe flight.

6.9.4.2. If the intruder aircraft is equipped with TCAS, both systems will communicate with each other and provide individual RAs to provide positive separation. However, it is possible that the other pilot may not respond appropriately and maneuver in an unexpected direction contradictory to the RA provided.

6.9.4.3. Traffic acquired visually may not be the traffic causing the RA, or it may not be the only aircraft to which TCAS is responding.

6.9.4.4. Visual perception of the encounter may be misleading. It is difficult to visually determine the vertical displacement of other aircraft especially when ground reference information is unreliable or at cruise altitudes where the earth's horizon is obscured.

**Table 6.1. Recommended Pitch Change in Response to TCAS RA.**

<b>SPEED</b>	<b>PITCH ADJUSTMENT</b>
.80 MACH	2°
250 KIAS below 10,000 feet	4°
APPROACH below 200 KIAS	5° to 7°

6.9.5. Respond to RAs by disconnecting the autopilot and using prompt, smooth control inputs. Maneuver in the direction and vertical rate recommended by the TCAS. To achieve the required vertical rate (normally 1,500 feet per minute) on aircraft where the RA is displayed on a vertical speed indicator, it is recommended that the aircraft's pitch is changed using the guidelines shown in the table 6.1 above. Referring to the vertical speed indicator (VSI) or vertical speed tape, make any further pitch adjustments necessary to place the vertical speed in the green area.

6.9.6. On aircraft with pitch guidance for TCAS RA displays, follow the RA pitch command for initial, increase, and weakening RAs.

6.9.7. For TCAS to provide safe vertical separation, the PF is expected to initiate the appropriate RA maneuver within 5 seconds of when the RA is first displayed. Deviations from assigned altitude, when responding to an RA, typically will be no more than 300 to 500 feet. RA maneuvers should use vertical speeds within the green areas, or the indicated pitch angle, and avoid red areas on vertical speed indicators or tapes, or outlined pitch avoidance areas.

6.9.8. The PNF (Pilot Not Flying) should provide updates on the traffic location and monitoring the response to the RA. Proper crew resource management (CRM) should be applied.

6.9.9. Respond immediately to any “increase” or “reversal” RA. Initiation of the increase or reversal RA maneuver is expected within 2 ½ seconds after issuance of the advisory. Again, fly to the green area or indicated pitch angle and avoid red areas or outlined pitch avoidance areas.

6.9.10. If an RA is weakened, such as a ‘climb’ RA weakened to a ‘do not descend’ RA, respond to the weakening RA by adjusting the aircraft’s vertical speed or pitch angle as required by the RA display. Pilots are reminded that prompt and correct reaction to the weakened RA will minimize altitude deviations and disruptions to ATC. This will also reduce the possibility of additional RAs against the intruder or other traffic.

6.9.11. Excessive responses to RAs are disruptive to ATC and may result in additional RAs.

6.9.12. If an RA requires the pilot to maneuver their aircraft that is inconsistent with a recently given clearance or contradicts a traffic avoidance vector received by ATC, pilots shall follow the RA.

**6.10. ATC Considerations.** ATC may have older altitude data than the TCAS and normally will not know when a TCAS issues an RA. It is possible for ATC to unknowingly issue instructions that are contrary to the TCAS RA indications. When one aircraft maneuvers opposite the vertical direction indicated by TCAS and the other aircraft maneuvers as indicated by TCAS, a collision may occur. Therefore, if conflicting instructions are received from ATC that are contrary to the RA, maneuver the aircraft IAW paragraph 6.9.12 and AFI 11-202 Vol 3 General Flight Rules (the RA takes precedence).

6.10.1 ATC may not be providing separation service to the aircraft causing the RA or the intruder may not be known to ATC (e.g., military operations in some countries).

6.10.2. If an RA requires maneuvering contrary to “right-of-way” rules, “cloud clearance” rules for Visual Flight Rules (VFR), Instrument Flight Rules (IFR), or other such criteria, pilots are expected to follow the RAs to resolve the immediate traffic conflict. Deviations from rules or clearances should be kept to the minimum necessary to satisfy an RA, but the RA must be satisfied.

6.10.3. If an RA response requires deviating from an ATC clearance, comply with the RA and then correct back to the current ATC clearance in an expeditious manner when the traffic conflict is resolved or the TCAS “clear of conflict” message is heard.



6.10.4. If an RA requires a deviation from an assigned altitude, communicate with ATC immediately after responding to the RA.

6.10.5. When the RA is cleared, the flight crew should 1) immediately return to their previously assigned clearance and advise ATC of that maneuver, or 2) comply with any amended clearance issued

6.10.6. Stall warning, windshear, and Ground Proximity Warning System/Enhanced Ground Proximity Warning System/Terrain Awareness Warning System (GPWS/EGPWS/TAWS) alerts take precedence over TCAS RAs. Pilots shall respond to these alerts instead of RAs.

6.10.7. Pilots should use TCAS traffic information displays to assist in establishing visual contact with other aircraft. Certain Electronic Flight Information System (EFIS) TCAS installations operating in conjunction with “track up” mode may require the pilot to make allowances for the difference between the aircraft heading and track when visually searching for nearby aircraft.

6.10.8. Pilots are expected to operate TCAS while in-flight in all airspace, or as directed by MAJCOM guidance.

6.10.9. When feasible, flight crews should use the same altitude data source that is being used by the PF to provide altitude information to the TCAS and to ATC. Using a common altitude source precludes unnecessary RAs due to differences between altitude data sources.

**6.11. Operating Practices.** The following are recommended TCAS operating practices that have been established when using the system throughout the world.

6.11.1. To preclude unnecessary transponder interrogations and possible interference with ground radar surveillance systems, TCAS should not be activated (TA-only or TA/RA mode) until taking the active runway for departure and should be deactivated immediately after clearing the runway after landing.

6.11.2. During flight, TCAS traffic displays should be used to assist in visual acquisition. Displays that have a range selection capability should be used in an appropriate range setting for the phase of flight. For example, use lower range scales in the terminal area and longer range scales for climb/descent and cruise as appropriate.

6.11.3. If available and traffic density is a factor, the “Above” mode may be used during climb. Likewise, the “Below” mode may be used during descent.

6.11.3.1. NOTE: The configuration of the traffic display, e.g., range and Above/Below selection, does not affect the TCAS surveillance volume.

6.11.4. The normal operating mode of TCAS is TA/RA. It may be appropriate to operate TCAS in the TA only mode in conditions where ICAO States have approved specific procedures

permitting aircraft to operate in close proximity, in the event of particular in-flight failures, performance limiting conditions as specified by the Aircraft Technical Order, or as directed by MAJCOM/local directives.

6.11.4.1. NOTE: Careful consideration should be given when selecting the TA only mode. Operating in TA only mode eliminates the major safety benefit of TCAS.

6.11.5. Operating in TA/RA mode and then not following an RA is potentially dangerous. If an aircraft that does not intend to respond to an RA operates in the TA only mode other TCAS-equipped aircraft operating in TA/RA mode will have maximum flexibility in issuing RAs to resolve encounters.

6.11.6. When safe, practical, and in accordance with written guidance, pilots should limit vertical speeds to 1,500 fpm or less when within 1,000 feet of assigned altitudes. This procedure will reduce the frequency of unnecessary RAs and be in conformance with the ICAO guidance contained in PANS-OPS. Note that TCAS II Version 7 reduces alert thresholds to account for the reduction in vertical separation to 1000 feet above FL 290 in RVSM airspace.

6.11.7. Some ICAO States have taken actions to require vertical speed reductions when approaching an assigned altitude. These requirements, defined in the State's Aeronautical Information Publications (AIPs), were implemented as a means for reducing the probability of unnecessary RAs when an aircraft is climbing or descending to level at an adjacent altitude to another aircraft.

**6.12. Limitations of TCAS.** It is important to understand that TCAS will neither track or display non-transponder equipped aircraft or aircraft with an inoperable transponder. TCAS does not alter or diminish the pilot's basic authority and responsibility to ensure safe flight. Since TCAS does not track aircraft that are not transponder equipped or whose transponder is inoperative, TCAS alone does not ensure safe separation in every case. It is particularly important that pilots maintain situational awareness and continue to use good operating practices and judgement when using TCAS and following RAs. Maintain a frequent outside visual scan and continue to communicate with ATC.

6.12.1. TCAS Failures. TCAS will automatically cease functioning if the input from the aircraft's barometric altimeter, radio altimeter, or transponder is lost.

6.12.1.1. NOTE: In some installations, the loss of information from other on-board systems such as an inertial reference system (IRS) or attitude heading reference system (AHRS) may result in a TCAS failure. Pilots should be aware of what particular types of aircraft system failures will result in a failure of their TCAS.

6.12.2. Other System Limitations.

6.12.2.1 Some aircraft within 380 ft AGL or another nominal value may not be displayed. If TCAS is able to determine an aircraft below this altitude is airborne, it is usually displayed.

6.12.2.2. TCAS may not display all proximate, transponder-equipped aircraft in areas of high-density traffic. Because of design limitations, the bearing displayed by TCAS is not sufficiently accurate to support the initiation of horizontal maneuvers based solely on the traffic display.

6.12.2.3. Because of design limitations, TCAS will neither display nor give alerts against intruders with a vertical speed in excess of 10,000 ft/min. In addition, the design implementation may result in some short-term errors in the tracked vertical speed of a potential conflict during periods of high vertical acceleration by the intruder.

6.12.2.4. Stall warnings, GPWS/TAWS warnings, and windshear warnings take precedence over TCAS advisories. When either a GPWS/TAWS or windshear warning is active, TCAS aural annunciations will be inhibited, and TCAS will automatically switch to the TA only mode of operation. TCAS will remain in TA Only mode for 10 seconds after the GPWS/TAWS or windshear warning is removed.

6.12.3. When TCAS Functions are Inhibited. Certain functions of TCAS are inhibited under the following conditions:

6.12.3.1. Increase descent RAs are inhibited below 1450 ( $\pm 100$ ) ft AGL.

6.12.3.2. Descend RAs are inhibited below 1100 ( $\pm 100$ ) ft AGL.

6.12.3.3. All RAs are inhibited below 1000 ( $\pm 100$ ) ft.

6.12.3.4. All aural annunciations are inhibited below 500 ( $\pm 100$ ) ft AGL. This includes the aural annunciation for TAs.

6.12.3.5. In some aircraft types, the altitude and/or configuration may inhibit a climb and/or increase climb RAs given. TCAS can still issue climb and increase climb RAs when operating at the aircraft's maximum altitude or certified ceiling. Responses to climb RAs while operating at the maximum altitude or certified ceiling should be complied with in the normal manner.

6.12.3.5.1. **NOTE.** In some aircraft types, climb or increase climb RAs are never inhibited.

## Chapter 7

### COMMUNICATIONS, NAVIGATION, SURVEILLANCE (CNS)/AIR TRAFFIC MANAGEMENT (ATM)

**7.1. General Overview.** CNS/ATM is an umbrella term that encompasses all the avionics functions, including flight deck displays, which will enable the concept of Free Flight, a concept where aircraft operators select paths, altitudes, and airspeeds in real time to maximize either efficiency or mission timing. CNS/ATM describes the evolving requirements, enabling technologies, and international harmonization efforts aimed at improving air traffic safety and efficiency. Within DoD, CNS/ATM initiatives replace the GATM (Global Air Traffic Management) effort to enable operational compliance with domestic and international civil performance requirements in order to ensure continued global access to civil controlled airspace. CNS/ATM modernization allows for greater airspace capacity and routing flexibility while incorporating and improving upon safety enhancements. Failure to equip aircraft in line with performance criteria mandates will result in delayed clearances, less than optimal routing, and ultimately, restriction from airspace.

7.1.1. The purpose of this section is to provide a basic description of pertinent CNS/ATM concepts and requirements and is based upon information provided at the following websites:

HQ Air Force Flight Standards CNS Division (AF Portal access required)

<https://afkm.wpafb.af.mil/a3on>

USAF focal point for meeting changing CNS/ATM requirements

<https://igatm.hanscom.af.mil>

Federal Aviation Administration

<http://www.faa.gov>

The European Organization for the Safety of Air Navigation

<http://www.eurocontrol.int>

Strategic Projection of Airspace Requirements and Certifications

<https://sparc.qdmetrics.com>

7.1.2. As CNS/ATM technology implementation is evolving, current Transitional Flight Related Documents can be found at the Defense Internet NOTAM Service (DINS) website:

<https://www.notams.jcs.mil>

## 7.2. Communications.

7.2.1. 8.33 kHz VHF.

7.2.1.1. In the mid-1990's, European agencies recognized that the radio frequency spectrum in Europe was becoming too crowded. Increased demand for airspace and communications was becoming a definite safety hazard. In response, on 7 Oct 99, 8.33 kHz channel spacing radio

communication equipment became mandatory in the ICAO EUR Region for aircraft operating above FL 245. On 15 March 2007, this requirement was expanded to incorporate aircraft operating above FL 195. Many European nations now require 8.33 kHz channel spacing to enable operational improvements and airspace restructuring, increased airspace capacity, as well as improved safety.

7.2.1.2. Where 8.33 kHz spacing has been adopted, no alternative 25 kHz frequency will be published. Unless there is a specific exemption published elsewhere, the only non-8.33 kHz aircraft permitted to fly in 8.33 kHz airspace are State aircraft with UHF radios where UHF coverage is provided or special procedures are implemented. Civil Aviation Authorities (CAA) implementing the 8.33 kHz channel spacing are expected to make appropriate arrangements for the requirements of State aircraft operating as General Air Traffic (GAT) and unable to communicate on the 8.33 kHz spaced channels.

7.2.1.3. ICAO encourages European States to maintain and/or to achieve sufficient UHF coverage in the areas where the new channel spacing is introduced and to adapt their procedures accordingly.

7.2.1.4. Transmissions at traditional 25 kHz spacing in an 8.33 kHz channel spacing environment may not be received and will likely interfere with 8.33 kHz channel transmissions.

7.2.1.5. The emergency channel 121.5 MHz is not affected by the new channel spacing. Its availability and use remain unchanged.

## 7.2.2. FM Immunity.

7.2.2.1. Until 1979, a buffer zone existed between FM radio stations and VHF communication/navigation frequencies. Frequency congestion in Europe resulted in legacy VHF communication/navigation receivers being susceptible to FM radio interference, making them unreliable for IFR operations. Modifications to existing VOR and ILS receivers, new multi-mode receivers (MMR), or approved operational workarounds are now required. The FM spectrum is still protected in the U.S. National Airspace System (NAS). For more information, see FLIP General Planning (GP) and Area Planning (AP) series.

## 7.2.3. Data Link.

7.2.3.1. Data link is simply the electric transmission of digital data between aircraft and/or a ground station. Data link is an enabling technology to facilitate future air traffic management (ATM) criteria. Data link is essential to enable performance-based operations, including the provision of varying service levels to allow airspace users to equip based on varying need.

7.2.3.2. Future Air Navigation System (FANS-1/A) is a set of protocols and applications used for Air Traffic Services (ATS) communication. FANS-1/A comprises Automatic Dependent Surveillance (ADS), Controller-Pilot Data Link Communications (CPDLC), and ATS Facilities Notification (AFN) sent over ARINC 622-enhanced Aircraft Communications Addressing and Reporting System (ACARS). The LINK 2000+ program is a European initiative to expand the

use of domestic data link capability across adjacent ATS providers (ATSP). It is likely that both FANS and Aeronautical Telecommunications Network (ATN) will be accepted.

7.2.3.2.1. Controller Pilot Data Link Communications (CPDLC). CPDLC is a data link application that allows for the direct exchange of text-based messages between controller and pilot, improving communication capabilities for en route, terminal, and oceanic areas. Apart from the direct link, CPDLC adds a number of other benefits to the ATS system, to include:

7.2.3.2.1.1. Auto load of specific uplink messages into the flight management system (FMS) reducing crew-input errors.

7.2.3.2.1.2. Downlink of a pilot route clearance requested for controller approval.

7.2.3.2.1.3. Specific uplink messages arm the FMS to automatically downlink a report when an event, such as crossing a waypoint, occurs.

7.2.3.2.1.4 Specific downlink messages and the response to some uplink messages will automatically update the flight data record in some ground systems.

7.2.3.2.2. VHF Data Link (VDL). VDL is the name given to the sub-network supporting data communications that are sent over VHF frequencies. VDL Mode 0 (VDL-0) is currently used for ACARS for airline control and ATS messages and may be used to transmit FANS-1/A data. VDL-2 is designed to digitize VHF and approve the speed, or data rate, of the VHF link and will probably be used within CONUS as an interim data link solution for enroute ATC functions. VDL-3 is a future technology in development by the FAA for air-ground digital voice and data.

7.2.3.2.3. Satellite Communications (SATCOM). SATCOM supports aircraft communication in oceanic and remote areas where typical line of sight communication systems are nonexistent. SATCOM provides real-time pilot-to-controller communications and electronic message routing that supports reduced separation oceanic tracks. Traditional methods of long-range communication using HF (high frequency) radios are difficult and inefficient. With SATCOM, users tap into a satellite network that provides worldwide, 24/7 coverage of digital voice and data services. Air Force aircraft use the INMARSAT satellite services.

### **7.3. Navigation.**

7.3.1. Performance-Based Navigation (PBN). PBN is an internationally-recognized concept encompassing both Area Navigation (RNAV) and Required Navigation Performance (RNP). As described in the FAA's Roadmap for Performance-Based Navigation, "PBN is a framework for defining a navigation performance specification along a route, during a procedure, or in airspace within which an aircraft must comply with specified operational performance requirements. It provides a simple basis for the design and implementation of automated flight paths and for airspace design, aircraft separation, and obstacle clearance. It also offers a straightforward means to communicate the performance and operational capabilities necessary for the utilization of such paths and airspace." Through the implementation of RNAV and RNP performance standards, PBN offers more flexible routings and reduced separation criteria to accommodate increasing demands on airspace capacity while improving IFR capability into locations previously constrained by terrain, noise abatement, high traffic density, and other limitations.

7.3.2. Area Navigation (RNAV). RNAV is a method of navigation permitting aircraft operation on any desired course within the coverage and capabilities of the aircraft onboard navigation equipment. Increasingly, there will be greater dependence on the use of RNAV in lieu of routes defined by ground-based navigation aids. The FAA has the goal to mandate RNAV by 2015 as traditional ground based NAVAIDs are decommissioned. The RNAV concept incorporates random RNAV routes, published RNAV routes, and RNAV departure, arrival, and approach procedures. Specific guidance for conducting RNAV operations is included in AFM 11-217V1. Furthermore, as mandated by civil standards within certain designated airspace, the aircraft RNAV system must be capable of achieving specified levels of accuracy and functionality. Referencing figure 7.1, when an RNAV type is specified for a specific procedure or airspace, the aircraft RNAV system is required to maintain a track-keeping accuracy for the RNAV type for 95% of the flight time (e.g., RNAV 5 requires the aircraft to be able to maintain positional accuracy within 5 miles of the desired track 95% of the time). Various RNAV designations may also require certain operational standards, such as autopilot or flight director usage, database management/certification processes, etc. Safety is assured through a combination of navigation system accuracy, radar monitoring, and airspace buffers.

7.3.3. Required Navigation Performance (RNP). RNP is RNAV with on-board navigation monitoring and alerting. This incorporates the concepts of containment region, containment integrity, containment continuity, and database requirements as defined in the industry developed “RNP RNAV” concept (RTCA DO-236B). Although it appears that neither the FAA nor ICAO will adopt the term “RNP RNAV” per se, the concept of containment is the key factor distinguishing RNP from RNAV. RNP may have additional functional requirements beyond those of RNAV, e.g., alerting of the loss of RNP capability must occur in the flight crew’s primary field of view. RNP avionics assume the ATS provider ensures their navigation infrastructure meets desired performance requirements. However, since all ATS providers may not provide identical performance from their navigation infrastructure, aircrews must ensure the service provider’s existing infrastructure supports the desired RNP operation.

7.3.3.1. Containment Region. The containment region (see figure 7.1) for cross-track (cross-track containment limit) is currently defined as twice the RNP value (e.g., for RNP-0.3 RNAV the containment region is 0.6 NM). Future definitions are expected for along-track containment and vertical containment.

**Figure 7.1 RNAV accuracy vs. RNP containment.**

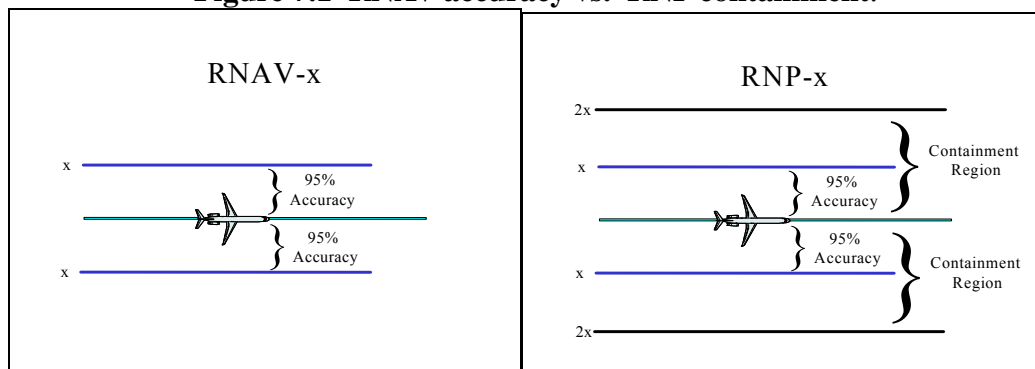

7.3.3.2. Containment Integrity. Containment integrity is a measure of confidence that the navigation system will not exceed the containment region without detecting and annunciating the

deviation to the crew. The probability that an aircraft will exceed the cross-track containment limit without annunciation cannot exceed  $10^{-5}$  per flight hour. In other words, containment integrity assures a 99.999% probability per flight hour that the crew will be alerted when the Total System Error (TSE) is greater than  $2 \times \text{RNP}$ . This performance assurance is intended to facilitate the assessment of operational risk and safety for applications where ATC intervention is not feasible or timely (e.g., instrument procedure).

7.3.3.3. Containment Continuity. Containment continuity is a measure of confidence that the navigation system will satisfy containment integrity without unscheduled interruptions. This includes actual annunciated loss of navigation capability, as well as false alarms. The probability of an annunciated loss of RNP capability cannot exceed  $10^{-4}$  per flight hour. In other words, containment continuity assures a 99.99% probability per flight hour that an annunciated loss of RNP—true or false alarm—will not occur.

7.3.3.4. Database requirements. Database requirements are concurrently mandated with avionics hardware performance for compliance with RNP and P-RNAV airspace access. Specifically, RNP-4 or more accurate navigational performance or P-RNAV (RNAV 1) require databases from approved suppliers. The database is updated on a regular schedule and resides in the flight management or mission computer, providing the reference information that is the basis for executing the flight plan. The FAA and DoD have approved database suppliers. The National Geospatial-Intelligence Agency (NGA) has been designated as the primary supplier for the DoD. Both the FAA and DoD reference RTCA DO-200A, *Standard for Processing Aeronautical Data* and RTCA DO-201A, *Standard for Aeronautical Information*, to define the processes and quality of the database content required to be provided by an approved database supplier.

7.3.4. PBN Harmonization. Regional implementations of RNAV and RNP have resulted in a lack of harmonization with respect to naming conventions, definitions, navigation specifications, and functional requirements. As a result, some current RNP designations do not actually require containment monitoring and alerting. Furthermore, various functional and operational requirements create differences in airspace/procedures that go beyond the simple RNAV or RNP type designation. *Therefore, certification and approval to operate in more stringent PBN airspace does not automatically qualify an aircraft to operate in less stringent PBN airspace.* Certification authorities and operators must reference the specific criteria for the airspace in question in order to determine qualification to participate in that airspace. Recognizing this divergence in standards, ICAO has begun a harmonization effort to ensure a common global understanding of RNAV and RNP system functionality. The new published 2008 ICAO Doc 9613 was revised and renamed the *Performance-Based Navigation Manual* and explains the global application of PBN. It is expected that ICAO will define the key distinction between future applications of RNAV and RNP to be the requirement for on-board performance monitoring and alerting. The following diagrams, taken from a presentation made by the ICAO RNP Special Operational Requirements Study Group at the Thirtieth Meeting of the ICAO Implementation Task Force, 12-16 March 2007, illustrate some expected outcomes.

**Figure 7.2. Performance-Based Navigation**



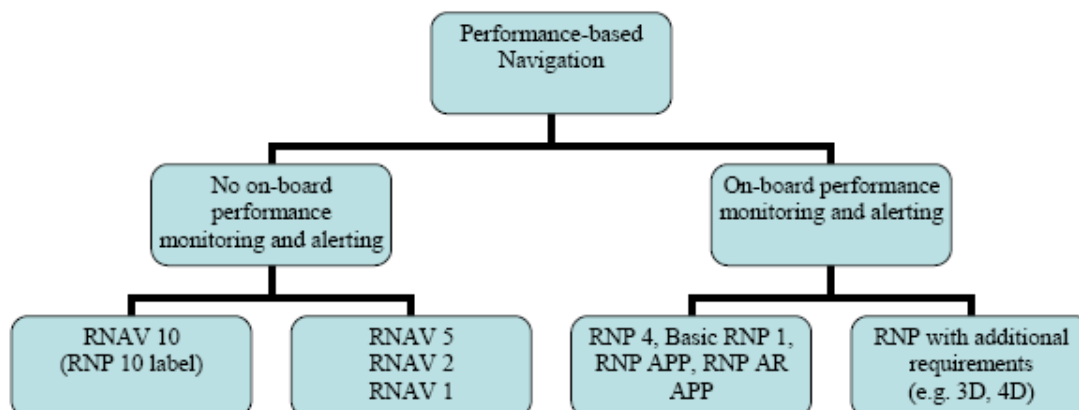

**Table 7.1. Airspace RNP and RNAV Accuracy Requirements**

Area of Application	Navigation Accuracy (NM)	Designation of Navigation Standard (current)	Designation of Navigation Standard (new)	Requirement for performance monitoring and alerting
Oceanic/Remote	10	RNP 10	RNAV 10 (RNP 10 label)	no
	4	RNP 4	RNP 4	yes
Enroute – Continental	5	RNP 5 Basic RNAV	RNAV 5	no
Enroute – Continental and Terminal	2	US-RNAV type A	RNAV 2	no
Terminal	1	US-RNAV type B and P-RNAV	RNAV 1	no

7.3.5. Current PBN Implementations. The following paragraphs provide a brief description of current implementations. There is no intent to address all functional and operational requirements. As stated in the previous paragraph, certification authorities and operational approval authorities must refer to respective source guidance for comprehensive specifications. Air Force aviators should consult their MAJCOM guidance prior to flying RNAV/RNP procedures.

7.3.5.1. RNP-10 has been designated in oceanic/remote areas where 50nm lateral separation standards are applied (Pacific regions). RNP-10 does not require containment monitoring and alerting. FAA Order 8400.12, *Required Navigational Performance 10 (RNP-10) Operational Approval*, is a guide to RNP-10 aircraft and operator approval. Order 8400.12 does not address communications or surveillance requirements that may be specified to operate on a particular route or in a particular area. Those requirements are specified in documents such as Aeronautical Information Publication (AIP) and ICAO Regional Supplementary Procedures (Doc. 7030).

7.3.5.2. RNP-4 has been implemented on a trial basis in certain oceanic airspace (Pacific) where 30nm lateral and longitudinal separation standards (30/30) are being applied. RNP 4 approval requires a number of functional and operational requirements, including use of CPDLC and ADS-C. Civil standards are addressed in FAA Order 8400.33, *Procedures for Obtaining*

*Authorization for Required Navigation Performance 4 (RNP-4) Oceanic and Remote Area Operations.*

7.3.5.3. Minimum Navigation Performance Specification (MNPS) airspace has been designated in the North Atlantic (NAT) and northern Canada. Although MNPS predates the implementation of RNP, it is consistent with the principles and is generally equivalent to RNP-12.6 (without the requirement for containment monitoring and alerting). Civil requirements are addressed in AC 120-33, *Operational Approval of Airborne Long-Range Navigation Systems for Flight Within the North Atlantic Minimum Navigation Performance Specifications Airspace*, as well as the *NAT MNPS Airspace Operations Manual* which may be found at <http://www.nat-pco.org/mnpsa.htm>.

7.3.5.4. Basic RNAV (B-RNAV)/Precision RNAV (P-RNAV). Since 1998, Europe has mandated a B-RNAV capability (equivalent to RNAV 5) for operations in European en route airspace. More recently, certain European terminal airspace has been designated P-RNAV (equivalent to RNAV 1). JAA AMJ 20X2 and JAA TGL 10 are the European source documents for obtaining B-RNAV and P-RNAV approval, respectively. The FAA has incorporated these requirements into AC 90-96A, *Approval of U.S. Operators and Aircraft to Operate Under IFR in Airspace Designated for B-RNAV and P-RNAV*.

7.3.5.5. RNAV 1/RNAV 2. The FAA recently implemented RNAV 1 and RNAV 2 criteria applicable to RNAV SIDS, RNAV STARS, and U.S. RNAV routes (Q-routes and T-routes), not including over water RNAV routes or Alaska VOR/DME RNAV routes. These designations replace the former Type A and B designations for DPs and SIDs. Civil standards for RNAV 1 and RNAV 2 are published in AC 90-100A, *U.S. Terminal and En Route RNAV Operations*.

7.3.5.6. Basic RNP. Within the NAS, standards are under development for Basic RNP which is expected to encompass the previously defined “standard RNP levels” used for various RNAV routes and procedures. The U.S. standard RNP Levels are 2.0 for en route and terminal area operations, 1.0 for initial and intermediate approach segments, 0.3 for final approach segments, and 1.0 for missed approach segments. The Basic RNP designation is expected to incorporate the performance and functional characteristics of TSO-C129A (GPS) and TSO-C146A (WAAS) systems with the implication that containment monitoring and alerting will be accomplished through RAIM and/or CDI displacement.

7.3.5.7. RNP Special Aircraft and Aircrew Authorization Required (SAAAR) approach procedures have been implemented in more challenging locations to leverage the advanced capabilities of modern avionics and navigation systems. RNP SAAAR incorporates very stringent reliability, performance, and operational standards, along with advanced capabilities such as radius-to-fix legs, fixed radius turns, and time-of-arrival control, to create more efficient and reliable approach and departure paths to lower minima. AC 90-101, *Approval Guidance for RNP Procedures with SAAAR*, addresses civil standards for airworthiness and operational approval.

7.3.6. Differential GPS (DGPS). DGPS is a term encompassing technologies that augment the GPS signal by applying corrections for inherent GPS navigation system errors, such as atmospheric error, multi-path error, ephemeris error, and clock error. DGPS has the potential to

enable precision GPS approaches equivalent to Cat I, II, and III ILS. DGPS systems use precisely surveyed ground reference stations to receive and measure the accuracy of GPS signals, then relay a correction back to the aircraft.

7.3.6.1. Satellite-Based Augmentation Systems (SBAS) use geosynchronous satellites to relay corrections to aircraft equipped with the appropriate receiver and avionics. Therefore, SBAS systems provide a larger coverage area. The FAA has implemented the Wide Area Augmentation System (WAAS), which is an SBAS system, within the CONUS and Alaska. Likewise, other regions throughout the world have plans for SBAS implementations in the near term. TSO-C145A and TSO-C146A address the technical specifications for WAAS equipment, and ACs 20-130A and 20-138A address airworthiness installation of the equipment.

7.3.6.2. Ground-Based Augmentation Systems (GBAS) use local VHF transmitters to relay corrections to aircraft equipped with a compliant multi-mode receiver (MMR). GBAS provides coverage for a more localized area, essentially within VHF radio range. GBAS technology could potentially offer a relatively inexpensive and agile IFR approach capability for tactical situations. The FAA is exploring implementation of GBAS via the Local Area Augmentation Systems (LAAS) with trials being conducted at various locations. The DoD is exploring the development of a Joint Precision Approach Landing System (JPALS) as a potential GBAS implementation.

#### **7.4. Surveillance.**

7.4.1. CNS/ATM surveillance technologies include the Mode-S transponder, TCAS, and Automatic Dependent Surveillance (ADS and ADS-Broadcast, ADS-B). Improved surveillance enhances situational awareness for aircrew and air traffic control, collision avoidance, and automatic position reporting. The Mode S is an evolutionary upgrade to the Air Traffic Control Radar Beacon System (ATCRBS). Mode S is required in all TCAS II installations and in Europe for military aircraft starting 2009

7.4.1.1. Mode S is based on an international standard for aircraft surveillance under the civilian air traffic control (ATC) system. The costly utilization of primary ATC radar relies on radio signal transmissions that are passively reflected back from the skin of the aircraft. Secondary Surveillance Radar (SSR) interrogates aircraft transponders and processes the transponder replies. The aircraft's Mode 3/A code is displayed on the ATC SSR display. Mode C (altitude reporting) enhances the controller's vertical situational awareness through the aircraft's barometric altimeter reporting. Mode 3/A is commonly referred to as the 4096 code, because there are only 4,096 combinations with the 4-digit code. Mode S provides a data link capability for surveillance purposes (e.g., to communicate aircraft identification and flight parameters) and an improved positional accuracy.

7.4.1.1.1. Mode S relies on a unique 24-bit address assigned to each aircraft. Civilian aircraft have this address permanently installed so that the address is identified with that particular aircraft throughout its service life (or until the aircraft changes state registry). Military Mode S transponders allow aircrew or ground personnel to change the address on the aircraft to preserve operational security of military aircraft. No two aircraft may have the same address. There are two basic reasons for this. First, one feature of the beacon system is the ability to selectively interrogate a particular aircraft. ATC can send an addressed message (via its data link capability)

directly to a specific aircraft based on its unique address. If more than one aircraft had the same address, then a message cannot be sent to the single intended aircraft. Second, a unique Mode S address allows the surveillance radar to separate targets that are close together (this is a problem with the older ATRBS). The ATRBS may not be able to provide surveillance on two aircraft within 2 miles of one another. The display to the Air Traffic Controller of the tracks for two such aircraft may merge, be lost, or cross over identification.

7.4.1.1.2. In order for military aircraft to continue to use civil airspace throughout the world, with military aircraft having the ability to change their Mode S address, it is imperative that the loaded operational address is from an appropriate issuing authority ensuring a unique code for each aircraft. ICAO has issued a block of Mode S addresses to the US. Within this block, the FAA has issued the DoD a subset of addresses. An address for a US military aircraft is issued by the DoD AIMS program office through HQ AFFSA/A3ON.

7.4.1.2. Surveillance is rapidly evolving into several levels of transmission formats. Basic surveillance begins with an interrogation by ATC or by an aircraft's acquisition squitter (if TCAS equipped) followed by a reply from an aircraft receiving the interrogation. The reply is a stream of data, the extent of which depends on the target aircraft's equipment and can include Mode C altitude, Mode S address, vertical rate status, and max speed. ATC merges this information with primary radar data to create a situational awareness picture for ground controllers.

7.4.1.2.1. Mode S European Elementary Surveillance (ELS) takes basic surveillance and expands it to include additional information such as data link capability report, aircraft identification, and TCAS/ACAS active resolution advisory report. As the name implies this is only being implemented within the European Union. ELS uses this unique 24-bit aircraft address for selective interrogation and to acquire down-linked aircraft identification. Among other attributes associated with ELS is the ability to acquire altitude in 25 foot increments.

7.4.1.2.2. Mode S European Enhanced Surveillance (EHS) consists of ELS supplemented by the extraction of Downlink Aircraft Parameters (DAPs) for use in the air traffic management (ATM) systems. These parameters include vertical intent, track turn, heading and speed reports. Some parameters are for display to the controller and others are for ATM system function enhancements. EHS allows for improved situational awareness and eases congestion, thus enhancing safety and capacity. It will help to reduce the increasing amount of altitude deviations and improve the performance of other safety net tools. EHS is only being implemented in a limited number of states within the European Union.

7.4.1.2.3. Aircraft Identification. The reporting of Aircraft Identification (or Flight ID) is an ICAO requirement for Mode S, level 2 and above, transponders. It permits direct radar identification by a controller and has the capability to relieve the shortage of Mode 3/A codes. Correct setting of Flight ID (entered by the aircrew in the cockpit) is also essential for the correlation of radar tracks with flight plan data in ATM system. Aircraft ID will be identical to the designation entered by the aircrew on the flight plan.

7.4.1.3. Automatic Dependent Surveillance (ADS) provides for the automatic exchange of aircraft position, intent and flight data by data link from the aircraft to the ATC facility without pilot interaction.

7.4.1.3.1. Automatic—periodically transmits information with no pilot or operator input required. Information includes identification, position or other flight plan-related data of a given aircraft.

7.4.1.3.2. Dependent—position and velocity vector are derived from the aircraft's GPS or FMS.

7.4.1.3.3. Surveillance—a method of determining position of specific aircraft, vehicles or other asset.

7.4.1.4. Automatic Dependent Surveillance Contract (ADS-C). ADS-C (previously referred to as ADS-Address, ADS-A in the US) transmits surveillance information to a location for use by ATC. After connectivity is established, the controller can use the link to obtain aircraft position data either on demand (send the requested data now), periodically (send every x minutes), or event-driven (send it when an altitude, waypoint, vertical speed, or cross-track error threshold is exceeded). Methods of ADS-C transmission may include High Frequency Data Link (HFDL), SATCOM, ACARS, and VDL-2.

7.4.1.5. Automatic Dependent Surveillance-Broadcast (ADS-B).

7.4.1.5.1. ADS-B equipped aircraft broadcast surveillance data that may include position, data integrity information, velocity and other flight information. There are two primary ADS-B links in the US—1090 MHz Mode S Extended Squitter (1090 ES) and the 787 MHz Universal Access Transceiver (UAT). To help manage the frequency spectrum, the FAA will allow both links to be developed and rely on ground rebroadcast stations to translate between the two. ADS-B provides coverage at low altitudes and on the ground. It can be used to monitor traffic on the taxiways and runways of an airport. Additionally, it is effective in remote areas and in mountainous terrain where there is no radar coverage, or where radar coverage is limited. Other applications may include enhanced visual traffic acquisition, situational awareness, ground operations, in-trail climb and descent, and decreased final approach spacing.

7.4.1.5.2. Both ADS-A/C and ADS-B data is received by ATC through a two-step process. First, the data is transmitted to a ground station, and then it travels by telephone or Internet to the intended receiver. Additionally, data goes through the two-step process for ATC and operations centers, but it can also be received air-to-air by nearby aircraft if they carry the proper ADS-B avionics.

7.4.1.6. Third Party Surveillance relies on some external sensor to gather traffic information which is transmitted to aircraft requesting this information.

7.4.1.6.1. Joint Tactical Information Distribution System (JTIDS). JTIDS is one form of third party surveillance already in use by the military. This data link system allows both airborne and ground assets to transmit and receive information. By sharing information, an expanded, more complete picture is developed and available to use by all that are able to connect to the system.

7.4.1.6.2. Traffic Information Service (TIS) provides transmission of ground-based derived traffic information to an aircraft. TIS is an alerting service providing automatic traffic advisories from a Mode S sensor to a requesting Mode S-equipped aircraft. The information is tailored to the requesting aircraft to up-link the closest intruders with each scan. The TIS service is intended to improve the pilot's ability to visually see other traffic in the air and on the airport surface so that pilots can more effectively apply traditional "see-and-avoid" techniques. The information provided on other traffic is NOT intended to be used as a collision avoidance system and does NOT relieve the pilot of the responsibility to "see-and-avoid" other aircraft.

7.4.1.6.3. Traffic Information Service—Broadcast (TIS-B) is a ground-based surveillance service using the ADS-B format. The purpose of TIS-B is to provide ADS-B transmissions for aircraft that are not ADS-B equipped. Positional data from ground radars is broadcasted using the ADS-B format and frequencies.

7.4.1.6.4. Traffic Information Service—Re-Broadcast (ADS-R). ADS-R is provided by a ground station. Its purpose is to translate between the two ADS-B links authorized in the United States (1090ES and UAT). A broadcast from a UAT equipped aircraft received on the ground is re-broadcast as a 1090ES ADS-B message. Similarly, a 1090ES broadcast from an aircraft is rebroadcast as a UAT ADS-B message. This allows full use on ADS-B in air-to-air applications in a mixed equipage environment.

**7.5. CNS/ATM Compliance.** USAF aircraft modernization programs must meet performance requirements based upon the civil directives. Certification and approval of CNS/ATM upgrades must be made in accordance with AFD 63-13 "Communications, Navigation, Surveillance/Air Traffic Management and Navigation Safety Performance for USAF Aircraft", and AFI 63-1301, "Assurance of Communications, Navigation, Surveillance/Air Traffic management and Navigation Safety Performance".

## Chapter 8

### AIRCRAFT INSTRUMENTS

#### 8.1. Pressure Instruments.

8.1.1. Pitot and Static Systems. Altitude, speed, and vertical velocity are measured by sensing the pressures surrounding an aircraft. These pressures are furnished either directly to the instruments or to a central air data computer (CADC) by the pitot and static systems.

8.1.1.1. Pitot pressure, or impact air pressure, is taken through the open-end pitot tube that is pointed directly into the relative wind flowing around the aircraft. The pitot tube provides the information to the airspeed indicator.

8.1.1.2. Static pressure is measured at a flush port where the air is not disturbed. The ports are in a location shown by flight tests to be in undisturbed air. They are normally paired, one on either side of the aircraft. This prevents lateral movement of the aircraft from giving erroneous static pressure indications. The static ports provide information to the altimeter, airspeed indicator, and vertical speed indicator (also referred to as a vertical velocity indicator or VVI).

8.1.2. Pitot and Static Sensing Errors. Both the pitot and static systems have inherent characteristics that affect the pressures being supplied to the instruments.

8.1.2.1. Position Error. This error is sometimes referred to as “installation error” and is the result of erroneous static pressure being supplied from the static port or ports. In the design of aircraft, engineers attempt to place the static port (or ports) in locations where, under most flight operations, the air pressure being sensed is being provided by undisturbed free-flowing air. However, under some flight conditions and/or configurations, (e.g., at high angles of attack with the landing gear and flaps down) the air around the static port may become disturbed enough to cause errors in the instruments that require static input, primarily airspeed, mach, and altitude indications. Although the vertical velocity indicator will initially show a pressure change, it is not appreciably affected and stabilizes with the proper indication relatively quickly. The amount and direction of this error is determined by flight test and is found in the performance section of the aircraft flight manual.

8.1.2.2. Compressibility Error.

8.1.2.2.1. For simplicity of design, the airspeed indicator is built to operate in air that is incompressible. Since air is compressible, the error introduced is called compressibility error. The error is zero at sea level density, regardless of airspeed, and increases with altitude as density decreases. It is negligible below 10,000 feet and 250 knots calibrated airspeed (CAS). Above sea level, CAS is always equal to or greater than equivalent airspeed. To correct for compressibility error, refer to the performance data in the aircraft flight manual or apply the “F” factor found on most dead reckoning (DR) computers (see figure 8.1). The error applies only to standard airspeed indicators that are calibrated by the manufacturer to read correctly at sea level

conditions. It does not apply to mach or true airspeed indicators since compressibility is factored into the calibration of those indicators.

Figure 8.1. Correction for Compressibility on DR Computer.

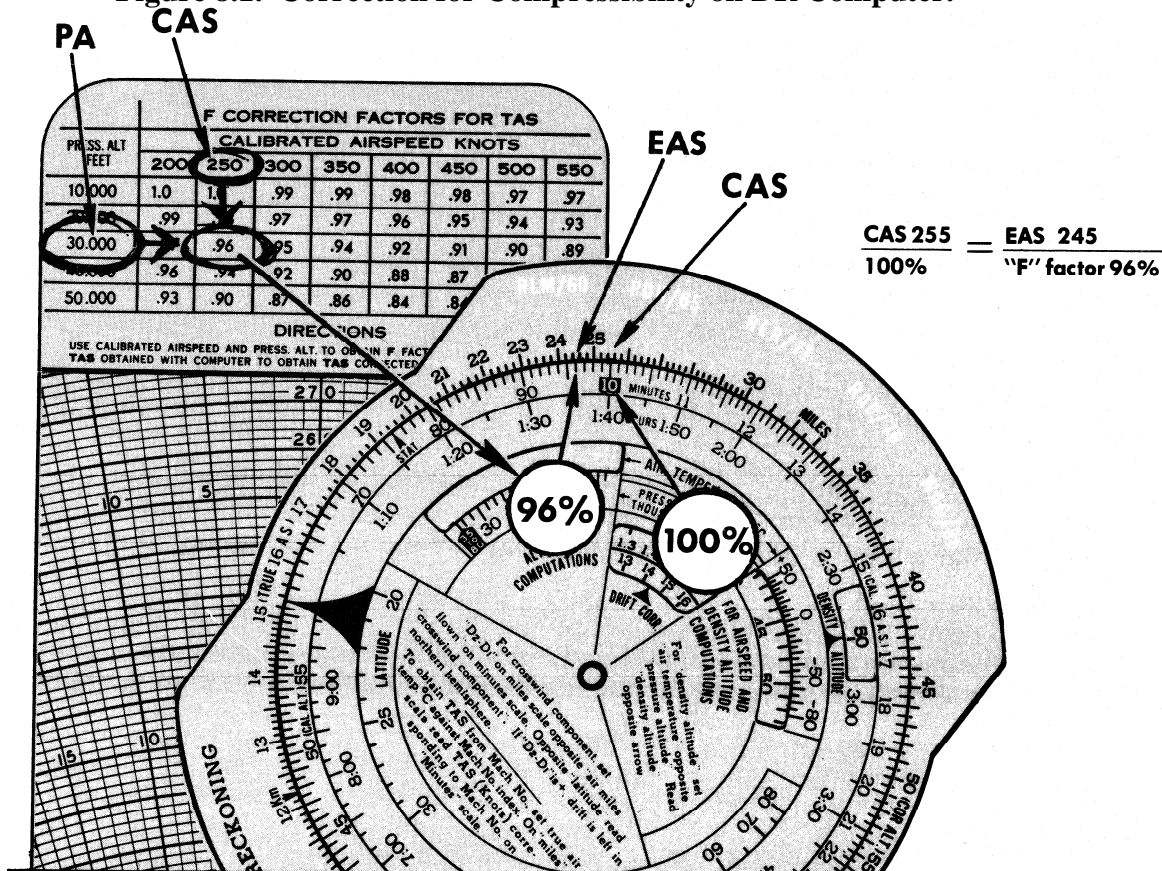

8.1.2.2.2. It is important that the appropriate altimeter position error correction be applied to ensure the aircraft is flying the proper attitude or flight level. The direction (positive or negative) of this error is found in the performance charts and it is critical for the aircrew to understand whether the correction value to be applied should be added or subtracted from the altimeter readout. For example, if your aircraft has an error of - 1,500 feet when cruising at FL250, you should fly at an indicated altitude of FL 235 because of installation error. This error must be applied whether flying IFR or VFR to ensure proper altitude separation between aircraft.

8.1.2.2.2.1. **NOTE:** Altimeter corrections for installation error are not required on aircraft equipped with a servo/pneumatic AIMS system unless operating in the standby mode.

8.1.2.3. Reversal Error. This error is caused by a momentary static pressure change when the aircraft pitch attitude is changed.



8.1.2.3.1. Rotation. When an aircraft is rotated for takeoff, the instruments may indicate a temporary descent and loss of altitude and airspeed due to a momentary higher pressure being sensed by the static system. The effects of this error can be minimized by smooth pitch changes.

8.1.2.3.2. Power. When power (collective) is applied for helicopter takeoff, the instruments may indicate a temporary descent and loss of altitude due to a momentary higher pressure being sensed by the static system. The effects of this error can be reduced by smooth power inputs.

### 8.1.3. Alternate Static System.

8.1.3.1. With Alternate System. An alternate static system is provided in some aircraft in the event the normal system fails or becomes obstructed (e.g., icing). The alternate static ports are usually located at a point within the airframe that is not susceptible to contamination by outside sources. There is normally a pressure difference between the alternate and normal systems that will change the indications of airspeed, mach, and altitude. If the amount and direction of this error is not available in the flight manual, you should familiarize yourself with the differences in cruise, letdown, and especially the approach configurations.

8.1.3.2. Without Alternate System. For aircraft that do not have an alternate static system, consult your flight manual. Here are other actions that you may want to consider:

8.1.3.2.1. Icing. If the failure is due to icing, use the attitude indicator as the primary reference and establish a known power setting. (Check angle of attack). Depart the icing conditions as soon as possible.

8.1.3.2.2. Making an Alternate System. If an alternate static source is not available, you can make one in the cockpit by gently breaking the glass seal of any non-electric differential pressure instrument, such as the VVI, altimeter, airspeed indicator, mach indicator, etc. Select one that is not mandatory for recovery (e.g., mach indicator). If it becomes necessary to use an alternate static source, don't forget that you will have to depressurize the cockpit. You may, as a result, have to descend to comply with oxygen requirements in AFI 11-202 Volume 3, *General Flight Rules*.

8.1.3.2.2.1. NOTE: When using an alternate static source, indicated readings may be higher than actual due to the venturi effect. The direction and magnitude of the error will vary with type of aircraft.

8.1.4. Central Air Data Computer (CADC). Many aircraft use electrically operated vertical tape instruments as well as electrically driven round dial counter-drum-pointer altimeters. To provide the necessary electrical signals to drive these instruments, a CADC or an altitude computer is used. These computers often correct instrument displays for positional and scale errors.

8.1.4.1. CAUTION: Failure of instrument components receiving inputs from a CADC can result in the display of erroneous information without an accompanying warning flag or light.

### 8.1.5. Altimeter and Altitude Measurement.

8.1.5.1. Barometric Altimeter. There are many ways to measure the altitude of an aircraft; probably the simplest is with a barometric altimeter. The pressure of the Earth's atmosphere decreases as height above the Earth increases. If this pressure difference is measured by some mechanical means, it can be directly related to height in feet, meters, or other linear measurement. The height at which a particular pressure is sensed varies with atmospheric conditions.

8.1.5.2. Atmosphere Chart. A standard atmosphere chart provides a reference for altitude measurement. Barometric altimeters are designed to display altitude relative to the pressure difference shown on the chart. For example, if the barometric scale is referenced to 29.92" Hg (sea level, standard conditions) and the instrument is supplied with a static pressure of 20.58" Hg (pressure at 10,000 feet, standard conditions), the altimeter should indicate 10,000 feet. The pressure difference between the sea level and 10,000 feet on a standard day is 9.34 inches of mercury. Any time the altimeter senses this pressure difference between the barometric scale setting and the actual static pressure supplied to the instrument, it will indicate 10,000 feet. Since the actual height of these standard pressure levels varies with atmospheric conditions, the altimeter rarely indicates a true height. This does not cause any aircraft separation problem for ATC purposes since all aircraft flying in the same area are similarly affected. However, under certain conditions, terrain clearance can be a very real problem.

**Figure 8.2. Altimeters.**

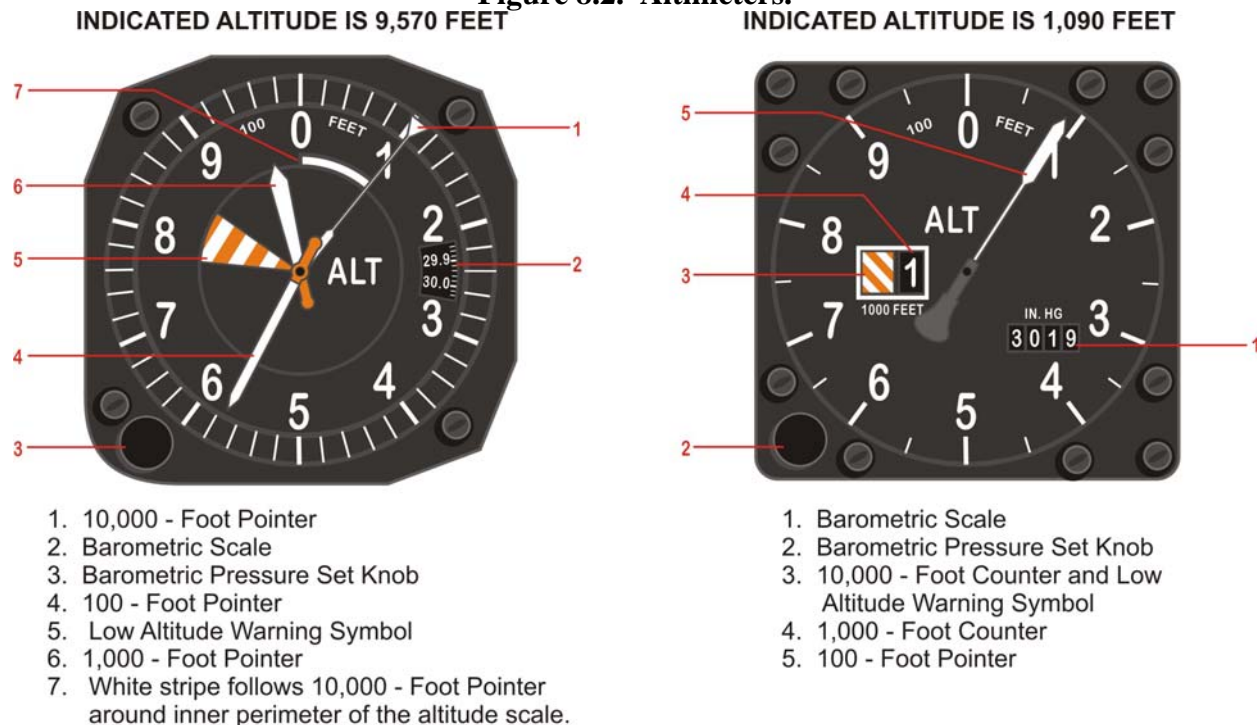

8.1.5.3. Altimeter Errors. Although the altimeter is designed to very close tolerances, there are inherent errors that may affect its accuracy. These are:

8.1.5.3.1. Temperature Error. Pressure altimeters are calibrated to indicate true altitude (the aircrafts actual altitude MSL) under International Standard Atmospheric (ISA) conditions. Any deviation from the standard temperature (or pressure) will result in an error induced into the

altimeter. When the air is warmer than standard, the aircraft is actually higher than the altimeter indicates. Likewise, when the air is colder than standard, the aircraft is lower than is actually being indicated on the altimeter. How much higher or lower from actual versus indicated altitude is determined by the magnitude of the temperature deviation from standard and proportional to the height of the aircraft above the altimeter setting source. The amount of error is approximately 4 feet per thousand feet for each degree Celsius (from ISA). With regards to terrain or obstruction clearance, warmer than standard temperatures are not a factor. However, when operating in extreme cold conditions, it is important that the pilot compensate for the reduction in terrain or obstruction clearance (e.g. when conducting an instrument approach) by adding a cold temperature correction. When conducting an instrument approach, mandatory procedures for applying cold temperature corrections is outlined in AFI 11-202, Volume 3, *General Flight Rules*. The correction table along with an example is found in Section D of the Flight Information Handbook (FIH).

8.1.5.3.2. Scale Error. This error is caused by the aneroids not assuming the precise size designed for a particular pressure difference. It is irregular throughout the range of the instrument; that is, it might be -30 feet at 1,000 feet and +50 feet at 10,000 feet. The tolerances for this error become larger as the measured altitude is increased. At 40,000 feet an error of  $\pm 200$  feet would be considered within tolerance. The amount of scale error *actually* encountered varies with each altimeter. Instrument maintenance personnel calibrate the altimeter prior to installation. No aircrew action is required.

8.1.5.3.3. Friction Error. This error is caused by friction in the moving parts of mechanical altimeters and causes lags in instrument indications. Usually, natural vibrations will resolve friction error in reciprocating engine aircraft. Jet engine aircraft usually have instrument panel vibrators installed to eliminate this error. If the vibrator is inoperative, lightly tapping the instrument at certain intervals may be necessary. These intervals must be determined by the proximity of the aircraft to minimum altitudes. There is an internal vibrator installed in counter-pointer and counter-drum-pointer altimeters. When operating in the non-electrical mode with the internal vibrator inoperative, the 100-foot pointer has been known to “hang up.”





8.1.5.3.4. Mechanical Error. This error is caused by misalignment or slippage in the gears or linkage connecting the aneroids to the pointers or in the shaft of the barometric set knob. It is checked by the altimeter setting procedure during the instrument cockpit check.

8.1.5.3.5. Hysteresis Error. This error is a lag in the altitude indications caused by the elastic properties of the materials used in the aneroids. It occurs after an aircraft has maintained a constant altitude for a period of time and then makes a large, rapid altitude change. The lag in indication occurs because it takes time for the aneroids to “catch up” to the new pressure environment. This error has been significantly reduced in modern altimeters and is considered negligible (less than 100 feet) at normal rates of descent for jet aircraft (4,000-6,000 fpm).

#### 8.1.5.4. Altimeter Settings.

8.1.5.4.1. There are three different altimeter settings (QNH, QFE, and QNE, see figures 8.3 and 8.4) referenced in FLIP and it is important to understand the different settings, how each are derived, and what information is being indicated.

Figure 8.3. Altimeter Settings.

	STANDARD DAY	CORRECTION TO STANDARD DAY	QNH	QFE	QNE
		CONVERT 29.32 AT 1000' TO SEA LEVEL 28.86			
1000'		PAV 0.46 Hg    432' ↓                    ↑ 29.32            28.86			
SEA LEVEL	1000' - 29.92 PRESSURE DIFFERENTIAL 1.06 Hg ↓ 29.92	1.06 Hg ↓ SDP 29.92	1000' - 30.38 ↓ 29.92	0' - 29.32 ↓ 29.92	568' - 29.92 ↓ 29.92
SDP	29.92 SEA LEVEL AND STANDARD DATUM PLANE	PAV 0.46 Hg    432' ↓                    ↑ 30.38            29.92	432' 30.38	432' 30.38	30.38

8.1.5.4.1.1. QNH Altimeter Setting. Set QNH when descending through and operating below the transition level. This setting is obtained by measuring the existing surface pressure and converting it to a pressure that would theoretically exist at sea level at that point. This is accomplished by adding the pressure change for elevation above sea level on a standard day. To illustrate this, consider an airport with an elevation of 1,000 feet (standard atmospheric value 28.86) and an actual observed surface pressure of 29.32 inches of mercury that is a pressure altitude variation (PAV) of 0.46 inches or 432 feet. To obtain the QNH altimeter setting, the pressure differential of 1.06" Hg (29.92"-28.86") is added to the observed surface pressure (29.32" + 1.06") resulting in an altimeter setting of 30.38" Hg. Theoretically, the altimeter will indicate 1,000 feet when 30.38" is set on the barometric scale. The QNH altimeter setting is usually standard throughout most of the world; however, some nations may report QFE. It is very important that the aircrew understand which altimeter setting (QNH or QFE) is being reported and should be used.

8.1.5.4.1.2. QFE Altimeter Setting. This setting is the actual surface pressure and is not corrected to sea level. Using the previous example, if 29.32 inches of mercury were set on the barometric scale, the altimeter would indicate zero feet although field elevation is 1,000 feet. This is because there is no pressure difference between the altimeter reference on the barometric scale and the existing surface pressure that is sensed by the static system. The QNH altimeter setting result in the altimeter indicating height above MSL, while QFE altimeter setting results in the altimeter indicating height above field elevation.

8.1.5.4.1.3. QNE Altimeter Setting. Set QNE when operating at, climbing through, or operating above the transition altitude. This setting is always 29.92 inches of mercury and results in the

altimeter indicating height above the standard datum plane or pressure altitude. This altimeter setting is used at and above transition altitude. Many nations use this altimeter setting for all flights above a specific transition altitude. In these cases, the minimum en route altitude for airways is based on the lowest barometric pressures ever recorded and obstacle height.

8.1.5.4.2 NOTE: Altimeter setting accuracy varies with the distance from where the surface pressure is measured and is considered reliable only when in the vicinity of where it was measured. Local pressure disturbances from wind flow around large buildings may also affect the accuracy of the altimeter. Both QNH and QFE settings may be reported in millibars or hectopascals (one millibar is equivalent to one hectopascal) of pressure rather than inches of mercury. You must then correct this setting to inches of mercury using the conversion tables found in FLIP.

**Figure 8.4. Types of Altitude.**

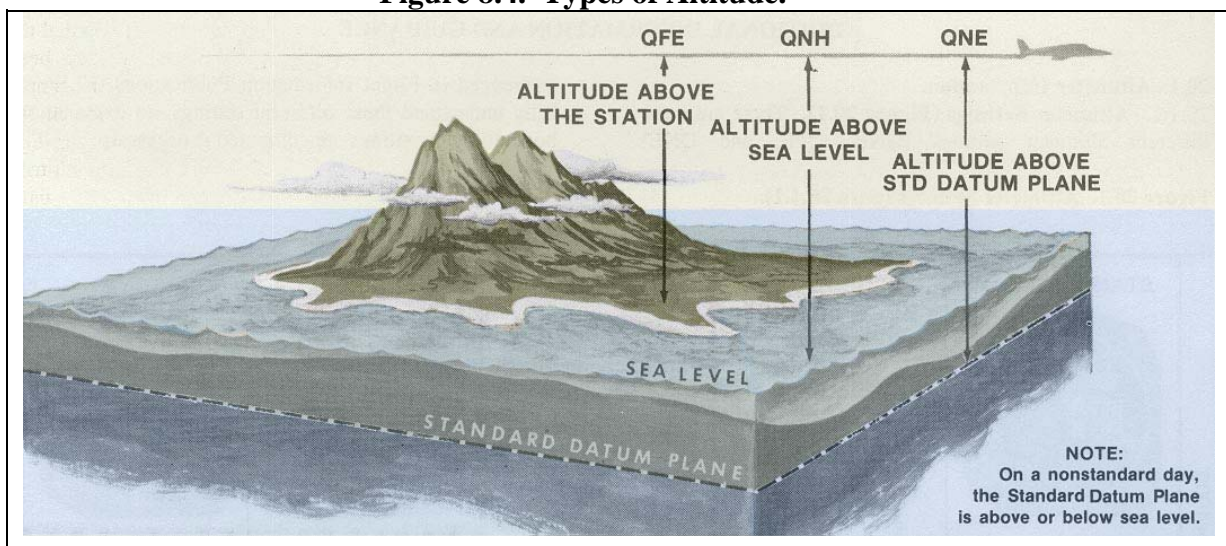

#### 8.1.5.5. Types of Altitude.

8.1.5.5.1. Absolute Altitude. The altitude above the terrain directly below the aircraft.

8.1.5.5.2. Pressure Altitude. The altitude above the standard datum plane (SDP). SDP is the pressure plane where air pressure is 29.92" Hg, corrected to plus 15°C.

8.1.5.5.3. Density Altitude. The pressure altitude corrected for temperature. Pressure and density altitudes are the same when conditions are standard (refer to standard atmosphere table). As the temperature rises above standard, the density of the air decreases resulting in an increase in density altitude.

8.1.5.5.4. Indicated Altitude. The altitude displayed on the altimeter.

8.1.5.5.5. Calibrated Altitude. The indicated altitude corrected for installation error.

8.1.5.5.6. True Altitude. The calibrated altitude corrected for nonstandard atmospheric conditions. It is the actual height above mean sea level.

8.1.5.5.7. Flight Level. A surface of constant atmospheric pressure related to the SDP. In practice, it is calibrated altitude with 29.92' Hg reference on the barometric scale.

### 8.1.6. Speed Measurement.

8.1.6.1. Airspeed measurements are a comparison of pitot (ram) pressure to static (ambient) pressure. The difference between these two pressures is differential (dynamic) pressure. The airspeed indicator measures this dynamic pressure by supplying pitot pressure to a flexible metallic diaphragm and static pressure to the airtight chamber that surrounds the diaphragm.

**Figure 8.5. Airspeed Measurement.**

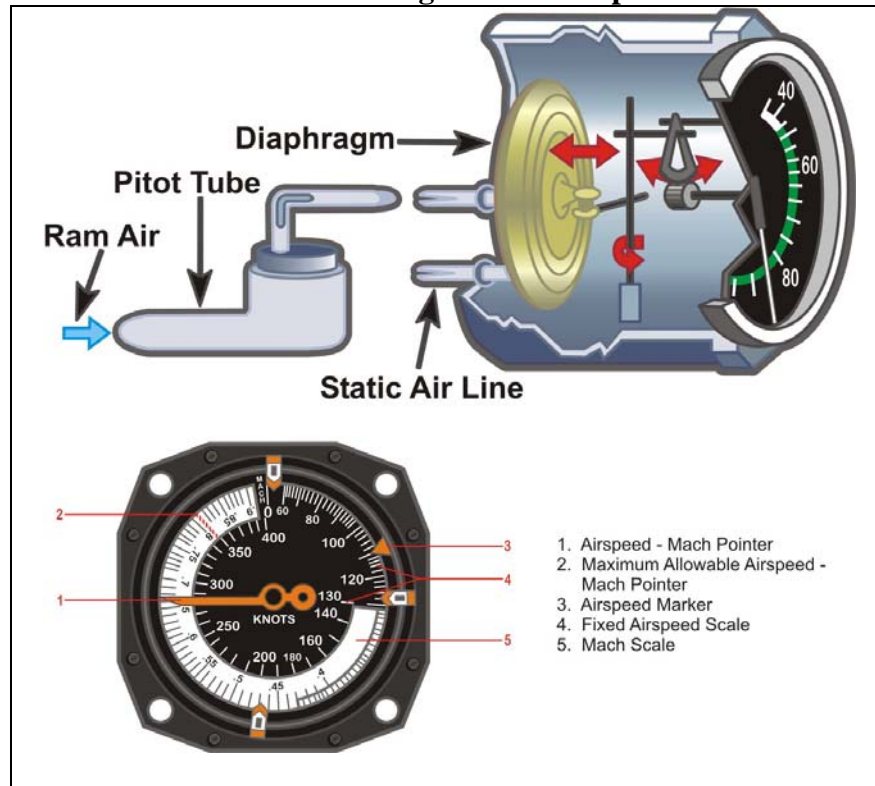

8.1.6.2 When the pitot system is blocked by something, such as ice, the ram pressure is trapped and the static pressure is not, the airspeed indicator then acts as an altimeter. As the aircraft climbs, airspeed indications increase. On most supersonic aircraft, the static source is located on the pitot boom, so if the boom ices over, probably both systems are blocked. In this case the airspeed will remain constant, indicating the speed it had when blockage occurred. On subsonic aircraft the static ports are usually located somewhere on the aircraft not significantly influenced by the airstream. If the static source is blocked and the pitot boom is not, the airspeed will decrease as the aircraft climbs. This situation is possible even with the pitot heat operating, since most aircraft do not have static port heaters. Many aircraft have an alternate static source located in the cockpit for this occurrence.

8.1.6.3. The most important action you should take if you suspect an airspeed error is to establish a known pitch attitude and power setting, then consult your flight manual. Other actions you may consider taking include ensuring your pitot heat is on. If it is on, recheck the

circuit breakers. Check the attitude indicator against the standby attitude indicator or against the other pilot's attitude indicator. Crosscheck the angle of attack indicator (if available).

#### 8.1.6.4. Types of Airspeed.

8.1.6.4.1. Indicated Airspeed (IAS). The airspeed displayed by the airspeed indicator. (This airspeed is uncorrected for all errors associated with airspeed measurement.)

8.1.6.4.2. Calibrated Airspeed (CAS). The indicated airspeed corrected for installation error.

8.1.6.4.3. Equivalent Airspeed (EAS). Calibrated airspeed is corrected for the effects of compressibility.

8.1.6.4.4. True Airspeed (TAS). The equivalent airspeed corrected for air density.

8.1.6.4.5. Groundspeed (GS). The true airspeed corrected for wind.

8.1.6.4.6. Indicated Mach Number (IMN). The Mach number displayed on the mach indicator.

8.1.6.4.7. True Mach Number (TMN). The indicated Mach number corrected for installation error.

8.1.6.5. NOTE: Depending on your aircraft's instrumentation; calibrated, equivalent, and true mach numbers may be determined by referring to the performance data section of your aircraft's flight manual.

#### 8.1.7. Vertical Velocity Measurement.

8.1.7.1. VVIs use "rate of change of static pressure" for measuring vertical rate. The rate of change of static pressure is obtained by supplying static pressure directly to a thin metallic diaphragm and through a calibrated orifice to an airtight case surrounding the diaphragm. As the aircraft climbs from level flight, the static pressure in the case is momentarily "trapped" by the calibrated orifice and the static pressure in the diaphragm is allowed to decrease immediately. This decrease causes the diaphragm to contract and, through a mechanical linkage, the pointer indicates a climb. In a descent, the opposite is true. Case static pressure is momentarily "trapped" at the lower static pressure while the diaphragm expands because of the higher static pressure. This expansion causes the pointer to indicate a descent. Because of this "delay" or "lag" caused by the calibrated orifice, it may require up to 9 seconds for indications to stabilize. However, due to the fact that the needle will point in the proper direction immediately, trend information is available. Many of the "instantaneous" types of indicators use either a pitch gyro signal or an accelerometer signal for the initial indication and then stabilize the indication with barometric information.

**Figure 8.6. Vertical Velocity Indicator.**

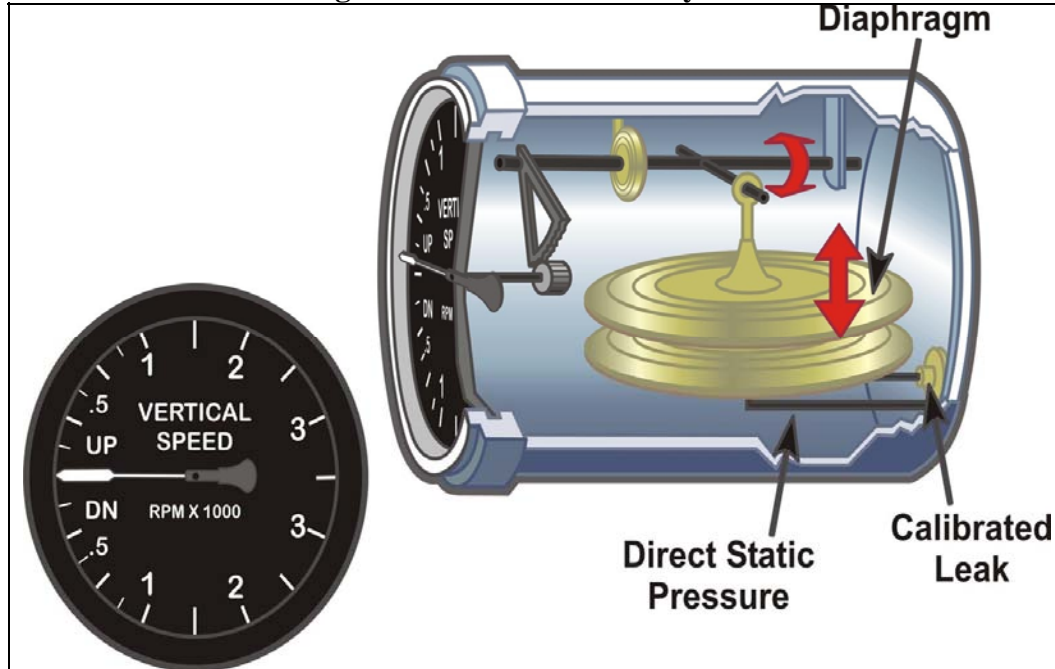

## 8.2. AIMS.

8.2.1. Components of AIMS. Aims is an acronym for:

8.2.1.1. Air Traffic Control Radar Beacon System (ATCRBS)

8.2.1.2. Identification Friend or Foe (IFF)

8.2.1.3. Mark XII Identification

8.2.1.4. AIMS is a system that provides altitude reporting and several selective identification features. The equipment is capable of automatically reporting a coded altitude and aircraft identification signal to ground stations upon interrogation. This information provides selective identification and altitude readout for control of air traffic. Two types of AIMS systems presently being used in Air Force aircraft are the servo/pneumatic system and the altitude encoder system. Consult your flight manual for a description of the system utilized in your aircraft.

8.2.2. Servo/Pneumatic AIMS System.

8.2.2.1. Components. The servo/pneumatic type system generally consists of an IFF and selective identification feature (IFF/SIF) transponder, precision pressure altimeter, servo-mechanism, altitude computer, controls, and other associated equipment. In this system, pitot and static pressures are provided to an altitude computer that is designed to apply a correction for



installation error. The computer supplies calibrated altitude information to the transponder for altitude reporting and to the servoed altimeter for display to the pilot.

8.2.2.2. Modes. The AAU-19 servo/pneumatic counter-drum-pointer altimeter has two modes of operation: the primary or servoed mode (reset) and the secondary or nonservoed mode (standby). In the primary (servoed) mode, the altimeter displays calibrated altitude. The installation error correction is applied to the barometric altitude by a servo-mechanism using electrical signals supplied by the altitude computer. A secondary (nonservoed) mode is provided in the event of malfunction. The altimeter display then operates directly from static air pressure, and the appropriate altimeter installation error correction must be applied to ensure the aircraft is at the proper altitude. As long as the altitude computer is operating properly, it will supply an altitude reporting signal to the air traffic control radars, regardless of the mode displayed on the pilot's altimeter.

8.2.3. Altitude Encoder AIMS System. The altitude encoder type system is found in aircraft with small or negligible installation error. It generally consists of an IFF/SIF transponder, precision pressure altimeter and an altitude encoder. In this system, the altimeter and altitude encoder are a single unit. The encoder portion of the unit simply takes the barometric altitude measured by the altimeter and converts it to signals for altitude reporting. The appropriate altimeter installation error correction must be applied at all times to ensure the aircraft is at the proper altitude.

8.2.3.1. Altitude Reporting. AIMS systems report altitude based on the standard datum plane (29.92" Hg), regardless of the value set in the altimeter barometric scale. When aircraft are flying below the lowest usable flight level, ground station computers automatically apply the local altimeter setting to display accurate altitude to the air traffic controller. In order for cockpit altimeters to reflect the correct altitude as displayed to the controller, the proper value must be set in the altimeter barometric scale.

8.2.3.2. NOTE: "Code of P" and "standby" flags on AIMS altimeters do not always mean that altitude reporting has been lost. If a warning flag appears, verify that your altitude is being reported to the air traffic controller.

8.2.4. Automated Radar Terminal System (ARTS). ARTS is designed to provide controllers with an alphanumeric display of aircraft identification and groundspeed on aircraft equipped with transponders, along with altitude readout on those aircraft capable of automatic altitude reporting (Mode C). This information is displayed on the controller's radar display as a data block in addition to the "primary" traffic target return. ARTS is installed at many, but not all, terminal areas.

8.2.4.1. Advantages. ARTS equipment has simplified coordination with the terminal ATC facilities and significantly reduced the pilot and controller radio calls. This reduction in communications allows the controller to concentrate more attention on control decisions and planning.

8.2.4.2 Flight Considerations. While the FAA has provided automated ground equipment, the benefit to individual aircraft operation is dependent on the status of the airborne transponder equipment. The following are recommendations to assist pilots in obtaining optimum use of transponder equipment.

8.2.4.2.1. Aircraft with Transponders. Aircraft with transponders having altitude reporting capability should have them turned on before takeoff and contacting departure or approach control.

8.2.4.2.2. Discrete Code. When you are assigned a discrete code (four digits) and you are not sure of the number, ask for a repeat. It is important to dial the correct code as it is a discrete code specified for your aircraft alone. If you dial the wrong code, there is a chance that it has already been assigned to another aircraft. The computer cannot distinguish between two aircraft on the same code in the same radar coverage area.

8.2.4.2.2.1. NOTE: Squawking a four-digit code does not supply the ground equipment with altitude readout. Altitude reporting is a separate function and must be specifically selected on the transponder.

8.2.4.2.3. Beacon Code. When dialing in the assigned beacon code, delay in the selection of each digit of the assigned beacon code can result in the transmission and recognition by the computer of a code assigned to a different aircraft. As noted above, the computer cannot distinguish between two aircraft on the same code in the same radar coverage area. Consistent with safe aircraft control, avoid hesitating between the selection of each digit. As a technique, the pilot or aircrew member can momentarily switch the transponder to “standby,” change the beacon code, and then turn back to the transmit.

8.2.4.2.4. Automatic Altitude. For controllers to use your automatic altitude report, they must first verify your altitude. In order to use the automatic altitude data, it must not have an error of 300 feet or more of the pilot’s reported altitude. Actual altitude reports will permit the controller to verify the automated altitude report transmitted by your transponder. (There are several ways the controller can verify altitude without directly asking you; therefore, you are not always aware that your altitude has been verified).

### **8.3. Attitude Instruments.**

8.3.1. Attitude Indicator. This indicator provides you with a substitute for the Earth’s horizon to maintain a desired aircraft attitude during instrument flight. This is accomplished by displaying an attitude sphere positioned by a self-contained gyro, remote gyros, or an inertial platform. The figures represented below represent typical attitude indicators.

**Figure 8.7. Three-Axis Attitude Director Indicator (ADI).**

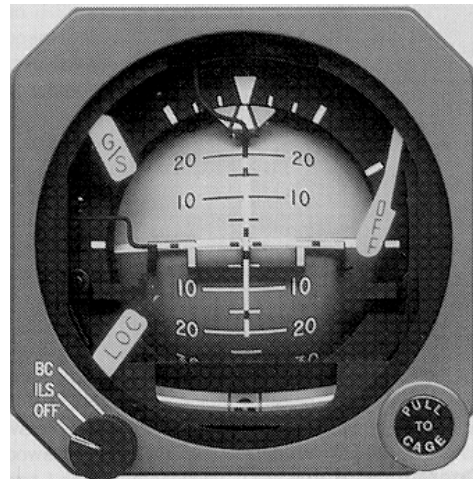

8.3.1.1. Precession. To serve as an attitude reference, the gyroscope spin axis must remain aligned with relation to the Earth's surface. Any movement (real or apparent) of the spin axis is called:

8.3.1.1.1. Apparent Precession. As the Earth rotates or as a gyro is flown from one position on the Earth to another, the spin axis remains fixed in space. However, to an observer on the surface of the Earth, the spin axis appears to change its orientation in space. Either the Earth's rotation (Earth rate precession) or transportation of the gyro from one geographical fix to another (Earth transport precession) may cause apparent precession.

8.3.1.1.2. Real Precession. Movement of the gyro spin axis from its original alignment in space is real precession. It is caused by a force applied to the spin axis. This force may be unintentional force such as rotor imbalance or bearing friction, or an intentional force applied by the erection mechanism or torque motor.

8.3.1.1.3. Erection Mechanisms. The erection mechanisms compensate for precession by keeping the gyros aligned with the Earth's surface.

**Figure 8.8. Precession of Gyroscope Resulting from Applied Deflective Force.**

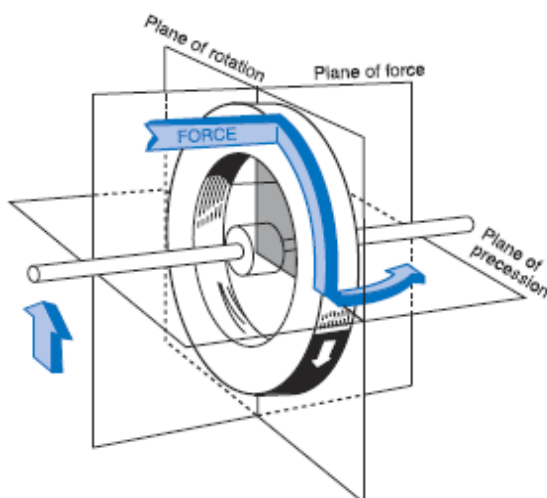

8.3.2. Turn and Slip Indicator. The principal functions of the turn and slip indicator (see Figure 8.9) are to provide an alternate source of bank control and to indicate a need to correct, if required, for a yaw trim. One needle-width deflection on the turn indicator provides for a 360° turn in either 2 minutes (3°/sec) for a 2-minute indicator, or 4 minutes (1½°/sec) for a 4-minute indicator.

8.3.2.1. NOTE: A standard-rate turn is 3° per second and a half standard-rate turn is 1½° per second.

**Figure 8.9. Turn and Slip Indicators.**

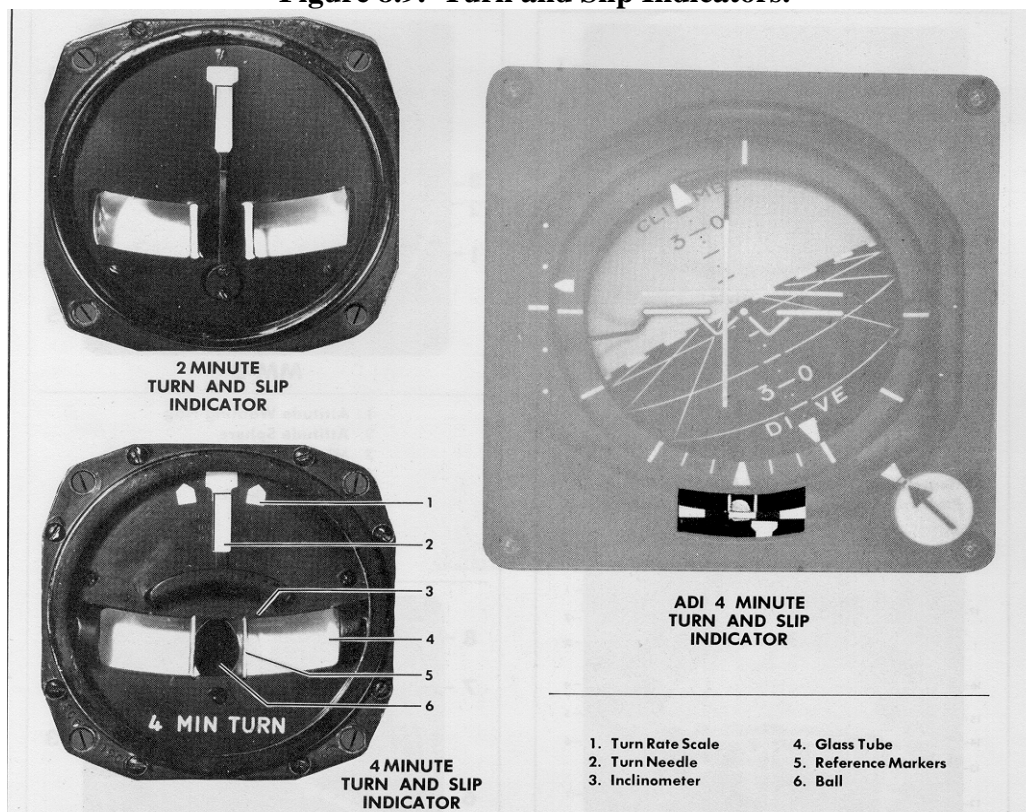

## 8.4. Heading Systems.

8.4.1. Heading Information. Heading information is usually obtained by using the Earth's magnetic lines of force. The magnetic compass is a self-contained instrument that operates independently of the electrical system and converts these magnetic lines of force to aircraft heading information. Other heading systems require electrical power to convert the magnetic lines of force to aircraft heading.

8.4.2. Basic Operation of Magnetic Compass. The magnetic field that surrounds the earth consists of invisible lines of flux. These lines leave the surface of the earth at the magnetic north

pole and reenter at the magnetic South Pole. The Earth's magnetic north pole does not actually coincide with the geographic North Pole, but is located at a position that approximates 200 nm north of Resolute Bay, Canada. Also, the location tends to move within the confines of a magnetic polar area several hundred miles in diameter. Thus, there is actually no exact position of the magnetic North Pole. These lines of magnetic flux have two important characteristics: any magnet that is free to rotate will align with them, and an electrical current is induced into any conductor that cuts across them. Most magnetic direction indicators installed in an aircraft make use of one or both of these two characteristics. One of the oldest and simplest instruments for indicating direction is the magnetic, or "whiskey" compass. An aircraft magnetic compass has two small magnets attached to a metal float sealed inside a bowl of clear compass fluid similar to kerosene. A graduated compass card marked with the four cardinal directions of the compass (N, S, E, and W) as well as smaller increments, is wrapped around the float and viewed through a glass window with a lubber line across it. The float and card assembly has a hardened steel pivot in its center that rides inside a special, spring-loaded, hard-glass jewel cup. The buoyancy of the float takes most of the weight off the pivot, and the fluid damps the oscillation of the float and card. This jewel-and-pivot type mounting allows the float to freely rotate and tilt up to approximately 18° angle of bank. At steeper bank angles, the compass indications may become erratic and unpredictable.

8.4.2.1. Variation. Variation is the difference between true and magnetic direction. Maps and charts are drawn using meridians of longitude that pass through the geographic poles. Directions measured from the geographic poles are called "true" directions. Directions measured from the magnetic poles are called "magnetic" directions. Isogonic lines (see Figure 8.10) are lines of equal variation traced on the surface of the globe. They connect places at which the deviation of the magnetic needle from true north is the same. The line that passes near Chicago is called the agonic line, and anywhere along this line the two poles are aligned, and there is no variation. East of this line, the magnetic pole is to the west of the geographic pole and a correction must be applied to a compass indication to get a true direction. West of this line, the magnetic pole is to the east of the geographic pole and a correction must be applied as well. Add west variation to the true course to obtain the magnetic course. Subtract east variation to the true course to obtain the magnetic course. Variation does not change with the heading of the aircraft; it is the same anywhere along the isogonic line.

**Figure 8.10. Isogonic Lines.**

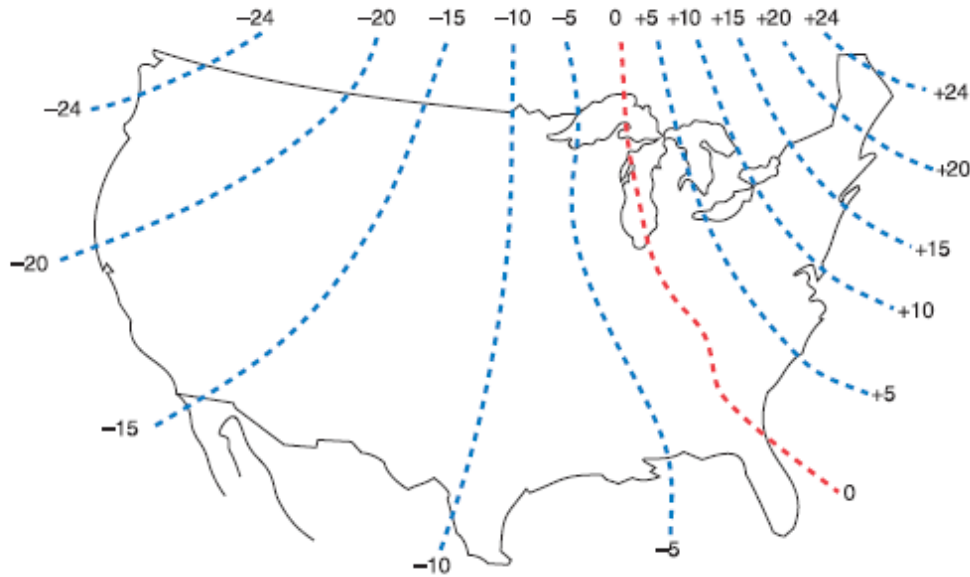

8.4.2.2. Deviation. Deviation is an error in the magnetic heading introduced by production of local magnetic fields. Electrical currents flowing in the structure of the aircraft induce localized magnetic fields that can cause deviation in the magnetic compass. Localized magnetic fields outside the aircraft can induce deviation errors as well. Whereas variation error cannot be reduced or changed, deviation error can be minimized by calibrating the magnetic compass to compensate for known localized magnetic fields within the aircraft. This is a maintenance task known as a “compass swing”. Most airports have a compass rose, which is a series of precisely aligned lines drawn in an area of the airport where there is no magnetic interference. By aligning the aircraft with the known magnetic headings, maintenance personnel can calibrate the magnetic compass. The compass correction card shows the amount of deviation on various compass headings. Corrections for variation and deviation must be applied in the correct sequence. To find the magnetic course when the true course is known:  $\text{True Course} \pm \text{Variation} = \text{Magnetic Course} \pm \text{Deviation} = \text{Compass Course}$ . To find the true course that is being flown when the magnetic course is known:  $\text{Compass Course} \pm \text{Deviation} = \text{Magnetic Course} \pm \text{Variation} = \text{True Course}$ .

8.4.2.3. Dip Errors. The lines of magnetic flux are considered to leave the Earth at the magnetic North Pole and enter at the magnetic South Pole. At both locations the lines are perpendicular to the Earth’s surface. At the magnetic equator, which is halfway between the poles, the lines are parallel with the surface. Since the magnets in the compass are designed to align with the horizontal component of the magnetic field, the compass card tends to progressively dip or tilt (error induced become more pronounced) near the poles. The float is balanced with a small dip-compensating weight, so it stays relatively level when operating in the middle latitudes of the northern hemisphere. This dip along with this weight causes two very noticeable errors: northerly turning error and acceleration error.

8.4.2.3.1. Northerly Turning Error. The pull of the vertical component of the Earth’s magnetic field causes northerly turning error, which is apparent on a heading of north or south. When an aircraft is flying on a heading of north, if a turn toward east is made, as the aircraft banks to the

right it will cause the compass card to tilt to the right. The vertical component of the Earth's magnetic field pulls the north-seeking end of the magnet to the right, and the float rotates, causing the card to rotate toward west, the direction opposite the direction the turn is being made. If the turn is made from north to west, the aircraft banks to the left and the card tilts to the left. The magnetic field pulls on the end of the magnet that causes the card to rotate toward east. This indication is again opposite to the direction the turn is being made. The rule for this error is: when starting a turn from a northerly heading, the compass indication lags behind the turn (see figure 8.11). When an aircraft is flying on a heading of south and begins a turn toward east, the Earth's magnetic field pulls on the end of the magnet that rotates the card toward east, the same direction the turn is being made. If the turn is made from south toward west, the magnetic pull will start the card rotating toward west—again, in the same direction the turn is being made. The rule for this error is: When starting a turn from a southerly heading, the compass indication leads the turn (see figure 8.11).

**Figure 8.11. Northerly and Southerly Turning Error.**

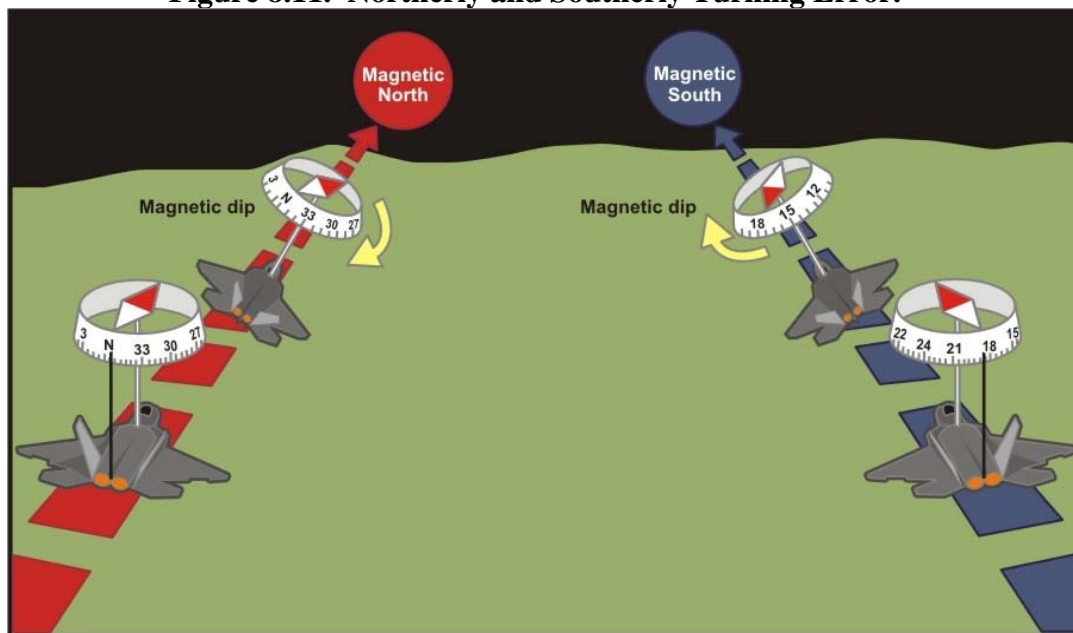

8.4.2.3.2. Acceleration/Deceleration Error. In the acceleration error, the dip-correction weight causes the end of the float and card marked N (this is the south-seeking end) to be heavier than

the opposite end. When the aircraft is flying at a constant speed on a heading of either east or west, the float and card are level. The effects of magnetic dip and the weight are approximately equal. If the aircraft accelerates on a heading of east, the inertia of the weight holds its end of the float back, and the card rotates toward north. As soon as the speed of the aircraft stabilizes, the card will swing back to its east indication. If, while flying on this easterly heading, the aircraft decelerates, the inertia causes the weight to move ahead and the card rotates toward south until the speed again stabilizes. When flying on a heading of west, the acceleration errors or induced. Inertia from acceleration causes the weight to lag, and the card rotates toward north. When the aircraft decelerates on a heading of west, inertia causes the weight to move ahead and the card rotates toward south. An acronym that is used to describe this error is “ANDS” which means that when an aircraft is on an easterly or westerly heading, “Accelerate = North, Decelerate = South.” Figure 8.12 provides a graphical presentation of the acceleration/deceleration error.

**Figure 8.12. Acceleration/Deceleration Error.**

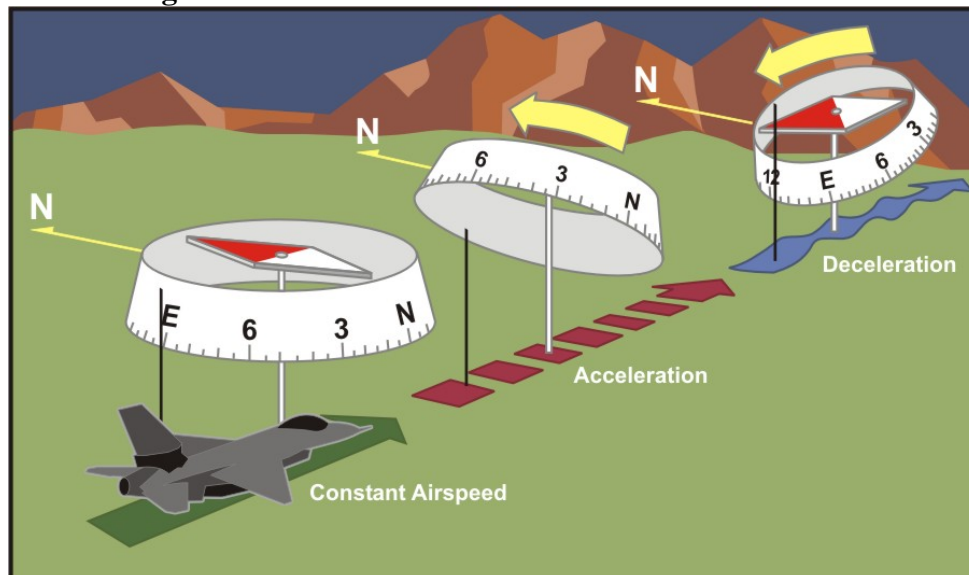

8.4.2.4. Oscillation Error. Oscillation is a combination of all of the other errors, and it results in the compass card swinging back and forth around the heading being flown. When setting the gyroscopic heading indicator to agree with the magnetic compass, use the average indication between the swings.

8.4.3. Slaved and Non-Slaved Heading Systems. There are many types of heading systems, but each may be classified as either slaved or non-slaved. The non-slaved system uses a gyro to supply the directional reference, while the slaved system uses the signals from a remote compass transmitter to orient the system to magnetic north. In both systems the gyro acts as a stabilizing component to reduce the inherent errors.



8.4.3.1. Heading System Errors. All heading systems are subject to errors produced by real and apparent precession. In many modern aircraft heading systems, provisions to correct for these errors are usually incorporated making them negligible and transparent to the crew.

8.4.3.1.1. Real Precession. During turns and periods of acceleration and deceleration, forces are produced which combine with the force of gravity causing the erection mechanism and the remote compass transmitter to induce errors in the heading system. However, once wings-level, unaccelerated flight is resumed, the remote compass transmitter and the erection mechanism sense true gravity and correct any errors.

8.4.3.1.2. Apparent Precession. As discussed earlier, apparent precession is caused by two factors: the rotation of the Earth; and transportation of the gyro from one location on the Earth to another. The gyro is kept horizontal by the erection mechanism.

**8.5. Angle of Attack System.** Angle of attack information is obtained by comparing the relative wind to the chord line of the wing. Its primary use in instrument flight is usually during the final phase of an instrument approach. Maintaining the computed final approach airspeed during un-accelerated (1G) flight should also maintain the approach angle of attack. The information can be used in the same manner as airspeed. This allows either angle of attack or airspeed to be flown while using the other indication as a backup. Refer to the aircraft flight manual for specific guidance on the use of angle of attack.

**8.6. Radar Altimeters.** A radar altimeter is used to measure the height of the aircraft in reference to the terrain directly below it and normally only accurate in straight and level flight over landmasses. Due to these design limitations, it usually will not provide accurate information while turning or warning information regarding rapidly rising terrain ahead of the aircraft. In addition, altitude readouts over areas covered by water, ice, and snow may also be unreliable. Consult your flight manual for proper operation and use of your aircraft's particular radar altimeter (if installed).

8.6.1. Except where authorized in your flight manual, the radar altimeter should not be used to determine when you have arrived at the DH or MDA. If authorized, it may be used to identify the DH when conducting a Cat II or III ILS. This is because a Cat II/III ILS will depict the height of the aircraft above the terrain at the DH point.

## Chapter 9

### EXTREME LATITUDE NAVIGATION.

**9.1. Areas of Magnetic Unreliability (AMU).** The AMUs consist of two large areas of operation, centered around the earth's poles where unique features significantly complicate air navigation. The two major factors affecting navigation in the polar regions are magnetic variation and the convergence of true meridians at the poles.

9.1.1. Since the horizontal component of the Earth's magnetic field vanishes near the magnetic poles, magnetic compasses are highly unreliable and unusable in an area approximately 1000 nm from each magnetic pole. Within these areas, air navigation is further complicated by very rapid changes in magnetic variation over short distances as the isogonic lines converge. For example, when flying between the magnetic north pole and the geographic north pole, a heading of true north results in a magnetic heading of south (a magnetic variation of 180°).

9.1.2. Since the two major AMUs also occur near the geographic poles, the convergence of meridians also present an additional navigation problem. When flying courses at the extreme latitudes (polar operations), convergence of the meridians can create rapid changes in true headings and true courses with small changes in aircraft position. While maintaining a course (without turning), your true heading will change strictly based on your aircraft's relative position to the true pole as you cross meridians. Figure 9.1 provides a graphical depiction of how heading information changes in relation to the angular difference from true north as meridians are crossed. As a result, relatively small errors introduced can make determining the aircraft's actual position very difficult when trying to determine the proper heading to fly to maintain or correct back to the desired flight path. When even small errors occur, very large navigation errors can develop over extremely short distances.

9.1.3. Due to the combined effects of magnetic unreliability and the geographic convergence of meridians at acute angles, when flying in the polar regions, to navigate more precisely, a "grid" system was developed (see para 9.3). Navigating in the AMU was also enhanced by the development of gyro driven heading indicators (also see paragraph 8.4 for more information on heading systems and the associated errors).

**9.2. Boundaries of the AMU.** AFI 11-202 Volume 3, General Flight Rules and AFMAN 11-217 Volume 1, Instrument Flight Procedures, delineate the location and requirements for operations in the AMU.

9.2.1. For the northern hemisphere, the Canadian Aeronautical Information Publication (AIP) establishes the basic boundaries for the AMU. In general, this corresponds to Canadian Northern Domestic Airspace, and the entire Canadian Northern and Arctic Control Areas. AMU's are also depicted on Canadian Enroute Charts. The FAA refers to the AMU in the northern hemisphere as the "North Polar Area" and defines this region as all geographical area and airspace located above 78 degrees North.

9.2.2. For the southern hemisphere, the FAA refers to the AMU as the “South Polar Area” and defines this region as any area south of the 60° South latitude.

**Figure 9.1. Heading Indications while Crossing Meridians.**

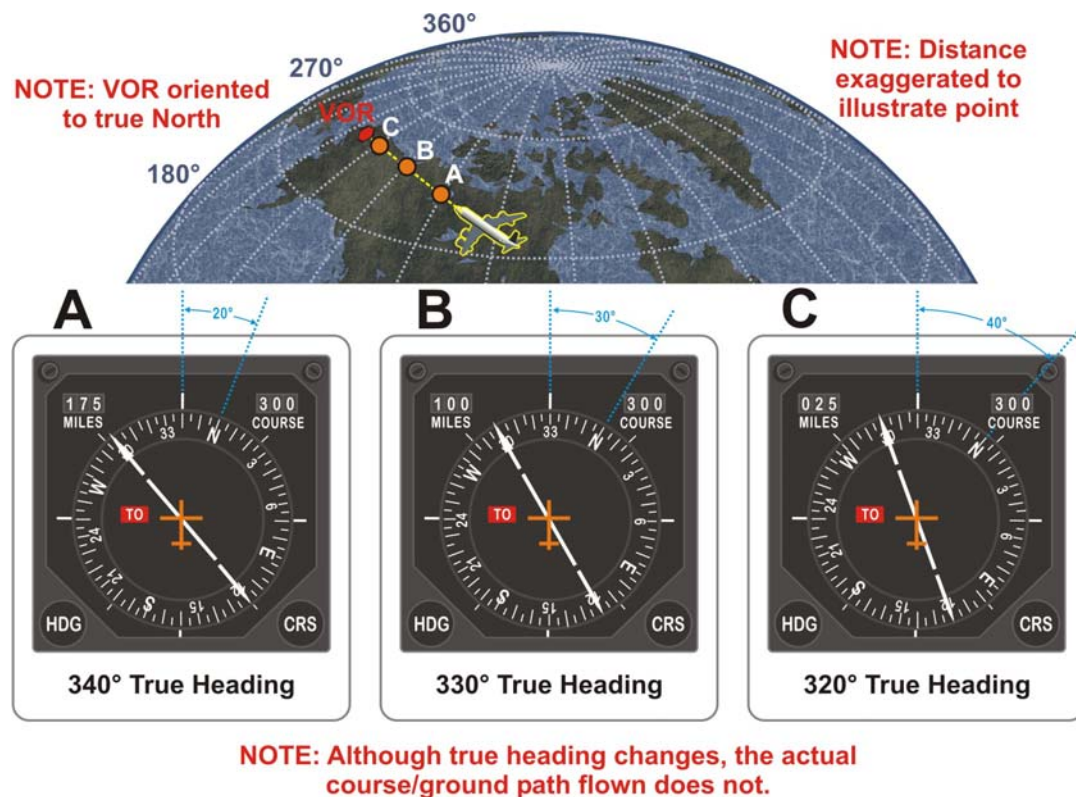

**9.3. Grid Operations.** Grid navigation is a reorientation of the standard heading references and is used to offset the difficulties of trying to navigate in an AMU (North or South Polar Area) using conventional techniques and procedures. Grid navigation uses a set of parallel and perpendicular “green” lines depicted on most GNC and JNC charts and enables the aircrew to fly a constant grid heading (GH) while crossing rapidly changing longitudinal lines and contend with the erratic magnetic variations present in the AMU. The use of a GH, whether provided automatically by on board systems or manually calculated, provides a method upon which an aircrew can safely navigate in an AMU region. Most modern USAF aircraft incorporate a switch (sometimes referred to as a “Heading Reference Select switch” or HRS) that allows the pilot to select between “True, Magnetic, or Grid.” With the HRS selected to “Grid” mode, the on board navigation systems should automatically switch to “grid” operations and update the navigational displays to reflect aircraft grid heading/position. In “Grid” mode, the onboard navigation magnetic variation is automatically set to “0” (zero) and therefore magnetic heading (MH) is equal to true heading (TH). The on-board system then applies a known correction (added or subtracted), based on the current longitudinal line to provide a Grid Heading (GH) for the pilot to fly.

9.3.1. There are several ways grid lines may be depicted on charts depending on the type of projection. For example, the Polar Grid chart is designed using the Prime Meridian as the base reference line of longitude. A particular GH is then calculated based on this standard reference.

9.3.2. To manually calculate a GH, the pilot needs to multiply the appropriate longitude with the chart's convergence factor (normally stated in the margin) and then add or subtract the aircraft true heading (TH). The convergence factor is particular to the chart being used and is determined by the angle at which the "longitudinal line" cuts across the "grid" line. This angle is known as the convergence angle. In the Southern Hemisphere, the pilot must add "East Longitudinal" lines and subtract "West Longitudinal" lines to calculate a GH. It is the opposite in the Northern Hemisphere (add "West Longitude" and subtract "East Longitude"). Since the convergence factor on the Polar Grid Chart is equal to 1 (one), to obtain GH, the pilot must simply add or subtract the longitudinal line to TH. As an example, at McMurdo Station, the longitudinal line of the Pegasus Field (NZPG) runway is 167 "East;" therefore for any given TH, adding 167 will give you GH. Refer to AFPAM 11-216, Chapter 14, for more details on "Grid Navigation."

**9.4. Definition of an Emergency in the AMU.** Many situations are considered an emergency regardless of geographic location. For example, engine failure is considered an emergency by most aircrews whether in or out of the AMU. When operating in the AMU, USAF directives require aircraft to be equipped with a heading source other than magnetic. However, there are situations (electrical power loss, gyro failure, etc.) where the heading source may become inoperative after entering the AMU. A simple gyro failure typically would not be considered an emergency outside the AMU, especially if an alternative means of navigation is available. This situation; however, is dramatically different in the AMU where navigation options may be extremely limited, diversion airfields widely spaced, radar vectors are generally unavailable, weather conditions are less than optimal, and communications often unreliable. Any equipment failure in the AMU that leaves an aircrew with magnetic information as the sole source of heading information is typically considered an emergency.

9.4.1. AMU Emergency Procedures. The techniques outlined below are useful for emergency navigation should the true/grid heading source become inoperative or unreliable while operating in the AMU. Use of these techniques should be limited to emergency navigation to an alternate, the planned destination, or out of the AMU. They should not be used as normal navigation procedures for aircraft not equipped with a heading source other than magnetic.

9.4.1.1. In the unlikely event that all navigation systems become unavailable, reversion to manual navigation (i.e. dead reckoning (DR)) is required. Radar, NAVAIDS or visual fixes may be available. Application of basic navigational principles will ensure that the aircraft proceeds in a direction that at least approximates the desired track until such time as more accurate navigation or a safe landing is possible. A thorough review of basic DR techniques and procedures is recommended prior to flight in the AMU, particularly without a navigator on board. You should always have a backup DR plan ready for every flight in the AMU.

9.4.1.1.1. **WARNING:** Accurately plotting the cleared flight path track on a suitable chart, along with frequent position checks, helps ensure the flight remains on course. This not only

increases and maintains positional awareness, but enables the pilot/crew to make the transition to DR (if required) should one or more navigation systems fail.

9.4.1.2. If your aircraft has the additional AHRS (Aircraft Heading Reference System), you may be able to operate the system in Directional Gyro (DG) mode and manually set the heading to coincide with the FMS/True/Inertial heading from your primary navigation source IAW flight manual instructions. This will provide a backup true heading reference in case the GPS, INS, or other primary navigation system fails. Update the heading periodically IAW your flight manual to correct for AHRS DG drift.

9.4.1.2.1. NOTE: This technique is not acceptable for use as the primary means of navigation, but is very useful as an emergency backup source of true heading information.

## **9.5. Using the VOR in the AMU.**

### 9.5.1. Flight Instrument Indications and Interpretation.

9.5.1.1. Because of problems associated with magnetic referenced navigation in the AMU, VOR navigation stations are aligned to true north in this area. See AFMAN 11-217 Volume 1 *Instrument Flight Procedures* for charting of NAVAIDS oriented to true north.

9.5.1.2. Flight instrument indications and interpretation for VORs in the AMU are different than for conventional VORs outside the AMU. This is due to convergence of the meridians and the fact that VOR radials are defined at the station, not at the aircraft. The VOR display does not provide a “relative bearing” to the VOR, it uses the received radial and displays it against that azimuth value on the HSI. At lower latitudes, the received radial matches the relative bearing to the station, so there appears to be no difference between them. In the AMU, it is quite likely that the VOR bearing pointer will not be pointed at the station or even at the correct true bearing to the station. This is due to the fact that the radial being sent out from the station is specific to true north from the station which is slightly different from true north seen at the aircraft.

9.5.1.3. True VOR radials, which are based on phase relationships formed at the VOR transmitter are decoded in the aircraft. The radial leaving the VOR station is based on the meridian (true north) location of the station, while at the aircraft, the VOR radial information is decoded and portrayed using a heading which is based on the meridian at the location of the aircraft, not the VOR station. The difference or apparent error seen on the instruments depends on the aircraft distance from the VOR and the convergence angle of the meridians involved. The difference seen will become zero as the VOR station is crossed, where the station and aircraft meridians are the same.

9.5.1.4. Aligning the VORs to true north eliminates the magnetic variation problem and compass unreliability factors, but does not eliminate the convergence angle problem.

### 9.5.2. Navigating TO the Station.

9.5.2.1 If you were navigating strictly by using a VOR and wanted to proceed direct to the station, center the Course Deviation Indicator (CDI) with an inbound bearing and make heading

corrections as necessary to keep the CDI centered. Make heading corrections as you would wind corrections to maintain a desired track. As you approach the station, your true heading will change progressively until, as you pass the station, it is the same as the CDI course (+/- wind drift). Reference the VOR indications versus the heading indications represented in figure 9.1. Do not select magnetic heading references, stay in true heading. You should not turn to a true heading that places the bearing pointer at the top of the case and keep it there until you arrive over the station. Doing this would eventually get you to the station, but it would take you off the direct course.

### 9.5.3. Navigating FROM the Station.

9.5.3.1. Making use of VOR bearing information in this case is the reverse of the paragraph above. Set the desired outbound radial and keep the CDI centered. The heading required to keep the CDI centered will progressively diverge from the CDI course. If the outbound radial is not printed on the chart and you still want outbound information, you will have to draw a true North line from the station symbol, then plot a course line from the station and measure the course. Set that radial and keep it centered. This should not be relied upon as your primary means of navigation.

### 9.5.4. Using Off-Route True VORs to Perform Coast-in/out, and Enroute Accuracy Checks.

9.5.4.1. Interpreting bearing information from an off-route VOR station is somewhat involved. Plot a true north line from the station as a reference to draw the true radial or bearing that represents the centered CDI radial. Locate the aircraft's position on this line using the DME indicated distance.

9.5.4.2. To check the FMS indicated true track to the station, plot a true north line from the plotted aircraft position and measure the true track back to the VOR station using the true north line at the aircraft location. This should match the indicated FMS true track. The FMS distance to the VOR station should match the DME indication.

## 9.6. Using an NDB in the AMU.

9.6.1. Despite some inherent errors that may cause minor inaccuracies, (see chapter on Ground Based NAVAIDS for further information), the NDB offers an excellent source upon which to navigate from in the AMU since the basic operating principle remains unaffected. The ADF needle simply points directly towards the NDB station. Even if the compass card and other navigational anomalies are occurring from operating in the AMU, the ADF needle will point to a properly tuned and identified NDB station. This attribute of the NDB can greatly reduce some of the concerns experienced when dealing with the navigational complexities caused by the rapidly changing magnetic variation or meridian convergence at higher latitudes.

## Chapter 10

### TERMINAL INSTRUMENT PROCEDURES (TERPS)

**10.1. United States Standard for TERPS.** FAA Order (FAAO) 8260.3B (also called AFMAN 11-226 (I)) is the regulatory document that provides mandatory rules and information for the construction of instrument procedures at civil and military airports where the United States has jurisdiction. FAA Order (FAAO) 8260.3B prescribes standardized methods for designing instrument flight procedures. AFI 11-230, Instrument Procedures is the US Air Force supplement to FAA Order (FAAO) 8260.3B. It provides USAF specific guidance on establishing, approving, revising, or deleting instrument procedures. It applies to flying activities at all airfields where the Air Force, or an Air Force component of a unified command conducts or supports instrument flight. AFI 11-230 is used in conjunction with FAAH 8260.3B (AFMAN 11-226) to develop instrument procedures at installations where the USAF has TERPS responsibility.

#### 10.2. General Criteria and Common Information.

10.2.1. Obstacle Clearance Surface (OCS). The OCS is an obstacle evaluation surface associated with each segment of an instrument procedure. The OCS can be either level or sloping. See Required Obstacle Clearance (ROC) discussion below.

10.2.2. Required Obstacle Clearance (ROC). ROC is the minimum measure of obstacle clearance considered to supply a satisfactory level of vertical protection. The ROC is added to the OCS. The level of vertical protection provided is based on variety of factors. First, the aircraft meets required performance standards based on the certification process. Second, the pilot operates the aircraft IAW procedures outlined in the T.O. Additionally, it also assumes that all aircraft systems are functioning normally, the required NAVAIDS are performing within flight inspection parameters, and the pilot is conducting instrument operations in accordance with directives. ROC is provided through application of either a level or sloping ROC.

10.2.2.1. Level ROC. The level OCS concept is applicable to level flight segments. This is intended for enroute, initial, intermediate segments, and non-precision final approaches. A single ROC value is applied over the length of the segment. These values were determined through testing and observation of aircraft and pilot performance in various flight conditions. Typical ROC values are: for enroute procedure segments, 1,000 feet (2,000 feet in designated mountainous terrain); and for initial segments, 1,000 feet, and 500 feet in intermediate segments. In determining ROC for the final segments, 350, 300, or 250 feet may be applied and is dependent on the type of non-precision procedure and a variety of other factors (e.g. whether DME is available, if a final-approach-fix (FAF) exists, location of the FAF, remote altimeter setting required, etc...). For additional information regarding how ROC is applied, see FAAO 8260.3, *United States Standards for TERPS* and AFI 11-230, *Instrument Procedures*.

**Figure 10.1. Relationship of OCS and ROC for Level Segment.**

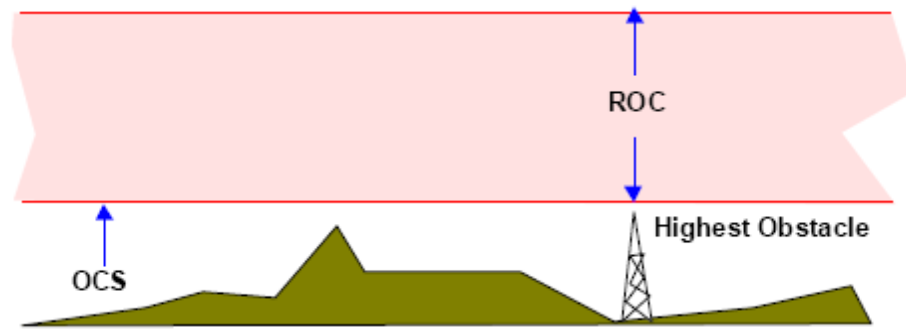

10.2.2.2. Sloping ROC. Sloping ROC is applicable to segments dedicated to descending on a glidepath or climbing in a departure or missed approach segment. This requires a different obstacle clearance concept than the level OCS because the ROC value varies throughout descent or climb segment. The value of ROC near the runway is relatively small, while the value at the opposite end of the segment is designed to satisfy one of the level standards discussed in paragraph 10.2.2.1.

**Figure 10.2 Relationship of OCS and ROC for Sloping Segment.**

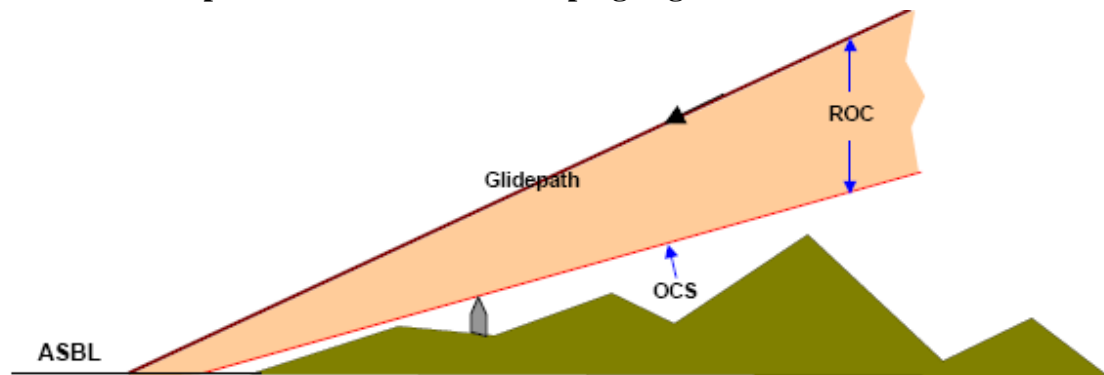

10.2.3. Units of Measurement (US TERPS Only).

10.2.3.1. Bearings and courses are expressed in degrees magnetic (except in the AMU).

10.2.3.2. Radials are expressed in degrees magnetic (except in the AMU) and are prefaced by the letter "R" to the magnetic bearing FROM the facility.

10.2.3.3. Altitudes are expressed in feet. Published heights below the transition level (18,000 feet) are expressed in feet above MSL. Published heights at and above the transition level are expressed as flight levels.

10.2.3.4. Distances are expressed in nm and hundredths, except where feet are required. When applied to visibility, distance is expressed in statute miles (sm) and appropriate fractions. In



overseas areas, visibility may be expressed in nm or meters where it coincides with host nation practice.

10.2.3.5. Aircraft speeds are expressed in KIAS.

10.2.4. Positive Course Guidance. Positive course guidance is provided for feeder routes, most initial segments, intermediate and final segments. Positive course guidance should be provided within the service volume of the facility(ies) used except when Expanded Service Volume (ESV) has been authorized. This means that if a course is published, even if outside the normal service volume, it has been authorized for use in accordance with that published procedure.

10.2.5. Approach Categories. Aircraft performance differences have an effect on the airspace and visibility needed to perform certain maneuvers. Because of these differences, categories are assigned by either the manufacturer or operational directives so that appropriate obstacle clearance areas and takeoff, approach and landing minimums can be established. Aircraft categories are assigned by FAR Part 97 and further explained in AFMAN 11-217 Volume 1, *Instrument Flight Procedures*.

**10.3. Procedure Construction.** An instrument approach procedure (IAP) usually has four separate segments. They are the initial, intermediate, final, and missed approach segments. In addition, an area for circling the airport in visual conditions is usually considered, but not always required when designing an IAP. Fixes associated with each segment are named to coincide with the associated segment. The initial approach fix (IAF), intermediate fix (IF), FAF, and MAP identify the fixes along the procedure. Referring to figure 10.3, you can see that as the aircraft transitions from one segment to the next during the approach, the segment corridors narrow and ROC tolerances are reduced. Upon executing a missed approach, the parameters expand.

**Figure 10.3. Segments of an Approach Procedure.**

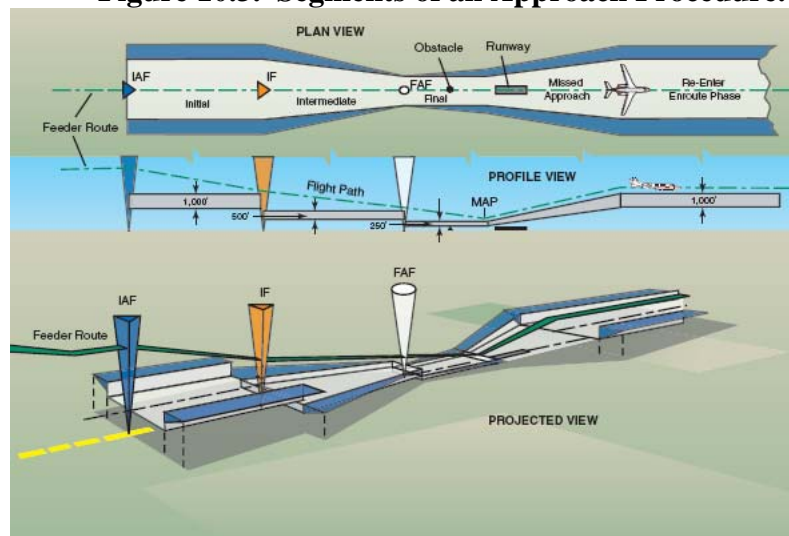

## 10.4. Enroute Operations.

10.4.1. Feeder Routes. When the IAF is part of the enroute structure, there is no need to designate additional routes for aircraft to proceed to the IAF. However, when an IAF is not part of the enroute structure, it is necessary to provide a route that enables the aircraft to transition from the enroute phase of flight to the approach phase. This is accomplished through the use of feeder routes to the IAF. Enroute airway obstacle clearance is applied to feeder routes. The minimum altitude on a feeder route will not be less than the altitude published at the IAF. The angle between the feeder route and the next straight segment (feeder or initial) will not exceed 120°. The optimum descent gradient in a feeder route is 250 ft/nm. The maximum permissible descent gradient is 500 ft/nm.

**10.5. Minimum Safe/Sector Altitudes (MSA) and Emergency Safe Altitudes (ESA).** An explanation of MSA and ESA altitudes and obstruction clearances is in AFMAN 11-217 Volume 1, Instrument Flight Procedures.

**10.6. Initial Approach Segment.** The instrument approach begins at the IAF. In the initial approach, the aircraft has departed the enroute phase of flight and is maneuvering to enter an intermediate segment. When the intermediate segment is part of the enroute structure, it may not be necessary to have an initial approach segment. The initial approach segment has no defined minimum length; however, it should be long enough to ensure sufficient distance is available to permit altitude changes required by the procedure. The length should not exceed 50 NM unless an operational requirement exists.

10.6.1. Composition of Initial Segment. An initial approach may be made along an arc, radial, course, heading, radar vector, or combination. Additional parts of a procedure that comprise the initial segment also include procedure turns, holding pattern descents, and high altitude penetrations. Positive course guidance is required except where dead reckoning courses can be established over limited distances. Although there may be more than one IAF, the number should be limited to the minimum required to accommodate traffic flow and operational requirements. When holding is required, the holding fix and the IAF usually coincide. When this is not possible, the IAF will be located within the holding pattern on the inbound holding course.

10.6.2. Course Alignment. The angle between the initial approach course and the intermediate course will not exceed 120°. If the angle is greater than 90°, a lead radial or bearing that provides at least 2 nm of lead will be published to aid the pilot in determining a potential point upon which to commence a turn from the initial segment to the course associated with the intermediate segment. This published lead radial may or may not work depending on your aircraft's airspeed; therefore, the pilot may elect to determine an alternate lead point or radial based on the concepts provided in chapter 3 of this manual.

10.6.3. Obstacle Clearance. The total width of the initial approach segment is 6 nm on each side of the initial approach course. This width is divided into two segments: a primary area and a secondary area. The primary area extends 4 nm on either side of the course. The secondary area extends laterally on either side of the primary area for 2 nm on each side.

10.6.3.1. Obstacle clearance in the primary area is a minimum of 1,000 feet.

10.6.3.2. Obstacle clearance in the secondary area starts at 500 feet and tapers to 0 feet at the outer edge.

10.6.3.3. Allowances are made for precipitous terrain.

10.6.3.4. When any portion of the initial approach segment is over 50 nm from the navigation facility, the criteria for enroute airways applies.

**Figure 10.4. Obstacle Clearance.**

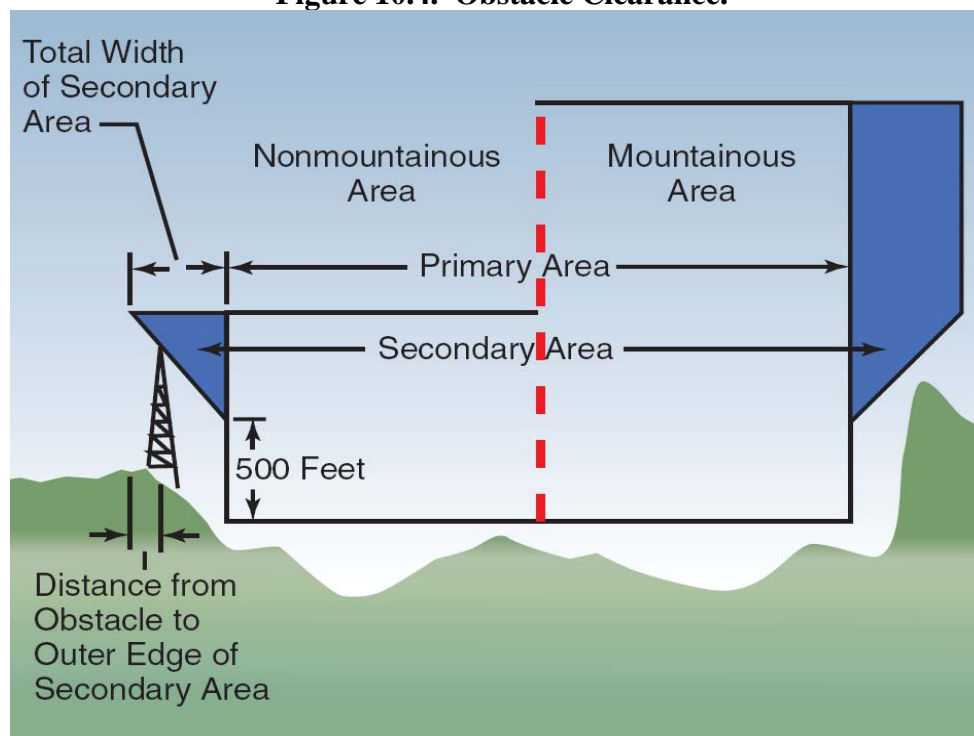

10.6.4. Descent Gradient. The optimum descent gradient in the initial approach segment is 250 ft/nm. Where a higher descent gradient is necessary, a maximum of up to 500 ft/nm may be used. The optimum descent gradient for a high altitude penetration is 800 ft/nm. Where a higher descent gradient is necessary, the maximum is 1,000 ft/nm.

10.6.5. Procedure Turns. A procedure turn is normally used when it is necessary to reverse the direction of travel to establish an aircraft on either the intermediate or final approach course. If there is a holding pattern established at the FAF, an intermediate segment is not constructed. Ideally, the minimum holding altitude is the same as the FAF altitude. In cases where this is not possible, the minimum holding altitude is limited to no more than 300 feet above the FAF altitude.

10.6.5.1. NOTE: If a holding pattern is established over the intermediate fix, the minimum holding altitude will permit descent to the FAF altitude within the same descent gradient tolerances prescribed for the intermediate segment.

#### 10.6.6. High Altitude Teardrop Penetration.

10.6.6.1. The teardrop penetration consists of departing an IAF on an outbound course, followed by a turn toward and intercepting the inbound course at or prior to the intermediate fix or point. Its purpose is to permit an aircraft to reverse direction while losing considerable altitude within a relatively confined airspace.

10.6.6.2. The outbound penetration course will be between  $18^{\circ}$  and  $26^{\circ}$  to the left or right of the reciprocal of the inbound course. The actual angular divergence between the courses will vary inversely with the distance from the facility at which the turn is made.

10.6.6.3. The optimum descent gradient is 800 ft/nm. The maximum descent gradient is 1,000 ft/nm.

10.6.6.4. The size of the penetration turn area must be sufficient to accommodate both the penetration turn and the altitude loss required by the procedure. The turn distance will not be less than 20 nm from the facility. The penetration turn distance depends on the altitude to be lost in the procedure and the point at which the descent is started. The procedure is designed so the aircraft should lose half the total altitude or 5,000 feet, whichever is greater, outbound prior to starting the inbound turn. The penetration turn area has a width of 6 nm on both sides of the flight track up to the intermediate fix or point and will encompass all the areas within the turn.

10.6.6.4.1. All of the penetration turn area, with the exception of the outer 2 nm of the 6-mile obstacle clearance area on the outer side of the penetration track, is primary area. The outer 2 miles is secondary area. The outer 2 miles on both sides of the inbound penetration course should be treated as secondary area.

10.6.6.4.2. Obstacle clearance in the primary area is a minimum of 1,000 feet. Obstacle clearance in the inner edge of the secondary area is 500 feet tapering to zero feet at the outer edge.

**10.7. Intermediate Approach Segment.** The intermediate approach segment blends the initial approach segment into the final approach segment. It is the segment in which aircraft configuration, speed, and positioning adjustments are made for entry into the final approach segment. The intermediate segment begins at the intermediate fix, or point, and ends at the FAF.

#### 10.7.1. Composition of Intermediate Segment.

10.7.1.1. There are two types of intermediate segments: the radial or course, and the arc. In either case, positive course guidance must be provided.

10.7.1.2. The length of the intermediate segment depends on the angle between the initial and intermediate segments. The minimum length of the intermediate segment is 5 nm for categories A/B and 6 nm for Categories C/D/E. The optimum length is 10 nm and the maximum length is 15 nm.

10.7.1.3. The width of the intermediate segment is the same as the width of the segment it joins. Where the intermediate segment joins an initial segment and a final segment, the width begins at the width of the initial segment and tapers to the width of the final segment. When the intermediate segment is not aligned with the initial or final segments, the resulting gap on the outside of the turn is a part of the preceding segment and is closed by an appropriate arc.

10.7.2. Course Alignment. Normally, the course defining the intermediate segment will be the same as the final approach course. The exception is when the FAF is the navigation facility and it is not practical for the courses to be identical. In such cases, the intermediate course will not differ from the final approach course by more than 30°.

10.7.3. Obstacle Clearance. The intermediate segment is divided into primary and secondary areas. In the primary area, 500 feet of obstacle clearance will be provided. In the secondary area, 500 feet of obstacle clearance is provided at the inner edge, tapering to zero feet at the outer edge. There is an allowance for precipitous terrain. Of note, it is important for the pilot to understand that the receipt of positive course guidance (“case break”) or upon reaching a pre-calculated lead point does not necessarily guarantee that the aircraft has entered the “primary area” and thus safe to descend. This may occur when the NAVAID providing course guidance is located well beyond the landing runway on the opposite side of the airport from which the approach is flown (geographically separated from the airport environment). Therefore, when making a turn from the initial to the intermediate segment (e.g. from an arc), the pilot should exercise caution prior to initiating an immediate or rapid descent to the next lower published altitude since the aircraft could may exceed the parameters of TERPS protected airspace. When conducting an instrument approach, to ensure that the aircraft is in a safe position to descend; follow the “established on course” guidance found in Chapter 11 of 11-217V1. Detailed information regarding the use of primary and secondary areas in IAP development may be found in Chapter 2, General Criteria, in AFMAN 11-226, *United States Standards for Terminal Instrument Procedures (TERPS)*.

10.7.4. Descent Gradient.

10.7.4.1. The intended purpose of the intermediate segment is to allow the aircraft to establish the airspeed and configuration to enter the final approach segment. Consequently, the gradient should be as flat as possible. The optimum gradient is 150 ft/nm. The maximum gradient is 318 ft/nm except for a localizer approach published in conjunction with an ILS procedure. In this case, a higher gradient equal to the commissioned ILS glideslope is permissible. Even in this case, the angle should not exceed 3°. Higher gradients are possible due to arithmetic rounding.

10.7.4.2. When the descent gradient does exceed 318 ft/nm, there should be a segment prior to the intermediate segment to prepare the aircraft speed and configuration for entry into the final segment. This segment should be a minimum of 5 nm and its descent gradient should not exceed 318 ft/nm.

**10.8. Final Approach Segment.** This segment sets up for alignment and descent for landing. The final approach segment considered for obstacle clearance begins at the FAF and ends at the

runway or MAP, whichever is encountered last. A visual portion within the final approach segment may be included for straight-in non-precision approaches. The alignment and dimensions of the final approach segment varies with the location and type of navigation facility.

### 10.8.1. Visual Area.

10.8.1.1. The visual area is an area evaluated for obstacles to determine whether night operations must be prohibited because of close-in unlighted obstacles, or if visibility minimums must be restricted. There are three areas evaluated, depending on the type of final approach guidance and alignment with the runway centerline. They are: standard, straight-in, and offset.

10.8.1.2. The standard visual area is for runways to which an aircraft is authorized to circle. The standard visual area begins 200 feet from the threshold at the threshold elevation and extends out 10,000 feet along the runway centerline. The beginning width is 200 feet on either side of the centerline (400 feet total). The sides splay outward relative to the runway centerline.

**Figure 10.5. Standard Visual Area.**

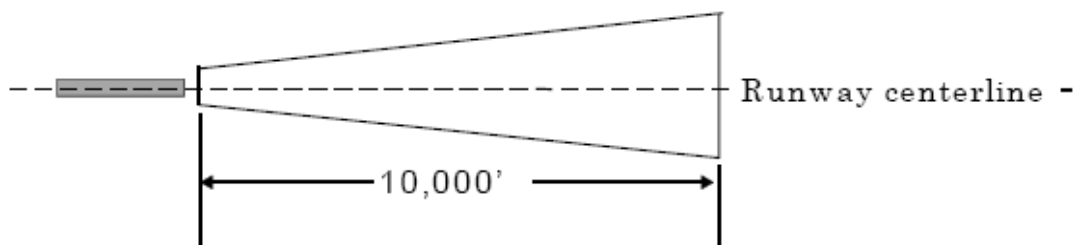

10.8.1.3. The straight-in visual area is for runways with approach procedures aligned with the runway centerline. The visual area for a straight-in approach begins 200 feet from the threshold at the threshold elevation, and extends to the DH for precision procedures and the VDP (even if one is not published) for non-precision procedures. The beginning width of the visual area is 400 feet either side of the centerline (800 feet total). The sides splay outward relative to the runway centerline.

**Figure 10.6. Straight-in Visual Area.**

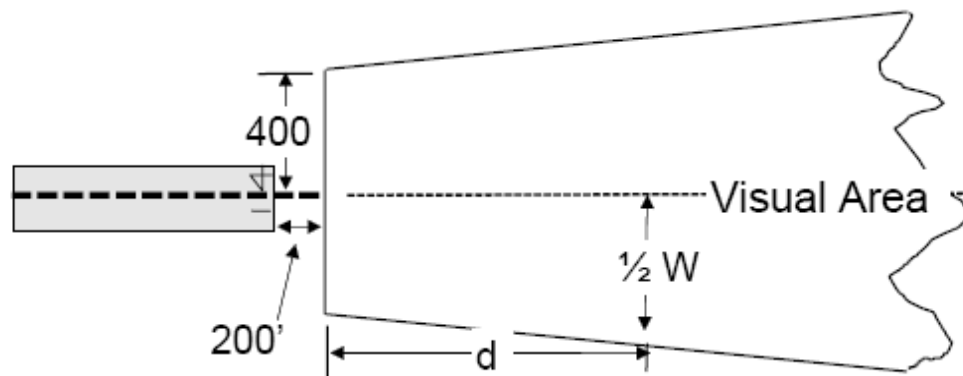

10.8.1.4. The offset visual area is for a straight-in approach not aligned with the runway centerline. When the final approach course does not coincide with the runway centerline, the visual area will be modified to account for this via a series of formulae. The exact dimensions and calculations are not important for aircrew to understand. It is important to remember that it is offset based on the angular difference of the final approach course and the extended runway centerline.

10.8.2. Obstacle Clearance in the Visual Area. Two obstacle identification surfaces (OIS) overlie the visual area with slopes of 20:1 and 34:1 from the approach end of the runway. When a runway is evaluated for circling, the 20:1 surface is used. When evaluating a runway for straight-in approaches, both the 20:1 and the 34:1 surfaces are used. Obstacles that penetrate either of these surfaces will affect visibility minimums for that runway.

10.8.2.1. 34:1 Slope Penetration. If the surface is penetrated by an obstacle, the TERPS specialist must take one of the following actions:

10.8.2.1.1. Coordinate with appropriate agencies to have the obstacle height adjusted or have the obstacle removed, or;

10.8.2.1.2. Limit the visibility to  $\frac{3}{4}$  mile.

10.8.2.2. 20:1 Slope Penetration For a straight-in approach, if the 20:1 surface is penetrated, the TERPS specialist must take one of the following actions:

10.8.2.2.1. Coordinate with appropriate agencies to have the obstacle height adjusted or have the obstacle removed, or;

10.8.2.2.2. No VDP will be published, visibility will be limited to 1 mile, and the obstacles will be marked and lighted, or;

10.8.2.2.3. No VDP will be published, visibility will be limited to 1 mile, and a note will be published prohibiting the approach (both straight-in and circling) to the affected runway at night.

10.8.2.3. If the 20:1 surface is penetrated on circling runways, marking and lighting of the obstacle(s) is required or a note will be published prohibiting circling to the affected runway at night.

10.8.3. Descent Gradient. The optimum non-precision final segment descent gradient is 318 ft/nm, which approximates a 3° gradient. The maximum is 400 ft/nm, which approximates a 3.77° gradient. When the maximum descent gradient will be exceeded, then straight-in minimums will not be published.

10.8.3.1. NOTE: For RNAV (GPS), RNP, and Wide Area Augmentation System (WAAS) approaches see AFMAN 11-217 Volume 1, *Instrument Flight Procedures* Chapter 8 for discussion on descent angles for final approach.

10.8.4. Visual Descent Point. VDPs are applicable to straight-in approaches only. Where dual minimums are published, the lowest MDA is used to calculate the published VDP. If one is not published or you are going to fly to an MDA based on higher minima, you may compute your own VDP. However, when computing a VDP to use when one is not published, the pilot/aircrew need to carefully consider the information presented below. Additional information is found in AFMAN 11-217 Volume 1, *Instrument Flight Procedures*. A VDP may be published for all non-precision approaches, except as follows:

10.8.4.1. An obstacle penetrates the 20:1 surface.

10.8.4.2. When determination of the MDA is based on part-time or full-time remote altimeter settings, or;

10.8.4.3. When the VDP would be prior to a step-down fix, or;

10.8.4.4. When the VDP would be between the MAP and the end of the runway.

10.8.4.5. Even if all the parameters in paragraph's 10.8.4.1 through 10.8.4.4 are met, the TERPS specialist is not required to publish a VDP.

10.8.4.5.1. **NOTE:** Since there is no way to determine if an obstacle prevented the a VDP from being published or it was due to another reason (listed above), pilots/aircrew need to exercise extreme caution when departing the MDA using their own VDP calculation in lieu of one that was not published.

10.8.5. Circling Approaches. The size of the circling area depends on the approach category of the aircraft. Some aircraft will be in a higher approach category for circling approaches based on the airspeed upon which the pilot chooses to fly the circling maneuver at. See AFMAN 11-217 Volume 1, *Instrument Flight Procedures* for airspeed ranges by aircraft category.

**Figure 10.7. Circling Approach Area Construction.**



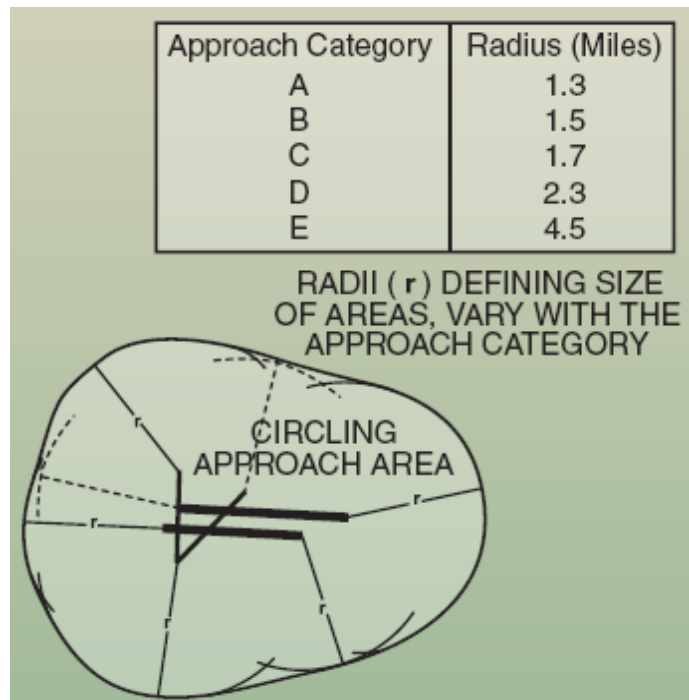

10.8.5.1. Circling Obstacle Clearance. A minimum of 300 feet of obstacle clearance is provided in the circling approach area. The TERPS specialist may exclude certain sectors from consideration where prominent obstacles exist in this area provided a safe approach and landing can be conducted without using the sector. In this case, a note is provided on the procedure excluding this sector from use during the circling maneuver with reference to the runway centerline(s). Sometimes illumination of certain runway lights may be required.

10.8.5.1.1. **NOTE:** There is no secondary obstacle clearance area for circling approaches.

10.8.5.1.2. **NOTE:** The circling area is determined by drawing a series of arcs of the appropriate radius from the ends of each useable runway. The extremities of the adjacent arcs are joined with lines drawn tangent to the arcs. The arc radii distance will vary dependent on the aircraft's approach category. See figure 10.7.

**10.9. Missed Approach Segment.** A missed approach procedure will be established for every IAP. The missed approach procedure commences at the DH or MAP for the procedure being flown and ends at a clearance limit.

10.9.1. Missed Approach Composition. The missed approach procedure will specify an altitude, a routing, and a clearance limit. The altitude will be high enough to permit holding or enroute flight.

10.9.2. Missed Approach Course Alignment. Wherever practical, the missed approach course should be a continuation of the final approach course. However, there are cases where this is not

possible due to airspace, terrain, or other concerns. For these situations, turns are permitted by TERPS, but should be minimized in the interest of safety and simplicity.

10.9.2.1. NOTE: When the missed approach course is within  $15^\circ$  of the final approach course, it is considered a straight missed approach.

### 10.9.3. Missed Approach Obstacle Clearance.

10.9.3.1. Obstacle clearance for missed approach from a precision approach (ILS or Precision Approach Radar (PAR)) accounts for a momentary dip below DH during the go-around maneuver to account for the downward vector of the aircraft during the descent to DH. Obstacle clearance for a missed approach from a non-precision approach does not allow for any deviations below the published MDA. This is important to remember when applying the technique of using precision glidepath information as a guide for a constant rate descent to a non-precision MDA.

10.9.3.2. Obstacle clearance for missed approach takes into account a primary and secondary area. Of note, in the US and at USAF installations, “alternate” missed approach instructions (those received from ATC) are developed using the same obstacle clearance TERPS criteria used in the design of published missed approach procedures. This may or may not be the case when executing missed approach instructions received by a host nation ATC facility; therefore, due diligence and an emphasis on maintaining situational awareness in relation to obstacle clearance is paramount when executing “alternate” missed approach under these circumstances.

10.9.3.2.1. For straight missed approaches, the width of the primary area is equal to the final approach area at the MAP and expands uniformly to the width of the initial approach. The width of the secondary area varies at the MAP and expands uniformly to 2 nm outside the primary area 15 nm from the MAP (see figure 10.8, Straight Missed Approach Area).

**Figure 10.8. Straight Missed Approach Area.**

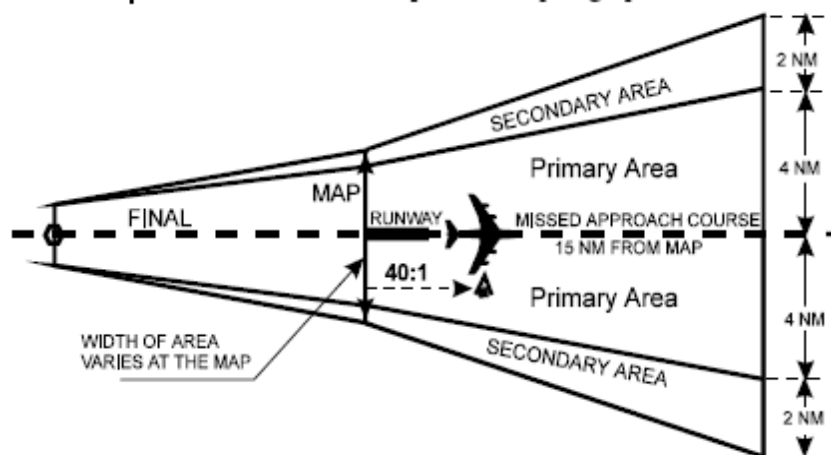

10.9.3.2.2. For turning missed approaches the primary and secondary area widths vary based on the number of degrees of turn required, the width of the final approach area at the MAP, and the categories of aircraft authorized to use the procedure.

10.9.3.2.3. If the HAT is less than 400 feet, then a combination straight and turning missed approach will be constructed to accommodate the climb to 400 feet AGL prior to turning.

10.9.3.2.4. Within the primary area the OCS begins at the MDA/DH for the procedure at the MAP. It extends upward on a 40:1 slope (2.5% gradient, or 152 ft/nm) to the clearance limit (see figure 10.9). ROC is added to this to account for less than ideal conditions.

#### 10.9.4. Missed Approach Climb Gradient Considerations.

10.9.4.1. As with departures, the historical standard ROC for missed approaches is 48 ft/nm. The FAA has changed their criteria for computation of ROC for missed approach from 48 ft/nm to a formula based on 24% of the climb gradient required to clear the obstacle (see figure 10.10). This transition will take a number of years for all FAA designed procedures. During the transition there is no way of knowing which criteria were used to calculate the ROC for a particular FAA procedure; however, there will always be at least 48 ft/nm ROC. Both the USAF and ICAO are continuing to use 48 ft/nm.

10.9.4.2. Most missed approach climb gradients require the standard 200 ft/nm. This is because when a penetration of the OCS causes the missed approach climb gradient to increase beyond 200 ft/nm, the TERPS specialist usually raises the minimums for the approach in order to eliminate the obstacle. This is not always feasible. Although rare, it is important to understand that due to the need to publish a lower minimum, the TERPS specialist may have to publish a missed approach climb gradient that is greater than 200 ft/nm.

**Figure 10.9. Missed Approach Cross Section.**

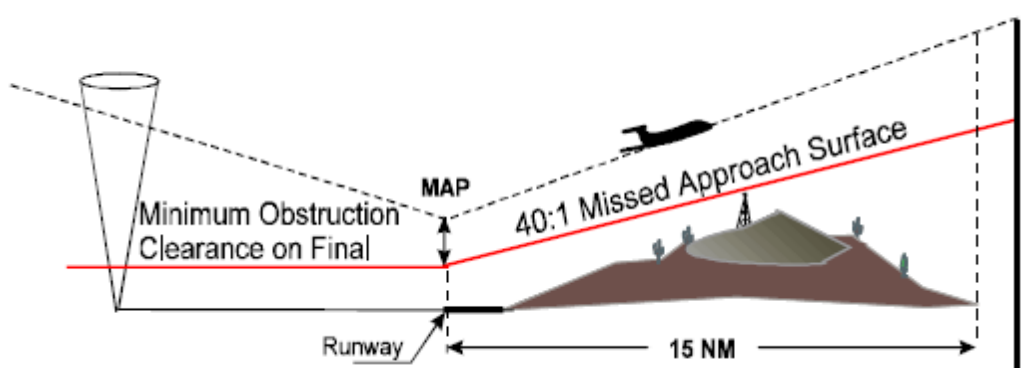
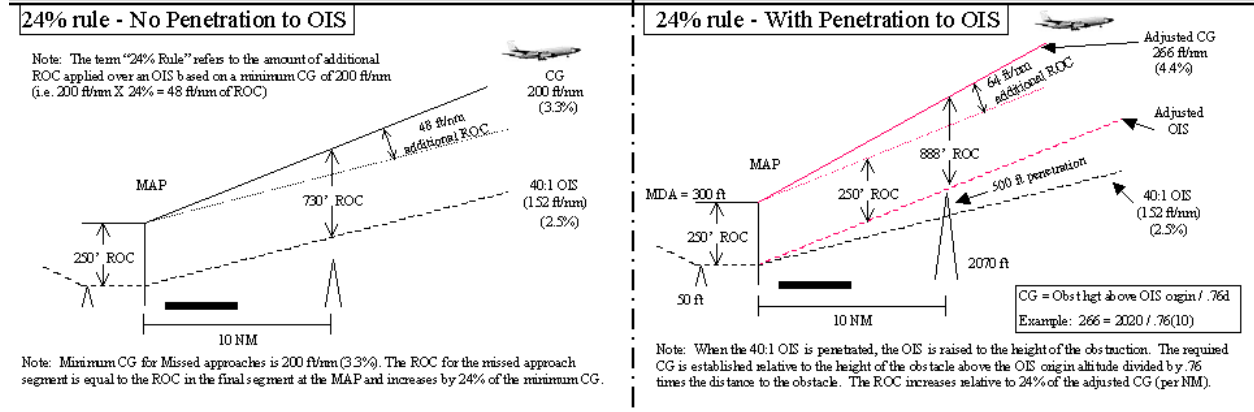
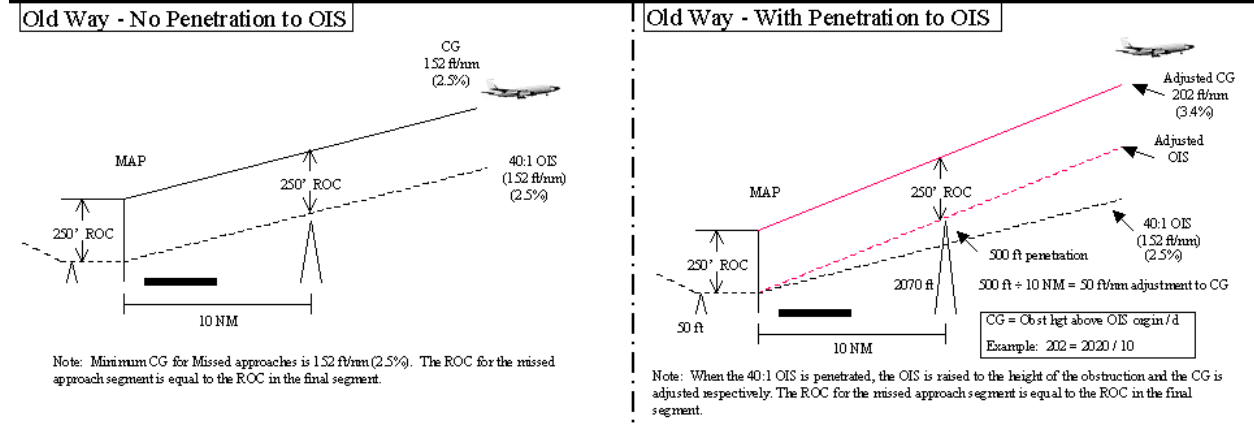

**Figure 10.10. Obstacle Clearance Surface for Missed Approach.**

24% Rule, at a glance

Non Precision Missed Approach

Terms Used: OIS = Obstacle Identification Surface  
 ROC = Required Obstacle Clearance  
 CG = Climb Gradient  
 MAP = Missed Approach Point  
 d = Distance from MAP



**10.10. Holding.** Criteria for holding pattern airspace is provided in FAA Order 7130.3. There are currently 31 separate holding pattern templates. The template the TERPS specialist uses to design a specific holding pattern will vary based on altitude, location, distance from the facility, airspace type, whether the holding fix is defined by conventional ground based NAVAIDs or GPS, whether outbound leg length is predicated on time or DME, along with other factors. Since it is impossible for a crew to determine which factors affected the design of a particular holding pattern, the specific dimensions of each will not be discussed; however, certain basic criteria apply.

10.10.1. Turn Effect. Pilot procedures specify that entry and holding turns should be conducted using 30° of bank or standard rate turn, whichever requires the least bank angle. However, due to instrument tolerances, pilot technique, holding pattern design criteria is based upon 25° of bank. Additionally, for the entry turn, 6 seconds at the highest aircraft airspeed is applied in the direction of protected airspace to compensate for any pilot delay in recognizing and reacting to fix passage.

10.10.2. Wind Effect. Analysis of winds recorded at various levels over a five-year period led to a standard wind velocities being applied to holding pattern design. Starting at 4,000 feet MSL, 50 knots is applied to the computations and increases at a rate of 3 knots per 2,000 feet of altitude.

10.10.3. Holding Course Alignment. Whenever practical, holding patterns should be aligned to coincide with the flight course to be flown after leaving the holding fix.

10.10.3.1. A holding pattern will not be aligned with an arc. In this case, the holding fix will be aligned with a radial.

10.10.3.2. When a holding pattern is located at the FAF and a procedure turn is not used, the inbound holding course will be the same as the final approach course unless the FAF is the facility. When the FAF is the facility, the inbound holding course will not be more than 30° from the final approach course.

10.10.4. Holding Obstacle Clearance. When designing a holding pattern, the TERPS specialist applies a template that provides for obstacle clearance with a primary and secondary area taken into consideration.

10.10.4.1. Primary Area. A minimum of 1,000 feet of obstacle clearance will be provided throughout the primary area.

10.10.4.2. Secondary Area. The secondary area provides 500 feet of obstacle clearance at the inner edge, tapering to zero feet at the outer edge. There is an allowance in TERPS for precipitous terrain. The secondary area is 2 nm wide and surrounds the primary area.

**10.11. Summary.** Flight procedures in the terminal area are developed by the TERPS specialist and designed to accommodate the performance capabilities of civil and military aircraft. Which factors and rule sets are applied to the approach or departure design is very complex; however, under all circumstances, a primary consideration is obstacle clearance. This chapter was designed to provide the aircrew member a basic introduction and some insights into the criteria and considerations a TERPS specialist takes into account when constructing an instrument procedure.

## Chapter 11

### USING NON-DOD/NACO INSTRUMENT PROCEDURES

**11.1. Introduction.** Throughout the world, various sets of criteria are used to create and publish instrument procedures. The DoD (NGA) and FAA (NACO) use U.S. TERPS criteria and the USAF applies additional criteria through AFI 11-230. In order for an instrument procedure to be published in DoD or NACO FLIP, the procedure must pass a stringent set of checks designed to ensure the procedure meets US standards for safety. Other nations; however, may or may not use U.S. TERPS criteria. They may have their own criteria, use ICAO or ICAO criteria with a list of exceptions or combination thereof when designing an instrument procedure. As a result, the SECDEF has established a policy requiring a U.S. TERPS review of any instrument procedure not developed by the DoD or FAA. This review insures the instrument procedures meet U.S. TERPS standards and provide an equivalent level of safety prior to use by any aircrew. AFI 11-230 outlines this review process. AFI 11-202 Volume 3 General Flight Rules also provides aircrew specific guidance regarding the use of host nation procedures published by sources other than NGA or NACO.

**11.2. Commercial Products.** Instrument procedures published by a commercial vendor (e.g., Jeppesen) are drawn directly from data provided by the host nation and are simply reformatted. While the product may have many useful features regarding lay-out, ease of use, and some esthetic qualities, it may or may not be safe to fly. This is because, unlike DoD/NACO procedures, commercially reproduced procedures are not flight checked or verified against a standard set of criteria and thus, cannot guarantee proper obstruction clearance even if flown correctly. A DoD/NACO designed instrument procedure, if properly flown, is able to guarantee obstacle clearance. Because of this difference between commercially reproduced procedures and those provided by DoD/NACO, commercial vendors will normally carry a legal disclaimer assuming no responsibility for obstruction clearance. As a result, all commercially produced procedures require a TERPS review prior to use.

**11.3. Using FLIP Other Than NGA or NACO.** In addition to the potential design safety issues previously discussed, other nations may not (and frequently don't) use the same charting standards as NGA and NACO. Aircrew can be completely unfamiliar with symbology, wording, abbreviations, etc. contained in host nation procedures. The same is true of instrument procedures produced by commercial vendors. As a result, AFI 11-202V3 stipulates that aircrew members are required to obtain MAJCOM approval to use FLIP other than those produced by NGA or NACO. Also prior to their initial use, the aircrew must also receive MAJCOM directed training.

**11.4. Determining Review Status.** One way to determine whether your MAJCOM has approved the use of a host nation or commercial product is via the AMC GDSS web site at <https://www.afd.scott.af.mil>. The Approach/Departure Information section of both the ASRR and Giant Report contain a list of procedures available (see Fig 11.1) along with which ones have received a TERPs review (see Fig 11.2). Figure 11.3 from the "Giant Report" depicts which MAJCOM provided the TERPS review of the procedure(s) and approved their use (in this example – USAFE). AFI 11-202V3 states that procedures approved by one MAJCOM may be

flown by aircrew from any other MAJCOM. Use caution here; your MAJCOM may have more restrictive guidance on this policy. Additionally, your MAJCOM is still required to provide you with training prior to the use of host nation or commercial products.

**Figure 11.1 Example ASRR Instrument Procedure Information.**

NOTE: NOT FOR NAVIGATION

TOP <span style="float: right;">DOD Approaches/NOAA <a href="#" style="color: white; text-decoration: none;">Help</a></span>														
DOD/NOAA Volume:	ENAME, VOL 4													
As Of:	09-Aug-2007													
Airfield has DME														
RWY	ILS	PAR	ASR	TAC	VOR	NDB	LOC LLZ	RNAV	LCTR	LDA	SDF	MLS	LOC BC	OTHER (REMARKS)
15	Y			Y										NONE
TOP <span style="float: right;">JEP Approach <a href="#" style="color: white; text-decoration: none;">Help</a></span>														
Jeppesen Airfield Name:	ISTRES, FRANCE													
Jeppesen Book:	CD													
As Of:	09-Aug-2007													
Airfield has DME														
RWY	ILS	PAR	ASR	TAC	VOR	NDB	LOC LLZ	RNAV	LCTR	LDA	SDF	MLS	LOC BC	OTHER (REMARKS)
15	Y													NONE
33	Y					Y								NONE

Figure 11.2. Example ASRR TERPS Review Page

<b>NOTE: NOT FOR NAVIGATION</b>	
<b>PROCEDURES APPROVED, IAW BELOW RESTRICTIONS, FOR ALL MISSIONS OPERATING THROUGH:</b>	30-Aug-2007
<b>GENERAL AREA NOTES:</b>	
<p>a. Area considered as mountainous terrain: No</p> <p>b. MSA discrepancies: See STAR review.</p> <p>c. USAF recommended map scales: Not Applicable.</p> <p>d. Accreditation Status: Accredited</p> <p>e. Diverse Departure Not Authorized.</p> <p>Please direct questions and feedback to USAFE/APF, DSN 314-480-7024 Comm. +49-6371-47-7024 or email usafe.terps@ramstein.af.mil; FAX 314-480 9816 Comm. +49-6371-47-9816. In case of emergency 24 hour POC is USAFE Watch at DSN 314-480-8200, Commercial +49-6371-47-8200.</p>	
<b>Procedures:</b>	
<b>Procedure Name: ARRIVALS</b>	<b>Jepp[X] Host[] Page: 10-2</b>
	<b>Effective: 28-Sep-2006</b>
<p>STAR REVIEW 2007-1316</p> <p>STAR</p> <p>Istres Le Tube, France (LFMI)</p> <p>1. Source information: France Civil AIP AD2 LFMI STAR 1 dated 28 Sep 06; Jeppesen DIBER 3D, JULEE 3D, NG 3D, OB 3D PPG 3D SOSUR 3D, TINOT 3D ARRIVALS page 10-2 dated 15 Sep 06 Eff 28 Sep 06.</p> <p>2. Findings of NATO procedure review.</p> <p>a. Only the SOSUR 3D evaluated/authorized.</p> <p>b. Caution: No assurance to the accuracy of the GPS position or navigation database development integrity. Unable to determine if waypoints are accurately contained in the FMS database and/or if the data is current.</p> <p>c. Host MSA source centered on ITR TACAN Safety Height 40 NM: 7900ft, Jeppesen MSA NOT AUTHORIZED.</p> <p>d. Host and Jeppesen do not depict routing altitudes, Jeppesen states transition level by ATC.</p> <p>e. VOR/DME and ADF REQUIRED</p> <p>f. Holding over ITR TACAN NOT AUTHORIZED.</p>	



Figure 11.3. Example ASRR MAJCOM TERPS Review Page.

NOTE: NOT FOR NAVIGATION

**Approved By:**

<input type="checkbox"/> AMC/ DO	<input type="checkbox"/> ACC/ DO	<input type="checkbox"/> AFMC/ DO	<input type="checkbox"/> AETC/ DO	<input checked="" type="checkbox"/> USAFE/ DO
<input type="checkbox"/> PACAF/ DO	<input type="checkbox"/> AFSOC/ DO	<input type="checkbox"/> AFSPC/ DO	<input type="checkbox"/> AFRC/ DO	<input type="checkbox"/> ANG/ DO

## Chapter 12

### NIGHT VISION DEVICES (NVD)

**12.1. Introduction.** Arguably one of the most important senses used in flight is vision because it allows a crewmember to quickly ascertain their position in space. The brain rapidly interprets visual cues during daylight. Unfortunately, when we transition to night operations, visual acuity decreases as the illumination levels reduced. To compensate for this and improve our ability to operate in the night environment, the Air Force uses night vision devices (NVDs). NVDs permit us to operate more effectively in the low-illumination environment, but we must remember that NVDs have important limitations. To effectively exploit the night using NVDs, you must recognize those limitations and then exercise proper planning and good judgment.

**12.2. Dark Adaptation.** Dark adaptation is the process by which your eyes increase their sensitivity to lower levels of illumination. People adapt to the dark in varying degrees and at different rates. For most people, the sensitivity of the eye increases roughly 10,000-fold during the first 30 minutes, with little increase after that time. One of the variables that determines the time for dark adaptation to take place is the length of exposure to bright light. If you have not been exposed to long periods of bright light, either through the use of sunglasses or spending the day indoors, you will likely dark adapt normally. On the other hand, if you are exposed to a large amount of unfiltered white light during the day, dark adaptation will take much longer. In extreme cases (snow-blindness or very reflective sand and water conditions), dark adaptation may not be possible for hours or even days. Under normal circumstances, complete dark adaptation is reached in approximately 30 to 45 minutes. If the dark-adapted eye is then exposed to a bright light, the sensitivity of that eye is temporarily impaired, with the amount of impairment depending on the intensity and duration of the exposure. Brief exposure to a bright light source can have minimal effect upon night vision because the pulses of energy are of such short duration. However, exposure to a bright light source (e.g., lightning or flares) for longer than one second can seriously impair your night vision. Depending on the intensity and duration of exposure, recovery to a previous level of dark adaptation can take anywhere between 5 and 45 minutes. The average image luminance in a night vision goggle (NVG) is not particularly bright, and your eyes will be in an intermediate state of dark adaptation when viewing scenes of typical uniformity. Once reaching this intermediate state and after discontinuing goggle use, it will take you approximately 5-8 minutes to regain full dark adaptation. Consequently, NVG use should be discontinued for a period of time prior to your requiring full dark adaptation (e.g., performing a landing without the use of NVGs).

**12.3. Spatial Orientation and NVGs.** Spatial orientation, or the ability to determine one's position and relative movement with respect to some frame of reference (usually the earth's surface), requires inputs from the two components of the visual system. Those two components are focal vision, which is primarily responsible for object recognition, and ambient vision, which is primarily responsible for spatial orientation. The use of NVGs allows aircrews to see objects at night that could not be seen during unaided operations. However, you must use your focal vision to interpret the NVG image. Since interpretation of focal vision is a conscious process, more time and effort is required to maintain spatial orientation during NVG operations than during daytime operations. Additionally, due to the goggles reduced field of view (FOV) and the

lack of visual cues in the periphery, more reliance is placed on focal vision. This reliance on focal vision can increase the aviator's workload and susceptibility to spatial disorientation.

## 12.4. The Night Environment.

12.4.1. Electromagnetic Spectrum (see Figure 12.1). Areas on the electromagnetic spectrum represent both the light that stimulates the unaided eye and the energy intensified by NVGs. The human eye is sensitive to the visible spectrum (approximately 400 to 700 nm), which progresses from violet to blue, green, yellow, orange, then red. A substantial amount of near-infrared (IR) energy (approximately 700 nm to 900 nm) is present in the night sky, so NVGs were designed to be sensitive to both visible and near-IR wavelengths. Thermal imaging systems, such as forward-looking infrared (FLIR) devices, are sensitive to energy in the mid- and far-IR regions.

12.4.2. Terms. The following terms are used to describe properties of light:

12.4.2.1. Illuminance. Illuminance (illumination) refers to the amount of light that strikes an object or surface at some distance from the source. An example is the amount of ambient light that strikes the ground from the moon.

12.4.2.2. Luminance. Luminance refers to the amount of light emitted or reflected from a surface area. An example is the apparent brightness of a surface that is illuminated by moonlight.

12.4.2.3. Albedo. Albedo is the ratio between luminance to illuminance, in other words, the ratio of reflected to incident electromagnetic radiation. Simply put, albedo is the fraction of light or other electromagnetic radiation reflected by a surface. For example, a mirror would have an albedo of near 1 or 100% while something that is very dark (black) would have an albedo near zero. Illumination from a light source may remain constant, but the luminance of different terrain features or objects will vary depending on their different albedos. The light source provides illumination, but what our eyes see, and what NVGs intensify, is the energy reflected from objects and terrain.

**Figure 12.1. The Electromagnetic Spectrum.**

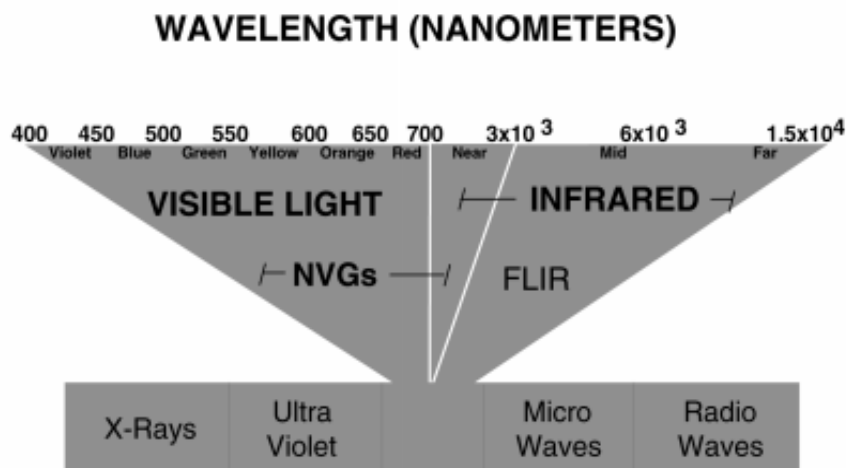

12.4.2.4. Contrast. Contrast is a measure of the luminance difference between two or more surfaces. In the night terrain environment, contrast is dependent upon differing albedo values for each type of terrain surface.

12.4.2.5. Nanometer (nm). The nanometer, (1 billionth meter) is a measurement of the wavelength of radiant energy.

**12.5. Sources of Illumination.** Many natural and artificial sources of energy combine to illuminate the night environment. Natural sources include the moon, stars, solar light and other atmospheric reactions, while artificial sources include city lights, fires, weapons discharge, searchlights and/or flares.

12.5.1. Moon. When present, the moon is the primary source of natural illumination in the night sky. The amount of moon illumination reaching the earth's surface is dependent on moon elevation above the horizon (moon angle) and the lunar phase.

12.5.1.1. Moon angle. Illumination from the moon is greatest when the moon is at its highest point (zenith) and at its lowest when the moon is just above the horizon. This effect is caused by absorption of energy as it travels through the atmosphere; at low moon angles there is more atmosphere for the energy to penetrate and hence more energy absorption occurs. Particulates in the atmosphere (e.g., rain, fog, dust) will also increase this absorptive effect. An additional problem associated with a low angle moon concerns the adverse effect it has on the NVG image. The bright light source (moon) will degrade the image, making it difficult to see terrain detail such as ridgelines. In fact, flying towards a low angle moon results in problems similar to those experienced when flying towards a low angle sun. All these factors should be considered during mission planning.

12.5.1.2. Phases of the Moon. Illumination is also affected by the phases of the moon. There are four distinct phases in the lunar cycle: new moon, first quarter, full moon and third quarter. For a period of time during the new moon phase, the moon is in conjunction with the sun and the dark side of the moon faces earth. However, this phase, which lasts about 8 days, also includes periods when approximately one quarter of the moon's surface is illuminated. A relatively low light level is characteristic of the new moon phase. Following the new moon phase is the first quarter (waxing) moon phase. One quarter to three quarters of the moon disk is visible during this phase, which lasts approximately 7 days, and good illumination is provided. The full moon phase covers the period when more than three quarters of the moon disk is visible and lasts approximately 8 days. The third quarter (waning) moon is the last phase and lasts about 7 days. It covers the time period when three quarters to one quarter moon disk illumination is present. Good illumination is provided during this phase, though slightly less than during the first quarter due to the type of lunar surface (mountainous) being illuminated by the sun. The entire cycle is repeated each "lunar month," which lasts approximately 29 days.

12.5.1.3. Moon Shadows. Another characteristic of the changing moon position is shadowing. Moonlight creates shadows during nighttime just as sunlight does during the day. However, understanding what you cannot see in nighttime shadows is critical to NVG operations. Since they contain little or no energy (and some energy must be present for the NVGs to provide an image), shadows can completely hide obstructions such as ridgelines or towers, and may make it

difficult to detect waypoints, targets, landing zones (LZ), drop zones (DZ), etc. The term foreshadowing refers to a particular shadowing situation in which near objects may be masked by the shadow created by a distant, higher object. Any of these effects can be a serious threat during low level flight.

12.5.2. Stars. The stars provide about 20 percent of the night sky illuminance on a moonless night. They contribute some visible light, but most of their contribution is in the form of near-IR energy. This means the majority of the energy is invisible to the human eye but is within the response range of NVG image intensifiers.

12.5.3. Solar Light. Skyglow is ambient light from the sun that can adversely affect NVG operations up to 1 ½ hours after sunset and ½ hour prior to sunrise, depending on latitude and time of year. For example, in Alaska skyglow will have a prolonged effect during the time of year when the sun does not travel far below the horizon. Skyglow will affect the gain of the goggle and thus reduce image quality. The effect is similar to flying into a sunset and results in the loss of visual cues when looking either west (sunset) or east (sunrise). Mission planning should take skyglow and its effects into consideration.

12.5.4. Other Background Illumination. The greater portion (approximately 40 percent) of energy in the night sky originates in the upper atmosphere and is produced by chemical reaction (ionization) processes. Other minor sources of night illumination are the aurora and zodiacal light caused by the scattering of sunlight from interplanetary particulate matter.

12.5.5. Artificial Sources. Lights from cities, industrial sites, and fires are also sources of illumination. Light from missile fly-out, weapon flashes, flares, and explosions can adversely affect NVG performance, but the effects are usually short lived due to the nature of the source (e.g., short 20mm/30mm bursts). In this case, the goggle image would return to normal as soon as the offending light source disappears.

**12.6. Night Vision Goggle Characteristics.** The NVG is an advanced night vision system. The goggles chosen by the Air Force are binocular-style, helmet mounted, image intensification devices that amplify visible and near-IR energy. This amplification is a passive process, meaning no emissions are created by the goggles themselves.

12.6.1. Basic Components of the Image Intensifier Tubes. The NVG is a lightweight, fully adjustable binocular assembly consisting of two monoculars, one for each eye. Each monocular amplifies available ambient light and presents an intensified image to one eye. Each monocular is comprised of the following components.

12.6.1.1. Objective Lens. The objective lens of each monocular consists of a combination of optical elements which focus the incoming photons of light onto the photocathode of the intensifier tube. During this process the image is inverted.

12.6.1.2. Minus Blue Filter. Coated onto the inside of the objective lens, the minus blue filter prevents certain wavelengths from entering the intensification process. This allows the use of properly filtered cockpit lighting to aid the pilot in viewing the cockpit instruments with unaided vision underneath the goggles. There are three standard classes of minus blue filters on goggles

produced in the United States. Class A filters use a 625 nm minus blue filter that blocks energy with a wavelength shorter than 625 nm—primarily wavelengths in the blue, green and yellow regions. Class B filters use a 665 nm minus blue filter to block energy with a wavelength shorter than 665 nm. This type filter reduces the NVG response in the orange and red region and allows the use of more colors in cockpit lighting. Class C filters are a modification of the Class B filter and add a small “notch” that allows an additional specific wavelength of energy to pass through and be sensed and intensified by the NVG and be seen by the aircrew. This is specifically intended for viewing of the heads-up display (HUD) in the intensified image.

12.6.1.3. Photocathode. The photocathode is the first element in an intensifier tube; it is a light-sensitive surface onto which the scene being viewed is focused by the objective lens of the monocular. It is similar to the film in a camera. It is made of gallium arsenide, and releases electrons when photons impact it, starting the intensification process.

12.6.1.4. Microchannel Plate. The microchannel plate is the next element in an intensifier tube. It consists of a thin wafer containing millions of microscopic glass tubules that channel the electrons exiting the photocathode. The tube walls release multiple electrons when an electron impacts the wall. The tubules are tilted to ensure electron impact with the tubule wall. The result is a “cascade effect,” which is an essential part of the intensification process. As a result of this process, for every single electron that enters one of the tubules, over one thousand exit.

12.6.1.5. Phosphor Screen. The phosphor screen is the next successive element in an intensifier tube. The screen is located on the front surface of the fiber optic inverter, next to the rear (exit) surface of the microchannel plate, and consists of a chemical that emits energy in the visible spectrum (light) when struck by electrons. Thus, as the electrons exiting the microchannel plate strike the phosphor, an image is created. Due to the type of phosphor selected for NVGs, the resultant image is green.

12.6.1.6. Fiber Optic Inverter. The fiber optic inverter serves to convey the intensified image created on the phosphor screen to the output of the intensifier tube. The inverter reorients the image that was inverted by the objective lens.

12.6.1.7. Diopter (eyepiece) Lens. The diopter lens is the final optical component of the image intensifier tube. The lens is adjustable and focuses the image onto the retina.

**Figure 12.2. NVG Components and the Image Intensification Process.**

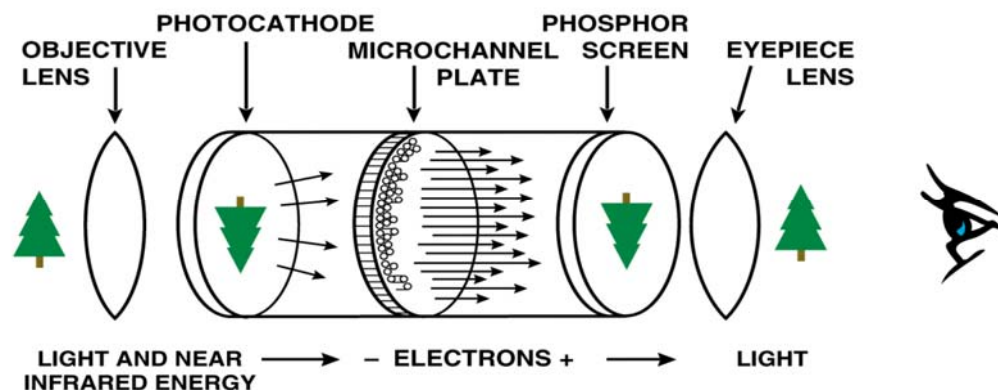

## 12.7. NVG Characteristics.

12.7.1. Gain. Gain refers to the ratio of output to input, or the amount of energy the intensification process produces relative to the amount that entered the intensification process. A NVG has circuitry that determines the amount of energy entering the intensification process, and this circuitry automatically controls the level of intensification needed to produce images of consistent brightness over a wide range of illumination levels. The control of the level of intensification is called automatic brightness control (ABC). At some point, the ability of the intensifier to increase gain is reached and image brightness and quality begin to degrade. Image degradation caused by lowering light levels can be very insidious and leads to problems for the aircrew.

12.7.2. Image color. The NVG image appears in shades of green. Since there is only one color, the image is said to be monochromatic.

12.7.3. Visual performance. When compared to the human eye under daylight conditions, your vision is limited while utilizing NVGs—detection ranges decrease and recognition of objects, terrain and targets can be severely limited. While NVGs can be vastly superior to the human eyes' performance under night conditions, NVGs DO NOT TURN NIGHT INTO DAY.

## 12.8. NVG Limitations. The following visual limitations are common to most NVGs.

12.8.1. Field of view. FOV refers to the total instantaneous area covered by the NVG image. Regardless of the type of NVG utilized, it is important to understand that the FOV it is able to provide is less than your eye's FOV, particularly in your peripheral vision. This loss of peripheral vision is often a contributing factor in the onset of spatial disorientation.

12.8.2. Resolution. Resolution refers to the capability of the goggle to present an image that makes clear and distinguishable the separate components of a scene or object. Though not technically accurate, it is easiest to discuss resolution in terms of Snellen visual acuity (the same system used for vision testing during flight physicals). Current NVGs have a resolution capability of 20/25 to 20/40 Snellen. Though quite an improvement for NVGs, the performance is still less than 20/20, which is accepted as "normal day vision." However, NVG performance far exceeds the eye's unaided visual performance at night, which is approximately 20/200 to 20/400. It should be noted that while NVGs have a rated acuity of 20/25 to 20/40 Snellen, this is the best an aircrew can expect to achieve under optimum conditions. There are many factors that affect NVG operations and degrade the expected acuity. These factors are discussed in the next section.

12.8.2.1. NVGs will not correct for sight deficiencies such as myopia or astigmatism. If you wear glasses during the day, you will still have to wear them when flying with NVGs to see properly.

12.8.3. Depth Perception and Distance Estimation. Depth perception is the ability to determine where objects are located relative to each other, whereas distance estimation is the ability to

determine the distance to something, such as the ground or a target. Depth and distance are discussed together because they use the same visual cues—binocular and monocular.

12.8.4. Binocular Cues. An aircrew's binocular cues are usually quite degraded due to the design of the goggle. Binocular cues are needed for tasks relatively close (within an arm's reach) and for tasks at distances up to approximately 200 meters. Binocular cues, by definition, require the use of both eyes functioning together and include stereopsis, vergence and accommodation.

12.8.5. Monocular Cues. Monocular cues appear to be most important for deriving distance information while flying. Monocular cues do not require the coordination of both eyes and are available beyond the distances at which binocular cues are. NVGs adversely affect monocular cues several ways. The decreased resolution of the NVG image results in a loss of sharp contrast and definition, both helpful for determining depth and distance. The limited FOV of the image diminishes depth and distance tasking by reducing the availability of cues. Also, anything adversely affecting the image (e.g., low illumination) will aggravate the problem. Examples of monocular cues used when flying include:

12.8.5.1. Size constancy. If two hangers are known to be equal in size, the one appearing smaller must be further away.

12.8.5.2. Motion parallax (optical flow). Nearer objects appear to be moving past more quickly than distant objects.

12.8.5.3. Linear perspective. The convergence of parallel lines at a distance.

**12.9. Avoiding Depth and Distance Problems.** Be aware that anything adversely affecting the NVG image will also adversely affect the assessment of depth and distance. Avoid the tendency to fly lower or closer in order to see more detail. Over a period of time, an aircrew member "learns" how to assess depth and distance when flying in the same area. However, the "learned" techniques may not transfer to a new area where terrain and objects might be completely different in size and perspective. In general, there is a tendency for aircrew to overestimate how well they can see when using NVGs.

12.9.1. Contrast. As with resolution, contrast in the NVG image is degraded relative to that perceived by the unaided eye during daytime. Also, any bright light source within or near the NVGs FOV will further reduce contrast by reducing gain, creating veiling glare across the image, or both. Additionally, there are differences in sensitivity to contrast among crewmembers, which may lead to differences in image interpretation.

12.9.2. Dynamic Visual Cues. Dynamic visual cues provide information that helps to determine direction, altitude and speed. The three primary dynamic cues are:

12.9.2.1. Static Cue Motion. Static cue motion is the summed effect of the change in one or more of the static cues caused by aircraft movement. Static cues include elevation, known size,



and perspective. Central vision tracking is a method for seeing static cue motion and will be degraded when using NVGs.

12.9.2.2. Optical Flow. Optical flow is the angular rate and direction of movement of objects as a result of aircraft velocity measured relative to the aviator's eyepoint. This provides our visual system the information necessary to interpret speed and direction of motion. If there is no relative motion, there is no optical flow. We use central vision to obtain optical flow information. Since visual acuity is degraded with NVGs, the optical flow cues will be degraded when compared to daytime cues.

12.9.2.3 Peripheral Vision Motion. Peripheral vision motion is a subconscious method of detecting optical flow. It is dependent on a wide FOV and is the primary attitude sensory input. With the reduction in FOV due to NVGs, this cue is severely degraded and central vision tracking becomes the primary attitude detection means. This leads to one of the most insidious dangers when flying low altitude—flying at a lower than expected/allowed altitude. Just as in the day, visual acuity will improve as the aircraft gets closer to the ground. However, because of the reduction in peripheral vision motion, the ensuing “speed rush” that would indicate close proximity to the ground is degraded and controlled flight into terrain becomes a real danger.

12.9.3. NVG Scan. The reduction in FOV necessitates an active, aggressive scan on the part of the NVG wearer. By continually scanning, aircrew members increase their field of regard by increasing the mental image of the surrounding terrain, aircraft, and cultural features. This information can then be compared and added to the aircraft flight instruments. Aircrew members should establish a scan pattern that allows information from outside the cockpit to be merged with cockpit flight instrumentation. Fixating in one direction may be necessary for a short duration (e.g., identifying a waypoint), but the scan should be continued after just a few seconds. A crewmember's scan pattern may be disrupted during high cockpit workloads or when fatigued. Under these conditions, an extra emphasis needs to be given to the scan pattern, especially keeping the horizon in the field of regard.

**Figure 12.3. Basic Night Vision Goggle Components.**

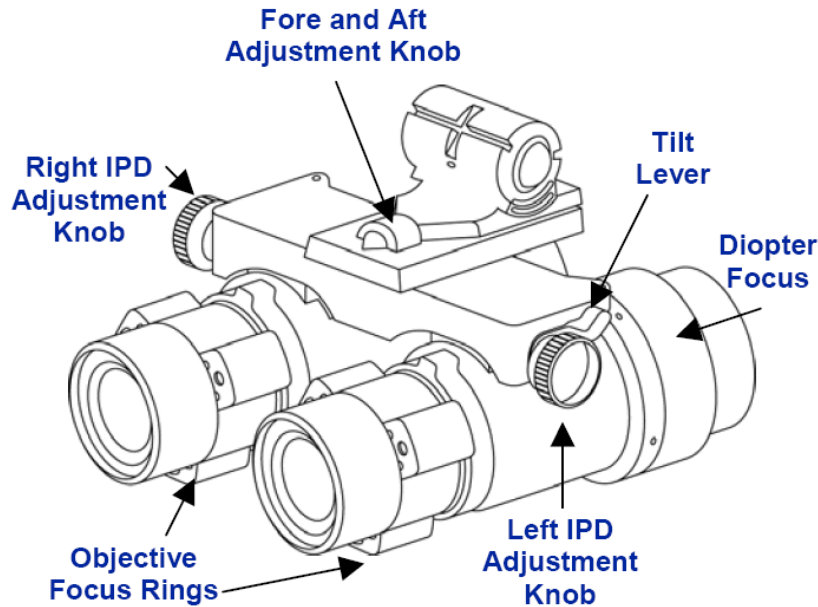

12.9.4. Preflight Adjustment and Assessment. Following proper NVG adjustment procedures prior to each flight is imperative to ensure a safe and effective operational capability. Even a small error in goggle adjustment can significantly degrade NVG aided visual acuity. The problem is compounded by the fact that it is nearly impossible to measure a loss in visual acuity without a controlled test environment, which means you can lose visual performance and not realize it.

12.9.4.1. Tube alignment. The human visual system is designed to subconsciously fuse the images from each eye into a single image without the perception of two separate images. This concept is called binocular fusion. To ensure proper alignment, the aircrew member should be able to see a complete circle through each monocular independently, and when viewed by both eyes the image should come close to forming a circle. Eye strain, fatigue, disorientation, or nausea can occur if NVG alignment errors are significant. If fusion becomes difficult, double images can form. Even if improperly aligned NVGs appear to have no adverse effects when used for short periods, they may prove intolerable when used for longer periods.

12.9.4.2. Assessment of Visual Acuity. The assessment of visual acuity is the most critical function of goggle preflight. It is impossible to accurately assess the acuity of the goggle without the use of a defined measuring device. The Air Force primarily utilizes the Hoffman ANV-20/20 Visual Acuity Box with a Night Vision Lane as a back up. It is paramount that individuals are familiar with the proper use and function of the 20/20 Box. Proper assessment of goggle acuity allows crewmembers to accurately determine the best case acuity of their specific goggles prior to flight. The visual acuity obtained with both image intensifier tubes should always be at least as good as the vision of the best image intensifier tube alone. If this is not the case, the goggles should be returned.

**Figure 12.4. ANV- 20/20 Visual Acuity Box Image**

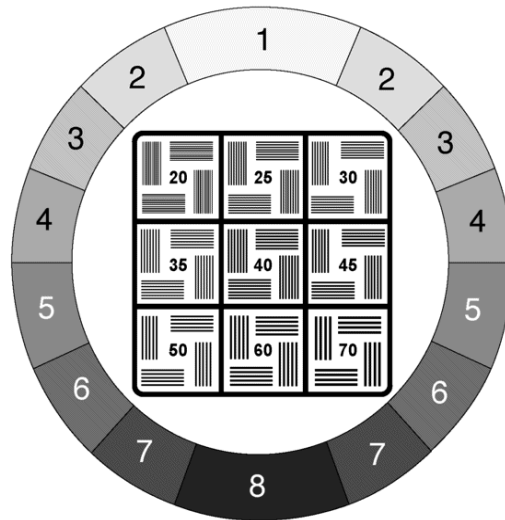

12.9.4.3. Assessment of Image. The following image defects are typical deficiencies that can be either normal or defective in nature. It is important to understand the difference to determine the proper course of action.

12.9.4.3.1. Shading. Shading is a condition encountered when a full image cannot be obtained and a dark area appears along the edge of the image. Attempt to eliminate shading by readjusting either the tilt or the interpupillary distance (IPD), or by shifting the helmet's position. Shading can also occur as a result of a shift in the microchannel plate caused by the goggles being dropped or handled roughly. If shading can not be corrected by readjustments or by repositioning the mounting bracket on the helmet, turn the goggles in for maintenance.

12.9.4.3.2. Edge glow. Edge glow appears as a bright area along the outer edge of the image. It can result from an incompatible light source outside the goggle FOV, a shift in the microchannel plate due to mishandling, or a power supply problem within the tube assembly. If edge glow is noted, move your head or cup your hand around the periphery of the objective lens in an attempt to alleviate the condition. If the edge glow does not disappear, turn the goggles in for maintenance.

12.9.4.3.3. Honeycomb. At times of very high luminance, a hexagonal (honeycomb) pattern may be visible across the intensified field of view. This pattern is a result of the manufacturing process during which the fiber optic inverter is assembled within the tube. Normally it is faint in appearance and does not affect NVG performance. Should it appear as a bold outline or during low luminance conditions, turn the goggles in for maintenance.

12.9.4.3.4. Bright spots. Bright spots are the result of irregular emission points on the photocathode, usually occurring during the manufacturing process. Because these spots are normally detected during the quality control process at the manufacturer, you will seldom see them. However, if an NVG has an excessive number of spots present in the image, or if the spots are distracting, turn the goggles in for maintenance.

12.9.4.3.5. Dark spots. Dark spots are simply the bright spots described above that have been corrected at the manufacturing facility. This correction is accomplished by exposing the light spots to laser energy and burning out that portion of the photocathode. Dark spots may also be caused by material allowed to enter the system during maintenance. NVG acquisition contracts usually include a specification that limits the number, size, and location of dark spots. Nevertheless, if you are distracted by the dark spots, even if the NVG is within specification, turn the goggles in for maintenance.

12.9.4.3.6. Distortion. The two most common types of distortion are bending and shear. Bending distortion results in the image having a wavy appearance, usually in a horizontal or vertical direction. Shear distortion results in a choppy appearance somewhere in the image. If distortion is present and likely to interfere with normal operations, turn the goggles in for maintenance. Flying with tube distortion can cause problems in distance and altitude estimations.

12.9.4.3.7. Scintillation. A sparkling effect normally occurs in the NVG image during low illumination conditions as a result of increased goggle gain and system noise. In flight, it can be an indication of decreasing illumination caused by such things as deteriorating weather conditions or flight into shadows.

**Figure 12.5. NVG Image Defects.**

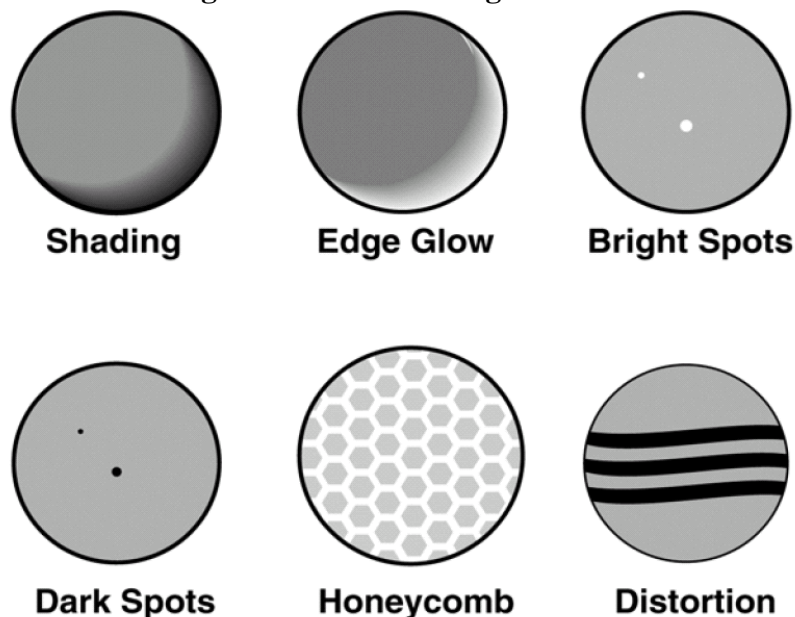

## 12.10. Factors Affecting NVG Operations.

12.10.1. Cockpit Lighting. NVG compatible cockpit lighting allows the crewmember to see cockpit instruments underneath the NVG while not measurably affecting NVG performance. Although NVG filters allow the use of cockpit lighting that will not adversely effect gain and image quality, unfiltered aircraft lighting is incompatible. If the lighting is not properly modified, it will emit wavelengths that affect NVG performance. There are aircraft in the inventory that

have not been fully modified to be NVG compatible. The following points are provided for clarification:

12.10.1.1. Just because a light is green or blue does not mean it is compatible. When the filament in a light glows, it releases a significant amount of near-IR energy which will affect NVG gain and performance. Light bulbs and other energy sources in the cockpit must be modified in some manner to block the emission of all energy to which NVGs are sensitive in order to make them NVG compatible.

12.10.1.2. Turning down the brightness of incompatible cockpit lighting will not make them compatible because NVGs are also sensitive to the near-IR energy emitted by the lights. Attempting to turn down lighting to reduce the effect on goggles can be a two edged sword—the NVG image will still be degraded and vital instruments may not be readable with the unaided eye.

12.10.1.3. An incompatible light does not have to be within the NVG FOV for it to have an effect on gain. MAJCOMs have specific lighting modification procedures if your aircraft cockpit lighting is not NVG compatible. When modifying your cockpit, remember that AFI 11-202 Volume 3 requires you to always have primary flight instrumentation present and properly illuminated. It must provide full-time attitude, altitude, and airspeed information; an immediately discernible attitude recognition capability; an unusual attitude recovery capability; and complete fault indications.

12.10.2. Transparency Transmissivity. Another impact on NVG performance is the degradation caused by windscreens, canopies, or other transparencies through which aircrew must look. Some transparencies transmit visible wavelengths fairly well, but near-IR wavelengths very poorly. Since NVGs are sensitive to near-IR wavelengths, transparencies that “trap” much of that energy will degrade NVG performance. All transparencies absorb near-IR energy to some extent, so there will be some goggle degradation in your cockpit.

12.10.3. Weather and Visibility Factors. Any atmospheric condition which absorbs, scatters, or refracts illumination, either before or after it strikes the terrain, will effectively reduce the usable energy available to the NVG. This reduction, in turn, degrades our ability to see key features critical for flight. The exact amount of reduction is difficult to predict because a common factor cannot be applied to each condition.

12.10.3.1. Clouds. Because of their variability, it is very difficult to predict the effect clouds may have on NVG operations. In general, NVGs easily “see” clouds that are dense but may not see clouds that are less dense. In the case of the more dense clouds, both visible and near-IR energy is reflected and the NVG can see the cloud (just as you can see the cloud unaided if there is enough light), especially if silhouetted against the night sky. However, dense clouds will reduce the amount of illumination striking the ground and therefore reduce the luminance available for NVG use. Thin (less dense) clouds have more space between their particles. Because the near-IR wavelength is slightly longer, it has a greater chance of passing through these type clouds than does the shorter visible wavelength. It is possible for the thin and wispy

clouds (which may be seen with the naked eye during daytime) to be invisible when viewed through the NVG. This potential invisibility is possible given three conditions:

12.10.3.1.1. The clouds are less dense,

12.10.3.1.2. The clouds are low level, and set in against the terrain rather than being silhouetted against the night sky, and

12.10.3.1.3. Ambient illumination is either very high or very low.

12.10.3.1.3.1. **NOTE:** The invisibility of thin clouds can create a severe hazard for NVG operations. Even though a cloud is “invisible,” you may not be able to see the terrain behind it because the cloud reduces luminance, which in turn reduces scene contrast and texture. This may, in turn, produce a false perception of distance, resulting in the pilot either not seeing the terrain or thinking it is farther away than it actually is. Additionally, the cloud may get progressively thicker, allowing the pilot to progress into the cloud without initially perceiving it or the terrain beyond. If a cloud is detected, the perception may be that it is at a distance.

12.10.3.2. Fog. Fog is another atmospheric condition of concern for the NVG operator. Its effects on goggles are similar to those of clouds, but there is a greater tendency for fog to be less dense and therefore more of a problem. It is important to know when and where fog may form in your flying area. Typically, coastal and mountainous areas are most susceptible.

12.10.3.3. Rain. Like clouds, the effect rain may have on goggle performance is difficult to predict. Droplet size and density are key ingredients to its visibility or invisibility. Light rain or mist may not be seen with NVGs, but will affect contrast, distance estimation, and depth perception. Heavy rain is more easily perceived due to the large droplet size and energy attenuation.

12.10.3.4. Snow. Snow occurs in a wide range of particle sizes, shapes, and densities. Snow crystals, while small in size, are generally large in comparison to the wavelength of visible light and near-IR energy, and will easily block or scatter those wavelengths. As with clouds, rain, and fog, the more dense the airborne snow, the greater the effect on NVG performance. On the ground, snow has a mixed effect depending on terrain type and the illumination level. In mountainous terrain, snow may add contrast, especially if trees and rocks protrude through the snow. In flatter terrain, snow may cover high contrast areas, reducing them to areas of low contrast. On low illumination nights, snow may reflect the available energy better than the terrain it covers and thus increase the level of illumination.

12.10.3.5. Sand, Dust, Smoke and Similar Obscurants. The effect of sand, dust, smoke and similar obscurants is similar to that created by the weather factors. However, the individual particulates in these obscurants are usually far more dense, which means they can block energy even if less concentrated.

12.10.4. All the atmospheric conditions described above reduce illumination levels. Recognition of this reduction in the cockpit is very difficult. The change is often a very subtle reduction in contrast that is not easily perceived with NVGs. Cues can be very subtle and the

crewmember will have to stay aware to catch their significance. Common cues to reductions in ambient illumination due to visibility restrictions include loss of celestial lights, loss of ground lights, reduced contrast, reduced depth perception or distance cues, reduced acuity or resolution, increased graininess or scintillation, and a more pronounced “halo” effect around incompatible light sources outside the aircraft.

12.10.5. Cockpit lighting, weather, transparency effects, the illumination level, and terrain type all have an effect on NVG performance. The visual acuity you achieve in the eye lane will usually not be what you get in the aircraft during the mission—it will usually be less. It is therefore imperative you maximize NVG performance before flight and avoid doing anything to the goggle during flight to disrupt it (e.g., readjust the diopter). Maximizing the NVGs performance will help offset the negative effects discussed.

**12.11. Night Operations with NVGs.** The NVG environment is always changing, so you must always be aware of what cues are presented and work to interpret them. Even then, beware of the potential misperceptions or illusions in any NVG scene. Many terrain characteristics influence our ability to see features or objects and distinguish differences. Due to the variability of the weather, the illumination level, and the moon angle, any given scene may look radically different on consecutive nights. A basic understanding of NVG operations requires the crewmember to blend the following considerations with an awareness of those changing conditions over different types of terrain.

12.11.1. Terrain Albedo (Reflectivity). Differences in terrain albedo, or reflectivity, will greatly influence luminance. For example, surfaces such as snow will reflect more energy than surfaces like asphalt or dark rock. Since NVGs intensify reflected energy, different albedos become critical in interpreting the NVG scene. Albedo will also vary with specific conditions of terrain even though the terrain type remains constant. For instance, dry sand is twice as reflective as wet sand.

12.11.2. Terrain Contrast. Terrain contrast is a measure of the difference between the reflectivity of two or more surfaces. The greater the differences in contrast, the more “normal” the scene appears in the NVG image, and the easier it becomes to pick out objects. Contrast generally improves with higher light levels, but there comes a point where there is actually too much light. This is usually noted when flying over low contrast terrain during high illumination conditions. Normally, however, as the ambient light level increases, overall definition is improved. Some examples of the effects of contrast in varying conditions are below.

12.11.3. Roads. The ability to detect roads with goggles depends primarily on the albedo difference between the road and the surrounding terrain. For example, the highly reflective surface of a concrete highway is easily identified in a grassy area during most illumination levels because of the difference in their albedos. However, asphalt roads are usually difficult to identify in heavily vegetated areas because both the asphalt road and the vegetation absorb available energy, and therefore have similar albedos. Conversely, in desert areas the reflective sand can make asphalt roads easily detectable.

12.11.4. Water. Still water, when seen with NVGs, normally looks dark when viewed at high angles from higher altitudes. Under low illumination, there is very little contrast between a vegetated landmass and a body of water. In desert areas, lakes and small bodies of water are normally detectable as a dark area in a light background. Lakes in a forested area are more difficult to detect due to the low reflectivity of the surrounding terrain. As light levels increase, land-water contrast increases. Due to the reflective nature of water, when over-flying large bodies of calm water, the stars appear to move across the surface as the angle of reflection is changed by the movement of the aircraft. This phenomenon may contribute to or induce the onset of spatial disorientation. Any action on the water caused by wind, such as white caps, may improve the contrast, aiding in surface identification. Over the ocean, the normal wave action breaks up reflections, thus reducing the problem. As in non-NVG flight, however, all night flight over open water is best performed with a heavier reliance on primary instruments.

12.11.5. Open fields. Contrast is usually very good over fields that are tended for crops. Various types of vegetation differ widely in their near-IR reflectance characteristics. For example, due to differences in the near-IR reflectance of chlorophyll, an oak tree will appear brighter than a pine tree. The same holds for crops. However, if flying over a large area of similar vegetation, contrast will be reduced. Additionally, the differences in the surface texture due to plowing are very apparent. A freshly plowed field may lack vegetation, but may produce a good NVG image when the coarse texture of the upturned soil contrasts well with the relatively undisturbed soil between the rows.

12.11.6. Desert. Open desert without vegetation can produce a washed-out NVG image. This is due to the high reflectivity of the sand and poor contrast offered by the lack of different albedos in the scene. Desert environments which have bushes, low trees, and cacti provide better contrast cues, allowing for more detail in the image. In general, flying over this type of terrain is similar to flying over water and is best accomplished with more reliance on your instruments.

12.11.7. Mountain Ranges. Normally, mountain ranges can easily be identified if the lower reflectivity of the mountains contrast with a lighter, more reflective desert floor. However, if ridges between your aircraft and a distant ridge have similar albedos, the intermediate ridges can for all practical purposes be “invisible.” Low, rolling terrain with the same reflectivity as the surrounding terrain can also blend together and be difficult to distinguish. These effects are more pronounced in low-light situations, but can occur under any conditions.

12.11.8. Forested areas. Heavily forested areas do not reflect energy efficiently, and solid canopied forests or jungles look like a dark mass at night. Excellent contrast does exist between deciduous (leafy) and coniferous (pines, firs, etc.) trees as well as between open fields, exposed rocks, and surrounding forest areas.

12.11.9. Snow. Fresh, wet snow reflects approximately 85 percent of the energy reaching it, thus providing the best natural reflectivity of any terrain surface. Under high illumination, this can provide excessive light which can, in turn, lower intensifier tube output and decrease resolution. During periods of predicted low illumination conditions, snow may add to the illumination level. Snow on the ground can also be a factor for flight planning; landmark recognition may be difficult if deep snow obscures prominent terrain features.



12.11.10. Terrain Shadows. Shadows form at night just as they do during the day, and anything blocking moonlight will create a shadow. The amount of terrain obscuration within a shaded area is dependent on the amount of ambient illumination and relative position of the moon. The smaller the moon disc, the darker the shadowed area and the more difficult to see detail. However, never plan on seeing any terrain features within shadows, regardless of the moon disc size.

**12.12. NVG Misperceptions and Illusions.** While most misperceptions and illusions encountered during NVG operations are simply a carryover of those experienced during daytime flight, others are specific to the NVGs themselves. Reduced resolution, limited field of view, and susceptibility to obscuration can intensify misperceptions and illusions. The most common NVG misperceptions and illusions are discussed below.

12.12.1. Depth Perception and Distance Estimation Errors. A common belief is that depth perception (DP) and distance estimation (DE) capabilities do not exist when using NVGs. It is true that these abilities are degraded by environmental conditions and goggle limitations, but techniques can be developed to assess depth and distance. The most helpful depth and distance cues are those with which the aircrew is most familiar. Flying over familiar terrain and culture features can reduce DP and DE errors. When flying over different terrain with unfamiliar features, serious errors in DP and DE can develop. For example, if someone normally flies over terrain with 30 foot trees, but is then deployed to an area populated with 5 foot shrubs, that person may fly lower than normal trying to make the scene look as it normally does. Using visual information alone, that person would likely think they were higher than they actually were. In this situation, bringing a radar altimeter into the cross-check would help minimize the effects of the illusion. Overall, the best way to train for the lack of DP and DE cueing is through proper planning, training, and a good discussion of differences between the deployed location and the normal area of operations. Training over a wide variety of terrain, features, and illumination levels can build the experience level of the aircrew to handle varying situations. Additionally, a thorough pre-brief should be incorporated to familiarize aircrew with the cues expected in the area of NVG operations. Be aware that a light source's halo intensity is not an accurate representation of its distance from the aircraft. The various wavelengths of light affect halo size significantly. When viewing light sources with NVGs, a technique that may help DP and DE is to look at the source with unaided vision. By looking underneath or around the goggles, not only can colors be determined, but the halo effect produced by the NVGs is eliminated. This additional information can be combined with the information presented in the NVG scene to improve the accuracy of your assessments.

12.12.2. Terrain Contour Misperceptions. Terrain contour misperceptions are exaggerated by anything that degrades the NVG image. The following are a few techniques to aid the aircrew in correct terrain perception.

12.12.2.1. Discriminating Between Near and Distant Terrain. One way to discriminate between near and distant terrain that contain little contrast difference is being attentive to motion parallax between the two. For example, a hidden ridgeline close to you may be highlighted by noting its movement relative to a distant, higher mountain.

12.12.2.2. Gradual Changes in Terrain Elevation. Gradually rising or descending terrain can be very difficult to assess when the terrain is low contrast. It becomes even more difficult when there are few cultural features available for comparison. To aid in detection of the gradual changes, an aggressive NVG scan must be maintained. By scanning aggressively, indicators of changes in terrain elevation may be picked up in areas other than directly in line with the flight path. Also, an aggressive instrument scan—when altitude, mission, and terrain type allow—can provide additional inputs to the developing situation.

12.12.2.3. Maintaining Scene Detail. If for any reason scene detail is reduced, there may be a tendency to fly lower in an attempt to regain the lost detail. In the worst case, this can lead to ground impact. Examples of when scene detail can be reduced include transitioning from an area of high contrast to one of low contrast, or when transitioning from an area of high illumination to an area of low illumination.

12.12.2.4. Undetected or Illusory Motion. Motion illusions experienced by aircrews are usually due to flights over areas of reduced contrast, or a sudden loss of contrast and flow cues. This can result from the lack of perceived “flow” information in the NVG image and may create the illusion that the aircraft has slowed down or stopped. This situation can induce spatial disorientation, especially if coupled with other factors such as loss of the horizon. An increased instrument scan will help alleviate the problem. Another insidious aspect of undetected motion is when an aircrew perceives they are motionless. Helicopter crews hovering over low contrast terrain, whether a large field or over open water, can actually be moving at fairly high speeds without knowing it. Without cues to provide stimulus to the visual system, this movement can go undetected and is very dangerous. Again, this is a known problem even during daytime, but the decreased resolution and FOV of the NVG image can accentuate the effects.

12.12.3. Recommendations. Susceptibility to illusions and misperceptions can be lessened by maximizing visual acuity. The best way to accomplish this is proper preflight adjustment and assessment of the goggles, ensuring the best NVG image. In-flight attentiveness is another building block to ensure NVG effectiveness. As stated earlier, reliance solely on visual cues will nearly always result in a flight path that is lower, closer, or steeper than intended, so the aircraft instruments must be readable and included in your cross-check. Use all information available to you, not just one piece of the puzzle. By using the entire picture, you lessen the likelihood of relying too much on NVGs. As usual, an aggressive scan is required to maintain situational awareness and spatial orientation.

**12.13. Emergency Situations.** In general, consider the type of emergency and what actions might be required from the pilot or the crew. If the NVGs will not be useful during emergency procedures, consider removing them. However, if you can still gain valuable information from the NVGs, aircrews may continue to use them.

12.13.1. Ejection. Ejection seat aircrew members must remove the NVGs prior to ejection unless they are ejection seat compatible. During the ejection sequence, with the NVGs in place on the helmet, fatal neck injuries can occur due to the forward center of gravity and weight of the goggles. It is for this reason that aircrews not leave the NVGs in a raised position during

emergencies that may lead to an ejection sequence. It is probable that you will forget you are wearing them in a highly stressful situation.

12.13.2. Inadvertent IMC. One of the most dangerous situations that can be experienced with NVGs is flight into undetected meteorological conditions. The inability of the NVGs to see various areas of moisture can lull the aircrew to continue further into instrument meteorological conditions (IMC) to a point where there is virtually no visual information. This can result in a gradual loss of scene detail and place the aircrew in an area of heavy moisture and, in the low-level environment, place the aircrew in a potential conflict with masked terrain. The following NVG cues will help alert you to impending IMC:

12.13.2.1. Halos surrounding incompatible light sources outside the cockpit (e.g., external lights from another aircraft) may change in appearance. Normally sharp edges to the halos can become less distinct and the halo may appear larger due to energy dispersion from the moisture.

12.13.2.2. A gradual loss of scene detail, visual acuity, or terrain contrast.

12.13.2.3. Partial or complete obscuration of the moon and stars.

12.13.2.4. An increase in scintillation.

12.13.2.5. The glow or flash from your aircraft external lights/strobes/landing lights/searchlights may become visible or intensify.

12.13.2.6. Looking underneath or around the NVGs with the unaided eye can aid in detecting IMC, but be aware that you can be in precipitation without seeing it in the NVG image. Use all the cues available to you.

**12.14. Spatial Disorientation.** Spatial disorientation can occur at any time during flight. Although NVGs usually improve situational awareness and reduce the possibility of spatial disorientation, they can also enhance momentary disorientation. This is due to the limited field of view and lower resolution. Maintaining spatial orientation at night requires complex conscious processing of data from various instruments, displays, and references. The task of maintaining spatial orientation competes with the usual tasking of navigation, terrain masking, threat avoidance, etc. Add to this the fact that fatigue occurs more frequently at night and it is easy to understand why the incidence of spatial disorientation in this environment appears to be logarithmic as variables are added. Constant vigilance and a good scan pattern, both inside and outside the cockpit, must be maintained to help prevent spatial disorientation. Keeping the horizon in the NVG scan can help avoid spatial disorientation. If you feel disoriented, react in exactly the same way as if you were on a non-NVG flight.

12.14.1.1 NOTE: Preventing Aircraft Mishaps Due to Spatial Disorientation. Refer to AFMAN 11-217, Volume 1 *Instrument Flight Procedures*, for a discussion on preventing aircraft mishaps due to spatial disorientation.

**12.15. Overconfidence in NVG's.** It is important that aircrew members not become over confident in the capabilities of NVGs. Goggles are only one tool used during night flight, and many situations can degrade or eliminate their effectiveness. Aircrews need to be cognizant of NVG limitations and prepared to transition to other flight aids, primarily aircraft instrumentation. Remember that NVGs do not turn night into day. After your initial NVG flying experience, there may be a natural tendency to be overly confident in your abilities. While, over time, there will undoubtedly be an increase in your skill level, it is not enough to compensate for the multiple variables in the night environment. The complacent mind-set could be a setup for a mishap.

**12.16. Other Night Vision Device Systems.** FLIR technology is based on the fact that all objects warmer than absolute zero emit heat. FLIR can discriminate between objects with a temperature of less than one-degree difference, or of the same temperature if they emit heat at different rates. The rate of emission depends upon composition of individual objects. FLIR sensors detect the differences in the thermal properties of these materials and creates an image on either a head up or head down display. This process, called thermal imaging, is presented as a monochromatic image for the aircrew that can be gray or green depending on the display.

12.16.1. Comparison of FLIR and NVG (Table 12.1). NVGs and FLIR systems are complementary sensors and can aid mission accomplishment through their integration.

**Table 12.1. NVG and FLIR Comparisons.**

NVG	FLIR
Use reflected energy (visible light and near IR)	Use emitted energy (mid or far IR)
Images reflective contrast	Images thermal contrast
Requires at least some illumination	Totally independent of light
Penetrates moisture more effectively	Penetrates smoke
Attenuated by smoke, haze, and dust	Attenuated by moisture (humidity)

## Chapter 13

### OCEANIC NAVIGATION

#### 13.1. Introduction.

13.1.1. This chapter is informational and is intended as a starting point for preparing for operating oceanic, also referred to as Class II airspace. Class II airspace is defined as long-range navigation beyond the limits of the operational service volume of ground-based NAVAIDS (formerly known as a Category I route). It is also provided in an effort to reduce Gross Navigational Errors (GNEs). A GNE occurs when an aircraft drifts more than 25 miles from the cleared route, is off assigned altitude by more than 300 feet, or an ETA difference of 3 minutes or more (erosion of longitudinal separation) is experienced exiting oceanic airspace. Unfortunately, the majority of incidents involving a GNE are normally the result of aircrew error.

13.1.2. Aircraft separation and air traffic procedures are standardized by ICAO in international oceanic airspace (defined as 12 miles off coastline). The responsibility for Air Traffic Services (ATS) in oceanic airspace is delegated to the various ICAO member states according to geographic proximity and availability of the required resources. Regulatory guidance for aircraft operations in oceanic airspace are contained in relevant ICAO Annexes, PANS/ATM (Doc. 4444), Regional Supplementary Procedures (Doc. 7030), State AIPs and current NOTAMs. Procedures are extracted from those sources and written into AFIs and FLIP for Air Force aircrews to follow as regulatory. Therefore, all planning for flight in oceanic airspace by Air Force aircrews should include a thorough review of the AFI 11-3MDS Volume 3 and applicable FLIP. A review of General Planning (GP), the Flight Information Handbook (FIH), Area Planning (AP), Enroute Supplement(s), and ICAO North Atlantic MNPS Airspace Operations Manual begin the planning process. Further information may be obtained at the sources listed in Table 13.1:

**Table 13.1. Useful Oceanic Travel Planning Website Resources.**

Useful Web Resources:	Information:
Defense Internet NOTAM Service (DINS) <a href="https://www.notams.jcs.mil/dinsQueryWeb/">https://www.notams.jcs.mil/dinsQueryWeb/</a>	-Region specific NOTAMs -FAA's Notice to Airmen (NTAP) -Aircrew Data Link Documents
National Geospatial-Intelligence Agency (NGA) If already have registration, use: <a href="https://www.extranet.nga.mil">https://www.extranet.nga.mil</a> If registration required, follow directions at: <a href="http://164.214.2.62/products/usfif/index.cfm">http://164.214.2.62/products/usfif/index.cfm</a>	-Flight Information Publications -Planning/Enroute Supplements

<p>North Atlantic Program Coordination Office  <a href="http://www.nat-pco.org">http://www.nat-pco.org</a></p>	<ul style="list-style-type: none"> <li>-Oceanic Errors Safety Bulletin (OESB)</li> <li>-North Atlantic Minimum Navigation Performance Specification Airspace (MNPSA) Operations Manual</li> <li>- North Atlantic International General Aviation Operations Manual</li> <li>-Sample Oceanic Checklist</li> <li>-High Frequency Management Guidance Material for the NAT Region</li> <li>- Monthly Navigational Error Statistics</li> </ul>
<p>HQ Air Force Flight Standards Agency  <a href="https://wwwmil.tinker.af.mil/AFFSA">https://wwwmil.tinker.af.mil/AFFSA</a></p>	<ul style="list-style-type: none"> <li>-Track &amp; Distance Tables (useful for verifying track and distance of waypoints inserted into LRNS)</li> </ul>
<p>Oceanic and Offshore Operations  <a href="http://www.faa.gov/about/office_org/headquarters_offices/ato/service_units/enroute/oceanic/">http://www.faa.gov/about/office_org/headquarters_offices/ato/service_units/enroute/oceanic/</a></p>	<ul style="list-style-type: none"> <li>-Reduced Vertical Separation Minimum (RVSM)</li> <li>-Surveillance and Broadcast Services information</li> </ul>
<p>Oceanic FIR Websites  <a href="http://occ.iviao.ca/index.php">http://occ.iviao.ca/index.php</a>  <a href="http://zak.vatusa.org/">http://zak.vatusa.org/</a></p>	<ul style="list-style-type: none"> <li>-Shannon/Gander FIR</li> <li>-Oakland FIR</li> </ul>

**13.2. Oceanic Flight.** The current oceanic ATC system is procedural in nature, using pre-coordinated flight routing and position reports to track an aircraft's progress and ensure separation is maintained. Deficiencies in communications, navigation, and radar surveillance necessitate large horizontal separation minima. The progress of aircraft is monitored by ATC using position reports sent by the aircraft over HF radio or data link. Position reports are infrequent (approximately one report per hour in the Atlantic and 1 hour 20 minutes in the Pacific), and the accuracy of these reports depends on the accuracy of the aircraft's on-board navigation system and timing. HF communication is subject to interferences, disruptions, and delays due to weather phenomena, sunspot activity, and requires that radio operators relay messages between pilots and controllers.

#### 13.2.1. North Atlantic Ocean (NAT Tracks).

13.2.1.1. With an ever increasing flow of traffic from North America to Europe and back, a system of non-radar control has been developed (since radar is only effective for about 250 NM) to maintain positive separation for the hundreds of airline, private jets and military flights that

move across the North Atlantic daily (referred to as the North Atlantic Track, NAT). This feat is accomplished by the use of an Organized Track System (OTS) that is developed daily for east and westbound flights.

13.2.1.2. The airlines/private jets/military that cross the Atlantic using the NAT system must meet many operating standards and procedures must be adhered to. Not only should pilots understand the standards and procedures for operating in the NAT systems, the aircraft is required to meet unique certification specifications to fly in it. The rules that govern this airspace are called Minimum Navigational Performance Specification Airspace (MNPSA). The vertical dimension of the MNPSA is between FL285 and FL410 (i.e. in terms of normally used cruising levels, from FL290 to FL410 inclusive). Specific lateral dimensions for the separate oceanic Control Areas (CTAs) are found in the *ICAO Regional Supplementary Procedures (Doc 7030)*. This document and other information concerning MNPSA is available at <http://www.nat-pco.org/>.

13.2.1.3. Two primary oceanic centers are responsible for the two CTAs, Gander Center and Shanwick Center, one on each side of the Atlantic. These two oceanic centers are responsible for creating the daily tracks. Since the major traffic flow between North America and Europe takes place in two distinct time periods during the course of a 24-hour cycle, Gander Centre creates eastbound “night-time” tracks which are centered around 0400 UTC at 30°W and Shanwick Center creates westbound “day-time” tracks which are centered around 1500 UTC at 30°W.

13.2.1.4. Due to the major flow of eastbound flights from North America in the evening hours and an almost equal flow of westbound flights from Europe in the morning, the NAT airspace can become quite congested at peak hours. With the ever-changing nature of the North Atlantic weather patterns, including the presence of jet streams, eastbound and westbound tracks are seldom identical. In short, the NAT airspace is very congested and the actual track location change daily based on weather and forecasted winds. To produce the track system, a computer takes into account a variety of information (e.g., weather on the NAT, location of the jet stream, number of flights expected); then, based on the results, controllers will formulate the track system for use during a particular period.

13.2.1.5. To ensure a smooth transition from night to day organized track systems and vice-versa, a period of several hours is spaced between the termination of one track system and the commencement of the next.

13.2.1.6. Gander Oceanic control and Shanwick Oceanic control use 30°W as their dividing line for control transfer point. High Frequency (HF) radios are used to transmit position reports to the IFSS (International Flight Service Station) operators at both Oceanic Centers. This information is passed onto the controllers working the assigned Tracks for the day or night periods.

13.2.2. The following (see figure 13.1) is an example of one entry from a daily NAT message for east and westbound flights. The tracks are lettered A (the northernmost track) to K for westbound tracks and U (the northernmost track) to Z for eastbound travel.

13.2.2.1. For each route, there will be a route identifier followed a coast-out fix and routing, 4 or more latitude/longitude points of the track itself and then a coast-in fix on the other side. Available flight levels for direction of flight are also given along with joining routes that can be filed from the coast in fix(s).

13.2.2.2. The North American Routes (NAR) System interfaces with the NAT Oceanic and Domestic Airspace, and is used by air traffic transiting the North Atlantic. NARs extend to/from established oceanic coastal fixes to major airports throughout Canada and the U. S. These routes allow controllers to help keep the flow of east/west bound flights to/from the NATs organized and allows aircraft operators, in some cases, expedited routing. The NAR's will be based on either inland fixes to coastal fixes or vice-versa. Explanations and descriptions of NAR routes can be found in the Canadian Forces Flight Supplement.

**Figure 13.1. Example of NAT Track Message.**

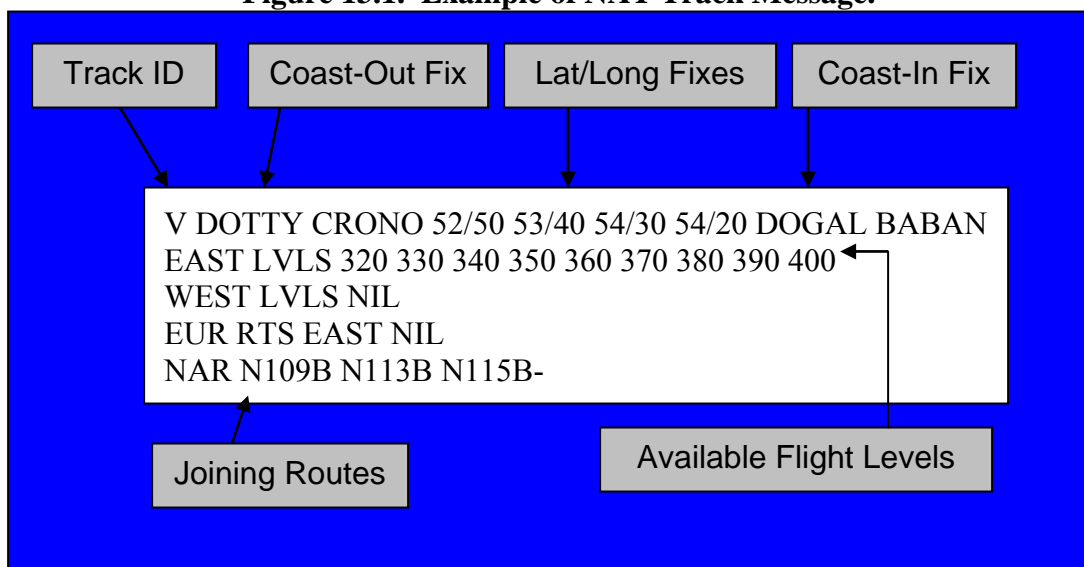

13.2.2.3. Other organized track systems (OTS) exist for other parts of the world, but they all work in similar fashion. Examples of other track systems are listed here:

13.2.2.3.1. PACOTS. Traffic on the Pacific Organized Track System (PACOTS) flows between North America and Hawaii to Asia and Australia. The flexible tracks are developed twice daily by the Oakland ARTCC Traffic Management Unit (TMU) and Tokyo Area Control Center to take maximum advantage of changing wind forecasts.

13.2.2.3.2. NOPAC. The Northern Pacific (NOPAC) Composite Route System (CRS) consists of five fixed tracks and nine transition routes from Alaska to the Asian and Pacific rim nations. The long distances involved between city pairs on these routes make wind optimized routing and flight profiles for fuel economy a high priority to users. Westbound routes from New York to Tokyo compete for northern routes which, although slightly longer, may save significant time by avoiding the jet stream.

13.2.2.3.3. CEP. The Central East Pacific (CEP) CRS connects the U.S. Central West Coast to Hawaii. It consists of a set of five interior unidirectional tracks that are generally dense with traffic, and two exterior bi-directional fixed tracks.



13.2.2.3.4. CENPAC. The Central Pacific (CENPAC) traffic region consists of PACOTS traffic between Hawaii and Japan, and Japan to the U.S. West Coast. This region is characterized by long stage length tracks and complex weather situations. Also in this region, the Pacific Northwest to Hawaii fixed tracks cross the U.S. to Japan PACOTS routes, creating additional complications for controllers.

13.2.2.3.5. SOPAC. The traffic flow between Hawaii and the South Pacific (SOPAC) utilizes fixed tracks and random tracks. SOPAC traffic is also characterized by long stage length tracks. It includes the PACOTS tracks from San Francisco and Los Angeles to Sydney and Auckland.

13.2.2.3.6. Guam. The area around Guam contains the traffic flow from the Orient to the South Pacific. Most aircraft in this region use fixed tracks. Traffic is characterized as predominantly one-way, converging, and dense, with some opposite direction traffic. The north-south flow is crossed by traffic from the Far East to Hawaii and by the PACOTS tracks.

**13.3. Oceanic Navigational Errors.** Oceanic navigation errors reported by ATC are overwhelmingly caused by aircrew improperly handling an in flight re-route (i.e. not inserting the new clearance's waypoints into the Long Range Navigation System (LRNS) and cross-checking the new clearance). Basic human factor mistakes by aircrew negatively impact ATC efforts to reduce separation standards. Complacency in relying on technology, waypoint insertion errors, and flying the flight plan instead of the clearance are errors that can be resolved by simply applying "common sense checks" in monitoring the flight path of the aircraft. The following information not only provides ICAO Standard Operating Procedures (SOP) common to all oceanic regions, but also incorporates recommended steps to help mitigate the common errors described.

**13.4. Oceanic Checklist.** The following generic oceanic flight checklist was derived from multiple sources including ICAO North Atlantic Working Groups composed of industry, ATC and state regulators. Specific region procedures and NOTAMs should be reviewed for unique or temporary applications. Units without an oceanic checklist are encouraged to use this sample and tailor it to their specific requirements. This checklist provides an orderly planning and in-flight flow and contains methods to reduce oceanic navigational errors. HQ AFFSA maintains some oceanic flight and training information on its website. Aircrews should also review the expanded checklist and the Oceanic Errors Safety Bulletin (OESB) found at [www.nat-pco.org](http://www.nat-pco.org).

**Figure 13.2. Sample Oceanic Checklist.**

<b>FLIGHT PLANNING</b>	
<input type="checkbox"/>	Airspace Review – FLIP, NOTAMs, websites, etc.
<input type="checkbox"/>	Plotting Chart – plot route from coast out to coast in
<input type="checkbox"/>	Equal Time Points (ETP) – plot
<input type="checkbox"/>	Track message (current copy available for all crossings) - Note nearest tracks on plotting chart
<input type="checkbox"/>	Review possible navigation aids for accuracy check prior to coast out
<input type="checkbox"/>	ALTRV APPVL (if required)

**PREFLIGHT**

- Master Clock for all ETAs/ATAs – Synchronized to acceptable UTC time signal
- Aircraft Maintenance Forms – check for any navigation/communication/surveillance or RVSM issues
- RVSM
  - Altimeter checks (tolerance)
  - Wind shear or turbulence forecast
- Computer Flight Plan (CFP) –vs- 1801 Flight Plan (check routing, fuel load, times, groundspeeds)
- Dual Long Range NAV System (LRNS) for remote oceanic operations
- HF check (including SELCAL)
- Confirm Present Position coordinates (best source)
- Master CFP (symbols: O, V, \, X)
- LRNS programming
  - Check currency and software version
  - Independent verification
  - Check expanded coordinates of waypoints
  - Track and distance check (+/- 2° and +/- 2nm)
  - Upload winds, if applicable
- Groundspeed check

**TAXI AND PRIOR TO TAKE-OFF**

- Groundspeed check
- Present Position check

**CLIMB OUT**

- Transition altitude – set altimeters to 29.92 in (1013.2 hPa)
- Manually compute ETAs above FL180

**PRIOR TO OCEANIC ENTRY**

- Gross error accuracy check – record results
- HF check, if not done during pre-flight
- Log on to CPDLC or ADS 15 to 45 minutes prior, if equipped
- Obtain oceanic clearance from appropriate clearance delivery at least 40 minutes prior to entry into oceanic airspace (some require only 20 minutes)
  - Confirm and maintain correct Flight Level at oceanic boundary
  - Confirm Flight Level, Mach and Route for crossing
- € Obtain oceanic clearance from appropriate clearance delivery (continued)
  - Advise ATC When Able Higher (WAH)
  - Ensure aircraft performance capabilities for maintaining assigned altitude/assigned Mach
- Reclearance – update LRNS, CFP and plotting chart
  - Check track and distance for new route utilizing track and distance charts in FIH (annotate on CFP for new waypoints and crosscheck LRNS track and distance for reasonableness (+/- 2° and +/- 2nm))
- Altimeter checks - record readings

<input type="checkbox"/> Compass heading check – record
<p><b><u>AFTER OCEANIC ENTRY</u></b></p> <input type="checkbox"/> Squawk 2000 – 30 minutes after entry (if applicable for region) <input type="checkbox"/> Maintain assigned Mach (if applicable) <input type="checkbox"/> VHF radios-set to interplane and guard frequency <input type="checkbox"/> Strategic Lateral Offset Procedure (SLOP) – 0, 1 or 2 nm Right (this is an ICAO Standard Operating Procedure) <input type="checkbox"/> Hourly altimeter checks
<p><b><u>APPROACHING WAYPOINTS</u></b></p> <input type="checkbox"/> Confirm next latitude/longitude <input type="checkbox"/> Re-confirm LRNS and CFP reflects clearance - if re-clearance, confirm non-applicable waypoints are removed
<p><b><u>OVERHEAD WAYPOINTS</u></b></p> <input type="checkbox"/> Confirm aircraft transitions to next waypoint - Check track and distance against Master CFP <input type="checkbox"/> Confirm time to next waypoint - Note: 3-minute or more change requires ATC notification <input type="checkbox"/> POSITION REPORT
<p><b><u>10-MINUTE PLOT (APPROXIMATELY 2° OF LONGITUDE AFTER WAYPOINT)</u></b></p> <input type="checkbox"/> Record time and latitude/longitude on plotting chart - Use non-steering LRNS for plotting information
<p><b><u>MIDPOINT BETWEEN WAYPOINTS</u></b></p> <input type="checkbox"/> Midway between waypoints compare winds from CFP, LRNS and upper millibar wind charts <input type="checkbox"/> Confirm time to next waypoint and update estimate with ATC if ETA changes by 3-minutes or greater
<p><b><u>COAST IN</u></b></p> <input type="checkbox"/> Compare ground based NAVAID to LRNS <input type="checkbox"/> Remove Strategic Lateral Offset <input type="checkbox"/> Confirm routing after oceanic exit
<p><b><u>DESCENT</u></b></p> <input type="checkbox"/> Transition level - set altimeters to QNH
<p><b><u>DESTINATION/BLOCK IN</u></b></p> <input type="checkbox"/> Navigation Accuracy Check <input type="checkbox"/> RVSM write-ups
<p><b><u>OTHER ISSUES</u></b></p> 1. Contingencies <ol style="list-style-type: none"> <li>(a) Published Weather Deviation Procedure</li> <li>(b) 15 NM offset (now applicable in all oceanic regions)</li> <li>(c) Lost Comm/NAV Procedures</li> </ol> 1. ETOPS

2. Weather – Destination/Alternate(s) Airport(s)
3. Data Link Contingency Procedures
4. Dead Reckoning (DR)
5. GPS – RAIM/FDE Requirements

### 13.5. Flight Planning.

13.5.1. Plotting Chart. A plotting chart of appropriate scale should be used for all remote oceanic operations. This includes using a plotting chart for published oceanic routes and tracks. ICAO groups who review oceanic errors have determined that the routine use of a plotting chart is an excellent aid to reduce lateral errors. A plotting chart can also serve as a critical aid in case of partial or total navigation failure. It should be noted that the pilot should read from the plotting chart back to the master CFP when verifying data. To read from the Master CFP to the plotting chart is a human factor's issue that has led to errors based on seeing what we expect to see.

13.5.2. Equal Time Point (ETP). ETPs should be computed for contingencies such as medical divert, engine loss or rapid depressurization. A simultaneous engine loss and rapid depressurization should also be considered. It is advisable to note the ETPs on the plotting chart. Crewmembers should review with each other the appropriate diversion airport(s) when crossing ETPs. Pilot procedures should also include a manual method for computing ETPs. The ETP is the point along the extended overwater leg from which it takes the same amount of time to return to departure (or the last suitable airfield prior to beginning the overwater leg of the mission) as it would to continue to destination (or the first suitable airfield for landing). The ETP is not necessarily the midpoint in time from departure to destination. Its location is somewhere near the midpoint of the route (between suitable airfields), and it is dependent upon the wind factors (aircraft groundspeed). An ETP can be computed using the formula outlined in Figure 13.3.

#### Figure 13.3. Equal Time Point (ETP) Calculation.

$$\text{ETP (in NM)} = \frac{\text{TD} \times \text{GS return}}{\text{GS return} + \text{GS continue}}$$

Where: TD = Total Route Distance between suitable airfields.

GS return = Groundspeed Returning to suitable landing field

GS continue = Groundspeed Continuing to destination (or diversion) field

Note: The resultant ETP (in NM) is measured from the "return" field or one behind the aircraft, not from the airfield in front of the aircraft.

Note: Groundspeed is TAS minus headwind (plus tailwind). Consider more than one ETP computation – one based on winds at your cruising level, and one or more based on forecasted winds at 10,000 feet. An ETP at 10,000 feet will differ significantly from the one at cruising altitude, and will provide you important information in the event of cabin decompression or engine loss. Remember to consider TAS and Fuel Flow differences at the lower altitude.

13.5.3. Track Message. Crews must have a current track message even if filed for a random route. Reviewing the date, effective Zulu time and Track Message Identifier (TMI) ensures

having a current track message on board. The TMI is the Julian Date. Aircrew must also ensure their flight planning and operational control process notify crewmembers in a timely manner of any amendments to the daily track message. Plotting tracks near the assigned route can help situational awareness in case the crew needs to execute a contingency. Track messages for both the North Atlantic and Pacific regions may be found under the “Advanced NOTAM Functions” section at: <https://www.notams.jcs.mil/> or from the FAA at the following link: <https://pilotweb.nas.faa.gov/distribution/atcsc.html>.

13.5.4. Altitude Reservation (ALTRV). Altitude Reservations are normally employed for the mass movement of aircraft or special missions that cannot be accomplished otherwise using standard air traffic control (ATC) separation. ALTRVs are designated as moving or stationary. A moving ALTRV normally includes the enroute and arrival phases of flight up to and including the initial approach fix serving the airport of intended landing, it may also include the departure phase of flight as well. A stationary ALTRV normally is defined by a fixed airspace area and altitude block to be used for a specified amount of time. An altitude reservation approval is authorization by ATC to use the airspace under prescribed conditions. An ALTRV APVL is pre-coordinated ATC clearance and will be followed. Deviation from an ALTRV APVL, except in the interest of flight safety, must be cleared through the controlling ATC facility and may result in the cancellation of the entire ALTRV. An ALTRV, unless otherwise coordinated, starts at the first cruising altitude or entry altitude and within the time window identified in the ALTRV APVL message. If the mission requires an ALTRV, the C2 agency will normally request it from the appropriate Central Altitude Reservation Facility (CARF) of the nation in which the ALTRV originates. ALTRV requests (APREQ) and approvals normally occur via message traffic. The crew should ensure they are in possession of their mission-specific ALTRV APPVL (Approval) message, vice the APREQ (ALTRV Request) message, as the CARF may change the requested routing and altitudes. Normally, your DD1801 flight plan will reflect the ALTRV routing and altitudes as specified in the ALTRV APPVL message. Consult FAAO Joint Order 7610.4 and your MAJCOM for more information on ALTRVs.

**13.6. Review Coast-Out Positional Accuracy.** It is good practice to discuss in advance a primary and secondary ground based navigational aid that will be used to verify the accuracy of the Long Range Navigation System (LRNS). This planning may help to identify intended navigation aids that are limited or NOTAMed unusable and is helpful when departing airports close to oceanic airspace. Examples include Shannon (EINN), Lisbon (LRRT), Los Angeles (KLAX), etc.

13.6.1. Master Clock. Preflight procedures for oceanic operations should include a UTC time check and synchronization to the aircraft master clock. This time source, which is typically the Flight Management System (FMS), should be used for all ETAs and ATAs. The use of multiple time sources on the aircraft has led to inconsistencies in reporting times to ATC and resulted in a loss of longitudinal separation.

13.6.2. RVSM. Refer to GP, MNPS documents, and theater specific AP FLIP for RVSM requirements/procedures. Consult your MAJCOM for current guidance. Also see expanded information and guidance on RVSM regarding requirements and operational procedures in this Chapter 4 of this manual.

13.6.3. Aircraft Maintenance Forms. Before entering a special area of operation, crews should ensure that their aircraft is properly equipped and certified for the area of operation. Check the maintenance forms for any discrepancies that could affect communication, navigation, surveillance or RVSM requirements. For example, if two VHF radios are required, and only one is operational, the aircraft requires maintenance before penetrating the airspace in which the two radios are required.

13.6.3.1. Altimeter Checks. Before taxi, crews should set their altimeters to the airport QNH. Both primary altimeters must agree within + 75 feet of field elevation. The two primary altimeters must also agree within the limits noted in the aircraft operating manual.

13.6.4. Computer Flight Plan (CFP). The document designated as the Master CFP should be carefully checked for date, type aircraft, fuel load and performance requirements. Crosschecks should also be done for routing and forecast groundspeeds. The CFP should be carefully checked against the ICAO filed flight plan to ensure the routing is in agreement with both documents. The enroute time on the CFP should be compared against the distance to destination for a reasonable groundspeed. The enroute time should also be compared against the total distance for a reasonable fuel load.

13.6.5. Wind Shear or Turbulence Forecast. The route of flight within RVSM airspace should be reviewed for weather to include wind shear or turbulence forecasts. Forecast moderate or greater turbulence could lead to RVSM suspension. Operators are cautioned against flight planning through areas of forecast moderate or greater turbulence.

13.6.6. Dual Long Range NAV System (LRNS). Two operational LRNSs are required for most remote oceanic operations. An aircraft with a single FMS may not be authorized for remote oceanic operations. Consult your MAJCOM to determine if the aircraft is certified to fly in remote or oceanic airspace.

13.6.7. HF check. An HF check should be conducted on the primary and secondary HF radios in areas where dual HF radios are required. If possible, the HF checks should be done on the ground or before entering oceanic airspace. A SELCAL check should also be accomplished, if equipped and permitted by your MAJCOM.

13.6.8. Confirm Present Position coordinates. Both pilots (and/or navigator) should independently verify the present position coordinates using either published ramp coordinates or determine position from the airfield diagram. They should not rely solely on the present position when the LRNS was shut down from a previous flight. A master source such as an enroute chart should also be used to confirm accuracy of coordinates at the oceanic boundaries.

13.6.9. Master CFP symbols. Operators are encouraged to use consistent symbology on the Master CFP. As technique, a circled number (O) means the second crewmember has independently verified the coordinates entered or crosschecked by the first crewmember. A checkmark (☑) may indicate that the track and distances have been confirmed. A diagonal line (\\) may indicate that the crew has confirmed the coordinates of the approaching and next way

point. An X-symbol (X) may indicate having flown overhead the way point. An example of this technique is provided below (see figure 13.4).

**Figure 13.4. Example – Use of Master CFP Symbols.**

BLOCK IN	---	ON	---	T/O	---	T/O FUEL	---						
BLOCK OUT	---	OFF	---	ETE	---	LDG FUEL	---						
TOTAL	---	TOTAL	---	ETA	---	F USED	---						
ETP CYGX/EINN 0201 0072NM M030/P000 BURN 0082 N54402W034215													
MNPS / RVSM													
RAMP COORD- _____				COAST OUT COORD- _____									
ALTIMETER NO.1- _____				ALTIMETER NO.1- _____									
NO.2- _____				NO.2- _____									
STBY- _____				STBY- _____									
CYJT ELEV 00004FT													
CPT	FL	T	WIND	S	TAS	MCB	AWY	DBT	ETE	CT	ETA	ZFU	FFE
FREQ	TRD	TDV	COMP	GRS	MH	MKA	DSTR	ATE	DCT	ATA	FFR	AFR	
TOC	370							117	0017	0017	0021	0021	0257
								2276					
<del>370</del>	370	52	2405Z	3	484	087	-	039	0004	0021	0003	01858	
	35	P08	P062		516	097	040	2237		0254			
<del>410</del>	410	52	2303Z	2	483	093	-	207	0025	0046	0016	01021	
	35	P05	P030		499	094	040	2030		0236			

### 13.6.10. LRNS programming.

13.6.10.1. Check currency and software version. It is important to check the effective date of the database. Crews should note if the database is projected to expire during their trip. Crews are discouraged from flying with expired databases. MELs may allow relief to fly with an expired database but require the crews to manually crosscheck all data. The software version of the database should also be confirmed in case there has been a change.

13.6.10.2. Independent verification. As a technique, it is highly recommended that when a crewmember manually enters a waypoint or waypoints, another crewmember should independently verify the accuracy of the navigational data entered. It should be noted that the pilot should read from the FMS screen back to the master CFP when verifying data. To read from the Master CFP to the FMS is a human factor's issue that has led to GNEs.

13.6.10.3. Check expanded coordinates of waypoints. Most FMSs allow entering abbreviated oceanic coordinates. There have been cases when there was an error in the expanded waypoint coordinate, but crews only checked the abbreviated coordinate. Verifying only the abbreviated coordinate could lead to a lateral error. Flight crews should conduct a magnetic course and distance check between waypoints to further verify waypoint coordinates.

13.6.10.4. Track and distance check. To minimize oceanic errors, it is important to conduct a magnetic course and distance check from oceanic entry to oceanic exit. Operators should establish a tolerance such as  $\pm 2^\circ$  and  $\pm 2$  NM. The course and distance checks comparing the Master CFP against the LRNS are critical in detecting errors that may not have been noticed by simply checking coordinates. A difference of more than  $2^\circ$  between waypoints may be due to a difference of the magnetic variation in the database versus the variation used in the Master CFP. Any difference outside the  $\pm 2^\circ$  or  $\pm 2$  NM should be rechecked and verified.

13.6.10.5. Upload winds. Some LRNS units allow the crew to upload projected winds. This procedure allows more accurate reporting of ETAs.

13.6.10.6. Groundspeed check. The pilot/crew should confirm a groundspeed of zero (0) knots prior to taxiing the aircraft. This procedure is a good practice to detect developing errors in the LRNS.

### **13.7. Taxi and Prior to Take-Off.**

13.7.1. Groundspeed check. During taxi to the active runway, pilots should ensure the groundspeed is reasonable.

13.7.2. Present Position check. After departing the original parking location, the crew should conduct another positional check against a known airfield location to ensure the accuracy of the navigation system. Any out of tolerance condition or error in the LRNS should be resolved prior to departing.

### **13.8. Climb Out.**

13.8.1. Transition altitude. Crews should brief the transition altitude based on information from the approach plate or from the ATIS. After climbing through the transition altitude, the altimeters should be set according to airspace requirements.

13.8.2. Manually compute ETAs. After climbing above the sterile altitude and time permitting crews should manually compute ETAs from departure to destination. These should be noted on the Master CFP. This is an excellent crosscheck against ETAs computed by the LRNS.

### **13.9. Prior to Oceanic Entry.**

13.9.1. Gross error accuracy check. Before oceanic entry, the accuracy of the LRNS should be checked against a ground-based NAVAID. The results of the accuracy check should be recorded with the time and position. A large difference between the ground-based NAVAID and the LRNS may require immediate corrective action. Unless specifically stated in the aircraft manual, crews should normally not attempt to correct an error by conducting an in-flight alignment or by manually updating the LRNS. Research has indicated that if done incorrectly, the possibility of a GNE increases.

13.9.2. HF checks. If the crew was unable to accomplish the HF and SELCAL checks on the ground, these checks must be accomplished before oceanic entry.

13.9.3. **Datalink Communications.** Datalink communications are gradually being introduced into the NAT environment for position reporting (via FANS 1/A ADS & CPDLC and also via FMC WPR through ACARS) and for other air/ground ATS exchanges (using FANS 1/A CPDLC). Operators approved to use Controller Pilot Data Link Communications (CPDLC), Automatic Dependent Surveillance (ADS) or ACARS should log on to the appropriate FIR 15 to 45 minutes prior to the boundary.



#### 13.9.4. Obtain oceanic clearance.

13.9.4.1. The aircrew should obtain oceanic clearance from the appropriate clearance delivery. (Clearance via voice should be at least 40 minutes prior to oceanic entry and via data link should be 30 to 90 minutes prior to oceanic entry). It is important that aircrews confirm the navigational waypoints and enter oceanic airspace at the assigned altitude (this may be different than the domestic cleared flight level). An oceanic clearance typically includes a route, flight level and assigned MACH. Crews should include their requested flight level in their initial clearance request. Some oceanic centers require pilots to advise them at the time of their oceanic clearance “When Able Higher” (WAH). Crews should be confident that they are able to maintain requested flight levels based on aircraft performance capabilities. For example, *“Global Air 543, 40 North 040 West at 1010, Flight Level 350, Estimating 40 North 050 West at 1110, 40 North 060 West Next. Able Flight Level 360 at 1035, Able Flight Level 370 at 1145, Able Flight Level 390 at 1300.”* It should be noted that ATC acknowledgement of a WAH report (and any included requests) is NOT a clearance to change altitude.

13.9.4.2. Within RVSM Airspace greater opportunity exists for step climbs. Operators may include step climbs in the flight plan, although each change of level during flight must be requested from ATC by the pilot. The chance of approval of such requests will, of course, be entirely dependent upon potential traffic conflicts. Outside the OTS there is a good likelihood of achieving the requested profiles. However, within the prime OTS levels at peak times, ATC may not always be able to accommodate requested flight level changes and prudent pre-flight fuel planning should take this into consideration.

13.9.4.3. If a flight is expected to be level critical, operators should contact the initial Oceanic Area Control Center (OAC) prior to filing of the flight plan to determine the likely availability of specific flight levels.

13.9.5. Re-clearance. A re-clearance (that is different from the oceanic route requested with the filed flight plan) is the primary cause upon which Gross Navigation Errors (GNEs) occur. A crew should be very cautious when receiving a re-clearance. To mitigate a GNE occurrence during the re-clearance process, after receiving the new routing, the aircrew should conduct independent crosschecks after the LRNS, Master CFP and Plotting Chart are updated. It is critical that crews check the magnetic course and distance between the new waypoints as noted in PREFLIGHT under the paragraph “LRNS Programming.” Track and Distance charts are an excellent resource to verify the accuracy of re-clearance waypoints inserted into the LRNS, as the CFP may no longer be an accurate resource for this check. Track and Distance charts along with other useful information is available at HQ AFFSA/A3ON on the Air Force Portal in the file labeled Oceanic Navigation (under the “Communities” tab, search for HQ AFFSA/A3ON). As a technique, a suggested checklist to use when receiving a re-clearance is provided in figure 13.5.

#### **Figure 13.5. Suggested re-clearance checklist.**

1. **Both Pilots in the Seat**
2. **Both Pilots on Headset (Not speaker)**
3. **Both Pilots write Re-Clearance**
4. **PNF will Change Master Document**
  - **PNF Clearly Cross-out Old Waypoints**
5. **PNF Re-plots points on plotting chart**
6. **PNF Programs New Clearance in the FMS**
7. **PF independently Checks all PNF Actions**
  - **Waypoints, Distances, Magnetic Course**
8. **Re-compute Equal Time Point (if ETA changes by +/-3 Min.)**
9. **New Domestic Clearance Obtained Before Oceanic Exit Point**

13.9.6. Altimeter checks. Since oceanic flight is normally conducted at RVSM altitudes (see Chapter 4 of this manual), crews are recommended to crosscheck the two primary altimeters to ensure they remain within T.O. tolerances (usually no more than within 200 ft of each other). This check is conducted while at level flight. The stand-by altimeter should also be noted. The altimeter readings should be recorded along with the time.

13.9.7. Compass heading check. It is recommended to conduct a compass heading check and record the results. This check is particularly helpful with inertial systems. The check can also aid in determining the most accurate compass if a problem develops over water.

### **13.10. After Oceanic Entry.**

13.10.1. Squawk 2000. Thirty minutes after oceanic entry crews should Squawk 2000, if applicable. Reference the Flight Information Publications, Area Planning and Enroute Supplement for the airspace to find the specific regional differences. There may be regional differences such as Squawking 2100 in Bermuda's airspace or maintaining last assigned Squawk in the West Atlantic Route System (WATRS). Crews transiting Reykjavik's airspace must maintain last assigned Squawk.

13.10.2. Maintain assigned Mach. Some oceanic clearances include a specific Mach. There is no tolerance for this assigned Mach. The increased emphasis on longitudinal separation requires crew vigilance in a separation based on assigned Mach. The requirement is to maintain the true Mach which has been assigned by ATC. In most cases, the true Mach is the indicated Mach. Some aircraft, however, require a correction factor.

13.10.3. VHF radios. After going beyond the range of the assigned VHF frequency, crews should set their radios to guard frequency (121.5) and inter-plane (123.45 in most regions).

13.10.4. Strategic Lateral Offset Procedure (SLOP). This procedure is highly recommended while operating within the organized track systems (OTS). The procedure entails either flying the route centerline or offsetting the route by 1 NM or 2 NM to the right of centerline. Despite existing safeguards provided by air traffic systems throughout the world, occasionally aircraft end up at the wrong altitude or route. With the advent of highly accurate space based navigation systems, when combined with an operational error, the risk of a midair collision increases. SLOP allows a pilot or crew to choose an offset at random, thus, a lateral distribution of aircraft

is achieved reducing the overall risk of a midair collision along a particular route. As stated in para 13.15.2, pilots and aircrew need to remove any lateral offset prior to reaching the “coast-in” point when applied to oceanic navigation. Although a pilot/crew is normally required to navigate their aircraft within 4 nm of airway centerline (sometimes higher deviations are acceptable), due to the extreme accuracy of new navigation systems, SLOP still allows an aircraft to remain within the permissible limits of the airway system. It also replaces the contingency procedures developed for aircraft encountering wake turbulence. Despite its effectiveness, depending upon winds aloft, coordination between aircraft to avoid wake turbulence may be necessary. Aircraft that do not have an automatic offset capability (that can be programmed in the LRNS) should fly the centerline only. See AFI 11-202 Vol 3, *General Flight Rules* for additional guidance.

13.10.5. Hourly altimeter checks. Crews are required to observe the primary and stand-by altimeters each hour. It is recommended that these hourly checks be recorded with the readings and times. This documentation can aid crews in determining the most accurate altimeter if an altimetry problem develops.

### **13.11. Approaching Waypoints.**

13.11.1. Confirm next latitude/longitude. Within a few minutes of crossing an oceanic waypoint crews should crosscheck the coordinates of that waypoint and the next waypoint. This check should be done by comparing the coordinates against the Master CFP based on the currently effective ATC clearance.

### **13.12. Overhead Waypoints.**

13.12.1. Confirm aircraft transitions to next waypoint. When overhead an oceanic waypoint, crews should check the aircraft transitions to the next leg. This is confirmed by noting the magnetic heading and distance to the next waypoint compared against the Master CFP.

13.12.2. Confirm time to next waypoint. It is important to give ATC an accurate ETA to the next waypoint. Since longitudinal separations have decreased in many regions, usually a change a change of three minutes (or more depending on operational region) from the ETA requires a notification to ATC to ensure traffic conflicts do not arise.

13.12.3. Position report. After passing over the oceanic waypoint, crews that give a position report to ATC must use the standard format. Flights designated as meteorological (MET) reporting flights or flights on random routes should be including in the position report additional items such as winds and temperatures. Crews should also note and record their fuel status at each oceanic waypoint. This is especially important if the cleared route and flight level differ significantly from the filed flight plan.

### **13.13. 10-Minute Plot.**

13.13.1. Record time and latitude/longitude on plotting chart. Approximately 10 minutes after passing an oceanic waypoint, crews should plot the latitude, longitude and time on the plotting

chart. It is advisable to plot the non-steering LRNS. A 10-minute plot can alert the crew to any lateral deviation from their ATC clearance prior to it becoming a Gross Navigation Error. A good crosscheck for the position of the 10-minute plot is that it is approximately 2° of longitude past the oceanic waypoint at mid-latitudes on the East-West routing (e.g. at 460 knots groundspeed at 50° latitude, 10 minutes of flight equates to 77 nm which is the distance of 2° of longitude).

#### **13.14. Mid-Point.**

13.14.1. Midway between waypoints. It is good practice to crosscheck winds midway between oceanic waypoints by comparing the Master CFP, LRNS and upper millibar wind chart. As noted before, this information will be included in a position report if the flight has either been designated as a MET reporting flight or is a flight on a random route. This crosscheck will also aid crews in case there is a need for a contingency such as Dead Reckoning (DR).

13.14.2. Confirm time. It is recommended that during a wind check the crews also confirm the ETA to the next waypoint noting the three (3) minute tolerance.

#### **13.15. Coast In.**

13.15.1. Compare ground based NAVAID to LRNS. When departing oceanic airspace and acquiring ground based NAVAIDs, crews should note the accuracy of the LRNS by comparing it to those NAVAIDs. Any discrepancy should be noted in the Maintenance Log.

13.15.2. Remove Strategic Lateral Offset. Crews using a “lateral offset” of 1NM or 2NM right of centerline at oceanic entry should remove this “lateral offset” at coast in prior to exiting oceanic airspace at the exit point. It is advisable to include this as a checklist item.

13.15.3. Confirm routing after oceanic exit. Before entering the domestic route structure, crews must confirm their routing to include aircraft speed.

#### **13.16. Descent.**

13.16.1. Transition Level. During the approach briefing, crews should note the transition level on the approach plate or verified by ATIS. Crews must be diligent when descending through the transition level to reset the altimeters to QNH. This is particularly important when encountering IFR, night or high terrain situations. Any confusion between a QNH setting with inches of Mercury or hPa must be clarified.

#### **13.17. Destination/Block-In.**

13.17.1. Navigation Accuracy Check. When arriving at the destination gate, crews should note any drift or circular error in the LRNS. A GPS Primary Means system normally should not exceed 0.27NM for the flight. Some inertial systems may drift as much as 2NM per hour. Because the present generation of LRNSs is highly accurate, operators should establish a drift

tolerance which if exceeded would require a write-up in the Maintenance Log. RNP requirements demand that drift be closely monitored.

13.17.2. RVSM write-ups. Problems noted in the altimetry system, altitude alert or altitude hold must be noted in the Maintenance Log. The RVSM airspace is closely monitored for any Height Deviations. An aircraft not meeting the strict RVSM standards must not be flight-planned into RVSM airspace without corrective action.

### **13.18. Information Collection, Records, and Forms:**

13.18.1. Information collections. No information collections are accomplished by this publication.

13.18.2. Records. The program records created as a result of the processes prescribed in this publication are maintained in accordance with AFMAN 33-363 and disposed of IAW the AFRIMS RDS located at <https://www.my.af.mil/gcss-af61a/afirms/afirms/>.

13.18.3. Forms (Adopted and Prescribed).

13.18.3.1 Adopted Forms. AF Form 673, *Air Force Publication/Form Action Request*, and AF Form 847, *Recommendation for Change of Publication*.

13.18.3.2. Prescribed Forms. No forms are prescribed by this publication.

DANIEL J. DARNELL, Lt Gen, USAF  
DCS, Operations, Plans & Requirements

**Attachment 1****GLOSSARY OF REFERENCES AND SUPPORTING INFORMATION****References**

AIM, *Aeronautical Information Manual*, 2008

AC 20-129, *Airworthiness Approval of Vertical Navigation (VNAV) Systems for use in the U.S. National Airspace System (NAS) and Alaska*, 12 September 1998

AC 20-130A, *Airworthiness Approval of Navigation or Flight Management Systems Integrating Multiple Navigation Sensors*, 14 June 1995

AC 20-131A, *Airworthiness Approval of TCAS and Mode-S Transponders*, 29 March 1993

AC 20-138A, *Airworthiness Approval of GNSS Equipment*, 22 Dec 2002

AC 20-151, *Airworthiness Approval of TCAS II Version 7.0 and Mode-S*, 7 February 2007

AC 90-23F, *Aircraft Wake Turbulence*, 20 February 2002

AC 90-91H, *North American Route Program (NRP)*, 30 July 2004

AC 90-96A, *Approval of U.S. Operators and Aircraft to Operate Under Instrument Flight Rules (IFR) in European Airspace Designated for Basic Area Navigation (B-RNAV) and Precision Area Navigation (P-RNAV)*, 13 January 2005

AC 90-97, *Use of Barometric Vertical Navigation (VNAV) for Instrument Approach Operations Using Decision Altitude*, 19 October 2000

AC 90-100A, *U.S. Terminal and En Route Area Navigation (RNAV) Operations*, 1 March 2007

AC 90-101, *Approval Guidance For RNP Procedures with SAAAR*, 15 December 2005

AC 90-RVSM, *Approval of Aircraft and Operators for flight in Airspace Above Flight Level (FL) 290 where a 1,000 Foot Vertical Separation Minimum is Applied*, 14 March 1994

AFI 11-202 Volume 3, *General Flight Rules*, 5 April 06

AFI 11-208, *Department of Defense Notice to Airmen (NOTAM) System*, 1 August 2004

AFI 11-218, *Aircraft Operations and Movement on the Ground*, 1 August 2002

AFI 11-230, *Instrument Procedures*, 12 August 2004

AFI 33-360, *Publications and Forms Management*, 18 May 2006

AFPD 11-2, *Aircraft Rules and Procedures*, 1 April 1997

AFMAN 33-363, *Management of Records*, 1 March 2008

AFPAM 11-216, *Air Navigation*, 1 March 2001

AFRIM RDS, <https://www.my.af.mil/gcss-af61a/afrims/afrims/>

FAAO 8260.3B, *United States Standard for Terminal Instrument Procedures (TERPS)*, 7 December 2007

FAAO 8260.54A, *United States Standard for Area Navigation (RNAV)*, 7 December 2007

FAR Part 1, *Definitions and Abbreviations*, 2008

FAR Part 91, *General Operations and Flight Rules*, 2008

FAA-H-8083-15, *Instrument Flying Handbook*, 2001

FAA-H-8261-1A, *Instrument Procedures Handbook*, 2007

ICAO, *North Atlantic MNPS Airspace Operations Manual*, 2005

ICAO, *Manual on Required Navigational Performance*, 1999

ICAO, *Standards and Recommended Practices (SARPS)*, 2001

ORDER JO 7110.65S, *Air Traffic Control*, 14 February 2008

ORDER JO 7610.4M, *Special Operations*, 18 January 2007

TI 8200.52, *Flight Inspection Handbook*, November 2007

TSO-C129A, *Airborne Supplemental Navigation Equipment Using the Global Positioning System (GPS)*, 20 February 1996

TSO-C145C, *Airborne Navigation Sensors Using the Global Positioning System Augmented by the Satellite Based*, 2 May 2008

TSO-C146C, *Stand-Alone Airborne Navigation Equipment Using The Global Positioning System Augmented By The Satellite Based Augmentation System*, 9 May 2008

### ***Abbreviations and Acronyms.***

**AC**—Advisory Circular

**ADF**—Automatic Direction Finding

**ADI**—Attitude Director Indicator

**AFFSA**—Air Force Flight Standards Agency

**AGL**—Above Ground Level

**AIM**—Aeronautical Information Manual

**AIP**—Aeronautical Information Publication

**AMI**—Airspeed Mach Indicator

**AMU**—Areas of Magnetic Unreliability

**ANG**—Air National Guard

**ANP**—Actual Navigation Performance

**AP**—Area Planning

**AQP**—Airport Qualification Program

**ARTCC**—Air Route Traffic Control Center

**ASR**—Airport Surveillance Radar  
**ATC**—Air Traffic Control  
**ATIS**—Automatic Terminal Information Service  
**BC**—Back Course  
**CAS**—Calibrated Airspeed  
**CDI**—Course Deviation Indicator  
**CFIT**—Controlled Flight Into Terrain  
**CNS/ATM**—Communication Navigation System / Air Traffic Management  
**CONUS**—Continental United States  
**CSW**—Course Selector Window  
**DA**—Decision Altitude  
**DER**—Departure End of Runway  
**DG**—Directional Gyro  
**DH**—Decision Height  
**DINS**—DoD Internet NOTAM System  
**DME**—Distance Measuring Equipment  
**DoD**—Department of Defense  
**DP**—Departure Procedure  
**DVA**—Diverse Vector Area  
**EAS**—Equivalent Airspeed  
**ETA**—Estimated Time of Arrival  
**ETD**—Estimated Time of Departure  
**ETE**—Estimated Time Enroute  
**FAA**—Federal Aviation Administration  
**FAF**—Final Approach Fix  
**FAR**—Federal Aviation Regulation  
**FCG**—Foreign Clearance Guide  
**FCIF**—Flight Crew Information File  
**FIH**—Flight Information Handbook  
**FIR**—Flight Information Region  
**FLIP**—Flight Information Publication  
**FMS**—Flight Management System  
**FL**—Flight Level



**FOV**—Field of View  
**fpm**—Feet Per Minute  
**ft/nm**—Feet Per Nautical Mile  
**FSS**—Flight Service Station  
**GLONASS**—Global Orbiting Navigation Satellite System  
**GNSS**—Global Navigation Satellite System  
**GP**—General Planning  
**GPS**—Global Positioning System  
**GS**—Ground Speed  
**GS**—Glideslope  
**GSI**—Glide Slope Indicator  
**HAA**—Height Above Aerodrome  
**HAT**—Height Above Touchdown  
**Hg**—Mercury  
**HILO**—Holding In Lieu of Procedure Turn  
**HIRL**—High Intensity Runway Lighting  
**HSI**—Horizontal Situation Indicator  
**HUD**—Head-Up-Display  
**Hz**—Hertz (cycles per second)  
**IAF**—Initial Approach Fix  
**IAP**—Instrument Approach Procedure  
**IAS**—Indicated Airspeed  
**IAW**—In Accordance With  
**ICAO**—International Civil Aviation Organization  
**IFIS**—Integrated Flight Instrument System  
**IFR**—Instrument Flight Rules  
**ILS**—Instrument Landing System  
**IM**—Inner Marker  
**IMC**—Instrument Meteorological Conditions  
**IMN**—Indicated Mach Number  
**INS**—Inertial Navigation System  
**ISA**—International Standard Atmospheric  
**kHz**—Kilohertz

**KIAS**—Knots Indicated Airspeed  
**KTAS**—Knots True Airspeed  
**LAAS**—Local Area Augmentation System  
**LDA**—Localizer Type Directional Aid  
**LLZ**—Localizer (ICAO)  
**LNAV**—Lateral Navigation  
**LOC**—Localizer  
**LOM**—Locator Outer Marker  
**MAJCOM**—Major Command  
**MAP**—Missed Approach Point  
**MCA**—Minimum Crossing Altitude  
**MDA**—Minimum Descent Altitude  
**MDS**—Mission Design Series  
**MEA**—Minimum Enroute Altitude  
**MHz**—Megahertz  
**MIRL**—Medium Intensity Runway Lighting  
**MLS**—Microwave Landing System  
**MM**—Middle Marker  
**MOCA**—Minimum Obstruction Clearance Altitude  
**MVA**—Minimum Vectoring Altitude  
**NACO**—National Aeronautical Charting Office  
**NAS**—National Airspace System  
**NATS**—North Atlantic Track System  
**NAVAID**—Navigation Aid  
**NDB**—Nondirectional Beacon  
**NGA**—National Geospatial-Intelligence Agency  
**NM**—Nautical Miles  
**NOTAM**—Notices to Airman  
**NRP**—National Route Plan  
**NVD**—Night Vision Devices  
**NVG**—Night Vision Goggles  
**ODP**—Obstacle Departure Procedure  
**OBS**—Omni Bearing Selector

**OIS**—Obstacle Identification Surface  
**OM**—Outer Marker  
**PANS-OPS**—Procedures for Air Navigation Services-Aircraft Operations (ICAO)  
**PT**—Procedure Turn  
**RA**—Resolution Advisory  
**RAIM**—Random Autonomous Integrity Monitoring  
**RMI**—Radio Magnetic Indicator  
**RNAV**—Area Navigation  
**RNP**—Required Navigational Performance  
**ROC**—Required Obstacle Clearance  
**RVR**—Runway Visual Range  
**RVSM**—Reduced Vertical Separation Minimums  
**SARPS**—Standards and Recommended Practices  
**SD**—Spatial Disorientation  
**SDF**—Simplified Directional Facility  
**SDP**—Special Departure Procedure  
**SID**—Standard Instrument Departure  
**SM**—Statue Miles  
**STAR**—Standard Terminal Arrival  
**TACAN**—Tactical Air Navigation  
**TAS**—True Airspeed  
**TCAS**—Traffic Alert and Collision Avoidance System  
**TCH**—Threshold Crossing Height  
**TDZE**—Touchdown Zone Elevation  
**TERPS**—Terminal Instrument Procedures  
**TMN**—True Mach Number  
**TO**—Technical Order  
**TSO**—Technical Standard Order  
**UHF**—Ultra High Frequency  
**USA**—United States Army  
**USAF**—United States Air Force  
**USN**—United States Navy  
**VASI**—Visual Approach Slope Indicator

**VDP**—Visual Descent Point

**VFR**—Visual Flight Rules

**VHF**—Very High Frequency

**VMC**—Visual Meteorological Conditions

**VOR**—VHF Omni-directional Range

**VORTAC**-- VHF Omni-directional Range/Tactical Air Navigation

**VOT**—VOR Test Facility

**VVI**—Vertical Velocity Indicator

**WAAS**—Wide Area Augmentation System

### *Terms*

*Some terms printed here are reserved for future use or are intended to define a common vocabulary for HQ AFFSA, MAJCOM, USAF aircrew and industry users of this AFMAN.*

**1090 ES – 1090mHz Extended Squitter:** The most mature of the 3 ADS-B link options. A “Squitter” provides a spontaneous transmission containing information about the aircraft’s identification, position, altitude, velocity, and route of flight information. It uses the Mode S transponders as a basis for operation.

**8.33 KHz spacing** – Due to frequency congestion in the 118-137 MHz range (voice communications) in Europe, the normal spacing between frequencies (25 kHz) was further divided into three 8.33 kHz bands.

**ADS-B - Automatic Dependent Surveillance Broadcast:** Aircraft equipment that automatically broadcasts routine messages which include its position (such as lat, long), velocity, and altitude. Other information may also be included.

**ADF – Automatic Direction Finder** – An aircraft radio navigation system which senses and indicates the direction to a L/MF nondirectional radio beacon (NDB) ground transmitter. Direction is indicated to the pilot as a magnetic bearing or as a relative bearing to the longitudinal axis of the aircraft depending on the type of indicator installed. In certain applications, such as military, ADF operations may be based on airborne and ground transmitters in the VHF/UHF frequency spectrum.

**AFFSA - Air Force Flight Standards Agency:** HQ USAF Field Operating Agency (FOA) charged with the development, standardization, evaluation and certification of procedures, equipment and standards to support global flight operations. Centrally manages ATCALs, the AQP/SDP program, performs combat flight inspection, and instructs the Air Force Advanced Instrument School for USAF pilots. Central agency responsible for global USAF Terminal Instrument Procedures.

**Airfield Qualification and Familiarization Program.** A contractor-managed program that supplements other USAF and MAJCOM methods to familiarize pilots with unique airports in accordance with ICAO requirements. The published booklet or online version provides pictorial, textual and graphical information on selected airfields (worldwide) that have been deemed to be unique due to surrounding terrain, obstructions or complex approach and departure procedures.

**Along Track Distance (LTD)** - The distance measured from a point-in-space by systems using area navigation reference capabilities that are not subject to slant range errors.

**Altimeter Setting** - The barometric pressure reading used to adjust a pressure altimeter for variations in existing atmospheric pressure or to the standard altimeter setting (29.92).

**Altitude** - The height of a level, point, or object measured in feet Above Ground Level (AGL) or from Mean Sea Level (MSL).

**ANP – Actual Navigational Performance.** A measure of the current estimated navigational performance. Also referred to as Estimated Position Error (EPE).

**ARC** - The track over the ground of an aircraft flying at a constant distance from a navigational aid by reference to distance measuring equipment (DME).

**Area Navigation** - Area Navigation (RNAV) provides enhanced navigational capability to the pilot. RNAV equipment can compute the airplane position, actual track and ground speed and then provide meaningful information relative to a route of flight selected by the pilot. Typical equipment will provide the pilot with distance, time, bearing and crosstrack error relative to the selected "TO" or "active" waypoint and the selected route. Several distinctly different navigational systems with different navigational performance characteristics are capable of providing area navigational functions.

**ATC - Air Traffic Control** - A service operated by appropriate authority to promote the safe, orderly and expeditious flow of air traffic.

**Aircraft Approach Category** - A grouping of aircraft based on a speed of 1.3 times the stall speed in the landing configuration at maximum gross landing weight. An aircraft must fit in only one category. If it is necessary to maneuver at speeds in excess of the upper limit of a speed range for a category, the minimums for the category for that speed must be used.

**Aircraft Classes** - For the purposes of Wake Turbulence Separation Minima, ATC classifies aircraft as Heavy, Large, and Small as follows:

- a. Heavy- Aircraft capable of takeoff weights of more than 255,000 pounds whether or not they are operating at this weight during a particular phase of flight.
- b. Large- Aircraft of more than 41,000 pounds, maximum certificated takeoff weight, up to 255,000 pounds.
- c. Small- Aircraft of 41,000 pounds or less maximum certificated takeoff weight.

**Alternate Airport** - An airport at which an aircraft may land if a landing at the intended airport becomes inadvisable.

**Bearing** - The horizontal direction to or from any point, usually measured clockwise from true north, magnetic north, or some other reference point through 360 degrees.

**Civil Twilight.** The period that begins at sunset and ends in the evening when the center of the sun's disk is 6 degrees below the horizon and begins in the morning when the center of the sun's disk is 6 degrees below the horizon, and ends at sunrise. Use an authorized weather source, the latest version of the Air Almanac, MAJCOM-approved computer program or US Naval Observatory data to determine and calculate light and moon data.

**Coastal Fix** - A navigation aid or intersection where an aircraft transitions between the domestic route structure and the oceanic route structure.

**Communication, Navigation, Surveillance, and Air Traffic Management (CNS/ATM)**—An umbrella term used to describe the emerging avionics technologies and architecture of space and ground-based systems designed to bring about the concept of “Free Flight.” Examples include: RNAV/RNP, RVSM, CPDLC, ADS-B, elementary and enhanced Mode S, 8.33 kHz radios, FM Immunity, TCAS, and TAWS. Previously termed Global Air Traffic Management (GATM) by the DoD.

**CPDLC - Controller-Pilot Data Link Communications:** An “email-like” data link between pilots and ATC that will augment and may replace voice communications. The two environments for CPDLC are currently Future Aeronautical Navigation System 1/A (FANS-1/A) and the Aeronautical Telecommunications Network (ATN).

**DAP- Down link Aircraft Parameters:** This is data down-linked to the ground, via the Mode S transponder, that provides information about the aircraft operations and planned route. The three types of DAP are “basic functionality” (flight ID, transponder capability, and flight status), “enhanced” [EHS] and “elementary” [ELS] surveillance features also provide flight intent information.

**DA/DH -- Decision Altitude/Decision Height:** As part of a precision approach (ILS, MLS or PAR), it is the specified altitude at which a decision must be made to either continue the approach if the pilot acquires the required visual references or execute a missed approach. Outside the NAS, decision altitude (DA) is referenced to mean sea level and decision height (DH) is referenced to the threshold elevation.

**Diverse Departure.** If the airport has at least one published approach, the absence of any non-standard takeoff minimums and/or IFR departure procedures for a specific runway normally indicates that runway meets diverse departure criteria. Pilots departing a diverse runway may climb runway heading to 400 ft. above the departure end of the runway (DER) elevation and then turn in any direction provided the aircraft maintains a minimum climb gradient of 200 ft/NM until reaching the appropriate IFR altitude.

**Diverse Vector Area** - In a radar environment, it is that area in which a prescribed departure route is not required as the only suitable route to avoid obstacles. It is the area in which random radar vectors below the MVA/MIA, established in accordance with the TERPS criteria for diverse departures, obstacles and terrain avoidance, may be issued to departing aircraft.

**DoD FLIP** - Department of Defense Flight Information Publications used for flight planning, en route, and terminal operations. FLIP is produced by the National Imagery and Mapping Agency (NIMA) for world-wide use. United States Government Flight Information Publications (en route charts and instrument approach procedure charts) are incorporated in DoD FLIP for use in the National Airspace System (NAS).

**DP** – see Instrument Departure Procedure.

**EGI – Embedded GPS/INS:** A military, self-contained navigation system that provides positioning, velocity, and acceleration data for the aircraft. The EGI receives signals from the GPS.

**EHS – Enhanced Surveillance:** Support of EHS consists of populating and maintaining three Mode S transponder registers beyond those required for ELS: Selected Vertical Intention, Track and Turn Report, and Heading and Speed Report.

**ELS – Elementary Surveillance:** Support of ELS consists primarily of populating and maintaining four Mode S transponder registers: Data Link Capability Report, Common-Usage Ground Initiated Comm B (GICB) Capability Report, Aircraft Identification (Flight ID), and Airborne Collision Avoidance System (ACAS) resolution advisory.

**Final Approach Course** - A bearing/radial/track of an instrument approach leading to a runway or an extended runway centerline all without regard to distance.

**FAF - Final Approach Fix** – On a IAP, it is the fix from which the final approach to an airport is executed and which identifies the beginning of the final approach segment. It is designated on Government charts by the Maltese Cross symbol for nonprecision approaches and the lightning bolt symbol for precision approaches; or when ATC directs a lower-than-published glideslope/path intercept altitude, it is the resultant actual point of the glideslope/path intercept.

**FDE- Fault Detection/Exclusion:** A GPS receiver capable of autonomously determining which GPS satellite(s) is (are) causing the RAIM alert and then excluding the faulty satellite(s) from the navigation solution. Flight in some civil airspace requires both RAIM and FDE.

**Final Approach Point** - The point, applicable only to a nonprecision approach with no depicted FAF (such as an on airport VOR), where the aircraft is established inbound on the final approach course from the procedure turn and where the final approach descent may be commenced. The FAP serves as the FAF and identifies the beginning of the final approach segment.

**Fix** - A geographical position determined by visual reference to the surface, by reference to one or more radio NAVAIDs, by celestial plotting, or by another navigational device.

**FMC/FMS – Flight Mission Computer / Flight Management System:** An on-board computer system that uses a database to allow routes and other navigation data to be preprogrammed. The system is updated with respect to position accuracy by reference to conventional navigation aids.

**Free Flight -** A safe and efficient operating capability under instrument flight rules in which the pilot has the freedom to select routing, altitude, and speed in real time.

**GBAS – Ground-Based Augmentation System:** GBAS augments ground systems (typically at an airport) with equipment similar in functionality to a GPS satellite. This augmentation allows a properly equipped aircraft to increase the accuracy of the vertical/lateral GPS solution. The US LAAS is a GBAS equivalent system.

**GLS – GNSS Landing System:** Hardware and software that augments the GPS SPS to provide for precision approach and landing capability. Based on differential GPS concepts, the GLS augments the basic GPS position data in order to increase the integrity, continuity, and accuracy needed for a precision approach.

**GMU – GPS-based Monitoring Unit:** An on-board monitoring and recording unit composed of a GPS receiver, computer and flight deck windows antennae. An alternative to the ICAO requirement of overflying a Height Monitoring Unit (HMU) as a means to check aircraft for RVSM compliance.

**GNSS - Global Navigation Satellite System:** An umbrella term adopted by ICAO to encompass any independent satellite navigation system. GNSS provides suitably equipped aircraft with enroute/terminal navigation with non-precision approach and precision approach capabilities. The U.S. system is GPS.

**GPS - Global Positioning System:** A constellation of satellites that enables the user to receive signals from six operational satellites nearly 100% of the time from most locations on Earth. RAIM and FDE ensures the GPS derived solution meets the accuracy, availability, and integrity requirements critical to flight safety

**GPS-D – Differential GPS:** DGPS is a GPS augmentation that uses *differential corrections* to the basic satellite measurements that are performed within the receiver. DGPS is based upon accurate knowledge of the geographic location of Earth reference stations. This knowledge is used to compute corrections to GPS parameters, error sources, and/or resultant positions. These differential corrections are then transmitted to GPS users, either from a ground-based station [e.g., GBAS, LAAS] or from a satellite-based system [WAAS, EGNOS, GALILEO, etc]. GPS receivers apply the corrections to their received GPS signals and compute a more precise /optimum position. With differential GPS, civilian users can improve accuracy from 100 meters to better than 10 meters. See GPS-PPS for military application.

**GPS-PPS – GPS-Precise Positioning Service:** The military maintains exclusive access to the more accurate "P-code" (pseudo random code). It is much more accurate, much harder to jam



and spoof. To provide better protection to military aircraft, the DoD has encrypted the P-code to form Y-code. Horizontal accuracy is less than ten meters.

**GPS-SPS – GPS Standard Positioning Service:** One of two levels of GPS service used by both the military and civil aviation community in order to support aircraft navigation and landing. Since a Presidential Order turned Selective Availability off, SPS horizontal accuracy is about ten meters [vs. about 100 meters when SA is on].

**HAT - Height Above Touchdown** - The height of the Decision Height or Minimum Descent Altitude above the highest runway elevation in the touchdown zone (first 3,000 feet of the runway). HAT is published on instrument approach charts in conjunction with all straight-in minimums.

**HMU - Height Monitoring Unit** - A passive, ground-based system that measures the geometric height of an aircraft for comparison with the geometric height of the flight level at which it is being flown. The HMU calculates altimetry system error using meteorological information and the Mode-C/S height data. Overflight of an HMU satisfies the ICAO requirement to check aircraft for RVSM compliance. Additional information on RVSM monitoring program can be found at: [http://www.tc.faa.gov/act-500/niaab/rvsm/naarmo\\_intro.asp](http://www.tc.faa.gov/act-500/niaab/rvsm/naarmo_intro.asp)

**ICAO - International Civil Aviation Organization** – ICAO is a UN Specialized Agency, headquartered in Montreal, Canada, and is the global forum for civil aviation that works to achieve its vision of safe, secure and sustainable development of civil aviation through cooperation amongst its member States. ICAO promotes understanding and security through cooperative aviation regulation.

**Inner Marker** - A marker beacon used with an ILS (CAT II) precision approach located between the middle marker and the end of the ILS runway, transmitting a radiation pattern keyed at six dots per second and indicating to the pilot, both aurally and visually, that he/she is at the designated decision height (DH), normally 100 feet above the touchdown zone elevation, on the ILS CAT II approach. It also marks progress during a CAT III approach.

**INS - Inertial Navigation System:** A self contained, dead reckoning system that senses the acceleration along the three axes of the aircraft and calculates the distance traveled from a reference point. Accuracy of the system decreases with time.

**IAP - Instrument Approach Procedure** - A series of predetermined maneuvers for the orderly transfer of an aircraft under instrument flight conditions from the beginning of the initial approach to a landing or to a point from which a landing may be made visually.

**Instrument Departure Procedure (DP)** - A preplanned instrument flight rule (IFR) departure procedure published for pilot use, in graphic or textual format, that provides obstruction clearance from the terminal area to the appropriate en route structure. There are two types of DP, Obstacle Departure Procedure (ODP), printed either textually or graphically, and, Standard Instrument Departure (SID), which is always printed graphically.

**IMC - Instrument Meteorological Conditions.** Meteorological conditions expressed in terms of visibility, distance from cloud, and ceiling less than the minima specified for visual meteorological conditions.

**IF - Intermediate Fix** - The fix that identifies the beginning of the intermediate approach segment of an instrument approach procedure. The fix is not normally identified on the instrument approach chart.

**IFR - Instrument Flight Rules** - Rules governing the procedures for conducting instrument flight. Also a term used by pilots and controllers to indicate type of flight plan.

**LNAV- Lateral Navigation:** A function of area navigation (RNAV) equipment which calculates, displays, and provides lateral guidance to a profile or path.

**Land and Hold Short Operations (LAHSO).** Procedures developed to expedite traffic flow at civil and joint-use airports needing additional tools to increase capacity. Allows civilian aircraft to operate on intersecting runways simultaneously.

**Low Close-in Obstacles.** Those obstacles within the Initial Climb Area that require an excessive climb gradient to a climb-to-altitude of 200 feet or less above the Departure End of Runway elevation or alternate takeoff weather minima. These obstacles are published in NOTAMs, on the SID chart or in the IFR Take-off Minimums and (Obstacle) Departure Procedures section of the terminal procedure booklet. Typical chart notation is: "NOTE: Rwy 17L, tree 5610' from DER, 212' left of centerline, 82' AGL/2723' MSL."

**LPV-** A type of approach with vertical guidance (APV) based on WAAS, published on RNAV (GPS) approach charts. This procedure takes advantage of the precise lateral guidance available from WAAS. The minima is published as a decision altitude (DA).

**Marker Beacon** - Marker beacons are identified by their modulation frequency and keying code, and when received by compatible airborne equipment, indicate to the pilot, both aurally and visually, that he/she is passing over the facility.

**Minimum Descent Altitude** - The lowest altitude, expressed in feet above mean sea level, to which descent is authorized on final approach or during circle-to-land maneuvering in execution of a standard instrument approach procedure where no electronic glideslope is provided.

**MMR – Multi-Mode Receiver:** A radio receiver capable of processing several different navigation and approach path functions that include Instrument Landing System (ILS), ILS Marker Beacon, VOR, Microwave Landing System and GPS functions (such as WAAS and LAAS).

**MNPS – Minimum Navigation Performance Specification:** Implemented in the North Atlantic region between FL285-420, it specifies a number of equipment, training, and procedural requirements. MNPS navigation accuracy is equivalent to RNP 12.6. Dual long-range navigation systems (LRNS) and dual long-range communication systems are required. RVSM is mandatory in MNPS airspace. Aircraft that cannot meet dual LRNS requirements may be

accommodated on special routings ("Blue Spruce" routes). Aircraft that cannot meet RVSM requirements are excluded from MNPS airspace unless operating on an ALTRV.

**Mode 4.** Transponder mode established to enable IFF (Identification Friend or Foe) functions between military aircraft or military aircraft and military ground stations. Uses classified codes, but operates on 1030 MHz and 1090 MHz, the same frequency pair used by the Air Traffic Control Radar Beacon System that civil air traffic uses for Mode 3A/C, Mode S, and TCAS. Mode 4 interrogation signals can suppress civil airborne transponders, therefore all Mode 4 operations in the NAS require prior authorization through the Air Force Frequency Management Agency (AFFMA): [affma.cc@pentagon.af.mil](mailto:affma.cc@pentagon.af.mil).

**Mode 5.** Mode 5 is the performance upgrade to the current Mark XII IFF transponder system. Mode 5 provides new waveforms, new cryptography, more data, and improved radio frequency (RF) link margin to resolve many of the deficiencies identified with Mark XII. It will eventually replace the analog Mode 4 IFF system with digital IFF message formats which embed unprecedented combat relevant data.

**Mode S - Mode Select:** The primary role of the Mode S transponder is to "selectively" respond to interrogations [as opposed to responding to *all* interrogations] from a ground sensor or TCAS to provide airborne data information including identification, equipage, and altitude.

**Mountainous Terrain.** Defined in 14 CFR §95.11 for CONUS, Alaska, Hawaii and Puerto Rico. PANS-OPS defines mountainous terrain as an area over which the changes of surface elevation exceed 900m (3,000 ft) within a distance of 18.5 km (10.0 NM), or 300 ft over a 1 NM distance. AFFSA believes the PANS OPS definition is too restrictive, so instead chose to use the definition from NATO's ATP 56(B) (Part 3, Chapter 4) that defines mountainous terrain as 500 ft surface elevation change over a ½ NM distance.

**National Airspace System (NAS).** The NAS is the common network of *United States* (U.S.) airspace: air navigation facilities, equipment, services, airports or landing areas, aeronautical charts, information/services, rules, regulations, procedures, technical information, manpower and material. Included are system components shared jointly with the military. *United States*, in a geographical sense, means (1) the States, the District of Columbia, Puerto Rico, and the possessions, including the territorial waters (within 12 nautical miles) and (2) the airspace of those areas. **Note:** IAW ICAO Article 12 and Annex 2 and 11, the United States has accepted responsibility for providing air traffic services within airspace overlying the high seas beyond 12 miles from the coast (also known as international airspace). These flight information regions of international airspace are: Oakland Oceanic, Anchorage Oceanic, Anchorage Continental, Anchorage Arctic, Miami Oceanic, Houston Oceanic and New York Oceanic. Aircrews should be aware that although they are being provided air traffic services by the FAA, they are operating in international airspace and ICAO SARPS, FLIP, and AFIs are applicable. (See paragraph 1.2)

**NOTAM – Notice to Airmen** - A notice containing information (not known sufficiently in advance to publicize by other means) concerning the establishment, condition, or change in any component (facility, service, or procedure of, or hazard in the National Airspace System) the timely knowledge of which is essential to personnel concerned with flight operations.

**Night.** The time between the end of evening civil twilight and the beginning of morning civil twilight, as published in the Air Almanac, converted to local time.

**Obstacle** - An existing object, object of natural growth, or terrain at a fixed geographical location or which may be expected at a fixed location within a prescribed area with reference to which vertical clearance is or must be provided during flight operation.

**Obstacle Climb Gradient.** FLIP products often provide different climb gradients, ATC and Obstacle. Only the obstacle climb gradient need be considered for OEI departure planning. If no obstacle climb gradient is published, the aircraft must achieve a minimum climb gradient of 200 ft/nm, or as specified in paragraph 8.12.6. for OEI.

**OCS - Obstacle Clearance Surface.** The OCS is an obstacle evaluation surface associated with each segment of an instrument procedure. The OCS can be either level or sloping. See Required Obstacle Clearance (ROC) discussion below.

**ODP – Obstacle Departure Procedure** - A preplanned instrument flight rule (IFR) departure procedure printed for pilot use in textual or graphic form to provide obstruction clearance via the least onerous route from the terminal area to the appropriate en route structure. ODPs are recommended for obstruction clearance and may be flown without ATC clearance unless an alternate departure procedure (SID or radar vector) has been specifically assigned by ATC.

**Oceanic Airspace** - Airspace over the oceans of the world, considered international airspace, where oceanic separation and procedures per the International Civil Aviation Organization are applied. Responsibility for the provisions of air traffic control service in this airspace is delegated to various countries, based generally upon geographic proximity and the availability of the required resources.

**Oceanic Published Route** - A route established in international airspace and charted or described in flight information publications, such as Route Charts, DOD Enroute Charts, Chart Supplements, NOTAMs, and Track Messages.

**Organized Track System** - A series of ATS routes which are fixed and charted; i.e., CEP, NOPAC, or flexible and described by NOTAM; i.e., NAT TRACK MESSAGE.

**Oceanic Transition Route** - An ATS route established for the purpose of transitioning aircraft to/from an organized track system.

**One Engine Inoperative (OEI).** Multi-engine aircraft are typically certified as airworthy after demonstrating satisfactory control authority and climb capability after suffering the loss of one engine at the most critical moment on takeoff. USAF multi-engine aircraft must be operated so the aircraft is capable of experiencing such an event and still vertically clear all departure path obstacles (even at night or while IMC). Therefore, using civilian “see and avoid” rules is prohibited, unless specifically authorized by the MAJCOM/CC or as published in a Special MAJCOM Certification procedure.

**OROCA.** An off-route altitude which provides obstruction clearance with a 1,000 ft. buffer in non-mountainous terrain areas and a 2,000 ft. buffer in designated mountainous areas within the United States. This altitude may not provide signal coverage from ground-based navigational aids, air traffic control radar, or communications coverage.

**ORTCA.** An off-route altitude that provides terrain clearance with a 3,000 ft. buffer from terrain. This altitude may not provide signal coverage from ground-based navigational aids, air traffic control radar, or communications coverage. This altitude is used on en route charts covering those areas outside the United States.

**Outer Marker** - A marker beacon at or near the glideslope intercept altitude of an ILS approach.

**PANS-OPS.** ICAO documents detailing specific procedures for the safety of air traffic navigation agreed to by ICAO signatories.

**P-RAIM – Predictive RAIM:** Using a standard set of algorithms, the availability of RAIM may be determined based on the satellite coverage expected at an aircraft's ETA. Due to terrain masking and other factors (e.g. satellite fails after RAIM prediction made), P-RAIM does not *guarantee* there will actually be sufficient satellite coverage on arrival. P-RAIM does not have to reside in the GPS receiver. It can be provided by FAA Flight Service (US NAS only) and other ground based RAIM algorithms.

**PRM Approach.** An instrument landing system (ILS) approach conducted to parallel runways whose extended centerlines are separated by less than 4,300 ft. and the parallel runways have a Precision Radar Monitoring (PRM) system that permits simultaneous independent ILS approaches. See: [http://www.faa.gov/education\\_research/training/prm/](http://www.faa.gov/education_research/training/prm/).

**Precision Approach Procedure** - A standard instrument approach procedure in which an electronic glideslope/glidepath is provided; e.g., ILS, MLS, and PAR.

**Procedure Turn** - The maneuver prescribed when it is necessary to reverse direction to establish an aircraft on the intermediate approach segment or final approach course. The outbound course, direction of turn, distance within which the turn must be completed, and minimum altitude are specified in the procedure. However, unless otherwise restricted, the point at which the turn may be commenced and the type and rate of turn are left to the discretion of the pilot.

**QNE** - The barometric pressure used for the standard altimeter setting (29.92 inches Hg.).

**QNH** - The barometric pressure as reported by a particular station.

**RADAR** – A device which, by measuring the time interval between transmission and reception of radio pulses and correlating the angular orientation of the radiated antenna beam or beams in azimuth and/or elevation, provides information on range, azimuth, and/or elevation of objects in the path of the transmitted pulses.

**Radar Required.** This note on an instrument procedure indicates aircraft using the procedure will be monitored by ATC radar during a particular phase of flight or throughout the entire procedure, as applicable. Coordination with air traffic is necessary to ensure ATC capability and agreement to provide these services before adding the note to any instrument procedure. Note: Instrument procedures with radar requirements should be avoided whenever possible.

**RAIM - Receiver Autonomous Integrity Monitoring:** RAIM is a two-step process used to assess the integrity of the GPS signals in the receiver. First, the GPS receiver determines if five or more working satellites are above the horizon and in the proper geometry to make RAIM available. Second, based upon the range solutions from those satellites it must determine if the RAIM algorithm indicates a potential navigation error. Flight in some civil airspace requires RAIM and FDE.

**Reduced Same Runway Separation.** Allows reduction of the normal ATC aircraft separation standards during landing/touch-and-go and restricted low approach operations to increase the airport/runway capacity.

**Remote/Island Destination.** Any aerodrome that, due to its unique geographic location, offers no suitable alternate (civil or military) within two (2) hours flying time.

**Reporting Point** – A geographical location in relation to which the position of an aircraft can be reported.

**RMI - Radio Magnetic Indicator** - An aircraft navigational instrument coupled with a gyro compass or similar compass that indicates the direction of a selected NAVAID and indicates bearing with respect to the heading of the aircraft.

**RNP - Required Navigation Performance:** Prescribes the system performance necessary for operation in a specified airspace, based on its required accuracy (RNP value). The basic accuracy requirement for RNP-X airspace is for the aircraft to remain within X nautical miles of the cleared position for 95% of the time in RNP airspace.

**RNAV – Area Navigation:** Rather than fly established airways from one ground NAVAID to another, RNAV permits suitably equipped aircraft to operate on any desired course between virtual waypoints.

**RNAV Approach** - An instrument approach procedure which relies on aircraft area navigation equipment for navigational guidance.

**ROC - Required Obstacle Clearance** - ROC is the minimum measure of obstacle clearance considered to supply a satisfactory level of vertical protection. The ROC is added to the OCS. The level of vertical protection provided is based on variety of factors. First, the aircraft meets required performance standards based on the certification process. Second, the pilot operates the aircraft IAW procedures outlined in the T.O. Additionally, it is predicated on all aircraft systems functioning normally, required NAVAIDS are performing within flight inspection parameters,

and the pilot is conducting instrument operations in accordance with directives. ROC is provided through application of either a level or sloping ROC.

**Runway Environment.** The runway environment consists of one or more of the following elements: The approach light system (except that the pilot may not descend below 100 ft. above the Touch Down Zone Elevation using the approach lights as a reference unless the red termination bars or the red side row bars are also visible and identifiable), the threshold, threshold markings or threshold lights, the runway end identifier lights, the touchdown zone lights, the runway or runway markings, the runway lights, the visual approach slope indicator. For more information, refer to AFMAN 11-217, Volume 1.

**RVR - Runway Visual Range** - The maximum distance in the direction of takeoff or landing at which the runway, or the specified lights or markers delineating it, can be seen from a position above a specified point on its center line at a height corresponding to the average eye-level of pilots at touch down. This value is normally determined by instruments located alongside and about 14 ft. above the runway and calibrated with reference to the high-intensity runway lights.

**RVSM - Reduced Vertical Separation Minimum** - Reduces the vertical separation between properly equipped and certified aircraft to 1000 ft in special qualification airspace, normally between FL290-410 inclusive.

**SDP - Special Departure Procedure** - A procedure designed to allow a safe takeoff for multi-engine aircraft whose OEI climb rate would otherwise not meet the minimum climb gradient requirement. The runway and all obstacles along a chosen takeoff path are analyzed and compared to the aircraft OEI takeoff and climb performance. The procedure provides a maximum allowable takeoff gross weight for given performance conditions that ensure vertical and lateral obstacle clearance safety margins. The minimum allowable gross and net climb gradients for SDPs are typically lower than TERPS standards. Unlike TERPS, the takeoff path is selected to minimize obstacle clearance requirements and only those obstacles within the lateral limits of the chosen flight path are considered. The term SDP encompasses both the use of the textual obstacle data table information and the graphical departure procedures.

**Single Medium Display** - A single medium display is a Head-Up Display (HUD), Head-Down Display (HDD), or Helmet-Mounted Display (HMD) presenting flight instrumentation on a single display such as a HUD combiner, a “glass” multifunction display, or a helmet visor.

**Simplified Directional Facility** - A NAVAID used for nonprecision instrument approaches. The final approach course is similar to that of an ILS localizer except that the SDF course may be offset from the runway, generally not more than 3 degrees, and the course may be wider than the localizer, resulting in a lower degree of accuracy.

**SID - Standard Instrument Departure** - A preplanned instrument flight rule (IFR) air traffic control (ATC) departure procedure printed for pilot/controller use in graphic form to provide obstacle clearance and a transition from the terminal area to the appropriate en route structure.

**Standard Rate Turn** – A turn of three degrees per second.

**Standard Terminal Arrival (STAR)** - A preplanned instrument flight rule (IFR) air traffic control arrival procedure published for pilot use in graphic and/or textual form. STARS provide transition from the en route structure to an outer fix or an instrument approach fix/arrival waypoint in the terminal area.

**Stepdown Fix** – A fix permitting additional descent within a segment of an instrument approach procedure by identifying a point at which a controlling obstacle has been safely overflowed.

**TACAN** – An ultra-high frequency electronic air navigation aid which provides suitably equipped aircraft a continuous indication of bearing and distance to a TACAN station.

**TAWS - Terrain Alert Warning System** - Generic term for any on-board system taking inputs from terrain databases, radar altimeter, aircraft position sensors, etc. to activate a Ground Proximity Warning System (GPWS) or Automatic Ground Collision Avoidance System (AGCAS). Developed to help prevent Controlled Flight Into Terrain (CFIT) mishaps.

**TCAS - Traffic Collision Avoidance System** - An airborne system that functions independently of the ground-based radar to provide collision avoidance protection between suitably equipped aircraft. TCAS I provides proximity warnings to pilots in the form of traffic advisories (TAs). TCAS II provides both TAs and recommended vertical escape maneuvers, known as resolution advisories (RAs).

**TDZE – Touchdown Zone Elevation** - The highest elevation in the first 3,000 feet of the landing surface. TDZE is indicated on the instrument approach procedure chart when straight-in minimums are authorized.

**Traffic Management Unit** – The entity in ARTCCs and designated terminals directly involved in the active management of traffic flow in a defined region or at a specific facility.

**Transponder** – The airborne radar beacon receiver/transmitter which automatically receives radio signals from interrogators on the ground, and selectively replies with a specific reply pulse or pulse group only to those interrogations being received on the mode to which it is set to respond.

**TCH - Threshold Crossing Height** – The theoretical height above the runway threshold at which the aircraft's glideslope antenna would be if the aircraft maintains the trajectory established by the mean ILS glideslope of MLS glidepath.

**Terminal Area** – A general term used to describe airspace in which approach control service or airport traffic control service is provided.

**Unmonitored Navigational Aid** - Most NAVAIDs have internal monitoring systems that provide automatic shutdown or notification when a malfunction occurs. Unmonitored NAVAIDs lack the ability to immediately notify ATC when a malfunction occurs. The pilot may still use the NAVAID for all types of navigation, including instrument approaches, but must



monitor the NAVAID for a loss of identification since no prior warning of operation may be available from ATC.

**VHF – Very High Frequency** - The frequency band between 30 and 300 MHz. Portions of this band, 108 to 118 MHz, are used for certain NAVAIDs; 118 to 136 MHz are used for civil air/ground voice communications.

**VDP – Visual Descent Point** - A defined point on the final approach course of a nonprecision straight-in approach procedure from which normal descent from the MDA to the runway touchdown point may be commenced, provided the approach threshold of that runway, or approach lights, or other markings identifiable with the approach end of that runway are clearly visible to the pilot.

**VMC - Visual Meteorological Conditions** - Meteorological conditions in which visual flight rules may be used; expressed in terms of visibility, ceiling height, and aircraft clearance from clouds along the path of flight. When these criteria do not exist, instrument meteorological conditions prevail and instrument flight rules must be followed.

**Vortices** - Circular patterns of air created by the movement of an airfoil through the air when generating lift. As an airfoil moves through the atmosphere in sustained flight, an area of low pressure is created above it. The air flowing from the high pressure area to the low pressure area around and about the tips of the airfoil tends to roll up into two rapidly rotating vortices, cylindrical in shape. These vortices are the most predominant parts of aircraft wake turbulence and their rotational force is dependent upon the wing loading, gross weight, and speed of the generating aircraft. The vortices from medium to heavy aircraft can be of extremely high velocity and hazardous to smaller aircraft.

**VNAV- Vertical Navigation.** A function of area navigation (RNAV) equipment which calculates, displays, and provides vertical guidance to a profile or path. Also used as a term that describes using GPS lateral and vertical guidance to define the minimums for a GPS non-precision or precision approach.

**Wake Turbulence** - Phenomena resulting from the passage of an aircraft through the atmosphere. The term includes vortices, thrust stream turbulence, jet blast, jet wash, propeller wash, and rotor wash both on the ground and in the air.

**WGS-84.** World Geodetic Survey-1984: Developed by the U.S. for world mapping, WGS 84 is an earth fixed global reference frame. It is the ICAO standard.