

Quick Start Guide HAWK MV-4000 Smart Camera



Copyright ©2019 Omron Microscan Systems, Inc.

84-9111025-02 Rev C

Step 1 — Check Hardware

The list of hardware below can be used in a variety of applications and configurations. Consult with Omron Microscan for further information about which items are most appropriate for your application.

Item	Description	Part Number
1	HAWK MV-4000 Smart Camera	8X1X-XXX0-0PPP
2	QX-1 Interface Device	98-000103-02
3	Cordset, Common, M12 12-Pin Socket to M12 12-Pin Plug, 1 m <i>or</i>	61-000162-02
	Cordset, Common, M12 12-Pin Socket to M12 12-Pin Plug, 3 m	61-000148-02
4	Cable, Adapter, HAWK MV-4000 to QX-1	61-9000132-01
5	Power Supply, 100-240VAC, +24VDC, M12 12-Pin Socket	97-000012-01
6	Cable, Ethernet, M12 8-Pin Plug to RJ45, X-Code/RJ45 CAT 6A, 1 m, 3 m, or 5 m	61-9000134-01, -02, -03
7	Photo Sensor, M12 4-Pin Plug, NPN, Dark On, 2 m	99-000020-02
8	QX Cordset, Smart Series Light to QX-1, Continuous Power	61-000204-01
9	QX Cordset, Smart Series Light to QX-1, Strobe, NPN	61-000218-01
10	NERLITE Smart Series Illuminator	NER-011660XXXG

Note: Additional cables available in the Omron Microscan Product Pricing Catalog.

Step 2 — Connect the System

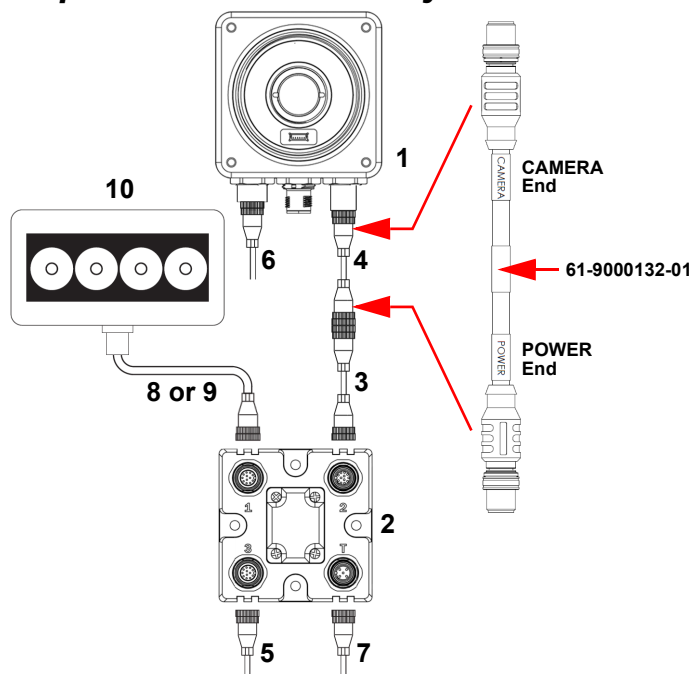

Ethernet Configuration (Standard HAWK MV-4000)

1. Connect the Ethernet cable (6) from the 100/1000 Base-T connector on the camera (1) to the network.
2. Connect the power supply cable (5) to "3" on the QX-1 (2).
3. Connect the photo sensor (7) to "T" on the QX-1.
4. Connect the "CAMERA" end of the adapter cable (4) to the camera, and the "POWER" end to the "Common" cable (3). Then connect the "Common" cable to "2" on the QX-1.
5. Connect the Smart Series cable (8 or 9) to your choice of Smart Series light and to "1" on the QX-1.
6. Plug in the power supply.

Step 3 — Mount and Position the Camera

Position the camera at a standoff of 150 mm or more from the part. Proper lighting is critical to the success of a machine vision application.

Consider the following:

- Is the surface of the object flat, slightly bumpy, or very bumpy?
- Is the surface matte or shiny?
- Is the object curved or flat?
- What is the color of the object or area being inspected?
- Is the object moving or stationary?

Machine vision lighting should maximize contrast of the areas or features being inspected while minimizing the contrast of everything else.

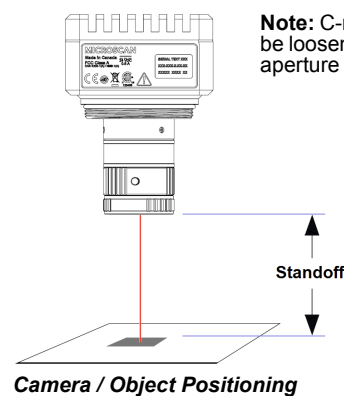

Note: C-mount set screws can be loosened to allow focus and aperture adjustment.

Step 4 — Install AutoVISION

AutoVISION can be found on the Omron Microscan Tools Drive that is packaged with the camera.



1. Follow the prompts to install AutoVISION from the Tools Drive.
2. Click on the AutoVISION icon to run the program.

Note: AutoVISION can also be installed from the [Download Center](http://www.microscan.com) at www.microscan.com.

Minimum System Requirements

- Intel® Core™ i3 Processor @1.6GHz
- Internet Explorer 11 / Google Chrome
- 2GB RAM (Windows 7 SP1 / Windows 7 Embedded Standard SP1)
- 3GB hard drive space
- 32-Bit color display, 1366 x 768 or 1280 x 960
- 4.0 Windows Experience Index (particularly for graphics)
- 1 USB 2.0 port and 1 network port

Step 5 — Connect to the Camera

After you launch AutoVISION, you will see the **Select a device to start editing a job** view.

Note: If there is a default job on the camera, AutoVISION will automatically skip the **Connect** step and you will see the **Image** view.

1. Select your camera from the **Select Device** dropdown menu.
2. Click the **Modify** button beneath the camera settings details to change camera settings.
3. Choose whether you want to create a new job, load a job (.avp), or upload a job from the camera.

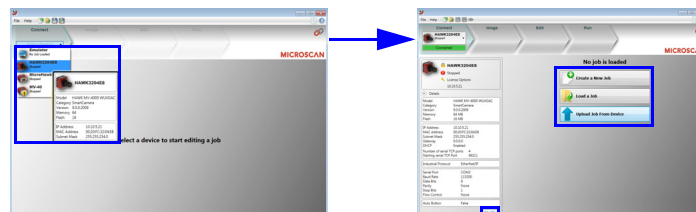

Note: The HAWK MV-4000's default IP address is: **192.168.AA.BB** where **AA.BB** are the last 2 octets in decimal of the device MAC Address with subnet Class B 255.255.0.0. Set your PC to the same subnet (192.168.0.1, for example).

To access the camera's "health status", enter the address [http://\[your camera name\]:8088](http://[your camera name]:8088) in a browser, where **[your camera name]** is the name of the device – **HAWK3204E8**, for example.

Step 6 — Evaluate a Captured Image and Auto Calibrate

You will see the **Image** view after selecting your device. This view allows you to evaluate your first image capture, providing information such as image size and a histogram. Click the **Auto Calibration** button to set optimal camera parameters automatically. You can also adjust **Exposure**, **Gain**, and **Focus** as needed, and set the desired **Lighting Mode**.

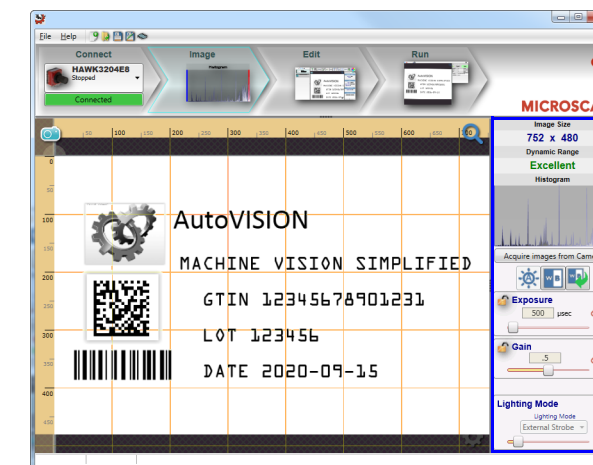

Step 7 — Create Your First Job with AutoVISION

After you have evaluated a captured image and Auto Calibrated the camera in the **Image** view, you will move to the **Edit** view. This interface allows you to set camera parameters, add machine vision tools to captured images, set tool parameters, and configure I/O inspection outputs.

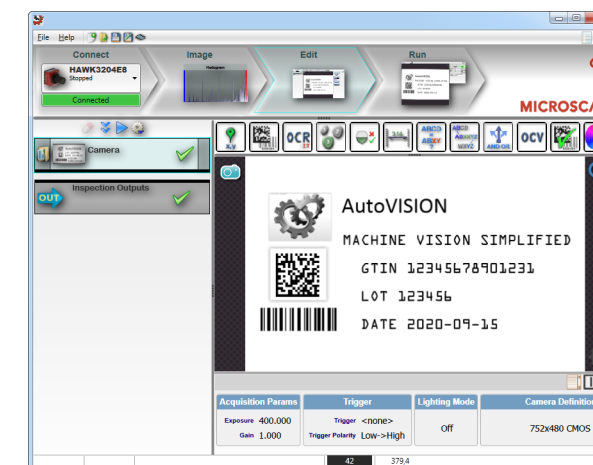

Step 8 — Explore the Interface

The **Edit** view features a large image area with tool icons above and tool parameters below or to the right depending on user preference. When a tool is selected, its specific parameters appear.

Tools that have been added are shown in the job list to the left of the image area, below **Camera**. Image settings can be controlled using the icons in the corners of the image area.

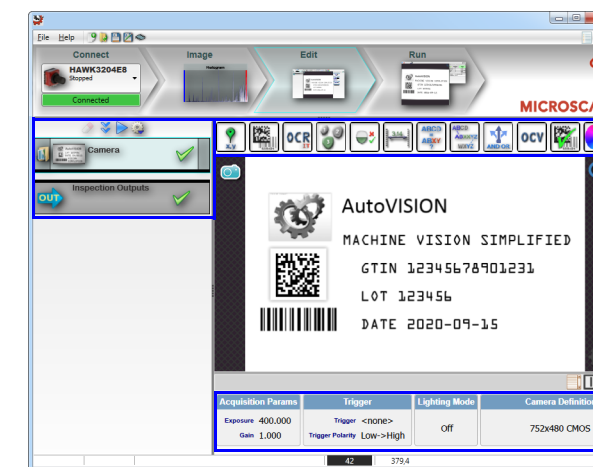

Step 9 — Set Camera Parameters

1. Click on the **Camera** box to the left of the image area.
2. In the camera parameters below the image area, select the desired type of **Trigger**, **Trigger Polarity**, **Photometry** (Exposure and Gain), and **Lighting**.

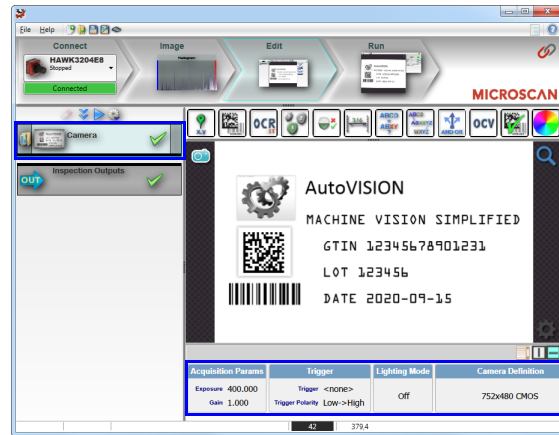

Step 10 — Add Tools to the Job

1. Click on the **Decode Tool** or drag it onto the image area.
2. Use the anchor points at the corners of the region of interest to form a box around the Data Matrix symbol. Leave plenty of space on each side of the symbol.
3. Now add a second Decode Tool and do the same for the 1D symbol below the Data Matrix symbol.
4. Finally, add an **OCR Tool** and drag the region of interest around the area of the image where "123456" is printed.

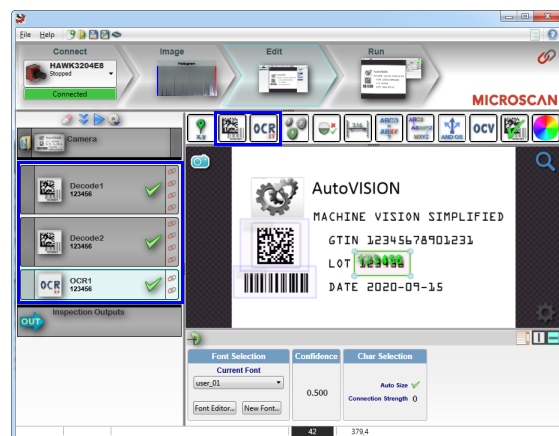

Step 11 — Try Out the Job

Once you have configured the tools as desired, use the arrow icons in the Job area to try the job you have just created.

Note: Most jobs will inspect multiple captured images. If only one image is being inspected, the effect of the arrow icons will not be evident.

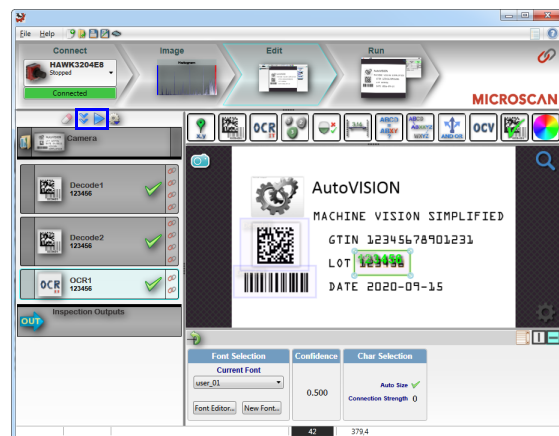

 **Try Out Job Once**

 **Try Out Job in Loop**

Step 12 — Run the Job

When all job parameters are set, click on the **Run** step at the top of the interface. The software will download the vision job just created to the camera and will begin the inspection. Inspection results and the list of active tools are shown at the right of the image view. That information can also be moved below the image area by clicking the orientation buttons above the inspection results area.

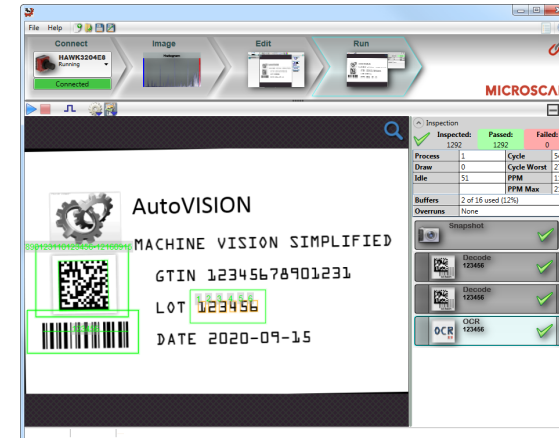

Test Jobs

Note: For descriptions of more advanced functionality, such as setting **Inspection Outputs** or using the **Locate Tool** and **Decode Tool's Dynamic Locate** functionality to track multiple tools from image to image, see the help documentation in AutoVISION software.

Decode Tool, OCR Tool, Match Strings Tool, String Format Tool

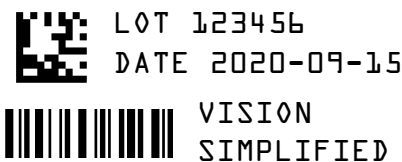

Measure Tool, Count Tool



Measure:
Measure the distance between the jaws of the caliper gauges at left.

Count:
Count the circles on the dice shown at right.



Power Requirements and Pin Assignments

HAWK MV-4000-03, -03C, -13, -13C, -20, -20C, -50, -50C	
Operating Voltage for the HAWK MV-4000 under Testing Conditions	24V
Rated Current	600 mA
Operating Voltage Tolerance	±10%

See the HAWK MV-4000 Smart Camera Guide for full electrical specifications.

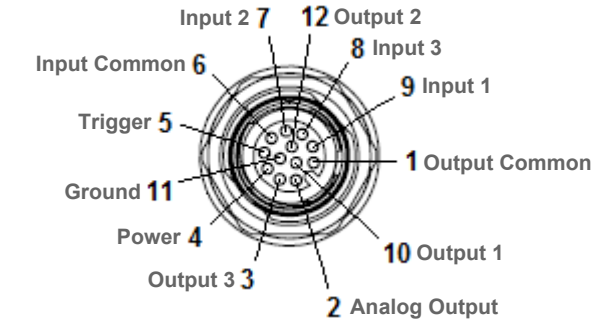

Digital I/O and Power Connector – M12 12-Pin Socket

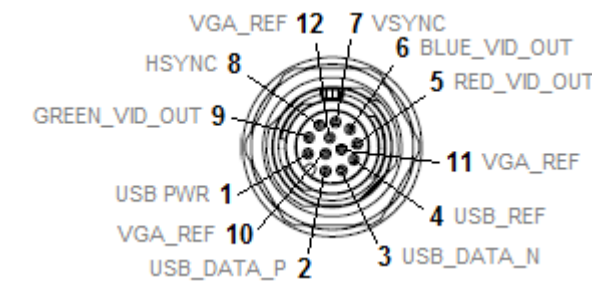

VGA/USB Connector
M12 12-Pin Plug

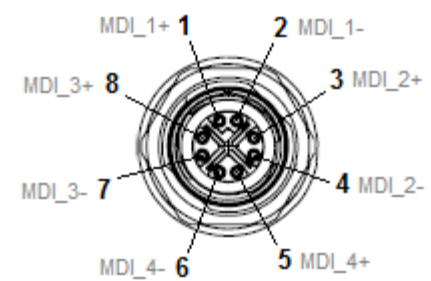

10/1000 Base-T Connector
M12 8-Pin X-Coded Socket

HAWK MV-4000 Lenses

Standard-Fidelity Lenses for 0.3 Megapixel, 1.3 Megapixel, and 2.0 Megapixel Sensors	
98-9000167-01	Kit, Lens, C-Mount, F1.2/6 mm, 1.5 MP, 2/3"
98-9000168-01	Kit, Lens, C-Mount, F1.4/9 mm, 1.5 MP, 2/3"
98-9000169-01	Kit, Lens, C-Mount, F1.4/12.5 mm, 1.5 MP, 2/3"
98-9000170-01	Kit, Lens, C-Mount, F1.4/16 mm, 1.5 MP, 2/3"
98-9000171-01	Kit, Lens, C-Mount, F1.4/25 mm, 1.5 MP, 2/3"
98-9000172-01	Kit, Lens, C-Mount, F1.6/35 mm, 1.5 MP, 2/3"
High-Fidelity Lenses for 0.3 Megapixel, 1.3 Megapixel, and 2.0 Megapixel Sensors	
98-9000165-01	Kit, Lens, C-Mount, F1.6/8 mm, 5 MP, 2/3"
98-9000166-01	Kit, Lens, C-Mount, F1.6/12 mm, 5 MP, 2/3"
98-9000154-01	Kit, Lens, C-Mount, F1.6/16 mm, 5 MP, 2/3"
98-9000164-01	Kit, Lens, C-Mount, F1.6/25 mm, 5 MP, 2/3"
98-9000163-01	Kit, Lens, C-Mount, F1.9/35 mm, 5 MP, 2/3"
98-9000192-01	Kit, Lens, C-Mount, F1.9/6 mm, 5 MP, 2/3"
High-Fidelity Lenses for 5 Megapixel 1" Sensors	
98-9000174-01	Kit, Lens, C-Mount, F1.4/12.5 mm, 9 MP, 1"
98-9000175-01	Kit, Lens, C-Mount, F1.4/16 mm, 9 MP, 1"
98-9000176-01	Kit, Lens, C-Mount, F1.4/25 mm, 9 MP, 1"
98-9000177-01	Kit, Lens, C-Mount, F1.4/35 mm, 9 MP, 1"

See the HAWK MV-4000 Smart Camera Guide for a full list of accessories. All accessories are available in the Omron Microscan Product Pricing Catalog.

HAWK MV-4000 Part Number Structure

HAWK MV-4000 part numbers follow the format 8ABS-LFFA-LPPP .	
8 = HAWK MV-4000 Smart Camera	
(A) Model	0 = No Lens Cover; 1 = 50 mm Lens Cover; 2 = 70 mm Lens Cover
(B) Software	1 = Machine Vision
(S) Sensor Type	1 = VGA, Mono; 2 = 1.3 MP, Mono; 3 = 2 MP, Mono; 4 = 5 MP, Mono; 5 = VGA, Color; 6 = 1.3 MP, Color; 7 = 2 MP, Color; 8 = 5 MP, Color
(L) Lens	0 = No Lens; 1 = 2/3" Standard Def.; 2 = 2/3" High Def.; 3 = 1" High Def.
(FF) Lens Focal Length	00 = No Lens; XX = Focal Length (mm) (See lens table above.)
(A) Accessories	0
(L) Lighting	0
(PPP) License	100 = AutoVISION Sensor; 101 = AutoVISION; 102 = AutoVISION + Visionscape; 103 = AutoVISION + Verification/OCV; 104 = AutoVISION + Visionscape + Verification/OCV