

**BRANSON**



# Ultrasonic Horn Catalog

Branson Ultrasonics, a business of Emerson Industrial Automation, manufactures a variety of superior ultrasonic horns and tooling. The following catalog is designed to help simplify the selection and ordering of ultrasonic horns through general descriptive information, illustrations and tabular data. Standard horns listed in the catalog are compatible with most of today's ultrasonic welding equipment.



For over 60 years, Branson has been responsive to customers' needs by providing superior solutions and technical expertise for the most demanding challenges. Branson's highly trained technical engineers are constantly working to improve and find innovative solutions.

With over 70 Branson technical centers, manufacturing facilities and sales and support offices strategically positioned throughout the Americas, Europe and Asia, Branson can respond to your needs quickly, wherever you are located.

Using Finite Element Analysis (FEA) our skilled engineers analyze the most crucial factors to design tooling with the best possible combination of acoustical and mechanical properties.

From basic standard horns to specialized designs with contoured shapes, composite horns, vacuum horns, horns with nodally mounted devices, and full wavelength horns, Branson provides fast, efficient service guaranteeing the highest quality products and technical advances available.

### Same Day Quoting

Contact the Branson quote-and-order hotline to speak with an expert, or email [Branson.applications@emerson.com](mailto:Branson.applications@emerson.com) for a same day quote for standard, modified standard, catalog listed or specialized horns. Whatever your need, Branson makes it possible.



**BRANSON**

## Contents

	<b>Page</b>
<b>Introduction</b>	
How to Use the Catalog.....	3
Ordering Information .....	3
Horn Theory .....	4
<b>Horns</b>	
Catenoidal.....	9
Exponential .....	9
Circular Solid.....	10
Circular High Gain .....	10
Circular Hollow.....	11
Circular Slotted .....	12
Rectangular (round corners).....	12
Rectangular (square corners) .....	13
Rectangular Slotted.....	14-15
<b>Accessories</b>	
20 kHz Steel Horns .....	16
20 kHz Spool Horns .....	16
20 kHz Block Horns .....	17
20 kHz Titanium Food Cutting Blade Horns .....	17, 18, 19
20 kHz Textile Cutting and Sealing, and Pinsonic Horns.....	19
40 kHz Horns.....	20
30 kHz Horns.....	21
15 kHz Horns.....	21
Knurled Horns .....	22
Knurled Tips .....	22
Staking Tips.....	22-23
Spot Welding Tips .....	23
Flat and Overweight Tips.....	24
Acoustic Interface Washers .....	24
Torque Wrench Kits.....	24
Universal 20 kHz Stack Vise .....	24
Boosters .....	25
Textile Cutting and Sealing Horns, Anvils, and Wheels.....	26-27

## How to Use the Catalog

This catalog describes and illustrates standard horns manufactured by Branson for 15, 20, 30 and 40 kHz ultrasonic plastic assembly equipment.

Following an introductory explanation of horns and horn theories, matrices detail each type of horn such as catenoidal, circular, rectangular, etc. Drawings and photographs of various horn configurations accompany each matrix.

In addition to dimensions, the matrices contain the following information:

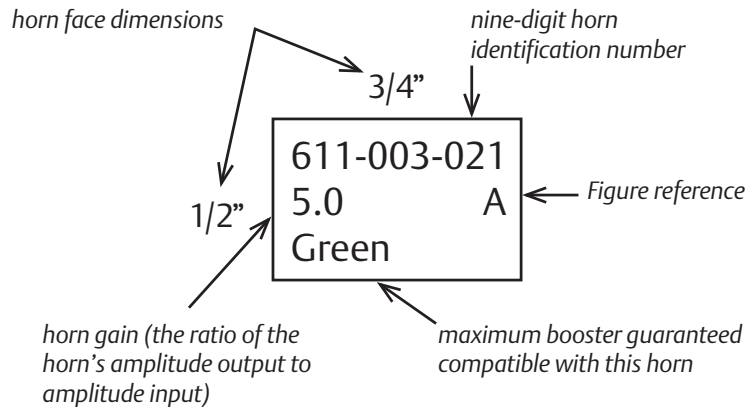

### Ordering Information

**PRICING:** The catalog provides all information necessary for ordering. Price quotes can be obtained by contacting Branson. All quotes on horns and accessories are in effect for 60 days from date of issue. Pricing not covered by a written quote are subject to change without notice.

**STANDARDS:** All items are manufactured to Branson's standard specifications. Orders for items other than Branson specifications must be submitted in written detail and approved. Verbal orders will not be accepted. If dimensions are not stated, the item will be manufactured to dimensions at Branson's discretion.

**RETURN POLICY:** No materials will be accepted for return without the written authorization of a Branson representative. Standard stock horns may

be returned within 30 days of receipt by the purchaser, and are subject to a 10 percent restocking fee. Return freight is the purchaser's responsibility. Non-standard horns are made to order and normally non-refundable.

**TERMS OF PAYMENT:** Net cash 30 days, FOB Danbury, Connecticut

**ORDER DESCRIPTION:** Orders for a horn or tip must include the description of the item, size and Branson EDP number. Example of information required is listed below:

CIRCULAR HOLLOW HORN  
2½" O.D. x 2" I.D.      308-010-021

and a tip order would appear as:

STAKING TIP  
Identification letter "D"  
Std. profile 1/8" dia. stud      101-148-037

Orders for non-standard horns should specify the horn contact area and include as much information as possible such as: part material, expected annual volume, weld requirement. Also, 3D CAD drawings of the parts to be welded must be supplied in native format. Drawings of all the components present during the welding process are necessary to determine the proper clearances required.

Horns are tested in our applications laboratory, free of charge. A tooling checkout report detailing the weld parameters used is provided.

**QUANTITIES:** Quantity discounts are quoted on request.

**GUARANTEES:** Branson horns carry a one-year guarantee on parts and labor if defective due to material or workmanship when used under normal operating conditions. Branson will replace a horn that meets these criteria at no charge to the customer. Should the second horn fail, Branson will be under no obligation to repeat manufacture of this type of horn. Branson can assume no other liability for damages, consequential or otherwise, incurred by the customer related to this application.

# Horn Theory

## Components of an Ultrasonic Assembly System

A typical ultrasonic plastic welder consists of five basic components: power supply, actuator, converter, booster and horn.

The power supply converts 115V 60 Hz electrical energy into 15, 20, 30 or 40 kHz electrical energy.

The welding stand houses the converter, booster and horn in a rigid, column-mounted cabinet. A pneumatically activated carriage mechanism applies pressure to the part, and an electronic programmer controls ultrasonic exposure and clamping time.

The converter transforms electrical energy from the power supply into 15, 20, 30 or 40 kHz mechanical vibrations. The heart of the converter is a lead zirconate titanate electrostrictive element which expands and contracts at its resonant frequency when excited by electrical energy.

The ultrasonic horn, usually one-half wavelength long at a resonant frequency of 15, 20, 30 or 40 kHz, transfers mechanical vibratory energy

from the converter to the work piece. In addition, the horn maintains the pressure necessary to form a weld once joint surfaces have been melted.

When a horn is vibrated at its resonant frequency, its two ends move in opposite directions, lengthening and shortening the horn. No longitudinal motion occurs at the horn's center or nodal area, but stress concentration is greatest in this area.

Horn amplitude is measured as peak-to-peak displacement of the horn face. Amplitude is increased or decreased by changing the mass ratio of the horn or by altering the input amplitude. The ratio of a horn's output amplitude to its input amplitude is called "gain." The horn amplitude required for a specific application is dependent on the type of plastic, type of operation (e.g. welding, staking, etc.), part geometry, and joint design of that application. The figure below shows how to calculate the stack amplitude output. The stack is the assembly of the converter, booster and horn:

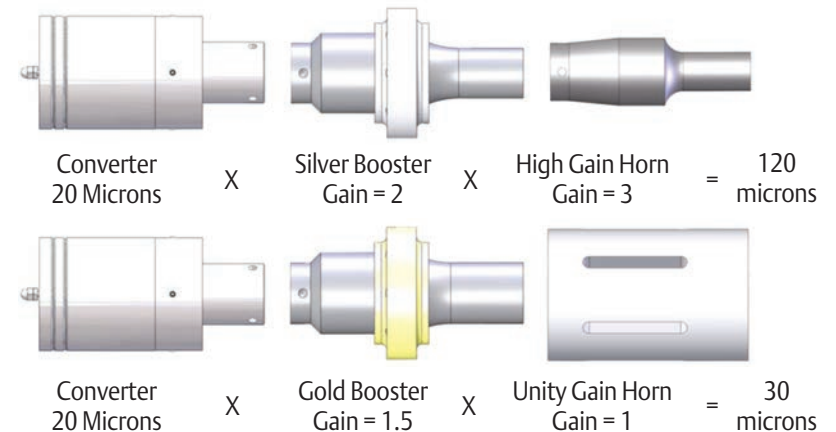
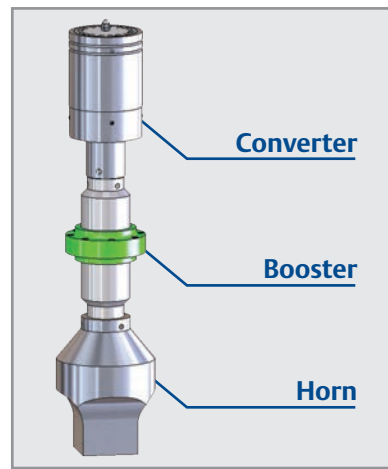

### Converter output:

15 kHz: 30 μm  
20 kHz: 20 μm  
30 kHz: 15 μm  
40 kHz: 8 μm

### Booster gain:

Purple: 0.6:1  
Green: 1:1  
Gold: 1:1.5  
Silver: 1:2.0  
Black: 1:2.5  
Natural: 1:3.0

## Materials

Horns are made of materials which have a good combination of acoustical and mechanical properties. Titanium has the best acoustical properties of the high strength alloys and its high fatigue strength enables it to withstand high cycle rates at high amplitudes. It also has a higher hardness than aluminum and therefore holds up better against wear. Branson utilizes Titanium 7-4 to fabricate most of the catalog horns. This higher end grade of titanium is roughly 15% stronger than the more common Titanium 6-4 grade, allowing it to withstand higher stresses. As such, higher amplitude can be achieved with horns made out of 7-4.

Titanium horns can be carbide-coated for added wear resistance when welding abrasive materials containing glass or talc. They can also be nitride-coated when lubricity is desired (namely in food processing applications). Horns made out of titanium are typically more expensive than other materials due to the higher cost of the material and machining time.

Aluminum heat-treated alloy has excellent acoustical properties and is used to make horns not requiring high amplitude, strength or hardness. Aluminum horns can be chrome-plated to help prevent part marking. They can also be clear-anodized to prevent transferring aluminum oxide to the parts.

Information such as coating thickness, typical application and hardness can be found on Branson's Technolog TL-19. Also, to read more about the advantages of Titanium 7-4 or 6-4, please refer to TL-18. These documents can be found on Branson's website:

**[www.bransonultrasonics.com](http://www.bransonultrasonics.com)**

Horns made of alloy steel can be heat-treated for a wear-resistant surface, but the low acoustical efficiency of steel limits its use to horns for low amplitude applications such as insertion.

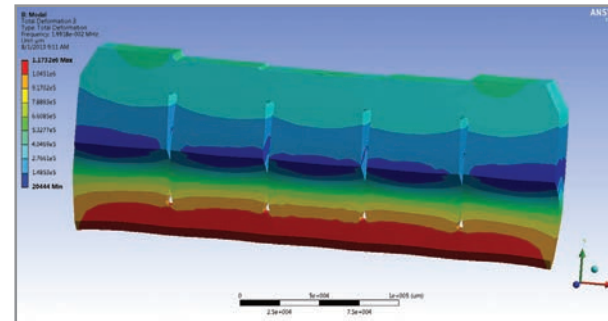

be accurately tuned to a specific frequency. Incorrectly tuned horns can cause damage to the converter and/or power supply. Branson's Tooling Engineers use Finite Element Analysis (FEA) to design and optimize horns, for proper tuning, stress level, amplitude level and uniformity.

## Horn Types

Horns are made in several basic styles and amplitudes to meet the requirements of various applications. For example, a small, high gain bar horn might be used for welding a small rectangular part while a large, slotted bar horn might be used for welding a large part requiring less displacement amplitude.

The following are Branson's basic horn types listed in this catalog by name:

**Stepped horns** consist of two different sections, each having a uniform cross-sectional area. The transition from one section to another is made near the nodal point by a radius. Stepped horns have the highest gain of all horns due to the abrupt change in cross-sectional area at the nodal plane. Stress is maximum near the transition or center region. These horns can be used for any high gain application including welding, staking, degating, swaging and cell disruption.

**Exponential horns** have a cross-sectional area which follows an exponential equation. The gradual taper of exponential horns distributes internal stress over a greater length so that lower peak

Horn design is not a simple process. Correct material must be selected, horns must be balanced, designed for the required amplitude, and



## HORN TYPES *continued*

stress results. Consequently, these horns have desirable stress curves and are used mainly for applications requiring high force and low amplitude such as insertion.

**Catenoidal horns** combine the desirable gain of the stepped horn with the desirable stress distribution of the exponential horn. They are most suitable for welding and staking small plastic parts.

Staking, spot welding and inserting operations frequently require special horn tip configurations. As such, stepped, exponential, and catenoidal horns may be tapped to accept replaceable tips machined to the weight for which the horn was tuned. These are meant to be used for low volume applications.

**Rectangular or “bar” horns** are made in numerous designs from both rectangular and cylindrical stock. Small rectangular horns are usually stepped. Those over 3 1/2” in length have slots to reduce lateral stress. Standard slotted rectangular horns are made up to 10” wide.

**Circular horns** can be either hollow or solid. Hollow horns are generally used for parts requiring contact only on the circumference, or clearance over a central protrusion. Circular horns over 3 1/2” in diameter usually have slots to allow axial motion.

### Developmental/Special tooling

Do you have a special application for which you cannot locate a horn or fixture in this catalog? Branson works directly with customers to develop and test special tool designs for unique applications. These tools may range from long bar horns or block designs to special cutting tools and advanced coatings. The following provides a quick glance at some of the special tools that can be developed.

For information on your special application or a free consultation with our technical development engineers, contact your local Branson sales engineer or your inside tooling project engineer.

### Plunger Horn

The plunger horn has a nodal-mounted plunger that can be used to exert pressure on a given surface of the part contacted by the horn. They are often used to eliminate diaphragming issues, caused by a thin section on the top part that is free to vibrate.



### Part Sensor Horn:

Similar to the nodal-plunger horn, the part sensing horn features an internal cavity partially or fully encapsulating a nodal-mounted sensing device. The sensing device can be a conventional switch mechanism such as a push-button, or a more complex system utilizing distance-measuring ultrasonic sensors, optical sensors, color detection sensors, etc.

The sensing device is coupled with a sensor control unit which outputs a signal to the main power supply or a PLC. This signal can be used to trigger an alarm, abort the weld cycle, or even weld to a different predetermined set of weld parameters. The part-sensing horn can be used to confirm a welding orientation, part color, or whatever the sensor is designed to detect.

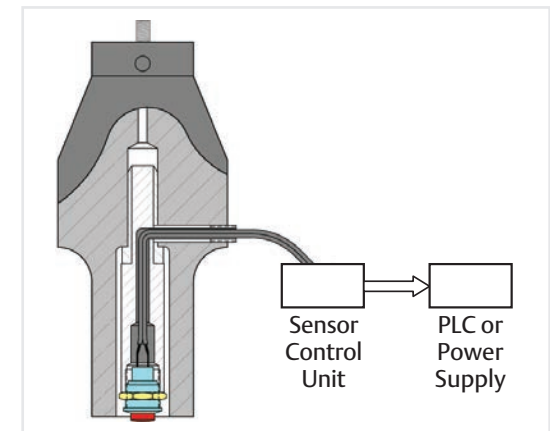

### Vacuum Horn

Vacuum horns are used to hold difficult-to-position parts prior to welding or inserting. A cavity at the face of the vacuum horn conforms to the shape of the part. A small hole, drilled from the center of the cavity up to the horn's nodal region, connects to a perpendicular hole leading out of the horn to a vacuum pump. The part is placed in the tip by hand and the vacuum holds it in place until welded.

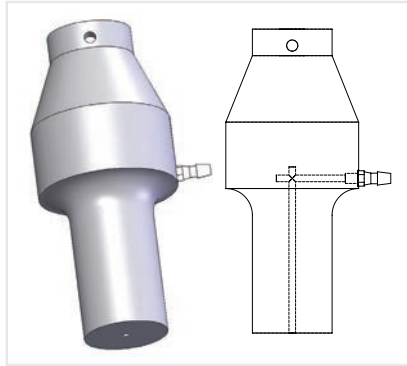

Vacuum horns eliminate positioning error which, in turn, speeds production. Vacuum horns can be made in most configurations.

### Cross Horn

A cross horn is designed to have lateral/horizontal vibrations on the left/right protrusions, to allow welding parts on any of these extremities compared to a standard horn designed to only have axial/vertical vibrations.

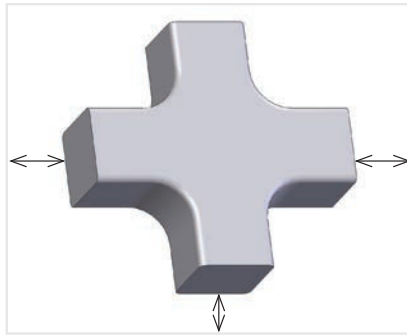

### Contoured Horn

Contoured horns can be contoured to make intimate contact with the part geometry. The horn can be machined using part 3D CAD data or from part laser-scanned data.



### EB Welded Horn

EB welded horns can be electron-beam welded to a booster. This is used in cases where the interface between these two components is a known issue (e.g. failure in the stud area and/or too much friction and heat generation at the interface). It is also used to provide additional reach, in deep parts.

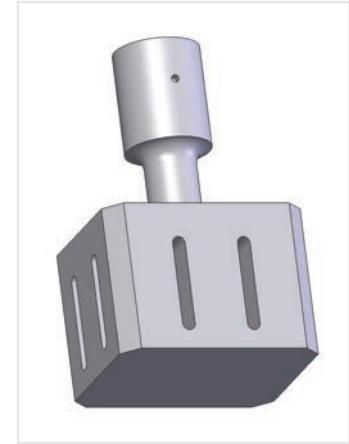

### Elbert Horn

The Elbert horn design allows contacting flat faced square parts that are up to 3.5" wide by 3.5" long. This design does not incorporate slots. As such, it can run on higher gain booster and thus provide more amplitude than a block horn.



### Booster Horn

The booster horn is typically used in automation (when stack size is an issue). As it features a ring at the nodal area for clamping, it eliminates the need to use a booster for that purpose.



### Composite Horn

The composite horn has two or more front drivers mounted to a back driver. The front drivers can be flat, contoured, knurled or have spot welding or staking configuration. Composite horns are also used on applications where there may be a clearance/reach issue.



### Full Wave Horn (in/out)

Full wave horns provide long reach to either weld down the bottom of a deep part, or to weld around the perimeter of a tall part (as shown here in red). Most standard horns can be designed in full wave lengths.



### Rotary Horn

Rotary horns are used in textile or film application for continuous processing. Various patterns/knurls can be added to the face.



### Balun Horn

Balun horns can be designed to use multiple converters to provide more power available for welding compared to a single bar horn on one converter.

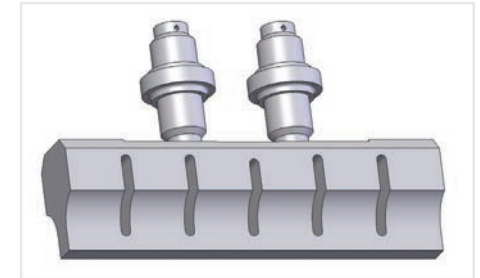

### Side Slitting Horn

Side slitting horns are used in continuous food processing applications. The side slitters have a sawing action and are best utilized on slow moving products exiting from the cooling tunnels such as: nougat, granola, brownies, snack cakes, pastries or cheese slabs.

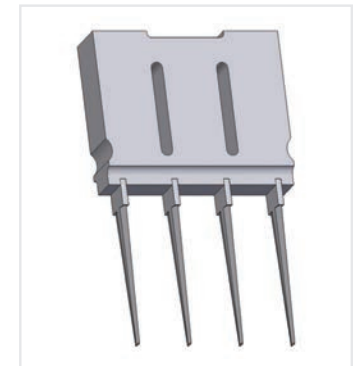

### End Slitting Horn

End slitting horns are used in continuous food processing applications. End slitters are typically used for thin products with low weight and high density such as fruit leather or taffy. They are also used on product moving through the knives at a higher rate of speed. The end slitters have a chopping action that lowers the coefficient of friction against the product. Longer end slitter blades are used on sandwiches which are typically taller and have several densities of product to cut through i.e. bread, meat, cheese, lettuce etc.

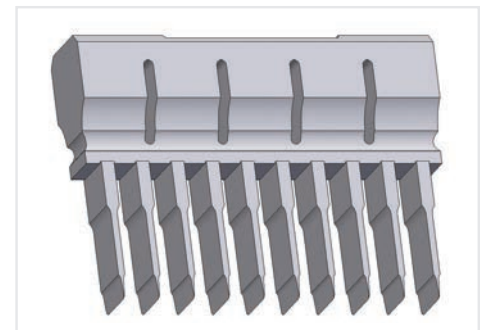



**Catenoidal**

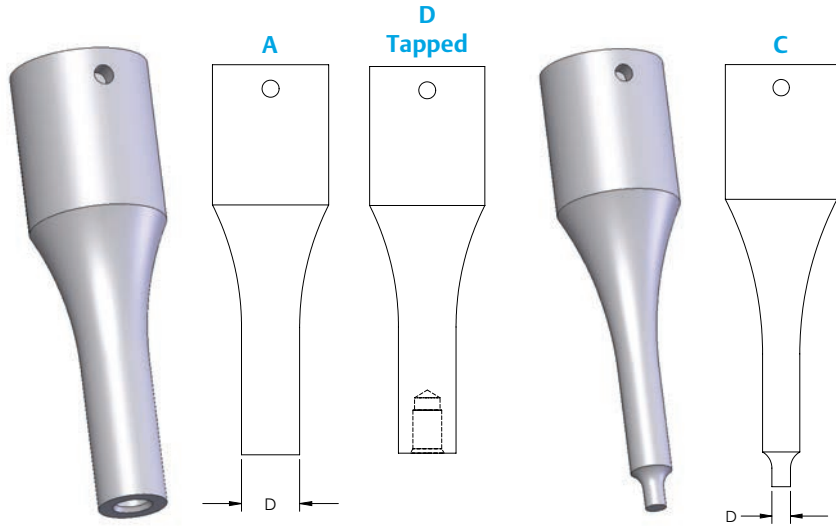

**Exponential**

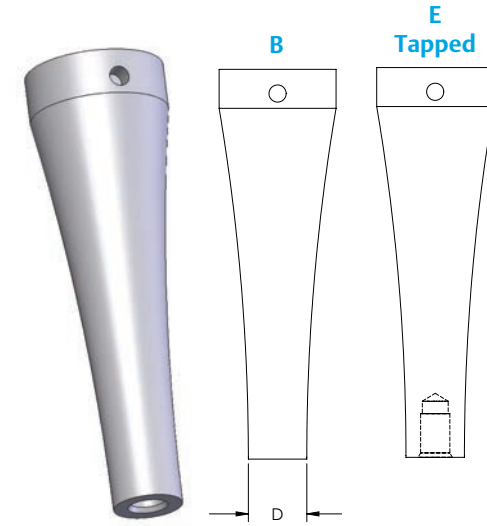

Diameter (inches)

	1/8	1/4	3/8	1/2	5/8	3/4	7/8	1
<b>Catenoidal</b>	609-002-021 7.5 C Green	609-003-021 7.5 C Green	608-001-021 7.5 A Purple	609-001-021 7.3 A Green	610-001-021 4.5 A Gold	611-001-021 3.5 A Silver	612-001-021 2.6 A Black	613-001-021 2 A Black
<b>Exponential</b>		601-001-021 9.2 B Green	602-001-021 5.9 B Gold	603-001-021 4.1 B Silver	604-001-021 3.1 B Black	605-001-021 2.4 B Black	606-001-021 1.9 B Black	607-001-021 1.6 B Black
<b>Tapped Catenoidal</b>				609-010-021 7.3 D Green	610-004-021 4.5 D Green	611-005-021 3.5 D Green	612-005-021 2.6 D Green	613-012-021 2 D Green
<b>Tapped Exponential</b>				603-002-021 4.1 E Silver	604-002-021 3.1 E Silver	605-002-021 2.4 E Gold	606-002-021 1.9 E Gold	607-002-021 1.6 E Gold

NOTE: Horns listed above are tapped 1/2" - 20 studs. To order horns tapped for 3/8" - 24 studs, change the last three digits from "021" to "020".

20 kHz

**Circular Solid**

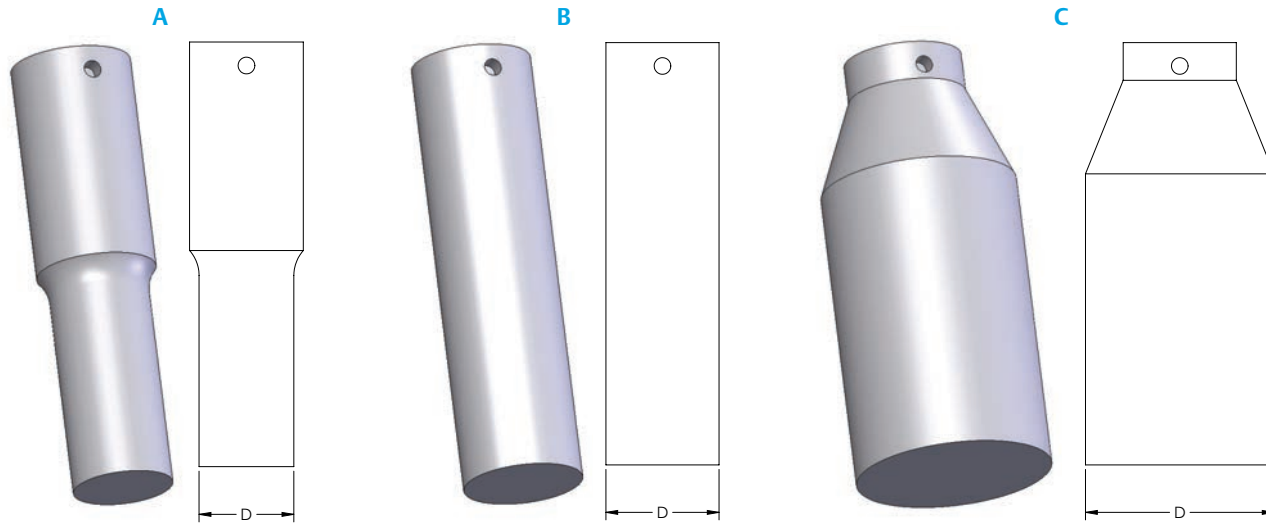

**Circular High Gain**

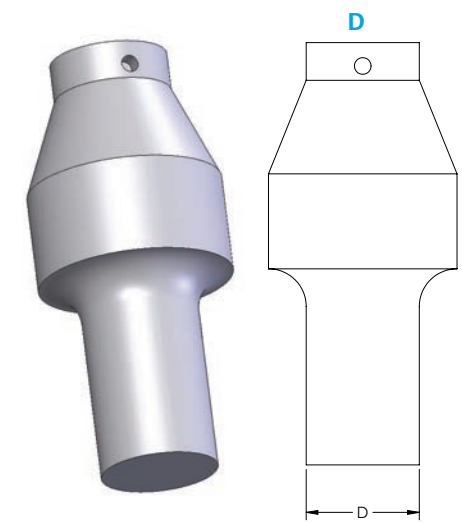

| Diameter (inches)

	1	1 1/4	1 1/2	1 3/4	2	2 1/4	2 1/2	2 3/4	3	3 1/4	3 1/2	3 3/4	4
<b>Circular Solid</b>		620-001-021 1.3 A Black	600-001-021 1 B Black	302-001-021 0.8 C Black	304-001-021 0.8 C Black	306-001-021 0.8 C Black	308-001-021 0.7 C Black	310-001-021 0.8 C Black	312-001-021 0.7 C Black	314-001-021 0.7 C Black	316-001-021 0.6 C Black	317-001-021 0.6 C Black	318-001-021 0.6 C Black
<b>Circular High Gain</b>	302-009-021 2.5 D Silver	306-009-021 2.3 D Silver	308-014-021 1.9 D Black	312-013-021 1.9 D Black	316-017-021 1.7 D Black	318-002-021 1.5 D Black	318-004-021 1.2 D Black	318-006-021 1.1 D Black	318-008-021 0.9 D Black				

NOTE: Horns listed above are tapped 1/2" - 20 studs. To order horns tapped for 3/8" - 24 studs, change the last three digits from "021" to "020".

# Circular Hollow

20 kHz

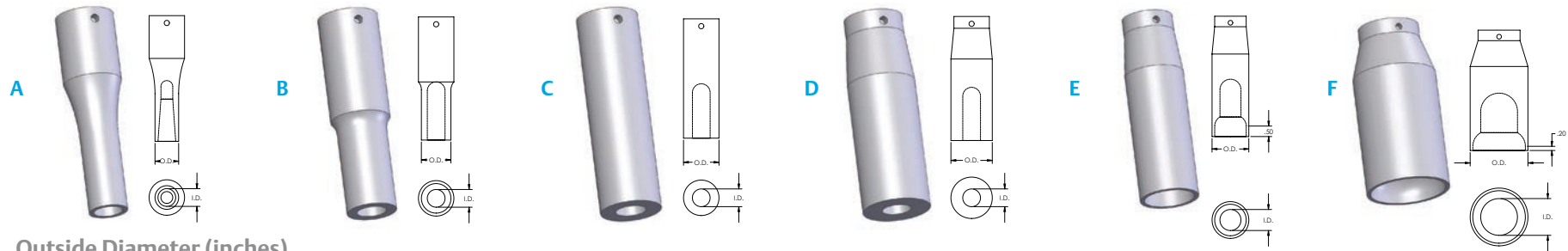

ID | Outside Diameter (inches)

	3/4	1	1 1/4	1 1/2	1 3/4	2	2 1/4	2 1/2	2 3/4	3	3 1/4	3 1/2
1/2	611-003-021 4.4 A Green	613-003-021 2.7 A Gold	628-006-021 1.6 B Black	600-007-021 1.1 C Black								
3/4		613-005-021 3.0 A Gold	628-008-021 2.1 B Gold	600-009-021 1.3 C Black	302-002-021 1.0 D Black							
1			628-010-021 2.6 A Gold	600-011-021 1.7 C Silver	302-004-021 1.2 D Black	304-002-021 1.1 D Black	306-003-021 0.9 D Black	308-002-021 0.9 D Black				
1 1/4				600-014-021 1.1 E Silver	302-006-021 1.7 D Black	304-004-021 1.3 D Black	306-002-021 1.1 D Black	308-004-021 1.0 D Black	310-002-021 1.0 D Black			
1 1/2					302-008-021 1.4 E Black	304-006-021 1.8 D Black	306-004-021 1.4 D Black	308-006-021 1.2 D Black	310-004-021 1.1 D Black	312-002-021 1 D Black	314-003-021 0.8 D Black	316-002-021 0.7 D Black
1 3/4						304-008-021 1.3 E Black	306-006-021 1.9 D Silver	308-008-021 1.4 D Black	310-006-021 1.3 D Black	312-004-021 1.1 D Black	314-002-021 1.0 D Black	316-004-021 0.9 D Black
2							306-008-020 1.6 E Black	308-010-021 2.0 D Silver	310-008-021 1.6 D Black	312-006-021 1.3 D Black	314-004-021 1.2 D Black	316-006-021 1.0 D Black
2 1/4								308-012-021 1.4 E Black	310-010-021 2.2 D Gold	312-008-021 1.7 D Black	314-006-021 1.0 E Black	316-008-021 0.9 F Black
2 1/2									310-012-021 1.5 F Black	312-010-021 2.4 D Gold	314-008-021 1.1 E Black	316-010-021 0.9 F Black
2 3/4										312-012-021 1.4 F Black	314-010-021 1.1 E Black	316-012-021 1.0 F Black
3											314-012-021 1.7 F Black	316-014-021 1.0 F Black
3 1/4												316-016-021 1.0 F Black

NOTE: Horns listed above are tapped 1/2" - 20 studs. To order horns tapped for 3/8" - 24 studs, change the last three digits from "021" to "020".

20 kHz

**Circular Slotted**

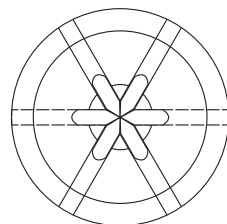
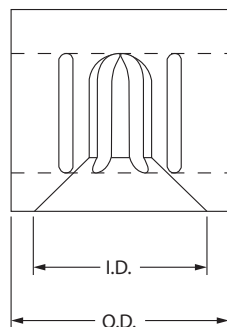

**Rectangular (round corners)**

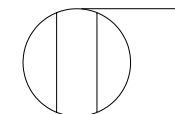
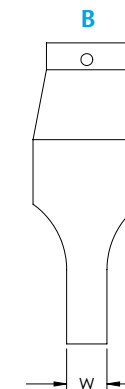
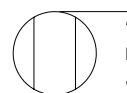
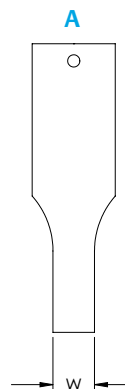

**ID | Outside Diameter (inches)**

	4	4 1/2	5	5 1/2
<b>2</b>	324-001-021 Black			
<b>3</b>	324-005-021 Black	328-003-021 Black	332-001-021 Black	
<b>4</b>		328-007-021 Black	332-005-021 Black	336-003-021 Black
<b>5</b>				336-007-021 Black

**W | Length (inches)**

	1 1/2	1 3/4	2	2 1/4	2 1/2
<b>1/4</b>	600-040-021 3.8 A Gold	302-015-021 3.8 B Gold	304-015-021 4.0 B Gold	306-015-021 4.3 B Green	308-020-021 4.5 B Green
<b>1/2</b>	600-034-021 2.0 A Black	302-021-021 2.0 B Black	304-021-021 2.1 B Black	306-021-021 2.3 B Black	308-026-021 2.4 B Silver
<b>3/4</b>	600-024-021 1.5 A Black	302-027-021 1.5 B Black	304-027-021 1.6 B Black	306-028-021 1.6 B Black	308-032-021 1.6 B Black
<b>1</b>	600-017-021 1.2 A Black	302-034-021 1.2 B Black	304-034-021 1.2 B Black	306-034-021 1.3 B Black	308-038-021 1.3 B Black

NOTE: Horns listed above are tapped 1/2" - 20 studs. To order horns tapped for 3/8" - 24 studs, change the last three digits from "021" to "020".

# Rectangular (Square Corners)

20 kHz

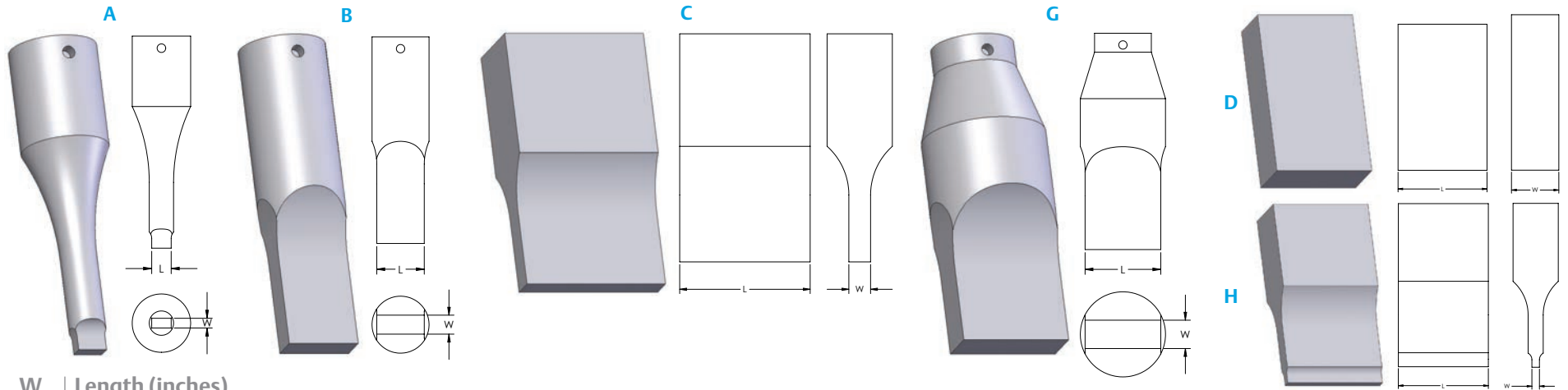

W | Length (inches)

	1/4	1/2	3/4	1	1 1/4	1 1/2	1 3/4	2	2 1/4	2 1/2	2 3/4	3	3 1/4	3 1/2
1/4	609-014-021 7.5 A Purple	610-006-021 5.0 A Green	612-007-021 2.8 A Black	600-038-021 5.0 B Green	628-019-021 4.6 B Green	302-013-021 4.4 G Green	304-013-021 4.7 G Green	306-013-021 4.8 G Green	308-018-021 5.0 G Green	409-011-021 4.7 C Green	407-011-021 4.5 C Green	405-011-021 2.4 H Silver	403-011-021 2.2 H Black	401-011-021 3.7 H Gold
1/2		611-010-021 3.6 A Silver	613-009-021 2.2 A Black	600-032-021 3.0 B Silver	628-015-021 2.4 B Silver	302-019-021 2.3 G Silver	304-019-021 2.4 G Silver	306-019-021 2.5 G Silver	308-024-021 2.6 G Silver	409-009-021 2.4 C Black	407-009-021 2.4 C Black	405-009-021 1.8 C Black	403-009-021 2.2 C Black	401-009-021 2.0 C Black
3/4				600-022-021 2.1 B Black	628-013-021 1.7 B Black	302-025-021 1.7 G Black	304-025-021 1.7 G Black	306-026-021 1.8 G Black	308-030-021 1.8 G Black	409-007-021 1.7 C Black	407-007-021 1.6 C Black	405-007-021 1.6 C Black	403-007-021 1.5 C Black	401-007-021 1.3 C Black
1				600-015-021 1.6 B Black	302-032-021 1.5 G Black	304-031-021 1.5 G Black	304-033-021 1.3 G Black	306-033-021 1.4 G Black	308-037-021 1.4 G Black	409-005-021 1.3 C Black	407-005-021 1.2 C Black	405-005-021 1.2 C Black	403-005-021 1.2 C Black	401-005-021 1.1 C Black
1 1/4					304-038-021 1.5 G Black	304-040-021 1.2 G Black	306-038-021 1.3 G Black	308-043-021 1.3 G Black	310-015-021 1.4 G Black	409-003-021 1.0 C Black	407-003-021 1.2 C Black	405-003-021 1.0 C Black	403-003-021 1.1 C Black	401-003-021 0.9 C Black
1 1/2						306-041-021 1.2 G Black	308-048-021 1.3 G Black	308-050-021 1.0 G Black	310-021-021 1.2 G Black	409-001-021 0.8 D Black	407-001-021 0.9 D Black	405-001-021 0.8 D Black	403-001-021 0.8 D Black	401-001-021 0.7 D Black
1 3/4							308-054-021 1.1 G Black	310-024-021 1.0 G Black	312-019-021 1.0 G Black	509-003-021 0.9 C Black	507-003-021 0.9 C Black	505-003-021 0.9 C Black	503-002-021 1.0 C Black	501-003-021 0.8 C Black
2								312-023-021 1.1 G Black	314-016-021 1.0 G Black	509-001-021 0.8 D Black	507-001-021 0.8 D Black	505-001-021 0.8 D Black	503-001-021 0.9 D Black	501-001-021 0.8 D Black
2 1/4									314-020-021 0.9 G Black	709-003-021 0.9 C Black	707-003-021 0.9 C Black	705-003-021 0.8 C Black	703-003-021 0.9 C Black	701-003-021 0.8 C Black
2 1/2										316-020-021 0.8 G Black	707-001-021 0.8 D Black	705-001-021 0.8 D Black	703-001-021 0.9 D Black	701-001-021 0.8 D Black

NOTE: Horns listed above are tapped 1/2" - 20 studs. To order horns tapped for 3/8" - 24 studs, change the last three digits from "021" to "020".



# 20 kHz

W | Length (inches)

	4	4 1/2	5	5 1/2	6	6 1/2
1/4	413-023-021 2.6 A Silver	416-103-021 2.6 B Silver	416-107-021 2.7 B Silver	416-111-021 2.8 A Gold	420-023-021 2.8 A Gold	424-023-021 2.6 A Silver
1/2	413-019-021 2.5 D Silver	416-082-021 2.2 C Silver	416-087-021 2.5 C Silver	416-091-021 2.5 D Silver	420-019-021 2.6 D Silver	424-019-021 2.6 D Silver
3/4	413-014-021 1.9 D Black	416-062-021 1.7 C Black	416-066-021 1.7 C Black	416-070-021 1.7 D Black	420-014-021 1.7 D Black	424-014-021 1.8 D Black
1	413-010-021 1.4 D Black	416-042-021 1.2 C Black	416-046-021 1.3 C Black	416-050-021 1.4 D Black	420-010-021 1.4 D Black	424-010-021 1.4 D Black
1 1/4	413-005-021 1.2 D Black	416-022-021 1.1 C Black	416-026-021 1.1 C Black	416-030-021 1.1 D Black	420-005-021 1.1 D Black	424-005-021 1.1 D Black
1 1/2	413-001-021 1.0 F Black	416-002-021 0.9 E Black	416-006-021 0.9 E Black	416-001-021 0.9 F Black	420-001-021 0.9 F Black	424-001-021 0.9 F Black
1 3/4	513-005-021 1.1 D Black	516-029-021 1.1 C Black	516-025-021 1.1 C Black	516-021-021 1.1 D Black	520-005-021 1.0 D Black	524-005-021 1.0 D Black
2	513-001-021 0.9 F Black	516-009-021 1.0 E Black	516-005-021 1.0 E Black	516-001-021 0.9 F Black	520-001-021 1.0 F Black	524-001-021 1.0 F Black
2 1/4	712-005-021 0.9 D Black	715-006-021 1.0 C Black	716-020-021 1.0 C Black	716-024-021 1.0 D Black	720-005-021 1.0 D Black	724-005-021 1.0 D Black
2 1/2	712-001-021 0.9 F Black	715-001-021 0.9 E Black	716-005-021 0.9 E Black	716-001-021 0.9 F Black	720-001-021 0.9 F Black	724-001-021 0.9 F Black

## Rectangular Slotted

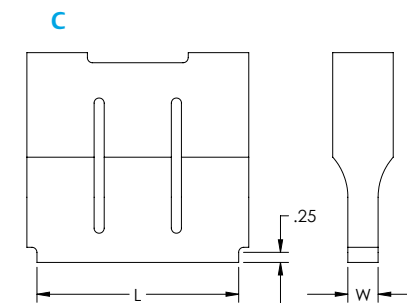
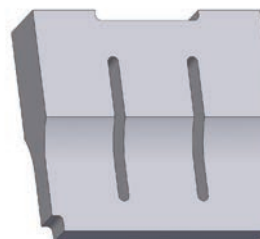
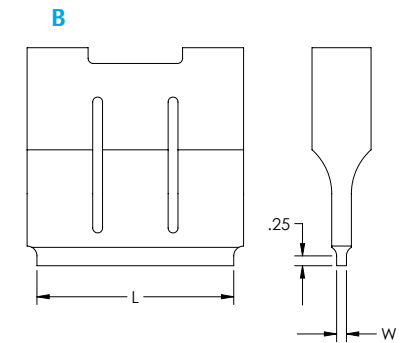
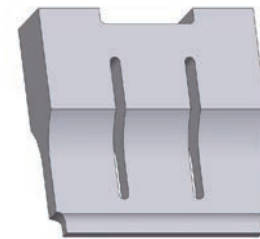
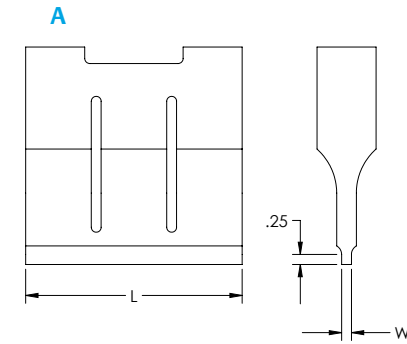
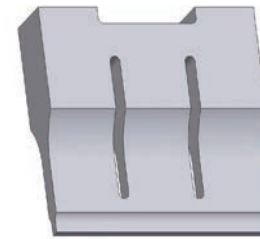

NOTE: Horns listed above are tapped 1/2" - 20 studs. To order horns tapped for 3/8" - 24 studs, change the last three digits from "021" to "020".

W | Length (inches)

	7	7 1/2	8	8 1/2	9	9 1/2	10
1/4	428-022-021 2.7 A Silver	432-022-021 2.6 A Silver	436-022-021 2.6 A Silver	440-022-021 2.6 A Silver	444-022-021 2.5 A Silver	448-022-021 2.5 A Silver	452-022-021 2.6 A Silver
1/2	428-018-021 2.6 D Black	432-018-021 2.6 D Black	436-018-021 2.6 D Silver	440-018-021 2.6 D Silver	444-018-021 2.6 D Silver	448-018-021 2.6 D Silver	452-018-021 2.6 D Silver
3/4	428-014-021 1.8 D Black	432-014-021 1.7 D Black	436-014-021 1.7 D Black	440-014-021 1.7 D Black	444-014-021 1.6 D Black	448-014-021 1.7 D Black	452-014-021 1.8 D Black
1	428-010-021 1.4 D Black	432-010-021 1.4 D Black	436-010-021 1.4 D Black	440-010-021 1.4 D Black	444-010-021 1.3 D Black	448-010-021 1.4 D Black	452-010-021 1.4 D Black
1 1/4	428-005-021 1.1 D Black	432-005-021 1.1 D Black	436-005-021 1.1 D Black	440-005-021 1.1 D Black	444-005-021 1.1 D Black	448-005-021 1.1 D Black	452-005-021 1.1 D Black
1 1/2	428-001-021 0.9 F Black	432-001-021 0.9 F Black	436-001-021 0.9 F Black	440-001-021 0.9 F Black	444-001-021 0.9 F Black	448-001-021 0.9 F Black	452-001-021 1.0 F Black
1 3/4	528-005-021 1.0 D Black	532-005-021 1.0 D Black	536-005-021 1.0 D Black	540-005-021 1.0 D Black	544-005-021 1.0 D Black	548-005-021 1.0 D Black	552-005-021 1.0 D Black
2	528-001-021 1.0 F Black	532-001-021 1.0 F Black	536-001-021 1.0 F Black	540-001-021 1.0 F Black	544-001-021 1.0 F Black	548-001-021 1.0 F Black	552-001-021 1.0 F Black
2 1/4	728-005-021 1.0 D Black	732-005-021 1.0 D Black	736-005-021 1.0 D Black	740-005-021 1.0 D Black	744-005-021 1.0 D Black	748-005-021 1.0 D Black	752-005-021 1.0 D Black
2 1/2	728-001-021 0.9 F Black	732-001-021 0.9 F Black	736-001-021 0.9 F Black	740-001-021 0.9 F Black	744-001-021 0.9 F Black	748-001-021 0.9 F Black	752-001-021 0.9 F Black

Rectangular Slotted

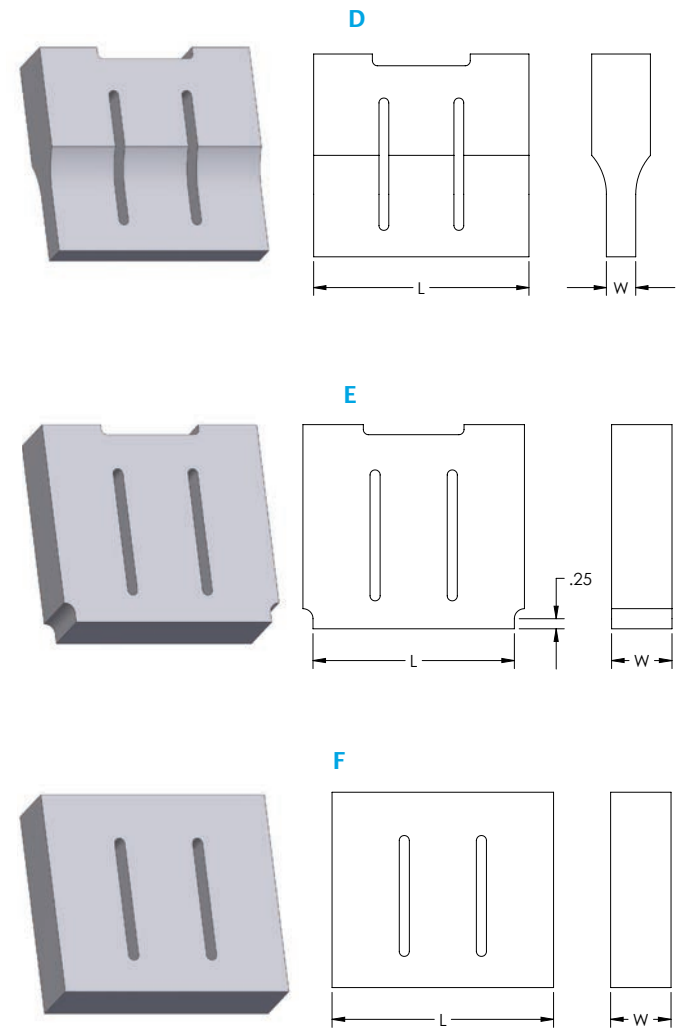

NOTE: Horns listed above are tapped 1/2" - 20 studs. To order horns tapped for 3/8" - 24 studs, change the last three digits from "021" to "020".

## 20 kHz

### 20 kHz Steel Horns

Steel horns have good wear properties, but do not have the tensile strength of aluminum or titanium. Therefore, they are most suitable for low gain applications such as inserting. All have 1/2" - 20 studs.



Diameter (inches) | EDP No. | Booster

Diameter (inches)	EDP No.	Booster
*1/2"	108-006-883	Gold
*5/8"	108-006-890	Gold
*3/4"	108-006-809	Gold
*7/8"	108-006-916	Gold
*1"	108-006-887	Gold
*1 1/4"	108-006-629	Silver
1 1/2"	108-006-623	Silver

\*Angles begin at the face of the horn and taper back at 5° to 20° angles depending upon the horn. All the above horns are made with 1 1/2" diameter stock. Steel horns are heat treated to obtain a Rockwell hardness of RC-58-62.

### 20 kHz Spool Horns

Branson offers a variety of standard spool horns in the most commonly used sizes. All have 1/2" - 20 studs.

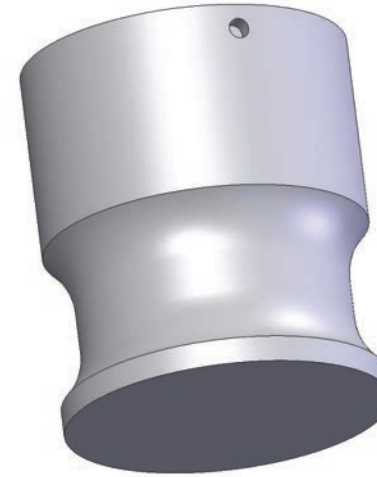

Diameter (inches) | EDP No. | Material | Coating | Booster

Diameter (inches)	EDP No.	Material	Coating	Booster
3"	108-017-126 108-017-127 108-009-706	Al Al Titanium	C/A C/P	Black Black Natural
4"	108-017-130 108-017-131 108-009-710	Al Al Titanium	C/A C/P	Black Black Natural
5"	108-017-123 108-017-134 108-009-714	Al Al Titanium	C/A C/P	Black Black Natural

C/A = Clear Anodize

C/P = Chrome Plate

### 20 kHz Block Horns

Branson offers a variety of standard block horns in the most commonly used sizes. All horns listed below have a 1:1 gain ratio and have 1/2" - 20 studs.

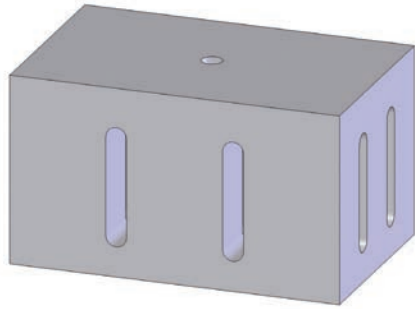

Size	EDP No.	Material	Coating	Booster
3" x 7"	109-078-441	Al	C/A	Black
	109-078-442	Al	C/P	Black
3.5" x 7"	109-115-1938	Al	C/A	Gold
	109-115-1939	Al	C/P	Gold
4.5" x 8.75"	109-078-433	Al	C/A	Silver
	108-004-919	Al	C/P	Silver
5" x 7.87"	109-115-1925	Al	C/A	Gold
	109-115-1926	Al	C/P	Gold
5" x 5"	108-020-281	Al	C/A	Silver
	108-020-339	Al	C/P	Silver
5.12" x 6.35"	109-115-002	Al	C/A	Silver
	109-115-004	Al	C/P	Silver
5" x 7"	109-115-1940	Al	C/A	Gold
	109-115-1941	Al	C/P	Gold
6.5" x 9.0"	109-115-1927	Al	C/A	Silver
	109-115-1928	Al	C/P	Silver
7.48" x 7.48"	108-020-451	Al	C/A	Silver
	108-020-452	Al	C/P	Silver
	108-020-684	Ti		Black
8" x 8"	108-020-769	Al	C/A	Silver
	108-020-770	Al	C/P	Silver
	108-020-772	Ti		Black

C/A = Clear Anodize  
C/P = Chrome Plate

### Standard 20 kHz Titanium Food Cutting Blade Horns

All have 3/8" - 24 studs and are rated for a green booster.

#### Half-Wave - Thin Blade (7°)

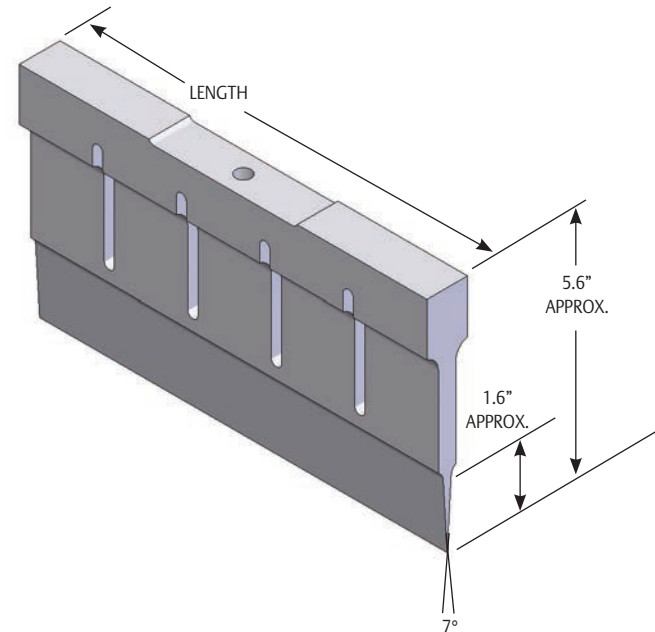

Length (inches)	Without coating Branson EPD No.	With Titanium Nitride coating Branson EPD No.
6"	109-630-001	109-630-101
7"	109-630-002	109-630-102
8"	109-630-003	109-630-103
9"	109-630-004	109-630-104
10"	109-630-005	109-630-105
11"	109-630-006	109-630-106
12"	109-630-007	109-630-107

# 20 kHz

## Half Wave – Broad Angle (11°)

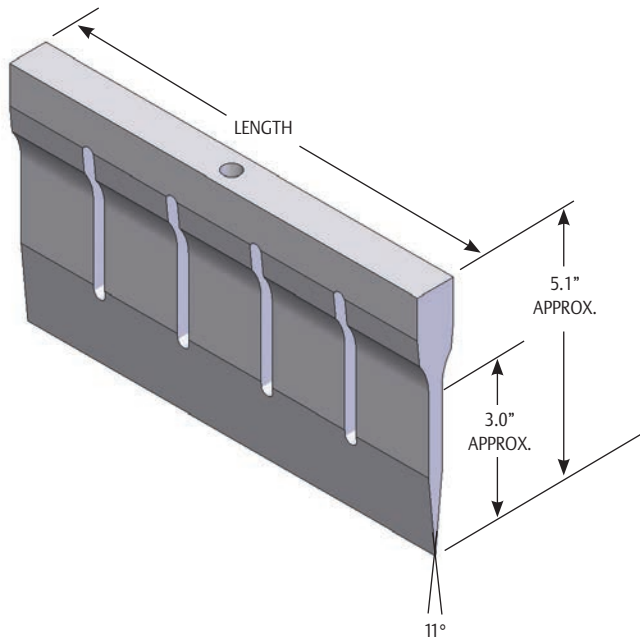

Length (inches)	Without coating Branson EPD No.	With Titanium Nitride coating Branson EPD No.
6"	109-630-008	109-630-108
7"	109-630-009	109-630-109
8"	109-630-010	109-630-110
9"	109-630-011	109-630-111
10"	109-630-012	109-630-112
11"	109-630-013	109-630-113
12"	109-630-014	109-630-114

## Full Wave – Broad Angle (12°)

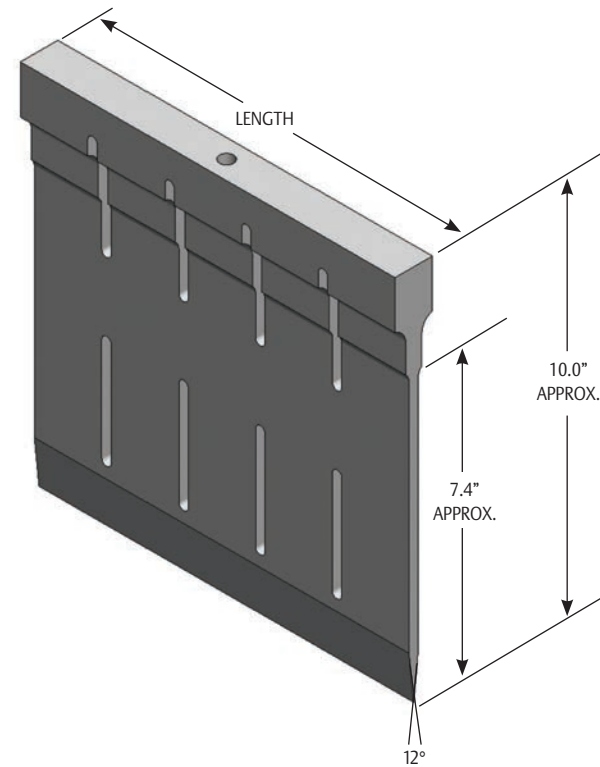

Length (inches)	Without coating Branson EPD No.	With Titanium Nitride coating Branson EPD No.
6"	109-630-015	109-630-115
7"	109-630-016	109-630-116
8"	109-630-017	109-630-117
9"	109-630-018	109-630-118
10"	109-630-019	109-630-119



**Half Wave Wedge Horn (14°-15°)**

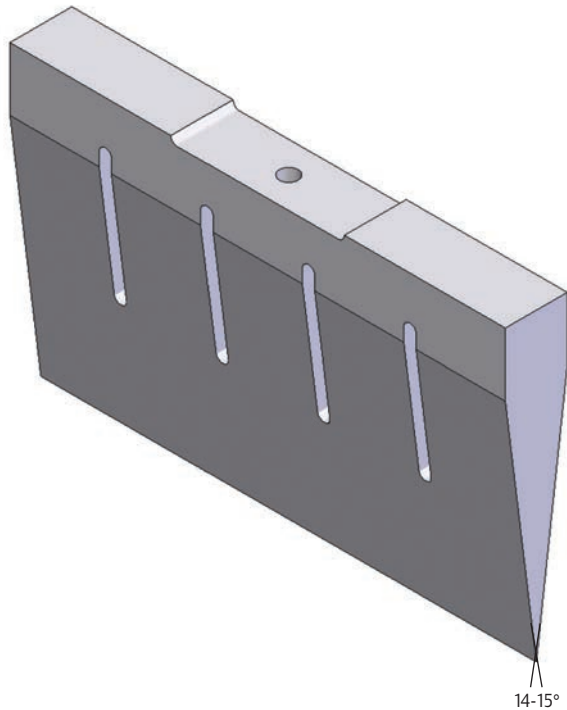

Length (inches)	Without coating Branson EPD No.	With Titanium Nitride coating Branson EPD No.
6"	109-630-020	109-630-120
8"	109-630-021	109-630-121
10"	109-630-022	109-630-122
12"	109-630-023	109-630-123

**Textile Cutting and Sealing Horn**

**Sealing Horn for F-20 slitter, FS-90, FS-180**  
 1" diameter titanium, carbide-faced. 3/8" - 24 stud.  
 This horn is rated for a silver booster.  
 EDP# 101-147-034



**Pinsonic Horns (Titanium)**

Pinsonic horns are rated for a silver booster.

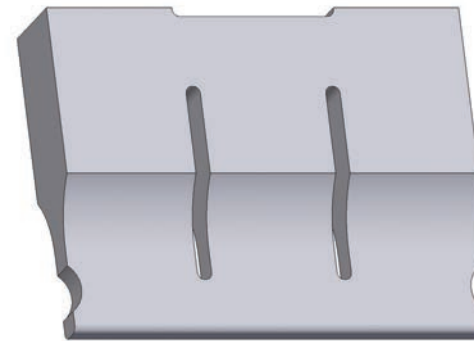

7 1/4" x 1/2" Horn, 1/8" Radius (1/2"-20 stud)

Branson EDP No.

Solid carbide	109-163-2009
Hard carbide, coated ground	109-163-2010
No coating	109-163-2011

9" x 1/2" Horn, 1/8" Radius (1/2"-20 stud)

Branson EDP No.

Solid carbide	109-163-2012
Hard carbide, coated ground	109-163-2013
No coating	109-163-2014

## 40 kHz

### 40 kHz Spool Horns

All 40 kHz horns have M-8 studs.

Diameter	Material	EDP No.	Booster
1.5"	Al	109-122-2001	Black
1.5"	Ti	109-122-2002	Black
2.0"	Al	109-122-2003	Black
2.0"	Ti	109-122-2004	Black
2.5"	Al	109-122-2005	Black
2.5"	Ti	109-122-2006	Black

### 40 kHz Catenoidal Horns

Diameter	Material	EDP No.	Gain	Booster
1/2"	Ti	109-122-2008	1.6	Black
1/2"	Ti tapped	109-122-2009	1.6	Green

### 40 kHz Exponential Horns

Diameter	Material	EDP No.	Gain	Booster
1/2"	Ti	109-122-2010	1.4	Black
1/2"	Ti tapped	109-122-2011	1.4	Green

### 40 kHz High Gain Horns

Diameter	Material	EDP No.	Gain	Booster
1/2"	Ti	109-122-2012	2.8	Gold
1/2"	Ti tapped	109-122-2013	2.8	Green

## 40 kHz

### 40 kHz Horns

Size	Material	EDP No.	Gain	Booster
1/2" x 3 1/2"	Alum C/P	108-013-621	1.4	Silver
1/4" x 2"	Alum C/P	108-013-128	2.5	Silver
1/2" x 1 1/2"	Alum C/P	108-013-259	1.4	Black
1/4" x 1"	Alum C/P	108-013-270	2.5	Black
1/4" ID x 1" OD	Alum C/P	108-013-419	1.5	Silver
1/2" ID x 1" OD	Alum C/P	108-013-305	1.5	Silver
3/4" ID x 1 1/2" OD	Alum C/P	108-013-622	1.5	Black
1/2" Dia. Step	Titanium	108-013-298	2.2	Gold
3/8" Dia. Step	Titanium	108-013-341	3.0	Gold
1/4" Dia. Step	Titanium	108-013-338	4.0	Green
1/2" Dia. Tapped	Titanium	108-013-637*	2.0	Green

\*This horn uses any standard weight 1/2" diameter titanium tip.  
C/P = Chrome Plate

### 40 kHz Half Wave Blade Tire Cutting Horns

Length (inches)	Material	Coating	EDP No.	Booster
3 1/4"	Titanium		109-122-003	Green
3 1/4"	Titanium	Titanium Nitride	109-122-689	Green
7 1/2"	Titanium	Titanium Nitride	109-122-1872	Green

### 40 kHz Tire Cutting Knife

Material	EDP No.	Booster
Titanium	109-122-471	Green

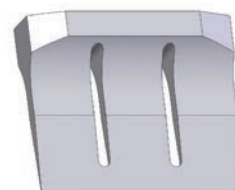

3 1/4" Long

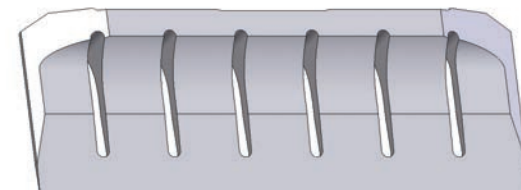

7.5" Long

## 30 kHz

### 30 kHz Spool Horns

All 30 kHz horns have 3/8" - 24 studs.

Diameter	Material	EDP No.	Booster
2.0"	Alum C/A	109-169-627	Silver
2.0"	Ti	109-169-628	Black
2.67"	Alum C/A	109-169-629	Silver
2.67"	Ti	109-169-630	Black
3.34"	Alum C/A	109-169-631	Silver
3.34"	Ti	109-169-632	Black

C/A = Clear Anodize

### 30 kHz Catenoidal Horns

Diameter	Material	EDP No.	Gain	Booster
1/2"	Ti	109-169-633	3.6	Gold
1/2"	Ti tapped	109-169-634	3.6	Green
5/8"	Ti	109-169-635	3.1	Silver
5/8"	Ti tapped	109-169-636	3.1	Green

### 30 kHz Exponential Horns

Diameter	Material	EDP No.	Gain	Booster
1/2"	Ti	109-169-637	2.5	Black
1/2"	Ti tapped	109-169-638	2.5	Silver
5/8"	Ti	109-169-639	1.8	Black
5/8"	Ti tapped	109-169-640	1.8	Silver

### 30 kHz High Gain Horns

Diameter	Material	EDP No.	Gain	Booster
1/2"	Ti	109-169-641	3.6	Green
1/2"	Ti tapped	109-169-642	3.6	Green
5/8"	Ti	109-169-643	3.2	Green
5/8"	Ti tapped	109-169-644	3.2	Green

## 15 kHz

### 15 kHz Spool Horns

All 15 kHz horns have 1/2" - 20 studs

Diameter	Material	Coating	EDP No.	Booster
4.0"	Al	C/A	109-168-425	Silver
4.0"	Ti		109-168-426	Black
5.33"	Al	C/A	109-168-427	Silver
5.33"	Ti		109-168-428	Black
6.65"	Al	C/A	109-168-429	Silver
6.65"	Ti		109-168-430	Black

### 15 kHz Blocks Horns

Diameter	Material	Coating	EDP No.	Booster
6.67" X 9.00"	Al	C/A	109-168-453	Green
8.00" X 10.00"	Al	C/A	109-168-452	Gold
10.66" x 10.66"	Al	C/A	109-168-446	Silver
10.66" x 10.66"	Ti		109-168-479	Silver

### 15 kHz High Gain Horns

Diameter	Material	EDP No.	Gain	Booster
1 1/2"	Ti	109-168-447	2.5	Gold
2 1/2"	Ti	109-168-448	1.7	Silver

C/A = Clear Anodize

For more information, visit [www.bransonultrasonics.com](http://www.bransonultrasonics.com) or call 1-877-946-7679

### Knurled Horns

Knurled surfaces of horns and anvils are classified as “fine,” “medium,” and “coarse.” These designations refer to the approximate number of teeth or cavities per inch of knurled surface. A “fine” knurled surface contains approximately 33 teeth per inch, a “medium” knurl has approximately 21 teeth per inch, and a coarse knurl has approximately 14 teeth per inch. Knurled surfaces can also be either “female,” with a multitude of cavities or “male” with teeth protruding outward in a diamond shape.

The following chart shows knurled surfaces used on Branson horns and anvils. Information on other sizes available upon request.

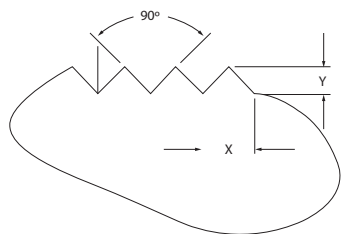

Knurl Type	“X” Dim.	“Y” Dim.	Tool No.
Male Fine	0.030”	0.015”	—
Male Medium	0.040”	0.020”	—
Male Coarse	0.050”	0.025”	—
Female Fine	—	—	KPM 230
Female Medium	—	—	KPM 225
Female Coarse	—	—	KPM 220

### Knurled Tips

Economical knurled tips are designed for ultrasonic welding and staking, and enable easy part alignment in hand-held operations. The standard 1/2” diameter knurled tips available are listed in the table below.

Knurl Type	Male	Female
1/2” Diameter Fine	101-148-081	101-148-084
1/2” Diameter Medium	101-148-082	101-148-085
1/2” Diameter Coarse	101-148-083	101-148-086

### Staking Tips

Ultrasonic staking is most commonly used to attach dissimilar materials. For example, one or more studs molded in a plastic part protrudes through holes in a circuit board. A horn (with specially-contoured replaceable tips) contacts the studs, melting and reforming them as locking heads in the shape of the staking tip.

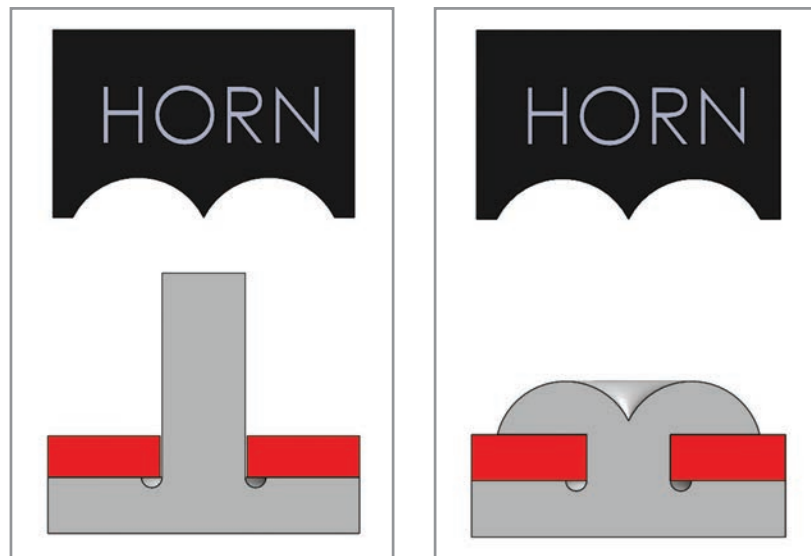

Numerous replaceable staking tips can be used with one horn to perform a variety of applications. Standard and low profile staking tips are listed below, other profiles such as dome or hollow staking tips can be made to special order.

Tip Diameter	Identification Letter and Description	Stud Diameter	Stud Height*	EDP No.
1/2"	A std. prof.	1/32"	0.050"	101-148-034
1/2"	B std. prof.	1/16"	0.100"	101-148-035
1/2"	C std. prof.	3/32"	0.150"	101-148-036
1/2"	D std. prof.	1/8"	0.200"	101-148-037
1/2"	E std. prof.	5/32"	0.250"	101-148-038
1/2"	F std. prof.	3/16"	0.300"	101-148-039
1/2"	G low prof.	1/32"	0.019"	101-148-040
1/2"	H low prof.	1/16"	0.038"	101-148-041
1/2"	I low prof.	3/32"	0.056"	101-148-042
1/2"	J low prof.	1/8"	0.075"	101-148-043
1/2"	K low prof.	5/32"	0.094"	101-148-044
1/2"	L low prof.	3/16"	0.112"	101-148-045
5/8"	M std. prof.	7/32"	0.350"	101-148-046
5/8"	N std. prof.	1/4"	0.400"	101-148-047
5/8"	O low prof.	27/64"	0.253"	101-148-048
5/8"	P low prof.	15/32"	0.281"	101-148-049

\*Stud height is defined as the height of the stud that protrudes above the material to be staked.

Branson also offers a **staking tip kit** containing all the above tips and a storage case, listed under EDP 101-063-027.

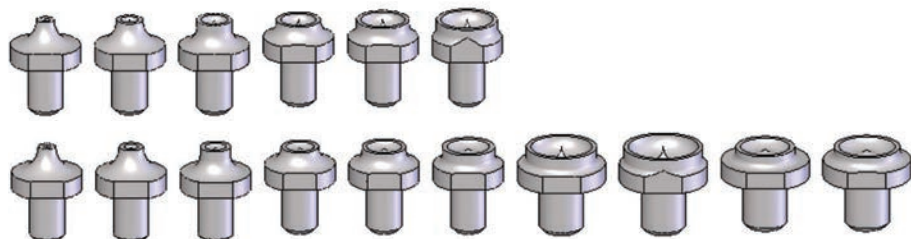

### Spot Welding Tips

Ultrasonic spot welding is a method of joining two sheets of thermoplastic material. A radial cavity in the tip of an ultrasonic horn shapes displaced molten plastic into a neat raised ring on the surface of the part. A standard spot welding tip produces a head having a diameter three times the thickness of the top layer. Spot welding tips are threaded for easy replacement and changing application requirements.

Tip Diameter	Identification Letter	Top Sheet Thickness*	EDP No.
1/2"	A	1/32"	101-148-050
1/2"	B	3/64"	101-148-051
1/2"	C	1/16"	101-148-052
1/2"	D	5/64"	101-148-053
1/2"	E	3/32"	101-148-054
1/2"	F	7/64"	101-148-055
3/4"	G	1/8"	101-148-056
3/4"	H	5/32"	101-148-057
3/4"	I	3/16"	101-148-058
3/4"	J	7/32"	101-148-059
1"	K	1/4"	101-148-060
1"	L	9/32"	101-148-061

\*Bottom sheet should be equal to or greater than the top sheet thickness.

Branson also offers a **spot welding kit** containing all the above tips and a storage case, listed under EDP 101-063-028.

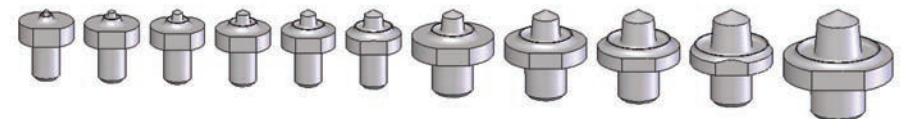



### Flat and Overweight Tips

Flat tips are designed for standard tapped horns and do not require modifications to the horn. Overweight tips are supplied heavier than necessary so that a specific configuration may be machined into the tip face to conform to the part. The final weight of an overweight tip should fall within the tolerances shown to be used with standard horns.

Acceptable tolerance ranges for tips after machining are shown below:

- 1/2" diameter 3.5g ± 0.2g
- 5/8" diameter 5.0g ± 0.3g
- 3/4" diameter 8.5g ± 0.5g
- 7/8" diameter 12.5g ± 0.6g
- 1" diameter 18.0g ± 0.7g

Tip Size and Description	Thread	EDP No.
1/2" Diameter Flat	1/4" - 28	101-148-024
5/8" Diameter Flat	5/16" - 24	101-148-011
3/4" Diameter Flat	3/8" - 24	101-148-009
7/8" Diameter Flat	7/16" - 20	101-148-064
1" Diameter Flat	1/2" - 20	101-148-065
1/2" Diameter Overweight	1/4" - 28	101-148-023
5/8" Diameter Overweight	5/16" - 24	101-148-012
3/4" Diameter Overweight	3/8" - 24	101-148-010
7/8" Diameter Overweight	7/16" - 20	101-148-067
1" Diameter Overweight	1/2" - 20	101-148-068

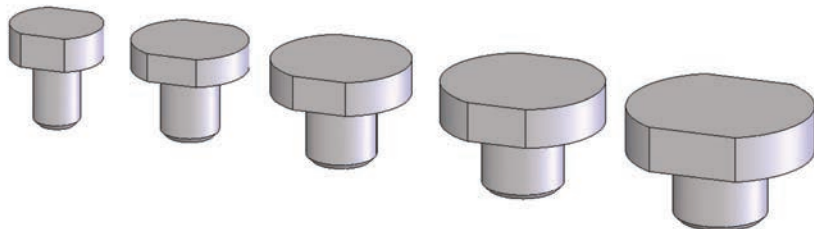

### Acoustic Interface Washers

Acoustic interface washers are used at the interfaces between the converter and booster, and the booster and horn.

1/2" - 20 Washer Kit (150 ct.)

EDP No. 100-063-471

### Torque Wrench Kits

For torque specifications, please refer to Branson's Technolog TL-8.

Welding systems function with the greatest efficiency when the stack components are properly assembled and torqued. Branson's torque wrench kits allow for accurate torquing that is traceable back to NIST standards.

EDP No.

15 kHz circular horns with OD greater than 4.75"

101-118-047

15, 20 and 30 kHz

101-063-787

40 kHz

101-063-618



### Universal 20 kHz Stack Vise

EDP No.

For separation and torquing of 20 kHz stacks.

100-063-642



## Boosters

Boosters can either increase or decrease the amount of amplitude at the face of the horn. They are color-coded to represent different magnification ratios (color of body for aluminum boosters and color of ring for titanium boosters). The color code and ratios are listed below.

### 20 kHz 2000X Series

All have 1/2" - 20 studs at converter end and are drilled/tapped 1/2"-20 at horn end. Boosters using an o-ring design are available in aluminum or titanium. Solid mount boosters are made using titanium. The boosters are designed for use with the CJ20 and CR20 converters.

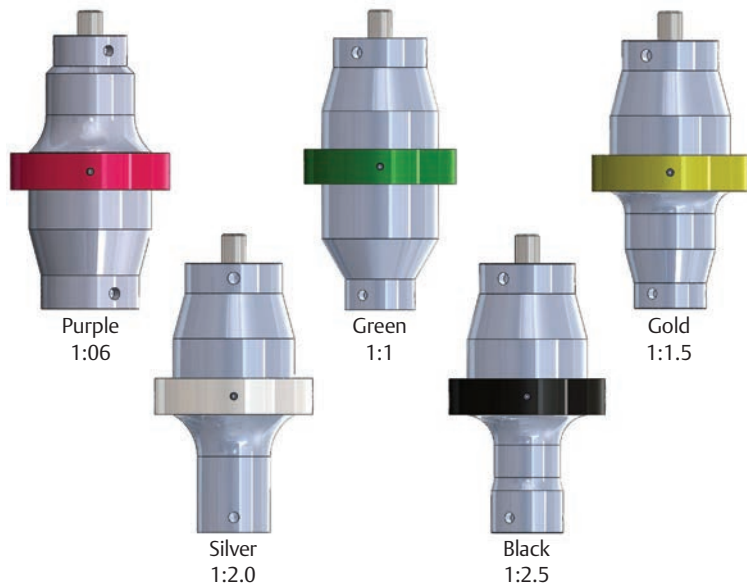

Color	Amplitude Ratio	EDP No. Aluminum O-ring	EDP No. Titanium O-ring	EDP No. Titanium Solid Mount
Purple	1:0.6	101-149-055	101-149-060	101-149-095
Green	1:1	101-149-051	101-149-056	101-149-096
Gold	1:1.5	101-149-052	101-149-057	101-149-097
Silver	1:2.0	101-149-053	101-149-058	101-149-098
Black	1:2.5		101-149-059	101-149-099
Natural	1:3.0		109-016-428	

### 15 kHz Boosters

All have 1/2" - 20 studs at converter end and are drilled/tapped 1/2" - 20 at horn end. The boosters below are designed for use with the CJ15 and CR15 converters.

Color	Amplitude Ratio	EDP No. Titanium O-ring	EDP No. Titanium Solid Mount
Green	1:1	159-149-107	109-116-1967
Gold	1:1.5	159-149-108	109-116-1808
Silver	1:2.0	159-149-109	109-116-1797
Black	1:2.5	159-149-110	159-149-1523

### 30 kHz Boosters

All have 3/8" - 24 studs at converter end and are drilled/tapped 3/8" - 24 at horn end. The boosters below are designed for use with the CA30, CR30, CH30, CS30 and CP30 converters.











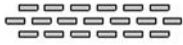





Color	Amplitude Ratio	EDP No. Titanium O-ring	EDP No. Titanium Solid Mount
Purple	1:0.6	101-149-124	159-149-142
Green	1:1	101-149-123	159-149-141
Gold	1:1.5	101-149-122	159-149-140
Silver	1:2.0	101-149-121	159-149-139
Black	1:2.5	101-149-120	159-149-138

### 40 kHz Boosters

All have M-8 studs at converter end and are drilled/tapped M-8 at horn end. The boosters below are designed for use with the 4TJ, 4TR, 4TH, 4TP and CR40 converters.

Color	Amplitude Ratio	EDP No. Aluminum O-ring	EDP No. Titanium O-ring	EDP No. Titanium Solid Mount
Purple	1:0.6	101-149-087		109-149-178
Green	1:1	101149-079	101-149-085	109-041-177
Gold	1:1.5	101-149-080	101-149-086	109-041-176
Silver	1:2.0	101-149-081R	101-149-083	109-041-175
Black	1:2.5	101-149-082	101-149-084	109-041-174

## Textile Cutting and Sealing Horn, Anvils and Wheels FS-90 and FS-180 Wheels

	Pattern Description	Branson EDP No.
	Single Stitch	101-160-911
	Staggered Triple Stitch	109-015-416
	Solid Bar Double Stitch	109-015-422
	Dot Stitch	101-160-936
	Zigzag 1/4" Wide	101-160-921
	Zigzag 1/8" Wide	101-160-920
	Zigzag, Split Pattern 1/4" Wide	101-160-926
	Zigzag, Split Pattern 1/8" Wide	101-160-925
	Rope Pattern	101-160-941
	Serpentine Pattern 1/4" Wide	101-160-931
	Serpentine Pattern 1/8" Wide	109-015-200
	Medium Male Knurl 1/4" Wide	101-160-968
	Medium Male Knurl 1/8" Wide	109-015-138
	Medium Female Knurl 1/4" Wide	101-160-973
	Medium Female Knurl 1/8" Wide	109-015-139
	Blank 1/8" Wide*	101-160-901
	Blank 1/4" Wide*	101-160-902
	Flat Seam 1/16" Wide	101-160-998

\*Blanks are ready for engraving but not hardened or chrome finished.

Stitching wheels may be combined to produce different patterns.

## FS-90 and FS-180 Cutting Anvils

### Center Cut (2.5" diameter) | Branson EDP No.

<b>0.005" Radius (0.127 mm)</b>	109-015-251
<b>0.015" Radius (0.381 mm)</b>	109-015-252
<b>0.025" Radius (0.635 mm)</b>	109-015-253



### Edge Cut (2.5" diameter) | Branson EDP No.

<b>0.005" Radius (0.127mm)</b>	109-015-248
<b>0.015" Radius (0.381 mm)</b>	109-015-249
<b>0.025" Radius (0.635 mm)</b>	109-015-250



### Edge Cut (2.5" diameter) | Branson EDP No.

<b>0.015" Radius (0.381 mm)</b>	109-015-121
---------------------------------	-------------



### Anvils (1" Diameter) | Branson EDP No.

0.065 Radius	100-187-013
45°/0.010" Radius	109-044-082
90°/0.010" Radius	109-044-083
110°/0.010" Radius	109-044-085
90° Sharp (No Radius)	109-044-349
110° Sharp (No Radius)	109-067-604
120° Sharp (No Radius)	109-067-606
130° Sharp (No Radius)	109-067-607
140° Sharp (No Radius)	109-067-608
150° Sharp (No Radius)	109-067-609
155° Sharp (No Radius)	109-067-610
160° Sharp (No Radius)	109-067-611
165° Sharp (No Radius)	109-067-612
0.094" Full Radius	109-067-613
0.062" Full Radius	109-067-614
0.031" Full Radius	109-067-615
90°/0.020" Radius	109-067-292
30°/0.020" Flat	109-086-571
30°/0.040" Flat	109-086-722

## Global Technologies. Local Solutions.

Branson Ultrasonics, a business of Emerson Industrial Automation, is the world leader in the development and application of ultrasonic plastic welding equipment and processes. Our unmatched global resources ensure optimal solutions for the most challenging applications. With 1600+ employees in over 70 sites worldwide, we can rapidly respond to our customers' needs, wherever they are located. We partner

with companies of every size and scope to help resolve critical issues ranging from market changes, product quality/life cycles and production costs, to employee safety and environmental compliance.

Branson is a leading innovator within the Emerson Industrial Automation, a diversified global manufacturing and technology company. Emerson is a progressive company working to develop products and processes

to resolve global issues, including energy supply and distribution, information and networking, climate and environment, manufacturing efficiency, and product performance. Emerson is dedicated to the pursuit of breakthrough technology developments never before envisioned.

Branson brings exceptional quality, fast delivery and competitive prices. Contact your nearest regional center today.

### Americas

Branson Ultrasonics Corp.  
41 Eagle Road  
Danbury, CT 06813-1961  
T: 203-796-0400  
F: 203-796-0450  
[www.bransonultrasonics.com](http://www.bransonultrasonics.com)

### Europe

Branson Ultraschall  
Niederlassung der Emerson  
Technologies GmbH & Co. OHG  
Waldstrasse 53-55  
63128 Dietzenbach, Germany  
T: +49-6074-497-0  
F: +49-6074-497-199  
[www.branson.eu](http://www.branson.eu)

### Asia

Branson Ultrasonics (Shanghai) Co., Ltd.  
758 Rong Le Dong Road  
Song Jiang, Shanghai, PRC, 201613  
T: 86-21-3781-0588  
F: 86-21-5774-5100  
[www.branson-china.com](http://www.branson-china.com)

Horn Catalog © Branson Ultrasonics Corporation 2014  
The Emerson logo is a trademark and service mark of Emerson Electric Co. Revised and printed in the U.S.A. 7/14  
PJ-DAN-0076-12