

STEAM TURBINES FOR STAG™ COMBINED-CYCLE POWER SYSTEMS

M. Boss
 GE Power Systems
 Schenectady, NY

ABSTRACT

A broad steam turbine product line is available for the wide range of STAG combined cycle systems, depending upon the number of gas turbines employed, gas turbine characteristics, steam cycle/HRSG selection, and site specific space, cooling and operating considerations. The addition of the H technology to the STAG combined cycle systems is described. Thermodynamic design aspects are discussed, and useful screening tables are presented for steam turbine selection. Application considerations of reheat versus nonreheat, multi-shaft versus single shaft and axial exhaust versus down exhaust are reviewed. Unique design features for sliding pressure, boiler following operation are described, as well as GE steam turbine product line design features which enhance installation, maintainability and reliability.

INTRODUCTION

GE has built over 200 steam turbine-generator units totaling more than 15,000 MW of capacity for application in both reheat and nonreheat combined-cycle power plants. Last-stage buckets up to 40 inches/1016 mm at 3600 rpm and 42 inches/1067 mm at 3000 rpm have been applied, allowing for compact High Power Density™ (HPD) arrangements which complement recent increases in GE gas turbine sizes. The use of longer last-stage buckets permits a more cost-effective, compact HPD design with a minimum number of casings, while still providing ample exhaust annulus area for optimal thermal efficiency.

GE offers a complete line of STAG™ (Steam And Gas) combined-cycle steam turbines which are matched to the exhaust energy of one or more GE gas turbines and Heat Recovery Steam Generator(s) (HRSGs). HRSGs are used to convert the gas turbine exhaust into useful steam for the bottoming portion of the combined-cycle. Flexibility is incorporated to allow the steam turbine design to be optimized for site-related parameters such as process extractions

and condenser pressure.

The trend toward higher gas turbine firing and exhaust temperatures has made reheat combined-cycles common. These reheat steam cycles, with advanced gas turbine designs, are termed Advanced Combined-Cycles (ACC). A structured, modular approach to the combined-cycle steam turbine product line allows application of nonreheat steam cycles with advanced gas turbines as well. GE STAG steam turbine designs can accommodate one, two and three pressure steam cycles. The data in this paper is presented based on three pressure nonreheat cycles for gas turbines with approximately 1000 F/538 C or lower exhaust temperature, and three pressure reheat steam cycles for ACCs utilizing the 6FA, 7EC, 7FA, 9EC, and 9FA gas turbines.

The latest addition to the GE STAG product line involves a platform for the 7G, 9G, 7H and 9H STAG systems. These machines are combined-cycle technology that integrate the gas turbine, steam turbine and generator into a seamless system, where each component is optimized for the highest level of performance. The data in this paper describes the advance machine platform based on a three pressure reheat steam cycle. The 7H and 9H STAG advanced machines are additionally integrated with steam cooling in the gas turbine.

STAG combined-cycle systems are designated with a code system to capture key system parameters: the first digit is the number of gas turbines per steam turbine, the second is not significant for heavy-duty gas turbines, and the third, fourth, and fifth places contain the gas turbine frame size and model letter(s). An example is a STAG 207FA, where two model 7FA gas turbines are applied in a "two-on-one" configuration with a single steam turbine. One-on-one configurations are further qualified as being multi-shaft (MS), or single shaft (SS). An example is a STAG 109E MS, indicating that the combined-cycle contains a single frame 9E gas turbine generator and a separate GE steam turbine generator on two different shafts.

Two or more steam turbine choices are available for each STAG system. Units with different

exhaust annulus areas are offered to permit optimization to site-specific cooling conditions and project specific economic evaluation criteria.

GE steam turbines for STAG plants are available for a wide range of applications up to 1800 psig/124 bar and 1050 F/566 C for both reheat and nonreheat cycles. Automatic extraction modules are available for nonreheat units in cogeneration combined-cycles. Each unit is specifically designed for combined-cycle, sliding pressure operation. Numerous features are included for optimum performance and highest reliability with minimum installation, operation and maintenance costs. Recognizing the frequent and rapid starting-and-loading duty required of many combined-cycle units, STAG turbines incorporate design geometries that enhance suitability for high cyclic life without compromise of base load capability. STAG steam turbines benefit from GE's large operating fleet experience. Design tools and features developed for fossil, nuclear and industrial applications all contribute in unique ways to the STAG steam turbine product line. The result is GE's leadership in sustained efficiency, reliability, maintainability and extended life for combined-cycle steam turbines.

STEAM TURBINE APPLICATION TO STAG PLANTS

STAG Structure

GE has established a structured line of steam

turbines to meet the requirements of the combined-cycle market. Principally focused on current GE gas turbine models, an array of steam turbine components have been developed to form a comprehensive product line. Sufficient flexibility has been retained to allow variations in product offerings to accommodate cogeneration applications, STAG "add-ons" (conversions of simple cycle plants to combined-cycle), or match the equipment of other gas turbine suppliers.

Table 1 lists the GE gas turbines commonly applied in combined-cycle applications. Models 6B and 6FA utilize gear-driven generators and are applied at both 50 and 60 Hz. LM6000 designates an aircraft derivative gas turbine which is also applied at both 50 and 60 Hz. The exhaust characteristics and approximate output are listed for ISO standard conditions, with an indication of the steam cycles available. Gas turbines with exhaust temperatures of approximately 1000 F/538 C or lower are applied in nonreheat cycles. Gas turbines with exhaust temperatures above 1000 F/538 C are routinely applied in reheat cycles; however, steam turbines for nonreheat cycles are also available for these applications.

Table 2 presents approximate gross power available from combined-cycles based on the gas turbines listed in Table 1. Gas turbine output differs from the power listed in Table 1, due to the effect of increased exhaust pressure drop associated with the HRSG. A three-pressure HRSG is used for both reheat and nonreheat steam cycles. The steam turbine output varies considerably depending upon the exhaust pres-

Table 1
GE GAS TURBINE EXHAUST CHARACTERISTICS

Hz	GT MODEL	EXH TEMP	EXH TEMP DEG F	FLOW DEG C	FLOW K LB/HR	GTTG KG/HR	STAG CYCLE
60	LM6000	866	463	989.6	44880	40	NRH
60	6B	1002	539	1104.4	500760	39	NRH
60	6FA	1107	597	1591.0	721660	70	RH OR NRH
60	7EA	1002	539	2365	1072847	85	NRH
60	7EC	1031	555	2822.0	128006-	116	RH OR NRH
60	7FA	1104	596	3509.0	1591680	169	RH OR NRH
50	LM6000	866	463	989.6	44880	40	HRH
50	6B	1002	539	1104.0	500760	39	NRH
50	6FA	1108	598	1587.0	719860	70	RH OR NRH
50	9E	1003	539	3254.0	1476010	123	RH OR NRH
50	9EC	1036	558	4032.0	1828910	169	RH OR NRH
50	9FA	1110	599	5119	2322054	240	RH OR NRH

Table 2
STAG POWER PLANTS - APPROXIMATE OUTPUT

Frequency (Hz)	GT Model	STAG Model	Steam Cycle	GTG (MW)	STG (MW)	Total (MW)
60	LM6000	260	NRH	75	31	106
60	6B	106B	NRH	38	22	60
60	6B	206B	NRH	76	45	121
60	6B	406B	NRH	152	91	124
60	6FA	106FA	RH	67	40	107
60	6FA	206FA	RH	134	83	217
60	7EA	107EA	NRH	84	46	130
60	7EA	207EA	NRH	166	98	264
60	7EC	107EC	RH	114	66	180
60	7EC	207EC	RH	228	135	363
60	7FA	107FA	RH	166	93	259
60	7FA	207FA	RH	332	190	522
50	LM6000	260	NRH	74	30	104
50	6B	106B	NRH	38	22	60
50	6B	206B	NRH	76	45	121
50	6B	406B	NRH	152	90	243
50	6FA	106FA	RH	67	40	107
50	6FA	206FA	RH	134	85	219
50	9E	109E	NRH	123	67	190
50	9E	209E	NRH	245	138	384
50	9EC	109EC	RH	163	96	259
50	9EC	209EC	RH	326	197	523
50	9FA	109FA	RH	240	133	376
50	9FA	209FA	RH	478	280	758

sure and the selected steam turbine configuration. More detailed information is provided in Tables 4 through 8.

Steam Turbine Exhaust Size Selection

The steam leaving the last stage of a condensing steam turbine can carry considerably useful power to the condenser as kinetic energy. The turbine designer needs to select an exhaust area for a particular application that provides a balance between exhaust loss and capital investment in turbine equipment. For an optimum selection to be made, the turbine designer needs to understand the present worth value of output and efficiency. Efficiency may be expressed in terms of fuel cost, steam turbine heat rate, or combined-cycle heat rate. Any other relevant data, such as anticipated capacity factor, or a weighting of various anticipated load

points, should be specified to the turbine designer in requests for quotations.

Figure 1 is an illustrative exhaust loss curve for a condensing steam turbine. Exhaust loss, expressed in specific energy terms, is plotted versus the velocity of the steam passing through the exhaust annulus (V_{AN}). The dashed curve is leaving loss, the kinetic energy carried by the exhaust flow assuming uniform axial flow through the annulus. At low velocities, the total exhaust loss is much greater than the axial leaving loss component, due to internal off-design inefficiency and off-angle effects. Most applications are selected to operate at intermediate annulus velocities, about 500 to 1000 ft/s (150 to 300 m/s). Other losses come into play at high velocities - above 1000 ft/s (300 m/s).

Annulus velocity is approximated by the continuity equation, $V_{AN}=Q/A$; where Q is the volume flow and A is the exhaust annulus area.

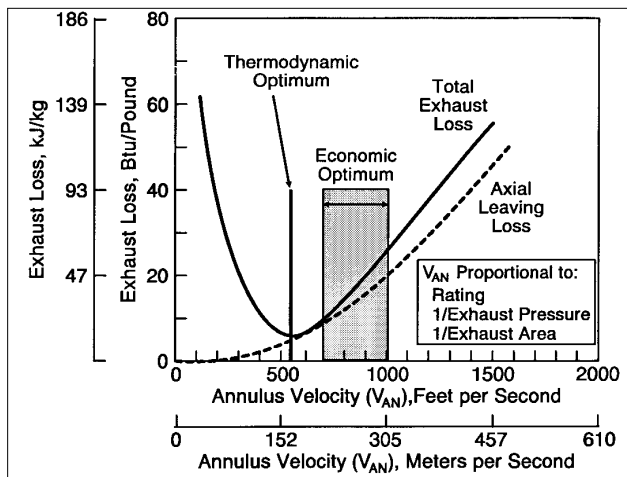

Figure 1. Illustrative exhaust loss curve

Volume flow, Q , is also the product of mass flow and the specific volume. Velocity is then directly proportional to the specific volume for a constant mass flow. For convenience, specific volume can be approximated as the reciprocal of exhaust pressure. Annulus velocity is then inversely proportional to both exhaust pressure and exhaust annulus area, as indicated in Figure 1.

The thermodynamic optimum value of annulus velocity, V_{AN} , is the lowest point on the exhaust loss curve. The band labeled “economic optimum” reflects that, historically, it has not been economically justifiable to invest in sufficient exhaust area to operate at full load at the bottom of the curve. Sizing the turbine in this way also may cause excessively low V_{AN} , and consequently high exhaust loss, at part load. As thermal efficiencies have been continuously driven upward by economic and environmental considerations, this “economic band” has in fact shifted closer toward the thermodynamic optimum.

Exhaust sizing considerations are critical for any condensing steam turbine, but particularly so for combined-cycle applications. There are usually no extractions from the steam turbine, since feedwater heating is generally accomplished within the HRSG. Generation of steam at multiple pressure levels (intermediate pressure and/or low pressure admissions to the turbine downstream of the throttle) increases the mass flow as the steam expands through the turbine. Mass flow at the exhaust of a combined-cycle unit in a three-pressure system can be as much as 30% greater than the throttle flow. This is in direct contrast to most units with fired boilers, where exhaust flow is about 25% to 30% less than the throttle mass flow, because of extractions from the turbine for multiple stages of

feedwater heating. The last turbine stage of a combined-cycle unit can generate up to 15% of the unit’s power, compared to 10% or less for the last stage of a typical unit with feedwater heating extractions.

Combined-cycles are influenced by ambient conditions. Steam turbine exhaust volume flow and annulus velocity are affected in two ways: both directly in mass flow to the condenser (GT/HRSG steam production) and volume flow as influenced by exhaust pressure. For example, at low ambient temperatures, gas turbine output and HRSG steam production can be considerably increased above plant rating point. Condenser (exhaust) pressure, is directly related to ambient air or cooling water temperature. Condenser pressure is expected to be lowest at low ambient air/cooling water temperature, and exhaust annulus velocity will be the highest.

Provisions need to be considered in design of the plant’s control philosophy to maintain an exhaust pressure/exhaust velocity within reasonable limits.

At high ambients, gas turbine airflow and HRSG steam production may be reduced, thereby lowering mass flow to the steam turbine, and decreasing V_{AN} . At the same time, high ambient air temperature and/or high circulating water temperature increases exhaust pressure, which further reduces V_{AN} because of decreased specific volume. This may be somewhat offset by a lower exhaust pressure, resulting from the reduced condenser duty, associated with lower steam flow to the condenser. These aspects should underscore the importance for the turbine designer to have an understanding of the combined-cycle operation envelope, such that the steam turbine is designed for satisfactory operation throughout the required range. Other variables such as supplementary exhaust firing in the HRSG, and variations in process steam flow for cogeneration applications must also be considered in exhaust sizing.

Table 3 lists the current family of GE last-stage buckets (LSB) for use in 50 and 60 Hz combined-cycle steam turbines. Of note are several buckets suitable for high back pressure operation. Capability for full load operation at 15 inches HgA/381 mm HgA is achieved with the 20H and 22H buckets, and up to 20 inches HgA/508 mm HgA with the 13H LSB. The availability of these designs provides flexibility in station siting. Plants using air-cooled condensers may require the additional operational flexibility afforded by these rugged high back pressure designs.

Table 3
LAST STAGES AVAILABLE FOR COMBINED-CYCLE STEAM TURBINES

Frequency	Length		Pitch Diameter		Exhaust Annulus Area For Number of Parallel Flows			
	Hertz/Rpm	(Inches)	(mm)	(Inches)	(mm)	1 (SQ FT)	1 (SQ M)	2 (SQ FT)
60/3600	12.3*	312	52.8	1342	14.2	1.32	-	-
60/3600	14.9	378	58.5	1487	19.0	1.76	-	-
60/3600	17.5	445	54.4	1382	20.8	1.93	-	-
60/3600	13H*	330	68.0	1727	19.3	1.79	-	-
60/3600	20	508	60.0	1524	26.2	2.43	-	-
60/3600	20H*	508	75.0	1905	32.7	3.04	65.4	6.08
60/3600	23	584	65.5	1664	32.9	3.06	65.8	6.11
60/3600	26	660	72.0	1830	41.1	3.82	82.2	7.64
60/3600	30	762	85.0	2160	55.6	5.16	111.2	10.33
60/3600	33.5	851	90.5	2300	66.1	6.14	132.2	12.28
60/3600	40**	1016	100.0	2540	87.3	8.11	174.6	16.22
50/3000	15*	381	64.2	1631	21.0	1.95	-	-
50/3000	17.5	445	70.0	1778	26.9	2.50	-	-
50/3000	22H*	559	88.0	2235	42.2	3.92	84.4	7.84
50/3000	26	660	91.0	2310	51.6	4.79	103.2	9.59
50/3000	33.5	851	99.5	2530	72.7	6.75	145.4	13.51
50/3000	42	1067	110.4	2804	101.2	9.40	202.4	18.80
50/3000	48**	1219	120.0	3048	125.7	11.68	251.4	23.36

* Suitable for extended ranges of exhaust pressure

** Application limited to reheat cycles

Figure 2 illustrates six representative configurations and the effect of exhaust end selection on steam turbine output for a range of exhaust pressures. It is clear from these curves that the units with largest annulus area have the best performance at low back pressures. The curves cross over around 2 inches HgA/51 mm HgA. The units with smaller exhaust ends have better performance at high back pressure. Steam turbine selection must balance output across the expected operating range against the equipment investment.

It should be apparent that the best steam turbine choice for any combined-cycle is strongly influenced by the site exhaust pressure, which, in turn, is largely determined by the temperature of the cooling media.

Nonreheat Cycle Steam Conditions

The exhaust temperature of the 6B, 7EA and 9E gas turbines listed in Table 2 is approximate-

ly 1000 F/538 C and supports a main steam throttle temperature of about 950 F/510 C. The lower exhaust temperature of the aero-derivative LM6000 supports a main steam throttle temperature of about 850 F/454 C.

Throttle pressure is selected based upon the size of the steam turbine, in conjunction with economic considerations. Higher throttle pressures provide superior thermodynamic performance for multiple pressure HRSGs. However, higher pressure reduces steam turbine inlet volume flow, which makes the nozzles and buckets shorter, and increases stage leakage losses as a fraction of total flow. The result is that practical benefits of increased throttle pressure are greater for larger units than smaller STAG plants with multi pressure steam cycles. Detailed studies of pressure optimization have resulted in selection of 850 psig/59 bar for smaller STAG plants with multiple pressure steam cycles. Units in the intermediate range from 40 MW to 60 MW utilize a throttle pressure

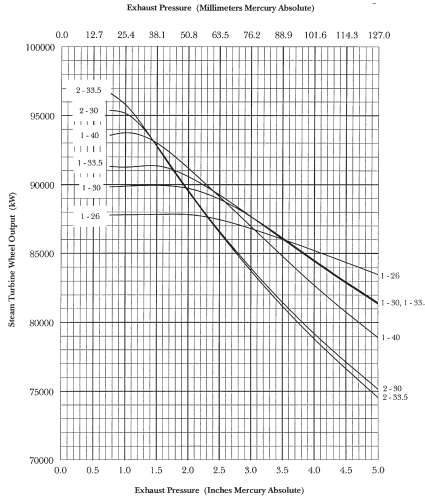

Figure 2a 107FA 60 Hz Steam Turbine

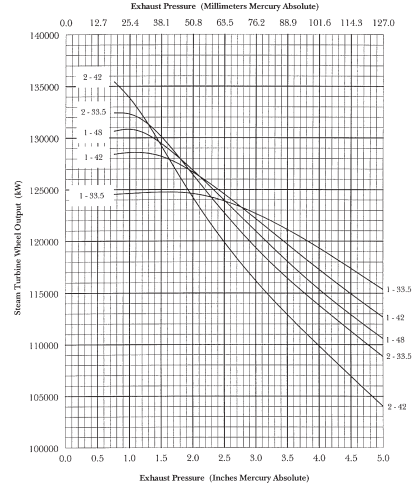

Figure 2b 109FA 50 Hz Steam Turbine

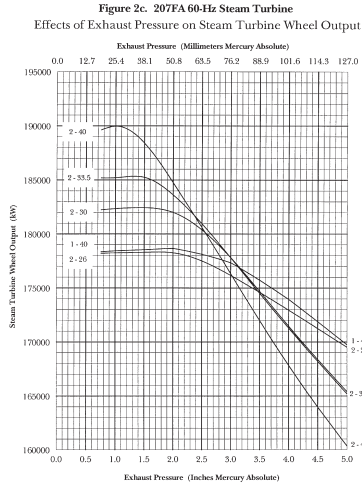

Figure 2c 207FA 60 Hz Steam Turbine

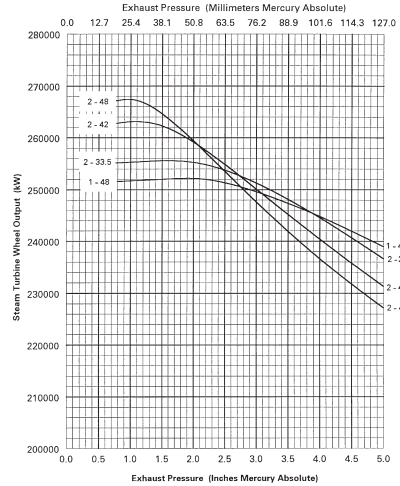

Figure 2d 207FA 50 Hz Steam Turbine

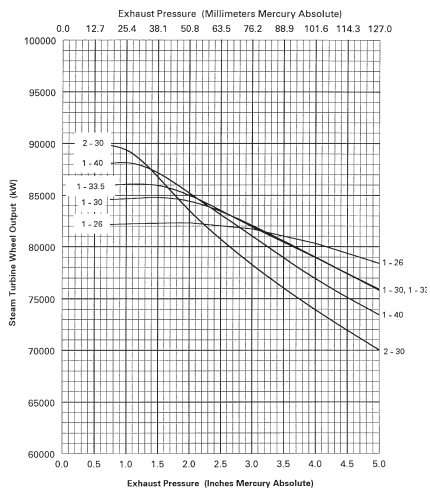

Figure 2e 206FA 60 Hz Steam Turbine

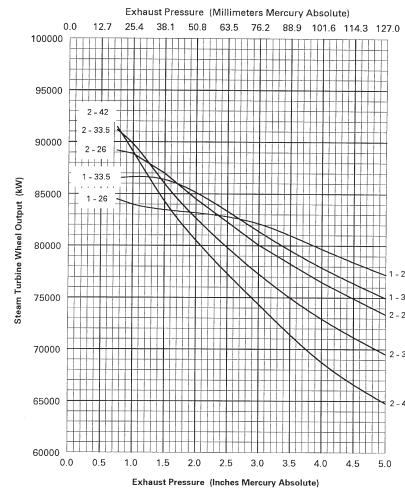

Figure 2f 206FA 50 Hz Steam Turbine

Figure 2. Steam turbine wheel output as a function of exhaust pressure and exhaust size, reheat STAG1400 psig 1000F/1000F (96 BAR 538C/538C) steam conditions

of approximately 1000 psig/69 bar. 1250 psig/86 bar is typical for steam turbine ratings greater than 60 MW.

Since sliding pressure operation with full arc admission is employed, the design point throttle flow and pressure must be set with consideration of the maximum throttle flow to be seen by the steam turbine. This ensures that the casing inlet is not subjected to pressure greater than the maximum allowable. For example, the design throttle pressure may be set to 1200 psig/83 bar for a 120 MW unit, so that the throttle pressure for flows greater than design flow falls within the 1250 psig/86 bar nominal limit for the casing inlet.

The nonreheat cycles employ Intermediate Pressure (IP) and Low Pressure (LP) admissions to the steam turbine, downstream of the throttle. Typically, no extractions are taken for feedwater heating. If site conditions require a steam turbine extraction due to HRSG/stack minimum temperature requirements, provisions are made within the low pressure turbine design to accommodate feedwater heating extraction(s). In general, the design approach for combined-cycles is to achieve an HRSG stack temperature which is as low as possible, extracting as much gas turbine exhaust energy as possible to maximize cycle efficiency. Occasionally, a concern with high sulfur gas turbine fuels is acid condensation on low temperature heat transfer surfaces. In these cases, an LP turbine extraction may be used to heat feedwater above the acid dew point prior to feedwater supply to the HRSG economizer.

Reheat Cycle Steam Conditions

The exhaust temperatures of the 6FA, 7EC, 7FA, 9EC, 9FA 7G, 7H, 9G and 9H gas turbines are sufficiently high to justify the use of a reheat cycle. Figure 3 compares reheat and nonreheat expansions for initial conditions of 1450 psig and 1000F (100 bar and 538C). The first portion of both expansions, A-B, is the same. In the nonreheat case, the expansion continues unbroken to the condenser, B-C, with a relatively high moisture content in the low pressure turbine section. In the reheat case, the steam exhaust from the high pressure turbine, B, is returned to the HRSG, where it is reheated back to the initial temperature, D. The remaining expansion, D-E, is therefore hotter and drier than the nonreheat case.

The reheat cycle benefits thermodynamic performance by adding heat to the steam cycle at a higher average temperature than the nonreheat

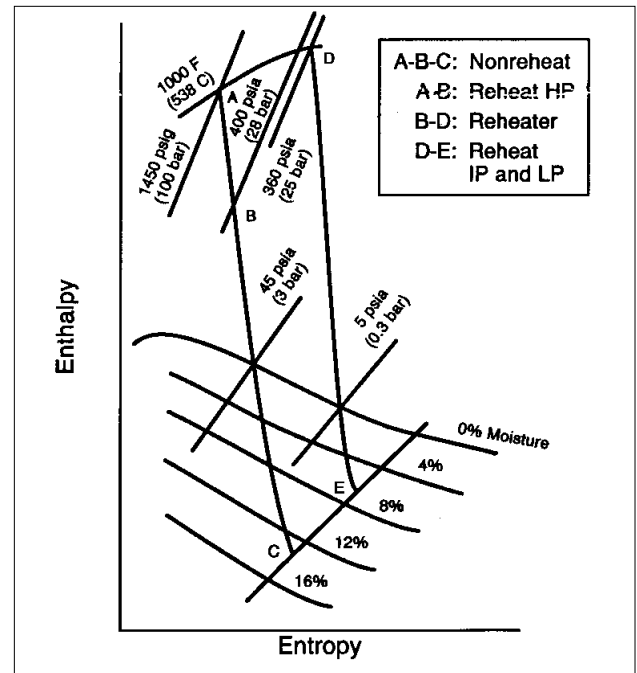

GT24380

Figure 3. Comparison of nonreheat and reheat expansions

cycle, and by reducing moisture loss in the low pressure section. The drier low pressure section expansion reduces the potential for last-stage moisture erosion. The gain from the reheat cycle is seen as greater steam turbine output for the same heat to the HRSG. Reduced heat rejected to the condenser reduces the size of the cooling system and the amount of cooling flow required.

Analysis has shown that initial steam conditions of 1450 psig, 1000F with reheat to 1000F (100 bar, 538C with reheat to 538C) are an economical design, based on moderate economic evaluation parameters. 1800 psig, 1000F, with reheat to 1000F (124 bar, 538C with reheat to 538C) is attractive for some of the larger STAG cycles, when the steam turbine rating is 125 MW or greater. Like nonreheat cycles, the actual design point pressure should be set with consideration of the maximum throttle flow/throttle pressure for the steam turbine across the operating range.

A three-pressure HRSG permits selection of a reheat pressure that optimizes heat addition to the steam cycle, while also achieving maximum heat recovery within the HRSG. The three-pressure reheat combined-cycle is shown schematically in Figure 4. Two secondary admissions (IP and LP) of steam from the HRSG at 350 psig/24 bar and 40 psig/3 bar are employed. The IP admission is usually piped to the cold reheat line, downstream of the high pressure turbine

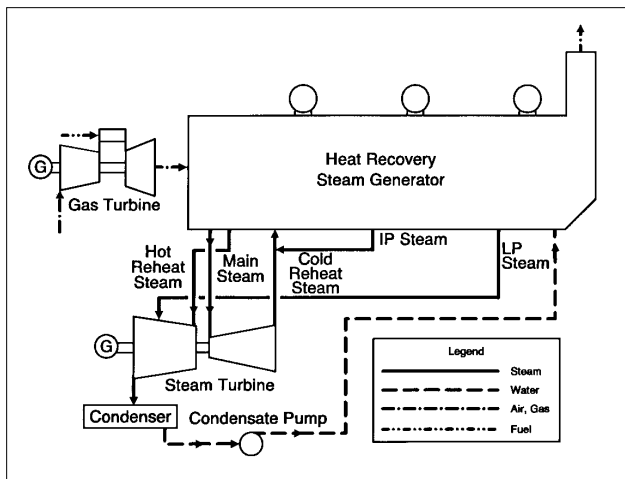

Figure 4. Three pressure reheat cycle diagram

section. This IP admission steam then flows through the reheater and is seen by the steam turbine as an increased mass flow, compared to the high pressure turbine section flow. Since the IP steam cannot reach the condenser without passing through the combined reheat valves, no additional protective valving is required for the steam turbine. The LP admission is piped into the steam turbine casing at an appropriate stage location in the steam path, which sets the LP drum pressure in the HRSG. Two separate hydraulically-operated butterfly valves are installed in the LP admission steam line near the turbine to provide redundant lines of defense against overspeed. A similar approach is used for IP admissions on nonreheat units with three pressure steam cycles.

The H technology use a three pressure reheat steam cycle with initial steam conditions of either 2400 psig/1050F/1050F (583 C/583 C) or 1800 psig/124 bar 1050F/1050F (583 C/583 C). The higher initial pressure steam system gives the higher performance and results in a multi-casing design with a short inner shell over the first few HP stages. The 1800 psig/124 bar initial pressure allows for an optimized system with lower fuel cost or a mid-range peaking duty cycle.

The 7H and 9H gas turbines utilize the advanced technology, closed-circuit steam-cooling systems. The gas turbine cooling system is integrated in two key areas as follows:

- Steam is supplied from the high pressure (HP) steam turbine exhaust and the HRSG intermediate pressure (IP) evaporator to the closed circuit system that cools the gas turbine stage 1 and 2 nozzles and buckets.

The cooling steam is returned to the steam cycle in the hot reheat line. Thus, the cooling system operates in parallel with the reheater.

- Air extracted from the gas turbine compressor discharge is cooled externally prior to readmission to cool the wheels in the high-pressure stages of the compressor. Water from the discharge of the IP economizer in the HRSG cools the cooling air and subsequently heats the natural gas fuel.

STAG STEAM TURBINE PRODUCT STRUCTURE

Performance

Tables 4 through 9 present the performance of the structured product line of steam turbines for use in the STAG systems listed in Table 2. Approximate steam turbine output is listed for various combinations of steam turbine configurations and exhaust pressures. Table 4 lists STAG plants with steam turbines less than 60 MW, with relatively low steam conditions, for both 50 and 60 Hz units.

Table 5 covers the STAG plants whose steam turbines have ratings between 40 MW and 60 MW, while Table 6 considers the larger nonreheat units greater than 60 MW.

Tables 7 and 8 provide data for advanced combined-cycles. 50 Hz reheat steam turbines with the advanced 6FA, 9EC and 9FA gas turbines are listed in Table 7. Table 8 lists 60 Hz reheat steam turbines with the advanced 6FA, 7EC and 7FA.

Tables 4 through 8 give a suggested turbine type in terms of last-stage bucket size and number of low pressure turbine flows for different condenser (exhaust) pressures. The relation between exhaust annulus area and exhaust pressure can be clearly seen by following across a row for a particular STAG model. In most cases, more than one steam turbine design is suggested for a combination of STAG model and exhaust pressure. The units with larger annulus areas yield additional output. In these cases, the choice requires consideration of the annual variation in exhaust pressure level, the anticipated capacity factor of the plant and the difference in the capital cost of the units.

The H combined cycle power generation systems are designed to achieve 60% net plant efficiency. The operational and performance char-

Table 4
STAG STEAM TURBINE SELECTION CHART NONREHEAT
STEAM TURBINES LESS THAN 40 MW
850 PSIG (58.5 BAR) 950F (510C)

EXHAUST PRESSURE, INCHES (MM) MERCURY ABSOLUTE									
0.75 (19) 1.5 (38) 2.5 (64) 3.5 (89)									
HERTZ	STAG	STEAM TURBINE	WHEEL OUTPUT	STEAM TURBINE	WHEEL OUTPUT	STEAM TURBINE	WHEEL OUTPUT	STEAM TURBINE	WHEEL OUTPUT
60	106B	1 x 26	24.0						
		1 x 23	23.6	1 x 23	22.9				
						1 x 17.5	21.7	1 x 17.5	21.0
60	260	1 x 33.5	33.5						
		1 x 30	33.1						
				1 x 26	31.6				
				1 x 23	31.3	1 x 23	30.1		
						1 x 20	29.9		
						1 x 17.5	29.4	1 x 17.5	28.8
50	106B	1 x 26/91	24.2						
				1 x 17.5	23.1	1 x 17.5	22.1		
				1 x 15	21.9	1 x 15	21.5	1 x 15	21.0
50	260	1 x 33.5	35.0						
		1 x 26/91	34.0	1 x 26/91	32.9				
				1 x 17.5	30.9	1 x 17.5	30.3		
						1 x 15	28.0	1 x 15	27.7

Note: Throttle steam temperature for STAG 260 plants is 835F (446C).

Table 5
STAG STEAM TURBINE SELECTION CHART
NONREHEAT 40-60 MW STEAM TURBINES
1000 PSIG (69 BAR) 950F (510C)

EXHAUST PRESSURE, INCHES (MM) MERCURY ABSOLUTE									
0.75 (19) 1.5 (38) 2.5 (64) 3.5 (89)									
HERTZ	STAG	STEAM TURBINE	WHEEL OUTPUT	STEAM TURBINE	WHEEL OUTPUT	STEAM TURBINE	WHEEL OUTPUT	STEAM TURBINE	WHEEL OUTPUT
60	206B	2 x 30	49.9						
		2 x 26	49.3						
		1 x 33.5	48.5						
				1 x 30	47.0				
				1 x 26	46.3	1 x 26	44.9		
						1 x 23	44.7		
						1 x 20	43.7	1 x 20	43.1
								1 x 17.5	42.4
60	107EA	2 x 30	51.0						
		2 x 26	50.3						
		1 x 33.5	49.4	1 x 30	48.0				
				1 x 26	47.1	1 x 26	45.7		
						1 x 23	45.4	1 x 23	44.2
						1 x 20	44.3	1 x 20	43.7
50	206B	1 x 42	49.8						
		1 x 33.5	48.8	1 x 33.5	47.1				
				1 x 26/91	46.9	1 x 26/91	44.7		
						1 x 17.5	44.2	1 x 17.5	43.4

Table 6
STAG STEAM TURBINE SELECTION CHART NONREHEAT STEAM TURBINES
GREATER THAN 60 MW 1250 PSIG (86 BAR) 950F (510C)

EXHAUST PRESSURE, INCHES (MM) MERCURY ABSOLUTE

HERTZ	STAG	0.75 (19)		1.5 (38)		2.5 (64)		3.5 (89)	
		STEAM TURBINE	WHEEL OUTPUT	STEAM TURBINE	WHEEL OUTPUT	STEAM TURBINE	WHEEL OUTPUT	STEAM TURBINE	WHEEL OUTPUT
60	406B	2 x 33.5	97.3						
		2 x 30	95.7	2 x 30	94.4				
				2 x 26	93.0	2 x 26	90.0		
						1 x 33.5	89.9		
60	207EA					1 x 30	89.0	1 x 30	87.0
		2 x 33.5	100.3						
		2 x 30	98.5	2 x 30	97.5				
				2 x 26	95.9	2 x 26	92.9		
60						1 x 33.5	92.6		
						1 x 30	91.6	1 x 30	89.8
		50	406B	2 x 42	94.8				
						2 x 33.5	94.6		
50				2 x 26/91	94.2				
				1 x 42	94.1	1 x 42	89.9		
						1 x 33.5	90.3		
								1 x 26/91	87.0
50	109E	1 x 42	72.7	1 x 33.5	70.0				
				1 x 26/91	68.2	1 x 26/91	67.0	1 x 26/91	64.7
50	209E	2 x 42	146.2						
				2 x 33.5	141.0				
				2 x 26/91	137.4	2 x 26/91	134.9		
						1 x 42	134.7	1 x 42	130.3
								1 x 33.5	130.5

Table 7
STAG STEAM TURBINE SELECTION CHART 50 HERTZ ADVANCED COMBINED-CYCLES
1400 PSIG (96 BAR) 1000F/1000F (538C/538C)

EXHAUST PRESSURE, INCHES (MM) MERCURY ABSOLUTE

HERTZ	STAG	0.75 (19)		1.5 (38)		2.5 (64)		3.5 (89)	
		STEAM TURBINE	WHEEL OUTPUT	STEAM TURBINE	WHEEL OUTPUT	STEAM TURBINE	WHEEL OUTPUT	STEAM TURBINE	WHEEL OUTPUT
50	106FA	1 x 42	44.7						
		1 x 33.5	44.5						
		1 x 26/91	43.5	1 x 26/91	42.5				
50	206FA					1 x 17.5	41.5	1 x 17.5	40.4
		2 x 42	91.2						
		2 x 33.5	90.9						
				1 x 33.5	86.1	1 x 33.5	83.1		
50	109EC					1 x 26/91	82.9	1 x 26/91	80.7
		2 x 42	102.3						
		2 x 33.5	101.3						
				1 x 33.5	95.6	1 x 33.5	93.3		
50	209EC					1 x 26/91	92.2	1 x 26/91	90.3
		2 x 48	203.7	2 x 48	197.8				
				2 x 42	197.3				
				2 x 33.5	194.4				
50	109FA					1 x 48	189.6	1 x 48	183.8
						1 x 42	187.4	1 x 42	183.9
		2 x 42	135.5						
		2 x 33.5	132.5	2 x 33.5	130.2				
50	209FA			1 x 48	129.8				
				1 x 42	124.5	1 x 42	124.5		
						1 x 33.5	124.0	1 x 33.5	121.1
		2 x 48	267.4	2 x 48	264.3				
50				2 x 42	262.3				
						2 x 33.5	253.9	2 x 33.5	248.1
						1 x 48	251.8	1 x 48	248.0

Table 8
STAG STEAM TURBINE SELECTION CHART 60 HERTZ ADVANCED COMBINED-CYCLES
1400 PSIG (96 BAR) 1000F/1000F (538C/538C)

EXHAUST PRESSURE, INCHES (MM) MERCURY ABSOLUTE										
0.75 (19) 1.5 (38) 2.5 (64) 3.5 (89)										
HERTZ	STAG	STEAM TURBINE	WHEEL OUTPUT	STEAM TURBINE	WHEEL OUTPUT	STEAM TURBINE	WHEEL OUTPUT	STEAM TURBINE	WHEEL OUTPUT	
60	106FA	1 x 33.5	44.5							
		1 x 30	44.0							
				1 x 26	42.5					
				1 x 23	42.0	1 x 23	40.9			
						1 x 20	40.4			
						1 x 17.5	39.8	1 x 17.5	39.3	
60	206FA	2 x 33.5	90.8							
		2 x 30	89.8							
		1 x 40	88.1							
				1 x 33.5	86.0					
				1 x 30	84.8	1 x 30	83.4			
						1 x 26	82.3	1 x 26	80.8	
60	107EC	2 x 33.5	70.1							
		2 x 30	69.7							
		1 x 40	68.7	1 x 40	66.7					
				1 x 33.5	66.4					
				1 x 30	65.9					
						1 x 26	63.4			
						1 x 23	62.8	1 x 23	61.6	
60	207EC	2 x 40	139.7	2 x 40	135.6					
				2 x 33.5	135.0					
				2 x 30	134.0					
				1 x 40	131.7	1 x 40	129.8			
						1 x 33.5	127.8			
						1 x 30	125.9	1 x 30	125.0	
60	107FA	2 x 33.5	96.7							
		2 x 30	95.4							
				1 x 40	93.0					
				1 x 33.5	91.4	1 x 33.5	89.3			
						1 x 30	88.9			
								1 x 26	86.0	
60	207FA	2 x 40	189.6	2 x 40	188.4					
				2 x 33.5	185.2					
				2 x 30	182.4	2 x 30	180.3			
						1 x 40	178.1	1 x 40	175.7	

acteristics for the H technology gas turbine/combined cycle products are summarized in Table 9. The significant efficiency increases over the F technology product line are achieved by advancing the operational conditions — pressure ratio and firing temperature. These advantages are achieved with the STAG 109H and STAG 107H systems, while maintain-

ing single-digit NO_x and CO capability.

Casing Arrangements

Schematics of available STAG steam turbine casing arrangements are shown in Figures 5 through 7.

Table 9
G & H VS. FA CHARACTERISTICS
AND PERFORMANCE

Characteristics	7FA	7G	7H	9FA	9G	9H
Firing Temperature Class, F(C)	2350(1300)	2600/1430	2600/1430	235(1300)	2600(1430)	2600(1430)
Air Flow, Lb/Sec (kg/sec)	974(442)	1230/558	1230/558	1327(602)	1327(602)	1327(602)
Pressure Ratio	15	23	23	15	15	23
Preformance						
Simple Cycle Ouput, MW	168	-	-	240	-	-
Simple Cycle Efficiency, %	36	-	-	36	-	-
Combined Cycle Net Output, MW	259	350	400	376	420	480
Combined Cycle Net Efficiency, %	55	58	60	55	58	60

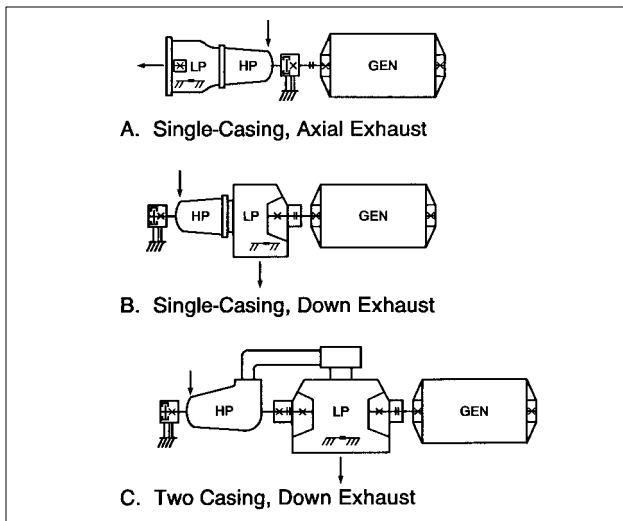

GT24381

Figure 5. Nonreheat steam turbine arrangements for multi-shaft STAG
A. Single-casing, axial exhaust
B. Single-casing, down exhaust
C. Two-casing, down exhaust

Nonreheat Multi-shaft

Figure 5 shows nonreheat configurations for multi-shaft STAG applications. The steam turbine generator is completely independent of the gas turbine generator(s). Axial flow exhausts are available for single flow applications. Shown in Figure 5A, the axial arrangement permits locating the condenser near the same level as

the turbine, reducing foundation height and permitting slab type construction of the foundation. With the condenser at the turbine exhaust, the generator is driven from the high pressure end of the turbine. A flexible expansion joint between the turbine exhaust and the condenser can accept the axial thermal growth, permitting flexible support of the turbine exhaust. The high pressure end of the turbine is fixed to the foundation. The thrust bearing is located within the turbine front standard (high pressure end support), which allows for maintenance of close axial clearances in the high pressure stages. Figure 6 illustrates a cross section of a single casing unit with an axial exhaust.

Large axial exhaust units utilizing last-stage buckets (LSB) greater than 30 inches (762 mm) are fixed to the foundation at the exhaust end. The turbine front standard accommodates axial expansion of the stationary parts with either a flexible support arrangement or a sliding base plate support. With single casing axial exhaust units, the thrust bearing is located in the front standard, close to the high pressure stages.

Figures 5B and 5C illustrate single flow and double flow down exhaust arrangements. In these cases, the exhaust must be keyed to the foundation to minimize the shear which would otherwise occur in the condenser expansion joint. The generator is driven in the traditional arrangement from the low pressure end of the

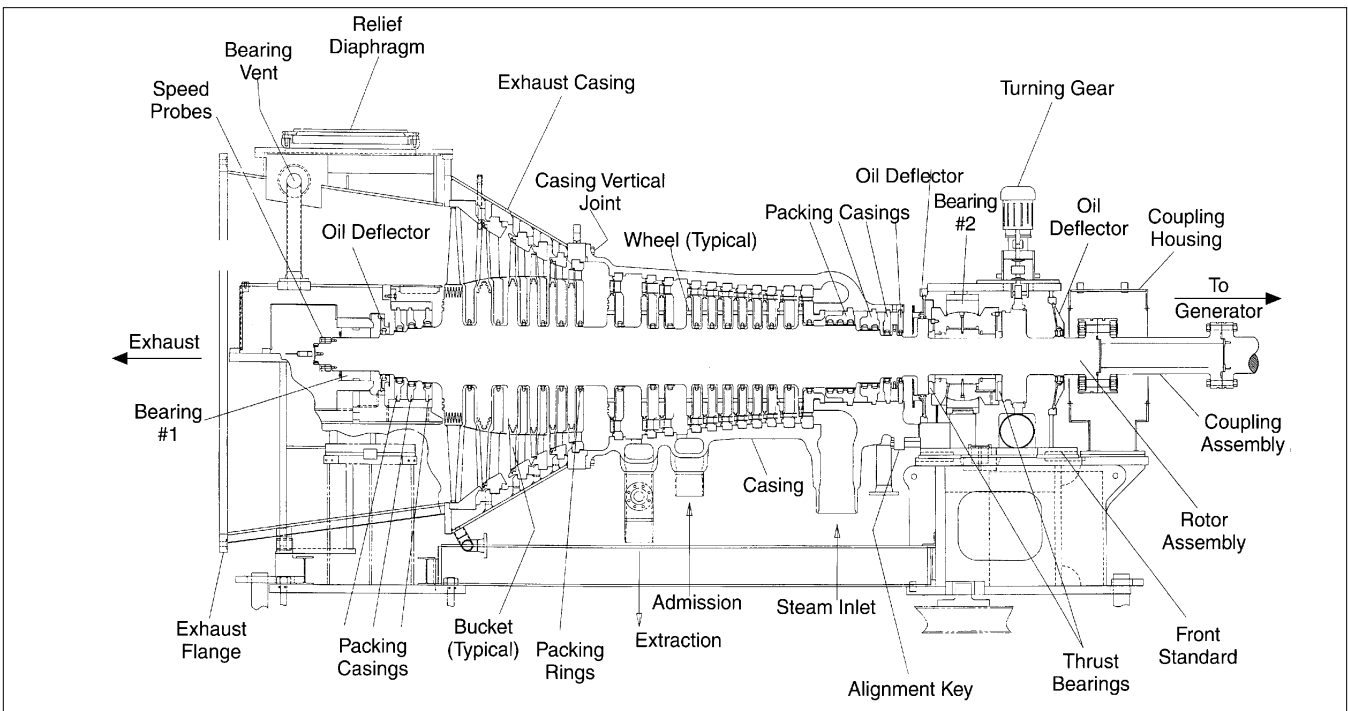

GT24388

Figure 6. Nonreheat, single-casing, axial exhaust steam turbine

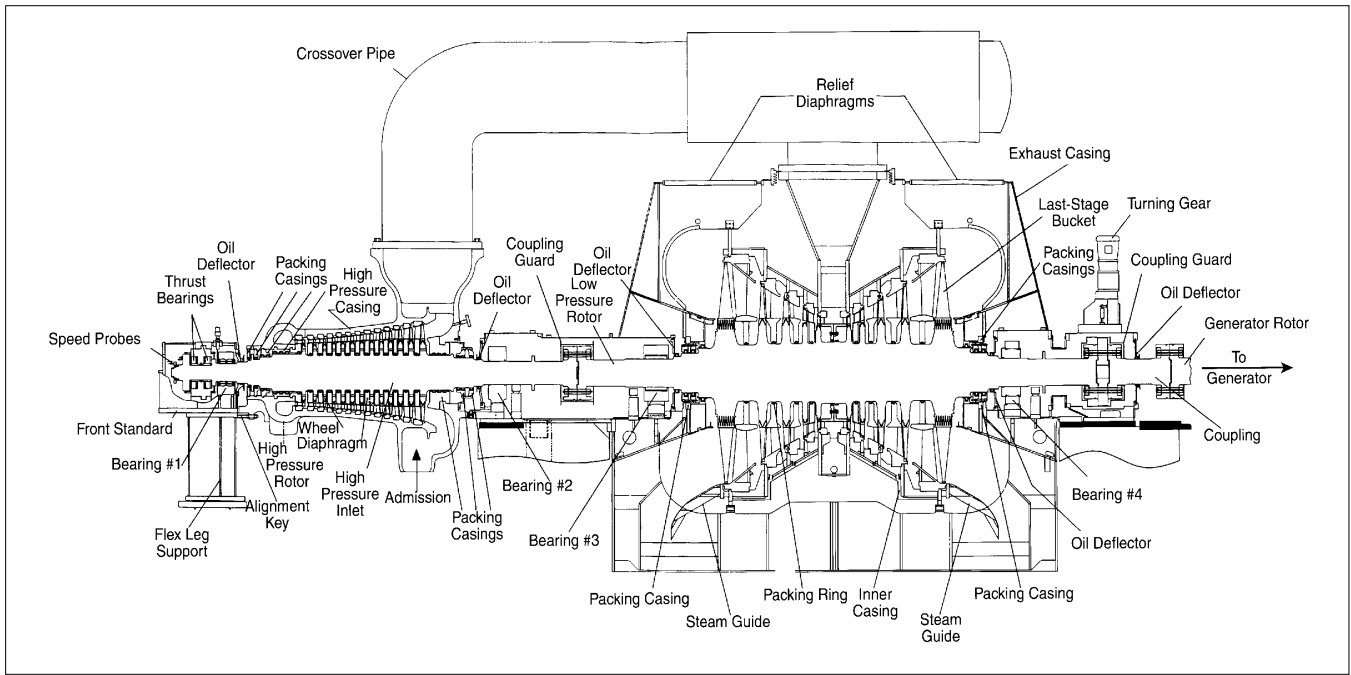

GT24389

Figure 7. Nonreheat, double flow down exhaust unit

turbine. The condenser is directly below the turbine exhaust. The turbine front standard is supported with either a flex leg support or a sliding support arrangement. The thrust bearing is located in the turbine front standard. The double flow configuration is illustrated in cross section in Figure 7.

Nonreheat Single Shaft

In single shaft STAG configurations, one steam turbine and one gas turbine drive a common generator. Nonreheat single shaft arrangements are shown in Figure 8. The gas turbine is coupled to the main generator coupling, while the steam turbine drives the generator from the opposite (collector) end. Each turbine has its own thrust bearing and overspeed protection. A flexible coupling, which accepts limited axial motion, is located between the generator and the steam turbine. Keying and expansion arrangements differ in some cases, from multi-shaft arrangements, due to limitations in the amount of axial expansion which can be accommodated by the flexible coupling.

Nonreheat single shaft STAG steam turbines are designed for removal when the generator rotor is pulled from the stator for inspection or maintenance. Piping connections are flanged, rather than welded, to facilitate removal.

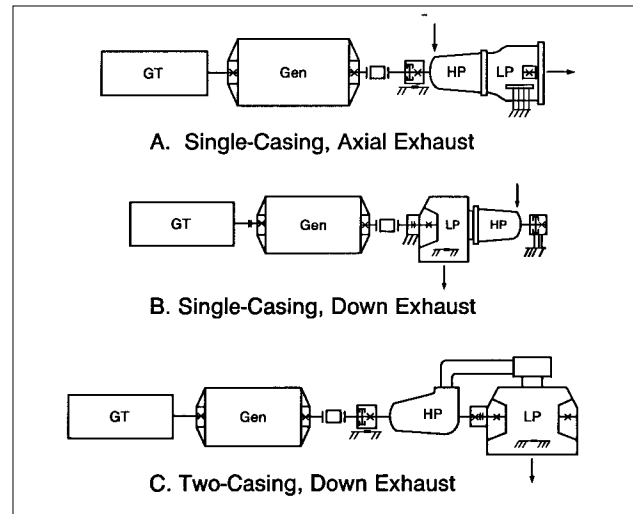

GT24382

Figure 8. Nonreheat steam turbine arrangements for single shaft STAG
A. Single-casing, axial exhaust
B. Single-casing, down exhaust
C. Two-casing, down exhaust

Reheat Multi-shaft

Figure 9 shows arrangements for multi-shaft reheat STAG units, where the steam turbine drives its own generator. Figure 9A illustrates a compact single casing configuration, used with moderate steam conditions and megawatt ratings. GE’s experience with this configuration dates to the 1950s. It has most recently been applied to multi-shaft 107FA units at an air-

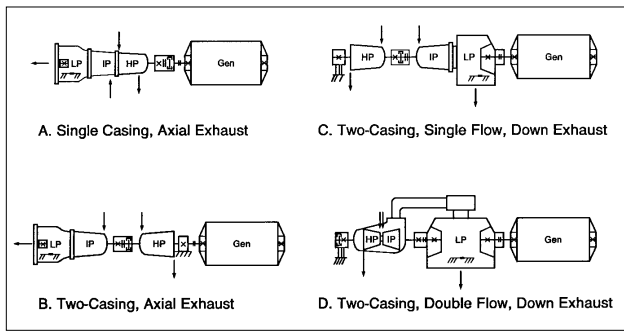

GT24383

Figure 9. Reheat steam turbine arrangements for multi-shaft STAG

- A. Single-casing, axial exhaust**
- B. Two-casing, axial exhaust**
- C. Two-casing, single flow down exhaust**
- D. Two-casing, double flow down exhaust**

cooled condenser site. A cross section of a single casing reheat unit for STAG application is shown in Figure 10.

The single flow units with two casings, Figures 9B and Figure 9C, are built with a separate high pressure (HP) section and a combined intermediate pressure and low pressure (IP/LP) section. This arrangement is compact and clean, with no need for crossover or cross-around piping between the two turbine casings. This arrangement is shown in cross section in Figure 11.

The multi-shaft double flow exhaust arrangement is shown in Figure 9D. Conventional reheat design practice is followed with the low pressure turbine section keyed to the foundation near its center, and accommodation of the thermal expansion at the turbine front standard.

Reheat Single Shaft

Figure 12 shows arrangement sketches for single shaft reheat STAG units in which the gas and steam turbines drive a common generator. These advanced machines are much more highly integrated than earlier generations of nonreheat single shaft STAG units. The flexible coupling of the steam turbine to the generator is eliminated, and a single thrust bearing serves the entire turbomachine. The generator is driven from one end only, which allows easy access for generator rotor removal. The common thrust bearing is located in the gas turbine compressor inlet, which is rigidly keyed to the foundation, as are the steam turbine front bearing standards and exhaust hoods. With complete mechanical integration, coordinated starting and loading of the gas turbine and steam turbine are facilitated, and operation is simplified. Single shaft configurations also offer maximum reliability and compact plant arrangements.

Figure 12A shows the single flow arrange-

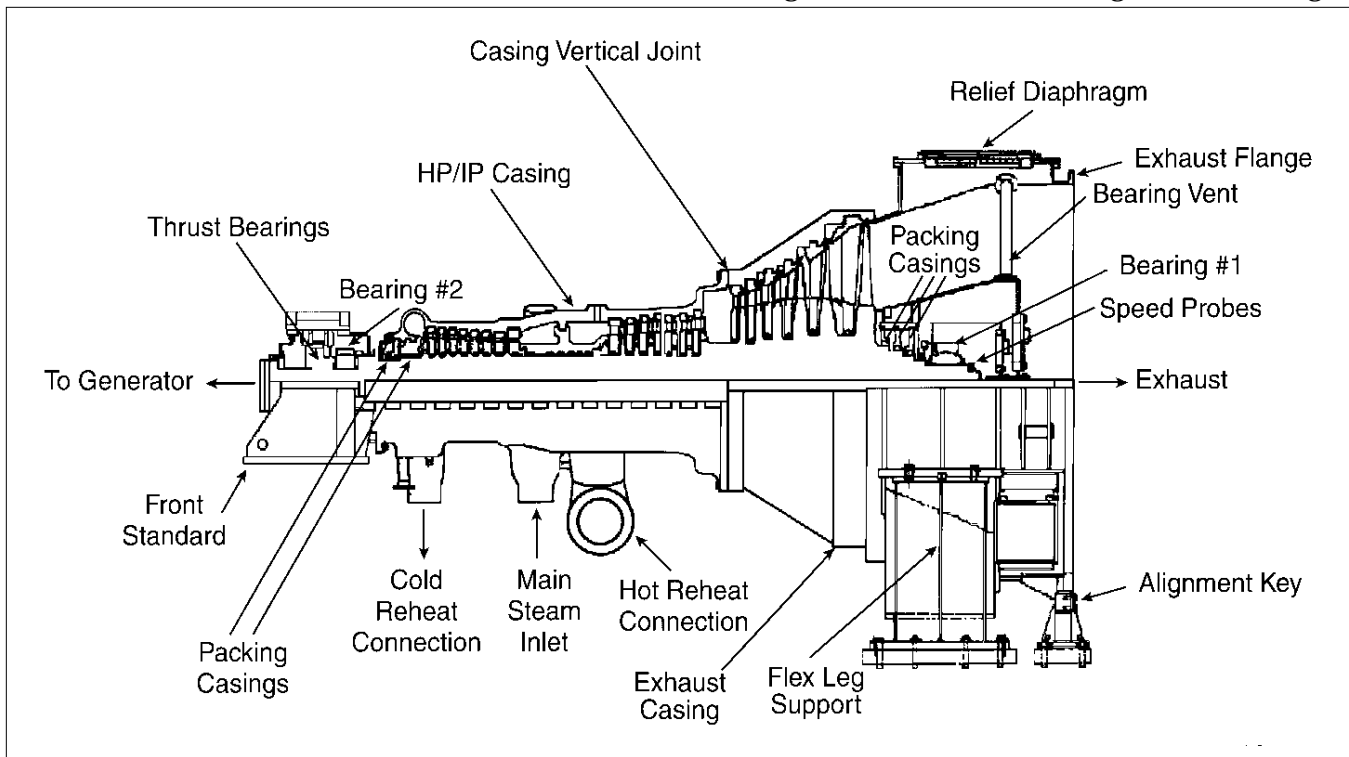

GT24384

Figure 10. Single-casing reheat turbine with axial exhaust

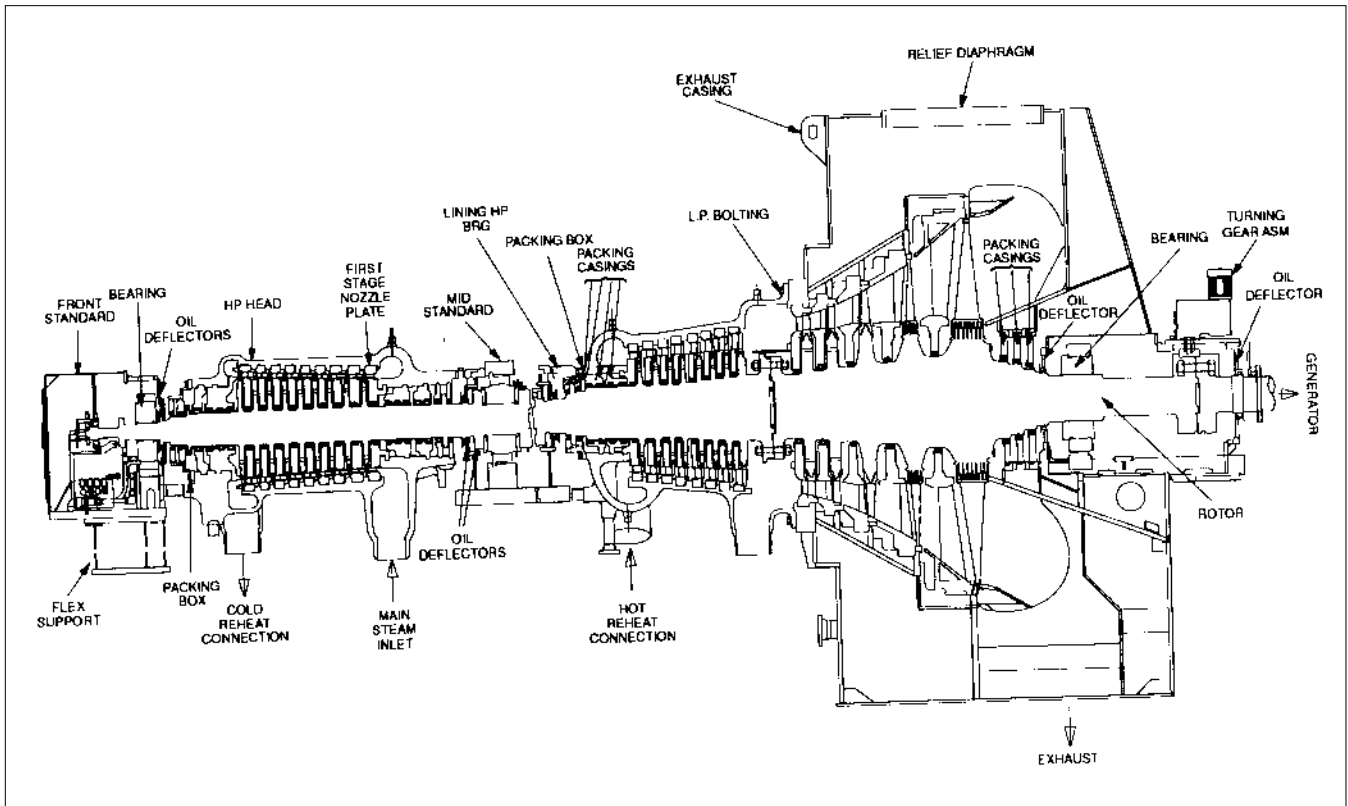
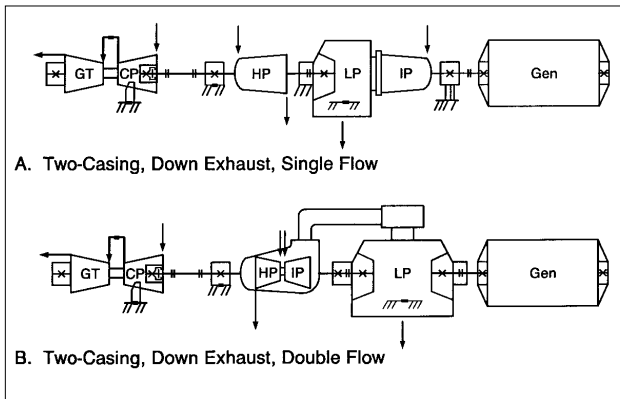

Figure 11. Two-casing reheat turbine with single flow down exhaust

GT22194



GT1939A

Figure 12. Reheat steam turbine arrangements for single shaft STAG
A. Two-casing, down exhaust, single flow
B. Two-casing, down exhaust, double flow

ment, consisting of an HP section and a combined IP and LP section. There is no need for crossover or cross-around piping, since the two casings are interconnected by the HRSG reheater and reheat steam piping. The HP casing and the rotor expand away from the front standard, maintaining close axial clearances, while the IP casing grows from the fixed exhaust casing. Special care is exercised in the design to

accommodate the relatively large differential expansion between the hot and cold conditions in the IP section, and to provide for axial movement between the HP exhaust and LP turbine, since both are independently keyed to the foundation.

Figure 12B illustrates the design for a single shaft reheat STAG unit with a double flow LP turbine section. Here the two casings are an opposed-flow HP/IP section and a double flow LP. As with the single flow unit, both casings are anchored to the foundation. Provision is made for relatively large movement between the two steam turbine casings and between the rotating and stationary parts in the LP.

The single shaft reheat STAG unit's unique integration has the benefit of not requiring combined reheat valves to protect the combined gas/steam turbine-generator from overspeed. The large rotor inertia of the combined machine and the power required to drive the gas turbine compressor act as an energy sink, allowing the full volume of the steam in the reheater and the hot and cold reheat piping to expand through the reheat turbine to the condenser without causing speed to rise above the emergency overspeed set point. Safety relief valves are not required for the reheater, simplifying plant piping and reducing cost.

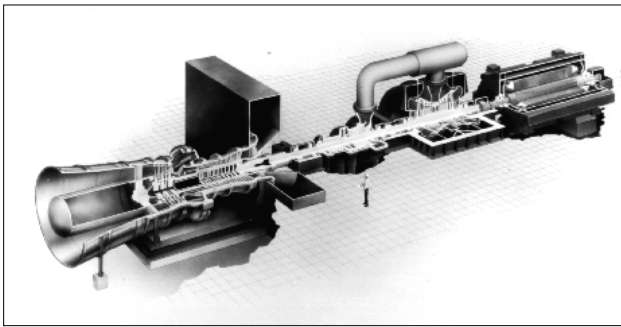

GT19644

Figure 13. Reheat single shaft gas and steam turbine-generator

A single shaft reheat STAG arrangement with a double flow low pressure section is shown in Figure 13. Figure 13 corresponds to the arrangement of Figure 12B. The steam turbine components to the right of the gas turbine inlet plenum are the front standard, the opposed-flow HP/IP section, mid-standard, crossover pipe to the LP section, LP turbine section and generator. Eight of these units are presently operating for TEPCO in Japan in a 2800 MW, 109FA STAG installation.

FEATURES FOR REDUCED INSTALLATION AND MAINTENANCE COSTS

GE steam turbines for STAG plants have been specifically designed for combined-cycle applications. They incorporate a number of special features for optimum installation, operation and maintenance costs.

Stop-and-Control Valve Arrangement

Steam is admitted to the turbine through one or two combined stop-and-control valves, which are piped to the lower half of the turbine casing. These combined valves, specifically designed for combined-cycle applications, are similar to combined reheat stop-and-intercept valves often used with traditional units. The control valve and main stop valve are contained within the same valve casing, and the valve disks share the same seat. The actuators, stems and disks are otherwise completely independent for control and overspeed protection. Each valve is testable on-line via an operator command from the control room. Normal operating mode is control valve full open, with the throttle pressure sliding up or down as HRSG steam production varies. The control valve is used for speed/load and inlet pressure control during start-up and shut-

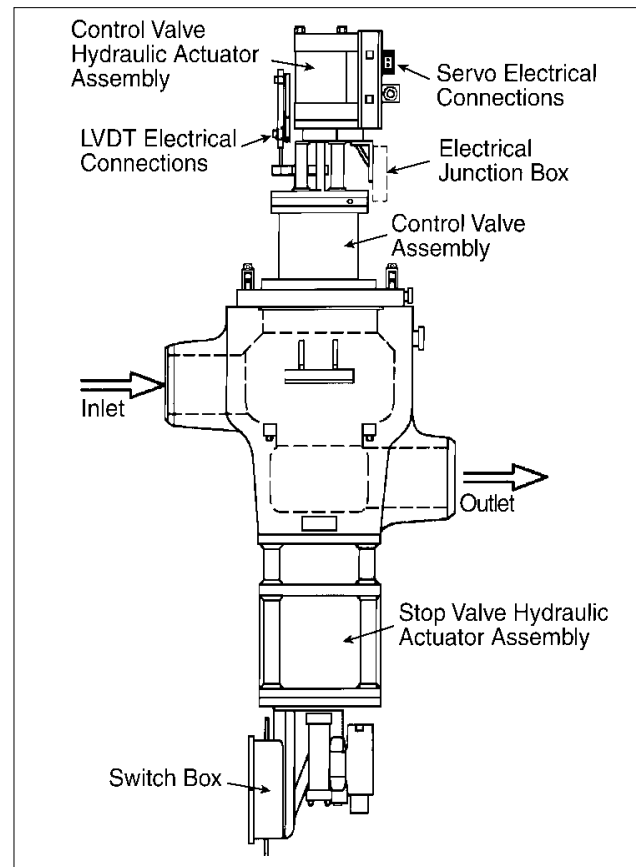

GT24385

Figure 14. Combined stop-and-control valve outline

down. A combined stop-and-control valve is shown in Figure 14.

Low-Profile Installation

The steam turbines applied in the nonreheat single shaft STAG systems and small-to-medium size multi-shaft STAG systems can be configured in single casing, single flow axial exhaust units. The location of the condenser at the end of the steam turbine can reduce the foundation height, with possible savings in the foundation, the crane support structure, and the steam turbine building (for indoor installations).

The round axial exhaust connection is a bolted flange, which is typically connected to a transverse condenser via a flexible expansion joint. The axial exhaust portion of the turbine casing carries a cone assembly, which contains the exhaust end turbine bearing. The bearing is accessed via a hatch in the upper half exhaust casing. The bearing housing is vented to the atmosphere by an inlet pipe in the lower half exhaust casing and a discharge pipe in the upper half. A recent STAG 107EA multi-shaft installation is shown in Figure 15. The axial



GT24386

Figure 15. Axial exhaust steam turbine in air condenser application

exhaust steam turbine at the right of the photograph is shown with the condenser expansion joint at center. The large steam ductwork at center and left connects the axial exhaust to an air condenser. The steam turbine auxiliaries are in the foreground.

Support and axial alignment of the turbine are accomplished by one of two means. An exhaust end flex leg and a foundation-keyed front standard may be used. Alternatively, a flex leg or sliding front standard may be required for units with LSB greater than 30 inches (762 mm), in conjunction with a foundation-keyed exhaust casing. A condenser expansion joint is recommended both for units with flexible exhaust supports and units which are keyed at the exhaust end.

Assembled Shipment

STAG steam turbines are designed to meet the objectives of low installation and maintenance costs, short shipment cycles, compact size, high efficiency and modular construction. Wherever possible they are shipped assembled, complete with rotor, diaphragms and front standard, so that site work is minimized. Piping is factory-fitted on packaged units, reducing installation cycle time and field piping work.

Axial exhaust, single flow nonreheat units with last-stage buckets up through 30 inches/762 mm are shipped assembled. Smaller down exhaust units, up through 20-inch/508 mm LSB, can be shipped assembled as well. High pressure and combined HP/IP sections for tandem compound units can be shipped assembled, with the steam path completely installed.

Assembled shipment reduces the number of parts to be handled on-site. Inventory require-

ments and lost or damaged parts are minimized. The units are assembled by trained factory personnel who are thoroughly familiar with steam turbine assembly. Critical, time-consuming tasks such as fit-up and clearance checks are performed in the controlled environment of the factory, where ready access is available to tooling and engineering support. A recent 207FA installation significantly reduced the steam turbine-generator centerline installation cycle by ordering the HP/IP sections as factory-assembled modules.

Maintainability

Since no shell-mounted valves are used, removal of the turbine upper half is facilitated. With the combined stop-and-control valve arrangement, a minimum number of valve casings need to be opened for valve inspections.

A traditional GE design feature for maintainability is vertical orientation of the main steam valves. This approach allows for rapid disassembly and assembly of these important valves during routine inspections, utilizing the station crane.

Since STAG inlet conditions are typically less than or equal to 1800 psig/124 bar, single shell construction is used, simplifying disassembly, alignment and reassembly. With the exception of crossover piping connections on some two casing units, all main steam piping connections are made to the lower half casings.

CYCLIC DUTY FEATURES

Recognizing the unique ability of gas turbines to be stopped and started easily and quickly, STAG steam turbines incorporate a number of special features which ensure compatibility with cyclic duty without compromise of base load capability.

The use of wheel-and-diaphragm construction allows use of relatively small shaft diameters in the vicinity of high temperature stages, minimizing thermal stresses in this most critical rotor section during startup, load changes and shutdown. Large fillets are employed between the wheels and the rotor body to reduce thermal stress concentrations.

Axial clearances are carefully selected to allow for large differential expansions between rotor and casing during rapid start-up and shutdowns, without compromising interstage leakage. Each stage is individually aligned to set clearances.

Coupling spans are designed with sufficient length to avoid bearing unloading, which can

occur when bearing support elevation changes due to rapid steam temperature swings or changes in exhaust pressure. Bearings are frequently fitted with tilting pad designs to maximize misalignment tolerance, ensuring stable operation and minimal shaft vibration.

Shells are designed with optimum proportions between flange and wall thicknesses. Surface geometries are controlled to permit uniform heat transfer and reduce stress concentrations during cyclic changes in critical areas. Thermal gradients between first-stage nozzle arcs are eliminated with full arc admission. Since a governing stage is not required with full arc admission, the first-stage wheel is reduced in size, reducing the thermal inertia of the rotor.

GE DESIGN FEATURES

All GE steam turbines incorporate design features developed from across GE's broad steam turbine product line. This contributes to their outstanding record of reliability, sustained efficiency and long life.

Combined-cycle steam turbines have inherent reliability advantages compared to more traditional applications. STAG steam turbines operate at modest steam conditions which permit simpler designs, are smaller in size with less thermal expansion, and many drive simple air-cooled generators. The result is a distinct advantage leading to outstanding reliability - greater than 97%.

Wheel-and-Diaphragm Impulse Design

GE uses an impulse stage design which requires fewer stages than would be used for a reaction steam path. This permits the use of wheel-and-diaphragm construction. The moving buckets are carried in the rims of wheels machined from a solid rotor forging. The high centrifugal stress of the bucket attachment area is away from the rotor surface, where thermal stress is highest. The result is separation of the areas with highest thermal and centrifugal stresses. The fixed nozzles are carried in welded nozzle diaphragms, which seal on the shaft at the minimum diameter, using a rub tolerant spring-backed packing design.

The alternative reaction design is usually executed in drum rotor construction, in which the moving blades are inserted in the surface of the drum, concurrent with the high thermal stress field. The fixed blades seal on the drum surface near the steam path diameter.

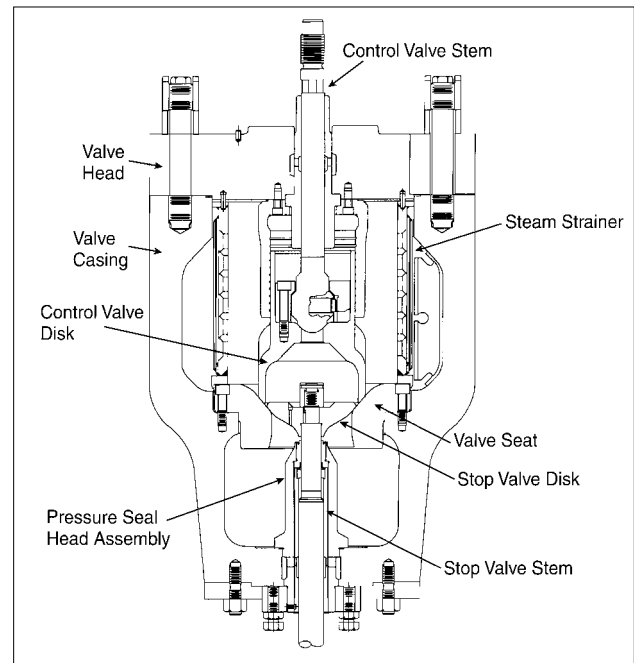

GT24387

Figure 16. Combined stop-and-control valve cross section

The wheel-and-diaphragm construction provides the benefit of minimal interstage loss. The relatively small shaft diameters minimize transient thermal stresses and enhance starting and loading characteristics.

Steam Turbine Admission Arrangement

Steam turbines for power-generation-only STAG applications are designed for operation in the boiler (HRSG) following mode, where the steam pressure varies with load. The off-shell combined stop-and-control valve is normally full open. Figure 16 shows a cross section of a combined stop-and-control valve. The control valve is used for start-up, inlet (HRSG) pressure control at light loads, and as the first line of defense against overspeed. This sliding pressure mode does not require multiple inlet valves for part load efficiency. Since the steam cycle is only approximately one-third of the STAG plant's power output, operators can use the gas turbines to contribute to grid frequency control. This simple, single admission inlet is shown for a combined HP/IP section in Figure 17. Heating and cooling of the admission parts are uniform, thermal stresses are minimized, and rapid starting, loading and unloading are facilitated.

For cogeneration applications, it may be desirable to use a more conventional inlet arrangement with shell-mounted control valves.

Centerline Support

All main structural turbine parts and stationary steam path parts are supported at or near the turbine centerline. This arrangement minimizes the effect of distortion and misalignment caused by temperature changes and maintains radial clearances. During start-ups or rapid load swings, turbine shells are free to expand axially and radially, while the diaphragms remain concentric with the shaft. Since alignment adjustment is straightforward with centerline support, time spent in installation is minimized.

Horizontal Joint Flange

The horizontal joint flanges are designed with optimum proportions, confirmed by extensive finite element modeling. Shell support and bolting flange requirements are integrated into the casing design. The horizontal joint faces are precision machined to ensure uniform contact and sealing surfaces between upper and lower halves. In general, the entire shell is supported near the flange level. The internal components are supported very close to the flange level to minimize distortion and alignment change effects.

Moisture Removal

Moisture separation features are applied throughout the wet regions of the steam path to improve efficiency and to reduce the potential for moisture erosion. GE's extensive design experience with wet stage designs benefits today's combined-cycle turbines. Several design features applied to latter stages such as grooved buckets, flame hardening, and collection grooves in the stationary steam path allow GE to

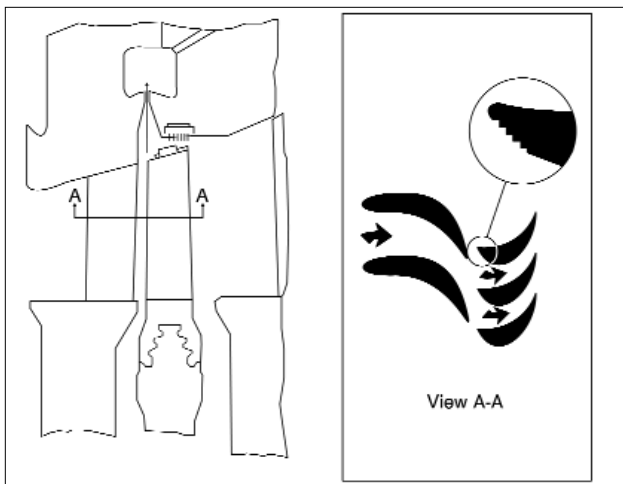

Figure 19. Moisture removal provisions

GT22963B

confidently apply long last-stage buckets in non-reheat STAG applications. Figure 19 illustrates key moisture removal design features.

Steam Path

For effective resistance to corrosion and erosion, the steam path is constructed largely of 12 chrome steels. Rugged, impulse-type turbine buckets utilize external dovetails for attachment to the rotor wheels and protection of the wheel rims. In order to attain maximum thermal efficiency, steam paths are constructed in conical form (progressively increasing stage inner ring diameters). This permits the use of slant root-and-tip buckets, and maximizes the bucket active lengths in the high pressure stages. Three-dimensional flow analysis is used for design of the low pressure stages.

Buckets and nozzles utilize carefully selected aerodynamic profiles throughout the steam path. Each stage design is individually stress-analyzed to ensure conformity to allowable stresses and specific factors of safety. Most importantly, each stage is dynamically analyzed and tuned to avoid incidence of major frequency resonances during operation. Vibratory stresses are calculated for each bucket stage and reviewed relative to accepted stress limits.

Last-Stage Buckets

GE STAG steam turbines benefit from the use of continuously-coupled, last-stage bucket designs, originally developed for large fossil-fired central station units. These buckets feature full coupling at the tip and mid-vane, supersonic tip steam passages, and self-shielding erosion protection. These designs are available for 3000 rpm and 3600 rpm units with last-stage buckets greater than 23 inches/584 mm.

The continuously-coupled construction joins each bucket at its tip and at the mid-vane position such that no bucket or group of buckets can move independently. The first benefit is the high tolerance of buffeting conditions found at low loads. The second benefit is that the converging-diverging steam path geometry near the tip, where the flow is supersonic, is controlled so that efficiency losses due to shock waves are minimized. Figure 20 illustrates a representative selection of last-stage buckets. The mid-vane connection is made with small nubs machined from the bucket forging. An aerodynamically shaped sleeve is inserted between adjacent buckets during installation, and captured between bucket nubs. This loose coupling, without weld-

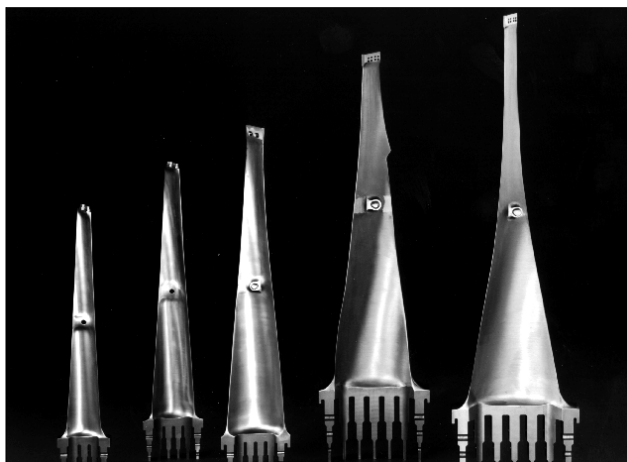

GT22198

Figure 20. 3600 RPM last-stage bucket family

ed connections or tie-wire holes through the bucket vane, readily accommodates bucket untwist. As the rotor reaches running speed, centrifugal force provides a continuous coupling effect via the aerodynamic sleeves.

Self-shielding is an important erosion-resisting feature of GE's longer last-stage buckets. An alloy steel is used for the entire vane that provides erosion resistance comparable to Stellite™ shields, without the maintenance and inspection requirements associated with welded shields. The problem of loss or erosion of a separate shield and subsequent rapid erosion of a softer underlying material is eliminated.

The ability of long buckets to tolerate the high moisture level found in nonreheat applications has been improved by a redesign of LSB tip seals. Since much of the moisture in the steam path forms a water film on the outer wall of the diaphragm, the bucket-tip sealing arrangement has been designed to allow the film to pass over the tip without creation of a droplet spray which would impact on the bucket vane.

Rotors

Turbine rotors are machined from alloy steel forgings which have passed extensive testing, including magnetic particle, ultrasonic and thermal stability checks. Modern turbine rotor forgings reflect decades of close cooperation between steel mills and GE engineers. The quality of forgings is evaluated using the latest ultrasonic techniques. GE has been a world leader in the development of forging chemistry, production and quality evaluation. Large single flow rotors require different properties at each end. These are referred to as HP/LP or IP/LP rotors. The high pressure or intermediate pressure end

requires good high temperature properties, while the low pressure end requires higher ductility and toughness, to handle the large centrifugal stresses encountered with long last-stage buckets. This design challenge is handled in two ways. Differential heat treatment processes have been developed which allow single forgings to be produced with different properties at each end. Alternatively, a solid bolted connection is used, in which separate forgings of different materials are joined with a precision rabbet coupling in the factory to provide a rotor with the requisite high and low temperature properties. This coupling is not required to be disassembled for maintenance. GE has over forty years of successful experience with bolted rotor construction. Bolted rotor construction is seen in the IP/LP section of Figure 11.

Diaphragms

The diaphragm and outer rings are constructed of various steels, depending upon the mechanical design requirements of the particular stage location. The aerodynamically shaped nozzles and side walls which form the steam path passages are made from 12 chrome steels.

Spring-backed packings are mounted in the bore of all diaphragms. Large back clearances provide a high degree of rub tolerance. Packing rings are made from soft leaded bronze or ductile iron materials. The packing rings are designed for optimum clearance/leakage control, prevention of shaft damage in the event of rubs, and minimal wear for sustained efficiency.

CONCLUSION

The special features and designs discussed here for matching the steam turbine to the characteristics of the gas turbine, HRSG, and site-related conditions have been highly successful in both reheat and nonreheat, single shaft, and multi-shaft applications. GE steam turbines for STAG combined-cycle plants have been highly reliable since their inception in the mid-1960s. Operating modes have varied from daily start-and-stop service to full base load applications. Reliability of GE steam turbines in STAG service exceeds 97%.

GE has a structured STAG product line for aero-derivative, conventional heavy-duty, and advanced heavy-duty gas turbines. Steam turbine design flexibility is allowed for cogeneration applications, and optimization to project-related site and economic considerations. The ultimate in compact, efficient advanced combined-cycle

units is available in GE's 107FA, 107G, 109FA, 109G, 109H and 109FA single shaft gas/steam turbines.

REFERENCES

1. Baily, F.G., "Steam Turbines For Advanced Combined-Cycles," GE Power Generation Turbine Technology Reference Library Paper No. GER-3702B, 1993.
2. Brooks, F.J., "GE Gas Turbine Performance Characteristics," GE Power Generation Turbine Technology Reference Library Paper No. GER-3567D, 1993.
3. Tomlinson, L.O., Chase, D. L., Davidson, T.L., and Smith, R.W., "GE Combined-Cycle Product Line and Performance," GE Power Generation Turbine Technology Reference Library Paper No. GER-3574D, 1993.
4. Cofer, J.I., Reinker, J.K., and Sumner, W.J., "Advances in Steam Path Technology," GE Power Generation Turbine Technology Reference Library Paper No. GER-3713B, 1993.
5. Tomlinson, L.O. "Single Shaft Combined-Cycle Power Generation System," GE Power Generation Turbine Technology Reference Library Paper No. GER-3767, 1993.
6. Bievenue, R.T., Ruegger, W. A., and Stoll, H.G., "Features Enhancing Reliability and Maintainability of GE Steam Turbines," GE Power Generation Turbine Technology Reference Library Paper No. GER-3741A, 1993.
7. Schofield, P., "Steam Turbine Sustained Efficiency," GE Power Generation Turbine Technology Reference Library Paper No. GER-3750A, 1993.

LIST OF FIGURES

- Figure 1. Illustrative exhaust loss curve
- Figure 2. Steam turbine wheel output as a function of exhaust pressure and exhaust size, reheat STAG 1400 psig 1000 F/1000 F (96 bar 538 C/538 C) steam conditions
- Figure 3. Comparison of nonreheat and reheat expansions
- Figure 4. Three pressure level reheat cycle diagram
- Figure 5. Nonreheat steam turbine arrangements for multi-shaft STAG
 A. Single-casing, axial exhaust
 B. Single-casing, down exhaust
 C. Two-casing, down exhaust
- Figure 6. Nonreheat, single-casing, axial exhaust steam turbine
- Figure 7. Nonreheat, double flow down exhaust unit
- Figure 8. Nonreheat steam turbine arrangements for single shaft STAG
 A. Single-casing, axial exhaust
 B. Single-casing, down exhaust
 C. Two-casing, down exhaust
- Figure 9. Reheat steam turbine arrangements for multi-shaft STAG
 A. Single-casing, axial exhaust
 B. Two-casing, axial exhaust
 C. Two-casing, single flow down exhaust
 D. Two-casing, double flow down exhaust
- Figure 10. Single-casing reheat turbine with axial exhaust
- Figure 11. Two-casing reheat turbine with single flow down exhaust
- Figure 12. Reheat steam turbine arrangements for single shaft STAG
 A. Two-casing, single flow down exhaust
 B. Two-casing, double flow down exhaust
- Figure 13. Reheat single shaft gas and steam turbine-generator
- Figure 14. Combined stop-and-control valve cross section
- Figure 15. Axial exhaust steam turbine in air condenser application
- Figure 16. Combined stop-and-control valve cross section
- Figure 17. STAG admission design - opposed-flow HP/IP section
- Figure 18. Package cogeneration unit with multiple inlet control valves and automatic extraction
- Figure 19. Moisture removal provisions
- Figure 20. 3600 RPM last-stage bucket family

LIST OF TABLES

- Table 1. GE gas turbine exhaust characteristics
- Table 2. STAG power plants - approximate outputs
- Table 3. Last stages available for combined-cycle steam turbines
- Table 4. STAG steam turbine selection chart: nonreheat steam turbines less than 40 MW
 850 psig/58.5 bar, 950 F/510 C
- Table 5. STAG steam turbine selection chart: nonreheat steam turbines
 1000 psig/69 bar, 950/510 C
- Table 6. STAG steam turbine selection chart: nonreheat steam turbines greater than 60 MW
 1250 psig/86 bar, 950/510 C
- Table 7. STAG steam turbine selection chart: 50 Hz advanced combined-cycles
 1400 psig (96 bar) 1000 F/1000 F (538 C/538 C)
- Table 8. STAG steam turbine selection chart: 60 Hz advanced combined-cycles
 1400 psig (96 bar) 1000 F/1000 F (538 C/538 C)
- Table 9. G & H vs. FA Characteristics and Performance



Michael J. Boss

Mr. Boss is presently a Product design engineer in Advance Design, for Steam Turbine Design and Development Engineering. In this position he is responsible for the overall design and performance of the Advanced Steam Turbine designs.

Mr. Boss previously was Technical Leader of the Automated Steam Path Layout Program (ASPL), where he established the method for the computerized steam turbine designs. Prior to that assignment he was Technical Leader in Thermodynamics and Application Engineering.

Mr. Boss is a lecturer for the ASME Fundamentals Course and Advanced Course in Steam Turbine Design, Operation and Maintenance.