

60 cents

hcr

focus
on
communications
technology . . .

ham radio

DECEMBER 1968

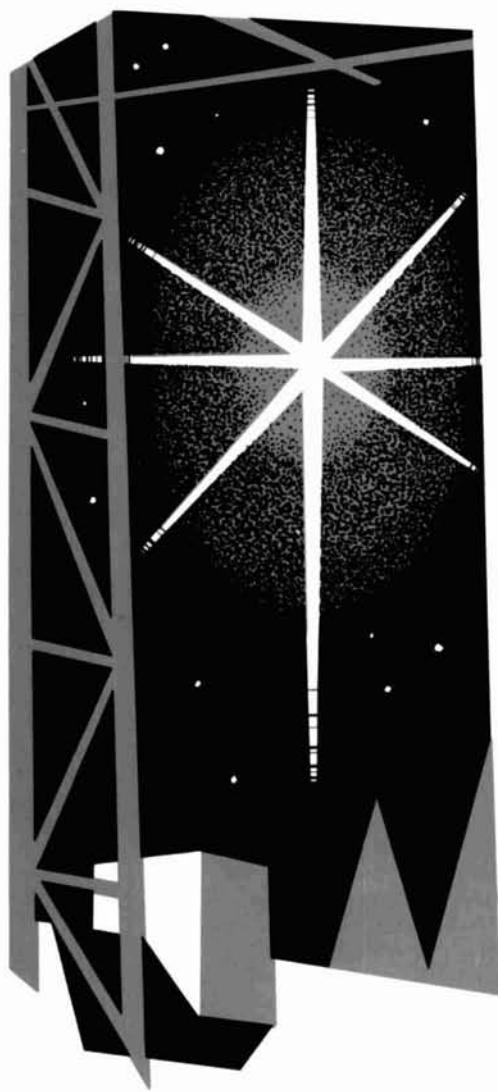

this month

- digital frequency counter 8
- wideband bridge baluns 28
- 6-meter transverter 44
- ramp generators 56



Every day, MARS brings servicemen
home for a few minutes.

These brief reunions are made possible by
dedicated amateur radio operators who donate their
time and the use of their stations.

To all operators along the MARS nets — who
are giving even more of their time during
the holidays — Collins sends
especially warm season's greetings.



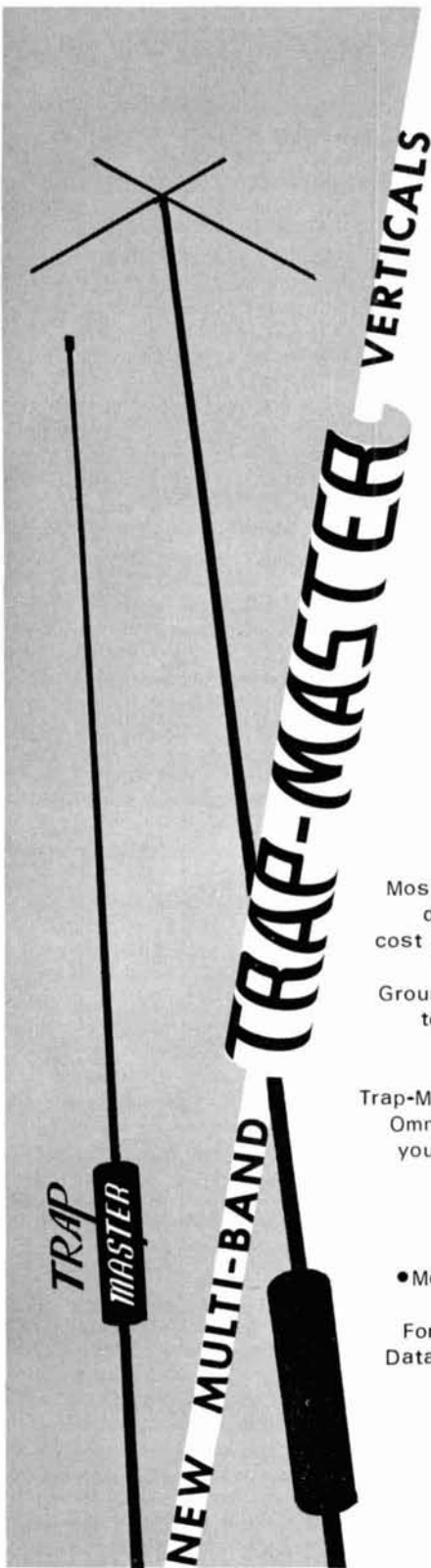

Great Things are Happening with Verticals

at **Mosley**

- All New 3 and 5 Band Operation
- Improved 4-Band Performance
- New Simplified Ground Mount
- Versatile Ground or Roof-Top Installation

Mosley's World-Renowned TRAP-MASTER traps offer a new dimension in Vertical Performance . . . plus easy, low cost installation. Three New RV-Series Verticals with the Versatility of Six! New design - from the Simplified Ground Mount (no longer is a concrete footing necessary) to the addition of a 'Top Hat' where it counts most for a low, low angle of roof-top radiation.

Trap-Master Verticals will take you places . . . Outstanding Omni-Directional Radiation - Top DX-Ability. Whatever your needs, Mosley has a New RV-Vertical designed and engineered to give you a real 5-9 signal.

- Model RV-3C for 10, 15, and 20 Meter Bands
- Model RV-4C for 10, 15, 20, and 40 Meter Bands
- Model RV-5C for 10, 15, 20, 40, and 75/80 Meter Bands

For detailed Brochure on Specifications and Performance Data, see your nearest authorized Mosley dealer, or write factory direct: Dept. 170

Mosley Electronics, Inc. 4610 N. Lindbergh Blvd.,
Bridgeton, Mo. 63042

NEW DRAKE MODEL **TR-6** 6-M SIDEBAND TRANSCEIVER



Model TR-6 **\$599⁹⁵** Amateur Net

COMPARE THESE FEATURES

- Full coverage of 6 meter band plus MARS.
- Four IF band widths: 2.4 kHz upper sideband (supplied), 2.4 kHz lower sideband, 6.0 kHz AM, 0.3 kHz CW, all selectable with front panel switch.
- Function switch selects product or envelope detector as well as built-in AM screen modulator. Compatible with linear amplifiers.
- No carrier balance or carrier insertion adjustment for AM or CW
- Shift carrier CW system for compatibility and versatility.
- Ultra-stable linear VFO. 600 kHz in one range. 1 kc readability.
- Built-in PTT, VOX, ANTI-VOX, 100 kHz calibrator.
- ALC prevents flat-topping.
- Ample metering provisions with two meters. For ALC, S-Meter, Transmitter Plate Current, Relative RF Output.
- RV6 External VFO allows split-frequency operation. (RV3, RV4 usable).
- Fast or slow AGC for receiving. For meteor scatter work, selectable from front panel.
- Ultimate receiver front end performance using FET's. Less than 1/10 μ V required for 10 dB S/N ratio on SSB.
- Input and outputs provided for Drake TC-2 or other 2-meter transverters. All switching done internally with band switch.
- 300 watts CW and PEP input.
- 6JB6 final tubes eliminate replacement problems.
- Extra input and output jacks for converters and/or outboard receivers. Permits monitoring of more than one frequency simultaneously.

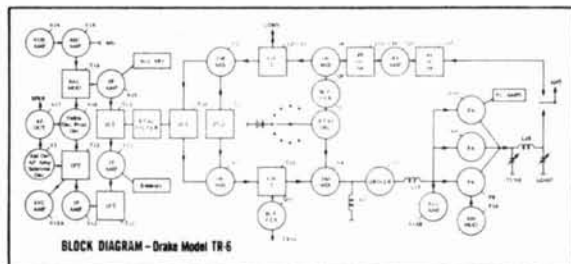

See your distributor or write for free brochure:

R. L. DRAKE COMPANY

Dept. 4128, 540 Richard St., Miamisburg, Ohio 45342

- **Exclusive Features**
- **Greatest Value**
- **Unmatched Performance**

GENERAL SPECIFICATIONS

SIZE: 5 $\frac{3}{4}$ " high, 10 $\frac{3}{4}$ " wide, 16 $\frac{1}{4}$ " deep (plus feet and knobs). WEIGHT: 15 $\frac{3}{4}$ lbs.

FREQUENCY COVERAGE: 49.4 to 54.0 MHz (crystals supplied for 49.9 to 51.1 only).

VFO DIAL CALIBRATION: 1 kHz divisions; dial accuracy is within ± 1 kHz.

CALIBRATOR: 100 kHz calibrator built in.

FREQUENCY STABILITY: Less than 100 Hz overall drift per hour after 15 minutes warm-up; less than 100 Hz for 10% supply voltage change.

SPLIT FREQUENCY OPERATION: Xmt and Rcv frequencies may be separated by up to 600 kHz by use of the RV-6 or FF-1 accessories.

MODES: SSB, AM, and CW.

POWER SUPPLIES: Drake AC-3, AC-4, DC-3, DC-4 or DC-24.

TUBES AND SEMICONDUCTORS: 19 tubes, 7 bipolar and 3 field effect transistors, 12 diodes.

RECEIVER SPECIFICATIONS

SENSITIVITY: Less than 1/10 microvolt for 10 dB S+N/N ratio at 2.4 kHz band width.

SELECTIVITY: 6 dB bandwidth 2.4 kHz with USB filter provided. Accessory filters available for LSB, AM (6 kHz) and CW (.3 kHz).

AUDIO RESPONSE: 400 to 2800 Hz at 6 dB.

INPUT: 50 ohms unbalanced.

OUTPUT: 4 ohms to speaker or headphones.

AUDIO OUTPUT POWER: 2 watts at 10% HD.

AVC: Output variation less than 3 dB for 60 dB input change. Fast attack. Release time selectable.

MANUAL GAIN CONTROLS: RF gain control sets threshold for AVC, AF gain control.

DETECTORS: Switch on front panel. Product detector for SSB and CW Envelope detector for AM.

NOISE BLANKER: On-off switch for accessory noise blanker on front panel.

INPUT: 13.9 to 14.5 MHz receiving input/output jack for converters and/or outboard IF receivers.

TRANSMITTER SPECIFICATIONS

POWER INPUT: 300 W PEP on SSB, 300 W PEP on AM, 300 W CW (50% maximum duty cycle).

OUTPUT IMPEDANCE: 50 ohms nom. unbalanced, 2:1 max. SWR. Adjustable loading.

MODES: SSB (USB provided, LSB with accessory filter), AM (controlled carrier system), CW (semi-tone in, Sidetone).

AMPLIFIED AGC: Prevents flat-topping.

CARRIER INSERTION AND SHIFT: Automatic on AM and CW, shifted carrier CW system.

VOX AND PTT: VOX and Anti-VOX built-in.

AUDIO RESPONSE: 400 to 2800 Hz at 6 dB.

40 dB SIDEBAND SUPPRESSION above 1 kHz, 50 dB carrier suppression.

DISTORTION PRODUCTS: Down 30 dB minimum from PEP level.

MONITORING AND METERING: Final plate current, AGC action, and relative output can be read on meters. Sidetone for keyed CW.

14 MHz OUTPUT: 13.9 to 14.5 MHz output for Drake TC-2 and other transverters.



TR-6 ACCESSORIES

RV6 Remote VFO. Separates receive and transmit frequencies within the same range. **\$99.95**

FF1 Fixed frequency adaptor **\$24.50**

MMK-3 Mobile mounting kit **\$6.95**

Power supplies

AC-4 120 V 50/60 Hz **\$99.95**

DC-4 12 VDC **\$125.00**

DC-24 24 VDC **\$210.00**

MS-4 Matching speaker **\$19.95**



ham radio

staff

editor

James R. Fisk,
W1DTY

roving editor

Forest H. Belt

vhf editor

Robert M. Brown,
K2ZSQ/W9HBF

associate editors

A. Norman Into, Jr.,
W1CCZ
Nicholas D. Skeer,
K1PSR
James A. Harvey
WA6IAK

art director

Jean Frey

publisher

T. H. Tenney, Jr.,
W1NLB

offices

Greenville, New Hamp-
shire 03048
Telephone: 603-878-1441

ham radio is published
monthly by Communi-
cations Technology,
Inc., Greenville, New
Hampshire 03048. Sub-
scription rates, world
wide: one year, \$5.00,
three years, \$10.00.
Application to mail at
second-class postage
rates pending at
Greenville, New Hamp-
shire 03048.

Copyright 1968 © by
Communications Tech-
nology, Inc. Title reg-
istered at U. S. Patent
Office. Printed in
Montpelier, Vermont
05602, U.S.A. Micro-
film copies of current
and back issues are
available from Univer-
sity Microfilms, 313 N.
First Street, Ann
Arbor, Michigan 48103.
Postmaster: Please
send form 3579 to ham
radio, Greenville, New
Hampshire 03048.

contents

15-MHz Digital Frequency Counter	A. A. Kelley, K4EEU	8
Wide-Band Bridge Baluns	William Orr, W6SAI, and William Sayer, WA6BAN	28
Equipment for QRP Operation	Howard S. Pyle, W7OE	36
Medium Power Six-Meter Transverter	F. N. Davis, K8DOC, and A. F. Dolgosh, K8EUR	44
Tuning Antennas with a Grid-Dip Meter	Robert M. Brown, K2ZSQ	48
Time-to-Reply Statistics for DX QSL's	Lee C. Vogel, WB6IUH	50
Ramp Generators	Henry D. Olson, W6GXN	56
Silver Plating for the Serious Amateur	Ralph W. Campbell, W4KAE	62
Miniature Crystal Oscillator	Everett G. Taylor, W6DOR	68
New 40-GHz Record	Harold M. Jackson, K7PMY	70
James Research Permaflex Key	James R. Fisk, W1DTY	73
December Propagation Predictions	Victor R. Frank, WB6KAP	76

departments

A Second Look	4	Comments	92
A Word of Thanks	7	Flea Market	97
Advertisers Index	106	New Products	86
Annual Index of Articles	108	Next Month	52
		Propagation	76

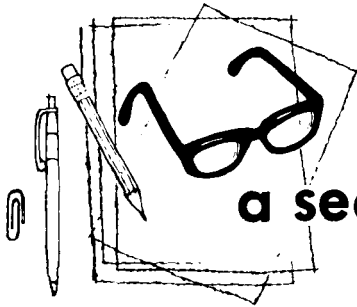

a second look

by jim
fisk

Although integrated circuits have only recently started making a real dent in the consumer market, they are actually celebrating their tenth birthday this year. It was during the summer and fall of 1958 that Jack S. Kilby of Texas Instruments built the first integrated circuit. Other firms had been working on ways to miniaturize electronic circuits, but most of these approaches used miniature components of one kind or another. Kilby was the first to use semiconductor material for both the active (transistors) and passive elements (resistors and capacitors) to build a complete circuit on a single piece of germanium.

His first circuits, a phase-shift oscillator and multivibrator, demonstrated the feasibility of this approach. Since germanium was well established and silicon was not, Kilby used germanium. On top of the germanium substrate were the contacts of the diffused transistors, junction capacitors and resistors. A gold-plated metal frame protruded from the lower surface of the substrate and thermally-bonded gold wires were used for connections between those elements not linked by the wafer itself.

The first circuits were large and irregular—a lot different from the precision units that are available today. The photo masks and resists necessary to ic manufacturing were yet to be developed, so the patterns were hand painted on the semiconductor chip with black wax. Needless to say, they were rather crude looking.

About the same time that ic's were first being built, Fairchild Semiconductor developed the planar process—an innovation that

is generally conceded to be the foremost semiconductor discovery of the decade. The planar process made semiconductors more reliable and cheaper to produce, as well as accelerating ic progress and acceptance.

Since these early discoveries, the number of circuits per unit area has increased and prices have gone down. In 1962, a typical ic flip-flop chip was 0.1-inch square; a similar circuit today is ten times smaller. You can buy a dual flip-flop for a couple of dollars or a complete decade counter for about seven. Linear ic's are available for all types of applications at reasonable prices: audio amplifiers, i-f amplifiers, audio output stages (with powers up to 5 watts) and voltage regulators, just to name a few. If you haven't tried them yet, you should give them a try—most manufacturers will be glad to furnish data sheets and most large distributors carry inexpensive integrated circuits in stock.

With the low costs involved, it is possible for the amateur to attempt construction projects that he would never even consider in the past. This is also true of commercial amateur equipment. Look for some interesting uses of integrated circuits in new amateur equipment that will reach the market early next year. In the meantime, why not get your feet wet with some of the simple ic projects that have appeared in the various magazines? I wouldn't recommend the digital frequency counter featured in this issue, but it will give you an idea of the complex equipment that you can economically build in your basement. It wasn't too many years ago that only large laboratories with big budgets could afford such an instrument.

Jim Fisk, W1DTY
Editor

EIMAC

**3-400Z's or 3-500Z's
interchangeable in new
Swan Mark II amplifier.**

Swan's new Mark II linear amplifier uses EIMAC high-mu power triodes to achieve 2 kW PEP SSB input and 1000 watt input on CW, AM, or RTTY.

Unique circuitry permits the choice of a pair of either 3-400Z or 3-500Z zero-bias triodes in this all purpose high-frequency linear amplifier.

Swan chose the heavy duty EIMAC power triodes because these rugged, low-cost power grid tubes are ideal for cathode-driven grounded-grid service, providing a power gain of up to 20 in linear service.

For more information on either the 3-400Z or the 3-500Z, or any other tube in EIMAC's line for advanced transmitters, write Amateur Services Department or contact your nearest EIMAC distributor.

TYPICAL OPERATION

	3-500Z	3-400Z
DC plate voltage (Vdc)	2500	2500
Zero-sig DC plate current (mA)*	130	73
Single-tone DC plate current (mA)	400	400
Single-tone DC grid current (mA)	120	142
Two-tone DC plate current (mA)	280	274
Two-tone DC grid current (mA)	70	82
Peak envelope useful output power (W)	600	560
Resonant load impedance (ohms)	3450	3450
Intermodulation distortion products (dB)	-33	-35
Plate dissipation rating (W)	500	400

*Approximate

EIMAC

Division of Varian

San Carlos, California 94070





Open the best on Christmas Day (or any other day)... a Swan transceiver from Henry Radio



MODEL 500C A complete SSB-AM-CW transceiver. Five bands, 520 watts . . . for home station, mobile and portable operation. Voice quality, performance and reliability are in the Swan tradition of being second to none. **\$520.00**



MODEL 350C An improved version of the classic Model 350. An SSB-CW-AM transceiver, featuring 5 bands, 520 watts SSB P.E.P. input. Ideal for home station, mobile or portable operation. Dependable and loaded with worthwhile features. **\$420.00**

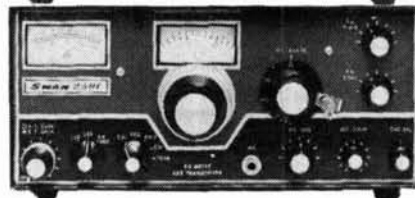

MODEL 250C The newest member of the Swan family. A full 6 meter SSB-AM-CW transceiver. 240 watts P.E.P. input, selectable sideband, built-in 250 kc calibrator . . . plus many more worthwhile features. **\$420.00**

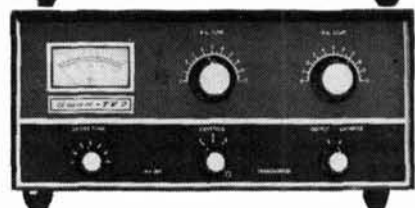

MODEL TV-2 2 meter single sideband, 144-148 mc 240 watts P.E.P. input. The new Swan TV-2 transverter is a superb receiving and transmitting converter for the 2 meter band, designed to operate with most Swan transceivers. **\$295.00**

Henry Radio and Swan, long a great team and old time friends of Hams the world over, presents a choice of transceivers to fill the heart of any amateur with joy. There is no better time to buy than now and, of course, the very best place to shop is Henry Radio. At Henry Radio you can compare makes and models from exceptionally large stocks. You can trade in your old equipment and take advantage of our generous terms.

Exports! Of course, Henry Radio makes it simple for amateurs around the world to own the finest American radio equipment. Write for details.



CALL DIRECT . . . USE AREA CODE

Butler, Missouri, 64730	816 679-3127
11240 W. Olympic, Los Angeles, Calif., 90064	213 477-6701
931 N. Euclid, Anaheim, Calif., 92801	714 772-9200

"World's Largest Distributor of Amateur Radio Equipment"

a word of thanks

As our first year of **Ham Radio** draws to a close, all of use can look back on what has certainly been a most exciting year. A year ago this magazine seemed like little more than a dream. We had no subscribers, no advertisers and a nearly empty room for an office equipped with one small table, two chairs, a telephone and a cardboard box for a filing cabinet.

Next came an ad in Gus Browning's **DXer's Magazine** introducing **Ham Radio** and offering \$1.00 trial subscriptions. Soon the mail started to come in and we found ourselves with over 100 subscribers. About the same time we approached the many advertisers in the amateur field and enough of them said, "OK," to start our magazine rolling.

The following months flew by as we worked too many hours a day to line up a printer, to make arrangements with the many authors, artists and others who are so necessary to the successful magazine which you see today. At the same time we had to spread the word about **Ham Radio** to as much of the amateur community as possible to build up our all-important subscriber list. Ham-fests, radio club meetings, visits to radio stores helped. All these activities and more became part of our new routine.

Our pace today is perhaps a bit more organized, but is certainly no slower moving as we work to further improve the magazine, to add new subscribers and to better serve what has now grown to a list of thousands of subscribers.

One person has been very important throughout all of this past year; that is you—the reader of **Ham Radio**. Without you there would be nothing. Your hundreds of letters of encouragement have helped us over the rough spots. Your criticism has also been a big help. You have brought us advertisers and other subscribers. For all of this we want to say thanks.

We wish all of you—readers, advertisers and distributors—a Merry Christmas and a very Happy New Year loaded with lots of cooperative sunspots and many pleasant hours from our hobby.

Skip Tenney, W1NLB
Publisher

RCA has all-new FCC commercial license training

**Get your license—
or your money back!**

Now RCA Institutes Home Study Training has the FCC License preparation material you've been looking for—all-new, both the training you need, and the up-to-date methods you use at home—at your own speed—to train for the license you want!

2 Convenient Payment Plans—You can pay for lessons as you order them, or take advantage of easy monthly payment plan. Choose the FCC License you're interested in—third, second or first phone. Take the course for the license you choose. If you need basic material first, apply for the complete License Training Program.

SPECIAL TO AMATEURS. This course—while designed for Commercial license qualification—contains much of the new material called for by FCC Docket 15928—advanced and extra class you'll want to qualify for before November of 1969. QRX until you get the information.

Mail coupon today for full details and a 64-page booklet telling you how RCA Institutes Home Training can show you the way to a new career—higher income—and your FCC License.

RCA

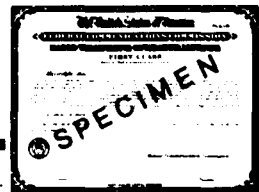

RCA INSTITUTES, INC.
Dept. HR-D8
320 West 31st Street, New York, N.Y. 10001

Please rush me, without obligation, information on your all-new FCC Commercial License training.

Name _____

Address _____

City _____ State _____ Zip _____

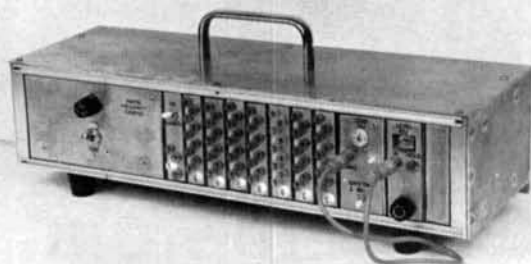

digital frequency counter

Application
of low-cost IC's
in
a highly accurate
frequency standard
featuring
automatic operation
up to 15 MHz

You won't put WWV out of business with this extremely versatile and accurate instrument, but you certainly won't have to take a back seat to anybody in a frequency-measuring contest. It's hard to beat the combination of a crystal-controlled time base and digital frequency counter for accuracy and stability. It puts the old heterodyne frequency meter in the high-button shoes class, and if you're mathematically inclined you can use statistical methods to determine the mean and standard deviation of your measurement samples. The accuracy of the final result will be limited only by the number of samples and your patience.

This digital frequency counter, which employs inexpensive RTL (resistor-transistor logic) IC's and surplus transistors, features digital readout and counting capability up to 20 MHz.* It can be used to:

1. Calibrate audio oscillators.
2. Check the 19-kHz subcarrier of stereo fm stations.
3. Check 3.579545-MHz television color subcarriers.
4. Determine the exact value of compensating capacitors for receiver local oscillators.
5. Monitor vfo drift.
6. Measure toroids for RTTY applications.

Bert Kelley, K4EEU, 2307 S. Clark Avenue, Tampa, Florida 33609

The home construction project that resulted in this counter was started several months ago as an educational study of the digital and integrated circuits that were beginning to appear in equipment with which I worked at WFLA-AM-FM-TV. It turned out to be a most interesting project, and the completed counter met and even exceeded my expectations.

in ten million should be obtainable. An idea of the magnitude of this measurement error may be had when you consider that one ten-millionth of the distance from San Francisco to New York is about 16 inches.

The input impedance is in the vicinity of 50,000 ohms, and the sensitivity varies from 0.05 V p-p at 1000 Hz to 1 V p-p at 15 MHz. Operation is automatic once the input level

Frequency counter with the control and time-base modules pulled out.

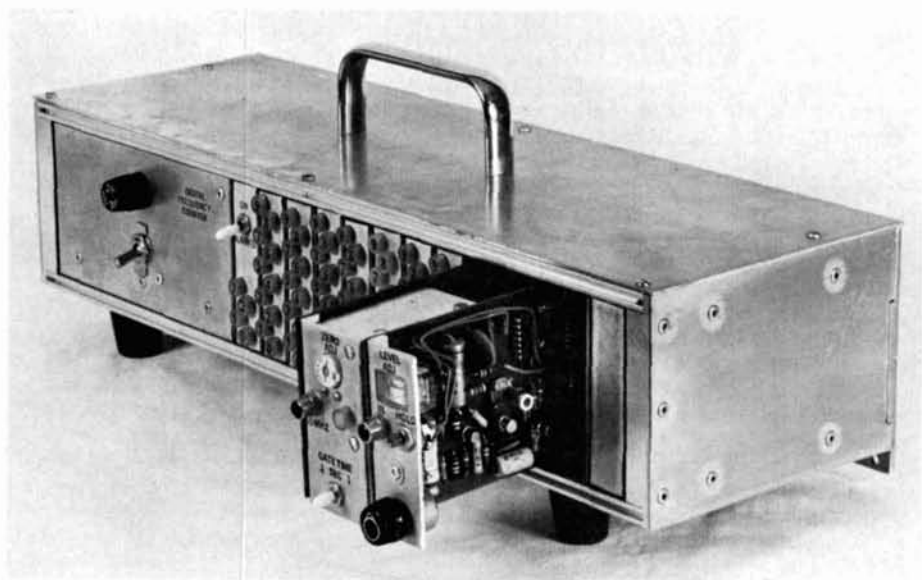

The accuracy of the unit depends directly on how accurately the counter crystal is zeroed with WWV. To this error is added the plus-minus one-digit error inherent in any electronic counter.¹ You should be able to obtain long-period accuracy of the order of one part in one million. With calibration checks against WWV, accuracies of one part

* The upper frequency limit of the counter depends on the particular batch of IC's you use and the ambient temperature. The author built two models of this counter; although the RTL IC's he used are only rated to 8 MHz, the first worked to 22 MHz, the other to 19 MHz. In tests here, I found that counting to 15 MHz was reliable—above this, it was necessary to adjust the level pot carefully to get meaningful counts. **Editor.**

control is adjusted.

The published information on Motorola MC790P RTL integrated circuits* rated the units to "toggle" to 8 MHz. However, my experiments indicated that it was possible to push this upper limit to the vicinity of 25 MHz. The counter decades were built so they could be interchanged, and I found that all decades would toggle above 16 MHz. This upper limit seemed to depend on the module's ambient temperature. The first completed model of the counter consistently counted to 22 MHz, while the second model,

* Data sheets are available. Write to Motorola Semiconductor Products, Box 955, Phoenix, Arizona 85001.

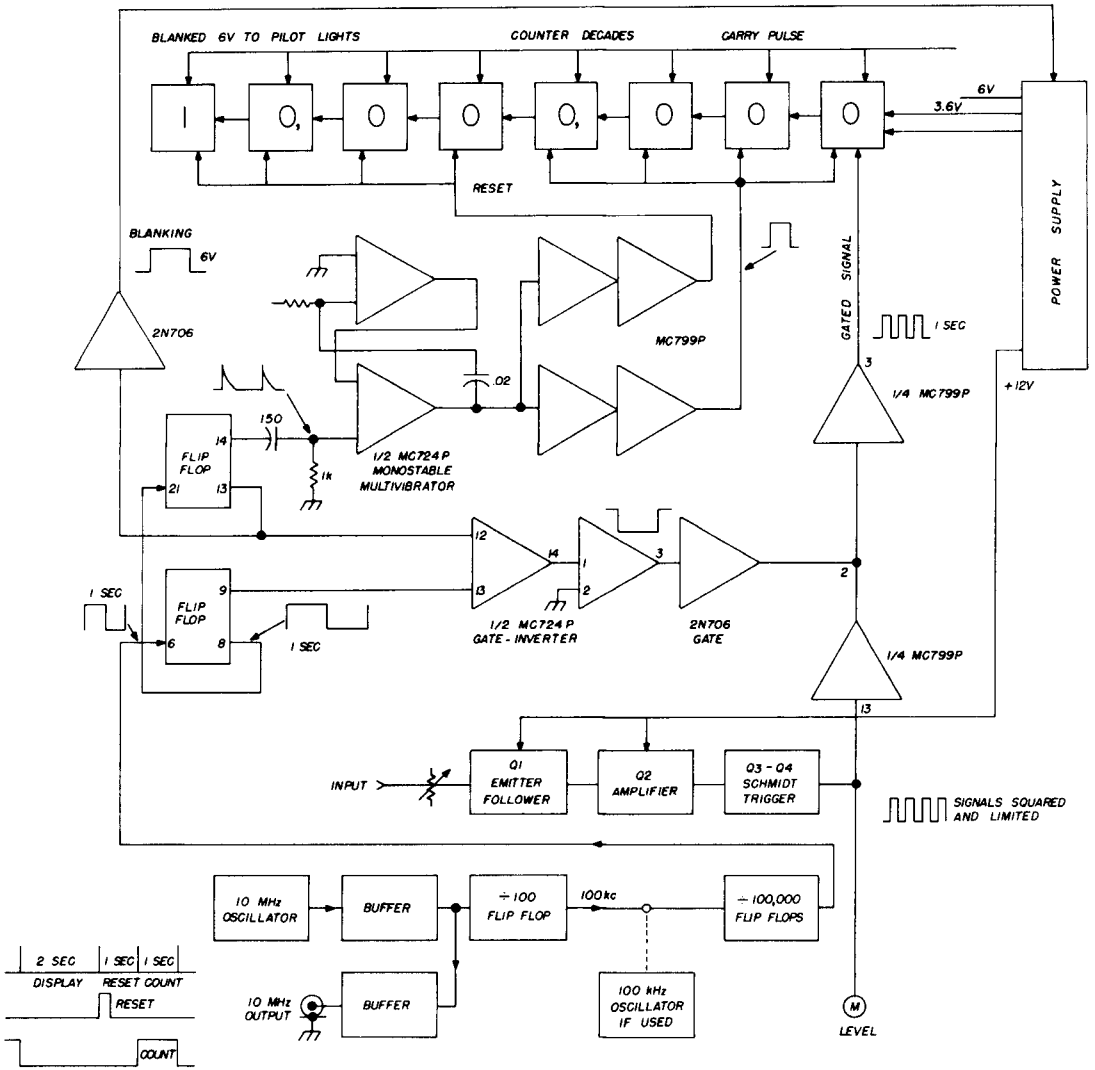

fig. 1. Block diagram of the digital frequency counter.

with MC790P's from a different production run, counted to 19 MHz. In any event, the performance well exceeds Motorola's ratings for these inexpensive integrated circuits.

circuit elements

The complete unit is moderately complex. It uses 48 IC's, 67 transistors, and 75 pilot lamps for indicating the measured frequency. The instrument consists of a time base (clock) module containing a 10-MHz crystal oscillator and associated dividers, a control module, the RTL counter decades, and a

power supply. It is compact but not crowded. Dimensions are four inches high by six inches deep by seventeen inches wide. The entire instrument weighs only nine pounds.

Plug-in, "building block" construction is used. The counter can be built in sections, and construction can be simplified by omitting some of the decades. If maximum accuracy is not required, a 100-kHz crystal can be used, thus eliminating four MC790P JK flip-flops. If an input impedance of 1000 ohms is satisfactory, the higher impedance input stage can be omitted. The 12-V sec-

tion of the power supply may then be omitted, since it won't be needed in the control module; also you can eliminate the blanking circuit for the indicator lights. Like most things, you get what you pay for; and the fewer the number of decades, the lower the upper count frequency.

The transistors are available in surplus at seven for a dollar. The IC's can be obtained from Allied for about two dollars each.

Three different readout methods are in general use in digital frequency counters; nixies, neon bulbs, and incandescent lamps. Of these, the lamps are the least expensive. The other two require a high-voltage supply, and there is also a strong possibility of cross-talk.

This counter, which features digital instead of binary readout, uses a design published by Lancaster,² and those interested are urged to refer to his article for additional information as well as for a source of decade parts. Other parts used in the counter are in the Allied industrial catalog and Meshna surplus listings.

Before attempting to build and test the equipment described in this article, you should have some experience with transistorized circuits. If your experience has been only with tube equipment, it is a good idea to take a course such as the RCA home study series. You will learn everything needed, and the subject matter is not too technical.

test equipment

Test equipment should include a multimeter such as the Simpson 260. If the meter has a polarity reversing switch, the meter can be used to check transistors and diode junctions. The current ranges can be used to check power consumption of the JK flip-flops. Each MC790P should draw from 40 to 50 mA. Transistors can be zapped very easily when checking them with a multimeter. Make certain there is no excessive voltage on the test leads.

It's convenient, but not absolutely necessary, to have a bench power supply than can be adjusted from zero to about 10 volts, at a rating of about 1 A.

As a minimum requirement a scope is necessary with a frequency response to 4 or 5 MHz. Many circuit malfunctions can be isolated with a low-priced kit scope. Much of

the work in the later stages of construction consists of adjusting circuits to extend the high-frequency counting range and tailoring bias circuits to fit the transistors. Furthermore, some transistors don't have the high-frequency response to give clean square waves in the signal processing circuit at 10 MHz. You will therefore need access to a

fig. 3. Time-base module using a 100-kHz crystal. This circuit may be substituted into fig. 2 if so desired.

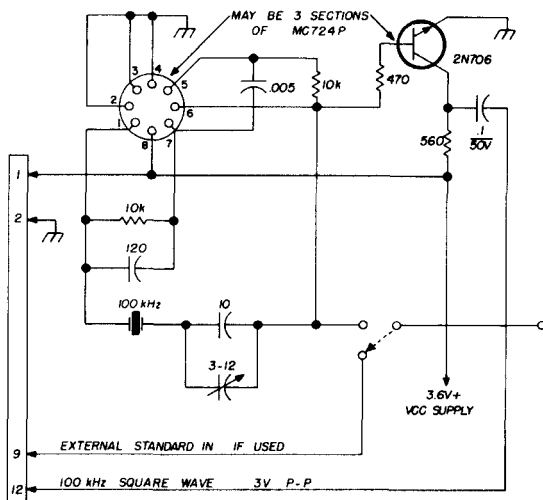

wide-band (15-MHz or higher) oscilloscope.

Two signal sources, an audio oscillator and an rf signal generator, are needed. You should also have a receiver that will tune WWV, of course.

circuit boards

IC's and printed circuit wiring permit compact construction without crowding. Kepro etching materials were used, but a possible alternate would be perforated Vector boards and hand wiring. The etched boards are preferred because of the close pin spacing on the IC's (0.1 inch center-to-center).

Using etched circuit boards is not at all difficult. Circuit layout is drawn full-scale on 10-line-per-inch paper. Hole centers are transferred with a sharp awl punch to the copper side of the board, using light taps. Holes are drilled with a number-60 drill, and burrs are removed by burnishing with crocus

cloth or emery paper. Circuit trails are then drawn in to match the paper layout. These connect the component mounting holes. The finished marking job must be carefully checked against the circuit diagram. After etching, the board is burnished again and is then ready for parts. It's a good idea to make a circuit extender board so modules can be tested under actual operating conditions.

Parts should be soldered using a 22-watt

ter described, Amphenol number 143-012-01 sockets were used in the first model and are recommended. If unetched circuit board is used, Amphenol number 133-012-21 mating connectors may be secured to the board with small machine screws. Pop rivets were used for much of the aluminum fastening. The etched board can be obtained from Meshna or Allied.

For ease in reading, the counter modules

fig. 4. Circuit that derives a time-base from the 60-Hz ac line. Stability compares favorably with a 100-kHz crystal-controlled time base.

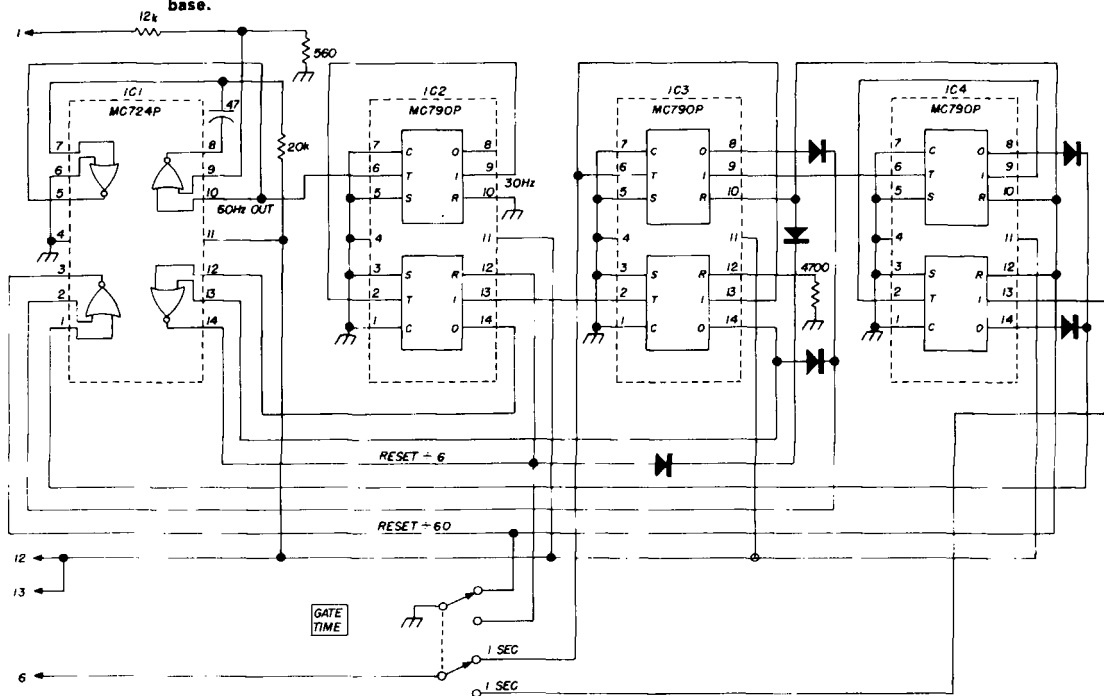

iron, with particular care given to the solder connections. Poor solder connections and hairline voids on printed circuit trails are the greatest cause of trouble. Proceed slowly, making sure there is a connection to the pins, and, when finished, examine the work closely for solder shorts to adjacent pins, etc. Etching instructions are packed with the Kepro circuit boards, and there is further useful information in the current Radio Amateurs Handbook, page 523.

construction

Two aluminum straps support the printed circuit sockets. Though not used in the coun-

ter should be arranged in line and as close together as practical. The indicator lights are special 50-mA bulbs obtained from the source given in reference 2. These come with small plastic holders and a supply of number decals. If desired, Allied number 60F7413 (Sylvania type 6ES) lamps are a satisfactory substitute. In any case it is necessary to get low current lamps to keep the total power requirements down and stay within the ratings of the lamp driver transistors.

The case is a military surplus version of an Elco Varipack printed circuit enclosure, fitted with extra Elco 63-9016-1204 slides. A local metal shop sheared a supply of 0.064-inch

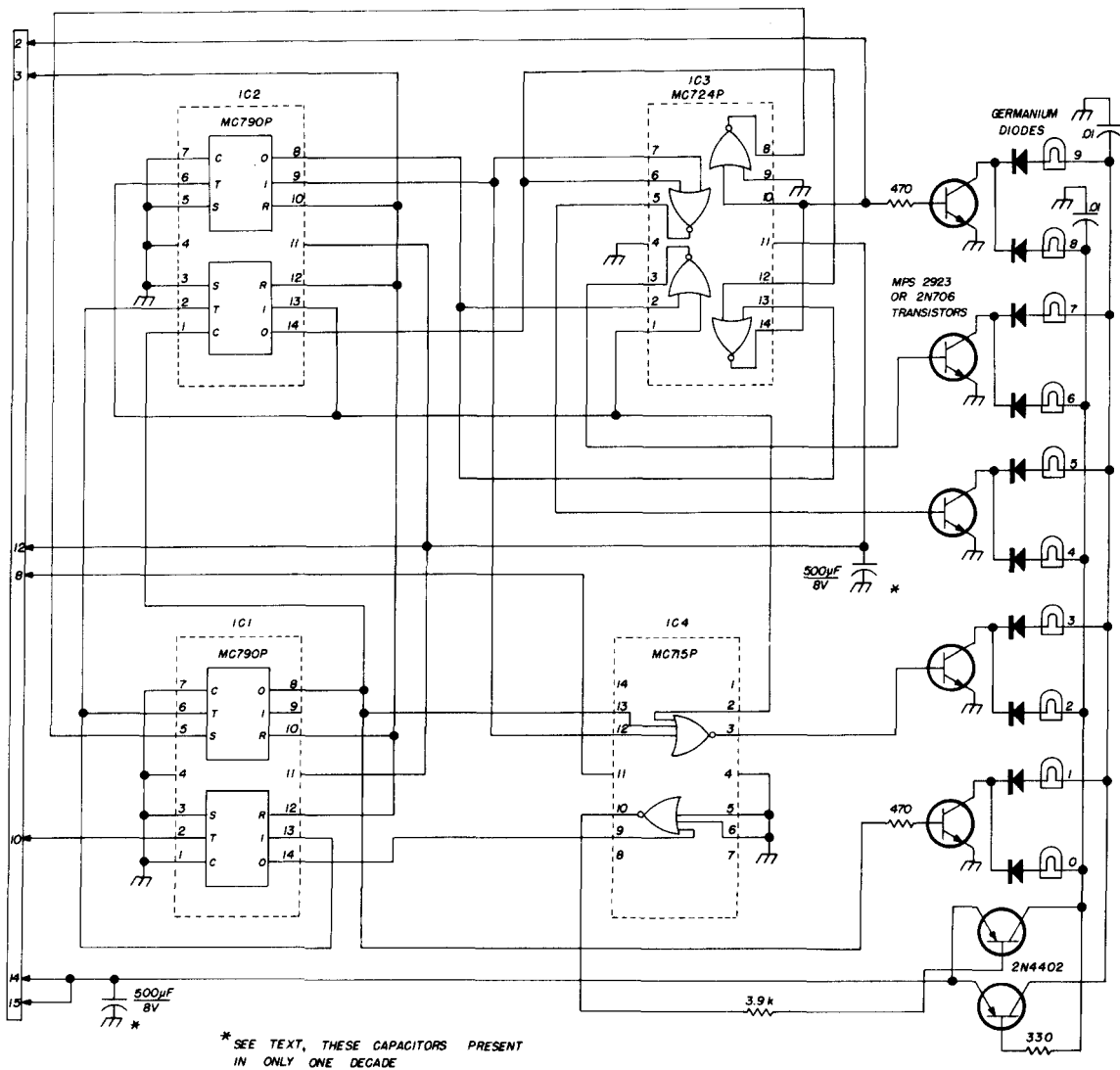

fig. 5. Decade counter module. Printed circuit board layout for this decade is shown in fig. 16.

aluminum to 3-inch widths for later use in constructing module fronts, and three other pieces were obtained for the sides and top. I left the bottom open, and mounted feet from an old TV set to raise the unit above the table to ensure air circulation through the modules.

power supply

The power supply should be constructed first. An aluminum tray approximately 6-inches wide is formed to fit the case. Parts

are mounted inside. Two power transformers are necessary; one is a miniature 12-V transformer for the crystal oven, and the other is an ordinary 6.3-V filament transformer. Parts should be arranged for most efficient utilization of space, and the fit is a little snug, especially if the 12-V supply is built (fig. 13). The power regulator transistors and power connection sockets are mounted on the back wall. A little silicon grease should be used on the transistor mica washers to aid in heat transfer.

After construction, the 3.6- and 6-V outputs should be loaded to about 1 A each and voltage and ripple checked. The supply must deliver between 3.6 and 4.0 V, and, if necessary, the output voltage can be adjusted by substituting slightly different zener diodes from an assortment available from Allied (stock number 24C9340) or by adding or removing the silicon diode in series with the regulator zener.

The hum content on the 3.6-V supply should be less than 0.1 volt p-p, but the 6-V supply is not as critical, and the surplus capacitor specified is sufficient. RTL IC's are sensitive to spikes and hum in the power supply, so it may be necessary to add 500- μ F/8-V electrolytic capacitors across the 3.6- or 6-V supply in other modules if it is suspected that the flip-flops are toggling on noise. Additional 0.01- μ F disc capacitors would be advisable.

The 12-V supply is necessary for the high-impedance input circuits in the control module, so if this is constructed, it should be checked for approximately 12-V dc with low hum content. There is no heavy drain on this supply, and it was built larger than necessary to permit future modifications in other modules.

time-base module

The time-base module (fig. 2) provides the precise signal that controls the time interval gate in the control module. It contains a crystal referenced to WWV and a divider network to divide the crystal frequency down to 10 or 1 Hz, depending on the setting of the gate time switch. The 1-Hz pulse is ideal for the initial checking of counter modules, therefore the time-base module should be constructed next.

fig. 6. Left-hand counter module. Because of the frequency limitation of the counter, this module only counts up to 3. Printed circuit board layout is shown in fig. 17.

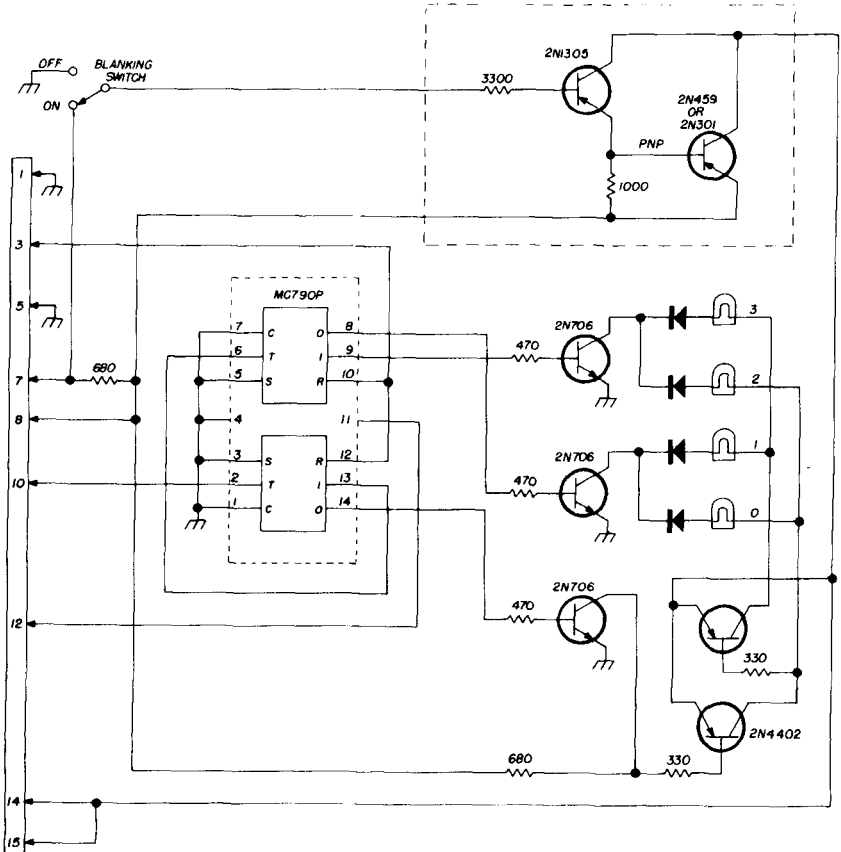

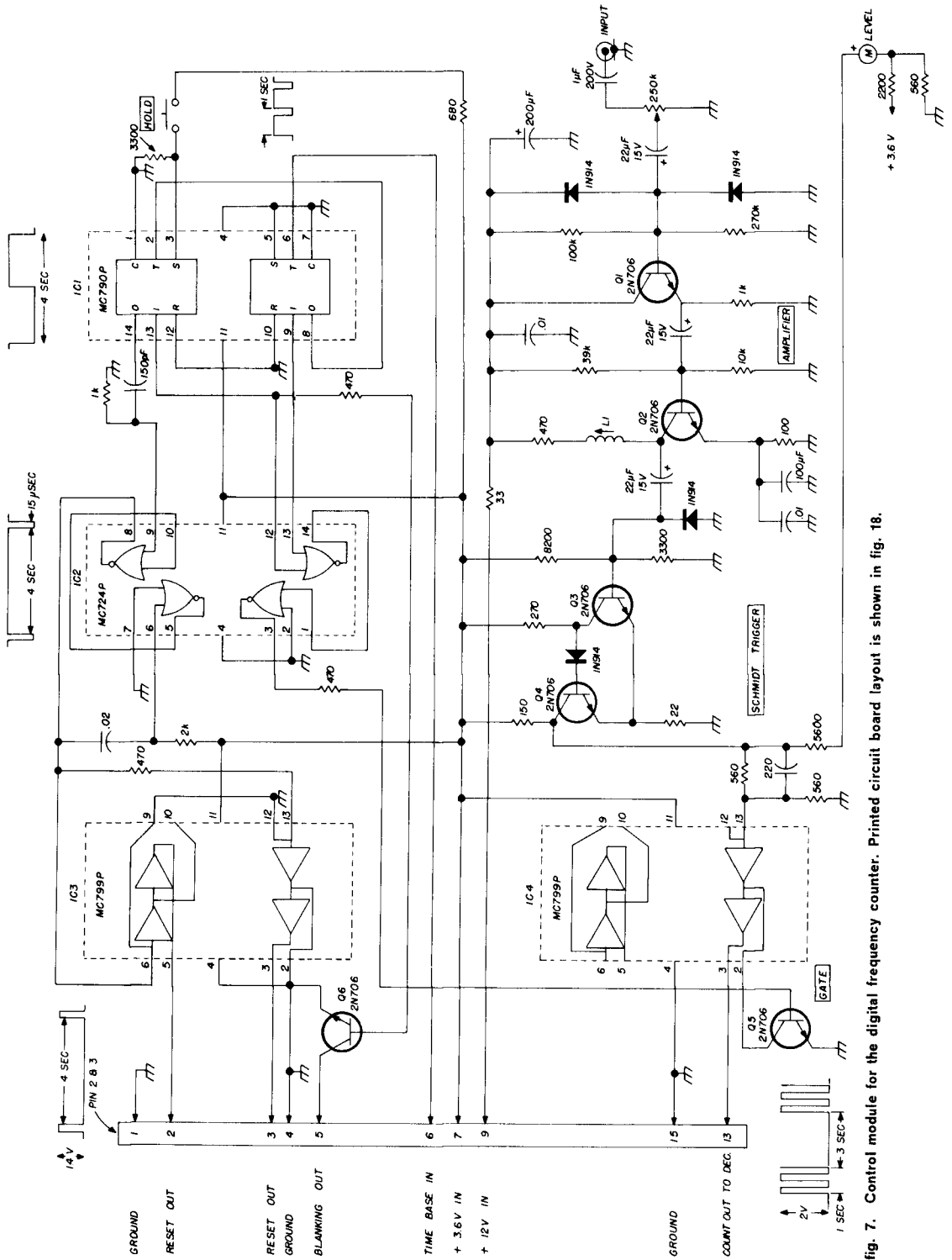

fig. 7. Control module for the digital frequency counter. Printed circuit board layout is shown in fig. 18.

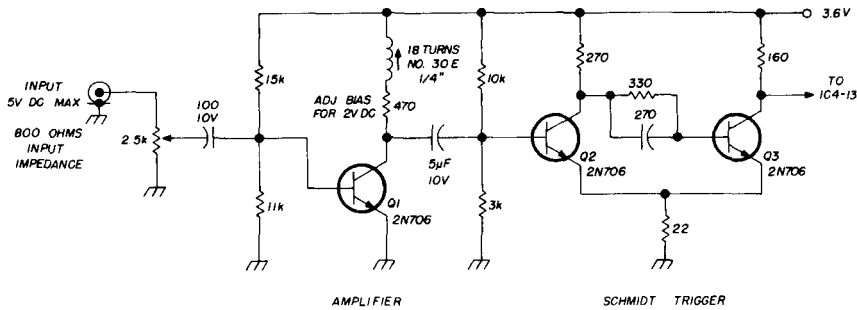

fig. 8. Alternative input circuit if high-impedance input is not required.

The time-base circuits were divided into two modules in the original model. The first contained a 100-kHz crystal and the dividers necessary to derive a 1-Hz pulse. This counter was operated for a time in this configuration, but the 100-kHz reference was later replaced with a 10-MHz reference oven. This oven oscillator and four MC790P dividers were constructed on another module, and the resulting 100-kHz signal was jumpered into the original time base module in place of the low-frequency crystal, which was removed.

The second version has all the components mounted in one module. This requires careful circuit layout and double deck construction. All oscillator components were mounted on a 1³/₄-inch × 1¹/₂-inch circuit board, which is mounted by a single tapped standoff pillar inside a small shield enclosure. The crystal oven plugs into a socket at the back of the enclosure, and as much unetched copper as possible was left beneath this enclosure to provide shielding, and small circuit trails were etched to provide an exit for 3.6 V dc, 12 V ac, and 10 MHz to the first divider pair. The board also contains a dual driver IC that is used for isolation and to provide a strong signal to the test jack.

After the oscillator assembly is checked out and zeroed with WWV, you can wire the first two MC790P dividers and check them for 1-MHz output. If this checks, wire MC790P JK flip-flops in pairs, checking each pair as you go for division by 10. Use care not to bend back the pins, and be sure the IC is oriented so the number 11 pin goes to 3.6 V before soldering as the IC's are difficult to remove, once mounted. If you have trouble getting the first divider pair working, check the 10-MHz signal at pin 2 with a wide-band

scope. The rf signal should rise from near zero to about 1.4 V p-p. If there is a large dc component, the JK will not toggle, so it will be necessary to make some adjustment to the bias on pin 6 of the MC799P. Remedies might include replacing the 2N706 emitter follower, adjusting the base bias on the oscillator, or modifying the value of the internal 1000-ohm resistor in the MC799P by substituting an external resistor. Temporary use of a 10k-ohm pot will quickly determine the optimum resistor size.

In this unit the crystal is a Collins oven from an AN/ARC-27 spectrum oscillator assembly operated with 12 V ac on the oven heater. If a small oven cannot be obtained, it would be worthwhile to mount an ordinary 10-MHz crystal inside the enclosure with the other oscillator components. The oscillator circuit is the most stable and non-critical of several tried, and any active crystal will oscillate, within a frequency range of at least 400 kHz to 10 MHz. Therefore it could be used with a 1-MHz oven with no changes except minor adjustment in the 22-pF series capacitor to permit WWV zeroing.

The divider outputs also can provide a variety of precise signals that can be used to check counter operation or for marker purposes. For example, with a 10-MHz crystal, 5 and 1-MHz; and 500, 100, 10, and 1-kHz square waves of approximately 1 V p-p are available for external use, provided that the output is not loaded too heavily. These waves have extremely fast rise times and high harmonic content. An alternative circuit for a 100-kHz crystal is given. This circuit puts out a nearly square wave that is ideal for direct connection to the JK flip-flops.

low-cost time base

After building the crystal-controlled 10-MHz time-base generator, I built another time base (fig. 4) to check the accuracy of the local power-line frequency. From comments in other articles^{4,6} it appeared that the true frequency was very close to 60 Hz. I found this to be true.

The 60-Hz time base was operated along with the 10-MHz time base. The 1-Hz pulse outputs were selected by a spdt switch; the counter was connected to a stable 10-MHz crystal oscillator for comparisons between the two time bases. With the 60-Hz line-frequency derived time base, readings were always within 1500 Hz of 10 MHz; usual

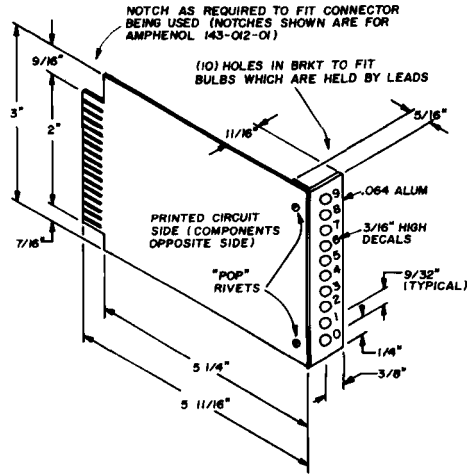
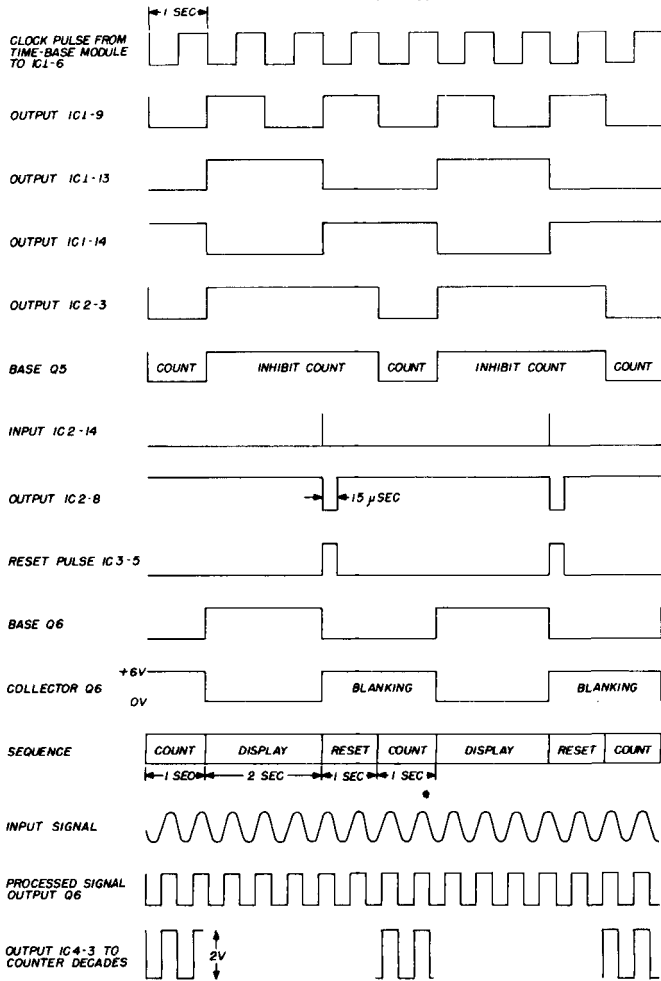

fig. 10. Typical module size and layout designed for Amphenol 143-012-01 receptacle. Printed circuit boards are Kepro type PI-365.

fig. 9. Control-module waveforms.



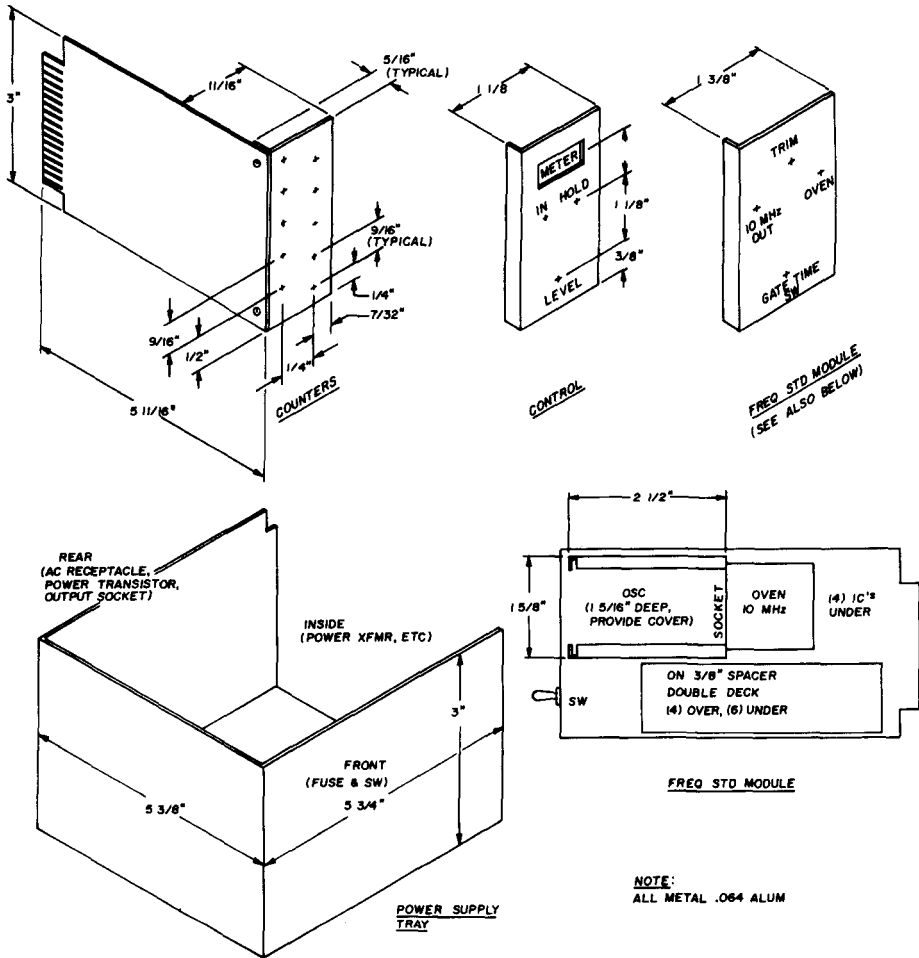

fig. 11. Module sizes.

readings were within 700 Hz of the true frequency. This works out to be a maximum error of 15 Hz per 100 kHz or 1.5 Hz per 10 kHz and compares favorably with an earlier counter that used a 100-kHz crystal-controlled time base. Performance with the 60-Hz time base was so good it doesn't appear worthwhile to use an ordinary 100-kHz standard since the 60-Hz unit can be built for one-third the cost.

On the negative side, short-term stability does not match the crystal. Readings changed continuously within the limits noted above. For example, on one count the reading might

be 200 Hz low and the next, 500 Hz high. Readings with the crystal-controlled time base never drifted any more than 1 Hz.

These variations are a result of the line voltage characteristics—there is no precise point on the ac waveform that stays constant—the waveshape and slope change from cycle to cycle. In addition, there are small voltage spikes on the line which can cause the monostable multivibrator to misfire. Once the one-shot has fired, the frequency division is very accurate, but the variation in trigger point is an unavoidable drawback of the power-line time base.

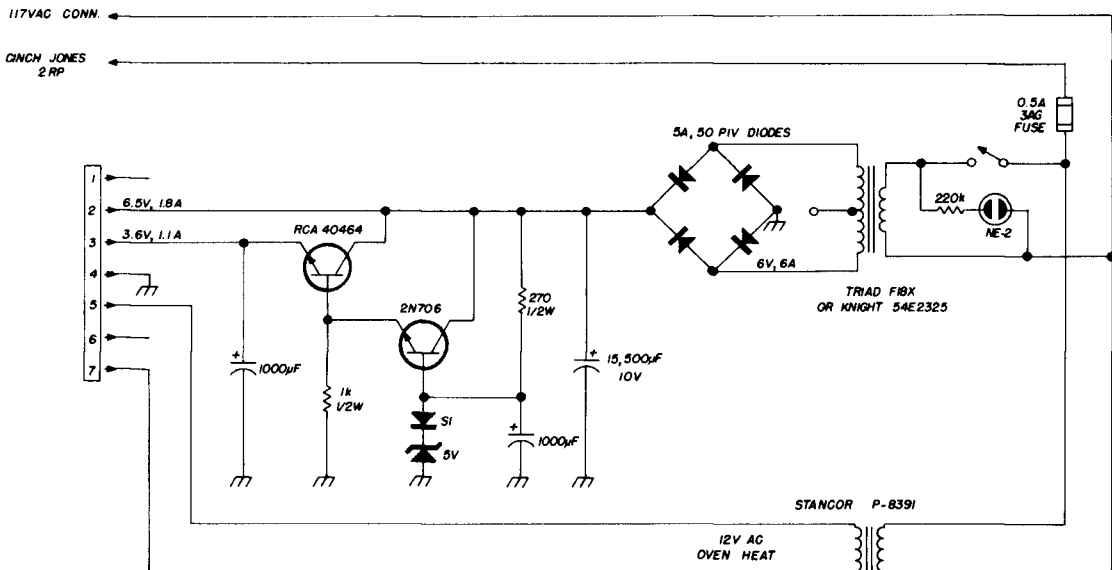

fig. 12. Power supply for the digital frequency counter.

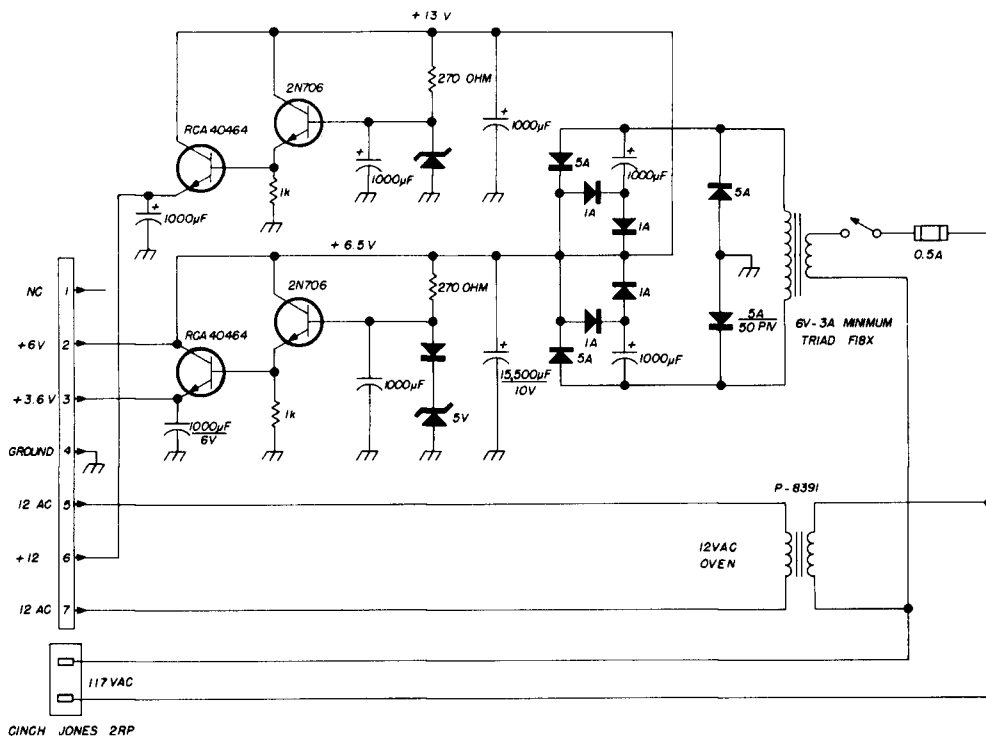

fig. 13. Power supply circuit if the high-impedance input circuit is used.

counter decades

If the counter decade kit* is used, construction can be relatively simple. The boards can be assembled and bolted to a bracket assembly that contains the indicator lights and the printed-circuit plug. There are some minor differences between the commercial kit and the counters used in this version.

In the commercial unit, 33-ohm swamping resistors were used to equalize indicator lamp drain, and all lights glow dimly all the

cating a count. Diodes were placed in series with each light to remove sneak paths. This eliminated two 33-ohm equalizing resistors. The current drain on the 6-V supply for each module dropped to 50 mA. The 6-V power for the lamps and the MC715P's was separated, and the lamp voltage was then controlled by a blanking circuit housed in the left decade. This decade is a simplified version of the others, and there is plenty of spare room for it.

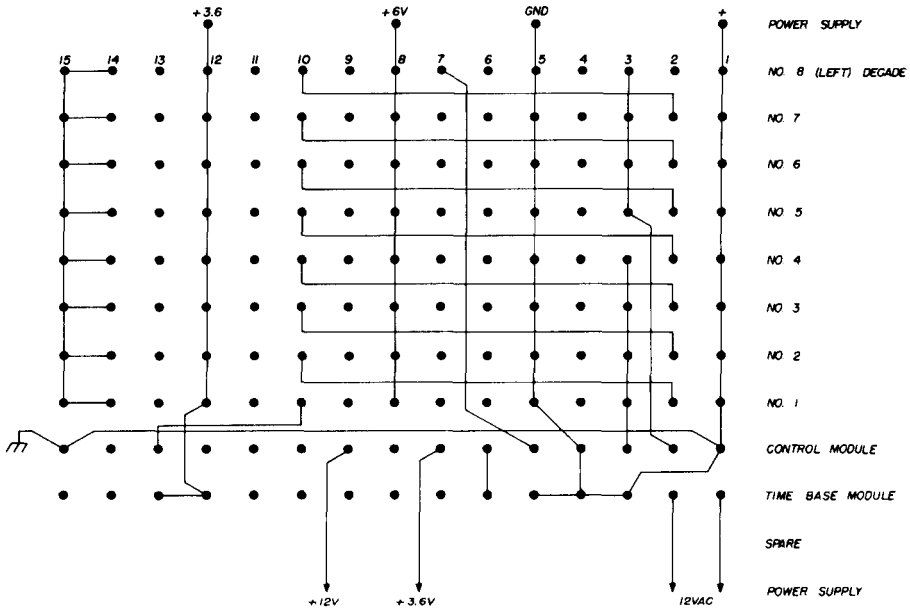

fig. 14. Module interconnections. This shows the wiring that must be run between the various circuit-board receptacles.

time. This greatly increases the total current drain on the power supply. The first version did use this swamping resistor circuit, however, and it worked very well. The pilot light glow is so dim that it is not a problem.

In the second version of the counter, I decided to include a blanking circuit to shut off lights during the time they were not indi-

Construction of the decades (fig. 5) is well covered elsewhere.² It's unnecessary to add more except to note that it's a good idea to check each light with an ohmmeter and to check the completed module for about 40 ohms between ground and the 3.6-V pin, observing ohmmeter polarity. The 6-V lamp circuit should also be checked for a short.

The completed decades can be checked by connecting the 1-Hz output from the time base module to the "count" input of the decade. When power is applied, the lights should advance at the rate of 1 each second, to the top of the decade, and start over again at zero. In the event of trouble, read

* Decade kits include etched and drilled printed-circuit board, set of 10 lamps with plastic covers and spare bulb, and complete set of electronic parts. Order from Southwest Technical Products Corporation, 219 W. Rhapsody, San Antonio, Texas 78216. \$12.00 postpaid in the U.S.A. One kit required for each decade.

10-MHz oscillator board

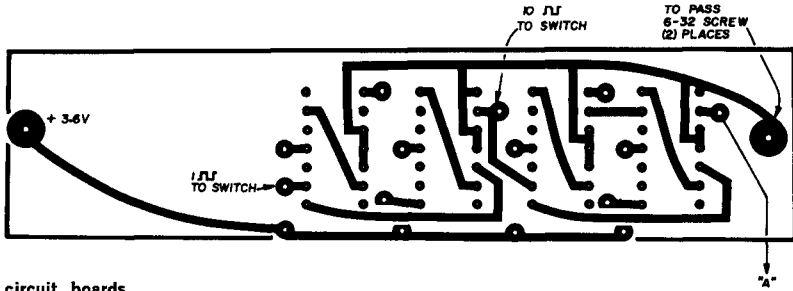
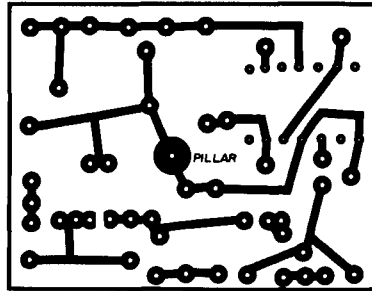
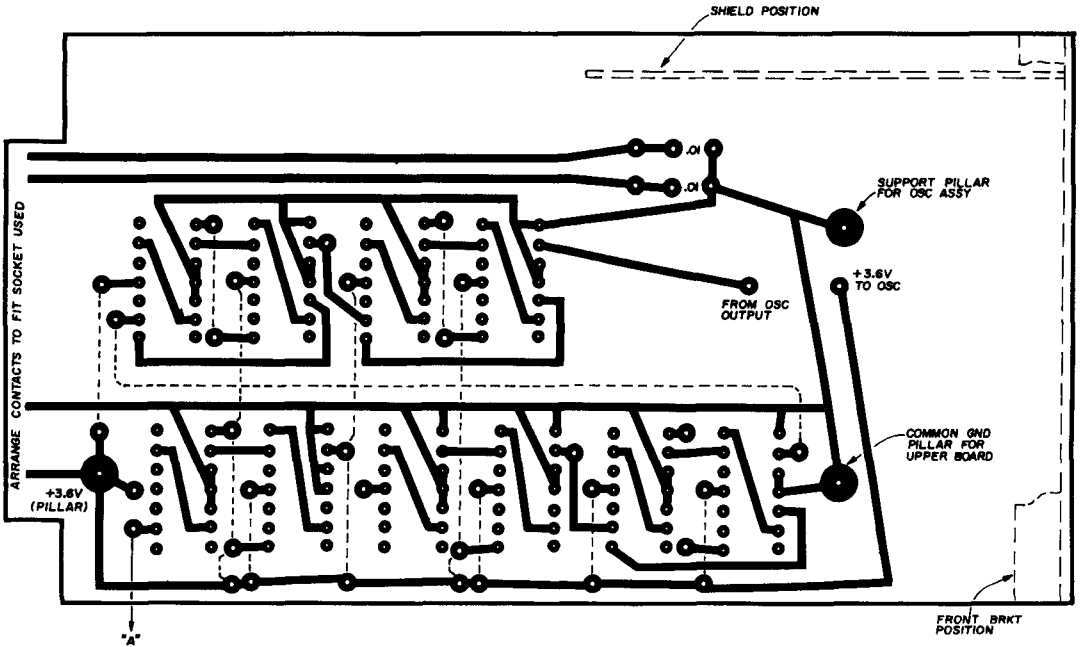

fig. 15. Printed circuit boards for the frequency-standard module. Boards are positioned as shown in fig. 11. Pillars are used for both support and as electrical paths.



Upper deck frequency divider



Basic control-module board. Small dotted lines indicate wiring underneath the board.

the circuit theory and check with a multi-meter or scope. It is worth keeping in mind that the IC's are the least likely to cause trouble.

control module

After three or four decades are finished,

the counter can read out audio frequencies, and the control module construction can begin. The control module (fig. 7) is the heart of the unit, so its circuits will be explained.

In order to count frequency in the electronic counter, several operations must take place in the proper sequence. The input sig-

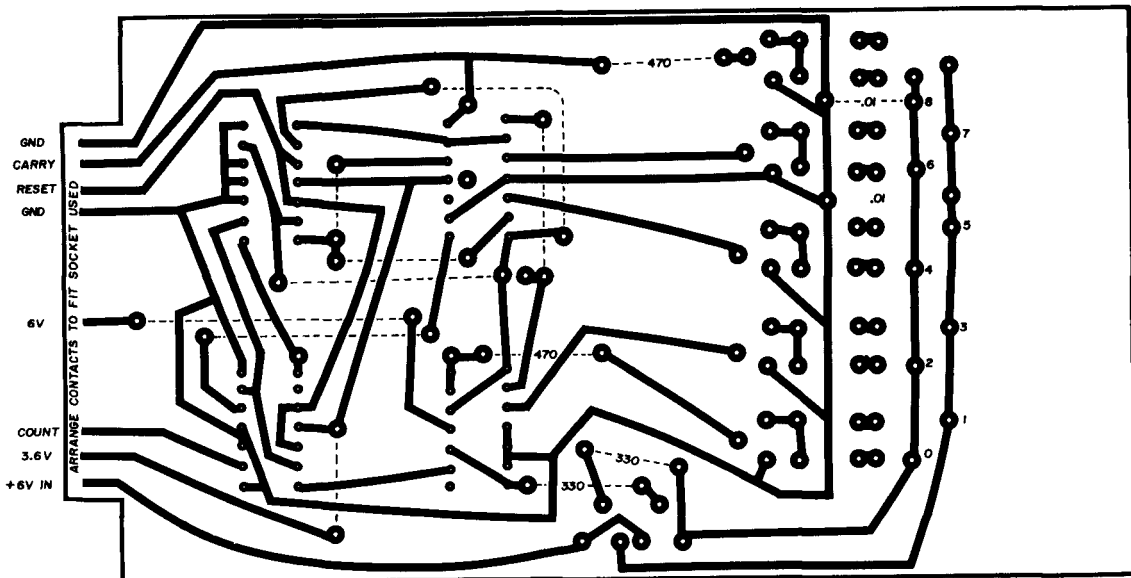

fig. 16. Printed circuit board for the decade counter.

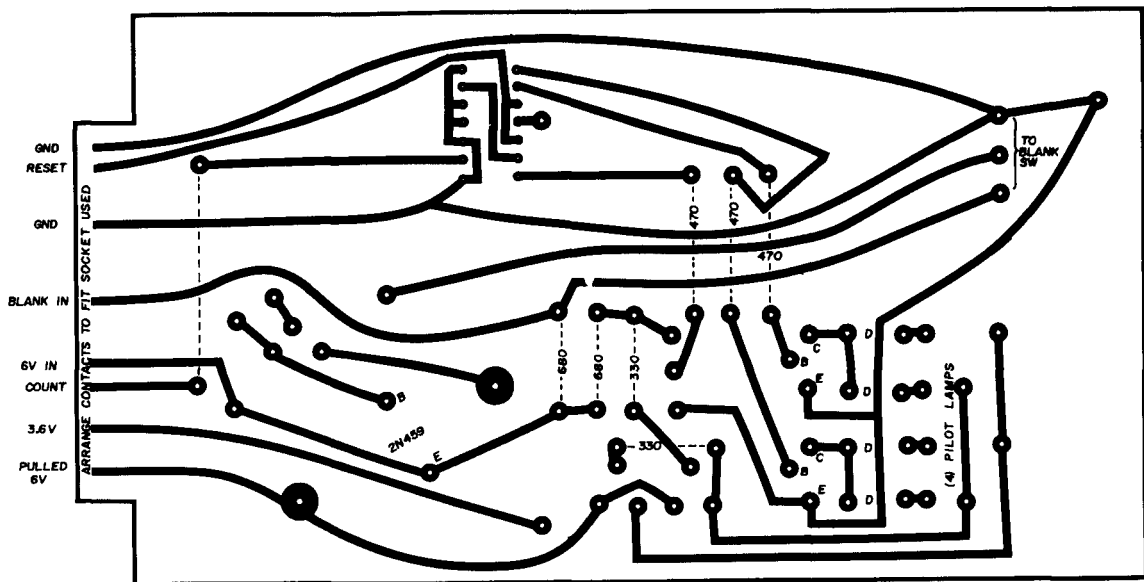

fig. 17. Printed circuit board for the left-hand counter and lamp blanking circuit.

nal must be shaped and limited so it has uniform amplitude and a fast fall time. The optimum fall time is in the order of 100 nanoseconds. The processed signal must then be gated on and off for exactly one second while the counting process takes place. A two-second interval then follows during

which the pilot lights are read. A reset pulse follows to reset all decades back to zero for the next count. The process then repeats.

input circuit

The signal enters the control module via the phono jack on the front panel and ap-

appears across the input level pot. The input impedance of the circuit is set by the high impedance of the emitter follower stage and the resistance of the pot. The limitations as to maximum dc input voltage is set by the rating of the 1- μ F coupling capacitor, and high voltage surges and excessive ac input levels are clamped by the two reverse biased diodes across the input line. These diodes aren't expected to stand extreme surges, so it is good practice to connect the counter with the input pot turned down. Note the 33-ohm resistor in series with the 12-V power supply that is intended to protect the power supply if these diodes short.

amplifier

The next stage is an amplifier with a passband from 20 Hz to 25 MHz. The inductor (L1) is a peaking coil to extend the frequency range and is composed of a 3/8-inch long winding of number-30 enamel wire on a Meshna number-479 coil form. The best way to adjust this circuit is to use a TV sweep generator, disconnect the 22- μ F capacitor at the junction of the 3300- and 8200-ohm resistors and substitute a 1000-ohm load to ground.

Connect the scope demodulator probe across this 1k resistor and vary the inductance until the passband extends to 25 MHz and falls off immediately after. Check the dc voltage from the 2N706 collector to ground to see if it is from 6 to 7 V. If not, the value of the 39k bias resistor must be changed. The idea is to drop half the supply voltage across the transistor.

Schmidt trigger

After the signal leaves the amplifier stage it enters the Schmidt trigger circuit. This circuit converts the input signal to a square wave. Due to the wide tolerances in transistors it is necessary to adjust the 8200-ohm bias resistor to the input transistor used, and it may be convenient to temporarily connect a pot to the circuit until the circuit is optimized. It is worthwhile to spend the time necessary to select the best transistors for the Schmidt trigger circuit.

Assuming the wide-band amplifier has been checked out and is working properly, the procedure is to connect an unmodulated

signal generator to the input jack and a wide-band oscilloscope to the 150-ohm collector load resistor. Temporarily disconnect the 220-pF mica coupler to the MC799P. With no input signal the voltage on the collector of Q3 is high. Adjust the 8200-ohm resistor bias until Q3 is on the stable edge of conduction.

Now a signal applied to the base of Q3 causes it to conduct, the collector voltage drops sharply, dropping the forward bias on Q4 base, and the greatly reduced current through Q3 reduces the emitter bias on the 22-ohm resistor. This reduced bias accelerates the action in Q3 until Q3 reaches saturation. Q3 in saturation cuts off Q4 until the reverse polarity of the incoming signal again exerts control on Q3 base and starts a reduction in Q3 collector current. The reverse action then takes place with Q4 in saturation.

With an input signal of from 6 to 10 MHz, the Schmidt trigger should provide a good square wave of approximately 50-percent duty cycle at a noncritical adjustment of the input level pot. The square wave will be rounded somewhat at 10 MHz (possibly due to the scope used here), but should have excellent waveform at 4 or 5 MHz. If it does not, substitute new transistors for Q3 or 4 and try different diodes. The purpose of the diode from Q3 base to ground is to clamp Q3's bias with input level changes and aid in obtaining a 50-percent duty cycle square wave. The diode coupler between Q3 and Q4 further sharpens signal transitions.

Once the Schmidt trigger is working properly, the 220-pF capacitor can be reconnected and the 470-ohm resistor in the Q5 gate base circuit lifted. Check the 10-MHz at pin 3 of the MC799P (IC4). It should have a good waveform. The MC799P extends the frequency range of the counter, due probably to the fact that it drives the counter decade with a low impedance driving source.

the level meter

Since the input signal must drive Schmidt trigger Q4 properly if the unit is to count, use is made of this to operate a level meter connected to Q4's collector. This meter is not absolutely essential to the operation of the counter, but it is very useful and is recommended. The best meter located so far is a Calrad EW75L level meter with a 140- μ A

movement. I was unable to locate a second Calrad meter for this version of the counter and therefore used a Lafayette meter from a Citizen's Band transceiver of unknown type number. It is adequate, and the main thing to keep in mind when searching for a substitute is to try to locate a 100- to 150- μ A movement. Modify the 5600-ohm resistor as required to make the meter read properly

base is near zero volts. When pin 9 of IC1 goes positive, it shuts off Q5 gate, and the gate remains shorted for the following three seconds.

After a two-second interval, the voltage on pin 14 of IC1 rises, and a spike is coupled through the 150-pF capacitor. This triggers the one-shot section of IC2, and it puts out a pulse 15 micro-seconds long. This pulse is

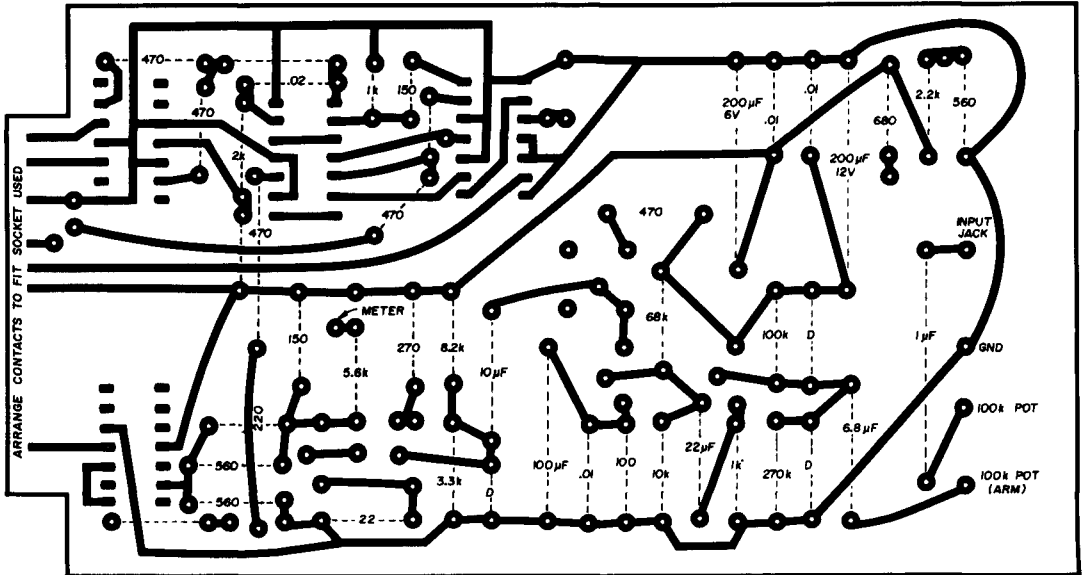

fig. 18. Printed-circuit board for the control module.

when the trigger is working under optimum conditions, then reconnect the 470-ohm resistor on Q5 base.

gate switch

Once the signal is properly processed, it must be gated on and off. This is accomplished by the three integrated circuits in the control module. The MC790P (IC1) divides the 1-Hz time base signal to 0.5 Hz and 0.25 Hz. These two signals are then applied to a gate that provides an output at pin 14 of IC2 only when both signals to pin 12 and 13 on IC2 are low at the same time. This is the count interval. It is coupled by the inverter stage of IC2 to the base of Q5 gate.

Q5 acts as a short to the count signal when its base is high, and passes the count signal during those 1-second intervals when the

inverted and amplified in both sections of IC3, and the two outputs reset 4 decades each. The reset pulse occurs during a one-second interval just prior to the count. Therefore there is more than sufficient time for the reset action (15 μ s) to take place.

The "hold" button holds up the count-reset process so that a multi-digit count can be read easily from the pilot lights. It holds the voltage on pin 13 of IC1 to a "high," and therefore the counter will not reset or count until the button is released. It can be pressed to hold the next count anytime after the reset action has taken place.

Since the 4-second count time is a little slow for adjusting some equipment, the action can be speeded up by switching the "gate time" switch on the time-base module to 0.1 second. This speeds up the process by a

factor of 10 and also results in the counter dropping the last digit. The whole count shifts to the right one decade. This is a convenient position when accuracy down to the last Hz is not needed. It follows that a 3-decade counter will then count four digits; however it is not practical to speed up the count by another factor of 10 to save decades, because the incandescent pilot lights will not follow the count.

blinking circuit

Since the reset pulse sets all counter decades to zero for the next count, the light action should alternate from a row of zeros to the final count alternately unless a blanking circuit is provided. It is easier to read the count if only the final count is presented and lights are off at all other times.

When the reset and count action is taking place, pin 13 of IC1 is zero. This is applied to the base of Q6, which generates a 6-V pulse at its collector that is used in module 8 to control the circuitry that turns off the lights. When the voltage at Q6 collector is high (6 V), it cuts off the 2N1305, which in turn shuts off the 2N459 power transistor. When the voltage at Q6 collector swings to zero, the 2N1305 is forward biased and turns on the power transistor. This supplies voltage to the pilot lamp circuit, and the lamps that have been enabled by the count circuitry are then lighted.

in the event of trouble

If there is any difficulty in the IC1, IC2, IC3 (control module) circuit the easiest procedure is to use a dual-trace scope and check simultaneous waveforms. Since the 15- μ s reset pulse is too fast for easy observation, it is convenient to disconnect the 1-Hz output from the time base module temporarily and substitute the 10-kHz output at the junction of one of the divider pairs. This will speed up the action in the gating reset circuit so that it is more easily followed.

Many hints have already been given that will help in trouble-shooting. In particular, try to debug each assembly as it is finished. If all trouble shooting is left until last, the possible combination of difficulties can be almost overwhelming, or even doom the project.

In the event of trouble with the counter modules, you should carefully note what lights do light, and in what order. If a 1-Hz input pulse is applied to the input count pins, JK flip-flop action can be verified by using a multimeter at the flip-flop output terminals. A good flip-flop will show an alternating 0 and 1-V output, while a JK that is hung up will show a fixed 1-V or 0-V output. A hang-up usually means a poor solder connection or short somewhere.

In general, if two or three lights don't light, the JK's are all right, and the trouble is in some circuit common to these lights. This can be deduced by examining the counter block diagram (the one for decades only). Do not overlook the possibility of bad transistors, but if transistors have been previously checked on an ohmmeter before insertion, it is usually more productive to signal trace than to interchange transistors blindly. Dim pilot lights are caused by low beta transistors and by defective lamps.

Most of the hard-to-find parts are available from Allied Radio, 100 N. Western Avenue, Chicago, Illinois 60680. Here is a list, along with Allied catalog numbers, price and shipping weight. Be sure to include enough for postage.

Amphenol 143-012-01 receptacle, Allied 47F2675, \$1.21, 3 oz; Amphenol 133-012-21 plug, Allied 47F2857, \$2.45, 2 oz; Motorola MC724P quad 2-input NAND/NOR gate, Allied 50F26MC724P-MOT, \$1.08, 1 oz; Motorola RTL MC790P dual JK flip-flop, Allied 50F26MC790P-MOT, \$2.00, 1 oz; Motorola MC799P dual buffer, Allied 50F26MC799P-MOT, \$1.08, 1 oz; zener diode assortment, Allied 24C9340, \$1.98, 4 oz.

references

1. See the Hewlett Packard test instrument catalog section on electronic counters. Also refer to *Electronics World*, October, 1967.
2. D. Lancaster, "Low Cost Counting Unit," *Popular Electronics*, February, 1968, p. 27.
3. D. Lancaster, "For Low Cost, Count on RTL," *Electronics*, January, 1968.
4. J. Hall, "Binary-Decimal Counter," Technical Correspondence, *QST*, April, 1968, p. 54.
5. R. Suding, "Cheap and Easy Frequency Counter," 73, November, 1967, p. 6.
6. G. Jones, "An Integrated Circuit Electronic Counter," 73, February, 1968, p. 6; additional notes, 73, June, 1968, p. 74.

ham radio

Take a good first look at the new HQ-200 general coverage receiver.

At only \$229.50, you won't need a second look.

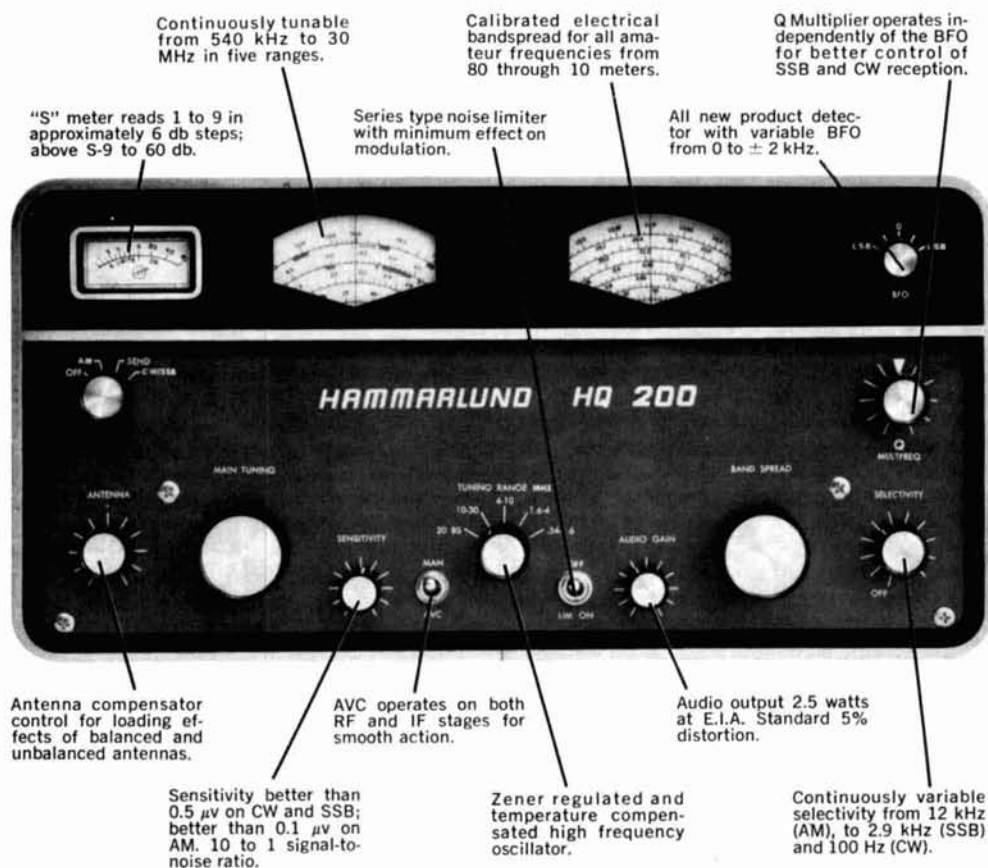

Write for the HQ-200 catalog sheet and a CQ magazine review of the outstanding HQ-215 Solid State Communications Receiver.



The **HAMMARLUND**
Manufacturing Company Incorporated

A subsidiary of Electronic Assistance Corporation
73-88 Hammarlund Drive, Mars Hill, North Carolina 28754

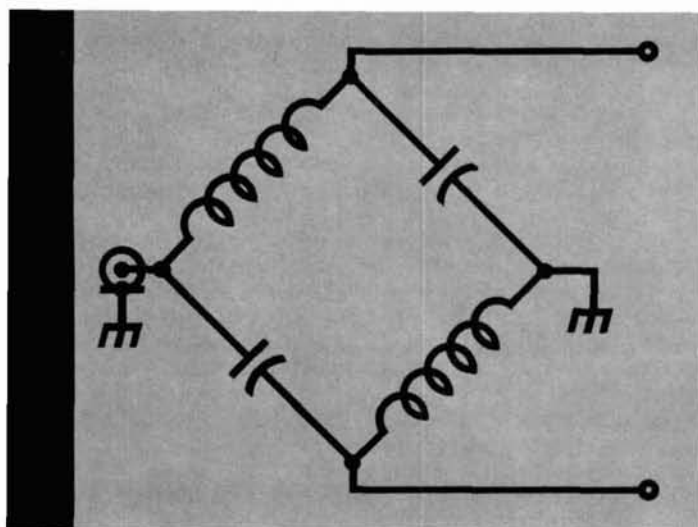

wide-band bridge baluns

Bill Orr, W6SAI, Manager, Amateur Service,
Willy Sayer, WA6BAN, Project Engineer,
Eimac Division of Varian

Various balun designs have appeared in the literature which provide a match between balanced and unbalanced systems over various bandwidths and which have transformation ratios of 4-to-1 or 1-to-1.^{1, 2, 3}

However, these devices don't solve the problem of matching an antenna with a radiation resistance higher or lower than the nominal 50-ohm value of many coaxial transmission lines. In addition to the desired balancing action, the matching circuit may be called upon to match the transmission line to a load which does not have a 4-to-1 or 1-to-1 ratio to the line impedance.

A single-band Yagi, for example, exhibits a typical radiation resistance value of about 20 ohms, while a quad antenna may have a

radiation resistance in the neighborhood of 80 to 100 ohms. How may these devices be properly matched to a 50-ohm unbalanced transmission line? The lumped-constant, symmetrical-bridge balun is the answer.

This simple balun with the unwieldy name is suitable for use as a broad-band

operational bandwidth of the balun decreases, as discussed later in the text. This tradeoff of bandwidth for transformation ratio should cause the user no pain, as it is common to all matching devices of this type. Realistically, it is possible to maintain good operational bandwidth (say, over a 2-to-1 frequency span) within the impedance transformation ratios normally encountered in amateur practice. Thus the bridge balun is ideally suited for a monoband- or a triband-beam antenna system.

Two articles^{4, 5} provide information for designing symmetrical lattice-style bridge baluns, and these articles are the basis for the graphical information in this article. The graphs reduce calculations to a minimum and make home construction of practical bridge baluns a simple task.

the bridge balun

A symmetrical bridge circuit can be used as a broad-band matching device as shown in **fig. 1**. To design a useful balun, the required transformation ratio in terms of the input and output impedances must be known and the desired operational bandwidth specified. The following design procedure determines balun constants, defines bandwidth and indicates the magnitude of introduced swr caused by the addition of a balun to the antenna system.

The inductance (L) of each balun coil and the value of the associated capacitance (C) may be determined from the following design formulas:

$$Z_m = \sqrt{Z_1 \times Z_2} \quad (1)$$

$$f_m = \frac{f_1 + f_2 - f_1}{3} \quad (2)$$

$$L = \frac{Z_m}{6.28 \times f_m} \quad (3)$$

$$C = \frac{10^6}{6.28 \times f_m \times Z_m} \quad (4)$$

$$R = Z_1/Z_2 \text{ or } Z_2/Z_1 \quad (5)$$

fig. 1. The lumped-constant symmetrical-bridge balun acts as a balancing device and transformer. One side of the input may be grounded without disturbing balance. For proper operation, no coupling should exist between the coils. The circuit is redrawn in B to illustrate the bridge.

matching device capable of coupling an unbalanced 50- or 70-ohm transmission line to a balanced load within the range of about 5 to 1000 ohms. The operational bandwidth of the balun is greater as the transformation ratio between line and load becomes smaller, and it is **theoretically** possible to maintain a 1-to-1 balun transformation over an infinite frequency range.

As the transformation ratio increases, the

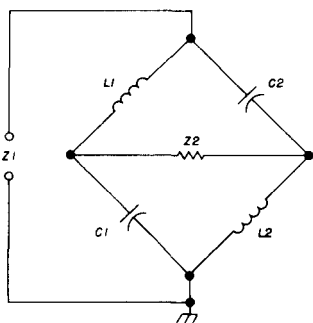
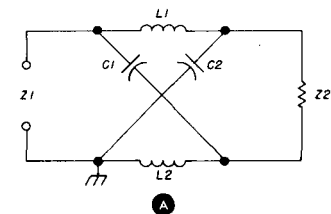

$$L_1 = L_2 \quad C_1 = C_2 \quad Z_1 = \frac{2(Z_L \cdot Z_C) + (Z_L + Z_C)Z_2}{Z_L + Z_C + 2Z_2}$$

where:

- Z_m = design factor of the balun in ohms.
- Z_1 = input impedance in ohms.
- Z_2 = output impedance in ohms.
- f_m = mid-frequency point of the design range in MHz.
- f_1 = lower-frequency limit of the design range in MHz.
- f_2 = upper-frequency limit of the design range in MHz.
- L = inductance in microhenries.
- C = capacitance in picofarads.
- R = transformation ratio.

The general steps for determining the circuit constants and typical operational bandwidth of a particular balun design are:

1. Determine f_1 and f_2 and the maximum desired swr limit at these frequencies.
2. Solve eq. 1 for Z_m .
3. Solve eq. 3 and 4 for balun components L and C.
4. Determine the typical operational bandwidth of the balun from appropriate charts (fig. 4 and 7).

bridge balun for a yagi

As a practical example, a bridge balun will be designed to match a 22-ohm balanced load (the split driven element of a three-element parasitic-beam antenna) to a 50-ohm unbalanced transmission line. The balun is specified to work at any frequency between 14 MHz (f_1) and 30 MHz (f_2). Determine the

constants of the balun and the typical operating range defined by the 1.5:1 swr points* at the feed terminals.

Therefore: $Z_1 = 50$ ohms and $Z_2 = 22$ ohms. From eq. 1, $Z_m = 33$ ohms; from eq. 2, $f_m = 14 + 16/3 = 19.3$ MHz; from eq. 3,

* Swr limits for a transmission-line system are somewhat arbitrary and are usually chosen to provide a reasonable load for the output matching network of the transmitter, generally 2:1 or less.

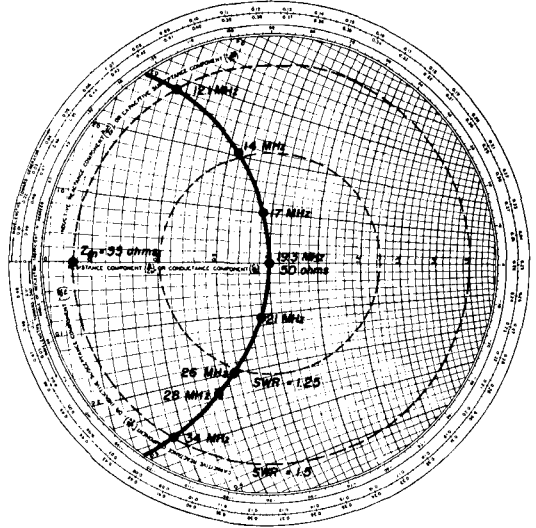
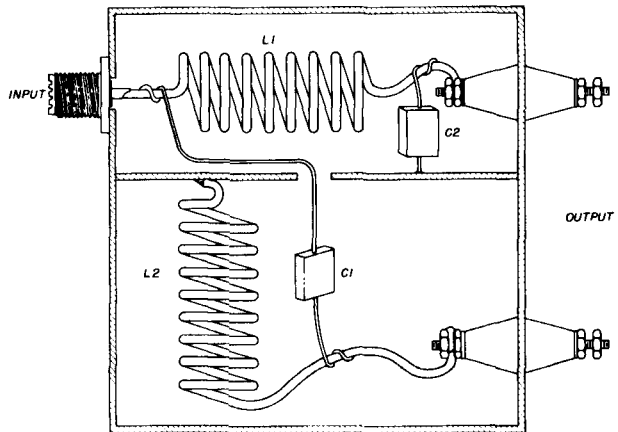

fig. 3. Smith chart* plot of a bridge balun designed to match the balanced 22-ohm input impedance of a three-element beam to 50-ohm coax. The swr plot passes through the swr = 1.5 circle at 12.1 and 34 MHz; swr is less than 1.25:1 between 14 and 26 MHz.

fig. 2. The bridge balun should be built in a shielded box with a center partition running the length of the interior. The coils are placed at right angles to each other. For up to several kilowatts, the capacitors should be ceramic types such as the Centralab 850 series; for 100 watts or so, 500-V silver micas are suitable. For higher power levels, it's recommended that the coils be made from small commercial air-wound inductors wound with number-14 wire.



$L = 33/6.28 \times 19.3 = 0.272 \mu\text{H}$; from eq. 4, $C = 10^6/6.28 \times 19.3 \times 33 = 250 \text{ pF}$; and from eq. 5, $R = 50/22 = 2.28$. The balun constants are shown in fig. 2. As a cross check on your mathematics, the derived values of L and C should be resonant at the mid-frequency point (f_m).

$$\text{lower-frequency limit, } f_1 = k_1 \times f_m \quad (6)$$

$$\text{upper-frequency limit, } f_2 = k_2 \times f_m \quad (7)$$

where k_1 and k_2 are simple unit ratios as shown in fig. 4.

To determine f_1 and f_2 , the maximum swr

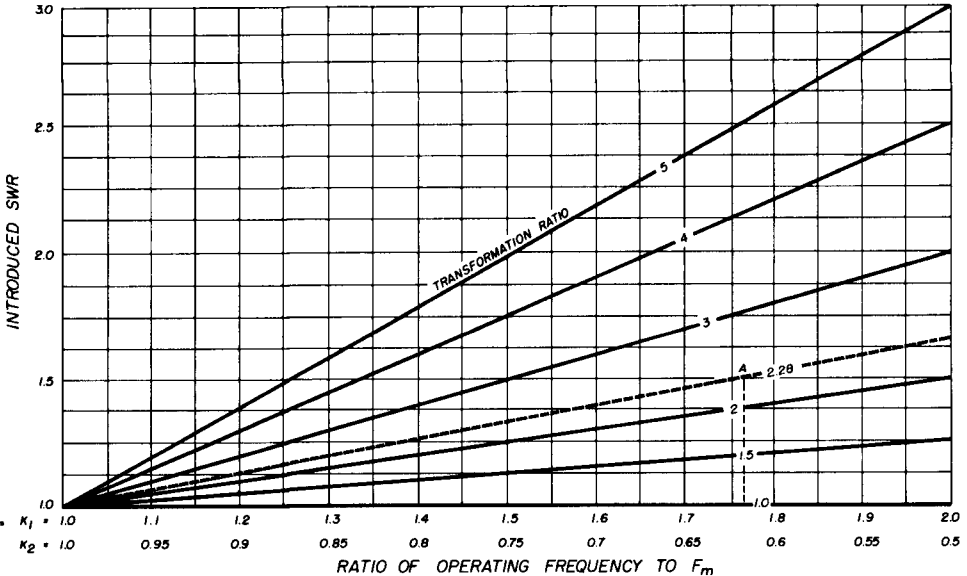

fig. 4. Introduced swr vs operational bandwidth. If the transformation ratio is known, the introduced swr of the balun can be calculated for any operational bandwidth from one-half ($0.5f_m$) to twice the design frequency ($2f_m$). In the example shown, for a transformation ratio of 2.28 and swr less than 1.5:1, the upper and lower frequency limits are $1.76 f_m$ and $0.63 f_m$.

operational bandwidth

The broadband characteristics of the bridge balun can be determined by plotting the introduced swr of the balun against a ratio of the center frequency, f_m , as shown in fig. 4. As mentioned earlier, the band pass of the balun is inversely proportional to the impedance transformation ratio R .

In the case of the Yagi balun just discussed, the transformation ratio is 2.28, and it is desired that the swr be held to 1.5 or less when the balun is terminated in a "perfect" load. Under these limitations, what is the operational pass band of this design?

The upper- and lower-frequency limits defined for a chosen value of maximum swr are determined by these formulas:

limit is found on the y-axis and the coordinate is traced across the graph until it intercepts the proper ratio line. In this case, no line exists for a ratio of 2.28, and the line must be estimated (dashed line). The intercept is at point A. The intercept of A on the x-axis indicates that k_1 and k_2 are 1.76 and 0.63, respectively. Accordingly, the k factors are applied in eq. 6 and 7 to the mid-frequency point of the design range, f_m , as follows:

$$\text{lower-frequency limit, } f_1 = 0.63 \times 19.3 = 12.1 \text{ MHz.}$$

$$\text{upper-frequency limit, } f_2 = 1.76 \times 19.3 = 34 \text{ MHz.}$$

The operational bandwidth of this design, for a maximum introduced swr of 1.5, is thus 12.1 to 34 MHz.

* An expanded Smith chart is used, the General Radio 5301-7561-NE.

swr at 20, 15 and 10 meters

The typical introduced swr on the 20-, 15- and 10-meter bands may be determined by establishing k , then using **fig. 4** in a reverse manner to that outlined above. The nominal value of k for each band is:

$$k = \frac{\text{desired frequency (MHz)}}{\text{mid-frequency point (MHz)}} \quad (8)$$

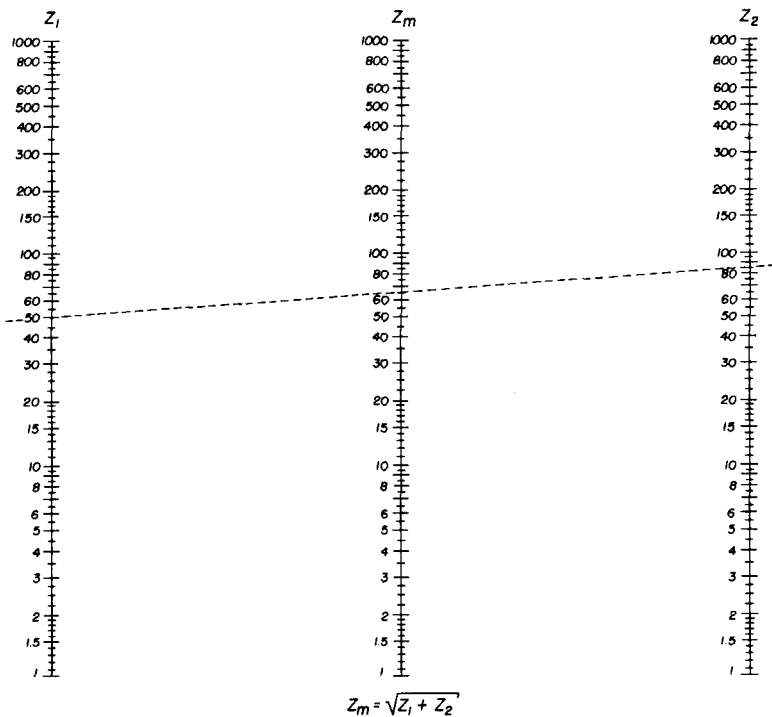

fig. 5. Nomograph to determine Z_m from Z_1 and Z_2 . The design factor, Z_m , of a bridge balun can be determined by laying a straight edge across Z_1 and Z_2 and reading Z_m on the middle scale. In the example shown, $Z_1 = 50$ and $Z_2 = 85$; $Z_m = 66$ ohms.

For 20 meters, $k = 14/19.3 = 0.725$; for 15 meters, $k = 21/19.3 = 1.09$ and for 10 meters, $k = 29.7/19.3 = 1.53$.

The typical introduced swr for these bands is now found by entering **fig. 4** from the ratio axis (x-axis), meeting the proper ratio line (in this case the dotted 2.28 line) and observing the intercept on the swr axis (y-axis) as follows: for 20 meters, $\text{swr} = 1.26$; for 15 meters, $\text{swr} = 1.13$ and for 10 meters, $\text{swr} = 1.32$.

These swr values may be interpreted as those values read at the input terminals of the balun when it is terminated in a non-inductive 50-ohm load. As no practical antenna exhibits this magic number across any amateur band, the figure indicates that the existing swr on the transmission line will be increased by this amount when adding the balun, as compared to an imaginary balun

having a perfect transformation ratio.

As a point of interest, **fig. 4** shows that a balun having a 2-to-1 ratio (step-up or step-down) has a frequency coverage (defined by the $\text{swr} = 1.5$ limits) of one-half to twice the mid-frequency design point. Larger transformation ratios are achieved at the expense of higher swr values at the frequency extremes, or by narrowing the bandwidth for a given maximum value of swr. This should cause you no distress, as similar restrictions apply to all matching devices.

bridge balun for the quad

Bridge baluns may be designed from the various charts shown in this article. A good example is the design of a practical balun for quad antennas for the 10-, 15- or 20-meter bands.

It has been claimed by the uninformed that the coax-fed quad antenna needs no balun, since the driven element loop serves as its

Since the balun should work with either a 20-, 15- or 10-meter quad (or perhaps a tri-band quad) the mid-frequency of design is again taken to be 19.3 MHz. Here we go!

1. The value of Z_m is determined from **fig. 5** and is 65 ohms.
2. The chart of **fig. 6** may be used to determine balun constants for a center frequency

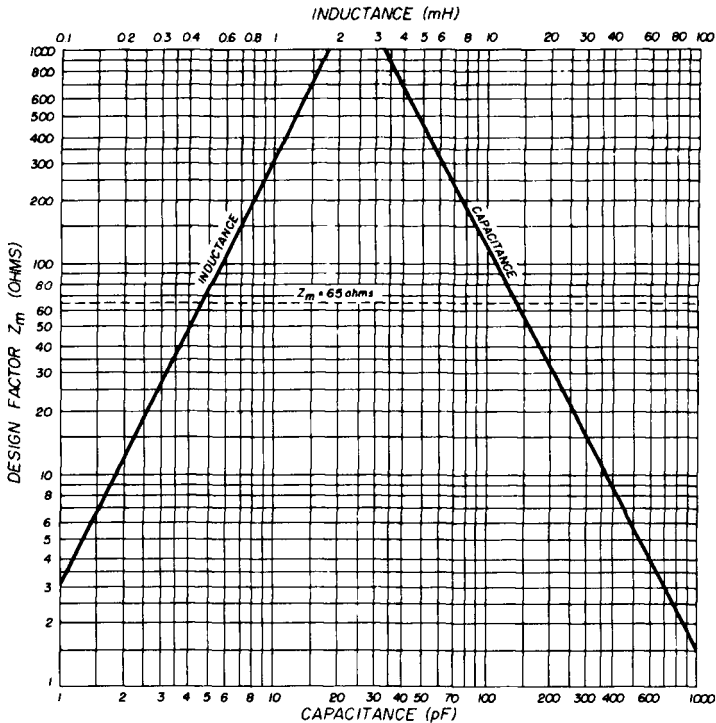

fig. 6. Chart to determine balun LC values when Z_m is known and $f_m = 19.3$ MHz. In the example shown for $Z_m = 65$ ohms, $L = 0.46 \mu\text{H}$ and $C = 145$ pF.

own balun. This is not so, as the quad is a balanced antenna (both feed points above reference ground) and the coaxial line is an unbalanced device (one conductor at ground). Therefore a balancing device is required to satisfy the demands of symmetry.

In addition, an impedance transformation is called for, since the radiation resistance for a simple quad antenna typically falls about 85 ohms or so depending upon antenna design and element spacing. Taking the figure of 85 ohms as par, then, a balancing device having a transformtaion ratio of 1.7 (85/50) is required.

of 19.3 MHz, and is useful for balun designs for 20, 15 and 10 meters.

Similar charts may be constructed for other values of f_m for other bands. The chart may be used for load values of Z_2 from 3 to 1000 ohms. The 65-ohm situation is indicated by a dashed line, showing that $L = 0.46 \mu\text{H}$ and $C = 145$ pF.

The chart of **fig. 4** is again shown in **fig. 7** in an expanded form for the 20-, 15- and 10-meter bands, useful for transformation ratios up to 4 and for swr limits as high as 1.8/1. For the case of the quad balun, the transfor-

mation ratio line of 1.75 may be used as it is sufficiently close to the actual transformation value of 1.7-to-1 to introduce no serious error in the results. The introduced value of swr for this balun design, then, is:

- 20 meters : 1.14
- 15 meters : 1.07
- 10 meters : 1.18

Using the design formulas, charts may be

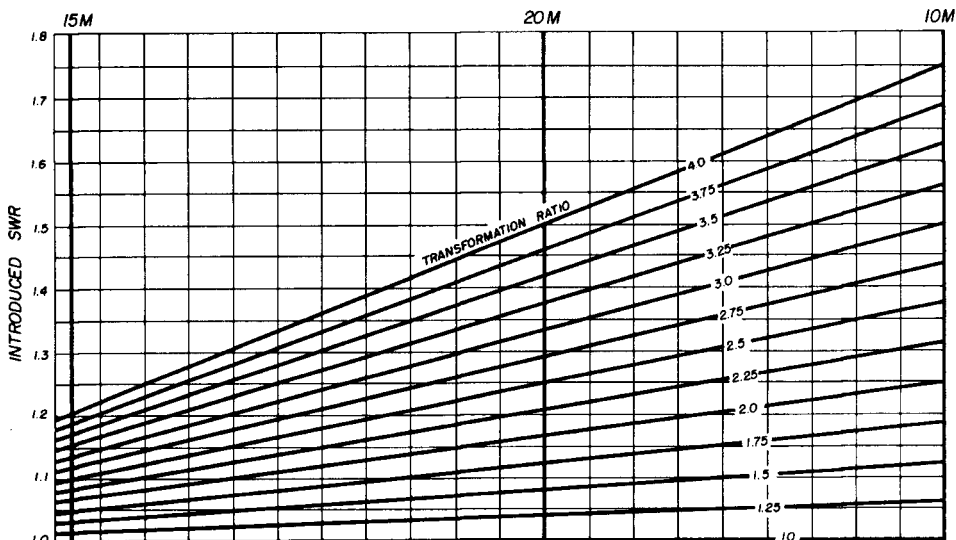

fig. 7. Expanded chart of introduced swr vs operational bandwidth for the 10-, 15- and 20-meter bands when $f_m = 19.3$ MHz.

constructed for balun design for various frequency spans or for various impedance transformations other than the examples just given.

building your bridge balun

The bridge balun components must be protected from the weather, and a minimum of coupling should exist between the two coils of the device. Other than this, no special precautions must be observed when building the balun. It's suggested that the unit be built in an aluminum box which has a partition placed across it (fig. 2).

The coils should be mounted on either side of the partition at right angles to each other. A coaxial fitting is used for the input termination, and two ceramic feedthrough insula-

tors are used for the balanced output leads. Wiring is done with number-12 solid-copper wire using short, direct leads. The compartments should be large enough so that coil Q is not appreciably degraded—a space at least twice the coil diameter is recommended.

The seams of the box should be protected in some way so that water doesn't enter the enclosure. They may be sealed with roofing compound or taped and coated with epoxy

cement. When completed, the balun may be mounted to the antenna structure in proximity to the drive point of the antenna. The box should be considered to be at ground potential.

references

1. W. Orr, W6SAI, "Broadband Antenna Baluns," *ham radio*, June, 1968, p. 6.
2. W. Orr, W6SAI, "A Broadband Balun for a Buck," *CQ*, February, 1966, p. 42.
3. R. Turrin, W2IMU, "Broadband Balun Transformers," *QST*, August, 1964, p. 33.
4. D. Tranbarger, "Symmetrical Bridge Subs as Balun," *EDN Magazine*, October, 1967, p. 58.
5. J. Frankel, "Coupling Networks Between Unbalanced and Balanced Circuits," *Proceedings of the IRE*, September, 1941, p. 486.

ham radio

We say:

the

2K-3

is the best \$1000 linear amplifier ever made for the amateur service

Other manufacturers look at the 2K-3 and shake their heads in disbelief. They say it can't be sold for \$745. But we do it! We do it by working a little harder, by being a little more efficient and by selling DIRECT from factory to user.

(and we sell it for only \$745)

Compare the quality of the components used in the 2K-3 and its true value becomes more apparent.

1. Look at the superb 20 mfd 5000 volt test oil filter condenser...exceptional dynamic voltage regulation.
2. Heft the heavy duty, high efficiency transformer...38 pounds of brute power with exceptional voltage regulation and peak current capability.
3. Observe the rugged, high-cost, double section bandswitch.
4. Note the commercial duty 25 ampere mercury power relay.
5. Experience the reliability of special design solid state bridge rectification.
6. Relax with a host of other conservatively rated deluxe components no other competitive amplifier can equal...high efficiency, silver-plated tank coil, silver-plated L-section coil, unique toroid type filament choke, resonant input filter choke, high reliability bronze gear drive assembly, modern design illuminated push-button start-stop switch, all DC relay systems. And there is more, but let us send you a descriptive brochure on the 2K-3. Let us help you own this outstanding linear amplifier.

The 2K-3, Floor Console or Desk Model \$745.00

ATTENTION! Military, commercial, industrial and scientific users... please write for information on our custom line of high power communication linear amplifiers and RF power generators.

EASY FINANCING • 10% DOWN OR TRADE-IN DOWN • NO FINANCE CHARGE IF PAID IN 90 DAYS • GOOD RECONDITIONED APPARATUS • Nearly all makes & models.



1.

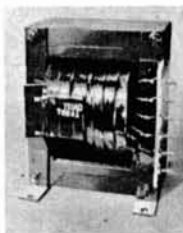

2.



3.



4.



5.

Henry Radio Stores

CALL DIRECT . . . USE AREA CODE

Butler, Missouri, 64730	816 679-3127
11240 W. Olympic, Los Angeles, Calif., 90064	213 477-6701
931 N. Euclid, Anaheim, Calif., 92801	714 772-9200
East Coast Rep.: John W. Richardt, Route 46, Pine Brook, N.J. 07058, (201) 228-0600	

"World's Largest Distributor of Amateur Radio Equipment"

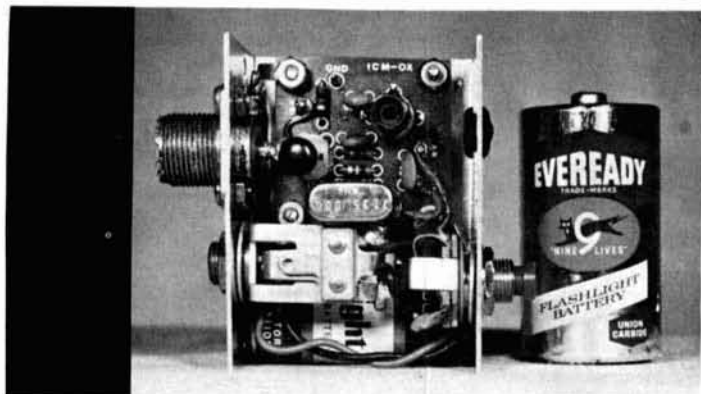

the needle swings to QRP

A run down
on QRP operation
and some
of the equipment
being used
to set
new DX records

Howard S. Pyle, W7OE, 3434-74th Avenue, SE, Mercer Island, Washington 98040

Are you aware of the rapidly increasing interest in low-power operation on the ham bands? "CQ QRP" is heard with increasing frequency; as more and more records are publicized, there's a tendency to experience new thrills and exciting contacts through the medium of flea-powered gear.

When we hear of break-throughs such as the recent performance of W6TYP who worked New Jersey with 50 milliwatts input on 40 meters and earned the top award of the International QRP Amateur Radio Club crediting him with **210,000 miles-per-watt**, it

The Omega Electronics 5-watt 80- and 40-meter transmitter and power supply.

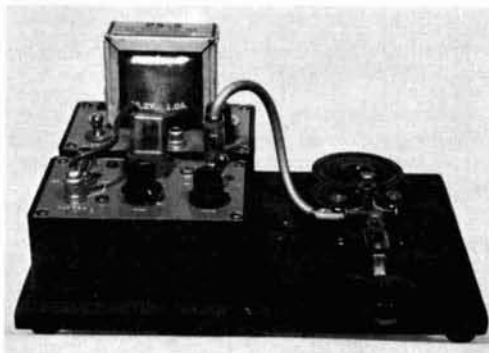

is exciting news indeed! To the best of my knowledge, Art currently holds the world's record for miles per watt . . . any challengers?

What constitutes QRP? As one of the 'Q' signals established by the Radio Act of 1912, it is interpreted as, "Decrease power" or, if followed by a question mark, "Must I decrease power?" It was originally used to afford relief from inherently broad spark signals in the early maritime wireless service.

Loosely interpreted in amateur practice, QRP simply means that the station using it is in the low-power class as distinguished from the higher powered hams with their kilo-

their own; the little fellow found it increasingly difficult to fight through the powerful signals. As a result, a group of western hams, led by K6JSS, organized the QRP Amateur Radio Club eight years ago. They were committed to a maximum power input of 100 watts (200 PEP). Their primary aim was to encourage more extensive use of low-power in an effort to reduce QRM and provide more equitable communication status for the modestly powered ham station.

Initial enthusiasm wasn't great. "How are you going to buck a kilowatt with 100 watts or less?" was the question on many ham

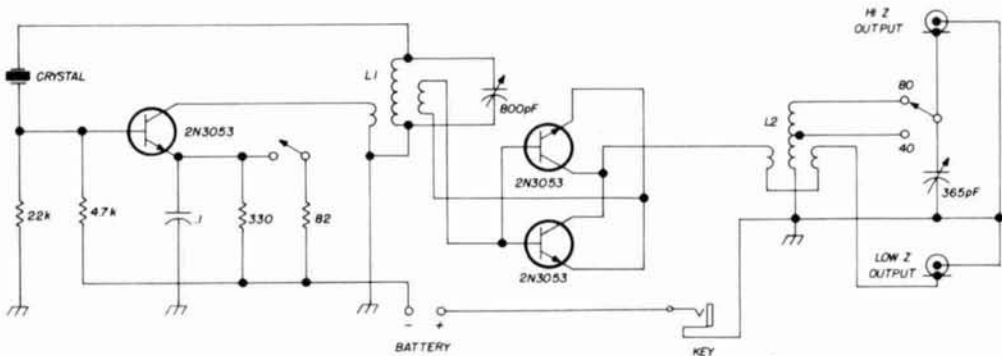
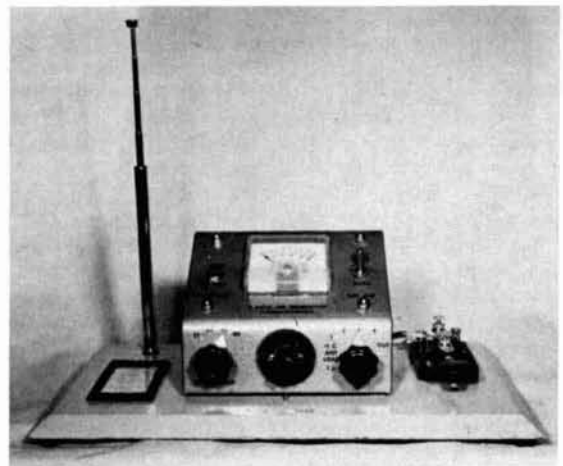

fig. 1. QRP rig used at W7IGV. Power input depends on battery voltage and runs from 1 to 5 watts. L1 is number-30 enameled wire on an Amidon* T-50-2 toroid, wound to fully fill the circumference. L2 is 32 turns number-18 wire on an Amidon T-80-2 toroid; 40-meter tap at 14 turns.

watts. While no definite criterion has been formally established as a dividing line, hams generally consider 100 watts input (200 PEP) as maximum power input in the low-power category. This is the figure used by the QRP Amateur Radio Club. Between 100 and 500 watts is generally classified as medium power and anything from 500 watts to the legal maximum automatically falls into the high-power group.

With the steady growth of amateur radio and the proportionate increase in high power stations a few years ago, the interference problem was becoming acute. A small proportion of hams were able to meet the high power competition by acquiring a kilowatt of

Four-band QRP transmitter uses 4 International Crystal OX oscillators and has a built-in whip antenna and antenna tuning unit.



* Amidon Associates, 12033 Otsego Street, North Hollywood, California 91607. T-50-2 toroid is 45c; T-80-2 toroid is 60c. Add 25c per order for packing and shipping.

tongues. Rolling up their sleeves, the club members went to work. Their objective was to increase equipment and antenna efficiency to the greatest possible extent and improve their operating skills at the same time.

Careful impedance matching between transmitters and antennas, improved output coupling and more effective antennas were

all given careful attention. Operating proficiency was upgraded—not only in actual communication techniques but by choice of bands vs time of day, frequency selection for the desired distance and by finding holes that were relatively interference free.

All these points generated increased interest in QRP operation. As proficiency and

Front and back of QSL card confirming W6TYP's 210,000-miles-per-watt contact on 7 MHz.

WB2GFQ

South River, New Jersey



RADIO W6TYP CONFIRMING QSO NOV. 6 1967.

AT 0746 ZST. UR 2.2 MC. fone CW SIG RST. 599 ^{see} bank.

XMTR Ham. Dev. R. 200 vts. RCVR. SI-101A

REMARKS Best QRP dx yet. - FB. PSE QSL TNX

208 Willet Avenue
08892

"J.B."

73, John M. Bogath
W6TYP PRINT

LOG DATA:

Your power input:	Your RST:
500 mw. -----	5 3/7 9
90 mw. -----	5 1/2 9
75 mw. -----	5 1 9
50 mw. -----	4 (1/2) 9

No copy under 50 mw. QRN & QRM

Your QTH: San Francisco, California

My RST: 479

My Power: 200 watts

My QTH location: *June 201-257-313*

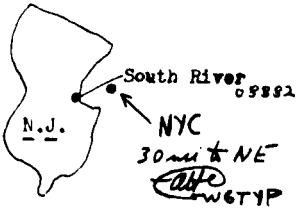

Looks like a record Art. Great spy here. Gld to do it aga - maybe wid less pwr. ; 25 mw. or so ? ?

technical advancement improved, more and more of the low-powered class began gradual power reductions; going gradually downward from 100 watts to 75, 50, 25 and finding that with their new skills they were establishing some rather amazing records. A few hardy souls even dipped into the 5- and 10-watt field and experienced surprisingly good coverage.

However, a plateau was reached in the range of 5 to 25 watts. They had just about reached their limit in low-power performance with available vacuum tubes; what now? How about those little transistors which had been nudging the electronics field the past few years? Were there hidden possibilities there? After all, transistorized, pocket-sized broadcast receivers were beginning to make more than a casual dent in radio reception equipment, and toy shops and department stores were offering walkie-talkies.

A few hams took a second look and with tongue in cheek gingerly tackled the problem. Some made a couple of half-hearted tries

with little or no success and abandoned the project. Those with more determination stuck with it and began to encounter some delightful surprises! Most of these latter experimenters were QRP club members who had the advantage of working as an organized, though separated, group who could exchange experiences on common ground.

Probably the most dedicated member of

pulled the rug out from under the other manufacturers with their little LT-5 transmitter and its companion power unit, the PS-5.

It's not my intent to give you complete construction details for any of these little rigs. However, with the schematics you can use your ingenuity and work up your own component layouts. I'll wager you'll find a whole new world opening before you!

fig. 2. Rig used by W6TYP for his record-breaking 210,000-miles-per-watt contact with WB2GFQ. The 4k, 2W potentiometer permits input power adjustment from 1 to 500 milliwatts. Output circuit A is used with 50- or 75-ohm coaxial lines; B is used with 600- to 1000-ohm feedlines.

- C1 is a 970-pF trimmer (Arco L-314);
- C2 is a 2830-pF trimmer (Arco L-306);
- L1 is 50 turns number - 28 enameled, close wound on 1/4" form;
- L2 is 12 turns number - 28 enameled, close wound on 1/4" form

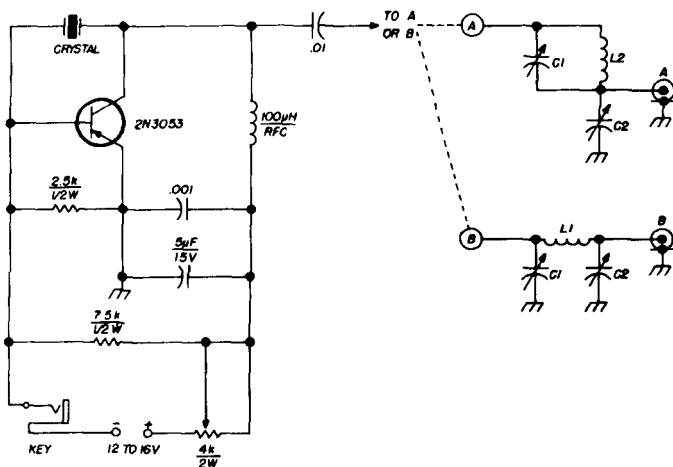

the group was Art Child, W6TYP, who envisioned the untouched possibilities of the little genies and went seriously to work with them. We mentioned Art's phenomenal 210,000 miles-per-watt record earlier. Suffice it to say that his steady progress has gained his unqualified acceptance by the QRP fraternity as "King of the QRPP'ers." The extra P is applied to rigs that run with an input power of one watt or less!

equipment

Let's take a look at some of the gear being used to make 1000-mile-per-watt contacts every day. These are just a few of the minirigs currently being used and have demonstrated exceptional performance. Almost without exception, equipment is all homebrewed. At this writing I know of only one manufacturer who offers a commercially-built transistorized amateur transmitter in the 5 watts or less category. Omega Electronics*

* Omega Electronics Company, 10463 Roselle Street, San Diego, California 92121.

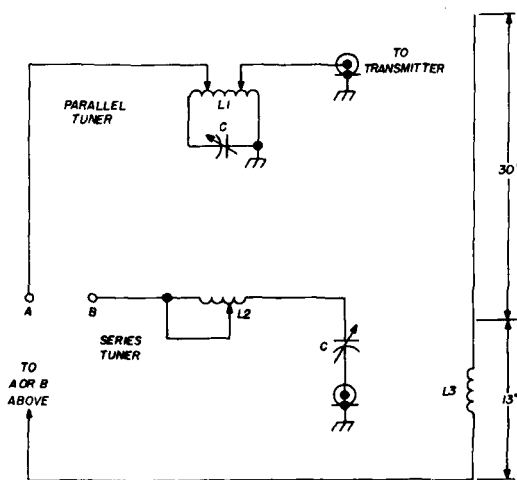

fig. 3. Simple vertical antenna used by W6TYP with milliwatt transmitters

- C 365 pF to cover through 16 meters; 50 pF adequate for 40 meters.
- L1, L2 36 turns number-14 enameled, 2" diameter.
- L3 195 turns number-14 closewound on 3/4" wood dowel 48" long.

Naturally, you'll have some questions; I'll try to anticipate them and offer some answers. First will undoubtedly be, "What about an antenna . . . what do I use?" That is an easy one; if you have a satisfactory antenna which produces results on your big rig, use

tical, right at the base insulator is desirable. Sure, if you can manage it; you'll lower your losses in the transmission line. However, from the experience many of the boys have had, what you gain isn't worth the mechanical complications.

fig. 5. Circuit used by Omega Electronics in their LT-5 five-watt transmitter. C1 is 100 pF; C2 is 365 pF; L is 36 turns 1" diameter, tapped at 18 turns for 40 meters.

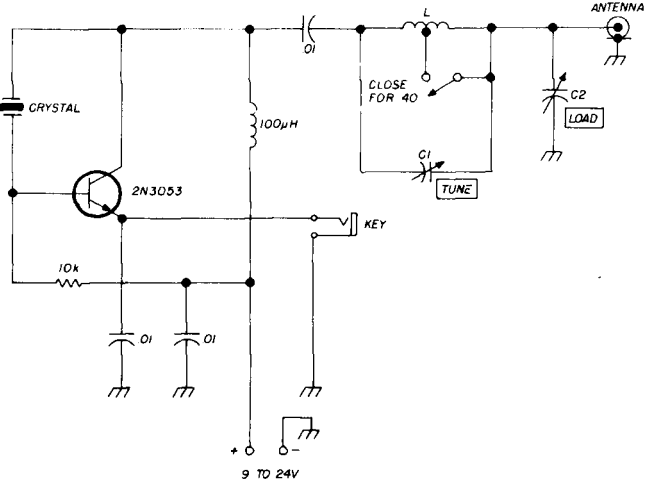

it! That's what 99% of today's transistor experimenters are using. If it performs well on your main transmitter, you can be pretty sure it will deliver equally well with mini-power. But be sure it's a good antenna first; well-matched, low swr, in the clear and built to stay put.

I've been asked if putting the mini-powered rig directly at the base of the transmission line just below the antenna or, if ver-

W6TYP uses a random length of transmission line—15 to 25 feet. I use my 40-meter half-wave dipole with one hundred feet of RG-59/U and have worked over 900 miles with .185 watts input! So, if you have an effective antenna now, you have no problem.

W6TYP is handicapped for space for a wire antenna, and practically all his work has been done with a Joy Stick extending from the fourth-floor window of his hotel room.

fig. 4. International Crystal Company's OX oscillator circuit. The values of L, C and R vary with frequency and are furnished with the kit.* Circuit may be keyed in either the plus or minus battery lead.

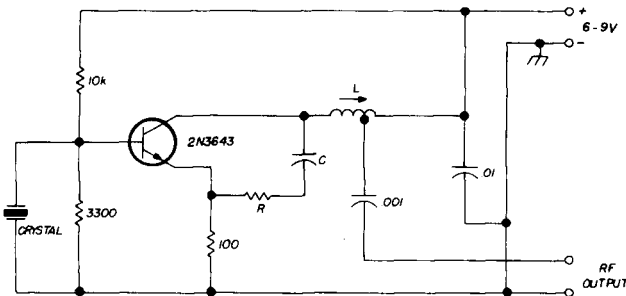

* \$2.35 postage paid from International Crystal Manufacturing Company, Inc., 10 North Lee, Oklahoma City, Oklahoma 73102. EX crystals for the OX oscillator are \$3.75 each postage paid.

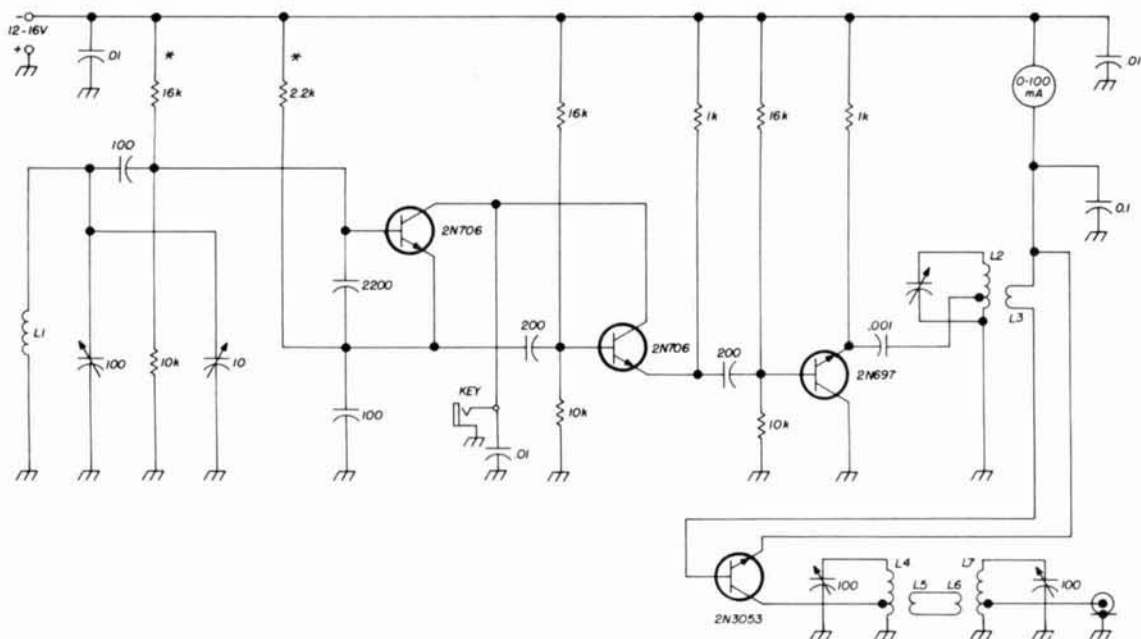

- L1 18 turns number 20, airwound on 1" diameter.
- L2 30 turns number 20, airwound on 1" diameter, tapped at 12 turns.
- L3 3 turns around cold end of L2.

- L4, L7 30 turns number 20, airwound on 1" diameter, tapped at 6 turns.
- L5, L6 3 turns around cold end of L4 and L7 respectively.

fig. 6. This little rig developed by W6EAC runs one to five watts with vfo control. Resistors marked with an asterisk should be adjusted for best keying.

He also uses a modified version of this antenna which is shown in fig. 3. Art has tried dipoles and Windoms on the hotel roof, long wires from here to there and variations of these, but he always comes back to a single, compact vertical for assurance of real success.

Next you'll ask, "What bands are being used?" For the most part, QRP operation has centered around 40 meters, but results are just as satisfying on any of the popular bands. For example, with four little OX oscillators from the International Crystal Company I have realized excellent performance on 15, 20, 40 and 80; a four-band arrangement with a separate 2-inch-square transmitter on each band! A few experimenters have had satisfactory reports up to several hundred miles on 160 meters with inputs of one watt or less!

And now, "Are all of the rigs crystal controlled?" Not by a long shot; W6EAC is

QRP transmitter at W7NUN uses an International Crystal OX oscillator. The oscillator board plugs into the base; band changing is a matter of plugging in another board.

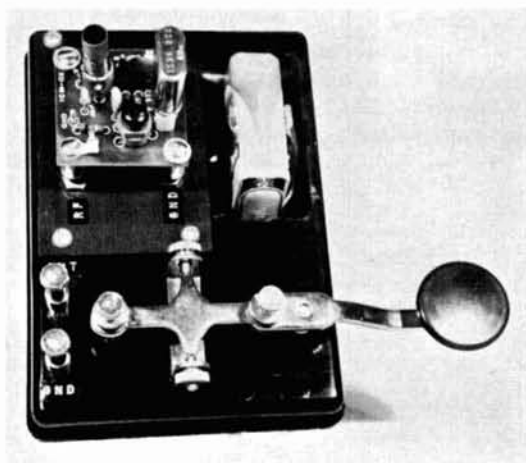

getting excellent results with his home-brew transistorized one-watt vfo! W7IGV in Idaho with his own vfo design equals W6EAC's results. Others have built their own vfo's and encountered no problems. Crystal control is the logical first step; after you get your feet wet, see what you can do with a vfo.

Antenna tuning unit? No problem; make up a simple series or parallel arrangement such as W6TYP uses or use a conventional pi-network. The various Z-matches, trans-matches and similar are just as effective with

their results. Undoubtedly you will find one or more hams in your own vicinity who are deeply engrossed in the art of QRP operation. Contact them and work with them; remember that many of the significant developments in the electronics field were ham conceived and ham developed.

If you really want to keep abreast of what the QRP and QRPP gang are doing, the QRP Amateur Radio Club-International, with 3000 members in 57 countries, is the spot for you! Drop a postcard to Jim Loring, WA1BEB,* and

fig. 7. Simple regenerative receiver used by W7GNT for portable operation. L and C values chosen for desired amateur band.

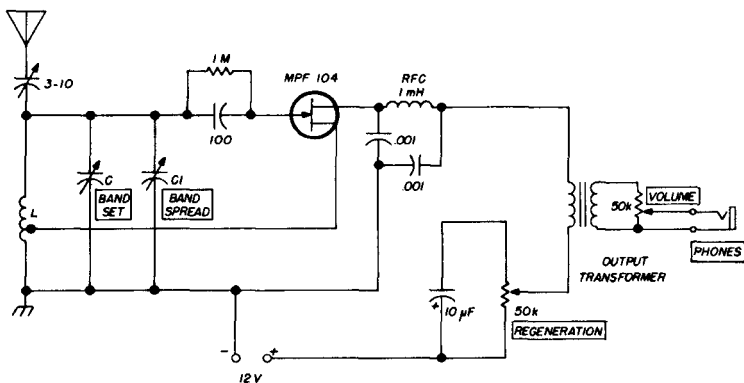

these little rigs as they are with their big brothers. Handle the output just as you would that from a more powerful tube transmitter.

What about modulation? Well, why not? The present trend is to concentrate on the rf angles; modulation is just around the corner. Of course, there is no reason why the little rigs can't be expanded to include modulation as well. Some efforts have been made along these lines; it's been reported that one W6 station has worked several hundred miles with voice on 160 meters with less than one watt input!

It's my guess that modulation experiments will be confined to a-m initially; there are too many hurdles to jump with ssb at this early stage. Take a lesson from the walkie-talkies and the increasing number of transistorized CB rigs; there are a lot of hidden tips there if you want to pursue this angle.

I have only scratched the surface of this exciting new field. I have shown you a few examples of accomplishment by Western hams because I am intimately familiar with

ask for an information sheet and application blank to a club that offers a life membership for only \$2.00 and no dues!

* Jim Loring, WA1BEB, General Secretary, QRP Amateur Radio Club—International, RFD 2, Gilead, Bethel, Maine 04217.

ham radio

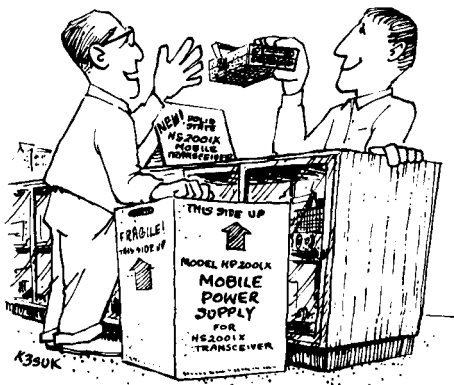

"It's just loafing along at 2000 watts PEP . . . power supply is external of course . . ."

Merry Christmas!

BUT WHY WAIT?



START NOW TO ENJOY THE BETTER QSO'S THESE
FB ACCESSORIES CAN HELP YOU GET!

73 *Bil Harrison*
W2AVA

DUMMY LOAD/WATTMETERS

An effective means of measuring and peaking RF power into a dummy load. Four calibrated scales permit accurate readings of RF watts. Protective warning light.



MODEL 334A

1000 watts. 2 to 230 MHz . . . \$135.

MODEL 374

1500 watts. 2 to 30 MHz . . . \$135.

You can peak up any antenna and match its impedance more easily and precisely, with the new:

MODEL TE7-01
OMEGA-T ANTENNA



NOISE BRIDGE

\$24⁹⁵

COMPACT PORTABLE "CASSETTE" RECORDERS

Bore your friends green with envy! Make 'em listen to your rare DX and unusual QSO's you have recorded for posterity. These new solid state, battery operated tape recorders are always ready for instant use and immediate playback. No fumbling with tape or reels — each pop-in

Cassette cartridge will take a solid hour of your thrilling moments (even baby's first words).

Each comes with remote control microphone, batteries, and a Cassette — ready to use. Compact, portable.



AIWA

PANASONIC



Weights only 3 lbs!
Has VU meter
Worth more!

\$39⁹⁵

SPECIAL OFFER!

Extra 60 minute
Cassette cartridges
(with recorder order) EACH

89c

Includes radio recording
patch cord.
5½ lbs.
Harrison's
price

\$49⁹⁵

(quantity limited)

Great to get . . . or to give . . .

Harrison Gift
Certificates

for any amount you name

May also be charged to your
Harrison charge account, and
payments spread over many months.

Harrison
"HAM HEADQUARTERS, USA"®

22 Smith St., Farmingdale, L.I., N.Y. 11735
(516) 293-7990

—VISIT OUR NEW STORES—

FARMINGDALE, L.I. Route 110 at Smith St. (516) 293-7995
NEW YORK CITY—8 Barclay St. (212) Barclay 7-7922
JAMAICA, L.I.—139-20 Hillside Ave. REpublic 9-4101

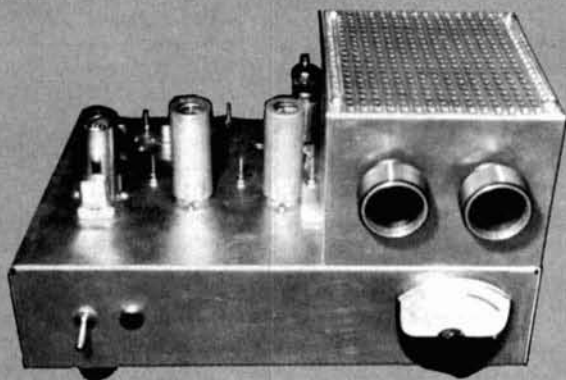

medium power six meter transverter

Construction details of a
14-MHz to 50-MHz
transverter
with greater than
150 watts output

Rick Davis, K8DOC, RD 2, Creek Road, Jefferson, Ohio 44047
Alex Dolgosh, K8EUR, 3905 Station Ave., Ashtabula, Ohio 44004

Looking for new horizons to conquer? With the predicted sunspot activity, six-meter DX may be more a reality than a phenomenon. Older vhf enthusiasts will recall the fine E-layer openings of 1957 to 1959 and the occasional F2 openings to both Europe and Asia. Now, with ssb facilities, you can enjoy the openings with longer and more reliable contacts than ever before.

Here is a low-cost, medium-power transmitting and receiving converter or transverter that is adaptable to most 14-MHz ssb stations, whether equipped with a separate transmitter and receiver, or a transceiver. Sufficient output power is available to drive a high-power grounded-grid linear amplifier more than adequately.

circuit

This circuit has evolved over a period of several years from the original W6RET design in the August 1965 issue of **QST**. It has been redesigned to provide greater power capabilities with improved receiving converter performance. In fact, it bears little resemblance to the original. Three models of this transverter are currently being used with good results.

The overtone crystal oscillator uses the triode section of a 6U8A, while the pentode section is used as an isolation amplifier to minimize loading effects on the oscillator and furnish sufficient drive to the control grid of the 5763 mixer. Drive is introduced in the screen circuit of the mixer through L6 and L7.

The 50-MHz output of the mixer is developed across L3 and coupled to the grid of the 5763 driver. The 10-ohm resistor loads the circuit sufficiently to insure stability. Cathode bias is obtained by the drop across a 15-volt, 1-watt zener diode, simplifying bias circuitry and providing automatic regulation. The diode is bypassed to prevent possible damage by rf energy.

A small metal shield should be installed across the driver tube socket to prevent coupling between the grid and plate circuits. A parasitic choke is used to further insure stability. The signal from the driver plate is coupled to the grid of the final amplifier with a capacitor. A parasitic choke is used in the final plate circuit for stability.

The bias for the 4X150A (or 4CX250B) is regulated at 47 volts by a 1-watt zener diode. A set of relay contacts breaks the bias network ground return on receiver, biasing both the driver and final beyond cut-off. In transmit, the bias drops to normal operating values. The 4X150A, operating in class AB₁, idles at about 50 mA.

The 4X150A screen by-pass capacitor shown is an integral part of the socket I used. However, less expensive sockets may be substituted if an external .001- μ F bypass is installed at the screen terminal. The concentrically bypassed socket is not an absolute necessity at 50 MHz.

The plate tank is a conventional pi network. The 33-pF input capacitor should be spaced for the chosen plate voltage, but the output capacitor may be a close-spaced broadcast variety. No part numbers are given since these were salvaged from the junkbox. The coil dimensions were carefully selected using a wattmeter to determine the best L-C ratio. An Ohmite Z-50 choke is used as a safety measure to keep high voltage off the tank coil if the blocking capacitor fails in service.

Cooling air is provided by a Dayton 2C782

15-cfm blower. Adequate air flow through the heat-radiating anode fins of the final amplifier is a **must**. The chassis should be airtight. If you use another blower, greater air flow should be considered. I wouldn't use a fan under any conditions (as opposed to a centrifugal blower) since a fan cannot deliver adequate air against the back pressure created by the 4X150A.

receiving converter

The receiving converter circuit is a straightforward triode cascode rf amplifier coupled to a triode mixer. For simplicity, I used 6CW4 nuvistors throughout. The 50-MHz signal is coupled to the rf amplifier through a parallel-tuned 14-MHz trap which eliminates any 20-meter leakthrough. The rf amplifier plate/mixer grid tank is tuned to 50-MHz by L10; 36-MHz energy is coupled to the mixer grid from the 6U8A isolation amplifier.

construction

I won't attempt to provide exact carbon-copy construction details—this will be left to the resources of the individual builder. However, the Bud AC408 7x12x3 chassis and Bud AU1029 4x5x6 utility box used afford almost perfect sizing for good component layout. One variation was built with an 8x17x3 chassis to provide top mounting for the blower and rack mounting of the entire unit.

It's suggested that the transverter be constructed in stages. First, the crystal oscillator and isolation amplifier should be made operational, followed by the receiving converter. After this, the mixer, driver, and final amplifier stages should be completed and tested individually. Make sure the zener diodes are correctly installed—observe polarity. Good vhf construction practices should be followed throughout although there is no magic to making tuned circuits work well on six meters. A grid-dip oscillator should be used extensively at all points to avoid resonating tuned circuits on the incorrect sum, difference, or multiple frequency.

Only the minimum relay and control circuitry is shown since you will want to design your own controls to suit the needs of your station. It should be noted that one more set of relay contacts may be needed with some transceivers for receiving antenna switching.

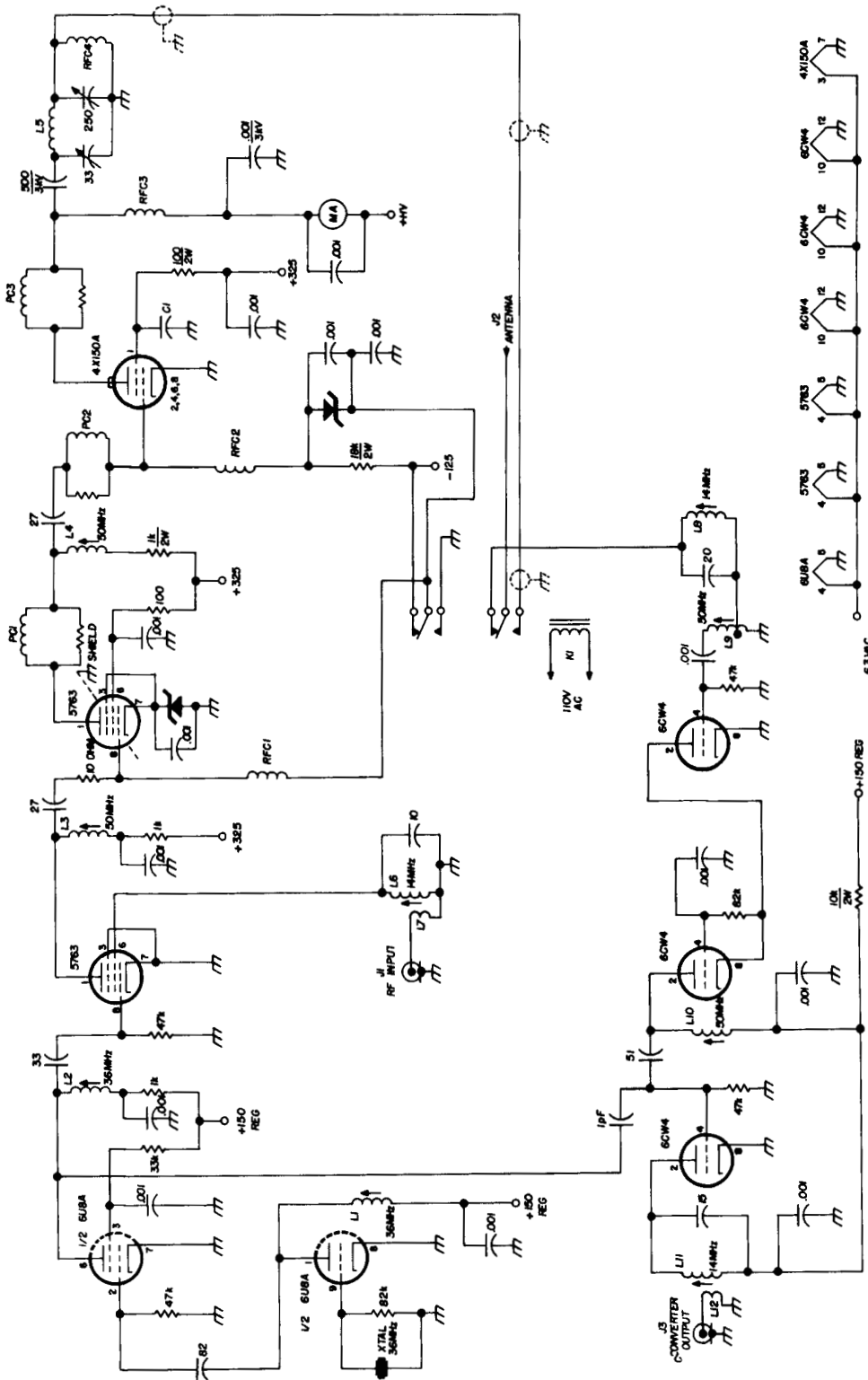

fig. 1. 150-watt six-meter transverter. There should be a .001- μ F bypass capacitor from the lower end of L4 to ground.

- D1 15-volt, 1-watt zener diode (Mallory ZA-15)
 D2 47-volt, 1-watt zener diode (Mallory ZA-47)
 J1, J2 SO-239 coaxial receptacle
 J3 RCA phono jack
 K1 dpdt relay, 155-Vac coil (Potter and Brumfield KRP-11AG, removed from plastic case)
 L1 12 turns number-30 enameled on $\frac{1}{4}$ " slug-tuned form
 L2 15 turns number-30 enameled on $\frac{1}{4}$ " slug-tuned form
 L3 12 turns number-24 enameled on $\frac{1}{4}$ " slug-tuned form
 L4 10 turns number-24 enameled on $\frac{1}{4}$ " slug-tuned form
 L5 5 turns number-10 space wound, 1" diameter, 1" long
 L6, L8, 40 turns number-30 enameled on $\frac{1}{4}$ " slug-tuned form
 L11 4 turns number-22 hookup wire wound around cold end of L6
 L9, 11 turns number-24 enameled on $\frac{1}{4}$ " slug-tuned form. L9 tapped at 2 turns from cold end
 L10 4 turns number-22 hookup wire wound around cold end of L11
 L12 4 turns number-22 hookup wire wound around cold end of L11
 PC1, 4 turns number-24 enameled wound on 47-ohm, $\frac{1}{2}$ -watt resistor
 PC2 4 turns number-14 enameled wound on 47-ohm, 2-watt resistor
 PC3 7- μ H rf choke (Ohmite Z-50)

Use Eimac SK-606 chimney or equivalent for proper air ducting.

alignment

If you check out the transverter one stage at a time, you shouldn't run into any difficulties. Before final tuneup, resonate all coils to the desired frequencies with a grid-dip meter. It's possible to tune the whole works up on 36 MHz if you're not careful. All receiving converter coils except the 14-MHz trap should be peaked for maximum received signal strength. The 14-MHz trap is adjusted for minimum 20-meter leakthrough.

All slug-tuned coils in the transmitting section should be peaked for maximum plate current indication with 14-MHz drive applied to the mixer. Needless to say, the final amplifier plate current should not rise above the idling value unless 14-MHz drive is applied to the mixer. The final is tuned up in the normal manner. About 250 mA of plate current is optimum under full carrier.

It's best to use an swr bridge or wattmeter and tune for maximum output with the key down. When driven by a ssb signal, the indicated peak plate current should not exceed 50% of the key down value. Since only a small amount of 14-MHz drive is required, a pad will be necessary to attenuate the output of most exciters.

Neutralization has been found to be unnecessary on any of the three transverters now in use, even at plate potentials as high

fig. 2. Power supply for the six-meter transverter uses a transformer from an old television set.

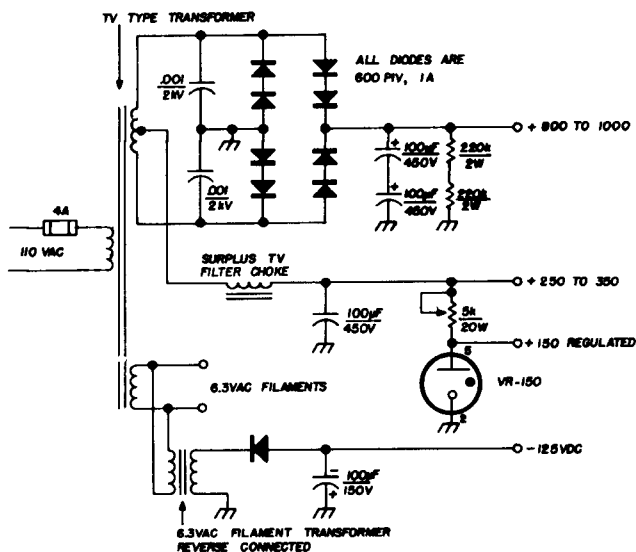

as 1400 volts. This is attributed to final amplifier shielding and complete isolation between grid and plate tuned circuits. The transverter may be run at full key down input power on CW, and may even be operated on am at reduced power and efficiency.

power supply

Power supply requirements may be met most economically by using an old TV power transformer with a 6.3-volt filament winding and a center-tapped secondary winding of 600 to 1000 volts. A bridge rectifier and capacitive filter circuit is used for the high voltage. With this circuit, the average TV transformer will provide about 800 to 900 volts under load. The low voltage for the mixer and driver plates and final amplifier screen is taken from the center tap of the high voltage winding.

A 5000-ohm, 20-watt adjustable resistor is used to drop this voltage to the proper value for the VR-150 regulator. The receiving converter, overtone crystal oscillator and isolation amplifier are also powered by this regu-

lated voltage. Bias voltage is obtained by reverse connecting a small 6.3 volt filament transformer to the filament winding of the TV transformer and rectifying the output.

It's suggested that the 110-volt ac line be brought to the transverter chassis; install an outlet on the rear for the power supply. This way, 110 volts will be available for the blower, and the power supply may be located remotely. Although the filament voltage is fractionally higher than the recommended 6.0 volts, no shortening of tube life has been experienced.

operation

This transverter makes an excellent driver for a high-power grounded-grid linear amplifier. Output in excess of 150 watts may be expected, so it also provides a very substantial barefoot signal. In addition, this simple design will put six-meter operation within reach of most amateurs without the half-kilobuck expense of a commercial transceiver and power supply.

ham radio

new uses for a grid-dip meter

Every once in a while I get interested in playing around with antennas from the standpoint of home design. There are many books available, and all describe characteristics of beam antennas in terms of electrical length. Since the electrical length varies with tapering rod diameter and type of antenna (folded vs normal dipole), it is extremely hard to measure in terms of linear—and conventional—dimensions.

The grid dipper is one of the most versatile instruments available to the ham and is next in importance, perhaps, to the multimeter. Ken Lockhart, K2HAK, has been able to resolve the antenna situation by proving out the theory and permitting us to publish his findings.

As is well known, the coil of the gdo, when coupled to a rod, shows the rod's resonant frequency. This corresponds to a half-wavelength of the rod—with such illusive parameters as length-to-diameter ratio and propa-

gation velocity thrown in. Measurements made in this way are exact and provide the practical answer we're seeking.

However, one practical limitation not accounted for by manufacturers of test instruments is this: A small coil produces a rather constricted field pattern; while this field will link a small rod, it will not link a rod that is comparable in diameter to that of the coil itself (see fig. 1A). This condition is easily remedied by the rather obvious technique of building a larger diameter coil whose

table 1. Television and fm frequencies which can be used for calibrating a grid-dip meter.

channel	video	sound	video —4.5 MHz	video	sound
				second	second
				har-	har-
				monic	monic
2	55.25	59.75	50.75	27.6	29.9
4	67.25	71.75		33.6	35.9
5	77.25	81.75		38.6	40.9
fm	88-108			44 to 54 MHz	

larger field pattern can be coupled to larger diameter rods (see **fig. 1B**).

antenna gdo

One method of solving the problem is shown in **fig. 2**. The unit is calibrated by comparing the radiated energy to various TV sta-

fig. 1. It is difficult to couple a grid-dip meter to large antenna elements because of the small diameter of the coil (A). A larger coil, shown in B will do the job.

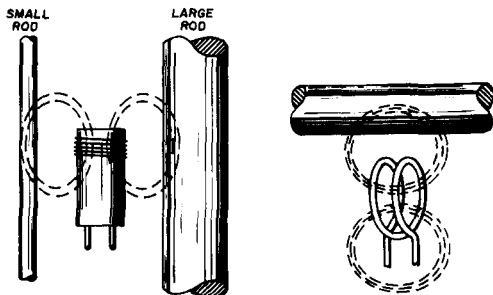

tions. If the gdo is tuned to channel 2, for example, the picture will tend to roll out of sync; if tuned to ± 4.5 MHz from this frequency the sound will be garbled or blank completely. If the TV signals are strong, it may be difficult to blank the sound with the oscillator tuned to the picture (51.25 MHz), but this can be overcome by disconnecting the TV antenna.

You can calibrate the grid dipper above 6 meters with TV signals. This won't work below 6 meters; this can be accomplished by beating the second harmonic of the oscillator with the stations shown in **table 1**. If an fm receiver is handy, excellent checkpoints may be obtained by using the second harmonic of the gdo. If a smooth curve is plotted in this manner, extrapolated accuracy is good enough for the most demanding purposes.

constructing an antenna by gdo

Let's try an example. A good three-element beam is the one with 0.15-wavelength spacing from driven element to reflector; the reflector is approximately 1.06 times the length of the driven element. The director is 0.943 the length of the driven element and spaced 0.1 wavelength away.

Since boom length is 0.25 wavelength at 50 MHz, its resonant frequency will be 100

MHz; the length is cut until gdo resonance is indicated. The driven element is shorted out (either with a direct short or a terminating resistor) and cut until it resonates at 50 MHz. The director is cut to resonance at 50×1.06 or 53 MHz and the reflector at 50×0.943 or 47 MHz. Now we have the complete antenna specified in terms of the resonant frequencies we can measure with a grid dip meter:

boom:	100 MHz
driven element:	50 MHz
reflector:	47 MHz
director:	53 MHz

Once this method has been mastered, it's likely that you'll never refer to antenna elements in feet or inches but in MHz. I have

fig. 2. Method of building a large coil for your grid-dipper.

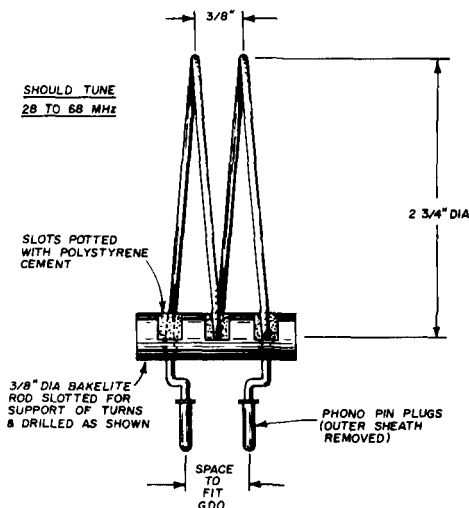

now built several antennas using this technique (two trapped jobs for 6, 10 and 15 meters; one for 6 and 10 meters, and one for 220 MHz) and have had excellent results.

If you should decide to plot the radiation pattern of your new antenna, the coil and your gdo will work nicely as a low-power source of rf. The coil should be horizontally polarized and in the horizontal field of your beam—so you'll have to get it up as high as humanly possible.

Bob Brown, K2ZSQ



time-to-reply statistics for dx qsl's

Now that you
have worked
that rare one,
what's
the best approach
for getting
a QSL?

Lee Vogel, WB6LUH, 1048 W. Hill Avenue, Fullerton, California 92633

How long should you expect to wait for that QSL card you need for DXCC? What are your chances for receiving a QSL in a month? . . . in six months? . . . in a year after the QSO? How much will you improve the chance of eventually receiving the card if you send IRC's? How about an addressed envelope complete with foreign stamps?

This article answers these questions and is based on statistics gathered during the past few years. During this time I have tried all of the various QSL'ing methods proposed in previous articles and kept an account of their success. There is nothing magic about a WB6 call so you should realize at least the same results. If you are rare for the DX station then you can expect to do better. In any case, the relative merits of various QSL'ing procedures should still apply.

The QSL courtesy is recognized throughout the world, and a number of articles have been published on the art and ethics of QSL'ing.^{1,2,3,4,5} Most authors discuss the problems faced by the rare DX station and describe techniques which will insure the QSL by alleviating his load.^{6,7,8} However, I know of no published data available on the effectiveness of the various methods.

This article presents statistics gathered over a three-year period from 1500 DX QSO's. Several methods of requesting a QSL are compared including: direct request with IRC's enclosed, direct request with a self-addressed envelope and foreign stamps from the DX country, direct QSL card request only, request via the bureau (by air and surface mail) and request through a QSL manager.

the problem

After an exciting QSO with a rare DX station you are immediately faced with how best to obtain a confirming QSL. The most economical choice is clear if the station has a QSL manager; check all of the latest lists.* However, if there is no manager then you have several options. You can QSL via the foreign bureau and wait very patiently; send

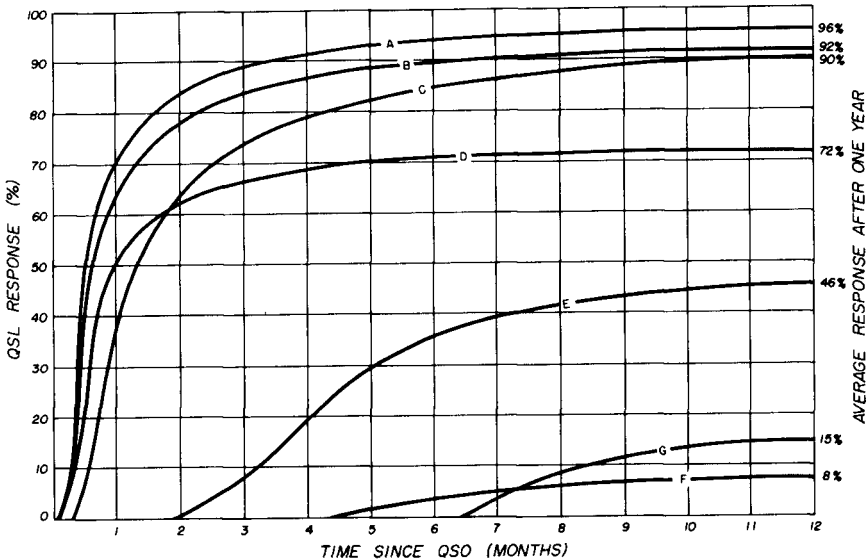

- Curve A** Response to QSL request accompanied by self-addressed stamped envelope
- Curve B** Response to QSL with IRC's enclosed
- Curve C** Response via QSL manager when self-addressed stamped envelope supplied
- Curve D** Direct reply to a routine direct request with your card
- Curve E** QSLs received via the bureau before the DX station has heard from you
- Curve F** Reply via the bureau to a direct request
- Curve G** Bureau replies to your request via the DX bureau

fig. 1. Graph of time-to-reply statistics for various methods of QSL'ing. Curves F and G eventually reach 67%.

The average time required to receive an answer to each of these methods is compared as well as the over-all percentage reply.

Since I am a professional statistician, it was more or less second nature for me to keep complete DX contact data in my log. In addition to the entries required by law, I also record the QSL method I use and the time required to receive a reply. A study of this data over the past few years clearly demonstrates the timesaving which results from the proper QSL'ing procedure. Let's take a look at my QSL'ing experience.

your card directly to him hoping he'll be a good guy and reply in kind; send your QSL card with IRC's to help pay postage or obtain stamps from his country and send a self-addressed, stamped envelope with your QSL card—possibly enclosing a photograph and personal note in his language!

During the last three years I have tried all of these methods. Let's look at three ways of comparing QSL methods; you can decide which is most important.

1. The average elapsed time between QSO and receipt of QSL

2. The elapsed time to 50:50 chance of receiving a given card; the time half of the cards will arrive

3. The over-all percentage response one year from the QSO

These answers are summarized in **fig. 1** which gives the percentage response versus time for each QSL'ing procedure. The curves are identified as follows:

Curve A Response to QSL request accompanied by a self-addressed stamped envelope.

The best and fastest method on all counts is to supply the DX station with a completely prepared envelope! The average time for receipt of a QSL was only about 5 weeks; there is a 50:50 chance of receiving a given card in only two weeks. Better than 95% replies were received within a year.

Curve B Response to QSL with IRC's enclosed.

This is the second best QSL'ing method by all accounts. The correct number of IRC's varies from country to country and is given in the **Radio Amateur Callbook**. The average time to receipt was only 5¹/₄ weeks with a 50:50 chance of receiving the card in three weeks. Over-all response within a year was a creditable 92%.

Curve C Response via a QSL manager when you furnish a self-addressed stamped envelope.

This was the next best method. Generally it is the cheapest since many DX stations have stateside managers. Average time to respond was 8¹/₂ weeks with a 50:50 chance for

receiving a card in about 5 weeks. About 90% of the cards were received within a year of the QSO date.

Curve D Direct reply to a routine direct request with your card.

This method rated next. The average time to respond (for those who eventually did!) was 6¹/₂ weeks with a 50:50 chance for a reply in 5 weeks. However, there was only 72% response within a year after the QSO. For this reason the effective average time will be longer to account for this increase in failure to reply. A side note: Sending your card via air mail will, on the average, save about one and one-half weeks.

replies via qsl bureaus

The remaining curves, marked E, F and G, represent results for cards sent via the bureau. When the address of a DX station is not known you can only send your card to the QSL bureau in his country. Addresses for these bureaus are listed in **QST** periodically as well as the foreign edition of the **Callbook**. Your card is forwarded from the bureau usually to club stations for eventual delivery to the amateur himself.

Returning cards are sent by the foreign bureau to ARRL headquarters where they are bundled and forwarded to the QSL bureaus in each W/K call area. Cards received locally are sorted and periodically forwarded in self-addressed stamped envelopes furnished by the amateur. The average delay in the local QSL bureau is often a month or more, depending upon the voluntary club members who run the bureau.

In general, the response through the bureau is slower and not as reliable as the direct methods are. You can expect to receive only

next month in ham radio magazine:

VHF/UHF Effects in Gridded Tubes

Putting MOSFETs in a Vacuum-Tube Receiver

Solid-State SSB Circuits

Notes on the Cubical Quad

220-MHz MOSFET Converter

Two-Meter Linear Amplifier

Plus many more . . .

CHRISTMAS
SUBSCRIPTION
OFFER



ham radio

Here is a wonderful opportunity to give your ham friends a gift which they will appreciate all next year and save yourself money doing it.

You pay our regular price of \$5.00 per year for the first subscription. Each additional subscription is just \$4.00 per year and if you wish to subscribe or renew, your own subscription can count in this offer.

Each gift recipient will receive an attractive card announcing your gift. This offer is good world-wide and a good way to remember many of your DX friends or you might use it to loosen up that rare QSL card you need so badly.

Name Call

Address

City State Zip

Name Call

Address

City State Zip

Name Call

Address

City State Zip

Name Call

Address

City State Zip

If you need more space please attach a separate list.

Your Name Call

Address

City State Zip

This special offer expires December 24, 1968

about two out of every three QSL's within a year of the QSO. By then the response rate is practically nil. Therefore the percentage of replies will not increase much in another year or so. If you haven't heard within a year, you had better send a second card with special inducement if you want the card!

Curve E QSL's sent to you via the bureau before the DX station heard from you.

In countries with outgoing bureaus, the majority of amateurs send their card via the bureau before they receive yours. Usually the card is marked "pse QSL" to remind you that he would like to receive your card. **Curve E** presents results tabulated for these replies. Thus it represents the one-way time via outgoing bureaus. The average time to reply (assuming he replies within a year) is over 22 weeks. A 50:50 chance of reply occurs at about 15 months after the QSO with only about 46% reply response after one year. Note that it takes almost 2 months before the first cards begin to arrive.

Curve F Reply via the bureau to a direct request on your card.

This represents those DX stations who wait for your card and then send their card to you through the outgoing bureau. The first reply of this type arrives about 4½ months after the QSO. After a year, about 8% of the overall 67% bureau response will reply in this fashion. Note that sending your card by air mail will result in an average saving of 3 weeks for these replies.

Curve G Bureau replies to your request via the DX bureau.

This last category represents the slowest method—both amateurs using the DX bureau. The first cards begin to arrive after about 6½ months. About 15% out of the 67% bureau responses will be received this way a year after the QSO. While these last two curves are not as flat after a year as the other methods, it is obvious that replies will not increase rapidly thereafter.

final comments

The curves in **fig. 1** can be used also to estimate your chances for receiving a card at

various times after a QSO. Simply enter the graph at the time of interest and move up vertically until you intersect the curve applying to the method you used. Read the percentage after this time on the left-hand axis.

These statistics graphically demonstrate the payoff for various QSL'ing options. This data should help you to decide when the added expense is worth the savings in time to reply. Perhaps even more important, how the added effort on your part increases the chances of receiving an important card.

references

1. J. Attaway, "Getting the QSL Card," *CQ*, September, 1967, p. 92.
2. J. Attaway, "QSL Machine," *RSCB Bulletin*, March, 1968, p. 175-241.
3. Franklin, "QSL'ing," *QST*, March, 1965, p. 96.
4. T. Hannah, "QSL Via Box 88," *QST*, September, 1967, p. 77.
5. I. Kazaisij, "On Sports Ethics for Short-Wavers," *Radio (USSR)*, Volume II, February, 1967.
6. E. Le Jeune, "How Do You QSL?," *CQ*, October, 1962, p. 41.
7. L. E. Persons, "How to Get Better Returns from Your QSL," *QST*, February, 1968, p. 48.
8. T. Wilds, "On the Art of QSL'ing," *QST*, October, 1963, p. 61.

* W6GSV's *QSL Managers' Directory* for example. \$3.95 from Bookbinder Publishing Company, Box 54222, Terminal Annex, Los Angeles, California 90054.

Foreign postage is available from the DX Stamp Service, Webster, New York 14580, run by W2SAW. If you'll write to him, he'll send you a complete price list.

ham radio

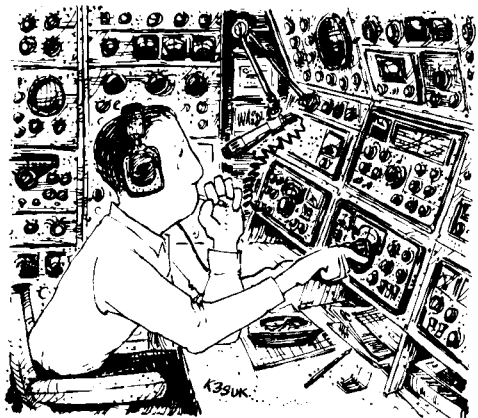

"... OSS ... OSS ... OSS
I wonder what that means?"

State of the Art for '69 ?



YES !

The hottest thing to come along in years for high performance receiver design is the MOSFET (Metal Oxide Silicon Field Effect Transistor). New types—only recently available for general use—are capable of equaling or surpassing the performance of the best popular vacuum tubes in critical front end applications. Properly used, they finally lick the old transistor hang-up of achieving low noise plus extremely wide dynamic range. (Without the ability to handle very large as well as very small signals, your receiver is susceptible to cross-modulation interference from strong off-channel stations, and to distortion of strong on-channel stations due to inadequate AGC range.)

Certain of the newer MOSFET's combine the large-signal linearity necessary to avoid cross-modulation and the ability to be gain-controlled over a wide range without compromising that linearity—no more auxiliary RF attenuators to supplement marginal AGC!

Transistors are still pretty hard to beat for low voltage, relatively high dissipation applications, too . . . like power amplifiers and voltage regulators.



... AND NO

Digital integrated circuits have already taken the computer field away from transistors, and they're now revolutionizing instrumentation as well. Digital frequency counters using IC's, for example, do the job of much larger transistor units at a fraction of the cost.

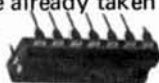

Intensive development of Linear IC technology has paid off more recently. A short time ago linear IC's were very limited in performance, expensive, hard to get. Now they're readily available in a multitude of varieties . . . and inexpensive. . . doing for applications like I.F., audio, and control amplification what the digitals did for computers.



Linear or digital, an IC does the job of several transistors plus the diodes, resistors, and interconnections that make them into a complete ready-to-use functional block. Be it a complex JK flip-flop or a high-gain I.F. amplifier, the IC often costs less than just the resistors of the conventional circuitry it replaces! (Equipment reliability benefits, too . . . because of all the separate components and soldered joints that are eliminated.)

The POINT is, modern component technology has made available a remarkable variety of sophisticated devices.

The TRICK is in knowing WHICH ones to use WHERE for the best results . . . and HOW.
THAT'S OUR BUSINESS!

 **signal/one**

A Division of Electronic Communications, Inc.

2200 Anvil Street N. • St. Petersburg, Florida 33710

ramp generators

"It looks like a sawtooth oscillator to me, Charlie. I wonder why this guy calls it a ramp generator?" Actually the question of whether a wave form like that shown in **fig. 1** is a ramp or a sawtooth is merely a matter of word choice. Some might argue that "ramp" is the more general description since it does not infer a sequence of waveforms like that between "0" and "t" in the example. But the sawtooth advocate could claim that the word "sawtooth" is singular, too, and possibly claim prior use historically. In this discussion I will refer to waveforms like that in **fig. 1** as ramps (choosing this term for brevity only) and hopefully will not be accused of taking sides in the semantics battle.

Ramp generators probably were first designed for horizontal sweep use in cathode-ray oscilloscopes. The ramp-generator circuit used in most of the early oscilloscopes was the thyatron relaxation oscillator. This circuit is really just a modification of the old neon-lamp relaxation oscillator shown in **fig. 2**. The neon lamp circuit, used for a novelty type flasher, has probably been built by every electronic experimenter alive. **Fig. 3** shows how a thyatron (a neon tube with a grid) is substituted in the circuit. The grid allows adjustment of the firing voltage of the tube so t_1 can be varied by adjusting grid bias. Of course, sync pulses can be easily injected at the control grid.

You'll notice in **fig. 2** and **3** that the waveform is not a linear ramp as desired, but rather an exponential curve—the portion of the voltage of a capacitor charging through

a resistor. To make the waveform of **fig. 3** more nearly linear, it's possible to return the top of R to a voltage higher than E_{BB} , which better approximates **constant-current charging**.

This constant-current charging is an important concept in understanding ramp generation. For example, suppose you have a black box with a one-million-volt battery inside it. In series with the battery is a 10-megohm resistor, also inside the box. The resistor and the common side of the battery are connected to two terminals in the side of the box as in **fig. 4**. On the outside of the box a 1000-ohm variable resistor is connected across the terminals.

An observer is invited to adjust the variable resistor and measure the voltage across it while doing so. He finds that the voltage across the variable resistor is proportional to its resistance since the current flow in the whole circuit will hardly change at all, percentage-wise, as R changes.

The current through R will be approximately 100 milliamps regardless of the setting of R. The observer would say, "In this black box is a constant-current source

fig. 1. A ramp waveform.

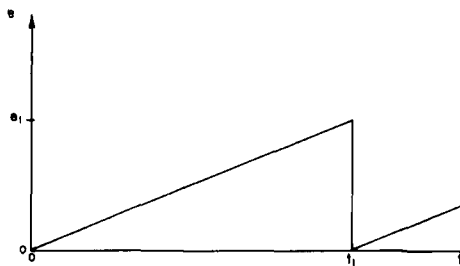

Hank Olson, W6CXN, P. O. Box 339, Menlo Park, California 94025

of 100 mA." I'd like to point out that this is an illustrative example only and not for actual construction. (If you do build it, for goodness sake don't ever discon-

fig. 2. Neon-lamp relaxation oscillator and its output waveform.

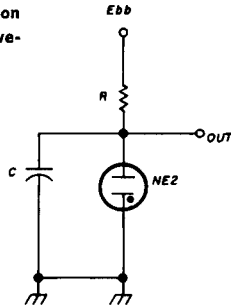

nect the resistor!)

The constant-current generator can be conveniently thought of as a large voltage in series with a large resistance, at least for a mental handle. In actual practice, more realizable approximations to constant-current generators are used in circuits. One such approximation is the pentode vacuum tube. If a pentode is substituted for the charging resistor, as shown in fig. 5, near-linear ramps are obtained. This method was used in some

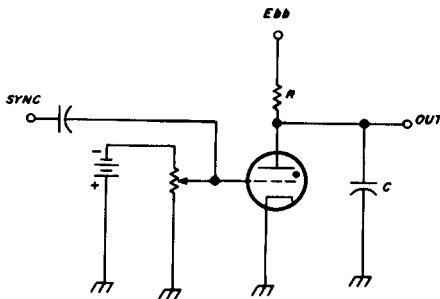
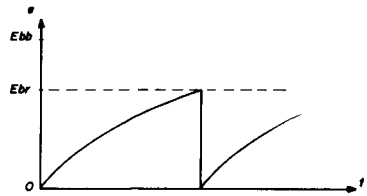

fig. 3. Thyatron ramp generator.

of the early ARRL Handbooks in their oscilloscope sweep circuits but dropped in later editions.¹

By now you should realize that the neon or thyatron is nothing more than a voltage-sensitive switch. The fact that the switch is sensitive to voltage means that ramp generators are self-resetting; that is, they put out ramp after ramp in a continuous sawtooth-like wave train.

By substituting a triode for the thyatron, it's possible to change the free-running ramp generator to a driven ramp generator. In fig. 6, when V_1 is



biased "off," the ramp grows linearly with time. But at t_1 , V_1 is made to conduct by the positive pulse applied to its grid, and C is discharged. This "triggered sweep" is the type of ramp generator that is used in most modern oscilloscopes.

The bootstrap circuit (so called because it "pulls itself up by its own bootstraps") is shown in fig. 7. This circuit is very similar to that of fig. 3 except that a cathode-follower has been added that couples the output ramp voltage back to

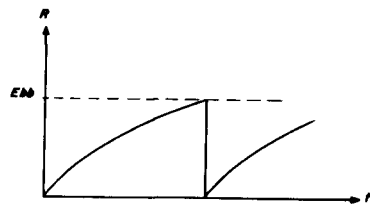

the charging resistor. Therefore, the voltage which operates the RC circuit rises as charging proceeds. This is an effective method of obtaining constant-current charging and yields very nearly linear ramps.

The last variety of tube-type ramp-generator to be discussed here is the Miller integrator. The sanatron and phantastron circuits are variations of the

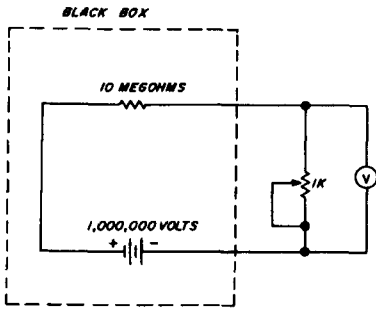

fig. 4. Illustrative example of a constant-current generator.

Miller integrator and will not be described in detail. The Miller integrator is also similar to fig. 3, except that C is replaced by the Miller-effect capacitance—one of the facts of life that is undesirable in building rf amplifiers; it is the apparent input capacitance “seen” from grid to cathode due to grid-to-plate capacitance (C_{gp}).

The fact that C_{gp} is connected between the input and the amplified and out-of-phase output of the amplifier makes it appear much larger than C_{gp} . In fact, the apparent capacity to the cathode is approximately $\mu \times C_{gp}$, the voltage gain of the tube times the grid-to-plate capacitance! Since the μ of a pentode (the type of tube usually used in Miller integrators) is often 1000 or more, the effective C can be quite large. Is it any wonder that neutralization is so important in rf amplifiers?

By adding a lumped capacitance across the grid and plate, we can make μC_{gp} really of useable size. Then a very large capacity is charged to a small voltage (at the grid) so it stays on the nearly linear portion of the exponential charging curve near zero voltage. The amplification of V_2 , however, provides a larger useable ramp. It is possible to analyze the Miller integrator in other ways and even to show that it is equivalent to the bootstrap circuit, as shown in reference 2.

It may seem that a great deal of space has been used in describing “obsolete” vacuum-tube circuitry. But we will see that these tube circuits form the basis of many of the newer solid-state circuits. In fact, now that FET’s are coming into wide use, many of the old tube circuits can be used directly.

A simple solid-state circuit that is

fig. 6. Circuit modification to fig. 5 to make a driven ramp generator.

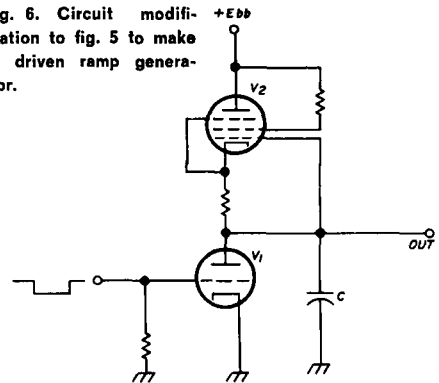
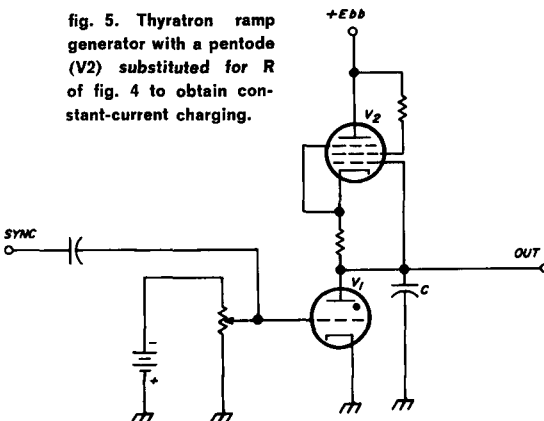

fig. 5. Thyratron ramp generator with a pentode (V_2) substituted for R of fig. 4 to obtain constant-current charging.



very much like the neon-lamp relaxation oscillator of fig. 2 is shown in fig. 7. The diode is a Shockley four-layer type which displays a negative resistance on break-over.

Fig. 10 shows how a unijunction transistor can be used as a relaxation oscillator. The breakover voltage can be controlled by choosing the zener voltage, since the ujt breakdown is always a constant fraction of the voltage between B_1 and B_2 . This circuit can be modified (much as fig. 3 was modified to fig. 5) for constant-current charging by replacing R with a bipolar transistor, an FET,

or a field-effect diode as shown in **fig. 11**. An example of a solid-state bootstrap circuit is shown in **fig. 12**. This particular bootstrap circuit is self-resetting. It is described in more detail in reference 3.

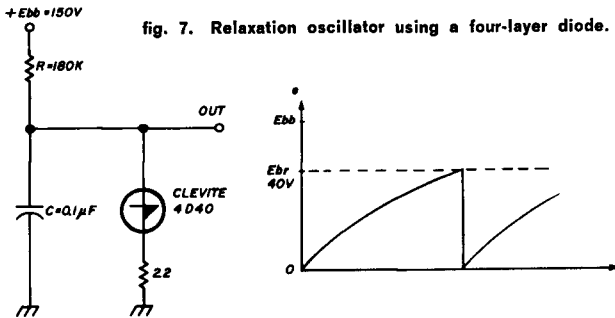

fig. 7. Relaxation oscillator using a four-layer diode.

fig. 8. The bootstrap ramp generator. The ramp waveform starts when the switch tube (V1) is biased off; V2 is a cathode-follower that controls feedback.

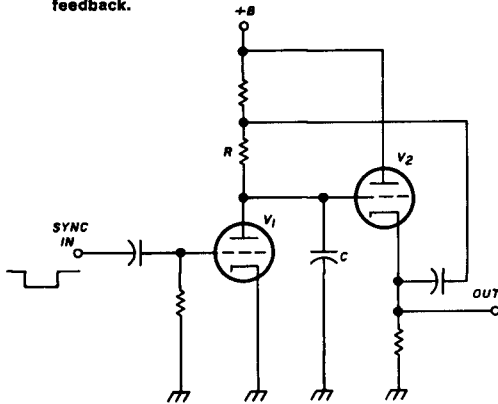
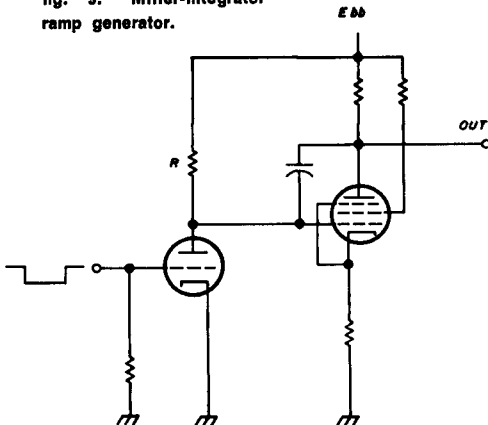

fig. 9. Miller-integrator ramp generator.



The Miller integrator is easily constructed using an FET as the amplifier stage, as shown in **fig. 13**. The Miller integrator is only one example of this general class of feedback ramp generator; as mentioned before, the bootstrap is a similar circuit. You will find that the amplifier tube or FET may be replaced with nearly any high-input-impedance, low-output-impedance, inverting, voltage amplifier.

Such a device is the so-called operational amplifier that is available in packaged form from at least half a dozen firms. Operational amplifiers were originally designed for use in analog computers but now find wide use in other electronic systems.

Wider usage of operational amplifiers, and the tremendous potential price cuts promised by monolithic integrated operational amplifiers, should make the feedback method of ramp generation more popular in the future. The higher the voltage gain of the op-amp, the more nearly the ramp approaches perfect linearity, providing the input-output phase can be made to stay at 180°.

The uses of the ramp generator are many. Every oscilloscope uses a ramp generator for horizontal sweep and so do tv cameras and tv receivers and panoramic receivers (spectrum analyzers). By applying the ramp voltage to a voltage-controlled oscillator (VCO) a swept frequency may be produced. Such voltage-

fig. 10. Unijunction-transistor relaxation oscillator. The output frequency is 5 kHz when $R = 24k$ and $C = 0.022 \mu F$.

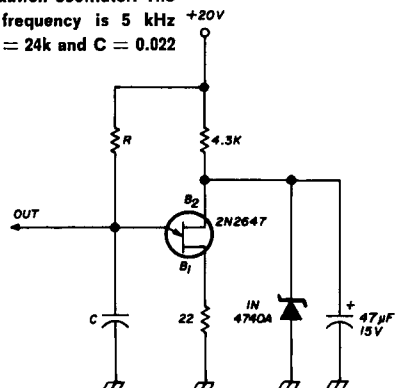

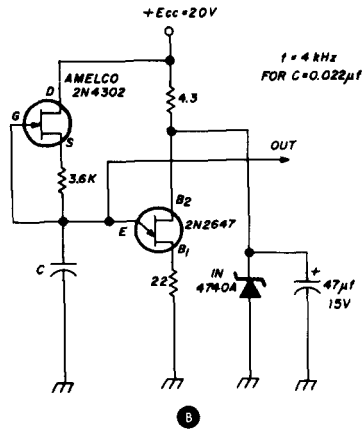
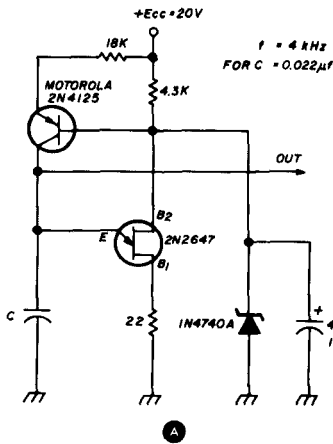

fig. 11. Modifying the relaxation oscillator shown in fig. 10 for constant charging with a bipolar transistor (A), an FET (B) and field-effect diode (C).

controlled frequency sweeps are used in sweep generators and spectrum analyzers.

The ramp generator is the basis for most electronic timers and similarly can be used to build a pulse generator with pulse length as a function of voltage. This is shown in block diagram in fig. 14 and an actual circuit is shown in fig. 15.

The testing of components at various voltages can be a tedious job if done

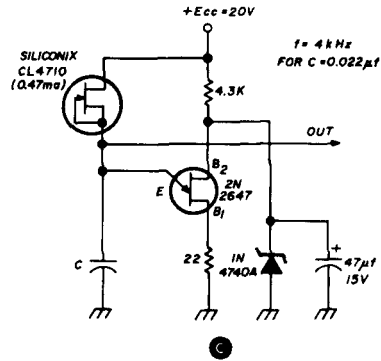
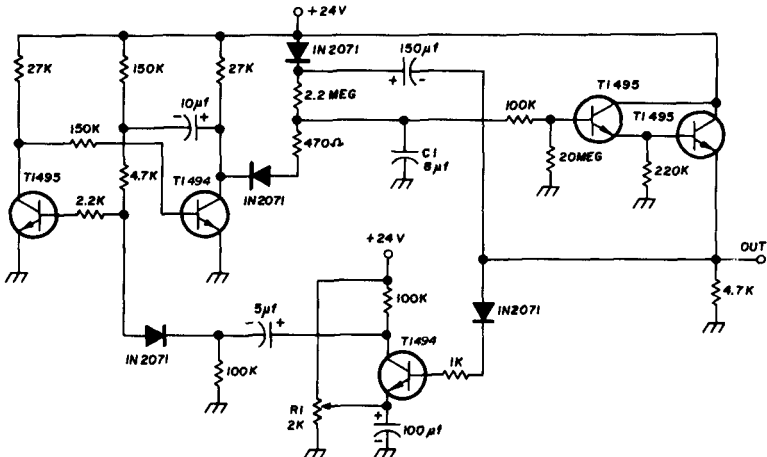

fig. 12. Bootstrap ramp generator. As C1 starts to charge through the 2.2M resistor, the ramp voltage is coupled out through the two T1495 emitter-follower output stages. The output ramp is coupled back to the top of the 2.2M resistor through a 150-µF capacitor, reverse biasing the 1N2071 and allowing the voltage operating the resistor to exceed 24 volts.

NOTE: C1 IS MYLAR AND NON-POLARIZED. ALL RESISTORS ARE 1/2W 1%. TIME CYCLE IS SET BY R1. TIME CYCLE FOR CIRCUIT SHOWN IS 2-20 SEC ± 5% IF AMBIENT TEMPERATURE RANGE IS -20°C TO +65°C.



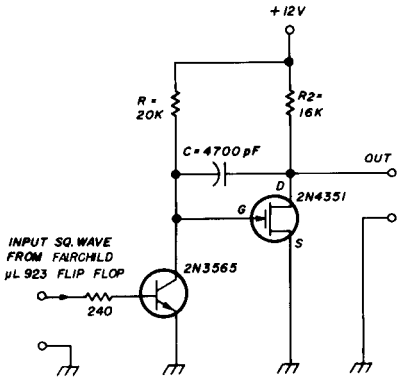
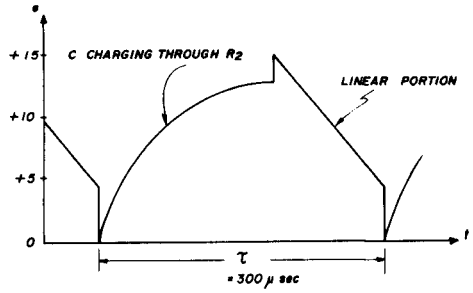

fig. 13. Miller-integrator ramp generator using an enhancement-mode MOSFET.



manually. By applying a ramp of voltage to the device under test while monitoring the performance on an oscilloscope with an identical sweep, the testing can be done automatically and recorded photographically. This is the sort of thing done in transistor curve tracers.

fig. 14. A voltage-controlled pulser where the pulse width of the pulse train is controlled by a dc voltage

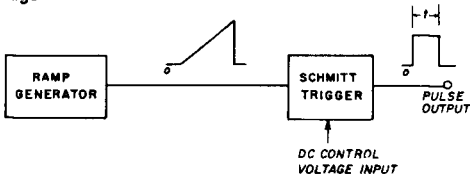
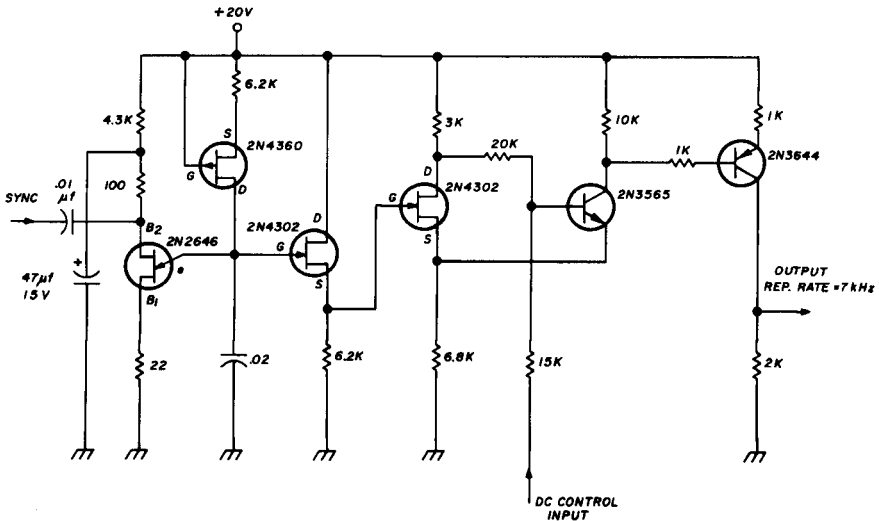

fig. 15. Actual circuit of the block diagram shown in fig. 14.



There are many more uses for the ramp generator; your imagination and the linearity of various voltage-to-whatever transducers are the only limitations. I want to thank Texas Instruments for permission to use fig. 12.

references

1. ARRL, "The Radio Amateur's Handbook," 1945 Edition, p. 428.
2. M.I.T. Radiation Lab Series, "Waveforms," Boston Technical Lithographers, Inc., p. 35.
3. Texas Instruments, "Transistor Circuit Design," McGraw-Hill, New York, 1963, p. 415.
4. J. Pettit, "Electronic Switching, Timing, and Pulse," McGraw-Hill, New York, 1959, Ch. 6.

ham radio

silver plating

for the
serious amateur

make
your own lab
for
silver plating
vhf components;
it's easy
and inexpensive

Ralph W. Campbell, W4KAE, 316 Mariemont Drive, Lexington, Kentucky 40505

The advantages of using plating on electronic components are well known. At W4KAE I've found that vhf tank circuit efficiency improved considerably after silver plating. Silver oxide on critical connections such as mike connectors and antenna conducting bolts pays off in increased reliability. Transmitting tube pins, uhf cavities, and klystron connections all benefit from silver replating. The movable parts in tuned cavities in fm transmitters, for example, frequently break down because of worn plating on metallic interfaces.

Successful silver plating has been a problem ever since I started to build amateur equipment for 2 meters. Of all the popular methods tried, brush plating (described below) was closest to yielding acceptable results, even though it was too slow for amateur purposes. This kind of plating, I thought, was also more potentially dangerous since it used cyanide salts in a water-soluble base.

In this article, silver plating is shown to be a practical means for improving conductors and conductive surfaces. And the method can be used with safety by following the rules printed by the manufacturer on containers. An equipment description and a step-by-step set of instructions are presented. For those unaccustomed to plating terms, a glossary of by-word-of-mouth

shop-talk definitions appears at the end of the article.

plating methods

There are three basic methods for depositing metal onto metal: **brushing**, **tank plating**, and **immersion**. The first two are true electroplating methods. The third, also known as electroless plating, is an ionic displacement method where the plating solution is heated and electricity is not used.

Brush plating is probably the simplest to use. The work to be plated (called the cathode) is brushed repeatedly with the

fig. 1. The materials needed for high-quality silver plating.

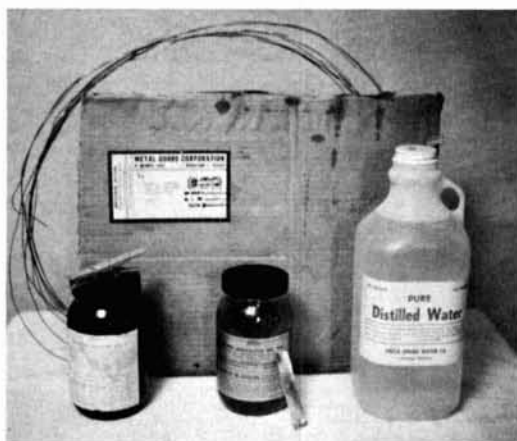

anode until the desired plating buildup is obtained. The anode, which is generally made of the metal to be deposited, is wrapped with a gauze-covered wad of cotton. Before each brushing this is dipped into a solution containing cyanide salts of the metal to be deposited. Both cathode and anode are connected to a dc source to complete the electroplating circuit. Voltages between 1.5 and 6 Vdc are normally used for silver plating.

Tank plating, which is the most practical method, is the one described here. Experiments have shown that tank plating is probably best for most amateur work. If you have enough patience and time, however, brush plating would be the logical choice for use on circuit boards, which

have discontinuous conducting elements and are thus difficult to plate using the tank method.¹

what's available

Having had some success with the brush-plating method I wrote the people who made these kits to see if there was anything better available.* There was. Kits of chemicals (with plater) and metallic anodes could be supplied at reasonable prices over most other sources. For industry they offer their "Rapid-Plater." For amateur, design-lab and experimental use, small amounts of plating supplies can be obtained. My initial inquiry resulted in quick response plus their latest catalog.

As it turned out, many different compounds and metals were available. To gain experience, I tried copper plating first, then bright nickel and "Rapidmetal;" then silver. Electrolytes other than the cyanide salts in solution were tried, but they had almost no throwing power.

Organic compounds have apparently been added to Rapid's electrolyte number 316 to prevent formation of hydrogen cyanide. (This stuff, incidentally, is the same gas used in prison death chambers, so it's not hard to see why the manufacturer has taken pains to inhibit its formation).

For my tank plating, I used the following chemicals and materials: Coatalyte number 316 electrolyte, silverizing activator number 4 and number 536 without sleeve. These form the basic elements of a simple but effective homemade plating lab.

equipment

Fig. 1 shows most of the apparatus needed for professional quality silver-plating. Starting at the left, a bottle of Rapid activator number 4 is shown. This is used for preparing copper, brass and bronze for silver and gold plating. No water rinse is needed with this activator. The chemical action of the activator is known as "striking or silverizing" nonferrous base metals for high-integrity deposition of silver.

* Rapid Electroplating Process, Inc., 1414 S. Wabash Ave., Chicago, Illinois 60605.

On top of the activator bottle is a wooden clothespin—the single most handy device I used. Next is electrolyte number 316, with a piece of number 536 pure silver anode resting on the container; then a half-gallon of distilled water.

In tank plating, the Coatalyte should be used full strength. Dilution by more than 10 percent will destroy the throwing power of the electrolyte for future use. But if you must dilute, don't attempt to use the weakened solution again for smaller work.

I bought two bottles for this reason. One jar is used for large surfaces (using meticulous care and agitation), and the remaining jar is kept at full strength. Only undiluted Coatalyte will have enough throwing power to deposit 1 mil total plating thickness on piecework in fifteen minutes. Then the work must be stripped down for final or additional coats.

Behind the jars is some stainless steel wire which is used to connect the piecework and anode to the voltage source. Stainless steel is preferred because it minimizes buildup of ferro-cyanide, which contaminates the solution. Loose particles of foreign material floating in the electrolyte tend to cause roughness in the deposition of silver onto the work.¹ Ordinary pure copper wire can be used; however, number 18 stainless can be obtained COD on a "minimum billing" from the Metal Goods Corporation for less than \$5.00.*

Fig. 2 shows several acrylonitrile number 31 sleeves used to cover boot-shaped anodes (for Rapid or "sleeve plating"), and in the background is a nylon funnel with three rings which I silver plated. To the front is an applicator (anode + sleeve + handle) and two heavy-duty Mueller clips which are used for connections to the dry cell or battery charger. Also, there is a smaller nylon funnel shown with a polyethylene lid, and a homemade separator, resting on a piece of Scotch-brite abrasive cleaning pad.

Fig. 3 shows an in-tank view of my plat-

ing method. Only 1½ volts are used from a number 6 dry cell. Normally, the concentrated electrolyte is kept in its jar or in a roll-film tank. Cost of silver solutions is typically \$4.80 per 16-oz container of number 316. For this reason, small containers are preferred. Stripping the work for successive coats should be done every fifteen minutes. Lightly sanding with crocus cloth is preferable. Rapid Electroplating Process "portable platers" use sleeves which negate the chore of stripping at regular intervals. This yields an even higher integrity coat than tank plating, but you must buy a plater to do this well.

fig. 2. More of the materials used for plating along with three rings that I silver plated.

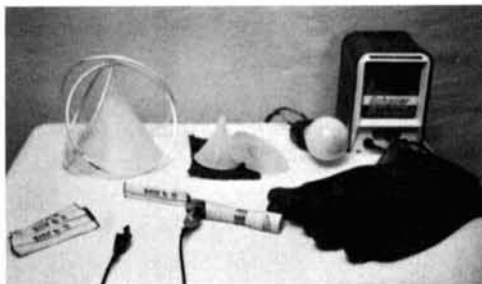

step-by-step plating

1. First take the work to be plated to a clean, well-ventilated area and wash the work with a strong detergent. Take off any scale or dirt with a single-edged razor blade, preferably by scraping. Then rough up with abrasive.
2. Place work in metal cleaner. Remove after tarnish is brightened, wash, and dry. Use a towel!
3. Using rubber gloves, open a jar of activator number 4. Place work in solution.
4. Cut off two lengths of wire and connect them to the dry cell or battery charger; positive connection is made to the silver anode. Mark with red nail polish.
5. Repeat step three until surface shows a white silver haze. If it is difficult to get this,

* P. O. Box 1452, Houston, Texas.

Ed. note. The stainless-steel treble "E" string for plectrum banjos is about number 22 AGW. It is three feet long and costs about 30c in music stores.

HOLIDAY SALE! PACKAGE SALE!



SR-400 Cyclone Transceiver



HA-20 VFO

hallicrafters



SR 400

\$799.95

PS 500 AC

\$119.95

\$919.90

Write for

SPECIAL PRICE!

DISCOUNT PRICES. NO ONE ANYWHERE will beat our price! We will **TOP** any advertised or written price from any other dealer. We trade on both new and used equipment and we service what we sell. Instant credit on both new and used equipment. American Express and General Electric revolving charge.

AMATEUR - WHOLESALE ELECTRONICS

A DIVISION OF



International Electronic Systems, Inc.

280 ARAGON AVENUE, CORAL GABLES, FLORIDA 33134

Cable: "INTEL" 305-444-6207 Export orders our specialty

try grinding in the activator or striker with Scotch-brite saturated in the appropriate solution. If you are plating aluminum, it will be necessary to strike the work first with activator number 5, and then wash and repeat the silverizing process with activator number 4. Rubber gloves are essential!

6. Attach other wire (negative) to piece-work; next place both in electrolyte number 316. Activator solutions must be kept separate from Coatalytes, except for number 4, which need not be rinsed off completely.

fig. 3. In-tank view of my plating setup.



7. Agitate while plating. Thick coats can be built up faster than the first, and critical, one.

8. Remove work, wash, and dry. Work set aside for later use should be resilverized immediately before an additional coat.

9. Plating time: up to four hours can be used with a current of 100 milliamperes, as a general rule.

some after thoughts

If you plan to do a lot of silver plating, it's a good idea to salvage the solutions. Reference 1 lists companies that buy plating solutions for recovering the precious metals in them.

Reference 1 also recommends alternate plating and deplating. A short period of deplating (by reversing the polarity of the voltage source) will remove any metal that has not been soundly deposited during the previous plating cycle. Thus each plating cycle deposits onto a base of firmer, smoother metal. This results in a brighter finish. The deplating cycle is very short: of the order of a few seconds.

glossary

building up	silver deposited in excess of 1 mil on the base metal
electroless plating	a molecular displacement chemical reaction where silver is deposited without electricity
coatalyte	electrolyte
integrity	quality of deposited silver
nonferrous	any metal not iron
silverizing	activating copper, brass and bronze for silver plating. Aluminum is first struck; then it is silverized
striking	activating the work or base metal for silver plating
stripping	process of lightly scraping or sanding successively plated work before building up
tank plating	immersion plating with electricity
throwing power	ability of a given electrolyte solution to deposit silver from an anode, through the solution used as electrolyte, to the properly activated base metal

references

1. *Metal Finishing Guidebook Directory for 1968*, Metals and Plastics Publications, Inc., 99 Kinderkamack Road, Westwood, N. J. 07675.

ham radio

FM FROM CW

That's right, CW ELECTRONIC SALES, CO.
is the exclusive distributor for the



NEW, VHF ASSOCIATES FMT-1 TWO METER FM TRANSCEIVER

Using integrated circuits in two IF stages and in the audio power amplifier the FMT-1 offers 2 watts nominal RF power output and 0.3 microvolt sensitivity for 20DB quieting.

This all solid state unit has ample power to activate even insensitive repeaters. It can operate on any of three independently selected crystal controlled receive and transmit channels. Crystals are provided for the national repeater channel 146.34 — 146.94 or another set of your choice.

Available in mid-December 1968

Advance orders now being accepted

UNDER \$200.00

Complete with mobile mount and high quality ceramic mike.

The old radio corner for over a quarter century. Come in and pay us a visit or get in touch with one of our staff today.



JOHN WA0ADV
WILLARD W0BQO
GARY WA0KLP

ELECTRONIC SALES CO.

1237 - 16TH ST., DENVER, COLO. 80202

303 / 244-5523

JOHN W0FU
MIKE WA0KXR
JEFF KOUFA/W0LDU

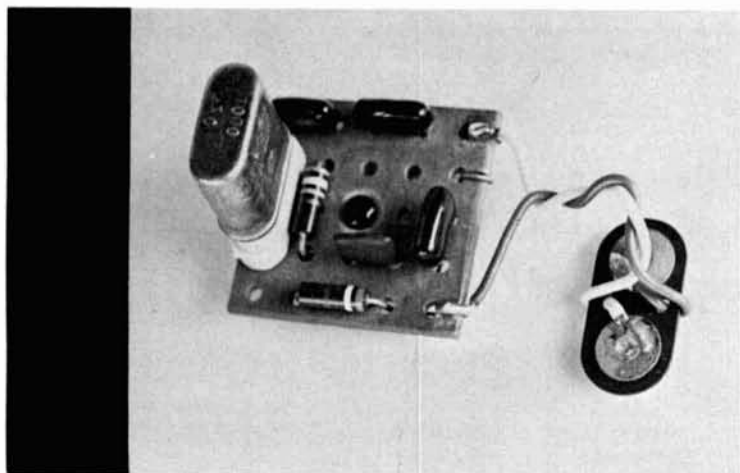

miniature crystal oscillator

A reliable low-cost
crystal oscillator
that isn't much larger
than a postage stamp

Ev G. Taylor, W6DOR/W7BYF, 4100 Worthington Drive, North Highlands, California 95660

I wonder how many frequency standards were never built for the want of a special choke that is called out, lack of time to finish soldering all of the wires to the tube socket or need of a spare power supply to try it out? This oscillator doesn't require any of these things. The circuit is simplicity itself. The part requirements are four capacitors, two resistors, a crystal socket and a transistor. It's so simple that you don't even need hookup wire—the parts are placed so the component leads serve as the connections. The few parts that are used were placed on a piece of pre-punched terminal board slightly larger than a postage stamp. To be exact, it measures 1-3/8 inches square!

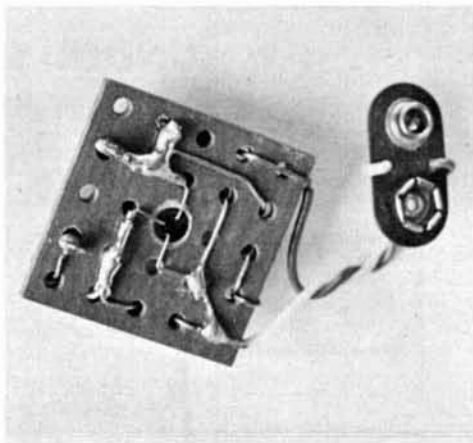
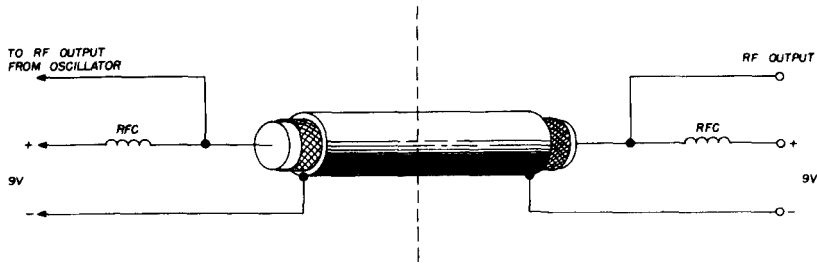

fig. 2. Method of getting dc power to the oscillator if you bury it in the ground for stability.



The power source is a 9-volt battery that can be picked up at your corner supermarket or drug store. If you use the oscillator as a 100- or 1000-kHz marker as a net-frequency "spotter," you can pick up the supply voltage from the cathode bias on the output tube. If your receiver is transistorized, you can use the battery in the set. If you put a low reading milliammeter in series with the voltage source, you can use this circuit as a crystal checker the next time you go looking for a good rock at your favorite surplus store.

This is a simple but reliable circuit. Even overtone crystals will work in it; 100-kHz crystals will oscillate with a 3-volt supply.

fig. 1. Circuit of the postage-stamp oscillator.

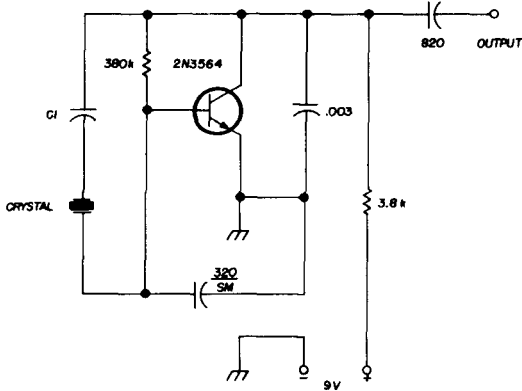

The pre-punched terminal board is cut so that one of the holes is in the center. This hole is enlarged sufficiently to accommodate the transistor.

The transistor is a vhf type that is available for less than a dollar. The board somewhat stabilizes what little heat is generated by the transistor since the board and transistor are in direct contact if you use the correct size drill. The other parts fit in like one, two, three.

A fixed capacitor is put in series with one lead of the crystal socket so you can set the frequency on the nose—its value may be different with various crystals and different frequencies. With a 1-mHz crystal that I used, the capacitor turned out to be 120 pF. It might be simpler for you to use a small trimmer in case you want to use this circuit with various crystals. For long-time stability be sure to use a silver-plated trimmer.

If you use this oscillator for checking WWV, I have a little suggestion for further stabilization. Put the unit in a glass jar, fill it with oil and bury it a few feet in the ground. The voltage supply may be fed through coax if you use isolation chokes at each end. This is the system used to feed power to CATV-system amplifiers.

ham radio

new dx record for 40,000 mhz

WA7EDI and W7CAF
work over
a 3720-foot path
on
40,100 MHz

A new DX record for two-way communications above 40,000 MHz was established at the Southwest Division Convention in Phoenix on the first of September. The new distance record, 3720 feet, was accomplished on 40,100 MHz; the old record, set in 1967 by W6FUV and W6SJO was 700 feet.

One station, WA7EDI/7, operated by Lorraine Cripps, was located on top of an office building in downtown Phoenix; on hand as witness was Ray Cripps, WA7EDH. In front of the Townhouse Hotel at the other end of the link was Gary Hamman, W7CAF/7; the witness at the hotel location was John Huntoon, W1LVQ, ARRL General Manager.

Similar equipment was used at each end of the 3720-foot path and consisted of microwave laboratory equipment furnished by Motorola's Aerospace Center of Scottsdale. The transmitter was made up of a Hewlett-Packard signal generator at 20,500 MHz driving a frequency doubler to 40,100 MHz; power output was 1 milliwatt. Modulated CW was used as shown in **fig. 1**.

Each receiver used a crystal detector with the output coupled to an HP-415E vswr meter which had an internal high-gain amplifier. Output from the high-gain preamp was coupled into an audio power amplifier to drive a speaker. Full break-in CW operation was provided by a 10-dB direction coupler as shown in **fig. 1**.

The antenna system at each end of the link was a three-foot parabolic reflector fed with an open-ended piece of waveguide. The measured half-power beamwidth of each antenna was 0.7 degrees; calculated gain was 48 dB above an isotrope or about 46 dB above a dipole. The mounting stands for the antennas and other equipment were designed and built by WA7EDH.

ham radio

Hal Jackson, K7PMY, 6626 East Coronado Road, Scottsdale, Arizona 85257

Gary Hamman, W7CAF/7, with John Huntoon, W1LVQ, and John Griggs, W6KW.

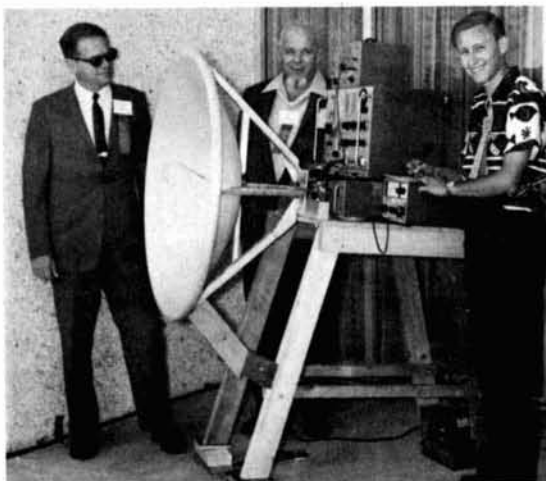
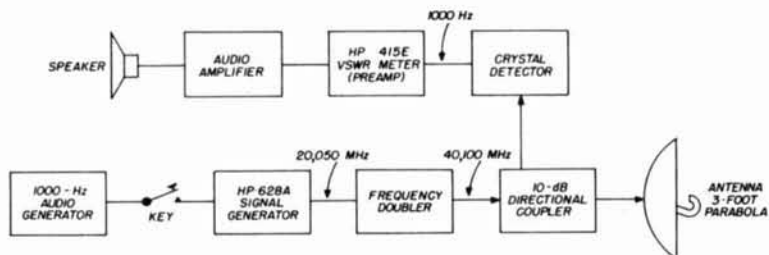

fig. 1. Block diagram of the system used at both ends of the path. Full break-in operation was provided by the 10-dB directional coupler.



Lorraine Cripps, WA7ED1/7, at the key on one end of the path with her husband, Ray, WA7-EDH, looking on.



NOT FOR THE NOVICE



THE FT DX 400 "FULL HOUSE"

Conservatively rated at 500 watts PEP on all bands 80 through 10 the FT dx 400 combines high power with the hottest receiving section of any transceiver available today. In a few short months the Yaesu FT dx 400 has become the pace setter in the amateur field.

FEATURES: Built-in power supply • Built-in VOX • Built-in dual calibrators (25 and 100 KHz) • Built-in Clarifier (off-set tuning) • All crystals furnished 80 through the complete 10 meter band • Provision for 4 crystal-controlled channels within the amateur bands • Provision for 3 additional receive bands • Break-in CW with sidetone • Automatic dual acting noise limited • and a sharp 2.3 KHz Crystal lattice filter with an optimum SSB shape factor of 1.66 to 1.

Design features include double conversion system for both transmit and receive functions resulting in, drift free operation, high sensitivity and image rejection • Switch selected metering • The FT dx 400 utilizes 18 tubes and 42 silicon semi-conductors in

hybrid circuits designed to optimize the natural advantages of both tubes and transistors • Planetary gear tuning dial cover 500 KHz in 1 KHz increments • Glass-epoxy circuit boards • Final amplifier uses the popular 6KD6 tubes.

This imported desk top transceiver is beautifully styled with non-specular chrome front panel, back lighted dials, and heavy steel cabinet finished in functional blue-gray. The low cost, matching SP-400 Speaker is all that is needed to complete that professional station look.

SPECIFICATIONS: Maximum input: 500 W PEP SSB, 440 W CW, 125 W AM. Sensitivity: 0.5 uv, S/N 20 db. Selectivity: 2.3 KHz (6 db down), 3.7 KHz (55 db down). Carrier suppression: more than 40 db down. Sideband suppression: more than 50 db down at 1 KHz. Frequency range: 3.5 to 4, 7 to 7.5, 14 to 14.5, 21 to 21.5, 28 to 30 (megahertz). Frequency stability: Less than 100 Hz drift in any 30 minute period after warm up.

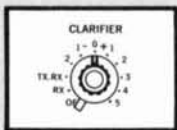

CLARIFIER CONTROL — Does the work of an external VFO — allows operator to vary receive frequency 10KHZ from transmit frequency, or may be used as an extra VFO combining transmit and receive functions.

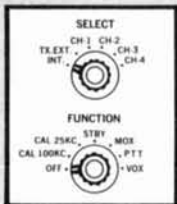

SELECT CONTROL — Offers option of internal or outboard VFO and crystal positions for convenient preset channel operation.

FUNCTION CONTROL — Selects crystal calibration marker frequency and desired transmit mode of operation.

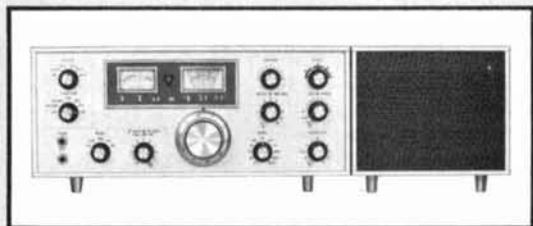

FT DX 400 \$599.95 — SP-400 \$14.95



SPECTRONICS BOX 356, LOS ALAMITOS, CALIFORNIA 90720

— PROFESSIONAL EQUIPMENT FOR THE AMATEUR —

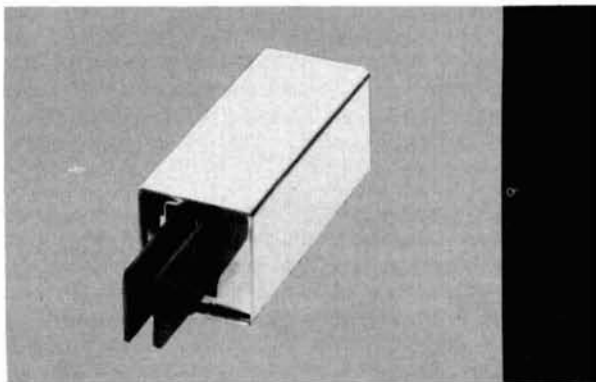

the james research permaflex key

A new design
for
solid-state
keyers

Jim Fisk, W1DTY, Post Office Box 25, Rindge, New Hampshire 03461

A number of different keys have been introduced and manufactured over the years, and each new design borrows a little something from previous units. First came the hand key, then the bug and the cootie key (or was it the other way around), and finally, adaptations of the basic bug for use with electronic keyers. The new James Research Permaflex key represents a radical departure in key design. It doesn't even look like a key in its handsome chrome-plated case. The function is still the same, but modern materials, design and technology are used to manufacture a key to meet the needs of today's solid-state electronic keyers.

If you have ever used a conventional bug with a solid-state keyer, particularly integrated-circuit units, you can appreciate the problems caused by corroded silver keying contacts. Problems don't show up with vacuum-tube keyers because there's enough current drawn through the contacts to keep them clean. However, with solid-state devices, it's a completely different story. The current through the contacts is infinitesimal, and if you don't clean the keying contacts fairly often you'll be plagued with erratic

keying. I've tried a number of solid-state keyers, but problems with erratic keying had always forced my back to the 'old reliable' vacuum-tube unit. I wonder how many other amateurs have had the same problem?

Another problem with conventional keys is contact bounce. Transistor and integrated-circuit keyers are a lot faster than most vacuum tube units; if your key has any contact bounce (and most of them do), you'll experience further trouble with badly made CW characters. Any corrosion that the contacts may pick up further aggravates this problem. If you have any doubts about contact bounce, just run a little dc through your keying contacts and take a look at the waveform on an oscilloscope. You'll be amazed at the 'fuzzy'

any contact bounce at all. This shows up when using solid-state keyers too. With a conventional key, I was plagued by extraneous dots when the paddle was pushed to the dash side. With the Permaflex any keying errors I get are completely my own.

The Permaflex key is small—only 1-9/16-inches square by 3-3/34-inches long—but the silicone rubber feet do a remarkable job of preventing key "walking" during operation—as long as you keep them clean. Actually, there are two sets of feet on the key—one set is used when the key is operated as a sideswiper, the other set when it's used as a hand key. This is one of the more interesting applications of the Permaflex key; if you're working a station where a hand key would

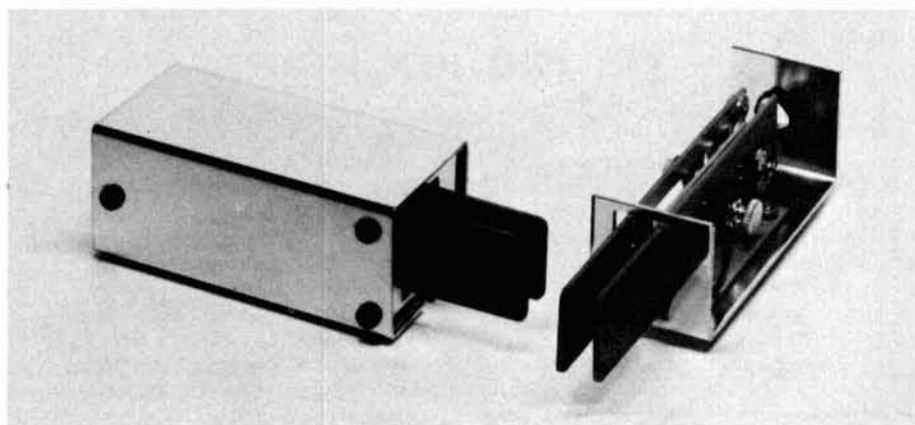

leading edges caused by bounce.

The James Research Company took a very close look at these problems, and then designed a unit that would solve them. For the corrosion problem, they used gold-diffused silver; the contacts will take up to 8 amperes and will not corrode. The pivotless two-paddle design using fiberglass epoxy with gold-plated conductors results in a low-mass paddle with equal performance at both low and high currents. Tension can be adjusted from 5 to 50 grams. None of the adjusting screws carries any current, so there are no problems with high-resistance paths.

Contact bounce with the Permaflex key is practically non-existent. In oscilloscope tests that I've made, I've been unable to detect

be more suitable than an electronic bug, you simply turn the key on its side and use it as a hand key! Three additional silicone-rubber feet are provided for this purpose.

The biggest problem with the Permaflex key is getting used to it. After using a regular "bug" for a number of years, it's difficult to adapt to a keyer that has 5 grams armature pressure. If you operate an electronic key, you probably bat the keyer around a lot—I know I do. Keying with the Permaflex doesn't take any effort at all, so it takes a little getting used to. But after you've mastered it, it's pretty hard to go back to the high-mass paddles used in conventional designs.

ham radio



THE **ICE-1**

2 METER FM TRANSCEIVER

FULLY SOLID STATE - NO TUBES

- Operates on 117 VAC — 12 VDC — or optional internal NI-CAD battery
- Self-contained 3" X 5" speaker
- Military type fiberglass printed circuit boards
- Epoxy painted cabinet
- Regulated power supply — cannot be damaged by reverse polarity
- May be ordered for either wide or narrow band operation at no extra charge (wide band supplied unless specified)
- Small size: 8" w X 3½" h X 9½" d
- Light weight — Less than 4½ lbs.
- Built in 117 VAC power supply
- Simply plug in proper power cable to charge from 117 VAC to 12 VDC operation
- Transmitter and receiver channels individually switchable
- 3 channels transmit — 3 channels receive
- Push-to-talk operation

⚡	<p>COMPLETE WITH ONE SET OF CRYSTALS ON 146.94, 117 VAC AND 12 VDC POWER CABLES, LESS MICROPHONE AND ANTENNA \$285.00 EXTRA CRYSTALS (TRANSMIT OR RECEIVE) 7.00 BUILT IN NI-CAD BATTERY AND CHARGER 47.00</p>	⚡
---	--	---

ICE

MANUFACTURED IN U.S.A. BY

INTERNATIONAL COMMUNICATIONS AND ELECTRONICS, INC.

1917 NW MILITARY HIGHWAY/SAN ANTONIO, TEXAS 78213/512 341-1311

propagation

predictions for december

Old sol
exposed for
a
cold winter's
column

Winter has arrived in the northern-hemisphere ionosphere. Unlike the earth-atmosphere weather system, which has a thermal time constant of about a month and a half, the ionosphere responds almost directly to changing solar declination. The ionization time constant is measured in minutes for the E- and F1-layers, and probably tens of minutes for the F2-layer.

Little seasonal change in ionospheric parameters is expected during December or most of January since the solar declination is close to 22 to 23 degrees south during most of these months. Accordingly, the range predictions presented this month are sufficiently accurate for both months.

The seasonal changes from earlier months are these:

1. Lower noise levels
2. Higher daytime F2-layer muf's in north temperate latitudes
3. Lower nighttime muf's in north temperate latitudes
4. Shorter duration (and maximum path length) of Northern Hemisphere daytime band openings.

The shorter hours of daylight will reduce somewhat the path muf's for Northern Hemisphere paths greater than 5000 miles in length—even though the path muf's for single-hop paths may be increased slightly over those of November. December and January are also the months of a secondary peak in occurrence of sporadic-E in northern-hemisphere temperate latitudes.

the quiet sun

Last month I indicated dissatisfaction with the use of running average smoothed sunspot numbers for prediction of median ionospheric conditions (critical frequencies). This month I will describe the quiet sun so that you will have a background for the discus-

Victor R. Frank, WB6KAP, 12450 Skyline Boulevard, Woodside, California 94062

sions of solar-terrestrial relations that will follow in coming months.

The sun is powered by self-sustaining thermonuclear reactions confined by gravity. The solar diameter is about 864,000 miles, almost four times the distance from the earth to the moon. Composed primarily of hydrogen and helium, average density is less than that of the earth; however, the forces of gravity compress the deep interior of the sun to about 5 times the density of gold.

The temperature at the center of the sun is believed to be about 13 million degrees Kelvin and almost all (about 88%) of the atoms are ionized. Most of the nuclear energy of the sun, from the transmutation of hydrogen to helium, is produced near the center of the sun where the temperature is sufficient to permit fusion.

Nuclear energy, gravitational energy and thermal energy form a feedback system that keeps the interior of the sun in thermal equilibrium. Energy is transported through most of the solar interior by radiation; however, there is a surface layer about 60,000 miles thick where the principal energy transport mechanism is convection. The solar temperature falls from a hot million degrees at the base of the convection layer to about 4400°K just outside the visible disk (photosphere).

The radiation from the center of the visible disk is, to first order, that of a black body at a temperature of 6100°K. Thus the peak intensity of radiation occurs in the visi-

ble part of the spectrum. The amount of visible light emitted by the sun is essentially constant with time. However, the day-to-day variations in the quiet ionosphere suggest that the ultraviolet and x-ray emissions (not black-body) do vary appreciably from day to day and throughout the solar cycle.

Superimposed on the black-body spectrum are absorption and emission resonance lines and bands from ionization of hydrogen, helium, oxygen, nitrogen, calcium, carbon, silicon, magnesium and iron in the sun's atmosphere. Only one particle in 6000 is ionized at the photosphere, but the temperature and ionization percentage increase with height in the sun's atmosphere.

The inner atmosphere, called the chromosphere, extends to about 12,000 miles from the photosphere. The temperature of the photosphere rises from 4400°K near the photosphere to about 300,000°K near the corona, which is the outer atmosphere of the sun. The corona is at a temperature of 1 to 2 million degrees and extends to as great as 20 solar radii (8.6 million miles).

A small fraction of the solar atmosphere is accelerated to supersonic velocities in the corona and continually escapes to form the solar wind. The earth is constantly bombarded by the solar wind, which has a quiescent density in the vicinity of the earth of about 10 particles per cubic centimeter and a velocity of 200 miles per second. The solar wind distorts, and in fact terminates, the earth's

fig. 1. Time chart of predicted median MUF for December 1968 for the American continent.

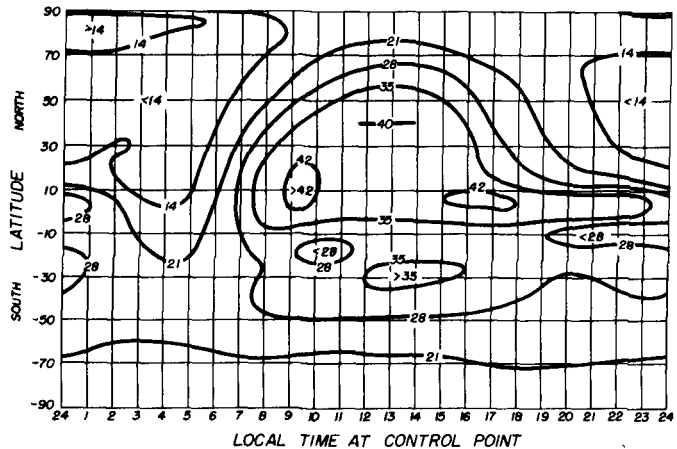

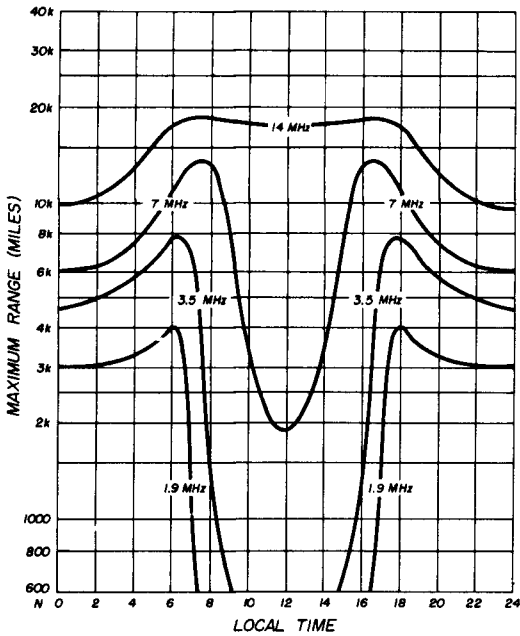

fig. 2. Maximum range to the north from 38° N latitude due to absorption.

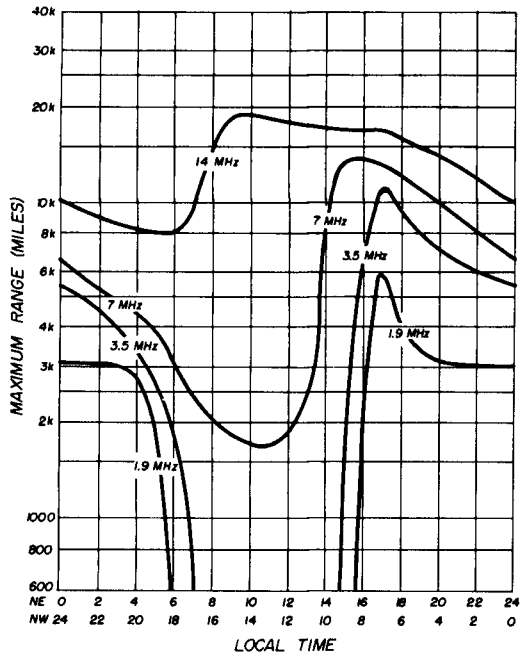

fig. 3. Maximum range to the north-east (top time scale) and to the north-west (lower time scale) from 38° N latitude due to absorption.

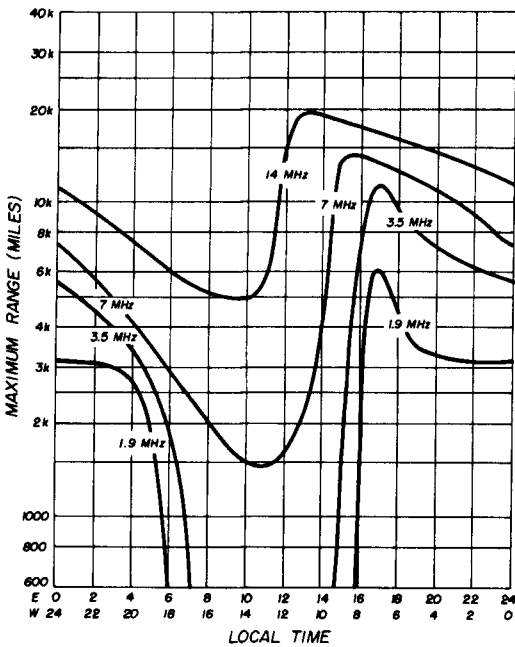

fig. 4. Maximum range to the east (top time scale) and to the west (lower time scale) from 38° N latitude due to absorption.

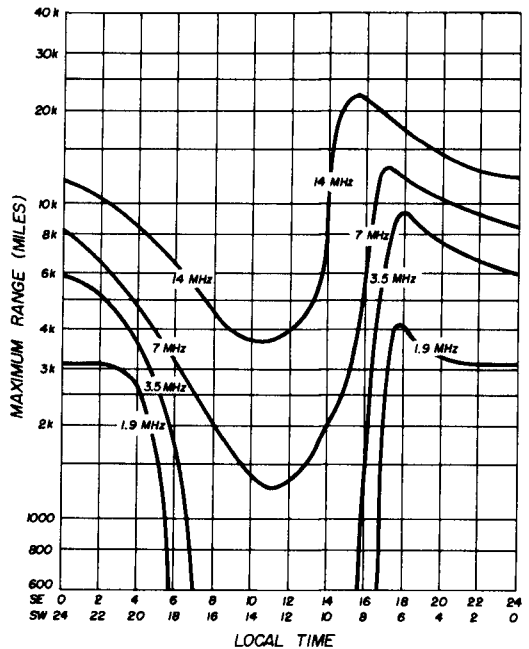

fig. 5. Maximum range to the south-east (top time scale) and to the south-west (lower time scale) from 38° N latitude due to absorption.

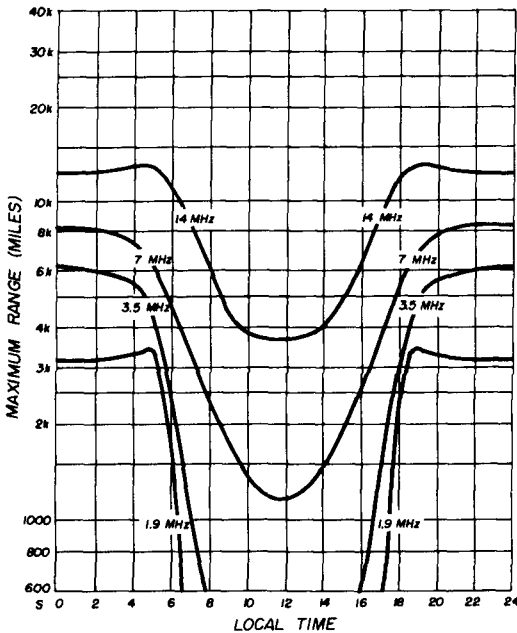

fig. 6. Maximum range to the south from 38° N latitude due to absorption.

magnetic field in space and is responsible for the aurora. The solar wind is believed to extend past the orbit of Mars.

propagation summary for december

160 meters. During December and January, low night-time *muf*'s will spread over large areas of the Northern Hemisphere, resulting in reflection from higher altitudes (and thus longer hops and less path loss for long paths) than possible during earlier and later months. Morning and evening horizontal gradients of ionization are also greatest during these two months. Communication over long paths to the Southern Hemisphere is not expected due to large summertime atmospheric noise levels at the other end of the path. Night-time 160-meter ranges will be almost equal to 80-meter ranges for a 10-dB increase in power or antenna gain. Daytime absorption can be used to advantage to reduce interference from LORAN stations, and East-Coast stations can work west just before sunrise when there is no propagation to the East-Coast LORAN stations; East-Coast stations can work east just after sunset when there is no propagation to the West-Coast LORAN stations.

80 meters. Some of the same comments made about 160 meters apply. During disturbed conditions and after about 10 PM local time, skip zones may occur to a couple of hundred miles. Local operations may be troubled at night by interference from stations 1000 to 2500 miles away.

40 meters. Forty will be the best band for nighttime DX but will be crowded. Try operating near sunrise and sunset (for west and east, respectively) and between 10 PM and 4 AM for maximum skip distances.

20 meters. Twenty will be good for daylight openings to the Northern Hemisphere and twilight openings to the south. Don't count on twenty being open to anywhere before 5 AM or after 10 PM local time, except for an occasional sporadic-E opening.

15 meters. Fifteen meters will offer somewhat wider coverage (especially for polar paths) than ten meters, but signals may be slightly weaker. Fifteen should open about 6 AM to the southeast and close about 8 PM to the southwest.

10 meters. Ten meters will open about 1 hour later and close about 1 hour earlier than 15. Two-hop polar paths are most likely near noon, path-midpoint time.

6 meters. Some single-hop F2-layer openings may occur between coasts (1800 to 2000 GMT) and to the south (9 AM to 4 PM local time). Some combination sporadic-E and F2-layer openings may offer extreme range contacts to the south of east and west.

Sporadic-E. A minor sporadic-E peak will occur during December and January allowing 20, 15, 10, and 6 meter openings to distances up to 1400 miles by single hop and occasionally 2500 miles plus by multiple hops. During the peak of the previous sunspot cycle 144 MHz sporadic-E was worked during the winter E_s season, and so 144.1 MHz or whatever frequency you watched this summer would bear watching again.

Meteors. The Geminids meteor shower is expected December 10 through 14 and the Quadrantids meteor shower is expected January 1 through 4.

ham radio

TYPE PERFECT CODE

with the NEW AUTOVOLT ALPHACODER

Model AC-1



TYPE PERFECT CODE

will complete it and, indeed, let you depress the next key without disturbing it. The AC-1 has provision to make AR, SK etc. without gaps.

\$395.00

The new Autovolt Alphacoder, AC-1, makes any letter or digit with one stroke of your finger. You can produce perfectly uniform code, including preset letter-to-letter spacing using the standard electric typewriter keyboard of the AC-1.

It is only necessary to start a letter, an automatic electronic latch

also

The AUTOVOLT MEMOKEY, MK-2

A self-completing automatic keyer featuring

- Instant letter start
- Both dot and dash memories
- lambatic output



The instant letter start frees you from the frustration of synchronizing yourself with a pulse stream when starting a new letter. The MK-2 starts immediately when you hit the first contact.

The memories allow you to "read in" one dot or dash ahead and still produce perfect code. In practice, it's best to aim a little ahead, but less than the full amount possible. Then the memories will absorb timing errors in either direction.

The lambatic output (•—• etc.) is generated when you close both contacts of a dual paddle key. This enables you to make many letters by a single educated squeeze of the paddles.

If you use a single lever key the Memokey will function perfectly in that mode. The

motions that operate a non-memory keyer will also operate a Memokey. Similarly with the instant start. Later on, you may want to get a dual paddle key and try squeeze keying. The price of the Memokey has been made competitive by using the more efficient circuitry that made the Alphacoder, AC-1, practical. The ability of the Memokey to cover all bases makes it a best buy.

The MK-2 has a built in sidetone with loudspeaker output and a built in power supply to operate it from the 117 V. 60 Hz line.

If you already have a sidetone system, you can obtain identical results from the MK-1, which omits the sidetone and runs from 8 penlite cells. This is practical because the novel circuitry of the MK-1 uses only 7 ma, key "up" and 40 ma. keyed. It's in the same attractive enclosure as the MK-2.

MEMOKEY, MK-1 \$65.00

MK-2 \$85.00

All of the units described are of solid state design. They include a reed-type relay with "floating contacts" for greatest flexibility in transmitter control.

All prices FOB Boston, Mass. 25% with COD orders, please
To order or for further amplification of details write



AUTOVOLT, INC.

68 RICHMOND RD., BELMONT, MASS. 02178 • 484-4954

VALUE ENGINEERED

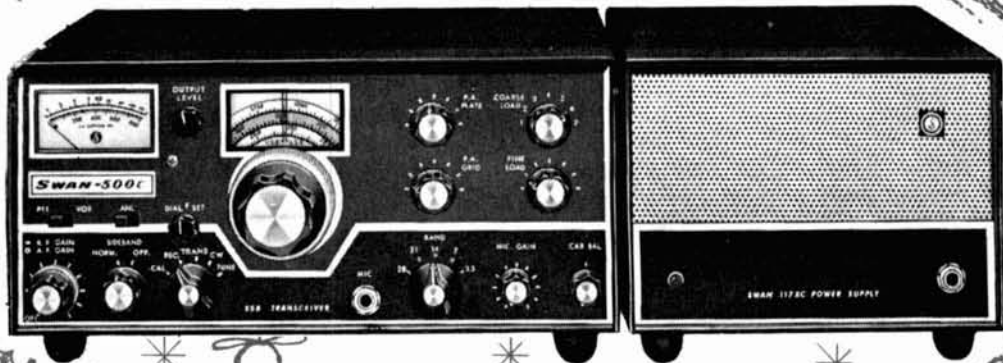

SWAN 500-C

**WRITE FOR
SPECIAL HOLIDAY
PACKAGE PRICE!**

**LIKE NEW TRADE-IN
EQUIPMENT**

AMECO	
TX-62	\$ 79.00
B&W	
5100 & 515B	\$105.00
CENTRAL ELECTRONICS	
100V	\$225.00
200V	\$375.00
600L	\$149.00
Model "B"	\$ 35.00
CLEGG	
22'er	\$149.00
Thor 6 with AC/mod	\$125.00
COLLINS	
75A-4(early)	\$325.00
75A-4(late)	\$345.00
75S-1	\$295.00

75S-3B	\$425.00
KWM-2 with PM-2	\$795.00
75S-1(early)	\$265.00
75S-3	\$375.00
516F-2	\$115.00
75A-1 & HC-10	\$125.00

R. L. DRAKE

1-A	\$119.00
2-A	\$129.00
2-B	\$159.00
2-BQ	\$ 29.00
R-4A extra xtals	\$295.00
TR-3	\$300.00
AC-3	\$ 59.00
DC-3	\$ 79.00

GALAXY

Galaxy 5	
Mk 11	\$265.00
AC supply	\$ 59.00
DAC-35	
console	\$ 75.00
Gonset G-76 & AC-DC	\$ 99.00

HALLICRAFTERS

SX-99	\$ 79.00
SX-100	\$ 99.00
SX-101	
MK 111-A	\$ 99.00
HT-37	\$179.00
HT-32B	\$245.00

HAMMARLUND

HQ-110	\$ 99.00
HQ-170AC	\$179.00
HQ-180AC	\$249.00
HQ-170	\$139.00

HEATHKIT

DX-40	\$ 29.00
DX-60	\$ 55.00
HA-10 Linear	\$ 99.00
HP-23	\$ 24.00
HR-10	\$ 45.00
HW-12A	\$ 79.00
HW-22A	\$ 79.00
HW-32A	\$ 79.00
HW-20	\$135.00
VF-1	\$ 9.50

JOHNSON

Viking 11	\$ 59.00
122-VFO	\$ 9.00
Ranger 1	\$ 89.00
Valiant 1	\$119.00
Thunderbolt 500	\$195.00
	\$195.00

KNIGHT

T-60	\$ 34.00
R-100A	\$ 49.00

NATIONAL

NC-155	\$ 89.00
NC-270	\$ 89.00
NC-303	\$189.00
NCX-3	\$150.00
NCX-A	\$ 50.00

PIERSON

KE-93 w/AC & SPK "S" meter	\$ 69.00
----------------------------	----------

POLYTRONICS

PC-6	\$125.00
------	----------

SWAN

240	\$149.00
350 (early)	\$255.00
350 (latest)	\$275.00
117XC	\$ 65.00
500	\$345.00
500C & AC	\$495.00

UTICA

650	
xcvr/VFO	\$ 89.00

TMC

GPR-90 & GSB-1	\$375.00
----------------	----------

HIGHEST TRADES! **NO ONE ANYWHERE** will beat our price! We will **TOP** any advertised or written price from any other dealer. We trade on both new and used equipment and we service what we sell. Instant credit on both new and used equipment. General Electric revolving charge.

AMATEUR - WHOLESALE ELECTRONICS

A DIVISION OF



International Electronic Systems, Inc.

280 ARAGON AVENUE, CORAL GABLES, FLORIDA 33134

305-444-6207 Cable: "INTEL" Export orders our specialty

NEW FET SIX METER CONVERTER



The Horizon VI incorporates the latest in solid state VHF techniques. Field-effect transistors are used throughout the unit to provide excellent protection against overload and cross modulation.

All power is provided by a built-in 115 volt AC power supply — (no need to buy extras). An additional crystal position has been provided to allow the owner the option of expanded frequency coverage. Local oscillator output is accessible from the front of the unit for those who desire transceive operation.

The low noise figure of the Horizon VI assures the operator of excellent performance when stations are weak.

See your local dealer for a demonstration of the Horizon VI; you'll be impressed by its exceptional performance.

SPECIFICATIONS

Freq. range: 50 — 54 MHz; **I.F. output:** 14 — 18 MHz; **Input impedance:** 50 ohms; **Output impedance:** 50 ohms; **Noise figure:** 3 dB typical; **Gain:** 15 dB nominal; **One 36 MHz crystal installed;** **Built-in power supply:** 115 volts AC; **Weight:** 18 ounces; **Dimensions:** L-6 $\frac{1}{4}$ " x W-3 $\frac{3}{4}$ " x D-2"; **Price:** \$59.95.

AUTHORIZED DEALERS (listed alphabetically)

AMATEUR ELECTRONIC SUPPLY

4828 W. Fond du Lac Avenue
Milwaukee, Wisconsin 53216
Tel: 414 — 442-4200

AMRAD SUPPLY, INC.

3425 Balboa Street
San Francisco, California 94121
Tel: 415 — 751-4661

AMRAD SUPPLY, INC.

1025 Harrison Street
Oakland, California 94607
Tel: 415 — 451-7755

COLE ELECTRONICS SUPPLY COMPANY

335 South Bonner
Tyler, Texas 75701
(214) LY-4-3545

COSTON ELECTRONIC DISTRIBUTORS

2345 Ferguson Road
Cincinnati, Ohio 45238
(513) 481-8555

ELECTRONIC CENTER, INC.

107 3rd Ave. North
Minneapolis, Minnesota
Tel: 612 — 338-5881

EVANSVILLE AMATEUR RADIO SUPPLY

1311 North Fulton Ave.
Evansville, Indiana 47710

GRAHAM ELECTRONICS SUPPLY, INC.

122 S. Senate Avenue
Indianapolis, Indiana 46225
Tel: 317 — 634-8486

HAM RADIO OUTLET

999 Howard Avenue
Burlingame, California 94010
Tel: 415 — 342-5757

THE HAM SHACK (Tel-Appliance Center, Inc.)

1966 Hillview Street
Sarasota, Florida 33579
Tel: 813 — 955-7161

HENRY RADIO STORE

931 N. Euclid
Anaheim, California 92801
Tel: 714 — 772-9200

HENRY RADIO STORE

11240 West Olympic Blvd.
Los Angeles, California 90064
Tel: 213 — 477-6701

L. A. AMATEUR RADIO SUPPLY

2302B Artesia Blvd.
Redondo Beach, California 90278

ED MOORY WHOLESALE RADIO

Box 506 -
De Witt, Arkansas
Tel: 501 — WH 6-2820

PIONEER-STANDARD ELECTRONICS, INC.

5403 Prospect Avenue
Cleveland, Ohio 44103
Tel: 216 — 432-0010

PIONEER-STANDARD ELECTRONICS, INC.

SREPCO ELECTRONICS DIVISION
314 Leo Street
Dayton, Ohio 45404
Tel: 513 — 224-0871

TYDINGS COMPANY

933 Liberty Avenue
Pittsburgh, Pennsylvania 15222
(412) 281-6640

UNIVERSAL SERVICE

114 North Third Street
Columbus, Ohio 43215
Tel: 614 — 221-2335

VALLEY HAM SHACK

4109 N. 39th Street
Phoenix, Arizona
Tel: 602 — 955-4850

WORLD RADIO LABORATORIES

3415 West Broadway
Council Bluffs, Iowa 51501
(712) 328-1851

DEALERSHIPS AVAILABLE IN SOME AREAS — WRITE FOR FREE SPECIFICATION SHEET

RAYTRACK
Company

NEW IDEAS FOR PROGRESS
IN ELECTRONICS

2111 SPRINGHILL DRIVE

Columbus, Ohio 43221

TELEPHONE 614/486-7090

WRITE TO SANTA'S HELPER!

Maybe last year those gentle hints you dropped didn't get through to Santa, and (much to your dismay!) you didn't find one of our fine products under your Christmas tree.

This year we can drop those subtle hints for you. Simply fill out the blank and mail it directly to Raytrack Company; within a few days, your Santa (he or she) will receive a letter which contains all the information needed to purchase your gift. Please don't wait too long, though, because Santa's Helper is going to rely on the U.S. Mail . . .

Best Wishes for a Merry Christmas!

Raytrack Company

TALK POWER



The AutoLevel is the ultimate in volume compressors. This unique device provides all the talk power your transmitter can use. The AutoLevel was designed for use with SSB or AM transmitters, with or without ALC capabilities.

The AutoLevel is not an audio or RF clipper — all compression is attained by a photo-optical regulator which provides 14 dB's of compression with a minimum of wave form distortion.

The AutoLevel is easily installed in the mike line, and it contains its own power supply; (there's no need to bother with batteries). It can also be used with your phone patch for the utmost in ease of operation.

When you're ready for the finest, ask your local dealer for the AutoLevel.

SPECIFICATIONS

dB's compression — 14 dB minimum

Wave form distortion — negligible

Input impedance — suitable for dynamic or crystal microphone

Output impedance — 50K (nominal)

Power supply — 115 volts AC

Dimensions — 2-3/4" x 4-11/16" x 6-3/8"
H W D

Weight — 32 ounces

Color — Bone White with Black front panel

Price — \$87.50

(Please print or type)

YOUR Name: Call:

Address:

City: State: Zip:

SANTA'S Name:

Address:

City: State: Zip:

TELL SANTA I WANT:

The AutoLevel Electronic Volume Compressor The Horizon VI 6-meter Receiving Converter

VALUE ENGINEERING

... to 2 meters



SWAN 250C SIX METER TRANSCEIVER

We are proud to announce production of the deluxe model 250C, new contender for top honors on the 6 meter band. The 250C is built to performance standards of the highest order, including a receiver front end employing dual Nuvisitors in cascode with a noise figure of less than 3 db. Deluxe features include a built in 250 KC crystal calibrator; 'S' meter; selectable sideband; vernier control of the megacycle tuning range; and accessory sockets on the rear apron to receive the model 210 external VFO, the new Swan Noise Silencer and the VX-2.

The famous model 250 is a consistent winner in VHF competition —The 250C is designed to set new records! We are confident that the 250C will satisfy the most critical requirements of the serious VHF operator.

\$420

SPECIFICATIONS:

- Frequency Range: 50-54 MC
- Power Rating: 240 watts PEP Input in SSB mode, 180 watts CW Input, 75 watts AM input
- Two 6146 B Power output tubes
- Distortion Products: down approx. 30 db
- Unwanted Sideband: down more than 40 db
- Carrier Suppression: better than 50 db
- Receiver Noise Figure: Better than 3 db, with two 6CW4 nuvisitors in Cascode
- Selectivity: 2.8KC at 6 db down, with crystal lattice filter at 10.9 MC.
- Antenna Matching: Wide range Pi network.
- Metering circuits: S-meter on Receive mode, P.A. Cathode Current and relative output in transmit mode.
- 250 KC Crystal calibrator
- Selectable upper and lower sideband
- Receiver Mode switch provides for AM reception
- Accessory sockets for noise silencer, external VFO and VOX unit

ACCESSORIES:

MATCHING AC POWER SUPPLY

Model 117XC\$105

12 VOLT DC SUPPLY

Model 14-117\$130

SWAN NOISE SILENCER

Model NS-1\$ 36

EXTERNAL VFO

Model 210\$120

PLUG-IN VOX UNIT

Model VX-2\$ 35

PHONE PATCH

Model FP-1\$ 48

2KW LINEAR AMPLIFIER

Model 6B. With power supply\$660

AND FOR 2 METERS SWAN TV2 TRANSVERTER

A receiving and transmitting converter, which may be used with the 250C or 500C to operate in the 144-148mc band. Provides 240 watts P.E.P. transmit power, and low noise receiver front end with Nuvisitors in Cascode.

\$295

One of the main reasons Swan maintains its position as the leading manufacturer of amateur radio equipment is our dedication to the principles of Value Analysis, and Value Engineering.

We continually examine our products to find ways of improving their performance, reducing costs, and making them better values. As new components are developed in the electronic field, we analyze them to see how they can be used to improve the performance of our transceivers.

The most recent results of our Value Analysis and Value Engineering are shown on these pages: The 500C 5 band SSB Transceiver, our new External VFO, the 510X Mars Oscillator, and introducing our new 6 Meter Transceiver, the 250C.

Yet with all the improvements, the increased reliability, and proven performance, Swan's Value Engineering results in substantially lower prices than competitive equipment. And every piece of Swan equipment is backed up by service second to none.

Value Analysis, Value Engineering keep Swan in the lead. Visit your Swan dealer soon.



SWAN
ELECTRONICS
OCEANSIDE, CALIFORNIA
A Subsidiary of Cubic Corp

VALUE ANALYSIS

From 80 meters . . .



SWAN 508 FULL COVERAGE EXTERNAL VFO

The Model 508 Frequency Control Unit is designed for full coverage of 80, 40, 20, 15, and 10 meters. It provides for transmitting and receiving on separate frequencies, and plugs directly into the back of the 500C. A separate Dual-VFO adaptor is no longer required, since the relay control circuitry is built into the 508. A panel control permits selection of VFO's so that operation may be transceive mode with the 500C VFO, transceive with the 508 VFO, or transmit on the 500C and receive on the 508. The Model 508 features eight ranges of 500 kc each, with 5 kc calibration. It may also be used with the 350C transceiver.

\$125



MARS OSCILLATOR

Ten crystal controlled channels with vernier frequency control. Plugs directly into Model 500C and may also be used with Model 350C and other Swan transceivers.

**MODEL 510X
(less crystals) . . . \$45**

**SWAN SPEAKS
YOUR LANGUAGE**

SWAN 500C FIVE BAND TRANSCEIVER

80 through 10 meters • 520 watts • Home station, mobile, portable operation • SSB-CW-AM.

The new model 500C is the latest evolutionary development of a basic well proven design philosophy. It offers greater power and additional features for even more operator enjoyment. Using a pair of the new heavy duty RCA 6LQ6 tetrodes, the final amplifier operates with increased efficiency and power output on all bands. PEP input rating of the 500C is conservatively 520 watts. Actually an average pair of 6LQ6's reach a peak input of over 570 watts before flattopping!

The 500C retains the same superior selectivity for which Swan transceivers are noted. The filter is made especially for us by C-F Networks, and with a shape factor of 1.7 and ultimate rejection of more than 100 db, it is the finest filter being offered in any transceiver today.

For the CW operator the 500C includes a built-in sidetone monitor, and by installing the Swan VOX Accessory (VX-2) you will have break in CW operation.

Voice quality, performance and reliability are in the Swan tradition of being second to none.

\$520



SWAN

ELECTRONICS

OCEANSIDE, CALIFORNIA

A Subsidiary of Cubic Corp

SWAN 117XC MATCHING AC POWER SUPPLY

Complete A.C. supply for 117 volts, 50-60 cycles, in a matching cabinet with speaker, phone jack, and indicator light. Includes power cable with plug for transceiver, and A.C. line cord. Ready to plug in and operate.

\$105

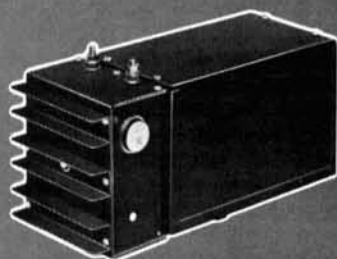

SWAN 14-117 12 VOLT DC SUPPLY

Complete D.C. supply for 12 volt mobile or portable operation. Includes cables, plugs, and fuses. Will also operate from 117 volt A.C. by detaching the D.C. module & plugging in 117 volt line cord. Negative ground standard. Positive ground available on special order.

\$130

**PHONE PATCH,
Model FP-1 \$48**

**ASK THE HAM . . .
WHO OWNS ONE**



new products

radio communication handbook

The new Radio Communication Handbook published by the Radio Society of Great Britain is one of the most exciting handbooks I have seen in a long time. This new book, which weighs in at six pounds, covers every aspect of amateur radio communications and is filled with solid-state projects and circuits.

The topics that are covered include electronic principles, vacuum tubes, semiconductors, hf and vhf/uhf transmitters and receivers, keying and break-in, modulation systems, single sideband, rtty, propagation, hf and vhf antennas, noise, mobile equipment, power supplies, interference, measurements and station layout.

To give you an idea of the contents of the book, let's take a look at the chapter on single sideband, 108 pages that is almost a handbook itself. This chapter leads off with a comparison with a-m, delves into a lengthy discussion of balanced modulators with many good circuits and as well as circuits that should be avoided.

The section on ssb filters covers both mechanical and crystal types, shows response

curves and how to measure them and circuits that are designed for the various types. Following filters is an excellent discussion of frequency conversion, along with charts for determining frequencies that will result in minimum spurious signals.

The section on linears discusses various circuits with the advantages and disadvantages of each. Measurements of operating linear-amplifier parameters are covered in detail. The construction section features four complete ssb transmitters and transceivers as well as several linears and power supplies. Perhaps most interesting is the solid-state six-band transceiver that covers all the bands from 160 to 10 meters: the only vacuum tubes are in the driver and final power-amplifier stages.

Nearly all of the transistors and tubes used in the projects in the **Radio Communication Handbook** have American equivalents, so there is no problem in duplicating them. The staff of the RSGB has thoughtfully provided many of these equivalents in the text; the device equivalents that are not listed in the text are listed on a small sheet that is supplied with all copies in the United States and Canada.

If you're troubled by the lack of semiconductor circuits and modern technology in the other handbooks, the **Radio Communication Handbook** is the answer; it is the most up-to-date radio handbook that has crossed my desk. \$11.95 postpaid in the United States and Canada from Comtec, Book Division, Box 592, Amherst, New Hampshire 03031.

Make this a **GALAXY** Christmas

500 WATTS
FOR ONLY
\$420.00



with a new **GALAXY V MARK 3**
from either

L. A. AMATEUR RADIO SUPPLY

or

EVANSVILLE AMATEUR RADIO SUPPLY



A new ASTATIC \$32.95 GD-104 microphone included at no extra charge with any GALAXY V ordered before December 31, 1968.

Write or come in today for the BEST cash package anywhere.

L. A. AMATEUR RADIO SUPPLY

2302B ARTESIA
REDONDO BEACH, CALIF. 90278
213-376-4455
William Ogg, Manager

EVANSVILLE AMATEUR
RADIO
SUPPLY

1311 N. FULTON AVENUE
EVANSVILLE, INDIANA
812-422-4551
James Ogg, Manager

BOTH STORES CLOSED THURSDAYS



the radio communication handbook



Radio Society of Great Britain Publisher

A brand new edition of this famous handbook now available in the U.S.A. Enlarged over 50% to cover virtually every aspect of amateur radio. No ham can afford to be without it.

832 pages Hardbound
postpaid in U.S. and Canada **11.95**

RSGB is the British equivalent of ARRL and is well known for its many excellent amateur radio publications—most are available from us.

To order the Amateur Radio Handbook and for information on other RSGB publications write today to:

BOOK DIVISION

comtec

BOX 592

AMHERST, N. H. 03048

dealer inquiries invited

fet applications handbook

Field-effect transistors are becoming more and more popular as prices start to drop. This book, edited by Jerome Eimbinder, is based on current practical material prepared by some of the most capable men in industry. It contains a wealth of data on field-effect transistors and their applications in practical circuit designs. FET types, parameters and characteristics are covered in the early chapters, followed by many practical circuit designs covering all phases of electronics.

To provide the reader with a good solid base to work from, current-voltage relationships and biasing considerations, complete with transfer curves, are thoroughly discussed. Considerable attention is devoted to the FET as a constant-current source with detailed information on the constant-current element and cascaded operations. Other topics include oscillators, noise measurements, audio and vhf amplifier design and applications for the photo-FET. The appendix contains most often-needed FET design data and charts arranged to serve as a quick-reference source of useful field-effect transistor information. \$12.95 from TAB Books, Blue Ridge Summit, Pennsylvania 17214.

new vhf fet from motorola

You vhf and uhf enthusiasts will be happy to know that Motorola has just introduced two budget priced plastic versions of the popular 2N4416 JFET. The MPF106 and MPF107 feature unusually low noise figures—2.0 dB maximum at 100 MHz and 4.0 dB maximum at 400 MHz. In addition to being ideal for rf front ends, they will work equally well in any low-noise, high-gain amplifier from dc to 400 MHz.

These N-channel devices provide a power gain of 18 dB minimum at 100 MHz and 10 dB minimum at 400 MHz. Input and output capacitances are 5.0 and 2.0 pF, respectively. For more information on the MPF106 or MPF107, or Motorola's complete line of new FET's, write on your company letterhead to Motorola Semiconductor Products, Inc., Department TIC, P.O. Box 20924, Phoenix, Arizona 85036.

**OUR OWN
PROFESSIONAL
STEREO-MONAUROAL PHONES**



"\$25 VALUE"

QPH-1 8 OHMS — \$12.95

QPH-2 600 OHMS — \$15.95

ADD \$1 FOR SHIPPING

**Professionally Approved
Deluxe 20,000 Ohm/Volt VOM
COMPLETE WITH LEATHER CASE**

20,000 OHMS/VOLT DC—10,000 OHMS/VOLT AC

- Quick Range Selection
- Two-Color Expanded Scale
- Precision 1% Resistors
- Low Circuit Loading
- Jeweloid Meter Movement

- DC Voltage: 5-25-100-500-1000
- AC Voltage: 5-75-100-500-1000
- DC Current: 50- μ A-5-500-5000 MA
- Resistance: 6K-60K-600K- Ω Meg-40M Ω
- Decibels: —20 to +62 DB

THOUSANDS OF THESE FINE METERS SOLD TO
HAMS, EXPERIMENTERS, GOVERNMENT AND
INDUSTRIAL PLANTS

\$13.95

SHIPPED PREPAID USA



COMPLETE OUTFIT

Furnished with
leather carrying
case, test leads, in-
struction manual
and batteries.



A BIG
Q
QUEMENT
PRODUCT



ALL
NOVA-TECH
MODELS
IN STOCK!

WITH FREE ANTENNA
\$129⁹⁵

WE
GIVE
A

**FREE! OUTDOOR
ANTENNA**
with every

**nova-tech
RECEIVER**

WITH
FREE
ANTENNA
\$129⁹⁵



YOUR CHOICE

WITH
FREE
ANTENNA
\$129⁹⁵



YOUR CHOICE

...ALL NOVA-TECH RECEIVERS SHIPPED PREPAID...



**OUR MOST COPIED PRODUCT
"THOUSANDS SOLD"**

MAY BE LEFT
IN LINE, UP
TO 2000 WATTS

S.W.R. BRIDGE

- MODEL SWB-2
- READS FORWARD AND REFLECTED POWER SIMULTANEOUSLY
- "EASY READ" METERS
- USE FOR REFERENCE POWER METER
- DUAL 100-MICROAMP METER MOVEMENTS
- LOW INSERTION LOSS
- SIZE-5"X2"X2"

THE BEST
VALUE WE
HAVE
EVER
OFFERED!

\$15.95

ADD \$1 POSTAGE

**JUDSON
ELECTRIC
MAGNETO
REGULAR 49.95,
AT QUEMENTS**

37⁵⁰

- Reduces fuel consumption
- Double plug and point life
- Instant starting every time
- Reduces down time
- It's like a permanent tune up
- Better ignition guarantee



**"ONE OF THE HOT-
TEST ITEMS WE
HAVE EVER SOLD"**

ADD \$2 POSTAGE

- Compact
- Accurate
- Self-contained
- Highest Stability
- Heavy Dip

**ALL-TRANSISTORIZED
GRID DIP METER**

\$29.95

Allow \$1.00 for
packing and
shipping.
California resi-
dents include
sales tax.

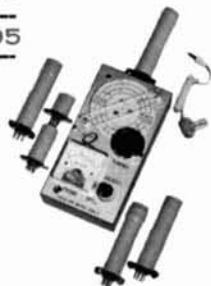

Assembled & test-
ed, complete with
six coils, ear phone
and battery.
TUNES 500 Kc
THRU 150 Mc
DOZENS OF USES

GDM-3

NEVER BEFORE
HAS A PRECISION
INSTRUMENT LIKE
THIS BEEN OFFERED
AT SUCH A LOW PRICE.



SINCE 1933

PHONE AREA 408 294-0464

FAST SERVICE

QUEMENTS

1000 SOUTH BASCOM AVE.

SAN JOSE, CALIF. 95128

NOTICE: CALIFORNIA RESIDENTS INCLUDE 5 PERCENT SALES TAX

LOW PRICE, QUALITY, COAXIAL SWITCHES...



Don't pay for the 5th and 6th position. The average HAM rarely uses more than 4!

SPECIFICATIONS: Silvered Contacts. Write-on ERASABLE escutcheon plate. AVAILABLE EITHER 4 PST (COAX-4) OR LINEAR (COAX-LINEAR) IN-OUT VERSION. Handles 1000 W AM or 2000 W SSB. Insertion loss negligible to 160 Mc. VSWR: Less than 1.2 at 160 Mc. Size: 3 1/4" dia. x 1 1/4" overall. Single hole mount. SPECIFY MODEL. \$7.65 ea.

COAXIAL LIGHTNING ARRESTORS

Zero power loss. No increase in SWR at 150 Mc. Does not attenuate signals. Model 210 for 1000 W (AM) or 2000 W (SSB). Model 211 Electronic static arrester for 50 W (AM) or 100 W (SSB). SO-239 UHF type fittings. Other fittings available. Size approx. 3 1/2" x 1/4" dia. #210 \$3.15 ea. #211 \$4.65 ea. SPECIFY model #.



PRICES above are amateur net. Shipped ppd. in U.S.A. Send Check or M.O. (N.J. ADD 3% Sales Tax)

OTHER PRODUCTS: Feed thru capacitors. Tuned noise filters. Alternator, generator, low-pass and field filters. SEND FOR CATALOG.

"COMMUNICATION ENGINEERED"
By "HAMMIE" RICHARDT—W2WIY

ELECTRONIC APPLICATIONS CO.
ROUTE 46, Pine Brook, N. J. 07058

easy way to service radio receivers

This brand new book by Leo G. Sands shows you how to diagnose and correct troubles in just about every kind of a-m broadcast receiver—tube or transistor. The book starts out with descriptions of typical receiver circuits and how they work. Following chapters are devoted to various troubles with step-by-step procedures for efficient trouble shooting. To help speed the diagnosis, numerous charts are presented that show trouble symptoms and the most probable causes.

Other chapters provide complete details on alignment, quick-check techniques, circuit modifications, test equipment and how to use it and special worthwhile test procedures. With this book, you should be able to repair any a-m receiver quickly. \$6.95 hardbound; \$3.95 paperback from TAB Books, Blue Ridge Summit, Pennsylvania 17214.

new ways to diagnose electronic troubles

With this new book, Jack Darr makes even the most complicated electronic circuit seem simple. He draws on his many years of experience to explain how almost any troubleshooting job can be boiled down to a logical sequence. By analyzing typical schematics, the reader will be able to find his way through even the most complicated looking power supplies and associated circuits—regulators, filters and voltage-distribution networks. Author Darr also covers quick ways to check color sweep circuits, including high-voltage supplies, as well as vertical oscillator and output stages and video circuits. Other chapters cover tuners, troublesome agc and sync circuits, trouble symptoms and signal tracing. If you ever have to put a radio or television set on your workbench, this book should save you a lot of time. \$3.95 paperback, \$6.95 hardbound from TAB Books, Blue Ridge Summit, Pennsylvania 17214.

W2AU BALUN LETS ENTIRE ANTENNA RADIATE!

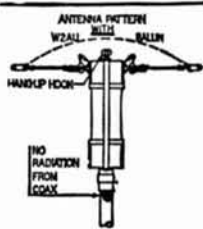

STOP WASTING YOUR SIGNAL!
REMEMBER, YOUR ANTENNA
IS THE MOST IMPORTANT
PIECE OF GEAR YOU OWN.

- No Radiation from Coax
- No Center Insulator Needed
- Perfect for Inverted Vees (Use Hang-up Hook)
- Built-in Lightning arrester
- Broad-Band 3 to 40 Mc.
- Takes Legal Power Limit
- Two Models:
 - 1:1 50 ohm coax to 50 ohm balanced
 - 4:1 75 ohm coax to 300 ohm balanced
- A must for Inverted Vees, Doublets, Quads, Yagis and Multiple Dipoles.

\$12.95 AMATEUR
NET

W2AU Complete pretuned Fiberglass Quad\$99.95
W2AU Complete pretuned Vinyl Quad.....\$64.95

UNADILLA RADIATION PRODUCTS
Unadilla, New York 13849

MORE NEW BOOKS!

RADIO COMMUNICATION HANDBOOK — Fourth Edition

A complete guide to virtually all technical aspects of amateur radio. Over 50% larger than previous editions. Prepared by the outstanding amateurs in Great Britain today. **832 pages** **Hardbound** **\$11.95**

Other Radio Society of Great Britain Publications

AMATEUR RADIO TECHNIQUES — Second Edition — J. Pat Hawker, G3VA

Brand new edition — completely revised. A very complete collection of short articles and ideas covering many aspects of amateur radio. Includes new enlarged semiconductor section.

160 pages **Only \$2.50**

AMATEUR RADIO CIRCUITS BOOK

Completely revised — new edition. A very handy collection of many useful circuits for amateur use. Loaded with good ideas for that new converter, exciter or other project you are working on.

Only \$2.00

RADIO DATA REFERENCE BOOK — Second Edition — By G. K. Jessop, G6JP

Here in a 148 page book is one of the most complete compilations of radio and electronic charts, nomographs, formulas and design data available. Whether you design, build or operate, this is a book you must have.

Only \$2.50

WORLD AT THEIR FINGER TIPS — John Clarricotts G6CL

A very interesting history of the RSGB and of amateur radio in Great Britain. It gives a great insight into the development of our hobby.

Paper back edition \$2.50
Deluxe edition \$6.50

Other Important Volumes for Your Radio Library

RADIO HANDBOOK — 17th Edition

How to design, build and operate the latest types of amateur transmitters, receivers, transceivers and amplifiers. Provides extensive, simplified theory on practically every phase of radio.

848 pages **Only \$12.95**

ALL ABOUT CUBICAL QUAD ANTENNAS by W6SAI

Construction and tuning data. Multiband Quads. Charts, drawings and photos for your Quad. Full complete data on home-made Quad antennas. The new X-Q Quad.

\$3.95

VHF HANDBOOK by Orr, W6SAI and Johnson, W6QKI

First complete Handbook covering the VHF spectrum! Many VHF construction projects! Design and construction of VHF transmitters, receivers and antennas! Make your VHF station work!

\$3.75

BETTER SHORTWAVE RECEPTION, by Wm. Orr, W6SAI

Your introduction to shortwave radio. How to hear DX. How to buy a receiver. Amateur radio. How to align your receiver. Antennas! QSLs. Getting your ham license.

\$3.25

THE CARE AND FEEDING OF POWER GRID TUBES by Robert Sutherland, W6UOV

Just as the title says, a very complete rundown on the use of power tubes. Be sure to read this before you start work on your new linear.

Only \$3.95

BEAM ANTENNA HANDBOOK by William Orr, W6SAI

New edition. Theory, design, construction, and the installation of rotary beam antennas! SWR data! Multiband beams, 40 meter beams, 20 meter DX beams! How to make your beam work! 200 pages.

\$3.95

NOVICE & TECHNICIAN HANDBOOK by W6SAI and W6TNS

All about amateur radio in nontechnical language! How to learn the code. How to assemble your ham station. Transmitters! Receivers! DX! How to Get QSL cards.

\$2.95

ELECTRONIC CONSTRUCTION HANDBOOK by Robert Lewis, W8MQU

All about design - construction - layout and testing of electronic equipment. Non-technical guide for kit-builders and your best key to better performance of your equipment!

\$2.95

ALL PRICES POSTPAID IN U. S. A. AND CANADA

book division

comtec

Box 592 • Amherst, New Hampshire 03031

"WE ARE THE EXCLUSIVE NORTH AMERICAN DISTRIBUTOR FOR RSGB PUBLICATIONS — DEALER INQUIRIES INVITED"

TOROID CORES

Red "E" Cores-500 kHz
to 30 MHz- $\mu = 10$

#	OD	ID	H	EACH
T-200-2	2.00"	1.25"	.55"	\$3.00
T-94-2	.94	.56	.31	.75
T-80-2	.80	.50	.25	.60
T-68-2	.68	.37	.19	.50
T-50-2	.50	.30	.19	.45
T-37-2	.37	.21	.12	.40
T-25-2	.25	.12	.09	.30
T-12-2	.125	.06	.05	.25

Yellow "SF" Cores-10 MHz
to 90 MHz- $\mu = 8$

T-94-6	.94	.56	.31	.95
T-80-6	.80	.50	.25	.80
T-68-6	.68	.37	.19	.65
T-50-6	.50	.30	.19	.50
T-25-6	.25	.12	.09	.35
T-12-6	.125	.06	.05	.25

Black "W" Cores-30 MHz
to 200 MHz- $\mu = 7$

T-50-10	.50	.30	.19	.60
T-37-10	.37	.21	.12	.45
T-25-10	.25	.12	.09	.40
T-12-10	.125	.06	.05	.25

FERRITE BEADS: .125" x .125", $\mu = 900$. With Spec Sheet & Application Notes Pkg of 12, \$2.00

KILOWATT TOROID BALUN KIT: Still only \$5.00
EXPERIMENTER'S 2 CORE TOROID KIT—This famous kit contains cores, wire, and charts so that you can make your own high Q modern inductors for hundreds of practical applications.: \$1.50

MINIMUM ORDER: \$1.00

Please Add 25¢ per order
for Packing & Shipping

AMIDON ASSOCIATES

12033 Otsego Street
North Hollywood, Calif. 91607

Beware . . . of the Dreaded SHREW

linear amplifier

- 200 watt PEP.
- 25-54 MHz.
- 2-20 watts drive.

\$89.95

Matching AC Power Supply . . . \$39.95
DC-2 12 Volt Supply . . . \$44.95

Write for complete details & FREE SHREW Patch

G

Communications Division
GAUTHIER INDUSTRIES
P. O. Box 216
Lynwood, California 90262
Dealer Inquiries Invited



MOTOR KITS

FOR THE HAND WINDERS
FITS ANY CRANK UP TOWER
COMPLETE WITH WATERPROOF MOTOR
\$199.95

Without Motor \$129.95

HYGAIN — MOSLEY — NEW-TRONICS
TRISTAO — MYLAR ROPE — TIMES COAX

Write for latest catalog

ANTENNA MART

BOX 7, RIPPEY, IOWA 50235
Telephone 2279



comments

Dear HR:

Congratulations on your new magazine. The April issue, which is the only copy I've seen, intrigues me. Particularly, Larry Allen's "Repair Bench" column fills a long-standing need in ham publications . . .

Louis G. Madsen, WA6QYN

Dear HR:

I happened across your first edition here in W9/K9 land, and all I can say is **wow!** Even my somewhat non-technically oriented xyl was impressed by the appearance of the magazine.

Elliott Kanter, K4YOC/9

Dear HR:

Thought I would drop a line commending your fine magazine, **ham radio**. Being interested in keeping up with the state of the art, especially in vhf and antennas, I so far find your periodical well worth adding to my library of magazines which consists of **QST** (December 1916 to present) and **CQ** (January 1945 to present).

Bill Wakefield, WB6WBC

Dear HR:

I received your magazine and I couldn't help sending my congratulations on a beautiful job and well done. I have been in ham radio 39 years and a pressman printer 53 years, so I know a good job when I see it.

Bill Stone, W6FAV

Dear HR:

. . . I have the first three issues—but can't seem to find June—so, the only alternative is to subscribe. You have a new, fresh and constructive approach which should do much to upgrade the state of the art. Good luck!

John Koehler, W9DGB

Dear HR:

As an individual amateur radio operator for the past ten—almost eleven—years. I have read and enjoyed many electronics-oriented publications. Having received my formal education in the field of English, I can obviously claim that any knowledge that I have gained of electronics has been sweatfully developed through "trial-and-error" cramming, or thank goodness, through another and infinitely more enjoyable means. This other means of which I speak is, of course, such publications as the new **ham radio**. I feel that your new venture captures much of what is good about our hobby itself, encompassing the joys of experimentation, discovery and learning. Consequently one of the prime products of the unique amateur radio experience has always been, and continues to be, young men (and, yes, occasionally ladies) who are intellectually and scientifically awake.

I am most confident that your publication will be very successful, since you have already presented several excellent features which really represent "communications technology" of **today**. While confessing that some of the material has not been within my grasp thus far, I commend the manner in which you present these difficult phases of modern electronic technology. Please make no mistake—I also enjoy the "operating" aspect of our hobby, and subscribe to other amateur publications which tend to accent these areas of our hobby. But I trust that our hobby will long be the better off by the addition of your magazine to the electronics publishing scene.

With cordial 73 for your continued success,

Will Smith, K4SAY



DECEMBER CLEARANCE RECONDITIONED HAM GEAR

CLEGG Zeus 2-6 M 185 watts XMTR	\$319.00
COLLINS 75A4 (early Model) RCVR 75S-1 RCVR	\$349.00 295.00
DRAKE 2B Q Multiplier Drake 2B RCVR Drake 2-C RCVR	\$ 29.00 179.00 195.00
GALAXY Galaxy III Galaxy V	\$229.00 319.00
GONSET Gonset Comm. II 2M XCVR Comm. III 6M XCVR GSB 100 XMTR	\$119.00 99.00 179.00
HALLICRAFTERS SX99 RCVR SX96 RCVR SX110 RCVR S120 RCVR SX108 RCVR SX115 RCVR HT 37 XMTR	\$ 79.00 129.00 99.00 49.00 129.00 369.00 229.00
HAMMARLUND HQ140X RCVR HQ110C RCVR HQ145X RCVR HQ170C RCVR SP600 RCVR	\$129.00 129.00 179.00 189.00 199.00
HEATH HR-20 RCVR MR-1 w/p.s. HW12 80 meter XCVR	\$ 69.00 29.00 89.00
JOHNSON Valiant XMTR Thunderbolt 80-10M Linear Ranger II XMTR	\$159.00 260.00 149.00
NATIONAL NC173 RCVR NC183D RCVR NCX-5 XCVR NCL-2000 Linear	\$ 79.00 129.00 385.00 385.00
SWAN SW175 XCVR 75 meters Swan 240 (75-40-20) XCVR with TCU VFO Swan 420 VFO 400 XCVR	\$129.00 269.00 79.00 339.00

ALL CASH ORDERS SHIPPED FREE
IN THE 48 STATES

MISSION HAM ELECTRONICS

3316 Main Street, Riverside 3, California 92501
Phone 683-0523 (area code 714)

FREE!
ONE YEAR
OF
ham
radio

A one year subscription is \$5.00.
Take a three year subscription for
\$10.00 and you get the last year
for nothing.

Yes, I'd like the free year. Enclosed
is \$10.00. Send 3 years of HAM RADIO.



HAM RADIO MAGAZINE
GREENVILLE, N. H. 03048

Name Call

Address

City Zip

Dear HR:

Received my latest magazine three days ago and I've already gone through it from cover to cover. Let me say I honestly believe you've a truly superior magazine; better than any other so-called amateur radio magazine put out today.

Your articles are fine, well written in not too difficult-to-understand fashion, well illustrated, etc. It is my type magazine—one who is primarily interested in how-to-build-it articles and some theory review. The ssb articles have been fine.

Joseph H. Smith, W9ZDN

Dear HR:

I received a free copy of your magazine a few days ago. I was very pleased with the magazine. Almost all of the articles were the practical, useful type that I like to have in my library. I am studying for an amateur license and I appreciate the careful explanation of the why of the circuits. The magazine is remarkable in the high quality and quantity of useful information. I was as pleased with the absence of sections devoted to special interest groups. . .

David Robertson
St. Louis, Missouri

Dear HR:

. . . I like the timely publication, title arrangement, presentation, size, and the type of paper used and the price seems right. Each of your feature articles was well prepared, informative and easy to read, and with few exceptions, appeared to me to be accurate. Of course, advertisements help to defray expenses and are generally necessary to balance the books, in addition to bringing one up to date and knowing what is on the market.

Professionally I am generally involved in a systems aspect. However, personally I enjoy technical magazines, predominately electronics, and prefer articles in circuitry using solid-state devices for receivers, transmitters (especially ssb), control devices, and not to forget, antennas. I am not interested in operating news or amusing stories, although I suppose it does have some reader appeal.

J. Roy Wolfskill, W1YLO

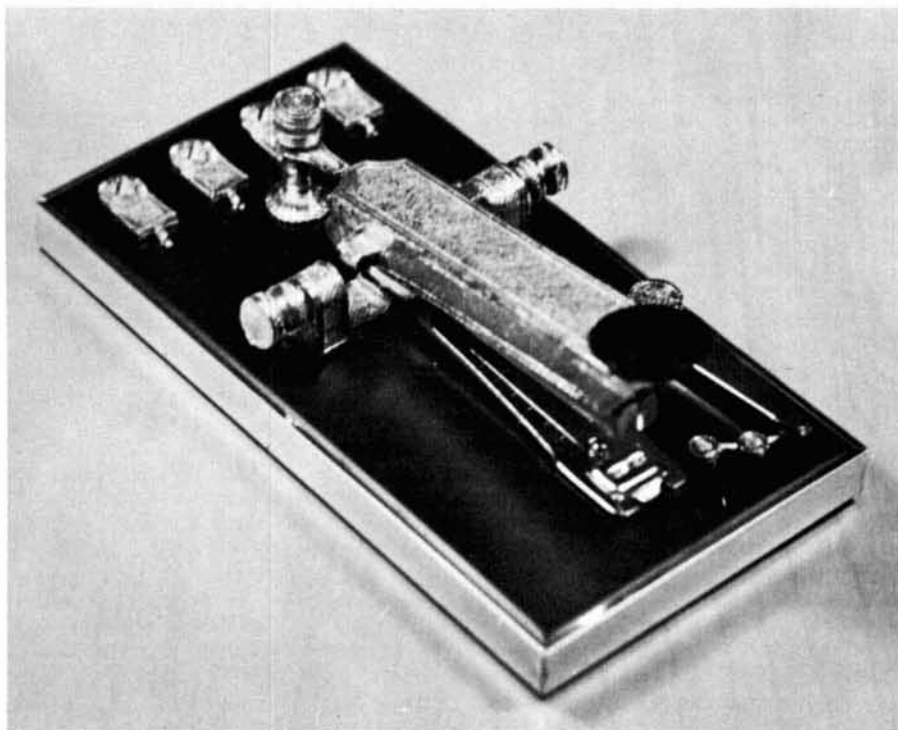

TELEGRAPH KEY STAPLER

HANDSOME REPRODUCTION OF ANTIQUE TELEGRAPH KEY

THIS MORSE CODE TELEGRAPH KEY CLEVERLY FUNCTIONS AS A STAPLER. BOSTITCH STAPLING MECHANISM. THE RHEOSTAT IS A STAPLE REMOVER. ANTIQUE GOLD FINISH ON BLACK METAL WITH CHINESE-RED VELVET BASE. 6½ X 3½. IDEAL FOR AN ORIGINAL GIFT FOR THE OFFICE OR THE SHACK.

PLEASE SEND TELEGRAPH KEY STAPLERS AT \$10.59
 PLUS 80c POSTAGE. ENCLOSED CHECK FOR
 NAME..... CALL.....
 STREET.....
 CITY..... STATE..... ZIP.....

BUILT TO LAST
\$10.59 + 80c POSTAGE
 10 DAYS MONEY BACK GUARANTEE
 SORRY NO C.O.D.

HUGO H. ROUSSEAU & SONS

210 POST STREET • SUITE 915
 SAN FRANCISCO CALIFORNIA 94108

SAROC

Sahara Amateur
Radio Operators Convention

FOURTH NATIONAL FUN CONVENTION

hosted by Southern Nevada ARC, Inc.
in HOTEL SAHARA'S new
SPACE CONVENTION CENTER
LAS VEGAS, NEVADA

JAN. 8, 9, 10, 11, 12, 1969



EXCITING ENTERTAINMENT...

Buddy Hackett and Dean Jones in
Hotel Sahara's Congo Room

LUXURIOUS ACCOMMODATIONS...

1,000 beautiful rooms. Special "SAROC"
ROOM RATE OF ONLY \$10 plus room tax per
night, Single or Double occupancy

"SAROC" CONVENTION SPECIAL EVENTS...

- Ladies Program in Don the Beachcomber
- Golf and Bridge Tournaments
- Breakfasts and Luncheons

- Ham Radio Awards
- Three evening Cocktail Parties hosted
by HALLICRAFTERS . . . SWAN . . . GALAXY

ADVANCE REGISTRATION \$12

per person accepted until Jan. 1, 1969;
regular registration at the door

INCLUDED IN REGISTRATION...

- Special "SAROC" room rate
- Buddy Hackett and Dean Jones, late show
and drinks
- Admittance to Exhibit Area, Technical Seminars,
Cocktail Parties
- Sunday Safari Hunt Breakfast 10 am to 2 pm

Ray E. Meyers, W6MLZ, Master of Ceremonies
Edward Perkins, W7PRM, Club President
L. M. Norman, W7PBV, "SAROC" Chairman

Send separate checks now for registration and
accommodations to "SAROC"

HOTEL
SAHARA!
LAS VEGAS, NEVADA 89109

flea market



■ **RATES** Commercial Ads 25¢ per word; non-commercial ads 10¢ per word payable in advance. No cash discounts or agency commissions allowed.

■ **COPY** No special layout or arrangements available. Material should be typewritten or clearly printed and must include full name and address. We reserve the right to reject unsuitable copy. **Ham Radio** can not check out each advertiser and thus cannot be held responsible for claims made. Liability for correctness of material limited to corrected ad in next available issue. Deadline is 15th of second preceding month.

■ **SEND MATERIAL TO:** Flea Market, Ham Radio, Greenville, N. H. 03048.

WANTED PLUG-IN PREAMP for Hewlett Packard 150A scope. Also Fairchild 781 frequency standard. **SELL AN/APR-4Y** receiver converted AC \$30. Howell, 2492 Habersham, Atlanta, Georgia 30303.

DAYTON Hamvention April 26, 1969: Sponsored by Dayton Amateur Radio Association for the 18th year. Technical sessions, exhibits and hidden transmitter hunt. An interesting ladies program for XYL. For information watch ads or write Dayton Hamvention; Dept. H, Box 44, Dayton, Ohio 45401.

5 inch **DUMONT** scope. Model 208B with manual \$70. **EICO** grid dipper \$18. Les Kalmus, K2SHL, 201 E. 18 St., Brooklyn, NY 11226.

SWAN 250 6 METER TRANSCEIVER with power supply, \$250. Vanguard TV camera, \$175. Lafayette HA-6, \$65. P. Franson WA7KRE, 7312 E. Oak Street, Scottsdale, Arizona 85257. 602-947-6052.

DON'T MISS RADIO COMMUNICATION HANDBOOK. 832 pages — Complete technical guide — Brand new — Only \$11.95 postpaid U.S.A. and Canada. Comtec, Box 592, Amherst, N. H. 03031

EX5Z4JW — LAWRENCE are you on the air? Please write. Any one else with info. WB2UAO.

FOR SALE MOSLEY MCQ-3B Cubical Quad 10-15-20 Meters — Brand New — Unopened Factory — Box \$75.00 — K1TWK Ken Nokes, 17 Island Park Road, Ipswich, Mass. 01938.

TOROIDS, 88 and 44 MHY., Unused, Centertapped, 5/\$1.50 Postpaid — 11/16" oiled reperf Tape \$3/Box. Johnson 6N2 Transmitter and Matching 6N2VFO \$99. Ameco CN144W and Ameco P.S. \$30. Dow-Key \$8. AR22 Rotator \$20. Hallicrafters HT-37 SSB \$175. "AZL" Two meter converter \$25. Wanted — Drake 2B and 2BQ, tower, FM equipment. Stamp for list. Van W2DLT 302H. Passaic, Stirling, N. J. 07980.

CHRISTMAS GIFT subscriptions to **HAM RADIO.** See Special offer this issue. Order today.

73, **FEBRUARY 1961** thru 1964, \$14; QST, 1958 thru 1963, \$27 or \$5 yr.; Heath HD-10, \$30; Vibroplex Zephyr, \$11; Simpson I-176 VOM, \$12. All postpaid. K6SRM, 484 Fourth Street East, Sonoma, California 95476.

SWAP: Have 26-ampere, 117 volt **variable transformer** (similar to a Variac) with adjustable output from zero to 135 volts. Wanted: 10-amp, 220 volt variable transformer with or without over-voltage. Also wanted, January and March 1961 issues of 73 magazine. Jim Fisk, W1DTY, Box 25, Rindge, N. H. 03461.

WRL'S USED GEAR has trial-terms-guarantee! 900A Sidewinder — \$219.95; Galaxy 5 — \$289.95; Galaxy 300 — \$159.95; HW22 — \$89.95; HT40 — \$49.95; HX500 — \$289.95; 51J3 — \$449.00; 75A1 — \$169.95; NC155 — \$119.95; NC190 — \$139.95; SB300 — \$249.95; RME6900 — \$149.95 and hundreds more. **FREE** Blue Book list. Write WRL, Box 919, Council Bluffs, Iowa 51501.

LINEAR — 6 OR 10 METER — Brand New assembled Knight T 175. AM 120 Watts Plate Input — 300 Watts PEP SSB Output. Kit cost \$108.00 delivered. \$70.00 FOB. F. P. Pursell, Mont Vernon, N. H. 03057.

MERRY XMAS and HAPPY NEW YEAR from W0CVU. See you at Des Moines, Iowa June 20-22 ARRL 1969 National Convention.

TECH MANUALS — TS-323/UR, TS-173/UR, TDA-2, BC-638-A, R-274/FRR, \$5.00 each. Sam Consalvo, W3IHD, 4905 Roanne Drive, Washington, D. C. 20021.

SPACE PROBLEMS SOLVED with Joystick Variable Frequency Antennas. With Tuners for 10 thru 160 Meters. Under \$50. Brochure. Shortwave Guide, 218-H Gifford, Syracuse, NY 13202.

WANTED ANTIQUE RADIOS, catalogs, tubes. Send model, price, condition. Farrell, 2252 Dixie, Pontiac, Michigan 48055.

SELL NEW SX-130. Won at a hamfest and still in factory carton. Best offer over \$125. Tom Hentz, WA9MCB, Room 326, Thomas Jefferson Hall, Rolla, Missouri 65401.

SELL SB400, excellent condition, \$275. or make offer, S.A.S.E., Jim WB6MQE, 517 East Emerson Avenue, Monterey Park, California 91754.

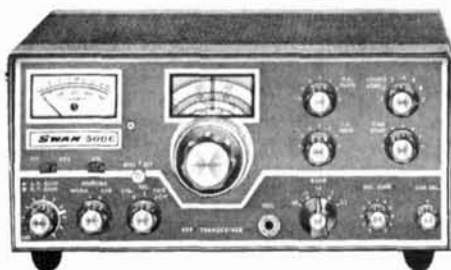

**The new SWAN 500-C
5 band, 520 Watt
SSB-AM-CW TRANSCEIVER**

The new Swan 500C offers you higher power, improved styling, and many new deluxe features, yet maintains the same high standards of performance, rugged reliability and craftsmanship that have become the trademark of the Swan Line. Backed by a full year warranty and a service policy second to none, we feel the Swan 500C will establish a new standard of value for the industry.

\$520

ACCESSORIES

117XC Matching AC supply with speaker \$105
14-117 12 VDC Mobile Supply \$130

**WANTED:
WE BUY USED AMATEUR
AND CB EQUIPMENT FOR CASH!**

**RECONDITIONED USED GEAR:
FULLY GUARANTEED**

GALAXY

V Mk2 with AC/PS (Near New) . . . \$395.00
V (No P/S) \$325.00
Deluxe Console (Used) \$ 75.00

DRAKE

2C and Xtal Cal. (New) \$210.00

HAMMARLUND

HQ-170 (Used) \$175.00

LOTS OF GOOD CHOICE GEAR FOR SALE OR
TRADE — WRITE FOR LATEST LIST.
IN STOCK FOR IMMEDIATE DELIVERY, GALAXY,
SWAN, SBE AND DRAKE.

Bob's **AMATEUR**
ELECTRONICS

"THE COMPLETE HAM STORE" Phone CE 5-6387
927 N.W. 1st Oklahoma City, Oklahoma 73106

"WE TAKE TRADE-INS ON ALL LINES OF NEW EQUIPMENT"
TWO-WAY RADIOS — SALES • SERVICE • INSTALLATIONS

FOR THAT
"Extra Class"
YOU NEED THE

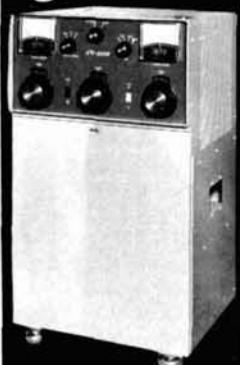

**BTI LK-2000
LINEAR
AMPLIFIER**

For SSB, CW, RTTY
Maximum legal input
Full loading 80-10M
Rugged Eimac 3-1000Z
Dependable operation
Easy to load and tune
No flat topping with ALC
Distinguished console
Instant transmit
High efficiency circuit
Designed for safety
Fast band switching
Real signal impact

Price . . . \$795⁰⁰
READY TO OPERATE!

BTI AMATEUR DIVISION
Hafstrom Technical Products
4616 Santa Fe, San Diego, Ca. 92109



**CQ de W2KUW
BEST OFFER!!**

Paid for any piece of aircraft or ground
radio units, also test equipment. All types of tubes.
Particularly looking for 4-250 • 4-400 • 833A • 3047L
• 4CX1000A • 4CX5000A et al. 17L • 31X • 390A
• ARM • GRM • GRC • UPM • URM • USM units.
TED DAMES CO., 310 Hickory St., Arlington, N.J. 07032

the permaflex key



- both a twin lever & straight hand key in a pivotless 2 paddle design.
- gives instant choice of automatic semi-automatic & straight hand keying.
- use directly with any transmitter or through an electronic keyer.
- 8 amp. gold diffused silver contacts adjust from 0-.060" & 5-50 grams.
- distinctive blue paddles are of rugged G-10 fiberglass epoxy.
- cabinet is 16 gauge polished chrome steel: 1.95" sq. x 3.75", paddles extend 1.25", weight app. 1 pound.
- silicone rubber feet for stability.
- 100% US made & guaranteed for 1 yr.

1995 complete,
ppd usa & can.
send a check or m.o.
sold by mail only

James Research company, dep't: HR- K
11 schermerhorn st., brooklyn ny. 11201

LIBERTY PAYS MORE!!

WILL BUY FOR CASH — ALL TYPES
Electron Tubes • Semiconductors • Test Equipment
Military Electronic Equipment
Wire, write, phone collect! We pay freight on all purchases!
LIBERTY ELECTRONICS, INC.
548 Broadway, New York, N. Y. 10012
Phone: 212/925-6000

... THE BEST
**6 METER
 CONVERTER**



Model 407
\$34.95
 ppd.

50-52 MHz in. 28-30 MHz out
 or 52-54 MHz with a second crystal.

A full description of this fantastic converter would fill this page, but you can take our word for it (or those of hundreds of satisfied users) that it's the best. The reason is simple — we use three RCA dual gate MOSFETs, one bipolar, and 3 diodes in the best circuit ever. Still not convinced? Then send for our free catalog and get the full description, plus photos and even the schematic.

Can't wait? Then send us a postal money order for \$34.95 and we'll rush the 407 out to you. NOTE: The Model 407 is also available in any frequency combination up to 450 MHz (some at higher prices) as listed in our catalog. New York City and State residents add local sales tax.

VANGUARD LABS

Dept. R, 196-23 Jamaica Ave., Hollis, N.Y. 11423

SPACE PROBLEMS SOLVED WITH
JOYSTICK
 VARIABLE FREQUENCY ANTENNAS

Send for Brochure
SHORTWAVE GUIDE
 218-H GIFFORD ST., SYRACUSE, N. Y. 13202

IN STOCK
 FOR
CHRISTMAS DELIVERY

NEW IN SEALED BOXES

Swan 500C Transceiver	\$520.00
Swan 350C Transceiver	\$420.00
Swan TV-2 Transverter	\$295.00
Swan 405X MARS Oscillator	\$45.00
Swan VX-2 VOX	\$35.00
Swan Model 55 Remote Control Mobile Antenna	\$95.00
Swan 117XC Power Supply	\$105.00
Swan 14-117 DC Mobile Supply	\$130.00

GOOD DEALS, TOP TRADES,
 IMMEDIATE SHIPMENT.

BILL SLEP, W4FHY

SLEP ELECTRONICS CO.
 2412 NORTH HIGHWAY 301 N. ELLENTON, FLORIDA 33532
 PHONE (813) 722-1843

HIGHEST \$ \$ PAID FOR TUBES



120 WEST 18th STREET

NEW YORK 10011 • 212-242-7400

Free Tube List

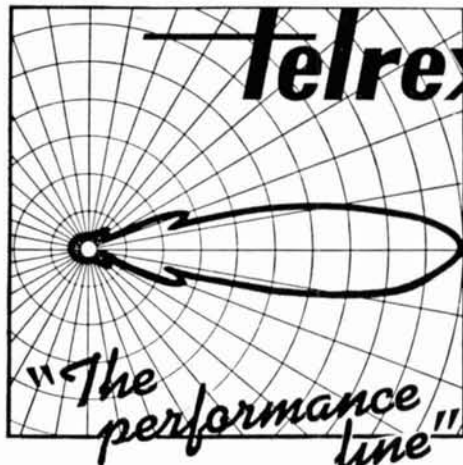

"The performance line"

— with a MATERIAL DIFFERENCE!

Use, is one of the most dependable testimonials of endorsement, and Telrex products are in use in 139 Lands

"Beamed-Power" ANTENNAS, "BALUNS" I. V. KITS and ROTATOR SYSTEMS!

Most Technically-Perfect, Finest Communication Arrays in the World! Precision-Tuned-Matched and "Balun" Fed for "Balanced-Pattern" to assure "TOP-MAN-ON-THE-FREQUENCY" Results

Enjoy World renown TELREX performance, value and durability! Send for PL68 tech. data and pricing catalog, describing professionally engineered communication antenna systems, rotator-selsyn-indicator-systems, "Baluns", I.V. Kits, Towers, "Mono-Pole", "Big-Berthas", accessories, etc. etc.

COMMUNICATION SYSTEMS SINCE 1921
 Engineering Laboratories
telrex
 ASBURY PARK, NEW JERSEY 07712, U.S.A.

FOLLOW ME TO for your



stellar industries
DIV. OF STELLAR I, Inc.
SALES AND SERVICE

AEROTRON
AMECO
ANTENNA SPECIALISTS
COLLINS
CORNELL DUBILIER
CUSH CRAFT
R. L. DRAKE
DOW KEY
EDITORS & ENGINEERS LTD.
EICO
ELECTRO-VOICE
ESSCO
E-Z WAY
GALAXY

GONSET
HALLETT
HALLICRAFTERS
HAMMARLUND
HY-GAIN
ICE
E. F. JOHNSON
LINEAR SYSTEMS
MARS (PAUSAN)
McINTOSH
MOSLEY
MOTOROLA
NATIONAL
NEWTRONICS

OMEGA-T
RSGB
RADIO AMATEUR CALLBOOK
REGENCY
RUSSELL INDUSTRIES
SBE — WEBSTER
SHURE
SWAN
TELEX
TURNER
UNADILLA
VIBROPLEX
WATERS
WILCOX

needs

GLEN FADDEN, W2CXX/2

10 GRAHAM ROAD WEST · ITHACA, N. Y. 14850 · TELEPHONE AREA CODE 607 273-9333

HOURS: 9:00 A.M. to 5:30 P.M. Monday through Friday 9:00 A.M. to 5:00 P.M. Saturday



Radio Amateurs
Reference Library
of Maps and Atlas

WORLD PREFIX MAP — Full color, 40" x 28", shows prefixes on each country . . . DX zones, time zones, cities, cross referenced tables postpaid \$1.00

RADIO AMATEURS GREAT CIRCLE CHART OF THE WORLD — from the center of the United States! Full color, 30" x 25", listing Great Circle bearings in degrees for six major U.S. cities: Boston, Washington, D.C., Miami, Seattle, San Francisco & Los Angeles. postpaid \$1.00

RADIO AMATEURS MAP OF NORTH AMERICA! Full color, 30" x 25" — includes Central America and the Caribbean to the equator, showing call areas, zone boundaries, prefixes and time zones, FCC frequency chart, plus informative information on each of the 50 United States and other Countries. postpaid \$1.00

WORLD ATLAS — Only atlas compiled for radio amateurs. Packed with world-wide information — includes 11 maps, in 4 colors with zone boundaries and country prefixes on each map. Also includes a polar projection map of the world plus a map of the Antarctica — a complete set of maps of the world. 20 pages, size 8 3/4" x 12" postpaid \$2.00

Complete reference library of maps — set of 4 as listed above postpaid \$3.00

See your favorite dealer or order direct.

WRITE FOR FREE BROCHURE! RADIO AMATEUR **callbook** INC.
Dept. Q 4844 W. Fullerton Ave.
Chicago, Ill. 60639



KEEP UP TO
DATE ON
YOUR DXING

A weekly magazine (16 to 24 pages each week).

Current DX that's on the air, and info about what's planned for the immediate future. What's being heard by the boys. Etc.

FULL DX INFO EVERY WEEK.

Per year—Surface mail (they say most 1st class mail actually goes via air) \$11.00

The DXERS Magazine, (W4BPD)
Route 1, Box 161-A,
Cordova, S.C. 29039

LET W3KT FORWARD YOUR DX QSLs

Join the thousands of satisfied hams who have been using this service for the past seven years. During 1967 alone, over 200,000 QSLs were forwarded to DX stations. This is a DELUXE service, insuring prompt and continuous mailings, and involving a minimum of effort on your part.

Just fill in your QSLs and send them to W3KT. You don't have to address the cards, or indicate the QSL manager, or send any SASEs. Where a DX station uses a stateside QSL manager, your card will be sent to him with an SASE, and the reply will come back to W3KT, who will send it to your call area QSL bureau. Other QSLs will be sent to the proper QSL Bureau, or, if necessary, direct.

Remember, your QSL is a personal message. Therefore W3KT sends it by FIRST CLASS MAIL only.

The charge: Four cents per QSL, 30 cards per dollar. NO MEMBERSHIP FEE.

SAVE TIME! SAVE MONEY!

W3KT QSL SERVICE

RD 1, Valley Hill Road Malvern, Penna. 19355

W2SAW's DX STAMP SERVICE

For
"WORLD WIDE POSTAGE"

Receive Your QSL's Fast and Direct

SEND FOR CATALOG
Includes Many Good QSL Tips

466 Weaver Rd., Webster, N. Y. 14580

"Your Friendly Supplier"

FROM STOCK! OFFERS
CHRISTMAS GIFT SUGGESTIONS
A COMPLETE "LINE-UP" OF ACCESSORIES
FOR THE HAM-SHACK

EICO

Vibroplex

ASTATIC

AMECO

MASTERCRAFTERS
& PENNWOOD
24 HR CLOCKS

WELLER

TRIMM

TURNER

COMDEL

E. F. JOHNSON

JONES MICRO-MATCH

W2AU
BALUNS

B.W.

ElectroVoice

XCELITE

DOW-KEY

... plus many more nationally
advertised standard brands.

We maintain the largest stock of used equipment
in the Northeast — Engineering Department — Time
Payment Plan available.

WRITE FOR LATEST COMPLETE LIST

Evans RADIO

BOX 893

CONCORD NH 03301

PHONE 603-225-3358

QUAD BARGAIN!

2 elements 3 Bands (10-15-20)
Single or Triple feed lines (Your Choice)
Top quality, fire hardened, and varnished
bamboo spreaders

Everything complete — \$59.95 FOB

"ESSENTIALS" KIT

- Eight spreaders • 2 spiders
- 8 x 8 x 1/4 Aluminum Center Plate
- Instruction booklet

Only \$39.95



SKYLANE PRODUCTS

406 BON AIR AVENUE, TEMPLE TERRACE, FLA. 33617

New!

TEKRAD Mark V ANTENNA SYSTEM \$32⁵⁰

TAX & POSTAGE
PAID

CHARACTERISTICS:

- 80 through 10 meters
- Essentially constant feed impedance
- Balanced system for high efficiency
- Balanced 450 ohm feed
- Very light, minimum wind-resistance
- Omnidirectional
- Large aperture
- Wide angle of radiation for constant hi-level signals
- A matching device is required — 50 ohm unbalanced to 450 ohm balanced

The Tekrad Mark V Antenna system is ready for delivery in completely assembled units, ready to hang up with supporting cords and transmission line attached.

TEKRAD, INC.
P.O. BOX 57

VALPARAISO, FLORIDA 32580

NOISE BLANKER FOR THE SWAN 250

Westcom Engineering is now offering the TNB Noise Blanker in a version specifically designed for use with the Swan 250 transceiver.

The TNB-250 Noise Blanker effectively suppresses noise generated by auto ignitions, appliances, power lines, etc., permitting the recovery of weak DX and scatter signals normally lost in noise.

Features include modern solid state design techniques utilizing dual-gate MOS FET transistors and two stages of IF noise clipping for the efficient removal of impulse noise at the transceiver IF frequency. The use of MOS FETs and a special gain controlled amplifier circuit provide excellent cross-modulation characteristic in strong signal locations.

TNB-250 shown installed on Swan 250 by means of the pre-punched accessory holes.

TNB-250 \$29.95 ppd.
(Priced well below that of a VOX accessory. Can you afford not to have one?)



Model TNB Noise Blanker, designed to operate with VHF converters by connecting in the coax between converter and receiver.

Choice of 12-18, 100-140, or 125-160 VDC, RCA phono or BNC connectors. Specify for 40, 20, or 10 meter converter output.

Model TNB \$29.95 ppd.



Refer to the New Products column of the August '68 issue of Ham Radio Magazine for additional information on the TNB Noise Blanker or write for technical brochure.

Prepaid orders shipped postpaid. C.O.D. orders accepted with \$5.00 deposit. California residents add sales tax.

All products are warranted for one year and offered on a satisfaction guaranteed or return basis.

WESTCOM ENGINEERING COMPANY
P. O. Box 1504 San Diego, Cal. 92112

PRECISION RESISTORS
±1% 5¢ EACH
150Ω 332Ω 604Ω
301Ω 549Ω 1.21KΩ

ELECTROLYTIC CAPACITORS
160 mfd @ 450 vdc .150
1000 mfd @ 25 vdc .35
20-20-20 mfd @ 250 1.00

TUBES

2AP1 \$ 5.00 250TH \$20.00
5UP1 \$10.00 304TH \$30.00
5UP7 \$10.00 811 \$ 1.50

FT-243 XTALS—75¢ EA.
8.100mc 8.500mc 7.700mc
8.200mc 8.650mc
8.300mc 7.575mc
Socket for FT243 XTALS 3-25¢

Send for our catalog.

BOB-FRANK ELECTRONICS, Box 1327, Harrisburg, Pa. 17105

ATV'ERS

For the largest US ATV magazine;
Technical reports & ATV directory
SEND \$2 for a 1 year subscription
TO:

A5 MAGAZINE

150 Delong Ave.,
Dumont, NJ 07628

... THE BEST 2 METER CONVERTER



Model 407

\$34.95

ppd.

**144-146 MHz in. 28-30 MHz out
or 146-148 MHz with a second crystal**

A full description of this fantastic converter would fill this page, but you can take our word for it (or those of hundreds of satisfied users) that it's the best. The reason is simple — we use three RCA dual gate MOSFETs, one bipolar, and 3 diodes in the best circuit ever. Still not convinced? Then send for our free catalog and get the full description, plus photos and even the schematic.

Can't wait? Then send us a postal money order for \$34.95 and we'll rush the 407 out to you. NOTE: The Model 407 is also available in any frequency combination up to 450 MHz (some at higher prices) as listed in our catalog. New York City and State residents add local sales tax.

VANGUARD LABS

Dept. R, 196-23 Jamaica Ave., Hollis, N.Y. 11423

NEW FROM PALOMAR



**Only
\$37.50**

- Crystal controlled secondary frequency standard.
- Generates both 100-KHz and 10-KHz markers.
- 100-KHz to 30-MHz adjustable to .0001%.
- Send QSL or postcard for free brochure.

PALOMAR ENGINEERS

BOX 455, ESCONDIDO, CA 92025

JOHN MESHNA JR.

19 ALLERTON ST. LYNN, MASS. 01904

COMPUTER GRADE CAPS

4,000 mfd at 50 volt ...\$1.00 ea., 12 for \$10.00
6,500 mfd at 18 volt ...\$1.00 ea., 12 for \$10.00



60 WATT TRANSISTORS 80 VOLTS

From computer assemblies, board with 4 each power transistors 2N1137B, 60 watt, 80 volt PNP power \$1.25 per board



SUPER VALUE \$2.50

Computer boards with 8 each 2N1137B power transistors and mounting hardware, also include on the board, 4 each 10 volt zeners, 4 silicon diodes 1 amp 800 volt PIV, computer grade cap 2000 mfd 65 volt Bourns trimpots, precision resistors, etc. Complete assembly like new Ship wgt. 3 lb. \$2.50

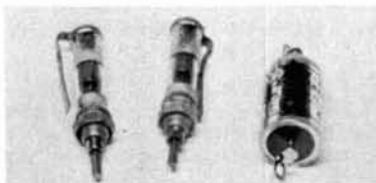

RF FILTER

From HAWK MISSILE termination contract. Good for 5 amps, 600 volt, 10 cycles to 500 mc, insertion loss 60 DB-plus, low pass pin-network type, excellent as feed-thru filter in converters, transmitters. Hermetically sealed inside are 2 toroidal chokes and 4 low induct. caps. #41102 \$1.00 each, 6 for \$5.00

PISTON CAPS

Corning glass, direct traverse type, min. Q at max. C—500 at 50MC. 500 volt breakdown. Capacitance range 1-8 uufd. Brand new military surplus 3 for \$1.00 or \$3.00 per doz.

10 amp TRIACS

SALE	PRV	100	200	300	400
	Sale	1.40	1.75	2.25	2.60

VARACTOR SIMILAR TO MA4060A

Good for 40 watts at 432 MC, ea. tested in circuit, w/diagram for 432 MC tripler. \$5.00 ea.

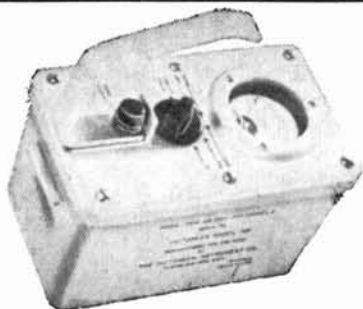

GEIGER COUNTER, MLTRY SURPLUS

like new with book, untested
SURPLUS SPECIAL \$10.00

FACTORY NEW INTEGRATED CIRCUITS



Manufacturer's name withheld, but you will find it marked on every unit. Manufactured to Fairchild 900 RTL Series. All first grade, spec sheets included. A really amazing buy. Never previously offered by anyone at these ridiculous prices.

1.00 each or \$10.00 dozen

Buffer	900
Dual Input Gate	2-903
Quad 2-Input Gate	2-914
JK Flip Flop	923
Dual JK Flip Flop	2-923
Dual 2-Input Gate,	
Dual Expander	1-914, 1-925
Dual 2-Input Gate Expander	925

\$10 TRANSISTOR IGNITION \$10

Complete electronic 2 transistor dual ignition system for cars, boats, trucks. Fully wired harness, dual primary coil, instant changeover from transistor to conventional or back. Neg. ground, 6 or 12 volt system. Complete with instructions, ready to install. Original price \$35. Now only \$10.00 postpaid

IBM Memory Cores w/spec sheet	200/1.10
Resistor - Mix 100 units 1/2 watt	100/1.10
Disc Ceramic Capacitors, mixed	100/1.10
2000 volt 1 amp diode	ea/ .80
3000 volt 1 amp diode	ea/1.20
Reed Switch miniature glass	6/1.10
Photo-Cell resistive type	2/1.10
Photo-Cell, generates electricity	2/1.10
Silicon Diodes	
1 1/2 amp mixed voltages	15/1.10
Geiger Counter chassis, less tube	4.50
Infra Red viewing tube, see in dark, w/specs	4.50

MESHNA WINTER CATALOG 1968-2 NOW OUT!

• FATTEST CATALOG YET

Send 25¢ handling and mailing charge

Super • Stupendous • Astounding • Bargains Galore

SILICON RECTIFIER AND HEAT SINK ASSEMBLY

4 for \$2.50
This is by far the best rectifier deal we have ever offered. Four heat sinks each containing two Motorola or Delco 1N3661 25 ampere 200 PIV rectifiers. These are not factory rejects but unused termination material. With the four assemblies containing eight (8) diodes you can make either one 50 ampere bridge, two 25 AMP bridges, or four 25 AMP full wave center tapped rectifiers. Comp. w/inst. 4SRHS \$2.50PP

D. C. to 400 CYCLE POWER SUPPLY KIT

This is an indispensable item if you want to run Gov't Surplus aircraft or missile electronics. It will convert 12VDC or 6VDC to 110 volts, 400 cycle 35 watts. The kit includes a high quality potted transformer, transistors, resistors, diodes and instructions. No hardware or cabinet is provided. The output waveform is square, rather than sinusoidal, but our experience has been that this will not make any difference since military equip. is insensitive to waveform distortion. Wt. 3 lb. 400 Hz P.S. \$3.50.



LIMITED QUANTITY SPECIALS

- Dumont 304H Oscilloscope \$75.00
 - GR/FME Signal Gen. Md. LP \$140.00
 - AN/URC-11 Tranceivers pair \$75.00
- Above Shipped By Freight Collect.

B & F ENTERPRISES

P. O. BOX 44, HATHORNE, MASS. 01937
GOV'T SURPLUS • ELECTRONIC • OPTICAL • HOROLOGICAL • MECHANICAL
Send for our most unusual 68 Page Catalog of Surplus Bargains 25¢, free with an order. P.P. — Postage Paid

VER-R-R-Y
INTER-R-R-ESTING!



PSYCHEDELIC LIGHTING

Sylvania type R4336 Strobe Light Tube used for Airport lighting. This is the biggest tube Sylvania makes, rated at one 400 watt-second flash every three seconds, or faster flashing rates at lower power. 50 million peak lumens output. Sylvania circuit for flash tube included. Use for laser pump source psychedelic lighting, marine beacons, etc. R4336 \$15.50 P.P.



DUMONT TYPE 295 OSCILLOSCOPE CAMERA

This camera uses Wollensaks finest F: 1.5 Oscillo Raptor lens. Fairchild Dumont net price \$760.00. May be hand operated for single exposures, or battery operated for rapid sequence. Uses standard 35 mm film and mounts on any 5 inch Oscilloscope. Only a few available, so hurry. \$95.00 Shipping Weight 20 lbs.



NICKEL CADMIUM RECHARGEABLE BATTERIES



NiCad Bussed Battery Pack with 12 volts DC output. A neat package of 10 cell in a stainless steel container. Makes a nice portable lab power supply, also convenient for running portable TV or marine accessories etc. Has infinite life. Wt. 5# 10 AMP hour rating \$20.00. Individual Battery cells available of 1.2 volts each.

4 AHB 4 Amp hour plastic case \$2.00 pp
10 AHB 10 Amp hour plastic case \$3.00 pp
20 AHB 20 Amp hour plastic case \$4.50 pp

POCKET TRANSIT

The army used this transit for roughing in gun emplacements. But anyone who needs quick and accurate surveying information will appreciate the precision and convenience of this instrument. These transits are selling at least 50% below current retail prices. We do not expect the supply to last long. For quick, accurate surveying, this transit functions as a sighting compass, prismatic compass, hand level and clinometer. Convenient for topographic and preliminary surveys of all kinds. With case and operating instructions. BPT \$24.50 P.P.



radio amateur callbook

GET YOUR NEW ISSUE NOW!

Over 283,000 QTHs in the U.S. edition
\$6.95

Over 135,000 QTHs in the DX edition
\$4.95

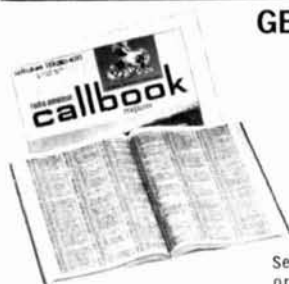

These valuable EXTRA features included in both editions!

- QSL Managers Around the World!
- Census of Radio Amateurs throughout the world!
- Radio Amateurs' License Class!
- World Prefix Map!
- International Radio Amateur Prefixes
- Radio Amateurs' Prefixes by Countries!
- A.R.R.L. Phonetic Alphabet!
- Where To Buy!
- Great Circle Bearings!
- International Postal Information!
- Plus much more!

See your favorite dealer or order direct (add 25¢ for mailing in U.S., Possessions & Canada. Elsewhere add 50¢).

WRITE FOR FREE BROCHURE!

RADIO AMATEUR
callbook INC
Dept. Q 4844 W. Fullerton Ave.
Chicago, Ill. 60639

MOCHTEN SIE WISSEN WAS DIE VHF- UND UHF- AMATEURTECHNIK IN EUROPA LEISTET?

Lesen Sie die UKW-BERICHTE, die autoritative Viertel-Jahres Veröffentlichung in Deutscher Sprache. Jedes Heft enthält sechzig Seiten mit praktischen Artikeln über VHF- und UHF-Radiotechnik, beige-tragen von den führenden Amateuren Europas.



INTERESTED IN WHAT EUROPEAN HAMS ARE ACCOMPLISHING AT THE HIGHER FREQUENCIES?

Read UKW-BERICHTE, the authoritative German quarterly, now with English summaries! Applications of the latest VHF and UHF techniques; equipment and antenna construction details. Each sixty-page issue packed with practical articles written by the most outstanding amateurs in Europe.

Annual subscription U.S.A. \$3.00,
Canada \$3.25

H. Ingwersen, PA0AFN Box 87, Topsfield, Mass. 01983

mark 2 oscillator/monitor

- makes an audible tone to monitor the RF of any CW transmitter from 10Mw to 1 Kw & 100Kc to 1000Mc, using only an 8" pickup antenna.
- can be self-triggered for code practice or the testing of solid state components and circuits.
- aids in tuning up & testing RF oscillator and power circuits.
- 4 transistor, 2 diode circuit, speaker, tone adjust, AA pencil, test leads, 8" ant., & magnetic base.
- cabinet is 16 gauge black & clear anodized aluminum, 3.4 x 2.3 x 1.2" US made & guaranteed for 1 year.



1495 complete,
send a check or m.o.
sold by mail only

James Research company, dep't: HR-M
11 schermerhorn st., brooklyn n.y. 11201

WE PAY CASH FOR TUBES

LEWISPAUL ELECTRONICS INC.
303 W. Crescent Avenue
Allendale, New Jersey 07401

SURPLUS EQUIPMENT WANTED TO BUY BY THE FASTEST GUN IN THE EAST



No horsing around, we pay fast . . . in 24 hours . . . and we pay more. We'll swap or trade new equipment too . . . We quote fast too. We also pay for shipping, insurance, etc. You call fast, now, collect, for fast quote.

SPACE ELECTRONICS
div. of MILITARY ELECTRONICS CORP.

11 Summit Ave., East Paterson, N. J. 07407. (201) 791-5050

CONVENTION 69
ARRL NATIONAL
DES MOINES, IOWA
JUNE 20, 21, 22
P.O. Box 1051, 50311

PAYS . . . CASH

You can be sure with Barry Fair dealing since '38

Send lists of your unused TUBES, Receivers, Semi Conductors, Vac. Variables, Test Equipment. No Quantity too Small, No Quantity too Large

Write or Call now . . . BARRY W2LNI

BARRY ELECTRONICS

512 BROADWAY · NEW YORK, N. Y. 10012
212-WA 5-7000

DIODES

EVERY DIODE WE SELL IS CURVE TRACED ON A SPECIAL TESTER. THIS TESTER DRIVES 2 AMPS AVERAGE CURRENT THROUGH THE UNIT IN THE FORWARD DIRECTION WHILE THE REVERSE LEAKAGE IS MEASURED. (25 MICRO-AMPS). THE OPERATOR EXAMINES THE CURRENT-VOLTAGE PLOT OF EACH DIODE ON AN OSCILLOSCOPE SCREEN. WE FULLY GUARANTEE EVERY UNIT SOLD OR YOUR MONEY REFUNDED.

PIV	TOP-HAT 1.5 AMP	EPOXY 1.5 AMP	EPOXY 3 AMP	STUD- MOUNT 6 AMP
50	.04	.06	.12	.15
100	.06	.08	.16	.20
200	.08	.10	.20	.25
400	.12	.14	.28	.50
600	.14	.16	.32	.58
800	.17	.20	.40	.65
1000	.20	.24	.48	.75

M. WEINSCHENKER K3DPJ
PO BOX 353
IRWIN, PA. 15642

ELDICO SSB Adapter SBA-1 with book, converts any receiver with 455 kc IF to SSB; select either upper or lower side band; in neat cabinet \$127.50

SILIC. RECT. 8000 PIV 400 ma. Pair \$5.30

R-23/ARC-5 Cmd rcvr 190-550 kc. Shpg wt 9 lb. 14.95

A.R.C. 12 #22 Cmd rcvr 540-1600 kc. 9 lb. 17.95

LM-14 freq. meter, .01% 125 kc-20 mc. 15 lb. 57.50

TS-323/UR freq. meter 20-480 mc. .001% 169.50

TS-175 freq. meter 85-1000 mc. .04% 125.00

CLOSING OUT Radio Receivers 38-4000 mc at CRAZY

LOW PRICES! Ask for APR-4Y/CV-253 sheet.

R-392: Compact version of R-390. Tubes work on 24v

3A. Same digit tuning. W/pwr sply & book 525.00

WANTED: GOOD LAB TEST EQUIP & MIL COMMUNIC.

WE PROBABLY HAVE THE LARGEST & BEST INVENTORY OF GOOD LAB TEST EQUIPMENT IN THE COUNTRY, BUT PLEASE, DO NOT ASK FOR CATALOG! ASK FOR SPECIFIC ITEMS OR KINDS OF ITEMS YOU NEED! WE ALSO BUY! WHAT DO YOU HAVE?

R. E. GOODHEART CO. INC.
Box 1220-HR, Beverly Hills, Calif. 90213



NOW

RAZOR SHARP CW
RECEPTION WITH
YOUR TRANSCEIVER!

WITH A *Main* CWF-1
Between Your Headphones
And Your Rig

REQUEST BROCHURE \$19.95
Money Back
Guarantee

- ★ No Power Required
- ★ Plugs Into Phone Jack
- ★ Low Insertion Loss
- ★ 120 Cycles Narrow
- ★ 2 to 4 Ohms In. 2K Out



ELECTRONICS, INC.

Dept. H-6
353 Pattie
Wichita, Kans. 67211
(316) 267-3581

WE PAY **HIGHEST**
PRICES FOR ELECTRON
TUBES AND SEMICONDUCTORS

H & L ASSOCIATES

ELIZABETHPORT INDUSTRIAL PARK
ELIZABETH, NEW JERSEY 07206
(201) 351-4200

DX-ARRAY

NEW 20 ELEMENT
ANTENNAS

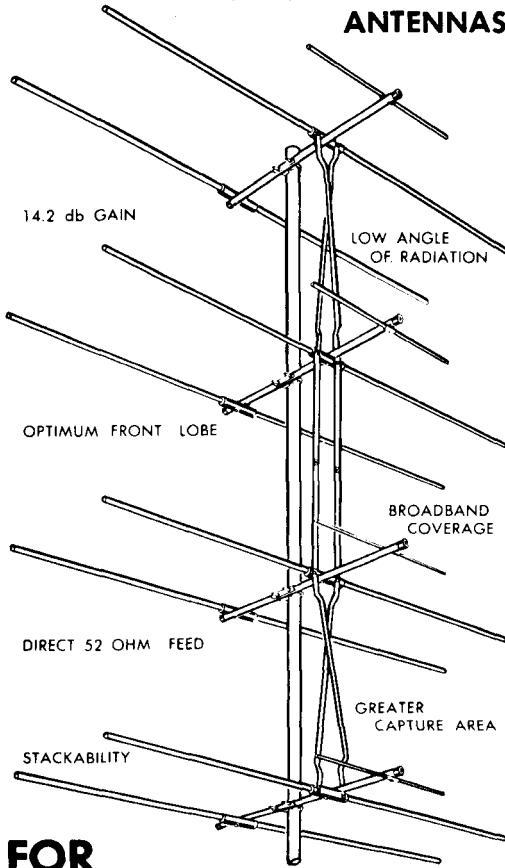

FOR 144 mhz 220 mhz 432 mhz

A breakthrough in VHF/UHF Amateur antennas! The new Cush Craft DX-Arrays combine the best yagi and colinear features into the World's most advanced amateur communication antennas.

Realizing that the antenna is the most important part of your station, Cush Craft engineers have devoted two years of intensive development and testing to perfect DX-Array. DX-Arrays have already established new records in Dx-ing and moonbounce programs.

Whatever your interest may be, ragchewing, contests, DX, or moonbounce, get in on the excitement of VHF hamming today with DX-Array.

DX-120 — 144 mhz \$29.50
DX-220 — 220 mhz 22.50
DX-420 — 432 mhz 17.50

See your local distributor or write for complete specifications on these exciting new antennas from the world's leading manufacturer of UHF/VHF Communication Antennas.

Cush Craft 621 HAYWARD STREET
MANCHESTER N H 03103

Advertisers Index

A-5 Magazine	102
Aerotron, Inc.	Cover IV
Amateur-Wholesale Electronics	65, 81
Amidon Associates	92
Antenna Mart	92
Autovolt, Inc.	80
B & F Enterprises	104
Barry Electronics Corporation	105
Bob Frank	102
Bob's Amateur Electronics	98
CW Electronic Sales Co.	67
Ceco	99
Collins Radio Co.	Cover II
Comdel, Inc.	107
Comtec, Book Division	88, 91
Convention '69	105
Cushcraft	106
Dames Co., Theodore E.	98
Drake Co., R. L.	2
DX Stamp Service	101
DXer's Magazine	100
Eimac Division of Varian	5
Electronic Applications Co.	90
Evans Radio	101
Evansville Amateur Radio Supply	87
Gauthier Industries	92
Goodheart Co., Inc., R. E.	105
Gordon Co., Herbert W.	Cover III
H & L Associates	105
Hafstrom Technical Products	98
Ham Radio Magazine	53, 94
Hammarlund Manufacturing Co., Inc.	27
Harrison Radio	43
Henry Radio Stores	6, 35
International Communications and Electronics, Inc.	75
International Electronic Systems, Inc.	65, 81
James Research	98, 105
L. A. Amateur Radio Supply	87
Lewispaal Electronics, Inc.	105
Liberty Electronics	98
Main Electronics, Inc.	105
Meshna, John, Jr.	103
Military Electronics Corp.	105
Mission Ham Electronics	93
Mosley Electronics, Inc.	1
Palomar Engineers	102
Quement Electronics	89
Radio Amateur Callbook, Inc.,	100, 104
Raytrack Co.	82, 83
RCA Institutes, Inc.	7
Rousseau, Hugo H., and Sons	95
SAROC	96
Shortwave Guide	99
Signal One	55
Skylane Products	101
Slep Electronics Co.	99
Spectronics	72
Stellar Industries	100
Swan Electronics	84, 85
Tekrad, Inc.	101
Telrex Communication Engineering Laboratories	99
UKW Magazine	104
Unadilla Radiation Products	90
Vanguard Labs	99, 102
W3KT QSL Service	101
Weinschenker, M.	105
Westcom Engineering Co.	102

COMDEL

Speech Processor

for optimum voice power & clarity

- 10 dB power gain
- instantaneous limiting
- no harmonic distortion
- all silicon solid state

COMDEL
inc.

beverly airport
beverly, mass.



\$120
less batteries



THIS ADVERTISEMENT IS A REPLICA OF A DISPLAY UNIT AVAILABLE TO ALL ELECTRONIC EQUIPMENT OUTLETS. WRITE FOR DETAILS ON COMDEL'S INTRODUCTORY OFFER TO DISTRIBUTORS AND DEALERS.

index to ham radio magazine volume 1-1968

This index covers all articles published in **ham radio** during 1968. The articles are listed alphabetically under each category along with the author, page number and month. Categories are: antennas and transmission lines; audio-frequency equipment; commercial equipment; construction techniques; features and fiction; fm and repeaters; integrated circuits; keying and control; measurements and test equipment; miscellaneous technical; power supplies; propagation; receivers and converters; RTTY; semiconductors; single sideband; transmitters and power amplifiers; and vhf, uhf and microwave. Articles followed by (HN) appeared in the **ham notebook**.

antennas and transmission lines

- Antenna Switching, Solid-State (W2EEY) p. 30, Nov.
- Big Beam for 10 Meters (VE1TG) p. 32, March
- Baluns, Wideband Bridge (W6SAI, WA6BAN) p. 28, Dec.
- Broad-band Antenna Baluns (W6SAI) p. 6, June
- Coaxial Cable, What You Know About (W9ISB) p. 30, Sept.
- Coaxial Cable Supports (HN) p. 56, June
- Dummy Loads, Experimental (W8YFB) p. 36, Sept.
- Folded Mini-Monopole Antenna (W6SAI) p. 32, May
- GDO, New Uses for (K2ZSQ) p. 48, Dec.
- Hook, Line 'n Sinker (HN) p. 76, Sept.
- J-Pole Antenna for 6-Meters (K4SDY) p. 48, August
- Keeping Your Beam, Tips For (W6BLZ) p. 50, August
- RF Current Probe (HN) p. 76, Oct.
- Simple 1-, 2- and 3-Band Antennas (W9EGQ) p. 54, July
- Solenoid Rotary Switches (W2EEY) p. 36, April
- Three-Band Ground Plane (W6HPH) p. 32, Oct.
- Tiltover Tower Base, Low-Cost (WA1ABP) p. 86, April

- Two-Meter Antenna, Simple (HN) p. 78, August
- Two-Meter Mobile Antennas (W6BLZ) p. 76, May
- VHF Antenna Switching Without Relays (HN) p. 76, Sept.
- Whips and Loops as Apartment Antennas (W2EEY) p. 80, March

audio-frequency equipment

- Audio Amplifier and Squelch Circuit (W6AJF) p. 36, August
- Compressor, Dual Channel (W2EEY) p. 40, July
- Headphones, Lightweight p. 34, Sept.
- Speech Processing (W1DTY) p. 60, June

commercial equipment

- Drake W-4 Directional Wattmeter (W1DTY) p. 86, March
- EX Crystal and Oscillator (WB2EGZ) p. 60, April
- Heath HW-100, The New (W1NLB) p. 64, Sept.
- Heath SB-300, RTTY with (W2ARZ) p. 76, July
- James Research Oscillator/Monitor (W1DTY) p. 91, March
- James Research Permafex Key (W1DTY) p. 73, Dec.
- Quement Circular Slide Rule (W2DXH) p. 62, April
- Swan 120, Converting to Two Meters (K6RIL) p. 8, May

construction techniques

- A Dab of Paint, A Drop of Wax (HN) p. 78, August
- Aluminum's New Face (W4BRS) p. 60, May
- Deburring Holes (HN) p. 75, July
- Filter Chokes, Unmarked (WØKMF) p. 60, Nov.
- For That Professional Look (VE3GFN) p. 74, March
- Grommet Shock Mount (HN) p. 77, Oct.
- Industrial Cartridge Fuses, Using (HN) p. 76, Sept.
- Punching Aluminum Panels (HN) p. 57, June

Rack and Panel Construction (W7OE) p. 48, June
 Silver Plating for the Amateur (W4KAE) p. 62, Dec.
 Simple Solder Dispenser (HN) p. 76, Sept.
 Soldering Fluxes (HN) p. 57, June
 Small Parts Tray (HN) p. 58, June
 Tilt Your Rig (HN) p. 58, June

features and fiction

Dynistor, The (W6GNX) p. 49, April
 Early Wireless Stations (W6BLZ) p. 64, Oct.
 Electronic Bugging (K2ZSQ) p. 70, June
 How to Be DX (W4NXD) p. 58, August
 QSL Return, Statistics on (WB6IUH) p. 50, Dec.
 Secret Society, The (W4NXD) p. 82, May
 What is It? (WA1ABP) p. 84, May

fm and repeaters

Amateur VHF FM Operation (W6AYZ) p. 36, June
 Short Circuit p. 34, August
 Audio-Amplifier and Squelch Unit (W6AJF) p. 36, August
 Narrow-Band FM System, Using IC's in (W6AJF) p. 30, Oct.

integrated circuits

Amateur Uses of the MC1530 IC (W2EEY) p. 42, May
 Frequency Counter, Digital (K4EEU) p. 8, Dec.
 IC-Regulated Power Supply for IC's (W6GXN) p. 28, March
 Using IC's in a NBFM System (W6AJF) p. 30, Oct.

keying and control

Code Practice—The RF Way (WA4NED) p. 65, August
 CW Monitor and Code-Practice Oscillator (K6RIL) p. 46, April
 Solenoid Rotary Switches (W2EEY) p. 36, April
 Station Control Center (W7OE) p. 26, April
 Transmitter Switching, Solid-State (W2EEY) p. 44, June

VOX and MOX Systems for SSB (Belt) p. 24, Oct.

measurements and test equipment

Amateur Frequency Measurements (K6KA) p. 53, Oct.
 Beta Master, The (K8ERV) p. 18, August
 Calibrators and Counters (K6KA) p. 41, Nov.
 Curve Master, The (K8ERV) p. 40, March
 Dipper Without Plug-In Coils, Transistorized (W6BLZ) p. 64, May
 Drake W-4 Directional Wattmeter (W1DTY) p. 86, March
 Dummy Loads, Experimental (W8YFB) p. 36, Sept.
 Frequency Counter, Digital (K4EEU) p. 8, Dec.
 GDO, New Uses for (K2ZSQ) p. 48, Dec.
 Grid Current Measurement in Grounded-Grid Amplifiers (W6SAI) p. 64, August
 High-Power Troubleshooting (Allen) p. 52, August
 Impedance Bridge, The E-Z (WA9QJP) p. 40, April
 Instrumentation and the Ham (VE3GFN) p. 28, July
 James Research Oscillator/Monitor (W1DTY) p. 91, March
 Makeshift Test Equipment (HN) p. 77, Sept.
 Mini-Spotter Frequency Checker (W7OE) p. 48, May
 Noise Generators, Using (HN) p. 79, August
 Panoramic Reception, Simple (W2EEY) p. 14, Sept.
 Precision Capacitor (W4BRS) p. 61, March
 Receiver Alignment (Allen) p. 64, June
 RF Current Probe (HN) p. 76, Oct.
 RF Generator Chip (W1DTY) p. 58, March
 S-Meter Readings (HN) p. 56, June
 Signal Injection in Ham Receivers (Allen) p. 72, May
 Signal Source for 432 and 1296 MHz (K6RIL) p. 20, Sept.

Signal Tracing in Ham Receivers
(Allen) p. 52, April

Transformer Shorts (W6BLZ) p. 36, July

Transistor Tester (WA6NIL) p. 48, July

Transistor Tester for Leakage and Gain
(W4BRS) p. 68, May

Troubleshooting Around FET's
(Allen) p. 42, Oct.

Troubleshooting by Resistance
Measurement (Allen) p. 62, Nov.

Troubleshooting Transistor Ham Gear
(Allen) p. 64, July

Unmarked Filter Chokes
(WØKMF) p. 60, Nov.

Voltmeter, Improved Transistor
(Maddever) p. 74, April

Voltmeter, Transistor, Part II
(Maddever) p. 60, July

miscellaneous technical

Amateur Anemometer
(W6GXN) p. 52, June

Short Circuit p. 34, August

Amateur Radio in Space—a
Bibliography (W6OLO) p. 60, August

Addenda p. 77, Oct.

Amateur Uses of the MC1530 IC
(W2EEY) p. 42, May

Basic Electronic Units
(W2DXH) p. 18, Oct.

More Electronic Units
(W1EZZ) p. 56, Nov.

Broad-band Antenna Baluns
(W6SAI) p. 6, June

Coaxial Cable, What You Should
Know About (W9ISB) p. 48, Sept.

Converting Vacuum Tube Equipment to
Solid-State (W2EEY) p. 30, August

Converting Wavelength to Inches
(HN) p. 56, June

Current Flow?, Which Way Does
(W2DXH) p. 34, July

Double-Balanced Mixers
(W1DTY) p. 48, March

Pi and Pi-L Networks
(W6SAI) p. 36, Nov.

QRP Operation (W70E) p. 36, Dec.

Ramp Generators (W6GXN) p. 56, Dec.

Satellite Picture Transmission,
Recording (W6CCN) p. 6, Nov.

Single-Tuned Interstage Networks,
Designing (K6ZGQ) p. 59, Oct.

Solar Activity, Aspects of
(K3CHP) p. 21, June

Stable Transistor VFO's
(W1DTY) p. 14, June

Short Circuit p. 34, August

Thermoelectric Power Supplies
(K1AJE) p. 48, Sept.

Three-Phase Motors (HN) p. 79, August

TV Sweep Tubes in Linear Service,
Full-Blast Operation of
(W6SAI, W6OUV) p. 9, April

Wind Direction Indicator, Digital
(W6GXN) p. 14, Sept.

10-Meter Timer from Heath CA-1
(HN) p. 74, June

power supplies

Diodes for Power Supplies, Choosing
(W6BLZ) p. 38, July

High-Power Trouble Shooting
(Allen) p. 52, August

IC-Regulated Power Supply for IC's
(W6GXN) p. 28, March

Short Circuit p. 80, May

Line Transient Protection
(HN) p. 75, July

Low Voltage Supply With Short Circuit
Protection (WB2EGZ) p. 22, April

Low-Voltage Supply (HN) p. 57, June

Transformer Shorts
(W6BLZ) p. 36, July

Thermoelectric Power Supplies
(K1AJE) p. 48, Sept.

Zener Diodes (HN) p. 79, August

receivers and converters

Audio Amplifier and Squelch Circuit
(W6AJF) p. 36, August

BC-603 Tank Receiver, Updating the
(WA6IAK) p. 52, May

Detectors, SSB (Belt) p. 22, Nov.

ESSA Weather Receiver
(W6GXN) p. 36, May

FET Converter, Bandswitching, for
40, 20, 15 and 10 (VE3GFN) p. 6, July

FET Converters for 50, 144, 220 and
432 MHz (W6AJF) p. 20, March

I-F Cathode Jack (W6HPH) p. 28, Sept.

Neutralizing the 2-Meter MOSFET
Converters (WB2EGZ) p. 77, Oct.

Panoramic Reception, Simple (W2EEY) p. 14, Oct.
 Outboard Receiver With a Transceiver, Using (W1DTY) p. 12, Sept.
 Overtone Oscillator (HN) p. 77, Oct.
 Receiver Alignment (Allen) p. 64, June
 Receiver Impedance Matching (HN) p. 79, August
 RTTY with SB-300 (W2ARZ) p. 76, July
 S-Meter Readings (HN) p. 56, June
 Signal Injection in Ham Receivers (Allen) p. 72, May
 Signal Tracing in Ham Receivers (Allen) p. 52, April
 Six-Meter MOSFET Converter (WB2EGZ) p. 22, June
 Short Circuit p. 34, August
 Two-Band Novice Superhet (Thorpe) p. 66, August
 Two-Meter Converter, 1.5 dB NF (WA6SXC) p. 14, July
 Two-Meter MOSFET Converter (WB2EGZ) p. 22, August
 Two-Meter Preamp, MM5000 (W4KAE) p. 49, Oct.
 VHF Converter Performance, Optimizing p. 18, July
 Weather Receiver, Low-Frequency (W6GXN) p. 36, Oct.
 28-MHz Superregen Receiver (K2ZSQ) p. 70, Nov.
 432-MHz FET Converter, Low-Noise (WA6SXC) p. 18, May
 455-kHz BFO, Transistorized (W6BLZ, K5GXR) p. 12, July

rtty

AFSK Oscillators, Solid-State (WA4FGY) p. 28, Oct.
 RTTY with the SB-300 (W2ARZ) p. 76, July

semiconductors

Beta Master, The (K8ERV) p. 18, August
 Converting Vacuum Tube Equipment to Solid-State (W2EEY) p. 30, August
 Crystal Oscillator, Miniature (W6DOR) p. 68, Dec.
 Curve Master, The (K8ERV) p. 40, March
 Long-Tail Transistor Biasing (W2DXH) p. 64, April

Motorola MPS Transistors (W2DXH) p. 42, April
 Replace the Unijunction Transistor (K9VXL) p. 58, April
 Screen Clamp, Solid-State (WØLRW) p. 44, Sept.
 Transistor Storage (HN) p. 58, June
 Transistor Tester (WA6NIL) p. 48, July
 Transistor Tester for Leakage and Gain (W4BRS) p. 68, May
 Transistor-Tube Talk (WA4NED) p. 25, June
 Troubleshooting Around FET's (Allen) p. 42, Oct.
 Troubleshooting Transistor Ham Gear (Allen) p. 64, July
 Zener Diodes (HN) p. 79, August

single sideband

Converting A-M Power Amplifiers to SSB Service (WA4GNW) p. 55, Sept.
 Converting the Swan 120 to Two Meters (K6RIL) p. 8, May
 Double-Balanced Mixers (W1DTY) p. 48, March
 Detectors, SSB (Belt) p. 22, Nov.
 Filters, Single-Sideband (Belt) p. 40, August
 Frequency Translation in SSB Transmitters (Belt) p. 22, Sept.
 Generating SSB Signals with Suppressed Carriers (Belt) p. 24, May
 Guide to Single Sideband, A Beginner's (Belt) p. 66, March
 Linear Power Amplifiers (Belt) p. 16, April
 Oscillators, SSB (Belt) p. 26, June
 Phase-Shift SSB Generators (Belt) p. 20, July
 Speech Processing (W1DTY) p. 60, June
 SSB Exciter, 5-Band (K1UKX) p. 10, March
 Transverter, 6-Meter (K8DOC, K8TVP) p. 44, Dec.
 TV Sweep Tubes in Linear Service, Full-Blast Operation of (W6SAI, W6OUV) p. 9, April
 VOX and MOX Systems for SSB (Belt) p. 24, Oct.
 3-500Z in Amateur Service, The (W6SAI) p. 56, March

transmitters and power amplifiers

- Aligning VHF Transmitters
(Allen) p. 58, Sept.
- Converting A-M Power Amplifiers to
SSB Service
(WA4GNW) p. 55, Sept.
- Converting the Swan 120 to Two Meters
(K6RIL) p. 8, May
- Frequency Translation in SSB
Transmitters (Belt) p. 22, Sept.
- Grid-Current Measurement in
Grounded-Grid Amplifiers
(W6SAI) p. 64, August
- Linear for 1296 MHz, High-Power
(WB6IOM) p. 8, August
- Linear Power Amplifiers
(Belt) p. 16, April
- Low-Frequency Transmitter, Solid-
State (W4KAE) p. 16, Nov.
- Pi and Pi-L Networks
(W6SAI) p. 36, Nov.
- Screen Clamp, Solid-State
(WØLRW) p. 44, Sept.
- SSB Exciter, 5-Band
(K1UKX) p. 10, March
- Six-Meter Transmitter, Solid-State
(WB2EGZ) p. 6, Oct.
- Transmitter, Flea Power
(K2ZSQ) p. 80, Dec.
- Transmitter Switching, Solid-State
(W2EEY) p. 44, June
- Transmitters, QRP (W7OE) p. 36, Dec.
- Transverter, High-Level HF
(K4ERO) p. 68, July
- Transverter, 6-Meter
(K8DOC, K8TVP) p. 44, Dec.
- Tunnel Diode Phone Rig, 6-Meter
(HN) p. 74, July
- TV Sweep Tubes in Linear Service,
Full-Blast Operation of
(W6SAI, W6OUV) p. 9, April
- VFO's Stable Transistor
(W1DTY) p. 14, June
- Short Circuit p. 34, August
- 3-500Z in Amateur Service, The
(W6SAI) p. 56, March
- 28-MHz Transmitter, Solid-State
(K2ZSQ) p. 10, July
- 40 Meters, Transistor Rig for
(W6BLZ, K5GXR) p. 44, July
- 432-MHz Amplifier, 2-kW
(W6SAI, W6NLZ) p. 6, Sept.

vhf, uhf and microwave

- Aligning VHF Transmitters
(Allen) p. 58, Sept.
- Amateur VHF FM Operation
(W6AYZ) p. 36, June
- APX-6 Transponder, Notes on
(W6OSA) p. 32, April
- Converting the Swan 120 to Two Meters
(K6RIL) p. 8, May
- Crystal Mount, Untuned
(W1DTY) p. 68, June
- FET Converters for 50, 144, 220 and
432 MHz (W6AJF) p. 20, March
- Moonbounce to Australia
(W1DTY) p. 85, April
- Noise Generators, Using
(HN) p. 79, August
- Six-Meter J-Pole Antenna
(K4SDY) p. 48, August
- Six-Meter MOSFET Converter
(WB2EGZ) p. 22, June
- Short Circuit p. 34, August
- Six-Meter Transmitter, Solid-State
(WB2EGZ) p. 6, Oct.
- Six-Meter Transverter
(K8DOC, K8TVP) p. 44, Dec.
- Six-Meter Tunnel Diode Phone Rig
(HN) p. 74, July
- Two-Meter Antenna, Simple
(HN) p. 78, August
- Two-Meter Converter, 1.5-dB NF
(WA6SXC) p. 14, July
- Two-Meter Mobile Antennas
(W6BLZ) p. 76, May
- Two-Meter Preamp, MM5000
(W4KAE) p. 49, Oct.
- VHF Antenna Switching Without Relays
(HN) p. 77, Sept.
- VHF Converter Performance,
Optimizing p. 18, July
- 40-GHZ Record (K7PMY) p. 70, Dec.
- 432-MHz Amplifier, 2-kW
(W6SAI, W6NLZ) p. 6, Sept.
- 432-MHz FET Converter, Low-Noise
(WA6SXC) p. 18, May
- 432- and 1296-MHz Signal Source
(K6RIL) p. 20, Sept.
- 1296-MHz Linear, High-Power
(WB6IOM) p. 6, August
- Short Circuit p. 54, Nov.

SWAN AND VHF

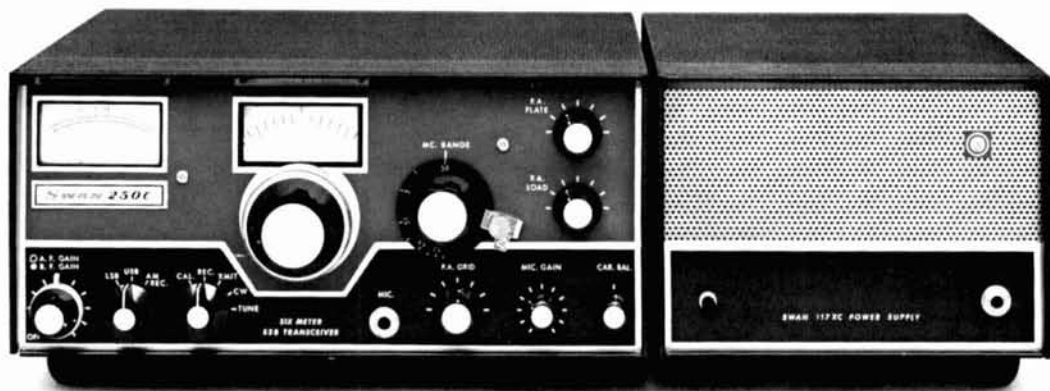

The new Swan 250C features a noise figure under 3dB with 1/2 microvolt sensitivity at 50ohms for 10dB signal plus noise-to-noise ratio.

Not many hams realize that for almost fifteen years Herb Johnson, W6QKI, founder of Swan, has been a major contributor to VHF activities, especially antenna designs. You will see this when you purchase Radio Publication's VHF Handbook by Bill Orr and W6QKI. Herb's love for the VHF challenge led to the immensely popular Swan 250, thousands of which have been sold.

Now Swan has vastly bettered the 250 with their C model, available concurrently with this ad. Although the price has gone to \$420.00, many additions or refinements have been made. To begin with, the megacycle control knob has been recalibrated and fitted with a vernier. This, together with a built-in 250 KC marker calibrator, enables full band coverage with an accuracy of 2 KC.

The panel meter now functions as an S meter on receive and additionally serves as an RF voltmeter for tune-up as well as cathode current monitoring of the final. The 6146B's continue to be used with 240 watts PEP input on either upper or lower sideband. On CW its rating is 180 watts while on AM the input runs 75 watts.

The front end of the receiver has been redesigned for lower noise figure by means of nuvistorized 6CW4's in cascode. A

smoother, quieter tuning results. Stability has been further improved by using a 13.1 MHz solid state VFO. The balanced modulator uses a 7360; the filter is a 6 pole lattice network providing 28 KHz bandpass.

Optionally available accessories include the VX-2 VOX at \$35.00, the external 210C VFO at \$120.00, the external crystal oscillator type 510X at \$45.00, and the newly announced mobile noise blanker which Swan is coming out with shortly. All of these items are provided for with accessory sockets and built-in wiring.

Swan offers its familiar AC console supply, model 117XC at \$105.00 and for a DC supply on 12 volts, the model 14-117 at \$130.00.

Many Swan owners already have these supplies. The addition of the 250C and easily erected 6 meter beams will permit you to mount a most fascinating VHF challenge and this when the North South MUF is at its peak. Your continued use of six will help all of us to preserve our legal right to stay on these frequencies and really, there is no reason why we have to stick to 50.110 MHz. Join the crowd. Get on six and share the fun.

HERBERT W. GORDON COMPANY

Harvard, Massachusetts 01451 • Telephone 617 - 456 - 3548

"Helping Hams to Help Themselves"



PRESENTING THE ALL NEW
AMECO PT
 ALL BAND TRANSCEIVER
 PREAMPLIFIER

■ 6 THRU 160 METERS ■ FEEDS 2nd RECEIVER

Model PT, with built-in power supply, transfer relay, connecting cables, wired and tested. Amateur Net \$49.95

- A frame grid pentode provides low noise figure with ability to handle strong signals, greatly improving the sensitivity of the receiver section of a transceiver.
- A unique built-in transfer circuit enables the PT to by-pass itself while the transceiver is transmitting. The PT also feeds the antenna input of a 2nd receiver as well as muting it.

AMECO

DIVISION OF AEROTRON, INC. ■ P. O. BOX 6527 ■ RALEIGH, N. C. 27608



GSB 201 MK III
 10-80 METER LINEAR AMPLIFIER

...THE WORK HORSE



Exceptionally compact—only 8½" high, 12⅝" wide and 17" deep—the GSB 201 lends itself readily to table top mounting.

- Four (not two) type 572B tubes for a full 2000 watt P.E.P. SSB input.
- Full wave solid state power supply.
- Universal rear of cabinet circuitry may be connected for transceiver or receiver-transmitter use without internal modification.
- Plus many, many more features.

AMATEUR NET \$375.00

Also available: GSB 201 MK II — employs four type 811A economical triodes for 1500 watt P.E.P. input.

AMATEUR NET \$325.00

See your favorite distributor
 — Write for brochure

GONSET® ANOTHER DIVISION OF AEROTRON, INCORPORATED
 P. O. Box 6527 / Raleigh, North Carolina 27608