

CHEFMAN®

RJ16-LOCK SERIES

ELECTRIC

HOT WATER POT



CUSTOMER SUPPORT: 888.315.6553 | customersupport@chefman.com



Thank you for your purchase!

Every Chefman product is manufactured to the highest standards of performance and safety. We are confident that you will be so satisfied with your purchase that Chefman will be your go-to company for appliances in the future.

Customer satisfaction is a key element of our company's philosophy. The Chefman brand exists to fill a void on retail shelves and in consumer kitchens for a truly value-focused kitchen appliance. By questioning and adding value and innovation at every touchpoint in the manufacturer to end user journey, Chefman provides home chefs with the tools they need to achieve picture-perfect results with maximum efficiency. In addition to Chefman products being dependable and affordable, they're built with intuitive features to enhance the kitchen experience so home cooks can become home chefs.

Should a problem arise, each product is backed by a comprehensive manufacturer's one-year warranty, as well as, outstanding after-sales service support through our dedicated customer service team. In the unlikely event that your product does not operate as described in this user guide, please feel free to call or email customer service for assistance. We understand that sometimes products can malfunction, so if you feel that your appliance is not operating as it should, warranty claims can be made within one year from the date of purchase when accompanied by a dated receipt.

This guarantee is in addition to your statutory rights; your statutory rights are not affected. This limited warranty does not apply in cases of damage caused by accident, improper use, abuse or force majeure.

This warranty gives you specific legal rights. Rights may vary depending on your state or province of residence. Some locations do not allow limitations on implied warranties or special incidental, or consequential damages, so the limitations may not apply to you. This limited warranty will be invalidated if the appliance is tampered with in any way whatsoever.

Call Chefman Customer Support at 1 (888) 315-6553 or email customersupport@chefman.com for help with questions or to receive technical assistance. We're available Monday through Friday 9 a.m. to 5 p.m. EST.



READ ALL INSTRUCTIONS BEFORE USE

For your safety and continued enjoyment of this product, always read the instruction manual before using.

INTRODUCTION

We're so glad you've chosen the Chefman 3.6L Electric Hot Water Pot to be the latest addition to your kitchen. From everyday to holidays, this water boiler and dispenser will be your favorite new appliance.

Use it as part of your morning routine to make a cup of coffee or tea. Take advantage of its large capacity and unique algorithm for maintaining heat. Enjoy its 360° swivel base while entertaining guests, and be sure to keep it within reach for cooking ramen or hot cereal when the mood strikes.

To learn about the Chefman Electric Hot Water Pot before getting started, read this entire User Guide.



FUN FACTS

- As you chew, hot food cools increasing taste intensity. The taste receptors on our tongue are most active with foods at 86°-95°F.
- Black and herbal teas are best made with water that's just under a boil, which is about 210°F.
- To achieve the best results for recipes that call for boiled water, it's best to boil then measure the water. One cup of water can lose up to an ounce, on average, from being boiled and evaporating.

CONTENTS

- 1** Safety Instructions
- 3** Features
- 4** Operating Instructions
- 7** Notes
- 9** Terms and Conditions
- 10** Warranty Card

SAFETY INSTRUCTIONS

IMPORTANT SAFEGUARDS

When using electrical appliances, basic safety precautions should always be followed, including the following:

1. Read all Instructions.
2. Do not touch hot surfaces. Use caution when handling hot liquids.
3. To protect against fire, electric shock and injury to persons, do not immerse cord or plugs in water or other liquid.
4. Close supervision is necessary when any appliance is used by or near children.
5. Unplug from outlet when not in use and before cleaning. Allow to cool before putting on or taking off parts, and before cleaning the appliance.
6. Do not operate any appliance with a damaged cord or plug or after the appliance malfunctions, or has been damaged in any manner. Contact Chefman Customer Support at 1-888-315-6553 or customerservice@chefman.com
7. The use of accessory attachments not recommended by the appliance manufacturer may result in fire, electric shock or injury to persons.
8. Do not use outdoors.
9. Do not let cord hang over edge of table or counter or touch hot surfaces.
10. Do not place on or near a hot gas or electric burner, or in a heated oven.
11. Plug cord into the appliance first, then into the wall outlet. To disconnect, turn off, then remove plug from wall outlet.
12. Do not use appliance for other than intended use.
13. This appliance is intended for water only.
14. Do not fill the pot directly from the tap, as over-flowing water could cause a short circuit or electric shock.
15. When filling this appliance with water, the water should not be filled higher than the “full” line mark indicated on the inner pot.
16. Do not refill water during a boiling cycle or right after a boiling cycle. Hot water may splash resulting in serious burns.
17. Do not stand over the appliance when opening the lid. Hot steam will rise and may cause serious burns.
18. Do not cover the steam vents.
19. Save these instructions.

*California Proposition 65:
(Applicable for California Residents only)*



WARNING:
Cancer and Reproductive Harm -
www.P65Warnings.ca.gov.



**Do not place the appliance
on a stovetop or any other
heated surface.**

SAFETY PRECAUTIONS

IMPORTANT SAFEGUARDS

SHORT CORD INSTRUCTIONS

A short power supply cord is provided to reduce the hazards of entanglement or tripping over a longer cord. Longer detachable power-supply cords or extension cords are available and may be used if care is exercised in their use. If a longer detachable power-supply extension cord is used:

1. The marked electrical rating of the extension cord should be at least as great as the electrical rating of the appliance.
2. The cord should be arranged so that it will not drape over the countertop or tabletop where it can be pulled on by children or tripped over unintentionally.

POWER CORD SAFETY TIPS

1. Never pull or yank on cord or the appliance.
2. To insert plug, grasp it firmly and guide it into outlet.
3. To disconnect appliance, grasp plug and remove it from outlet.
4. Before each use, inspect the power cord for cuts and/or abrasion marks. If any are found, this indicates that the appliance should be serviced, and the power cord replaced. Please return it to an authorized service representative or contact Chefman Customer Service for assistance.
5. Never wrap the cord tightly around the appliance, as this could place undue stress on the cord where it enters the appliance and cause it to fray and break.

DO NOT OPERATE APPLIANCE IF THE POWER CORD SHOWS ANY DAMAGE OR IF APPLIANCE WORKS INTERMITTENTLY OR STOPS WORKING ENTIRELY.

FEATURES

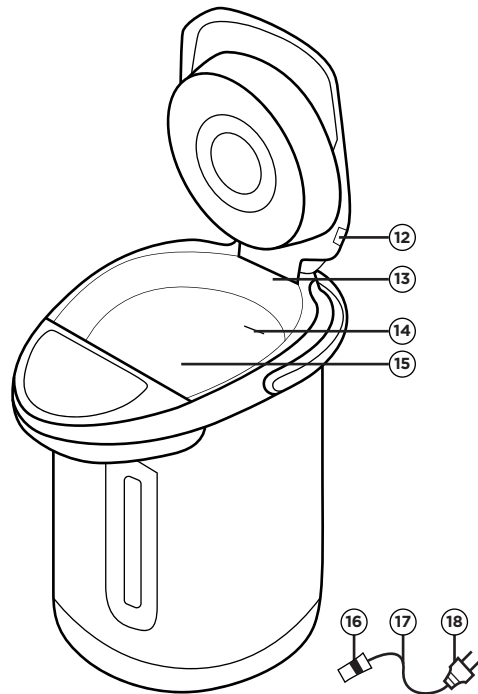
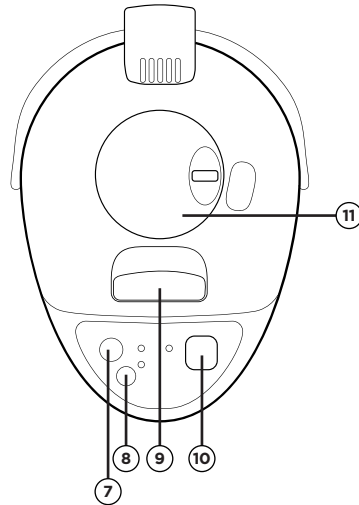
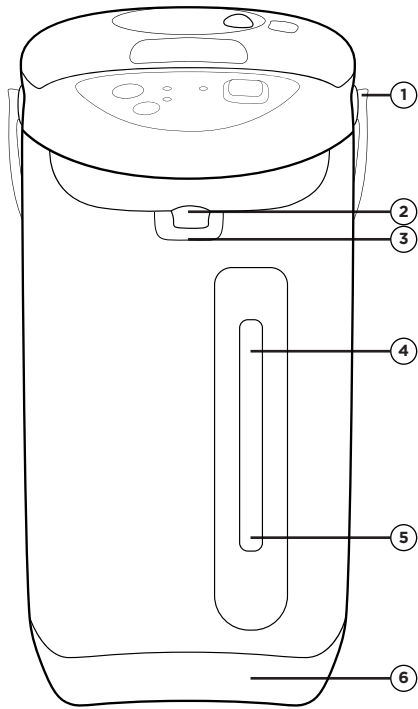

1. Carrying Handle
2. Spout
3. Cup Touch Switch
4. Water View Window
5. Refill Mark
6. Swivel Base
7. Reboiling Button
8. Lock Mode Button
9. Lid Handle
10. Dispensing Button
11. Manual Push Dial
12. Steam Vent
13. Hinge
14. Full Water Guide Mark
15. Inner Pot
16. Appliance Plug
17. Cord
18. Power Supply Plug

OPERATING INSTRUCTIONS

NOTE: This appliance is intended for water only. Using anything other than water (soup, milk, tea, coffee) will cause bubbles resulting in hot liquid spilling out from the appliance and potentially causing burns. Using non-water liquids will cause the pump to cease working and prevent the flow of water. The inner pot could erode as well.

HOW TO USE

1. Before using your Chefman Hot Water Pot for the first time, boil and discard one full pot of water by following the instructions below. You may notice a plastic smell for the first time when you use the dispenser. This is normal and will fade over time.
2. Fill the Hot Water Pot by pouring cold water from another container such as a jug.
WARNING: Do not fill the pot directly from the tap, as over-flowing water could cause a short circuit or electric shock.
3. Do not add water above the FULL WATER line on the inside of the pot. Hot water may overflow, causing burns.
4. Be careful not to splash water on the control panel or on the outside of the Hot Water Pot. Splashing water can damage the Hot Water Pot and cause an electric shock.
5. Carefully close the lid by pushing down until you hear it click in place.
6. When you plug in the power cord, the water will automatically begin to boil.

TROUBLESHOOTING

| CONDITION | CAUSE | SOLUTION |
|--|--|--|
| Water does not boil. | Plug is not plugged into electrical outlet. | Check the plug connections. |
| | Metal object or dirt is on the tip of the magnetic plug. | Clean the tip of the magnetic plug. |
| Water does not become hot or does not pour properly. | Plug is not plugged into electrical outlet. | Check the plug connections. |
| | Mineral deposits or the like have accumulated on the inside of the pot. | Clean the Hot Water Pot. |
| | Hot water may not pour properly a few minutes after boiling. | Open the lid once to release air bubbles, and close lid. WARNING: Watch out for steam when opening the lid. |
| Water pours out by itself. | Check that the pot is not filled beyond the Full guide mark. | Pour out the excess amount of water until it is below the Full line. |
| White deposits appear in the hot water. | Deposits are created by the mineral content of the water you are using. They are not due to corrosion of the inner pot or peeling of the non-stick fluorine coating. | Clean the inside of the water pot by boiling water mixed with vinegar or lemon extract. |
| Loud boiling sounds can be heard. | Excessive accumulation of mineral deposits and the like on the inside of the water pot can cause loud boiling sounds. | |
| Hot water has a bad odor. | The odor of chlorine may be detectable in your tap water. | |
| | A mild plastic odor may be noticeable in a new Hot Water Pot. This odor will fade over time. | |

OPERATING INSTRUCTIONS

ABOUT THE OVERHEAT PROTECTION FEATURE

The overheat protection feature operates when the power cord is plugged in but the inner pot is empty of water. If the Hot Water Pot has shut off automatically, unplug the power cord from the electrical outlet and wait for the Hot Water Pot to cool, and then add water.

DISPENSING WATER

There are three ways to dispense water.

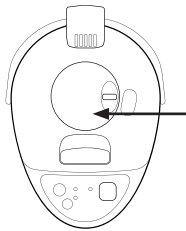

Push the manual button on the lid.

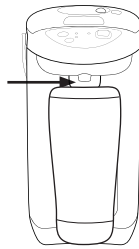

Place a mug or cup under the spout and press it against the cup touch switch.



Press the dispense button on the control panel.

RE-BOILING WATER

When the Hot Water Pot is in Keep Warm Mode, use the Reboil button to boil the water. The boiling light will illuminate once pressed.

- Once the water has re-boiled, the Keep Warm light will illuminate.
- Before boiling, ensure the water level is above the refill mark in water window.
- The re-boil function will be deactivated immediately after the water has finished a re-boil cycle.

LOCK MODE

1. Press Lock button to activate Lock Mode and indicator light will turn on. Lock Mode deactivates and locks both the manual dispense button and reboil button.
 2. To deactivate Lock Mode, simply press the Lock button again. This reactivates the Auto Dispense buttons and Reboil button. When Lock Mode is activated, the Keep Warm and Reboil indicator lights will be off.
- **NOTE:** If you open and close the lid while the Hot Water Pot is on (even in Lock Mode), it will continue to function without any change just as when the lid is closed. It will not automatically shut off and the function indicator lights will not turn on or off.
 - To manually lock the spout so no water can come out, rotate the Manual Push Dial on top of the lid up to the red lock symbol. To unlock, simply turn the dial down to the blue unlock symbol. **NOTE:** This does not affect any mode or function the Hot Water Pot may be running in. This action simply locks the spout as an added safety feature.

OPERATING INSTRUCTIONS

WHEN NOT IN USE

Unplug the dispenser. Detach the lid by opening it. Then, using your thumbs, pull the inner hinge wide enough so that you can remove the lid. Pour out any remaining water.

REMOVING THE LID

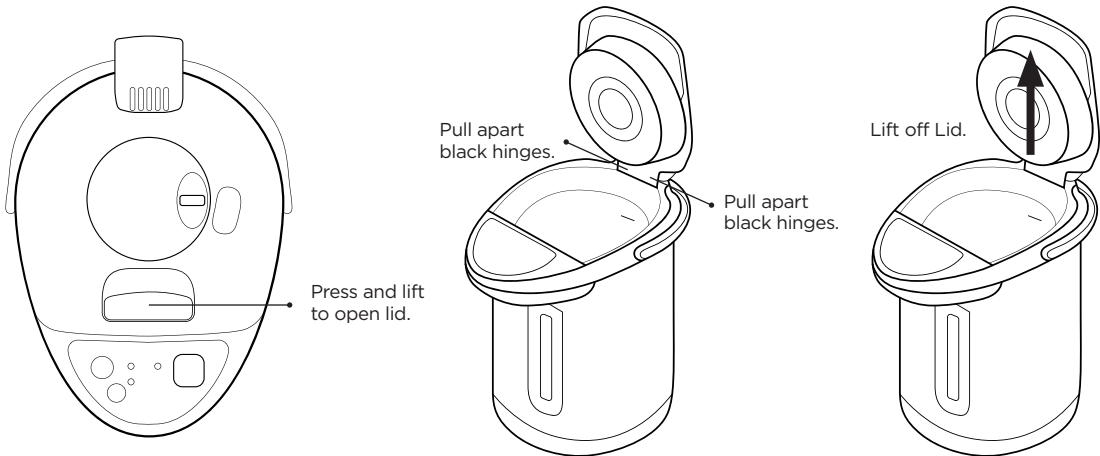

NOTE: Empty the pot at least once a day. Water left in the pot can cause unpleasant odor and accumulation of mineral deposits.

WARNING: To avoid serious burns, always detach the lid before pouring out the hot water. Do not allow water to splash onto the operation panel, hinge, handle or power supply plug.

CLEANING AND MAINTENANCE

1. Unplug the hot water pot and allow it to cool completely. Remove the power cord before cleaning and be sure that the socket is kept dry.
2. Wipe the hot water pot exterior with a soft, damp cloth.
3. Do NOT use abrasive cleaners or scouring pads on the inside or outside of the hot water pot.
4. **NOTE:** Do NOT immerse the appliance in water.
5. Clean the inner pot with 2 cups water and 1 cup vinegar. Press reboil to boil the water/vinegar combination. Then pour out, rinse with new water. **NOTE:** It is best to use filtered, non-tap water for cleaning.

CONSIGNES DE SÉCURITÉ

GARANTIES IMPORTANTES

1. Lors de l'utilisation d'appareils électriques, des précautions de sécurité élémentaires doivent toujours être suivies, notamment les suivantes:
2. Lisez toutes les instructions.
3. Ne touchez pas les surfaces chaudes. Soyez prudent lorsque vous manipulez des liquides chauds.
4. Pour éviter tout risque d'incendie, de choc électrique ou de blessures, ne plongez pas le cordon ni la fiche dans l'eau ou tout autre liquide.
5. Une surveillance étroite est nécessaire lorsqu'un appareil est utilisé par ou à proximité d'enfants.
6. Débranchez-le de la prise lorsqu'il n'est pas utilisé et avant de le nettoyer. Laissez-le refroidir avant d'ajouter ou de retirer des pièces et avant de nettoyer l'appareil.
7. Ne faites pas fonctionner un appareil avec un cordon ou une fiche endommagé, après un dysfonctionnement de l'appareil ou s'il a été endommagé de quelque manière que ce soit. Contactez le service clientèle de Chefman au 1-888-315-6553 ou à l'adresse customerservice@chefman.com.
8. L'utilisation d'accessoires non recommandés par le fabricant de l'appareil peut entraîner un incendie, un choc électrique ou des blessures corporelles.
9. Ne pas utiliser à l'extérieur.
10. Ne laissez pas le cordon pendre du bord de la table ou du comptoir, ni toucher des surfaces chaudes.
11. Ne placez pas l'appareil sur ou à proximité d'un brûleur électrique ou à gaz chaud, ni dans un four chaud.
12. Branchez d'abord le cordon dans l'appareil, puis dans la prise murale. Pour débrancher, éteignez puis débranchez la fiche de la prise murale.
13. N'utilisez pas cet appareil pour un usage autre que celui prévu.
14. Cet appareil est conçu pour l'eau uniquement.
15. Ne remplissez pas le pot directement au robinet, un excès d'eau pourrait provoquer un court-circuit ou un choc électrique.
16. Lorsque vous remplissez cet appareil avec de l'eau, l'eau ne doit pas être remplie plus haut que le repère de ligne «plein» indiqué sur la cuve.
17. Ne remplissez pas d'eau pendant un cycle d'ébullition ou juste après un cycle d'ébullition. L'eau chaude peut éclabousser et causer de graves brûlures.
18. Ne vous placez pas au-dessus de l'appareil lorsque vous ouvrez le couvercle. La vapeur chaude va monter et peut causer de graves brûlures.
19. Ne couvrez pas les événements de vapeur.
20. Conservez ces instructions.

CONSIGNES DE SÉCURITÉ

MODE D'EMPLOI:

REMARQUE: Cet appareil est conçu pour l'eau uniquement. Si vous utilisez autre chose que de l'eau (soupe, lait, thé, café), des bulles se formeront et le liquide chaud s'écoulera de l'appareil et causera éventuellement des brûlures. Si vous utilisez des liquides non aqueux, la pompe cessera de fonctionner et empêchera l'écoulement de l'eau. Le pot intérieur pourrait aussi s'éroder.

Remplissez le pot d'eau chaude en versant de l'eau froide à partir d'un autre récipient, tel qu'un pichet. **AVERTISSEMENT:** Ne remplissez pas le pot directement du robinet, un excès d'eau pourrait provoquer un court-circuit ou un choc électrique.

DÉPANNAGE:

AVERTISSEMENT: Faites attention à la vapeur lors de l'ouverture du couvercle.

Mode de verrouillage:

REMARQUE: Si vous ouvrez et fermez le couvercle alors que le chauffe-eau est allumé (même en mode verrouillé), il continuera de fonctionner sans changement, comme lorsque le couvercle était fermé. Il ne s'éteindra pas automatiquement et les voyants de fonction ne s'allumeront pas.

Pour verrouiller manuellement le bec afin que l'eau ne puisse pas sortir, tournez le bouton poussoir manuel situé sur le dessus du couvercle jusqu'au symbole de verrouillage rouge. Pour déverrouiller, tournez simplement la molette vers le symbole bleu de déverrouillage.

REMARQUE: Ceci n'affecte aucun mode ni aucune fonction dans lesquels le Hot Pot fonctionne. Cette action verrouille simplement le bec en tant que caractéristique de sécurité supplémentaire.

Nettoyage et entretien:

REMARQUE: N'immergez PAS l'appareil dans l'eau.

TERMS & CONDITIONS

Limited Warranty

CHEFMAN® warrants, subject to the conditions stated below, that from the date of purchase, this product will be free from mechanical defects for a period of ONE (1) year. CHEFMAN®, at its option, will repair or replace this product found to be defective during the warranty period. Should this product become defective by reason of improper workmanship or material defect during the specified warranty period, CHEFMAN® will repair or replace the same effecting all necessary parts replacements for a period of one year from the date of purchase. If product is no longer available we will replace it with a product of equal value. Transportation charges on parts, or products in whole, submitted for repair or replacement, under this warranty, must be borne by the purchaser. This warranty is void if the product is used for other than single-family household use or subjected to any voltage and waveform other than as specified on the rating label (e.g., 120V - 60 Hz).

This warranty is available to consumers only. You are a consumer if you own a CHEFMAN® product that was purchased at retail for personal, family or household use. Except as otherwise required under applicable law, this warranty is not available to retailers or other commercial purchasers or owners.

CONDITIONS: This warranty is valid for the original USA and Canada retail purchaser from the date of initial retail purchase and is not transferable. Keep the original sales receipt. Proof of purchase is required to obtain warranty service or replacement. Dealers, service centers, or retail stores do not have the right to alter, modify or in any way, change the terms and conditions of this warranty. Warranty registration is not necessary to obtain warranty on CHEFMAN® Products. Save your proof of purchase receipt.

ABOUT YOUR PRODUCT WARRANTY: Most warranty repairs are handled routinely, but sometimes requests for warranty service may not be appropriate. For example, warranty service would NOT apply if the product damage occurred because of misuse, lack of routine maintenance, shipping, handling, 3rd party warehousing or improper installation. Similarly, the warranty is void if the manufacturing date or the serial number on the product has been removed or the equipment has been altered or modified. During the warranty period, the authorized service dealer, at its option, will repair or replace any part that, upon examination, is found to be defective under normal use and service.

NORMAL WEAR: This warranty does not cover normal wear of parts or damage resulting from any of the following: negligent use or misuse of the product; improper voltage or current; use contrary to the operation instructions; deviation from instructions regarding storage and transportation; repair or alteration by anyone other than CHEFMAN® or an authorized service center. Further, the warranty does not cover Acts of God, such as fire, flood, hurricanes and tornadoes. CHEFMAN® shall not be liable for any incidental or consequential damages caused by the breach of any express or implied warranty. Except to the extent prohibited by applicable law, any implied warranty of merchantability or fitness for a particular purpose is limited in duration to the duration of the above warranty. Some states, provinces or jurisdictions do not allow the exclusion or limitation of incidental or consequential damages or limitations on how long an implied warranty lasts, so the above limitations or exclusion may not apply to you. This warranty gives you specific legal rights, and you may also have other rights that vary from state to state or province to province.

HOW TO OBTAIN WARRANTY SERVICE: If your CHEFMAN® product should prove to be defective within the warranty period, we will repair it, or if we think necessary, replace it. To obtain warranty service, simply email customersupport@chefman.com or call our toll-free number 1-888-315-6553 for additional information from our Customer Support Representatives, or send the defective product to Customer Support at Chefman, 200 Performance Drive, Mahwah, NJ 07495.

This warranty is effective for the time periods listed above and subject to the conditions provided for within this policy.

CALIFORNIA RESIDENTS ONLY:

California law provides that for In-Warranty Service, California residents have the option of returning a nonconforming product (A) to the store where it was purchased or (B) to another retail store which sells CHEFMAN® products of the same type. The retail store shall then, at its discretion, either repair the product, refer the consumer to an independent repair facility, replace the product, or refund the purchase price less the amount directly attributable to the consumer's prior usage of the product. If the above two options do not result in the appropriate relief to the consumer, the consumer may then take the product to an independent repair facility if service or repair can be economically accomplished. CHEFMAN® and not the consumer will be responsible for the reasonable cost of such service, repair, replacement, or refund for nonconforming products under warranty.

CHEFMAN® is a registered trademark of RJ BRANDS, LLC.

WARRANTY



ELECTRIC HOT WATER POT

CHEFMAN®

All data fields are required in order for us to process your request:

Model Number: _____

Full Name: _____

Address: _____

Phone: _____ Email: (if applicable) _____

Date of Purchase*: _____

*We recommend you keep the receipt with this warranty card

Retail Store of Purchase: _____

Description of Malfunction:

Return your completed warranty card to:

**RJ Brands
200 Performance Drive
Suite 207
Mahwah, NJ
07495**

ELECTRIC HOT WATER POT

**MODEL:
RJ16-LOCK
SERIES**

888.315.6553

customersupport@chefman.com

Phone lines available Monday to Friday, 9am-5pm EST
1-YEAR LIMITED WARRANTY

CHEFMAN®



CHEFMAN.COM | @MYCHEFMAN