



**AIR-COOLED SCREW  
LIQUID CHILLERS**

**RENEWAL PARTS**

Supersedes: 201.28-RP1 (817)

Form: 201.28-RP1 (918)

**MODEL YVAA STYLE A  
AIR-COOLED SCREW LIQUID CHILLERS WITH  
VARIABLE SPEED DRIVE**

**YVAA FRAME SIZE 015 - 027  
2 COMPRESSOR 60 HZ  
(150-350 TONS)**

**YVAA FRAME SIZE 054 - 098  
2 COMPRESSOR 50 HZ  
(525-950 KW)**

**(MANUFACTURED BEFORE APRIL 2012)**



LD15045

**HFC-134A  
OR HFC-513A**

Issue Date:  
September 28, 2018



# IMPORTANT!

## READ BEFORE PROCEEDING!

### GENERAL SAFETY GUIDELINES

This equipment is a relatively complicated apparatus. During rigging, installation, operation, maintenance, or service, individuals may be exposed to certain components or conditions including, but not limited to: heavy objects, refrigerants, materials under pressure, rotating components, and both high and low voltage. Each of these items has the potential, if misused or handled improperly, to cause bodily injury or death. It is the obligation and responsibility of rigging, installation, and operating/service personnel to identify and recognize these inherent hazards, protect themselves, and proceed safely in completing their tasks. Failure to comply with any of these requirements could result in serious damage to the equipment and the property in

which it is situated, as well as severe personal injury or death to themselves and people at the site.

This document is intended for use by owner-authorized rigging, installation, and operating/service personnel. It is expected that these individuals possess independent training that will enable them to perform their assigned tasks properly and safely. It is essential that, prior to performing any task on this equipment, this individual shall have read and understood the on-product labels, this document and any referenced materials. This individual shall also be familiar with and comply with all applicable industry and governmental standards and regulations pertaining to the task in question.

---

### SAFETY SYMBOLS

The following symbols are used in this document to alert the reader to specific situations:



*Indicates a possible hazardous situation which will result in death or serious injury if proper care is not taken.*

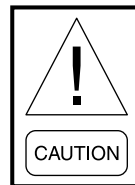

*Identifies a hazard which could lead to damage to the machine, damage to other equipment and/or environmental pollution if proper care is not taken or instructions are not followed.*



*Indicates a potentially hazardous situation which will result in possible injuries or damage to equipment if proper care is not taken.*

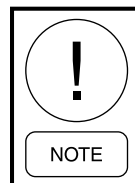

*Highlights additional information useful to the technician in completing the work being performed properly.*



*External wiring, unless specified as an optional connection in the manufacturer's product line, is not to be connected inside the control cabinet. Devices such as relays, switches, transducers and controls and any external wiring must not be installed inside the micro panel. All wiring must be in accordance with Johnson Controls' published specifications and must be performed only by a qualified electrician. Johnson Controls will NOT be responsible for damage/problems resulting from improper connections to the controls or application of improper control signals. Failure to follow this warning will void the manufacturer's warranty and cause serious damage to property or personal injury.*

## CHANGEABILITY OF THIS DOCUMENT

In complying with Johnson Controls' policy for continuous product improvement, the information contained in this document is subject to change without notice. Johnson Controls makes no commitment to update or provide current information automatically to the manual or product owner. Updated manuals, if applicable, can be obtained by contacting the nearest Johnson Controls Service office or accessing the Johnson Controls QuickLIT website at <http://cgproducts.johnsoncontrols.com>.

Operating/service personnel maintain responsibility for the applicability of these documents to the equipment.

If there is any question regarding the applicability of these documents, the technician should verify whether the equipment has been modified and if current literature is available from the owner of the equipment prior to performing any work on the chiller.

### CHANGE BARS

Revisions made to this document are indicated with a line along the left or right hand column in the area the revision was made. These revisions are to technical information and any other changes in spelling, grammar or formatting are not included.

---

## ASSOCIATED LITERATURE

MANUAL DESCRIPTION	FORM NUMBER
Installation, Operation, and Maintenance	201.28-NM1.1

THIS PAGE INTENTIONALLY LEFT BLANK



## LIST OF FIGURES

<b>FIGURE 1</b> - Typical Unit Data Plate .....	7
<b>FIGURE 2</b> - Evaporator Components.....	21
<b>FIGURE 3</b> - Condenser Coils, Typical Configuration.....	24
<b>FIGURE 4</b> - Fan Components for Low Sound, Ultra Quiet and High Flow / High Static Fans .....	26
<b>FIGURE 5</b> - Refrigeration Circuits .....	29
<b>FIGURE 6</b> - Refrigeration Circuits .....	30
<b>FIGURE 7</b> - Refrigeration Circuits .....	31
<b>FIGURE 8</b> - Glycol Loop Components .....	32
<b>FIGURE 9</b> - Compressor Components.....	36
<b>FIGURE 10</b> - Control Panel Wiring.....	39
<b>FIGURE 11</b> - Control Panel Components.....	42
<b>FIGURE 12</b> - Control Panel Components.....	45
<b>FIGURE 13</b> - Control Panel Components.....	49
<b>FIGURE 14</b> - Power Assembly Components.....	52
<b>FIGURE 15</b> - Fan Assembly Components.....	53
<b>FIGURE 16</b> - Control Panel Enclosure Components.....	54
<b>FIGURE 17</b> - Base Rail Components .....	61
<b>FIGURE 18</b> - Frame Components - Model 0200/0700 .....	64
<b>FIGURE 19</b> - Frame Components - All Models except 0200/0700.....	65
<b>FIGURE 20</b> - Oil Separator/ Flash Tank (ASME / PED) .....	70
<b>FIGURE 21</b> - Relief Kit Components .....	71
<b>FIGURE 22</b> - Sensor and Gasket Locations - Glycol Pump .....	73
<b>FIGURE 23</b> - Sensor, Transducer, and Valve Locations, System 1.....	74
<b>FIGURE 24</b> - Sensor, Transducer, and Valve Locations, System 2.....	75
<b>FIGURE 25</b> - Sensor Locations, Economizer Feed Valve and Eductor, System 1 and 2.....	76
<b>FIGURE 26</b> - Sensor Locations, Entering/Leaving Water Temperature and System 2 Discharge Pressure.....	77
<b>FIGURE 27</b> - Wire Enclosure Kit Components - Top.....	88
<b>FIGURE 28</b> - Wire Enclosure Kit Components - Bottom, Models 0153 and 0200.....	89
<b>FIGURE 29</b> - Wire Enclosure Kit Components - Bottom, Models 0165 thru 0198, 0213 thru 0303, and 0323 (10, 12, 14 and 16 Fans) .....	92
<b>FIGURE 30</b> - Wire Enclosure Kit Components - Bottom (Grille Mounting Angles), Models 0165 thru 0198, 0213 thru 0303, and 0323 (10, 12, 14 and 16 Fans) .....	93
<b>FIGURE 31</b> - Wire Enclosure Kit Components - Bottom, Models 0308, 0333 and 0343 .....	94
<b>FIGURE 32</b> - Wire Enclosure Kit Components - Bottom, Model 0345 .....	95
<b>FIGURE 33</b> - Louvered Enclosure Kit Components - Top, Models 0153 and 0200.....	101
<b>FIGURE 34</b> - Louvered Enclosure Kit Components - Top, All Models except 0153 and 0200 .....	102
<b>FIGURE 35</b> - Louvered Enclosure Kit Components - Bottom, Models 0153 and 0200.....	105
<b>FIGURE 36</b> - Louvered Enclosure Kit Components - Bottom, All Models except 0153 and 0200 .....	106
<b>FIGURE 37</b> - End Louver (Hail Guard) Panel Enclosure Kit Components .....	107
<b>FIGURE 38</b> - V-Guard Panel Enclosure Kits .....	110
<b>FIGURE 39</b> - V-Guard Panel Enclosure Kit Components.....	112
<b>FIGURE 40</b> - Evaporator Water Box Heater Parts .....	114
<b>FIGURE 41</b> - Top Edge Guards - Models 0153/0543 and 0200/0700.....	117
<b>FIGURE 42</b> - Top Edge Guards - All Models except 0153/0543 and 0200/0700.....	118

## LIST OF TABLES

<b>TABLE 1</b> - Complete PIN Number Description .....	8
<b>TABLE 2</b> - Evaporators .....	17
<b>TABLE 3</b> - Evaporator Components.....	19
<b>TABLE 4</b> - Condenser Coils, Aluminum and Post Coated .....	23
<b>TABLE 5</b> - Fan Components for Low Sound, Ultra Quiet and High Flow/ High Static Fans .....	25
<b>TABLE 6</b> - Refrigerant Piping Components .....	27
<b>TABLE 7</b> - Glycol Loop Components .....	32
<b>TABLE 8</b> - Standard Compressor (17, 28, 46, 58 Voltage Code) .....	33
<b>TABLE 9</b> - Standard Compressor (40, 50 Voltage Code) .....	33
<b>TABLE 10</b> - Standard Compressor (40, 50 Voltage Code) With High Ambient Kit.....	34
<b>TABLE 11</b> - Optimized* Compressor (17, 28, 56, 58 Voltage Code).....	34
<b>TABLE 12</b> - Optimized* Compressor (40, 50 Voltage Code) .....	35
<b>TABLE 13</b> - Optimized* Compressor (40, 50 Voltage Code) With High Ambient Kit.....	35
<b>TABLE 14</b> - Compressor Components.....	36
<b>TABLE 15</b> - Control / Power Panels, Complete .....	37
<b>TABLE 16</b> - Control Panel Wiring.....	39
<b>TABLE 17</b> - Control Panel Components .....	40
<b>TABLE 18</b> - Control Panel Components .....	43
<b>TABLE 19</b> - Control Panel Components .....	46
<b>TABLE 20</b> - Power Assembly Components.....	50
<b>TABLE 21</b> - Fan Assembly Components.....	53
<b>TABLE 22</b> - Control Panel Enclosure Components .....	54
<b>TABLE 23</b> - Base Rail Components.....	55
<b>TABLE 24</b> - Frame Components, All Models .....	62
<b>TABLE 25</b> - Oil Separator/ Flash Tank (PED) * .....	67
<b>TABLE 26</b> - Oil Separator/ Flash Tank / (ASME) .....	67
<b>TABLE 27</b> - Relief Kit Components.....	68
<b>TABLE 28</b> - Sensors/System Wiring Components.....	73
<b>TABLE 29</b> - System #1 Sensor Wiring .....	78
<b>TABLE 30</b> - System #2 Sensor Wiring .....	79
<b>TABLE 31</b> - Unit Sensor Wiring.....	81
<b>TABLE 32</b> - Unit Control Wiring .....	81
<b>TABLE 33</b> - Vibration Isolators.....	83
<b>TABLE 34</b> - Field Installed Option Kits.....	84
<b>TABLE 35</b> - Wire Enclosure Kits .....	85
<b>TABLE 36</b> - Wire Enclosure Kit Components - Top.....	86
<b>TABLE 37</b> - Wire Enclosure Kit Components - Bottom, Models 0153 and 0200 .....	89
<b>TABLE 38</b> - Wire Enclosure Kit Components - Bottom, Models 0165 thru 0198, 0213 thru 0303, and 0323 (10, 12, 14 and 16 Fans) .....	90
<b>TABLE 39</b> - Wire Enclosure Kit Components - Bottom, Models 0308, 0333 and 0343 .....	94
<b>TABLE 40</b> - Wire Enclosure Kit Components - Bottom, Model 0345 .....	95
<b>TABLE 41</b> - Louvered Enclosure Kits.....	96
<b>TABLE 42</b> - Louvered (Condenser Only) Enclosure Kits .....	97
<b>TABLE 43</b> - Wire / Louvered Enclosure Kits .....	98
<b>TABLE 44</b> - Louvered and Wire/Louvered Enclosure Kit Components - Top .....	99
<b>TABLE 45</b> - Louvered and Wire/Louvered Enclosure Kit Components - Bottom .....	103
<b>TABLE 46</b> - End Louver (Hail Guard) Panel Enclosure Kit and Components.....	107
<b>TABLE 47</b> - V-Guard Panel Enclosure Kits (Assembly).....	108
<b>TABLE 48</b> - V-Guard Kits .....	109
<b>TABLE 49</b> - Hail Guard .....	109
<b>TABLE 50</b> - V-Guard Panel Enclosure Kit Components .....	111
<b>TABLE 51</b> - Evaporator Water Box Heater Kits.....	113
<b>TABLE 52</b> - Evaporator Water Box Heater Parts .....	114
<b>TABLE 53</b> - Top Edge Guard Kit .....	115
<b>TABLE 54</b> - Top Edge Guards.....	116
<b>TABLE 55</b> - SI Metric Conversion .....	121

## UNIT NOMENCLATURE

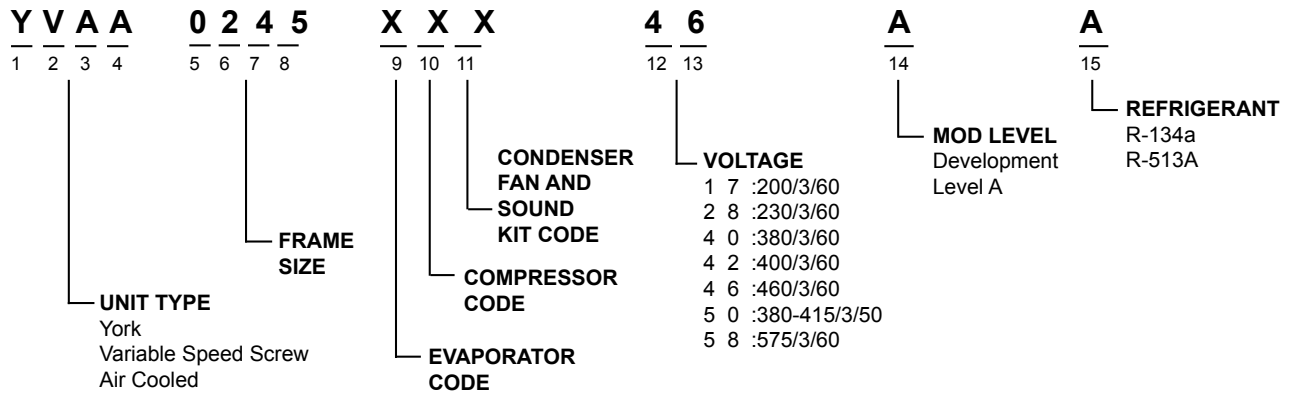

### MODEL AND SERIAL NUMBERS

In order to ensure that the correct replacement parts are supplied please provide your Johnson Controls Parts Center with the Model and Serial No. of your unit; these are detailed on the unit data plate shown on Figure 1 below.

A typical serial number could be:

**RMRM016840**

Where the four letters identify the location and time of manufacture and the 6 numbers (including the 0) are the serial number issued to the unit.

#### Model Number

The model number consists of the first 15 digits of the unit pin as shown above.

#### PIN

Table 1 details options that may fitted to your unit, the PIN on the unit data plate should be used to identify these options when ordering spare parts.

#### Serial Number

The serial number is a combination of four letters and the six numbers (see Figure 1 example below). It is important that both the letters and the number are provided.

Model/PIN		MOD		PIN				Serial #	SER
Refrigerant	Max. Allowable Pressure -Bar (psig):		High Side	B	Low Side	C	System Pressure Test On		
A	at High Side		E	Low Side	F	Short Circuit Withstand			
OUTDOOR USE		Volt-Phase-Hertz	Utilization Range	Min. Circuit Ampacity	Max. Dual Element Fuse Size	Max. Circuit Breaker Size	Short Circuit Withstand		
Unit Power	Supply:	L	M	N	O	P	Q		
Protection Device Size - Amps		SYS No.		Compressor RLA		Fans		Refrigerant	
System(s) No.	Min. Circuit Ampacity	Max. Dual Element Fuse Size	Max. Circuit Breaker Size	FLA	LRA	No.	Kg (lb)		
S13	1A	1B	1C	S1	1E	1G	1H	1I	
				S2	2E	2G	2H	2I	
				S3	3E	3G	3H	3I	
S24	2A	2B	2C	S4	4E	4G	4H	4I	
YORK INTERNATIONAL CORP. York, PA		029-24572-001 REV. F		Control Transformer:		No. Volts-Phase-Hertz	KVA	Unit Shipping Weight	
				X	LA	Y	Kg (lb)		
								Z	

**FIGURE 1 - TYPICAL UNIT DATA PLATE**

**TABLE 1 - COMPLETE PIN NUMBER DESCRIPTION**

FEATURE	FEATURE DESCRIPTION	OPTION	OPTION DESCRIPTION
MODEL	Model (PIN 1)	Y	York
COMPRTYP	Compressor Type (PIN 2)	V	Variable Speed Screw
CHILLERTYP	Chiller Type (PIN 3)	A	Air-cooled Chiller
DESIGNER	Design Series (PIN 4)	A	Design Series
UNTDSG	Unit Designator (PIN 5-8) (PINS 5 through 7 are the Frame Size)	0153	0153 / 0543
		0543	
		0183	0183 / 0643
		0643	
		0213	0213 / 0743
		0743	
		0233	0233 / 0843
		0843	
		0263	0263 / 0943
		0943	
		0273	0273/0963
		0963	
		0303	0303 / 1093
		1093	
		0323	0323/1143
		1143	
		0333	0333/1173
		1173	
		0343	0343 / 1193
		1193	
		0373*	0373 / 1343
		1343*	
		0413*	0413 / 1443
		1443*	
		0443*	0443 / 1543
		1543*	
0483*	0483 / 1693		
1693*			
0523*	0523 / 1843		
1843*			
0165	0165 / 0565		
0565			

Note: \* Option has not yet been designed

**TABLE 1 - COMPLETE PIN NUMBER DESCRIPTION (CONT'D)**

FEATURE	FEATURE DESCRIPTION	OPTION	OPTION DESCRIPTION
UNTDSG (Cont'd)	Unit Designator (PIN 5-8) (PINS 5 through 7 are the Frame Size) (Cont'd)	0195	0195 / 0665
		0665	
		0215	0215 / 0765
		0765	
		0245	0245 / 0865
		0865	
		0275	0275 / 0965
		0965	
		0295*	0295 / 1015
		1015*	
		0305*	0305 / 1065
		1065*	
		0345	0345 / 1215
		1215	
		0375*	0375 / 1315
		1315*	
		0425*	0425 / 1515
		1515*	
		0475*	0475 / 1665
		1665*	
		0178	0178 / 0588
		0588	
		0198	0198 / 0688
		0688	
		0218	0218 / 0788
		0788	
		0248	0248 / 0888
		0888	
		0278	0278 / 0988
		0988	
		0308	0308 / 1088
		1088	
		0318*	0338 / 1188
		1188*	
		0368*	0368 / 1288
		1288*	
		0398*	0398 / 1388
		1388*	
		0428*	0428 / 1488
		1488*	
0200	0200 / 0700		
0700			
0500*	0500 / 1750		
1750*			

Note: \* Option has not yet been designed

**TABLE 1 - COMPLETE PIN NUMBER DESCRIPTION (CONT'D)**

FEATURE	FEATURE DESCRIPTION	OPTION	OPTION DESCRIPTION
FLOADEFF	Full Load Efficiency (PIN 9)		For Marketing Purposes Only
PLOADEFF	Part Load Efficiency (PIN 10)		For Marketing Purposes Only
SOUND	Sound (PIN 11)		For Marketing Purposes Only
VOLTAGE	Voltage (PIN 12, 13)	17	200/3/60
		28	230/3/60
		40	380/3/60
		46	460/3/60
		50	380-415/3/50
		58	575/3/60
MODLVL	Modification Level (PIN 14)	A	Modification Level
REF	Refrigerant (PIN 15)	A	R-134a or R-513A Refrigerant
STARTERTYP	Starter Type (PIN 16)	V	Standard VSD
		R*	VSD with Active Filter
		Q	Special quote
POWERFLD	Power Field (PIN 17)	B	SP Circuit Breaker w/ Lockable Handle
		D*	MP Supply TB
		M*	MP Circuit Breaker w/Lockable Handle
		N	SP NF Disconnect Switch w/Lockable Handle
		P*	MP NF Disconnect Switch w/ Lockable Handle
		S	SP Supply TB
		Q	Special quote
PIN18	PIN 18	X	No selection
		Q	Special quote
PANELOPT	Panel Options (PIN 19)	X	No selection
		O*	Convenience outlet
		M*	Convenience Outlet with KW meter
		W*	KW meter
		Q	Special quote
AMB	Ambient Kits PIN 20	X	No selection
		B*	Both Low and High Ambient kits
		H	High Ambient kit
		L*	Low Ambient kit
		Q	Special quote
BAS	BAS Reset/Offset (PIN 21)	X	No selection
		B	BAS/EMS Both Temp and Current Reset/Offset
		C	BAS/EMS Current Reset/Offset
		E	BACNet Elink Kit (factory mounted)
		L	LON E-Link Kit (factory mounted)
		T	BAS/EMS Temp Reset/Offset
		Q	Special quote

Note: \* Option has not yet been designed

**TABLE 1 - COMPLETE PIN NUMBER DESCRIPTION (CONT'D)**

FEATURE	FEATURE DESCRIPTION	OPTION	OPTION DESCRIPTION
LANGDESP	Language/Display (PIN 22)	A	English
		C	English LCD with Chinese keypad overlay
		E*	Chinese
		F	French
		G	German
		H	Hungarian
		I	Italian
		J*	Japanese
		K*	Korean
		L	Polish
		N*	Dutch
		P	Portuguese
		R*	Russian
		S*	Spanish
		W*	Swedish
		Z*	Czech
Q*	Special quote		
SYSPARM	System Parameter (PIN 23)	X	No selection
		K	Quick Start
		M	Quick Start and Silent Night / Load limiting control option
		N	Silent Night sound / Load limiting control option
		Q	Special quote
SAFETYCODE	Safety Code (PIN 24)	C	European Safety Code (CE)
		G*	China Safety Code (GB)
		L	N. American Safety Code (cUL/cETL)
		Q	Special Safety Code
SENSOR	Sensor (PIN 25)	X	No selection
		Q	Special quote
PUMPCTRL	Pump Control (PIN 26)	X	No selection
		Q	Special quote
REMOTEPNL	Remote Panel (PIN 27)	X	No selection
		O*	Optiview Remote Control Panel
		Q	Special quote
SEQCTRL	Sequence Control (PIN 28)	X	No selection
		S*	Sequence Control and Automatic Lead Transfer = {seq}
		Q	Special quote
PIN29	PIN 29	X	No selection
		Q	Special quote
PIN30	PIN 30	X	No selection
		Q	Special quote
LWT	Leaving Water Temp (PIN 31, 32)	NUM	Leaving Water Temp = {LWT} Degrees
		TS*	Thermal storage
		QQ	Special quote

Note: \* Option has not yet been designed

**TABLE 1 - COMPLETE PIN NUMBER DESCRIPTION (CONT'D)**

FEATURE	FEATURE DESCRIPTION	OPTION	OPTION DESCRIPTION
PIPECODE	Piping Code (PIN 33)	X	No selection
		C*	Chicago Code Relief
		R	Dual Relief Valves
		Q	Special quote
METERDEV	Metering Device (PIN 34)	E*	EEV
		O	Orifice
		Q	Special quote
VALVEOPT	Valve Options (PIN 35)	X	No selection
		F*	Suction and filter dryer service valve
		S	Suction service valve
		Q	Special quote
PIN36	PIN 36	X	No selection
		Q	Special quote
PIN37	PIN 37	X	No selection
		Q	Special quote
CPRVAR	Compressor Variation (PIN 38)	S	Standard Compressor
		V	Optimized Compressor
		Q	Special quote
CPRFQ	Compressor Frequency (PIN 39, 40, 41)	NUM	Compressor Frequency = {CNUM}
		QQQ	Special quote
HTR	Heaters (PIN 42)	X	No selection
		W	Water box heaters
		Q	Special quote
DWP	DWP (PIN 43)	1	150psig DWP Waterside
		3*	300psig DWP Waterside
		Q	Special quote
INS	Insulation (PIN 44)	D	Double Thickness
		S	Single Thickness
		Q	Special quote
SHPLOSFLG	Ship Loose Flange Kit (PIN 45)	X	No selection
		F	Victaulic Flanges with welded mating flanges (4 shipped loose)
		M	Weldable flanges with mating weldable flanges (4 shipped loose)
		V	Victaulic Flanges (2 shipped loose)
		W	Weldable flanges (2 shipped loose)
		Q	Special quote

Note: \* Option has not yet been designed



**TABLE 1 - COMPLETE PIN NUMBER DESCRIPTION (CONT'D)**

FEATURE	FEATURE DESCRIPTION	OPTION	OPTION DESCRIPTION
FLOW	Flow Switch (PIN 46)	X	No selection
		D	One Differential Pressure Switch
		E	Two Differential Pressure Switches
		F	Three Differential Pressure Switches
		G	One Thermal Dispersion Switch
		H	Two Thermal Dispersion Switch
		I	Three Thermal Dispersion Switch
		S	One Flow Switch
		T	Two Flow Switches
		U	Three Flow Switches
		Q	Special quote
VESSEL	Vessel Codes (PIN 47)	A	ASME Pressure Vessel Codes
		E	PED Pressure Vessel Codes
		G*	GB Pressure Vessel Codes
		Q	Special quote
CLR	Cooler (PIN 48)	1*	Integral One Water Pass Cooler
		2	Integral Two Water Pass Cooler
		3*	Integral Triple Water Pass Cooler
		A*	Remote One Water Pass Cooler
		B*	Remote Two Water Pass Cooler
		C*	Remote Triple Water Pass Cooler
		Q	Special quote
EVAPCONN	Evaporator Connection location (PIN 49)	B	Back Fluid Inlet Connection (opposite control panel end)
		F*	Front Fluid Inlet Connection (control panel end)
		Q	Special quote
COILS	Coils (PIN 50)	A*	Copper tube aluminum fin coils
		B*	Pre-Coated Slit-Fin Coils (tube and fin)
		C*	Copper Fin Coils (tube and fin)
		E*	Pre-Coated Non-Slit Fin Coils (tube and fin)
		M	Microchannel coils
		N	Post-coated Microchannel coils
		P*	Post-Coated Dipped Coils (tube and fin)
		Q	Special quote
PIN51	PIN 51	X	No selection
		Q	Special quote

Note: \* Option has not yet been designed

**TABLE 1 - COMPLETE PIN NUMBER DESCRIPTION (CONT'D)**

FEATURE	FEATURE DESCRIPTION	OPTION	OPTION DESCRIPTION
FANTYP	Fan Type (PIN 52)	F	Low Sound Fans
		G	High Airflow Fans
		H	High Static Fans
		K	High Airflow Fans with Variable Speed Control
		L	Ultra Quiet Fans
		M	Ultra Quiet Fans with Variable Speed Control
		V	Low Sound Fans with Variable Speed Control
		W*	Whisper Quiet Fans
		Z*	Whisper Quiet Fans with Variable Speed Control
		Q	Special quote
ENCLPNL	Enclosure Panels (PIN 53)	X	No selection
		1	Wire (Full Unit) Encl Panels (factory)
		2*	Wire (Full Unit) Encl Panels (field)
		3	Wire/Louvered Encl Panels (factory)
		4*	Wire/Louvered Encl Panels (field)
		5	Louvered (cond only) Encl Panels (factory)
		6*	Louvered (cond only) Encl Panels (field)
		7	Louvered (full unit) Encl Panels (factory)
		8*	Louvered (full unit) Encl Panels (field)
		9	End Louver (End Hail Guard) Encl Panels (Factory)
		A*	End Louver (End Hail Guard) Encl Panels(Field)
		B	V-Guard Panels only (factory)
		C*	V-Guard Panels only (field)
		D	V-Guard Panels plus Hail Guards (factory)
		E*	V-Guard Panels plus Hail Guards (field)
		F	Top Edge Guard (factory)
		G*	Top Edge Guard (field)
		Q	Special quote
NOISERDCT	Noise Reduction Kit (PIN 54)	X	No selection
		E	Economical Low Noise kit
		N	Low Noise kit (level 2 reduction) (factory)
		O*	Low Noise kit (level 2 reduction) (field)
		R	Low Noise kit (level 1 reduction) (factory)
		S*	Low Noise kit (level 1 reduction) (field)
		U*	Low Noise kit (level 3 reduction) (factory)
		V*	Low Noise kit (level 3 reduction) (field)
		Q	Special quote
ISOL	Vibration Isolators (PIN 55)	X	No selection
		1	1" Deflection Isolators
		N	Neoprene Isolators
		S	Seismic Isolators
		Q	Special quote

Note: \* Option has not yet been designed

**TABLE 1 - COMPLETE PIN NUMBER DESCRIPTION (CONT'D)**

FEATURE	FEATURE DESCRIPTION	OPTION	OPTION DESCRIPTION
STRMOD	Structural Modification (PIN 56)	X	No selection
		D*	Unit shipped in two pieces
		S*	Seismic Unit
		Q	Special quote
PIN57	PIN 57	X	No selection
		Q	Special quote
SPAPP	Special Applications (PIN 58)	X	No selection
		D*	Desuperheater
		F*	Free cooling
		H*	Full heat recovery
		Q	Special quote
PMPPKG	Pump Package (PIN 59)	X	No selection
		Q	Special quote
PMPPKGOPT	Pump Package options (PIN 60)	X	No Selection
		Q	Special quote

Note: \* Option has not yet been designed

THIS PAGE INTENTIONALLY LEFT BLANK

## SECTION 1 - EVAPORATOR COMPONENTS

**TABLE 2 - EVAPORATORS**

MODEL	DESCRIPTION	PART NUMBER
0153/0543 0165/0565 0198/0688 0233/0843 0263/0943	Evaporator, Single Insulated, with Economical Low Noise Kit (ASME)	375 89864 001
	Evaporator, Double Insulated, with Economical Low Noise Kit (ASME)	375 89864 002
	Evaporator, Single Insulated, (ASME)	375 89864 003
	Evaporator, Double Insulated, (ASME)	375 89864 004
	Evaporator, Single Insulated, with Low Noise Kit (ASME)	375 89864 005
	Evaporator, Double Insulated, with Low Noise Kit (ASME)	375 89864 006
	Evaporator, Single Insulated, with Economical Low Noise Kit (PED)	375 89864 991
	Evaporator, Double Insulated, with Economical Low Noise Kit (PED)	375 89864 992
	Evaporator, Single Insulated, (PED)	375 89864 993 *
	Evaporator, Double Insulated, (PED)	375 89864 994 *
	Evaporator, Single Insulated, with Low Noise Kit (PED)	375 89864 995 *
	Evaporator, Double Insulated, with Low Noise Kit (PED)	375 89864 996 *
	0178/0588 0215/0765 0218/0788 0245/0865 0248/0888 0303/1093 0333/1173	Evaporator, Single Insulated, with Economical Low Noise Kit (ASME)
Evaporator, Double Insulated, with Economical Low Noise Kit (ASME)		375 93209 002
Evaporator, Single Insulated, (ASME)		375 93209 003
Evaporator, Double Insulated, (ASME)		375 93209 004
Evaporator, Double Insulated, with Low Noise Kit (ASME)		375 93209 006
Evaporator, Single Insulated, with Economical Low Noise Kit (PED)		375 93209 991
Evaporator, Double Insulated, with Economical Low Noise Kit (PED)		375 93209 992
Evaporator, Single Insulated, (PED)		375 93209 993 *
Evaporator, Double Insulated, (PED)		375 93209 994 *
Evaporator, Single Insulated, with Low Noise Kit (PED)		375 93209 995 *
Evaporator, Double Insulated, with Low Noise Kit (PED)		375 93209 996 *
0183/0643 0195/0665 0213/0743	Evaporator, Single Insulated, with Economical Low Noise Kit (ASME)	375 93930 001
	Evaporator, Double Insulated, with Economical Low Noise Kit (ASME)	375 93930 002
	Evaporator, Single Insulated, (ASME)	375 93930 003
	Evaporator, Double Insulated, (ASME)	375 93930 004
	Evaporator, Single Insulated, with Low Noise Kit (ASME)	375 93930 005
	Evaporator, Double Insulated, with Low Noise Kit (ASME)	375 93930 006
	Evaporator, Single Insulated, with Economical Low Noise Kit (PED)	375 93930 991
	Evaporator, Double Insulated, with Economical Low Noise Kit (PED)	375 93930 992
	Evaporator, Single Insulated, (PED)	375 93930 993 *
	Evaporator, Double Insulated, (PED)	375 93930 994 *
	Evaporator, Single Insulated, with Low Noise Kit (PED)	375 93930 995 *
	Evaporator, Double Insulated, with Low Noise Kit (PED)	375 93930 996 *
0200/0700	Evaporator, Single Insulated, with Low Noise Kit (ASME)	375 93209 005

Notes: 1. Evaporators include insulation and heaters. For evaporators without insulation and heater plus other evaporator components, see Table 3 on page 19.

2. \* Not available at time of printing.

**TABLE 2 - EVAPORATORS (CONT'D)**

MODEL	DESCRIPTION	PART NUMBER
0273/0963	Evaporator, Single Insulated, with Economical Low Noise Kit (ASME)	392 02454 001
	Evaporator, Double Insulated, with Economical Low Noise Kit (ASME)	392 02454 002
	Evaporator, Single Insulated, (ASME)	392 02454 003
	Evaporator, Double Insulated, (ASME)	392 02454 004
	Evaporator, Single Insulated, with Low Noise Kit (ASME)	392 02454 005
	Evaporator, Double Insulated, with Low Noise Kit (ASME)	392 02454 006
	Evaporator, Single Insulated, with Economical Low Noise Kit (PED)	392 02454 991
	Evaporator, Double Insulated, with Economical Low Noise Kit (PED)	392 02454 992
	Evaporator, Single Insulated, (PED)	392 02454 993 *
	Evaporator, Double Insulated, (PED)	392 02454 994 *
	Evaporator, Single Insulated, with Low Noise Kit (PED)	392 02454 995 *
	Evaporator, Double Insulated, with Low Noise Kit (PED)	392 02454 996 *
0275/0965 0278/0988 0308/1088 0323/1143 0343/1193 0345/1215	Evaporator, Single Insulated, with Economical Low Noise Kit (ASME)	375 93189 001
	Evaporator, Double Insulated, with Economical Low Noise Kit (ASME)	375 93189 002
	Evaporator, Single Insulated, (ASME)	375 93189 003
	Evaporator, Double Insulated, (ASME)	375 93189 004
	Evaporator, Single Insulated, with Low Noise Kit (ASME)	375 93189 005
	Evaporator, Double Insulated, with Low Noise Kit (ASME)	375 93189 006
	Evaporator, Single Insulated, with Economical Low Noise Kit (PED)	375 93189 991
	Evaporator, Double Insulated, with Economical Low Noise Kit (PED)	375 93189 992
	Evaporator, Single Insulated, (PED)	375 93189 993 *
	Evaporator, Double Insulated, (PED)	375 93189 994 *
	Evaporator, Single Insulated, with Low Noise Kit (PED)	375 93189 995 *
	Evaporator, Double Insulated, with Low Noise Kit (PED)	375 93189 996 *

Notes: 1. Evaporators include insulation and heaters. For evaporators without insulation and heater plus other evaporator components, see Table 3 on page 19.

2. \* Not available at time of printing.

**TABLE 3 - EVAPORATOR COMPONENTS**

ITEM	MODELS	DESCRIPTION	PART NUMBER	QUANTITY	FIGURE
1	0153/0543 0165/0565 0198/0688 0233/0843 0263/0943	Evaporator, less Heater and Insulation	375 89864 000 <sup>1</sup>	1	2
	375 89864 990 <sup>1</sup>		1	2	
1	0275/0965 0278/0988 0308/1088 0323/1143 0343/1193 0345/1215	Evaporator, less Heater and Insulation	375 93189 000 <sup>1</sup>	1	2
	375 93189 990 <sup>1</sup>		1	2	
1	0178/0588 0200/0700 0215/0765 0218/0788 0245/0865 0248/0888 0303/1093 0333/1173	Evaporator, less Heater and Insulation	375 93209 000 <sup>1</sup>	1	2
	375 93209 990 <sup>1</sup>		1	2	
1	0183/0643 0195/0665 0213/0743	Evaporator, less Heater and Insulation	375 93930 000 <sup>1,2</sup>	1	2
	0183/0643 0195/0665 0213/0743 0273/0963		375 93930 990 <sup>1,3</sup>	1	2
1	0273/0963	Evaporator, less Heater and Insulation	392 02454 000 <sup>1,2</sup>	1	2
			392 02454 990 <sup>1,3</sup>	1	2
3	0153/0543	Waterbox, Back, Weldment Ffe230	375 93963 000	1	2
	0165/0565				
	0178/0588				
	0198/0688				
	0200/0700				
	0215/0765				
	0218/0788				
	0233/0843				
	0245/0865				
	0248/0888				
	0263/0943				
	0303/1093				
0333/1173					

Notes: 1. Evaporators are without heater and insulation. For evaporator part numbers with insulation and heater see Table 2 on page 17.

2. ASME pressure vessel code.

3. PED pressure code.

**TABLE 3 - EVAPORATOR COMPONENTS (CONT'D)**

ITEM	MODELS	DESCRIPTION	PART NUMBER	QUANTITY	FIGURE		
3	0183/0643 0195/0665 0213/0743	Waterbox, Back	375 93934 000	1	2		
	0273/0963		375 93934 000 <sup>4</sup>	1	2		
			375 93963 000 <sup>3</sup>	1	2		
	0275/0965 0278/0988 0308/1088 0323/1143 0343/1193 0345/1215		375 93190 000	1	2		
	4		0153/0543 0165/0565 0198/0688 0233/0843 0263/0943	Waterbox, Front	375 93959 000	1	2
			0183/0643 0195/0665 0213/0743		375 93933 000	1	2
0273/0963		375 93977 000 <sup>3</sup>			1	2	
			375 93933 000 <sup>4</sup>		1	2	
0275/0965 0278/0988 0308/1088 0323/1143 0343/1193 0345/1215		375 93191 000	1		2		
0178/0588 0200/0700 0215/0765 0218/0788 0245/0865 0248/0888 0303/1093 0333/1173		375 93977 000	1		2		
5		ALL	Gasket, Channel, 50 Durometer		028 09951 000	A/R	2
6		ALL	Heater, 280W, 120V (not shown)		025 22691 000	2	2
10		ALL	Well Thermo		026 32328 000	2	2
18		ALL	Plug Pipe, 1/4", Square Head		023 01972 000	2	2
19	ALL	Plug Pipe, 1/2", Square Head	023 03822 000	4	2		
20	ALL	Plug Pipe, 3/4", Square Head	023 04053 000	2	2		
21	ALL	Plug Pipe, 1", Square Head	023 04054 000	2	2		
22	ALL	Sight Glass	028 12961 036	1	2		
23	ALL	O-ring, Sight Glass	028 12961 000	2	2		
24	ALL	Sensor, Water Temperature (not shown)	025 40334 000	2	2		

Notes: 1. Evaporators are without heater and insulation. For evaporator part numbers with insulation and heater see Table 2 on page 17.

2. ASME pressure vessel code.

3. PED pressure code.



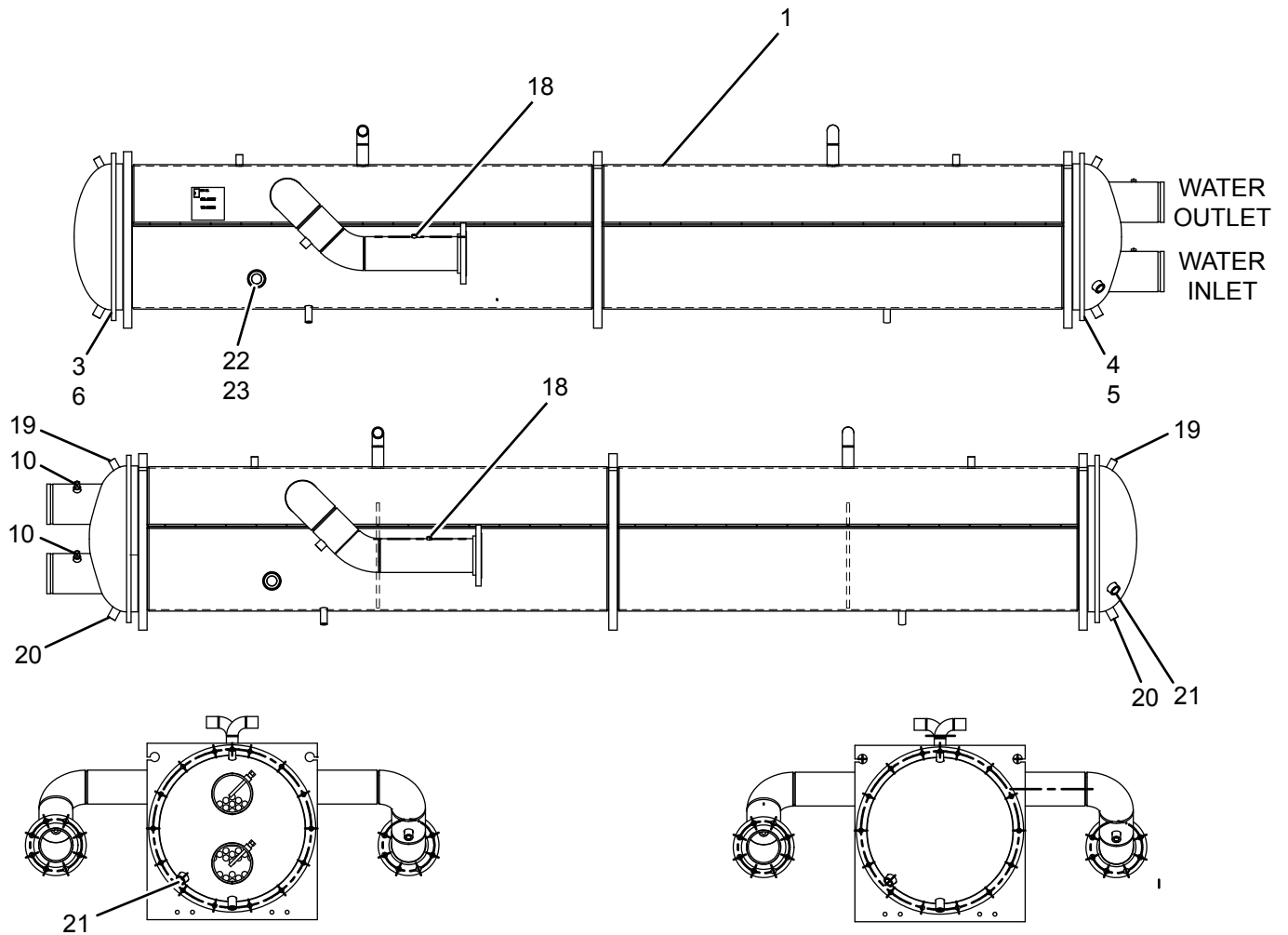

LD15900

FIGURE 2 - EVAPORATOR COMPONENTS

THIS PAGE INTENTIONALLY LEFT BLANK

## SECTION 2 - CONDENSER COILS

**TABLE 4 - CONDENSER COILS, ALUMINUM AND POST COATED**

ITEM	MODEL	COILS PER UNIT	PART NUMBER	DESCRIPTION	FIGURE
2	0153/0543	8	026 45677 000	Coil, Microchannel	3
	0165/0565	10			
	0178/0588	12			
	0183/0643	10			
	0195/0665	12			
	0198/0688	14			
	0200/0700	8			
	0213/0743	12			
	0215/0765	12			
	0218/0788	14			
	0233/0843	12			
	0245/0865	14			
	0248/0888	16			
	0263/0943	14			
0275/0965	14				
0278/0988	16				
2	0273/0963	14	026 46798 000	Coil, Microchannel	3
	0303/1093	16			
	0308/1088	18			
	0323/1143	16			
	0333/1173	18			
	0343/1193	18			
	0345/1215	20			
2	0153/0543	8	326 45677 000	Coil, Microchannel, Post Coated	3
	0165/0565	10			
	0178/0588	12			
	0183/0643	10			
	0195/0665	12			
	0198/0688	14			
	0200/0700	8			
	0213/0743	12			
	0215/0765	12			
	0218/0788	14			
	0233/0843	12			
	0245/0865	14			
	0248/0888	16			
	0263/0943	14			
0275/0965	14				
0278/0988	16				
2	0273/0963	14	326 46798 000	Coil, Microchannel, Post Coated	3
	0303/1093	16			
	0308/1088	18			
	0323/1143	16			
	0333/1173	18			
	0343/1193	18			
	0345/1215	16			

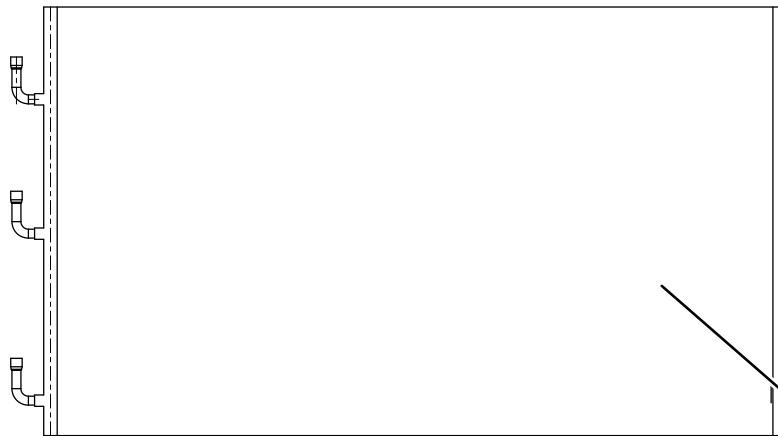

026-45677-000 (microchannel, standard aluminum)  
326-45677-000 (microchannel, post coated)  
MAXIMUM WORKING PRESSURE = 375 PSIG



026-46798-000 (microchannel, standard aluminum)  
326-46798-000 (microchannel, post coated)  
MAXIMUM WORKING PRESSURE = 375 PSIG

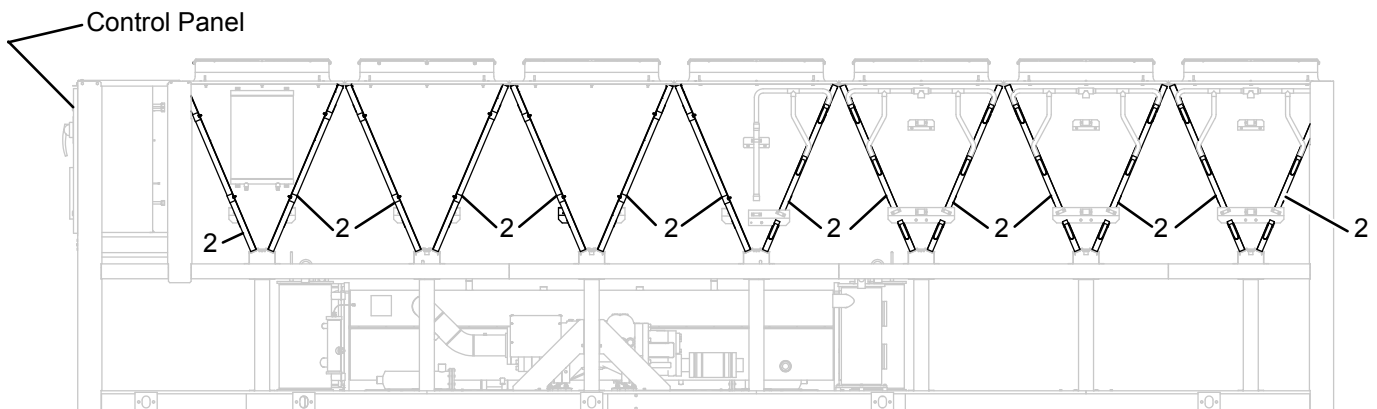

0218/0788. 0263/0943. 0275/0965 SHOWN

LD15159

**FIGURE 3 - CONDENSER COILS, TYPICAL CONFIGURATION**

## SECTION 3 - FAN COMPONENTS

**TABLE 5 - FAN COMPONENTS FOR LOW SOUND, ULTRA QUIET AND HIGH FLOW/ HIGH STATIC FANS**

ITEM	DESCRIPTION	VOLTAGE CODE	FAN TYPE				FIGURE
			LOW SOUND	ULTRA QUIET FAN	HIGH AIR-FLOW	HIGH STATIC	
1	Orifice, Flanged	ALL	026-45682-000				4
2	Guard, Fan	ALL	026-46008-000				4
	Guard, Fan Ce	50	026-46008-001				4
3	Motor, Fan, 2 Hp, 6 Pole, 950 RPM	17, 28, 46, 50, 58	024-36873-107	----	----	----	4
	Motor, Fan, 2 Hp, 6 Pole, 1150 RPM	40, 42	024-36873-104	----	----	----	4
	Motor, Fan, 8 Pole, 690/850 RPM	17, 28, 46, 58	----	024-34980-101	----	----	4
	Motor, Fan, 8 Pole, 850 RPM	40, 42	----	024-34980-105	----	----	4
	Motor, Fan, 8 Pole, 690 RPM	50	----	024-34980-103	----	----	4
	Motor, Fan, 5 Hp, 6 Pole, 1150 RPM	17, 28, 46, 58	----	----	024-36874-003	024-36081-003	4
	Motor, Fan, 5 Hp, 1150 RPM	40, 42	----	----	024-36874-002	024-36081-003	4
	Motor, Fan, 5 Hp, 6 Pole, 950 RPM	50	----	----	024-36874-004	024-36081-003	4
4	Support, Fan Motor	17, 28, 46, 50, 58	026-46735-000	----	----	----	4
	Support, Fan Motor	40, 42	026-46735-000	----	----	----	4
	Support, Fan Motor	ALL	----	026-45533-000	----	----	4
	Bracket, Fan Support	ALL	----	----	075-67014-000	075-67014-000	4
5	Support, Ring	ALL	026-36367-000	----	----	----	4
6	Fan Impeller, 900mm	17, 28, 46, 40, 42, 58	026-41594-000	----	----	----	4
	Fan Impeller, 900mm	50	026-41943-000	----	----	----	4
	Fan Impeller, 900mm	17, 28, 46, 50, 58	----	026-41942-000	----	----	4
	Fan Impeller, 900mm	50	----	026-45549-000	----	----	4
	Fan Impeller, 900mm	17, 28, 46, 40, 58	----	----	026-45538-000	026-45538-000	4
	Fan Impeller, 900mm	50	----	----	026-46066-000	026-46066-000	4
10	Screw, Cap Hex Head, M8 X 1.25-6g	ALL	021-18494-000	----	----	----	4
	Screw, Cap Hex Head, M10 1.5-6h	ALL	----	----	021-17791-000	021-17791-000	4
14	Spacer, Fan Motor	ALL	----	----	075-40485-000	075-40485-000	4
15	Spacer, Fan Motor	ALL	075-29007-000	----	----	----	4
	Spacer, Fan Motor	ALL	----	----	075-67017-000	075-67017-000	4
16	Spacer, Fan Motor	ALL	075-40484-000	----	----	----	*
17	Hub, Square	ALL	026-41939-005	----	----	----	4

**NOTE:** Items with an \* are NOT represented.

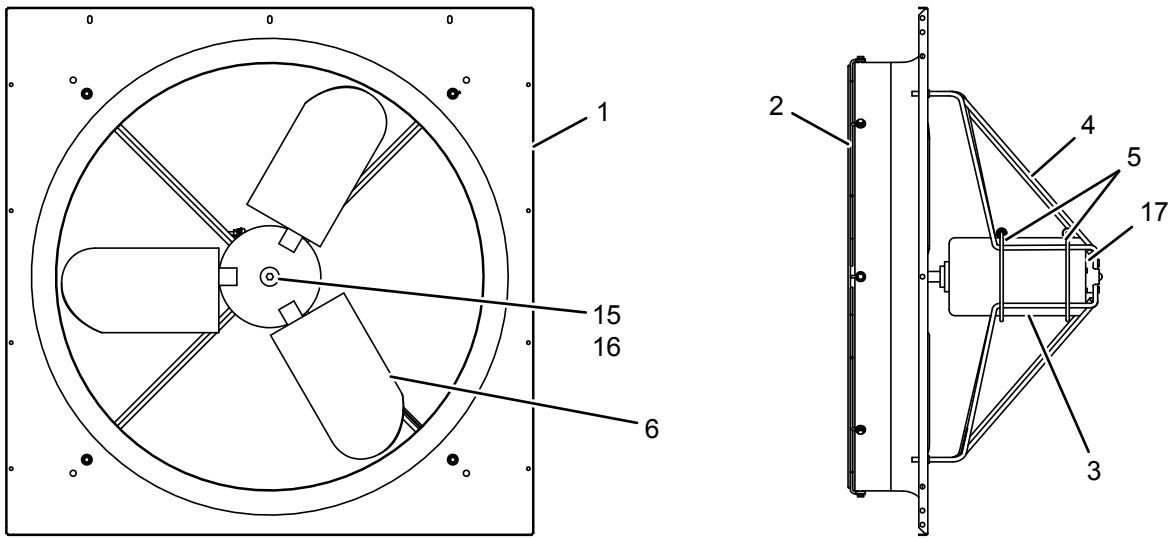

LOW SOUND AND ULTRA QUIET FAN

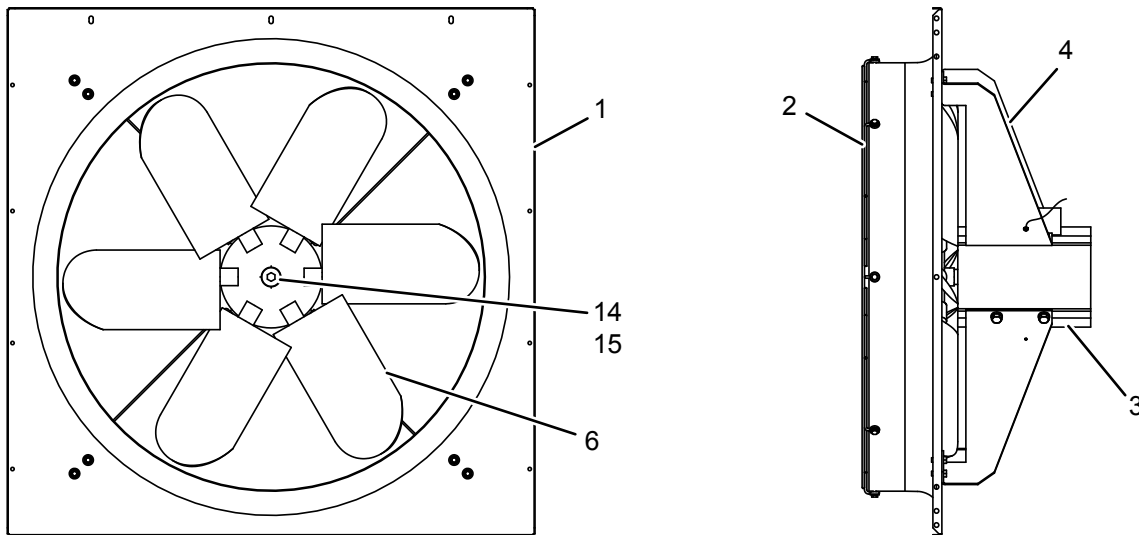

HIGH FLOW / HIGH STATIC FAN

LD15905

FIGURE 4 - FAN COMPONENTS FOR LOW SOUND, ULTRA QUIET AND HIGH FLOW / HIGH STATIC FANS

## SECTION 4 - REFRIGERANT PIPING

**TABLE 6 - REFRIGERANT PIPING COMPONENTS**

ITEM	MODELS	DESCRIPTION	PART NUMBER	QUANTITY PER UNIT	FIGURE
1	0153/0543 thru 0178/0588	Muffler	375 89871 000	2	5
1	0183/0643	Muffler	375 89871 000	1	5
1A		Muffler	375 58655 000	1	5
1	0195/0665 thru 0345/1215	Muffler	375 58655 000	2	5
2	ALL	Filter Drier, 3/8"	026 37563 000	2	7
3	ALL	O-Ring, Neo1, 00.364 ID .070 thick	028 12961 012	8	7
9	ALL	O-Ring, Neo1, 00.924 ID .116 thick	028 12961 006	2	7
11	ALL	O-Ring, Neo1, 00.739 ID .070 thick	028 12961 015	2	7
205	ALL	Dehydrator, Less Cores	026 16960 000	2	5
205	ALL	Core, Dehydrator	026 37540 000	2	5
206	ALL	Valve	022 09779 000	2	5
208	0153/0543 thru 0178/0588	Shut Off Ball Valve	022 11326 000	2	5
208	0183/0643	Shut Off Ball Valve	022 11326 000	1	5
208A		Shut Off Ball Valve	022 11325 000	1	5
208	0195/0665 thru 0345/1215	Shut Off Ball Valve	022 11325 000	2	5
209	0153/0543 thru 0278/0988	Condenser Drain Valve (Flash Tank Feed Valve)	025 41565 000	1	5
209	0303/1093 thru 0345/1215	Condenser Drain Valve (Flash Tank Feed Valve)	025 44027 000	1	5
210	0153/0543 thru 0308/1088	Condenser Drain Valve (Flash Tank Feed Valve)	025 41565 000	1	5
210	0323/1143 thru 0345/1215	Condenser Drain Valve (Flash Tank Feed Valve)	025 44027 000	1	5
211	ALL	Economizer Control Valve	025 44027 000	2	6
212	ALL	Indicator Moist Liquid Body	026 32399 000	4	5
213	ALL	Indicator Moist Liquid Cap	026 32800 000	4	5
215	ALL	Valve Angle Compressor Mueller	022 11358 000	2	6
216	0303/1093 thru 0308/1088	Eductor Assembly	375 93265 000	1	7
216	0323/1143 thru 0345/1215	Eductor Assembly	375 93265 000	1	7
216	0153/0543 thru 0278/0988	Eductor Assembly	375 79597 000	2	7
217	0303/1093 thru 0308/1088	Eductor Assembly	375 79597 000	2	7
220	ALL	Valve Ball 1/2 OD C X C)	022 09172 000	2	7
222	ALL	Valve, Charging Brass	022 09754 000	6	5 & 7
224	0153/0543 thru 0178/0588	Gasket, Flange, 3.00 ID 5.75 bc	028 15296 001	2	5
224	0183/0643	Gasket, Flange, 3.00 ID 5.75 bc	028 15296 001	1	5
224	0195/0665 thru 0345/1215	Gasket, Flange, 3.625 ID 5.75 bc	028 15296 000	2	5
225	0183/0643	Gasket, Flange, 3.625 ID 5.75 bc	028 15296 000	1	5
226	0153/0543 thru 0178/0588	Gasket, Round Flange, ANSI 300 #	028 15965 001	2	5
226	0183/0643	Gasket, Flange, 3.00 ID 5.75 bc	028 15296 000	1	5
226	0195/0665 thru 0345/1215	Gasket, Round Flange, ANSI 300 #	028 15965 001	2	5
227	0183/0643	Gasket, Flange, 3.00 ID 5.75 bc	028 15296 001	1	5
228	ALL	Switch, Liquid Level	025 43324 101	2	5

4

**TABLE 6 - REFRIGERANT PIPING COMPONENTS (CONT'D)**

ITEM	MODELS	DESCRIPTION	PART NUMBER	QUANTITY PER UNIT	FIGURE
232	ALL	Valve, Transducer 1/4 Mpt X	022 09503 000	2	5
233	ALL	Valve, ball 1-5/8 Ods Conn's	022 08883 000	2	6
235	ALL	Valve, ball 3/8" Ods Conn	022 11906 000	2	7
241	ALL	Valve, Butterfly, Size 5	022 10641 005	2	7
249	0153/0543 thru 0278/0988	Isolator, 1-1/4 Dia X 1 Lg	028 02596 001	8	5
249	0323/1143 thru 0345/1215	Isolator, 1-1/2 Dia X 1-3/8 Lg	028 02596 002	8	5
253	0308/1088	Isolator, 1-1/2 Dia X 1-3/8 Lg	028 02596 002	4	5
255	0303/1093 thru 0308/1088	Isolator, 1-1/4 Dia X 1 Lg	028 02596 001	4	5
255	0303/1093	Isolator, 1-1/2 Dia X 1-3/8 Lg	028 02596 002	4	5
264	ALL	Check Valve, Magnetic	022 12037 000	2	6



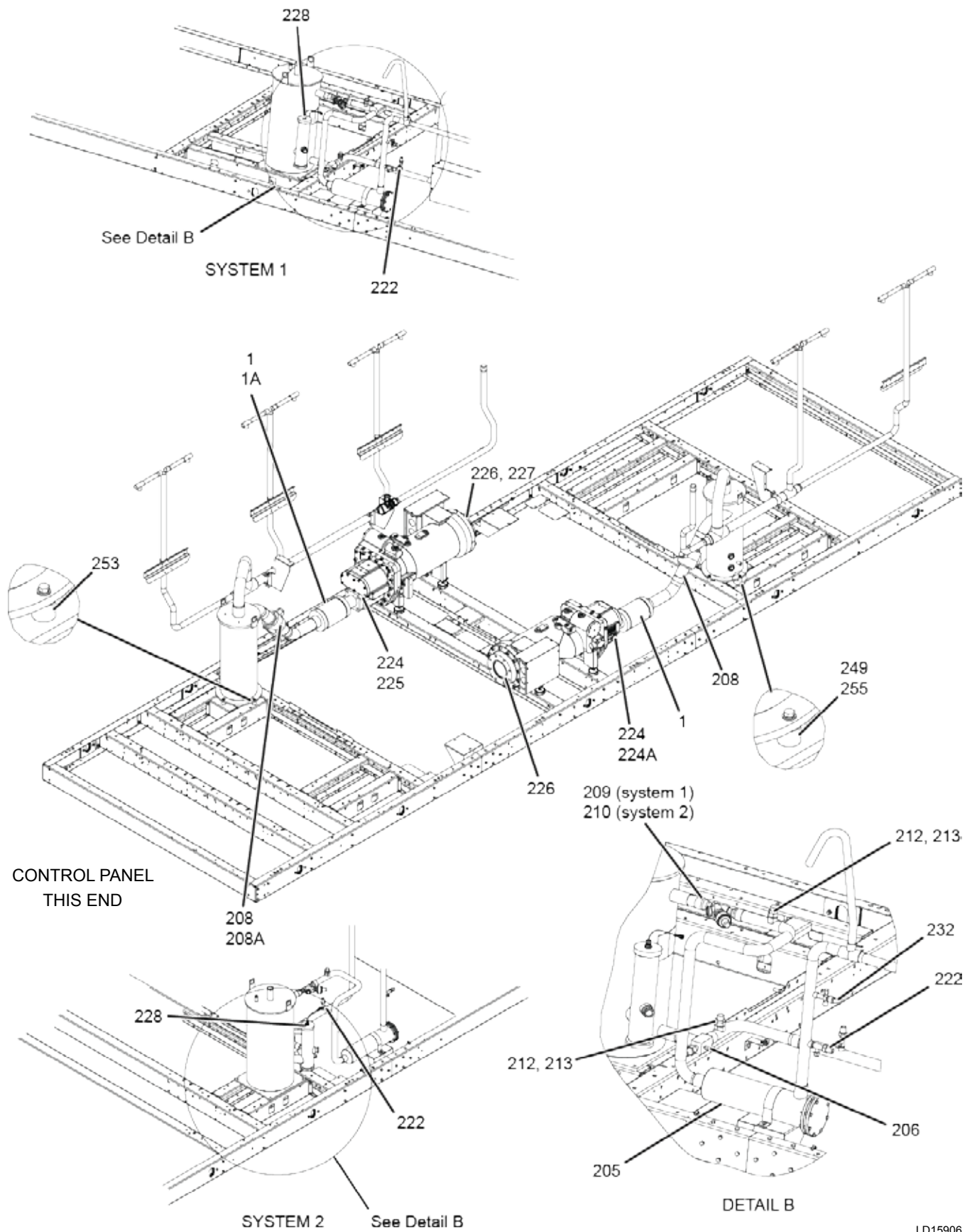
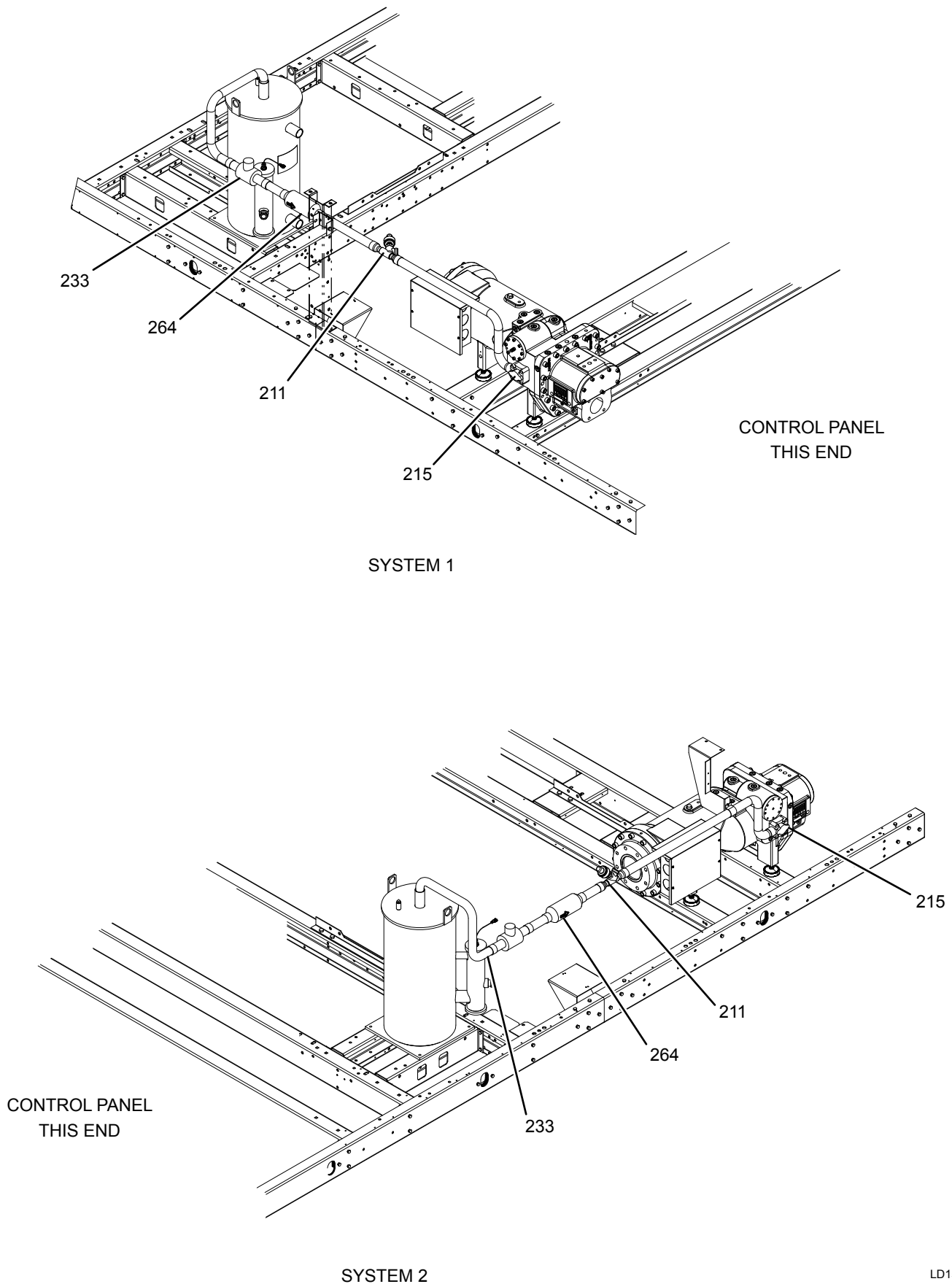

FIGURE 5 - REFRIGERATION CIRCUITS



**FIGURE 6 - REFRIGERATION CIRCUITS**

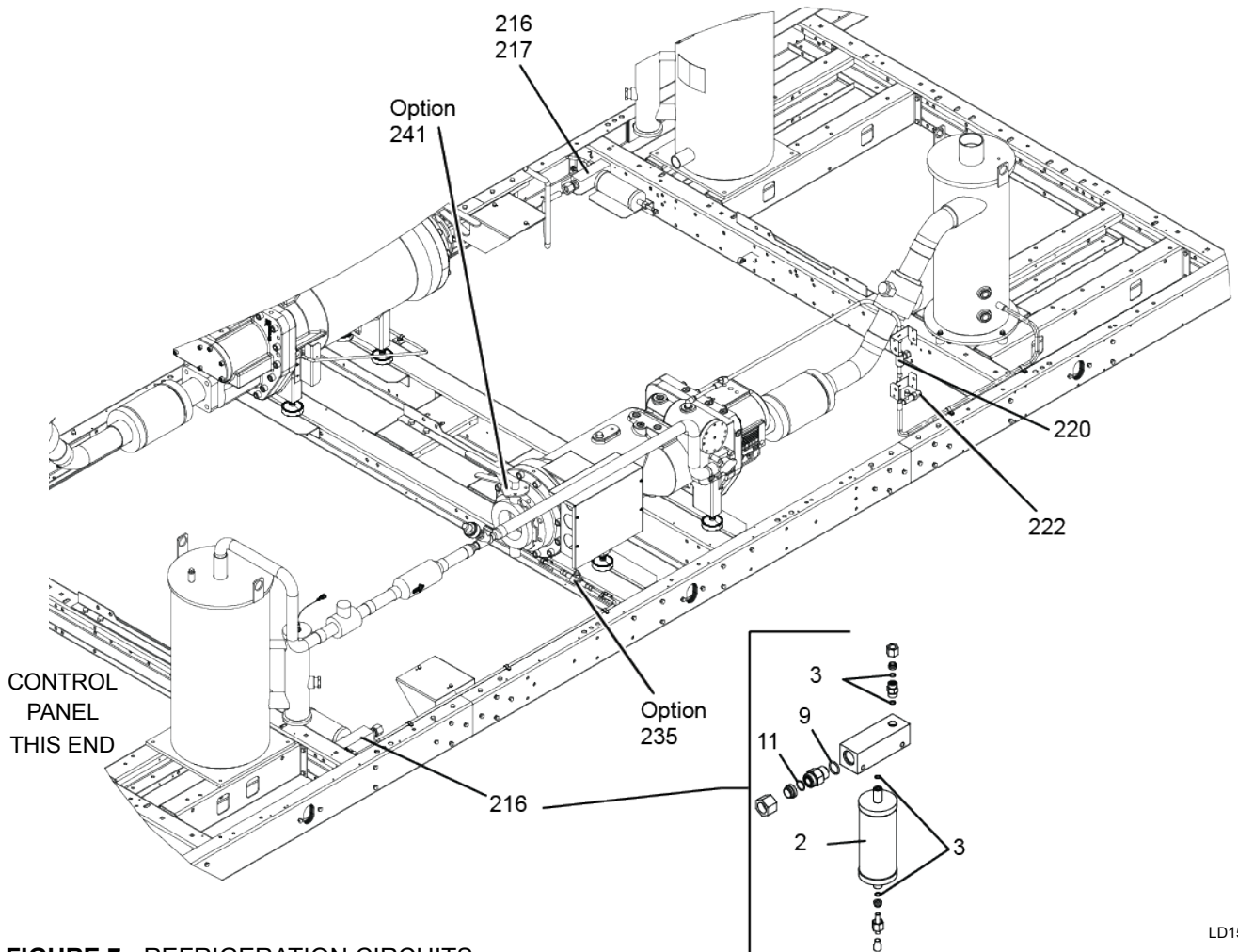
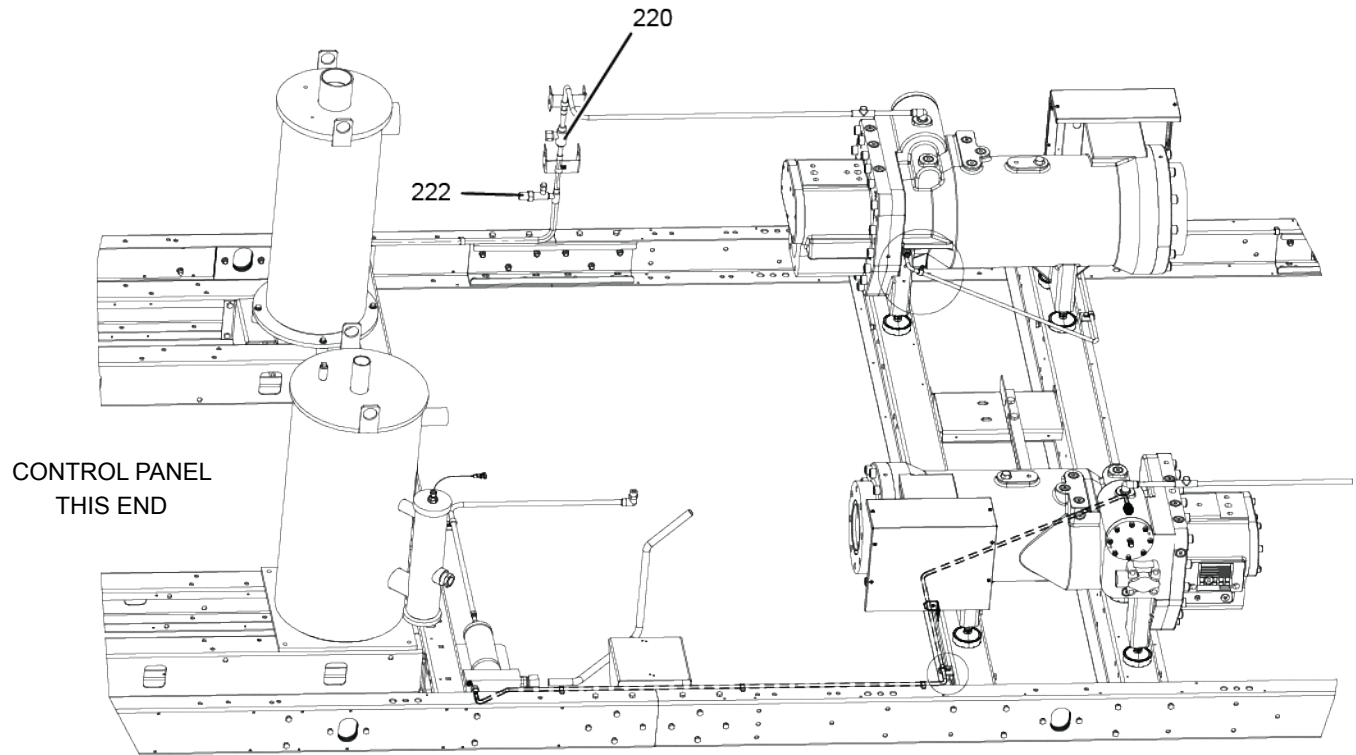

FIGURE 7 - REFRIGERATION CIRCUITS

LD15908

**TABLE 7 - GLYCOL LOOP COMPONENTS**

ITEM	DESCRIPTION	PART NUMBER	FIGURE
10	Cap, Radiator	023 21927 000	8
11	Tube, Glycol	075 55649 000	8
12	Pump, Single Stage (60 Hz)	026 41611 000	8
	Pump, Single Stage (50 Hz)	026 41611 001	8
13**	Coolant, Propylene Glycol, 1 gal. non-EU compliant	013-03345-000	*
	Coolant, Propylene Glycol, 5 gal. non-EU compliant	013-03344-000	*
	Coolant, Propylene Glycol, 5 gal. EU compliant	013-03849-001	*
14	Reducer	023 21941 000	8
15	Fitting, Hose Barb	023 21929 000	8
16	Tee	023 22526 000	*
17	Bushing	023 21934 000	8
18	Bushing	023 21935 000	8
19	Valve, Drain	023 21874 000	8

**NOTE:** Items with an \* are not represented.

\*\* For all Europe-bound YVAA chillers built after October 7, 2015, the coolant/glycol charged into the VSD cooling system is European compliant Dowcal 200 (013-03849-001). For either service or maintenance purposes, top off or replace the coolant with Dowcal 200 only. YVAA chillers built before October 7, 2015, Dowfrost HD (013-03344-000) were charged. Use Dowfrost HD to top-off the unit. For maintenance, replace the coolant with either Dowcal 200 or Dowfrost HD, but **do not mix them**.

For all other regions, use Dowfrost HD (013-03344-000) only.

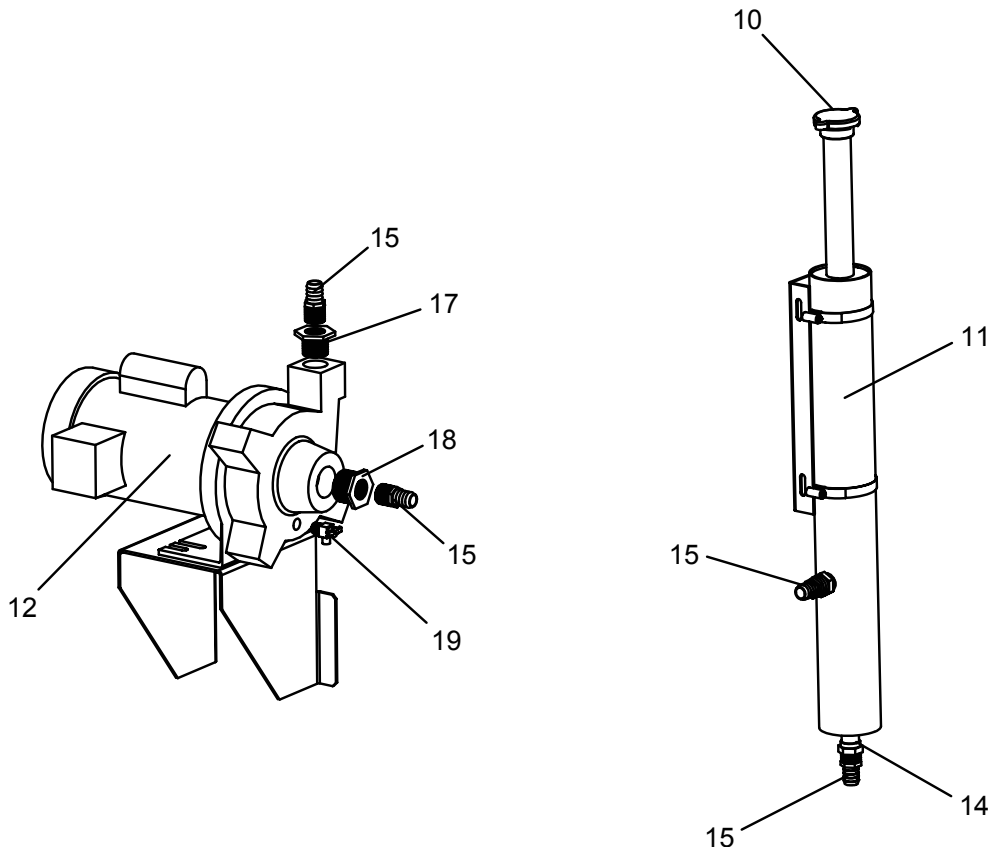
**FIGURE 8 - GLYCOL LOOP COMPONENTS**

## SECTION 5 - COMPRESSORS

**TABLE 8 - STANDARD COMPRESSOR (17, 28, 46, 58 VOLTAGE CODE)**

MODEL	DESCRIPTION	PART NUMBER	QUANTITY
0153/0543 thru 0178/0588	Compressor, Screw, CTS24SAAD460/200C	364 50820 460	2
0183/0643	Compressor, Screw, CTS36SAAD460/200A (System 1)	364 50821 460	1
	Compressor, Screw, CTS24SAAD460/200C (System 2)	364 50820 460	1
0195/0665	Compressor, Screw, CTS36SAAD460/200A (System 1)	364 50821 460	1
	Compressor, Screw, CTS24SAAD460/200C (System 2)	364 50820 460	1
0198/0688	Compressor, Screw, CTS36SAAD460/200A (System 1)	364 50821 460	1
	Compressor, Screw, CTS24SAAD460/200C (System 2)	364 50820 460	1
0200/0700	Compressor, Screw, CTS36DAAD460/200A	364 50821 461	2
0213/0743 thru 0218/0788	Compressor, Screw, CTS36SAAD460/200A	364 50821 460	2
0233/0843	Compressor, Screw, CTS45SAAD460/200B (System 1)	364 50822 460	1
	Compressor, Screw, CTS36SAAD460/200A (System 2)	364 50821 460	1
0245/0865	Compressor, Screw, CTS45SAAD460/200B (System 1)	364 50822 460	1
	Compressor, Screw, CTS36SAAD460/200A (System 2)	364 50821 460	1
0248/0888	Compressor, Screw, CTS45SAAD460/200B (System 1)	364 50822 460	1
	Compressor, Screw, CTS36SAAD460/200A (System 2)	364 50821 460	1
0263/0943 thru 0278/0988	Compressor, Screw, CTS45SAAD460/200B	364 50822 460	2
0303/1093	Compressor, Screw, CTS51SAAD460/200 (System 1)	364 51906 460	1
	Compressor, Screw, CTS45SAAD460/200B (System 2)	364 50822 460	1
0308/1088	Compressor, Screw, CTS51SAAD460/200 (System 1)	364 51906 460	1
	Compressor, Screw, CTS45SAAD460/200B (System 2)	364 50822 460	1
0323/1143 thru 0345/1215	Compressor, Screw, CTS51SAAD460/200	364 51906 460	2

See Figure 9 on page 36 for compressor components.

**TABLE 9 - STANDARD COMPRESSOR (40, 50 VOLTAGE CODE)**

MODEL	DESCRIPTION	PART NUMBER	QUANTITY
0153/0543 thru 0178/0588	Compressor, Screw, CTS24SBAD400/200C	364 50820 400	2
0183/0643	Compressor, Screw, CTS36SBAD400/200A (System 1)	364 50821 400	1
	Compressor, Screw, CTS24SBAD400/200C (System 2)	364 50820 400	1
0195/0665	Compressor, Screw, CTS36SBAD400/200A (System 1)	364 50821 400	1
	Compressor, Screw, CTS24SBAD400/200C (System 2)	364 50820 400	1
0198/0688	Compressor, Screw, CTS36SBAD400/200A (System 1)	364 50821 400	1
	Compressor, Screw, CTS24SBAD400/200C (System 2)	364 50820 400	1
0200/0700 thru 0218/0788	Compressor, Screw, CTS36SBAD400/200A	364 50821 400	2
0233/0843	Compressor, Screw, CTS45SBAD400/200B (System 1)	364 50822 400	1
	Compressor, Screw, CTS36SBAD400/200A (System 2)	364 50821 400	1
0245/0865	Compressor, Screw, CTS45SBAD400/200B (System 1)	364 50822 400	1
	Compressor, Screw, CTS36SBAD400/200A (System 2)	364 50821 400	1
0248/0888	Compressor, Screw, CTS45SBAD400/200B (System 1)	364 50822 400	1
	Compressor, Screw, CTS36SBAD400/200A (System 2)	364 50821 400	1
0263/0943 thru 0278/0988	Compressor, Screw, CTS45SBAD400/200B	364 50822 400	2
0303/1093	Compressor, Screw, CTS51SAAD400/200 (System 1)	364 51906 400	1
	Compressor, Screw, CTS45SBAD400/200B (System 2)	364 50822 400	1
0308/1088	Compressor, Screw, CTS51SAAD400/200 (System 1)	364 51906 400	1
	Compressor, Screw, CTS45SBAD400/200B (System 2)	364 50822 400	1
0323/1143 thru 0345/1215	Compressor, Screw, CTS51SAAD400/200	364 51906 400	2

Note: See Figure 9 on page 36 for compressor components.

**TABLE 10 - STANDARD COMPRESSOR (40, 50 VOLTAGE CODE) WITH HIGH AMBIENT KIT**

MODEL	DESCRIPTION	PART NUMBER	QUANTITY
0153/0543 thru 0178/0588	Compressor, Screw, CTS24LBAD400/200	364 50820 402	2
0183/0643	Compressor, Screw, CTS36LBAD400/200 (System 1)	364 50821 402	1
	Compressor, Screw, CTS24LBAD400/200 (System 2)	364 50820 402	1
0195/0665	Compressor, Screw, CTS36LBAD400/200 (System 1)	364 50821 402	1
	Compressor, Screw, CTS24LBAD400/200 (System 2)	364 50820 402	1
0198/0688	Compressor, Screw, CTS36LBAD400/200 (System 1)	364 50821 402	1
	Compressor, Screw, CTS24LBAD400/200 (System 2)	364 50820 402	1
0200/0700 thru 0218/0788	Compressor, Screw, CTS36LBAD400/200	364 50821 402	2
0233/0843	Compressor, Screw, CTS45LBAD400/200 (System 1)	364 50822 402	1
	Compressor, Screw, CTS36LBAD400/200 (System 2)	364 50821 402	1
0245/0865	Compressor, Screw, CTS45LBAD400/200 (System 1)	364 50822 402	1
	Compressor, Screw, CTS36LBAD400/200 (System 2)	364 50821 402	1
0248/0888	Compressor, Screw, CTS45LBAD400/200 (System 1)	364 50822 402	1
	Compressor, Screw, CTS36LBAD400/200 (System 2)	364 50821 402	1
0263/0943 thru 0278/0988	Compressor, Screw, CTS45LBAD400/200	364 50822 402	2
0303/1093 thru 0345/1215	N/A	N/A	N/A

See Figure 9 on page 36 for compressor components.

**TABLE 11 - OPTIMIZED\* COMPRESSOR (17, 28, 56, 58 VOLTAGE CODE)**

MODEL	DESCRIPTION	PART NUMBER	QUANTITY
0153/0543 thru 0178/0588	Compressor, Screw, CTS24DAAD460/200C	364 50820 461	2
0183/0643	Compressor, Screw, CTS36DAAD460/200A (System 1)	364 50821 461	1
	Compressor, Screw, CTS24DAAD460/200C (System 2)	364 50820 461	1
0195/0665	Compressor, Screw, CTS36DAAD460/200A (System 1)	364 50821 461	1
	Compressor, Screw, CTS24DAAD460/200C (System 2)	364 50820 461	1
0198/0688	Compressor, Screw, CTS36DAAD460/200A (System 1)	364 50821 461	1
	Compressor, Screw, CTS24DAAD460/200C (System 2)	364 50820 461	1
0200/0700 thru 0218/0788	Compressor, Screw, CTS36DAAD460/200A	364 50821 461	2
0233/0843	Compressor, Screw, CTS45DAAD460/200B (System 1)	364 50822 461	1
	Compressor, Screw, CTS36DAAD460/200A (System 2)	364 50821 461	1
0245/0865	Compressor, Screw, CTS45DAAD460/200B (System 1)	364 50822 461	1
	Compressor, Screw, CTS36DAAD460/200A (System 2)	364 50821 461	1
0248/0888	Compressor, Screw, CTS45DAAD460/200B (System 1)	364 50822 461	1
	Compressor, Screw, CTS36DAAD460/200A (System 2)	364 50821 461	1
0263/0943 thru 0278/0988	Compressor, Screw, CTS45DAAD460/200B	364 50822 461	2
0303/1093	Compressor, Screw, CTS45DAAD460/200B (System 1)	364 51906 461	1
	Compressor, Screw, CTS45DBAD400/200B (System 2)	364 50822 401	1
0308/1088	Compressor, Screw, CTS45DAAD460/200B (System 1)	364 51906 461	1
	Compressor, Screw, CTS45DBAD400/200B (System 2)	364 50822 401	1
0323/1143 thru 0345/1215	Compressor, Screw, CTS51SBAD460/200	364 51906 461	2

Notes: 1. \* Step VI

2. See Figure 9 on page 36 for compressor components.

**TABLE 12 - OPTIMIZED\* COMPRESSOR (40, 50 VOLTAGE CODE)**

MODEL	DESCRIPTION	PART NUMBER	QUANTITY
0153/0543 thru 0178/0588	Compressor, Screw, CTS24DBAD400/200C	364 50820 401	2
0183/0643	Compressor, Screw, CTS36DBAD400/200A (System 1)	364 50821 401	1
	Compressor, Screw, CTS24DBAD400/200C (System 2)	364 50820 401	1
0195/0665	Compressor, Screw, CTS36DBAD400/200A (System 1)	364 50821 401	1
	Compressor, Screw, CTS24DBAD400/200C (System 2)	364 50820 401	1
0198/0688	Compressor, Screw, CTS36DBAD400/200A (System 1)	364 50821 401	1
	Compressor, Screw, CTS24DBAD400/200C (System 2)	364 50820 401	1
0200/0700 thru 0218/0788	Compressor, Screw, CTS36DBAD400/200A	364 50821 401	2
0233/0843	Compressor, Screw, CTS45DBAD400/200B (System 1)	364 50822 401	1
	Compressor, Screw, CTS36DBAD400/200A (System 2)	364 50821 401	1
0245/0865	Compressor, Screw, CTS45DBAD400/200B (System 1)	364 50822 401	1
	Compressor, Screw, CTS36DBAD400/200A (System 2)	364 50821 401	1
0248/0888	Compressor, Screw, CTS45DBAD400/200B (System 1)	364 50822 401	1
	Compressor, Screw, CTS36DBAD400/200A (System 2)	364 50821 401	1
0263/0943 thru 0278/0988	Compressor, Screw, CTS45DBAD400/200B	364 50822 401	2
0303/1093	Compressor, Screw, CTS51SBAD400/200 (System 1)	364 51906 401	1
	Compressor, Screw, CTS45DBAD400/200B (System 2)	364 50822 401	1
0308/1088	Compressor, Screw, CTS51SBAD400/200 (System 1)	364 51906 401	1
	Compressor, Screw, CTS45DBAD400/200B (System 2)	364 50822 401	1
0323/1143 thru 0345/1215	Compressor, Screw, CTS51SBAD400/200	364 51906 401	2

See Figure 9 on page 36 for compressor components.

**TABLE 13 - OPTIMIZED\* COMPRESSOR (40, 50 VOLTAGE CODE) WITH HIGH AMBIENT KIT**

MODEL	DESCRIPTION	PART NUMBER	QUANTITY
0153/0543 thru 0178/0588	Compressor, Screw, CTS24MBAD400/200	364 50820 403	2
0183/0643	Compressor, Screw, CTS36MBAD400/200 (System 1)	364 50821 403	1
	Compressor, Screw, CTS24MBAD400/200 (System 2)	364 50820 403	1
0195/0665	Compressor, Screw, CTS36MBAD400/200 (System 1)	364 50821 403	1
	Compressor, Screw, CTS24MBAD400/200 (System 2)	364 50820 403	1
0198/0688	Compressor, Screw, CTS36MBAD400/200 (System 1)	364 50821 403	1
	Compressor, Screw, CTS24MBAD400/200 (System 2)	364 50820 403	1
0200/0700 thru 0218/0788	Compressor, Screw, CTS36MBAD400/200	364 50821 403	2
0233/0843	Compressor, Screw, CTS45MBAD400/200 (System 1)	364 50822 403	1
	Compressor, Screw, CTS36MBAD400/200 (System 2)	364 50821 403	1
0245/0865	Compressor, Screw, CTS45MBAD400/200 (System 1)	364 50822 403	1
	Compressor, Screw, CTS36MBAD400/200 (System 2)	364 50821 403	1
0248/0888	Compressor, Screw, CTS45MBAD400/200 (System 1)	364 50822 403	1
	Compressor, Screw, CTS36MBAD400/200 (System 2)	364 50821 403	1
0263/0943 thru 0278/0988	Compressor, Screw, CTS45MBAD400/200	364 50822 403	2
0303/1093 thru 0345/1215	N/A	N/A	N/A

Notes: 1. \* Step VI

2. See Figure 9 on page 36 for compressor components.



**TABLE 14 - COMPRESSOR COMPONENTS**

ITEM	MODELS	DESCRIPTION	PART NUMBER	QUANTITY	FIGURE
2	0233/0843 thru 0345/1215	Coil - Solenoid Valve (Optimized Compressor)	025 35151 000	2	9
3	0233/0843 thru 0345/1215	Valve Solenoid (Optimized Compressor)	025 43901 000	2	9
3	ALL	Gasket, Compressor Junction Box	028 15268 000	1	9
13	ALL	Compound, Heat Conductive, 4 Oz	013 00898 000	A/R	9
14	ALL	Sensor, Temperature	025 32924 000	1	9
15	ALL	Transducer, 0-125 PSI	025 29583 001	1	9
16	ALL	Transducer 0-400 PSI, 5V Input	025 29139 001	1	9
18	ALL	Valve, Transducer	022 09503 000	1	9
22	ALL	O-Ring Neoprene	028 13540 000	1	9
25	ALL	Isolator, Compressor, Level Rubber	029 25868 000	4	9
31	ALL	Heater, Compressor, System 1	575 54455 202	1	9
31	ALL	Heater, Compressor, System 2	575 54455 203	1	9
33	ALL	Switch, HPCO	025 39956 001	2	9

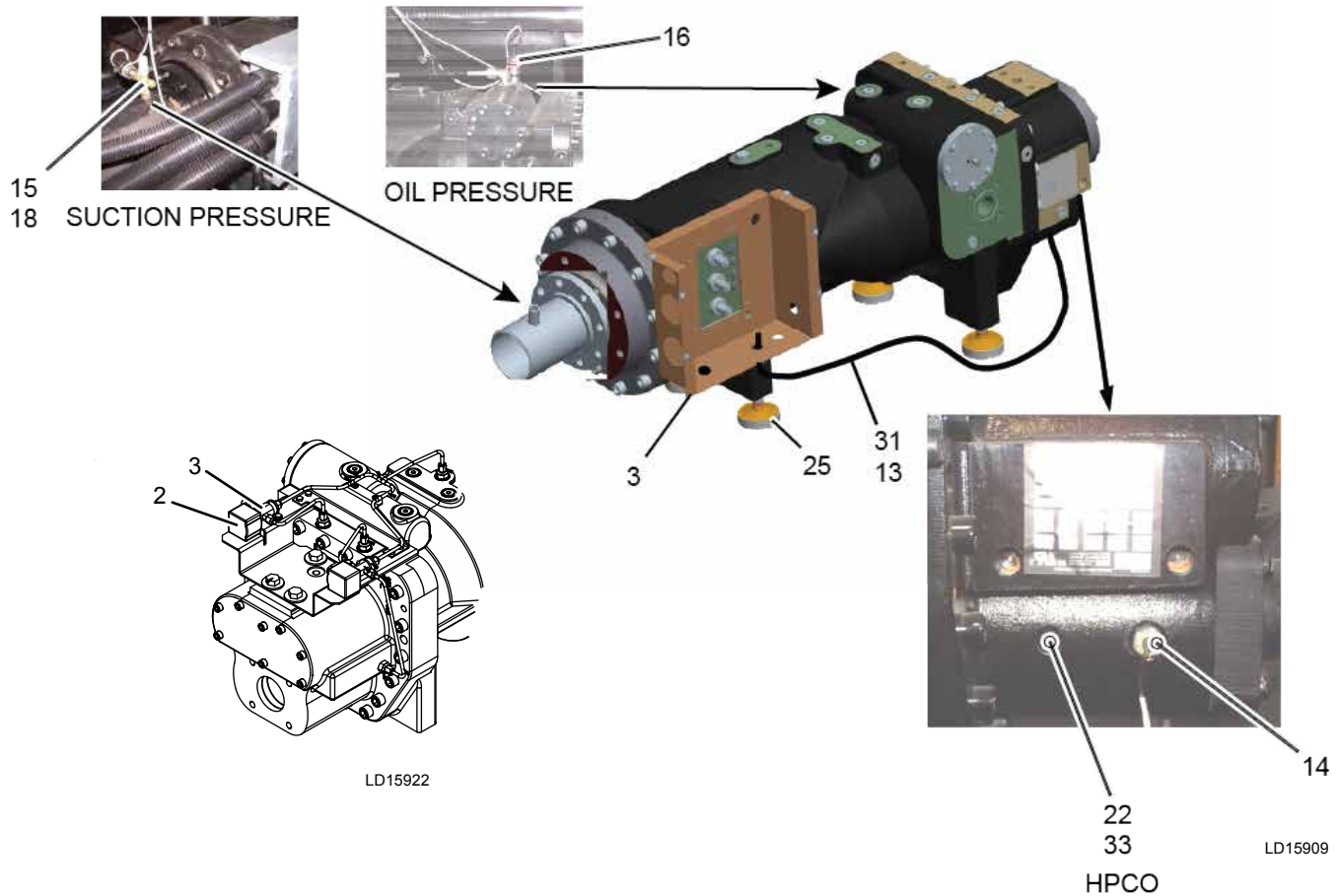

**FIGURE 9 - COMPRESSOR COMPONENTS**



## SECTION 6 - CONTROL PANELS

**TABLE 15 - CONTROL / POWER PANELS, COMPLETE**

**200/3/60 LOW SOUND FANS AND ULTRA QUIET FANS (FIXED AND VARIABLE SPEED)**

MODEL	SINGLE POLE TERMINAL BLOCK	SP CIRCUIT BREAKER	SP NF DISCONNECT SWITCH
153/0543 thru 0278/0988	371 05578 101	N/A	N/A
0303/1093 thru 0345/1215	N/A	N/A	N/A

**200/3/60 HIGH AIRFLOW AND HIGH STATIC FANS (FIXED SPEED)**

MODEL	SINGLE POLE TERMINAL BLOCK	SP CIRCUIT BREAKER	SP NF DISCONNECT SWITCH
0153/0543 thru 0275/0965	371 05578 134	N/A	N/A
0278/0988 thru 0345/1215	N/A	N/A	N/A

**230/3/60 LOW SOUND FANS AND ULTRA QUIET FANS (FIXED AND VARIABLE SPEED)**

MODEL	SINGLE POLE TERMINAL BLOCK	SP CIRCUIT BREAKER	SP NF DISCONNECT SWITCH
0153/0543 thru 0278/0988	371 05578 102	371 05578 113	N/A
0303/1093 thru 0345/1215	N/A	N/A	N/A

**230/3/60 HIGH AIRFLOW AND HIGH STATIC FANS (FIXED SPEED)**

MODEL	SINGLE POLE TERMINAL BLOCK	SP CIRCUIT BREAKER	SP NF DISCONNECT SWITCH
0153/0543 thru 0278/0988	371 05578 135	371 05578 146	N/A
0303/1093 thru 0345/1215	N/A	N/A	N/A

**380/3/60 LOW SOUND FANS AND ULTRA QUIET FANS (FIXED AND VARIABLE SPEED)**

MODEL	SINGLE POLE TERMINAL BLOCK	SP CIRCUIT BREAKER	SP NF DISCONNECT SWITCH
0153/0543 thru 0178/0588	371 05578 103	371 05578 114	371 05578 125
0183/0643 thru 0198/0688 0213/0743 thru 0218/0788	371 05578 104	371 05578 115	371 05578 126
0200/0700, 0233/0843 thru 0278/0988	371 05578 105	371 05578 116	371 05578 127
0303/1093 thru 0345/1215	371 05678 101	371 05678 105	371 05678 109

**380/3/60 HIGH AIRFLOW AND HIGH STATIC FANS (FIXED SPEED)**

MODEL	SINGLE POLE TERMINAL BLOCK	SP CIRCUIT BREAKER	SP NF DISCONNECT SWITCH
0153/0543 thru 0178/0588	371 05578 136	371 05578 147	371 05578 158
0183/0643 thru 0198/0688 0213/0743 thru 0218/0788	371 05578 137	371 05578 148	371 05578 159
0200/0700, 0233/0843 thru 0278/0988	371 05578 138	371 05578 149	371 05578 160
0343/1193	371 05678 105	371 05678 117	371 05678 121
0303/1093 thru 0345/1215	371 05678 113	371 05678 117	371 05678 121

Note: See Table 16 on page 39 for Control Panel Wiring and Table 17 on page 40 for Control Panel Components.

6

**TABLE 15 - CONTROL / POWER PANELS, COMPLETE (CONT'D)****460/3/60 LOW SOUND FANS AND ULTRA QUIET FANS (FIXED AND VARIABLE SPEED)**

MODEL	SINGLE POLE TERMINAL BLOCK	SP CIRCUIT BREAKER	SP NF DISCONNECT SWITCH
0153/0543 thru 0198/0688 0213/0743 thru 0218/0788	371 05578 109	371 05578 120	371 05578 131
0200/0700 0233/0843 thru 0278/0988	371 05578 110	371 05578 121	371 05578 132
0303/1093 thru 0345/1215	371 05678 103	371 05678 107	371 05678 111

**460/3/60 HIGH AIRFLOW AND HIGH STATIC FANS (FIXED SPEED)**

MODEL	SINGLE POLE TERMINAL BLOCK	SP CIRCUIT BREAKER	SP NF DISCONNECT SWITCH
0153/0543 thru 0198/0688 0213/0743 thru 0218/0788	371 05578 142	371 05578 153	371 05578 164
0200/0700 0233/0843 thru 0278/0988	371 05578 143	371 05578 154	371 05578 165
0303/1093 thru 0345/1215	371 05678 115	371 05678 119	371 05678 123

**380-415/3/50 LOW SOUND FANS AND ULTRA QUIET FANS (FIXED AND VARIABLE SPEED)**

MODEL	SINGLE POLE TERMINAL BLOCK	SP CIRCUIT BREAKER	SP NF DISCONNECT SWITCH
0153/0543 thru 0178/0588	371 05578 106	371 05578 117	371 05578 128
0183/0643 thru 0198/0688 0213/0743 thru 0218/0788	371 05578 107	371 05578 118	371 05578 129
0200/0700 0233/0843 thru 0278/0988	371 05578 108	371 05578 119	371 05578 130
0303/1093 thru 0345/1215	371 05678 102	371 05678 106	371 05678 110

**380-415/3/50 HIGH AIRFLOW AND HIGH STATIC FANS (FIXED SPEED)**

MODEL	SINGLE POLE TERMINAL BLOCK	SP CIRCUIT BREAKER	SP NF DISCONNECT SWITCH
0153/0543 thru 0178/0588	371 05578 139	371 05578 150	371 05578 161
0183/0643 thru 0198/0688 0213/0743 thru 0218/0788	371 05578 140	371 05578 151	371 05578 162
0200/0700 0233/0843 thru 0278/0988	371 05578 141	371 05578 152	371 05578 163
0303/1093 thru 0345/1215	371 05678 114	371 05678 118	371 05678 122

**575/3/60 LOW SOUND FANS AND ULTRA QUIET FANS (FIXED AND VARIABLE SPEED)**

MODEL	SINGLE POLE TERMINAL BLOCK	SP CIRCUIT BREAKER	SP NF DISCONNECT SWITCH
0153/0543 thru 0278/0988	371 05578 111	371 05578 122	371 05578 133
0303/1093 thru 0345/1215	371 05678 104	371 05678 108	371 05678 112

**575/3/60 HIGH AIRFLOW AND HIGH STATIC FANS (FIXED SPEED)**

MODEL	SINGLE POLE TERMINAL BLOCK	SP CIRCUIT BREAKER	SP NF DISCONNECT SWITCH
0153/0543 thru 0278/0988	371 05578 144	371 05578 155	371 05578 166
0303/1093 thru 0345/1215	371 05678 116	371 05678 120	371 05678 124

**TABLE 16 - CONTROL PANEL WIRING**

ITEM	MODELS	VOLTAGE CODE	FANS	DESCRIPTION	PART NO	QUANTITY	FIGURE
45	0153/0543 thru 0278/0988	ALL	ALL	Strap, Ground	525 37839 001	4	10
	0303/1093 thru 0345/1215	40, 46, 50, 58					
46	0153/0543 thru 0278/0988	ALL	ALL	Strap, Grounding	525 32508 001	3	10
	0303/1093 thru 0345/1215	40, 46, 50, 58					
54	0153/0543 thru 0278/0988	ALL	ALL	Cable, 2 Compressor Condenser Fan VSD	571 04178 256	1	10
	0303/1093 thru 0345/1215	40, 46, 50, 58	ALL	Cable, 2 Compressor Condenser Fan VSD	571 04178 257	1	10
68	0153/0543 thru 0278/0988	ALL	ALL	Cable, Ribbon, Display	571 04178 261	1	10
69	0153/0543 thru 0278/0988	ALL	ALL	Cable, Ribbon, Keypad	571 04178 262	1	10
71	0153/0543 thru 0278/0988	ALL	ALL	Cable, Logic To Control	571 04178 271	1	10
	0303/1093 thru 0345/1215	40, 46, 50, 58	ALL	Cable, Logic To Control	571 04179 271	1	10
86	0153/0543 thru 0278/0988	ALL	ALL	Cable, Shielded	571 05578 291	1	10
	0303/1093 thru 0345/1215	40, 46, 50, 58					

**6**

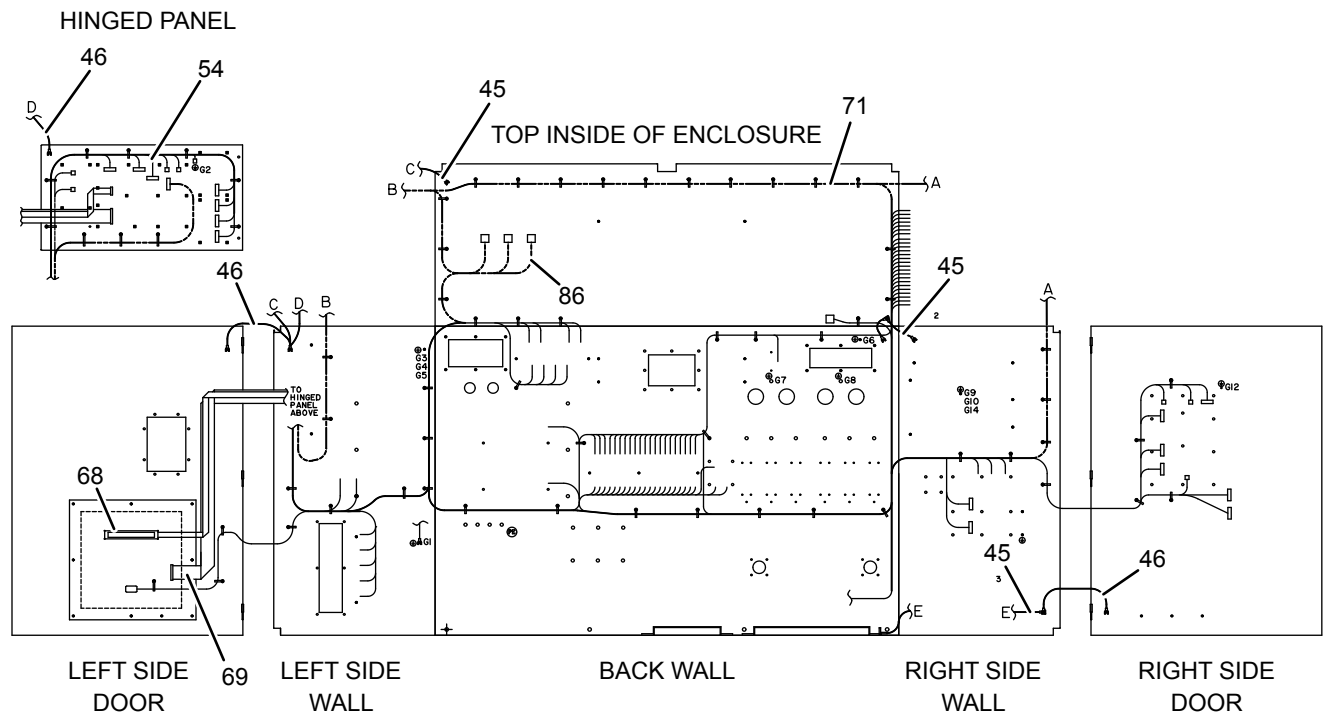

**FIGURE 10 - CONTROL PANEL WIRING**

**TABLE 17 - CONTROL PANEL COMPONENTS**

ITEM	MODELS	VOLTAGE CODE	FANS <sup>1</sup>	DESCRIPTION	PART NUMBER	QUANTITY	FIGURE
5	0153/0543 thru 0278/0988	ALL	ALL	Relay, Control, DPST-NO, 120 VAC	024 30441 000	1	11
	0303/1093 thru 0345/1215	40, 46, 50, 58					
7	0153/0543 thru 0278/0988	ALL	ALL	Transformer, Class 2	025 27911 000	3	11
	0303/1093 thru 0345/1215	40, 46, 50, 58					
15	0153/0543 thru 0278/0988	ALL	ALL	Fuseholder-Modular, 1-Pole	025 39951 000	5	11
	0303/1093 thru 0345/1215	40, 46, 50, 58					
17	0153/0543 thru 0278/0988	ALL	ALL	Control, Voltage	031 02453 000	1	11
	0303/1093 thru 0345/1215	40, 46, 50, 58					
22	0153/0543 thru 0278/0988	ALL	ALL	Resistor, Power Wirewound	025 35953 000	12	11
	0303/1093 thru 0345/1215	40, 46, 50, 58					
23	0153/0543 thru 0278/0988	ALL	ALL	Capacitor, DV/DT Network	025 39806 000	6	11
	0303/1093 thru 0345/1215	40, 46, 50, 58					
25	0153/0543 thru 0278/0988	ALL	ALL	Thermal Pad, Resistor, 3/4" Wide	028 15299 000	12	11
	0303/1093 thru 0345/1215	40, 46, 50, 58	ALL				
31	0153/0543 thru 0278/0988	ALL	ALL	Control, Tme Bus Isolator	031 01624 000	1	11
	0303/1093 thru 0345/1215	40, 46, 50, 58					
32	0153/0543 thru 0278/0988	ALL	ALL	Gasket, Field Power	028 15246 000	1	11
	0303/1093 thru 0345/1215	40, 46, 50, 58					
33	0153/0543 thru 0278/0988	ALL	ALL	Gasket, Customer Connection	028 15247 000	1	11
	0303/1093 thru 0345/1215	40, 46, 50, 58					
35	0153/0543 thru 0278/0988	ALL	ALL	Gasket, Auto Transformer	028 15249 000	1	11
	0303/1093 thru 0345/1215	40, 46, 50, 58					
41	0153/0543 thru 0278/0988	ALL	ALL	Cable, Trigger To Gate	571 04178 251	1	11
	0303/1093 thru 0345/1215	40, 46, 50, 58					
72	ALL	ALL	ALL	Stepper Motor	031 02742 000	1	11
88	0153/0543 thru 0278/0988	ALL	ALL	Fuse, Semi Conductor	025 38523 000	3	11
	0303/1093 thru 0345/1215	40, 46, 50, 58					
90	0153/0543 thru 0278/0988	ALL	ALL	Fuse, Cartridge Type, 10 Amp	025 35905 000	1	11
	0303/1093 thru 0345/1215	40, 46, 50, 58					
92	0153/0543 thru 0278/0988	ALL	ALL	Fuse, Cartridge Type, 15 Amp	025 34141 000	1	11
	0303/1093 thru 0345/1215	40, 46, 50, 58					
93	0153/0543 thru 0278/0988	ALL	ALL	Fuse, Cartridge Type, 20 Amp	025 35908 000	1	11
	0303/1093 thru 0345/1215	40, 46, 50, 58					
94	0153/0543 thru 0278/0988	ALL	ALL	Fuse, Cartridge Type, 6 Amp	025 35902 000	3	11
	0303/1093 thru 0345/1215	40, 46, 50, 58					
95	0153/0543 thru 0278/0988	ALL	ALL	Fuse, Cartridge Type, 10 Amp	025 35905 000	1	11
156	0153/0543 thru 0178/0588	ALL	HA/HS	Lug, Elec Sgl Bbl, #4-500	025 32835 000	A/R	11
166	ALL	ALL	HA/HS	Control Trigger Board	031 02060 001	1	11
167	0153/0543 thru 0198/0688 0213/0743 thru 0218/0788	40	HA/HS	Transformer, 3KVA, 380:120VAC	025 40114 008	1	11
167	0153/0543 thru 0278/0988	40	ALL <sup>3</sup>	Transformer, 2KVA, 380:120VAC	025 40114 007	1	11

Notes: 1. LS/UQ = Low Sound/Ultra Quiet Fans. HA/HS = High Airflow/High Static Fans

2. Non Fused Disconnect Switch and Circuit Breaker

3. Terminal Board and Non Fused Disconnect Switch (HA/HS), Terminal Board (LS/UQ)

4. Terminal Board only (HA/HS)

**TABLE 17 - CONTROL PANEL COMPONENTS (CONT'D)**

ITEM	MODELS	VOLTAGE CODE	FANS'	DESCRIPTION	PART NUMBER	QUANTITY	FIGURE
167	ALL	50	ALL	Transformer, 2KVA, 480:120VAC	025 40114 001	1	11
167	ALL	50	ALL	Transformer, 2KVA, 400:120VAC	025 40114 005	1	11
173	0153/0543 thru 0275/0965	17	HA/HS	Contactora, 3 Pole, 25A 480VAC	024 35905 000	8	11
173	0153/0543 thru 0278/0988	28, 40, 46, 50, 58	LS/UQ	Contactora, 3 Pole, 25A 480VAC	024 35905 000	12	11
		ALL	LS/UQ	Contactora, 3 Pole, 8A 480VAC	024 34916 000	4	11
		ALL	HA/HS	Contactora, 3 Pole, 8A 480VAC	024 34916 000	8	11
182	0153/0543 thru 0275/0965	17	HA/HS	Fuse, Cartridge Type, 30 Amp	025 39683 000	24	11
182	0153/0543 thru 0278/0988	17, 28	LS/UQ	Fuse, Cartridge Type, 30 Amp	025 39683 000	12	11
		40, 46, 50, 58					
		40, 46, 50, 58	HA/HS	Fuse, Cartridge Type, 30 Amp	025 39683 000	24	11
182	0303/1093 thru 0345/1215	40, 46, 50, 58	LS/UQ	Fuse, Cartridge Type, 30 Amp	025 39683 000	18	11
			HA/HS	Fuse, Cartridge Type, 30 Amp	025 39683 000	30	11
183	ALL	17,28,46, 58,	ALL	Fuse, Cartridge Type 10 Amp	025 35905 000	2	11
183	0153/0543 0213/0743thru0218/0788	46	ALL <sup>4</sup>	Fuse, Cartridge Type 10 Amp	025 35905 000	3	11
183	0153/0543 thru 0178/0588	40, 50	ALL	Fuse, Cartridge Type 12 Amp	025 35906 000	2	11
183	0153/0543 thru 0278/0988	58	HA/HS	Fuse, Cartridge Type 12 Amp	025 35906 000	2	11
183	0153/0543 thru 0278/0988	46	HA/HS/HS <sup>5</sup>	Fuse, Cartridge Type 12 Amp	025 35906 000	3	11

- Notes: 1. LS/UQ = Low Sound/Ultra Quiet Fans. HA/HS = High Airflow/High Static Fans  
 2. Non Fused Disconnect Switch and Circuit Breaker  
 3. Terminal Board and Non Fused Disconnect Switch (HA/HS), Terminal Board (LS/UQ)  
 4. Terminal Board only (HA/HS)

**6**

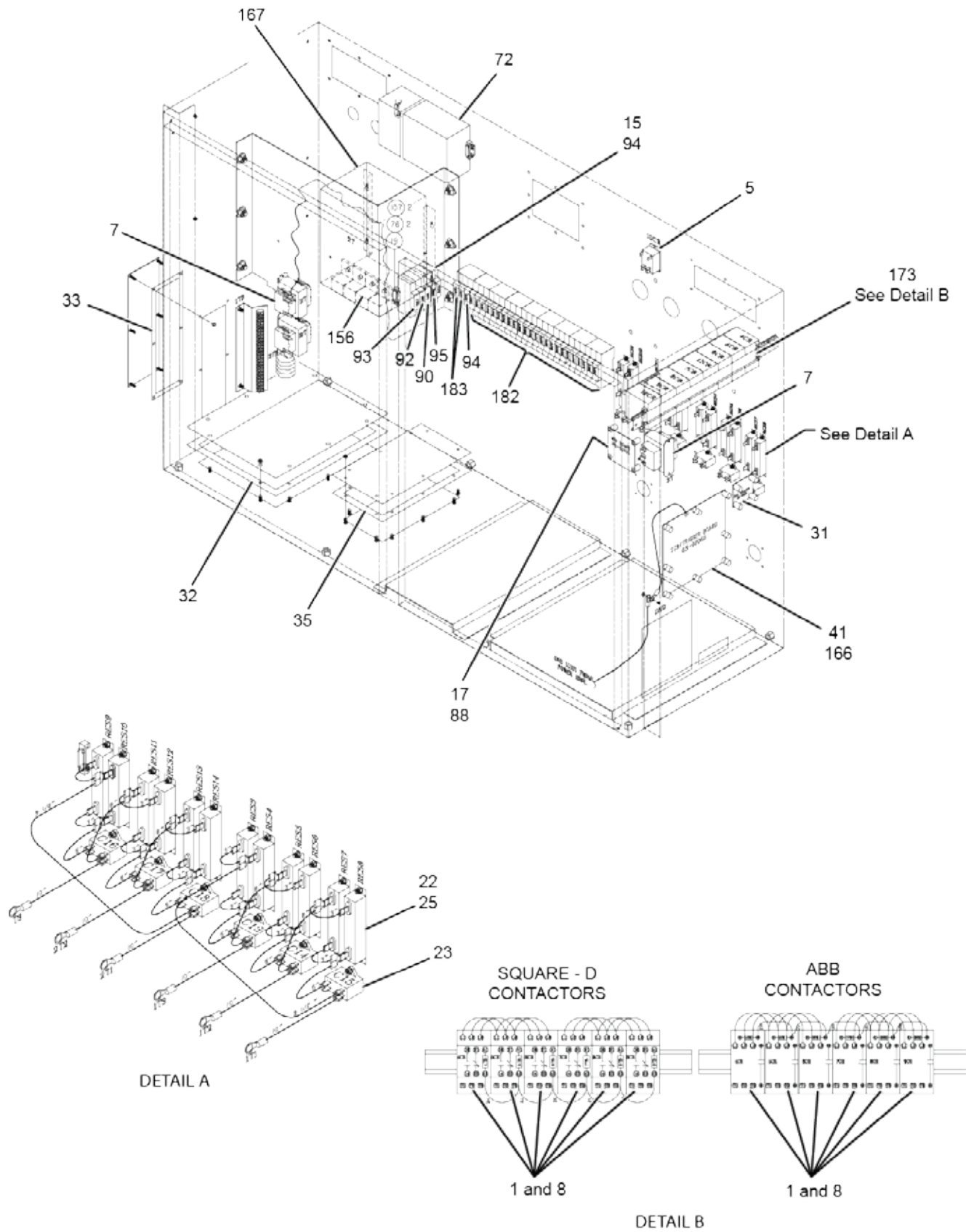

FIGURE 11 - CONTROL PANEL COMPONENTS

071-05578-006 REV -

**TABLE 18 - CONTROL PANEL COMPONENTS**

ITEM	MODELS	VOLTAGE CODE	FANS <sup>1</sup>	DESCRIPTION	PART NUMBER	QUANTITY	FIGURE	
37	0153/0543 thru 0278/0988	ALL	ALL	Gasket, Coil Drive	028 15251 000	1	12	
	0303/1093 thru 0345/1215	40, 46, 50, 58						
41	0153/0543 thru 0278/0988	ALL	ALL	Cable, Trig To Gate	571 04178 251	1	12	
	0303/1093 thru 0345/1215	40, 46, 50, 58		Cable, Trig-Gate, "D"	571 05678 251	1	12	
42	0153/0543 thru 0278/0988	ALL	ALL	Cable, Gate Driver	571 04178 281	1	12	
	0303/1093 thru 0345/1215	40, 46, 50, 58		Cable, Gate-Logic, "D"	571 05678 281	1	12	
43	0153/0543 thru 0278/0988	ALL	ALL	Cable, Gate Driver	571 04178 282	1	12	
	0303/1093 thru 0345/1215	40, 46, 50, 58		Cable, Gate-Logic, "D"	571 05678 282	1	12	
157	0153/0543 thru 0178/0588	40, 50	HA/HS	Inductor, Drive, 2 Compressor	025 42133 000	1	12	
	0153/0543 thru 0198/0688 0213/0743 thru 0218/0788	46						
157	0153/0543 thru 0278/0988	58	HA/HS	Inductor, Drive, 2/4 Compressor	025 40742 000	1	12	
	0183/0643 thru 0278/0988	40, 50						
	0200/0700 0233/0843 thru 0278/0988	46						
157	0303/1093 thru 0345/1215	40, 50	ALL	Inductor, Drive, 3 Compressor	025 40741 000	1	12	
157	0303/1093 thru 0345/1215	46, 58	ALL	Inductor, Drive, 3 Compressor	025 39676 000	1	12	
175	0153/0543 thru 0275/0965	17	HA/HS	Transformer, Drive, System #1	371 04178 365	1	12	
	0153/0543 thru 0278/0988	28	HA/HS					
		17, 28	LS/UQ					
	0153/0543 thru 0345/1215	40, 46, 50, 58	LS/UQ HA/HS					
175	0200/0700 0233/0843 thru 0278/0988 0303/1093 thru 0345/1215	40, 50 46, 58	ALL	Transformer, Drive, System #1	371 04178 369	1	12	
	176	0153/0543 thru 0275/0965	17	HA/HS	Transformer, Drive, System #2	371 04178 367	1	12
		0153/0543 thru 0278/0988	28	HA/HS				
17, 28			LS/UQ					
0153/0543 thru 0345/1215	40, 46, 50, 58	ALL						
176	0200/0700 0233/0843 thru 0345/1215	40, 50	ALL	Transformer, Drive, System #2	371 04178 378	1	12	
	0303/1093 thru 0345/1215	46, 58	ALL					
178	0153/0543 thru 0275/0965	17	HA/HS	Fuse, Semi, 900A, 700V	025 40786 000	3	12	
178	0153/0543 thru 0178/0588	28	HA/HS	Fuse, Semi, 900A, 700V	025 40786 000	3	12	
	0200/0700 0233/0843 thru 0278/0988							
178	0153/0543 thru 0178/0588	40 <sup>3</sup>	LS/UQ	Fuse, Semi, 630A, 700v	025 42142 000	3	12	
178	0183/0643 thru 0198/0688 0213/0743 thru 0218/0788	40	ALL	Fuse, Semi, 900A, 700V	025 40786 000	3	12	

Notes: 1. LS/UQ = Low Sound/Ultra Quiet Fans, HA/HS = High Airflow/High Static Fans  
2. Circuit Breaker and Non Fused Disconnect Switch  
3. Terminal Block

**6**

**TABLE 18 - CONTROL PANEL COMPONENTS (CONT'D)**

ITEM	MODELS	VOLTAGE CODE	FANS <sup>1</sup>	DESCRIPTION	PART NUMBER	QUANTITY	FIGURE
178	0200/0700 0233/0843 - 0278/0988	40	LS/UQ	Fuse, Semi, 900A, 700V	025 40786 000	3	12
178	0303/1093 - 0345/1215	40 <sup>4</sup>	HA/HS	Fuse, Semi, 1250A, 700V	025 40764 000	3	12
178	0153/0543 - 0178/0588	40, 50	HA/HS	Fuse, Semi, 700A, 700V	025 39681 000	3	12
178	0303/1093 - 0345/1215	40, 50	ALL	Fuse, Semi, 1400A, 700V	025 40787 000	3	12
178	0153/0543 - 0198/0688 0213/0743 - 0218/0788	46	ALL	Fuse, Semi, 700A, 700V	025 39681 000	3	12
178	0200/0700 0233/0843 - 0278/0988	46	HA/HS	Fuse, Semi, 900A, 700V	025 40786 000	3	12
178	0303/1093 - 0345/1215	46, 58	HA/HS	Fuse, Semi, 1100A, 600V	025 39682 000	3	12
178	0153/0543 - 0178/0588	50	LS/UQ	Fuse, Semi, 630A, 700V	025 42142 000	3	12
178	0183/0643 - 0198/0688 0213/0743 - 0218/0788	50	ALL	Fuse, Semi, 900A, 700V	025 40786 000	3	12
178	0153/0543 - 0178/0588 0200/0700 0233/0843 - 0278/0988	58	HA/HS	Fuse, Semi, 900A, 700V	025 40786 000	3	12

Notes: 1. LS/UQ = Low Sound/Ultra Quiet Fans, HA/HS = High Airflow/High Static Fans

2. Circuit Breaker and Non Fused Disconnect Switch

3. Terminal Block



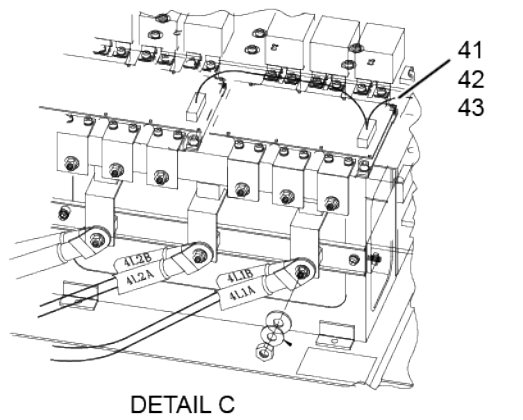
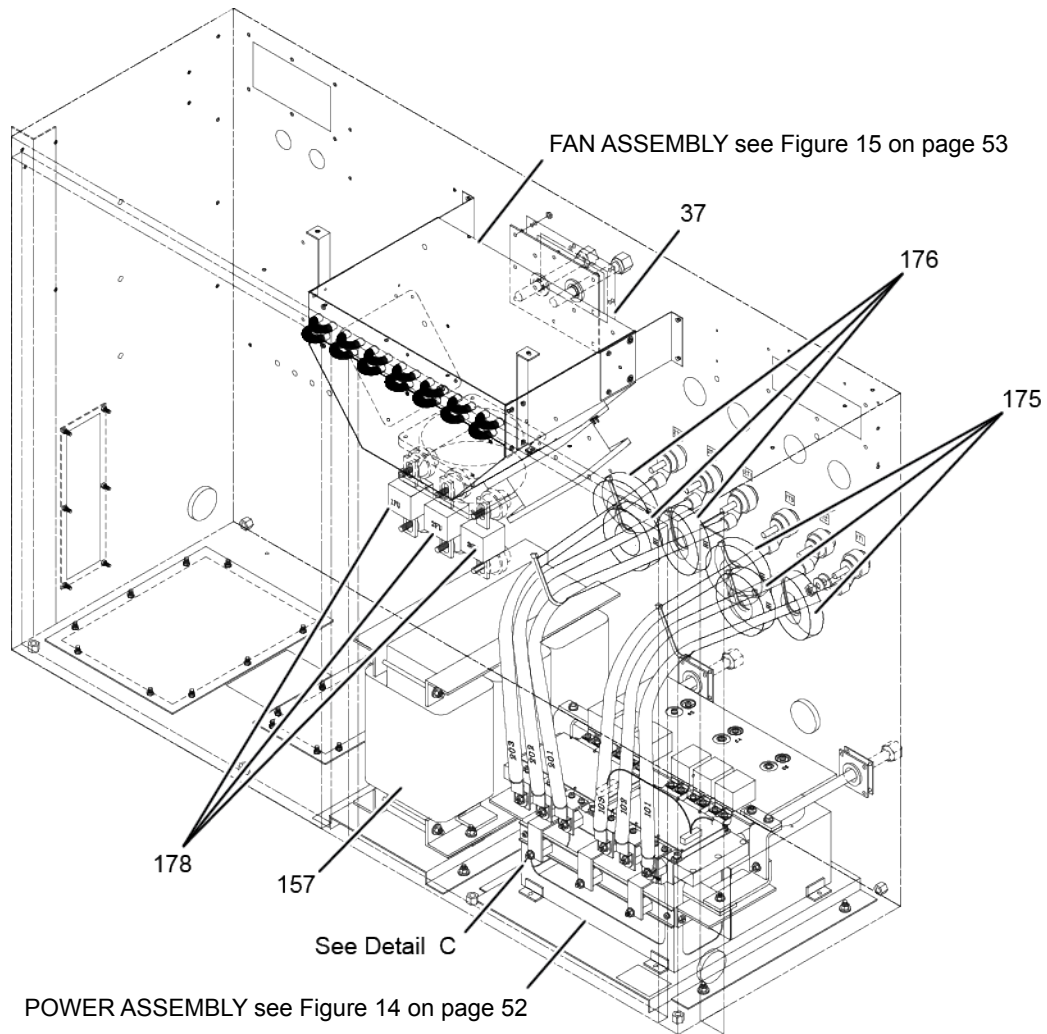

071-05578-006 REV-

FIGURE 12 - CONTROL PANEL COMPONENTS

**TABLE 19 - CONTROL PANEL COMPONENTS**

ITEM	MODELS	VOLTAGE CODE	FANS <sup>1</sup>	DESCRIPTION	PART NUMBER	QUANTITY	FIGURE
8	0153/0543 thru 0278/0988	ALL	ALL	Shielded, 2 Compressor, Right	071 05183 000	1	13
	0303/1093 thru 0345/1215	40, 46, 50, 58		Shield, 3 Compressor, Right	071 05187 000	1	13
9	0153/0543 thru 0278/0988	ALL	ALL	Shielded, 2/3 Compressor	071 05184 000	1	13
	0303/1093 thru 0345/1215	40, 46, 50, 58					
20	0153/0543 thru 0278/0988	ALL	ALL	Control Relay Board	031 02479 001	2	13
	0303/1093 thru 0345/1215	40, 46, 50, 58					
28	0153/0543 thru 0278/0988	ALL	ALL	Control, System	331 03478 101	1	13
	0303/1093 thru 0345/1215	40, 46, 50, 58					
34	0153/0543 thru 0278/0988	ALL	ALL	Gasket, Circuit Breaker, 2 Compressor	028 15824 000	1	13
	0303/1093 thru 0345/1215	40, 46, 50, 58	ALL	Gasket, Circuit Breaker	028 15248 000	1	13
58	0153/0543 thru 0278/0988	ALL	ALL	SD Card with Software, Control Board	031 03476 010	1	13
	0303/1093 thru 0345/1215	40, 46, 50, 58		Blank SD Card	031 03466 000		
59	0153/0543 thru 0278/0988	ALL	ALL	EPROM PWM GEN VSD	031 02522 001	1	13
	0303/1093 thru 0345/1215	40, 46, 50, 58	ALL	EPROM, Logic Board	031 02522 010	1	13
61	0153/0543 thru 0278/0988	ALL	ALL	Switch, Keypad	024 34930 000	1	13
	0303/1093 thru 0345/1215	40, 46, 50, 58					
62	0153/0543 thru 0278/0988	ALL	ALL	Display, LCD	031 02508 000	1	13
	0303/1093 thru 0345/1215	40, 46, 50, 58					
63	0153/0543 thru 0278/0988	ALL	ALL	Switch, DPST, Two Position	024 34951 000	1	13
	0303/1093 thru 0345/1215	40, 46, 50, 58					
68	0153/0543 thru 0278/0988	ALL	ALL	Cable, Ribbon, Display	571 04178 261	1	13
	0303/1093 thru 0345/1215	40, 46, 50, 58	ALL	Cable, Display/Control Board	571 04178 268	1	13
69	0153/0543 thru 0278/0988	ALL	ALL	Cable, Ribbon, Keypad	571 04178 262	1	13
	0303/1093 thru 0345/1215	40, 46, 50, 58	ALL	Cable, Keypad/Control Board	571 04178 269	1	13
70	0153/0543 thru 0278/0988	ALL	ALL	Cable, Ribbon, Relay	571 04178 263	1	13
	0303/1093 thru 0345/1215	40, 46, 50, 58					

Notes: 1. LS/UQ = Low Sound/Ultra Quiet Fans. HA/HS = High Airflow/High Static Fans

2. Flash Drive used on Single Pole Terminal Block and Circuit Breaker units, EPROM used on Single Pole Non Fused Disconnect Switch units.

3. Used on 380 and 460 Volt units ending in A or B.

**TABLE 19 - CONTROL PANEL COMPONENTS (CONT'D)**

ITEM	MODELS	VOLTAGE CODE	FANS <sup>1</sup>	DESCRIPTION	PART NUMBER	QUANTITY	FIGURE
77	0153/0543 thru 0278/0988	ALL	ALL	Cable, Ribbon, Relay	571 04178 264	1	13
	0303/1093 thru 0345/1215	40, 46, 50, 58					
152	0153/0543 thru 0178/0588	40	LS/UQ	Breaker, 500 Amp	371 05264 007	1	13
			HA/HS	Breaker, 600 Amp	371 05264 001	1	13
152	0153/0543 thru 0178/0588	50	LS/UQ	Breaker, 500 Amp	371 05264 007	1	13
			HA/HS	Breaker, 600 Amp	371 05264 001	1	13
152	0153/0543 thru 0198/0688 0213/0743 thru 0218/0788	46	ALL	Breaker, 600 Amp Breaker, 600 Amp	371 05264 001	1	13
152	0153/0543 thru 0278/0988	28	ALL	Breaker, 1200 Amp	371 05264 003	1	13
152	0153/0543 thru 0278/0988	58	ALL	Breaker, 600 Amp	371 05264 004	1	13
152	0183/0643 thru 0198/0688 0213/0743 thru 0218/0788	40	LS/UQ	Breaker, 600 Amp	371 05264 001	1	13
152	0183/0643 thru 0198/0688 0213/0743 thru 0218/0788	40	HA/HS	Breaker, 800 Amp	371 05264 006	1	13
152	0183/0643 thru 0198/0688 0213/0743 thru 0218/0788	50	LS/UQ	Breaker, 600 Amp	371 05264 001	1	13
			HA/HS	Breaker, 800 Amp	371 05264 005	1	13
152	0200/0700 0233/0843 thru 0278/0988	40	LS/UQ	Breaker, 800 Amp	371 05264 005	1	13
152	0200/0700 0233/0843 thru 0278/0988	46	LS/UQ	Breaker, 600 Amp	371 05264 001	1	13
			HA/HS	Breaker, 800 Amp	371 05264 006	1	13
152	0200/0700 0233/0843 thru 0278/0988	50	ALL	Breaker, 800 Amp	371 05264 005	1	13
152	0303/1093 thru 0345/1215	40	LS/UQ	Circuit Breaker Kit, 1000 Amp	371 05264 008	1	13
			HA/HS	Circuit Breaker Kit, 1200 Amp	371 05264 009	1	13
152	0303/1093 thru 0345/1215	46	LS/UQ	Breaker, 800 Amp	371 05264 005	1	13
			HA/HS	Circuit Breaker Kit, 1000 Amp	371 05264 008	1	13
152	0303/1093 thru 0345/1215	50	LS/UQ	Circuit Breaker Kit, 1000 Amp	371 05264 008	1	13
			HA/HS	Circuit Breaker Kit, 1200 Amp	371 05264 009	1	13
152	0303/1093 thru 0345/1215	58	ALL	Breaker, 800 Amp	371 05264 002	1	13
153	0303/1093 thru 0345/1215	40	ALL	Kit, Disconnect, 1200 Amp	371 05271 004	1	13
153	0303/1093 thru 0345/1215	46	HA/HS	Kit, Disconnect, 1000 Amp	371 05271 003	1	13
			LS/UQ	Kit, Disconnect, 800 Amp	371 05271 002	1	13
153	0303/1093 thru 0345/1215	50	HA/HS	Kit, Disconnect, 1200 Amp	371 05271 004	1	13
			LS/UQ	Kit, Disconnect, 1200 Amp	371 05271 003	1	13

- Notes: 1. LS/UQ = Low Sound/Ultra Quiet Fans. HA/HS = High Airflow/High Static Fans  
 2. Flash Drive used on Single Pole Terminal Block and Circuit Breaker units, EPROM used on Single Pole Non Fused Disconnect Switch units.  
 3. Used on 380 and 460 Volt units ending in A or B.

**TABLE 19 - CONTROL PANEL COMPONENTS (CONT'D)**

ITEM	MODELS	VOLTAGE CODE	FANS <sup>1</sup>	DESCRIPTION	PART NUMBER	QUANTITY	FIGURE
153	0303/1093 thru 0345/1215	58	HA/HS	Kit, Disconnect, 800 Amp	371 05271 000	1	13
			LS/UQ	Kit, Disconnect, 800 Amp	371 05271 006	1	13
171	0153/0543 thru 0178/0588	40, 50	ALL	Flash Control, VSD	031 02649 002	1	13
171	0153/0543 thru 0198/0688 0213/0743 thru 0218/0788	46	ALL	Flash Control, VSD	031 02649 001	1	13
171	0153/0543 thru 0275/0965	17	ALL	Flash Control, VSD	031 02649 001	1	13
171	0153/0543 thru 0278/0988	28, 58	ALL	Flash Control, VSD	031 02649 001	1	13
171	0183/0643 thru 0198/0688 0213/0743 thru 0218/0788	40, 50	ALL	Flash Control, VSD	031 02649 002	1	13
171	0200/0700 0233/0843 thru 0278/0988	40	LS/UQ	Flash Control, VSD	031 02649 003	1	13
		46	ALL	Flash Control, VSD	031 02649 001	1	13
		50	ALL	Flash Control, VSD	031 02649 003	1	13
171	0200/0700 0233/0843 thru 0278/0988	40 <sup>3</sup>	HA/HS	EPROM, Logic Board	031 02649 012	1	13
			HA/HS	Flash Control, VSD	031 02649 003	1	13
171	0303/1093 thru 0345/1215	40, 46, 50, 58	ALL	EPROM, Logic Board	031 02649 012	1	13
190	0153/0543 thru 0198/0688 0213/0743 thru 0218/0788	40, 50 <sup>4</sup>	ALL	Control, VSD Logic Board	031 02507 100	1	13
190	0153/0543 thru 0275/0965	17	HA/HS	Control, VSD Logic Board	031 02507 000	1	13
190	0153/0543 thru 0278/0988	17, 28, 46, 58	LS/UQ	Control, VSD Logic Board	031 02507 000	1	13
		28, 46, 58	HA/HS				
		40, 50					
		40, 50	LS/UQ				
190	0303/1093 thru 0345/1215	40, 46, 50, 58	HA/HS	Control, VSD Logic Board	031 02507 000	1	13
			LS/UQ				

Notes: 1. LS/UQ = Low Sound/Ultra Quiet Fans. HA/HS = High Airflow/High Static Fans

2. Flash Drive used on Single Pole Terminal Block and Circuit Breaker units, EPROM used on Single Pole Non Fused Disconnect Switch units.

3. Used on 380 and 460 Volt units ending in A or B.

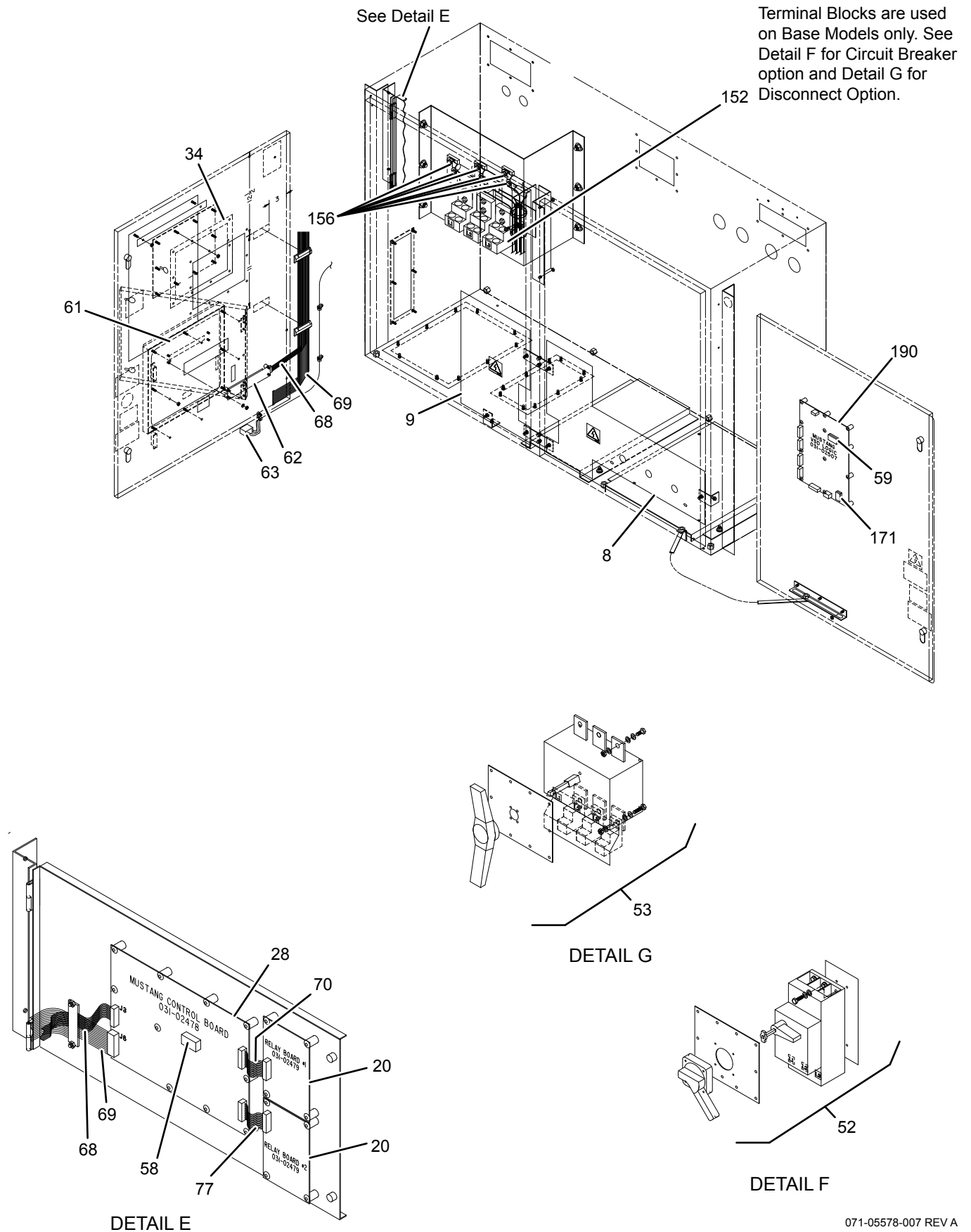

6

**FIGURE 13 - CONTROL PANEL COMPONENTS**

071-05578-007 REV A

**TABLE 20 - POWER ASSEMBLY COMPONENTS**

ITEM	MODELS	VOLTAGE CODE	FANS <sup>1</sup>	DESCRIPTION	PART NUMBER	QUANTITY PER UNIT	FIGURE
2	ALL	ALL	ALL	Capacitor, Polypropylene Film	025 35972 000	6	14
5	0153/0543 thru 0178/0588	40, 50	ALL	Capacitor, 450V, 12,000uf	025 39573 000	4	14
5	0153/0543 thru 0198/0688 0213/0743 thru 0218/0788	46	ALL	Capacitor, 450V, 12,000uf	025 39573 000	4	14
5	0153/0543 thru 0275/0965	17	HA/HS	Capacitor, 450V, 12,000uf	025 39573 000	6	14
5	0153/0543 thru 0278/0988	17	LS/UQ	Capacitor, 450V, 12,000uf	025 39573 000	6	14
		28, 58	ALL				
5	0183/0643 thru 0198/0688 0213/0743 thru 0218/0788	40, 50	ALL	Capacitor, 450V, 12,000uf	025 39573 000	6	14
5	0200/0700 0233/0843 thru 0278/0988	40, 46, 50	ALL	Capacitor, 450V, 12,000uf	025 39573 000	6	14
5	0303/1093 thru 0345/1215	40, 46, 50, 58	ALL	Capacitor, 450V, 12,000uf	025 39573 000	8	14
24	0153/0543 thru 0178/0588	40, 50	ALL	Insulator, Capacitor	071 02769 319	4	14
24	0153/0543 thru 0198/0688 0213/0743 thru 0218/0788	46					
24	0153/0543 thru 0275/0965 0153/0543 thru 0278/0988	17	HA/HS	Insulator, Capacitor	071 02769 319	6	14
		17	LS/UQ				
24	0153/0543 thru 0278/0988	28, 58	ALL				
24	0183/0643 thru 0198/0688 0213/0743 thru 0218/0788	40, 50	ALL				
24	0200/0700 0233/0843 thru 0278/0988	40, 46, 50	ALL				
24	0303/1093 thru 0345/1215	40, 46, 50, 58	ALL	Insulator, Capacitor	071 02769 319	8	14
32	ALL	ALL	ALL	Thermal Pad, Resistor, ¾" Wide	028 15299 000	2	14
34	ALL	ALL	ALL	Resistor, Power Wirewound	025 35157 000	2	14
40	ALL	ALL	ALL	Kit, Suppressor, 480 VAC	331 02556 001	3	14
104	0153/0543 thru 0178/0588	40, 50	ALL	IGBT Assembly Kit, VSD Frame A&B <sup>3</sup>	371 04479 001	2	14
104	0153/0543 thru 0198/0688 0213/0743 thru 0218/0788	46	ALL	IGBT Assembly Kit, VSD Frame A&B <sup>3</sup>	371 04479 001	2	14
104	0153/0543 thru 0275/0965	17	HA/HS	IGBT Assembly Kit, VSD Frame A&B <sup>3</sup>	371 04479 001	2	14
104	0153/0543 thru 0278/0988	17	LS/UQ	IGBT Assembly Kit, VSD Frame A&B <sup>3</sup>	371 04479 001	2	14
		28, 58	ALL				
104	0183/0643 thru 0198/0688 0213/0743 thru 0218/0788	40, 50	ALL	IGBT Assembly Kit, VSD Frame A&B <sup>3</sup>	371 04479 001	2	14

Notes: 1. LS/UQ = Low Sound/Ultra Quiet Fans. HA/HS = High Airflow/High Static Fans.

2. Includes IGBT Gate Driver and IGBT Module as an assembly. DO NOT attempt to replace the IGBT Gate Driver or the IGBT Module individually.

**TABLE 20 - POWER ASSEMBLY COMPONENTS (CONT'D)**

ITEM	MODELS	VOLTAGE CODE	FANS <sup>1</sup>	DESCRIPTION	PART NUMBER	QUANTITY PER UNIT	FIGURE
104	0200/0700 0233/0843 thru 0278/0988	40, 50	ALL	IGBT Assembly Kit, VSD Frame C&D <sup>3</sup>	371 04479 002	2	14
		46	ALL	IGBT Assembly Kit, VSD Frame A&B <sup>3</sup>	371 04479 001	2	14
104	0303/1093 thru 0345/1215	40, 46, 50, 58	All	IGBT Assembly Kit, VSD Frame C&D <sup>3</sup>	371 04479 002	2	14
105	0153/0543 thru 0178/0588	40, 50	ALL	SCR/Diode Module Replacement Kit, VSD Frame A	371 04478 003	3	14
105	0153/0543 thru 0198/0688 0213/0743 thru 0218/0788	46	ALL	SCR/Diode Module Replacement Kit, VSD Frame A	371 04478 003	3	14
105	0153/0543 thru 0275/0965 0153/0543 thru 0278/0988	17	HA/HS	SCR/Diode Module Replacement Kit, VSD Frame B	371 04478 001	3	14
		17	LS/UQ				
105	0153/0543 thru 0278/0988	28, 58	ALL	SCR/Diode Module Replacement Kit, VSD Frame B	371 04478 001	3	14
105	0183/0643 thru 0198/0688 0213/0743 thru 0218/0788	40, 50	ALL	SCR/Diode Module Replacement Kit, VSD Frame B	371 04478 001	3	14
105	0200/0700 0233/0843 thru 0278/0988	46	ALL	SCR/Diode Module Replacement Kit, VSD Frame B	371 04478 001	3	14
		40, 50	ALL	SCR/Diode Module Replacement Kit, VSD Frame C	371 04478 002	3	14
105	0303/1093 thru 0345/1215	40, 46, 50, 58	ALL	SCR/Diode Module Replacement Kit, VSD Frame D	371 04539 002	3	14
106	All	All	All	Buss Plate Kit	371-04538-001	1	14
107	0303/1093 thru 0345/1215	40, 46, 50, 58	All	Gasket	028 15113 000	2	14
108	0303/1093 thru 0345/1215	40, 46, 50, 58	All	Harness, SCR to Trigger Board	571 04192 221	1	14
109	0303/1093 thru 0345/1215	40, 46, 50, 58	All	Harness, Ground	571 04181 242	1	14
110	0303/1093 thru 0345/1215	40, 46, 50, 58	All	Harness, Equalizer	571 04192 241	1	14

Notes: 1. LS/UQ = Low Sound/Ultra Quiet Fans. HA/HS = High Airflow/High Static Fans.

2. Includes IGBT Gate Driver and IGBT Module as an assembly. DO NOT attempt to replace the IGBT Gate Driver or the IGBT Module individually.

**6**

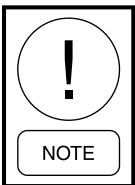
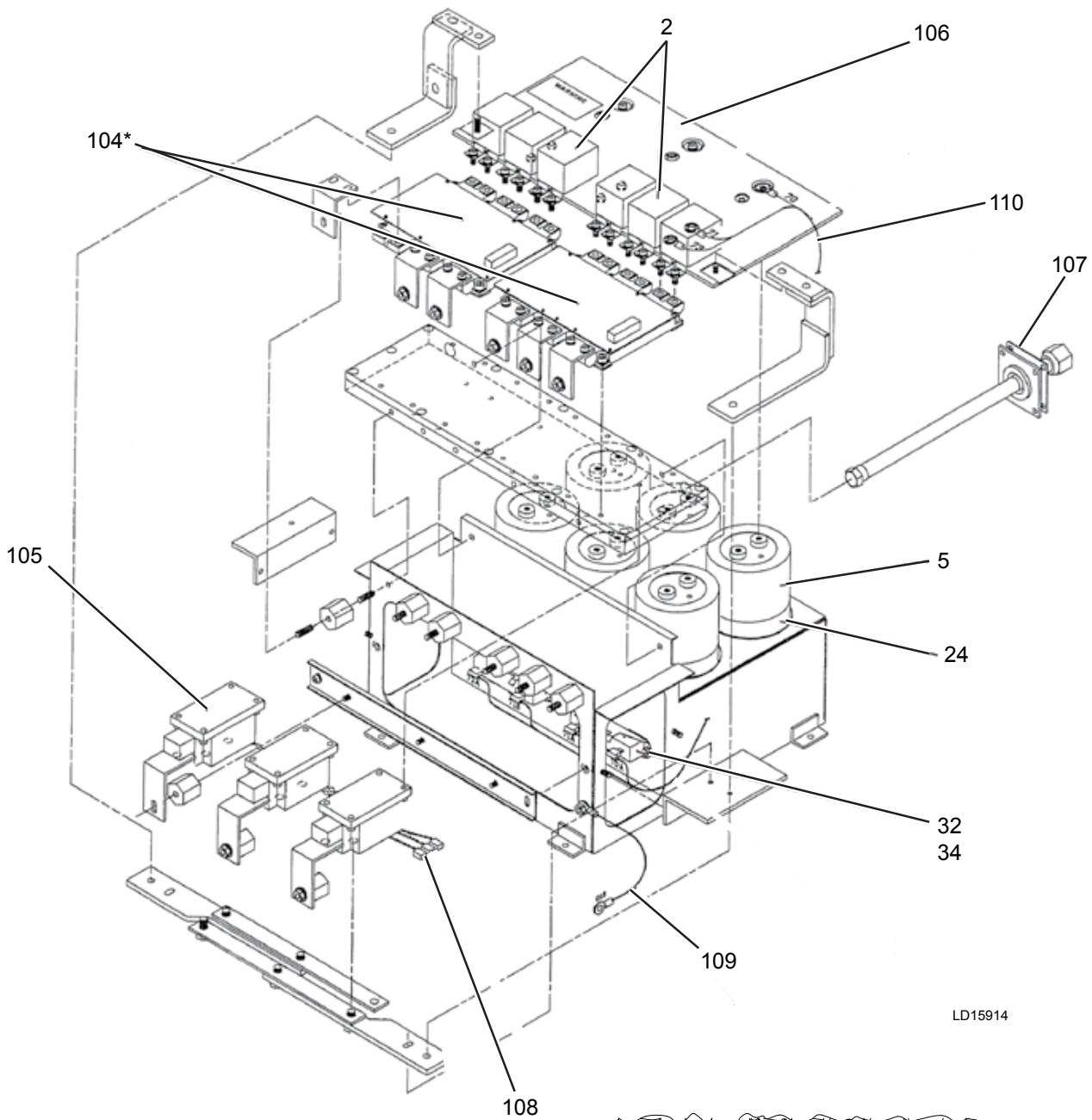

*Includes IGBT Gate Driver and IGBT Module as an assembly. DO NOT attempt to replace the IGBT Gate Driver or the IGBT Module individually.*

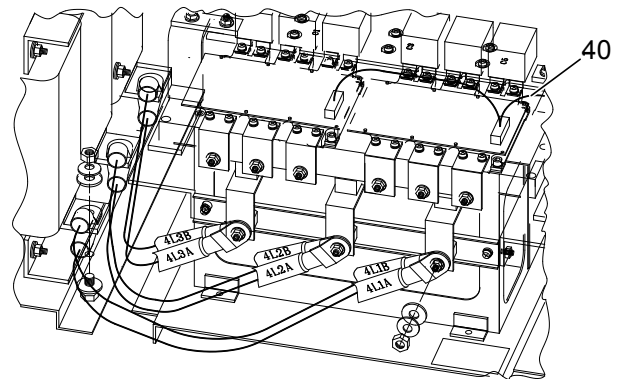

**FIGURE 14 - POWER ASSEMBLY COMPONENTS**

LD15913



**TABLE 21 - FAN ASSEMBLY COMPONENTS**

ITEM	MODELS	VOLTAGE CODE	FANS <sup>1</sup>	DESCRIPTION	PART NUMBER	QUANTITY	FIGURE
1	ALL	ALL	ALL	Coil Assembly, Water Cooling	026 41590 000	1	15
4	0153/0543 thru 0178/0588	40, 50	ALL	Fan, Cooling, 115V 70W 330 CFM	025 32557 000	2	15
4	0153/0543 thru 0198/0688 0213/0743 thru 0218/0788	46	ALL	Fan, Cooling, 115V 70W 330 CFM	025 32557 000	2	15
4	0153/0543 thru 0275/0965 0153/0543 thru 0278/0988	17	HA/HS	Fan, Cooling, 115V 70W 330 CFM	025 40105 000	2	15
		17	LS/UQ				
4	0153/0543 thru 0278/0988	28, 58	ALL	Fan, Cooling, 115V 70W 330 CFM	025 40105 000	2	15
4	0183/0643 thru 0198/0688 0213/0743 thru 0218/0788	40	ALL	Fan, Cooling, 115V 70W 330 CFM	025 40105 000	2	15
		50	ALL	Fan, Cooling, 115V 70W 330 CFM	025 40105 000	3	15
4	0200/0700 0233/0843 thru 0278/0988	40	ALL	Fan, Cooling, 115V 70W 330 CFM	025 32557 000	2	15
		50	ALL	Fan, Cooling, 115V 70W 330 CFM	025 32557 000	3	15
		46	ALL	Fan, Cooling, 115V 70W 330 CFM	025 40105 000	2	15
4	0303/1093 thru 0345/1215	40, 46, 50, 58	ALL	Fan, Cooling, 115V 70W 330 CFM	025 32557 000	3	15
11	ALL	ALL	ALL	Grommet, 5/8" OD, Tubing	028 04873 000	2	15

**6**

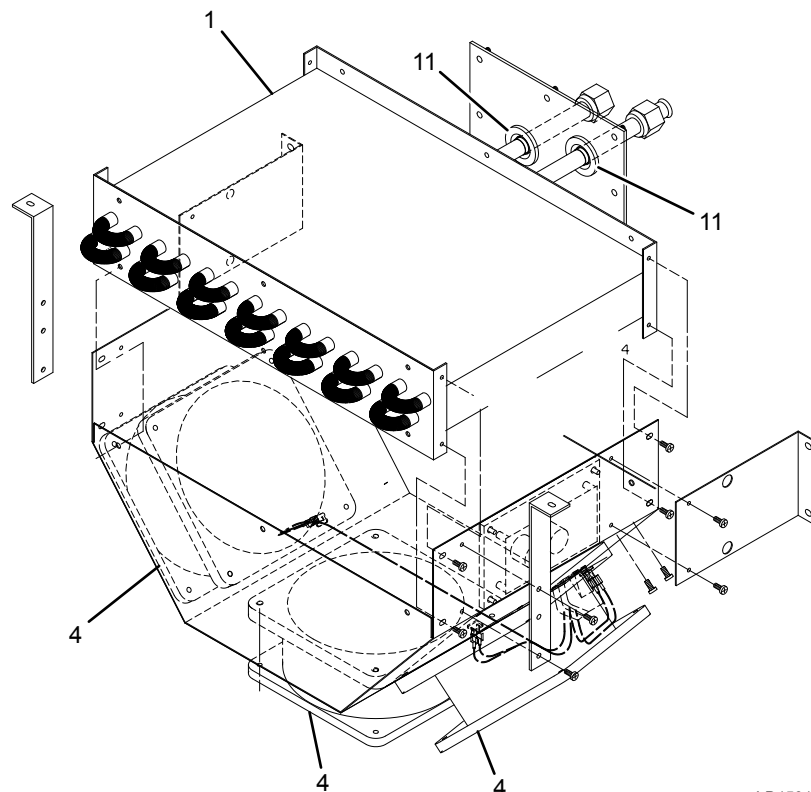

**FIGURE 15 - FAN ASSEMBLY COMPONENTS**

LD15915

**TABLE 22 - CONTROL PANEL ENCLOSURE COMPONENTS**

ITEM	MODELS	VOLTAGE CODE	FANS	DESCRIPTION	PART NUMBER	QUANTITY	FIGURE
12	0303/1093 thru 0345/1215	40, 46, 50, 58	ALL	Latch, Triangular Twist Assembly	029 23455 000	6	16
26	0303/1093 thru 0345/1215	40, 46, 50, 58	ALL	Latch, Small Keyed Wing Knob	029 25103 000	1	16
30	0303/1093 thru 0345/1215	40, 46, 50, 58	ALL	Latch, Door	071 04178 319	2	16
31	0303/1093 thru 0345/1215	40, 46, 50, 58	ALL	Latch, Small Wing Knob	021 18956 070	1	16
32	0303/1093 thru 0345/1215	40, 46, 50, 58	ALL	Key, Small Wing Knob Latch	029 25104 000	1	*
33	0303/1093 thru 0345/1215	40, 46, 50, 58	ALL	Key-Twist Latch	029 23454 000	1	*

NOTE: Items with an \* are not represented.

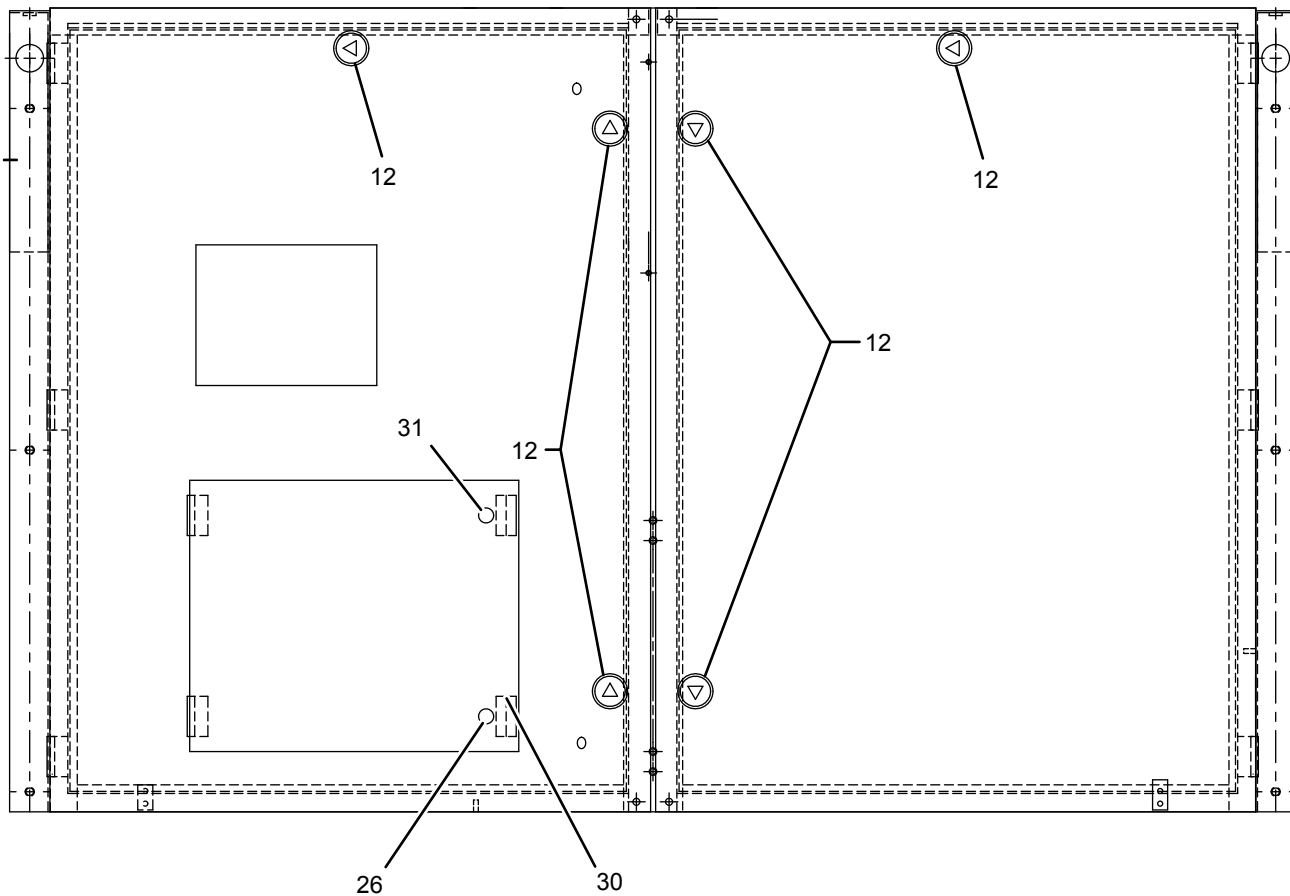

LD15196

**FIGURE 16 - CONTROL PANEL ENCLOSURE COMPONENTS**

## SECTION 7 - BASE RAIL AND FRAME COMPONENTS

**TABLE 23 - BASE RAIL COMPONENTS**

ITEM	MODELS	DESCRIPTION	PART NUMBER	QUANTITY	FIGURE
1	0153/0543	Rail, Base	075 94058 000	2	17
	0165/0565	Rail, Base	075 79507 000	2	
	0178/0588	Rail, Base	075 89911 000	2	
	0183/0643 thru 0198/0688	Rail, Base	075 79507 000	2	
	0200/0700	Rail, Base	075 93292 000	2	
	0213/0743	Rail, Base	075 79507 000	2	
	0215/0765 thru 0218/0788	Rail, Base	075 89911 000	2	
	0233/0843 thru 0245/0865	Rail, Base	075 79507 000	2	
	0248/0888	Rail, Base	075 89911 000	2	
	0263/0943	Rail, Base	075 79507 000	2	
	0273/0963 thru 0345/1215	Rail, Base	075 89911 000	2	
2	0153/0543	Rail, Base	075 94059 000	2	17
	0165/0565	Rail, Base	075 79508 000	2	
	0178/0588	Rail, Base	075 93318 000	2	
	0183/0643	Rail, Base	075 93316 000	2	
	0195/0665 thru 0198/0688	Rail, Base	075 79508 001	2	
	0200/0700	Rail, Base	075 93293 000	2	
	0213/0743	Rail, Base	075 79508 001	2	
	0215/0765	Rail, Base	075 93318 000	2	
	0218/0788	Rail, Base	075 94695 000	2	
	0233/0843	Rail, Base	075 79508 000	2	
	0245/0865	Rail, Base	075 94090 000	2	
	0248/0888	Rail, Base	075 93330 000	2	
	0263/0943	Rail, Base	075 79508 000	2	
	0273/0963 thru 0278/0988	Rail, Base	075 89912 000	2	
	0303/1093	Rail, Base	092 03477 000	2	
	0308/1088	Rail, Base	092 03502 000	2	
	0323/1143	Rail, Base	075 89912 000	2	
0333/1173	Rail, Base	092 03527 000	2		
0343/1193 thru 0345/1215	Rail, Base	075 89912 000	2		
3	0153/0543	Rail, Base	075 94060 000	2	17
	0165/0565	Rail, Base	075 79509 000	2	
	0178/0588	Rail, Base	075 93319 000	2	
	0183/0643	Rail, Base	075 93315 000	2	
	0195/0665	Rail, Base	075 93736 001	2	
	0198/0688	Rail, Base	075 94105 000	2	
	0200/0700	Rail, Base	075 93294 000	2	
	0213/0743	Rail, Base	075 93736 001	2	
	0215/0765	Rail, Base	075 93319 000	2	
	0218/0788	Rail, Base	075 94669 000	2	
	0233/0843	Rail, Base	075 93736 000	2	
	0245/0865	Rail, Base	075 94091 000	2	
	0248/0888	Rail, Base	075 93331 000	2	

7

**TABLE 23 - BASE RAIL COMPONENTS (CONT'D)**

ITEM	MODELS	DESCRIPTION	PART NUMBER	QUANTITY	FIGURE
3	0263/0943	Rail, Base	075 93238 000	2	17
	0273/0963 thru 0275/0965	Rail, Base	075 89190 000	2	
	0278/0988	Rail, Base	075 89913 000	2	
	0303/1093	Rail, Base	092 03486 000	2	
	0308/1088	Rail, Base	092 03012 000	2	
	0323/1143	Rail, Base	075 89913 000	2	
	0333/1173	Rail, Base	092 03528 000	2	
	0343/1193	Rail, Base	092 03012 000	2	
	0345/1215	Rail, Base	075 89913 000	2	
5	0153/0543 thru 0278/0988	Rail, Base	075 79511 000	2	17
	0303/1093 thru 0308/1088	Rail, Base	092 03039 000	2	
	0323/1143 thru 0345/1215	Rail, Base	075 93259 000	2	
6	0153/0543	Rail, Base	075 93297 000	2	17
	0165/0565 thru 0178/0588	Rail, Base	075 79520 000	4	
	0183/0643	Rail, Base	075 79520 000	3	
	0195/0665	Rail, Base	075 79520 000	4	
	0198/0688	Rail, Base	075 79520 000	5	
	0200/0700	Rail, Base	075 93297 000	4	
	0213/0743	Rail, Base	075 79520 000	4	
	0215/0765 thru 0245/0865	Rail, Base	075 79520 000	5	
	0248/0888	Rail, Base	075 79520 000	3	
	0263/0943 thru 0278/0988	Rail, Base	075 79520 000	5	
	0303/1093	Rail, Base	075 79520 000	3	
	0308/1088 thru 0343/1193	Rail, Base	075 79520 000	5	
	0345/1215	Rail, Base	075 79520 000	6	
7	0153/0543	Rail, Base	075 94062 000	4	17
	0165/0565	Rail, Base	075 79521 000	4	
	0178/0588	Rail, Base	075 93258 000	6	
	0183/0643 thru 0198/0688	Rail, Base	075 79521 000	4	
	0200/0700	Rail, Base	075 94081 000	2	
	0213/0743	Rail, Base	075 79521 000	4	
	0215/0765 thru 0218/0788	Rail, Base	075 93258 000	8	
	0233/0843 thru 0245/0865	Rail, Base	075 79521 000	4	
	0248/0888	Rail, Base	075 93258 000	4	
	0263/0943	Rail, Base	075 79521 000	4	
	0273/0963 thru 0278/0988	Rail, Base	075 93258 000	4	
	0303/1093 thru 0308/1088	Rail, Base	075 93258 000	6	
	0323/1143	Rail, Base	092 02996 000	4	
	0333/1173 thru 0343/1193	Rail, Base	075 93258 000	4	
	0345/1215	Rail, Base	075 93272 000	8	
8	0153/0543	Rail, Base	075 93262 000	3	17
	0165/0565	Rail, Base	075 93262 000	2	
	0178/0588	Rail, Base	075 93262 000	1	
	0183/0643 thru 0195/0665	Rail, Base	075 93262 000	1	

**TABLE 23 - BASE RAIL COMPONENTS (CONT'D)**

ITEM	MODELS	DESCRIPTION	PART NUMBER	QUANTITY	FIGURE
8	0198/0688	Rail, Base	075 93262 000	2	17
	0213/0743	Rail, Base	075 93262 000	1	
	0215/0765 thru 0263/0943	Rail, Base	075 93262 000	2	
	0303/1093 thru 0308/1088	Rail, Base	075 93263 000	1	
	0323/1143 thru 0345/1215	Rail, Base	075 93263 000	2	
9	0153/0543 thru 0165/0565	Plate, Lifting	075 65620 000	40	17
	0178/0588	Plate, Lifting	075 65620 000	50	
	0183/0643	Plate, Lifting	075 65620 000	40	
	0195/0665	Plate, Lifting	075 65620 000	50	
	0198/0688 thru 0200/0700	Plate, Lifting	075 65620 000	40	
	0213/0743 thru 0233/0843	Plate, Lifting	075 65620 000	50	
	0245/0865 thru 0263/0943	Plate, Lifting	075 65620 000	40	
	0273/0963 thru 0278/0988	Plate, Lifting	075 65620 000	48	
	0303/1093	Plate, Lifting	075 65620 000	40	
	0308/1088	Plate, Lifting	075 65620 000	56	
	0323/1143 thru 0333/1173	Plate, Lifting	075 65620 000	48	
	0343/1193 thru 0345/1215	Plate, Lifting	075 65620 000	56	
10	0153/0543 thru 0195/0665	Channel, Side Connection	075 65622 001	4	17
	0198/0688	Channel, Side Connection	075 65622 001	6	
	0200/0700 thru 0215/0765	Channel, Side Connection	075 65622 001	4	
	0218/0788	Channel, Side Connection	075 65622 001	6	
	0233/0843	Channel, Side Connection	075 65622 001	4	
	0245/0865 thru 0343/1193	Channel, Side Connection	075 65622 001	6	
0345/1215	Channel, Side Connection	075 65622 001	8		
11	0153/0543	Rail, Base	075 93299 000	1	17
	0165/0565 thru 0198/0688	Rail, Base	075 79554 000	2	
	0200/0700	Rail, Base	075 93299 000	1	
	0213/0743 thru 0345/1215	Rail, Base	075 79554 000	2	
12	0153/0543	Bracket, Cooler	075 55617 000	3	17
	0165/0565	Bracket, Cooler	075 55617 000	2	
	0178/0588 thru 0345/1215	Bracket, Cooler	075 55617 000	3	
13	0323/1143 thru 0345/1215	Support, Compressor	075 89933 000	4	17
14	0153/0543	Bracket, Filter Drier	075 89942 000	2	17
	0165/0565	Bracket, Filter Drier	075 79582 000	2	
	0178/0588 thru 0183/0643	Bracket, Filter Drier	075 89942 000	2	
	0195/0665	Bracket, Filter Drier	075 89942 000	1	
	0198/0688 thru 0200/0700	Bracket, Filter Drier	075 89942 000	2	
	0213/0743	Bracket, Filter Drier	075 89942 000	2	
	0215/0765 thru 0263/0943	Bracket, Filter Drier	075 89942 000	2	
0303/1093 thru 0345/1215	Bracket, Filter Drier	075 89942 000	2		
15	ALL	Bracket, Eductor	075 79579 000	2	17
16	0198/0688	Rail, Base	075 79509 000	2	17
	0218/0788 thru 0245/0865	Rail, Base	075 89191 000	2	17
	0248/0888	Rail, Base	075 89878 000	2	17
	0263/0943	Rail, Base	075 79509 000	2	17

7

**TABLE 23 - BASE RAIL COMPONENTS (CONT'D)**

ITEM	MODELS	DESCRIPTION	PART NUMBER	QUANTITY	FIGURE
16	0273/0963 thru 0275/0965	Rail, Base	075 89191 000	2	17
	0278/0988 thru 0303/1093	Rail, Base	075 89878 000	2	
	0308/1088	Rail, Base	092 03013 000	2	
	0323/1143	Rail, Base	075 89878 000	2	
	0333/1173 thru 0343/1193	Rail, Base	092 03013 000	2	
	0345/1215	Rail, Base	075 89878 000	2	
17	0323/1143 thru 0345/1215	Support, Cooler Base	075 89932 000	1	17
18	0198/0688	Channel, Side, Outer, R.H.	075 93239 000	1	17
	0218/0788	Channel, Side, Outer, R.H.	075 89916 000	1	
	0245/0865	Channel, Side, Outer, R.H.	075 93239 000	1	
	0248/0888	Channel, Side, Outer, R.H.	075 89916 000	1	
	0263/0943	Channel, Side, Outer, R.H.	075 93239 000	1	
	0273/0963 thru 0345/1215	Channel, Side, Outer, R.H.	075 89916 000	1	
19	0198/0688	Channel, Side, Outer, R.H.	075 93240 000	1	17
	0218/0788	Channel, Side, Outer, R.H.	075 94692 000	1	
	0245/0865	Channel, Side, Outer, R.H.	075 94092 000	1	
	0248/0888	Channel, Side, Outer, R.H.	075 93332 000	1	
	0263/0943	Channel, Side, Outer, R.H.	075 93240 000	1	
	0273/0963 thru 0278/0988	Channel, Side, Outer, R.H.	075 89917 000	1	
	0303/1093	Channel, Side, Outer, R.H.	092 03478 000	1	
	0308/1088 thru 0323/1143	Channel, Side, Outer, R.H.	075 89917 000	1	
	0333/1173	Channel, Side, Outer, R.H.	092 03529 000	1	
0343/1193 thru 0345/1215	Channel, Side, Outer, R.H.	075 89917 000	1		
20	0198/0688	Channel, Side, Outer, R.H.	075 93241 000	1	17
	0218/0788	Channel, Side, Outer, R.H.	075 94693 000	1	
	0245/0865	Channel, Side, Outer, R.H.	075 94093 000	1	
	0248/0888	Channel, Side, Outer, R.H.	075 93333 000	1	
	0263/0943	Channel, Side, Outer, R.H.	075 93241 000	1	
	0273/0963 thru 0275/0965	Channel, Side, Outer, R.H.	075 89918 004	1	
	0278/0988	Channel, Side, Outer, R.H.	075 94074 000	1	
	0303/1093	Channel, Side, Outer, R.H.	092 03479 000	1	
	0308/1088	Channel, Side, Outer, R.H.	092 03503 000	1	
	0323/1143	Channel, Side, Outer, R.H.	075 94074 000	1	
	0333/1173	Channel, Side, Outer, R.H.	092 03530 000	1	
	0343/1193	Channel, Side, Outer, R.H.	075 94074 000	1	
0345/1215	Channel, Side, Outer, R.H.	075 89918 000	1		
21	0198/0688	Channel, Side, Outer, R.H.	075 94106 000	1	17
	0218/0788 thru 0245/0865	Channel, Side, Outer, R.H.	075 94694 000	1	
	0248/0888	Channel, Side, Outer, R.H.	075 93334 000	1	
	0263/0943	Channel, Side, Outer, R.H.	075 93242 000	1	
	0273/0963 thru 0275/0965	Channel, Side, Outer, R.H.	075 89192 000	1	
	0278/0988	Channel, Side, Outer, R.H.	075 89919 000	1	
	0303/1093	Channel, Side, Outer, R.H.	092 03487 000	1	
0308/1088	Channel, Side, Outer, R.H.	092 03472 000	1		

**TABLE 23 - BASE RAIL COMPONENTS (CONT'D)**

ITEM	MODELS	DESCRIPTION	PART NUMBER	QUANTITY	FIGURE
21	0323/1143	Channel, Side, Outer, R.H.	075 89919 000	1	17
	0333/1173 thru 0343/1193	Channel, Side, Outer, R.H.	092 03472 000	1	
	0345/1215	Channel, Side, Outer, R.H.	075 89919 000	1	
22	0198/0688	Channel, Side, Outer, L.H.	075 93239 001	1	17
	0218/0788	Channel, Side, Outer, L.H.	075 89916 001	1	
	0245/0865	Channel, Side, Outer, L.H.	075 93239 001	1	
	0248/0888	Channel, Side, Outer, L.H.	075 89916 001	1	
	0263/0943	Channel, Side, Outer, L.H.	075 93239 001	1	
22	0273/0963 thru 0345/1215	Channel, Side, Outer, L.H.	075 89916 001	1	17
23	0198/0688	Channel, Side, Outer, L.H.	075 93240 001	1	17
	0218/0788	Channel, Side, Outer, L.H.	075 94692 001	1	
	0245/0865	Channel, Side, Outer, L.H.	075 94092 001	1	
	0248/0888	Channel, Side, Outer, L.H.	075 93332 001	1	
	0263/0943	Channel, Side, Outer, L.H.	075 93240 001	1	
	0273/0963 thru 0278/0988	Channel, Side, Outer, L.H.	075 89917 001	1	
	0303/1093	Channel, Side, Outer, L.H.	092 03478 001	1	
	0308/1088 thru 0323/1143	Channel, Side, Outer, L.H.	075 89917 001	1	
	0333/1173	Channel, Side, Outer, L.H.	092 03529 001	1	
0343/1193 thru 0345/1215	Channel, Side, Outer, L.H.	075 89917 001	1		
24	0198/0688	Channel, Side, Outer, L.H.	075 93241 001	1	17
	0218/0788	Channel, Side, Outer, L.H.	075 94693 001	1	
	0245/0865	Channel, Side, Outer, L.H.	075 94093 001	1	
	0248/0888	Channel, Side, Outer, L.H.	075 93333 001	1	
	0263/0943	Channel, Side, Outer, L.H.	075 93241 001	1	
	0273/0963 thru 0275/0965	Channel, Side, Outer, L.H.	075 89918 005	1	
	0278/0988	Channel, Side, Outer, L.H.	075 94074 001	1	
	0303/1093	Channel, Side, Outer, L.H.	092 03479 001	1	
	0308/1088	Channel, Side, Outer, L.H.	092 03503 001	1	
	0323/1143	Channel, Side, Outer, L.H.	075 94074 001	1	
	0333/1173	Channel, Side, Outer, L.H.	092 03530 001	1	
	0343/1193	Channel, Side, Outer, L.H.	075 94074 001	1	
0345/1215	Channel, Side, Outer, L.H.	075 89918 001	1		
25	0198/0688	Channel, Side, Outer, L.H.	075 94106 001	1	17
	0218/0788 thru 0245/0865	Channel, Side, Outer, L.H.	075 94694 001	1	
	0248/0888	Channel, Side, Outer, L.H.	075 93334 001	1	
	0263/0943	Channel, Side, Outer, L.H.	075 93242 001	1	
	0273/0963 thru 0275/0965	Channel, Side, Outer, L.H.	075 89192 001	1	
25	0278/0988	Channel, Side, Outer, L.H.	075 89919 001	1	17
	0303/1093	Channel, Side, Outer, L.H.	092 03487 001	1	
	0308/1088	Channel, Side, Outer, L.H.	092 03472 001	1	
	0323/1143	Channel, Side, Outer, L.H.	075 89919 001	1	
	0333/1173 thru 0343/1193	Channel, Side, Outer, L.H.	092 03472 001	1	
0345/1215	Channel, Side, Outer, L.H.	075 89919 001	1		
26	0345/1215	Rail, Base	075 89928 000	2	17

**7**

**TABLE 23 - BASE RAIL COMPONENTS (CONT'D)**

ITEM	MODELS	DESCRIPTION	PART NUMBER	QUANTITY	FIGURE
27	0308/1088	Channel, Side, Outer, R.H.	092 03473 000	1	17
	0333/1173	Channel, Side, Outer, R.H.	092 03531 000	1	
	0343/1193	Channel, Side, Outer, R.H.	092 03473 000	1	
	0345/1215	Channel, Side, Outer, R.H.	075 89929 000	1	
31	0308/1088	Channel, Side, Outer, L.H.	092 03473 001	1	17
	0333/1173	Channel, Side, Outer, L.H.	092 03531 001	1	
	0343/1193	Channel, Side, Outer, L.H.	092 03473 001	1	
	0345/1215	Channel, Side, Outer, L.H.	075 89929 001	1	
32	0153/0543 thru 0278/0988	Rail, Base	075 89909 000	2	17
	0303/1093 thru 0308/1088	Rail, Base	092 03040 000	2	
33	0153/0543	Rail, Base	075 94061 000	4	17
	0165/0565	Rail, Base	075 79553 000	4	
	0183/0643	Rail, Base	075 94040 000	2	
	0195/0665	Rail, Base	075 79553 000	2	
	0198/0688	Rail, Base	075 93258 000	4	
	0200/0700	Rail, Base	075 94082 000	2	
	0213/0743	Rail, Base	075 79553 000	2	
	0233/0843	Rail, Base	075 79553 000	4	
	0245/0865	Rail, Base	075 93258 000	4	
	0263/0943	Rail, Base	075 79553 000	4	
	0323/1143	Rail, Base	075 93258 000	4	
0343/1193	Rail, Base	092 02996 000	4		
34	0200/0700	Plate, Spacer	092 03272 000	1	17
35	0200/0700	Rail, Base	075 94083 000	1	17
	0303/1093 thru 0308/1088	Rail, Base	075 93262 000	1	
36	0153/0543	Rail, Base	075 79554 000	1	17
	0200/0700	Rail, Base	075 79554 000	1	
37	0178/0588 thru 0183/0643	Bracket, Mounting, Oil Separator	075 93298 000	1	17
	0195/0665	Bracket, Mounting, Oil Separator	092 03225 000	1	
	0213/0743	Bracket, Mounting, Oil Separator	092 03225 000	1	
	0248/0888	Bracket, Mounting, Oil Separator	092 03225 000	2	
	0273/0963 thru 0275/0965	Bracket, Mounting, Oil Separator	092 03225 000	2	
	0303/1093 thru 0308/1088	Rail, Base	092 02996 000	2	
	0333/1173	Rail, Base	092 02996 000	4	
38	0178/0588 thru 0183/0643	Bracket, Mounting, Oil Separator	075 93298 000	1	17
	0195/0665	Bracket, Mounting, Oil Separator	075 89915 000	2	
	0213/0743	Bracket, Mounting, Oil Separator	075 89915 000	1	
	0248/08883 thru 0278/0988	Bracket, Mounting, Oil Separator	075 89915 000	2	
39	0200/0700	Rail, Base	075 94072 000	1	17
40	0178/0588 thru 0195/0665	Rail, Base	075 93297 000	1	17
	0213/0743	Rail, Base	075 93297 000	1	
	0273/0963 thru 0303/1093	Rail, Base	075 89908 000	2	
42	0165/0565	Bracket, Support Pump (Not Shown)	075 65646 000	1	17
43	0273/0963 thru 0275/0965	Bracket, Glycol Pump	092 06146 000	1	17
44	0200/0700	Rail, Base	075 79520 000	1	17
45	0153/0543	Rail, Base	075 79520 000	1	17



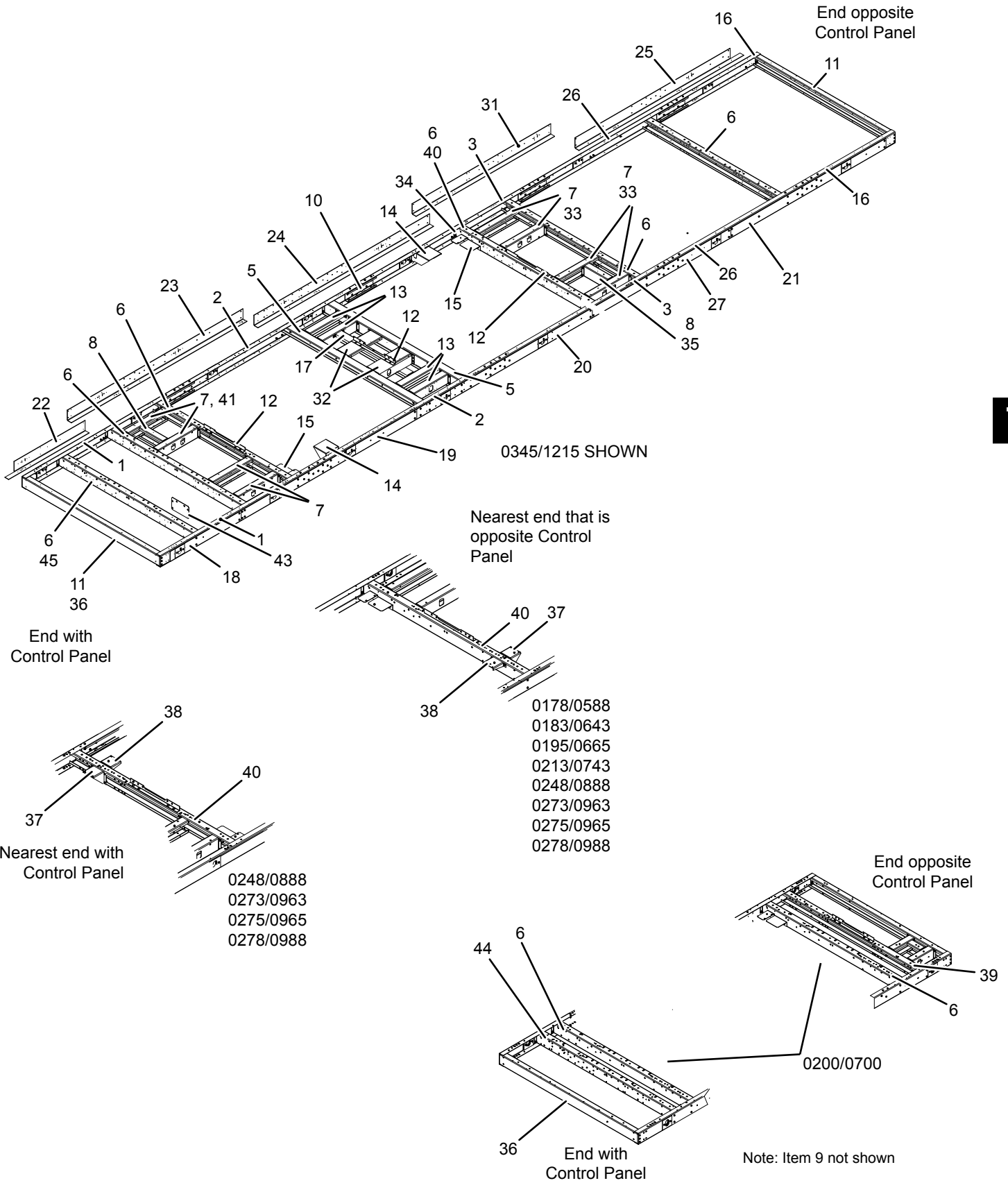

7

FIGURE 17 - BASE RAIL COMPONENTS

LD15197

**TABLE 24 - FRAME COMPONENTS, ALL MODELS**

ITEM	MODEL	DESCRIPTION	PART NUMBER	QUANTITY	FIGURE
1	ALL	Leg, Support, Front Left	075 79555 000	1	18 - 19
2	ALL	Leg, Support, Front Right	075 79556 000	1	18 - 19
3	ALL	Leg, Support, Rear Right Hand	075 79557 000	1	18 - 19
4	ALL	Leg, Support, Rear Left Hand	075 79558 000	1	18 - 19
5	0153/0543 0200/0700	Leg, Support	075 79540 000	8	18 - 19
	0165/0565 0183/0643	Leg, Support	075 79540 000	10	
	0178/0588 0195/0665 0213/0743 0215/0765 0233/0843	Leg, Support	075 79540 000	12	
	0198/0688 0218/0788 0245/0865 0263/0943 thru 0275/0965	Leg, Support	075 79540 000	14	
	0248/0888 0278/0988 thru 0303/1093 0323/1143	Leg, Support	075 79540 000	16	
	0308/1088 0333/1173 thru 0343/1193	Leg, Support	075 79540 000	18	
	0345/1215	Leg, Support	075 79540 000	20	
6	0200/0700	Panel Cover, Wiring Tray	075 93308 000	2	18
7	0200/0700	Panel, Top Cover	075 93303 000	1	18
8	ALL except 0200/0700	Channel, Support, Side	075 79566 000	1	18 - 19
	0200/0700	Channel, Support, Side	075 79566 000	2	
9	ALL except 0200/0700	Channel, Support, Side	075 79565 000	1	18 - 19
	0200/0700	Channel, Support, Side	075 79565 000	2	
10	0308/1088 0333/1173 thru 0345/1215	Channel, Side, Coil Support	075 93306 000	2	18 - 19
11	ALL	Brace, Rear	075 93309 000	1	18 - 19
15	ALL except 0200/0700	Channel, Side, Coil Support	075 79533 000	1	18 - 19
	0200/0700	Channel, Side, Coil Support	075 93304 000	1	
16	0165/0565, 0183/0643	Channel, Side, Coil Support	075 79539 000	2	18 - 19
	0178/0588 0195/0665 thru 0198/0688 0213/0743 thru 0343/1193	Channel, Side, Coil Support	075 79539 000	4	
	0200/0700	Channel, Side, Coil Support	075 94073 000	2	
17	0153/0543	Channel Side Coil Support	092 03247 000	1	18 - 19
	0165/0565 0183/0643	Channel, Side, Coil Support	075 79541 000	1	
	0178/0588 0195/0665 thru 0245/0865 0263/0943 thru 0275/0965	Channel, Side, Coil Support	075 93244 000	1	
	0248/0888 0278/0988 thru 0345/1215	Channel, Side, Coil Support	075 89876 000	1	

**TABLE 24 - FRAME COMPONENTS, ALL MODELS (CONT'D)**

ITEM	MODEL	DESCRIPTION	PART NUMBER	QUANTITY	FIGURE
18	ALL except 0200/0700	Channel, Side, Coil Support	075 79572 000	1	18 - 19
	0200/0700	Channel, Side, Coil Support	075 93305 000	1	
19	0153/0543	Channel, Side, Coil Support	092 03248 000	1	18 - 19
	0165/0565 0183/0643	Channel, Side, Coil Support	075 79573 000	1	
	0198/0688 0200/0700 0218/0788 0245/0865 0263/0943 thru 0275/0965	Channel, Side, Coil Support	075 93245 000	1	
	0178/0588 0195/0665 0213/0743 thru 0215/0765 0233/0843	Channel, Side, Coil Support	075 93739 000	1	
	0248/0888 0278/0988 thru 0345/1215	Channel, Side, Coil Support	075 89877 000	1	
20	0153/0543	Plate, Splice	075 79574 000	2	18 - 19
	0165/0565 0183/0643,0200/0700	Plate, Splice	075 79574 000	4	
	0178/0588 0195/0665 thru 0198/0688 0213/0743 thru 0303/1093 0323/1143	Plate, Splice	075 79574 000	6	
	0308/1088 0333/1173 thru 0345/1215	Plate, Splice	075 79574 000	8	
21	ALL	Panel Cover, Wiring Tray	075 79567 000	2	18 - 19
22	ALL	Panel Cover, Wiring Tray	075 79568 000	2	18 - 19
23	0153/0543 thru 0195/0665 0200/0700 thru 0215/0765 0233/0843	Panel Cover, Wiring Tray	075 93307 000	2	18 - 19
	0198/0688 0218/0788 0245/0865 thru 0343/1193	Panel Cover, Wiring Tray	075 79569 000	4	
	0345/1215	Panel Cover, Wiring Tray	075 79569 000	6	
24	ALL	Panel Cover, Wiring Tray	075 79570 000	2	18 - 19
25	0178/0588 0195/0665 thru 0198/0688 0213/0743 thru 0245/0865 0263/0943 thru 0275/0965	Bracket, Support	075 65645 000	4	19
	0248/0888 0278/0988 thru 0303/1093 0323/1143	Bracket, Support	075 65645 000	10	
	0308/1088 0333/1173 thru 0345/1215	Bracket, Support	075 65645 000	8	
26	0333/1173 thru 0343/1193	Channel, Side Coil Support	075 93306 000	2	19

7

**TABLE 24 - FRAME COMPONENTS, ALL MODELS (CONT'D)**

ITEM	MODEL	DESCRIPTION	PART NUMBER	QUANTITY	FIGURE
48	0200/0700	Screw, Thread (not shown)	021 19309 000	80	*
	0153/0543 thru 0165/0565 0183/0643			88	
	0178/0588,0195/0665 0213/0743 thru 0215/0765 0233/0843			104	
	0198/0688 0218/0788 0245/0865 0263/0943 thru 0275/0965			120	
	0248/0888 0278/0988 thru 0323/1143			136	
	0333/1173 thru 0343/1193			152	
	0345/1215			168	

**NOTE:** Items with an \* are not represented.

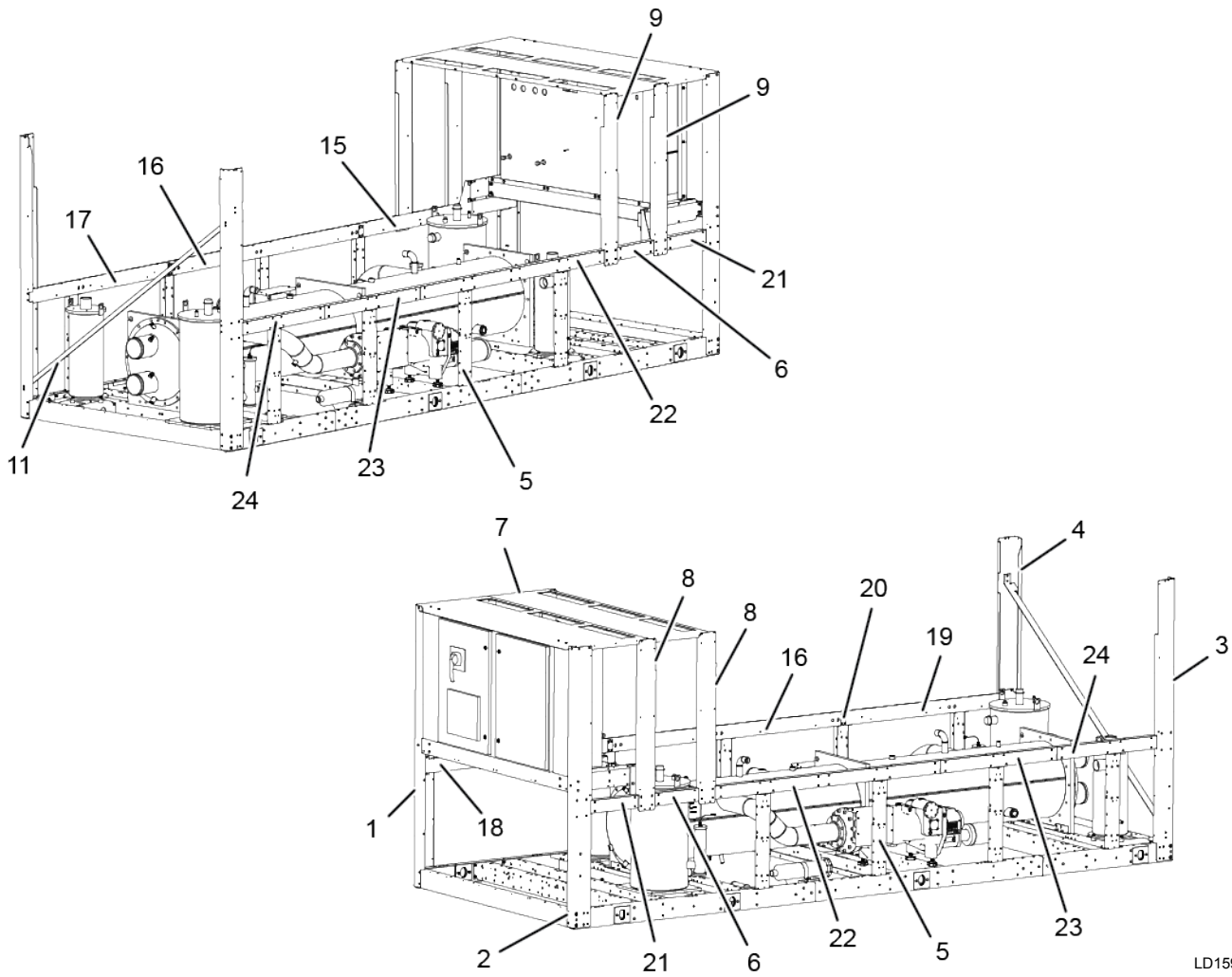

**FIGURE 18 - FRAME COMPONENTS - MODEL 0200/0700**

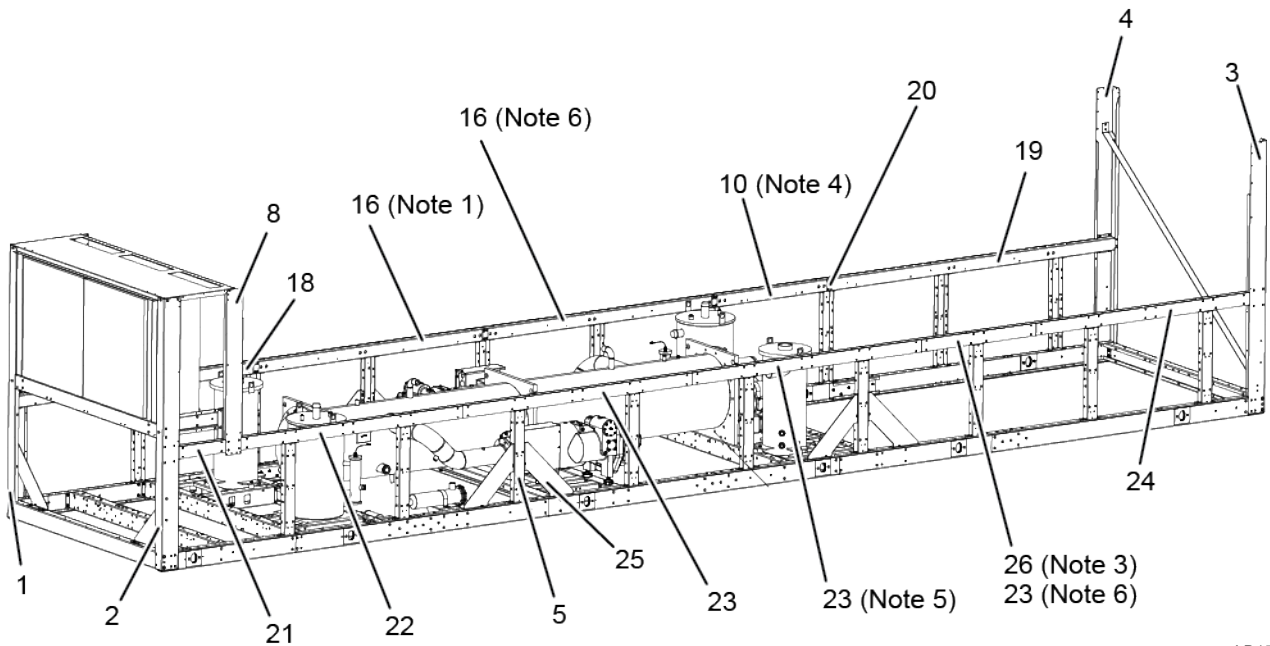
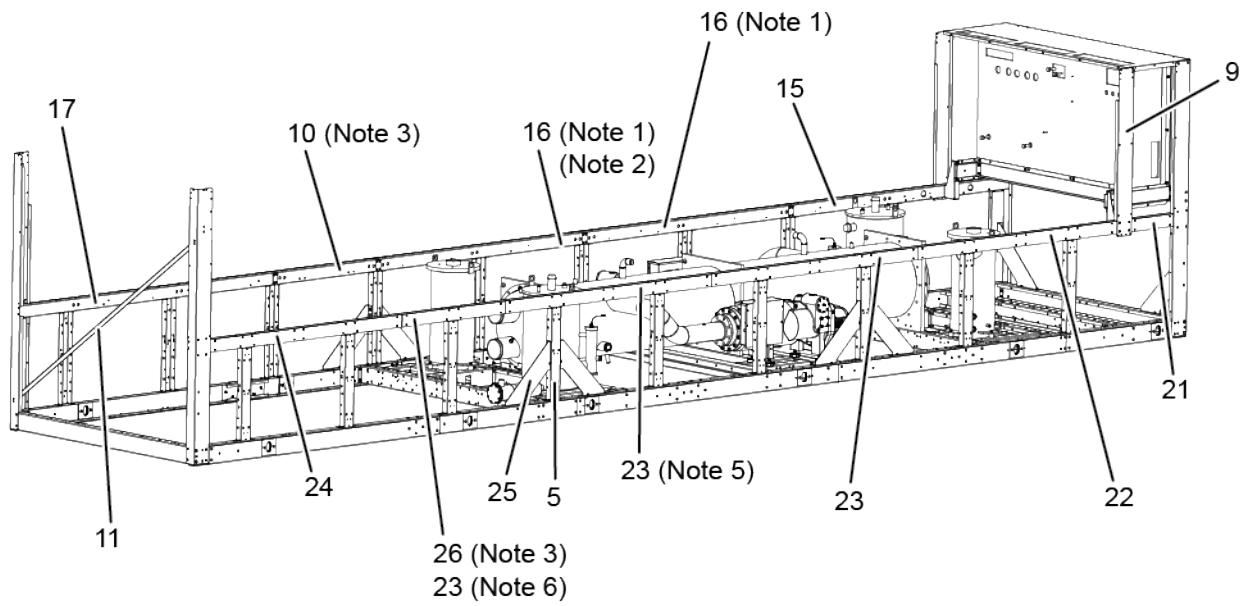

0333/1173 shown

LD15921

Notes:

1. Not used on 0153/0543.
2. The 2nd item 16 is not used on 0165/0565 , 0183/0643 and 0200/0700.
3. Used on models 0333/1173 thru 0343/1193 only.
4. Used on models 0198/0688, 0218/0788 and 0245/0865 only.
5. The 2nd Item 23 is used on 0198/0688, 0218/0788, 0245/0865 thru 0343/1193 and 0345/1215 only.
6. The 3rd Item 23 is used on 0345/1215 only.

**FIGURE 19 - FRAME COMPONENTS - ALL MODELS EXCEPT 0200/0700**

THIS PAGE INTENTIONALLY LEFT BLANK

## SECTION 8 - OIL SEPARATOR AND FLASH TANK

**TABLE 25 - OIL SEPARATOR/ FLASH TANK (PED) \***

ITEM	MODELS	DESCRIPTION	PART NUMBER	QUANTITY	FIGURE
401	0153/0543 thru 0165/0565 0183/0643	Flash Tank, 14" O.D., PED	375 79551 990	2	20
	0195/0665 thru 0198/0688 0213/0743 0233/0843 0263/0943				
	0178/0588 0200/0700				
	0215/0765 thru 0218/0788 0245/0865 thru 0248/0888 0273/0963 thru 0278/0988 0303/1093 thru 0345/1215				
	Flash Tank, 18" O.D., PED				
402	0153/0543 thru 0178/0588	Oil Separator, 8" O.D. PED	375 93290 990	2	20
402	0183/0643	Oil Separator, 10"O.D. PED	375 79591 990	1	
402	0195/0665 thru 0278/0988	Oil Separator, 10"O.D. PED	375 79591 990	2	
402	0303/1093 thru 0308/1088	Oil Separator, 14"O.D. PED	375 89951 990	1	
402	0323/1143 thru 0345/1215	Oil Separator, 14"O.D. PED	375 89951 990	2	
403	0183/0643	Oil Separator, 8" O.D. PED	375 93290 990	1	
403	0303/1093 thru 0308/1088	Oil Separator, 10"O.D. PED	375 79591 990	1	

**TABLE 26 - OIL SEPARATOR/ FLASH TANK / (ASME)**

ITEM	MODELS	DESCRIPTION	PART NUMBER	QUANTITY	FIGURE
13	0183/0643 thru 0308/1088	Plug, Sight Glass	026 46487 000	2	20
14	0183/0643 thru 0308/1088	O-Ring, Hnbr	028 16331 000	2	20
401	0165/0565 0195/0665 thru 0198/0688 0233/0843	Tank, Flash, 14" O.D.	375 79551 000	2	20
	0263/0943 thru 0273/0963				
	0178/0588 0200/0700				
401	0215/0765 thru 0218/0788 0245/0865 thru 0248/0888 0275/0965 thru 0345/1215	Tank, Flash 18" O.D.	375 89884 000	2	20
	0183/0643				
	0195/0665 thru 0278/0988				
	0303/1093 thru 0308/1088				
402	0183/0643	Oil Separator	375 79591 000	1	20
402	0195/0665 thru 0278/0988	Oil Separator	375 79591 000	2	
402	0303/1093 thru 0308/1088	Oil Separator	375 89951 000	1	
402	0333/1173 thru 0345/1215	Oil Separator	375 89951 000	2	
402	0153/0543 thru 0178/0588 0323/1143	Oil Separator	375 93290 000	2	
403	0183/0643	Oil Separator	375 93290 000	1	20
403	0303/1093 0308/1088	Oil Separator	375 79591 000	1	

Notes: \* European Pressure Equipment Directive

**TABLE 27 - RELIEF KIT COMPONENTS**

ITEM	MODEL	DESCRIPTION	PART NUMBER	QUANTITY	FIGURE
1	0153/0543 thru 0165/0565 0183/0643 thru 0198/0688 0213/0743 0233/0843 0263/0943	Valve, Relief, 1/2 NPTE" X 5/8	022 11312 000	2	20
	0178/0588 0200/0700 0215/0765 thru 0218/0788 0245/0865 thru 0248/0888 0273/0963 thru 0345/1215	Valve, Relief, 1/2" NPT, 235 Psig	022 12080 000	2	20
2	all	Tube, Relief Valve, DXST	375 30919 000	2	20
3	all	Valve, Relief, 3/8 NPTE X 1/2	022 12045 000	4	20
4	all	Tube, Relief Valve, DXST	375 37978 000	4	20
5	all	Pressure Switch, UL	375 66947 001	1	*
6	0183/0643	Line Relief, Oil Separator	092 02090 012	1	21
	0195/0665 0213/0743	Line Relief, Oil Separator	092 02090 021	1	21
	0200/0700	Line Relief, Oil Separator	092 02090 013	1	21
	0303/1093 thru 0308/1088	Line Relief, Oil Separator	092 02090 000	1	21
10	0153/0543	Line Relief, Evaporator	092 02090 010	2	21
	0165/0565	Line Relief, Evaporator	092 02090 004	2	21
	0178/0588 0215/0765 thru 0218/0788 0248/0888 0303/1093 0333/1173	Line Relief, Evaporator	092 02090 006	2	21
	0183/0643	Line Relief, Evaporator	092 02090 011	1	21
	0195/0665 0213/0743	Line Relief, Evaporator	092 02090 002	1	21
	0198/0688	Line Relief, Evaporator	092 02090 030	1	21
	0200/0700	Line Relief, Evaporator	092 02090 016	1	21
	0233/0843 0263/0943	Line Relief, Evaporator	092 02090 004	1	21
	0245/0865	Line Relief, Evaporator	092 02090 006	1	21
	0273/0963	Line Relief, Evaporator	092 02090 028	2	21
	0275/0965 thru 0278/0988 0308/1088 0323/1143 0343/1193	Line Relief, Evaporator	092 02090 007	2	21
	0345/1215	Line Relief, Evaporator	092 02090 025	2	21
	11	0153/0543	Line Relief, Oil Separator	092 02090 008	2
0165/0565 0198/0688 215/0765 thru 0278/0988		Line Relief, Oil Separator	092 02090 000	2	21
0178/0588		Line Relief, Oil Separator	092 02090 012	2	21

NOTE: Items with an \* are not represented.



**TABLE 27 - RELIEF KIT COMPONENTS (CONT'D)**

ITEM	MODEL	DESCRIPTION	PART NUMBER	QUANTITY	FIGURE
11	0183/0643 thru 0195/0665 0200/0700 thru 0213/0743	Line Relief, Oil Separator	092 02090 000	1	21
	0303/1093 thru 0308/1088	Line Relief, Oil Separator	092 02090 023	1	21
	0323/1143 thru 0345/1215	Line Relief, Oil Separator	092 02090 023	2	21
12	0153/0543 0198/0688	Line Relief, Flash Tank	092 02090 009	2	21
	0165/0565	Line Relief, Flash Tank	092 02090 022	1	21
	0178/0588 0215/0765 thru 0218/0788 0248/0888	Line Relief, Flash Tank	092 02090 020	2	21
	0183/0643	Line Relief, Flash Tank	092 02090 019	1	21
	0195/0665 0213/0743	Line Relief, Flash Tank	092 02090 001	1	21
	0200/0700	Line Relief, Flash Tank	092 02090 015	1	21
	0233/0843 0263/0943	Line Relief, Flash Tank	092 02090 014	1	21
	0245/0865	Line Relief, Flash Tank	092 02090 020	1	21
	0345/1215	Line Relief, Flash Tank	092 02090 024	2	21
	0165/0565	Line Relief, Flash Tank	092 02090 031	1	21
13	0183/0643 thru 0195/0665 0213/0743 0233/0843 0263/0943	Line Relief, Flash Tank	092 02090 009	1	21
	0200/0700 0245/0865	Line Relief, Flash Tank	092 02090 017	1	21
	0165/0565	Line Relief, Evaporator	092 02090 032	1	21
14	0183/0643 thru 0195/0665 0213/0743	Line Relief, Evaporator	092 02090 029	1	21
	0198/0688 0233/0843 0263/0943	Line Relief, Evaporator	092 02090 027	1	21
	0200/0700 0245/0865	Line Relief, Evaporator	092 02090 018	1	21
	all	Valve, 3/8" 3-Way Dual Shut Off	022 11716 000	4	21
25	all	Valve, Relief, 3/8 NPTE X 1/2	022 12045 000	8	21
26	all	Tube, Relief Valve, DXST	375 37978 000	8	21
27	all	Valve, 1/2", 3-Way Dual Shut Off	022 11717 000	2	21
28	all	Valve, Relief, 1/2 NPTE X 5/8	022 11312 000	4	21
29	all	Tube, Relief Valve, DXST	375 30919 000	4	21
030	all	Pressure Switch UL	375 66947 001	1	21
104*	all	Pressure Switch, CE PED	375 94077 990	1	21

NOTE: Items with an \* are not represented.

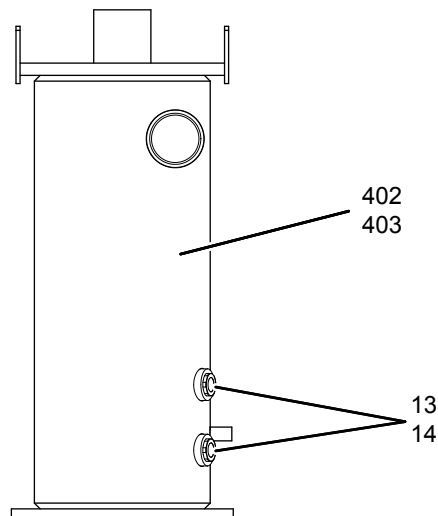
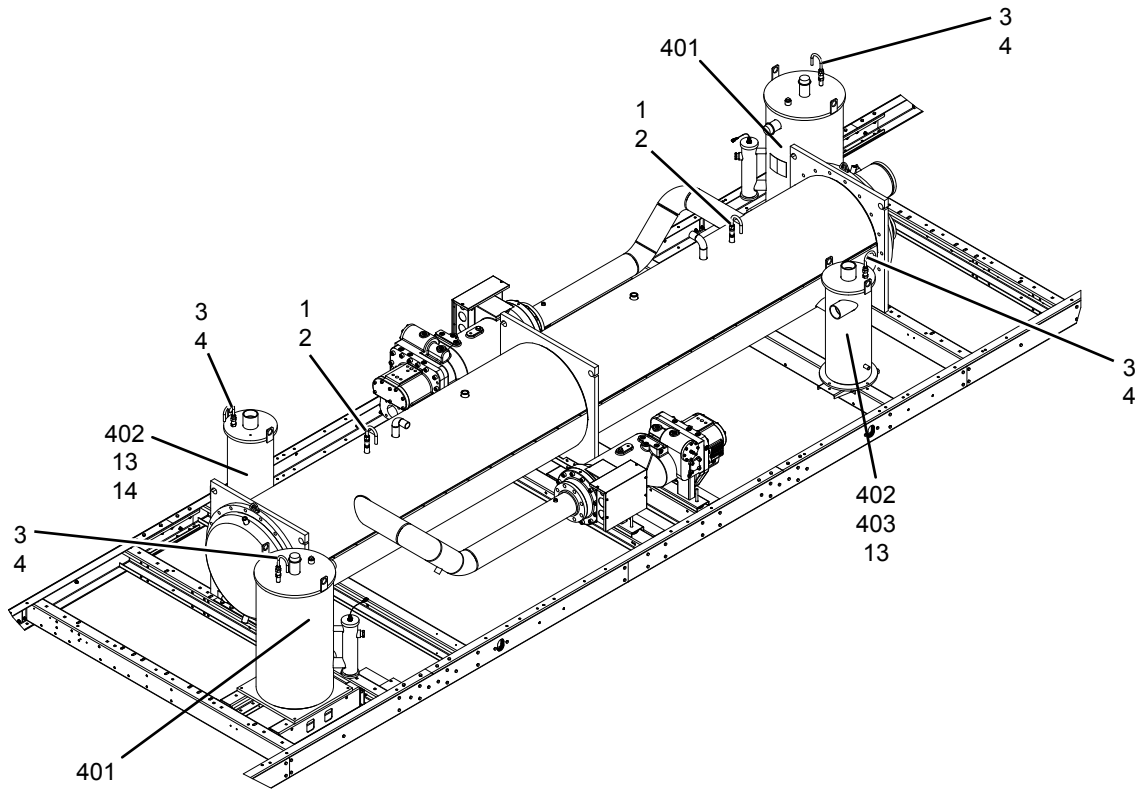

**FIGURE 20 - OIL SEPARATOR/ FLASH TANK (ASME / PED)**

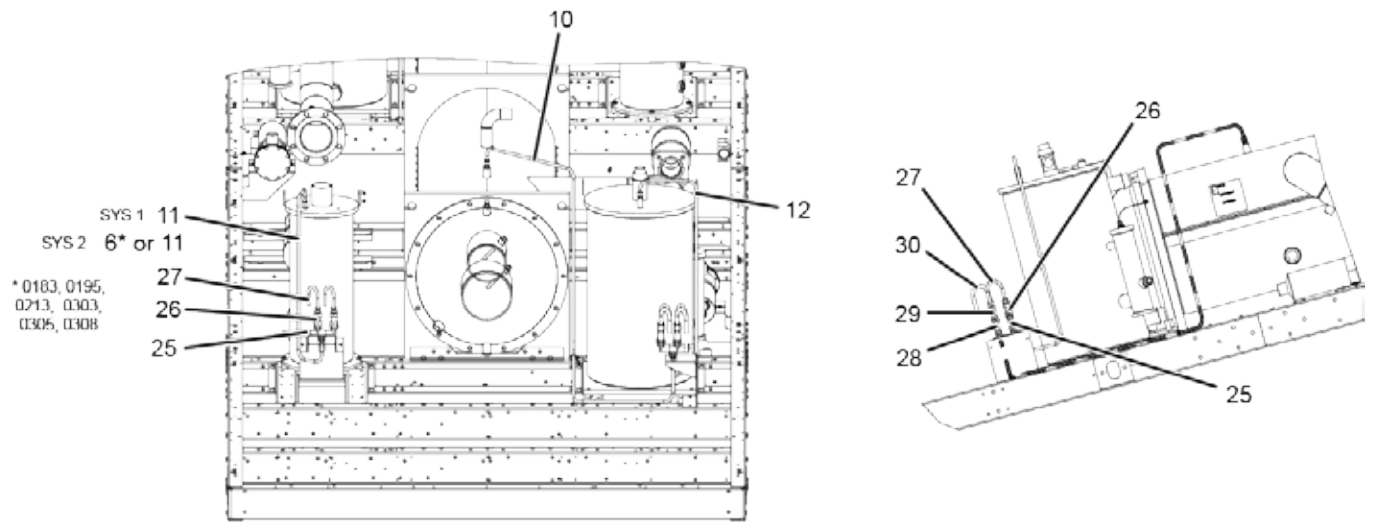

SYSTEM 1 AND 2

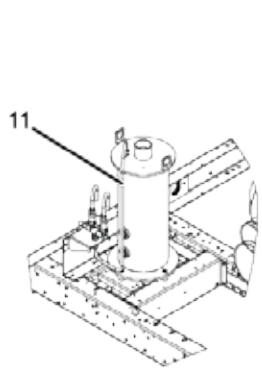

0153 oil separator arrangement for both system 1 and 2.

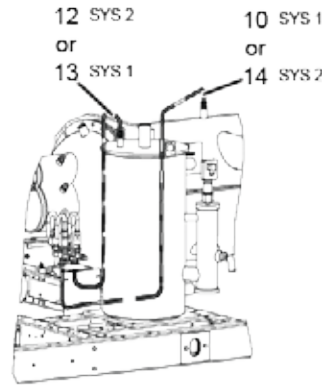

0165 evaporator and flash tank arrangement for both system 1 and 2.

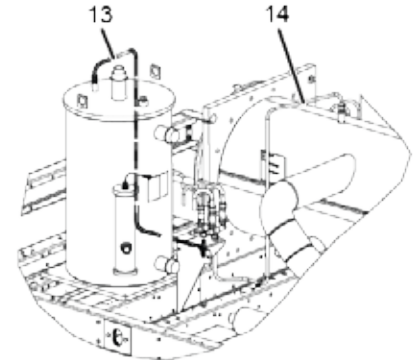

0200 and 0245 evaporator and flash tank arrangement for system 2.

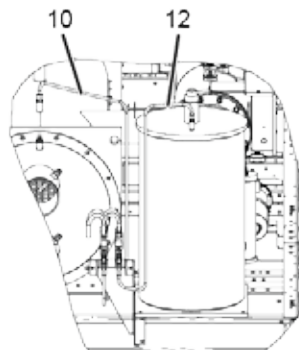

0183 and 0200 evaporator and flash tank arrangement for system 1.

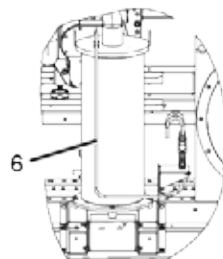

0200 oil separator arrangement for system 2.

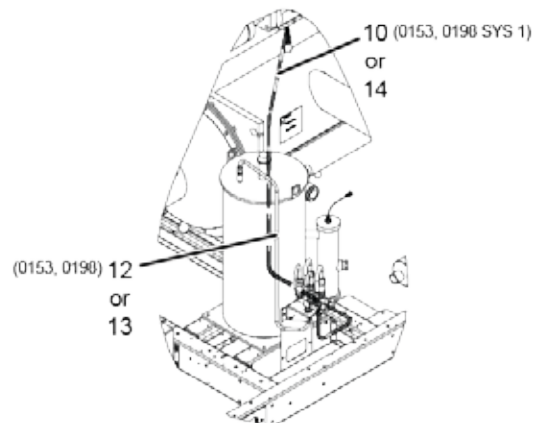

0153 and 0198 evaporator and flash tank arrangement for both system 1 and 2.  
 0183, 0213, 0233, 0263 system 2.

8

FIGURE 21 - RELIEF KIT COMPONENTS

LD15928

THIS PAGE INTENTIONALLY LEFT BLANK

## SECTION 9 - SENSORS

**TABLE 28 - SENSORS/SYSTEM WIRING COMPONENTS**

ITEM	MODEL	DESCRIPTION	PART NUMBER	QUANTITY	FIGURE
1	ALL	Sensor, Temperature, 3000 Ohms	025 40334 000	2	26
2	ALL	Compound, Heat Conductive, 4 Oz	013 00898 000	A/R	26
4	ALL	Sensor, Temperature, 3000 Ohms	025 28935 000	4	23, 24, 25
6	ALL	Assembly, Outside Air Temperature Sensor	371 01180 223	1	22
14	ALL	Gasket, Sensor Harness	028 15272 000	1	22
16	ALL	Transducer, 0-400 Psi, 5V Input	025 29139 001	4	23, 24, 26
17	ALL	Valve, Transducer 1/4"	022 09503 000	4	23, 24, 26
228	0248/0888 0303/1093	Switch, Liquid Level	025 43324 100	2	*

**NOTE:** Items with an \* are not represented.

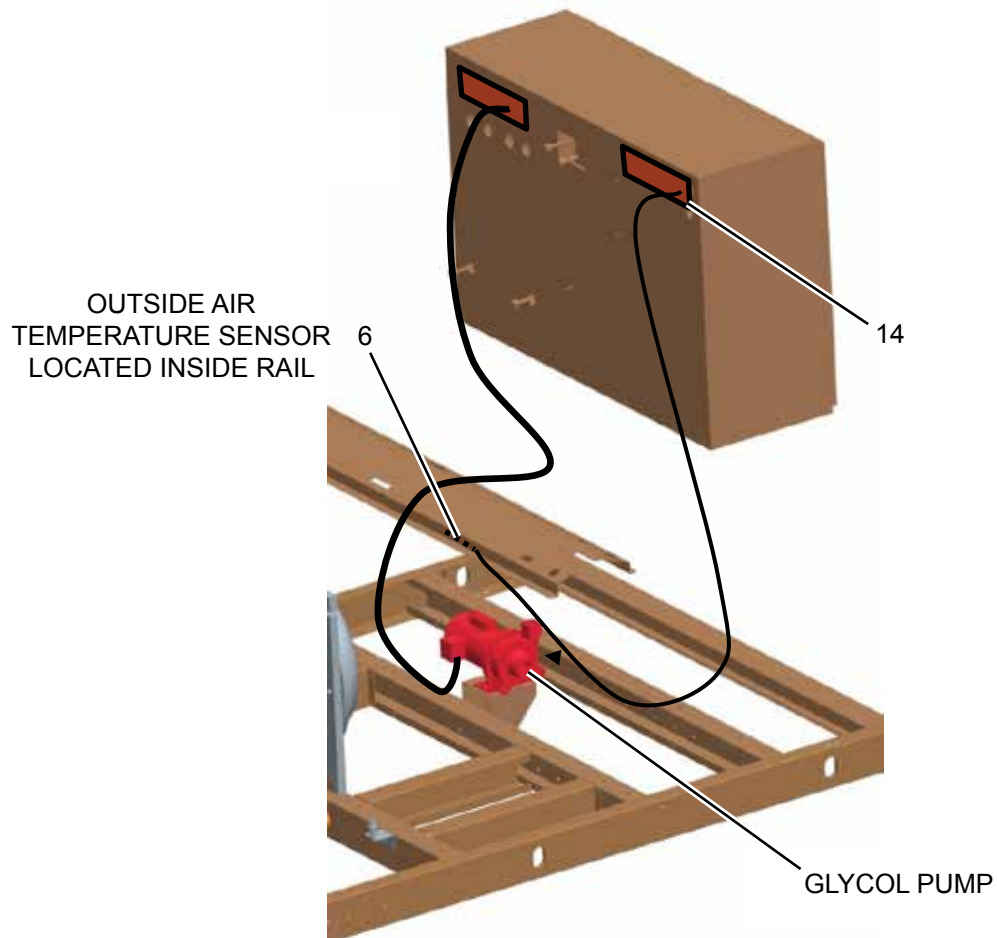

LD15924

**FIGURE 22 - SENSOR AND GASKET LOCATIONS - GLYCOL PUMP**

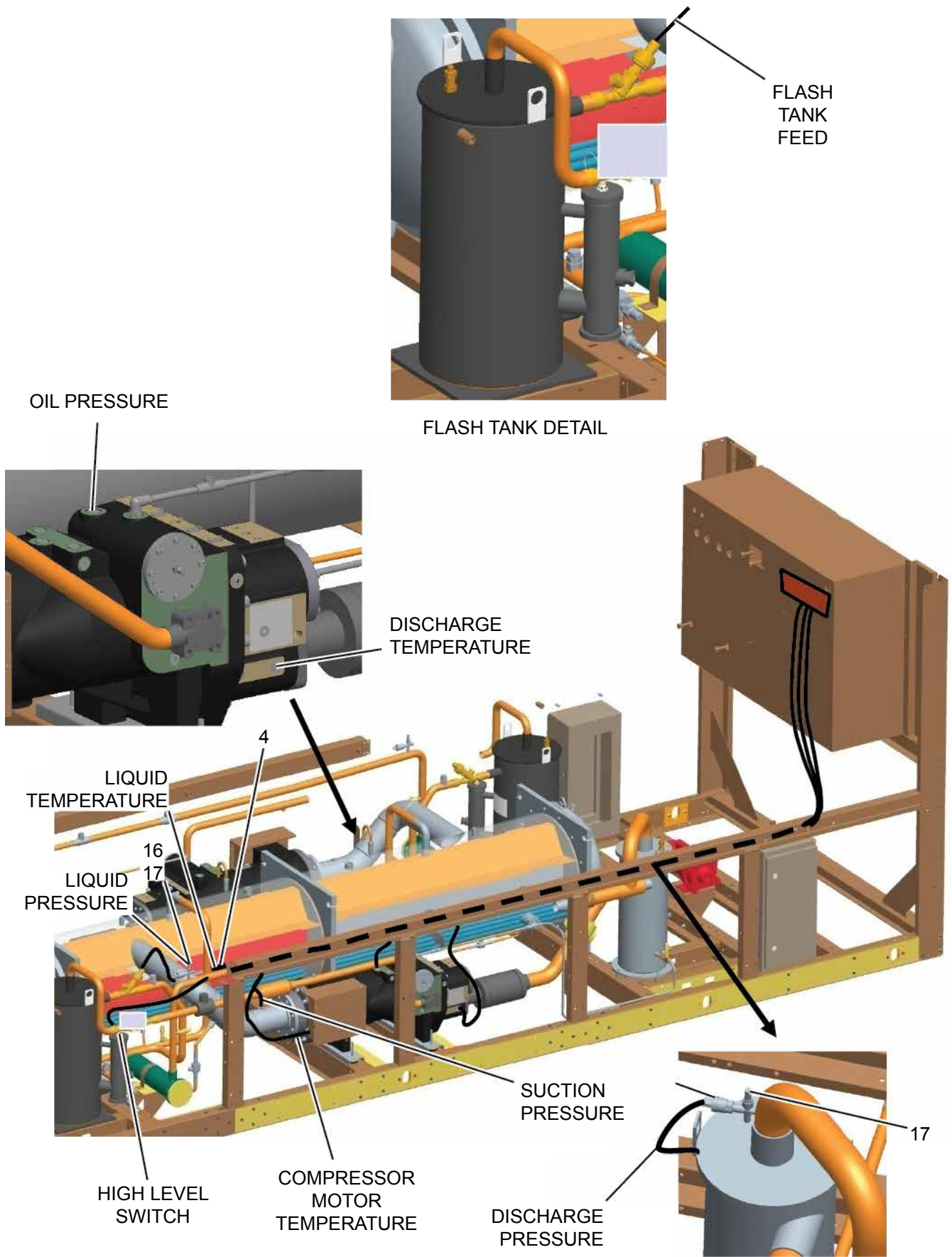

LD15925

**FIGURE 23 - SENSOR, TRANSDUCER, AND VALVE LOCATIONS, SYSTEM 1**

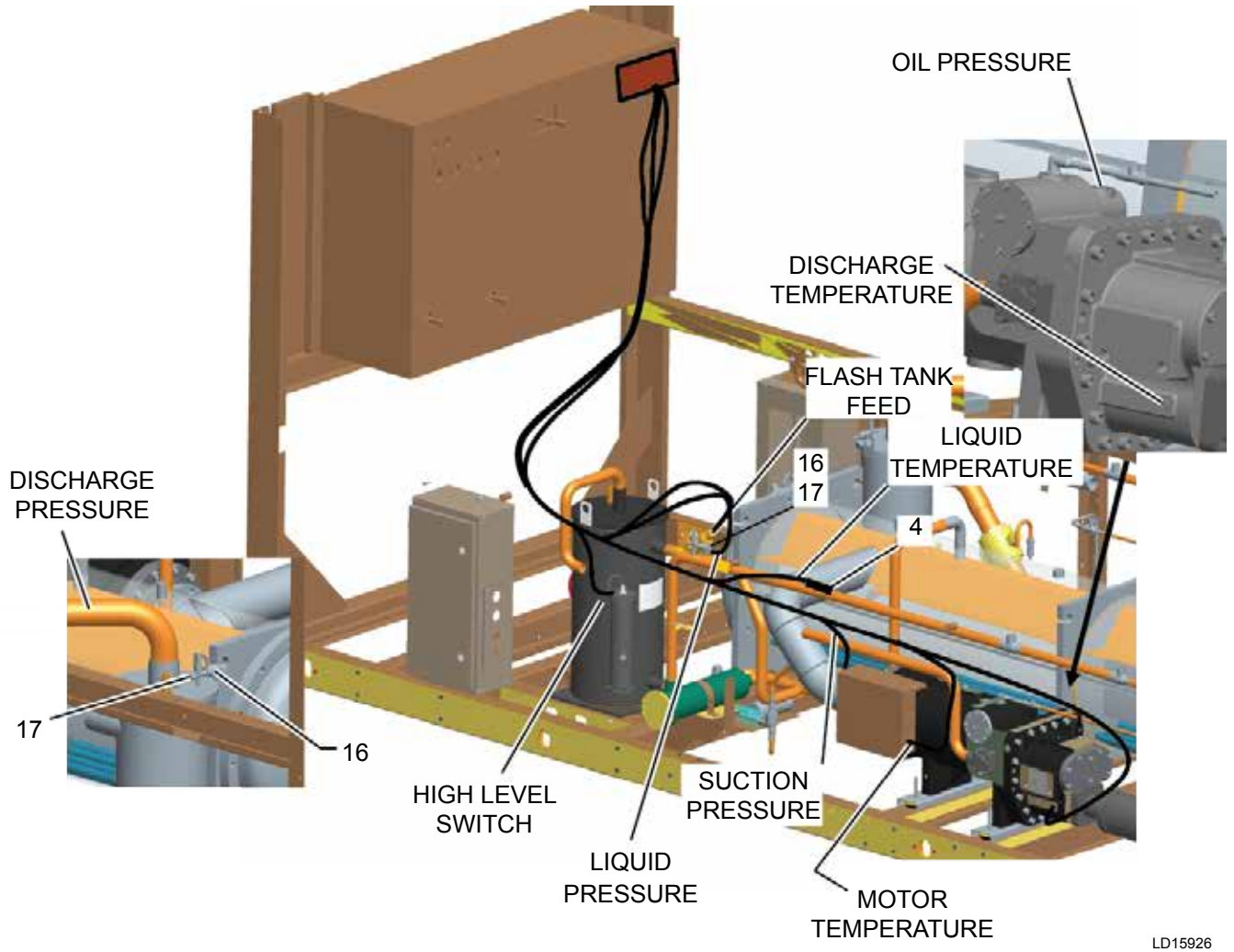

LD15926

**FIGURE 24 - SENSOR, TRANSDUCER, AND VALVE LOCATIONS, SYSTEM 2**



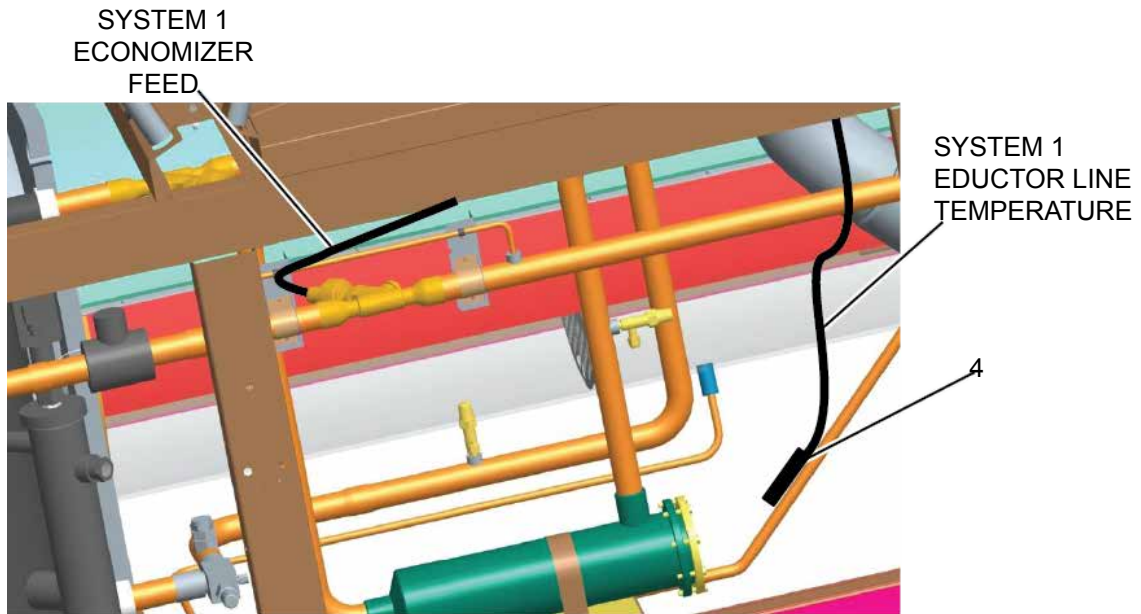

SYSTEM 1 ECONOMIZER FEED VALVE AND EDUCTOR LINE TEMPERATURE SENSOR

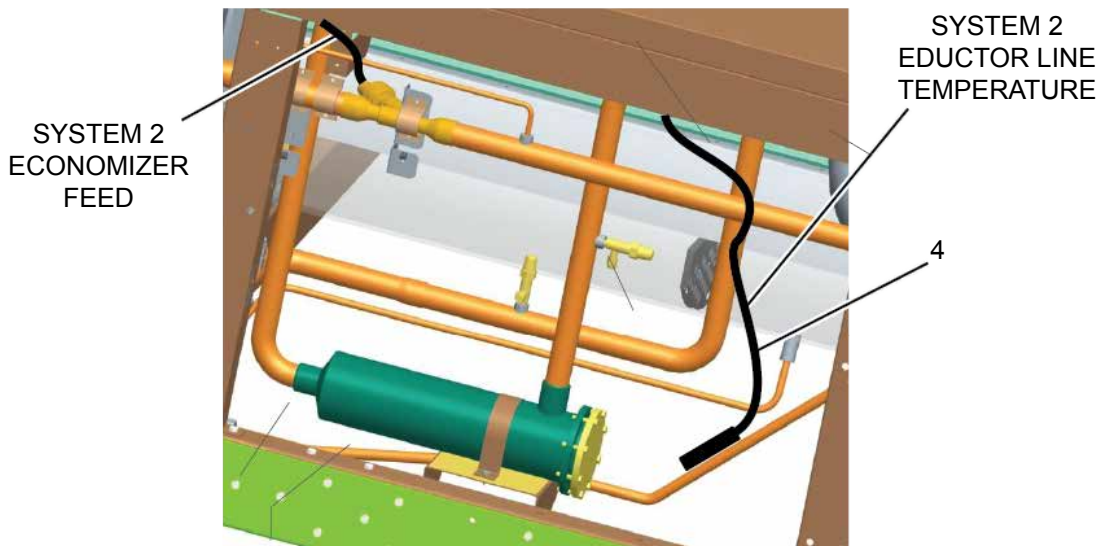

SYSTEM 2 ECONOMIZER FEED VALVE AND EDUCTOR LINE TEMPERATURE SENSOR

LD15927

**FIGURE 25 - SENSOR LOCATIONS, ECONOMIZER FEED VALVE AND EDUCTOR, SYSTEM 1 AND 2**



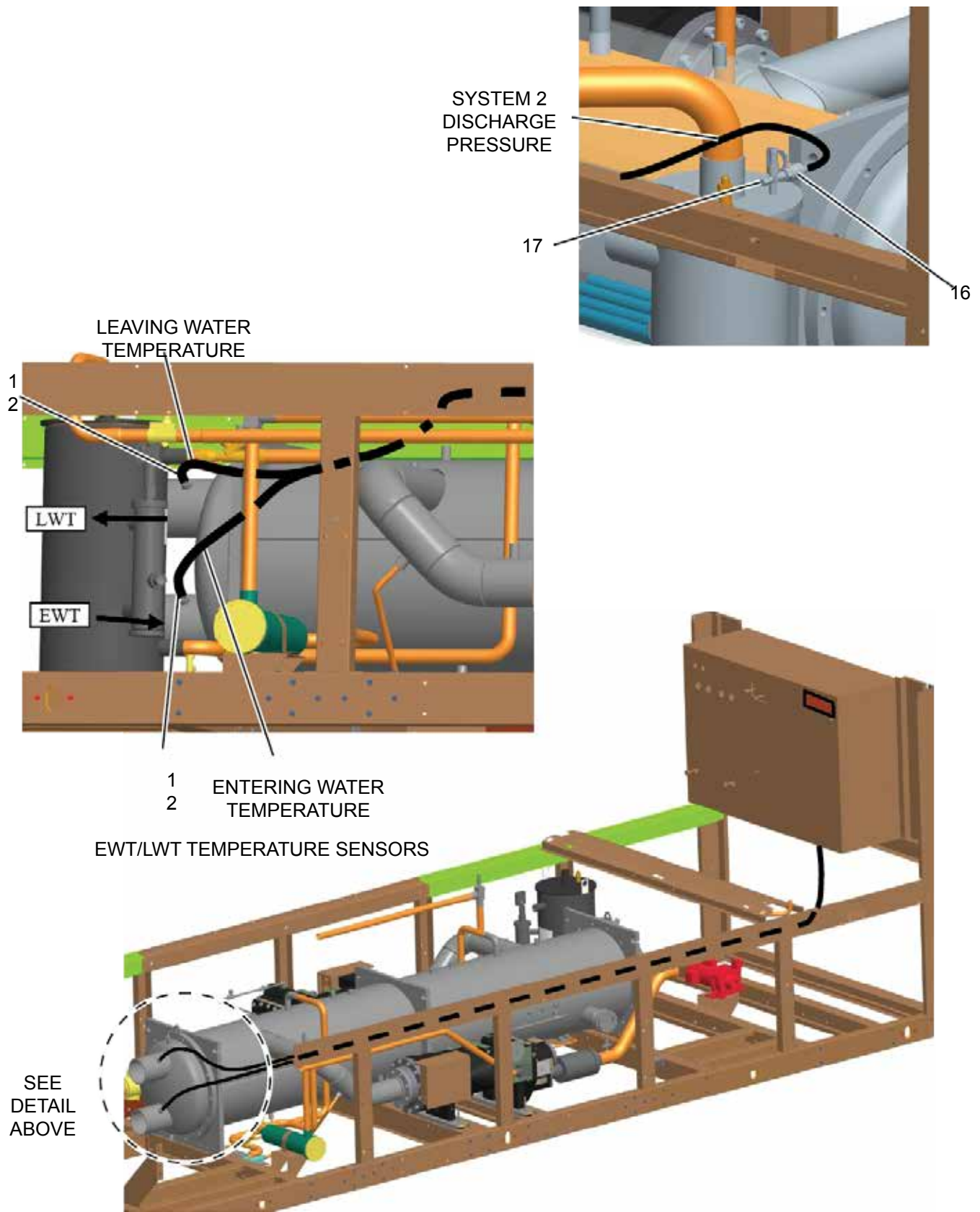

9



**FIGURE 26 - SENSOR LOCATIONS, ENTERING/LEAVING WATER TEMPERATURE AND SYSTEM 2 DISCHARGE PRESSURE**

LD16175













TABLE 29 - SYSTEM #1 SENSOR WIRING

PLUG DETAIL	PLUG AND PIN P/N	PLUG "P" NO.	PLUG PIN NO.	WIRE COLOR	CABLE CODE	FUNCTION	HARNESS ASSEMBLY PART NUMBERS		
	Plug = 025-28383-000  Pin = 025-28386-000	P26	1	Green	4	System #1 Compressor Motor Temperature	575 77880 317		
			2	Red			575 77880 343		
3	Black	575 77880 369							
4	White	575 77880 422							
5	Drain	575 77880 900							
			6	Black	9	System #1 High level Switch	575 77880 327		
			7	Red			575 77880 357		
			8	Drain			575 77880 370		
							575 77880 423		
							575 77880 907		
	Plug = 025-29185-000  Pin = 025-28386-000	P27	1	Black	6	System #1 Condenser Liquid Temperature	575 77880 308		
			2	Red			575 77880 358		
			3	Drain			575 77880 371		
							575 77880 424		
							575 77880 901		
	Plug = 025-28384-000  Pin = 025-28386-000	P28	1	Black	8	System #1 Discharge Temperature	575 77880 310		
			2	Red			575 77880 345		
			3	Drain			575 77880 372		
					5	Green	22	System #1 Economizer Feed	575 77880 425
					6	Red			575 77880 908
					7	Black			575 77880 361
					8	White			575 77880 365
					9	Green	23	System #1 Flash Tank Feed	575 77880 373
					10	Red			575 77880 426
			11	Black	575 77880 909				
			12	White	575 77880 320				
							575 77880 359		
							575 77880 374		
							575 77880 427		
							575 77880 910		
	Plug = 025-28385-000  Pin = 025-28386-000	P29	1	White	10	System #1 Suction Pressure	575 77880 302		
			2	Red			575 77880 347		
			3	Black			575 77880 375		
			4	Drain			575 77880 428		
					6	White	11	System #1 Oil Pressure	575 77880 902
					7	Red			575 77880 304
					8	Black			575 77880 349
					9	Drain			575 77880 376
									575 77880 429
									575 77880 911
									575 77880 912
					11	White	12	System #1 Discharge Pressure	575 77880 306
			12	Red	575 77880 355				
			13	Black	575 77880 377				
			14	Drain	575 77880 430				
							575 77880 700		
							575 77880 912		

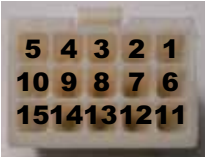

**TABLE 29 - SYSTEM #1 SENSOR WIRING (CONT'D)**

PLUG DETAIL	PLUG AND PIN P/N	PLUG "P" NO.	PLUG PIN NO.	WIRE COLOR	CABLE CODE	FUNCTION	HARNESS ASSEMBLY PART NUMBERS
	Plug = 025-29185-000  Pin = 025-28386-000	P49	1 2 3	Black Red Drain	27	System #1 Eductor Line	575 77880 363 575 77880 367 575 77880 392 575 77880 445 575 77880 923
	Plug = 025-28959-000  Pin = 025-28386-000	P76	1 2 3 4	White Red Black Drain	49	System #1 Liquid Pressure	575 77880 325 575 77880 360 575 77880 390 575 77880 443 575 77880 906

**TABLE 30 - SYSTEM #2 SENSOR WIRING**

PLUG DETAIL	PLUG AND PIN P/N	PLUG "P" NO.	PLUG PIN NO.	WIRE COLOR	CABLE CODE	FUNCTION	HARNESS ASSEMBLY PART NUMBER
	Plug = 025-28383-001  Pin = 025-28386-000	P30	1	Green	5	System #2 Compressor Motor Temperature	575 77880 318
			2	Red			575 77880 344
	Plug = 025-29185-001  Pin = 025-28386-000	P31	3	Black	13	System #2 Condenser Liquid Temperature	575 77880 378
			4	White			575 77880 431
	Plug = 025-28384-001  Pin = 025-28386-000	P32	5	Black	15	System #2 Discharge Temperature	575 77880 913
			6	Red			575 77880 328
	Plug = 025-28383-001  Pin = 025-28386-000	P30	7	Black	16	System #2 High Level Switch	575 77880 379
			8	Red			575 77880 395
	Plug = 025-28384-001  Pin = 025-28386-000	P32	8	Drain	20	System #2 Economizer Feed	575 77880 432
			9	White			575 77880 914
	Plug = 025-28384-001  Pin = 025-28386-000	P32	10	Green	21	System #2 Flash Tank Feed	575 77880 311
			11	Red			575 77880 346
	Plug = 025-28384-001  Pin = 025-28386-000	P32	12	Black	21	System #2 Flash Tank Feed	575 77880 381
			1	White			575 77880 434
	Plug = 025-28384-001  Pin = 025-28386-000	P32	2	Green	21	System #2 Flash Tank Feed	575 77880 916
			3	Red			575 77880 362
	Plug = 025-28384-001  Pin = 025-28386-000	P32	4	Black	21	System #2 Flash Tank Feed	575 77880 366
			5	White			575 77880 382
	Plug = 025-28384-001  Pin = 025-28386-000	P32	6	Green	21	System #2 Flash Tank Feed	575 77880 435
			7	Red			575 77880 917
	Plug = 025-28384-001  Pin = 025-28386-000	P32	8	Black	21	System #2 Flash Tank Feed	575 77880 322
			9	White			575 77880 383
	Plug = 025-28384-001  Pin = 025-28386-000	P32	10	Green	21	System #2 Flash Tank Feed	575 77880 397
			11	Red			575 77880 436
	Plug = 025-28384-001  Pin = 025-28386-000	P32	12	Black	21	System #2 Flash Tank Feed	575 77880 918
			1	White			575 77880 918

**TABLE 30 - SYSTEM #2 SENSOR WIRING (CONT'D)**

PLUG DETAIL	PLUG AND PIN P/N	PLUG "P" NO.	PLUG PIN NO.	WIRE COLOR	CABLE CODE	FUNCTION	HARNESS ASSEMBLY PART NUMBER
	Plug = 025-28385-001  Pin = 025-28386-000	P33	1	White	17	System #2 Suction Pressure	575 77880 303
			2	Red			575 77880 348
			3	Black			575 77880 384
			4	Drain			575 77880 437
			6	White	18	System #2 Oil Pressure	575 77880 305
			7	Red			575 77880 350
			8	Black			575 77880 385
			9	Drain	575 77880 438		
			11	White	19	System #2 Discharge Pressure	575 77880 307
12	Red	575 77880 356					
13	Black	575 77880 386					
14	Drain	575 77880 439					
575 77880 701	575 77880 903						
	Plug = 025-29185-000  Pin = 025-28386-000	P53	1	Black	38	System #2 Eductor Line	575 77880 364
2	Red	575 77880 368					
3	Drain	575 77880 393					
575 77880 446	575 77880 924						
	Plug = 025 28959 001  Pin = 025-28386-000	P77	1	White	50	System #2 Liquid Pressure	575 77880 326
2	Red	575 77880 391					
3	Black	575 77880 398					
4	Drain	575 77880 444					
575 77880 922							

**TABLE 31 - UNIT SENSOR WIRING**

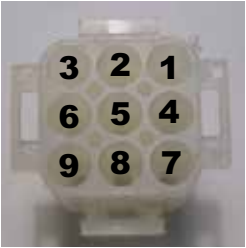
PLUG DETAIL	PLUG AND PIN P/N	PLUG "P" NO.	PLUG PIN NO.	WIRE COLOR	CABLE CODE	FUNCTION	HARNESS ASSEMBLY PART NUMBER			
	Plug = 025-21192-000  Pin = 025-19673-000	<b>P25</b>	1	Black	1	Leaving Water Temperature	575 77880 312			
			2	Red			575 77880 353			
			3	Drain			575 77880 387			
						4	Black	2	Entering Water Temperature	575 77880 440
						5	Red			575 77880 904
						6	Drain			575 77880 313
						7	Black	3	Outside Air Temperature	575 77880 354
						8	Red			575 77880 388
						9	Drain			575 77880 441
							575 77880 905			
							575 77880 314			

**TABLE 32 - UNIT CONTROL WIRING**

PLUG DETAIL	PLUG AND PIN P/N	PLUG "P" NO.	PLUG PIN NO.	WIRE COLOR	FUNCTION	HARNESS ASSEMBLY PART NUMBER
	Plug = 025-21417-000  Pin = 025-19673-000	<b>P36</b>	1	2	Cooler Heaters (3 HTR) (6 HTR)	575 77880 204
			2	29		
			3	34		
			4	Ground		

9

THIS PAGE INTENTIONALLY LEFT BLANK

## SECTION 10 - OPTIONS

**TABLE 33 - VIBRATION ISOLATORS**

<b>ONE INCH DEFLECTION SPRING ISOLATOR CROSS REFERENCE</b>				
<b>WEIGHT RANGE (LBS)</b>	<b>WEIGHT RANGE (KG.)</b>	<b>VENDOR PART NUMBER</b>	<b>COLOR</b>	<b>YORK PART NUMBER</b>
FOR UNITS WITH <b>ALL</b> POINT LOADS LESS THAN 1404 LBS. (637 KG)				
UP to 435 LBS	UP to 197	CP-1D-510	Black	029 25334 002
435 to 766 LBS	197 to 347	CP-1D-900	Dark Green	029 25334 003
766 to 1021 LBS	347 to 463	CP-1D-1200	Gray	029 25334 004
1021 to 1157 LBS	463 to 525	CP-1D-1360	White	029 25334 005
1157 to ***1785 LBS	525 to 810	CP-1D-1785N	Gray/Red	029 25334 006
FOR UNITS WITH <b>ANY</b> POINT LOADS LESS THAN 1404 LBS. (637 KG)				
UP to 1149 LBS	UP to 521	C2P-1D-1350	Dark Purple	029 25334 008
1149 to 1531 LBS	521 to 694	C2P -1D-1800	Dark Green	029 25334 009
1531 to 2041 LBS	694 to 926	C2P-1D-2400	Gray	029 25334 010
2041 to 2313 LBS	926 to 1049	C2P-1D-2720	White	029 25334 012
2313 to ***3570 LBS	1049 to 1619	C2P-1D-3570N	Gray/Red	029 25334 013

<b>NEOPRENE ISOLATOR CROSS REFERENCE</b>				
<b>**WEIGHT RANGE (LBS)</b>	<b>WEIGHT RANGE (KG.)</b>	<b>VENDOR PART NUMBER</b>	<b>COLOR</b>	<b>YORK PART NUMBER</b>
UP to 826 LBS	UP to 375	RD-3 Charcoal-WR	Charcoal	029 25335 001
826 to 1689 LBS	375 to 766	RD-4 Brick Red-WR	Brick Red	029 25335 002
1689 to ***4000 LBS	766 to 1814	RD-4 Charcoal-WR	Charcoal	029 25335 004

<b>TWO INCH DEFLECTION SEISMIC ISOLATOR CROSS REFERENCE</b>				
<b>WEIGHT RANGE (LBS)</b>	<b>WEIGHT RANGE (KG.)</b>	<b>VENDOR PART NUMBER</b>	<b>COLOR</b>	<b>YORK PART NUMBER</b>
UP to 392 LBS	UP to 178	Y2RSI-2D-460	Green	029 25336 006
392 to 605 LBS	178 to 274	Y2RSI-2D-710	Dark Brown	029 25336 008
605 to 741 LBS	274 to 336	Y2RSI-2D-870	Red	029 25336 009
741 to 1021 LBS	336 to 463	Y2RSI-2D-1200N	Red/Black	029 25336 010
1021 to 1438 LBS	463 to 652	Y2RSI-2D-1690	Pink	029 25336 011
1438 to 2245 LBS	652 to 1018	Y2RSI-2D-2640N	Pink/Gray	029 25336 012
2245 to 2619 LBS	1018 to 1188	Y2RSI-2D-2870N	Pink/Gray/Orange	029 25336 013
2619 to ***3740 LBS	1188 to 1696	Y2RSI-2D-3280N	Pink/Gray/Dark Brown	029 25336 014

Notes: \* Value is de-rated by 15%

\*\*Value is de-rated by 25%

\*\*\*Value is not de-rated

Isolators with 1" deflection (PIN 55=1) must be of the same class for the entire unit. IE. Must use C2P's at all locations on a selected unit, or all CP's.

10

**TABLE 34 - FIELD INSTALLED OPTION KITS**

MODEL	DESCRIPTION	PART NUMBER	QUANTITY
ALL	Differential Pressure Switch	025 03919 000	1, 2 or 3
ALL	Flow Switch, 150 PSIG DWP	024 26116 000	1, 2 or 3
ALL	Flow Switch, 300 PSIG DWP*	024 12144 000	1, 2 or 3
ALL	Thermal Dispersion Switch	375 94519 001	1, 2 or 3
0153/0543 thru 0165/0565 0183/0643 thru 0198/0688 0213/0743 0233/0843 0263/0943	Chicago Relief Kit (ASME)	375 89936 000	1
0178/0588 0200/0700 0215/0765 thru 0218/0788 0245/0865 thru 0248/0888 0273/0963 thru 0345/1215		392 03015 000	
0153/0543 thru 0273/0963 0303/1093 0333/1173	Kit, Victaulic Flange, 6 Connector	023 19049 000	1
0275/0965 thru 0278/0988 0323/1143 0308/1088 0343/1193 thru 0345/1215	Kit, Victaulic Flange, 8 Connector	023 19046 000	1

Note: \* Option has not yet been designed



**TABLE 35 - WIRE ENCLOSURE KITS**

<b>PIN 54 = X ( NO SELECTION) OR E (ECONOMICAL LOW NOISE KITS)</b>				
<b>MODEL</b>	<b>FANS</b>	<b>FULL KIT NUMBER</b>	<b>TOP SECTION PART NUMBER</b>	<b>BOTTOM SECTION PART NUMBER</b>
0153/0543	8	375 93247 000	375 93247 001	375 93247 002
0165/0565 0183/0643	10	375 93247 010	375 93247 011	375 93247 012
0178/0588 0195/0665 0213/0743 thru 0215/0765 0233/0843	12	375 93247 020	375 93247 021	375 93247 022
0198/0688 0218/0788 0245/0865 0263/0943 thru 0275/0965	14	375 93247 030	375 93247 031	375 93247 032
0200/0700	8	375 93247 100	375 93247 101	375 93247 102
0248/0888 0278/0988 thru 0303/1093 0323/1143	16	375 93247 040	375 93247 041	375 93247 042
0308/1088 0333/1173 thru 0343/1193	18	392 03482 000	392 03482 001	392 03482 002
0318/1188 0345/1215	20	375 93247 060	375 93247 061	375 93247 062
<b>PIN 54 = R (LOW NOISE LEVEL 1 KITS)</b>				
<b>MODEL</b>	<b>FANS</b>	<b>FULL KIT NUMBER</b>	<b>TOP SECTION PART NUMBER</b>	<b>BOTTOM SECTION PART NUMBER</b>
0153/0543	8	392 02052 000	392 02052 001	392 02052 002
0165/0565 0183/0643	10	392 02040 010	392 02040 011	392 02040 012
0178/0588 0215/0765	12	392 02043 020	392 02043 021	392 02043 022
0195/0665 0213/0743 0233/0843	12	392 02040 020	392 02040 021	392 02040 022
0198/0688 0263/0943	14	392 02040 030	392 02040 031	392 02040 032
0200/0700	8	392 02052 100	392 02052 101	392 02052 102
0218/0788	14	392 02043 030	392 02043 031	392 02043 032
0245/0865	14	392 03673 030	392 03673 031	392 03673 032
0248/0888 0278/0988	16	392 02049 040	392 02049 041	392 02049 042
0273/0963 thru 0275/0965	14	392 02046 030	392 02046 031	392 02046 032
0343/1193	18	392 03491 000	392 03491 001	392 03491 002

**10**

**TABLE 36 - WIRE ENCLOSURE KIT COMPONENTS - TOP**

ITEM	MODEL	DESCRIPTION	PART NUMBER	QUANTTIY	FIGURE
100	ALL	Rail Support	075 84415 000	1	27
101	ALL	Panel Cover, Wiring Tray	075 79567 001	1	27
102	ALL	Panel Cover, Wiring Tray	075 79568 001	1	27
103	0165/0565 thru 0195/0665 0213/0743 thru 0198/0688 0213/0743 thru 0233/0843	Panel Cover, Wiring Tray	075 79569 001	2	27
	0198/0688 0218/0788 0245/086 thru 0343/1193			4	
	0318/1188 0345/1215			6	
104	0153/0543 178/0588 0195/0665 0200/0700 thru 0215/0765 0233/0843 0248/0888 0278/0988 thru 0345/1215	Panel Cover, Wiring Tray	075 79570 003	1	27
	0165/0565 0183/0643 0198/0688 0218/0788 0245/0865 0263/0943 thru 0275/0965		075 79570 001	1	
105	ALL	Panel Cover, Wiring Tray	075 79567 002	1	27
106	ALL	Panel Cover, Wiring Tray	075 79568 002	1	27
107	0153/0543 0178/0588 0195/0665 0200/0700 thru 0215/0765 0233/0843 0248/0888 0278/0988 thru 0345/1215	Panel Cover, Wiring Tray	075 79570 004	1	27
	0165/0565 0183/0643 0198/0688 0218/0788 0245/0865 0263/0943 thru 0275/0965		075 79570 002	1	
108	ALL	Support, Grill	075 93336 000	1	27
109	0153/0543 thru 0198/0688 0213/0743 thru 0345/1215	Support, Grill	075 93336 001	2	27
110	0165/0565, 0183/0643	Support ,Grill	075 93336 002	2	27
	0178/0588, 0195/0665, 0213/0743 thru 0215/0765, 0233/0843			2	
	0198/0688, 0218/0788, 0245/0865, 0263/0943 thru 0275/0965			4	

**TABLE 36 - WIRE ENCLOSURE KIT COMPONENTS - TOP (CONT'D)**

ITEM	MODEL	DESCRIPTION	PART NUMBER	QUANTITY	FIGURE
110	0200/0700	Support, Grill	075 93336 001	2	27
	0248/0888, 0278/0988 thru 0303/1093, 0323/1143			4	
	0308/1088, 0333/1173 thru 0343/1193		075 93336 002	4	
	0318/1188, 0345/1215			6	
111	0153/0543 0200/0700	Support, Grill	075 93336 005	2	27
	0165/0565 0183/0643 0198/0688 0218/0788 0245/0865 0263/0943 thru 0275/0988			075 93336 003	
	0178/0588 0195/0665 0213/0743 thru 0215/0765 0233/0843		075 93336 004	2	
	0248/0888 0278/0988 thru 0345/1215		075 93336 006	2	
112	0200/0700	Panel Cover, Wiring Tray	075 94088 001	2	27
112	0308/1088 0333/1173 thru 0343/1193	Support, Grill	075 93336 007	2	
113	0308/1088 0333/1173 thru 0343/1193	Panel Cover, Wiring Tray	075 79570 020	2	27
200	ALL	Wire Grille	026 46614 000	2	27
201	ALL	Wire Grille	026 46612 000	2	27
202	0153/0543	Wire Grille	026 46602 000	4	27
	0165/0565, 0183/0643			6	
	0178/0588, 0195/0665, 0213/0743 thru 0215/0765, 0233/0843			8	
	0198/0688, 0218/0788, 0245/0865, 0263/0943 thru 0275/0965			10	
	0200/0700			4	
	0248/0888, 0278/0988 thru 0303/1093, 0323/1143			12	
	0308/1088, 0333/1173 thru 0343/1193			14	
	0318/1188, 0345/1215			16	
203	ALL	Wire Grille	026 46613 000	2	27
204	ALL	Wire Grille	026 46609 000	2	27
217	0200/0700	Wire Grille	026 46724 000	2	27

**10**

ALL UNITS EXCEPT 0200/0700  
0345/1215 SHOWN

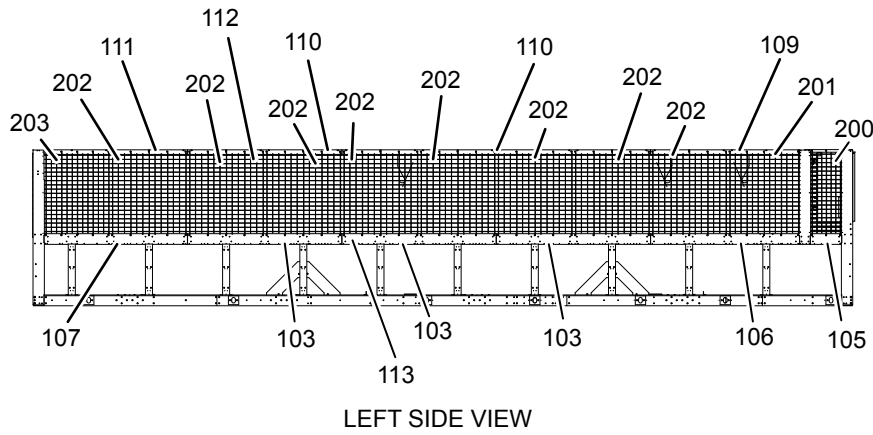
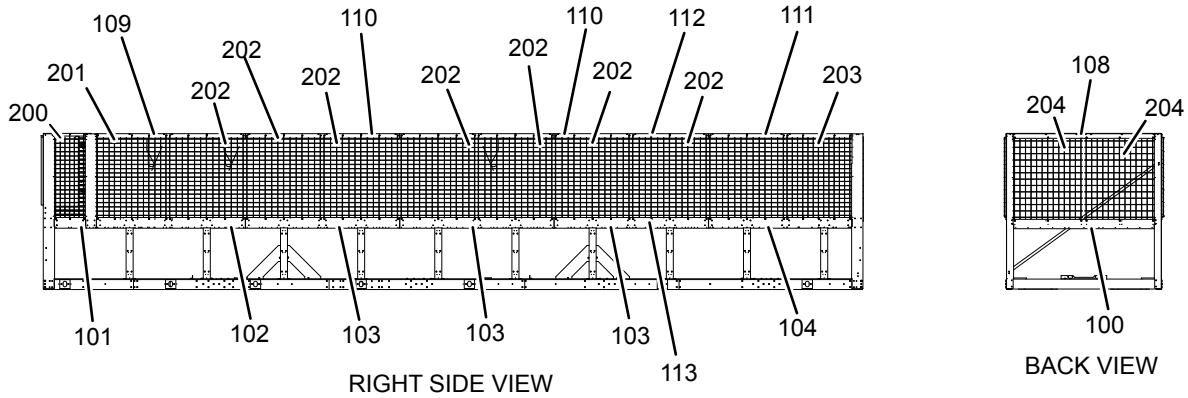

0200/0700 UNIT ONLY

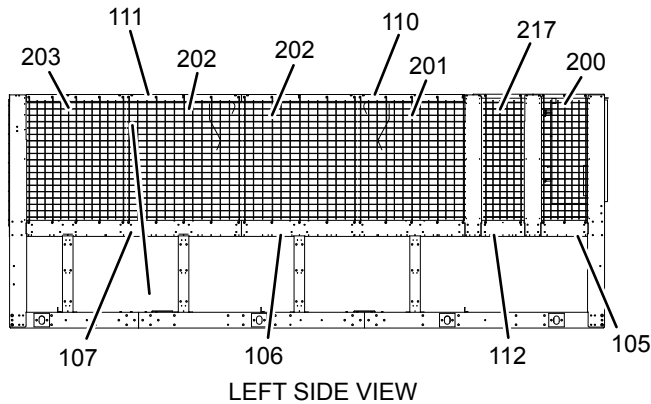
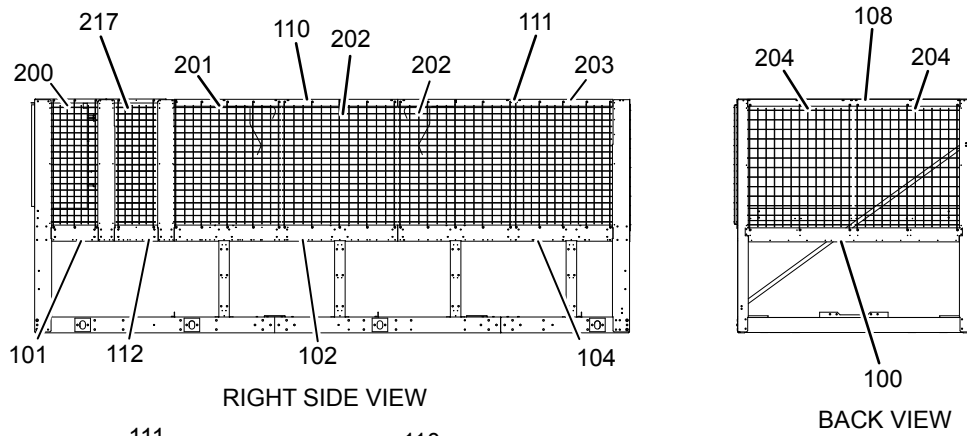

LD15929

FIGURE 27 - WIRE ENCLOSURE KIT COMPONENTS - TOP

**TABLE 37 - WIRE ENCLOSURE KIT COMPONENTS - BOTTOM, MODELS 0153 AND 0200**

ITEM	MODEL	DESCRIPTION	PART NUMBER	QUANTITY	FIGURE																																																												
101	0153/0543	Angle, Support, Louvers	075 94066 001	2	28																																																												
102	0153/0543	Angle, Support, Louvers	075 94066 002	2	28																																																												
103	0153/0543 and 0200/0700	Angle, Support, Louvers	075 94066 003	2	28																																																												
106	0153/0543	Angle, Support, Louvers	075 94066 006	6	28																																																												
113	0153/0543 and 0200/0700	Angle, Support, Louvers	075 94066 007	2	28																																																												
114	0200/0700	Angle, Support, Louvers	075 94066 008	2	28																																																												
115	0200/0700	Angle, Support, Louvers	075 94066 009	2	28																																																												
116	0200/0700	Angle, Support, Louvers	075 94066 010	2	28 </tr <tr> <td>117</td> <td>0200/0700</td> <td>Angle, Support, Louvers</td> <td>075 94066 011</td> <td>2</td> <td>28</td> </tr> <tr> <td>200</td> <td>0153/0543</td> <td>Wire Grille</td> <td>026 46610 000</td> <td>2</td> <td>28</td> </tr> <tr> <td>201</td> <td>0153/0543 and 0200/0700</td> <td>Wire Grille</td> <td>026 46615 000</td> <td>2</td> <td>28</td> </tr> <tr> <td>202</td> <td>0153/0543 and 0200/0700</td> <td>Wire Grille</td> <td>026 46616 000</td> <td>4</td> <td>28</td> </tr> <tr> <td>203</td> <td>0153/0543</td> <td>Wire Grille</td> <td>026 46617 000</td> <td>2</td> <td>28</td> </tr> <tr> <td>204</td> <td>0153/0543 and 0200/0700</td> <td>Wire Grille</td> <td>026 46601 000</td> <td>2</td> <td>28</td> </tr> <tr> <td>205</td> <td>0153/0543 and 0200/0700</td> <td>Wire Grille</td> <td>026 46600 000</td> <td>2</td> <td>28</td> </tr> <tr> <td>211</td> <td>0200/0700</td> <td>Wire Grille</td> <td>026 46692 000</td> <td>1</td> <td>28</td> </tr> <tr> <td>212</td> <td>0200/0700</td> <td>Wire Grille</td> <td>026 46725 000</td> <td>2</td> <td>28</td> </tr> <tr> <td>213</td> <td>0153/0543 and 0200/0700</td> <td>Wire Grille</td> <td>026 46726 000</td> <td>1</td> <td>28</td> </tr>	117	0200/0700	Angle, Support, Louvers	075 94066 011	2	28	200	0153/0543	Wire Grille	026 46610 000	2	28	201	0153/0543 and 0200/0700	Wire Grille	026 46615 000	2	28	202	0153/0543 and 0200/0700	Wire Grille	026 46616 000	4	28	203	0153/0543	Wire Grille	026 46617 000	2	28	204	0153/0543 and 0200/0700	Wire Grille	026 46601 000	2	28	205	0153/0543 and 0200/0700	Wire Grille	026 46600 000	2	28	211	0200/0700	Wire Grille	026 46692 000	1	28	212	0200/0700	Wire Grille	026 46725 000	2	28	213	0153/0543 and 0200/0700	Wire Grille	026 46726 000	1	28
117	0200/0700	Angle, Support, Louvers	075 94066 011	2	28																																																												
200	0153/0543	Wire Grille	026 46610 000	2	28																																																												
201	0153/0543 and 0200/0700	Wire Grille	026 46615 000	2	28																																																												
202	0153/0543 and 0200/0700	Wire Grille	026 46616 000	4	28																																																												
203	0153/0543	Wire Grille	026 46617 000	2	28																																																												
204	0153/0543 and 0200/0700	Wire Grille	026 46601 000	2	28																																																												
205	0153/0543 and 0200/0700	Wire Grille	026 46600 000	2	28																																																												
211	0200/0700	Wire Grille	026 46692 000	1	28																																																												
212	0200/0700	Wire Grille	026 46725 000	2	28																																																												
213	0153/0543 and 0200/0700	Wire Grille	026 46726 000	1	28																																																												

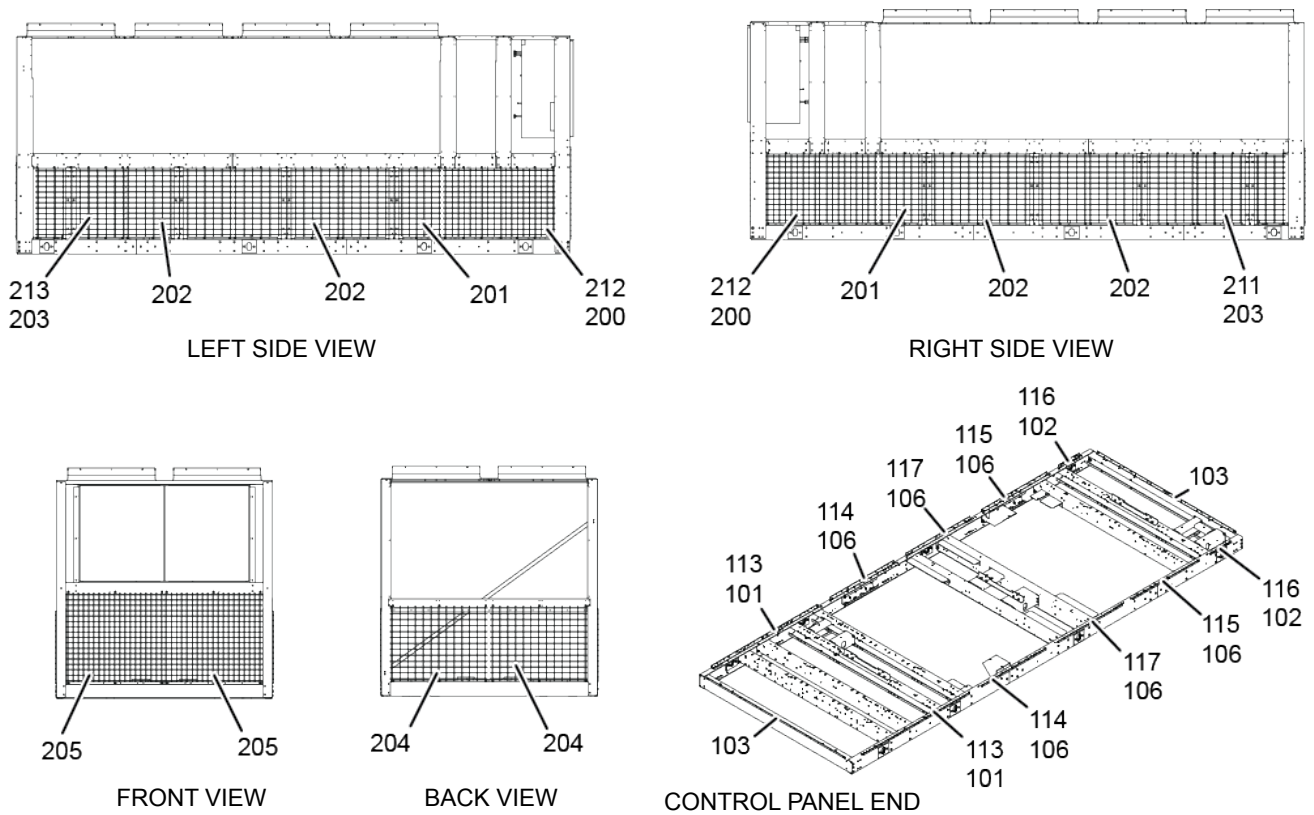

0200/0700 SHOWN

**FIGURE 28 - WIRE ENCLOSURE KIT COMPONENTS - BOTTOM, MODELS 0153 AND 0200**

**TABLE 38 - WIRE ENCLOSURE KIT COMPONENTS - BOTTOM, MODELS 0165 THRU 0198, 0213 THRU 0303, AND 0323 (10, 12, 14 AND 16 FANS)**

ITEM	MODEL	NUMBER OF FANS	DESCRIPTION	PART NUMBER	QUANTITY	FIGURE
100	0178/0588 0195/0665 0213/0743 thru 0215/0765 0233/0843	12	Angle, Support, Louvers		6	30
	0198/0688 0218/0788 0245/0865 0263/0943 thru 0275/0965	14			8	
	0248/0888 0278/0988 thru 0303/1093 0323/1143	16			10	
101	ALL	ALL	Angle, Support, Louvers	075 94066 001	2	30
102	ALL	ALL	Angle, Support, Louvers	075 94066 002	2	30
103	0165/0565 thru 0195/0665 0213/0743 thru 0215/0765 0233/0843 0248/0888 0278/0988 thru 0303/1093 0323/1143	10, 12 and 16	Angle, Support, Louvers	075 94066 003	2	30
104	0178/0588 0195/0665 thru 0198/0688 0213/0743 thru 0303/1093 0323/1143	12 14 and 16	Angle, Support, Louvers	075 94066 004	2	30
105	0178/0588 0195/0665 thru 0198/0688 0213/0743 thru 0303/1093 0323/1143	12, 14 and 16	Angle, Support, Louvers	075 94066 005	2	30
106	0165/0565 0183/0643	10	Angle, Support, Louvers	075 94066 006	4	30
	0198/0688 0218/0788 0245/0865 0263/0943 thru 0275/0965	14	Angle, Support, Louvers	075 94066 003	2	
200	ALL	ALL	Wire Grille	026 46610 000	2	29
201	ALL	ALL	Wire Grille	026 46615 000	2	29
202	0165/0565 thru 0198/0688 0213/0743 thru 0245/0865 0263/0943 thru 0275/0965	10, 12, 14	Wire Grille	026 46616 000	6	29
	0248/0888 0278/0988 thru 0303/1093 0323/1143	16			12	
203	0165/0565 0183/0643 0198/0688 0218/0788 0245/0865 0263/0943 thru 0275/0965	10 and 14	Wire Grille	026 46617 000	2	29

**TABLE 38 - WIRE ENCLOSURE KIT COMPONENTS - BOTTOM, MODELS 0165 THRU 0198, 0213 THRU 0303, AND 0323 (10, 12, 14 AND 16 FANS) (CONT'D)**

ITEM	MODEL	NUMBER OF FANS	DESCRIPTION	PART NUMBER	QUANTITY	FIGURE
<b>203</b>	0178/0588 0195/0665 0213/0743 thru 0215/0765 0233/0843 0248/0888 0278/0988 thru 0303/1093	12 and 14	Wire Grille	026 46692 000	2	29
<b>204</b>	ALL	ALL	Wire Grille	026 46601 000	2	29
<b>205</b>	ALL	ALL	Wire Grille	026 46600 000	2	29
<b>206</b>	0198/0688 0218/0788 0245/0865 0263/0943 thru 0275/0965	14	Wire Grille	026 46618 000	2	29
<b>207</b>	0178/0588 0195/0665 0213/0743 thru 0215/0765 0233/0843	12	Wire Grille	026 46618 000	2	29
	0198/0688 0218/0788 0245/0865 0263/0943 thru 0275/0965					

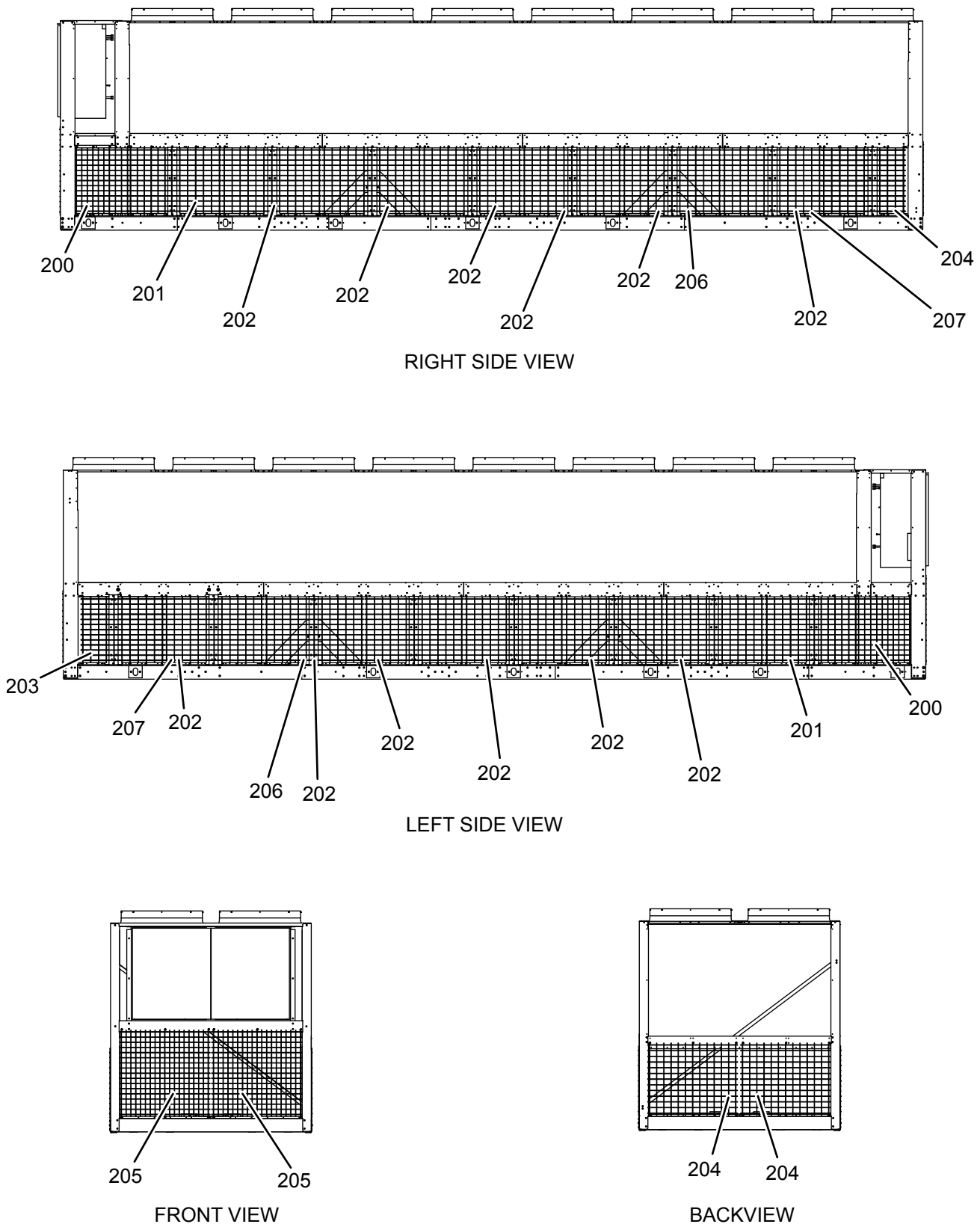

LD15933

**FIGURE 29 - WIRE ENCLOSURE KIT COMPONENTS - BOTTOM,  
MODELS 0165 THRU 0198, 0213 THRU 0303, AND 0323 (10, 12, 14 AND 16 FANS)**



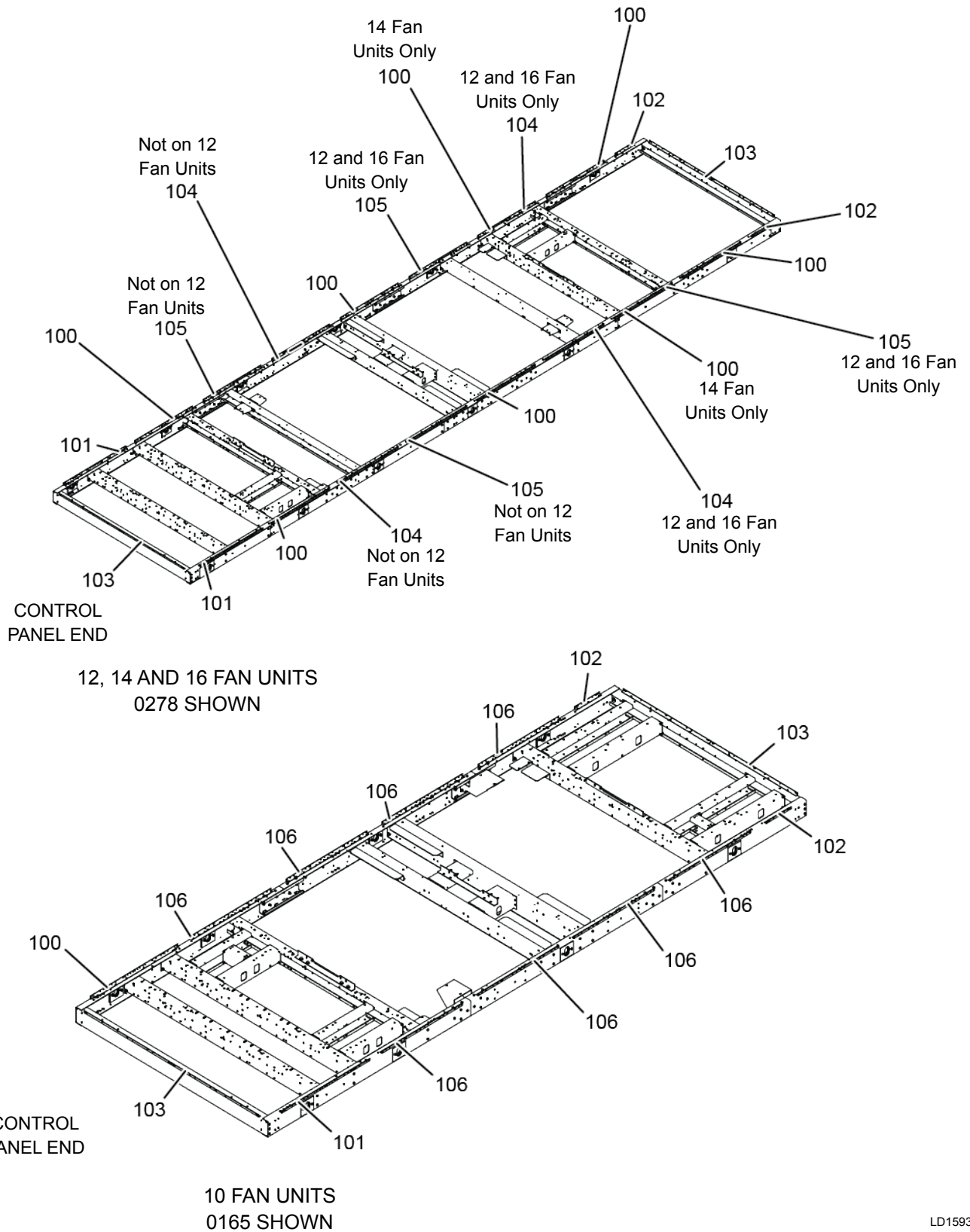

10

FIGURE 30 - WIRE ENCLOSURE KIT COMPONENTS - BOTTOM (GRILLE MOUNTING ANGLES), MODELS 0165 THRU 0198, 0213 THRU 0303, AND 0323 (10, 12, 14 AND 16 FANS)

**TABLE 39 - WIRE ENCLOSURE KIT COMPONENTS - BOTTOM, MODELS 0308, 0333 AND 0343**

ITEM	DESCRIPTION	PART NUMBER	QUANTITY	FIGURE
100	Angle, Support, Louvers	075 94066 000	6	31
101	Angle, Support, Louvers	075 94066 001	2	31
102	Angle, Support, Louvers	075 94066 002	2	31
103	Angle, Support, Louvers	075 94066 003	5	31
104	Angle, Support, Louvers	075 94066 004	5	31
105	Angle, Support, Louvers	075 94066 005	5	31
200	Wire Grille	026 46610 000	2	31
201	Wire Grille	026 46615 000	2	31
202	Wire Grille	026 46616 000	14	31
203	Wire Grille	026 46692 000	2	31
204	Wire Grille	026 46601 000	2	31
205	Wire Grille	026 46600 000	2	31

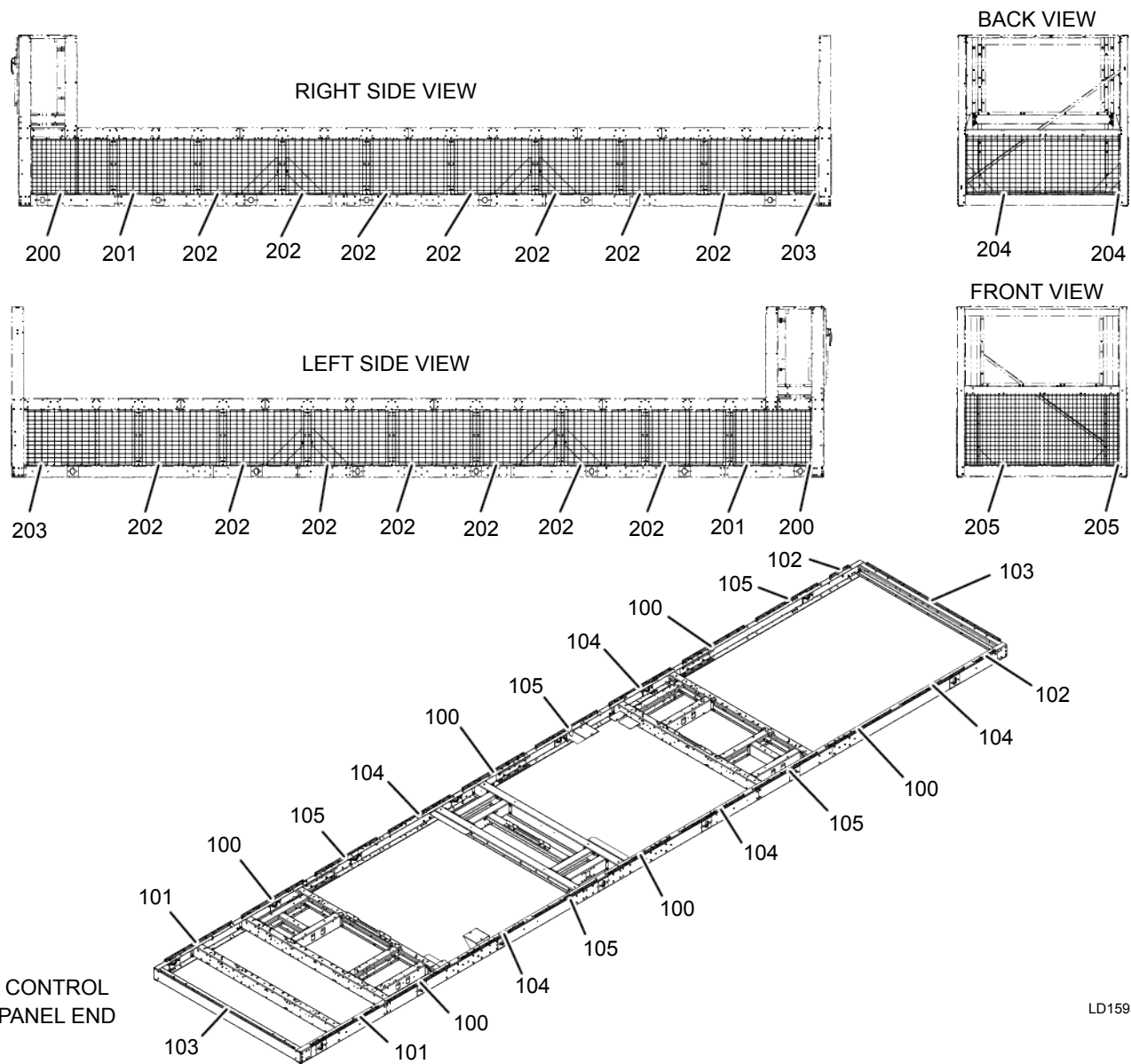

LD15936

**FIGURE 31 - WIRE ENCLOSURE KIT COMPONENTS - BOTTOM, MODELS 0308, 0333 AND 0343**

**TABLE 40 - WIRE ENCLOSURE KIT COMPONENTS - BOTTOM, MODEL 0345**

ITEM	DESCRIPTION	PART NUMBER	QUANTITY	FIGURE
100	Angle, Support, Louvers	075 94066 000	10	32
101	Angle, Support, Louvers	075 94066 001	2	32
102	Angle, Support, Louvers	075 94066 002	2	32
103	Angle, Support, Louvers	075 94066 003	2	32
104	Angle, Support, Louvers	075 94066 004	4	32
105	Angle, Support, Louvers	075 94066 005	4	32
200	Wire Grille	026 46610 000	2	32
201	Wire Grille	026 46615 000	2	32
202	Wire Grille	026 46616 000	16	32
203	Wire Grille	026 46692 000	2	32
204	Wire Grille	026 46601 000	2	32
205	Wire Grille	026 46600 000	2	32

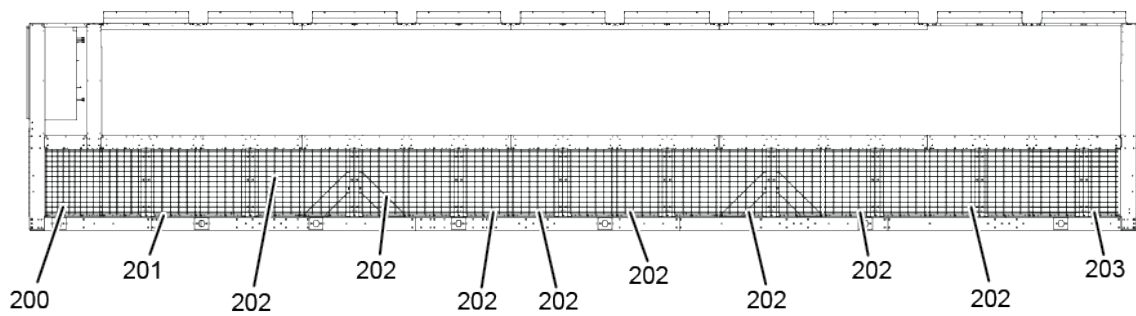

RIGHT SIDE VIEW

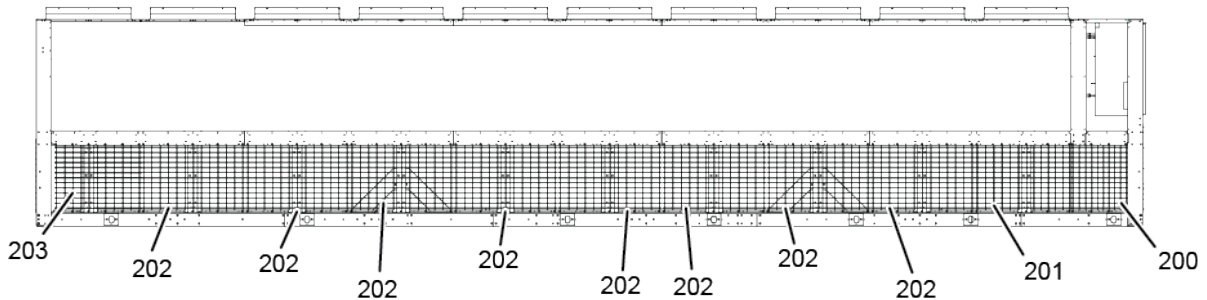

LEFT SIDE VIEW

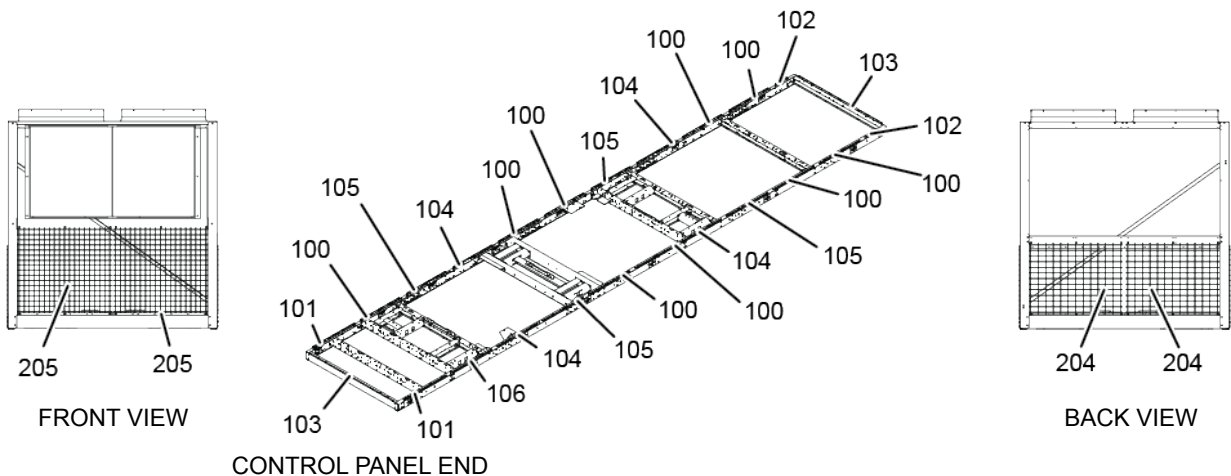

FRONT VIEW

CONTROL PANEL END

BACK VIEW

**FIGURE 32 - WIRE ENCLOSURE KIT COMPONENTS - BOTTOM, MODEL 0345**

**10**

**TABLE 41 - LOUVERED ENCLOSURE KITS**

<b>PIN 54 = X ( NO SELECTION) OR E (ECONOMICAL LOW NOISE KITS)</b>				
<b>MODEL</b>	<b>FANS</b>	<b>KIT PART NUMBER</b>	<b>TOP SECTION KIT PART NUMBER <sup>1</sup></b>	<b>BOTTOM SECTION KIT PART NUMBER <sup>2</sup></b>
0153/0543	8	375 93248 000	375 93248 001	375 93248 002
0165/0565 0183/0643	10	375 93248 010	375 93248 011	375 93248 012
0178/0588 0195/0665 0213/0743 thru 0215/0765 0233/0843	12	375 93248 020	375 93248 021	375 93248 022
0198/0688 0218/0788 0245/0865 0263/0943 thru 0275/0965	14	375 93248 030	375 93248 031	375 93248 032
0200/0700	8	375 93248 100	375 93248 101	375 93248 102
0248/0888 0278/0988 thru 0303/1093 0323/1143	16	375 93248 040	375 93248 041	375 93248 042
0305/1065 thru 0308/1088 0333/1173 thru 0343/1193	18	392 03481 000	392 03481 001	392 03481 002
0318/1188 0345/1215	20	375 93248 060	375 93248 061	375 93248 062
<b>PIN 54 = R (LOW NOISE LEVEL 1 KITS)</b>				
<b>MODEL</b>	<b>FANS</b>	<b>KIT PART NUMBER</b>	<b>TOP SECTION KIT PART NUMBER</b>	<b>BOTTOM SECTION KIT PART NUMBER</b>
0153/0543	8	392 02051 000	392 02051 001	392 02051 002
0165/0565 0183/0643	10	392 02039 010	392 02039 011	392 02039 012
0178/0588 0215/0765	12	392 02042 020	392 02042 021	392 02042 022
0195/0665 0213/0743 0233/0843	12	392 02039 020	392 02039 021	392 02039 022
0198/0688 0263/0943	14	392 02039 030	392 02039 031	392 02039 032
0200/0700	8	392 02051 100	392 02051 101	392 02051 102
0218/0788	14	392 02042 030	392 02042 031	392 02042 032
0245/0865	14	392 03672 030	392 03672 031	392 03672 032
0248/0888 0278/0988	16	392 02048 040	392 02048 041	392 02048 042
0273/0963 thru 0275/0965	14	392 02045 030	392 02045 031	392 02045 032
0303/1093	16	392 04500 040	392 04500 041	392 04500 042
0308/1088 0333/1173	18	392 04503 050	392 04503 051	392 04503 052
0343/1193	18	392 03490 000	392 03490 001	392 03490 002

Notes: 1. See Table 44 on page 99, Figure 33 on page 101 and Figure 34 on page 102 for Top Section Components.

2. See Table 45 on page 103, Figure 35 on page 105 and Figure 36 on page 106 for Bottom Section Components.

**TABLE 41 - LOUVERED ENCLOSURE KITS (CONT'D)**

<b>PIN 54 = N (LOW NOISE LEVEL 2 KITS)</b>				
<b>MODEL</b>	<b>FANS</b>	<b>KIT PART NUMBER</b>	<b>TOP SECTION KIT PART NUMBER <sup>1</sup></b>	<b>BOTTOM SECTION KIT PART NUMBER <sup>2</sup></b>
0153/0543	8	375 93252 000	375 93252 001	375 93252 002
0165/0565 0183/0643	10	375 93252 010	375 93252 011	375 93252 012
0195/0665 0213/0743 thru 0215/0765	12	392 02036 020	392 02036 021	392 02036 022
0198/0688 0263/0943	14	392 02038 030	392 02038 031	392 02038 032
0233/0843	12	375 93252 020	375 93252 021	375 93252 022
0273/0963 thru 0275/0965	14	375 93252 030	375 93252 031	375 93252 032

Notes: 1. See Table 44 on page 99, Figure 33 on page 101 and Figure 34 on page 102 for Top Section Components.  
2. See Table 45 on page 103, Figure 35 on page 105 and Figure 36 on page 106 for Bottom Section Components.

**TABLE 42 - LOUVERED (CONDENSER ONLY) ENCLOSURE KITS**

<b>MODEL</b>	<b>KIT NUMBER<sup>1</sup></b>
0153/0543	375 93248 001
0178/0588 0195/0665 0213/0743 thru 0215/0765 0233/0843	375 93248 021
0183/0643 thru 0165/0565	375 93248 011
0198/0688 0218/0788 0245/0865 0263/0943 thru 0275/0965	375 93248 031
0200/0700	375 93248 101
0248/0888 0278/0988 thru 0303/1093 0323/1143	375 93248 041
0305/1065 thru 0308/1088 0333/1173 thru 0343/1193	392 03481 001
0318/1188, 0345/1215	375 93248 061

Note: See Table 44 on page 99, Figure 33 on page 101 and Figure 34 on page 102.

**10**

**TABLE 43 - WIRE / LOUVERED ENCLOSURE KITS**

<b>ECONOMICAL LOW NOISE KITS</b>				
<b>MODEL</b>	<b>FANS</b>	<b>FULL KIT NUMBER</b>	<b>TOP SECTION PART NUMBER <sup>1</sup></b>	<b>BOTTOM SECTION PART NUMBER <sup>2</sup></b>
0153/0543	8	375 93249 000	375 93248 001	375 93247 002
0165/0565 0183/0643	10	375 93249 010	375 93248 011	375 93247 012
0178/0588 0195/0665 0213/0743 thru 0215/0765 0233/0843	12	375 93249 020	375 93248 021	375 93247 022
0198/0688 0218/0788 0245/0865 0263/0943 0273/0963 thru 0275/0965	14	375 93249 030	375 93248 011	375 93247 012
0200/0700	8	375 93249 100	375 93248 101	375 93247 102
0248/0888 0278/0988 0295/1015 0303/1093 0323/1143	16	375 93249 040	375 93248 041	375 93247 042
0305/1065 thru 0308 0333/1173 thru 0343/1193	18	392 03489 000	392 03481 001	392 03482 002
0318/1188 0345/1215	20	375 93249 060	375 93248 061	375 93247 062
<b>LOW NOISE LEVEL 1 KITS</b>				
<b>MODEL</b>	<b>FANS</b>	<b>FULL KIT NUMBER</b>	<b>TOP SECTION PART NUMBER <sup>1</sup></b>	<b>BOTTOM SECTION PART NUMBER <sup>2</sup></b>
0153/0543	8	392 02053 000	392 02051 001	392 02052 002
0165/0565 0183/0643 0195/0665	10, 12	392 02041 010	392 02039 011	392 02040 012
0178/0588 0215/0765	12	392 02044 020	392 02042 021	392 02043 022
0198/0688 0263/0943	14	392 02041 030	392 02039 031	392 02040 032
0200/0700	8	392 02053 100	392 02051 101	392 02052 102
0213/0743 0233/0843	12	392 02041 020	392 02039 021	392 02040 022
0218/0788	14	392 02044 030	392 02042 031	392 02043 032
0245/0865	14	392 03674 030	392 03672 031	392 03673 032
0248/0888 0278/0988	16	392 02050 040	392 02048 041	392 02049 042
0273/0963 thru 0275/0965	14	392 02047 030	392 02045 031	392 02046 032

Notes: 1. See Table 44 on page 99, Figure 33 on page 101 and Figure 34 on page 102 for Top Section Components

2. See Table 45 on page 103, Figure 35 on page 105 and Figure 36 on page 106 for Bottom Section Components

**TABLE 44 - LOUVERED AND WIRE/LOUVERED ENCLOSURE KIT COMPONENTS - TOP**

ITEM	MODEL	FANS	DESCRIPTION	PART NUMBER	QUANTITY	FIGURE
100	ALL	ALL	Panel, Enclosure	075 93275 001	2	33, 34
101	ALL	ALL	Panel, Enclosure	075 93275 004	1	33, 34
102	0153/0543 0200/0700	8	Panel, Enclosure	075 93275 002	4	33
	0165/0565 0183/0643	10			6	34
	0178/0588 0195/0665 0213/0743 thru 0215/0765 0233/0843	12			8	34
	0198/0688 0218/0788 0245/0865 0263/0943 thru 0275/0965	14			10	34
	0248/0888 0278/0988 thru 0303/1093 0323/1143	16			12	34
	0305/1065 thru 0308/1088 0333/1173 thru 0343/1193	18			14	34
	0318/1188 0345/1215	20			16	34
103	ALL	ALL	Panel, Enclosure	075 93275 003	1	33, 34
104	ALL	ALL	Panel, Enclosure	075 93275 006	1	33, 34
105	ALL	ALL	Panel, Enclosure	075 93275 005	1	33, 34
106	ALL	ALL	Panel, Enclosure	075 93275 007	1	33, 34
107	ALL	8	Panel, Enclosure	075 93275 008	1	33, 34
108	ALL	ALL	Rail Support	075 84415 000	1	33, 34
109	ALL	ALL	Panel Cover, Wiring Tray	075 79567 001	1	33, 34
110	ALL	ALL	Panel Cover, Wiring Tray	075 79568 001	1	33, 34
111	0165/0565 thru 0195/0665 0213/0743 thru 0215/0765 0233/0843	10, 12	Panel Cover, Wiring Tray	075 79569 001	2	34
	0198/0688 0218/0788 0245/0865 thru 0343/1193	14, 16, 18			4	34
	0318/1188 0345/1215	20			6	34
112	0305/1065 thru 0308/1088 0333/1173 thru 0343/1193	18	Panel Cover, Wiring Tray	075 79570 020	2	34
113	0153/0543 0178/0588 0195/0665 0200/0700 thru 0215/0765 0233/0843 0248/0888 0278/0988 thru 0345/1215	8, 12 16, 18, 20	Panel Cover, Wiring Tray	075 79570 003	1	33, 34

Note: See Figure 33 on page 101 for models 0153 and 0200. See Figure 34 on page 102 for all other models.

**10**

**TABLE 44 - LOUVERED AND WIRE/LOUVERED ENCLOSURE KIT COMPONENTS - TOP (CONT'D)**

ITEM	MODEL	FANS	DESCRIPTION	PART NUMBER	QUANTITY	FIGURE
113	0165/0565	10, 14	Panel Cover, Wiring Tray	075 79570 001	1	34
	0183/0643					
	0198/0688					
	0218/0788					
	0245/0865					
0263/0943 thru 0275/0965						
114	ALL	ALL	Panel Cover, Wiring Tray	075 79567 002	1	33, 34
115	ALL EXCEPT 0153/0543, 0200/0700	10, 12, 14, 16, 20	Panel Cover, Wiring Tray	075 79568 002	1	34
116	0153/0543 0200/0700	8	Panel Cover, Wiring Tray	075 79568 002	1	33
	0305/1065 thru 0308/1088 0333/1173 thru 0343/1193	18	Panel Cover, Wiring Tray	075 79570 004	1	34
117	0153/0543 0178/0588 0195/0665 0200/0700 thru 0215/0765 0233/0843 0248/0888 0278/0988 thru 0303/1093 0318/1188 thru 0323/1143 0345/1215	8, 12, 16, 20	Panel Cover, Wiring Tray	075 79570 004	1	33, 34
	0165/0565 0183/0643 0198/0688 0218/0788 0245/0865 0263/0943 thru 0275/0965	10, 14	Panel Cover, Wiring Tray	075 79570 002	1	34
118	0200/0700	8	Panel, Enclosure	075 93275 036	2	33
119	0200/0700	8	Panel Cover, Wiring Tray	075 94088 001	2	33

Note: See Figure 33 on page 101 for models 0153 and 0200. See Figure 34 on page 102 for all other models.



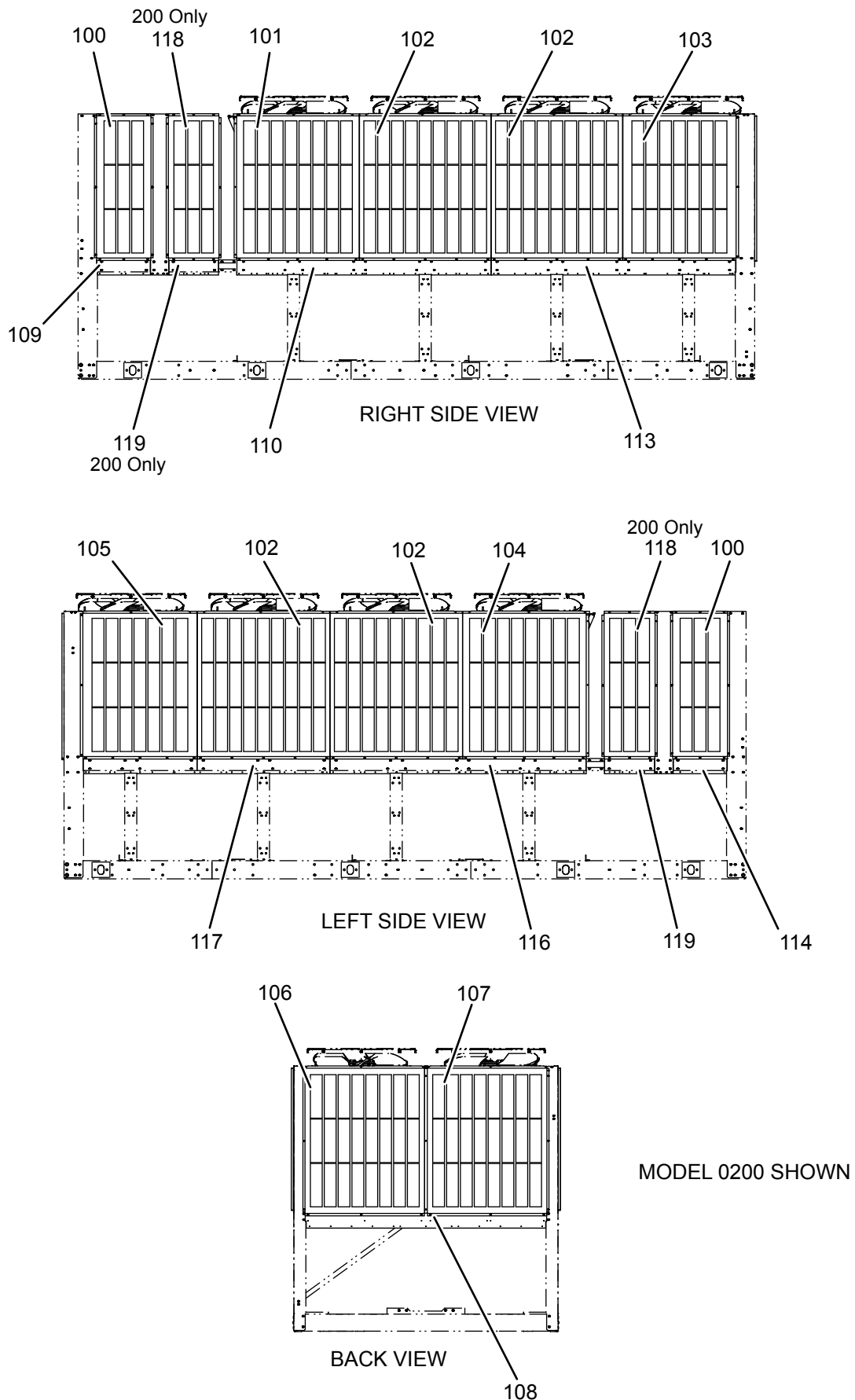

10

FIGURE 33 - LOUVERED ENCLOSURE KIT COMPONENTS - TOP, MODELS 0153 AND 0200

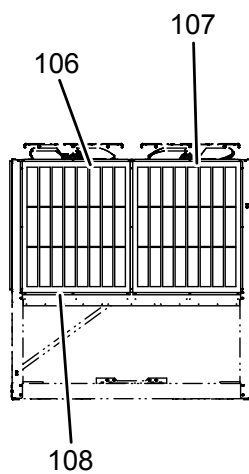
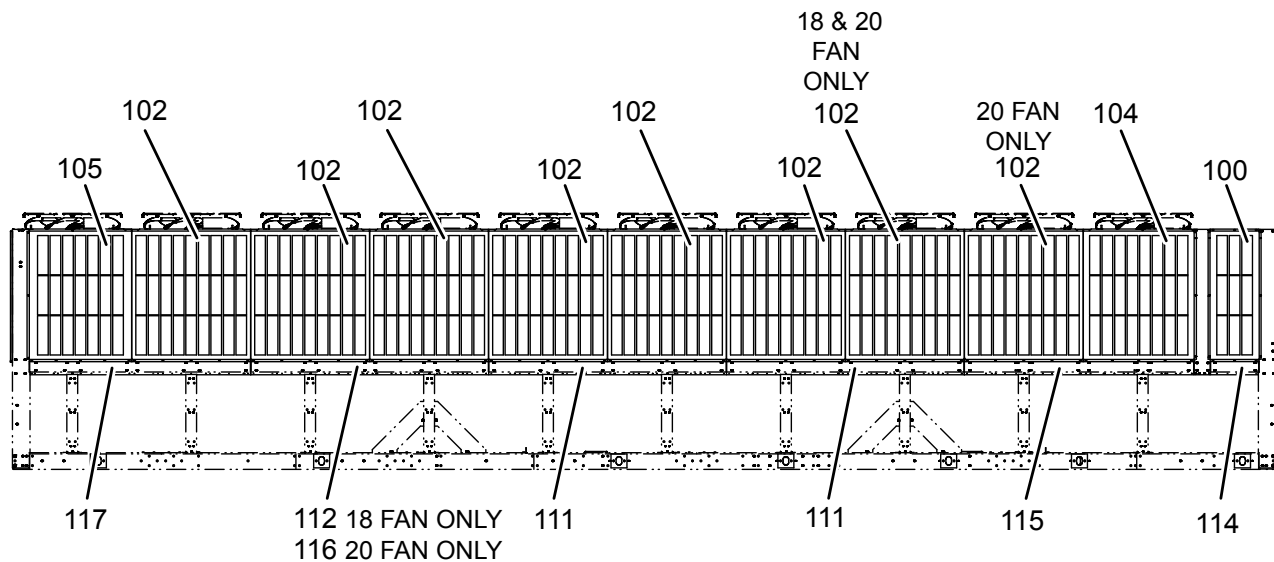
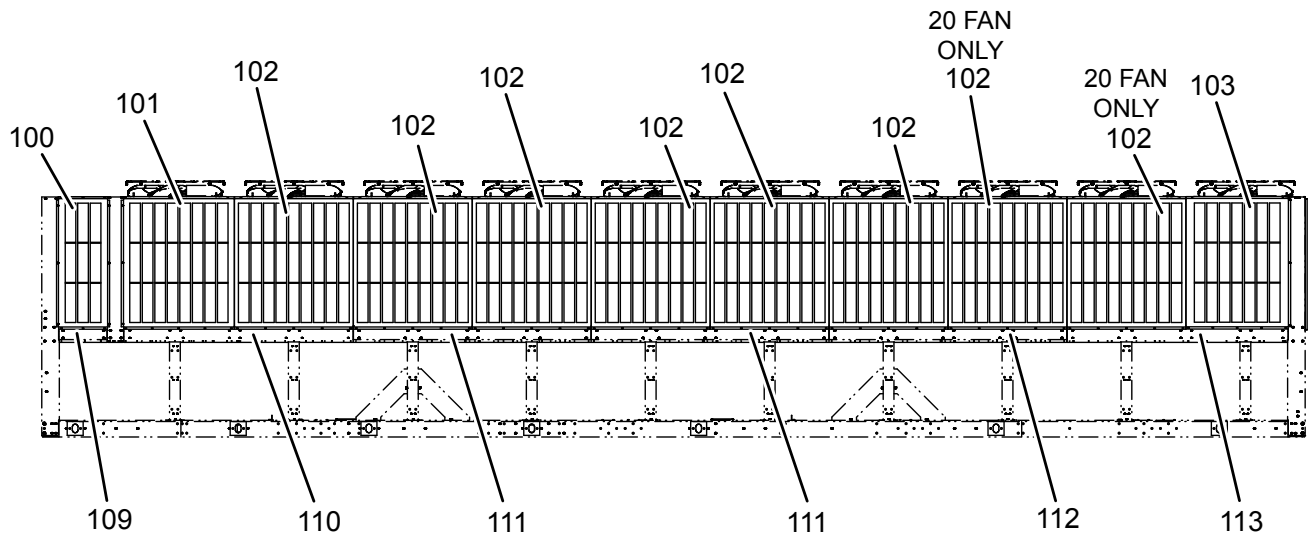

MODEL 0345 SHOWN

LD16161

FIGURE 34 - LOUVERED ENCLOSURE KIT COMPONENTS - TOP, ALL MODELS EXCEPT 0153 AND 0200

**TABLE 45 - LOUVERED AND WIRE/LOUVERED ENCLOSURE KIT COMPONENTS - BOTTOM**

ITEM	MODEL	FANS	DESCRIPTION	PART NUMBER	QUANTITY	FIGURE
100	ALL	ALL	Panel, Enclosure	075 93275 012	2	35, 36
101	All except 0153/0543 and 0200/0700	10, 12, 14, 16, 18, 20	Panel, Enclosure	075 93275 031	4	36
103	0153/0543 0178/0588 0195/0665 0200/0700 thru 0215/0765 0233/0843	8, 12	Panel, Enclosure	075 93275 010	6	35
103	0165/0565 0183/0643	10	Panel, Enclosure	075 93275 010	4	36
103	0198/0688 0218/0788 0245/0865 0263/0943 thru 0275/0965	14	Panel, Enclosure	075 93275 010	8	36
103	0248/0888 0278/0988 thru 0303/1093 0323/1143	16	Panel, Enclosure	075 93275 010	10	36
103	0305/1065 thru 0308/1088 0333/1173 thru 0343/1193	18	Panel, Enclosure	075 93275 010	12	36
103	0318/1188 0345/1215	20	Panel, Enclosure	075 93275 010	14	36
104	all	all	Panel, Enclosure	075 93275 034	1	35, 36
106	All except 0153/0543 and 0200/0700	10, 12, 14, 16, 18, 20	Panel, Enclosure	075 93275 029	4	36
108	all	all	Panel, Enclosure	075 93275 035	1	35, 36
109	all	all	Panel, Enclosure	075 93275 030	4	35, 36
110	all	all	Panel, Enclosure	075 93275 032	2	35, 36
111	0200/0700	8	Angle, Support	075 94066 007	2	35
111	All except 0200/0700	all	Angle, Support	075 94066 001	2	35, 36
112	0153/0543	8	Angle, Support	075 94066 006	6	35
112	0165/0565 0183/0643	10	Angle, Support	075 94066 006	8	36
112	0178/0588 0195/0665 0213/0743 thru 0215/0765 0233/0843 0248/0888 0278/0988 thru 0343/1193	12, 16, 18	Angle, Support	075 94066 000	6	36
112	0198/0688 0218/0788 0245/0865 0263/0943 thru 0275/0965	14	Angle, Support	075 94066 000	8	36
112	0200/0700	8	Angle, Support	075 94066 008	2	35
112	0318/1188 0345/1215	20	Angle, Support	075 94066 000	10	36
113	0200/0700	8	Angle, Support	075 94066 010	2	35

Note: See Figure 35 on page 105 for models 0153 and 0200. See Figure 36 on page 106 for all other models.

**TABLE 45 - LOUVERED AND WIRE/LOUVERED ENCLOSURE KIT COMPONENTS - BOTTOM (CONT'D)**

ITEM	MODEL	FANS	DESCRIPTION	PART NUMBER	QUANTITY	FIGURE
113	All except 0200/0700	all	Angle, Support	075 94066 002	2	36
114	all	all	Angle, Support	075 94066 003	2	35, 36
115	0178/0588 0195/0665 thru 0198/0665 0213/0743 thru 0245/0865 0263/0943 thru 0275/0965	12, 14	Angle, Support	075 94066 004	2	36
115	0248/0888 0278/0988 thru 0303/1093 0323/1143 0318/1188 0345/1215	16, 20	Angle, Support	075 94066 004	4	36
115	0305/1065 thru 0308/1088 0333/1173 thru 0343/1193	18	Angle, Support	075 94066 004	5	36
116	0178/0588 0195/0665 thru 0198/0688 0213/0743 thru 0245/0865 0263/0943 thru 0275/0965	12, 14	Angle, Support	075 94066 005	2	36
116	0248/0888 0278/0988 thru 0303/1093 0323/1143 0318/1188 0345/1215	16, 20	Angle, Support	075 94066 005	4	36
116	0305/1065 thru 0308/1088 0333/1173 thru 0343/1193	18	Angle, Support	075 94066 005	5	36
116	0318/1188 0345/1215	20	Angle, Support	075 94066 005	4	36
117	all	ALL	Rail, Support	075 84415 001	1	35, 36
118	0200/0700	8	Panel, Enclosure	075 93275 037	2	35
119	0200/0700	8	Angle, Support	075 94066 009	2	35
120	0200/0700	8	Angle, Support	075 94066 011	2	35

Note: See Figure 35 on page 105 for models 0153 and 0200. See Figure 36 on page 106 for all other models.

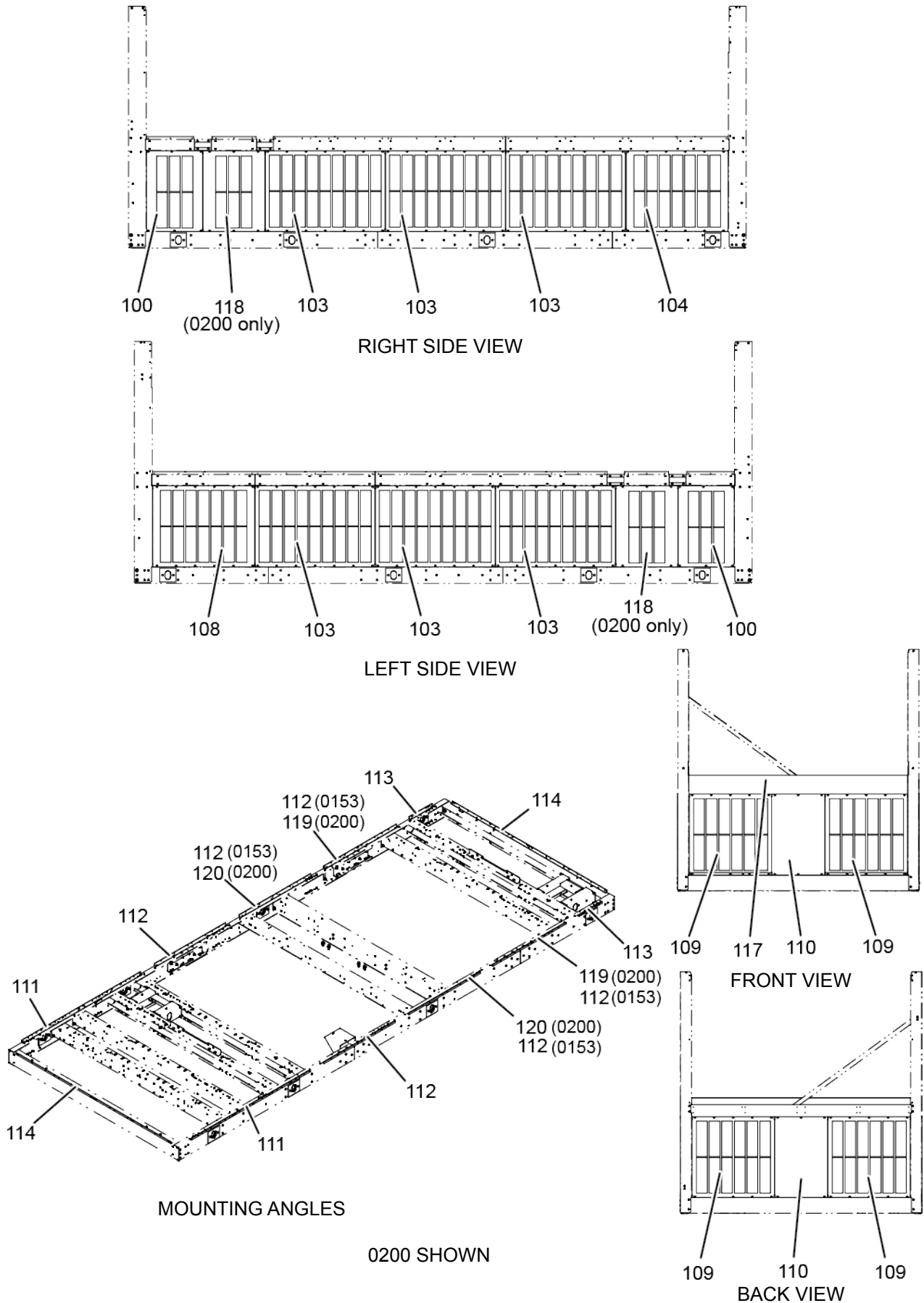

**10**

**FIGURE 35 - LOUVERED ENCLOSURE KIT COMPONENTS - BOTTOM, MODELS 0153 AND 0200**

LD16163

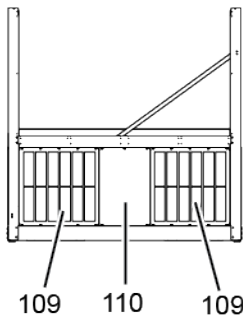
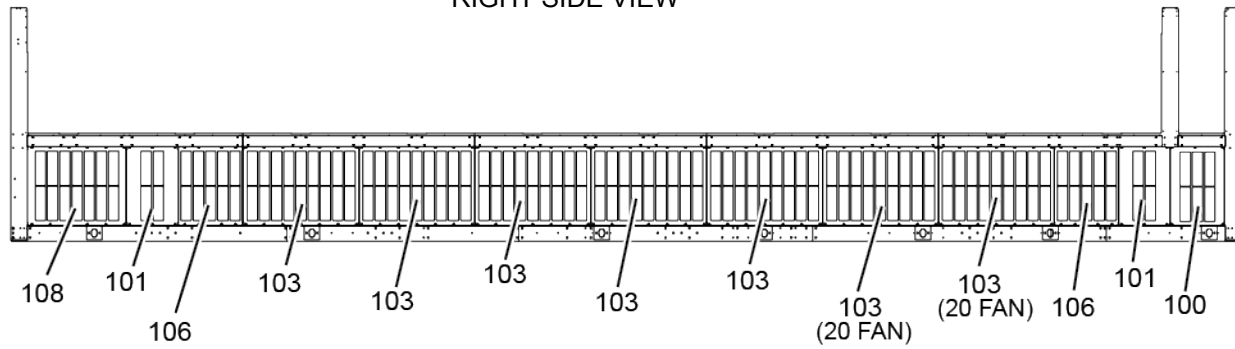
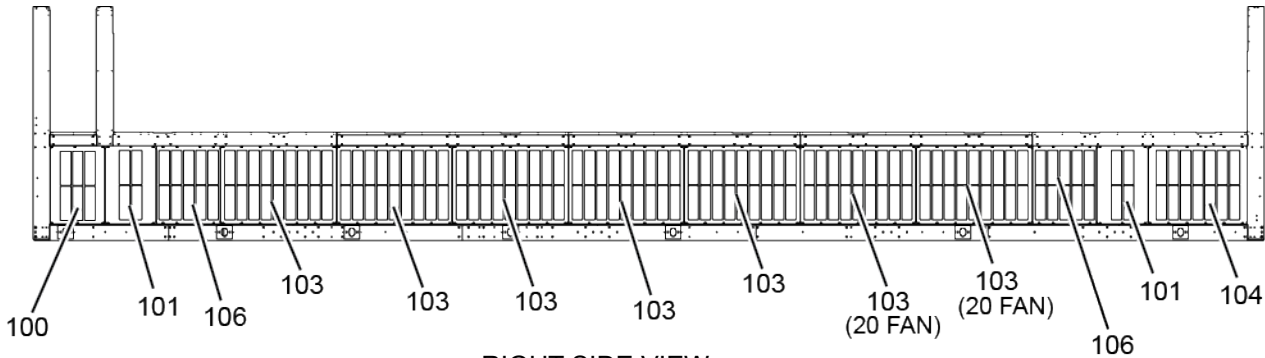

0345 SHOWN

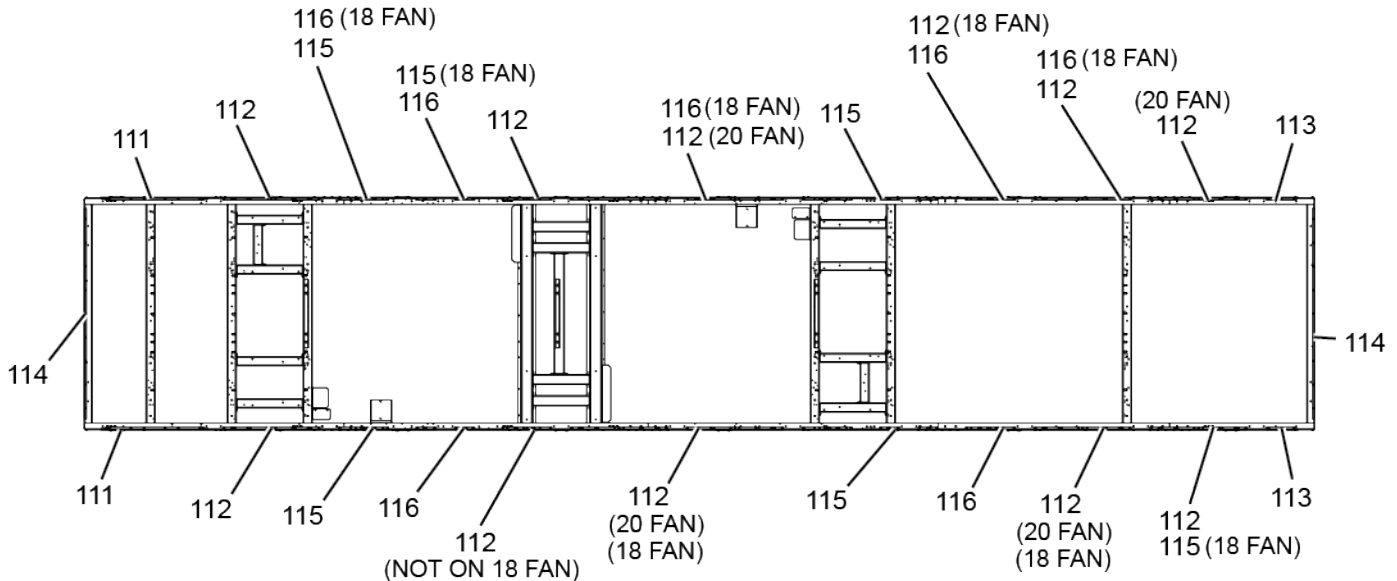
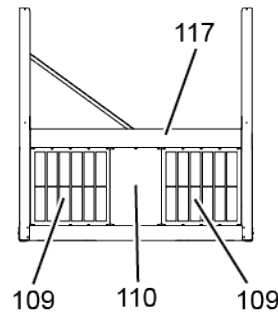

LD16164

FIGURE 36 - LOUVERED ENCLOSURE KIT COMPONENTS - BOTTOM, ALL MODELS EXCEPT 0153 AND 0200

**TABLE 46 - END LOUVER (HAIL GUARD) PANEL ENCLOSURE KIT AND COMPONENTS**

ITEM	MODEL	DESCRIPTION	PART NUMBER	QTY	FIGURE
---	0153/0543 thru 0278/0988	End Louver (Hail Guard) Panel Enclosure Kit	375 93243 000	---	---
---	0295/1015 thru 0345/1215	End Louver (Hail Guard) Panel Enclosure Kit	375 93243 001	---	---
<b>106</b>	all	Panel, Enclosure	075 93275 007	1	37
<b>107</b>	all	Panel, Enclosure	075 93275 008	1	37
<b>108</b>	all	Rail, Support	075 84415 000	1	37
<b>109</b>	all	V-Panel, Louvers	075 94038 005	1	37
<b>110</b>	0153/0543 thru 0278/0988	V-Panel, Louvers	075 94038 006	1	37
<b>110</b>	0295/1015 thru 0345/1215	V-Panel, Louvers	075 94038 006	2	37
<b>111</b>	0153/0543 thru 0278/0988	Gasket, Neoprene, 1/2 X 1 X Roll	028 11838 000	2	37
<b>111</b>	0295/1015 thru 0345/1215	Gasket, Neoprene, 1/2 X 1 X Roll	028 11838 000	3	37
<b>112</b>	0153/0543 thru 0278/0988	Bracket	075 94037 000	2	37
<b>112</b>	0295/1015 thru 0345/1215	Bracket	075 94037 000	3	37

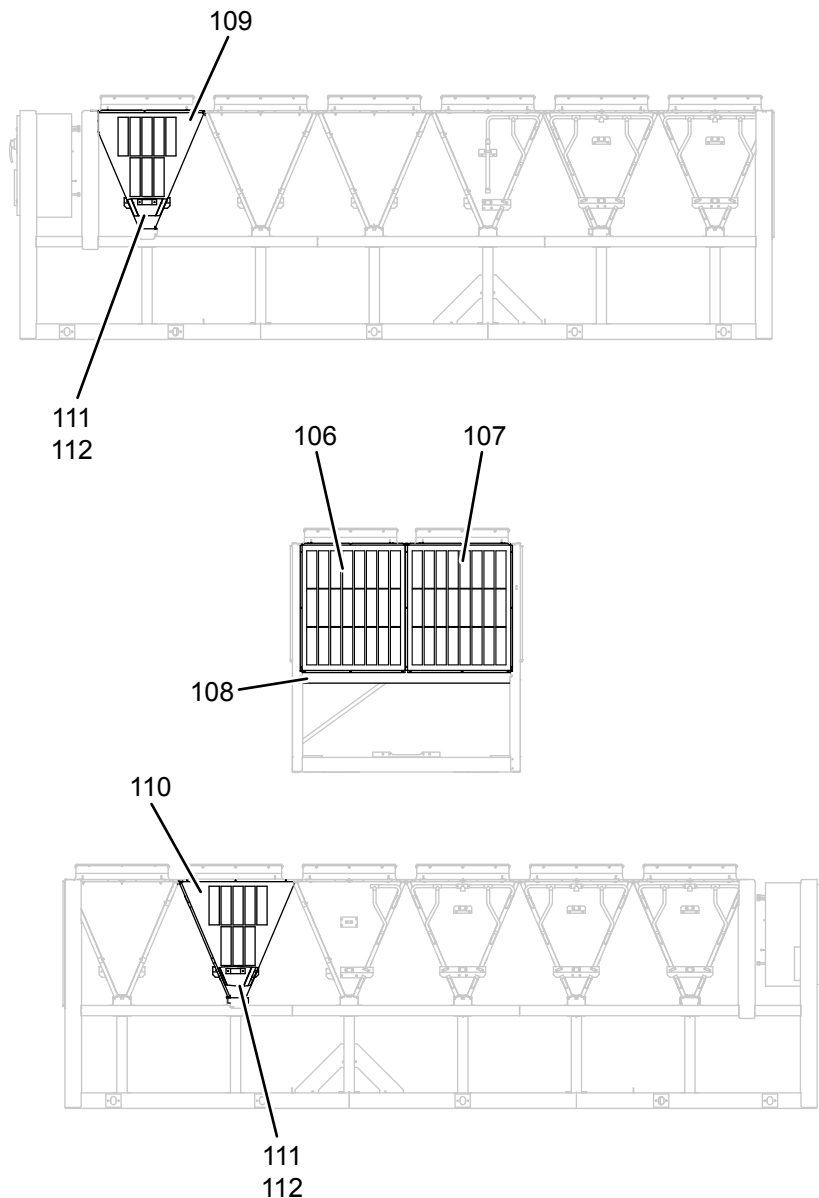

**10**

**FIGURE 37 - END LOUVER (HAIL GUARD) PANEL ENCLOSURE KIT COMPONENTS**

**TABLE 47 - V-GUARD PANEL ENCLOSURE KITS (ASSEMBLY)**

MODEL	FANS	PART NUMBER	
		V-GUARD ONLY	V-GUARD AND HAIL GUARD
0153/0543 0200/0700	8	375 94046 001	375 94046 101
0165/0565 0183/0643	10	375 94046 002	375 94046 102
0178/0588 0195/0665 0213/0743 thru 0215/0765	12	375 94046 003	375 94046 103
0198/0688 0273/0963	14	375 94046 010	375 94046 110
0233/0843	12	375 94046 004	375 94046 104
0218/0788 0245/0865 0263/0943 0275/0965	14	375 94046 005	375 94046 105
0278/0988	16	375 94046 006	375 94046 106
0248/0888 0323/1143	16	375 94046 007	375 94046 107
0295/1015 thru 0303/1093	16	375 94046 012	375 94046 112
0305/1065 thru 0308/1088	18	375 94046 011	375 94046 111
0318/1188 0345/1215	20	375 94046 008	375 94046 108
0333/1173 thru 0343/1193	18	375 94046 009	375 94046 109

1. See Table 48 on page 109 and Figure 38 on page 110 for V-Guard Kits.
2. See Table 50 on page 111 and Figure 39 on page 112 for V-Guard components



**TABLE 48 - V-GUARD KITS**

ITEM	MODEL	PART NUMBER	DESCRIPTION	QUANTITY	FIGURE
1	all	375 94041 001 <sup>2</sup>	V-Guard Kit	1	38
	all	375 94041 006 <sup>3</sup>	V-Guard Kit	1	38
2	0153/0543 0200/0700	375 94041 002	V-Guard Kit	1	38
	0165/0565 0183/0643 0233/0843			2	
	0178/0588 0195/0665 0213/0743 thru 0218/0788 0245/0865 0263/0943 0275/0965, 0303/1093			3	
	0198/0688 0248/0888 0273/0963 0323/1143 0333/1173 thru 0343/1193			4	
	0278/0988 0305/1065 thru 0308/1088			5	
	0318/1188 0345/1215			6	
3	0218/0788 thru 0245/0865 0263/0943 0275/0965 0295/1015 thru 0303/1093 0333/1173 thru 0343/1193	375 94041 003	V-Guard Kit	1	38
4	all	375 94041 004 <sup>2</sup>	V-Guard Kit	1	38
	0153/0543 thru 0245/0865 0263/0943 thru 0275/0965	375 94041 007 <sup>3</sup>	V-Guard Kit	1	
5	all	375 94041 005	V-Guard Kit	1	38

Notes: 1. V-Guard Kits used on both V-guard only and V-guard plus Hail Guard assemblies except as noted.

2. Used on V-guard assemblies only.

3. Used on V-guard plus Hail Guard assemblies only.

**TABLE 49 - HAIL GUARD**

ITEM	MODEL	PART NUMBER	DESCRIPTION	QUANTITY
2*	all	075 93252 000	Hail Guard	1

Note: \* Not shown.

**10**

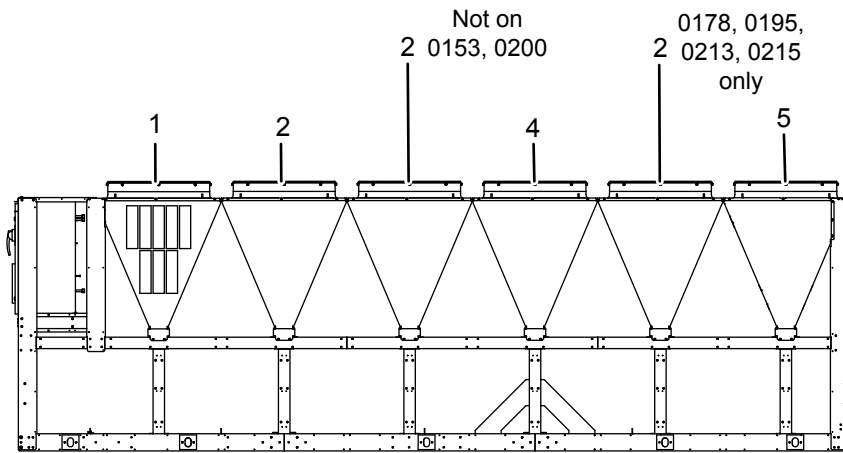

MODELS 0153, 0165, 0178, 0183, 0195, 0200, 0213, 0215 0215 SHOWN

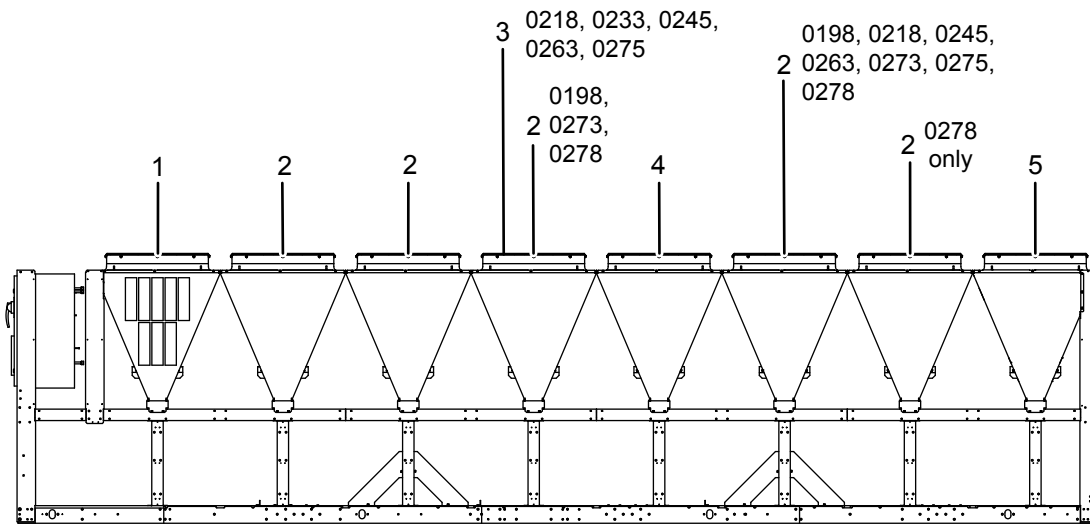

MODELS 0198, 0218, 0233, 0245, 0263, 0273, 0275, 0278 0278 SHOWN

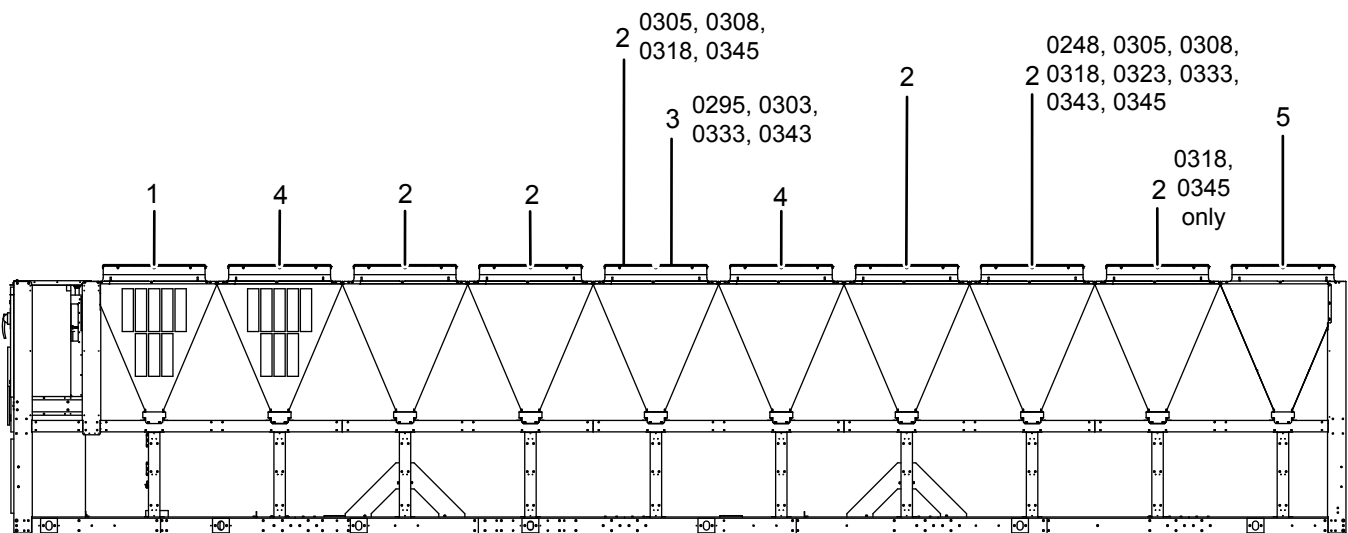

MODELS 0248, 0295, 0303, 0305, 0308, 0318, 0323, 0333, 0343, 0345 0345 SHOWN

LD16166

FIGURE 38 - V-GUARD PANEL ENCLOSURE KITS

**TABLE 50 - V-GUARD PANEL ENCLOSURE KIT COMPONENTS**

ITEM	MODEL	FANS	V-GUARD KIT	DESCRIPTION	PART NUMBER	QTY	FIGURE
1	0153/0543 thru 0245/0865 0263/0943 thru 0278/0988	8, 16, 18	375 94041 004	V-Panel, Louvers	075 94038 006	1	39
	0218/0788 thru 0245/0865 0263/0943 0275/0965	12, 14, 16, 18	375 94041 003	Aesthetic V-Panel	075 94038 000	2	
	0295/1015 thru 0303/1093 0333/1173 thru 0343/1193						
	all	all	375 94041 002	Aesthetic V-Panel	075 94038 000	2	
			375 94041 001 <sup>2</sup>		075 94038 001	1	
375 94041 006 <sup>3</sup>			075 94038 004		1		
2	0153/0543 thru 0245/0865 0263/0943 thru 0278/0988	8, 16, 18	375 94041 004 <sup>2</sup> 375 94041 007 <sup>3</sup>	Aesthetic V-Panel	075 94038 000	1	39
	all	all	375 94041 005	Aesthetic V-Panel	075 94038 003	1	
			375 94041 001	V-Panel, Louvers	075 94038 005	1	
3	0153/0543 thru 0245/0865 0263/0943 thru 0278/0988	8, 16, 18	375 94041 004	Bracket	075 94037 000	1	39
	0218/0788 thru 0245/0865 0263/0943 0275/0965	12, 14, 16, 18	375 94041 003		075 94037 002	1	
	0295/1015 thru 0303/1093 0333/1173 thru 0343/1193						
	all	all	375 94041 005		075 94037 000	1	
			375 94041 001 <sup>2</sup>		075 94037 001	1	
375 94041 006 <sup>3</sup>			075 94037 001	1			
4	0153/0543 thru 0245/0865 0263/0943 thru 0278/0988	8, 16, 18	375 94041 004 <sup>2</sup> 375 94041 007 <sup>3</sup>	Bracket	075 94037 001	1	39
	0218/0788 thru 0245/0865 0263/0943 0275/0965	12, 14, 16, 18	375 94041 003	Bracket	075 94037 001	1	
	0295/1015 thru 0303/1093 0333/1173 thru 0343/1193						
	all	all	375 94041 001	Bracket	075 94037 000	1	
			375 94041 002		075 94037 000	1	
375 94041 005			075 94037 001		1		
9	all	all	all	Gasket, Neoprene 1/2 X 1 X Roll	028 11838 000	2	39

Notes: 1. V-Guard components used on both V-guard only and V-guard plus Hail Guard assemblies except as noted.

2. Used on V-guard only assemblies.

3. Used on V-guard plus Hail Guard assemblies.

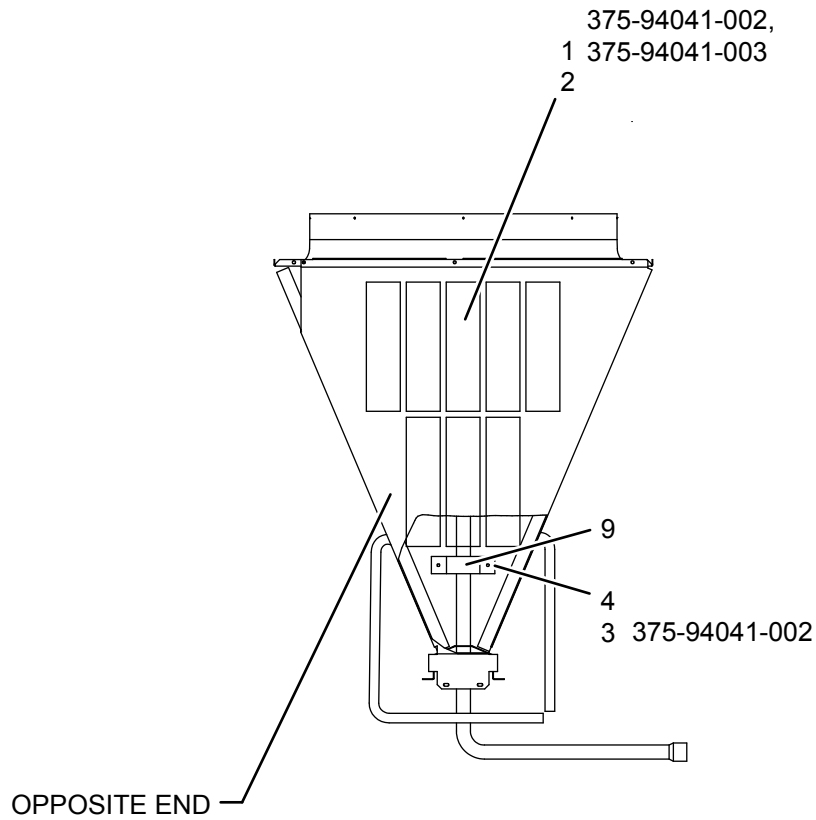
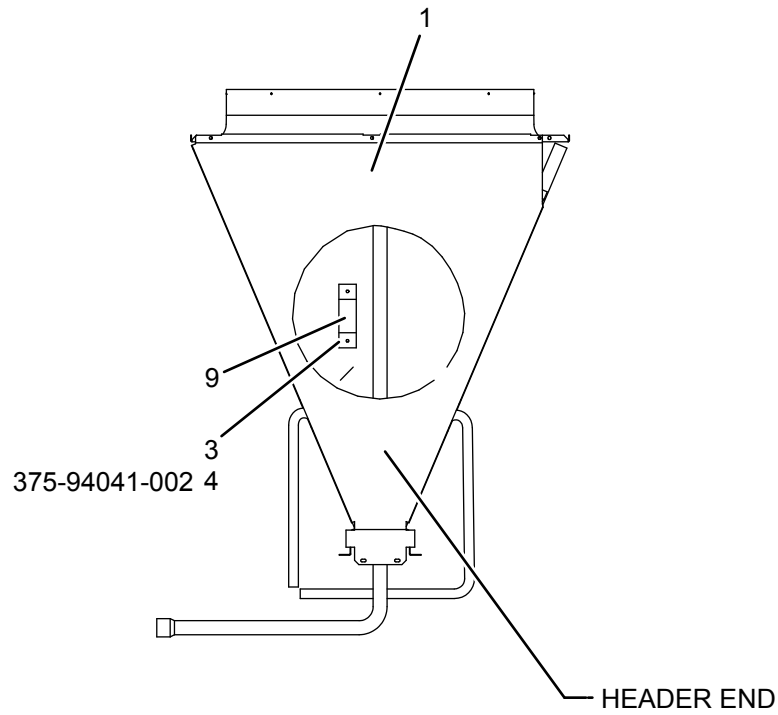

**TYPICAL V-GUARD PANEL ENCLOSURE KIT  
375-94041-001 SHOWN**

**FIGURE 39 - V-GUARD PANEL ENCLOSURE KIT COMPONENTS**

**TABLE 51 - EVAPORATOR WATER BOX HEATER KITS**

MODEL	KIT PART NUMBER	
	200, 230, 380, 460 AND 575V	380 415V 50HZ
0153/0543	375 94414 001	375 94414 002
0165/0565 0198/0688 0233/0843 0263/0943	375 94414 003	375 94414 004
0178/0588 0218/0788 0248/0888 0303/1093 thru 0305/1065 0333/1173	375 94414 005	375 94414 006
0183/0643 thru 0195/0665 0213/0743	375 94414 007	375 94414 008
0200/0700	375 94414 009	375 94414 010
0215/0765	375 94414 011	375 94414 012
0245/0865	375 94414 013	375 94414 014
0273/0963 thru 0295/1015 0308/1088 thru 0323/1143 0343/1193 thru 0345/1215	375 94414 015	375 94414 016

1. See Table 52 on page 114 for Water Box Heater Parts.

**TABLE 52 - EVAPORATOR WATER BOX HEATER PARTS**

ITEM	MODEL	VOLTAGE	DESCRIPTION	PART NUMBER	QUANTITY	FIGURE
10	ALL	ALL	Circuit Breaker, 2 Pole	024 37464 000	1	40
11	ALL	200, 230, 380, 460 and 575V	Heater, Immersion	025 42430 000	2	40
11	ALL	380 - 415V 50HZ	Heater, Immersion	025 44460 000	2	40
19	ALL	ALL	Relay Base	024 37460 000	1	40
20	ALL	ALL	Relay	024 37461 000	1	40

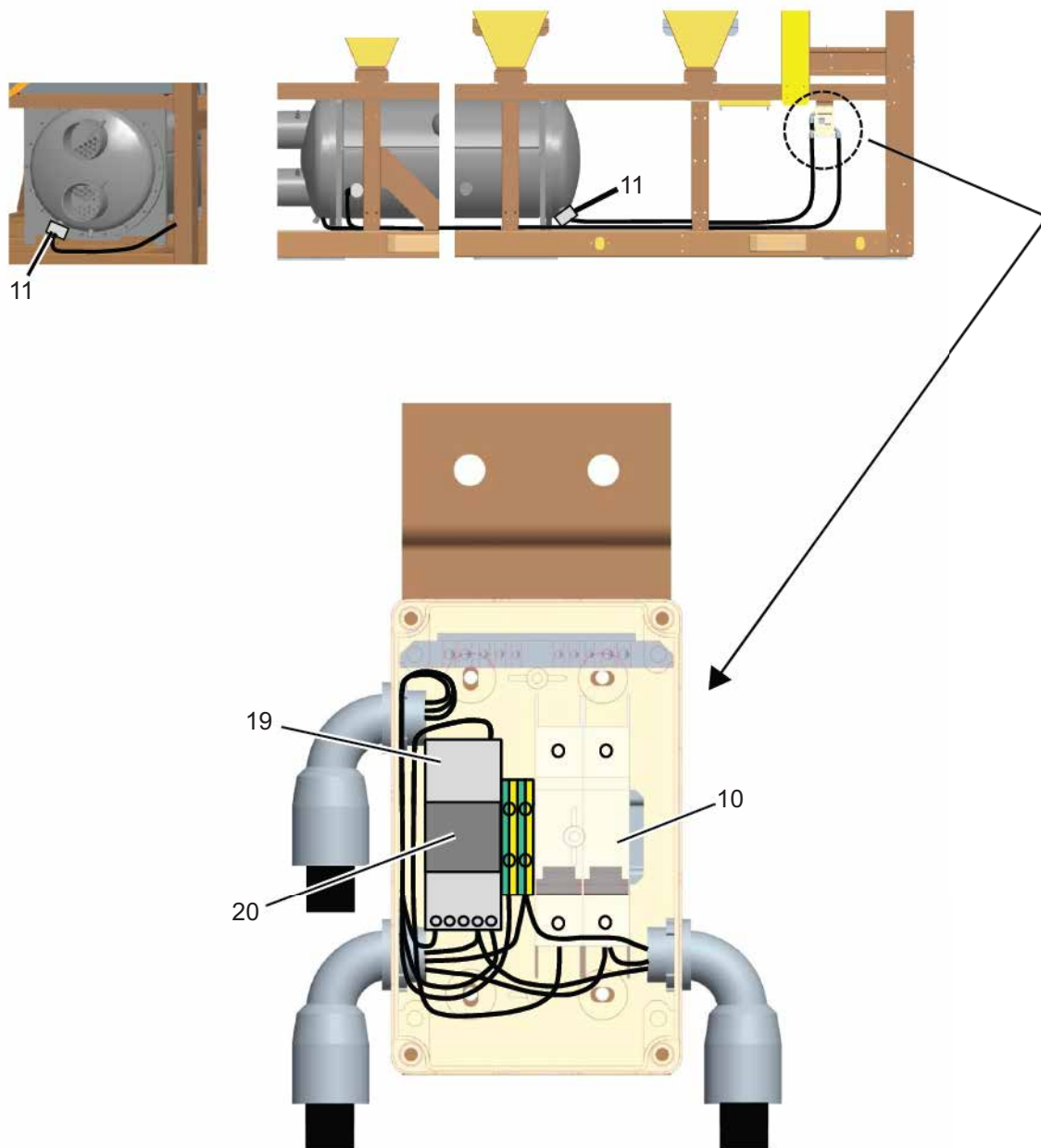

LD16172

**FIGURE 40 - EVAPORATOR WATER BOX HEATER PARTS**

**TABLE 53 - TOP EDGE GUARD KIT**

MODEL	FANS	EDGE GUARD KIT
0153/0543	8	375 94097 008
0165/0565 0183/0643	10	375 94097 010
0178/0588 0195/0665 0213/074 3thru 0215/0765 0233/0843	12	375 94097 012
0198/0688 0218/0788 0245/0865 0263/0943 thru 0275/0965	14	375 94097 014
0200/0700	8	375 94097 200
0248/0888 0278/0988 0295/1015 thru 0303/1093 0323/1143	16	375 94097 016
0305/1065 thru 0308/1088 0333/1173 0343/1193	18	375 94097 018
0318/1188 0345/1215	20	375 94097 020

1. See Table 54 on page 116 and Figure 41 on page 117 and Figure 42 on page 118 for individual Top Edge Guards.

**TABLE 54 - TOP EDGE GUARDS**

ITEM	MODEL	FANS	DESCRIPTION	PART NUMBER	QUANTITY	FIGURE
1	all	all	Top Edge Guard Component	075 94098 001	1	41, 42
2	all	all	Top Edge Guard Component	075 94098 002	1	41, 42
3	0165/0565 thru 0195/0665 0213/0743 thru 0215/0765 0233/0843	10, 12	Top Edge Guard Component	075 94098 003	2	41, 42
	0198/0688 0218/0788 0245/0865 thru 0303/1093 0318/1188 thru 0323/1143 0345/1215	14, 16			4	
	0200/0700	8			1	
	0305/1065 thru 0308/1088 0333/1173 0343/1193	18, 20			6	
4	0153/0543 0178/0588 0195/0665 0200/0700 thru 0215/0765 0233/0843 0248/0888 0278/0988 thru 0303/1093 0318/1188 thru 0323/1143 0345/1215	8, 12, 16, 20	Top Edge Guard Component	075 94098 007	1	41, 42
	0165/0565 0183/0643 0198/0688 0218/0788 0245/0865 0263/0943 thru 0275/0965 0305/1065 thru 0308/1088 0333/1173 thru 0343/1193	10, 14, 18	Top Edge Guard Component	075 94098 004	1	
5	0153/0543 0178/0588 0195/0665 0213/0743 thru 0215/0765 0233/0843 0248/0888 0278/0988 thru 0303/1093 0318/1188 thru 0323/1143 0345/1215	8, 12, 16, 20	Top Edge Guard Component	075 94098 008	1	41, 42
	0165/0565 0183/0643 0198/0688 0218/0788 0245/0865 0263/0943 thru 0275/0965 0305/1065 thru 0308/1088 0333/1173 thru 0343/1193	10, 14, 18	Top Edge Guard Component	075 94098 005	1	
	0200/0700	8	Top Edge Guard Component	075 94098 006	2	



**TABLE 54 - TOP EDGE GUARDS (CONT'D)**

ITEM	MODEL	FANS	DESCRIPTION	PART NUMBER	QUANTITY	FIGURE		
6	0153/0543	8	Top Edge Guard Component	075 94098 006	2	41, 42		
	0165/0565 thru 0195/0665 0213/0743 thru 0215/0765 0233/0843	10, 12			4			
	0198/0688 0218/0788 0245/0865 thru 0303/1093 0323/1143	14, 16			6			
	0200/0700	8			Top Edge Guard Component		075 94098 009	1
	0305/1065 thru 0318/1188 0333/1173 thru 0345/1215	18, 20			Top Edge Guard Component		075 94098 006	8
	7	0200/0700			8		Top Edge Guard Component	075 94098 010
	all except 0200/0700	all	Top Edge Guard Component	075 94098 009	1			
8	all	all	Top Edge Guard Component	075 94098 011	2	41, 42		

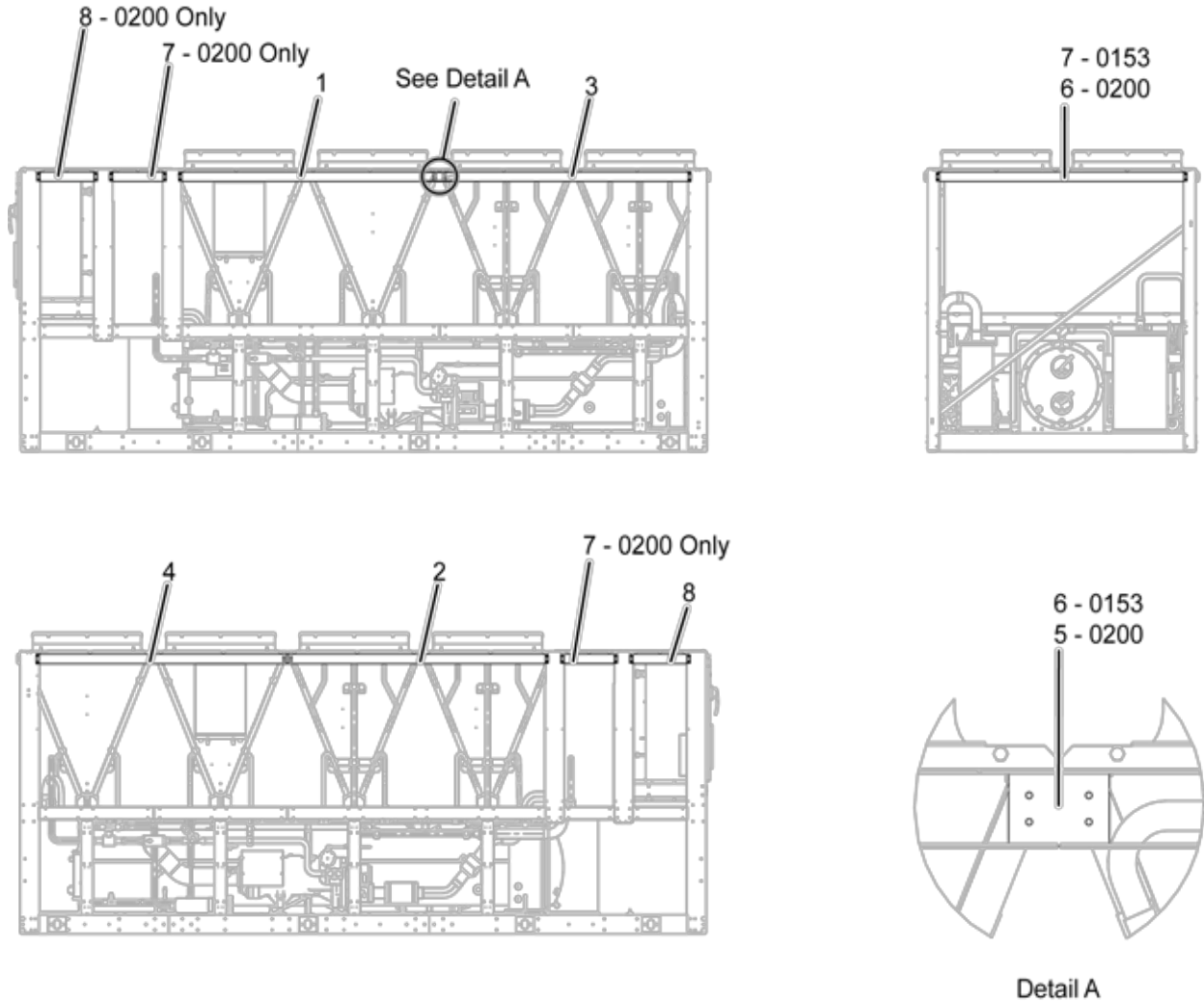

**10**

**FIGURE 41 - TOP EDGE GUARDS - MODELS 0153/0543 AND 0200/0700**

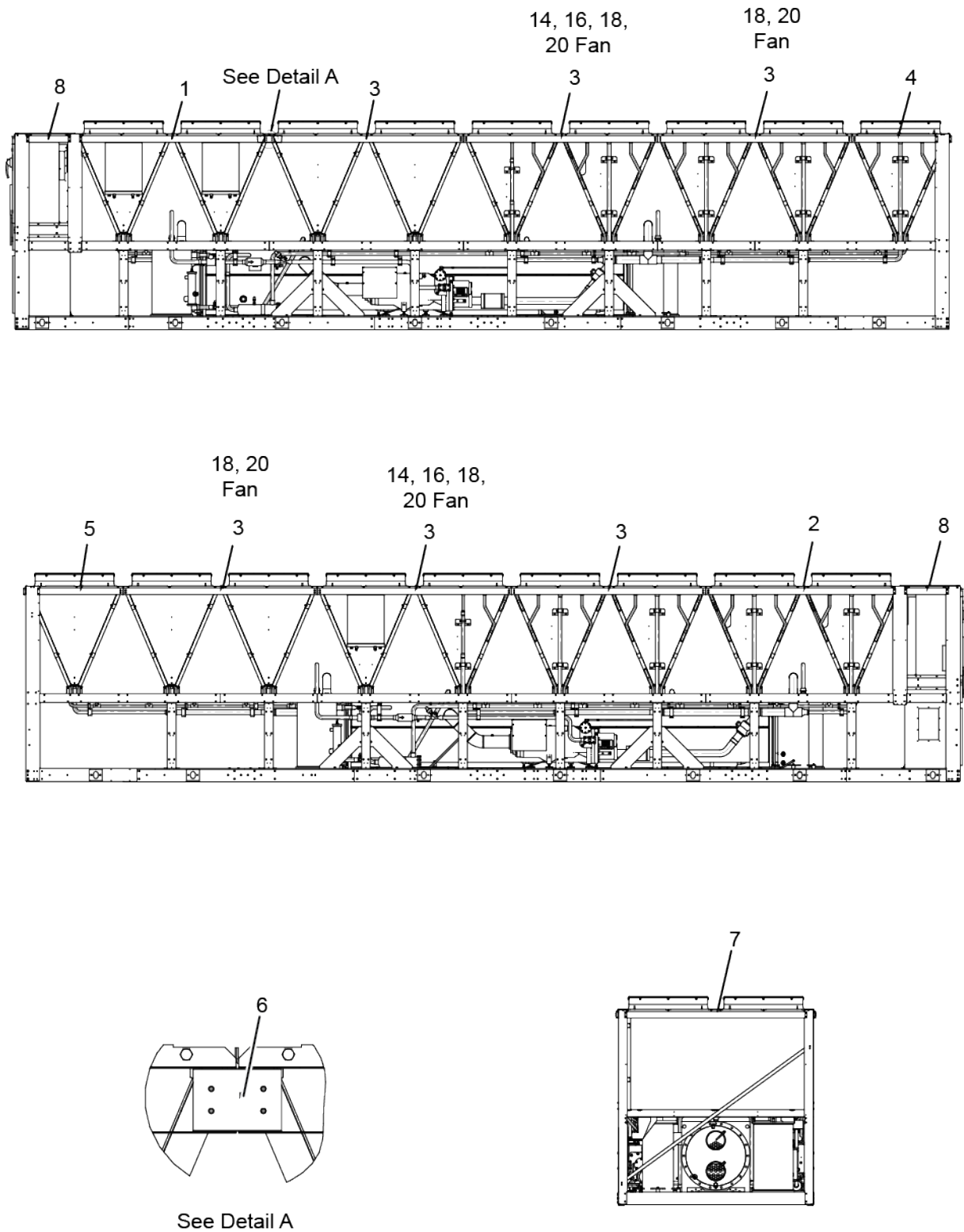

LD16173

**FIGURE 42 - TOP EDGE GUARDS - ALL MODELS EXCEPT 0153/0543 AND 0200/0700**

## RECOMMENDED SPARE PARTS

ITEM	MODEL	VOLTAGE	DESCRIPTION	PART NUMBER	TABLE AND PAGE
3	ALL	17, 28, 46, 50, 58	Motor, Fan, (Low Sound)	024 36873 107	Table 5 on page 25
		40	Motor, Fan, (Low Sound)	024 36873 104	
		17, 28, 46, 58	Motor, Fan, (Ultra Quiet Fan)	024 34980 101	
		40	Motor, Fan, (Ultra Quiet Fan)	024 34980 105	
		50	Motor, Fan, (Ultra Quiet Fan)	024 34980 103	
		17, 28, 46, 58	Motor, Fan, (High Airflow/High Static)	024 36874 003	
		40	Motor, Fan, (High Airflow/High Static)	024 36874 002	
6	ALL	17, 28, 46, 40, 58	Fan Impeller (Low Sound)	026 41594 000	
		50	Fan Impeller (Low Sound)	026 41943 000	
		17, 28, 46, 50, 58	Fan Impeller (Ultra Quiet Fan)	026 41942 000	
		50	Fan Impeller (Ultra Quiet Fan)	026 45549 000	
		17, 28, 46, 40, 58	Fan Impeller (High Airflow/High Static)	026 45538 000	
		50	Fan Impeller (High Airflow/High Static)	026 46066 000	
205	ALL	ALL	Core, Dehydrator	026 37540 000	
209	0153/0543 thru 0278/0988	ALL	Condenser Drain Valve (Flash Tank Feed Valve)	025 41565 000	Table 6 on page 27
	0303/1093 thru 0345/1215			025 44027 000	
210	0153/0543 thru 0308/1088			025 41565 000	
	0323/1143 thru 0345/1215			025 44027 000	
10	ALL	ALL	Cap, Radiator	023 21927 000	Table 7 on page 32
13	ALL	ALL	Coolant, Propylene Glycol, 1 gal. non-EU compliant	013 03345 000	Table 7 on page 32
			Coolant, Propylene Glycol, 5 gal. non-EU compliant	013-03344-000	Table 7 on page 32
			Coolant, Propylene Glycol, 5 gal. EU compliant	013-03849-001	Table 7 on page 32
1	ALL	ALL	Sensor, Temperature	025 40334 000	Table 10 on page 34
4			Sensor, Liquid Temperature	025 28935 000	
6			Sensor, Outside Air Temperature	371 01180 223	
16			Transducer, Liquid Pressure	025 29139 001	
72	ALL	ALL	Stepper Motor	031 02742 000	Table 17 on page 40
28	0153/0543 thru 0278/0988	ALL	Control Board	331 03478 101	Table 19 on page 46
	0303/1093 thru 0345/1215	40, 46,			
58	0153/0543 thru 0278/0988	50, 58	SD Card with Software, Control Board	031 03476 010	Table 19 on page 46
	0303/1093 thru 0345/1215		Blank SD Card	031 03466 000	

## NOTES

The following factors can be used to convert from English to the most common SI Metric values.

**TABLE 55 - SI METRIC CONVERSION**

MEASUREMENT	MULTIPLY ENGLISH UNIT	BY FACTOR	TO OBTAIN METRIC UNIT
Capacity	Tons Refrigerant Effect (ton)	3.516	Kilowatts (kW)
Power	Horsepower	0.7457	Kilowatts (kW)
Flow Rate	Gallons / Minute (gpm)	0.0631	Liters / Second (l/s)
Length	Feet (ft)	0.3048	Meters (m)
	Inches (in)	25.4	Millimeters (mm)
Weight	Pounds (lbs)	0.4538	Kilograms (kg)
Velocity	Feet / Second (fps)	0.3048	Meters / Second (m/s)
Pressure Drop	Feet of Water (ft)	2.989	Kilopascals (kPa)
	Pounds / Square Inch (psi)	6.895	Kilopascals (kPa)

## TEMPERATURE

To convert degrees Fahrenheit (°F) to degrees Celsius (°C), subtract 32° and multiply by 5/9 or 0.5556.

Example:  $(45.0^{\circ}\text{F} - 32^{\circ}) \times 0.5556 = 7.22^{\circ}\text{C}$

To convert a temperature range (i.e., a range of 10°F) from Fahrenheit to Celsius, multiply by 5/9 or 0.5556.

Example:  $10.0^{\circ}\text{F range} \times 0.5556 = 5.6^{\circ}\text{C range}$

