



BUILDING STRENGTH™

**FORMING ACCESSORIES
HANDBOOK**

**CONCRETE
CONSTRUCTION
PRODUCTS**

 **DAYTON®
SUPERIOR**



ave.

LEFT TURN SIGNAL

WRONG WAY

WRONG WAY

RIGHT TURN

LEFT TURN SIGNAL

LEFT TURN SIGNAL

Left Turn Signal
1007 1007

General and Technical Information..... 1	Medium/Heavy Forming47	General Slabwork.....77
Definitions 1	B1 Two Strut Coil Tie and B2 Four Strut Coil Tie 47	C1B and C1C Wedge Hangers77
Safety Notes and Product Application..... 1	B1B3 and B2B3 Screw-On Coil Tie..... 48	C2 Coil Hanger Saddle Type..... 78
Dayton Superior Technical Services 1	Coils..... 49	C3 Coil Half Hanger 79
Usage Affecting a Product's Safe Working Load2	B6 Welding Coil Tie..... 49	C13 Plate Saddle Hanger..... 79
Induced Tension Loads..... 6	B7 and B22 Inserts (Crimp) 49	C13A All-Wire Saddle Hanger 80
Induced Shear Loads 6	B11 Flat Washers..... 50	C14 Channel Hanger..... 81
Combined Shear and Tension Loads..... 6	B12 Coil Rod..... 50	Methods of Screeding 82
Forming Accessories Selection..... 7	B12A D/R Thread Bar 51	G1 Pipe Holder 83
Load Carrying Capacity Classifications:..... 7	B13 Coil Nut and B25 Heavy Coil Nut 52	G1U Special U-Shaped Cradle Head 83
Method of Use Classifications:..... 7	B14 Coil Bolts..... 52	G2 Screed Chair Bases 83
Lumber and Form Tie Analysis..... 7	B14A Adjustable Coil Bolt..... 53	G2J Joist Type Adjustable Screed Base..... 83
Calculations for Formwork Costs..... 8	B14W Wale Bolt Assembly 54	G2S Special Height Screed Base..... 84
Determining Required Quantities of Form Ties 8	B15 Plastic Cone Removal Wrench..... 54	G3 Screed Chair Base With Sand Plate..... 84
Typical Formwork Designs for Wall Forms..... 9	B16 Coil Loop Insert Straight 54	G4 and G4A Screed Bases, Drive Type..... 84
Vertical Formwork Design Loads 10	B17 Double Flared Coil Loop Insert..... 55	G5 Screed Bases, Free Fit Type..... 85
Slab Formwork Design Loads..... 11	B18 Single Flared Coil Insert..... 55	G7 Screed Chair Base for Steel Deck..... 85
Technical Data–Plywood..... 12	B20 Wale Holder..... 56	G8 Form Bracket 85
Technical Data–Lumber..... 13	B21 Plylag..... 56	G11 Screed Stake for Pipe 86
	B27 and D6 Nut Washer 57	G14 Heavy Duty Screed Holders..... 86
Light Forming 19	B29 Loose Plastic Cone 57	G15 Heavy Duty Screed Support 86
A2 Plastic Cones..... 19	B30 Screw-On Plastic Cones 58	G16 Heavy Duty Screed Chair Base..... 87
A3 Standard Snap Tie 19	B31 Rock Anchor 58	G27 Round Stake..... 87
A3 Heavy Snap Tie..... 20	B32 Handle Coil Nut 59	G28 and G29 Screed Bracket..... 87
A4H Hex Head Snap Tie 20	B33 Double Flared Criss Cross Coil Loop Insert..... 59	G33 Screed Key Joint 88
How to Break Back A4 Snap Ties..... 21	B37 Toggle Tie..... 60	G34 Load Key Joint 88
A5 Threaded PullOut Tie..... 21	B39 Wing Nut 60	G35 Plastic Cap Strip 88
A6 Spandrel Point Tie..... 21	B40 Plastic Setback Plug 61	G37 Stake..... 88
A7 Spandrel Hook Tie..... 22	B42 and D22 Batter Washer..... 61	How to Use Screed Key Joint 89
A7A Spandrel Plate Tie..... 22	B43 Triple Flared Coil Loop Insert 61	Proper Method for Installing Load Key Joint 91
A9 / A9H Tip-To-Tip Tie, Standard and Heavy 22	D1 and D18 Inside Tie Rods..... 62	Supports for Rebar and Wire Mesh..... 93
A10 Plate Tie..... 23	D1-J, D1LA and D1L Hook Bolts 63	
A13 Metal Strapping..... 23	D1S Anchor Bolt Sleeve 63	Miscellaneous 97
A16 Omni Wedge..... 23	D2 and D30 She-Bolts 64	Formliner Materials 97
A16SB Snap Bracket..... 23	D4 Hex Coupling Nut 65	F56, F57, F58, F59, F60, F61 Expanded Coil Inserts..... 98
A18 Panel Bolt..... 23	D9 Taper Ties 65	F42 Loop Ferrule Insert..... 98
A19 Corner Washer..... 24	D9A D/R Thread Bar Taper Tie..... 66	F44 Thin Slab Ferrule Insert..... 98
A21 Strap Ties And Accessories..... 24	D12 Rod Clamps..... 66	F7, F7L Shelf Angle Insert..... 98
A21X Flat Tie..... 25	D12A Pencil Rod..... 67	F54 Ductile Embed..... 98
A22 Spreader Cleats 26	D12F Form Clamp..... 67	F54C Nylon Rail Track Insert 98
A27 and A27-M Turnbuckle Form Aligners 27	D14 Tightening Wrench 67	
A28 Adjustable Kicker..... 27	D21 Rebar Clip and Form Spreader..... 68	Index..... 99
A29 Snap Tie Wrench..... 28	D24 Weld Angle Bracket 68	
A31 Wrench Head Snap Tie Socket..... 28	D25 Fitting Up Bolt and D26 Fitting Up Nut 69	
A40 Cone Removal Wrench..... 28	D27 Lag Bolt..... 69	
A43 Footing Tie 28	D30A D/R Thread Bar She-Bolt 70	
A44 Stainless Steel Snap Tie 29	D32 Closed Coupler 70	
A45 Base Tie 29	D33 Water Resistant Washer 70	
A46 Loop Panel Tie, Standard and Heavy..... 29	D40 He-Bolts..... 71	
A48 Gang Loop Tie, Standard and Heavy 30	Typical He-Bolt Anchors..... 72	
A51 Wedge Bolt..... 30	Special He-Bolt Inserts..... 72	
A52 Z Tie Holder and A53 Waler Tie 30	D42 Bag Ties 72	
A54 Snapplug® 31	PC110 Impalement Safety Cap..... 73	
A55 Sure-Lock Tie, A56 Sure-Lock Bracket, 31	D46 Tie Wire 73	
A57 Sure-Lock Strongback Bracket, 31	D48 Sure-Guard Rebar Protective Cap 73	
A63 Strongback Loop Tie 32	A58 Sure Plug 74	
A81 Jahn® "A" Bracket 32	A59 Insertion Tool..... 74	
A82 Jahn® "C" Bracket 33	F1 Screw Anchor and F2 Screw Anchor Bolt..... 75	
A83 Jahn® Cornerlock 33		
A89 Jahn® Scaffold Jack..... 34		
How to Use the Jahn® Forming System 35		
Using Single Vertical Wales for Curved Walls 42		
Column and Pilaster Forming Suggestions 42		
A90 Scaffold Bracket Jack..... 43		
A93C Sure Guard® Rail Post System..... 44		
A97 4x4 Post Shore Clamp 44		
A100 Speed Step® Bracket..... 45		
A110 Dayton Superior Metal Rib..... 45		



Accessories



Chemicals



Forming



Paving

Dayton Superior's reputation as the industry leader in the design, manufacturing and distribution of specialized concrete construction products is the result of innovation backed by more than 100 years of experience. Proven concrete solutions that span a wide breadth of industry disciplines and the most comprehensive product offering in concrete construction makes Dayton Superior the preferred partner for distributors, contractors, architects and engineers.

Dayton Superior's products are found on virtually every major construction site in North America including:

- Local roadways, national highways, runways and bridges
- High-profile urban high-rises and suburban mixed-use structures
- Water treatment and government service facilities, education and healthcare institutions
- Entertainment venues, retail and restaurant projects

With an unwavering commitment to continuous improvement, Dayton Superior employs creativity and discipline to develop timely and innovative solutions that add value for customers and distributors through:

- The largest, most experienced engineering and sales team in the industry
- Access to a wealth of detailed technical information via the Dayton Superior website coupled with a highly skilled team of technical service professionals
- A team of 70+ customer service advisors providing responsive customer care along with Dayton Access®, a 24/7 web-based tool providing order status information
- A nationwide distribution network of over 2,700 dealer distributor locations and 14 strategically located, company-owned distribution centers
- An unmatched track record of product innovation and industry leadership

In the concrete construction industry, Dayton Superior's reputation for quality, service and support is unequalled.

Definitions

- Safe Working Load — The maximum working load that should be applied to any forming product.
- Ultimate Load — The load at which a product fails or will no longer support or carry a load.
- Safety Factor — The theoretical reserve capability defined by dividing the ultimate load of the product by its safe working load. This is expressed as a ratio, such as 2:1 or 2 to 1 (ultimate to safe working load).
- Concrete Form Pressure — The lateral pressure applied per square foot of form contact.
- Slab Formwork Dead Load — The weight of fresh concrete and reinforcement bars plus the weight of the formwork.
- Slab Formwork Live Load — Any additional loads imposed during the construction process, such as materials, workmen, equipment, including lateral forces.
- Slab Formwork Design Load — Dead load plus live load per square foot of contact.
- Formwork Impact Load — Loads caused by dumping concrete or the starting/stopping of construction related equipment.

Safety Notes and Product Application

Dayton Superior ensures that all products meet or exceed appropriate safety requirements. However, the performance of a product can be greatly affected by the manner in which it is used. It is imperative that the user properly installs and uses the products displayed in this publication.

Production runs are constantly tested to assure a high standard of quality. Safe working loads listed in this publication were determined from independent testing and results of the Company quality assurance/quality control program.

Safety factors may be dependent on the application of a particular product. Job site conditions can often affect the safety factor of a product. Concentrated loads, such as, unsymmetrical loading, uplift, impact and lateral forces are examples of job site conditions that may affect the safety factor. The user must adjust safety factors accordingly to accommodate these various conditions.

Dayton Superior publishes the minimum safe working loads and the associated safety factors of its products and strongly advises that the minimum safety factors displayed in the table below not be compromised. When there are unusual job conditions such as mentioned above, the minimum safety factors must be increased by the user. Refer to the provisions of the American National Standards Institute (ANSI A 10.9), the Occupational Safety and Health Administration (OSHA) Act, Part 1910 and the American Concrete Institute (ACI) Recommended Practice for Concrete Formwork (ACI 347-94) when considering product safety factors.

Minimum Safety Factors of Formwork Accessories

Accessory	Safety Factor	Type of Construction
Form Tie	2.0 to 1	All applications.
Form Anchor	2.0 to 1	Formwork supporting form weight and concrete pressures only.
Form Anchor	3.0 to 1	Formwork supporting form weight, concrete, construction live loads and impact.
Form Hangers	2.0 to 1	All applications.
Anchoring Inserts (Used as Form Ties)	2.0 to 1	Precast concrete panels when used as formwork.

Dayton Superior Technical Services

Dayton Superior maintains three strategically located technical departments that are well staffed with trained personnel to service inquiries concerning Dayton Superior products and/or methods.

Usage Affecting a Product's Safe Working Load

Forming accessories may be subjected to excessive wear, field modification/bending and straightening. Any product so noted must be discarded. Do not try to straighten bent forming accessories; discard and replace them. Also discard any reusable device that has experienced excessive loading, 70% or more, of ultimate load. Such items may have become brittle.

Every user must establish a control program that replaces reusable forming products after a predetermined time period or number of uses, regardless of product appearance. All reusable forming accessories shown in this publication are subject to wear, misuse, overloading, corrosion, deformation, intentional alteration and other factors which may affect the product's safe working load. Therefore, it is mandatory that the user inspect all reusable accessories to determine their condition. The frequency of inspection is dependent on factors such as frequency of use, period of use, environment, etc., and is best determined by the user consistent with good construction practices.

When in doubt about the proper use or installation of Dayton Superior forming accessories, contact Dayton Superior for clarification. Failure to do so may result in exposure of workers to safety hazards, resulting in possible injury and/or death.

All safe working loads shown in this publication contain an approximate minimum safety factor. The safe working loads were established with the following factors in mind:

1. All safe working loads are based on the accessory being in new or in "as new" condition. The safe working load is considered to be the maximum load that should be applied to a product.
2. The safe working load of Dayton Superior Snap Ties and related products can only be developed when used in conjunction with A16 Omni Wedges, A81 Jahn A Brackets or A82 Jahn C Brackets.
3. Care is taken to ensure that internal vibration has not caused snap tie wedges to loosen, bounce around or fall off.

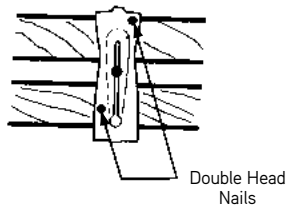

Right

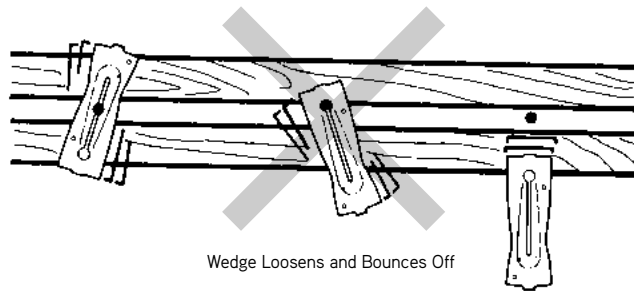

Wrong

4. It is important that the snap tie head and wedge be positioned properly.

The proper tie head position is at the midpoint, or higher, of the wedge slot. The tie head must not be positioned lower than the midpoint of the wedge.

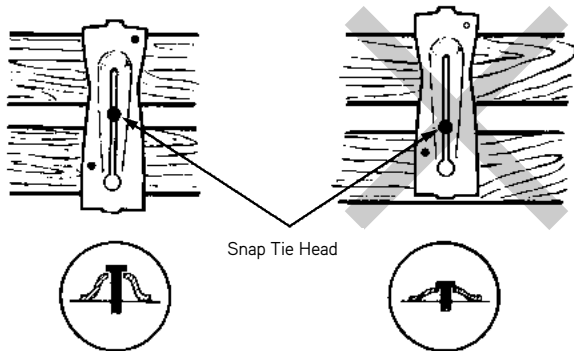

Right

Wrong

5. When using snap ties, correct spacing between double wales is 5/8" to 3/4".

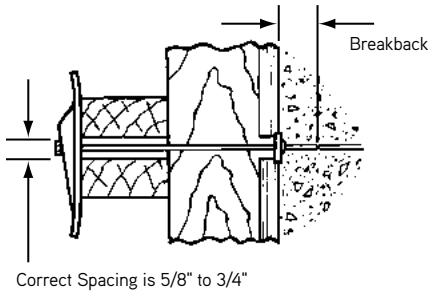

Correct Spacing is 5/8" to 3/4"

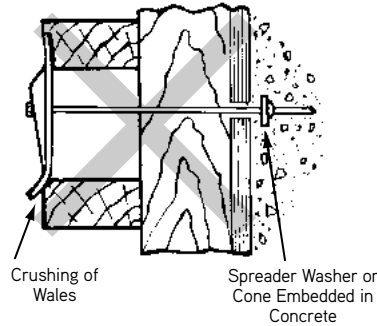

Crushing of Wales

Spreader Washer or Cone Embedded in Concrete

Right

Wrong

Too much space allowed between the wales may cause crushing of the wales and/or the bending of the wedge allowing the form to bulge outward. This results in incorrect wall thickness and causes the tie spreader washers or cones to become embedded and trapped in the concrete. Trapped tie washers or cones will cause difficulties during the tie breakback operation.

6. The plastic tie cones and metal washers are designed to act as form spreaders only.

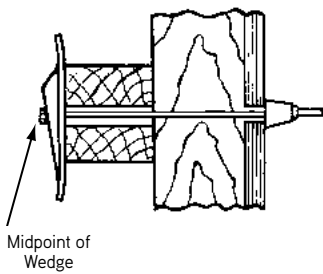

Midpoint of Wedge

Right

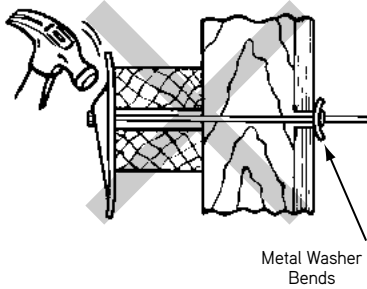

Metal Washer Bends

Wrong

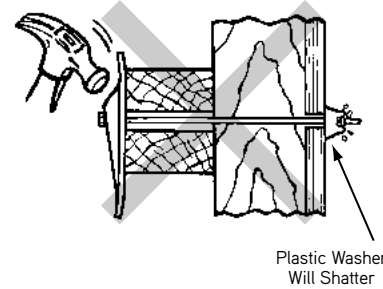

Plastic Washer Will Shatter

Do not attempt to draw-up warped wales with the wedge. Do not over tighten the wedge in any manner. Over tightening will cause metal spreader washers to bend out of shape or will break plastic cones resulting in incorrect wall thickness.

7. Care must be taken to be sure that all form ties are installed and used properly.

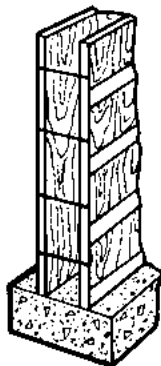

Right

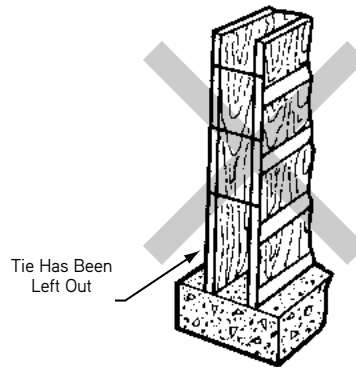

Tie Has Been Left Out

Wrong

Failure to install all of the required ties or their required mating hardware will cause excessive loads to be transferred to adjacent ties and may result in form failure.

Care must be taken to ensure that form ties are properly aligned. Misalignment may result in form failure due to increased loads placed on the form ties. Misalignment may also cause damage to the form tie during installation that may result in reduced load capacities.

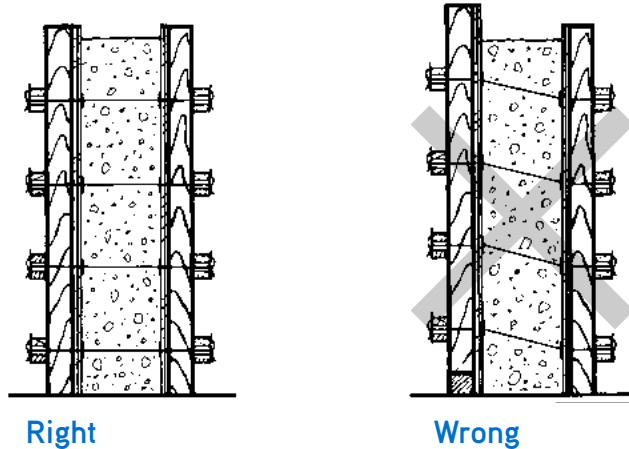

Right

Wrong

8. When using coil bolts, coil ties, coil hanger saddles, he-bolts, taper-ties, she-bolts and other coil thread items, maximum spacing between the double wales should be $1/2''$ more than the nominal diameter of the bolting device being used. When too much space is allowed between the wales, the wales may crush or the washers may bend. This causes the

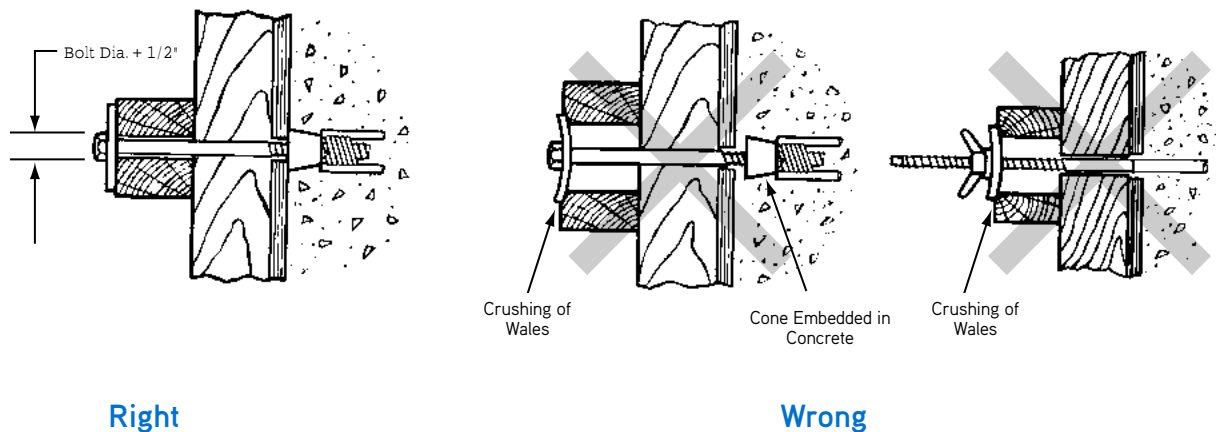

Right

Wrong

form to move outward to cause incorrect wall thickness and allowing the spreader cones to become trapped in the concrete. The higher than anticipated lateral form pressure can also deflect the washers resulting in incorrect wall thickness.

9. Coil bolts, coil rod and other coil thread products must have proper coil penetration. A bolting device with proper coil penetration will extend past the coil a minimum of one diameter of the bolting device. For example, a properly penetrating 1/2" diameter coil bolt will extend past the coil a minimum of 1/2". Incorrect penetration of threaded items may result in form failure.

Failure to obtain proper penetration will cause excessive wear on the first few threads of the bolt, but more importantly it

Right

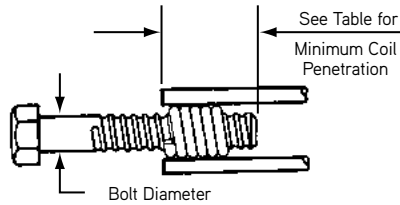

Bolt Diameter	Minimum Coil Penetration
1/2"	2"
3/4"	2-1/4"
1"	2-1/2"
1-1/4"	2-1/2"
1-1/2"	3"

Wrong

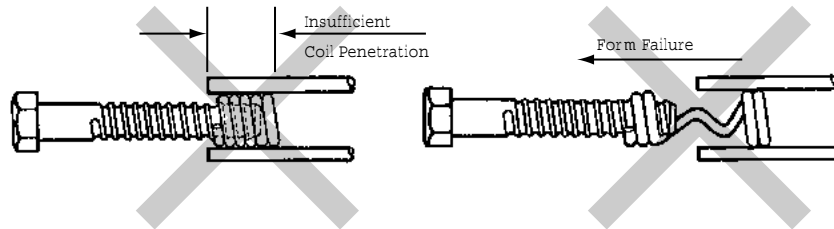

places the entire bolt load on a smaller portion of the coil welds. The increased loading can cause the coil welds to fail and result in form failure.

10. Do not beat on the end of loop ties to force them into position. This may damage the tie and result in form failure.
11. Use only correct length form ties. Incorrect length ties, when mixed with correct ones, will cause a transfer of lateral pressure to adjacent ties and may result in form failure.
12. Do not climb on form ties.
13. Do not use impact wrenches to tighten form-tying devices.
14. Do not over-vibrate the concrete. Excessive vibration will cause concrete at the bottom of the form to remain in a liquid state longer than expected. This will result in higher than anticipated lateral form pressure and may result in a form failure. Depth of vibration should be limited to within four (4) feet of the top of the fresh concrete.

Right

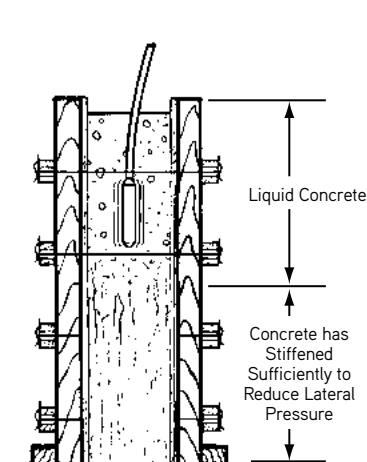

Wrong

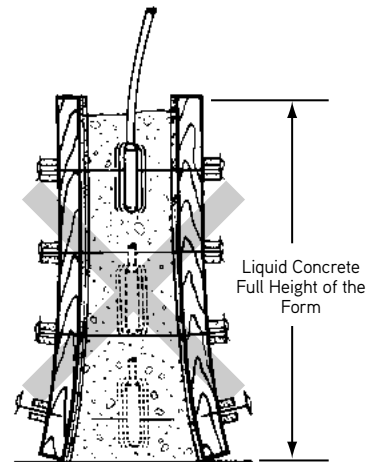

15. Do not exceed the recommended rate of placement and do not continue to place concrete while the concrete in the bottom of the form is still in a liquid state. A form failure may result.
16. Do not use forming accessories with underrated working parts.
17. All forming accessories and related hardware must be of proper length, diameter and capacity. If a greater safety factor is necessary for any reason, the user must reduce the safe working load accordingly.
18. Extreme caution must be used when welding any forming system item. Welding may affect material properties resulting in lower product performance. It is necessary to have a good working knowledge of materials, heat treating and welding procedures before welding any forming accessory. Since Dayton Superior cannot control field conditions or workmanship, Dayton Superior **does not guarantee** any product altered in any way after leaving the factory.

Wrong

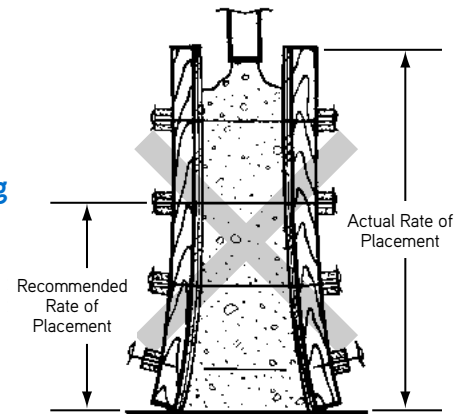

Induced Tension Loads

It is important to remember that tying at an angle causes an increase in the tension that is applied to the angled tie. The table lists various angles and the corresponding multiplication factor to use in calculating the tension load in an angled tie.

Angle	Multiplication Factor
15°	1.04
30°	1.16
45°	1.42
60°	2.00

Note: Tension = Pressure x Multiplication Factor

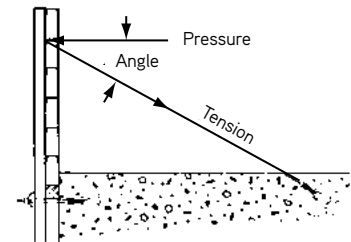

Induced Shear Loads

It is important to remember that tie downs placed at an angle will produce shear loads as shown. The total shear load may be several times greater than the shear load produced by the weight of the form alone.

Both tension and shear loads must be taken into consideration when deciding which form tie system to be used for a particular forming application.

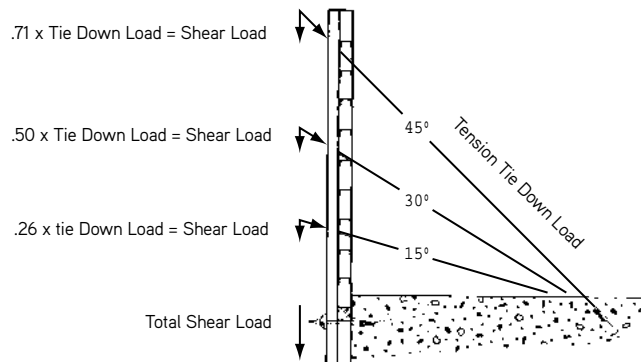

Combined Shear and Tension Loads

Form accessories and inserts that are subjected to combined shear and tension loading should satisfy the following equation:

$$(f_t/F_t)^{5/3} + (f_v/F_v)^{5/3} \leq 1.0$$

Where

- f_t = induced tension load,
- F_t = insert tension safe working load or bolt tension safe working load, whichever is less,
- f_v = induced shear load,
- F_v = insert shear safe working load or bolt shear safe working load, whichever is less.

Forming Accessories Selection

Dayton Superior Concrete Accessories manufactures and supplies a large variety of form tying devices for concrete formwork. Form tying devices can generally be classified in two ways, by load carrying capacity and by method of use.

Load Carrying Capacity Classifications:

- Light Forming — Light forming form ties have safe working load values of 3,750 pounds or less. Typical light duty ties include Snap Ties, Loop Ties and Pencil Rod.
- Medium/Heavy Forming — Medium/heavy form ties have safe working load values over 3,750 pounds. Typical medium/heavy form ties include Coil Ties, She-Bolts, Taper Ties, etc.

Method of Use Classifications:

- Through Ties — This type of tie extends through the wall thickness and through both sides of the formwork. Dayton Superior manufactures four types of through ties to satisfy most forming application requirements. Snap Ties, Loop Ties, Taper Ties and Pencil Rod are all quality through tie systems.
- Coil Ties — The Coil Tie System consists of two Coil Bolts, two Flat Washers, optional Tie Cones and a Coil Tie. The optional Tie Cones act as an internal spreader and assures proper set-back of the tie. Continuous Threaded Coil Rod can be used in place of the Coil Bolts in emergency conditions or in applications requiring varying bolt lengths.
- She-Bolts — A She-Bolt has external threads on the large end and internal threads on the tapered end. The external threads provide adjustment for varying form thickness. The internal threads provide attachment for the Inside Rod that ties the two She-Bolt sections together. Various working parts and form anchorages, are available for use with the She-Bolt System.

Lumber and Form Tie Analysis

Assume a project contains 100,000 square feet of form contact area. 12" thick walls x 14'-0" high and that 10,000 square feet of form will be constructed. Schedule will be six months with form reuse based on three uses per month.

Assume that the working parts are purchased. Experience has shown that Example A working parts have a life of 10 uses and Example B working parts have a life of 50 uses. Form lumber in Example A has a salvage value of 25% while Example B has a salvage value of 60%.

For this analysis the cost of nails, band iron, connecting bolts, lifting devices, etc., have been omitted. Both examples were calculated in the same manner with the exception of the number of uses of the working parts and the difference in salvage value as noted.

Example A	Example B
3/4" Plywood	3/4" Plywood
2"x4" Studs @ 12" o.c.	2"x4" Studs @ 6" o.c.
2-2"x4" Wales @ 24" o.c.	2-3"x6" Wales @ 24" o.c.
A3, A4 or A44 Standard	B1 Heavy Coil Ties @ 32" o.c.
Snap Ties @ 24" o.c.	D1 or D18 Inside Rod with She-Bolts @ 32" o.c.
Rate of Placement:	Rate of Placement:
50° F. = 2-1/4 ft./hr.	50° F. = 10 ft./hr.
70° F. = 3-1/4 ft./hr.	70° F. = 10 ft./hr.

Note: Refer to "Typical Formwork Designs for Wall Forms" footnotes for data regarding allowable stresses for plywood and lumber, concrete temperature and short term loading conditions.

The two examples present average costs for lumber and form ties. The examples are only displayed to give the reader an outline to prepare similar cost analyses for specific formwork designs. Note that labor costs must be added to the material costs. Example A has 12,500 ties that must be installed and removed and 25,000 tie holes to be patched. Example B has 9,375 ties to install and remove and 18,750 tie holes to patch.

These comparative figures illustrate the advantage of "balanced" formwork designs; proper capacity form ties matched with appropriate lumber size and strength results in an efficient, economical form design. Also evident is the small material cost difference in building a heavy form compared to a light duty form. Users must account for the significant labor cost difference of installing, removing and patching the additional form ties.

Note also that the placement rate for Example B is 4-1/2 times greater than Example A. The placing crew cost savings must be considered to arrive at the total in-place cost per unit of measure.

Calculations for Formwork Costs

Description	Example A	Example B
a) Form Contact Area Per Tie = $\frac{\text{Wale Center (in.)} \times \text{Tie Centers (in.)} \times 2}{12}$	8 sq. ft.	10.67 sq. ft.
b) Unit Cost of Tie	\$0.93	\$3.02
c) Tie Cost per sq. ft. of Form Contact Area = (b ÷ a)	\$0.12	\$0.28
d) Working Part Cost/Tie	\$3.38	\$29.96
e) Working Part Cost/Tie per sq. ft. of Form Contact Area per Use	\$0.042	\$0.056
f) Total Tie Cost per sq. ft. of Form Contact Area per Use = (c + e)	\$0.162	\$0.336
g) Board Feet of Lumber per sq. ft. of Form, Excluding Plywood. See note below.	1.43	2.76
h) Material Cost of Lumber per sq. ft. of Form. See note below.	\$1.99	\$2.91
i) Lumber cost per sq. ft. of Form Contact Area = $\frac{(10,000 \text{ sq. ft.}) (h)}{100,000 \text{ sq. ft. of Form Contact Area}}$	\$0.20	\$0.29
j) Salvage Value per sq. ft. of Form Contact Area = (i x .25) or (i x .60)	= \$0.05	\$0.17
k) Net Lumber Cost per sq. ft. of Form Contact Area = (i -- j)	= \$0.15	\$0.12
l) Total Form Tie and Lumber Cost per sq. ft. of Form Contact Area = (f + k)	= \$0.31	\$0.456
m) Total Number of Ties Required	12,500 pcs.	9,375 pcs.

Check (Example A):

Total Tie Cost	= (0.162)(100,000)	= \$ 16,200
Total Lumber Cost	= (1.99)(10,000)(.75)	= <u>14,925</u>
	TOTAL COST	= \$ 31,125

Cost per sq. ft. of Form Contact Area = $\frac{\$31,125}{100,000}$ = \$0.31

Note: Depending upon local prices, the plywood and structural lumber costs in Example A may be separated as follows:

3/4" Plyform Class 1, Grade B-B	=	\$ 1.00/sq. ft.
1.43 bd. ft. @ \$630/M	=	0.90
Bracing Lumber @ 10%	=	0.09
Total Lumber Cost/sq. ft.		\$ 1.99/sq. ft.

Determining Required Quantities of Form Ties

Form Tie Calculator Based on 10,000 sq. ft. of Wall Area
or 20,000 sq. ft. of Form Contact Area

Form Tie Spacing	Form Ties Required
16" x 16" = 1.77 sq. ft.	5,650
24" x 24" = 4.0 sq. ft.	2,500
24" X 32" = 5.33 sq. ft.	1,877
32" x 32" = 7.11 sq. ft.	1,407
32" x 48" = 10.67 sq. ft.	938
48" x 48" = 16 sq. ft.	625
60" X 60" = 25 sq. ft.	400

Typical Formwork Designs for Wall Forms

The table below lists several of the most common form lumber sizes and spacings that are being used in the industry today. For each formwork design, the appropriate form tie is shown.

Typical Formwork Designs

Recommended Form Ties	Form Tie Safe Working Load (lbs.)	Maximum Rate of Placement Vertical Feet per Hour		Maximum Form Tie Spacings		Form Design Single Vertical Studs		Form Design Double Horizontal Wales	
		50°F	70°F	Vertical	Horizontal	Size	Centers	Size	Centers
A3, A4 or A44 Snap Ties, Standard	2,250	2-1/4	3-1/4	24"	24"	2"x4"	12"	2"x4"	24"
		5-3/4	10	16"	16"	2"x4"	8"	2"x4"	16"
A3 Snap Tie, Heavy	3,350	2-2/3	3-2/3	24"	32"	2"x4"	12"	2"x6"	24"
		3-3/4	5-1/3	24"	24"	2"x4"	8"	2"x4"	24"
B1 Coil Tie, Standard	4,500	2-2/3	3-3/4	32"	32"	2"x6"	12"	2"x6"	32"
		5-1/3	8-3/4	24"	24"	2"x4"	8"	2"x6"	24"
B1 Coil Tie, Heavy	6,750	2-2/3	3-3/4	32"	48"	2"x6"	12"	2"x8"	32"
		4-1/3	6-1/4	32"	32"	2"x4"	8"	2"x6"	32"
		6	10	24"	32"	2"x4"	8"	2"x6"	24"
B1 Coil Tie, Heavy D1 or D18 Inside Rod with She-Bolts	9,000	3-1/3	4-2/3	32"	48"	2"x4"	8"	2"x8"	32"
		6	10	32"	32"	2"x6"	8"	2"x6"	32"
		10	10	24"	32"	2"x4"	6"	3"x6"	24"
D9 Taper Tie	18,000	5-1/3	8-3/4	48"	48"	Aluminum or steel studs and wales are normally used for these conditions			
B2 Coil Tie, Standard	18,000	5-1/3	8-3/4	48"	48"				
D1 or D18 Inside Rod with She-Bolts	18,000	5-1/3	8-3/4	48"	48"				
D9A (15mm) Taper Ties	18,750	5-1/3	8-3/4	48"	48"				
B2 Coil Tie, Standard	27,000	5	7-3/4	60"	60"				
D9A (20mm) Taper Tie	32,500	6-2/3	10	60"	60"				
D9 Taper Tie	34,000	6-2/3	10	60"	60"				
D1 or D18 inside	37,500	5	7	72"	72"				
Rod with She-Bolts									
D9 Taper Tie	50,000	5-1/3	8-3/4	72"	72"				

Note: The above table is based on the following conditions:

- Concrete – Made with type 1 cement weighing 150 pcf. contains no admixtures, slump of 4" or less and normal internal vibration to a depth of 4 ft. or less. If conditions vary, contact Dayton Superior for additional recommendations.
- Concrete Temperature – For practical purposes, 50°F. is used by many form designers as the temperature of fresh concrete during winter, with 70°F. being used as the summer temperature. This "rule of thumb" appears to work satisfactory unless the concrete has been heated or cooled to a controlled temperature.
- Plywood Sheathing – 3/4" plyform class 1 or structural 1 used the strong direction. Experience has shown that 3/4" plywood is more economical in form usage than other thickness even though initial cost may be slightly more. Deflection has been limited to 1/360 or 1/16" whichever is less and plyform is supported by four or more studs.
- Studs – Fiber Stress in bending = varies psi, modulus of elasticity = 1,400,000 psi horizontal shear = 225 psi, deflection limited to 1/270 or 1/8" whichever is less with studs continuous over four or more wales.
- Double Wales – Fiber Stress in bending = varies psi, modulus of elasticity = 1,400,000 psi horizontal shear = 225 psi, deflection limited to 1/270 or 1/8" whichever is less with wales continuous over four or more ties.
- Short Term Loading Conditions – Allowable stresses, except for modulus of elasticity include a 25% increase for short term loading.
- Form Ties – Safe working loads are based on a factor of safety of approximately 2 to 1 (ultimate to SWL).

Vertical Formwork Design Loads

The selection of the proper sheathing, studs and/or wales for concrete formwork requires knowledge of maximum lateral pressure which will be exerted by the concrete. Dayton Superior is in agreement with the **Lateral Pressure Design Formulas** contained in the American Concrete Institute's "Guide to Formwork for Concrete", (ACI 347 latest revision). Designers of formwork for concrete walls or columns find the following information useful:

- For general purpose conditions and unless the special conditions listed below are met, all formwork should be designed for the lateral pressure of the newly placed concrete using the formula of:

$$P = W \times H$$

Where P = lateral pressure, lbs/sq ft;

W = unit weight of fresh concrete, lbs per cu ft or 150 pcf for normal weight concrete;

H = depth of fluid or plastic concrete in feet. (Normally height of wall or column form.)

Please note that the maximum and minimum values given for the formulas under the special conditions do not apply to the above lateral pressure formula.

- Special Condition No. 1** — For concrete made with type 1 cement, weighing 150 lbs per cu ft, containing no pozzolans or admixtures, having a slump of 4" or less and normal internal vibration to a depth of 4 ft. or less. Then the formwork may be designed for a lateral pressure as follows:

For columns:

$$P = 150 + \frac{9,000 \times R}{T}$$

with a maximum of 3,000 lbs per sq ft, a minimum of 600 lbs per sq ft, but in no case greater than W x H.

For walls with a rate of placement less than 7 ft. per hour:

$$P = 150 + \frac{9,000 \times R}{T}$$

with a maximum of 2,000 lbs per sq ft, a minimum of 600 lbs per sq ft, but in no case greater than W x H.

For walls with a rate of placement of over 7 ft. / hour but less than 10 ft. / hour:

$$P = 150 + \frac{43,400}{T} + \frac{2800 \times R}{T}$$

with a maximum of 2,000 lbs per sq ft, a minimum of 600 lbs per sq ft, but in no case greater than W x H.

Where P = lateral pressure, lbs per sq ft;

R = rate of placement, feet per hour, and

T = temperature of concrete in the form, degree fahrenheit. For practical purposes, 50°F. is used by many form designers as the temperature of fresh concrete during the winter, with 70°F. being used as the summer temperature. This "rule of thumb" appears to work satisfactorily unless the concrete has been heated or cooled to a controlled temperature.

- Special Condition No. 2** — If concrete is to be pumped from the base of the form, the form should be designed for a full hydrostatic head of concrete (W x H) plus a minimum allowance of 25% for pump surge pressure. In certain instances pressures may be as high as the face pressure of the pump piston.
- Special Condition No. 3** — Caution must be taken when using external vibration or concrete made with shrinkage compensating or expansive cements. Pressure in excess of equivalent hydrostatic may occur.

Wall forms must meet wind load requirements of American National Standards Institute A-58.1 (Reference to section 2-6) or of the local building code, whichever is more stringent. The minimum wind design load must be 15 lbs per sq ft. Bracing for wall forms must also be designed for a horizontal load of at least 100 lbs per lineal ft of wall applied at the top of the form.

Lateral Pressure of Concrete for General Purpose Conditions

Depth of Fluid or Plastic Concrete	Pounds Per Square Foot in Feet
4	600
5	750
6	900
7	1,050
8	1,200
9	1,350
10	1,500
12	1,800
14	2,100
16	2,400
18	2,700
20	3,000

Lateral Pressure of Concrete for Special Condition No. 1 – Walls

Rate of Placement Feet Per Hour	Pounds per Square Foot for Indicated Temperature	
	50°	70°
2	600	600
3	690	600
4	870	664
5	1,050	793
6	1,230	921
7	1,410	1,050
8	1,466	1,090
9	1,522	1,130
10	1,578	1,170

Note: Do not use lateral pressures in excess of 150 x height of fluid or plastic concrete in forms.

Points to Remember

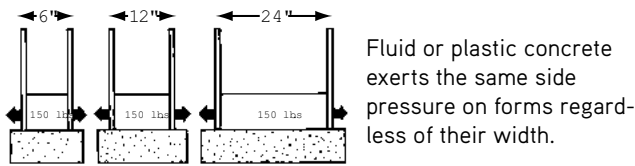

Fluid or plastic concrete exerts the same side pressure on forms regardless of their width.

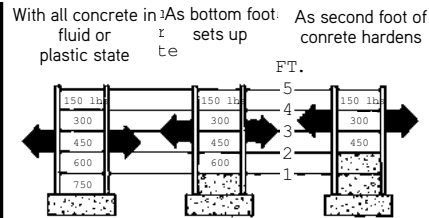

As concrete hardens, lateral pressure on forms decreases.

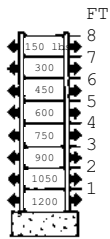

As you add more fluid or plastic concrete to forms, the pressure will build up toward the bottom at about the rate of 150 pounds per foot of depth. This will be true as long as all concrete remains in a plastic state.

Example: Eight feet of fluid or plastic concrete bears on the bottom foot of forms with a pressure of 8 x 150 pounds or 1200 pounds per square foot.

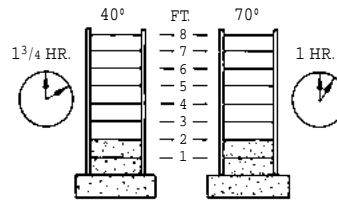

Concrete sets up or hardens faster with an increase in temperature.

Example: At 70°F concrete sets in approximately 1 hour. At 40°F concrete will set up in about 1-3/4 hours.

Slab Formwork Design Loads

The loadings used in the designs of slab formwork consists of a dead load and a live load. The weight of the formwork plus the concrete is considered dead load while the live load is made up of the weight of workers, equipment, material storage and other like items which is supported by the formwork. The tables below tabulate design loads based on the concrete weight for the thicknesses indicated, and includes 10 pounds per square foot for the weight of forms and a live load of 50 or 75 pounds per square foot as indicated. A live load of 75 pounds per square foot is generally used when motorized carts are used to transport concrete during the placing operation.

Slab Formwork Design Load for Uniform Slab Thickness

(Includes 50 psf Live Load)

Pounds per Square Foot for Indicated Thickness

2"	4"	6"	8"	10"	12"	14"	16"	18"	20"
100	110	135	160	185	210	235	260	285	310

(Includes 75 psf Live Load)

Pounds per Square Foot for Indicated Thickness

2"	4"	6"	8"	10"	12"	14"	16"	18"	20"
125*	135	160	185	210	235	260	285	310	335

Note: Chart is based on a concrete weight of 150 pounds per cubic foot.

* ACI 347 recommends a minimum 100 psf for form design or 125 psf if motorized carts are used.

For a complete explanation of general objectives in formwork design, planning, materials and accessories, loads and pressures, design tables and much more, it is recommended that a copy of ACI publication SP-4 "Formwork for Concrete" be obtained. The current edition is available from American Concrete Institute, P.O. Box 9094, Farmington Hills, MI 48333. Website: www.concrete.org.

Technical Data—Plywood

Data is based on information supplied by the American Plywood Association (APA). The recommended spacings listed in the following table are for Plyform Class 1 or STRUCTURAL 1 Plyform. Plyform is a special exterior type of plywood designed by APA for use in formwork for concrete construction.

Though not manufactured specifically for concrete forming, grades other than Plyform have been used in formwork. The spacings shown in the table give a good estimate of performance for sanded grades such as APA A-C Exterior, APA B-C Exterior and unsanded grades such as APA RATED SHEATHING Exterior and Exposure 1 (CDX) (marked PSI), provided the plywood is used in the same direction only.

For additional information on APA Plyform, please contact the American Plywood Association, P.O. Box 11700, Tacoma, WA 98411.

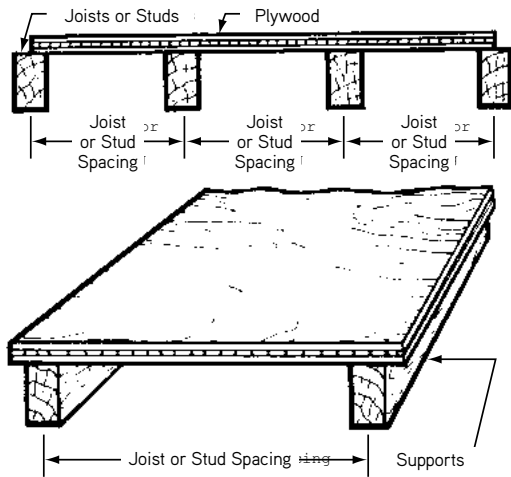

**Plywood Used Strong Way
Face Grain Across Supports**

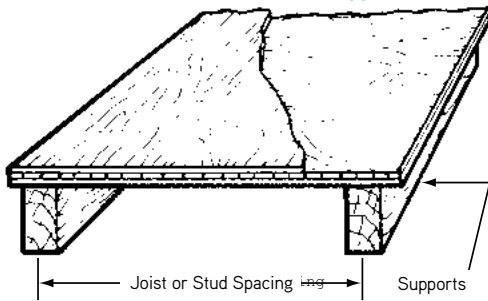

**Plywood Used Weak Way
Face Grain Along Supports**

Safe Spacing in inches of Support for Plyform Sheathing Continuous Over Four or More Supports

Design Load of Concrete Pounds Per Sq. Ft.	F _b = 1,930 psi; Rolling Shear = 72 psi E = 1,500,000 psi							
	Plyform Used Weak Way				Plyform Used Strong Way			
	19/32"	5/8"	23/32"	3/4"	19/32"	5/8"	23/32"	3/4"
100	13"	14"	17"	19"	20"	21"	23"	24"
125	12"	13"	16"	17"	19"	19"	22"	22"
150	11"	12"	15"	16"	17"	18"	20"	21"
175	10"	11"	14"	15"	17"	17"	19"	20"
200	10"	11"	14"	15"	16"	17"	18"	19"
225	10"	10"	13"	14"	15"	16"	18"	18"
250	9"	10"	13"	14"	15"	15"	17"	18"
275	9"	10"	12"	13"	14"	15"	17"	17"
300	9"	9"	12"	13"	14"	14"	16"	17"
350	8"	9"	11"	12"	13"	14"	15"	16"
400	8"	9"	11"	12"	13"	13"	15"	15"
500	7"	8"	10"	11"	12"	12"	14"	14"
600	7"	7"	9"	10"	11"	11"	13"	13"
700	6"	7"	9"	10"	10"	11"	12"	12"
800	6"	7"	8"	9"	10"	10"	11"	11"
900	6"	6"	7"	8"	9"	9"	10"	11"
1,000	5"	6"	7"	7"	9"	9"	10"	10"
1,200	5"	5"	6"	6"	8"	8"	9"	9"
1,400	4"	4"	5"	5"	7"	7"	8"	8"
1,600	4"	4"	5"	5"	6"	6"	8"	8"
1,800	4"	4"	4"	5"	6"	6"	7"	7"
2,000	3"	3"	4"	4"	5"	5"	6"	6"

Support spacings are governed by bending, shear or deflection. Maximum deflection $\ell/360$ of spacing, but not more than $1/16"$. Contact Dayton Superior for safe spacing of supports when plyform is used over two or three supports.

Plywood Data

Curved Forms: Plyform can be used for building curved forms. However, the following radii have been found to be appropriate minimums for mill run panels of the thicknesses shown, when bent dry. An occasional panel may develop localized failure at these radii.

Plywood Thickness	Approximate Weight, lbs.		Min. Bending Radii, ft.	
	4 x 8 Sheet	Sq. Ft.	Across Grain	Parallel to Grain
1/4"	26	.8	2	5
5/16"	32	1.0	2	6
11/32" or 3/8"	35	1.1	3	8
15/32" or 1/2"	48	1.5	6	12
19/32" or 5/8"	58	1.8	8	16
23/32" or 3/4"	70	2.2	12	20

Technical Data-Lumber

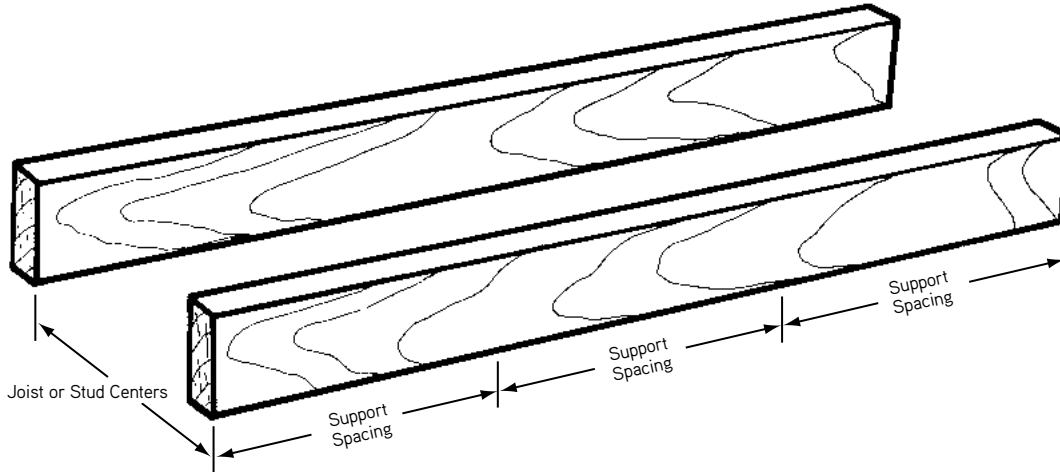

Safe Spacing of Supports for Joists or Studs Continuous Over Four or More Supports
Based on use of No. 2 Grade Southern Pine or Douglas Fir-Larch

Uniform Load, Pounds per Linear Foot (Equals Design Load, Pounds per Sq. Ft. Times Joist or Stud Centers in Feet.)	$F_b = \text{varies psi}$ $E = 1,400,000 \text{ psi}$ $F_v = 225 \text{ psi}$ Nominal Size Lumber, b x h (S4S) at 19% Maximum Moisture					
	2 x 4	2 x 6	2 x 8	3 x 6	4 x 2	4 x 4
	F_b psi					
	1625	1438	1313	1438	1438	1625
100	64"	89"	110"	101"	42"	79"
200	53"	75"	92"	85"	34"	66"
300	45"	66"	83"	77"	27"	60"
400	39"	57"	72"	72"	24"	56"
500	35"	51"	64"	66"	21"	53"
600	32"	47"	59"	60"	19"	48"
700	29"	43"	54"	56"	18"	45"
800	27"	40"	51"	52"	17"	42"
900	25"	38"	48"	49"	16"	39"
1,000	23"	36"	45"	47"	15"	37"
1,100	21"	34"	43"	44"	14"	36"
1,200	20"	32"	42"	43"	14"	34"
1,300	19"	30"	40"	41"	13"	33"
1,400	18"	29"	38"	39"	13"	32"
1,500	18"	28"	36"	38"	12"	30"
1,600	17"	26"	35"	37"	12"	29"
1,700	16"	26"	34"	35"	12"	29"
1,800	16"	25"	33"	34"	11"	27"
1,900	15"	24"	32"	33"	11"	26"
2,000	15"	23"	31"	32"	11"	25"
2,200	14"	22"	29"	30"	10"	24"
2,400	14"	21"	28"	28"	10"	22"
2,600	13"	21"	27"	27"	9"	21"
2,800	13"	20"	26"	26"	9"	20"
3,000	12"	19"	25"	25"	8"	19"

Note: F_b and F_v shown above includes a 25% increase because of short term loading conditions.
Horizontal shear stress adjustment assumes members have no splits, checks or shakes.

Support spacings are governed by bending, shear or deflection. Maximum deflection $l/270$ of spacing, but not more than $1/8"$.
Contact Dayton Superior for safe spacings of supports for joists or studs used over two or three supports.

Technical Data-Lumber

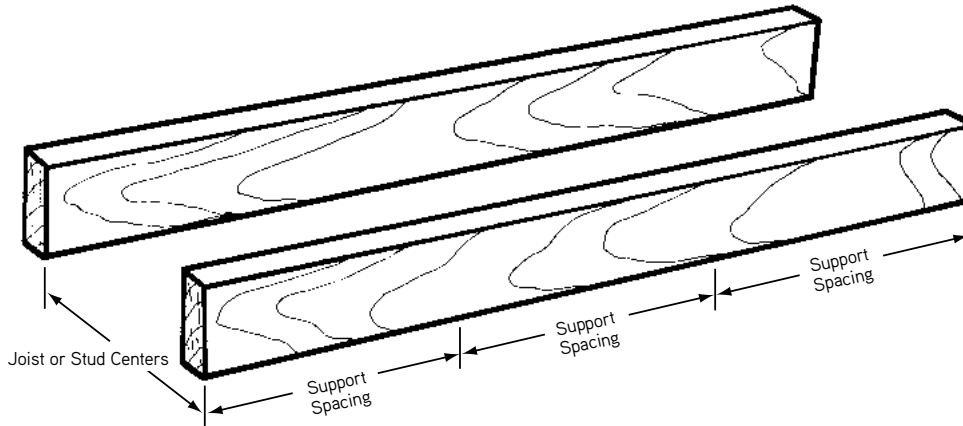

Safe Spacing of Supports for Joists or Studs Continuous Over Four or More Supports
Based on use of No. 2 Grade Spruce-Pine-Fir or Hem-Fir

Uniform Load, Pounds per Linear Foot (Equals Design Load, Pounds per Sq. Ft. Times Joist or Stud Centers in Feet.)	$F_b = \text{varies psi}$ $E = 1,300,000 \text{ psi}$ $F_v = 175 \text{ psi}$ Nominal Size Lumber, b x h (S4S) at 19% Maximum Moisture					
	2 x 4	2 x 6	2 x 8	3 x 6	4 x 2	4 x 4
	$F_b \text{ psi}$					
	1594	1381	1275	1381	1275	1594
100	62"	88"	108"	99"	41"	77"
200	52"	74"	91"	84"	32"	65"
300	44"	65"	82"	76"	26"	59"
400	38"	56"	71"	70"	22"	55"
500	32"	50"	63"	65"	20"	52"
600	27"	43"	57"	59"	18"	48"
700	25"	39"	51"	55"	17"	44"
800	22"	35"	46"	51"	16"	41"
900	21"	32"	43"	47"	15"	39"
1,000	19"	30"	40"	43"	14"	36"
1,100	18"	29"	38"	40"	14"	33"
1,200	17"	27"	36"	38"	13"	31"
1,300	16"	26"	34"	36"	12"	29"
1,400	16"	25"	33"	34"	12"	27"
1,500	15"	24"	31"	32"	11"	26"
1,600	15"	23"	30"	31"	11"	25"
1,700	14"	22"	29"	30"	10"	24"
1,800	14"	22"	29"	29"	10"	23"
1,900	13"	21"	28"	28"	9"	22"
2,000	13"	21"	27"	27"	9"	21"
2,200	13"	20"	26"	26"	9"	20"
2,400	12"	19"	25"	24"	8"	19"
2,600	12"	18"	24"	23"	8"	18"
2,800	11"	18"	24"	22"	7"	17"
3,000	11"	17"	23"	22"	7"	17"

Note: F_b and F_v shown above includes a 25% increase because of short term loading conditions.
Horizontal shear stress adjustment assumes members have no splits, checks or shakes.

Support spacings are governed by bending, shear or deflection. Maximum deflection $l/270$ of spacing, but not more than $1/8"$.
Contact Dayton Superior for safe spacings of supports for joists or studs used over two or three supports.

Technical Data-Lumber

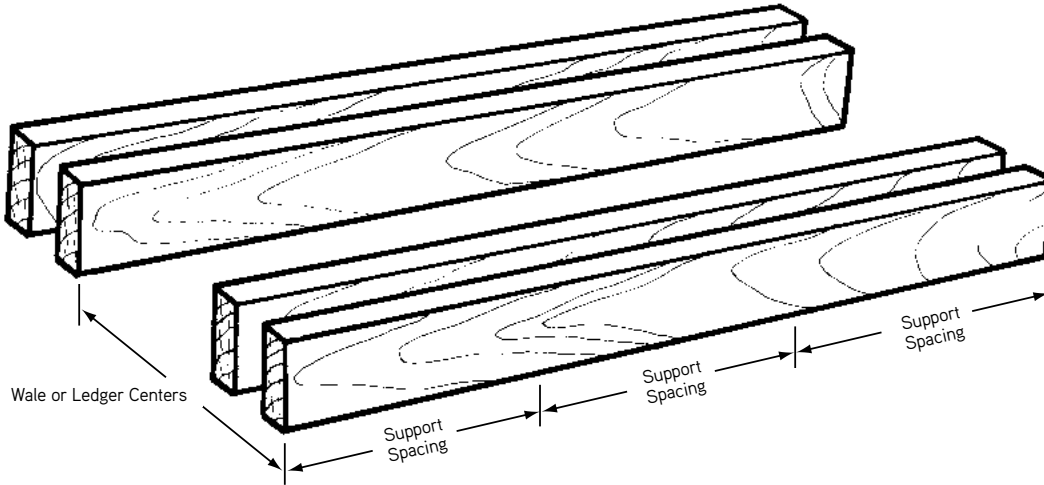

Safe Spacing of Supports for Double Ledgers or Wales Continuous Over Four or More Supports
Based on use of No. 2 Grade Southern Pine or Douglas Fir-Larch

Uniform Load, Pounds per Linear Foot (Equals Design Load, Pounds per Sq. Ft. Times Ledger or Wale Centers in Feet.)	F _b = varies psi E = 1,400,000 psi F _v = 225 psi Nominal Size Lumber, b x h (S4S) at 19% Maximum Moisture				
	Double 2 x 4	Double 2 x 6	Double 2 x 8	Double 3 x 6	Double 3 x 8
	F _b psi				
	1625	1438	1313	1438	1313
1,000	35"	51"	64"	66"	83"
1,100	33"	49"	61"	63"	79"
1,200	32"	47"	59"	60"	76"
1,300	30"	45"	56"	58"	73"
1,400	29"	43"	54"	56"	70"
1,500	28"	42"	53"	54"	68"
1,600	27"	40"	51"	52"	66"
1,700	26"	39"	49"	51"	64"
1,800	25"	38"	48"	49"	62"
1,900	24"	37"	47"	48"	60"
2,000	23"	36"	45"	47"	59"
2,200	21"	34"	43"	44"	56"
2,400	20"	32"	42"	43"	54"
2,600	19"	30"	40"	41"	51"
2,800	18"	29"	38"	39"	50"
3,000	18"	28"	36"	38"	48"
3,200	17"	26"	35"	37"	46"
3,400	16"	26"	34"	35"	45"
3,600	16"	25"	33"	34"	44"
3,800	15"	24"	32"	33"	43"
4,000	15"	23"	31"	32"	42"

Note: F_b and F_v shown above includes a 25% increase because of short term loading conditions.
Horizontal shear stress adjustment assumes members have no splits, checks or shakes.

Support spacings are governed by bending, shear or deflection. Maximum deflection $l/270$ of spacing, but not more than $1/8"$.
Contact Dayton Superior for safe spacings of supports for joists or studs used over two or three supports.

Technical Data-Lumber

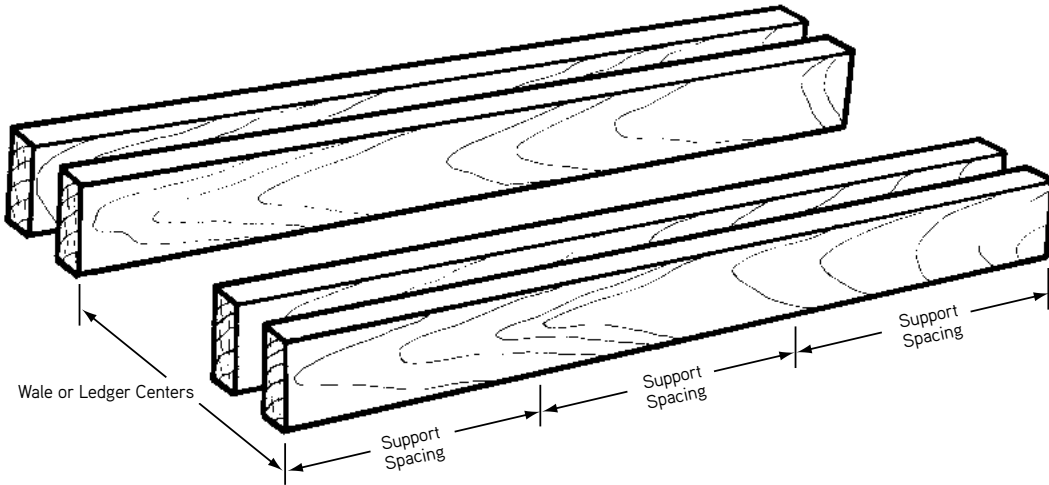

Safe Spacing of Supports for Double Ledgers or Wales Continuous Over Four or More Supports
Based on use of No. 2 Grade Spruce-Pine-Fir or Hem-Fir

Uniform Load, Pounds per Linear Foot (Equals Design Load, Pounds per Sq. Ft. Times Ledger or Wale Centers in Feet.)	$F_b = \text{varies psi}$ $E = 1,300,000 \text{ psi}$ $F_v = 175 \text{ psi}$ Nominal Size Lumber, b x h (S4S) at 19% Maximum Moisture				
	Double 2 x 4	Double 2 x 6	Double 2 x 8	Double 3 x 6	Double 3 x 8
	F_b psi				
	1594	1381	1275	1381	1275
1,000	32"	50"	63"	65"	82"
1,100	29"	46"	60"	62"	78"
1,200	27"	43"	57"	59"	75"
1,300	26"	41"	54"	57"	72"
1,400	25"	39"	51"	55"	69"
1,500	23"	37"	48"	53"	67"
1,600	22"	35"	46"	51"	65"
1,700	21"	34"	44"	49"	63"
1,800	21"	32"	43"	47"	61"
1,900	20"	31"	41"	45"	59"
2,000	19"	30"	40"	43"	57"
2,200	18"	29"	38"	40"	53"
2,400	17"	27"	36"	38"	50"
2,600	16"	26"	34"	36"	47"
2,800	16"	25"	33"	34"	45"
3,000	15"	24"	31"	32"	43"
3,200	15"	23"	30"	31"	41"
3,400	14"	22"	29"	30"	39"
3,600	14"	22"	29"	29"	38"
3,800	13"	21"	28"	28"	37"
4,000	13"	21"	27"	27"	36"

Note: F_b and F_v shown above includes a 25% increase because of short term loading conditions.
Horizontal shear stress adjustment assumes members have no splits, checks or shakes.

Support spacings are governed by bending, shear or deflection. Maximum deflection $l/270$ of spacing, but not more than $1/8"$.
Contact Dayton Superior for safe spacings of supports for joists or studs used over two or three supports.

Technical Data-Lumber

Formulas for Calculating Safe Support Spacings of Lumber Formwork Members			
To Check	for Single Span Beam	for Two-Span Beam	for Three of More Span Beam
$\Delta_{\max} = \ell/360$	$\ell = 1.37 \sqrt[3]{\frac{EI}{W}}$	$\ell = 1.83 \sqrt[3]{\frac{EI}{W}}$	$\ell = 1.69 \sqrt[3]{\frac{EI}{W}}$
$\Delta_{\max} = \ell/270$	$\ell = 1.51 \sqrt[3]{\frac{EI}{W}}$	$\ell = 2.02 \sqrt[3]{\frac{EI}{W}}$	$\ell = 1.86 \sqrt[3]{\frac{EI}{W}}$
$\Delta_{\max} = 1/16$ in.	$\ell = 2.75 \sqrt[4]{\frac{EI}{W}}$	$\ell = 3.43 \sqrt[4]{\frac{EI}{W}}$	$\ell = 3.23 \sqrt[4]{\frac{EI}{W}}$
$\Delta_{\max} = 1/8$ in.	$\ell = 3.27 \sqrt[4]{\frac{EI}{W}}$	$\ell = 4.08 \sqrt[4]{\frac{EI}{W}}$	$\ell = 3.84 \sqrt[4]{\frac{EI}{W}}$
$\Delta_{\max} = 1/4$ in.	$\ell = 3.90 \sqrt[4]{\frac{EI}{W}}$	$\ell = 4.85 \sqrt[4]{\frac{EI}{W}}$	$\ell = 4.57 \sqrt[4]{\frac{EI}{W}}$
Bending	$\ell = 9.80 \sqrt[2]{\frac{F_b S}{W}}$	$\ell = 9.80 \sqrt[2]{\frac{F_b S}{W}}$	$\ell = 10.95 \sqrt[2]{\frac{F_b S}{W}}$
Horizontal Shear	$\ell = \frac{16F_v b h}{w} + 2h$	$\ell = \frac{192F_v b h}{15w} + 2h$	$\ell = \frac{40F_v b h}{3w} + \frac{2h}{3}$

Notation: A = area of cross section, sq. in.
 b = width of section, in.
 E = modulus of elasticity, psi
 F_b = design value for extreme fiber in bending, psi
 F_v = design value in horizontal shear, psi
 F_c = design value in compression parallel to grain, psi
 F_c = design value in compression perpendicular to grain, psi
 †

h = depth of section, in.
 I = moment of inertia, in.⁴
 ℓ = safe spacing of supports, in.
 S = section modulus, in.³
 w = load, lbs. per lineal ft.
 Δ = deflection, in.

Technical Data-Lumber

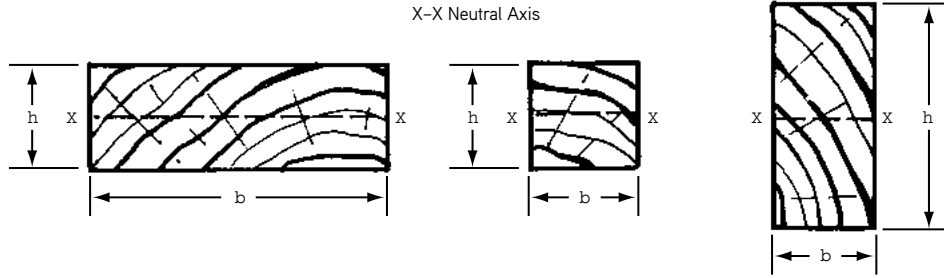

*Rough dry sizes are 1/8 in. larger, both dimensions.

Properties and weights of American Standard Board, Dimension and Timber sizes commonly used for formwork construction are based on data supplied by the National Forest Products Association.

Approximate weights listed are based on lumber weighing 35 lbs. per cubic foot.

Properties of Structural Lumber

Nominal Size in Inches, $b \times h$	American Standard Sizes in Inches, $b \times h$ S4S* 19% Maximum Moisture	Area of section $A = bh$, sq. in.		Moment of Inertia, in.4 $I = \frac{bh^3}{12}$		Section Modulus, in.3 $S = \frac{bh^2}{6}$		Board Feet per Lineal Foot of Piece	Approx. Weight per Lineal Foot (lbs.) of S4S Lumber
		Rough	S4S	Rough	S4S	Rough	S4S		
4x1	3-1/2 x 3/4	3.17	2.62	0.20	0.12	0.46	0.33	1/3	.7
6x1	5-1/2 x 3/4	4.92	4.12	0.31	0.19	0.72	0.52	1/2	1.0
8x1	7-1/4 x 3/4	6.45	5.44	0.41	0.25	0.94	0.68	2/3	1.4
10x1	9-1/4 x 3/4	8.20	6.94	0.52	0.32	1.20	0.87	5/6	1.7
12x1	11-1/4 x 3/4	9.95	8.44	0.63	0.39	1.45	1.05	1	2.1
4x2	3-1/2 x 1-1/2	5.89	5.25	1.30	0.98	1.60	1.31	2/3	1.3
6x2	5-1/2 x 1-1/2	9.14	8.25	2.01	1.55	2.48	2.06	1	2.0
8x2	7-1/4 x 1-1/2	11.98	10.87	2.64	2.04	3.25	2.72	1-1/3	2.7
10x2	9-1/4 x 1-1/2	15.23	13.87	3.35	2.60	4.13	3.47	1-2/3	3.4
12x2	11-1/4 x 1-1/2	18.48	16.87	4.07	3.16	5.01	4.21	2	4.1
2x4	1-1/2 x 3-1/2	5.89	5.25	6.45	5.36	3.56	3.06	2/3	1.3
2x6	1-1/2 x 5-1/2	9.14	8.25	24.10	20.80	8.57	7.56	1	2.0
2x8	1-1/2 x 7-1/4	11.98	10.87	54.32	47.63	14.73	13.14	1-1/3	2.7
2x10	1-1/2 x 9-1/4	15.23	13.87	111.58	98.93	23.80	21.39	1-2/3	3.4
2x12	1-1/2 x 11-1/4	18.48	16.87	199.31	177.97	35.04	31.64	2	4.1
3x4	2-1/2 x 3-1/2	9.52	8.75	10.42	8.93	5.75	5.10	1	2.2
3x6	2-1/2 x 5-1/2	14.77	13.75	38.93	34.66	13.84	12.60	1-1/2	3.4
3x8	2-1/2 x 7-1/4	19.36	18.12	87.74	79.39	23.80	21.90	2	4.4
3x10	2-1/2 x 9-1/4	24.61	23.12	180.24	164.89	38.45	35.65	2-1/2	5.7
3x12	2-1/2 x 11-1/4	29.86	28.12	321.96	296.63	56.61	52.73	3	6.9
4x4	3-1/2 x 3-1/2	13.14	12.25	14.39	12.50	7.94	7.15	1-1/3	3.0
4x6	3-1/2 x 5-1/2	20.39	19.26	53.76	48.53	19.12	17.65	2	4.7
4x8	3-1/2 x 7-1/4	26.73	25.38	121.17	111.15	32.86	30.66	2-2/3	6.2
4x10	3-1/2 x 9-1/4	33.98	32.38	248.91	230.84	53.10	49.91	3-1/3	7.9
6x3	5-1/2 x 2-1/2	14.77	13.75	8.48	7.16	6.46	5.73	1-1/2	3.4
6x4	5-1/2 x 3-1/2	20.39	19.25	22.33	19.65	12.32	11.23	2	4.7
6x6	5-1/2 x 5-1/2	31.64	30.25	83.43	76.26	29.66	27.73	3	7.4
6x8	5-1/2 x 7-1/2	42.89	41.25	207.81	193.36	54.51	51.56	4	10.0
8x8	7-1/2 x 7-1/2	58.14	56.25	281.69	263.67	73.89	70.31	5-1/3	13.7

A2 Plastic Cones

Dayton Superior A2 Plastic Cones can be added to A3, A4 and A44 Snap Ties and A46 and A48 Loop Ties. The cones act as internal spreaders, reduce grout leakage and aid in the breakback operation.

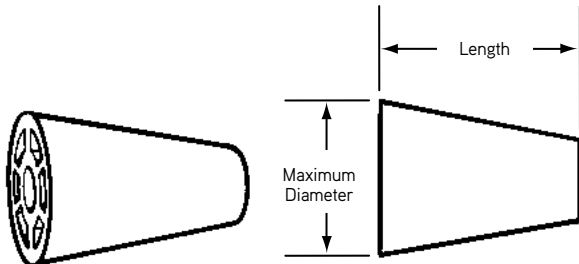

A2 Plastic Cone

A2 Plastic Cone Selection Chart

Diameter	Length
3/4"	1", 1-1/2"
1"	1", 1-1/2" 2"
1-1/4"	1-1/2"

A2 Plastic Cones are recommended when specifications require a nominal 1", 1-1/2", 2" or greater breakback. Breakback is approximately 3/16" less than the cone length.

Note: Plastic Cones are designed to act as internal form spreaders only. They are not intended to support loads applied by personal fall arrest systems and/or scaffold brackets.

A3 Standard Snap Tie

Dayton Superior A3 Standard Snap Ties are manufactured with either hot or cold forged integral heads. A3 snap ties have a nominal 1" breakback with 1/4" and 1/2" breakbacks available on special order. Breakbacks over 1" can be provided on special order, but due to the increased concrete bond, Dayton Superior cannot guarantee that the ties will consistently provide proper breakback. Coating the tie ends with wax will aid in breakback operation.

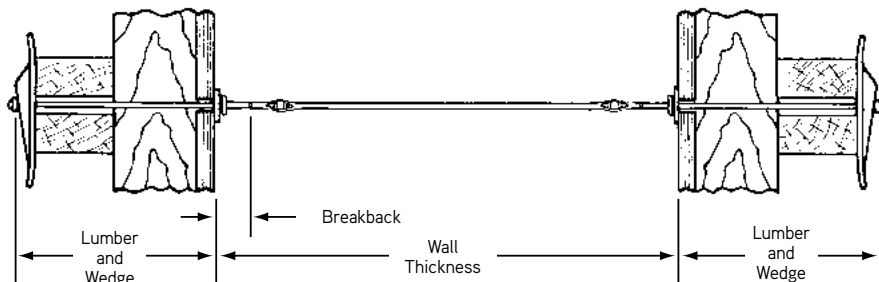

2,250 lbs.
Safe Working Load

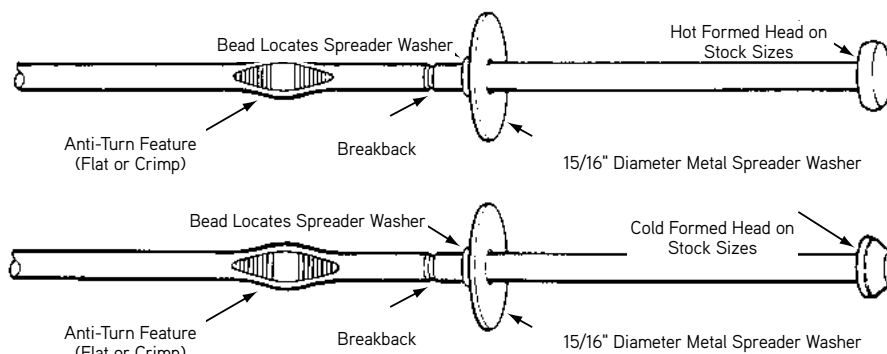

A3 Snap Ties

To Order:
Specify: (1) quantity, (2) name, (3) wall thickness, (4) lumber and wedge dimension (allow 1/2" for wedge take up), (5) break back.

Example:
3,00 pcs. A3 Standard Snap Tie, 18" wall, 8-1/4" L&W, 1" break back.

SWL provides a factor of safety of approximately 2 to 1.

Each A3 snap tie is fabricated with flats or crimps to prevent the snap tie from turning in the concrete during breakback operations. A3 Snap Ties are available with fixed metal spreader washers.

All snap ties can be manufactured with a tight fitting neoprene washer located near the center of the tie. The water resistant snap tie is designed to help eliminate water seepage along the tie by breaking the surface continuity of the wire.

Drill holes in plywood 1/8" larger than the Snap Tie head. Normally, a 5/8" drill bit is sufficient.

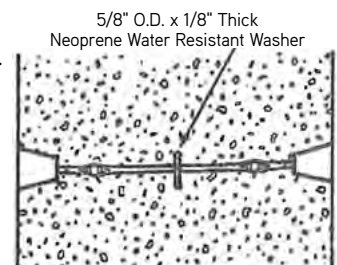

A3 Heavy Snap Tie

Dayton Superior A3 Heavy Snap Ties are used when a higher safe working load is required. The A3 snap tie is manufactured with cold forged integral heads and is equipped with flats or crimps to prevent turning.

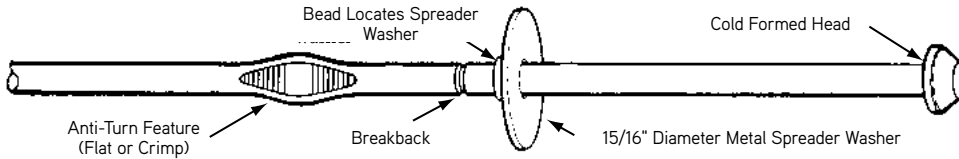

A3 Heavy Snap Tie

See A3 Snap Tie for additional pertinent information on breakback and fixed metal washers.

**3,350 lbs.
Safe Working Load**

To Order:

Specify: (1) quantity, (2) name, (3) wall thickness, (4) lumber and wedge dimension (allow 1/2" for wedge take up), (5) break back.

Example:

3,00 pcs. A3 Heavy Snap Tie, 18" wall, 8-1/4" L&W, 1" break back

SWL provides a factor of safety of approximately 2 to 1.

Light Forming Products

A3 Snap Tie with Hook

A3 Snap Ties with Hooks are manufactured with a standard forged head on one end and nut and plate on another end. They are used for connecting site-built wood forms to vertical rebar for blind-side wall applications. For use with the A110 Metal Rib.

- Low cost solution for blindside wall application
- A3 Snap Ties are made with standard 1" breakback
- Ultimate load is 3,750 lbs.
- The largest rebar diameter for A3 Snap Ties is #8
- Available with plastic cone
- Available in any length from 6" to 48"



A3B1 Combination Tie

A3B1 Combination Ties are manufactured with a standard forged head on one end and 1/2" coil tie on another. A3B1 Combination Ties are used for connecting site-built wood forms to coil rod for blind-side wall application.

- Low cost solution for blindside wall application
- Available in any length from 7" to 36"
- Ultimate load is 4,500 lbs.
- Available with plastic cone or loose washer



A4H Hex Head Snap Tie

Dayton Superior A4H Hex Head Snap Ties are manufactured with hot forged integral 1/2" hex shaped heads. The hex head allows short-end snap ties to be broken back with the formwork still in place.

The standard A4H uses 1" x 1" A2 Plastic Cones to provide a nominal 1" breakback. Other size cones are available on special order.

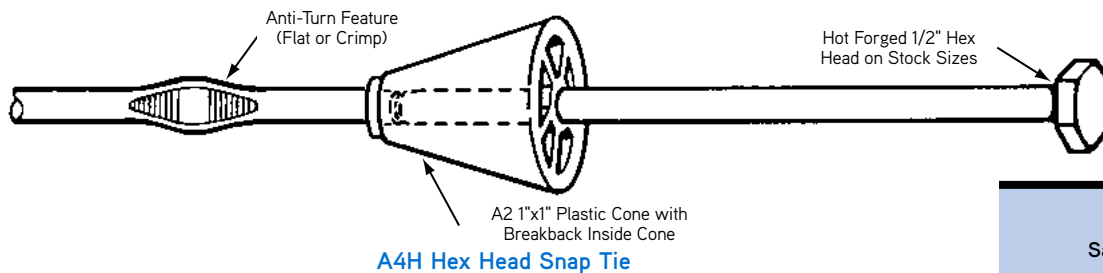
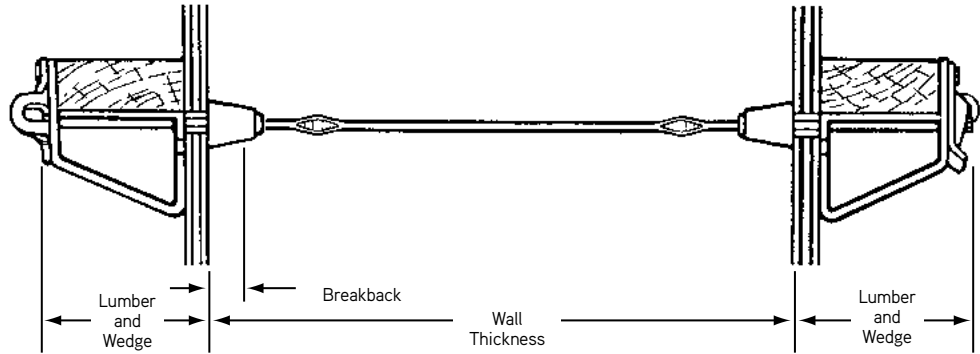

2,250 lbs.
Safe Working Load

To Order:
Specify: (1) quantity, (2) name, (3) wall thickness, (4) lumber and wedge dimension (allow 1/2" for wedge take up), (5) break back, (6) type of washer or cone.

Example:
2000 pcs. A4-H Hex Head Snap Tie, 12" wall, 4-3/4" L&W, 1" break back with A2 1"x1" Plastic Cones.

SWL provides a factor of safety of approximately 2 to 1.

How to Break Back A4 Snap Ties

1. Place a 1/2" six-point socket and ratchet over the head of the tie (see A31 Hex Head Snap Tie Socket).
2. Push the bracket eccentric away from the tie head.
3. Standing in front of the tie, hold the socket on the hex head with one hand and turn the ratchet with the other. A 1/4 to 1/2 turn of the ratchet will normally break the tie end.

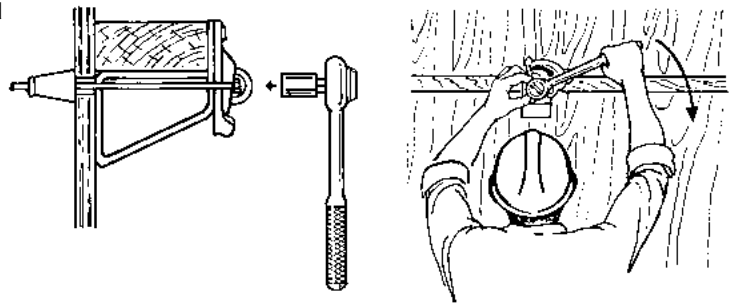

Light Forming Products

A5 Threaded PullOut Tie

Dayton Superior A5 Threaded PullOut Tie is manufactured with a standard forged head on one end and 2" of 1/4" - 28 UNF-2A thread on the opposite end. Washers and nut are supplied loose and are placed on the tie after the tie has been installed through the form plywood.

Note: The A5 Threaded PullOut Tie needs to be coated with a form release agent or a water resistant grease, before the concrete is placed, to facilitate tie removal.

To remove the A5 tie from the set concrete, one end of the tie must be cut off between the plywood and the wales and then extracted by pulling on the opposite end.

To Order:

Specify: (1) quantity, (2) name, (3) fixed end = wale and wedge dimension (allow 1/2" for wedge take up), (4) dimension inside to inside of wales, (5) threaded end = wale + 1-1/2", (6) with or without spreader washers.

Example:

2100 pcs. A5 Threaded PullOut Tie, 4" fixed end dimension, 20-1/2" inside to inside of wales, 5" threaded end, with spreader washers.

SWL provides a factor of safety of approximately 2 to 1.

A6 Spandrel Point Tie

**1,875 lbs.
Safe Working Load**

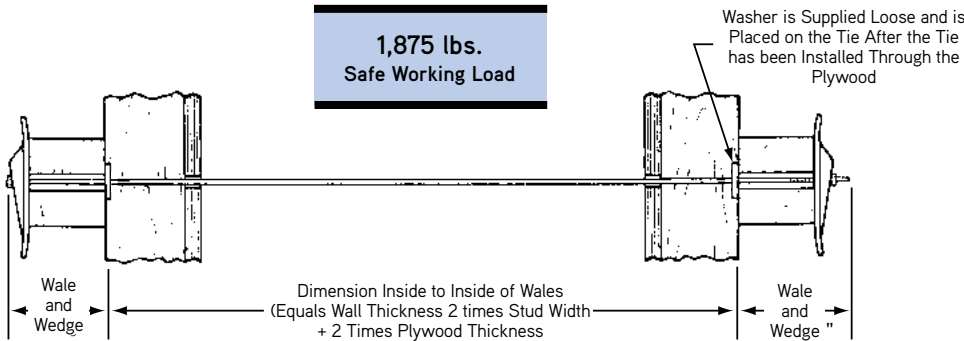

Dayton Superior A6 Spandrel Point Tie is available for tying light outside spandrel beam forms. One end is fabricated with a standard end with any style plastic cone or spreader washer. The opposite end is bent 90° with a chisel point that is driven into the deck formwork. Breakback dimension is the same as standard snap ties.

Dayton Superior recommends placing a 1-1/4" fence staple over the tie within 1" of the bend.

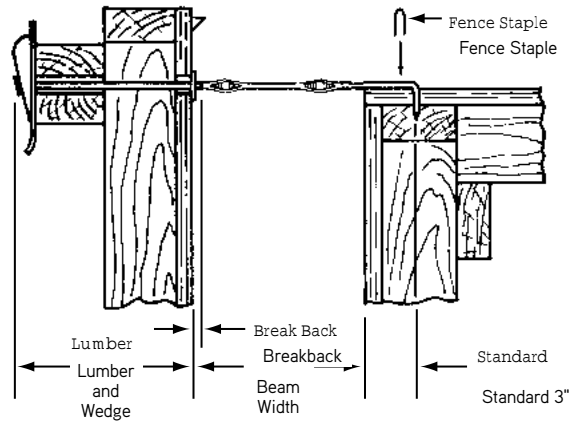

**250 lbs.
Safe Working Load**

To Order:

Specify: (1) quantity, (2) name, (3) beam thickness, (4) lumber and wedge (5) type of form spreaders and break back.

Example:

400 pcs. A6 Spandrel Point Tie, 12" beam thickness, 8-1/4" L&W, (3" automatically added to beam thickness) with A2 1"x1" Plastic Cones and 1" break back.

SWL provides a factor of safety of approximately 2 to 1. Safe Working Load is controlled by wood spreader.

A7 Spandrel Hook Tie

Dayton Superior A7 Spandrel Hook Tie is available for securing light outside spandrel beam forms to structural steel beams. The A7 is similar to the A3 tie with the exception of the end configuration. The hook-end of the A7 tie fits over the beam flange and is tack welded on the underside of the beam flange. The A7 tie is available with any type of spreader washer or plastic cones.

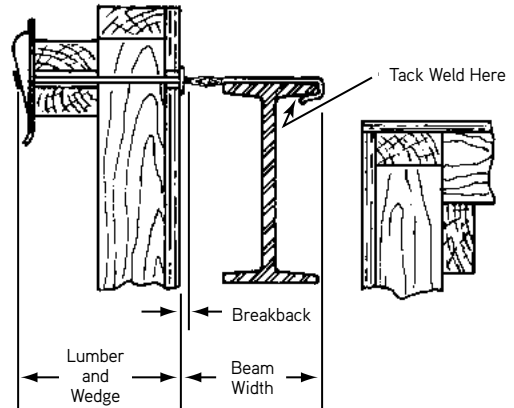

To Order:
Specify: (1) quantity, (2) name, (3) tie length, (4) flange thickness, (5) lumber and wedge, (6) Type of form spreader and break back.

Example:
700 pcs. A7 Spandrel Hook Tie, 16" tie length, 1/2" flange, 8-1/4" L&W, with 15/16" dia. Spreader Washers and 1/2" break back.

SWL provides a factor of safety of approximately 2 to 1.

**250 lbs.
Safe Working Load**

Light Forming Products

A7A Spandrel Plate Tie

Dayton Superior A7A Spandrel Plate Tie is used in the same type applications as the A6 Spandrel Point Tie. The A7A tie is fabricated with a 16 gauge steel plate which allows the tie to be nailed directly to the deck formwork with 6d nails. The A7A tie is available with plastic cones or metal spreader washers.

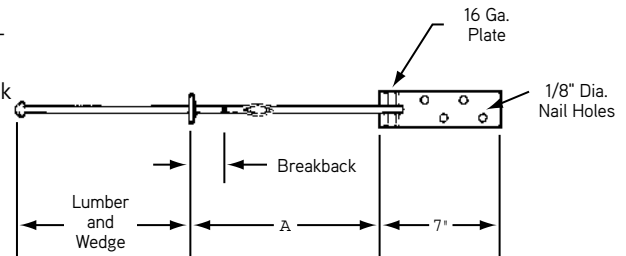

To Order:
Specify: (1) quantity, (2) name, (3) "A" dimension, (4) lumber and wedge, (5) type of form spreaders and break back.

Example:
1000 pcs. A7A Spandrel Point Tie, "A" = 12", 8-1/4" L&W with 1"x1" Plastic Cone, 1" break back.

SWL provides a factor of safety of approximately 2 to 1.
Safe Working Load is controlled by wood spreader.

**250 lbs.
Safe Working Load**

A9 Tip-To-Tip Tie

Dayton Superior A9 Tip-To-Tip Tie is a plain rod with headed ends. The A9 tie is usually withdrawn from the concrete or cut off after stripping the formwork. It is also used as an outside corner tie with the A19 Corner Washer.

To Order:
Specify: (1) quantity, (2) name, (3) total length inside of heads (allow 1" total length increase for take up of wedges)

Example:
5000 pcs. A9 Tip-To-Tip Tie, 37" total length inside of heads.

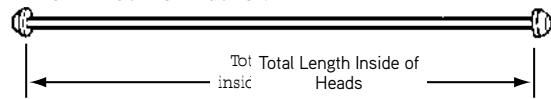

A9 Tip-To-Tip Tie

SWL provides a factor of safety of approximately 2 to 1.

**2,250 lbs.
Safe Working Load**

A10 Plate Tie

Dayton Superior A10 Plate Tie is a plain rod with headed ends and square washers.



A10 Plate Tie

A13 Metal Strapping

Dayton Superior A13 Metal Strapping is used to fabricate and reinforce unusual forming requirements on the job site. The 300' roll is 3/4" wide 25 gauge steel.

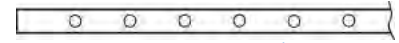

A13 Metal Strapping

A16 Omni Wedge

Dayton Superior A16 Omni Wedge is a high strength snap tie wedge designed to slip over the head of standard or heavy duty snap ties to provide ample bearing area for proper load distribution into the wales.

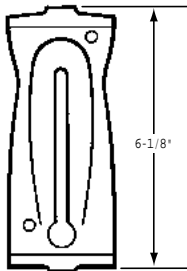

A16 Omni Wedge

To Order:
Specify: (1) quantity, (2) name.

Example:
5,000 pcs. A16 Omni Wedge.

A16SB Snap Bracket

Dayton Superior A16SB Snap Bracket is fabricated from heavy gauge galvanized steel for corrosion resistance. This versatile bracket can be installed horizontally, vertically, and even inverted with a 2x4 kicker plate. The Snap Bracket uses 4-3/4" L&W Snap Ties, and its sliding wedge has a 5/8" adjustment range to accommodate lumber variation. This bracket can be installed before or after the wales have been positioned.



A18 Panel Bolt

Dayton Superior A18 Panel Bolt is used in conjunction with the A16 Omni Wedge to fasten adjoining studs. The standard panel bolt accepts two studs dressed to 1-1/2" each as shown in the sketch. Other sizes are available on special order. A round cut washer should be used under the head of the panel bolt to better distribute the loads.

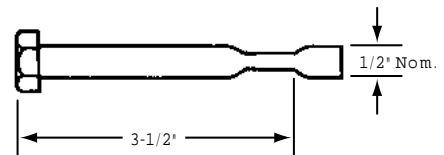
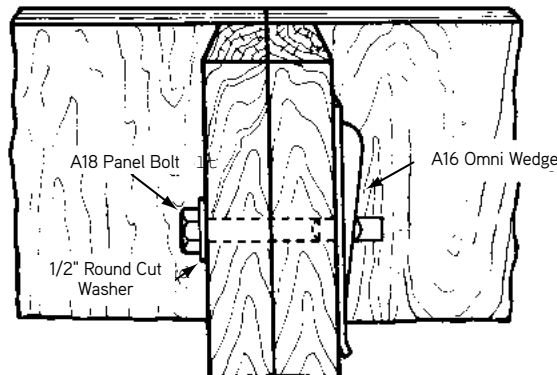

To Order:
Specify: (1) quantity, (2) name, (3) total net lumber thickness.

Example:
5,000 pcs. A18 Panel Bolt, 3" lumber.

A19 Corner Washer

Dayton Superior A19 Corner Washer is fabricated from 3/16" x 3" flat stock bent to form a wedge block. The ample bearing flanges are drilled for nailing to the wales. The A19 Corner Washer accommodates an A9 Tip-To-Tip Tie or a 1/2" B12 Coil Rod.

To Order:
Specify: (1) quantity, (2) name.

Example:
350 pcs. A19 Corner Washer.

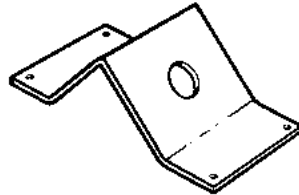

A19 Corner Washer

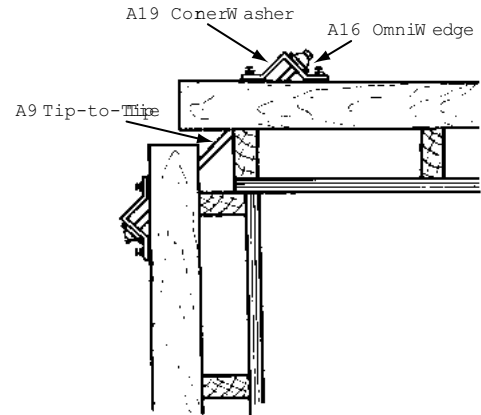

A21 Strap Ties And Accessories (For Steel Frame Form Panels)

A21U Strap Tie

Dayton Superior A21U Strap Tie is used to align, tie and secure steel frame form panels. Ties are available for wall thickness of 6" through 24" in 1/2" increments. Standard breakback for A21U ties is 1/2".

A21K Tie Key

Dayton Superior A21K Tie Key is used to secure the tie to the form. The A21K key is 4" long and tapers from 3/8" to 1/8". Each tie requires four (4) Tie Keys.

A21C Clamp

Dayton Superior A21C Clamp is used to connect forms.

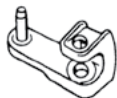
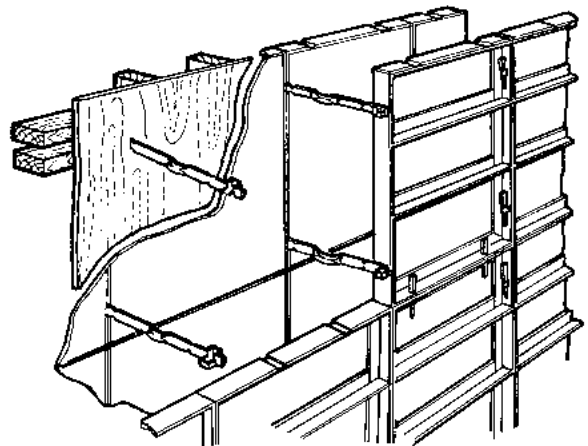

A21C Clamp

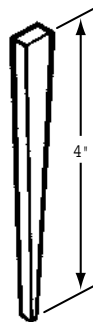

A21K Tie Key

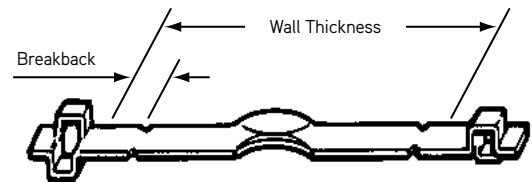

A21U Strap Tie

2,250 lbs.
Strap Tie Safe Working Load

<p>To Order A21U: Specify: (1) quantity, (2) name, (3) wall thickness.</p>	<p>Example: 2,500 pcs. A21U Strap Tie, 6" wall</p>
<p>To Order A21C: Specify: (1) quantity, (2) name.</p>	<p>Example: 2,000 pcs. A21C clamp</p>
<p>To Order A21K: Note: Available in Full Cartons Only. Each Carton is 50 lbs or approximately 1,000 tie keys Specify: (1) quantity, (2) name.</p>	<p>Example: 3 cartons. A21K Tie Key.</p>

SWL provides a factor of safety of approximately 2 to 1.

Light Forming Products

A21F Flat Tie

Dayton Superior A21F Flat Tie is used to tie steel frame form panels together. A21K Tie Keys are inserted through adjoining panels and the tie key slot. A21C Panel Clamps are required at each tie location to prevent lateral form movement. A21F Flat Ties are available from 6" through 24" in 1/2" increments. Standard breakback is 1/2".

To Order:
Specify: (1) quantity, (2) name, (3) wall thickness.

Example:
1,000 pcs. A21F Flat Tie, 16" wall.

SWL provides a factor of safety of approximately 2 to 1.

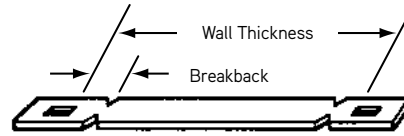

A21F Flat Tie

2,250 lbs.
Safe Working Load

A21X Flat Tie

Dayton Superior A21X Flat Tie is used with the A51 Wedge Bolt to secure and space modular forms. A21X ties are available in 6" up to 84" in 1/2" increments. Standard breakback is 1/4".

To Order:
Specify: (1) quantity, (2) name, (3) wall thickness.

Example:
2,500 pcs. A21X Standard Flat Tie, 12" wall.

SWL provides a factor of safety of approximately 2 to 1.

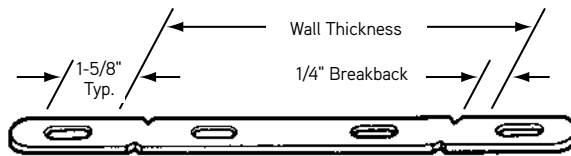

A21X Flat Tie

3,500 lbs. Heavy
3,000 lbs. Standard
Safe Working Load

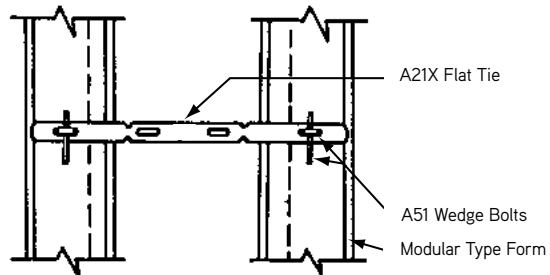

A22 Spreader Cleats

Dayton Superior A22 Spreader Cleats are used to form footers or grade beams up to 32" high. On panels up to 24" high the cleats are spaced at 32" maximum center to center spacing. For panels over 24", and up to 32", the cleats should be spaced at 24" maximum center to center spacing. Two versions of the spreader cleat are available. The stamped metal cleat is available for 5-5/8", 6", 7-5/8", 8", 10" and 12" wall thicknesses with 3/4" or 1-1/8" lumber ends. The other spreader cleat version utilizes two lumber ends attached with a wire strut. This version is available for wall thicknesses over 5" with 3/4", 1-1/8", 1-5/8" and 2-1/4" lumber ends.

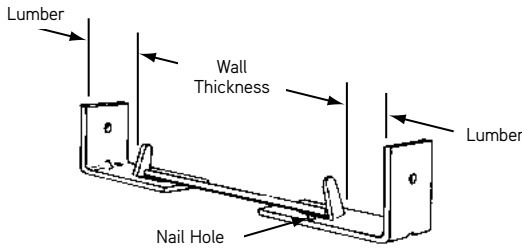

A22 Spreader Cleat with Wire Strut

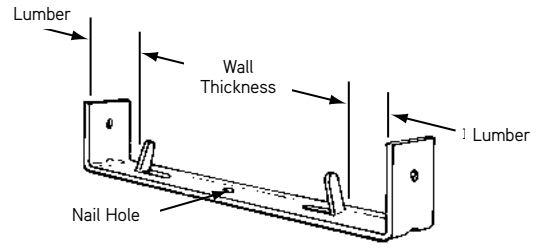

A22 Spreader Cleat-Stamped Metal

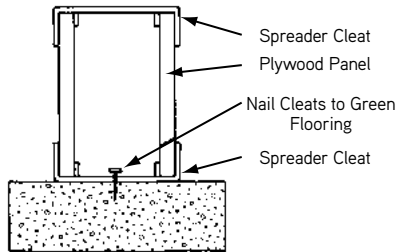

**750 lbs.
Safe Working Load**

To Order:
Specify: (1) quantity, (2) name, (3) end dimension, (4) wall thickness.

Example:
500 pcs. A22 Spreader Cleat with wire strut,
2-1/4" end & 18" wall thickness.

SWL provides a factor of safety of approximately 2 to 1.

A27 and A27M Turnbuckle Form Aligners

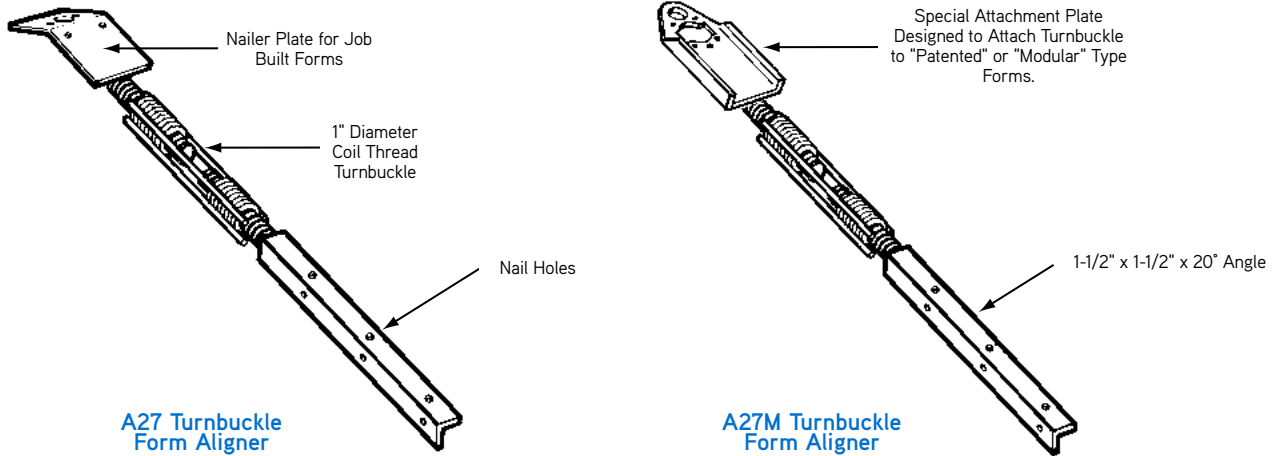

Light Forming Products

Dayton Superior A27 and A27M Turnbuckle Form Aligners are designed to accurately position and plumb vertical forms. The turnbuckle section of the aligner features a 1" diameter self-cleaning coil thread for fast adjustments. Overall length of the aligner is 37" minimum and 40" maximum, offering 3" of effective adjustment.

The A27 aligner has bent nailing plate equipped with nail holes and a 15/16" hole to accept 3/4" or 7/8" steel stakes. The A27M aligner has a special attachment plate that allows direct attachment to modular type forms. Both models are rugged units that offer high reuse and labor savings. The safe working load of the aligners is limited by the lumber, nailing and/or staking methods.

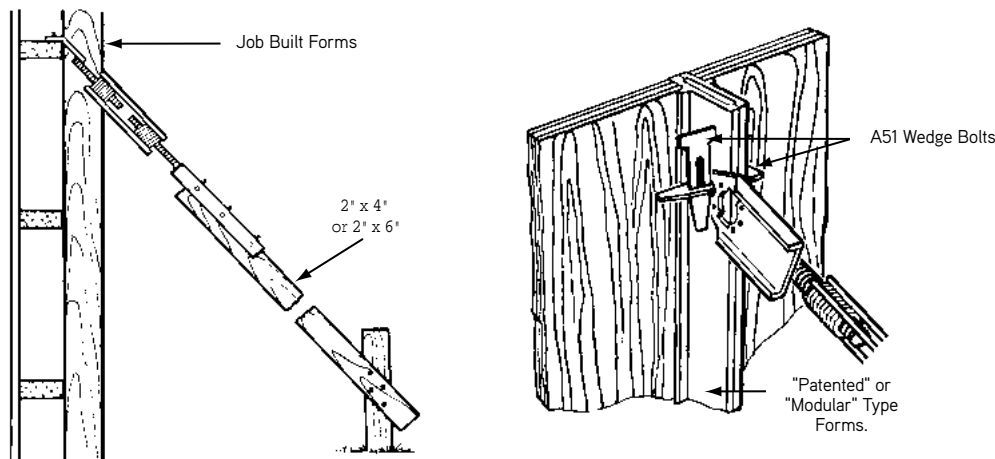

To Order:
Specify: (1) quantity, (2) name.

Example:
116 pcs.
A27 Turnbuckle Form Aligner.

A29 Snap Tie Wrench

Dayton Superior A29 Snap Tie Wrench is designed to facilitate snap tie breakback.

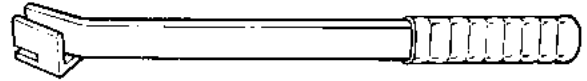

A29 Snap Tie Wrench

Using the A29 Snap Tie Wrench:

1. After the form has been removed slide the wrench up the tie until the front of the wrench contacts the concrete.
2. Keep the wrench tight against the concrete and push the handle towards the concrete, thus bending the tie nearly 90°. Next, rotate the wrench around the centerline of the tie. 1/4 to 1/2 turn is usually sufficient to snap off the tie end.

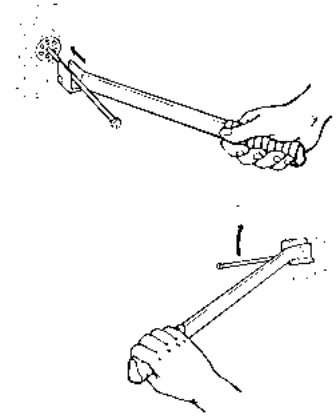

A31 Wrench Head Snap Tie Socket

A31 is designed to facilitate A4-H Hex Head Snap Tie breakback.



A31 Wrench Head Snap Tie Socket

A40 Cone Removal Wrench

Dayton Superior A40 Cone Removal Wrench is designed to facilitate plastic cone removal.



A43 Footing Tie

The A43 Footing Tie is used to form footers or grade beams up to 42" wide. Footing Ties provide an economical way to support concrete forms from bowing or collapsing while concrete is being poured. The Safe Working Load is limited to lumber and/or nailing.



A43 Footing Tie

A46 Snap Tie With Loop

A46 Snap Ties with Loops are manufactured with a standard loop on one end and nut and keeper on another end. For use with A110 Metal Rib.

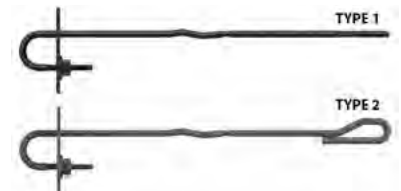

A46B1 Combination Tie

A46B1 Combination Ties are manufactured with a standard loop on one end and 1/2" coil tie on another. They are used for connecting Steel-Ply forms to coil rod for blind-side wall application.



A46B1 (Special) Combination Tie

A46B1 (Special) Combination Ties are manufactured with a standard loop on one end and 1/2" coil tie on another. They are used for connecting Steel-Ply forms to coil rod for blind-side wall application.



A44 Stainless Steel Snap Tie

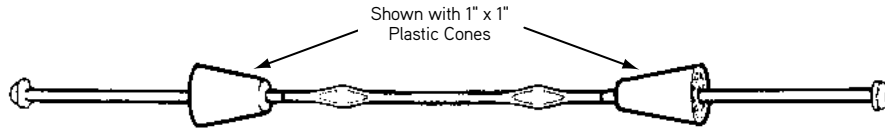

A44 Stainless Steel Snap Tie

2,150 lbs.
Safe Working Load

Dayton Superior A44 Stainless Steel Snap Ties are available for applications that require ties resistant to rusting or other similar corrosion. The A44 tie is available with button style head. Hex head or penta head not available. It has either 15/16" diameter metal spreader washers or standard plastic cones. The tie holes left after breakback may be left open and ungrouted to give an architectural design in the concrete.

Note: Due to the ductility of the type 304 stainless steel wire, Dayton Superior can not guarantee that these ties will consistently provide proper breakback. SWL provides a factor of safety of approximately 2 to 1.

To Order A25:
Specify: (1) quantity, (2) name, (3) wall thickness (4) lumber and wedge dimension (allow 1/2" for wedge take up) (5) cone size or with washers (break back).

Example:
2,500 pcs. A44 Stainless Steel Snap Ties, 12" wall, 8-1/4" L&W, 1"x1" Plastic Cone.

A45 Base Tie

Dayton Superior A45 Base Ties are used at the base and/or top of modular type formwork. Standard base ties are furnished without cones or breakback.

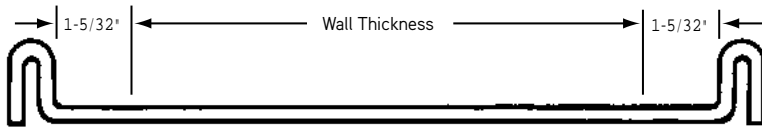

A45 Base Tie

To Order:
Specify: (1) quantity, (2) name, (3) wall dimension.
Example:
500 pcs. A45 Base Tie for 8" Wall.

A46 Loop Panel Tie, Standard and Heavy

Dayton Superior A46 Loop Panel Ties are designed for securing and spacing modular type forms. Standard units are fabricated with 2-1/8" ends and 1" breakback. Other breakbacks are available on special order.

A46 Loop Panel Ties are available with plastic cones and water-resistant washer. The water-resistant washer is designed to help eliminate water seeping along the tie by breaking the surface continuity of the wire.

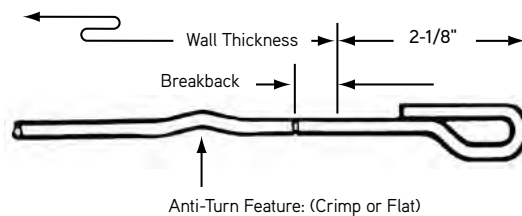

A46 Loop Panel Tie

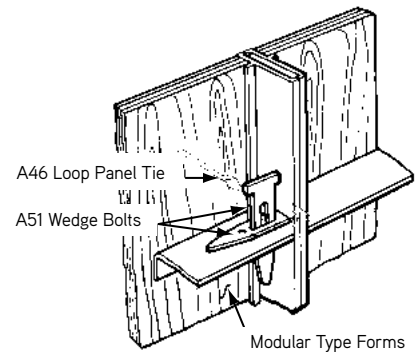

When erecting modular type forms, the A46 ties are placed in the slots between the form panels. An A51 Wedge Bolt is placed through the adjoining form and into the loop of each tie. A second Wedge Bolt is then placed through the slot of the first Wedge Bolt to secure the tie and form together.

A46 Stainless Steel Loop Ties are available for applications that require ties resistant to rusting or other similar corrosion. A46 Stainless Steel Loop Ties are available with plastic cone and water resistant washer.

Note: Due to the ductility of the type 304 stainless steel wire, Dayton Superior can not guarantee that these ties will consistently provide proper breakback. SWL provides a factor of safety of approximately 2 to 1.

2,250 lbs. for Standard Ties
2,500 lbs. for Stainless Steel Ties
3,000 lbs. for Heavy Ties
Safe Working Loads

SWL provides a factor of safety of approximately 2 to 1.

To Order:
Specify: (1) quantity, (2) name, (3) standard or heavy, (4) wall thickness, (5) special features desired.

Example:
5,000 pcs., A46 Loop Panel Tie, Standard for 12" wall with 1"x1" Plastic Cones.

A48 Gang Loop Tie, Standard and Heavy

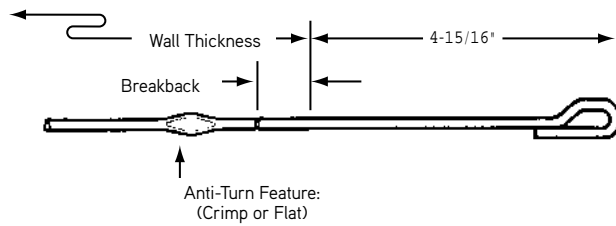

A48 Gang Loop Tie

Dayton Superior A48 Gang Loop Tie is similar to the A46 tie, but has end dimensions extended to 4-15/16". The longer length allows the tie to be used with gang form bolts (supplied by others) and to be broken back before the form has been stripped. 1" breakback is standard. Other breakbacks, plastic cones and/or water resistant washers are available on special order.

2,250 lbs. for Standard Ties
3,000 lbs. for Heavy Ties
 Safe Working Loads

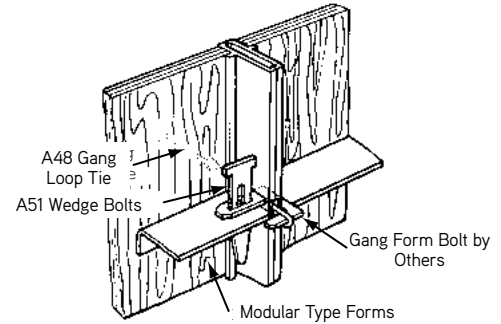

To Order:
 Specify: (1) quantity, (2) name, (3) standard or heavy, (4) wall thickness, (5) special features desired.

Example:
 5,000 pcs. A48 Gang Loop Tie, Standard for 12" wall with 1"x1" Plastic Cones.

SWL provides a factor of safety of approximately 2 to 1.

Light Forming Products

A51 Wedge Bolt

Dayton Superior A51 Wedge Bolt is used with A46 Loop Panel Ties, B21 Plylags, etc., to secure modular type forms.



A51 Wedge Bolt

3,750 lbs.
 Safe Working Load

To Order A25:
 Specify: (1) quantity, (2) name.

Example:
 5,000 pcs. A51 Wedge Bolt.

SWL provides a factor of safety of approximately 2 to 1.

A52 Z Tie Holder and A53 Waler Tie

Dayton Superior A52 Z Tie Holder is used in conjunction with the A53 Waler Tie to secure double 2x lumber wales to modular type forms. The A53 Waler Tie is available in two sizes to accommodate 2 x 4 and 2 x 6 lumber.

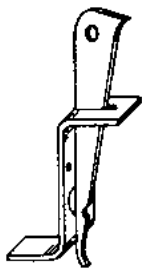

A52 Z Tie Holder

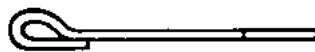

A53 Waler Tie

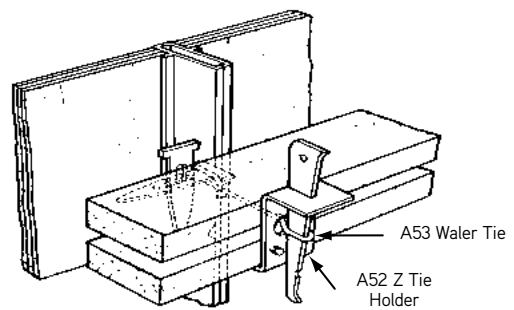

A53 Selection Chart

Tie Type	Overall Length	Designed to Fit
A53	6-3/16"	Double 2x4 Wales
A53	8-1/32"	Double 2x6 Wales

For attaching strongbacks see A63 Strongback Tie

To Order A52 Z:
 Specify: (1) quantity, (2) name.

Example:
 500 pcs. A52 Z Tie Holder.

To Order A53:
 Specify: (1) quantity, (2) name, (3) length.

Example:
 500 pcs. A53 Waler Tie, 6-3/16" long.

A54 Snaplug®

Dayton Superior Snapplugs patch plastic cone tie holes. The Snaplug is easily installed using Snaplug® Bonder. The plug is designed to fit the hole of a 1" x 1" plastic cone and comes in a concrete gray color. Other colors are available on special order. Two styles are available: Flush (PC 304121) and 1/4" Reveal/Setback (PC 304122).

To Order:
Specify: (1) quantity, (2) name.

Example:
5,000 pcs. A54 Snapplugs.

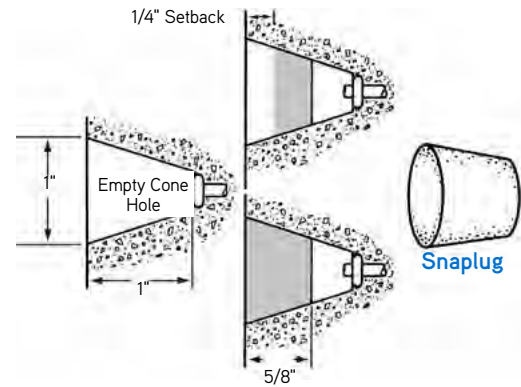

Light Forming Products

A55 Sure-Lock Tie, A56 Sure-Lock Bracket, A57 Sure-Lock Strongback Bracket

Dayton Superior Sure-Lock Forming System consists of the A55 Sure-Lock Tie, A56 Sure-Lock Bracket and the A57 Sure-Lock Strongback Bracket. This system is an economical single waler forming method based on 2 x 4 lumber and 3/4" plywood. A series of 7/8" diameter holes are required in plywood for A55 loop to pass through.

The A55 Sure-Lock Tie is manufactured with self-centering 1" x 1" plastic cones that provide a nominal 1" breakback. Other breakbacks and water resistant washers are available for the A55 tie on special order.

The A56 Sure-Lock Bracket is a sturdy bracket designed with a rotating arm that captures the loop of the A55 tie and firmly secures the tie and waler to the form.

The A57 Sure-Lock Strongback Bracket attaches to the back of the A56 bracket and holds a 2x4 strongback firmly to the form.



A55 Sure-Lock Tie



A56 Sure-Lock Bracket



A57 Sure-Lock Strong Back Clamp

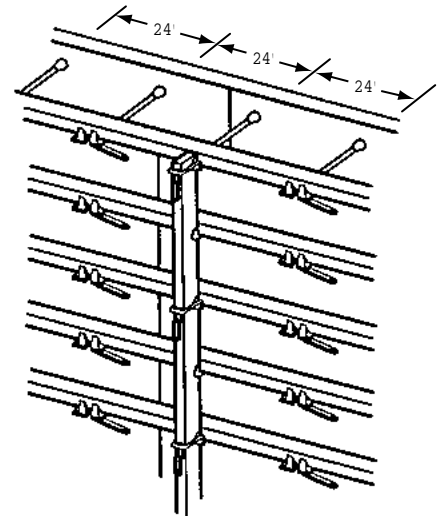

2,250 lbs.
Safe Working Load

SWL provides a factor of safety of approximately 2 to 1.

To Order A55 Sure-Lock Tie:
Specify: (1) quantity, (2) name, (3) wall thickness, (4) special features desired.

Example:
5,000 pcs. A55 Sure-Lock Ties, 10" wall with waterseal washers.

To Order A56 Sure-Lock Bracket:
Specify: (1) quantity, (2) name

Example:
500 pcs. A56 Sure-Lock Brackets.

To Order A57 Sure-Lock Strong Back Clamp:
Specify: (1) quantity, (2) name.

Example:
200 pcs. A57 Sure-Lock Strong Back Clamps.

A63 Strongback Loop Tie

Dayton Superior A63 Strongback Loop Tie is a long-ended loop tie used in conjunction with the A52 Z Tie Holder to securely attach wales and strongbacks to modular forms. A63 ties are available in three sizes to fit various lumber combinations. See chart below.

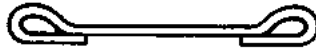

A63 Strongback Loop Tie

A63 Strongback Loop Tie Selection Chart

Tie Type	Overall Length	Designed to Fit
A63	9-3/4"	2x4 Wales and Double 2x4 Strongbacks
A63	11-5/8"	2x4 Wales and Double 2x6 Strongbacks
A63	13-1/2"	2x6 Wales and Double 2x6 Strongbacks

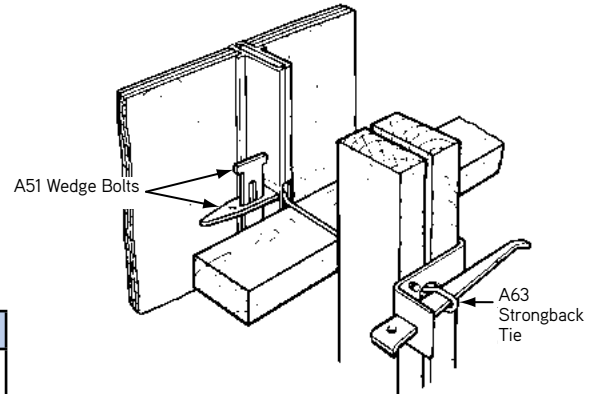

To Order:
Specify: (1) quantity, (2) name, (3) length.

Example:
500 pcs. A63 Strongback Loop Tie, 9-3/4" long.

A81 Jahn® "A" Bracket

Dayton Superior A81 Jahn "A" Bracket is fabricated from high strength steel with a cad plated eccentric and painted body. The 5/8" take-up of the eccentric compensates for minor lumber variations in thickness. The A81 bracket can be utilized to hold a single horizontal wale or a single vertical stud with any type of wall form; round, curved, battered, beam and/or columns

The A81 bracket can be installed before or after the wales have been positioned. The slots in the bracket allow it to slip over the snap tie end without laborious threading through holes. When properly installed, the A81 bracket will not loosen from internal

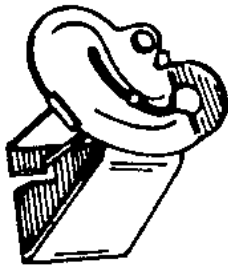

A81 Jahn "A" Bracket

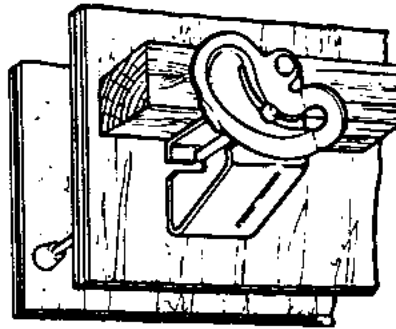

To Order:
Specify: (1) quantity, (2) name.

Example:
2,000 pcs. A81 Jahn "A" Bracket.

vibration of the concrete. Pressure from the bracket is against the 2 x 4 instead of the plywood.

The A81 bracket uses 4-3/4" L&W snap ties, is easy to install and strip, requires no nailing and is very fast. See preparation steps after A89 for bracket spacing and concrete placement rates.

Light Forming Products

A82 Jahn® “C” Bracket

Dayton Superior A82 Jahn “C” Bracket is designed for use with single 2 x 4 studs, double 2 x 4 wales and 8-1/4" L&W snap ties to attach vertical strongbacks to the form. The bracket eccentric compensates for lumber size imperfections. The A82 bracket can also be used with double wales to support a horizontal plywood joint. See preparation steps after A89 for bracket spacing and concrete placement rates.



A82 Jahn “C” Bracket

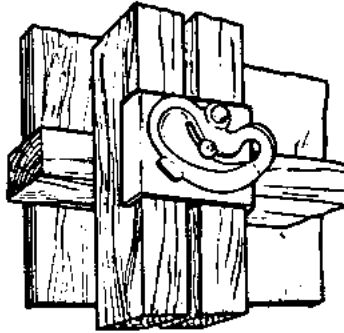

To Order:
Specify: (1) quantity, (2) name.
Example:
4,950 pcs. A82 Jahn “C” Bracket.

A83 Jahn® Cornerlock

Dayton Superior A83 Jahn Cornerlock is used at outside corners to secure the 2 x 4 wales. Nail holes are provided for secure attachment and grips on the underside provide a positive non-slip action. The cam action of the locking handle draws the wales together. No special tools are required for installation or stripping.

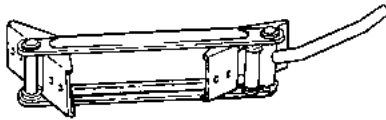

A83 Jahn Cornerlock

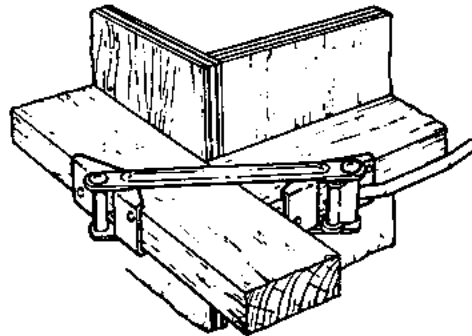

To Order:
Specify: (1) quantity, (2) name.
Example:
100 pcs. A83 Jahn Cornerlock.

A89 Jahn® Scaffold Jack

Dayton Superior A89 Jahn Scaffold Jack is an all steel unit designed to fit 24" x 24" and 16" x 24" tie and wale spacing. This jack is equipped with a built-in guard rail receptacle and is designed to hold two 2 x 10 planks for a comfortable work platform.

The scaffold jack attaches to two "A" brackets with the horizontal rod and is equipped with nailing holes top and bottom to secure it in place. Maximum spacing for the A89 jack is 8'-0".

The horizontal rod slides easily through the body of the "A" bracket for support, with the long end being installed first. Nail holes are provided for securing the jack to both the top and bottom support walers.

Warning: A89 Jahn Scaffold Bracket is designed to support 25 psf walkway loads only, after both sides of the formwork have been installed. Heavy loads placed on a scaffold jack may cause metal snap tie washers to bend or plastic snap tie cones to crush resulting in incorrect wall thickness.

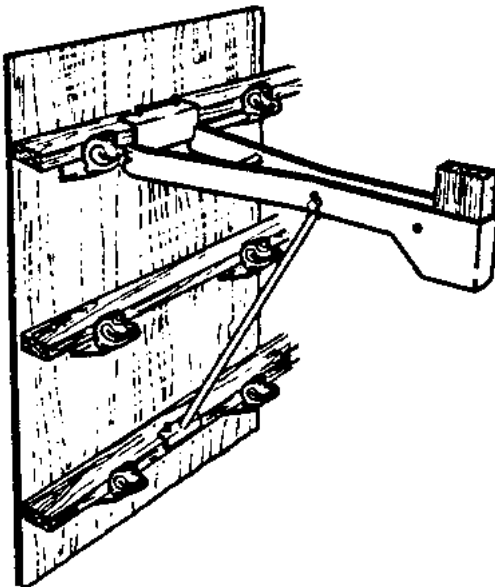

Jack Adjusted for 16" Spacing of Wales

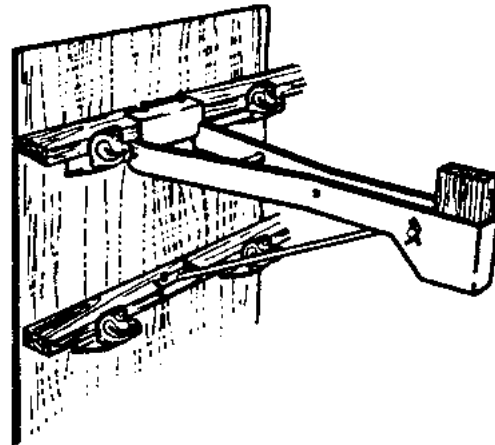

Jack Adjusted for 24" Spacing of Wales

To Order:
Specify: (1) quantity, (2) name.
Example:
50 pcs. A89 Jahn Scaffold Jack.

Light Forming Products

How to Use the Jahn® Forming System

1. Preparation

Gang drilling the plywood is the only preparation required. Holes need to be drilled 1/8" larger than the snap tie head. Normally, a 5/8" diameter drill bit will be required.

The 5/8" take-up of the eccentric on the Jahn "A" Bracket allows a snap tie with a L&W dimension of 4-3/4" to be used with 5/8" or 3/4" plywood. The 5/8" take-up on the "C" bracket allows it and 8-1/4" snap ties to be used on 5/8" and 3/4" plywood.

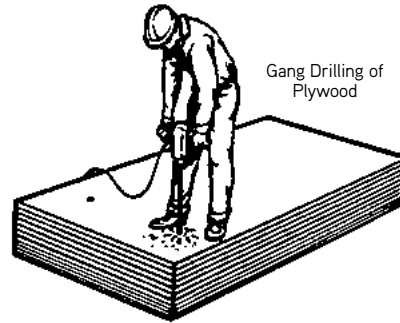

2. Snap Tie Spacing and Rate of Placement

The most common snap tie spacings being used with the Jahn Forming System are shown below. For different rates of pour and/or other tie spacing, contact a Dayton Superior Technical Services Department. Refer to the web site for addresses and phone numbers.

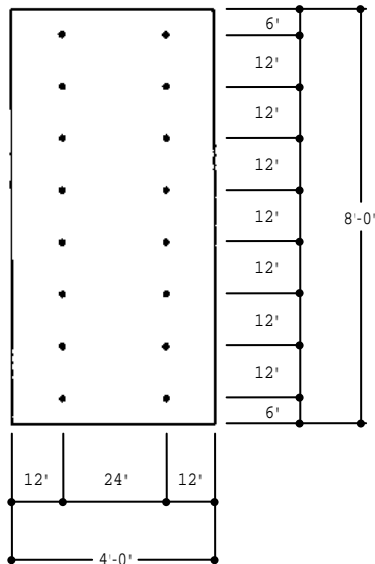

12" vertical x 24" horizontal
Snap Tie Spacing.
Recommended rate of
placement 4.5 ft./hr. at 70°.

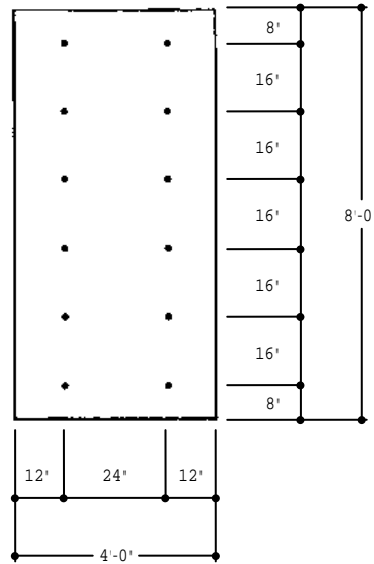

16" vertical x 24" horizontal
Snap Tie spacing.
Recommended rate of
placement 2.0 ft./hr. at 70°.

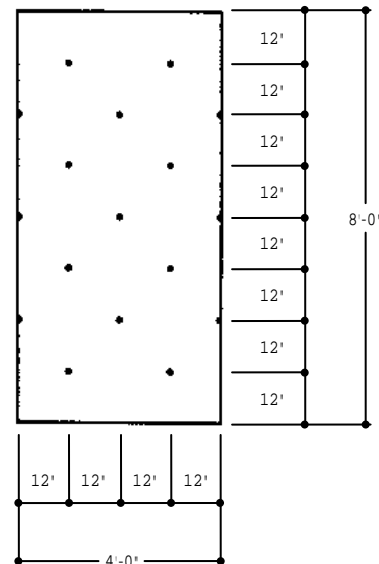

12" vertical x 12" horizontal
Snap Tie spacing.
Recommended rate of
placement 4.5 ft./hr. at 70°.

Plywood Used Strong Way (Face Grain Parallel to Spacing)

Notes: The above recommendations are based on the use of 3/4" Plyform Class I, and 2x4 S4S studs (Douglas Fir-Larch, Southern Pine or equal having a minimum allowable fibre stress of 1,200 psi).

Design is based on all formwork members being continuous over four or more supports.

For multi-lift forming, see 12 Joint Cover Details.

3. Footing Plates

Good forming practices require that a level footing be used as a starting point for all forming applications.

Snap a chalk line in back of the plywood thickness and nail down a 2 x 4 plate.

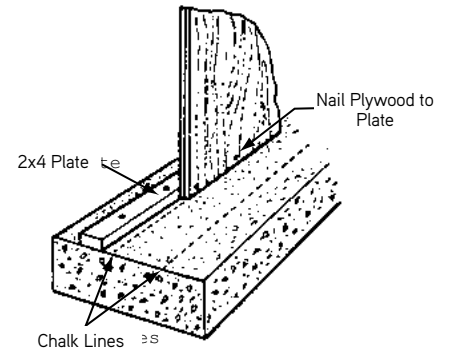

4. Plywood Panel Erection

Erect, plumb, nail to plate and temporarily brace the first sheet of plywood.

Erect additional sheets of plywood by nailing them to the 2x4 plate and temporary wood cleats at the top corners. Make sure the joints are tight. If panels are to be stacked, ensure that the panel tops are level.

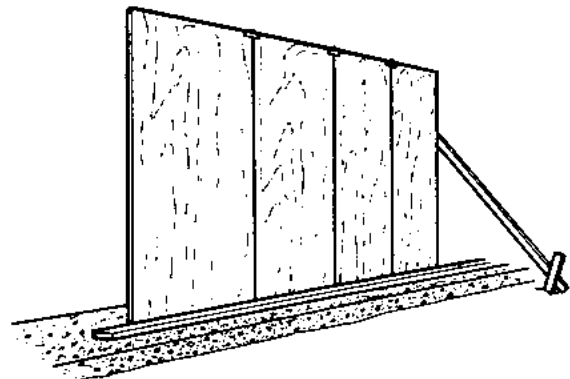

5. Installation of Snap Ties and "A" Brackets

Place the ends of the Snap Ties through the holes in the plywood. The 4-3/4" L&W A3 Snap Tie, Standard is recommended for use with the Jahn "A" Brackets, 5/8" or 3/4" plywood and 2x4 wales.

Two workmen can install the snap ties with speed and economy. One inserts the tie through the tie hole and the other attaches the "A" bracket.

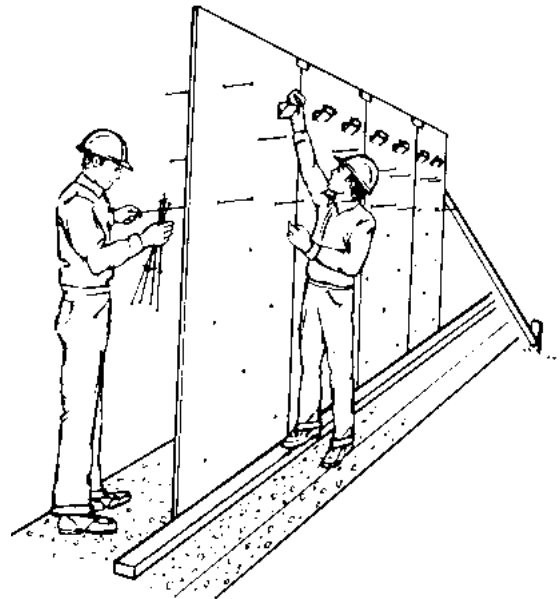

Proper "A" Bracket Installation

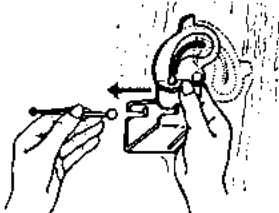
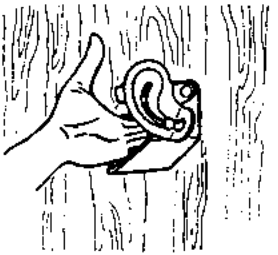
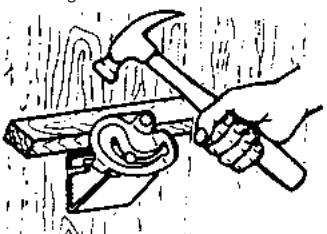
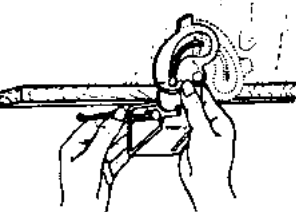
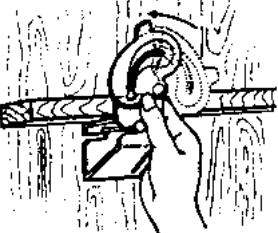
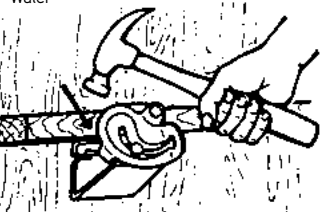
<p>Without Water In Place:</p>  <p>5A. Place The "A" bracket on the tie end by slipping the tie end into the slots in the bracket body.</p>	 <p>5B. Rotate the eccentric loosely over the tie end.</p>	<p>Placing Waler</p>  <p>5C. Drop 2x4 waler in place. Seat 2x4 with hammer, if necessary.</p>
<p>With Water In Place:</p>  <p>5D. Slip the back slot in the bracket body over the tie directly behind the head.</p>	 <p>5F. Push the bracket toward the plywood until the tie head emerges through the front of the bracket.</p>	<p>Tightening Waler</p>  <p>5G. Rotate the eccentric over the tie head and tighten.</p>

6. Installation of Wales

Install the walers into the brackets working from top to bottom of the panel and tightening the eccentric as you go. Waler joints should occur at a bracket or scab should be utilized to reinforce the joint (see sketch).

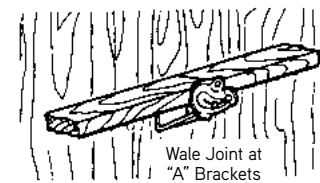
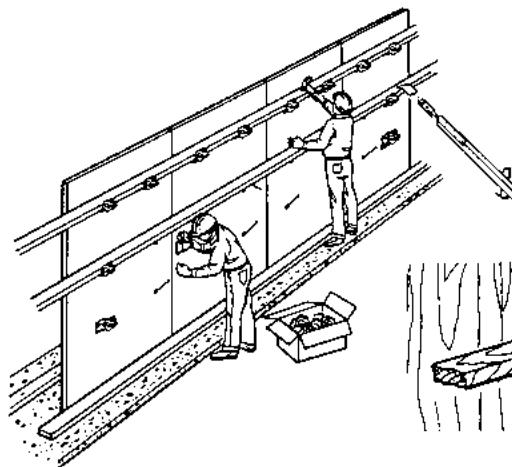
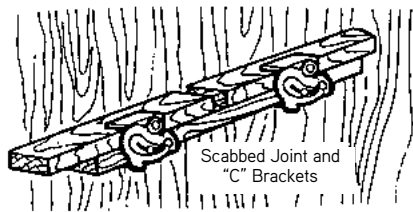

7. Inside Wall Panel Erection

The inside panel sequence is the same as the outside panel described above except for the placement of the plywood panels over the tie ends. This can be accomplished by two workmen by starting at the bottom and moving the panel from side to side and up and down to align the snap ties with the holes in the plywood.

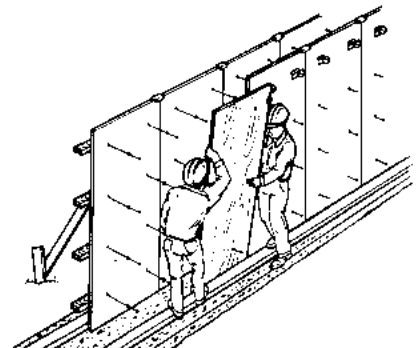

8. Inside Corner Forming

No special treatment is required for inside corners other than the alternating of the wales as shown in the sketch. It is advantageous to start the inside corners with full size plywood panels to facilitate forming the outside corners.

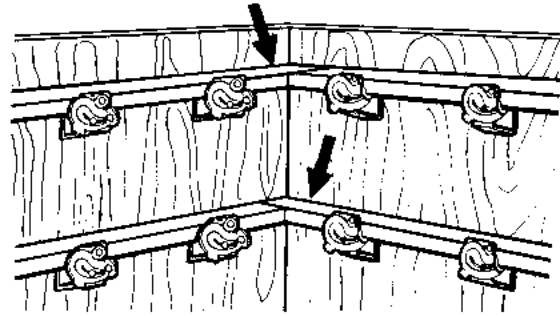

9. Outside Corner Forming

Install the first outside panel in line with the first inside panel. Filler panels, the same thickness as the wall plus the plywood thickness, are then used to fill out the exterior corner.

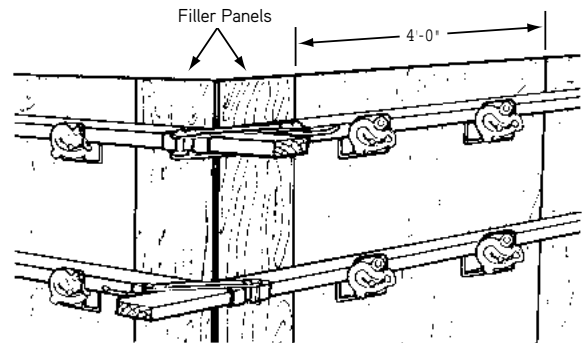

10. Installation of A83 Jahn Cornerlock

The A83 cornerlock eliminates costly overlapping and blocking of the wales. Its cam action draws the wales securely together. Place one wale flush at the corner and let the other extend past the flush one. Slip the cornerlock into place with the handle perpendicular to the wale. Nail the cornerlock in place and rotate the handle 90° toward the wale. A snug, tight outside corner is accomplished.

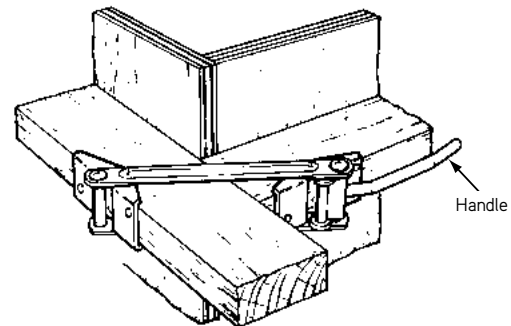

11. Installation of Strongbacks

Strongbacks are used to aid in form alignment and to tie stacked panels together. Loose 2x4's are used in conjunction with A82 Jahn "C" Brackets and 8-1/4" L&W snap ties or 4-3/4" L&W snap ties with the A86 Jahn Tie Extenders to strongback the forms. Normal strongback spacing is 8'-0" on center.

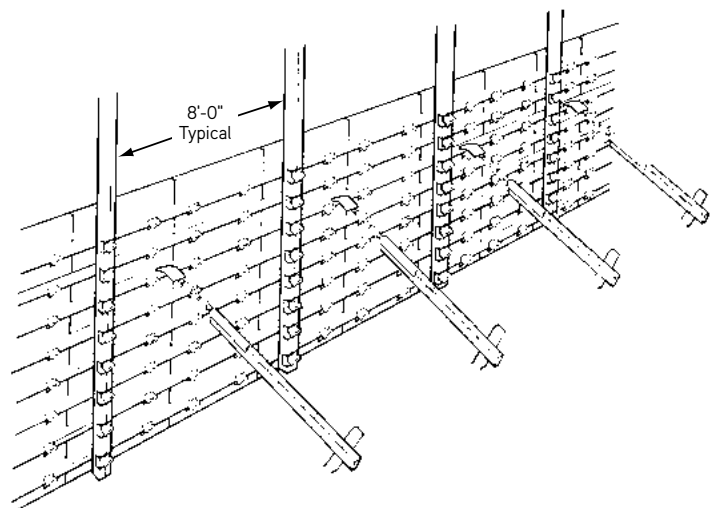

12. Joint Cover Details

Alternate A - Drill 5/8" diameter hole 1-1/8" down from top edge of the lower sheet of plywood. Install snap tie, "A" Brackets and wale and then the upper sheet of plywood. Nail the upper sheet of plywood to the wale.

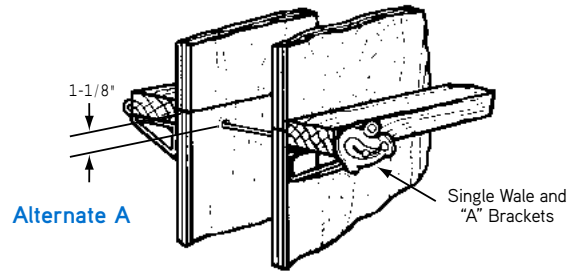

Alternate B - Install snap tie in the joint between the panels. Add double wales and a "C" Bracket.

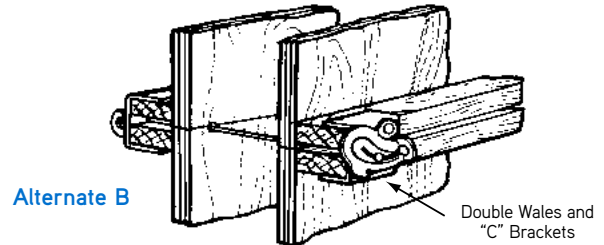

Alternate C - Nail 4x4 wale to lower sheet of plywood, hold the wale in place with strongbacks and add upper sheet of plywood.

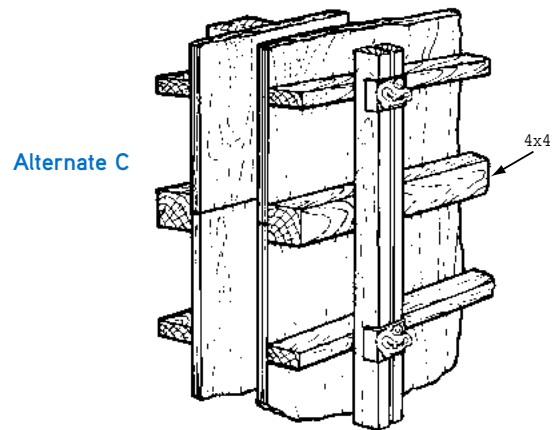

13. Installation of Second Lift of Plywood

Lift the plywood sheet and place it into position. Hold the sheet in place with a short 2x4 spacing block, snap tie and "C" Bracket placed toward the top of the panel and nail the bottom of the sheet to the joint cover wale.

Set additional panels by nailing them to the joint cover wale and securing them to the previous panel with a small wood cleat.

Install the snap ties, brackets and wales - working bottom to top.

Note: Snap ties are not designed to carry scaffold bracket loads.

Note: A89 Jahn Scaffold Bracket is designed to support 25 psf walkway loads, after both sides of the formwork have been installed. Scaffold Brackets should not be used when the bracket is supported by one sided forming, as metal snap tie washers can bend, or plastic snap tie cones can fracture resulting in incorrect wall thickness, personal property damage, personal injury, and/or death.

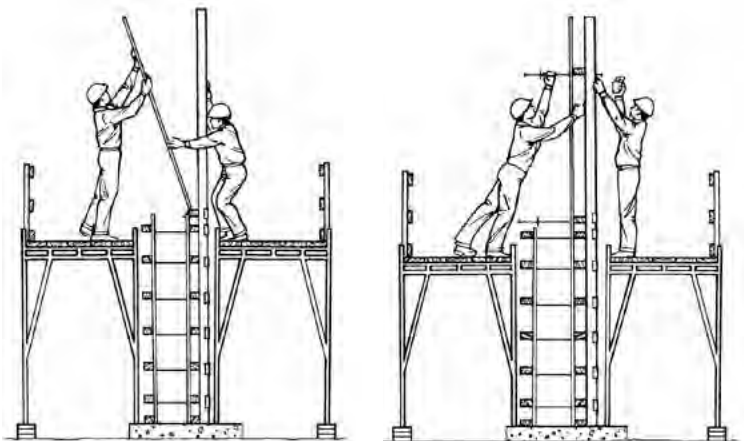

14. Haunch or Corbel Forming

A low wall with a light corbel or haunch can be formed using the method illustrated below.

For heavy corbels or haunches forming use vertical strongbacks, T shores and "A" and "C" Brackets.

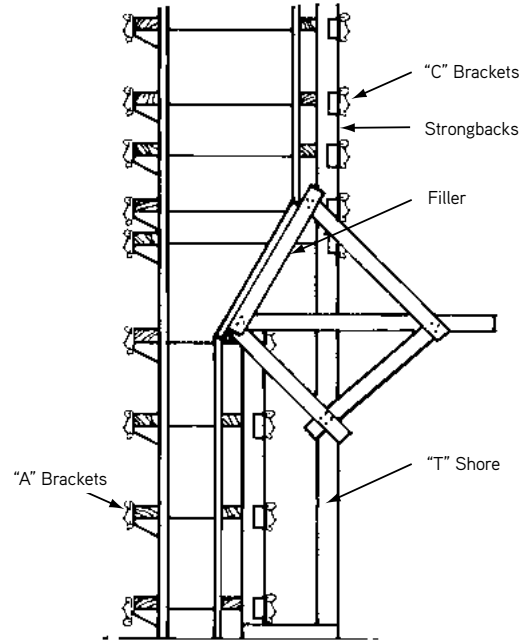
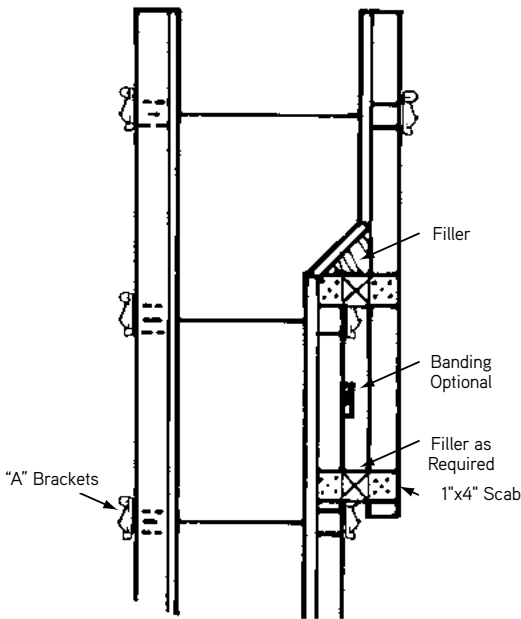

15. Step Forming

Use of Jahn "C" Brackets and Jahn Tie Extenders to attach strongbacks allows 2x4 wales to run free and holes do not have to line up at stepdowns.

When tie alignment is fairly close, "C" Brackets can be used as shown in the sketch.

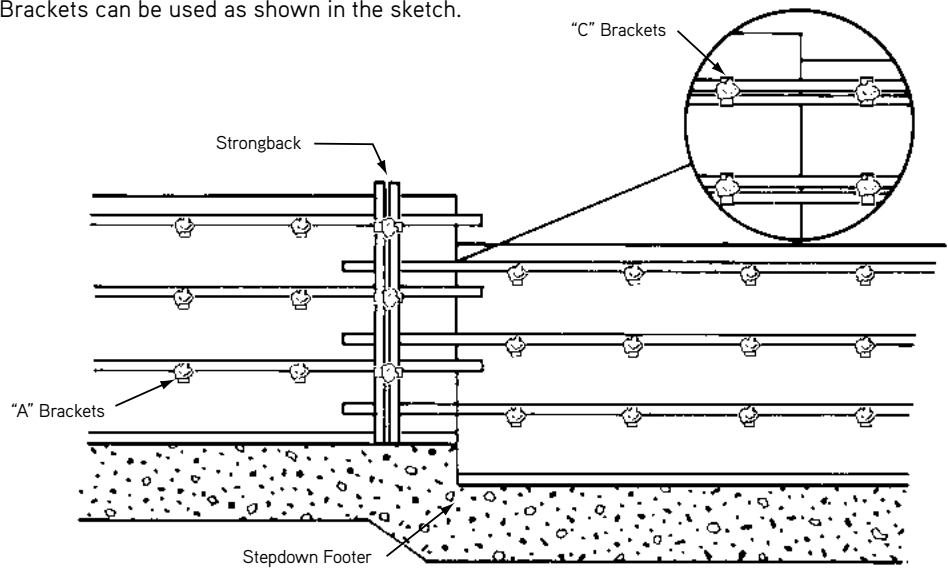

Light Forming Products

16. Brick Ledge Forming

Brick ledges can be quickly formed with 2x4s placed either vertically or horizontally. By adding shims of required thickness to a 2x4, ledges of varying thickness can be formed.

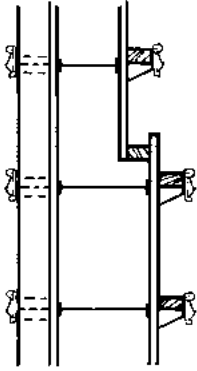

All "A" Brackets

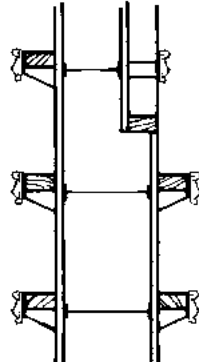

All "A" Brackets

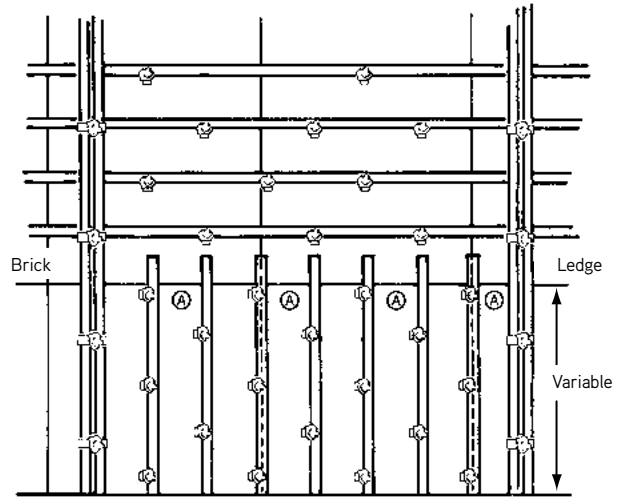

17. 3-Way Wall Forming

3-way walls can be formed using "A" and "C" Brackets with single and double wales, as shown in the sketches.

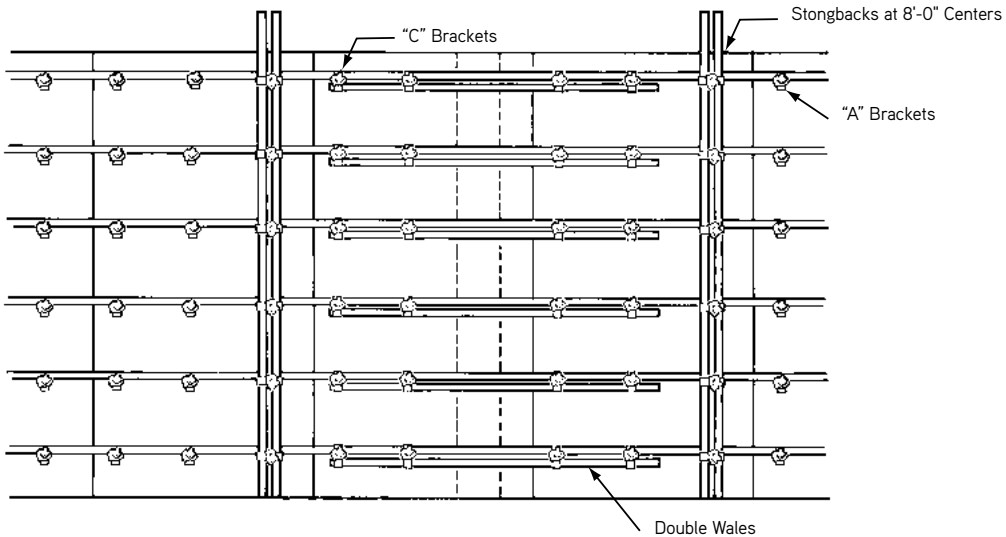
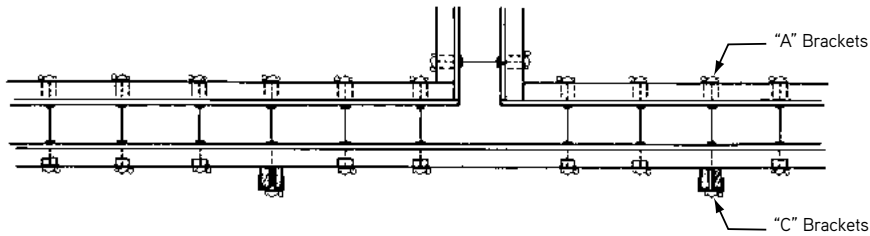

Using Single Vertical Wales for Curved Walls

"A" Brackets are always positioned on the left side of the 2x4 so that the eccentric is set in a "vibration-proof" posture. "A" Brackets can be installed after the studs are in place.

Filler strips may be required on the outside face. To eliminate the filler strip requirement, the two sides of the interior panels may be trimmed to take care of the difference in circumference of the inner and outer forms.

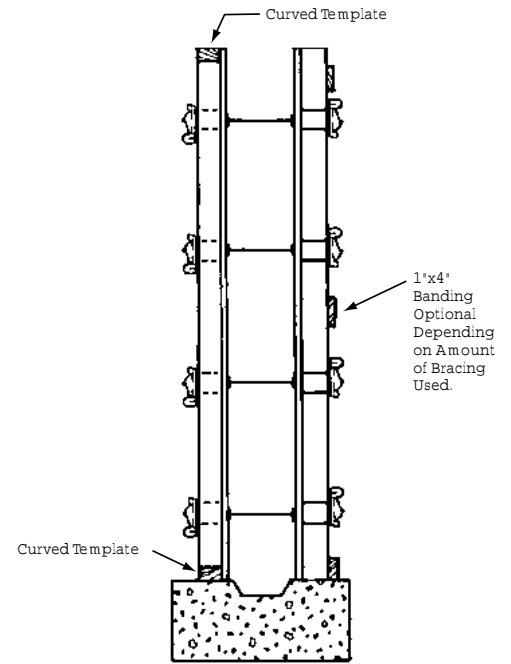

Light Forming Products

Column and Pilaster Forming Suggestions

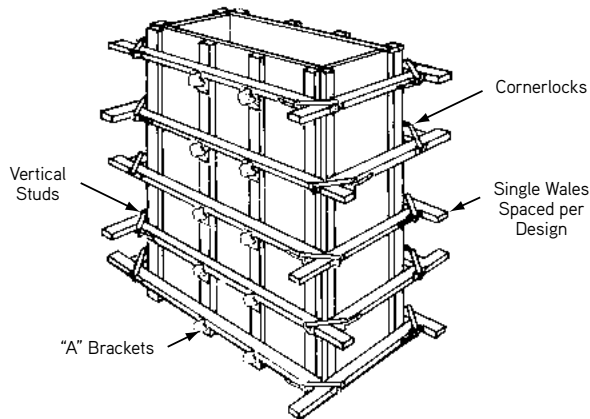

Sketch of Column Form

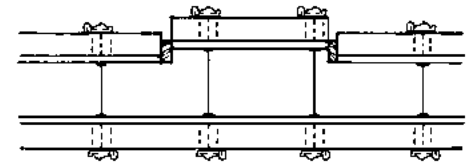

Detail of Small Pilaster Forming

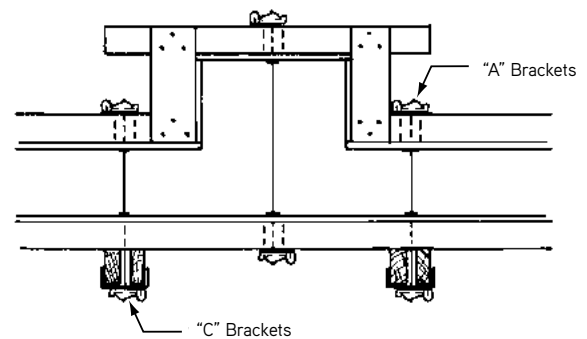

Detail of Large Pilaster Forming

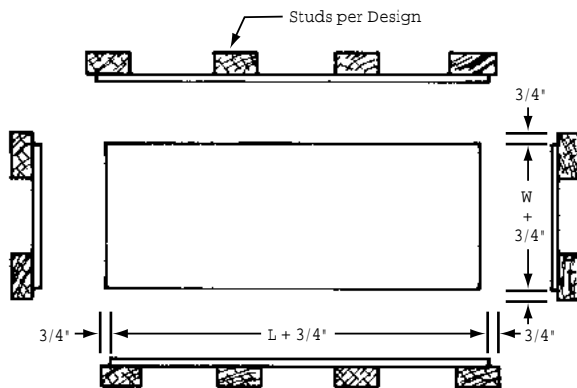

Detail of Column Form

A90 Scaffold Bracket Jack

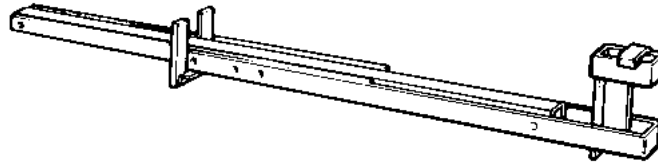

Dayton Superior A90 Scaffold Bracket Jack meets state building codes and OSHA minimum requirements and supports scaffolding on nearly any type of formwork. By changing the position of the pins in the vertical and horizontal members the bracket can be quickly adjusted to fit 2x4, 2x6 or 2x8 wales or positioned flush against a wall.

Attachment can be made to a concrete wall by attaching the bracket to an exposed coil tie, insert or other appropriate device. The bracket has a 1" diameter pipe coupling welded to the vertical leg which can be used in conjunction with a six inch long pipe nipple to attach the bracket to an exposed she-bolt inside rod.

The A90 Scaffold Bracket Jack folds for easy storage and convenient shipping.

Replacement parts for the A90 bracket are available on special order. Contact a Dayton Superior Service Center for cost and availability.

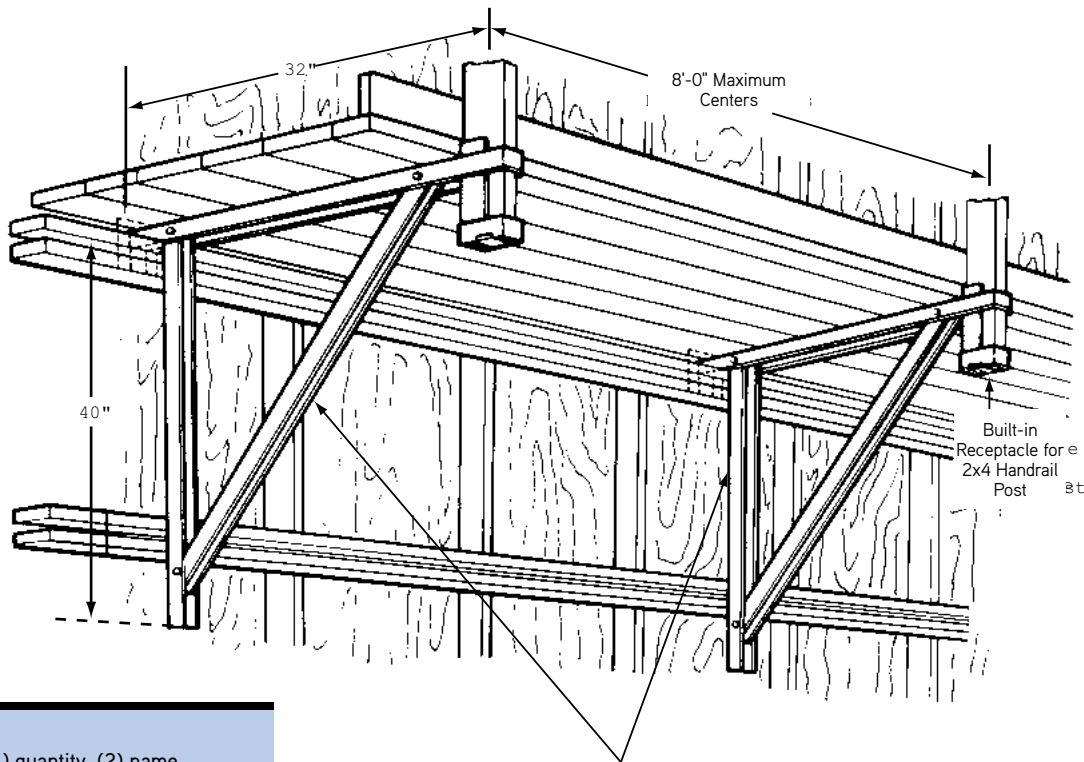

A90 Scaffold Jack

To Order:
Specify: (1) quantity, (2) name.

Example:
250 pcs. A90 Scaffold Bracket Jack.

A93C Sure Guard® Rail Post System

The Sure Guard Rail Post System meets OSHA safety requirements

The Sure Guard Rail Post System opens wide and tightens quickly, allowing for application to practically any project. The post is easily installed utilizing a top adjusting wing nut which creates the ability to tighten from a standing position. A specially designed base adds to the simplicity of setup with predrilled holes providing trouble-free fastening to decks.

This post can adjust to any floor slab thickness between 4" and 29". A drop pin makes the Sure Guard Rail Post System simple and efficient to use. The 30 lb. Sure Guard Rail Post System is also hot-dipped galvanized for durability and designed to withstand the toughest jobsite conditions.

Note: This item can be rented.

* **WARNING:** Rail Post must be secured to deck with proper fasteners to ensure safety.

To Order:
Specify: (1) quantity, (2) name.

Example:
150 pcs., A93C Sure Guard Rail Post System

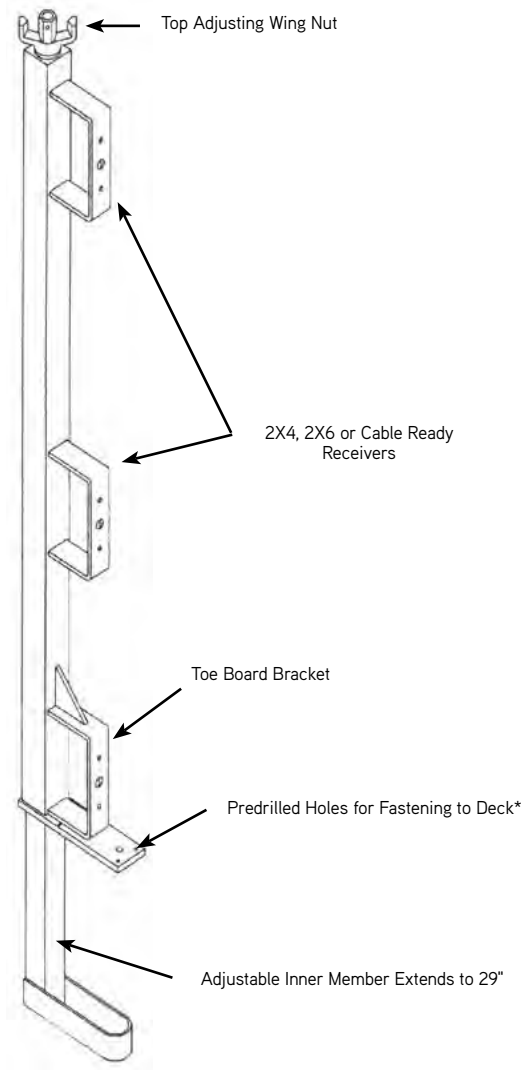

A93C
Sure Guard Rail Post System

Light Forming Products

A100 Speed Step® Bracket

Dayton Superior Speed Step Bracket (A100) is a reusable, high grade composite resin forming bracket designed to simplify layout, set-up and stripping of concrete stair forming. The brackets are nailed to 2 x 4 stringers and adjusted for a 4" to 8" riser and 10" to 20" tread. One size fits all standard stairs.

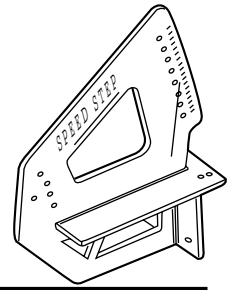

Step 1

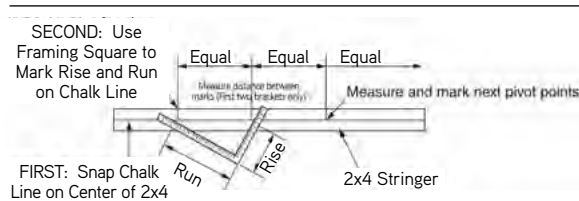

Step 2

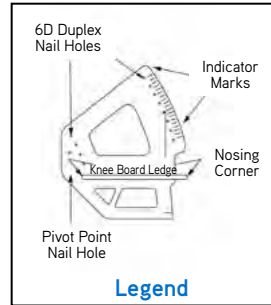
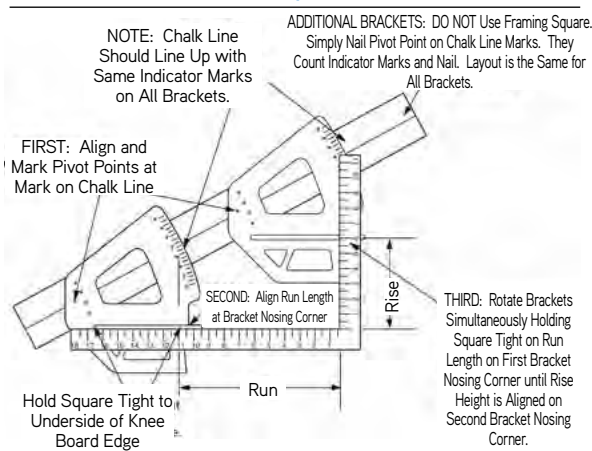

To Order:
Specify: (1) quantity, (2) name.

Example:
150, A100 Speed Step Brackets

Step 3

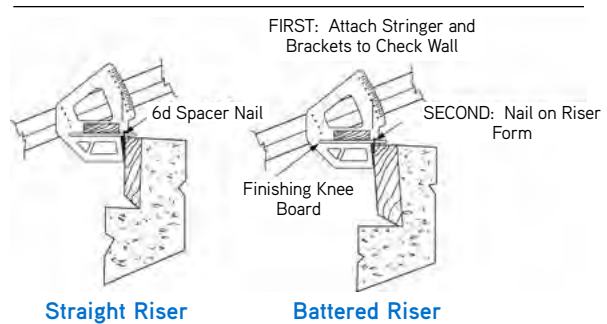

A110 Dayton Superior Metal Rib

Dayton Superior Metal Rib is the formwork solution for tough forming situations. It can be cut in the field with tin snips, and be bent to form curves. Dayton Superior Metal Rib is versatile enough for any type or size structure.

Features:

- Lightweight sheets are easily cut and installed in the field, reducing labor costs
- Formwork is left in place, so no stripping of forms required – simply remove bracing
- Easily locate any penetrations in formwork
- Enables the pour to be visually monitored
- No need to clean, reface or oil formwork
- Can be used in applications ranging from pile caps and footings, to blind side walls and tunnels
- Concrete pours in 3 to 4 foot lifts are preferable with this forming system
- Can be used with Symons Steel-Ply (A46 Snap Ties with Loops or job-built forms (A3 Snap Ties with Hooks)

Metal Rib Properties

Product Code	139700
Sheet Size	27" x 97"
Surface/sheet	18 sq.ft
Pallet/Ordering	250 sheets/4500 sq.ft
Rib Space	3.80"
Sheet Thickness	26 Ga
Weight per piece	11.90 lb

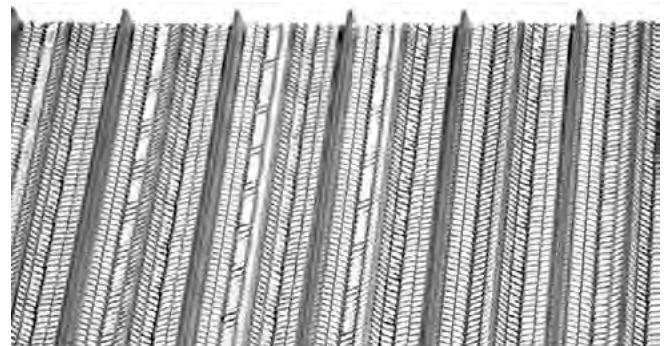

DSC A110 Metal Rib Load Versus Deflection

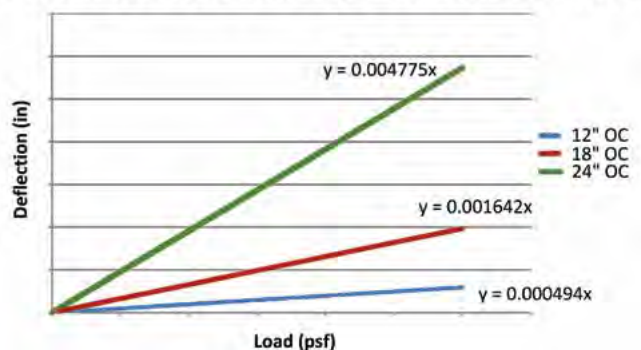

B1 Two Strut Coil Tie and B2 Four Strut Coil Tie

Dayton Superior B1 and B2 Coil Ties are strong, versatile resistance welded ties designed to take the abuse encountered in medium and heavy concrete construction. The coil tie is an extremely simple tie that is capable of servicing many applications and uses in the field. It can be used with or without cones or combined with coil rod to form an adjustable tie. The coil threads are fast acting and self-cleaning.

To determine the required coil tie length, subtract two times the desired or specified setback from the wall thickness. [Wall thickness - (2x setback) = coil tie length].

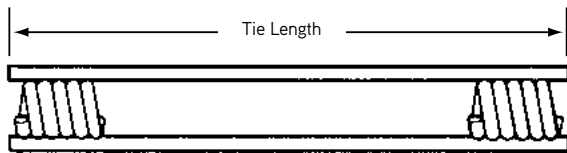

B1 Two Strut Coil Tie

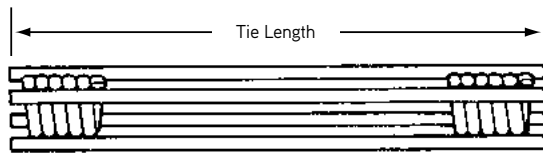

B2 Four Strut Coil Tie and B2 Four Strut Coil Tie Coupler

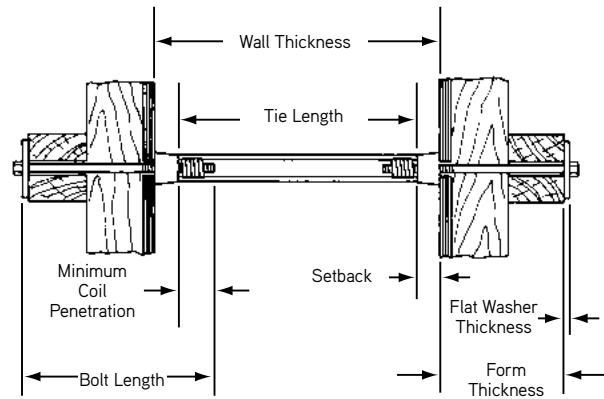

Coil Tie with Loose (Spreader) Cones

Cones are generally used when wall thickness is very thick or an architectural finish is specified.

B1 and B2 Coil Tie Selection Chart

Type	Bolt Diameter	Number of Strut Wires	Safe Working Load Tension (lbs.)
B1 Standard	1/2"	2	4,500
B1 Heavy	1/2"	2	6,750
B1 Standard	3/4"	2	6,750
B1 Heavy	3/4"	2	9,000
B1 Standard	1"	2	13,500
B1 Standard	1-1/4"	2	13,500
B2 Standard	1/2"	4	9,000
B2 Heavy	1/2"	4	13,500
B2 Standard	3/4"	4	13,500
B2 Heavy	3/4"	4	18,000
B2 Standard	1"	4	18,000
B2 Heavy	1"	4	27,000
B2 Standard	1-1/4"	4	27,000
B2 Heavy	1-1/4"	4	37,000
B2 Standard	1-1/2"	4	27,000

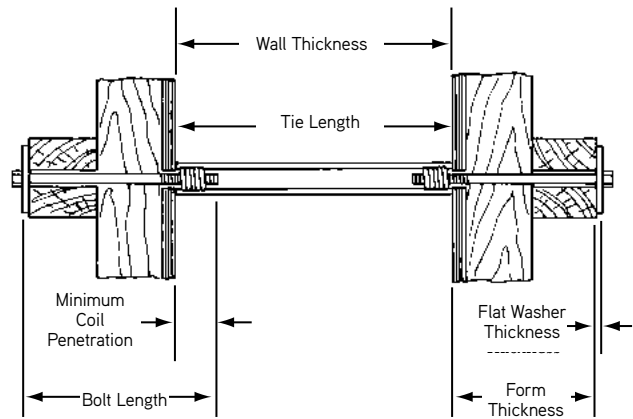

Coil Tie as Spreader and Tie

The coil tie can be used as a combination tie and form spreader when it is not necessary to keep the ends of the tie back from the face of the concrete. If a number of form reuse is contemplated, standard cut washers should be used at the tie ends to protect the form face.

SWL provides a factor of safety of approximately 2 to 1.

Warning: See minimum coil penetration information in General and Technical Information.

To Order:

Specify: (1) quantity, (2) name, (3) safe working load, (4) bolt diameter, (5) tie length, (6) wall thickness, (7) setback.

Example:

3,000 pcs. B1 Standard Coil Tie, 4,500 lbs. SWL, 1/2" diameter, 12" long for a 14" wall, 1" setback.

B1B3 and B2B3 Screw-On Coil Tie

Dayton Superior Screw-On Coil Tie is designed with longer coils that extend beyond the end of the struts. Plastic cones screw onto the projections to provide a positive setback and act as a fixed internal form spreader.

To determine proper screw-on coil tie length, subtract the required total setback (both sides) from the wall thickness.

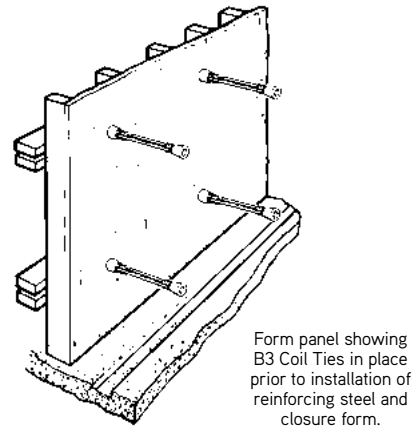
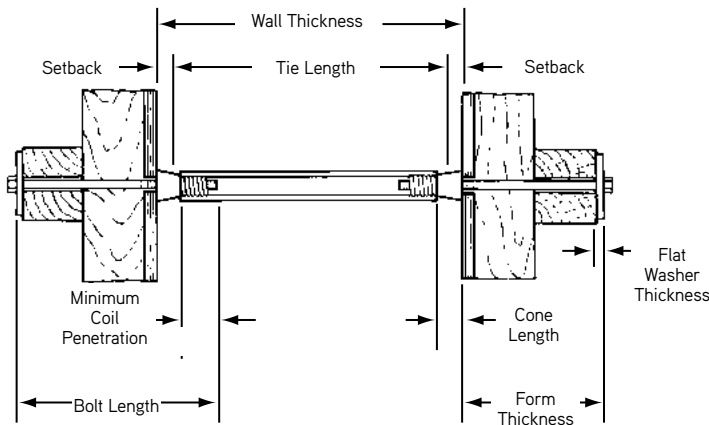
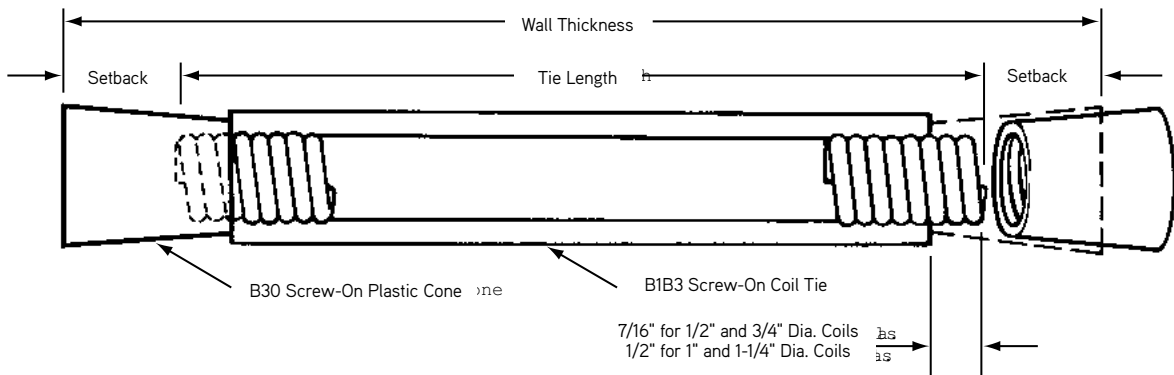

B1B3 and B2B3 Screw-On Coil Tie Selection Chart

Type	Bolt Diameter	Number of Strut Wires	Safe Working Load Tension (lbs.)
B1B3 Standard	1/2"	2	4,500
B1B3 Heavy	1/2"	2	6,750
B1B3 Extra Heavy	1/2"	2	9,000
B1B3 Standard	3/4"	2	6,750
B1B3 Heavy	3/4"	2	9,000
B1B3 Standard	1"	2	13,500
B2B3 Standard	1/2"	4	9,000
B2B3 Standard	3/4"	4	13,500
B2B3 Heavy	3/4"	4	18,000
B2B3 Standard	1"	4	18,000
B2B3 Heavy	1"	4	27,000
B2B3 Heavy	1-1/4"	4	27,000
B2B3 36K	1-1/4"	4	37,000

To Order:
Specify: (1) quantity, (2) name, (3) safe working load, (4) bolt diameter, (5) tie length, (6) wall thickness, (7) setback.

Example:
1,500 pcs. B1B3 Screw-On Coil Tie, 6,750 lbs. SWL, 1/2" diameter, 22 long for a 24" wall, 1" setback.

SWL provides a factor of safety of approximately 2 to 1.

Warning: See minimum coil penetration information in General and Technical Information.

Medium/Heavy Forming Products

Coils

Standard coils are available for 1/2", 3/4", 1", 1-1/4" and 1-1/2" diameter bolts.

Coil Dimensions

Bolt Diameter	A	B	Wire Diameter	Threads Per Inch
1/2"	1-1/8"	25/32"	.162"	6
3/4"	1-9/16"	1-3/32"	.218"	4-1/2
1"	2"	1-7/16"	.281"	3-1/2
1-1/4"	2"	1-11/16"	.281"	3-1/2
1-1/2"	2-5/16"	1-15/16"	.281"	3-1/2

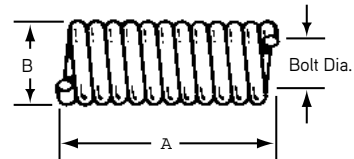

B6 Welding Coil Tie

Dayton Superior B6 Welding Coil Tie is manufactured with two struts welded to a coil at one end only. The opposite, open end of the tie is utilized for field welding. The B6 tie is used effectively in heavy and special forming applications. Available in 1/2", 3/4" and 1" diameters. See related welding warning inside cover.

B6 Welding Coil Tie Selection Chart

Coil Bolt Diameter	Maximum SWL Tension (lbs.)	Wire Strut		Minimum Weld Length	A	Minimum Tie Length
		Diameter	AISI No			
1/2"	3,750	.306"	1008	1"	3/4"	3"
3/4"	6,750	.375"	1018	1-1/2"	1"	4"
1"	13,500	.440"	1035	2"	1-3/8"	5"

SWL provides a factor of safety of approximately 2 to 1 and is dependent on the field weld.

Warning: See minimum coil penetration information in General and Technical Information.

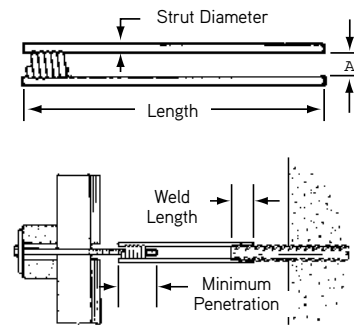

To Order:
Specify, (1) quantity, (2) name, (3) diameter, (4) length

B6R Rebar Hook

B6R Rebar Hooks are strong resistance welded ties. They are used to connect 1/2" coil rod with #6 or #8 rebar for blind-side wall application.



B7 and B22 Inserts (Crimp)

The B7 (two strut) and B22 (four strut) inserts are manufactured to meet your unusual forming requirements.

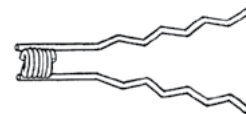

B7 Insert

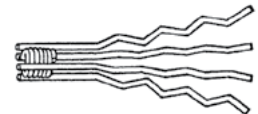

B22 Insert

B11 Flat Washers

Dayton Superior B11 Flat Washers are made from flat steel plate and are available in the sizes shown in the accompanying chart. For best results, the space spanned by the washer should not exceed the bolt diameter plus 1/4".

B11 Flat Washer Selection Chart

Bolt Diameter	Type	Safe Working Load (lbs.)	Size
1/2"	Standard	6,750	3" x 4" x 1/4"
1/2"	Heavy	8,750	4" x 5" x 1/4"
3/4"	Standard	6,750	4" x 5" x 1/4"
3/4"	Heavy	14,000	5" x 5" x 3/8"
1"	Standard	18,500	5" x 5" x 1/2"
1"	Heavy	38,000	7" x 7" x 3/4"
1-1/4"	Standard	22,750	5" x 5" x 1/2"
1-1/4"	Heavy	50,750	7" x 7" x 3/4"
1-1/2"	Standard	26,250	5" x 5" x 3/4"
1-1/2"	Heavy	41,500	7" x 7" x 3/4"

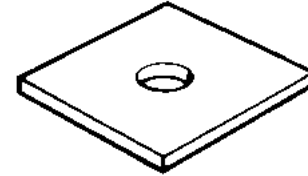

B11 Flat Washer

To Order:
Specify: (1) quantity, (2) name, (3) bolt diameter.

Example:
1,200 pcs. B11 Standard, 1/2" bolt.

SWL provides a factor of safety of approximately 2 to 1.

B12 Coil Rod

Dayton Superior B12 Coil Rod is available in 1/2" to 1-1/2" diameters in 12' lengths. Field cutting can be accomplished with bolt cutters or carborundum blades.

B12 threaded rod can be used with Coil Ties in many forming combinations to tie formwork, for adjustable ties, for concrete embedments and/or emergency ties.

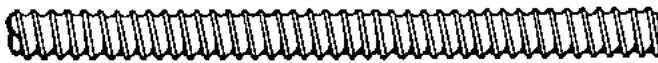

B12 Coil Rod

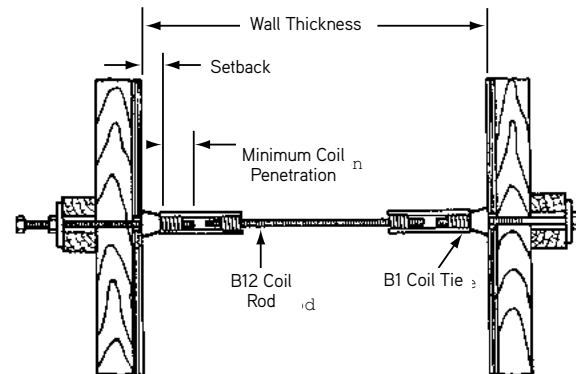

B12 Coil Rod Selection Chart

Coil Rod Diameter	Safe Working Loads		Minimum Root Area (sq. in.)	Tensile Stress (psi.)	Yield Stress (psi.)	Minimum Coil Penetration	Thread per inch
	Tension (lbs.)	Shear (lbs.)					
1/2"	9,000	6,000	.1385	130,000	110,000	2"	6
5/8"	12,000	8,000	.2124	113,000	96,000	2-1/4"	5
3/4"	18,000	12,000	.3079	117,000	100,000	2-1/4"	4.5
7/8"	24,000	16,000	.4477	117,000	100,000	2-1/2"	4.5
1"	38,000	25,300	.5410	140,000	120,000	2-1/2"	3.5
1-1/8"	46,000	30,000	.7163	126,600	105,000	2-1/2"	3.5
1-1/4"	56,000	37,500	.9161	123,000	105,000	2-1/2"	3.5
1-1/2"	68,000	45,300	1.3892	98,000	85,000	3"	3.5

SWL provides a factor of safety of approximately 2 to 1.

Warning: See working load info in General and Technical Information before using B12 Coil Rod.

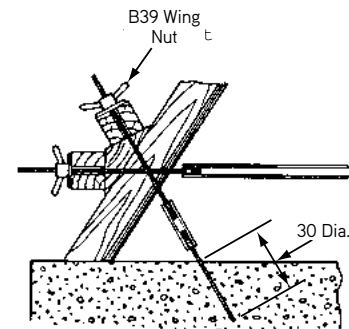

To Order:
Specify: (1) quantity, (2) name, (3) diameter, (4) length.

Example:
500 pcs. B12 Coil Rod, 1" diameter x 12'-0" long.

B12A D/R Thread Bar

Dayton Superior's D/R Thread Bar is a high strength, 15mm and 20mm ductile steel with a full length, cold-rolled contour thread. The bar's 2-1/2 threads per inch offers fast installation and stripping. D/R Thread Bar is available in 20'-0" standard lengths and can be cut to specific project requirements. Field cutting, with Carborundum blades, is easily accomplished without thread damage.



B12A D/R Thread Bar

15mm — 20,000 lbs.
20mm — 32,000 lbs.
Maximum Safe Working Load

SWL provides a factor of safety of approximately 2 to 1.

B12AD D/R Euro Thread Bar

The D/R Euro Thread Bar is a hot-rolled high strength steel with two flat sides in the thread pattern. This bar has been used in Europe on all types of projects for years. The flat sides provide self-cleaning and allow a gripping surface for turning the bar. Euro Thread Bar is available in both 15mm and 20mm diameters and is standard in 19'-1" lengths. Euro Thread Bar is bendable. For water resistant washer, see D23.

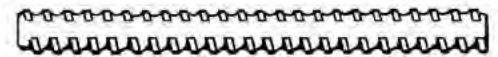

B12AD D/R Euro Thread Bar

15 mm — 21,300 lbs.
20 mm — 38,800 lbs.
Maximum Safe Working Load

SWL provides a factor of safety of approximately 2 to 1.

B12ACN Cast Hex Nut and B12ASN D/R Steel Hex Nut

15mm and 20mm hex nuts, in cast and steel versions, are available with 2-1/2 threads per inch to be used in conjunction with the appropriate Euro or D/R Thread Bar.

- 15mm B12ACN - 21,900 lbs. Safe Working Load
- 20mm B12ACN - 39,200 lbs. Safe Working Load
- 15mm B12ASN - 20,130 lbs. Safe Working Load
- 20mm B12ASN - 26,380 lbs. Safe Working Load

Double nuts are required to meet D/R Thread Bar capacity.

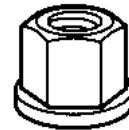

B12ACN
Cast Hex Nut

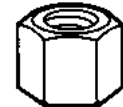

B12ASN
Steel Hex Nut

B12AW D/R Wing Nut and B12ASW D/R Swivel Wing Nut

15mm and 20mm Wing Nut is a high strength malleable steel nut with 2-1/2 threads per inch for use with the Euro or D/R Thread Bar. For added versatility, the Swivel Wing Nut features a heavy duty, ribbed washer base, reducing the number of loose working parts required.

- 15mm B12AW - 21,900 lbs. Safe Working Load
- 20mm B12AW - 39,200 lbs. Safe Working Load
- 15mm B12ASW - 21,900 lbs. Safe Working Load
- 20mm B12ASW - 39,200 lbs. Safe Working Load



B12AW Wing
Nut

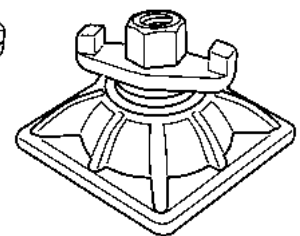

B12ASW
Swivel Wing Nut

B12AC D/R Hex Coupler

15mm and 20mm Hex Couplers are available to couple two Euro or D/R Thread Bars. The Hex Coupler is supplied with 2-1/2 threads per inch and a positive stop.

- 15mm B12AC - 21,900 lbs. Safe Working Load
- 20mm B12AC - 38,700 lbs. Safe Working Load

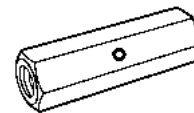

B12AC Hex
Coupler

B12ANF D/R Welding Flange

Welding flange can be used with both the Euro and D/R thread bar. The welding flange is designed to be used in one-sided forming applications by welding to a soldier beam or piling to attach the form tie. Welding flange is available in 15mm size only.



B12ANF



B12AWN

B12AWN Cast Nut Washer

15mm and 20mm cast nut washers are made of malleable iron with 2-1/2 threads per inch for use with the Euro and D/R thread bar. It is designed to distribute the applied loads over the form members, combining the special advantages of a washer and nut into one piece.

- 15mm B12AWN 21,900 lbs Safe Working Load
- 20mm B12AWN 39,200 lbs Safe Working Load

Other Accessories

- B12AHC Heavy Cones - Available in 15mm and 20mm
- B12AB D/R Bolt - Available in 15mm
- Euro Cone - Available in 15mm
- D30AS Setting She Bolt Cone - Available in 15mm

To Order B12A: Specify: (1) quantity, (2) name, (3) length.	Example: 500 pcs. B12A D/R Thread Bar, 20'-0" long.
To Order D/R Thread Bar Working Parts: Specify: (1) quantity,	Example: 200 pcs. B12ASW D/R Swivel Wing Nuts.

B13 Coil Nut and B25 Heavy Coil Nut

Dayton Superior B13 Coil Nuts and B25 Heavy Coil Nuts are available with coil threads in 1/2", 3/4", 1", 1-1/4" and 1-1/2" diameters. These nuts are available with right hand or left hand threads.

B13 Coil Nut and B25 Heavy Coil Nut Selection Chart

Coil Nut Type	Dia.	Approx. Height	Width Across Flats A	Safe Working Load Tension (lbs.)	
				Using One B13 Nut	Using Two B13 Nuts or One B25 Heavy Nut
B13	1/2"	7/16"	7/8"	6,000	9,000
B25	1/2"	1-3/16"	1-1/8"	—	9,000
B13	3/4"	5/8"	1-1/8"	9,000	18,000
B25	3/4"	1-3/16"	1-1/8"	—	18,000
B13	1"	1"	1-5/8"	24,000	38,000
B25	1"	2"	1-5/8"	—	38,000
B13	1-1/4"	1-1/4"	2"	36,000	56,000
B25	1-1/4"	2-1/2"	2"	—	56,000
B13	1-1/2"	1-1/2"	2-3/8"	47,500	68,000
B25	1-1/2"	3-3/8"	2-3/8"	—	68,000

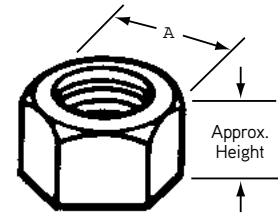

B13 Standard Coil Nut

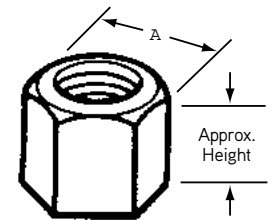

B25 Heavy Coil Nut

SWL provides a factor of safety of approximately 2 to 1.

Canadian B13 Coil Nut Selection Chart

Coil Nut Type	Dia.	Approx. Height	Width Across Flats A	Safe Working Load Tension (lbs.)	
				Using One B13 Nut	Using Two B13 Nuts
B13	1/2"	39/64"	7/8"	9,000	18,000
B13	3/4"	55/64"	1-1/4"	18,000	36,000

To Order:
Specify: (1) quantity, (2) name, (3) bolt diameter.

Example:
200 pcs. B13 Coil Nut, 3/4".

Medium/Heavy Forming Products

B14 Coil Bolts

Dayton Superior B14 Coil Bolts are designed for ease of use and durability. Coil bolts have fast acting, self-cleaning coil threads.

Coil bolts are designed to be reusable, but they do wear and must be continuously inspected and replaced when wear or damage is noted. A waterproof grease should be applied to the portion of bolt that will be embedded in the concrete. This will facilitate bolt removal from the set concrete.



B14 Coil Bolt

Minimum Coil Penetration Information

When determining the minimum required overall length of coil bolts, you must consider the following items:

- Formwork grip (including washer thickness).
- Setback of the form tie or insert.
- Minimum coil penetration (applies to all coil products).

See B14 Coil Bolt Selection and Minimum Coil Penetration Chart.

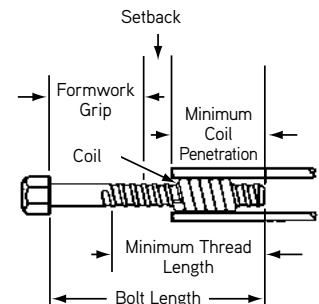

To Order:
Specify: (1) quantity, (2) name, (3) bolt diameter, (4) length of bolt.

Example:
500 pcs. B14 Coil Bolt, 3/4" diameter, 12" long.

B14 Coil Bolt Selection and Minimum Coil Penetration Chart

1/2" Dia. Forged Hex Head Safe Work Load		3/4" Dia. Forged Hex Head Safe Work Load		1" Dia. Forged Hex Head Safe Work Load		1-1/4" Dia. Forged Hex Head Safe Work Load		1-1/2" Dia Forged Hex Head Safe Work Load	
Tension	Shear	Tension	Shear	Tension	Shear	Tension	Shear	Tension	Shear
9,000 lbs.	6,000 lbs.	20,050 lbs.	13,360 lbs.	36,350 lbs.	24,200 lbs.	50,850 lbs.	33,900 lbs.	73,750 lbs.	49,150 lbs.
Minimum Coil Penetration 2" Minimum Root Area .1385 Sq. In.		Minimum Coil Penetration 2-1/4" Minimum Root Area .3079 Sq. In.		Minimum Coil Penetration 2-1/2" Minimum Root Area .5410 Sq. In.		Minimum Coil Penetration 2-1/2" Minimum Root Area .9161 Sq. In.		Minimum Coil Penetration 3" Minimum Root Area 1.3890 Sq. In.	
Threads per inch 6		Threads per inch 4-1/2		Threads per inch 3-1/2		Threads per inch 3-1/2		Threads per inch 3-1/2	
Bolt Length	Minimum Thread Length	Bolt Length	Minimum Thread Length	Bolt Length	Minimum Thread Length	Bolt Length	Minimum Thread Length	Bolt Length	Minimum Thread Length
3"	2-1/4"	3"	2-1/4"	3"	2"	3"	2"	-	-
4"	3-1/4"	4"	3-1/4"	4"	3"	4"	3"	4"	3"
5"	4-1/4"	5"	4-1/4"	5"	4"	5"	4"	5"	4"
6"	5"	6"	5"	6"	5"	6"	5"	6"	5"
Over 6"	5"	Over 6"	5"	Over 6"	5"	Over 6"	5"	Over 6"	5"

SWL provides a factor of safety of approximately 2 to 1.

Warning: See working load info in General and Technical Information before using B12 Coil Rod.

B14A Adjustable Coil Bolt

Dayton Superior B14A Adjustable Coil Bolt consists of a length of B12 Coil Rod with a B13 Coil Nut welded on one end and a free-running B13 Coil Nut on the other end. The B14A allows formwork adjustments to be made with the free-running nut and can accommodate various form thickness as with one size adjustable bolt. This is especially useful in forming battered walls.

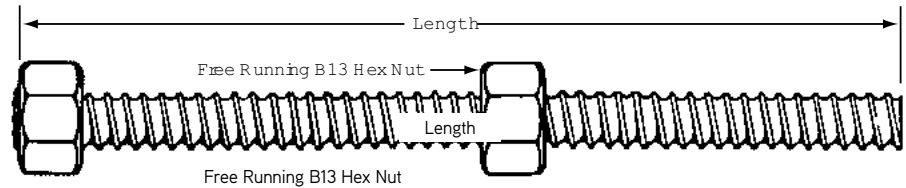

B14A Adjustable Coil Bolt

B14A Adjustable Coil Bolts are designed to be reusable, but they do wear and must be continuously inspected and replaced when wear or damage is noted. A waterproof grease should be applied to the portion of bolt that will be embedded in the concrete. This will facilitate bolt removal from the set concrete.

The safe working load of the B14A bolt is limited by the safe working load of the welded coil nut head.

B14A Adjustable Coil Bolt Selection Chart

Diameter	Safe Working Load Tension (lbs.)	Safe Working Load Shear (lbs.)	Minimum Area (sq. in.)	Minimum Coil Penetration
1/2"	6,000	4,500	.1385	2"
3/4"	9,000	6,000	.3079	2-1/4"

SWL provides a factor of safety of approximately 2 to 1.

Warning: See working load info in General and Technical Information before using B12 Coil Rod.

To Order:

Specify: (1) quantity, (2) name, (3) diameter, (4) length.

Example:

400 pcs. B14A Adjustable Coil Bolt, 1/2" diameter, 18" length.

B14W Wale Bolt Assembly

Dayton Superior B14W Wale Bolt Assembly consists of a 1/2" "L" Bolt, a round cut washer, a B11 Flat Washer and two 1/2" B13 Coil Nuts. The B14W assembly is used to fasten wales to crane-handled gang forms. One size assembly will secure wales up to 10" thick. The bolt has 8" of coil thread on the long end and 1-1/2" of coil thread on the short end.

The short end of the bolt is inserted through a 9/16" hole drilled through the center of the stud. The cut washer and 1/2" nut fastens the bolt to the stud. The long end of the bolt extends between the wales and allows the wales to be drawn tightly against the stud using a flat washer and the second 1/2" nut.

Wale Bolt Assemblies are normally spaced at four feet intervals along the wales. The safe working load of the assembly is dependent on the wale members being used.

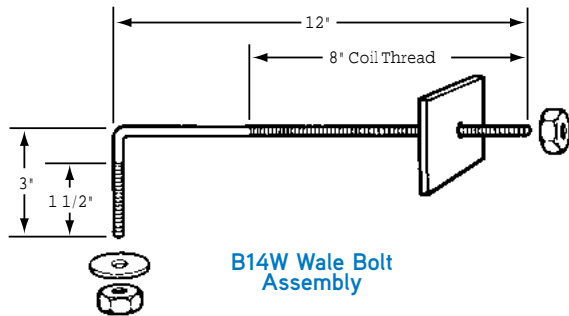
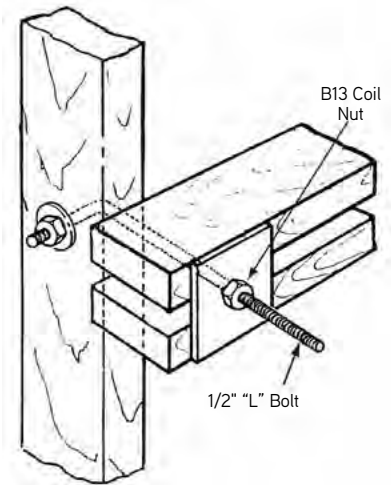

B14W Wale Bolt Assembly

To Order:
Specify: (1) quantity, (2) name.

Example:
300 pcs. B14W Wale Bolt Assembly, complete with nuts and washers.

B15 Plastic Cone Removal Wrench

Dayton Superior B15 Plastic Cone Removal Wrench is designed to remove the plastic cones from Screw-On Coil Ties. Available for 1/2", 3/4", 1" and 1-1/4" diameter cones.



1-Piece B15 Hex - Bent for 1/2" Cones



2-Piece B15 Hex Head - Smooth Round Handle for 3/4", 1", 1-1/4" Cones

B16 Coil Loop Insert Straight

Dayton Superior B16 Coil Loop Insert Straight is made of a single looped wire strut welded to a helix coil. B16 inserts are available in 1/2", 3/4" and 1" nominal diameter standard or screw-on coil and in various standard lengths. The B16 is also available in other than standard lengths and with a nailing washer face on special order.

B16 Coil Loop Insert, Straight Selection Chart

Bolt Diameter	Insert Length	Wire Strut Diameter	Safe Working Load Tension (lbs.)	Minimum Concrete Strength (psi)
1/2"	3"	.223	4,500	2,000
1/2"	4"	.223	4,500	2,000
1/2"	6"	.306	7,500	2,000
3/4"	4"	.306	4,500	2,000
3/4"	6"	.306	7,500	2,000
3/4"	6"	.375	9,000	2,000
3/4"	9"	.375	9,000	2,000
1"	6"	.306	7,500	2,000
1"	8"	.306	7,500	2,000



B16 Coil Loop Insert

To Order:
Specify:
(1) quantity,
(2) name,
(3) diameter,
(4) insert length

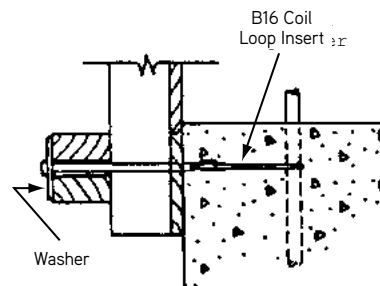

SWL provides a factor of safety of approximately 2 to 1.

SWL may vary with concrete weight and strength, as well as with insert setback and edge distance. Contact the Dayton Superior Technical Service Department for variables.

B17 Double Flared Coil Loop Insert

Dayton Superior B17 Double Flared Coil Loop Insert is made with two looped wire struts welded to a helix coil. The B17 insert is suitable for heavy form anchorage in mass concrete construction. Standard length is 12" for 1", 1-1/4" and 1-1/2" diameter units. Standard 6" nominal flares are supplied unless special size or shaped flares are requested.

B17 Double Flared Coil Loop Insert Selection Chart

Bolt Diameter x Insert Length	Flare width	Wire Strut Diameter	Safe Working Load Tension (lbs.)	Minimum Concrete Strength (psi)	Minimum Edge Distance
1" x 12" Std.	5-3/4"	.375"	18,000	2,000	15"
1" x 12" Hvy.	5-3/4"	.442"	27,000	2,000	15"
1-1/4" x 12" Std.	6"	.375"	18,000	2,000	15"
1-1/4" x 12" Hvy.	6"	.442"	27,000	2,000	15"
1-1/2" x 12" Std.	6-1/4"	.375"	18,000	2,000	15"
1-1/2" x 12" Hvy.	6-1/4"	.442"	27,000	2,000	15"

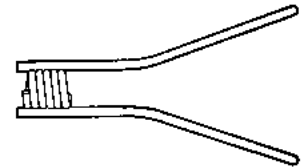
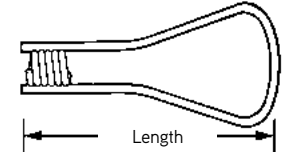

B17 Double Flared Coil Loop Insert

SWL provides a factor of safety of approximately 2 to 1.

SWL may vary with concrete weight and strength, as well as with insert setback and edge distance. Contact the Dayton Superior Technical Service Department for variables.

To Order:
Specify: (1) quantity, (2) name, (3) size, (4) SWL.
Example:
500 pcs. B17 Double Flared Coil Loop Inserts, 1-1/4" diameter, 27,000 lbs. SWL.

B18 Single Flared Coil Insert

Dayton Superior B18 Single Flared Coil Insert is made with the loop end flared for greater anchorage in the concrete. Standard lengths and sizes are shown in the chart. Special lengths and flare shapes can be special ordered.

To Order:
Specify: (1) quantity, (2) bolt diameter, (3) length, (4) SWL.
Example:
500 pcs. B18 Single Flared Coil Loop Insert, 3/4", 9", 7,500 SWL.

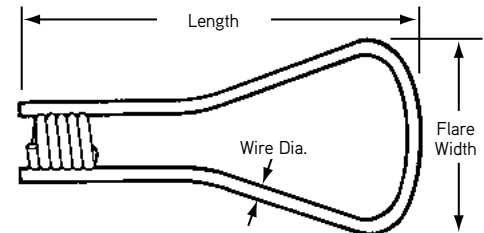

B18 Single Flared Coil Insert

B18 Single Flared Coil Loop Insert Selection Chart

Bolt Diameter x Insert Length	Flare width	Wire Strut Diameter	Safe Working Load Tension (lbs.)	Minimum Concrete Strength (psi)	Minimum Edge Distance
1/2" x 4" or 6" or 9"	3"	.223"	4,500	2,000	11"
3/4" x 6" or 9" or 12"	5-1/2"	.306"	7,500	2,000	13"
3/4" x 6" or 9" or 12"	5-1/2"	.375"	9,000	2,000	13"
3/4" x 9" or 12"	5-1/2"	.442"	13,500	2,000	13"
1" x 6" or 9" or 12"	5-1/2"	.375"	9,000	2,000	15"
1" x 9" or 12"	5-1/2"	.442"	15,000	2,000	15"
1-1/4" x 12"	5-1/2"	.375"	9,000	2,000	15"
1-1/4" x 12"	5-1/2"	.442"	15,000	2,000	15"
1-1/4" x 12"	5-1/2"	.442"	15,000	2,000	15"

SWL are based on 1/2" set back from face of concrete.

SWL provides a factor of safety of approximately 2 to 1.

SWL vary with concrete weight and strength as well as insert setback. For use in other than 2,000 psi normal weight concrete, contact technical services.

B20 Wale Holder

Dayton Superior B20 Wale Holder consists of a 1/2" or 3/4" reinforced coil welded to a flat plate. The B20 is nailed to the stud and allows the wales to be bolted securely to the form. Strength of the holder is dependent on the shear capacity of the nails. The B20 is not to be used in lifting applications.

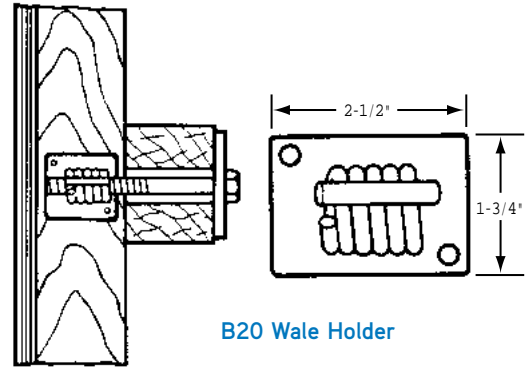

B20 Wale Holder

To Order:

Specify: (1) quantity, (2) name, (3) size.

Example:

400 pcs. B20 Wale Holder, 1/2" diameter.

B21 Plylag

Dayton Superior B21 Plylags are used externally on modular forms to attach wales/strongbacks or internally to attach coil ties, rock anchors, etc., to the form. Plylags are manufactured from 1/2" diameter coil rod and are stocked in 6-1/4", 6-3/4", 9-3/4" and 14-3/4" lengths. Other lengths are available on special order. See A51 Wedge Bolt.

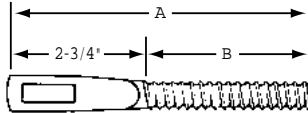

B21 Plylag

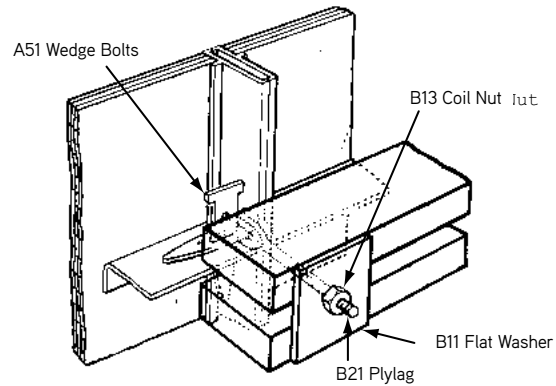
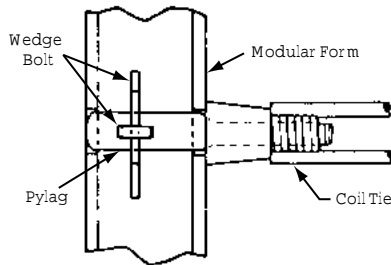

B21 Plylag Selection Chart

Type	Diameter	Dimensions	
		A Overall length	B Thread length
B21	1/2"	6-1/4"	3-1/2"
B21	1/2"	6-3/4"	4"
B21	1/2"	7-1/4"	4-1/2"
B21	1/2"	8-3/4"	6"
B21	1/2"	9-3/4"	7"
B21	1/2"	10-3/4"	8"
B21	1/2"	12-3/4"	10"
B21	1/2"	14-3/4"	12"
B21	1/2"	16-3/4"	14"

3,250 lbs.
Maximum Safe Working Load

SWL provides a factor of safety of approximately 2 to 1.

To Order:

Specify: (1) quantity, (2) name, (3) Overall length.

Example:

875 pcs., B21 Plylag, 9-3/4" Overall length.

See B25 Heavy Coil Nut with B13 Coil Nut

B27 and D6 Nut Washer

Dayton Superior B27 and D6 Nut Washers combine the advantages of a washer and nut into a one-piece ductile iron unit. The nut washer is equipped with nailing holes to secure them to the formwork and are designed to spread the forming loads over the wood forming members. The B27 Nut Washer has coil thread in the sizes displayed in the chart and can be used with all appropriate coil threaded devices. The D6 Nut Washer is equipped with Acme thread and is normally used with the D2 She-Bolt.

B27 and D6 Nut Washer Selection Chart

Type	Thread		Safe Working Load Tension (lbs.)	D
	Diameter	Type		
B27	1/2"	Coil	4,500	4"
B27	3/4"	Coil	9,000	4"
B27	7/8"	Coil	12,000	5"
B27	1"	Coil	18,000	5"
D6	3/4"	Acme	9,000	4"

SWL provides a factor of safety of approximately 2 to 1.

To Order:
Specify: (1) quantity, (2) name, (3) diameter, (4) thread type.

Example:
100 pcs., B27 Nut Washer, 1/2" coil thread.

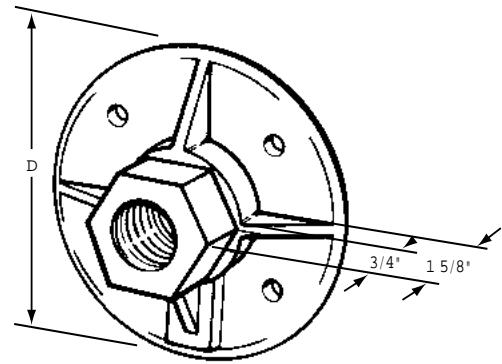

B27 Nut Washer

B29 Loose Plastic Cone

Dayton Superior B29 Loose Plastic Cones are used with B1 and B2 Coil Ties. They are placed on the coil bolts after the coil bolts have been inserted through the form face but prior to threading the bolt into the coil tie. The large end of the cone provides sufficient bearing surface to prevent crushing of the plywood around the bolt hole. B29 plastic cones are removed from the concrete with a B15 Cone Removal Wrench and can be reused.

B29 Loose Cone Selection Chart

Bolt Diameter	Setback (Cone Length) A	B	C
1/2"	1"	1-1/4"	1"
1/2"	1-1/2"	1-1/4"	1"
1/2"	2"	1-1/4"	1"
3/4"	1"	1-5/8"	1-7/16"
3/4"	1-1/2"	1-5/8"	1-7/16"
3/4"	2"	1-5/8"	1-7/16"
1"	2-1/2"	2-1/8"	1-3/4"
1-1/4"	2-1/2"	2-3/8"	2-1/8"

SWL provides a factor of safety of approximately 2 to 1.

Warning: Cones are to be used for spreader action only and are not designed for scaffold bracket or other accessory loads.



B29 Plastic Cone

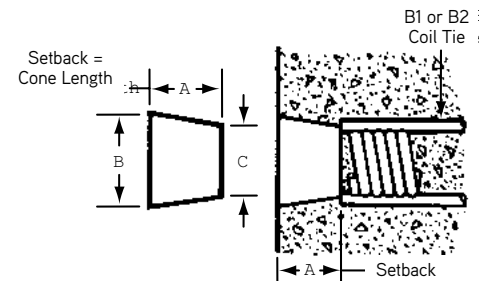

To Order:
Specify: (1) quantity, (2) name, (3) bolt diameter, (4) setback.

Example:
2,000 pcs. B29 Loose Plastic Cone, 1/2", 2" setback.

B30 Screw-On Plastic Cones

Dayton Superior Screw-On Plastic Cones are designed to thread onto the protruding coil of a B3 Screw-On Coil Tie. Use a B15 Cone Removal Wrench to back the cone off the tie and out of the concrete. B30 plastic cones are normally reusable.

B30 Screw-On Selection Chart

Bolt Dia.	Setback	A	B	C
1/2"	1"	1-3/8"	1-1/4"	1"
1/2"	1-1/2"	1-7/8"	1-1/4"	1"
1/2"	2"	2-3/8"	1-1/4"	1"
3/4"	1"	1-1/2"	1-5/8"	1-7/16"
3/4"	1-1/2"	2"	1-5/8"	1-7/16"
3/4"	2"	2-1/2"	1-3/4"	1-7/16"
3/4"	3"	3-1/2"	1-7/8"	1-7/16"
1"	1"	1-1/2"	2-1/8"	1-13/16"
1"	2"	2-1/2"	2-1/8"	1-13/16"
1-1/4"	2"	2-1/2"	2-3/8"	2-1/8"

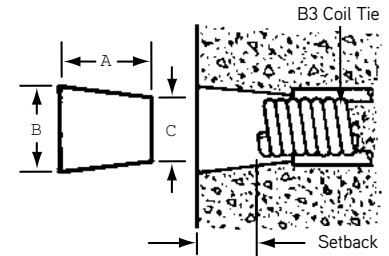

Warning: Cones are to be used for spreader action only and are not designed for scaffold bracket or other accessory loads.

B31 Rock Anchor

Dayton Superior B31 Rock Anchor is a preassembled unit tapped with 1/2", 3/4" or 1" diameter coil thread. NC thread is available on special order. Rock anchors used in sound rock or concrete allows one-sided forming of walls or similar applications to be completed quickly and economically.

The rock anchor is threaded onto the coil rod until the backstop of the anchor. The plastic retaining sleeve is removed and the rock anchor/coil rod assembly is placed into the bore hole. The assembly is installed so that the anchor backstop "bottoms" in the bore hole. Tightening the coil rod will draw the anchor wedges forward to expand the anchor's shell. Care should be taken to not overtighten the anchor.

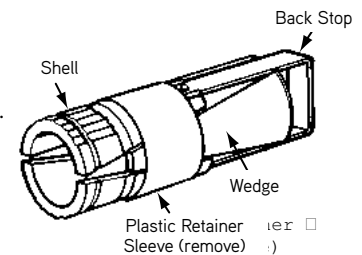

B31 Rock Anchor Selection Chart

Coil Rod Diameter	Minimum Hole Depth "L" *	Required Hole Diameter "D"	Safe Working Load Tension (lbs.) **
1/2"	6"	1-3/8"	4,500
3/4"	8"	1-5/8"	9,000
1"	10"	1-3/4"	18,000

SWL provides a factor of safety of approximately 2 to 1 in 3,500 psi concrete.

***NOTE:** It is extremely important to drill the proper size bore hole for the appropriate rock anchor. Avoid "dog leg" or "rifled" holes, they will hinder anchor installation. It is also important to avoid letting the drill dwell at the bottom of the hole. This can cause an enlargement at the bottom of the hole and result in a loss of anchorage strength.

The bore hole for the rock anchor must be drilled perpendicular to the exposed bearing surface. The load carrying capacity of the rock anchor is greatly reduced when there is an angle between the nut on the coil rod and the bearing surface.

The B31 Rock Anchor is not a reusable device. After the rock anchor has been set and the forming completed, do not attempt to reuse the rock anchor.

****WARNING:** For safe construction practice, the most critical factor to consider is the actual anchorage capacity provided by the rock strata or concrete in which the rock anchor is to be installed. Correct hole depth and actual rock anchor capacity must always be determined by field tests before placing rock anchors into general use on a project.

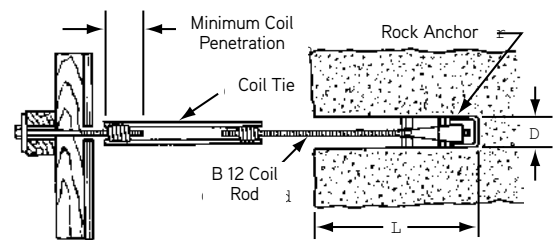

To Order:

Specify: (1) quantity, (2) name, (3) coil rod diameter.

Example:

600 pcs. B31 Rock Anchor, 1/2" coil thread.

B32 Handle Coil Nut

Dayton Superior B32 Handle Coil Nut is a B13 Hex Coil Nut which has a wire loop handle welded to it. It is designed for use in situations which require quick application or removal of a nut. It speeds up installation and stripping of formwork.

B32 Handle Coil Nut Selection Chart

Diameter	Safe Work Load Tension (lbs.)
1/2"	4,500
3/4"	9,000
1"	18,000
1-1/4"	27,000

SWL provides a factor of safety of approximately 2 to 1.

To Order:
Specify: (1) quantity, (2) name, (3) diameter.

Example:
600 pcs. B32 Handle Coil Nut, 1/2" coil thread.

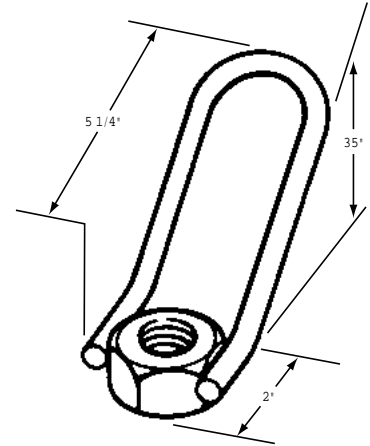

B32 Handle Coil Nut

B33 Double Flared Criss Cross Coil Loop Insert

Dayton Superior B33 Double Flared Criss Cross Coil Loop Insert consists of two flared wire loops welded to a helix coil. B33 inserts are available in 1", 1-1/4" and 1-1/2" diameters and are used in conjunction with the D40 He-Bolt for form anchorage.

B33 Double Flared Criss Cross Coil Loop Insert Selection Chart

Bolt Dia. x Insert Length	Safe Working Load Tension (lbs)	Concrete Strength (psi)	Minimum Edge Distance	Dimensions					
				A	B	C	D	E	F
1" x 12-3/8"	18,000	2,000	15"	12-3/8"	2-1/16"	2-1/16"	.375"	5-9/16"	5-9/16"
1" x 12-1/2"	27,000	2,000	15"	12-1/2"	2 1/4"	2-1/16"	.442"	5-3/4"	5-3/4"
1-1/4" x 12-3/8"	18,000	2,000	15"	12-3/8"	2 5/16"	2-1/16"	.375"	5-9/16"	5-9/16"
1-1/4" x 12-1/2"	27,000	2,000	15"	12-1/2"	2 1/2"	2-1/16"	.442"	5-3/4"	5-3/4"
1-1/2" x 12-3/8"	18,000	2,000	15"	12-3/8"	2 9/16"	2-3/8"	.375"	5-9/16"	5-9/16"
1-1/2" x 12-1/2"	27,000	2,000	15"	12-1/2"	2 3/4"	2-3/8"	.442"	5-3/4"	5-3/4"

SWL are based on 1/2" setback from face of concrete.

SWL provides a factor of safety of approximately 2 to 1.

SWL vary with concrete weight and strength as well as insert setback. For use in other than 2,000 psi normal weight concrete, contact our technical service department.

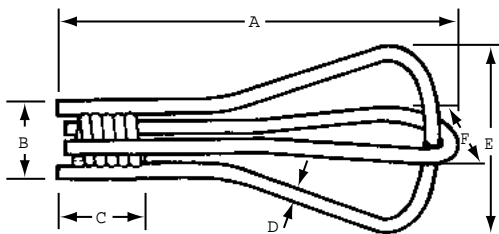

To Order:
Specify: (1) quantity, (2) name, (3) bolt dia. (4) length, (5) safe working load, (6) plain or Electroplated.

Example:
450 pcs. B33 Double Flared Criss Cross Coil Loop Insert, 1" x 12-3/8" long, 18,000 lbs. SWL, plain.

B37 Toggle Tie

Dayton Superior B37 Toggle Tie is used to tie one-sided formwork to steel sheet pilings. The tie requires a 1-3/8" hole in the sheathing to permit entry of the tie. The toggle tie can also be welded to the sheathing. Refer to safety information on the inside front cover concerning welding operations.

The B37 Toggle Coil Tie is available in 1/2" diameter only.

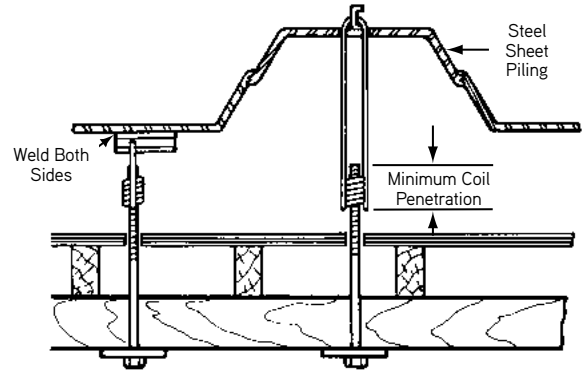
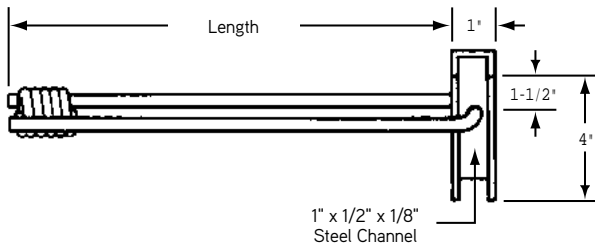

To Order:
Specify: (1) quantity, (2) name, (3) length.

Example:
700 pcs. B37 Toggle Tie, 18-1/2" length.

3,750 lbs.
Maximum Safe Working Load

Medium/Heavy Forming Products

B39 Wing Nut

Dayton Superior B39 Wing Nut is made of ductile iron and can be used for any application requiring quick removal and application of a nut.

B39 Wing Nut Selection Chart

Coil Rod Diameter	Safe Working Load Tension (lbs.)	A	B	C	D
1/2"	9,000	5"	1-1/4"	2-3/8"	1-3/8"
3/4"	18,000	5-7/8"	1-1/4"	2-1/2"	1-3/4"
7/8"	18,000	6"	1-5/8"	2-3/4"	1-3/4"
1"	38,000	6"	1-5/8"	3"	2"
1-1/4"	52,000	5-5/8"	1-5/8"	2-3/4"	2-1/4"
1-1/2"	80,000	6-3/4"	1-7/8"	2-3/4"	2-7/8"

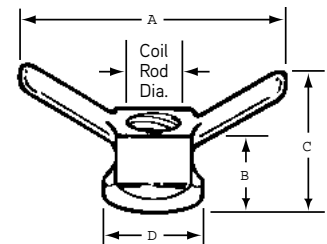

To Order:
Specify: (1) quantity, (2) name, (3) diameter

SWL are based on 1/2" setback from face of concrete.

Note: Wing nuts may vary slightly in configuration from that shown.

B40 Plastic Setback Plug

Dayton Superior B40 Plastic Setback Plugs seal the hole left when Screw-On Cones are removed from the concrete. Plugs are available for use with 1/2" diameter coil ties setback 1" or 1-1/2" from the concrete face, and are stocked in light and dark grey to blend with the natural color of the concrete. Contrasting colors are available on special order.

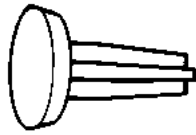

B40 Plastic Setback Plug

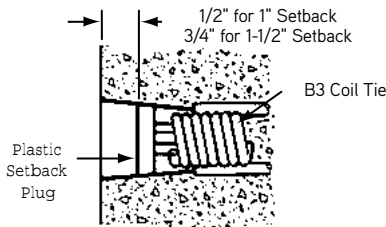

To Order:
Specify: (1) quantity, (2) name, (3) color.

Example:
2,000 pcs. B40 Plastic Setback Plugs, light gray.

B42 and D22 Batter Washer

Dayton Superior Batter Washers are used when the wales are at an angle to the ties. Permits any angle from 90° to 45°. For use with B39 Wing Nut.

Nail holes are provided for securing to wood form members.

B42 and D22 Batter Washer Selection Chart

Type	Bolt Diameter	Hole Diameter	A	B	C
B42	1/2"	9/16"	3-9/16"	3"	1"
B42	3/4"	7/8"	4-3/4"	4-1/4"	1-9/16"
D22	1"	1-1/16"	6-3/4"	5-1/4"	1-3/4"
D22	1-1/4"-1-3/8"	1-5/8"	6"	7"	1-7/8"
D22	1-1/2"-1-5/8"	1-3/4"	6-1/2"	7-3/4"	2-1/8"

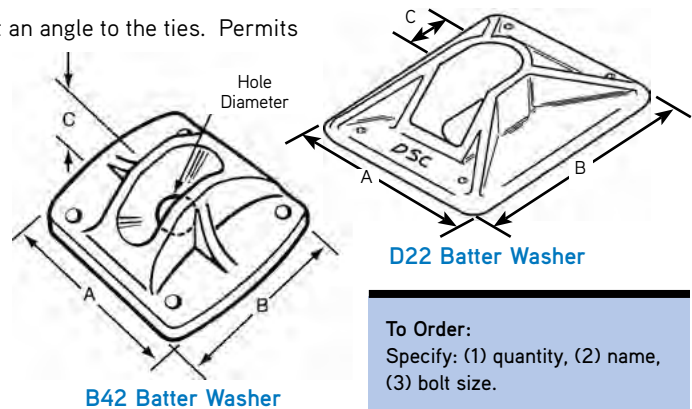

B42 Batter Washer

D22 Batter Washer

To Order:
Specify: (1) quantity, (2) name, (3) bolt size.

Example:
200 pcs. B42 Batter Washer, 3/4" bolts.

B43 Triple Flared Coil Loop Insert

Dayton Superior B43 Triple Flared Coil Loop Insert consists of three flared wire loops welded to a helix coil. B43 inserts are available in 1-1/4" diameter and are used in conjunction with a D40 He-Bolt in form anchorage applications.

B43 Triple Flared Loop Insert Selection Chart

Type	Bolt Dia. x Insert Length	Safe Working Load Tension (lbs.)	Concrete Strength (psi)	Dimensions					
				A	B	C	D	E	F
B43	1-1/4" x 12"/15"	34,000	2,000	15"	2-1/2"	2-1/16"	.440"	5-3/4"	5-3/4"

SWL are based on 6" setback from face of concrete and 32" minimum edge distance. SWL provides a factor of safety of approximately 2 to 1 in normal weight concrete.

SWL vary with concrete weight and strength as well as insert setback and minimum edge distance. For use in other than 2,000 psi concrete, contact our technical service department.

To Order:
Specify: (1) quantity, (2) name, (3) length.

Example:
500 pcs. B43 Triple Flared Coil Loop Insert, 12" long.

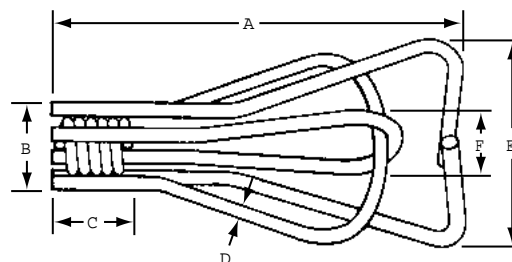

D1 and D18 Inside Tie Rods

Inside tie rods are used with she-bolts to provide a highly adaptable forming system. The inside tie rods are made from high carbon steel with coil threads. National coarse threads can be provided on special order.

The correct inside tie rod length is determined by subtracting the total required setback (both sides) from the wall thickness. Flats are available to prevent turning of the inside tie rods in the concrete and are recommended for wall thickness of 24" or less.

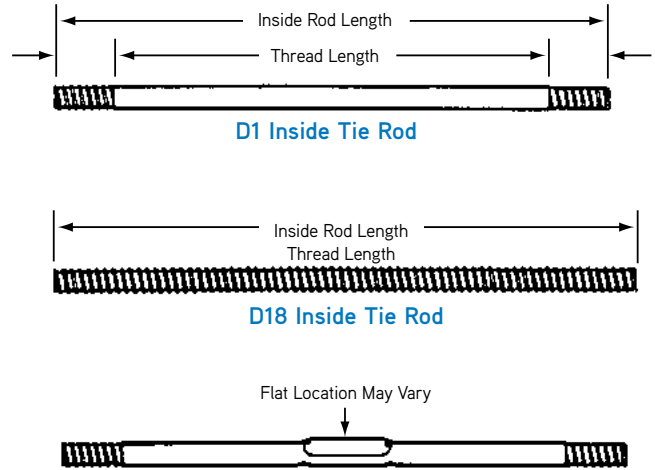

To Order:

Specify: (1) quantity, (2) name, (3) diameter (4) O.A. length, (5) with flat or crimp.

Example:

800 pcs. D1 Inside Tie Rod with Coil Threads, 3/4" diameter, 22" long, with flat.

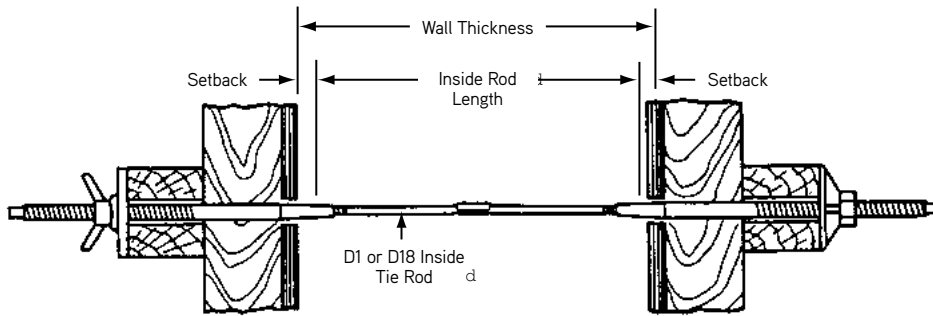

D1 and D18 Inside Tie Rod Selection Chart

Type	Safe Working Load Tension (lbs)	Inside Tie Rod			Dimensions	
		Thread Diameter	Thread Type	Thread Length	Minimum Length	Maximum Length
D1	9,000	1/2"	N.C. or Coil	1-1/4"	5", 6" with flat	20'-0"
D18	9,000	1/2"	Coil	Continuous	5"	20'-0"
D1	12,000	5/8"	N.C. or Coil	1-3/4"	5", 6" with flat	12'-0"
D18	12,000	5/8"	Coil	Continuous	5"	20'-0"
D1	18,000	3/4"	N.C. or Coil	1-3/4"	5", 6" with flat	12'-0"
D18	18,000	3/4"	Coil	Continuous	5"	20'-0"
D1	38,000	1"	N.C. or Coil	2-1/4"	5", 6" with flat	
D18	38,000	1"	Coil	Continuous	5"	

SWL provides a factor of safety of approximately 2 to 1.

7/8", 1-1/8", 1-1/4" and 1-1/2" and D18 Inside Rods are available on special order.

See D33 for water resistant washer for D1 Inside Tie Rods.

D1J, D1LA and D1L Hook Bolts

Hook Bolts are used with She-Bolts in concrete forming applications. The standard hook wraps around rebar or other steel to allow for blind wall forming.

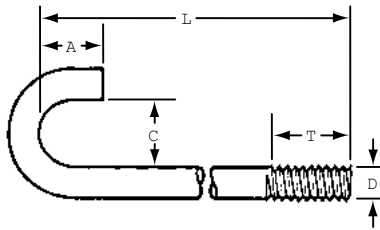

D1J Hook Bolt, Round Bend
(L, C, A, T)
Available with 1/2", 5/8", 3/4", or 7/8"
Coil or NC threads

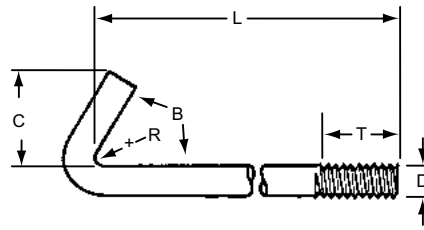

D1LA Hook Bolt, Special
(L, C, A, R, B)
B expressed in degrees

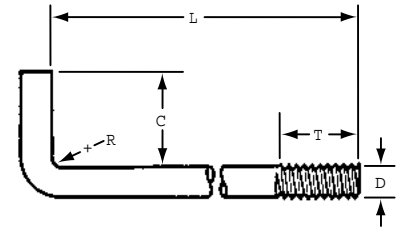

D1L Hook Bolt Right Angle Bend
(L, C, T, R)

Hook Bolt Selection Chart

D Coil Thread Diameter	NC Thread Diameter	Minimum T	Minimum AISI Number (Ref.)
1/2"	1/2"	1"	1018
3/4"	3/4"	1-1/2"	1018

To Order:

Specify: (1) quantity, (2) name, (3) thread type, (4) then dimensions of the bent bolt in the order indicated by the dimension letters in brackets below each illustration.

Example:

500 pcs. D1J Hook Bolt, Round Bend 1/2" coil thread, L = 12", C = 1-1/2", A = 3", T = 1", and R = 3/4".

D1S Anchor Bolt Sleeve

Dayton Superior D1S Anchor Bolt Sleeve allows one size sleeve to accommodate two or more anchor bolt diameters. The unique high-density polyethylene plastic design provides flexibility and reduces inventory requirements. If sizing is required, simply cut the sleeve at the gage line as shown.

Anchor Bolt Sleeves provide a grout pocket around the anchor bolt to allow the bolt to be positioned exactly. They provide a quick, easy way to make final adjustments and a clean pocket for grouting at lower cost than other methods.

D1S Anchor Bolt Sleeve Sizes and Color Code

Color Code	Shell Size (in.)	Bolt Diameter
Yellow	2 x 5	1/2", 3/4"
White	2 x 7	5/8", 3/4", 7/8"
Green	3 x 10	1", 1-1/4"
Red	4 x 15	1-1/2", 1-3/4"
Blue	4 x 18	2", 2-1/4"
Brown	6 x 24	2-1/2", 3"
Black	6 x 24	4", 5"

To Order:

Specify: (1) quantity, (2) name, (3) shell size.

Example:

100 pcs. D1S Anchor Bolt Sleeve,
2" x 7" shell size.

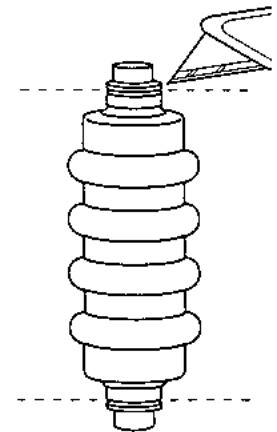

D2 and D30 She-Bolts

Dayton Superior D2 and D30 She-Bolts are heavy duty, reusable form ties for medium and heavy concrete construction. The D2 She-Bolt has a 3/4" diameter and is equipped with Acme thread. The D30 She-Bolt has coil thread and is available in 3/4" through 1-5/8" diameters in 1/8" increments. She-Bolts are used in conjunction with D1 or D18 Inside Rods to form tie a wide range of formwork thickness.

D2 and D30 She-Bolt Selection Chart

Type	Safe Working Load (lbs)	She-Bolt External Thread		Inside Tie Rod		A	B	C	D	E	L	External Hardware Required
		Diameter	Type	Thread Diameter	Type							
D2	9,000	3/4"	Acme	1/2"	NC	5/8"	1/2"	1-1/4"	3/4"	3"	20"	3/4" Dia. D6
D30	9,000	7/8"	Coil	1/2"	Coil	1"	1/2"	1-1/2"	7/8"	2-3/4"	18" 20" 24"	7/8" Dia B27 or B39
D30	12,000	7/8"	Coil	5/8"	Coil	1"	1/2"	1-1/2"	7/8"	2-3/4"	18" 20" 24"	7/8" Dia. B39
D30	18,000	1-1/4"	Coil	3/4"	Coil	1"	3/4"	2"	1-1/4"	4"	20" 24" 30" 35"	1-1/4" Dia B39.
D30	37,500	1-1/2"	Coil	1"	Coil	1"	3/4"	2"	1-1/2"	4"	20" 24" 30" 35"	1-1/2" Dia B39
D30	56,000	1-1/2"	Coil	1 1/4"	Coil	1"	3/4"	2-3/4"	1-3/4"	4"	20" 24" 30" 35"	1-1/2" Dia B39

Note: She-Bolts are meant to be reused, but they do wear, so they must be continually inspected. When wear or damage is noted, they must be replaced. SWL provides a factor of safety of approximately 2 to 1.

A water proof grease should be applied to the embedded portion of the she-bolt to facilitate removal.

Standard sizes are listed in the chart, other than standard sizes are available on special order.

Caution: The pitch (threads/inch) of the 3/4" diameter Acme thread varies in certain geographical areas of the United States, please check before ordering.

Medium/Heavy Forming Products

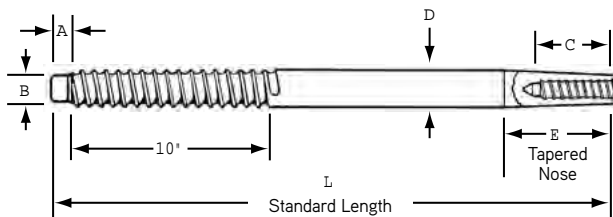

D2, D30 She-Bolt

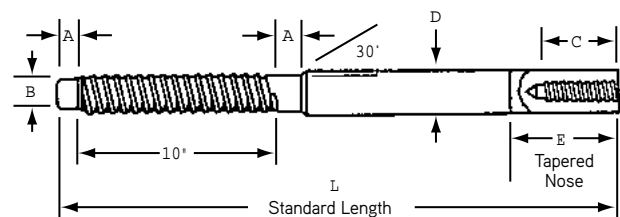

D30 High Strength She-Bolt

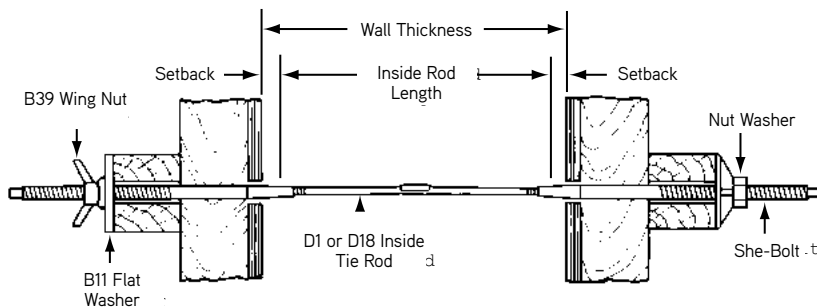

To Order:
Specify: (1) quantity, (2) name, (3) diameter, (4) length, (5) tapped for diameter of inside coil or NC threaded rods.

Example:
200 pcs. D2 She-Bolt, 3/4" diameter, 20", O.A. length, tapped for 1/2" inside rods with coil threads.

D4 Hex Coupling Nut

Dayton Superior D4 Hex Coupling Nuts are used to splice D1 Inside Tie Rods. Threads are right hand national course and will accept standard machine bolts. In order to develop the rated load you must make certain that you have equal engagement of the inside threaded rods or bolts. Hex coupling nut is not provided with a center stop.

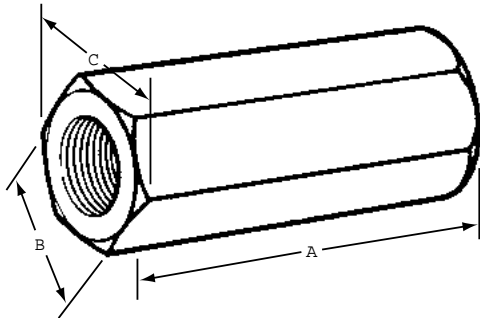

D4 Hex Coupling Nut

D4 Hex Coupling Nut Selection Chart

National Course Thread Dia.	A	B	C	Safe Working Load Tension (lbs.)
3/8"	1-3/4"	5/8"	11/16"	3,750
1/2"	1-3/4"	11/16"	3/4"	9,000
5/8"	2-1/8"	13/16"	1-5/16"	12,000
3/4"	2-1/4"	1"	1-1/8"	18,000
1"	2-3/4"	1-3/8"	1-9/16"	36,000

SWL provides a factor of safety of approximately 2 to 1.

To Order:
Specify: (1) quantity, (2) name, (3) thread diameter.

Example:
2,000 pcs. D4 Hex Coupling Nuts, 1/2" thread.

See D6 Nut Washer information with B27

D9 Taper Ties

Dayton Superior D9 Taper Ties are used where specifications require or permit complete removal of the form tie from the concrete. Standard taper ties are supplied with coil thread in the diameters and lengths shown in the chart. Other lengths are available on special order.

A complete taper tie assembly consists of one taper tie, two flat washers and two appropriate nut devices. Standard taper ties are manufactured with a taper up to 30" in length. Longer tapers are available on special order.

For wrench turning purposes, taper ties are manufactured with a square end. On the opposite end (smaller end) is designed with a protruding nose to prevent thread damage during the removal operation. Coating the taper tie with waterproof grease will facilitate taper tie removal.

Note: Taper ties will wear and get damaged. They must be continually inspected and replaced if wear or damage is noted.

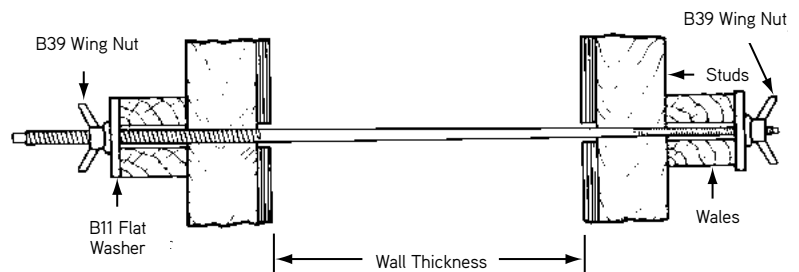

To Order:
Specify: (1) quantity, (2) name, (3) diameter, large and small, (4) O.A. length.

Example:
250 pcs. D9 Taper Ties, 1-1/4" dia. to 1" dia., 54" O.A. length.

D9 Taper Ties Selection Chart

Safe Working Load Tension (lbs.)	Large End of Tie		Small End of Tie		Standard Tie Lengths	Tapered Body Diameter
	Coil Thread Diameter	Length of Thread	Coil Thread Diameter	Length of Thread		
7,500	3/4"	10"	1/2"	2"	34", 43", 52"	.670" to .500"
18,000	1"	10"	3/4"	6"	30", 36", 42", 48", 54", 60", 72"	.884" to .750"
34,000	1-1/4"	10"	1"	6"		1.113" to 1.00"
50,000	1-1/2"	10"	1-1/4"	6"		1-1/2" to 1-1/4"
75,000 H.S.	1-3/4"	10"	1-1/2"	6"	36", 48", 60", 72"	1-3/4" to 1-1/2"

SWL provides a factor of safety of approximately 2 to 1.

D9A D/R Thread Bar Taper Tie

Dayton Superior D/R Thread Bar Taper Ties (D9A) are used when specifications require or permit complete removal of the form tie from the concrete. The D9A features the D/R Thread Bar's 2-1/2 threads per inch for rapid installation and stripping. Standard 5/8" and 7/8" diameter taper ties are available in the sizes shown in the chart. See B12A D/R Thread Bar.

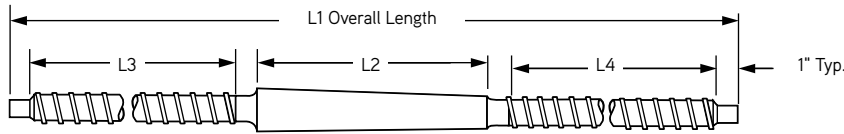

D9A D/R Thread Bar Taper Tie

To Order:
Specify: (1) quantity, (2) name, (3) diameter, (4) overall length, (5) L3 and/or L4 lengths, if other than standard.

Example:
250, D9A D/R Thread Bar Taper Ties, 7/8" dia. X 66" overall length.

D9A 5/8" Taper Tie

Taper	L1	L2	L3**	L4**	Safe Working Load
1" to 5/8"	42"	16"	11-1/2"	11-1/2"	18,750 lbs.
	50"	24"			
	58"	32"			

*Safe Working Load based on approximate 2 to 1 safety factor
** Standard thread length shown, other lengths available on request.

D9A 7/8" Taper Tie

Taper	L1	L2	L3**	L4**	Safe Working Load
1-1/4" to 7/8"	42"	16"	11-1/2"	11-1/2"	32,500 lbs.
	50"	24"			
	58"	32"			
	66"	40"			

*Safe Working Load based on approximate 2 to 1 safety factor
** Standard thread length shown, other lengths available on request.

Medium/Heavy Forming Products

D12 Rod Clamps

Dayton Superior D12 Rod Clamps are cast malleable iron clamps used with smooth or deformed 1/4", 3/8" and 1/2" rod to tie forms. The rod is clamped securely by a bolt or nut/bolt combination. Nail holes are provided to affix the clamp to the wales. For an additional safety measure, Dayton Superior recommends bending the rod approximately 90° behind the clamp (See application sketch)

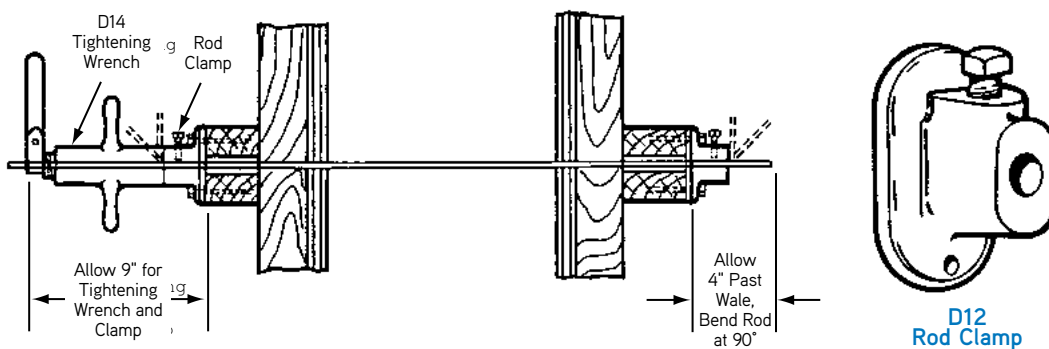

D12 Rod Clamp

D12 Rod Clamp Selection Chart

Type	Rod Diameter	Safe Working Load Tension (lbs.)
D12	1/4"	1,125
D12	3/8"	2,250
D12	1/2"	3,750

SWL provides a factor of safety of approximately 2 to 1.

To Order:
Specify: (1) quantity, (2) name, (3) size.

Example:
500 pcs. D12 Rod Clamp, 1/4".

D12A Pencil Rod

Dayton Superior D12A Pencil Rod is available in 0.25" and 0.375" mild steel smooth rod for use with Dayton Superior Rod Clamps. Pencil Rod is available in 100 feet coils or straightened and cut to length.

Minimum ultimate load is 2,400 lbs for 0.25" diameter Pencil Rod and 6,800 lbs for 0.375" diameter Pencil Rod.

To Order:
Specify: (1) quantity, (2) name, (3) diameter.

Example:
2 coils, D12A Pencil Rod, .225" diameter.

See D12 Rod Clamp for SWL

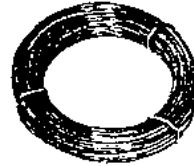

D12A Pencil Rod

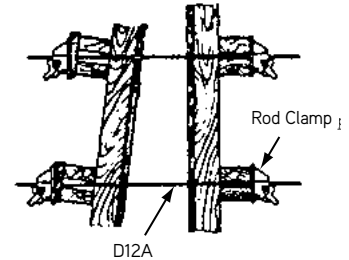

D12F Form Clamp

Dayton Superior D12F Form Clamp is available in one size to handle all smooth and deformed rod diameters from 1/4" to 3/8". This strong and versatile clamp is used effectively on all types of forming requirements, especially suited for battered or curved wall applications.

D12F Form Clamp Selection Chart

Rod Size	Approx. Safe Working Load
1/4"	1,250
3/8"	3,000

SWL provides a factor of safety of approximately 2 to 1.

To Order:
Specify: (1) quantity, (2) name, (3) size.

Example:
500 pcs. D12F Form Clamp, 3/8"

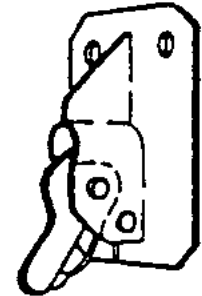

D12F Form Clamp

D14 Tightening Wrench

Dayton Superior Tightening Wrench is placed over a smooth or deformed rod behind a rod clamp and is used to draw the assembly tight allowing the clamp to be properly tightened. The D14 wrench is available in 1/4" size.

Caution: Do not use the D14 Tightening Wrench for straightening forms or for pulling smooth rod from set concrete.

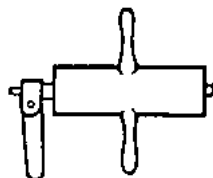

D14 Tightening Wrench

To Order:
Specify: (1) quantity, (2) name, (3) size.

Example:
5 pcs. D14 Tightening Wrench, 1/4".

See D18 Inside Tie Rod with D1 info

D21 Rebar Clip and Form Spreader

Dayton Superior D21 Rebar Clip and Form Spreader was developed to serve as a combination form spreader and rebar spacer when the forming does not provide internal spreading action. The D21 spreader is available for any wall thickness and rebar cover. It will assure walls of proper thickness and will increase the speed of placing the rebar. The ends of the spreader are plastic protected to resist corrosion and to prevent marring of the form face.

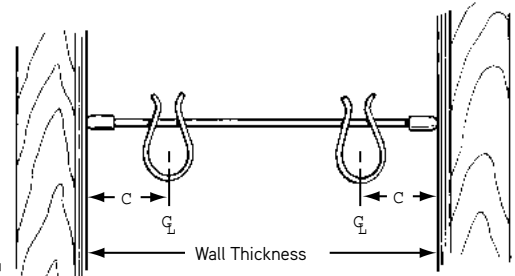

D21 Rebar Clip and Form Spreader
Typical Application

To Order:

Specify: (1) quantity, (2) name, (3) rebar diameter, (4) wall thickness, (5) distance between centerline of rebar and face of concrete.

Example:

See D22 Batter Washer with B42

D24 Weld Angle Bracket

Dayton Superior D24 Weld Angle Bracket is designed to tie one sided forming to steel piles, metal beams, weld plates, etc. The pivot pin is furnished with coil or D/R thread, NC thread is available on special order.

The D24 allows the form tie a pivot range of 110° (55° each direction) and exceeds the tensile capacity of the form tie when properly installed by a certified welder. See safety note concerning welding inside back cover.

Warning: To insure proper thread engagement the form tie must penetrate beyond the pivot bar a minimum of one diameter (the diameter of the form tie being used). An easy way to accomplish this is to position the form tie perpendicular to the piling and thread it through the pivot bar until it contacts the piling.

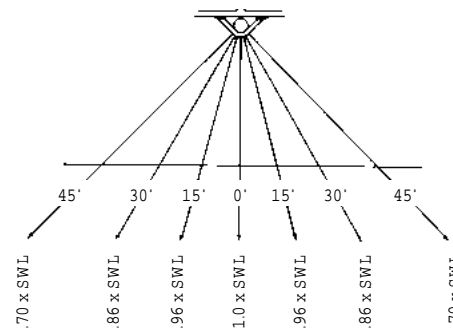
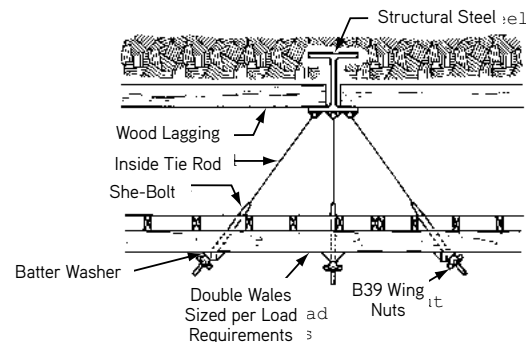
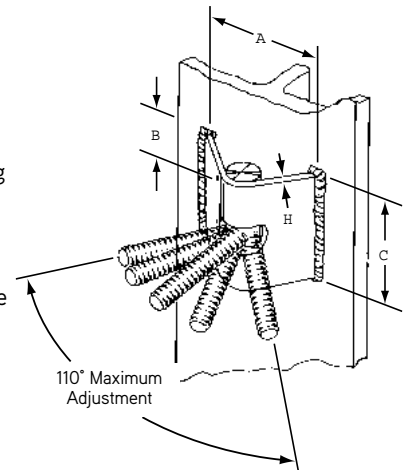

D24 Weld Angle Bracket Selection Chart

Coil Thread Diameter	Maximum Safe Working Load Tension (lbs.)*	A	B	C	H
1/2"	9,000	6"	2-1/4"	4"	.250"
5/8"	10,500	6"	2-1/4"	4"	.250"
3/4"	18,000	6"	2-1/4"	4"	.250"
7/8"	25,000	6"	2-1/4"	4"	.250"
1"	31,500	6"	3-1/16"	5"	.375"
1-1/8"	42,500	6"	3-1/16"	5"	.375"
5/8" D/R	22,400	6"	2-1/4"	4"	.250"
7/8" D/R	39,200	6"	3-1/16"	5"	.250"

*Actual SWL depends on the strength of the field weld, coil rod used and angle between the coil rod and the weld plate.

D25 Fitting Up Bolt and D26 Fitting Up Nut

Dayton Superior Special Fitting Up Bolts and Nuts are used for securing steel form panels together—available in 3/4" diameter x 2" long. The tapered nose of the bolt acts as a draft pin and helps align the forms. The thread design and clearances between the nut and bolt permits quick assembly and dismantling of the forms. The open thread design permits concrete to be easily knocked out of the threads.

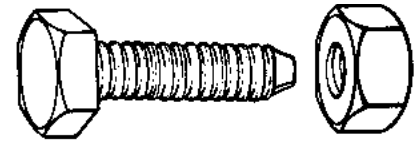

D25 Fitting Up Bolt

D26 Fitting Up Nut

D25 Fitting Up Bolt and D26 Fitting Up Nut

Item	Diameter	Length	Grade	Packaging
D25 Bolt	3/4"	2"	SAE Grade 5	Sold only in sets of 400 pcs.
D26 Nut	3/4"	-	ASTM A194 Grade 2H	

To Order:
Specify: (1) quantity, (2) name.
Example:
800 pcs. D25 Fitting Up Bolts and D26 Fitting Up Nuts.

D27 Lag Bolt

D27 Lag Bolt is designed to provide a temporary means of attaching formwork to wood timbers. Typical application is one-sided blind forming against steel soldier piles with wood lagging. Safe Working Load is approximately 1,700 lbs. (treated wood) and 2,500 lbs. (untreated wood) with 2:1 safety factor. SWL depends on quality of lumber. Lag bolts should have full thread engagement to carry the required load.

Product Code	Diameter	Length	Thread	Weight
143551	3/4"	5" LONG	1/2" NC Thread	0.51 LB

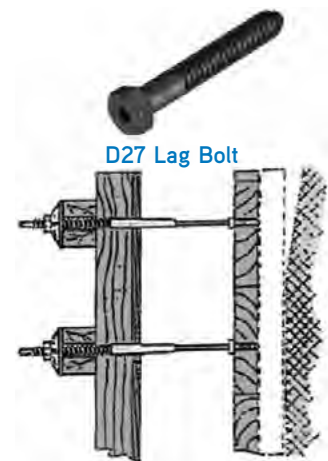

Typical Application

D30A D/R Thread Bar She-Bolt

Dayton Superior D/R Thread Bar She-Bolts (D30A) are heavy duty, reusable form ties for medium and heavy concrete construction. The D30A features the D/R Thread Bar's 2-1/2 threads per inch for rapid installation and stripping. Two She-Bolts are used with a length of B12A D/R Thread Bar to tie formwork for any wall thickness. D30A She-Bolts are available in the sizes and lengths shown in the chart. Other sizes available on request.

D30A 5/8" and 7/8" She-Bolts

Nom. Size	Overall Length	D	L1	L2	Taper	Safe Working Load
5/8"	18" or 24"	3/4"	7-3/4"	4"	1" to 7/8"	22,400
5/8"	18" or 24"	1-1/4"	7-3/4"	4"	1-1/4" to 1-1/8"	
7/8"	18" or 24"	1-1/2"	7-3/4"	4"	1-1/2" to 1-3/8"	39,200

*SWL provides a factor of safety of approximately 2 to 1.

To Order:

(1) quantity, (2) name, (3) diameter, (4) nominal size, (5) overall length, (6) taper.

Example:

200, D30A D/R Thread Bar She-Bolts, 5/8" nom. size with 1-1/4" to 1-1/8" taper.

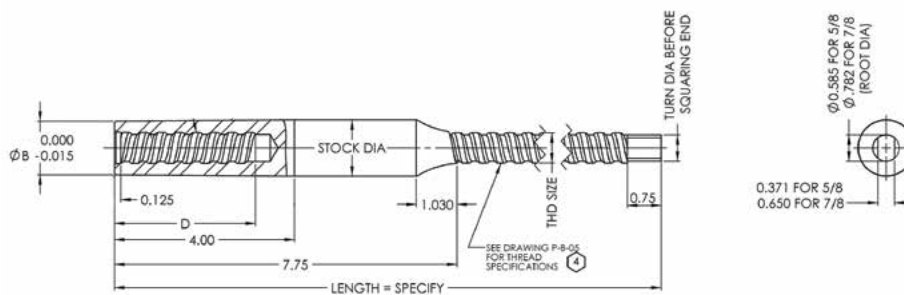

D30A D/R Thread She-Bolt

Medium/Heavy Forming Products

D32 Closed Coupler

Dayton Superior D32 Closed Coupler is available with coil threads for use with D1 and D18 Inside Tie Rods or B12 Coil Rod. The coil threads have been tapped from each end of the coupler providing a positive stop at the center of the coupler. In order to develop the rated load, the inside tie rods or coil rods must be threaded into the coupler until they reach the stop. Other sizes are available on special order.

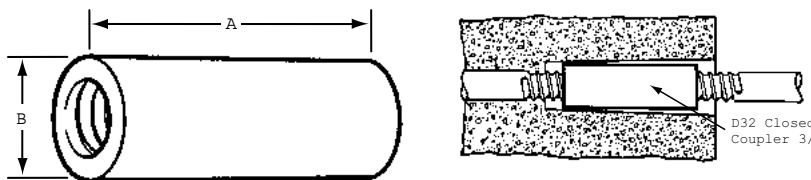

D32 Closed Coupler

D32 Closed Coupler Selection Chart

Coil Thread Diameter	Length A	Dia. B	Safe Working Load Tension (lbs.)
1/2"	2-3/4"	3/4"	9,000
5/8"	3-1/4"	1"	12,000
3/4"	3-1/4"	1-1/8"	18,000
7/8"	4-1/4"	1-3/8"	31,000
1"	4-1/2"	1-1/2"	37,500
1-1/8"	5-1/4"	1-3/4"	45,000
1-1/4"	5-3/4"	1-7/8"	56,000
1-1/2"	7"	2-1/8"	67,500

SWL provides a factor of safety of approximately 2 to 1.

Unique Application

A D32 Closed Coupler for 3/4" diameter inside tie rod will engage a tie rod in the cavity left by a she-bolt. Can be used for anchorage or to form a second pour.

D33 Water Resistant Washer

Dayton Superior D33 Water Resistant Washers are neoprene washers used on D1 Inside Rods to break the continuity of the tie to help eliminate water seepage along the tie.

Generally specified when she-bolts are used to form water containment structures.

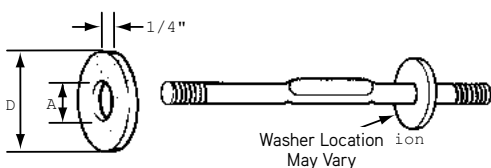

D33 Water Resistant Washer

D33 Water Resistant Washer Selection Chart

Inside Tie Rod Diameter	"A"	"D"
1/2" Coil	0.397"	1"
5/8" Coil	0.5	1.25"
5/8" Euro Bar	0.5	1.25"
5/8" D/R Bar	0.563	1.5"
3/4" Coil	0.625"	1.5"
7/8" Coil	0.75	1.5"
7/8" D/R Bar	0.75	1.5"
1" Coil	0.84"	1.5"
1-1/4" Coil	1.085	1.75

D40 He-Bolts

Dayton Superior D40 He-Bolts provide an economical and flexible anchoring system for use with cantilevered forms in mass concrete construction. Lifts of 5 to 10 ft. can be economically anchored without changing hardware. He-Bolts are produced with a taper to permit easy removal.

He-Bolts are designed to be reused – however they will wear and must be continually inspected and replaced when wear or damage is noted. A waterproof grease should be applied to that portion of the bolt which will be embedded into the concrete to facilitate removal.

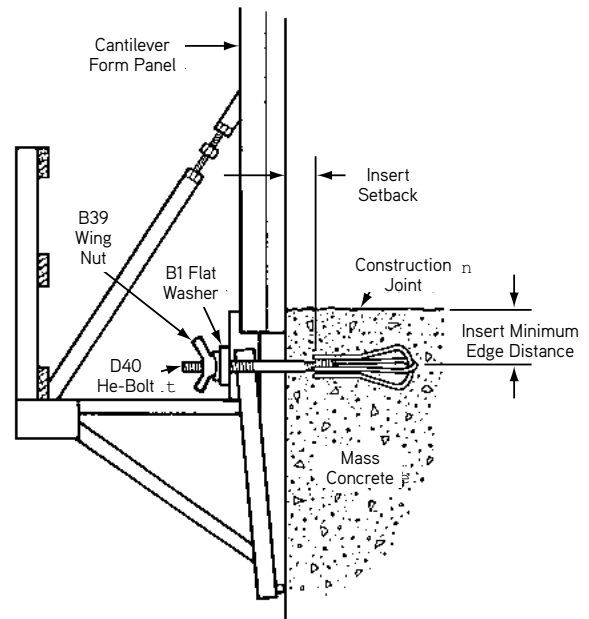

To Order:
Specify: (1) quantity, (2) name, (3) diameter, (4) O.A. length, (5) required T dimension.

Example:
500 pcs. D40 He-Bolts, 1-1/4" diameter, 28" long, T=10".

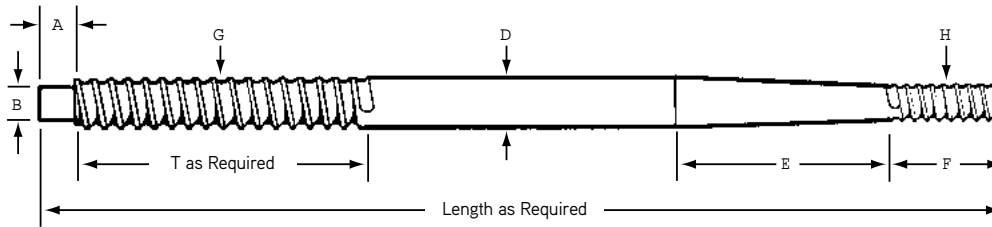

D40 He-Bolts

D40 He-Bolt Selection Chart

Size	Maximum Safe Working Load Tension (lbs.)	Maximum H Diameter Safe Working Load Shear (lbs.)	A	B	D	E	F	Coil Thread Diameter G	Coil Thread Diameter H
1-1/4"	34,000	22,600	1"	3/4"	1-1/4"	5"	3-1/2"	1-1/4"	1"
1-1/2"	50,000	33,300	1"	1"	1-1/2"	5"	3-1/2"	1-1/2"	1-1/4"

SWL provides a factor of safety of approximately 2 to 1.

Typical He-Bolt Anchors

These Dayton Superior anchors are effectively used in conjunction with the D40 He-Bolt to anchor cantilever forms. The B18 Single Flared Coil Loop Insert is recommended for 5' lifts, the B33 Double Flared Coil Loop Insert is recommended for 5' to 7-1/2' lifts and the B43 Triple Flared Coil Loop Insert is recommended for 7-1/2' to 10' lifts.

- See B18 Single Flared Coil Loop Insert.

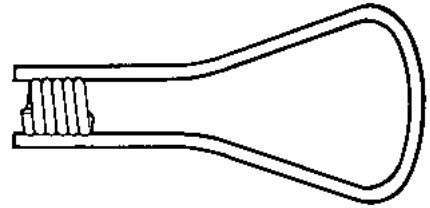

B18 Single Flared Coil Loop Insert

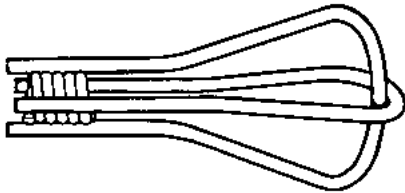

B33 Double Flared Coil Loop Insert

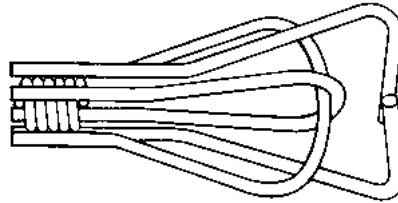

B43 Triple Flared Coil Loop Insert

- See B33 Double Flared Coil Loop Insert.
- See B43 Triple Flared Coil Loop Insert.

To Order:

Specify: (1) quantity, (2) name, (3) bolt diameter, (4) length, (5) safe working load, (6) finish (plain or Electroplated).

Example:

450 pcs. B18 Single Flared Coil Loop, 1" x 9"

Special He-Bolt Inserts

Special inserts can be manufactured to meet your unusual forming requirements. Please contact a Dayton Superior Technical Service Department with your requirements. Several special inserts that have been developed are shown below.

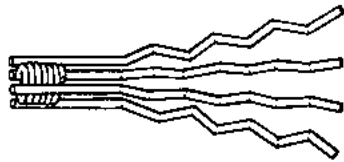

**B7 Two Strut
B22 Four Strut**



**B34-4
Four Strut**

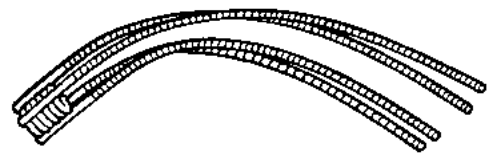

**Four Strut
Draped Insert**

Medium/Heavy Forming Products

D42 Bag Ties

Dayton Superior Bag Ties (D42) are 16 gauge, annealed loop-ended wire ties used for tying rebar and other non-construction applications, such as bags and carpet rolls. D42 Bag Ties are available in 4", 5", 6", 7", 8", 10" and 12" lengths. Other lengths and gauges are available on special order. D42 Bag Ties are sold by the bag or pallet only. 4" through 8" lengths are packaged in coils of 1,000 pieces, five coils per bag (5,000 pcs.). 10" and 12" lengths are packaged 2,500 pieces per bag.

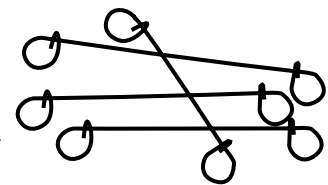

D42 Bag Ties

To Order:
Specify: (1) quantity, (2) name.
Example:
5 bags (25,000 pcs.), D42 Bag Ties.

PC110 Impalement Safety Cap

- Protects workers from protruding rebar
- Impalement protection
- One size fits #4 – #9 rebar
- Safety orange color
- Fully tested and approved (CAL-OSHA #C-1716AG)
- Meets Cal OSHA max. drop test requirements
- Complies with Cal OSHA, Section 1712



PC110
Impalement Safety Cap

D46 Tie Wire

Dayton Superior Tie Wire (D46) is 16 gauge black, annealed wire used for tying rebar or similar applications. D46 Tie Wire is packaged twenty (20) 3-1/2 pound coils per carton (approx. 385 feet per coil). Available only in full cartons or in 48 carton pallets.

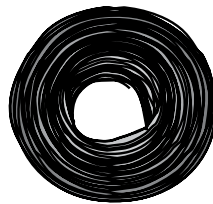

D46 Tie Wire

To Order:

Specify: (1) quantity (sold by carton and/or skid only), (2) name.

Example:

5 cartons, D46 Tie Wire

D48 Sure-Guard Rebar Protective Cap

The Dayton Superior D48 Sure-Guard Rebar Protective Caps have been developed to protect workmen from the hazards of protruding rebar. The D48 cap is available in all rebar sizes, and packaged in bags of 50.



D48 Sure-Guard
Rebar Protector

To Order:

Specify: (1) quantity, (2) name, (3) bar size.

Example:

600, D48 Sure-Guard Rebar Protective Caps for #6 rebar.

A58 Sure Plug

The Sure Plug is easily pushed into a hole the specified depth by using the A59 Insertion Tool. The A58 Sure Plug should be installed ONLY with the A59 Insertion Tool. Pushing against the bottom of the blind center hole of the plug forces the plug's oversize body to elongate as it enters the hole. When the pushing force is stopped, the plug elastically returns towards its original diameter creating a high radial pressure against the walls of the hole. When properly installed, the A58 Sure Plug will withstand a hydrostatic pressure equal to approximately a 277 ft. liquid head of water. Test report is available on request.

As the plug is gray colored to blend with concrete, it may be positioned flush with the concrete face, or recessed, depending on the architectural effect desired. Depending on how the A59 insertion tool is adjusted, it will install the plug either flush to the surface or approximately a 1-1/2" maximum depth.

When recessed, the Sure Plugs may also serve as backing for flush or recessed grouting. Ribbs inside the plug are designed to anchor the grout.

A58 Sure Plug is not intended to be installed to the center of a wall and attempts to do so can in most cases rupture the plug.

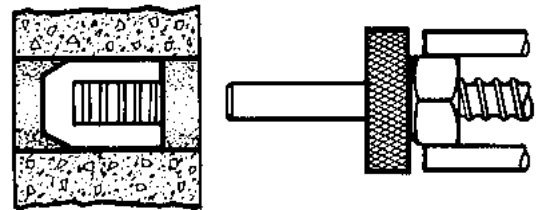
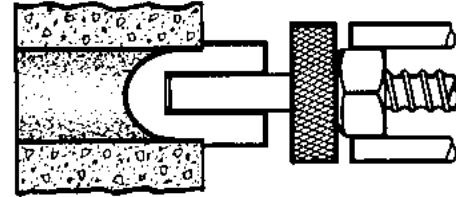
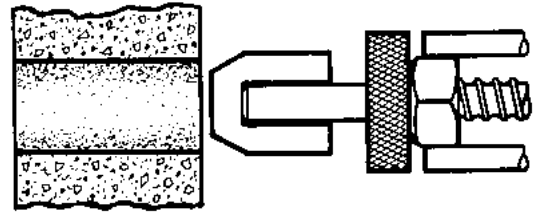

A58 Sure Plug Selection Chart

Plug Size	Nominal Hole Diameter	Plug Length
11	11/16"	1"
14	7/8"	1-1/8"
16	1"	1-1/4"
18	1-1/8"	1-3/8"
20	1-1/4"	1-3/8"
22	1-3/8"	1-1/2"
24	1-1/2"	1-1/2"
28	1-3/4"	1-5/8"
29	1-7/8"	1-5/8"

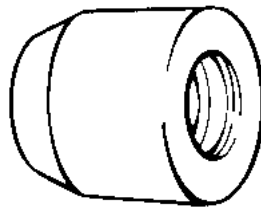

A58 Sure Plug

To Order:
Specify: (1) quantity, (2) name, (3) plug size.

Example:
500 pcs. A58 Sure Plug, size 11.

A59 Insertion Tool

Used to insert A58 Sure Plugs flush with face of concrete or recessed to various depths.

Note: Please specify plug size when ordering insertion tool.

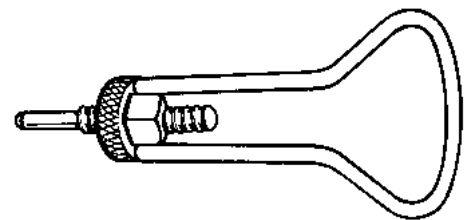

A59 Insertion Tool

To Order:
Specify: (1) quantity, (2) name, (3) plug size.

Example:
20 pcs. A59 Insertion Tool, size 14.

F1 Screw Anchor and F2 Screw Anchor Bolt

F1 Screw Anchors are excellent for re-anchor of forms and have been used for years. The flat wire of the anchor, in full contact with the bolt threads, transfers the load into the surrounding concrete. The screw anchor must be threaded onto the bolt and locked against the skein threads of the bolt by a hard twist. The screw anchor is the most economical insert to use when depth of embedment is available.

The safe working loads shown can only be developed when the assembled bolt and anchor is embedded at least ten times the bolt diameter. If the screw anchor is inserted after the concrete is placed, the concrete must be thoroughly vibrated in order to develop the safe working loads.

CAUTION: The Screw Anchor Bolt is not interchangeable with either a Coil Bolt or National Course Bolts.

For ease of bolt removal, coat screw anchor bolts with a water resistant grease. It is important that the bond between the bolt and concrete be broken by twisting the bolt at least one turn as soon as the concrete has reached a compressive strength of 1,000 to 1,500 psi.

F1 Screw Anchor Selection Chart

Bolt Dia. ASTM A307 with Skein Threads	Safe Working Load (lbs.)		Concrete Strength (psi)	Minimum Edge Distance	Dimensions		
	Tension	Shear			A	B	C
3/4"	8,200	5,400	3,000	9"	4"	3-1/2"	1-1/4"
1"	15,400	10,200	3,000	11"	6"	4"	1-1/2"
1-1/4"	23,000	15,300	3,000	13"	7"	5-1/2"	2"
1-1/2"	35,000	23,200	3,000	17"	8"	7"	2-1/4"

1-3/4" and 2" F1 and F2 are available on special order.
SWL provides a factor of safety of approximately 2 to 1.

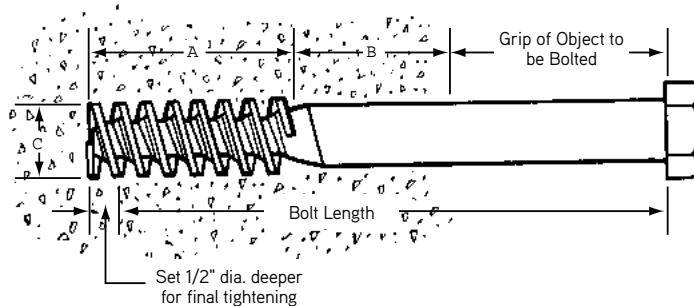

Assembled Bolt and Anchor
(A&B Must Equal Ten Times Bolt Dia.)



F1 Screw Anchor

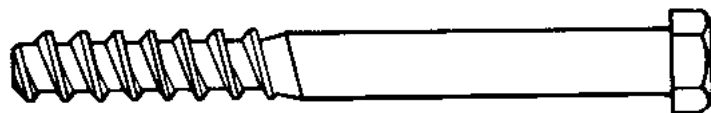

F2 Screw Anchor Bolt

To Order:

Specify: (1) quantity, (2) name, (3) size, (4) finish (Plain or Electroplated).

Example:

1,000 pcs. F1 Screw Anchors, 3/4" diameter, Electroplated.

To Order:

Specify: (1) quantity, (2) name, (3) diameter of bolt, (4) length of bolt, (5) finish (Plain or Electroplated).

Example:

50 pcs. F2 Screw Anchor Bolts, 3/4" diameter, 8" long, Electroplated.

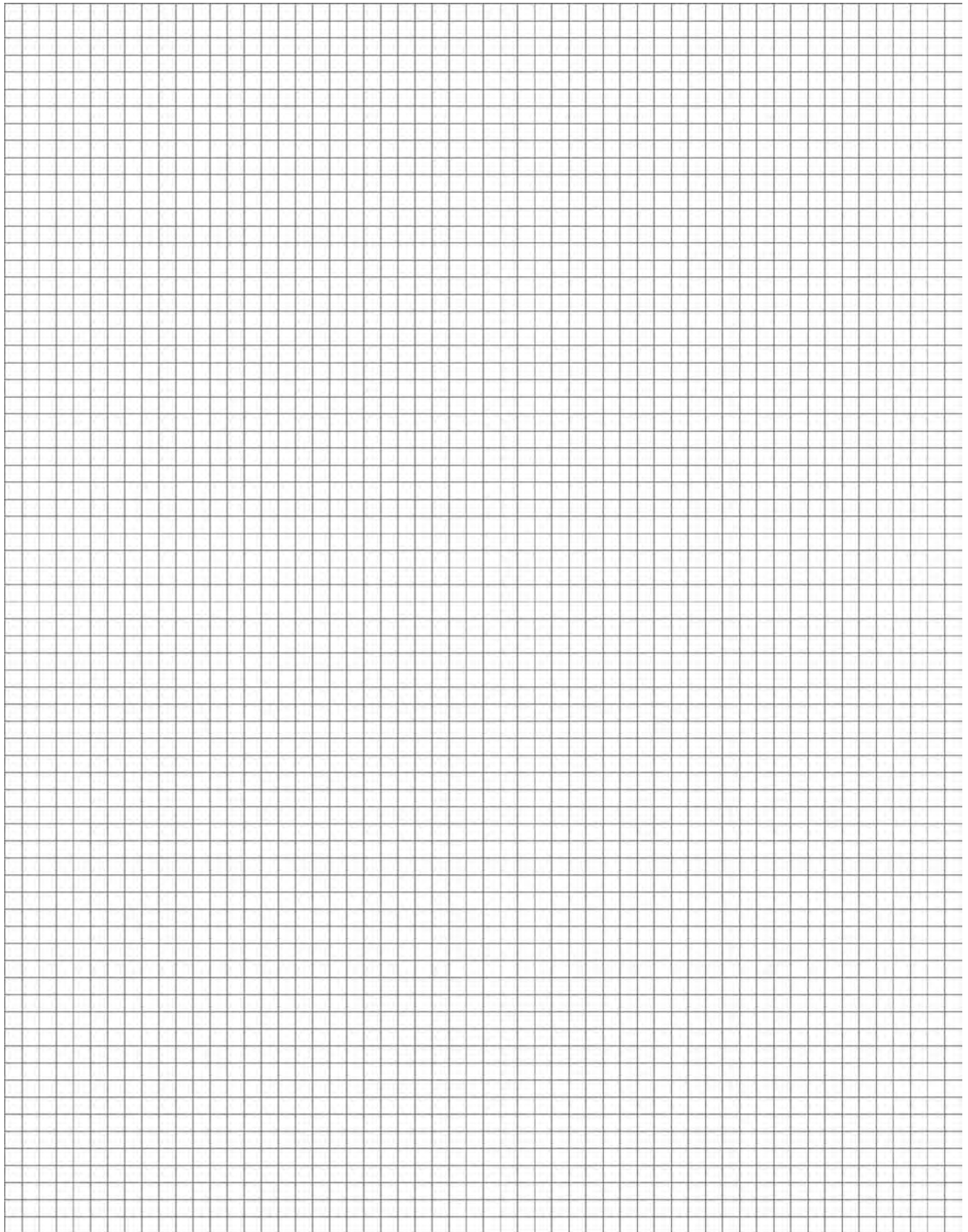

Medium/Heavy Forming Products

C1B and C1C Wedge Hangers

Dayton Superior C1B (with metal spreader washers) and C1C Wedge Hangers (without spreader washers) are standard or heavy snap ties that have been shaped to fit over structural steel beams to support fireproofing formwork. Wedge Hangers are normally furnished with a 1" breakback, other breakbacks are available on special order

When using C1B Wedge Hangers (with spreader washers) A16 Omni Wedges bear on drilled

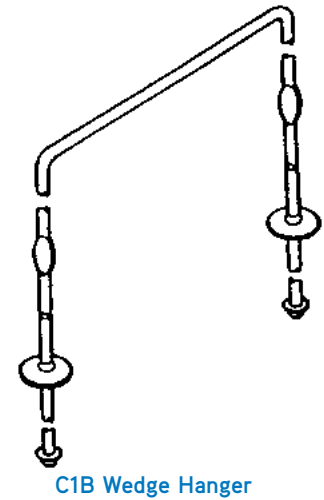
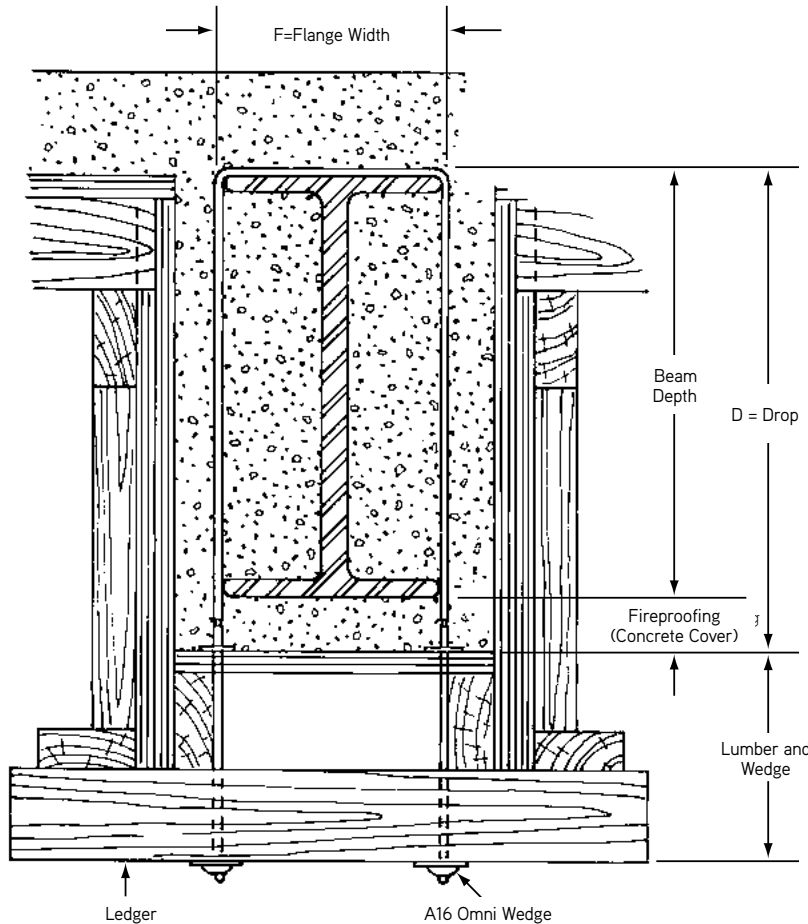

single or double ledgers. This secures the beam bottom against the spreader washers to provide a rigid form and correct depth of fireproofing. C1C Wedge Hangers (without spreader washers) are recommended for use only with soffit spacers.

Warning: Hanger must be equally loaded, on both sides of the beam, to prevent hanger rotation.

Wedge Hanger Selection Chart

Type	Safe Working Load
Standard	1,500 lbs./side
Heavy	2,000 lbs./side

SWL provides a factor of safety of approximately 2 to 1.

To Order:

Specify: (1) quantity, (2) name, (3) flange width, (4) beam depth, (5) fireproofing (cover), (6) lumber and wedge.

Example:

500 pcs. C1B Standard Wedge Hangers, 12" flange width, 36" beam depth, 2" fireproofing, 4-3/4" L&W.

C2 Coil Hanger Saddle Type

Dayton Superior C2 Coil Hanger Saddle Type consists of a two strut coil tie shaped to fit over a structural steel beam to support fireproofing formwork.

Warning: Hanger must be equally loaded, on both sides of the beam, to prevent hanger rotation.

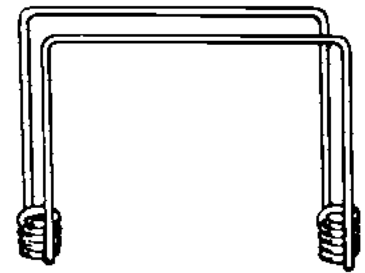

C2 Coil Hanger

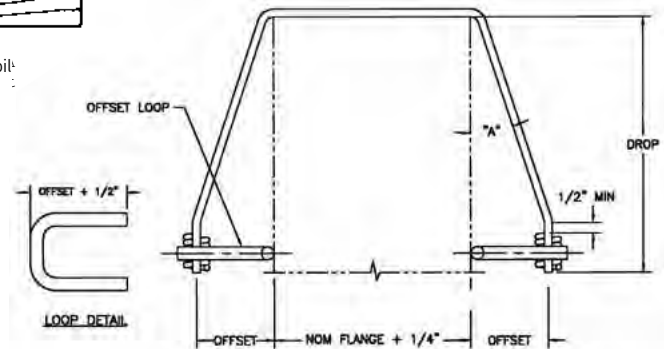
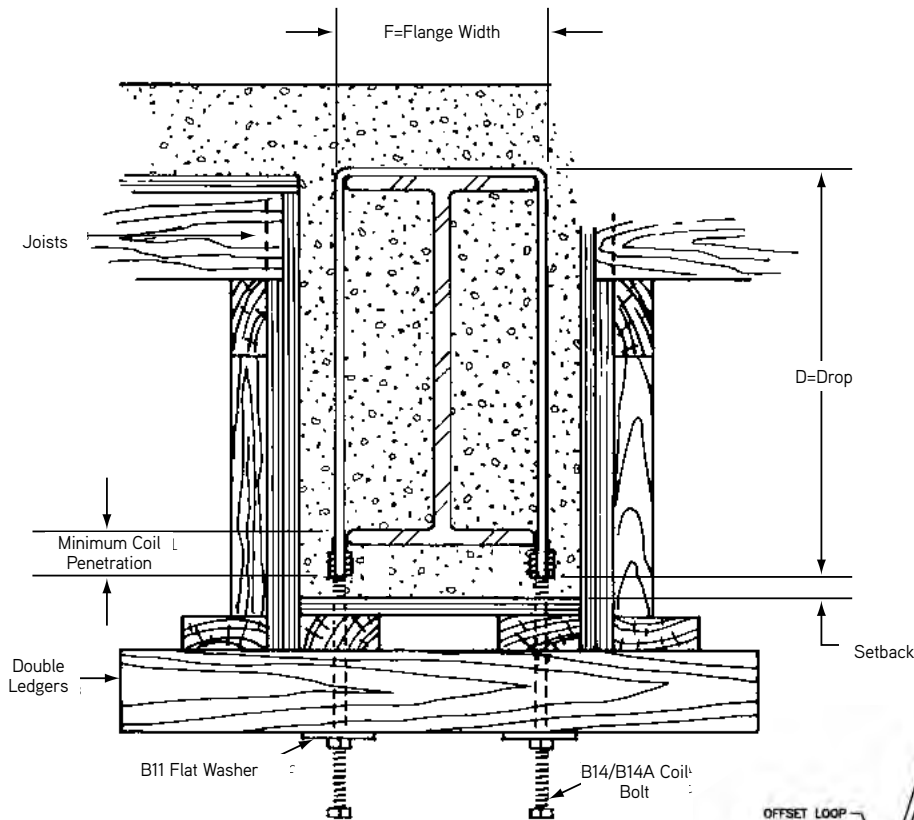

Coil Hanger Selection Chart

Coil Bolt Diameter	Safe Working Load
1/2"	2,250 lbs./side
3/4"	5,625 lbs./side
1"	7,500 lbs./side

SWL provides a factor of safety of approximately 2 to 1.

To Order:

Specify: (1) quantity, (2) name, (3) diameter, (4) flange width, (5) drop, (6) leg angle if special, (7) leg length D1 if special.

Example:

500 pcs. C2 Coil Hangers, 3/4" diameter, 12" flange width, 38" drop/each side.

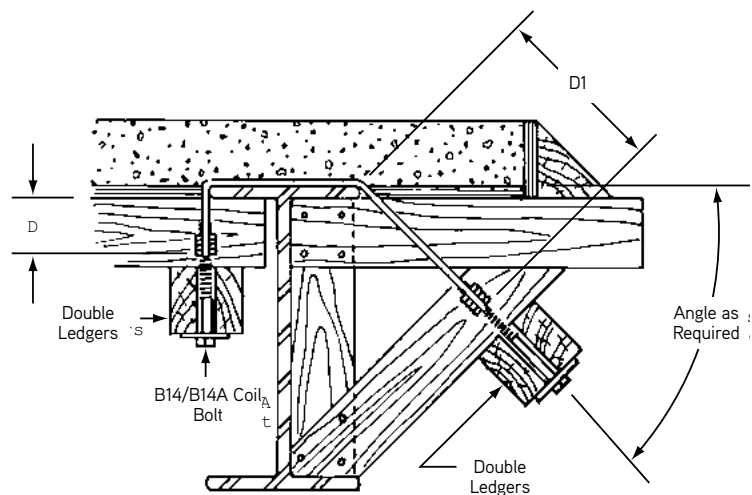

C3 Coil Half Hanger

Dayton Superior C3 Coil Half Hangers are two strut coil hangers used on exterior structural steel beams. The free end is designed to be welded to the beam flange, or if welding is not permitted, can be bent around and back under the beam flange for a distance of approximately 2".

See safety note on inside of cover pertaining to welding.

C3 Coil Half Hangers are designed for light duty loads only. Safe working load is dependent on the strength of bend or field weld. Tests should be conducted in the field to determine actual safe working loads before implementation.

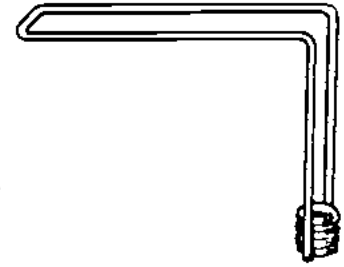

C3 Coil Half Hanger

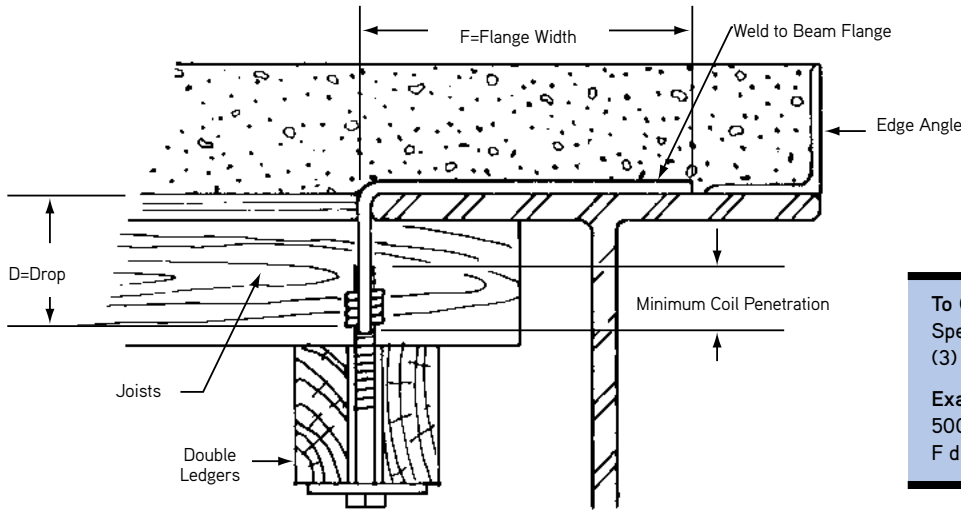

To Order:
Specify: (1) quantity, (2) name, (3) diameter, (4) F dimension, (5) drop.

Example:
500 pcs. C3 Half Hangers, 1/2" dia., 12" F dimension, 6" drop.

C13 Plate Saddle Hanger

Dayton Superior C13 Plate Saddle Hanger is primarily used with steel beam construction but can be used effectively on precast beams and concrete block walls. No working parts or adjustments are required. Just hang the hanger over a beam, insert the joists over the plates and lay plywood. The bearing plates are 1/2" wide and are fixed in position by swaging the wire. Standard plates are available for 2x4 and 4x4 SAS dressed lumber. C13 hangers are available with any drop dimension and any beam width over 2" and with heavy duty 4 gauge wire. C13 hangers are recommended for use with lumber joists only and should not be utilized to support metal joists.

Joist lumber should extend past the hanger bearing support a minimum of 2".

Warning: Hanger must be equally loaded on both sides to prevent unequal loading and resulting rotation of the hanger.

Special Application: This application requires care to ensure adequate lumber bearing on the hanger. Use duplex head nail behind the hanger plate to prevent the joist from slipping off of the hanger plate. Continuous inspection, before and during concrete placement, is required.

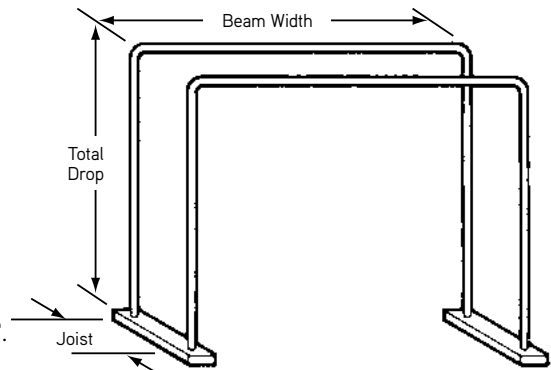

C13 Plate Saddle Hanger

Recommended for use with lumber joists only.

1,500 lbs. for C13

SWL provides a factor of safety of approximately 2 to 1.

To Order:

Specify: (1) quantity, (2) name, (3) flange width, (4) drop, (5) joist lumber.

Example:

1,200 pcs. C13 Plate Saddle Hanger, standard 12" flange width, 8-1/4" drop, 2x lumber.

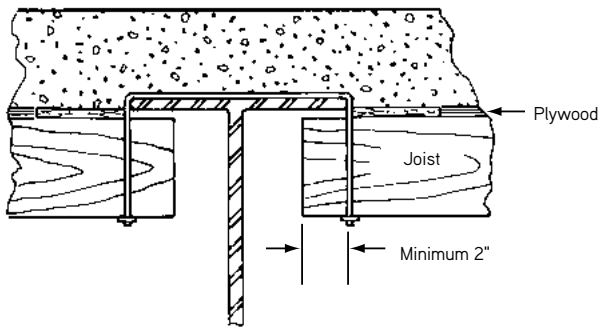

Steel Beam Type

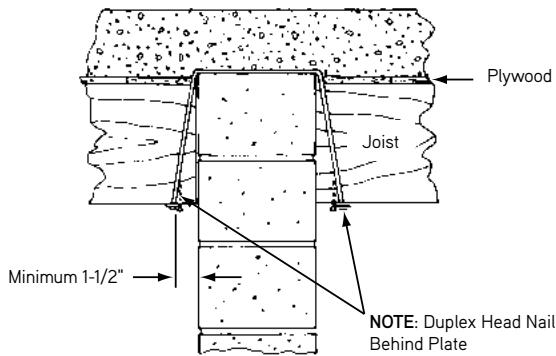

Special Application

C13A All-Wire Saddle Hanger

Dayton Superior C13A All-Wire Saddle Hanger is formed from a single wire and butt-welded over the flange area. Wire sizes, working loads and applications are similar to the C13 hanger, above. The C13A hanger is recommended for lumber joists only. Do not utilize for metals joists. See warning note below.

Warning: Soft wood joists will crush in the area of the wire, even under light loads. Tests show that the wood will crush approximately 1/8" at 300 pounds per side; approximately 1/4" at 500 pounds each side and up to 3/4" at 1,000 pounds each side.

Warning: Hangers must be equally loaded, on both sides of the beam, to prevent rotation of the hanger.

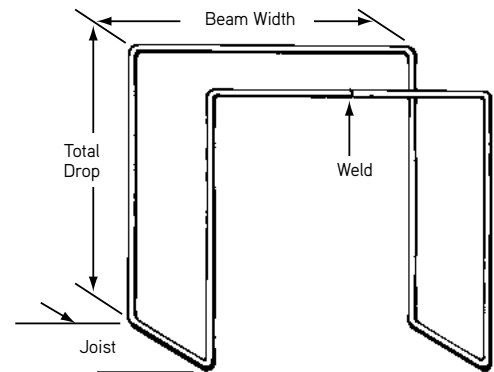

C13A All-Wire Saddle Hanger

To Order:
Specify: (1) quantity, (2) name, (3) wire size, (4) width, (5) drop, (6) joist lumber.

Example:
800 pcs. C13A All-Wire Saddle Hanger,
4 ga., 12" width, 8-1/4" drop, for 4" x 8" joist.

Recommended for use with lumber joists only.

C14 Channel Hanger

Dayton Superior C14 Channel Hanger is similar to the C13 hanger with the exception of channels instead of plates to support the wood joists. The channels increase the safe working load on the hanger and help reduce crushing of the wood. Soft wood joists may crush up to 3/16" at safe working loads.

Warning: Hanger must be equally loaded, on both sides of the beam, to prevent hanger rotation.

Special Application: This application requires care to ensure adequate lumber bearing on the hanger. Use duplex head nail behind the hanger plate to prevent the joist from slipping off of the hanger plate. Continuous inspection, before and during concrete placement, is required..

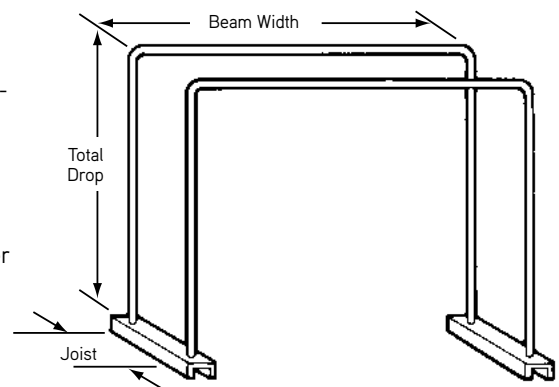

C14 Channel Hanger

2,250 lbs. per side
Safe Working Loads

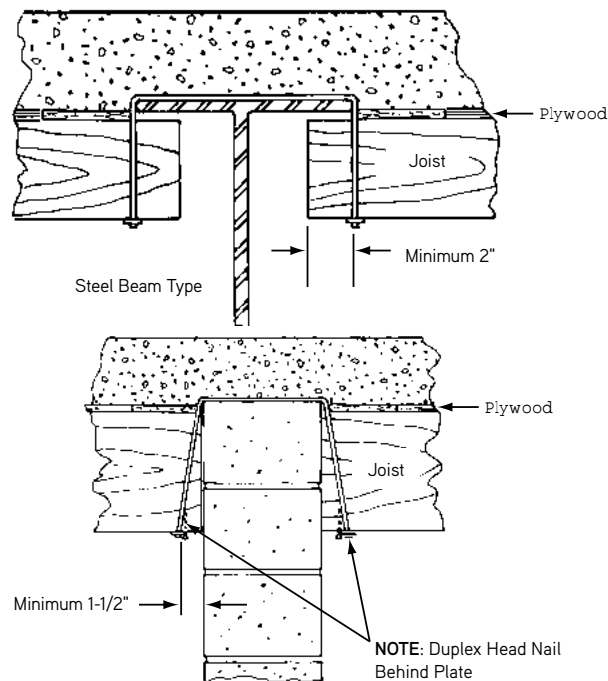

Special Application

To Order:
Specify: (1) quantity, (2) name, (3) width, (4) drop, (5) joist lumber.

Example:
800 pcs. C14A All-Wire Saddle Hanger,
12" width, 8-1/4" drop, for 4" x 8" joist.

SWL provides a factor of safety of approximately 2 to 1.

PAS Aztec® Screed Chair

For elevated slabs and slabs on grade.

- Fits 2x4 lumber or 1-1/2" diameter pipe screeds
- Includes a base, adjustable ring and a screed receiver
- Designed to allow up to ±1" in height adjustment
- 1" O.D. PVC pipe (not included) can be cut to any height
- 300 lb. safe working load compression

PRODUCT CODE	QTY/BOX	WT. LBS. PER BOX
123568	100	17



Methods of Screeding

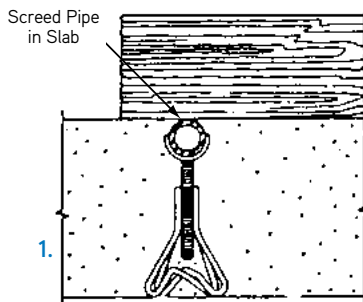

Typical Screed Detail

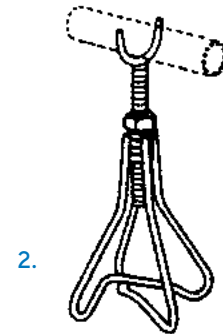
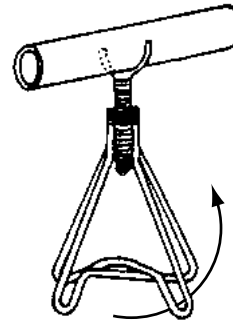

Adjusting to Grade

1. Turn base for final adjustment.
2. Turn coil nut for final adjustment on "free-fit" type bases.

Chair Size Chart

Screed Chair	Dimensions		Cradle Head Adjust. Length in	Slab-1" Pipe		Slab-1-1/2" Pipe		Suggested Working Load less than 1/10" Def. lbs.
	Height in.	Width in.		Min. in.	Max. in.	Min. in.	Max. in.	
G2	1"*	2-3/4"	1"*	2-1/4"	2-3/4"	2-1/4"	2-3/4"	900
	1-1/2"	2-3/4"	1-1/2"	3"	3-1/2"	3-1/2"	4"	900
	1-1/2"	2-3/4"	2-1/2"	3-3/4"	4-1/2"	4-1/4"	5"	900
G2	2-1/2"	3-1/2"	3"	4-1/2"	6"	5"	6-1/2"	800
	3-1/2"	4-1/2"	4"	5-1/2"	8"	6"	8-1/2"	900
	4-1/2"	4-1/2"	4"	6-1/2"	9"	7"	9-1/2"	850
	5-1/2"	4-1/2"	6"	7-1/2"	12"	8"	12-1/2"	800
	7-1/2"	7-1/2"	8"	9-1/2"	16"	10"	16-1/2"	600
	10"	7-1/2"	12"	13-1/2"	22-1/2"	14"	23"	500

*1" Cradle Head accepts 3/4" screed pipe, only.

Spacing Chart

Screed Pipe or Bar	Spacing*			
	Hand Screeding Using 1/2" Diameter Screed Bases		Machine Screeding Using 3/4" Diameter Screed Bases	
	Screed Length	Base Spacing	Screed Length	Base Spacing
3/4" I.D. Pipe	8'-0" to 10'-0"	3'-0" to 4'-0"	-	-
1" I.D. Pipe	8'-0" to 10'-0"	4'-0" to 5'-0"	10'-0" to 12'-0"	2'-0" to 2'-6"
1-1/4" or 1-1/2" I.D. Pipe	10'-0" to 12'-0"	4'-0" to 6'-0"	12'-0" to 15'-0"	2'-6" to 4'-0"
1/2" x 1-1/2" Flat Bar	8'-0" to 10'-0"	3'-0" to 4'-0"	-	-
1-1/4" x 1-1/4" x 3/16" T-Bar	8'-0" to 10'-0"	4'-0" to 5'-0"	-	-
2" x 2" x 1/4" T-Bar	10'-0" to 12'-0"	4'-0" to 6'-0"	12'-0" to 15'-0"	2'-6" to 4'-0"

* Spacings are approximate. Judgement of field conditions, weight of screeds, etc., will control.

G1 Pipe Holder

Dayton Superior G1 Pipe Holder is designed to be used with 1/2" or 3/4" screed chairs to support pipe screed bars. Standard lengths and adjustment ranges are shown in the accompanying table on previous page.

To Order:
Specify: (1) quantity, (2) name, (3) diameter, (4) length.

Example:
800 pcs. G1 Pipe Holder, 1/2" diameter, 4" long

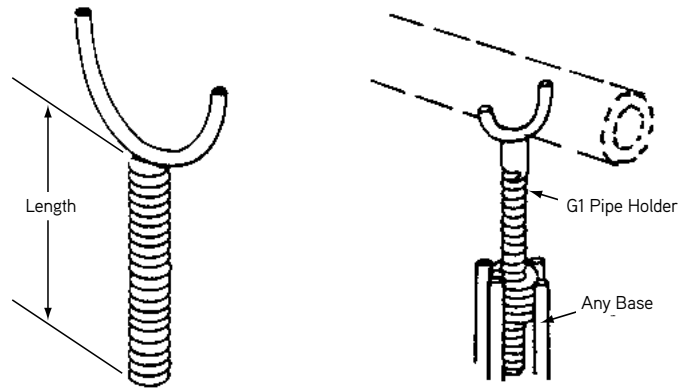

G1 Pipe Holder

G1U Special U-Shaped Cradle Head

Dayton Superior G1U Special U-Shaped Cradle Head is designed for use with a flat screed bar or other similar shapes. G1U holders are available in the same lengths as the G1 holder, above.

To Order:
Specify: (1) quantity, (2) name, (3) diameter, (4) length.

Example:
1500 pcs. G1U Special U-Shaped Cradle Head, 1/2", 6" long.

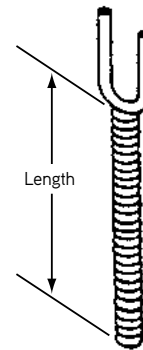

G1U Special U-Shaped Cradle Head

G2 Screed Chair Bases

Dayton Superior G2 Screed Chair Bases are available in two styles in 1/2" and 3/4" nominal diameters. Refer to the chart on previous page for pertinent dimensions. G2 bases are used in conjunction with G1 or G1U cradle heads to support screed pipes or bars.

To Order:
Specify: (1) quantity, (2) name, (3) diameter (4) height.

Example:
2,000 pcs. G2 Screed Chair Bases, 1/2" diameter, 1-1/2" height.

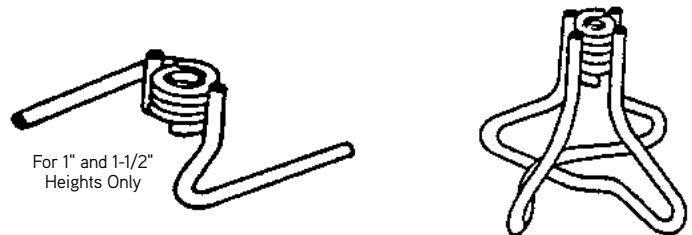

G2 Screed Chair Bases

G2J Joist Type Adjustable Screed Base

Dayton Superior G2J Joist Type Adjustable Screed Base is used with bar joist and rib lath construction. Two of the legs are bent down to penetrate the lath on both sides of the joist while the other two legs rest flat on top of the lath. Standard heights are 1" and 1-1/2". Special heights are available on special order.

To Order:
Specify: (1) quantity, (2) name, (3) diameter, (4) height.

Example:
1500 pcs. G2J Joist Type Adjustable Screed Base, 1/2", 1-1/2" height.

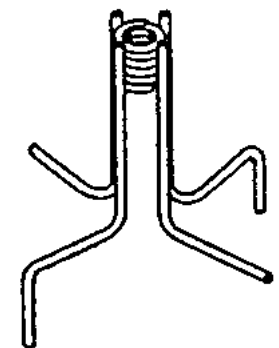

G2J Joist Type Adjustable Screed Base

Flat Slab Forming Products

G2S Special Height Screed Base

Dayton Superior G2S Special Height Screed Base can be fabricated to any desired height over 7". The G2S base is fabricated with substantial wire legs laced together with wire cross-braces. Lacing height (dimension "L") is 2" on bases up to 9" in height and 4" on bases over 10".

To Order:
Specify: (1) quantity, (2) name, (3) diameter, (4) height.

Example:
1500 pcs. G2S Special Height Screed Base, 1/2", 9" height.

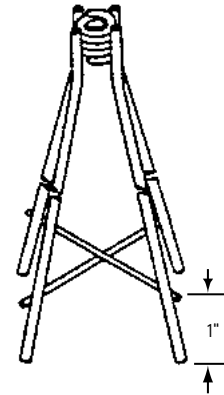

G2S Special Height Screed Base

G3 Screed Chair Base With Sand Plate

Dayton Superior G3 Screed Chair Base with Sand Plate is designed for use on fill dirt over vapor barriers or on special materials that are not to be penetrated.

To Order:
Specify: (1) quantity, (2) name, (3) diameter, (4) height.

Example:
1500 pcs. G3 Screed Chair Base with Sand Plate, 1/2", 6" height.

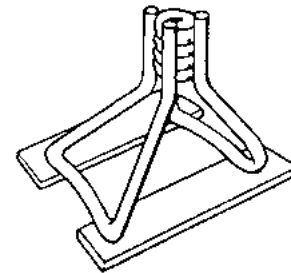

G3 Screed Chair Base with Sand Plate

G4 and G4A Screed Bases, Drive Type

Dayton Superior G4 and G4A Screed Bases, Drive Type are recommended for use on fill where greater bearing is required. The G4 base offers increased stability with extended legs which are driven into the fill. G4 bases are available in standard 2-1/2", 3-1/2", and 5-1/2" heights with taller bases available on special order.

The G4A base is fabricated with heavier wire that allows it to be driven into most sub-grades. The G4A is available in standard 1-1/2", 2-1/2", 3-1/2" and 5-1/2" heights with taller bases available special order.

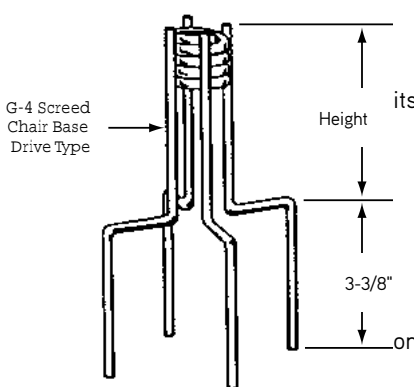

Type G4 Screed Base

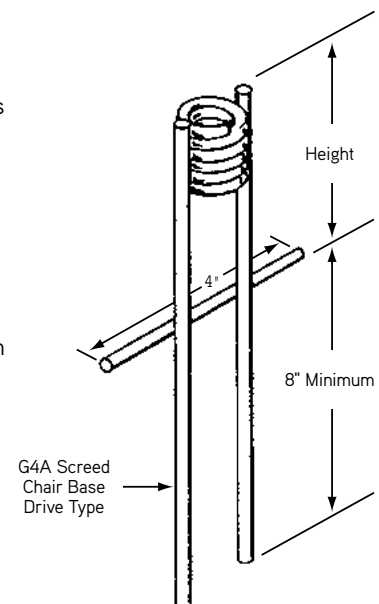

Type G4A Screed Base

To Order:
Specify: (1) quantity, (2) name, (3) diameter, (4) height.

Example:
1500 pcs. G4 Screed Chair Base Drive Type, 1/2", 3-1/2" height.

Flat Slab Forming Products

G5 Screed Bases, Free Fit Type

G5 Screed Bases, Free Fit Type can be furnished with an oversize, slip-fit ferrule. This arrangement allows for adjustment without turning the base or the cradle head. Adjustment is obtained by turning the jam nut.

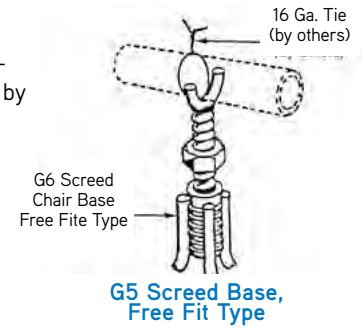

G7 Screed Chair Base for Steel Deck

Dayton Superior G7 Screed Chair Base for Steel Deck is a 1" high screed base designed with wide bearing struts to adequately span the corrugations of metal decking. The G7 base is available in two versions; one spans flush with the lands of the decking while the other sets down into the valley.

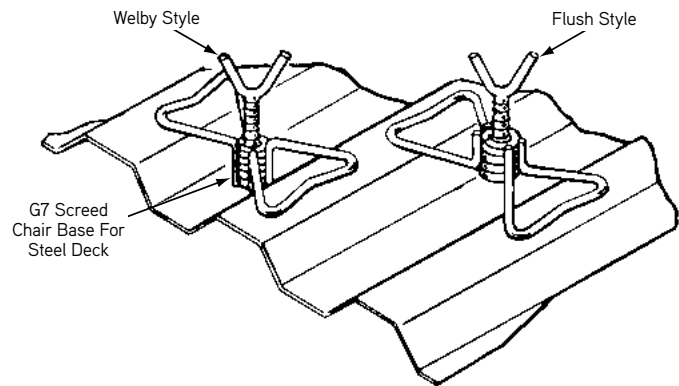

G7 Screed Chair Base Application

To Order:
Specify: (1) quantity, (2) name, (3) style.

Example:
400 pcs. G7 Screed Chair Base for Steel Deck, flush style.

G8 Form Bracket

Dayton Superior Form Bracket (G8) consists of a 1/2" or 3/4" coil thread nut welded to a steel plate.

The bracket can be nailed or welded to a joist to support a screed bolt extending through the decking or used with a form bolt to support and position a curb form.

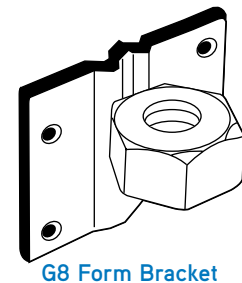

G8 Form Bracket

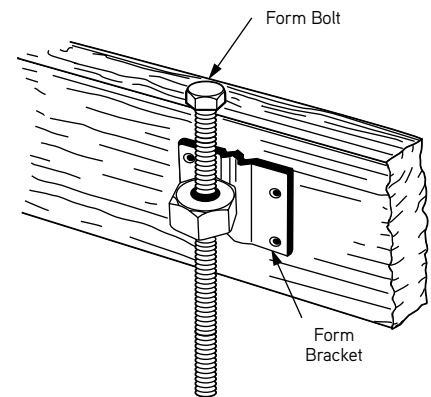

To Order:
Specify: 1) quantity, (2) name, (3) diameter.

Example:
150, G8 Form Brackets, 1/2" diameter.

G11 Screed Stake for Pipe

Dayton Superior G11 Screed Stake for Pipe is designed to be driven into the subgrade to support 1" screed pipe. G11 stakes are available in 15" and 18" lengths.

To Order:
Specify: (1) quantity, (2) name, (3) length.

Example:
200 pcs. G11 Screed Stakes, 18" long.

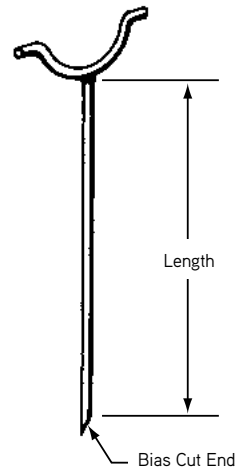

G11 Screed Stake

G14 Heavy Duty Screed Holders

Dayton Superior G14 Heavy Duty Screed Holders consist of a rolled steel plate welded to a length of 1" diameter coil rod. The G14 screed holder is used with a free-fit screed base to support screed pipe of various sizes.

The "open style" is fabricated from grade 11 gauge steel and is limited to 2" O.D., or smaller, pipe. The "closed style" is fabricated from 1/4" steel and is fitted with two 3/8" diameter set screws. The closed style holder can accommodate screed pipe up to 3" O.D. Both styles are available in 4-1/4", 6-3/4" and 9-3/4" lengths with one Coil Nut included with each holder.

To Order:
Specify: (1) quantity, (2) name, (3) style, (4) length.

Example:
200 pcs. G14 Heavy Duty Screed Holders, closed style, 9-1/4" long.

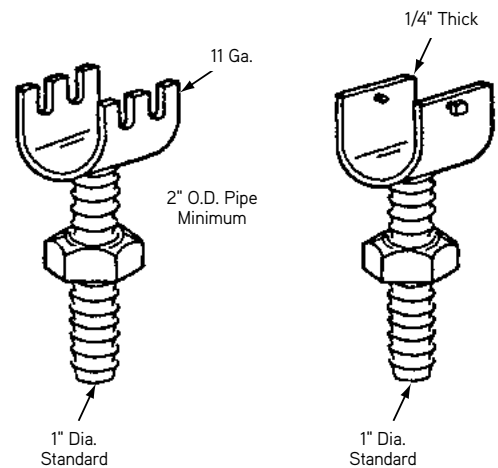

G14 Heavy Duty Screed Holders

G15 Heavy Duty Screed Support

Dayton Superior G15 Heavy Duty Screed Support is available in 1" and 1-1/4" diameters in 3", 4" and 6" heights. G15 screed supports are welded to a steel beam to provide a receptacle for a cradle head to support the screed pipe. Adjustment is accomplished by turning the jam nut on the cradle head.

To Order:
Specify: (1) quantity, (2) name, (3) length.

Example:
200 pcs. G15 Heavy Duty Screed Support, 6" long.

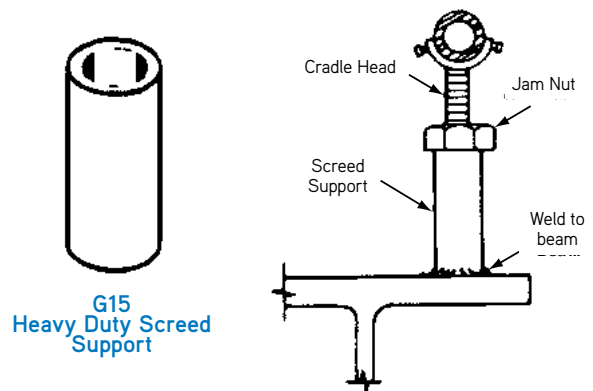

G15 Heavy Duty Screed Support

G16 Heavy Duty Screed Chair Base

Dayton Superior G16 Heavy Duty Screed Chair Base is a rigid support designed for heavy vibratory screed applications. G16 bases are available with standard 1" and 1-1/4" coils or free-fit ferrules. Standard heights for the G16 base are 4-1/2", 5-1/2", 7-1/2" and 10".

To Order:
Specify: (1) quantity, (2) name, (3) diameter, (4) height.

Example:
200 pcs. G16 Heavy Duty Screed Chair Base, 1" dia., 7-1/2" height.

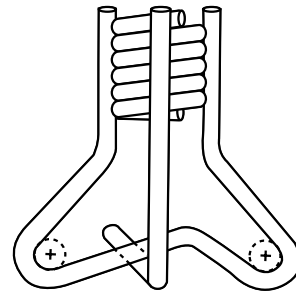

G16 Heavy Duty Screed

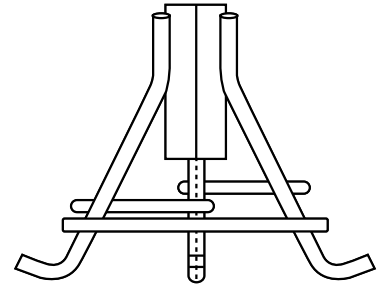

G16 Heavy Duty Screed Chair

Both Available with Coil Thread or Free Fit

G27 Round Stake

Dayton Superior G27 Round Stakes are manufactured from high quality steel with a sharp point to minimize rock deflection. G27 stakes are available in 3/4" and 7/8" diameters and in standard lengths of 12", 18", 24", 30", 36", 42" and 48". The G27 stake is available with spiral-patterned nail holes or without holes for use as form pins.

Dayton Superior G26 Stake Puller is available for easy removal of the G27 Round Stakes. Contact a Dayton Superior Service Center or dealer for price and availability.

To Order:
Specify: (1) quantity, (2) name, (3) diameter, (4) length, (5) with or without nail holes.

Example:
360 pcs. G27 Round Stakes, 3/4" diameter, 18" long, with nail holes.

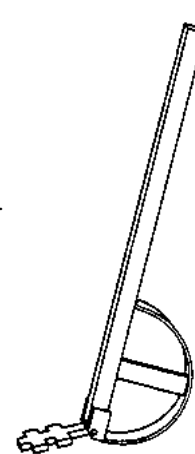

G26 Stake Puller



G27 Round Stake

G28 and G29 Screed Bracket

Dayton Superior G28 and G29 Screed Brackets clamp to the top of a nail stake and hold screed bar parallel to the form during flatwork finishing. Screed brackets are available for 1/2"x2" flat bar and 2x4s. G28 is used with 3/4" round nail stakes and G29 is used with 3/4" square nail stakes.

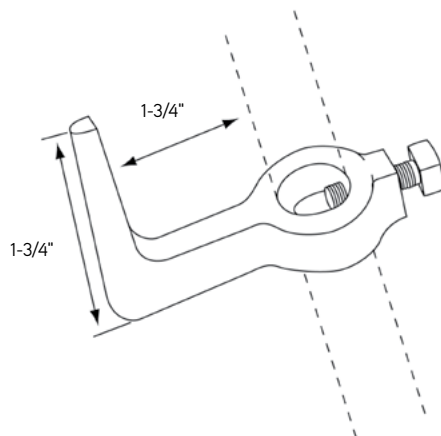

G28 Screed Bracket

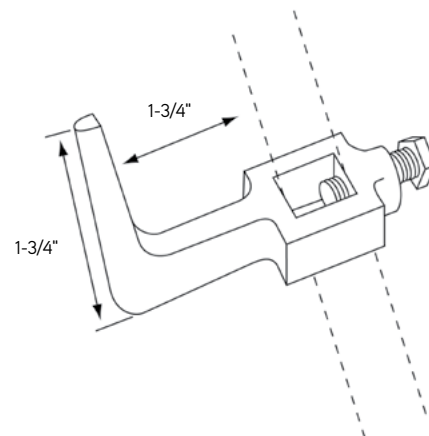

G29 Screed Bracket

G33 Screed Key Joint

Dayton Superior G33 Screed Key Joint is 24 gauge steel available in 10' lengths in heights of 3-1/2", 4-1/2" and 5-1/2" for use in 4", 5" and 6" on-grade concrete floor slabs. G33 meets ASTM A653 G40 Type B mill galvanized requirements. Screed Key Joint produces a smooth, flush surface joint that requires no filling. The use of Screed Key Joint minimizes random cracking and provides proper load transfer from slab to slab.

The use of Screed Key Joint is more economical than bulk-headed forms that must be prepared, installed, stripped, cleaned, repaired or replaced and stored. With Screed Key Joint an entire slab or strips can be poured at one time. Costly and time-consuming checker boarding is eliminated. Install the Screed Key Joint and pour the concrete - finish flush to the joint and the slab is finished.

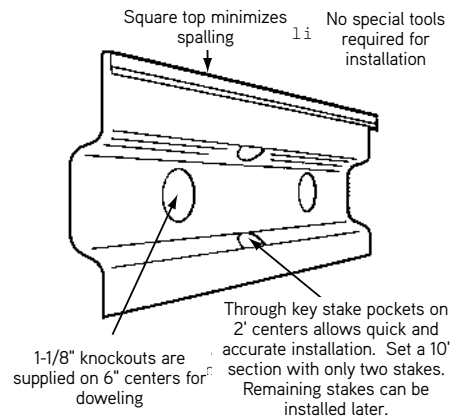

To Order:

Specify: (1) quantity, (2) name, (3) height.

Example:

200 pcs. G33 Screed Key Joints, 5-1/2" heights.

G34 Load Key Joint

Dayton Superior G34 Load Key Joint is 24 gauge steel available in heights of 7-1/2" and 9-1/2". It is furnished in 10' lengths for use in 8" and 10" slabs or thickened joints. G34 meets ASTM A653 G40 Type B mill galvanized requirements. G34 Load Key Joint produces a floor that is ready to use without costly filling.

The use of Load Key Joint insures a strong, high quality floor at a low initial cost and with minimum maintenance costs.

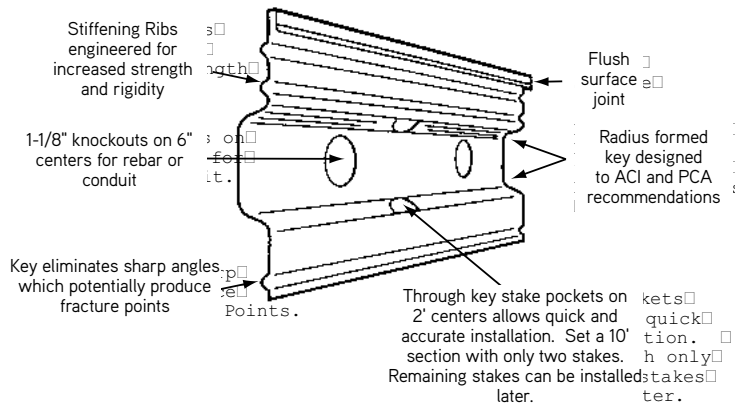

To Order:

Specify: (1) quantity, (2) name, (3) height.

Example:

200 pcs. G34 Load Key Joints, 7-1/2" height.

G35 Plastic Cap Strip

Dayton Superior G35 Plastic Cap Strip is used on G33 or G34, shown above, when a joint sealant is specified. The 10' G35 strip is easily removed after the concrete hardens leaving a wedge shaped joint that is easily and economically sealed.

To Order:

Specify: (1) quantity, (2) name.

Example:

200 pcs. G35 Plastic Cap Strip.

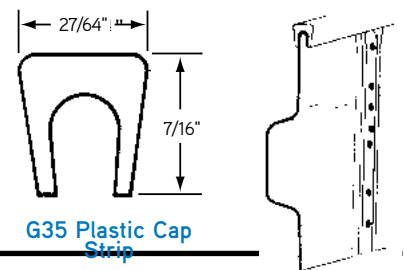

G37 Stake

Dayton Superior G37 Stake is available for use with G33 and G34, above. The G37 Stake is 3/4" wide 16 gauge steel available in 12", 15", 18" and 24" lengths.

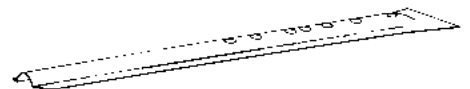

To Order:

Specify: (1) quantity, (2) name, (3) length.

Example:

200 pcs. G37 Stakes, 18" long.

How to Use Screed Key Joint

Step 1:

Stretch a line over the entire length. Drive stakes are placed on approximately 20'. Set stakes 1/8" below finished floor elevation. Secure the line to the top of the stakes (as shown in the inset). Drive additional stakes to the bottom of the line at the end location of each screed key section.

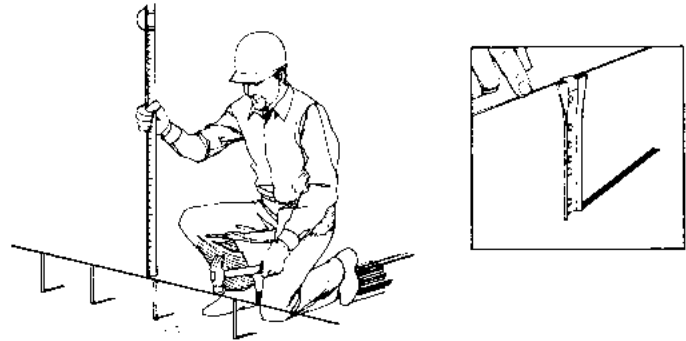

Step 2:

Install Screed Key Joint on the stakes as shown. It is preferable to have the key facing the initial concrete placement. Butted joints are aligned over a stake, as shown in the inset.

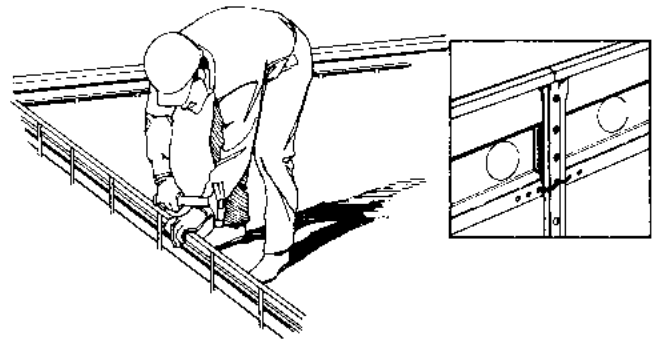

Step 3:

Drive intermediate stakes through the holes provided in the pre-formed key.

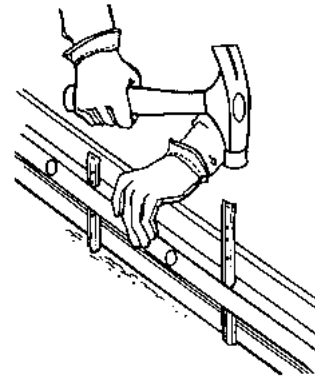

Step 5:

Tin snips or a metal cutting saw can be used to trim or cut the key, when necessary.

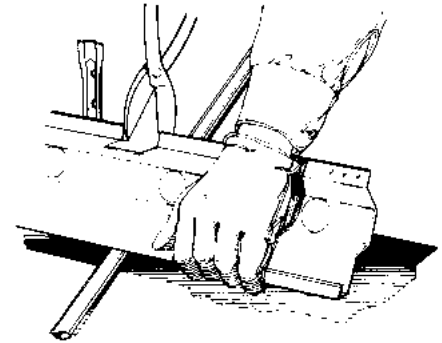

Step 6:

Where joints meet at right angles, key joint should be trimmed to fit as shown. Note close proximity of the stakes to the joint.

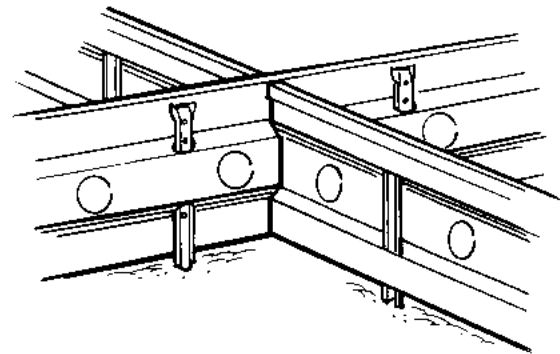

Step 7:

1-1/8" knockouts are supplied, as shown, on 6" centers when doweling is specified. When Scream Key Joint is used as a bulkhead for a construction joint, the knockout would be bent back into the pour at a 45° angle, as shown.

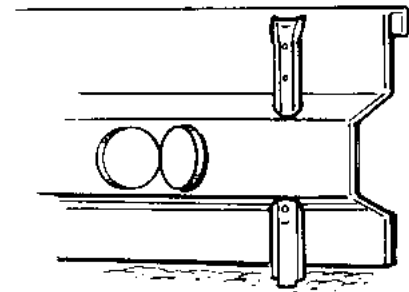

Step 8:

Entire slabs may be poured at the same time by leaving out 10' sections of Scream Key Joint temporarily until the concrete truck can pull ahead and the section replaced.

Good slab construction practice dictates that slab reinforcement be properly supported by rebar supports after the truck has passed.

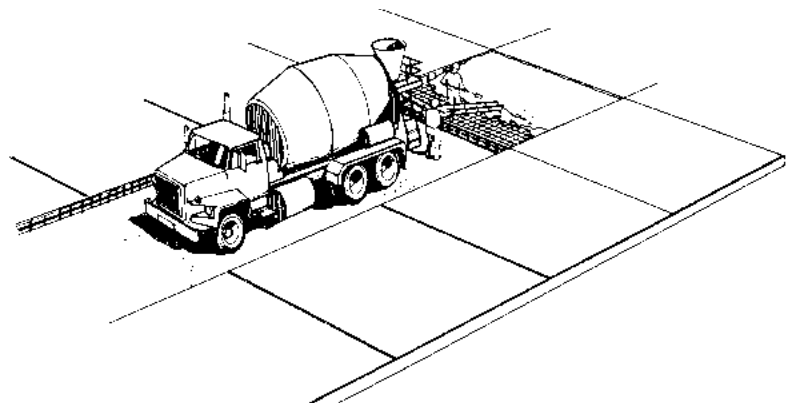

Proper Method for Installing Load Key Joint

Step 1:

When a thickened contraction joint is specified, and the shape and/or dimensions are not given, experience and research have shown that the slab thickness should be $\frac{2}{3}$ of the joint thickness, with the increase in thickness being obtained by a straight slope in the outer two feet of the slab, as shown in the sketch. Key dimensions should be as shown, with the key centered vertically in the joint.

Note: Joint thickness should be determined by the designer, so that repeated stress does not exceed 50% of the ultimate strength.

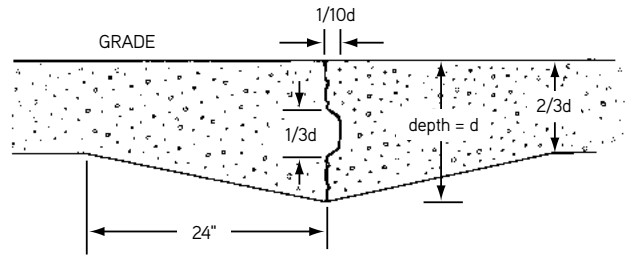

Step 2:

Stretch a line over the entire length. Drive stakes are placed on approximately 20 foot centers. Set stakes $\frac{1}{8}$ " below finished floor elevation. Secure the line to the top of the stakes (as shown in the inset). Drive additional stakes to the bottom of the line at the end location of each Load Key section.

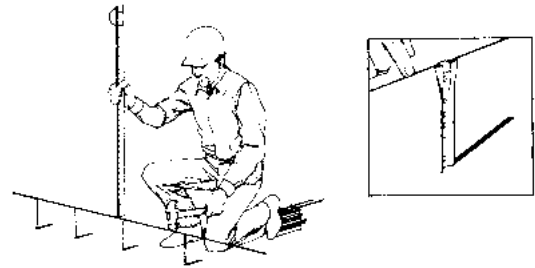

Step 3:

Stake Driving can be facilitated with the use of the G36 Stake Driving Tool (available on special order). The G36 tool prevents the top of the stake from being flattened, as well as acting as a guide. A 2x4 placed adjacent to the stake will help align the stake vertically.

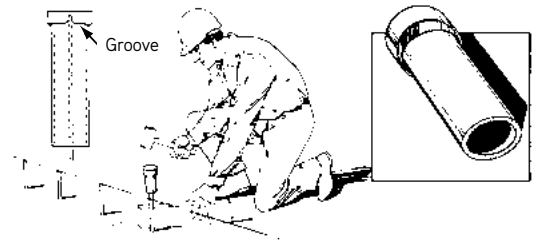

Step 4:

Install Load Key Joint on the stakes as shown. Butt joints are aligned at a stake as shown in the inset.

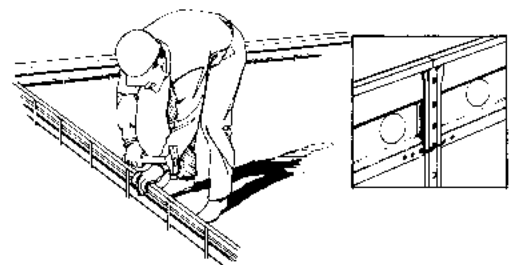

Step 5:

Drive intermediate stakes through holes provided in the formed keyway.

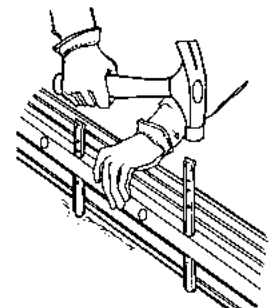

Step 6:

When joints meet at right angles, Load Key can be trimmed to fit as shown. Note the stakes are placed in close proximity to the joint.

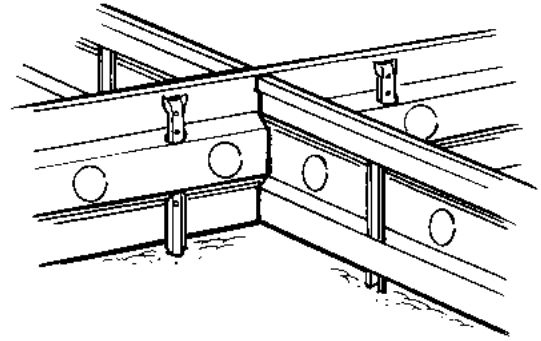

Step 7:

1-1/8" knockouts are supplied, as shown, on 6" centers when doweling is specified. When Load Key Joint is used as a bulkhead for a construction joint, the knockout would be bent back into the pour at a 45° angle, as shown. The knockout holes may be used to pass conduit up to 1" O.D. Additional bracing (as shown) will be required for bulkhead pours. Load Key Joint should remain in place when bulkhead bracing is removed.

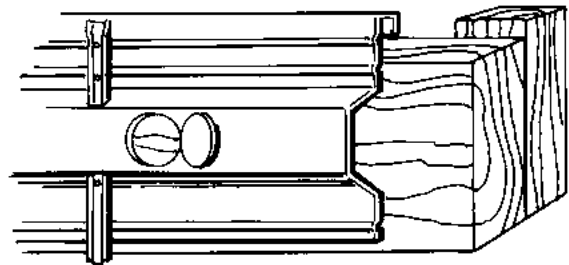

Step 8:

Load Key Joint will only support a manual screed, to strike-off concrete, when concrete is placed simultaneously on both sides of the Load Key before screeding. Failure to place concrete equally on both sides of the joint may cause misalignment or bending of the Load Key.

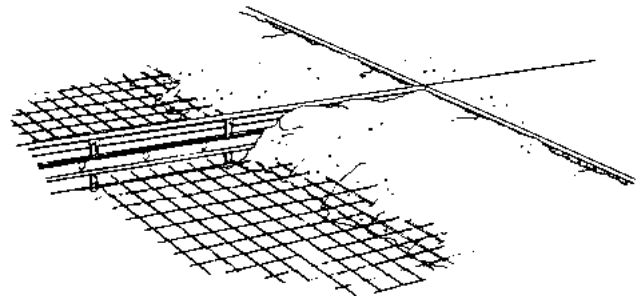

Step 9:

A common and economical method is to pour concrete in strip fashion as shown. When a strip is poured and finished, there are no added steps such as, cutting or stripping. Use temporary bulkhead for support behind each key joint.

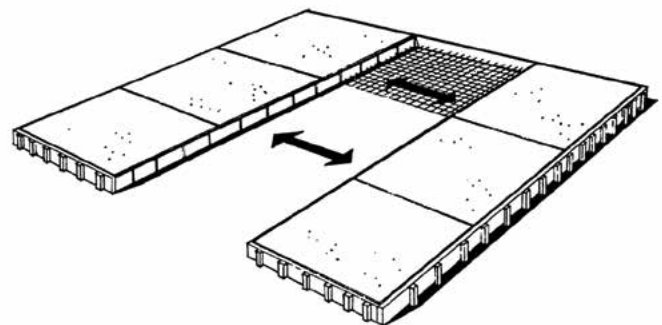

Supports For Rebar and Wire Mesh

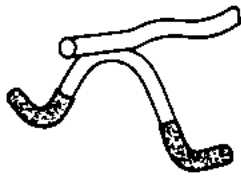

Baked on Plastic Feet

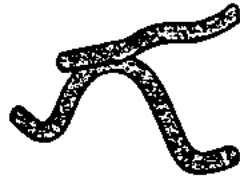

Epoxy-Coated

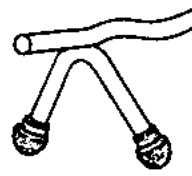

Plastic Tipped Feet

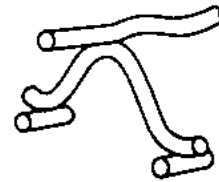

Stainless Steel Tips

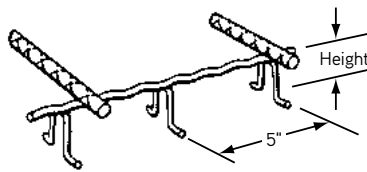

SB Slab Bolster

Available in heights of 3/4" to 3" in increments of 1/4" in 5 ft. lengths

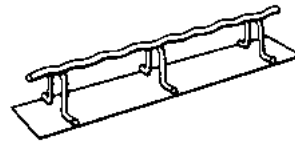

SBP Slab Bolster with Plate

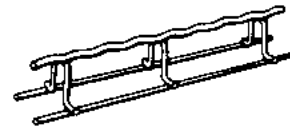

SBU Slab Bolster Upper



JC Joist Chair

Available in heights of 3/4" 1" and 1-1/2"

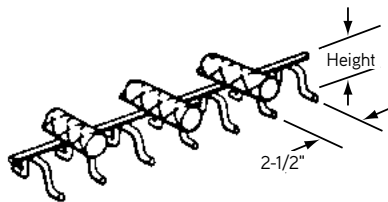

BB Beam Bolster

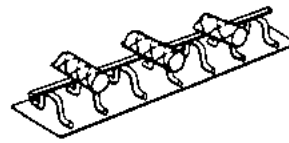

BBP Beam Bolster with Plate

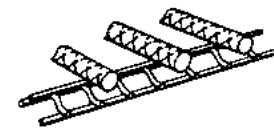

BBU Beam Bolster Upper

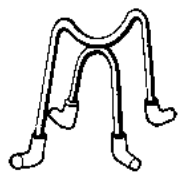

HC Individual High Chairs
(Plastic Tipped Legs Available)

Available in heights of 2" to 40" in increments of 1/4"



HCP Individual High Chair with Plates



FHC High Chair for Fill

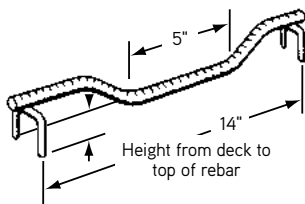

JCU Joist Chair Upper

Available in heights of 1" to +3-1/2"

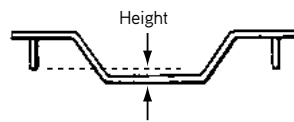

Style 1

From 1/4" to 1"

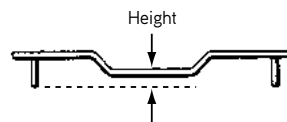

Style 2

From 0" to +1"



Style 3

From + 1-1/4" to +3-1/2"

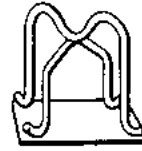

BC Bar Chair Plate **BCP Bar Chair with Plate**
Available in heights of 3/4" 1" and 1-1/2"

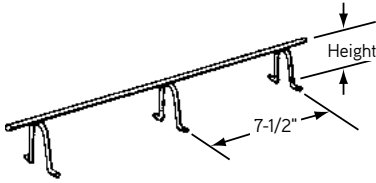

CHC Continuous High Chair **CHCU-Cont. High Chair Upper**
Available in heights of 2" to 20" in increments of 1/4" in 5' lengths

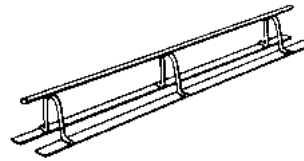

CHCP-Cont. High with Plate
Manufactured to Order



HBC Heavy Bar Chair
Available in heights of 3/4" 1" and 1-1/2"

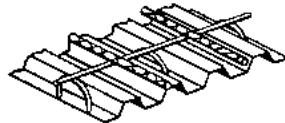
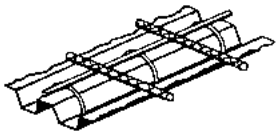

CHC Continuous High Chairs for Metal Decking
Available in heights of 2" to 9" with leg spacing of 4-1/2" to 10"

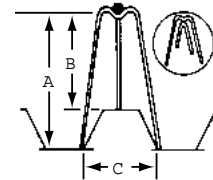
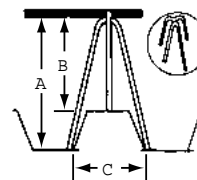

CHC Continuous High Chairs for Metal Decking
Available in heights of 2" to 9" with leg spacing of 4-1/2" to 10"



PC Precast Chair. Made from Type 430 Stainless Steel.

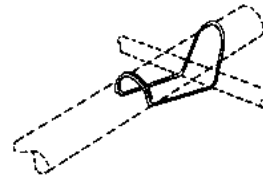

DC Dowel Clip
Available for 1/2" to 1-5/8" bars

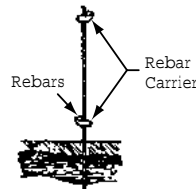

Drive Rebar Support in Ground and Attach Rebar Carrier

SLHC Straight Leg High Chair
Available in heights of 2-1/4", 2-1/2" and 2-3/4"

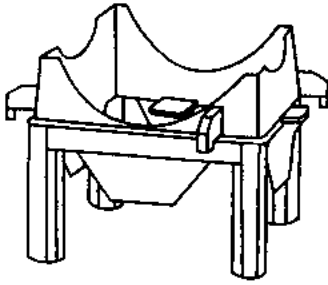

PBC Tower Bar Chair

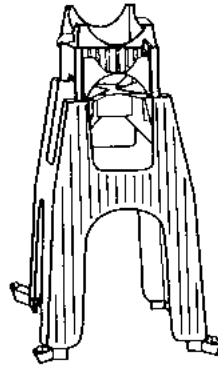

PTC Tower High Chair

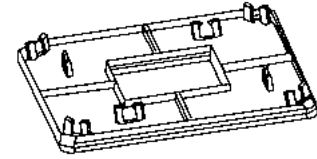

PTCSB Tower Chair Sand Plate

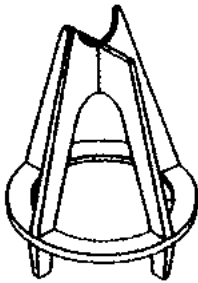

PEZ E-Z Chair®

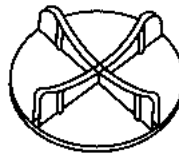

PSP Sand Plate

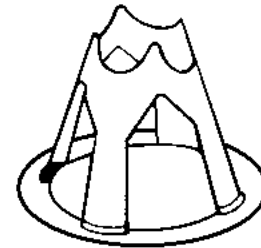

PCC Castle Chair

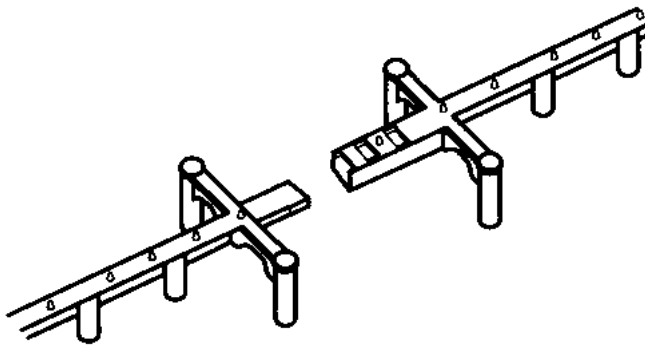

PSB E-Z LOK Slab Bolster

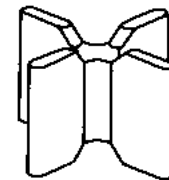

PXC X-Chair

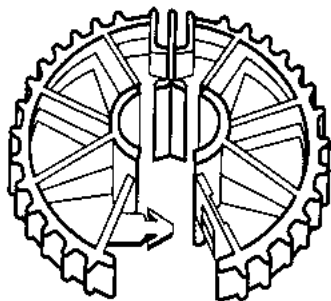

PLW E-Z Lok Wheel

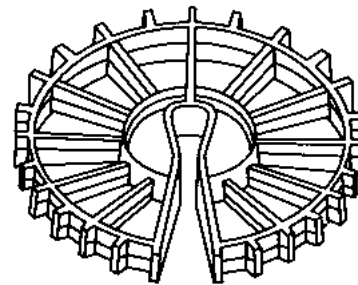

PSW Space Wheel

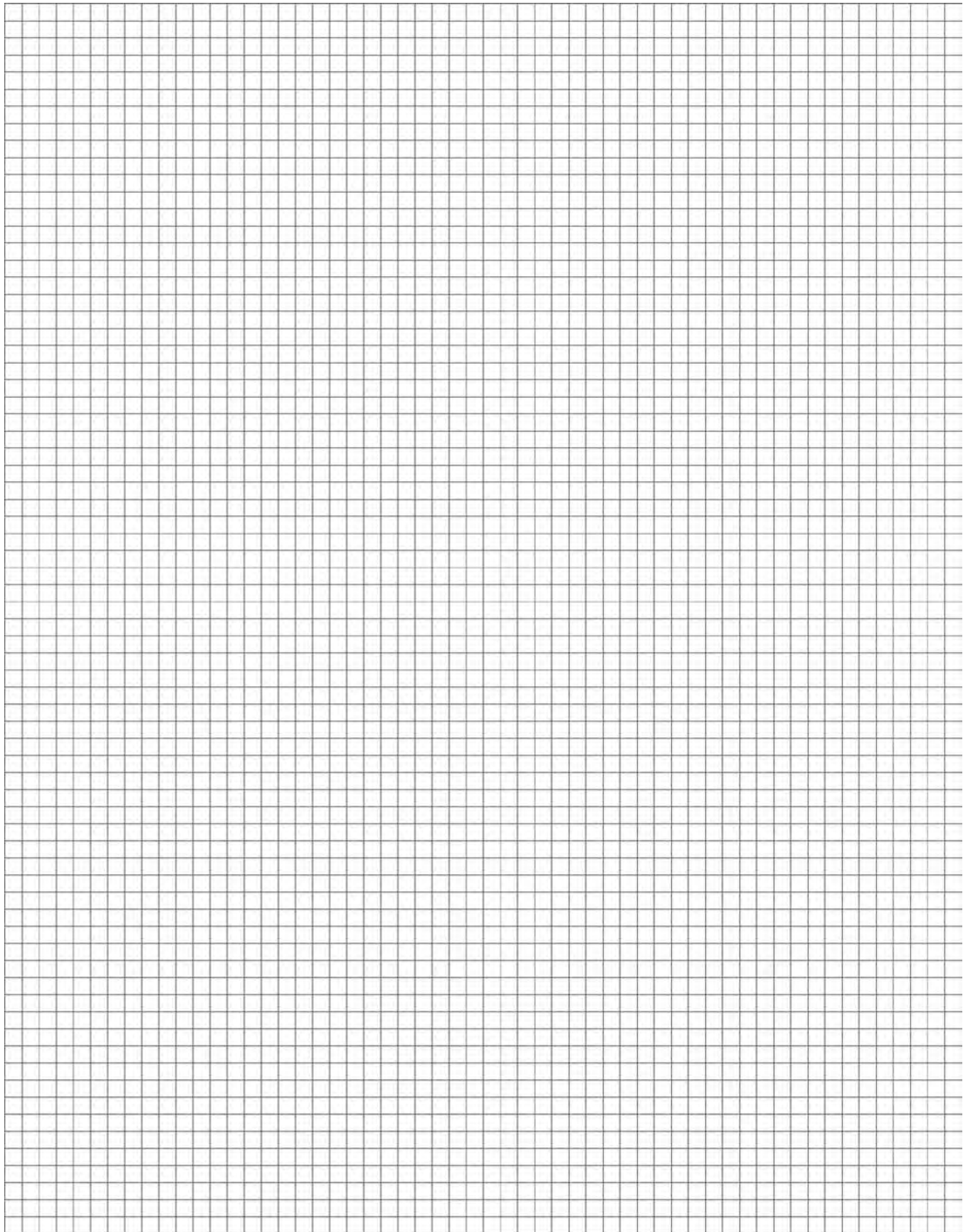

Formliner Materials

Materials to match budget and job needs.

SPS Plastic™

A polystyrene formliner for single use applications. This inexpensive option is easy to store or attach to forms, and has a quick delivery time.



ABS Plastic

An ABS formliner that provides durability and performance for 5-10 uses. This inexpensive option is easy to store or attach to forms, and has a quick delivery time.

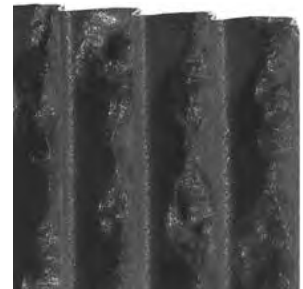

Custom Formliners Available



F56, F57, F58, F59, F60, F61 Expanded Coil Inserts

Dayton Superior Expanded Coil Inserts are coil or closed ferrule structural connection inserts available in two, four or six strut versions, in 3/4" through 1-1/2" diameters, with or without nailing washer.

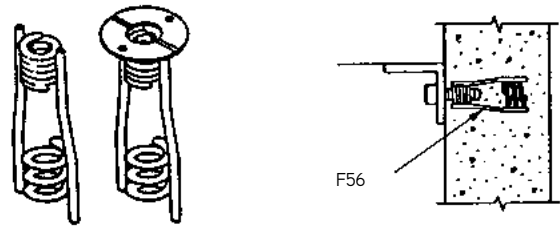

Expanded Coil Inserts

F42 Loop Ferrule Insert

Dayton Superior F42 Loop Ferrule Insert is a versatile insert suited for structural connections and suspension of equipment, ceilings, piping, etc. Available in 1/4" to 1" diameter closed ferrules in 1/8" increments.



F42 Loop Ferrule Insert

F44 Thin Slab Ferrule Insert

Dayton Superior F44 Thin Slab Ferrule Insert is used where the depth of embedment is limited. The F44 is specially designed to develop good working loads in very thin concrete slabs. Available in 1/4" through 1" diameter, in 1/8" increments, closed ferrules.



F44 Thin Slab Ferrule Insert

F7, F7L Shelf Angle Insert

Dayton Superior Shelf Angle Insert is a malleable iron casting with a wedge shaped holding face that works in conjunction with a special Askew Head bolt. Available in standard and long configurations.

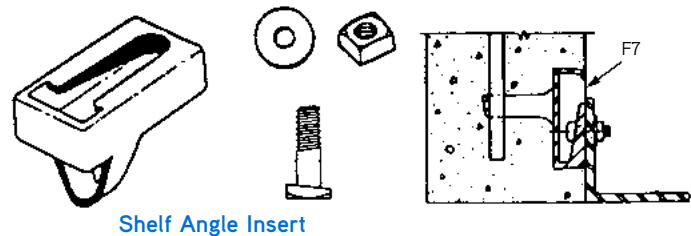

Shelf Angle Insert

F54 Ductile Embed

Dayton Superior F54 Ductile Embed is a structural embed available in 5/8" through 1-1/4" diameters and is available in several configurations. This is an integrally forged embed with no welds. It is designed to develop pullout and shear loads exceeding A325 bolt capacities.

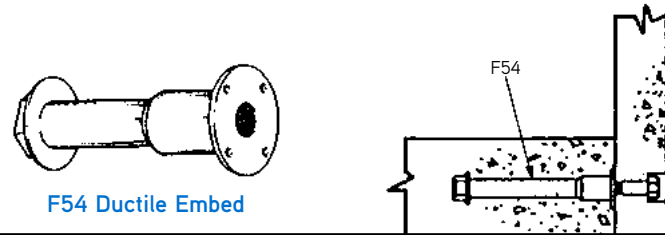

F54 Ductile Embed

F54C Nylon Rail Track Insert

Dayton Superior's Rail Track Insert is an internally threaded rail track fastener for a 7/8"- 9 UNC threaded bolt. It is manufactured from a Nylon 6/6, 33% glass-filled material. The inserts may either be cast-in-place in a concrete substrate or post placed in a drilled hole using an epoxy adhesive.

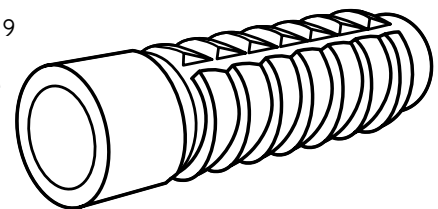

F54C Nylon Rail Track Insert

Features and Benefits

- Non-conductive material
- Non-corrosive — will not rust
- Over 3-1/2" of thread engagement for a variety of bolt lengths and/or shimming applications
- Exterior wedges allow transfer of loads to adjacent concrete
- Special ribs prohibit rotation
- Convenient packaging of 200 pieces per box.

A2	19	B2B3.....	48	Corner Washer.....	24
A3.....	19	B6.....	49	D1	62
A4H.....	20	B7.....	49	D1J.....	63
A5.....	21	B11.....	50	D1L.....	63
A6.....	22	B12.....	50	D1LA.....	63
A7.....	22	B12A.....	51	D1S.....	63
A7A.....	22	B12ANF.....	51	D2	64
A9.....	23	B12AWN.....	51	D4	65
A9H.....	23	B13.....	52	D-6.....	57, 65
A10.....	23	B14.....	52	D9.....	65
A16.....	23	B14A.....	53	D9A.....	66
A18.....	23	B14W.....	54	D12.....	66
A19.....	24	B15.....	54	D12A.....	67
A21.....	24	B16.....	54	D12F.....	67
A21F.....	25	B17.....	55	D14.....	67
A21X.....	25	B18.....	55	D18.....	62, 68
A22.....	26	B20.....	56	D21.....	68
A27.....	27	B21.....	56	D22.....	61, 68
A27M.....	27	B22.....	49	D24.....	69
A28.....	27	B25.....	52, 56	D25.....	69
A29.....	28	B27.....	57	D26.....	69
A31.....	28	B29.....	57	D30.....	64
A40.....	28	B30.....	58	D30A.....	70
A43.....	28	B31.....	58	D32.....	70
A44.....	29	B32.....	59	D33.....	70
A45.....	29	B33.....	59	D40.....	71
A46.....	29	B37.....	60	D42.....	72
A48.....	30	B39.....	60	D46.....	73
A51.....	30	B40.....	61	D48.....	73
A52.....	30	B42.....	61	Double Flared Coil Loop Insert.....	55
A54.....	31	B43.....	61	Double Flared Criss Cross Coil Loop Insert.....	59
A55.....	31	Bag Ties.....	72	D/R® Thread Bar.....	51
A56.....	31	Base Tie.....	29	D/R® Thread Bar She Bolt.....	70
A57.....	31	Batter Washer.....	61, 68	D/R® Thread Bar Taper Tie.....	66
A58.....	74	C1B.....	77	D/R® Welding Flange.....	51
A59.....	74	C1C.....	77	Ductile Embed.....	98
A63.....	32	C2.....	78	Dura-Tex Lite®.....	98
A81.....	32	C3.....	79	Elasto-Tex®.....	98
A82.....	33	C13.....	79	Expanded Coil Inserts.....	98
A83.....	33	C13A.....	80	F1.....	75
A89.....	34	C14.....	81	F2.....	75
A90.....	43	Cast Nut Washer.....	51	F7.....	98
A93C.....	44	Channel Hanger.....	81	F7L.....	98
A100.....	45	Closed Coupler.....	70	F42.....	98
A110.....	45	Coil Bolts.....	52	F44.....	98
ABS Plastic.....	99	Coil Half Hanger.....	79	F54.....	98
Adjustable Coil Bolt.....	53	Coil Hanger Saddle Type.....	78	F54C.....	98
Adjustable Kicker.....	27	Coil Loop Insert Straight.....	54	F56.....	98
All-Wire Saddle Hanger.....	80	Coil Nut.....	52	F57.....	98
Anchor Bolt Sleeve.....	63	Coil Rod.....	50	F58.....	98
Archi-Foam®.....	99	Coils.....	49	F59.....	98
B1.....	47	Column and Pilaster Forming Suggestions.....	42	F60.....	98
B1B3.....	48	Cone Removal Wrench.....	28	F61.....	98
B2.....	47				

Fitting Up Bolt.....	69	Jahn® Scaffold Jack	34	Spreader Cleats.....	26
Fitting Up Nut.....	69	Joist Type Adjustable Screed Base	83	SPS Plastic™	98
Flat Tie	25	Load Key Joint	88	Stainless Steel Snap Tie.....	29
Flat Washers	50	Loop Ferrule Insert	98	Stake	88
Footing Tie	28	Loop Panel Tie.....	29	Standard Snap Tie.....	19
Form Bracket	85	Loose Plastic Cone	57	Strap Ties And Accessories.....	24
Form Clamp.....	67	Metal Rib	45	Strongback Loop Tie.....	32
Formliners	97	Metal Strapping.....	23	Supports for Rebar and Wire Mesh.....	93
Four Strut Coil Tie	47	Methods of Screeding	82	Sure Guard® Rail Post System	44
G1	83	Nut Washer	57, 65	Sure-Guard® Rebar Protective Cap	73
G1U	83	Nylon Rail Track Insert.....	98	Sure-Lock Bracket.....	31
G2	83	Omni Wedge	23	Sure-Lock Strongback Bracket	31
G2J	83	Panel Bolt	23	Sure-Lock Tie	31
G2S.....	84	PC110.....	73	Sure Plug.....	74
G3.....	84	Pencil Rod.....	67	Taper Ties.....	65
G4	84	Pipe Holder.....	83	Thin Slab Ferrule Insert.....	98
G4A.....	84	Plastic Cap Strip.....	88	Threaded PullOut Tie.....	21
G5.....	85	Plastic Cone Removal Wrench	54	Tie Wire.....	73
G7.....	85	Plastic Cones	19	Tightening Wrench	67
G8.....	85	Plastic Setback Plug.....	61	Tip-To-Tip Tie.....	23
G11.....	86	Plate Saddle Hanger	79	Toggle Tie	60
G14.....	86	Plate Tie.....	23	Triple Flared Coil Loop Insert	61
G15.....	86	Plylag.....	56	Turnbuckle Form Aligners	27
G16.....	87	Proper Method for Installing Load Key Joint	91	Two Strut Coil Tie.....	47
G27	87	Rebar Clip and Form Spreader	68	Vertical Wales for Curved Walls.....	42
G28	87	Rock Anchor.....	58	Wale Bolt Assembly	54
G29	87	Rod Clamps	66	Wale Holder	56
G33	88	Round Stake.....	87	Waler Tie.....	30
G34	88	Safety Cap	73	Water Resistant Washer	70
G35	88	Scaffold Bracket Jack	43	Wedge Bolt.....	30
G37.....	88	Screed Bases, Drive Type	84	Wedge Hangers.....	77
Gang Loop Tie.....	30	Screed Bases, Free Fit Type.....	85	Weld Angle Bracket.....	69
Handle Coil Nut.....	59	Screed Bracket.....	87	Welding Coil Tie.....	49
Heavy Coil Nut.....	52, 56	Screed Chair Base for Steel Deck.....	85	Wing Nut	60
Heavy Duty Screed Chair Base.....	87	Screed Chair Bases	83	Wrench Head Snap Tie Socket	28
Heavy Duty Screed Holders	86	Screed Chair Base With Sand Plate.....	84	Z Tie Holder	30
Heavy Duty Screed Support.....	86	Screed Key Joint	88		
Heavy Snap Tie.....	20	Screed Stake for Pipe	86		
He-Bolt Anchors.....	72	Screw Anchor.....	75		
He-Bolt Inserts	72	Screw Anchor Bolt	75		
He-Bolts.....	71	Screw-On Coil Tie.....	48		
Hex Coupling Nut.....	65	Screw-On Plastic Cones.....	58		
Hex Head Snap Tie	20	She-Bolts.....	64		
Hook Bolts	63	Shelf Angle Insert	98		
How to Use Screed Key Joint	89	Single Flared Coil Insert	55		
Impalement Safety Cap	73	Snapplug®	31		
Insertion Tool	74	Snap Tie Wrench	28		
Inserts (Crimp)	49	Spandrel Hook Tie.....	22		
Inside Tie Rod.....	68	Spandrel Plate Tie.....	22		
Inside Tie Rods	62	Spandrel Point Tie.....	22		
Jahn® "A" Bracket.....	32	Special Height Screed Base.....	84		
Jahn® "C" Bracket.....	33	Special U-Shaped Cradle Head.....	83		
Jahn® Cornerlock.....	33	Speed Step® Bracket.....	45		
Jahn® Forming System.....	35				

	<div data-bbox="539 237 1448 357" style="background-color: red; color: white; padding: 5px; text-align: center;"> WARNING</div> <div data-bbox="539 357 1448 625" style="padding: 10px;"><p style="text-align: center;">Improper Use of Concrete Accessories Can Cause Severe Injury or Death</p><p>Read, understand and follow the information and instructions in this publication before using any of the Dayton Superior concrete accessories displayed herein. When in doubt about the proper use or installation of any Dayton Superior concrete accessory, immediately contact the nearest Dayton Superior Service Center or Technical Service Department for clarification. See back cover for your nearest location.</p></div>
---	--

Dayton Superior products are intended for use by trained, qualified and experienced workers only. Misuse or lack of supervision and/or inspection can contribute to serious accidents or deaths. Any application other than those shown in this publication should be carefully tested before use.

The user of Dayton Superior products must evaluate the product application, determine the safe working load and control all field conditions to prevent applications of loads in excess of a product's safe working load. Safety factors shown in this publication are approximate minimum values. The data used to develop safe working loads for products displayed in this publication are a combination of actual testing and/or other industry sources. Recommended safe working loads given for the products in this publication must never be exceeded.

Worn Working Parts

For safety, concrete accessories must be properly used and maintained. Concrete accessories shown in this publication may be subject to wear, overloading, corrosion, deformation, intentional alteration and other factors that may affect the device's performance. All reusable accessories must be inspected regularly by the user to determine if they may be used at the rated safe working load or should be removed from service. The frequency of inspections depends upon factors such as (but not limited to) the amount of use, period of service and environment. It is the responsibility of the user to schedule accessory hardware inspections for wear and remove the hardware from service when wear is noted.

Shop or Field Modification

Welding can compromise a product's safe working load value and cause hazardous situations. Knowledge of materials, heat treating and welding procedures is necessary for proper welding. Consult a local welding supply dealer for assistance in determining required welding procedures.

Since Dayton Superior cannot control workmanship or conditions in which modifications are done, Dayton Superior cannot be responsible for any product

Interchangeability

Many concrete accessory products that Dayton Superior manufactures are designed as part of a system. Dayton Superior strongly discourages efforts to interchange products supplied by other manufacturers with components supplied by Dayton Superior. When used properly, and in accordance with published instructions, Dayton Superior products have proven to be among the best designed and safest in the industry. Used improperly or with incompatible components supplied by other manufacturers, Dayton Superior products or systems may be rendered unsafe.

Installation

WARNING

1. Dayton Superior Corporation products shall be installed and used only as indicated on the Dayton Superior Corporation installation guidelines and training materials.
2. Dayton Superior Corporation products must never be used for a purpose other than the purpose for which they were designed or in a manner that exceeds specific load ratings.
3. All instructions are to be completely followed to ensure proper and safe installation and performance
4. Any improper misuse, misapplication, installation, or other failure to follow Dayton Superior Corporation's instruction may cause product malfunction, property damage, serious bodily injury and death.

THE CUSTOMER IS RESPONSIBLE FOR THE FOLLOWING:

1. Conformance to all governing codes
2. Use of appropriate industry standard hardware
3. The integrity of structures to which the products are attached, including their capability to safely accept the loads imposed, as evaluated by a qualified engineer.

SAFETY INSTRUCTIONS:

All governing codes and regulations and those required by the job site must be observed. Always use appropriate safety equipment

Design Changes

Dayton Superior reserves the right to change product designs, rated loads and product dimensions at any time without prior notice.

Note: See Safety Notes and Safety Factor Information.



DAYTON[®]
SUPERIOR

1125 Byers Road
Miamisburg, OH 45342
937-866-0711
888-977-9600

**BUILDING
STRENGTH**[™]

DS6
12/15