

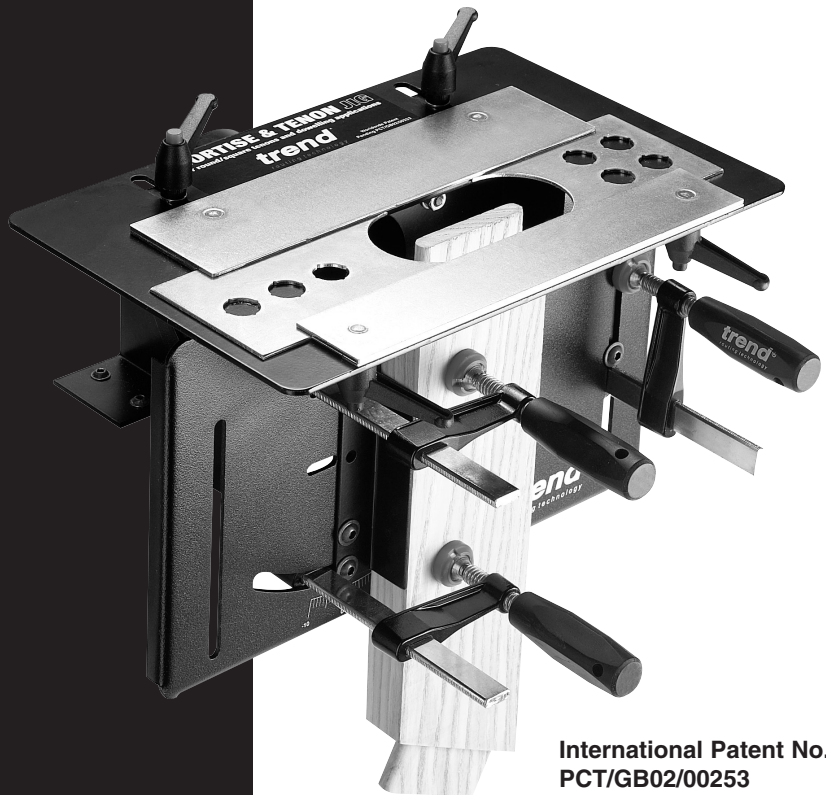

MT/JIG



International Patent No.:
PCT/GB02/00253

trend[®]
routing technology



Please read these instructions before use.

Dear Customer

Thank you for purchasing this Trend product, we hope you enjoy many years of creative and productive use.

Please remember to return your guarantee card within 28 days of purchase.

CONTENTS

TECHNICAL DATA _____	1
SAFETY _____	2-3
ITEMS ENCLOSED _____	4
DESCRIPTION OF PARTS _____	5
ACCESSORIES _____	6
ASSEMBLY & ADJUSTMENT _____	7
– Assembly of the Top Plate _____	8
– Cutter & Guide Bush Selection _____	9
– Fitting of Guide Bushes _____	10
– Fitting the Optional Dust Extraction Kit _____	11
TIMBER PREPARATION & MARKING OUT _____	12
– Marking out the tenon _____	12
OPERATION _____	
– Set Timber Height _____	13
– Set Tenon Length _____	14
– Set Centre Line _____	15
– Routing Procedure _____	16
– Side Angled Tenon _____	17
– Front Angled Tenon _____	18
– Setting Up for the Mortise _____	19
– Cutting the Mortise _____	20
– Square Mortise & Tenons _____	21
– Dowelling _____	22-23
MAINTENANCE _____	23
ENVIRONMENTAL PROTECTION & GUARANTEE _____	23
SPARE PARTS _____	
– Spare Parts List _____	24
– Spare Parts Diagram _____	25



If you require further safety advice, technical information or spare parts, please call Trend Technical Support or visit www.trend-uk.com

TECHNICAL DATA

Material thickness	min.	12mm
	max.	47mm
Tenon thickness	min.	4.8mm
	max.	16mm
Using Vertical Guide:		
Tenon width	max.	90mm ⁺
Tenon length (approx.)	max.	25mm ⁺⁺
Mortise length	max.	90mm ⁺⁺⁺
Angle tilt compound		-10° to 45°
Weight		6kg

⁺ on end of 100mm wide material.

⁺⁺ depends on cut length and plunge depth of the router.

⁺⁺⁺ unlimited if vertical guide is removed and wood is repositioned.

Min/Max Mortise & Tenon Sizes

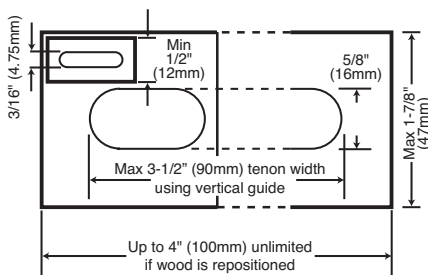

The following symbols are used throughout this manual:



Denotes risk of personal injury, loss of life or damage to the tool in case of non-observance of the instructions in this manual.



Refer to the instruction manual of your power tool.

This unit must not be put into service until it has been established that the power tool to be connected to this unit is in compliance with 2006/42/EC (identified by the CE marking on the power tool).

INTENDED USE

This jig is intended to be used with a plunge router fitted with a suitable cutter and guide bush to cut mortise and tenons in natural wood.

SAFETY



WARNING:

Observe the safety regulations in the instruction manual of the power tool to be used. Please read the following instructions carefully. Failure to do so could lead to serious injury. When using electric tools, basic safety precautions, including the following should always be followed to reduce the risk of fire, electric shock and personal injury. Also observe any applicable additional safety rules. Read the following safety instructions before attempting to operate this product.

PLEASE KEEP THESE INSTRUCTIONS IN A SAFE PLACE.

The attention of UK users is drawn to The Provision and Use of Work Equipment Regulations 1998, and any subsequent amendments.

Users should also read the HSE/HSC Safe Use of Woodworking Machinery Approved Code of Practice and Guidance Document and any amendments.

Users must be competent with woodworking equipment before using our products.

IMPORTANT NOTE:

Residual Risk. Although the safety instructions and operating manuals for our tools contain extensive instructions on safe working with power tools, every power tool involves a certain residual risk which cannot be completely excluded by safety mechanisms. Power tools must therefore always be operated with caution!

General

1. Disconnect power tool and attachment from power supply when not in use, before servicing, when making adjustments and when changing accessories such as cutters. Ensure switch is in "off" position. Always ensure cutter has stopped rotating.
2. Always mount the power tool, accessory or attachment in conformity with the instructions. Only use attachment and accessories specified in the power tool manual. The tool or attachment should not be modified or used for any application other than that for which it was designed. Do not force tool.
3. Keep children and visitors away. Do not let children or visitors touch the tool, accessory or attachment. Keep children and visitors away from work area. Make the workshop child proof with padlock and master switch.
4. Dress properly. Do not wear loose clothing or jewellery, they can be caught in moving parts. Rubber gloves and non-skid footwear is recommended when working

outdoors. Wear protective hair covering to contain long hair.

5. Consider working environment. Do not use the product in the rain or in a damp environment. Keep work area well lit. Do not use power tools near gasoline or flammable liquids. Keep workshop at a comfortable temperature so your hands are not cold. Connect machines that are used in the open via a residual current device (RCD) with an actuation current of 30 mA maximum. Use only extension cables that are approved for outdoor use.
6. The accessory or attachment must be kept level and stable at all times.
7. Keep work area clean. Cluttered workshops and benches can cause injuries. Ensure there is sufficient room to work safely.
8. Secure idle tools. When not in use, tools should be stored in a dry and high or locked up place, out of reach of children.
9. For best control and safety use both hands on the power tool and attachment. Keep both hands away from cutting area. Always wait for the spindle and cutter to stop rotating before making any adjustments.
10. Always keep guards in place and in good working order.
11. Remove any nails, staples and other metal parts from the workpiece.
12. Maintain tools and cutters with care. Keep cutters sharp and clean for better and safer performance. Do not use damaged cutters. Follow instructions for lubricating and changing accessories. Keep handles dry, clean and free from oil and grease.
13. Maintain accessories. Do not use damaged accessories. Only use accessories recommended by the manufacturer.
14. Check damaged parts. Before operation inspect the attachment, the power tool, the cable, extension cable and the plug carefully for signs of damage. Check for alignment of moving parts, binding, breakage, mounting and any other conditions that may affect its operation. Have any damage repaired by an Authorised Service Agent before using the tool or accessory. Protect tools from impact and shock.
15. Do not use tool if switch does not turn it on or off. Have defective switches replaced by an Authorised Service Agent
16. Don't over reach. Keep proper footing and balance at all times. Do not use

awkward or uncomfortable hand positions.

17. Don't abuse the cable. Never carry power tool or accessory by cord or pull it to disconnect from the socket. Keep cord from heat, oil and sharp edges. Always trail the power cord away from the work area.
18. Connect dust extraction equipment. If devices are provided for the connection of dust extraction and collection facilities, ensure these are connected and properly used.
19. Check all fixing and fastening nuts, bolts and screws on power tool, attachment and cutting tools before use to ensure they are tight and secure. Periodically check when machining over long periods.
20. Stay alert. Watch what you are doing. Use common sense. Do not operate tools when you are tired, under the influence of drugs or alcohol.
21. Personal Protective Equipment (PPE) for eye, ear and respiratory protection must be worn. All PPE must meet current UK and EU legislation.
22. Do not leave tools running unattended. Do not leave tool until it comes to a complete stop.
23. Always clamp workpiece being machined securely.
24. Only use cutting tools for woodworking that meet EN847-1/2 safety standards, and any subsequent amendments.
25. Vibration levels. Hand held power tools produce different vibration levels. You should always refer to the specifications and relevant Health & Safety Guide.

Routing Safety

1. Read and understand instructions supplied with power tool, attachment and cutter.
2. Keep hands, hair and clothing clear of the cutter.
3. Remove adjusting keys and spanners. Check to see that keys and adjusting spanners are removed from the router tool, cutter and attachment before turning router on. Make sure cutter can rotate freely.
4. Noise. Take appropriate measures for the protection of hearing if the sound pressure of 85dB(A) is exceeded. Routing sound pressure may exceed 85dB(A), so ear protection must be worn.
5. Eye protection. Always wear eye protection in the form of safety goggles, spectacles or visors to protect the eyes.

6. Respiratory protection. Wear a face or dust mask, or powered respirator. Dust masks/filters should be changed regularly.
7. Do not switch router on with the cutter touching the workpiece. At the end of the cut, release the router plunge and allow spindle to stop rotating. Never use the spindle lock as a brake.
8. The direction of routing must always be opposite to the cutter's direction of rotation. Do not back-cut or climb-cut.
9. Check before cutting that there are no obstructions in the path of the router. Ensure there are no obstacles beneath workpiece when cutting full thickness, and that a sacrificial work surface is used.

Router Cutter Safety

1. Cutting tools are sharp. Care should be taken when handling them. Do not drop cutters or knock them against hard objects. Handle very small diameter cutters with extra care. Always return cutter to its packaging after use.
2. Always use cutters with a shank diameter corresponding to the size of the collet installed in your tool.
3. The maximum speed (n.max) marked on the tool, or in instructions or on packaging shall not be exceeded. Where stated the speed range shall be adhered to. Recommended speeds are shown in the Trend Routing Always use router cutters in a router. Drill and boring bits must not be used in a router. Router cutters must only be used for the material cutting application for which they are designed. Do not use on metal or masonry.
5. Never use cutters with a diameter exceeding the maximum diameter indicated in the technical data of the power tool or attachment used.
6. Before each use check that the cutting tool is sharp and free from damage. Do not use the cutting tool if it is dull, broken or cracked or if in any other damage is noticeable or suspected.
7. Cutters should be kept clean. Resin build up should be removed at regular intervals with Resin Cleaner. The use of a PTFE dry lubricant will reduce resin build up. Do not use PTFE spray on plastic parts.
8. When using stacked tooling (multi-blade, block and groover etc.) on a spindle arbor, ensure that the cutting edges are staggered to each other to reduce the cutting impact.
9. Cutter shanks should be inserted into the collet all the way to the line indicated on the shank. This ensures

that at least 3/4 of the shank length is held in the collet. Ensure clamping surfaces are cleaned to remove dirt, grease, oil and water.

10. Observe the correct assembly and fitting instructions in the router instruction manual for fitting the collet, nut and cutter.
11. Tool and tool bodies shall be clamped in such a way that they will not become loose during operation. Care shall be taken when mounting cutting tools to ensure that the clamping is by the shank of the cutting tool and that the cutting edges are not in contact with each other or with the clamping elements.
12. It is advisable to periodically check the collet and collet nut. A damaged, worn or distorted collet and nut can cause vibration and shank damage. Do not over-tighten the collet nut.
13. Do not take deep cuts in one pass; take several shallow or light passes to reduce the side load applied to the cutter and router. Too deep a cut in one pass can stall the router.
14. In case of excessive vibrations whilst using the router stop immediately and have the eccentricity of the router, router cutter and clamping system checked by competent personnel.
15. All fastening screws and nuts should be tightened using the appropriate spanner or key and to the torque value provided by the manufacturer.
16. Extension of the spanner or tightening using hammer blows shall not be permitted.
17. Clamping screws shall be tightened according to instructions provided by the manufacture. Where instructions are not provided, clamping screws shall be tightened in sequence from the centre outwards.

Using Routers In A Fixed Position

1. Attention should be made to the HSE's Safe Use of Vertical Spindle Moulding Machines Information Sheet No.18 and any revisions.
2. After work, release the router plunge to protect the cutter.
3. Always use a push-stick or push-block when making any cut less than 300mm in length or when feeding the last 300mm of the cut.
4. The opening around the cutter should be reduced to a minimum using suitably sized insert rings in the table and closing the back fence cheeks or fitting a false fence on the back fence.
5. Whenever possible use a work holding device or jig to secure

component being machined. Ensure any attachment is securely fitted to the workbench, with table surface at approximately hip height.

6. Use a No-Volt Release Switch. Ensure it is fixed securely, easily accessible and used correctly.
7. In router table (inverted) mode, stand to the front right of the table. The cutter will rotate anti-clockwise when viewed from top so the feed direction is from the right (against the rotation of the cutter). In overhead mode, stand to the front left of the machine table and the feed direction is from the left.
8. Do not reach underneath table or put your hands or fingers at any time in the cutting path while tool is connected to a power supply.
9. Never thickness timber between the back of the cutter and the backfence.

Useful Advice When Routing

1. Judge your feed rate by the sound of the motor. Feed the router at a constant feed rate. Too slow a feed rate will result in burning.
2. Trial cuts should be made on waste material before starting any project.
3. When using some attachments e.g. a router table or dovetail jig, a fine height adjuster is recommended.
4. When using a template guide bush, ensure there is sufficient clearance between cutter tip and inside edge of bush and that it cannot come into contact with collet and nut. Ensure cutter and guide bush are concentric.

Router Cutter Repair/Maintenance

1. Repair of tools is only allowed in accordance with the manufacturers instructions.
2. The design of composite (tipped) tools shall not be changed in process of repair. Composite tools shall be repaired by a competent person i.e. a person of training and experience, who has knowledge of the design requirements and understands the levels of safety to be achieved.
3. Repair shall therefore include, e.g. the use of spare parts which are in accordance with the specification of the original parts provided by the manufacturer.
4. Tolerances which ensure correct clamping shall be maintained.
5. Care shall be taken that regrinding of the cutting edge will not cause weakening of the body and the connection of the cutting edge to the body.

**ITEMS
ENCLOSED**

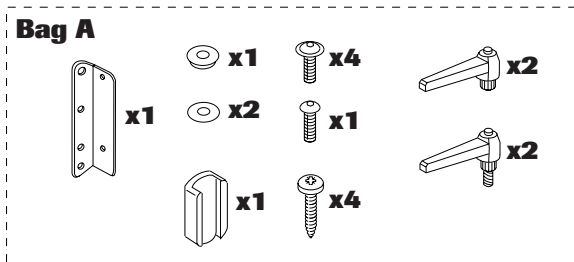
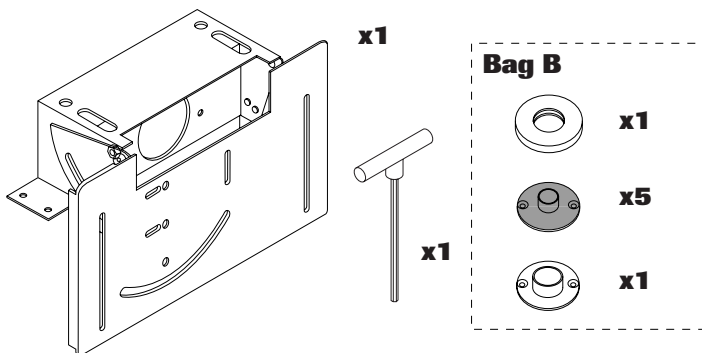

**Please note: Guide bushes
supplied with jig could be
a mix of plastic and metal.**

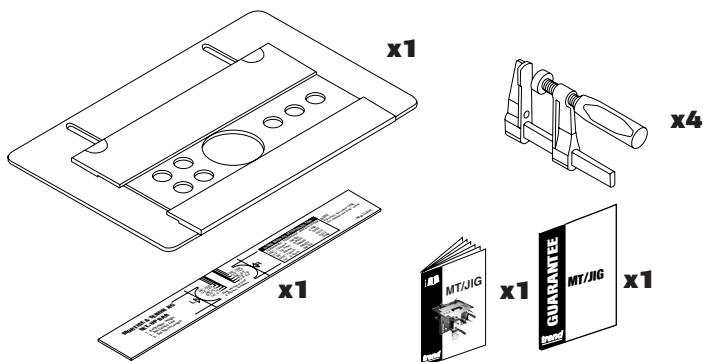

ITEMS REQUIRED

- Plunge router with suitable collet fitted.
- Router cutter set Ref. SET/MT1 for Imperial Jig or Ref. SET/MT2 for Metric Jig.
- Hand tools.
- Spanner 10mm A/F.

**DESCRIPTION
OF PARTS**

(A) Female adjustable lever

(B) Top plate assembly

(C) Template clamp (back)

(D) Long template

(E) Set-up bar

(F) Template clamp (front)

(G) Male adjustable lever

(H) F clamp handle

(I) Short template

(J) Main body

(K) Tilting back plate

(L) Vertical guide

(M) Flanged machine screw

(N) F clamp bar

(O) Collar
Imperial 25.4mm - 54mm
Metric 30mm - 54mm

(P) Plastic guide bushes

(Q) Metal guide bush

(R) F clamp cap

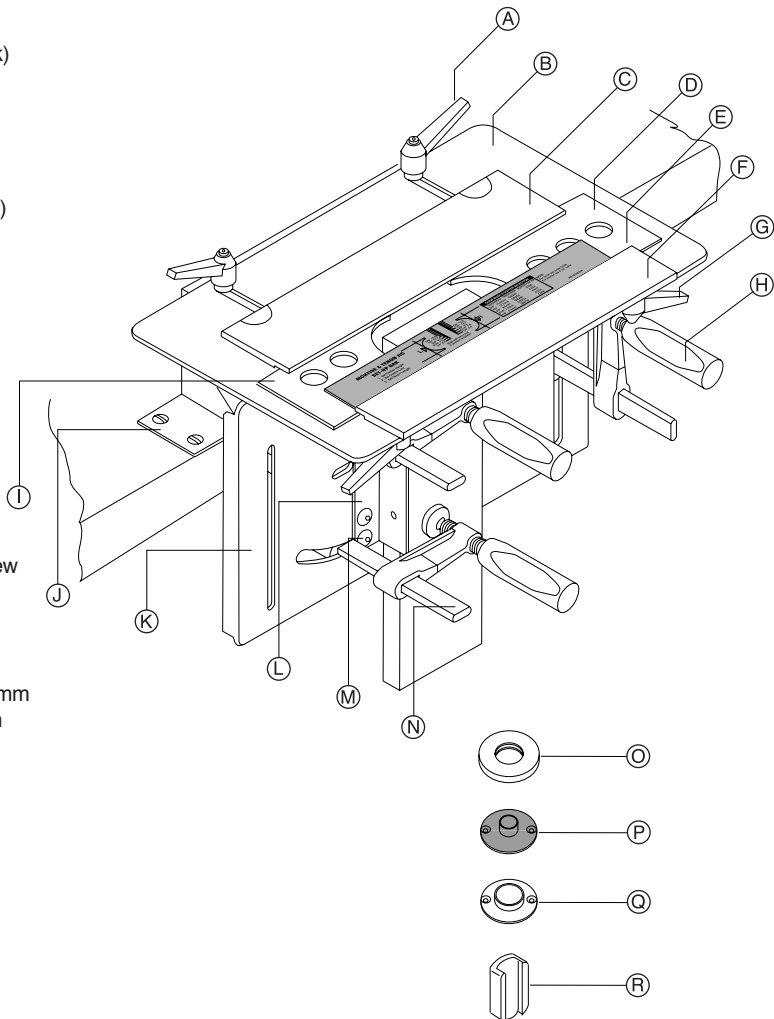

ACCESSORIES

Please use only Trend original accessories.

Suitable Router Cutters

Although standard router cutters can be used having the appropriate diameter, a set of five long reach straight cutters with 1/4" or 8mm shanks are available. Spiral bits can be used for an improved finish.

Imperial Jig Cutter Set

Ref. SET/MT1X1/4TC or
SET/MT1X8MMTC or SET/MT1X1/2TC

Metric Jig Cutter Set

Metric Euro jig requires cutter set
Ref. SET/MT2X8MMTC.

Dia.	Ref.	Set Ref.
6.3mm (1/4")	C008	SET/MT1
7.9mm (5/16")	C012	
9.5mm (3/8")	C015	
12.7mm (1/2")	C022	
15.8mm (5/8")	C026	
Other cutters for alternative Tenon		
4.8mm (3/16")	C003	
11.1mm (7/16")	C018A	
14.3mm (9/16")	C024	

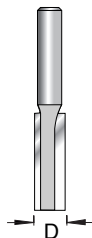

Dia.	Ref.	Set Ref.
6mm	C005A	SET/MT2
8mm	C012A	
10mm	C016B	
12mm	C171	
16mm	C025B	
Other cutters for alternative Tenon		
14mm	C023B	

These cutters are also available separately.

Optional Extraction Dust Kit

Ref. MT/DUSTKIT

For dust-free working, this kit allows connection to a 39mm OD or 57mm OD hose.

The dust shield is only used when routing 90° tenons.

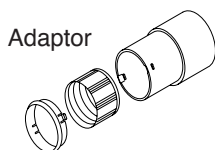
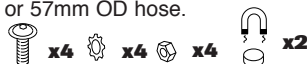

Adaptor

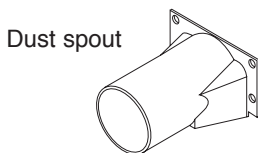

Dust spout

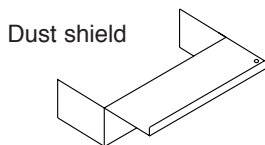

Dust shield

Metal Guide Bushes

These can be purchased to replace the plastic versions supplied with the jig or for alternative sizes of tenons.

IMPERIAL JIG	
Dia.	Ref.
15.9mm (5/8")	GB158
22.2mm (7/8")	GB222
23.8mm (15/16")	GB238
27mm (1 1/16")	GB27
28.6mm (1 3/8")	GB286
30.2mm (1 3/16")	GB302
31.8mm (1 1/4")	GB318
33.3mm (1 5/16")	GB333

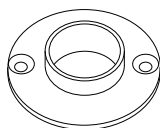

METRIC JIG	
Dia.	Ref.
15.9mm	GB158
22mm	GB22
26mm	GB26
28mm	GB28
30mm	GB30
32mm	GB32

ASSEMBLY & ADJUSTMENT

① Secure the tilting back plate in its 45° position with the two hex screws.

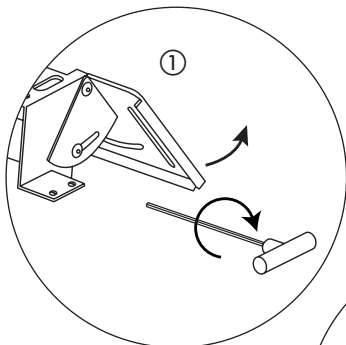

② Position the main body on the edge of the workbench or workboard and drill four 3mm/1/8" holes 15mm deep.

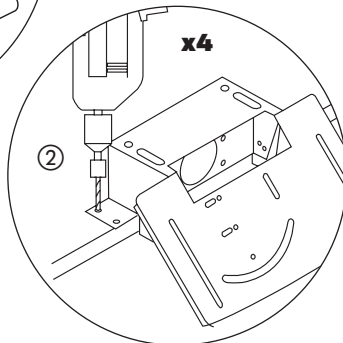

③ Secure the jig with the 4 self-tapping screws with a No.2 Pozi screw driver.

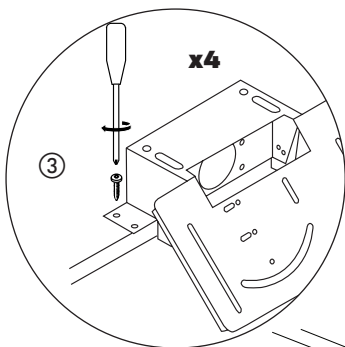

④ Fit the three F clamps and vertical guide as shown. Screws will thread into the tapped holes in the clamps. Noting that the longer hex screw without a flange is used in conjunction with the pivot bush.

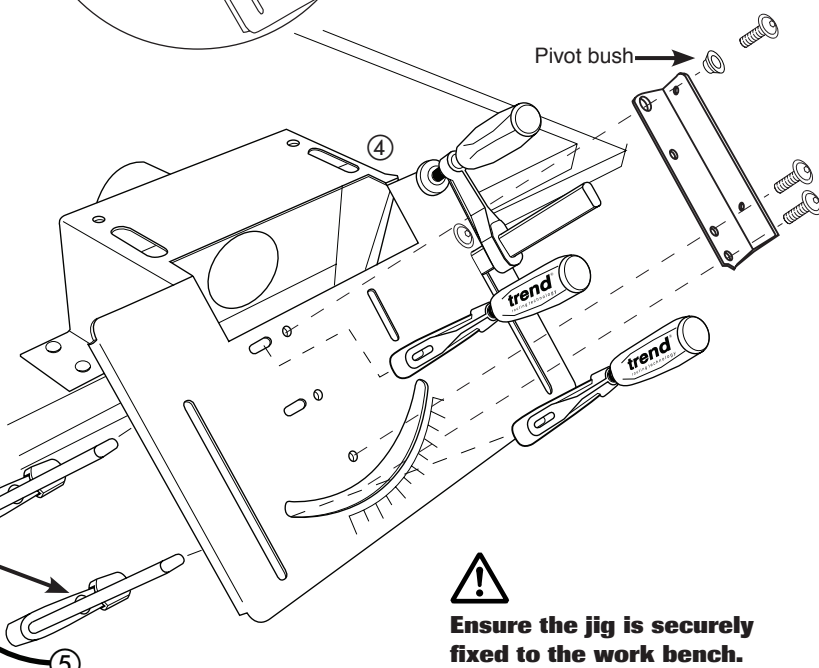

⑤ Return the tilting back plate to the 0° position and lock.

Tapped holes

Pivot bush



Ensure the jig is securely fixed to the work bench.

Assembly of the Top Plate

- ① Remove the transit nuts with a 10mm spanner and discard.
- ② Fit the two female adjustable levers. If fitting the optional dust extraction kit refer to page 11.
- ③ Turn the top plate over so that it's facing up and secure the top plate with the two male adjustable levers and washers.

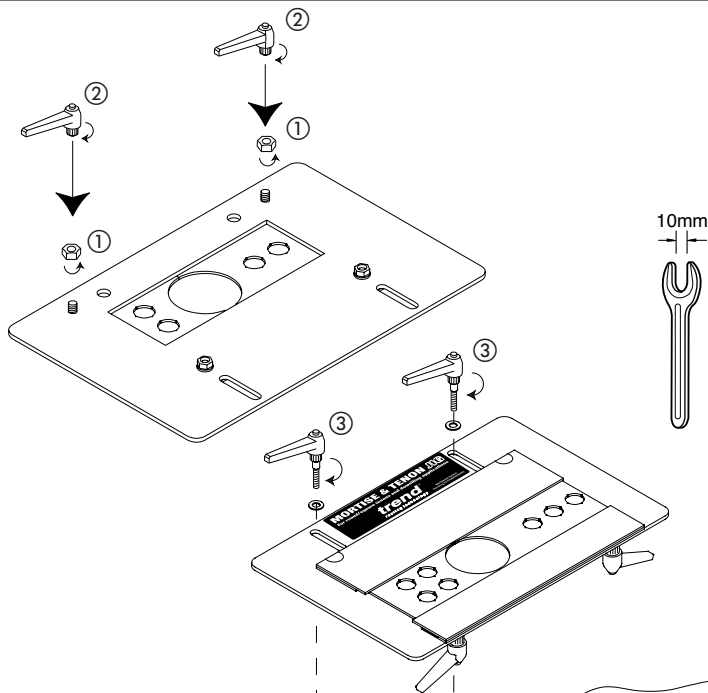

Ensure jig is at a suitable and comfortable working height.



Keep proper footing at all times.



To adjust tightness of the templates undo the nuts on the underside of the top plate. Holding the plate clamping piece by the thumb notches, gently tap the plate to reset. Tighten the nuts to secure.

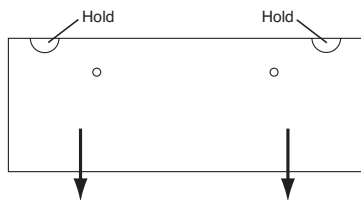
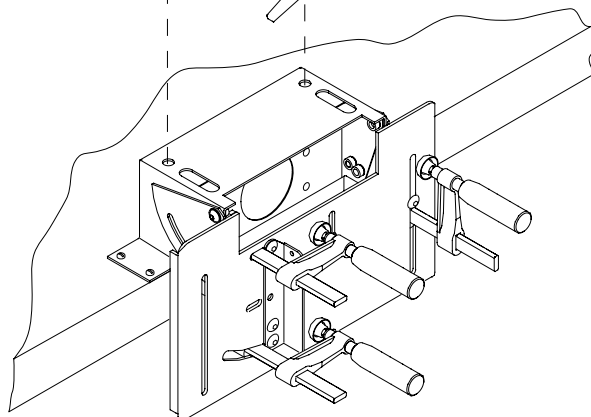

Cutter & Guide Bush Selection

①

$$X = \frac{W}{3}$$

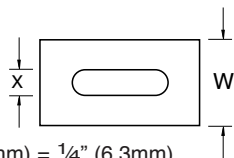

Example

Tenon Width (X) = $\frac{\text{Timber width of (W)} \frac{3}{4}'' (19\text{mm})}{3} = \frac{1}{4}'' (6.3\text{mm})$

① Calculate an appropriate tenon width 'X' for the timber width 'W' e.g. $X = \frac{1}{4}''$ and choose the nearest appropriate tenon width from the chart below.

②

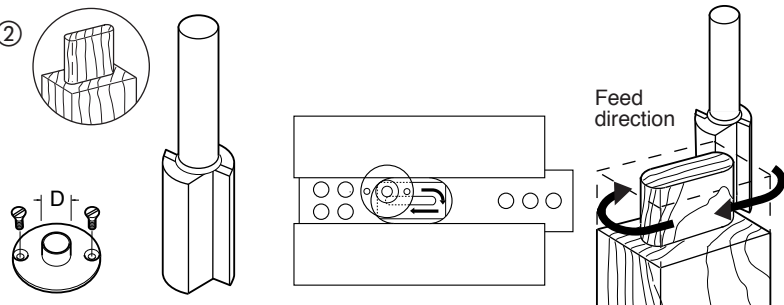

② For the tenon choose the appropriate guide bush diameter 'D' from the chart below for the tenon width, e.g. $D = 1 \frac{1}{4}''$. Tenon cutter will always be Ref. C026.

③

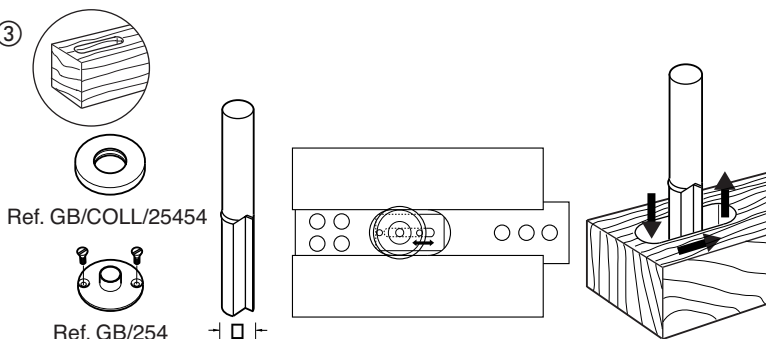

③ For the mortise choose the cutter to suit the tenon width 'X' e.g. C008. Guide bush will always be the metal GB254 fitted with the collar.

Imperial Jig - UK

TENON WIDTH Imperial X	TENON			MORTISE	
	Guide Bush Diameter D	Guide Bush Ref.	Cutter Ref.	Guide Bush Dia (Ref.)	Cutter Ref.
$\frac{1}{4}'' (6.3\text{mm})$	$1 \frac{1}{4}'' (31.8\text{mm})$	GB318	Use	Use	C008
$\frac{5}{16}'' (7.9\text{mm})$	$1 \frac{3}{16}'' (30.2\text{mm})$	GB302	C026	1" (GB254)	C012
$\frac{3}{8}'' (9.5\text{mm})$	$1 \frac{1}{8}'' (28.6\text{mm})$	GB286	for	plus	C015
$\frac{1}{2}'' (12.7\text{mm})$	1" (25.4mm)	GB254	all	collar	C022
$\frac{5}{8}'' (15.8\text{mm})$	$\frac{7}{8}'' (22.2\text{mm})$	GB222	cuts.		C026
Other sizes possible.*					
$\frac{3}{16}'' (4.8\text{mm})$	$1 \frac{5}{16}'' (33.3\text{mm})$	GB333			C003
$\frac{7}{16}'' (11.1\text{mm})$	$1 \frac{1}{16}'' (27\text{mm})$	GB27			C018A
$\frac{9}{16}'' (14.3\text{mm})$	$1 \frac{5}{16}'' (23.8\text{mm})$	GB238			C024

*Guide bushes not included with jig.

Metric Jig - Euro

TENON WIDTH Metric X	TENON			MORTISE	
	Guide Bush Diameter D	Guide Bush Ref.	Cutter Ref.	Guide Bush Dia (Ref.)	Cutter Ref.
6mm	32mm	GB32	Use	Use	C005A
8mm	30mm	GB30	C025B	30mm (GB30)	C012A
10mm	28mm	GB28	for	plus collar	C016B
12mm	26mm	GB26	all	Ref.	C171
16mm	22mm	GB22	cuts.	GB/COLL/3054	C025B
Other sizes possible.*					
14mm	24mm	GB24			C023B

*Guide bushes not included with jig.

Fitting the Guide Bushes

The guide bushes supplied with the jig will fit all TBC routers as listed.



TREND T3, T5, T5MK2, T9, T10, T11

AEG OF450S, 500S, OFE710

ATLAS COPCO OFS50, 720, OFSE850, 1000

AXMINSTER AW635R

BLACK&DECKER SR100, BD780(E),

KW779, 780(E), 800(E), 850ET

CHAMPION CPR850

CHALLENGE 1020W

CHALLENGE EXTREME MR5757

CLARKE CR1

DEWALT DW613, 614, 615

DRAPER R850V

EINHELL EOF850SP

ELU MOF96(E) Mk2, MOF69

FERM FBF-6E, 8E

FELISATTI R346EC

HOLZHER 2335, 2336, 2356

JCBP PR, 1217

KANGO R8550S

KRESS FM6955

NUTOOL NPT850, 102

PERFORMANCE POWER 1020W

PERLES OF808(E), OF2-808(E)

POWER DEVIL PDW5026, 5027, 5037PRA

POWER MASTER 710W

SILVERLINE SL762

STAYER PR50

VIRUTEX FR77C, 78C, 66F

WICKES 900W, 1200W

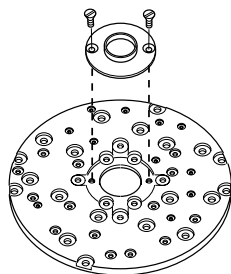

Ref. UNIBASE

A sub-base Ref. Unibase will be required for all other makes of router as listed.

ATLAS COPCO OFSE2000

B&D BD780(E), KW779, 780(E), 800(E), SR100

BOSCH POF52A, 400A, 500A, 600ACE,

800ACE, GOF900A, 900ACE, 1300ACE,

1600A, 1700ACE

CASALS FT750, 1000E, 2000VCE

DEWALT DW620, 621, 624, 625EK, 629

DRAPER R1900V

ELU OF97E, 131, 177(E) MK2

FESTO OF900E, 1000E, 1010EBC, 2000E

FREUD FT1000(E), 2000(E)

FELISATTI TP246(E)

HITACHI FM8, ZK2008, M8, 8V, 12(V), M12SA

MAFELL LO50E

MAKITA RP0910, 1110C, 3600B, 3620,

3612BR, 3612(C)

MAX PRO MIR-KW02-12

METABO OF528, 1028, 1612, OFE1229, 1812

PEUGEOT DEF570E, DF55E

RYOBI R150, 151, 155, 500, 502, 600, 600N,

RE120, RE155K, RE600(N), RE601,

SKIL 1835U, 1875U1

SPARKY X52E

WADKIN R500

**Fitting the
Optional Dust
Extraction Kit.**

Ref. MT/DUSTKIT

① Fit the dust spout using the 4 bolts, shake-proof washers and nuts.

② Assemble the ring, fitting and body of the adaptor onto the 39mm hose if required.

③ Fit the two magnets by gently knocking them into the front edge on the underside of the top plate with a wooden mallet until flush.

④ The optional dust shield should only be fitted when cutting 90° tenons. It is held in place by magnets.

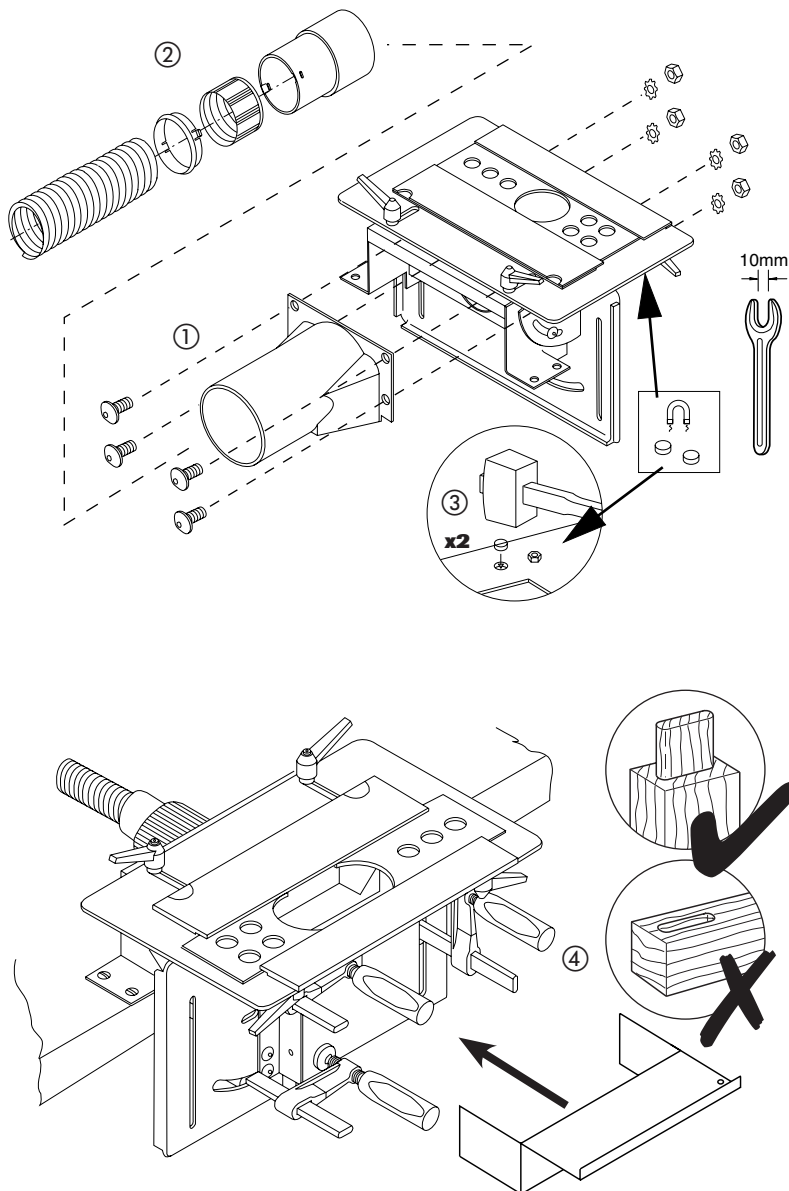

**TIMBER PREPARATION
& MARKING OUT**

**Marking Out
the Tenon**

① It is essential that the timber be square all round. Study the drawings and select the appropriate type of tenon.

② Mark up the centre line on the end of the first piece of timber using a marking gauge.

③ Mark the tenon end marks using a set square. Generally aim for the end tenon marks to be equal to the width of the tenon (X). This may not always be possible for side angled tenons as the length of the tenon and the angle required may cause restrictions.

④ Mark out the length of the tenon. Generally keep the tenon as long as possible for increased gluing surface. For through tenons, make the tenon length equal to the timber width plus 3.2mm (1/8") for trimming afterwards

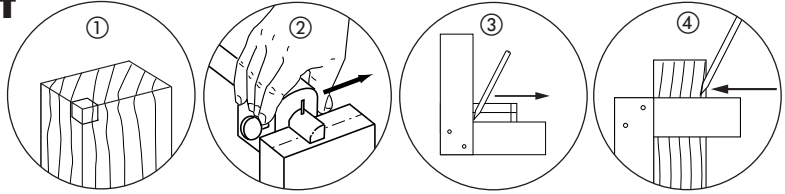

Straight tenon

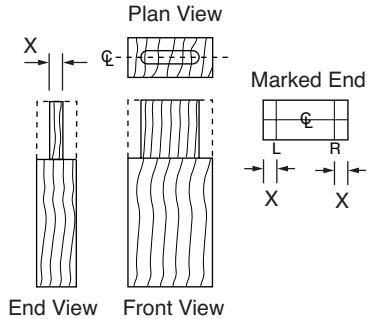
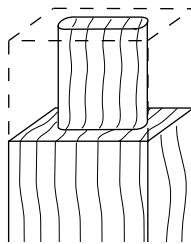

30° Side angled tenon

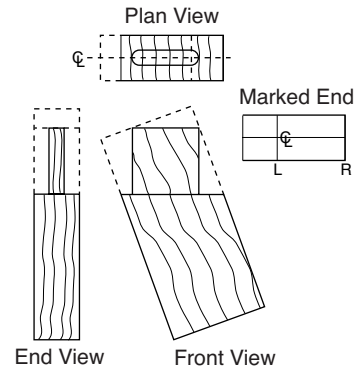
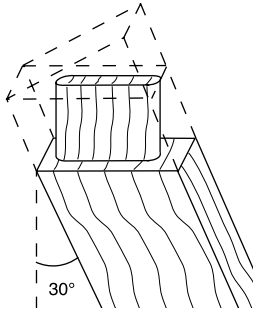

15° Front angled tenon

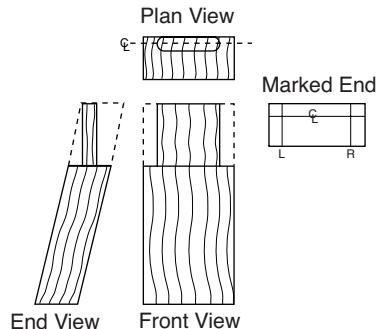
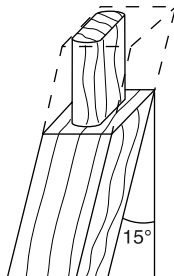

**When mounting timber
in the jig keep the face
side towards the jig.**

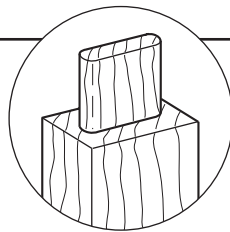

OPERATION



Set Timber Height



① Place set-up bar on templates and push it against touching clamping plate (A).

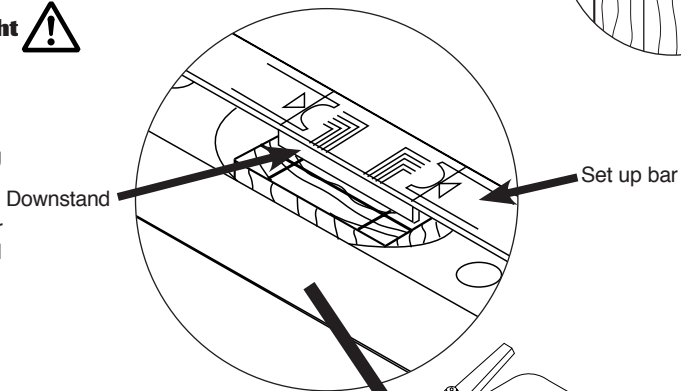

② & ③ Place timber up against vertical guide (B) and raise until it touches downstand of set-up bar.

④ Tighten F clamp handles securely.

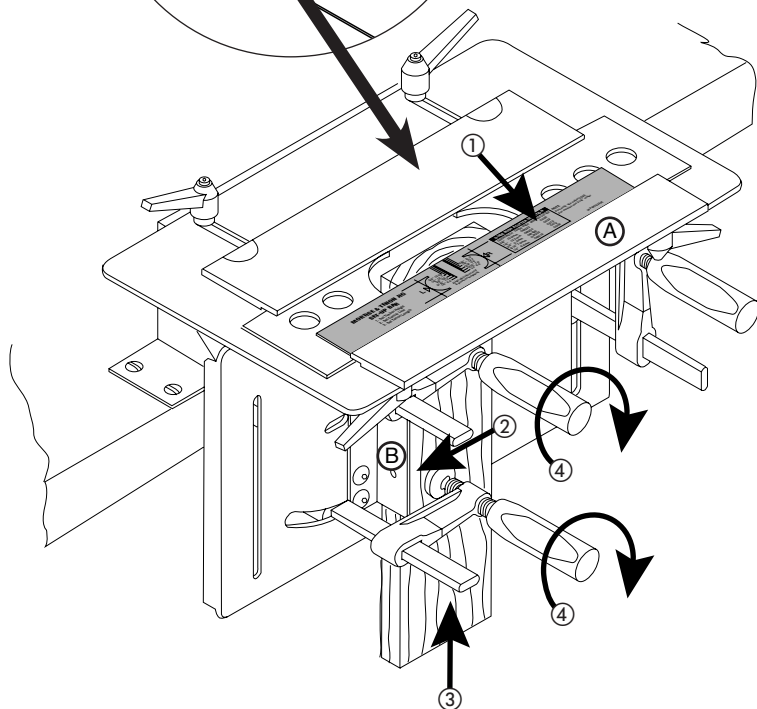

Ensure working position is comfortable. Keep proper footing and balance at all times.

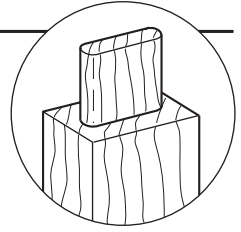

Set Tenon Length

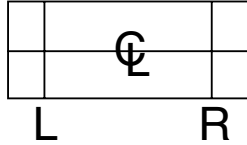

- ① Release levers.
- ② Align mark on set-up bar with relevant left hand tenon mark. E.g. 1/4" mark if using 3/4" timber.
- ③ Slide left hand template to the right until it contacts the down stand of the set bar.
- ④ Tighten lever.
- ⑤ Repeat procedure ① to ④ for right hand template using relevant right hand mark on set-up bar.

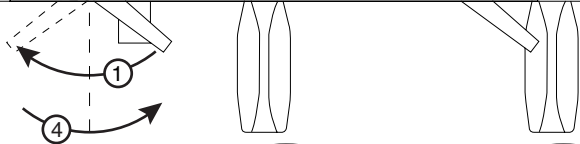
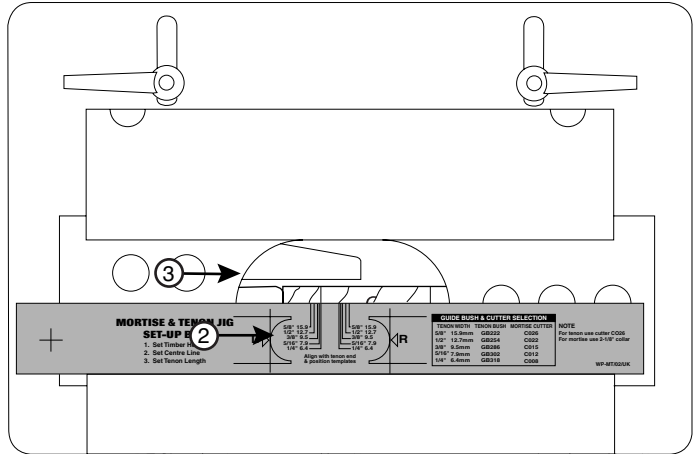

NOTE:
Problems with tenons of 5/8" may occur as corners of the timber may remain after normal routing procedures. This can be overcome by routing material A and B prior to routing the tenon.

First move the top plate approximately 1/4" forwards and rout away material A. Then move the top plate 1/4" rearwards of the tenon centre line and rout away material B. Then continue to set-up the top plate and rout as normal.

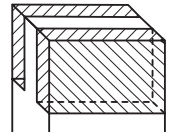
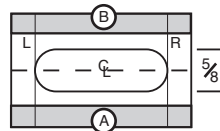
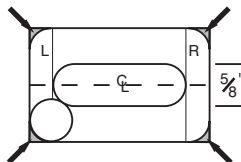
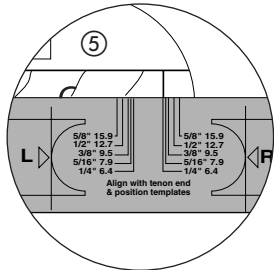
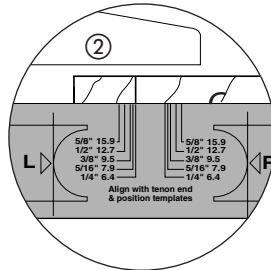

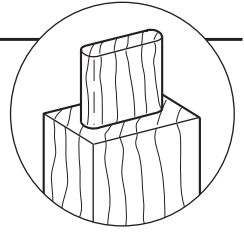

Set Centre Line



- ① Release levers.
- ② Adjust position of top plate until the down stand of the set-up bar aligns with the centre line.
- ③ Tighten levers.

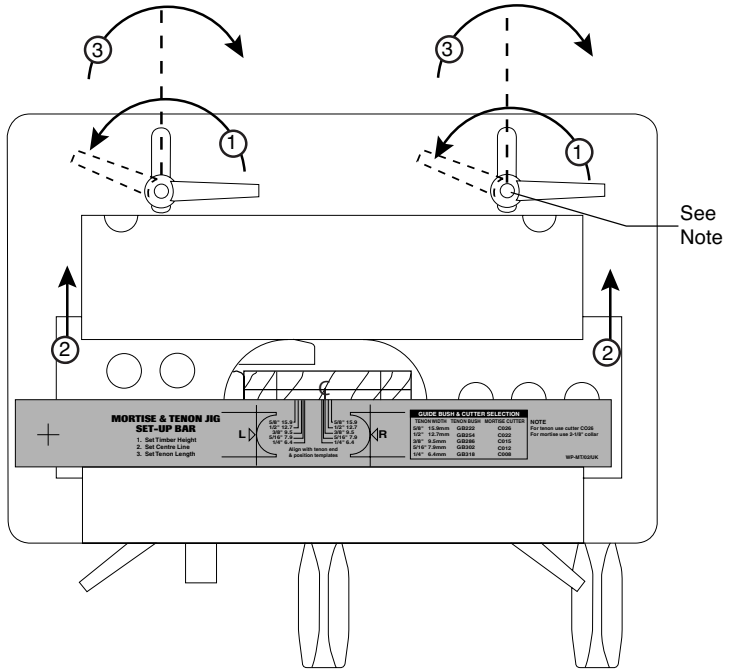

NOTE:
If routing a long mortise on maximum size timber it may be necessary to remove the right hand male adjustable lever and replace it with an unused F clamp flanged machine screw Ref. WP-SCW/73.

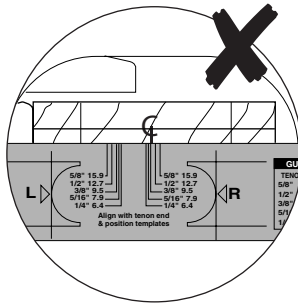

②

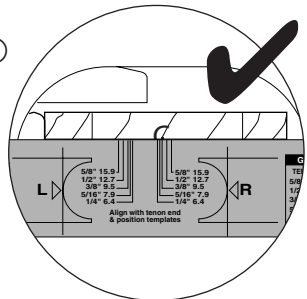

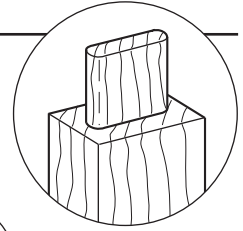

Routing Procedure



① After fitting the Ref. C026 bit and appropriate guide bush, lower cutter down until it touches end of timber and lock off plunge of router.

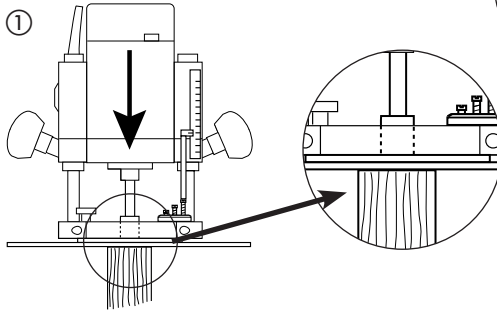

② Raise and lock the depth stop to the length of the tenon required.

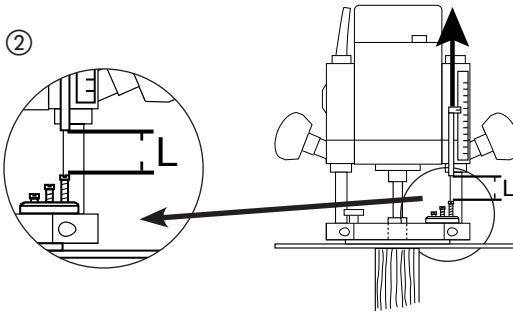

③ Plunge and rout in a clockwise direction at a depth of no more than 3/16" in repeated passes until the full depth is reached as set by the depth stop.

However care should be taken to ensure the guide bush is kept firmly pressed against the circles of the templates and edges of the clamping plates. Should some splintering of the timber occur then pre-scribing the shoulder line with a sharp knife is advisable.

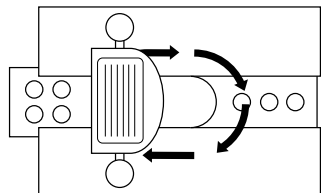
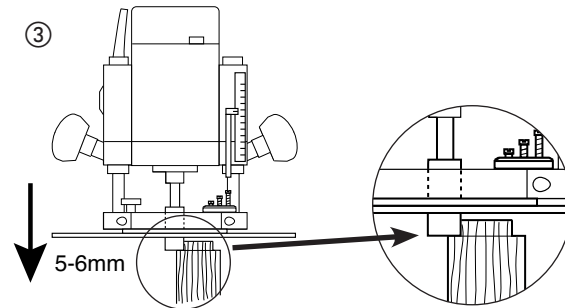

Retract bit into the router base before raising the router up from the jig.



Take shallow passes at a slow steady pace with a sharp cutter to prevent snatching.

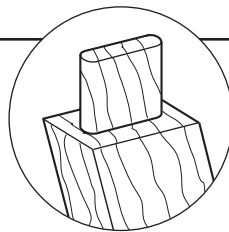

Side Angled Tenon

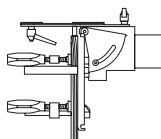
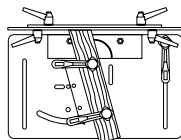

- ① Remove bolt A if fitted. Undo bolt B. Remove the lower F clamp head. Adjust the position of the vertical guide as required.

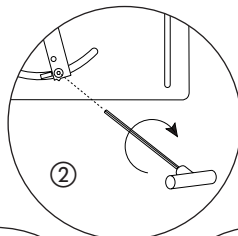
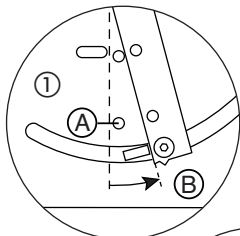

- ② Tighten the bolt B with the hex key and refit the F clamp head.

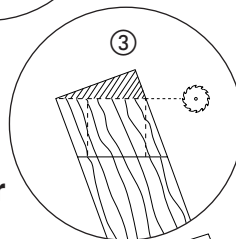
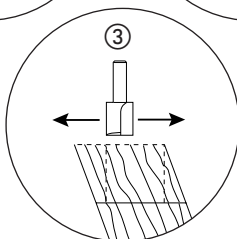

or

- ③ Rout the end of the timber parallel to the top plate or cut it at the appropriate angle on a snip-off saw.



- ④ Fit and clamp the timber at the correct height using the set-up bar. (See p.13)

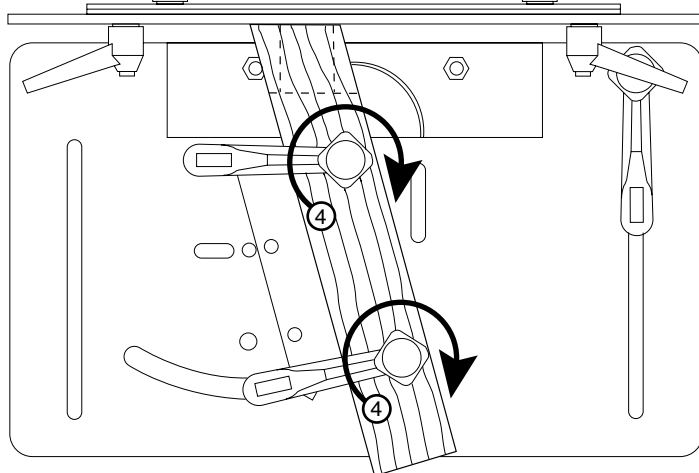

Set the templates to the required tenon length. (See p.14)

Set the top plate to the centre line. (See p.15)

- ⑤ Set the depth of cut and rout in increasing depths to complete the tenon. (See p.16)

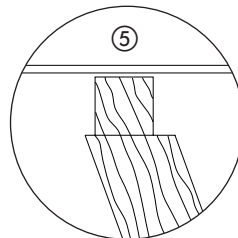
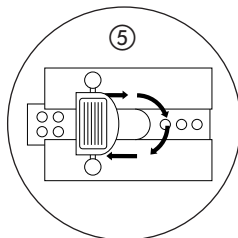

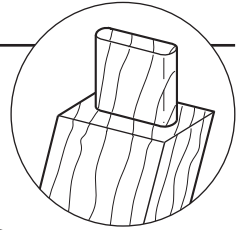

Front Angled Tenon

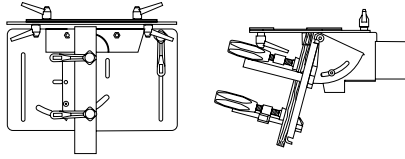

- ① Remove the two side bolts. Adjust the tilting back plate to the position required.
- ② Tighten the two side bolts with the hex key.
- ③ Rout the end of the timber parallel to the top plate or cut at the appropriate angle on a snip-off saw.

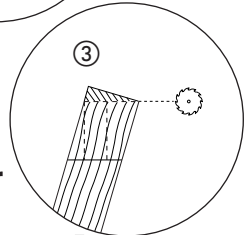
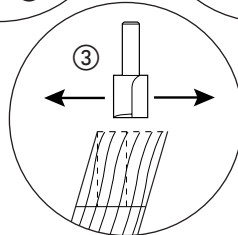
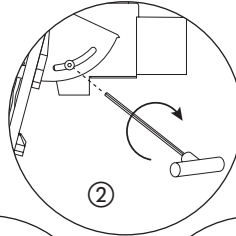
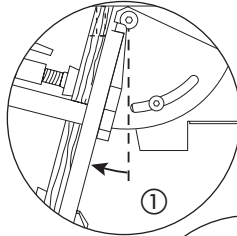

or

- ④ Fit and clamp the timber at the correct height using the set-up bar. (See p.13)

Set the templates to the required tenon length. (See p.14)

Set the top plate to the centre line. (See p.15)

- ⑤ Set the depth of cut and rout in increasing depths to complete the tenon.

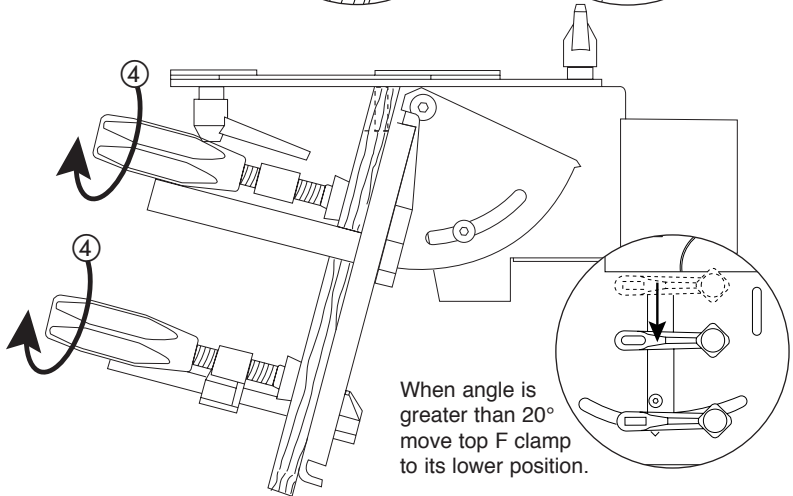

When angle is greater than 20° move top F clamp to its lower position.

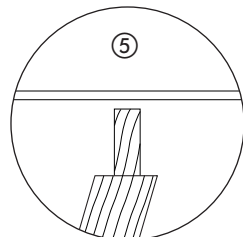
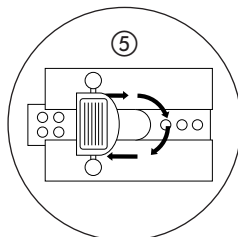

Setting Up for the Mortise



(A)
① Clamp the timber for the mortise horizontally flush underneath the top plate.

② When narrow timbers are to be used and when the mortise is at the end of the timber, the fourth F clamp can be used to secure it. The plastic cap should be fitted as shown.

③ A scrap piece of timber can also be clamped vertically to give support and to assist in positioning of the horizontal timber.

(B) This alternative set-up with fourth F clamp fitted in position on the left slot of the tilting back plate can be used.

(C) Wider timber can be also accommodated by using the top clamp of the vertical guide.

(D) Or removing the vertical guide and clamps and using a clamp in the left slot of the tilting back plate.

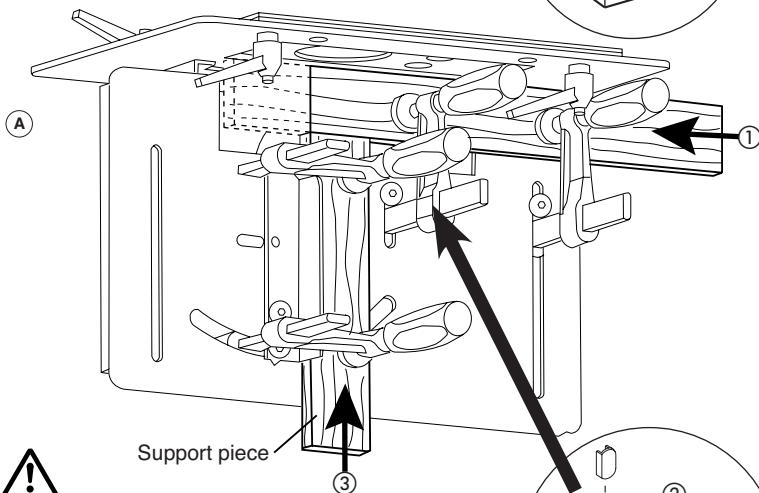

When cutting at the end of the timber it is advisable to add extra support or alternatively use a longer length of timber and then cut it to length.

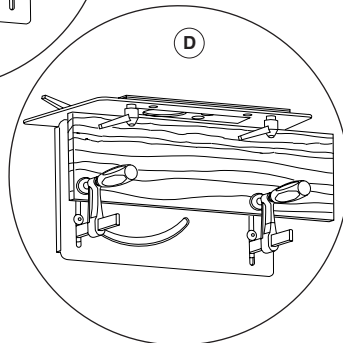
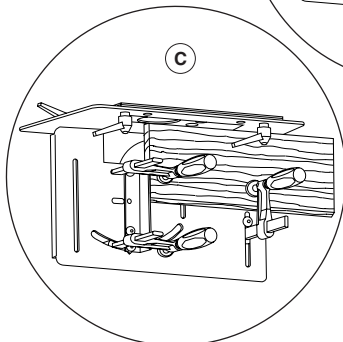
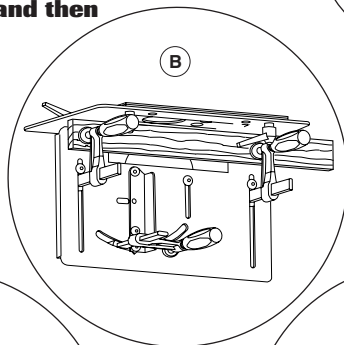
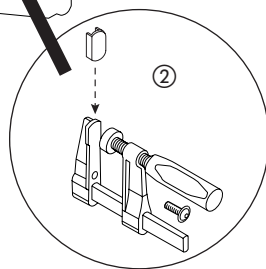

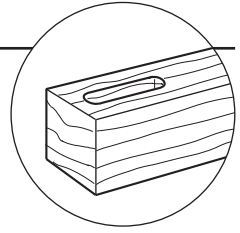

Cutting the Mortise



① After fitting appropriate cutter and 1" guide bush Ref. GB254. Lower cutter down until it touches end of timber and lock off plunge of router.

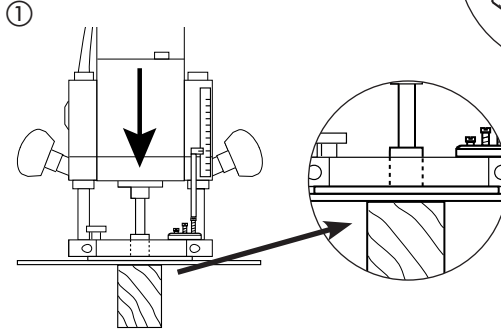

② Raise and lock the depth stop to the length of the tenon required plus 2mm.

③ Plunge and rout backwards and forwards at a depth of no more than 5-6mm in repeated passes until the full depth is reached as set by the depth stop.

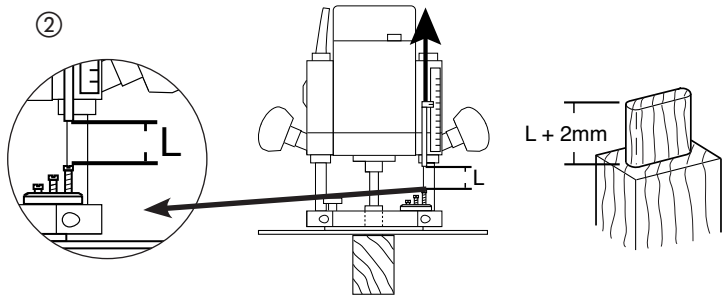

If when in use the sliding left-hand and right-hand templates slip, then the shims under the front and back clamp plate can be removed. To remove clamping plate undo locking nut on underside of the top plate. Refit in reverse order.

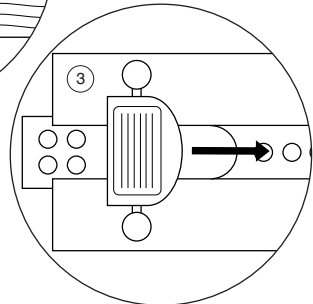
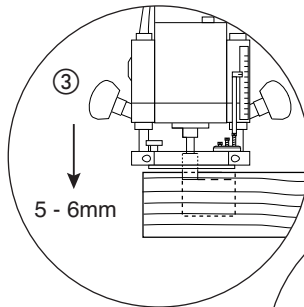

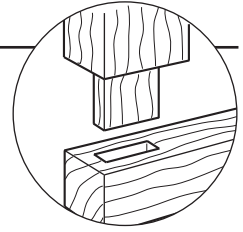

Square Mortise & Tenons



Tenons

- ① Release locking levers.
- ② Turn each template around. Set-up positions of top plate and templates as for round tenons.
- ③ Rout in a clockwise direction following the template.

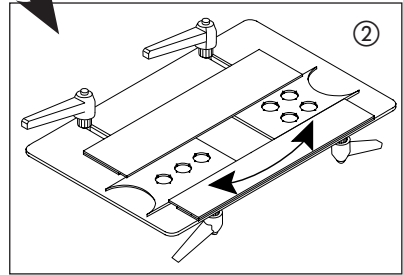
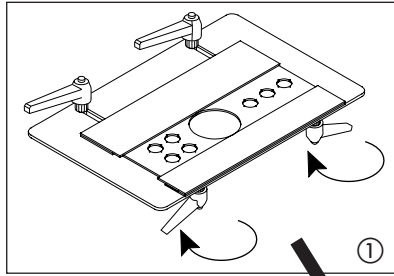

Mortise

- ④ The mortise is routed in the same way. Square the ends of the mortise with a suitable size of chisel.

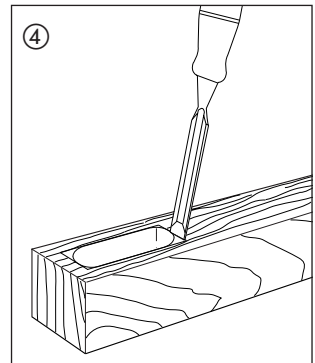
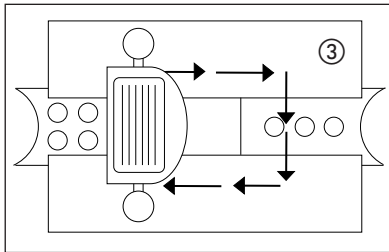

Dowelling



① Select and fit the 5/8" plastic guide bush and a straight router cutter to suit the diameter of the dowels being used.

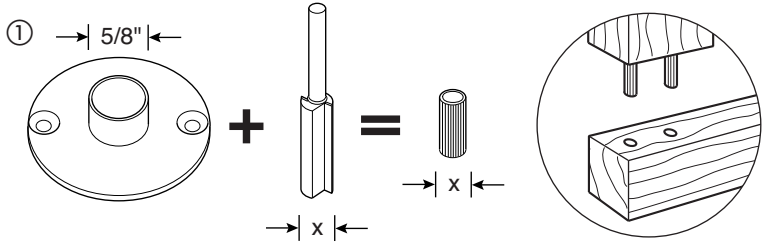

② Select the short or long template depending on the formation of holes to be used.

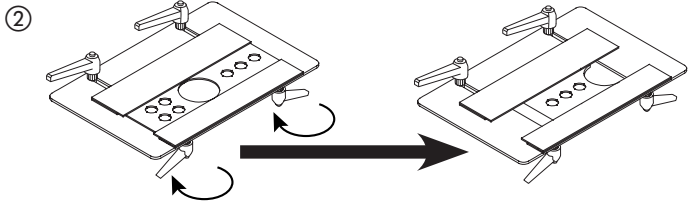

③ Mark the timber centre line and dowel positions. Note the template hole centres are at 1" (25mm) centres.



④ Set-up and secure the timber in the same way as for mortise and tenons. But align the top plate using the centre line notches on the template holes. Set the cutter depth to slightly more than half the dowel length.

Locate the guide bush in each hole and rout the holes in a series of plunge cuts to prevent waste from packing around the cutter.

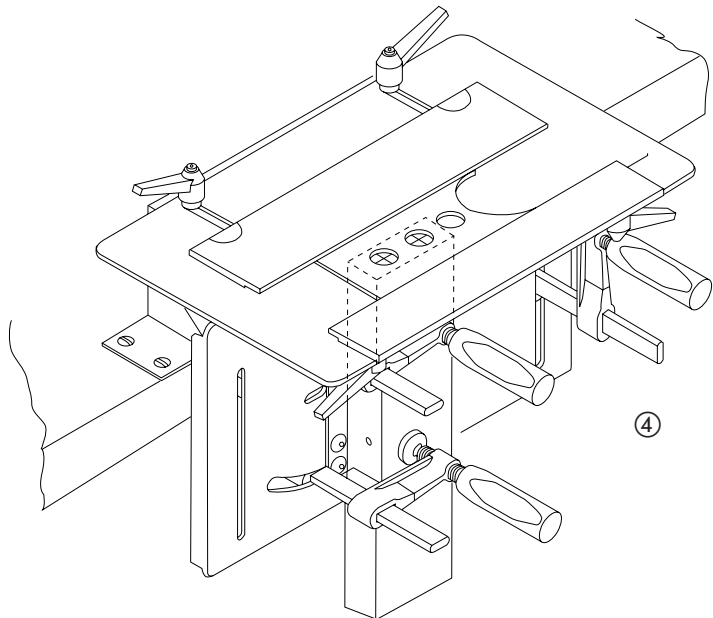

Dowelling the Horizontal Timber Section



- A**
- ① Position the horizontal timber tight to the underside of the top plate.
 - ② Then clamp it securely using a vertical timber piece as a support.
 - ③ Plunge rout the holes as before.

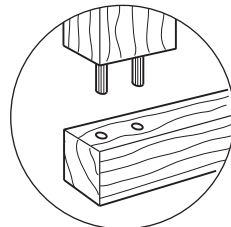
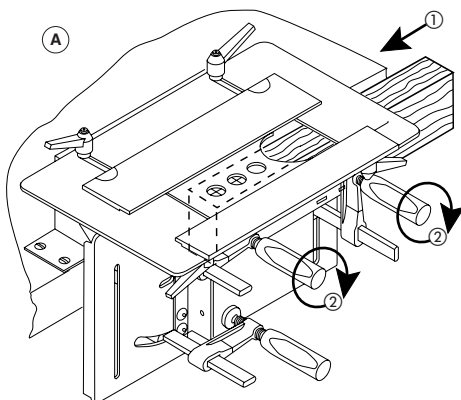

- B**
- Use the short plate for an alternative formation of holes.

After use, keep jig assembled and store jig carefully.

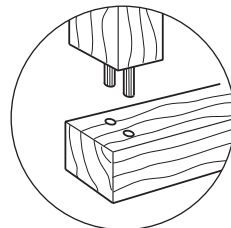
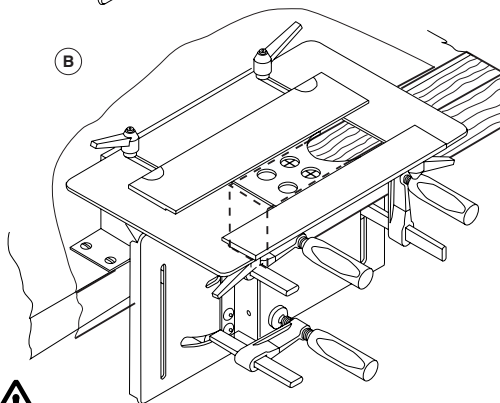

MAINTENANCE



Please use only Trend original spare parts and accessories.

This jig has been designed to operate over a long period of time with a minimum of maintenance. Continual satisfactory operation depends upon proper tool care and regular cleaning.

Cleaning

- Regularly clean the jig with a soft cloth.

Lubrication

- Your jig requires no additional lubrication.

Storage

- After use, store jig in its packaging or place in a cupboard.

ENVIRONMENTAL PROTECTION



Recycle raw materials instead of disposing as waste.

Packaging should be sorted for environmental-friendly recycling.

The product and its accessories at the end of its life should be sorted for environmentally friendly recycling.

GUARANTEE

The jig carries a manufacturers guarantee in accordance with the conditions on the enclosed guarantee card.

MT/JIG - SPARE PARTS LIST Please use only Trend original spare parts.			v3.0 01/2017
No.	Qty.	Desc.	Ref.
1	4	F Clamp for MT/JIG with Screw	WP-MT/01A
2	1	MT/JIG Set-up Bar (Imperial/Metric Scale) UK	WP-MT/02/UK
	1	MT/JIG Set-up Bar (Metric Scale) EURO	WP-MT/02/EURO
3	1	Label Trend MT/JIG	WP-MT/03
4	1	Main Body	WP-MT/04
5	1	Vertical Guide	WP-MT/05
6	1	Inner Body	WP-MT/06
7	1	Tilting Back Plate	WP-MT/07
8	1	Top Plate	WP-MT/08
9	1	Back Clamp Plate Packing Piece	WP-MT/09
10	3	Pivot Bush	WP-MT/10
11	1	F Clamp Square Cap	WP-MT/11
12	1	Back Clamp Plate	WP-MT/12
13	1	Front Clamp Plate Packing Piece	WP-MT/13
14	1	Front Clamp Plate	WP-MT/14
15	1	Template Long	WP-MT/15
16	1	Template Short	WP-MT/16
17	2	Adjustable Lever M6 x 15mm	CR/KB/PK8
18	3	Machine Screw Button M6 x 16mm Skt	WP-SCW/75
19	2	Adjustable Lever M6 Female	CR/KB/PK9
20	2	Nut Hex M6	WP-NUT/06
21	2	Washer M6 Form C	WP-WASH/12
22	6	Machine Screw Button M6 x 12mm Skt	WP-SCW/73
22A	4	Machine Screw Button M6 x 20mm Flanged Socket	WP-SCW/128
22B	4	Washer M6 Form C	WP-WASH/12
23	1	Guide Bush Set Imperial 6 off UK	WP-MT/23/UK
	1	Guide Bush Set Metric 6 off EURO	WP-MT/23/EURO
24	1	Guide Bush 25.4mm (1") Diameter UK	GB254
	1	Guide Bush 30mm Diameter EURO	GB30
25	1	Guide Bush Collar 25.4mm to 54mm UK	GB/COLL/25454
	1	Guide Bush Collar 30mm to 54mm EURO	GB/COLL/3054
26	1	T Handle Hex Key 4mm x 150mm	HK/T/04
27	4	Self Tapping Screw Pan No.10 x 3/4" Pozi	WP-SCW/108
28	2	Clamping Bar Shims	WP-MT/28
29	1	Manual	MANU/MT
DUST EXTRACTION KIT (OPTIONAL)			
30	1	Dust Kit Complete	MT/DUSTKIT
31	1	Dust Shield	WP-MT/31
32	1	Dust Spout	WP-SRT/16
33	1	Magnet Pack 10mm x 3mm (Pack of 4)	MAG/PACK/2
34	4	Machine Screw Button Flange M6 x 12mm Skt	WP-SCW/73
35	4	M6 Internal Shakeproof Washer	WP-WASH/31
36	4	Nut Hex M6	WP-NUT/06
37	0	Hose Adaptor 58mm to 39mm	CRT/3
38	1	Adaptor Body for CRT/3	WP-CRT/97
39	1	Adaptor Fitting for CRT/3	WP-CRT/98
40	1	Adaptor Clip for CRT/3	WP-CRT/99
CUTTER SETS (OPTIONAL)			
41	0	Cutter Set Imperial 5pc UK	SET/MT1
	0	Cutter Set Metric 5pc EURO	SET/MT2

MT/JIG - SPARE PARTS DIAGRAM

v3.0 01/2017

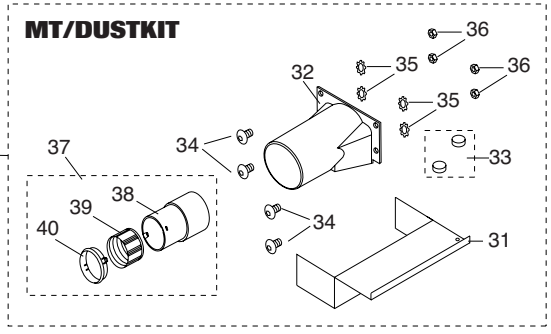
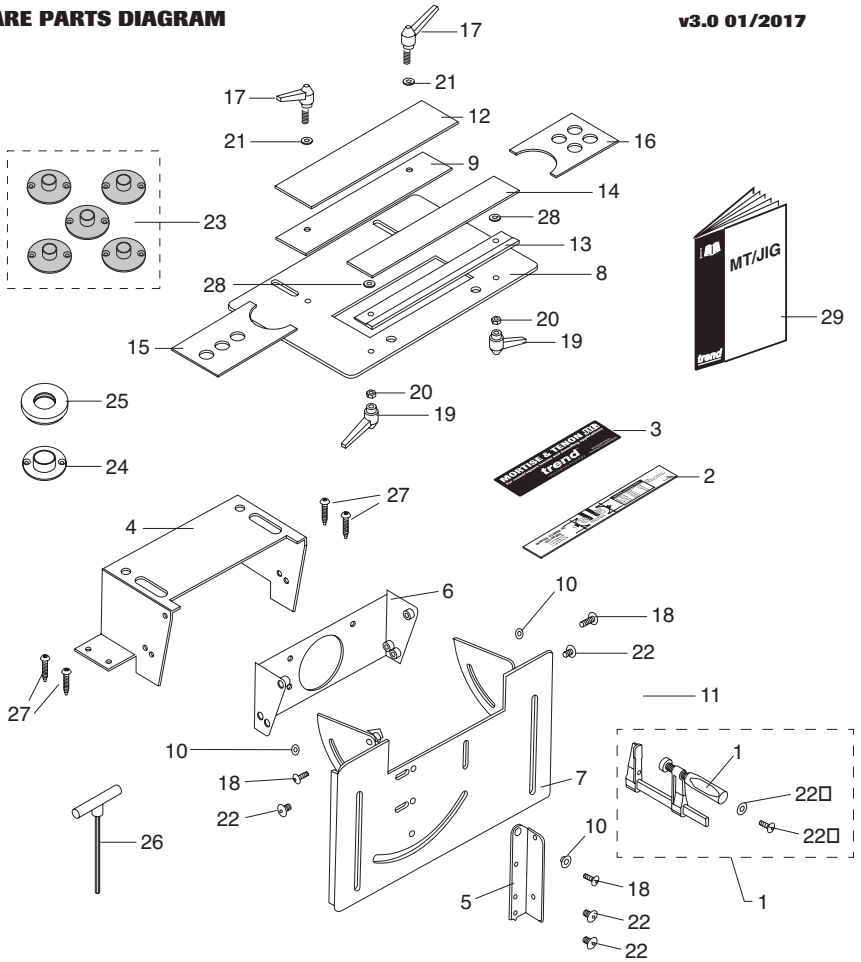

MANU/MT v6.0



RECYCLABLE

Trend Machinery & Cutting Tools Ltd.

Odhams Trading Estate St Albans Road
Watford WD24 7TR England

Tel: 0044(0)1923 249911
technical@trendm.co.uk

www.trend-uk.com

© Copyright Trend 2015, 2016, 2017. No part of this publication may be reproduced, stored or transmitted in any form without prior permission. Our policy of continuous improvement means that specifications may change without notice. Trend Machinery and Cutting Tools cannot be held liable for any material rendered unusable or any form of consequential loss. E&OE

® All trademarks acknowledged.