

FEATURES

SPI with error detection

Includes CRC, invalid read and write address, and SCLK count error detection

Supports burst mode and daisy-chain mode

Industry-standard SPI Mode 0 and Mode 3 interface compatible

Integrated passive components

Route through of digital signals and supplies

Guaranteed break-before-make switching allowing external wiring of switches to deliver multiplexer configurations

1.5 Ω typical on resistance at 25°C (± 15 V dual supply)

0.3 Ω typical on resistance flatness at 25°C (± 15 V dual supply)

0.1 Ω typical on resistance match between channels at 25°C (± 15 V dual supply)

V_{SS} to V_{DD} analog signal range

Fully specified at ± 15 V, ± 5 V, and $+12$ V

1.8 V logic compatibility with 2.7 V $\leq V_L \leq 3.3$ V (excludes SPI readback to a 1.8 V device)

4 mm \times 5 mm, 30-terminal LGA

APPLICATIONS

Automated test equipment

Data acquisition systems

Sample-and-hold systems

Audio and video signal routing

Communications systems

Relay replacement

GENERAL DESCRIPTION

The ADGS1414D contains eight independent SPST switches. A serial peripheral interface (SPI) controls the switches. The SPI has robust error detection features, such as cyclic redundancy check (CRC) error detection, invalid read and write address detection, and SCLK count error detection.

It is possible to daisy-chain multiple ADGS1414D devices together. Daisy-chain mode enables the configuration of multiple devices with a minimal amount of digital lines. The route of digital signals and supplies through the ADGS1414D allows for a further increase in channel density. Integrated passive components eliminate the need for external passive components.

FUNCTIONAL BLOCK DIAGRAM

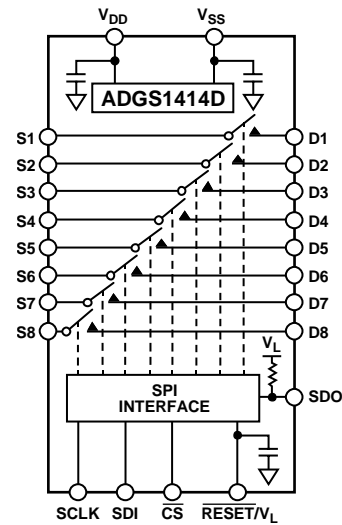

Figure 1.

The ADGS1414D is suited to high density switching applications, such as large switching matrices and fanout applications.

Each switch conducts equally well in both directions when on, and each switch has an input signal range that extends to the supplies. In the off condition, signal levels up to the supplies are blocked.

Multifunction pin names may be referenced by their relevant function only.

PRODUCT HIGHLIGHTS

1. The SPI removes the need for parallel conversion and logic traces and reduces the general-purpose input and output (GPIO) channel count.
2. Daisy-chain mode removes additional logic traces when multiple devices are used.
3. Route through of digital signals and supplies eases routing and allows for an increase in channel density.
4. Integrated passive components eliminate the need for external passive components.
5. CRC error detection, invalid read and write address detection, and SCLK count error detection ensure a robust digital interface.
6. CRC, invalid read and write address, and SCLK error detection capabilities allow for the use of the ADGS1414D in safety critical systems.
7. Minimum distortion.

Rev. 0

[Document Feedback](#)

Information furnished by Analog Devices is believed to be accurate and reliable. However, no responsibility is assumed by Analog Devices for its use, nor for any infringements of patents or other rights of third parties that may result from its use. Specifications subject to change without notice. No license is granted by implication or otherwise under any patent or patent rights of Analog Devices. Trademarks and registered trademarks are the property of their respective owners.

TABLE OF CONTENTS

Features	1	Clearing the Error Flags Register	21
Applications	1	Burst Mode.....	21
General Description	1	Software Reset.....	21
Functional Block Diagram	1	Daisy-Chain Mode.....	21
Product Highlights	1	Power-On Reset.....	22
Revision History	2	Applications Information	23
Specifications	3	System Channel Density	23
±15 V Dual Supply	3	Break-Before-Make Switching	24
±5 V Dual Supply	5	Digital Input Buffers	24
12 V Single Supply	7	Power Supply Rails.....	24
Continuous Current per Channel, Sx or Dx	9	Power Supply Recommendations.....	24
Timing Characteristics	9	1.8 V Logic Compatibility.....	24
Absolute Maximum Ratings	11	Register Summary	25
Thermal Resistance	11	Register Details	26
Electrostatic Discharge (ESD) Ratings	11	Switch Data Register	26
ESD Caution.....	11	Error Configuration Register	26
Pin Configuration and Function Descriptions	12	Error Flags Register.....	27
Typical Performance Characteristics.....	13	Burst Enable Register.....	27
Test Circuits	17	Software Reset Register	27
Terminology.....	19	Outline Dimensions.....	28
Theory of Operation	20	Ordering Guide	28
Address Mode	20		
Error Detection Features.....	20		

REVISION HISTORY

6/2020—Revision 0: Initial Version

SPECIFICATIONS

±15 V DUAL SUPPLY

$V_{DD} = +15\text{ V} \pm 10\%$, $V_{SS} = -15\text{ V} \pm 10\%$, $V_L = 2.7\text{ V}$ to 5.5 V , and $GND = 0\text{ V}$, unless otherwise noted.

Table 1.

Parameter	+25°C	-40°C to +85°C	-40°C to +125°C	Unit	Test Conditions/Comments
ANALOG SWITCH					
Analog Signal Range			V_{DD} to V_{SS}	V	
On Resistance, R_{ON}	1.5			Ω typ	Source voltage, $V_S = \pm 10\text{ V}$, source current, $I_S = -10\text{ mA}$, see Figure 29
On-Resistance Match Between Channels, ΔR_{ON}	1.8 0.1	2.3	2.6	Ω max Ω typ	$V_{DD} = +13.5\text{ V}$, $V_{SS} = -13.5\text{ V}$ $V_S = \pm 10\text{ V}$, $I_S = -10\text{ mA}$
On-Resistance Flatness, $R_{FLAT(ON)}$	0.18 0.3	0.19	0.21	Ω max Ω typ	$V_S = \pm 10\text{ V}$, $I_S = -10\text{ mA}$
	0.36	0.4	0.45	Ω max	
LEAKAGE CURRENTS					
Source Off Leakage, I_S (Off)	± 0.03			nA typ	$V_{DD} = +16.5\text{ V}$, $V_{SS} = -16.5\text{ V}$ $V_S = \pm 10\text{ V}$, drain voltage, $V_D = \mp 10\text{ V}$, see Figure 32
Drain Off Leakage, I_D (Off)	± 0.55 ± 0.03	± 2	± 12.5	nA max nA typ	$V_S = \pm 10\text{ V}$, $V_D = \mp 10\text{ V}$, see Figure 32
Channel On Leakage, I_D (On), I_S (On)	± 0.55 ± 0.15	± 2	± 12.5	nA max nA typ	$V_S = V_D = \pm 10\text{ V}$, see Figure 28
	± 2	± 4	± 30	nA max	
DIGITAL OUTPUT					
Output Voltage Low, V_{OL}			0.4 0.3	V max V max	Sink current, $I_{SINK} = 1\text{ mA}$ $I_{SINK} = 100\text{ }\mu\text{A}$
High, V_{OH}			$V_L - 1.25\text{ V}$ $V_L - 0.125\text{ V}$	V min V min	Source current, $I_{SOURCE} = 1\text{ mA}$ $I_{SOURCE} = 100\text{ }\mu\text{A}$
Digital Output Capacitance, C_{OUT}	4			pF typ	
DIGITAL INPUTS					
Input Voltage High, V_{INH}			2 1.35	V min V min	$3.3\text{ V} < V_L \leq 5.5\text{ V}$ $2.7\text{ V} \leq V_L \leq 3.3\text{ V}$
Low, V_{INL}			0.8 0.8	V max V max	$3.3\text{ V} < V_L \leq 5.5\text{ V}$ $2.7\text{ V} \leq V_L \leq 3.3\text{ V}$
Input Current Low, I_{INL} or High, I_{INH}	0.001			μA typ	Input voltage, $V_{IN} =$ ground voltage, V_{GND} or V_L
Digital Input Capacitance, C_{IN}	4		± 0.1	μA max pF typ	
DYNAMIC CHARACTERISTICS¹					
On Time, t_{ON}	400			ns typ	Load resistance, $R_L = 300\text{ }\Omega$, load capacitance, $C_L = 35\text{ pF}$
Off Time, t_{OFF}	475 160 190	480	485	ns max ns typ ns max	$V_S = 10\text{ V}$, see Figure 37 $R_L = 300\text{ }\Omega$, $C_L = 35\text{ pF}$ $V_S = 10\text{ V}$, see Figure 37

Parameter	+25°C	-40°C to +85°C	-40°C to +125°C	Unit	Test Conditions/Comments
Break-Before-Make Time Delay, t_D	215		170	ns typ ns min	$R_L = 300 \Omega$, $C_L = 35$ pF Source 1 voltage, $V_{S1} =$ Source 2 voltage, $V_{S2} = 10$ V, see Figure 36
Charge Injection, Q_{INJ}	-20			pC typ	$V_S = 0$ V, source resistance, $R_S = 0 \Omega$, $C_L = 1$ nF, see Figure 38
Off Isolation	-76			dB typ	$R_L = 50 \Omega$, $C_L = 5$ pF, frequency, $f = 1$ MHz, see Figure 31
Channel to Channel Crosstalk	-75			dB typ	$R_L = 50 \Omega$, $C_L = 5$ pF, $f = 1$ MHz, see Figure 30
Total Harmonic Distortion + Noise, THD + N	0.014			% typ	$R_L = 110 \Omega$, 15 V p-p, $f = 20$ Hz to 20 kHz, see Figure 33
-3 dB Bandwidth	170			MHz typ	$R_L = 50 \Omega$, $C_L = 5$ pF, see Figure 34
Insertion Loss	-0.2			dB typ	$R_L = 50 \Omega$, $C_L = 5$ pF, $f = 1$ MHz, see Figure 34
Source Capacitance, C_S (Off)	20			pF typ	$V_S = 0$ V, $f = 1$ MHz
Drain Capacitance, C_D (Off)	21			pF typ	$V_S = 0$ V, $f = 1$ MHz
C_D (On), C_S (On)	111			pF typ	$V_S = 0$ V, $f = 1$ MHz
POWER REQUIREMENTS					
Positive Supply Current, I_{DD}	0.04		4.0	μ A typ μ A max	$V_{DD} = +16.5$ V, $V_{SS} = -16.5$ V All switches open
	480		800	μ A typ μ A max	All switches closed, $V_L = 5.5$ V
	480		800	μ A typ μ A max	All switches closed, $V_L = 2.7$ V
Load Current, I_L					
Inactive	6.3		8.0	μ A typ μ A max	Digital inputs = 0 V or V_L
Inactive, SCLK = 1 MHz	14			μ A typ	$\overline{CS} = V_L$ and SDI = 0 V or V_L , $V_L = 5$ V
	7			μ A typ	$\overline{CS} = V_L$ and SDI = 0 V or V_L , $V_L = 3$ V
SCLK = 50 MHz	390			μ A typ	$\overline{CS} = V_L$ and SDI = 0 V or V_L , $V_L = 5$ V
	210			μ A typ	$\overline{CS} = V_L$ and SDI = 0 V or V_L , $V_L = 3$ V
Inactive, SDI = 1 MHz	15			μ A typ	\overline{CS} and SCLK = 0 V or V_L , $V_L = 5$ V
	7.5			μ A typ	\overline{CS} and SCLK = 0 V or V_L , $V_L = 3$ V
SDI = 25 MHz	230			μ A typ	\overline{CS} and SCLK = 0 V or V_L , $V_L = 5$ V
	120			μ A typ	\overline{CS} and SCLK = 0 V or V_L , $V_L = 3$ V
Active at 50 MHz	1.8			mA typ	Digital inputs toggle between 0 V and V_L , $V_L = 5.5$ V
	0.7		2.1	mA max mA typ	Digital inputs toggle between 0 V and V_L , $V_L = 2.7$ V
Negative Supply Current, I_{SS}	0.04		1.0	mA max μ A typ	Digital inputs = 0 V or V_L
			4.0	μ A max	
V_{DD}/V_{SS}			$\pm 4.5/\pm 16.5$	V min/V max	GND = 0 V

¹ Guaranteed by design. Not subject to production test.

±5 V DUAL SUPPLY

$V_{DD} = +5\text{ V} \pm 10\%$, $V_{SS} = -5\text{ V} \pm 10\%$, $V_L = 2.7\text{ V}$ to 5.5 V , and $GND = 0\text{ V}$, unless otherwise noted.

Table 2.

Parameter	+25°C	-40°C to +85°C	-40°C to +125°C	Unit	Test Conditions/Comments
ANALOG SWITCH					
Analog Signal Range			V_{DD} to V_{SS}	V	
On Resistance, R_{ON}	3.3			Ω typ	$V_S = \pm 4.5\text{ V}$, $I_S = -10\text{ mA}$, see Figure 29
	4	4.9	5.4	Ω max	$V_{DD} = +4.5\text{ V}$, $V_{SS} = -4.5\text{ V}$
On-Resistance Match Between Channels, ΔR_{ON}	0.13			Ω typ	$V_S = \pm 4.5\text{ V}$, $I_S = -10\text{ mA}$
	0.35	0.43	0.45	Ω max	
On-Resistance Flatness, $R_{FLAT(ON)}$	0.9			Ω typ	$V_S = \pm 4.5\text{ V}$, $I_S = -10\text{ mA}$
	1.1	1.24	1.31	Ω max	
LEAKAGE CURRENTS					
Source Off Leakage, I_S (Off)	± 0.03			nA typ	$V_{DD} = +5.5\text{ V}$, $V_{SS} = -5.5\text{ V}$ $V_S = \pm 4.5\text{ V}$, $V_D = \mp 4.5\text{ V}$, see Figure 32
	± 0.55	± 2	± 12.5	nA max	
Drain Off Leakage, I_D (Off)	± 0.03			nA typ	$V_S = \pm 4.5\text{ V}$, $V_D = \mp 4.5\text{ V}$, see Figure 32
	± 0.55	± 2	± 12.5	nA max	
Channel On Leakage, I_D (On), I_S (On)	± 0.05			nA typ	$V_S = V_D = \pm 4.5\text{ V}$, see Figure 28
	± 1.0	± 4	± 30	nA max	
DIGITAL OUTPUT					
Output Voltage					
Low, V_{OL}			0.4	V max	$I_{SINK} = 1\text{ mA}$
			0.3	V max	$I_{SINK} = 100\text{ }\mu\text{A}$
High, V_{OH}			$V_L - 1.25\text{ V}$	V min	$I_{SOURCE} = 1\text{ mA}$
			$V_L - 0.125\text{ V}$	V min	$I_{SOURCE} = 100\text{ }\mu\text{A}$
Digital Output Capacitance, C_{OUT}	4			pF typ	
DIGITAL INPUTS					
Input Voltage					
High, V_{INH}			2	V min	$3.3\text{ V} < V_L \leq 5.5\text{ V}$
			1.35	V min	$2.7\text{ V} \leq V_L \leq 3.3\text{ V}$
Low, V_{INL}			0.8	V max	$3.3\text{ V} < V_L \leq 5.5\text{ V}$
			0.8	V max	$2.7\text{ V} \leq V_L \leq 3.3\text{ V}$
Input Current					
Low, I_{INL} or High, I_{INH}	0.001			μA typ	$V_{IN} = V_{GND}$ or V_L
			± 0.1	μA max	
Digital Input Capacitance, C_{IN}	4			pF typ	
DYNAMIC CHARACTERISTICS¹					
On Time, t_{ON}	510			ns typ	$R_L = 300\text{ }\Omega$, $C_L = 35\text{ pF}$
	645	680	710	ns max	$V_S = 3\text{ V}$, see Figure 37
Off Time, t_{OFF}	280			ns typ	$R_L = 300\text{ }\Omega$, $C_L = 35\text{ pF}$
	365	400	435	ns max	$V_S = 3\text{ V}$, see Figure 37
Break-Before-Make Time Delay, t_D	245			ns typ	$R_L = 300\text{ }\Omega$, $C_L = 35\text{ pF}$
			200	ns min	$V_{S1} = V_{S2} = 3\text{ V}$, see Figure 36
Charge Injection, Q_{INJ}	10			pC typ	$V_S = 0\text{ V}$, $R_S = 0\text{ }\Omega$, $C_L = 1\text{ nF}$, see Figure 38
Off Isolation	-76			dB typ	$R_L = 50\text{ }\Omega$, $C_L = 5\text{ pF}$, $f = 1\text{ MHz}$, see Figure 31
Channel to Channel Crosstalk	-75			dB typ	$R_L = 50\text{ }\Omega$, $C_L = 5\text{ pF}$, $f = 1\text{ MHz}$, see Figure 30

Parameter	+25°C	−40°C to +85°C	−40°C to +125°C	Unit	Test Conditions/Comments
Total Harmonic Distortion + Noise, THD + N	0.03			% typ	$R_L = 110 \Omega$, 5 V p-p, $f = 20$ Hz to 20 kHz, see Figure 33
−3 dB Bandwidth	130			MHz typ	$R_L = 50 \Omega$, $C_L = 5$ pF, see Figure 34
Insertion Loss	−0.3			dB typ	$R_L = 50 \Omega$, $C_L = 5$ pF, $f = 1$ MHz, see Figure 34
Source Capacitance, C_S (Off)	30			pF typ	$V_S = 0$ V, $f = 1$ MHz
Drain Capacitance, C_D (Off)	31			pF typ	$V_S = 0$ V, $f = 1$ MHz
C_D (On), C_S (On)	116			pF typ	$V_S = 0$ V, $f = 1$ MHz
POWER REQUIREMENTS					
Positive Supply Current, I_{DD}	0.04			μ A typ	$V_{DD} = +5.5$ V, $V_{SS} = -5.5$ V Digital inputs = 0 V or V_L , $V_L = 5.5$ V
	28		4.0	μ A max	All switches closed, $V_L = 2.7$ V
			60	μ A typ	
				μ A max	
Load Current, I_L					
Inactive	6.3			μ A typ	Digital inputs = 0 V or V_L
			8.0	μ A max	
Inactive, SCLK = 1 MHz	14			μ A typ	$\overline{CS} = V_L$ and SDI = 0 V or V_L , $V_L = 5$ V
	7			μ A typ	$\overline{CS} = V_L$ and SDI = 0 V or V_L , $V_L = 3$ V
SCLK = 50 MHz	390			μ A typ	$\overline{CS} = V_L$ and SDI = 0 V or V_L , $V_L = 5$ V
	210			μ A typ	$\overline{CS} = V_L$ and SDI = 0 V or V_L , $V_L = 3$ V
Inactive, SDI = 1 MHz	15			μ A typ	\overline{CS} and SCLK = 0 V or V_L , $V_L = 5$ V
	7.5			μ A typ	\overline{CS} and SCLK = 0 V or V_L , $V_L = 3$ V
SDI = 25 MHz	230			μ A typ	\overline{CS} and SCLK = 0 V or V_L , $V_L = 5$ V
	120			μ A typ	\overline{CS} and SCLK = 0 V or V_L , $V_L = 3$ V
Active at 50 MHz	1.8			mA typ	Digital inputs toggle between 0 V and V_L , $V_L = 5.5$ V
			2.1	mA max	
	0.7			mA typ	Digital inputs toggle between 0 V and V_L , $V_L = 2.7$ V
Negative Supply Current, I_{SS}	0.04		1.0	mA max	
			4.0	μ A typ	Digital inputs = 0 V or V_L
				μ A max	
V_{DD}/V_{SS}			$\pm 4.5/\pm 16.5$	V min/V max	GND = 0 V

¹ Guaranteed by design. Not subject to production test.

12 V SINGLE SUPPLY

$V_{DD} = 12\text{ V} \pm 10\%$, $V_{SS} = 0\text{ V}$, $V_L = 2.7\text{ V}$ to 5.5 V , and $GND = 0\text{ V}$, unless otherwise noted.

Table 3.

Parameter	+25°C	-40°C to +85°C	-40°C to +125°C	Unit	Test Conditions/Comments
ANALOG SWITCH					
Analog Signal Range			0 V to V_{DD}	V	
On Resistance, R_{ON}	2.8			Ω typ	$V_S = 0\text{ V}$ to 10 V , $I_S = -10\text{ mA}$, see Figure 29
On-Resistance Match Between Channels, ΔR_{ON}	3.5 0.13	4.3	4.8	Ω max Ω typ	$V_{DD} = 10.8\text{ V}$, $V_{SS} = 0\text{ V}$ $V_S = 0\text{ V}$ to 10 V , $I_S = -10\text{ mA}$
On-Resistance Flatness, $R_{FLAT(ON)}$	0.35 0.6	0.43	0.45	Ω max Ω typ	$V_S = 0\text{ V}$ to 10 V , $I_S = -10\text{ mA}$
	1.1	1.2	1.3	Ω max	
LEAKAGE CURRENTS					
Source Off Leakage, I_S (Off)	± 0.02			nA typ	$V_{DD} = 13.2\text{ V}$, $V_{SS} = 0\text{ V}$ $V_S = 1\text{ V}/10\text{ V}$, $V_D = 10\text{ V}/1\text{ V}$, see Figure 32
Drain Off Leakage, I_D (Off)	± 0.55 ± 0.02	± 2	± 12.5	nA max nA typ	$V_S = 1\text{ V}/10\text{ V}$, $V_D = 10\text{ V}/1\text{ V}$, see Figure 32
Channel On Leakage, I_D (On), I_S (On)	± 0.55 ± 0.15	± 2	± 12.5	nA max nA typ	$V_S = V_D = 1\text{ V}/10\text{ V}$, see Figure 28
	± 1.5	± 4	± 30	nA max	
DIGITAL OUTPUT					
Output Voltage					
Low, V_{OL}			0.4 0.3	V max V max	$I_{SINK} = 1\text{ mA}$ $I_{SINK} = 100\text{ }\mu\text{A}$
High, V_{OH}			$V_L - 1.25\text{ V}$ $V_L - 0.125\text{ V}$	V min V min	$I_{SOURCE} = 1\text{ mA}$ $I_{SOURCE} = 100\text{ }\mu\text{A}$
Digital Output Capacitance, C_{OUT}	4			pF typ	
DIGITAL INPUTS					
Input Voltage					
High, V_{INH}			2 1.35	V min V min	$3.3\text{ V} < V_L \leq 5.5\text{ V}$ $2.7\text{ V} \leq V_L \leq 3.3\text{ V}$
Low, V_{INL}			0.8 0.8	V max V max	$3.3\text{ V} < V_L \leq 5.5\text{ V}$ $2.7\text{ V} \leq V_L \leq 3.3\text{ V}$
Input Current					
Low, I_{INL} or High, I_{INH}	0.001		± 0.1	μA typ μA max	$V_{IN} = V_{GND}$ or V_L
Digital Input Capacitance, C_{IN}	4			pF typ	
DYNAMIC CHARACTERISTICS¹					
On Time, t_{ON}	470 570	595	615	ns typ ns max	$R_L = 300\text{ }\Omega$, $C_L = 35\text{ pF}$ $V_S = 8\text{ V}$, see Figure 37
Off Time, t_{OFF}	170 215	240	265	ns typ ns max	$R_L = 300\text{ }\Omega$, $C_L = 35\text{ pF}$ $V_S = 8\text{ V}$, see Figure 37
Break-Before-Make Time Delay, t_D	280			ns typ	$R_L = 300\text{ }\Omega$, $C_L = 35\text{ pF}$
Charge Injection, Q_{INJ}	10		225	ns min pC typ	$V_{S1} = V_{S2} = 8\text{ V}$, see Figure 36 $V_S = 6\text{ V}$, $R_S = 0\text{ }\Omega$, $C_L = 1\text{ nF}$, see Figure 38
Off Isolation	-76			dB typ	$R_L = 50\text{ }\Omega$, $C_L = 5\text{ pF}$, $f = 1\text{ MHz}$, see Figure 31

Parameter	+25°C	-40°C to +85°C	-40°C to +125°C	Unit	Test Conditions/Comments
Channel to Channel Crosstalk	-75			dB typ	$R_L = 50 \Omega$, $C_L = 5 \text{ pF}$, $f = 1 \text{ MHz}$, see Figure 30
Total Harmonic Distortion + Noise, THD + N	0.06			% typ	$R_L = 110 \Omega$, 6 V p-p, $f = 20 \text{ Hz to } 20 \text{ kHz}$, see Figure 33
-3 dB Bandwidth	130			MHz typ	$R_L = 50 \Omega$, $C_L = 5 \text{ pF}$, see Figure 34
Insertion Loss	-0.3			dB typ	$R_L = 50 \Omega$, $C_L = 5 \text{ pF}$, $f = 1 \text{ MHz}$, see Figure 34
Source Capacitance, C_S (Off)	27			pF typ	$V_S = 6 \text{ V}$, $f = 1 \text{ MHz}$
Drain Capacitance, C_D (Off)	28			pF typ	$V_S = 6 \text{ V}$, $f = 1 \text{ MHz}$
C_D (On), C_S (On)	116			pF typ	$V_S = 6 \text{ V}$, $f = 1 \text{ MHz}$
POWER REQUIREMENTS					
Positive Supply Current, I_{DD}	0.04			$\mu\text{A typ}$	$V_{DD} = 13.2 \text{ V}$ All switches open
			4.0	$\mu\text{A max}$	
	420			$\mu\text{A typ}$	All switches closed, $V_L = 5.5 \text{ V}$
			800	$\mu\text{A max}$	
	520			$\mu\text{A typ}$	All switches closed, $V_L = 2.7 \text{ V}$
			850	$\mu\text{A max}$	
Load Current, I_L					
Inactive	6.3			$\mu\text{A typ}$	Digital inputs = 0 V or V_L
			8.0	$\mu\text{A max}$	
Inactive, SCLK = 1 MHz	14			$\mu\text{A typ}$	$\overline{CS} = V_L$ and $SDI = 0 \text{ V or } V_L$, $V_L = 5 \text{ V}$
	7			$\mu\text{A typ}$	$\overline{CS} = V_L$ and $SDI = 0 \text{ V or } V_L$, $V_L = 3 \text{ V}$
SCLK = 50 MHz	390			$\mu\text{A typ}$	$\overline{CS} = V_L$ and $SDI = 0 \text{ V or } V_L$, $V_L = 5 \text{ V}$
	210			$\mu\text{A typ}$	$\overline{CS} = V_L$ and $SDI = 0 \text{ V or } V_L$, $V_L = 3 \text{ V}$
Inactive, SDI = 1 MHz	15			$\mu\text{A typ}$	\overline{CS} and $SCLK = 0 \text{ V or } V_L$, $V_L = 5 \text{ V}$
	7.5			$\mu\text{A typ}$	\overline{CS} and $SCLK = 0 \text{ V or } V_L$, $V_L = 3 \text{ V}$
SDI = 25 MHz	230			$\mu\text{A typ}$	\overline{CS} and $SCLK = 0 \text{ V or } V_L$, $V_L = 5 \text{ V}$
	120			$\mu\text{A typ}$	\overline{CS} and $SCLK = 0 \text{ V or } V_L$, $V_L = 3 \text{ V}$
Active at 50 MHz	1.8			mA typ	Digital inputs toggle between 0 V and V_L , $V_L = 5.5 \text{ V}$
			2.1	mA max	
	0.7			mA typ	Digital inputs toggle between 0 V and V_L , $V_L = 2.7 \text{ V}$
			1.0	mA max	
V_{DD}			5/20	V min/V max	$GND = 0 \text{ V}$, $V_{SS} = 0 \text{ V}$

¹ Guaranteed by design. Not subject to production test.

CONTINUOUS CURRENT PER CHANNEL, Sx OR Dx**Table 4. Eight Channels On**

Parameter	25°C	85°C	125°C	Unit
CONTINUOUS CURRENT, Sx OR Dx ¹				
$V_{DD} = +15\text{ V}, V_{SS} = -15\text{ V} (\theta_{JA} = 65.5^\circ\text{C/W})$	273	156	80	mA maximum
$V_{DD} = +12\text{ V}, V_{SS} = 0\text{ V} (\theta_{JA} = 65.5^\circ\text{C/W})$	221	133	72	mA maximum
$V_{DD} = +5\text{ V}, V_{SS} = -5\text{ V} (\theta_{JA} = 65.5^\circ\text{C/W})$	206	126	70	mA maximum

¹ Sx refers to the S1 to S8 pins, and Dx refers to the D1 to D8 pins.

Table 5. One Channel On

Parameter	25°C	85°C	125°C	Unit
CONTINUOUS CURRENT, Sx OR Dx ¹				
$V_{DD} = +15\text{ V}, V_{SS} = -15\text{ V} (\theta_{JA} = 65.5^\circ\text{C/W})$	490	225	87	mA maximum
$V_{DD} = +12\text{ V}, V_{SS} = 0\text{ V} (\theta_{JA} = 65.5^\circ\text{C/W})$	399	200	84	mA maximum
$V_{DD} = +5\text{ V}, V_{SS} = -5\text{ V} (\theta_{JA} = 65.5^\circ\text{C/W})$	373	192	83	mA maximum

¹ Sx refers to the S1 to S8 pins, and Dx refers to the D1 to D8 pins.

TIMING CHARACTERISTICS

$V_L = 2.7\text{ V}$ to 5.5 V , $GND = 0\text{ V}$, and all specifications minimum temperature (T_{MIN}) to maximum temperature (T_{MAX}), unless otherwise noted. Guaranteed by design and characterization, not production tested. See Figure 2 to Figure 4 for the timing diagrams.

Table 6.

Parameter	Limit	Unit	Test Conditions/Comments
TIMING CHARACTERISTICS			
t_1	20	ns min	SCLK period
t_2	8	ns min	SCLK high pulse width
t_3	8	ns min	SCLK low pulse width
t_4	10	ns min	\overline{CS} falling edge to SCLK active edge
t_5	6	ns min	Data setup time
t_6	8	ns min	Data hold time
t_7	10	ns min	SCLK active edge to \overline{CS} rising edge
t_8	20	ns max	\overline{CS} falling edge to SDO data available
t_9^1	30	ns max	SCLK falling edge to SDO data available
t_{10}	30	ns max	\overline{CS} rising edge to SDO returns to high
t_{11}	20	ns min	\overline{CS} high time between SPI commands
t_{12}	8	ns min	\overline{CS} falling edge to SCLK becomes stable
t_{13}	8	ns min	\overline{CS} rising edge to SCLK becomes stable

¹ Measured with a 20 pF load. t_9 determines the maximum SCLK frequency when SDO is used.

Timing Diagrams

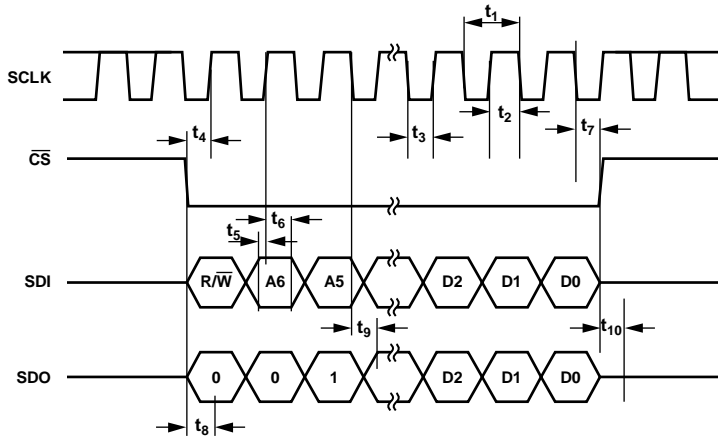

Figure 2. Address Mode Timing Diagram

23895-002

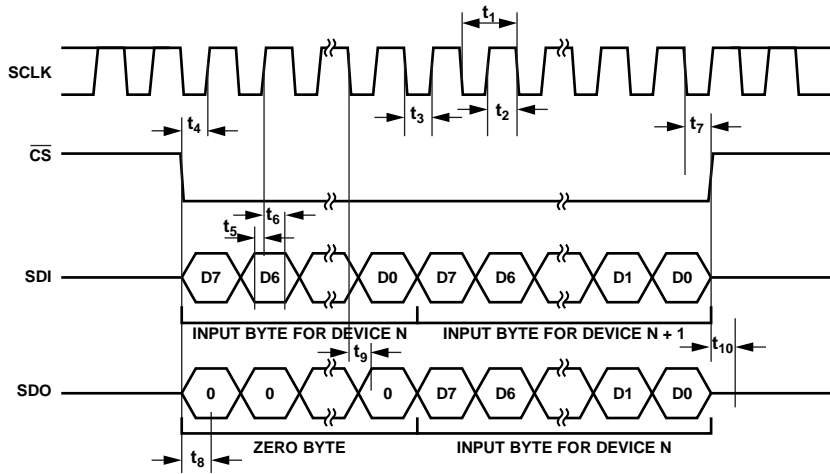

Figure 3. Daisy-Chain Timing Diagram

23895-003

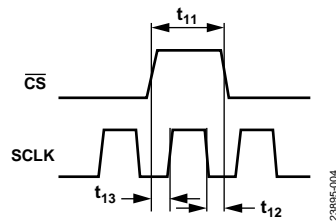

Figure 4. SCLK and CS Timing Relationship

23895-004

ABSOLUTE MAXIMUM RATINGS

$T_A = 25^\circ\text{C}$, unless otherwise noted.

Table 7.

Parameter	Rating
V_{DD} to V_{SS}	35 V
V_{DD} to GND	-0.3 V to +25 V
V_{SS} to GND	+0.3 V to -25 V
V_L to GND	
For $V_{DD} \leq 5.5$ V	-0.3 V to $V_{DD} + 0.3$ V
For $V_{DD} > 5.5$ V	-0.3 V to +6 V
SDO	-0.3 V to $V_L + 0.3$ V or 6 mA, whichever occurs first
Analog Inputs ¹	$V_{SS} - 0.3$ V to $V_{DD} + 0.3$ V or 30 mA, whichever occurs first
Digital Inputs ¹	-0.3 V to +6 V
Peak Current, Sx or Dx ²	550 mA (pulsed at 1 ms, 10% duty cycle maximum)
Continuous Current, Sx or Dx ^{2,3}	Data + 15%
Temperature	
Operating Range	-40°C to +125°C
Storage Range	-65°C to +150°C
Junction	150°C
Reflow Soldering Peak Temperature, Pb Free	260(+0/-5)°C

¹ Overvoltages at the digital Sx and Dx pins are clamped by internal diodes. Limit current to the maximum ratings given.

² Sx refers to the S1 to S8 pins, and Dx refers to the D1 to D8 pins.

³ See Table 4 and Table 5.

Stresses at or above those listed under Absolute Maximum Ratings may cause permanent damage to the product. This is a stress rating only; functional operation of the product at these or any other conditions above those indicated in the operational section of this specification is not implied. Operation beyond the maximum operating conditions for extended periods may affect product reliability.

Only one absolute maximum rating can be applied at any one time.

THERMAL RESISTANCE

Thermal performance is directly linked to printed circuit board (PCB) design and operating environment. Careful attention to PCB thermal design is required.

θ_{JA} is the natural convection junction to ambient thermal resistance measured in a one cubic foot sealed enclosure. θ_{JCB} is the junction to the bottom of the case value.

Table 8. Thermal Resistance

Package Type	θ_{JA}	θ_{JCB}	Unit
LGA ¹	65.5	48.12	°C/W

¹ Thermal impedance simulated values are based on a JEDEC 2S2P thermal test board with four thermal vias. See JEDEC JESD-51.

ELECTROSTATIC DISCHARGE (ESD) RATINGS

The following ESD information is provided for handling of ESD-sensitive devices in an ESD protected area only.

Human body model (HBM) per ANSI/ESDA/JEDEC JS-001.

Field induced charged device model (FICDM) per ANSI/ESDA/JEDEC JS-002.

ESD Ratings for ADGS1414D

Table 9. ADGS1414D, 30-Terminal LGA

Package Type	Withstand Threshold (V)	Class
HBM	±2000	2
FICDM	±1250	C3

ESD CAUTION



ESD (electrostatic discharge) sensitive device. Charged devices and circuit boards can discharge without detection. Although this product features patented or proprietary protection circuitry, damage may occur on devices subjected to high energy ESD. Therefore, proper ESD precautions should be taken to avoid performance degradation or loss of functionality.

PIN CONFIGURATION AND FUNCTION DESCRIPTIONS

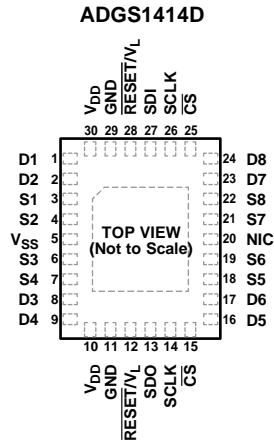

- NOTES**
1. NIC = NOT INTERNALLY CONNECTED.
 2. EXPOSED PAD. THE EXPOSED PAD IS CONNECTED INTERNALLY. FOR INCREASED RELIABILITY OF THE SOLDER JOINTS AND MAXIMUM THERMAL CAPABILITY, IT IS RECOMMENDED THAT THE EXPOSED PAD IS CONNECTED TO V_{SS}.

23885-005

Figure 5. Pin Configuration

Table 10. Pin Function Descriptions

Pin No.	Mnemonic	Description
1	D1	Drain Terminal 1. The D1 pin can be an input or an output.
2	D2	Drain Terminal 2. The D2 pin can be an input or an output.
3	S1	Source Terminal 1. The S1 pin can be an input or an output.
4	S2	Source Terminal 2. The S2 pin can be an input or an output.
5	V _{SS}	Most Negative Power Supply Potential. In single-supply applications, tie the V _{SS} pin to ground.
6	S3	Source Terminal 3. The S3 pin can be an input or an output.
7	S4	Source Terminal 4. The S4 pin can be an input or an output.
8	D3	Drain Terminal 3. The D3 pin can be an input or an output.
9	D4	Drain Terminal 4. The D4 pin can be an input or an output.
10, 30	V _{DD}	Most Positive Power Supply Potential. Both V _{DD} pins are connected internally.
11, 29	GND	Ground (0 V) Reference. Both GND pins are connected internally.
12, 28	RESET/V _L	RESET/Logic Power Supply Input (V _L). Under normal operation, drive RESET/V _L with a 2.7 V to 5.5 V supply. Pull RESET/V _L low to complete a hardware reset. After a reset, all switches open, and the appropriate registers are set to their default. Both RESET and V _L are connected internally.
13	SDO	Serial Data Output. Use the SDO pin for daisy-chaining a number of these devices together or for reading back the data stored in a register for diagnostic purposes. The serial data is propagated on the falling edge of SCLK.
14, 26	SCLK	Serial Clock Input. Data is captured on the positive edge of SCLK. Data can be transferred at rates up to 50 MHz. Both SCLK pins are connected internally.
15, 25	CS	Active Low Control Input. CS is the frame synchronization signal for the input data. Both CS pins are connected internally.
16	D5	Drain Terminal 5. The D5 pin can be an input or an output.
17	D6	Drain Terminal 6. The D6 pin can be an input or an output.
18	S5	Source Terminal 5. The S5 pin can be an input or an output.
19	S6	Source Terminal 6. The S6 pin can be an input or an output.
20	NIC	Not Internally Connected.
21	S7	Source Terminal 7. The S7 pin can be an input or an output.
22	S8	Source Terminal 8. The S8 pin can be an input or an output.
23	D7	Drain Terminal 7. The D7 pin can be an input or an output.
24	D8	Drain Terminal 8. The D8 pin can be an input or an output.
27	SDI	Serial Data Input. Data is captured on the positive edge of SCLK.
	EPAD	Exposed Pad. The exposed pad is connected internally. For increased reliability of the solder joints and maximum thermal capability, it is recommended that the exposed pad is connected to V _{SS} .

TYPICAL PERFORMANCE CHARACTERISTICS

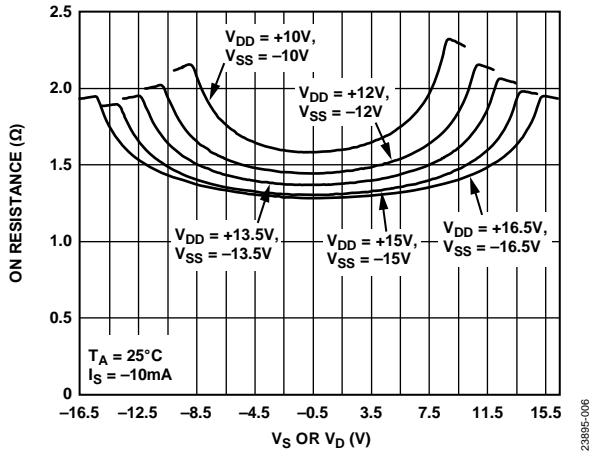

Figure 6. On Resistance vs. V_S or V_D for Various Dual Supplies, ± 10 V to ± 16.5 V

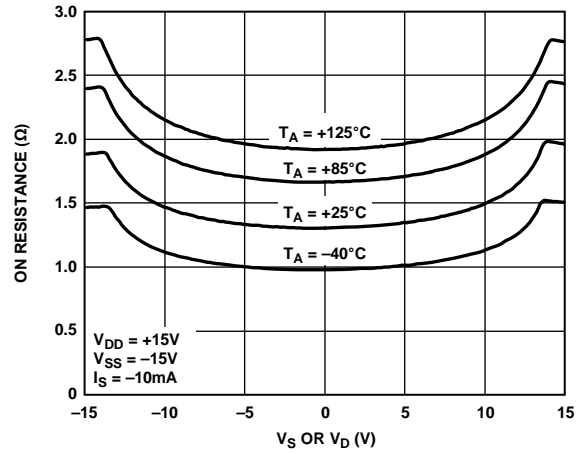

Figure 9. On Resistance vs. V_S or V_D for Various Temperatures, ± 15 V Dual Supply

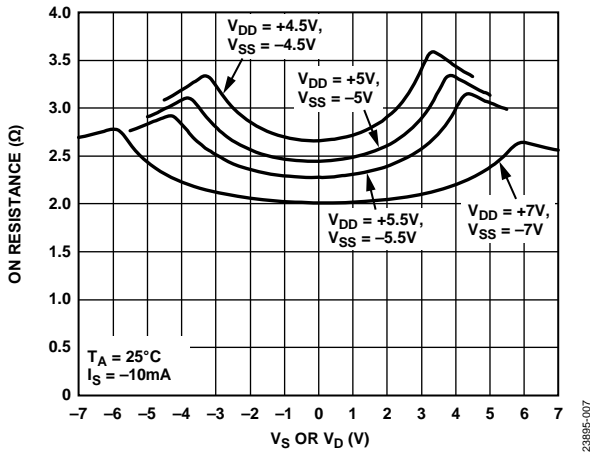

Figure 7. On Resistance vs. V_S or V_D for Various Dual Supplies, ± 4.5 V to ± 7 V

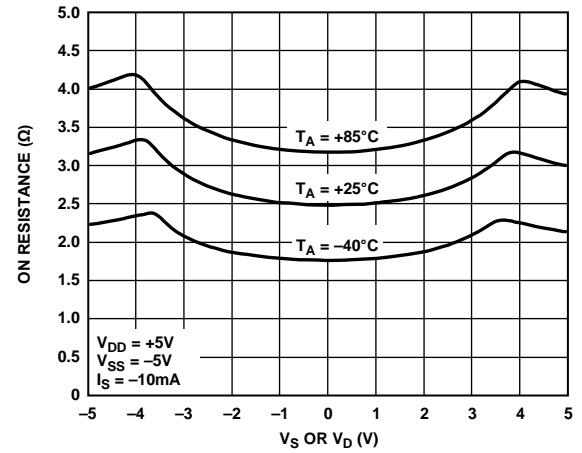

Figure 10. On Resistance vs. V_S or V_D for Various Temperatures, ± 5 V Dual Supply

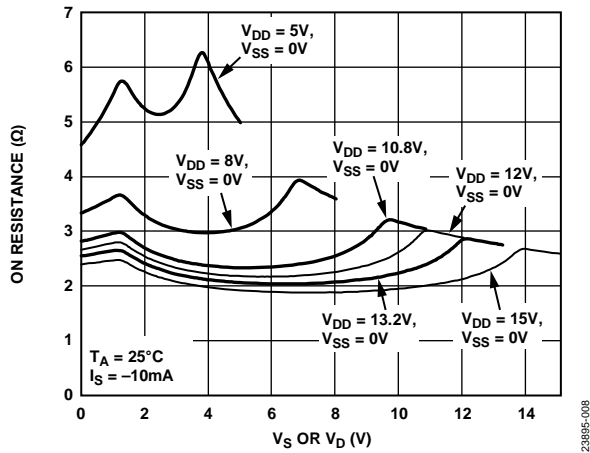

Figure 8. On Resistance vs. V_S or V_D for Various Single Supplies

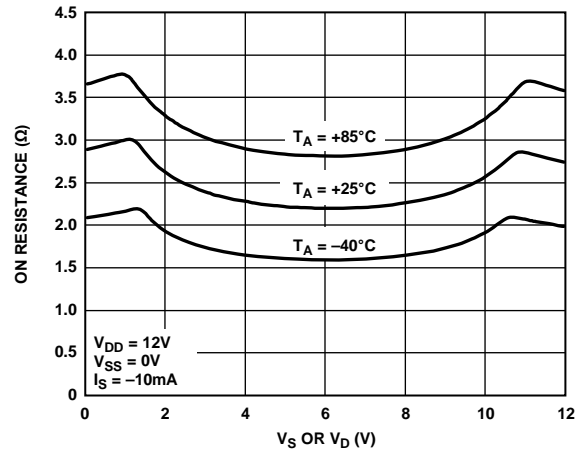

Figure 11. On Resistance vs. V_S or V_D for Various Temperatures, 12 V Single Supply

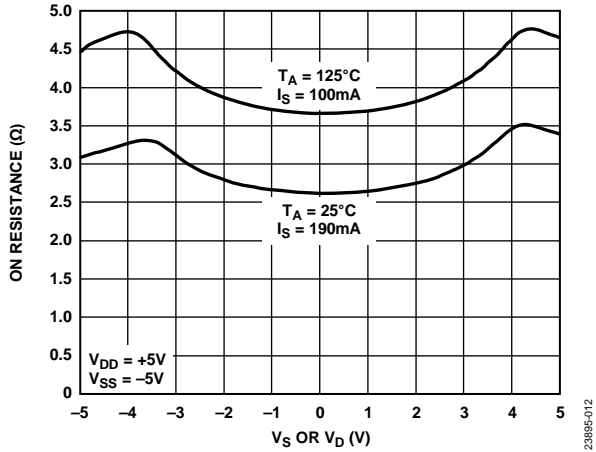

Figure 12. On Resistance vs. V_S or V_D for Various Current Levels and Temperatures, ± 5 V Dual Supply

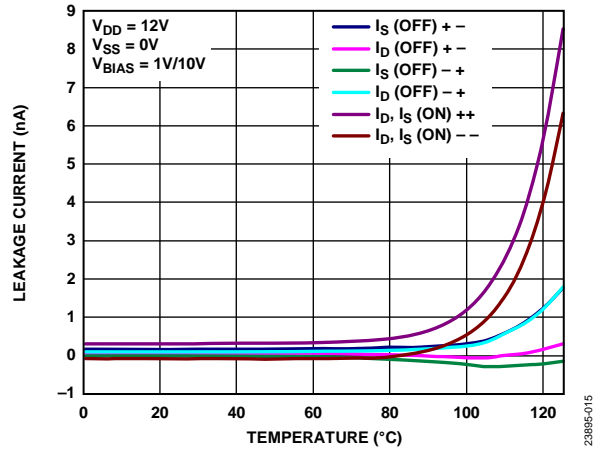

Figure 15. Leakage Current vs. Temperature, 12 V Single Supply

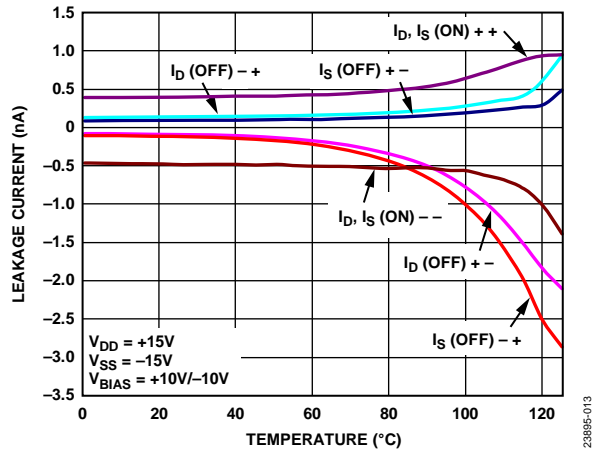

Figure 13. Leakage Current vs. Temperature, ± 15 V Dual Supply (V_{BIAS} = Bias Voltage)

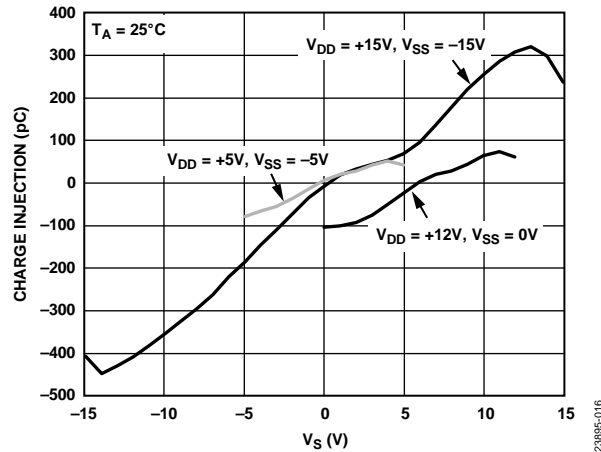

Figure 16. Charge Injection vs. V_S

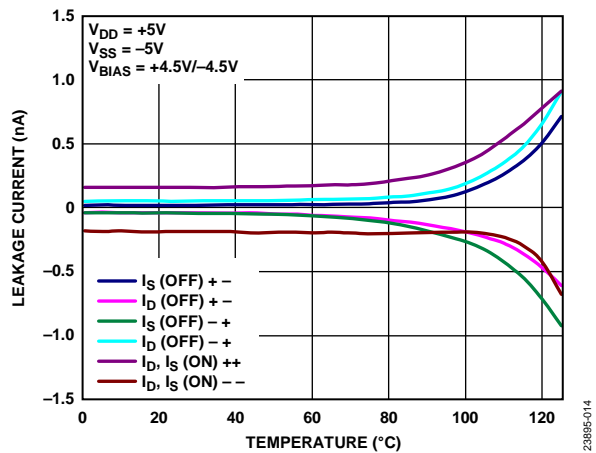

Figure 14. Leakage Current vs. Temperature, ± 5 V Dual Supply

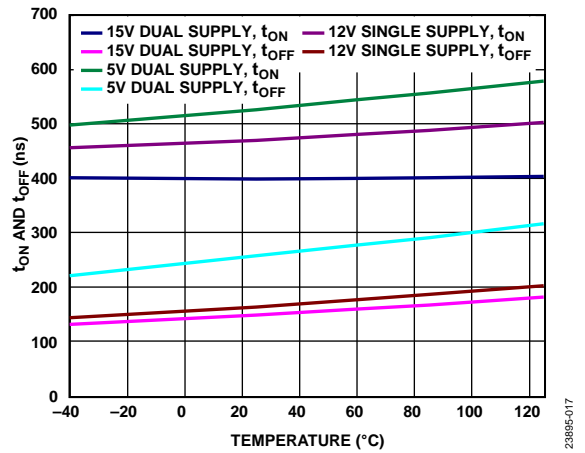

Figure 17. t_{ON} and t_{OFF} vs. Temperature for Single Supply and Dual Supply

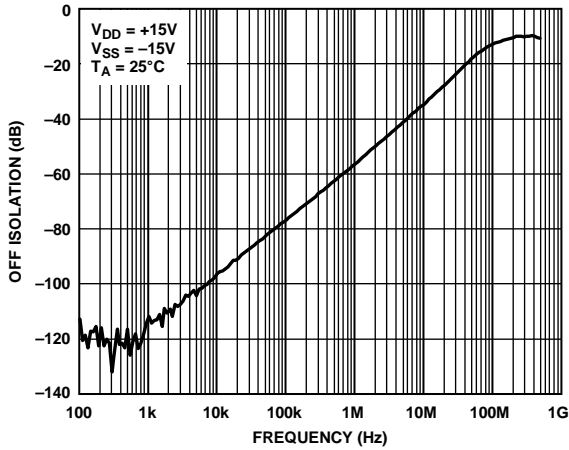

Figure 18. Off Isolation vs. Frequency, ±15 V Dual Supply

23895-018

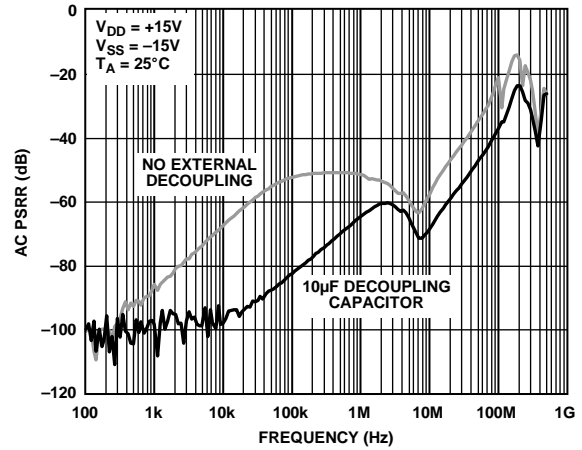

Figure 21. AC Power Supply Rejection Ratio (AC PSRR) vs. Frequency, ±15 V Dual Supply

23895-021

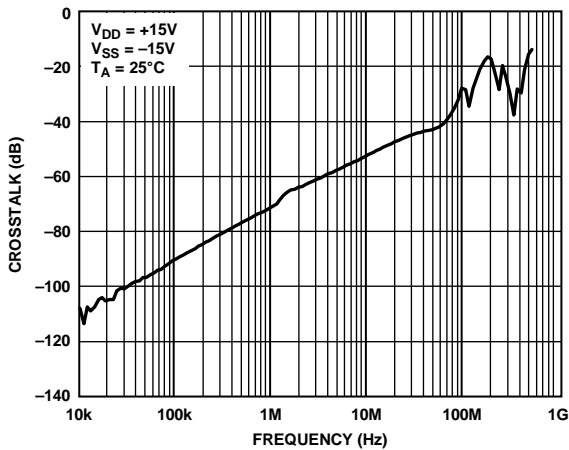

Figure 19. Crosstalk vs. Frequency, ±15 V Dual Supply

23895-019

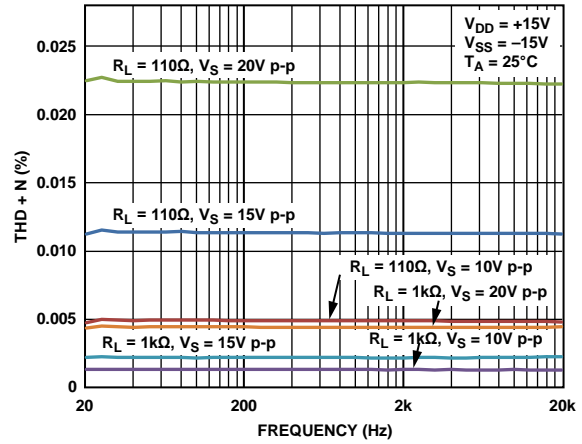

Figure 22. THD + N vs. Frequency, ±15 V Dual Supply

23895-022

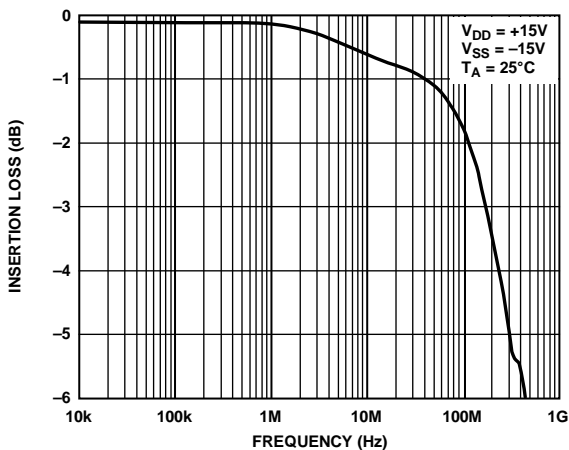

Figure 20. Insertion Loss vs. Frequency, ±15 V Dual Supply

23895-020

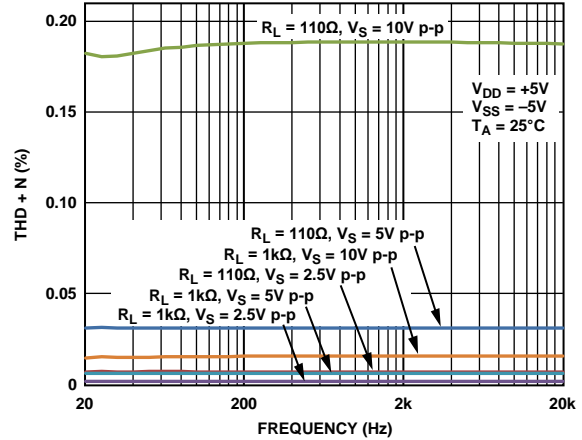

Figure 23. THD + N vs. Frequency, ±5 V Dual Supply

23895-023

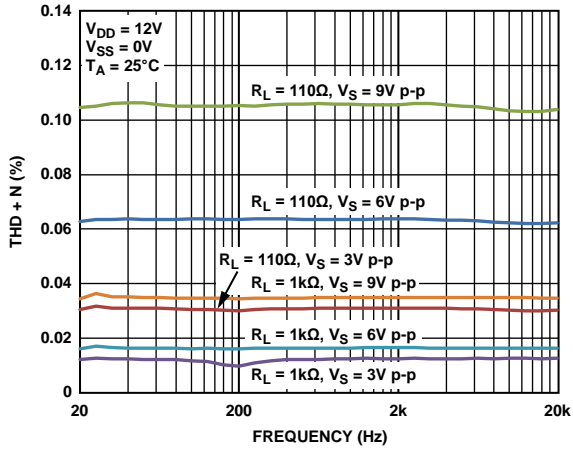

Figure 24. THD + N vs. Frequency, 12 V Single Supply

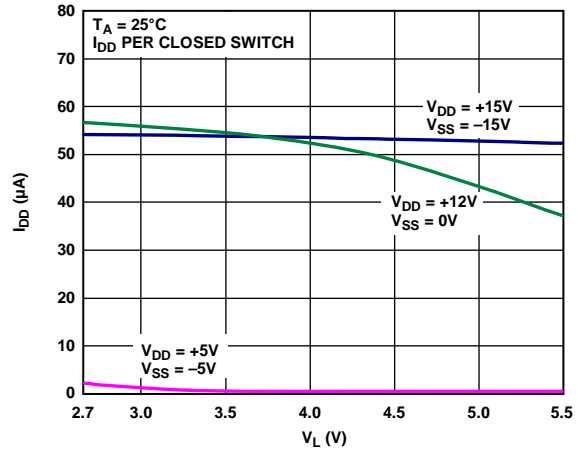

Figure 26. I_{DD} vs. V_L

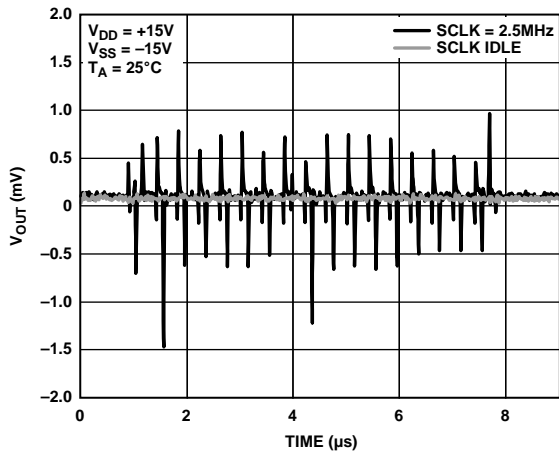

Figure 25. Digital Feedthrough (V_{OUT} = Output Voltage)

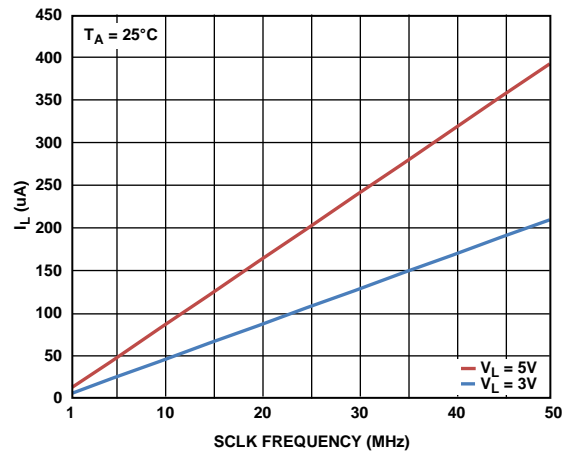

Figure 27. I_L vs. SCLK Frequency When \overline{CS} Is High

TEST CIRCUITS

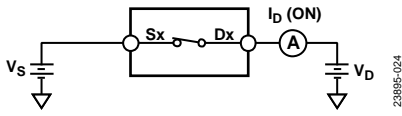

Figure 28. On Leakage

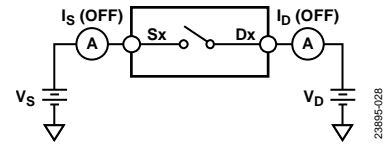

Figure 32. Off Leakage

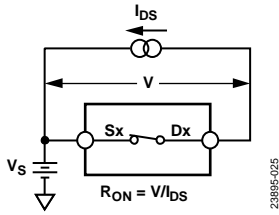

Figure 29. On Resistance
(I_{DS} = Drain and Source Current)

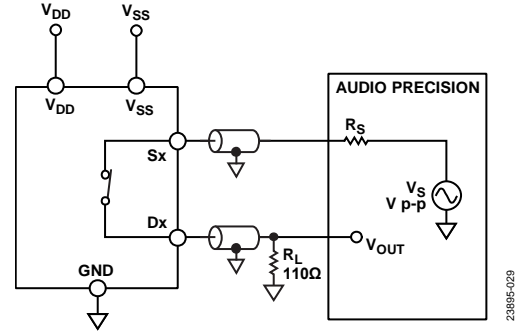
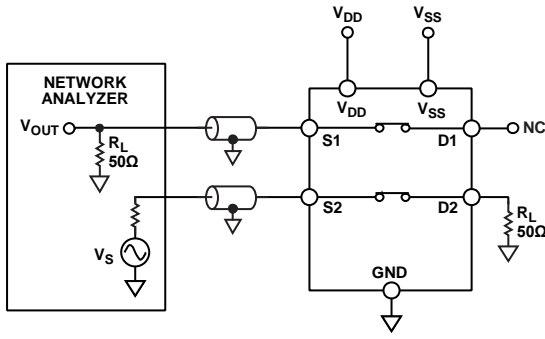
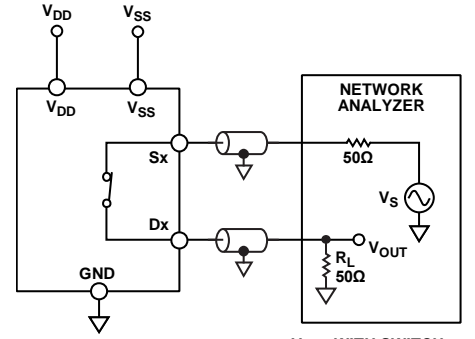

Figure 33. THD + N



$$\text{CHANNEL TO CHANNEL CROSSTALK} = 20 \log \frac{V_{OUT}}{V_S}$$

Figure 30. Channel to Channel Crosstalk



$$\text{INSERTION LOSS} = 20 \log \frac{V_{OUT} \text{ WITH SWITCH}}{V_S \text{ WITHOUT SWITCH}}$$

Figure 34. -3 dB Bandwidth

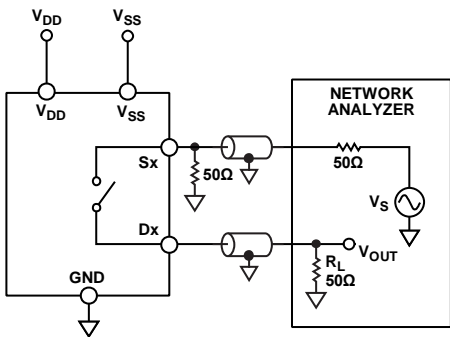

$$\text{OFF ISOLATION} = 20 \log \frac{V_{OUT}}{V_S}$$

Figure 31. Off Isolation

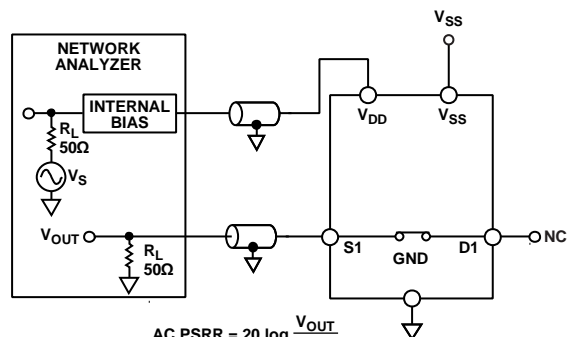

$$\text{AC PSRR} = 20 \log \frac{V_{OUT}}{V_S}$$

Figure 35. AC PSRR

NOTES
1. BOARD AND COMPONENT EFFECTS ARE NOT DE-EMBEDDED FROM THE AC PSRR MEASUREMENT.

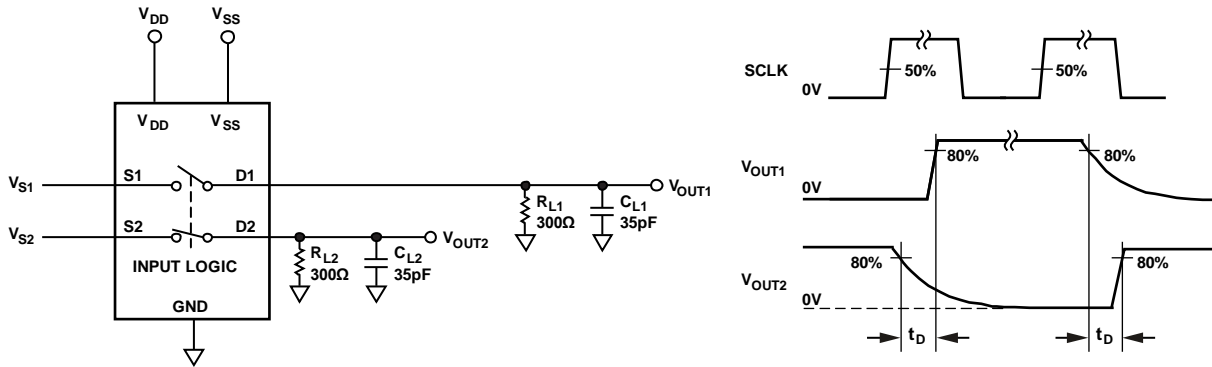

Figure 36. Break-Before-Make Time Delay, t_D

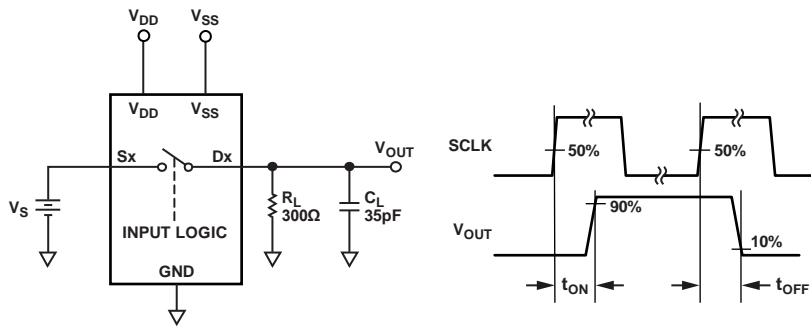

Figure 37. Switching Times, t_{ON} and t_{OFF}

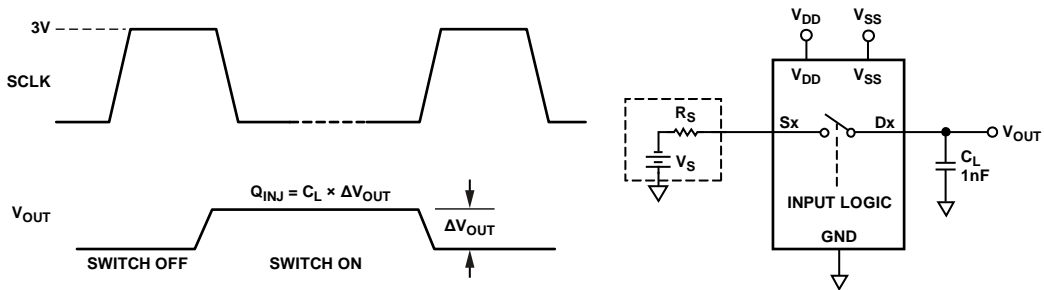

Figure 38. Charge Injection, Q_{INJ} (ΔV_{OUT} = Change in Output Voltage)

TERMINOLOGY

I_{DD}

I_{DD} represents the positive supply current.

I_{SS}

I_{SS} represents the negative supply current.

V_D, V_S

V_D and V_S represent the analog voltage on Terminal Dx and Terminal Sx, respectively.

R_{ON}

R_{ON} represents the ohmic resistance between Terminal Dx and Terminal Sx.

ΔR_{ON}

ΔR_{ON} represents the difference between the R_{ON} of any two channels.

$R_{FLAT(ON)}$

$R_{FLAT(ON)}$ is flatness that is defined as the difference between the maximum and minimum value of on resistance measured over the specified analog signal range.

I_S (Off)

I_S (Off) is the source leakage current with the switch off.

I_D (Off)

I_D (Off) is the drain leakage current with the switch off.

I_D (On), I_S (On)

I_D (On) and I_S (On) represent the channel leakage currents with the switch on.

V_{INL}

V_{INL} is the maximum input voltage for Logic 0.

V_{INH}

V_{INH} is the minimum input voltage for Logic 1.

I_{INL}, I_{INH}

I_{INL} and I_{INH} represent the low and high input currents of the digital inputs.

C_D (Off)

C_D (Off) represents the off switch drain capacitance, which is measured with reference to ground.

C_S (Off)

C_S (Off) represents the off switch source capacitance, which is measured with reference to ground.

C_D (On), C_S (On)

C_D (On) and C_S (On) represent on switch capacitances, which are measured with reference to ground.

C_{IN}

C_{IN} is the digital input capacitance.

C_{OUT}

C_{OUT} is the digital output capacitance.

t_{ON}

t_{ON} represents the delay between applying the digital control input and the output switching on.

t_{OFF}

t_{OFF} represents the delay between applying the digital control input and the output switching off.

Off Isolation

Off isolation is a measure of unwanted signal coupling through an off switch.

Charge Injection

Charge injection is a measure of the glitch impulse transferred from the digital input to the analog output during switching.

Crosstalk

Crosstalk is a measure of unwanted signal that is coupled through from one channel to another as a result of parasitic capacitance.

-3 dB Bandwidth

Bandwidth is the frequency at which the output is attenuated by 3 dB.

On Response

On response is the frequency response of the on switch.

Insertion Loss

Insertion loss is the loss due to the on resistance of the switch.

Total Harmonic Distortion + Noise (THD + N)

THD + N is the ratio of the harmonic amplitude plus noise of the signal to the fundamental.

AC Power Supply Rejection Ratio (AC PSRR)

AC PSRR is the ratio of the amplitude of the signal on the output to the amplitude of the modulation. AC PSRR is a measure of the ability of the device to avoid coupling noise and spurious signals that appear on the supply voltage pin to the output of the switch. The dc voltage on the device is modulated by a sine wave of 0.62 V p-p.

THEORY OF OPERATION

The ADGS1414D is a set of serially controlled, octal SPST switches with error detection features. SPI Mode 0 and Mode 3 can be used with the ADGS1414D, and the device operates with SCLK frequencies up to 50 MHz. The default mode for the ADGS1414D is address mode in which the registers of the device are accessed by a 16-bit SPI command that is bounded by \overline{CS} . The SPI command is a 24-bit command if the user enables CRC error detection. Other error detection features include SCLK count error and invalid read and write error. Read the error flags register to detect if any of these SPI errors occur. The ADGS1414D can also operate in two other modes: burst mode and daisy-chain mode.

The interface pins of the ADGS1414D are \overline{CS} , SCLK, SDI, and SDO. Hold \overline{CS} low when using the SPI. Data is captured on the SDI on the rising edge of SCLK, and data is propagated out on the SDO on the falling edge of SCLK.

ADDRESS MODE

Address mode is the default mode for the ADGS1414D upon power up. A single SPI frame in address mode is bounded by a \overline{CS} falling edge and the succeeding \overline{CS} rising edge. The SPI frame is comprised of 16 SCLK cycles. The timing diagram for address mode is shown in Figure 39. The first SDI bit indicates if the SPI command is a read or write command. When the first bit is set to 0, a write command is issued, and if the first bit is set to 1, a read command is issued. The next seven bits determine the target register address. The remaining eight bits provide the data to the addressed register. The last eight bits are ignored during a read command, because during these clock cycles, SDO propagates out the data contained in the addressed register.

The target register address of an SPI command is determined on the eighth SCLK rising edge. Data from this register propagates out on SDO from the 8th to the 15th SCLK falling edge during SPI reads. A register write occurs on the 16th SCLK rising edge during SPI writes.

During any SPI command, SDO sends out eight alignment bits as the first eight bits. The alignment bits observed at SDO are 0x25.

ERROR DETECTION FEATURES

Protocol and communication errors on the SPI are detectable. There are three error detection features: incorrect SCLK count error detection, invalid read and write address error detection, and CRC error detection. Each of these error detection features has a corresponding enable bit in the error configuration register. In addition, there is an error flag bit for each of these error detection features in the error flags register.

Cyclic Redundancy Check (CRC) Error Detection

The CRC error detection feature extends a valid SPI frame by 8 SCLK cycles. These eight extra cycles are needed to send the CRC byte for that SPI frame. The CRC byte is calculated by the SPI block using the 16-bit payload: the R/W bit, the register address, Bits[6:0], and the register data, Bits[7:0]. The CRC polynomial used in the SPI block is $x^8 + x^2 + x^1 + 1$ with a seed value of 0. For a timing diagram with CRC enabled, see Figure 40. Register writes occur at the 24th SCLK rising edge with CRC error checking enabled.

During an SPI write, the microcontroller or central processing unit (CPU) provides the CRC byte through SDI. The SPI block checks the CRC byte just before the 24th SCLK rising edge. On this same edge, the register write is prevented if an incorrect CRC byte is received by the SPI. The CRC error flag asserts in the error flags register in the case of the incorrect CRC byte being detected.

During an SPI read, the CRC byte is provided to the microcontroller through SDO.

The CRC error detection feature is disabled by default and can be configured by the user through the error configuration register.

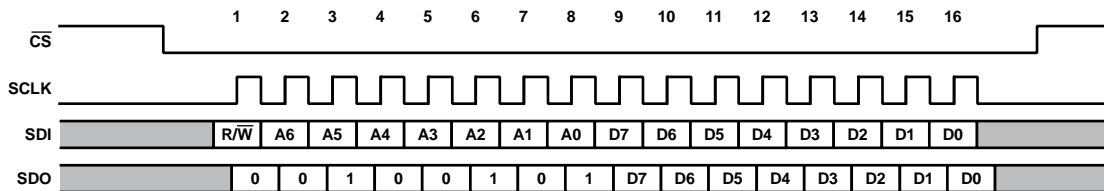

Figure 39. Address Mode Timing Diagram

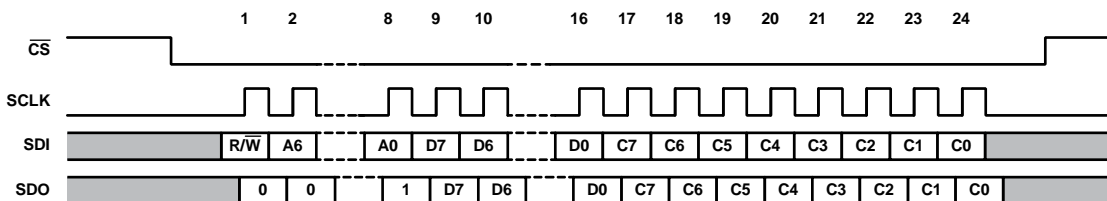

Figure 40. Timing Diagram with CRC Enabled

SCLK Count Error Detection

SCLK count error detection allows the user to detect if an incorrect number of SCLK cycles are sent by the microcontroller or CPU. When in address mode, with CRC disabled, 16 SCLK cycles are expected. If 16 SCLK cycles are not detected, the SCLK count error flag asserts in the error flags register. When less than 16 SCLK cycles are received by the device, a write to the register map does not occur. When the ADGS1414D receives more than 16 SCLK cycles, a write to the memory map still occurs at the 16th SCLK rising edge, and the flag asserts in the error flags register. With CRC enabled, the expected number of SCLK cycles is 24. SCLK count error detection is enabled by default and can be configured by the user through the error configuration register.

Invalid Read and Write Address Error

An invalid read and write address error detects when a nonexistent register address is a target for a read or write. In addition, this error asserts when a write to a read only register is attempted. The invalid read and write address error flag asserts in the error flags register when an invalid read and write address error occurs. The invalid read and write address error is detected on the ninth SCLK rising edge, which means a write to the register does not occur when an invalid address is targeted. Invalid read and write address error detection is enabled by default and can be disabled by the user through the error configuration register.

CLEARING THE ERROR FLAGS REGISTER

To clear the error flags register, write the special 16-bit SPI frame, 0x6CA9, to the device. This SPI command does not trigger the invalid R/W address error. When CRC is enabled, the user must also send the correct CRC byte for a successful error clear command. At the 16th or 24th SCLK rising edge, the error flags register resets to zero.

BURST MODE

The SPI can accept consecutive SPI commands without the need to deassert the CS line, which is called burst mode. Burst mode is enabled through the burst enable register. This mode uses the same 16-bit command to communicate with the device. In addition, the response of the device at SDO is still aligned with the corresponding SPI command. Figure 41 shows an example of SDI and SDO during burst mode.

The invalid read and write address and CRC error checking functions operate similarly during burst mode as these error checking functions do during address mode. However, SCLK count error detection operates in a slightly different manner. The total number of SCLK cycles within a given CS frame are counted, and if the total is not a multiple of 16, or a multiple of 24 when CRC is enabled, the SCLK count error flag asserts.

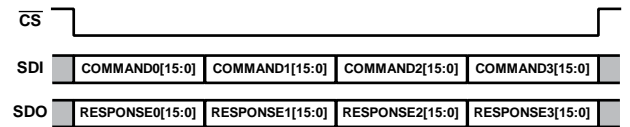

Figure 41. Burst Mode Frame

SOFTWARE RESET

When in address mode, the user can initiate a software reset by writing two consecutive SPI commands, 0xA3 followed by 0x05, targeting Register 0x0B. After a software reset, all register values are set to default.

DAISY-CHAIN MODE

The connection of several ADGS1414D devices in a daisy-chain configuration is possible, and Figure 42 illustrates this setup. All devices share the same CS, SCLK, and V_L line, whereas the SDO of a device forms a connection to the SDI of the next device, creating a shift register. In daisy-chain mode, SDO is an eight cycle delayed version of SDI. When in daisy-chain mode, all commands target the switch data register. Therefore, it is not possible to make configuration changes while in daisy-chain mode.

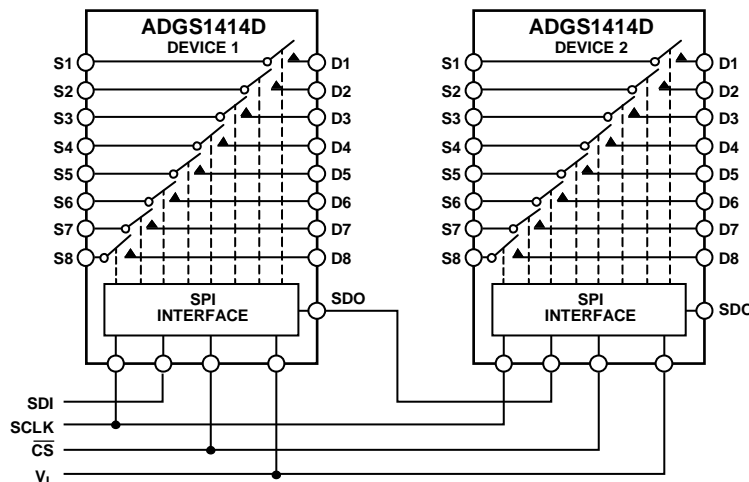

Figure 42. Two ADGS1414D Devices Connected in a Daisy-Chain Configuration

When in address mode, the ADGS1414D can only enter daisy-chain mode by sending the 16-bit SPI command, 0x2500 (see Figure 43). When the ADGS1414D receives this command, the SDO of the device sends out the same command because the alignment bits at SDO are 0x25, which allows multiple daisy connected devices to enter daisy-chain mode in a single SPI frame. A hardware reset is required to exit daisy-chain mode.

For the timing diagram of a typical daisy-chain SPI frame, see Figure 44. When CS goes high, Device 1 writes Command 0, Bits[7:0] to its switch data register, Device 2 writes Command 1, Bits[7:0] to its switches, and so on. The SPI block uses the last eight bits it received through SDI to update the switches. After entering daisy-chain mode, the first eight bits sent out by SDO

on each device in the chain are 0x00. When CS goes high, the internal shift register value does not reset back to zero.

An SCLK rising edge reads data on SDI while data is propagated out SDO on an SCLK falling edge.

POWER-ON RESET

The digital section of the ADGS1414D goes through an initialization phase during V_L power up. This initialization also occurs after a hardware or software reset. After V_L power-up or a reset, ensure that a minimum of 120 μs passes from the time of power-up or reset before any SPI command is issued. Ensure that V_L does not drop out during the 120 μs initialization phase because it may result in the incorrect operation of the ADGS1414D.

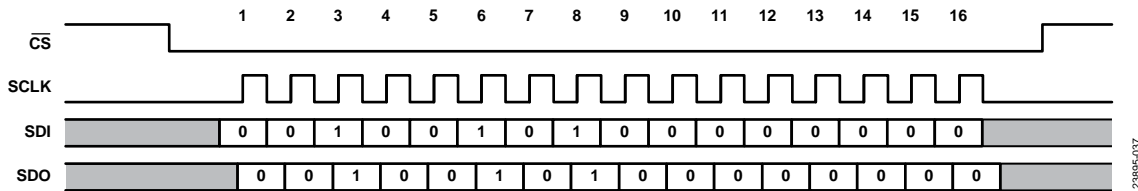
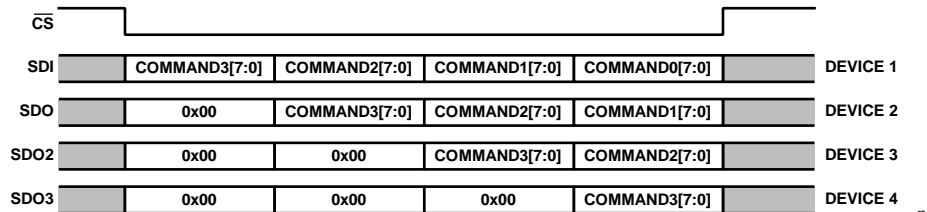

Figure 43. SPI Command to Enter Daisy-Chain Mode



NOTES
1. SDO2 AND SDO3 ARE THE OUTPUT COMMANDS FROM DEVICE 2 AND DEVICE 3, RESPECTIVELY.

Figure 44. Example of an SPI Frame Where Four ADGS1414D Devices Connect in Daisy-Chain Mode

APPLICATIONS INFORMATION

SYSTEM CHANNEL DENSITY

The ADGS1414D feature set allows for large system channel density. These features include route through pins for the digital signals and power supplies, as well as integrated passive components.

Route Through Pins

When multiple ADGS1414D devices are used in a system, the route through pins allow for a greater channel density layout. The route through pins enable the passing of power supplies and digital lines between devices with ease. The V_{DD} , $\overline{\text{RESET}}/V_L$, and GND power lines, as well as the SCLK, $\overline{\text{CS}}$, SDI, and SDO digital lines, are available on both the top and bottom pins of the package. These route through pins simplify PCB routing and reduce the need for vias when connecting many

ADGS1414D devices together. Figure 45 shows an example layout where the route through pins on four ADGS1414D devices configured in daisy-chain mode are used to reduce the overall size of the layout.

Integrated Passive Components

Note the lack of external passive components in the layout in Figure 45. The ADGS1414D has integrated decoupling capacitors for the V_{DD} , V_{SS} , and $\overline{\text{RESET}}/V_L$ power supplies. Therefore, the need for external decoupling capacitors is eliminated, reducing the total system footprint of the ADGS1414D. If additional decoupling is required for extremely noise sensitive applications, add an external decoupling capacitor. Figure 21 shows the AC PSRR performance with and without external decoupling capacitors.

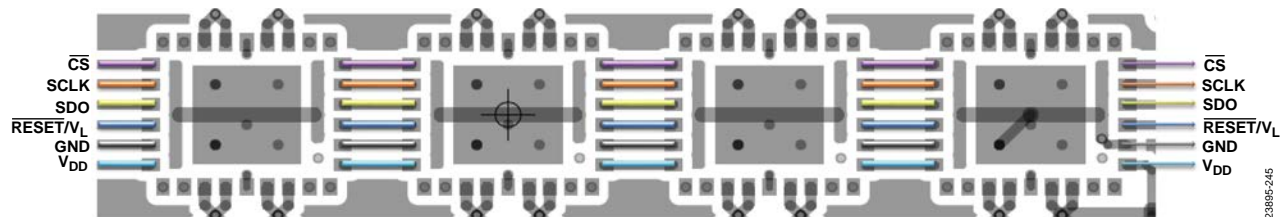

Figure 45. Layout Example Showing the Use of the Route Pins and the Elimination of External Passive Components

BREAK-BEFORE-MAKE SWITCHING

The ADGS1414D exhibits break-before-make switching action. This feature allows for the use of the device in multiplexer applications. To use the device as a multiplexer, externally hardwire a device into the desired mux configuration, as shown in Figure 46.

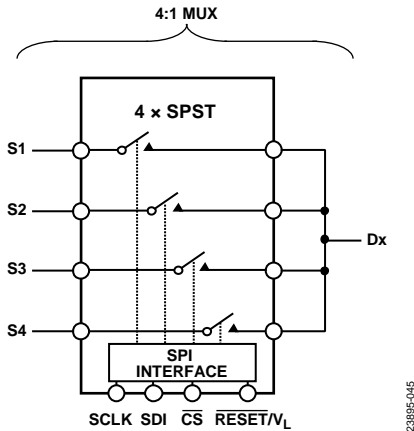

Figure 46. An SPI Controlled Switch Configured into a 4:1 Mux

DIGITAL INPUT BUFFERS

There are input buffers present on the digital input pins (\overline{CS} , SCLK, and SDI). These buffers are active at all times. Therefore, there is current draw from the V_L supply if SCLK or SDI is toggled, regardless of whether \overline{CS} is active. For typical values of this current draw, refer to the Specifications section and Figure 27.

POWER SUPPLY RAILS

The ADGS1414D can operate with bipolar supplies between ± 4.5 V and ± 16.5 V. The supplies on V_{DD} and V_{SS} do not have to be symmetrical. However, the V_{DD} to V_{SS} range must not exceed 33 V. The ADGS1414D can also operate with single supplies between 5 V and 20 V with V_{SS} connected to GND. The voltage range that can be supplied to V_L is from 2.7 V to 5.5 V. The device is fully specified at ± 15 V, ± 5 V, and +12 V analog supply voltage ranges.

POWER SUPPLY RECOMMENDATIONS

Analog Devices, Inc., has a wide range of power management products to meet the requirements of high performance signal chains.

An example of a bipolar power solution is shown in Figure 47. The LT3463 (a dual switching regulator) generates a positive and negative supply rail for the ADGS1414D, an amplifier, and/or a precision converter in a typical signal chain. Also shown in Figure 47 are two optional low dropout regulators (LDOs), the ADP7142 and ADP7182 (positive and negative LDOs, respectively), which can reduce the output ripple of the LT3463 in ultralow noise sensitive applications.

The ADP7142 can generate the V_L voltage that is required to power digital circuitry within the ADGS1414D.

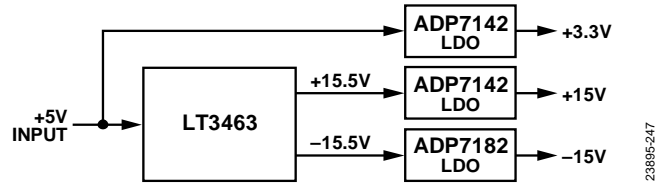

Figure 47. Bipolar Power Solution

Table 11. Recommended Power Management Devices

Product	Description
LT3463	Dual micropower, dc to dc converter with Schottky diodes
ADP7142	40 V, 200 mA, low noise, CMOS, LDO linear regulator
ADP7182	-28 V, -200 mA, low noise, LDO linear regulator

1.8 V LOGIC COMPATIBILITY

The SDI, \overline{CS} , and SCLK digital inputs of the ADGS1414D are compatible with 1.8 V logic when V_L is between or equal to 2.7 V and 3.3 V.

The SDO digital output levels are proportional to the V_L voltage. For example, if $V_L = 3$ V, a logic high on the SDO is approximately 3 V. When performing an SPI readback from the ADGS1414D with a controller device using 1.8 V logic, there may be an issue if the digital pins on the controller cannot tolerate digital input signals that exceed 1.8 V.

Figure 48 describes how to use the ADG3231 level translator to perform a 1.8 V SPI readback with a device that has 1.8 V logic ports, such as a microcontroller or field programmable gate array (FPGA). Place the ADG3231 between the SDO of the ADGS1414D and the microcontroller or FPGA. Supply V_{CC1} of the ADG3231 with the V_L voltage of the ADGS1414D and connect V_{CC2} to the 1.8 V supply from the microcontroller or FPGA. The ADG3231 then translates the logic level of the SDO from V_L to 1.8 V.

This solution is only required if the 1.8 V microcontroller or FPGA cannot tolerate digital input signals that exceed 1.8 V.

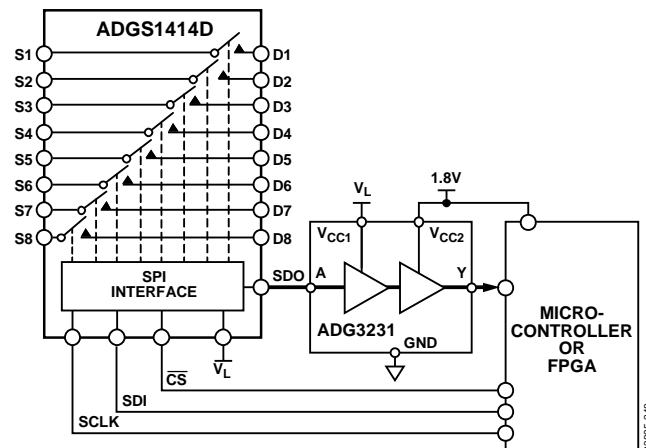

Figure 48. Using the ADG3231 to Perform a 1.8 V SPI Readback

REGISTER SUMMARY

Table 12. Register Summary

Reg.	Name	Bit 7	Bit 6	Bit 5	Bit 4	Bit 3	Bit 2	Bit 1	Bit 0	Default	R/W
0x01	SW_DATA	SW8_EN	SW7_EN	SW6_EN	SW5_EN	SW4_EN	SW3_EN	SW2_EN	SW1_EN	0x00	R/W
0x02	ERR_CONFIG	Reserved					RW_ERR_EN	SCLK_ERR_EN	CRC_ERR_EN	0x06	R/W
0x03	ERR_FLAGS	Reserved					RW_ERR_FLAG	SCLK_ERR_FLAG	CRC_ERR_FLAG	0x00	R
0x05	BURST_EN	Reserved							BURST_MODE_EN	0x00	R/W
0x0B	SOFT_RESETB	SOFT_RESETB								0x00	W

REGISTER DETAILS

SWITCH DATA REGISTER

Address: 0x01, Reset: 0x00, Name: SW_DATA

Use the switch data register to control the status of the eight switches of the ADGS1414D.

Table 13. Bit Descriptions for SW_DATA

Bit	Bit Name	Setting	Description	Default	Access
7	SW8_EN	0 1	Enable the SW8_EN bit for Switch 8. Switch 8 open. Switch 8 closed.	0x0	R/W
6	SW7_EN	0 1	Enable the SW7_EN bit for Switch 7. Switch 7 open. Switch 7 closed.	0x0	R/W
5	SW6_EN	0 1	Enable the SW6_EN bit for Switch 6. Switch 6 open. Switch 6 closed.	0x0	R/W
4	SW5_EN	0 1	Enable the SW5_EN bit for Switch 5. Switch 5 open. Switch 5 closed.	0x0	R/W
3	SW4_EN	0 1	Enable the SW4_EN bit for Switch 4. Switch 4 open. Switch 4 closed.	0x0	R/W
2	SW3_EN	0 1	Enable the SW3_EN bit for Switch 3. Switch 3 open. Switch 3 closed.	0x0	R/W
1	SW2_EN	0 1	Enable the SW2_EN bit for Switch 2. Switch 2 open. Switch 2 closed.	0x0	R/W
0	SW1_EN	0 1	Enable the SW1_EN bit for Switch 1. Switch 1 open. Switch 1 closed.	0x0	R/W

ERROR CONFIGURATION REGISTER

Address: 0x02, Reset: 0x06, Name: ERR_CONFIG

Use the error configuration register to enable and disable the relevant error features as required.

Table 14. Bit Descriptions for ERR_CONFIG

Bits	Bit Name	Settings	Description	Default	Access
[7:3]	Reserved		Bits[7:3] are reserved. Set Bits[7:3] to 0.	0x0	R
2	RW_ERR_EN	0 1	Enable the RW_ERR_EN bit to detect an invalid read and write address. Disabled. Enabled.	0x1	R/W
1	SCLK_ERR_EN	0 1	Enable the SCLK_ERR_EN bit to detect the correct number of SCLK cycles in an SPI frame. 16 SCLK cycles are expected when CRC is disabled and burst mode is disabled. 24 SCLK cycles are expected when CRC is enabled and burst mode is disabled. A multiple of 16 SCLK cycles are expected when CRC is disabled and burst mode is enabled. A multiple of 24 SCLK cycles are expected when CRC is enabled and burst mode is enabled. Disabled. Enabled.	0x1	R/W

Bits	Bit Name	Settings	Description	Default	Access
0	CRC_ERR_EN	0 1	Enable the CRC_ERR_EN bit for CRC error detection. SPI frames are 24 bits wide when enabled. Disabled. Enabled.	0x0	R/W

ERROR FLAGS REGISTER

Address: 0x03, Reset: 0x00, Name: ERR_FLAGS

Use the error flags register to determine if an error has occurred. To clear the error flags register, write the special 16-bit SPI command, 0x6CA9, to the device. This SPI command does not trigger the invalid R/W address error. When CRC is enabled, include the correct CRC byte during the SPI write for the clear error flags register command to succeed.

Table 15. Bit Descriptions for ERR_FLAGS

Bits	Bit Name	Settings	Description	Default	Access
[7:3]	Reserved		Bits[7:3] are reserved and are set to 0.	0x0	R
2	RW_ERR_FLAG	0 1	Error flag for invalid read and write address. The error flag asserts during an SPI read if the target address does not exist. The error flag also asserts when the target address of an SPI write does not exist or is read only. No error. Error.	0x0	R
1	SCLK_ERR_FLAG	0 1	Error flag for the detection of the correct number of SCLK cycles in an SPI frame. No error. Error.	0x0	R
0	CRC_ERR_FLAG	0 1	Error flag that determines if a CRC error has occurred during a register write. No error. Error.	0x0	R

BURST ENABLE REGISTER

Address: 0x05, Reset: 0x00, Name: BURST_EN

Use the burst enable register to enable or disable burst mode. When burst mode is enabled, the user can send multiple consecutive SPI commands without deasserting \overline{CS} .

Table 16. Bit Descriptions for BURST_EN

Bits	Bit Name	Settings	Description	Default	Access
[7:1]	Reserved		Bits[7:1] are reserved. Set Bits[7:1] to 0.	0x0	R
0	BURST_MODE_EN	0 1	Burst mode enable bit. Disabled. Enabled.	0x0	R/W

SOFTWARE RESET REGISTER

Address: 0x0B, Reset: 0x00, Name: SOFT_RESETB

Use the software reset register to perform a software reset. Consecutively write 0xA3 followed by 0x05 to this register, and the registers of the device reset to their default state.

Table 17. Bit Descriptions for SOFT_RESETB

Bits	Bit Name	Settings	Description	Default	Access
[7:0]	SOFT_RESETB		To perform a software reset, consecutively write 0xA3 followed by 0x05 to the SOFT_RESETB register.	0x0	W

OUTLINE DIMENSIONS

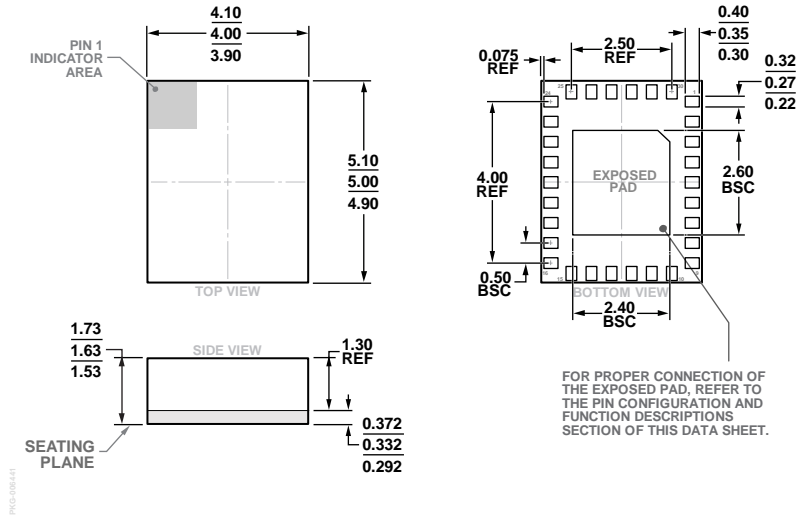

Figure 49. 30-Terminal Land Grid Array [LGA]
(CC-30-3)
4 mm x 5 mm Body and 1.63 mm Package Height
Dimensions shown in millimeters

ORDERING GUIDE

Model ¹	Temperature Range	Package Description	Package Option
ADGS1414DBCCZ	-40°C to +125°C	30-Terminal Land Grid Array [LGA]	CC-30-3
ADGS1414DBCCZ-RL7	-40°C to +125°C	30-Terminal Land Grid Array [LGA]	CC-30-3
EV-ADGS1414DSDZ		Evaluation Board	

¹ Z = RoHS Compliant Part.