

OPERATION AND PARTS MANUAL

STOW

A DIVISION OF MULTIQUIP INC.

CUTTER 1

MODEL CD613H18

(HONDA GX390 GASOLINE ENGINE)

MODEL CD605E16

(5 HP ELECTRIC MOTOR)

CONCRETE/ASPHALT SAW

Revision #6 (06/06/08)

To find the latest revision of this
publication, visit our website at:
www.stowmfg.com



THIS MANUAL MUST ACCOMPANY THE EQUIPMENT AT ALL TIMES.

P/N 25498



CALIFORNIA — Proposition 65 Warning

Engine exhaust and some of its constituents, and some dust created by power sanding, sawing, grinding, drilling and other construction activities contains chemicals known to the State of California to cause cancer, birth defects and other reproductive harm. Some examples of these chemicals are:

- Lead from lead-based paints.
- Crystalline silica from bricks.
- Cement and other masonry products.
- Arsenic and chromium from chemically treated lumber.

Your risk from these exposures varies, depending on how often you do this type of work. To reduce your exposure to these chemicals: **ALWAYS** work in a well ventilated area, and work with approved safety equipment, such as dust masks that are specially designed to filter out microscopic particles.

STOW CUTTER 1 SAW — TABLE OF CONTENTS

Proposition 65 Warning 2
 Table Of Contents 4
 Parts Ordering Procedures 5
 Safety Message Alert Symbols 6-7
 Rules For Safe Operation 8-10
 Specifications (Saw) 11
 Specifications (Engine) 12

HONDA GX390K1QWT2/ GX390U1QWT2 ENGINES

Air Cleaner Assembly 42-43
 Camshaft Assembly 44-45
 Carburetor Assembly 46-47
 Control Assembly 48-49
 Crankcase Cover Assembly 50-51
 Crankshaft Assembly 52-53
 Cylinder Barrel Assembly 54-55
 Cylinder Head Assembly 56-57
 Fan Cover Assembly 58-59
 Flywheel Assembly 60-61
 Fuel Tank Assembly 62-63
 Ignition Coil Assembly 64-65
 Muffler Assembly 66-67
 Piston Assembly 68-69
 Recoil Starter Assembly 70-71
 Labels 72-73

STOW — CUTTER 1 SAW

Controls & Components 13
 Basic Engine 14
 Preparation/Pre-Inspection 15-17
 Blades 18
 Blade Placement 19
 Initial Start-Up 20-21
 Operation 21
 Maintenance 22-23
 Troubleshooting (Saw) 24
 Troubleshooting (Engine) 25-26
 Explanation of Codes in Remarks Column 28
 Suggested Spare Parts 29
 Nameplate and Decals 30-31
 Engine, Belts And Pulleys Assembly 32-33
 Electric Motor Assembly 34-35
 Undercarriage Assembly 36-37
 Blade Assembly & Water System Assembly 38-39
 Pointer Assembly 40-41

Terms and Conditions of Sale — Parts 74

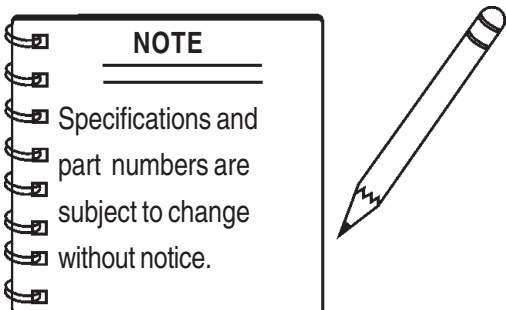

STOW CUTTER 1 SAW — PARTS ORDERING PROCEDURES

When ordering parts, please supply the following information:

- Dealer account number
- Dealer name and address
- Shipping address (if different than billing address)
- Return fax number
- Applicable model number
- Quantity, part number and description of each part
- Specify preferred method of shipment:
 - ✓ FedEx or UPS Ground
 - ✓ FedEx or UPS Second Day or Third Day
 - ✓ FedEx or UPS Next Day
 - ✓ Federal Express Priority One
 - ✓ DHL
 - ✓ Truck

Note: Unless otherwise indicated by customer, all orders are treated as "Standard Orders", and will ship within 24 hours. We will make every effort to ship "Air Shipments" the same day that the order is received, if prior to 2PM west coast time. "Stock Orders" must be so noted on fax or web forms.



Here's how to get help...

Please have the model and serial number on hand when calling.

STOW MAIN OFFICE

18910 Wilmington Ave. 800-421-1244
 Carson, CA 90746 FAX: 310-537-3927
 Email: stow@stowmfg.com
 Internet: www.stowmfg.com

SALES DEPARTMENT

310-661-4242 Fax: 310-604-9237
 877-289-7869 (877-BUY-STOW)

PARTS DEPARTMENT

800-427-1244 FAX: 800-672-7877
 310-537-3700 FAX: 310-637-3284

SERVICE DEPARTMENT

800-478-1244 FAX: 310-537-4259
 310-537-3700

TECHNICAL ASSISTANCE

800-478-1244 FAX: 310-631-5032

WARRANTY DEPARTMENT

800-421-1244, EXT. 279 FAX: 310-537-1173
 310-537-3700, EXT. 279

Place Your Parts Order Via Web or Fax For Even More Savings!

(Domestic USA Dealers Only)

Extra Discounts!

All parts orders which include complete part numbers and are received by our automated web parts order system, or by fax qualify for the following extra discounts:

Ordered via	Standard orders	Stock orders (\$750 list and above)
Fax	3%	10%
Web	5%	10%

Special freight allowances when you order 10 or more line items via Web or Fax! **

FedEx Ground Service **at no charge for freight**
 No other allowances on freight shipped by any other carrier.

**Common nuts, bolts and washers (all items under \$1.00 list price) do not count towards the 10+ line items.

NOTE: DISCOUNTS ARE SUBJECT TO CHANGE

STOW

A DIVISION OF MULTIQUIP INC.
STOW CONSTRUCTION EQUIPMENT
 A DIVISION OF MULTIQUIP INC.

POST OFFICE BOX 6254 CARSON, CA 90749
 888-252-STOW [888-252-7869] 310-537-3700
 FAX: 310-537-1986 FAX: 800-556-1986
 E-MAIL: stow@multiquip.com INTERNET: www.stowmfg.com

Direct TOLL-FREE access to our Parts Department:

Toll-free nationwide — 800-427-1244

Toll-free FAX — 800-6-PARTS-7 (800/672-7877)

STOW CUTTER 1 SAW — SAFETY MESSAGE ALERT SYMBOLS

FOR YOUR SAFETY AND THE SAFETY OF OTHERS!

Safety precautions should be followed at all times when operating this equipment. Failure to read and understand the Safety Messages and Operating Instructions could result in injury to yourself and others.

NOTE

This Owner's Manual has been developed to provide complete instructions for the safe and efficient operation of the **STOW CUTTER 1 SAW**. For engine maintenance information, please refer to the engine manufacturers instructions for data relative to its safe operation.

Before using this CONCRETE/ASPHALT SAW, ensure that the operating individual has read and understands all instructions in this manual.

SAFETY MESSAGE ALERT SYMBOLS

The three (3) Safety Messages shown below will inform you about potential hazards that could injure you or others. The Safety Messages specifically address the level of exposure to the operator, and are preceded by one of three words: **DANGER**, **WARNING**, or **CAUTION**.



DANGER: You **WILL** be **KILLED** or **SERIOUSLY** injured if you **DO NOT** follow directions.



WARNING: You **CAN** be **KILLED** or **SERIOUSLY** injured if you **DO NOT** follow directions.



CAUTION: You **CAN** be injured if you **DO NOT** follow directions.

Potential hazards associated with STOW CUTTER 1 SAW operation will be referenced with "**Hazard Symbols**" which appear throughout this manual, and will be referenced in conjunction with Safety "**Message Alert Symbols**".

HAZARD SYMBOLS



Lethal Exhaust Gases



Engine exhaust gases contain poisonous carbon monoxide. This gas is colorless and odorless, and can cause death if inhaled. **NEVER** operate this equipment in a confined area or enclosed structure that does not provide ample free flow air.



Explosive Fuel



Gasoline is extremely flammable, and its vapors can cause an explosion if ignited. **DO NOT** start the engine near spilled fuel or combustible fluids. **DO NOT** fill the fuel tank while the engine is running or hot. **DO NOT** overfill tank, since spilled fuel could ignite if it comes into contact with hot engine parts or sparks from the ignition system. Store fuel in approved containers, in well-ventilated areas and away from sparks and flames. **NEVER** use fuel as a cleaning agent.



Burn Hazards



Engine components can generate extreme heat. To prevent burns, **DO NOT** touch these areas while the engine is running or immediately after operations. **NEVER** operate the engine with heat shields or heat guards removed.



Rotating Parts



NEVER operate equipment with covers, or guards removed. Keep **fingers, hands, hair** and **clothing** away from all moving parts to prevent injury.

STOW CUTTER 1 SAW — SAFETY MESSAGE ALERT SYMBOLS



Accidental Starting



OFF **ALWAYS** place the engine ON/OFF switch in the **OFF** position, when the saw is not in use.



Respiratory Hazard



ALWAYS wear approved respiratory protection.



Over Speed Conditions



NEVER tamper with the factory settings of the engine governor or settings. Personal injury and damage to the engine or equipment can result if operating in speed ranges above maximum allowable.



Sight and Hearing hazard

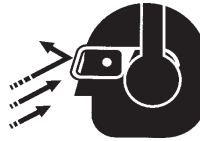

ALWAYS wear approved eye and hearing protection.



Guards and Covers In Place



NEVER operate the saw without blade guards and covers in place. Adhere to safety guidelines ANSI, OSHA, or other applicable local regulations.



Equipment Damage Messages

Other important messages are provided throughout this manual to help prevent damage to your concrete saw, other property, or the surrounding environment.



Rotating Blade



Rotating blade can cut and crush. Keep hands and feet clear.

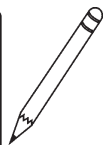
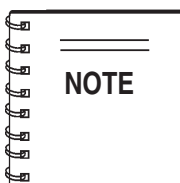

This **concrete/asphalt saw**, other property, or the surrounding environment could be damaged if you do not follow instructions.

STOW CUTTER 1 SAW — RULES FOR SAFE OPERATION

RULES FOR SAFE OPERATION

CAUTION:



Failure to follow instructions in this manual may lead to serious injury or even death! This equipment is to be operated by trained and qualified personnel only! This equipment is for industrial use only.

The following safety guidelines should always be used when operating the STOW CUTTER 1 SAW. Unless otherwise noted, these guidelines refer to saws with gasoline powered engines.

SAFETY

- **DO NOT** operate or service this equipment before reading this entire manual.



- This equipment should not be operated by persons under 18 years of age.

- **NEVER** operate the saw without proper protective clothing, shatterproof glasses, steel-toed boots and other protective devices required by the job.



- **NEVER** operate this equipment when not feeling well due to fatigue, illness or taking medicine.



- **NEVER** operate the saw under the influence of drugs or alcohol.



- **NEVER** use accessories or attachments, which are not recommended by STOW or Multiquip for this equipment. Damage to the equipment and/or injury to user may result.

- Manufacturer does not assume responsibility for any accident due to equipment modifications. Unauthorized equipment modification will void all warranties.

- Whenever necessary, replace nameplate, operation and safety decals when they become difficult read.

- **ALWAYS** check the saw for loosened hardware such as nuts and bolts before starting.

- **NEVER** touch the hot exhaust manifold, muffler or cylinder. Allow these parts to cool before servicing the saw.



- **High Temperatures** – Allow the engine to cool before adding fuel or performing service and maintenance functions. Contact with **hot!** components can cause serious burns.

- The engine of this saw requires an adequate free flow of cooling air. **NEVER** operate the saw in any enclosed or narrow area where free flow of the air is restricted. If the air flow is restricted it will cause serious damage to the saw's engine and may cause injury to people. Remember the saw's engine gives off **DEADLY** carbon monoxide gas.

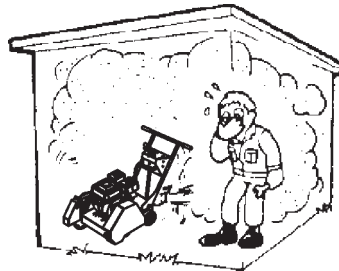

- **ALWAYS** refuel in a well-ventilated area, away from sparks and open flames.

- **ALWAYS** use extreme caution when working with **flammable** liquids. When refueling, **STOP** the engine and allow it to cool.

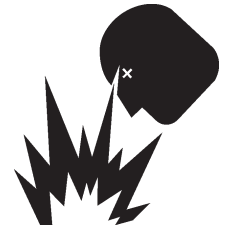

- **NEVER** smoke around or near the machine. Fire or explosion could result from **fuel vapors**, or if fuel is spilled on a **hot!** engine.



- **NEVER** operate the saw in an explosive atmosphere where fumes are present or near combustible materials. An explosion or fire could result causing severe **bodily harm or even death**.

- Topping-off to filler port is dangerous, as it tends to spill fuel.

- **NEVER** use fuel as a cleaning agent.

STOW CUTTER 1 SAW — RULES FOR SAFE OPERATION

General Safety

- **ALWAYS** read, understand, and follow procedures in Operator's Manual before attempting to operate equipment.
- **ALWAYS** be sure the operator is familiar with proper safety precautions and operating techniques before using the saw.
- **NEVER** leave the machine *unattended* while running.
- Block the unit when leaving or when using on a slope.
- **ALWAYS** check to make sure that the operating area is clear before starting the engine.
- Maintain this equipment in a safe operating condition at all times.
- **ALWAYS** stop the engine before servicing, adding fuel and oil.
- **NEVER** run the engine without the air filter. Severe engine damage could occur.
- **ALWAYS** service air cleaner frequently to prevent carburetor malfunction.
- **AVOID** wearing jewelry or loose fitting clothing that may snag on the controls or moving parts, this can cause a serious injury.
- **ALWAYS** keep clear of *rotating* or *moving parts* while the saw is in operation.
- **ALWAYS** store equipment properly when it is not being used. Equipment should be stored in a clean, dry location out of the reach of children.
- **NEVER** use accessories or attachments which are not recommended by the manufacturer for this equipment. Damage to the equipment and/or injury to user may result.



WARNING

- **ALWAYS** check to make sure that the operating area is clear before starting the engine.
- Keep all inexperienced and unauthorized people away from the equipment at all times.

Electric Saws

- **ALWAYS** connect electric motor of the saw to a power source in compliance with all local and state electrical codes. This must be performed by a qualified electrician. After this connection is made, it will be necessary to check the rotation of the motor shaft. The shaft rotation should be *counter-clockwise* when viewing the motor from the shaft extension end. If the rotation of the shaft is incorrect make necessary changes for the correct shaft rotation.

- **MAKE CERTAIN** the power cord/extension cord is free from damage and that the grounding circuit is operational.
- **MAKE CERTAIN** the extension cord that you are using is intended to be used in the environment you are using it in. If an extension is used, **NEVER** submerge the connection in water. To reduce the risk of electric shock, always make water-tight connections.
- **MAKE CERTAIN** the "ON/OFF" switch is in the "OFF" position before plugging in the power cord/extension cord to avoid accidental starting.
- Use only the gauge wire and length of cord recommended for the motor size. Refer to Table 3 in this manual.
- When cutting, **ALWAYS** be aware of the location of the cord.
- **NEVER** use a *worn, frayed* or *damaged* extension cord.

Diamond Blade Safety

- Use appropriate steel centered diamond blades manufactured for use on concrete saws.



WARNING

- **ALWAYS** inspect diamond blades before each use. The blade should exhibit no cracks, dings, or flaws in the steel centered core and/or rim. Center (arbor) hole must be undamaged and true.
- Examine blade flanges for damage, excessive wear and cleanliness before mounting blade. Blade should fit snugly on the shaft and against the inside/outside blade flanges.
- Ensure the blade is marked with an operating speed greater than the blade shaft speed of the saw.
- Only cut the material that is specified by the diamond blade. Read the specifications of the diamond blade to ensure the proper tool has been matched to the material being cut.
- **ALWAYS** keep blade guards in place. Exposure of the diamond blade must not exceed 180 degrees.
- Ensure that the diamond blade does not come into contact with the ground or surface during transportation. **DO NOT** drop the diamond blade on ground or surface.
- The engine governor is designed to permit maximum engine speed in a no-load condition. Speeds that exceed this limit may cause the diamond blade to exceed the maximum safe allowable speed.
- Ensure that the blade is mounted for proper operating direction.



STOW CUTTER 1 SAW — RULES FOR SAFE OPERATION

Saw Transportation Safety

- Use appropriate lifting equipment to ensure the safe movement of the saw.
- **DO NOT** use the handle bars and/or front pointer as lifting points.
- When transporting of the saw is required, place saw directly inside towing vehicle truck-bed and tie-down securely. **NEVER** tow saw directly behind towing vehicle.
- **DO NOT** use the saw on slopes or on extremely un-level surfaces. An engine tipped to extreme angles may cause oil to gravitate into the cylinder head making the engine start difficult.

EMERGENCIES

- **NEVER** transport the saw with the blade protruding.
- **ALWAYS** know the location of the nearest **fire extinguisher**.



- **ALWAYS** know the location of the nearest **first aid kit**.



- In emergencies **always** know the location of the nearest phone or **keep a phone on the job site**. Also know the phone numbers of the nearest **ambulance, doctor, and fire department**. This information will be invaluable in the case of an emergency.



Machine Operation And Safety Decals

The STOW CUTTER 1 SAW is equipped with a number of operation and safety decals. Should any of these decals become unreadable, replacements can be obtained from your dealer.



P/N 25249-001



P/N 25250-001



P/N 22122-001

STOW
P/N 22972-003
6.00 LG

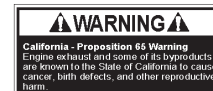

P/N 28997-001

STOW
P/N 22972-004
7.00 LG

CUTTER
1
P/N 23653-001



P/N 25215-001
(ELECTRIC MODEL ONLY)



P/N 23330-001



P/N 11246
(Sheet-Intl. Stds)



CONTACT STOW
SERVICE DEPARTMENT

Figure 1. STOW CUTTER 1 SAW Decals

STOW CUTTER 1 SAW — SPECIFICATIONS (SAW)

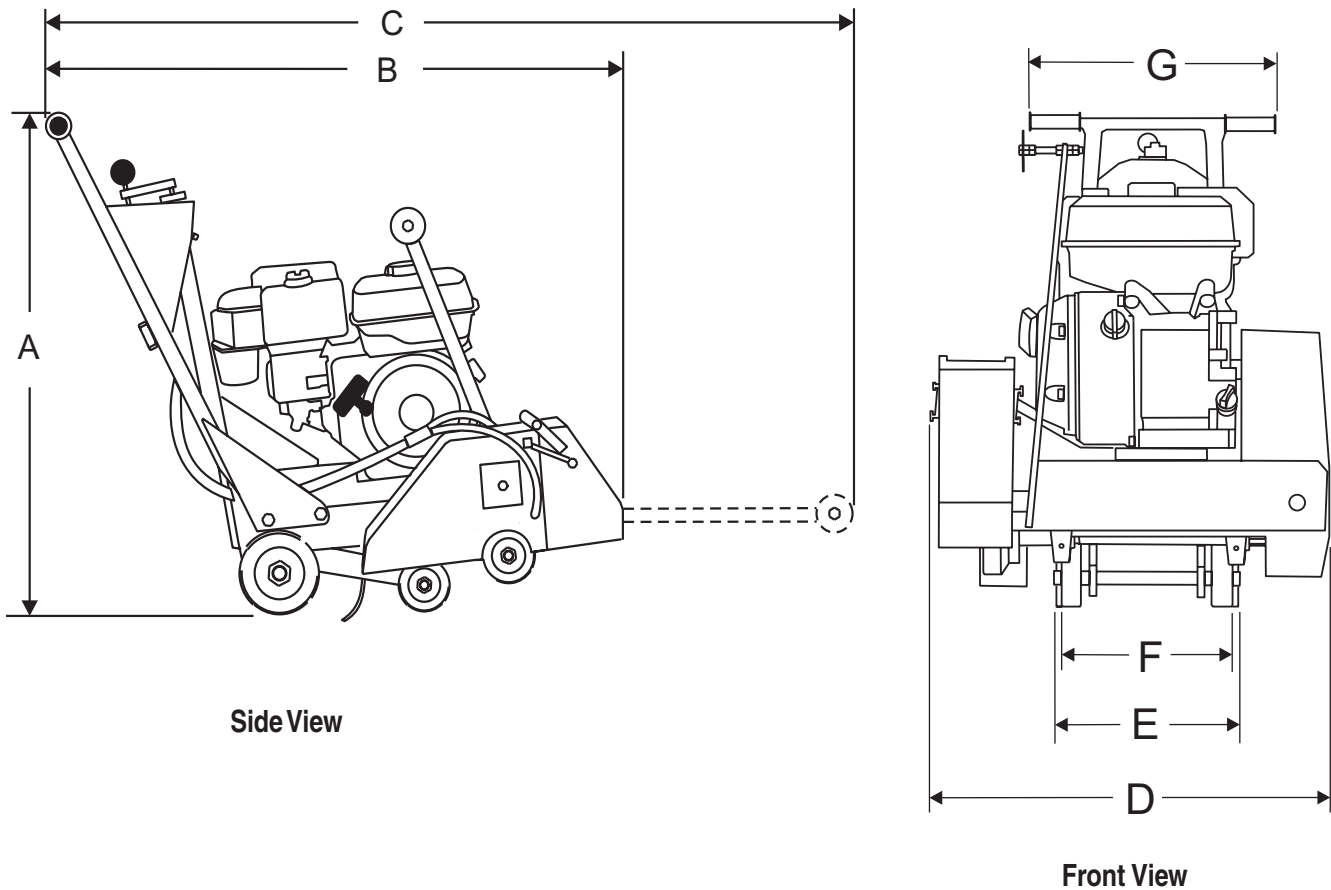

Figure 2. STOW CUTTER 1 SAW Dimensions

Table 1. Cutter 1 Specifications

REFERENCE LETTER	DESCRIPTION	DIMENSION (cm)
A	Max Height	37.0 In. (94 cm)
B	Max Length (Front Pointer Raised)	32.0 In. (80 cm)
C	Max Length (Front Pointer Lowered)	54.5 In. (138 cm)
D	Max Width	21.5 In. (55 cm)
E	Rear Wheel Base	17.0 In. (40 cm)
F	Front Wheel Base	10.0 In. (25.4 cm)
G	Handle Bar Width	21.5 In. (55 cm)
ENGINE TYPE	DESCRIPTION	WEIGHT (KG)
	CUTTER 1, 13 HP HONDA ENGINE	214 lbs. (97 K.g)

STOW CUTTER 1 SAW — SPECIFICATIONS (ENGINE)

Table 2. Specifications (Engine)

Table 2. Specifications (Engine)		
Engine	Model	HONDA GX390K1QWT2/GX390U1QWT2
	Type	Air-cooled 4 stroke, Single Cylinder, OHV, Gasoline Engine
	Bore X Stroke	3.5 in. X 2.5 in. (88 mm x 64 mm)
	Displacement	23.7 cu-in. (389 cc)
	Max Output	13.0 H.P./3600 R.P.M.
	Fuel Tank Capacity	Approx. 1.72 U.S. Gallons (6.5 Liters)
	Fuel	Unleaded Automobile Gasoline 86 Octane or higher
	Lube Oil Capacity	1.16 US qt (1.1 liter)
	Speed Control Method	Centrifugal Fly-weight Type
	Starting Method	Recoil Start
Dimension (L x W x H)	15.0 x 17.7 X 17.4 in. (380 X 450 X 443 mm)	
Dry Net Weight	68.4 lbs (31 Kg.)	

STOW CUTTER 1 SAW — CONTROLS & COMPONENTS

CONTROLS & COMPONENTS

Figure 3 shows the location of the basic controls or components for the STOW CUTTER 1 SAW. Listed below is a brief explanation of each control or component. (Gasoline-powered unit shown)

1. **Hand Grips/Handlebar** – When operating the saw, place both hands on each grip to maneuver the saw. Replace hand grips when they become worn or damaged.
2. **Handle Lock** – Lock blade depth to desired position.
3. **Garden Hose Connector** – Connect to water source to provide blade cooling while cutting concrete or asphalt.
4. **Air Filter** – Prevents dirt and debris from entering the engine air intake. Check filter periodically and keep cleaned or replace when necessary.
5. **Recoil Starter Handle** – Pull to engage and start the engine.
6. **Recoil Starter Assembly** – Engages the engine when the handle is pulled and rewinds the starter rope when the handle is released.
7. **Wheels/Carriage Assembly** – Heavy-duty polyurethane wheels with permanently sealed ball bearings.
8. **Cutting Blade** – Use appropriate type blades for cutting concrete or asphalt.
9. **Blade Guard** – Covers saw blade and flips up to allow blade to be changed.
10. **Belt Tension Adjuster** – Adjusts belt tension.
11. **Front Pointer** – Front pointer wheel assists in straight tracking.
12. **Front Pointer Arm** – Stows up for storage and pivots down for use.
13. **Cutting Depth Adjuster** – turn operating crank clockwise or counter-clockwise to adjust the cutting depth up or down.
14. **Fuel Tank** – Use unleaded gasoline. Do not overfill.
15. **Blade Coolant System** – Provides cooling water to blade during cutting operations.
16. **V-Belt Cover** – Remove this cover to gain access to the V-belt. **NEVER** operate the saw with this cover removed.
17. **Arbor Shaft Grease Zerks** – Conveniently located for lubrication.
18. **On/Off Switch** – Turn to the "ON" position to allow engine to be started and turn to the "OFF" position to shut the engine off.

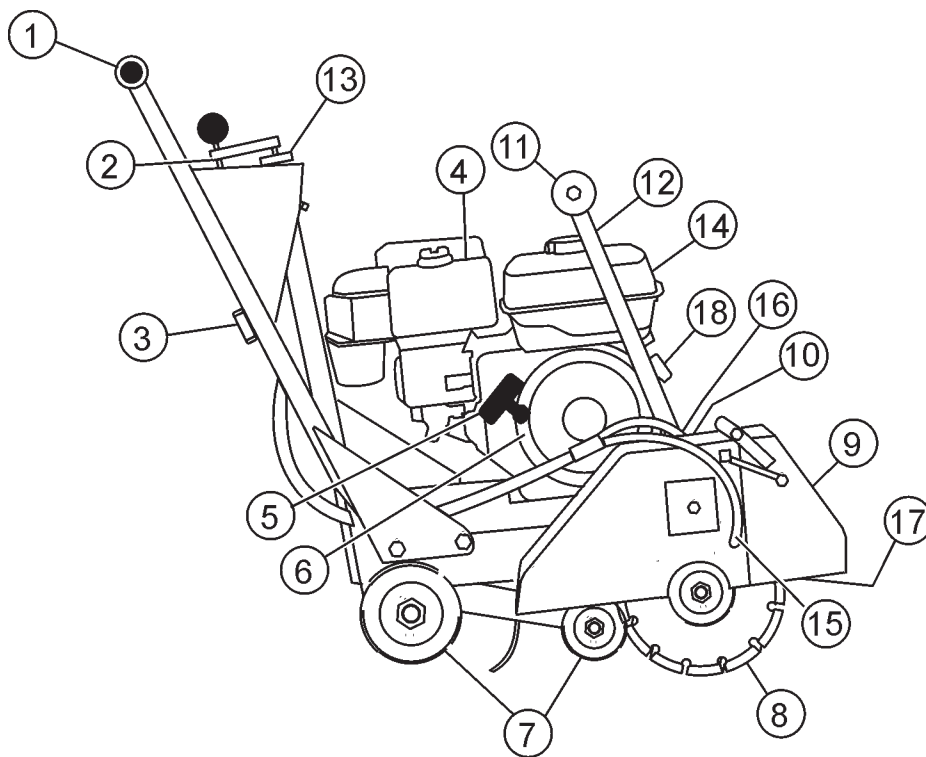

Figure 3. Cutter 1

STOW CUTTER 1 SAW — BASIC ENGINE

BASIC ENGINE

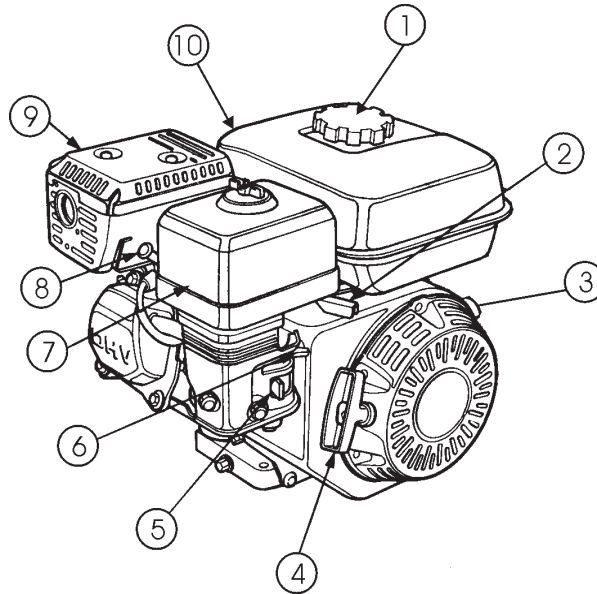
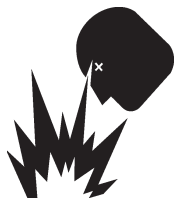

Figure 4. Engine Controls and Components

Initial Servicing

The engine (Figure 4) must be checked for proper lubrication and filled with fuel prior to operation. Refer to the manufacturers engine manual for instructions & details of operation and servicing.

1. **Fuel Filler Cap** – Remove this cap to add unleaded gasoline to the fuel tank. Make sure cap is tightened securely. **DO NOT** over fill.



Adding fuel to the tank should be done only when the engine is stopped and has had an opportunity to cool down. In the event of a fuel spill, **DO NOT** attempt to start the engine until the fuel residue has been completely wiped up, and the area surrounding the engine is dry.

2. **Throttle Lever** – Used to adjust engine RPM speed (lever advanced forward **SLOW**, lever back toward operator **FAST**).
3. **Engine ON/OFF Switch** – **ON** position permits engine starting, **OFF** position stops engine operations.
4. **Recoil Starter (pull rope)** – Manual-starting method. Pull the starter grip until resistance is felt, then pull briskly and smoothly.
5. **Fuel Valve Lever** – **OPEN** to let fuel flow, **CLOSE** to stop the flow of fuel.

6. **Choke Lever** – Used in the starting of a cold engine, or in cold weather conditions. The choke enriches the fuel mixture.
7. **Air Cleaner** – Prevents dirt and other debris from entering the fuel system. Remove wing-nut on top of air filter cannister to gain access to filter element.

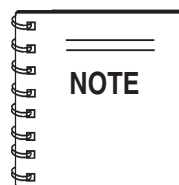

Operating the engine without an air filter, with a damaged air filter, or a filter in need of replacement will allow dirt to enter the engine, causing rapid engine wear.

8. **Spark Plug** – Provides spark to the ignition system. Set spark plug gap to 0.6 - 0.7 mm (0.028 - 0.031 inch) Clean spark plug once a month.
9. **Muffler** – Used to reduce noise and emissions.



Engine components can generate extreme heat. To prevent burns, **DO NOT** touch these areas while the engine is running or immediately after operating. **NEVER** operate the engine with the muffler removed.

10. **Fuel Tank** – Holds unleaded gasoline. For additional information refer to engine owner's manual.

STOW CUTTER 1 SAW — PREPARATION/PRE-INSPECTION

PREPARATION / PRE-INSPECTION

1. Read and fully understand this manual, the safety instructions in particular, and the engine manufacturer's manual supplied with the saw.



2. Select the correct blade for each application. If abrasive blades are used, **MAKE CERTAIN** they are designed for use on a concrete floor saw. They must be reinforced and have a hole for the driving pin. When wet cutting with an abrasive blade, **MAKE CERTAIN** the blade is intended for wet cutting. Water will destroy a dry cut abrasive blade. Some diamond blades require water cooling and failure to do so will destroy them almost immediately. Other diamond blades can be used with or without water. Refer to the Blades and Blade Placement sections on pages 18 and 19 for further information.
3. Handle all blades with care and **NEVER** use a damaged blade. **NEVER** use an abrasive blade that has been dropped.

Electric Powered Saws (50 or 60 HZ)

1. The electric motor of this saw requires 230 VAC input voltage (50/60 Hz, single-phase). Always make certain that the rated operating line voltage of the motor is correct when cutting. Electric motors can burn out when the line voltage falls 10% below the voltage rating of the motor.
2. After the correct input voltage has been applied to the saw, turn the saw on, and check the rotation of the motor shaft. The shaft rotation **MUST** be **counter-clockwise** when viewing the motor from the shaft extension end. If the rotation of the shaft is incorrect make the necessary changes for the correct shaft rotation.
3. **MAKE CERTAIN** the correct size extension cord is used. Undersize extension cords can burn out an electric motor. Use Table 3 to determine the correct extension cord size.
4. **NEVER!** use a **worn** or **frayed** extension cord.
5. Record the model and serial number of the saw on the front of the Operating and Parts Manual for future reference.

Table 3. Extension Cord Size

No. 12 Wire	No. 10 Wire	No. 8 Wire	No. 6 Wire
50 (feet) (15.24 meters)	75 (feet) (22.86 meters)	100 (feet) (30.48 meters)	200 (feet) (60.96 meters)

WARNING

ALWAYS use a grounded (3-wire) extension cord and **MAKE CERTAIN** that the motor is connected to a properly grounded electric circuit to protect the operator from possible electric shock.

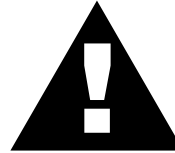

NEVER! touch the power cord (Figure 5) with **wet hands** or while **standing in water** when it is connected to a power source. The possibly exists of electrical shock (electrocution) even death. **NEVER!** spray water directly on the electric motor.

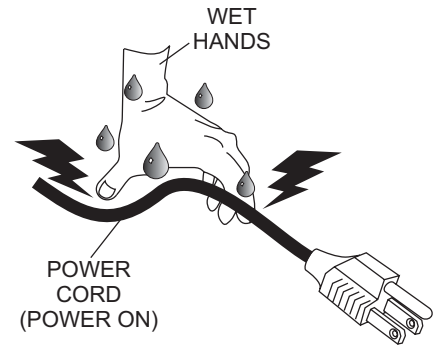

Figure 5. Extension Cord (Wet Hands)

Gasoline Powered Saws

1. Clean the **saw**, removing dirt and dust, particularly the engine cooling air inlet, carburetor and air cleaner.
2. Check the air filter for dirt and dust. If air filter is dirty, replace air filter with a new one as required.
3. Check carburetor for external dirt and dust. Clean with dry compressed air.
4. Check fastening nuts and bolts for tightness.

Engine Oil Check

1. To check the engine oil level, place the saw on secure level ground with the engine stopped. The frame platform **must be level** to accurately check the engine oil.
2. Remove the filler dipstick from the engine oil filler hole (Figure 6) and wipe it clean.

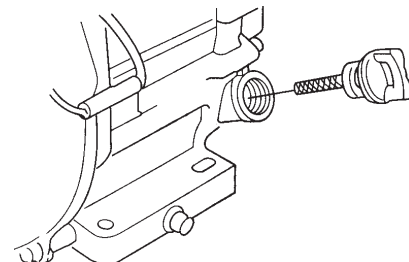
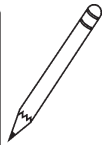
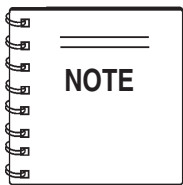

Figure 6. Engine Oil Dipstick (Removal)

STOW CUTTER 1 SAW — PREPARATION/PRE-INSPECTION

3. Insert and remove the dipstick without screwing it into the filler neck. Check the oil level shown on the dipstick.
4. If the oil level is low (Figure 7), fill to the edge of the oil filler hole with the recommended oil type (Table 4).



Reference manufacturer engine manual for specific servicing instructions.

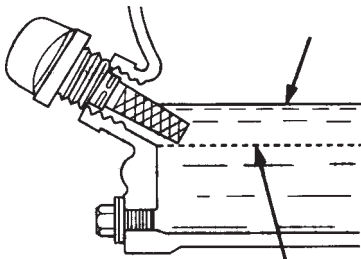

Figure 6. Engine Oil Dipstick (Oil Level)

Table 4. Oil Type

Season	Temperature	Oil Type
Summer	25°C or Higher	SAE 10W-30
Spring/Fall	25°C~10°C	SAE 10W-30/20
Winter	0°C or Lower	SAE 10W-10



Explosive Fuel

Fuel Check

Motor fuels are highly flammable and can be dangerous if mishandled. **DO NOT** smoke while refueling. **DO NOT** attempt to refuel the trowel if the engine is **hot!** or **running**.

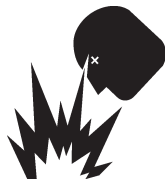

1. Remove the gasoline cap located on top of fuel tank.
2. Visually inspect to see if fuel level is low. If fuel is low, replenish with unleaded fuel.
3. When refueling, be sure to use a strainer for filtration. **DO NOT** top-off fuel. Wipe up any spilled fuel.

Guards And Covers



WARNING



NEVER operate the saw without blade guards and covers in place. **DO NOT** operate with the front of the blade guard raised. The blade exposure cannot exceed 180 degrees during operation. Adhere to the safety guidelines of the **American National Standards Institute (ANSI) B7.1 and B7.5**.



Figure 7. Blade Guard

CHECK the following on the **blade guard** (Figure 8):

- Ensure the capacity of the blade guard matches the diameter of your diamond blade.
- Check that the guard is bolted firmly upon the saw frame.
- Check that the spring tensioned front cover of the guard is firmly seated with the rear section of the guard and there are no gaps. **NEVER** lift the blade guard while cutting.

ENSURE the **V-belt Cover** is in place and securely fastened during operation of the saw (Figure 8).

V-Belt Check

A worn or damaged V-belt can adversely affect the performance of the saw. If a V-belt is defective or worn, replace **ALL** the V-belts. V-belts should always be replaced in sets.

CAUTION



NEVER attempt to check the V-belt with the engine running. Severe injury can occur. Keep fingers, hands, hair, and clothing away from all moving parts.



STOW CUTTER 1 SAW — PREPARATION/PRE-INSPECTION

V-belt Alignment and Tensioning

This saw is equipped with a premium V-belt that has been aligned and tensioned by factory personnel. The V-belt must be aligned and tensioned for proper operation of the saw.

Use the following procedure to check the alignment of V-belt:

1. Remove the bolts that secure the V-belt cover (Figure 9) to the saw frame.

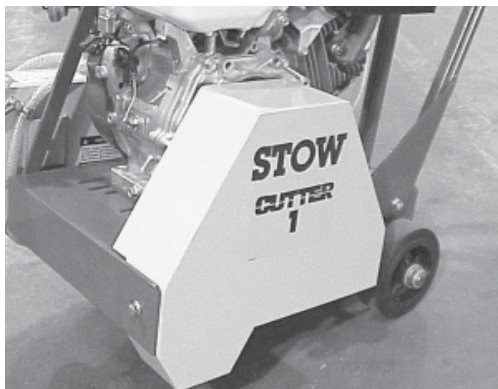

Figure 9. V-Belt Cover

2. Check uniform parallelism (Figure 10) of V-belt and pulley (sheaves). Use a straight-edge or machinist's square against both pulleys and adjust both pulleys until equally aligned.

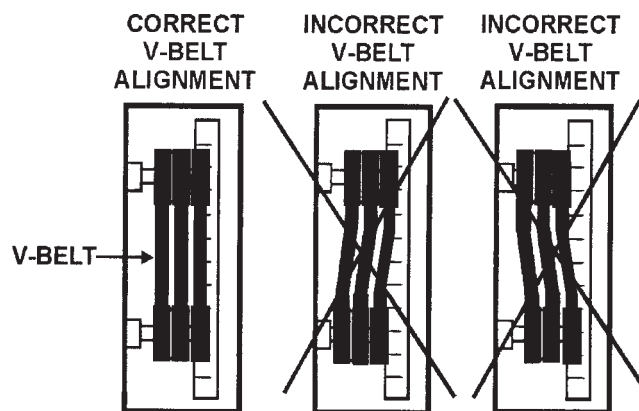
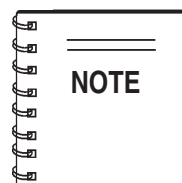

Figure 10. Pulley Alignment

3. Check V-belt tension by using a tension meter (3.0 lbs.) against the inside belt at a mid point between the two pulleys, or by deflecting the center belt at a mid point $3/16$ " (5 mm).
4. **DO NOT** over or under tighten the V-belt. Severe damage can occur to the saw and engine crankshaft if the belt is over-tensioned. A decrease of power to the blade and poor performance will result if the belt is under-tensioned (loose on pulleys).



V-belt alignment must be rechecked after adjusting belt tension.

BLADES

Saw blades, or cutting disks, are available in either an abrasive design or as diamond blades. Either blade will work on the STOW CUTTER 1 SAW, however, diamond blades are recommended. Ask your dealer about your specific cutting application.

SAW BLADE INSPECTION



Failure to thoroughly inspect the diamond blade (Figure 11) for operational safety could result in damage to the blades or the saw and may cause injury to the user or others in the operating area.

1. **Stress Relief Holes (Gullets)** - Check the steel core for cracks that may have propagated from the slots and/or gullets. Cracks indicate extreme fatigue failure and if sawing continues, catastrophic failure will occur.

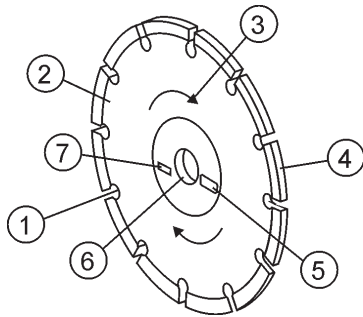

Figure 11. Diamond Blade

2. **Edge of the Steel Core** - Check the diameter edge for discoloration (blue oxidation) indicating an overheating condition caused by insufficient cooling water/air. Overheating of blades may lead to loss of core tension and/or increase the possibility for blade failure. Make sure the steel core's width is uniform about the rim of the blade, and not succumbing to an "under-cutting" condition brought about by highly abrasive material or improper under-cutting core protection.
3. **Directional Arrow** - Ensure that the blade is oriented properly on the blade shaft for sawing. Reference the directional arrow on the blade and place it so the direction of rotation "downcuts" with the turn of the shaft.
4. **Diamond Segment or Rim** - Ensure there are no cracks, dings, or missing portions of the diamond segment/rim. **DO NOT use a blade that is missing a segment or a portion of the rim.** Damaged and/or missing segments/rims may cause damage to your saw or injury to the user or others in the operating area.
5. **Specifications** - Ensure that the blade specifications, size, and diameter properly match up to sawing operations. Utilizing a blade not matched properly to the task may result in poor performance and/or blade damage.
6. **Arbor Hole** - It is essential that the arbor hole diameter properly matches the blade, and that it is free from distortion. Correct blade flanges (collars) must be used. The inside face of the flanges must be clean and free of debris. An out-of-round arbor condition will cause damage to the blade and the saw.
7. **MAX RPM** - This RPM reference is the maximum safe operating speed for the blade selected. **NEVER** exceed the max RPM on the diamond blade. Exceeding the maximum RPM is dangerous and may cause poor performance and may damage the blade.

STOW CUTTER 1 SAW — BLADE PLACEMENT

BLADE PLACEMENT



Failure to thoroughly inspect the diamond blade for operational safety could result in damage to the blades or the saw and may cause injury to the user or others in the operating area.

1. **Blade Guard** - Pivot the blade guard front cover all the way back. The guard tension spring will keep the front cover in position.
2. **Blade Hex Nut** - Unscrew the blade shaft nut (right side loosens clockwise and tightens counter-clockwise while the left side loosens counter-clockwise and tightens clockwise. **DO NOT** overtighten the nut (approximately 45-50 ft. lb/61-68 N/m) when finalizing the assembly.
3. **Outside Blade Flange (Collar)** - Ensure that the outside blade flange is placed flush against the diamond blade. The inside surface of the flange must be free of debris and permit a tight closure on the surface of the blade core.
4. **Diamond Blade** - Ensure that the proper diamond blade has been selected for the job. Pay close attention to the directional arrows on the blade. The blade's operating directional arrows must point in a "down-cutting" direction to perform correctly. When placing the blade onto the blade shaft, ensure the arbor hole of the blade matches the diameter of the shaft.
5. **Inner Flange (Collar)** - This flange is fixed upon the blade shaft. The inside surface of the flange must be free of debris and permit a tight closure on the surface of the blade.

Blade Speed

A diamond blade's performance is directly connected to specific peripheral (rim) speeds.

The following shaft rotational speeds have been factory set to ensure optimum blade performance.

- CUTTER 1- 18-inch (457.2 mm) Capacity - 2,836 RPM.

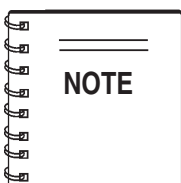

The following steps should be accomplished before using the saw on any cutting surface.



Dropping or forcing the blade onto the cutting surface can severely damage the diamond blade and may cause serious damage to the saw and bodily harm.



Blade Removal and Replacement

1. Set the engine ON/OFF switch to the "OFF" position. (Unplug electric models.)
2. Place the saw on a stable level working surface.
3. Ensure the blade is raised and the raise/lower crank is locked into position.

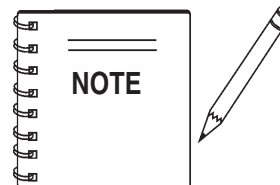

When removing or installing a diamond blade, please note that the blade retaining nuts are left and right-hand threaded.

5. Lift up the blade guard cover to gain access to the blade.
6. Use the provided blade nut and blade shaft locking wrenches to remove and install the blade.
 - While holding the blade shaft with the locking wrench, remove the blade hex nut (clockwise direction) and outer blade flange.
 - Remove the old blade and install a new blade in the same rotational direction as marked on the old blade.
 - Reinstall the outer blade flange and hex nut. Tighten the nut firmly (counter-clockwise direction). **DO NOT OVERTIGHTEN.**

Cutting Depth Adjustment

The saw is equipped with a Raise/Lower Assembly that is supported by the following components.

- Raise/Lower Acme Screw
- Jack Arm
- Blade Guard
- Adjusting Handle Crank

STOW CUTTER 1 SAW — INITIAL START-UP

INITIAL START-UP

CAUTION



DO NOT attempt to operate the saw until the Safety, General Information and Inspection sections of this manual have been read and thoroughly understood. Depending on engine manufacturer, operating steps may vary. See engine manufacturer's operating manual.

CAUTION



NEVER operate the saw in a confined area or enclosed area structure that does not provide ample *free flow of air*.



ALWAYS wear approved eye and hearing protection before operating the saw.

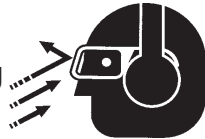

NEVER place hands or feet inside the belt guard or blade guard while the engine is running. **ALWAYS** shut the engine down before performing any kind of maintenance service on the saw.



1. Ensure the diamond blade has been mounted correctly and that it is raised above the surface you are about to saw.
2. Place the **fuel valve lever** (Figure 12) to the "ON" position.

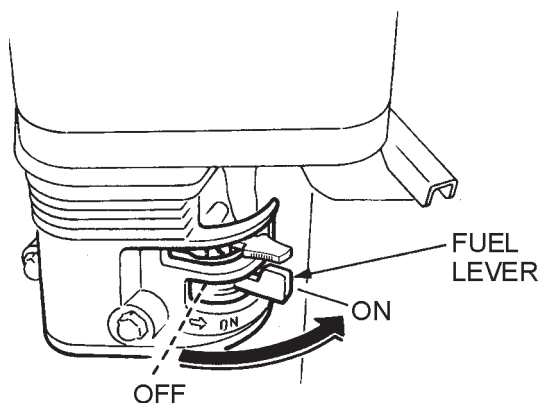

Figure 12. Engine Fuel Valve Lever

3. Place the **Engine ON/OFF switch** (Figure 13) in the "ON" position.

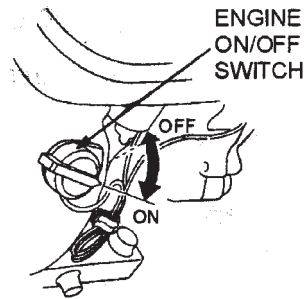
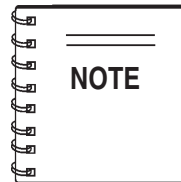

Figure 13. Engine ON/OFF Switch



The **CLOSED** position of the choke lever enriches the fuel mixture for starting a **COLD** engine. The **OPEN** position provides the correct fuel mixture for normal operation after starting, and for restarting a warm engine.

4. Place the **Choke Lever** (Figure 14) in the "**CLOSED**" position.

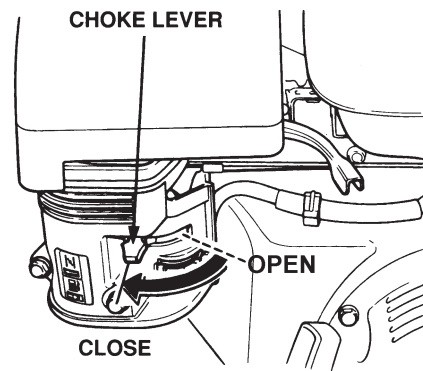

Figure 14. Choke Lever

CAUTION



The engine speed has been set at the factory. Changing the governor speed could damage the blade and/or the saw.



STOW CUTTER 1 SAW — INITIAL START-UP/OPERATION

5. Rotate the **throttle lever** (Figure 15) halfway between **fast** and **slow** for starting. All sawing is done at **full throttle**. The engine governor speed is factory set to ensure optimum blade operating speeds.

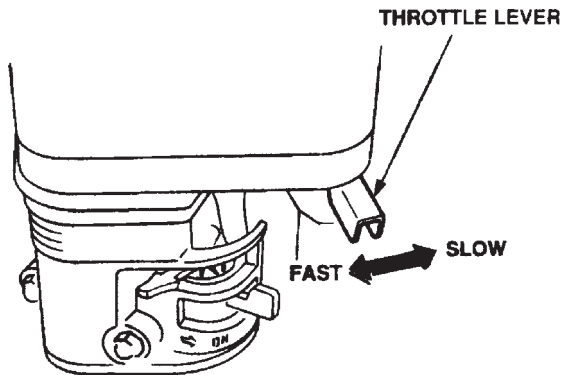

Figure 15. Throttle Lever

6. Grasp the starter grip (Figure 16) and slowly pull it out. The resistance becomes the hardest at a certain position, corresponding to the compression point. Pull the starter grip briskly and smoothly for starting.

CAUTION



DO NOT pull the starter rope all the way to the end. **DO NOT** release the starter rope after pulling. Allow it to rewind as soon as possible.

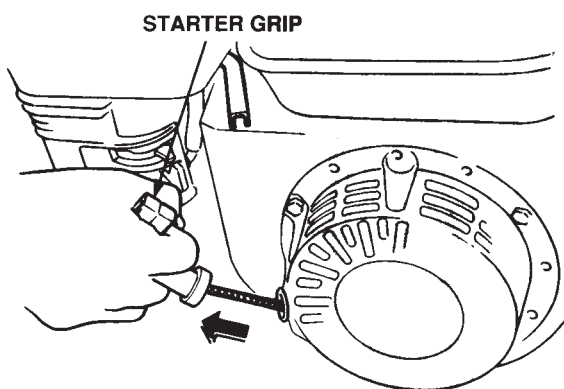

Figure 16. Starter Grip

7. If the engine has started, slowly return the choke lever (Figure 14) to the **"OPEN"** position. If the engine has not started repeat steps 1 through 6.

8. Before the saw is placed into operation, run the engine for several minutes. Check for fuel leaks, and noises that would associate with a loose guards and/or covers.

OPERATION

1. Start the engine. Rotate the throttle lever (Figure 14) toward full throttle.



WARNING

ALWAYS cut with the saw at **FULL THROTTLE**. Attempting to cut with the saw at less than full throttle could cause the blade to bind or stop abruptly in the slab resulting in serious injury to the operator or others in the area.



WARNING

ALWAYS keep clear of **rotating** or **moving** parts while operating this equipment.

2. To begin sawing, lower the rotating blade allowing it to cut to the preset depth.
3. When blade has reached full cutting depth, slowly walk behind the saw at a rate that will allow the engine to operate without losing optimum RPM.

CAUTION



DO NOT try to cut faster than the blade will allow. Cutting too fast will cause the blade to rise up out of the cut. Improper cutting rate can decrease the life of the engine and blades.

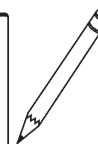
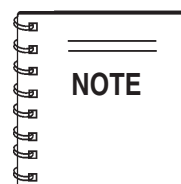

Mark the cutting line clearly and always saw in a **STRAIGHT LINE ONLY**.

4. When the end of the cut has been reached, raise the blade out of the cut by pulling back on the handlebars (using a downward pressure) until the raise/lower rod drops into its slot with the blade in the raised position.
5. If cutting is complete, turn the engine off and wait for the blade to stop rotating.

STOW CUTTER 1 SAW — MAINTENANCE

MAINTENANCE

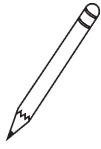
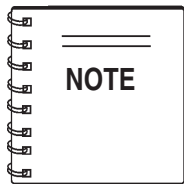

See the engine manual supplied with your machine for appropriate engine maintenance schedule and troubleshooting guide for problems.

CAUTION!



ALWAYS allow the engine to cool before servicing. **NEVER** attempt any maintenance work on a **hot!** engine.



WARNING

ALWAYS ensure that the engine **ON/OFF** switch is in the "OFF" position, (power cable **UNPLUGGED** on electric models), and that the arbor shaft has **COMPLETELY STOPPED ROTATING** before performing any of the following operations:



- **REMOVING** or **INSTALLING** blades
- **ADJUSTING** front or rear pointers
- **LUBRICATING** any components
- **REMOVING** engine mounting bolts
- **INSPECTING, ADJUSTING, OR REPLACING** drive-belt, arbor shaft, arbor shaft bearings or **ANY** engine part



Saw Blade Removal and Installation

Saw blade removal and installation is covered on page 19.

Front Pointer Adjustment

The front pointer wheel has been set at the factory. Use these procedures only if the pointer is suspect of being out of alignment.

1. Chalk out a straight line on the prepared slab or cutting surface.
2. Use a 4 foot straightedge or level by placing it flat against the blade.
3. Adjust the front pointer wheel so it just touches the side of the straightedge or level.
4. Remove the straightedge or level.
5. Position the front pointer and blade directly over the chalk line.
6. Start the saw and lower the blade onto the chalk line.
7. Begin cutting and make sure the blade follows the chalk line as closely as possible.
8. The pointer should follow the chalk line as well. If it does not, adjust the pointer by loosening then tightening the jam nuts on the pointer until the pointer follows the same path as the blade.

Chassis Lubrication

- **Blade Shaft Bearings** - Two zerk fittings are located at the lower-front area of the saw. Lubricate before daily use. Use a good quality automotive or general purpose grease. Check and lubricate more often if unit is under heavy use. Do not overfill bearings. Overfilling can damage the grease seals which can result in bearing exposure to dirt and contaminants which can then shorten the life of the bearings. Excess grease can also drip onto the cutting surface.

Drive Belt

Refer to pages 16 and 17 of this manual for Drive Belt adjustment procedures and Removal and Replacement procedures.

Engine

Follow the maintenance procedures outlined in the engine owner's manual.

Engine Oil Change

Drain the used oil while the engine is warm by the following:

Refer to Figure 17.

1. Place an oil pan or suitable container below the engine drain plug to catch the used oil.
2. Remove the filler cap/dipstick and the drain plug.
3. Drain the oil completely and reinstall the drain plug. Ensure the drain plug is tightened securely.

STOW CUTTER 1 SAW — MAINTENANCE

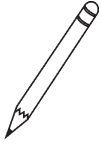
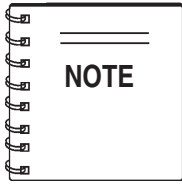

Dispose of used oil properly. **DO NOT** pour used oil on the ground, down a drain, or throw in the trash. Used oil can generally be taken to your local recycling center or service station for reclamation.

4. Make sure the engine is in a level position and fill to the outer edge of the oil filler hole with the recommended oil. (See Table 4.) Engine oil capacity is 1.16 US quart (1.1 liter).
5. Screw in the filler cap/dipstick securely.

CAUTION



Running the engine with a low oil level can cause engine damage.

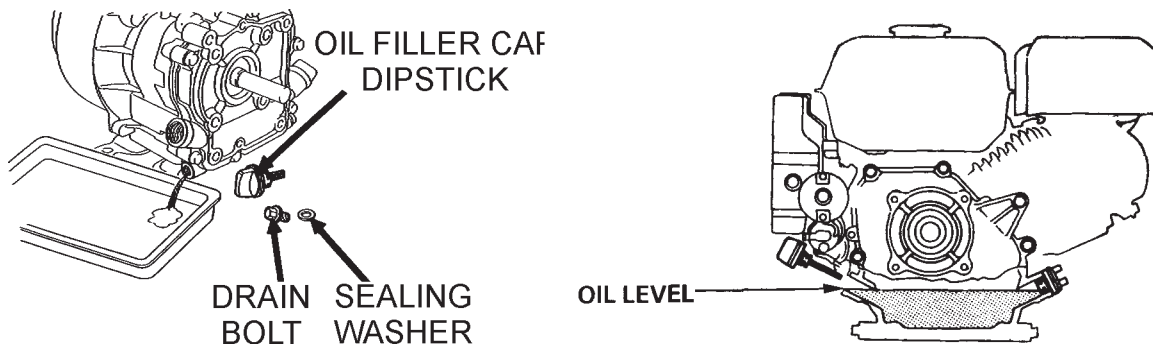

Figure 17. Engine Oil Change

STOW CUTTER 1 SAW — TROUBLESHOOTING (SAW)

TABLE 5. BLADE TROUBLESHOOTING

SYMPTOM	POSSIBLE PROBLEM	SOLUTION
Blade slows or stops cutting.	Blade too hard for the material being cut?	Consult Dealer or Multiquip for correct blade. Try cutting very soft material (sandstone, silica brick, cinder block) to "Redress" the blade.
	Engine torque diminished because of loose V-belt?	Tighten and/or replace V-Belts.
	Insufficient engine power?	Check throttle setting. Check Engine horsepower.
	Improper direction of rotation?	Check that the blade is properly oriented and rotational arrow points in a "Down-Cutting" direction.
	Blade is slipping on the blade shaft?	Check that the blade & flange pin are properly installed on the blade shaft.
Blade does not cut straight and/or true.	Blade being used on misaligned saw?	Check blade shaft bearings and alignment integrity.
	Blade is excessively hard for the material being cut?	Check specification of the blade with the material being cut. Consult Dealer or Multiquip for information.
	Blade being used at improper RPM?	Ensure blade surface feet per minute speed (SFPM) is approximately 6,000.
	Blade improperly mounted on arbor shoulders and flanges?	Ensure blade is properly affixed on the blade shaft.
	Excessive force applied to blade while cutting?	DO NOT force the blade in the cut. Apply a slow and steady pace when sawing.
Blade discoloring, crackling and/or wearing excessively.	Blades too hard for the material being cut?	Consult Dealer or Multiquip for correct blade. Try cutting very soft material (sandstone, silica brick, cinder block) to "Redress" the blade.
	Blade improperly mounted on arbor shoulders and flanges?	Ensure blade is properly affixed on the blade shaft.
	Blade not receiving enough cooling water or air?	Ensure proper flow & volume of water is provided for wet cutting blades. Ensure sufficient cooling air is circulated about a dry cutting blade.
	Arbor hole out of round?	Ensure blade is properly affixed on the blade shaft.
	Incorrect blade chosen for material being cut?	Check specification of the blade with the material being cut. Consult Dealer or Multiquip for information.
	Excessive force applied to blade while cutting?	DO NOT force the blade in the cut. Apply a slow and steady pace when sawing.

STOW CUTTER 1 SAW — TROUBLESHOOTING (ENGINE)

TABLE 6. TROUBLESHOOTING (ENGINE)

SYMPTOM	POSSIBLE CAUSE	SOLUTION
Difficult to start, "fuel is available, but no SPARK at spark plug".	Spark plug bridging?	Check gap, insulation or replace spark plug.
	Carbon deposit on spark plug?	Clean or replace spark plug.
	Short circuit due to deficient spark plug insulation?	Check spark plug insulation, replace if worn.
	Improper spark plug gap?	Set to proper gap.
	Ignition coil defective?	Replace ignition coil.
Difficult to start, "fuel is available, and SPARK is present at the spark plug".	ON/OFF switch is shorted?	Check switch wiring, replace switch.
	Improper spark gap, points dirty?	Set correct spark gap and clean points.
	Condenser insulation worn or short circuiting?	Replace condenser.
	Spark plug wire broken or short circuiting?	Replace defective spark plug wiring.
Difficult to start, "fuel is available, spark is present and compression is normal".	Wrong fuel type?	Flush fuel system, and replace with correct type of fuel.
	Water or dust in fuel system?	Flush fuel system.
	Air cleaner dirty?	Clean or replace air cleaner.
	Choke Open?	Close Choke.
Difficult to start, "fuel is available, spark is present and compression is low".	Suction/exhaust valve stuck or protruded?	Re-seat valves.
	Piston ring and/or cylinder worn?	Replace piston rings and/or piston.
	Cylinder head and/or spark plug not tightened properly?	Torque cylinder head bolts and spark plug.
	Head gasket and/or spark plug gasket damaged?	Replace head and/or spark plug gaskets.
No fuel present at the carburetor.	Fuel not available in fuel tank (tank empty)?	Fill with correct type of fuel.
	Fuel filter clogged?	Replace fuel filter.
	Fuel tank cap breather hole clogged?	Clean or replace fuel tank cap.
	Air in fuel line?	Bleed fuel line.

STOW CUTTER 1 SAW — TROUBLESHOOTING (ENGINE)

TABLE 6. TROUBLESHOOTING (ENGINE, CONTINUED)

SYMPTOM	POSSIBLE CAUSE	SOLUTION
"Weak in power" compression is proper and does not misfire.	Air cleaner not clean?	Clean or replace air cleaner.
	Improper fuel level in carburetor?	Check float adjustment.
		Rebuild carburetor.
	Defective spark plug?	Clean or replace spark plug.
	Improper spark plug gap?	Set to proper gap.
"Weak in power" compression is proper but misfires.	Water in fuel system?	Flush fuel system and replace with correct type fuel.
	Ignition coil defective?	Replace ignition coil.
	Dirty spark plug?	Clean or replace spark plug.
Engine overheats.	Wrong fuel type?	Flush fuel system, and replace with correct type of fuel.
	Spark plug heat value improper?	Replace with correct type of spark plug.
	Cooling fins dirty?	Clean cooling fins.
Rotational speed fluctuates.	Governor adjusted correctly?	Adjust governor.
	Governor spring defective or missing?	Replace governor spring.
	Fuel flow restricted?	Check entire fuel system for leaks or clogs.
Recoil starter malfunction.	Recoil mechanism clogged with dust and dirt?	Clean recoil assembly with soap and water.
	Spiral spring loose?	Replace spiral spring.

EXPLANATION OF CODE IN REMARKS COLUMN

The following section explains the different symbols and remarks used in the Parts section of this manual. Use the help numbers found on the back page of the manual if there are any questions.

The contents and part numbers listed in the parts section are subject to change **without notice**. Multiquip does not guarantee the availability of the parts listed.

Sample Parts List:

NO.	PART NO.	PART NAME	QTY.	REMARKS
1	12345	BOLT	1	INCLUDES ITEMS W/*
2*		WASHER, 1/4 IN.		NOT SOLD SEPARATELY
2*	12347	WASHER, 3/8 IN. ... 1		MQ-45T ONLY
3	12348	HOSE	A/R	MAKE LOCALLY
4	12349	BEARING	1	S/N 2345B AND ABOVE

NO. Column

Unique Symbols - All items with same unique symbol (*, #, +, %, or >) in the number column belong to the same assembly or kit, which is indicated by a note in the "Remarks" column.

Duplicate Item Numbers - Duplicate numbers indicate multiple part numbers are in effect for the same general item, such as different size saw blade guards in use or a part that has been updated on newer versions of the same machine.



When ordering a part that has more than one item number listed, check the remarks column for help in determining the proper part to order.

PART NO. Column

Numbers Used - Part numbers can be indicated by a number, a blank entry, or TBD.

TBD (To Be Determined) is generally used to show a part that has not been assigned a formal part number at time of publication.

A blank entry generally indicates that the item is not sold separately or is not sold by Multiquip. Other entries will be clarified in the "Remarks" Column.

QTY. Column

Numbers Used - Item quantity can be indicated by a number, a blank entry, or A/R.

A/R (As Required) is generally used for hoses or other parts that are sold in bulk and cut to length.

A blank entry generally indicates that the item is not sold separately. Other entries will be clarified in the "Remarks" Column.

REMARKS Column

Some of the most common notes found in the "Remarks" Column are listed below. Other additional notes needed to describe the item can also be shown.

Assembly/Kit - All items on the parts list with the same unique symbol will be included when this item is purchased.

Indicated by:

"INCLUDES ITEMS W/(unique symbol)"

Serial Number Break - Used to list an effective serial number range where a particular part is used.

Indicated by:

"S/N XXXXX AND BELOW"

"S/N XXXX AND ABOVE"

"S/N XXXX TO S/N XXXX"

Specific Model Number Use - Indicates that the part is used only with the specific model number or model number variant listed. It can also be used to show a part is NOT used on a specific model or model number variant.

Indicated by:

"XXXXX ONLY"

"NOT USED ON XXXX"

"Make/Obtain Locally" - Indicates that the part can be purchased at any hardware shop or made out of available items. Examples include battery cables, shims, and certain washers and nuts.

"Not Sold Separately" - Indicates that an item cannot be purchased as a separate item and is either part of an assembly/kit that can be purchased, or is not available for sale through Multiquip.

STOW CUTTER 1 SAW — SUGGESTED SPARE PARTS

SUGGESTED SPARE PARTS

STOW CUTTER 1 SAW CONCRETE/ASPHALT SAW

1 TO 3 UNITS WITH HONDA 13 HP GX390K1QWT2/GX390U1QWT2 ENGINES
AND 5HP ELECTRIC MOTOR.

1 to 3 Units

Qty.	P/N	Description
3	20478	HAND GRIP
4	2621	GREASE ZERK, SPINDLE BEARING
4	1162 A	CAP, GREASE ZERK
3	13249	BELT (3VX315) 13HP HONDA
3	16779-006	BELT (3VX300) 5HP ELECTRIC MOTOR
3	9807956846	SPARK PLUG, BPR6ES, NKG
1✘	17620ZH7023	TANK CAP, BLACK, (S/N 3605677 AND BELOW)
1✘	17620Z0T305	TANK CAP, CHROME PLATED, (S/N 3605678 AND ABOVE)
1◇	17620Z0T305	TANK CAP, CHROME PLATED
2	17210ZE3010	AIR CLEANER ELEMENT
1✘	28462ZV7003	ROPE, RECOIL STARTER
1◇	28462ZE3W01	ROPE, RECOIL STARTER
2	28086001	8" REAR WHEEL (GAS MODEL)
2	23668001	6" REAR WHEEL (ELECTRIC MODEL)
2	26221001	4" FRONT WHEEL
1	29013001	1-1/2" BOX WRENCH

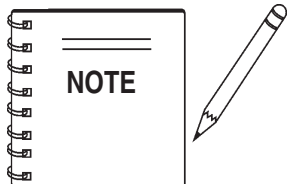

The contents of this parts catalog are subject to change without notice.

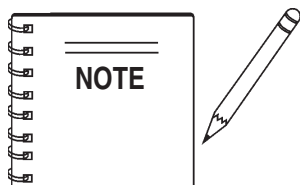

- ✘ GX390K1QWT2: Model S/N DECEMBER 2005 AND BELOW
- ◇ GX390U1QWT2: Model S/N JANUARY 2006 AND ABOVE

STOW CUTTER 1 SAW — NAMEPLATE AND DECALS

DECALS

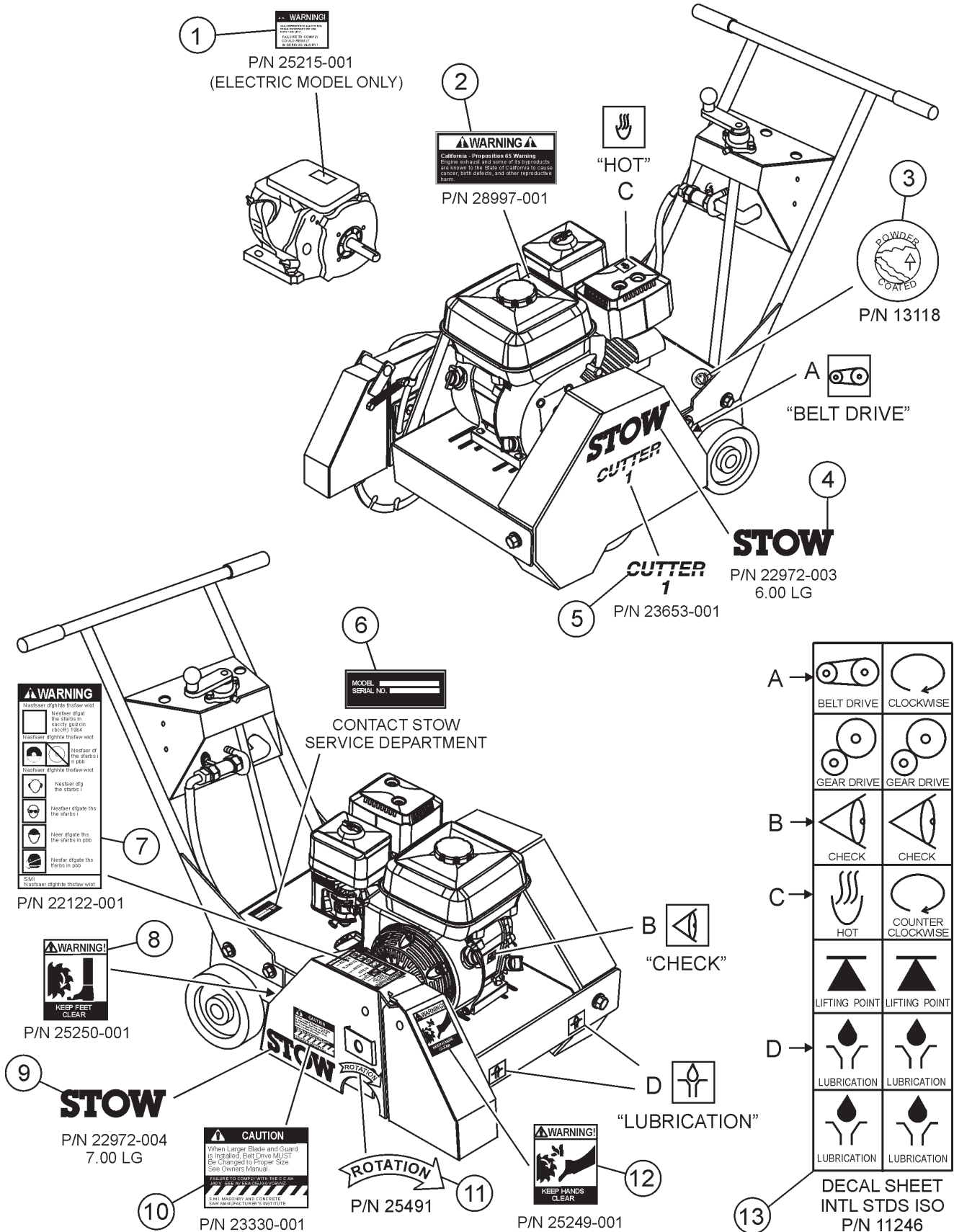

STOW CUTTER 1 SAW — NAMEPLATE AND DECALS

NAMEPLATE AND DECALS

<u>NO.</u>	<u>PART NO.</u>	<u>PART NAME</u>	<u>QTY.</u>	<u>REMARKS</u>
1	25215-001	DECAL, WARNING	1	ELECTRIC MODEL ONLY
2	28997-001	DECAL, PROP 65 WARNING	1	
3	13118	DECAL, POWDER COATED	1	
4	22972-003	DECAL, STOW 6.00	1	
5	23653-001	DECAL, STOW CUTTER 1 SAW	1	
6		SERIAL NUMBER PLATE	1	CONTACT PARTS DEPT.
7	22122-001	DECAL, WARNING	1	
8	25250-001	DECAL, WARNING FEET	1	
9	22972-004	DECAL, STOW 7.00	1	
10	23330-001	DECAL, CAUTION BLADE GUARD	1	
11	25491	DECAL, ROTATION	1	
12	25249-001	DECAL, WARNING HANDS	1	
13	11246	DECAL SHEET, INTL STDS.	1	

STOW CUTTER 1 SAW — ENGINE, BELTS AND PULLEYS ASSY.

ENGINE, BELTS AND PULLEYS ASSY.

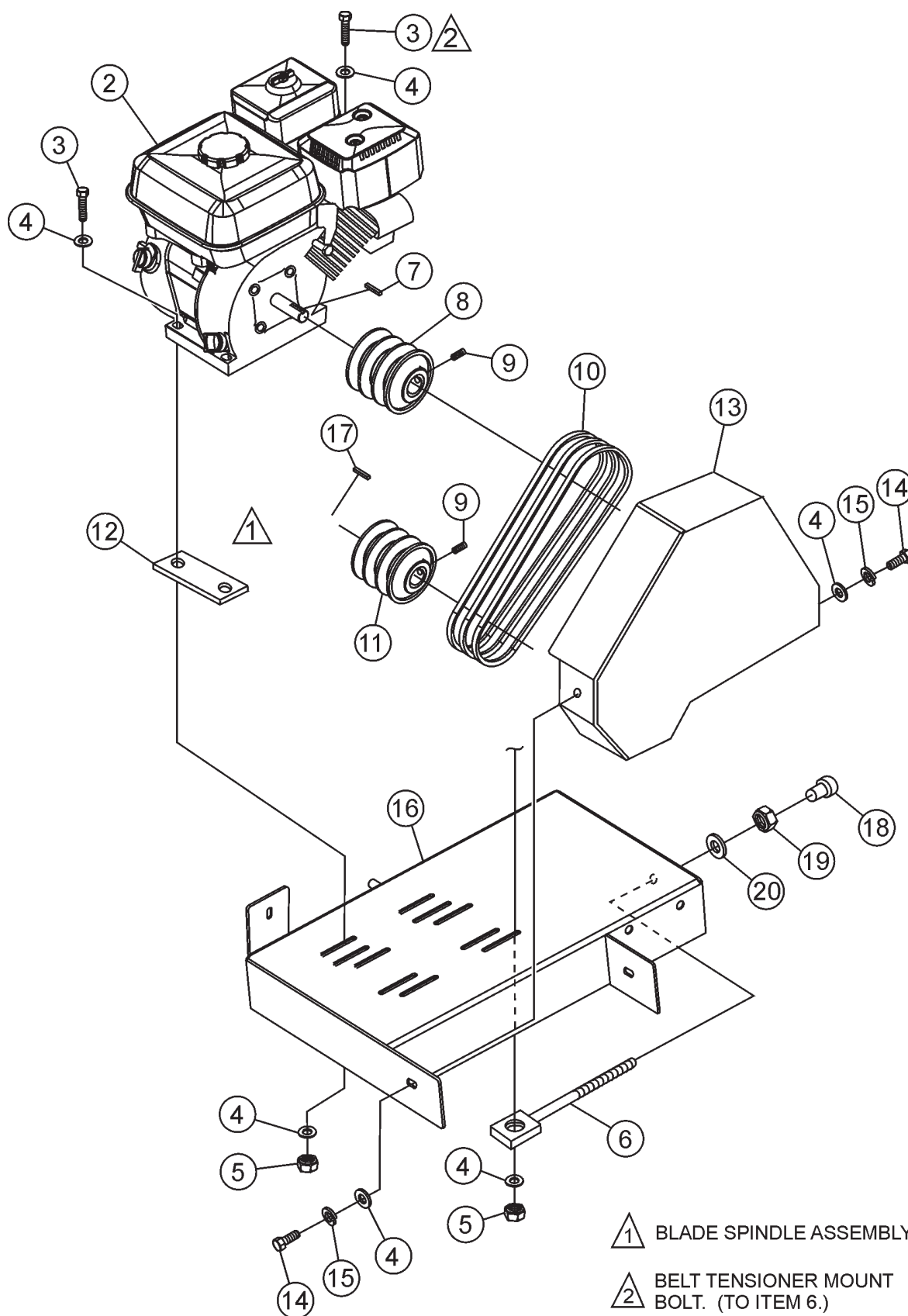

STOW CUTTER 1 SAW — ENGINE, BELTS AND PULLEYS ASSY.

ENGINE, BELTS AND PULLEYS ASSY.

<u>NO.</u>	<u>PART NO.</u>	<u>PART NAME</u>	<u>QTY.</u>	<u>REMARKS</u>
2	15103	ENGINE 13 HP HONDA CYCLONE	1	
3	0669 A	SCREW. HHCS 5/16-18 x 2-1/4"	4	
4	0300 B	FLAT WASHER 5/16"	10	
5	5283	NUT, 5/16 - 18 LOCK	4	
6	23811-352	BELT TENSIONER	2	
7	6059 B	SQUARE KEY, 1/4 X 2	1	
8	23665-001	PULLEY, ENGINE	1	
9	25354	SCREW, SHS 1/4 - 20 X 1/2 ALLOY	4	
10	13249	BELT, 3VX315	3	
11	23665-009	PULLEY, SPINDLE	1	
12	27044-001	SPACER	2	
13	26105-351	BELT GUARD, 13HP	1	
14	0202	SCREW, 5/16 - 12 X 1	2	
15	161 C	WASHER, LOCK 5/16	2	
16	26112-354	FRAME	1	
17	9152	KEY, 1/4 X 1-3/4	1	
18	10779-011	CAP	2	
19	10133	NUT, 3/8 - 16	2	
20	10136	WASHER, FLAT 3/8	2	

STOW CUTTER 1 SAW — ELECTRIC MOTOR ASSY.

ELECTRIC MOTOR ASSY.

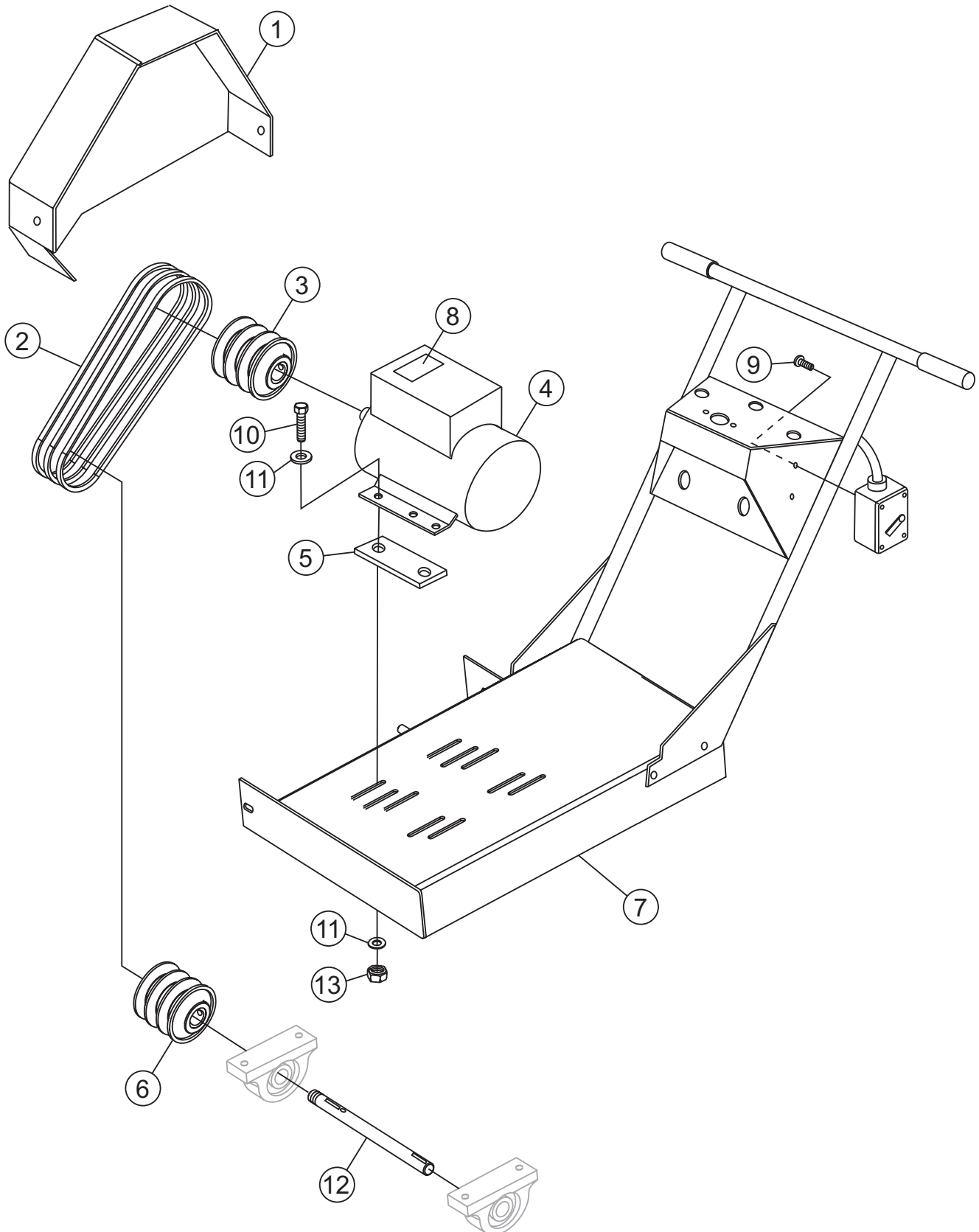

STOW CUTTER 1 SAW — ELECTRIC MOTOR ASSY.

ELECTRIC MOTOR ASSY.

<u>NO.</u>	<u>PART NO.</u>	<u>PART NAME</u>	<u>QTY.</u>	<u>REMARKS</u>
1	26142-352	BELT GUARD	1	
2	16779-006	BELT - 3VX300	3	
3	23665-005	PULLEY (MOTOR)	1	
4	26152-502	MOTOR, 5 HP ELECTRIC	1	
5	27084-002	SPACER	2	
6	23665-009	PULLEY (SPINDLE)	1	
7	26145-351	FRAME	1	
8	25215-001	LABEL, WARNING	1	
9	23865-001	SCREW, 10 - 24 X 3/4	2	
10	2623	SCREW, HHC 5/16 - 18 x 1-1/4"	4	
11	07030-005	FLAT WASHER 5/16	8	
12	26136-004	SPINDLE	1	
13	5283	NUT, 5/16 - 18 LOCK	4	

STOW CUTTER 1 SAW — UNDERCARRIAGE ASSY.

UNDERCARRIAGE ASSY

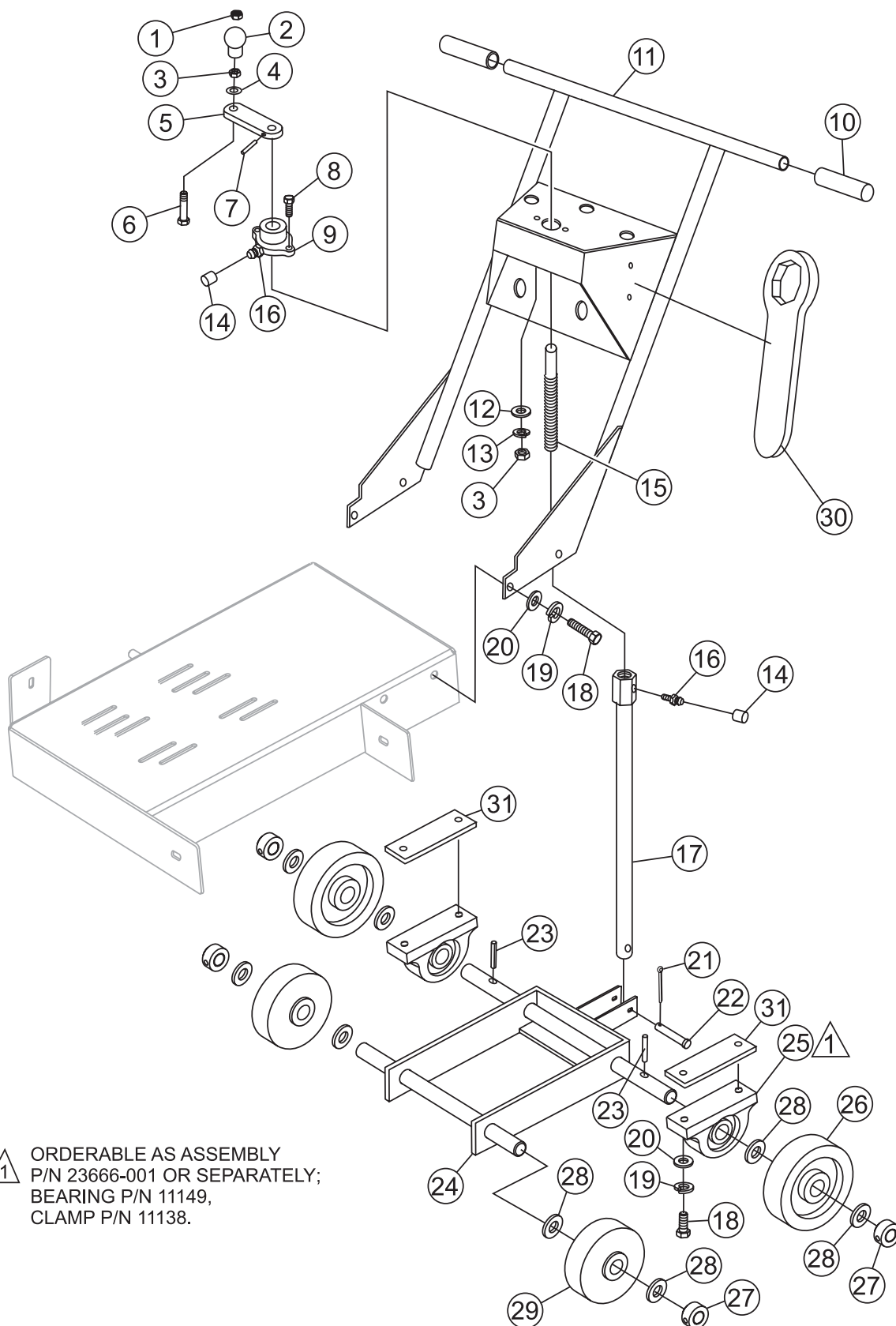

STOW CUTTER 1 SAW — UNDERCARRIAGE ASSY.

UNDERCARRIAGE ASSY.

<u>NO.</u>	<u>PART NO.</u>	<u>PART NAME</u>	<u>QTY.</u>	<u>REMARKS</u>
1	08233-005	LOCKNUT, 5/16 - 18	1	
2	18637-001	KNOB	1	
3	0161 D	HEX NUT, 5/16 - 18	3	
4	25496	BUSHING	1	
5	28808-002	CRANK HANDLE	1	
6	26164-001	LOCK PIN	1	
7	4568	ROLL PIN 3/16 X 1	1	
8	07046-011	BOLT, CARRIAGE 5/16-18 X 1-1/2	2	
9	23284-001	WRAPPER-BLADE GUARD	1	
10	20478	HAND GRIP	2	
11	26126-352	HANDLE	1	
12	0300 B	FLAT WASHER 5/16	2	
13	0161 C	LOCK WASHER 5/16	2	
14	1162 A	CAP, GREASE ZERK	4	
15	26137-002	ACME SCREW	1	
16	2621	ZERK, GREASE STR 1/4 - 28	1	
17	29408-352	JACK ARM (SUPPORT TUBE)	1	
18	0205	SCREW, HHCS 3/8 - 16 X 1-1/4	8	
19	0166 A	LOCK WASHER, 3/8	8	
20	10136	FLAT WASHER 3/8	8	
21	6014 B	COTTER PIN 3/32 X 1	1	
22	08326-019	PIN 3/8 X 2-5/16	1	
23	07402-024	ROLL PIN 1/8 X 1-1/2	2	
24	26120-352	WHEEL BASE ASSEMBLY	1	
25	23666-001	CLAMP & BEARING ASSEMBLY	2	
25A	11138	CLAMP ASSEMBLY	2	
25B	11149	BEARING	2	
26	23668-001	REAR WHEEL, (6X2 ELECTRIC MODEL)	2	
26	28086-001	REAR WHEEL, (8X2 GAS MODEL)	2	
27	26133-001	LOCKING COLLAR	4	
28	8151	FLAT WASHER, 3/4	6	
29	26121-001	FRONT WHEEL	2	
30	29013-001	1-1/2" BOX WRENCH	1	
31	25677	SPACER, REAR AXLE BEARING	2	

STOW CUTTER 1 SAW — WATER SYSTEM AND BLADE ASSY.

WATER SYSTEM AND BLADE ASSY.

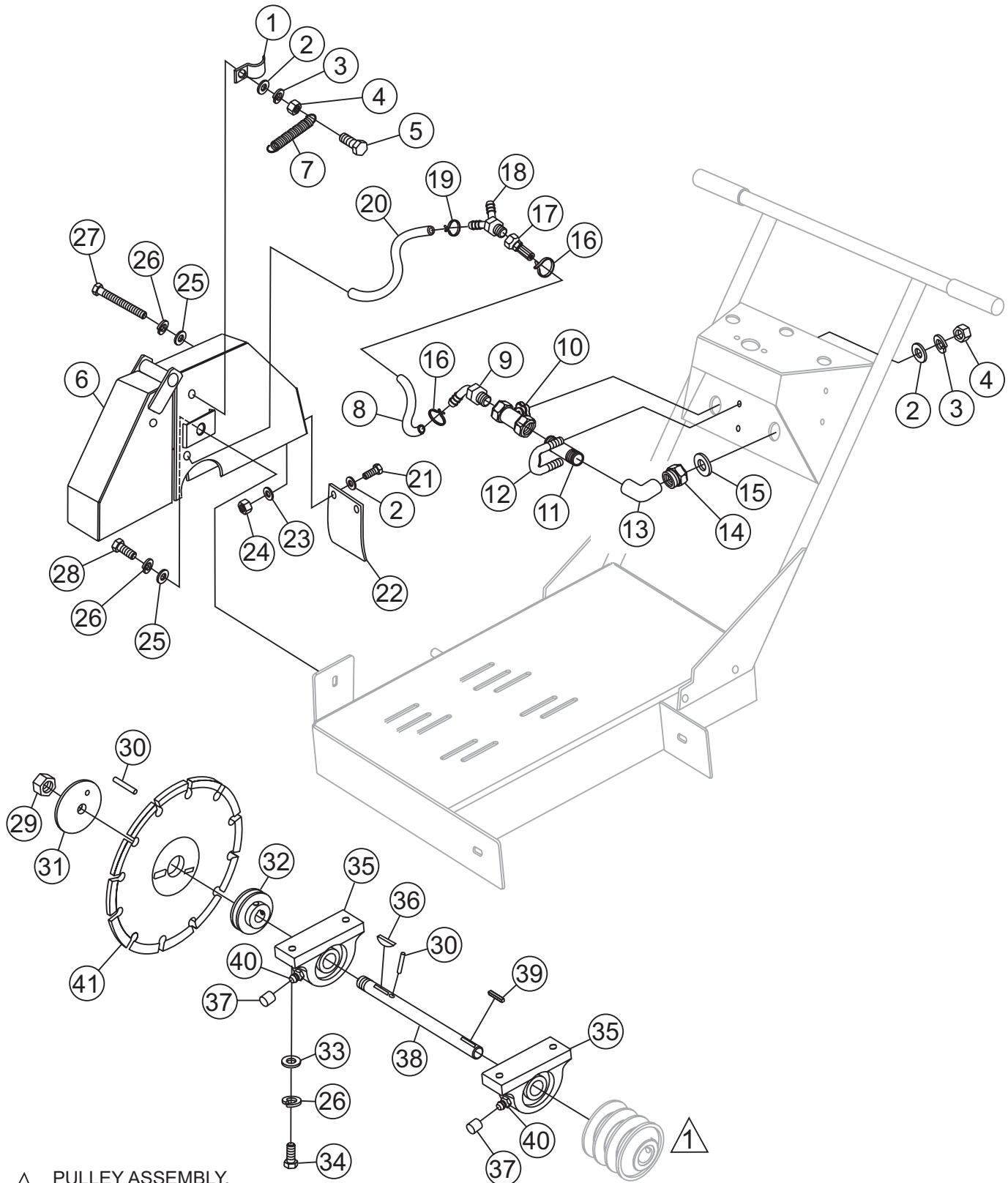

1 PULLEY ASSEMBLY.
SEE PAGE 30.

STOW CUTTER 1 SAW — WATER SYSTEM AND BLADE ASSY.

WATER SYSTEM AND BLADE ASSY.

<u>NO.</u>	<u>PART NO.</u>	<u>PART NAME</u>	<u>QTY.</u>	<u>REMARKS</u>
1	22129-001	CLAMP	2	
2	0948	FLAT WASHER, 1/4	5	
3	0181 B	LOCK WASHER 1/4	5	
4	0949	HEX NUT 1/4 - 20	5	
5	0424	SCREW, HHCS 1/4 - 20 X 1	4	
6	29406-352	BLADE GUARD	1	
7	18626-001	SPRING	2	
8	23255-011	HOSE 26"	1	
9	23566-001	BARBED FITTING 90 DEG.	1	
10	35122-402	VALVE	1	
11	11708	NIPPLE 1/2	1	
12	16378-005	U-BOLT 1/4	1	
13	23252-002	ELBOW 1/2	1	
14	15544	CONNECTOR, GARDEN HOSE	1	
15	13336-001	WASHER, RUBBER	1	
16	12694-006	HOSE CLAMP	2	
17	24778-001	SWIVEL CONNECTOR	1	
18	24642-001	Y-FITTING	1	
19	12694-004	HOSE CLAMP	2	
20	60021	HOSE, 1.0 FT.	2	SOLD PER FOOT
21	0131 A	SCREW, HHCS 1/4 - 20 X 3/4	2	
22	28729-005	CHIP GUARD	1	
23	10930	FENDER WASHER 1/4	2	
24	10024	LOCKNUT, 1/4 - 20	2	
25	10136	FLAT WASHER 3/8	6	
26	0166 A	LOCK WASHER 3/8	2	
27	06501-032	SCREW, HHCS 3/8 - 16 X 4	1	
28	0205	SCREW, HHCS 3/8 - 16 X 1	1	
29	06922-003	NUT L.H. 1 - 1/4	1	
30	15046	DOWEL PIN 3/8 X 1-1/4	2	
31	26928-004	FLANGE, OUTER	1	
32	28811-001	FLANGE, INNER	1	
33	4001	FLAT WASHER	4	
34	1284	SCREW, HHCS 3/8 - 16 X 1-1/2	4	
35	3200	BEARING	2	
36	0125	WOODRUFF KEY 1/4 X 1	1	
37	1162 A	CAP, GREASE ZERK	2	
38	26135-002	SPINDLE	1	
39	9152	KEY 1/4 X 1-3/4	1	
40	2621	GREASE ZERK	2	
41	9SWG	BLADE, DIAMOND BACK	1	

STOW CUTTER 1 SAW — POINTER ASSY.

POINTER ASSY.

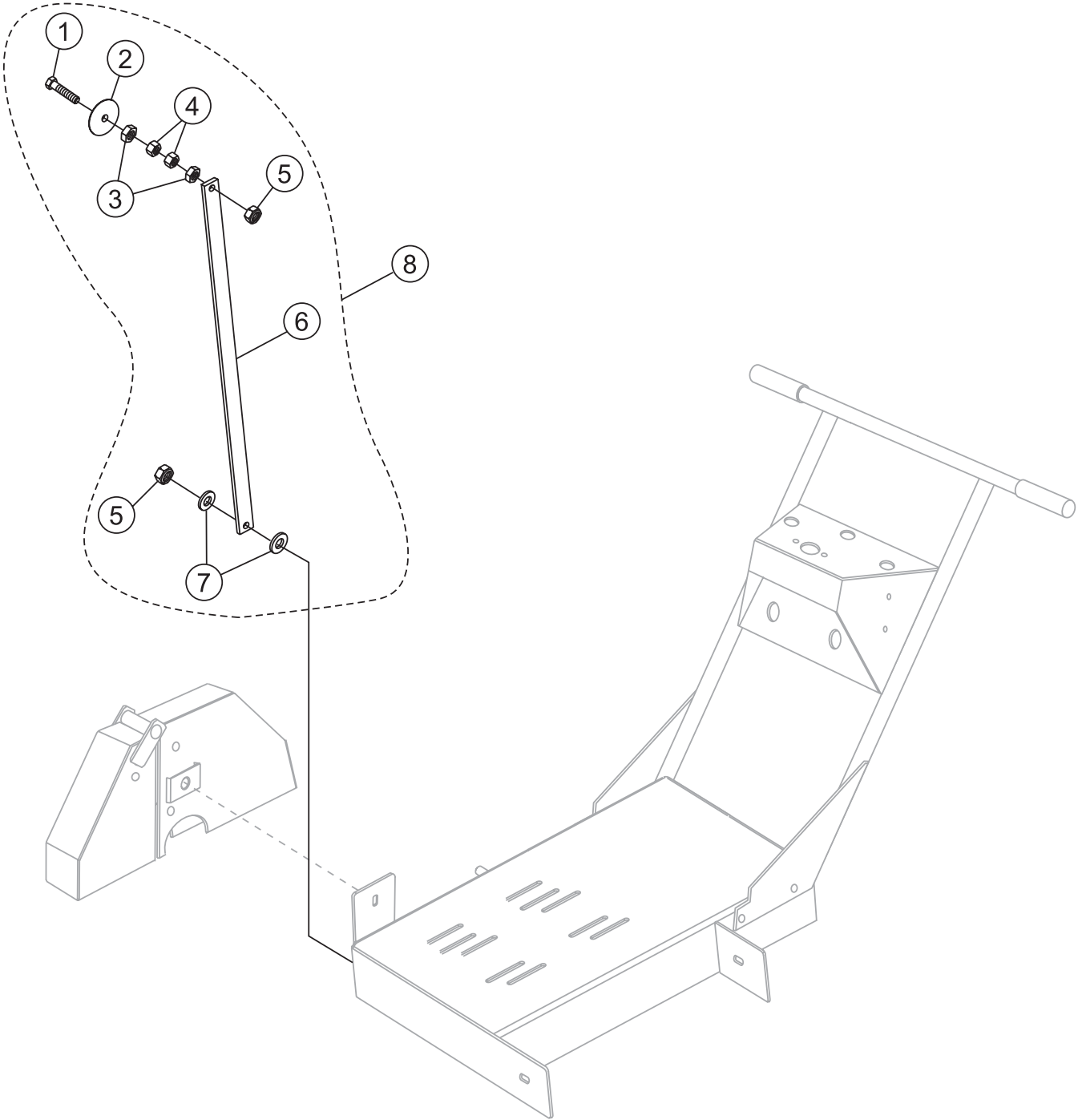

STOW CUTTER 1 SAW — POINTER ASSY.

POINTER ASSY.

<u>NO.</u>	<u>PART NO.</u>	<u>PART NAME</u>	<u>QTY.</u>	<u>REMARKS</u>
1 *	21017	SCREW, POINTER ARM	1	
2 *	29043-001	WHEEL, POINTER	1	
3 *	1007	NUT, HEX JAM 3/8 - 16	2	
4 *	1456	NUT, HEX FINISH 3/8 - 16	2	
5 *	10133	NUT, NYLOC 3/8 - 16	2	
6 *	27073-001	ARM, POINTER	1	
7 *	10136	WASHER, FLAT 3/8	2	
8	29042-501	INDICATOR ASSEMBLY	1	INCLUDES ITEMS W/ *

HONDA GX390K1QWT2/GX390U1QWT2 ENG. — AIR CLEANER ASSY.

AIR CLEANER ASSY.

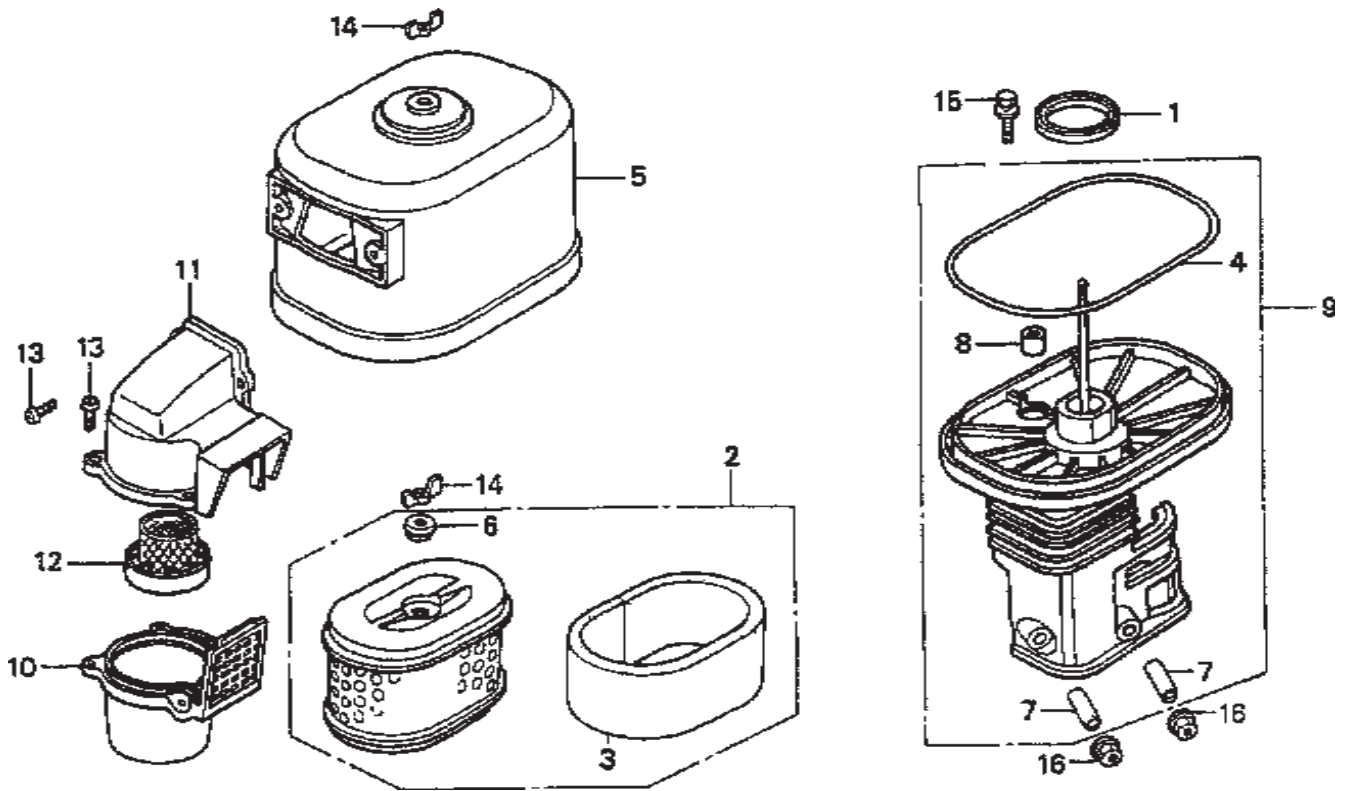

HONDA GX390K1QWT2/GX390U1QWT2 ENG. — AIR CLEANER ASSY.

AIR CLEANER ASSY.

<u>NO.</u>	<u>PART NO.</u>	<u>PART NAME</u>	<u>QTY.</u>	<u>REMARKS</u>
1✘	16271ZE2000	GASKET, ELBOW	1	
1◇	16271ZE2010	GASKET, ELBOW	1	
2	17210ZE3010	ELEMENT, AIR CLEANER	1	INCLUDES ITEMS W/*
3*	17218ZE3000	FILTER, OUTER	1	
4#	17219ZE3840	SEAL, AIR CLEANER COVER	1	
5	17230ZE3841	COVER, AIR CLEANER (CYCLONE)	1	
6*	17232891000	GROMMET, AIR CLEANER	1	
7#	17238ZE2310	COLLAR, AIR CLEANER	2	
8#	17239ZE3840	COLLAR B, AIR CLEANER	1	
9	17410ZE3840	ELBOW, AIR CLEANER	1	INCLUDES ITEMS W/#
10✘	17470ZE3841	CASE, PRE AIR CLEANER	1	
10◇	17470ZE3842	CASE, PRE AIR CLEANER	1	
11	17475ZE3841	CAP, PRE AIR CLEANER	1	
12	17476ZE3841	GUIDE, PRE AIR CLEANER	1	
13	90142MB0000	SCREW, PAN 5X16.5	5	
14	90325044000	WINGNUT, TOOL BOX SETTING	2	
15	90009ZE2003	BOLT- WASHER 6X22	1	
16	9405006000	NUT, FLANGE 6MM	2	

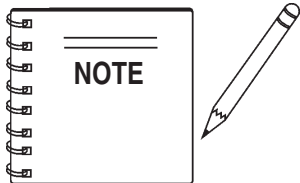

- ✘ GX390K1QWT2: Model S/N DECEMBER 2005 AND BELOW
- ◇ GX390U1QWT2: Model S/N JANUARY 2006 AND ABOVE

HONDA GX390K1QWT2/GX390U1QWT2 ENG. — CAMSHAFT ASSY.

CAMSHAFT ASSY.

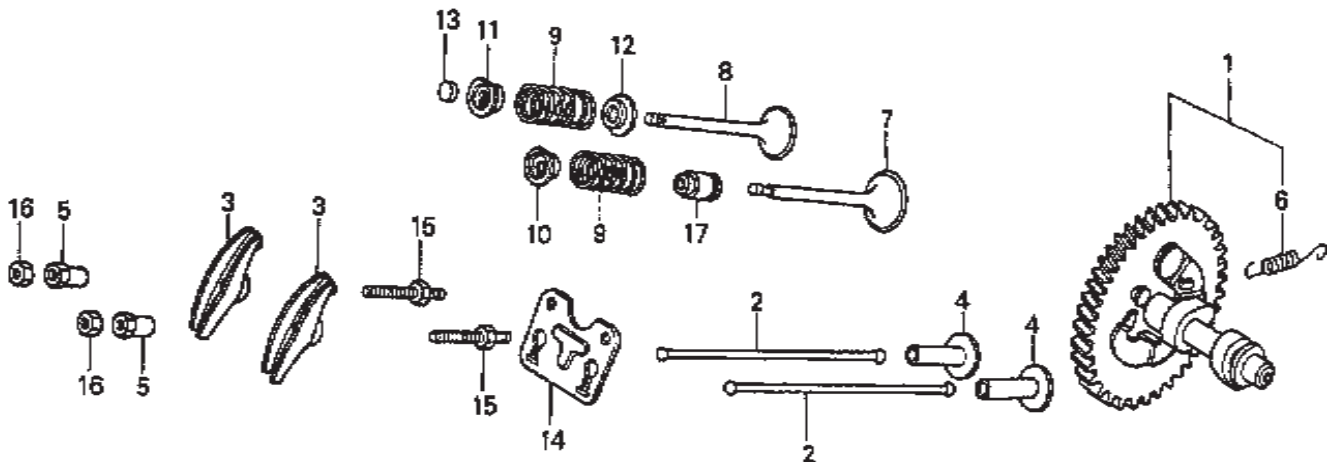

HONDA GX390K1QWT2/GX390U1QWT2 ENG. — CAMSHAFT ASSY.

CAMSHAFT ASSY.

<u>NO.</u>	<u>PART NO.</u>	<u>PART NAME</u>	<u>QTY.</u>	<u>REMARKS</u>
1	14100ZF6W01	CAMSHAFT ASSEMBLY	1	INCLUDES ITEM W/*
2	14410ZE3013	ROD, PUSH	2	
3	14431ZE2010	ARM, VALVE ROCKER	2	
4	14441ZE2000	LIFTER, VALVE	2	
5	14451ZE1013	PIVOT, ROCKER ARM	2	
6*	14568ZE1000	SPRING, WEIGHT RETURN	1	
7	14711ZE3000	VALVE, INTAKE	1	
8	14721ZE3000	VALVE, EXHAUST	1	
9	14751ZE2003	SPRING, VALVE	2	
10	14771ZE2000	RETAINER,INTAKE VALVE SPRING	1	
11	14773ZE2000	RETAINER, EXHAUST VALVE SPRING	1	
12	14775ZE2010	SEAT, VALVE SPRING	1	
13	14781ZE2000	ROTATOR, VALVE	1	
14	14791ZE2010	PLATE, PUSH ROD GUIDE	1	
15	90012ZE0010	BOLT, PIVOT 8MM	2	
16	90206ZE1000	NUT, PIVOT ADJ.	2	
17	12209ZE8003	SEAL, VALVE STEM	1	

HONDA GX390K1QWT2/GX390U1QWT2 ENG. — CARBURETOR ASSY.

CARBURETOR ASSY.

<u>NO.</u>	<u>PART NO.</u>	<u>PART NAME</u>	<u>QTY.</u>	<u>REMARKS</u>
1	16010ZE2812	CARBURETOR, GASKET SET	1	INCLUDES ITEMS W/+
2\$	16011ZA0931	VALVE SET, FLOAT	1	
3\$	16013ZA0931	FLOAT SET	1	
4\$	16015ZE8005	CHAMBER SET, FLOAT	1	INCLUDES ITEM 4A
			INCLUDES ITEM W/>
4A+		GASKET, CHAMBER SET FLOAT		NOT SOLD SEPARATELY
5\$	16016ZH7W01	SCREW SET, PILOT	1	
6\$>	16024ZE1811	SCREW SET, DRAIN,	1	INCLUDES ITEM 6A
6A+		GASKET, SCREW SET DRAIN		NOT SOLD SEPARATELY
7\$	16028ZE0005	SCREW SET	1	INCLUDES ITEM 7A
7A+		GASKET, SCREW SET		NOT SOLD SEPARATELY
8\$	16044ZE3W20	CHOKE SET	1	
9\$	16100ZF6V21	CARBURETOR ASSY. (BE85C B)	1	INCLUDES ITEMS W/\$
10\$	16124ZE0005	SCREW, THROTTLE STOP	1	
11\$	16166ZF6W10	NOZZLE, MAIN	1	
12\$+	16173001004	GASKET, FUEL STRAINER CUP	1	
13	16211ZF6000	INSULATOR, CARBURETOR	1	
14	16220ZA0702	SPACER, CARBURETOR	1	
15	16221ZF6800	GASKET, CARBURETOR	1	
16	16223ZE3W00	GASKET, INSULATOR	1	
20	16610ZE1000	LEVER, CHOKE (STD)	1	INCLUDES ITEM W/*
22\$	16953ZE1812	LEVER, VALVE	1	
23\$	16954ZE1812	PLATE, LEVER SETTING	1	
24\$	16956ZE1811	SPRING, VALVE LEVER	1	
25\$+	16957ZE1812	GASKET, VALVE	1	
26\$	16967ZE0811	CUP, FUEL STRAINER	1	
28\$	93500030061H	SCREW, PAN (3X6)	2	
31*	9430520122	PIN, SPRING (2X12)	1	
33\$	99101ZH80950	JET, MAIN (#95) (OPTIONAL)	1	
33\$	99101ZH80980	JET, MAIN (#98) (OPTIONAL)	1	
33\$	99101ZH81000	JET, MAIN (#100)	1	
34\$	99204ZA00450	JET SET, PILOT (#45)	1	INCLUDES ITEM 34A
34A+		GASKET, JET SET PILOT (#45)		NOT SOLD SEPARATELY
35\$	16172ZE3W10	COLLAR, SET	1	

HONDA GX390K1QWT2/GX390U1QWT2 ENG. — CONTROL ASSY.

CONTROL ASSY.

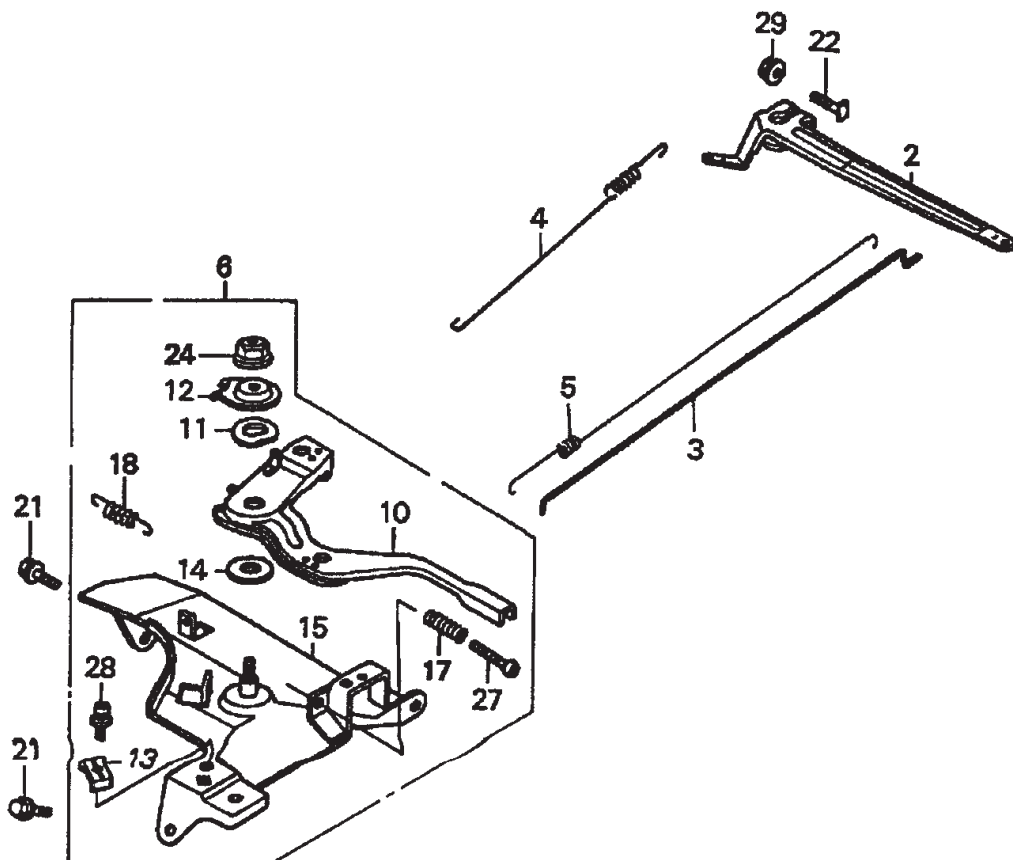

HONDA GX390K1QWT2/GX390U1QWT2 ENG. — CONTROL ASSY.

CONTROL ASSY.

<u>NO.</u>	<u>PART NO.</u>	<u>PART NAME</u>	<u>QTY.</u>	<u>REMARKS</u>
2	16551ZE3000	ARM, GOVERNOR	1	
3	16555ZE3000	ROD, GOVERNOR	1	
4	16561ZE3000	SPRING, GOVERNOR	1	
5	16562ZE3000	SPRING, THROTTLE RETURN	1	
6	16570ZE3W20	CONTROL ASSY. (REMOTE)	1	INCLUDES ITEMS W/*
10*	16571ZE3W00	LEVER, CONTROL	1	
11*	16574ZE1000	SPRING, LEVER	1	
12*	16575ZE2W00	WASHER, CONTROL LEVER	1	
13*	16576891000	HOLDER, CABLE	1	
14*	16578ZE1000	SPACER, CONTROL LEVER	1	
15*	16581ZE3W00	BASE, CONTROL	1	
17*	16584883300	SPRING, CONTROL ADJUSTING	1	
18*	16592883310	SPRING, CABLE RETURN	1	
21	90013883000	BOLT, FLANGE (6X12) (CT200)	2	
22	90015ZE5010	BOLT, GOVERNOR ARM	1	
24*	90114SA0000	NUT, SELF-LOCK (6MM)	1	
27*	93500050320A	SCREW, PAN (5X32)	1	
28*	93500050160A	SCREW, PAN (5X16)	1	
29	9405006000	NUT, FLANGE (6MM)	1	

HONDA GX390K1QWT2/GX390U1QWT2 ENG. — CRANKCASE ASSY.

CRANKCASE COVER ASSY.

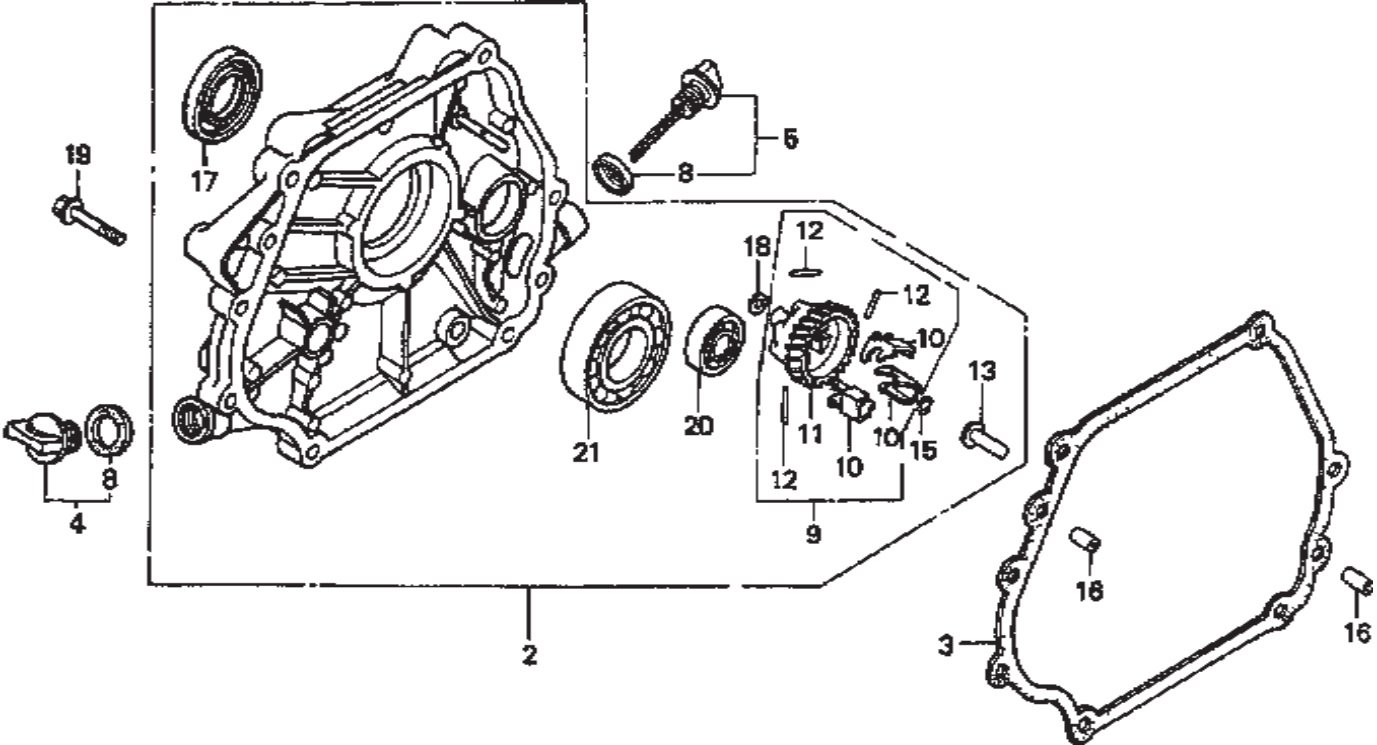

HONDA GX390K1QWT2/GX390U1QWT2 ENG. — CRANKCASE ASSY.

CRANKCASE COVER ASSY.

<u>NO.</u>	<u>PART NO.</u>	<u>PART NAME</u>	<u>QTY.</u>	<u>REMARKS</u>
2✘	11300ZE3602	COVER ASSY., CRANKCASE	1	S/N 3287256 AND BELOW INCLUDES ITEMS W/>
2✘	11300ZE3604	COVER ASSY., CRANKCASE	1	S/N 3287257 AND ABOVE INCLUDES ITEMS W/%
2◇	11300ZE3604	COVER ASSY., CRANKCASE	1	INCLUDES ITEMS W/\$
3	11381ZE3801	GASKET, CASE COVER	1	
4	15600ZG4003	CAP ASSY., OIL FILLER	1	INCLUDES ITEM W/#
5	15600735003	CAP ASSY., OIL FILLER	1	INCLUDES ITEM W/*
8#*	15625ZE1003	GASKET, OIL FILLER CAP	2	
9	16510ZE3000	GOVERNOR ASSY.....	1	INCLUDES ITEMS W/+
10>%\$+	16511ZE8000	WEIGHT, GOVERNOR	3	
11>%\$+	16512ZE3000	HOLDER, GOVERNOR WEIGHT	1	
12>%\$+	16513ZE2000	PIN, GOVERNOR WEIGHT	3	
13✘>%\$	16531ZE2000	SLIDER, GOVERNOR	1	S/N 3287256 AND BELOW
13✘>%\$	16531Z0A000	SLIDER, GOVERNOR	1	S/N 3287257 AND ABOVE
13◇>%\$	16531Z0A000	SLIDER, GOVERNOR	1	
15>%\$	90602ZE1000	CLIP, GOVERNOR HOLDER	1	
16	90701HC4000	PIN, DOWEL (8X12)	2	
17>%\$	91201ZE3004	OIL SEAL (35X52X8)	1	
18>%\$	9410106800	WASHER, PLAIN (6MM)	1	
19	957010804000	BOLT, FLANGE (8X40)	7	
20>%\$	961006202000	BEARING, RADIAL BALL (6202)	1	
21>%\$	961006207000	BEARING, RADIAL BALL (6207)	1	

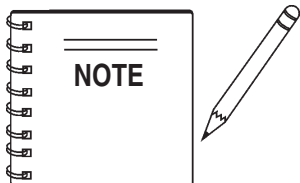

- ✘ GX390K1QWT2: Model S/N DECEMBER 2005 AND BELOW
- ◇ GX390U1QWT2: Model S/N JANUARY 2006 AND ABOVE

HONDA GX390K1QWT2/GX390U1QWT2 ENG. — CRANKSHAFT ASSY.

CRANKSHAFT ASSY.

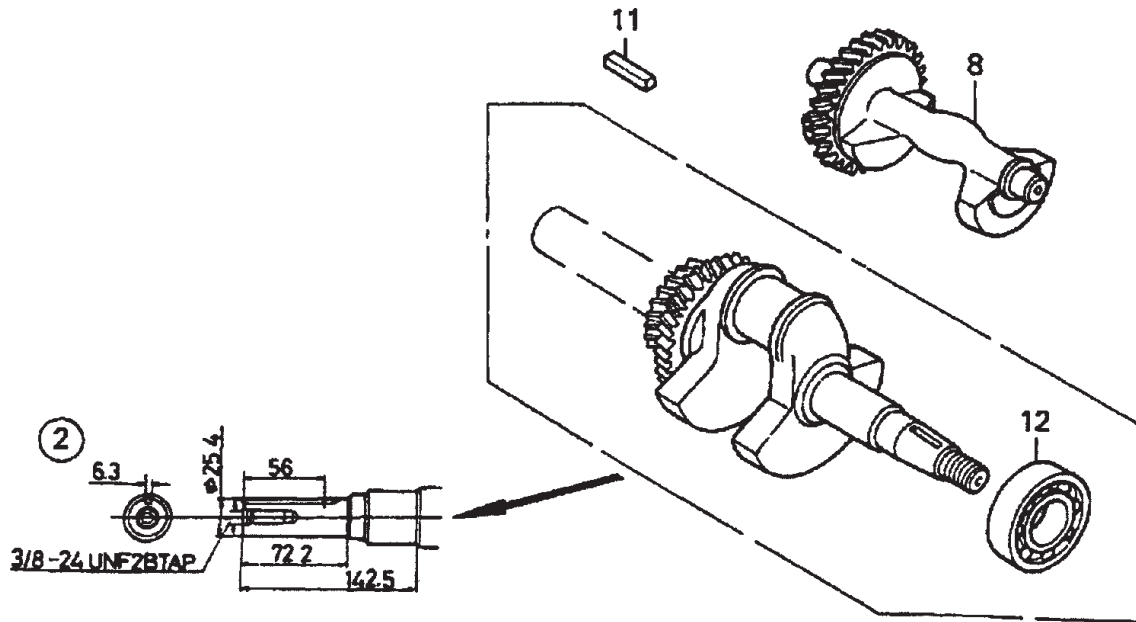

HONDA GX390K1QWT2/GX390U1QWT2 ENG. — CRANKSHAFT ASSY.

CRANKSHAFT ASSY.

<u>NO.</u>	<u>PART NO.</u>	<u>PART NAME</u>	<u>QTY.</u>	<u>REMARKS</u>
2✕	13310ZF6W10	CRANKSHAFT	1	INCLUDES ITEM W/*
2◇	13310ZF6W11	CRANKSHAFT	1	INCLUDES ITEM W/#
			S/N 1113739 AND BELOW
2◇	13310ZF6W12	CRANKSHAFT	1	INCLUDES ITEM W/+
			S/N 1113740 AND ABOVE
8	13351ZE3010	WEIGHT, BALANCER	1	
11	90745ZE2600	KEY(6.3X6.3X43)	1	
12✕*	91001ZF6003	BEARING, RADIAL BALL (6207S)	1	
12◇#	91001ZF6003	BEARING, RADIAL BALL (6207S)	1	S/N 1113739 AND BELOW
12◇+	91001ZF6013	BEARING, RADIAL BALL (6207SH)	1	S/N 1113740 AND ABOVE

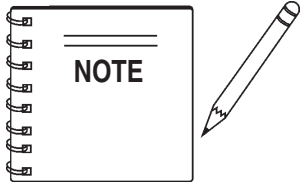

- ✕ GX390K1QWT2: Model S/N DECEMBER 2005 AND BELOW
- ◇ GX390U1QWT2: Model S/N JANUARY 2006 AND ABOVE

HONDA GX390K1QWT2/GX390U1QWT2 ENG. — CYLINDER BARREL ASSY.

CYLINDER BARREL ASSY.

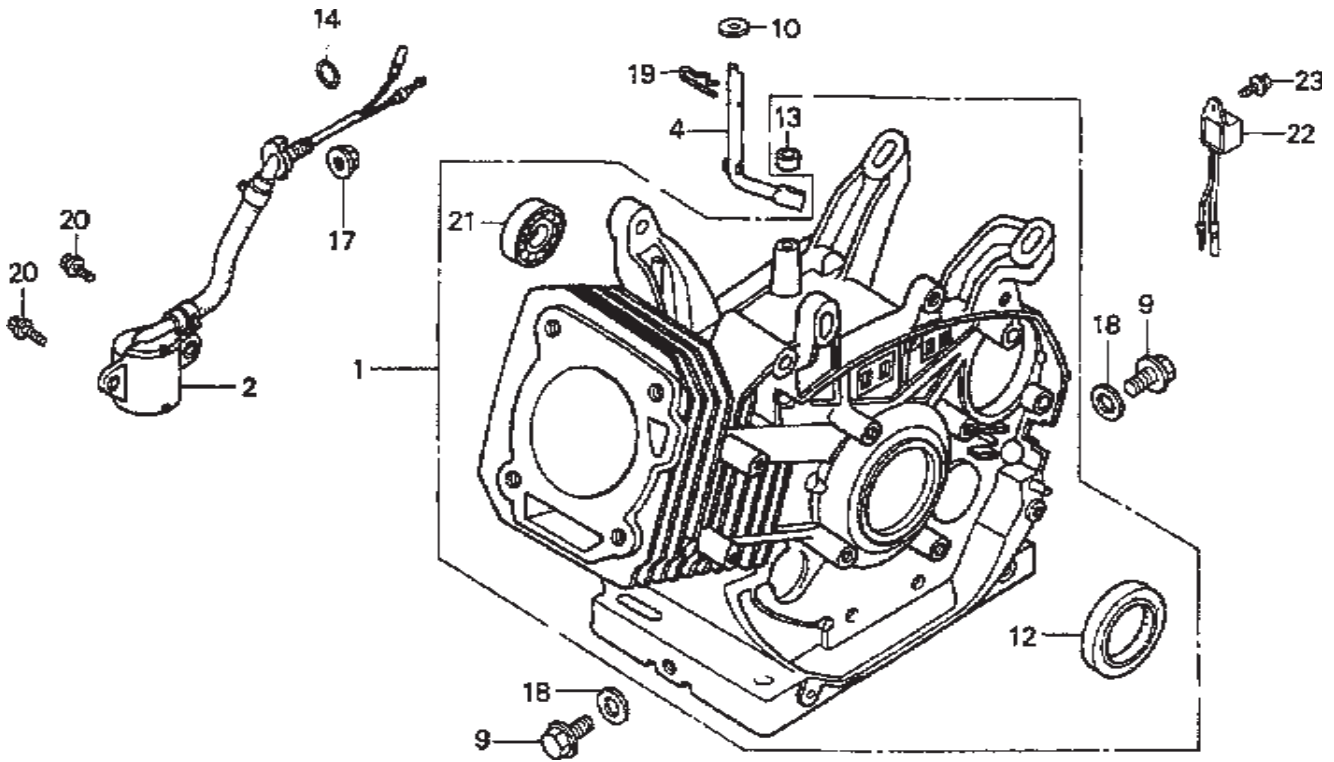

HONDA GX390K1QWT2/GX390U1QWT2 ENG. — CYLINDER BARREL ASSY.

CYLINDER BARREL ASSY.

<u>NO.</u>	<u>PART NO.</u>	<u>PART NAME</u>	<u>QTY.</u>	<u>REMARKS</u>
1✖	12000ZF6W13	CYLINDER ASSY. (ALERT)	1	INCLUDES ITEMS W/%
1◇	12000ZF6417	CYLINDER ASSY.	1	INCLUDES ITEMS W/#
2✖	15510ZE2043	SWITCH ASSY., OIL LEVEL	1	
2◇	15510ZE2043	SWITCH ASSY., OIL LEVEL	1	S/N 1412956 AND BELOW
2◇	15510ZE2053	SWITCH ASSY., OIL LEVEL	1	S/N 1412957 AND ABOVE
4	16541ZE3010	SHAFT, GOVERNOR ARM	1	
9	90131883000	BOLT, DRAIN PLUG 12X15	2	
10	90446KE1000	WASHER (8.2X17X0.8)	1	
12%#	91201ZE3004	OIL SEAL (35X52X8)	1	
13	91203952771	OIL SEAL (8X14X5)	1	
14	91353671004	O-RING (14MM) (NOK)	1	
17	9405010000	NUT, FLANGE (10MM)	1	
18	9410912000	WASHER, DRAIN PLUG (12MM)	2	
19	9425110000	PIN, LOCK (10MM)	1	
20	957010601200	BOLT, FLANGE (6X12)	2	
21%#	961006202000	BEARING, RADIAL BALL (6202)	1	
22✖	34150ZH7003	ALERT UNIT, OIL	1	
22◇	34150ZH7003	ALERT UNIT, OIL	1	S/N 1419413 AND BELOW
22◇	34150ZH7013	ALERT UNIT, OIL	1	S/N 1419414 AND ABOVE
23	90013883000	BOLT, FLANGE (6X12) (CT200)	1	

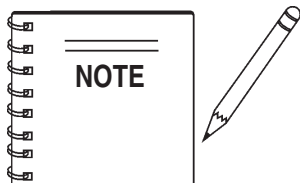

✖ GX390K1QWT2: Model S/N DECEMBER 2005 AND BELOW

◇ GX390U1QWT2: Model S/N JANUARY 2006 AND ABOVE

HONDA GX390K1QWT2/GX390U1QWT2 ENG. — CYLINDER HEAD ASSY.

CYLINDER HEAD ASSY.

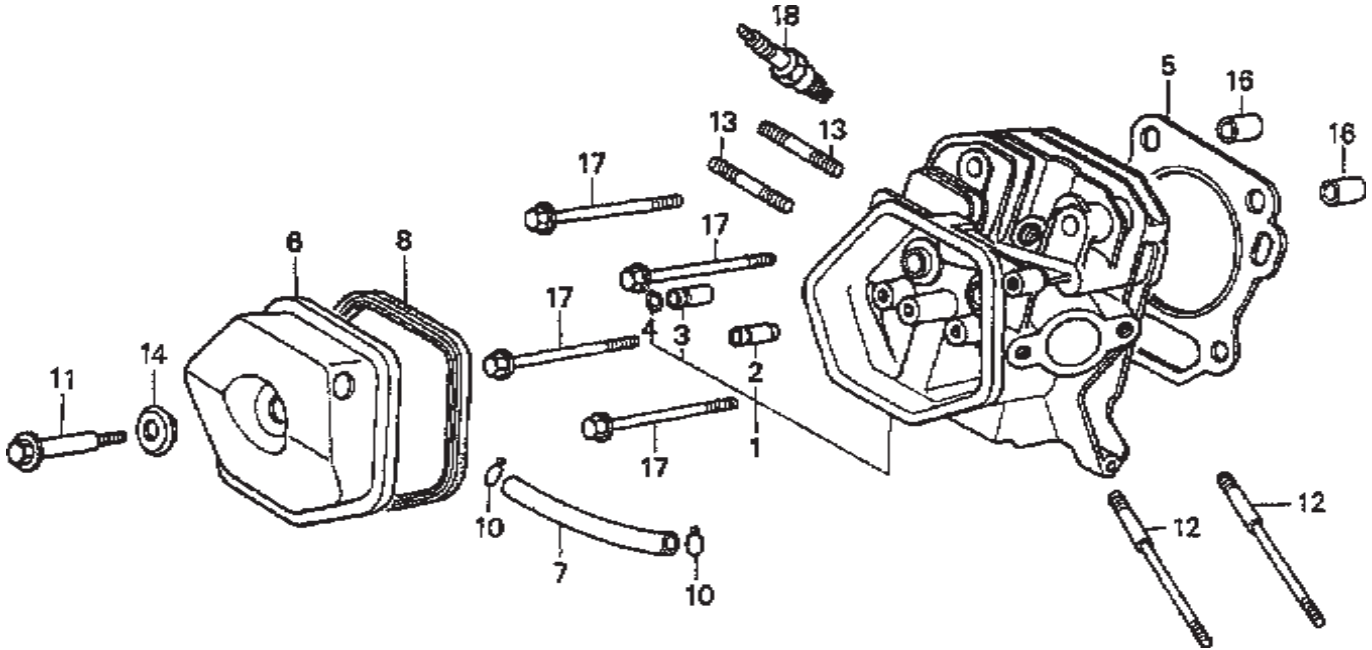

HONDA GX390K1QWT2/GX390U1QWT2 ENG. — CYLINDER HEAD ASSY.

CYLINDER HEAD ASSY.

<u>NO.</u>	<u>PART NO.</u>	<u>PART NAME</u>	<u>QTY.</u>	<u>REMARKS</u>
1✖	12200ZF6W01	CYLINDER HEAD	1	INCLUDES ITEMS W/*
1◇	12200ZF6406	CYLINDER HEAD	1	INCLUDES ITEMS W/%
2*%	12204ZE2306	GUIDE, VALVE (OS) (OPTIONAL)	1	
3*%	12205ZE2305	GUIDE, EX. VALVE (OS) (OPTIONAL)	1	
4*%	12216ZE2300	CLIP, VALVE GUIDE	1	
5	12251ZF6W00	GASKET, CYLINDER HEAD	1	
6	12310ZE3791	COVER, HEAD	1	
7	12315ZE3840	TUBE, BREATHER	1	
8	12391ZE2020	GASKET, CYLINDER HEAD COVER	1	
10	17316611000	CLIP, BREATHER TUBE	2	
11	90014ZE2000	BOLT, HEAD COVER	1	
12	90042ZE8000	BOLT, STUD (8X131.5)	2	
13	92900080320E	BOLT 2, STUD (8X32)	2	
14	90441ZE2010	WASHER, HEAD COVER	1	
16	9430112200	PIN A, DOWEL (12X20)	2	
17✖	957251008000	BOLT, FLANGE (10X80)	4	
17◇	957251008000	BOLT, FLANGE (10X80)	4	S/N 1411816 AND BELOW
17◇	957011008000	BOLT, FLANGE (10X80)	4	S/N 1411817 AND ABOVE
18	9807955846	SPARK PLUG (BPR5ES) (NGK) (OPT.)	1	
18	9807955855	SPARK PLUG (W16EPR-U) (DENSO)	1	
18	9807956846	SPARK PLUG (BPR6ES) (NGK)	1	
18	9807956855	SPARK PLUG (W20EPR-U) (DENSO)	1	

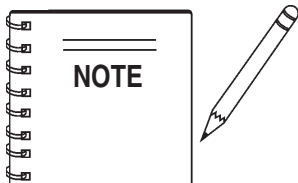

- ✖ GX390K1QWT2: Model S/N DECEMBER 2005 AND BELOW
- ◇ GX390U1QWT2: Model S/N JANUARY 2006 AND ABOVE

HONDA GX390K1QWT2/GX390U1QWT2 ENG. — FAN COVER ASSY.

FAN COVER ASSY.

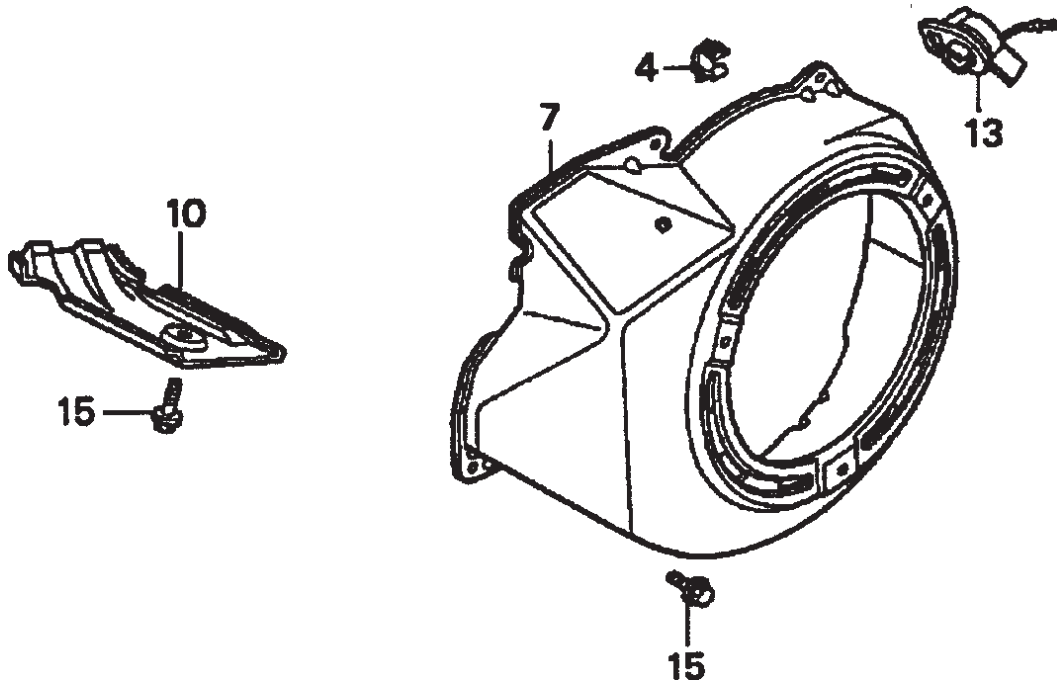

HONDA GX390K1QWT2/GX390U1QWT2 ENG. — FAN COVER ASSY.

FAN COVER ASSY.

<u>NO.</u>	<u>PART NO.</u>	<u>PART NAME</u>	<u>QTY.</u>	<u>REMARKS</u>
4	16731ZE2003	CLIP, TUBE	1	
7	19610ZE3010ZB	COVER, FAN *NH1* (BLACK)	1	
10	19631ZE3W00	SHROUD	1	
13✘	36100ZH7003	SWITCH ASSY., ENGINE STOP	1	
13◇	36100ZF6P81	SWITCH ASSY., ENGINE STOP	1	S/N 1412956 AND BELOW
13◇	36100ZF6P82	SWITCH ASSY., ENGINE STOP	1	S/N 1412957 AND ABOVE
15	90013883000	BOLT, FLANGE (6X12) (CT200)	6	

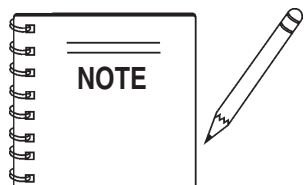

- ✘ GX390K1QWT2: Model S/N DECEMBER 2005 AND BELOW
- ◇ GX390U1QWT2: Model S/N JANUARY 2006 AND ABOVE

HONDA GX390K1QWT2/GX390U1QWT2 ENG. — FLYWHEEL ASSY.

FLYWHEEL ASSY.

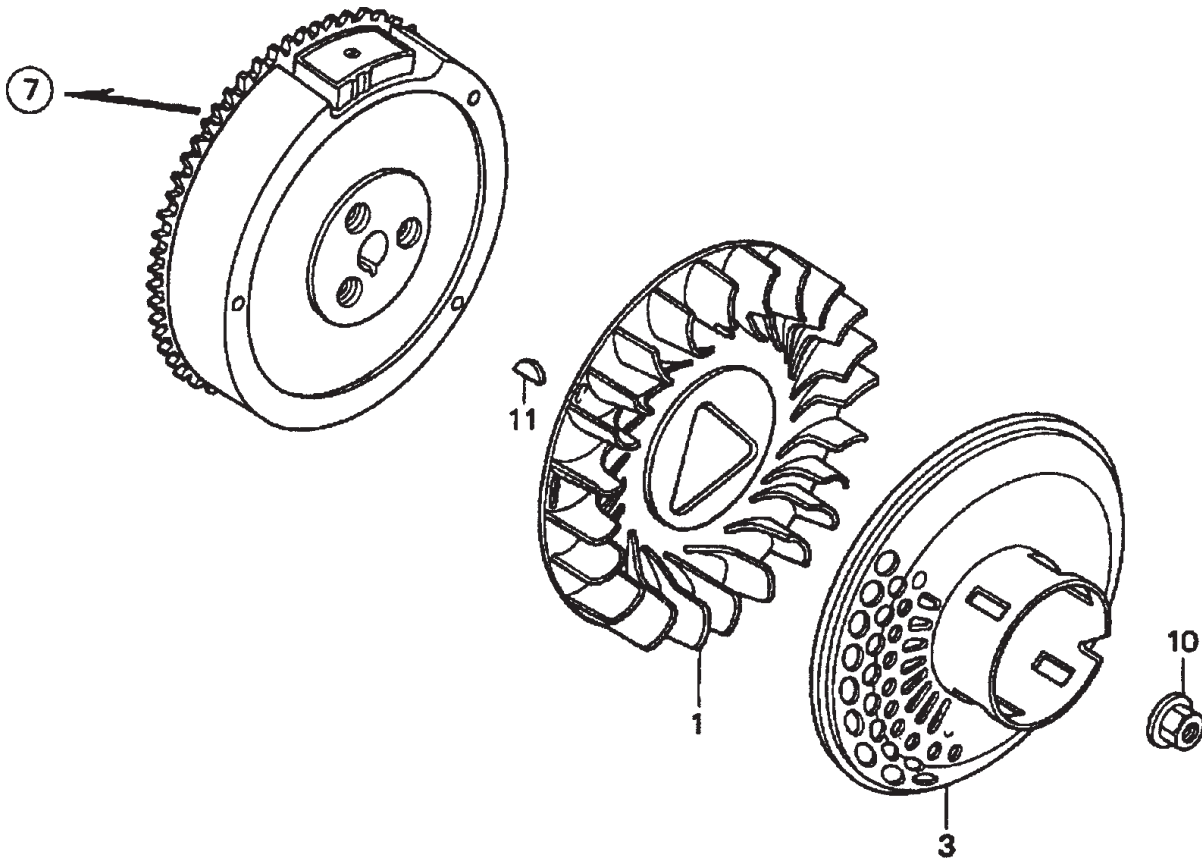

HONDA GX390K1QWT2/GX390U1QWT2 ENG. — FLYWHEEL ASSY.

FLYWHEEL ASSY.

<u>NO.</u>	<u>PART NO.</u>	<u>PART NAME</u>	<u>QTY.</u>	<u>REMARKS</u>
1	19511ZE3000	FAN, COOLING	1	
3	28450ZE3W11	PULLEY, STARTER (SCREEN GRID)	1	
7	31100ZE3701	FLYWHEEL	1	
10✕	90201ZE3V00	NUT, SPECIAL (16MM) (1)	1	
10◇	90201ZE3V00	NUT, SPECIAL (16MM) (1)	1	S/N 1317976 AND BELOW
10◇	90201ZE3790	NUT, SPECIAL (16MM) (1)	1	S/N 1317977 AND ABOVE
11	90741ZE2000	KEY, SPECIAL WOODRUFF (25X18)	1	

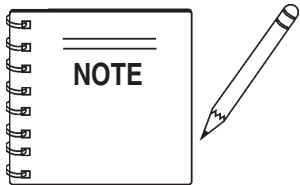

- ✕ GX390K1QWT2: Model S/N DECEMBER 2005 AND BELOW
- ◇ GX390U1QWT2: Model S/N JANUARY 2006 AND ABOVE

HONDA GX390K1QWT2/GX390U1QWT2 ENG. — FUEL TANK ASSY.

FUEL TANK ASSY.

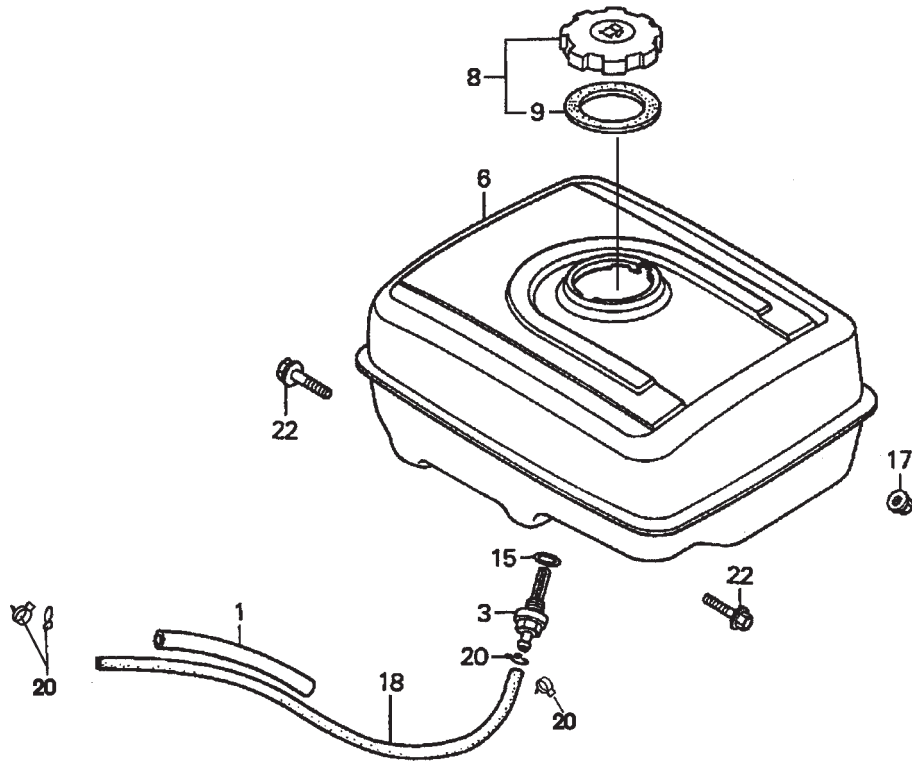

HONDA GX390K1QWT2/GX390U1QWT2 ENG. — FUEL TANK ASSY.

FUEL TANK ASSY.

<u>NO.</u>	<u>PART NO.</u>	<u>PART NAME</u>	<u>QTY.</u>	<u>REMARKS</u>
1	16854ZH8000	RUBBER, SUPPORTER (107MM)	1	
3	16955ZE1000	JOINT, FUEL TANK	1	
6✖	17510ZE3010ZB	TANK, FUEL *NH1*	1	
6◇	17510ZE3020ZB	TANK, FUEL *NH1*	1	S/N 1213085 AND BELOW
6◇	17510ZE3800ZA	TANK, FUEL *NH1*	1	S/N 1213086 THRU 1383799
6◇	17510ZE3801ZA	TANK, FUEL *NH1*	1	S/N 1383800 AND ABOVE
8✖	17620ZH7023	CAP, FUEL FILLER (BLACK)	1	INCLUDES ITEM W/*
8◇	17620Z0T305	CAP, FUEL FILLER (CHROME PLATED)	1	INCLUDES ITEM W/#
9*	17631ZH7003	GASKET, FUEL FILLER CAP	1	
9#	17631Z0T812	GASKET, FUEL FILLER CAP 39X62X3	1	
15	91353671004	O-RING (14MM) (NOK)	1	
17	9405008000	NUT, FLANGE (8MM)	2	
18✖	950014523540	BULK HOSE, FUEL (4.5X235)	1	REPLACES 950014500160M
18◇	950014523540	BULK HOSE, FUEL (4.5X235)	1	REPLACES 950014500160M
			S/N 1105013 AND BELOW
18◇	91424Z5L801	BULK HOSE, FUEL (4.5X235) (FKM)	1	S/N 1105014 AND ABOVE
20✖	9500202080	CLIP, TUBE (B8)	2	
20◇	9500202080	CLIP, TUBE (B8)	2	S/N 1105013 AND BELOW
20◇	950024080008	CLAMP, TUBE (D8)	2	S/N 1105014 AND ABOVE
22	957010802500	BOLT, FLANGE (8X25)	2	

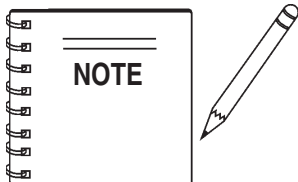

- ✖ GX390K1QWT2: Model S/N DECEMBER 2005 AND BELOW
- ◇ GX390U1QWT2: Model S/N JANUARY 2006 AND ABOVE

HONDA GX390K1QWT2/GX390U1QWT2 ENG. — IGNITION COIL ASSY.

IGNITION COIL ASSY.

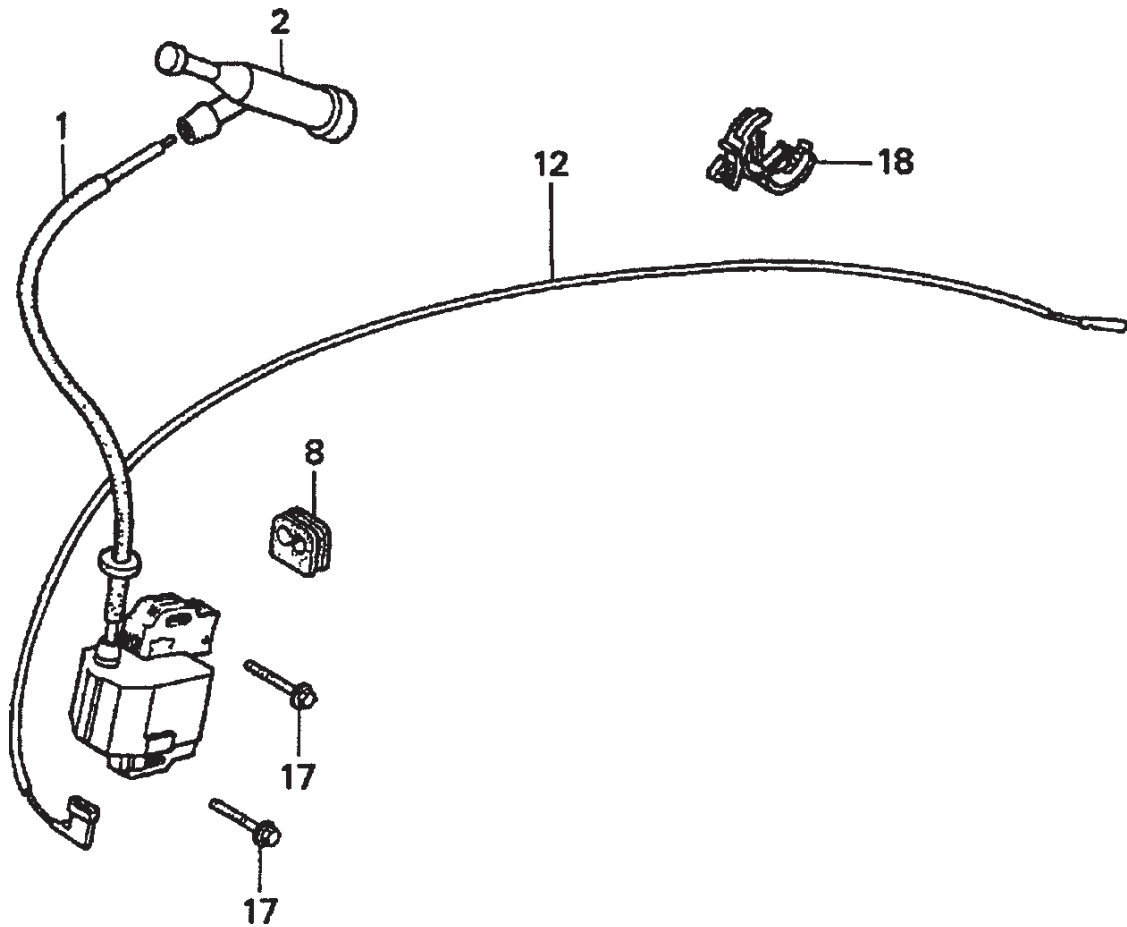

HONDA GX390K1QWT2/GX390U1QWT2 ENG. — IGNITION COIL ASSY.

IGNITION COIL ASSY.

<u>NO.</u>	<u>PART NO.</u>	<u>PART NAME</u>	<u>QTY.</u>	<u>REMARKS</u>
1✖	30500ZF6W02	COIL ASSY., IGNITION	1	
1◇	30500ZF6W02	COIL ASSY., IGNITION	1.....	S/N 1411816 AND BELOW
1◇	30500ZF6W03	COIL ASSY., IGNITION	1.....	S/N 1411817 AND ABOVE
2	30700ZE1013	CAP ASSY., NOISE SUPPRESSOR	1	
8	31512ZE2000	GROMMET, WIRE	1	
12	36101ZE2701	WIRE, STOP SWITCH (430MM)	1	
17	90015883000	BOLT, FLANGE (6X28)	2	
18	90684ZA0601	CLIP, WIRE HARNESS	1	

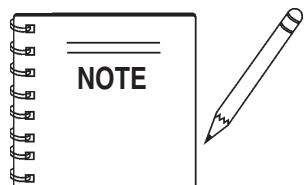

- ✖ GX390K1QWT2: Model S/N DECEMBER 2005 AND BELOW
- ◇ GX390U1QWT2: Model S/N JANUARY 2006 AND ABOVE

HONDA GX390K1QWT2/GX390U1QWT2 ENG. — MUFFLER ASSY.

MUFFLER ASSY.

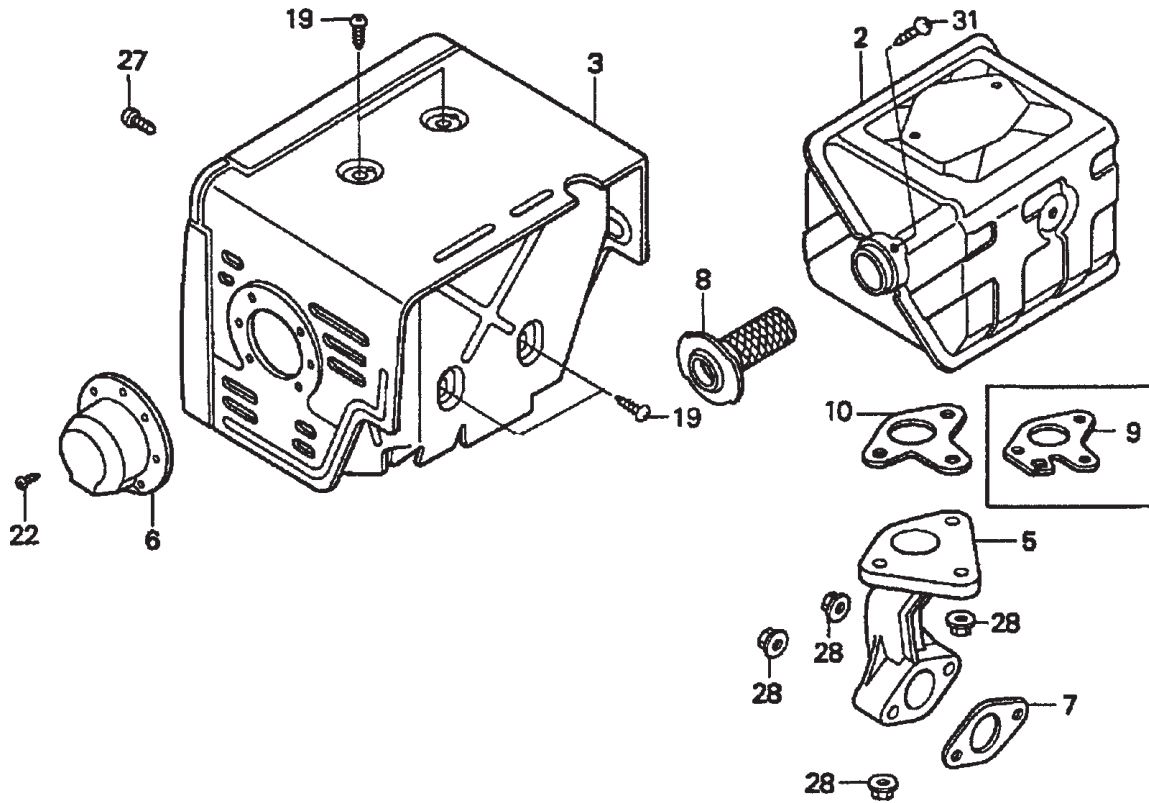

HONDA GX390K1QWT2/GX390U1QWT2 ENG. — MUFFLER ASSY.

MUFFLER ASSY.

<u>NO.</u>	<u>PART NO.</u>	<u>PART NAME</u>	<u>QTY.</u>	<u>REMARKS</u>
2	18310ZE2W61	MUFFLER	1	
3	18320ZE2W61	PROTECTOR, MUFFLER	1	
5	18330ZE2W00	PIPE, EX.	1	
6✖	18331ZE3810	CAP, MUFFLER	1	
6◇	18331ZE3810	CAP, MUFFLER	1	S/N 1166160 AND BELOW
6◇	18331ZE3811	CAP, MUFFLER	1	S/N 1166161 AND ABOVE
7	18333ZF6W01	GASKET, EX. PIPE	1	
8	18355ZE2W00	ARRESTER, SPARK (OPTIONAL)	1	
9	18381ZE2W10	GASKET, MUFFLER (ARRESTER) (OPTIONAL)	1	
10	18381ZE2800	GASKET, MUFFLER	1	
19	90050ZE1000	SCREW, TAPPING (5X8)	4	
22	90055ZE1000	SCREW, TAPPING (4X6)	3	
27	90006ZE2000	SCREW, TAPPING (6X10)	1	
28	9405008000	NUT, FLANGE (8MM)	5	
31	90055ZE1000	SCREW, TAPPING (4X6)	1	

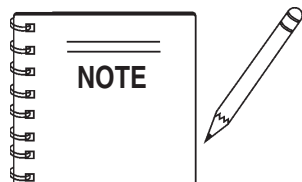

- ✖ GX390K1QWT2: Model S/N DECEMBER 2005 AND BELOW
- ◇ GX390U1QWT2: Model S/N JANUARY 2006 AND ABOVE

HONDA GX390K1QWT2/GX390U1QWT2 ENG. — PISTON ASSY.

PISTON ASSY.

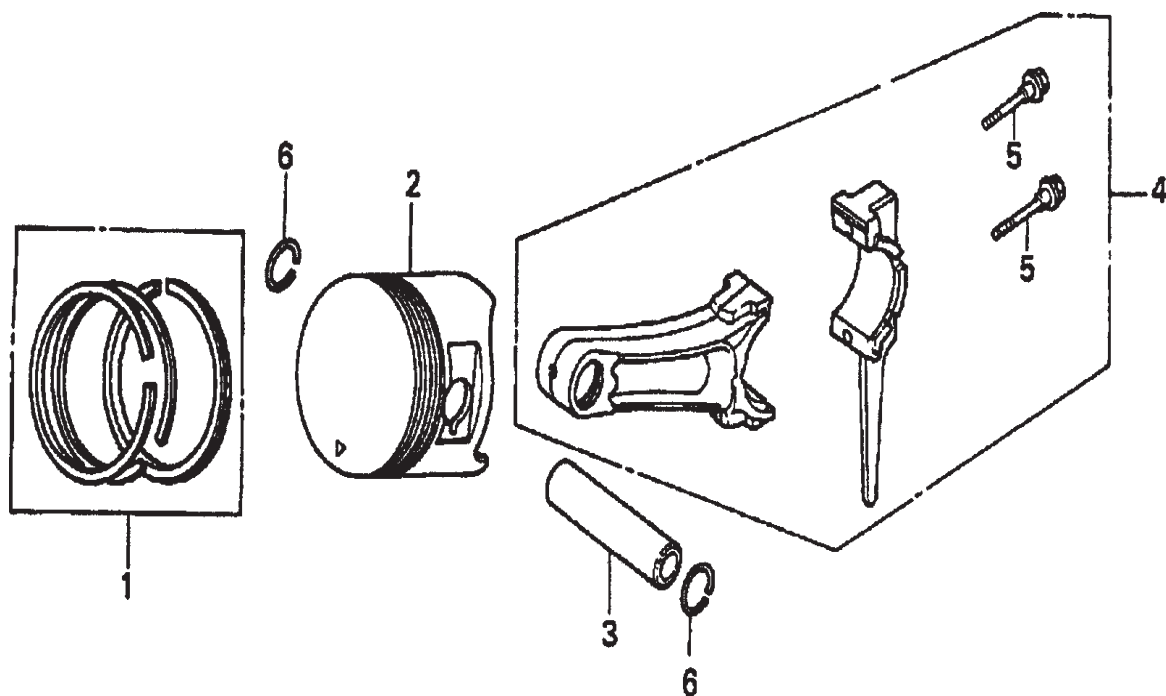

HONDA GX390K1QWT2/GX390U1QWT2 ENG. — PISTON ASSY.

PISTON ASSY.

<u>NO.</u>	<u>PART NO.</u>	<u>PART NAME</u>	<u>QTY.</u>	<u>REMARKS</u>
1	13010ZF6005	RING SET, PISTON (STD)	1	
1	13011ZF6005	RING SET, PISTON (0.25)	1	
1	13012ZF6005	RING SET, PISTON (0.50)	1	
1	13013ZF6005	RING SET, PISTON (0.75)	1	
2	13101ZF6W00	PISTON (STD)	1	
2	13102ZF6W00	PISTON (0.25)	1	
2	13103ZF6W00	PISTON (0.50)	1	
2	13104ZF6W00	PISTON (0.75)	1	
3	13111ZF6W00	PIN, PISTON	1	
4	13200ZE3020	ROD ASSY., CONNECTING (STD)	1	INCLUDES ITEM W/*
4	13200ZE3315	ROD ASSY., CONNECTING (0.25 UNDERSIZE)	1	
5*	90001ZE8000	BOLT, CONNECTING ROD	2	
6	90601ZE3000	CLIP, PISTON PIN (20MM)	2	

HONDA GX390K1QWT2/GX390U1QWT2 ENG. — RECOIL STATER ASSY.

RECOIL STARTER ASSY.

<u>NO.</u>	<u>PART NO.</u>	<u>PART NAME</u>	<u>QTY.</u>	<u>REMARKS</u>
1	28400ZE3W01ZB	STARTER ASSY., RECOIL *NH1* (BLACK)	1	INCLUDES ITEMS W/*
2*	28410ZE3W01ZB	CASE, RECOIL STARTER *NH1* (BLACK)	1	
3*	28421ZE3W01	PULLEY, RECOIL STARTER	1	
4*	28422ZE2W01	RATCHET, STARTER	2	
5*	28441ZE2W01	SPRING, FRICTION	1	
6*	28442ZE2W01	SPRING, STARTER RETURN	1	
7*	28443ZE2W01	SPRING, RATCHET	2	
8*	28444ZE2W01	RETAINER, SPRING	1	
10*	28461ZE2W02	GRIP, STARTER	1	
11**	28462ZV7003	ROPE, RECOIL STARTER	1	
11◇*	28462ZE3W01	ROPE, RECOIL STARTER	1	
13*	90004ZE2W01	SCREW, CENTER	1	
14	90008ZE2003	BOLT, FLANGE (6X10)	3	

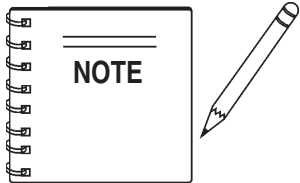

- ** GX390K1QWT2: Model S/N DECEMBER 2005 AND BELOW
- ◇ GX390U1QWT2: Model S/N JANUARY 2006 AND ABOVE

HONDA GX390K1QWT2/GX390U1QWT2 ENG. — LABELS ASSY.

LABELS ASSY.

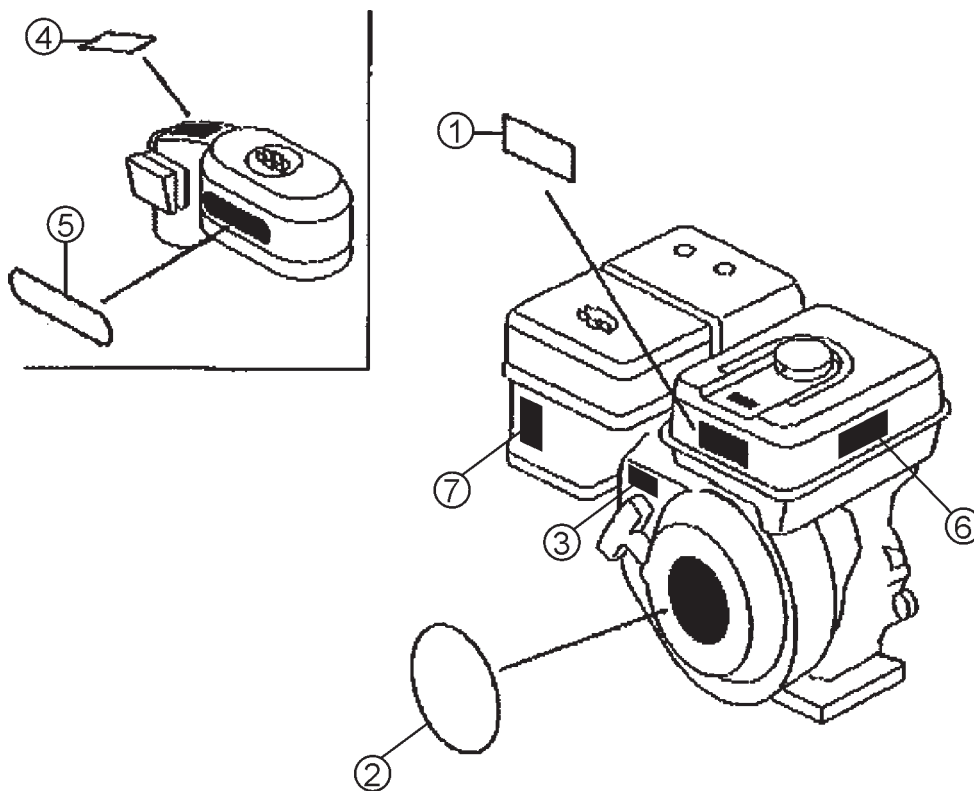

HONDA GX390K1QWT2/GX390U1QWT2 ENG. — LABELS ASSY.

LABELS ASSY.

<u>NO.</u>	<u>PART NO.</u>	<u>PART NAME</u>	<u>QTY.</u>	<u>REMARKS</u>
1✖	87522ZH9010	LABEL, CAUTION(ENGLISH ETC.)	1	
1◇	87516ZH7000	MARK OPERATOR CAUTION	1	
1◇	87516ZH7810	MARK OPERATOR PICTOGRAPH (OPTION)	1	
2✖	87521ZF6W02	EMBLEM (GX390 HONDA 13.0)	1	
2◇	87521ZF6W03	EMBLEM (GX390 HONDA 13.0)	1	S/N 1398206 AND BELOW
2◇	87521ZF6W04	EMBLEM (GX390 HONDA 13.0)	1	S/N 1398207 AND ABOVE
3◇	87532ZH7000	MARK, THROTTLE INDICATION	1	
4	87534ZE1841	LABEL, AIR CLEANER CAUTION	1	
5◇	87535ZE1841	MARK, AIR CLEANER SALES POINT	1	
6✖	87532ZH8810	MARK, OIL ALERT (E)	1	
7✖	87528ZE2810	MARK, CHOKE (EXTERNAL)	1	

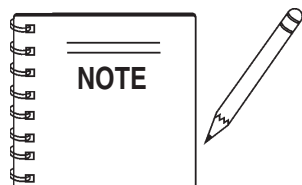

- ✖ GX390K1QWT2: Model S/N DECEMBER 2005 AND BELOW
- ◇ GX390U1QWT2: Model S/N JANUARY 2006 AND ABOVE

STOW

A DIVISION OF MULTIQUIP INC.

Terms and Conditions of Sale STOW Construction Equipment

PAYMENT TERMS

Terms of payment for unit sales are 2% 15 days net 30 days from date of invoice unless otherwise specifically stated on our invoice. Parts invoices have terms of net 10 days.

Minimum parts billing is \$15.00 net.

Applicable discounts will be computed on merchandise value only. Late charges will be assessed at prevailing rates. Cash discounts cannot be taken on current billings if any previously billed amounts are past due.

FREIGHT POLICY

Freight policy is established to offer customers every advantage possible. Due to bulk freight ratings on some equipment and other shipping considerations, freight policies differ by equipment type. Actual back freight may be charged for shipments originating from other than specified FOB warehouses. **See Freight Policy for details.**

All STOW domestic sales are FOB nearest available designated MQ/STOW warehouse. Export orders are ex-works factory located in Carson, CA or Boise, ID.

Additions to orders already shipped cannot be accepted for freight minimums.

Should STOW elect to make partial shipments of an order originally complying with the "freight allowed" requirements, transportation charges will be absorbed by STOW on any subsequent shipment applying to that order.

All other orders will be shipped collect or prepaid with charges added to the invoice. STOW's responsibility ceases when a signed manifest has been obtained from the carrier, and any claim for shortage or damage must be settled between the consignee and the carrier.

Parts: FOB Carson, California or Boise, Idaho. **See Freight Policy for details and additional discounts.**

DROP SHIPMENTS

STOW reserves the right to refuse Drop Shipments outside the normal service area of the purchasing dealer.

FIELD WAREHOUSES

Field Warehouses are currently located in California, Georgia, Idaho, Iowa, and New Jersey

SPECIAL EXPEDITING SERVICE

The higher of a \$35.00 surcharge or actual costs will be added to the invoice for special handling, including bus shipments, or in cases where STOW personnel must personally deliver the equipment or parts to the carrier.

RETURNED GOODS POLICY

Return shipments may be accepted and credit allowed, subject to the following provisions.

1. A Returned Material Authorization (RMA) must be approved by STOW prior to shipment. Approvals for returned goods must be with just cause and are at the sole discretion of STOW. A copy of the Authorization must accompany the shipment to the designated Warehouse.
2. Parts being returned must be listed as currently supplied on the current parts list.
3. Parts must be in new and resalable condition in the original package, with part numbers clearly marked.
4. Units and accessories must be current models in the latest price list and in new and resalable condition.
5. Special order items are not returnable for credit.
6. Credit on returned parts and units will be issued at actual dealer net price at time of purchase less 15% restocking charge.
7. All returned shipments are to be made to the STOW designated receiving point, freight prepaid at the sender's expense.

The sender will be notified of any material received that does not meet the above provisions. Such material will be held for 30 days from notification pending instructions. If a reply is not received within 30 days, the material will be returned to the sender at his expense with no credit issued.

PRICING, REBATES AND SPECIFICATIONS

Every effort will be made to provide adequate notice of changes; however, prices and equipment specifications are subject to change without notice.

Price changes are effective on a specific date and all orders received on or after that date will be billed at the revised price.

Rebates for price reductions and added charges for price increases will not be made for stock in dealer inventory at the time of a price change.

STOW reserves the right to quote and sell direct to Government agencies and to Original Equipment Manufacturer accounts who use our products as integral parts of their own products.

LIMITATION OF SELLER'S LIABILITY

STOW shall not be liable hereunder for damages in excess of the purchase price of the item with respect to which damages are claimed and in no event shall STOW be liable for loss of profit or good will or for any other special, consequential or incidental damages.

LIMITATION OF WARRANTIES

There are no warranties, express or implied, made by STOW hereunder on Products manufactured or distributed by it except the warranty against defects in material and workmanship on new Products to the original purchaser, as set forth in the STOW New Product Limited Warranty.

Effective: July 15, 2003

STOW

A DIVISION OF MULTIQUIP INC.

Atlanta • Boise • Newark • Quebec, Canada
Manchester, UK • Rio de Janeiro, BR • Puebla, MX

STOW CONSTRUCTION EQUIPMENT

POST OFFICE BOX 6254
CARSON, CALIFORNIA 90749
310-661-4242 • 877-BUY-STOW
FAX: 310-604-9237
E-MAIL: stow@stowmfg.com
www.stowmfg.com

OPERATION AND PARTS MANUAL

HERE'S HOW TO GET HELP

PLEASE HAVE THE MODEL AND SERIAL
NUMBER *ON-HAND* WHEN CALLING

PARTS DEPARTMENT

800-427-1244 FAX: 800-672-7877
310-537-3700 FAX: 310-637-3284

SERVICE DEPARTMENT

800-478-1244 FAX: 310-537-4259
310-537-3700

TECHNICAL ASSISTANCE

800-478-1244 FAX: 310-631-5032

WARRANTY DEPARTMENT

800-421-1244, EXT. 279 FAX: 310-537-1173
310-537-3700, EXT. 279

SALES DEPARTMENT

310-661-4242 FAX: 310-604-9237
877-289-7869 (877-BUY-STOW)

© COPYRIGHT 2008, MULTIQUIP INC.

Multiquip Inc, and the STOW logo are registered trademarks of Multiquip Inc. and may not be used, reproduced, or altered without written permission. All other trademarks are the property of their respective owners and used with permission.

This manual MUST accompany the equipment at all times. This manual is considered a permanent part of the equipment and should remain with the unit if resold.

The information and specifications included in this publication were in effect at the time of approval for printing. Illustrations, descriptions, references and technical data contained in this manual are for guidance only and may not be considered as binding. Multiquip Inc. reserves the right to discontinue or change specifications, design or the information published in this publication at any time without notice and without incurring any obligations.

Your Local Dealer is:

STOW
A DIVISION OF MULTIQUIP INC.
Atlanta • Boise • Newark • Quebec, Canada
Manchester, UK • Rio de Janeiro, BR • Puebla, MX

MQ STOW CONSTRUCTION EQUIPMENT

A DIVISION OF MULTIQUIP INC.
POST OFFICE BOX 6254
CARSON, CA 90749
310-537-3700 • 888-252-MQ STOW [888-252-7869]
FAX: 310-537-1986 • FAX: 800-556-1986
E-MAIL: MQ STOW@multiquip.com • WWW: stowmfg.com