United States Stove Company

Project # 19-495

Model: 6041

AKA: 6041I, SP6000

Type: Pellet-Fired Room Heater

July 26, 2019

**ASTM E2779 Standard Test Method for
Determining Particulate Matter
Emissions from Pellet Heaters**

United States Stove Company
227 Industrial Park Road
South Pittsburg, TN 37380

(423) 837-2100

Prepared by: Sebastian Button,
Laboratory Supervisor



11785 SE Highway 212 – Suite 305

Clackamas, OR 97015-9050

(503) 650-0088

WWW.PFSTECO.COM

This page intentionally left blank.

Contents

- Affidavit 3
- Introduction 4
 - Notes 4
- Pellet Heater Identification and Testing 5
- Test Procedures and Equipment 6
- Results 7
 - Summary Table 7
 - Test Run Narrative 8
 - Run 1 8
- Test Conditions Summary 8
 - Appliance Operation and Test Settings 8
 - Settings & Run Notes 8
- Appliance Description 9
 - Appliance Dimensions 9
- Test Fuel Properties 12
 - Pellet Fuel Analysis 13
- Sampling Locations and Descriptions 13
 - Sample Points 14
- Sampling Methods 15
- Analytical Methods Description 15
- Calibration, Quality Control and Assurances 15
- Appliance Sealing and Storage 15
 - Sealing Label 15
 - Sealed Unit 16

Affidavit

PFS-TECO was contracted by United States Stove Company to provide testing services for the 6041 Pellet-Fired Room Heater per ASTM E2779, *Determining PM Emissions from Pellet Heaters*. All testing and associated procedures were conducted at PFS-TECO's Portland Laboratory on 7/17/2019. PFS-TECO's Portland Laboratory is located at 11785 SE Highway 212 – Suite 305, Clackamas, Oregon 97015. Testing procedures followed ASTM E2779. Particulate sampling was performed per ASTM E2515, *Standard Test Method for Determination of Particulate Matter Emissions Collected by a Dilution Tunnel*.

PFS-TECO is accredited by the U.S. Environmental Protection Agency for the certification and auditing of wood heaters pursuant to subpart AAA of 40 CFR Part 60, New Source Performance Standards for Residential Wood Heaters and subpart QQQQ of 40 CFR Part 60, Standards of Performance for New Hydronic Heaters and Forced Air Furnaces, Methods 28R, 28WHH, 28 WHH-PTS, and all methods listed in Sections 60.534 and 60.5476. PFS-TECO holds EPA Accreditation Certificate Numbers 4 and 4M (mobile). PFS-TECO is accredited by IAS to ISO 17020:2012 "Criteria for Bodies Performing Inspections", and ISO 17025:2005 "Requirements for Testing Laboratories." PFS-TECO is also accredited by Standards Council of Canada to ISO 17065:2012 "Requirements for Bodies Operating Product Certification Systems."

The following people were associated with the testing, analysis and report writing associated with this project.



Sebastian Button, Laboratory Supervisor

Introduction

United States Stove Company of South Pittsburg, TN, contracted with PFS-TECO to perform EPA certification testing on 6041 Pellet-Fired Room Heater. All testing was performed at PFS-TECO's Portland Laboratory. Testing was performed by Mr. Sebastian Button.

Notes

- Prior to start of testing, 50 hours of conditioning was performed per ASTM E2779
- Prior to start of testing, the dilution tunnel was cleaned with a steel brush.
- Front filters were changed on sample train A at one hour after the test began.
- A single, integrated test run, in accordance with ASTM E2779 was performed:
 - The medium burn rate setting used was the same as the low burn rate setting, as that is the only setting that yields a burn rate of <50% of the high burn rate, as required by ASTM E2779.

Pellet Heater Identification and Testing

- Appliance Tested: **6041**
- Serial Number: **4805F; PFS Tracking Number 0028**
- Manufacturer: **United States Stove Company**
- Catalyst: **No**
- Heat exchange blower: **Integral**
- Type: **Pellet Stove**
- Style: **Free Standing**
- Date Received: **Monday, June 03, 2019**
- Testing Period – Start: **Wednesday, July 17, 2019** Finish: **Wednesday, July 17, 2019**
- Test Location: **PFS-TECO Portland Laboratory, 11785 SE HWY 212 - Suite 305, Clackamas, OR 97015**
- Elevation: **≈131 Feet above sea level**
- Test Technician(s): **Sebastian Button**
- Observers: **N/A**

Test Procedures and Equipment

All Sampling and analytical procedures were performed by Sebastian Button. All procedures used are directly from ASTM E2779 and ASTM E2515. See the list below for equipment used. See Appendix C submitted with this report for calibration data.

Equipment List:

Equipment ID#	Equipment Description
041	Rice Lake 3'x3' floor scale w/digital weight indicator
053	APEX XC-60 Digital Emissions Sampling Box A
054	APEX XC-60 Digital Emissions Sampling Box B
055	APEX Ambient sampling box
057	California Analytical ZRE CO2/CO/O2 IR ANALYZER
064	Digital Barometer
109A/B	Troemner 100mg/200mg Audit Weights
107	Sartorius Analytical Balance
051	10 lb audit weight
095	Anemometer
111	Microtector
SA17187	Gas Analyzer Calibration Span Gas
CC170624	Gas Analyzer Calibration Mid Gas

Results

The integrated test run emission rate for test Run 1 was measured to be **1.28 g/hr** with a Higher Heating Values efficiency of **57.6%** and a CO emission rate of **0.46 g/min**. The calculated first hour particulate emission rate was **0.33 g/hr**. The United States Stove Company Model 6041 Pellet-Fired Room Heater meets the 2020 PM emission standard of ≤ 2.0 g/hr per CFR 40 part 60, §60.532 (b).

Detailed individual run data can be found in Appendix A submitted with this report.

Summary Table

EPA Application Table											
Run Number	Date	Segments		Run Time (min)	Heat Output (BTU/hr)	1st Hr Emissions (g/hr)	Integrated Total (g/hr)	CO Emissions (g/min)	Overall CO Emissions (g/min)	Heating Efficiency (%HHV)	Overall Heating Efficiency (%HHV)
		Setting	BR								
1	7/17/2019	H	1.67	60	21811	0.33	1.28	0.58	0.46	67.4%	57.6%
		M	0.79	120	8311			0.48		54.2%	
		L	0.75	180	7540			0.42		52.1%	
		OA	0.92	360	10214			0.46		57.6%	

Test Run Narrative

Run 1

Run 1 was performed on 7/17/2019 as an attempted integrated test run per ASTM E2779. The overall test duration was 360 minutes. The particulate emissions rate for the integrated test run was 1.28 g/hr. The run had an overall HHV efficiency of 57.6%. The train A front filter was changed at 1 hr. All test results were appropriate and valid and the burn rate requirement for the integrated test run were achieved. There were no anomalies and all criteria were met.

Test Conditions Summary

Testing conditions for all runs fell within allowable specifications of ASTM E2779 and ASTM E2515. A summary of facility conditions, fuel burned, and run times is listed below.

Runs	Ambient (°F)		Relative Humidity (%)		Average Barometric Pressure (In. Hg.)	Preburn Fuel Weight (lbs)	Test Fuel Weight (lbs)	Test Fuel Moisture (%DB)	Test Run Time (Min)
	Pre	Post	Pre	Post					
1	74	77	41.4	33.8	29.88	4.1	12.5	3.12	360

Appliance Operation and Test Settings

The appliance was operated according to procedures as described in the Operations Manual, found in Appendix B submitted with this report. Detailed run information can be found in Appendix A submitted with this report.

Settings & Run Notes

Pre-Burn		Test Run
Run 1	Heat Setting #5	High Segment: Heat Setting #5 Medium Segment: Heat Setting #1 Low Segment: Heat Setting #1

Appliance Description

Model(s): 6041

Additional Models Discussion: In addition to the tested model, this design is offered under several different models by the manufacturer, including: 6041I and SP6000. These models differ only in overall unit dimensions and branding designations. All models utilize the same basic design with respect to performance and emission controls, differing only in their outward aesthetics. All models listed above are presumed to have the same emissions performance as the test specimen provided for certification.

Appliance Type: Pellet-Fired Room Heater

Air Introduction System: Air enters the burn chamber by being pulled through the firepot, via the exhaust blower, see air flow diagram in Appendix D.

Combustion Control: Feed rate is electronically controlled via user-selectable controls.

Baffles: N/A

Flue Outlet: 3-inch exhaust outlet located on the bottom/rear of the appliance.

Appliance Dimensions

6041 Dimensions

Height	Width	Depth	Firebox Volume
29"	27.75"	29.25	N/A – Pellet Stove

Appliance design drawings can be found in Appendix D submitted with the CBI copy of this report.

Appliance Front



Appliance Left



Appliance Right



Appliance Rear



Test Fuel Properties

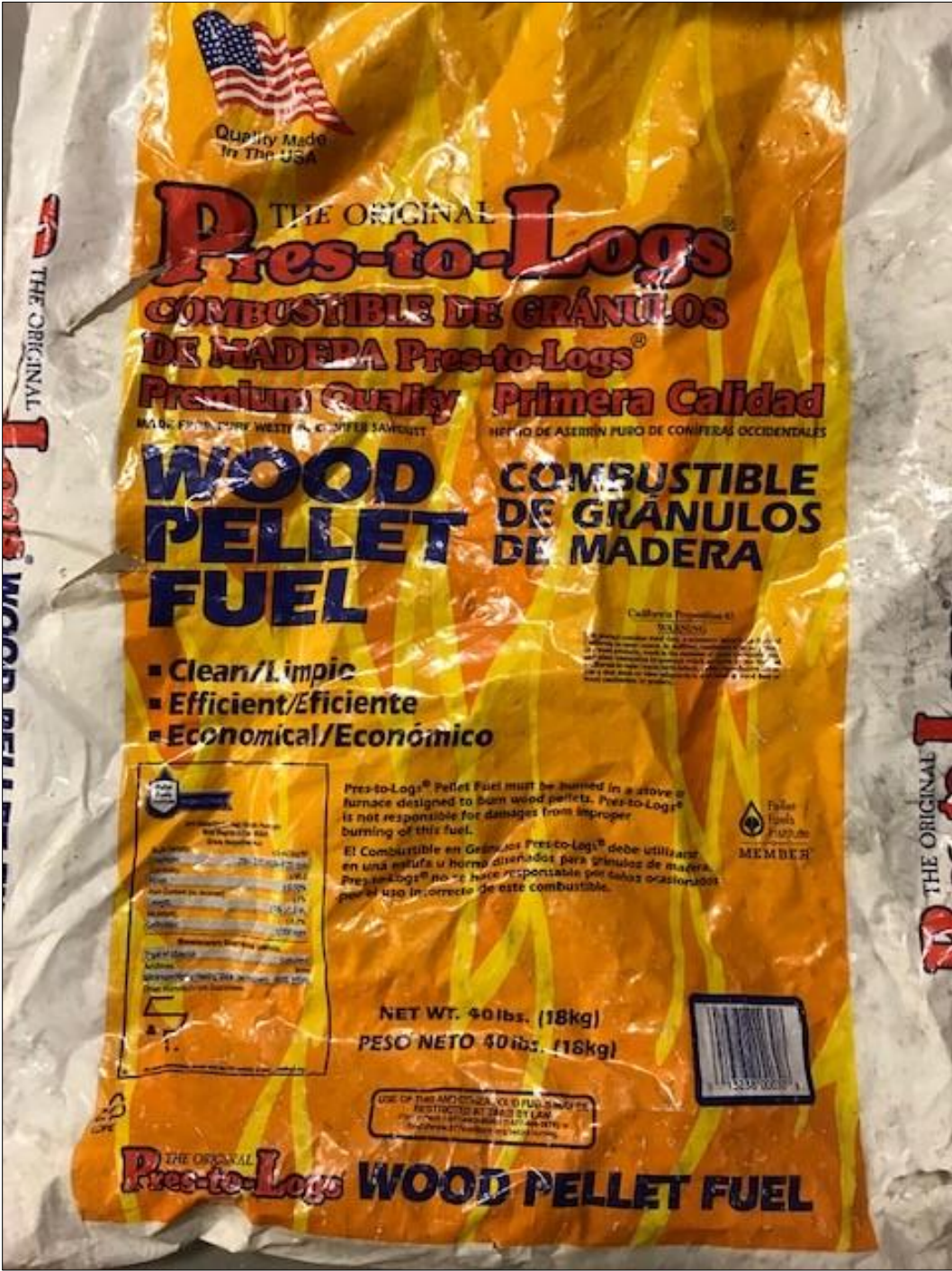

Test fuel used was Pres-to-Logs Wood Pellet Fuel, a PFI Certified Premium Pellet Brand. A sample of pellets was sent to Twin Ports Testing for analysis, see report below.

Pellet Fuel Analysis



Twin Ports Testing, Inc.
 1301 North 3rd Street
 Superior, WI 54880
 p: 715-392-7114
 p: 800-373-2562
 f: 715-392-7163
 www.twinportstesting.com

Report No: USR:W218-0155-01
Issue No: 1

Analytical Test Report

Client: PFS-TECO
 11785 SE Hwy 212
 Clackamas, OR 97015
Attention: Sebastian Button
PO No: S. Button

Signed: *Stephen Sundeen*
 Stephen Sundeen
 Chemistry Laboratory Manager
Date of Issue: 2/27/2018
THIS DOCUMENT SHALL NOT BE REPRODUCED EXCEPT IN FULL

Sample Details			
Sample Log No:	W218-0155-01	Sample Date:	
Sample Designation:	Presto Log - Pure Western Conife	Sample Time:	
Sample Recognized As:	Wood Pellets	Arrival Date:	2/15/2018

Test Results				
	METHOD	UNITS	MOISTURE FREE	AS RECEIVED
Moisture Total	ASTM E871	wt. %		3.03
Ash	ASTM D1102	wt. %	0.20	0.19
Volatile Matter	ASTM D3175	wt. %		
Fixed Carbon by Difference	ASTM D3172	wt. %		
Sulfur	ASTM D4239	wt. %	0.006	0.006
SO ₂	Calculated	lb/mmbtu		0.013
Net Cal. Value at Const. Pressure	ISO 1928	GJ/tonne	19.07	18.42
Net Cal. Value at Const. Pressure	ISO 1928	J/g	19075	18424
Gross Cal. Value at Const. Vol.	ASTM E711	J/g	20397	19780
Gross Cal. Value at Const. Vol.	ASTM E711	Btu/lb	8770	8504

Carbon	ASTM D5373	wt. %	50.57	49.04
Hydrogen*	ASTM D5373	wt. %	6.08	5.89
Nitrogen	ASTM D5373	wt. %	< 0.20	< 0.19
Oxygen*	ASTM D3176	wt. %	> 42.95	> 41.65

*Note: As received values do not include hydrogen and oxygen in the total moisture.

Chlorine	ASTM D6721	mg/kg		
Fluorine	ASTM D3761	mg/kg		
Mercury	ASTM D6722	mg/kg		

Bulk Density	ASTM E873	lbs/ft ³		
Fines (Less than 1/8")	TPT CH-P-06	wt.%		
Durability Index	Kansas State	PDI		
Sample Above 1.50"	TPT CH-P-06	wt.%		
Maximum Length (Single Pellet)	TPT CH-P-06	inch		
Diameter, Range	TPT CH-P-05	inch		to
Diameter, Average	TPT CH-P-05	inch		
Stated Bag Weight	TPT CH-P-01	lbs		
Actual Bag Weight	TPT CH-P-01	lbs		

Comments

Sample Points

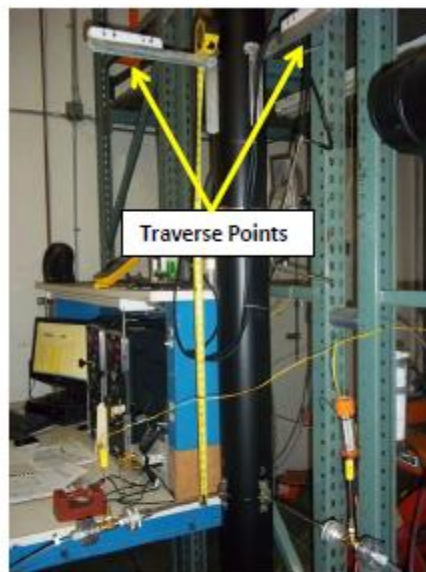
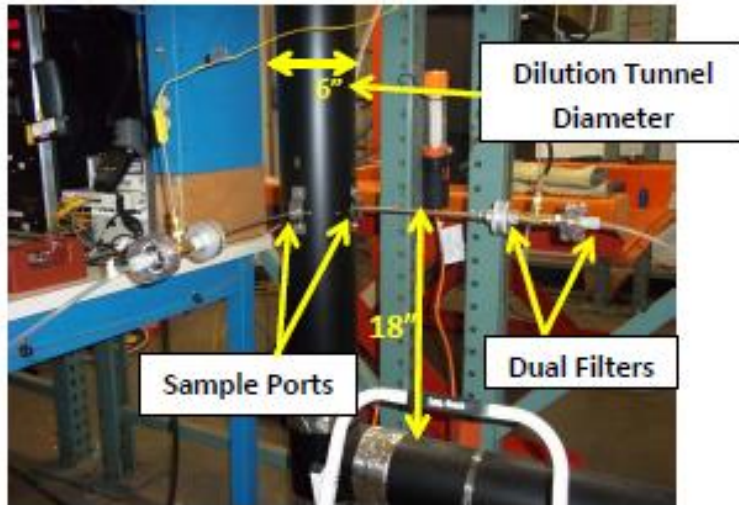

Sampling Methods

ASTM E2515 was used in collecting particulate samples. The dilution tunnel is 6 inches in diameter. All sampling conditions per ASTM E2515 were followed. No alternate procedures were used.

Analytical Methods Description

All sample recovery and analysis procedures followed ASTM E2515 procedures. At the end of each test run, filters, O-Rings and probes were removed from their housings, dessicated for a minimum of 24 hours, and then weighed at 6 hour intervals to a constant weight per ASTM E2515-11 Section 10.

Calibration, Quality Control and Assurances

Calibration procedures and results were conducted per EPA Method 28R, ASTM E2515-11 and ASTM E2780-10. Test method quality control procedures (leak checks, volume meter checks, stratification checks, proportionality results) followed the procedures outlined.

Appliance Sealing and Storage

Upon completion of testing, the appliance was secured with metal strapping and the seal below was applied, the appliance was then returned to the manufacturer's location at: 227 Industrial Park Road, South Pittsburg, TN 37380 for archival.

Sealing Label

ATTENTION:

THIS SEAL IS NOT TO BE BROKEN WITHOUT PRIOR AUTHORIZATION FROM THE
UNITED STATES ENVIRONMENTAL PROTECTION AGENCY.

THIS APPLIANCE HAS BEEN SEALED INACCORDANCE WITH REQUIREMNTS OF 40CFR
PART 60 SUBPART AAA §60.535 (a)(2)(vii)

REPORT # _____

DATE SEALED _____

MANUFACTURER _____

MODEL # _____

Sealed Unit



List of Appendices

The following appendices have been submitted electronically in conjunction with this report:

Appendix A – Test Run Data, Technician Notes, and Sample Analysis

Appendix B – Labels and Manuals

Appendix C – Equipment Calibration Records

Appendix D – Design Drawings (CBI Report Only)

Appendix E – Manufacturer QAP (CBI Report Only)

Conditioning Data

Client: US Stove	Job #: 19-495
Model: 6041	Tracking #: 028
Date(s):	Technician: SJB

Elapsed Time (hrs)	Scale Reading (lbs)	Average:	324.7	77.6	N/A
		Weight Change (lbs)	Flue (°F)	Ambient (°F)	Catalyst Exit (°F)
0	37.1	-	312	74	N/A
1	34.9	-2.2	321	78	N/A
2	32.8	-2.1	326	81	N/A
3	30.5	-2.3	323	83	N/A
4	51.8	21.3	326	86	N/A
5	49.5	-2.3	340	88	N/A
6	47.2	-2.3	340	88	N/A
7	45.0	-2.2	326	87	N/A
8	42.6	-2.4	341	83	N/A
9	40.3	-2.3	330	80	N/A
10	37.9	-2.4	331	78	N/A
11	35.6	-2.3	326	76	N/A
12	33.3	-2.3	324	74	N/A
13	31.0	-2.3	325	73	N/A
14	28.7	-2.3	319	73	N/A
15	26.5	-2.2	309	72	N/A
16	24.2	-2.3	309	70	N/A
17	22.0	-2.2	310	71	N/A
18	19.6	-2.4	320	69	N/A
19	17.4	-2.2	317	69	N/A
20	15.1	-2.3	306	64	N/A
21	13.0	-2.1	301	67	N/A
22	51.8	38.8	302	70	N/A
23	49.6	-2.2	316	72	N/A
24	47.5	-2.1	318	79	N/A
25	45.2	-2.3	324	82	N/A
26	42.9	-2.3	342	83	N/A
27	40.6	-2.3	335	84	N/A
28	56.4	15.8	330	84	N/A
29	54.1	-2.3	334	86	N/A
30	51.7	-2.4	348	89	N/A
31	49.4	-2.3	340	89	N/A
32	47.0	-2.4	341	88	N/A
33	44.6	-2.4	338	84	N/A
34	42.3	-2.3	326	82	N/A
35	39.9	-2.4	336	80	N/A
36	37.6	-2.3	331	78	N/A
37	35.2	-2.4	335	78	N/A
38	32.8	-2.4	329	78	N/A
39	30.5	-2.3	319	77	N/A
40	28.2	-2.3	324	77	N/A
41	25.8	-2.4	328	75	N/A
42	23.6	-2.2	324	74	N/A
43	21.3	-2.3	321	73	N/A
44	19.0	-2.3	317	64	N/A
45	16.7	-2.3	312	67	N/A
46	14.4	-2.3	309	69	N/A
47	12.2	-2.2	312	72	N/A
48	10.0	-2.2	328	76	N/A
49	7.7	-2.3	322	80	N/A
50	5.3	-2.4	334	82	N/A

Equations and Sample Calculations – ASTM E2779 & E2515

Client US Stove Company
 Model: 6041
 Tracking #: 028
 Run: 1

Equations used to calculate the parameters listed below are described in this appendix. Sample calculations are provided for each equation. The raw data and printout results from a sample run are also provided for comparison to the sample calculations.

- M_{Bdb} – Weight of test fuel burned during test run, dry basis, kg
- M_{BSidb} – Weight of test fuel burned during test run segment i , dry basis, kg
- BR – Average dry burn rate over full integrated test run, kg/hr
- BR_{Si} – Average dry burn rate over test run segment i , kg/hr
- V_s – Average gas velocity in the dilution tunnel, ft/sec
- Q_{sd} – Average gas flow rate in dilution tunnel, dscf/hr
- $V_{m(std)}$ – Volume of Gas Sampled Corrected to Dry Standard Conditions, dscf
- m_n – Total Particulate Matter Collected, mg
- C_s - Concentration of particulate matter in tunnel gas, dry basis, corrected to STP, g/dscf
- E_T – Total Particulate Emissions, g
- PR - Proportional Rate Variation
- PM_R – Average particulate emissions for full integrated test run, g/hr
- PM_F – Average particulate emission factor for full integrated test run, g/dry kg of fuel burned

M_{Bdb} – Weight of test fuel burned during test run, dry basis, kg
ASTM E2779 equation (1)

$$M_{Bdb} = (M_{Swb} - M_{Ewb})(100/(100 + FM))$$

Where,

- FM = average fuel moisture of test fuel, % dry basis
- M_{Swb} = weight of test fuel in hopper at start of test run, wet basis, kg
- M_{Ewb} = weight of test fuel in hopper at end of test run, wet basis, kg

Sample Calculation:

- FM = 3.12 %
- M_{Swb} = 12.5 lbs
- M_{Ewb} = 0.0 lbs
- 0.4536 = Conversion factor from lbs to kg

$$M_{Bdb} = [(12.5 \times 0.4536) - (0.0 \times 0.4536)] (100/(100 + 3.12))$$

$$M_{Bdb} = 5.5 \text{ kg}$$

M_{BSidb} – Weight of test fuel burned during test run segment i , dry basis, kg
ASTM E2779 equation (2)

$$M_{BSidb} = (M_{SSiwb} - M_{ESiwb})(100/(100 + FM))$$

Where,

M_{SSiwb} = weight of test fuel in hopper at start of test run segment i , wet basis, kg

M_{ESiwb} = weight of test fuel in hopper at end of test run segment i , wet basis, kg

Sample Calculation (from medium burn rate segment):

$$FM = 3.12 \%$$

$$M_{SSiwb} = 8.7 \text{ lbs}$$

$$M_{ESiwb} = 5.1 \text{ lbs}$$

0.4536 = Conversion factor from lbs to kg

$$M_{BSidb} = [(8.7 \times 0.4536) - (5.1 \times 0.4536)] (100/(100 + 3.12))$$

$$M_{BSidb} = 1.58 \text{ kg}$$

BR – Average dry burn rate over full integrated test run, kg/hr

ASTM E2779 equation (3)

$$BR = \frac{60 M_{Bdb}}{\theta}$$

Where,

θ = Total length of full integrated test run, min

Sample Calculation:

$$M_{Bdb} = 5.50 \quad \text{kg}$$

$$\theta = 360 \quad \text{min}$$

$$BR = \frac{60 \times 5.5}{360}$$

$$BR = \mathbf{0.92} \quad \text{kg/hr}$$

BR_{Si} – Average dry burn rate over test run segment *i*, kg/hr
ASTM E2779 equation (4)

$$BR_{Si} = \frac{60 M_{BSidb}}{\theta_{Si}}$$

Where,

$$\theta_{Si} = \text{Total length of test run segment } i, \text{ min}$$

Sample Calculation (from medium burn rate segment):

$$M_{BSidb} = 1.58 \text{ kg}$$

$$\theta = 120 \text{ min}$$

$$BR = \frac{60 \times 1.58}{120}$$

$$BR = \mathbf{0.79} \text{ kg/hr}$$

V_s – Average gas velocity in the dilution tunnel, ft/sec

ASTM E2515 equations (9)

$$V_s = F_p \times K_p \times C_p \times (\sqrt{\Delta P})_{avg} \times \sqrt{\frac{T_s}{P_s \times M_s}}$$

Where:

- F_p = Adjustment factor for center of tunnel pitot tube placement, $F_p = \frac{V_{strav}}{V_{scent}}$, ASTM E2515 Equation (1)
- V_{scent} = Dilution tunnel velocity calculated after the multi-point pitot traverse at the center, ft/sec
- V_{strav} = Dilution tunnel velocity calculated after the multi-point pitot traverse, ft/sec
- k_p = Pitot tube constant, 85.49
- C_p = Pitot tube coefficient: 0.99, unitless
- ΔP^* = Velocity pressure in the dilution tunnel, in H₂O
- T_s = Absolute average gas temperature in the dilution tunnel, °R; (°R = °F + 460)
- P_s = Absolute average gas static pressure in dilution tunnel, = $P_{bar} + P_g$, in Hg
- P_{bar} = Barometric pressure at test site, in. Hg
- P_g = Static pressure of tunnel, in. H₂O; (in Hg = in H₂O/13.6)
- M_s = **The dilution tunnel wet molecular weight; $M_s = 28.78$ assuming a dry weight of 29 lb/lb-mole

Sample calculation:

$$F_p = \frac{15.08}{17.22} = 0.876$$

$$V_s = 0.876 \times 85.49 \times 0.99 \times 0.253 \times \left(\frac{107.5 + 460}{29.88 + \frac{-0.17}{13.6}} \right)^{1/2} \times 28.78$$

$$V_s = \mathbf{15.24 \text{ ft/s}}$$

*The ASTM test standard mistakenly has the square root of the average delta p instead of the average of the square root of delta p. The current EPA Method 2 is also incorrect. This was verified by Mike Toney at EPA.

**The ASTM test standard mistakenly identifies M_s as the dry molecular weight. It should be the wet molecular weight as indicated in EPA Method 2.

Q_{sd} – Average gas flow rate in dilution tunnel, dscf/hr
 ASTM E2515 equation (3)

$$Q_{sd} = 3600 \times (1 - B_{ws}) \times v_s \times A \times \frac{T_{std}}{T_s} \times \frac{P_s}{P_{std}}$$

Where:

- 3600 = Conversion from seconds to hours (ASTM method uses 60 to convert in minutes)
- B_{ws} = Water vapor in gas stream, proportion by volume; assume 2%
- A = Cross sectional area of dilution tunnel, ft²
- T_{std} = Standard absolute temperature, 528 °R
- P_s = Absolute average gas static pressure in dilution tunnel, = P_{bar} + P_g, in Hg
- T_s = Absolute average gas temperature in the dilution tunnel, °R; (°R = °F + 460)
- P_{std} = Standard absolute pressure, 29.92 in Hg

Sample calculation:

$$Q_{sd} = 3600 \times (1 - 0.02) \times 15.24 \times 0.1963 \times \frac{528}{107.5 + 460} \times \frac{29.88 + \frac{-0.17}{13.6}}{29.92}$$

Q_{sd} = **9803.8** dscf/hr

$V_{m(std)}$ – Volume of Gas Sampled Corrected to Dry Standard Conditions, dscf
 ASTM E2515 equation (6)

$$V_{m(std)} = K_1 \times V_m \times Y \times \frac{P_{bar} + \left(\frac{\Delta H}{13.6} \right)}{T_m}$$

Where:

- K_1 = 17.64 °R/in. Hg
- V_m = Volume of gas sample measured at the dry gas meter, dcf
- Y = Dry gas meter calibration factor, dimensionless
- P_{bar} = Barometric pressure at the testing site, in. Hg
- ΔH = Average pressure differential across the orifice meter, in. H₂O
- T_m = Absolute average dry gas meter temperature, °R

Sample Calculation:

Using equation for Train A:

$$V_{m(std)} = 17.64 \times 53.610 \times 0.999 \times \frac{\left(29.88 + \frac{2.21}{13.6} \right)}{\left(82.9 + 460 \right)}$$

$$V_{m(std)} = \mathbf{52.277} \text{ dscf}$$

Using equation for Train B:

$$V_{m(std)} = 17.64 \times 53.151 \times 0.996 \times \frac{\left(29.88 + \frac{2.19}{13.6} \right)}{\left(96.4 + 460 \right)}$$

$$V_{m(std)} = \mathbf{50.416} \text{ dscf}$$

Using equation for ambient train:

$$V_{m(std)} = 17.64 \times 70.05 \times 0.992 \times \frac{\left(29.88 + \frac{0.00}{13.6} \right)}{\left(75.8 + 460 \right)}$$

$$V_{m(std)} = \mathbf{68.356} \text{ dscf}$$

m_n – Total Particulate Matter Collected, mg

ASTM E2515 Equation (12)

$$m_n = m_p + m_f + m_g$$

Where:

m_p = mass of particulate matter from probe, mg

m_f = mass of particulate matter from filters, mg

m_g = mass of particulate matter from filter seals, mg

Sample Calculation:

Using equation for Train A (first hour):

$$m_n = 0.0 + 0.3 + 0.0$$

$$m_n = 0.3 \text{ mg}$$

Using equation for Train A (remainder):

$$m_n = 0.2 + 3.9 + 2.3$$

$$m_n = 6.4 \text{ mg}$$

Train A Aggregate = **6.7 mg**

Using equation for Train B:

$$m_n = 0.3 + 4.2 + 2.3$$

$$m_n = \mathbf{6.8} \text{ mg}$$

C_s - Concentration of particulate matter in tunnel gas, dry basis, corrected to standard conditions, g/dscf
 ASTM E2515 equation (13)

$$C_s = K_2 \times \frac{m_n}{V_{m(std)}}$$

Where:

- K_2 = Constant, 0.001 g/mg
 m_n = Total mass of particulate matter collected in the sampling train, mg
 $V_{m(std)}$ = Volume of gas sampled corrected to dry standard conditions, dscf

Sample calculation:

For Train A:

$$C_s = 0.001 \times \frac{6.7}{52.28}$$

$$C_s = \mathbf{0.00013} \text{ g/dscf}$$

For Train B:

$$C_s = 0.001 \times \frac{6.8}{50.42}$$

$$C_s = \mathbf{0.00013} \text{ g/dscf}$$

For Ambient Train

$$C_r = 0.001 \times \frac{0.1}{68.36}$$

$$C_r = \mathbf{0.000001} \text{ g/dscf}$$

E_T – Total Particulate Emissions, g
 ASTM E2515 equation (15)

$$E_T = (c_s - c_r) \times Q_{std} \times \theta$$

Where:

- C_s = Concentration of particulate matter in tunnel gas, g/dscf
- C_r = Concentration particulate matter room air, g/dscf
- Q_{std} = Average dilution tunnel gas flow rate, dscf/hr
- θ = Total time of test run, minutes

Sample calculation:

For Train A

$$E_T = (\underline{0.000128} - 0.000001) \times \underline{9803.8} \times \underline{360} / 60$$

$$E_T = \underline{7.45} \text{ g}$$

For Train B

$$E_T = (\underline{0.000135} - 0.000001) \times \underline{9803.8} \times \underline{360} / 60$$

$$E_T = \underline{7.85} \text{ g}$$

Average

$$E = \underline{7.65} \text{ g}$$

Total emission values shall not differ by more than 7.5% from the total average emissions

- 7.5% of the average = 0.57
- Train A difference = 0.20
- Train B difference = 0.20

PR - Proportional Rate Variation

ASTM E2515 equation (16)

$$PR = \left[\frac{\theta \times V_{mi} \times V_s \times T_m \times T_{si}}{\theta_i \times V_m \times V_{si} \times T_{mi} \times T_s} \right] \times 100$$

Where:

- θ = Total sampling time, min
- θ_i = Length of recording interval, min
- V_{mi} = Volume of gas sample measured by the dry gas meter during the "ith" time interval, dcf
- V_m = Volume of gas sample as measured by dry gas meter, dcf
- V_{si} = Average gas velocity in the dilution tunnel during the "ith" time interval, ft/sec
- V_s = Average gas velocity in the dilution tunnel, ft/sec
- T_{mi} = Absolute average dry gas meter temperature during the "ith" time interval, °R
- T_m = Absolute average dry gas meter temperature, °R
- T_{si} = Absolute average gas temperature in the dilution tunnel during the "ith" time interval, °R
- T_s = Absolute average gas temperature in the dilution tunnel, °R

Sample calculation (for the first 1 minute interval of Train A):

$$PR = \left(\frac{360 \times 0.128 \times 15.24 \times (82.9 + 460) \times (#### + 460)}{1 \times 53.61 \times 15.90 \times (107.5 + 460) \times (78.0 + 460)} \right) \times 100$$

$$PR = \underline{84} \%$$

PM_R – Average particulate emissions for full integrated test run, g/hr
ASTM E2779 equation (5)

$$PM_R = 60 (E_T/\theta)$$

Where,

E_T = Total particulate emissions, grams

θ = Total length of full integrated test run, min

Sample Calculation:

$$E_T \text{ (Dual train average)} = 7.65 \text{ g}$$

$$\theta = 360 \text{ min}$$

$$PM_R = 60 \times (7.65 / 360)$$

$$PM_R = 1.28 \text{ g/hr}$$

PM_F – Average particulate emission factor for full integrated test run, g/dry kg of fuel burned
ASTM E2779 equation (6)

$$PM_F = E_T / M_{Bdb}$$

Where,

E_T = Total particulate emissions, grams

M_{Bdb} = Weight of test fuel burned during test run, dry basis, kg

Sample Calculation:

$$E_T \text{ (Dual train average)} = 7.65 \text{ g}$$

$$M_{Bdb} = 5.50 \text{ kg}$$

$$PM_F = 7.65 / 5.50)$$

$$PM_F = \mathbf{1.39} \text{ g/kg}$$



Twin Ports Testing, Inc.
 1301 North 3rd Street
 Superior, WI 54880
 p: 715-392-7114
 p: 800-373-2562
 f: 715-392-7163
 www.twinportstesting.com

Report No: USR:W218-0155-01
Issue No: 1

Analytical Test Report

Client: PFS-TECO
 11785 SE Hwy 212
 Clackamas, OR 97015
Attention: Sebastian Button
PO No: S. Button

Signed: *Stephen Sundeen*
 Stephen Sundeen
 Chemistry Laboratory Manager
 Date of Issue: 2/27/2018
THIS DOCUMENT SHALL NOT BE REPRODUCED EXCEPT IN FULL

Sample Details
Sample Log No: W218-0155-01 **Sample Date:**
Sample Designation: Presto Log - Pure Western Conife **Sample Time:**
Sample Recognized As: Wood Pellets **Arrival Date:** 2/15/2018

Test Results

	METHOD	UNITS	MOISTURE FREE	AS RECEIVED
Moisture Total	ASTM E871	wt. %		3.03
Ash	ASTM D1102	wt. %	0.20	0.19
Volatile Matter	ASTM D3175	wt. %		
Fixed Carbon by Difference	ASTM D3172	wt. %		
Sulfur	ASTM D4239	wt. %	0.006	0.006
SO ₂	Calculated	lb/mmbtu		0.013
Net Cal. Value at Const. Pressure	ISO 1928	GJ/tonne	19.07	18.42
Net Cal. Value at Const. Pressure	ISO 1928	J/g	19075	18424
Gross Cal. Value at Const. Vol.	ASTM E711	J/g	20397	19780
Gross Cal. Value at Const. Vol.	ASTM E711	Btu/lb	8770	8504

Carbon	ASTM D5373	wt. %	50.57	49.04
Hydrogen*	ASTM D5373	wt. %	6.08	5.89
Nitrogen	ASTM D5373	wt. %	< 0.20	< 0.19
Oxygen*	ASTM D3176	wt. %	> 42.95	> 41.65

*Note: As received values do not include hydrogen and oxygen in the total moisture.

Chlorine	ASTM D6721	mg/kg		
Fluorine	ASTM D3761	mg/kg		
Mercury	ASTM D6722	mg/kg		

Bulk Density	ASTM E873	lbs/ft ³		
Fines (Less than 1/8")	TPT CH-P-06	wt. %		
Durability Index	Kansas State	PDI		
Sample Above 1.50"	TPT CH-P-06	wt. %		
Maximum Length (Single Pellet)	TPT CH-P-06	inch		
Diameter, Range	TPT CH-P-05	inch		to
Diameter, Average	TPT CH-P-05	inch		
Stated Bag Weight	TPT CH-P-01	lbs		
Actual Bag Weight	TPT CH-P-01	lbs		

Comments

PELLET TEST DATA PACKET
ASTM E2779/E2515



Run 1 Data Summary

Client: US Stove Company
Model: 6041
Job #: 19-495
Tracking #: 028
Test Date: 7/17/2019

A handwritten signature in black ink, appearing to be "RL", is written above a horizontal line.

Techician Signature

7/22/2019

Date

TEST RESULTS - ASTM E2779 / ASTM E2515

Client: US Stove CompanyModel: 6041Run #: 1Job #: 19-495Tracking #: 028Technician: SJBDate: 7/17/2019

Burn Rate Summary	
High Burn Rate (dry kg/hr)	1.67
Medium Burn Rate (dry kg/hr)	0.79
Low Burn Rate (dry kg/hr)	0.75
Overall Burn Rate (dry kg/hr)	0.92

47.4% of High Burn Rate

44.7% of High Burn Rate

	Ambient Sample	Sample Train A	Sample Train B	1st Hour Filter
Total Sample Volume (ft ³)	70.052	53.610	53.151	8.796
Average Gas Velocity in Dilution Tunnel (ft/sec)	15.2			
Average Gas Flow Rate in Dilution Tunnel (dscf/hr)	9803.8			
Average Gas Meter Temperature (°F)	75.8	82.9	96.4	79.2
Total Sample Volume (dscf)	68.356	52.277	50.416	8.635
Average Tunnel Temperature (°F)	107.5			
Total Time of Test (min)	360			
Total Particulate Catch (mg)	0.1	6.7	6.8	0.3
Particulate Concentration, dry-standard (g/dscf)	0.0000015	0.0001282	0.0001349	0.0000347
Total PM Emissions (g)	0.09	7.45	7.85	0.33
Particulate Emission Rate (g/hr)	0.01	1.24	1.31	0.33
Emissions Factor (g/kg)	-	1.36	1.43	0.20
Difference from Average Total Particulate Emissions (g)	-	0.20	0.20	-
Difference from Average Emissions Factor (g/kg)	-	0.04	0.04	-

Final Average Results	
Total Particulate Emissions (g)	7.65
Particulate Emission Rate (g/hr)	1.28
Emissions Factor (g/kg)	1.39
HHV Efficiency (%)	57.6%
LHV Efficiency (%)	61.5%
CO Emissions (g/min)	0.46

Quality Checks	Requirement	Observed	Result
Dual Train Precision	Each train within 7.5% of average emissions (in grams), or emission factors within 0.5 g/kg	See Above	OK
Filter Temps	<90 °F	80	OK
Face Velocity	< 30 ft/min	8.2	OK
Leakage Rate	Less than 4% of average sample rate	0.002 cfm	OK
Ambient Temp	55-90 °F	Min: 73 / Max: 77	OK
Negative Probe Weight Evaluation	<5% of Total Catch	Probe Catch Not Negative	OK
Pro-Rate Variation	90% of readings between 90-110%; none greater than 120% or less than 80%	See Data Tabs	OK
Medium Burn Rate	< 50% of High	47.4%	OK

Overall Pellet Test Efficiency Results

Manufacturer: US Stove Company
Model: 6041
Date: 07/17/19
Run: 1
Control #: 19-495
Test Duration: 360
Output Category: Integrated

Test Results in Accordance with CSA B415.1-09

	HHV Basis	LHV Basis
Overall Efficiency	57.6%	61.5%
Combustion Efficiency	99.5%	99.5%
Heat Transfer Efficiency	57.9%	61.9%

Output Rate (kJ/h)	10,768	10,214	(Btu/h)
Burn Rate (kg/h)	0.92	2.02	(lb/h)
Input (kJ/h)	18,697	17,736	(Btu/h)

Test Load Weight (dry kg)	5.50	12.12	dry lb
MC wet (%)	3.03		
MC dry (%)	3.12		
Particulate (g)	7.65		
CO (g)	166		
Test Duration (h)	6.00		

Emissions	Particulate	CO
g/MJ Output	0.12	2.57
g/kg Dry Fuel	1.39	30.23
g/h	1.28	27.71
g/min	0.02	0.46
lb/MM Btu Output	0.28	5.98

Air/Fuel Ratio (A/F)	45.90
-----------------------------	-------

VERSION:

2.2

12/14/2009

Max Burn Rate Segment Efficiency Results

Manufacturer: US Stove Company
Model: 6041
Date: 07/17/19
Run: 1
Control #: 19-495
Test Duration: 60
Output Category: Maximum

Test Results in Accordance with CSA B415.1-09

	HHV Basis	LHV Basis
Overall Efficiency	67.4%	72.1%
Combustion Efficiency	99.4%	99.4%
Heat Transfer Efficiency	67.8%	72.5%

Output Rate (kJ/h)	22,992	21,811	(Btu/h)
Burn Rate (kg/h)	1.67	3.69	(lb/h)
Input (kJ/h)	34,103	32,351	(Btu/h)

Test Load Weight (dry kg)	1.67	3.69	dry lb
MC wet (%)	3.03		
MC dry (%)	3.12		
Particulate (g)	N/A		
CO (g)	35		
Test Duration (h)	1.00		

Emissions	Particulate	CO
g/MJ Output	N/A	1.50
g/kg Dry Fuel	N/A	20.64
g/h	N/A	34.50
g/min	N/A	0.58
lb/MM Btu Output	N/A	3.49

Air/Fuel Ratio (A/F)	24.01
-----------------------------	-------

VERSION:

2.2

12/14/2009

Medium Burn Rate Segment Efficiency Results

Manufacturer: US Stove Company
Model: 6041
Date: 07/17/19
Run: 1
Control #: 19-495
Test Duration: 120
Output Category: Medium

Test Results in Accordance with CSA B415.1-09

	HHV Basis	LHV Basis
Overall Efficiency	54.2%	58.0%
Combustion Efficiency	99.5%	99.5%
Heat Transfer Efficiency	54.5%	58.3%

Output Rate (kJ/h)	8,762	8,311	(Btu/h)
Burn Rate (kg/h)	0.79	1.75	(lb/h)
Input (kJ/h)	16,154	15,324	(Btu/h)

Test Load Weight (dry kg)	1.58	3.49	dry lb
MC wet (%)	3.03		
MC dry (%)	3.12		
Particulate (g)	N/A		
CO (g)	57		
Test Duration (h)	2.00		

Emissions	Particulate	CO
g/MJ Output	N/A	3.26
g/kg Dry Fuel	N/A	36.10
g/h	N/A	28.59
g/min	N/A	0.48
lb/MM Btu Output	N/A	7.58

Air/Fuel Ratio (A/F)	49.64
-----------------------------	-------

VERSION:

2.2

12/14/2009

Minimum Burn Rate Segment Efficiency Results

Manufacturer: US Stove Company
Model: 6041
Date: 07/17/19
Run: 1
Control #: 19-495
Test Duration: 180
Output Category: Minimum

Test Results in Accordance with CSA B415.1-09

	HHV Basis	LHV Basis
Overall Efficiency	52.1%	55.7%
Combustion Efficiency	99.5%	99.5%
Heat Transfer Efficiency	52.4%	56.0%

Output Rate (kJ/h)	7,948	7,540	(Btu/h)
Burn Rate (kg/h)	0.75	1.65	(lb/h)
Input (kJ/h)	15,257	14,473	(Btu/h)

Test Load Weight (dry kg)	2.24	4.95	dry lb
MC wet (%)	3.03		
MC dry (%)	3.12		
Particulate (g)	N/A		
CO (g)	75		
Test Duration (h)	3.00		

Emissions	Particulate	CO
g/MJ Output	N/A	3.15
g/kg Dry Fuel	N/A	33.50
g/h	N/A	25.05
g/min	N/A	0.42
lb/MM Btu Output	N/A	7.33

Air/Fuel Ratio (A/F)	61.55
-----------------------------	-------

VERSION:

2.2

12/14/2009

DILUTION TUNNEL & MISC. DATA - ASTM E2779 / E2515

Client: **US Stove Company**
 Model: **6041**
 Run #: **1**
 Test Start Time: **9:08**

Job #: **19-495**
 Tracking #: **028**
 Technician: **SJB**
 Date: **7/17/2019**

High Burn End Time (min): **60**
 Medium Burn End Time (min): **180**
 Total Sampling Time (min): **360**
 Recording Interval (min): **1**

Meter Box γ Factor: **0.999** (A)
 Meter Box γ Factor: **0.996** (B)
 Meter Box γ Factor: **0.992** (Ambient)

Induced Draft Check (in. H₂O): **0**
 Smoke Capture Check (%): **100%**
 Date Flue Pipe Last Cleaned: **7/15/2019**

	Pre-Test	Post Test	Avg.
Barometric Pressure (in. Hg)	29.9	29.86	29.88
Relative Humidity (%)	41.4	33.8	
Room Air Velocity (ft/min)	0	0	
Scale Audit (lbs)	10.0	10.0	
Ambient Sample Volume:		70.052 ft ³	

Sample Train Post-Test Leak Checks

(A)	0.002	cfm @	-13 in. Hg
(B)	0.001	cfm @	-15 in. Hg
(Ambient)	0.003	cfm @	-14 in. Hg

DILUTION TUNNEL FLOW

Traverse Data

Point	dP (in H ₂ O)	Temp (°F)
1	0.038	114
2	0.054	114
3	0.058	114
4	0.040	114
5	0.038	114
6	0.050	114
7	0.054	114
8	0.038	114
Center	0.062	114

Dilution Tunnel H₂O: **2.00** percent
 Tunnel Diameter: **6** inches
 Pitot Tube Cp: **0.99** [unitless]
 Dilution Tunnel MW(dry): **29.00** lb/lb-mole
 Dilution Tunnel MW(wet): **28.78** lb/lb-mole
 Tunnel Area: **0.1963** ft²

V_{strav} : **15.08** ft/sec
 V_{scent} : **17.22** ft/sec
 F_p : **0.876** [ratio]

Initial Tunnel Flow: **157.1** scf/min

Static Pressure: **-0.170** in. H₂O

TEST FUEL PROPERTIES

Default Fuel Values

Fuel Type:	D. Fir	Oak
HHV (kJ/kg)	19,810	19,887
%C	48.73	50
%H	6.87	6.6
%O	43.9	42.9
%Ash	0.5	0.5

Actual Fuel Used Properties

Pellet Brand:	Presto Log
Pellet Fuel Grade:	PFI Premium
HHV (kJ/kg)	20,397
%C	50.57
%H	6.08
%O	43.15
%Ash	0.2
MC (%DB)	3.12

PELLET STOVE PREBURN DATA - ASTM E2779

Client: US Stove CompanyJob #: 19-495Model: 6041Tracking #: 028Run #: 1Technician: SJBDate: 7/17/2019
 Recording Interval (min): 1
 Run Time (min): 60

Average:			-0.044	375	73
Elapsed Time (min)	Scale Reading (lbs)	Weight Change (lbs)	Flue Draft (in H ₂ O)	Flue (°F)	Ambient (°F)
0	45.1	-	-0.019	123	74
1	45.1	0	-0.002	146	74
2	45.0	-0.1	-0.007	170	74
3	45.0	0	-0.017	196	73
4	44.9	-0.1	-0.029	226	73
5	44.8	-0.1	-0.027	256	73
6	44.7	-0.1	-0.036	294	73
7	44.5	-0.2	-0.054	334	73
8	44.3	-0.2	-0.034	360	73
9	44.2	-0.1	-0.043	368	73
10	44.2	0	-0.042	370	73
11	44.1	-0.1	-0.046	367	73
12	44.1	0	-0.042	368	73
13	44.0	-0.1	-0.044	368	73
14	44.0	0	-0.047	372	73
15	43.8	-0.2	-0.051	376	73
16	43.9	0.1	-0.045	379	73
17	43.8	-0.1	-0.041	380	73
18	43.7	-0.1	-0.043	384	73
19	43.7	0	-0.050	385	72
20	43.6	-0.1	-0.039	387	73
21	43.5	-0.1	-0.048	391	73
22	43.5	0	-0.040	390	73
23	43.4	-0.1	-0.063	391	73
24	43.3	-0.1	-0.044	393	73
25	43.2	-0.1	-0.042	396	73
26	43.2	0	-0.054	400	73
27	43.1	-0.1	-0.052	401	73
28	43.1	0	-0.037	401	73
29	43.0	-0.1	-0.047	400	73
30	43.0	0	-0.061	399	73
31	42.9	-0.1	-0.042	399	72
32	42.8	-0.1	-0.050	403	73
33	42.7	-0.1	-0.053	404	73
34	42.6	-0.1	-0.046	407	73
35	42.6	0	-0.041	409	73
36	42.5	-0.1	-0.051	410	73
37	42.4	-0.1	-0.049	411	73
38	42.4	0	-0.046	410	73
39	42.3	-0.1	-0.056	413	73
40	42.2	-0.1	-0.055	412	73
41	42.2	0	-0.036	414	73
42	42.1	-0.1	-0.044	415	74
43	42.0	-0.1	-0.053	416	73
44	42.0	0	-0.045	414	73
45	42.0	0	-0.054	412	73
46	41.9	-0.1	-0.046	412	73

BOX A TEST DATA - ASTM E2779 / ASTM E2515

Client: US Stove CompanyJob #: 19-495Model: 6041Tracking #: 028Run #: 1Technician: SJBDate: 7/17/2019

Elapsed Time (min)	Particulate Sampling Data							Fuel Weight (lb)		Temperature Data (°F)			
	Gas Meter (ft ³)	Sample Rate (cfm)	Dilution Tunnel dP (in H ₂ O)	Orifice dH (in H ₂ O)	Meter Temp (°F)	Meter Vacuum (in Hg)	Pro. Rate (%)	Scale Reading	Weight Change	Dilution Tunnel	Flue	Filter	Ambient
0	0.000		0.060	0.02	78	-0.14		12.5		113	410	75	74
1	0.128	0.128	0.069	2.27	78	-0.9	84	12.5	0.0	113	407	75	73
2	0.273	0.145	0.060	2.26	78	0	102	12.4	-0.1	112	409	75	73
3	0.423	0.150	0.055	2.24	79	-1.02	110	12.3	-0.1	113	412	76	74
4	0.567	0.144	0.056	2.24	79	-2.19	105	12.3	0.0	112	412	75	73
5	0.715	0.148	0.064	2.22	78	0	101	12.2	-0.1	112	411	75	73
6	0.858	0.143	0.061	2.23	79	-2.19	99	12.1	-0.1	112	412	75	73
7	1.007	0.149	0.062	2.21	78	-1.26	103	12.1	0.0	113	411	76	73
8	1.149	0.142	0.064	2.21	78	-1.73	97	12.0	-0.1	113	413	76	73
9	1.298	0.149	0.064	2.20	78	-0.54	101	11.9	-0.1	113	415	76	74
10	1.441	0.143	0.065	2.18	78	0	97	11.7	-0.2	112	416	76	74
11	1.589	0.148	0.070	2.19	79	-0.86	96	11.8	0.1	113	417	76	74
12	1.732	0.143	0.075	2.21	78	-1.24	90	11.7	-0.1	113	418	76	74
13	1.880	0.148	0.069	2.17	78	0	97	11.7	0.0	113	422	76	74
14	2.022	0.142	0.060	2.19	79	-0.28	100	11.5	-0.2	113	421	76	73
15	2.171	0.149	0.064	2.20	78	-2.3	101	11.6	0.1	113	421	76	74
16	2.314	0.143	0.061	2.18	78	-2.23	100	11.5	-0.1	113	417	76	74
17	2.462	0.148	0.067	2.19	79	-2.33	98	11.4	-0.1	113	419	76	74
18	2.605	0.143	0.064	2.16	79	0	97	11.4	0.0	114	422	76	74
19	2.752	0.147	0.066	2.17	79	-0.12	98	11.3	-0.1	113	422	76	74
20	2.895	0.143	0.061	2.18	79	-0.75	100	11.2	-0.1	114	418	76	73
21	3.041	0.146	0.068	2.17	79	-1.29	96	11.2	0.0	113	418	76	74
22	3.185	0.144	0.070	2.18	79	-0.05	94	11.1	-0.1	113	419	76	74
23	3.331	0.146	0.061	2.16	79	-0.16	102	11.0	-0.1	113	421	76	73
24	3.474	0.143	0.062	2.16	80	0	99	11.0	0.0	113	424	76	74
25	3.619	0.145	0.061	2.15	80	0	101	10.9	-0.1	113	426	76	74
26	3.764	0.145	0.060	2.16	79	-0.11	102	10.9	0.0	113	423	76	74
27	3.909	0.145	0.077	2.15	79	-2.12	90	10.8	-0.1	113	422	76	74
28	4.055	0.146	0.066	2.16	80	-2.16	98	10.7	-0.1	114	420	76	74
29	4.199	0.144	0.066	2.13	79	-1.84	96	10.7	0.0	114	418	76	74
30	4.346	0.147	0.068	2.25	79	-0.65	97	10.6	-0.1	113	418	76	74
31	4.494	0.148	0.068	2.24	79	0	98	10.5	-0.1	113	416	76	74
32	4.643	0.149	0.058	2.24	79	0	106	10.5	0.0	112	418	76	74

BOX A TEST DATA - ASTM E2779 / ASTM E2515

Client: US Stove CompanyJob #: 19-495Model: 6041Tracking #: 028Run #: 1Technician: SJBDate: 7/17/2019

Elapsed Time (min)	Particulate Sampling Data							Fuel Weight (lb)		Temperature Data (°F)			
	Gas Meter (ft ³)	Sample Rate (cfm)	Dilution Tunnel dP (in H ₂ O)	Orifice dH (in H ₂ O)	Meter Temp (°F)	Meter Vacuum (in Hg)	Pro. Rate (%)	Scale Reading	Weight Change	Dilution Tunnel	Flue	Filter	Ambient
33	4.790	0.147	0.066	2.26	80	-0.74	98	10.4	-0.1	112	417	76	74
34	4.939	0.149	0.062	2.25	79	0	103	10.3	-0.1	112	422	76	74
35	5.087	0.148	0.066	2.24	79	-1.66	99	10.3	0.0	113	421	77	74
36	5.235	0.148	0.058	2.23	78	-0.16	106	10.1	-0.2	113	423	76	74
37	5.385	0.150	0.061	2.24	79	-1.38	104	10.1	0.0	113	423	76	74
38	5.532	0.147	0.059	2.25	80	-0.17	104	10.1	0.0	113	424	76	75
39	5.681	0.149	0.066	2.25	80	-0.1	100	10.0	-0.1	113	424	76	74
40	5.828	0.147	0.075	2.25	80	0	92	10.0	0.0	113	423	77	74
41	5.978	0.150	0.064	2.24	80	-1.74	102	9.9	-0.1	113	421	77	74
42	6.125	0.147	0.064	2.22	80	-0.55	100	9.8	-0.1	113	423	77	74
43	6.275	0.150	0.064	2.24	79	-0.89	102	9.8	0.0	113	423	77	74
44	6.421	0.146	0.065	2.24	80	-0.82	98	9.7	-0.1	113	425	77	74
45	6.571	0.150	0.060	2.25	80	-1.15	105	9.6	-0.1	113	425	77	74
46	6.716	0.145	0.060	2.25	80	-1.49	102	9.6	0.0	113	424	77	75
47	6.868	0.152	0.061	2.21	80	-1.43	106	9.4	-0.2	113	426	77	74
48	7.013	0.145	0.063	2.22	80	-2.23	99	9.3	-0.1	113	425	77	74
49	7.164	0.151	0.064	2.23	80	0	102	9.3	0.0	113	427	77	75
50	7.309	0.145	0.063	2.23	80	-0.3	99	9.3	0.0	112	427	77	74
51	7.461	0.152	0.055	2.23	80	0	111	9.2	-0.1	112	425	77	75
52	7.607	0.146	0.055	2.24	80	-1.02	107	9.2	0.0	113	424	77	74
53	7.759	0.152	0.066	2.24	80	-2.15	102	9.1	-0.1	113	424	77	75
54	7.905	0.146	0.059	2.23	80	-0.97	103	9.0	-0.1	114	424	77	75
55	8.056	0.151	0.075	2.24	81	-0.04	95	9.0	0.0	114	426	77	75
56	8.202	0.146	0.066	2.22	80	-2.14	98	8.9	-0.1	113	425	77	75
57	8.353	0.151	0.058	2.22	80	-1.81	108	8.8	-0.1	113	423	77	75
58	8.499	0.146	0.059	2.24	80	-0.72	103	8.8	0.0	113	425	77	75
59	8.649	0.150	0.061	2.23	80	-1.63	104	8.7	-0.1	114	423	77	75
60	8.796	0.147	0.063	2.24	80	0	101	8.7	0.0	114	423	77	75
61	8.950	0.154	0.068	2.29	81	-2.21	101	8.7	0.0	114	422	77	75
62	9.099	0.149	0.066	2.24	81	0	99	8.5	-0.2	114	424	77	75
63	9.248	0.149	0.063	2.24	81	-2.02	102	8.5	0.0	114	422	77	75
64	9.398	0.150	0.058	2.24	81	-0.02	107	8.4	-0.1	113	418	77	75
65	9.546	0.148	0.063	2.21	81	-1.08	101	8.4	0.0	112	416	77	75

BOX A TEST DATA - ASTM E2779 / ASTM E2515

Client: US Stove CompanyJob #: 19-495Model: 6041Tracking #: 028Run #: 1Technician: SJBDate: 7/17/2019

Elapsed Time (min)	Particulate Sampling Data							Fuel Weight (lb)		Temperature Data (°F)			
	Gas Meter (ft ³)	Sample Rate (cfm)	Dilution Tunnel dP (in H ₂ O)	Orifice dH (in H ₂ O)	Meter Temp (°F)	Meter Vacuum (in Hg)	Pro. Rate (%)	Scale Reading	Weight Change	Dilution Tunnel	Flue	Filter	Ambient
66	9.697	0.151	0.058	2.23	81	-2.09	107	8.3	-0.1	112	413	77	75
67	9.843	0.146	0.061	2.24	81	-2.2	101	8.4	0.1	112	410	77	75
68	9.995	0.152	0.062	2.23	81	-2.28	104	8.3	-0.1	112	409	77	75
69	10.141	0.146	0.069	2.23	82	-0.67	95	8.3	0.0	112	405	77	75
70	10.292	0.151	0.064	2.22	81	-0.08	102	8.2	-0.1	112	403	77	75
71	10.439	0.147	0.072	2.22	81	0	94	8.2	0.0	111	402	78	75
72	10.592	0.153	0.064	2.24	81	-2.12	104	8.2	0.0	112	397	78	75
73	10.738	0.146	0.063	2.23	81	-0.65	99	8.2	0.0	111	395	78	75
74	10.890	0.152	0.070	2.22	81	-1	98	8.1	-0.1	111	394	78	75
75	11.037	0.147	0.072	2.24	81	-2.29	94	8.1	0.0	111	392	78	75
76	11.188	0.151	0.066	2.25	81	-1.36	101	8.1	0.0	111	391	78	75
77	11.335	0.147	0.060	2.23	81	-0.62	103	8.0	-0.1	110	389	77	75
78	11.486	0.151	0.061	2.24	82	0	104	8.0	0.0	111	384	77	75
79	11.634	0.148	0.067	2.25	81	-1.3	98	8.1	0.1	110	382	78	75
80	11.783	0.149	0.059	2.25	81	-2.08	105	7.9	-0.2	110	383	78	75
81	11.934	0.151	0.065	2.24	82	-2.21	101	7.9	0.0	111	380	78	75
82	12.083	0.149	0.058	2.23	81	-0.96	106	7.8	-0.1	110	380	78	75
83	12.233	0.150	0.064	2.24	81	-0.67	101	7.9	0.1	109	375	78	75
84	12.381	0.148	0.061	2.24	81	-0.07	102	7.7	-0.2	110	372	78	75
85	12.532	0.151	0.069	2.24	81	-0.09	98	7.8	0.1	110	375	78	75
86	12.678	0.146	0.072	2.23	82	-0.92	93	7.7	-0.1	109	373	78	75
87	12.831	0.153	0.063	2.23	82	-0.94	104	7.7	0.0	110	370	78	75
88	12.977	0.146	0.066	2.23	81	-0.02	97	7.8	0.1	110	369	78	75
89	13.129	0.152	0.067	2.24	82	-2.22	100	7.6	-0.2	110	367	78	75
90	13.277	0.148	0.072	2.23	82	0	94	7.6	0.0	110	374	78	75
91	13.429	0.152	0.063	2.22	82	-1.53	103	7.6	0.0	110	373	78	75
92	13.576	0.147	0.062	2.23	82	0	101	7.6	0.0	110	368	78	75
93	13.728	0.152	0.056	2.23	82	-2.2	110	7.6	0.0	110	371	78	75
94	13.875	0.147	0.065	2.22	82	-1.46	98	7.5	-0.1	109	365	78	75
95	14.026	0.151	0.069	2.25	82	-2.21	98	7.5	0.0	109	367	77	75
96	14.174	0.148	0.075	2.25	82	-2.28	92	7.4	-0.1	109	363	78	75
97	14.324	0.150	0.061	2.22	82	-0.03	103	7.4	0.0	109	359	78	75
98	14.474	0.150	0.062	2.22	82	-2.21	103	7.4	0.0	109	357	78	75

BOX A TEST DATA - ASTM E2779 / ASTM E2515

Client: US Stove CompanyJob #: 19-495Model: 6041Tracking #: 028Run #: 1Technician: SJBDate: 7/17/2019

Elapsed Time (min)	Particulate Sampling Data							Fuel Weight (lb)		Temperature Data (°F)			
	Gas Meter (ft ³)	Sample Rate (cfm)	Dilution Tunnel dP (in H ₂ O)	Orifice dH (in H ₂ O)	Meter Temp (°F)	Meter Vacuum (in Hg)	Pro. Rate (%)	Scale Reading	Weight Change	Dilution Tunnel	Flue	Filter	Ambient
99	14.624	0.150	0.057	2.24	82	-1.94	107	7.4	0.0	109	359	78	75
100	14.774	0.150	0.070	2.23	82	-0.76	97	7.3	-0.1	108	355	78	75
101	14.923	0.149	0.067	2.25	82	-2.3	98	7.2	-0.1	109	353	78	75
102	15.074	0.151	0.059	2.26	82	0	106	7.3	0.1	109	348	78	76
103	15.220	0.146	0.065	2.22	82	-2.24	98	7.2	-0.1	109	354	78	76
104	15.373	0.153	0.073	2.22	82	-0.81	96	7.2	0.0	109	350	78	75
105	15.519	0.146	0.068	2.22	82	0	95	7.1	-0.1	109	350	78	76
106	15.672	0.153	0.063	2.24	82	-0.2	104	7.1	0.0	109	351	78	76
107	15.820	0.148	0.073	2.24	82	-1.94	93	7.1	0.0	108	345	78	76
108	15.972	0.152	0.073	2.23	82	-0.59	96	7.1	0.0	108	344	78	76
109	16.120	0.148	0.068	2.24	82	0	97	7.1	0.0	108	340	78	76
110	16.271	0.151	0.068	2.25	82	-2.24	99	7.0	-0.1	108	337	78	76
111	16.419	0.148	0.066	2.24	82	-2.27	98	7.0	0.0	107	338	78	76
112	16.569	0.150	0.071	2.23	82	-2.2	96	7.0	0.0	107	333	78	76
113	16.718	0.149	0.059	2.24	82	-1.31	104	7.0	0.0	107	328	78	76
114	16.869	0.151	0.069	2.21	82	-2.19	98	6.8	-0.2	107	326	78	76
115	17.020	0.151	0.065	2.20	83	-2.08	101	6.9	0.1	107	325	77	76
116	17.168	0.148	0.060	2.23	83	-2.13	103	6.9	0.0	107	322	78	76
117	17.320	0.152	0.064	2.24	82	-0.2	102	6.9	0.0	107	320	78	76
118	17.466	0.146	0.070	2.24	82	-1.86	94	6.8	-0.1	106	317	78	76
119	17.619	0.153	0.068	2.23	82	-0.45	100	6.8	0.0	106	324	78	75
120	17.765	0.146	0.064	2.23	82	-2.13	98	6.9	0.1	106	325	78	76
121	17.918	0.153	0.063	2.23	83	-0.03	103	6.7	-0.2	106	324	78	76
122	18.066	0.148	0.074	2.23	82	-0.75	93	6.7	0.0	107	324	78	76
123	18.218	0.152	0.073	2.22	82	-0.11	96	6.6	-0.1	106	323	78	76
124	18.366	0.148	0.057	2.23	83	0	105	6.7	0.1	107	318	78	76
125	18.517	0.151	0.060	2.23	83	-0.45	105	6.6	-0.1	106	318	78	76
126	18.665	0.148	0.064	2.24	83	0	99	6.6	0.0	106	317	78	76
127	18.816	0.151	0.069	2.25	83	-0.27	98	6.5	-0.1	106	315	78	76
128	18.965	0.149	0.066	2.23	83	0	98	6.5	0.0	107	315	78	76
129	19.115	0.150	0.059	2.25	83	-0.24	105	6.5	0.0	106	314	78	76
130	19.266	0.151	0.065	2.22	83	-2.2	100	6.4	-0.1	106	313	78	75
131	19.415	0.149	0.065	2.23	83	-2.06	99	6.5	0.1	105	313	78	76

BOX A TEST DATA - ASTM E2779 / ASTM E2515

Client: US Stove CompanyJob #: 19-495Model: 6041Tracking #: 028Run #: 1Technician: SJBDate: 7/17/2019

Elapsed Time (min)	Particulate Sampling Data							Fuel Weight (lb)		Temperature Data (°F)			
	Gas Meter (ft ³)	Sample Rate (cfm)	Dilution Tunnel dP (in H ₂ O)	Orifice dH (in H ₂ O)	Meter Temp (°F)	Meter Vacuum (in Hg)	Pro. Rate (%)	Scale Reading	Weight Change	Dilution Tunnel	Flue	Filter	Ambient
132	19.567	0.152	0.067	2.24	83	-0.95	100	6.5	0.0	105	309	78	76
133	19.714	0.147	0.068	2.24	83	0	96	6.4	-0.1	106	310	78	76
134	19.866	0.152	0.052	2.25	83	-2.11	113	6.4	0.0	105	312	78	75
135	20.012	0.146	0.059	2.24	83	-2.27	102	6.3	-0.1	105	311	78	76
136	20.165	0.153	0.069	2.23	83	-2.2	99	6.2	-0.1	105	308	78	76
137	20.313	0.148	0.068	2.24	83	-0.35	96	6.3	0.1	105	305	78	75
138	20.466	0.153	0.064	2.22	83	-1.81	102	6.2	-0.1	105	311	78	76
139	20.613	0.147	0.066	2.21	83	-2.1	97	6.1	-0.1	105	313	78	75
140	20.765	0.152	0.066	2.24	83	-1.31	100	6.2	0.1	105	311	78	75
141	20.912	0.147	0.068	2.23	83	-2.28	96	6.2	0.0	105	310	78	75
142	21.063	0.151	0.063	2.24	83	-0.62	102	6.0	-0.2	105	312	78	75
143	21.212	0.149	0.062	2.24	83	-1.5	101	6.1	0.1	105	310	78	75
144	21.363	0.151	0.055	2.23	83	-2.2	109	6.1	0.0	106	309	78	76
145	21.514	0.151	0.056	2.23	83	-1.05	108	6.1	0.0	106	308	78	75
146	21.663	0.149	0.062	2.23	83	0	101	6.0	-0.1	105	303	78	75
147	21.815	0.152	0.067	2.23	83	0	100	5.9	-0.1	105	303	78	75
148	21.961	0.146	0.060	2.23	83	-1.39	101	6.0	0.1	105	306	78	75
149	22.114	0.153	0.065	2.24	83	-1.53	102	6.0	0.0	105	306	78	75
150	22.260	0.146	0.061	2.24	83	-2.36	100	5.9	-0.1	105	299	78	75
151	22.413	0.153	0.071	2.22	83	-1.66	97	5.9	0.0	105	302	78	76
152	22.561	0.148	0.067	2.23	83	-1.67	97	5.9	0.0	105	308	78	76
153	22.714	0.153	0.066	2.23	83	-2.04	101	5.8	-0.1	105	301	78	75
154	22.862	0.148	0.067	2.23	83	-0.07	97	5.8	0.0	105	302	78	75
155	23.013	0.151	0.061	2.23	83	-1.61	104	5.8	0.0	105	305	78	76
156	23.160	0.147	0.063	2.21	83	-0.42	99	5.8	0.0	105	305	78	76
157	23.312	0.152	0.066	2.23	83	-0.2	100	5.7	-0.1	105	299	78	76
158	23.461	0.149	0.063	2.23	83	-0.79	101	5.7	0.0	106	303	78	76
159	23.611	0.150	0.063	2.23	83	0	101	5.6	-0.1	105	303	78	76
160	23.762	0.151	0.060	2.22	83	-2.23	105	5.7	0.1	106	303	78	75
161	23.911	0.149	0.060	2.23	83	-0.86	103	5.6	-0.1	105	304	78	76
162	24.063	0.152	0.067	2.22	83	-2.36	100	5.6	0.0	105	301	78	76
163	24.209	0.146	0.062	2.23	83	-1.1	99	5.6	0.0	105	303	78	76
164	24.362	0.153	0.071	2.25	83	-1.15	97	5.5	-0.1	106	304	78	76

BOX A TEST DATA - ASTM E2779 / ASTM E2515

Client: US Stove CompanyJob #: 19-495Model: 6041Tracking #: 028Run #: 1Technician: SJBDate: 7/17/2019

Elapsed Time (min)	Particulate Sampling Data							Fuel Weight (lb)		Temperature Data (°F)			
	Gas Meter (ft ³)	Sample Rate (cfm)	Dilution Tunnel dP (in H ₂ O)	Orifice dH (in H ₂ O)	Meter Temp (°F)	Meter Vacuum (in Hg)	Pro. Rate (%)	Scale Reading	Weight Change	Dilution Tunnel	Flue	Filter	Ambient
165	24.508	0.146	0.061	2.23	83	-1.04	100	5.5	0.0	105	303	78	76
166	24.662	0.154	0.063	2.22	83	0	104	5.5	0.0	105	300	78	76
167	24.809	0.147	0.066	2.22	83	-1.48	97	5.5	0.0	105	301	78	76
168	24.962	0.153	0.067	2.22	83	-2.18	100	5.4	-0.1	105	296	78	76
169	25.110	0.148	0.073	2.25	83	-1.34	93	5.4	0.0	105	296	78	76
170	25.261	0.151	0.071	2.24	83	-0.93	96	5.4	0.0	105	298	78	75
171	25.409	0.148	0.059	2.23	83	-2.28	103	5.3	-0.1	105	304	79	76
172	25.560	0.151	0.064	2.23	83	-0.69	101	5.3	0.0	105	304	79	75
173	25.709	0.149	0.065	2.23	83	-2.27	99	5.3	0.0	105	302	78	75
174	25.859	0.150	0.070	2.23	83	-1.72	96	5.3	0.0	105	304	78	75
175	26.010	0.151	0.063	2.22	83	-1.31	102	5.2	-0.1	105	302	79	76
176	26.159	0.149	0.066	2.23	83	-2.35	98	5.2	0.0	105	300	79	76
177	26.311	0.152	0.063	2.22	83	-0.38	103	5.2	0.0	105	300	78	75
178	26.457	0.146	0.058	2.24	83	-0.26	103	5.2	0.0	105	300	79	76
179	26.610	0.153	0.065	2.25	83	-2.02	102	5.1	-0.1	105	299	79	76
180	26.756	0.146	0.060	2.24	83	0	101	5.1	0.0	105	294	79	75
181	26.909	0.153	0.069	2.21	83	-1.53	99	5.1	0.0	105	295	79	75
182	27.057	0.148	0.068	2.21	83	-0.01	96	5.0	-0.1	105	297	79	76
183	27.209	0.152	0.062	2.23	83	-0.03	103	5.0	0.0	105	294	79	76
184	27.357	0.148	0.062	2.21	83	-1.42	101	5.0	0.0	105	294	79	76
185	27.508	0.151	0.071	2.22	83	-1.46	96	4.9	-0.1	105	294	79	76
186	27.655	0.147	0.066	2.24	83	-2.21	97	4.9	0.0	105	293	79	76
187	27.807	0.152	0.071	2.23	83	-1.25	97	4.9	0.0	105	301	79	76
188	27.955	0.148	0.058	2.23	83	-2.26	104	4.9	0.0	105	298	79	76
189	28.106	0.151	0.060	2.21	84	-0.95	104	4.8	-0.1	105	295	78	76
190	28.257	0.151	0.060	2.21	83	-0.81	104	4.8	0.0	105	300	78	76
191	28.405	0.148	0.063	2.21	84	-1.1	100	4.8	0.0	105	296	79	76
192	28.557	0.152	0.069	2.20	83	-0.34	98	4.8	0.0	104	294	79	76
193	28.704	0.147	0.056	2.23	84	-0.3	105	4.7	-0.1	105	296	79	76
194	28.855	0.151	0.064	2.21	83	-0.05	101	4.7	0.0	104	299	79	76
195	29.002	0.147	0.061	2.22	84	-0.31	101	4.7	0.0	104	296	79	76
196	29.154	0.152	0.071	2.21	84	-2.12	96	4.6	-0.1	105	297	79	76
197	29.302	0.148	0.073	2.22	84	-0.96	93	4.6	0.0	105	296	79	76

BOX A TEST DATA - ASTM E2779 / ASTM E2515

Client: US Stove CompanyJob #: 19-495Model: 6041Tracking #: 028Run #: 1Technician: SJBDate: 7/17/2019

Elapsed Time (min)	Particulate Sampling Data							Fuel Weight (lb)		Temperature Data (°F)			
	Gas Meter (ft ³)	Sample Rate (cfm)	Dilution Tunnel dP (in H ₂ O)	Orifice dH (in H ₂ O)	Meter Temp (°F)	Meter Vacuum (in Hg)	Pro. Rate (%)	Scale Reading	Weight Change	Dilution Tunnel	Flue	Filter	Ambient
198	29.454	0.152	0.067	2.21	84	0	99	4.6	0.0	105	298	79	76
199	29.601	0.147	0.061	2.21	84	-0.69	101	4.6	0.0	105	293	79	76
200	29.754	0.153	0.071	2.20	84	0	97	4.6	0.0	105	295	79	76
201	29.901	0.147	0.063	2.23	84	-0.17	99	4.5	-0.1	104	292	79	76
202	30.051	0.150	0.066	2.22	84	-0.72	99	4.5	0.0	104	292	79	76
203	30.200	0.149	0.055	2.22	84	-2.21	107	4.5	0.0	105	292	79	76
204	30.349	0.149	0.057	2.21	84	-1.94	106	4.5	0.0	105	290	79	76
205	30.499	0.150	0.066	2.20	84	-2.21	99	4.4	-0.1	104	293	79	76
206	30.649	0.150	0.062	2.20	84	0	102	4.4	0.0	105	293	79	76
207	30.800	0.151	0.061	2.20	84	-2.15	103	4.4	0.0	105	294	79	76
208	30.948	0.148	0.061	2.21	84	-2.29	101	4.2	-0.2	105	296	79	76
209	31.099	0.151	0.062	2.21	84	-0.74	103	4.2	0.0	105	298	79	76
210	31.246	0.147	0.061	2.23	84	0	101	4.3	0.1	105	297	79	76
211	31.398	0.152	0.070	2.21	84	-1.18	97	4.2	-0.1	105	295	79	76
212	31.544	0.146	0.071	2.21	84	-1.4	93	4.2	0.0	105	296	79	76
213	31.696	0.152	0.056	2.21	84	-0.02	109	4.2	0.0	105	299	79	76
214	31.843	0.147	0.061	2.20	84	-2.32	101	4.1	-0.1	105	300	79	76
215	31.996	0.153	0.061	2.20	84	0	105	4.1	0.0	105	300	79	76
216	32.142	0.146	0.065	2.22	84	-0.13	97	4.1	0.0	105	296	79	76
217	32.295	0.153	0.057	2.20	84	-0.79	108	4.1	0.0	105	298	79	76
218	32.441	0.146	0.061	2.21	84	-0.37	100	3.9	-0.2	105	303	79	76
219	32.592	0.151	0.070	2.21	84	0	97	4.0	0.1	106	304	79	76
220	32.740	0.148	0.063	2.22	84	-2.44	100	4.0	0.0	106	303	79	76
221	32.891	0.151	0.067	2.21	84	-0.36	99	4.0	0.0	106	303	79	76
222	33.040	0.149	0.066	2.19	84	-0.02	98	3.9	-0.1	105	303	79	76
223	33.190	0.150	0.064	2.18	84	-1.53	100	3.9	0.0	105	302	79	76
224	33.340	0.150	0.065	2.20	84	-0.67	100	3.9	0.0	105	299	79	76
225	33.488	0.148	0.061	2.20	84	-0.05	101	3.8	-0.1	105	297	79	76
226	33.639	0.151	0.072	2.17	85	-0.19	95	3.6	-0.2	105	299	79	76
227	33.786	0.147	0.068	2.22	84	-2.26	95	3.8	0.2	105	296	79	76
228	33.937	0.151	0.063	2.22	84	-0.05	102	3.8	0.0	105	290	79	76
229	34.084	0.147	0.065	2.21	85	-0.05	97	3.7	-0.1	105	296	79	77
230	34.236	0.152	0.053	2.20	84	-1.79	112	3.7	0.0	105	296	79	76

BOX A TEST DATA - ASTM E2779 / ASTM E2515

Client: US Stove CompanyJob #: 19-495Model: 6041Tracking #: 028Run #: 1Technician: SJBDate: 7/17/2019

Elapsed Time (min)	Particulate Sampling Data							Fuel Weight (lb)		Temperature Data (°F)			
	Gas Meter (ft ³)	Sample Rate (cfm)	Dilution Tunnel dP (in H ₂ O)	Orifice dH (in H ₂ O)	Meter Temp (°F)	Meter Vacuum (in Hg)	Pro. Rate (%)	Scale Reading	Weight Change	Dilution Tunnel	Flue	Filter	Ambient
231	34.382	0.146	0.067	2.20	84	-2.35	95	3.7	0.0	104	293	79	77
232	34.535	0.153	0.064	2.19	85	0	102	3.7	0.0	104	295	79	76
233	34.682	0.147	0.053	2.18	85	-0.39	108	3.6	-0.1	104	293	79	77
234	34.833	0.151	0.073	2.19	84	-0.57	95	3.6	0.0	105	295	79	77
235	34.980	0.147	0.068	2.19	85	-0.18	95	3.5	-0.1	105	296	79	77
236	35.132	0.152	0.063	2.19	85	-2.34	102	3.5	0.0	105	300	79	77
237	35.278	0.146	0.071	2.21	84	-2.35	93	3.5	0.0	105	300	79	77
238	35.429	0.151	0.066	2.18	84	-0.16	99	3.5	0.0	105	299	79	77
239	35.577	0.148	0.060	2.18	84	-2.13	102	3.3	-0.2	105	299	79	77
240	35.726	0.149	0.060	2.21	84	0	103	3.4	0.1	105	299	79	77
241	35.875	0.149	0.053	2.19	84	-0.76	109	3.4	0.0	105	292	79	77
242	36.025	0.150	0.065	2.19	84	-2.18	100	3.4	0.0	105	297	79	77
243	36.175	0.150	0.057	2.20	84	-0.07	106	3.3	-0.1	106	301	79	77
244	36.323	0.148	0.070	2.18	84	-1.73	95	3.3	0.0	106	300	79	77
245	36.474	0.151	0.060	2.16	84	-0.35	104	3.3	0.0	106	301	79	77
246	36.621	0.147	0.071	2.19	84	-2.26	93	3.2	-0.1	105	296	79	77
247	36.771	0.150	0.067	2.19	85	-2.02	98	3.2	0.0	105	297	79	77
248	36.917	0.146	0.070	2.18	84	-0.44	93	3.2	0.0	106	298	79	77
249	37.069	0.152	0.074	2.19	84	-1.83	95	3.2	0.0	105	297	79	77
250	37.215	0.146	0.067	2.19	85	-2.33	95	3.1	-0.1	106	302	79	77
251	37.367	0.152	0.060	2.18	84	-0.05	105	3.1	0.0	105	301	79	77
252	37.513	0.146	0.071	2.19	84	-0.07	93	3.1	0.0	105	302	79	77
253	37.665	0.152	0.059	2.17	84	-0.72	106	3.0	-0.1	106	304	79	77
254	37.812	0.147	0.068	2.19	84	-2.26	95	3.0	0.0	105	302	79	77
255	37.963	0.151	0.057	2.19	84	-0.15	107	2.9	-0.1	105	306	80	77
256	38.110	0.147	0.064	2.20	85	-0.07	98	2.8	-0.1	106	305	79	77
257	38.260	0.150	0.055	2.20	84	-0.92	108	2.9	0.1	106	305	80	77
258	38.406	0.146	0.065	2.20	85	-0.26	97	2.9	0.0	106	308	79	77
259	38.557	0.151	0.066	2.17	84	-0.39	100	2.8	-0.1	106	306	79	77
260	38.704	0.147	0.063	2.18	85	-2.37	99	2.8	0.0	107	306	79	77
261	38.854	0.150	0.068	2.17	85	-2.07	97	2.8	0.0	106	305	79	77
262	39.002	0.148	0.071	2.18	85	-1.3	94	2.9	0.1	106	305	79	77
263	39.151	0.149	0.063	2.19	84	-0.03	101	2.6	-0.3	106	305	79	77

BOX A TEST DATA - ASTM E2779 / ASTM E2515

Client: US Stove CompanyJob #: 19-495Model: 6041Tracking #: 028Run #: 1Technician: SJBDate: 7/17/2019

Elapsed Time (min)	Particulate Sampling Data							Fuel Weight (lb)		Temperature Data (°F)			
	Gas Meter (ft ³)	Sample Rate (cfm)	Dilution Tunnel dP (in H ₂ O)	Orifice dH (in H ₂ O)	Meter Temp (°F)	Meter Vacuum (in Hg)	Pro. Rate (%)	Scale Reading	Weight Change	Dilution Tunnel	Flue	Filter	Ambient
264	39.301	0.150	0.072	2.16	85	-0.78	94	2.7	0.1	106	306	79	77
265	39.449	0.148	0.061	2.19	85	-1.24	101	2.7	0.0	106	305	79	77
266	39.599	0.150	0.064	2.18	85	-0.55	100	2.7	0.0	106	301	79	77
267	39.747	0.148	0.062	2.18	84	-0.5	101	2.6	-0.1	106	300	80	77
268	39.897	0.150	0.065	2.18	85	-2.27	99	2.6	0.0	106	303	80	77
269	40.042	0.145	0.062	2.18	84	-0.16	99	2.6	0.0	106	299	80	77
270	40.193	0.151	0.068	2.18	85	-2.2	98	2.6	0.0	106	297	79	77
271	40.339	0.146	0.061	2.18	85	-0.3	100	2.5	-0.1	106	295	80	77
272	40.490	0.151	0.058	2.18	85	-0.65	106	2.5	0.0	106	301	80	77
273	40.636	0.146	0.067	2.17	85	-0.71	95	2.4	-0.1	105	297	80	77
274	40.788	0.152	0.057	2.18	86	-0.5	107	2.4	0.0	105	297	80	77
275	40.934	0.146	0.062	2.19	85	-0.01	99	2.4	0.0	106	298	80	77
276	41.085	0.151	0.061	2.16	85	-1.56	103	2.4	0.0	106	300	80	77
277	41.231	0.146	0.060	2.17	85	-0.12	101	2.3	-0.1	106	302	80	77
278	41.382	0.151	0.072	2.19	85	-0.63	95	2.3	0.0	106	307	80	77
279	41.529	0.147	0.071	2.15	85	-2.36	93	2.3	0.0	106	306	80	77
280	41.679	0.150	0.057	2.18	85	-0.96	106	2.3	0.0	106	306	80	77
281	41.825	0.146	0.066	2.17	85	-2.28	96	2.2	-0.1	106	303	80	77
282	41.975	0.150	0.060	2.19	85	-0.15	103	2.2	0.0	106	299	80	77
283	42.122	0.147	0.059	2.15	85	-2.31	102	2.2	0.0	106	301	80	77
284	42.272	0.150	0.060	2.18	85	-0.21	104	2.1	-0.1	107	304	80	77
285	42.419	0.147	0.064	2.17	85	-0.17	98	2.1	0.0	107	302	80	77
286	42.568	0.149	0.067	2.16	85	-0.04	97	2.1	0.0	107	302	80	77
287	42.716	0.148	0.065	2.16	85	-1.44	98	2.0	-0.1	106	300	80	77
288	42.865	0.149	0.068	2.17	85	-2.39	97	2.0	0.0	107	300	80	77
289	43.014	0.149	0.063	2.17	85	-1.12	100	2.0	0.0	106	300	80	77
290	43.162	0.148	0.056	2.17	85	-1.39	106	1.9	-0.1	106	300	80	77
291	43.311	0.149	0.059	2.16	85	-0.84	104	1.9	0.0	106	306	80	77
292	43.458	0.147	0.061	2.16	85	-0.4	101	1.9	0.0	106	300	80	77
293	43.609	0.151	0.063	2.16	85	-0.33	102	1.9	0.0	105	295	80	77
294	43.755	0.146	0.060	2.17	86	-0.79	101	1.8	-0.1	106	299	80	77
295	43.905	0.150	0.058	2.23	85	-2.33	105	1.8	0.0	106	298	80	77
296	44.053	0.148	0.065	2.23	85	-1.52	98	1.8	0.0	106	296	80	77

BOX A TEST DATA - ASTM E2779 / ASTM E2515

Client: US Stove CompanyJob #: 19-495Model: 6041Tracking #: 028Run #: 1Technician: SJBDate: 7/17/2019

Elapsed Time (min)	Particulate Sampling Data							Fuel Weight (lb)		Temperature Data (°F)			
	Gas Meter (ft ³)	Sample Rate (cfm)	Dilution Tunnel dP (in H ₂ O)	Orifice dH (in H ₂ O)	Meter Temp (°F)	Meter Vacuum (in Hg)	Pro. Rate (%)	Scale Reading	Weight Change	Dilution Tunnel	Flue	Filter	Ambient
297	44.205	0.152	0.063	2.23	85	-2.46	102	1.7	-0.1	106	299	80	77
298	44.352	0.147	0.068	2.22	85	-2.23	95	1.7	0.0	105	301	80	77
299	44.505	0.153	0.058	2.21	85	-2.33	107	1.7	0.0	106	306	80	77
300	44.652	0.147	0.061	2.21	85	-2.39	101	1.6	-0.1	107	304	80	77
301	44.805	0.153	0.062	2.20	85	-2.42	104	1.6	0.0	107	303	80	77
302	44.952	0.147	0.070	2.21	85	-0.45	94	1.6	0.0	106	301	80	77
303	45.103	0.151	0.066	2.21	85	-2.49	99	1.5	-0.1	106	299	80	77
304	45.251	0.148	0.060	2.23	85	-0.24	102	1.5	0.0	106	299	80	77
305	45.401	0.150	0.056	2.19	85	-2.55	107	1.5	0.0	106	301	80	77
306	45.550	0.149	0.071	2.21	85	-1.24	94	1.5	0.0	106	295	80	77
307	45.700	0.150	0.061	2.21	85	-0.14	103	1.4	-0.1	106	295	80	77
308	45.851	0.151	0.064	2.21	85	-1.58	101	1.4	0.0	106	301	80	77
309	45.999	0.148	0.061	2.20	86	-0.59	101	1.4	0.0	106	299	80	77
310	46.151	0.152	0.059	2.20	85	-2.23	106	1.4	0.0	106	296	80	77
311	46.297	0.146	0.061	2.22	85	-0.81	100	1.4	0.0	106	303	80	77
312	46.449	0.152	0.066	2.22	85	-1.74	100	1.3	-0.1	106	304	80	77
313	46.596	0.147	0.067	2.21	85	-0.14	96	1.3	0.0	106	300	80	77
314	46.748	0.152	0.058	2.21	85	-0.05	107	1.3	0.0	106	302	80	77
315	46.895	0.147	0.068	2.21	85	-0.57	95	1.2	-0.1	106	302	80	77
316	47.048	0.153	0.060	2.19	85	-2.44	106	1.2	0.0	106	301	80	77
317	47.195	0.147	0.067	2.22	85	-0.48	96	1.2	0.0	106	303	80	77
318	47.347	0.152	0.062	2.22	85	-1.89	103	1.2	0.0	107	305	80	77
319	47.494	0.147	0.055	2.23	85	-0.88	106	1.1	-0.1	107	301	80	77
320	47.644	0.150	0.067	2.22	85	-0.1	98	1.1	0.0	107	303	80	77
321	47.792	0.148	0.060	2.21	85	-2.42	102	1.1	0.0	106	305	80	77
322	47.942	0.150	0.072	2.20	85	-1.7	95	1.0	-0.1	107	303	80	77
323	48.092	0.150	0.062	2.20	85	-0.27	102	1.0	0.0	106	301	80	77
324	48.241	0.149	0.064	2.19	85	-1.78	100	1.0	0.0	106	302	80	77
325	48.392	0.151	0.057	2.20	85	-1.61	107	1.0	0.0	107	305	80	77
326	48.540	0.148	0.070	2.19	85	-1.98	95	0.9	-0.1	106	301	80	77
327	48.692	0.152	0.068	2.20	85	-0.21	99	0.9	0.0	106	304	80	77
328	48.838	0.146	0.066	2.21	85	-2.29	96	0.8	-0.1	106	304	80	77
329	48.989	0.151	0.070	2.17	85	-0.13	96	0.8	0.0	106	300	80	77

BOX A TEST DATA - ASTM E2779 / ASTM E2515

Client: US Stove CompanyJob #: 19-495Model: 6041Tracking #: 028Run #: 1Technician: SJBDate: 7/17/2019

Elapsed Time (min)	Particulate Sampling Data							Fuel Weight (lb)		Temperature Data (°F)			
	Gas Meter (ft ³)	Sample Rate (cfm)	Dilution Tunnel dP (in H ₂ O)	Orifice dH (in H ₂ O)	Meter Temp (°F)	Meter Vacuum (in Hg)	Pro. Rate (%)	Scale Reading	Weight Change	Dilution Tunnel	Flue	Filter	Ambient
330	49.136	0.147	0.069	2.20	85	-1.79	95	0.8	0.0	106	300	80	77
331	49.287	0.151	0.059	2.19	85	-0.24	105	0.7	-0.1	106	298	80	77
332	49.434	0.147	0.067	2.19	85	-0.56	96	0.8	0.1	106	297	80	77
333	49.587	0.153	0.054	2.18	85	-0.25	111	0.7	-0.1	107	300	80	77
334	49.733	0.146	0.060	2.19	85	-0.35	101	0.7	0.0	106	298	80	77
335	49.885	0.152	0.070	2.17	85	-1.9	97	0.7	0.0	106	298	80	77
336	50.033	0.148	0.066	2.20	85	-2.47	97	0.6	-0.1	106	304	80	77
337	50.183	0.150	0.058	2.20	85	-2.3	105	0.6	0.0	107	303	80	77
338	50.330	0.147	0.061	2.21	85	-1.69	101	0.5	-0.1	106	300	80	77
339	50.480	0.150	0.068	2.20	85	-2.46	97	0.5	0.0	106	301	80	77
340	50.628	0.148	0.060	2.19	85	-1.68	102	0.5	0.0	106	297	80	77
341	50.778	0.150	0.061	2.19	85	-1.23	103	0.5	0.0	106	294	80	77
342	50.928	0.150	0.064	2.19	85	-1.85	100	0.5	0.0	106	296	80	77
343	51.077	0.149	0.064	2.19	85	-1.39	100	0.2	-0.3	106	303	80	77
344	51.227	0.150	0.069	2.19	85	-1.29	97	0.4	0.2	106	304	80	77
345	51.374	0.147	0.063	2.18	85	-2.24	99	0.4	0.0	106	303	80	77
346	51.526	0.152	0.070	2.17	85	-0.07	97	0.4	0.0	106	299	80	77
347	51.672	0.146	0.060	2.19	85	-2.21	101	0.3	-0.1	106	302	80	77
348	51.823	0.151	0.065	2.19	85	-2.51	100	0.3	0.0	107	307	80	77
349	51.969	0.146	0.064	2.20	85	-1.77	98	0.3	0.0	107	304	80	77
350	52.120	0.151	0.065	2.18	85	-0.22	100	0.2	-0.1	107	307	80	77
351	52.267	0.147	0.070	2.19	85	-2.38	94	0.2	0.0	107	303	80	77
352	52.420	0.153	0.057	2.17	85	-1.95	108	0.2	0.0	107	299	80	77
353	52.566	0.146	0.059	2.17	85	-2.32	102	0.2	0.0	106	297	80	77
354	52.718	0.152	0.065	2.19	85	-1.64	101	0.1	-0.1	107	301	80	77
355	52.865	0.147	0.066	2.17	85	-0.3	97	0.1	0.0	107	301	80	77
356	53.016	0.151	0.073	2.19	85	-2.23	95	0.1	0.0	107	303	80	77
357	53.162	0.146	0.062	2.19	85	-2.42	99	0.0	-0.1	107	302	80	77
358	53.313	0.151	0.057	2.18	85	-0.42	107	0.0	0.0	106	301	80	77
359	53.461	0.148	0.073	2.19	85	-1.5	93	0.0	0.0	107	299	80	77
360	53.610	0.149	0.066	2.19	85	-1.42	98	0.0	0.0	106	301	80	77
Avg/Tot	53.610	0.149	0.064	2.21	83	-1.11	100			108	333	78	76

BOX B TEST DATA - ASTM E2779 / ASTM E2515

Client: US Stove CompanyJob #: 19-495Model: 6041Tracking #: 028Run #: 1Technician: SJBDate: 7/17/2019

Elapsed Time (min)	Particulate Sampling Data							Flue Gas Data		
	Gas Meter (ft ³)	Sample Rate (cfm)	Orifice dH (in H ₂ O)	Meter Temp (°F)	Meter Vacuum (in Hg)	Pro. Rate (%)	Filter (°F)	Flue Draft (in H ₂ O)	CO ₂ (%)	CO (%)
0	0.000		0.00	78	-1		75	0.000	4.79	0.08
1	0.120	0.120	2.25	78	-2.48	81	75	-0.060	4.21	0.06
2	0.265	0.145	2.22	78	-0.74	105	76	-0.060	4.47	0.09
3	0.411	0.146	2.22	78	-1.04	111	77	-0.060	5.03	0.06
4	0.554	0.143	2.21	78	-0.84	108	77	-0.050	4.89	0.04
5	0.701	0.147	2.21	78	-2.41	103	76	-0.040	4.68	0.08
6	0.844	0.143	2.18	78	-0.77	103	76	-0.040	4.70	0.07
7	0.991	0.147	2.19	79	-2.42	105	76	-0.050	4.65	0.07
8	1.134	0.143	2.19	79	-0.96	100	75	-0.060	5.42	0.07
9	1.280	0.146	2.18	79	-2.31	103	75	-0.050	4.92	0.11
10	1.422	0.142	2.18	79	-1.81	99	75	-0.050	5.77	0.04
11	1.568	0.146	2.17	79	-1.16	98	76	-0.050	5.07	0.06
12	1.709	0.141	2.18	80	-0.82	91	77	-0.050	4.78	0.09
13	1.855	0.146	2.16	80	-1.63	99	77	-0.050	5.60	0.05
14	1.997	0.142	2.17	80	-0.74	103	77	-0.050	4.99	0.05
15	2.143	0.146	2.15	80	-0.98	102	76	-0.060	5.01	0.07
16	2.286	0.143	2.17	80	-1.55	103	76	-0.050	4.45	0.08
17	2.431	0.145	2.18	81	-1.54	99	75	-0.050	5.09	0.06
18	2.574	0.143	2.17	81	-1.99	100	75	-0.070	5.18	0.04
19	2.718	0.144	2.15	81	-2.28	99	75	-0.050	5.70	0.08
20	2.861	0.143	2.16	82	-1.04	102	75	-0.060	4.37	0.08
21	3.004	0.143	2.14	82	-2.16	97	77	-0.050	4.66	0.09
22	3.149	0.145	2.14	82	-2.08	97	77	-0.050	5.31	0.09
23	3.291	0.142	2.14	82	-0.8	102	77	-0.060	5.20	0.11
24	3.437	0.146	2.15	83	-0.67	103	77	-0.050	5.05	0.11
25	3.579	0.142	2.15	83	-0.95	101	76	-0.050	5.56	0.11
26	3.725	0.146	2.15	83	-0.79	105	76	-0.060	4.30	0.10
27	3.866	0.141	2.14	84	-2.09	89	75	-0.050	4.33	0.10
28	4.012	0.146	2.15	84	-1.88	100	75	-0.050	4.77	0.08
29	4.153	0.141	2.13	84	-1.76	97	75	-0.050	4.50	0.07
30	4.299	0.146	2.15	84	-1.92	99	75	-0.050	4.97	0.09
31	4.441	0.142	2.14	85	-1.64	96	76	-0.050	4.22	0.09

BOX B TEST DATA - ASTM E2779 / ASTM E2515

Client: US Stove CompanyJob #: 19-495Model: 6041Tracking #: 028Run #: 1Technician: SJBDate: 7/17/2019

Elapsed Time (min)	Particulate Sampling Data							Flue Gas Data		
	Gas Meter (ft ³)	Sample Rate (cfm)	Orifice dH (in H ₂ O)	Meter Temp (°F)	Meter Vacuum (in Hg)	Pro. Rate (%)	Filter (°F)	Flue Draft (in H ₂ O)	CO ₂ (%)	CO (%)
32	4.587	0.146	2.15	85	-1.02	106	77	-0.050	5.52	0.09
33	4.730	0.143	2.15	85	-0.94	98	77	-0.060	4.81	0.08
34	4.875	0.145	2.15	86	-2.37	102	77	-0.050	5.53	0.10
35	5.018	0.143	2.14	86	-1.58	98	76	-0.060	5.17	0.09
36	5.162	0.144	2.13	86	-2.44	105	76	-0.050	5.28	0.06
37	5.306	0.144	2.13	86	-2.46	102	76	-0.060	5.23	0.08
38	5.449	0.143	2.13	87	-0.93	103	75	-0.050	5.33	0.11
39	5.594	0.145	2.14	87	-0.75	99	75	-0.050	5.06	0.12
40	5.737	0.143	2.14	87	-1.77	91	75	-0.040	5.18	0.05
41	5.882	0.145	2.14	87	-0.71	100	76	-0.050	4.59	0.13
42	6.025	0.143	2.14	88	-2.45	99	77	-0.070	5.21	0.11
43	6.172	0.147	2.15	88	-2.43	102	77	-0.040	5.51	0.07
44	6.313	0.141	2.14	88	-0.8	97	77	-0.050	6.12	0.06
45	6.460	0.147	2.14	88	-2.44	105	76	-0.050	5.24	0.09
46	6.601	0.141	2.13	89	-2.43	100	76	-0.040	4.93	0.08
47	6.748	0.147	2.14	89	-1.61	104	76	-0.050	5.26	0.09
48	6.889	0.141	2.12	89	-1.25	98	75	-0.040	5.10	0.06
49	7.036	0.147	2.14	89	-1.37	101	75	-0.060	5.80	0.08
50	7.179	0.143	2.13	89	-0.78	99	75	-0.050	5.05	0.09
51	7.325	0.146	2.12	90	-2.42	108	75	-0.040	4.76	0.09
52	7.468	0.143	2.14	90	-1.36	106	77	-0.040	4.84	0.10
53	7.614	0.146	2.14	90	-0.79	99	77	-0.050	5.09	0.11
54	7.758	0.144	2.15	90	-1.84	103	77	-0.060	4.42	0.17
55	7.903	0.145	2.13	90	-1.97	92	77	-0.050	5.81	0.09
56	8.047	0.144	2.13	91	-2.44	97	76	-0.040	4.65	0.13
57	8.191	0.144	2.14	91	-1.77	104	76	-0.070	4.66	0.10
58	8.336	0.145	2.13	91	-2.31	104	76	-0.060	5.37	0.08
59	8.479	0.143	2.12	91	-2.45	101	75	-0.050	4.71	0.09
60	8.624	0.145	2.13	91	-0.72	101	75	-0.050	5.11	0.08
61	8.768	0.144	2.13	92	-1.58	96	75	-0.050	4.50	0.12
62	8.916	0.148	2.25	92	-1.53	100	76	-0.050	4.64	0.08
63	9.063	0.147	2.24	92	-2.04	102	77	-0.060	4.53	0.11

BOX B TEST DATA - ASTM E2779 / ASTM E2515

Client: US Stove CompanyJob #: 19-495Model: 6041Tracking #: 028Run #: 1Technician: SJBDate: 7/17/2019

Elapsed Time (min)	Particulate Sampling Data							Flue Gas Data		
	Gas Meter (ft ³)	Sample Rate (cfm)	Orifice dH (in H ₂ O)	Meter Temp (°F)	Meter Vacuum (in Hg)	Pro. Rate (%)	Filter (°F)	Flue Draft (in H ₂ O)	CO ₂ (%)	CO (%)
64	9.213	0.150	2.23	92	-0.74	108	77	-0.050	3.57	0.13
65	9.361	0.148	2.24	92	-2.49	102	77	-0.050	4.15	0.10
66	9.510	0.149	2.24	92	-1.73	107	77	-0.050	3.38	0.06
67	9.659	0.149	2.25	92	-1.71	105	76	-0.050	3.30	0.12
68	9.807	0.148	2.24	93	-2.31	103	76	-0.050	3.59	0.07
69	9.956	0.149	2.24	93	-1.78	98	76	-0.050	3.20	0.07
70	10.104	0.148	2.26	93	-1.01	101	75	-0.050	3.77	0.05
71	10.254	0.150	2.25	93	-1.98	97	75	-0.050	3.45	0.10
72	10.400	0.146	2.26	93	-0.75	100	75	-0.050	2.93	0.10
73	10.550	0.150	2.25	93	-1.94	103	75	-0.050	3.52	0.06
74	10.697	0.147	2.26	93	-0.86	96	77	-0.060	3.58	0.08
75	10.848	0.151	2.24	93	-2.06	97	77	-0.060	2.80	0.09
76	10.994	0.146	2.25	94	-2.26	98	77	-0.050	3.00	0.08
77	11.145	0.151	2.24	94	-1.94	106	76	-0.050	3.15	0.07
78	11.292	0.147	2.24	94	-1.95	103	76	-0.060	2.94	0.10
79	11.443	0.151	2.25	94	-0.98	101	76	-0.050	2.76	0.06
80	11.590	0.147	2.25	94	-1.08	104	76	-0.050	3.66	0.11
81	11.741	0.151	2.24	94	-0.81	102	75	-0.040	2.66	0.11
82	11.888	0.147	2.26	94	-1.64	105	75	-0.040	3.06	0.07
83	12.038	0.150	2.24	94	-2.4	102	75	-0.050	2.86	0.10
84	12.184	0.146	2.24	94	-2.04	102	76	-0.050	2.32	0.11
85	12.335	0.151	2.23	95	-2.5	99	77	-0.050	3.18	0.04
86	12.482	0.147	2.25	95	-0.77	94	77	-0.040	3.05	0.07
87	12.632	0.150	2.25	95	-2.44	103	77	-0.050	2.48	0.08
88	12.780	0.148	2.24	95	-0.98	99	76	-0.050	2.65	0.07
89	12.930	0.150	2.26	95	-1.83	100	76	-0.060	2.87	0.05
90	13.079	0.149	2.24	95	-0.88	96	76	-0.040	3.06	0.05
91	13.228	0.149	2.24	95	-1.78	102	75	-0.050	2.63	0.09
92	13.377	0.149	2.25	95	-0.84	103	75	-0.050	2.33	0.11
93	13.526	0.149	2.27	95	-2.37	108	75	-0.040	2.91	0.08
94	13.675	0.149	2.24	95	-1.94	101	76	-0.040	2.52	0.07
95	13.822	0.147	2.25	95	-2.14	96	77	-0.040	2.84	0.08

BOX B TEST DATA - ASTM E2779 / ASTM E2515

Client: US Stove CompanyJob #: 19-495Model: 6041Tracking #: 028Run #: 1Technician: SJBDate: 7/17/2019

Elapsed Time (min)	Particulate Sampling Data							Flue Gas Data		
	Gas Meter (ft ³)	Sample Rate (cfm)	Orifice dH (in H ₂ O)	Meter Temp (°F)	Meter Vacuum (in Hg)	Pro. Rate (%)	Filter (°F)	Flue Draft (in H ₂ O)	CO ₂ (%)	CO (%)
96	13.973	0.151	2.24	95	-1.78	95	77	-0.040	2.70	0.08
97	14.120	0.147	2.24	96	-2.38	102	77	-0.040	2.34	0.05
98	14.271	0.151	2.24	96	-1.05	104	76	-0.040	2.03	0.06
99	14.418	0.147	2.25	96	-1.14	106	76	-0.040	2.75	0.10
100	14.569	0.151	2.25	96	-1.33	98	76	-0.050	2.46	0.07
101	14.716	0.147	2.24	96	-2.48	98	76	-0.040	2.17	0.10
102	14.867	0.151	2.24	96	-1.81	107	75	-0.060	2.15	0.09
103	15.014	0.147	2.22	96	-1.3	99	75	-0.040	2.92	0.04
104	15.166	0.152	2.25	96	-1.82	97	75	-0.040	2.26	0.09
105	15.312	0.146	2.24	96	-2.44	96	76	-0.040	2.97	0.06
106	15.463	0.151	2.23	96	-1.62	103	77	-0.040	2.40	0.09
107	15.610	0.147	2.24	96	-1.93	93	77	-0.040	2.00	0.10
108	15.760	0.150	2.25	96	-1.94	95	77	-0.040	1.98	0.09
109	15.908	0.148	2.23	96	-1.83	97	77	-0.040	2.24	0.05
110	16.059	0.151	2.23	97	-2.52	99	76	-0.040	1.85	0.06
111	16.208	0.149	2.25	97	-2.51	99	76	-0.050	2.25	0.09
112	16.357	0.149	2.24	97	-2.34	96	76	-0.040	1.94	0.10
113	16.507	0.150	2.24	97	-2.43	106	76	-0.040	1.96	0.07
114	16.655	0.148	2.24	97	-2.39	96	75	-0.040	2.14	0.05
115	16.805	0.150	2.23	97	-1.98	101	75	-0.040	2.11	0.06
116	16.952	0.147	2.23	97	-0.84	103	75	-0.030	2.01	0.05
117	17.103	0.151	2.24	97	-2.43	102	76	-0.040	2.01	0.07
118	17.250	0.147	2.24	97	-1.8	95	77	-0.040	1.71	0.07
119	17.401	0.151	2.24	97	-0.82	99	77	-0.040	2.26	0.08
120	17.548	0.147	2.23	97	-2.15	99	77	-0.030	2.38	0.04
121	17.700	0.152	2.22	97	-1.27	104	76	-0.040	2.14	0.07
122	17.847	0.147	2.24	97	-2.14	92	76	-0.040	1.84	0.07
123	17.999	0.152	2.24	97	-1.95	96	76	-0.030	2.19	0.07
124	18.145	0.146	2.23	98	-2.11	104	76	-0.030	2.07	0.05
125	18.296	0.151	2.24	97	-0.81	105	75	-0.030	1.99	0.03
126	18.443	0.147	2.24	97	-1.08	99	75	-0.040	2.21	0.06
127	18.594	0.151	2.24	97	-2.02	98	75	-0.040	1.92	0.11

BOX B TEST DATA - ASTM E2779 / ASTM E2515

Client: US Stove CompanyJob #: 19-495Model: 6041Tracking #: 028Run #: 1Technician: SJBDate: 7/17/2019

Elapsed Time (min)	Particulate Sampling Data							Flue Gas Data		
	Gas Meter (ft ³)	Sample Rate (cfm)	Orifice dH (in H ₂ O)	Meter Temp (°F)	Meter Vacuum (in Hg)	Pro. Rate (%)	Filter (°F)	Flue Draft (in H ₂ O)	CO ₂ (%)	CO (%)
128	18.741	0.147	2.24	98	-1.93	98	75	-0.030	1.73	0.04
129	18.892	0.151	2.24	98	-2.51	106	76	-0.040	2.45	0.03
130	19.041	0.149	2.23	98	-2.26	100	77	-0.020	1.99	0.07
131	19.190	0.149	2.24	98	-2.3	100	77	-0.040	2.22	0.08
132	19.340	0.150	2.24	98	-2.43	99	76	-0.030	1.51	0.08
133	19.489	0.149	2.24	98	-2.2	97	76	-0.030	2.05	0.03
134	19.639	0.150	2.24	98	-0.82	112	76	-0.040	1.88	0.07
135	19.786	0.147	2.24	98	-1.4	103	76	-0.040	2.31	0.05
136	19.937	0.151	2.24	98	-2.44	98	76	-0.030	1.63	0.06
137	20.084	0.147	2.23	98	-2.38	96	75	-0.030	1.55	0.09
138	20.235	0.151	2.22	98	-2.06	102	75	-0.050	2.46	0.07
139	20.383	0.148	2.25	98	-1.05	98	75	-0.040	2.29	0.03
140	20.535	0.152	2.24	98	-0.84	101	77	-0.040	1.97	0.10
141	20.681	0.146	2.24	98	-2.46	95	77	-0.050	1.78	0.09
142	20.833	0.152	2.23	98	-0.95	103	77	-0.040	1.96	0.09
143	20.980	0.147	2.24	98	-1.84	101	77	-0.060	1.79	0.10
144	21.130	0.150	2.24	98	-1.09	109	77	-0.040	1.96	0.05
145	21.278	0.148	2.24	98	-1.48	107	76	-0.030	2.07	0.07
146	21.428	0.150	2.24	98	-0.82	103	76	-0.040	1.79	0.07
147	21.576	0.148	2.22	98	-2.32	97	76	-0.040	1.76	0.07
148	21.727	0.151	2.24	98	-2.03	105	75	-0.030	2.38	0.06
149	21.876	0.149	2.24	98	-2.48	100	75	-0.030	2.29	0.06
150	22.025	0.149	2.24	98	-2.05	103	75	-0.040	1.17	0.09
151	22.175	0.150	2.23	98	-1.2	96	76	-0.040	1.86	0.10
152	22.324	0.149	2.24	99	-2.54	98	77	-0.030	2.69	0.04
153	22.474	0.150	2.24	98	-2.35	100	77	-0.050	1.40	0.08
154	22.621	0.147	2.22	98	-0.9	97	77	-0.030	2.11	0.06
155	22.772	0.151	2.24	99	-1.03	104	77	-0.040	1.61	0.09
156	22.919	0.147	2.24	99	-1.31	100	76	-0.040	2.42	0.08
157	23.070	0.151	2.23	99	-0.8	100	76	-0.040	1.45	0.10
158	23.217	0.147	2.23	99	-2.1	100	76	-0.040	2.16	0.05
159	23.370	0.153	2.24	99	-2.12	104	75	-0.030	1.93	0.09

BOX B TEST DATA - ASTM E2779 / ASTM E2515

Client: US Stove CompanyJob #: 19-495Model: 6041Tracking #: 028Run #: 1Technician: SJBDate: 7/17/2019

Elapsed Time (min)	Particulate Sampling Data							Flue Gas Data		
	Gas Meter (ft ³)	Sample Rate (cfm)	Orifice dH (in H ₂ O)	Meter Temp (°F)	Meter Vacuum (in Hg)	Pro. Rate (%)	Filter (°F)	Flue Draft (in H ₂ O)	CO ₂ (%)	CO (%)
160	23.516	0.146	2.24	99	-0.94	102	75	-0.040	1.80	0.07
161	23.668	0.152	2.24	99	-2.48	106	75	-0.050	2.13	0.06
162	23.815	0.147	2.24	99	-2.35	97	76	-0.030	1.84	0.08
163	23.965	0.150	2.24	99	-2.42	103	77	-0.050	1.64	0.10
164	24.113	0.148	2.24	99	-1.67	95	77	-0.030	1.94	0.05
165	24.263	0.150	2.24	99	-2.12	103	77	-0.030	2.11	0.05
166	24.411	0.148	2.23	99	-2.53	100	77	-0.030	1.71	0.10
167	24.561	0.150	2.24	99	-1.93	99	76	-0.030	2.45	0.11
168	24.710	0.149	2.22	99	-1.25	98	76	-0.030	1.35	0.08
169	24.860	0.150	2.23	99	-0.83	94	76	-0.050	1.96	0.11
170	25.009	0.149	2.23	99	-2.23	95	75	-0.040	1.92	0.06
171	25.158	0.149	2.24	99	-1.07	104	75	-0.040	2.20	0.08
172	25.308	0.150	2.23	99	-2.02	101	75	-0.040	2.33	0.11
173	25.455	0.147	2.22	99	-1.08	98	75	-0.020	1.52	0.09
174	25.606	0.151	2.23	99	-2.49	97	75	-0.040	1.90	0.03
175	25.752	0.146	2.23	99	-1.05	99	76	-0.030	1.91	0.04
176	25.904	0.152	2.22	99	-2.07	101	77	-0.040	1.80	0.05
177	26.051	0.147	2.24	99	-2.34	100	77	-0.020	1.96	0.08
178	26.203	0.152	2.22	99	-2.5	107	77	-0.040	1.85	0.08
179	26.349	0.146	2.22	99	-1.66	97	76	-0.040	2.03	0.07
180	26.501	0.152	2.22	99	-2.48	106	76	-0.030	1.21	0.09
181	26.648	0.147	2.24	99	-2.26	95	76	-0.030	1.91	0.03
182	26.799	0.151	2.23	99	-1.96	99	75	-0.030	1.73	0.06
183	26.945	0.146	2.24	99	-1.51	100	75	-0.040	1.90	0.08
184	27.096	0.151	2.24	99	-2.47	103	75	-0.030	1.94	0.05
185	27.243	0.147	2.23	99	-0.81	94	75	-0.030	2.00	0.11
186	27.393	0.150	2.22	99	-2.49	99	75	-0.010	1.38	0.10
187	27.542	0.149	2.22	99	-1.91	95	76	-0.030	2.62	0.04
188	27.692	0.150	2.21	99	-2.47	106	77	-0.040	2.28	0.04
189	27.841	0.149	2.23	99	-0.83	104	77	-0.050	1.55	0.07
190	27.989	0.148	2.22	99	-2.47	103	77	-0.030	2.11	0.09
191	28.140	0.151	2.24	99	-1.85	102	77	-0.040	1.92	0.04

BOX B TEST DATA - ASTM E2779 / ASTM E2515

Client: US Stove CompanyJob #: 19-495Model: 6041Tracking #: 028Run #: 1Technician: SJBDate: 7/17/2019

Elapsed Time (min)	Particulate Sampling Data							Flue Gas Data		
	Gas Meter (ft ³)	Sample Rate (cfm)	Orifice dH (in H ₂ O)	Meter Temp (°F)	Meter Vacuum (in Hg)	Pro. Rate (%)	Filter (°F)	Flue Draft (in H ₂ O)	CO ₂ (%)	CO (%)
192	28.287	0.147	2.23	100	-1.72	95	76	-0.040	1.35	0.07
193	28.437	0.150	2.23	99	-2.09	108	76	-0.010	2.20	0.07
194	28.584	0.147	2.22	99	-1.08	99	76	-0.050	2.20	0.09
195	28.735	0.151	2.22	99	-2.49	104	75	-0.050	1.47	0.07
196	28.881	0.146	2.23	100	-2.16	93	75	-0.030	1.86	0.09
197	29.032	0.151	2.22	99	-2.1	95	75	-0.040	1.68	0.08
198	29.179	0.147	2.21	99	-1.91	97	75	-0.030	2.09	0.09
199	29.331	0.152	2.22	100	-2.26	105	75	-0.020	1.68	0.05
200	29.477	0.146	2.22	100	-2.48	93	77	-0.030	1.88	0.07
201	29.629	0.152	2.22	100	-1.32	103	77	-0.040	1.43	0.05
202	29.776	0.147	2.23	100	-1.48	97	77	-0.030	1.88	0.04
203	29.926	0.150	2.22	100	-1.75	109	76	-0.040	1.54	0.07
204	30.072	0.146	2.22	100	-2.49	104	76	-0.030	1.61	0.05
205	30.223	0.151	2.22	100	-2.51	100	76	-0.020	2.07	0.04
206	30.370	0.147	2.22	100	-2.37	100	76	-0.030	2.27	0.05
207	30.520	0.150	2.22	100	-2.02	103	75	-0.030	1.89	0.04
208	30.668	0.148	2.21	100	-1.46	102	75	-0.030	1.89	0.06
209	30.818	0.150	2.22	100	-0.84	102	75	-0.040	2.25	0.06
210	30.967	0.149	2.21	100	-2.52	102	75	-0.040	1.69	0.06
211	31.116	0.149	2.21	100	-1.91	96	76	-0.030	1.91	0.08
212	31.265	0.149	2.21	100	-1.83	95	77	-0.020	1.97	0.04
213	31.413	0.148	2.21	100	-0.9	106	77	-0.030	2.24	0.07
214	31.563	0.150	2.21	100	-0.85	103	77	-0.030	2.03	0.07
215	31.709	0.146	2.21	100	-2.28	100	76	-0.040	1.67	0.05
216	31.859	0.150	2.21	100	-1.2	100	76	-0.030	1.75	0.01
217	32.006	0.147	2.22	100	-1.37	105	76	-0.040	1.68	0.07
218	32.156	0.150	2.21	100	-2.55	103	76	-0.040	2.41	0.09
219	32.303	0.147	2.20	100	-1.15	94	75	-0.020	2.22	0.06
220	32.454	0.151	2.20	100	-0.96	102	75	-0.040	2.05	0.08
221	32.605	0.151	2.21	100	-1.25	99	75	-0.030	2.32	0.03
222	32.756	0.151	2.21	100	-1.03	100	75	-0.030	2.06	0.04
223	32.903	0.147	2.21	100	-2.51	99	75	-0.040	1.90	0.08

BOX B TEST DATA - ASTM E2779 / ASTM E2515

Client: US Stove CompanyJob #: 19-495Model: 6041Tracking #: 028Run #: 1Technician: SJBDate: 7/17/2019

Elapsed Time (min)	Particulate Sampling Data							Flue Gas Data		
	Gas Meter (ft ³)	Sample Rate (cfm)	Orifice dH (in H ₂ O)	Meter Temp (°F)	Meter Vacuum (in Hg)	Pro. Rate (%)	Filter (°F)	Flue Draft (in H ₂ O)	CO ₂ (%)	CO (%)
224	33.054	0.151	2.20	100	-1.97	101	76	-0.040	1.73	0.10
225	33.200	0.146	2.20	100	-2.31	100	77	-0.030	1.79	0.02
226	33.351	0.151	2.22	100	-1.65	96	77	-0.040	1.90	0.06
227	33.497	0.146	2.21	100	-2.37	95	77	-0.030	1.74	0.05
228	33.647	0.150	2.20	100	-1.33	102	76	-0.020	1.03	0.07
229	33.793	0.146	2.20	100	-0.95	97	76	-0.030	2.12	0.07
230	33.944	0.151	2.21	100	-0.91	111	76	-0.040	2.06	0.07
231	34.090	0.146	2.21	100	-0.85	96	76	-0.030	1.41	0.05
232	34.240	0.150	2.21	100	-2.54	101	76	-0.040	1.72	0.08
233	34.388	0.148	2.21	100	-1.08	109	75	-0.040	1.43	0.06
234	34.538	0.150	2.20	100	-2.42	94	75	-0.040	2.07	0.05
235	34.686	0.148	2.20	100	-2.54	96	75	-0.030	2.38	0.04
236	34.835	0.149	2.20	100	-1.39	101	75	-0.030	2.22	0.02
237	34.983	0.148	2.20	100	-2.45	94	75	-0.030	1.99	0.04
238	35.131	0.148	2.17	100	-2.22	98	77	-0.030	1.83	0.00
239	35.281	0.150	2.22	100	-1.94	104	77	-0.040	2.07	0.04
240	35.428	0.147	2.21	100	-1.63	102	77	-0.030	2.36	0.05
241	35.577	0.149	2.21	100	-1.95	110	77	-0.040	1.38	0.06
242	35.724	0.147	2.20	100	-1.05	98	76	-0.040	1.91	0.03
243	35.875	0.151	2.20	100	-1.44	108	76	-0.040	2.23	0.07
244	36.021	0.146	2.20	100	-1.8	94	76	-0.030	2.04	0.10
245	36.171	0.150	2.20	100	-1.87	104	76	-0.030	2.29	0.11
246	36.317	0.146	2.19	100	-1.57	93	75	-0.030	1.45	0.07
247	36.468	0.151	2.20	100	-2.49	99	75	-0.020	1.92	0.05
248	36.614	0.146	2.19	100	-1.91	94	75	-0.020	2.51	0.04
249	36.765	0.151	2.20	100	-1.12	94	75	-0.040	1.62	0.06
250	36.911	0.146	2.19	100	-1.93	96	75	-0.030	2.48	0.03
251	37.061	0.150	2.20	100	-1.09	104	75	-0.030	1.85	0.04
252	37.207	0.146	2.18	100	-1.97	93	75	-0.040	1.77	0.03
253	37.358	0.151	2.21	100	-2.18	106	76	-0.040	2.06	0.07
254	37.504	0.146	2.19	100	-0.93	95	77	-0.030	1.96	0.03
255	37.654	0.150	2.19	100	-1.24	107	77	-0.030	2.68	0.09

BOX B TEST DATA - ASTM E2779 / ASTM E2515

Client: US Stove CompanyJob #: 19-495Model: 6041Tracking #: 028Run #: 1Technician: SJBDate: 7/17/2019

Elapsed Time (min)	Particulate Sampling Data							Flue Gas Data		
	Gas Meter (ft ³)	Sample Rate (cfm)	Orifice dH (in H ₂ O)	Meter Temp (°F)	Meter Vacuum (in Hg)	Pro. Rate (%)	Filter (°F)	Flue Draft (in H ₂ O)	CO ₂ (%)	CO (%)
256	37.800	0.146	2.20	100	-1.38	98	77	-0.030	2.15	0.03
257	37.949	0.149	2.20	100	-1.4	108	76	-0.030	1.88	0.08
258	38.096	0.147	2.20	101	-2.4	98	76	-0.040	2.13	0.05
259	38.246	0.150	2.19	100	-2.53	99	76	-0.040	2.31	0.04
260	38.392	0.146	2.19	100	-1.68	99	76	-0.030	1.91	0.05
261	38.541	0.149	2.19	100	-0.93	97	75	-0.030	1.50	0.07
262	38.689	0.148	2.19	100	-0.97	94	75	-0.040	2.02	0.06
263	38.838	0.149	2.19	100	-0.97	101	75	-0.030	2.16	0.06
264	38.986	0.148	2.18	101	-1.51	94	75	-0.040	1.77	0.03
265	39.135	0.149	2.19	101	-2.58	102	75	-0.030	2.20	0.02
266	39.283	0.148	2.19	101	-2.16	99	76	-0.020	1.68	0.07
267	39.431	0.148	2.19	101	-1.12	101	77	-0.030	1.60	0.04
268	39.580	0.149	2.18	101	-2.58	99	77	-0.030	2.45	0.05
269	39.727	0.147	2.21	101	-2.57	100	77	-0.030	1.80	0.07
270	39.876	0.149	2.19	101	-2.2	97	76	-0.040	1.48	0.06
271	40.023	0.147	2.20	101	-0.87	101	76	-0.040	1.74	0.04
272	40.172	0.149	2.20	101	-2.69	105	76	-0.030	2.07	0.06
273	40.318	0.146	2.18	100	-1.99	96	76	-0.040	1.62	0.05
274	40.468	0.150	2.20	101	-2.59	107	76	-0.030	2.14	0.03
275	40.614	0.146	2.19	101	-1.24	100	75	-0.040	1.99	0.04
276	40.764	0.150	2.19	101	-2.67	103	75	-0.040	2.32	0.06
277	40.910	0.146	2.19	101	-2.61	101	75	-0.040	1.98	0.07
278	41.060	0.150	2.18	101	-0.94	95	75	-0.040	2.32	0.06
279	41.206	0.146	2.17	101	-2.51	93	75	-0.030	2.09	0.07
280	41.357	0.151	2.19	101	-2.15	107	76	-0.030	2.19	0.08
281	41.502	0.145	2.18	101	-2.27	96	77	-0.040	2.09	0.05
282	41.653	0.151	2.18	101	-2.61	105	77	-0.040	1.40	0.04
283	41.798	0.145	2.18	101	-1.2	101	77	-0.040	2.03	0.05
284	41.948	0.150	2.18	101	-2.56	104	77	-0.030	2.70	0.09
285	42.094	0.146	2.18	101	-1.77	98	77	-0.030	1.73	0.04
286	42.244	0.150	2.17	101	-0.92	98	76	-0.040	1.83	0.07
287	42.390	0.146	2.20	101	-2.11	97	76	-0.030	1.79	0.05

BOX B TEST DATA - ASTM E2779 / ASTM E2515

Client: US Stove CompanyJob #: 19-495Model: 6041Tracking #: 028Run #: 1Technician: SJBDate: 7/17/2019

Elapsed Time (min)	Particulate Sampling Data							Flue Gas Data		
	Gas Meter (ft ³)	Sample Rate (cfm)	Orifice dH (in H ₂ O)	Meter Temp (°F)	Meter Vacuum (in Hg)	Pro. Rate (%)	Filter (°F)	Flue Draft (in H ₂ O)	CO ₂ (%)	CO (%)
288	42.540	0.150	2.17	101	-2.66	98	76	-0.030	1.80	0.06
289	42.685	0.145	2.20	101	-2.68	98	76	-0.040	1.98	0.09
290	42.835	0.150	2.19	101	-2.35	108	76	-0.030	1.98	0.04
291	42.980	0.145	2.19	101	-2.55	101	75	-0.040	2.34	0.05
292	43.130	0.150	2.17	101	-2.59	103	75	-0.040	1.53	0.05
293	43.276	0.146	2.19	101	-2.17	99	75	-0.030	1.36	0.09
294	43.426	0.150	2.18	101	-2.69	104	75	-0.030	1.86	0.06
295	43.572	0.146	2.18	101	-1.51	103	76	-0.030	2.04	0.04
296	43.721	0.149	2.19	101	-0.97	99	77	-0.040	1.62	0.07
297	43.867	0.146	2.18	101	-0.96	99	77	-0.020	1.86	0.05
298	44.016	0.149	2.16	101	-1.81	97	77	-0.020	1.92	0.05
299	44.163	0.147	2.17	101	-2.51	104	77	-0.050	2.44	0.06
300	44.312	0.149	2.17	101	-2.62	102	76	-0.030	1.83	0.05
301	44.459	0.147	2.18	101	-2.48	100	76	-0.040	1.78	0.08
302	44.607	0.148	2.17	101	-1.42	95	76	-0.030	2.10	0.02
303	44.755	0.148	2.18	101	-1.54	98	76	-0.040	1.49	0.07
304	44.903	0.148	2.18	101	-2.1	103	76	-0.020	1.91	0.06
305	45.050	0.147	2.16	101	-2.16	105	75	-0.040	2.18	0.03
306	45.198	0.148	2.18	101	-2.37	94	75	-0.040	1.26	0.07
307	45.346	0.148	2.17	101	-1.9	102	75	-0.030	1.36	0.05
308	45.493	0.147	2.16	101	-1.22	99	75	-0.040	2.47	0.04
309	45.642	0.149	2.18	101	-0.91	102	77	-0.030	2.06	0.02
310	45.788	0.146	2.17	101	-1.92	102	77	-0.030	1.45	0.08
311	45.937	0.149	2.18	101	-1.85	102	77	-0.030	2.46	0.06
312	46.083	0.146	2.18	101	-2.58	96	77	-0.040	2.24	0.07
313	46.231	0.148	2.18	101	-1.16	97	77	-0.030	1.76	0.05
314	46.377	0.146	2.19	101	-2.43	103	76	-0.040	1.91	0.03
315	46.526	0.149	2.17	101	-1.32	97	76	-0.030	1.99	0.05
316	46.672	0.146	2.17	101	-2.51	101	76	-0.040	1.93	0.05
317	46.822	0.150	2.18	101	-2.06	98	76	-0.030	2.04	0.07
318	46.967	0.145	2.17	101	-2.44	99	76	-0.030	2.30	0.03
319	47.116	0.149	2.17	101	-1.9	108	75	-0.040	1.43	0.06

BOX B TEST DATA - ASTM E2779 / ASTM E2515

Client: US Stove CompanyJob #: 19-495Model: 6041Tracking #: 028Run #: 1Technician: SJBDate: 7/17/2019

Elapsed Time (min)	Particulate Sampling Data							Flue Gas Data		
	Gas Meter (ft ³)	Sample Rate (cfm)	Orifice dH (in H ₂ O)	Meter Temp (°F)	Meter Vacuum (in Hg)	Pro. Rate (%)	Filter (°F)	Flue Draft (in H ₂ O)	CO ₂ (%)	CO (%)
320	47.262	0.146	2.19	101	-1.76	96	75	-0.040	2.40	0.06
321	47.411	0.149	2.17	101	-2.63	103	75	-0.030	2.33	0.07
322	47.556	0.145	2.16	101	-2.44	92	76	-0.030	1.83	0.03
323	47.706	0.150	2.17	101	-2.31	102	77	-0.040	1.63	0.06
324	47.851	0.145	2.16	101	-2.66	97	77	-0.050	2.21	0.03
325	48.001	0.150	2.17	101	-1.98	107	77	-0.040	2.11	0.06
326	48.147	0.146	2.17	101	-2.47	94	77	-0.040	1.90	0.02
327	48.296	0.149	2.15	101	-2.53	97	76	-0.040	2.13	0.05
328	48.441	0.145	2.16	101	-2.24	96	76	-0.050	1.80	0.05
329	48.591	0.150	2.16	101	-1.41	96	76	-0.040	1.77	0.05
330	48.736	0.145	2.16	101	-2.43	94	76	-0.020	1.86	0.03
331	48.886	0.150	2.16	101	-2.74	105	76	-0.030	1.85	0.02
332	49.031	0.145	2.16	101	-1.07	95	75	-0.040	1.67	0.07
333	49.181	0.150	2.16	101	-1.5	110	75	-0.030	2.09	0.05
334	49.326	0.145	2.16	101	-2.52	100	75	-0.030	1.93	0.02
335	49.476	0.150	2.15	101	-1.73	96	75	-0.040	1.82	0.04
336	49.621	0.145	2.16	101	-1.92	96	76	-0.040	2.62	0.06
337	49.770	0.149	2.15	101	-2.68	105	77	-0.030	2.19	0.06
338	49.916	0.146	2.14	101	-1.04	100	77	-0.030	1.58	0.06
339	50.065	0.149	2.17	101	-1.34	97	77	-0.030	1.98	0.03
340	50.210	0.145	2.18	101	-0.99	100	77	-0.030	1.76	0.03
341	50.359	0.149	2.15	101	-1.28	102	77	-0.030	1.30	0.07
342	50.504	0.145	2.17	101	-2.24	97	76	-0.020	1.74	0.04
343	50.654	0.150	2.17	101	-1.02	101	76	-0.040	2.55	0.08
344	50.798	0.144	2.17	101	-2.33	93	76	-0.030	2.17	0.06
345	50.947	0.149	2.16	101	-1.06	101	76	-0.030	1.93	0.06
346	51.092	0.145	2.17	101	-1.11	93	75	-0.030	1.52	0.03
347	51.241	0.149	2.15	101	-2.31	103	75	-0.040	2.25	0.03
348	51.386	0.145	2.17	101	-2.23	97	75	-0.040	2.40	0.06
349	51.535	0.149	2.18	101	-2.24	100	75	-0.030	2.13	0.05
350	51.680	0.145	2.16	101	-2.62	97	75	-0.040	2.14	0.01
351	51.829	0.149	2.15	101	-2.18	96	77	-0.030	1.86	0.04

BOX B TEST DATA - ASTM E2779 / ASTM E2515

Client: US Stove CompanyJob #: 19-495Model: 6041Tracking #: 028Run #: 1Technician: SJBDate: 7/17/2019

Elapsed Time (min)	Particulate Sampling Data							Flue Gas Data		
	Gas Meter (ft ³)	Sample Rate (cfm)	Orifice dH (in H ₂ O)	Meter Temp (°F)	Meter Vacuum (in Hg)	Pro. Rate (%)	Filter (°F)	Flue Draft (in H ₂ O)	CO ₂ (%)	CO (%)
352	51.974	0.145	2.14	101	-2.71	103	77	-0.030	1.61	0.03
353	52.124	0.150	2.16	101	-2.61	105	77	-0.040	1.57	0.05
354	52.269	0.145	2.17	101	-1.01	97	77	-0.040	2.50	0.06
355	52.418	0.149	2.18	101	-2.72	99	77	-0.030	2.04	0.00
356	52.563	0.145	2.16	101	-2.05	91	76	-0.030	2.08	0.04
357	52.712	0.149	2.16	101	-2.59	102	76	-0.030	2.01	0.03
358	52.857	0.145	2.16	101	-1.13	103	76	-0.020	2.06	0.06
359	53.006	0.149	2.16	101	-2.28	94	76	-0.040	1.56	0.06
360	53.151	0.145	2.16	101	-1.44	96	76	-0.040	2.08	0.07
Avg/Tot	53.151	0.148	2.19	96	-1.79	100			2.60	0.07

LAB SAMPLE DATA - ASTM E2515

Client: US Stove Company
 Model: 6041
 Run #: 1

Job #: 19-495
 Tracking #: 028
 Technician: SJB
 Date: 7/17/2019

	Sample ID	Tare, mg	Total, mg	Final, mg	Catch, mg
Train A Filters - First Hour	3525	120.4	120.4	120.7	0.3
Train A Filters - Remainder	3526	120.9	241.0	244.9	3.9
	3527	120.1			
Train A Probe	7A	116741.2	116741.2	116741.4	0.2
Train A O-Rings	7A	3570.1	3570.1	3572.4	2.3
Train B Filters	3528	119.9	240.3	244.5	4.2
	3529	120.4			
Train B Probe	7B	117289.0	117289.0	117289.3	0.3
Train B O-Rings	7B	3519.0	3519.0	3521.3	2.3
Background Filter	3530	120.0	120.0	120.1	0.1

Placed in Dessicator on:	7/17 - 15:30
---------------------------------	--------------

Train A Filters - First Hour	120.7	7/19 8:00	120.7	7/19 16:18		
Train A Filters - Remainder	245.0	7/19 8:00	244.9	7/19 16:18		
Train A Probe	116741.3	7/19 8:00	116741.4	7/20 16:18		
Train A O-Rings	3572.4	7/19 8:00	3572.4	7/19 16:18		
Train B Filters	244.6	7/19 8:00	244.5	7/19 16:18		
Train B Probe	117289.3	7/19 8:00	117289.3	7/19 16:18		
Train B O-Rings	3521.2	7/19 8:00	3521.3	7/19 16:19		
Background Filter	120.2	7/19 8:00	120.1	7/19 16:19		

1st hour Sub-Total, mg:	0.3
Remainder Sub-Total, mg:	6.4
Train 1 Aggregate, mg:	6.7
Train 2 Aggregate, mg:	6.8
Ambient Aggregate, mg:	0.1

ASTM E2779 Pellet Heater Run Sheets

Client: US Stove Company Job Number: 19-495 Tracking #: 028
 Model: 6041 Run Number: 1 Test Date: 7/17/2019

Pellet Heater Control Settings

High Burn Rate Settings: PR-5

Medium Burn Rate Settings: PR-1

Low Burn Rate Settings: PR-1

Preburn Notes

Preburn Start Time: 8:08

Time	Notes
N/A	N/A

Test Notes

Test Burn Start Time: 9:08

Time	Notes
60 min 360 min	Changed 1-hour filter turned down to medium/low burn rate setting. End of Test

Test Burn End Time: 15:08

Flue Gas Concentration Measurement

Calibration Gas Values: Span Gas CO₂ (%): 17.00 CO (%): 4.31
 Mid Gas CO₂ (%): 10.00 CO (%): 2.51

Calibration Results:

	Pre Test			Post Test		
	Zero	Mid	Span	Zero	Mid	Span
Time	8:16	8:20	8:19	15:31	15:33	15:34
CO ₂	0.00	10.08	17.00	0.00	10.18	17.23
CO	0.00	2.491	4.31	0.009	2.516	4.348

Flue Gas Probe Leak Check: Initial: No Leakage

Final: No Leakage

Technician Signature: 

Date: 7/17/2019

Sample Pre-Test Tare Sheet: Probes

Filters

O-Rings

Date/Time In Desiccator: 5/3/19 15:00 Balance ID#: 107 Audit Weight ID# / Weight(mg): 109A-100mg

Sample ID	Date/Time	Weight (mg)	Date/Time	Weight (mg)	Date/Time	Weight (mg)	Date/Time	Weight (mg)	Tech. Initials	Project/Run #
3511	5/9/19	120.4	5/10/19	120.3					A	19-475 #4
3512		119.3		119.3					A	↓
3513		119.9		119.9					A	19-475 #5
3514		118.8		118.8					A	↓
3515		119.4		119.5					A	↓
3516		119.1		119.3					A	↓
3517		120.1		120.0					A	↓
3518		119.9		119.9					A	↓
3519		119.8		119.9					A	19-475 #6
3520		119.7		119.3					A	↓
3521		119.4		119.6					A	↓
3522		120.0		120.0					A	↓
3523		119.8		118.8					A	↓
3524		119.6		119.6					A	↓
3525	7/16-16:00	120.5	7/17-8:30	120.4					SB	19-495 #1
3526		120.8		120.9					SB	↓
3527		120.1		120.1					SB	↓
3528		119.8		119.9					SB	↓
3529		120.3		120.4					SB	↓
3530		120.0		120.0					SB	↓
3531		120.2		120.2					SB	↓
3532		119.2		119.2					SB	↓
3533										
3534										
3535										
3536										
3537										
3538										
3539										
3540										

ASTM E2515 - Probes

Sample	Weight 1	Weight 2	Weight 3	Weight 4	Initial	Project	Run
1A	115630.0	115630.2	-	-	SB	18-449	#1
1B	115903.7	115903.8	-	-	SB		
2A	116240.5	116240.5	-	-	SB	18-449	#2
2B	116330.5	116330.6	-	-	SB		
3A	116078.1	116078.1	-	-	SB	18-449	#3
3B	116340.8	116340.9	-	-	SB		
4A	116183.6	116183.8	-	-	SB	19-480	#1
4B	116365.8	116366.0	-	-	SB		
5A	116769.1	116769.7	116769.1	116769.3	SB	19-480	#2
5B	116876.8	116877.2	116876.8	116876.9	SB		

Weight 1 Date/Time:
6/10 - 7:00

Weight 2 Date/Time:
6/11 - 7:45

Weight 3 Date/Time:
6/13 - 8:30

Weight 4 Date/Time:
6/14 - 7:30

Sample	Weight 1	Weight 2	Weight 3	Weight 4	Initial	Project	Run
6A	116544.8	116545.5	116545.3	-	SB	19-480	#3
6B	116117.9	116118.4	116118.4	-	SB		
7A	116740.8	116741.1	116741.2	-	SB	19-485	#1
7B	117289.4	117289.1	117289.0	-	SB	↓	↓
8A	116823.4	116824.4	116824.3	-	SB	19-496	#1
8B	116825.8	116826.3	116826.2	-	SB	↓	#1
9A	116714.4	116714.2	-	-	SB	19-496	#2
9B	117920.6	117920.1	117920.3	-	SB		
10A	116820.7	116820.5	-	-	SB	19-496	#3
10B	117905.3	117905.2	-	-	SB		

Weight 1 Date/Time:
6/13 - 8:30

Weight 2 Date/Time:
6/14 - 7:30

Weight 3 Date/Time:
6/17 - 7:00

Weight 4 Date/Time:

Sample	Weight 1	Weight 2	Weight 3	Weight 4	Initial	Project	Run
11A	117035.5	117035.7	-	-	SB		
11B	117489.9	117489.9	-	-	SB		
12A	116889.3	116889.1	-	-	SB		
12B	117957.1	117957.2	-	-	SB		
13A	117456.0	117455.8	-	-	SB		
13B	117054.7	117054.9	-	-	SB		
14A	116818.1	116817.8	116817.7	-	SB		
14B	116772.0	116771.7	116771.5	-	SB		
15A	117418.9	117418.8	-	-	SB		
15B	116905.2	116905.3	-	-	SB		

Weight 1 Date/Time:
7/22 - 7:00

Weight 2 Date/Time:
7/23 - 8:00

Weight 3 Date/Time:
7/24 - 8:00

Weight 4 Date/Time:

ASTM E2515 - O-Rings

Sample	Weight 1	Weight 2	Weight 3	Weight 4	Initial	Project	Run
1A	3562.7	3562.8	-	-	SB	18-449	#1
1B	3551.3	3551.3	-	-	SB		
2A	3548.4	3548.5	-	-	SB	18-449	#2
2B	3566.9	3567.1	-	-	SB		
3A	3575.6	3575.7	-	-	SB	18-449	#3
3B	3564.0	3564.2	-	-	SB		
4A	3588.4	3588.5	-	-	SB	19-480	#1
4B	3576.1	3576.3	-	-	SB		
5A	3530.2	3530.2	-	-	SB	19-480	#2
5B	3526.8	3526.9	-	-	SB		

Weight 1 Date/Time:
6/10 - 7:00

Weight 2 Date/Time:
6/11 - 7:45

Weight 3 Date/Time:

Weight 4 Date/Time:

Sample	Weight 1	Weight 2	Weight 3	Weight 4	Initial	Project	Run
6A	3611.1	3611.2	-	-	SB	19-480	#3
6B	3387.9	3387.8	-	-	SB		
7A	3570.0	3570.1	-	-	SB	19-495	#1
7B	3518.8	3519.0	-	-	SB		
8A	3548.8	3549.0	-	-	SB	19-496	#1
8B	3582.2	3582.3	-	-	SB		
9A	3579.9	3580.1	-	-	SB	19-496	#2
9B	3522.5	3522.7	-	-	SB		
10A	3427.7	3427.9	-	-	SB	19-496	#3
10B	3568.4	3568.6	-	-	SB		

Weight 1 Date/Time:
6/10 - 7:00

Weight 2 Date/Time:
6/13 - 8:30

Weight 3 Date/Time:

Weight 4 Date/Time:

Sample	Weight 1	Weight 2	Weight 3	Weight 4	Initial	Project	Run
11A	3421.6	3422.2	3422.3	-	SB		
11B	4232.2	4232.8	4232.8	-	SB		
12A	3393.9	3394.0	-	-	SB		
12B	3403.9	3404.1	-	-	SB		
13A	3358.8	3359.0	-	-	SB		
13B	3443.2	3443.6	3443.6	-	SB		
14A	3364.1	3364.2	-	-	SB		
14B	3338.3	3338.5	-	-	SB		
15A	3567.9	3568.1	-	-	SB		
15B	3568.3	3568.7	3568.8	-	SB		

Weight 1 Date/Time:
7/22 - 7:15

Weight 2 Date/Time:
7/24 - 8:00

Weight 3 Date/Time:
7/25 - 7:00

Weight 4 Date/Time:

REVISION HISTORY			
REV	DESCRIPTION	DATE	BY
A	INITIAL RELEASE	4/8/09	CDB
B	ADDED PHONE NUMBER	2/22/11	REC
C	ADDED STANDARD DATE PER OMNI	7/15/13	ALW
D	REVISED PER EPA 2015	4/21/15	CDB
A	ADDED PFS CHANGED TO EPA 2020	7/24/19	SEH

NOTES:

MATERIAL: 0.012 THK. ALUMINUM / 3M 9672 (or equivalent) ADEHESIVE BACKED.

FINISH: BLACK BACKGROUND, ALUMINUM TO SHOW THRU
(ALL TEXT AND ILLUSTRATIONS) UNLESS NOTED OTHERWISE.

TEXT: ALL TEXT TO BE 0.08 HIGH UNLESS OTHERWISE SPECIFIED

BOARDER, LOGS, AND FLAMES ARE TO BE RED, 1" sq. 0.25 TEXT HEIGHT 0.125 TEXT HEIGHT



CAUTION: HOT WHILE IN OPERATION-DO NOT TOUCH. KEEP CHILDREN AND CLOTHING AWAY. CONTACT MAY CAUSE SKIN BURNS. SEE NAMEPLATE AND INSTRUCTIONS. KEEP FURNISHINGS AND OTHER COMBUSTIBLE MATERIALS A CONSIDERABLE DISTANCE AWAY FROM THE APPLIANCE. OPERATE THIS UNIT ONLY WITH THE FUEL HOPPER LID CLOSED. FAILURE TO DO SO MAY RESULT IN EMISSION OF PRODUCTS OF HOPPER UNDER CERTAIN CONDITIONS. MAINTAIN HOPPER SEAL IN GOOD CONDITION. DO NOT OVERFILL HOPPER.

PREVENT HOUSE FIRES - Install and use ONLY in accordance with the installation and operating Instructions. Contact local building or fire officials about restrictions and installation inspection in your area. DO NOT connect this unit to a chimney flue serving another appliance. See local building code and manufacturer's instructions for precautions required for passing through a combustible wall or ceiling. Inspect and clean exhaust vent system frequently in accordance with manufacturer's instructions. Keep viewing and ash removal doors tightly closed during operation. Exhaust vent required for residential installation or mobile home installation is a listed type "L" or "PL" venting - 3"/75mm or 4"/100mm diameter.

CAUTION: RISK OF EXCESSIVE TEMPERATURES. HOT OR MOVING PARTS MAY CAUSE INJURY. DO NOT OPERATE WITH SIDE PANELS REMOVED. REPLACE GLASS ONLY WITH 5MM CERAMIC GLASS.

DANGER: RISK OF ELECTRICAL SHOCK. DISCONNECT POWER BEFORE SERVICING UNIT. ROUTE SUPPLY CORD AWAY FROM UNIT.

WARNING: DO NOT INSTALL IN A SLEEPING ROOM. THE STRUCTURAL INTEGRITY OF THE MANUFACTURED HOME'S FLOOR, WALL, AND CEILING/ROOF MUST BE MAINTAINED.

This wood heater needs periodic inspection and repair for proper operation. Consult the owner's manual for further information. It is against federal regulations to operate this wood heater in a manner inconsistent with the operating instructions in the owner's manual.

START UP: Automatic Ignition - Shut door, Press the "ON" button, Select Heat setting.
SHUT DOWN: Turn the heat setting to "OFF". Unit will shut down automatically after fuel burns out and unit cools down.

MANUFACTURED BY: U.S. STOVE COMPANY - 227 INDUSTRIAL PARK ROAD, P.O. BOX 151, SOUTH PITTSBURG, TN 37380



REPORT NO. 215-S-01d-2



REPORT NO. 19-495

THIS PELLET FIRED APPLIANCE HAS BEEN TESTED AND LISTED FOR USE IN MOBILE HOMES.
"FOR USE WITH PELLET FUEL or SHELLD CORN (15% or LESS MOISTURE)"
MODEL: 6041

Serial No. Manufacture Date.

Certified to ASTM E1509, (UM) 84HUD
U.S. Environmental Protection Agency
Certified to comply with 2020 particulate emission standards.
Tested to method ASTM E2779 / Method 28R 1.28 g/hr

ELECTRICAL RATING: 120V, 15A, 60Hz INPUT RATING: 32,000 BTU/HR (PELLET FUEL)

MINIMUM CLEARANCES TO COMBUSTIBLE MATERIALS

PARALLEL — A - BACKWALL TO FLUE 3 IN/75MM
B - BACKWALL TO UNIT 9 IN/228MM
C - SIDEWALL TO FLUE 13 IN/330MM
D - SIDEWALL TO TOP EDGE OF UNIT 8 IN/203MM

CORNER — E - ADJACENT WALL TO UNIT 4 IN/100MM
F - ADJACENT WALL TO FLUE 3 IN/75MM

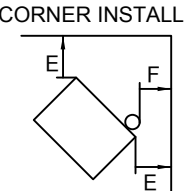
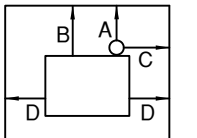
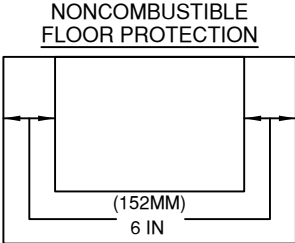
NONCOMBUSTIBLE FLOOR PROTECTION
(152MM)
6 IN

A 1" THICK NONCOMBUSTIBLE FLOOR PROTECTOR IS RECOMMENDED FOR THIS INSTALLATION.

DO NOT REMOVE OR COVER THIS LABEL

851771E

B

B

A

A

A

A

SERIAL & DATE BOX DETAIL

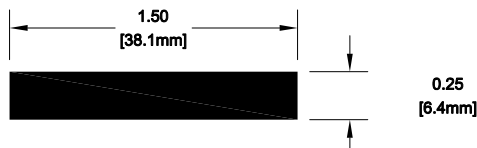

<p>© 2010 United States Stove Company</p> <p>ALL RIGHTS RESERVED THE DATA CONTAINED HEREIN IS PROPRIETARY TO U. S. STOVE COMPANY. THIS DATA SHALL NOT BE DUPLICATED, TRANSFERRED, MADE AVAILABLE, OR USED BY ANY THIRD PARTY FOR ANY PURPOSE EXCEPT SPECIFICALLY AUTHORIZED IN WRITING BY U. S. STOVE COMPANY.</p>		<p>TOLERANCES ± .005" EXCEPT DECIMAL AS XX = 0.03 XXX = 0.010 NOTED ANGULAR ± 2°</p>	<p>DESCRIPTION SEE NOTE FINISH SEE NOTE REFERENCE 6041</p>	<p>SCALE 1:1 DWN BY CDB DATE 2/19/09</p>	<p>SIZE B REV E</p>	<p>UNITED STATES STOVE COMPANY ESTABLISHED 1869</p>	<p>TITLE LABEL, CERTIFICATION</p>	<p>NUMBER 851771</p>	<p>SHEET 1 OF 1</p>
------------------------------------------------------------------------------------------------------------------------------------------------------------------------------------------------------------------------------------------------------------------------------------------------------------------------	--	--------------------------------------------------------------------------------------------------------------	--------------------------------------------------------------------------------	--------------------------------------------------------------	---------------------------------	----------------------------------------------------------------	---------------------------------------	--------------------------	-------------------------

4

3

2

1

Installation/Operator's Manual

Model(s) 6041, 6041I

READ THIS ENTIRE MANUAL, THOROUGHLY, BEFORE ATTEMPTING TO INSTALL AND/OR BURN YOUR NEW AMERICAN HARVEST *MULTI-FUEL HEATER. FAILURE TO FOLLOW THESE INSTRUCTIONS MAY RESULT IN PROPERTY DAMAGE, BODILY INJURIES OR EVEN DEATH.

Safety Notice: If this heater is not properly installed, a **house fire may result**. For your safety, follow the installation directions. Contact local building or fire officials about restrictions and installation requirements peculiar to your area. **Do Not Plug** this appliance into an electrical outlet before reading and understanding all operations and **always unplug** the unit before attempting any work or maintenance. Do not connect this heater to any chimney flue already serving another appliance. Carefully observe and maintain all **clearances to combustibles**.

A note about fuel: Use only **dried shelled corn** with a moisture content of 14% or less (**11 to 12% provides the best results**); any pellet fuel used should have an ash content of 1% or less. If not, efficiency will suffer. This heater has successfully burned pellets with a 2-1/2% ash content, though less ash is preferred and more efficient.

Your American Harvest Multi-Fuel Heater operates on a negative pressure. Therefore, **all venting connections (elbows, T-pipe) must be sealed and airtight**.

① **Use Hi-Temp silicone at each joint or connection.**

***This heater is capable of burning wood, biomass pellets and a wide variety of grains, including corn, soybeans, cherry and olive pits, and all larger seeds.**

SAVE THESE INSTRUCTIONS

UNITED STATES STOVE COMPANY GRANTS NO WARRANTY, IMPLIED OR STATED, FOR THE INSTALLATION OR MAINTENANCE OF THE HEATER AND ASSUMES NO RESPONSIBILITY FOR ANY CONSEQUENTIAL DAMAGE(S).

CALIFORNIA PROPOSITION 65 WARNING:

This product can expose you to chemicals including carbon monoxide, which is known to the State of California to cause cancer, birth defects and/or other reproductive harm. For more information, go to www.P65warnings.ca.gov

U.S. Environmental Protection Agency

Certified to comply with 2020 particulate emissions standards.

This unit is not intended to be used as a primary source of heat.



**UNITED STATES
STOVE CO**
EST[®] 1869

This unit was tested and listed ASTM E1509-04 & (UM) 84-HUD by OMNI-Test Laboratories.

United States Stove Company • 227 Industrial Park Road, P.O. Box 151 • South Pittsburg, TN 37380 • www.usstove.com

851772F-3002I

You've purchased one of America's Finest Multi-fuel Burning Heaters. By heating with fuels such as corn and pellets, you're helping CONSERVE AMERICA'S ENERGY!

NOTE: YOUR UNIT MUST BE INSTALLED BY A QUALIFIED INSTALLER, such as an NFI (National Fireplace Institute) Certified Specialist

We strongly suggest installing smoke detectors in your home if not already installed.
Initial burn off may cause slight smoke and odor the first few hours of operation.
Perform initial burn outside if possible

SPECIFICATIONS

United States Stove Company reserves the right to alter products, specifications and price without notice.

Safety Tested & Listed to ASTM- E 1509, (UM) 84-HUD, by OMNI Test Laboratories, Inc., Portland, Oregon USA

Heating Capacity	1,000-2,000 Sq. Ft
Fuel Storage Capacity	60 Lbs.
Width	29 in./737mm
Height	24 in./610mm
Depth	28 in./711mm

- BTU output will vary, depending on the brand, type and quality of fuel and the moisture content. Consult your dealer for best results.
- Based on post 1982 home construction, requiring 35 BTU/Hr per Sq. Ft.

Remember, this heater should not be used as the only source of heat in the house. Power outages and neglect of periodic maintenance will result in a total loss of heat.



This manual describes the installation and operation of the American Harvest and Hearth Focus, 6041, 6041I wood heater. This heater meets the 2020 U.S. Environmental Protection Agency's crib wood emission limits for wood heaters sold after May 15, 2020. Under specific test conditions this heater has been shown to deliver heat at rates ranging from 7,540 to 21,811 Btu/hr output.

Note: Register your product on line at www.usstove.com. Save your receipt with your records for any claims.

6041I ASSEMBLY

DISCONNECT THE POWER CORD BEFORE SERVICING THIS HEATER

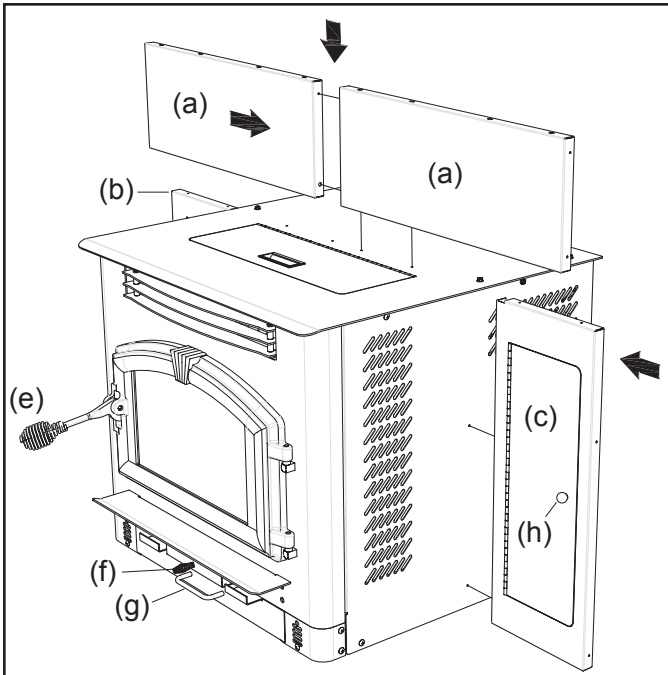

For the following assemblies, we suggest locating the unit near it's desired location. Depending on installation, you may want to connect the exhaust venting before installing the facade parts.

Assembly - Facade (Surround)

Remove contents from packaging and make sure you have all components:

- (2) Top Facade (a)
- (1) Left Side Facade (b)
- (1) Right Side Facade (c)
- (4 pieces) Facade Trim Kit (d)
- (1) Feed Door Spring Handle (e)
- (1) Damper Spring Handle (f)
- (1) Ash Pan "U" shaped Handle (g)
- (1) Access Door Knob (h)
- (1) PCB Cover (i)
- (1) Panel Cover (j)
- (1) Auger (in ash pan)
- (1) Power Cord
- (1) Burnpot Poker (k)
- Mounting Hardware

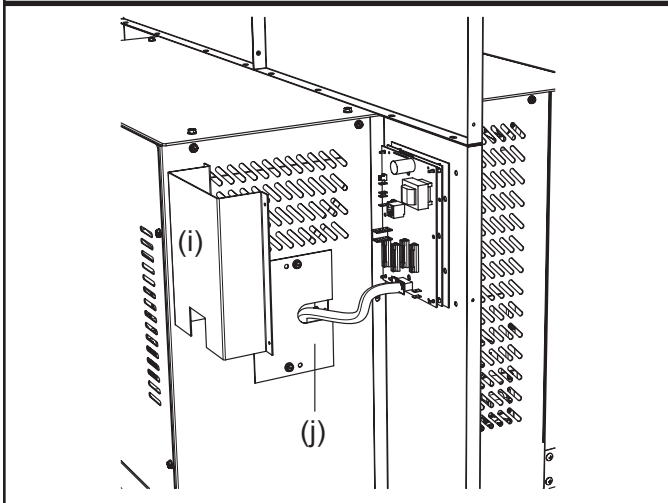

Start by mounting either the left or right side facade pieces to the unit using four(4) of the supplied #10 x 1/2 screws. Then put the two(2) top facade pieces together with two(2) of the #10 x 1/2 screws provided. Attach the top facade assembly to the unit with eight(8) of the same screws.

Control Board (PCB) Re-location

Remove the left side front panel from the unit. While holding the PCB with one hand, remove the two(2) hex head screws holding the board in place. It is not necessary to unplug the PCB cable. Route the board and cable through the opening and mount it to the Left Facade using two of the #10 x 1/2 phillips head screws provided. Then attach the PCB cover to the back of the facade covering the board. Next, use the two hex head screws removed earlier and mount the cover panel over the opening where the PCB was located. See illustration to the left.

Facade Trim

Remove trim from shipping tube. There should be one(1) left side, one(1) right side, two(2) top pieces, and mounting hardware. Using one blank corner key and one corner key with set screws, assemble the left trim and one of the top pieces together. As illustrated, place the blank key behind the key with the set screws. Adjust corners and tighten set screws. Repeat this for the right side

Before removing tape, place trim assembly against facade to get an idea of how it is to be mounted. Remove the strip from the adhesive and carefully secure the trim in place by firmly pressing it to the facade.

Burnpot Poker

The burnpot poker may be used several ways. It is used primarily as a fuel-loading assistant to help push the fuel to the rear of the hopper for maximum fueling. It may also be used for cleaning of ashes or removal of clinkers.

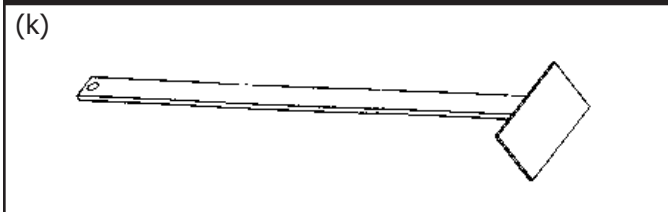
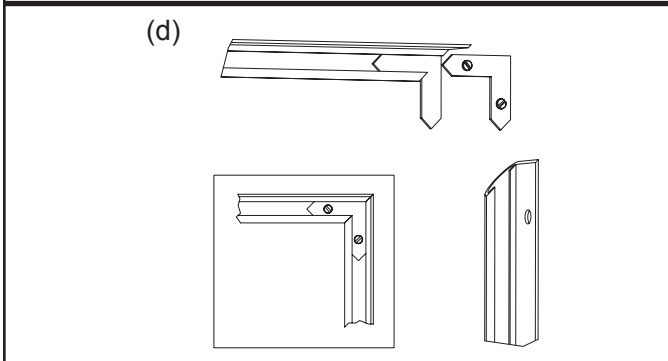

COMPONENT LOCATION

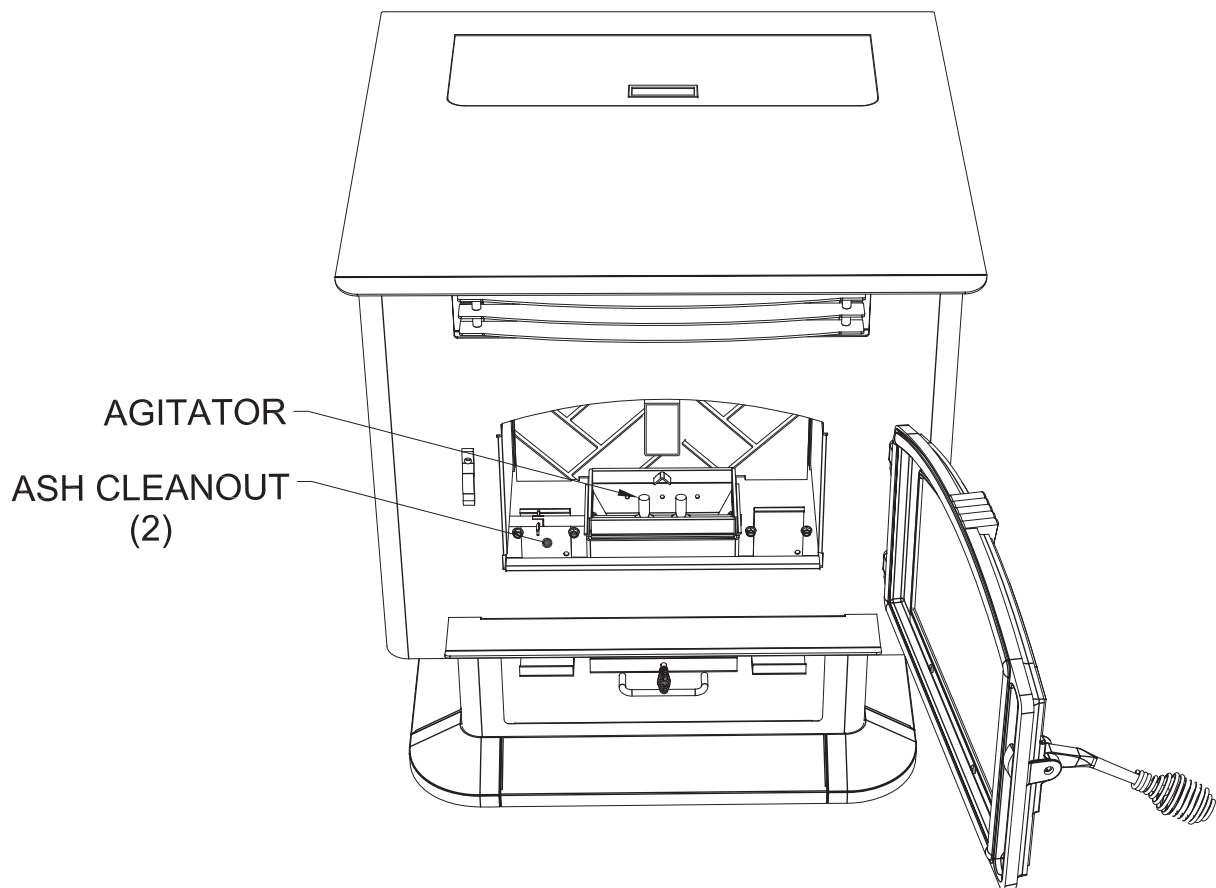
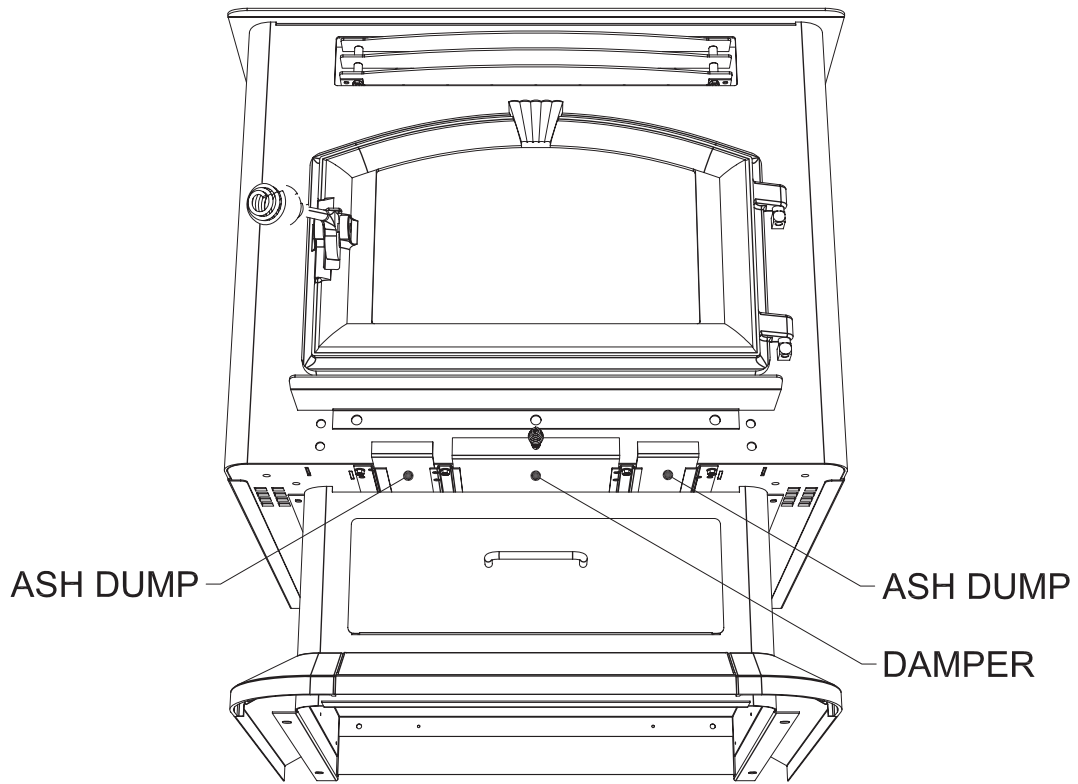

SAFETY STEPS

IMPORTANT

Proper installation of this heater is necessary for safe and efficient operation. Installing this product improperly may result in a house fire and personal injury. All applicable building codes for your location must be followed. In areas where building codes require additional steps to the installation of this product not included in this manual, the building codes will take precedent and must be followed. Contact your local building inspector to obtain any necessary permits or inspection guidelines before installing the product.

- The **American Harvest** heater is designed to burn dry shelled corn, cherry pits, or pelletized fuel such as wood and biomass pellets. The burning of other solid fuels such as cord wood or wood chips in this heater is not permitted.
- This product requires simple periodic maintenance for proper operation and long life of the heater. Read and follow the maintenance schedule closely.
- **DISCONNECT THE POWER CORD BEFORE SERVICING THIS HEATER!**
- **A power surge protector is required.** The unit must be plugged into a **grounded** 110-volt power source. Circuit Boards are very expensive - protect yours!
- Always route the power cord away from the unit. Do not route cord in foot traffic areas. Do not pinch cord under furniture. Do not route the cord across the exhaust pipe.
- A working smoke detector must be installed in the same room as this product.
- Flammable or explosive liquids such as gasoline, naphtha, alcohol, lighter fluid, or engine oil must **NEVER** be used in or around this heater. These liquids must be stored well away from this heater as the open flame in the burner chamber could ignite the fumes of such liquids.
- The moving parts of this heater are propelled by high torque electric motors. The Auger and Fuel Agitator can cause severe injury to body parts that may get near them. Keep all body parts away from the Auger and Fuel Agitator while the heater is plugged into an electrical outlet. These moving parts may begin to move at any time while the heater is plugged in.
- According to HUD requirements, when installed in a mobile home, this heater must be grounded directly to the steel chassis of the mobile home and bolted to the floor. Direct air access must be provided - Use 69FAK Fresh Air Kit
- This heater is not intended for use in commercial installations.
- Do not connect this heater to "B" vent. **Use UL Listed Pell Vent ONLY!**
- Do not elevate the fire by use of grate or any other means other than the supplied burnpot.

BURNING SOLID FUELS

Ashes will have to be removed from the heater for proper operation. See cleaning procedure.

Your Multi-fuel heater, due to the nature of solid fuels, will require brief periodic attention. Please do not expect to light your heater and walk away from it. A few moments of adjustment and cleaning is an important part of burning solid fuels, due to the vast differences in fuel, humidity and outside temperature.

The Multi-fuel heater has been designed to burn dry shelled corn, wood pellets and other pelletized fuels that meet the Pellet Fuel Institute (PFI) standards.

BURNING SOLID FUELS continued...

SHELLED CORN (Dry, preferably corn with 11- 12% moisture content)

- **Corn must contain less than 14% moisture content.** Wet corn will rapidly deteriorate heater components, reduce efficiency and void all warranties. Purchase a moisture tester if in doubt.
- Corn must be clean and free from debris. Never burn corn right from the field. Damage caused by dirty corn is not covered by the product warranty. Ask for clean **filtered** bagged corn only. Stalk parts, excessive fines and cob remnants will clog the auger. Check your corn for foreign objects.
- **NEVER BURN SEED CORN IN YOUR Heater.** Seed corn is treated with chemical pesticides that are harmful or fatal if swallowed, therefore, seed corn is dangerous to have in the house, especially where children can reach it.
- Never burn "Deer Corn." It frequently contains molasses, sugars and salts.
- Store your corn supply in a dry place and keep bags or container sealed to prevent your corn from absorbing excess moisture. Test the moisture content periodically to ensure the proper dryness.
- There are many varieties of corn grown around the world. Each variety has unique characteristics including the shape and size of the kernel. Your heater will burn more consistently with a small to midsize kernel corn. If the kernel size of the corn varies greatly or if you switch sources frequently, you will get a less consistent burn. Therefore, purchasing corn from the same source will help achieve a more consistent burn. **DO NOT USE CORN WITH A HIGH WAX CONTENT!**

WOOD AND BIOMASS PELLETS

- As with corn, be consistent in your pellet supplier. Pellets will vary in content and burn characteristics from supplier to supplier. A consistent supply of pellets will result in a more consistent and efficient burn.
- Check your pellets for foreign objects. Your heater warranty will not cover damage done to your heater due to foreign objects in the fuel supply.
- **Store your pellets in a dry place to prevent them from absorbing added moisture.**
- To decrease sawdust buildup, the hopper and auger tube will need to be vacuumed out after every 6-8 bags of pellets or more often if the pellets are poor quality. The hopper should be empty of fuel when this is performed. You may have to screen each bag of pellets if sawdust becomes a problem.
- Wood Pellets vary in size and ash content from less than 1% to 3% or more. Your heater will burn more efficiently with small to midsize pellets (Preferred pellet size is 1/4" diameter x 1" length). Low ash content pellets will allow you to burn the heater longer between cleanings. Only wood pellets manufactured to the Pellet Fuel Institute (P.F.I) standard for residential pellets fuels are recommended. Performance will suffer if nonstandard pellets are used. Consult your local **American Harvest** dealer for more information on approved wood pellet fuel.

CAUTION:

DO NOT PLACE SUCH FUELS WITHIN THE SPACE HEATER'S INSTALLATION CLEARANCES OR WITHIN THE SPACE REQUIRED FOR FUELING AND ASH REMOVAL.

INSTALLATION REQUIREMENTS

FLOOR PROTECTION

The Multifuel Heater may be installed on a combustible floor, **with proper floor protection**, or on a masonry hearth. The hearth or noncombustible floor protector must extend a minimum of (6) inches (152mm) in front and (6) inches (152mm) from each side of the unit.

CLEARANCES TO COMBUSTIBLES 6041

The heater must be installed with the following minimum clearances to side and back wall combustible materials.

NOTE: These are minimum clearances to combustible walls established by the testing lab.

- | | |
|---------------------------------------------|--------------|
| PARALLEL - A - Sidewall to Top Edge of Unit | 8 in./203mm |
| B - Sidewall to Flue | 13 in./330mm |
| C - Backwall to Flue | 3 in./75mm |
| D - Backwall to Unit | 9 in./228mm |
| CORNER - E - Adjacent Wall to Flue | |
| F - Adjacent Wall to Unit | 4 in./100mm |

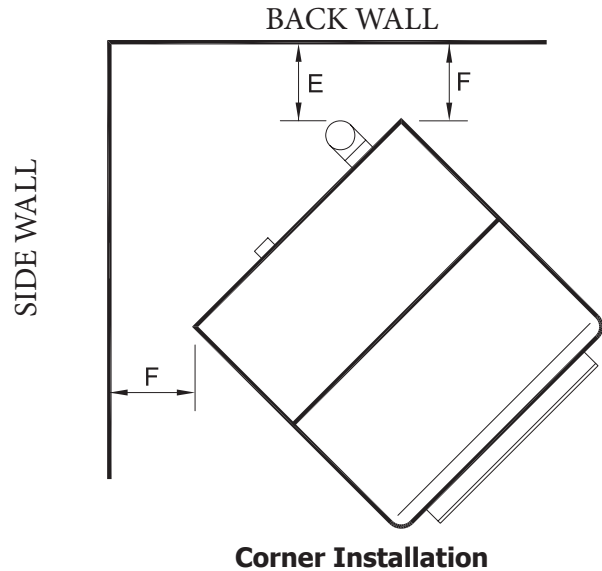
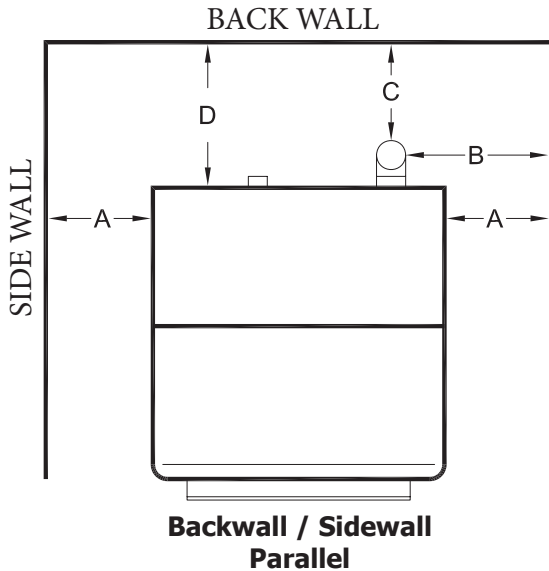

NOTE:
Allow sufficient space to remove the left and right side panels for maintenance purposes.

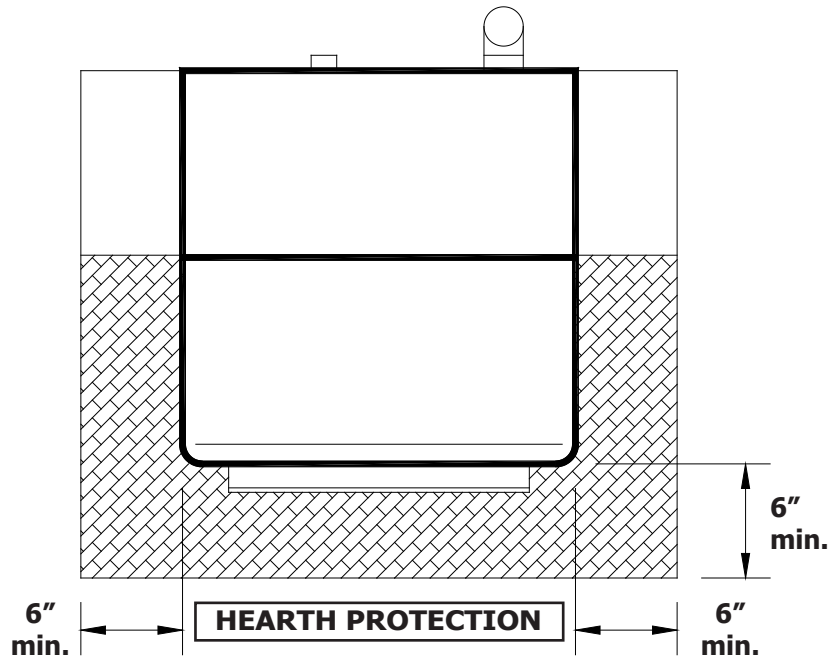

These clearances must be maintained.

CLEARANCES TO COMBUSTIBLES 6041I

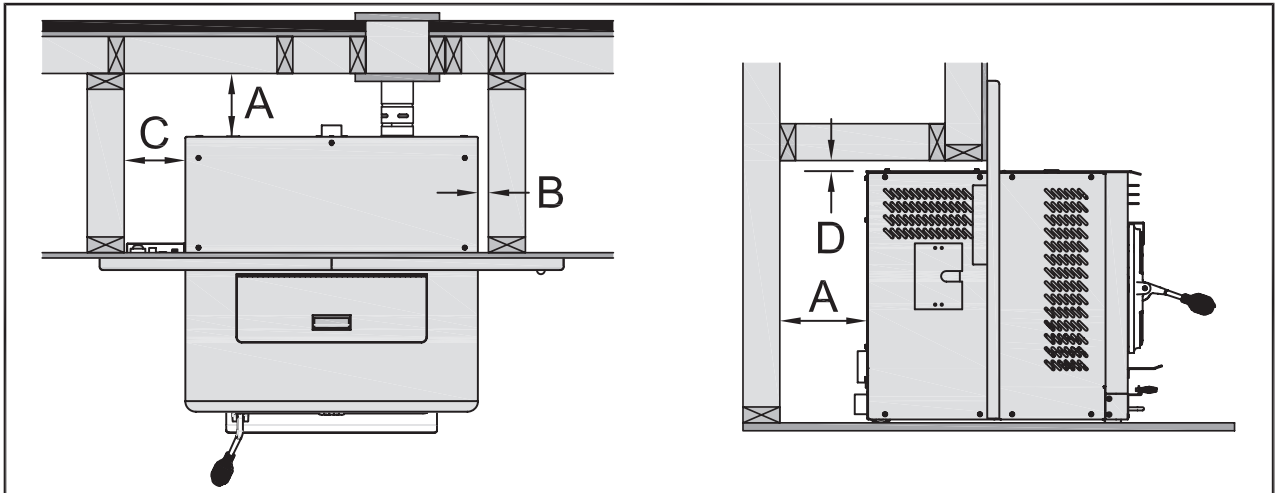

AS A BUILT-IN

KEY		INCHES
A	BACK OF UNIT TO WALL	6
B	RIGHT SIDE OF UNIT TO WALL	1
C	LEFT SIDE OF UNIT TO WALL	6
D	TOP OF UNIT TO WALL	1

EXTERNAL CLEARANCE TO COMBUSTIBLES		
KEY		INCHES
A	FLOOR PROTECTOR EDGE TO FRONT OF UNIT	6
B	FLOOR PROTECTOR EDGE TO SIDE OF UNIT	6
C	LEFT SIDE OF UNIT TO WALL	8
D	FLOOR TO MANTEL	53

MINIMUM OPENING FOR MASONRY AND FACTORY-BUILT FIREPLACES		
KEY		INCHES
A	HEIGHT	24
B	WIDTH	40
C	DEPTH	20

GUIDELINES FOR EXHAUST VENTING SYSTEMS DESIGN

IMPORTANCE OF PROPER DRAFT

Draft is the force which moves air from the appliance up through the chimney. The amount of draft in your chimney depends on the length of the chimney, local geography, nearby obstructions and other factors. Too much draft may cause excessive temperatures in the appliance. Inadequate draft may cause backpuffing into the room and 'plugging' of the chimney.

Inadequate draft will cause the appliance to leak smoke into the room through appliance and chimney connector joints. An uncontrollable burn or excessive temperature indicates excessive draft.

Take into account the chimney's location to insure it is not too close to neighbors or in a valley which may cause unhealthy or nuisance conditions.

It is recommended that only an authorized installer install your multi-fuel heater, preferably an NFI certified specialist. The following installation guidelines must be followed to ensure conformity with both the safety listing of this heater and to local building codes.

INSTALL VENT AT CLEARANCES SPECIFIED BY THE VENT MANUFACTURER.

- A UL listed 3" or 4" type "PL" pellet vent exhaust system must be used for installation and attached to the pipe connector provided on the back of the heater. Use a 3" to 4" adapter for 4" pipe. A cap must be used at the termination of type "L" vent chimneys. 4" PL is required for elevations above 2,500 feet above sea level.
- Do not terminate vent in any enclosed or semi-enclosed area, such as; carports, garage, attic, crawl space, under a sundeck or porch, narrow walkway or close area, or any location that can build up a concentration of fumes such as a stairwell, covered breezeway etc.
- Vent surfaces can get hot enough to cause burns if touched by children. Noncombustible shielding or guards may be required.
- **Do not install a flue damper in the exhaust vent of this unit.**
- Termination must exhaust above air inlet elevation. Installation MUST include three (3) vertical feet of pellet vent pipe. This will create some natural draft to prevent the possibility of smoke or odor during appliance shutdown and to keep exhaust from causing a nuisance or hazard from exposing people or shrubs to high temperatures. **Do not connect this unit to a chimney flue serving another appliance. Do not connect directly to a masonry chimney.**
- The installation must include a cleanout tee to enable collection of fly ash and to permit periodic cleaning of the exhaust system. 90° elbows accumulate fly ash and soot thereby reducing exhaust flow and performance of the heater. Each elbow or tee reduces draft potential by 30% to 50%. Use no more than 180 degrees of elbows (two 90-degree elbows, or two 45-degree and one 90-degree elbow, etc.) and one cleanout tee to maintain adequate draft. Cleanout tees and elbows should not be connected to the rear of the unit unless a 3-inch adapter is used.
- Total length of horizontal vent must not exceed 48"(4ft.)/1,200mm. The maximum recommended vertical venting height is 12-feet for 3-inch type "PL" vent. For venting higher than 12-feet, 4-inch "PL" vent must be used. All joints in the vent system must be fastened by at least 3 screws, and all joints must be sealed with RTV silicone sealer to be airtight.
- The area where the vent pipe penetrates to the exterior of the home must be sealed with silicone or other means to maintain the vapor barrier between the exterior and the interior of the home.

NOTE: These are guidelines only. Proper venting is accomplished by design and necessary requirements. In most installations 3 inch diameter venting is adequate. If it does not vent properly you will have to change it to 4 inches. You should not exceed 4 inch diameter venting.

DO NOT CONNECT TO ANY AIR DISTRIBUTION DUCT OR SYSTEM

VENT TERMINATION CLEARANCES:

A) Min. 4-ft clearance below or beside any door or window that opens.

B) Min. 1-ft clearance above any door or window that opens.

C) Min. 3-ft clearance from any adjacent building.

D) Min. 7-ft clearance from any grade when adjacent to public walkways.

E) Min. 2-ft clearance above any grass, plants, or other combustible materials.

F) Min. 3-ft clearance from a forced air intake of any appliance.

G) Min. 2-ft clearance below eaves or overhang.

H) Min. 1-ft clearance horizontally from combustible wall.

I) Must be a minimum of 36-inches above the roof and 24-inches above the highest point or the roof within 10-feet.

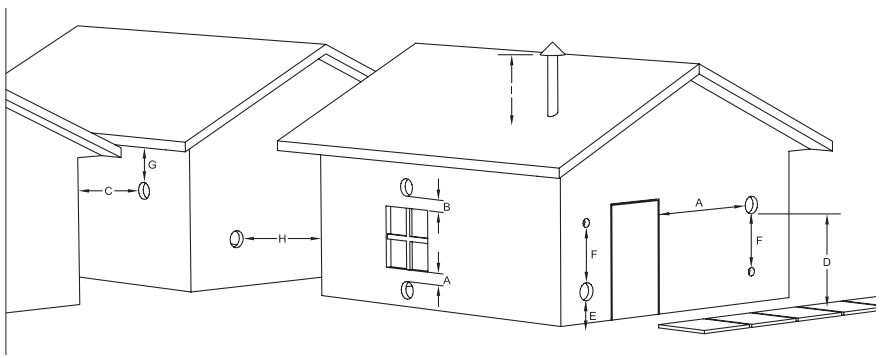

DESIGN GUIDELINES FOR OUTSIDE COMBUSTION AIR CONNECTION

1. For installations with horizontal through-the-wall exhaust, it is strongly recommended that the heater combustion air be connected to the outside. If the home is newer or has been tightly insulated, it is required to install outside combustion air.
2. Connection to outside the house is REQUIRED for mobile home installations. We strongly urge use of the 69FAK Fresh Air Kit.

90 DEGREE BEND TERMINATION

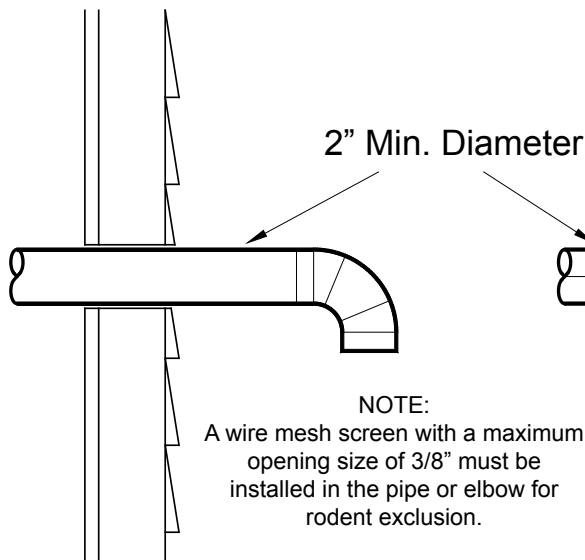

WIND HOOD TERMINATION

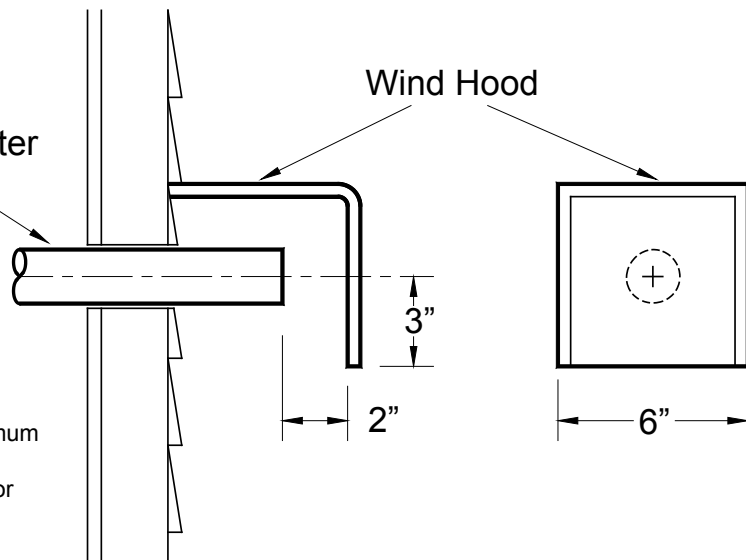

3. Only noncombustible pipe 2 inches (or greater) in diameter is approved to use for outside air connections (straight or flexible). PVC pipe is NOT approved and should NEVER be used.
4. If the air inlet is connected to the outside, it MUST be terminated with a vertical 90-degree bend (down) or with a wind hood. Failure to do so could result in a burn back during high winds blowing directly up the air inlet during a simultaneous power failure (see diagram above).
5. Blockage, excessive length, or extra bends in the air intake pipe will starve the heater of combustion air. A 90-degree bend is equivalent in restriction to approximately 30 inches of straight inlet pipe.

CAUTION: The operation of exhaust fans such as bath room fans, attic fans, etc. might starve the heater of combustible air creating a negative pressure in the room. Provide adequate ventilation in the room accompanying the heater. If not, the pressure switch may shut off operation of the heater. (Due to negative pressure)

INSTALLATION CONFIGURATIONS

The Multifuel Heater Model 6041 may be installed as follows:

- 1) A freestanding unit

The Multifuel Heater Model 6041I insert may be installed as follows:

- 1) In a pre-fab firebox (Factory Built)
- 2) In an existing masonry fireplace
- 3) As a build-in

MOBILE HOME INSTALLATION REQUIREMENTS

IN ADDITION TO THE STANDARD INSTALLATION INSTRUCTION, THE FOLLOWING REQUIREMENTS ARE MANDATORY FOR INSTALLATION IN A MOBILE HOME:

WARNING
DO NOT INSTALL IN SLEEPING ROOM

- 1) Heater must be permanently bolted to the floor. Remove the Base Trim and bolt thru the base flange.
- 2) Heater must have permanent outside air source. (69FAK)
- 3) Heater must be permanently electrically grounded to the steel chassis of the mobile home.
- 4) All vertical chimney vent must have wall supports.
- 5) All exhaust systems must have a spark arrestor.

CAUTION
**THE STRUCTURAL INTEGRITY OF THE MOBILE HOME FLOOR, WALL AND CEILING/
ROOF MUST BE MAINTAINED.**

Check with your local building official as other codes may apply.

Note: Always check dimensions on unit before cutting hole in wall

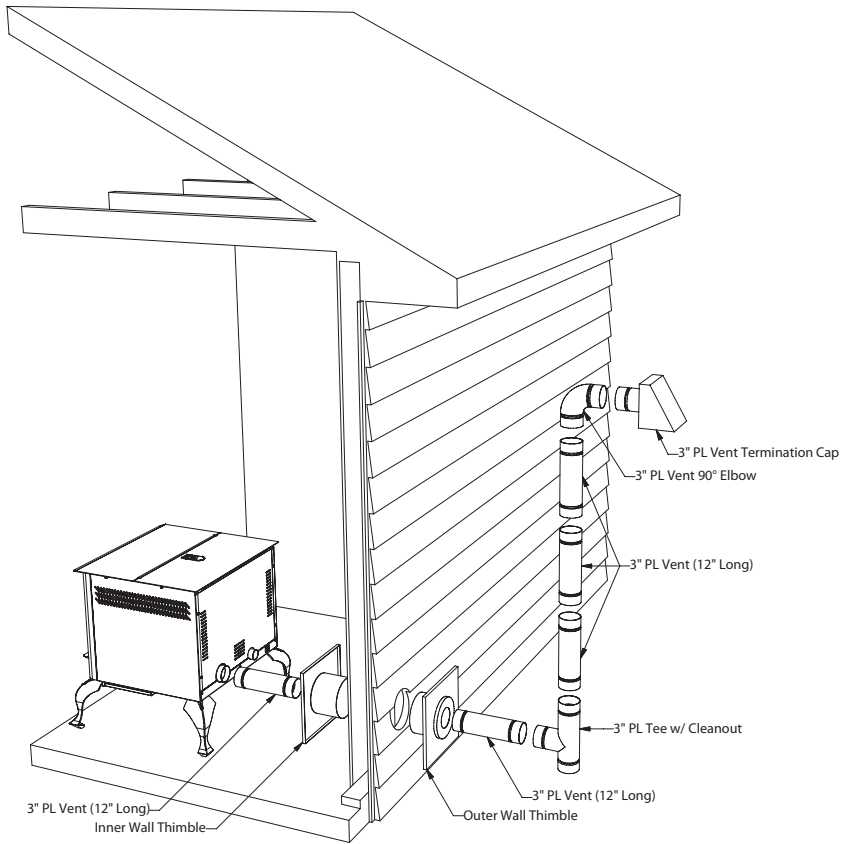

A MINIMUM OF 3 VERTICAL FEET OF PIPE OUTSIDE THE HOME IS REQUIRED!

*For illustrations purposes only

THROUGH THE WALL, VERTICAL PIPE INSTALLATION WITH TERMINATION CAP

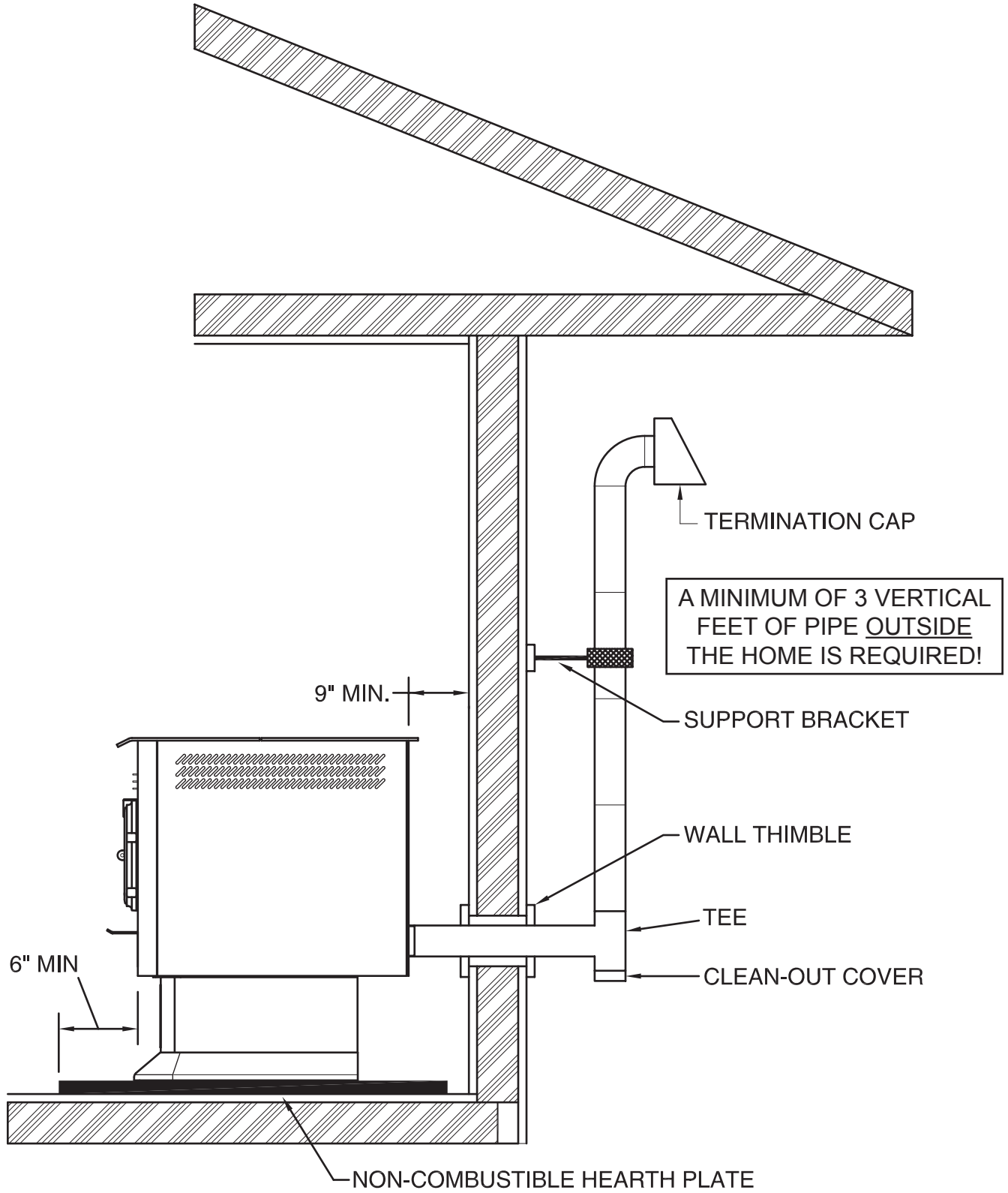

The Hearth Pad is not required under the unit if the floor is noncombustible but is required 6 inches (152mm) beyond the front of the unit and 6 inches (152mm) beyond each side of the door if the floor is a combustible floor. (wood flooring, carpet, linoleum, etc.)

DESIGN GUIDELINES FOR 6041I INSERT INSTALLATION

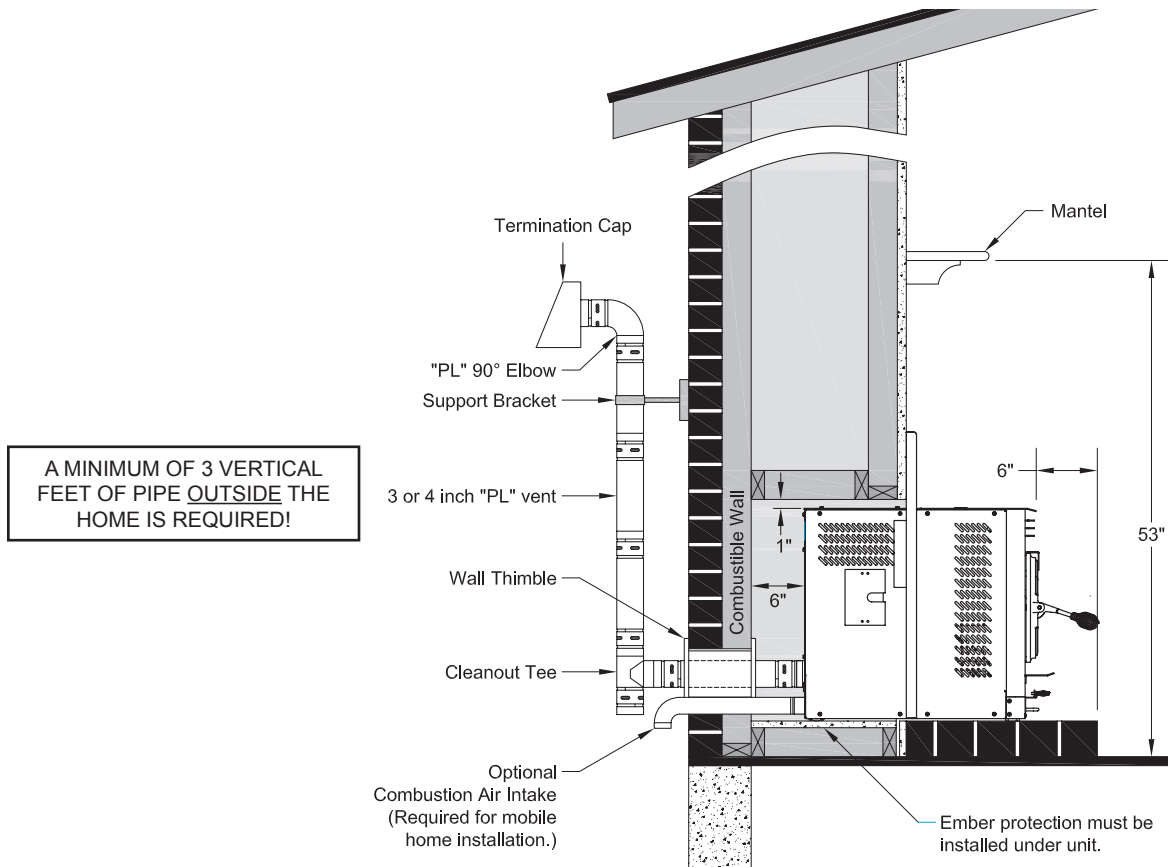

INSTALLATION AS A BUILT-IN FIREPLACE

A continuous sheet of non-combustible floor protection must be installed underneath the unit to prevent the possibility of embers falling through to the combustible floor. If the floor beneath the unit is of non-combustible material, the protector is not required.

See the "Clearance to Combustibles" section of this manual for installation clearances.

ALTERNATIVE EXHAUST VENTING

Depending on your installation, you might consider routing your cleanout tee as illustrated below for ease of cleaning. The access panel in the right side facade allows you to reach the tee from the front side of the unit if venting is assembled as shown. The cleanout tee is attached to a 90° elbow mounted to the unit then rotated at approx. 15-20 degrees. A 12 inch section of "PL" vent is connected to reach the top of the unit to which a flexible pipe may be attached for further termination through a chimney. Clearance to combustibles must be considered if this installation is chosen. A distance of 3 inches must be maintained from the exhaust vent to any combustible material.

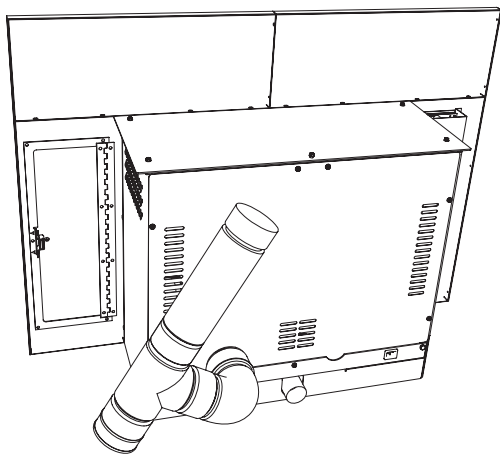

DESIGN GUIDELINES FOR 6041I INSERT INSTALLATION

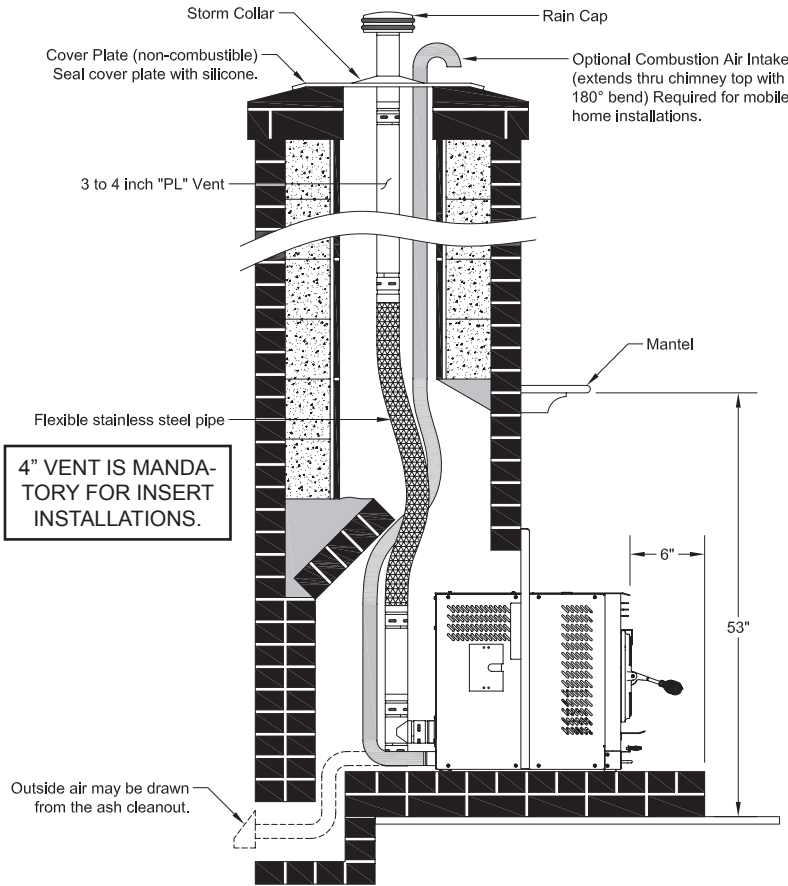

INSTALLATION INTO A MASONRY FIREPLACE

When installing into a masonry fireplace, **DO NOT** remove any bricks or masonry, with the following exception: masonry or steel, including the damper plate, may be removed from the smoke shelf and adjacent damper frame, if necessary, to accommodate a chimney liner. Do this only if their removal will not weaken the structure of the fireplace or the chimney, and will not reduce protection for combustibles to less than that required by national building codes.

Installation must include a chimney liner (4" Pell Vent "PL" Piping) that extends the full height of the chimney and meets type HT requirements. The liner must be securely attached to the insert and the chimney top. The chimney must be sealed either at the top or at the damper area with a non-combustible plate to prevent room air passage to chimney cavity.

Outside combustion air may be drawn through the chimney top or through an existing ash cleanout.

INSTALLATION INTO A FACTORY-BUILT (METAL) FIREPLACE

When installing into a zero clearance fireplace, The firebox must accept the insert without modification other than removing bolted or screwed together pieces such as smoke shelf/deflectors, ash lips, screen or door tracks, and damper assemblies. These items must be re-installed if the insert is removed and not replaced. The removal of any part must not alter the integrity of the listed fireplace in any way.

The factory built fireplace must be listed per UL 127. Installation must include a chimney liner (4" Pell Vent "PL" Piping) that extends the full height of the chimney and meets type HT requirements. The liner must be securely attached to the insert and the chimney top. The chimney must be sealed either at the top or at the damper area with a non-combustible plate to prevent room air passage to chimney cavity.

For raised hearth installations, adjust the leveling bolts under the front of the unit.

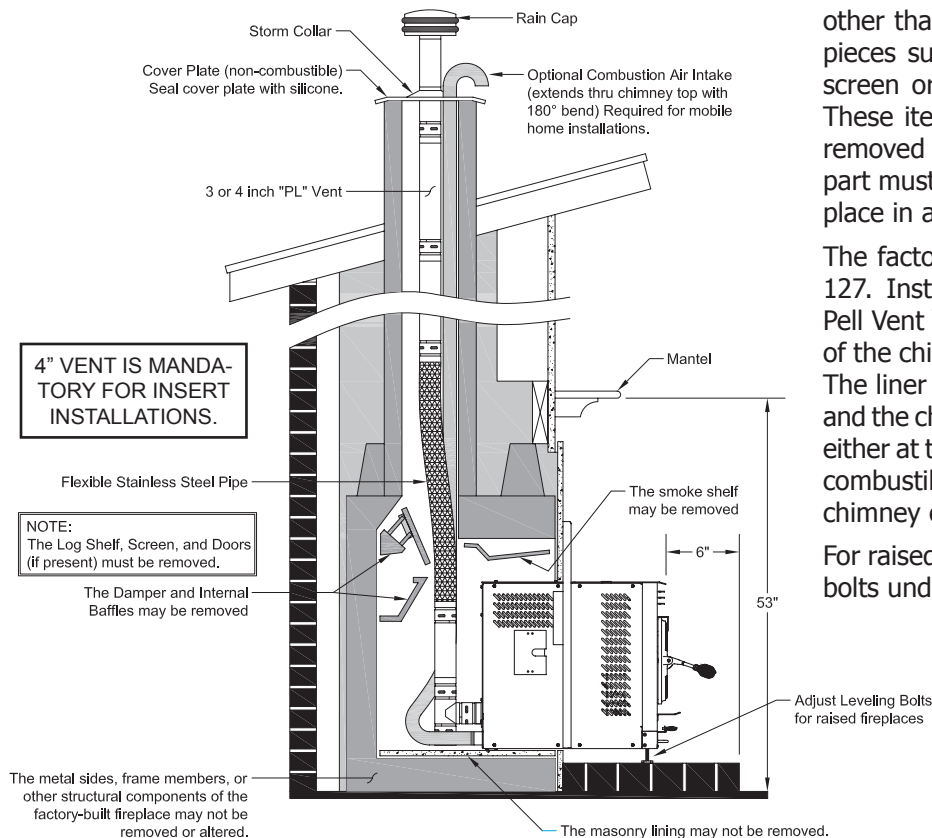

GLASS MAINTENANCE, REMOVAL AND REPLACEMENT

Your **Multi-Fuel Heater** comes to you with the glass door installed in place, ready for use. The glass is surrounded on the edges with a gasket and seated in a glass channel. It is held in place with two (2) clips. This unit's door uses a 1/2" diameter rope gasket.

REMOVAL OF BROKEN OR DAMAGED CERAMIC GLASS

Open the door and then lift it off of the hinges. If the door is tight, tap gently on the bottom of the door with your hand or rubber hammer. Lay door down on newspaper with glass clips facing you. Using a #2 Phillips screwdriver, loosen the screws and take off the glass clips. Remove the broken glass carefully and discard.

Reverse the above procedure for replacing new glass with new gasket. Do not over tighten the screws. Over tightening can cause the glass to break.

WARNING

**Do not operate unit with broken glass.
Do not substitute original factory glass.
You must use only factory authorized glass;
Do not slam door shut.
Do not strike glass.
Do not use abrasive cleaners.**

CLEANING THE GLASS

When the fire is first started, it will produce some smoke. The soot might accumulate on the glass surface. Before the glass surface gets hot, open the door and wipe the glass surface off with a rag. Do not touch the surface with your hands. If after constant use, the glass is dirty, you must clean the glass so that it will not become etched with the fly ash. When the glass has cooled off, take a damp rag and clean with **Hearth Glass Cleaner** available from your dealer. Do not use a rag that contains nylon because it will melt to the glass.



UNDERSTANDING THE CONTROL BOARD

CONTROL PANEL

Turning the heater OFF/ON, as well as adjustments for the fuel feed rate and room fan speed are performed by pressing the appropriate button(s) on the control panel which is located on the lower left-hand side of your American Harvest heater. The insert model 6041I is located on the left facade.

This unit has two fuel operation modes for different fuels, corn or pellet. It may also be changed between an automatic operation or a manual operation in either of the fuel modes. The heater comes from the factory in the corn mode.

Pressing the "ON" button on the control panel will begin the start-up sequence for the heater. The start-up sequence differs depending on which fuel operation mode you select. See Lighting Instructions for details. Pressing and holding the "ON" button will rotate the auger continuously until button is released, which feeds additional fuel.

Pressing the "OFF" button on the control panel will cause the heater to enter its shut-down sequence. The fuel feed system will stop pulling fuel from the hopper and, once the fire goes out and the heater cools down, the fans will stop running.

Pressing the "Heat Range" arrows, up or down, will adjust the amount of fuel being delivered to the burnpot.

The draft fan (exhaust) will come on as soon as the "ON" button is pressed. The fan will automatically adjust its speed in accordance to the heat range setting. However, this speed can be manually operated by pressing the "Draft Fan" arrows up or down. "Draft Fan" when pressed, the display will show "Df-A", which is automatic. Press the arrows again to adjust fan speed. When adjusting the Draft Fan setting, try only 1 setting above or below the heat setting. It is better to leave the heater in the automatic mode and adjust the manual draft slide to control the combustion air.

The room fan will come on once the unit has reached operating temperature (approx. 110°F). By pressing the "Room Fan" buttons, the display will show "Rf-A" which is automatic or "Rf-1" through "Rf-9" for manual settings. In auto mode, the room fan's speed will automatically be adjusted in accordance with the heat range setting. By pressing the "Room Fan" up arrow, you can adjust the fan speed setting up to "Rf-9". The fan speed can be adjusted to a higher setting than the heat setting but not lower than the corresponding heat range.

The "Aux" button is for Agitator operation. When the unit is "OFF" and the heater is cool, pressing the "Aux" arrows will rotate the agitator for easy removal for cleaning. The agitator, when in Automatic mode, will operate at set intervals. However, these can be changed by pressing the arrows on the "Aux" button. The agitator can be adjusted from 0 to 9, setting "0" is off and setting "9" is high.

The "Auger Delay" button can be used to pause rotation of the Auger and Agitator for approx. 1 minute. This can be cancelled by pressing the "ON" button. The "Auger Delay" is normally used only during the start up cycle to slow the fuel delivery down during the initial ignition.

The "Mode" button is used to switch between manual and automatic mode. When in auto mode, the fan, auger, and agitator will operate at preset intervals unless changed manually using the buttons mentioned above. When in manual mode, the draft fan (exhaust) will operate at full speed (100%), so the air must be controlled with the manual slide damper just below the viewing door. When the heater is in the manual mode, the optional thermostat will not properly control the unit.

During normal operation, the unit is constantly monitored for problems. In the event of an error condition, the unit will stop and an error will be displayed. See the list of error codes found at the end of this manual.

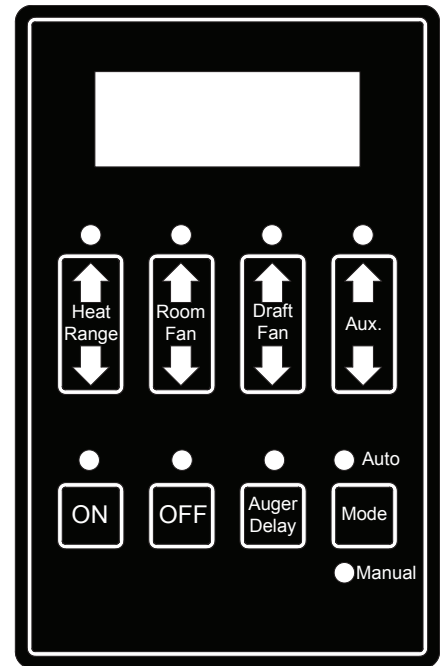

LIGHTING INSTRUCTIONS

CAUTION: DO NOT USE CHEMICALS OR FLUIDS TO START THE FIRE. HOT WHILE IN OPERATION. KEEP CHILDREN, CLOTHING AND FURNITURE AWAY. CONTACT MAY CAUSE SKIN BURNS.

Before lighting your heater for the first time, make sure that all items are out of the hopper, ash pan and firebox area. Close all doors and lids. Choose which fuel setting that you wish to operate in, Corn or Pellet. Do this by first pressing the "ON" button, then press the "Heat Range" Up and Down arrows together for approximately 3-4 seconds and release. A "C" or "P" in the first digit of the display will indicate the mode. The ON LED will be blinking and the display will show "Cr-1" or "Pr-1", depending on the mode. The "Heat Range" indicator LED and the "Auto" LED should be lit and the dash in the Heat Range display should be flashing. You will notice the draft fan starts immediately. If you press the "Heat Setting" button up, the draft fan changes speed, increasing speed the higher the heat setting. You should begin to see the igniter, located in the center and behind the burnpot, begin to glow after a short period of time. In Corn Mode, the auger and agitator will start rotating after a few minutes, allowing for proper fuel ignition. In Pellet Mode, the auger will turn immediately, then the agitator will begin to rotate once the heater reaches operating temperature. **Note:** The room fan will not operate at this time, as a temperature of at least 110 degrees must be reached before operating. If proper operation of your heater is confirmed, press the "OFF" button, then fill your hopper with the desired fuel. Ensure there is no foreign matter in your fuel, hopper or burnpot. You are now ready to light your Multi-Fuel Heater.

TO START A FIRE...

- **Never use gasoline, gasoline-type lantern fuel, kerosene, charcoal lighter fluid, or similar liquids to start or "freshen up" a fire in this heater. Keep all such liquids well away from the heater while it is in use.**

Using Wood Pellets: Ensure your display shows a "Pr" for pellets.

This heater is designed to burn only PFI Premium grade pellets. This appliance can also burn pellets rated as standard after May 16, 2015

DO NOT BURN:

- (1) Garbage;
- (2) Lawn clippings or yard waste;
- (3) Materials containing rubber, including tires;
- (4) Materials containing plastic;
- (5) Waste petroleum products, paints or paint thinners, or asphalt products;
- (6) Materials containing asbestos;
- (7) Construction or demolition debris;
- (8) Railroad ties or pressure-treated wood;
- (9) Manure or animal remains;
- (10) Salt water driftwood or other previously salt water saturated materials;
- (11) Unseasoned wood; or
- (12) Paper products, cardboard, plywood, or particleboard. The prohibition against burning these materials does not prohibit the use of fire starters made from paper, cardboard, saw dust, wax and similar substances for the purpose of starting a fire in an affected wood heater.

Burning these materials may result in release of toxic fumes or render the heater ineffective and cause smoke.

- Close all doors, lids, and cleanouts.
- Press the "ON" button and select desired heat range. This will start the ignition sequence.
- At this point, the igniter will come on and run for preset time limit (approximately 9 minutes). The auger will begin to turn and feed fuel into the burnpot. After the 9 minutes or if the heater reaches operating temperature, the igniter will shut off and normal operation will begin.
- Make fine adjustments to the air/fuel with the damper located centered, under the hearth.
- Once the heater reaches warm temperature, the room fan will start to circulate air into the room.
- If you would like to increase the life of your ignitor, you can run your heater in the "Cr" mode. However, you **must** place pellets in the burnpot, up to the igniter level as shown in the illustration below for auto ignition. Close the door and press the "ON" button. The igniter only runs approximately half the time in "Cr" as oppose to the "Pr" mode.

Using Corn, Soy Beans, Cherry Pits: Ensure your display shows a "Cr" for corn.

NOTE: Wood pellets MUST be used for auto ignition of the fuel. Corn, Soy Beans, and Cherry Pits have a higher flash point and requires more heat to combust as opposed to wood pellets. Trying to light the heater with a fuel other than wood pellets will decrease the life expectancy of your igniter cartridge.

The use of starter gel or starter pellets is not required for this heater.

- Fill the burnpot with wood pellets up to the level of the igniter port; See illustration.
- Close all doors, lids, and cleanouts.
- Press the "ON" button and select desired heat range. This will start the ignition sequence.

Once the wood fuel is ignited and the heater senses heat, the auger and agitator will begin to rotate, feeding fuel to the burnpot. **NOTE:** If the starting fuel is not burning hot enough, you may see the fire begin to go out as new fuel is being added. If this occurs, pressing the "Auger Delay" button will allow the auger to pause for 1 minute. Pressing the "ON" button will resume the auger if 1 min. is too long. If not enough fuel is the reason for not burning, pressing and holding the "ON" button will allow the auger to continuously deliver fuel until you release the button.

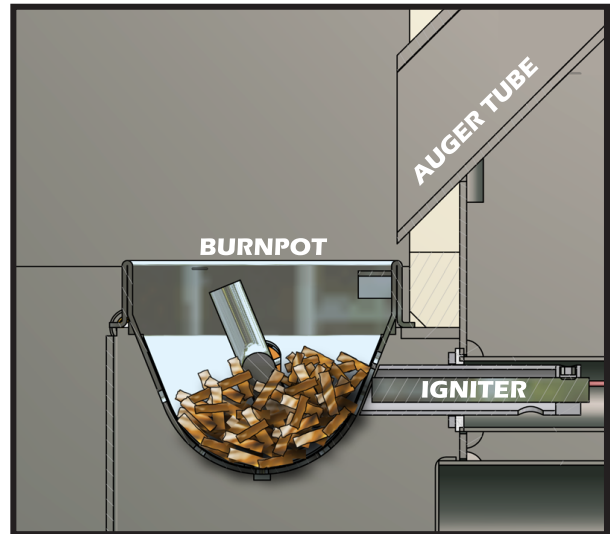

- Continue to observe the fire until most of the wood pellets have been consumed and only corn or your selected fuel is burning aggressively.
- Make fine adjustments to the air/fuel with the damper located centered, under the hearth. You should pull the damper out approximately 1 inch. It may need to be pulled out more or less depending on your selected heat setting and fuel quality. Try opening or closing by a 1/4 inch at a time.
- Once the heater reaches warm temperature, the room fan will start to circulate air into the room.
- **Overfire Protection** - If the heater is being overfired, burned too hot, the heater will automatically shutdown to avoid damage to components in the heater. Refer to "Lighting Instructions" for proper use.

TURNING THE HEATER OFF

Pressing the OFF button will cause the heater to enter a shutdown mode. If the heater has reached operating temperature, the OFF Indicator will blink until the shutdown procedure succeeds in lowering the heater temperature. The Room Fan will stay on to cool the heater, and the Exhaust Fan will stay on to remove smoke and heat from the combustion chamber. The Agitator will rotate continuously until shutdown is complete. The Auger will bump the fuel out every few seconds to prevent the fuel in the auger from burning. Once the temperature of the burn chamber falls below approximately 90 degrees Fahrenheit and the pressure switch detects that the door is closed, the fans will stop and the Auger will run for a few seconds to purge the auger system of any burned fuel. At this point, the OFF Indicator will go out and the heater will turn completely off. If during burning, the heater reached at least 120 degrees Fahrenheit, the shutdown procedure will include a 15 minute shutdown cycle that will keep the heater in the shutdown state for at least 15 minutes regardless of whether it is cool or pressure is detected. The 15 minute cycle can be turned off by pressing the off button during shutdown. This will cause the system to exit shutdown and return to the "OFF" mode as soon as the door is closed and the heater is cool.

Continue to monitor the heater / insert after the shutdown procedure has begun. And remember, varying ambient conditions may result in a lengthy period of time for adequate cool down and the resultant shut down. Be patient, this is normal. The control board is telling the heater / insert to gradually "shut down," rather than initiate a sudden halt of fuel to the fire pot. In this way, the possibility of smoke entering the home is avoided.

ⓘ NEVER shutdown or unplug the heater and leave it unattended. Observe operations for at least 20 minutes.

VISIBLE SMOKE

The amount of visible smoke being produced can be an effective method of determining how efficiently the combustion process is taking place at the given settings. Visible smoke consist of unburned fuel and moisture leaving your stove. Learn to adjust the air settings of your specific unit to produce the smallest amount of visible smoke. Wood that has not been seasoned properly and has a high wood moisture content will produce excess visible smoke and burn poorly.

DISPOSAL OF ASHES

DISPOSAL OF ASHES

Ashes should be placed in a metal container with a tight fitting lid. The closed container of ashes should be placed on a noncombustible floor or on the ground, well away from all combustible materials, pending final disposal. If the ashes are disposed of by burial in soil or otherwise locally dispersed, they should be retained in the closed container until all cinders have been thoroughly cooled.

SMOKE AND CO MONITORS

Burning wood naturally produces smoke and carbon monoxide(CO) emissions. CO is a poisonous gas when exposed to elevated concentrations for extended periods of time. While the modern combustion systems in heaters drastically reduce the amount of CO emitted out the chimney, exposure to the gases in closed or confined areas can be dangerous. Make sure you stove gaskets and chimney joints are in good working order and sealing properly to ensure unintended exposure. It is recommended that you use both smoke and CO monitors in areas having the potential to generate CO,

MAINTENANCE INSTRUCTIONS

SOOT AND FLYASH - FORMATION AND NEED FOR REMOVAL

The products of combustion will contain small particles of flyash. The flyash will collect in the exhaust venting system and restrict the flow of flue gases. Incomplete combustion, such as occurs during startup, shutdown, or incorrect operation of the room heater will lead to some soot formation which will collect in the exhaust venting system. The exhaust venting system should be inspected at least once per month (of heavy use) to determine if cleaning is necessary. Corn has a high ash content.

DAILY MAINTENANCE

- **Surfaces on the front of the heater will be extremely hot during operation.** Always wear heat resistant gloves to perform periodic maintenance.
- Using a wooden stick, tap the side heat exchangers that are located on the left and right sides of the firebox. When you open the door, they are located directly inside to the left and right. When you tap the sides with the wooden stick the loose fly ash will drop out of these holes.
- Inspect inside heater for excessive ash build up. You will learn some fuels produce more ash than others. If excessive, remove the inside ash clean-outs. Once you have cleaned out the ashes, replace the clean-outs. Depending on your fuel and use, these clean-outs may be removed only weekly.
- If clinkers develops in the firepot, clean thoroughly. You may have to do this once or twice a day depending on the moisture content of the corn. If this is not cleaned out, it could cause the agitator to jam. USSC highly recommends an additive (see Fuel Additive) be added to your corn to eliminate these clinkers. Contact your local dealer for availability and cost. You will need this additive if the agitator "fingers" develop an accumulation or build-up.
- The clinkers on the agitator and burnpot are easily removed when soaked in warm water for 10 minutes.
- The ash pan (especially the model 6041I) should be cleaned out on a daily basis or as needed depending ash build-up.

SPECIAL CLEANING/OPERATIONAL INSTRUCTIONS:

After cleaning or when operating the heater, you need to make sure that "both" clean-outs are in their proper position. If left out or placed incorrectly, the combustion air is effected greatly and the heater will not burn properly. Also, make sure that the ash dumps on each side of the damper are pushed in completely. This will also effect the combustion air.

WEEKLY MAINTENANCE

- Shut down the heater as directed in the operating instructions. Allow the heater to cool to room temperature. Remove the small clean-out slides in the lower corners of the firebox. Tap the sides of the burn chamber with a wooden stick. Do not tap the firewall behind the burn box as it may damage the ceramic firebrick. Scrape the fly ash from the clean-out chambers toward the front of the burn chamber. Remove the fly ash from the burn chamber and replace the clean-outs.
- Remove the ash pan and dump the ash into a metal container.
- Cleaning of the exhaust system will depend upon the ash and debris content of your fuel. If your fuel has a high ash content and/or significant debris in it, your exhaust system will require weekly cleaning. Cleaner fuels will allow for monthly cleaning of the exhaust system. Remove the exhaust pipe from the back of your heater and remove any ash that may have collected in the pipes. Replace the pipes to the heater and seal with high temperature seal tape. If you have installed proper clean out tees you will not have to take the chimney sections apart.

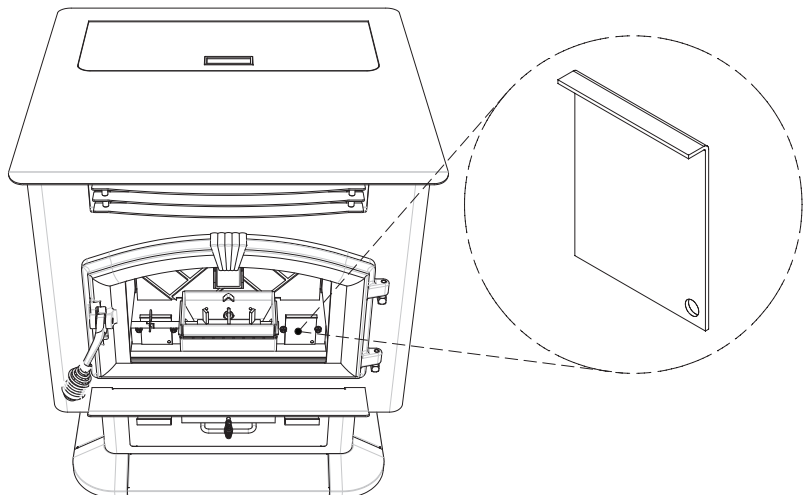

SPRING CLEANING

When the heating season is over make sure that you clean out all of the fuel in the hopper, firebox area, ash pan and firepot area. Corn and any ash can accumulate moisture over the summer months causing the unit to rust and the fuel to mold. Corn left in the unit will attract mice and can cause internal wiring and insulation damage.

When the unit is cleaned out, take the venting apart, clean out the fly ash, rinse the venting out with a water hose and let dry, take the draft fan off and clean, clean out all areas such as back heat exchanger and lubricate the auger, auger tube, firepot area, agitator shaft and bearings and hopper area with a light oil (something like Pam cooking oil works great to coat the inside of the unit and the moving parts). Clean the glass, doors and outer cabinet so that you are ready for the next heating season. Use of a wet/dry vacuum makes all cleaning easier.

WARNING

These automatic safety features must not be bypassed

Power Outage

- During a power outage, the heater will shut down. It will not automatically restart when the power returns, unless the heater is still above the proper operating temperature and a flame still exist in the burnpot.

Overheating

- A high temperature switch will automatically shut down the heater if it overheats. The heater will need to be manually relit. Allow 45 minutes before relighting. This wood heater has a manufacturer-set minimum low burn rate that must not be altered. It is against federal regulations to alter this setting or otherwise operate this wood heater in a manner inconsistent with operating instructions in this manual.
- Attempts to achieve heat output rates that exceed heater design specifications can result in permanent damage to the heater.

Hopper Safety Switch and Pressure Switch

FUEL ADDITIVE

- If the hopper lid is open, or if the front viewing door is not closed properly, the auger will not operate.

Chicken Scratch for my Corn Burner?

Yes - Crazy as it may sound, ground Oyster Shells, (calcium carbonate) same as fed to chickens, is the ideal additive to promote clean burning, especially when the Corn Fuel is extra high in starch. And it's available at your local Feed and Seed.

The "average" mixture is 1/2 pound of Oyster Shells (about 2 handfuls) to 60 pound of Corn, a full hopper. IF the "fingers" on your agitator (stirrer or rouser) have a noticeable buildup of "clinkers" or stubborn deposits, you have either a high starch fuel OR are burning with too much air for proper combustion and are reaching the "fusion" temperature of the Potassium and/or Starch in the Corn. You need Oyster Shells - and maybe more than a couple handfuls.

If you notice a heavy accumulation of "whitish powder" in your burn pot, reduce the amount of Oyster Shell Additive.

Remember, using this additive- as necessary - promotes efficiency (higher heat output), reduces maintenance, clinkers and ash content.

ATTENTION:

This wood heater needs periodic inspection and repair for proper operation. It is against federal regulations to operate this wood heater in a manner inconsistent with operating instructions in this manual.

CONTROL BOARD FUNCTIONS

START-UP SEQUENCE OF EVENTS

Once the control panel is turned on, a timer begins that will start, stop and continue operation of the Multi-fuel Heater as a preset temperature is achieved.

COMPONENT	OPERATION START	OPERATION END
Draft Fan	Starts Immediately	Will continue until shutdown. Shutdown will occur when the operating temperature is below approx. 90 degrees.
Agitator	Begins to turn once the heater reaches operating temperature	Will continue intermediately, as determined by the "HEAT SETTING", until shutdown.
Auger	In Pellet mode: Auger turns immediately. In Corn mode: Three minutes after starting, the auger will begin to turn	The auger will continue at the feed rate specified by the "HEAT SETTING". NOTE: Safety switches, HI limit and vacuum sensor, must be activated to continue proper operation.
Room Fan	Begins to run when heater reaches operating temperature	Will continue to operate until the heater cools down to below approx. 90 degrees. This may take several hours.
Automatic Shutdown	If after 15 minutes, the heater has not reached the preset operating temperature, the unit will begin to automatically shut down.	Should the timer expire before the preset operating temperature is achieved, simply reset the heater by pressing the "ON" button.
Normal Operation	If after 15 minutes the preset operating temperature of approx. 110 degrees is achieved, normal operation will continue.	Operation will continue until either the heater's control is to the "OFF" position, or the operating temperature falls below approx. 90 degrees. At such time the heater will default to the "Automatic Shut Down".
Igniter	Starts immediately	Will continue operation for a preset time, then shut-off

SHUTDOWN SEQUENCE OF EVENTS

Once the Heater has reached the normal operating temperature and switched to the "OFF" position, the unit will initiate a slow down, reducing the fuel rate until the heater's "LOW LIMIT SAFETY" sensor tells the control board it is safe to shutdown.

COMPONENT	SHUTDOWN	OPERATION END
Draft Fan	Unchanged operation until preset "OFF" temperature is achieved.	Continues until the operating temperature falls below approx. 90 degrees. May take several hours.
Agitator	Rotates continuously until preset "OFF" temperature is achieved.	Continues until the operating temperature falls below approx. 90 degrees.
Auger	Slows down to a reduced fuel setting until preset "OFF" temperature is achieved.	The auger will continue at the reduced feed rates until the operating temperature falls below approx. 90 degrees. NOTE: Safety switches, HI limit and vacuum sensor, must be activated to continue proper operation.
Room Fan	Unchanged operation until preset "OFF" temperature is achieved.	Will continue to operate until the heater cools down to below approx. 90 degrees. This may take several hours.
Automatic Shutdown	If the heater's "HI LIMIT" sensor snaps open, this will cause an automatic shutdown. An error code will be displayed (Err1). NOTE: "HI LIMIT" errors are usually the result of operating at the highest heat setting for long periods of time, room fan failure or loose wire connection.	It is rare that the HI LIMIT temperature is reached. However, should this error occur, let the heater cool down for an hour then restart.

CAUTION: When performing any internal electrical maintenance

- Moving parts inside of the cabinet may cause injury. Do not operate unit with panels removed or open.
- **HOT** parts. Do not operate the unit with panel open.
- Risk of electric shock. Disconnect power before servicing unit.
- In the event of component failure, replace with the original factory equipment.

ERROR CODES and DISPLAY INDICATORS

Error Code	Error Description	Possible Causes
Err1	The high limit temperature sensor has tripped.	<ul style="list-style-type: none"> • Inadequate ventilation. • Room fan failure. • Exhaust Blockage. • Electrical Open in the over temperature switch or wiring.
Err2	The low limit temperature sensor has tripped.	<ul style="list-style-type: none"> • Hopper Empty. • Auger output failure or jam. • Poor flame or fuel quality caused fire to burn too slowly or go out. • Electrical Open in low temperature switch or wiring. • Fire was not well established before the PCB's programmed time limit expired.
Err3	The heater was unable to reach the Room Fan On temperature within the startup time.	<ul style="list-style-type: none"> • Poor flame or fuel quality caused fire to burn too slowly or go out. • Auger output failure or jam Hopper empty on startup.
Err4	The power failed while the heater was hot, and when power was restored, the fire was out.	<ul style="list-style-type: none"> • Electrical Open in low temperature switch or wiring. • Power loss
Err5	The Auger output fuse has blown.	<ul style="list-style-type: none"> • Auger motor jammed or bad.
Err6	The Agitator output fuse has blown.	<ul style="list-style-type: none"> • Agitator motor jammed or bad.
Err7	The Draft Fan (Exhaust Fan) output fuse has blown.	<ul style="list-style-type: none"> • Draft Fan motor jammed or bad.
Err8	The Room Fan output fuse has blown.	<ul style="list-style-type: none"> • Room fan motor jammed or bad.
Err9	Zero Crossing Input failed	<ul style="list-style-type: none"> • AC supply frequency out of range.
Err10	The Igniter output fuse has blown	<ul style="list-style-type: none"> • Igniter output has shorted/blown or igniter overload.

DISPLAY INDICATORS

Several situations or events are indicated in normal operation by blinking display indicators or segments in the display:

Flashing On Indicator: This means that the heater is in the “Start Up” awaiting for the ignition procedure to complete.

Flashing Off Indicator: This indicates that the heater is in the “Shutdown” state waiting for the OFF button, or for a 15 minute period after the heater was turned off, or for the heater to cool down, or for the door to be closed.

Flashing dash in Heat Range Display: This indicates that the heater is in the normal run mode and is ramping from the current heat range setting to the target heat range setting. Once the ramp is complete, the dash will stop flashing. For ramping from heat range 1 to 5, the default time is 12 minutes (with a 90 second ramp time).

Flashing heat range value in “Heat Range” display: For example, if the display is showing “Hr-3” and the ‘3’ is blinking, this indicates that the heater thermostat input is open and not calling for heat. While this is happening, the actual heat range value is 1 (low).

Flashing Automatic Mode Indicator: This indicates that the heater is in normal operation and is running in the automatic mode. However, either the Draft Fan or Auxiliary setting is manually configured.

Flashing Draft Fan Setting Indicator: This indicates that the heater is in normal operation and that the vacuum sensor detects a loss of pressure either because the door is open or because there is a negative pressure in the room with respect to the exhaust.

Flashing Aux Indicator: This indicates that the igniter is on during the lighting stage.

Quick (changes twice per second) Flashing Heat Range Setting Indicator : This indicates that the heater is in normal operation and that an over temperature condition exists causing the fuel to stop.

Slow (changes once per second) Flashing Heat Range Setting Indicator : This indicates that the heater is in a cutback condition in an attempt to prevent an over temperature shutdown.

FACTORY DEFAULTS

To return the control to its original factory default settings, press and hold the AUX UP and AUX DOWN buttons together for three seconds.

TROUBLE SHOOTING

① **Disconnect the power supply before performing any maintenance! NOTE: Turning the heater to “OFF” does not disconnect the power to all of the electrical components of the heater.**

① **Never try to repair or replace any part of the heater unless instructions for doing so are given in this manual. All other work should be done by a trained technician.**

PROBLEM	CAUSE: Too rich air/fuel mixture
Orange, lazy flame, excessive fuel build-up in the burnpot.	<ul style="list-style-type: none"> • Clean out the burnpot • Make sure the cleanouts on each side of the damper are closed completely. • Not enough combustion air. Adjust the air damper to a more open position. • Make sure that the viewing door is closed and sealed properly. If not, adjust the door catch or replace the gasket. • Check that all outside connections are clear of any obstructions. • Check the exhaust system, clean as needed.
PROBLEM	Cause: Burnpot out of fuel
Fire goes out or heater shuts down	<ul style="list-style-type: none"> • Hopper is empty, refill the hopper • Loss of draft pressure. Make sure the viewing door is closed and sealed properly. Check the outside connections for any obstructions. Check the exhaust system; clean as needed. • Check that the pressure switch connection to the firebox is free of ashes or clear of any obstructions. • Auger system may be jammed or there is a “bridging” of fuel in the hopper preventing fuel flow into the auger feed system. • Too much combustion air. Adjust damper to a more closed position.
PROBLEM	Cause: Auto-Start Igniter fails to ignite the fuel in the burnpot.
Heater does not start a fire when the “ON” button is pressed.	<ul style="list-style-type: none"> • Check the pellets quality. If moist or damp, replace with dryer fuel. • Check that the auto-start igniter port is not blocked with ash or soot. (The igniter is located behind the burnpot.) • The auto-start igniter should glow on start-up. If you can not visible see the igniter glowing, then it may need to be replaced or there is a problem with the electrical system. Check wiring. • Loss of draft pressure. Make sure the viewing door is closed and sealed properly. Check the outside connections for any obstructions. Check the exhaust system; clean as needed.
PROBLEM	Cause: Not enough combustion air or fuel has too much moisture.
Viewing glass becomes black shortly after start-up.	<ul style="list-style-type: none"> • Adjust the air damper to a more open position. • Use a fuel with less moisture content.
PROBLEM	Cause: Not enough combustion air or fuel has too much moisture.
“Black Popcorn” is present in the burn chamber.	<ul style="list-style-type: none"> • Not enough combustion air. Adjust the air damper to a more open position. • Check moisture content in corn. Use corn with a moisture content of 11-12% or less.
PROBLEM	Cause: Corn is wet or has a high moisture content.
Corn builds up in burnpot or is not burning completely. Steam is coming from corn.	<ul style="list-style-type: none"> • Not enough combustion air. Adjust the air damper to a more open position. • Check moisture content in corn. Use corn with a moisture content of 11-12% or less.
PROBLEM	Cause: Chemical reaction between the starches in corn and the heat.
“Clinkers” form in burnpot and on agitator.	<ul style="list-style-type: none"> • Adjust air mixture. • Add calcium carbonate (aka chicken scratch or oyster shell) • Try running a mixture of wood pellets and corn.

WIRING DIAGRAM

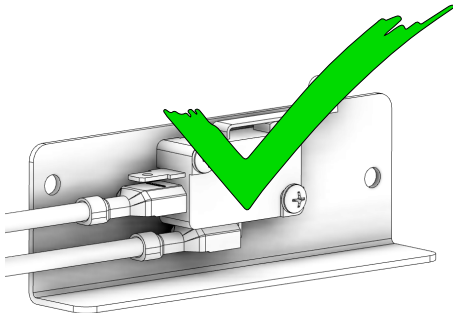
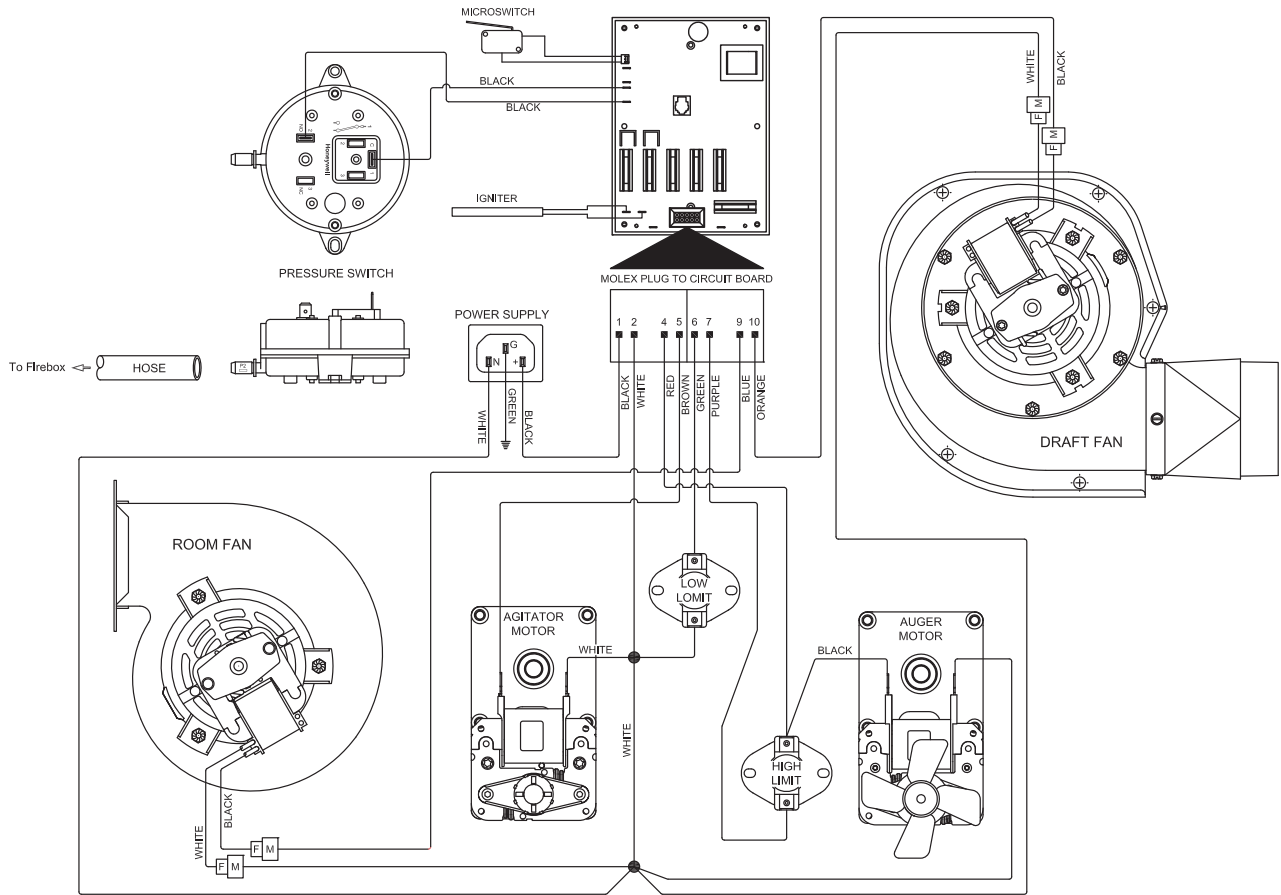

CORRECT

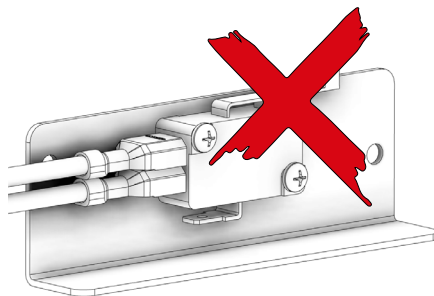

WRONG

Insure the wires are connected to the bottom two prongs of the hopper switch as shown.

WIRING SCHEMATIC

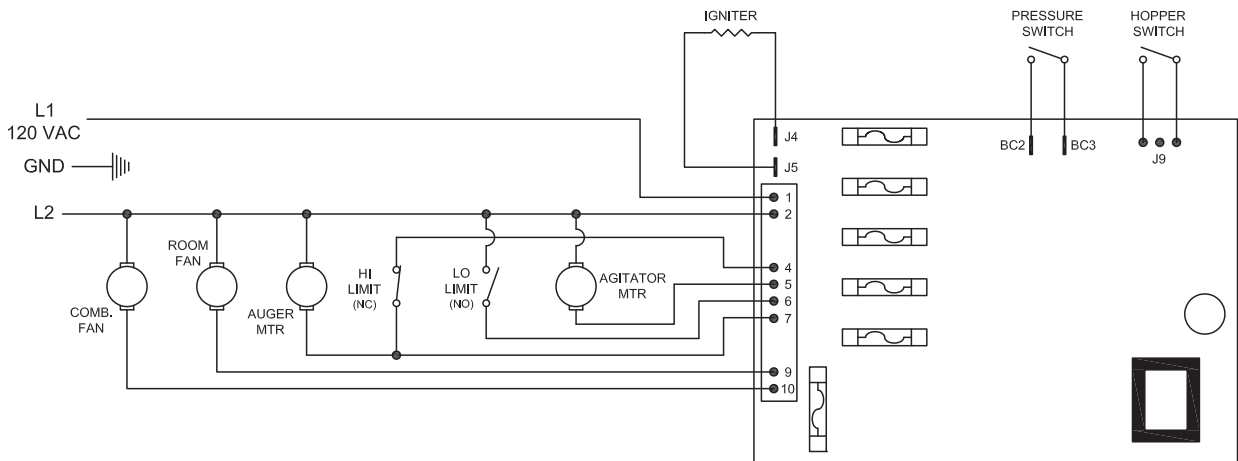

PARTS DIAGRAM

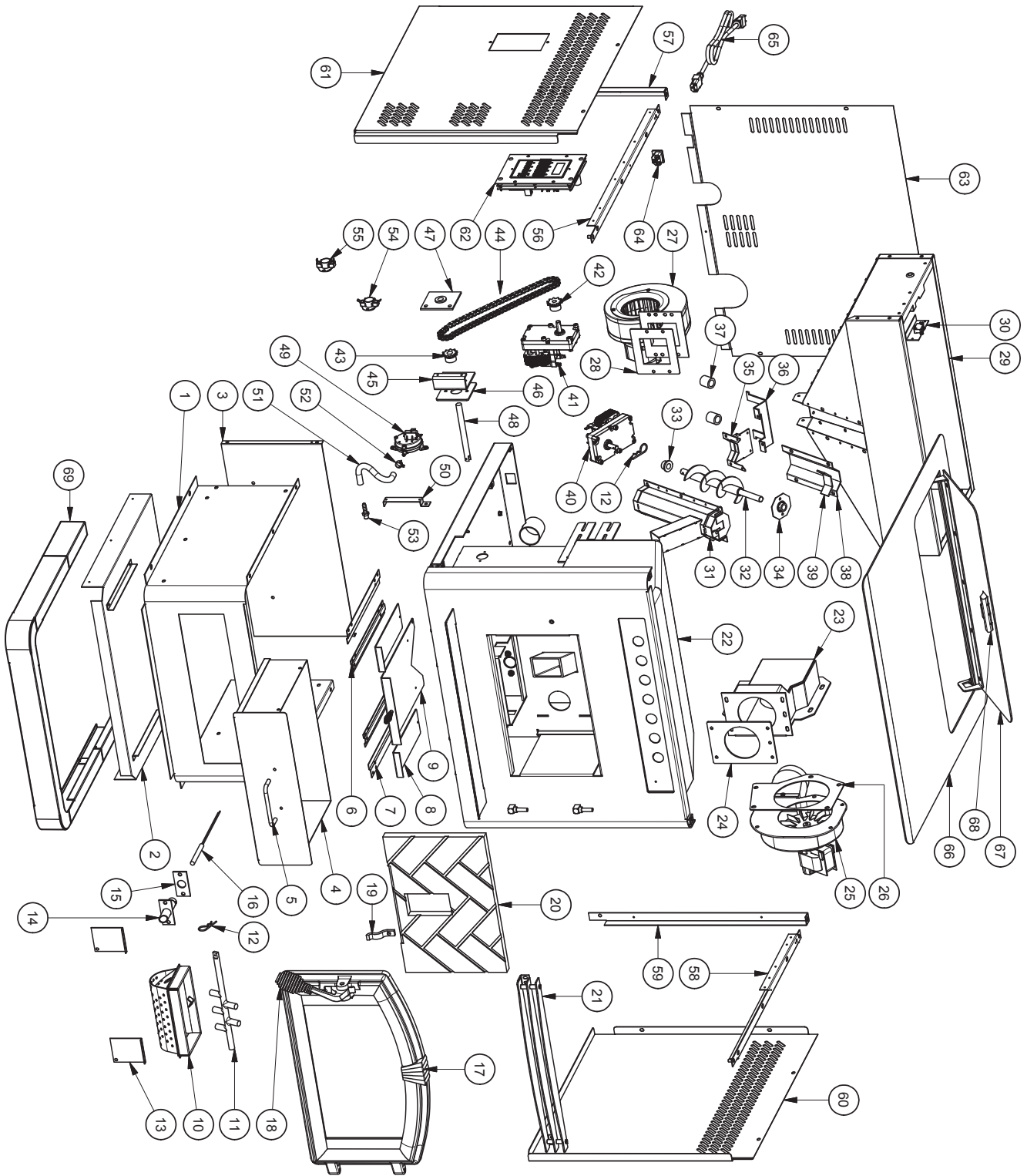

PARTS LIST

Key	Part No.	Description	Qty.
1	69529	Pedestal	1
2	25410	Pedestal Bottom	1
3	25451	Pedestal Back	1
4	69478	Ash Pan	1
5	891137	Handle	1
6	25533	Damper/Cleanout Guide	2
7	25532	Cleanout Guide	2
8	25531	Ash Cleanout (Lower)	2
9	69528	Damper	1
10	891660	Burnpot	1
11	891059	Agitator	1
12	83529	Hair Pin	2
13	25524	Ash Cleanout (Inner)	2
14	69593	Igniter Tube Weldment	1
15	88118	Igniter Flange Gasket	1
16	80543	Igniter Cartridge	1
17	69516	Feed Door Assembly	1
18	891135	Spring Handle (Large)	1
19	25080	Door Latch	1
20	891705	Vermaculite Board (Herringbone)	1
21	69497	Louver Assembly	1
22	88116	Insulation (Kaowool)	1
23	86627	Exhaust Duct	1
24	88114	Exhaust Duct Weldment	1
25	80473	Exhaust Blower	1
26	88100	Exhaust Blower Gasket	1
27	80472	Distribution Blower	1
28	88106	Distribution Blower Gasket	1
29	69598	Hopper Assembly - Complete	1
30	80491	Micro Switch	1
31	891164	Auger Housing Weldment	1
32	891141	Auger	1
33	891132	Bottom Bushing (Retaining Ring - Pt #: 83534)	1
34	69514	Top Bushing Plate Assy.	1
35	891248	Bottom Plate Retainer	1

Key	Part No.	Description	Qty.
36	891195	Drive Motor Bracket	1
37	891169	Hose (2 per)	0.167 ft
38	891180	Auger Cover	
39	88120	Gasket, 0.188 x 1.0 Flat FbrGlss.	0.25 ft
40	80488	Drive Motor (Auger)	1
41	80456	Drive Motor (Agitator)	1
42	891083	Sprocket, Motor	1
43	891057	Sprocket, Shaft	1
44	891058	Chain - 36 Links	1
45	69594	Primary Bushing Assembly	1
46	88111	Agitator Bracket Gasket	1
47	69595	Secondary Bushing Assembly	1
48	891706	Drive Shaft - Agitator	1
49	80549	Pressure Switch	1
50	25648	Pressure Switch Bracket	1
51	891121	Silicone Hose	0.4 ft
52	83564	Hose Clamp	1
53	89586	Auger Nipple	1
54	80381	110°F Snap Disc (Low Limit)	1
55	80390	170°F Snap Disc (High Limit)	1
56	69506	Cabinet Support, Top/Left	1
57	25448	Support Frame, Back/Left	1
58	69505	Cabinet Support, Top/Right	1
59	25447	Support Frame, Back/Right	1
60	25412	Right Cabinet Side	1
61	25411	Left Cabinet Side	1
62	80575	PCB, Circuit Board	1
N/S	80485	Wiring Harness, Main	1
63	25682	Cabinet Back	1
64	80462	Receptacle, 3-Prong	1
65	80461	Power Supply Cord	1
66	69586MB	Top/Lid Assembly	1
67			
68	891148	Plastic Handle	1
69	891963	Pedestal Trim (One Piece)	1
N/S = Not Shown			

**IN ORDER TO MAINTAIN WARRANTY, COMPONENTS MUST BE REPLACED USING ORIGINAL MANUFACTURERS PARTS PURCHASED THROUGH YOUR DEALER OR DIRECTLY FROM THE APPLIANCE MANUFACTURER.
USE OF THIRD PARTY COMPONENTS WILL VOID THE WARRANTY.**

PARTS DIAGRAM - 6041I

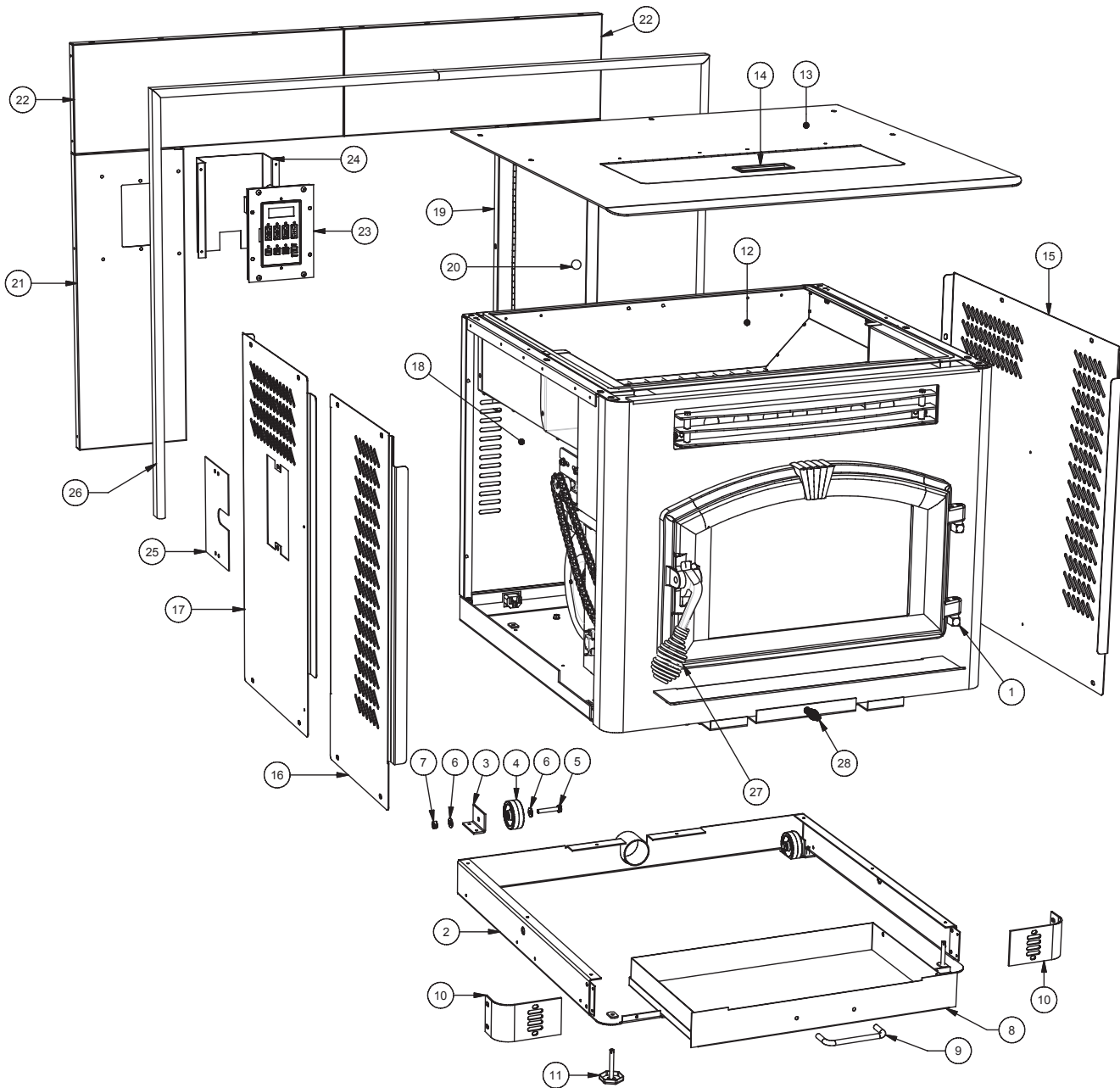

PARTS LIST - 6041I

Key	Part No.	Description	Qty.
1	891373	Pad, Door Hinge (Threaded)	2
2	69547	Weldment Sub-Base	1
3	25569	Bracket, Caster	2
4	891424	Caster, Plastic	2
5	83412	1/4-20 x 1-1/2 Hex Bolt	2
6	83136	Washer	4
7	83261	1/4-20 Lock Nut	2
8	69548	Weldment, Ash Pan	1
9	891137	Handle (Brushed Nickel)	1
10	25570	Facade, Bottom	2
11	83479	Leveler	2
12	69619	Hopper Assembly	1
13	69765	Weldment, Cabinet Top	1
14	891148	Handle, Plastic	1
15	25581	Right Side Cabinet	1
16	25579	Left Side-Front Cabinet	1
17	25580	Left Side-Rear Cabinet	1
18	25578	Back, Cabinet	1
19	69766	Wldmt., Facade Panel Rt-Side	1
20	89943	Knob, Cabinet Door	1
21	25585	Panel-Left Side Facade	1
22	25590	Top-Panel, Facade (2 piece)	2
23	80575	Circuit Board (PCB)	1
24	25583	Cover, PCB	1
25	25582	Cover, Panel	1
26	891435	Kit, Facade Trim (B-Lux)	1
27	891135	Handle, Spring (Large)	1
28	891331	Handle, Spring (Small)	1

Add the suffix "MB" to the part number of any painted part.

Notice:

For all other repair components not listed above, refer to the 6041TP Repair list and diagrams for info.

PARTS DIAGRAM/LIST

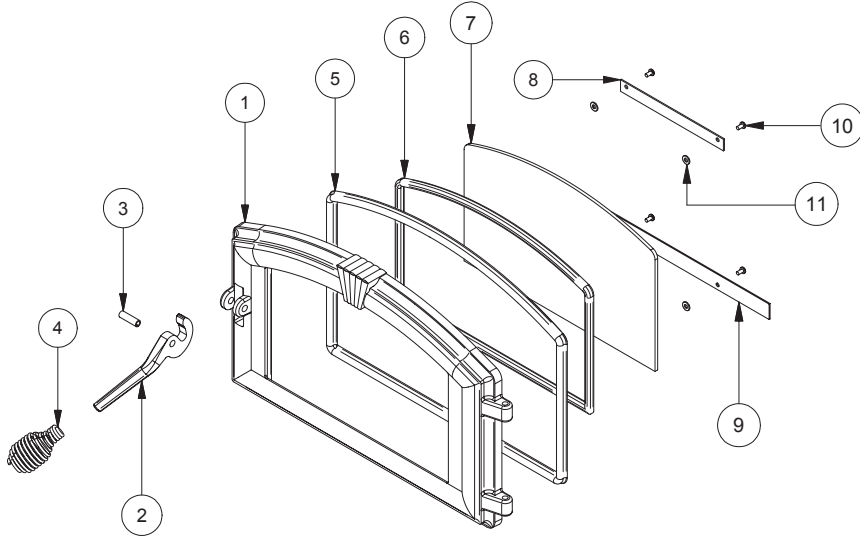

Parts List	Key	Part No.	Description	Qty.	Key	Part No.	Description	Qty.
	1	25491	Feed Door	1	7	891131	Glass Ceramic	1
	2	25492	Handle, Door	1	8	25464	Retainer, Top Glass	1
	3	83506	Roll Pin, 3/8 x 1-1/4	1	9	25465	Retainer, Bottom Glass	1
	4	891135	Handle, Spring (Parts Bag)	1	10	83202	Machine Screw	4
	5	88112	Gasket, 1/2" Sq. Rope	5 ft	11	83278	#10 Flat Washer	4
	6	88087	Gasket, Glass (1 x 3/16)	4 ft				

NOTES

HOW TO ORDER REPAIR PARTS

This manual will help you obtain efficient, dependable service from the furnace, and enable you to order repair parts correctly.

Keep this manual in a safe place for future reference.

When placing an order or for warranty claims, please provide the following information found on the Certification Plate located below the ash door.

PART NUMBER

PART DESCRIPTION

MODEL NUMBER

SERIAL NUMBER

United States Stove Company

227 Industrial Park Road
P.O. Box 151
South Pittsburg, TN 37380
(800)-750-2723

NOTES:

MATERIAL: 0.012 THK. ALUMINUM / 3M 9672 (or equivalent) ADEHESIVE BACKED.

FINISH: BLACK BACKGROUND, SILVER TEXT AND ILLUSTRATIONS UNLESS NOTED OTHERWISE.

TEXT: ALL TEXT TO BE 0.08 HIGH UNLESS OTHERWISE SPECIFIED

HEATER MANUFACTURER INSTRUCTIONS:

ALL PLATES ARE TO BE STAMPED BY THE HEATER MFG. WITH A FACTORY IDENTIFIER NUMBER ISSUED BY USSC. (i.e. 00000-XX)

WHEN LABEL IS APPLIED TO THE HEATER, IT IS TO BE FIRMLY PRESSED OVER THE ENTIRE SURFACE TO ENSURE IT PROPERLY ADHERES TO THE MATING SURFACE OF THE HEATER.

REVISION HISTORY

REV	DESCRIPTION	DATE	BY
A	INITIAL RELEASE	4/8/2009	CDB
B	ADDED USSC PHONE NUMBER	2/22/2011	REC
C	REVISED PER EPA RULING 2015	5/12/2015	CDB
D	NEW OMNI LOGO CHANGED "TESTED TO" TO "CERTIFIED TO"	11/28/8	SEH
E	CHANGED TO EPA 2020	7/24/19	SEH

CAUTION: HOT WHILE IN OPERATION-DO NOT TOUCH. KEEP CHILDREN AND CLOTHING AWAY. CONTACT MAY CAUSE SKIN BURNS. SEE NAMEPLATE AND INSTRUCTIONS. KEEP FURNISHINGS AND OTHER COMBUSTIBLE MATERIALS A CONSIDERABLE DISTANCE AWAY FROM THE APPLIANCE. OPERATE THIS UNIT ONLY WITH THE FUEL HOPPER LID CLOSED. FAILURE TO DO SO MAY RESULT IN EMISSION OF PRODUCTS OF HOPPER UNDER CERTAIN CONDITIONS. MAINTAIN HOPPER SEAL IN GOOD CONDITION. DO NOT OVERFILL HOPPER.

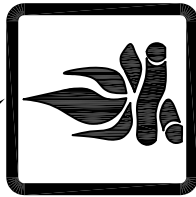

THIS PELLET FIRED APPLIANCE HAS BEEN TESTED AND LISTED FOR USE IN MOBILE HOMES. "FOR USE WITH PELLET FUEL or SHELLED CORN (15% or LESS MOISTURE)"

MODEL: 6041i
Certified to ASTM E1509, (UM) 84HUD

U.S. Environmental Protection Agency
Certified to comply with 2020 particulate emission standards. Tested to method ASTM E2779 / Method 28R 1.28 g/hr

ELECTRICAL RATING: 120V, 15A, 60Hz

INPUT RATING: 32,000 BTU/HR (PELLET FUEL)

REPORT NO. 215-S-01d-2

REPORT NO. 19-495

MINIMUM CLEARANCES TO COMBUSTIBLE MATERIALS

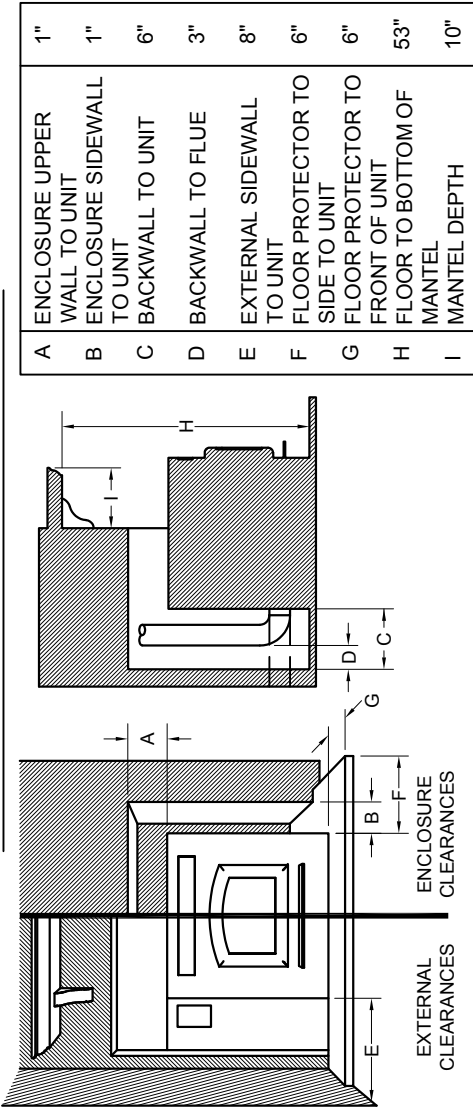

PREVENT HOUSE FIRES - Install and use ONLY in accordance with the installation and operating instructions. Contact local building or fire officials about restrictions and installation inspection in your area. DO NOT connect this unit to a chimney flue serving another appliance. See local building code and manufacturer's instructions for precautions required for passing through a combustible wall or ceiling. Inspect and clean exhaust vent system frequently in accordance with manufacturer's instructions. Keep viewing and ash removal doors tightly closed during operation. Exhaust vent required for residential installation or mobile home installation is a listed type "L" or "PL" venting - 3"/75mm or 4"/100mm diameter.

CAUTION: RISK OF EXCESSIVE TEMPERATURES. HOT OR MOVING PARTS MAY CAUSE INJURY. DO NOT OPERATE WITH SIDE PANELS REMOVED. REPLACE GLASS ONLY WITH 5MM CERAMIC GLASS.

DANGER: RISK OF ELECTRICAL SHOCK. DISCONNECT POWER BEFORE SERVICING UNIT. ROUTE SUPPLY CORD AWAY FROM UNIT.

WARNING: DO NOT INSTALL IN A SLEEPING ROOM. THE STRUCTURAL INTEGRITY OF THE MANUFACTURED HOME'S FLOOR, WALL, AND CEILING/ROOF MUST BE MAINTAINED.

This wood heater needs periodic inspection and repair for proper operation. Consult the owner's manual for further information. It is against federal regulations to operate this wood heater in a manner inconsistent with the operating instructions in the owner's manual.

START UP: Automatic Ignition - Shut door, Press the "ON" button, Select Heat setting.
SHUT DOWN: Turn the heat setting to "OFF". Unit will shut down automatically after fuel burns out and unit cools down.

DO NOT REMOVE OR COVER THIS LABEL

U.S. STOVE COMPANY • 227 INDUSTRIAL PARK ROAD • SOUTH PITTSBURGH, TN 37380 • Ph. #: (800) 750-2723 • www.USSTOVE.com

851780E

0.125 TEXT HEIGHT

9.50

0.125 TEXT HEIGHT

0.25 TEXT HEIGHT

BOARDER, LOGS, AND FLAMES ARE TO BE RED, 1" sq.

<p>© 2010 United States Stove Company ALL RIGHTS RESERVED THE DATA CONTAINED HEREIN IS PROPRIETARY TO U. S. STOVE COMPANY. THIS DATA SHALL NOT BE DUPLICATED, TRANSFERRED, MADE AVAILABLE, OR USED BY ANY THIRD PARTY FOR ANY PURPOSE EXCEPT SPECIFICALLY AUTHORIZED IN WRITING BY U. S. STOVE COMPANY.</p>		<p>TOLERANCES EXCEPT AS NOTED</p>	<p>HOLES ± .005" DECIMAL XX = 0.03 XXX = 0.010 ANGULAR ± 2"</p>	<p>DESCRIPTION SEE NOTE FINISH SEE NOTE REFERENCE 6041 INSERT</p>	<p>SCALE 1:1 DWN BY CDB DATE 2/19/09</p>	<p>SIZE B REV E TITLE LABEL, CERTIFICATION</p>	<p>UNITED STATES STOVE COMPANY ESTABLISHED 1869 NUMBER 851780</p>	<p>SHEET 1 OF 1</p>
---------------------------------------------------------------------------------------------------------------------------------------------------------------------------------------------------------------------------------------------------------------------------------------------------------------------	--	---------------------------------------	-------------------------------------------------------------------------------------	---------------------------------------------------------------------------------------	--------------------------------------------------------------	--------------------------------------------------------------------	-------------------------------------------------------------------------------	-------------------------

REVISION HISTORY			
REV	DESCRIPTION	DATE	BY
A	INITIAL RELEASE	4/12/2012	CDB
B	REVISED PER EPA RULING 2015	5/13/2015	CDB
C	ADDED PFS CHANGED TO BE EPA 2020	7/23/19	SEH

NOTES:

MATERIAL: 0.012 THK. ALUMINUM / 3M 9672 (or equivalent) ADEHESIVE BACKED.

FINISH: BLACK BACKGROUND, ALUMINUM TO SHOW THRU
(ALL TEXT AND ILLUSTRATIONS) UNLESS NOTED OTHERWISE.

TEXT: ALL TEXT TO BE 0.08 HIGH UNLESS OTHERWISE SPECIFIED

BOARDER, LOGS, AND FLAMES ARE TO BE RED, 1" sq. 0.25 TEXT HEIGHT 0.125 TEXT HEIGHT

CAUTION: HOT WHILE IN OPERATION-DO NOT TOUCH. KEEP CHILDREN AND CLOTHING AWAY. CONTACT MAY CAUSE SKIN BURNS. SEE NAMEPLATE AND INSTRUCTIONS. KEEP FURNISHINGS AND OTHER COMBUSTIBLE MATERIALS A CONSIDERABLE DISTANCE AWAY FROM THE APPLIANCE. OPERATE THIS UNIT ONLY WITH THE FUEL HOPPER LID CLOSED. FAILURE TO DO SO MAY RESULT IN EMISSION OF PRODUCTS OF HOPPER UNDER CERTAIN CONDITIONS. MAINTAIN HOPPER SEAL IN GOOD CONDITION. DO NOT OVERFILL HOPPER.

PREVENT HOUSE FIRES - Install and use ONLY in accordance with the installation and operating Instructions. Contact local building or fire officials about restrictions and installation inspection in your area. DO NOT connect this unit to a chimney flue serving another appliance. See local building code and manufacturer's instructions for precautions required for passing through a combustible wall or ceiling. Inspect and clean exhaust vent system frequently in accordance with manufacturer's instructions. Keep viewing and ash removal doors tightly closed during operation. Exhaust vent required for residential installation or mobile home installation is a listed type "L" or "PL" venting - 3"/75mm or 4"/100mm diameter.

CAUTION: RISK OF EXCESSIVE TEMPERATURES. HOT OR MOVING PARTS MAY CAUSE INJURY. DO NOT OPERATE WITH SIDE PANELS REMOVED. REPLACE GLASS ONLY WITH 5MM CERAMIC GLASS.

DANGER: RISK OF ELECTRICAL SHOCK. DISCONNECT POWER BEFORE SERVICING UNIT. ROUTE SUPPLY CORD AWAY FROM UNIT.

WARNING: DO NOT INSTALL IN A SLEEPING ROOM. THE STRUCTURAL INTEGRITY OF THE MANUFACTURED HOME'S FLOOR, WALL, AND CEILING/ROOF MUST BE MAINTAINED.

This wood heater needs periodic inspection and repair for proper operation. Consult the owner's manual for further information. It is against federal regulations to operate this wood heater in a manner inconsistent with the operating instructions in the owner's manual.

START UP: Automatic Ignition - Shut door, Press the "ON" button, Select Heat setting.
SHUT DOWN: Turn the heat setting to "OFF". Unit will shut down automatically after fuel burns out and unit cools down.

MANUFACTURED BY: 109 East 17th Street, Suite 5478 • Cheyenne, WY 82001 • Phone: 833-222-3421 • Web: www.acadiahearth.com



THIS PELLET FIRED APPLIANCE HAS BEEN TESTED AND LISTED FOR USE IN MOBILE HOMES. "FOR USE WITH PELLET FUEL or SHELLED CORN (15% or LESS MOISTURE)"



MODEL: SP6000



Certified to ASTM E1509, (UM) 84HUD
U.S. Environmental Protection Agency
Certified to comply with 2020 particulate emission standards.
Tested to method ASTM E2779 / Method 28R 1.28 g/hr

REPORT NO. 19-495

Serial No. Manufacture Date.

ELECTRICAL RATING: 120V, 15A, 60Hz INPUT RATING: 32,000 BTU/HR (PELLET FUEL)

- MINIMUM CLEARANCES TO COMBUSTIBLE MATERIALS**
- PARALLEL — A - BACKWALL TO FLUE 3 IN/75MM
 - B - BACKWALL TO UNIT 9 IN/228MM
 - C - SIDEWALL TO FLUE 13 IN/330MM
 - D - SIDEWALL TO TOP EDGE OF UNIT 8 IN/203MM
 - CORNER — E - ADJACENT WALL TO UNIT 4 IN/100MM
 - F - ADJACENT WALL TO FLUE 3 IN/75MM

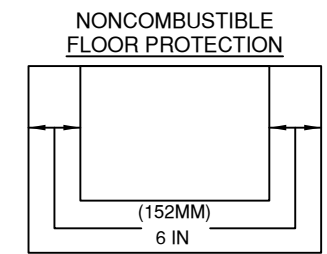
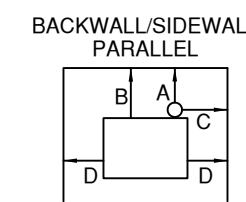
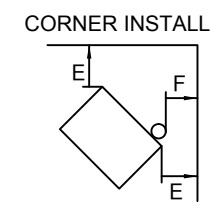

A 1" THICK NONCOMBUSTIBLE FLOOR PROTECTOR IS RECOMMENDED FOR THIS INSTALLATION.

DO NOT REMOVE OR COVER THIS LABEL

851983C

SERIAL & DATE BOX DETAIL

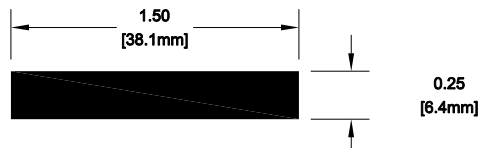

<p>© 2010 United States Stove Company</p> <p>ALL RIGHTS RESERVED THE DATA CONTAINED HEREIN IS PROPRIETARY TO U. S. STOVE COMPANY. THIS DATA SHALL NOT BE DUPLICATED, TRANSFERRED, MADE AVAILABLE, OR USED BY ANY THIRD PARTY FOR ANY PURPOSE EXCEPT SPECIFICALLY AUTHORIZED IN WRITING BY U. S. STOVE COMPANY.</p>		<p>TOLERANCES EXCEPT AS NOTED</p> <p>HOLES ± .005" DECIMAL .XX = 0.03 .XXX = 0.010 ANGULAR ± 2°</p>	<p>DESCRIPTION FINISH REFERENCE</p> <p>SEE NOTE SEE NOTE SP6000</p>	<p>SCALE DWN BY DATE</p> <p>1:1 CDB 4/12/12</p>	<p>SIZE REV</p> <p>B C</p>	<p>TITLE NUMBER SHEET</p> <p>LABEL, CERTIFICATION 851983 1 OF 1</p>	<p>UNITED STATES STOVE COMPANY ESTABLISHED 1869</p>
------------------------------------------------------------------------------------------------------------------------------------------------------------------------------------------------------------------------------------------------------------------------------------------------------------------------	--	-----------------------------------------------------------------------------------------------------------------	-------------------------------------------------------------------------------------	-----------------------------------------------------------------	------------------------------------	-------------------------------------------------------------------------------------	----------------------------------------------------------------

Limited Warranty

The operation of this unit in a manner inconsistent with the owner's manual will void the warranty and is also against federal regulations. United States Stove Company warrants this product to be free from defects in material and workmanship, to the original retail purchaser only, for the time period identified below, measured from the date of the initial purchase as evidenced on an invoice, cancelled check, sales receipt, etc., to receipt of a claim by United States Stove Company ("USSC") or an authorized dealer, as follows:

TIME PERIOD	
Firebox / Heat Exchanger	Limited Lifetime
Door	One Year
Cabinets and Trim	One Year
Gaskets	One Year
All Electrical Components (Blower, Auger / Agitator Motor, PC Board, Switches)	One Year
Ceramic Glass	One Year

WARRANTY CONDITIONS

- This warranty only covers USSC appliances that are purchased through an USSC authorized retailer, dealer or distributor.
- This warranty is only valid while the USSC appliance remains at the site of original installation. This warranty does not apply to products purchased for rental use.

CLAIM PROCEDURE

Contact United States Stove Company for warranty service. You will be asked to provide detailed descriptions and pertinent data, including proof of purchase which will be returned upon request. Providing the heater has been installed and used in accordance with the Owner's Manual supplied with the heater and the issue does not fall under a situation of exclusion, United States Stove Company will either:

- Replace the defective part free of charge. Parts and/or service replacements made under the terms of this warranty are warranted only for the remaining period of the original heater warranty.
- Replace the heater free of charge. Should the heater be replaced by United States Stove Company "free of charge", all further warranty obligations are thereby met.
- Where the defect is of a cosmetic (non-functional) nature, United States Stove Company will bear reasonable expense to repair the heater, including such items as welding, painting, and incidental labor. A "reasonable expense" is defined by terms of this warranty as \$30.00/hour with full refund for any purchase of parts.

WARRANTY EXCLUSIONS

This warranty does not cover the following:

- Damage to or changes in surface finishes as a result of normal use. As a heating appliance, some changes in color or interior and exterior surface finishes may occur. This is not a flaw and is not covered under warranty.
- Damage to printed, plated, or enameled surfaces caused by fingerprints, accidents, misuse, scratches, melted items, or other external sources and residues left on the plated surfaces from the use of abrasive cleaners or polishes.
- Repair or replacement of parts that are subject to normal wear and tear during the warranty period. These parts include: paint, pellet, and the discoloration of glass.
- Minor expansion, contraction, or movement of certain parts causing noise. These conditions are normal and complaints related to this noise are not covered by this warranty.
- Damages resulting from: (1) failure to install, operate, or maintain the appliance in accordance with the installation instructions, operating instructions, and listing agent identification label furnished with the appliance; (2) failure to install the appliance in accordance with local building codes and/or authorities having jurisdiction; (3) shipping or improper handling; (4) improper operation, abuse, misuse, continued operation with damaged, corroded or failed components, accident, alteration, or improperly/incorrectly performed repairs; (5) environmental conditions, weather, inadequate ventilation, negative pressure, or drafting caused by tightly sealed constructions, insufficient make-up air supply, or handling devices such as exhaust fans or forced air furnaces or other such causes; (6) use of fuels other than those specified in the operating

- instructions; (7) installation or use of components not supplied with appliance or any other components not expressly authorized and approved by USSC; (8) modification of the appliance not expressly authorized and approved by USSC in writing; and/or (9) interruptions or fluctuations of electrical power supply to the appliance.
- Non-USSC venting components, hearth components or other accessories used in conjunction with the appliance.
- USSC's obligation under this warranty does not extend to the appliance's capability to heat the desired space. Information is provided to assist the consumer and the dealer in selecting the proper appliance for the application. Consideration must be given to appliance location and configuration, environmental conditions, insulation and air tightness of the structure.
- Problems relating to smoking or creosote. Smoking is attributable to inadequate draft due to the design or installation of the flue system or installation of the heater itself. Creosote formation is largely attributable to improper operation of the unit and/or draft as mentioned above.
- Any cost associated with product removal and re-installation, travel, transportation, or shipping.
- Service calls to diagnose trouble (unless authorized in writing by the manufacturer, distributor, or dealer).

THIS WARRANTY IS VOID IF

- The appliance has been over-fired or operated in atmospheres contaminated by chlorine, fluorine, or other damaging chemicals. Over-firing can be identified by, but not limited to, warped plates or tubes, rust colored cast iron, bubbling, cracking and discoloration of steel or enamel finishes.
- The appliance is subjected to prolonged periods of dampness or condensation.
- There is any damage to the appliance or other components due to water or weather damage which is the result of, but not limited to, improper chimney or venting installation.

LIMITATIONS OF LIABILITY

The owner's exclusive remedy and USSC's sole obligation under this warranty, under any other warranty, express or implied, or in contract, tort or otherwise, shall be limited to replacement, repair, or refund, in USSC's sole and absolute discretion. In no event will USSC be liable for any incidental or consequential damages. THE LIMITED WARRANTY SET FORTH HEREIN IS THE SOLE WARRANTY PROVIDED TO PURCHASER AND IS IN LIEU OF ALL OTHER WARRANTIES AND REPRESENTATIONS, EXPRESS OR IMPLIED. USSC MAKES NO REPRESENTATIONS OR WARRANTIES WHATSOEVER, EXPRESS OR IMPLIED, WITH RESPECT TO THE PRODUCT, OTHER THAN (i) THE LIMITED WARRANTY ABOVE, AND (ii) ANY IMPLIED WARRANTIES IMPOSED BY APPLICABLE LAW WHICH CANNOT BE WAIVED OR DISCLAIMED UNDER APPLICABLE LAW. ALL OTHER WARRANTIES OF ANY KIND, INCLUDING WITHOUT LIMITATION IMPLIED WARRANTIES OF MERCHANTABILITY AND FITNESS FOR A PARTICULAR PURPOSE, ARE HEREBY DISCLAIMED AND EXCLUDED TO THE FULLEST EXTENT NOT PROHIBITED BY APPLICABLE LAW. This Limited Warranty gives the purchaser specific legal rights; a purchaser may have other rights depending upon where he or she resides. Some states do not allow the exclusion or limitation of special, incidental or consequential damages, or state law may affect the duration of limitations, so the above exclusion and limitations may not be applicable.

WARRANTOR

The warrantor of record is United States Stove Company, PO Box 151, 227 Industrial Park Road, South Pittsburg, Tennessee 37380. Phone number: (800)-750-2723. Register your product on line at www.usstove.com. Save your proof of purchase, as documented in a receipt or invoice, with your records for any claims.

IMPORTANT

We congratulate you on your selection of United States Stove Company and its products. As the oldest solid fuel manufacturer in the United States (since 1869), the United States Stove Company is very proud of its products, service, employees, and satisfied customers. We would like to hear from you if you are not satisfied with the manner in which you have been handled by our distributor, dealer, representative, customer service department, parts department, or sales department. Please reach out to us by using any of the contact information listed above.

Garantie limitée

L'utilisation de cette unité en contradiction avec le manuel de l'utilisateur annulera la garantie, tout en enfreignant les réglementations fédérales. United States Stove Company garantit, uniquement à l'acheteur au détail original, que ce produit est exempt de défauts des matériaux et de qualité de l'exécution, pendant la période indiquée ci-dessous, de la date initiale d'achat prouvée par une facture, un chèque oblitéré, un reçu de vente, etc., de United States Stove Company (« USSC ») ou d'un détaillant autorisé, comme suit:

DÉLAI PRESCRIT	
Boîte à feu/échangeur de chaleur	À vie limitée
Porte	Un an
Cabinets et garniture	Un an
Joint d'étanchéité	Un an
Tous les composants électriques (Souffleur, moteur de la vis/agitateur, carte de circuit imprimé, commutateurs)	Un an
Vitre céramique	Un an

CONDITIONS DE LA GARANTIE

- La garantie ne couvre que les appareils USSC achetés chez un détaillant ou distributeur USSC autorisé.
- Cette garantie n'est valide que si l'appareil USSC demeure sur le site d'installation d'origine. Cette garantie ne s'applique pas aux produits achetés pour la location.

PROCÉDURE DE RÉCLAMATION

Contactez United States Stove Company pour un service sur garantie. Il vous sera demandé de fournir les descriptions et données pertinentes, incluant la preuve d'achat qui sera retournée sur demande. Sous réserve que l'appareil de chauffage ait été installé et utilisé conformément avec le Manuel du propriétaire fourni avec cet appareil de chauffage et que le problème ne porte pas sur une situation d'exclusion, United States Stove Company:

- Remplacera sans frais la pièce défectueuse. Les pièces et/ou les remplacements d'entretien effectués selon les termes de cette garantie le sont uniquement pour le reste de la période originale de la garantie de ce produit.
- Remplacer l'appareil de chauffage sans frais. Si l'appareil de chauffage doit être remplacé par United States Stove Company « sans frais », tous les engagements au titre de cette garantie seront respectés.
- Si le défaut est de nature esthétique (non fonctionnel), United States Stove Company assumera les frais pour réparation de l'appareil de chauffage, incluant les éléments comme la soudure, la peinture et la main-d'œuvre accessoire. Les « frais raisonnables » définis aux termes de cette garantie sont de 30,00 \$/heure avec un remboursement complet pour tout achat de pièces.

EXCLUSIONS DE LA GARANTIE

Cette garantie ne couvre pas ce qui suit:

- Dommage ou modification du fini de la surface causé par une utilisation normale. Comme il s'agit d'un appareil de chauffage, il pourrait se produire une certaine modification de la couleur et des finis de la surface intérieure et extérieure. Il ne s'agit pas d'un défaut et ce n'est pas couvert par la garantie.
- Détérioration des surfaces imprimées, plaquées ou émaillées par les marques de doigts, accidents, abus, égratignures et pièces qui ont fondu ou autres causes externes, ainsi que les résidus laissés sur les surfaces plaquées par l'utilisation de nettoyants ou produits à polir abrasifs.
- Réparation ou remplacement des pièces soumises à une usure normale pendant la période de garantie. Ces pièces comprennent : peinture, granulés et décoloration de la vitre.
- Bruit causé par la dilatation, contraction ou déplacements mineurs de certaines pièces. Ces conditions sont normales et les réclamations liées à ce bruit ne sont pas couvertes par cette garantie.
- Dommages causés par : (1) l'installation, l'utilisation ou la maintenance de l'appareil sans tenir compte des instructions d'installation et d'utilisation, et sans consulter l'étiquette d'identification de l'agent de listé; (2) le non-respect des codes du bâtiment locaux et/ou des autorités ayant juridiction pendant l'installation de l'appareil; (3) l'expédition ou la mauvaise manutention; (4) la mauvaise utilisation, l'abus, l'utilisation continue alors que des composants sont endommagés, corrodés ou défectueux, l'utilisation après un accident, des modifications ou des réparations négligentes/incorrectes; (5) les conditions liées à l'environnement et à la météo, une mauvaise ventilation, une pression négative ou un mauvais tirage en raison de l'étanchéité de la construction, l'approvisionnement insuffisant en air d'appoint ou d'autres dispositifs tels que

- des ventilateurs de tirage, des chaudières à air pulsé ou toute autre cause; (6) l'utilisation de combustibles autres que ceux mentionnés dans les instructions d'utilisation; (7) l'installation ou l'utilisation de composants qui n'ont pas été fournis avec l'appareil ou de tout autre composant n'ayant pas été expressément autorisé et approuvé par USSC; (8) les modifications de l'appareil qui n'ont pas été expressément autorisées et approuvées par écrit par USSC; et/ou (9) les interruptions ou fluctuations de l'alimentation électrique de l'appareil.
- Composants d'évacuation des gaz, composants de l'âtre ou accessoires utilisés avec l'appareil et qui n'ont pas été fournis par USSC.
- Obligations de USSC, en vertu de cette garantie, ne couvrent pas la capacité de l'appareil à chauffer l'espace souhaité. Des informations sont fournies pour aider le consommateur et le détaillant lors de la sélection de l'appareil adéquat pour l'application envisagée. On doit tenir compte de l'emplacement et de la configuration de l'appareil, des conditions liées à l'environnement, de l'isolation et de l'étanchéité de la structure.
- Problèmes liés à la fumée ou au créosote. La fumée provient généralement d'un tirage inadéquat en raison de la conception ou de l'installation du système de conduit ou de l'installation de l'appareil de chauffage lui-même. La formation de créosote est largement attribuable au mauvais fonctionnement de l'unité et/ou du tirage, comme il est mentionné ci-dessus.
- Tous les coûts associés à l'enlèvement et à la réinstallation du produit, son déplacement, transport ou expédition.
- Appels de service afin de diagnostiquer les problèmes (à moins d'être reconnu par écrit par le fabricant, le distributeur ou le détaillant).

CETTE GARANTIE EST ANNULÉE SI

- L'appareil a subi une surchauffe ou a été utilisé avec de l'air contaminé par le chlore, le fluor ou d'autres produits chimiques nuisibles. La surchauffe peut être établie, sans s'y limiter, par la déformation des plaques ou tubes, la couleur rouille de la fonte, l'apparition de bulles et de craquelures, et la décoloration des surfaces en acier ou émaillées.
- L'appareil est soumis à l'humidité ou à la condensation pendant de longues périodes.
- Les dommages causés à l'appareil ou aux autres composants par l'eau ou les intempéries en raison, entre autres, d'une mauvaise installation de la cheminée ou du conduit d'évacuation.

RESTRICTIONS DE LA GARANTIE

Le seul recours du propriétaire et la seule obligation de USSC en vertu de cette garantie ou de toute autre garantie, explicite ou tacite, contractuelle, à tort ou à raison, sont limités au remplacement, à la réparation ou au remboursement. En aucun cas, USSC ne saurait être tenue responsable des dommages fortuits ou consécutifs. LA GARANTIE LIMITÉE INCLUSE AUX PRÉSENTES EST LA SEULE DISPONIBLE POUR L'ACHETEUR, TENANT LIEU DE TOUTES AUTRES GARANTIES OU DÉCLARATIONS, FORMELLE OU TACITE. USSC NE FAIT AUCUNE DÉCLARATION OU GARANTIE DE TOUTE SORTE, QU'ELLE SOIT TACITE OU FORMELLE, RELATIVEMENT AU PRODUIT, AUTRE QUE (i) LA GARANTIE LIMITÉE MENTIONNÉE CI-DESSUS, ET (ii) TOUTE GARANTIE TACITE IMPOSÉE PAR LE DROIT APPLICABLE PAR LAQUELLE ELLE NE PEUT ÊTRE ANNULÉE OU DÉCLINÉE SELON LE DROIT APPLICABLE. TOUTES AUTRES GARANTIES DE TOUT GENRE, INCLUANT, MAIS SANS S'Y LIMITER, AUX GARANTIES TACITES DE QUALITÉ MARCHANDE OU D'APTITUDE À L'EMPLOI, SONT DONC AUX PRÉSENTES, DÉCLINÉES ET EXCLUES JUSQU'À LA LIMITE DU DROIT APPLICABLE. Cette garantie limitée confère à l'acheteur des droits juridiques spécifiques; les droits de l'acheteur pourraient différer selon son lieu de résidence. Certains États ne permettent pas l'exclusion ou la limitation de dommages particuliers, accessoires ou indirects, ou des lois d'État peuvent avoir un impact sur la durée des limitations; ainsi, l'exclusion et les limitations précédentes pourraient ne pas s'appliquer.

GARANT

Le garant de ce dossier est United States Stove Company, PO Box 151, 227 Industrial Park Road, South Pittsburg, Tennessee 37380. Numéro de téléphone : (800)-750-2723. Enregistrez votre produit en ligne au www.usstove.com. Conservez votre preuve d'achat, documentée sous forme de facture ou de reçu, en cas de réclamation.

IMPORTANT

Félicitation d'avoir choisi United States Stove Company et ses produits. Étant le plus ancien fabricant de combustible solide aux États-Unis (depuis 1869), United States Stove Company est fière de ses produits, son service, ses employés, et ses clients satisfaits. Nous aimerions le savoir si vous êtes insatisfait de la façon dont vous auriez répondu l'un de nos distributeurs, détaillants, représentants, service à la clientèle, service des pièces ou service des ventes. Veuillez nous joindre en utilisant l'un des moyens pour nous contacter indiqués ci-dessous.

Model SP6000



BRECKWELL

PLEASE READ THIS ENTIRE MANUAL BEFORE INSTALLATION AND USE OF THIS PELLET FUEL-BURNING ROOM HEATER. FAILURE TO FOLLOW THESE INSTRUCTIONS COULD RESULT IN PROPERTY DAMAGE, BODILY INJURY OR EVEN DEATH.

If this heater is not properly installed, a house fire may result. For your safety, follow the installation directions. Contact Local Building or Fire Officials About Restrictions and Installation Inspection in Your Area. Do Not Plug this appliance into an electrical outlet before reading and understanding all operations and always unplug the unit before attempting any work or maintenance. Do not connect this heater to any chimney flue already serving another appliance. Carefully observe and maintain all clearances to combustibles.

Use only dried shelled corn with a moisture content of 14% or less (11 to 12% provides the best results); any pellet fuel used should have an ash content of 1% or less. If not, efficiency will suffer. This heater has successfully burned pellets with a 2-1/2% ash content, though less ash is preferred and more efficient.

Your Breckwell Multi-Fuel Heater operates on a negative pressure. Therefore, all venting connections (elbows, T-pipe) must be sealed and airtight. Use Hi-Temp silicone at each joint or connection.

*This heater is capable of burning wood, biomass pellets and a wide variety of grains, including corn, soybeans, cherry and olive pits, and all larger seeds.
SAVE THESE INSTRUCTIONS

BRECKWELL GRANTS NO WARRANTY, IMPLIED OR STATED, FOR THE INSTALLATION OR MAINTENANCE OF THE HEATER AND ASSUMES NO RESPONSIBILITY FOR ANY CONSEQUENTIAL DAMAGE(S).

This unit is not intended to be used as a primary source of heat.

U.S. Environmental Protection Agency
Certified to comply with 2020 particulate emissions standards.

⚠ CALIFORNIA PROPOSITION 65 WARNING:
This product can expose you to chemicals including carbon monoxide, which is known to the State of California to cause cancer, birth defects and/or other reproductive harm. For more information, go to www.P65warnings.ca.gov



Safety Tested to ASTM
E1509-04, (UM) 84-HUD

109 East 17th Street, Suite 5478 • Cheyenne, WY 82001 •
Phone: 833-222-3421 • Web: www.acadiaearth.com

851940D-1904E



QUALITY CONTROL SERVICES

LABORATORY EQUIPMENT • SALES • SERVICE • CALIBRATION • REPAIRS
2340 SE 11TH Ave. Portland, Oregon 97214 • Box 14831 Portland, Oregon 97293
(503) 236-2712 • FAX (503) 235-2535 • www.qc-services.com



PFS Teco
11785 SE Hwy 212 STE#305
Clackamas, OR 97015

Report Number: DIRI01A05026181218

A2LA ACCREDITED CERTIFICATE OF CALIBRATION WITH DATA

INSTRUMENT INFORMATION

Item	Make	Model	Serial Number	Customer ID	Location
Scale	Rice Lake	IQ+355E-2A x 100l	A05026	#041	Lab
Units	Readability	SOP	Cal Date	Last Cal Date	Cal Due Date
lbs	0.1	QC033	12/18/18	6/13/18	12/2019

FUNCTIONAL CHECKS

SHIFT TEST		LINEARITY		REPEATABILITY		ENVIRONMENTAL CONDITIONS
Test Wt:	Tol:	Test Wt:	Tol:	Test Wt:	Tol:	<input type="checkbox"/> Good <input checked="" type="checkbox"/> Fair <input type="checkbox"/> Poor Temperature: 16.9°C
250	1	HB44	HB44	100	1	
As-Found:		As-Found:		As-Found:		
Pass: <input checked="" type="checkbox"/>	Fail: <input type="checkbox"/>	Pass: <input checked="" type="checkbox"/>	Fail: <input type="checkbox"/>	Pass: <input checked="" type="checkbox"/>	Fail: <input type="checkbox"/>	
As-Left:		As-Left:		As-Left:		
Pass: <input checked="" type="checkbox"/>	Fail: <input type="checkbox"/>	Pass: <input checked="" type="checkbox"/>	Fail: <input type="checkbox"/>	Pass: <input checked="" type="checkbox"/>	Fail: <input type="checkbox"/>	

CALIBRATION DATA

Standard	As-Found	As-Left	Expanded Uncertainty
1000	999.3	1000.2	0.12
700	699.7	700.1	0.12
500	499.7	500.1	0.08
300	299.8	300.1	0.08
100	99.9	100.0	0.05
50	50.0	50.0	0.05

CALIBRATION STANDARDS

Item	Make	Model	Serial Number	Cal Date	Cal Due Date	NIST ID
Avoirdupois Cast W	Rice Lake	25 and 50lb	PWO990-CA	11/24/17	11/2019	20172265

Permanent Information Concerning this Equipment:

12 month calibration cycle. 2000lb platform.

Comments/Information Concerning this Calibration

12/18 - RH = 67%. Adjusted span.

Report prepared/reviewed by: ServiceTechDC Date: 12/28/18

Technician: R. Kauble
Signature: [Signature]

THIS CERTIFICATE SHALL NOT BE REPRODUCED, EXCEPT IN FULL, WITHOUT THE APPROVAL OF QUALITY CONTROL SERVICES, INC.

The uncertainty is calculated according to the ISO Guide to the Expression of Uncertainty in Measurement and includes the uncertainty of standards used combined with the observed standard deviation of the unit under test. The uncertainty is expanded with a k factor of 2 for an approximate 95% level of confidence. Instruments listed above were calibrated using standards traceable to the National Institute of Standards and Technology (NIST). Calibration data reflect results at the time and location of calibration. Calibration data should be reviewed to insure that the instrument is performing to its required accuracy.

Dry Gas Meter Calibration

Meter Manufacturer: Apex
 Model: XC-60-ED
 Lab ID #: 53
 Serial #: 1902130
 Calibration Date: 12/17/2018
 Calibration Expiration: 6/17/2019
 Barometric Pressure: 29.87 in. Hg



Reference Standard DGM	
Manufacturer:	Apex
Model:	SK25DA
Lab ID#:	47
Serial #:	1101001
Calibration Expiration Date:	3/5/2019
Calibration γ Factor:	0.998

Unit Under Test Previous Calibration	
Date	12/13/2018
γ Factor:	1.002
Allowable Deviation ($\pm 5\%$):	0.0501
Actual Deviation:	0.00
Result:	PASS

Calibration Data	Run 1	Run 2	Run 3
Standard DGM Initial Volume (L)	0.000	0.000	0.000
Standard DGM Final Volume (L)	166.180	147.027	169.354
Standard DGM Temperature ($^{\circ}$ F)	71.7	72.5	73.0
Standard DGM Pressure (in H ₂ O)	0.00	0.00	0.0
DGM Initial Volume (ft ³)	0.000	0.000	0.000
DGM Final Volume (ft ³)	5.950	5.296	6.132
DGM Temperature ($^{\circ}$ F)	83.0	91.0	93.0
DGM Pressure (in H ₂ O)	2.60	2.00	1.5
Time (min)	37.0	37.0	49.0
Net Volume for Standard DGM (ft ³)	5.869	5.192	5.981
Net Volume for DGM (ft ³)	5.950	5.296	6.132
Dry Gas Meter γ Factor	0.999	1.007	1.006
γ Factor Deviation From Average	0.999	1.007	1.006

Average Gas Meter γ Factor 1.004

Calculations:

- Deviation = |Average value for all runs - current run value|
- $\gamma = [V_{std} \times (Y_{std}) \times (P_{bar} + P_{std}/13.6) \times (T_{DGM} + 460)] / [V_{DGM} \times (T_{std} + 460) \times (P_{bar} + P_{DGM}/13.6)]$

Standard Reference Meter is calibrated to NIST traceable standards. Uncertainty of measurement is $\pm 0.5\%$.

Dry Gas Meter Calibration

Meter Manufacturer: Apex
 Model: XC-60-ED
 Lab ID #: 54
 Serial #: 1902133
 Calibration Date: 12/17/2018
 Calibration Expiration: 6/17/2019
 Barometric Pressure: 29.87 in. Hg



Reference Standard DGM	
Manufacturer:	Apex
Model:	SK25DA
Lab ID#:	47
Serial #:	1101001
Calibration Expiration Date:	3/5/2019
Calibration γ Factor:	0.998

Unit Under Test Previous Calibration	
Date	12/13/2018
γ Factor:	0.997
Allowable Deviation ($\pm 5\%$):	0.04985
Actual Deviation:	0.00
Result:	PASS

Calibration Data	Run 1	Run 2	Run 3
Standard DGM Initial Volume (L)	0.000	0.000	0.000
Standard DGM Final Volume (L)	153.596	138.287	193.022
Standard DGM Temperature ($^{\circ}$ F)	73.0	73.0	74.0
Standard DGM Pressure (in H ₂ O)	0.00	0.00	0.0
DGM Initial Volume (ft ³)	0.000	0.000	0.000
DGM Final Volume (ft ³)	5.594	5.047	7.058
DGM Temperature ($^{\circ}$ F)	94.5	95.0	96.0
DGM Pressure (in H ₂ O)	2.60	2.00	1.5
Time (min)	35.0	36.0	57.0
Net Volume for Standard DGM (ft ³)	5.424	4.884	6.816
Net Volume for DGM (ft ³)	5.594	5.047	7.058
Dry Gas Meter γ Factor	1.000	1.001	1.000
γ Factor Deviation From Average	1.000	1.001	1.000

Average Gas Meter γ Factor 1.000

Calculations:

- Deviation = |Average value for all runs - current run value|
- $\gamma = [V_{std} \times (Y_{std}) \times (P_{bar} + P_{std}/13.6) \times (T_{DGM} + 460)] / [V_{DGM} \times (T_{std} + 460) \times (P_{bar} + P_{DGM}/13.6)]$

Standard Reference Meter is calibrated to NIST traceable standards. Uncertainty of measurement is $\pm 0.5\%$.

Dry Gas Meter Calibration

Meter Manufacturer: Apex
 Model: Apex-AK-600
 Lab ID #: 055
 Serial #: 810016
 Calibration Date: 6/15/2018
 Calibration Expiration: 6/15/2019
 Barometric Pressure: 29.83 in. Hg



Reference Standard DGM	
Manufacturer:	Apex
Model:	SK25DA
Lab ID#:	047
Serial #:	1101001
Calibration Expiration Date:	3/5/2019
Calibration γ Factor:	0.998

Unit Under Test Previous Calibration	
Date	1/18/2017
γ Factor:	0.997
Allowable Deviation ($\pm 5\%$):	0.04985
Actual Deviation:	0.00
Result:	PASS

Calibration Data	Run 1	Run 2	Run 3
Standard DGM Initial Volume (L)	0.000	0.000	0.000
Standard DGM Final Volume (L)	145.479	148.058	143.802
Standard DGM Temperature ($^{\circ}$ F)	71.0	71.0	71.0
Standard DGM Pressure (in H ₂ O)	0.00	0.00	0.0
DGM Initial Volume (ft ³)	0.000	0.000	0.000
DGM Final Volume (ft ³)	5.146	5.254	5.114
DGM Temperature ($^{\circ}$ F)	75.0	76.5	77.5
DGM Pressure (in H ₂ O)	1.80	1.80	1.8
Time (min)			
Net Volume for Standard DGM (ft ³)	5.138	5.229	5.078
Net Volume for DGM (ft ³)	5.146	5.254	5.114
Dry Gas Meter γ Factor	0.999	0.999	0.999
γ Factor Deviation From Average	0.999	0.999	0.999

Average Gas Meter γ Factor 0.999

Calculations:

- Deviation = |Average value for all runs - current run value|
- $\gamma = [V_{std} \times (\gamma_{std}) \times (P_{bar} + P_{std}/13.6) \times (T_{DGM} + 460)] / [V_{DGM} \times (T_{std} + 460) \times (P_{bar} + P_{DGM}/13.6)]$

Standard Reference Meter is calibrated to NIST traceable standards. Uncertainty of measurement is $\pm 0.5\%$.



QUALITY CONTROL SERVICES

LABORATORY EQUIPMENT • SALES • SERVICE • CALIBRATION • REPAIRS
2340 SE 11TH Ave. Portland, Oregon 97214 • Box 14831 Portland, Oregon 97293
(503) 236-2712 • FAX (503) 235-2535 • www.qc-services.com



Report of Calibration

Firm: Dirigo Laboratories
Address: 11785 SE Hwy 212, Ste 305
City/State/Zip: Clackamas, OR 97015

Test Completed: 03/21/17
Submitted By: John Steiner
Traceable Number: 20170468

Test Item: 200mg and 100mg Individual Weights
Serial No.: Listed in Table

Manufacturer: Troemner

<u>Material</u>	<u>Assumed Density</u>	<u>Range</u>	<u>Tolerance Class</u>
Stainless Steel	7.95 g/cm ³	200mg & 100mg	ASTM Class 1

Method and Traceability

The procedure used for this calibration is NIST IR 6969 SOP 4 Double Substitution Weighing Design. Standards used for comparison are traceable to the National Institute of Standards and Technology (reports on file) and are part of a comprehensive measurement assurance program for ensuring continued accuracy and traceability within the level of uncertainty reported. The Traceable Number listed above is Traceable to National Standards through an unbroken chain of comparison each having stated uncertainties.

Standards Used:

100g to 1mg Working Standards Were Calibrated: 03/03/17 Due: 03/31/18 Standards ID: 723318
Mass Comparators Used: MET-05 Tested by: D. Thompson

Conventional Mass: “The conventional value of the result of weighing a body in air is equal to the mass of a standard, of conventionally chosen density, at a conventionally chosen temperature, which balances this body at this reference temperature in air of conventionally chosen density. International Recommendation 33 (OIML IR 33 1973, 1979). “Conventional Value of the Result of Weighing in Air” (Previously known as “Apparent Mass vs. 8.0g/cm³”).

Uncertainty Statement: The uncertainty conforms to the ISO Guide to the Expressions of Uncertainty in Measurement. Uncertainty as reported is based on a coverage factor k=2 for an approximate 95 percent level of uncertainty. Uncertainty components include the standard deviation of the process, the uncertainty of the standard used, an uncertainty component associated with the potential drift of the standard used, and the estimated uncertainty related to measuring and determining the air buoyancy effect.

Conventional Mass Values are listed on page 2 of this report.

page 1 of 2

Quality Control Services, Inc.
Metrology Laboratory Manager
E-mail dthompson@qc-services.com

Date: 03/21/17

Signature David S. Thompson

This document shall not be reproduced, except in full, without the written approval of Quality Control Services Mass Laboratory.

Member: National Conference of Standards Laboratories and Weights & Measures



QUALITY CONTROL SERVICES

LABORATORY EQUIPMENT • SALES • SERVICE • CALIBRATION • REPAIRS
2340 SE 11TH Ave. Portland, Oregon 97214 • Box 14831 Portland, Oregon 97293
(503) 236-2712 • FAX (503) 235-2535 • www.qc-services.com



Report of Calibration

Firm: Dirigo Laboratories
Address: 11785 SE Hwy 212, Ste 305
City/State/Zip: Clackamas, OR 97015

Test Completed: 03/21/17
Submitted By: John Steiner
Traceable Number: 20170468

Test Item: 200mg and 100mg Individual Weights
Serial No.: Listed in Table

Manufacturer: Troemner

Laboratory Environment at time of test

Temperature °C	Pressure mmHg	Humidity %RH
21.967	753.44	49.44

Conventional Mass Value

Nominal Value	As Found grams	As Found Correction* (mg)	Uncertainty (mg)	Tolerance (mg)
200mg SN 1000101395	0.2000061	0.0061	0.0026	0.01
100mg SN 1000126267	0.1000046	0.0046	0.0028	0.01

*Correction is the difference between the conventional mass value of a weight and its nominal value.

Comments: These weights were new from the manufacturer and were within ASTM Class 1 tolerances As Found. No adjustments or changes were made so As Found values should be considered to be As Left values.

Accredited by the American Association for Laboratory Accreditation (A2LA) under Calibration Laboratory Code 115953 and Certificate Number 1550.01. This laboratory meets the requirements of ISO/IEC 17025:2005 *General Requirements for the Competence of Testing and Calibration Laboratories*. This laboratory also meets the requirements of ANSI/NCSL Z540-1-1994 and any additional program requirements in the field of calibration.

page 2 of 2

Quality Control Services, Inc.
Metrology Laboratory Manager
E-mail dthompson@qc-services.com

Date: 03/21/17

Signature David S. Thompson



QUALITY CONTROL SERVICES

LABORATORY EQUIPMENT • SALES • SERVICE • CALIBRATION • REPAIRS
2340 SE 11TH Ave. Portland, Oregon 97214 • Box 14831 Portland, Oregon 97293
(503) 236-2712 • FAX (503) 235-2535 • www.qc-services.com



Report of Calibration

Firm: Dirigo Laboratories
Address: 11785 SE Hwy 212, Ste 305
City/State/Zip: Clackamas, OR 97015

Test Completed: 01/15/16
Purchase Order: 1001
Traceable Number: 20152489

Test Item: 20lb and 10lb Individual Grip Handle Weights
Serial No.: Listed in Table

Manufacturer: Unknown

Laboratory Environment at time of test

Temperature °C	Pressure mmHg	Humidity %RH
21.448	760.64	44.58

Conventional Mass Value

Nominal Value	As Found pounds	As Found Correction* (mg)	Uncertainty (mg)	Tolerance (mg)
20lb #098	19.9995450	-206.4	6.4	910
10lb #097	10.0006510	295.3	5.1	450
10lb #051	10.0003421	155.2	5.1	450

*Correction is the difference between the conventional mass value of a weight and its nominal value.

Comments: These weights were received in good condition and were within NIST Handbook 105-1 Class F tolerances As Found. No adjustments or changes were made so As Found values should be considered to be As Left values.

Accredited by the American Association for Laboratory Accreditation (A2LA) under Calibration Laboratory Code 115953 and Certificate Number 1550.01. This laboratory meets the requirements of ISO/IEC 17025:2005 *General Requirements for the Competence of Testing and Calibration Laboratories*. This laboratory also meets the requirements of ANSI/NCSL Z540-1-1994 and any additional program requirements in the field of calibration.

page 2 of 2

Quality Control Services, Inc.
Metrology Laboratory Manager
E-mail dthompson@qc-services.com

Date: 01/15/16

Signature David S. Thompson



QUALITY CONTROL SERVICES

LABORATORY EQUIPMENT • SALES • SERVICE • CALIBRATION • REPAIRS
2340 SE 11TH Ave. Portland, Oregon 97214 • Box 14831 Portland, Oregon 97293
(503) 236-2712 • FAX (503) 235-2535 • www.qc-services.com



PFS Teco
11785 SE Hwy 212 STE#305
Clackamas, OR 97015

Report Number: DIRI0134307497181218

A2LA ACCREDITED CERTIFICATE OF CALIBRATION WITH DATA

INSTRUMENT INFORMATION

Item	Make	Model	Serial Number	Customer ID	Location
Balance	Sartorius	ENTRIS224-1S	34307497	#107	Lab
Units	Readability	SOP	Cal Date	Last Cal Date	Cal Due Date
g	0.0001	QC012	12/18/18	6/13/18	12/2019

FUNCTIONAL CHECKS

ECCENTRICITY		LINEARITY		STANDARD DEVIATION			ENVIRONMENTAL CONDITIONS
Test Wt:	Tol:	Test Wt:	Tol:	Test Wt:	Tol:		
100	0.0003	50 x 4	0.0002	100	0.0001		<input type="checkbox"/> <input checked="" type="checkbox"/> <input type="checkbox"/>
As-Found:		As-Found:		1. 100.0001	5. 100.0002	9. 100.0001	Good Fair Poor
Pass: <input checked="" type="checkbox"/>	Fail: <input type="checkbox"/>	Pass: <input checked="" type="checkbox"/>	Fail: <input type="checkbox"/>	2. 100.0001	6. 100.0001	10. 100.0001	
As-Left:		As-Left:		3. 100.0001	7. 100.0001	<u>Result</u>	Temperature: 21.3°C
Pass: <input checked="" type="checkbox"/>	Fail: <input type="checkbox"/>	Pass: <input checked="" type="checkbox"/>	Fail: <input type="checkbox"/>	4. 100.0001	8. 100.0002	0.00004	

A2LA ACCREDITED SECTION OF REPORT

Standard	As-Found	As-Left	Expanded Uncertainty
200	200.0002	200.0001	0.00014
100	100.0001	100.0001	0.00014
50	50.0003	50.0001	0.00014
20	20.0001	20.0001	0.00014
1	1.0001	1.0000	0.00014
0.1	0.1000	0.1000	0.00014

CALIBRATION STANDARDS

Item	Make	Model	Serial Number	Cal Date	Cal Due Date	NIST ID
Weight Set	R.L./Troemner	10kg to 1mg	G782	1/3/18	1/2019	20172421

Permanent Information Concerning this Equipment:
12 month calibration cycle.

Comments/Info Concerning this Calibration:
12/18 - RH = 56%. Adjusted span.

Report prepared/reviewed by: ServiceTech X Date: 12/28/18

Technician: R. Kauble
Signature:

THIS CERTIFICATE SHALL NOT BE REPRODUCED WITHOUT THE APPROVAL OF QUALITY CONTROL SERVICES, INC.

The uncertainty is calculated according to the ISO Guide to the Expression of Uncertainty in Measurement and includes the uncertainty of standards used combined with the observed standard deviation and readability of the unit under test. The uncertainty is expanded with a k factor of 2 for an approximate 95% level of confidence. Instruments listed above were calibrated using standards traceable to the National Institute of Standards and Technology (NIST). Calibration data reflect results at the time and location of calibration. Calibration data should be reviewed to insure that the instrument is performing to its required accuracy. Calibrations comply with ISO/IEC 17025 and ANSI/Z540-1-1994 quality standards.



CERTIFICATE OF CALIBRATION

CUSTOMER:	PFS-TECO : CLACKAMAS, OR	CALIBRATION DATE:	03/14/2019
PO NUMBER:	N/A	CALIBRATION DUE:	03/14/2020
INST. MANUFACTURER:	DWYER	PROCEDURE:	T.O.33K6-4-1769-1
INST. DESCRIPTION:	VELOMETER	CALIBRATION FLUID:	AIR @ 14.7 PSIA 70°F
MODEL NUMBER:	471	RECEIVED CONDITION:	WITHIN MFG. SPECS.
SERIAL NUMBER:	CP288559 (ID# 095)	LEFT CONDITION:	WITHIN MFG. SPECS.
RATED UNCERTAINTY:	SEE NOTES BELOW.	AMBIENT CONDITIONS:	762 mm HGA 43% RH 69°F
UNCERTAINTY GIVEN:	± .20% RD ; k=2	CERTIFICATE FILE #:	490265.2019
NOTES:	± 3% FS (0-500 / 0-1500) *** ± 4% F.S. (0-5000) ***± 5% F.S. (0-15000) *** ± 2 °F		
NOTES CONT. :	Q.MANUAL IM 1.5 REV 2017.1 DATED 7-18-2017		

UUT INDICATED FT/MIN	DM.STD. ACTUAL FT/MIN	UUT INDICATED DEG. F	DM STD. ACTUAL DEG. F
64	65	0 TO 200°F	0 TO 200°F
110	112	43.4	43.5
206	210	69.0	68.9
498	509	99.4	99.2
503	505		
1049	1058		
1497	1514		
509	513		
3419	3460		
4992	5068		
5136	5235		
13928	14232		

STANDARDS USED:

A220: 12" WIND TUNNEL 0 - 8000 FPM CMC ± .203% RD TRACE# 1520423238	DUE	05/23/2019
A24: HART SCIENTIFIC TEMP. STANDARD ±.024 F TRACE# 1520423238	DUE	03/07/2020

All instruments used in the performance of the shown calibration have traceability to the National Institute of Standards and Technology (NIST). The uncertainty ratio between the calibration standards (DM.STD.) used and the unit under test (UUT) is a minimum of 4:1, unless otherwise noted. Calibration has been performed per the shown procedure number, in accordance with ISO 10012:2003, ISO 17025:2005, ANSI/NCSL-Z-540.3, and/or MIL-STD-45662A. Test methods: API2530-92 & ASME MFC-3M-1989.

Dick Munns Company • 11133 Winners Circle • Los Alamitos, CA 90720
Phone (714) 827-1215 • Fax (714) 827-0823

This Calibration Certificate shall not be reproduced, except in full, without approval by DICK MUNNS COMPANY. The data shown applies only to the instrument being calibrated and under the stated conditions of calibration.

Date:

3/14/2019

Approved by:

Calibration Technician:

D.C.



Model 1430 Microtector® Electronic Point Gage

Installation and Operating Instructions



Model 1430 Microtector® Portable Electronic Point Gage combines modern, solid-state integrated circuit electronics with a time-proven point gage manometer to provide fast, accurate pressure measurements.

SPECIFICATIONS AND FEATURES

- Accurate and repeatable to $\pm .00025$ inches water column
- Pressure range: 0 - 2" w.c., positive, negative, or differential pressures
- Non-toxic and inexpensive gage fluid consists of distilled water mixed with a small amount of fluorescein green color concentrate
- Convenient, portable, lightweight and self-contained, the unit requires no external power connections and is operated by a 1.5 volt penlight cell
- A.C. detector current eliminates point plating, fouling and erosion
- Micrometers are manufactured in accordance with ASME B89.1.13-2001, and are traceable to a standard at the National Institute of Standards and Technology
- Three-point mounting, dual leveling adjustment, and circular level vial assure rapid setup
- Durablock® precision-machined acrylic gage body
- Sensitive 0 - 50 microamp D.C. meter acts as a detector and also indicates battery and probe condition
- Heavy 2" thick steel base plate provides steady mounting
- Top-quality glass epoxy circuit board and solid-state, integrated circuit electronics
- Electronic enclosure of tough, molded styrene acrylonitrile provides maximum protection to components yet allows easy access to battery compartment
- Rugged sheet steel cover and carrying case protects the entire unit when not in use
- Accessories included are (2) 3-foot lengths Tygon® tubing, (2) 1/8" pipe thread adapters and 3/4 oz. bottle of fluorescein green color concentrate with wetting agent

Maximum pressure: 100 psig with optional pipe thread connections.

Tygon® is a registered trademark of Saint-Gobain Corporation

DWYER INSTRUMENTS, INC.

P.O. BOX 373

MICHIGAN CITY, INDIANA 46361, U.S.A.

Phone: 219/879-8000

Fax: 219/872-9057

www.dwyer-inst.com

e-mail: info@dwyer-inst.com



CERTIFICATE OF ANALYSIS / EPA PROTOCOL GAS

Customer & Order Information

PXPKG TUALATIN OR H
10450 SW TUALATIN SHERWOOD ROAD
TUALATIN OR 97062

Certificate Modification Date: 10/01/2018
Praxair Order Number: 70743165
Part Number: NI CD17CO8E-AS

Fill Date: 09/26/2018
Lot Number: 70086826911
Cylinder Style & Outlet: AS CGA 590
Cylinder Pressure and Volume: 1290 psig 140 ft3

Certified Concentration

Expiration Date:	10/01/2026	NIST Traceable
Cylinder Number:	SA17187	Expanded Uncertainty
17.00 %	Carbon dioxide	± 0.3 %
4.31 %	Carbon monoxide	± 0.6 %
16.99 %	Oxygen	± 0.2 %
Balance	Nitrogen	

ProSpec EZ Cert



Certification Information:

Certification Date: 10/01/2018 Term: 96 Months Expiration Date: 10/01/2026

This cylinder was certified according to the 2012 EPA Traceability Protocol, Document #EPA-600/R-12/531, using Procedure G1.
Do Not Use this Standard if Pressure is less than 100 PSIG.
CO2 responses have been corrected for Oxygen IR Broadening effect. O2 responses have been corrected for CO2 interference.

Analytical Data:

(R=Reference Standard, Z=Zero Gas, C=Gas Candidate)

1. Component: Carbon dioxide
Requested Concentration: 17 %
Certified Concentration: 17.00 %
Instrument Used: Horiba VIA-510 S/N 20C194WK
Analytical Method: NDIR
Last Multipoint Calibration: 09/21/2018

First Analysis Data:		Date	
Z: 0	R: 20.1	C: 17	Conc: 17
R: 20.1	Z: 0	C: 17	Conc: 17
Z: 0	C: 17.01	R: 20.11	Conc: 17.01
UOM: %	Mean Test Assay:		17 %

Reference Standard: Type / Cylinder #: GMIS / CC187238
Concentration / Uncertainty: 20.10 % ±0.24%
Expiration Date: 06/07/2026
Traceable to: SRM # / Sample # / Cylinder #: RGM#CC193512 / NIA / RGM#CC193512
SRM Concentration / Uncertainty: 26.99% / ±0.05%
SRM Expiration Date: 05/15/2023

Second Analysis Data:		Date	
Z: 0	R: 0	C: 0	Conc: 0
R: 0	Z: 0	C: 0	Conc: 0
Z: 0	C: 0	R: 0	Conc: 0
UOM: %	Mean Test Assay:		%

2. Component: Carbon monoxide
Requested Concentration: 4.25 %
Certified Concentration: 4.31 %
Instrument Used: Horiba VIA-510 S/N UB9UCSYX
Analytical Method: NDIR
Last Multipoint Calibration: 09/21/2018

First Analysis Data:		Date	
Z: 0	R: 5	C: 4.31	Conc: 4.31
R: 5	Z: 0	C: 4.3	Conc: 4.3
Z: 0	C: 4.32	R: 5.01	Conc: 4.32
UOM: %	Mean Test Assay:		4.31 %

Reference Standard: Type / Cylinder #: GMIS / CC242633
Concentration / Uncertainty: 5.00 % ±0.543%
Expiration Date: 04/03/2025
Traceable to: SRM # / Sample # / Cylinder #: SRM 2642a / 51-D-23 / FF23106
SRM Concentration / Uncertainty: 7.859% / ±0.039%
SRM Expiration Date: 07/15/2019

Second Analysis Data:		Date	
Z: 0	R: 0	C: 0	Conc: 0
R: 0	Z: 0	C: 0	Conc: 0
Z: 0	C: 0	R: 0	Conc: 0
UOM: %	Mean Test Assay:		%

3. Component: Oxygen
Requested Concentration: 17 %
Certified Concentration: 16.99 %
Instrument Used: OXYMAT 5E
Analytical Method: Paramagnetic
Last Multipoint Calibration: 09/04/2018

First Analysis Data:		Date	
Z: 0	R: 20.86	C: 16.99	Conc: 16.99
R: 20.86	Z: 0	C: 16.99	Conc: 16.99
Z: 0	C: 16.99	R: 20.86	Conc: 16.99
UOM: %	Mean Test Assay:		16.99 %

Reference Standard: Type / Cylinder #: GMIS / CC75874
Concentration / Uncertainty: 20.86 % ±0.111%
Expiration Date: 11/07/2025
Traceable to: SRM # / Sample # / Cylinder #: SRM 2659a / 71-E-19 / FF22331
SRM Concentration / Uncertainty: 20.863% / ±0.021%
SRM Expiration Date: 08/23/2021

Second Analysis Data:		Date	
Z: 0	R: 0	C: 0	Conc: 0
R: 0	Z: 0	C: 0	Conc: 0
Z: 0	C: 0	R: 0	Conc: 0
UOM: %	Mean Test Assay:		%

Analyzed By Jose Vasquez

Certified By Danielle Burns



CERTIFICATE OF ANALYSIS / EPA PROTOCOL GAS

Customer & Order Information

PXPKG TUALATIN OR H
10450 SW TUALATIN SHERWOOD ROAD
TUALATIN OR 97062

Certificate Modification Date: 09/05/2018
Praxair Order Number: 70716136
Part Number: NI CD10CO33E-AS

Fill Date: 08/31/2018
Lot Number: 70086824308
Cylinder Style & Outlet: AS CGA 590
Cylinder Pressure and Volume: 2000 psig 140 ft3

Certified Concentration

Expiration Date:	09/05/2026	NIST Traceable	
Cylinder Number:	CC170624	Expanded Uncertainty	
10.00 %	Carbon dioxide	± 0.3 %	
2.51 %	Carbon monoxide	± 0.7 %	
10.50 %	Oxygen	± 0.6 %	
Balance	Nitrogen		

ProSpec EZ Cert



Certification Information:

Certification Date: 09/05/2018 Term: 96 Months Expiration Date: 09/05/2026

This cylinder was certified according to the 2012 EPA Traceability Protocol, Document #EPA-600/R-12/531, using Procedure G1.
Do Not Use this Standard if Pressure is less than 100 PSIG.

CO responses have been corrected for CO2 interference. CO2 responses have been corrected for Oxygen IR Broadening effect. O2 responses have been corrected for CO2 interference.

Analytical Data:

(R=Reference Standard, Z=Zero Gas, C=Gas Candidate)

1. Component: Carbon dioxide

Requested Concentration: 10 %
Certified Concentration: 10.00 %
Instrument Used: Horiba VIA-510 S/N 20C194WK
Analytical Method: NDIR
Last Multipoint Calibration: 08/20/2018

Reference Standard: Type / Cylinder #: GMIS / CC141375
Concentration / Uncertainty: 14.02 % ± 0.3 %
Expiration Date: 06/11/2026

Traceable to: SRM # / Sample # / Cylinder #: SRM 1675b / 6-F-51 / CAL014538
SRM Concentration / Uncertainty: 13.963 % / ± 0.034 %
SRM Expiration Date: 05/16/2022

First Analysis Data:				Date
Z: 0	R: 14.02	C: 10	Conc: 10	09/05/2018
R: 14.02	Z: 0	C: 10	Conc: 10	
Z: 0	C: 10	R: 14.02	Conc: 10	
UOM: %				
Mean Test Assay: 10 %				

Second Analysis Data:				Date
Z: 0	R: 0	C: 0	Conc: 0	
R: 0	Z: 0	C: 0	Conc: 0	
Z: 0	C: 0	R: 0	Conc: 0	
UOM: %				
Mean Test Assay: %				

2. Component: Carbon monoxide

Requested Concentration: 2.5 %
Certified Concentration: 2.51 %
Instrument Used: Horiba VIA-510 S/N UB9UCSYX
Analytical Method: NDIR
Last Multipoint Calibration: 08/20/2018

Reference Standard: Type / Cylinder #: GMIS / CC102045
Concentration / Uncertainty: 2.48 % ± 0.448 %
Expiration Date: 04/03/2025

Traceable to: SRM # / Sample # / Cylinder #: SRM 2641a / 52-D-30 / CAL017193
SRM Concentration / Uncertainty: 4.009 % / ± 0.017 %
SRM Expiration Date: 07/15/2019

First Analysis Data:				Date
Z: 0	R: 2.48	C: 2.51	Conc: 2.51	09/05/2018
R: 2.48	Z: 0	C: 2.51	Conc: 2.51	
Z: 0	C: 2.51	R: 2.48	Conc: 2.51	
UOM: %				
Mean Test Assay: 2.51 %				

Second Analysis Data:				Date
Z: 0	R: 0	C: 0	Conc: 0	
R: 0	Z: 0	C: 0	Conc: 0	
Z: 0	C: 0	R: 0	Conc: 0	
UOM: %				
Mean Test Assay: %				

3. Component: Oxygen

Requested Concentration: 10.5 %
Certified Concentration: 10.50 %
Instrument Used: OXYMAT 5E
Analytical Method: Paramagnetic
Last Multipoint Calibration: 09/04/2018

Reference Standard: Type / Cylinder #: NTRM / DT0010402
Concentration / Uncertainty: 9.88 % ± 0.4 %
Expiration Date: 11/18/2022

Traceable to: SRM # / Sample # / Cylinder #: NTRM #170701 / N/A / NTRM #DT0010402
SRM Concentration / Uncertainty: 9.875 % / ± 0.040 %
SRM Expiration Date: 11/18/2022

First Analysis Data:				Date
Z: 0	R: 9.88	C: 10.49	Conc: 10.49	09/05/2018
R: 9.88	Z: 0	C: 10.5	Conc: 10.5	
Z: 0	C: 10.5	R: 9.88	Conc: 10.5	
UOM: %				
Mean Test Assay: 10.5 %				

Second Analysis Data:				Date
Z: 0	R: 0	C: 0	Conc: 0	
R: 0	Z: 0	C: 0	Conc: 0	
Z: 0	C: 0	R: 0	Conc: 0	
UOM: %				
Mean Test Assay: %				

Analyzed By: 
Danielle Burns

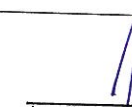
Certified By: 
Jose Vasquez

Information contained herein has been prepared at your request by qualified experts within Praxair Distribution, Inc. While we believe that the information is accurate within the limits of the analytical methods employed and is complete to the extent of the specific analyses performed, we make no warranty or representation as to the suitability of the use of the information for any purpose. The information is offered with the understanding that any use of the information is at the sole discretion and risk of the user. In no event shall the liability of Praxair Distribution, Inc., arising out of the use of the information contained herein exceed the fee established for providing such information.



Calibration complies with ISO/IEC 17025, ANSI/NCSL Z540-1, and 9001



Cert. No.: 4198-9765787

Traceable® Certificate of Calibration for Hand Held Barometer

Customer :PFS TECO Suite 305 ,11785 SE Highway 212 ,Clackamas ,OR-97015 ,U.S.A.

Instrument Identification:

Model: 4198, S/N: 80531676 Manufacturer: Control Company

Standards/Equipment:

Table with 4 columns: Description, Serial Number, Due Date, NIST Traceable Reference. Rows include Digital Barometer and Digital Thermometer.

Certificate Information:

Technician: 57 Procedure: CAL-32 Cal Date: 29 Aug 2018 Cal Due Date: 29 Aug 2019
Test Conditions: 62.73%RH 23.92°C 1018mBar

Calibration Data:

Table with 11 columns: Unit(s), Nominal, As Found, In Tol, Nominal, As Left, In Tol, Min, Max, ±U, TUR. Rows show calibration data for temperature and pressure.

This certificate indicates Traceability to standards provided by (NIST) National Institute of Standards and Technology and/or a National Standards Laboratory.

A Test Uncertainty Ratio of at least 4:1 is maintained unless otherwise stated and is calculated using the expanded measurement uncertainty. Uncertainty evaluation includes the instrument under test and is calculated in accordance with the ISO "Guide to the Expression of Uncertainty in Measurement : (GUM). The uncertainty represents an expanded uncertainty using a coverage factor k=2 to approximate a 95% confidence level.

Nominal=Standard's Reading; As Left=Instrument's Reading; In Tol=In Tolerance; Min/Max=Acceptance Range; ± U=Expanded Measurement Uncertainty; TUR=Test Uncertainty Ratio; Accuracy=±(Max-Min)/2; Min=As Left Nominal(Rounded) - Tolerance; Max= As Left Nominal(Rounded) + Tolerance;

Nicol Rodriguez, Quality Manager

Aaron Justice, Technical Manager

Note :

Maintaining Accuracy:

In our opinion once calibrated your Hand Held Barometer should maintain its accuracy. There is no exact way to determine how long calibration will be maintained. Hand Held Barometer change little, if any at all, but can be affected by aging, temperature, shock, and contamination.

Recalibration:

For factory calibration and re-certification traceable to National Institute of Standards and Technology contact Control Company.

CONTROL COMPANY 12554 Galveston RD Suite B230 Webster TX USA 77598
Phone 281 482-1714 Fax 281 482-9448 sales@control3.com www.control3.com

Control Company is an ISO/IEC 17025:2005 Calibration Laboratory Accredited by (A2LA) American Association for Laboratory Accreditation, Certificate No. 1750.01.
Control Company is ISO 9001:2008 Quality Certified by DNV GL, Certificate No. CERT-01805-2006-AQ-HOU-RvA.
International Laboratory Accreditation Cooperation (ILAC) - Multilateral Recognition Arrangement (MRA).



Certificate of Conformity

Issued to: United States Stove Company
227 Industrial Park Rd
South Pittsburgh, TN 37380
(423) 837-2100
6041
Model: 6041I, SP6000
AKA: August 6, 2019
Effective Date: 19-495
Report #

Certification tests were performed by PFS-TECO located at 11785 SE Highway 212, Suite 305, Clackamas, OR 97015

PFS TECO certifies conformity to the following per 40 CFR Part 60 §60.533 (f) (A):

- The test report is complete and accurate.
- The instrumentation used for the test was properly calibrated.
- The representative model tested meets the applicable emission limits.
- The tests have been conducted per the appropriate guidelines.
- The manufacturer's Quality Control Plan has been reviewed to ensure that all production units are similar in all material respects that would affect emissions to the tested/certified model and that the units in the model line will meet all (other) applicable requirements.

PFS TECO certifies that the emissions levels as measured in the test report are in compliance with the 2020 PM emission limit of ≤ 2.0 g/hr using pellet fuel.

The average emissions for the 6041 pellet heater is **1.3 g/hr** with an average efficiency of **57.6%**. Average CO emissions are **0.5 g/min.**

Issued by: PFS TECO
11785 SE Highway 212
Suite 305
Clackamas, OR 97015

A handwritten signature in blue ink, appearing to read "John Steinert", positioned above a horizontal line.

John Steinert, General Manager