

TiM781S

Safety related 2D LiDAR sensor

SICK
Sensor Intelligence.



Product described

TiM781S (part number 1096363)

Manufacturer

SICK AG
Erwin-Sick-Str. 1
79183 Waldkirch
Germany

Legal information

This work is protected by copyright. Any rights derived from the copyright shall be reserved for SICK AG. Reproduction of this document or parts of this document is only permissible within the limits of the legal determination of Copyright Law. Any modification, abridgment or translation of this document is prohibited without the express written permission of SICK AG.

The trademarks stated in this document are the property of their respective owner.

© SICK AG. All rights reserved.

Original document

This document is an original document of SICK AG.



Contents

1	About this document.....	6
1.1	Information on the operating instructions.....	6
1.2	Target groups.....	6
1.3	Explanation of symbols.....	7
1.4	Further information.....	8
2	Safety information.....	9
2.1	Intended use.....	9
2.1.1	Reasonably foreseeable misuse.....	9
2.2	Improper use.....	10
2.3	Internet protocol (IP) technology.....	10
2.4	Limitation of liability.....	10
2.5	Modifications and conversions.....	10
2.6	Requirements for skilled persons and operating personnel.....	11
2.7	Operational safety and particular hazards.....	12
2.8	Norms and standards of functional safety management.....	12
3	Product description.....	13
3.1	Device.....	13
3.2	Configuration software.....	13
3.3	Scope of delivery.....	13
3.4	Type label.....	13
3.5	Device layout.....	14
3.6	Accessories.....	15
3.6.1	Mounting kit.....	15
3.6.2	Cables.....	15
3.6.3	Wire assignment, part numbers 6054973/6054972.....	15
3.7	Measurement principle.....	16
3.8	Safety function.....	17
3.9	Safety characteristic values.....	18
3.10	Safety-related detection capability (horizontal/vertical).....	18
3.10.1	Restrictions.....	18
3.10.2	Blind zone.....	18
3.10.3	Measurement on reflector.....	18
3.10.4	Limits of the system.....	18
4	Transport and storage.....	20
4.1	Transport.....	20
4.2	Unpacking.....	20
4.3	Transport inspection.....	20
4.4	Storage.....	20
5	Mounting.....	22
5.1	Notes on mounting.....	22

5.2	Mutual interference.....	22
6	Commissioning and configuration.....	24
6.1	Prerequisites for safe operation of the device.....	24
6.2	Electrical block diagram.....	25
6.3	Wiring notes.....	25
6.4	Installation of SOPAS Engineering Tool.....	26
6.4.1	System requirements for SOPAS ET, version 3.3.3.....	26
6.4.2	Installation process.....	26
6.4.3	Installing the device driver.....	26
6.4.4	ROS driver.....	26
6.5	Parameterization of the device.....	27
6.5.1	Establishing the connection.....	27
6.5.2	Configure the device.....	27
6.5.3	Display of the current operational status.....	27
6.5.4	Changing parameters.....	28
6.5.5	Parameterization.....	28
6.5.6	Passwords.....	32
6.6	Editing fields.....	33
6.6.1	Operating modes/operational statuses.....	33
6.6.2	Digital inputs/outputs.....	35
6.6.3	Function and status displays.....	38
6.6.4	Measurement data interface.....	38
7	Error behavior.....	40
7.1	General.....	40
7.2	Detected errors.....	40
7.3	Undetected errors and faults.....	40
7.4	Fault exclusions.....	41
7.5	Manipulation.....	41
8	Project planning.....	42
8.1	Manufacturer of the machine.....	42
8.2	Operating entity of the machine.....	42
8.3	Protection tasks.....	43
8.4	Preventing unprotected areas.....	43
8.5	Response time of the device.....	44
8.6	Contour as Reference field.....	44
8.7	Timing of analysis case switching.....	45
8.8	Hazardous area protection.....	45
8.9	Hazardous point protection.....	47
8.10	Access protection.....	48
8.11	Mobile hazardous area protection.....	49
9	Regular thorough checks.....	52
10	Working with the product.....	53

10.1	Safety.....	53
10.2	Maintenance and care.....	53
10.3	Transport and storage.....	53
10.4	Repair.....	53
10.5	Disassembly and disposal.....	53
11	Technical data.....	54
11.1	General technical data.....	54
11.2	Safety-related technical data.....	55
12	Annex.....	57
12.1	EU declaration of conformity / Certificates.....	57
12.2	Licenses.....	57

1 About this document

1.1 Information on the operating instructions

These operating instructions provide important information on how to use devices from SICK AG.

Prerequisites for safe work are:

- Compliance with all safety notes and handling instructions supplied.
- Compliance with local work safety regulations and general safety regulations for device applications

The operating instructions are intended to be used by qualified personnel and electrical specialists.



NOTE

Read these operating instructions carefully to familiarize yourself with the device and its functions before commencing any work.

The operating instructions are an integral part of the product. Store the instructions in the immediate vicinity of the device so they remain accessible to staff at all times. Should the device be passed on to a third party, these operating instructions should be handed over with it.

These operating instructions do not provide information on operating the machine or system in which the device is integrated. For information about this, refer to the operating instructions of the specific machine.

Related publications

Please also observe the following related publications:

- Safety notes for **safety-related 2D/3D LiDAR sensors with a class 1 laser**, part number 8022486, included with the product

1.2 Target groups

These operating instructions are intended for the following target groups: project developers (planners, developers, designers), installers, electricians, safety experts (such as CE authorized representatives, compliance officers, people who test and approve the application), operators, and maintenance personnel.

Target group specific contents

In many applications, the target groups consist of the manufacturer and the operating entity of the machine in which the device is integrated, as follows:

Target group		Specific chapters of these operating instructions ¹
Manufacturer	Project developers (planners, developers, designers)	"Project planning", page 42 "Commissioning and configuration", page 24 "Technical data", page 54, "Accessories", page 15
	Installers	"Mounting", page 22
	Electricians	"Commissioning and configuration", page 24
	Safety experts	"Project planning", page 42, "Commissioning and configuration", page 24 "Regular thorough checks", page 52 "Technical data", page 54
Operating entity	Operator of the device	"Parameterization of the device", page 27
	Maintenance personnel	"Regular thorough checks", page 52 "Accessories", page 15

¹ Chapters not listed here are intended for all target groups. All target groups must comply with the safety notes in all of the operating instructions!

1.3 Explanation of symbols

Warnings and important information in this document are labeled with symbols. Signal words introduce the instructions and indicate the extent of the hazard. To avoid accidents, damage, and personal injury, always comply with the instructions and act carefully.



DANGER

... indicates a situation of imminent danger, which will lead to a fatality or serious injuries if not prevented.



WARNING

... indicates a potentially dangerous situation, which may lead to a fatality or serious injuries if not prevented.



CAUTION

... indicates a potentially dangerous situation, which may lead to minor/slight injuries if not prevented.



NOTICE

... indicates a potentially harmful situation, which may lead to material damage if not prevented.



NOTE

... highlights useful tips and recommendations as well as information for efficient and trouble-free operation.

1.4 Further information



NOTE

Further documentation for the device can be found on the online product page at:

- www.sick.com/TiM-S

There, additional information has been provided depending on the product, such as:

- Model-specific online data sheets for device variants, containing technical data, dimensional drawing, and specification diagrams
 - EU declarations of conformity for the product family
 - Dimensional drawings and 3D CAD dimension models of the device variants in various electronic formats
 - This documentation, available in English and German, and in other languages if necessary
 - Other publications related to the devices described here
 - Publications dealing with accessories
-

2 Safety information

2.1 Intended use

The TiM781S is a safety-related LiDAR sensor (laser scanner) that is suitable for the following applications:

- Hazardous area protection
- Hazardous point protection
- Access protection
- Mobile hazardous area protection (protection of mobile platforms)

The device is intended for use as a sensor in personal protection equipment, in mobile applications on electrically operated autonomous platforms in industrial environments, as well as in stationary applications for access protection and presence monitoring in industrial environments.

The safety-related 2D LiDAR sensor must only be used within the limits of the prescribed and specified technical data (see [see "Safety-related technical data", page 55](#)) and operating conditions at all times.

Use inconsistent with the intended use, operation beyond the technical limits, improper modification of, or manipulation of the device, will invalidate any warranty from SICK; in addition, any responsibility and liability of SICK AG for damage and consequential damage caused by this is excluded.

2.1.1 Reasonably foreseeable misuse



WARNING

Risk of ineffectiveness of the protective device!

Persons and parts of the body to be protected may not be recognized in case of non-observance.

The device works as an indirect protective measure and cannot provide protection from pieces thrown from the application nor from emitted radiation. Objects within the blind zone and outside of the safety-related detection zone as well as transparent objects will not be detected.

- You must only use the device as an indirect protective measure.

The device is **not** suitable for the following applications (this list is not exhaustive):

- Outdoors
- Underwater
- In explosion-hazardous areas
- Use beyond the technical specifications

As a safety-related sensor, the device with performance level b (PL b), Category B (according to EN ISO 13849-1:2015) and performance class B (according to IEC TS 62998-1:2019) is only intended to perform part of the safety function (partial safety function). In its safety function, it provides sensor information to a downstream logic unit for further processing.

The safety function arises only in context with the target application, for example machine tools, a mobile platform, or a service robot.

Requirements and features of the application may differ from the features and characteristic values of the product and must be evaluated within the scope of project planning.

2.2 Improper use

Any use outside of the stated areas, in particular use outside of the technical specifications and the requirements for intended use, will be deemed to be incorrect use.



WARNING

Danger due to improper use!

Any improper use can result in dangerous situations.

Therefore, observe the following information:

- Device should be used only in accordance with its intended use.
 - All information in these operating instructions must be strictly observed.
-

2.3 Internet protocol (IP) technology



NOTE

SICK uses standard IP technology in its products. The emphasis is placed on availability of products and services.

SICK always assumes the following prerequisites:

- The customer ensures the integrity and confidentiality of the data and rights affected by its own use of the aforementioned products.
 - In all cases, the customer implements the appropriate security measures, such as network separation, firewalls, virus protection, and patch management.
-

2.4 Limitation of liability

Relevant standards and regulations, the latest technological developments, and our many years of knowledge and experience have all been taken into account when compiling the data and information contained in these operating instructions. The manufacturer accepts no liability for damage caused by:

- Non-adherence to the product documentation (e.g., operating instructions)
- Incorrect use
- Use of untrained staff
- Unauthorized conversions
- Technical modifications
- Use of unauthorized spare parts, consumables, and accessories

With special variants, where optional extras have been ordered, or owing to the latest technical changes, the actual scope of delivery may vary from the features and illustrations shown here.

2.5 Modifications and conversions



NOTICE

Modifications and conversions to the device may result in unforeseeable dangers.

Interrupting or modifying the device or SICK software will invalidate any warranty claims against SICK AG. This applies in particular to opening the housing, even as part of mounting and electrical installation.

2.6 Requirements for skilled persons and operating personnel



WARNING

Risk of injury due to insufficient training.

Improper handling of the device may result in considerable personal injury and material damage.

- All work must only ever be carried out by the stipulated persons.
-

Project planning

For project planning, a person is considered qualified when he/she has expertise and experience in the selection and use of protective devices on machines in the respective area of application, and is familiar with the relevant technical rules and national work safety regulations.

Mechanical mounting

For mechanical mounting, a person is considered qualified when he/she has the expertise and experience in the relevant field and is sufficiently familiar with the use of the protective device on machines in the respective area of application to be able to assess whether it is in an operationally safe state.

Electrical installation

For electrical installation, a person is considered qualified when he/she has the expertise and experience in the relevant field and is sufficiently familiar with the use of the protective device on machines in the respective area of application to be able to assess whether it is in an operationally safe state.

Configuration

For configuration, a person is considered qualified when he/she has the expertise and experience in the relevant field and is sufficiently familiar with the use of the protective device on machines in the respective area of application to be able to assess whether it is in an operationally safe state.

Commissioning

For commissioning, a person is considered qualified when he/she has the expertise and experience in the relevant field and is sufficiently familiar with the use of the protective device on machines in the respective area of application to be able to assess whether it is in an operationally safe state.

Operation and maintenance

For operation and maintenance, a person is considered qualified when he/she has the expertise and experience in the relevant field, is sufficiently familiar with the use of the protective device on machines in the respective area of application, and has been instructed by the operating entity of the machine in the details of operation.

An operator may clean the device and carry out specific thorough checks as instructed.

Regular thorough checks

For these regular thorough checks, a person is considered qualified when he/she has the expertise and experience in the relevant field and is sufficiently familiar with the use of the protective device on machines in the respective area of application to be able to assess whether it is in an operationally safe state.

2.7 Operational safety and particular hazards

Please observe the safety notes and the warnings listed here and in other chapters of this product documentation to reduce the possibility of risks to health and avoid dangerous situations.



CAUTION

Optical radiation: Laser class 1

The accessible radiation does not pose a danger when viewed directly for up to 100 seconds. It may pose a danger to the eyes and skin in the event of incorrect use.

- Do not open the housing. Opening the housing may increase the level of risk.
 - Current national regulations regarding laser protection must be observed.
-



WARNING

Electrical voltage!

Electrical voltage can cause severe injury or death.

- Work on electrical systems must only be performed by qualified electricians.
 - The power supply must be disconnected when attaching and detaching electrical connections.
 - The product must only be connected to a voltage supply as set out in the requirements in the operating instructions.
 - National and regional regulations must be complied with.
 - Safety requirements relating to work on electrical systems must be complied with.
-



WARNING

Risk of injury and damage caused by potential equalization currents!

Improper grounding can lead to dangerous equipotential bonding currents, which may in turn lead to dangerous voltages on metallic surfaces, such as the housing. Electrical voltage can cause severe injury or death.

- Work on electrical systems must only be performed by qualified electricians.
 - Follow the notes in the operating instructions.
 - Install the grounding for the product and the system in accordance with national and regional regulations.
-

2.8 Norms and standards of functional safety management

The safety-related 2D-LiDAR sensor TiM781S fulfils the requirements of EN ISO 13849-1:2015 regarding CAT B/PL b and the requirements of the following application standards:

- EN ISO 13482:2014 – Robots and robotic devices – Safety requirements for personal assistance robots
- ANSI/ITSDF B 56.5:2012 – Safety Standard for Driverless, Automatic Guided Industrial Vehicles and Automated Functions of Manned Industrial Vehicles
- EN ISO 13855:2010 – Safety of machinery – Positioning of protective devices with respect to the approach speeds of parts of the human body
- DIN CLC/TS 62046:2009 – Safety of machinery – Application of protective equipment to detect the presence of persons
- IEC TS 62998-1:2019 – Safety of machinery – Safety-related sensors

3 Product description

3.1 Device

- Device type: safety-related 2D LiDAR sensor
- Item description: TiM781S-2134101
- Design: PNP
- Part number: 1096363
- Valid firmware version: V3.13 or above

3.2 Configuration software

- Item description: SOPAS ET
- Valid software version: 3.3.3 or above

3.3 Scope of delivery

- TiM781S-2134101 including mounting kit 1 (2 straight plates, 2 M3 x 4 mm screws)
- Printed safety notes with reference to the operating instructions in German and English; in other languages via the SICK AG website, if required
- Other optional accessories (if these have been ordered)

3.4 Type label



3.5 Device layout

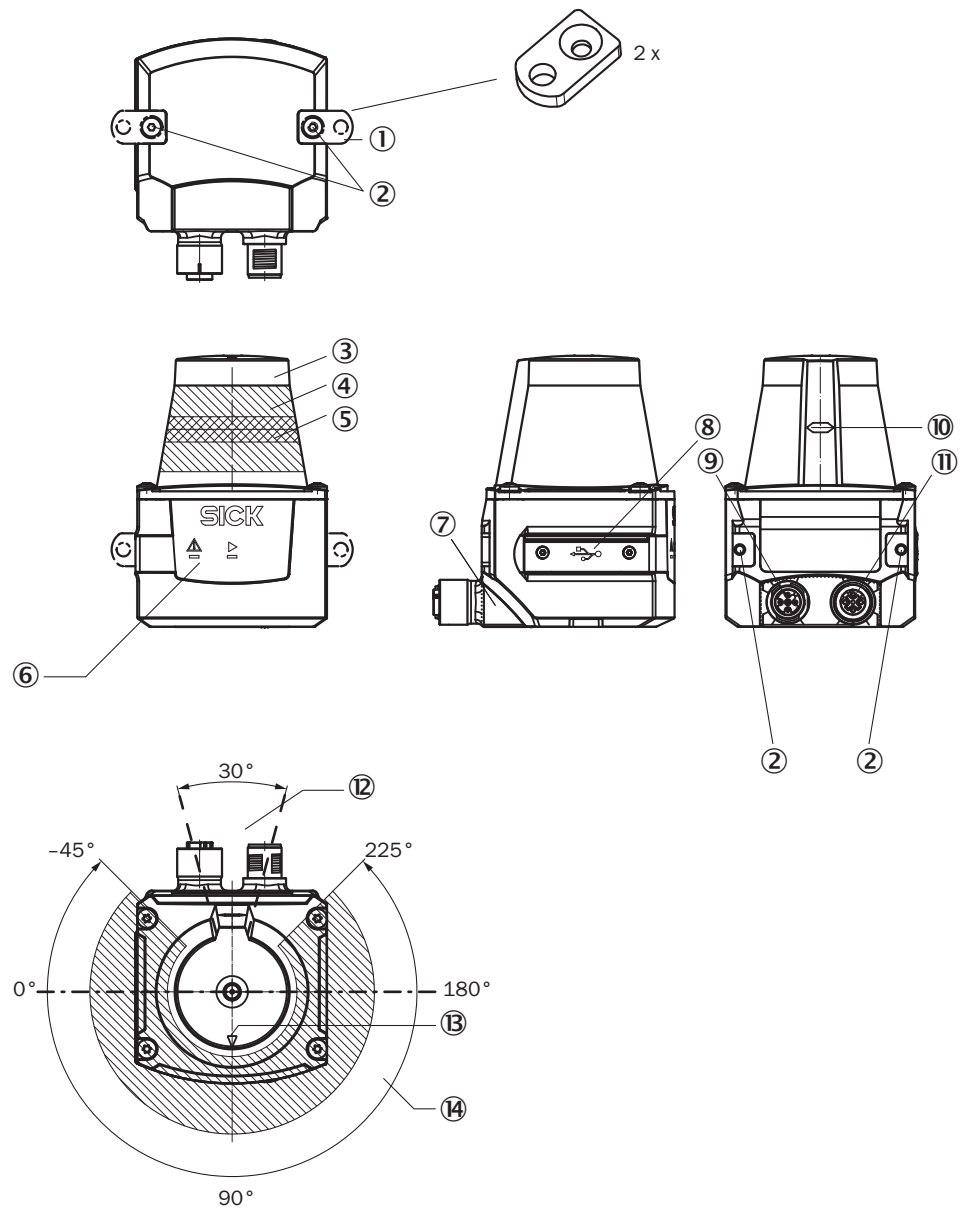

- ① Mounting kit 1: 2 x straight plates with M3 x 4 mm screw (included in scope of delivery)
- ② M3 threaded mounting hole, 2.8 mm deep (blind hole thread)
- ③ Optics cover
- ④ Receiving range (light inlet)
- ⑤ Transmission range (light emission)
- ⑥ Red and green LED (status indicators)
- ⑦ Swivel connector unit with electrical connections
- ⑧ Micro USB port, behind the black plaster cover ("Aux interface" connection for configuration with PC)
- ⑨ "Power/inputs and outputs" connection, 12-pin M12 male connector
- ⑩ Marking for the position of the light emission level
- ⑪ "Ethernet" connection, 4-pin M12 female connector
- ⑫ Area in which no reflective surfaces are permitted when the device is mounted
- ⑬ Bearing marking to support alignment (90° axis)
- ⑭ 270° aperture angle (visual range)

3.6 Accessories

The following accessories are permissible for safety-related use in connection with the TiM781S.

3.6.1 Mounting kit

The mounting kit with fine adjustment (part number 2086761) acts as a bracket, including the option of performing fine adjustment of the scan level, and also provides impact protection. The device can also be mounted directly on the bracket without the adapter plate (mechanical collision protection only).

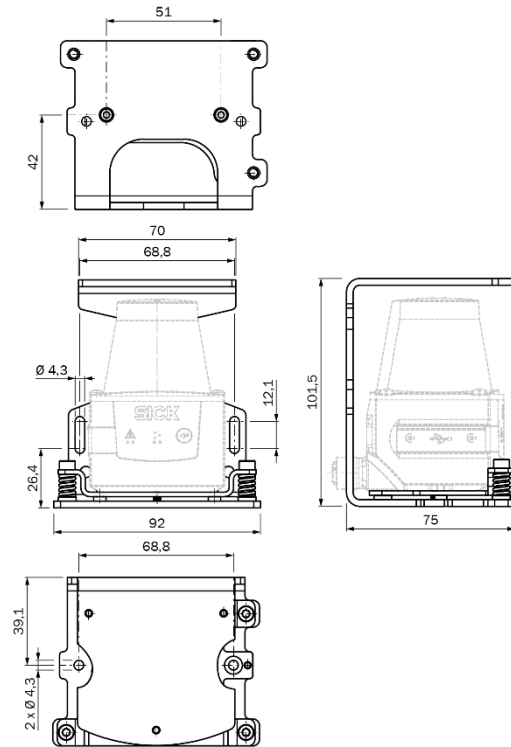

3.6.2 Cables

Designation	Part number
USB – Guide for configuring the sensor	6036106
M12 female connector – open, 10 m, 12-wire, shielded, PUR, halogen-free	6054973
M12 female connector – open, 20 m, 12-wire, shielded, PUR, halogen-free	6054972
M12 male connector - M12 male connector, Ethernet cable, 5 m	6045277
M12 male connector - M12 male connector, Ethernet cable, 10 m	6045279
M12 male connector - M12 male connector, Ethernet cable, 20 m	6063693

3.6.3 Wire assignment, part numbers 6054973/6054972

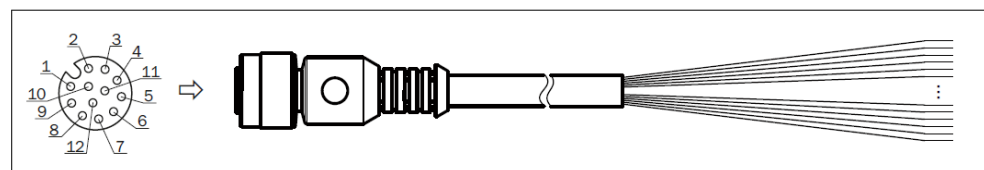

Female connector, M12, 12-pin, A-coded (view from front)	Illustration may differ
----------------------------------------------------------	-------------------------

PIN	Signal	Function	Wire color, cable 6054973 (10 m), 6054972 (20 m)
1	GND	Ground	Blue
2	DC 9 V ... 28 V	Supply voltage	Brown
3	IN 1	Switching input 1 (field set selection)	Red
4	IN 2	Switching input 2 (field set selection)	Green
5	OUT 1	Switching output 1 (field breach)	Pink
6	OUT 2	Switching output 2 (field breach)	Yellow
7	OUT 3	Switching output 3 (field breach)	Black
8	OUT 4	Switching output 4 (index/error)	Gray
9	PNP: INGND	PNP: Common ground for all inputs	White
	NPN: IN DC 9 V ... 28 V	NPN: Common reference potential of all inputs	
10	IN 3	Switching input 3 (field set selection)	Violet
11	IN 4	Switching input 4 (field set selection)	Gray-pink
12	N. c.	-	Red-blue
-	-	Screen	

3.7 Measurement principle

The device is an opto-electronic 2D LiDAR sensor that uses laser beams to scan the outline of its surroundings on a plane. The device measures its surroundings in two-dimensional polar coordinates, relative to its measurement origin in the middle of the optics cover. The arrow visible on the optics cover marks the 90° angle as the middle of the scanning range. If a laser beam strikes an object, the position of that object is determined in terms of length (distance) and direction (angle).

The device uses a rotating mirror to deflect the emitted laser beams, thereby scanning its surroundings in a circular pattern across a 270° segment. The measurements are triggered internally by an encoder in regular angle increments.

The device works with a scanning frequency of 15 Hz (15 measurements per second).

Working range

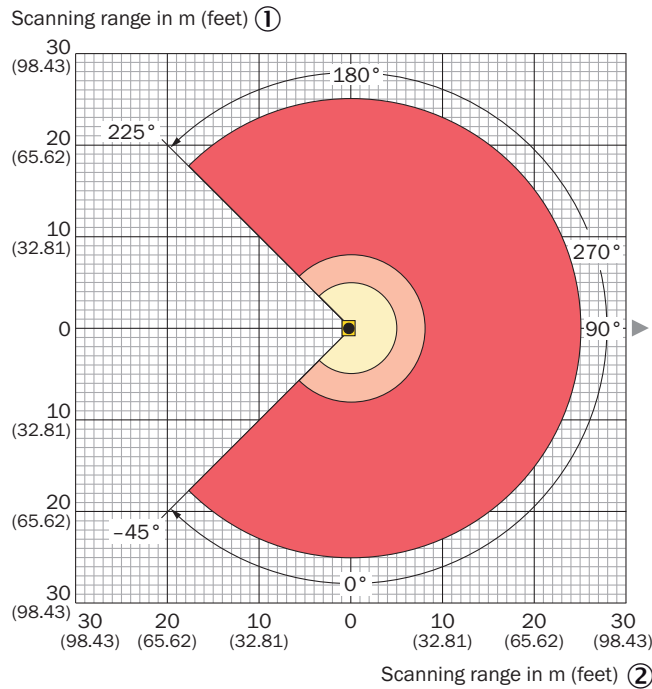

- Range for **not safety-related** detection at > 50% remission:
 0.05 m (0.17 feet) to max. 25 m (82.02 feet) ③
- Range for **not safety-related** detection 10% remission:
 0.05 m (0.17 feet) to max. 8 m (26.25 feet) ④
- Range for **safety-related** detection at 5% remission:
 0.05 m (0.17 feet) to max. 5 m (16.40 feet) ⑤

Attention! From the measurement origin up to a distance of 0.05 m (0.17 feet) no objects are detected (blind zone!) over the entire radial field of view (scanning range of 270°). ⑥

Figure 1: TiM781S working range diagram, decimal separator: period

- ① Sensing range in meters (feet)
- ② Sensing range in meters (feet)
- ③ Scanning range for **non safety-related** detection at > 50% remission: 0.05 m to max. 25 m
- ④ Scanning range for **non safety-related** detection at 10% remission: 0.05 m to max. 8 m
- ⑤ Scanning range for **safety-related detection** at 5% remission: 0.05 m to max. 5 m
- ⑥ **WARNING!** No objects will be detected within a range of 0.05 m from the measurement origin and across the entire radial field of view (scanning range of 270°) (blind zone!).

3.8 Safety function

The device is intended for use in personal protective equipment for detecting safety-related objects in mobile and stationary applications in industrial environments.

It also comes with a safety function (see also chapter ["Operating modes/operational statuses"](#), page 33)

During normal operation (monitoring mode), its **safety function** is to report the presence or penetration of objects it has detected in its active protective fields.

The device meets the requirements of performance level b (PL b), Category B, according to EN ISO 13849-1:2015 and performance class B (according to IEC TS 62998-1:2019). It can be used within its area of application for risk reduction according to its features.

3.9 Safety characteristic values

The device has the following safety characteristic values in acc. with EN ISO 13849-1:2015:

- Performance level b (PL b)
- Category (Cat.): B
- Mean Time To Dangerous Failure (MTTF_D): 100 years (at 25 °C ambient temperature)¹⁾
- Mission Time (MT) (period of use): 20 years

The device has the following safety characteristic values in acc. with EC TS 62998-1:2019 performance class B.

3.10 Safety-related detection capability (horizontal/vertical)

Values see ["Safety-related technical data", page 55](#)

3.10.1 Restrictions

The safety-related detection capability (determined by the measurement procedure) can be impaired for measurement of objects with edges and/or corners and/or those moving too quickly. This can result in incorrect distance values, causing impairment, reduction or complete loss of detection capability, and the device no longer being able to perform its function.

3.10.2 Blind zone

No objects will be detected within a range of 0.05 m from the measurement origin.

3.10.3 Measurement on reflector

When using reflectors (max. remission of 330 Cd/lx*m²) as the target, the statistical and systematic measurement accuracy diminishes at lower temperatures and therefore also the detection capability of the sensor.

Values: see ["General technical data", page 54](#).

3.10.4 Limits of the system

A measurement with minimal remission combined with maximum remission (reflector) represents the most challenging situation.

The most unfavorable case here - like in the visible spectrum - is spill from a weak emitter in front of a strong reflector.

If the dark object is relatively small and the reflector is moved to less than 1.5 meters behind the object, it may not be possible to distinguish the reflector from an object edge. The measured value could therefore be reduced by up to half the distance of the dark object from the reflector, like for an edge evaluation (see ["Restrictions", page 18](#)). This effect can be attributed to scattered light from the periphery of the laser beam falling onto the highly amplifying reflector.

Conversely, a reflector in the foreground, for example on a person's clothing, and in front of a dark background poses no difficulties and leads to a reliable detection. This object migration effect also does not occur for dark objects in front of normal white backgrounds with a remission of approx. 100%.

¹⁾ At higher ambient temperatures, the MTTF_D value decreases according to the Arrhenius equation. These values can be requested from SICK.

If strongly amplifying reflectors at a distance of less than 1.5 meters behind objects with a low remission cannot be excluded, then their impact on the safety function of the overall system needs to be specifically evaluated.

**WARNING**

Due to the necessary system reserve of the device, its detection range and/or system range is greater than the assured distances for safety-related detection.

This system reserve **must not** be used for safety-related analysis!

4 Transport and storage

4.1 Transport

For your own safety, please read and observe the following notes:



NOTICE

Damage to the product due to improper transport.

- The device must be packaged for transport with protection against shock and damp.
 - Recommendation: Use the original packaging as it provides the best protection.
 - Transport should be performed by trained specialist staff only.
 - The utmost care and attention is required at all times during unloading and transportation on company premises.
 - Note the symbols on the packaging.
 - Do not remove packaging until immediately before you start mounting.
-

4.2 Unpacking

- Before unpacking, it may be necessary to equalize the temperature to protect the device from condensation.
- Handle the device with care and protect it from mechanical damage.
- Remove the protective caps on the electrical connections immediately before connecting the connecting cable to prevent dirt and water from entering.

4.3 Transport inspection

Immediately upon receipt in Goods-in, check the delivery for completeness and for any damage that may have occurred in transit. In the case of transit damage that is visible externally, proceed as follows:

- Do not accept the delivery or only do so conditionally.
 - Note the scope of damage on the transport documents or on the transport company's delivery note.
 - File a complaint.
-



NOTE

Complaints regarding defects should be filed as soon as these are detected. Damage claims are only valid before the applicable complaint deadlines.

4.4 Storage

Store the device under the following conditions:

- Recommendation: Use the original packaging.
- Electrical connections are provided with protective caps and plugs (as they are on delivery).
- Do not store outdoors.
- Store in a dry area that is protected from dust.
- So that any residual damp can evaporate, do not package in airtight containers.
- Do not expose to any aggressive substances.
- Protect from sunlight.
- Avoid mechanical shocks.

- Storage temperature: [see "Technical data", page 54.](#)
- For storage periods of longer than 3 months, check the general condition of all components and packaging on a regular basis.

5 Mounting

5.1 Notes on mounting

- Mount the device using the optionally available mounting accessories, "[Accessories](#)", [page 15](#).
- Mount the device on a prepared bracket.
- The device should be mounted and operated as free from shock and vibration as possible.
- The device can be mounted in any position depending on the application purpose.
- Mount the device so that it is not exposed to direct sunlight (window, skylight) or other sources of heat. This prevents the temperature inside the device from increasing unacceptably, or a reduction or loss of detection capability.
- During mounting, make sure there is no reflective surface behind the internal reference target, "[Device layout](#)", [page 14](#). In general, to prevent a reduction or loss of detection capability, the mounting position of the device should be chosen so as to exclude any dazzle in the sensor's back area (behind the internal reference target) due to other light sources.

5.2 Mutual interference



NOTE

Optical sensors and other IR light sources can influence the measurement and detection capabilities of the device.

The device has been designed to minimize the probability of mutual interference with devices of the same type. To rule out even the slightest effects on the measurement accuracy, the devices should be arranged such the laser beams are not received by another device.

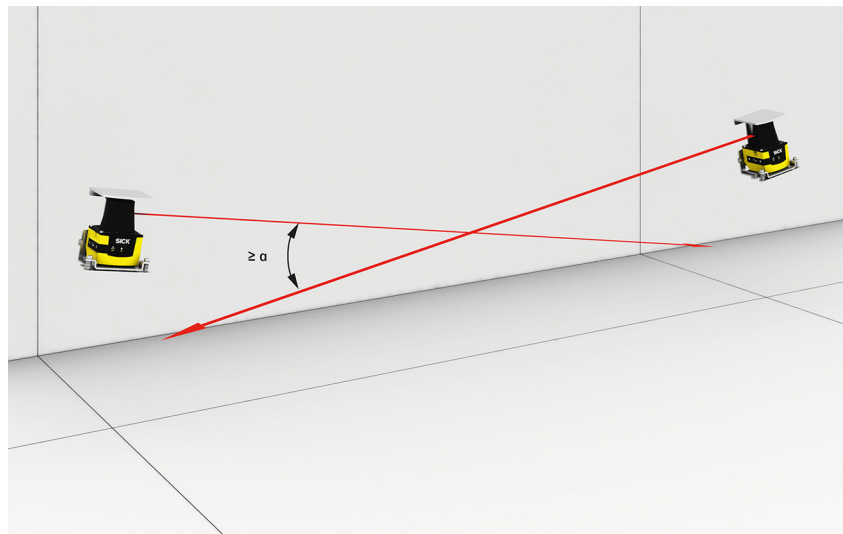

Figure 2: Angle $\geq 6^\circ$

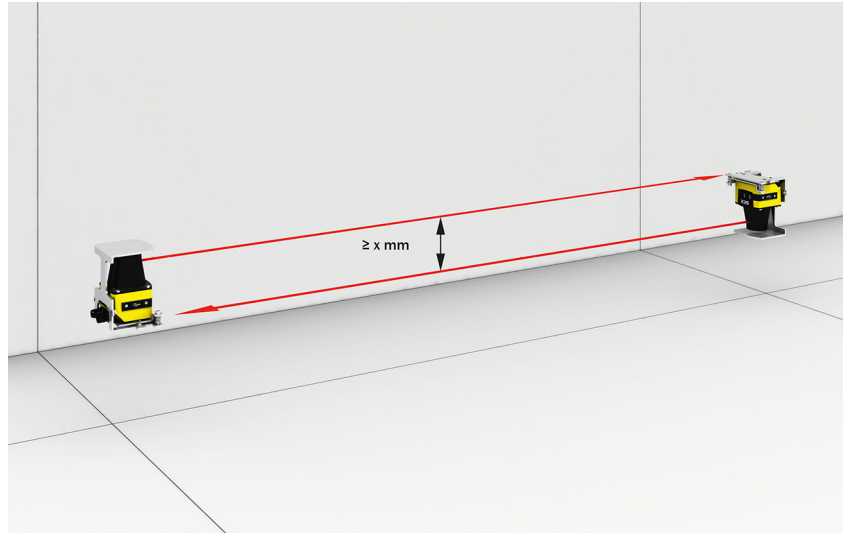

Figure 3: Distance $\geq 200 \text{ mm}$

6 Commissioning and configuration

6.1 Prerequisites for safe operation of the device



WARNING

Risk of injury and damage caused by electrical current!

As a result of equipotential bonding currents between the device and other grounded devices in the system, faulty grounding of the device can give rise to the following dangers and faults:

- Dangerous voltages are applied to the metal housings.
- Devices will behave incorrectly or be destroyed.
- Cable shielding will be damaged by overheating and cause cable fires.

Remedial measures

- Only skilled electricians should be permitted to carry out work on the electrical system.
 - If the cable insulation is damaged, disconnect the voltage supply immediately and have the damage repaired.
 - Ensure that the ground potential is the same at all grounding points.
 - Where local conditions do not meet the requirements for a safe earthing method, take appropriate measures (e.g., ensuring low-impedance and current-carrying equipotential bonding).
-

The device is connected to the peripheral devices (voltage supply, any local trigger sensor(s), system controller) via shielded cables. The cable shield – for the data cable, for example – rests against the metal housing of the device. The device can be grounded through the cable shield or through a blind tapped hole in the housing, for example.

If the peripheral devices have metal housings and the cable shields are also in contact with their housings, it is assumed that all devices involved in the installation have the **same ground potential**.

This is achieved by complying with the following conditions:

- Mounting the devices on conductive metal surfaces
- Correctly grounding the devices and metal surfaces in the system
- If necessary: low-impedance and current-carrying equipotential bonding between areas with different ground potentials

If these conditions are not fulfilled, equipotential bonding currents can flow along the cable shielding between the devices due to differing ground potentials and cause the hazards specified. This is, for example, possible in cases where there are devices within a widely distributed system covering several buildings.

Remedial measures

The most common solution to prevent equipotential bonding currents on cable shields is to ensure low-impedance and current-carrying equipotential bonding. If this equipotential bonding is not possible, the following solution approaches serve as a suggestion.



NOTICE

We expressly advise against opening up the cable shields. This would mean that the EMC limit values can no longer be complied with and that the safe operation of the device data interfaces can no longer be guaranteed.

Measures for widely distributed system installations

On widely distributed system installations with correspondingly large potential differences, the setting up of local islands and connecting them using commercially available **electro-optical signal isolators** is recommended. This measure achieves a high degree of resistance to electromagnetic interference.

The use of electro-optical signal isolators between the islands isolates the ground loop. Within the islands, a stable equipotential bonding prevents equalizing currents on the cable shields.

Measures for small system installations

For smaller installations with only slight potential differences, insulated mounting of the device and peripheral devices may be an adequate solution.

Even in the event of large differences in the ground potential, ground loops are effectively prevented. As a result, equalizing currents can no longer flow via the cable shields and metal housing.



NOTICE

The voltage supply for the device and the connected peripheral devices must also guarantee the required level of insulation.

Under certain circumstances, a tangible potential can develop between the insulated metal housings and the local ground potential.

6.2 Electrical block diagram

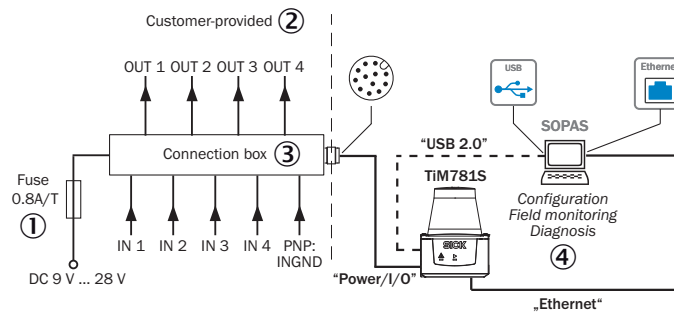

Figure 4: Block diagram for the TiM781S connection

- ① 0.8 A/T fuse
- ② Provided by customer
- ③ Switch-on device
- ④ Configuration, field analysis, diagnostics

6.3 Wiring notes



NOTE

Preassembled cables can be found online at:

- www.sick.com/TiM-S



NOTICE

Faults during operation and device or system defects!

Incorrect wiring may result in operational faults and defects.

- Follow the wiring notes precisely.

The protection class stated in the technical data is achieved only with screwed plug connectors or cover caps.

Protect the device from dust and moisture when the USB cover flap is open.

All electrical circuits connected to the device must be configured as SELV or PELV circuits (SELV = Safety Extra Low Voltage, PELV = Protective Extra Low Voltage).

Protect the device with an external 0.8 A slow-blow fuse at the beginning of the supply cable.

Connect the connecting cables in a de-energized state. Switch on the supply voltage only after complete installation/connection of all connecting cables to the device and control system.

6.4 Installation of SOPAS Engineering Tool

6.4.1 System requirements for SOPAS ET, version 3.3.3

System	Minimum requirement
CPU	Standard Intel Pentium PC or compatible, at minimum Pentium III 500 MHz
Frequency and working memory	Min. 1 GHz / 1 GB RAM
Interface	USB 2.0 or compatible
Operating system	Windows XP, Vista, Windows 7 or Windows 8 (32/64 bit)
Minimum resolution	1024 x 768 px
Memory	At least 450 MB

6.4.2 Installation process



NOTE

Use the standard version of the software, not the portable version. Using the standard version ensures that all SOPAS ET functions and drivers are available. For installation, it may also be necessary to have administrator authorizations.

- Select the installation language.

This selection only determines the language of the installation wizard. Regardless of the selected installation language, all SOPAS ET languages can be selected subsequently.

- Chose whether you want to have an icon on the desktop or on the Start Menu bar, and click **Next >**.
- Select the installation location for SOPAS ET.

It is recommended not to change the suggested location.

- Click **Next >**.

The installation process starts. Please wait until it is fully complete and the next page appears. The **Run SOPAS Engineering Tool** checkbox is preselected.

- Use the **Close** button to complete the installation and launch SOPAS ET.

6.4.3 Installing the device driver

The device driver is installed automatically the first time a connection is established between SOPAS ET and the device.

6.4.4 ROS driver

Suitable drivers for integrating the TiM781S into a ROS (Robot Operating System) are available for download on the product page: www.sick.com/TiM-S

6.5 Parameterization of the device

The device is parameterized using the SOPAS ET PC software.



WARNING

Risk of ineffectiveness of the protective device!

- Before establishing a connection between SOPAS ET and the device and before beginning parameterization, ensure that the machine, plant or application in which the device is involved as part of a safety function is in a safe state.

6.5.1 Establishing the connection

Before launching SOPAS ET, a suitable cable (see chapter [see "Accessories", page 15](#)) must be used to establish a USB connection between the parameterization interface of the device and the PC.

- ▶ To run SOPAS ET, double-click the program icon – a new project is opened.

A quick search for connected devices is performed.

The progress bar shows how far the process has progressed. The x symbol to the right of the progress bar can be used to cancel the search process.

Found devices are listed in the search results window. If the device was previously connected to the PC via USB, it will appear in the search results.

Found devices can be inserted into the project from the search results area via drag & drop, double-click, the Enter pushbutton, or the **Add** icon. They will remain in the search results but are displayed in gray.

Devices can only be configured and observed if they are inserted into the project.

No actions can be performed on the device in the search results window.

A device driver must be installed before establishing a connection with the device for the first time. Follow the instructions provided by SOPAS ET. When selecting the source for the driver installation, choose the “Upload from device” option.

6.5.2 Configure the device

- ▶ To configure a device, double-click on the desired device.

This opens the device window which displays all the device parameters. You can configure the device, download parameters to and from the device, or observe parameter values in this window.

The parameter values then also remain in the project after you close the device window.

After closing the main window, you will be informed that parameters must be permanently saved in the device and parameter values will be lost if the project has not been saved.

6.5.3 Display of the current operational status

The **Field Evaluation Monitor** page (in the navigation area of the device window, below the **Monitor** node) displays the current operational status consisting of measurement data, status of the individual fields as well as status of the switching inputs and switching outputs.

The **field monitor**, which is located in the middle of the page, displays measurement data as blue points and/or a blue line. Occupied fields are shown in yellow; free fields appear in green.

6.5.4 Changing parameters



WARNING

Risk of injury/risk of damage due to incorrect parameters!

- Parameter changes are transferred to the device and take effect immediately after being edited. Permanent saving (in the non-volatile memory of the device) does not occur, however, until the **Save permanent** button is clicked.
- After parameter changes, the effectiveness of the protective device in the application must be reviewed and documented.
- Before beginning the parameterization, ensure that the machine, plant or application in which the device is involved as part of a safety function is in a safe state.

Please note:

The individual parameters of the device can be changed on the pages below the **Parameters** node in the navigation area.

The device must be configured/parameterized using the SOPAS configuration software.

6.5.5 Parameterization

The product is delivered with the following default parameterization, which prevents unintentional or inadvertent activation of the sensor.



WARNING

Risk of ineffectiveness of the protective device!

- After parameterizing the device or subsequently modifying the parameters, the effectiveness of the protective device in the application must be reviewed and documented. For a safety-related use of the device, this may in certain circumstances include a comprehensive safety assessment.



NOTE

The parameterization and commissioning in the case of a safety-related use of the device must only be performed by appropriately qualified personnel. This applies in particular to settings that differ from the default parameterization, and the resultant requirement for an assessment of the safety-related sensor function within the application.

6.5.5.1 Particle filter, median filter, moving average filter

Default: All filters “inactive”

General filter

Particle filter active

Scan data output

Median filter active

Moving average filter

Moving average filter active Number of scans

The filters should be deactivated, otherwise objects that appear sporadically and for a short time will not be detected and/or filtered out. Filters can also slow down the response of the switching outputs, and the outputting of measured values via the Ethernet interface.

6.5.5.2 Duration time for the outputs

Default: Maximum duration time of the outputs (150 scans / 10,050 ms)

Evaluation cases

Duration time output:

Scan(s)

ms

The device automatically releases its protective field outputs when no more objects are detected. The maximum output delay therefore prevents immediate restart.

Continuous restart interlock with reset function must be implemented by the user in the application.

6.5.5.3 Response time for object detection

Default: Minimum response time for object detection

Parameters for blanking fields

Response time:
1 Scan(s)
67 ms

Blanking size:
10 mm

Parameters for contour fields

Response time:
1 Scan(s)
67 ms

Blanking size:
10 mm

The shortest configurable response time is preset to 134 ms and represents the most rapid object detection.

6.5.5.4 Object sensitivity

Default: Smallest blanking size (10 mm)

Parameters for blanking fields

Response time:
1 Scan(s)
67 ms

Blanking size:
10 mm

Parameters for contour fields

Response time:
1 Scan(s)
67 ms

Blanking size:
10 mm

The smallest configurable blanking size of 10 mm represents the greatest degree of object detection (i.e., the smallest detectable object).

6.5.5.5 Ethernet interface

Default: Measurement data output using an LMDscandata (CoLa-B) data telegram via the Ethernet interface

Ethernet Host Port

CoLa Dialect

Server / Client IP-Port

The telegram-related checksums when using binary CoLa enable a downstream controller to detect errors during telegram transmission.

6.5.5.6 Switching outputs

Default: All outputs are set to Active low in the PNP version.

Output 1

Output 1 Logic

Output 2

Output 2 Logic

Output 3

Output 3 Logic

Output 4

Output 4 Logic

Index Signal active

The active-low logic uses the principle of energy release as active status.

6.5.5.7 Index Signal

Default: Index signal active is enabled

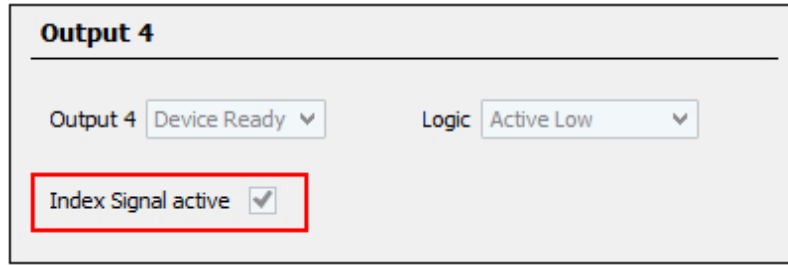

The index signal (1x per scan) of the device can be used by a downstream controller.

6.5.5.8 Protective fields

Default: No protective fields are parameterized, i.e., all field points of a protective field are deleted (no entries).

The **Contour as Reference** function is deactivated for all fields in all field sets.

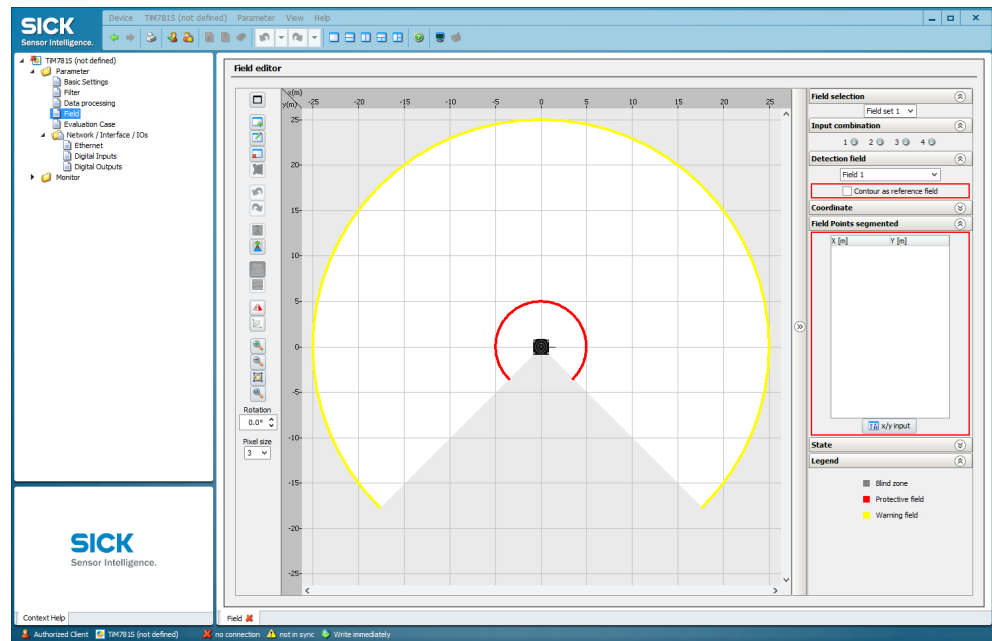

Deleting the field points means that the corresponding outputs for signaling protective field infringements are active (active low) until they are actively changed.

When the field points are deleted, the field editor will not display any protective fields!

6.5.6 Passwords

Software access to the device is protected by various passwords. After configuring the device successfully, the respective password must be changed so that it can fulfill its protective function.

User levels	Password
Maintenance	Does not have a factory-set password. The password is created by the Authorized client user (i.e., it is not possible to log in initially as Maintenance).
Authorized client	The password SICKSAFE is set at the factory. Change this password to protect the device against unauthorized access.

6.6 Editing fields

Fields can be created and edited on the **Fields** page (below the **Parameters** node).

Before editing a field, first select the desired field set itself and the desired field within the field set.

Field set no. 1 and Field no. 1 are preset.

Different from all other parameters, changes to fields (adding, moving or removing individual field points or entire fields) are not transferred to the device until the **Download of all fields to device** button is clicked.

6.6.1 Operating modes/operational statuses

The device has the following operating modes and operational statuses:

6.6.1.1 Power On and boot phase

Begins after connecting and/or interruption of the supply voltage, and ends with operational readiness or fault/error

6.6.1.2 Operational readiness

Begins after Power On and boot phase, and ends 1 min or more after connection of the supply voltage. Operational readiness is indicated optically by the “green” LED on the device.

6.6.1.3 Operational status (monitoring mode)

(See also Normal functioning)

The device automatically enters this status after reaching operational readiness and after the “Device Ready” output (OUT4) has changed to the “high” status. To do so, the device must not be in parameterization mode, "[Configuration mode](#)", [page 33](#).

The sensor can only be employed for safety-related purposes once it is operating in monitoring mode. Other safety-oriented measures may, in some circumstances, therefore need to be implemented until the sensor becomes operational.

6.6.1.4 Configuration mode

Once the device is connected to the SOPAS ET parameterization software via the USB interface, the device can be configured.

The “Device Ready” output remains unchanged until write access to the device is initiated by SOPAS (e.g., changing a parameter, downloading field data, or accessing the **Save permanent** function), then the “Device Ready” (OUT4) output enters the status “low” for a certain period of time.

6.6.1.5 Fault/error

The device automatically enters this status when it detects an internal error. If there is an internal error, the output “Device Ready” (OUT4) is deactivated and enters the “low” status. This status is shown optically on the device.

6.6.1.6 Safety function

The device is equipped with two safety functions:

Safety function 1 is detecting the presence or entry of an object in a defined detection field (protective field).

Valid for default configuration only: When **safety function 1** is requested, the **defined status 1** is entered within max. 134 ms (max. 2 scans) and the safety-related output signals (OUT1-3) assigned according to the detection field are switched off (inactive state).

Example:

When an automated guided vehicle (AGV) system approaches a person, a warning field can trigger an optical or acoustic signal. If the person does not respond and the AGV system continues to approach, the infringement of a protective field by the person can be used to stop the AGV system via the associated safety outputs before it reaches the person.

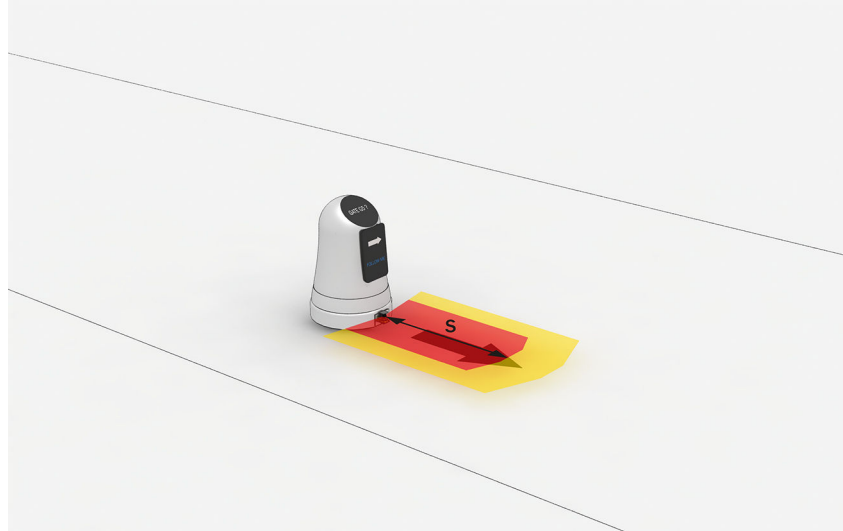

Safety function 2 is the derivation of a distance value between the 2D LiDAR sensor (measurement origin) and an object that is present or has entered the safety-related detection zone.

When **safety function 2** is requested, the **defined status 2** is entered within an average response time of 134 ms or less and the distance value between the device (measurement origin) and an object that is present or has entered the detection zone is transmitted via the Ethernet interface.

6.6.1.7 Defined statuses

The device has four defined statuses.

When **safety function 1** is requested, **defined status 1** is used to switch off (deactivated status) the safety-related output signal (OUT1, OUT2, OUT3) assigned according to the detection field.

When **safety function 2** is requested, **defined status 2** is used to transmit, via the measured value interface (Ethernet interface), a distance value between the 2D LiDAR sensor and an object that is present or has entered the detection zone.

Defined status 3 is the status in which one or more of the safety-related output signals (OUT1, OUT2, OUT3) has entered the switched off (deactivated) status while the **safety function 1** was not requested.

Defined status 4 is the status in which the safety-related “Device Ready” (OUT4) output signal has entered the switched off (deactivated) status for more than 67 ms.

6.6.1.8 Response times for defined statuses

Upon request of the **safety function 1**, the device enters **defined status 1** within a response time of 134 ms or less (max. 2 scans), and upon request of the **safety function 2**, it enters **defined status 2** within an average response time of 134 ms or less.

It enters **defined status 3** within a response time of 3,000 ms or less (45 scans), and **defined status 4** within a response time of 3,000 ms or less (45 scans).

6.6.1.9 Protective field evaluation monitor and derivation of a measured value

In normal operation (monitoring mode), the device reports the entry or presence of an object it has detected in its active protective fields and delivers, with an angular resolution of 0.33°, a distance value between the device and the object detected in the detection field (detection range). Please note the previously specified response times.

6.6.1.10 Protective fields

The device can simultaneously analyze 3 independent protective fields (detection fields). Each protective field is assigned to a digital output OUT1, OUT2, OUT3 which is activated upon infringement of the protective field (active low). The 3 independent protective fields are configured in a field set in the device and saved.

If a field set change occurs, the device activates analysis of the new protective fields with a response time of 134 ms or less (max. 2 scans).

6.6.1.11 Field Sets

The device has 16 independent field sets. Selection of the active field set, and therefore also of the active protective fields, is performed via inputs IN1, IN2, IN3, IN4.

6.6.2 Digital inputs/outputs

The device has the following safety-related interfaces, the statuses of which only become valid after operational readiness is reached (see also Operating modes/operational statuses):

6.6.2.1 Digital inputs

The device has 4 digital PNP switching inputs (IN 1-4), which by means of selecting the corresponding binary combination (see table, below), activate one of the 16 available field data sets, and therefore the active protective fields.

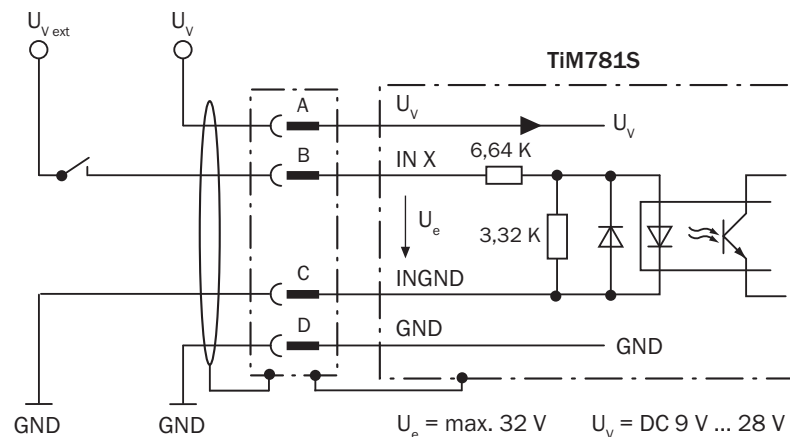

Figure 5: Configuration and switching principle of the IN 1, IN 2, IN 3, IN 4 inputs

Field set factory settings – switching inputs:

Field set	Switching inputs			
	IN 1	IN 2	IN 3	IN 4
1	0	0	0	0
2	1	0	0	0
3	0	1	0	0
4	1	1	0	0
5	0	0	1	0
6	1	0	1	0
7	0	1	1	0
8	1	1	1	0
9	0	0	0	1
10	1	0	0	1
11	0	1	0	1
12	1	1	0	1
13	0	0	1	1
14	1	0	1	1
15	0	1	1	1
16	1	1	1	1

Input level:

PNP: Low (in resting position): $\leq 2\text{ V}$, high (in working position): $\geq 8\text{ V}$

Characteristic data of the switching inputs:

The characteristic data is identical for of all switching inputs.

Switching behavior	Current to the input starts the assigned function in the device. Default: "active high" level, 10 ms debounce
Properties	Opto-decoupled Switchable with an electronic switch (PNP output) or mechanical switch
PNP electrical values	Low: $U_e \leq 2\text{ V}$, $I_e \leq 0.3\text{ mA}$ High: $8\text{ V} \leq U_e \leq 32\text{ V}$, $0.7\text{ mA} \leq I_e \leq 5\text{ mA}$

6.6.2.2 Digital outputs

Infringement of the respective protective field is displayed in the active field data set by means of 3 available digital PNP switching outputs (OUT1 ... OUT3).

The factory setting for the digital outputs is the status "Field 1, 2, and 3 infringed".

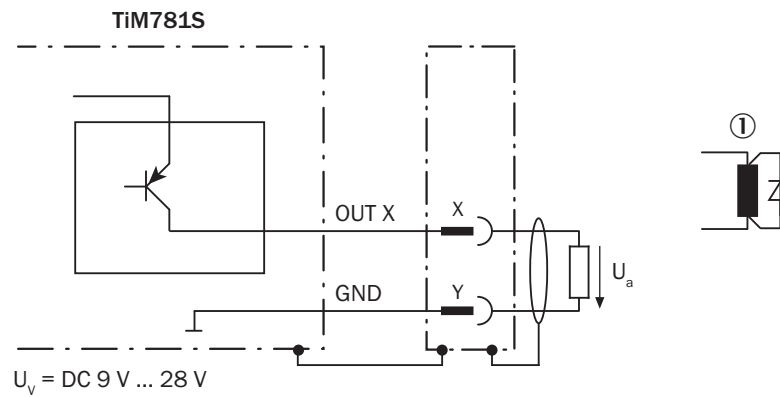

Assignment of infringed fields – switching outputs:

Fields of a field set	Switching outputs		
	OUT 1	OUT 2	OUT 3
Fields 1, 2, and 3 infringed	Active	Active	Active
Fields 2 and 3 infringed	Deactivated	Active	Active
Field 3 infringed	Deactivated	Deactivated	Active
All fields free	Deactivated	Deactivated	Deactivated

Active: in working position; deactivated: in resting position

Initial level:

The level of the PNP switching outputs OUT 1 ... OUT 3 is “active low” (deactivated status, resting position high, in working position low (field infringed)).

All fields of a field set are considered infringed upon switching on, booting, in the event of an error and when the device is switched off.

PNP switching output 4 works with the following levels:

Function	Level
Device Ready	High
Index signal (15 Hz), corresponds to measurement at 90°	Low peaks
Fault	Low

6.6.2.3 Characteristic data of the switching outputs

PNP switching behavior	<p>PNP switching to supply voltage U_V.</p> <ul style="list-style-type: none"> OUT1 ... OUT3: Resting level high (no field infringement), working level low (field infringed) Response time 134 ms ... 30 s (configurable via SOPAS ET), holding time 0 ms ... 10 s (configurable via SOPAS ET) OUT4: Resting level high (device ready), working level low (error), low pulse (15 Hz, index, corresponds to measurement at 90°)
------------------------	----------------------------------------------------------------------------------------------------------------------------------------------------------------------------------------------------------------------------------------------------------------------------------------------------------------------------------------------------------------------------------------------------------------------------------------------------------------------

Properties	Short-circuit protected and temperature protected Not electrically isolated from supply voltage U_v
PNP electrical values	$0\text{ V} \leq V_{\text{out}} \leq V_S$ $(V_S - 1.5\text{ V}) \leq V_{\text{out}} \leq V_S$ at $I_{\text{out}} \leq 100\text{ mA}$

Important! Longer connecting cables at the switching outputs of the device should be avoided due to the resulting fall in voltage. This is calculated as follows:

$$\Delta U = 2 \times \text{length} \times \text{current/conductance value} \times \text{cross-section}$$

Conductance value for copper $56\text{ m}/\Omega\text{ mm}^2$

6.6.3 Function and status displays

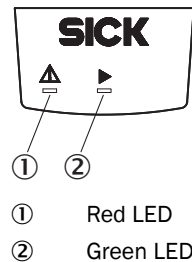

Red LED	Green LED	Status
-	Lights up	Device ready/monitoring mode
Lights up	Lights up	Field infringement
Flashing	-	Fault
-	-	Device without supply voltage

6.6.4 Measurement data interface

A safety-related distance value (between the measurement origin and the detected object) is transmitted as a measured value via the Ethernet interface. The transmitted measured values contain the following information:

- 0 m: no object present or no object detected!
- > 0 to 0.016 m: error codes (not measured values)
- > 0.016 to < 0.05 m: not defined! (not measured values)
- 0.05 to 25 m: distance values (valid measured values)

The safety-related range of measured values is between 0.05 m and max. 5 m with a resolution of 1 mm.

The LMDscandata telegram supports the following options for querying the measurement data:

- The request of exactly one measured value using the `sRN LMDscandata` telegram (the last measured scan is transmitted).
- Continuous request of measured data using the `sEN LMDscandata` telegram (measured data is transmitted until the output of measured values is stopped with the `sEN LMDscandata` telegram)

The detailed structure of the output telegram as well as the flow of requests and outputs is described in the “Measurement output telegram” chapter in the Telegram listing publication (English, no. 8014631). The document also describes all telegrams available in the TiM781S.

**NOTE**

Parameterization of the device via the Ethernet interface is not permitted.

**WARNING****Risk of ineffectiveness of the protective device!**

The Ethernet interface is intended for measurement data transmission **only** and must **not** be used for any other purpose. The number of devices that can be connected to the Ethernet interface is limited to 2 x TIM781S and a controller for analyzing the data. Devices connected to the Ethernet interface that have incorrect IP settings are not recognized and can lead to corruption of the measurement data and to **loss of the safety function**.

In the delivery state, the device can transmit measurement data using the following connection settings:

IP-Address	192.168.0.1
Subnet mask	255.255.255.0
TCP port	2112

The IP address and subnet mask settings of the device can be changed using the SOPAS Engineering Tool (SOPAS ET).

7 Error behavior

7.1 General

A non-hazardous failure of the device occurs:

- When the device switches to defined status 1 and/or 2 **without the safety functions having being requested**.
- When the device switches to defined status 3 and/or 4 in the event of a **detected internal error**.

A hazardous undetected failure occurs:

- When the device fails to switch to defined status 1 and/or 2, or to defined status 3 and/or 4 upon request of the **safety functions**.

7.2 Detected errors

The device detects some internal errors merely to improve its availability and support troubleshooting in the event of a fault.

The device has a diagnostic coverage (DC) of zero in accordance with EN ISO 13849-1:2015 PL b. The internal errors detected by the sensor **cannot** be used to increase the DCs within the meaning of this standard! (See also Error codes of the 2D LiDAR sensor)

7.3 Undetected errors and faults

The device will **not** detect the following errors and faults, among others:

- **Digital inputs:** wire break, short-circuit, cross-circuit to the digital inputs for field set selection (IN1, IN2, IN3, IN4), making it possible to select an incorrect field set.
- **Digital outputs:** wire break, short-circuit, cross-circuit to the digital outputs for field set infringement (OUT1, OUT2, OUT3) and Device Ready (OUT4), with the effect that the defined statuses can no longer be detected by the downstream controller.
- **Measurement data interface:** wire break, short-circuit, cross-circuit, EMC influences, and devices with the same IP address on the Ethernet measurement data interface, with the effect that corrupted or no measurement data are transmitted to the downstream controller.
- **Status indicators:** Failure of the status indicators for field set status, with the result that infringement of the protective field is not correctly displayed optically on the device.
- **Contamination:** Contamination of the optics and/or the front screen, causing impairment, reduction or complete loss of detection capability, and the device no longer being able to perform the safety function.
- **Ambient light:** Malfunctions due to faults of other scanners and light sources within the level of the scan field, causing impairment, reduction or complete loss of detection capability, and the device no longer being able to perform its function.
- **Incorrect measurements:** Measurement of objects with edges and/or corners and/or which are moving too quickly (determined by the measurement procedure) can result in incorrect distance values, causing impairment, reduction or complete loss of detection capability, and the device no longer being able to perform the safety function.
- **Blind zone:** Objects, especially covering objects, located within the blind zone extending f 0.05 m from the measurement origin of the device, causing impairment, reduction or complete loss of detection capability, and the device no longer being able to perform the safety function.

**WARNING****Risk of ineffectiveness of the protective device!**

Undetected errors and faults can cause impairment, reduction or complete loss of detection capability, such that the device is no longer able to perform the safety function.

NOTE

The device has a diagnostic coverage (DC) of zero in accordance with EN ISO 13849-1:2015 PL b, i.e., it is not required to detect errors, and if they do occur, they can result in loss of the **safety functions**.

The downstream controller, for example, can be used to detect errors by means of testing and diagnostic measures.

7.4 Fault exclusions

No fault exclusions have been specified for the device. The occurrence of faults can result in the loss of the **safety function**.

7.5 Manipulation

The device does not have any protective measures against manipulation, especially none that relate to the optical system. Objects, especially covering objects on the optics cover and/or in the blind zone, are not detected by the device, causing impairment, reduction or complete loss of detection capability, and the device no longer being able to perform the safety function.

Manipulations with effects similar to undetected faults (see chapter [see "Undetected errors and faults", page 40](#)) are also not detected.

8 Project planning

8.1 Manufacturer of the machine

**WARNING****Risk of ineffectiveness of the protective device!**

Persons and parts of the body to be protected may not be recognized in case of non-observance.

- ▶ Use of the device requires a risk assessment. Check whether additional protective measures are required.
- ▶ Comply with the applicable national regulations derived from the application (e.g., work safety regulations, safety rules, or other relevant safety guidelines).
- ▶ Apart from the procedures described in this document, the components of the device must not be opened.
- ▶ The device must not be tampered with or changed.
- ▶ Improper repair of the device can lead to loss of the safety function. The protective device must only be repaired by the manufacturer or by someone authorized by the manufacturer.

8.2 Operating entity of the machine

**WARNING****Risk of ineffectiveness of the protective device!**

Persons and parts of the body to be protected may not be recognized in case of non-observance.

- ▶ Changes to the electrical integration of the device in the machine controller and changes to the mechanical mounting of the device necessitate a new risk assessment. The results of this risk assessment may require the entity operating the machine to meet the obligations of a manufacturer.
 - ▶ Changes to the device's configuration may impair the safety function of the device. Therefore the device's safety function and the effectiveness of the protective device must be checked after any change in configuration. The person carrying out the change is responsible for maintaining the safety function of the device and the protective device.
 - ▶ The device must not be tampered with or changed.
 - ▶ Improper repair of the device can lead to loss of the safety function. The protective device must only be repaired by the manufacturer or by someone authorized by the manufacturer.
-

**WARNING****Danger due to optical and electromagnetic ambient conditions!**

Optical and electromagnetic ambient conditions can impair the functioning of the device. This can result in loss of the **safety functions**.

- Please note the following:
-
- ▶ Avoid having strong electric fields in the vicinity of the device. These may be caused by nearby welding or induction cables, for example.
 - ▶ Prevent condensation on and/or contamination of the optics cover. To ensure the continuing, reliable safety function of the device, the optics cover must be cleaned regularly.

8.3 Protection tasks

People approach the monitoring plane parallel or orthogonally, depending on the orientation of the protective field in your application.

- Hazardous area protection (horizontal): Typically, for a horizontal approach, the requirement is to detect the leg. The typical object resolution is the leg (70 mm).
- Access protection (vertical): Typically, for access protection, the requirement is to detect a person. The typical object resolution is the body (200 mm).
- Hazardous point protection (vertical): Typically, for hazardous point protection, the requirement is to detect a hand. The typical object resolution is the hand (40 mm).

Contour as Reference monitoring

If the monitoring plane has a vertical alignment, a contour (such as the floor, a part of the machine bed, or an access threshold) must typically be defined and monitored as a reference contour.

Object resolution

The object resolution defines the size that an object must be to allow it to be reliably detected.

Typical object resolutions are:

- 40 mm = hand detection/arm detection
- 50 mm = leg detection/arm detection
- 70 mm = leg detection
- 200 mm = body detection

The object resolution affects the available protective field range. The finer the desired object resolution, the shorter the available protective field range.

Further necessary safety-related parameters can be derived from the protection task, object resolution, and the application-specific constraints, for example:

- Minimum distance
- Height of the scan plane
- Protective field lengths
- Protective field widths
- Height of barriers

These parameters must be determined for each specific application. The safety-related technical data of the device, and the requirements of relevant national and international standards (e.g., ISO 13855, ISO 13857,...) must be taken into consideration when doing so.

8.4 Preventing unprotected areas



WARNING

Risk of ineffectiveness of the protective device!

Persons and parts of the body to be protected may not be recognized in case of non-observance.

- Make sure that the following design requirements are met so that the device can fulfill its protective function.
-
- The device must be affixed so that people or parts of the body are reliably detected upon entry into the hazardous area.
 - The device must be affixed so that no mirrors or other exceedingly reflective objects are in the protective field.
 - The device must be affixed so that people cannot enter unsecured areas.

- The device must be affixed so that no small objects (e.g. cables) are in the protective field, even if the safety outputs do not switch to the OFF state as a result.
- The device must be affixed so that no obstacles disrupt the safety sensor's field of view. Take additional protective measures if a risk arises due to unavoidable obstacles.
- If people can stay between the protective device and the hazardous point without being detected, check if additional protective measures (e.g., restart interlock) are required.
- Reaching under, over and around, crawling beneath and stepping over the device, as well as moving it, must be prevented.



WARNING

Risk of ineffectiveness of the protective device!

Persons and parts of the body to be protected may not be recognized in case of non-observance.

The optical beam path must not be disrupted, e.g. if the system is incorporated into paneling.

- Do not attach an additional front screen.
-

8.5 Response time of the device

The device's response time must be taken into account, among other things, so that the device can be positioned in a suitable location and the protective fields can be sized correctly.

The response times are specified in the technical data.

8.6 Contour as Reference field

The contour as reference field monitors a contour of the environment. The device switches all safety outputs to the OFF state if a contour does not match the set parameters, because, for example, the mounting of the device has been changed.

The contour as reference field detects unintentional and intentional changes to the position or alignment of the device. Unintentional changes may be caused, for example, by vibrations. An example of an intentional change is deliberate tampering to disable the device's functionality.

National and international standards require or recommend that a contour as reference is monitored, if the safety sensor is used in vertical operation for hazardous point protection or for access protection.



WARNING

Risk of ineffectiveness of the protective device!

Persons and parts of the body to be protected may not be recognized in case of non-observance.

- Use a contour from the environment as a reference to protect the protective device from inadvertent adjustment or tampering.
-

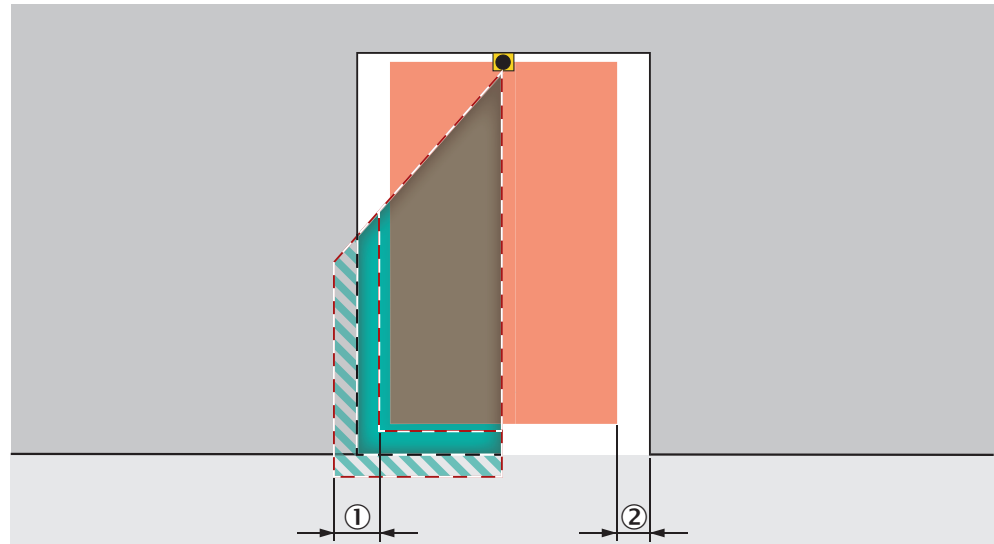

Figure 6: Tolerance band of the contour as reference field (protective field within the protected opening, edge of the protected opening = reference contour)

- ① Tolerance band of the contour as reference field
- ② Distance of the protective field from the contour, to ensure availability

8.7 Timing of analysis case switching

When switching between analysis cases (field sets), it is possible that a person may already be in the newly activated protective field when switching takes place. Only timely switching (namely before the danger arises at this location) can ensure protection.



WARNING

Risk of ineffectiveness of the protective device!

Persons and parts of the body to be protected may not be recognized in case of non-observance.

- Switching of the analysis case should be timed so that the device detects a person in the protective field with a sufficient minimum distance before the dangerous state occurs.

8.8 Hazardous area protection

The TiM781S device is mounted with a horizontal scan plane in a stationary application, for example on a machine where the hazardous area is not completely surrounded by a physical guard. During hazardous area protection, the device detects a person's legs. The protective field is parallel to the person's direction of approach.

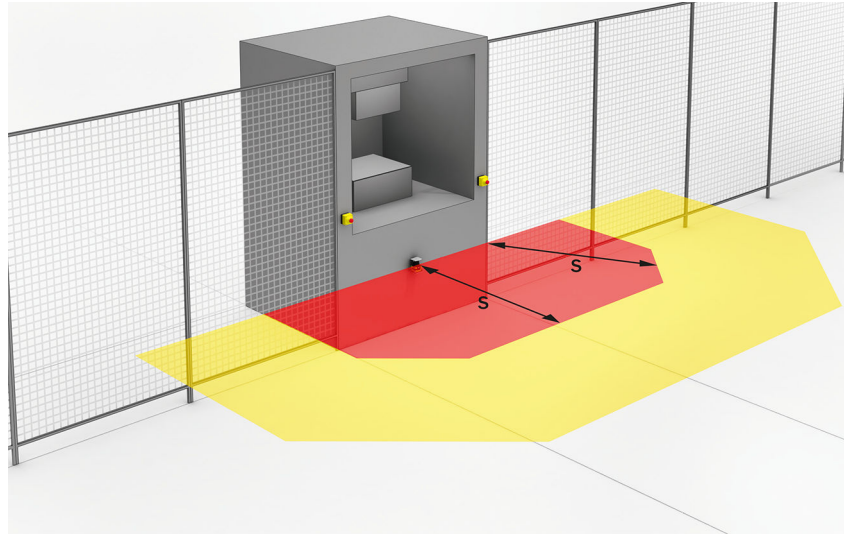

Protective field

The protective field (S) must be designed so that it detects a person at a minimum distance from the hazardous point. This distance is required to prevent a person or part of their body from reaching the hazardous area before the end of the machine's dangerous state.

In hazardous area protection, the minimum distance typically defines the protective field size required.

If you define a number of analysis cases with different protective fields, you must calculate the protective field size separately for each protective field used.

In many cases, a resolution of 50 mm or 70 mm is suitable for hazardous area protection.

Height of the scan plane



WARNING

Risk of ineffectiveness of the protective device!

It is possible to get around the protective device by crawling beneath.

- Prevent people from being able to crawl beneath the protective field by mounting the device appropriately.
- If you mount the protective device higher than 300 mm, you must use additional measures to prevent people crawling underneath.



WARNING

Risk of ineffectiveness of the protective device!

Persons and parts of the body to be protected may not be recognized in case of non-observance.

Body parts to be protected may not be detected under coarse resolution.

- Use a resolution of 70 mm or finer for hazardous area protection.
- For hazardous area protection with a resolution of 70 mm: make sure that it is possible to detect a human leg.
- For hazardous area protection with a resolution of 70 mm: mount the device at a height of at least 300 mm (height of the scan plane).
- If it is not possible to mount the device at a height of at least 300 mm, use a finer resolution.

Calculating minimum distance

The calculation of the minimum distance is based on international or national standards and statutory requirements applicable at the place of installation of the machine.

The minimum distance depends, among other things, on the following:

- Machine stopping time (time interval between triggering the sensor function and the end of the machine's dangerous state, including signal propagation times in the network and processing time in the control)
- Response time of the protective device
- Reach or approach speed of the person
- Resolution (detection capability) of the device
- Type of approach: parallel
- Parameters specified based on the application
- Supplements for general and, possibly, reflection-based measurement errors
- Supplement to protect against reaching over
- Height of the scan plane
- Switching time between monitoring cases

8.9 Hazardous point protection

The device is mounted with a vertical scan plane in a stationary application, for example on a machine where the operator must stay close to the hazardous point.

There is a fixed barrier in front of the hazardous point. The required height is specific to the particular application, and the applicable standards (for example ISO 13857) should be taken into consideration when calculating the height.

The operator can reach over the barrier and through the scan plane into the hazardous point. But the operator cannot climb over the barrier. If there is no such barrier available, access protection may be required.

During hazardous point protection, the device detects the arm or another part of a person's body. The protective field is orthogonal to the direction of approach of the body part. A resolution of 40 mm is required to ensure detection of the arm during hazardous point protection.

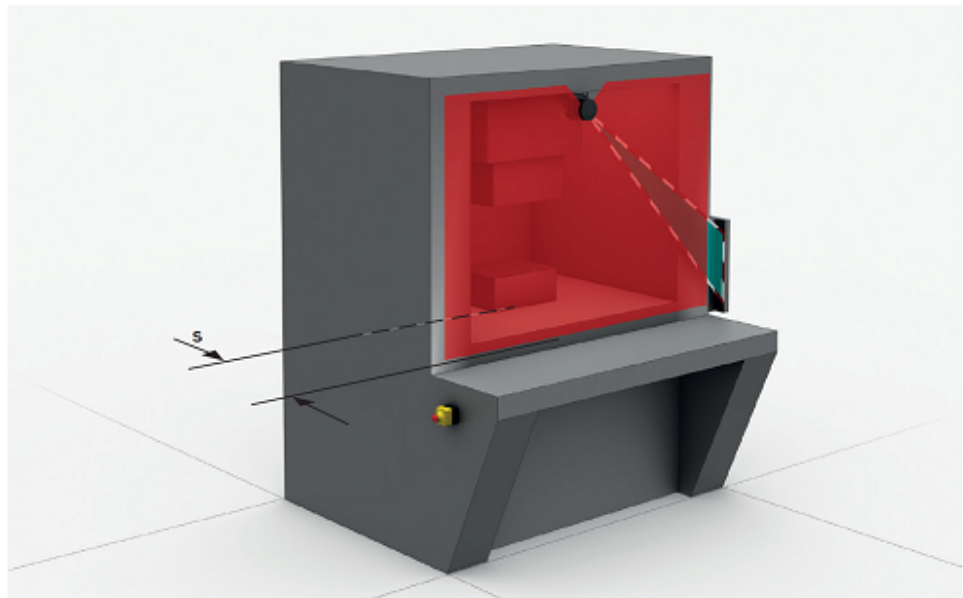



WARNING

Risk of ineffectiveness of the protective device!

Persons and parts of the body to be protected may not be recognized in case of non-observance.

- Never use the device for applications requiring the detection of fingers. The device is not suitable for finger detection because the finest resolution is 40 mm.
 - Use the contour of the surroundings as a reference to protect the protective device from inadvertent adjustment or tampering.
-

Protective field

The protective field must be designed so that it detects access by a person at a minimum distance from the hazardous point. This distance is required to prevent a person or part of their body from reaching the hazardous area before the end of the machine's dangerous state.

In hazardous area protection, the minimum distance typically defines the position at which the device is mounted.

In many cases, a resolution of 40 mm is suitable for hazardous point protection.



WARNING

Risk of ineffectiveness of the protective device!

Persons and parts of the body to be protected may not be recognized in case of non-observance.

- Always mount the device so that it is impossible to reach around or behind it.
 - Provide suitable additional measures if necessary.
-

Calculating minimum distance

The calculation of the minimum distance is based on international or national standards and statutory requirements applicable at the place of installation of the machine.

The minimum distance depends, among other things, on the following:

- Machine stopping time (time interval between triggering the sensor function and the end of the machine's dangerous state)
- Response time of the protective device
- Reach or approach speed of the person
- Resolution (detection capability) of the safety sensor
- Type of approach: orthogonal
- Parameters specified based on the application

8.10 Access protection

The device is mounted with a vertical scan plane in a stationary application, for example on a machine, for which access to the hazardous area may be defined structurally. For access protection, the device detects an intrusion by a whole body. The protective field is orthogonal to the person's direction of approach.

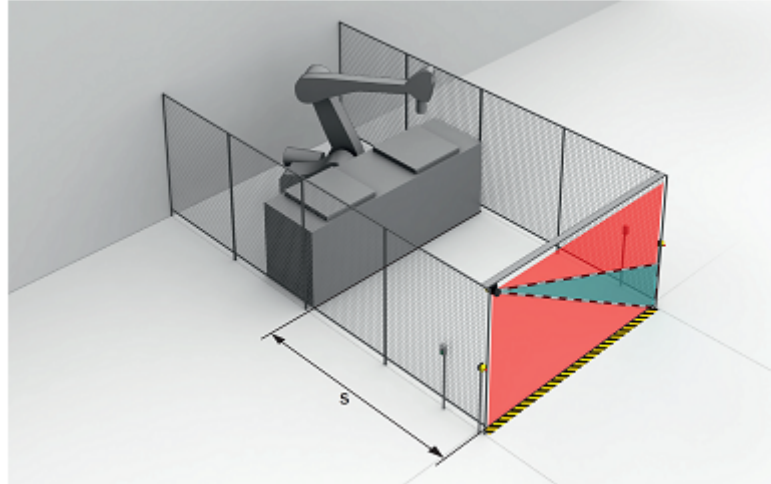
**WARNING****Ineffectiveness of the protective device**

Persons and parts of the body to be protected may not be recognized in case of non-observance.

- Use a resolution of 200 mm or finer. Otherwise, protection will not be ensured during access protection.
- Use the contour of the surroundings as a reference to protect the protective device from inadvertent adjustment or tampering.

Protective field

The protective field must be designed so that it detects a person at a minimum distance from the hazardous point. This distance is required to prevent a person or part of their body from reaching the hazardous area before the end of the machine's dangerous state.

In access protection, the minimum distance typically defines the position at which the device is mounted.

Calculating minimum distance

The minimum distance depends, among other things, on the following:

- Machine stopping time (time interval between triggering the sensor function and the end of the machine's dangerous state)
- Response time of the protective device
- Reach or approach speed of the person
- Resolution (detection capability) of the safety sensor
- Type of approach: orthogonal
- Parameters specified based on the application
- Supplement to prevent reaching through

8.11 Mobile hazardous area protection

The device is mounted with a horizontal scan plane in a mobile application, for example on an automated guided vehicle. In mobile hazardous area protection, the device protects the hazardous area created by the vehicle's movement. The device detects a person's legs. The protective field is parallel to the direction of approach.

**NOTE**

- In a mobile application, a resolution of 70 mm (leg detection) is sufficient for detecting people. In contrast to stationary hazardous point protection, this is also true for a low mounting height, as the device moves together with the vehicle.
- In typical protective field calculations, only the vehicle speed is taken into account, not the speed of a walking person. This is based on the assumption that the person recognizes the danger and stands still

Protective field length

The protective field must be designed so that it detects a person at a minimum distance from the hazardous point. This distance is required to ensure that the vehicle comes to a stop before it reaches a person or an object.

In mobile hazardous area protection, the minimum distance typically defines the protective field length required. When calculating the protective field length, the impact of turning must be considered separately.

If you define a number of analysis cases with different protective fields, you must calculate the protective field size separately for each protective field used.

Protective field width

The protective field must be wide enough to cover the width of the loaded vehicle with supplements for measurement error and the lack of ground clearance. When calculating the protective field width, the impact of turning must be considered separately.

The minimum protective field width is determined based on a max. speed of moving objects of 1.6 m/s. The minimum protective field width is 0.3 m taking into consideration the specified reaction times and scan frequency (see "Technical data", page 54). For the maximum safety detection distance of 5 m, this minimum protective field width corresponds to an angular resolution of 4.5° , which is well above the minimum angular resolution of 0.33° .

Calculating minimum distance

The minimum distance depends, among other things, on the following:

- Response time of the protective device
- Position of the device on the vehicle
- Approach speed of personnel
- Resolution of the device
- Speed of the vehicle

- Reflection-related measurement error
- Ground clearance of the device on the vehicle
- Braking force of the vehicle
- Parameters specified based on the application

Height of the scan plane



WARNING

Ineffectiveness of the protective device

Persons and parts of the body to be protected may not be recognized in case of non-observance.

- Always mount the device so that the maximum scan plane height is 200 mm.
-

People who are lying down are reliably detected if the scan plane is at a height of no more than 200 mm.

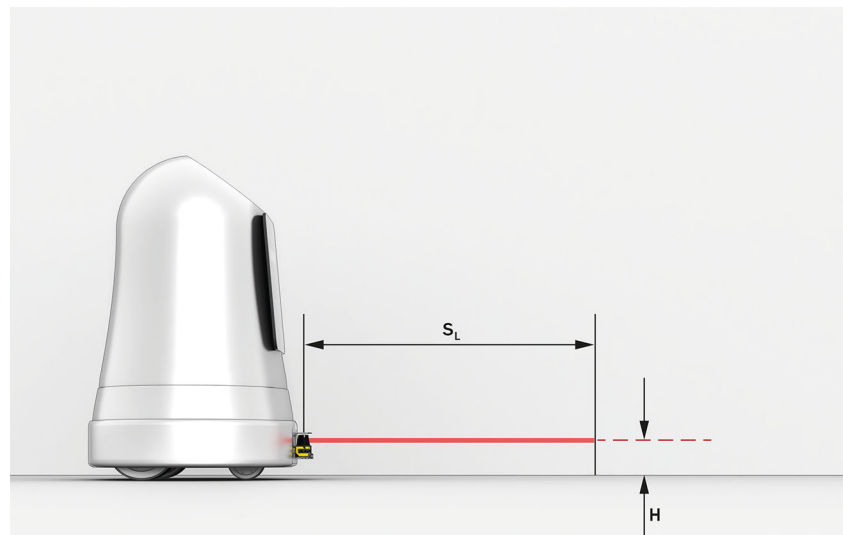

9 Regular thorough checks

At regular intervals the user must demonstrate that the measures taken still fulfill the protective purpose, and that the protective device still functions correctly in the application during the service life.

Thorough checks and tests are required in this regard:

- Upon commissioning (e.g., initial commissioning, recommissioning)
- After changes and extraordinary events (e.g., conversion, change of parameters, modification, retrofitting and equipment, damage, repair, ...)
- At regular intervals (e.g., recurring thorough checks intended to ensure that a safety-related function and/or safety function still functions correctly in the application)

These thorough checks must be documented clearly and comprehensibly.

Determination of the time intervals for thorough checks at regular intervals must be decided and established by the manufacturer of the machine and/or by the operating entity depending on the specific application, place of application and influencing factors prevailing there. (e.g., dirt, demand rate, EMC, ...).

Example: thorough check of the effectiveness of protective fields

The effectiveness of protective fields can be demonstrated, for example, by positioning a suitable test object with the diameter and remission of the desired detection capability at multiple points along the effective protective range, and having the device detect them.

10 Working with the product

10.1 Safety

Risk of ineffectiveness of the protective device

Persons and parts of the body to be protected may not be recognized in case of non-observance.

- Do not do repair work on device components.
- Do not make changes to or manipulate device components (including the software).
- The device components must not be opened.
- If the device is damaged or defective, it must be replaced.

10.2 Maintenance and care

The device does not contain any components that require maintenance. The device must not be opened. Maintenance is not necessary to ensure compliance with laser class 1, either.

- ▶ The black, infrared-transparent optics cover should be cleaned, at regular intervals and in the event of contamination, with a lint-free lens cloth (part no. 4003353) and plastic cleaning agent (part no. 5600006). In this regard, the cleaning interval essentially depends on the ambient conditions.

10.3 Transport and storage

The device must be transported and stored in its original packaging with the USB protective cap screwed on. Do not store outdoors. To ensure that any residual moisture present can escape, do not store the device in airtight containers. Do not expose to aggressive media (e.g. solvents).

Storage conditions: Dry, dust-free, no direct sunlight, as little vibration as possible, storage temperature $-40 \dots +75 \text{ }^{\circ}\text{C}$, relative humidity max. 90% (non-condensing).

10.4 Repair

Repair work on the device may only be performed by qualified and authorized service personnel from the company SICK AG.

10.5 Disassembly and disposal

Any device which can no longer be used must be disposed of in an environmentally friendly manner in accordance with the applicable country-specific waste disposal regulations.

As it is classified as electronic waste, the device must never be disposed of with household waste.

11 Technical data



NOTE

The relevant online data sheet for your product, including technical data, dimensional drawing, and connection diagrams can be downloaded, saved, and printed from the Internet:

- www.sick.com/TiM-S

11.1 General technical data

Characteristic	Values
Field of view	Radial, aperture angle 270°
Angular resolution	0.33°
Scanning frequency	15 Hz (15 scans/s)
Detection range/system distances	0.05 m ... 5 m; at 5% remission 0.05 m ... 8 m; at 10% remission 0.05 m ... 25 m; at > 50% remission
Minimum physical object sizes (cross-section)	121 mm at a distance of 8 m, 66 mm at a distance of 4 m, 38 mm at a distance of 2 m, at respective remission
Measurement error/accuracy	Statistical error (SE): ± 20 mm (CL: 1-0.317) Systematic error: ± 60 mm The systematic error is below the specified value over the entire temperature range. The statistical error may fluctuate over the temperature range but will remain within the specified limits.
Measurement error/accuracy when measuring on a reflector	The following measurement errors apply for temperatures above 25 °C Statistical error (SE): ± 20 mm (CL: 1-0.317) Systematic error: ± 60 mm The measurement errors increase for temperatures below 25 °C. The statistical error increases from max. 20 mm to max. 40 mm. The systematic error increases linearly from max. 60 mm to 120 mm.
Light source	Laser diode, infrared ($\lambda = 850 \text{ nm} \pm 10 \text{ nm}$)
Laser class	Laser class 1 according to EN 60825-1:2015 (eye-safe)
Max. radiated power	1.5 W
Max. pulse duration	5 ns
Configuration interface	USB 2.0 for configuration, max. 3 m connecting cable
Electrical connections	1 x 12-pin M12 power male connector 1 x 4-pin. M12 Ethernet female connector 1 x micro USB female connector, type B (covered)
Optical indicators	2 x LEDs
Supply voltage	DC 9 ... 28 V, SELV and PELV According to IEC 60364-4-41
Power consumption	Typical power consumption of 4 W with unloaded switching outputs Max. power consumption 16 W with max. four loaded switching outputs
Protection	The supply voltage must be protected with a max. 0.8 A slow-blow fuse

Characteristic	Values
Housing	Lower part: Aluminum die cast Optics cover: Polycarbonate with scratch-resistant coating
Weight	Approx. 250 g without cables
Electrical safety	According to IEC 61010-1 (ed.3)
Protection class	III, acc. to EN 61140: IEC 60010-1 (ed. 3)
Ambient light immunity	At least 80,000 lx (indirect on the surface)
Ambient temperature	-25° ...50 °C
Temperature change	Thorough check N according to EN 60068-2-14
Damp heat	In accordance with EN 60068-2-30
Air humidity	≤ 80% (non-condensing)
Enclosure rating	IP67
Altitude	Max. 2,900 m above sea level
EMC	Residential area according to EN 61000-6-3 Industrial area according to EN 61000-6-2
Vibration resistance	In accordance with EN 60068-2-6
Shock resistance	In accordance with EN 60068-2-27
Contamination	Contamination level 1, EN 61010-1 outside housing Contamination level 3, EN 61010-1 outside housing, with sealed USB connection (All specifications regarding contamination do not apply to the optics)

11.2 Safety-related technical data

Characteristic	Values
Performance level (PL)	b according to EN ISO 13849-1:2015
Category (Cat.)	Cat. B according to EN ISO 13849-1:2015
Mean Time To Dangerous Failure (MTTF _D)	100 years according to EN ISO 13849-1:2015 (at 25 °C ambient temperature) ¹
Mission Time (service life)	20 years
Performance class	B according to IEC TS 62998-1:2019
Safety-related detection range	0.05 m ... 5 m; at 5% remission
Safety-related detection capability	Up to a relative speed of 1.6 m/s and at min. 5% remission: Objects 40 mm in diameter at a distance of 0.05 m up to max. 1.5 m Objects 50 mm in diameter at a distance of 0.05 m up to max. 2 m Objects 70 mm in diameter at a distance of 0.05 m up to max. 2.5 m Objects 200 mm in diameter at a distance of 0.05 m up to max. 5 m,
Safety-related measurement error/accuracy	Safety-related statistical error (SSE): ± 100 mm CL: 1-1E-5) in accordance with IEC TS 62998-1 The safety-related statistical error may fluctuate over the temperature range but will remain within the specified limits. This value is not achieved for measurement on reflectors, in particular not at lower temperatures.
Blind zone	No objects are detected across the entire radial visual range (scanning range of 270°) from the measurement origin up to a distance of 0.05 m

Characteristic	Values
Response time	Response of the switching outputs upon detection of an object Max. 134 ms (max. 2 scans)
Protective field/Field evaluation	1 analysis case with 1 field set and up to 3 independent protective fields, signaling of field infringements via a combination of 3 PNP switching outputs (OUT1 ... OUT3)
Protective field tolerance	+100 mm; 0.66° acc. to IEC 62046 at 5% remission Temperature drift: 1.5 mm/Kelvin
Number of field sets	16 field sets with 3 independently configurable protective fields each
Switching inputs	PNP inputs: 4 x IN, IN1...IN4, ($U_e = \text{max. } 28 \text{ V}$, $I_e = \text{max. } 5 \text{ mA}$), opto-decoupled, debouncing time approx. 10 ms
Switching outputs	PNP outputs: 4x OUT, OUT1...OUT4, (each $I_a \text{ max. } 100 \text{ mA}$), not galvanically isolated from the supply voltage, short-circuit protected/temperature protected Adjustable for OUT 1 ... OUT 3: Response time (134 ms ... 30 s) Holding time (0 ms ... 10 s) ²⁾
Safety-related measurement range	Output of safety-related distance values between the measurement origin and detected objects: > 0.05 m ... to 5 m; with a resolution of 1 mm
Measured value interface	Ethernet interface To be used exclusively for measured value transmission max. data rate: 10 Mbit and 100 Mbit, cable length limited to max. 100 m

¹ At higher ambient temperatures, the $MTTF_D$ value decreases according to the Arrhenius equation. These values can be requested from SICK.

NOTE

The product is intended for use in industrial environments, under indoor conditions. It is not suitable for use in special surroundings (e.g., radiation and sparks from welding systems, strong sources of infrared, thermal convection, fluorescent and stroboscopic light sources, snow, rain, contamination) or must yet be made suitable, if applicable.

²⁾ The TiM has an internal, system-related time delay of 67 ms

12 Annex

12.1 EU declaration of conformity / Certificates

The EU declaration of conformity and other certificates can be downloaded from the Internet at:

12.2 Licenses

SICK uses open-source software. This software is licensed by the rights holders using the following licenses among others: the free licenses GNU General Public License (GPL Version2, GPL Version3) and GNU Lesser General Public License (LGPL), the MIT license, zLib license, and the licenses derived from the BSD license.

This program is provided for general use, but WITHOUT ANY WARRANTY OF ANY KIND. This warranty disclaimer also extends to the implicit assurance of marketability or suitability of the program for a particular purpose.

More details can be found in the GNU General Public License. View the complete license texts here: www.sick.com/licensetexts. Printed copies of the license texts are also available on request.

Australia

Phone +61 (3) 9457 0600
1800 33 48 02 – tollfree
E-Mail sales@sick.com.au

Austria

Phone +43 (0) 2236 62288-0
E-Mail office@sick.at

Belgium/Luxembourg

Phone +32 (0) 2 466 55 66
E-Mail info@sick.be

Brazil

Phone +55 11 3215-4900
E-Mail comercial@sick.com.br

Canada

Phone +1 905.771.1444
E-Mail cs.canada@sick.com

Czech Republic

Phone +420 234 719 500
E-Mail sick@sick.cz

Chile

Phone +56 (2) 2274 7430
E-Mail chile@sick.com

China

Phone +86 20 2882 3600
E-Mail info.china@sick.net.cn

Denmark

Phone +45 45 82 64 00
E-Mail sick@sick.dk

Finland

Phone +358-9-25 15 800
E-Mail sick@sick.fi

France

Phone +33 1 64 62 35 00
E-Mail info@sick.fr

Germany

Phone +49 (0) 2 11 53 010
E-Mail info@sick.de

Greece

Phone +30 210 6825100
E-Mail office@sick.com.gr

Hong Kong

Phone +852 2153 6300
E-Mail ghk@sick.com.hk

Hungary

Phone +36 1 371 2680
E-Mail ertekezes@sick.hu

India

Phone +91-22-6119 8900
E-Mail info@sick-india.com

Israel

Phone +972 97110 11
E-Mail info@sick-sensors.com

Italy

Phone +39 02 27 43 41
E-Mail info@sick.it

Japan

Phone +81 3 5309 2112
E-Mail support@sick.jp

Malaysia

Phone +603-8080 7425
E-Mail enquiry.my@sick.com

Mexico

Phone +52 (472) 748 9451
E-Mail mexico@sick.com

Netherlands

Phone +31 (0) 30 229 25 44
E-Mail info@sick.nl

New Zealand

Phone +64 9 415 0459
0800 222 278 – tollfree
E-Mail sales@sick.co.nz

Norway

Phone +47 67 81 50 00
E-Mail sick@sick.no

Poland

Phone +48 22 539 41 00
E-Mail info@sick.pl

Romania

Phone +40 356-17 11 20
E-Mail office@sick.ro

Russia

Phone +7 495 283 09 90
E-Mail info@sick.ru

Singapore

Phone +65 6744 3732
E-Mail sales.gsg@sick.com

Slovakia

Phone +421 482 901 201
E-Mail mail@sick-sk.sk

Slovenia

Phone +386 591 78849
E-Mail office@sick.si

South Africa

Phone +27 10 060 0550
E-Mail info@sickautomation.co.za

South Korea

Phone +82 2 786 6321/4
E-Mail infokorea@sick.com

Spain

Phone +34 93 480 31 00
E-Mail info@sick.es

Sweden

Phone +46 10 110 10 00
E-Mail info@sick.se

Switzerland

Phone +41 41 619 29 39
E-Mail contact@sick.ch

Taiwan

Phone +886-2-2375-6288
E-Mail sales@sick.com.tw

Thailand

Phone +66 2 645 0009
E-Mail marcom.th@sick.com

Turkey

Phone +90 (216) 528 50 00
E-Mail info@sick.com.tr

United Arab Emirates

Phone +971 (0) 4 88 65 878
E-Mail contact@sick.ae

United Kingdom

Phone +44 (0)17278 31121
E-Mail info@sick.co.uk

USA

Phone +1 800.325.7425
E-Mail info@sick.com

Vietnam

Phone +65 6744 3732
E-Mail sales.gsg@sick.com

Detailed addresses and further locations at www.sick.com