



DISCOVERY

HF/50MHz Transceiver **TX-500**



USER MANUAL

v03.2021

Using this Manual



Searching for Keywords

Search for keywords such as "Interface" and "menu" to find a topic. If you are using Adobe Acrobat Reader to read this document, press Ctrl+F on Windows or Command+F on Mac to begin a search.



Navigating to a Topic

View a complete list of topics in the table of contents. Click on a topic to navigate to that section. To return to the table of contents click on the page number.



Printing this Document

This document supports high resolution printing.

LEGEND



Warning



Important



Note



This content is subject to change.

Download the latest version from
<https://lab599.com/downloads/>

If you have any questions about this document, please contact Lab599 by sending a message to support@lab599.com.

Copyright © 2020 Lab555 All Rights Reserved.

Table of Contents

Introduction	5
Controls end user interface	6
Device body and controls	6
User Interface	8
Protections	10
Basic Operations	12
Getting Started	12
Using the Menu	12
Band Selection	12
Mode Selection	13
VFOs A and B	13
RIT	14
XIT	14
VFO lock/unlock	14
Transmit Settings	14
Receive Settings	16
Advanced Operating	18
Frequency Memories	18
DIG MODES (Audio Data Modes)	18
Split and XIT	18
Receive Audio Equalization (RX EQ)	19
Transmit Audio Equalization (TX EQ)	19
Cross-Mode Operation	19
External power amplifier control	20
CW keyer memory	20
Voice message memory	21
Accessories	22
Firmware Upgrades	24
Remote Control	25
Menu Functions	26
00. Valcoder	26
01. IF DSP	26

02. CW Pitch	26
03. CW Speed	26
04. CW Weight	26
05. CW Key	26
06. AGC	27
07. RF	27
08. Power	27
09. GAIN	27
10. NR Level	27
11. NB Level	27
12. SQL	27
13. VOX L	27
14. VOX	27
15. AM/FM	28
16. CMR Level	28
17. Save Band VFO	29
18. EQL	29
19. RPAN	29
20. TPAN	29
21. TIME	29
22. Corr TIME	29
23. TX Metr	29
24. Type Tone	29
25. VOX	30
26. Beep Key	30
27. Backlight	30
28. Contrast	30
Maintenance	31
Specifications	33
FCC information	35

Introduction

On behalf of our development team, we want to thank you for choosing the TX-500 Discovery. The TX-500 is an ultra compact all-mode transceiver ideal for travelling. Its compact size and weight mean that you can take the instrument to remarkable places, where radio work will give you an unforgettable experience.

The strong casing, protection against splashes and dust ensure the use of TX-500 in extreme conditions and guarantee its reliability. A sharp monochrome display will allow you to clearly see the information in either bright sunshine or low light, thanks to a multi-mode backlight. The transceiver parameters and functions will also make it possible to successfully use the unit at a home station or as a mobile version. Record-low current consumption in reception mode (up to 110 mA) will extend the battery life, providing for longer stay on the air without recharging.

Because the TX-500 is a software-defined radio (SDR), you can expand its capabilities using computer applications and adding new features with free firmware updates. The TX-500 Discovery has an integrated high-performance spectrum analyzer, allowing you to see signals before you hear them.

It's high time to go off into the deep blue yonder, taking the TX-500 with you.

Controls end User Interface

DEVICE BODY AND CONTROLS

Front view

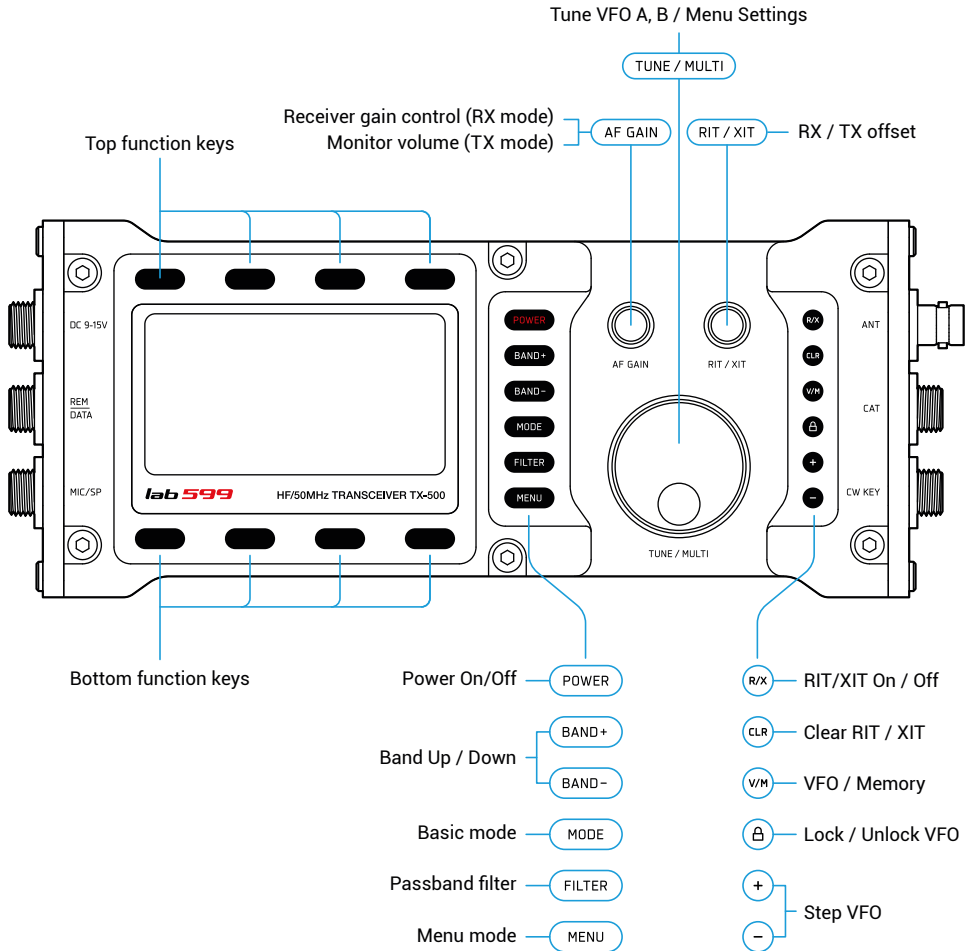

Left side

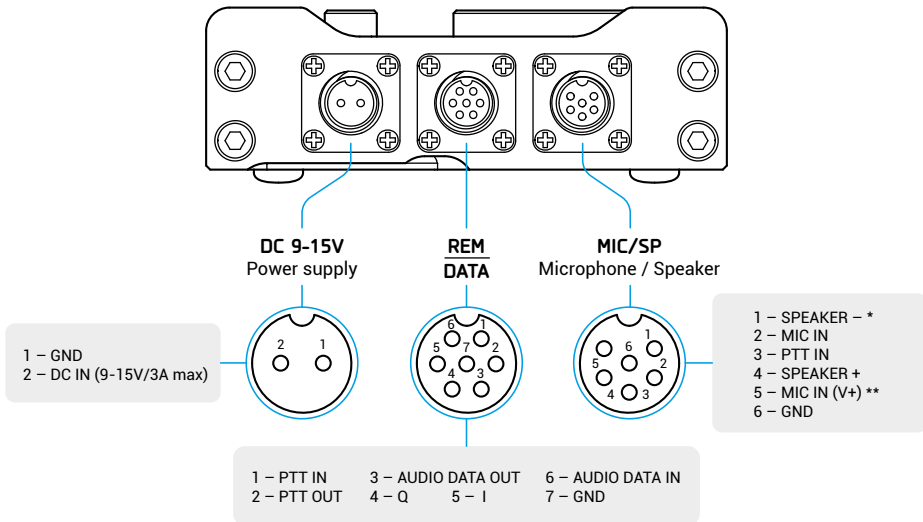

- ! * Connect a speaker or headphones with the appropriate pins 1 & 4, SPEAKER (-) and SPEAKER (+). Do not connect a speaker to ground, pin 6.
- ** For connecting an external electret microphone that requires additional power supply.

Right side

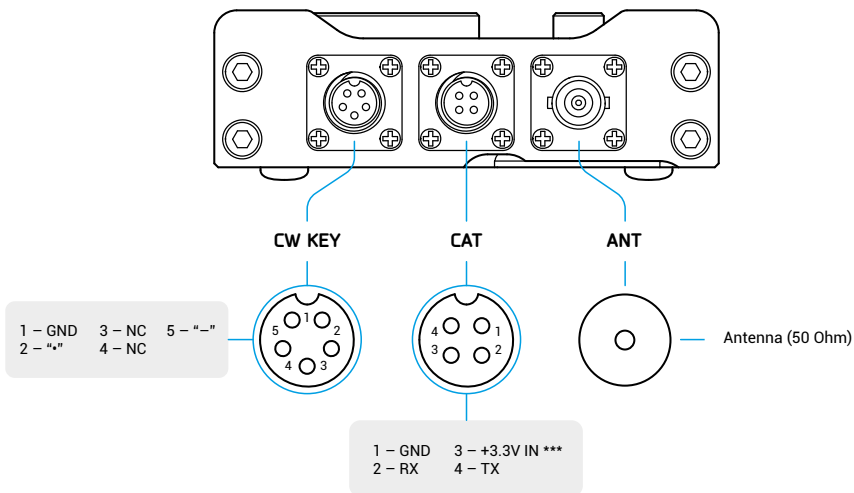

- ! *** When connecting with a third-party USB adapter, make sure that an input voltage of 3.3V (10mA) is supplied to the pin.

USER INTERFACE

Main display

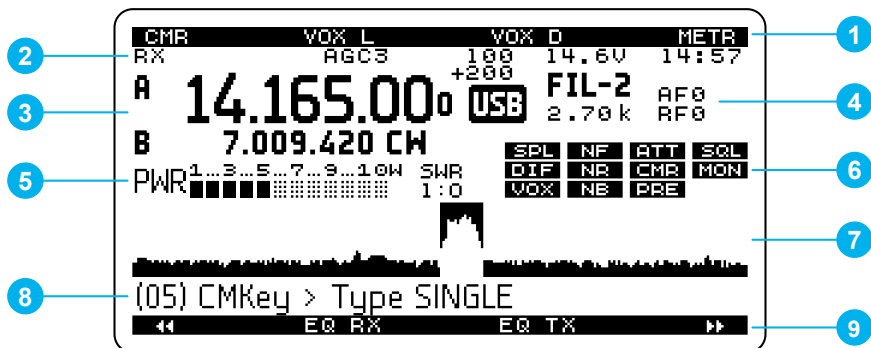

1 9 — Function buttons

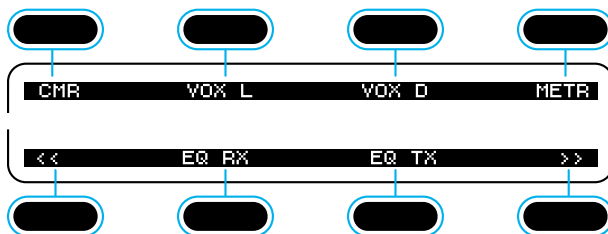

2 — Information bar title

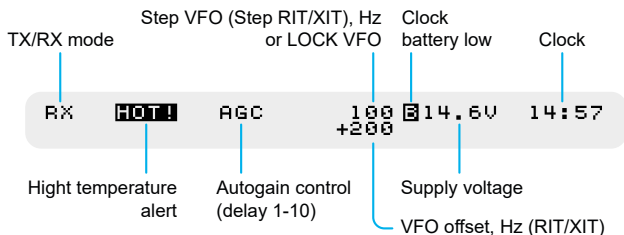

3 — VFO A / B

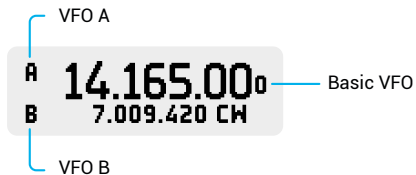

4 — Info block 1

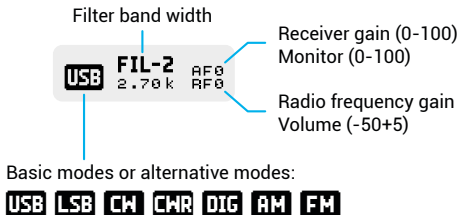

5 — Graph bar

Receive mode:



Transmit mode:



6 — Info block 2

- NR** – Noise reduction ON
- NB** – Noise blanking ON
- NF** – Notch filter ON
- ATT** – Attenuator ON
- MON** – Monitor ON
- VOX** – VOX ON
- CMR** – Speech compression ON
- PRE** – Preamp ON
- SQ** – Squelch ON
- SPL** – Split mode effect ON
- DIF** – Virtual intermediate frequency ON

7 — Pan-adapter

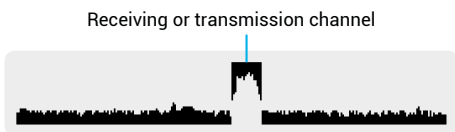

8 — Menu

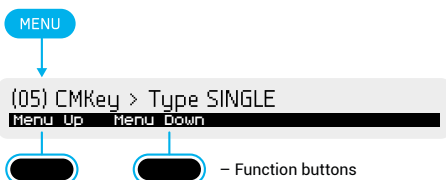

Protections

OVERVOLTAGE PROTECTION

When exceeding 15.0 volts, the transceiver won't allow switching to TX mode, (the voltage indicator on the display will become inverse) a significant excess (more than 16 volts) it can cause the protective fuse to burn out, as well as the failure of the transceiver! Use a power source or battery with a voltage of 9 to 15 volts and a current of at least 3 Amps.



ATTENTION! Exceeding the supply voltage above 15 volts can damage the transceiver!

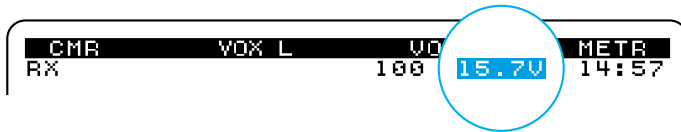

REVERSE POLARITY PROTECTION

If you connected a minus voltage source or battery instead of a plus, the transceiver will not turn on. You must connect the external power supply correctly, please, see the pinout of the power connector in the section "Controls end user interface".

OVERHEAT PROTECTION

The transceiver has an internal protection against the overheating of the output stage of the transmitter. If the TX continuous mode is too long, the output stage as well as the transceiver body can be heated up. If the limit value is exceeded (about 60 degrees Celsius), the transceiver won't allow switching to TX mode. After the temperature drops, the TX prohibition mode will turn off automatically.



ATTENTION! During long-term TX mode (digital modes) do not block the air access to the rear cover of the transceiver, or reduce the power.

TIP: *Unfold both rear legs to increase the air flow convection.*

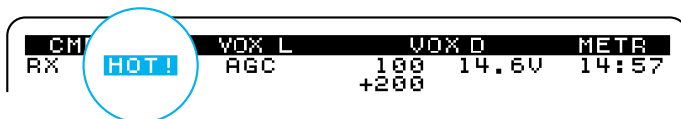

HIGH SWR PROTECTION

If the impedance of the antenna is different than 50 ohms and there is no antenna tuner connected, the SWR indicator on the display will show a value greater than 1.0. If the SWR value is 3.0 or more (the SWR indicator on the display will be inverse), the transceiver will automatically reduce the power output. If the value of SWR is greater than 3.0, then the output power will decrease more.

! ATTENTION! Use a tuned antenna with a wave impedance of 50 ohms, this is ideal (max output power), or use a matching device (automatic or manual tuner).

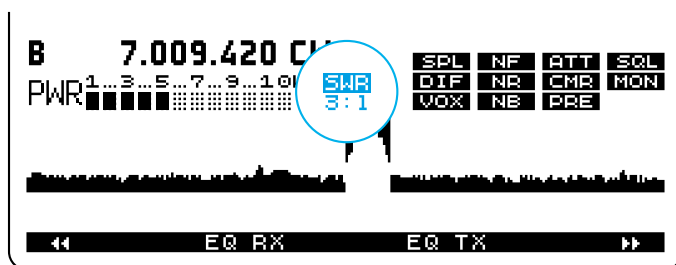

Basic Operations

GETTING STARTED

Before using the TX-500, you'll need to connect a power supply, speaker-microphone and an antenna, at minimum.

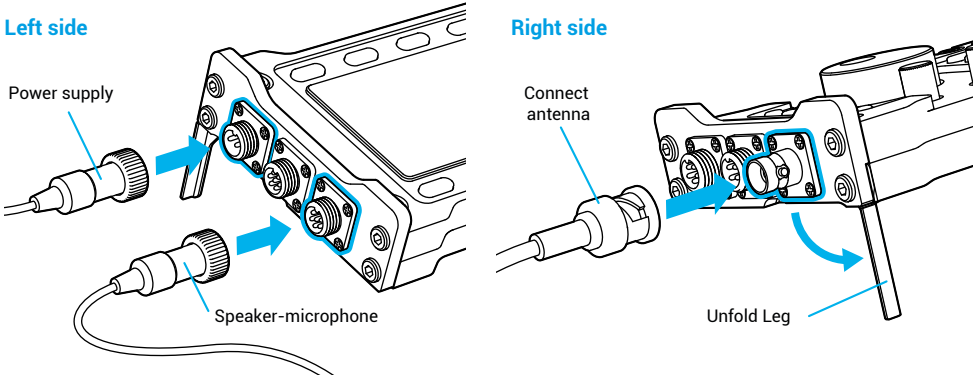

AF GAIN – Controls receiver AF gain (volume).

USING THE MENU

The menu is used to tailor the transceiver to your operating preferences. To access the menu, push **MENU** until the any menu entry appears in the pan-adapter area. To change the value of a menu parameter, rotate **TUNE/MULTI** (large knob). To exit the menu, push **MENU** again.



BAND SELECTION

The TX-500 covers the 160-6 m amateur bands. Characteristics of each band are summarized below.

Band (m)	Rang (Mhz)	Best DX	Band (m)	Rang (Mhz)	Best DX
160	1.8-2.0	☾	17	18.068-18.168	☀
80	3.5-4.0	☾	15	21.0-21.45	☀
60	~5.3-5.4	☾	12	24.89-24.99	☀
40	7.0-7.3	☾	10	28.0-29.7	☀
30	10.0-10.15	☀☾	6	50-54	☀☾
20	14.0-14.35	☀☾			

MODE SELECTION

Each mode is described briefly below. Later sections cover each mode in detail. Tap **MODE** one or more times to select USB (LSB), CW (CWR), DIG, AM or FM mode. Long push selects alternate modes, such as CW reverse (CWR). Also, long push returns normal mode.

- **SSB:** Single-Sideband modes are narrow-banded voice modes that conserves space in crowded band segments. They're the most popular modes overall, they are: LSB (lower-sideband) usually used in 160, 80 and 40 meters, while other bands use USB (upper-sideband).
- **CW:** Continuous Wave mode requires narrow bandwidth, providing a high signal-to-noise ratio which is ideal for low-power (QRP) use. It's also a popular mode for DXing and contests. CWR Continuous Wave Reverse is the alternate mode, and may reduce the level of interference (QRM).
- **AM:** Amplitude Modulation mode is characterized by good fidelity. It's much less power-efficient than SSB modes. You can easily find AM amateur stations in 160, 80, 40 and 10 meters.
- **FM:** Frequency Modulation mode is most often used for local communications, and can be found on 10 m and up.
- **DIG:** Digital Mode is usually used with a computer connected to the transceiver to send/receive data. Although SSB modes can also be used for this purpose, the TX-500's audio-based data modes (**DIG**) optimize settings for data rather than voice.

VFOS A AND B

The TX-500 provides two VFOs. Use of VFO B is optional. Each VFO has independent frequency, mode, and filter settings:

- **VFO A** normally controls both the receive and transmit frequency. Most contacts occur between stations tuned to about the same frequency.
- **VFO B** can serve as a holding register for a second frequency of interest, then swapped with VFO A as needed (see A<>B).
- **+ - Tuning rates:** Tapping **+** or **-** selects VFO tuning rate LSB, USB, DIG (10Hz, 100Hz, 1kHz, 2.5kHz, 5kHz), CW, CWR (1Hz, 10Hz, 100Hz, 1kHz, 2.5kHz), AM, FM (100Hz, 500Hz, 1kHz, 2.5kHz, 5kHz). SSB stations often align on 0.5 or 1.0kHz boundaries.
- **A->B To copy VFO A's frequency to VFO B:** Tap **MODE** → **A->B**. Tapping also copies VFO A's mode and filter settings to VFO B as well.
- **B->A To copy VFO B's frequency to VFO A:** Tap **MODE** → **B->A**. Tapping also copies VFO B's mode and filter settings to VFO A as well.
- **A<>B VFO A and B swap:** Tap **MODE** → **A<>B** to exchange VFO frequencies, modes, and all other settings.



*Due to the special feature of the internal signal conversion, there may be a certain number of frequencies that can be heard in the headphones as clicks. This is not a hardware problem, it is the features of the device architecture. In this case, we recommend using the **DIG** function.*

RIT

Incremental Tuning, or receive incremental tuning, provides a means of adjusting the receive frequency without affecting your transmit frequency. This control is sometimes called a clarifier since it can be used to tune in SSB voice signals. But RIT can also be used in all modes, in the event that a station calls you slightly off-frequency. RIT and XIT use the tuning rate (1/10/100/200/300 Hz), tapping **+** or **-**.

XIT

XIT or transmit incremental tuning, adjusts the transmit frequency without affecting the receive frequency. RIT and XIT use the tuning rate (1/10/100/200/300 Hz), tapping **+** or **-**.

- **To use RIT or XIT:** First, tap **R/TX** RIT (RX mode) or tap **R/TX** XIT (TX mode). This turns on the "+0" on the display. Then adjust the offset using RIT/XIT knob.
- **To zero the RIT/XIT offset** tap **CLR**.

🔒 VFO LOCK/UNLOCK

When the mode is activated, the inscription appears in the upper line of the display **🔒** (lock), frequency tuning is not possible. To deactivate the mode, press the button **🔒** again.

TRANSMIT SETTINGS

- **Voice Modes (SSB, AM, FM):** Choose a mode: Tap **MODE** to select **USB** / **LSB**, **AM** or **FM** mode.
- **MON, Monitor:** Push **MON** → **MON** in the bottom line for MON on. Hold PTT to set the voice monitor level, rotate **AF GAIN** knob. High MON settings may result in audio clipping or distortion. Start with 3 to 5.

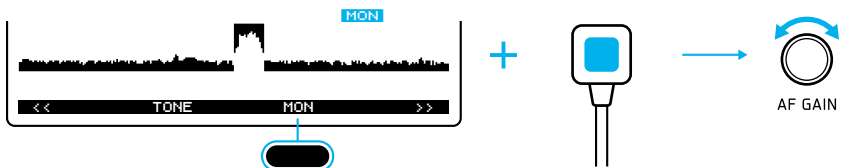

*Do not use the hand speaker-mic at the same time as monitor **MON** function in voice modes (**USB** **LSB** **AM** **FM**) – this creates the risk of audio coupling with high noise levels, distorting the real sound.*

- **Adjust mic gain level:** Push **METR** and select MIC, rotating **TUNE/MULTI**.

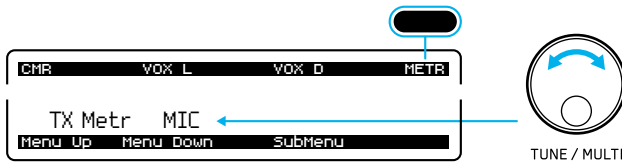

While speaking into the mic, adjust **MENU** → 09 > Gain > MIC (mic gain).

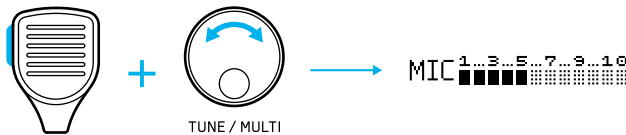

While speaking, adjust mic gain for maximum 5-7 bars on a scale. Mic gain for the TX-500 mic is typically 3-7.

- **CMR Speech compression:** To use speech compression, tap **MENU** → **CMR** in the top line. Adjust the level using the **MENU** → 15 > CMR Level or long push **MENU** → **CMR**. High CMR settings may result in distortion. Start with 1 to 3.
- **POWER:** Set the power level (10-100%): tap **POWER** in the top line and rotate the knob **TUNE/MULTI**. Do not use MIC gain to set power level. Set mic gain to a fixed level as described above.
- **VOX:** Selects push-to-talk (PTT) or voice-operated (VOX) transmit (**VOX** icon on). VOX hold time is set with **MENU** → 14 VOX > MIC (time, ms). **MENU** → 13 VOX L (VOX level) should be set to trigger at normal speech level, but not in response to incidental noise. Start with low settings (80-90).
- **VOX Transmitter keying method:** The VOX switch selects either VOX or PTT keying for CW mode. Most operators use VOX, allowing the transmitter to be keyed immediately whenever a hand key or keyer paddle is used. Tap **MENU** → **VOX_D** in top line and rotate TUNE/MULTI or tap **MENU** → 14 > VOX > CW (time ms).
- **METR:** You can switch the transmit bar graph from MIC, ALC, PWR, SWR, PWR Num, SWR Num, by tapping **MENU** → **METR** in the top line. Rotate **TUNE/MULTI** knob.
- **CW modes (CW, CWR):** To switch modes tap **MODE** to select **CW** (CW normal). In some cases an interfering received signal can be eliminated by switching to **CWR** (CW reverse) using long push **MODE**.
- **CWPITH:** Set sidetone pitch using **CWPITCH**. The ideal pitch for most operators falls in the range of 600-700 Hz. The receiver's passband will be centered at the pitch you select. Tap **MENU** → **CWPITCH** and rotate TUNE/MULTI or **MENU** → 02 > CW Pitch (Hz). Set sidetone volume using **AF GAIN** in TX mode, **MON** ON.

RECEIVE SETTINGS

- **RF gain** is normally left at (-0). Reducing RF gain may be useful in some strong-signal conditions.
- **SQL:** Squelch is used to mute the receiver until a signal appears. The control adjusts the signal threshold required for squelch to “open,” unmuting the receiver.
- **IF DSP:** Virtual Intermediate Frequency: Specifies the Mode of the Receiver.

ENABLE: This is the operating mode, utilizing all DSP features of the radio. This mode uses a virtual Intermediate Frequency, which is offset from the operating frequency by a few kHz. This is similar to ‘homodyne’ technology.

DISABLE: When IF is disabled, the radio operates in simple Direct Digital Conversion mode, and has soft reduced performances.
- **FILTER:** DSP filter tuning functions (LF/HF) The (LF/HF) control is used to shape the TX-500’s receive filter passband. In general, a narrow passband reduces interference (QRM) and noise (QRN), while a wider passband improves fidelity. In voice modes, CW and DIG modes long push **FILTER** selects low-cut (LF) and high-cut (HF) frequency. Pushing **FILTER** select number of filter (1-4)RX, (1-2)TX. These functions remove low- or high-pitched interfering signals. Reducing the width or shifting the passband may attenuate an interfering signal above or below the desired one.
- **PRE/ATT:** Preamp **PRE** and Attenuator **ATT** turns on the RF preamp. It should be used only when signals are very weak. Preamp gain can be set on a per-band basis. **ATT** turns on the 20-dB RF attenuator, which can protect the receiver from strong interfering signals.
- **NR:** Noise reduction removes random background noise (hiss or static). It has a characteristic “hollow” sound. Higher settings may attenuate weak signals. Tap **NR** turns on noise reduction, holding **NR** and displays its setting, which can be adjusted using the knob **TUNE/MULTI**. Tap return to exit the setting display. Tap **NR** again to turn noise reduction off.
- **NB:** Noise blanking **NB** can eliminate repetitive noise such as that from power lines, appliances, and vehicle ignitions systems. The NB setting is adjusted in the same way as NR (see above).
- **NF** in SSB and AM modes, **NF** turns on auto-notch, which locates and suppresses one or more carriers automatically, Push **NF** to enable or disable the Notch Filter.
- **TONE (Transmission tone):** The transceiver will transmit a single tone. Pressing “Tone” **TONE** again puts the transceiver in RX mode. A long press of **TONE** displays the selection mode NORMAL (1000 Hz) or DUAL (two tones of 1000 Hz and 2000 Hz). The transmission power is approximately 50%.

EXAMPLE (RX) SSB FILTER ADJUSTMENT: (CHANGE FIL-3)**Set FIL-3: Bandwidth: 2.4 kHz; Passband: 600Hz to 3kHz**

1. Long-Push **FILTER** to enter filter adjustment menu. The parameter to be adjusted is shown in the bottom line of the display.

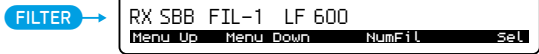

2. Push **NUMFIL** until FIL-3 is selected (in the bottom line).

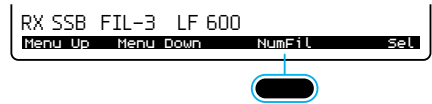

3. Push **SEL** once to select "HF". The display might now look like this: "RX SSB FIL-3, HF2700". ('2700' might be any other value).



4. Rotate **TUNE/MULTI** to change 2700 to 3000 (notice the frequencies are in Hz, not in kHz).

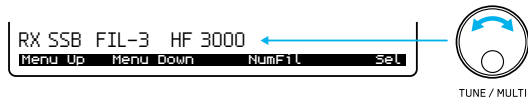

5. Push **FILTER** to save changes and exit the filter adjustment menu.

6. CHECK YOUR WORK: Push **FILTER** a few times until FIL-3 is selected. It should now display 2.40 k.



Advanced Operating

FREQUENCY MEMORIES

V/M (VFO/Memories) – The TX-500 has 100 general-purpose frequency memories (00-99). Each memory stores VFO frequency, modes, and other settings.

To store a general-purpose memory (00-99): Push **V/M**, then locate the desired memory by rotating the **TUNE/MULTI** knob. The VFO frequencies presently stored in each memory will be shown as you scroll through them. When you reach the desired memory number, push **VFO** → **Mem** to finish, or tap **V/M** to cancel.

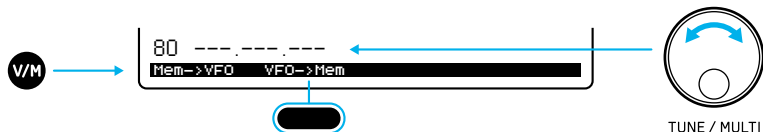

To recall a general-purpose memory: Push **V/M**, then select memory 00-99 using **TUNE/MULTI**. Tap **V/M** to exit.

To erase a general-purpose memory: While scrolling through memories to save or recall, push **CLR**.

DIG MODES (AUDIO DATA MODES)

Many audio-generated data transmissions can be heard on the bands, using PSK31, RTTY, JT65 and other modes. A computer, sound card, and appropriate software are normally used. DIG mode is provided for this purpose.

Unlike SSB modes, DIG disables MIC and enables use AUDIO cable (connector REM/DATA).

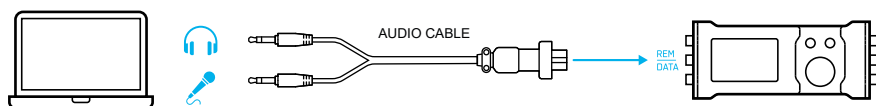

Also DIG mode has individual audio level settings. Upper sideband is the default.

```
09 > Gain > DIG (level settings)
```

RX / TX switching can be via CAT cable (see Remote Control). You can also use the VOX function (see Basic Operations).

DIG mode settings: tap **MENU** → 13 VOX L > DIG > (vox level)
tap **MENU** → 14 VOX > DIG > (time, ms)

SPLIT AND XIT

Sometimes you'll hear a DX station being called by many other stations. To ensure that he has a clear transmit channel, the DX station may say "UP" or "DOWN" to indicate that he's listening above or below his transmit frequency.

To use split, first tap **⏻** → **A->B** to set VFO B to the same mode, frequency, and filter settings as VFO A. Then tune VFO B up about 2 kHz. Finally, tap **⏻** → **SPL** (the **SPL** icon will turn on). VFO B is now controlling your transmit frequency.

This is where the **A<->B** switch comes in: it reverses the A and B VFOs so that you're temporarily receiving on your transmit frequency. During this time, tune VFO A around a bit to see if you can identify who is presently working the DX station, then position yourself just above this frequency. With any luck your next transmission will occur right where he's listening.

XIT as an alternative to split: If you're trying to preserve VFO B as a holding register tuned someplace else in the band, you may want to use XIT rather than split in the above situation. In this example, you'd turn on XIT and rotate the offset control to about +2.00 kHz. You'll then be transmitting 2 kHz above VFO A. To do the equivalent of A<->B, you can briefly turn RIT on as well. Turn off RIT to listen to the DX station.

RECEIVE AUDIO EQUALIZATION (RX EQ)

The TX-500 provides 3 bands of receive audio equalization via the **MENU** → 18 EQL > RX menu entry. EQ RX can compensate for physical acoustics (of the room, headphones, internal speaker, external speaker), tailoring the audio to your personal preference.

TRANSMIT AUDIO EQUALIZATION (TX EQ)

If required, transmit audio equalization can compensate for microphone and voice variations.

MENU → 18 EQL > TX works exactly the same as EQ RX, and can be used during transmit. EQ TX is not applicable to CW. While adjusting EQ TX, monitor your voice using headphones (use **⏻** → **MON** to set the level), or listen to your transmitted signal on another receiver. If you hear distortion, reduce all EQ TX bands. You may also have excessive mic gain or compression.



Most microphones, including the TX-500, will provide good audio quality with little or no EQ TX. High settings can cause distortion.



*Do not use the hand speaker-mic at the same time as monitor **MON** function in voice modes (**USB LSB AM FM**). This creates the risk of audio coupling with high noise levels, distorting the real sound.*

CROSS-MODE OPERATION

(CW-in-SSB) Cross-mode operation is possible in some cases. For example, you could set up VFO A for SSB receive, and VFO B for CW transmit, then enter **⏻** → **SPL**.

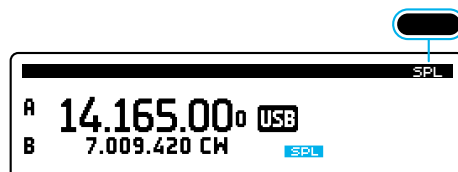

EXTERNAL POWER AMPLIFIER CONTROL

To control the PTT function of the power amplifier, you must connect pin 2 (PTT OUT), open collector, of the REM / DATA connector to the PTT control relay of the external power amplifier (usually this is the "PTT" connector). Also, pin 7 (GND) of the REM / DATA connector must be connected to the GND of the external power amplifier.

It is also necessary to connect the BNC type "ANT" connector of the transceiver to the amplifier input (usually named as the "TRX" connector) with a 50 Ohm coaxial cable.

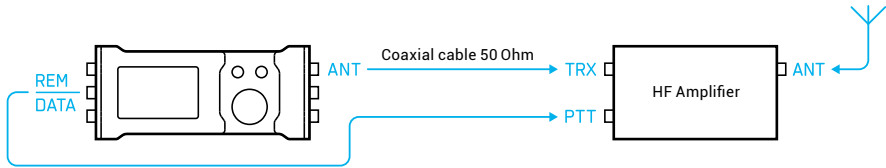

If the amplifier does not have an automatic band detection function, then it must be selected manually.

Note: Connecting cables are not supplied.



ATTENTION! The maximum switching voltage must not exceed 25 V and the maximum switched current must not exceed 0.5 A

CW KEYSER MEMORY

For recording and later playback of the short CW messages, the TX-500 provides 4 memory slots with a duration of 25 seconds.

To record, you need to press and hold one of the "CWM" keys 1, 2, 3, 4 for more than 1 second. The **REC** icon appears on the screen. Then, you can perform your own CW manipulations, and at the end, press shortly the same "CWM" 1, 2, 3, 4 key.

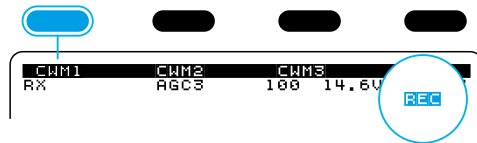

To play a recorded message, press shortly one of the "CWM" 1, 2, 3, 4 keys. The **PLY** icon will appear on the screen. Pressing shortly will stop playback.

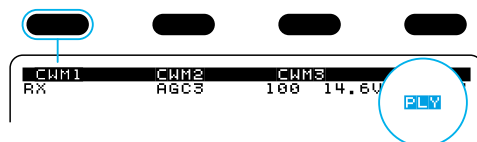

VOICE MESSAGE MEMORY

For recording and later playback of the short voice messages, the TX-500 provides 2 memory slots with a duration of 20 seconds each.

To record, you need to press and hold one of the "VXM" keys 1, 2 for more than 1 one second. After one second the **REC** icon appears on the screen. Then you can dictate your own message, and at the end, press shortly the same "VXM" 1, 2 key.

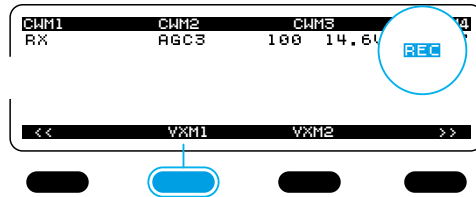

To play a recorded message, press shortly one of the "VXM" 1, 2 keys. The **PLY** icon will appear on the screen. Pressing shortly will stop playback.

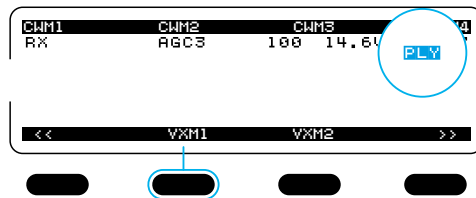

*Do not use the hand speaker-mic at the same time as monitor **MON** function. This creates the risk of audio coupling with high noise levels, distorting the real sound.*

Accessories

HAND SPEAKER-MIC

Hand speaker-mic, The hand speaker-mic was designed specifically for the TX-500. It includes a high-quality mic element, speaker, rugged plug, PTT switch and external speaker plug.

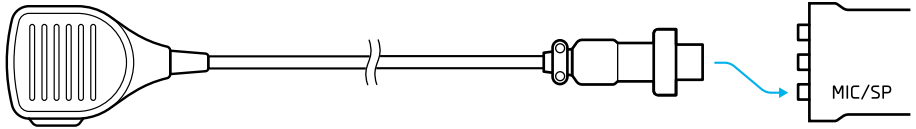

POWER CABLE

The power cable for external power source DC 9-15V with 3A FUSE.

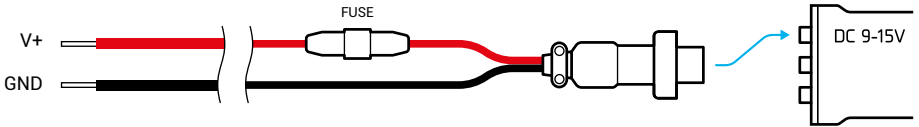

MICROPHONE AND HEADPHONE ADAPTER WITH PTT

With this adapter, you can connect a regular headset or microphone and headphones. The adapter also has a PTT button to control TX/RX.

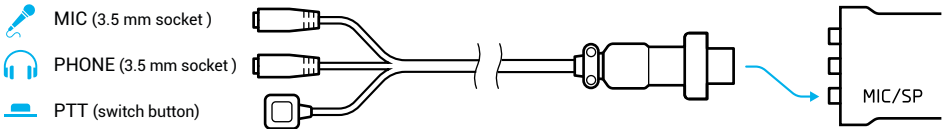

AUDIO CABLE

You can use digital modes (Audio Data Modes) with this cable. The cable connects to the PC, the connectors are used – a microphone PC (3.5 mm jack) and headphones PC (3.5 mm jack).

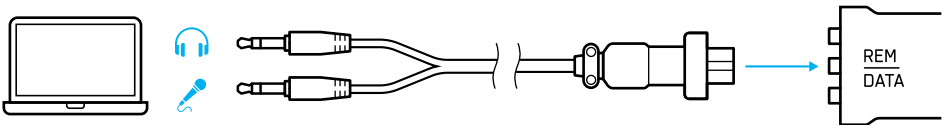

CW ADAPTER

With this adapter you can connect a CW key through a 3.5mm jack connector. Key reverse can be enabled in the menu.

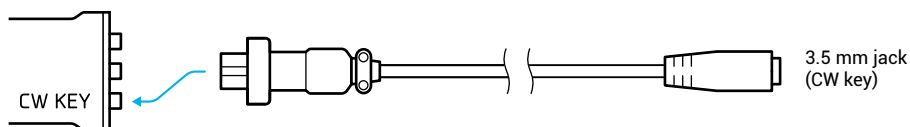

CAT-USB CABLE

The TX-500 can interface to most common types of computers via included CAT cable. It has an FT232 and PL2303 chipset. For adapter with PL2303 chipset uses driver, that can be downloaded from www.lab599.com. For the adapter with the FT232 chipset, additional installation of drivers is not required.*

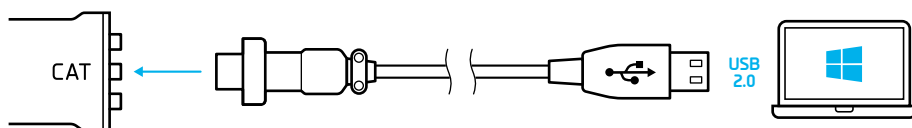

* For Windows operating system

Firmware Upgrades

New features and improvements are available to all TX-500 owners via firmware upgrades. Visit the Discovery TX-500 software download page (lab599.com/downloads/) to download the latest versions of the required drivers, software and the transceiver firmware upgrades.

CHECKING YOUR FIRMWARE VERSION

After switching on your Discovery TX-500, the firmware version will appear briefly at the bottom of the screen.



DOWNLOAD THE SOFTWARE AND FIRMWARE

1. Download the latest Firmware Update application (for Windows or Linux) from the Discovery TX-500 software download page (lab599.com/downloads/).
2. Download the latest firmware update (lab599.com/downloads/).

FIRMWARE UPDATING

1. Connect the TX-500 to a computer and run TX-500 Utility, which will load new firmware. Use the 4-pin Cat-serial connection cable that came with your radio.
2. While holding the third top function key, turn on the TX-500. The screen will display "The loader is waiting..."
3. Start the update application. Select the COM Port (read note below) and the downloaded firmware file. Click "update" on the utility. The update will begin and progress will display in the update program and the TX-500 screen. **Do not turn off the computer or transceiver until the download is complete.** After the software download is complete, turn off the transceiver and turn it on again.
4. Check firmware version.



USB drivers notes: The transceivers were supplied with different versions of USB adapters: 1) on Prolific PL2303 chips (black case); 2) on FTDI FT232 chips (blue case). If your OS does not automatically install the drivers, please download the latest drivers (lab599.com/downloads/) and install the drivers manually.



COM port selection: Open Windows Device Manager and expand the "Ports (COM & LPT)" item. If you are using a serial port built into the computer, it will be listed as a "Communications Port". The USB to Serial Adapter will be listed as a "USB Serial Port". The COM port number will be seen alongside each device.

Remote Control

COMPUTER CONTROL AND LOGGING

With appropriate software, any computer with an RS232 or USB port can be used to control the TX-500. Use CAT-USB cable (see page "Accessories"). Third-party logging and contesting software is available for various computers and operating systems. Select KENWOOD as the target radio.

Its CAT Interface is fully compatible with the KENWOOD CAT Command set.

COM PORT SETTINGS:

- **RIG Type:** KENWOOD
- **Baud rate:** 9600
- **Data bits:** 8
- **Parity:** NONE
- **Stop bits:** 1

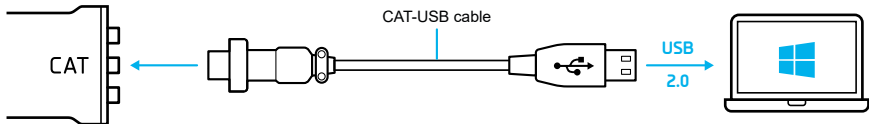

Menu Functions

00. Valcoder VFO Encoder Mode Selector

The valcoder specifies the mode of the VFO encoder. Select with ●TUNE/MULTI.

- **Plain:** The speed of change in frequency when turning the ●TUNE/MULTI knob is linear. The step is determined by the setting of ●+ ●- on the front panel, and is also mode-dependent.
- **Intel:** (Intelligent) The speed of change in frequency varies with the speed at which you rotate the ●TUNE/MULTI knob.

Default: Intel

01. IF DSP (Specifies the Mode of the Receiver) Select with ●TUNE/MULTI

- **ENABLE:** This is the operating mode, utilizing all DSP features of the radio. This mode uses a virtual Intermediate Frequency, which is offset from the operating frequency by a few kHz. This is similar to 'homodyne' technology.
- **DISABLE:** When IF is disabled, the radio operates in simple Direct Digital Conversion mode, and has reduced performance.

Default: Disable

02. CW Pitch Defines TX "Offset Frequency" for CW Mode

- Adjustable with ●TUNE/MULTI from 400Hz to 1200Hz.

When working CW, the transmitter's frequency must be offset from the received frequency such that it is equal to the frequency of the tone at which the operator wishes to copy CW. This automatically zero-beats the TX signal with the QSO partner's received signal. Different operators prefer to listen to different tone frequencies.

CW Pitch enables the operators to set the offset to their preferred tone.

Default: 700Hz

03. CW Speed Defines the speed of the built-in Auto-Keyer

- Adjust the speed of the Auto-Keyer with ●TUNE/MULTI. The minimum speed is 10cpm (2wpm), maximum speed is 300cpm (60wpm).

Default: 100cpm

04. CW Weight Defines the Dot/Dash Ratio of the Auto-Keyer

- Adjustable with ●TUNE/MULTI from 2:1 to 4.5:1.

Default: 3:1

05. CW Key Type / Auto / Rev Select sub-menu

The default is mode lambic A, which is a little more forgiving for first-time operators. Mode B may be preferred by operators who learned to do "squeeze-keying" with another keyer having this or a similar mode. Both modes provide dot- and dash-memories enabling fast code speeds, but with slightly different timing.

Change values with ●TUNE/MULTI.

- **Type:** Single (Straight Key) or Paddle.
- **Mode:** lambic A or lambic B.

➤ **Rev:** Disable or Enable.

When Enabled, the dit and dah side of the paddle are reserved. Side of the paddle are reversed. Preferred by left-handed Ops.

Default: Type = single; Auto = Iambic A; Rev = Disable.

06. AGC Defines the AGC Time Constant (slow-fast)

➤ **CW / SSB / AM**

Select **SUBMENU**, adjust with **TUNE/MULTI**: from 1 (slow) to 10 (fast). When in RX, the AGC Level is shown at the top line of the display.



During adjustment, it only shows changes to the AGC level in the top line of the display when adjusting the timing of the current mode the radio is in. It does not change while adjusting the AGC timing for other modes. For other modes, monitor change in the bottom line of the display.

Defaults: CW = 5; SSB = 3; AM = 3.

Adjust for personal preference, according to band conditions.

07. RF RF GAIN

➤ **CW / SSB / DIG / AM / FM** (Adjustable by **MODE**)

Select **SUBMENU**, adjust with **TUNE/MULTI**. Adjust for personal preference, according to band conditions.

Default: CW = 0; All other Modes = 0.

08. Power TX Power Adjustment

➤ **TX Power:** Adjustable with **TUNE/MULTI**

Adjustable in percentage (%) of maximum TX power, from 10% to 100%.

Default: 100%

09. GAIN MIC / DIG TX Audio Gain (Level)

Adjustment for Voice and Digi Modes.

➤ **MIC:** Microphone Gain; adjustable from 1 to 100.

➤ **DIG:** TX Audio Gain; adjustable from 1 to 100.

Default: MIC = 5; DIG = 20.

10. NR Level Noise Reduction Level.

➤ Select **SUBMENU**, adjust with **TUNE/MULTI**.

Digital Signal Processing (DSP) feature for reducing noise on a noisy band. NR is most effective on CW. It is also effective on SSB, but degrades the fidelity of the received signal somewhat.

Default: 50

Adjust for most effective noise reduction.

11. NB Level Noise Blanker

- › Adjustable from 40 to 100 with **● TUNE/MULTI**.

The Noise Blanker is a DSP feature used for reducing certain types of pulsed noise (i.e., lightning or automotive ignition noise).

Default: 50

Adjust for best noise reduction.

12. SQL Two types of Squelch: SSB/AM/FM

- › **SSB/AM**
- › **FM**

These are independently adjustable. Select **SUBMENU**, adjust with **● TUNE/MULTI**. SSB/AM also works DIG mode.

Adjust threshold from 0 to 100 with **● TUNE/MULTI**. On a clear (unoccupied) frequency, adjust threshold level until the audio just barely shuts off and **SQL** on the right of the screen lights up.

Defaults: SSB/AM = 0; FM = 0.

13. VOX L VOX Sensitivity Adjustment

Select **SUBMENU** to switch MIC/DIG mode

- › Adjust with **● TUNE/MULTI**: from 1 to 100.

Default: MIC = 50; DIG = 50.

14. VOX VOX Delay

Select **SUBMENU** to switch CW/MIC/DIG mode

- › Adjust with **● TUNE/MULTI**: from 100ms to 10 seconds in 100ms steps.

Default: CW = 400 ms; MIC = 1000 ms; DIG = 100ms.



*In CW mode, **VOX** may be switched on in order to transmit.*

Setting CW VOX Delay to a higher value (i.e., 400ms) reduces the relay clicking noise. Setting to 100ms enables Fast Semi-Break-in.

15. AM/FM Enable/Disable AM & FM Modes

- › Adjust with **● TUNE/MULTI**. Must be set by band.

Many operators do not use AM or FM Mode below 29 MHz, especially in Region One where IARU recommendations discourage use of these modes below 29 MHz.

When operating hf contests, these modes are not used. Disabling these modes enables changing modes without stepping through AM & FM.

Defaults: Enable.

16. CMR Level Speech Compressor Level (SSB Mode-Only)

Adjust with **MTUNE/MULTI**: from 1 to 100. Normally 40 should be maximum compression level used.

Default: 5

17. Save Band VFO

Band change occurs only VFO A (VFO A) or together with VFO B (VFO A&B).

Defaults: VFO A

18. EQL RX / TX

› Select RX or TX using **SUBMENU**

› Select Band (Low Freq. / Mid Freq. / High Freq.) with **SEL**.

Adjust Equalization Level with **TUNE/MULTI**: from 1 to 100;

Set to personal preference. You may use the built-in monitor for adjusting TX parameters.

Defaults RX EQL: LF = 100; MF = 75; HF = 50.

Defaults TX EQL: LF = 100; MF = 100; HF = 100.

19. RPAN RX Panadapter Settings

Select sub-menu with **SEL**, adjust value with **TUNE/MULTI**.

› **AVG**: Adjustable from 1 to 100;

› **Scale**: Adjustable from 0.1 to 5.0;

› **Shift**: Adjustable from -100 to +100.

Defaults: AVG = 5; Scale = 0.9; Shift = 30.

20 TPAN TX Panadapter Settings

Select sub-menu with **SEL**, adjust value with **TUNE/MULTI**.

› **AVG**: Adjustable from 1 to 100;

› **Scale**: Adjustable from 0.1 to 5.0;

› **Shift**: Adjustable from -100 to +100.

Defaults: AVG = 5; Scale = 2.7; Shift = 20.

21. TIME Set Clock Time

› Hour / Min

Select **SUBMENU**, adjust value with **TUNE/MULTI**.

22. Corr TIME Clock Accuracy Adjustment

Due to small variations in the production of the quartz resonator, the time may vary slightly. You can adjust by increasing or delaying the time variation using this setting.

Adjustable with **TUNE/MULTI** from -63 to +126.

Defaults: 0.

23. TX Metr SWR Num* / PWR Num* / SWR / PWR / ALC / MIC

Select parameter with **TUNE/MULTI**.

Selection defines what parameter (during TX Mode) to be displayed and the choice of display method. Normal display method is bar graph.

Defaults: PWR.

24. Type Tone Defines type of signal transmitted during TONE Mode.

Choose tone type with **TUNE/MULTI**.

- > **Normal** = one tone (1000 Hz) for tuning antenna matchbox or amplifier;
- > **Dual** = two tones (1000Hz and 2000Hz) for testing SSB IMD.

Defaults: Normal.

25. VOX VOX for CW, DIG or Voice Modes.

Select Mode **SUBMENU**

- > **CW / MIC / DIG:** Enable / Disable

Set Enable / Disable with **TUNE/MULTI**.

Defaults: CW = Enable; MIC = Disable; DIG = Disable.

26. Beep Key Mute or enable sound when you press keys.

Set Enable / Disable with **TUNE/MULTI**.

Defaults: Enable.

27. Backlight Backlight adjustment

Select parametr with **TUNE/MULTI**.

- > **dimly:** night mode
- > **brightly:** bright display
- > **auto:** night mode, when any key is pressed, the bright display turns on for a short time.

Defaults: brightly.

28. Contrast LCD contrast.

You can adjust the contrast of the display based on your viewing angle and personal preference. Adjust with **TUNE/MULTI** from 0 to 50

Defaults: 21

DEFAULT SETTINGS

To reset to default settings hold **MEM** and press **POWER** button.

To save user settings, monitor the state of the clock battery. If the low battery B appears on the display, replace the internal watch battery (CR2032).

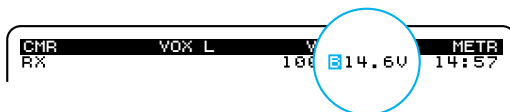

Maintenance

CLOCK BATTERY REPLACEMENT

Required tools and parts

1. Hex key 1.5 mm;
2. Hex key 3 mm;
3. Battery CR 2032.

1.

Remove the RF and RIT/XIT knobs. Using the hex key (1.5 mm), unscrew the TUNE/MENU knob.

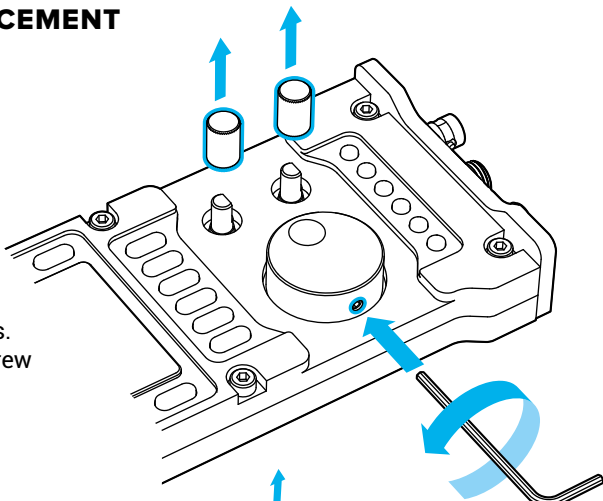

2.

With hex (3mm), unscrew the bolts indicated in the scheme.

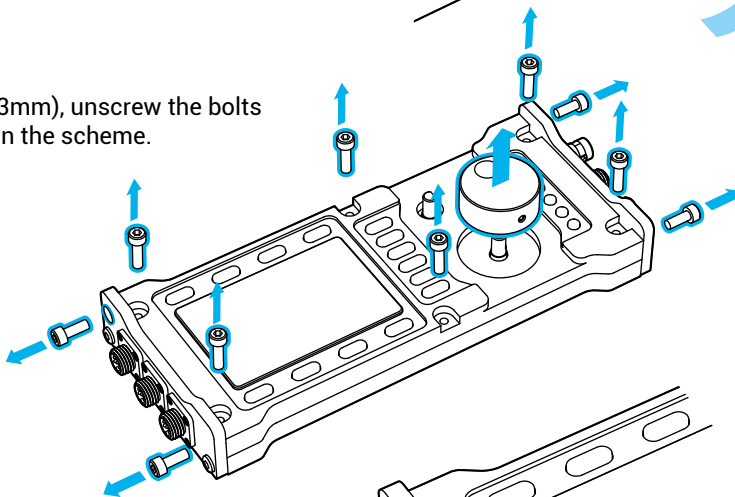

3.

With hex (3mm), loosen the bolts shown in the scheme (180 degrees) on both sides.

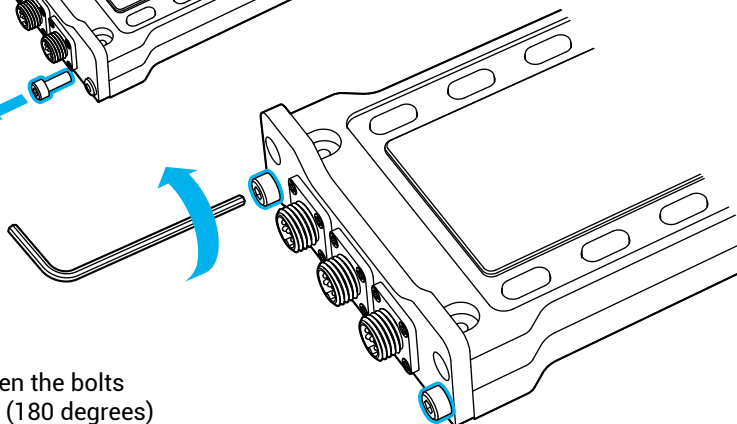

4.

Remove the top cover. Since the top cover is mounted on internal connectors, it is remove with effort.

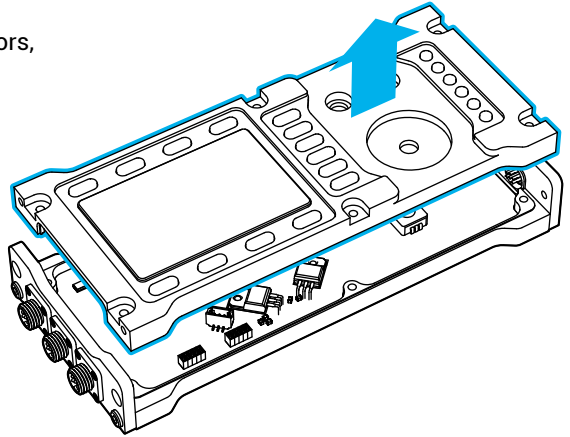

5.

Replace the battery (CR 2032).

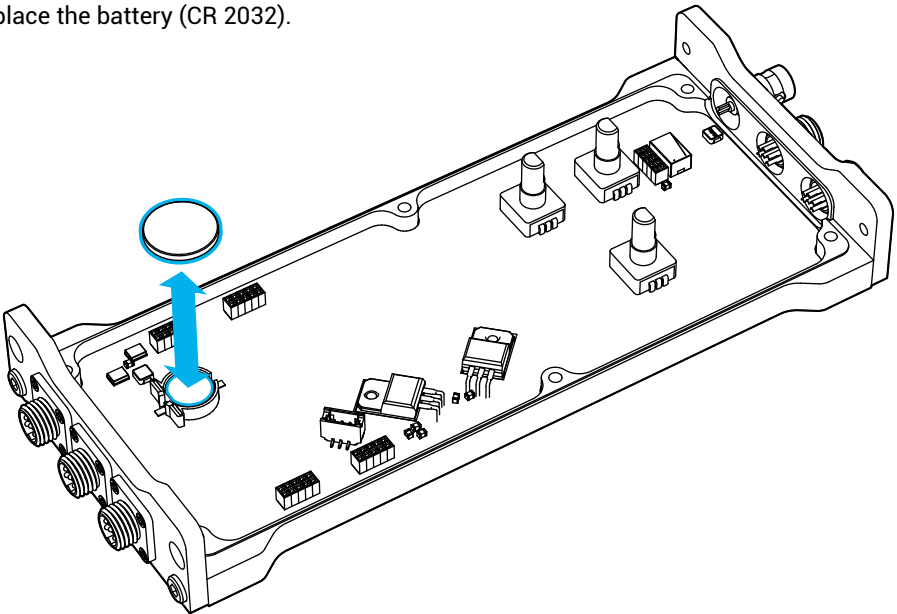

Reassemble the transceiver in reverse order.

Specifications

GENERAL FEATURES

- 160-6-meter ham bands;
- General 'receive' coverage 0.5 - 56.0 MHz;
- All modes: SSB, CW, DIG, AM, FM;
- High-performance 32-bit floating-point DSP;
- Current drain as low as 100 mA in 'receive' mode (backlight on, preamp off, no signal);
- External power supply DC 9-15V, 1 to 3A typical in transmit;
- High-contrast LCD with 256*128 px;
- High-performance real-time pan-adapter (48 kHz wide);
- On-line firmware updates;
- Rear folding kickstands for viewing angle and transportation;
- Ultra-compact size (H*W*D): 90 mm (3.5") * 207 mm (8.1") * 21 mm (0.8");
- Weight: 0.55 Kg (19.4 oz).

RECEIVER *

- Sensitivity (MDS) -136 dBm (typ. with preamp on);
- Quadrature down-sampling mixer compatible with PC-based SDR (software defined radio) applications;
- Receiver I / Q outputs for PC soundcard;
- Switchable low-noise preamp and attenuator;
- 3-band receive audio equalizer;
- 4 adjustable digital filters;
- Automatic notch filtering;
- Adjustable noise reduction and noise blanking;
- Audio Output ext. speaker, 3W typ.

TRANSMITTER *

- Adjustable output, 1 to 10W HF (7W 6m);
- Rugged, SWR and temperature-protected final amplifier stage;
- Carrier Suppression > 50 dB typ.;
- Harmonic / Spurious Outputs > 50 dB below carrier;
- CW Sidetone/Transmit offset 400-1200 Hz, adjustable;
- Speaker-microphone with PTT;
- 3-band microphone audio equalizer;
- 2 adjustable digital filters;
- DSP RF speech processing for excellent 'punch'.

* Specifications apply only within ham bands except as noted. All measurements taken with 13.8 VDC supply.

OTHER FEATURES

- Internal CW keyer with 10-300 CPM range;
- 100 general-purpose memories store VFOs, modes, etc.;
- Computer control via USB;
- Full remote-control command set (with kenwood emulates);
- One-click online firmware upgrades (with free PC software).

PACKAGE INCLUDE

1. Speaker-microphone;
2. CAT cable for on-line software update;
3. Power cable for external power source DC 9-15V (battery not include);
4. Headset and mic adapter with PTT (3.5 mm jack);
5. CW adapter (3.5 mm jack);
6. Additional connector GX12 type, 7 pins.



FCC information

FOR CLASS B UNINTENTIONAL RADIATORS

This equipment has been tested and found to comply with the limits for a Class B digital device, pursuant to part 15 of the FCC Rules. These limits are designed to provide reasonable protection against harmful interference in a residential installation. This equipment generates, uses and can radiate radio frequency energy and, if not installed and used in accordance with the instructions, may cause harmful interference to radio communications. However, there is no guarantee that interference will not occur in a particular installation. If this equipment does cause harmful interference to radio or television reception, which can be determined by turning the equipment off and on, the user is encouraged to try to correct the interference by one or more of the following measures:

- Reorient or relocate the receiving antenna.
- Increase the separation between the equipment and receiver.
- Connect the equipment into an outlet on a circuit different from that to which the receiver is connected.
- Consult the dealer or an experienced radio/TV technician for help.

FCC INFORMATION

This device complies with Part 15 of the FCC Rules. Operation is subject to the following two conditions: (1) this device may not cause harmful interference, and (2) this device must accept any interference received, including interference that may cause undesired operation.



WARNING: MODIFICATION OF THIS DEVICE TO RECEIVE CELLULAR RADIOTELEPHONE SERVICE SIGNALS IS PROHIBITED UNDER FCC RULES AND FEDERAL LAW.



CAUTION: Changes or modifications to this device, not expressly approved by Lab599 Inc., could void your authority to operate this device under FCC regulations.



Amateur Radio Operation Only

laboratory
599

Lab599 inc.
Russia, Altai region, Rubtsovsk city
support@lab599.com

www.lab599.com