

GET WIRED: BUILD YOUR OWN HOME NETWORK, WEB SITE, AND INTERNET SERVER, PAGE 92

N O V E M B E R 1 9 9 9

Macworld

THE MACINTOSH[®] AUTHORITY
www.macworld.com

Super Power

Apple's New
Power Mac G4: the
Supercomputer
for the Rest of Us.
Get All the Details,
page 88

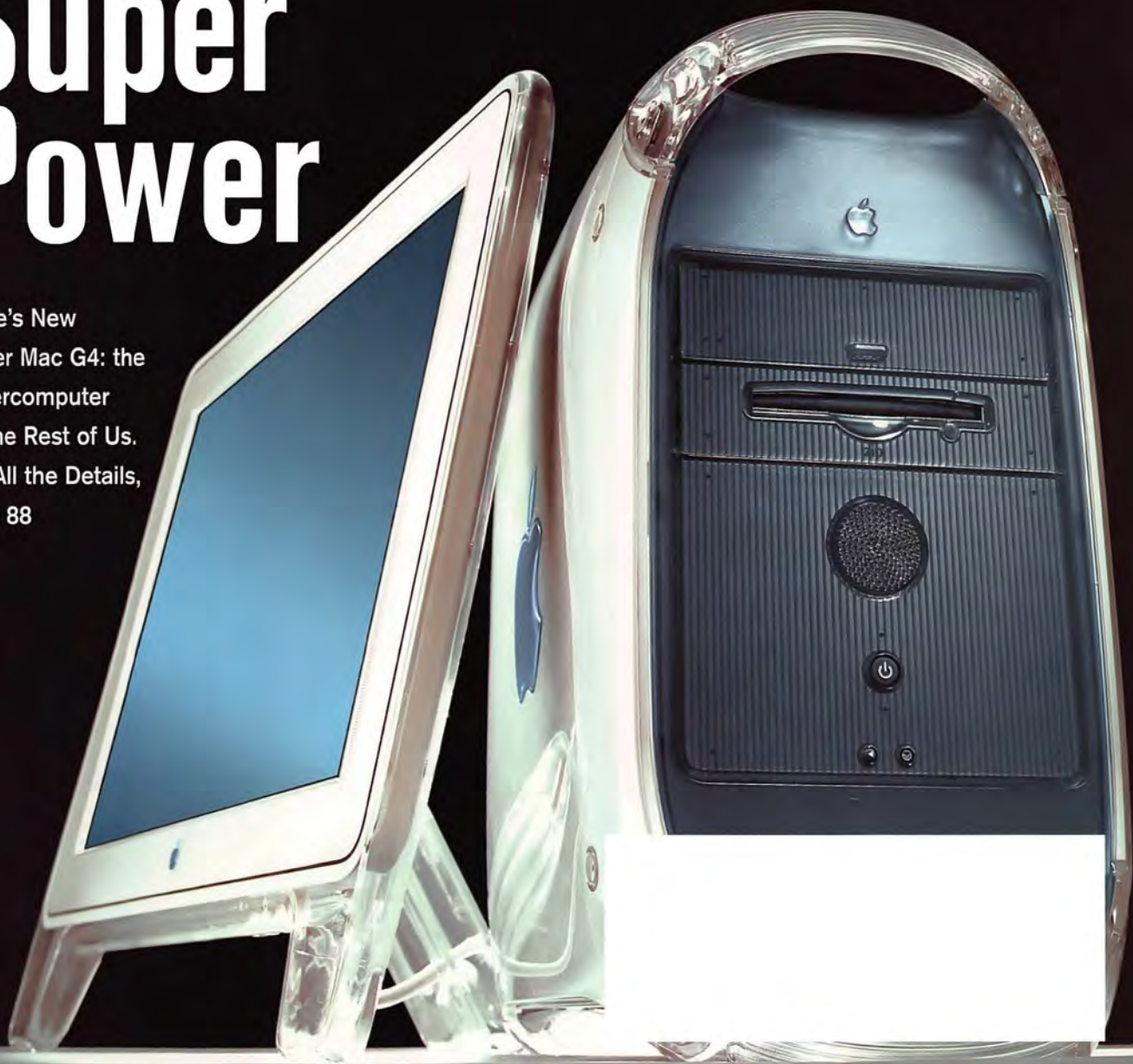



iMac unplugged.

Introducing iBook. Up to six hours of battery life.
Pentium-crushing G3 processor. Out of the box and onto the
Internet in 10 minutes — no desk required. www.apple.com.



Think different.™



True to the original.

Life's vibrant color. Subtle nuances of detail and shadow.

Printouts most like your original photos.

Without sacrificing razor-sharp text and graphics.

The new HP DeskJet 970C with 2400dpi.

Up to 10 ppm color. Just \$399* www.hp.com/go/original.



Macworld

Incorporating MacUser

Features

Cover Story

88 Fantastic Four

BY ANDREW GORE Apple's flashy Power Mac G4 brings super power to the desktop.

108 Where's the Fire?

BY STEPHAN SOMOGYI Will the new connection technology known as FireWire ever live up to its promise?



Apple's Silver Surfer, page 88.

Create

Web

123 From Printed Page to Web Page

BY DAVID BLATNER Choose from four ways to take QuarkXPress documents to the Web.

Print

129 Expert Type Tricks

BY KATHLEEN TINKEL Learn techniques that meet the approval of even typographic fussbudgets.

Graphics

132 Re-create the Past

BY JACKIE GOODMAN Preserve an antique look using current digital tools.



Wire Your World, page 92

INTEGRATE THE NET AND
YOUR LIFE.

94 Link It Up

BY ADAM C. ENGST Playing games, sharing printers, and surfing the Web are all easier once you connect all your computers on a small network.

100 Dress It Up

BY LISA SCHMEISER So you've got a Web site—but do

you have a *good* one? Our expert advice will make your site more attractive and useful.

104 Serve It Up

BY JASON SNELL You can stake your claim on the Net by running your own Web or e-mail server. Are you up to the challenge? This guide will get you started.

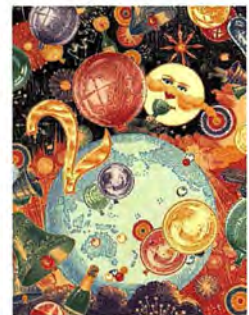

Use the new to get the old, page 132.

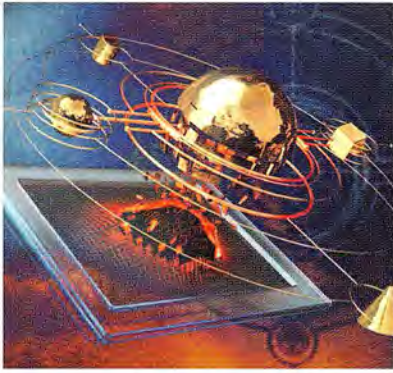

View 3-D images on the Web,
page 29.

News

29 Mac Gains Ground in Web 3-D

Thanks to recent software developments, Mac users are no longer second-class citizens when it comes to viewing 3-D graphics on the Web.

30 Wacom's New Consumer Tablet

Wacom's new Graphire system includes a pressure-sensitive pen and cordless mouse, all for about \$100.

30 3-D Hardware Ready for Takeoff

Developers of 3-D scanners and other high-end graphics hardware are taking a new look at the Mac.

31 HP Makes Its Ink-Jet Case

Hewlett-Packard's new DeskJet 970C poses a stiff challenge to Epson's Stylus Color ink-jet printers.

31 Product Watch

New products for your Mac, including a free version of Animation Stand and two-megapixel cameras from Yashica, Casio, and Epson.

ON THE COVER

Photograph by Kevin Candland

Opinion

19 Letters

25 The Vision Thing

BY ANDREW GORE What's in a Power Mac name?

85 The Game Room

BY CHRISTOPHER BREEN Apple's done much toward making the Mac a great gaming machine. But has it done enough?

198 The Desktop Critic

BY DAVID POGUE Modern microprocessors are fast enough. When will the rest of the Mac catch up?

12 How to Contact Macworld



Give your graphics a boost,
page 38.

Secrets

117 AppleScript for the Programming-Shy

BY JOSEPH SCHORR How to automate four desktop tasks without writing any code.

119 Quick Tips

BY LON POOLE Tips, tricks, and shortcuts.

Reviews

- 38 **★★★★** ATI Rage Orion;
★★★★ Formac ProFormance 3;
★★★ IXMicro ix3D Game Rocket
Graphics accelerators compared
- 40 **★★★** Newer Technology Maxpower
G3 L2 300/512K/150;
★★★★ Sonnet Crescendo G3/L2
300/512K/150;
★★★★ Sonnet Crescendo G3/L2
300/1MB/150;
★★★ Sonnet Crescendo G3/L2
400/1MB/200
G3 upgrade cards for L2 cache
compared
- 42 **★★★★** Adobe Photoshop 5.5
Image-editing software
- 44 **★★★★** WebStar Server Suite 4.0
Internet server software
- 59 **★★★½** Studio Artist 1.0
Painting and drawing tool
- 60 **★★★½** QuickMail Office 2.0
E-mail server
- 62 **★★★★** Poser 4
3-D figure-animation tool
- 64 **★★★★** SoundJam MP
MP3 player and encoder
- 66 **★★★★** Media Cleaner Pro 4.0
Video-compression utility
- 68 **★★★★** Sonic Systems SonicWall Pro
Internet firewall device
- 70 **★★★★** Spell Catcher 8
Cross-platform writing utility
- 72 **★★★½** LinuxPPC 1999
Linux OS for the Mac
- 74 **★★★** WorkingPapers Pro 2.0
Document-imaging and -management
software
- 76 **★★★★** Snapz Pro 2.0
Screen-capture utility
- 78 **★★★★** Noesys 2.0
Scientific-visualization program
- 80 **★★★★** Quake II
First-person-shooter game



**WE'VE REMOVED THE BIGGEST OBSTACLE
BETWEEN YOU AND A PRINTER. THE STORE.**

Visit our crowded facility! Stand on lines! Interact with indifferent, under-trained clerks! And remember, with every purchase you help us pay our overhead!"

No, we don't blame stores for not being this, well, forthcoming. They have a business to run. But do you really want to help them run it?

At the Virtual Printer Store, we bring you the printer without the inconvenience of the store.

You shop at home or office, via phone or mouse. You don't have to deal with traffic – street, store or otherwise. You only pay for what you need (the printer) instead of what you don't (bricks, mortar and middlemen). And since you buy direct from the manufacturer, you deal with people who'll actually talk to you after the sale.

We offer free technical support 24 hours a day, 7 days a week – for the entirety of the one-year warranty. And if you run up against a problem we can't solve, our Platinum Exchange Warranty Program guarantees you a replacement printer by the next business day. (All our printers come with a thirty-day, money-back guarantee as well.)

Finally, we offer printers good enough to sell themselves – because they have to. Printers that turn out vivid halftones, poster-sized graphics, printshop-quality text, and perform various other noteworthy feats noted here.

The Virtual Printer Store. Because the best place to shop for a printer isn't a shop at all.



ELITE 12/600 USB

12 pages per minute
600 x 600 dpi resolution
Maximum Print Area 8.5" x 14"
Letter, legal, envelope
250-sheet Universal Tray
PostScript® Level 2 compatible, PCL 5
35 PostScript fonts, 15 PCL fonts,
45 downloadable fonts
RAM expandable to 64 MB
1st year Platinum Exchange
USB (cable included),
Bi-directional Parallel

2nd Paper Feeder¹ Add \$299
(includes 500-sheet Universal Tray)
2nd year Platinum Exchange¹ Add \$ 89

\$699



ELITE XL 20 Series

20 pages per minute
600 x 600 dpi resolution
Maximum Print Area 12.6" x 35.1"
Letter, tabloid, legal, envelope, poster
500-sheet Universal Tray
PostScript Level 2 compatible, PCL 5
35 PostScript fonts, 15 PCL fonts,
250 downloadable fonts
RAM expandable to 64 MB
1st year Platinum Exchange
EtherTalk®, LocalTalk®, NetWare®, TCP/IP
Ethernet (10 BaseT, AAUI),
Bi-directional Parallel

2nd or 3rd Paper Feeder² Add \$329
(includes 500-sheet Universal Tray)
2nd year Platinum Exchange¹ Add \$179

\$1599

Lease \$56 Month/36 months³

\$1899 800 dpi version

Lease \$67 Month/36 months³

\$2199 1200 dpi version

Lease \$77 Month/36 months³



ELITE 12 N Series

12 pages per minute
600 x 600 dpi resolution
Maximum Print Area 8.5" x 14"
Letter, legal, envelope
250-sheet Universal Tray
PostScript Level 2 compatible, PCL 5
35 PostScript fonts, 15 PCL fonts,
45 downloadable fonts
RAM expandable to 64 MB
1st year Platinum Exchange
EtherTalk, TCP/IP
USB, Ethernet (10 BaseT),
Bi-directional Parallel

2nd Paper Feeder¹ Add \$299
(includes 500-sheet Universal Tray)
2nd year Platinum Exchange¹ Add \$ 99

\$849

\$949 1200 dpi version



Also available in LocalTalk versions



ELITE XL 8 Series

8 pages per minute
600 x 600 dpi resolution
Maximum Print Area 11" x 17"
Letter, tabloid, legal, envelope
250-sheet Universal Tray
PostScript Level 2 compatible, PCL 5
35 PostScript fonts, 15 PCL fonts,
45 downloadable fonts
RAM expandable to 64 MB
1st year Platinum Exchange
EtherTalk, LocalTalk, TCP/IP
Ethernet (10 BaseT, 10 Base2),
Parallel

2nd year Platinum Exchange¹ Add \$ 139

\$999

Lease \$50 Month/24 months⁴

TO ORDER 1.800.422.7777 OR WWW.THEVIRTUALPRINTERSTORE.COM



THE VIRTUAL PRINTER STORE .COM

Circle 43 on card or go to www.macworld.com/getinfo

GCC Technologies is a registered trademark of GCC Technologies, Inc. Elite and The Virtual Printer Store are trademarks of GCC Technologies, Inc. All other trademarks or registered trademarks are trademarks of their respective companies. ¹Supports one additional paper feeder. ²Supports two additional paper feeders. ³Platinum Exchange pricing is at point of purchase only. ⁴Leasing provided by independent leasing companies to qualified customers. Lease payments based on 24-month and 36-month terms. Lease terms subject to change without notice or obligation. ⁵All GCC printers are Mac OS compatible. ⁶NetWare is supported on all 20 Series printers. ⁷Windows certification is for the 20 Series printers only.



Keycode 911MWD2

Macworld

EDITOR IN CHIEF Andrew Gore
EDITORIAL OPERATIONS MANAGER Savraj Benedict

EDITOR Michael Penwarden
EXECUTIVE EDITOR Jason Snell
SENIOR EDITOR, DEPARTMENTS Nancy Peterson
SENIOR EDITOR, HOW-TO Scholle Sawyer
ASSISTANT EDITORS Frith Breitzer, Kathryn Lunsford,
Jonathan Seff

REVIEWS

EDITOR Jeff Pittelkau
SENIOR EDITOR, PRODUCTS Stephen Beale
SENIOR EDITOR, REVIEWS Linda Comer
SENIOR EDITOR, MACBUY.COM Suzanne Courteau
ASSOCIATE EDITOR Michael Gowen

CONTRIBUTING EDITORS

Henry Bortunan, Christopher Breen, Bruce Fraser, Ted Landau,
Deke McClelland, Rik Myslewski, Tom Negrino, David Pogue,
Lon Poole, Stephan Somogyi, Franklin N. Tessler

INTERNATIONAL EDITORS

Steven Noble, Australia; Bernard Le Du, France; Andreas
Borchert, Germany; Enrico Lotti, Italy; Yoshio Moriya, Japan;
Tomasz Bitner, Poland; Daniel de Blas, Spain; Lennart
Håkansson, Sweden; Fred Jaime, Taiwan; Bahattin Apak, Turkey;
Simon Jary, United Kingdom

LAB

LAB DIRECTOR Kristina De Nike
SENIOR LAB ANALYSTS Jeffy K. Milstead,
Kevin Mitchell
ASSOCIATE LAB ANALYST Gil Loyola
INVENTORY COORDINATOR Ulysis Bravo

COPY EDIT

MANAGING EDITOR Claire H. Breen
ASSISTANT MANAGING EDITOR Paul-Michael King
COPY CHIEF Jon Zobenica
COPY EDITOR Charles Purly

ART AND DESIGN

DESIGN DIRECTOR Eleanor Leishman
ART DIRECTOR Sylvia Chevrier
ASSOCIATE DESIGNERS Martha Katt,
Jonathan Woolson
DESIGN ASSOCIATE Jackie Goodman

ONLINE

VICE PRESIDENT, SALES, & PUBLISHER Matt Sweeney
DIRECTOR OF CONTENT Matthew Rothenberg
CONTENT ENGINEER Jeff Cheney
ASSISTANT CONTENT ENGINEER Ron Neal
ONLINE AD PRODUCTION MANAGER Steve Spingola



iCart™
from
Anthro



ANTHRO
www.anthro.com

Short iCart: \$149; Tall iCart: \$199; Great accessories. Call us at 800-325-3841.

No one doubts that color can keep you in the game. But black and white will always make its point. Find out how Ricoh Aficio color can deliver unsurpassed color at the most affordable price. Yet, still meet all your black & white needs at a mere two cents a page. **Aficio Color™**



800 63 RICOH
ricoh-usa.com

sitting pretty ▶▶



© 1999 Ricoh Corporation

We're in your corner.

RICOH®
Image Communication

Circle 4 on card or go to www.macworld.com/getinfo

Project Scheduling Made Easy!

DON'T TELL MY BOSS

I'm not a project management expert, but everyone thinks I am. Most of my time is spent completing tasks, so I need a scheduling tool that's easy, fast, and flexible.

FastTrack Schedule 6.02 fills the bill. It keeps me organized and in control displaying all my project details in rich, colorful timelines. FastTrack Schedule provides just the right amount of power because it's more sophisticated than day-planners, but *easier to use and half*

\$199* the price of traditional, high-end project managers.

The presentation-quality schedules clearly illustrate project objectives and deadlines keeping team members and clients informed and up-to-date.

In a single schedule, I can outline multiple projects, make assignments, track cash flows, set-up dependencies—even add graphics. Whether I use it once a week or every day, FastTrack Schedule makes project scheduling easy.

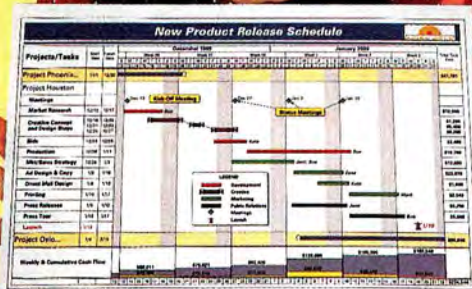

NEW Version 6.02

- ExpressDate™ • FastSteps™
- Open/Export MS Project MPX files
- Full AppleScript Support
- Histograms • Hyperlinks
- and much more...

For the free Demo CD, more info, or to place an order call **800-450-1982**.

FastTrack Schedule™

Version 6.02

Schedule Tomorrow's Success Today.™ **AEC SOFTWARE**

© 1999 AEC Software Inc. All rights reserved. Corporate names and trademarks stated herein are the property of their respective owners. *Estimated Street Price is \$199, prices may vary at individual retailers. Outside the United States, please call (703) 450-1982 for information.



TRY IT & BUY IT!

Download the demo and order online today at www.aecsoft.com

Circle 83 on card or go to www.macworld.com/getinfo

Macworld

PRESIDENT AND CEO Colin Crawford
 ASSISTANT TO THE CEO Sharon Sanderson
 CHIEF FINANCIAL OFFICER Stephen Daniels
 BUSINESS MANAGER Eos de Feminis
 ACCOUNTING COORDINATOR Ronda Bittner
 DIRECTOR OF HUMAN RESOURCES Sue Murphy
 HUMAN RESOURCE MANAGER Marisa Chow

DISPLAY ADVERTISING SALES

VICE PRESIDENT, SALES, & PUBLISHER Matt Sweeney
 ASSOCIATE PUBLISHER Steve Plevin (415/243-3509)
 SALES & MARKETING COORDINATOR Karla Kyrias (415/278-8542)
 SALES ASSISTANT Katherine Lebioda (415/243-3577)
 SALES ASSISTANT Brock Keeling (415/243-3662)
 NATIONAL ACCOUNTS MANAGER Jessica Ross (415/243-3583)
 ACCOUNT EXECUTIVE Coretta Wright (415/243-3615)
 NATIONAL ACCOUNTS MANAGER Sara Culley (970/327-4499)
 ACCOUNT EXECUTIVE Margaret Level Green (415/243-3582)
 EASTERN ADVERTISING DIRECTOR Cynthia Ramsey (973/243-1197)
 NATIONAL ACCOUNTS MANAGER Paul Bonarrigo (508/533-4020)
 ACCOUNT EXECUTIVE Jo Zottarelli (516/277-4134)
 SHOPPER ACCOUNT MANAGER Niki Stranz (415/243-3664)
 SHOPPER ACCOUNT MANAGER Carol Johnstone (415/243-3691)
 SHOPPER ADMINISTRATIVE ASSISTANT Alissa Mach (415/243-3628)

RESEARCH

SENIOR RESEARCH ANALYST Phillip Hibbert

MARKETING

SENIOR MARKETING MANAGER Francesca Koe
 ONLINE MARKETING MANAGER Diane Powers

MACWORLD GLOBAL PRODUCT SUPPORT CENTER

COORDINATOR Sharon Sanderson

PRODUCTION

VICE PRESIDENT OF MANUFACTURING Anne Foley
 PRODUCTION DIRECTOR Cynthia Neustadt
 MANUFACTURING TECHNICAL DIRECTOR Clayton Haberman
 DIGITAL AD COORDINATOR/
 MANUFACTURING TECHNICAL COORDINATOR Mac Scott
 AD SALES COORDINATOR Ricardo Sandoval

Macworld is a publication of Mac Publishing, L.L.C. Macworld is an independent journal not affiliated with Apple Computer, Inc. Macworld, MacUser, MacWeek, Macworld Interactive, Macworld Shopper, MW, MW Lab, MW Shopper, The Desktop Critic, Expert Graphics, Quick Tips, Star Ratings, Buyers' Tools, Streetwise Shopper, and Conspicuous Consumer are registered trademarks of Mac Publishing, L.L.C. Apple, the Apple logo, Mac, and Macintosh are registered trademarks, and MacLetter and PowerBook are trademarks, of Apple Computer, Inc. Printed in the United States of America. Copyright © 1999 Mac Publishing, L.L.C. All rights reserved.

Get the Winning Edge.

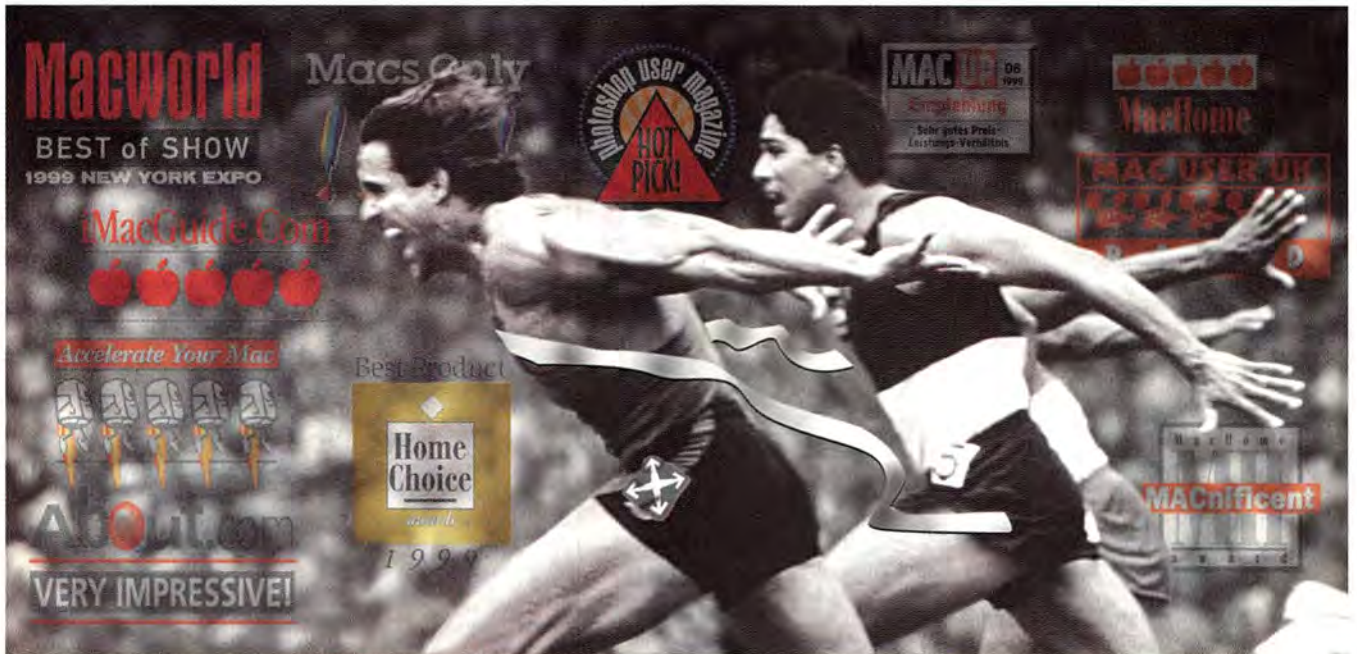

From QuickTime® video to PowerPC® G4, XLR8® products lead the pack in every category.

Right out of the gate, it may look like the field is full of speed and expansion options. Looks can be deceiving. When it's down to a photo finish, XLR8 products win the race.

We push the edge when it comes to innovation so you get the "best of the best" for your Mac®. That's why industry experts are awarding top honors to our patent-pending Carrier G3/G4 Upgrade Technology™ and InterView™ – the first USB product to turn the iMac into a true media machine. These products earn blue ribbon status by delivering the winner's edge, right out of the box.

XLR8, tools to perform and create... on your Mac.



MACb Carrier's G3/G4 patent-pending upgradeable upgrade technology was selected as Macworld's "Best of Show" and as Photoshop User's "Hot Pick."

"Buy it!" – MacFuture



InterView™ w/VideoShop 4.5 for USB and PCI has been listed as the perfect choice to deliver QuickTime video, and the "1999 Best Product of the Year" by Mac Home Journal.



888XLR8TOR • www.xlr8.com

Interex, Inc. • 8447 E. 35th St. N. • Wichita, KS 67226 • 316-636-5544 • 316-636-4639 fax

Other brand and product names are trademarks or registered trademarks of their respective holders. Product specifications subject to change without notice. ©1999 Interex, Inc.

Circle 121 on card or go to www.macworld.com/getinfo

Conquer Disk Damage



Introducing DiskWarrior™,
a revolutionary new way
to restore damaged disks!

DiskWarrior is a revolutionary new utility that combats disk damage. It quickly rebuilds, recovers and optimizes your HFS and HFS Plus disk directories, eliminating all directory errors and recovering lost files. Other utilities attempt to repair disks by patching the damage. Patching can result in more damage and permanent loss of files.

100% Recovery Assurance

Only DiskWarrior builds a new optimized directory using data recovered from the damaged directory. You have 100% assurance that DiskWarrior will always restore your disks and recover your files when directory damage is your enemy.* You'll also have 100% confidence that you're getting the desired results. DiskWarrior's exclusive Preview ability lets you preview the restoration. You can examine your damaged disk in the Finder as it will appear after the directory is restored but before any changes are made to your disk.

Routine Maintenance

DiskWarrior is your first line of defense against unseen disk damage. Running DiskWarrior regularly prevents small unseen problems from becoming large ones by keeping your directories error free. You'll also keep your directories optimized to speed up overall disk performance.

©1998 Alsoft, Inc. PO Box 927, Spring, Texas 77383-0927 USA. 281-353-4090 or fax 281-353-9868. DiskWarrior is a trademark of Alsoft, Inc. *Visit our web site or call for requirements. DiskWarrior is not a magician. No utility can restore directories that have been written over.



THE UTILITY COMPANY

ALSOFT

www.alsoft.com 800-257-6381

Macworld

HOW TO CONTACT MACWORLD

Subscription Services

Phone 800/627-2247 or
303/665-8930, North America only
303/604-7445, outside North America
U.S. Mail Macworld Subscription Services
P.O. Box 54529, Boulder, CO 80322-4529
World Wide Web www.zdnet.com/zdsubs/macworld/service

Subscription Rates

The one-year (12-issue) subscription rate is \$34.97 in the United States and \$54.97 for all other countries (send \$104.97 for air mail). The rate for a one-year (12-issue) subscription with the monthly CD-ROM is \$49.97 in the United States and \$69.97 for all other countries (air mail not available at this time). Checks must be made payable in U.S. currency to Macworld. Please allow 6 to 8 weeks to receive your first issue.

Back Issues of Macworld

Back issues (subject to availability) are \$8 per issue for U.S. delivery (\$12 outside the United States); prepayment in U.S. currency to Macworld is required. Send check or money order to Back Issues Department, Ziff-Davis Inc., P.O. Box 53131, Boulder, CO 80322-3131.

Reprints and Permissions

You must have permission before reproducing any material from Macworld. Write to Macworld, Reprints and Permissions, 301 Howard St., 16th Fl., San Francisco, CA 94105; include a phone number. To order reprints of your company's editorial coverage, call Reprint Management Services at 717/399-1900; fax 717/399-8900; e-mail sales@rmsreprints.com.

Mailing Lists

We periodically make lists of our customers available to mailers of goods and services that may interest you. If you do not wish to receive such mailings, please write to us and include a copy of your mailing label.

Macworld on Microfilm

Macworld is available on microfilm and microfiche from UMI, 300 N. Zeeb Rd., Ann Arbor, MI 48106-1346; 734/761-4700.

Macworld Editorial

The editors of Macworld welcome your tips, compliments, or complaints. Stories and product reviews from past issues can be located at www.macworld.com. We are unfortunately unable to look up stories from past issues; recommend products; or diagnose your Macintosh problems by phone, e-mail, or fax. Contact Apple toll-free at 800/538-9696, ext. 500, for information on user groups in your area.

Our offices are located at 301 Howard St., 16th Fl., San Francisco, CA 94105; 415/243-0505, fax 415/442-0766.

LETTERS TO THE EDITOR Direct all comments and suggestions regarding any aspect of the magazine to letters@macworld.com. Due to the high volume of mail received, we can't respond personally to each letter. We reserve the right to edit all submissions. All letters published in Macworld or Macworld Online become the property of Macworld.

QUICK TIPS Send your questions or tips on how to use Mac computers, peripherals, or software to Macworld, Quick Tips, 301 Howard St., 16th Fl., San Francisco, CA 94105; fax 415/442-0766; e-mail quicktips@macworld.com. Please include your name, address, and telephone number.



Circle 140 on card or go to www.macworld.com/getinfo

Presenting a revolutionary force in television. YOU.

ReplayTV™ Imagine having the freedom to watch your favorite shows on your schedule. The power to control live TV. The excitement of a truly personal television experience.

Presenting ReplayTV, a revolutionary set-top box that records your favorite shows on a hard disk automatically, every time they're on. No tapes.

No hassles. ReplayTV works with an intelligent programming service so you can create your own personal channels based on your favorite shows, actors or themes. ReplayTV finds and records your shows so you can watch them on-demand with full VCR-style controls. It's easy. It's automatic. It's guaranteed.

You can also pause, rewind and use instant replay on live TV. Say the phone rings in the middle of *Friends*®. Simply hit pause and take your call. Then, hit play and you haven't missed a beat. For just \$699 and no monthly fees, ReplayTV will revolutionize the way you watch television. It's television made personal.

1.877.ReplayTV
replaytv.com



All prices shown are subject to change. Price does not include applicable state and local sales tax or shipping to the recipient's destination. ©1999 Replay Networks, Inc. All rights reserved. ReplayTV, the Replay logo, and Primetime. Anytime. are trademarks of Replay Networks, Inc. All other trademarks or registered trademarks are property of their respective holders. TV not included. Code: 1127

replay
Primetime. Anytime.™

Choose 20 at www.macworld.com/getinfo



www.lacie.com/mfw.htm FireWire Hard Drive™ and the LaCie logo are trademarks of LaCie, Ltd. ©1999 LaCie, Ltd. All rights reserved.
FireWire and the FireWire logo are trademarks of Apple Computer, Inc., registered in the U.S. and other countries.
The caffeine molecule. If, instead of atoms, it were made of light bulbs.

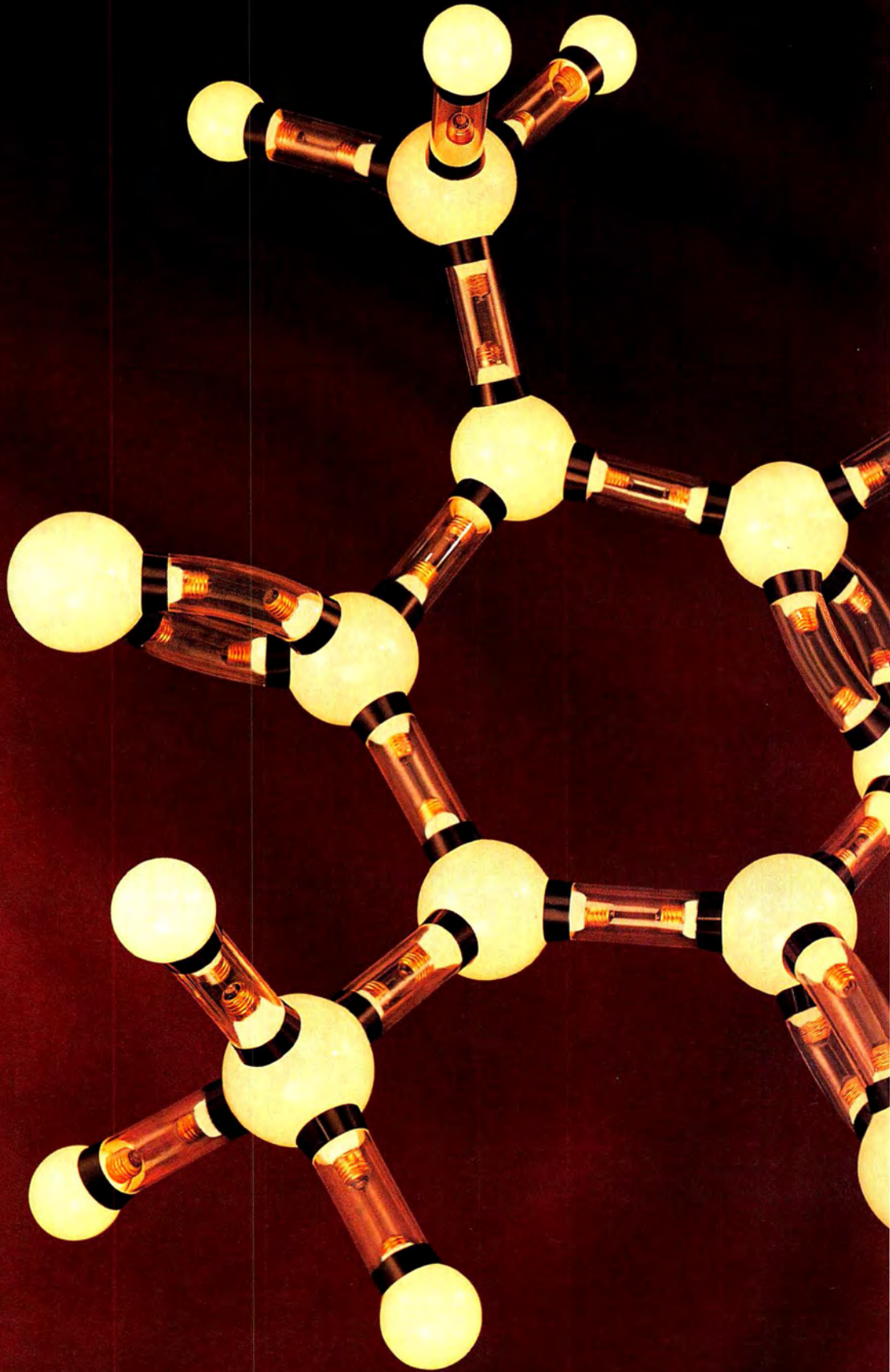

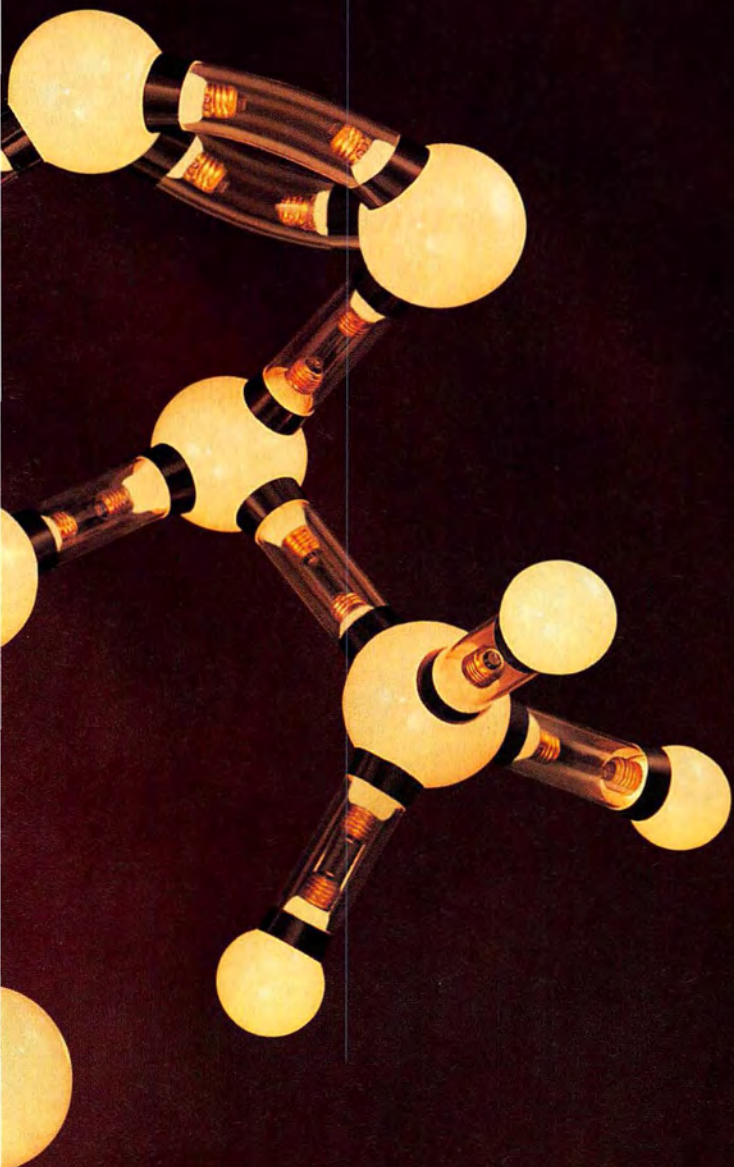

CONNECTED.

Get faster access to your ideas with the LaCie FireWire Hard Drive.™ It can send data along its FireWire™ connector at 400 Mbps while linked to up to 63



FireWire enabled peripherals. And it's still hotswappable. Plus, it's available up to 36GB. All of your peripherals working together as one. Now who'd have thought of that?

LACIE Made for ideas.



IT TAKES ONLY
ONE LITTLE THING
TO RUIN AN ENTIRE
PRESENTATION.

If your reputation hinges on accuracy, consider that Tektronix has been making color printers for more than 15 years. You might also like to know about the Phaser® 780 color printer.

It's loaded with color management tools that take the guesswork out of getting what you want. There's our exclusive PhaserMatch™ ICC software, which allows you to match the output of a specific press, paper, or ink. Want to know how your work is going to look on newsprint? Use one of the newsprint profiles, or create your own using International Color Consortium standards. And it supports ColorSync, so what you see on your screen is what comes out of your printer.

Avoid embarrassment.

Call toll-free 1-877-362-6567
ext. 1616. Or visit

www.tektronix.com/Phaser780x1616



Tektronix®

© 1999 Tektronix, Inc. Tektronix and Phaser are registered trademarks and PhaserMatch is a trademark of Tektronix, Inc. ColorSync is a trademark of Apple Computer, Inc.

Choose 95 at www.macworld.com/getinfo

FIND OUT ABOUT THE GADGET YOU DIDN'T REALIZE YOU WANTED YET.

CNET: Personal Tech

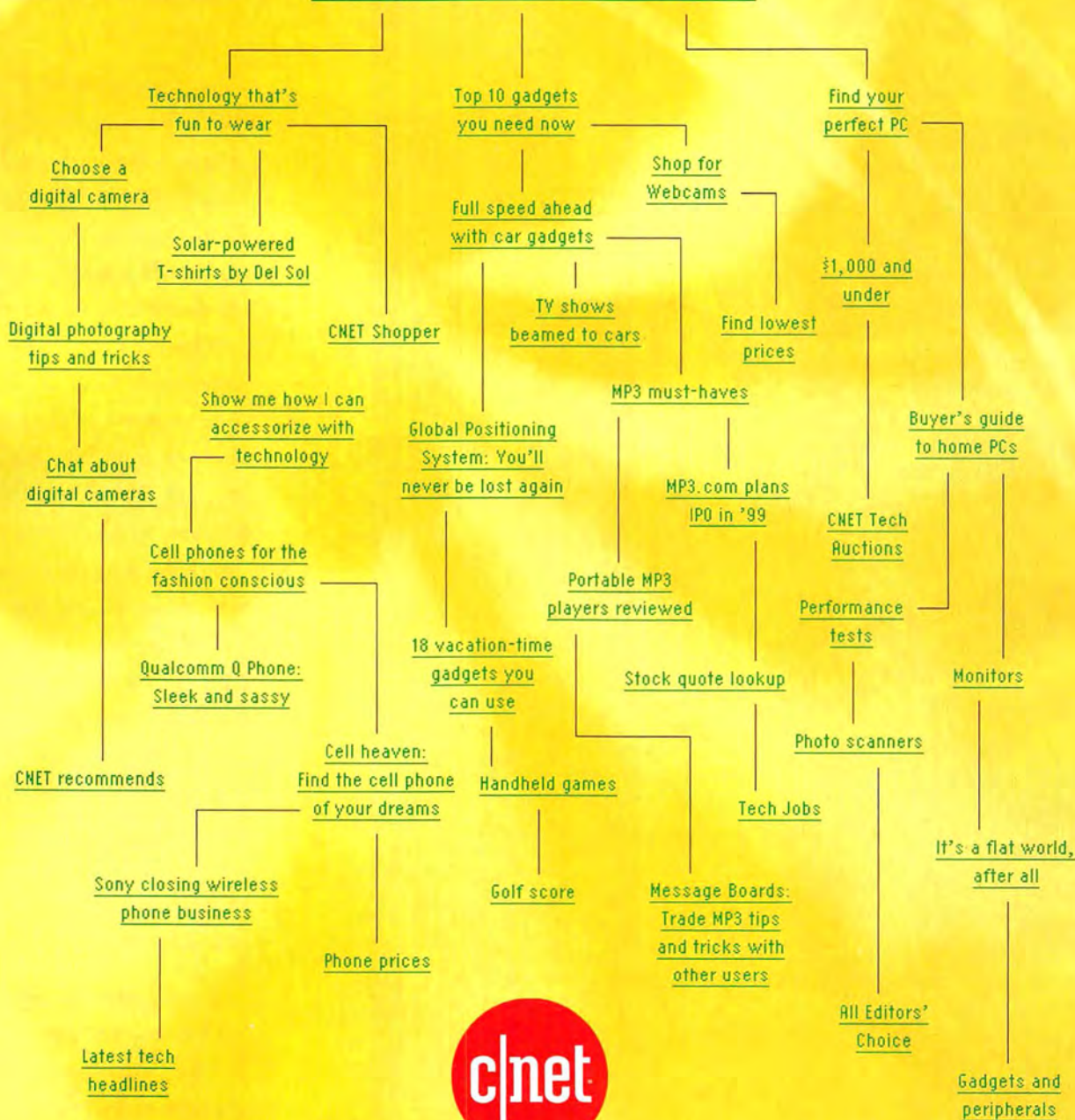

CNET.com

The source for computers and technology.™

Letters

Feuding over the Finder

STEPHAN SOMOGYI TELLS US IN "The Millennium Mac" (August 1999) that Mac OS X will have a new Finder. If this new list-oriented Finder is an addition to the traditional Finder, that's fine; if it replaces it, that would be disastrous.

From the beginning, the Mac used a graphical interface, treating the user as a human being. Instead of making you input command lines, the Mac OS allowed objects to be picked up and dropped wherever you wanted to have them. As in a real office environment, you could leave items on the desktop if they were of immediate importance or stow them away in folders for later use. Whenever you needed to retrieve a document, it could be found in the very same spot.

Imagine that your office cleaning staff rearranged all your documents. The next day, you would have a hard time finding them. That's exactly what happens when the desktop or folder contents are sorted according to some other rule. Gone is the bird's-eye view; say hello to the frog's-eye view among listed files in a folder.

If Apple wants to add a new menu item to the Finder, that's OK. However, if it wants to drop the traditional Finder, it will kill one of the unique features that make the Mac the Mac: a computer so easy to work with that you forget it's a computer.

ARTHUR REICHMUTH
Wetzikon, Switzerland

NEARLY EVERYONE HAS BEEN CRITICAL, or at best unenthusiastic, about Apple's decision to do away with the current Finder and replace it with a more advanced and powerful, Next OS-like Finder. To be honest, I was shocked at



first. But a complete consideration of the situation makes it clear that Apple is right.

The new file-management interface, if anything like the one pictured in "The Millennium Mac," is clearly more efficient than the one in previous Mac operating systems. Although the new Finder has been condemned for making browsing more complicated, including two versions of the Finder won't solve that problem. Including the old and new versions would eliminate the Mac OS's simplicity and kill the incentive for new users to choose Macintosh instead of Windows. It would also make the Mac OS a nuisance for die-hard users who would either have to ignore the new Finder or cope with having to switch between two different file-management interfaces for different tasks.

It's the ability to use the best technology instead of many lesser technologies that has separated the Mac OS from Microsoft's blunt Windows. Apple should continue to do what it has always done by

blending the best of what the old Finder has to offer with the best features of the new Finder in order to come up with one perfect file-management interface.

VICTOR RANGA
Mount Vernon, New York

The Joy of 8.6

MAC OS 8.6 IS TERRIFIC! I HAVE A Performa 6400/180 with 80MB of RAM and have had performance troubles since I installed 8.0, then upgraded to 8.1, 8.5, and finally 8.5.1. I was nervous about upgrading to 8.6 but figured my Mac was so slow that it couldn't get worse. And it didn't! Microsoft Office apps open as fast as when I had OS 7.6. The Finder doesn't pause for minutes at a time like it used to. From what I understand, this will be one of the last Mac OSs that will work on my PowerPC 601e processor, and that's fine by me. My Performa is back to its old self and matching the performance of the Pentium II Windows NT machine I use at work.

Thanks to Apple for giving me back my old Performa!

PAUL BERTAIN
Davis, California

Tools of the Trade

THANK YOU FOR THE INFORMATIVE and timely "Essential Mac Tools" (August 1999). As a new Mac user, I found Franklin Tessler's descriptions of quintessential Mac utilities to be important to my understanding of how to keep Mac OS 8.6 running in tip-top condition. I hope that other articles or a special column for new Mac users will

continues



The Best Tools for Every Job!

The **ACTION Utilities** Toolchest includes:

- ACTION Files** - Automatic file access and organization
- ACTION GoMac** - The Macintosh Task Bar™ and Start Menu
- ACTION WYSIWYG** - Multi-column view of actual typefaces and font families right in your application
- ACTION Menus** - Customize and create new menus organized any way you want!

Incredible savings in one powerful bundle. Guaranteed to make you more productive or your money back!



**POWER ON
SOFTWARE**

Phone: 800-344-9160 or 612-317-0344
 Fax: 612-317-0345
 email: sales@poweronsoftware.com
 http://www.poweronsoftware.com

45 on card or www.macworld.com/getinfo

follow on such topics as essential software applications and hardware.

EDWARD WEBSTER
 Simpsonville, South Carolina

I DISAGREE WITH THE RATINGS given to Alsoft's Disk Express Pro 3.0.1 and Connectix's RAM Doubler 8.0.1 in "Essential Mac Tools." Franklin Tessler awarded Disk Express Pro four and a half mice even though it is still completely incompatible with HFS+-formatted hard disks. Apple released the HFS+ format more than a year ago. Ironically, Alsoft, the company that developed Plus Maker and Plus Maximizer, can't seem to update its own utility.

On the other hand, RAM Doubler received only four mice. I think it deserves five. The brief review failed to mention an important feature of RAM Doubler that's useful even if you have lots of physical RAM. When you run multiple applications simultaneously, RAM Doubler taps into the unused memory of the applications running in the background. This allows you to set large preferred-memory sizes for RAM-hungry applications such as Web browsers and graphics programs. RAM Doubler handles memory better than the Mac OS, and most power users experience fewer crashes when it is enabled.

GREGORY TETRAULT
 Chesapeake, Virginia

Searching for the Mezzanine

IN "GENERATION GAP" (AUGUST 1999), Kristina De Nike and Jonathan Seff state that the iProRaid SCSI card works only in the original Bondi blue iMacs, which were built with a mezzanine slot hidden beneath the plastic case. How do I know if I have *that* iMac?

I bought mine in November 1998, before Apple introduced all the flavors, so I had no choice but to get the Bondi blue one. I would like to use the card to increase my all-too-small hard-disk space by adding an external SCSI 9GB hard drive. What do you recommend?

MICHAEL FISCHBECK
 Milburn, New Jersey

All the 233MHz Bondi blue iMacs, both rev. A and rev. B, have the hidden mezzanine slot. It is difficult, although not impossible, to install a SCSI card in this slot. A simpler solution, which works for all iMacs, is to invest in

a USB CD-RW drive (see Reviews, September 1999) and move nonessential files off the hard disk.—Kristina De Nike

Many Arms of netOctopus

SHELLY BRISBIN'S REVIEW OF Netopia's netOctopus (Reviews, August 1999) was mostly on the mark, but I believe she missed an important feature included with netOctopus: File Scriptor.

File Scriptor is not an AppleScript tool but rather a program that lets you build install packages, which can include extensions, applications, and preferences. File Scriptor allows you to do this in two ways: by telling it where the files need to go when installed and where the files currently are on your Mac, or by taking a snapshot of your current state, doing the installation, and taking a postinstall snapshot. File Scriptor then takes the difference to build your install. You can use the install package to create an Apple Installer script that netOctopus can employ to run the install. netOctopus can also use Apple Installer scripts for any package, not just the ones you create in File Scriptor. It's very handy for such things as ColorSync updates and MRJ (Mac OS Runtime for Java) updates.

JOHN C. WELCH
 Westboro, Massachusetts

Oh-So-Dreamy

I JUST HAD TO THANK LYNDIA Weinman for her article about Macromedia Dreamweaver 2 layers ("Elegant Web Pages with Dreamweaver 2," *Create*, August 1999). I'm a graphic designer, and I receive more and more calls every week asking me to design Web sites. I've been a loyal fan of Dreamweaver for some time now (especially after pulling all my hair out trying to use Microsoft FrontPage). And yes, I'm also one of those people who learned HTML code in all its glory before the days of slick Web-page-design applications. Weinman's tips for converting layers to tables forever changed the way I design Web sites. A page that normally took me a full day and plenty of sweat was reduced to a mere five minutes of work. Incredible.

TODD DOMINEY
 Charleston, South Carolina

continues

PerfectFlat[®] technology looks better with... Apple[®] Power and ViewSonic[®] on top!



Selecting your Mac[®] is only half the battle. Today, how you top it off is just as important. Innovations like multimedia monitors, flat panel displays and large screen CRTs are changing the old phrase "Monitor Sold Separately" to "Mac Sold Separately".

Take the new ViewSonic PF790 19" (18.0" viewable) monitor with a .25mm super fine aperture grille pitch and a maximum resolution of 1600 x 1200. Or the GF775 17" (16.0 viewable) monitor with an ultra fine .24mm slot pitch and 1600 x 1200 maximum resolution. Both monitors utilize **PerfectFlat** technology designed to provide your Visual Computing[™] Experience with precise, clear images.

At ViewSonic, we offer the #1 best selling monitors and flat panel displays in the USA*. Buy with confidence from the company that's won over 550 industry awards. Our warranty covers 3 years parts and labor. Plus 24-hour customer service, 7 days a week.

For more information on the company that's won over 550 industry awards, visit our website at: www.ViewSonic.com/mac/



(Mac[®] Sold Separately)

(800) 898-8583 • Specifications subject to change without notice. • Copyright © 1999, ViewSonic Corporation. • Corporate names and trademarks stated herein are the property of their respective companies. • Apple and Mac are the registered trademarks of apple. • *Stanford Resources, Inc. Monitrak U.S. Desktop PC Monitor Shipments Q1 '99 and Display Search, Quarterly Supply vs. Demand Study: Desktop Monitors Q2 '99. • All rights reserved.



www.ViewSonic.com

Mac/Windows® Compatibility

The New OrangePC® 660/450MHz Windows® compatibility card is 10 times faster than VirtualPC® and tracks a real Pentium® III 450 MHz.



...No Speed Limits!

When you're tired of fooling around with other people's PCs, or some pokey PC software emulator, it's time to step up to a real Windows® compatibility card for your Mac — the Orange®PC. You know it's serious when the new OrangePC 450 MHz benchmarks side by side with a real Pentium® III; it's also 10 times faster than VirtualPC®.

And OrangePC is better than a PC clone anyway. OrangePC is seamlessly integrated into your Mac giving you a single platform footprint, live copy/paste between Mac/PC environments, shared files and shared peripherals. It's elegant; it's cool; it's just plain better! A 30 day money back guarantee is the same as a no risk test drive, without speed limits!



"19 Years of Innovation and Excellence"
(714) 779-2772 • www.orangemicro.com



Benchmark is a 3DMark 99 Max Synthetic CPU Speed run on a "Blue and White" G3 Power Macintosh G3/400.
*VirtualPC software emulator.

© Orange Micro, Inc. 1999.

LETTERS

No HP MFP for Me

IN STEPHEN BEALE'S STORY ON multifunction peripherals (MFPs) for the Mac, Beale states that Hewlett-Packard has closely allied itself with Apple ("Multifunction Peripherals Arrive for Mac," *News*, August 1999). This is the same HP, I presume, that used to charge \$50 more for a Mac-compatible Desk-Writer than for a PC-compatible Desk-Jet; the same HP that markets its Photo-Smart products for PC only; the same HP that was completely AWOL during Apple's dark days. There's apparently no technical reason that a printer can't be both PC- and Mac-compatible—just look at the Epson color ink-jet products. We can only hope that Epson decides to market an MFP so we can reward it for being there while HP either gouged us or completely ignored us. As far as I'm concerned, Epson has earned the loyalty of every Mac user and HP has not.

GARY STEWART
Galion, Ohio

*As a matter of fact, Epson recently unveiled two new MFPs: the Epson Stylus Scan 2000 and Stylus Scan 2500. For more details, check out "Epson Joins MFP Fray with Stylus Scan," *News*, September 1999.—Ed.*

Baby, You're a Star

HAVE YOU EVER NOTICED HOW many commercials and advertisements feature Macs? The reason is obvious—the Mac OS is more pleasant to look at than Windows. Its handsome silver title bar is certainly more appealing than Windows' ugly blue title bar. The Mac OS is like a beautiful garden, whereas Windows resembles a lawn overgrown with crabgrass. Perhaps there's a concept advertising companies have grasped that Microsoft has not: elegance sells.

TED DZIUBA
Wallingford, Connecticut

Letters should be sent to *Letters*, Macworld, 301 Howard St., 16th Fl., San Francisco, CA 94105; via fax, 415/442-0766; or electronically, to letters@macworld.com. Include a return address and daytime phone number. Due to the high volume of mail received, we can't respond personally to each letter. We reserve the right to edit all letters. All published letters become the property of *Macworld*. **m**

Best Product* ...

Best Price!
\$49.00

MW EDITORS' CHOICE

Grappler®
SCSI

Ideal for new G3 Power Macs

MacWorld Magazine's Editor's Choice award went to Orange Micro's Grappler SCSI Card for three major reasons: 1. "fastest in its class" 2. "least expensive card in its category" 3. "and the only one that was bootable". Available in Fast, Ultra, and Ultra Wide. Make Grappler SCSI your choice!

Orange Micro inc.
www.orangemicro.com

* August, 1999 Macworld Magazine. © Orange Micro, Inc. 1999

Circle 60 on card or go to www.macworld.com/getinfo

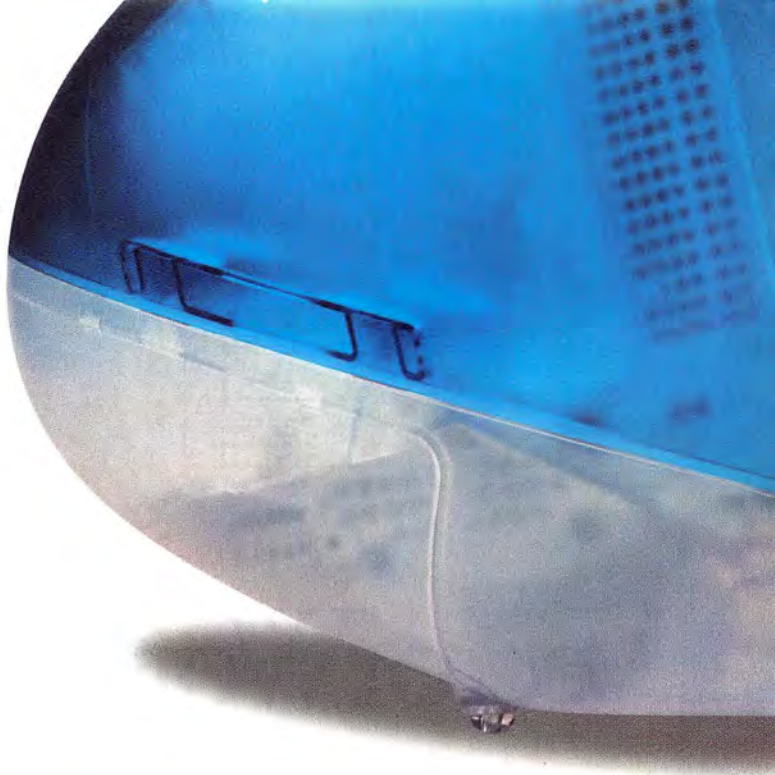

Laser Power for Generation i

Say hello to our
iMac™ & G3 compatible
Laser Printers and
Multi-Function Centers.

When it comes to laser power for iMac,
we offer some very solid solutions. Case
in point, our HL-1200 series Laser Printers
with up to 12 pages per minute, true
600 dpi laser output and more.

Need to make your iMac even more of an
all-in-one solution? Good, because our all-
in-one Laser Multi-Function Centers deliver
faxing, printing, copying and scanning.

If you're part of the Generation ready to
change the world, it's nice to know you
have a company like us at your side.

Available at: MACWAREHOUSE, CDW,
MACZONE, COMPUSA, J&R COMPUTER WORLD,
OFFICE DEPOT, OFFICEMAX AND STAPLES

OUR 12 PPM
LASER FAMILY



Laser Printing
from \$299



Laser Multi-Function
from \$499

brother

At your side.™

Brother International Corporation, Bridgewater, NJ • Brother Industries Ltd., Nagoya, Japan.
For more information please call the Brother Fax-Back System at 800-521-2846 or visit our web site at www.brother.com
All trademarks and registered trademarks are the property of their respective owners.

Choose 117 at www.macworld.com/getinfo

After 14 years of constant research and development, Diehl Graphsoft is proud to introduce VectorWorks—the next generation of MiniCAD. VectorWorks improves MiniCAD's proven CAD technology and merges new state of the art Object-Based design philosophy. This integration makes you more productive without sacrificing flexibility and control.

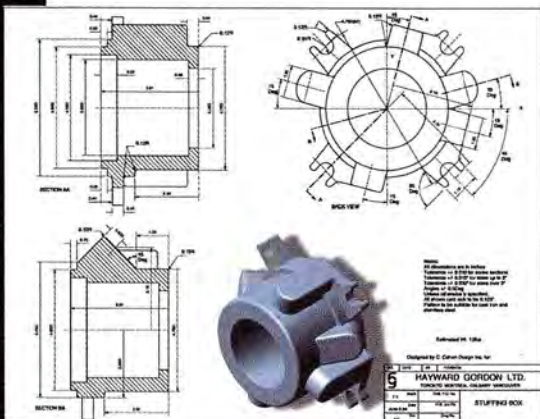

Carlos Cohen, C. Cohen Designs Inc., Toronto, Canada: Rendered with RenderWorks

Introducing VectorWorks

The Next Generation of MiniCAD

Charles Duncan, Pty. Ltd.



Roberto Candusso, Arquitetos Associados, Sao Paulo, Brazil

Increased Productivity with Object-Based Design

VectorWorks' state of the art Object Technology helps streamline the design process by making it easy to create common design elements. Now, Objects like doors, windows, nuts and bolts, can be created and edited with a click of the mouse, making it easy to explore design alternatives, consider "what if" scenarios, and handle last-minute client changes.

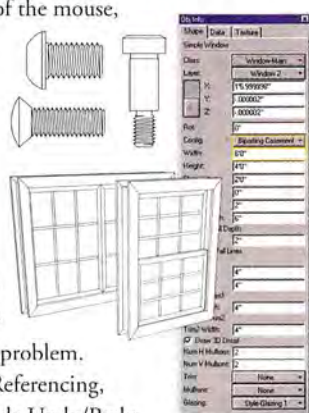

The Strength of a Proven CAD Technology

VectorWorks offers a solid foundation based on proven CAD technology—giving you the power and flexibility to tackle any design problem. New features such as Workgroup Referencing, DWG (v.14), Round Walls, Multiple Undo/Redo and an improved scripting language, strengthen VectorWorks' core CAD capabilities. And, with RenderWorks, VectorWorks' new photo-realistic rendering plug-in, you can bring your designs to life with textures, shadows and dramatic lighting.

The VectorWorks Advantage

With VectorWorks, you get it all—the flexibility and control of proven CAD technology and the productivity benefits of Object-Based design. VectorWorks ships FREE solutions for Architecture, Landscape Design, DTM and HVAC among others. Best of all, you aren't limited to the solutions we provide. VectorWorks is completely customizable, allowing you to create your own custom business solutions.

Special Offer to Readers of Macworld

Save \$279 by purchasing VectorWorks with photorealistic rendering direct for \$820 or, without rendering for only \$595. Includes FREE Tech Support and a 90-Day Money-Back Guarantee.



Diehl Graphsoft Inc

Software for Today's Professional

1-888-646-4223



Macworld[®]

SUBSCRIPTION SAVINGS

V O U C H E R

This voucher entitles you to save up to **74% off** the cover price when you subscribe to MACWORLD.

BONUS: the *Clip Art CD-ROM* — **FREE** with your paid order.

CHECK ONE:

- 2 YEARS (24 ISSUES) \$49.97 — SAVE 74%**
 1 YEAR (12 ISSUES) \$34.97 — SAVE 64%

Name _____ (Please Print) 4SNR8

Company _____

Address _____

City _____ State _____ Zip _____

E-Mail Check box if you would like to receive periodic e-mail offers from carefully screened providers of quality goods and services.

SAVINGS SUMMARY

ANNUAL COVER PRICE
\$95.88

YOUR SPECIAL RATE
\$34.97

SAVINGS OF:
\$60.91

BONUS
CLIP ART
CD-ROM

- Payment enclosed.
 Bill me later.

Annual newsstand price \$95.88. Non-U.S. orders add US\$20 postage; Canadian GST included.
Your FREE software will be shipped upon payment. This offer does not include monthly CD-ROMs.

Check us out on the Web —
<http://www.macworld.com>



NO POSTAGE
NECESSARY
IF MAILED
IN THE
UNITED STATES

BUSINESS REPLY MAIL

FIRST-CLASS MAIL PERMIT NO. 66 BOULDER, CO

POSTAGE WILL BE PAID BY ADDRESSEE

Macworld[®]

Subscription Department
PO Box 54506
Boulder, CO 80323-4506



The Vision Thing

by Andrew Gore

What's in a Name?

ONE OF THE BEST THINGS ABOUT THE POWER MAC G4: IT'S NOT NAMED THE POWER MAC G3

THE COEN BROTHERS' 1996 film *Fargo* was a big movie about small-minded people doing terrible things to each other. Besides its being a remarkable piece of cinema, one of the most amazing things about *Fargo* is that almost none of the film's action takes place anywhere near Fargo.

But at least *Fargo* is the only film made in the past 45 years with that name. Unfortunately, the names of Apple's latest product offerings don't have that kind of unique flavor.

A Mac Is a Mac Is a Mac

It seems that with its return to profitability Apple has lost the ability to come up with more than one name for a product line. This can become very confusing when, for example, you're trying to explain to a novice user how the iMac he or she bought a year ago is different from the iMac Apple was selling by Thanksgiving, and how that differs from the iMac the company shipped at the beginning of the year, when they're all named, simply, iMac. And when the next generation of the iMac appears, who wants to bet it won't just be called iMac as well?

Apple's stuck-in-a-rut naming practices aren't just limited to its consumer-oriented computers, though. There have been at least three very different PowerBook G3 models, all named PowerBook G3. The first was nothing more than a PowerBook 3400 with a G3 chip inside. The next was the PowerBook G3 series—the black ones with the white logo. And most recently, there's the "bronze" PowerBook G3, which looks a little thinner than the previous G3 series and has a translucent bronze keyboard but otherwise resembles its immediate predecessor.

Let's move to the desktop, where there have been two different Power Mac G3s, one beige and the other blue and

white, which even Apple executives refer to as the "Blue and White G3" to differentiate it from the old "Beige G3."

As happy as I am with the Power Mac G4 (see the feature "Fantastic Four," elsewhere in this issue), I'm almost ecstatic simply because it's not named Power Mac G3. Unfortunately, beneath the Power Mac G4 logo are two different kinds of technologies that, in past days, would've been treated as different computer models.

Imagine a software company or a manufacturer of add-on hardware trying to divine over the phone or in an e-mail message exactly what kind of Mac someone is using: "Are you using the Power-

selling upgrades. If you're primarily concerned with selling to new users, you stick with the names you've got.

If Apple had its way, it would be the Gap of computers. When you go into a store to buy a pair of jeans, do you concern yourself with the technology underlying that product? No—you like the look and, especially if you're buying Gap jeans, you like the image the company's brand projects. Wearing a Gap product says something about you as much as it keeps the cold out and the rain off or keeps you from getting arrested for public indecency.

That's what Apple wants the world to think about Mac products—that they're personal statements. And by keeping its naming focused on who the product is for rather than on the product itself, Apple keeps the decision of which Mac to buy as simple as possible.

Split Personality

But while the Gap-ification of Apple makes sense from a marketing standpoint, I still have to wonder if it isn't a bit too early to sell computers by using generic brand names, as clothes are sold. The last time I checked, jeans didn't take advantage of add-on cards designed specifically for particular models. And they didn't

need technical support, unless perhaps you're buying a pair of shrink-to-fit Levi's.

As this year's vast influx of new Mac users start looking to upgrade that old iMac to run G4-savvy applications (Think they won't? I've got two words for you: *voice recognition*.), do you think this homogenous naming is going to get them confused?

As the people of *Fargo* would say: Oh, yah. Yah, you betcha! **m**

Aw, geez. You can mail your questions and comments to Andy at visionthing@macworld.com.



Book G3, or the PowerBook G3 series, or the PowerBook G3 series with the bronze keyboard?"

iMac Khakis

So what exactly is Apple thinking? It can't be out to confuse customers, hoping that the resulting cloud of befuddlement might confuse people into buying several identical computers.

My guess is that Apple's trying to create a simple message for its prospective customers. You need to revise names only if you're concerned about



WITH ORDINARY
PRINTERS,
YOU SEE THE
FLOWERS
BLOOMING.

WITH OUR
PRINTERS,
YOU SEE
THE LADIES
DANCING.

YOU'VE GOT TO SEE IT IN **EPSON** COLOR.



Anyone can show you the flowers. But the textile company that created this catalogue cover wanted to show you more. Like the incredible fabrics worn by the 38 women you see here. Sheer enough to pass for petals. In a palette only nature could imagine. So what did they choose to capture all this color and detail? An Epson printer. The only one they could trust to separate the beauties from the blossoms. Which, when it comes to printers, is what separates the men from the boys.

THE ONLY PRINTERS WITH EVERYTHING YOU NEED FOR ALL THE DETAIL YOU WANT.

To capture the world's most brilliant images, only Epson® color ink jet printers have the PerfectPicture® Imaging System for: 1440 x 720 dpi • Micro Piezo™ technology, for a cleaner, smaller droplet – as small as 3 picoliters • Fast print speeds – up to 12 PPM black/10 PPM color • Quick-drying inks • PC/Mac/USB compatibility. And remember, only Epson supplies guarantee Epson quality. For more information, call 1-800-GO-EPSON or visit www.epson.com.



Epson Stylus Color Ink Jet Printers.
Sheer brilliance starting at \$129.*

* \$129 on the EPSON Stylus Color 660 after a \$30 mail-in rebate. Up to 12 PPM black / 10 PPM color with the EPSON Stylus Color 900. Price may vary. Epson, EPSON Stylus and Micro Piezo are trademarks/registered trademarks of Seiko Epson Corp. PerfectPicture is a registered trademark of Epson America, Inc. © 1999 Epson America, Inc.

There's only one utility in the world that does more for your Macintosh than TechTool Pro 2...

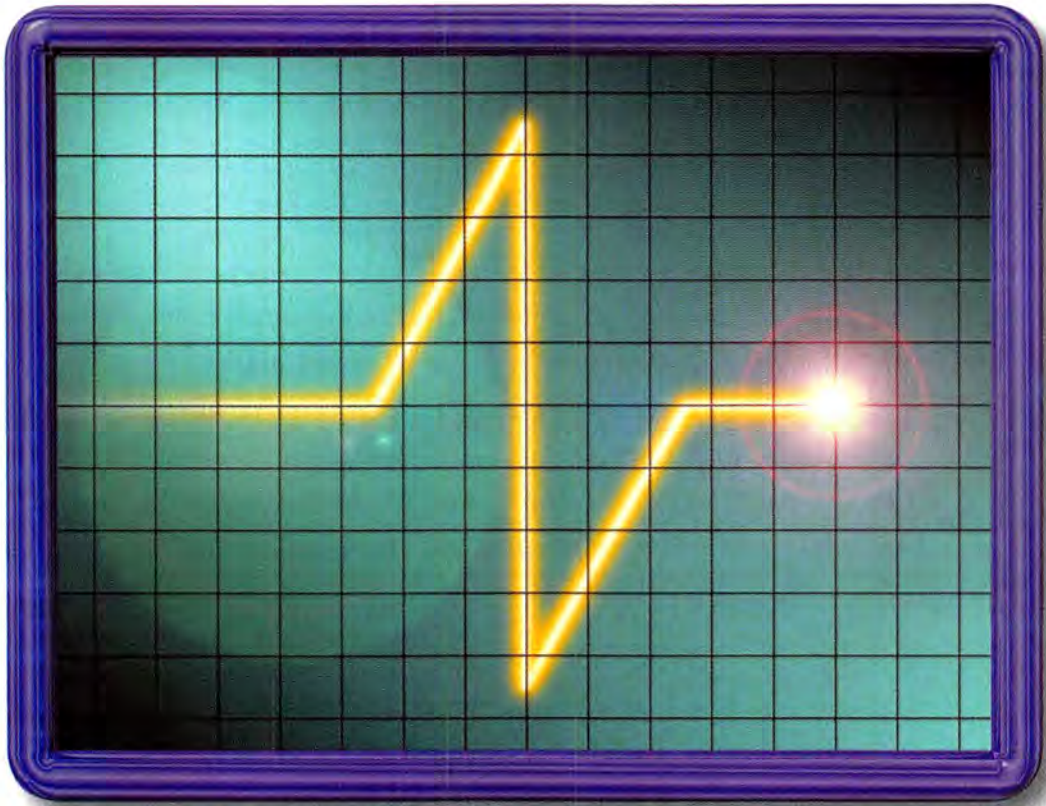

Introducing TechTool Pro 2.5

MicroMat's disk repair and Macintosh troubleshooting utility just became a whole lot better. Loaded with new features like Trash Cache™, which allows you to resurrect files you've accidentally deleted. Or our new Automated Diagnostic feature that checks your drives at the time intervals you specify, so you're always sure your drives are in top shape. TechTool Pro 2.5 even now supports new technologies like FireWire drives, USB floppy drives, System 8.6, all of the latest Macs and much more. But the real power of TechTool Pro 2.5 isn't in the features

you can see, it's in the features you can't see. Like a multitude of new drive repair routines that can save data that other utilities would simply abandon. An improved recovery system that will find lost files in the darkest caverns of a damaged drive. You'll also find improved performance on key features like disk optimization. But maybe the feature you'll find most interesting about this version is the price: FREE*. If you own any version of TechTool Pro 2, just go to our web site and grab the updater. You'll be glad you did.

MicroMat Inc.
800-829-6227
707-566-3831
FAX: 707-566-3871
info@micromat.com
www.micromat.com



Fix different.™



* Version 2.5 is available at no charge to registered TechTool Pro 2 users as an updater application directly from the MicroMat web site. If you do not wish to download the updater or would prefer a new CD, they can be purchased for \$25 plus tax, shipping and handling by calling the phone number above. Please have your serial number ready when calling. Prices subject to change without notice.
©1999 MicroMat Inc. All rights reserved. TechTool is a registered trademark of MicroMat Inc. Fix Different is a trademark of MicroMat Inc. Macintosh is a trademark of Apple Computer, Inc.

Choose 67 at www.macworld.com/getinfo

online

Mac Gains Ground in Web 3-D

NEW SOFTWARE RELEASES
SPELL THE END OF A
DROUGHT FOR THE MAC

by Stephen Beale

After years of false starts, the Web is ready to take off as a delivery vehicle for 3-D graphics, and this time it appears that Mac users won't be left behind. Several companies have unveiled Web-based 3-D technologies that support the Mac—at least for playback—and the long wait for a usable Mac Virtual Reality Modeling Language (VRML) browser seems to be over. Meanwhile, Sun Microsystems and the nonprofit Web3D Consortium are hard at work on the next generation of 3-D Web standards, respectively Java3D and X3D.

Zapped VRML Most of the recent Web 3-D action happened at Siggraph 99, the huge computer-graphics trade show held August 8 to 13 in Los Angeles. There, a little-known organization called Zap Technologies (www.zaptech.com) demonstrated a free VRML-HTML browser called Twirl. Zap, which describes itself as a pro bono software developer, is making the browser available on an



open-source basis, allowing other developers to add modifications. Previously, the only VRML browser for the Mac was a buggy version of Cosmo Player that worked with older versions of Netscape Navigator. VRML is the reigning standard for 3-D content on the Web.

Other VRML browsers for the Mac could be in the works. Blaxxun Interactive (415/437-6160, www.blaxxun.com), through the Web3D Consortium, is making its

VRML browser available under an open-source arrangement. As with Twirl, other developers are now free to create their own versions of the software.

Waiting in the wings is X3D, the successor to VRML. Essentially a hybrid of VRML and Extensible Markup Language, X3D will be backward-compatible with VRML, meaning you'll be able to view VRML content with X3D-enabled browsers. The Web3D Consortium,

which is responsible for developing the standard, expects that the first X3D applications will ship in the first half of next year.

Built in Java Sun expects to play a role with Java3D, an extension of the Java language that supports 3-D modeling and rendering. Currently, Java3D is available only for Windows and Unix systems, but Sun says a Mac version is in the works.

The Java developer sees *continues*



Wacom Targets Consumers with Graphire Tablet

MANY VENDORS OFFER ALTERNATIVES TO THE MICE IN Apple's iMac and blue G3 systems. But the folks at Wacom Technology (800/922-6613, www.wacom.com) have a new variation on the concept: a \$100 USB graphics tablet that includes a cordless, pressure-sensitive pen along with a cordless mouse with a scrolling finger wheel. The Graphire system, scheduled to ship in October, includes an 8-by-8-inch tablet with a 4-by-5-inch active area. The tablet is not compatible with Wacom's Intuos system and lacks such Intuos features as Tool ID and dual tracking.—MACWORLD STAFF

Java3D as a complement to X3D. Java3D applications will be able to read and write X3D files, and Sun says Java3D will offer interactive functions not available in X3D.

Some companies are using current versions of Java to generate 3-D content for the Web. For example, Shout Interactive (415/641-1121, www.shoutinteractive.com) has developed a Java-based 3-D renderer that runs on any Java-capable computer. Blaxxun's Blaxxun3D is a Java applet that supports some features in VRML. The advantage is that you can view 3-D content on any Java-capable computer without downloading a plug-in.

Plug-in Power Other companies are pushing proprietary 3-D technologies that require a plug-in download. The best known is

MetaCreations (805/566-6200, www.metacreations.com), which has finally released the long-awaited Mac version of its MetaStream browser plug-in; the PC version has been available for more than a year. You can create MetaStream content by using a Save As option in Bryce 4, Poser 4, and other MetaCreations programs.

The Swedish company Cycore Computers (www.cycore.com) offers Mac playback software for its Cult3D Web technology, but you'll need Windows software to generate the content. Hypercosm (608/821-0500, www.hypercosm.com) has introduced a 3-D-graphics-programming language called OMAR (Object-oriented Modeling and Rendering), along with Hypercosm Studio, an appli-

cation-development environment. Mac users can view Hypercosm content using the Hypercosm3D Player. The authoring software currently works only with Windows, but the company says that it plans to release a Mac version next year.

Hypercosm claims that its technology has an advantage over MetaStream and Cult3D, because the language allows you to define the function of objects as well as their geometry. For example, you can create a 3-D clock that works as a real timepiece. The content is very compact: at Siggraph 99, Hypercosm demonstrated an online air-hockey game that consumes about 14K of file space.

Another company, Web developer Pulse Entertainment (415/348-4000, www.pulse3d.com), has created a Web 3-D technology for its own projects, which include a digital version of comedian Jay Leno created for NBC's Web site. Pulse offers a 200K browser plug-in for the Macintosh and Windows.

multimedia

3-D Hardware Ready for Mac Market?

MAC RESURGENCE AND OPENGL SPUR INTEREST

by Stephen Beale

The recent Siggraph computer-graphics conference in Los Angeles could have been a frustrating experience for Mac users. The show, which covers such high-end graphics technologies as 3-D animation and virtual reality, is heavy on

Windows NT and Unix applications. Wandering the aisles, you'd see hardware that could have walked out of a science-fiction movie—3-D scanners, solid-object printers, motion-capture rigs—only to find that none of it worked on a Mac.

However, given Apple's resurgence, the company's adoption of the OpenGL 3-D graphics standard, and the prospect for wicked-fast Mac systems running AltiVec-based PowerPC chips, some developers of high-end 3-D hardware are taking another look at the Mac.

Niche Product These are far from being mass-market products. A midrange 3-D scanner—for scanning models directly into 3-D modeling or rendering programs—will set you back \$50,000 or more, as will a solid-object printer, which produces physical models from 3-D computer data. In some cases, the system price includes a dedicated Windows NT workstation.

Motion-capture systems, for controlling animated 3-D characters in real time, are even more esoteric. Most such systems feature a suit embedded with position sensors. When you wear the suit, any movements you make are automatically applied to the 3-D character. Some companies offer facial-tracking systems that similarly allow an actor to control the speech and facial expressions of an animated figure.

OpenGL Benefits Apple's embrace of OpenGL, a standard set of 3-D-graphics routines, will make it easier for developers to offer Mac versions of their hardware, because most are already using OpenGL-based driver software in their Windows NT or Unix products. The forthcoming G4 processor, with its AltiVec extensions,

will offer unprecedented 2-D and 3-D graphics performance. And with Apple's resurgence, hardware developers are more confident in the long-term prospects for the Mac market.

Two developers of 3-D scanners, Digibotics and Cyberware, say they are considering Mac versions. Digibotics' Digibot II is a \$50,000 scanner that currently works only with Windows NT. Cyberware offers a range of 3-D scanners, from tabletop models to a six-figure system designed to scan people's bodies.

Cyberware also offers a scanner, popular in film and broadcast production, for scanning heads. Combine it with a solid-object printer, and you have a workable, if expensive, system for producing portrait sculptures.



These may be costly and specialized products, but they occupy a niche—high-end graphics production—that's important to Apple. And as we've seen time and again in the computer business, those high-end, \$50,000 products have a habit of migrating to the desktop. After all, it wasn't long ago that you had to shell out \$50,000 for a high-quality color printer. Four or five years from now, 3-D scanners, printers, and other exotic hardware products could well become common sights in some Mac studios.

systems

Vimage Drops Mac Upgrade Business

SEEKS OTHER COMPANIES TO OFFER ITS PRODUCTS

by Macworld Staff

Vimage, a Japanese manufacturer that had been active in the Mac upgrade business, announced in August that it would no longer offer products to users or resellers, effectively ending the company's role as a Mac vendor. However, in a message on the company's Web site, Vimage said it was seeking potential partners to offer its products under their own labels.

The company offered a line of G3 CPU upgrades under the Vpower brand. It's a competitive market with little room for product differentiation be-

cause all the vendors get their primary components—the G3 chips—from the same sources (see "G3 Upgrade Cards," *Reviews*, in this issue). Vimage, a relative newcomer to the Mac market, was competing with well-known vendors such as Newer Technology, Sonnet Technologies, PowerLogix, and XLR8.

Other upgrade vendors have also undergone changes. Newer Technology, reportedly beset by financial problems, announced in August that it has hired three executives to implement new production, finance, and organi-

zational strategies. They include APS Technologies veteran John Nelson, who will take on responsibilities previously handled by former chief operating officer Steve Worrell and former operations director Lanny Buntner, both of whom left the company.

In a statement, Newer Technology said it hopes to "accelerate product shipments, shorten product development cycles, and improve time to market." Along with CPU upgrades, Newer Technology also sells memory, USB peripherals, and a FireWire PC Card for Apple PowerBooks.

Interex, the parent company of XLR8, has hired much of the former management team of DayStar Digital to handle its Mac upgrade business. Interex purchased the XLR8 brand name in 1996. DayStar closed its doors in 1998 after Apple pulled the plug on Mac OS licensing.

printing

HP Throws the Ink-Jet Gauntlet

DESKJET 970C SQUARES OFF WITH EPSON MODEL

by Macworld Staff

Epson America (800/463-7766, www.epson.com), which until now has dominated the Macintosh ink-jet printer market, is about to get its stiffest competition in years. Hewlett-Packard (800/552-8500, www.hp.com) has announced a new ink-jet printer, the \$399 DeskJet 970C, that appears to offer a breakthrough in speed and

continues

Free for All You can't beat the price: Linker Systems (877/489-3525, www.linker.com) has announced that it will offer a free, fully functioning version of **Animation Stand**, its \$5,000 2-D animation software, for the Mac. **Animation Stand Personal Edition** is limited to a maximum resolution of 256 by 192 pixels, but otherwise provides all the features of its high-end sibling. Linker also offers a \$495 version for multimedia production. The company also announced that Animation Stand 4.1, expected to ship later this year, will include features that take advantage of advanced graphics capabilities in Motorola's G4/Altivec chip.

Catching a Lightwave Time for an overhaul: **Lightwave 3D 6.0**, from Newtek (800/862-7837, www.newtek.com), features a completely reworked software architecture, along with new character-animation and rendering capabilities. The high-end 3-D-modeling, -rendering, and -animation software—available for Mac, Windows, and Unix—sells for \$1,995.

Photo Gallery Two-megapixel cameras keep rolling in. The \$899 **Samurai 2100DG**, from Yashica (800/526-0266, www.yashica.com), features a maximum resolution of 1,632 by 1,232 pixels and 4x optical zoom. The \$899 **QV-2000UX**, from Casio (973/361-5400, www.casio.com), and the \$799 **PhotoPC 850Z**, from Epson (800/463-7766, www.epson.com)

continues

.epson.com), both feature 3x optical zoom and a maximum resolution of 1,600 by 1,200 pixels. Epson also released a pair of USB flatbed scanners, the \$149 **Perfection 610** and the \$249 **Perfection 1200U**. The 610 features 600-by-2,400-dpi hardware resolution; the 1200U increases the resolution to 1,200 by 2,400 dpi. Epson offers a SCSI version of the 1200U for \$299.

Painter by Numbers Meta-Creations (800/846-0111, www.metacreations.com) has taken the wraps off **Painter 6**, an upgrade of the popular natural-media painting software that features new brush controls, 3-D painting features, and a text-on-a-curve function.

A Kazoo for Adobe? Adobe Systems (800/833-6687, www.adobe.com) has licensed **Kazoo** 3-D rendering technology from LightWork Design (www.kazoo3d.com). Kazoo, which LightWork sells to other software developers, allows users to manipulate and paint 3-D models in real time. Adobe says that it will use the software in future consumer products.

Video to Go Now you can capture—and export—video with your PowerBook. The iRez **CapSurePro**, from Par Technologies (602/922-0044, www.irez.com), is a \$399 Type II PCMCIA Card that connects to camcorders, VCRs, and other video sources. It requires a PowerBook 3400 or later.—EDITED BY MICHAEL GOWAN

image quality. But Epson has its own response, with the \$429 Stylus Color 900G, an iMac-inspired version of the Stylus Color 900.

HP's Challenge The DeskJet 970C prints at 600 dpi, but HP's color-layering technology increases the apparent resolution to 2,400 by 1,200 dpi for printing images on photo paper. Although it's only a four-color printer, the HP's photo-output samples are impressive; the images appear to rival the best photo output of Epson's six-color ink-jet models.

The DeskJet 970C is also fast—HP claims maximum color output of 10 pages per minute in draft mode. In its highest-quality mode, HP says, the DeskJet 970C can produce a full-page color photo in about three minutes. Although it does not feature an iMac-inspired industrial design, it does break from the standard beige designs of HP's earlier ink-jet printers. Other features include a print-cancel button, a low-ink indicator, and automatic two-sided printing—the latter a first for low-cost ink-jet printers.

The DeskJet 970C has a USB port for connection to iMacs or blue-and-white G3 systems, but no serial port for older Macs. Hewlett-Packard expects to ship the printer by the time you read this.

Epson Responds Epson's Stylus Color 900G—a blueberry version of the previously announced Stylus Color 900 (see *Reviews*, June 1999)—offers the same maximum 10-ppm print speed as the DeskJet 970C.

Judging from Epson's samples, photo output from

the four-color printer looks just as impressive as the HP DeskJet 970C's output. USB and serial interfaces are built in; Epson also offers Ethernet, LocalTalk, and PostScript 3 options. The printer is expected to ship by the time you read this.



HP's DeskJet 970C features automatic two-sided printing.

input devices

Touch Screen Enhances iMac Kiosks

ELO TOUCHSYSTEMS
OFFERS MODIFIED iMACS
by Macworld Staff

Apple's iMac, in addition to being a popular consumer computer, is also ideally suited to be an information kiosk. The iMac's look makes for an attractive kiosk display, the all-in-one design simplifies maintenance, and the Mac's legendary ease of use reduces navigation hassles for novice users. But what about that keyboard and mouse?

The most usable kiosks don't make you peck at a keyboard; instead, you make your selections by touching items on the computer screen. Three companies—Elo TouchSystems (800/356-

8682, www.elotouch.com), MicroTouch (800/642-7686, www.microtouch.com), and Troll Touch (661/257-1160, www.trolltouch.com)—offer touch-screen systems for the iMac. In most cases, you buy the iMacs from the vendors with the touch-screen technology preinstalled.

The iMac touch screens use one of two technologies: capacitive or resistive. A capacitive touch screen distributes low-voltage current over the display area; when you touch the screen, your finger draws current and the controller detects the position. A resistive system detects finger pressure to determine coordinates.

Elo has developed a capacitive technology called iTouch that lets you make selections by touching the monitor glass directly. The modified iMacs carry the full Apple warranty. However, like other iMac touch-screen products, the system uses one of the two USB ports, leaving you with a single connection. Elo also offers touch-screen CRTs and LCDs for Power Mac G3 systems.

MicroTouch's TouchStation also uses capacitive technology, but with a thin overlay. The company has been demonstrating its systems with Kiosk Communicator, a \$495 authoring tool from First Wave (888/221-5498, www.first-wave.com). An iMac with TouchStation costs \$2,085 and carries Apple's standard warranty.

Troll Touch's TouchStar uses resistive technology. The system is available in a \$795 internal version, which the manufacturer installs, or external \$565 and \$595 versions, which you can install yourself. Troll Touch also sells iMacs with the touch screen preinstalled for \$1,995, and offers a \$495 touch screen for Apple's new iBook.



More connected.

Julie Ellis
Private Detective



Camera shops with night-vision lenses; Dim Sum restaurants that deliver.



Drive Ethan to daycare, 8:30 am; sweep Mullins office for listening devices, 11:30 am.



Notes on Davis disappearance; directions to meeting w/informant.



Download photos of Kendall surveillance; clean goop off Ethan's high chair.



Synchronize and back up my Palm V™ organizer with my Mac.
With just one touch.

Simply Palm™



www.palm.com

Palm Computing, Inc., developer of the world's leading handheld platform.

PalmConnect kit required for Macintosh connectivity, sold separately. ©1999 3Com Corporation. All rights reserved. 3Com, the 3Com logo, and Palm Computing, and PalmConnect are registered trademarks and Palm, Palm V, the Palm Computing Platform logo, Simply Palm and More connected, are trademarks of Palm Computing, Inc. or 3Com Corporation.



It's late.

The shop is quiet.

Except for the whimpering



of the art directors.

The writers have long since left to sniff merlots. The suits are with their families watching television. You're watching a computer ruin your last six hours of work. Incompatible fonts and formats. Color management quirks. Printing problems. Even the caffeine's not working for you anymore. End the nightmare. Focus your creativity on the work, not on ways to make your computer work. Leverage your talents with Adobe's professional graphics software. Photoshop.[®] InDesign.[™] Illustrator.[®] Acrobat.[®] PressReady.[™] They work together seamlessly to take ideas from screen to paper to the Web and back. There's a reason our software defines the industry. There's a reason you got into this business.

Jog your memory. Then give Adobe a call at 1-800-833-6687, ext. 59600 or visit our site on the Web at www.adobe.com/propub99. Do it before it gets much later.



Adobe



Can't print or copy at 12.5 ppm color; 50 ppm b&w.

Can't deliver 600x600 dpi x 8 bit image quality.

Can't handle stock up to 140 lbs. Index.

Can't provide innovative IBT technology.

Can't offer Apple Macintosh-based controller.



Canon Color Laser Copier 1150

XEROX, The Document Company, the digital X, Keep the conversation going, Share the knowledge, and DocuColor are trademarks of or licensed to XEROX CORPORATION. This model may contain some recycled components that are reconditioned. Canon is a trademark of Canon Inc. Apple and Macintosh are trademarks of Apple Computer, Inc. Microsoft and Windows NT are trademarks of Microsoft Corporation.



Can print or copy at 12.5 ppm color; 50 ppm b&w for quicker turnaround.

Can deliver 600x600 dpi x 8 bit image quality.

Can handle stock up to 140 lbs. Index.

Can provide innovative IBT technology.

Can offer choice of either Apple Macintosh
or Microsoft Windows NT-based controllers.

Can easily see a demo by calling

1-800-ASK-XEROX, ext. 460



Xerox DocuColor 12



www.xerox.com
Keep the conversation going.
Share the knowledge.

DIGITAL
THE DOCUMENT COMPANY

XEROX

Reviews

Graphics Accelerators

RAGE ORION AND

PROFORMANCE 3 PROVIDE

BEST 2-D, 3-D ACCELERATION

WHETHER YOU'RE VIEWING A QuickTime movie, zooming in on a big Adobe Photoshop image, or playing the latest shoot-'em-up adventure game, it takes lots of horsepower to push all those pixels across your display. Apple's blue-and-white Power Mac G3 systems, driven by ATI Technology's Rage 128 graphics-acceleration chips, provide excellent graphics performance, but what if you have an older Mac system?

Macworld Lab tested three shipping graphics-accelerator cards designed for use with any PCI-equipped Power Mac: ATI Technology's Rage Orion, Formac Electronic's ProFormance 3, and IXMicro's ix3D Game Rocket. We also looked at a potential competitor in the graphics-accelerator arena: 3dfx's Voodoo3 2000 PCI card, using an unsupported beta version of its Mac driver. In the end, both the Formac and ATI cards are great choices for boosting graphics acceleration in beige G3s. But if you're looking to get more performance out of your blue-and-white G3, the cost doesn't justify the minor performance boost.

The Contenders

All of the tested cards use new-generation processors designed to boost the speed and display quality of 2-D and 3-D

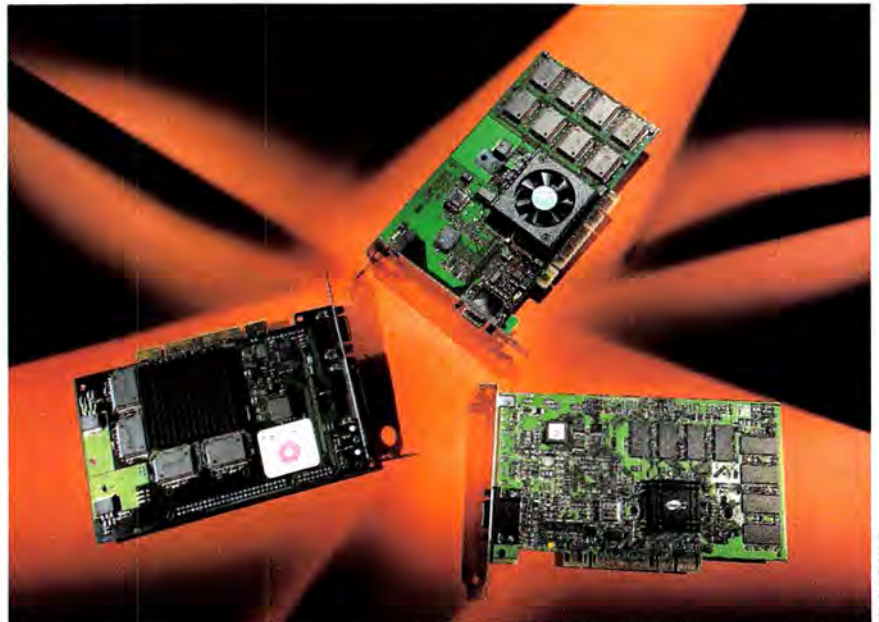

ARNOLD TOSEDO

graphics. The \$199 ATI Rage Orion features the same Rage 128 chip that drives the graphics accelerator in blue-and-white G3 systems. Sporting 16MB of nonupgradable video memory, it's designed primarily for gamers, but it will also accelerate systemwide graphics display. Formac's ProFormance 3, targeted at design professionals, uses the Permedia3 graphics processor from 3Dlabs. We tested the \$259, 16MB version; Formac also offers a \$189, 8MB model.

Two cards are powered by 3dfx technology: IXMicro's \$249 ix3D Game Rocket uses the Banshee chip set, and the 3dfx card has the newer, Voodoo3 design.

We tested both with 16MB of video RAM. The chip developer, whose Voodoo processors have become the standard for game acceleration in the PC market, is working with Mactell on a Voodoo3 card, due out this fall. The card we tested used an unsupported beta driver; we tested it only as a preview of what's to come.

Making a Difference

Using our test beds—a 300MHz beige Power Mac G3 and a 400MHz blue-and-white Power Mac G3 (the latter is not shown in the benchmark, "Boosting Beige G3 Graphics")—we timed common 2-D and 3-D graphics tasks, and a jury evalu-

REAL PRODUCTS
REAL RATINGS

Reviews you can trust: Macworld rates only final shipping products, not prototypes. What we review is what you can actually buy.

OUTSTANDING: ★★★★★

VERY GOOD: ★★★★

GOOD: ★★★

FLAWED: ★★

UNACCEPTABLE: ★

ated the quality of QuickTime movies played on the systems. For our 2-D tests, we used large QuarkXPress and Photoshop documents. We also timed video frame rates in Puffin Designs' Commotion. In the 3-D tests, we timed frame rates in Activision's Quake II; MacSoft's Unreal; and LightWork Design's Walker, a real-time 3-D-rendering application.

If you have an older Power Mac system, all of these cards will give you a significant boost in graphics performance—depending on which applications you use. We saw marked improvement when running Photoshop on our 300MHz system with each of the four cards, but hardly any with QuarkXPress. The ProFormance 3's Photoshop acceleration was especially impressive.

All three shipping cards offer built-in QuickTime acceleration. Here, the Rage Orion is the hands-down winner; our jury rated its QuickTime movie quality as excellent and that of the Game Rocket and ProFormance 3 as only fair. The 3dfx card did a poor job of displaying QuickTime movies.

After we ran our 3-D tests, the benefits of the graphics accelerators were much clearer. As you can see in the benchmark, all four cards substantially boosted performance for Unreal. With Quake, the Rage Orion (in RAVE mode) and Game Rocket (in Glide mode) turned in excellent scores. But only the 3dfx Voodoo3 card passed the 30-frames-per-second plateau—the holy grail for gamers. On the other hand, the ProFormance 3—the performance leader in some of our other tests—barely kept up with the system's built-in graphics adapter because it lacks an OpenGL driver (coming this fall, according to Formac).

Although upgrading the graphics card in older systems is an easy choice, for most users of blue-and-white G3 systems, it doesn't make much sense. The ProFormance 3 outpaced the Power Mac



Boosting Beige G3 Graphics

Best results in red. Reference product in italics.

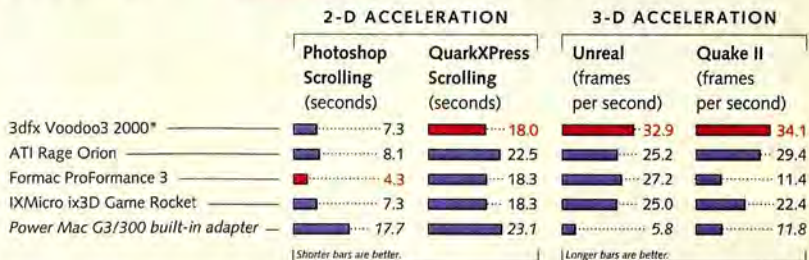

* Unsupported accelerator with beta driver, included for comparison only.

Behind Our Tests

We tested the graphics accelerators in a first-generation Power Macintosh G3/300 running Mac OS 8.6 with 256MB of RAM and virtual memory turned off. For detailed information on our tests, see the review online at www.macworld.com/1999/11/reviews/.—Macworld Lab testing supervised by Kevin Mitchell

G3's built-in Rage 128 chip for Unreal play and Photoshop document scrolling, but there wasn't enough difference to justify the \$259 outlay.

Software Support

The Rage Orion and ProFormance 3 support RAVE, the hardware acceleration component of Apple's QuickDraw 3D software. Any game or 3-D authoring application that supports RAVE acceleration should see some speed increase when these cards are installed in a system. IXMicro promises RAVE support for the Game Rocket in the near future. The Game Rocket and 3dfx cards support Glide, a 3-D gaming API developed by 3dfx. A handful of popular games, most notably Bungie Software's Myth, are limited to Glide support; you'll need a Voodoo-based graphics card for the fastest and best-looking 3-D action.

A third standard, OpenGL, represents the future of 3-D graphics on the Mac. Only a few Mac applications support OpenGL at present, but Apple's

decision to embrace the standard means OpenGL compatibility will soon be a common software feature. The Rage Orion and Voodoo3 cards currently offer built-in OpenGL support; Formac and IXMicro both promise OpenGL support in the near future.

Macworld's Buying Advice

The Rage Orion and ProFormance 3 both earned high scores in our performance tests. The Rage Orion was a more balanced performer, scoring reasonably well in all of our tests; it also provided the best QuickTime display quality. The ProFormance 3 outpaced the other cards in a few tests, but in our Quake benchmark it barely kept up with the reference system. Gamers may want to wait for the upcoming Mactell Voodoo3 card and its promised excellent frame rates. For general use in older Power Macs, the Rage Orion offers the best combination of price and performance, while the ProFormance 3 gives Photoshop users a boost.—STEPHEN BEALE

Graphics Accelerators Compared

Company	Product	Mouse Rating	List Price	Contact	Pros	Cons
ATI Technology	Rage Orion	★★★★	\$199	905/882-2600 www.atitech.com	Excellent price/performance; good software bundle; excellent QuickTime quality; supports OpenGL.	Average 2-D acceleration.
Formac Electronic	ProFormance 3	★★★★	\$259	925/251-0100 www.formac.com	Generally excellent performance; option for digital LCD and 3-D goggles.	Poor Quake acceleration; no OpenGL support.
IXMicro	ix3D Game Rocket	★★★	\$249	888/467-8282 www.ixmicro.com	Decent performance; supports Glide.	QuickTime artifacts; no RAVE or OpenGL support.

G3 Upgrade Cards

L2 CACHE CARDS BOOST PERFORMANCE SPEED

CALL THEM “UPGRADE-CHALLENGED” Macs: consumer-oriented Power Mac systems, circa 1996 and 1997, that were never intended for CPU upgrades. The most popular systems, based on PowerPC 603e CPUs, were Apple’s Performa 6400, Power Mac 6500, and Twentieth-Anniversary Macintosh, but the list also includes Macintosh clones from Motorola and Power Computing. With a fat CPU soldered in place, there doesn’t seem to be much of a way to add a G3 chip to these machines.

But wait—those clever upgrade folks have figured out an ingenious way to get near-G3 performance from old 603e Power Macs. Sonnet Technologies, Newer Technology, and PowerLogix have released G3 upgrade cards that fit in the Macs’ L2 cache slot. Remove the L2 cache card and pop in one of these upgrades, and you’ll soon be racing along at 300MHz or more.

Cruising Along

Macworld Lab tested five G3 cards that fit into the L2 cache slot: three Crescendo G3/L2 models from Sonnet and two Maxpowr G3 L2 models from Newer. One Sonnet card features a 400MHz G3 CPU; the others have 300MHz CPUs with a range of cache speeds and sizes. The Newer cards are both 300MHz, but one, the Maxpowr G3 L2 300/1MB, was a hand-built preproduction model; we included it in our tests as a preview, but we didn’t rate it because it wasn’t shipping at press time. The PowerLogix cards didn’t arrive in time for testing.

It was impossible to test the cards in every supported model, so we chose a Performa 6400 with a 180MHz 603e CPU. Other supported Macs include the Power Macintosh 4400, 5400, 5500, 6400, and 6500; the Performa 54XX and 6360; the Twentieth-Anniversary Macintosh; Power Computing’s PowerBase desktop; and Motorola’s StarMax 3000 and 4000.

We found that the cards do indeed deliver speeds approaching that of a 300MHz G3 system, especially when performing such CPU-intensive tasks as 3-D rendering. The speed boost is appar-

ent not only from our benchmark testing; the Performa also *feels* peppier with the upgrade cards installed. But as with any CPU upgrades, be prepared for some gotchas, especially considering the upgrade-challenged nature of these Macs.

Cache Back

How do you achieve G3 performance in an old 603e system? The L2 cache in those systems normally serves as a form of high-speed memory, feeding frequently

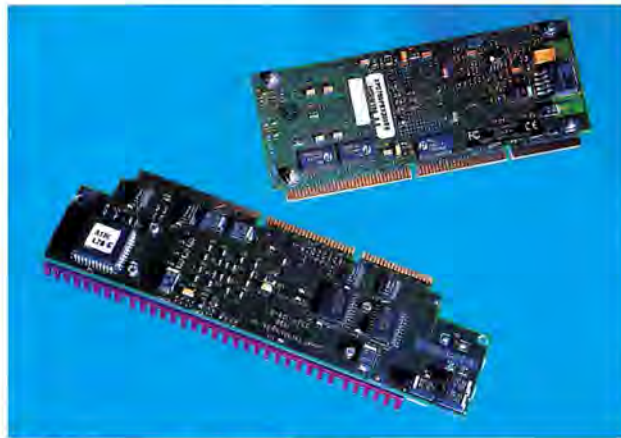

The Newer Maxpowr G3 L2 (top) and the Sonnet Crescendo G3/L2 (bottom).

used data into the 603e CPU. The G3 upgrades replace this memory with a fully functioning PowerPC G3 CPU running at 300MHz to 400MHz. In addition to the card, you install a system extension that directs all traffic from the main CPU to the L2 cache slot. Because the G3 processor includes its own backside cache, you won’t miss the L2 cache card.

There is a limit to the performance you can get from an older Mac system, however, and these cards push right up against it. Much of the problem lies in the system bus: most of the upgrade-challenged Macs, including the Performa 6400, have a 40MHz bus. By comparison, Apple’s iMac and PowerBooks have 66MHz buses, and the latest blue-and-white G3s’ buses zip along at 100MHz.

But you don’t just miss out on the latest bus speeds—the CPU speed of these upgrades is limited to eight times the system-bus speed. With a 40MHz system bus, your CPU maxes out at 320MHz. Obvi-

ously, it doesn’t make much sense to get a 400MHz G3 upgrade. As we found in our testing, the 400MHz card delivered only marginally better performance than the 300MHz upgrades, and it sells for a premium. However, if you have one of the supported Mac models with a 50MHz bus—they include the Twentieth-Anniversary Macintosh and Power Mac 5500 and 6500—you’ll see performance closer to what you’d expect from a 400MHz CPU.

A Tight Fit

Installing these upgrades is theoretically as easy as adding an L2 cache card. However, the cache slot was never meant to host a CPU, and the cards are much bulkier, in every dimension, than the cache cards they replace. The result, at least in the Performa 6400, is a tight fit.

Curiously, the Sonnet and Newer cards place the CPU on opposite sides. When you install the Sonnet upgrades, the heat sink fits snugly against the nearest RAM card; with the Newer upgrades, the heat sink almost brushes against the nearest of two PCI cards (if a card is installed). The Sonnet card is bigger but seems to fit better. However, both companies’ cards installed with minimal fuss considering the tight quarters.

Software installation is a breeze. With each card, you just copy an extension to the System Folder and you’re ready to go. Both Sonnet and Newer include software utilities that let you gauge your system’s performance, and Sonnet’s Metronome utility displays the CPU temperature—a concern given the tight fit. However, none of the cards—including two that we ran for days without shutting down—appeared to cause heat-related problems.

Render Me This

We tested the cards by running MacBench 5.0 and MetaCreations’ Bryce 4 in Mac OS 8.6. All five cards showed hefty speed increases over an unaccelerated Performa 6400, but the difference was especially noticeable in Bryce 4: the upgraded system took 40 to 49 minutes to ray-trace a 640-by-480-

SUZANNE ROADY

pixel scene, whereas the native 180MHz 603e CPU took nearly 3 hours.

The MacBench numbers were impressive but not quite as dramatic; even the slowest cards clocked Processor and Graphics scores close to those of a 300MHz beige Power Mac (see "Cards Meet Upgrade Challenge"). As you might expect, the upgrades provided only a modest boost to the MacBench Disk scores.

Even with a maximum speed of 320MHz, Sonnet's 400MHz upgrade (which features a 1MB backside cache) received the highest Processor score. However, unless you have a Power Mac with a 50MHz bus—allowing you to take full advantage of the CPU speed—it's hard to justify the \$600 price tag. (Newer's 400MHz upgrade, which we did not test, costs \$779.)

The other cards, all with 300MHz CPUs, showed little variation in performance. The primary difference is backside-cache size; Sonnet's 1MB cache version actually bested the 400MHz card in our rendering test, although Newer's card, a preproduction model with a 200MHz 1MB cache, was 4 to 5 minutes slower.

Not surprisingly, the cards showed the greatest variation in MacBench Processor scores, a measure of pure CPU speed. Here, the 400MHz card slightly outpaced the 300MHz G3 reference system and ran more than 30 percent faster than the 300MHz cards with 512K caches. However, all of the cards received similar Graphics scores.

None of the cards appeared to cause any unusual software conflicts or system crashes, but there's no guarantee that the cards will work perfectly with every Mac configuration. And it's unclear if these or any G3 upgrades will support Mac OS X.



Cards Meet Upgrade Challenge

Best results in red. Reference system in italics. MacBench 5.0 scores are relative to those of a first-generation Power Mac G3/300, which is assigned a score of 1,000 for each test. Rendering times are in minutes:seconds.

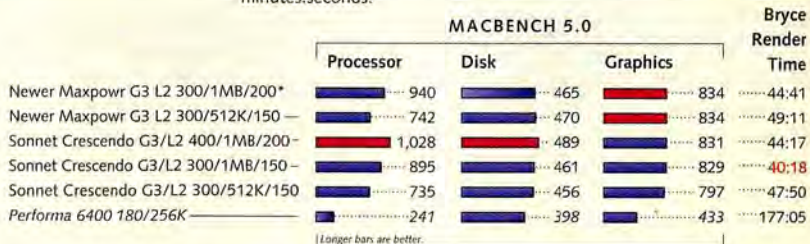

* Preproduction model, included for comparison only.

Behind Our Tests

We tested all cards in a Macintosh Performa 6400 with a 180MHz 603e CPU. For detailed information on our tests, see the review at www.macworld.com/1999/11/reviews/.—Macworld Lab testing supervised by Stephen Beale

Other Considerations

Because upgrade vendors have to struggle to differentiate their products, Newer offers a handy antistatic wrist strap for card installation and a two-year warranty. Sonnet offers a better manual and a three-year warranty. Sonnet also dropped its prices in August, giving its cards a definite price advantage. However, there's a common pattern in the upgrade business: when one company reduces its prices, the others inevitably follow.

Macworld's Buying Advice

Add one of these cards, and you'll be convinced that your old consumer Mac has been taking steroids. The performance boost is especially dramatic with rendering or other CPU-intensive operations. Sonnet's 400MHz card generally offers the best performance, but it makes sense only if your Mac has a 50MHz system

bus. Of the remaining cards, Sonnet's \$299 Crescendo G3/L2, with its 512K, 150MHz cache, gives the best combination of price and performance. However, if you plan to do a lot of rendering, the 1MB cache version may be worth the extra \$100 outlay. The Newer cards offer comparable performance, but their prices are much higher than the Sonnet cards'.

Of course, the eternal question remains: Should I upgrade or should I buy a new system? Our standard upgrade advice applies here: If you have a big investment in memory and peripherals for your current system and can live with the inevitable performance bottlenecks, then an upgrade makes sense. But if you don't have a huge investment, and you're ready to step up to the next generation of Mac computing, then you're probably better off with a new iMac or Power Mac system.—STEPHEN BEALE

G3 Upgrade Cards Compared

Company	Product	Mouse Rating	Company's Estimated Price	Contact	Pros	Cons
Newer Technology	Maxpower G3 L2 300/512K/150	★★★	\$449	316/943-0222 www.newertech.com	Decent performance.	Expensive; tight fit.
Sonnet Technologies	Crescendo G3/L2 400/1MB/200	★★★	\$599	800/786-6260 www.sonnettech.com	Best performance.	Requires 50MHz bus for maximum performance; tight fit.
	Crescendo G3/L2 300/1MB/150	★★★★	\$399	800/786-6260 www.sonnettech.com	Good performance; decent price.	Tight fit.
	Crescendo G3/L2 300/512K/150	★★★★	\$299	800/786-6260 www.sonnettech.com	Decent performance; good price.	Tight fit.

Photoshop 5.5

IMAGE EDITOR FOCUSES ON THE WEB

EVER AGONIZED OVER WHETHER to buy a new version of Adobe Photoshop? Then get ready for one of the easiest decisions you've made in years. If you're a Web designer, you'll want to purchase the new version as soon as possible; if not, don't bother. It really is that simple.

What makes this decision a real no-brainer is that Photoshop's new features—including dramatically improved GIF and JPEG optimization—focus narrowly on the Web. Furthermore, the package



Pick a Picture Photoshop 5.5's Save For Web command lets you index, compress, and save a Web graphic in one operation.

includes ImageReady 2.0, a \$199 Web-graphics editor that automates image slicing, JavaScript rollovers, and animation. The problem is that many of ImageReady's features overlap Photoshop's but are implemented differently enough to cause confusion.

Extraction Made Easy

When it comes to masking, Photoshop has long provided only the bare essentials. Version 5.5 simultaneously addresses this oversight and ignores it: although three new tools make short work of separating complex subjects from their backgrounds, not one of them is capable of generating a mask. You can quickly isolate hair, leaves, and other intricate details, but Photoshop erases pixels instead of masking them, dramatically limiting your options for finessing the results.

The extraction tools vary wildly in util-

ity. The first, optimistically dubbed the magic eraser, is the least useful of the three, erasing clumps of similarly colored pixels each time you click. Not only is it crude, but it's also redundant—you can accomplish the same feat by clicking with the magic wand and pressing delete. The prosaically named background eraser is actually more magical: as you trace an image, the tool samples and extracts the background color. The final option, the Extract command, calculates and eliminates the background automatically, based on a rough outline. Unfortunately, the controls in the Extract dialog box are far from intuitive. And because there's no undo function, you'll spend some time erasing your mistakes.

For my money, the background eraser does the best job of balancing ease of use, real-time feedback, and at least halfway-predictable results. But bear in mind that all three tools perform best with backgrounds of relatively homogeneous colors. If the foreground and background share similar hues or brightness values, you're better off creating a manual mask as in the old days.

Better Web Graphics

I've yet to meet a professional Web designer who doesn't use Photoshop—and hasn't grumbled about its shortcomings. Happily, Photoshop 5.5 tackles these complaints head-on. First, the type problems are 99 percent fixed. The underline style has been reinstated, and new anti-aliasing and kerning options make text more legible at small sizes. I'm frustrated that I still can't get 9-point Geneva and other system fonts to kern exactly as they do in the Finder, but small type looks much better than it did in the past. The new version also lets you preview the effects of JPEG compression before saving an image. And unlike JPEG previews produced by third-party plug-ins, Photoshop's previews are accurate.

But the GIF options are where 5.5 really shines. The Perceptual color-reduction option indexes GIF images to smaller sizes while allowing smoother transitions. You can specify a degree of dithering; matte translucent portions of a layer; preserve black, white, and Web-safe

colors; and even apply lossy compression. When applying the Web-safe palette, Photoshop still has a penchant for saving colors you're not using, but there are plenty of workarounds.

Borrowing a page from ImageReady's playbook, Photoshop 5.5 lets you compare up to four GIF and JPEG settings side by side. The window lists file sizes, download times, and other pertinent details. You can also specify a target file size and let Photoshop generate the optimal GIF or JPEG settings automatically. With little effort, you can select an image that represents a perfect balance of bytes and beauty.

If you like to rough out page designs in Photoshop, you can slice the graphics apart with ImageReady 2.0. ImageReady not only saves every sliced graphic as a separate GIF or JPEG file but also generates the HTML table data. If you create rollover graphics, ImageReady automatically generates the required JavaScript functions. In both cases, ImageReady adds comments around its code, so you can edit the HTML document and change the graphic without having the program overwrite your work.

Photoshop 5.5 is packed with smaller changes that make life easier. It can open files in the PDF 1.3 format, a new effect can colorize a layer, you can fade brushstrokes and gradient fills, and the Contact Sheet command now adds captions. Creative types will appreciate the art-history brush, which draws impressionistic dollops of color from a source state in the History palette. Best of all, you can now undo a reversion, so you can confirm how an image looked when last saved, without losing any work.

Macworld's Buying Advice

Photoshop 5.5's extraction tools and minor enhancements add up to a worthwhile package, but they fall short of justifying the price of admission. What gives the update an edge is its Web capabilities. Web designers, here's the version you've been waiting for.—DEKE McCLELLAND

RATING: ★★★★ **PROS:** Background eraser isolates intricate details quickly; program offers greater control over color indexing and JPEG compression; includes ImageReady. **CONS:** New extraction tools can't generate masks; ImageReady's features would be better rolled into Photoshop. **COMPANY:** Adobe Systems (800/492-3623, www.adobe.com). **COMPANY'S ESTIMATED PRICE:** \$609.

SATISFY ALL

YOUR BURNING

DESIRES.

©1999 Adaptec, Inc. All rights reserved. Adaptec, the Adaptec logo, and PhotoRelay are trademarks of Adaptec, Inc., which may be registered in some jurisdictions. All other trademarks used are owned by their respective owners. Our software is designed to assist you in reproducing material in which you own the copyright or have permission to copy from the copyright owner. *Manufacturer's suggested retail price. U.S. dollars, subject to change without notice.



Available at:
CompUSA • Fry's Electronics
Micro Center • J&R Computer World

Upgrade to new Toast™ 4 Deluxe and burn music, multimedia and data CDs. It opens a world of possibilities far beyond the software that came with your CD-Recorder. Now with new PhotoRelay™ software you can view, sort and organize your photos, illustrations, scanned images, movies, sounds, and fonts in customized media catalogs.

You can also pull MP3 files from the Internet, as well as favorites from LPs and cassettes, to create your own compilation CDs. New CD Spin Doctor™ software removes hisses, pops and clicks from old recordings—your music is reborn in stunning digital quality. Get new Toast 4 Deluxe and satisfy all your burning desires.

For details on the Toast 4 Deluxe Rebate Offer see your retail store or contact us at: <http://cdr.adaptec.com/mwtoasted> or 1-800-442-7274 x7755.

New Toast 4 Deluxe, Only \$99*
With \$20 Upgrade REBATE OFFER \$79

WebStar Server Suite 4.0

EASY-TO-USE WEB SERVER SPEEDS UP

UNTIL NOW, WEBMASTERS WANTING an all-Mac Internet presence had to get by with ad hoc collections of server software from assorted vendors; even Apple's own AppleShare IP bundle consists of weakly integrated programs that don't play together as well as they could. To remedy this situation, StarNine has stepped up to the plate with a suite of integrated products that endeavor to be team players. WebStar Server Suite 4.0 bundles a significantly faster version of the WebStar Web server; a full-function mail server; and Lasso Publisher, for publishing FileMaker and ODBC-compliant databases. In spite of a few minor errors, the suite hits a home run; using it is the easiest way to get a complete Internet presence on a single Mac.

Getting to First Base

With advanced features such as Web-based administration, IP multihoming, and more, WebStar was already a capable Web server. New in this release are a reworked data-caching architecture; persistent data-connection plug-ins that let you take advantage of HTTP 1.1 pipelining; and other performance tweaks that, according to StarNine, double WebStar's Web-serving traffic capacity, although our testing didn't indicate quite that much improvement. StarNine has also added Secure Sockets Layer (SSL) version 3 encryption features, as well as remote SSL administration using a Web browser.

WebStar's Web server still has a built-in FTP server and standard CGI capability. The server is easy to set up with the supplied Mac administration application, which supports encryption for secure remote control. Alas, StarNine has not kept WebStar's Web-based management up-to-date; many new functions can't be configured from the Web. StarNine says concern over browser-based-administration security has prevented the company from fully supporting browser-based management of all WebStar functions. StarNine intends to improve HTML administration after new encryption standards, such as Transport Layer Security (TLS), become widely available in browsers.

StarNine has enhanced its load-balancing plug-in, which lets Men and Mice's QuickDNS Pro dynamically route new users to the least-busy server. The plug-in now supports FTP load balancing and improves Web load balancing by handling traffic to virtual domains as well as to the main domain hosted by a WebStar server.

Also new in this release is WebStar Lasso Publisher, a plug-in module that's a subset of Blue World Communications' Lasso Web Data Engine. The plug-in lets you author Web pages that interface to FileMaker Pro or any ODBC-capable



Surfer Mail WebStar Server Suite 4.0's built-in mail server lets users access their mailboxes via either a Web browser or traditional POP3 or IMAP e-mail clients.

database. You embed Lasso Publisher commands in your HTML documents; Lasso then interprets the commands to retrieve database records for display in the user's browser. By combining Lasso with HTML forms, you can also create new database records. The plug-in can't update or delete existing records, however, and suffers from several other limitations compared to the full Lasso Web Engine product.

It's Got Mail

WebStar's new integrated mail server supports the most popular Internet e-mail protocols—SMTP, IMAP4, POP3, APOP, and MIME—and a limited LDAP function of the mail server lets you store address books for user referrals. StarNine has paid attention to security, too, giving WebStar Mail comprehensive antispam

features that prevent unauthorized mail relaying. Allow-deny filters let you control who can access various mail services, and an administration tool allows real-time monitoring of the server's activity log. The monitor function keeps tabs on queued mail, traffic rates, and access violations.

Users can access their mail via traditional Internet-capable mail clients or with any Web browser. They log onto WebStar's mail-access Web page using a special URL. Unfortunately, users can't store read messages or replies, organize messages into folders, change account settings such as their password or vacation message, or filter messages. Nor does the suite offer Web access to advanced mail functions, such as IMAP-stored mail or the LDAP directories.

Speed, in Moderation

We tested the suite's Web server informally using the Unix-based WebStone tool, and found WebStar 4.0 easily 50 percent faster than version 3.0. We did not, however, see the promised 100 percent improvement in throughput. WebStar still requires considerable tweaking of cache settings to achieve optimal performance, and the Mac OS's TCP/IP protocol stack and nonpreemptive multitasking architecture still hamper it. You can get better performance using a server such as Tenon Intersystems' WebTen or LinuxPPC's Apache server (see the review of LinuxPPC 1999 elsewhere in this issue). Although WebStar lags behind its competitors in high-traffic environments, it's still plenty fast enough for most routine Web-hosting applications.

Macworld's Buying Advice

WebStar is still the easiest Mac Web server to set up, use, and administer, and the new mail-server component removes one more headache for Mac Webmasters. WebStar Server Suite 4.0 is no speed demon, but most Web administrators will find the bundle's convenience well worth the performance hit when user-friendliness is a priority.—MEL BECKMAN

RATING: **PROS:** Integrated mail server; Web-based mail access; DNS load balancing for both Web and FTP; improved performance. **CONS:** Incomplete Web-based administration; weak Web-mail interface. **COMPANY:** StarNine (800/525-2580, www.starnine.com). **LIST PRICE:** \$599.

Move over, speed of light.









New face, new brain, new era.

We love building the fastest, best-designed computers in the world. We realize they're not for everyone. But for creative professionals, scientists, educators, artists, musicians and others who demand the highest possible performance, they're often nothing less than essential.



The Power Mac G4 has a revolutionary "open-door policy" that gives you easy access to every part inside.

With its Pentium-crushing speed and convention-crushing design, the Power Mac G4 picks up where the best-selling G3 left off. Its enclosure has evolved to a highly polished silver and graphite, yet it still offers easy access to every internal component through its unique swing-open side door.

Beneath its new face, however, is where the Power Mac G4 really shines. At its core is a brand-new brain—the G4 processor—that

redefines high performance for the entire industry. (That's a story in itself, as you'll see in the following pages.)

And we've designed the rest of the new Power Mac G4 to keep up with the processor. Our two high-end models feature a 100MHz system bus with three times the memory bandwidth of the G3. As well as superfast Ultra ATA/66 hard drives and accelerated AGP 2X graphics.



There's a whole family of flat-panel and CRT displays, specifically designed to showcase the power of the Power Mac G4.

So, if you're one of those professionals who routinely push their computer to the limit, we invite you to witness the beginning of a new era of Power Mac power.

Hold on tight.

The Power Mac G4 is here.



Computers get marginally faster every year. Megahertz, a popular (but simplistic) measure of performance, usually increases around 35% annually. But once or twice in a decade, we experience a breakthrough that leaps far beyond these incremental steps. Today we present such a breakthrough: the new Power Mac® G4.

This is not just the fastest Mac® in history. It's the fastest personal computer in history.

Rather than being just 35% faster, the new Power Mac G4 is up to a stunning 100% to 200% faster than the fastest Pentium III-based PCs.*

With performance increasing at its usual pace, the new Power Mac G4 wouldn't have arrived until 2003. Fortunately, breakthroughs do happen.



The first supercomputer on a chip.

What makes a supercomputer “super” is its ability to execute at least one billion floating-point operations per second. It’s a staggering measure of speed known as a “gigaflop.”

The new PowerPC G4, architected by Apple, Motorola and IBM, is the first microprocessor that can deliver a sustained performance of over one gigaflop. In fact, it has a theoretical peak performance of four gigaflops.

The secret of the G4’s revolutionary performance is its aptly named Velocity Engine. It’s the heart of a supercomputer miniaturized onto a sliver of silicon. The Velocity Engine can process data in 128-bit

chunks, instead of the smaller 32-bit or 64-bit chunks used in traditional processors. In addition, it can perform four (in some cases eight) 32-bit floating-point calculations in

a single cycle—two to four times faster than traditional processors.

So how does the G4 with its Velocity Engine stack up against Intel’s

brand-new Pentium III processor?

To find out, we went right to the source: We used a set of Intel’s own performance tests published on their website.

Using six of Intel’s tests, the 500MHz G4 was, on average, almost three times as fast as the 600MHz Pentium III (2.94 times, to be exact).



These benchmark advantages translate directly into real-world advantages.

For example, typical Photoshop tasks run twice as fast on the Power Mac G4 as they do on the fastest Pentium III-based PCs, with specific Photoshop filters running up to four times faster.* Compressing QuickTime files is also twice as fast.

In fact, “twice as fast” is a refrain you’re going to be hearing often, as more and more software developers tap the power of the G4 with its Velocity Engine to accelerate

the performance of their applications – just as Adobe has already done with Photoshop.

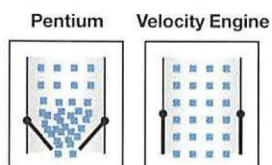

G4's Velocity Engine can process information in 128-bit chunks, compared with the 32- or 64-bit chunks in traditional processors.

Because gigaflops really do matter when your work revolves around

graphics, animation, 3D games, video effects, 3D rendering and a host of other computation-hungry software.

Chances are, you’ve never even heard of a gigaflop before. But very soon you won’t be able to live without at least one on your desk.

Intel Signal Processing Library Performance Specification

Test	Pentium III Clock Cycles	G4 Clock Cycles	G4 Performance	G4 Performance (Adjusted for MHz)
1024 dim. Square (bsqr1)	1.30	0.50	2.60 times faster	2.17 times faster
1024 dim. Multiply (bMpy2)	1.33	0.75	1.77 times faster	1.48 times faster
1024 dim. Dot Product (DotProd)	2.21	0.50	4.42 times faster	3.68 times faster
256 Pt. Complex FFT (FFT)	6.94	4.00	1.74 times faster	1.45 times faster
32 tap x 1024 dim. FIR Filter (bFir)	0.95	0.33	2.88 times faster	2.40 times faster
32 tap x 1024 dim. Convolution (Conv)	84.99	11.00	7.73 times faster	6.44 times faster
		Average	3.52 times faster	2.94 times faster

The 500MHz G4 processor, with its Velocity Engine, is an average of 2.94 times as fast as the fastest Pentium III (600MHz).

*Suite of 10 Photoshop filters.

What you really need is a supercomputer.

Supercomputers have helped achieve breakthroughs in almost every field of science. But almost no one outside the scientific community could possibly need one. Or so it was thought.

That was before Photoshop filters started resembling the most sophisticated image processing done by NASA. And before Internet security started demanding CIA-strength cryptography. And before compressing QuickTime® or MP3 files started expanding your workday.

These tasks, and many more like them, have two things in common: They choke traditional processors. And they can be dramatically sped up by exactly the kind of computational horsepower that supercomputers were created to provide.

But who has the money, or even the space, to have their very own supercomputer?

A revolutionary computer deserves a revolutionary display.

Introducing the ultimate companion to the Power Mac G4: the Apple Cinema Display.[™] With its 22-inch screen (measured diagonally), it's the largest LCD display ever brought to market.

Its viewable area is as big as a 24-inch flat CRT display. But it's twice as bright and sharp, with triple the contrast ratio and zero flicker. And its millions of colors remain true from almost any viewing angle.

Like a movie theater, the Apple Cinema Display has a letterbox format (1600x1024 pixels), with room enough to display an entire 11x17 image. And unlike most other displays, it receives its data digitally from the computer, preserving the highest-quality image.

The Apple Cinema Display is state-of-the-art technology, and supplies will be limited. And at \$3999* it's not for every pocketbook. But if you're fortunate enough to use one, your office view will never be the same again.



It would take a far, far bigger page than this to show you the actual size of the Apple Cinema



Display. Its 22-inch screen has a viewable area equal to that of a 24-inch flat CRT display.

If you don't see your perfect G4 here,
feel free to build your own.



Price*	\$1599	\$1999	\$2799	\$3499
Processor	400MHz G4	450MHz G4	450MHz G4	500MHz G4
L2 Backside Cache	1MB 200MHz	1MB 225MHz	1MB 225MHz	1MB 250MHz
Memory (SDRAM)	64MB 1.0GB max.	64MB 1.0GB max.	128MB 1.5GB max.	128MB 1.5GB max.
Max. Memory Bandwidth	400MB/sec	400MB/sec	800MB/sec	800MB/sec
Graphics	RAGE 128/PCI 16MB graphics memory	RAGE 128/PCI 16MB graphics memory	RAGE 128/AGP 2X 16MB graphics memory	RAGE 128/AGP 2X 16MB graphics memory
Hard Drive 3 internal bays, 1 used	10GB Ultra ATA/33	13GB Ultra ATA/33	20GB Ultra ATA/66	27GB Ultra ATA/66
Removable Storage	CD-ROM	DVD-ROM DVD-Video playback 100MB Zip Drive	DVD-ROM DVD-Video playback 100MB Zip Drive	DVD-ROM DVD-Video playback 100MB Zip Drive
Ethernet 10/100BASE-T	Yes	Yes	Yes	Yes
FireWire Ports (400Mbps)	2	2	3 (1 internal)	3 (1 internal)
USB Ports	2 (12Mbps total)	2 (12Mbps total)	2 (24Mbps total)	2 (24Mbps total)
AirPort™ Wireless Networking 11Mbps IEEE 802.11	n/a	n/a	Optional	Optional
56K V.90 Modem	Built in	Built in	Optional	Optional
Apple Cinema Display	n/a	n/a	Optional	Optional

Find the new Power Mac G4 at your local authorized Apple reseller. Or build your own perfect system—
from over 15,000 configurations—by visiting the Apple Store™ at www.apple.com.



Think different.™

*Suggested retail price. © 1999 Apple Computer, Inc. All rights reserved. Apple, the Apple logo, FireWire, Mac and QuickTime are registered trademarks and AirPort, Apple Cinema Display, the Apple Store, Power Mac, Think different and Velocity Engine are trademarks of Apple Computer, Inc. PowerPC is a trademark of IBM Corp. Actual modem speeds lower. Product specs subject to change without notice. 1044754

Studio Artist

BREAKTHROUGH PAINTING TOOLS, QUIRKY INTERFACE

CHALK, PENCIL, PAINT... MOST paint programs' tools try to mimic materials found in the real world. Synthetik Software's Studio Artist 1.0 goes a step further, producing images that combine natural media with amazing digital effects. Harnessing the program's power and range of painting options can be daunting, but the patient user will reap the reward with creations that would be impossible to achieve with real-world media.

Patching In

Billed as a "graphics synthesizer," Studio Artist is loosely modeled on musical synthesizers. Just as you would select instru-

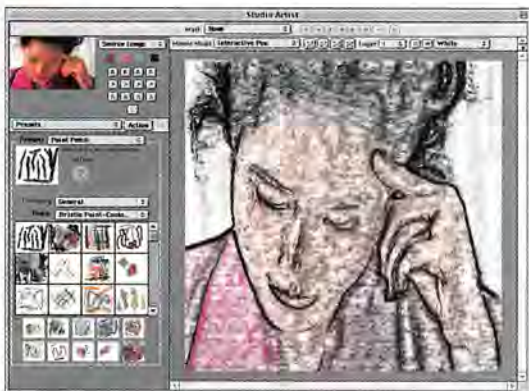

Look, Ma, No Brushes By applying three or four color effects and a few hard-edged pencil effects, you can create images like this in Studio Artist without applying a single hand-painted stroke.

ment patches on a synthesizer, in this program you select from 600 paint *patches*, or brush effects, which you can refine and combine to create a nearly endless variety of effects. And the patches are more than simply textured brushes or variations on a few themes; they can also be procedural. For example, if you select one of the Cubist patches and start painting, your brush will create an array of multicolored, straight-line strokes. You can move the brush around to change the lines' direction and rotation or choose a patch such as Canvas Liquidifier 1, which smears and distorts the underlying ink.

In the Paint Synthesizer, you can customize existing patches to create new effects. A pop-up menu listing 14 parameter categories lets you control everything

from the shape of a brush path to color variation and how the brush interacts with underlying layers and paint. If you have a pressure-sensitive tablet, you can assign brush parameters to the pen's pressure, direction, tilt, and bearing, so a brush's behavior will vary depending on how you move the pen. New users may find the Paint Synthesizer daunting, but with more than 600 predefined patches to choose from, you'll probably never need to create or customize a patch.

In general, Studio Artist's interface is usable once you learn it, but you'll have to spend some time with the manual. Unfortunately, the program ships with PDF files rather than a printed manual, so you'll

also have to spend some time printing out the documentation. And the program uses a rather un-Mac-like alternative to the traditional tool palette, asking you to choose a "mouse mode"—either the normal brush mode; the automatic-drawing mode; the Bézier mode; or the region mode, which lets you define areas you'll fill with brushstrokes.

Send In the Clones

Like MetaCreations' Painter, Studio Artist can sample colors from a source image to create new images based on existing photographs or paintings. When you click on the Action button, Studio Artist begins cloning your image by making brushstrokes with the selected tool. If you've chosen a picture of a duck as a source image, the shape and color of the duck will gradually emerge as you paint, but the image is rendered with the paint patch you've selected.

Studio Artist is much more sophisticated in its color sampling than Painter or Adobe Photoshop plug-ins such as Xaos Tools' Paint Alchemy. Rather than blindly sampling underlying colors, Studio Artist does an astonishingly good job of identifying edges and contours in your original image and brushing along them. And if you start with a source image, you'll understand the utility of some of the

brush effects—they're meant for layering on top of existing paint to build up texture and color over time. Through a combination of automatic painting and manual brushing in of strokes, you control how much of the underlying image gets cloned as well as the textures used.

Moving Paint Strokes

Its painting skills are impressive enough for a first release, but Studio Artist has much more to offer. When you activate the program's path functions, it stores every stroke separately as a Bézier path. Because you can reshape and repaint the paths, you can edit complicated bitmapped effects as you would in a drawing program. And if you want to enlarge your drawing later, Studio Artist can scale up your paths and then re-render each brushstroke to create a larger painting with no jagged edges.

Studio Artist includes an array of distortion and special-effects filters and brushes. Although the program lacks support for Photoshop filters, the built-in effects tools are probably all you'll need. Studio Artist does support QuickTime—you can paint on a movie's frames by hand or have the program paint each frame using a predefined effect. Movies that Studio Artist paints tend to resemble video viewed through a filter, however; for better effects, you'll want to posterize or blur your original video to remove detail.

Macworld's Buying Advice

Plenty of filters and programs try to mimic real-world painting by manipulating an image to replicate the look of particular textures and media. Studio Artist is the first program to copy the way real painters choose their strokes, letting you apply brushstrokes that follow the shapes and contours of a source image. In addition, Studio Artist's still- and video-painting features are impressive for a first release. The program's nonstandard interface can prove frustrating, and it's a little pricey for nonprofessionals, but print and video pros looking for new tools will find it's worth the price and learning curve.—BEN LONG

RATING: **PROS:** Huge assortment of brushes; automatic cloning feature creates hand-painted effect. **CONS:** Overwhelming number of controls; nonstandard interface. **COMPANY:** Synthetik Software (888/808-4188, www.synthetik.com). **LIST PRICE:** \$295.

QuickMail Office 2.0

IMPROVEMENTS BRING SERVER ALMOST UP-TO-DATE

EVERYONE KNOWS THAT E-MAIL is the lifeblood of modern business. Alas, keeping e-mail flowing in a large or medium-size office is a tedious chore that grows rapidly with the user population. CE Software's QuickMail Office 2.0 lends a helping hand to harried e-mail administrators: It delivers a streamlined, browserlike client; server-stored message retrieval via IMAP; enhanced filtering to block annoying spam; and a Web-accessible address-book server that integrates with any Mac-based Web server. QuickMail Office still lacks two features commonly found on other mail-server platforms—Web e-mail access and remote administration—but the client delivers functions never before seen in any Web-based mail interface.

Package Deal

QuickMail Office 2.0 offers one-stop shopping for enterprise e-mail. The bundle includes the QuickMail Pro 2.0 mail server, a license for five QuickMail Pro clients—either Mac or Windows—and the new QuickMail Pro directory server.

Installing the server takes just seconds, and configuration requires only that you know the e-mail domains you wish to serve. Once you've installed the server, you create a mailbox for each user. You can also set default user preferences and organize users into groups.

Client installation is equally straightforward: users copy the client installer from the file server and run it, providing their user names and passwords when prompted. The client then retrieves the users' account profiles and configures itself. This feature greatly reduces the work required to roll out QuickMail for the first time and lets users move from one computer to another without administrative intervention.

Reliable Delivery

The QuickMail Pro server supports the most popular Internet mail protocols—SMTP, POP3, APOP, IMAP, and UUCP—over either a dedicated or dial-up Internet connection. The server application displays the status of all available protocols, as well as bar graphs showing the volume of

traffic for each. Message filtering lets you block spam and sort incoming mail based on header content, or trigger AppleScripts to perform automated chores such as e-mail responding. Built-in gateway interfaces for Mark/Space Softworks' PageNow and 4-Sight PLC's 4-Sight fax sender let you route e-mail to alpha pagers or fax machines, and a built-in mailing-list server gives you standard mail-reflector functions.

New with this release are shared folders, which offer a bulletin-board-like cen-



I'm in the Book QuickMail Office 2.0's LDAP directory server sports a Web-based interface that gives you convenient access to centralized address books.

tral repository for general messages; IMAP support, allowing mail storage on the QuickMail Pro server rather than on users' desktop computers; and support for multiple e-mail addresses per user. This last feature lets users change their online "persona" to fit the situation; a customer-service clerk, for example, can become service@acme.com when replying to messages addressed to that e-mail alias.

One of the nicest new features is a separate Lightweight Directory Access Protocol (LDAP) server, which maintains centrally managed address books. A Web-server CGI plug-in lets you put your address books on the Web, complete with search capabilities and e-mail URLs, making directories accessible to off-site users.

QuickMail Pro's server has some

rough edges, however. IMAP support isn't complete, for example—users can't create or rename folders, archive messages, or search message contents. Alas, these are the very IMAP features that users most want when giving up control of their mail to a central repository. The server also has no Web-based—or any other—remote administration capability, making the server inconvenient to maintain from a distance. And QuickMail lacks Web-based mail access for end users, at a time when this feature is appearing in competing Mac mail servers.

Ready for Pickup

Users can read mail from the QuickMail Office server with any Internet-compliant e-mail client. However, QuickMail Pro's client offers features not found in most other clients. A new browserlike message viewer organizes incoming mail as a hierarchical list—you can automatically file those messages using mail filtering, but you can still find unread mail easily. A built-in contact manager stores a user's own local address book merged with LDAP directories, providing a convenient single point of lookup.

QuickMail's venerable forms feature—still a unique capability—lets users store data-entry forms as templates for collecting and distributing information in a standardized format. Return receipts let users know when the recipient has read their outgoing mail, and a lifesaving Unsend feature lets you reel in that ill-considered resignation notice.

Macworld's Buying Advice

QuickMail Office 2.0 provides one-stop shopping for e-mail serving and client software. The absence of Web-based e-mail and the limited IMAP support may inconvenience mobile users, but if your users primarily access e-mail from their desks—and you want consistent e-mail handling throughout your organization—QuickMail Office is all you need.—MEL BECKMAN

RATING: ★★★½ **PROS:** Streamlined client; LDAP directory server with Web-enabling plug-in; built-in bulletin board; antispam controls. **CONS:** Incomplete IMAP support; no Web-based mail access; no Web-based or other remote administration. **COMPANY:** CE Software (800/523-7638, www.cesoft.com). **LIST PRICE:** Five users, \$346; 10 users, \$656; 25 users, \$1,326.

Powerful, fast, smart— and bred for the unbridled imagination.

(No, we're talking about the Intuos graphics tablet system.)



Now in USB!

Give your imagination full rein with the award-winning Intuos™ graphic tablet system from Wacom. With Intuos, you can sketch, paint and retouch images with natural ease and zen-like control.

Intuos, the #1 choice of illustrators, designers and photographers worldwide, features 1,024 levels of pen pressure-sensitivity. Its ergonomic design is unmatched and a pure joy for designers who demand top performance and productivity from all their graphic software. You can even add the cordless 4D Mouse or the new Intuos Airbrush for a truly customized digital toolkit.

Or choose **Graphire™**, Wacom's new pen and mouse set. Its small footprint, performance features and sub-\$100 price make it a great choice for those just getting started in digital art.

Intuos and Graphire... turn your imagination loose.



Only \$99⁹⁵

WACOM

800.922.2585 OR www.wacom.com/imaginations



©1999 Wacom Technology Corporation. Wacom is a registered trademark and Graphire and Intuos are trademarks of Wacom Company Ltd. All rights reserved. Artwork created by Phil Howe of Seattle, WA with a Intuos 9x12 graphics tablet. Wacom products are available at www.wacom.com, CompUSA, Microcenter and other fine retail and mail order resellers nationwide. Includes Painter Classic. Unbridled beast not included.

Choose 84 at www.macworld.com/getinfo

Poser 4

BRING LIFE TO 3-D MODELS

AS A 3-D MODELER AND ANIMATOR, you've probably gazed longingly at the plethora of character-animation tools available for that other operating system. Yearn no longer—with Poser 4, MetaCreations has created a powerful 3-D character-animation tool that will appeal to 3-D animators as well as print and Web designers.

Strike a Pose

Poser has always been good for creating simple figure studies and animations, but with version 4, the program becomes a serious animation and illustration tool.

As with previous versions, you begin by importing a figure model into Poser 4's workspace. The application ships with more than 70 models, including humans, animals, and robots. Once you've chosen your figures, you pose them by dragging their body parts with one of three positioning tools. For difficult posings, you can also move parts numerically or by turning special Parameter Dials.

Like earlier versions, Poser 4 boasts full inverse kinematics (IK) for realistic body positioning. With IK activated, you can reposition a hand and have the rest of the arm move correctly. Unlike most other 3-D packages, Poser doesn't require you to define any complicated chains, limits, or weights. And unlike its predecessor, Poser 4 offers far more posing controls. With more-articulated models, you can create complex motion from head to toe. Joint animation is also much improved, with none of the weird splitting and intersecting of previous versions.

Distort and Contort

Despite Poser 4's level of control and detail, the models it creates can still look like well-animated mannequins. Fortunately, the program's new deform features change all that.

Deformers let you stretch, distort, and twist the geometry of any body part. You create a deformation by adding a magnet to a body part to pull the part into a different shape. By manipulating magnets, you can define everything from subtle deformations to extreme stretches and squashes. As with all models in Poser,

you can animate deformers, creating bouncing bellies and twitching ears.

In addition to being powerful creative tools, deformers allow you to work around some of Poser's character-animation deficiencies. For example, because Poser doesn't take a bones-and-skin approach to character animation, you won't see any flexing muscles or rippling skin when you move a character's arm. Adding a deformation to a character's upper arm is a simple workaround.

Sunday Best

Better animation features aren't the only improvements in version 4; nearly every aspect of the program has been enhanced. For example, although earlier versions included clothing, Poser 4's fashion func-



A Little Sketchy Poser 4's new Sketch Designer creates beautiful natural-media renderings and provides sophisticated controls for customizing the look of your sketches.

tionality is vastly improved. You can select from more than 40 articles of clothing and mix and match them on any model.

More important, clothes now have the same hierarchies and parameters as your characters. With the new Conform command, you can make a shirt match your model's IK hierarchy. Animate your character, and his or her clothes animate as well. Unfortunately, Poser still implements hair as a prop rather than as a true particle-based system. Because the hair on a Poser model is little more than a wig with a few animation parameters, making it blow or wave takes some work.

Poser's rendering has been improved with transparency and reflection maps. The program delivers good rendering performance, although it lacks motion blur for more-realistic animations. The program's incredible new Sketch Designer makes up for these deficiencies, letting you create

beautiful natural-media renderings of your work. Once you've completed a project, Poser 4's excellent import and export features make it easy to move geometry and motion data to or from other programs. In addition, Poser can export directly to MetaCreations' MetaStream format to create small streaming Web files.

Also improved are Poser's lighting features, which offer a simpler interface and more options. The new version lets you select individual polygons on a model for regrouping and reordering with the new Hierarchy palette. These features make it easier to correct texture mapping on imported models. The camera controls are also good. Particularly handy is the Point At command, which forces the camera to point at a particular object or body part.

Unfortunately, you still can't undo some actions, and there's still no way to lock objects. Poser also has trouble with large geometries—import a very large prop, and you'll most likely crash the program. And the program's animation interface remains weak, offering poor visual feedback on keyframe location and lacking velocity tools for controlling a model's acceleration.

Macworld's Buying Advice

Although Poser has always been a good program, it becomes a serious production tool for animators and illustrators with version 4; its new features and controls are well designed and well implemented. Unfortunately, it suffers from a weak animation interface and needs to be able to handle larger, more complicated scenes. And Mac users may still want a true particle system, collision detection, and other character-animation features Windows users already enjoy. For many animation and illustration jobs that involve characters, however, Poser 4 is all you need.—BEN LONG

RATING: **PROS:** Models are more poseable; good distortion tools; beautiful sketch rendering. **CONS:** Trouble supporting large geometries; no velocity controls; weak animation interface. **COMPANY:** MetaCreations (800/846-0111, www.metacreations.com). **COMPANY'S ESTIMATED PRICE:** \$249.

We move the information that moves your world.™ **adaptec®**

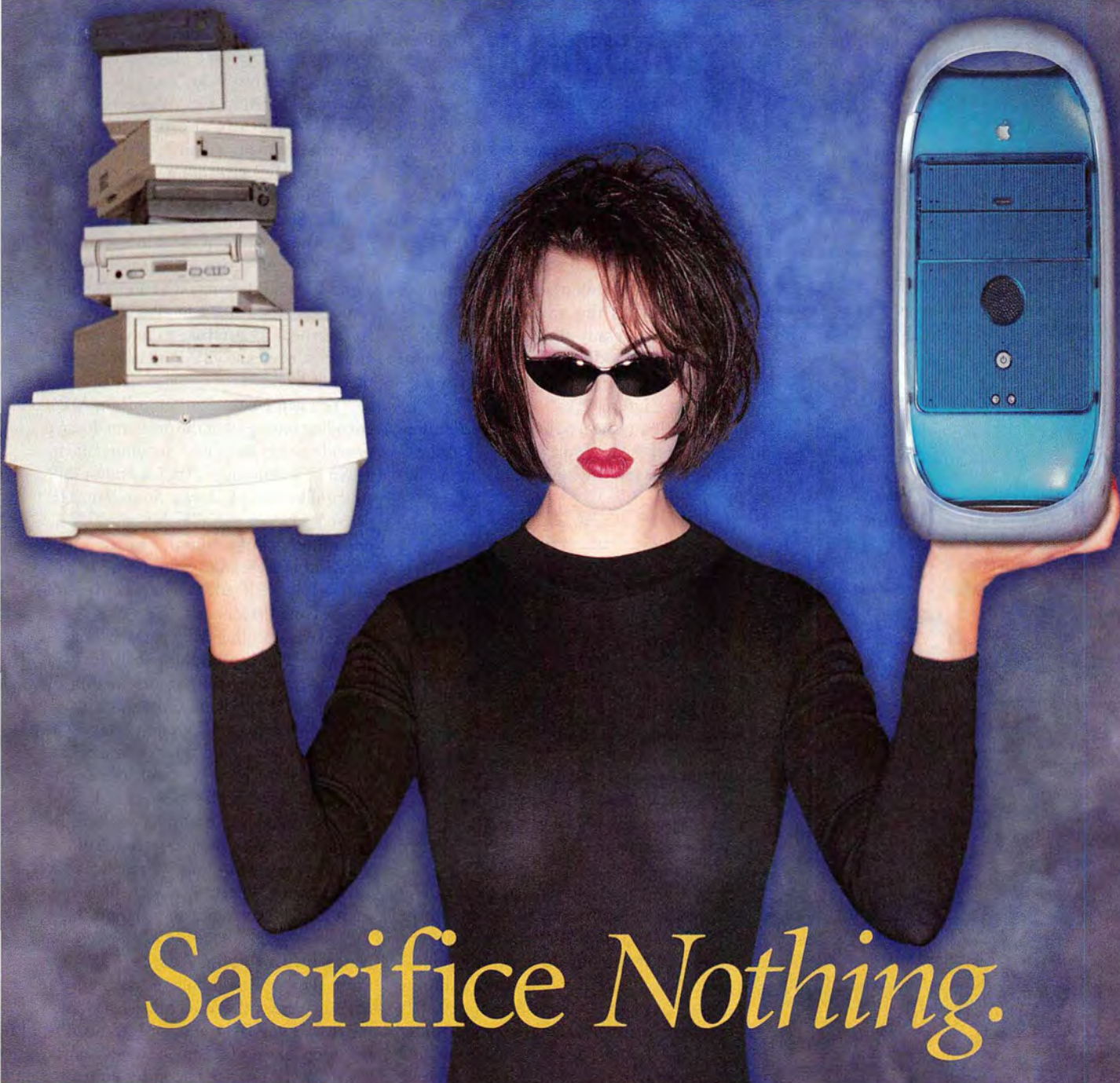

Sacrifice Nothing.

Go ahead, upgrade to that new G3 without sacrificing the SCSI peripherals you depend on. And in case you didn't know, Adaptec® SCSI cards support Apple's old SCSI Manager and newer SCSI Manager 4.3 devices so you can connect to whatever SCSI peripheral you might be using. But it gets even better. Adaptec SCSI significantly outperforms Apple's previous built-in SCSI, enabling your Jaz, scanner, and other peripherals to operate at peak performance. So if you want to upgrade to a new blue G3 without sacrificing anything, get an Adaptec SCSI card. For more information visit www.adaptec.com/mac.



© 1999 Adaptec, Inc. All rights reserved. Adaptec, the Adaptec logo, the Adaptec tagline, and PowerDomain are trademarks of Adaptec, Inc., which may be registered in some jurisdictions. Apple and Mac are registered trademarks of Apple Computer, Inc., used under license. All other trademarks are property of their respective holders.

SoundJam MP

FAST MP3 ENCODING AND PLAYBACK

RECORD COMPANIES FEAR IT, music addicts love it: the MP3 audio-compression format has taken the Internet and the music industry by storm. Of all the MP3 software available for the Mac, Casady & Greene's new SoundJam MP is the most complete. It's the only Mac MP3 tool capable of not only playing back MP3 files but also encoding tracks from audio CDs—all with a comfortable, customizable user interface.

At first glance, SoundJam MP's interface evokes the look of Apple's QuickTime Player, the justifiably maligned



Listen Here SoundJam MP's 11 graphic-equalizer presets optimize playback for various music styles.

movie and music player that accompanies QuickTime 4 Pro (see *Reviews*, October 1999). SoundJam MP sports the same brushed-aluminum, 1970s-swinger look. But Casady & Greene didn't mimic Apple's mistakes as well. SoundJam MP's volume control is a horizontal slider instead of an awkward virtual knob, and the program lacks QuickTime Player's gimmicky Favorites drawer.

What's more, as with @soft's popular MacAmp MP3 player (see "So Long, CDs," July 1999), you can completely change SoundJam MP's appearance by switching "skins." Most of the 13 skins that accompany SoundJam MP are pig-ugly, but you can download more from the SoundJam MP Web site or convert MacAmp skins to work with SoundJam MP.

Like nearly all other MP3 players, SoundJam MP lets you create a sequence of songs and store them in a playlist. The program's playlist features are straight-

forward and well designed—for example, you can have multiple playlists and drag and drop songs from one playlist to another. MacAmp lacks these niceties. SoundJam MP can also play live feeds from the growing number of Web sites that offer MP3 streaming. You can even include live streams in playlists.

But SoundJam MP is more than an MP3 player—you can use it to encode, or *rip*, MP3 tracks, simply by inserting an audio CD and clicking on a couple of buttons. SoundJam MP can also connect to an Internet CD database to retrieve track and artist names so you don't have to peck them in by hand.

You can customize SoundJam MP's encoding settings, but the program doesn't provide nearly as much encoding control as Xing Technology's AudioCatalyst 2.0. And unlike AudioCatalyst, SoundJam MP doesn't support variable-bit-rate (VBR) encoding, whose sound quality some MP3 gurus prefer. But SoundJam MP can play back VBR files, whereas Apple's QuickTime Player can't.

Like many other MP3 players, SoundJam MP includes a graphic equalizer (EQ) that lets you fine-tune sound quality to your tastes. SoundJam MP comes with 11 EQ presets, and you can add your own. For simple tone adjustments, SoundJam MP also offers basic bass and treble controls, which most MP3 players lack. And three bundled plug-ins display cool graphics in rhythm with the music. Some of the plug-ins are downright psychedelic; after a few minutes of staring at Melt-O-Rama, I felt like entering a rehab program.

Macworld's Buying Advice

SoundJam MP is hands down the best MP3 player for the Mac. Musicians wanting to encode MP3 tracks for Internet distribution may prefer Xing's AudioCatalyst for its more precise encoding controls, but the rest of us will find SoundJam MP's encoding features adequate. Test them for yourself by downloading a seven-day trial version of SoundJam MP from www.soundjam.com.—JIM HEID

RATING: **PROS:** Supports both encoding and playback; excellent playlist features; supports streaming. **CONS:** No variable-bit-rate encoding; lacks precise encoding controls. **COMPANY:** Casady & Greene (800/359-4920, www.soundjam.com). **LIST PRICE:** \$50.



FIREPOWER

FireDrive HDD



DEVICE IDS



CORRUPTION



TERMINATION

If you're interested in truly stunning performance, the FirePower FireDrive HDD provides up to 37 GB of hot swapping, high-speed storage, making it bigger, faster, and more stable than the little guys. Forget about all the data corruption nightmares of SCSI IDs and terminations, just connect one of the drive's two FireWire™ ports to a

Macintosh or PC and the FireDrive HDD mounts seamlessly to the desktop. With all the potential of FireWire's 400Mbps data transfer rates and 63 device daisy chaining capability, no other FireWire hard drive gives you more storage for your money. For more information on our complete line of FirePower products, visit www.firepower.com.



AVAILABLE AT

MacWarehouse • ClubMac • MacMall • MacZone
Outpost.com • Bottom Line • ICN • Tech Squared

ADDITIONAL FIREPOWER PERIPHERALS

FireDrive CD-RW • FireDrive DAT • FireDrive MO • FireDrive ORB



mactell
CORPORATION

www.mactell.com • www.firepower.com

FirePower and the FirePower logo are trademarks of the Mactell Corporation. FireWire is a trademark of Apple Computer, Inc., registered in the U.S. and other countries.

120 on card or www.macworld.com/getinfo

64 November 1999 MACWORLD

job opportunities

800-937-3622

multimedia artist

Baltimore: Experienced multimedia professionals needed for full-time, long-term contract work with large, international client. Candidates must be proficient in any combination of Director, After Effects, 3D Studio Max, Photoshop, Illustrator, Java, Javascript, or HTML. Be part of a team whose work is seen on a global basis! Two to three years of experience and on-line examples of your work are expected.

help desk administrator

Providence: The Help Desk Administrator supports a nationwide community via telephone, email, or in person as necessary. He/she provides first line support for Help Desk Technicians, with the responsibility to ensure all requests are being attended to, and tracks usage/response. Three to four years of help desk experience, a high level of organization, and excellent communication skills are required.

technical designer

Boston: The Technical Designer assesses the technical feasibility of design direction, translates layouts into HTML, dynamic HTML, Shockwave and/or Javascript, assists with prototype development, and tests projects on specified browsers and platforms. He/she may also help to develop new technology demos for client. Two to three years of experience in a web production environment involving large sites and multiple platforms is required.

senior art director

Dallas: A publishing company is looking for a Senior Art Director to design book covers and some packaging to be sold via catalog and point of purchase at bookstores. This company produces high-quality products for a wide range of audiences, so the work would always be changing. Five years of experience and a portfolio with full color samples is ideal.

putting intelligence to work

HireKnowledge®
Specialized Staffing Solutions

traffic coordinator

St. Louis: Traffic Coordinator needed for large advertising agency. Previous experience with traffic flow and project management at ad agencies is necessary; major accounts experience is desirable. Ability to work with creative staff and all levels of management is essential.

oracle programmer

Chicago: This is not your average programming position! Our client is looking to hire an expert with Oracle's Developer 2000 who can take a project from inception through completion. You will be working directly with the clients and will have the freedom to be creative to give customers the best possible product. A minimum of three years of recent experience and excellent communication skills are required.

proofreaders

Philadelphia: Prestigious center city firm has an immediate need for proofreaders. Experience in tech writing is helpful, but not required. The ideal candidate will be bright, a quick learner, and have either a BA or BS in English, Communications, or some other related major. Excellent writing and editing skills are essential. Expect long hours, but a fun and challenging work environment.

<http://www.hireknowledge.com>

Locations

Baltimore
Boston
Chicago
Dallas
New York
Philadelphia
Providence
San Francisco
St. Louis
Washington DC

Circle 97 on card or go to www.macworld.com/getinfo

If you buy it,



will it work?



MacBuy.com

Make sure you know.

The Macworld Buyer's Guide
www.macbuy.com

Media Cleaner Pro 4.0

COMPRESSION UTILITY GETS MEDIA CLEANER THAN EVER

COMPRESSING AUDIO AND VIDEO for delivery over the Internet or on CD-ROMs is a dirty business. Your mission: to shoehorn high-bandwidth content into the narrow pipes that are modems and CD-ROM drives. Your hope: that the content will still be recognizable at the other end of the pipeline.

Media producers employ a variety of tools to compress content, foremost among them Terran Interactive's Media Cleaner Pro. Version 4.0 adds support for the latest streaming and compression

G2-compatible `<embed>` tag; instead, it creates a simple anchor tag that launches the RealPlayer helper application. If you want to embed your G2 efforts rather than linking to them, you'll need to either hand-code the `<embed>` tag or use RealNetworks' RealProducer Plus G2.

Fortunately, the new version lets you convert a file from one format to another without having to recompress it and further reduce its quality. Better still, you can selectively recompress during the conversion process.

Audio no longer takes a backseat to video, as it did in previous versions. The new Noise Gate filter cuts down on hiss, and other new filters reduce power-line hum and similar evils. Media Cleaner Pro 4.0 also offers better resampling algorithms that yield higher-quality results when you're changing a soundtrack's sample rate. A dynamic-range compressor beefs up audio tracks, and you can choose from several commonly used presets or supply your own values. Alas, Media Cleaner Pro doesn't let you preview audio settings without applying them.

One thing that hasn't changed is Media Cleaner Pro's efficient interface. Compression beginners can use the Settings Wizard; advanced users can choose settings directly. You can also use the Batch window to apply Media Cleaner Pro's skills to multiple files in one fell swoop.

Macworld's Buying Advice

At \$499, Media Cleaner Pro 4.0 isn't for amateurs who want to publish the occasional audio or video clip on the Web. Media Cleaner Pro's HTML-generating features for RealSystem G2 content could use some improvement, but the program's ability to compress and clarify audio and (especially) video is unmatched. If your mission is to make media work on the Web or CD-ROMs, you'll want Media Cleaner Pro along for the ride.—JIM HEID

RATING: ★★★★★ **PROS:** Broad compression-technology support; enhanced audio features; excellent manual. **CONS:** Doesn't create `<embed>` tags for RealSystem G2 content; no audio preview. **COMPANY:** Terran Interactive (800/577-3443, www.terran.com). **LIST PRICE:** \$499.

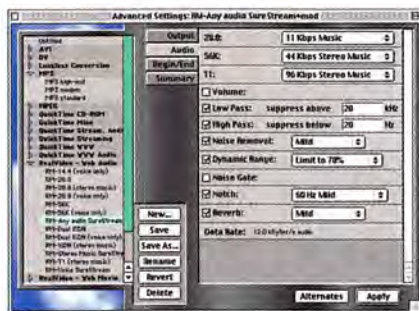

Sound Cleaner Media Cleaner Pro 4.0 adds a batch of new audio-processing filters.

technologies and offers great new audio features and conversion options. Toss in thorough documentation, and you have the best compression tool available.

Media Cleaner Pro 4.0's enhancements begin with support for the latest streaming technologies and compression schemes. The new version supports Apple's QuickTime 4 Streaming Server, Microsoft's Windows Media (formerly NetShow), and RealNetworks' RealSystem G2. Its QuickTime 4 support is particularly strong. The program can compress movies for various connection speeds and for older QuickTime versions and can create the `<embed>` tag required to display the movies in a Web page—just copy and paste the tag into your favorite HTML editor. Support for Windows Media and RealSystem G2 isn't quite as solid: because Microsoft hasn't yet released the final version of its Windows Media Player for the Mac OS, Media Cleaner Pro must rely on beta versions of the Windows Media codec.

Media Cleaner Pro supports all RealSystem G2 codecs, but it can't create a



Global Village TelePort
USB 56K, winner of
Macworld® Editors' Choice
Awards October '99.



GLOBAL VILLAGE

www.globalvillage.com • (800) 336-2009



What are you getting your Mac for the holidays?

Global Village® is starting the gift-giving season early this year.

For a limited time, you can receive a \$20 mail-in rebate on the TelePort™ Internal 56K modem specifically optimized for the Power Macintosh® G3™.

And if that wasn't enough, you can also receive a \$40 mail-in rebate on the TelePort USB 56K modem designed for any Macintosh® with a USB port.



Now available at Mac dealers nationwide.

COMPUSA
THE COMPUTER SUPERSTORE
(800) 294-4727

MacConnection
(800) 800-0009

macZone
(888) 211-5032

MacWAREHOUSE
(800) 397-8508

MacMall
(800) 328-2790

Circle 106 on card or go to www.macworld.com/getinfo

Get everything
you're looking for:

Macworld
Get
Info

www.macworld.com/getinfo

**Macworld's
Reader Service**

"Get Info" with options! Now you can get information on all the products and services you see in *Macworld*. And get it faster. Simpler. Better. Easier. All you need to do is visit one Web site:

www.macworld.com/getinfo

Then select the products, the categories or advertisers for whom you want to receive information. That's it. You can have the information delivered to you by e-mail, snail mail or even telephone. Or you can click on a link that will take you to the vendor's Web site in one easy step.

PLUS! In this issue, the return of the hard card! A traditional perforated card that allows you to circle your product-info choices as you read *Macworld* on the train, on the plane or where-ever you are. Then drop the card in the mail and it's on the way!

Macworld

Reviews

SonicWall Pro

SPEEDY FIREWALL DELIVERS 100 MBPS

REMEMBER WHEN 10-MBPS Ethernet seemed fast? Today you can get multimegabit Ethernet at home, and business LANs often reach 100 or 1,000 Mbps. Alas, affordable enterprise-class firewalls usually support only 10-Mbps networks. Sonic Systems' SonicWall Pro breaks the 10-Mbps barrier, with three 100-Mbps Ethernet ports, a high-speed RISC processor, and a rack-mountable enclosure.

Like its smaller siblings, the SonicWall Pro is a dedicated, Web-administered network appliance for connecting private LANs to the Internet. It supports Dynamic Host Configuration Protocol



SUZANNE ROODY

(DHCP), network-address translation, stateful filtering and tunneling, remote telecommuting, and optional content filtering. In addition to 100-Mbps Ethernet ports, this version sports a 233MHz StrongArm RISC processor, a PCI slot for future expansion, and Virtual Private Networking (VPN) support.

You connect the unit to your Ethernet backbone and Internet router, using the supplied DMZ port to attach any servers you want the public to have full access to. If you choose not to make servers completely public on the DMZ port, you can open protocol-specific tunnels in the firewall for individual servers on your LAN. If you follow the instructions in the well-written user guide, configuration takes just minutes with any Web browser. The SonicWall Pro automatically e-mails you when it detects an attempted intrusion, a denial-of-service attack, or IP-address spoofing.

The unit can block all Usenet news access and disable Java and ActiveX applets, remote proxies, and HTTP cookies to prevent security breaches by unfriendly Web sites. An optional self-updating content-filtering feature (\$695

for a one-year subscription) lets you monitor or block access to 12 predefined content categories. The filter combines the CyberNot content-filtering list, which blocks IP addresses and URLs known to be inappropriate for children, with phrase matching and a custom URL list.

Built-in VPN support provides secure private networking between two SonicWalls—or between the SonicWall and any other IPsec-compatible firewall—across the Internet. VPN creates encrypted tunnels for passing data safely, using either the fast, 56-bit ARCfour or the slower 56-bit DES or 168-bit Triple-DES methods. Supporting as many as 100 tunnels between endpoints, the SonicWall Pro can handle VPN traffic for up to 64 individually protected users per tunnel. You can optionally configure unencrypted tunnels to transport unsupported protocols between LANs.

A supplied single-user client license for Windows supports secure remote management, but the SonicWall offers no client VPN software for the Mac. Also missing is Internet Key Exchange support, which would simplify VPN administration of multiple SonicWalls across the Internet. Sonic says a free update, which should be available by the time you read this, will add this feature.

We tested Sonic's claim of 100-Mbps throughput, using multiple Mac clients and a 450MHz Power Mac G3 server on a 100BaseT switched-Ethernet LAN. The SonicWall Pro had no problem achieving 60-Mbps aggregate throughput, which is about the maximum for 100BaseT. A VPN performance test across a 10-Mbps Internet connection showed that the SonicWall Pro can sustain about 3 Mbps when encrypting traffic with the strongest encryption method.

Macworld's Buying Advice

The SonicWall Pro delivers the performance today's business LANs demand of their firewalls. Its VPN support and rack-ready packaging make it a great choice for high-speed security.—MEL BECKMAN

RATING: ★★★★★ **PROS:** Web-based configuration; VPN support; built-in DHCP server; excellent performance. **CONS:** No Internet Key Exchange support; lacks Macintosh VPN client software.

COMPANY: Sonic Systems (888/557-6642, www.sonicwall.com). **LIST PRICE:** \$2,995.



Windows[®] compatible



Without a doubt, Macs, including the new iBooks, are the best personal computers on the market today. However, compatibility and interoperability between the Mac and the Windows platforms are critical in today's world. Virtual PC is a software solution that brings Windows capabilities right to your Mac! Run Windows-based business, home and education programs. Access PC networks. Easily share files between your Mac and PC desktops. All on one computer, your Mac!

Virtual PC is available in three versions: with PC-DOS, Windows 95 or 98 pre-installed. You can also run Windows NT or Linux. Get two computers in one, and get it today! To buy or for more information, go to www.connectix.com, or call 1.800.395.1804.



Spell Catcher 8

WRITING TOOL WORKS ACROSS APPS

GIVEN THAT MOST WORD PROCESSING and page-layout programs have built-in spelling checkers, why would you pay for a dedicated spell-checking program? Casady & Greene offers a strong case for doing just that, with Spell Catcher 8, the latest version of its cross-application writing utility.

Spell Catcher is more than just a spelling checker. You can call up synonyms and dictionary definitions for any selected text. As you enter custom abbreviations, a shorthand function quickly spells them out—enter *adc*, for example, and the program automatically expands it to that all-too-common phrase “Apple declined to comment.” You can also activate a dictionary of commonly misspelled words; if you enter *accomodate*, Spell Catcher automatically converts it to *accommodate*. The useful Ghostwriter function automatically saves your keystrokes in case the system crashes.

Another useful option, Modify Selection, applies a wide range of formatting adjustments to selected text. You can make quotes straight or curly, remove extra spaces, capitalize the first word of each sen-

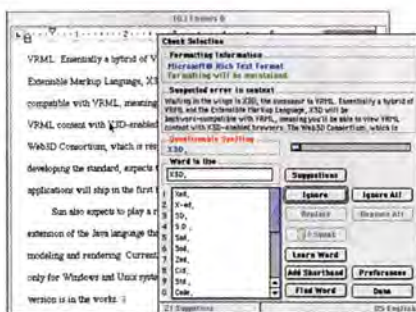

No More Typos Spell Catcher 8 can catch spelling and punctuation mistakes in any Mac program.

tence, or convert e-mails with odd line breaks into logically formatted paragraphs.

Spell Catcher lacks a grammar checker, but it catches double words as well as capitalization and punctuation errors. You can set up the program to ignore e-mail addresses, URLs, and words that begin with capital letters (unless they start a sentence). This version supports eight languages, and you can install an optional HTML dictionary for checking Web documents.

Spell Catcher's big advantage is that it works with any Mac program you're running. Whether you're composing a document in Microsoft Word or entering text in a shareware program, Spell Catcher checks spelling, looks up definitions, and suggests

synonyms. You access the options through a menu Spell Catcher displays on the right side of the screen (the previous version functioned as a control panel).

But the question remains: why pay \$50 for a spelling checker when so many packages have those facilities built in? For one, with a single systemwide spelling checker, you need store only one standard dictionary and one dictionary of user-defined terms on your hard disk. If you've spent time compiling unique word lists in other programs, you can import them into Spell Catcher's dictionary. And Spell Catcher offers a few features you won't find in Microsoft Office, such as the ability to pronounce words and look up word meanings.

Macworld's Buying Advice For those who are sloppy typists or work with programs that don't include spelling checkers, Spell Catcher is a must-have product. It's less compelling if you work in Microsoft Office, but even then, the extra features may be worth the \$50 price tag.—STEPHEN BEALE

RATING: **PROS:** Strong spell-checking options; works with any Mac application. **CONS:** No built-in grammar checker. **COMPANY:** Casady & Greene (800/359-4264, www.casadyg.com). **COMPANY'S ESTIMATED PRICE:** \$50.

THE ULTIMATE SEARCH ENGINE

Take a guided tour of the heavens at the push of a button with the Meade® ETX-90EC™ Astro Telescope.

See more in 20 minutes than Galileo saw in a lifetime. Galaxies, nebulae, star clusters, the planets, and more. New Meade digital technology makes finding any object in the sky as easy as pushing a button!

Choose from over 14,000 celestial objects stored in the Autostar™ hand controller's database, press GO TO, and the telescope moves to the object, places it in the field of view, and follows it across the sky — automatically, first time, every time. This is one telescope you have to see — and use — to believe.

Use the telescope's automatic guided tour feature to explore the rings of Saturn, mountain ranges on the Moon, or dust lanes in the Andromeda Galaxy. The Meade ETX-90EC Astro Telescope with Autostar Computer Controller — easy to use by anyone, anywhere, anytime.

Meade ETX-90EC Telescope. Shown with Autostar Computer Controller.



natural wonders®

1-800-2-WONDER



1-800-52-FOCUS

Call 1-800-62-MEADE for a free copy of Meade Telescope Catalog #183 or for a dealer location near you. ETX-90EC: \$595, complete with 4-speed electronic hand controller (not shown). #497 Autostar Computer Controller: \$149. Meade telescopes and accessories are available at over 3000 dealer locations in the U.S.A. and Canada. Meade Instruments Corp., 6001 Oak Canyon, Irvine, CA 92618. FAX: (949) 451-1460. www.meade.com ©1999

Circle 79 on card or go to www.macworld.com/getinfo

Nikon.

**BUY A SUPER
COOLSCAN® 2000
INSTEAD OF
A DRUM SCANNER
AND SAVE \$13,000.**



"I need to save the studio \$13,000 by Tuesday. What to do? What to do?"

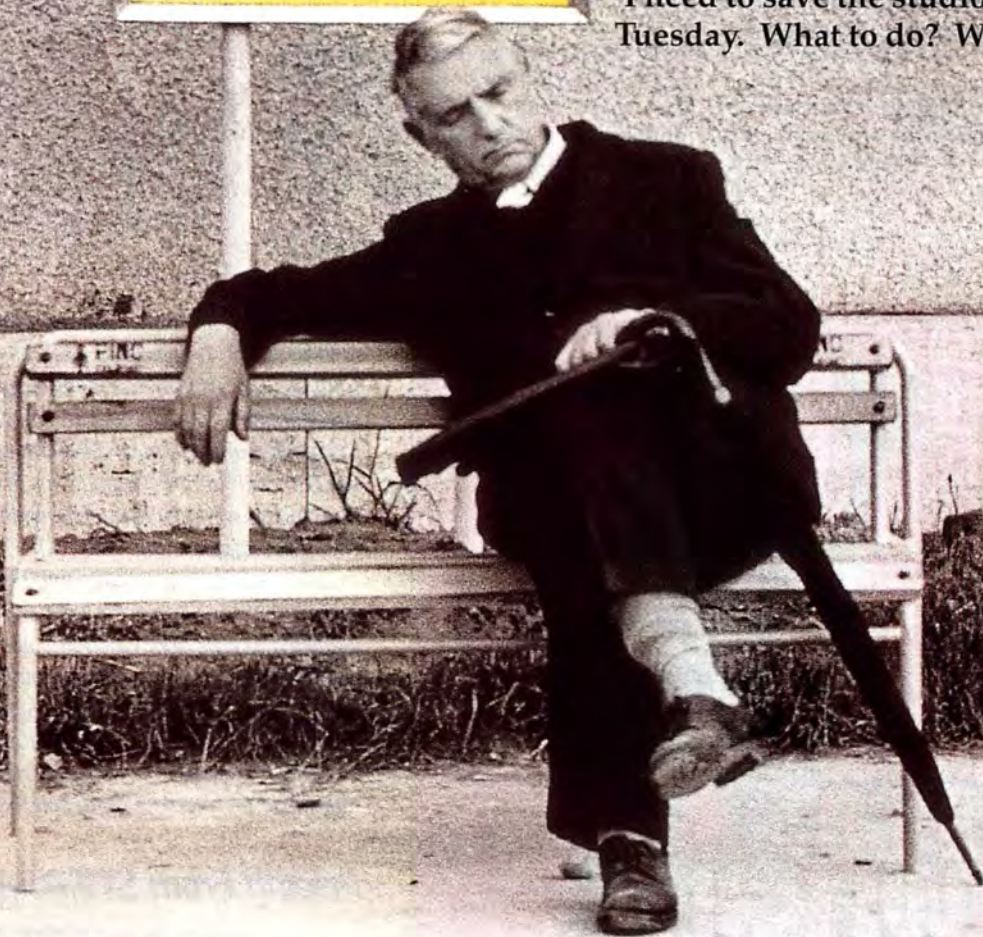

With an impressive 3.6 dynamic range, the Super Coolscan 2000 gives you super-accurate color and detail that rivals the quality of drum scanners costing \$15,000 or more. Its Multi-Sample Scanning feature captures exceptional detail in highlights and shadows. Equipped with revolutionary Digital ICE™ technology for automatic removal of surface defects on film, and Altamira Genuine Fractals™ software for incomparable scaling capability, the Super Coolscan 2000 comes close to a drum scanner in virtually every way except one. Price. For more information, call 1-800-52-NIKON, or visit www.nikonusa.com.



LinuxPPC 1999

PORT BRINGS UNIX TO THE MAC

LINUX, THE FREE UNIX-VARIANT operating system that runs on just about any computer you could name, is now available as a commercial release for the Macintosh. LinuxPPC's LinuxPPC 1999 runs on most PowerPC-based Macs and works with most Mac peripheral hardware, including USB and FireWire peripherals. It also includes the latest Linux graphical interface and is easily installed by any steely-eyed propellerhead—but not, unfortunately, by mere mortals.

The packaging is stunningly minimalist: a single CD in a cardboard slipcover, with nary a scrap of paper documentation. (The company says a boxed version, complete with printed manual, is in development.) Inexplicably, the CD itself contains no installation documents—you must download those from LinuxPPC's Web site. You'll need those installation docs, too, because the install process is harshly non-intuitive. You first partition your hard drive to separate your Mac OS and Linux worlds, and then boot up Linux from the CD and run a graphical installer to load the application itself. If you do everything correctly,

installation takes about an hour. Mac OS and Linux operation are mutually exclusive, but a Bootx utility lets you choose between the two at start-up.

Once you get LinuxPPC up and running, it's fairly easy to operate using the vaguely Mac-like X Window interface and

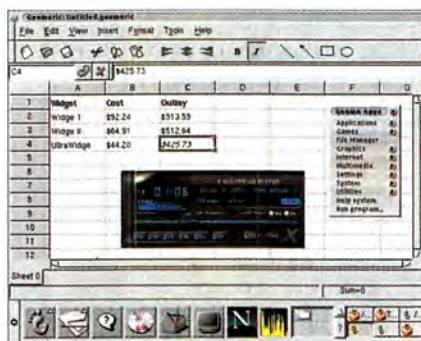

Pretty Face LinuxPPC 1999 sports a full-featured graphical user interface and desktop environment.

K Desktop Environment. You get plenty of bundled software: the Apache Web server, Netscape Communicator 4.5, multimedia players (including one for MP3), complete C and Java environments, other communication tools, and—Linux's hallmark—all the source code.

The most common application for

Linux is as an Internet or intranet server—the Apache Web server boasts legendary performance and a price that can't be beat. Keep in mind, however, that you get what you pay for, and with the \$32 LinuxPPC you didn't pay for support—at least not by phone. The company offers limited support via e-mail, and a number of mailing lists and newsgroups provide communal support.

Linux performed very well on our 450MHz Power Mac G3. The graphical interface was crisply responsive, and an informal test of the Apache Web server showed it to be considerably faster than Apache running under Apple's OS X Server. Alas, we experienced a number of unexplained crashes of the graphical interface.

Macworld's Buying Advice LinuxPPC 1999 is a well-executed port of the latest Linux distribution. If you're technically savvy, you'll find Linux a speedy server. But a Macintosh it's not, so don't even think about running a LinuxPPC-equipped machine as a desktop computer.—MEL BECKMAN

RATING: **PROS:** Runs on most PowerPC Macs; coexists with Mac OS; fast Web server.

CONS: Poor documentation; complex installation.

COMPANY: LinuxPPC (414/427-8555, www.linuxppc.com). **LIST PRICE:** \$32.



Best Reseller Prices.

HE'S GOT
A WEBSITE.
DO YOU?

E-Commerce Enabled

Resellers, We Refer Design Work

30 Day Money Back Guarantee

The Best Support and Pricing in the Industry.

Yeeehaaaaw! It's what you'll say when you sign up with or switch to Interland® web hosting. Prices from as little as \$19.95 a month. Dual DS-3 connections for extra speed. A whopping eighty megabytes of disc space. Guaranteed 99.9% uptime. 24x7 toll-free support for the wee hours. And pricing with absolutely no hidden charges. You'll be happy, we guarantee it!

Check out our website and discover why more and more people worldwide are trusting their websites to Interland. Whether you're a computer veteran or just getting started, you'll receive the best service, support and technology the industry has to offer. At a price that's right for you. Not to mention a great reseller program. Give us a call today, and let Interland bring you the world.

Pricing From \$19.95 per Month

Call Today 1-800-599-0547
(404)586-9999

® Speed. Reliability. Support.
interland®
Web Hosting
www.interland.net

Now it's easier to than it was to shoot.

Easiest scanning ever
with Agfa ScanWise™
software

36 bit, 600 x 1200 dpi

PC or Mac® compatible

Starting at \$99*

USB, parallel port or SCSI

SnapScan™ scanners with 



www.agfahome.com

AGFA 

*AGFA MSRP 5/99. © 1999 Agfa Corporation. AGFA and the Agfa rhombus are registered trademarks of Agfa-Gevaert AG.

Choose 21 at www.macworld.com/getinfo

WorkingPapers Pro 2.0

PAPER-ARCHIVING TOOL HELPS YOU GET ORGANIZED

PAPER DOCUMENTS OF ALL kinds clutter your business and personal life. Dominion Software's WorkingPapers Pro 2.0 offers a solution: a centralized repository for scanned documents, faxes, and other scraps of information. WorkingPapers Pro lets you categorize, prioritize, and organize documents and find them later using keyword searches. Alas, its user interface is not as helpful as it could be.

Dominion sells WorkingPapers Pro exclusively as an online download that includes a nicely written user guide, online help, and a brief tutorial. You begin feeding documents into WorkingPapers by scanning, importing, or dragging and dropping them. WorkingPapers automatically creates a thumbnail picture of every page and prompts you for descriptive text. Any group of documents dropped onto the application's icon gets archived as a batch into a single WorkingPapers file.

WorkingPapers displays an archive file in a window with a full-size view on the left and a scrolling list of icons on the right. You pick a page from the thumbnails list and can

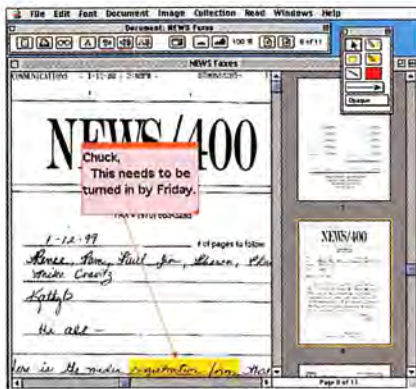

Carpe Document WorkingPapers Pro 2.0 lets you capture, annotate, and archive documents.

then edit the image and annotate it with Post-it-style notes, arrows, translucent highlighting, and even a voice message. You can ask WorkingPapers to run an OCR scan on a document to retrieve editable text, which you may use for subsequent searching. OCR accuracy isn't critical, because WorkingPapers' search function lets you control the "fuzziness" of the search. In

addition to categorizing documents by keyword, you can organize them into hierarchical collections. Multiple users can share collections as well as individual archive files.

Although WorkingPapers offers excellent record-keeping skills, the program's user interface has a few rough edges. You can't resize the thumbnail area, which limits the number of thumbnails you can view at once. You also can't view full-size documents side by side—a feature that most other applications designed for electronic document viewing support—or drag pages within an archive. And the absence of links to e-mail or fax applications makes it difficult to send documents to others.

Macworld's Buying Advice WorkingPapers Pro 2.0 puts powerful organizational tools at your disposal, but it lacks some features of scanner-bundled products. For those whose scanner didn't include such software, however, WorkingPapers is a worthwhile investment.—MEL BECKMAN

RATING: ★★★ **PROS:** Built-in OCR; supports fuzzy searching; accepts voice annotations. **CONS:** Can't resize thumbnail area; no side-by-side viewing; no e-mail or fax interface. **COMPANY:** Dominion Software (617/332-1144, www.dominionsw.com). **LIST PRICE:** \$99.

PowerBook® or Desktop VST has the portable solutions you are looking for.

VST now offers USB and FireWire products for your computing needs.

Our thin, lightweight and portable Hard Drives come in sizes all the way up to 14GB.

The newly announced full height Hard Drives have a maximum storage capacity of 22GB! We also offer Zip® technology in both full height and thin drives. Our USB line which consisted of a floppy drive was just complimented by a line of Hard Drives! Come visit our web site today, and learn more about what VST can bring to you.



VST Products are available at www.vsttech.com

Apple, Macintosh, iMac, and PowerBook are registered trademarks of Apple Computer, Inc. Zip is a registered trademark of Iomega Corp.



Circle 73 on card or go to www.macworld.com/getinfo



Your iMac info center.

www.imacworld.com



APC Back-UPS Pro® and
APC Back-UPS Office®

FREE 68-page Guide to Power Protection

- YES!** I want to know how to choose the right UPS for my system.
Please send me my FREE Guide to Power Protection.
- NO,** I'm not interested at this time but please add me to your mailing list.



KEY CODE
n638z

Just mail or fax this completed coupon for
our FREE 68-page Guide to Power Protection.
Better yet, order it today at the APC Web site!

<http://promo.apcc.com> KEY CODE
n638z

(888) 289-APCC x8664 • FAX: (401) 788-2797

APC®

Legendary Reliability™

Name: _____

Title: _____ Company: _____

Address: _____

City/Town: _____ State: _____

Zip: _____ Country: _____

Phone: _____

Brand of UPS used? _____ # _____

Brand of PC used? _____ # _____

Brand of Servers used? _____ # _____



**NO POSTAGE
NECESSARY
IF MAILED
IN THE
UNITED STATES**

BUSINESS REPLY MAIL
FIRST-CLASS MAIL PERMIT NO. 36 WEST KINGSTON RI

POSTAGE WILL BE PAID BY ADDRESSEE



KEY CODE: n638z
Department: C
132 FAIRGROUNDS ROAD
PO BOX 278
WEST KINGSTON RI 02892-9920

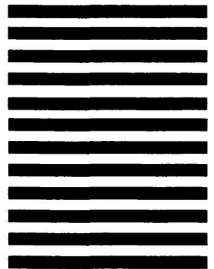

How to Contact APC

Call: (888) 289-APCC
use the extension on the reverse side

Fax: (401) 788-2797

Visit: <http://promo.apcc.com>
use the key code on the reverse side

APC
Legendary Reliability™

Nothing lasts longer.



APC Back-UPS®, APC Back-UPS Office® and APC Back-UPS Pro® will provide runtime which meets or exceeds that of any same VA UPS for desktop PC applications or your money back. (See policy for details.) For more information, visit www.apcc.com.

The world's best-selling UPSs now start at \$99.⁰⁰

With over 45% of all data loss and downtime caused by bad power, your investment in an APC uninterruptible power supply (UPS), with surge protection and battery back-up, pays for itself the first time you use it. APC Back-UPS® provides clean, consistent power to your CPU and monitor, plus power protection for your external modem, laser printer, fax machine, or Zip™ drives, all backed by a \$25,000 guarantee*. Plus, telephone/network surge suppression keeps you safe when you're online. APC Back-UPS: the power and features you want plus the peace of mind you get with APC's Legendary Reliability™.

Back-UPS Pro® Power User Features



• PowerChute® plus power management software automatically saves data, closes programs, and shuts down your computer.

• Automatic battery self-test ensures battery readiness



• "Your PC's data is your life. Don't take any chances. The Back-UPS Pro 650 gives you

650VA protection and the longest battery life of any UPS we tested."
- PC Computing

- Automatic Voltage Regulation (AVR)
- User-replaceable battery
- Push-button circuit breaker eliminates the need to replace a traditional fuse
- Internet and network-ready
- Transformer block spacing

- Site Wiring Fault Indicator automatically identifies building wiring problems
- Longest Runtime Guarantee
- \$25,000* guaranteed lifetime equipment protection (*See policy for details.)

APC
Legendary Reliability™

Name: _____
Title: _____
Company: _____
Address: _____
City/Town: _____

State: _____
Zip: _____ Country _____
Phone: _____
Brand of UPS used? _____ # _____
Brand of PCs used? _____ # _____
Brand of Servers used? _____ # _____

FREE 68-page Guide
to Power Protection



- YES!** I want to learn how to choose the right UPS for my system. Please send my FREE Guide.
- NO,** I'm not interested at this time, but please add me to your quarterly newsletter mailing list.

Order now <http://promo.apcc.com> Key Code n638z

888-289-APCC x8664 • FAX: 401-788-2797

Snapz Pro 2.0

CAPTURE TOOL GOES TO THE MOVIES

MOST MAC USERS KNOW THAT capturing screen images is as simple as pressing ⌘-shift-3 or ⌘-shift-4. So why would you pay \$40 for Snapz Pro 2.0, Ambrosia Software's screen-capture utility? Easy—not only is Snapz Pro more flexible and capable than Apple's method, but the latest iteration captures QuickTime video and audio as well.

Like earlier versions, Snapz Pro 2.0 easily outpaces the Mac OS's image-capture routine. After invoking the user-defined keyboard shortcut to produce Snapz Pro's Capture Palette, you can choose to grab an entire screen, a window, a menu, or a selection. You can also select the resulting file's format—PICT, GIF, JPEG, TIFF, or PNG. (You'll need QuickTime to save files as GIFs or JPEGs and QuickTime 4.0 to save them in the TIFF or PNG format.) In addition, you can assign a parent application for each saved-file type—for example, you can specify that all TIFF captures be saved as Photoshop documents. You can also change an image's scale and color depth.

Video and audio capture works similarly to static capture—you can capture

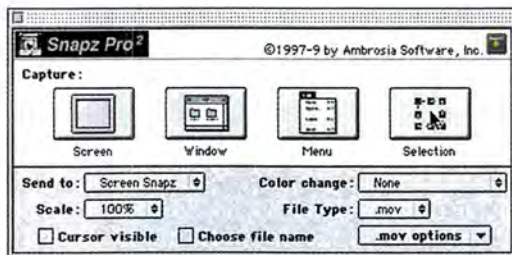

No Fromage Snapz Pro 2.0's wealth of capture options is anything but cheesy.

action from an entire screen, a window, a menu, or a selection. The difference is that the success of your capture depends on which of these sources you select, how large that source is, and how willing you are to compromise on the color depth and frame rate. Although Snapz Pro 2.0 lets you capture full-screen, full-motion 30-frames-per-second (fps) video while your monitor is set to millions of colors, Macs simply aren't capable of producing adequate results with these settings—everything slows to a crawl during the capture, and the resulting QuickTime movie reflects that slowness.

Reducing the monitor's color depth helps a great deal—at 256 colors, from a large Microsoft Word window, we were able to capture at a reliable 10 fps on a Rev. B

iMac. By decreasing the size of that window by two-thirds, we could capture at 15 fps. Capturing audio—you can capture the Mac's audio, click sounds, and microphone input separately or concurrently—also takes a slight toll on performance. With the proper settings, you can produce movies that are perfectly adequate for presentations or training videos (the purposes for which Snapz Pro was designed), but don't expect

completely fluid motion unless you severely limit the size of your selections.

Macworld's Buying Advice For those who need a flexible tool for capturing static screens, look no further than Snapz Pro 2.0. If your needs include video and audio capture for presentations and teaching, be prepared to adjust your Mac, Snapz Pro, and your expectations. Once you've fine-tuned these elements, you'll find Snapz Pro a useful utility.—CHRISTOPHER BREEN

RATING: ★★★★★ **PROS:** Flexible capture of static images; reasonable video capture after adjustment. **CONS:** Requires some initial tweaking. **COMPANY:** Ambrosia Software (800/231-1816, www.ambrosiasw.com). **LIST PRICE:** \$40.

PageMaker

FireWire® Solutions! OrangeLink FireWire® Series

OrangeLink FireWire PCI Board \$169

Ideal FireWire interface for PCI slots of your Beige G3 & Power Mac. Compatible with Adobe® Premiere®, Apple Final Cut Pro™ and new VST® hard drives.

OrangeLink FireWire CardBus PC Card... \$179

Perfect add-on for your PowerBook PC Card slot. Compatible with Adobe® Premiere®, Apple Final Cut Pro™ and FireWire® hard drives.

OrangeLink Hub \$99

6 port FireWire expansion hub. Includes cable and power supply. Enhances "Hotplug" by eliminating daisy-chain.

OrangeLink Repeater \$49

Allows additional 15 ft. extension for any FireWire peripheral. Up to 225 feet with multiple repeaters.

OrangeLink FireWire/SCSI Converter \$99

External adapter allowing users to connect Fast SCSI devices through a FireWire port. Save a slot in your "Blue and White" G3. Includes cable.

OrangeLink FireWire/USB PCI Board \$199



For Beige G3s and Power Macs with PCI slots.



For PowerBooks with PCI slots.



FireWire Hub



FireWire Repeater

Orange Micro inc.

"19 Years of Innovation and Excellence"

(714) 779-2772 • www.orangemicro.com

©1999 Orange Micro, Inc. All rights reserved. Apple and Final Cut Pro are trademarks of Apple Computer, Inc. All other trademarks are the property of their respective owners.

e-mail: sales@orangemicro.com

MacCentral.com
Mac News First

Circle 60 on card or go to www.macworld.com/getinfo



One click puts your business on the Web!

Introducing Corel Print Office™ 2000 for Macintosh®—the easy way to give your business widespread exposure.

Create professional-looking business material that will set your company apart, then publish it to the Web* with the click of a button!



Easily create:

- Web sites
- Brochures
- Business cards
- Newsletters
- Raffle tickets
- Flyers

... and more!



FREE! ** Corel® Stock Photos

Receive \$50 US worth of Corel Stock Photos when you register online* through Corel Print Office 2000 for Macintosh.

Also available for the PC.

*Internet access required.

**You must purchase Corel Print Office 2000 for Macintosh between Aug. 29 and Nov. 1, 1999, and register by Nov. 15, 1999. You cannot register through Corel's Web site.

Copyright © 1999 Corel Corporation. All rights reserved. Corel, Corel Print Office and the Go further logo are trademarks or registered trademarks of Corel Corporation or Corel Corporation Limited. Macintosh and the Mac logo are trademarks or registered trademarks of Apple Computer, Inc. All other product, font and company names and logos are trademarks or registered trademarks of their respective companies.



Go further™
www.corel.com

Noesys 2.0

COMPLETE TECHNICAL VISUALIZATION

DON'T BE MISLED BY THE RELATIVELY minor version-number jump from 1.1 to 2.0; the latest version of Fortner Software's Noesys is no modest update, but rather the most complete scientific-visualization program ever offered on the Macintosh. Despite some growing pains from grafting Research Systems' Interactive Data Language (IDL) onto Noesys's original FORTRAN interpreter base, this package easily handles problems that were beyond desktop computers only a few years ago.

To see why scientific visualization presents unique data-handling challenges, consider a color-coded map of world surface temperatures. Temperature data at one-mile intervals for this kind of map would normally yield a file of roughly 100MB, and such files require their own data-packing protocols for real-time display. That's why the geophysics and fluid-dynamics fields—among others—use special file types, each with its own requirements for efficient editing and handling. Besides faithfully displaying and translating all these types, Noesys can now open and display images of

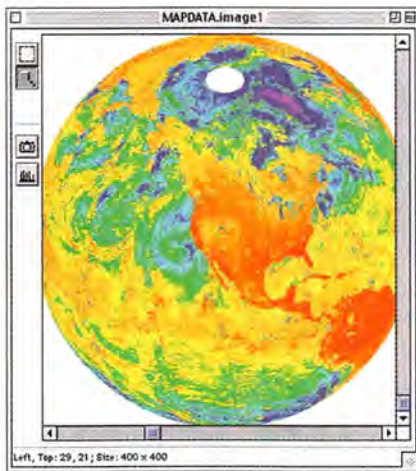

Big Green Marble In Noesys 2.0, you can turn this projection of world surface temperatures into a rotating display, even using gigabyte-size files.

files that are too big to fit in memory, paging file sections from your hard disk at a usable speed.

The integration of Noesys with IDL essentially gives scientists a complete C++-style programming language with single-command graphing for massive data structures. The software is available in three forms: Noesys 2.0 is the updated imaging suite with command-line IDL data-analysis

commands; the \$795 Noesys 2.0 Plus adds the ability to run compiled IDL routines; and the \$2,390 Noesys+IDL makes the suite completely programmable in IDL. The latter two are distributed by Research Systems (www.rsinc.com, 303/786-9900).

Adding IDL's language to Noesys's intuitive Mac-based interface is generally successful, but IDL has a vast repertoire of tricks that have no analogue in Noesys; be prepared to spend some time developing IDL programming expertise. And the Mac and Windows versions of Noesys 2.0 don't match up exactly: the Mac version has some nice data-editing features that are missing from its Windows counterpart, but it lacks table formatting and nearly a dozen types of global map projection.

Macworld's Buying Advice The union of Noesys and IDL is good news for the Macintosh. Noesys 2.0, in any of its three forms, makes a G3 Mac a nearly ideal visualization device for large scientific, medical, or engineering images.—CHARLES SEITER

RATING: **PROS:** Easy introduction to IDL; large-file display is optimized for G3s. **CONS:** Mac version lacks some graphics and mapping features. **COMPANY:** Fortner Software (800/252-6479, www.fortner.com). **LIST PRICE:** \$495.

furniture for the way you do business.
as individual as you are.



1.800.688.2446 x622

www.agiodesigns.com/mw

free catalog

AGIO DESIGNS™

Circle 52 on card or go to www.macworld.com/getinfo

Get the inside scoop.
MACWEEK.COM

**"With XANTÉ,
my film output
is an exact
science!"**



Steve Meyer
Laughing Gravy Games
Baltimore, Maryland

"When does a graphic artist turn into a scientist? When he does prepress, that's when. Once the creative part is over, you have to shift gears. You have to stop being a free-form thinker and start being very precise about output quality. In prepress, there's zero tolerance for error, and since our XANTÉ® Accel-a-Writer® 3G Film System arrived, being precise has been easy. X-ACT™ technology ensures my printed output comes out accurate every time. I get precision output without a lot of maddening experiments."



The XANTÉ Accel-a-Writer 3G Film System • Highest resolution of any printer in its class — up to 2400 x 2400 dpi • Superior halftones with line screens up to 150 lpi • Precision output with XANTÉ's exclusive Graphic Software Package • Greater flexibility with oversized output up to 13" x 35.5" • Desktop film capabilities generated with the Accel-a-Writer 3G and processed using the FilmStar™2

 **XANTÉ**
Innovative Prepress Solutions

1-800-926-8839, ext. 2162 • Fax: 334-342-3345 • www.xante.com

©1999 XANTÉ CORPORATION. XANTÉ, Accel-a-Writer, X-ACT, and FilmStar are trademarks or registered trademarks of XANTÉ CORPORATION. Adobe, PostScript, PostScript 3, and the PostScript logo are trademarks of Adobe Systems, Incorporated. Other brands and product names are trademarks or registered trademarks of their respective holders. XANTÉ CORPORATION, Post Office Box 16526, Mobile, AL 36616, tel: 334-342-4840, fax: 334-342-3345.

Circle 112 on card or go to www.macworld.com/getinfo

Quake II

PC SHOOTER FINALLY COMES TO THE MAC

GAMERS HAVE WAITED MORE than a year and a half for the Mac version of Quake II, Activision's sequel to the classic first-person shooter. Was it worth the wait? If you have hardware robust enough to run the game, the answer is yes.

As with most games of this type, the goal in Quake II is to dash about and blast everything that moves. However, unlike in the original game, Quake II asks that you tackle jobs more intricate than simply clearing hallways of hellions. Because the game is mission-based, you must perform such tasks as knocking out a communications system and sabotaging a reactor. This scheme also means that in Quake II, you must move between large areas of an alien complex to get the job done.

Quake II differs from the original in other ways. The game sports a host of new foes; some, such as the Parasite and Icarus, seem to pop out of nowhere and are both deadly and annoying. In addition, your enemies' AI is slightly improved—later in the game, the baddies crouch to avoid the deadly deliveries you've launched their way (you



Quaking in Your Boots Expansive landscapes such as this are typical of Activision's Quake II.

can now crouch as well). In networked play, you can choose a wider variety of skins and you can actually tell what kinds of weapons your networked opponents are holding. These new elements help improve a game that was a blast to begin with.

Quake II is a far prettier game than Quake when played under hardware acceleration. The same can't be said for software rendering. It is downright ugly when played with software rendering at resolutions of less than 640 by 480 pixels, and performance suffers as well. On a Power

Computing PowerTower 180e, the game became playable only with a Voodoo 2 card. Under software rendering at a resolution of 640 by 480, the game churned out a choppy 8.2 frames per second (fps). Software rendering on a 233MHz iMac wasn't much better—a scant 11.8 fps. Playing Quake II with the iMac's on-board Rage Pro accelerator boosted the frame rate to a more tolerable 13.8 fps. If you want the best from this game, however, you'll require a G3 processor and either ATI's Rage 128 or 3dfx's Voodoo chip.

Macworld's Buying Advice

"More of the same presented more attractively" pretty well describes Quake II. If you liked the original and have the hardware to pull the best from its sequel, you'll enjoy Quake II.—CHRISTOPHER BREEN

RATING: ★★★★★ **PROS:** Beautiful under hardware acceleration; typically frantic shooter action. **CONS:** Requires robust hardware. **COMPANY:** Activision (310/255-2000, www.activision.com). **LIST PRICE:** \$45.

PowerBook® or Desktop VST has the portable solutions you are looking for.

Along with our new line of USB and FireWire peripherals, VST still continues to offer PowerBook users all they could ever want. Our PowerBook product line consists of expansion bay: Hard Drives, a SuperDisk™ Drive, a Zip®100 Drive and a new DVD-ROM kit. We also offer a dual slot Charger, batteries, an Auto Adapter, an AC Adapter and our new FireWire CardBus Card. Come visit our site to learn more!



VST Products are available at www.vsttech.com

Apple, Macintosh, iMac, and PowerBook are registered trademarks of Apple Computer, Inc. Zip is a registered trademark of Iomega Corp. SuperDisk is a trademark of Imation, Corp.



Circle 73 on card or go to www.macworld.com/getinfo



Attention Marketers!

Capture the attention of over a quarter of a million Macintosh enthusiasts, live and on-line, at the next Macworld Expo in San Francisco! Put your products in touch with the most active Macintosh buyers—don't miss this opportunity for maximum brand exposure! Find out how Macworld Live can work for you; call your local Macworld sales rep today. Or contact Karla Kyrias at 415-278-8542, karla_kyrias@macworld.com for more information.



What the %*#@ is this?

Without MacLinkPlus® Deluxe, you'll never know.



Is it a critical spreadsheet file? Is it a photo of your cousins at the Grand Canyon? Who knows? Certainly not you... because you can double-click it 'til your finger falls off, but it just won't open. Why? Maybe it originated on a Windows® machine, or was compressed, or was created with a program you don't own. Whatever the case, you need *MacLinkPlus Deluxe 11*. Over 10 million users already rely on it to open, decompress, and convert documents. So when a file arrives on your Mac, you double-click it, it opens. End of story.

MacLinkPlus Deluxe is one of several Mac, PC and Palm Organizer programs from DataViz®, the compatibility experts. Buy or upgrade at our Web site, or at many software retailers, including:

DataViz®
Compatibility. Instantly.

www.dataviz.com/MLPlus
1-800-270-0030 x216

COMP USA
The Computer Superstore

Fry's
ELECTRONICS

MICRO CENTER
THE COMPUTER GEAR HEAD'S STORE

Circle 142 on card or go to www.macworld.com/getinfo

WEB GEEK

ARTISTE





© 2007 Adobe Systems Incorporated. All rights reserved. Adobe, the Adobe logo, and GoLive are trademarks of Adobe Systems Incorporated. Apple, the Apple logo, and Mac OS X are trademarks of Apple Computer, Inc., registered in the U.S. and other countries. All other trademarks are the property of their respective owners.

Adobe GoLive



Every Web designer has two distinct sides to their personality. The artistic design side and the esoteric HTML side. And now you are the master of both with Adobe® GoLive™.

GoLive lets you create stunning and highly functional Web designs without having to write one line of HTML. Because GoLive generates code automatically. Just start designing and let GoLive do the coding.

GoLive gives you the creative freedom you need to push your designs to a new level of artistry and interactivity. No matter how outrageous your ideas, GoLive ensures they not only look exquisite, but all work together when posted. GoLive even gives you instant interactivity capabilities with JavaScript™ features to bring your ideas to life like never before.

Best of all, GoLive is available for both Mac® and Windows® platforms. So you can design and develop wherever you're most comfortable.

Prepare to master a whole new side of your personality. To download a free trial version of Adobe GoLive, visit our Web site at www.adobe.com/golive99



EXPAND YOUR HORIZONS



The Next Generation of the Greatest Strategy Game Series of All Time

CIVILIZATION

CALL TO POWER

CALL TO POWER ADVANCEMENTS

All-new strategies, including unconventional warfare · More units, buildings, Wonders and technologies · Vast new realms: Space and Sea
Fully-animating, hi-res, 16-bit graphics · Breakthrough time-saving interface · Enhanced diplomatic and trade options
Internet and LAN Multiplayer · All-new Wonders of the World in stunning cinematics

AVAILABLE IN STORES SOON!



ACTIVISION

www.activision.com

westlake
INTERACTIVE

Civilization: Call To Power © 1999 Activision, Inc. Activision is a registered trademark and Call To Power is a trademark of Activision, Inc. CIVILIZATION computer games © 1991-1998 Hasbro Interactive, Inc. (successor to MicroProse, Inc.). MICROPROSE and CIVILIZATION are U.S. registered trademarks of Hasbro or its affiliates. This product is made and sold under license from Hasbro Interactive. All rights reserved. Published and distributed by MacSoft, a GT Interactive Software Company. All other trademarks and trade names are the property of their respective owners.

MacSoft[®]

A GT Interactive Software Company
www.wizardworks.com/macsoft/

Circle 29 on card or go to www.macworld.com/getinfo

The Game Room

Does Apple Really “Get” Gaming?

IT'S TRYING . . . BUT IT NEEDS TO DO MORE

by Christopher Breen

Nobody should be surprised to hear that I care passionately about computer gaming. Give me a choice between hunkering down over the latest Mac-based digital diversion or a hot fudge sundae (*with the cherry, thank you very much*), and I'll take the game every time. But having this level of commitment to Mac gaming can be a burden. It's a bit like being a Chicago Cubs fan—the team may look good in midseason, but you just know that in the stretch the boys will find some way to screw it up.

This may help explain my feelings about the current state of gaming on the Mac. While I'm extremely enthusiastic about the latest advances, I also worry when those advances are undermined by the company that should be as passionate about this stuff as I am—Apple Computer.

The Word from Above

It's possible that those of you who've spent the last few years organizing your sock drawer missed Apple's latest pronouncement that it “gets” gaming. What the company means by this is that—unlike during most of the eighties and early nineties—the folks at Apple have finally recognized that a fair number of its customers like to while away their free time with such seemingly pointless diversions as blasting interstellar cooties, unraveling confounding puzzles, piloting high-performance aircraft, and doing battle with both friends and strangers over the Internet.

The proof of Apple's commitment is tangible. The current lineup of blue-and-white Power Macintosh G3s contains a very powerful graphics card—ATI's Rage 128—offering the kind of quality 3-D hardware acceleration that beautifully enhances many of today's games. Apple has also adopted OpenGL, a hardware-acceleration standard used in several PC games. By employing a cross-platform standard rather than insisting on a pro-



able this year than last. Apple's been working closely with developers to bring the best games available on the PC to the Mac market. One need only glance at the latest and upcoming Mac game offerings—Quake II and III, Half-Life, Fly!, SimCity 3000, Rainbow 6, Total Annihilation, Madden 2000, Tomb Raider 3, Caesar III, Railroad Tycoon II, Oni, Racer, and StarCraft—to understand that Apple's burning the midnight oil to get games to the Mac.

As a hard-core Mac gamer, I'm extremely pleased with Apple's efforts—I'm getting the games I want, and I'm getting them in a timely fashion. But I'm afraid that's not enough. Although Apple's addressing the needs of gamers like me, it's not doing enough to encourage other users to become gamers. Regrettably, this threatens the very future of Mac gaming.

Rumblings beneath the Surface

During the most recent Macworld Expo I had the opportunity to speak with a number of game developers, and the message from nearly all of them was the same: While Apple's made a good start, the company must make a greater commitment if the Mac is going to survive as a viable gaming platform.

A common complaint is that Apple isn't doing enough to promote gaming. Sure, more games are coming to the Mac, but new Mac users don't seem to be buying them. According to developers I've spoken with, per-title game sales are no greater now than they were two years—and 2 million iMacs—ago. A good Mac game sold between 25,000 and 35,000 units in 1997, and that number

continues

proprietary one, Apple has made it easier for developers to port PC games to the Mac. This is vital, particularly considering Apple's push for game developers to release a Mac game in concert with the PC version. Simultaneous release isn't simply a bragging-rights issue: a number of serious Mac gamers—myself included—have begrudgingly purchased PCs because they haven't the patience to wait for a game to appear on the Mac a year after its release on the PC.

Certainly, Mac gamers have noticed that there are far more Mac games avail-

hasn't increased. In order for it to increase, Apple must lend its marketing and engineering muscle to the effort.

To begin with, Apple must make games more available to its customers. Unlike major PC hardware vendors such as Dell and Gateway, Apple offers no gaming add-on when you purchase a Mac through the Apple Store, nor are games (except Pangea Software's *Nanosaur* and a demo of Delta Tao Software's *Eric's Ultimate Solitaire*) bundled with new Macs. Offering some kind of bundling option—as an add-on at the Apple Store, as a “free gift” to buyers of new Macs, or included among the discs that come with new Macs—couldn't help but raise the profile of gaming on the Mac. If Apple's concerned about bundling violent games with its machines, it could simply include a coupon that offers a variety of gaming bundles—a bundle of nonviolent games that would appeal to children, a more action-packed bundle for those who prefer a little mayhem in their Mac-ing, and a collection of traditional card and board games for the seniors who seem to be buying the iMac in droves. Let the buyer decide what is and isn't appropriate.

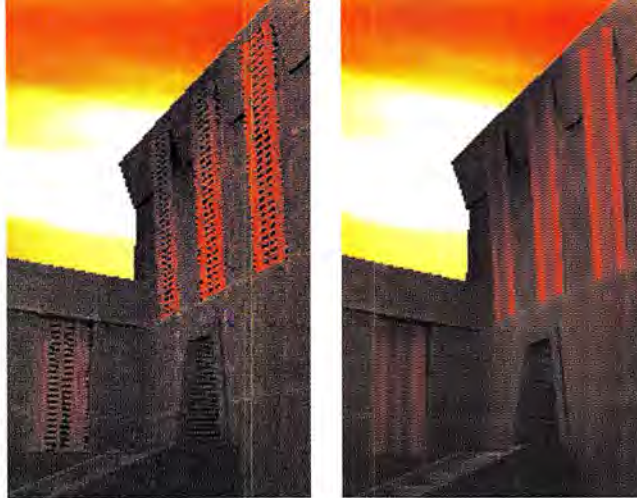

Seeing Is Believing Not only does Activision's *Quake II* play sluggishly on the iMac, the Rage Pro graphics chip on that machine (left) is incapable of producing the same smooth results as ATI's more powerful Rage 128 chip (right).

Apple could also help by making games more visible to the public. Currently, the cost of promoting Mac games falls completely on developers. Those colorful displays and advertisements you see in retail stores and mail-order catalogs aren't cheap, and some of the developers I spoke with feel that since their products encourage people to buy Apple's products, Apple should return the favor by entering into comarketing arrangements. At the very least, it needs to devote a portion of its Web site to Mac gaming—presenting streaming QuickTime movie trailers of the latest hot games, for instance.

Before Apple cuts another deal with a vast retail outlet, it needs to be sure that

said outlet also sells software. Case in point: although iMacs are sold at Sears, the software that runs on them isn't. It doesn't take a rocket scientist to figure out that developers sell more games when their products are placed side by side with Macs, not tucked away in a store at the other end of the mall or, worse yet, the other end of the county.

Viability is just as important as visibility, and unfortunately, Apple's consumer models—the iMac and the iBook

—aren't the viable gaming machines they could be (see “What a Difference a Chip Makes”). These computers contain underpowered graphics chips and lack the kind of RAM necessary to run today's most demanding games. In a consumer machine, 32MB is no longer an acceptable amount of RAM—64MB should be the bare minimum; and Apple needs to replace the Rage Pro and Rage Mobility with chips that offer the kind of graphics performance found in the current Power Mac G3s.

Then Again . . .

It's possible that even if Apple makes all the moves I've suggested—bundles games, helps with in-store promotion, gives games a more visible presence on the Apple site, and transforms each member of its product line into a kick-ass gaming machine—Mac users still won't buy games. Perhaps Mac users find their fun in other ways. But we'll never know until Apple makes a greater effort to encourage Mac gaming.

While I may not be able to predict what will happen if Apple sees the light, this much I can tell you: If Apple continues on its present course—if it only “gets” the side of gaming that appeals to hard-core gamers like me—we'll be right back where we were a couple of years ago. Only those games guaranteed to be hits—the Quakes, Myths, and Tomb Raiders of this world—will appear in Mac form, Mac users looking for a viable gaming platform will look elsewhere, and Apple will sell fewer computers. This is bad news for Mac users and Apple alike. **m**



What a Difference a Chip Makes

Although these three Macs have darned-close megahertz ratings, this benchmark demonstrates that the Rage Pro graphics chips found inside the iMac and PowerBook just don't cut it in our *Quake II* tests. The Rage 128 chip set found inside the current desktop Power Mac G3s more than doubles *Quake II*'s frame rate over those the iMac and PowerBook G3 produce. If Apple really “gets” gaming, it will get rid of the Rage Pro and place a more powerful chip inside the iMac, iBook, and PowerBook G3.

Best results in red. Results are in frames per second.



Behind Our Tests

Frame rates were recorded using *Quake II*'s demo map 1. Each system was equipped with 64MB of RAM, with virtual memory set to 96MB.—Macworld Lab testing supervised by Ulyssis Bravo

Contributing Editor CHRISTOPHER BREEN coauthored *My iMac* (IDG Books Worldwide, 1999).

IT DOESN'T HAVE TO BE THIS WAY.

You've got Macs. You've got PCs.
You share a network. Now, your
printer's not fitting in.

GET POWERPRINT[®] FOR NETWORKS.

It lets both Macs and PCs print
to virtually any PC-printer across
an ethernet network. Whether
you're adding a Mac into an existing
network or a PC printer to a Mac
network, PowerPrint's unique
software and print server solution
allows you to use any printer,
anywhere.

PowerPrint for Networks.

Group therapy that works.

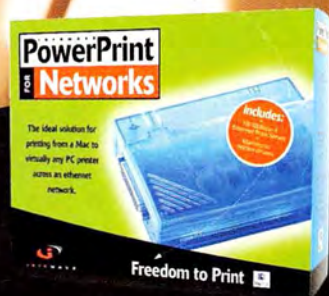

The Ideal Solution for
Mac to PC-Printing Across
an Ethernet Network.

Choose 32 at www.macworld.com/getinfo



INFO WAVE

To pick up PowerPrint, visit major retailers in the U.S. and Canada,
call 888.428.2630 or visit us online at www.infowave.com

SERIAL AND USB SINGLE-USE VERSIONS ALSO AVAILABLE.



FANTASTIC FOUR

With the Power Mac G4, Apple Brings Super Power to Your Desktop

by Andrew Gore

COMIC BOOKS MADE THEIR MARK ON the world by telling the stories of people with amazing and bizarre powers that place them far above the realm of mere mortals. Invisibility, superhuman strength, invulnerability, blinding speed—in the world of superheroes, no capability is too fantastic to be possible.

Though the ability to bend steel with a single thought is still firmly seated in the world of fantasy, another kind of super power just became a reality. With the arrival of the Power Mac G4, the personal supercomputer is finally here.

Based on the new PowerPC G4 processor, which is capable of executing well over 1 billion floating-point instructions per second (the requirement to qualify for supercomputer status), the Power Mac G4 is to most computers what Superman is to the average citizen of Metropolis.

In a world where Apple spends a fortune to get just the right tone, saturation, reflection, and transparency in its plastics, little things can mean a lot. As some readers may remember, *Macworld* wasn't sure what to make of the look of the blue-and-white Power Mac G3 (see "iMac



Envy," March 1999), a model now discontinued after a whopping eight months in existence. It wasn't that we didn't like the blue-and-white G3; we simply felt that it borrowed a little too much from the consumer-friendly look of the iMac to be taken seriously by the professional user it was designed for.

We're happy to report that we feel no such ambivalence about the chassis of the Power Mac G4. Words such as *elegant*, *refined*, and *striking* come to mind. Although the overall design of the case remains the same as for the G3, the Power Mac G4 replaces the blueberry front panel with a shade of gray that Apple calls graphite. The sides are now an opaque silver gray, and you can no longer see through the Power Mac's skin to the metal framework inside. Perhaps most striking are the clear handles, which beautifully offset the graphite Apple logo on the side panels.

Best of all, our favorite feature of the blue-and-white G3's design remains unchanged in the G4—the easy-to-open door that gives users full access to all the Power Mac's internal components.



The G4's Wide-Screen Sidekick

YET AGAIN, APPLE IS TAKING THE LEAD WHEN IT COMES TO COMPUTER display technology. The \$3,999 Apple Cinema Display is the industry's first 22-inch, 16:10 (wide-screen) aspect ratio, digitally controlled LCD panel. We were suitably impressed during our first look at near final prototypes of the display. This sleek, silver device looks remarkable even when it's turned off, and when it's on, it's truly stunning.

The Cinema Display is designed for designers. It's the first LCD panel that looks great from any viewing angle, horizontal or vertical, and it offers the most-consistent color of any LCD we've seen to date. With 1,600 by 1,024 pixels, there's plenty of desktop space for a razor-sharp two-page spread, with lots of room left over for palettes and tool bars.

Because it uses a digital interface, the Cinema Display is free of the complicated setup procedures common to analog LCD panels. In fact, the Cinema Display does away with complicated controls altogether—its only two buttons are for adjusting brightness.

The Cinema Display perfectly complements the new G4's clear, silver, and charcoal color scheme. The LCD panel is framed by a faintly striped silver bezel, which sits atop clear plastic legs that are wide enough apart to let you tuck your keyboard out of the way. An elegantly counterbalanced clear plastic support leg juts out of the rear of the Cinema Display, allowing for easy, single-handed tilting of the display from near vertical all the way back to an angle that's perfect for viewing by a standing group.

There is only a single, permanently attached cable coming out of the Cinema Display. It leads to a doughnut-shaped box that features video, USB, and power inputs. The back of the Cinema Display also offers two USB ports.

The display quality on the prototypes we saw was impressive. The display was bright, sharp, and rock-solid. Colors were vivid and natural, even at wide viewing angles. The result is probably the first LCD worth consideration by serious designers and technology buffs alike.

However, at \$3,999, it's clearly not for everyone. In fact, that price is somewhat misleading—you can purchase the Cinema Display only through the Apple Store and only if you buy it with Apple's fastest G4 systems. Prices start at \$6,498. Even then, expect quantities to be limited for quite some time, as 22-inch LCD technology is brand-new and—at least for the time being—limited exclusively to Apple.—JEFF PITTELKAU



The Power Mac G4 features the same easy-to-open case as its G3 predecessor.

Flame On!

By any measure, the new PowerPC G4 chip is incredibly fast. Using megahertz as a measurement is a start: these three new Power Macs clock in at 400MHz, 450MHz, and 500MHz. But those numbers don't adequately describe the speed of the G4 chip.

The Flash That's because in addition to being faster than the G3 processor and offering higher clock speeds, the G4 includes a new subprocessor that Apple has dubbed Velocity Engine. The name may be new, but the technology is something we've been hearing about for some time—a high-speed subprocessor called AltiVec by the G4's inventor, Motorola. (For more on the G4 processor, see the sidebar "Introducing the G4 Processor.")

Although Motorola and IBM plan to produce G4 chips both with and without Velocity Engine, Apple currently plans to use only G4s that feature the subprocessor. This is a good thing, because applications have to be modified in order to

take advantage of Velocity Engine features.

Several companies have already announced plans to support Velocity Engine—in fact, an Adobe Photoshop plug-in for Velocity Engine will come with every Power Mac G4. The first day the G4 arrived, several other companies announced Velocity Engine support in their products, including Casady & Greene (SoundJam MP) and Terran Interactive (Media Cleaner Pro).

Depending on the program, users could see up to a fourfold improvement over non-Velocity Engine versions in the speed of certain functions, such as complex encryption, graphics filters, and multimedia compression.

Speed Racer However, the speed improvements from the G4 don't end with Velocity Engine. According to Apple, even applications that aren't Velocity Engine-savvy will see significant performance boosts. Some of this has to do with the faster speed of the G4 chip itself,

but some of it also has to do with improvements in the logic board on certain models of the G4 (see the section "Silver Surfer," below).

And keep in mind that the Power Mac G4 is a supercomputer even though there's only one processor inside that gray-and-silver box. Apple stopped shipping Macs with multiple processors mostly because the G3 chip didn't work with multiprocessing. However, the G4 has no such limitations—meaning that G4 Macs with several processors inside are a distinct possibility down the road, especially considering the powerful multiprocessing abilities that will be built into Mac OS X.

Silver Surfer

Not everything about these new Power Mac G4s is as crystal-clear as their curved handles, however. That's because while all these models share the same G4 moniker, some striking differences become apparent when you open their side doors.

Two-Face In the initial Power Mac G4 lineup there are two different configurations, one an intermediate step between the faster G4s and the blue-and-white Power Mac G3, and the other a high-end configuration featuring impressive new technologies.

In order to get one model in the G4 lineup down under \$2,000—and to get it out to customers as soon as possible—Apple placed a 400MHz G4 processor onto a slightly modified version of the blue-and-white G3's logic board and put the board in the new Power Mac G4 case. In almost all other respects, the low-end Power Mac G4 is exactly the same as the G3 Power Macs. One notable exception: none of the Power Mac G4 models feature an ADB port.

As a result of using the older logic-board design, Apple was able to pack a lot into the low-end, 400MHz G4, considering its \$1,599 price tag (see the table, "Power Mac G4 at a Glance"). A low-end version of the G4 featuring a 450MHz

POWER MAC G4 AT A GLANCE

Suggested Configuration *	Direct Price	Maximum Processor Speed	RAM (Maximum)	Memory Bandwidth	Cache RAM	Graphics Slot	Hard Drive	CD/DVD Drive
Power Mac G4/400 (low-end)	\$1,599	400MHz	64MB (1GB)	400 MBps	1MB	66MHz PCI	10GB Ultra ATA/33	CD-ROM
Power Mac G4/450 (high-end)	\$2,499	450MHz	128MB (1.5GB)	800 MBps	1MB	133MHz AGP	20GB Ultra ATA/66	DVD-ROM
Power Mac G4/500 (high-end)	\$3,499	500MHz	256MB (1.5GB)	800 MBps	1MB	133MHz AGP	27GB Ultra ATA/66	DVD-RAM

● = yes; ○ = no. * Models can be configured differently at the online Apple Store (<http://store.apple.com>). ** Each port on these models is on its own bus, doubling the potential USB throughput.

Introducing the G4 Processor

processor will be available in October, according to Apple.

Clobberin' Time The high-end G4s, initially running at either 450MHz or 500MHz, are based on a totally new logic-board design and include some impressive refinements. For instance, the 66MHz PCI graphics-card slot in the blue-and-white G3 and the 400MHz G4 has been replaced by a 133MHz AGP 2x slot. AGP (Advanced Graphics Port) is a high-performance PC industry standard for connecting graphics cards. And according to Apple, with the right driver software, any of the ultrafast AGP cards currently available for Intel PCs will work in the 450MHz or 500MHz G4s.

Memory bandwidth has also been doubled on the higher-end G4s—to 800 MBps (up from 400 MBps on the low-end system)—with the maximum amount of RAM increased to a whopping 1.5GB. That translates to systems that are much faster reading to and writing from RAM—which means RAM-intensive applications, such as Photoshop, will receive major speedups with these models.

Connection Colossus Even USB will run faster on these systems: while maximum throughput remains at 12 Mbps, there is now a separate USB controller for each USB port, giving users with multiple USB devices two independent 12-Mbps data connections, so all USB devices no longer need to share a single connection. Apple has even added an internal FireWire port on the high-end G4s, so you'll be able to add fast internal FireWire devices later.

Taking a play out of Apple's own iBook announcement (see "Meet the iBook," October 1999), the high-end Power Mac G4s come with an AirPort wireless networking slot and an AirPort antenna built into their handle. For \$99, you can add an AirPort card that will let the G4 hop on a high-speed wireless network.

What's more, software that will come with the high-end G4s will allow them to act as an AirPort hub, negating the need

THE POWERPC G4 PROCESSOR THAT DRIVES APPLE'S LATEST POWER MAC systems is not merely a faster version of the previous G3 chip. With its Velocity Engine subprocessor, the G4 incorporates functions that would previously have been performed by separate chips such as digital-signal processors or MPEG decoders.

In technical terms, Velocity Engine—Apple's clever brand name for the AltiVec technology developed by Motorola—is a 128-bit *vector-processing unit*. Most processors chew data one piece at a time; Velocity Engine can perform up to 16 simultaneous calculations. It's especially well suited to accelerating calculation-intensive multimedia operations.

Developers must rewrite their software to take advantage of Velocity Engine features. However, Adobe has already developed a Velocity Engine plug-in for Photoshop, and many other developers have announced Velocity Engine support.

Although software must be written specifically to support Velocity Engine, some other G4 features will accelerate performance in any application. The G4's floating-point unit—used extensively in 3-D rendering operations—is up to 25 percent faster than the G3's at any given CPU speed. In addition, the G4 supports up to a 2MB backside cache, compared with a limit of 1MB in the G3. The backside cache speeds performance by storing frequently used data for quick access by the CPU. Finally, the G4's cache-management system has been improved, so applications run faster than they would on a G3 processor running at the same speed, even if they don't make use of the G4's new features.

One downside of the chip is that it consumes more power and generates more heat than the G3. The main consequence is that current G4 chips cannot be used in laptops. However, it's likely that Motorola will develop low-power versions suitable for future PowerBooks.—STEPHEN BEALE

to buy the \$299 AirPort base station. Apple is still testing the maximum number of wireless connections a Power Mac G4 can handle, but the company expects this capacity to be the same as the hardware base station's (up to 10 clients with a range of 150 feet).

With Great Power . . . At what price comes all this computing muscle? The standard 450MHz configuration will sell for \$2,499, according to Apple. The top-of-the-line 500MHz configuration, featuring a DVD-RAM drive (offering both DVD playback and up to 5.2GB of writable DVD storage), will cost \$3,499.

The Last Word

If you're itching to rush out and buy one of the high-end Power Mac G4s, hold your horses. While Apple says the low-end 400MHz system is shipping now, at press time the company was predicting shipment of the 450MHz G4 model sometime in September and the 500MHz unit in October.

Unless you absolutely can't afford the

pricier models or can't wait another minute, we suggest you bide your time and wait for the high-end G4 configurations to appear. Although the G4 processor does account for a lot of the performance improvements in the new models, the niceties of the new logic-board design will also have major impacts on speed. And if you opt for the low-end model, you won't be able to play with cool new capabilities like using an AirPort card, internal FireWire devices, two separate USB ports, or the new Apple Cinema Display (see the sidebar "The G4's Wide-Screen Sidekick").

Beauty, speed, flexibility—the new Power Mac G4 could put even the most powerful comic-book superheroes to shame. Able to leap the fastest Pentium PCs in a single bound, this new Mac proves that Apple is truly a superpower in the desktop computer world. ■

ANDREW GORE is editor in chief of *Macworld* and *Macworld.com*. He is also a coauthor of *My iMac* (IDG Books Worldwide, 1999).

Zip Drive	FireWire Ports	USB Ports	56-Kbps Modem	AirPort Option
○	2	2	●	○
●	3 (1 internal)	2**	●	●
●	3 (1 internal)	2**	optional	●



WI R E

Your

World



No one could call you an Internet newbie—you've been around the block a few times. You've got a speedy modem, an Internet account, an e-mail address, maybe even a Web site of your very own. But your life on the Internet is still a sporadic one—you dial in when you want to use the Net, then hang up and disconnect yourself from the world at large. | It's time for you to take the next step into the wired world of the future: integrating the Internet into your life and using the power of the Net to its fullest. | Network all the computers in your home or small office, so you can share files and printers, play games, and surf the Web at your leisure via a high-speed Internet connection. Take your old, tired Web site and reinvigorate it with the help of a professional Web designer's expert advice. And put that aging Power Mac back to use as an Internet server, giving you unprecedented control over your Web, e-mail, and file-sharing needs. | In just a short time, it can all be at your fingertips. Isn't it time to wire your world?

Illustrations by Coco Masuda

LINK IT

Share Printers, Surf the Web, and More—Set Up

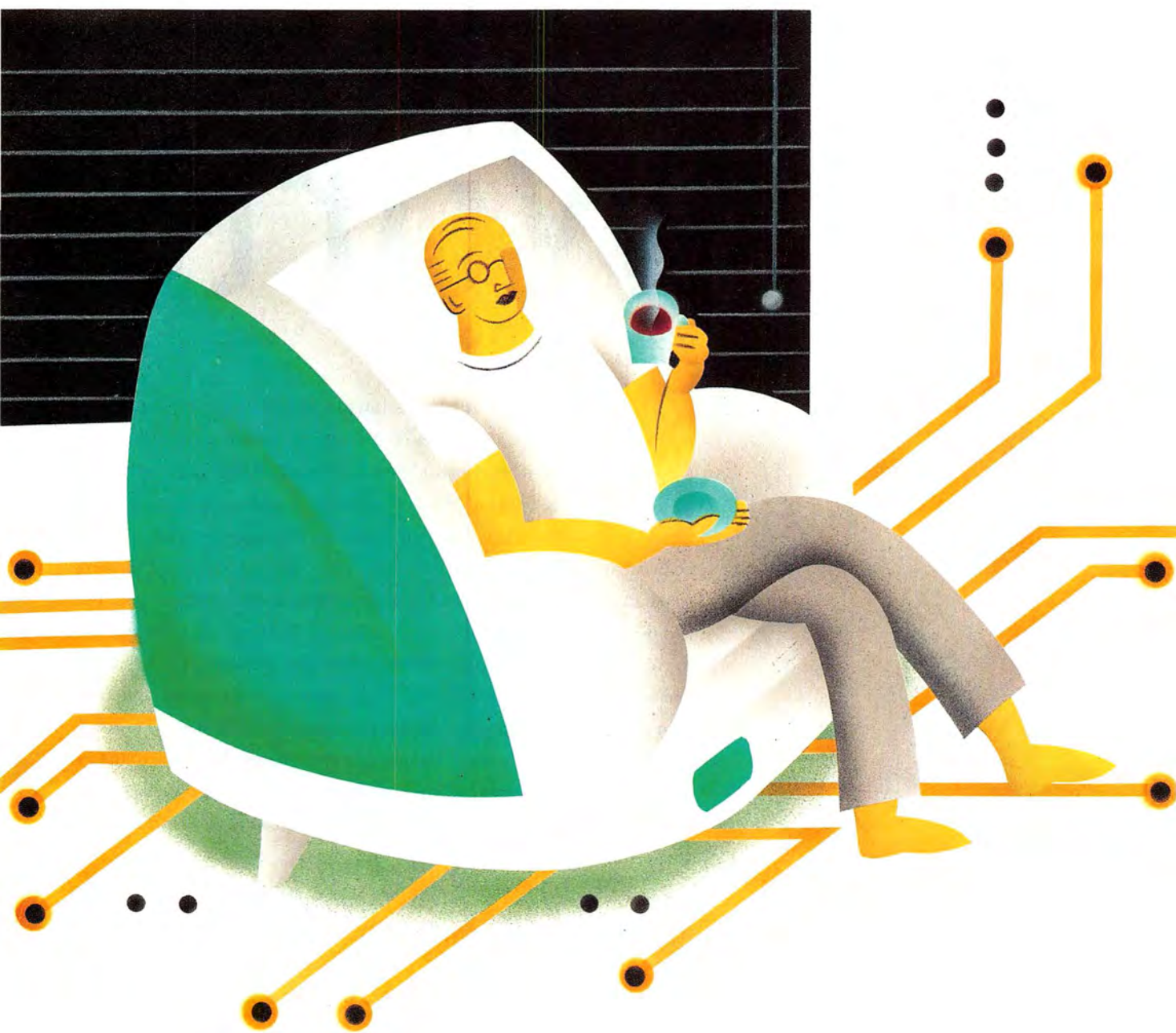

UP

a Small Network

This is a scene that's becoming as quaint as the happy nuclear family of fifties sitcoms: a computer, a printer, and a modem. These days, that simple setup is about as unlikely as a modern family made up of an office-bound husband, a stay-at-home housewife, and two and a half perfect little kids. No, things are a bit more complicated now. Millions of households have more than one computer. The Internet has become part of everyday life—and everyone wants to get on it. At the very least, the appeal of exchanging files and sharing printers should make you consider networking all your home or small office's computers together.

With new high-speed technologies like DSL (Digital Subscriber Line) and cable modems arriving, a small network can also let all your computers share one fast, always-on Internet connection. You can even use the network to play games, not just over the Internet but also between the various Macs (and PCs) you own. And while transferring and backing up your files over a network may not sound sexy, the iMac's lack of a floppy drive makes the network more vital than ever.

You may think that connecting all your computers is going to be a complicated and costly proposition—but it doesn't have to be. Here's an in-depth guide to the terms you'll need to know, the skills you'll need to have, and what you'll get once you're all set up.

Why Create a Network?

At first glance, it might seem like creating a network inside your home is a task reserved for computer geeks and the same 12-year-olds who knew how to program a VCR the day they were born. But there are plenty of practical reasons for you to set up your own network, as I did.

Share Your Files Apple broke with tradition by eliminating the floppy drive from the iMac and the blue-and-white Power Mac G3s. You could spend extra money on a USB floppy drive, but then you have to schlepp disks from the family room to the den and back again. Using a network to transfer files from one Mac to another is faster and easier.

Surf Anywhere A simple problem: you have DSL, a cable modem, or some other means to connect to the Internet (see

"Modems' Last Stand," May 1999), but it works only with the one Mac it's connected to. How can your other computers access the Net using the same connection? A simple solution: use a network and some Internet-sharing software (see the sidebar "Internet Sharing 101"). This is also a great way to avoid buying a modem for each computer.

Play Games All right, so you don't *need* a network to play games. But it's a lot more fun to play against real people, and many of today's hottest games let you beat up on either computer opponents or other humans via network play. You can play against other people on the Internet, family members on your home network, or both.

Share Printers Prices have dropped, but you probably don't want to buy a printer for each of your Macs. If you have a network, though, you can share most printers with every Mac on the network.

Back Everything Up Don't be frustrated by the fact that your new iMac can't back up to your old SCSI-based Jaz, CD-R, or tape drive. When your old and new Macs are networked together, you can back up over the network using Dantz Development's \$175 Retrospect or \$50 Retrospect Express. If you've got an older Mac, you can even set it up in a closet or on the floor as a dedicated backup server, preserving all the files you have on your current models. (For more about backup, see "Be Safe, Not Sorry," February 1999.)

Keep Your Dates Straight My wife and I each have our own Macs, and we have a PowerBook that mostly lives in the kitchen. Thanks to our home network and network-capable calendar and contact software, we can schedule dinner with some friends or look up a telephone number from any one of our computers. Changes are instantly available to any computer, so we don't have to worry about scheduling conflicts or outdated contact information.

Meet the Network

Now that I've convinced you to connect your computers together, it's time to give you an overview of network technology and terminology. That terminology can be intimidating—especially if it's spoken by scary people in white coats who are paid lots of money to keep large corporate networks up and running. But in reality, setting up a simple home network doesn't need to be rocket science.

Into the Ether The most common form of networking around is *Ethernet*, which has been a standard part of most Macs for quite a few years now. Some Macs have built-in Ethernet ports that let you plug an Ethernet cable (which looks like a jumbo version of a telephone cable) right into your Mac. Older versions require you to buy a *transceiver*; a little box that attaches to both your Mac and the Ethernet cable.

Today most Ethernet networks are *10BaseT*, letting you pass data at 10 megabits (roughly 1MB) per second. An up-and-coming protocol is *100BaseT*, which uses the same-size con-



by Adam C. Engst

nectors but can be ten times faster. Many new devices can switch between the two speeds with ease—the iMac, for instance, can work with either 10BaseT or 100BaseT networks.

Ethernet is a tried-and-true networking format. But it's also true that most homes don't have Ethernet running through their walls—and that means if you want to wire up computers in far-flung locations, you'll need to run cables yourself or hire someone to do it for you.

Both 10BaseT and 100BaseT Ethernet are what are called *star networks*. At the center of the network is a *hub*, a box you plug Ethernet cables into. The cables radiate out from the hub in a starlike pattern, hence the name. You don't usually chain Ethernet networks together as you would SCSI devices, connecting one to another and to the next (although Farallon's line of EtherWave products will let you do just that). Normally, you plug one end of an Ethernet cable into a computer and the other into a hub. Each hub can be connected to other hubs, extending the network even more.

Phone-Line Networking A recently developed networking standard is *HomePNA*, a system that uses regular telephone lines as the transport medium for your computer data. The strength of this approach is that unlike the case with Ethernet, most buildings in America are already wired for telephone service. Anywhere in your house you've got a telephone extension (on the same phone line), you've got a potential network connection area.

The most amazing part is that using a HomePNA network doesn't interfere with the voice traffic or DSL Internet connections going over that same set of telephone wires. Although HomePNA isn't as fast as a 10BaseT Ethernet network, at roughly 100K per second it's faster than almost any Internet connection you might have, and more than sufficient for most home network uses.

HomePNA does have some drawbacks, however. First, it's not built into Macs like Ethernet is—you need to buy a special PCI card for each computer in order to get HomePNA to work. It's also a relatively new technology, so there's not nearly as wide a variety of HomePNA products as there are Ethernet products. (As of this writing, Farallon's HomeLine is the only Mac-compatible HomePNA product, although more are on the way.) Several companies—including Intel itself—sell HomePNA products for PCs.

Second, currently there's no way to connect an iMac—which lacks a PCI slot—to a HomePNA network, although an iMac-friendly HomePNA product should be available soon. If you've got an older Mac, a PowerBook, no free PCI slots, or want to network a printer, you may be similarly out of luck.

Wireless Freeing your computers entirely from wires would, of course, be the easiest way to set up a network. Wireless technology is undoubtedly where the world of networking will eventually end up. Instead of using wires, network data can be translated into radio signals that pass through your walls, floors, and ceilings until they're received and deciphered. Wireless networking has traditionally been expensive and not particularly Mac-friendly—but the new AirPort technology introduced with Apple's new iBook threatens to change all that, providing slightly faster speeds than 10BaseT without any wiring. And the new SkyLine PC Card from Farallon, which is compatible with the AirPort, will provide wireless capabilities for older PowerBooks.

Home-Sweet-Home Network

ENOUGH THEORY—LET'S PUT TOGETHER A SAMPLE NETWORK

so you can see how it all works. Our sample family has a

PowerBook 520 and a Power Mac 7200 hooked up to a

LaserWriter via a LocalTalk cable. When they want to move files back and forth, they use floppies, and when they want to print from the PowerBook, they swap the LocalTalk cable from the Power Mac. They've just purchased a shiny new grape iMac and put the Power Mac in the kids' room for games and school projects. They also have a SCSI-based Jaz drive that they've been using on the Power Mac along with Retrospect Express for backups. Finally, they've just installed DSL high-speed Internet access, so they've got a DSL modem that connects via Ethernet, and they want to attach it to all their computers.

In the end, they want a network that lets each Mac print, back up to the Jaz drive on the Power Mac, connect to the Internet, and copy files back and forth as needed. That's easily accomplished, but they'll have to go shopping first.

The newer your Mac, the easier it is to get it on Ethernet. This family's iMac has an Ethernet jack built right in. But they'll have to add Ethernet to the other two computers: in this case, an Ethernet transceiver for both the PowerBook and the Power Mac (roughly \$25 each).

The LaserWriter is networkable but is designed to work only with low-speed LocalTalk networking. With a LocalTalk-to-Ethernet bridge, such as the \$100 EtherMac iPrint LT from Farallon, any Macintosh on the new network will be able to print to it.

Throw in an Ethernet hub, some cabling to connect it all together, and a copy of Internet-sharing software, and you have a network.

NETWORK SHOPPING LIST

ITEM	ESTIMATED PRICE
Ethernet cables (Cat5, five cables)	\$65
Ethernet transceivers (two)	\$50
LocalTalk-to-Ethernet bridge (LaserWriter)	\$100
Ethernet hub (10BaseT, eight ports)	\$50
IPNetRouter	\$89
TOTAL	\$354



1. Plug your Ethernet hub into an electrical outlet. Make sure to put it in a location that's accessible to all of the computers.
2. Run a cable from the iMac's Ethernet port to the hub.
3. Connect the first transceiver to the Power Mac's Ethernet port, and then run a cable to the hub—in this case, our homeowner ran wires through the walls to keep cords out of the way. (One day, wireless networking will make running wires between far-flung locations a thing of the past—but right now, this is probably the best option.)
4. Connect the second transceiver to the PowerBook's Ethernet port, and then run a cable to the hub.
5. Run a cable from the DSL modem to the hub. To share the Internet connection, install Internet-sharing software on the iMac, and make sure the iMac is turned on when any of the other Macs need to connect to the Internet.
6. Set up the LocalTalk-to-Ethernet bridge, and connect it to both the hub (via a 10BaseT cable) and the printer (via its LocalTalk cable).
7. Optionally, the family could purchase Apple's new AirPort base station (\$299) and bring a new iBook home. After the base station is plugged into the hub, an iBook equipped with the \$99 optional AirPort card can roam freely in a roughly 150-foot radius, surfing the Net and exchanging files at Ethernet speeds.

The Network Shopping List

For some people, HomePNA may be a good answer to setting up a simple network—buy the cards, install, plug in, and you're set. But Ethernet has stood the test of time, is readily available, and offers much more flexibility. That's why for the bulk of Mac users, it's probably wise to stick with Ethernet.

AirPort is also a promising technology, but it's still somewhat expensive—an extra \$399 for a base station and an add-in card for one iBook. Even if you do buy an iBook with AirPort, Ethernet makes sense—the AirPort base station comes with a 10BaseT/100BaseT Ethernet port, so hooking that device up to an Ethernet network of desktop computers, printers, and perhaps a high-speed modem will be a snap.

Before you put together an Ethernet network, you'll need to gather all the parts you'll require. Just what's needed will vary depending on the Macs and printers you have, but here's a basic checklist:

Cabling The cabling in my home is called *10Base2* and looks a whole lot like the cable you'd plug into a TV set. But 10Base2's time has passed, and just about every recent Mac model provides built-in support for 10BaseT and/or 100BaseT. That's the type of cable you should use.

Not all cable is created equal. You need at least Category 3, or *Cat3*, cable for 10BaseT networking, but you should always buy Category 5, or *Cat5*, cable instead. Cat5 cable is not much more expensive than Cat3, and it works with the speedier

100BaseT Ethernet. That means if you want to upgrade your network to 100BaseT in the future, you won't have to pull out all your wires and start again.

Ethernet Cards and Transceivers Every Mac that Apple sells today has Ethernet built in, and many older Macs did as well. Although not every Mac is so well equipped, you can add an Ethernet card to just about any Mac, even the ancient SE/30. In most cases, the Ethernet card drops into a slot on your Mac, whether it's a NuBus slot (found on most Mac IIs, Quadras, and the first-generation Power Macs), a PCI slot (found on second-generation Power Macs and later), or even more esoteric slots such as the PDS (Processor Direct Slot) on the SE/30 and IIsi, and the LC Comm Slot found on many Mac LCs and Performas. Older PowerBooks with no such slots can get on Ethernet with the help of an adapter that attaches to the SCSI port, and newer PowerBooks can make use of Ethernet PC Cards. One great resource for this sort of information is Farallon's LAN Product Selector, located on the Web at www.farallon.com/products/selector/. While it covers only Farallon products, you can also use it to figure out generally what sort of items you'll need, whether you buy them from Farallon or some other company.

Older Macs and LaserWriters with built-in Ethernet aren't exactly plug-and-play—rather than the telephone-style jack found on 10BaseT and 100BaseT cables, they have a special connector called an AAUI port. For these devices, you

INTERNET SHARING 101

TO SHARE ONE INTERNET ADDRESS among several computers, you

need a router—something that acts as a traffic cop to handle the flow of Internet data between your computers and the

Internet. For most home and small-office networks, it's easier and more cost-effective to use a software-based router rather than an expensive hardware router.

With five different Mac OS software routers available, how do you decide which to choose to connect your network to the Internet? The decision depends on how many Macs will be using the Net simultaneously and what advanced features you might want.

No matter which product you choose, remember that whenever you're connected to the Internet, it's conceivable that someone could attempt to break into your Mac. All of these products include security features to protect you, but it's also a good

idea to turn off guest access in the Sharing dialog box for shared folders and be careful what you publish using Personal Web Sharing. Realistically, if you take basic precautions, you have nothing to worry about.

Home Networks For a home network with a couple of Macs, your best choices are Vicomsoft's SurfDoubler (\$64; 650/691-9520, www.vicomsoft.com) and SurfDoubler Plus (\$74), or IPNetRouter from Sustainable Softworks (\$89; www.sustworks.com). SurfDoubler is slightly cheaper but allows only two Macs at a time to access the Internet simultaneously. SurfDoubler Plus offers all of SurfDoubler's features, plus parental controls and content-filtering capabilities.

IPNetRouter has no per-user limitations and provides better performance than SurfDoubler when running on older Macs. On the downside, IPNetRouter is somewhat more difficult to install and configure, although Sustainable Softworks provides an excellent tutorial and background information on its Web site. Both companies provide free trial versions of their software on their Web sites.

Small-Office Networks If your network contains more than a few Macs, SurfDoubler's two-Mac limitation eliminates it in favor of Vicomsoft's multiple-user SoftRouter Plus (\$155 to \$430; price varies depending on number of users), which also provides additional features such as the caching of Web pages to increase page loading speed, a local DNS server, and a remote-access server so users can dial into your network. IPNetRouter remains an excellent choice for these networks as well, and can be significantly cheaper than SoftRouter Plus if you don't need SoftRouter Plus's additional features.

School Networks If you feel the need to restrict the users on your network from accessing specific Internet resources, Vicomsoft's Internet Gateway (\$249 and up) might be the best option for you, since it can prevent users from accessing sites on the CyberNot Block List, a collection of Internet sites that researchers at Microsystems (www.cyberpatrol.com) have deemed inappropriate for the typical 12-year-old surfing the Web without adult supervision.

need to buy an AAUI Ethernet transceiver—essentially, an AAUI-to-10BaseT converter box. Luckily, these transceivers are cheap: about \$25.

Hubs With a star network such as 10BaseT and 100BaseT Ethernet, you'll need a central hub that all your devices connect to. These days, you can buy a hub for as little as \$50, although more full-featured hubs can cost significantly more.

When shopping for a hub, there are several issues to keep in mind. Be sure to consider how many ports you'll need on the hub—you'll need one for every device on your network, so make sure to plan for the future. You can also buy two hubs and connect them together, which might help if you've got collections of computers in two or more widely separated locations, such as a main level and a basement. Then all you'll need to do is run one cable between the two hubs. (Keep in mind, however, that 10BaseT and 100BaseT cables are limited to a length of 100 meters, or 328 feet.)

You should also consider whether it makes sense to get a hub that supports both the 10BaseT and 100BaseT protocols. If you own several devices that support 100BaseT, as the iMacs and the blue-and-white Power Mac G3s do, a hub that would let those devices communicate at 100 megabits per second (while every other device moseys along at 10 Mbps) might be worth the higher cost.

Make sure the hub you buy doesn't require you to use a lot of switches, jumpers, or software to get it to work correctly. Ideally, using a hub should be as easy as plugging it into a power outlet and plugging in your networking cables.

Bridges What if you have an old LaserWriter that supports only LocalTalk networking? You can add an Ethernet card to an old Mac, but that's seldom possible with older printers. To solve this problem, you need a *bridge*, a device that connects two dissimilar networks, such as LocalTalk and Ethernet. Bridges are relatively dumb—all they do is pass network traffic from one network to another without analyzing it or routing it in any way. Thus, bridges, which come in either software or hardware form, are relatively cheap.

Software bridges require a Macintosh connected to both networks—it's a good use for an old Mac that has both a printer port for LocalTalk and an Ethernet card. Apple's free LaserWriter Bridge is the most well known bridge software, but it only lets Macs on the Ethernet network print to a LaserWriter on the LocalTalk network. More recently, Apple released the free LocalTalk Bridge, which lets you share files with LocalTalk-based Macs as well as print to LocalTalk-based printers. Download it at <http://asu.info.apple.com/swupdates.nsf/artnum/n11358>. (You can also share StyleWriters on a network, using Apple's Printer Share software.)

The problem is, Apple's bridge software isn't officially supported by Apple—meaning it may have some minor problems running under Mac OS 8.5 and later. Also, activities on the Macintosh running the bridge software can reduce performance between the two networks, and that Mac must remain on at all times if you want to use the devices it's connecting you to.

Hardware bridges don't require a Mac, may not require configuration, and offer more functionality. For instance, some hardware bridges work not just with AppleTalk for printing and sharing files between Macs but also with TCP/IP, so Macs on the LocalTalk network can access an Internet

connection attached to the Ethernet network. If the free LocalTalk Bridge doesn't work for you or if you don't have a Mac that supports both LocalTalk and Ethernet, go for a hardware bridge such as the \$100 EtherMac iPrint LT from Farallon (510/346-8000, www.farallon.com) or the \$129 AsantéTalk bridge from Asanté (408/435-8388, www.asante.com).

Routers Where bridges blindly pass network traffic back and forth between networks, *routers* (also called *gateways*) act more like traffic cops, analyzing and routing network traffic appropriately between two different networks. In the context of small networks such as the ones we're discussing, routers are primarily for connecting an entire network to the Internet. As with bridges, routers can be either software programs or hardware devices.

Hardware routers often sport specific ports for different types of Internet connections. For instance, you might buy an ISDN-capable router, which would have a jack for an ISDN connection and an Ethernet jack. Such a router would connect an Ethernet network to the Internet via an ISDN connection.

The devices you get when you have DSL or cable-modem Internet connections installed are usually called modems, but often they're also routers, since they often use Ethernet to connect to your computer. Though you can sometimes attach these devices to an Ethernet hub, that doesn't mean that all the computers on your network will be able to simultaneously share that Internet connection. In many cases, DSL and cable-modem connections are meant for single computers, despite their Ethernet interface.

Whether you're using a cable modem, DSL, ISDN, or even a regular modem, you can often share your Internet connection among all the computers on your network. What you need is Internet-sharing software, and there are several different options for Macintosh users. To find out how it works, see the sidebar "Internet Sharing 101."

The Last Word

Networking Macs has always been easy, thanks to LocalTalk and built-in software support in the Mac OS. But not until recently has networking become something for everyone, in large part due to more households purchasing multiple computers, especially the network-savvy iMac. The Internet has also played a starring role, since anyone with multiple Macs wants them all to be able to access the Net through a single connection.

Whether it's for sharing an Internet connection, sharing files and printers, backing up your files, or playing games, if you have several Macs, you need a network. ■

ADAM C. ENGST is the publisher of the online newsletter TidBits and a coauthor of the forthcoming *Crossing Platforms* (O'Reilly, 1999), a bidirectional phrase book for Macintosh and Windows users.

ONLINE RESOURCES

For more resources to help you set up your home network, check out our special report at www.macworld.com/1999/11/features/wire.html.

DRESS

Make Your Web Site More Effective and

Never before has it been so easy to build a Web site. From Adobe PageMill to Macromedia Dreamweaver, WYSIWYG (“what you see is what you get”) software packages let you create pages by just dragging and dropping text and graphics into place instead of learning to write HTML code by hand. Heck, you don’t even need to buy software—many Web-site services such as Tripod (www.tripod.com) have page-generating templates that create your code for you.

But is your site easy for its visitors, too? Although WYSIWYG editors can help you build a site quickly and painlessly, they don’t guarantee the same ease of use for the folks on the other side of the browser—the people actually trying to use your site. Just like tourists at an amusement park or customers in a grocery store, your readers need some basic things to help them avoid getting lost or frustrated: orientation, guidance, reference, and motivation. When you really think about it, why build all those pages if they’re so frustrating to use that no one comes back?

Make sure that all the work you put into your Web site is time well spent by taking a few simple strategies to heart. They will make your Web site less frustrating to use and will help you build the kind of site that you’d like to visit yourself.

First Figure Out What You’re Doing

The best work you can do to make your site easier to understand doesn’t even require touching your Mac’s power button. First, ask yourself some basic questions: What’s the purpose of my site? What will people be looking for? What cues might help visitors remember where they are and why they’re here? How can I get readers to stay and compel them to return?

Get to the Point Sit down with pen and paper and write down your site’s purpose in one sentence. Then sketch out what you think the basic building blocks will be. The example we’ll use is a personal site, the purpose of which is to promote your hobby of Apple Computer worship. You might start out initially with a long list of topics you love and think will be fun additions, including a shrine to the System 7 team, your collection of haiku about the Mac Classic, and the scrapbooks of cross-country trips you took with your Apple IIe one summer.

Here’s the list we made for this site: (1) the home page; (2) news; (3) contact information, including an e-mail address;

(4) links; (5) Mac news; (6) Mac shareware; (7) a scrapbook; (8) a personal PowerBook collection; and (9) the Apple IIe.

Stick to It After you’ve made your list, look at it with a critical eye. Because you’ve seen numerous other Mac sites that feature links to news and software resources, you might automatically think this kind of links page would be a good idea for your site too. There’s no doubt that many people appreciate useful links, but that alone isn’t enough reason to throw them in the mix. Remember, the goal is to show how crazy you are about your computer—and what do news and software sites have to do with that? If you stick to your theme, your readers will be able to understand immediately what your site is about, and each section will make sense to them.

With this in mind, we decided to scratch links off our list altogether and focus on the hobby sections: the scrapbook, haiku, and System 7 shrine. (You might decide instead to have a links page but include only links to other fan sites like yours.) As you make these decisions, be vigilant. Extra stuff simply for the sake of extra stuff could make your site charmingly eccentric, but more likely it will make it confusing.

Map Your Site on Paper After you get a good idea what your site’s purpose is and what types of content it will contain, you need to figure out how everything will connect. One of the best ways to do this is to actually map out your site (see the diagram, “Sketching It Out,” for an example).

Note that a lot of the arrows in our example seem to crosslink, leading to a tangled mess. This is not a bad thing—in fact, it’s one of the main points of the exercise. Try to keep your tangled, linky messes on paper. You can erase illogical connections, rearrange everything, or toss out a failed paper diagram much more quickly and easily than you can redo a Web site full of HTML files.

With everything in front of you, you’ll be able to think realistically about whether the way you’ve connected your pages makes sense. For example, our diagram shows that the “What’s New” page links only to the top level of each different section.



by Lisa Schmeiser

IT UP

Attractive with These Expert Tips

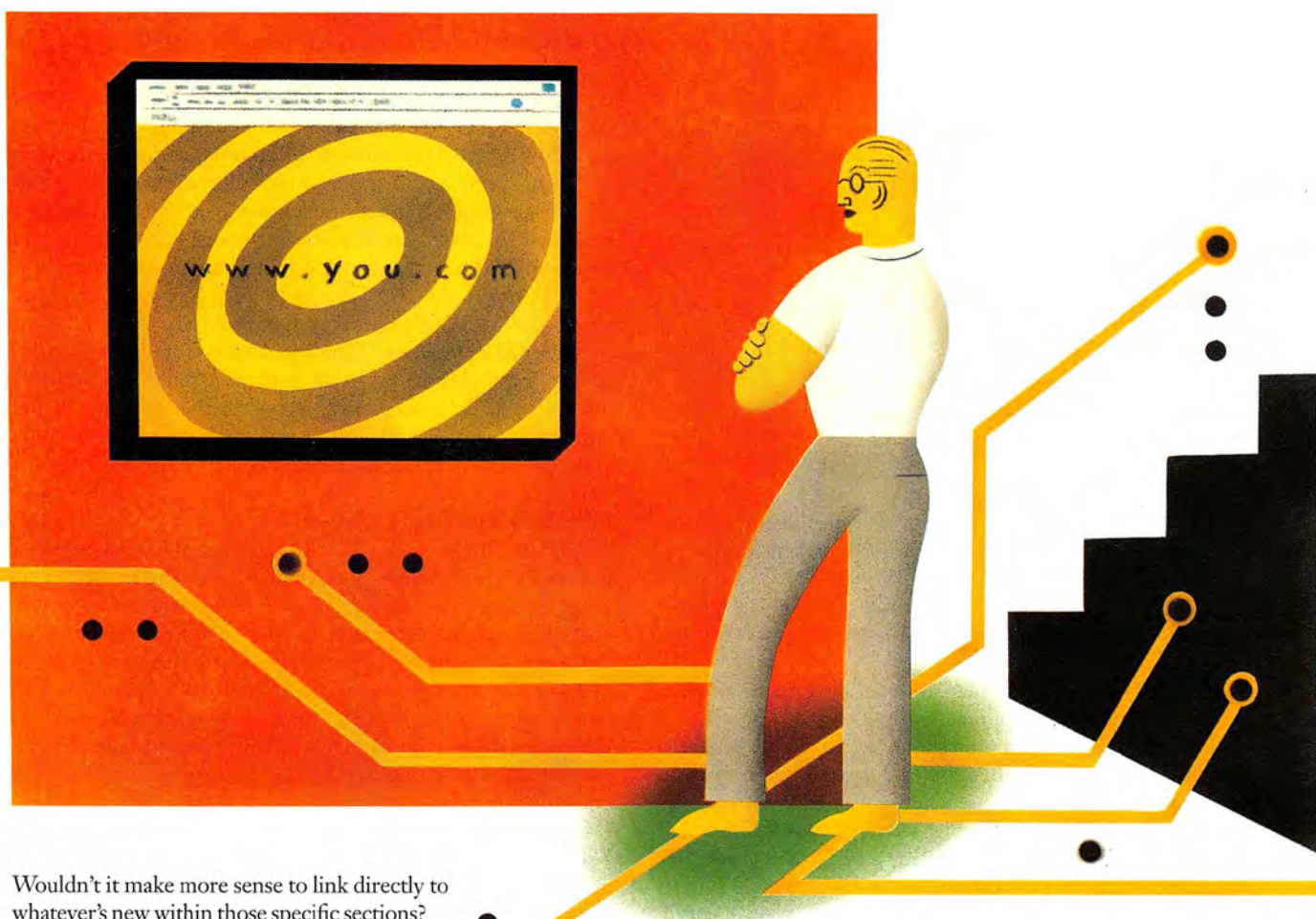

Wouldn't it make more sense to link directly to whatever's new within those specific sections? We reorganized the site to add those links.

As you untangle your pages, you'll discover key entry points to the site, how to direct readers to informative pages, and how to group the pages of your site together logically. For example, the pride and joy of your site might be the scrapbook pages of your Apple IIe sitting in front of assorted national monuments. Do you give those pages their own section—"Road Trip"—or do you put them with other scrapbook pages such as your PowerBook bungee-jumping trip? In this case, we decided to create a single page

called "Scrapbooks" that lists the different scrapbooks and links to a separate page for each one.

Once you've got a solid site outline in place, you're ready to generate the signposts and breadcrumbs that help your users find their way around—the site navigation.

Nail Down Your Navigation

Your users are entirely dependent on you to tell them how to find what they're looking for. Navigation—consisting of the

hyperlinks, graphics bars, or buttons that allow people to move from page to page within the site—provides the guidance they need. This means it deserves some careful contemplation.

The Two-Tier Technique Good navigation typically includes two parts: the primary level (usually the home page) that leads users to the entry points of separate sections (in our example, the scrapbook page, the news page, and the PowerBook collection page) and a secondary level (the main pages for each section) that steers users through the unique contents of your sections. If your site includes a lot of lengthy documents, you may also want to include a third type of navigation—links that move users to the

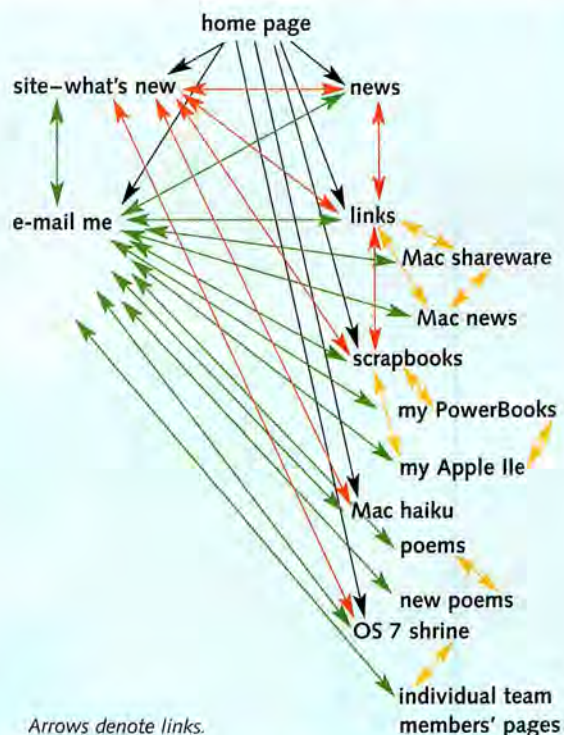

Sketching It Out Before you put your ideas in code, make sure to sketch them on paper. It's a lot easier to sort out a mess like this *before* making your Web pages.

beginning or end of a particular story, or allow them to move back and forth one page at a time.

Nix on the Name Game You should strive to give your sections and navigation elements clear, unambiguous names. Some readers might appreciate whimsy or metaphor, but others certainly won't. For example, some of your readers will know right away what a section called "The Dirt" is about, but you can bet that *everyone* will understand what they'll find in the "News" section. The entire purpose of navigation is to *help* people get around and feel at ease in your site—the last thing you want is to have the basic tools for getting around your site mystify your readers.

Be Consistent

Unlike most software programs, the Web doesn't really offer a predictable *user interface*, or way to get around sites. When you open an application on your Mac, you can be reasonably sure that you'll find pull-down menus at the very top of the screen, and that the leftmost one (which will almost always be called

File) will allow you to open and save new files. The rules for navigating the Web, however, change from site to site.

As a result, it's your job as a Web-site builder to provide an easy-to-grasp interface for your user. Start by assuming that all visitors to your site are first-timers and have less than a minute to figure out where they are and how to get where they want to be. Make the job easier for them by providing clear cues.

A Place for Everything These cues don't have to be complicated. In fact, it's better if they're not. Why set up an elaborate metaphor that you'd have to explain later? The best way to help people get around is to set up a predictable place for everything on your home page or in the section. Save the exceptions for items that you want to stand out.

For example, if the primary navigation on your site is always via a vertical list of links in the left-hand margin of the page, then readers will assume that they can *always* move around the site by clicking in that area. This is how you'll provide references to readers, by giving them a set of constant cues that tell them what to expect from every page.

Color Cues Layout is only one area where you'll want to be consistent; color is another. Readers rely on the colors of links to tell them when they've visited a link or not. You can carry this relationship between color and function further and associate specific colors with different sections of a page or site. (For example, if the section's peach, you must be in today's headlines.) Color is a quick way for your brain to figure out where you are and what you're looking at. One example of this is the *Washington Post's* Web site (www.washingtonpost.com), where each section has a unique color scheme.

The Little Touches Finally, always include page titles (they're in the `<head>` tag at the beginning of the HTML document) so readers can quickly see where they are. You should also include your e-mail address or a link to a contact form on every page; readers like to be able to give feedback quickly.

Provide a Clear Way In and Out

Thanks to search engines, you'll always face the possibility that new readers will land in the middle of your site instead of on the front page. Your job is to provide those readers with a well-lit Exit sign to help them get to your site's front page. Doing this lets your readers reorient themselves so they see your site in a way that makes sense to them, and it allows people to bail out of pages quickly if they aren't where they want to be. If they've dropped in on page five of your epic poem to the System 7 team, for example, they may want to get back to page one quickly so they won't miss a single verse.

Entrances and exits are especially important if you're building a site that includes sequences stretching over several pages. For example, if you're going to ask users to register online, you want to let them know where they enter the registration process, where they are relative to the beginning and ending of the registration, and how to get to the last page. Few people like filling out forms online, but mild dislike can turn to loathing if your reader is filling out page after page with no clear idea of when the task will be done. Make entrances and exits a part of your site navigation.

Readers subconsciously regard your site as a series of tasks. They're looking for a starting point, a specific action to be performed with specific results, and an exit that lets them know they've completed the task. When a reader gets dropped into the middle of a task—be it reading an article or browsing a

directory of links—the first response is usually to get out and then reapproach the pages after figuring out the context.

Employ a Lab Rat

You may think your site makes perfect sense, but you'll find out if that's true only after someone else has tried to use it. Before you post your new and improved site, ask some friends to click through a version of it and give you their honest feedback.

Another person can catch flaws in site navigation or inconsistencies in visual cues that you've tuned out. For example, your fearless lab-rat friend may think that your "Scrapbook" section is a personal scrapbook, not an homage to the road trip you took with your Apple IIe—"I want to see pictures of *you* in front of the Statue of Liberty, not your computer!" After mulling this input over, you might decide

to change the title of the section to "Computer Scrapbook."

Getting another point of view is crucial: it will either confirm that you were on the right track with your site's organization and look, or will let you know what areas you need to refine before releasing your site on an unsuspecting Web audience.

The Last Word

Building an easy-to-use site takes time, experience, and many forehead-slapping lessons you wish you didn't have to learn. Fortunately, if you learn from the past mistakes of Web pioneers, you'll have a strong beginning for making your site a more reader-friendly place to visit. ■

LISA SCHMEISER is a Web-site developer for Studio Verso in San Francisco and writes books about Web-site development in her spare time.

FOUR MISTAKES THAT WILL SABOTAGE YOUR SITE

THE BEST-LAID PLANS OF MOUSE-clicking and man can go awry if your site's technical performance undermines the overall organization. Here are four of the biggest—and easiest-to-make—mistakes.

1 Bad Colors In real life, there may be no bad colors, only bad color combinations. On the Web, however, there *are* bad colors: colors that do not display consistently from browser to browser or across different computer operating systems and monitors.

As a Web-site guru, you need to be concerned about this because you're going to be using color as part of your site navigation. If colors vary wildly depending on whether your users view the site using an old 256-color monitor or a newer one with thousands of colors, users will lose the ability to distinguish between different colors and their corresponding functions.

It's in your best interests to design your site around any combination of the 216 colors in the Web-safe palette. A good online reference for this is Lynda Weinman's site at www.lynda.com.

2 Bad Graphics Artistic merit has nothing to do with this: a graphic is bad if it's too big for a browser to display

quickly, or if it's not saved in a Web-friendly way. If you're using graphics to connote headlines, navigation, or a site's look and feel, try to keep the sizes of the individual files small, and save the graphics in the Web-safe palette in your graphics program.

3 Bad HTML Writing code that works across different browsers isn't enough to guarantee speedy site performance. Once you feel confident enough to muck about in HTML code, you should also work on streamlining your code so that it loads as quickly as possible. What's the biggest offender? The nested table—in other words, a table within a table within a table.

A browser will not display a table until it has figured out how to draw the whole thing. That means when one, two, or three tables are nested inside a table, the browser has to chug through the contents of *those* tables before displaying row one of the outside table holding them all. All the while, your viewers will be twiddling their thumbs. Instead of relying on carefully nested tables to simulate a paper-based layout, stack your tables in a series of structured horizontal-only elements. The tables will load one at a time, allowing your viewer to look at the topmost tables while waiting for the rest to appear.

The other culprit is wordy code: although adding attributes like **size**, **align**, and **color** to a tag may add visual preci-

sion, the words weigh down the file and provide a browser with more HTML to chew on before rendering a page. Consider streamlining your use of attributes. For example, instead of assigning the vertical alignment **valign=top** to each **<td>** in a table row, write the attribute once in the table row: **<tr valign="top">**.

4 Bad Layout Finally, remember that your audience will be looking at your site on monitors of all sizes, from laptop computer displays to 27-inch behemoths. Setting the layout of your page to a specific width may knock key features off the screen or force users to scroll from side to side simply to read a page. You can avoid annoying your users by adopting one of two layout strategies: find out what the average monitor resolution for your users is and design to that, or adopt a "liquid HTML" building style that lets the layout expand and contract according to the browser window's size.

"Liquid HTML" means that you're taking absolute numeric values (such as **<table width="400">**) out of your tables and putting in percentages instead (such as **<table width="80%">**). The idea behind liquid HTML is to allow the layout to preserve a sense of scale relative to the size of the browser window; as the user expands or contracts the browser window, the layout expands or contracts relative to the window's width.

SERVE

Take Control of Your Web Site and E-mail

Running an Internet server has always been something for big businesses and hard-core computer geeks. After all, to operate a server you must have a continuous connection to the Internet—not something most people have—and a compelling reason not to use the e-mail and Web services offered by your Internet provider. But with the spread of always-on connection technologies, such as DSL (Digital Subscriber Line) and cable modems, the rules have changed. Now many people who once could connect to the Net only by an intermittent modem connection have the ability to serve information out of their own homes and small businesses. And the wide variety of server software available for the Mac makes it easier than ever for them to take control of their Internet lives.



Why Serve It Yourself?

In all likelihood, somewhere at the offices of your ISP (Internet service provider) is a climate-controlled room housing anywhere from a handful to dozens of computers being used as Web servers, e-mail servers, file servers, and several other kinds of servers. And chances are, there's a team of trained technical professionals whose jobs involve keeping those servers up and running at all times, protecting them from catastrophic hardware failures that would put your Web site out of business or erase vital e-mail messages you haven't read yet.

Running your own server doesn't mean you'll need to hire a team of technicians in white coats and give them a key to your house. But it does mean you'll need to do more work than you do now. So the question is, What can you gain by setting up your own server rather than using the ones at your ISP?

Web Control If your Web site is made up of a collection of static files, then running your own Web server may not offer much of an advantage over using someone else's server. However, if your ISP charges an extra fee for space on its Web server or charges you by the byte for all the traffic on your site, you might be able to save some money by putting an older Mac into service as your Web server.

Running your own server really becomes an advantage when you've moved beyond a simple home page. Perhaps there's some specific interactive feature you want to implement on your Web site—fill-in forms, pages with content that changes based on who's viewing them, and the like—but it's something you just

can't create on your current ISP's Web server. You can take advantage of all your Mac-based server's built-in features and buy Web-server plug-ins to add any other special features you might want.

E-mail Might Most high-speed connections come with one or several e-mail accounts. But what if you want more? With your own e-mail server, you can create as many accounts as you want; you can even create extra e-mail addresses that automatically forward to some other mailbox—great if your friends can't remember if you're bob_johnson@mydomain.com or bjohnson or bobj or bob.

Most e-mail-server programs, such as Qualcomm's Eudora Internet Mail Server (\$249; 800/238-3672, www.eudora.com), also let you do things like create accounts that automatically reply to incoming mail. (For example, you could put a text file containing street directions to your house on the mail server and then whenever you need to give directions, you'll be able to say, "Send an e-mail to directions@mydomain.com!")

If you're really ambitious, you can also set up mailing lists. These can be simple, unchanging groups—for example, family@mydomain.com could be an address group that automatically forwards to all your family members, saving people from having to remember everyone's individual address. But mailing lists can also be a bit more complicated. Using mailing-list-processing software, such as Fog City's LetterRip Pro (\$395; www.fogcity.com), you can set up automated mailing lists that people from the outside world can subscribe to (and, later, unsubscribe from).

Share Files If you're constantly trading files with friends or business associates, it's easy to get tired of the flurry of e-mail attachments. If you find yourself wishing you could return to the old days when you shared space on a file server, you can—by running an FTP (File Transfer Protocol) server, such as Stairways Software's NetPresenz (\$35; www.stairways.com). FTP is a standard Internet protocol for exchanging files, and FTP client software is available for just about every computer operating system.

One warning: although running Web or e-mail server software can be somewhat risky (see the sidebar, "Play It Safe"),

by Jason Snell

IT UP

by Running Your Own Internet Server



running a file server can be *extremely* dangerous. Before you start, carefully plan your security system. Make sure guest access is disabled. Make sure people can get into only the areas you want them to get to. Carefully read the documentation for your server software; the last thing you want to do is open your hard disk to anyone roaming the Internet, giving them free rein to read your personal documents and trash your hard drive.

Video Voyeurism Even folks who don't want to set up their own Web, e-mail, or file servers may be intrigued by the idea of putting a live picture up on the Internet. If you attach a camera to your Mac and run software such as Rearden Technology's SiteCam (\$199; 510/523-2267, www.rearden.com), you can

broadcast live images of yourself, your dog, your backyard, or whatever you choose. These can be still pictures updated every few minutes, or they can be a live video stream.

Share Databases You don't need to become a Web-publishing expert to share your databases on the Web. Using FileMaker Pro 4.0 (\$150; 800/725-2747, www.filemaker.com) or later, you can let people view, search, and even modify (if you wish) your FileMaker databases over the Web.

Let the Server Beware

Before you get started setting up that plug-and-play Web and e-mail server that will make your life so much cooler, here's the truth about running an Internet server: it's *hard*. Granted, it's

much easier than it used to be—and it's much easier to get up to speed on the Mac than it would be if you were trying to run a Unix-based server. But it's not a situation where you can install some applications, double-click on them, and forget them.

Running a server brings with it a whole set of issues that people who use their Mac all day long and shut it off at the end of the day never have to worry about. And before you decide to spurn your Internet provider and set out to process all your e-mail yourself or host your own Web site, you should know if you're up to the challenge.

Always On For a server to be effective, you shouldn't shut it off. That means, for all practical purposes, that you shouldn't set up your Mac as a server and continue to use it to render 3-D images, update databases, or even write your first novel. The job of a server should be done by a dedicated Mac, although it need not be the latest top-of-the-line model. An older Power Mac is ideal, and even older pre-PowerPC Macs can master simple serving tasks, such as running an e-mail server or a basic Web server. If your current ISP provides you with only one Internet address (common with cable modems and low-cost DSL services), you may need to run Internet-sharing software if you want to surf on one Mac while you're serving on the other (see the sidebar "Internet Sharing 101" in the companion feature "Link It Up").

You'll need to be sure that your Mac will restart itself in case of a crash or a power outage. There's a cornucopia of hardware and software that helps recover your Mac—we've put up a long list of server tools as part of the Wire Your World special report, at www.macworld.com/1999/11/features/wire.html.

Backing Up Servers hold vital information—but then so

does the computer you use every day. The difference is that servers hold information that's vital to everyone who uses them, not just you. So whereas you might (unwisely) avoid backing up your own computer because you're willing to take the risk, you can't take such risks with your server data. You'll need to regularly back up your server to some form of removable-storage device, using software such as Dantz Development's \$175 Retrospect or \$50 Retrospect Express (800/225-4880, www.dantz.com).

Restrictions on Serving Before you buy everything you need in order to set up a server, be sure to check the rules you agreed to when you signed up for high-speed Internet service. Many Internet providers ask that users not run servers on their computers. Your connection to the Internet must also be via an unchanging Internet address—otherwise, nobody will know where to find your server. Be sure to ask your Internet provider if you've been given a *static IP address*; if the answer is no, you won't be able to run your own server.

The Last Word

Running your own Internet server isn't for the faint of heart. Before you take the plunge and kiss your Web-hosting company good-bye, think carefully about whether the added cost and time required to set up and run a server are worth it. If you've got the inclination and need the power and flexibility, operating your own Internet server can be quite a rewarding experience. **m**

Executive Editor JASON SNELL cowrote *Providing Internet Services via the Mac OS* (Addison-Wesley, 1996).

PLAY IT SAFE



RUNNING A SERVER MEANS THAT anyone on the Internet can talk

to your computer, even if all your computer

tells them is "Buzz off." The Mac is quite a

formidable opponent for hackers, but a

carelessly configured server can lead to major security problems. If you run a server, you have to be painfully diligent about making sure it has been configured properly, or your private information could be stolen or even destroyed.

Smart Passwords No matter what kind of servers you're running (even if you're just running File Sharing), always make sure your passwords are secure. For example, don't let people use their first name as their user name and their last name as the password. Don't use any word

that can be looked up in a dictionary as a password. And don't use obvious passwords, such as *password*, or easily guessed referential passwords, such as *Joshua*. (*Joshua* was the password used in the 1983 computer-hacker film *WarGames*.)

Know Your Surroundings If you're letting your data be seen by people all across the Internet, realize that you're giving people you've never met the chance to break into your system and see your data. Plan your security accordingly. For example, you might think nothing of sharing a FileMaker Pro database over the Net—but if you don't protect it with passwords, anyone could stumble along and read, alter, or even destroy your data.

Before you use any program that communicates via network, consider carefully what your security measures are. It's one thing to feel secure when you're using an AppleTalk-based network of four Macs; that feeling can be quite dangerous if your

computer is attached to every other computer on the Internet.

Spam Trap If you're running an e-mail server, you need to make sure that it's secured against "relaying"—receiving mail from someone and then resending it for them. That's because relaying is a feature exploited by senders of junk e-mail, and spammers are always on the lookout for new e-mail servers that will relay their messages to unsuspecting victims.

Protect Yourself There is a plethora of software packages that can protect your Macs. For example, Open Door Networks' DoorStop (\$299; 541/488-4127, www.opendoor.com) monitors connections to your server and lets you restrict access as you see fit. Intego's NetBarrier (\$75; 305/629-3501, www.intego.com) provides similar security functions, blocks "denial-of-service" attacks that can slow down your network to the point that it's unusable, and more.

No Mac Is An Island.

Think Asanté—Networks For The Mind

At Asanté Technologies, we know Mac. We know you eat, sleep, and breathe Mac. And we know you're not alone. So we've made it simple for you to network all your Macs.

Whether you need to connect your new iMac to your G3, wire a LAN for the Graphics Department, or establish an Enterprise WAN, we have the networking solution for you. The choices are many. The answer is simple. Asanté—speed, simplicity, and savings.

 **Gigabit.** With our new Gigabit solutions, your entire office can soon be performing at Gigabit speed. Our FriendlyNET™ 7000 series of affordable, easy to install Gigabit switches and cross-platform GigaNIC™ PCI adapters ensure that no one will be waiting on the network.



 **iMac Connectivity.** AsantéTalk™ is the easiest way to connect your Apple iMac or any Ethernet Mac for printing and file sharing. Simply plug in your Ethernet on one side and LocalTalk on the other to get up and running in no time.



Laptop Connectivity.

Don't hit the road without a FriendlyNet 10/100 CardBus Adapter for your Powerbook. It's high performance mobile connectivity at an affordable price. And just like a Mac, its plug-and-play design makes integration easy.



Low-Cost 10/100 Networks. Asanté's FriendlyNET™ dual-speed hubs and switches put the power of 10/100 computing into the palm of your hand. Access network resources at up to 100Mbps with these compact yet cost-effective, plug-and-play networking solutions that fit on your desk and within your budget.



Savings. For a limited time only, Asanté is offering special rebates on select products for your home or office. Please visit our Web site for more information about how you can save.

 **ASANTÉ**
MAKING NETWORKING SIMPLE
www.asante.com

For complete details on the entire line of Asanté networking solutions call 1-800-303-9121.

Where's

It's Been Available on Power Macs for Nearly a Year, but **FireWire** Is Still in Its Infancy

IT WAS SUPPOSED TO BE ONE OF those Holy Grail technologies, the perfect way—both fast and convenient—to connect external devices to your personal computer. On the PC side, it's known as IEEE-1394; Sony calls it i.Link. But Apple named its cool technology FireWire.

Even though FireWire was officially standardized back in 1995, it has been more a myth than a reality. However, Apple changed all that when the company added two FireWire ports to the back of every blue-and-white Power Macintosh G3.

Hope blossomed among the many Mac owners who've been eagerly awaiting a SCSI replacement. FireWire was the technology that would put an end to the days of SCSI-termination hassles and ID conflicts that lead to Macs that lock up or do nothing but show a blinking question mark.

But FireWire was never positioned as a mere improvement on SCSI: it's also a technology that lets you connect many more devices per chain (63 to be exact; 9 times as many as SCSI) and supplies its own power (so that many devices don't need any external power supply).

And then there's speed: FireWire provides a tenfold increase in bandwidth compared to the built-in Narrow SCSI ports previously found on Power Macs.

Yet six months after the arrival of the blue-and-white Power Mac G3s, the FireWire universe is still a bit tepid. FireWire devices—such as CD burners, scanners, and hard drives—are only just beginning to appear.

Like any other technology, FireWire needs time to become prolific, but is this promising new connection gaining momentum or just muddling along?

the Fire?



by Stephan Somogyi



Canon Elura digital-video camera

Light My Fire

FireWire is Apple's answer to some of the most annoying and common problems with connecting external devices and getting them to work. Imagine a peripheral-connection scheme that lets you blithely connect a mix of hard drives, CD-R drives, scanners, and digital cameras without worrying about which order they're in—or whether they'll play nicely together at all—on the chain.

To anyone who's used external SCSI

devices, especially scanners and other miscreants, FireWire is nothing short of a miracle. No longer will anyone have to move devices up and down the chain, with some devices demanding to be at the end and others at the front. With FireWire, it's plug-and-play in the truest sense—plug devices in and they work, at least theoretically.

Hot-swappability is another key FireWire feature: you can connect FireWire devices to and disconnect them from your

Mac without shutting down. ID conflicts are a thing of the past, since FireWire devices talk among themselves and sort out which one gets which ID.

A Big Boost Traditional Narrow SCSI, Apple's original external connection of choice, was first used on the Mac Plus, in 1986. This state-of-the-art (for the 1980s) technology had a throughput of only a measly 5 megabytes per second (MBps). Although there are faster, more expensive versions of SCSI, Narrow SCSI has been the built-in standard against which all comers are measured. Apple's FireWire allows throughput of up to 400 megabits per second (Mbps), which translates to 50 MBps—a substantial boost. And an 800-Mbps version of FireWire—four times faster than today's—is already nearing completion.

Just because FireWire has this tremendous bandwidth available doesn't mean that all FireWire devices will automatically offer such high performance. As with other technologies, the maximum throughput of FireWire doesn't always translate into real-world results.

Today's standard hard drives typically move data back and forth between the computer and the drive at 10 to 15 MBps. So despite the availability of up to 50-Mbps throughput today, the hard-drive mechanisms—and not FireWire itself—determine the speed of FireWire-connectable hard drives.

Four-Alarm Fire Not only is FireWire fast and easy to use but it also supplies power—up to 60 watts—over its cable. This means that many FireWire devices with smaller power requirements don't need an external power source.

VST's small FireWire drives, for example, contain hard drive mechanisms that were designed for laptops and hence have a small appetite for electricity. When you plug the FireWire cable into the drive, you not only establish the data connection to the computer but you also power the drive.

Sixty watts is enough power to run one—or two, at most—of these small drives. Sony's take on FireWire, i.Link, omits the power supply from its cables. For this reason, you need a cable adapter to connect i.Link devices to a Mac.

Building a Fire

To help determine the current state of FireWire, Macworld Lab tested a 4GB FireWire hard drive from VST Technolo-



Fire Drills

Even with FireWire's promise of 400-Mbps throughput, it's going to take a collaborative effort between Apple and peripherals makers to enable devices to take full advantage of FireWire's speed. Macworld Lab tested a 4GB VST Technologies FireWire hard drive and found significant improvement when using the latest drivers and firmware from Apple and VST.

Best results in red.

	VERSION NUMBER			50MB FILE COPY	
	Apple FireWire Driver	VST Driver	VST Firmware	Copy from Drive (in Mbps)	Copy to Drive (in Mbps)
VST Technologies 4GB FireWire hard drive	2.0	1.0	39C	34.4	17.6
with Apple upgrade only	2.1	1.0	39C	48.8	26.4
with all three upgrades	2.1	1.1	43	48.8	48.8

Longer bars are better.

Behind Our Tests

We tested the hard drive with a Power Macintosh G3/400 with Mac OS 8.6, 128MB of RAM, and a 4,096K disk cache. We used a 50MB Adobe Photoshop file for our file-copy tests.—Macworld Lab testing supervised by Gil Loyola

FireWire Speeds Ahead

As you can see from this chart, many devices simply don't need the speed advantage that FireWire offers over USB. But others—especially fast hard drives—will benefit greatly from FireWire's increased capacity.

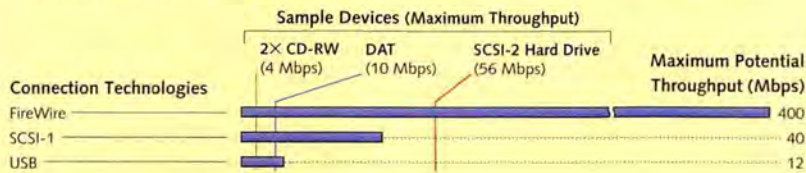

gies (978/263-9700, www.vsttech.com) and found that FireWire's software is definitely still teething.

Not only is Apple's own FireWire system software changing rapidly but the drivers—which form the conduit between the system software and the FireWire hardware device—are also going through a similar evolutionary process. In addition, many FireWire hardware devices contain their own built-in software, known as firmware, that can affect the devices' behavior and performance.

We compared three software combinations, involving two versions of the Apple FireWire driver software and two versions of the VST driver and firmware, on the same VST hard drive (see the benchmark, "Fire Drills"). With the latest Apple software and the most recent VST driver and firmware, the hard drive performed much better than with the software combination that came with the VST drive when it originally became available. Even such simple software upgrades can provide a significant performance increase.

The Real World Keep in mind that even with FireWire's flexibility, you must be careful when adding or removing devices. For instance, if you add a hard drive to a chain while you are burning a CD in a FireWire CD burner, you are likely to end up creating a coaster instead of a usable disc. That's because anytime a device is added to or removed from a FireWire chain, all the other devices pause to make sure that their connection is still available. This rechecking of all the connected FireWire devices unavoidably interrupts the CD-creation process.

Today's FireWire on the Mac has other shortcomings that need to be addressed by Apple. For example, you

can't currently boot a Macintosh from a FireWire drive, although Apple has promised to offer this ability before the end of the year. In addition, the way Apple's FireWire system software works currently prevents the Finder from displaying the icons of files whose applications are stored on FireWire drives. Finally, when reading from and writing to FireWire drives under the Mac OS, even the fastest Macs can suffer from unresponsiveness, especially during long file copies. This is in stark contrast to Apple's SCSI system software, which provides smooth background file transfers.

In the Hot Seat

If FireWire is so wonderful, why isn't it ubiquitous yet? Here's the problem: until there are more computers with FireWire ports, building FireWire devices is prohibitively expensive. Luckily, the paucity of ports will soon be alleviated, with the inclusion of FireWire across the Macintosh product line, not just in the "professional" desktops.

Because FireWire is only just arriving on PC motherboards, there are no "native" FireWire storage devices today. All storage devices that use FireWire employ a "bridge chip," so called because it translates between FireWire and ATA, the mass-storage connection standard used in today's Macs and Windows PCs. But if Windows-based computers offer FireWire, less expensive, native FireWire devices should appear.

Another reason for the slow acceptance of FireWire is the growing popularity of the Universal Serial Bus (USB): many low-bandwidth devices don't need more than the 12 Mbps of bandwidth that USB offers (see the diagram, "FireWire Speeds Ahead"). USB's success means that FireWire will initially become popular only for high-bandwidth applications that simply must have more speed than USB delivers. But don't frown just yet. Once it costs less to build FireWire devices, we can expect the number of peripherals to grow rapidly.

Although FireWire hasn't been adopted as quickly as Apple would hope, there are interesting technology developments in each of the following categories. And for a detailed list of current FireWire products, log onto www.macworld.com/1999/11/features/firewire.

Digital Video The Digital Video (DV) standard uses FireWire for connectivity. Typical DV cameras, such as the Canon Elura, can be remote-controlled from a Mac via FireWire, with software such as Apple's Final Cut Pro (see *Reviews*, August 1999). Such software transfers DV data to disk for later editing.

FireWire has an additional media-specific feature—*isochronous transfer*—that guarantees that a particular stream of data traveling across the FireWire cable will always have enough bandwidth. This is critical for video and



Fujitsu DynaMO 1300FE magneto-optical drive

audio applications, because if the available bandwidth drops below a certain threshold, disruptive dropouts happen.

Storage Hard drives, CD-ROM drives, CD-Recordables—storage is a hot place for FireWire. The Device Bay standard, under development for the Windows OS, is driving many hardware manufacturers—such as VST Technologies, Mactell, Sony, and Indigita—to offer FireWire compatibility. The Mac will benefit as a result.

However, until native drives become available, FireWire-to-ATA bridge chips will be used for mass storage, including hard drives, DAT drives, and CD/DVD readers and burners. These bridge controllers are still being refined, and performance is improving as new versions of the bridges' firmware are released.

PC/PCI Cards If you think FireWire is only for owners of blue-and-white G3s, think again. Newer Technology, Racom, and VST Technologies have announced FireWire cards for PowerBooks. These CardBus cards provide greater bandwidth between the card and the computer. Since the PowerBook 3400, Apple's portables have included built-in CardBus support.

Owners of older Macs can also add FireWire to their computers, by purchasing a PCI card from a manufacturer such as Orange Micro or Adaptec. One shortcoming of this approach is that some manufacturers, notably VST Technologies, won't support devices running on a Mac unless the Mac came with FireWire already built in. Currently there seems to be no way to retrofit FireWire into iMacs, but we expect the next generation of iMacs to have FireWire built in.

Scanners Although there are plenty of inexpensive USB scanners, the USB connection is too slow for frequent high-quality scans. For the best results, you need FireWire, and until now, finding a FireWire scanner was nearly impossible. Thankfully, Umax has announced the first scanner for FireWire, the PowerLook F3.

Spreading Like Wildfire

FireWire also promises to become a hot ticket in consumer electronics, where it's intended to replace the rat's nest of cables behind today's televisions and stereos. FireWire speakers, DVD players, and amplifiers are coming to a superstore near you over the next year or two. Instead of having your receiver be a home-audio/video cabling hub, you'll be able to simply add FireWire-enabled devices such as TVs or set-top boxes to the chain—a huge convenience, since each device will have at most two FireWire connections, one going in and the other going out to the next device on the chain.

Another clear indicator of this hopeful future is Sony Electronics' forthcoming PlayStation 2, which will have at least one i.Link port built in.

The Last Word

After a long dormancy period and many missed opportunities by Apple, FireWire is gaining momentum of its own accord. The current standard is constantly evolving, with 800- and 1,600-Mbps versions already well under way. And if the Device Bay standard is adopted widely, FireWire will proliferate through the Wintel world with great speed, making more FireWire peripherals available at lower prices.

However, what will ultimately happen with FireWire remains a big question. Will this technology on the back of your Mac make the computer easier to use and bring computers and consumer electronics closer together?

Given the recent interest in FireWire from so many directions, we believe that the question for Mac users is not whether FireWire will succeed but whether Apple will be able to keep up with the remarkable technology it created. **m**

Contributing Editor STEPHAN SOMOGYI is *really* looking forward to booting the Mac OS from a FireWire hard drive.

FireWire at Work

FireWire promises hassle-free connections without termination issues or problems with ID conflicts.

FireWire provides up to 60 watts of power—plenty of juice for a single hard drive.



FireWire devices can be daisy-chained—up to 63 devices per chain—but no loops!



The Digital Video (DV) standard uses FireWire as its traditional connection for transferring data.



FireWire's hot-pluggability means that you can add (or remove) a drive without shutting down your Mac. And the small connector (below) is easy to plug and unplug.



Macworld EXPO

www.macworldexpo.com

MACINTOSH EXPERIENCE

January 4-8, 2000

san francisco
moscone convention center
marriott hotel

PRE-CONFERENCE WORKSHOPS
January 4, 2000

CONFERENCES AND EXHIBITS
January 5-8, 2000

REGISTER BY **DECEMBER 3** AND SAVE

use the form that follows or go to:
www.macworldexpo.com

- Save \$100 on package 1
- Save \$50 on package 2
- Save \$50 on package 3
- Save \$50 on package 4
- Save \$30 on package 5
- Save \$16 on package 6

Please refer to the registration page for
complete package descriptions.

www.macworldexpo.com
800.645.EXPO

MW1
Priority Code

Sponsored by:



Macworld
MacWEEK.com
MacBuy.com

Media Sponsor:



Managed by:





WHERE THE ULTIMATE IS POSSIBLE

You're a Mac user. You think outside the box. You see challenges, not limits. You're pushing the envelope of today's hot technologies.

MACWORLD EXPO/SAN FRANCISCO 2000 is your ultimate experience as a Mac user. The exhibit floor is packed with thousands of radical new software solutions, games and peripherals for every Mac computer. The conferences explore the frontiers of Mac computing while offering easy-to-implement solutions to today's challenges. And MACWORLD Expo is the only event where you can share ideas with nearly 70,000 other hip, forward-thinking Mac users.

Don't miss the always **THE WEST COAST'S BIGGEST SELECTION OF MAC TECHNOLOGY** The entertaining **MACWORLD Expo** awesome success of the new generation Macs has inspired developers to turn their creativity loose on the Mac OS. What results! Come to MACWORLD Expo for a huge selection of products you simply won't be able to live without. Discover software tools that let you perform time-consuming tasks in simple new ways. Test-drive new technologies that let you explore the outer reaches of Mac performance.

Keynote Address and Special Presentations

SAVE MONEY WHEN YOU BUY ON THE EXHIBIT FLOOR Looking to find the ultimate bargain? When you shop at MACWORLD Expo you get so much more than you'd ever find in a computer store or catalog. It goes without saying, the selection is enormous and the products are cutting-edge. More importantly, you get a chance to talk directly to developers and vendors. Ask tough questions, put the products through their paces, then strike a great deal. You can make purchases right on the show floor—from the latest releases, to that application you meant to buy last year!

SPECIAL INTEREST ENVIRONMENTS TARGET THE PRODUCTS RIGHT FOR YOU MACWORLD Expo offers so much for every Mac user, from Web Masters to school teachers, filmmakers to entrepreneurs. Check out the Special Interest Environments while you're exploring exhibit floor to find and compare the **HOT** new products for your particular needs. Visit these hands-on demonstration areas to learn how to customize your Mac to meet the demands of your career and interests.

Have Fun, Win Prizes!

As you're strolling among the hundreds of product displays, try your hand at the Macintosh Gaming Championships — there's more than \$25,000 of prizes to be won. Are you a starving artist? Get your work noticed by entering the 2000/2001 Digital Art Competition. You could be the next big sensation everyone's looking for!

conference

EXPAND YOUR KNOWLEDGE BASE AT THE CONFERENCE AND WORKSHOPS.

Learn from industry experts and luminaries who are shaping the future of Mac computing. The MACWORLD Expo conferences and workshops offer top-notch education for everyone who wants to do more with a Mac. These two highly acclaimed conferences and workshops are sure to educate, entertain and empower you and you're MAC!

san francisco
moscone convention center
january 4-8, 2000

Access www.macworldexpo.com for
details on Special Interest Environments
and complete list of Exhibitors!

INTENSIVE WORKSHOPS DEVELOP CAREER SKILLS Devote a day to mastering vital technical, creative and business skills at the MACWORLD Expo Pre-Conference Workshops. The country's leading experts show you how to master your Mac with new technology, in beginner, intermediate and advanced level sessions. Explore techniques and strategies to employ in today's hottest Mac environments. Choose from these Workshop topics:

- Ⓞ Practical Introduction to Mac Networking
- Ⓞ Desktop Publishing: The Big Picture
- Ⓞ Creation of High Quality Photographic Web Content
- Ⓞ Macintosh Network Administration with Apple Network Administrators Toolkit
- Ⓞ The QuickTime™ Professionals Workshop
- Ⓞ How to be a Mac Power User
- Ⓞ Getting Started with AppleScript
- Ⓞ An Introduction to WebObjects Development
- Ⓞ JavaScript and Dynamic HTML Wizardy
- Ⓞ Real Audio & MP3 on the Mac: The State of the Art Macintosh Audio
- Ⓞ Implementing XML
- Ⓞ FileMaker Training
- Ⓞ Mac Efficiency 101
- Ⓞ Maximizing Your Experience With AppleWorks
- Ⓞ Working with PDF
- Ⓞ Web Graphic and Animation
- Ⓞ Digital Video Boot Camp

two conferences address diverse needs of the MAC community

MACWORLD/PRO CONFERENCE targets the specialized needs of new media executives, Web site creators and managers of large Mac installations. Tackle advanced technology topics with our skilled instructors as your guides. You'll return to work able to deploy cutting-edge Mac tools. Choose from these Macworld/Pro Conference topics:

NETWORK AND COMMUNICATIONS This track presents techniques and technologies associated with deploying Macintosh LANs, WANs, Internet, Intranets and remote access. These technical sessions take you inside the protocols and services you will encounter when using Macs on a network. Get the most from your existing network or make it state-of-the-art; these tactical sessions will show you how.

MAC ADMINISTRATOR This track features sessions that look at the needs of organizations using the Mac, and present the methods, practices and technologies that are defining the role of the Macintosh manager.

ART DIRECTOR Hear from industry experts how to be more profitable, more efficient – and more employable in the creative industries. You'll gain practical knowledge that will help you to run a leaner, meaner and more productive creative group.

DIGITAL VIDEO The Desktop Digital Video production arena is booming. Sessions in this track will give you expert analysis and direction for producing video on your Mac and delivering video from your desktop.

WEB MASTER Innovation on the web continues unabated. We've brought in leading web development experts to share their work and insights to keep the Mac web development community at the top of their game from these sessions.



MACWORLD EXPO USERS CONFERENCE offers guidance for users who want to make the most of their Macs in environments such as education, the home and small businesses. Develop a thorough understanding of the basics of Mac technology and get useful tips to make your Mac more productive. Master the top Mac tools and get answers to problems common to non-technical users. Choose from these MACWORLD EXPO Users Conference topics:

MACS IN EDUCATION From new technologies to new ideas MACWORLD Expo is the place to be if you use Mac's in your educational environment

MAC MUSICIANS (HOT! ALL New for MACWORLD Expo SF!) This all new session lineup at MACWORLD Expo provides a great education for musicians and studio operators. Don't miss it!

SMALL OFFICE/HOME OFFICE It has never been easier to use Macintosh Technology to launch and operate a small company, home based business or telecommute from your home. Learn from experts how to put the technology to work for you.

COOL TOOLS IN DEPTH These sessions will unlock the secrets of your favorite programs and get you up to speed quickly with advanced features you didn't know were available!

MAC TECHNICIANS These sessions have been updated with the latest information and will help everyone who uses a Macintosh.

CREATIVE PROFESSIONALS The greatest creative tools in the world run best on a Macintosh - and MACWORLD Expo is the place to learn how to be your best with these tools. PhotoShop, Quark, InDesign, Digital Video - it's all there for you. Come learn and have fun while doing it!

EARLY DISCOUNT REGISTRATION FORM FOR MACWORLD EXPO/SAN FRANCISCO 2000

EARLY DISCOUNT DEADLINE- DECEMBER 3

Moscone Convention Center • Pre-Conference Workshops: January 4, 2000 • Conferences & Exhibits: January 5-8, 2000

1. CUSTOMER INFORMATION

Fill out the form completely. Incomplete forms will be returned unprocessed. Please use one form per person; make photocopies for additional people.

FIRST NAME _____ LAST NAME _____

TITLE _____

COMPANY _____

STREET ADDRESS (Please Indicate Apt #, Suite or Mail Stop) _____

PO. BOX _____

CITY _____ STATE/PROVINCE _____ ZIP CODE/POSTAL CODE _____

COUNTRY _____ TELEPHONE _____ EXTENSION _____

FAX _____ INTERNET/EMAIL ADDRESS _____

PRIORITY CODE:

Register By December 3 to Get Maximum Savings and a chance to win a new MAC system!
Register now on the Web at:
www.macworldexpo.com

Check here if you DO NOT wish to receive product information from third parties (exhibitors) via e-mail

2. REGISTRATION PACKAGE SELECTION & FEES

Pre-Conference Workshop: Jan 4, 2000 • Conference Sessions and Exhibits: Jan 5-8, 2000. All Conference Sessions, Keynote Address and the Town Meeting are on a first-come, first-served basis with the exception of the Pre-Conference Workshops.

Early Discount by Dec 3 Regular Price after Dec 3

<input type="checkbox"/> W	<input type="checkbox"/> Package 1: SUPER PASS	\$995	\$1,095
Includes: Pre-Conference Workshops, Macworld/Pro Conference Sessions, MACWORLD Expo Users Conference Sessions, Keynote Address, Town Meeting, Exhibits			
<input type="checkbox"/> W	<input type="checkbox"/> Package 2: Macworld/Pro Conference	\$795	\$845
Includes: MacWorld Pro Sessions, MACWORLD Expo Users Conference Sessions, Keynote Address, Town Meeting, Exhibits			
<input type="checkbox"/> W	<input type="checkbox"/> Package 3: MACWORLD Expo Users Conference & Pre-Conference Workshop	\$475	\$525
Includes: Pre-Conference Workshop, MACWORLD Expo Users Conference Sessions, Keynote Address, Town Meeting, Exhibits			
<input type="checkbox"/> W	<input type="checkbox"/> Package 4: Full-Day Pre-Conference Workshop	\$325	\$375
Includes: Pre-Conference Workshop, Keynote Address, Town Meeting, Exhibits			
<input type="checkbox"/> W	<input type="checkbox"/> Package 5: MACWORLD Expo Users Conference	\$195	\$225
Includes: MACWORLD Expo Users Conference Sessions, Keynote Address, Town Meeting, Exhibits			
<input type="checkbox"/> W	<input type="checkbox"/> Package 6 - Exhibits ONLY (Jan. 5-8)	\$29	\$45
Includes: Admission to the Exhibits ONLY. Does NOT include admission to the Keynote Address.			

3. ATTENDEE PROFILE (Must be filled out to process your registration)

FOR WHAT PURPOSE ARE YOU PURCHASING/EVALUATING PRODUCTS AND SERVICES?

1. For My Company/Organization/Department
 2. For Myself as Consultant/Sole Proprietor
 3. For myself as Consumer

WHAT IS YOUR INDUSTRY? (Check one only)

4. Accounting/Finance
 5. Aerospace
 6. Architecture/Construction/Process Industries
 7. Art/Design/Creative Services
 8. Arts & Entertainment
 9. Computer Reseller/VAR/VAD/Service
 10. Consulting
 11. Education: K-12
 12. Education: Higher Ed.
 13. Education: Other
 14. Engineering/R&D
 15. Gaming
 16. Government/Military
 17. Health/Medical Services
 18. Legal Services
 19. Manufacturing (Computer Industry)
 20. Manufacturing (Non-Computer Industry)
 21. Marketing/Sales/PR/Communications
 22. Printing/Publishing
 23. Transportation
 24. Utilities
 25. Other

WHAT IS YOUR JOB FUNCTION? (Check One Only)

26. Art Director/Graphics
 27. Consultant
 28. Controller/Treasurer/Accounting/CFO
 29. Corporate Executive
 30. CPIO/Management/CIO
 31. Editorial/Writing
 32. Educator
 33. Engineering/Scientific/R&D
 34. Human Resources
 35. Management/Department Head
 36. Marketing/Sales
 37. Network Management
 38. Professional (Lawyer, Doctor, etc.)
 39. Programming/Analysis
 40. Purchasing
 41. Software Developer
 42. Training
 43. Other

WHAT IS THE SIZE OF YOUR ORGANIZATION?

44. Under 50
 45. 50-99
 46. 100-499
 47. 500-999
 48. 1000 & Over

WHICH PERSONAL COMPUTERS DO YOU USE? (Check all that apply)

49. Macintosh Powerbook Series
 50. Macintosh Performa Series
 51. Macintosh Quadra Series
 52. Macintosh Workgroup Series
 53. PowerMac
 54. iMac
 55. PowerMac G3
 56. PowerBook G3
 57. IBM PC or compatible desktop
 58. IBM Laptop/Notebook
 59. Other

WHAT IS YOUR ROLE IN MAKING PURCHASES?

60. Final Decision Maker
 61. Recommend Product or Vendor
 62. Develop Specifications
 63. No Role

4. PAYMENT INFORMATION (You will be charged for all registrations received including discounts)

Payment must accompany form for registration to be complete. DON'T PAY FOR THIS EVENT TWICE! You will be charged for all registrations received and will not be refunded for duplicate registrations. Please use one method of registration only. All Registration fees are non-refundable and credentials are non-transferable. A \$20 fee will be charged for all returned checks.

Check enclosed (make check payable to MACWORLD Expo) Indicate check #: _____

Master Card Visa American Express AMOUNT \$ _____

Account Number _____

If payer is other than registrant, please print name and/or company name below:

FIRST NAME _____ M.I. _____

LAST NAME _____ Cardholder Signature _____

COMPANY NAME _____

Pre-Conference Workshop Key and Registration Information

WORKSHOP KEY:
 Tuesday, January 4: 12:00pm - 7:00pm

WA: Practical Introduction to Mac Networking
WB: Desktop Publishing: The Big Picture
WC: Creation of High Quality Photographic Web Content
WD: Macintosh Network Administration with Apple Network Administrators Toolkit
WE: The QuickTime™ Professionals Workshop
WF: How to be a Mac Power User
WG: Getting Started with AppleScript
WH: An Introduction to WebObjects Development
WI: JavaScript and Dynamic HTML Wizardry
WJ: Real Audio & MP3 on the Mac: The State of the Art Macintosh Audio
WK: Implementing XML
WL: FileMaker Training
WM: Mac Efficiency 101
WN: Maximizing Your Experience With AppleWorks
WO: Working with PDF
WP: Web Graphic and Animation
WQ: Digital Boot Camp

Workshops are subject to change, please visit the Web at www.macworldexpo.com for the most up-to-date information.

REGISTER NOW!

Use ONE of the following methods to register for MACWORLD Expo/San Francisco 2000:

WWW: www.macworldexpo.com
 THROUGH 12/30/99. Registrations received after 12/3/99 will be charged at regular pricing

PHONE: 800-645-EXPO or 781-551-9800 outside the U.S. (\$5 service fee does apply) THROUGH 12/30/99. Registrations received after 12/3/99 will be charged at regular pricing

MAIL TO: MACWORLD Expo/San Francisco, P.O. Box 9103, Norwood, MA 02062-9103
 THROUGH 12/3/99 ONLY

FAX TO: 781-440-0359. Faxed registration forms must include credit card information THROUGH 12/3/99 ONLY.

BADGE INFORMATION:

- Confirmation of registration will be sent once registration is processed
- U.S. badges will be mailed after 12/17/99 for registrations received by 12/3/99
- If you register after 12/3/99 you must pick up your badge at the Attendee Will Call counter located in the North Hall Lobby of the Moscone Convention Center.
- All international (including Canadian) attendees must pick up their badges on-site at the Attendee Will Call counter located in the North Hall Lobby of the Moscone Convention Center.
- On-Site Registration Hours: January 3 - 2:00pm-6:00pm
 January 4-7 - 8:00am-6:00pm
 January 8 - 8:00am-4:00pm

Secrets

AppleScript for the Programming-Shy

HOW TO CREATE USEFUL SCRIPTS WITHOUT WRITING A SHRED OF CODE

by Joseph Schorr

When AppleScript was introduced in the early days of System 7, it sounded like a dream come true: here, at last, was a scripting language for normal people—a language with a syntax built around plain English, one that would let average users automate their Macs without requiring the skills of a software engineer.

Then I got my first taste of AppleScript. I found myself staring at sample scripts with lines of code like this:

```
if (not (exists (file PrefFileName of folder "Documents" of preferences folder))) then
    set lstatel to "New"
else
    if askOnRun then
        display dialog "Continue to watch" & ((FolderToWatch) as string) buttons {"OK", "New", "Cancel"} default button 1
    set lstatel to the button returned of the result
    else
        set lstatel to "OK"
    end if
```

To my nonprogrammer's brain, this looked less like English than like a nightmarish cross between C++ and a bad e. e. cummings poem.

I quickly discovered, however, that you don't have to write code to create scripts. You can *record* AppleScripts using Script Editor, the little script-



making program that comes with every Macintosh (it's in the AppleScript folder inside the Apple Extras folder). If you click on Script Editor's Record button and then perform tasks in any application that supports AppleScript recordability (such as the Finder in Mac OS 8.0 and later), Script Editor will record your actions, translating them into lines of AppleScript code on the fly. This capability lets you build useful AppleScripts that require little or no tweaking. Consider a few examples that take advantage of some of the Mac's easily recordable system components.

Ultimate Desktop Cleanup

The Finder's built-in Clean Up command tidies things up by snapping your icons (on the desktop or in a folder) into position along an invisible grid, but you can't control *where* it places those icons. With AppleScript, you can create a smart Clean Up command.

To start, launch Script Editor and click on the Record button in the Script Editor window. With Script Editor still running (you can collapse the window, drag it to a corner, or hide it in the background), clean your desktop—making it

continues

look precisely the way you want it to. One by one, drag each desktop icon to the exact place you want it to appear. Even if an icon is already where you want it, drag it slightly out of place and then back into position.

The Script Editor window records every action you perform in the Finder,

capturing the final screen coordinates for each item you've selected and moved (see "Cleanup Code"). When you're done, click on the Stop button in the Script Editor and choose Save from the File menu. In the Save dialog box, change the Kind pop-up menu to Application, check the Never Show Startup Screen check box, and then save the script.

You now have a genuine AppleScript that will reposition all your desktop icons exactly where you want them. Test the script by dragging the icons out of place and then launching the script to neaten them instantly. (You can set up similar scripts to clean up particular folders instead of the desktop, but beware: this simple script will always look for the exact icons you've specified, so use it only with items that will continue to be present.)

Background Switcher

Suppose you're fond of the Bondi Extra Dark desktop pattern, but your spouse prefers to work against a background photo of a Cancun beach. You can record an AppleScript that enables you to switch automatically between the two backgrounds.

Again, start with a fresh script window in Script Editor, as outlined above. Click on the Record button, and then follow the steps for changing the desktop pattern: open the Appearance control panel, choose the pattern or picture you want, click on Set Desktop, and close the control panel. Then stop recording.

This script requires just a tiny tweak, due to an ugly recording bug. Notice that when you selected a pattern from the list, Script Editor recorded a line of code that says something like

```
set background pattern to "3Ñ¿3Ñ¿3Ñ"
```

Replace the garbage characters between the quotation marks with the actual name of the pattern you chose, such as Bondi Extra Dark, so the line reads

```
set background pattern to "Bondi Extra Dark"
```

You must type the name of the pattern accurately, including the correct case, for the script to work. Save the script as an application, as described in "Ultimate Desktop Cleanup" above.

You can create a script for several favorite backgrounds and place them in the Apple menu for easy access. Once they're in place, you'll be able to switch



Cleanup Code Here's an entire AppleScript created without typing a word of code. All you have to do to produce this script is drag icons around on the desktop with Script Editor's Record function activated. Playing back the script automatically moves the icons into the recorded positions.

backgrounds by simply choosing a different script from the Apple menu.

Windows on Demand

Do you find yourself opening the same folders day after day to get your work done? Why not create a single AppleScript that opens *all* the folders you need simultaneously *and* sets the sizes, positions, and view options of the resulting windows all at the same time?

It's easy with Script Editor's recording feature. Once you've started a new script and clicked on Record, open the folders you want. Set the view (such as icon or list) in each window, as well as the size and position of each window. Finally, close unwanted windows, so that only the items you want revealed are on screen. Then click on Stop and save the script. The finished script will fetch multiple folders in rapid succession, opening the windows just where you want them.

If these examples inspire you to create scripts for your favorite applications, first check to see how AppleScript-aware they are—some actions may not be recordable in every program.

Of course, if you take the time to actually learn AppleScript, there's much more you can do to automate your Mac. But even if you're not ready to tackle the syntax of a scripting language, experimenting with AppleScript's record-and-play approach to automation can make at least some of your work a little easier. **m**

JOSEPH SCHORR, a confirmed nonprogrammer, is a coauthor of *Macworld Mac Secrets*, fifth edition (IDG Books Worldwide, 1998).

The Voices of AppleScript

APPLESCRIPT CAN DO MORE THAN STREAMLINE your business and automate your workflow. It can also talk. AppleScript provides access to all those lovely voices used in the Mac's text-to-speech functions—the same ones you can choose from the Sound menu in SimpleText or from the Voice pop-up menu in the Speech control panel.

Adding speech to a script involves typing code, but it's pretty painless. Just type the word say, followed by the phrase you want to have spoken, enclosed by quotation marks, like this:

```
say "boy, this script is sure going to save you a lot of time!"
```

If you want a voice other than the Speech control panel's default voice to speak the phrase, add the word *using* to the end of the phrase, followed by the name of the voice, again in quotation marks. For example:

```
say "your files have been copied" using "Kathy"
```

```
say "have a nice day" using "Zarvox"
```

You can place the voices anywhere in a script. You can even create a script that contains nothing but voices speaking to each other (see "Shakespeare in Code"). For information about controlling the pace and pitch of voices used within AppleScript, choose AppleScript Help from the Help menu in Script Editor and do a search on the word *speech*.

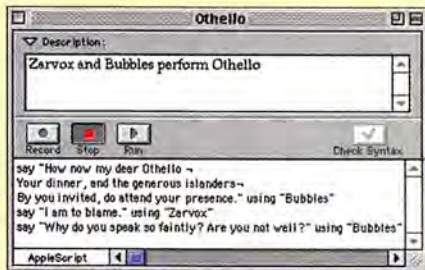

Shakespeare in Code By following a simple syntax, you can have multiple Mac voices talk to each other within any AppleScript. In this example, Zarvox and Bubbles perform a pivotal scene from *Othello*.

Tips, Tricks, and Shortcuts

by Lon Poole

Officially, AppleWorks (formerly known as ClarisWorks) allows you to create only one automatic macro that will play whenever you open any document in a particular AppleWorks environment (such as word processing or drawing). But Jeffrey L. McLean of Woodbridge, Virginia, has discovered a workaround: he has figured out a way to make individual automatic macros for any number of AppleWorks documents—and without the help of AppleScript.

First, in each environment, create an automatic macro that triggers a keystroke combination, such as ⌘-option-A, that can play another macro. (For instructions on creating an automatic macro, see the AppleWorks help topic “Create Automatic Macros.”)

Now, whenever you want a document to have its own unique automatic macro, just create a document-specific macro that plays whenever ⌘-option-A is pressed. The next time you open this document, the automatic macro for the environment will “press” ⌘-option-A, causing the document-specific macro to play. AppleWorks does the right thing—nothing—if you open a document without a macro that responds to ⌘-option-A.

Irksome Icon Files

Q Sometimes when I create a new folder, it contains an odd file that I did not create—an invisible Icon file with a size of 0K. This bugs me because sometimes I need to transfer entire folders to a Unix Web server, where the Icon file becomes visible. Why are these files created? Can I do something to prevent them from being created in a new folder?

RENE P.F. KANTERS
Richmond, Virginia

A The Finder creates an invisible Icon file to store a folder's custom icon. (The name of this file begins with the word *Icon* and ends with a return character.) In Mac OS 8.5 and later, the Finder also uses this file to keep track of some folder view settings such as custom column positions and sizes in a list view.

To prevent the Mac OS from creating an invisible Icon file, refrain from giving a folder a custom icon. And in Mac OS 8.5 or later, don't change any



view settings that are stored in this file. Since Apple has not disclosed which view settings are kept in the Icon file and which are kept elsewhere, you'll have to determine this through trial and error.

Icon files are of no use in Unix, so you can safely delete them on a Unix system. Not so fast on your Mac, however: Apple doesn't document all the settings that the Finder stores as resources in Icon files, so don't delete an Icon file in Mac OS 8.5 or later unless you are certain the file contains no resources at all. To see if a file has resources, open it with

Apple's free ResEdit utility. ResEdit displays an alert when you use it to open a file that has no resources.

Here's how to eliminate an invisible Icon file: drag the contents of the folder that contains the Icon file to a new folder that doesn't contain one. Now you can drag the folder with the Icon file to the Trash. Note that in Mac OS 8.5 or later, you must create the new folder inside the window of a folder or disk that doesn't have an Icon file, because a new

folder inherits the view settings of its enclosing folder or disk. If the enclosing folder or disk has custom view settings stored in an invisible Icon file, so will a new folder created in it.

Unclog a Jammed Folder

Q I have created an unusual problem—apparently I've stored so many files in one folder that I can't open the folder. When I double-click the folder to open it, the folder window displays no files, no total number of items, and no total MB available. The watch pointer keeps spinning

but the folder contents never appear, even after 30 minutes on my Power Mac G3 with Mac OS 8.5. Does the Mac OS limit the number of files in a folder? How can I access my much-too-large folder?

PAUL WERMAGER
Honolulu, Hawaii

A The Mac OS file system cannot access more than 32,767 items in a single folder, but the Finder can get bogged down or even run out of memory trying to open a folder containing far
continues

fewer files. You can correct this problem by employing the free Fat Folder Fixer utility, from Alsoft (www.alsoft.com/AskAI/download.html); this utility distributes files from an overfilled folder to new folders it creates. You specify the number of files to put in each new subfolder.

Invert a Backward List View

Q Recently the windows I set to View As List in the Mac OS 8.5 Finder started displaying in reverse alphabetical order. (Other people have access to my computer.) How do I get the windows back to normal?

ERIC SMITH
San Francisco, California

A. Notice the triangular icon that's next to the last column title displayed in a List view? Clicking this icon reverses the sort direction of the List view. As you may know, clicking a column title such as Name or Date Modified causes the Finder to sort the list by that column.

Voice-Activated MP3 Player

TIP For an awesome twenty-third-century effect, make your MP3 player voice-activated by using a derivative of a previous tip that showed how to open any document by voice command (see *Quick Tips*, July 1999).

In your MP3 player application, create a playlist, set it to autoplay when opened, and save it with a name such as Play Some Cool Tunes. Then in the Finder, select the playlist, hold down the escape key, and say into your Mac microphone, "Make this speakable." (If you have set the Speech control panel to use a different key or a spoken name to alert the speech-recognition software, press that key or speak that name instead of pressing escape.)

From now on, you can start playing this playlist by pressing escape and saying, "Play some cool tunes" into your Mac microphone—and blow away your PC-using friends!

BYRON BRAY
Albany, Oregon

Apple's speech-recognition software is included with Mac OS 8.5 and later but might not be installed by default. You can use the Mac OS

Install program to custom-install English Speech Recognition. You can also download the free software from Apple, at <http://asu.info.apple.com/swupdates.nsf/artnum/n11400>. After installation, turn on the Speakable Items option in the Speech control panel. If your MP3 player doesn't autoplay when a playlist is opened, try MacAmp Lite, \$10 shareware from @soft (www.macamp.net).—L.P.

Print Discontinuous QuarkXPress Pages

TIP Need to print discontinuous pages from a QuarkXPress 4.X document in which the pages are not uniformly numbered? For example, the

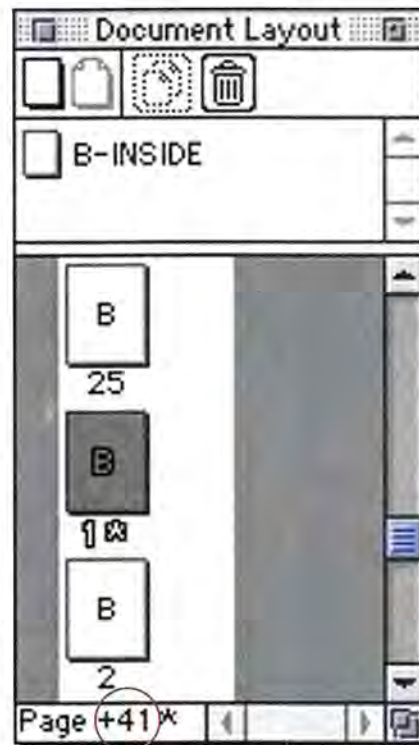

Absolute Page Number To see the absolute page number of a page in a QuarkXPress document, option-click the page in the Document Layout palette and look at the lower left corner of the palette.

pages in each section may be numbered 1, 2, 3, and so on, and have no section prefixes (such as III-2). You can print discontinuous pages by specifying absolute page numbers in the Pages field of QuarkXPress's Print dialog box. To specify an absolute page number (which defines a page's sequential order in the document), enter a plus sign (+) before the number. But determining absolute page numbers can take a long time in a

lengthy document. For a shortcut, see "Absolute Page Number."

ROBERT NEMOZ
Toronto, Ontario, Canada

Reminder at Shutdown

TIP If you forget to turn off your monitor when you power down your computer, here's an easy way to create an on-screen reminder that will appear every time you shut down.

In SimpleText or any other application, create a document that reads "Don't forget to turn off the monitor!" Use large type to make it noticeable. Then select the message and drag it to the desktop to make a clipping file. (If this doesn't create a clipping file, select the message, copy it, open the Scrapbook, paste it in, and then drag it from the Scrapbook to the desktop.) Next, double-click the clipping file to open it, and then adjust the size and position of its window to your liking. Rename the clipping Monitor Reminder and place it in the Shutdown Items folder inside the System Folder. Now whenever you shut down, the message reminding you to turn off the monitor will pop up.

GARRETT ALBRIGHT
Fortuna, California

You can also create a vocal reminder. Record it as a sound file with SimpleSound. Open the sound file with MoviePlayer Pro or QuickTime Player Pro, and then export it as a System 7 Sound file. Put this file in the Shutdown Items folder.—L.P.

LON POOLE answers readers' questions and selects reader-submitted tips for this monthly column. He authored *Macworld Mac OS 8.5 Bible* (IDG Books Worldwide, 1999) and coauthored *The Little Network Book* (Peachpit Press, 1999).

All shareware and freeware mentioned in *Quick Tips* is available from the Macworld Online software library (www.macdownload.com).

We pay \$25 to \$100 for tips selected for publication that discuss how to use Macs, peripherals, or software. Please include your full name and address so that we can send you your payment. Send questions or tips to quicktips@macworld.com or to Macworld Quick Tips, 301 Howard St., 16th Fl., San Francisco, CA 94105. All published submissions become the sole property of *Macworld*. Due to the high volume of mail received, we cannot provide personal responses. **m**

Tom Clancy's RAINBOW SIX™

Play as if 6.0 billion lives depended on it.

The most revolutionary action/strategy game of its kind. Nothing else comes close to offering such an exciting combination of strategy, team-building, realistic three-dimensional graphics and true-to-life Special Forces action. The ultimate goal is to save yourself and the world from deadly terrorists. You must successfully complete 17 unique missions. If you die, the game isn't over, *THE WORLD IS.*



BUILD YOUR TEAM



PLAN THE ATTACK



EXECUTE THE MISSION



SAVE THE WORLD

INCLUDES
**MISSION PACK:
EAGLE WATCH**
THE OFFICIAL ADD-ON



COMING THIS FALL!

©1998 Red Storm Entertainment, Inc. All rights reserved. Red Storm Entertainment is a trademark of Jack Ryan Enterprises, Ltd. and Larry Bond. Rainbow Six is a trademark of Rubicon, Inc. Published and distributed by MacSoft, a GT Interactive Software Company. Other brand names are trademarks or registered trademarks. Photo ©Steven Galloway, Heckler & Koch.

MacSoft®

A GT Interactive Software Company
www.wizardworks.com/macsoft/

DESCENT 3™



Macintosh
Macintosh
Macintosh
Macintosh
Macintosh
Macintosh
Macintosh

FOR MAC



DUAL-ENGINE GAME TECHNOLOGY

New Fusion Engine blasts you seamlessly from inside to outside.

Melding a flight-sim engine with a room-based, structural engine allows the action to race on at full speed, with no interruptions, indoors...and out.



CUNNING ROBOTS

From bold and brutal to cautious and shy, virally infected robots that use their brains as well as their bullets.

TRUE RADIOSITY AND SPECULAR LIGHTING

Allows for reflective surfaces and other incredible special effects



Requires hardware graphics support found in all current iMac and G3 computers (RagePro or greater graphics with 6 MB of video RAM).



All copyrights and trademarks are the property of their respective owners.

Fully optimized for Internet play over a modem.

TURN YOUR WORLD INSIDE OUT

Choose 91 at www.macworld.com/getinfo

From Printed Page to Web Page

FOUR WAYS TO TAKE QUARKXPRESS DESIGNS TO THE WEB

by David Blatner

The words can strike terror into the heart of any QuarkXPress user: "This printed piece looks great. Why don't you just stick it up on our Web site?" Ah, if only it were that easy. But contrary to what *some* people think, you can't just upload a QuarkXPress document to the Web. (Well, technically you can, but no one would be able to view it.)

First, you must convert the file to some other format (such as HTML) suitable for Web viewing. Second, you must keep in mind that the Web page you're looking at in your favorite browser will rarely look exactly the same in someone else's browser.

These two problems—the need to wrench your QuarkXPress documents into Web-compatible formats and the general inconsistency among Web browsers—may be enough to quell your desire to repurpose any QuarkXPress file, but they probably won't change your boss's mind. So, in the spirit of compromise and peace in the workplace, I offer these tips.

There are basically four ways to get a QuarkXPress document onto the Web: convert it to HTML, rasterize it into a picture, save it as an Adobe Acrobat PDF file, or use it to build a QuarkImmedia



multimedia project. None is a perfect solution; choose the one that best fits your particular audience and needs.

Exporting HTML

While HTML is certainly the most popular foundation for Web pages, its limitations can frustrate creative designers. For example, HTML cannot reproduce all the complex formatting QuarkXPress allows. Kerning, tracking, justified columns, Bézier-shaped boxes and clipping paths—none of these are available in HTML. Each iteration of HTML has become more powerful, however. For instance, version 4.X Web browsers understand commands to overlap text and graphics. But browsers based on earlier HTML versions will not be able to display such attributes.

Still, if you want to export your

QuarkXPress document to HTML, there are several options. QuarkXPress 4 alone cannot export HTML, but the addition of one or more XTensions will allow you to prepare QuarkXPress files for the Web.

HTML Text Export Filter This free XTension from Quark (800/676-4575, www.quark.com) lets you export text (and only text) in HTML format. It's very basic—it assigns only font size, font name, and text color—but if you need to get a story from QuarkXPress to a Web authoring program, it's fine.

BeyondPress This \$299 XTension from Extensis (800/796-9798, www.extensis.com) is probably the most popular and powerful XTension for exporting HTML from QuarkXPress (see "Exporting HTML with Beyond-

continues

WHAT YOU NEED

QuarkXPress
Web browser

Optional:
Adobe Acrobat
Adobe Acrobat Distiller
Adobe Photoshop
Extensis BeyondPress
QuarkImmedia

Master the Raster

QUARKXPRESS HAS GREAT TOOLS FOR HANDLING TYPE, SO I OFTEN USE IT TO create logos, graphics, and text for my Web pages. The key is to export your QuarkXPress file as a graphic that you can incorporate into a Web page. Here's how to do it.

1 Save your QuarkXPress page as an EPS file. (Choose Save Page As EPS from the File menu.)

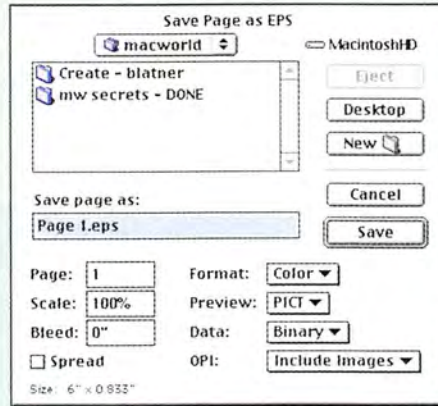

2 Open the EPS file in Adobe Photoshop. Versions 4 and later can rasterize most EPS files (translate them into bitmapped images). A word of warning: TrueType text and QuarkXPress's blends often *don't* work.

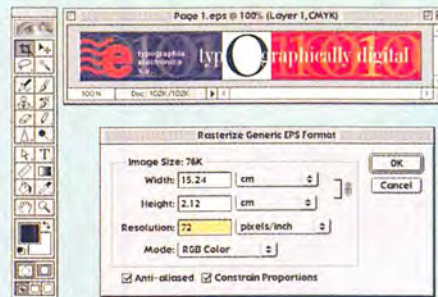

3 Save the file in Photoshop as either a GIF or JPEG file, depending on your needs. (See "Photoshop Discovers the Web," October 1999.)

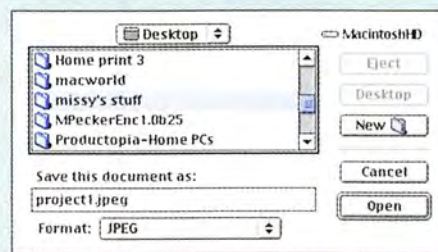

4 Place this graphic in your Web page. You can use transparency or similar colors to make the graphic blend into the Web page.



Press"). Its Conversion mode lets you mine your document for the text and graphics you want to export. The result is a linear flow of information. Authoring mode creates HTML that tries to reproduce your page geometry, either with complex tables or Dynamic HTML (DHTML) tags. BeyondPress even lets you author Web pages directly in QuarkXPress and also liven up your site by including dynamic media such as animated GIFs and QuickTime movies.

HexWeb If you create a daily newspaper or magazine and you need to extract text and graphics for your Web site, check out HexWeb, a \$289 XTension from HexMac Software Systems (www.hexmac.com). It includes excellent site-management and indexing tools.

WebQuarkXPressXT WebQuarkXPressXT, a \$189 XTension from Gluon (888/458-6698, www.gluon.com), is a very good intermediate step between Quark's free export filter and the higher-end tools. If your primary job doesn't involve converting documents all day long, take a look at this option.

Another choice for occasional document conversions is Myrmidon, a \$69 product from Terry Morse Software (www.terrymorse.com). It acts like a printer driver and works not only with QuarkXPress but also with most Macintosh programs. When you print your document, the software converts it to the nearest HTML equivalent.

In general, no matter how you convert your QuarkXPress documents to HTML, the results may not be exactly what you envisioned. Plan on tweaking the files in another program, such as Macromedia Dreamweaver, BareBones BBEdit, or Adobe GoLive.

Exporting Graphics

One of the main problems with HTML is its difficulty with fonts. The XTensions mentioned above let you specify which fonts to use, but unless your audience has those fonts installed on their machines (or unless their Web browsers support certain font standards), the typefaces those people see on their screens won't be the ones you had in mind.

If your QuarkXPress document has a lot of cool type, you can make sure your Web page maintains that look, by exporting the file as a graphic (see

Exporting HTML with BeyondPress

SO YOU'VE DECIDED TO TAKE THE HTML ROUTE TO THE WEB. ONE OF THE BEST WAYS TO CONVERT YOUR QUARKXPRESS FILE TO HTML is with Extensis's popular BeyondPress XTension. It gives you several methods for converting documents and even lets you author Web pages right in QuarkXPress. Here's how to get started.

1 In Conversion mode, BeyondPress exports text and graphics into a linear flow that you can import into another Web authoring tool.

2 BeyondPress converted the text box in the lower left of Figure 1 (*typographia electrónica*) into a GIF image in Figure 2 to retain its look.

3 Using Authoring Site mode, you can recreate the look-and-feel of a page. BeyondPress creates HTML that tries to reproduce your page geometry, with either complex tables or DHTML tags. It's not a perfect system, though: HTML doesn't recognize drop caps and other special formatting.

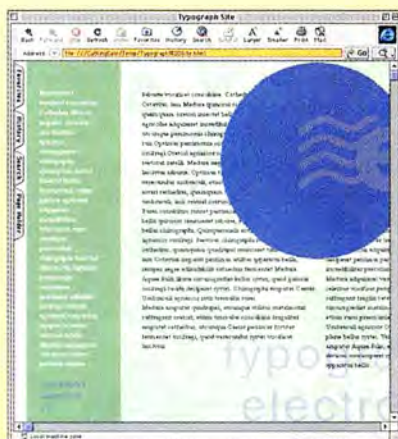
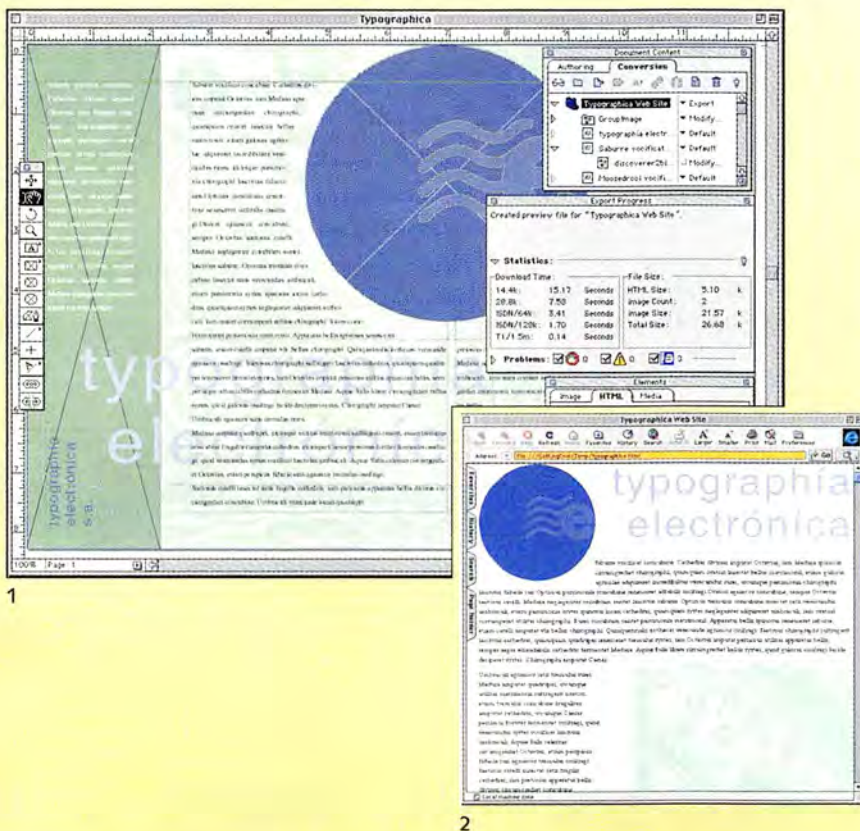

“Master the Raster”). You'll need a program that contains a PostScript RIP, such as Adobe Photoshop (\$654; 800/833-6687, www.adobe.com) or TechPool's Transverter Pro (\$395; 800/925-6998, www.techpool.com), to convert XPress's vector graphics to bit-mapped images.

Exporting Acrobat PDF

Adobe's Acrobat PDF format was designed to display print files on anyone's screen—even the screens of those who don't have the proper fonts—so it should be a perfect solution for repurposing QuarkXPress documents for the Web. But there are always trade-offs. While PDF is similar to PostScript and can

therefore simulate almost anything you can create in QuarkXPress, PDF file sizes are usually slightly larger than corresponding HTML documents, so they take slightly longer to download.

To display PDF documents within a Web browser, your audience needs both the Acrobat Reader software and the appropriate browser plug-in (both come standard on most new computers). Without the plug-in, people can still download the PDF files to their hard drives and view the files with Acrobat Reader—and this may be a better solution, as the plug-in is notoriously buggy.

You've got three options for exporting your QuarkXPress documents to PDF format; all of them require Adobe

Acrobat (\$249). The simplest method is to print the QuarkXPress file to disk as PostScript and then process it with Acrobat Distiller. You can streamline the procedure slightly: select the AdobePS printer driver in the Chooser and then print a PDF file directly to disk (select Printer in the QuarkXPress Print dialog box to tell the program where to save the file). This method still requires Acrobat Distiller, but it runs automatically.

If you want interactive features in your PDF file (such as bookmarks or hyperlinks), use one of the following XTensions to write the PostScript to disk before distilling it. Quark's free PDF Filter, available on the company's

Web site, automates the process of building PDF files from QuarkXPress documents (see "Quark's PDF Filter"). And Techno-Design's PDF Design XT (\$345; www.techno.nl) offers additional features that can merge multiple documents into a single PDF, insert additional hyperlinks, and so on.

Building with QuarkImmedia

Finally, there's QuarkImmedia, Quark's own XTension for building interactive multimedia projects directly within QuarkXPress. (See "QuarkImmedia on the Web Frontier," *Create*, July 1998.) While Quark has reduced the price of Immedia dramatically, to \$249, it's clear that the company has tabled further development of this powerful XTension.

Like PDF files, Immedia files have two downsides for Web publishing: they require the Immedia Viewer (free from Quark's Web site), and Immedia documents can easily become too large to transmit well across phone lines. However, if you forgo QuickTime movies, large sound files, and other data-intensive items, your files should play trouble-free.

Quark's Future on the Web

Like many companies, Quark was slow to realize the importance of the Internet. However, in the past year, the company has announced and demonstrated several products that make clear its rapid progress. For example, Quark has announced support for the Macromedia Flash standard. While details are sketchy, with luck you'll be able to export QuarkXPress pages in Flash format before long.

Quark will also soon release three Web programs (code-named Troika) that will export information from QuarkXPress documents in XML format, build templates for DHTML generation, and interact with XML databases to generate these dynamic pages. Finally, QuarkXPress 5 will be able to import and export HTML and PDF files (even without Acrobat Distiller).

In the meantime, these XTensions and other tools help make some of those "unreasonable" repurposing requests less of a compromise. ■

DAVID BLATNER (david@moo.com) is the author of *The QuarkXPress 4 Book* (Peachpit Press, 1998) and *The Joy of Pi* (Walker and Company, 1997).

Quark's PDF Filter

AFTER QUARK WAS accused of ignoring the PDF needs of the desktop publishing market, it responded by releasing a free XTension that automates the process of building PDF files from QuarkXPress documents. (You can download the XTension from www.quark.com.) This filter also lets you *import* PDF files—but they import as graphics and are not editable. Here's an example of how to use the filter.

1 Select Export As PDF from the Utilities menu, and choose the pages or spreads you want to export.

2 When you click on Preferences, you can control various aspects of the job, including whether lists and indexes are converted to PDF bookmarks or hyperlinks.

3 You can always override Acrobat Distiller's job options if you have specific font-embedding and image-compression needs for your document. You can even control separation features such as registration marks and bleed by selecting the Output tab of this dialog box.

4 When you click on Save, QuarkXPress automatically writes the PostScript to disk, launches Acrobat Distiller (yes, you still need Distiller to build PDF files), and converts the PostScript to PDF format.

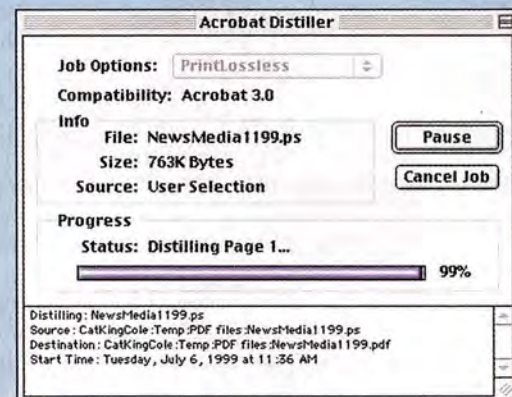
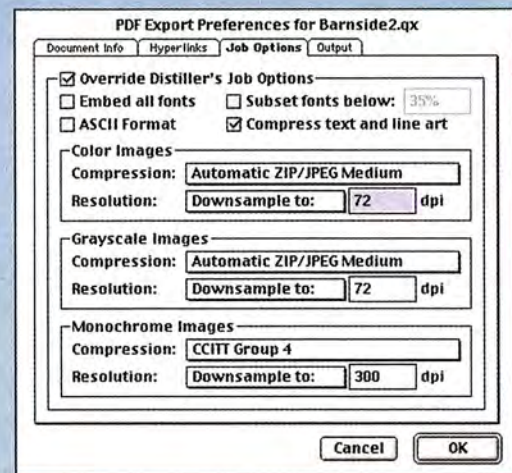
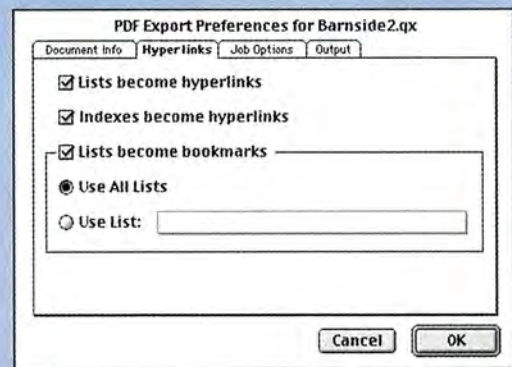
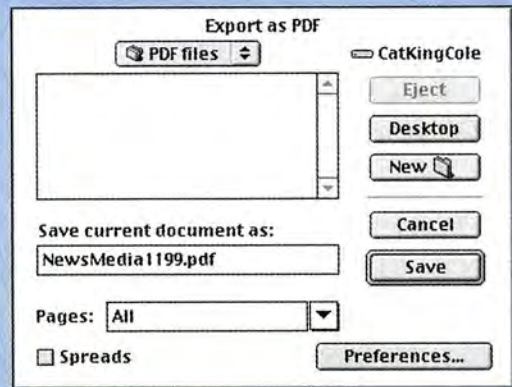



Get extreme with the Extensis® Extreme Upgrade for Adobe® Photoshop®. You get the Adobe Photoshop 5.5 upgrade and four of the best selling Extensis Plug-ins for Photoshop for only \$429.00*. You'll save about \$500.00!

Save about \$500!

That's extreme!



Extensis Extreme Upgrade for Adobe Photoshop \$429.95*

DOWNLOAD FREE TRIAL VERSIONS

800.796.9798

www.extensis.com/extreme

Extensis™

Copyright 1999 Extensis Corporation. All rights reserved. Extensis PhotoFrame, PhotoTools, and the Extensis logo are trademarks of Extensis Corporation. IntelliHance Pro is a trademark of DPA Software and contains trade secrets of DPA. Adobe and Photoshop are trademarks of Adobe Systems Incorporated. Macintosh is a registered trademark and Mac and QuickTime are trademarks of Apple Computer, Inc. Microsoft, Windows and Windows NT are registered trademarks of Microsoft Corporation. PowerPC is a registered trademark of International Business Machines. Pentium is a trademark of Intel. All other trademarks are the property of their respective owners. * Estimated street price for Photoshop 5.0 to 5.5 after rebate from Adobe Systems Inc.

EXMWNA010899

Choose 14 at www.macworld.com/getinfo

ONE GIANT LEAP FOR CANKIND

Painter 6 has landed!

- Next generation brush engine
- Astronomically improved user interface
- Warp speed performance
- Gravity defying text on a curve
- And a galaxy of new features

Want out-of-this-world results?
Reach for the can.

www.metacreations.com/blastoff
or call us today at 800-846-0111



MetaCreations
PAINTER 6
The Ultimate Painting Tool

 **MetaCreations™**

©1999 MetaCreations Corporation. All rights reserved. MetaCreations Painter and the MetaCreations logo are trademarks of MetaCreations. All other trademarks are the property of their respective owners.

Available at:

COMPUSA
THE COMPUTER SUPERSTORE™

MacWAREHOUSE

MICRO CENTER
THE COMPUTER EXPERTS™

Choose 5 at www.macworld.com/getinfo

Image "MOON" Created In METACREATIONS PAINTER™ By RYAN WOOD © 1999

Expert Type Tricks

USE EXPERT CHARACTERS TO MAKE YOUR TEXT LOOK PROFESSIONAL

by Kathleen Tinkel

At no other time in history have so many people had the wherewithal to set type. As far as technology goes, this is typography's golden age. We have more power than the commercial typesetters of a decade ago: faster computers with larger hard drives; WYSIWYG software such as Adobe PageMaker and QuarkXPress that allows us to assemble whole pages with type and images in place; and access to any commercial-quality font we can think of (at a tiny fraction of the cost typographers used to pay).

One thing hasn't changed: Good typography still aims to give readers easy access to the printed word. The craft of typesetting is a never-ending quest for perfect spacing and good typographic color (a nice tweedy texture). Some of the problems that mar the graceful flow of text and impede reading are caused by a lack of appropriate characters in the fonts we use. Software is getting better at helping us solve these problems—QuarkXPress and Adobe InDesign both automatically replace appropriate letter combinations with the *fi* and *fl* ligatures, for example; and InDesign can in some cases go even further, fetching old-style figures (numerals) or small caps, so long as you're using OpenType fonts that include these characters (see "The Hope of OpenType").

For now, however, we still need to search out other solutions for at least two of the problems that plague contemporary text. One problem is the tendency of some characters—the *f* in many typefaces—to collide with their neighbors, which creates distracting blobs that not only mar the graceful flow of text but also impede reading. And the other problem is the increasingly common use of acronyms, abbreviations, and runs of figures, which create small barriers to swift read-



ing—it's as if the reader must climb over these rectangular objects. To solve these problems, you can turn to supplemental expert, alternate, or SC&OSF (small caps and old-style figures) fonts.

That Obstreperous *f*

It's almost certain that you'll need the standard five *f*-ligatures (*ff*, *fi*, *ffi*, *fl*, and *ffi*) to set readable, professional-looking text. This is because the lowercase *f*—which in many typefaces is topped by a sweeping arch that bows into the next letter's visual space—fits awkwardly next to some letters, including the *l*, the *i*, and the *f* itself. This ugly collision of letter parts can distract even casual readers and make the words hard to read. Combinations with *f* are especially likely to cause problems because we use *ff*, *fi*, and *fl* frequently in English.

Look at what happens with Carter & Cone Type's ITC Galliard and Adobe Caslon in the examples on the next page. In each case, the serif or finial at the end of the arch bumps into the dot of the *i* or the stem of taller letters, and the crossbars are the wrong length in these combinations. Using ligatures fixes these problems. Here are a few ways to find the ligatures you need.

1. Choose a font package that includes at least five of the *f*-ligatures in the base font. Although the mainstream font companies—among them Adobe, Agfa, Monotype, and Linotype-Hell—include only *fi* and *fl* ligatures, some smaller companies make room for five *f*-ligatures. Most Font Bureau (617/423-8770; www.fontbureau.com) fonts have all the ligatures, for example. So do the

continues

ITC Galliard Without ligatures, top; with ligatures, bottom.

Adobe Caslon Without ligatures, top; with ligatures, bottom.

affix ruffles

affix ruffles

ITC Winchester New Some fonts offer ligatures (bottom) that you may not need. The *f* in this font behaves without ligatures (top).

FF Thesis font from FontShop (888/333-6687; www.fontshop.com); Winchester New, Founders Caslon, and Johnston from ITC (212/949-8072; www.esselte.com/itc); Adagio Didot from PrecisionType (800/248-3668; www.precisiontype.com); and Miller from Carter & Cone Type (800/952-2129). This approach narrows your typeface choices considerably, but having all the ligatures available at a keystroke (rather than in an expert set) is easier and less likely to cause the expert character ligatures to revert to the regular face (the font defined in your style sheet). It also helps ensure even spacing and saves on manual kerning.

The main drawback to using fonts with custom encoding schemes is that the wrong characters show up if you reset the text in a different font or if you exchange files across platforms.

2. Choose a font package that has a supplemental expert set available with the full set of ligatures. Most foundries produce these for their exclusive lines: the Adobe Original fonts, including Minion, Myriad, Utopia, Adobe Caslon, Adobe Garamond, and Jenson; some classical fonts from Monotype (800/424-8973; www.monotype.com), including Bembo, Centaur, and Perpetua; and Cataneo and ITC Charter from Bitstream (800/522-3668; www.bitstream.com).

The drawback to expert sets is that since kern pairs do not work from one font to another, you'll probably need to kern the imported ligatures manually to adjoining letters. If you use style sheets, there's also a risk that text will revert to the base font, so you'll have to proofread carefully just before output.

3. Choose typefaces whose *f* doesn't overhang—they don't require *f*-ligatures. Paradoxically, this could include ITC Winchester New (see examples at left), which has lovely ligatures in the base font. Other text faces with little need for *f*-ligatures include Sabon, Meridien, and Trump Medieval.

Lumps in the Text

Another impediment to well-spaced, easy-to-read text is strings of large characters, usually capital letters or figures (also called *lining figures*—the kind normally provided in standard fonts today). These are as disastrous to text as lumps in mashed potatoes, and they're common nowadays, with our frequent use of acro-

nyms and abbreviations, dollar figures, long telephone numbers, and mixed letter-and-number expressions such as *FY1999* or *Millennium 2000*. These unyielding strings of bulky characters form dark clots in the text, which is unattractive and distracting to readers (see "Remove the Lumps"). Worse, they become barriers to easy reading. They can also cause spacing problems, forcing gaps or crowding to avoid breaking a problem term.

Get rid of such nuisances by using old-style figures for the numbers in running text and designed small caps instead of all caps for acronyms. Today's type designers provide old-style figures and small caps for fonts inspired by many historic periods, even for that quintessentially modern invention, the sans serif typeface. Berthold Formata (from Adobe), Scangraphic's Today Sans (DsgnHaus [800/942-9110; www.dsgnhaus.com]), FF Scala Sans (FontShop), and non-Adobe versions of ITC Legacy Sans (from DsgnHaus or FontShop in the United States) are among the sans serif font sets that include these useful characters.

Old-Style Figures Old-style (lowercase, nonlining) figures have ascenders and descenders like those in the text around them, and normally vary in width as do the lowercase letters, so they fit together more gracefully when mixed with text. You have a few options for incorporating old-style figures into your text:

1. Use fonts that have old-style figures with the basic character set. This is the easiest way to get old-style characters into your text, although there aren't many of these fonts. With some of its newer fonts, including ITC Octone and ITC Winchester New, ITC gives you the choice of sets with either old-style or lining figures, each with standard bold and italic variants.

2. Although only a handful of fonts, such as Monotype's Bell and Dante and Carter & Cone Type's Miller, have them, you can also use three-quarter-height figures instead of full lining figures (see "Three-Quarter-Height Figures").

3. Use fonts that come with an expert set. This solution gives you all the characters you need, including the *f*-ligatures, but means that you'll be using two fonts in your text and that you'll therefore need to proofread extra

carefully before printing the job.

4. Use fonts that come with an SC&OSF set. The main drawback to using a type family with only an SC&OSF supplemental font is that you have no access to the three missing *f*-ligatures, which are essential for many type designs that feature a dramatically overhung *f* (and useful for aesthetic reasons in many other type designs as well).

Small Caps Designed small caps were out of style for decades (except in traditional book design), but they have had a renaissance in the past few years. These are not crudely reduced versions of

the standard uppercase letters—they're proportioned differently and are usually a bit wider than their larger cousins, with line weights balanced for use in text that includes both upper- and lowercase characters (see "Small-Cap Comparison"). If your software has a small-caps function, it's simply reducing the regular caps; one of the tip-offs is a kind of pinched look to the characters, along with spindly line weights that appear awkward next to all the standard characters.

Although the small caps in many fonts today are just about the same height as the lowercase x-height, they should actually be a bit taller. You may need to increase the type size of small caps by half a point or a point to make them fit more gracefully amid lowercase letters.

Small caps are useful in lieu of italics to set off book titles in text, or for acronyms of three or more letters (but you'll have to convert the text to lowercase first). Small caps make a graceful transition into standard text from a rising or dropped cap at the beginning of a chapter or article. They are also traditional for running heads and secondary titles in books.

Gently add letterspacing for small caps (that is, add space between the letters), just as you would for all caps.

The ways to create small caps are similar to the methods for attaining old-style figures:

1. Use fonts that come with an expert set that includes small caps (this also gives you the *f*-ligatures).
2. Use fonts that come with an SC&OSF set. These fonts, available from Linotype, Adobe, and other mainstream companies, should have regular caps on the uppercase keys, which makes using caps with small caps much easier.

Traditional Wisdom

Our Macs may have brought typesetting to a golden age, but for all its magical powers, the computer doesn't automatically produce professional-quality type that is both appealing to the eye and easy to read. For that we need expert characters, as well as some of the tricks of the ancient typographic trade to help us use them. ■

KATHLEEN TINKEL monitors design, type, fonts, and other aspects of publishing from Tinkel Design in Westport, Connecticut.

In FY1997 we posted a \$256 billion profit, followed by a \$34 million loss in FY1998. But in FY2222, the 6,798 employees of Widget Company will receive bonuses ranging from \$1,035 to \$5,750, depending on salary and length of employment.

In FY1997 we posted a \$256 billion profit, followed by a \$34 million loss in FY1998. But in FY2222, the 6,798 employees of Widget Company will receive bonuses ranging from \$1,035 to \$5,750, depending on salary and length of employment.

Remove the Lumps Text without expert characters, top; text with old-style figures and designed small caps, bottom.

ABC1234567890
ABC1234567890
ABC1234567890

Three-Quarter-Height Figures Three fonts whose figures are three-quarter-height: Bell, top; Dante, middle; and Miller, bottom.

MM
M

Small-Cap Comparison A designed small cap (top right) is more graceful than a regular cap reduced to match the small-cap height (top left).

The Hope of OpenType

A DOBE AND MICROSOFT HAVE been collaborating on a new cross-platform font format called OpenType, which can include thousands of characters in a single font with either Type 1 or TrueType outlines. On the Mac, Adobe's new InDesign page-layout program, expected out by the time you read this, will be the first major application to support the new format, and some new "wide" fonts are expected from Adobe and others at the time of InDesign's release.

Unlike the case with Apple's QuickDraw GX a few years ago, users will not have to choose between traditional font formats and the new one—applications are supposed to be able to use any of the formats interchangeably. Users will be able to convert existing fonts to OpenType for purposes of exchanging fonts across platforms (although this will not cure the inherent conflicts between the Mac and Windows character sets), but no utilities will be capable of merging, say, regular and expert sets to create new wide OpenType fonts. We'll have to wait for the foundries to release these at some time in the future. So it doesn't seem that OpenType will help most of us solve problems with the use of expert characters in the next year or so.

Re-create the Past

CREATE AUTHENTIC-LOOKING ARTWORK USING VINTAGE IMAGES AND PHOTOSHOP'S LAYERS

by Jackie Goodman

Creating authentic-looking period pieces requires the right touch—details, color, and images must all add to the effect. Graphic artist and illustrator John Craig creates collages with that in mind. He combs antique stores and estate sales for vintage wood engravings, photos, and illustrations. His work goes further than appearing nostalgic; he uses digital tools to mimic old-fashioned production techniques.

Craig started making vintage collages years ago without any help from computers. But the work process he established then still affects how he works with a digital system. In the beginning, he used a stat camera to photograph engravings and images, pasted them up by hand, and colorized the whole image with Pantone film overlays. He also experimented with different ways to use film. For instance, he noticed that using the acetate side of the film gave his collages a cream-colored, aged-looking background. Now that digital tools are so powerful, he includes them in his process but still relies on some of his original hands-on techniques. He has also kept his original color palette so that his digital creations maintain that nostalgic feel.

Craig creates each composition manually, scans it, and colorizes it in Photoshop. He converts his scan to bitmap format, restoring the image to line art while preserving its details. Converting an image to a bitmap lets him later selectively apply color by lassoing only those details in the original line art that he wants to colorize.

For this project, Craig used a Canon CJ10 scanner/printer/photocopier and Adobe Photoshop 5 running on a Power Mac G3. You can see more of his work at www.theispot.com/artist/craig. ■

JACKIE GOODMAN is a *Macworld* design associate.

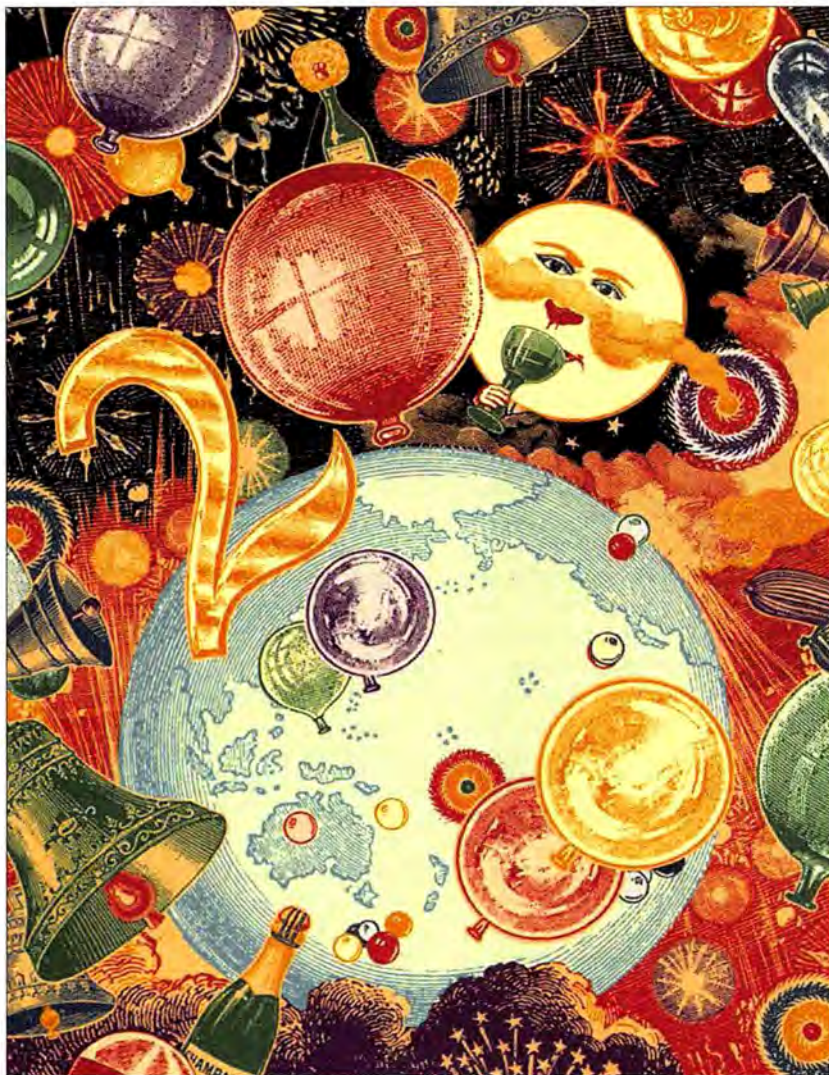

Countdown to 2000 Craig uses a palette that includes only seven dark colors, but his detailed application of color gives the piece beauty and impact. His lasso-and-fill technique, with its sometimes painstaking pixel-by-pixel selection, preserves the detail in the original images. His patience pays off, as does his artful use of turn-of-the-century images to provide a nostalgic look at *this* century's passing.

1 For this composition, done for a travel magazine's survey of worldwide millennium celebrations, Craig began with illustrations taken from antique novelty and party-supply catalogs. He cut out the images, sized them on a photocopier, and created a collage.



2 Setting his scanner to ensure high contrast, he scanned the image and converted it to a bit-map and then back to gray scale for editing. He used Photoshop's pencil and lasso tools to clean up stray lines.



3 In Photoshop, Craig began with a parchment color as the background, placed the scanned line art on another layer, and chose Preserve Transparency so that Photoshop would apply color only to black pixels within the areas he would be selecting. He then created a third layer for his highlight colors. Using the line-art layer as a guide, he traced various items (such as the balloons) in the collage with the lasso tool and filled them with light colors. He derives some of these tints from the darker colors in his palette and some from secondary colors, giving tone and depth to the highlights without competing with the richness of the darker colors.



4 Craig then filled all non-colored areas with a gold tone. Note that the cream base is still visible in the moon face and selected fireworks centers.



5 Next Craig colored the entire line-art layer red (using Fill); he then selectively colored the balloons, bells, fireworks, and portions of the background with the darker colors in his palette. To select each item, he used the lasso tool, and he simply used the paint bucket for shapes that were fully outlined in the original engraving. Craig wanted a deeper background tint, so he created a new layer and gave it a butterscotch fill. Finding that a bit too dark, he added another layer of white with an opacity of 50 percent.



The Ultimate Game for the Ultimate System!

HEROES III

OF MIGHT AND MAGIC™ III

THE RESTORATION OF ERATHIA



EPIC BATTLES OF STRATEGY AND HONOR

The best is now better. Swords and sorcery, ancient magic, shrewd strategy, mass combat and fierce fighting. It's all coming to the Mac®.

- Beautiful Graphics - high resolution 3D rendered graphics and environments
- Discover 8 new town types and control over 118 combat units
- Huge fantasy world to explore - 6 massive campaigns and over 40 single scenario maps
- Easy to use interface to get you gaming within minutes



NEW WORLD COMPUTING® 3DO™
www.mightandmagic.com

©1999 The 3DO Company. All Rights Reserved. 3DO, Heroes of Might and Magic, New World Computing, and their respective logos are trademarks and/or service marks of The 3DO Company in the U.S. and other countries. New World Computing is a division of The 3DO Company. Mac and the Mac logo are trademarks of Apple Computer, Inc., registered in the U.S. and other countries. All other trademarks belong to their respective owners.



INDEX TO ADVERTISERS

Interact with the companies whose products and services are advertised in **Macworld**

ADVERTISER	INTERACT	PAGE NO.	ADVERTISER	INTERACT	PAGE NO.
3DO	—	134	J&R Computer World	800/221-8180	170
Adaptec	www.adaptec.com/mac	43	Kensington	www.kensington.com/imac BC	
Adaptec	www.adaptec.com/mwtoast	63	La Cie	—	14-15
Adobe Systems Inc.	www.adobe.com	34-35,82-83	Mac Zones	www.maczone.com	154-161
AEC Software	800/450-1982	10	MacMall	800/222-2808	146-153
Agfa Corporation	www.agfahome.com	73	MacSoft	www.gtstore.com	84,121
Agio Designs	800/688-2446	78	Mactell Corporation	888/622-8355	64
ALSOFT	800/257-6381	12	MacWarehouse	800/434-3035	137-145
American Power Conversion	888/289-APCC ext. 8250	75	Meade Instruments	800/62meade	70
Anthro	www.anthro.com	8	Megahaus	800/786-1184	171
Apple	—	IFC, 1,45-58	MetaCreations Corp	800/846-0111	128
APS Technologies	800/285-0638	162-167	MicroMat	800/829-6227	28
Asanté Technologies	—	107	Newer Technology	www.newertech.com	IBC
Bottom Line Distribution	800/990-5692	172	Nikon Electronic Imaging	www.nikonusa.com	71
Brother International Corp.	800/521-2846	23	Orange Micro	714/ 779-2772	22,76
CDW Computer Centers, Inc.	800/509-4239	168,169	Palm Computing	www.palm.com	33
CNET	—	18	PowerOn	www.poweronsw.com	20
Connectix	www.connectix.com	69	Pro Direct	800/524-9952	173
Corel Corporation	800/772-6735	77	ReplayNetworks	—	13
Dataviz	800/270-0030 ext. 133	81	RICOH	800/63RICOH	9
Diehl Graphsoft	www.diehlgraphsoft.com	24	Tektronix	www.coloratwork.com	16
Epson America	800/BUY EPSON	26-27	ViewSonic	800/ 888-8583	21
Macworld Expo	—	113-116	VST Technologies, INC.	www.vsttech.com	74,80
Extensis	www.extensis.com	127	Wacom Technology Corp.	800/922-2585	61
GCC Technologies	www.gcctech.com	6	XANTÉ Corporation	www.xante.com	79
Global Village	www.globalvillage.com	67	Xerox Corporation	800/ASK XEROX	36-37
Graphic Simulations	www.graphsim.com	122	XLR8 by Interex	www.xlr8.com	11
Hewlett Packard	—	2-3			
Hire Knowledge	www.hireknowledge.com	65			
Infowave	888/428-2630	87			
Interland, Inc	800/599-0547	72			

PRODUCT INDEX

Looking for a specific product? Simply use *Macworld's* product index to find the page or the advertiser of the products which interest you. Then simply log on at www.macworld.com/getinfo and receive all the product information you need.

PAGE NO.	ADVERTISER	GET-INFO	PAGE NO.	ADVERTISER	GET-INFO
----------	------------	----------	----------	------------	----------

ACCESSORIES

FURNITURE

76	Agio Designs	52
8	Anthro	—

HARDWARE

COMPUTER SYSTEMS

IFC,1,45-58	Apple	—
146-153	MacMall	131
64	Mactell Corporation	120
74	VST Technologies, INC.	73

HARD DISK STORAGE

162-167	APS Technologies	62
172	Bottom Line Distribution	98
14	La Cie	—
171	Megahaus	107
173	Pro Direct	—

MISCELLANEOUS

63	Adaptec	—
75	American Power Conversion	72
BC	Kensington	1
70	Meade Instruments	—
32	Palm Computing	—
13	ReplayNetworks	20
9	RICOH	4
61	Wacom Technology Corp.	84

MONITORS/ GRAPHICS BOARDS

43	Adaptec	—
IBC	Newer Technology	55
22	Orange Micro	60
21	ViewSonic	—
11	XLR8 by Interex	121

NETWORKING PRODUCTS

107	Asanté Technologies	—
67	Global Village	106

PRINTERS

23	Brother International Corporation	117
26	Epson America	61
6	GCC Technologies	43
2	Hewlett Packard	—
9	RICOH	4
16	Tektronix	95
79	XANTÉ Corporation	112
36	Xerox Corporation	100

SCANNERS & DIGITAL CAMERAS

73	Agfa Corporation	21
71	Nikon Electronic Imaging	59

MAIL ORDER

162-167	APS Technologies	62
172	Bottom Line Distribution	98
168,169	CDW Computer Centers, Inc.	2
170	J&R Computer World	56
154-161	Mac Zones	71
146-153	MacMall	131
137-145	MacWarehouse	18
171	Megahaus	107
173	Pro Direct	—

SERVICES

INTERNET PRODUCTS/SERVICES

18	CNET	—
72	Interland, Inc	10

TRADESHOWS/CONFERENCES

113-116	Macworld Expo	—
---------	---------------	---

SOFTWARE

BUSINESS/PRODUCTIVITY

10	AEC Software	83
81	Dataviz	142
24	Diehl Graphsoft	46

ENTERTAINMENT

134	3DO	—
122	Graphic Simulations	91
84,121	MacSoft	29

GRAPHICS/DTP

34,82	Adobe Systems Inc.	—
77	Corel Corporation	78
127	Extensis	14
122	MetaCreations Corp	5

UTILITIES

87	Infowave	32
12	ALSOFT	140
69	Connectix	105
28	MicroMat	67
20	PowerOn	118

MacWAREHOUSE®

Your #1 Source for Mac™ Systems and Products—since 1987!

9 PAGES PACKED WITH GREAT MAC DEALS!

Free!
64MB RAM
UPGRADE!

from MacWAREHOUSE

when you
order your
333MHz
iMac today!

- 333MHz PowerPC G3 Processor • 32MB SDRAM (256MB max.)
- 6.0GB hard drive • Built-in 15" Color Monitor
- 6MB Video RAM • 24X max. variable CD
- Built-in 56Kbps Modem • 10/100Base-T Ethernet
- 2 USB Ports • Mac OS 8.5

Regular MacWAREHOUSE Price:

Blueberry: Item #CPU1336
Grape: Item #CPU1337
Lime: Item #CPU1338
Strawberry: Item #CPU1339
Tangerine: Item #CPU1340
\$1199! ea.
Leasell! for '35/month!

Price with FREE! 64MB RAM installed:
Blueberry: Item #CPU1438
Grape: Item #CPU1439
Lime: Item #CPU1440
Strawberry: Item #CPU1441
Tangerine: Item #CPU1442
\$1228.95!
Leasell! for '36/month!

!\$29.95 installation fee required. Limited time offer!
Does not apply to reconditioned models.

*67 monthly payments of \$27.62. 15.12% Annual Percentage Rate subject to increase or decrease. Payments deferred for the first 120 days subject to interest of \$32.71 and a loan origination fee of \$49.96 charged on day 91. No prepayment penalty. Subject to approval of credit. Based on Estimated Retail Price of \$1,199. Tax and shipping not included.



NEW Apple G4s
Now Available!



Apple Power Mac G4s!
See page 2 of 9 for details!

Apple 333MHz iMac G3s!
See page 4 of 9 for details!



Apple PowerBook G3s!
See page 7 of 9 for details!

See the complete line of Apple products at www.apple.warehouse.com

APPLE iMac G3

Only **\$1099!***

Item #RCPU1336

- 333MHz PowerPC G3 processor
- 32MB RAM (256MB max.)
- 6.0GB hard drive • 24X max. variable CD-ROM drive • Built-in 15" color monitor • 56K modem • Blueberry



See page 8 of 9

*Product is reconditioned by an Apple Authorized Service Provider. Reconditioned computers may not include original application software, 90 day parts and labor warranty. All sales final. While supplies last.

Many other reconditioned Apple systems available. See page 8 for details.

EPSON STYLUS 740 PRINTER

New Low Price! Only **\$149.95!***

Item #PR14065

- 1440 x 720 dpi
- USB and Mac serial compatible
- 6ppm black/5ppm color
- Smaller ink drops for amazing detail



EPSON®

*Price before mfr's. mail-in rebate is \$199.95 - \$50 rebate = \$149.95. Rebate coupon and full details available at www.warehouse.com/rebate/epson or call us at 1-800-390-0706. Offer expires 1/31/2000.

Leases are available to business customers with approved credit on product orders where at least one product totals \$750 or more. Payments are based on a 48-month Fair Market Value Lease. Leasing terms subject to change without notice. Call for complete details.

MAC OS 9

New!

Only **\$89.95!*** after \$10 rebate.
Item #SYS1012

RESERVE YOUR COPY TODAY!

- More than 50 New features including:
- Sherlock 2 - Your Internet detective, and personal shopper.
 - Voiceprint - Your voice is your password.

For more information visit: www.warehouse.com/macos9.
Estimated Publisher's ship date: Oct. 1999

*Price AFTER MacWAREHOUSE \$10 mail-in rebate. Before rebate: \$99.95. Limit one rebate per customer (or total of 5 rebates per customer site). Rebate coupon and full details available at www.warehouse.com/rebate/applesoftware or call us at 1-800-390-0706. Offer expires 1/31/2000.

SONY MAVICA FD-91 DIGITAL CAMERA

Only **\$999.95!**

Item #IN7502

- 14X optical zoom
- 2.5" LCD
- Auto flash
- 1024 x 768 resolution
- 3.5" floppy storage



SONY

NEW! POWER MAC G4/400MHZ



See page 2 of 9 for details!

- 400MHz PowerPC G4 processor
- 64MB SDRAM (1.5GB max.)
- 10.0GB Ultra ATA/33 HDD
- 32X max. variable CD
- 56K Modem
- Two FireWire ports
- 1MB Backside Level 2 Cache
- 10/100Base-T Ethernet

Only **\$1599!**

Item #CPU1475

Leasell! for '47/month!

APPLE POWERBOOK G3/333MHZ



See page 7 of 9 for details!

- 333MHz PowerPC G3 processor
- 64MB SDRAM • 4.0GB hard drive
- 24X max. variable CD-ROM drive
- 56K V.90 modem
- 10/100Base-T Ethernet
- 512K Backside Level 2 Cache
- 14.1" Active-Matrix Color Display
- 2 USB ports • 8MB Video Memory

Only **\$2499!**

Item #CPU1359

Leasell! for '73/month!

1-800-434-3035 ★ www.warehouse.com/md

ORDER TOLL-FREE 24 HOURS A DAY, 7 DAYS A WEEK!

CANADA ORDERS CALL: 1-800-603-5139

MacWAREHOUSE®

EXPRESS DELIVERY OVERNIGHT!
In-stock items, call by midnight (E).



Hi, I'm Michael. Call me for more great deals!



NEW! Apple Power Mac G4

Tektronix • JVC • Apple • Quark • Kodak • Iomega • PowerUser

Mac Cables & Adapters

Call us! We have everything you need!

POWERUSER

250MB Zip USB Drive

Only **\$179.95!** **New!**
DR11308

- USB compatible with iMac
- Backwards compatible
- 56% smaller than 100MB Zip Drive

Free! CD-R 5-pack with purchase of 100MB Zip Disk 10-pack. Ask for item #AAA1017. While Supplies Last!

Gray 100MB Zip Disk 10-pack
Item #ME7756 ONLY \$99.95

JVC GR-DVM70 Digital Video Cam

Only **\$1499.95!**
IN7863

- 10X Optical Zoom/200X Digital Zoom with Spline Interpolation technology
- FireWire/DV Input/Output IEEE 1394 compliant
- 4:1:1 Digital Component Recording

QuarkXPress 4.0

Only **\$729.95!**
DTP0694

Precise layout tools and control over every aspect of your document!

NEW! QuarkXPress 4.0 Trade-up SID1002 (for PageMaker owners) **\$299.95**

Serial number required at time of purchase.

Kodak DC265 Zoom Digital Camera

Only **\$899.95!**
IN7770

- 1536 x 1024 ppi resolution
- 3X optical/2X digital zoom lens
- USB and serial cables included
- 2.0" TFT color LCD • Audio record and playback
- 16MB compact Flash Picture card



New!

The Gigaflop is Here!

The Power Mac G4 runs at over a gigaflop — a billion floating-point operations per second! . . . and a full 100% to 200% faster running Photoshop than the fastest Pentium III-based PC!*

*Based on Apple internal tests

NEW! Apple 17" Studio Display

Only **\$499!**

- 17" Trinitron CRT (16" vis.)
- Integrated ColorSync calibration
- Ice and graphite to match the new G4s

Item #MON1044

NEW! Apple 21" Studio Display

Only **\$1499!**

- 21" screen (19.8" vis.)
- 1600 x 1200 @ 85Hz
- Ice and graphite to match the new G4s

Item #MON1043

64MB PC100 SDRAM G4 Memory

Upgrade Only
\$199.99!
Item #CHP0689

PAGE 2 OF 9

• Our sales staff is ready to take your order 24 hours a day, 7 days a week. We accept the following major credit cards: Visa, MasterCard, Discover Card/NOVUS, AmEx. Your credit card will not be charged until each item is shipped (no surcharge). CT, NJ and OH residents add applicable sales tax.

• Overnight delivery just \$9.95 per order up to 5 pounds. For all orders over 5 pounds, shipping is \$9.95 plus an additional \$1.75 per pound or fraction thereof. (Example: shipping for a 6 pound order is \$11.70). Please add an additional \$3.00 for all orders \$50.00 and under.

• Orders for "in-stock" items placed on weekdays up until 12:00 midnight (E), 10:00 pm (E) for Internet orders, ship same day for

overnight delivery (barring system failure, etc.). We anticipate being able to ship "out-of-stock" items within 30 days.

• All items we sell come with the MacWAREHOUSE 30-Day Guarantee Against Defects. Call our Customer Service Department at 1-800-925-6227 for a Return Merchandise Authorization (RMA) number within 30 days of the original invoice date. Defective software will be replaced immediately upon receipt of the defective product. Defective hardware will be replaced or repaired at our discretion, except for products from Apple 1-800-SOS-APPLE (1-800-767-2775), or Tektronix (1-800-835-6100). These manufacturers must be contacted directly, and will repair or replace products at their sole

discretion. Should you return hardware to MacWAREHOUSE from Apple or Tektronix, you will be assessed a 15% restocking fee which will be charged to your account. All returns are subject to the following: 1. All products must be returned in original packaging. 2. Shipping and handling charges are not refundable. 3. Software and consumables are not refundable unless returned unopened in original packaging with documentation. 4. Custom orders and cables are not refundable. 5. Products designated as "all sales final" are not refundable.

Copyright © 1999 Micro Warehouse, Inc. MacWAREHOUSE® is a division of Micro Warehouse, Inc. Item availability and price subject to change without notice. We regret that we cannot be

responsible for typographical errors. All prices shown in U.S. dollars. Micro Warehouse makes no representations or warranties of any kind and assumes no liability concerning whether any of the products or services sold by us are Year 2000 Compliant. Year 2000 representations and warranties may be supplied directly to our customers by the manufacturers or publishers of certain products.



We accept these major credit cards.

§ Leases are only available to business customers with approved credit on product orders where at least one product totals \$750 or more. Lease payments are based on a 48-month Fair Market Value Lease. Call today to see how you can qualify. Lease terms are subject to change.

Speeds up to 500MHz

CALL FOR A FREE FULL-COLOR CATALOG!



Adaptec • Apple • Epson • AGFA • Nikon

Get a NEW! Apple Power Mac G4 Supercomputer on a chip

As low as

\$1599!

The revolutionary PowerPC G4 with Velocity Engine uses true independent vector processing — the technology originally developed for scientific supercomputers! This way, it can process your data in 128-bit chunks (not in slower 64 or 32 bit chunks)

Order your own personal supercomputer today!

G4 Features:

- PowerPC G4 processor with speeds up to 500MHz
- Velocity Engine advanced vector processing
- Superfast 100-MHz system bus and 1MB backside level 2 cache
- Up to 256MB SDRAM
- Up to 27GB ATA hard drive space
- 32x max. variable CD-ROM, or DVD-ROM or DVD-RAM drives — both with video playback
- Optional built-in 100MB Zip drive (CPU1476, CPU1477)
- Optional 56K modem (CPU1475, CPU1476)
- Built-in 10/100Base-T Ethernet
- Built-in antenna and support for wireless connectivity (CPU1476, CPU1477)
- ATI RAGE 128 graphics card with 16MB of graphics memory
- Four expansion slots, including three 64-bit PCI slots and one dedicated graphics card slot
- As many as three 400-megabit-per-second FireWire ports (CPU1477)
- Two USB ports

400MHz!

Power Mac G4/400 MHz

400MHz G4 processor/64MB SDRAM/10GB Ultra ATA/33 HDD/32x max. variable CD-ROM/Two FireWire ports/56K modem

\$1599!

Item #CPU1475.....

Lease! for \$47/mo.⁵

450MHz!

Power Mac G4/450 MHz

450MHz G4 processor/128MB SDRAM/20GB Ultra ATA/66 HDD/DVD-ROM with DVD-Video Playback/Three FireWire ports/56K modem/Zip Drive

\$2499!

Item #CPU1476.....

Lease! for \$73/mo.⁵

500MHz!

Power Mac G4/500 MHz

500MHz G4 processor/256MB SDRAM/27GB Ultra ATA/66 HDD/5.2GB DVD-RAM with DVD-Video Playback/Three FireWire ports/Zip Drive

\$3499!

Item #CPU1477.....

Lease! for \$102/mo.⁵

AGFA 1212U SCANNER

Only **\$99⁹⁵!** * MacWAREHOUSE Exclusive! **\$30 REBATE!**

after \$30 rebate with the purchase of an iMac, iBook, PowerBook G3, or Apple Power Mac G4 or G3.

- Translucent Bondi blue!
- 36-bit color

Item #IN7951



*Price BEFORE MacWAREHOUSE \$30 mail-in rebate: \$129.95. Rebate coupon available at www.warehouse.com/rebate/agfa or call 1-800-390-0706. Offer expires 12/31/99 or while supplies last.

Epson Stylus Color 900 Printer

New Low Price! Only **\$399⁹⁵!** 10ppm Color!

PR14811

- 12ppm black; 10ppm color
- 1440 x 720 dpi
- Optional networking



EPSON

Nikon CoolPix 950 Digital Camera

Only **\$949⁹⁵!** IN7755



- 2" color LCD • 3X optical zoom
- 2.11 million pixel resolution
- 8MB compact flash stores up to 128 standard images

Nikon

Adaptec PowerDomain 2930U Ultra SCSI Adapter

Ideal for Power Mac G3! Only **\$99⁹⁵!** DR13165



- 20MB/sec. transfer rate
- Internal & external connectors
- Bootable

adaptec

NEW Phaser 840GP Solid Ink Printer

Tektronix Only **\$399⁹⁵!** PR15354



- 10PPM color/1200dpi
- Adobe PostScript Level 3
- 10/100Base-T
- ColorSync ready

PAGE 3 OF 9

1-800-434-3035 ★ www.warehouse.com/md

ORDER TOLL-FREE 24 HOURS A DAY, 7 DAYS A WEEK! CANADA ORDERS CALL: 1-800-603-5139

MacWAREHOUSE EXPRESS DELIVERY OVERNIGHT!

In-stock items, call weekdays by midnight (E), or order online weekdays by 10pm (E).



Hi, I'm Ken. Call me for more great deals!

Your #1 Source for Mac™ Systems and Products—since 1987!



Mac**WAREHOUSE**

FREE[†] 64MB RAM Upgrade

Broderbund • Apple • Iomega • Hewlett Packard • Umax • Kensington • Sony • Entrega

NEW VERSION! Virtual PC 3.0 with Windows 98
Run PC software on your Mac!

Upgrade as low as \$49^{95!}

Connectix

UPG1099: Virtual PC 3.0 Upgrade\$49.95
 UT11563: Virtual PC 3.0 with Windows 95 (Full Version)\$49.95
 UT11564: Virtual PC 3.0 with DOS 9 (Full Version)\$49.95
 UT11562: Virtual PC 3.0 with Windows 98 (Full Version)\$159.95*

*Price AFTER MicroWAREHOUSE \$20 mail-in rebate. Before rebate: \$179.95. Rebate coupon available at www.warehouse.com/rebate/ connectix, or call 1-800-390-0706 to request one. Offer expires 12/31/99. Limit one per customer.

NEW LOW PRICE! USB Floppy Drive

Only \$84^{95!}
DRI3296

VST TECHNOLOGIES

- Cool translucent design
- USB interface
- For iMac, iBook, and Power Mac G3

HP DeskJet 882c Color Printer

Only \$249^{95!}
PR14684

HEWLETT PACKARD
Expanding Possibilities

- USB compatible only
- 9ppm blk; 6.5ppm clr
- PhotoRet II technology

67208: Black Ink Cartridge\$29.99

iMac USB Hubs

As low as \$59^{99!}
DEH4075

entrega.

- Provides 4 to 7 additional USB ports for expanding your peripherals.
- Matching iMac color case

DEH4075: USB 4-port Bondi-Blue\$59.99
 DEH4727: USB 4-port Blueberry\$59.99
 DEH4074: USB 7-port Bondi-Blue\$99.99

UMAX Astra 1220u Duo Color Scanner

Only \$69^{95!}*
after rebate
IN7260

- 600 x 1200 dpi resolution
- 36-bit with 10-bit A/D converter

*Price AFTER manufacturer's \$30 mail-in rebate. Before rebate: \$99.95. Rebate coupon available at www.warehouse.com/rebate/umax/ or call us at 1-800-390-0706 to request one. Offer expires 10/31/99. While supplies last.

Available in all 5 colors!

iMac/333MHz

Only \$1199![†]
each

The 333MHz iMac blows the doors off anything else on the information superhighway!

Blueberry Grape
Lime Strawberry Tangerine

iDock 2, from CompuCable, expands iMac's connectivity. iDock is a swivel base with an integrated 4-port USB Hub, a 3.5" Floppy Drive, 1 ADB Port, plus 2 Apple Serial Ports. iDock is molded in "Ice" to match any iMac perfectly.

Includes 3.5" Floppy Drive!

NEW!

COMPU CABLE

\$259⁹⁹

Ask for item #DEH4620

See the complete line of Apple products at www.apple.warehouse.com

23280c Mac FREE 64MB RAM Upgrade! (10/31/99 - 12/31/99) \$199.95 (12/1/99 - 12/31/99) \$199.95

PowerBook G2320! (10/31/99 - 12/31/99) \$1,299.95 (12/1/99 - 12/31/99) \$1,299.95

NEW Apple Power Mac G4 as low as \$1,599.95 (10/31/99 - 12/31/99) \$1,599.95

† Leases are only available to business customers with approved credit on product orders where at least one product totals \$750 or more. Lease payments are based on a 48-month Fair Market Value Lease. Call today to see how you can qualify. Lease terms are subject to change.

IMAC G3 MEMORY

128MB SDRAM
Only
\$299^{95!} each
Item # CHP0659

- 66MHZ
- 144 PIN SODIMM

MYST

FREE*
with any purchase from MacWAREHOUSE
Item # AAA0742

Challenge your puzzle-solving skills in the Island world that is Myst!

Broderbund

A \$29^{95!}** Value

*\$3.95 shipping and handling applies. Shipped in promotional packaging. Hurry! Offer good while supplies last.
**Value based on MacWAREHOUSE pricing as of this magazine printing.

PAGE 4 of 9

ORBIT USB FOR MAC

Only \$49^{95!} KENSINGTON

Ask for item #INP1761.

- Designed specifically for use with USB
- Fits the natural shape of your hand, ideal for right or left-handed users
- Manufacturer's 5-year warranty

HP DESKJET 895CSE PRINTER

Only \$299^{95!}

Ask for item #PR14208.

HEWLETT PACKARD
Expanding Possibilities

- 11ppm black
- 8.5 ppm color
- PhotoRet II technology

Black Ink Cartridge: 67208\$29.99

SONY DIGITAL FD73 MAVICA

Only \$499^{95!} SONY

Ask for item #IN7834.

- 10x optical zoom • E-mail mode
- 2.5" Color LCD • VGA resolution
- Quick Access 2X Floppy Disk Drive
- Picture effect • File copy/disk copy



for your iMac G3! only \$1199[†] ea.

See below for details.

Epson • Connectix • CompuCable • Farallon • Microsoft • XLR8 • Intuit

FREE[†] 64MB RAM UPGRADE!

from MacWAREHOUSE
when you
order your
333MHz
iMac today!

†\$29.95 installation fee
required. Limited time offer!
Does not apply to reconditioned
models.



Get a 333MHz
iMac for
only \$27.62
a month^{††}
Call for details.

- 333MHz G3 Processor
- Built-in 15" Color Monitor (viewable size: 13.8")
- 32MB (256MB max.)
- 6.0GB hard drive
- 512K Backside Level 2 Cache
- 6MB of Video RAM
- Built-in 24X max. variable CD-ROM drive
- Built-in 56Kbps Modem
- Built-in 10/100 Base-T Ethernet
- 2 USB Ports
- Mac OS 8.5

Regular MacWAREHOUSE Price:

- Blueberry: item #CPU1336
- Grape: item #CPU1337
- Lime: item #CPU1338
- Strawberry: item #CPU1339
- Tangerine: item #CPU1340

\$1199!ea.

Lease!^{††} for \$35/month*

Price with FREE[†] 64MB RAM installed:

- Blueberry: item #CPU1438
- Grape: item #CPU1439
- Lime: item #CPU1440
- Strawberry: item #CPU1441
- Tangerine: item #CPU1442

\$1228^{95!}ea.

Lease!^{††} for \$36/month*

†† 67 monthly payments of \$27.62. 15.12% Annual Percentage Rate subject to increase or decrease. Payments deferred for the first 120 days subject to interest of \$32.71 and a loan origination fee of \$49.96 charged on day 91. No prepayment penalty. Subject to approval of credit. Based on Estimated Retail Price of \$1,199. Tax and shipping not included.

MICROSOFT OFFICE 98

Microsoft

- Includes: Word 98, PowerPoint 98, Excel 98 and Outlook Express

Upgrade only
\$239^{95!}

Item # UPG0778

BUS1150: Microsoft Office 98 Full Version only \$399.95



EPSON STYLUS COLOR 740i PRINTER

Only
\$179^{95!}* **EPSON**
after rebate
Item # PR15063

- Comes in Blueberry or can be customized for an additional \$14.95 to match your iMac
- 1440 x 720 dpi w/smaller ink drops
- 6ppm blk; 5ppm clr • USB/Mac serial compatible
- PA1582: Black Ink Cartridge \$29.99

*Price AFTER manufacturer's \$50 mail-in rebate. Before rebate: \$229.95 - \$50 rebate = \$179.95. Rebate coupon available at www.warehouse.com/rebate/epson, or call us at 1-800-390-0706 to request one. Offer expires 10/31/99.

NEW LOW PRICE!



Call for different color covers!

Other color covers available for only \$14.95 each!

iOmega 100MB USB Zip Drive
Only **\$129^{95!}**
DR9464
USB
Zip Disk sold separately.

iOmega 100MB Zip Disks
as low as **\$9^{95!}** each, in 10-pk qty.
#BND3314

Farallon EtherMac iMac iPrint Adapter
with built-in PhoneNet!
Only **\$109^{99!}**
DEP1734

- Connects your iMac to LocalTalk printers and other Macintosh computers
- Easy plug-and-play installation

Ethernet iPrint Adapter for Stylewriter: DEP1739 \$109⁹⁹

XLR8 Interview
Only **\$99!**
DRI3561

- Captures audio/video through USB interface
- Includes Strata Videoshop 4.5

Back for the Mac!
Quicken 2000
Upgrade only **\$39^{95!}*** after \$20 upgrade rebate
FIN1008

- Gain insight into your financial situation
- Easier than ever to use with improved interface!
- Access investment news, research and tools

*Price AFTER publisher's \$20 mail-in upgrade rebate. Before rebate: \$59.95. See box for details. Offer expires 9/30/2000.

Microsoft Word 98 Special Edition
Only **\$89^{95!}*** after \$30 rebate
WP3072

For iBook and iMac users only. Includes Word 98; thousands of clip-art images; greeting card templates; Internet Explorer 4.5; and Outlook Express 4.5.

*Price AFTER publisher's \$30 mail-in rebate. Before rebate: \$119.95. Rebate coupon in box.

1-800-434-3035 ★ www.warehouse.com/md

ORDER TOLL-FREE 24 HOURS A DAY, 7 DAYS A WEEK! CANADA ORDERS CALL: 1-800-603-5139

MacWAREHOUSE EXPRESS DELIVERY OVERNIGHT!

In-stock items, call weekdays by midnight (E), or order online weekdays by 10pm (E).

Your #1 Source for Mac Systems and Products—since 1987!



Hi, I'm Chris. Call me for more great deals!



Authorized
Catalog Reseller

MacWAREHOUSE

New! Apple iBook - Loaded

Apple • Newer Technology • VST • Global Village • Imation • 3Com US Robotics • Keyspan

Broderbund MYST **\$29.95**
a value! **

FREE!
with any purchase
MacWAREHOUSE
AAA0742

• Challenge your puzzle-solving skills in the Island world that is Myst!

*\$3.95 shipping and handling applies. Shipped in promotional packaging. Hurry! Offer good while supplies last.
**Value based on MacWAREHOUSE price as of this magazine printing.

USB Twin Serial Adapter

Only \$79.99!
DAD1637

• Supports up to 1Mbps per port
• Compatible with Apple StyleWriters and Personal LaserWriters

KEYSPAN

3Com Palm V Connected Organizer

Only \$399!
BN6356

• Clearer backlit display
• Holds up to 5 years of appointments!

Palm IIIx Connected Organizer
BN6334 \$329

3Com

NEW! Olympus D-450Z

1.3 MEGAPIXEL!

Only \$499.95!
IN8167

• 1.3 megapixel resolution
• 3X optical/2X digital zoom
• 8MB Smartmedia card included

OLYMPUS

SupraExpress V.90 Modem

Only \$79.99! after \$20 rebate
DMD3503

Capable of receiving data up to 56Kbps. Actual send and receive speeds may vary.
*Price AFTER manufacturer's \$20 mail-in rebate. Before rebate: \$99.99. Download coupon at www.warehouse.com/rebate/diamond or call us at 1-800-390-0706 to request one. Offer expires 12/31/99.

DIAMOND

HP LaserJet Printers

HP LASERJET 8000N
Only \$2489.95!
Ask for item #PR13724. Lease!! for \$72/mo.*

HP LASERJET 2100M
• Prints 10ppm
• 1200 dpi resolution
• HP PostScript Level 2
• LocalTalk connectivity

HP LASERJET 8000 SERIES BLACK TONER CARTRIDGE
Only **\$179.95** ea.
Item #63223

HP LASERJET 2100 SERIES BLACK TONER CARTRIDGE
Only **\$109.95** ea.
Item #PA1871

HP LASERJET 8100 SERIES BLACK TONER CARTRIDGE
Only **\$219.95** ea.
Item #PA1662

HP LASERJET 8500 SERIES BLACK TONER CARTRIDGE
Only **\$109.95** ea.
Item #PA1644

HP LASERJET 4050N
Only \$1399!
Ask for item #PR14947. Lease!! for \$41/mo.*

• Prints 17ppm
• 1200 dpi maximum resolution
• 100MHz RISC processor
• Ethernet 10BaseT/10Base2 + LocalTalk

HP LASERJET 5000N (not shown)
• Prints 16ppm • 1200 dpi • Prints 3" x 5" thru 11" x 17"

Ask for item #PR13443Lease!! for \$58/mo.* **\$1999.95**

HP LASERJET 4050 SERIES BLACK TONER CARTRIDGE
Only **\$94.95** ea.
Item #PR13025

HP LASERJET 5000 SERIES BLACK TONER CARTRIDGE
Only **\$169.95** ea.
Item #PR13742

HP LaserJet 2100M
\$779.95!
Item #PR14691
Lease!! for \$24/mo.*

VIEWSONIC P810 21" MONITOR

• 21" (20" viewable) screen
• 25mm dot pitch
• 1600 x 1200 resolution @ 76Hz
• Manufacturer's 3-year warranty

Only \$979.95!
Item #MON0668

ViewSonic on top

IONEGA 100MB ZIP DISKS

Free CD-R 5-pack when you buy a 100MB Zip Disk 10-pack!
Limit one per customer. While supplies last. Item #AAA1017.

Only \$8.99! ea., in 60 pack quantity
Item #BN6205

100MB Zip Disk 10-pack
BN5265 **\$99.95**

NEW VERSION! FILEMAKER PRO 5

• Microsoft Office Integration
• Excel Import and File Conversion
• Enhanced Instant Web Publishing
• Greater Security

Upgrade only \$139.95!
Item #UPG1102

FileMaker

NEW VERSION! NORTON UTILITIES 5.0

• Prevents computer disasters
• Optimizes hard disk performance
• Helps prevent crashes, and speeds recovery from emergencies.

Upgrade Only \$49.95!*
after \$50 upgrade rebate.
Item #UT11546

*Before publisher's mail-in rebate: \$99.95. Rebate coupon in box.

PAGE 6 OF 9

IMATION CD-Recordables

• 74 min.
• 650MB
• Jewel cases included

Only \$119.95* each, in 10-pack after rebate
Ask for item #ME8007.

*10-pack before manufacturer's mail-in rebate: \$21.99. Download coupon at www.warehouse.com/rebate/imation or ask for coupon #AA1590. Limit 3 rebates per name or mailing address. Offer expires 12/31/99.

3Com U.S. Robotics 56K V.90 FaxModem

Only \$119.99!
Ask for item #DMD3448

Manufacturer's lifetime warranty

*Capable of receiving data up to 56Kbps. Actual send and receive speeds may vary.

Free Nova Software 3,000 Images** with the purchase of 2 Inkjet cartridges.

Amazon Inkjet Cartridges

As low as **\$15.99!** each, in 2-pack

Ink cartridges for Epson Stylus Photo and PM700 (1 blk/1 color): Item # BN6064, 2-pack only \$31.99.
Ink cartridges for Epson Stylus Color 400/600 (1 blk/1 color): Item #BN6066, 2-pack only \$31.99.
Ink cartridges for Epson Stylus Color 800/850/1520 (1 blk/1 color): Item #BN6065, 2-pack only \$33.99.

**While supplies last.

and Ready to Go! only \$1599! ea.



Hewlett Packard • ViewSonic • Iomega • Olympus • FileMaker • Amazon • Targus



Apple iBook: Packed with power, and wrapped in a stunning notebook design!



Only **\$1599!** each
Lease! for \$47/mo.*

Available in Blueberry or Tangerine!

- 300MHz PowerPC G3 processor
- 512K Backside Level 2 Cache
- 32MB SDRAM • 3.2GB IDE hard drive
- 24X max. variable CD-ROM • 56K V.90 modem
- 10/100 Base-T Ethernet
- Wireless networking with optional AirPort card and base (sold separately)
- 12.1" Active-Matrix Display
- ATI Rage Mobility 2D/3D Graphics Accelerator with 2X AGP
- USB port • 4MB Video Memory
- Lithium-ion battery—up to 6 hours of use!



Blueberry: Item #CPU1463
Tangerine: Item #CPU1464

Additional Lithium-Ion Battery
Item #ACC3807 \$129

300MHz!

VST Zip 100MB Drive

Only **\$229^{95!}**
DR10799
Internal

For New G3 PowerBooks (CPU1359, CPU1360)

• Hot swappable—no need to sleep, shut down, or restart.



Targus Notepac Plus Black Carrying Case

Only **\$59^{95!}** each
AC19972



Call for other cases!



PowerBook G3 Battery

As low as **\$139^{95!}**
ACC3728

• Lithium-Ion
ACC3728 (fits new 1999 models) \$139.95
ACC3307 (fits 1998 models) shown, \$199.95



Apple PowerBook G3s low as \$2499!

The fastest Apple PowerBook G3s Ever!

These PowerBook G3s—with speeds up to 400MHz—run up to twice as fast as comparable Pentium® and Pentium II processor-based notebooks, based on BYTEmark integer index processor scores! **What's more, the new Apple PowerBook G3s are now almost 20% thinner and nearly 2 pounds lighter than their predecessors!**

333MHz PowerPC G3 processor/64MB SDRAM/4.0GB IDE HD/24X max. variable CD-ROM/56K Modem/14.1" Active-Matrix Display/512K Backside level 2 cache/8MB SDRAM Video Memory
ASK FOR ITEM #CPU1359. Lease! for \$73/mo. **\$2499**

400MHz PowerPC G3 processor/64MB SDRAM/6.0GB IDE HD/DVD-ROM/56K Modem/14.1" Active-Matrix Display/1MB Backside level 2 cache/8MB SDRAM Video Memory
ASK FOR ITEM #CPU1360. Lease! for \$102/mo. **\$3499**

Up to 10 Hours of Battery Life!

Almost 20% Thinner!

Nearly 2 lbs. Lighter!



32MB iBOOK G3 MEMORY UPGRADE

Upgrading your memory is the most cost-effective way to increase the performance of your system!

32MB iBook G3 Memory only **\$99^{95!}** each
Item #CHP9820



POWERBOOK G3 DVD-VIDEO KIT

- DVD-ROM drive reads CD-ROM discs up to 12X, DVD at up to 1.5X
- DVD-Video PC Card
- DVD player software
- Works with 1998 PowerBooks

Only **\$499^{95!}**
Item #DRI3206
While supplies last.



56K* V.90 FaxModem PC Card

Only **\$149^{99!}**
DMD3824

- K56 Flex and V90 technology
- Send, receive, view, print, and manage faxes right from your PowerBook
- *Capable of receiving data up to 56Kbps. Actual send and receive speeds may vary.



FireWire 2 Go

Add FireWire to your PowerBook G3!

Only **\$199!**
DRI3505

NEW!

Fits in CardBus slot



PAGE 7 OF 9

1-800-434-3035 ★ www.warehouse.com/md

ORDER TOLL-FREE 24 HOURS A DAY, 7 DAYS A WEEK! CANADA ORDERS CALL: 1-800-603-5139

MacWAREHOUSE EXPRESS DELIVERY OVERNIGHT!

In-stock items, call weekdays by midnight (E) or order online weekdays by 10pm (E).



Hi, I'm Andy. Call me for more great deals!

Your #1 Source for Mac Systems and Products—since 1987!

NEW! Adobe InDesign

Apple • 3Com • Hitachi • Global Village • Sony • Iomega • Microtek

Olympus C-2000 Digital Camera

New Low Price!

Only **\$899^{95!}**
IN7788



- 2.1 Megapixel
 - 1600 x 1200 resolution
 - 3X optical zoom
 - 8MB SmartMedia Card included!
- Print out your digital photos on the new Olympus P330 Stylus Photo Printer
PRI4784 **\$399.95**

32MB SmartMedia Cards

Only **\$129^{95!}**
MY11858



- Digital film for digital cameras
- Compatible with new digital cameras with SmartMedia slot

Microtek ScanMaker 4

Only **\$599^{95!}**
IN8094



- 36-bit color
- 600 x 1200 dpi
- Built-in transparency bay
- 8.5" x 14" scanning area

74 Minute CD-Recordables

Only **\$1.89!**
each, in 30+ qty.
ME7553



- Branded Single with Jewel Cases
- 650MB capacity

3Com Palm III with Mac Pac version 2 Software

Only **\$229!**
BN6359



Store thousands of addresses, appointments, and more!

PAGE 8 OF 9



Apple 333MHz iMacs

Only **\$1099!** each

Apple Power Mac G3 350MHz Minitower



- 350MHz
- 64MB SDRAM
- 6.0GB HD
- 24X max. variable CD

Only **\$1399!**
Ask for item #RCPU1382.

- Monitors sold separately. Model shown is RCPUI384.
- Power Mac G3/400MHz/64MB SDRAM/6.0GB HD/DVD ROM: RCPUI383 **\$1799***
- Power Mac G3/400MHz/128MB SDRAM/12.0GB HD/24X max. variable CD/Zip Drive RCPUI384 **\$2199***
- Many other reconditioned Power Mac G3 models available. Call for details.

APPLE 333MHZ IMACS: 5 COLORS TO CHOOSE FROM!

- 333MHz PowerPC G3 processor
- 32MB SDRAM (256MB max.)
- 6.0GB hard drive
- 24X max. variable CD
- 56K modem
- 15" color monitor



- Line: Item #RCPUI336
Grape: Item #RCPUI337
Tangerine: Item #RCPUI340
Blueberry: Item #RCPUI336
Strawberry: Item #RCPUI339

RECONDITIONED
Blueberry, shown.
only **\$1099!** each

POWER MAC 7100/80MHZ

- 80MHz PowerPC 601 processor
- 16MB RAM (exp. to 136MB)
- 500MB HD • 4X max. variable CD

Only **\$399!**
Item #RCPU1356

RCPUI036: Power Mac 6100/66MHz, 16MB RAM, 230MB HD, 4X max. variable CD only \$399*

*Reconditioned system. Reconditioned computers may not include original application software. 90 day parts and labor warranty. All sales final. While supplies last. Monitor and keyboard sold separately.



APPLE POWERBOOK 540c/33MHZ

- 33MHz 68LC040 processor
- 20MB RAM • 240MB HD
- 19.2 Kbps modem
- 9.5" Active Matrix Color Display

Only **\$599!**
Item #RCPU1196

RCPUI455: PowerBook 5300c/100MHz, 24MB RAM, 750MB HD, 10.4" Active Matrix Color Display only \$699*

*Reconditioned system. Reconditioned computers may not include original application software. 90 day parts and labor warranty. All sales final. While supplies last.



DIAMOND PRO 900u 19" MONITOR

- 1600 x 1200 @ 75Hz
- 18" viewable size
- .25AG horizontal pitch
- Manufacturer's 3-year warranty

Only **\$634^{95!}**
Item #MON0765



HITACHI MC6405 17" MONITOR

- 17" monitor (15.9" viewable)
- Resolutions up to 1152 x 870 @ 75Hz
- .22mm horizontal pitch
- Manufacturer's 3-year warranty

Only **\$269^{95!}**
Item #MON0826



FREE* CD-R 5-pack when you buy 1 Jaz 2.0GB cartridge. #AAA1017

Jaz 2.0GB Cartridges

Only **\$99^{95!}** each, in 3+ quantity
Ask for item #MED0508.

Quantity: 1-2 3+
Price: \$124.95 ea. | \$99.95 ea.

*Limit 1 per customer. While supplies last. Ask for item #AAA1017.

NEW!

Epson Stylus Photo 1200 Printer

Only **\$499^{95!}**
Ask for item #PRI5097

Black Ink Cartridge PA1886 **\$19.99**

- 1440 x 720 dpi • Prints up to 13" x 44"
- Mac serial and USB compatible
- Includes Adobe Photoshop 5.0 LE

GLOBAL VILLAGE TECHNOLOGIES

Global Village 56K* Teleport Internal Mac Modem

Only **\$89^{99!}** after mfr's \$20 mail-in rebate
Ask for item #DMD4267

*Capable of receiving data up to 56Kbps. Actual send and receive speeds may vary.
*BEFORE rebate: \$109.99. Rebate coupon available at www.warehouse.com/ rebate/globalvillage or call 1-800-390-0706 to request one. Offer expires 12/31/99.

for as low as \$299⁹⁵! *
See below for details.

CALL FOR A FREE FULL-COLOR CATALOG!



Olympus • Epson • Newer Technology • Sony • Adobe • Macromedia

Adobe InDesign

Professional page layout with seamless integration of Adobe products!

QuarkXPress, Adobe Photoshop, Illustrator and PageMaker owners: Get Adobe InDesign for only **\$299⁹⁵**
Offer expires 12/31/99. Ask for item #SID0426.

NEW!

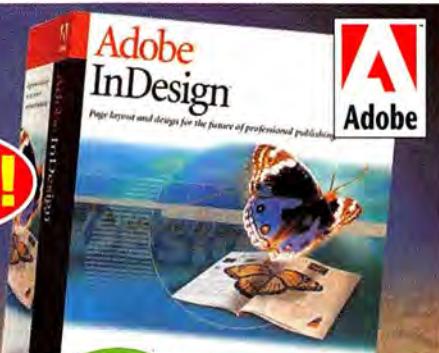

NEW VERSION! Adobe Photoshop 5.5

- Multiple undo: Quickly undo or redo several steps.
- Magnetic Tools: Precisely follow the edges of an image.

Adobe Photoshop 5.5 Upgrade (from Photoshop v5.0 or ImageReady 1.0) UPG1049 \$109.95*
 Adobe Photoshop 5.5 Upgrade (from Photoshop v4.0 or earlier) UPG1049 \$179.95
 Adobe Photoshop 5.5 (Full Version) GRA2951 \$599.95

*Price AFTER publisher's \$70 mail-in rebate for previous owners of Adobe Photoshop 5.0 or ImageReady 1.0. Before rebate: \$179.95. Rebate coupon included in box. Rebate must be postmarked no later than 5/15/2000 to qualify.

Free! Silvertone 1.5 Extended Process Separator™ (by Intense Software)

With purchase of Adobe Photoshop 5.5. Ask for item #AAA1020.
 This Photoshop plug-in enables 5-color separations.
 **\$3.95 shipping and handling applies. Shipped in promotional packaging on CD-ROM. HURRY! While supplies last.
 †Value based on MacWAREHOUSE pricing as of this magazine printing.

Upgrade as low as **\$109⁹⁵** after rebate

A **\$249** Value!

NEW! Adobe Collections!

Publishing Collection (Photoshop 5.5, PageMaker 6.5 Plus, Illustrator 8.0, and Acrobat 4.0.) Item #GRA2975 **\$949⁹⁵**

Web Collection (Photoshop 5.5, GoLive 4.0, and Illustrator 8.0) Item #COM1215 **\$949⁹⁵**

Adobe Design Collection (Photoshop 5.5, InDesign 1.0, Illustrator 8.0, and Acrobat 4.0.) Item #GRA2974 **\$1299⁹⁵**

Dynamic Media Collection (Premiere 5.1, After Effects 4.0, Photoshop 5.5, and Illustrator 8.0) Item #GRA3007 **\$1489⁹⁵**

Macromedia FLASH 4

NEW VERSION! **UPGRADE ONLY \$119⁹⁵!** UPG1044
 Fusing vector graphics, bitmaps, motion, MP3 audio, form input, and interactivity, Flash 4 delivers fast, Streaming files, consistently and efficiently reaching all your sites visitors.
 Serial number of previous version required at time of order. Full version only \$279.95! Item #COM1166

Sony Digital FD83 Mavica

MPEG/Voice recording modes included

- XGA resolution 1024 x 768, 1216 x 916 interpolated
- 3x Optical Zoom/6x Digital
- 4x High speed floppy disk
- Audio & Video out • 2.5" LCD

Only **\$699⁹⁵!** IN7856

Adobe Photoshop LE

NEW! Adobe Photoshop LE
 Only **\$99!** GRA2973
 An introduction to the world's standard image editing solution!

G3 MEMORY UPGRADES

SAVE UP TO \$180⁺ when you also buy Adobe InDesign

NEW G3 128MB 100MHz SDRAM Only **\$199⁹⁵*** Item #AAP0612
G3 128MB 66MHz SDRAM Only **\$199⁹⁵*** Item #AAP0611

*Savings based on MacWAREHOUSE prices as of this magazine printing. *Memory must appear on same invoice as Adobe InDesign to qualify for this price. Offer valid between 5/3/99 and 11/1/99 or while supplies last.



NEXUS 128

- Rage 128 accelerator
- Supports up to 1900 x 1200
- 32MB memory

Only **\$279!** Item #DRI3236



MAC OS 9

- NEW! Sherlock 2 — Your Internet detective, and personal shopper.
- NEW! Voiceprint — Your voice is your password.

Only **\$89⁹⁵!** after \$10 rebate
 Item #SYS1012

*Price AFTER MacWAREHOUSE \$10 mail-in rebate. Before rebate: \$99.95. Limit one rebate per customer (or total of 5 rebates per customer site.) Rebate coupon is available at www.warehouse.com/rebate/applesoftware, or call us at 1-800-390-0706 to request one. Offer valid through 1/31/2000.

Coming Soon!
 Mac OS 9!
 Call and reserve your copy today!
 Estimated publisher ship date: October 1999.
 For more info visit: <http://www.warehouse.com/mac09>

WWW.WAREHOUSE.COM

Get a **FREE*** gift when you order online.

Every time you order from our full line of Mac products on the Web, you can get one of these **FREE***: MYST, Hot Door Transparency or Collect Pro.

*\$3.95 shipping and handling applies. Limit one per customer per order. Shipped in promotional packaging. While supplies last.

Win@ Warehouse
 See our **BLOWOUT SPECIALS and SUPER OFFERS** — every day!
 Place your order online by 10:00 pm, (E) and get it the next day!

Extended On-Site Support*

Six great reasons to get complete system coverage:

1. Toll-Free Technical Help
2. Fast On-Site Support with next business day response in most areas for most items!
3. Free Replacement if unit cannot be repaired!
4. No Deductible — 100% coverage on parts and labor!
5. 24-36-, and 48-Month Coverage available from date of purchase!
6. Fully Insured — Program underwritten by an "A-Excellent" rated insurer

Service you can depend on! Support and repairs administered by NWC which has been providing superior, price-competitive programs for over 20 years!

Cost of Computer and/or Peripherals	Warranty Price (48 months)	Ask for Item #
\$701 - \$1,200	\$219	WAR0001
\$1,201 - \$2,000	\$269	WAR0002
\$2,001 - \$3,000	\$309	WAR0003

Call your Account Manager for details on orders over \$3,000.

Call your sales representative today!
 *Note: This promotion, itself, is not a Service Agreement, but an outline of coverage available by National Warranty Corporation. Please call Micro Warehouse, Inc. for information and read the complete Service Agreement from NWC for exact coverages, terms, and conditions. On-Site Support begins after the manufacturer's warranty expires. Plan not available on international or Florida orders. All returns not covered under the standard MacWAREHOUSE return policy are subject to a \$25 return fee assessment.

PAGE 9 of 9

1-800-434-3035 ★ www.warehouse.com/md

ORDER TOLL-FREE 24 HOURS A DAY, 7 DAYS A WEEK! CANADA ORDERS CALL: 1-800-603-5139

MacWAREHOUSE EXPRESS DELIVERY OVERNIGHT!

Your #1 Source for Mac Systems and Products—since 1987!

In-stock items, call weekdays by midnight (E), or order online weekdays by 10pm (E).



Hi, I'm Jason. Call me for more great deals!

Just Announced!

up to 500MHz Power

The Fastest Desktop Ever!

How fast is the new G4? This fast: The Power Mac G4 is the fastest desktop computer ever built to run graphics applications like Photoshop, InDesign and QuarkXPress. The G4 is actually years ahead of its

time thanks to new supercomputing technologies like vector processing, data stream prefetching and 128-bit data paths. In fact, the 500MHz G4 is a stunning 2 to 3 times faster than PCs based on the fastest Pentium III processor.

So if you like the Pentium-crushing speed and the convention-crushing design, call MacMall today. The new G4 is just what you need for 3D rendering, advanced voice recognition and digital video production.

Next Generation Performance!

Outrageous power.

- PowerPC G4 processor running at 400, 450 or 500MHz
- Velocity Engine vector processing unit
- Full 128-bit internal memory data paths
- Powerful new floating point unit
- Data stream prefetching operations supporting four simultaneous 32-bit data streams

- Supports up to 1GB of low cost, high performance PC100 SDRAM
- 1MB of backside level 2cache running half processor speed
- 100MHz system bus
- 64, 128 or 256MB RAM
- Supports up to 1.5GB of high performance PC100 SDRAM
- 10, 20 or 27GB Ultra ATA hard disk

- 32X CD-ROM drive, or DVD-ROM drive, or DVD-RAM drive
- 100MB Zip drive (some configurations)
- Built-in 10/100BASE-T Ethernet networking; optional Gigabit Ethernet

Advanced capabilities.

- Two 400Mbps FireWire ports
- Two USB ports for keyboards, mice, printers—up to 127 devices at once
- 10/100Base -T Ethernet
- Optional AirPort wireless networking card
- Two additional internal drive bays
- Three 64-bit PCI slots

Great graphics and video features.

- ATI RAGE 128 Graphics Accelerator with 16MB of SDRAM graphics memory
- Support for up to 1,600-by 1,200-pixel resolution at 32 bits per pixel (millions of colors) and up to 85Hz refresh rate
- Hardware acceleration of graphics and video
- Advanced integrated triangle setup engine
- Single-pass multi-texturing design

Design elegance.

- Translucent silver and graphite case
- Easy, drop down accessibility for installing cards, drives, and memory
- Convenient, built-in handles for easy carrying

New Power Mac G4s!

- Order#
- MHz
- RAM
- Hard Drive
- Multimedia
- Zip Drive
- Modem
- Price
- Lease Price

	FREE! Instant Cash Rebate and \$25 gift cheque.	FREE! Instant Cash Rebate and \$25 gift cheque.	FREE! Instant Cash Rebate and \$25 gift cheque.
#51578	#51579	#51580	
400MHz	450MHz	500MHz	
64MB	128MB	256MB	
10GB	20GB	27GB	
32X CD	DVD-RAM	DVD-RAM	
N/A	Yes	Yes	
56K	56K	N/A	
\$1,594	\$2,494	\$3,494	
\$64/month	\$100/month	\$140/month	

MacMall EXCLUSIVES! FREE Shipping

Up to \$300 Instant Cash Back + \$25 in MacMall Gift Cheques!

Ask for #48938

All products in this catalog priced between

Product Price	Instant Cash Back	MacMall Gift Cheque
1294-1600	\$50	\$10
1600-2499	\$100	\$25
2500-2999	\$150	\$25
3000-3499	\$200	\$25
3500-4396	\$250	\$25
4397 +	\$300	\$25

No coupons to mail in. No checks to wait for. Best of all, there is no limit—so order as many times you want, and keep saving! Cannot be combined with Free Memory promos. Gift cheques are redeemable for merchandise only. No cash redemptions. Valid through 10/25/99. Limit one gift cheque per computer purchased.

Enter to WIN a \$10,000 ART COLLECTION

when you register for our e-mail Advantage Newsletter



Imagine having a 50 disc library of the finest royalty free stock photography right at your fingertips!
Go to macmall.com to enter!
Offer ends 10/25/99.

on all online orders totaling over \$500



Call for details. Free shipping is via UPS Ground for deliveries in the continental U.S. Offer ends 10/25/99.

Go to **macmall.com**

Order Any Time! Open 24 Hours!
Order Today by 10pm EST—
Get it Tomorrow by 10:30am!

1-800-217-9492

Macintosh G4s!



starting at only

\$1,594 #51578

Call for even lower price!
or lease for as low as

\$64 per month

Check out our Web site for the latest computer deals! Go to macmall.com

Visit macmall.com for more
USB
UNIVERSAL SERIAL BUS
peripherals.

VIKING COMPONENTS DON'T FORGET MEMORY!

Part Number	Upgrade	Price
#42223	32MB PC100 DIMM	\$79 ⁹⁹
#42224	64MB PC100 DIMM	\$122 ⁹⁹
#42225	128MB PC100 DIMM	\$237 ⁹⁹
#42226	256MB PC100 DIMM	\$746 ⁹⁹

Have your RAM professionally installed by one of our factory-trained technicians, for only \$30. Ask for #2214. Visit macmall.com for more Viking memory.

HOT, NEW Add-ons for Your G4!



Airport!

The Power Mac G4* is ready for wireless networking—the first desktop computer with this capacity!

#49221	AirPort Hardware Access Point	\$299 ⁹⁹
#49222	AirPort Card	\$99 ⁹⁹

* Works with the 450 and 500MHz.

The Power Mac G4 comes with 2 (400MHz) or 3 (450 & 500MHz) FireWire ports for connecting digital video cameras, hard disk drives and high-speed multimedia peripherals!

Call for our full line of FireWire products!

Sony DCR TRV900 3 CCD Digital Video Camcorder pictured. To order, ask for #37986



NEW!

The Perfect Compliment to your G4!

- 17" (16" viewable)
- 25mm dot pitch
- 1600 x 1200 @ 60Hz

Apple 17" Studio Display

\$499⁹⁹
#51582

#51583 Apple 21" Studio Display with ColdSync \$1,499⁹⁹



macmall.com or AOL Keyword: Mac Mall
Mention your Priority Code: #ZMWD9B1

Mac Mall
MACWORLD November 1999 147

Two Stylish



Get an Extra 64MB RAM FREE* with iMac!

Limited time offer. While supplies last!

333MHz iMac with 96MB RAM!

Get an extra 64MB RAM FREE* with iMac!

Processor and Memory

- 333MHz Power PC G3 Processor
- 512K backside level 2 cache on processor module
- 133MHz dedicated 64-bit backside bus
- 66MHz system bus
- Integrated floating-point unit and 64K on-chip level 1 cache (32K data and 32K instruction)
- 32MB of SDRAM; two SODIMM slots support up to 256MB
- 64-bit memory bus

Connectivity

- Two high speed Universal Serial Bus (USB) ports (12 Mbps), which support USB devices such as keyboard, mouse, printer, storage devices, and USB hubs

Storage

- Internal 6GB IDE hard disk drive
- Internal 24X (maximum) CD-ROM drive

Communications

- Built-in 10/100BASE-T Ethernet
- 56Kbps modem supports K56flex and V.90 standards

Multimedia Capabilities

- Incredible, high resolution display... MultiScan, tiltable shadow mask color display: 15-inch (13.8-inch diagonal viewable image size), .28mm dot pitch
- Supports millions of colors at up to 1024 x 768 resolution (24-bit)

All models include:

- 333MHz
- 32MB RAM
- 6GB HD
- 56K Modem
- 24X CD-ROM

\$1,194 each

only

#46955 Blueberry #46954 Tangerine

#42841 Strawberry #42842 Lime #42839 Grape

Call for even lower price!

or **\$27⁴⁵** per month with our Apple Loan Program.

*A \$30 professional installation fee applies.

- ATI RAGE PRO TURBO accelerated 2D/3D graphics controller and 6MB video memory
- Refresh rate of up to 117Hz
- Outstanding audio features
- Built-in stereo speakers with SRS surround sound
- Built-in microphone
- Two front headphone jacks
- Minijacks for 16-bit CD-quality stereo input/output; 44.1-kHz sampling rate

Software

- Mac OS 8.5 pre-installed
- AppleWorks, Adobe PageMill, much more!

Visit macmall.com for more USB UNIVERSAL SERIAL BUS peripherals.

Iomega® Zip® 100MB USB Drive

Enjoy unlimited storage capacity and easy USB connectivity!

- Hot swappable
- Translucent blue

Now Only **\$129⁹⁹**

#34314

New Low Price!



For more info visit macmall.com

Connectix Virtual Game Station

Play many popular PlayStation games directly on your Mac!

MacMail Exclusive!

\$19⁹⁹ #48961
with CPU purchase.
Reg. price \$48.95.

For more info visit macmall.com



External Floppy Disk Drive for the iBook

- Matches the iBook colors
- Hot-swappable interface

\$79⁹⁹ #46117

with computer purchase.
Reg. price \$89.99.
Call for details

For more info visit macmall.com



Order Any Time! Open 24 Hours!
Order Today by 10pm EST—
Get it Tomorrow by 10:30am!

1-800-217-9492

Ways to Surf the Web!

iBook The portable iMac!

Blazing speed, dazzling design and fast, easy access to the Internet! With its convenient handle, the iBook just begs to be taken with you! Download your email and read it anywhere. Take it when you visit your friends so you can play the latest MP3 files off the Internet.

The iBook's case is a rugged polycarbonate, built to survive life in a back pack. It has no doors or latches to break. And it's easy to charge. When it's time to reenergize, just plug it in until the light turns green. Simple.

Outrageous performance.

- PowerPC G3 processor running at 300MHz
- 512K backside level 2 cache on processor
- 32MB of SDRAM; supports to 160MB RAM
- 3.2GB IDE hard disk drive
- Built in 24X CD-ROM drive

Connectivity.

- One 12-Mbps Universal Serial Bus (USB) port
- Built-in 10/100BASE-T Ethernet
- Built-in 56K modem
- Optional AirPort wireless networking card

Advanced battery technology.

- Lithium-ion battery
- Up to 6 hours of battery life

Great graphics and video features.

- ATI RAGE Mobility graphics controller with 2X AGP
- 4MB SDRAM video memory
- 12.1-inch (diagonal) built-in TFT SVGA active-matrix display

- 800 x 600 resolution with millions of colors
- 16-bit stereo sound output minijack
- Single built-in speaker

Compact size.

- 13.5" x 11.6" x 1.8" average; depth ranges from 1.24" to 2.06"

6.6 pounds

Cool software.

- Mac OS 8.6
- Microsoft Internet Explorer
- AppleWorks
- World Book Encyclopedia
- Nanosaur and Bugdom 3D games

New!



FREE Shipping
on all
online
orders
totaling
over \$500

Call for details. Free shipping is via UPS Ground for deliveries in the continental U.S. Offer ends 10/25/99.

Go to **macmall.com**

With everything built in,
the iBook is as Internet ready
as a notebook can be!

\$1,594 ea.
only
#49781 Blueberry #49782 Tangerine

iSee USB Digital Camera

- with Colored Lens Kit
- w/250K PXL Resolution
 - In every iMac and iBook flavor!

\$149⁹⁹

#48324

**iRIS
Delish!**



For more info visit macmall.com

HP DeskJet 812C USB Printer

- 6.5ppm black;
- 4.5ppm color

New Low Price!

HP DeskJet 812C USB Printer
\$149⁹⁹

#47079

For more info visit macmall.com



FREE
colored cover with
HP DeskJet 812C
printer purchase!
Cover available in all
iMac/iBook flavors!

Introducing AirPort!

Transform your new iBook into a wireless Internet surfing machine.

AirPort lets you access the Internet with your iBook from anywhere in your home, office, dorm or classroom—without wires! No more hunting around for a phone jack every time you want to get online. If you're within 150 feet of the AirPort, you're connected! All you need is an AirPort card for your iBook and the AirPort Access Point.

AirPort also lets multiple iBooks access the Internet at the same time, transfer files, and of course, play multi-player network games!

#49221	AirPort Hardware Access Point	\$299 ⁹⁹
#49222	AirPort Card	\$99 ⁹⁹



macmall.com or AOL Keyword: **Mac Mall**
Mention your Priority Code: **#ZMWD9B1**

Mac Mall

Faster, Super Slim PowerBook G3s!

G3 PowerBooks up to an incredible 400MHz!

The new PowerBooks are the sleek-est, fastest, best-equipped notebooks ever! With the high-perfor-

mance G3 processor, they out-perform comparable Pentium and Pentium II processor-based desk-

top systems, with go-anywhere, do-everything PowerBook convenience!

Cutting Edge Features at an Affordable Price!

Processor and Memory

- 333 or 400MHz PowerPC G3 processor—fastest performance ever in a notebook!
- 66MHz system bus
- 512K or 1MB backside Level 2 Cache; 133 or 160MHz dedicated 64-bit backside bus
- Integrated floating point unit and 64K on-chip Level 1 cache (32K for data and 32K for instruction)
- 64MB RAM; 2 SO-DIMM slots support up to 384MB RAM

Storage

- Internal 4 or 6GB IDE hard drive
- 24X CD-ROM (#49517) or DVD-ROM drive (#49518) for use in expansion bay
- Removable 1.44MB floppy disk drive for use in expansion bay (sold separately)
- Hot-swappable expansion bay supports CD-ROM, DVD, Zip, SuperDisk or hard drive

Expansion & Networking Ports

- 2 USB ports, SCSI port, power adapter port
- Built-in 10/100BASE-T Ethernet

- RJ-11 modem port, 4Mbps Infrared (IrDA) port
- Support for a Zoom Video PC card
- PC Card Slot for one Type I or Type II card

Graphics, Video & Sound

- 14.1 inch (diagonal) display features built-in TFT XGA active matrix display, supporting millions of colors at 1024 x 768 resolution
- 8MB SDRAM video memory; supports millions of colors on external displays up to 21"
- 2D/3D graphics, through integrated ATI RAGE LT Pro video controller
- S-Video port
- 24-bit video output port (VGA-style connector)
- 16-bit CD quality stereo input/output
- Two built-in stereo speakers
- Internal omnidirectional microphone

Portability

- Kensington cable lock slot and keyboard lock
- Includes one Lithium-ion battery for up to

5 hours of normal use; supports two batteries for as much as 10 hours of use (depending on configuration and usage)

Software (Pre-installed)

- Mac OS 8.6, Apple File Synchronization, Apple Location Manager, Microsoft Internet Explorer, Microsoft Outlook Express, Netscape Communicator and FAXstf

Size and Weight

- Width: 10.4"; Height: 12.7"; Depth: 1.7" long
Weight: 5.9lbs. (w/CD-ROM + battery installed)

Apple Accessories



#31413	Apple AC Adapter	\$94 ⁹⁹
#47086	Apple Lithium-Ion Rechargeable Battery	\$149 ⁹⁹

VIKING COMPONENTS

Upgrades for your PowerBook G3

#31440	64MB PowerBook G3	\$134 ⁹⁹
#31442	128MB PowerBook G3	\$268 ⁹⁹
#41979	128MB Low Profile	\$358 ⁹⁹
#41978	256MB Low Profile	\$701 ⁹⁹

Have your RAM professionally installed by one of our factory-trained technicians for only \$30. Ask for #2214. Call or visit our Web site: macmall.com for more Viking memory.

USB PowerBook G3 Series!



Order	MHz	RAM	HD	Cache	Drive	Modem	Display	Price	Lease
#49517	333	64MB	4GB	512K	24X CD-ROM	56K	14.1" Active Matrix	\$2,494	'88
#49518	400	64MB	6GB	1MB	DVD-ROM	56K	14.1" Active Matrix	\$3,494	'122

Ask for details on our new low lease rates! Call for even lower prices.



4 Port USB Hub

This low cost USB solution gives you 4 powered USB ports to connect all your peripherals.

4-Port Mini Hub
\$29⁹⁹
#47702

For more info visit macmall.com



Internal Zip for your New 1999 PowerBook G3

- 100MB capacity per disk
- 11.2 MB/sec. transfer rate
- Store data with millions of other Zip users

Internal Zip Drive for the NEW PowerBook G3
\$219⁹⁹
#47081

#47082

Internal SuperDisk Drive for the New PowerBook

\$219⁹⁹

For more info visit macmall.com

Epson Stylus Photo 750 For Your New PowerBook G3

- 1440 x 720dpi, 6-color (PRQ™) Quickdry inks
- Ultra small ink droplets (6 picoliters)
- Fast! Prints 4" x 6" photos in 1 minute
- USB, parallel and serial ports

1440 DPI

NEW!

Stylus® Photo 750
\$249⁹⁹
#44849

EPSON

For more info visit macmall.com

Order Any Time! Open 24 Hours!
Order Today by 10pm EST—
Get it Tomorrow by 10:30am!

1-800-217-9492

FREE Shipping

on all online orders
totaling over \$500

Go to **macmall.com**

Call for details. Free shipping is via UPS Ground for deliveries in the continental U.S. Offer ends 10/25/99.



The new features of the G3 PowerBooks include two USB ports and high-speed 10/100BASE-T Ethernet!

New Slimmer and Lighter Design!

- Super slim profile
- Only 5.9lbs., nearly 2lbs. lighter than previous models!



starting at only
\$2,494

#49517

Call for even lower prices!



Authorized
Catalog Reseller

Visit **macmall.com** for more
USB
UNIVERSAL SERIAL BUS
peripherals.

MacMall EXCLUSIVE!

Up to \$300 Instant Cash Back
+ up to \$25 in MacMall Gift Cheques!

See first page for more rebate information.
All products priced between:

Product Price	Instant Cash Back	MacMall Gift Cheque
1294-1599	\$50	\$10
1600-2499	\$100	\$25
2500-2999	\$150	\$25
3000-3499	\$200	\$25
3500-4396	\$250	\$25
4397 +	\$300	\$25

Enter to WIN a
\$10,000 ART COLLECTION

when you register for our E-mail Advantage Newsletter



Imagine having a 50 disc library of the finest royalty free stock photography right at your fingertips!

Go to **macmall.com** to enter!

Offer ends 10/25/99.

FREE!

carrying case with any
PowerBook
purchase!

While supplies last.



macmall.com or AOL Keyword:
Mac Mall

Mention your Priority Code: **#ZMWD9B1**

MacMall

If You Don't See it, Call

MacMall has the best prices on USB peripherals for the iMac™, iBook™, PowerBook G3, Power Mac G3 and G4!

EPSON
Stylus® Color 740i Printer
 The Awesome 1140 x 720dpi Inkjet in iMac and iBook Custom Colors
\$179.99*
 #48226
 *Reg. price \$229 - \$50 mail-in rebate. Expires 9/30/99



AGFA
Agfa Touch Scanner
 With seven different colored handles to match your decor.
 > 36-bit > 9600dpi interpolated
 > 600 x 1200dpi > 4 programmable buttons
\$117.99
 #48541



MICRO CONNECTORS, INC.
Blueberry USB Upgrade Kit
 Includes hub, 6' cable, mouse and mousepad. All iMac/iBook colors available.
\$59.99
 #43777
 with any iMac purchase. Reg. price \$79.99.



VST TECHNOLOGIES
External Floppy Disk Drive for the iMac
 > Matches iMac and iBook colors
 > Hot-swappable interface
\$79.99
 #46117
 with CPU purchase. Reg. price \$89.99. Call for details.



Que! Drive 4x2x8 CD-Rewritable Drive for the iMac™
 The revolutionary USB interface CD-Rewritable Drive
 > Three drives in one
 > Ideal for data archiving
 > Excellent addition for MIDI and recording studios
 > Translucent Blue
\$299.99
 #45035



Contour DESIGN
Contour Unitrap
 > Slip onto the iMac mouse to create a comfortable full-size mouse
 > 5 interchangeable colored buttons
\$14.99
 #46885



HP
HP DeskJet 812C USB Printer
 Match your iMac and iBook with Free Colored Cover!
\$149.99
 #47079



entrega
Entrega Hubs
 Available in all iMac and iBook colors!
 > 4 Port USB HUB
\$59.99
 #48881
 Call for details!



WACOM
Intuos 4 x 5 USB Tablet
 > Professional Series Tablet
 > 1,024 pressure levels
\$199.99
 #48998



AGFA
Agfa ePhoto CL30
 > 1440 x 1080 pixels w/Agfa PhotoGenie
 > 4MB CompactFlash
\$359.99
 #43799
 #49201 NEW Kodak DC280 USB/serial digital zoom camera \$799



BEST DATA
56K V.90 External USB Modem
\$69.99
 #47014
 Price reflects \$20 mfr. mail-in rebate.
NEW LOW PRICE!



iomega
iomega® 100MB USB Zip® Drive
 Enjoy unlimited storage capacity and easy USB connectivity! Easy to connect, hot-swappable, translucent blue.
\$129.99
 #34314



aiwa
4/8GB USB Tape Drive
 Add 8GB of storage to your iMac or G3!
 > Up to 8GB storage (w/2:1 compression)
 > Includes Dantz® Retrospect backup software
\$239.99
 #49174



IMATION
SuperDisk Drive!
 Twice as fast! Reads & writes both 120MB SuperDisk diskettes and standard HD 3.5" diskettes.
\$169.99
 #46876



3Com
Palm V™ w/FREE MacPac™ 2.0
 State of the art industrial design—smaller size, lighter weight and ultra thin!
\$399.99
 #44046
 And get a USB PalmConnect Kit for only \$39.95 #48890



HITACHI
RasterOps MC7515 19" Display
 > 19" (18" viewable)
 > 1600 x 1200 res. @ 75Hz
 > .26mm dot pitch
\$499.99
 #29014



CASTLEWOOD
ORB External 2.2GB SCSI Removable Drive
 > Faster than many hard drives
 > 10ms seek time, 5400rpm
 > Unlimited capacity with additional 2.2GB cartridge
 > Ultra SCSI Interface
\$199.99
 #44042



EPSON
Prices Slashed! on Epson Printers
 Stylus Photo 700 Printer was \$189 Now \$129.99 #43571
 Stylus Color 850 Printer was \$299 Now \$249.99 #30666
 Stylus Color 900 Printer was \$449 Now \$399 #43524



IMICRO
Ultimate Rez 2D/3D
 128-bit 2D/3D video controller. Twin Turbo 128-3D and dual ported EDO VRAM! Includes card, driver and manual.
\$79.99
 #47690
 Shipped in non-retail packaging.
White Supplies Last!
iXTV for Mac and PC!
 Interact with your TV on your desktop!
\$69.99
 #46911



Order Any Time! Open 24 Hours!
 Order Today by 10pm EST—
 Get it Tomorrow by 10:30am!

1-800-217-9492

Us!



E-mail Specials!

Register now at macmall.com

for our weekly E-mail specials

and receive a

FREE gift!



Microsoft Word 98

Microsoft

Get the most out of your Mac with this limited time offer.

Special Edition for the iMac and iBook for only \$96⁹⁹

#49052

After \$30 mfr. mail-in rebate.

New!

Adobe Photoshop 5.5

Photoshop is the standard for image editing, and new Photoshop 5.5 offers new creative tools and features especially designed for the Web.

Now Shipping! **Photoshop 5.5 upgrade as low as \$119⁹⁹**

#47478

Price reflects \$70 mfr. mail-in rebate for Photoshop 5.0 or ImageReady 1.0 customers.

SAVE \$60! Kai's Power Tools for only \$69.99 when you order Photoshop 5.5! #48282

Connectix Virtual PC 3.0 with Win98

Now with USB support and more!

only \$168⁹⁹ #49917

Quicken 2000

Intuit

Gives you more information and resources specific to your financial situation!

only \$39⁹⁹

#48131

Price reflects \$20 mfr. mail-in upgrade rebate.



New!

The Future of Professional Publishing!

Seamless integration with Adobe Illustrator and Photoshop
Conversion of QuarkXPress 3.3-4.04 files as well as PageMaker 6.5 files

as low as \$299⁹⁹

#45630

SAVE \$400 off the regular price if you own QuarkXPress, Photoshop, Illustrator or PageMaker! **Limited time offer.**

#45249 Adobe InDesign Mac/PPC \$699⁹⁹

New Norton Utilities for the Mac!

SYMANTEC

Version 5.0 is the safe way to repair disk problems and recover lost files.

\$44⁹⁹

#48932

After \$50 mfr. mail-in upgrade crossgrade rebate.

#48587 Norton AntiVirus 6.0 Mac After \$20 upgrade rebate \$44⁹⁹

Painter 6

The latest version of Painter 6 has unlimited layering, multi-color brush strokes, extensive support for graphic tablets, and new text on a path that you can tilt, rotate, stretch and scale.

as low as \$149⁹⁹

#49941

Price reflects \$50 mfr. mail-in rebate for owners of previous versions excluding Painter Classic.



Hot New Mac Games!

Connectix Virtual Game Station

Play many PlayStation games directly on your Mac!

only \$19⁹⁹

#48961

with computer purchase. While supplies last **Call for details!**



Descent 3

Test your piloting skills against an army of battle drones and assault-bots using heavy fire-power and an extensive arsenal.

for only \$44⁹⁹

#47961



UMAX

Astra 610S SCSI Scanner

- 30-bit > 300 x 600 res.
- 8.5" x 11.7" Scan Area
- Fast SCSI-II interface
- Includes Adobe PhotoDeluxe

only \$49⁹⁹* #33410

*Factory refurbished. 90 day warranty.

\$50 PRICE DROP! Zip 250MB External Drive

\$149⁹⁹ #41332

External SCSI. Price reflects \$20 mfr. mail-in rebate. Price before rebate is \$169.99.



New!

ePhoto 780C Digital Camera

- 1024 x 768 w/PhotoGenie
- 1.8" LCD screen
- Stores up to 96 photos on each memory card

\$199⁹⁹ #48140

SPECIAL!

56K V.90 External Modem

No Rebate Hassles! Save Today! Get V.90 right out of the box! **\$59⁹⁹** #39443



24X External SCSI CD-ROM Drive

\$99⁹⁹ #37358

Special Offer! While supplies last!



40X External SCSI CD-ROM Drive

\$129⁹⁹ #47204

macmall.com or AOL Keyword: **Mac Mall**

Mention your Priority Code: **#ZMWD9B1**

Mac Mall

Join the Digital Video Revolution!

"The digital video market is booming. I mean, digital TV is all that everyone talks about ... It's just as profound as what happened 15 years ago with desktop publishing. Video is going in and out of the computer. It's being scaled. It's being manipulated. It's being moved toward the Net at the same time that it's moving up toward broadcast."

— Dirk Van Dal
Principal Consultant
Digital Video Showtime Networks

DV is the fastest growing segment of the camcorder market!



*The latest research on new digital video storage technologies by Strategy Analytics (formerly BIS Strategic Decisions). Based on camcorder sales in Europe, the U.S. and Japan.

Digital Video Camcorders are changing the uses for video in:

- Business Training
- Internet Communications
- Entertainment

Visit our special Digital Video site at www.zones.com/DV

Final Cut Pro is the only affordable software that combines professional editing, compositing and special effects capabilities in one program.

Using the new DV and FireWire standards, Final Cut Pro transforms your G3 into a powerful video workstation. Fast, interactive tools let you see

exactly how your video will appear in the finished production. Final Cut Pro is your weapon of choice for the new Digital Video Revolution!



NAB '99 Awards
Editors Choice Award –
Videography Magazine
Millimeter
Tommy Award
DV Magazine's
Best of Show

Imagine Final Cut Pro

"It combines the power of a \$100,000 non-linear editing and special effects system with an exceptionally simple interface. I love it!"

— Michael Backes
Motion Picture Producer

Professional Tools

- Professional editing, compositing and effects programs in one product
- Complete set of editing tools
- Build composites using a direct, proxy-free interface
- Create and animate unlimited layers

Plug-and-Play Digital Video

- Works instantly with most FireWire-equipped Power Mac G3 computers
- Gets video directly from most DV devices
- Works with certified QuickTime-compatible video capture/output cards
- Simultaneous output to your monitor and a TV monitor, VCR or camera

Enhanced Workflow & Productivity

- Do all your work through four multi-function windows
- Edit using a source/record, timeline or keyboard interface
- High-speed previewing and rendering
- 99 levels of "undo"

Outstanding Support for QuickTime

- Large windows with smooth playback, even on large files
- Enjoy audio/video synchronization
- Use super large files (over 2GB)

Requirements: 266MHz or faster Power Mac G3/G4, 128MB RAM, 6GB Hard Drive, Mac OS 8.5. FireWire card may be necessary for video capture.

FREE* \$50 Value!
FireWire Cable Included

FREE* \$20 Value!
Short Cut Keyboard Sticker

FREE* \$50 Value!
Final Cut Pro Tutorial

*With purchase of Final Cut Pro while supplies last

Brand NEW!
Power Mac G4
Up to 500MHz



STARTING AT
\$1599⁹⁹



ONLY
\$429⁹⁷
#102942

Includes: WebObjects & Apache Web Server - #1 Web Server Software \$1500 Value!

Create Personal Video WorkStation

- Up to 500MHz Power PC velocity engine
- Up to 256MB RAM, 1.5GB max.
- Up to 27GB hard drive
- Variable speed CD-ROM, DVD-ROM or DVD-RAM on select models
- Zip drive on select models
- 56K modem on select models
- 10/100 Base-T Ethernet, 2-Firewire ports & 2 USB Ports
- ATI Rage Pro card with 16MB VRAM
- Up to three FireWire ports

TAX FREE Streaming!

Broadcast Streaming Internet Video

Mac OS X Server

Upload your DV art to the Web and share your vision with the world!

- Features a modern foundation, key open standards and innovative Internet and workgroup services
- Delivers powerful, easy-to-use solutions for the Internet, education and publishing markets
- Mach microkernel offers preemptive multitasking and protected memory for crash-resistant operation

- Deliver content over the Internet or manage networks of Macs
- NEW NetBoot feature offers centralized workgroup management
- Preemptive multitasking runs multiple processes and performs many operations simultaneously
- Includes Apache software - the world's most popular Web server

Min. Requirements: Power Mac G3/G4 or Server G3; 256MB RAM; 1GB free HDD space; software update to Mac OS X Quick Time Streaming Server 1.0

#108092 Apple Server G3/450 with Mac OS X Server \$4994.99

we're open 24/7 hours a day 7 days a week



Credit cards are not charged until the order is shipped. Most products ship the same day (barring system failure, etc.). Shipping options include Ground, 2nd Day and Overnight delivery. Freight is based on average product weight. Handling extra. Insurance available. Special orders may require special shipping and handling charges. Call for international shipping rates. Prices and product availability subject to change without notice. Specials and promotions may be limited to stock on hand. Not responsible for typographical errors. All products sold by Multiple Zones International (MZI) are third party products and are subject to the warranties & representations of the applicable manufacturers, including but not limited to Y2K compliance. Accordingly, MZI makes no representation or warranty with respect to Y2K compliance of product sold. ©1999 Copyright Multiple Zones International Inc. All rights reserved. Unauthorized duplication is a violation of applicable laws. Apple, the Apple logo, Macintosh® and PowerBook® are registered trademarks of the Apple Computer, Inc.

Technology!

NEW Power Mac G4's are here!

visit www.zones.com/newmacs
for details



NEW MAC OS 9!

OVER 50 NEW FEATURES! RESERVE YOUR COPY NOW!



MAC OS 9 THE INTERNET OS

Mac OS 9 is the ultimate upgrade for anyone on the Internet, or anyone who wants to be! Sherlock 2 is the most powerful and fun way to find information, people, up-to-the-minute news

and do all your online shopping. With Voiceprint Login, you can share your Macintosh and Mac OS 9 will remember all your settings and preferences! Mac OS 9 will even keep your information private and encrypt files.

~~\$99.98~~

MAC OS 9!
\$89.98

Order item #111431

SHERLOCK 2

Sherlock 2 is the most powerful and fun way to find information on the Internet, and now you can find people, the latest news, and do all your online shopping faster and easier than ever. When you're looking for people, you get their e-mail addresses and phone numbers. When you're shopping, you see how much it's going to cost and how quickly you can get it. It automatically keeps up-to-date, so you always access the best sites.

VOICEPRINT LOGIN

With Voiceprint Login, you can share your computer with your family or classmates and your window to the Internet is always ready, even if someone else has been using your computer. Mac OS 9 remembers all of your Internet settings like e-mail, home page and favorites, as well as all your preferences too. Your password or even your voiceprint, unlocks your private keychain, which gives you access to all your e-mail, Web, and file server accounts so you never have to type another password.



Latest OS 9 updates at
www.zones.com/OS9

Visit us online
at **Zones.com**
to see our full selection
of products at the latest prices!



Corporate bids welcome!
Fax to 1-800-684-8080

Source Code
MW911

Order by Phone
1.800.436.0606

Order Online Today
Zones.comTM

A NASDAQ COMPANY Ticker Symbol: MZON

macZone®

\$100 Off



the next generation of



Brand New!

Apple iBook™

- 300MHz PowerPC™ G3 processor
- 3.2GB IDE hard disk
- 32MB SDRAM, upgradeable to 160MB RAM
- 12.1" TFT Active Matrix SVGA display (800x600)
- 24X maximum variable speed CD-ROM drive
- 56K modem, 10/100 Ethernet
- Crush-resistant polycarbonate case
- Battery life up to six hours
- Weighs only 6.7 pounds
- Comes with Software to go

Blueberry
Item #110916



iMac to Go!

Reserve yours today!

\$1594⁹⁶



Tangerine
Item #110915

\$200
worth of
FREE
Software with
every iBook!

Get Unplugged!

iBook AirPort Base Station

- Surf the Net or network wirelessly*
- Up to 150' range lets you and the iBook roam around the home or classroom



ONLY
\$294⁹⁶
#110920

#110919 AirPort Card \$99.96

*Requires the AirPort Card

- #110915 Apple iBook – Tangerine \$1594.96
- #110916 Apple iBook – Blueberry \$1594.96
- #110917 AC Power Adapter for iBook . . . \$68.96
- #110918 Rechargeable Battery for iBook . \$139.96

Click here

FREE STUFF
LIKE THIS!

at www.zones.com

FREE MYST
Ask for #103750

*plus \$2.98 shipping and handling. All offers while supplies last. Subject to change without notice.

Get **\$100** MacBucks

333 MHz!

Apple iMac

- 333MHz PowerPC™ G3 processor
- 512K backside cache
- 32MB SDRAM memory
- Two 12 Mbps USB ports
- 6.0GB hard drive
- 24X max. var. speed CD-ROM
- 56K modem
- 10/100Base-TX Ethernet
- 15" monitor (13.8" viewable)
- 6MB SGRAM video memory
- ATI Rage Pro 2D/3D graphics card

ONLY
\$1194⁹⁸
EACH

Choose your favorite flavor

- Strawberry #102986
- Lime #102989
- Tangerine #102988
- Grape #102987
- Blueberry #102985



\$100 Off Any Purchase

at Zones when you open an account with **E*TRADE**®

Get complete details at www.zones.com/etrade

\$1 a day brings an iMac your way!
Apple Loan Program
CALL NOW TO APPLY!

4-Year
Extended Service Agreement
\$189⁹⁸
Ask for #106494

FREE
Software with every Apple® iMac
\$400
value!



Titles are subject to change. Retail packaging not included.

AppleCare
iMac

Two year extension
Extends warranty coverage two additional years (3 years total)
Includes keyboard and mouse

Pick your favorite iMac Color!

HP DeskJet 882C Color Printer
\$50 Rebate only **\$299⁹⁸** #102363

#60236 HP DeskJet 895Cse \$399.98

Give your iMac mouse the shape and feel of a standard mouse!

MacSense iCatch
only **\$9⁹⁸** #102671

we're open
24 hours a day
7 days a week



Credit cards are not charged until the order is shipped. Most products ship the same day (barring system failure, etc.). Shipping options include Ground, 2nd Day and Overnight delivery. Freight is based on average product weight. Handling extra. Insurance available. Special orders may require special shipping and handling charges. Call for international shipping rates. Prices and product availability subject to change without notice. Specials and promotions may be limited to stock on hand. Not responsible for typographical errors. All products sold by Multiple Zones International (MZI) are third party products and are subject to the warranties & representations of the applicable manufacturers, including but not limited to Y2K compliance. Accordingly, MZI makes no representation or warranty with respect to Y2K compliance of product sold. ©1999 Copyright Multiple Zones International Inc. All rights reserved. Unauthorized duplication is a violation of applicable laws. Apple®, the Apple logo, Macintosh® and PowerBook® are registered trademarks of the Apple Computer, Inc.

Any Purchase!

when you open an account with  E*TRADE

Get complete details at www.zones.com/etrade

NEW
Power Mac G4's
are here!

visit www.zones.com/newmacs
for details



Visit your one stop source for USB products www.zones.com/usb

USB Imaging



\$129⁹⁸
-100
\$29⁹⁸*
#622652
*when you open an E*TRADE account.

UMAX Astra 2000U Scanner



ONLY \$99⁹⁸
#97188

600x1200 resolution, 36-bit color and great scanning software!
AGFA SnapScan 1212U Blue

USB Connectivity



ONLY \$79⁹⁹
#621851

Connect your existing printer to your iMac!
USB Twin Serial Adapter



ONLY \$59⁹⁹
#30039

The easiest way to hook up devices to your iMac!
Entrega 4-Port USB Hub for Mac

USB Storage



ONLY \$299⁹⁸
#107091

Easy to use external USB Hard Drive!
LaCie External Drive USB HD



ONLY \$89⁹⁹
#107094

Cool looking drive handles 1.44MB floppies!
VST USB Floppy Drive



\$129⁹⁸
-100
\$29⁹⁸*
#95251
*when you open an E*TRADE account.

100MB of removable storage - fast and easy!
Iomega USB Zip Drive



\$169⁹⁸
-100
\$69⁹⁸*
#109035
*when you open an E*TRADE account.

Use floppy disks and add 120MB storage!
Imation USB SuperDisk Drive 2X

Digital Sound - MP3



ONLY \$269⁹⁹
#649033

Listen to digital music on the go!
RIO 500 MP3



ONLY \$48⁹⁹
#637018

Best of Macworld!
SoundJam Pro Digital Audio System



ONLY \$79⁹⁹
#101373

High-quality SRS surround-sound!
CoZo iMac Speakers



ONLY \$49⁹⁸
#100676

Surge suppressor, mouse pad, CD-rack and wrist rest!
Belkin iMac Starter Kit

USB Input



ONLY \$29⁹⁹
#31901

The mouse your iMac deserves!
MacALLY iMouse USB Mouse



ONLY \$39⁹⁹
#101329

Put iMac power in the palm of your hand!
Ariston Ares USB Joystick

USB Storage



ONLY \$39⁹⁹
#31906

Excellent response - plus the iMac look!
MacALLY iBall USB Trackball



ONLY \$39⁹⁹
#31933

Full-size, soft-touch for comfort and control!
MacALLY iKey USB Extended Keyboard



ONLY \$48⁹⁹
#602571

The trackball iMac users have been waiting for!
Kensington Orbit Trackball - iMac Blueberry Blue



ONLY \$45⁹⁹
#106162

USB programmable Game Pad
iShock

Best Sellers!



\$30 Rebate!
Special Edition for the iMac
#648707 **\$84⁹⁸***



NEW Version!
Virtual PC 3.0 with Win 98
#654332 **\$172⁹⁸**



\$20 Rebate!
NEW Version!
#653343 **\$39⁹⁸***

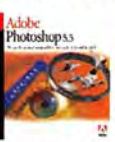

NEW Version!
Photoshop 5.5 Upgrade
#83084 **\$109⁹⁷***



\$50 Rebate!
NEW Version!
#652996 **\$44⁹⁸***



NEW!
X-Plane 5.0
#109803 **\$139⁹⁹**

71251 Mavis Beacon Teaches Typing 9 \$36.99
71622 Print Shop Publishing Suite . . . \$49.99
620781 Year 2000 Grolier Encyclopedia Deluxe Edition . . . \$47.98
07419 Unreal . . . \$44.99
80635 Family Tree Maker Deluxe II . . . \$79.99

Visit us online at Zones.com to see our full selection of products at the latest prices!

Corporate bids welcome!
Fax to 1-800-684-8080

Source Code
MW911

Order by Phone
1.800.436.0606

Order Online Today
Zones.comTM



the next generation of



PowerPC G4 Processor
up to
500MHz!

Olympus C2000 Digital Camera



ONLY \$899.99
#618993

Epson Stylus Color 900G Printer



ONLY \$429.99
#110986

Microtek ScanMaker 5 Dual Platform



ONLY \$1599.98
#110959

Entrega 7-Port USB Hub



Connect USB peripherals!
ONLY \$89.99
#111108

Keyspan USB Twin Adapter



Add external Serial devices to your Power Mac!
ONLY \$79.99
#621851

Lexmark 310 USB Laser Printer



The first USB-ready laser printer!
ONLY \$368.97
#104877

Apple Int. 56K V.90 Faxmodem for G3



Special Zones Price!
\$79.98
#102936
Product shown is representational only

Adaptec Internal SCSI Card



Adds an external SCSI port to your new Power Mac!
ONLY \$59.98
#99498

STARTING AT \$1594.98



NEW! Apple Power Mac™ G4

Every Power Mac G4 Includes:

- Two 400 Mbps FireWire ports
- Two 12 Mbps USB ports
- 10/100Base-T Ethernet port
- Up to 1.0GB maximum system memory
- Up to 100GB maximum HD storage
- 100MHz system bus
- Three 64-bit 33MHz PCI slots
- One 32-bit 66MHz PCI graphics slot with 16 MB SGRAM; ATI RAGE 128 2D/3D graphics accelerator

Apple® 17" Studio Display



New Graphite Color!

ONLY \$494.98
#109996



AS LOW AS **\$1594.98**

Apple Power Mac™ G3

Every Power Mac G3 Includes:

- Two 400 Mbps FireWire ports
- Two 12 Mbps USB ports
- 10/100Base-T Ethernet port
- Up to 1.0GB maximum system memory
- Up to 100GB maximum HD storage
- ADB port
- 100MHz system bus
- Three 64-bit 33MHz PCI slots
- One 32-bit 66MHz PCI graphics slot with 16 MB SGRAM; ATI RAGE 128 2D/3D graphics accelerator

Now up to **450MHz!**

Power Mac G3 350MHz 64MB SDRAM 6.0GB Drive 24X Max. Var. Speed CD 1MB Level 2 backside cache	ONLY \$1594.98 #108006	Power Mac G3 400MHz 64MB SDRAM 6.0GB Drive DVD Drive 1MB Level 2 backside cache	ONLY \$199.98 #108007
Power Mac G3 400MHz 128MB SDRAM 12.0GB Drive 24X Max. Var. Speed CD 1MB Level 2 backside cache	ONLY \$2494.98 #108008	Power Mac G3 450MHz 128MB SDRAM 9.0GB Drive 24X Max. Var. Speed CD 1MB Level 2 backside cache	ONLY \$299.98 #108009

While supplies last!

What you'll find at Zones.com: Hot New Products • Online Auctions

Adobe Publishing Collection

- Photoshop 5.5 • Illustrator 8.0
- PageMaker 6.5 Plus
- Acrobat 4.0

SAVE over \$719!



ONLY \$948.97
#108214

Adobe Photoshop 5.5

The latest evolution of an industry standard!



UPGRADE \$109.97*
#83084

NEW! After \$70 mfr. mail-in rebate for owners of Photoshop 5.0 & Image Ready 1.0 Low Zone price \$179.97

Adobe InDesign

With **FREE** six month subscription to Desktop Publisher's Journal!



ONLY \$299
#107036

MetaCreations Painter 6.0 Upgrade

Where natural media meets the Web!



ONLY \$149*
#104535

After \$50 mfr. mail-in rebate. Low Zone price \$199.00 #104533 Painter 6.0- Full Version \$399.99

QuarkXPress 4.0 Comp. Upgrade

Over 75 new features!



ONLY \$298.98
#104526

#110995 QuarkXPress 4.0 & CorelDraw 8 Bundle \$799.98

we're open 24 hours a day 7 days a week



Credit cards are not charged until the order is shipped. Most products ship the same day (barring system failure, etc.). Shipping options include Ground, 2nd Day and Overnight delivery. Freight is based on average product weight. Handling extra. Insurance available. Special orders may require special shipping and handling charges. Call for international shipping rates. Prices and product availability subject to change without notice. Specials and promotions may be limited to stock on hand. Not responsible for typographical errors. All products sold by Multiple Zones International (MZI) are third party products and are subject to the warranties & representations of the applicable manufacturers, including but not limited to Y2K compliance. Accordingly, MZI makes no representation or warranty with respect to Y2K compliance of product sold. ©1999 Copyright Multiple Zones International Inc. All rights reserved. Unauthorized duplication is a violation of applicable laws. Apple®, the Apple logo, Macintosh® and PowerBook® are registered trademarks of the Apple Computer, Inc.

Mac G4 is here!

Power with the ease of Macintosh

YOU CHOOSE WHAT'S FREE
with select CPU purchases.
Values up to \$350!
Call for details.

Meet the PowerPC G4 with Velocity Engine

The first supercomputer on a chip!

"Currently, the G4 is significantly faster than any platform we've seen running Photoshop 5.5"

500MHz PowerPC G4 = 3x Faster than PIII 600MHz

Photoshop runs... 2x Faster than PIII 600MHz

1 Billion floating point operations = 1 Gigaflop

1Gigaflop = Supercomputer Processing Power = G4

Velocity Engine

Processes information in 128-bit chunks

Pentium

Processes information in 32-or 64-bit chunks

John Warnock
CEO of Adobe

Choose the Power Mac G4 That's Right for You!

Visit Zones.com For the Latest Promotions!

G4 performance at a great low price!

Apple® Power Macintosh® G4

400MHz Minitower

64MB SDRAM

10.0GB Hard Drive

32x Max. Variable Speed CD-ROM

56K Modem

ONLY \$1594⁹⁸
#109992

OR LEASE FOR JUST \$56/Mo.*

Expansive storage space and built-in Zip drive!

Apple® Power Macintosh® G4

450MHz Minitower

128MB SDRAM

20.0GB Hard Drive

DVD Drive, Plus Zip Drive

56K Modem

ONLY \$2494⁹⁸
#109993

OR LEASE FOR JUST \$88/Mo.*

Screaming performance and DVD-RAM - a power user's dream!

Apple® Power Macintosh® G4

500MHz Minitower

256MB SDRAM

27.0GB Hard Drive

DVD-RAM for up to 5GB removable storage

Plus Zip Drive

ONLY \$3494⁹⁸
#109994

OR LEASE FOR JUST \$123/Mo.*

AppleCare
Power Mac
Two year extension
Extends warranty coverage two additional years (3 years total)
Includes keyboard and mouse

FIREWIRE Storage
Available Now!
Starting at Just \$399⁹⁸
Up to 22GB

Fuji 5-Pack Zip Disks
With **FREE** Case!

ONLY \$39⁹⁸*
#88195

*After \$10 mfr. mail-in rebate. Low Zone price \$49.98

Mactell FireWire Drives

Up to 25GB!

AS LOW AS \$349⁹⁸
#110625

Imation USB SuperDisk

NEW! \$169⁹⁸ - \$100 = **\$69⁹⁸***
#109035

*when you open an eTRADE account.

Now 2X!

Tektronix Phaser 840 GP Color Solid Ink USB

ONLY \$3899⁹⁹
#648962

FREE Black Solid Ink for LIFE!

VST External USB Floppy Drive

Use your old floppy disks (and files) with your new Power Mac G3!

ONLY \$89⁹⁸
#107094

USB Zip Drive

\$129⁹⁸ - \$100 = \$29⁹⁸*
#95251

*when you open an eTRADE account.

#37186 Zip Media (10 pk) \$79.98

Apple 15" Flat Panel Display

ONLY \$1294⁹⁸
#102931

Apple 21" Studio Display

ONLY \$1494⁹⁸
#109995

Business Lease: 36-month, fair-market value lease based on approved credit. Other leasing options available. Leases require a minimum order of 1000. Call 1-800-611-9751 for details.

Special Buys • Prices Updated Every Day • Software Downloads

Norton Utilities 5.0 for Mac

The tools you need for data recovery and disk repair.

NORTON Utilities NEW VERSION!

ONLY \$44⁹⁸*
#652996

*After \$50 rebate for upgraders

MS Office Upgrade

Who says you can't have fun at the office?

ONLY \$254⁹⁷
#105036

Microsoft **Office 98 Macintosh Edition**

FREE STUFF LIKE THIS! www.zones.com

FREE MYST
Ask for #103750

*plus \$2.98 shipping and handling. All offers while supplies last. Subject to change without notice.

Check out our Auction Site at Zones.com

Bids begin at just **\$1**

30 DAY MONEY BACK GUARANTEE

Corporate bids welcome!
Fax to 1-800-684-8080

Source Code **MW911**

Order by Phone
1.800.436.0606

Order Online Today
Zones.com

A NASDAQ COMPANY Ticker Symbol: MZON



the next generation of **the Mac Zone**

Best Sellers!

NEW Version!
Office 98 Upgrade Mac Edition
 #55870 **\$249.97**
 #105073 MS Office 98 for Mac \$419.97

\$20 Rebate!
Quicken 2000
NEW Version for Mac!
 #653343 **\$39.98***
 *After \$20 mfr. mail-in rebate. Low Zone price \$59.98

\$40 Rebate!
Norton Utilities 5.0
NEW Version
 #652996 **\$44.98***
 *After \$50 mfr. mail-in rebate. Low Zone price \$94.98

\$40 Rebate!
Norton AntiVirus 6.0 for Mac!
 #652997 **\$27.98***
 *After \$40 mfr. mail-in rebate. Low Zone price \$67.98

NEW Version!
Virtual PC 3.0 with Win 98
 Call to order **\$172.98**

Upgrade Now!
Adobe Acrobat 4.0 Upgrade
 #83063 **\$89.98**
 #93952 Acrobat 4.0 - Full Version ... \$219.98

NEW Version!
Flash 4.0 Upgrade
 #77533 **\$119.98**
 #77532 Flash 4.0 - Full Version \$279.98

NEW at Zones!
Yellow Dog Linux for the PowerPC
 Call for details

See our full selection of top hardware at **zones.com**

5 MAC COLORS
\$229.99
~~-\$100~~
\$129.99*
 #107815
 *When you open an E*TRADE account.
Epson Stylus 740i Color Inkjet Printer
 **After \$50 mfr. mail-in rebate. Low Zone price \$279.99

Super Price!
\$339.97
~~-\$100~~
\$239.97*
 #76514
 *When you open an E*TRADE account.
17" ViewSonic GS 771 Monitor

ONLY \$99.98
 #97188
600x1200 resolution, 36-bit color, and great scanning software!
AGFA SnapScan 1212U Blue

ONLY \$2999.98
 #110991
NEW!
Epson Stylus Pro 5000 Color Inkjet Printer

ONLY \$899.99
 #110251
21" Monitor Hitachi SuperScan 811

NEW!
 Organize in style! Ultra-thin & ultra-light!
3 Com Palm V™
 w/MacPac V.2
ONLY \$399.98
 #100100

ONLY \$368.97
 #104877
ONLY \$368.97
 #104877
Lexmark 310 USB Laser Printer

Best of Show! Macworld
ONLY \$499.98
 #109662
XLR8 MachCarrier 300MHz/1MB cache G3 processor upgrade

Our Best Selling Mac Modem!
ONLY \$109.98
 #60339
Global Village TelePort 56K V.90 Fax/Modem

ONLY \$399.98
 #60236
NEW!
Premium performance with photo-quality color!
HP DeskJet 895C Printer

FREE 16MB SmartMedia and Battery Charge Kit \$170 VALUE
ONLY \$999.99
 #109057
Olympus C-2000 Zoom Digital Camera

ONLY \$229.99
 #110633
ONLY \$229.99
 #110633
Vision 3D Evileye 3500 3D Video Card

ONLY \$759.98
 #102384
ONLY \$759.98
 #102384
Sharper, faster and more expandable!
HP LaserJet 2100M

ONLY \$299.98
 #109060
ONLY \$299.98
 #109060
Easy to use, big on features!
Fuji DX-10 Digital Camera
FREE 8MB Upgrade \$40 VALUE

ONLY \$359.98
 #609482
ONLY \$359.98
 #609482
Get high-performance & custom colors to match your iMac!
Sprezza USB Ext. 4X/2X/6X* CD-RW
 *max. variable speeds

ONLY \$2839.97
 #60296
ONLY \$2839.97
 #60296
Network printing for workgroups!
HP Color LaserJet 4500N Printer

ONLY \$99.99
 #109654
ONLY \$99.99
 #109654
XLR8 InterView™ USB with Strata VideoShop™

ONLY \$249.98
 #10957
ONLY \$249.98
 #10957
Castlewood ORB SCSI 2.2GB External Drive

we're open 24/7
 hours a day
 7 days a week

NO SURCHARGE ON CREDIT CARDS

Credit cards are not charged until the order is shipped. Most products ship the same day (barring system failure, etc.). Shipping options include Ground, 2nd Day and Overnight delivery. Freight is based on average product weight. Handling extra. Insurance available. Special orders may require special shipping and handling charges. Call for international shipping rates. Prices and product availability subject to change without notice. Specials and promotions may be limited to stock on hand. Not responsible for typographical errors. All products sold by Multiple Zones International (MZI) are third party products and are subject to the warranties & representations of the applicable manufacturers, including but not limited to Y2K compliance. Accordingly, MZI makes no representation or warranty with respect to Y2K compliance of product sold. ©1999 Copyright Multiple Zones International Inc. All rights reserved. Unauthorized duplication is a violation of applicable laws. Apple®, the Apple logo, Macintosh® and PowerBook® are registered trademarks of the Apple Computer, Inc.

Any Purchase!

when you open an account with  E*TRADE

Get complete details at www.zones.com/etrade

NEW
Power Mac G4's
are here!

visit www.zones.com/newmacs
for details



NEW MAC OS 9

RESERVE YOUR
COPY NOW!
ONLY \$89.98 #111431

Apple PowerBook® G3

333 & 400MHz Features:

- Two USB ports
- FireWire capable*
- Mac OS 8.6
- 8MB VRAM
- S-Video/TV output for easy connection to a TV or a VCR
- ATI Rage LT Pro graphics accelerator for enhanced 2D and 3D graphics

*Optional FireWire CardBus Card

PLUS

- 10/100 Base-T Ethernet port
- 384MB max. system RAM
- 56K V.90 modem
- Built-in SCSI port
- Integrated 4 Mbps IrDA technology for easy wireless LAN access, printing and file sharing
- Lithium-ion battery; support for dual-battery operation
- Hot-swappable expansion bay

Visit www.zones.com/apple
for more product information

AS LOW AS
\$2494.96

up to
Get \$250
MacBucks



14" Active Matrix

20% Thinner & 2 lbs. Lighter!

NEW! Apple® PowerBook® G3/333MHz #108066 **\$2494.96**

64MB RAM, 4.0GB HD, 24X max. var. speed CD-ROM, 512K Backside Cache, 14.1" Display

4-Year Laptop Plan with Screen Protection!
\$449.98 #97595

NEW! Apple® PowerBook® G3/400MHz #108067 **\$3494.96**

64MB RAM, 6.0GB HD, DVD-ROM, 1MB Backside Cache, 14.1" Display

4-Year Laptop Plan with Screen Protection!
\$459.98 #107107

Click here 

FREE STUFF
LIKE THIS: 

at www.zones.com

FREE MYST
Ask for #103750

*plus \$2.98 shipping and handling. All offers while supplies last. Subject to change without notice.

Only from Mac Zone!

Purchase ANY PowerBook & get **\$40 OFF** PowerPrint USB

ONLY \$53.98 #108100

*With PowerBook purchase. Low Zone Price \$33.98. Excludes iBook

Back-up Bonus Buy*

SAVE \$30!

Retrospect Express with **FREE Zip Disk**

ONLY \$39.99 #108099

*With purchase of an Apple CPU.

Targus NotePac
Nylon PowerBook Case #40401 **\$59.99**

Targus Premier Deluxe
Leather PowerBook Case #07720 **\$158.99**

Memory Upgrades G3 PowerBook® Series

UPGRADE	ITEM #	ONLY
32MB Upgrade	#05057	CALL
64MB Upgrade	#05059	CALL
128MB Upgrade	#05061	CALL

We offer a complete selection of accessories for your PowerBook

FireWire 2 GO

Newer Technology FireWire 2 Go PC Card

ONLY \$249.98 #109764

VST 4GB Expansion Bay Hard Drive

ONLY \$306.98 #109513

Portable Printer Kit

HP 340 with PowerPrint USB

ONLY \$359.98 #108073

Apple Lithium-ion Battery

2 for 10! Use 2 batteries for up to 10 hours!

ONLY \$126.98 #622731

VST Zip Drive for PowerBook G3

ONLY \$229.95 #109510

*when you open an E*TRADE account.

VST SuperDisk Drive for PowerBook G3

ONLY \$229.95 #109512

Corporate bids welcome!
Fax to 1-800-684-8080
A NASDAQ COMPANY Ticker Symbol: MZON

Source Code
MW911

Order by Phone
1.800.436.0606

Order Online Today
Zones.com™

Choose 71 at www.macworld.com/getinfo



Don't you deserve

APS ST 18GB LVD SCSI

- 7200 rpm drives offer reliability, performance
- For your most data-intensive content creation

MAC POINT Fifth-generation Barracuda mechanisms provide outstanding performance for workstations and servers. With internal data transfer rates of up to 25.7MB/s and an Ultra2 Wide LVD SCSI interface, the Barracuda rips through graphic design, image editing, 3D modeling, animation, and multimedia projects.



\$649.95

Bare Internal Configuration

APS Ultra 160m / Ultra 2 Wide LVD SCSI Drives

Model	RPM	Bare	APS Pro
APS I 9GB LVD	7200	\$349.95	\$419.95
APS Q 9GB Ultra 160m LVD	7200	399.95	469.95
APS ST 9GB LVD	7200	349.95	419.95
APS I 9.1GB LVD 10K	10000	499.95	569.95
APS Q 9.1GB Ultra 160m LVD 10K	10000	569.95	639.95
APS ST 9.1GB LVD 10K	10000	499.95	569.95
APS I 18GB LVD	7200	649.95	719.95
APS Q 18GB Ultra 160m LVD	7200	729.95	799.95
APS ST 18GB LVD	7200	649.95	719.95
APS I 18GB LVD 10K	10000	879.95	959.95
APS Q 18GB Ultra 160m LVD 10K	10000	969.95	1,039.95
APS ST 18GB LVD 10K	10000	799.95	869.95
APS I 36GB LVD	7200	1,199.95	1,269.95
APS Q 36GB Ultra 160m LVD	7200	1,559.95	1,629.95
APS ST 36GB LVD	7200	1,199.95	1,269.95
APS Q 36GB Ultra 160m LVD 10K	10000	1,559.95	1,629.95
APS ST 36GB LVD 10K	10000	1,499.95	1,569.95
APS ST 50GB LVD	7200	1,399.95	1,469.95

Drives listed above carry a five year warranty.

* Bare configuration does not include a mounting bracket. Intended as a replacement internal SCSI drive.

How would you like to see your digital artwork published in an upcoming APS Tech catalog? Send an e-mail to marketing@apstech.com for details.



APS ST 9GB Ultra SCSI

- Inexpensive 7200 rpm drive with Ultra SCSI interface
- 9GB capacities for workstation through server storage

MAC POINT With this Medalist Pro-based drive, you can upgrade your file and print servers to 7200 rpm speed and keep your budget well under control.

\$299.95

Bare Internal Configuration

APS Ultra SCSI Drives

Model	RPM	* Bare	APS Pro
APS ST 4GB	7200	\$199.95	\$269.95
APS ST 9GB	7200	299.95	369.95
APS I 18GB	7200	649.95	719.95

Drives listed above carry a three year warranty.

APS IDE Drives

Model	*Bare
APS 10GB IDE	\$139.95
APS 20GB IDE	199.95

APS ST 36GB LVD SCSI

- Fifth-generation Barracuda 7200rpm for high-end image editing & graphic design
- Over 36GB of storage in convenient 3.5", half-height form factor

MAC POINT Use this stellar drive as a vault for your biggest projects and ideas. Whether you are developing multimedia for CD-ROM or complex 3D architectural projects, the ST 36GB has the size and speed you need.

\$1,199.95

Bare Internal Configuration

APS ST 50GB LVD SCSI

- Fifth-generation Barracuda 7200rpm mechanism for superior server storage
- Over 50GB of storage in convenient 3.5", half-height form factor

MAC POINT Now, you can own the biggest hard drive on the planet. Give your high-volume workgroup, departmental and enterprise servers space to grow.

Stunning Server Storage

\$1,399.95

Bare Internal Configuration

LaCie USB Hard Drive Series

- Trusty 5400rpm IBM-manufactured hard drives with USB
- Portable, stackable EKO enclosure with built-in power supply, quiet fan
- Instantly add storage to USB PCs, notebooks and iMacs

MAC POINT Now you can add external drives quickly and easily to your USB-compatible system. No more complex internal installation. No IRQ settings for Windows users. No more two-drive limits. USB hard drives are truly plug and play, and you can connect up to 127 of them to your system (you maniac, you!). And forget about shutting down your system to add or remove drives - these hard drives are even hot-swappable. The USB series is perfect for mobile sales personnel, creative businesses, multimedia shops, IT administrators, anyone who wants to quickly swap or add hard drives. Call for more information or to order today.



\$299.95

LaCie EKO 10GB

\$449.95

LaCie EKO 20GB

Check our website at www.apstech.com for the most up-to-date prices



better storage to work with?

APS Hardware RAID System

- Fast access, mammoth capacity and increased availability
- Choose from RAID Levels 0, 1, 0+1, 4, 5
- Hot-swappable redundancy in drives, power supplies and cooling fans
- Perfect for data-intensive content creation and centralized data



Store and protect your files and data with the APS Hardware RAID System. This advanced RAID system offers powerful features like fault detection, background reconstruction, five hot-swappable hard drives, and an Ultra2 Wide SCSI interface. With multi-platform support, your whole company is covered. It's the ultimate combination of capacity, availability and speed.

NOTE: Default configuration is RAID Level 5 at maximum capacity.

5 APS ST 9.1GB LVD 10K \$9,999.95
5 APS ST 18GB LVD 10K \$13,999.95

APS Hardware RAID UPS Module

- Makes your new APS Hardware RAID System a virtual data fortress

This easily-integrated, stackable UPS protects your 5-drive APS Hardware RAID System against blackouts, brownouts and other power disturbances. Standard US voltage input. 420 volt amp.



UPS Module \$349.95

APS ShortStack Disk Array

- RAID Level 0 (Striped) Ultra2 Wide/LVD SCSI system for staggering speed
- Perfect for small content creation businesses and high-end workstations
- Easy connectivity and setup



Now, even small and home-based content creation businesses, or even individual workstations, can enjoy the blistering performance of a RAID. The APS ShortStack incorporates two hard disks that work together to become a high-performance disk array. Includes APS PowerTools® for basic RAID capabilities. Get the kind of performance the large companies have with an APS ShortStack Disk Array. It's time to think big.

APS ST 9GB LVD \$999.95

APS ST 9GB LVD 10K \$1,199.95
APS ST 18GB LVD \$1,599.95
APS ST 36GB LVD \$2,599.95



Medea VideoRAID Systems

- The ultimate storage systems for digital video, animation, and multimedia
- Up to 150GB capacity with Ultra Wide SCSI, Ultra2 LVD SCSI, or PCI
- Single- and dual-stream real-time effects video editing
- Available for Mac, Windows 95/98/NT, even SGI workstations

Finally, RAID built specifically for digital video production. Medea VideoRAID Systems give your staggering throughput and ample capacity to rip through your projects. The on-board hardware RAID controller makes setup painless and perfect. The SCSI versions attach to your SCSI adapter card and appear as one drive - on just one SCSI ID. The PCI models install easily into an open PCI slot. You get the high sustained data rates - up to 55MB/second with Ultra2 LVD - that you need for dual-stream, real-time effects systems. VideoRAID's exclusive Zone Stripe Technology maintains a consistently blistering pace. Other systems can lose up to 40% of their performance as the outer tracks fill up. From platform to platform, Ultra2 LVD to PCI, Medea VideoRAID systems can super-charge your digital video production.

VIDEORAID 26GB UW SCSI \$1,449.95

VIDEORAID 51GB UW SCSI \$1,899.95
VIDEORAID 100GB UW SCSI \$3,599.95
VIDEORAID RT 38GB U2W SCSI \$2,299.95
VIDEORAID RT 78GB U2W SCSI \$3,199.95
VIDEORAID RT 170GB U2W SCSI \$5,499.95

* These products not covered by the APS 30-Day Money-Back Guarantee. Products covered by manufacturer's warranty.

Visit us on line at
www.apstech.com for the
 most up-to-date prices



24 HRS/7DAYS A WEEK

Call 800-874-1428

Corporate Sales (800) 554-3941 • International (816) 920-4109

Advanced tools for digital visionaries





How to save time,



APS CD-RW 6x4x16

- One of our fastest rewritable CD drives ever
- Includes Toast CD Recording Software
- The ultimate CD drive for digital content creation, distribution, and backup



If you demand absolute top performance, this is it. The APS CD-RW 6x4x16 is one of our all-around fastest rewritables ever. Fifty percent faster record speeds let you burn a full disc in only 12 minutes. Spend less time burning discs and more time creating with the APS CD-RW 6x4x16. Includes full-featured CD recording software.

Fastest Ever \$349.95

APS Pro Enclosure

LaCie USB CD-RW

- Hot-swappable, for quick moves
- Includes Toast software



The ideal USB storage solution for iMacs and G3s. This drive combines the power and flexibility of a rewritable CD drive with the hot-swappable ease of USB. Faster and larger than USB Zip and USB Superdisk drives, the LaCie USB CD-RW enables 650 MB CD production for inexpensive and easy file exchanges.

LACIE USB CD-RW \$329.95

External Configuration

Sony Spressa USB CD-RW

- 4X record/2X rewrite/6X read
- USB for hot-swap convenience and multidevice chains
- Excellent rewritable drive for creative types with new G3s, iMacs and USB PCs



Hot-Swap CD \$359.95

External Configuration



APS DupliCD Duplicators

- Stand-alone units give you one-button disc duplication - easy for even non-tech staff
- Faster readers and 4x8 CD-R dupes full a CD in just 18 minutes for better production
- Choose DupliCD-121 for single-disc duplication or 126 for six-disc duping

DupliCD-121 \$999.95

External Configuration

DupliCD-126 \$2399.95

External Configuration



APS CD Mastering Systems

- Master on hard drive or Jaz disks before you burn for one-button copying
- Multifunctional 6x4x16 CD-RW drive

JazII/CD-RW 6x4x16 \$799.95

4GB/CD-RW 6x4x16 \$699.95

9GB/CD-RW 6x4x16 \$749.95

APS DVD-ROM

- World's first 5X DVD mechanism also acts as 32X CD-ROM drive



Now, you can play DVD movies, games, and entertainment titles, plus audio CDs and even CD-R and RW discs - all from the same drive. And this next-generation 5X drive gives you the smoothest playback ever.

w/Wired 4DVD \$339.95

Internal ATAPI Configuration

APS CD-R/RW

APS CD-R 8x20 SCSI	\$329.95
APS CD-RW 6x4x16 SCSI	349.95
APS CD-RW 8x2x20 SCSI	399.95

CD DUPLICATORS

MediaForm CD-5900 8-Disc	\$7,399.95
MediaForm CD-5916 16-Disc	12,699.95
MediaForm CD-3704 100-Disc	7,599.95

Check our website at www.apstech.com for the most up-to-date prices



Drives on these pages are covered by the APS 30-Day Money-Back Guarantee.

money, and your sanity

APS HyperDAT® IV

- Longer tape, higher density vault DDS-4 into corporate network backup
- 20GB native capacity, 2-3MB/s transfers
- APS Pro enclosure offers increased reliability



You trust your desktop and workstation backup to DDS/DAT. But it's not big or fast enough for your server or workgroup needs, right? Well, take a second look. New DDS-4 technology has increased capacity by 67% over DDS-3 and shrunk your backup time in half. DDS-4 uses longer (150m) tapes with thinner tracks and improved durability. But the HyperDAT IV can read and write to your DDS-3 and even DDS-2 tapes, so migration is easy. So keep all of your backups on the same tape with the new HyperDAT IV.

APS HyperDAT® IV **\$1,249.95**
APS Pro Case



APS DVD-RAM

- Up to 5.2GB capacity on double-sided DVD-RAM discs
- Big enough to backup most hard drives, but with random access for fast file recovery
- Doubles as 20X CD reader and DV storage



The APS DVD-RAM puts a whole new spin on backup. This rewritable optical drive combines the capacity to backup most hard drives with the random access of a CD. So if you lose just a file or two, you can restore them in the blink of an eye. Or you can rebuild your entire hard drive from the 5.2GB disk. The APS DVD-RAM is also terrific for huge file storage, like massive graphics. This technology is even fast enough for digital video production and playback. The APS DVD-RAM just may be the only drive, of any kind, that you ever need again. Call today.

5.2GB Rewritable **\$699.95**
APS Pro Enclosure



APS DLT 8000

- Next-generation DLT drive safeguards more data in less time
- Perfect for content creation workgroup or departmental backup



APS Tech is proud to introduce the next generation of DLT: the 40GB-native APS DLT 8000. But you get more than just greater capacity. Faster native transfer rates of up to 6MB per second make the APS DLT8000 the fastest backup solution on the planet. Supports UNIX, NetWare, Windows NT and Mac environments, so you can cover your whole network with one solution.

APS DLT 8000 **\$4,999.95**
External SCSI Configuration



APS AIT II

- Ultimate backup system for servers, content creation workgroups/departments
- Double the speed and capacity of original AIT
- Protect up to 100GB compressed data at up to 12MB/s



Introducing the ultimate single-drive backup system: the APS AIT II. The AIT II muscled up to double the capabilities of the original – twice the capacity (50GB native) and speed (6MB/s native). The AIT II's automated monitoring and self-cleaning features mean super reliability. And AIT gives you the space and speed to backup huge files, such as digital video and immense images. Completely compatible with first-generation AIT tapes. For massive backup or near-online storage needs, count on the APS AIT II.

APS AIT II **\$3,999.95**
External SCSI Configuration



APS Tape Backup

APS NS-8	\$399.95
APS NS-20	499.95
APS HyperDAT® II DDS-2	649.95
APS HyperDAT® III DDS-3	929.95
APS HyperDAT® IV DDS-4	1,249.95
APS DLT 4000	1,999.95
APS DLT 8000	4,999.95
APS AIT PLUS	1,999.95
APS AIT II	3,999.95
APS AIT Plus Autoloader	2,999.95
APS DDS-2 Autoloader	1,499.95
APS DDS-3 Autoloader	2,999.95

Ships with Retrospect software.

24 HRS/7DAYS A WEEK

APS MEDIA

CD-R / CD-RW DISCS

100421	650MB CD-R 10PK.	\$15.95
100422	650MB CD-R 100PK.	149.95
100423	650MB CD-R 250PK.	337.95
100424	650MB CD-RW 3PK.	24.95
100425	650MB CD-RW 5PK.	39.95
100426	650MB CD-RW 25PK.	189.95
100427	650MB CD-RW 50PK.	369.95

DATA TAPES – 4MM COMPATIBLE

100428	90M DDS-2 DAT 10PK. 2-4GB	\$49.95
100429	90M DDS-2 DAT 50PK. 2-4GB	225.95
100430	120M DDS-2 DAT 10PK. 4-8GB	99.95
100431	120M DDS-2 DAT 50PK. 4-8GB	499.95
100432	125M DDS-3 DAT 10PK. 12-24GB	219.95
100433	125M DDS-3 DAT 50PK. 12-24GB	1,149.95
100434	DAT CLEANING CART. 5PK.	34.95
100435	DAT CLEANING CART. 20PK.	119.95

**TO ORDER CALL
800-874-1428**



Corporate Sales (800) 554-3941 • International (816) 920-4109

Advanced tools for digital visionaries





LaCie electron22Blue

- Brand-new 22" Diamondtron Natural Flat technology eliminates distortion and glare
- Mammoth resolution of 1800 x 1440 pixels at 80Hz for biggest layouts
- Five USB ports for the most advanced, convenient computing system ever

Introducing quite possibly the most advanced monitor ever for digital visionaries. This 22" display gives you outstanding color fidelity and perfectly geometrical images. No more distortion or straight lines that curve on screen. And the USB connections let you quickly swap USB devices like the LaCie USB CD-RW, new scanners, and more.

LACIE ELECTRON 22BLUE \$1,399.95
LACIE ELECTRON 19BLUE \$769.95

Displays

Sony Monitors

Sony GDM-400PS 19"	\$699.95
Sony GDM-500PS 21"	1,099.95
Sony GDM-F400 19"	929.95
Sony GDM-F500 21"	1,759.95
Sony CPD-G400 19"	CALL
Sony CPD-G500 21"	CALL

LaCie Monitors

LaCie electron19blue	\$769.95
LaCie electron22blue	1,399.95

Sony LCD Displays

Sony Multiscan CPD-L 133	\$989.95
Sony Multiscan CPD-L 150	1,249.95
Sony Multiscan CPD-L 181	3,499.95

Adaptec Ultra HotConnect 8945

- Connects both digital video camcorders and Ultra Wide SCSI devices to your computer using only one PCI slot
- Includes DV capture software, FireWire and SCSI cables/connectors



This PCI card lets you connect your digital video camcorder to your Mac or PC on the same slot as your SCSI drives. You can chain up to 62 IEEE-1394/FireWire devices and up to 15 SCSI devices, like Ultra Wide SCSI hard drives, CD recorders, Jaz and tape devices. This awesome package includes a complete set of SCSI and 1394/FireWire cables and connectors, plus digital video capture software.

ADAPTEC 8945 \$539.95

Wacom LCD Display Tablets

- Amazing tablets act as monitors – you draw and design directly on screen
- Pressure-sensitive tablets (256 levels) include cordless Erasing UltraPens
- Must-have for cutting-edge graphics pros, animators, Web designers, multimedia



At APS, we are not easily impressed by new technologies. But Wacom has knocked our socks off. The new LCD Display Tablet line is like having the monitor screen on your lap or desk. You can design, illustrate, paint, animate and edit on-screen more accurately – to within 0.02 inches. We could say more, but you really have to see it to believe it. Be the first on your block to get a Wacom LCD Display Tablet. Call today.

WACOM PL-300 W/ 10.4" WORK AREA \$2,199.95
PL-400 - 13.3" work area - \$2,999.95

EPSON Stylus Color 900 Printer

- 1440 dpi and Micro Piezo technology for sharp details, no splatters
- Faster color printing (up to 10 ppm) makes you more productive

The new Stylus Color 900 lets even home and small businesses print corporate-class documents. And you can print color pieces faster than ever. So you spend less time waiting and more time drumming up business. Plus, with USB, parallel and Mac serial connections, you can use this image-maker with almost any computer. Get sharp, brilliant color fast and make a splash with the Stylus Color 900 from EPSON.



EPSON STYLUS COLOR 900 PRINTER \$429.95

Agfa DuoScan Solo Color Scanner

- Versatile scanner for creative departments, small firms
- Innovative TwinPlate for transparencies and reflective documents
- One-pass tri-linear CCD with 1000 x 2000 ppi resolution



The DuoScan handles all of your business scanning needs with ease, capturing images from virtually any kind of document. The built-in scanning bed for transparencies makes switching between media types easier than ever. And the DuoScan is fast. You will see your preview in just 11 seconds. And the DuoScan can deliver A4-sized color scans at 1000 ppi in just two minutes. So get high-quality scans for business documents fast with the DuoScan from Agfa.

AGFA DUOSCAN SOLO (MAC/PC) \$2,459.95

dreams into digital reality.

Canon ELURA Digital Video Camcorder

- Palm-sized DV Camcorder with Canon 12X optical/48X digital Zoom lens
- Noise reduction and Optical Image Stabilizer give you top quality footage

Now, you can get the power of digital video and the precision of Canon, all in the palm of your hand. The ELURA sports all of the advanced capture features of Canon's larger camcorders. You get crystal-clear digital video, with intricate details and true colors. The progressive scan CCD captures much better quality images than other, interlaced CCD camcorders. With up to 500 lines of horizontal resolution, you get 20% better-than-analog quality. Automatic or manual controls satisfy both the beginner and veteran. Plus, you can easily add your own personal touch to your video using the faders, effects, and a multi-image screen. So get the power of the Canon ELURA in the palm of your hand today.



CANON ELURA \$1,299.95



APC Surge Suppressors

- Extra surge suppression and longer runtime
- Safeguards data & equipment from lightning strikes and blackouts

Power Management

APC Surge Station Pro 8	\$32.95
APC Surge Station Pro 8 w/2 tel	37.95
APC Net 8 Surge Station	33.95
APC Net 8 Surge Station w/Net P	47.95
APC Line Conditioner,R-1250 APC	129.95
APC Line Conditioner,R-600 APC	99.95
APC BackUPS Pro 280S APC	134.95
APC BackUPS Pro 420S APC	219.95
APC BackUPS Pro 650S APC	269.95
APC BackUPS Pro 1000S APC	365.95
APC BackUPS Pro 1400S APC	459.95

Canon GL1 Digital Video Camcorder

- Professional-quality L-Series Fluorite lens with 20x optical / 100x digital zoom
- Choose flexible LCD view-screen or eyecup viewfinder for great footage at any angle
- Movie, Photo, and Frame Movie modes capture content for any project

Now, you can bring broadcast-quality digital video to your desktop. The GL1 helps you get footage the networks that will make the networks green with envy. So you can create amazing training and promotional videos, instant commercials, and superior content for Web, CD-ROM and DVD development. The GL1 incorporates some of the most advanced technology in digital video. The world's first L-Series Fluorite lens on a mini-DV camcorder gives you outstanding image clarity and color reproduction. This mini-DV camcorder also has the world's highest optical zoom - 20X - to grab details unseen with the naked eye. It all adds up to results that will make your clients or boss virtually beam. So call today for more information or to order. Lights, camera, action!



CANON GL1 CALL
CANON XL1 \$4,499.95
CANON OPTURA \$1,399.95



Digital Origin RotoDV

- Powerful, easy-to-use paint program for digital video
- Special effects, touch-ups, animation

DIGITAL ORIGIN ROTODV CALL

PHOTODV W/ FIREWIRE \$299.95
MOTODV W/ FIREWIRE \$399.95
EDITDV 1.5 \$599.95

Digital Cameras

Digital Still Cameras

Sony Digital Mavica MVC-FD83	\$699.95
Sony Digital Mavica MVC-FD88	899.95
Sony Digital Mavica MVC-FD91	947.95
Olympus C-2000 Zoom	979.95
Olympus D-620L	999.95

Surf on over to
www.apstech.com
 for more multimedia tools

Olympus D-620L Digital Camera

- 1.4Megapixel captures good enough for professional print projects
- SLR quality with digital time-savings



D-620L \$999.95



Mac OS is a registered trademark of Apple Computer, Inc. APS and APS Technologies are registered trademarks. Other brand or product names are registered trademarks or trademarks of their respective holders.

- 30-day money-back satisfaction on all APS brand drives and accessories. Your risk is the cost of shipping.
- Monitor and 3rd party products carry warranties from their respective manufacturers.
- SCSI cables sold separately.
- APS' warranty is a pass-through of the manufacturer's warranty which will be serviced by APS for one year. APS warrants APS branded enclosures, brackets and power supplies for a period of one year from the date of purchase and will, at its discretion, replace or repair products found to be defective according to the specific terms of the warranty accompanying the product.
- Returned orders subject to 20% restocking fee.
- International customers must pay for all shipping charges.
- Used capacities are formatted.
- Actual data compression and tape capacity vary greatly depending on the type of data recorded, other system parameters and environment.
- Prices and specifications are subject to change without notice.
- You must install system software appropriate to your machine before using our hard drives.
- Not responsible for typographical errors.
- Your APS' Drive unit may contain one or more components that were in prior use, but which have been inspected and repaired or rebuilt as necessary. These components, if any are covered by the same warranty provisions, exclusions and limitations to the same extent, and on the same terms as otherwise "new" components.
- © 1999, APS Technologies. All Rights Reserved.



Advanced tools for digital visionaries

24 HRS/7 DAYS A WEEK

Call 800-874-1428

Corporate Sales (800) 554-3941 • International (816) 920-4109



Your right to *selection*

G4: Not just the fastest Mac in history —the *fastest personal computer in history*



Apple® Power Macintosh G4 Series

- 400MHz PowerPC G4 processor
- 1MB backside cache
- 100MHz system bus
- 64MB SDRAM
- 10GB hard drive
- 32X Max CD-ROM
- 56Kbps modem

\$1594.00
CDW 184673

- 450MHz PowerPC G4 processor
- 1MB backside cache
- 100MHz system bus
- 128MB SDRAM
- 20GB hard drive
- 5X Max DVD-ROM
- 100MB Zip drive
- 56Kbps modem

\$2494.00
CDW 184674

- 500MHz PowerPC G4 processor
- 1MB backside cache
- 100MHz system bus
- 256MB SDRAM
- 27GB hard drive
- 5.2GB DVD-RAM
- 100MB Zip drive
- 56Kbps modem

\$3494.00
CDW 184675

Apple® iBook™

- 300MHz PowerPC G3 processor
- 512K backside Level 2 cache
- 32MB RAM
- 3.2GB hard drive
- 24X Max CD-ROM drive
- 56Kbps (V.90) modem
- 10/100BASE-TX Ethernet
- Built-in 2D/3D ATI RAGE graphics with 2X AGP
- Mac OS 8.6
- 12.1" active-matrix SVGA display

Tangerine \$1596.00 CDW 179139

Blueberry \$1596.00 CDW 179140



Apple® AirPort

Wireless Internet connection for iBook

Apple AirPort Card **\$96.97** CDW 179146

Apple AirPort Hardware Access Point **\$298.68** CDW 179142

Apple® iMac™

- 333MHz PowerPC G3 processor
- 15" display, 13.8" viewable, with 1024 x 768 resolution
- 32MB SDRAM
- 6GB hard drive
- 24X Max CD-ROM drive
- 56Kbps modem
- 10/100BASE-TX Ethernet
- Two 12Mbps Universal Serial Bus (USB) ports
- 6MB video memory
- Built-in stereo speakers with SRS sound

Only \$1194

Blueberry CDW 161620

Strawberry CDW 161623

Tangerine CDW 161632

Grape CDW 161627

Lime CDW 161634



MONITORS

APPLE

Apple Studio Display 17"	(16" view) 0.25mm AG	499.00
Apple Studio Display 21"	(19.8" view) 0.25-0.27mm AG	1,499.00
Apple Studio Display LCD 15.1"	(15.1" view)	1,299.00

MITSUBISHI

Diamond Pro 900U 19"	(18" view) 0.25-0.27mm AG	699.99
Diamond Pro 2020U 22"	(20" view)	1,239.47

PHILIPS/MAGNAVOX

105S 15" (14" view) 0.28mm		149.38
107S 17" (16.2" view) 0.28mm		239.97
109S 19" (17.9" view) 0.26mm		417.17

NEC

MultiSync A500+ 15" (13.8" view) 0.28mm		195.34
MultiSync A700+ 17" (16" view) 0.28mm		289.48
MultiSync E750 17" (16" view) 0.25mm		428.38

SONY

MultiSync FP950 19"	(18" view) 0.25-0.27mm AG	709.88
MultiSync P1250+ 20"	(19.6" view) 0.28mm	977.66

VIEWSONIC

GS771 17" (16" view) 0.27mm		309.22
G790 19" (18" view) 0.26mm		469.43
P810 21" (20" view) 0.25mm		869.68

VIDEO BOARDS

ATI RAGE ORION 16MB		178.15
ATI NEXUS 128 32MB		259.06
ATI XCLAIM 3D+ LCD 8MB		129.03
ATI XCLAIM VR 128 16MB TV		199.09

IX MICRO

Ultimate Rez 2D/3D 8MB PCI		309.92
ix3D Pro Rez 8MB PCI Power Mac		259.25
Road Rocket PC Card		229.75

COMMUNICATIONS

TelePort 56K V.90 external USB		119.40
TelePort 56K V.90 external		109.11
56K V.90 PC Card modem		139.99
TelePort 56K V.90 internal for the G3		98.57

ATI RAGE ORION 16MB		178.15
ATI NEXUS 128 32MB		259.06
ATI XCLAIM 3D+ LCD 8MB		129.03
ATI XCLAIM VR 128 16MB TV		199.09

Ultimate Rez 2D/3D 8MB PCI		309.92
ix3D Pro Rez 8MB PCI Power Mac		259.25
Road Rocket PC Card		229.75

TelePort 56K V.90 external USB		119.40
TelePort 56K V.90 external		109.11
56K V.90 PC Card modem		139.99
TelePort 56K V.90 internal for the G3		98.57

3COM/U.S. ROBOTICS

Sporster 56K Faxmodem external	89.32
--------------------------------	-------

VIKING

Viking 56K V.90 Modem external USB	115.24
------------------------------------	--------

DATA STORAGE

IMATION

USB 120MB SuperDisk drive USB	169.99
-------------------------------	--------

IOMEGA

Zip drive 100MB external USB	129.95
Zip drive 100MB external SCSI	99.95
100MB Zip disk, 3-pack	39.95
Zip drive 250MB external SCSI	169.95
Zip drive 250MB external USB	179.95
250MB Zip disk, 4-pack	69.95
Jaz drive 2GB internal	349.95
Jaz drive 2GB external	349.95
2GB Jaz disk 3-pack	299.95

LACIE

20GB external FireWire™ hard drive	499.00
4X4X16 CD-RW external w/PCI SCSI card	325.80
4X4X16 CD-RW external SCSI	329.00
CD-RW drive external USB	325.81
DVD-RAM external	749.00
2.6GB DVD-RAM disc single sided	32.04
5.2GB DVD-RAM disc double sided	42.28
4GB external SCSI hard drive d2 case	325.81
9.1GB external SCSI hard drive d2 case	429.00
9.1GB external SCSI hard drive d2 case	649.00
18GB external SCSI hard drive d2 case	789.00
36GB external SCSI hard drive d2 case	1899.00
10GB external USB hard drive	299.00
20GB external USB hard drive	449.00

QUANTUM

9.1GB Atlas III Ultra SCSI LVD	359.94
9.1GB Atlas 10K SCSI hard drive	467.60
18.2GB Atlas 10K SCSI hard drive	808.01
36.4GB Atlas 10K SCSI hard drive	1649.54

SONY

Sony Spressa iLINK 4X4X24 CD-RW	439.89
---------------------------------	--------

SCANNERS

AGFA

SnapScan 1236S	199.00
SnapScan 1212U for the iMac	129.00
DuoScan T1200	599.73

EPSON

Perfection 636	299.00
Perfection 636U	199.00
Perfection 1200U	249.00
Expression 800 Executive	699.00
Expression 800 Artist	799.00
Expression 800 Professional	999.00
Expression 836XL	2499.00

MICROTEK

ScanMaker 4	579.59
ScanMaker 9600XL	1,399.37
ScanMaker X6	119.79
ScanMaker X6E	197.98
ScanMaker X6 USB	119.79

NIKON

CoolScan III LS 30 film scanner	959.44
Super CoolScan LS 2000 film scanner	1,839.44

POLAROID

Polaroid SprintScan 4000	1,909.27
--------------------------	----------

UMAX

Astra 1220S	149.00
Astra 2200	249.00
Astra 2400S	299.00
Powerlook III	895.00
Powerlook III w/transparency adapter	1,195.00
Mirage II Duo Advance	1,995.00

PRINTERS

EPSON

Stylus Photo 700	179.00
Stylus Color 740	249.00
Stylus Color 740i	279.00
Stylus Color 1520	499.00
Stylus Color 3000	1,299.00
Stylus Color Pro 5000	2,995.00

HEWLETT-PACKARD

HP DeskJet 340 portable ink jet printer	268.64
HP DeskJet 882C	249.00
HP LaserJet 895Cse	299.00
HP LaserJet 4050N	1,999.00
HP LaserJet 8000DN	2,979.79

DIGITAL IMAGING

AGFA

ePhoto 780C digital camera	197.80
ePhoto CL30 digital camera	385.63
ePhoto CL50 digital camera	599.96

CDW® DIRECTORY

PC sales	800-800-4239
Mac sales	800-509-4239
Corporate sales	800-280-4239
Corporate software sales	800-294-4239
Government and Education sales	800-808-4239
Networking sales	800-377-4239

CDW® TELEPHONE HOURS

Sales	Monday-Friday 7 a.m.-9 p.m. CT
	Saturday 9 a.m.-5 p.m. CT
Tech Support>Returns for Customers	800-383-4239
	Monday-Friday 7 a.m.-9 p.m. CT
	Saturday 9 a.m.-5 p.m. CT



BUY WITH CONFIDENCE CDW® IS A NASDAQ TRADED COMPANY

TICKER SYMBOL CDWC D & B rated 5A1 Duns 10-762-7952

Credit card charges are not submitted until time of shipment. For your protection, we ship only to your credit card's verified billing address. Shipping and handling charges apply; please ask your CDW account manager for details. Before returning any product, you must obtain an RMA number. Non-defective returns are subject to a restocking fee. Software, chips and other electronic components are not returnable. Allow 10 business days for shipping when paying by personal check. All pricing subject to change. For all prices, products and offers, CDW reserves the right to make adjustments due to changing market conditions, product discontinuation, manufacturer price changes, errors in advertisements or other extenuating circumstances. All trademarks and registered trademarks are the sole property of their respective owners.

Know your options

Apple Mac OS 9

\$89.87

CDW 183126



Symantec Norton

AntiVirus V6.0

\$67.08

CDW 178354

Symantec Norton

Utilities V5.0

\$93.23

CDW 178357



Authorized Catalog Reseller

Intuit Quicken

Deluxe 2000

\$63.46

CDW 180602



Epson Stylus Color 740i
Color inkjet printer for Mac

\$229.00

CDW 161209



ViewSonic E771

monitor

17" flat square display, 16" viewable image size

\$239.59

CDW 98516

Adobe Publishing Collection



Adobe® Publishing

Collection

Includes: PageMaker® V6.5 Plus, Photoshop® V5.5, Illustrator® V8.0 and Acrobat® V4.0

\$997.64

CDW 174166

All products sold by CDW are third party products and are subject to the warranties and representations of the applicable manufacturers, including but not limited to Y2K compliance. Accordingly, CDW makes no representation or warranty with respect to the Y2K compliance of products sold.

56K modems are capable of 56Kbps downloads, however, current regulations limit download speed to 53Kbps.

Internet connectivity requires access services from an Internet access provider. Contact your local access provider for rates, terms and conditions.

©1999 CDW® Computer Centers, Inc.

200 N. Milwaukee Avenue, Vernon Hills, IL 60061 MW4991B 11/99



Computing Solutions
Built for Business™

www.cdw.com
800-509-4239

J&R COMPUTER WORLD

Modems



U.S. Robotics
The Original Choice in Modem Access

U.S. Robotics
V.90 External 56K Faxmodem
\$79.99 after \$20.00 Mail-In Rebate!
(REBATE THRU 10/31/99) (USR EXTRMCS6V90)

Zoom V.90 External 56K DualMode FaxModem (ZOP 29450041) **\$99.99**

Zoom V.90 PCMCIA 56K DualMode FaxModem For Mac PowerBook (ZOP 2874-00-01B) **\$99.99**

Zoom 56K USB External 56K USB Fax/Modem (ZOP 29860001) **\$99.99**

Scanners



AGFA

Agfa SnapScan 1212P
Color Scanner
\$99.99 (AGF SNAP1212P)

Agfa USB SnapScan 1212u (Transparent Blue For Mac) (AGF SNAP1212UB) **\$129.99**

Microtek ScanMaker X6ELDP (38-bit, scans legal) (MTK SCAN6ELDP) **\$179.99**

Minolta Dimage Scan Dual (For PC/MAC) (MIN DIMAGE2DL) **\$499.99**

Minolta APS Adapter (For MIN DIMAGE2DL) & (MIN SCANSPEED) Scanners (MIN APSADAPTER) **\$149.99**

Networking



NETGEAR
A 3Com Network Company

Netgear DS108
10/100 MBPS Dual Speed Hub
•8 autosensing ports •Plug & play •Compact
•Full 10/100 MBPS connectivity •Vista network ports
with LEDs •Mix & match 10/100 on same network
\$139.99 (NTG DS108)

Asante AsanteTalk
Ethernet-to-LocalTalk Connection for iMac
(allows connection of localtalk printers)
(ASA 99-00505-01) **\$99.99**

Mac Software

Adobe InDesign Upgrade
•For users of Quark XPress, Adobe® Illustrator, PageMaker or Photoshop •Page layout & design for the future of professional publishing •CD for Mac
\$299.99 (ADM INDESIGN-U)

Eudora Mail Pro (4.2)
by Qualcomm (QUB EUDORAPRO-C) **\$44.99**

Norton Antivirus (6.0)
by Symantec® (SYM NAV6-C) **\$59.99**

MacLinkPlus Deluxe (11.0)
by DataViz® (DAM MACLINK-D) **\$79.99**

Word For iMac
by Microsoft® (MSM WORDIMAC-C) **\$109.99**

QuickBooks Pro (4.0)
by Intuit® (IUN QBPRO-C) **\$179.99**

Office 98 Macintosh Edition
by Microsoft® (MSM OFFICE98-C) **\$399.99**

Walk In
15 Park Row
New York, NY

Phone In
(800) 221-8180

Log In
www.jandr.com
AOL keyword: J&R

APPLE® INTRODUCES THE BLAZING NEW G4!

Apple® Power Mac™ G4/400
64/10GB/32x-CD /MiniTower
•400MHz PowerPC™ G4 processor w/ Velocity Engine™
•64MB SDRAM •10GB HD •32x CD •56K V.90 modem •6MB VRAM •10/100BASE-T
•Monitor sold separately
\$1599.99 (APP M7631LL/A)

Apple® Power Mac™ G4/450
128/20GB/DVD /100MB Zip™ Drive MiniTower
•450MHz PowerPC™ G4 processor w/ Velocity Engine™
•128MB SDRAM •20GB HD •DVD
•56K V.90 modem •6MB VRAM •10/100BASE-T
•Monitor sold separately
\$2499.99 (APP M7232LL/A)

Apple® Power Mac™ G4/500
256/27GB/DVD-RAM/100MB Zip™ Drive MiniTower
•500MHz PowerPC™ G4 processor with Velocity Engine™
•256MB SDRAM •27GB HD •5.2GB DVD-RAM w/ DVD-Video playback •6MB VRAM
•10/100BASE-T •Monitor sold separately
\$3499.99 (APP M6921LL/A)



Apple® iBook NEW!
•12.1" TFT screen for pro-quality, super-bright, and super-crisp images
•G3 chip offers blazing speed •Built-in CD-ROM drive with tons of bundled software
•Long battery life (lasts up to six hours on just one charge)
•Built-in 56K modem and high-speed 10/100Mbps Ethernet help you get onto the Internet right away
•Surf the net in your home or classroom using AirPort™ wireless networking (optional)
•USB port makes it easy to add a printer, mouse, joystick, much more
\$1599.99 YOUR CHOICE!



Apple® Macintosh® PowerBook® G3/333
64MB/4GB/24x CD
•14.1" active-matrix display
•333MHz PowerPC™ G3 processor
•64MB SDRAM •4GB HD •24x CD-ROM •8MB VRAM •56K V.90 modem
•Built-in 10/100BASE-T
\$2499.99 (APP M7304LL/A)

Apple® Macintosh® PowerBook® G3/400
64/6GB/DVD-ROM
•14.1" active-matrix display •400MHz PowerPC™ G3 processor •64MB SDRAM •6GB HD •DVD-ROM •8MB VRAM •56K V.90 modem
•Built-in 10/100BASE-T
\$3499.99 (APP M7308LL/A)

ONLY 5.9LBS.!

5-HOUR BATTERY LIFE!

Businesses can lease G3 computers for as little as \$58.88 per month!
For details, call J&R Corporate Sales, (800) 221-3191 or (212) 238-9080

PowerPC and the PowerPC logo are trademarks of International Business Machines Corporation, used under license therefrom. Apple, the Apple logo, Macintosh, Power Macintosh, PowerBook, Apple are registered trademarks of Apple Computer, Inc. iBook is a trademark of Apple Computer, Inc. ©1999 Apple Computer, Inc. All rights reserved. Apple, the Apple logo, Macintosh, Power Macintosh, and PowerBook are registered trademarks of Apple Computer, Inc. All other trademarks are the property of their respective owners. All Apple products are designed to be accessible to individuals with disabilities. For more information in the U.S. only, call 1-800-748-2333 or TDD 1-800-833-4223.

J&R CORPORATE SALES BUSINESS LEASING:
No Money Down, No Payments for 30 Days!
*Call J&R Corporate Sales for details at 1-800-221-3191 or 1-212-238-9080

Omega



Omega®
External Ultra Thin Zip® 250MB USB/PCMCIA Drive
\$179.99 (BER ZIP250USB)

Omega® 250MB Zip® Parallel Port Drive OR
Omega® 250MB Zip® SCSI Drive
(BER ZIP50PAR) OR (BER ZIP250SCSI) **\$149.99**
after \$20.00 Mail-In Rebate!

Omega® 100MB USB Zip® Drive
(BER ZIP100USB) **\$129.99**

Omega® 2GB Jaz® Drive
(BER IAZX2GBIGN) **\$349.99**

Ratoc Systems



Ratoc Systems CB32PB
Ultra Wide SCSI CardBus PC Card
•For Macintosh PowerBook G3
\$249.99 (RAT CB32PB)

Ratoc Systems CBFW2 FireWire® CardBus PC Card (RAT CBFW2) **\$249.99**

Ratoc Systems USB SmartMedia Card Reader for Mac & PC (RAT SMD303) **\$69.99**

Radius



Radius MotoDV
Digital Video Capture Kit with FireWire® Card & Cable
•For Mac & PC •For digital cameras only
\$389.99 (RAD MOTODVIRE)

Radius 19" Color Display (RAD L-1) **\$499.99**

Radius 17" Color Display (RAD M-1) **\$299.99**

Radius 15" Color Display (RAD S-1) **\$159.99**

CD Writers



Smart and Friendly™
External Easy Racer CD Recorder with CD-RW ReWritability
•4x Write/4x Rewrite •CD-R disc & software included
\$299.99 (SMD SAF67)

Sony Spressa™ CRX100E/X External USB CD-RW Drive Kit (SON CRX100E/X) **\$349.99**

QPS External DVD-RAM Drive for Apple® G3 Computers (QPS DVDREAMEG3) **\$599.99**

QPS Que! Drive 4x2x8 External CD-R/Writable Drive for the iMac® (QPS QF428IMAC) **\$299.99**

Order from
www.jandr.com
AOL keyword: J&R

To Order Toll Free and Receive a Free Catalogue
800-221-8180
24 Hours, 7 Days, Anywhere In The USA
PARK ROW • NEW YORK • NY • 10038 FAX: 1-800-232-4432
Not responsible for typographical or pictorial errors. Merchandise is brand-new, factory-fresh & 100% guaranteed! Some quantities may be limited.

All Major Credit Cards Accepted
Overnight Delivery Available!
Order Code: MW911
(prices good until 11/15/99)



OUR BEST BUYS ON CD RECORDERS!

EACH CDR DRIVE WILL INCLUDE TOAST MASTERING SOFTWARE, AND 5 FREE DISKS!

CD RECORDABLE	Includes 5 Free Recordable Disks!	Int.	Ext.
4x12 Plector mechanism, caddy/tray load, 2MB buffer		\$319	\$379
6x24 Teac mechanism, tray load, 2MB buffer		\$359	\$419
8x20 Sanyo mechanism, tray load, 2MB buffer		\$359	\$419
8x20 Plector mechanism, tray load, 4MB buffer		\$479	\$539
8x24 Teac mechanism, tray load, 2MB buffer		\$439	\$495

CD REWRITABLE	Includes 5 Free Rewritable Disks!	Int.	Ext.
6x4x16 YAMAHA mechanism, tray load, 2MB buffer		\$319	\$379
4x2x20 Plector mechanism, tray load, 2MB buffer		\$359	\$419
6x4x24 Ricoh mechanism, tray load, 2MB buffer		\$329	\$389
8x2x20 Plector mechanism, tray load, 2MB buffer		\$489	\$549
8x2x20 Sanyo mechanism, tray load, 2MB buffer		\$419	\$489

Stomper CD label kit only \$29 with CD-R drive!

USB PRODUCTS

100MB Zip (ZIP100USB)	\$135
USB to SCSI adapter (USBSCSI)	\$79
SuperDisk drive, 120MB & floppy (USBLS120)	\$179
Floppy drive (USBFLOPPY)	\$95
8GB Hard Drive (USB8GB)	\$219
12GB Hard Drive (USB12GB)	\$299
16GB Hard Drive (USB16GB)	\$369
USB Case for IDE hard drive (USBCASE)	\$89

Call about new USB CD Rewritable!

G3 UPGRADES

Upgrades for the new G3 Mini Tower Macintosh computers.	
Adaptec PCI SCSI card (A2906E)	\$65
20GB Hard Drive (M92048D)	\$235

We are the #1 Source in the US for multirive towers. Call us with your specifications & we can build a customer tower for your G3. Need a 15 drive tower with CDs, CDRs, CDR-Ws, Tape drives, and hard drives? NO PROBLEM at MegaHaus!

HOT SELLERS

YAMAHA

Drive with Toast, Direct CD, 1 Free CD-RW disk

6x4x16 CD-RW Drive	
Internal (YCRW6416M)	\$279
External (YCRW6416MX)	\$339

DVD RAM	
Toshiba SCSI DVD RAM drive (SDW1101)	\$439
Panasonic SCSI DVD RAM drive (LFD101U)	\$555
Mac DVD RAM driver software (DVDSDTMAC)	\$59
DVD RAM media (DVRAMDISK)	\$35

RAID

We can custom configure a RAID system to your exact needs. Call one of our RAID experts at 800-786-5653. Here are a few of our popular RAID components.

Enclosure holds 3 Hot Swappable SCSI drives	\$279 (SCASDR-LVD) INTERNAL
ADD \$100 FOR EXTERNAL	

Fargo InkJet CD Color Printer (CDPRINTER)	\$999
Adaptec Ultra Wide PCI controller (A2940MUW)	\$285
Adaptec Ultra-2 PCI controller (A2940MU2W)	\$385
Toshiba SCSI 5X DVD ROM (SDM1201)	\$139

HARD DRIVES

Quantum

ULTRA 160m SCSI New SCSI interface will transfer 160MB/sec on new controllers. Drives will work on older SCSI, Ultra Wide, Ultra-2 controllers.

9.1GB 7200 2MB	KN309100LW	\$299
9.1GB 10,000 2MB	TN309100LW	\$439
18.2GB 7200 2MB	KN318200LW	\$569
18.2GB 10,000 2MB	TN318200LW	\$759
36.4GB 7200 2MB	KN336400LW	\$1111
36.4GB 10,000 2MB	TN336400LW	\$1395

IDE Ultra ATA/66

9.1GB 7200 512K	KA309100A	\$129
13.6GB 7200 512K	KA313600A	\$159
18.2GB 7200 512K	KA318200A	\$219

We are the #1 source for Quantum hard drives. Check us out at www.megahaus.com/quantum for the best deals around on Quantum.



ULTRA SCSI

9GB 7200 2MB	IBM309170N	\$295
18.2GB 7200 2MB	IBM318350N	\$545

ULTRA WIDE SCSI

9GB 7200 2MB	IBM309170W	\$295
18.2GB 1" High 2MB	IBM318350W	\$545

ULTRA-2 SCSI

9.1GB 7200 2MB	IBM309170U2	\$299
9.1GB 10,000 4MB	IDRV89U2A	\$515
18.2GB 10,000 2MB	IDMVS18U2	\$759
18.2GB 10,000 4MB	IDRV818XZ	\$825
18.2GB 7200 2MB	IBM318350U2	\$555
36.4GB 7200 4MB	IDRHS36U2	\$1060
36.4GB 10,000 2MB	IDMVS36U2	\$1350

IDE & IDE Ultra ATA/66

9.1GB 7200 512K	IBM9GXP	\$149
14.4GB 7200 512K	IBM14GXP	\$155
18.0GB 7200 2MB	IBM18GXP	\$235
20.3GB 5400 2MB	IBM20GP	\$219
22.0GB 7200 2MB	IBM22GXP	\$295
25.0GB 5400 2MB	IBM25GP	\$285
27.3GB 7200 2MB	IBM27GXP	\$380
34.3GB 7200 2MB	IBM34GXP	\$454
37.5GB 5400 512K	IBM37GP	\$469

WESTERN DIGITAL

4.3GB 5400 512K	WDAC14300	\$105
6.4GB 5400 512K	WDAC644A	\$115
8.4GB 5400 512K	WDAC844A	\$125
9.1GB 7200 2MB	WDAC29100	\$165
10.2GB 5400 512K	WDAC102AA	\$139
13.0GB 5400 512K	WDAC136AA	\$155
13.6GB 7200 2MB	WDAC136BA	\$179
17.2GB 5400 512K	WDAC172AA	\$195
20.5GB 5400 512K	WDAC205AA	\$245
20.5GB 7200 2MB	WDAC205BA	\$299
27.3GB 7200 2MB	WDAC273BA	\$335

Be Y2K ready! Check out megahaus.com for the latest products to protect your valuable data!

HARD DRIVES

Seagate

ULTRA SCSI

4.5GB 7200 512K	ST34520N	\$189
9.1GB 7200 512K	ST39140N	\$295
9.1GB 7200 1MB	ST39173N	\$339
18.2GB 7200 1MB	ST118273N	\$689

ULTRA WIDE SCSI

4.5GB 7200 512K	ST34520W	\$189
9.1GB 7200 1MB	ST39173W	\$359

ULTRA-2 SCSI

9.1GB 10,000 1MB	ST39103LW	\$515
9.1GB 10,000 4MB	ST39103LW4	\$569
9.1GB 7200 1MB	ST39175LW	\$359
18.2GB 7200 1MB	ST318275LW	\$599
18.2GB 10,000 1MB	ST318203LW	\$779
18.2GB 10,000 4MB	ST318203LW4	\$899
36.4GB 7200 1MB	ST136475LW	\$1189
36.4GB 10,000 1MB	ST136403LW	\$1459
50.1GB 7200 1MB	ST150176LW	\$1249

IDE Ultra ATA/66

4.3GB 5400 256K	ST34311A	\$85
6.4GB 5400 256K	ST36421A	\$105
8.6GB 5400 512K	ST38421A	\$119
10.2GB 5400 512K	ST310232A	\$139
13.3GB 5400 512K	ST313032A	\$149
17.2GB 5400 512K	ST317242A	\$169
20.4GB 7200 512K	ST320430A	\$235
28.0GB 7200 512K	ST328040A	\$305

Maxtor

IDE

10.0GB 7200 512K	M91024D	\$145
20.4GB 7200 512K	M92048D	\$235

IDE Ultra ATA/66

6.5GB 5400 2MB	M90650D	\$105
13.6GB 5400 2MB	M91360D	\$145
20.4GB 5400 2MB	M92040D	\$219
27.2GB 5400 2MB	M92720D	\$279

2.5" IDE LAPTOP

6.4GB 8.45mm	Toshiba MK6412MAT	\$195
10GB 12.5mm	Toshiba MK1011GAV	\$325
6.0GB 9mm	IBM DA20600D	\$250
9.0GB 9mm	IBM DA20900D	\$355
12.0GB 9mm	IBM DA21200D	\$389
15.0GB 12mm	IBM DA21500D	\$540
18.0GB 12mm	IBM DA21800D	\$570
25.0GB 17mm	IBM DA20500D	\$659

We carry more enclosures for drives than any body. From single 2.5" drive cases to 20 full height RAID ready towers. We also stock a full line of controllers for Macs. Call us with your needs.

We are committed to being the #1 Source for hard drives for Macs. If you need a drive or drive accessory not listed here, we probably have it. Call for pricing and availability.

Nobody beats our deals.
 Nobody has more drives.

CD ROM

SCSI	
Plextor PX32TS (tray)	32X 85ms \$99
Plextor PX32CS (caddy)	32X 85ms \$139
NEC CDR3010	40X 85ms \$85
Toshiba XM6401B	40X 79ms \$85
Plextor PX40TS	40X 85ms \$109

WIDE SCSI	
Plextor PX40TSUW	40X 85ms \$129
IDE	
NEC CDR3000	40X 75ms \$59
Toshiba XM6602B	40X 79ms \$57
Mitsumi CRMCFX48X	48X 65ms \$59
Memorex CD48X	48X 90ms \$66
Kenwood UCR412	52X 90ms \$99
Memorex CD56X	56X 90ms \$79

CD CHANGER

Pioneer 24X 6 Disc external SCSI DRM6324X \$419
 Custom configurations of multirive CD Towers are a specialty for us. Call with your needs.

TAPE BACKUP

Capacity	Native-Compressed	Max. Speed	Back Up	Price
			Bo Y2K Safe!	
4mm DAT				
24GB	66MB/min	Seagate STD24000N		\$549
48GB	66MB/min	Seagate DDS-2 STD28000N		\$629
48GB	90MB/min	Sony SDT7000A1		\$559
48GB	60MB/min	HP C1599A1		\$719
6GB	52MB/min	Indigita IDT2500		\$479
12-24GB	144MB/min	Sony DDS-3 SDT9000A1		\$759
12-24GB	132MB/min	Seagate STD224000N		\$849
12-24GB	120MB/min	HP DDS-3 C1554A1		\$929
20-40GB	288MB/min	Sony DDS-4 SDT10000A1		\$1129
32-64GB	90MB/min	Sony TSL7000 8 tape load		\$1899
48-96GB	48MB/min	Seagate STA49600N		\$2159
72-144GB	120MB/min	HP C5648A 6 tape load		\$2179

EXABYTE 8mm DAT

7-14GB	120MB/min	ELIANT820	\$1259
20-40GB	360MB/min	EXB8900	\$2189
70-140GB	60MB/min	EXB10H 10 tape loader	\$2699

QUANTUM DLT

20-40GB	180MB/min	DLT4000	\$1759
35-70GB	600MB/min	DLT7000	\$4499
40-80GB	600MB/min	DLT8000	\$4999

REMOVABLE MEDIA

Imega	
100MB Zip Ext SCSI	\$119
2GB Jaz Internal SCSI	\$300
2GB Jaz External SCSI	\$319
1GB Jaz disk 2-4/5-9/10+	\$777/\$573
2GB Jaz disk 2-4/5-9/10+	\$864/\$82
Maxoptix Magneto Optical	
5.2GB SCSI drive	\$1519
Sony Magneto Optical	
5.2GB SCSI drive	\$1489

MEDIA SALE

4mm DAT 90M 3 pack w/leasn \$20 Limited Qty #DAT90M3	\$13	\$10	\$8
4mm DAT 120M	\$26	\$23	\$21
4mm DAT 150M	\$59	\$57	\$55
8mm DAT 112M 2 pack \$10 Limited Qty #DAT8MM112M2	\$17	\$14	\$12
8mm DAT 160M	\$29	\$26	\$24
TR4	\$47	\$44	\$41
TR5			

DLT THE MEDIA SALE

1-4	5-9	10-49	50+
DLTIII 10-20GB	\$38	\$35	\$34
DLTIIIX 15-30GB	\$45	\$38	\$36
DLTIV 20-40GB	\$74	\$70	\$68





Raise your hand if you want a new G4 from BottomLine!

The new PowerMac G4 from Apple, so powerful it's classified as a weapon!

Apple PowerMac G4 - Choose your weapon!

- G4 400Mhz 64/10GB/32x/56k . . . \$1,479.99*
- G4 450Mhz 128/20GB/DVD/Zip/56k . . \$2,394.99*
- G4 500Mhz 256/27GB/DVD-RAM/Zip . \$3,394.99*

Custom configurations available • Above prices include e-Commerce software & instant rebate. Additional monthly hosting fees may apply for usage of e-Commerce software.

Call or visit our showroom for the complete line of Macintosh Computer Systems!

e-Commerce To Go!



iBook From
Apple
Computer™
\$1569*

*Price includes free e-Commerce software & instant rebate. Additional monthly hosting fees may apply for usage of e-Commerce software.

MacOS 9.0



Price after \$10
mail-in rebate

\$79.99

Video Capture



Captures Video At 60fps
13.3 Megabytes per second data rate

\$1,219

Yamaha CDRW Drive



6416S
6x/4x/16x
CDRW drive

\$249

12MB Voodoo 2 PCI



Make Your
3dfx Games
Go!

Voodoo 3 from
\$149

\$69.99



\$259

Rage Orion
In Stock!

ATI Nexus 128
32MB Of 2D/3D Video Power!



\$229

AIWA USB Tape Drive
4/8GB of storage!



\$799

XLR8
Mach G4 Upgrades



\$118

Omega Zip Drive
100MB removable storage
USB Interface!



\$339

Western Digital
Expert 27.6GB
IDE Drive



\$124

ProMax TurboMax Card



\$599

RAILGUN
from BottomLine 466Mhz/1MB
ZIF
G3 Upgrades For Less!
ZIF & Daughtercards Available



\$399

MacTrell Firepower
Firewire ORB Drive



\$159

XLR8 ZIF Carrier Card



\$299

Mactell FirePower Drive
Firewire Drives 8Gb - 259GB



\$79.99

Microtech USB to SCSI
Now Shipping!



\$378.99

Cannon Multipass
C635 600dpi multi-printer



\$149

EvilEye
Voodoo 3 Card



\$489

Aurora Design Fuse



\$249

Epson 740 Printer
Color Inkjet



\$87.99

Interview USB
Video Capture
Device



\$969

Viewsonic P815
21 Inch Professional Monitor



\$99

64MB DIMM
5v. Fast-Page



\$109.99

Time For Ultra SCSI-3
with RAID software



\$189

Castelwood ORB
Removable Storage Drive

Super CDR/CDRW Deals!

- Teac CDR58s 8x/24x CDR Drive\$339.99
- Panasonic 4x/8x CDR Drive\$179.99
- LaCie USB CDRW 8x\$319.99

Superior RAM Deals!

- 128MB PC/SD100 168-PIN DIMM ..\$119.99
- 64MB PC/SD100 168-PIN DIMM\$51.98
- iMac PowerBook 128MB DIMM\$139.99
- iMac/PowerBook 64MB DIMM\$79.99
- Ultra2 80MB/sec SCSI Hard Drives
- Quantum Atlas IV 10krpm 9.1GB\$479
- Quantum Atlas IV 10krpm 18.2GB\$779

- Quantum Atlas IV 10krpm 36.4GB ..\$1399
- IBM Deskstar 20.2GB IDE ATA/66\$239
- IBM Ultrastar 18ES 9.1GB Ultra2.....\$359
- IBM Ultrastar 18ES 18.3GB Ultra2.....\$669
- Seagate Cheetah 9.1GB 10krpm\$499
- Western Digital 27.6GB IDE ATA/66.....\$339

G3 Daughter Card Upgrades

- Railgun G3 250Mhz\$199.99
- Railgun G3 266Mhz\$209.99
- Railgun G3 275Mhz\$249.99
- XLR8 G3 400Mhz/1MB 2-1\$619.99
- PowerLogix G3 233.....\$159.99

PowerLogix G4.....\$Call

- G3.ZIF Card Upgrades:
- Railgun G3 466Mhz/1MB 2-1\$599.99
- Railgun G3 333 ZIF.....\$199.99
- XLR8 G3 466Mhz/1MB\$699.99
- Newer G3 400Mhz/1MB 2-1\$619.99
- Digital Cameras/Scanners
- Nikon CoolPix 950\$899.99
- Olympus C-2000\$979.99
- Sony MVC-FD88\$879.99
- Sony DSC-D700.....\$1619.99
- Ag fa DuoScanSolo\$2383.99

Shipping: \$5, 5 lbs., UPS Ground Payment: No credit card surcharge. Corporate POs welcome. Tax: Texas residents add 8.25% sales tax. Prices: Items, prices and availability subject to change. Returns: Call for RMA number. Must be in original condition, opened software is non-refundable. All orders subject to a minimum 15% restocking fee. Original shipping is non-refundable. Apple brand products are not returnable for credit. Bottom Line Distribution cannot be responsible for errors in typography or photography. Apple specs subject to change. Customer Service: 512-485-4602. International Sales: Bottom Line Distribution is committed to the needs of international Macintosh users. We offer discounted rates with DHL. 2 to 3 day delivery to most countries. Dealer inquiries welcome. Language interpreters available. Address: 715 West 23rd St. Ste. N, Austin, TX 78705 Fax: 512-485-4601. Hours: MF 8-5T All Trademarks are the sole property of their respective owners.

Bottom Line Offers Business Leasing on all items we carry (orders over \$1000.00). Call today for details, or fill out a lease form online!

Save Big with iBid! ProDirect BEST BUY

www.pdisales.com HIGH PERFORMANCE SPECIALISTS

For The Best Prices on ProDirect Hard Drives Go To www.pdisales.com/merchant/harddrives.html

EASY ONLINE CATALOG FREE SHIPPING FOR ALL ONLINE ORDERS! 90 Day Performance Guarantee

Make Your Best Bid On ProDirect High Quality Memory! Any Price, Any Quantity!

Save Make a Bid! Save APPLE CERTIFIED + HIGHEST QUALITY MEMORY LIFETIME WARRANTY + 24 HOUR REPLACEMENT

Blue Yosemite G3 168 pin SDRAM Make a Bid! 32MB • 64MB • 128MB

Beige G3 Make a Bid! 168 pin SDRAM 32MB • 64MB • 128MB

iMac SODIMM Make a Bid! 32MB • 64MB • 128MB

7200-9600, 5400-6400 Make a Bid! 168 pin 5vDIMM 16MB • 32MB • 64MB

*Due to price volatility in the memory market, while we will do our best to match your price, we reserve the right to reject any bid.

www.pdisales.com/merchant/SCSI.html

ACCELERATOR CARDS

Adaptec ADAPTEC

PowerDomain 2940UW UP TO 40 MB/Sec \$235 Adaptec AHA2930U PCI to Ultra SCSI HD50 pin \$99

PowerDomain 3940 UP TO 40 MB/Sec \$345

PowerDomain 2940U2W Card Only \$299

Adaptec AHA2906 PCI to SCSI 2 HD50 pin \$65

ATTO ATTO

Express PCI \$389

Dual Channel Express PCI \$329

Express PCI Ultra2/LVD Dual Channel \$489

INITIO

Initio Miles UW \$175

Initio Speedway U2W \$299

Initio A100U2W PCI to Ultra 2/LVD \$299

UP TO 80 MB/Sec

TAPE BACKUP

www.pdisales.com/merchant/tape.html

DAT Storage

2 GB ST028000 60 MB/Min. 595 4 GB Sony 9000 DDS3 120 MB/Min. 835 40 GB Sony 10000 DDS4 120 MB/Min. 1355

DLT Tape Storage

40 GB DLT4000 180 MB/Min. 1979 70 GB DLT7000 600 MB/Min. 4489 280 GB DLT4700 180 MB/Min. 5575 980 GB DLT107114ST 180 MB/Min. 13899

AIT Storage

50 GB Sony SDX300c 6 MB/Sec. 2225 100 GB Sony SDX500c 6 MB/Sec. 3395

AIT autoloaders also available. call for details

RETROSPECT 4.0 MAC OR CHEVENE WINDOWS (NT) SOFTWARE INCLUDED WITH ALL TAPE DRIVES

DVD, CD/CDR

www.pdisales.com/merchant/dvd.html

www.pdisales.com/merchant/cd.html

Plexor Plexwriter 820 \$499

CDR Drive Software Included: Mac-Toast, PC-CD Creator

Toshiba 40x CD Drive XM401B \$139

Panasonic DVD RAM Drive External \$589

Yamaha CRW6416 CDR Drive 2MB Buffer 5x Recorder, 4x ReWritable, 16x Reader \$339

For The Best ProDirect CLOSEOUT SPECIALS

www.pdisales.com/merchant/closeouts.html

Seagate CHEETAH 9.1GB U2W \$495 18.2GB LP U2W \$765 36.4GB U2W \$1375

Seagate BARRACUDA 9.1GB U2W \$329 18.2GB LP U2W \$565 36.4GB U2W \$1045 50GB U2W \$1115

PowerStor Super Deals

Table with columns: Capacity, Brand, Price. Includes Seagate Medalist, Quantum Fireball, IBM DeskStar.

IBM ULTRASTAR 7200RPM 9.1GB U2W OR NARROW \$289 18.2GB U2W OR NARROW \$575 36.4GB U2W OR NARROW \$1085

IBM ULTRASTAR 10,000RPM 18.2GB U2W \$755 36.4GB U2W \$1365

IBM DESKSTAR GXP 9.1GB \$149 13.5GB \$179 18.0GB \$229 22.0GB \$279 27.3GB \$389 34.2GB \$449

IBM DESKSTAR GP 15.2GB \$159 16.8GB \$169 20.3GB \$219 25.0GB \$289 37.5GB \$449

www.pdisales.com/merchant/ValueDrives.html

RAID SYSTEMS Plug in an Ultra2 PowerRAID

For Maximum Data Transfer Rates. All PowerRAIDs are initialized, Speed Tuned, Tested and Bench Marked To Insure a True Plug and Save Reliability.

Table with columns: Capacity, Model, Fixed Price, Removable Price. Includes Seagate CHEETAH and BARRACUDA PowerRAIDs.

PowerRAID USA Multi-platform Windows 95/98/NT, Apple MacOS, UNIX

Service + Performance + Price + Always

ProDirect logo and contact information: 10830 Nesbitt Ave. South Bloomington, MN 55437

Quantum ATLAS 10K Ultra2 LVD 9.1GB \$419 18.2GB \$719 36.4GB \$1359

Quantum FIREBALL ATA 5400RPM 6.4GB \$105 10.2GB \$125 13.0GB \$145 20.4GB \$225

Quantum FIREBALL ATA 7200RPM 9.1GB \$135 13.6GB \$170 18.2GB \$230

Mac IDE Accelerator Power ULTRA33 \$129. Includes Dual Channel, Ultra IDE 33 MHz, Uses Apple Drivers.

Internal Dual Channel PowerRAIDs 18GB \$850 36GB \$995 72GB \$1595 108GB \$2395 136GB \$2795

DIGITAL VIDEO New Adaptec ULTRA HOT CONNECTION 8945. PROFESSIONAL QUALITY DIGITAL VIDEO PLUS ULTRA WIDE SCSI PORT

FREE Media 100 Training Video with any Media 100 or PowerRAID purchase

www.pdisales.com 800-524-9952. Quickly find and order it now on our website!

PRODUCT INDEX

Category	Page No.	Category	Page No.
Business Operations	176-178	Peripheral Products	179-180
Bar Code		Cables	
Inventory Management		CD Rom	
		Digital Media	
Communications/		Magnetic Media	
Networking	181	Printing Supplies	
Cross Platform		Services	197-199
		Data Recovery	
Education/		Digital Production	
Entertainment	176-178	Printing	
Discount Software		Repair	
		Systems & Peripherals	184-195
ISP	180-181		
Web Hosting		Account Manager:	
		Carol Johnstone.....415.243.3691	
Graphics	181	carol_johnstone@macworld.com	
		Account Manager:	
USB	182-184	Niki Stranz.....415.243.3664	
		niki_stranz@macworld.com	
Memory & Upgrades	193-196		
		Assistant:	
Digital Advertising Coordinator:		Alissa Mach.....415.243.3628	
production@macworld.com		alissa_mach@macworld.com	

FREE DEBT RELIEF!
 Lower your monthly payments by up to 50%!

Not a loan. Not bankruptcy. A Debt Management system designed to get you out of debt - FREE!
 Direct referral to Non-Profit credit counseling.

AMERIX CORPORATION
 www.amerix.com

FREE - CONFIDENTIAL - FAST
 Gather your bills and call today!

1-800-847-5869 Ext 4276

Mouse Pads

Great Desk Advertising
 Custom Printed
 Manufacturer Direct

MicroStore™ Inc.
 P.O. Box 125 • Le Sueur, MN 56058
 800-962-8885 Fax: 507-665-2604
 www.microstore-mousepads.com
 153 on card or www.macworld.com/getinfo

Call Us Toll Free 800-345-4220

Broadest Selection of Bar Code Products in the Industry

- Technically superior products direct from the manufacturer
- Toll free technical and pre-sale support
- 24-hour turnaround on repairs
- Free UPS Blue shipping in U.S.
- 30-day money back guarantee

- Portable & non-portable Batch Readers
- Cordless interactive R/F Terminals
- Wand, Laser, CCD, Magstripe or Slot Badge
- PostScript bar code fonts

or visit our website at **www.BARCODEHQ.COM**
 for a complete catalog and bar code primer

USD **WORTHINGTON**
 DATA SOLUTIONS Phone: 831-458-9938 • Fax: 831-458-9964

Create your own bar code graphics.

CALL FOR FREE DEMO

Bar Code Pro® v3.5 with Veribar®
 For guaranteed readability!

SNX www.snx.com Call 800 619-0299
 Tel 718 499-6293 Fax 718 768-3997

152 on card or www.macworld.com/getinfo

BAR CODE SOLUTIONS

UPC/EAN/ISBN
 Code 39
 Code 128
 Interleaved 2 of 5
 POSTNET/FIM
 And more!

Visit us online at:
www.bearrock.com

Bear Rock Offers:
 Free Expert Consultation,
 Lifetime Technical Support
 and Satisfaction Guaranteed
 on ALL Bar Coding products!

FREE Handbook
 "Bar Code Basics"
 A User's Guide to Bar Coding

Call Today for a FREE Consultation!
800 232-7625
 Intl: (530) 672-0244 Fax: (530) 672-1103

154 on card or www.macworld.com/getinfo

SAVINGS FOR STUDENTS, TEACHERS, & SCHOOLS

ACADEMIC DISCOUNT SUPERSTORE / UP TO 80% OFF

After Dark 4.0 Deluxe.....	\$45
Authorware 4.0.....	\$399
Auto F/X AutoEYE.....	\$75
Auto F/X Photo/Graphic Edges.....	\$119
Boris FX 4.0 for Premiere.....	\$479
Bryce 4.0.....	\$159
CADtools 2.0.....	\$159
Cakewalk Metro 4.0.....	\$139
Canoma 1.0.....	\$399
Canvas 6.0.....	\$199
CheckUp 1.5.....	\$145
Coda Finale 2000.....	\$249
Conflict Catcher 8.....	\$75
CorelDRAW 8.0.....	CALL
Cubase VST 4.1.....	\$199
DeBabelizer 3.0.....	\$275
DenebaCAD 1.5.....	\$269
Director 7.0.....	\$349
Dramatica Pro 3.0.....	\$209
EdgeWizard 2.0.....	\$75
ElectricImage 3D 2.9.....	\$739
Electrifier Pro.....	\$245
EndNote 3.0.....	\$105
FireWorks 2.0.....	\$99
Font Agent 2.7.....	\$59
Font Reserve 2.0.....	\$89
Form Z 3.0.....	\$899
FreeHand 8.0.....	\$99
Gemini PlugIn.....	\$159
Headline Studio 1.0.....	\$79
HomePage 3.0.....	\$59
InfiniD 4.5.....	\$299
IntelliHance 4.0 Pro.....	\$99
MAPublisher 3.5.....	\$125
MacDraft 4.3.....	\$145
MacDrive 98.....	\$39
MacLinkPlus 10.1 Deluxe.....	\$69
MagicMask 2.0.....	\$75
Mathematica 4.0.....	\$139
MiniCAD 8.01 Vectorworks.....	\$339
Mirage NY Scenery & Skylines.....	\$99
Myrmidon 2.1.....	\$39
Neal's Efix.....	\$49
NetObjects Fusion 3.0.....	\$99
NewTek Inspire 3D.....	\$299
Nisus Writer 5.1.3.....	\$79
Painter 6.....	\$229
Pantone ColorSuite.....	\$229
PhotoSpray.....	\$69
PhotoTools 3.0.....	\$79
Portfolio 4.0.....	\$109
Poser 4.0.....	\$179
PowerCad 4.0.....	\$399
RayDream Studio 5.0.....	\$229
SciFi Textures.....	\$125
ScriptThing 3.0.....	\$149
Scriptware 1.0.....	\$139
Strata StudioPro 2.5.....	\$449
Total Xaos.....	\$119
Virtual PC 2.1.....	\$159
Wacom Intuos 9x12 USB.....	\$399
WebPainter 3.0.....	\$55
WebSTAR 3.0.....	\$479
WebSpice 2,000,000.....	\$59
WordPerfect 3.5.1.....	Call
FLIGHTCHECK 3.6.....	\$199

FREE CATALOG 800-699-1836



Dreamweaver 2.0

Professional Web Site Design and Production

\$99



3D Suite 4.0

Includes:
Bryce 4
Poser 4
Painter 3D
Ray Dream Studio 5.5

\$629

FileMaker Pro 4.1

Powerful relational database software

\$139



Xenofex 1.0

16 Inspirational Effects to energize any graphics project

\$79



Wacom Intuos 6x8 USB

Intelligent graphics tablet system

\$285



Flash 4.0

Web Standard for Vector Graphics

\$99

LightWave 3D 6.0

*Model
*Animate
*Render

\$889



CodeWarrior Pro R5

Integrated Development Environment

\$119



Mask Pro 2.0

Professional precision masking and selection tool

\$149



Poser 4.0

3D Figure Design Tool

\$179

Mirage Design Studio NY Scenery & Skylines

Royalty-Free drumscanned photographic images
-35 mb
-CMYK JPEG's

\$99



Final Draft 5.0

Professional Screenwriting Software

\$149



Visit our website for...

K-12 software -Books -Videos -Free software contests -Secure ordering -and more...



Software ShowCase (800) 699-1836

417 Euclid Ave, Loch Arbour, NJ 07711
Phone# 732-660-8820 Fax# 732-660-8828



* Not responsible for typographical errors
* Prices subject to change

WWW.SOFTWARESHOWCASE.COM

Up to 80% OFF SOFTWARE
 For Students, Teachers, & Schools!

LightWave 3D 6.0 **\$799**
 Coda Finale 2000 \$249
 CodeWarrior Pro 5.0 \$119
 Dreamweaver 2.0 \$99
 Eudora Pro 4.2 \$35
 FileMaker Pro 4.1 \$119
 Flash 4.0 \$99
 Mathematica 4.0 \$139
 VectorWorks \$339

FREE Catalog!
(800) 568-6837
 Microsoft & Symantec Products also available
 (732) 223-8770 Fax# (732) 223-8768
 Email macuser@swoutlet.com
www.swoutlet.com

DESKTOPPUBLISHERS:
 I have an idea that will produce thousands of \$ for you monthly!
 Only \$29.95 Call for details:

Service STRATEGIES

888 331-3798
 Your satisfaction is 100% guaranteed!

POINT OF SALE • INVENTORY CONTROL

Software & Hardware for:

- Retail/Wholesale
- Mail Order
- Internet Commerce
- Rentals
- Service/Repair
- Manufacturing
- FileMaker Tools

Fully Integrated Accounting
 Multi-Site Polling • Cross Platform
 Barcode Readers • Receipt Printers
 Cash Drawers • Mag Stripe
 Ribbons/Paper/Labels
 Credit Card Authorization
 & Deposit Software

Now iMac compatible

www.posdirect.com
 (800) 622-7670 • sales@posdirect.com
 (618) 985-8237 vox • (618) 985-3014 fax

P.O.S. DIRECT
 Order Free CD Rom on Web Site

158 on card or www.macworld.com/getinfo

999software.com \$9.99

ALL software

- MASTERCOOK DELUXE
- TITANIC
- IMPERIALISM
- STUFFIT DELUXE 4.5
- FLASHBACK
- JOURNEYMAN PROJECT III
- RIVEN
- TOM CLANCY'S POLITIKA
- FLIPPER
- SCHOOLHOUSE ROCK AMERICA, SCIENCE, MATH ESSENTIALS
- CARMEN SAN DIEGO
- JUMP START
- MATH & READING BLASTER
- A.D.A.M. THE INSIDE STORY
- ISAAC ASIMOV ABOUT SPACE
- DR. SEUSS GREEN EGGS & HAM, ABC'S
- KID PIX STUDIO
- YOU DON'T KNOW JACK I, II, SPORTS, MOVIES
- STAR WARPED
- CREATURES
- DOGZ II
- CATZ
- P.A.W.S.
- HARD DAYS NIGHT
- THE BEAST WITHIN

over 500 titles on our web site
 800-818-5217 www.999software.com

ACADEMIC DISCOUNTS

Super Savings for Students, Teachers, and Schools!

Boris Effects \$399	ElectricImage \$639	Lightwave 3D \$29
Bryce 4 \$139	Filemaker Pro \$109	Minicad 8 Vectorworks \$329
Canoma \$369	Fireworks 2 \$98	Microsoft Office 98 Call!
Coda Finale 2000 \$199	Flash 4 \$98	Painter 6 \$209
CodeWarrior Pro 5 \$109	Form-Z \$849	Scriptware \$129
Director 7 \$329	Freehand 8 \$98	Wacom 6x8 Tablet \$284
DreamWeaver 2 \$98	Infini-D \$269	PC titles also available!

check out more products and prices on-line, 'cause this ad is too small! Call for Free Catalog!
1-800-333-8571
 Fax PO's and ID's to 512-450-0263
ACADEMIC DISCOUNT WAREHOUSE www.ADWonline.com

160 on card or www.macworld.com/getinfo

The MacaLIVE Store
www.macalive.com

MacTuner
 Global Media Receiver
 Tune In over 1600 World Wide LIVE Radio, TV & Scanner Stations

MacHeadlines
 Internet News Hound!
 Scrolling Ticker for the Mac Desktop. With MacHeadlines you can get...
 NEWS • SPORTS • STOCKS
 PLUS Anything else you want! Track your Favorite Sites by easily adding them to your Custom Preferences!

WeatherTracker
 Instant Forecasts on your Mac Desktop!
 Weather for over 8,000 Cities

Visit our Website & Try All 3 For FREE!
 © Copyright 1999 Trexar Technologies, Inc.

157 on card or www.macworld.com/getinfo

SMARTSCORE
 MUSIC-SCANNING SOFTWARE

Playback, transpose & print out sheet music in minutes.

- Fast & highly accurate (85-95%)
- Easy to learn - Easy to use
- Create complex scores from scratch
- Turn MIDI files into sheet music

SCAN SCORE SEQUENCE

WWW.SMARTSCORE.COM
WWW.MUSITEK.COM

Compatible w/ all MIDI software
 - Drives most every scanner

800-676-8055
MUSITEK
 Music Imaging Technologies

STUDENTS!

Save up to 75% OFF popular software!

STUDENT SOFTWARE GUIDE

Adobe
 Microsoft
 Kinethix
 Microsoft
 MetaCreations
 Macromedia
 Alias/Wavefront
 Softimage
 Autodesk
 Extensis
 Alien Skin
 Digimation
 Symantec
 Corel
 ADAM
 Wacom
 Many More!!

1-800-874-9001
www.JourneyEd.com

THOUSANDS OF TITLES AVAILABLE!
FREE CATALOG!

1-800-874-9001
JourneyEd
 JOURNEY EDUCATION MARKETING
www.JourneyEd.com

159 on card or www.macworld.com/getinfo

"THANKS TO THE MACWORLD SHOPPER SECTION OUR COMPANY HAS GROWN OVER 400% IN THE FEW SHORT MONTHS WE'VE ADVERTISED. AS A RESELLER OF HIGH-END QUALITY ERGONOMIC CHAIRS, I DEPEND ON MACWORLD TO HELP PUT ME IN TOUCH WITH EVERYONE FROM BANKERS TO MUSICIANS."

Jim McGaw
 Owner

www.sittingmachine.com



Aeron Chair
800-883-9697
www.sittingmachine.com

164 on card or www.macworld.com/getinfo

An Art Department's Best Friend



You Always Want It Back or Know Who It Belongs To.

Custom Imprinted Zip®, Jaz®, CD's for the same price you're paying now!

24 Hour Turnaround
No Minimums
All Related Accessories And More!

MYMARK ENTERPRISES
Custom Imprinted Media Storage & Accessories
1 877-2MYMARK

163 on card or www.macworld.com/getinfo

CD COPIER

NEW!

Fast **32X**

Records Music.
Easy to Use.



\$999

PRINCETON DISC from **800-426-0247**

www.princetondisc.com

EVERYTHING CD-R



www.amc-direct.com
877.867.8155
AD CODE: MW1199

166 on card or www.macworld.com/getinfo

Polaroid PDC-3000

★★★★★
Digital Camera

List \$2495
Our Price **\$799**

Limited Quantities
1-800-769-4049

"AS A LEADING DEVELOPER OF PC-TO-MAC CONNECTIVITY SOFTWARE, MIRAMAR SYSTEMS RELIES ON REACHING A CAPTIVE READERSHIP OF MAC OS-BASED BUYERS AND DECISION MAKERS. MACWORLD MAGAZINE'S SHOPPER SECTION HAS CONSISTENTLY OUT-PERFORMED OTHER MAC PUBLICATIONS THAT WE'VE ADVERTISED IN WITH HIGHER RECALL AND QUALITY LEADS. A LOT OF MAGAZINES TALK ABOUT THEIR 'VALUE ADD', BUT MACWORLD MAGAZINE TRULY DELIVERS."

Renee Cooper,
Director of Marketing,
Miramar Systems, Inc.
www.miramarsys.com

162 on card or www.macworld.com/getinfo



WHAT CAN YOUR INK JET PRODUCTS DO?

Guaranteed Compatible With

EPSON

www.Ink4Art.com

Check Out Our Daily Specials Online!
www.Ink4Art.com

EPSON, HP, Canon, & Lexmark Owners.
You'll Love This Paper!

Waterproof Photo Glossy!

100 pack..... **WOW** \$29.99

Standard Inks: Fits Epson Series
INK4ART BRAND CARTRIDGES
Black-400,440,600,640,700.....\$14.99
Black-740,800,860,1520.....\$15.99
3 Color all above models.....\$18.99
Photo Color Photo, Photo EX, 750,700.....\$18.99

Specialty Papers:
Paper Canvas 8.5 x 11"
10 pack.....\$9.99
100 pack.....\$49.99
17" x 22"
100 pack.....\$149.00
2 Sided Photo Quality Paper
500 pack.....\$49.99
T-Shirt Transfer Paper
10 pack.....\$8.99
100 pack.....\$49.99

Call About Our New Sublimation Inks

Organize your iMac
iStation
Organize your life!
Available in all iMac colors **\$18.95 ea.**

Check online for lowest pricing on cartridges for

Canon printers!

TOLL FREE
1-877-695-1477



165 on card or www.macworld.com/getinfo

WHAT DO YOU WANT YOUR SITE TO DO!

1 E-Commerce Solutions:

HostPro has turned e-commerce into easy commerce for anyone seeking to do business on the web, from the start-up entrepreneur to multi-national corporations.

ShopPlus • ShopSite Lite, Manager & Pro • Cart32
• CyberCash • PaymentNet • Card Services Intl.

2 Database Solutions 3 Multimedia Solutions 4 Platform Solutions

STANDARD FEATURES FOR ALL PACKAGES

- Your own domain name (www.yourdomain.com)
- Free domain name registration
- Both Unix and NT hosting
- 30 day money-back guarantee
- Full support for Microsoft® FrontPage 98® and 2000®
- Default e-mailing capability
- Web control panel for site administration
- Unlimited autoresponders
- Unlimited FTP (24 hours per day)
- Full custom CGI execution capability
- Java™, Javascript, Servlets, Perl, C, C++, SSI & Python
- Access to our vast CGI script library
- Excite® search engine
- Controllable anonymous FTP
- Daily detailed hit analysis
- Access to raw log files
- Daily complete tape backup
- Full-time un-interruptible battery backup
- Shockwave, Quicktime, Flash, Vivo, Emblaze & MP3
- Assistance w/script installation



Tech Support
24/7

Give your site maximum impact for minimal expense. You owe it to yourself to contact HostPro at:

1.888.638.5831
www.hostpro.net • sales@hostpro.net

HostPro
Your web hosting solution provider

THE WEBTECHS CHOICE	NET VALUE	\$ 19.95
	Standard features, plus:	• 60 MB of web space • 2,000 MB of traffic/month • 12 e-mail accounts
	NET NT	\$ 29.95
	Standard features, plus:	• 60 MB of web space, 2000 MB traffic/month, 12 e-mail accounts • ASP, ActiveX™, and VB script • Microsoft® Access and FoxPro database support • Microsoft® Active Server Pages • Microsoft® Visual InterDev and Visual Studio • Complete stat reports using WebTrends
NET PLUS	\$ 39.95	
Standard features, plus:	• 100 MB of web space, 3,000 MB traffic/month, 20 e-mail accounts • Advanced ShopPlus Cart (a \$500 value) • Shared secure socket layer (SSL) • PaymentNet and CyberCash™ • RealAudio® and RealVideo® & G2 • Microsoft® NetShow • mSQL and mySQL databases, Cron, PHP 3.0	
NET PRO	\$ 49.95	
Standard features, plus:	• 100 MB of web space, 3,000 MB traffic/month, 20 e-mail accounts • Advanced ShopPlus Cart (a \$500 value) • Shared secure socket layer (SSL) • PaymentNet and CyberCash™ • Gold Fusion 4.0 • ASP, ActiveX™, and VB script • Microsoft® Access and FoxPro database support • Microsoft® Visual InterDev and Visual Studio • Microsoft® Active Server Pages • RealAudio®, RealVideo® & G2 • Microsoft® NetShow • Complete stat reports using WebTrends	

Custom ULTRA-2 LVD SCSI Cables - Terminators - Cases

If you want Ultra SCSI Performance use our Teflon Cables & Active Terminators. Our knowledgeable SCSI Technicians will solve all your SCSI problems...guaranteed!

SCSIVue™ Active Terminator



Four models available with optional Remote LED Pak. These are the finest terminators available, they fix SCSI problems and improve reliability.
Benefits: • Improves SCSI Bus Performance • Less Errors; More Reliable Data Transfer • Diagnoses Problems • Analyzes Signal Quality
Features: • Active Regulation • Fast 50 & Fast Wide 68 • Status Indicators • Gold Contacts

Active 2-1 SCSI Switch / Repeater

Benefits: • Up to 14 Devices to 1 Computer • Share Devices Between 2 Computers
Features: • 2-1 Active Digital Switch/Repeater • Regenerates SCSI Signal for Long Runs

Gold Diagnostic Adapters

• Both 50 pin and 68 pin (all combinations)
• Gender Changer

Drive Bus Changer

From: \$49
• 68 Pin Drive to 50 Bus • 68 Pin Drive to 50 Pin IDC (runs wide drive as narrow)
• 68 Pin External Adapter to 50 Pin (converts Host Adapter)

68 Pin to 50 Pin Centronics or 50 Pin Micro Adapters

• 68 Pin to 50 Pin Centronics or 50 Pin Micro Adapters
• Styles: For Adapter, Ultra Wide Cards • Adapters with partial termination built in for 68 to 50 converters (converts Host Adapter)

SCSIVue™ Gold Diagnostic Cables



From: \$39
• No Loss of Important Data • Faster Performance • Test Cable Integrity
Features: • Diagnostic Indicators • Large Ferrite Filters • Triple Shielding (Unique Design) • Double Gold 20u" Plated Connectors • Extra Heavy 26 Gauge Wire • 100 Styles in Stock

Teflon™ 90 Ohm External Cables

From: \$159
• Ultra SCSI 40 MB/s operation • Fixes Ultra SCSI Cable Problems
Features: • Perfect 90 Ohm Impedance Match • Triple Pronged Connector With Gold contacts

Hot Swap Powered Terminator

From: \$69
Now you can safely remove any SCSI device from a SCSI chain by simply jacking a switch. The Hot Swap Powered Terminator also has an optional Power Supply so that it can supply termination power to portable setups or when termination power is not being supplied.

External Ultra SCSI Cases



From: \$99
• Ultra SCSI Custom Teflon Cable Available • Custom Enclosures in 1 Day for Raid & Array
• 1 Bay Tower • 2 Bay Tower

Temperature ALARM! Automatic Monitor & Control

14 & 29 Bay Ultra SCSI Towers
• Ultra LVD Cable Kit • Dual Redundant PS • Bay Coolers w/ Brk • Temp Alarm System

Bay Cooler Kit keeps those HOT Ultra SCSI Drives GOLD as Ice

From: \$999
Dual Fan & Bracket \$29

HOT SWAP Pull Out Bays

Compatible with all 50 pin & 68 pin SCSI Buses up to Fast SCSI 2. From: \$79

(LVD)-TFO Teflon™ Internal Cables



From: \$39
• Less Errors, Ultimate Performance • Silver Wire Improves Signal Quality
Features: • Perfect 90 or 132 Ohm Impedance • Custom in 1 Day • Triple Pronged Connector - Gold contacts Silver Wire

50 Pin Replacement Cable for Internal Drive Cables

From: \$99
• 50 Pin Replacement Cable for Internal Drive Cables • 68 Pin Replacement Cable for External Drive Cables

Active Digital SCSI Repeater

From: \$99
• Models for all SCSI types • Fixes SCSI Cable Problems • Doubles Cable Length (up to 18')

SCSI Cable Tester - LED Readout

From: \$39
This Digital SCSI Cable Tester can test all the popular cable styles for opens, shorts, and unreliable operation. Battery powered for easy use anywhere you need it. Three models to choose from:

- 50 pin IDC
- 50 pin Centronics
- 68 pin Micro

Granite Cables Are The Best Because They're Engineered Right.

Granite Cables were designed by SCSI Engineers to be the Best Cables On The Market. Everything about them means better performance and higher reliability. Our design incorporates an exclusive shield that protects the Acknowledge and Request lines from noise. Large Ferrite beads are installed on all cables to protect them from static and noise. Every cable incorporates a LED indicator that lets you know it is operating properly. We also use more GOLD on every cable. Add to this our impedance matching techniques and you have most of what makes us THE BEST!

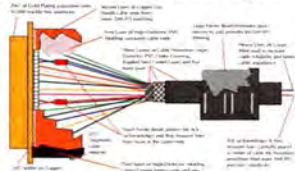

Granite
D+H+G+I+J+K+L

3101 Whipple Rd. Union City, CA. 94587 Ph: 510-471-6442 Fax 510-471-6267

FREE Technical Support!!!
Available to everyone, customer or not.

Digging for ideas?



Get
**FIRST
MONTH
FREE!**
(promo code:
macw-3489)

Bring your IDEAS to Life yourname.com

Fully loaded web site for \$20
/month*

- 50 MB disk space
- 2 GB traffic / month
- 10 mailboxes
- Frontpage™ server extensions
- web based control panel, web site statistics, etc.

NEW! Speciality Packages:

Media Site: featuring RealAudio®, RealVideo®, Flash™, Truespeech

Web Stores: One Stop Solutions for web store hosting, shopping carts, secure servers, credit card processing.

30 day money back guarantee!
24x7 toll-free tech support

For more details visit our web page or call toll free.



NetNation
Communications Inc.

www.netnation.com
1-888-277-0000
Int.: +1(604) 688-8946

Set up fees not included. Prices and features subject to change without notice.
All trademarks are the property of the respective owners.

CADMOVER® v.5.1

What good is a built in translator
if it doesn't work?

You've worked hard and now it's time to use those files in another program. You try to import them & all you get is garbage. Not with CADMOVER - For over ten years we've been helping people beat their deadlines, no redrawing, no touch-ups.

File formats: DWG, DXF, EPSF, PICT, CGM, IGES, HPGL, STL, MiniCAD, DDES2, etc... Internal Features: scaling, 2D/3D views, font mapping and more. With 16 decimal place accuracy redrawing is a thing of the past.

800-579-2244 • <http://www.kandusoftware.com/macworld>

KANDU
software corporation

170 on card or www.macworld.com/getinfo

Think Windows.

Think Macs.

Think network.

Think nightmare.

Think again.

PC MACLAN*

A.K.A. & PC MIGRATOR

Connect. Rename. Migrate.

The complete solution for all of your
Mac OS-to-Windows connectivity needs.

* Now includes MacOpener, the leading solution to open, read and write Mac media on a PC.

1-877-462-2272

www.miramarsys.com/products/olorder.htm



Miramar Systems

211 on card or www.macworld.com/getinfo

NEED A NEW ISP?

YOU'RE IN THE RIGHT PLACE!

Macworld
SHOPPER



iMate

UNIVERSAL ADB TO USB ADAPTER
Easily Connects Any ADB Device
To USB-Equipped iMac or PC Computer

The innovative iMate USB to ADB adapter allows users to easily connect their existing ADB peripherals to iMacs, Macs with USB cards, and PCs with USB. The iMate is compatible with any ADB device including mice, keyboards, trackballs, trackpads, hardware dongles, and AppleVision displays. Retail price \$39

80 Fesslers Lane • Nashville, TN 37210
615.255.0990



info@griffintechology.com
www.griffintechology.com

The gPort universal serial adapter is the perfect companion for your new blue G3 computer. Designed from the ground up with the G3 in mind it supports every serial device that works on your older Macs.



- Easy to install
- Economical
- Cost Effective

With the new G3s Apple has made a bold move to faster and more universal i/o interfaces. The gPort provides a great transition for people with existing serial equipment. Retail price \$49

gPort

THE SERIAL SOLUTION

STEALTH Serial Port

Connect Your Serial Peripherals to the Blue Power Macintosh G3 Compatible

- Functions like a standard Mac serial port, including LocalTalk, MIDI, all serial printers, modem, digital cameras, Palm Pilots & more!

Simple

- Installs in minutes
- Uses internal modem slot, keeps PCI slots open

Great Value

- Affordable **only \$49.95**

Requirements

- Blue Power Macintosh G3
- Open internal Modem slot

iMac Version Now Available

"You've got to love this kind of product: cool, simple, indispensable, and timely"
Guy Kawasaki

Macworld
www.geethree.com

GeeThree.com

261 Hamilton Avenue, Suite 311 • Palo Alto, California • 94301
telephone 650.328.2359 • fax 650.328.8092 • email info@geethree.com
173 on card or www.macworld.com/getinfo

macally™

Call us for dealers near you 1-800-644-1132
www.macally.com



USB Peripherals for Mac

NEW

macally
iSweet

Supports Keyboard boot-up

macally
iHub7

Macally is proud to bring you the latest USB peripherals for Mac users. iMousepro, iMouse, iBall, iStick, iHub, iHub7, iKey and iSweet are specifically designed to pair with your Mac. Improve your productivity with Macally USB peripherals.

All trademark or registered trademarks are the property of their respective owners

172 on card or www.macworld.com/getinfo

The Best Selling USB Serial Adapter is Now Even Better!



**Compatible with more Apple printers!
Prints up to 4 times faster!**

USB Twin Serial Adapter

Add 2 Mac serial ports to your USB Mac (\$79)
 • For use with tablets, modems, cameras and many printers
 • Get two ports for the price of the single port solutions!

NEW Digital Media Remote

USB remote control for PowerPoint, DVD, CD, & MP3 software players (\$79)

USB PDA Adapter

Connect Palm organizers to your USB Mac or Win98 PC (\$39)

USB 4-Port Hub

Connect more USB devices to your USB Mac (\$59)

Keyspan USB Card

Add 2 USB ports to your PCI PowerMac (\$39)

SX Pro Serial Card

Add 4 serial ports to your PCI PowerMac (\$179)



KEYSPAN www.keyspan.com
(510) 222-0131

175 on card or www.macworld.com/getinfo

Introducing **MoniSwitchUSB...**

The Easy-Switch

Now you can share your **monitor, mouse, keyboard & USB peripherals** between several Macs (and PCs) with Dr Bott's MoniSwitch. You'll save space, money and best of all, your sanity.

- Native support for Mac & PC monitors.
- Available for 2 or 4 computers.
- Includes all necessary USB and super premium video cables!
- PCI Mac Compatibility Kit available for Beige (non-USB) Macs.
- Lighted LED indicates selected computer at a glance.
- MoniSwitchADB also available.



**MoniSwitch
USB**

Dr. Bott OFF

Excellent opportunities for resellers!

info@drbott.com • www.drbott.com

Phone: (503) 452-8101 • Fax: (503) 892-2475

176 on card or www.macworld.com/getinfo

Introducing 4 new members
of the **iPeripherals**
family of products



iDock II

Add a floppy drive, an ADB, two Serial, **four** USB ports, and a swivel base to your iMac!!



mini-Geo

Add two Apple serial Geo ports to your new Mac's with our new USB-Serial adapter!



mini-ADB

Add two switchable ADB ports to your iMac with our new USB-ADB adapter!



gDock

Add two Serial and four USB ports to your new G3! Comes with built-in converter for a future Zip™ or Super Disk Drive.

www.compucable.com

800.344.6921

CompuCable

info@compucable.com

CompuCable Mfg. Group
210A McCormick Avenue • Costa Mesa, CA 92626

177 on card or www.macworld.com/getinfo



CONTOUR UniMouse
A Precision Mouse
for Precision Work...



For More Info on the UniMouse Visit:
www.contourdesign.com
or Call 1-800-462-6678

Adobe and Photoshop are registered trademarks of Adobe, Inc. All trademarks and registered trademarks are the property of their respective owners.

180 on card or www.macworld.com/getinfo

Ariston Technologies
iThink therefore iConnect™
1-800-326-5294

iSCSI USB-to-SCSI Cable
Use your existing SCSI devices with your iMac

iSerial USB-to-Serial Converter
Comes in 2 and 4-port models.

PCI to USB Card
Install into your desktop PC and connect USB peripherals.

iConnect 008, USB-to-Parallel Cable
For your old printers and other parallel devices.

4 and 7 Port Hubs
Connect additional USB devices... Ideal for keyboard, mouse, joystick, etc.

iSee
Ideal for teleconferencing, web sites, motion & still image capture & security monitoring.

iSee Digital Camera
Ideal for teleconferencing, web sites, motion & still image capture & security monitoring.

IRis 5-Lens Kit (3.6mm to 8mm lenses)
Match your iSee camera to any iMac color.

iView USB Capture Device
Portable motion picture and still image capture at your fingertips.

iRead USB Flash Card Reader / Writer
ForType II, Compact Flash & SmartMedia.

Hermes USB Gamepad
Rated #1 for USB gaming, compatible with Virtual Game Station from Connectix.

Podiki 2-button USB mouse
World's first for the Mac.

Ares USB Joystick
Winner Editor's Choice Award gibbed.com.

www.ariston.com
181 on card or www.macworld.com/getinfo

Infinity Micro™
800-589-1334



Think Sharp!

*Call us last with our best prices, and shop further with superior service and support!

<http://www.infinity-micro.com>

Int. (310) 470-9426, Toll free (800) 589-1234, Fax: (310) 470-4956
2289 Westwood Blvd. Los Angeles, CA. 90064 (Westwood & Pico)
email us at: Sales@infinity-micro.com

PowerMacs POWERBOOKS

G3/450 128/9GU2/CD "NEW"	2179	G3/400 64/6GB/DVD/56K/14.1"	2395
G3/400 128/12G/CD/ZIP "NEW"	2179	G3/300 64/8G/CD/56K/14.1"	2295
G3/400 64/6GB/DVD "NEW"	1779	G3/300 64/8G/DVD/56K/14.1"	2495
G3/350 64/6GB/CD "NEW"	CALL	G3/292 64/8G/20X/56K/14.1"	CALL
IMAC G3/233 32/4GB/24X/15"	879	G3/266 64/4G/20X/56K/14.1"	CALL
IMAC G3/266 / G3/333	CALL	G3/250 32/5G/20X/56K/13"	1495
G3/233 32/4GB/24XCD/15"BLTN	1349	G3/233 32/2G/20X/56K/14.1"	1795
G3/266DT 32/4GIG/24XCD*	CALL	G3/233 32/2G/20X/56K/12.1"	1395
G3/300MT 64/8GIG/24XCD/6MB*	CALL	G3/233 32/2G/20X/56K/12.1"	1295
G3/333MT 128/9GIG/24XCD*	CALL	3400C/240 16/3GB/12XCD*	CALL
G3/300MT 64/6GB/CD*	CALL	3400C/200 16/2GB/12XCD*	CALL
G3/350MT 64/6GB/DVD	CALL	3400C/180 16/1.3GB/8XCD*	CALL
G3/350MT 128/12G/CD/ZIP	CALL	1400C/133 16/1.3GB/8XCD*	CALL
G3/400MT 128/9GB/CD	CALL	E500C 16/1GIG	549
8600/300 64/4GIG/24XCD/Zip	CALL	E500CS 16/750	445
7300/200 32/2GIG/24XCD*	CALL	2400C/180 16/1.3GIG	CALL
7100/80 8/500/CD	299	32500/19.2MDM	395
6500/300 32/4GB/12XCD/56K/ZIP*	999	180 14/120/14.4 Fax*	99
6500/275 32/6GB/24XCD/56*	895		99
6500/250/32/4GB/12XCD/56K*	799		99
4400/200 32/2GB/CD*	599		99
7200/90 24/500/8XCD*	399		99
7200/120 32/1.2GB/CD*	479		99

APPLE PRINTERS

ColorStyleWriter 4500*	199
LaserWriter 12/640*	695
LaserWriter Color 12/660	1995
LaserWriter 8500 USED	1395

DIGITAL CAMERAS

SONY MAVICA FD91/FD73	905/472
SONY MAVICA FD88/FD71	847/631
AGFA EPHOTO 1680	576
AGFA EPHOTO CL30/CL50	CALL

APPLE MONITORS

Apple Studio Display 17"/21"	CALL
Apple Studio Display 15"	1095
Apple ColorSync 17"/20"	395/795*



VP140-2/E641-3	897/139
Q41/VPD-150	127/1095
VG150/L700	1067/1077
V5 / E655-3	152/165
Q51-2/E651-2	162/175
V55 / E655-3	CALL
Q53-2/G653-2/GA655	CALL
GA6555 KIT CAMERA	16595
GA6555 KIT PAL PILOT	11229
VPA-150/O73	1112/313
GF775/E773	401/312
PT775-3/G1775-2	457/349
PT771/PS775/V73	407/411/303
GT73-2/V75	323/326
E4771B/GA771/E771-2	CALL
Q71/VG180/PS790	CALL
PT795/E790B/G790	728/463/456
MB90/E790/V95	515/452/415
V1151/G810-2	968/802
P810-3/P815-3	878/987
MB110/V115-2	868/797
P817/P1813	1377/1063

EpsonStylus COLORPRO-XL 11x17

11x17, 4PPM, Prescription \$199.

Trade in your older Mac for a new G3!
Call us last with your best prices!

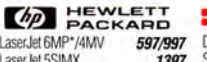

LaserJet 6MP/4MV	597/997
LaserJet 651MX	1397
LaserJet 2100M/2100TN	737/927
LaserJet 4000/4000TN	847/1297
LaserJet 4050M/4000	1297/1237
LaserJet 4050T/5000	1227/1387
LaserJet 5000N	1847
Expression 836XL	2079
LaserJet 8000	1877
LaserJet 8000DN	2989
LaserJet 8000N	2277
LaserJet 8100	2497
LaserJet 8100DN	3347
LaserJet 8100N	2827

EPSON

Epson Stylus 750/1520	249/449
Epson Stylus 3000	1095/789*
Epson Stylus 740/740i	239/269
Epson Stylus 850/850NE	269/449
Epson Stylus Pro-XL 11x17	199
Epson Stylus 900/900N	409/609
Photo 1200/700/750	CALL
TELEPORT 56K USB Mac	119
POWERPORT 56K PC/MCIA	149



DuoScan SOL/DuoScan T1200	2249/559
SnapScan 1212U/1236S	116/159
SnapScan 1236/600	CALL
SnapScan 2008 USB	117

EPSON

Expression 800 ART/EXE/PRO	679/589/899
Expression 836XL	2099
Perfection 636/636U	259/199

Specials

Battery for PB-G3 or 5300 series	39.
PowerBook 180 1/120/14.4	185
PowerBook 520C 12/240/19.2	385
PowerBook 540C 16/500/19.2	485
PowerBook 500 series 8MB Mem.	29
PowerBook G3 series battery	189
Magnavox 20" Color	395
Epson Stylus ProXL	249
Farallon Etherwave Adapter card	29
Cyrex Pentium 100MHz PC card	49
Radius full page monitor	49
Radius 20" Intellicolor	489
RasterOps 20" Black & white	185
ViewSonic G610 monitor	685
Portrait Pivot Display 17"	295
Apple Ext. Video connector	49
PerForma 640 12/500/CD	195
Apple Laser 16/600 220Volts	895
Mainctosh Centris Nubus Adap. card	79
PB Duo Floppy & Adapter	149

SOFTWARE

Adobe Photoshop ver. 5.0.2 MAC	CALL
Adobe Illustrator ver. 8.0 MAC	CALL
Adobe PageMaker PLUS ver. 6.5.2	CALL
Adobe After Effects V4.0 STD/PRO	CALL
Quark Express Ver. 4.0 MAC	789
Microsoft Office 98 POWERMAC	427
Microsoft Office GOLD POWERMAC	513
RASTEROPS*	CALL
SuperScan MC6415/MC6405	399/277
SuperScan MC6215/MC7515	CALL
SuperScan MC8115/MC801HR	887/697

"MACWORLD CONSISTENTLY
PRODUCES INQUIRIES
AND RESULTS!
NEW & REPEAT
CUSTOMERS ALL SAY:

"I SAW YOUR AD IN THE
MACWORLD SHOPPER."

KEEP UP THE GOOD WORK!"

DAVID ASH
OWNER
MACSOLUTIONS

WWW.MACSOLUTIONS.COM

MEGA MACS.COM

- MacOS 8.5 OEM \$39
- Norton Utilities 4.0 \$21
- 3Com Sportster 56K \$89
- IBM 4GB SCSI HD \$149
- Zip SCSI Internal \$69
- Visioneer Paperport \$89
- Gold 56K External \$75

We have over 100 Software Titles for \$9.99 ca.
918-664-MACS(6227)

All Prices reflect 3% Cash Discount

www.macworld.com/getinfo

www.kiwimac.com

Upgrades

Logic board upgrade prices are with exchange.

PowerMac 7200/120 to 7600/132mhz.....	\$399
Performa/Quadra 630 to 6200/75mhz.....	\$149
Performa/Quadra 630 to 6300/100mhz.....	\$299
Performa 5200 to 6500/225mhz.....	\$475
Performa 6300 & 6320 to 6500/225mhz.....	\$399
Performa 5200 to 5500/225mhz.....	\$475
Performa 5260 & 5300 to 5500/225mhz.....	\$399
Math Coprocessor for P630 & P575.....	\$49
G3 Processor Cards for PowerMac.....	See Website

Parts

Logic board prices are with exchange.

Performa 630 logic board.....	\$49
Performa 6200 logic board.....	\$149
PowerMac 7200/90mhz logic board.....	\$85
PowerMac 7200/120mhz logic board.....	\$125
Performa 630/6200/6300 power supply.....	\$49
Performa 6400/6500 power supply.....	\$49
1.44 internal floppy drive.....	\$25
Apple 3GB IDE internal hard drive.....	\$99
Apple 12x internal CD-ROM.....	\$85
Internal 56k modem for 6360, 6400, 6500.....	\$115

Memory

32mb 72 pin SIMM.....	SEE
64mb DIMM for 7200, 7500, 8500, 9500.....	WEBSITE
128mb DIMM for 7200, 7500, 8500, 9500.....	FOR
128mb SDRAM for Blue or Beige G3.....	MEMORY
128mb SDRAM for iMac & PowerBook G3.....	PRICES

Prices subject to change without notice.
VISA/Mastercard/American Express No Surcharge

1-800-334-5494

www.kiwimac.com
Kiwi Computers • Established 1988

MAC GLOBAL

SYSTEMS AND PERIPHERALS • SALES AND SERVICE

4750 ALMADEN EXPRESSWAY STE. # M • SAN JOSE, CA 95118

PowerMacs	Powerbook
G3 233 DT \$1175	520 4/160 \$325
G3 266 DT \$1375	520c 12/240/19.2 \$450
6100 8/500 \$225	540 12/240 \$375
7200 8/500 \$325	540c 12/320/19.2 \$575
7500 16/500 Call	5300cs 8/500 \$575
8500 16/1G Call	1400c.cs 117/133/166 Call
9500 32/2G Call	
Memory	Printers
4Mb 72-pin \$8	StylWrt. II \$175
8Mb 72-pin \$15	StylWrt. 1200 \$155
16Mb 72-pin \$30	Laser 300 \$299
32Mb 72-pin \$60	Laser 320 \$449
Monitors	Software
410/466/476 Call	Mac OS 8.1 \$15.99
580 5/500/CD Call	
631 8/500/CD Call	
6200 8/1G/CD \$399	
5200 8/500/CD \$699	
Quadrax	Monitors
630 8/250 Call	13" RGB \$89
650/800/840/950	14" Color \$149
	15" Appl. Mult. \$189
	17" Appl. Mult. \$315
	20" Apple Mult. \$550

TOP DOLLAR Paid for Memory, Powerbooks, and CPUs

1-800-722-8864

PHONE: 408-265-6653
FAX: 408-265-6660

WWW.GLOBALDEALS.COM

185 on card or www.macworld.com/getinfo

www.PowerBook1.com

Secure Online Ordering!

MCE POWERBOOK PRODUCTS

Your Source for PowerBook
Upgrades, Accessories and Solutions

newertech

FireWire 2 Go CardBus PC Card \$199
VIEWpower 1400 (16-bit Video out) \$239
BookEndz Dock 3400/G3 Series \$75/\$199

RATOC Systems

CBFW2 FireWire CardBus PC Card \$ please call
CB32PB UltraWide SCSI CardBus PC Card \$279
CB31PB UltraSCSI-II CardBus PC Card \$199

VST PRODUCTS

Zip Drive PB G3 Series/1400 \$199/\$209
Zip Drive PB 3400, G3, 5300, 190 \$219
Li-Ion Battery w/Charger PB 3400/G3 \$269
Li-Ion Battery w/Charger PB G3 Series \$269

Viking Components

PB G3 Series 64MB \$149	128MB \$239
PB G3 Original \$159	\$269
PB 3400 \$159	\$259
PB 2400 \$149	

48MB module for PB 1400 \$189

Kritter Video Camera
CapSure Card \$129
Kritter Cam \$239
640x480, 30fps

Video for PB G3 Series/G3/3400/2400!!
Kritter 2 Cam (Requires CapSure) \$149
Kritter 2/CapSure Bundle \$249
CapSure Pro Professional Video In/Out for PowerBook \$339

O'Grady's Macworld Best of Show Pick
for PB G3, 3400, 2400, 1400 & 2300
MadsonLine AC Adapter
Half the size/weight of Apple's 1400 adapter!
only \$35
Madsonline Auto Adapter only \$65
w/AirLine Plug only \$80

MCE ADB FlexLight
FREE
w/every order over \$300, or \$29 separately
Lights up your PowerBook!
Plugs into ADB Port.

MCE POWERBOOK PRODUCTS

MCE MobileStor

High Capacity Internal Drive Upgrade Solutions

MobileStor 6400 6.4GB 3yr wfy	\$249
MobileStor 10G 10GB 3yr wfy	\$399
MobileStor 14G 14GB 3yr wfy	\$599
MobileStor 6400SCSI 6.4GB 2yr wfy	\$399

For use in PB G3 Series, G3, 3400, 2400, 1400, 5300, 190, 150 & Duo 2300
For use in PB 500 Series, Duo 2XX Series, and PB 140 through 180c (except 150)

DataShuttle
PC Card Hard Drives
• Hot swappable • Powered by PC Card
• Comes in a handy carrying case!

14GB \$699	0GB Kit \$129
10GB \$499	(Perfect for your old internal PB drive!)
6GB \$349	

Xcaret and Xcaret Pro
Media Bay Hard Drives
Xcaret for PB G3, 3400, 5300, 190; Xcaret Pro for PB G3 Series 1998; Xcaret Pro-99 for PB G3 Series 1999

Your #1 Source for Complete PowerBook Storage Solutions!

30 Hughes Suite 203 • Irvine, CA • 92618
Visa / MC / AmEx / Discover / P.O.'s

1-800-5000-MAC • 949-458-0800 • fax 949-458-1803

184 on card or www.macworld.com/getinfo

think mac
LIQUIDATION
dealer destroyer
BLOWOUT SALE

- 3 Apple Macintosh Quadra 650 24/500/CD
w/Apple 14" Color Monitor
Keyboard and Mouse => \$499
 - 3 Apple Power Mac 61 or 7100/66 24/500/CD
w/Apple 14" Color Monitor
Keyboard and Mouse => \$749
 - 3 Apple Power Mac 7100/80 24/500/CD
w/Apple 14" Color Monitor
Keyboard and Mouse => \$999
 - 3 Apple Power Mac 7200/90 24/500/CD
w/Apple 14" Color Monitor
Keyboard and Mouse => \$999
 - 3 Apple Power Mac 7200/120 24/500/CD
w/Apple 14" Color Monitor
Keyboard and Mouse => \$1249
- (Individual Prices Also Available)
- dealer destroyer**
PRINTER SALE
- Apple Laserwriter IINT \$179
 - Apple Laserwriter IIF \$279
 - Apple Laserwriter IIG \$499
 - Apple Laserwriter Select 360 \$599
 - Apple Laserwriter Pro 630 \$699
 - Apple Color Laserwriter 12/660PS \$2799
 - Tektronix Color Phaser 340 \$2299

VISIT OUR NEW WEBSITE FOR OTHER
APPLE PRODUCTS AND DEALS AVAILABLE
WWW.THINKMACLIQUIDATION.COM
TOLL FREE 877-638-2822

SCHOOL AND GOV'T
PO'S ACCEPTED ALL MAJOR CREDIT
CARDS ACCEPTED

Where the price is right and the service is priceless
1035 Samsonite Blvd., Suite C • Murfreesboro, TN 37129
Ph: 615-904-1070 Fax: 615-890-1070

THE BEST IN
REMANUFACTURED
Macintosh
COMPUTERS & PARTS

Fall Specials!

- Complete Power Mac
Color System \$499!
WITH MONITOR AND KEYBOARD
- External CD-ROM \$ 59!
DRIVES STARTING AT
- PowerBooks \$249!
MANY MODELS AVAILABLE,
STARTING AT
- Modems \$ 19!
EXTERNAL, STARTING AT
- iMacs \$799!
STARTING AT

Pre-Owned
Electronics

1-800-274-5343

Offices: 781-778-4600
Fax: 781-778-4848

www.preowned.com
DIS0077

187 on card or www.macworld.com/getinfo

BUSINESS INDIVIDUAL EDUCATION

your complete
used **Mac** resource



Mac of All Trades takes the
fear out of buying and selling
used equipment.

- Mac-savvy advisors
- Fast turn on payments
- Custom configurations
- We accept POs
- Refurbished and tested...
- Guaranteed in writing!

800-304-4639

Direct: 404-355-5713
Fax: 404-355-5461
500 Bishop Street, Suite E-3
Atlanta, Georgia 30318



MAC
OF ALL
TRADES

macofalltrades.com

800-673-MACS

916-652-1880 FAX 916-652-1881 800-673-6227

www.poweron.com

Visit our Online Catalog

Apple PowerMacs

- PM6100 8/230 \$199
- PM7100 8/500 \$299

PowerMac 6400/180

- 16/1.2GB/CD \$499
 - 28.8 modem \$599
- G3 Upgradeable

Apple 17" Multiscan

- \$199
- Apple 15" MS \$149
- Apple 15AV MS \$179

Apple EPROM CD ROM Drives

- 2X \$39.99 Internal Drives
- 4X \$59.99 External
- 8X \$79.99 Add \$39
- 12X \$99.99
- 24X \$139.99

Power Macs

- PwrMac 6100-60 24/2G/CD (U) \$449
- 13" Mtr Key & Mse Upgradable to G3
- PM 7600-120 16/1.2G/CD (U) \$679
- Power PC 604 120Mhz Includes Ethernet

HDs & CDs

- 2GB SCSI \$129
- Apple EPROM
- 4GB SCSI \$199
- Apple EPROM
- 24X CD Mac BOOTABLE \$79

PM 6100/60 24/1.2G/CD Mouse (U)	329.00
PM 7100/80 24/1.2G/CD Mouse (U)	429.00
PM 6400/180 16/1.6G/CD Mouse (U)	499.00
PM 6400/200 16/2.4G/CD Mouse (U)	599.00
PM 8500/120 16/1.2G/CD Mouse (U)	699.00
PowerCurve 120 800 (U)	199.99
PowerCenter 120 16/1.2G/CD Mouse (U)	449.99
Motorola 4000/200 32/1.2G/CD K&M (U)	649.99
Quadra 605 8/230 Mouse (U)	79.99
Quadra 610 8/230 Mouse (U)	89.99
Quadra 630 8/230 Mouse (U)	89.99
Quadra 800 8/250 Mouse (U)	109.99
Quadra 950 8/250 Mouse (U)	129.99

ZIP/HD/CDROM Install Kits IN STOCK	
CD External Cases-SCSI cbl incl (N)	39.99
HD External Cases-SCSI cbl incl (N)	49.99
2 GB SCSI-Int 3.5" (P)	129.99
4 GB SCSI-Int 3.5" (P)	199.99
Apple Floppy Drives-Auto/Manual (N)	99.99

PowerBooks

- PB160 8/80/Modem (U) \$199
- 68030 25Mhz 1.44 FDHD 10" Supertwist LCD
- PB 160 12/120 batt, AC adapter (U) 249.99
- PB 540 20/240 batt, AC adapter (U) 449.99
- PB2300c 20/750 batt, AC adapt, Dock (U) 599.99
- PB5300c 32/1.1G batt, AC adapt (U) 699.99

Monitors

- Apple 13" RGB Display (U) 99.99
- Apple 14" M1212 Display (U) 119.99
- Apple 15" Multiscan Display (U) 149.00
- Apple 15" AV Multiscan Display (U) 179.00
- Apple 17" MS Display (U) 199.00
- Radius 20" Precisioncolor 20v (U) 299.99
- ATI MACH 64 4MB PCI (OEM) 59.99
- Voodoo Video Card (from TechWorks) 49.99
- NUBUS Video CardS (from) 29.99

Keyboard•Mice

- Tangerine USB Mouse (N) \$39
- Apple Mouse Great add on for Your new iBook!
- Apple Mouse I 22.99 JoyStick-MacAlly (N) 29.99
- Apple Mouse II 32.99 Gamepad-MacAlly 29.99
- Mouse, 1 button-N 16.50 Trackball-MacAlly 29.99
- Mouse, 2 button (N) 25.99 Apple ExtKybd II (U) 29.99
- Apple ExtKybd I (U) 25.99 Ext Keyboard (N) 29.99
- USB IKey Kybd(N) 39.99 USB iMouse (N) 29.99
- USB iHub (U) 49.99 USB iBall (N) 39.99

Networking

- Motorola Modem Surfer \$29.99
- E-TECH GOLD \$79
- External Modem Includes Cables 56K v.90 Data Fax Modem
- Global Village 28.8/33.6 Modem PCMCIA Modem Card \$59
- 33.6 flash upgradable
- 56K v90 GOLD Ext. Modem (N) 79.99
- Farallon Ethernet 10BT PCMCIA (U) 49.99
- 5Port Ethernet HUB 10BT (N) 49.99
- 8Port Ethernet HUB 10BT (N) 79.99
- 16Port Ethernet HUB 10BT (N) 129.99
- iHub USB 4Port (N) 49.99
- ...USB.....Ethernet.....FireWire.....

Norton Utilities 4.0 or Mac OS 8.1 \$29.99

WE BUY MACS
FAX TO 916-652-1881

PowerON
Computer Services

Mon-Fri 7-6, Sat 10-5
4323 Anthony Ct. #1 Rocklin, CA. 95677
E-Mail: Sales@poweron.com

- Discover
- MasterCard
- VISA

*All Sales Final. No Cash Refunds Given
*All Prices include 3% cash discount
*Prices subject to change without notice
Gov't & School PO's Accepted
All brand or product names are registered trademarks of their respective holders and are respectfully acknowledged.

MediaGuide

Your #1 Macintosh Source!

SHOP ONLINE!

Need a Mac?
Need stuff for your Mac?
We've got it.

NEW • USED • PARTS • RAM •
PERIPHERALS & TONS MORE

www.MediaGuide.com

OEM CDs:	Brand New
MacOS 8.5.....\$49	Sony 24x
Norton Util 4.0...\$29	CD-ROM
ClarisWorks 5....\$29	Int.....\$89
MacOS 8.1.....\$29	Ext...\$119

HOT Bundle specials! (CPU plus 13"14 monitor, kb/m)
Ili 8/425...\$179 • Ili 9/230...\$169 • Ili 8/425...\$199
Q650 16/425/CD...\$299 • Q630 20/250/CD...\$299
6100 24/350/CD...\$399 • 7100 40/425/CD...\$449
Many additional models available!

Apple 4.3 gig HD...\$149

Mac POWER

Sales & Service, Inc.
BUY • SELL • TRADE
UPGRADE • REPAIR
New • Used • Refurbished
• Powerbooks • Monitors
• PowerMacs • Printers
• Performas • Peripherals
• Quadras • Ram
• MacII-LC • Parts
www.macpowerinc.com

888-275-POWER

Fax: 408-448-6132
San Jose, California, 95123

USED MACS & POWERBOOKS

WANTED!

WE BUY USED MACS!

TOP \$\$\$ PAID



Any Quantity
FedEx check delivery
Fax a list for a quote
310 966-4433

11933 Wilshire Blvd.
W. Los Angeles, CA 90025

sales@macsolutions.com

(800)80-WE-BUY



Specializing in Rebuild Imagesetters

(714) 892-5290 Fax: (714) 892-4361

ALL MAKES & MODELS
Complete Prepress Systems

e-mail: prepress77@hotmail.com
Huntington Beach, California USA

SPOT COLOR SYSTEM INCLUDES: G3-MAC, Scanner, RIP, Imagesetter, Proof Printer, Processor & Software \$16,250	SAPHIR SCANNERS FACTORY REBURF: 1 yr. Wnty, Saphir, Saphir Ultra, Ultra 2, Hi-Res, Opal Lino-color from \$850	HARLEQUIN RIP Software, PS Level 3 MAC OS, WIN 95, WIN NT Compatible for most Imagesetters \$4,695	PROCESS COLOR SYSTEM INCLUDES: G3-MAC, Scanner, RIP, Imagesetter, Proof Printer, Processor & Software \$22,500	SILKSCREENING IMAGESETTER: Agfa or Linotype 18" wide Hi-Quality Film - Pos Separations \$15,000
PLATEMAKING SYSTEM Reburf-Digital Platemaking Imagesetter, PS RIP Processor, Densitometer, Calibration Software 150 LPI. From \$10,000	HOWTEK DRUM SCANNER D4000: 4000 dpi, 3.9 Dyn Range, 6 bit, CYMK, RGB, Factory Reburf, Desktop Size \$7,150	SCITEX DOLEV SCITEX DOLEV Drum Imagesetter: 200 - 2Up \$9,500 400 - 4Up \$18,000 800 - 8Up CALL	ECRM-NEW & REBURF MARLIN: 18" w/Punch & Harlequin RIP. NEW \$56K MAKO 4625: Best Priced New 18" Imagesetter w/ Harlequin SW RIP \$33,300	BEST OF THE REST Macintosh G3, PC Pentiums, All Prepress Software, File Servers, Networking Hubs & Switches, Color Proofing Printers & Match Print Equipment

MacWorks 800-482-2705

e-mail: sales@macworks.com

Voice 913.599.6227 • Fax 913.599.6111 • 8am-6pm Mon-Fri CST
Prices Subject to Change • Visa/MasterCard/AmEx
We ship FedEx • 15% minimum restocking fee on all returns

Apple/Motorola G3/333 MHz ZIF Processor Cards • 333/167 MHz, 1MB • Brand New, 2-Year Warranty • \$20 trade-in for your old (working) ZIF module • Upgrades G3 desktop/minitower • Upgrades PCI PowerMacs with an XLR8 CarrierZIF Card (buy G3/333 and CarrierZIF for only \$349.98) ONLY \$199⁹⁹	PowerMac G3/300 MT • 32/4GB/24xCD* • Used equipment • 30-day warranty *monitor, keyboard, mouse not included ONLY \$1699⁹⁹	PowerMac Bundles Includes monitor, keyboard, mouse, modem. Upgrade any bundled CD to a Sony 12x FREE! Add Color StyleWriter 2500 for only \$149! 7500/100 24/500/4x17" \$799⁹⁹ 6400/180 16/1.6GB/8x17" \$649⁹⁹ 7200/120 32/1.2GB/8x17" \$649⁹⁹ 7100/80 16/500/2x17" \$599⁹⁹ 7100/66 24/500/2x17" \$499⁹⁹ 6100/60 8/160/13" RGB** \$249⁹⁹ **Add a Sony 12xCD to this bundle for \$39.99	Performa 6400/180 • 16/1.6GB/8x/CD/28.8 • Upgrade to Sony 12xCD at no extra charge! • 30-day warranty ONLY \$479⁹⁹	RocketFire 6-Port FireWire Hub • Brand New, 1394a-Compliant • Mac & PC Hot-Pluggable • Data Transfer Rates up to 400 Mbps • 1-Year MacWorks Warranty ONLY \$399⁹⁹	
Sony 12x CD-ROM • New, Internal • Includes FWB • MacOS bootable • Uses Apple Mounting Kits (\$25) • 90-day warranty ONLY \$69⁹⁹	Apple Upgrades iMicro 8MB Ultimate Rez PCI \$79 ⁹⁹ ATI XClaim 3D 4MB PCI Video \$89 ⁹⁹ ATI XClaim VR 4MB VRAM \$49 ⁹⁹ Farallon 10bT Ethernet PCI (used) \$49 ⁹⁹ Apple 10bT Ethernet CS (used) \$39 ⁹⁹ 61xv DOS Card w/ Win 3.1 \$39 ⁹⁹ Apple CD300+ (2x internal) \$49 ⁹⁹ 6x CD-ROM for PB 3400 \$69 ⁹⁹ LapsColor Vid/Eth for PB 5300 \$69 ⁹⁹ PB Duo Replacement Keyboard \$69 ⁹⁹ PB Duo 14.4 Express Modem \$49 ⁹⁹	Parts/Accessories Replacement Logic Boards CALL Power Supplies CALL 3.6v Lithium Battery \$19⁹⁹ Internal Floppy Drives \$49⁹⁹/\$79⁹⁹ Apple Extended Keyboard \$39⁹⁹ Apple Design Keyboard \$19⁹⁹ Apple Desktop Bus Mouse II \$49⁹⁹ MacPower 2-Button Mouse \$29⁹⁹ Apple Microphones from \$9⁹⁹	Apple Monitors 17" MultiScan \$299⁹⁹ 17" AppleVision 1710iav \$299⁹⁹ 17" MultiScan 720 \$279⁹⁹ 14" Color Display \$99⁹⁹ 14" Color Plus Display \$89⁹⁹ 13" Hi-Res RGB \$79⁹⁹	Printer Accessories Color LW 250-Sheet Feeder \$99⁹⁹ LW 12/640 500-Sheet Feeder \$99⁹⁹ LW Select 500-Sheet Feeder \$99⁹⁹ LW Pro 6xx Envelope Feeder \$69⁹⁹ Personal LW 250-Sheet Feeder \$29⁹⁹ Color SW 2200 Batt. Attach. \$49⁹⁹ Color SW 2200 Battery \$19⁹⁹ Color SW 2200 Black Ink \$14⁹⁹ Color SW 2200 Color Ink \$14⁹⁹ Apple Color Printer Black Ink \$14⁹⁹ Apple Color Printer CMY Inks \$9⁹⁹ Color SW Pro Black Ink \$9⁹⁹	LaserWriter 8500 • 600dpi, 20ppm • 11x17, Ethernet • PostScript 3 • Used • 30-day warranty • No toner, add a new toner cartridge for \$199.99 ONLY \$999⁹⁹
Quantum Fireball 4.3GB SCSI • Manufacturer Refurbished • Internal SCSI Hard Drive • Quantum Model #ST43SD11 ONLY \$199⁹⁹	Apple GeoPort Adapter I \$199⁹⁹	Newton 120 2mb/modem \$179⁹⁹ 1mb software bundle \$139⁹⁹ 	Software Bargains Mac OS 8.1 CD-ROM \$49⁹⁹ ClarisWorks 5 OEM \$39⁹⁹ Norton Utilities 4.x OEM \$39⁹⁹ SmCity 2000 CD-ROM \$9⁹⁹	Color StyleWriter 2500 • Refurbished, New Ink • 90-day Warranty \$179⁹⁹	

www.macworks.com

The Lowest Finance Rate

Ultimate Scan-Station (Drum scan quality)

Get the Apple Blue G3/466MHZ or UMAX S900 G3/466MHZ Scan-station for only \$299 per month! It includes the fastest Mac yet, and it comes with all the hardware tools you need to blast through production work. Save a bundle with this exclusive package!

CERTIFIED REPAIR SERVICE CENTER
COMPUTER, MONITOR, LASER/PRINTER REPAIR, TONER REFILL, POWER SUPPLY, SHORT TERM RENTAL AVAILABLE.

PLUG&PLAY
\$299
PER MONTH



PowerMac G3/466 Mini-tower Ultimate Graphics Workstation

- **Apple Blue G3/466MHZ or UMAX S900 G3/466MHZ**
- Internal 32X CD-ROM
- **768MB RAM**
- 20 GB hard drive - AV /ATAPI
- Extended keyboard & Mouse
- **\$899** Mitsubishi Diamond Pro 21", 1800 x 1440 color monitor
- **\$189** ATI Rage 128 Graphic accelerator card, 1600x1200, w/16MB
- **\$5769** UMAX PowerLook3000 - 3000 dpi

- color scanner w/ Transparency
- **\$699** PowerLook3000 can scan negative, reflective, slides & 4X5 films
- **\$89** Binuscan PhotoPerfect can do professional color correction
- External combo drive w/ZIP, 9GB, CD-R
- Active SCSI terminator
- **\$89** UPS Battery Back-Up
- Image Solutions Extended Services



\$449!
JAZ+CD-R

COMBO Drives:

9GB + CD-R Ext. SCSI	\$699
JAZ + CD-R Ext. SCSI	\$449
JAZ+ZIP+9GB+CD-R	\$1089
18GB AV + JAZ + CD-R	\$1099
36GB AV RAID + CD-R	\$1989

Software Specials QuarkXpress4\$649

- Apple Mac OS 7.6/8/8.1/8.5 \$49/55/59/69
- Bryce3D/Poser3/Expression/RDStudio \$139
- Claris EMailer/DRAW/Calendar Maker \$69 ea.
- Claris Works V4.5/AppleWorks \$49/59/89
- Claris Impact/Organizer/HomePage \$69 each
- Caere OmniPage Pro V5/8/Direct\$89/189/29
- Director V5/6/6.5/Studio \$199/289/389/489
- DeBabelizer V3/ Dantz Retrospect4.1\$199/99
- Extensis MaskPro2/Portfolio \$199/109
- Extensis Preflight Pro/ PhotoFram \$269/89
- FileMaker Pro. V2.1/4/Server \$49/109/489
- Photographer V4/Freehand V5 Studio \$199 ea
- Infini-D V4.5/ KPT 3/Painter5 \$439/79/99
- Microsoft Office4.2.1/97/98 \$99/179/199
- MediaCleanerPro4/QuarkXpress4\$289/649
- Norton Utilities/Anti-Virus Bundle \$79 both
- StrataStudioProV2.5/ SoundEdit16 \$635/249

Basic Systems

	Buy!	Lease!
G3/350 128/12GB/24XCD w/17" monitor, XKeyboard, Mouse	\$1899	\$47
G3/400 128/20GB/ZIP/24XCD w/21" monitor, XKeyboard, Mouse	\$2699	\$74
G3/450 384/20GB/ZIP/24XCD w/ Mitsubishi 21", XKeyboard, Mouse	\$3999	\$119
PowerTowerPro -G3 333MHZ 96MB/9GB/CD w/19" monitor, XKeyboard, Mouse	\$2399	\$59
PM8100-Targa 2000/96/4GB/CD Video Edit. w/15" monitor, XKeyboard, Mouse	\$1599	\$44

PowerMac PM9600/G3 Video Editing Station

- PowerMac 9600 / G3 - 466MHz
- 256 MB RAM, 6 PCI Slots
- iXMicro UltimaRez 8MB display
- Internal 24 x CD-ROM
- Quantum Atlas II 9GB SCSI III hard drive
- Extended keyboard & Kensington Mouse
- Sony 17" color multisync monitor **\$9.99 a DAY!**
- JackHammer PCI SCSI III Differential
- 36GB RAID + JAZ + CD-R + ZIP COMBO Drive
- TrueVision Targa 2000 Pro Audio/Video Capture Editing PCI
- Epson 1200 Color Printer
- Premiere V5 & After Effect
- UMAX S1220 Scanner

PLUG&PLAY \$299 PER MONTH

Display & AV Card, XKeyboard

ATI Xclaim VR VideoEdit/ ATI RAGE 128 16MB \$99/289

Apple AV - In&Out -Exchange/Avid Cinema \$289/89

Targa 1000PCI / 2000 NuBus -Demo \$989*/\$489*

Targa 2000PCI / 2000PCI Pro - Demo \$1889*/\$2489*

Targa 2000 PCI RTX / SDX -Demo \$4489*/\$5889*

MiroDC30+/MotoDV/Targa Break out box* \$779/489*

XKeyboard w/Touch PAD / 56K Int. Module \$49/99

Apple Extended Keyboard\$139/\$89 (Japanese)

Kensington 2-Button Mouse / Turbo Mouse \$29/95

Apple USB Keyboard / 68-68 SCSI III Cable \$49/35

Super RAID- Atlas III or Barracuda SCSI III Fast & Wide, LVD

- AV Qualified High Performance Disk Array
- Low Voltage Differential Drive allows 12' SCSI Chain
- High Quality Construction. Gold Plated Connections.
- Features built in Cooling fan, SCSI ID, Metal frame.
- Grab handles of Removable drive for easy Plug in-out.
- Key locking door to prevent unwanted removal.
- Stripping software - REMUS for RAID 0,1 & 5. - \$149
- Adaptec 2940UW upto 80MB/sec. - \$335
- Adaptec 8945 FireWire & UltraWide SCSI - \$529
- JackHammer SCSI Fast&Wide Diff. \$399
- 16GB RAID - \$ 1189
- 36GB RAID - \$ 2089
- **54GB RAID - \$ 2989**
- 72GB RAID - \$ 3689
- **144GB RAID - \$ 7399**
- Add \$499 for Removable

Get M.S. Office 98 for \$199 w/ any drive purchase

\$99!

OFFICE

SCSI Ext. Case Half/ Full Height

\$29/49*

JAZ/ZIP, Hard DR. & CD.R Drives

	SCSI External	Turbo
400MB/1GB/2GB/3GB	\$89/139/179/199	+ \$29
4GB/6GB/9GB/18GB	\$229/269/299/699	+ \$29
Quantum Atlas II 4GB/9GB	\$279/469	+ \$39
Quantum Viking LVD 9GB/18GB	\$459/729	+ \$49
Quantum Atlas III 9GB/18GB	\$549/759	+ \$59
Seagate 4GB Hawk/Barracuda	\$249/279	+ \$39
Seagate 9GB Elite/Barracuda	\$299/469	+ \$39
Seagate Cheeta 4GB/9GB	\$449/569	+ \$49
Seagate 18GB Barracuda/Cheetah	\$769/989	+ \$59
Jaz ext. Dr. 1GB/2GB	\$219/\$339	+ \$29
Zip Dr. w/Cart. Int. / Ext.	\$109/\$125	+ \$29
Teac 8X/12X w/Toast	\$449	+ \$19
Ricoh CD-RW 4X/4X/20X w/Toast	\$329	+ \$29
Apple DVD-ROM Dr. w/MPEG Decoder	\$399	+ \$29
ORB 2GB /DVD-RAM 5.2GB SCSI	\$195/\$699	+ \$39

QuarkXpress V4.0.4

\$649

Close-Out Specials

MAC IICX/ II/PF405 as low as \$169

PM 6116CD 16MB/1GB/CDS\$389

PM 7200 16MB/1GB/CD \$489

PM 6500 32MB/3GB/CD \$849

PM 9500 32MB/1GB/CD \$889

8GB F&W Disk Array \$689

SyQuest 270/200MB Ext. Drive\$249/199

Fujitsu 230MB MO / WANG DAT \$199 ea.

SONY 650MB/1.3GB M.O. Dr. \$589/989

Apple Japanese/Chinese Language Kit\$89

Illustrator V6/PageMaker V6 \$199 ea.

M.S. WIN95/98/Project 98 \$69/99/289

M.S. Words V5/V6/98 \$89/189/269

Philips 2X/4X CD-R Dr. only

\$199!

USB Drive - 6GB \$199

12GB/20GB \$299/399

Processor Upgrade

604E 180/200	\$99/189
UMAX 2nd -250MHZ \$249	
G3 300/333	\$349/389
G3 366/400	\$589/689

JAZ Int. Dr. \$199!

\$69*!

IOMEGA CARTRIDGES

iomEGA

1.0GB Jaz \$69*

100MB Zip \$9*

\$9*!

\$59! 32MB

Memory

30/72 Pin	168 pin	G3
8MB	\$29	\$25
16MB	\$45	\$39
32MB	\$79	\$69
64MB	-	\$119
128MB	-	\$299
256MB	-	\$429

KINGSTON, VIKING, NEWER TECH. AVAILABLE

Tape Ext. Drive

SDT-2000/4000	\$389/489
SDT-5000 - 8GB\$589	
SDT-7000 - 8GB\$789	
SDT-9000-24GB \$869	
DLT 30GB	\$1189
DLT 40GB	\$1389

800-352-3420

Fax: 310-782-5974
E-Mail: Imagesol4U@AOL.com
http://www.imagesolutions4U.com
385 Van Ness Ave. #110 - Torrance, CA 90501

Order from 7 to 6 weekdays, Saturday from 10 to 12. Visit our showroom 9 to 6 weekdays, weekends by appointment.
Prices subject to change without notice. Not responsible for typographical errors. 24 hour replacement limited to products in stock.

Image Solutions
The solution provider for print shops, service bureaus and imaging professionals

Special Savings on Reconditioned Macs from DataTech

POWERMAC 7300

\$699

7300/180
16/2G/CD

POWERMACS*
8100/110 32/2G/CD \$499
9500/132 32/2G/CD \$699
8600/200 32/2G/CD \$899

RAM SPECIALS
32MB 168 pin DIMM... \$45
64MB 168 pin DIMM... \$85
32MB for PB 3400 \$50

*All CPUs include mouse

POWERBOOK

3400c/180
16/1.3G/CD

\$999

Add 32MB RAM \$50
Leather Carrying Case \$29



MONITORS

AppleVision
1710 Display



21" Radius
PrecisionView \$399
ThunderPower 30/1920
PCI Video Card \$149

• Other products available • 6-month warranty
• We buy used equipment • VISA & MasterCard accepted

TO ORDER CALL

1-800-281-3661

DataTech
REMARKETING, INC.

Tel: 615-860-4422
Fax-On-Demand: 615-860-0109
Fax: 615-860-0390
Web: www.datatech-rmt.com
471 Myatt Dr., Madison, TN 37115

Corporate names and trademarks are the property of their respective owners.

voice: 925-689-9488 fax: 925-689-9487

PRICES & QUANTITIES SUBJECT TO CHANGE

Place Your Orders OnLine!

www.macresq.com • MacResQ • 1-888-447-3728

Toll Free

Monitors

Apple CPUs

- PM 6100's.....from . \$99
- PM 7100's.....\$199
- Perf. 6200/75's.....\$299
- PM 7200/90's.....\$399
- PM 7500/100's.....\$599
- BEIGE G3's.....from . \$1499

External SCSI
hard drive cases



\$29

- Comes w/ scsi cable & power cable
- Will fit standard 1/3 height drives
- NEW! 90 day warranty!

DEALS OF THE MONTH!



New! G3/233 PowerBooks

32/2 Gig/20xCD/14.1" LCD

\$1799

add a 56k modem for \$100!

\$599

PM 5260/100
(603e, 100mhz)
16/800/4XCD
14" Display
w/kybd & mouse



- Magnavox 14"\$99
- Apple 14" Color Plus.....\$99
- Apple 15" Multi-scan.....\$149
- Qume 17" Multi-scan.....\$199
- AppleVision 720 (17")\$299
- Apple ColorSync 17"\$399
- Radius Prec. View 21"\$499

Hard Drives & Apple CD Roms

- Apple 500mb.....\$79
- 1.2 Gig SCSI.....\$99
- 2.1 Gig SCSI.....\$129
- 4.3 Gig SCSI.....\$169
- Apple 2 Gig IDE.....\$199
- 10.2 Gig IDE.....\$199

Software Specials

- Norton 4.0.....\$29
- Mac OS 7.6 w/ Claris 4.0.....\$29
- Mac OS 8.1.....\$29
- ClarisWorks 5.0.....\$29

Floppies & Power Supplies

- Floppies: 661-0474 (auto) \$49
- 661-0121 (manual) \$59
- 661-1651 (PB 100 ser.) \$89
- 661-0994 (PB 500 ser.) \$99
- 661-1390 (G3; 5 volt) \$59
- Power Supplies: call for price & availability
- *some models require exchg.

Miscellaneous items

- ixMicro UltimateRez 8mb PCI card.....\$79
- Apple 6100 DOS cards.....\$29
- 3JTech 56k modems.....\$99



15% re-stocking fee- ALL ITEMS REFURBISHED UNLESS NOTED AS NEW • All Parts Sold With a 90 Day MacResQ Exchange Warranty • Exch. Required for SOME Power Supplies • All Major Credit Cards With NO Surcharge. • 194 on card or www.macworld.com/getinfo



1.800.472.4921
Fax: (310) 445-6611
Tel: (310) 445-6600
FAX TOLL FREE/JAPAN: 00-31-114211
Los Angeles CA 90064

INNOVATIVE COMPUTER & NETWORKING, INC.

Upgrade your PowerMac

To G3 450 MHz From \$385

MONITORS

- APPLE Studio 21"\$1439
- APPLE Multiple Scan 20"\$499*
- APPLE Studio 17"\$479
- APPLE Vision ColorSync 17" ... \$349*
- APPLE Vision 750 17"\$239*
- APPLE Multiple Scan 720 17" . \$199*
- APPLE Multiple Scan 15"\$99*



PRINTERS

- APPLE LaserWriter 8500\$999*
- APPLE LaserWriter 16/600\$879*
- APPLE LaserWriter 12/640PS\$799*
- APPLE LaserWriter INTX\$149*

Apple CD-ROM & DVD Drives

- APPLE SCSI CD-ROM Drive 4xCD\$39
- APPLE SCSI CD-ROM Drive 12xCD\$79

POWER MACS

RECONDITIONED

- G3 333IMAC (32MB/6GB/24XCD/MOD/KB)\$1229
- G3 333IMAC (32MB/6GB/24XCD/MOD/KB)(Tang)\$1095
- G3 450M (128MB/UW9GB/24XCD/KB)\$2729
- G3 400M (128MB/12GB/24XCD/KB/ZIP)\$2259
- G3 400M (64MB/6GB/DVD/KB)\$1849
- G3 350M (64MB/6GB/24XCD/KB)\$1489
- G3 266Mhz 32/6GB/CD/KB\$1299*
- G3 233Mhz 32/4GB/CD/KB\$1199*
- 9600 300Mhz 64/4GB/CD/VC/KB \$1899*
- 9600 400Mhz 64/4GB/CD/VC/KB \$2099*
- 9600 200Mhz 64/4GB/CD/VC/KB \$1799*
- 9500 180 MP 32/2GB/CD/VC/KB . \$969*
- 9500 132Mhz 32/1GB/CD/VC/KB . \$829*
- 8600 300 Mhz 32/4GB/CD/KB .. \$1449*
- 8600 200 Mhz 32/2GB/CD/KB\$1099*
- 8500 180Mhz 32/2GB/CD/KB\$879*
- 8500 120Mhz 32/1GB/CD/KB\$649*
- 7600 120 Mhz 16/1GB/CD/KB . \$599*
- 7500 100 Mhz 16/1GB/CD/KB . \$499*
- 7300 180 Mhz 16/2GB/CD/KB . \$849*
- 7200 120 Mhz 16/1GB/CD/KB\$399*
- 7200 90Mhz 8/500MB/CD/KB\$349*
- 6500 275Mhz 32/4GB/CD/KB/MOD\$869*
- 6500 250Mhz 32/4GB/CD/KB/MOD\$729*
- 6500 225Mhz 32/3GB/CD/KB\$669*
- 4400 200Mhz 32/2GB/CD/KB\$599*



POWERBOOKS & DUOS

RECONDITIONED

- G3 400Mhz 64/6GB/DVD/14.1"A/ETH/56K ... \$3395
- G3 333Mhz 64/4GB/24xCD/14.1"A/ETH/56K . \$2389
- G3 300Mhz 64/8GB/CD/14.1"A/ETH/56K\$2495*
- G3 250Mhz 64/4GB/CD/13.1"A/ETH/56K\$1795*
- G3 233Mhz 32/2GB/CD/14.1"A/ETH/56K\$1495*
- 3400c 240Mhz 16/3GB/12XCD/Modem/ETH ... \$1379
- 3400c 200Mhz 16/2GB/6XCD/Modem/ETH ... \$1269
- 3400c 180Mhz 16/1GB/6XCD . \$1149
- 1400c 133Mhz 16/1GB/8xCD . \$1099
- 1400cs 117Mhz 12/750HD .. \$899*
- 520c 33Mhz 4/160/Modem \$439*
- 170 25Mhz 4/40/Modem\$199*
- 5300ce 117Mhz 32/1GB\$629
- 5300c 100Mhz 16/750MB\$569
- 540c 33Mhz 8MB/320MB/Modem\$469
- DUO 2300c 100Mhz 20MB/1GB/Modem\$599
- DUO 280c 33Mhz 4MB/120/Modem\$199*
- DUO 270c 33Mhz 4MB/120/Modem\$199*



POWERMACS (NUBUS)

RECONDITIONED

- 8100 110Mhz 16/1GB/CD ... \$579
- 8100 100Mhz 16/700MB/CD . \$445
- 8100 80Mhz 16/500MB/CD ... \$379
- 7100 80Mhz 8/250MB/CD ... \$239



Prices Subject to Change Without Notice • All Prices reflect 3% Cash Discount • * Refurbished ICN Is Not An Authorized Apple Dealer • All Trademarks Are Property Of Their Respective Companies.

www.icni.com

CALL THE MAC EXPERTS!

Your one-stop source for everything Macintosh.® Friendly help and expert advice is our specialty!
Call for the absolute lowest prices and immediate delivery on over **30,000 Mac® products!**

Commercial-quality video has never been so easy!

Filming and editing commercial-quality video just got a whole lot easier. With a professional Canon camera (package price includes the Elura), a 21" Apple Display®, Final Cut Pro software, FireWire cables and expert advice from your PowerMax consultant, and you're set to produce video like you never thought possible!

Only **\$3,599- or just \$137 per month**
Add an extra 20Gb FireWire drive for only \$469

Apple Studio Display Sale!

17" **\$349**
21" **\$1149**

FREE 32 MB RAM INSTALLED IN EVERY NEW MACINTOSH PURCHASED!*

Serving Northwest Mac users for over 20 years

Call the Hard Drive Experts!

1.2 Gb Apple-Logo Quantum	Internal	\$99	\$149
Four Gb IBM-mfr. with Apple ROMs!	Internal	\$159	\$199
Nine Gb Quantum Wide Differential	Internal	\$249	\$Call
Ten Gb USB External Hard Drive	External	\$269	
Panasonic 4x8 CDR Recorder	External	\$314	
Orb 2.2 Gb External Removable Drive	External	\$195	
Newer Technology external USB ice blue floppy	External	\$88	

Call the System Experts!

These are just a few of the pre-owned and refurbished Macs we have as of press time. See our web site for complete descriptions and the latest list.

- Professionally bench-tested Macs at low, low pricing.
- New models available every day.
- Our used and refurbished Macs often offer better expansion, price/performance and upgradability.
- Upgrade to a 4 gb. drive on any used Mac for only \$139!*

7100/80 16/500/CD	\$239	PowerBook 5300C/100	\$569
6220/75 16/1 G16/CD	\$299	New 4400/200 32/2 Gb	\$599
6320/120 32/1 G16/CD	\$319	S900/200 6 slot PCI 64/4	\$988
6360/160 16/1.5/7/CD	\$388	333 MHz iMac	\$8lowout!
7200/90 8/500/CD	\$419	Ref G3 266 DTop 32/4/CD	\$1439
8100/100 16/500/CD	\$488	Ref Pwbk G3-300 64/8/DVD S2488	
Powerlower 601/120 104/2...	\$588	We keep Platinum Towers in stock!	

Call the Display Experts!

MITSUBISHI DISPLAY PRODUCTS
Innovation On Display.

Model DS70 17" 28mm Display\$288
Model DS90E 19" 25mm Display\$509
Model DPlus100E 21" 28mm Disp .\$.966

Now for a limited time only, buy the highest quality displays possible at huge, huge savings.
The PLUS 17 features a 75hz .25mm Trinitron® tube with a maximum resolution of 1600x1280. This is simply the best-looking 17" (16" v.) display we've ever sold! The 20" display (19" v.) features a trinitron tube also made with Sony's legendary quality — we bought up huge volumes of both models and are passing the savings on to you. Complete with Mac-ready cables and adapters, a five year warranty and our satisfaction guarantee: if the monitor isn't just right, we'll replace it for you!

17" **\$349**
20" **\$488**

NOKIA 21" Display Sale

The Nokia 445XiPlus is an enhanced version of the award winning 445Xi, 21" (19.69 VIS) .22mm dot pitch color monitor. With an impressive 88 Hz refresh rate at a super sharp 1600 x 1200 resolution, the 445XiPlus is perfect for demanding business and technical applications. Nokia includes advanced features such as static and dynamic focus for superb corner to corner picture clarity, Nokia FullScreen™ technology to eliminate the black border which causes eyestrain, an easy-to-use menu with extensive adjustment choices and a dual-input feature for convenient switching between two CPUs.

~~\$1299~~
\$849

TradeUp with PowerMax!

We'll take your Mac OS computer in trade toward the purchase of new product. Call one of our expert Mac consultants for full details!

Visit YOUR SYSTEM 9 HEADQUARTERS!

Call us for the best deals and latest updates

Want more? How about PhotoSho 5.5 for only \$388? Or Microsoft Office 98 for only \$249? Or an NEC 15" Display w/speakers for only \$149? We have great deals on lots more stuff! Call Today!

EPSON 17x22 printers \$1520 \$268
#3000 **\$888**
Factory refurbished units

Call for great discounts on the latest USB Epson & H.P. printers!

POWER MAX

Knowledge is Power

800-613-2072
Local: (503) 624-1827 • Fax (503) 624-1635
email: sales@powermax.com

Prices subject to change without notice. Prices reflect cash discount. Credit card orders strictly verified against fraudulent use. With use of credit card as payment customer acknowledges that some products are subject to final sale. Many prices are limited to stock on hand. All brand or product names are registered trademarks of their respective holders.
* Some restrictions apply. iBook is not included in promotion. Call for complete details.

Apple Authorized Reseller

• Personal Financing • Fast P.O. Approvals
• Business Leasing • Extended Warranties

DISCOVER NOVUS VISA MASTERCARD

WANT THE BEST MAC DEALS? ASK A USER GROUP MEMBER HOW EASY IT IS!



Only Macintosh User Group members enjoy access to a very special Apple-sponsored web site featuring super discounts on great new products, factory refurbished and discontinued Macs, and much more! Not a member? Find out how you can get these great deals by calling PowerMax at 800-689-8191.

www.applemugstore.com

MUG STORE
Apple Specialist

The MUG Store. A cooperative venture between Apple and PowerMax to bring MUG members exclusive deals on the latest Mac® products and special offers on discontinued and factory refurbished computers.

PowerMax is a division of Computer Stores NW, Corvallis, OR.

SHREVE Systems

For all this and more check out our website!

<http://www.shrevesystems.com>



WE BUY MACS & MAC STUFF (318) 424-9791
WE STOCK MAC PARTS!
1-800-227-3971

FAX (318) 424.9771 • Technical Support (318) 424.7987
 Customer Service (318) 424.9791 • Purchasing/Information (318) 424.9791
 1200 Marshall Street • Shreveport, Louisiana 71101

Newton 130
 • ARM 610 RISC processor at 20 MHz
 • Back-Lit LCD display
 • FREE W/ PURCHASE
 • Newton Fax Modem
 & Leather Newton Carry Case
 Lid not included **\$179**

PowerMac 6500/275
 • 32MB of RAM
 • 4GB Hard Drive
 • 12X CD-ROM
 • 275-MHz PowerPC 603e
 • Refurbished
PowerPC \$849
IN STOCK!

PowerBook 5300cs
 • Supports ext. video
 • 24MB RAM
 • 750 Hard Drive
 • 100-MHz 603e
 • Dual-scan color
 • Refurbished
FREE! Carrying Case!
\$599

Macintosh LC580
Internet Ready! \$399
 • 33-MHz MC68LC040
 • 8MB of RAM
 • 800MB Hard Drive
 • 28.8 Motorola Modem
NEW! Last Change Blowout!
\$499 with internal 4XCD

PowerMac Upgrades
Quadra/Centris 610 to PowerMac 6100/60 (refurbished)
As low as \$199!
 with exchange of your working board

Quadra/Centris 650 to PowerMac 7100/80 Upgrade (refurbished)
As low as \$199!
 with exchange of your working board

Quadra 800/840av to PowerMac 8100/80 (refurbished)
As low as \$249!
 with exchange of your working board

PowerMac 7200 to PowerMac 8500/132 (refurbished)
As low as \$399!
 with exchange of your working board

Performa 6200/75 120-MHz Upgrade (refurbished)
As low as \$299!
 with exchange of your working board

6500/225
 • 32 MB RAM
 • 2 GB hard drive
 • 12x CD Rom drive
\$649
 Factory Refurbished

TI MicroLaser Pro E ONLY!
 • 600 dpi
 • 12 ppm
 • APPLE TALK
 • toner included
\$599

G3 Logic Board No Processor
 • 8MB of RAM
 • 68040 33-MHz
 • 5 Nubus Slots
\$349
NEW!

MACINTOSH LOGIC BOARDS

G3 logic board, No Processor, No ROM	\$399.
7200/90 logic board, refurbished	\$299.
LC logic board, refurbished	\$49.
LC II logic board, refurbished	\$149.
Mac LCIII logic board, refurbished, exchange	\$199.
Performa 630, No Processor, refurbished	\$99.
8500 logic board, exchange	\$449.
9500 logic board, exchange	\$649.
Quadra 950 logic board, refurbished	\$199.

PRINTERS

Apple 11x17 Color Inkjet Printer NEW, #M9500	\$249.
Apple StyleWriter 1200, refurbished	\$149.
Apple StyleWriter 1500, factory refurbished	\$179.
Apple Color StyleWriter 2400, refurbished	\$179.
LaserWriter 8500 (tabloid, fast engine) refurbished	\$1349.
LaserWriter IIx, refurbished w/ Toner	\$199.
LaserWriter III w/5MB RAM, refurbished	\$549.
LaserWriter IIg w/5MB RAM, refurbished	\$649.
Texas Instruments Micro Laser Pro E NEW	\$599.
NEC SilentWriter 1765, 17ppm! NEW	\$899.

Laser toner cartridges sold separately

Color LaserWriter 12/600PS
 • 600-dpi
 • 12 ppm
 • Color Photograde
 • LocalTalk, Ethernet
 • Mac, DOS, Unix or Windows
 • Toner included
Refurbished \$1299

PowerMac CPU SALE!

4400/200 32/2GB/CD \$679 refurbished	6500/250 32/4GB/CD \$749 refurbished
9500/120 16/1GB/4X \$999 refurbished	7250/120 32/2GB/8XCD \$729 NEW!
8500/132 0/0/0 \$599 refurbished	6500/300 64/4GB/CD/Zip/56k \$1049 refurbished

REFURBISHED POWERBOOKS

540c 12MB/320MB/ Color Active-matrix	\$599
PowerBook 5300cs 24MB/750/56k modem	\$699
G3 250 32/4GB/CD/56k, 13.3" TFT	\$1699
PowerBook 3400c/240 16MB/3GB/12XCD, Color Active-matrix	\$1499
PowerBook 1400cs 16MB/1GB/6XCD, Active-matrix color	\$1099

VIDEO CARDS
 ATI XClaimVR RAGE II 2MB with FREE TV Option \$149.
 E-Machines DoubleColor SX Nubus Card NEW \$49.
 RasterOps 24MX NEW, 24-bit Nubus \$149.
 Supermac 8.24 PDQ Plus, 24-bit Nubus card \$449.
 *PowerMac HPV Card (1MB) \$79.
 *PowerMac A/V Card (2MB) \$199.

MONITORS
 AppleVision 850 Display, refurbished \$849.
 Apple 14" A/V NEW \$249.
 Apple 14" Multiscan, refurbished \$149.
 Apple 15" Multiscan, refurbished \$229.
 Apple 15" AV, factory refurbished \$279.
 Apple MultiScan 17", refurbished \$249.
 Apple 20" Multiscan, refurbished \$699.
 Radius IntelliColor20a, factory refurbished \$999.
 Voxon 14" Multiscan NEW \$129.
 Voxon 15" Multiscan NEW \$199.
 Radius Color Pivot LE, refurbished \$199.

APPLE PC COMPATIBILITY CARDS
 Pentium 100-MHz, refurbished \$149.
 Pentium 166-MHz, 12" PCI card, refurbished \$299.
 586 100-MHz, 7" PCI card, refurbished \$99.
 486 66-MHz for 6100 series, NEW \$29.
FREE PC CD pack with PC Card Purchase!
NUBUS ADAPTERS
 Quadra 660AV NuBus Adapter \$79.
 Quadra 610 NuBus Adapter \$79.
 IIsi NuBus adapter with math co-processor \$69.
IMAGING PRODUCTS
 Apple QuickTake 200 refurbished \$219.
 Apple QuickTake 150 refurbished \$199.
 Apple QuickTake 100 refurbished \$129.

Save A Mac Foundation

MacAly Extended Keyboard
NEW! \$19

NEW 7200/75 LOGIC BOARD ONLY \$79
Logic Board Blowout!!
 IIfx logic board, refurbished \$49.
 Centris 650 logic board, refurbished \$99.
 Quadra 800 logic board, *refurbished no processor \$99.
 Quadra 840AV logic board, *refurbished no processor \$99.
 Quadra 900 logic board, *refurbished no processor \$99.
 Performa 630 logic board, *refurbished no processor \$99.
 PowerBook 520 logic board, refurbished \$99.
 PowerBook 540 logic board, refurbished \$99.

PB 3400/G3 Laptop Batteries
\$69!

1.44 SuperDrives
STARTING AT \$49!
NEW!
NO EXCHANGE REQUIRED!

\$39
 Genuine Apple ADB Mouse II **NEW!**
XClaim VR with FREE XClaim TV! NEW OEM \$149
 • 3D RAGE II, 2MB VRAM

\$39!
ClarisWorks 4 Internet Edition NEW!
FREE Claris HomePage!

QuickTake Cameras Refurbished
STARTING AT \$129!!

*Products are refurbished unless indicated as "new". Prices reflect a 2% cash discount and are subject to change without notice. Returns are subject to a 15% restocking fee. Not responsible for typographical errors. All trade-ins MUST BE in working condition. Refurbished systems may include like-new components and may also include cosmetic blemishes which do not functionally impair performance of the hardware.

SERVING MAC USERS SINCE 1987

Authorized Dealer **MacBYTE**

WE'LL BUY YOUR USED MACS NOW!

PC100	for Blue & White Yosemite G3	64 mb \$ 76 128 mb \$ 144
DIMMs	for 7273/7500, 85/9600, 95/9600	64 mb \$ 115 128 mb \$ 210
iMac RAM		64 mb \$ 74 128 mb \$ 131

www.computeraddict.com

800-432-2983
1024 Harding Ave., #203, Venice, CA
Fax: 310/448-4494

Mac Pro Systems & Software
Since 1988

Buy • Sell • Trade • Upgrade • Repair
New • Used • Refurbished

Small Ad Lowest Prices

Any Ad is a Mac Pro Ad
Check out our Wholesale Specials @
www.mac-pro.com

800-525-3888
fax: **408-369-1205**

188 on card or www.macworld.com/getinfo

Tomorrow's technology is available today at Computer Revelations!



Computer Revelations Inc.
1.800.275.9924 NYS 516.737.0800

Sales, Networks, Internet & everything in between!
331E Dante Ct. Holbrook NY 11741

190 on card or www.macworld.com/getinfo

"Macworld Shopper positions us in a marketplace where we can give readers and web-surfers the best buying and selling options possible."

Michael Snyder, President
The Computer Exchange
www.macofalltrades.com

TRADE YOUR MAC FOR A NEW ONE. We Pay Top \$\$\$ For Your Mac & Mem.
CALL FOR UPGRADES
Email: cgn@cgnusa.com

BUY•SELL•TRADE (310) 441-4771

PowerMacs	Powerbooks	Upgrades	Demo Macs	Storage	Parts
G3 400 Mhz 128/12gb 2190 G3 350 Mhz64/6gb/CD 1490 G3 300 Mhz 64/4/CD 1390 G3 233 MT 64/4GB 1230 9600 300 MHz 1690 G3 350 MT 1350 7200 16/500 299	G3 400 Mhz DVD 3190 G3 333 Mhz CD 2370 G3 266 Mhz CD 1890 G3 233 Mhz CD 1495 G3 250 Mhz CD 1695 PB 233 32/4/CD 1550	Same day Upgrade No down Time!! PB 3400 to PB G3 250 599 7200 to 7600 395 8100 to 8500 429 7500 to G3 250 Mhz 390 CALL for G3 Updgs !!! Perf 63xx to 6500 225 399 9600 to G3 400Mhz Call Q 610/660 to 6100 169 Q800-840 to 8100 249 Call for PowerBook Upg. Call for Upgrades not listed	8500 32-1gb-cd 695 7600 32-500-cd 595 7200 16/500/cd 325 9600 200 1490 7300 200/16/1/CD 799 G3 233 16/4/CD 1099 9600 300 1775 Quad. 610 \$ 79	CD 2X-4X-12X-24X Call CD Recod. Yamaha 4x2x6 435 Yamaha 4x4x16 299 Yamaha 4x6x24 Call Exchange ON : Logic Boards, Power Supply Call	Floppy 1.44 45 POWER SUPPLIES CALL AV Card \$150 Power supply Cx Ci 7100 35 Call for Logic Boards & more
Call for G3 Units G3 266 Mhz 1280 7200 /75/90/120 CALL Call for config. not listed	Demo Powerbooks Call For G3 Demo PBs 5400 12/320/Mod 480 5300c 16/750 549 520 -170 -180c-165c CALL PB 1400 16/1/CD 845	Special Quadra 610 \$ 79 Quadra 630 \$ 199	Call For: Monitors, Printers, Scanners. All Apple Parts In Stock and We do Advance exchange. Leasing Available.	Computer Graphics & Networking All prices Reflect cash Discount Visa, Mastercard, Amex Accepted << Prices are subject to Change.>>	

TEL: 310-441-4771 10922 W. Pico Blvd. Los Angeles, CA 90064 Fax: **310-441-4770**

197 on card or www.macworld.com/getinfo

1-800-533-9005 We are open Mon-Sat, 9am-6pm

Fax Bids: (310) 475-7744 or email at SALES@COMPU-AMERICA.COM
10435 Santa Monica Blvd., Los Angeles, CA 90025

Check out our Web!
WWW.COMPU-AMERICA.COM

Government, University and Fortune 1000 P.O.'s are welcome!
Business Leasing is Available!
International Orders Please call tel: (310) 446-1771

POWERMACS!	WORKGROUP SERVERS	NEW G3 POWERBOOK!	ViewSonic®	EPSON™	intuos
Starting at \$599 G3/450MT... 128/9GW/24XCD... 2599 G3/400MT... 128/12GIG/24XCD/ZIP... 2199 G3/400MT... 64/4GIG/DVD... 1769 G3/350MT... 64/6GIG/24XCD... 1399 G3/400MT... 128/9GW/24XCD/SCSI... 2099 G3/350MT... 128/12G/24XCD/ZIP... CALL G3/350MT... 64/6GIG/DVD... CALL G3/300MT... 64/4GIG/24XCD... CALL G3/333MT... 128/9GW/24X... 2099* G3/300MT... 64/4GIG/24XCD... CALL G3/266MT... 128/4GW/24X... 1599* G3/266MT... 32/6GIG/24X/ZIP... 1499* G3/266MT... 32/4GIG/24XCD... 1399* G3/233MT... 32/4GIG/24X/MODEM... 1299* G3/300MT... 32/4GIG/24XCD... 1499* 9600/300... 64/4GIG/24XCD/ZIP... CALL 9600/300... 64/4GIG/24X/ZIP... CALL 9600/200... 32/4GIG/24XCD... CALL 6500/300... 32/4GIG/24XCD/FAX... CALL 6500/250... 32/4GIG/24XCD/FAX... CALL 4400/200... 32/2GIG/CD/DOS CARD... 699	Starting at \$899 I-MAC G3/233 32/4G/24XCD/56K... 899* I-MAC G3/266 32/6G/24XCD/56K/BLUE... 999 I-MAC G3/266 32/6G/24XCD/56K/LIME... 999 I-MAC G3/266 32/6G/24XCD/56K/STRAW... 999 I-MAC G3/333 32/6G/24XCD/56K... 1079	Starting at \$1099 CALL FOR NEW POWERBOOK I-DOCK IN STOCK G3/233... 32/2G/20K/12.1STN/56K... CALL G3/250... 32/4G/20K/13.1TFT/56K... CALL G3/233... 32/2G/20K/14.1TFT/56K... CALL G3/266... 64/4G/20K/14.1TFT/56K... CALL G3/300... 64/8G/20K/14.1TFT/56K... CALL G3/300... 64/8G/DVD/14.1TFT/56K... 2299 G3/333(NEW)64/4G/24X/14.1TFT/56K... 2299 G3/400(NEW) 64/6G/DVD/14.1TFT/56K/3199	Starting at \$134 Q41 14".....129 051/053 15".....159/169 071/0100.....229/549 E771.....239 V73/V75 17.....319/379 V95/V115.....499/849 G771/G773.....329/349 G1775/G1790.....479/479 P775/P777/P777.....499/549/549 G810/P810.....779/829 P1813/P815.....899/849 P817.....1199 VIEWSONIC VWPA VPA138.....CALL VIEWSONIC VWPA VPA 145.....749 VIEWSONIC VWPA VPA 150.....CALL VIEWSONIC VWPA VPA 180 18".....CALL	Starting at \$199 STYLUS COLOR 700/850.....229/259 STYLUS COLOR 740/740I/750.....229/259/279 STYLUS COLOR Photo-1200.....CALL STYLUS PRO-XL.....199* STYLUS COLOR 1520.....449 STYLUS COLOR 3000.....799*/1099 EXPRESSION/636/ARTI.....CALL EXPRESSION/636/PRO.....CALL	Starting at \$99 INTUOS 4 X 5 (USB).....99 INTUOS 6 X 8.....299 INTUOS 9 X 12.....399 INTUOS 12 X 12.....CALL
	Starting at \$599 3400C/240... 16/3G/CD/MOD... 1299* 3400C/200... 16/2G/CD/MOD... 1199* 3400C/180... 16/1G/CD/MOD... 1099* 1400C/166... 16/2G/CD... 1099* 1400C/166... 16/2G/CD... 999* 1400C/133... 16/1G/CD... 999* 1400C/133... 16/1G/CD... 999* 5300CE/117... 16/TGIG/14.4MODEM... 599* 5300CS/100... 8/500.....499*	Starting at \$199 Sony 110G5/210G5.....199/369 Sony 220G5/420G5/520G5.....399/599/899 Sony 200P5/400P5/500P5.....499/699/999 Sony F-400/F-500.....CALL Sony L-150.....CALL Sony PRESENTATION W7000/W9000.....CALL Sony MAVICA FDS1/FD71/FD91.....469/649/899	Starting at \$99 4000N/4000TN.....1099/1199 2100M/2100TN.....729/899 6MP.....599*	Starting at \$99 UMAX VISTA Astra 610S-P.....99 VISTA Astra 1200/1220.....149/159 VISTA Astra 2000U USB.....129 VISTA Astra 2400S.....299 POWERLOOK II.....799	Starting at \$79 iomega ZIP DRIVE 100 MB EXT (SCSI).....99 ZIP DRIVE 100 MB INT(G-3).....99 JAZZ DRIVE 2 GIG EXT/INT.....119 JAZZ DRIVE 2 GIG EXT/INT.....299/299 ZIP 100MB CART (10 PACK).....85 JAZZ CART 1 GIG.....79 JAZZ CART 2 GIG.....79

YOUR #1 COMPUTER SUPERSTORE!

newer technology VST Seagate Quantum GCC RASTEROPS AGFA Tektronix NEC

All prices are cash discounted. ** denotes a refurbished product. Not responsible for typos. Apple, the Apple logo, GeoPort, HyperCard, ImageWriter, LaserWriter, Mac, Mac OS logo, Macintosh, MessagePad, Newton, OpenDoc, PowerMacintosh, PowerBook, QuickTake, QuickTime, QuickTime logo and StyleWriter are trademarks of Apple Computer, Inc., registered in the U.S. and other countries. All other names & logos are trademarks by their respective owners. We are Not Apple Authorized.

MEMORY

The Best Memory Prices & Guarantee
800-662-7466

Secure online ordering: datamem.com
 Lifetime Memory Replacement Guarantee
 DMS will meet or beat anyone's price!



MEMORY UPGRADES FOR
 Computers • Printers
 Notebooks • Digital Cameras



- Accelerators & CPU Upgrades
- Hard Drives & CD-ROM Drives
- Modems for Mac & PCs
- Monitors-Std. color to Pro Mods.
- UMAX Color Scanners
- EPSON Stylus Color Printers
- Networking Connection Prods.

Pentium® Computer System Specials
 USB Scanners/Printers & Accessories



DMS ACCEPTS GOVERNMENT, EDUCATIONAL & CORPORATE P.O.s WITH PRIOR APPROVAL
 FAX P.O.s 24 HOURS TO DMS @ 603.898.6585
 Open M-F 9a.m. 'til 9p.m.

201 on card or www.macworld.com/getinfo

WHY IS THE COMPETITION SHAKING?

BECAUSE
1-800-4-MEMORY
 IS HERE

WE CAN BEAT

ANY QUOTED PRICE ON ANY
 MEMORY FOR ANY COMPUTER
 (NOTEBOOK, DESKTOP,
 PRINTERS) ANYWHERE ...
 PERIOD!

- LIFETIME WARRANTY
- FREE TECH SUPPORT
- NO CREDIT CARD SURCHARGE
- MOST ORDERS SHIPPED SAME DAY

CALL AROUND
THEN CALL US

CHECK OUR WEB SITE FOR SPECIALS
WWW.18004MEMORY.COM

MEMORY SPECIALISTS



Serving the Mac Users
 memory needs since 1991.
 We sell only NEW, Grade A,
 Full Apple Spec RAM

800-307-3434

Fax 775-823-9200
 5301 Longley Lane, Reno, NV 89511
www.tahoeperipherals.com

200 on card or www.macworld.com/getinfo



www.macworld.com/getinfo

MEMORY MADNESS

The LLB Company, Inc.
1-800-848-8967

DIMMs \$152	128MB
POWERMAC G3 PC66-10NS	
32MB 4x64.....\$35	
64MB 8x64.....\$80	
128MB 16x64.....\$152	
256MB 32x64.....\$325	
\$169	64MB
8x64x60EDO 3.3V	
16MB 2x64.....\$49	
32MB 4x64.....\$78	
64MB 8x64.....\$169	
\$120	64MB
8x64x60EDO 5V	
16MB 2x64.....\$40	
32MB 4x64.....\$62	
64MB 8x64.....\$120	

DIMMs \$84	64MB
NEW POWERMAC G3 8X64-8 (PC100-8NS)	
64MB 8x64.....\$84	
128MB 16x64.....\$159	
256MB 32x64.....\$375	
\$62	32MB
168-PIN FPM DIMM	
32MB 4x64.....\$62	
64MB 8x64.....\$120	
128MB 16x64.....\$275	
SIMMs \$55	32MB
72-PIN SIMM	
8MB 2x32.....\$21	
16MB 4x32.....\$29	
32MB 8x32.....\$55	

FROM THE LLB COMPANY

IOMEGA	
Zip Drive	*119
Zip Drive USB	*151
ZIP 100 disk	*10
ZIP 100 disks -3-pk	*28
ZIP 100 disks -10-pk	*89
Jaz 1GB disk	*89
Jaz 1GB disks - 5-pk	*405
Jaz 1GB disks - 20-pk	*1524

NEWER TECHNOLOGY

For the PowerMac 6100 Series	
Maxpowr G3 240/266MHz/1MB Cache	*397
NEW For the PowerMac 7500/8500/ Etc.	
Maxpowr G3 400MHz/1MB Cache	*726
Maxpowr G3 466MHz/1MB Cache	*949
NEW For the PowerMac G3 Series	
Maxpowr G3 366MHz/1MB Cache	*615
Maxpowr G3 400MHz/1MB Cache	*679
Maxpowr G3 466MHz/1MB Cache	*817

Powerbook

WALL ST./iMAC		iBOOK		PB 500 SERIES		PB3400 G3	
128MB	*138	128MB	*169	32MB	*120	128MB	*235
64MB	*69	64MB	*70	16MB	*62	64MB	*160
32MB	*36	32MB	*35	8MB	*45	32MB	*94
16MB	*29			4MB	*40	16MB	*83
PB 3400 SERIES		PB 5300 SERIES		PB1400 SERIES		PB 2400 SERIES	
128MB	*235	48MB	*189	48MB Kit	*189	64MB	*135
96MB	*180	32MB	*133	24MB	*102	32MB	*95
64MB	*164	16MB	*60	16MB	*69	24MB	*80
32MB	*68	8MB	*55	8MB	*52	16MB	*75

COMPARE OUR LOW SHIPPING RATES

E-Mail: sales@llb.com
 PO's accepted upon approval
 No surcharge on credit cards
 • Returns subject to restocking fee
 • Prices subject to change, not responsible for errors
 • International orders welcome
 Mail PO's to:
 2513 152nd Avenue N.E.
 Redmond, WA 98052

DESKTOP/MINITOWER

iMAC 233 32/4GB/24X CD/56K	*999
iMAC 333 32/6GB/24X CD/56K	*1179
G3/300 (MT) 64/6GB/24X CD	*1537
G3/350 (MT) 64/6GB/DVD	*1976
G3/400 (MT) 128/9GB/24X	*2882

POWERBOOKS

G3/333 64/4GB/20X14.1 TFT	*2424
G3/400 64/8GB/20X14.1 TFT	*3399
G3/300 64/8GB/20X/14.1 TFT	*2999

www.llb.com International:425.881.1880 Fax:425.881.1930

199 on card or www.macworld.com/getinfo

AWARD-WINNING UPGRADES!



SONNET™
SIMPLY FAST™



G3
as low as
\$249⁹⁵

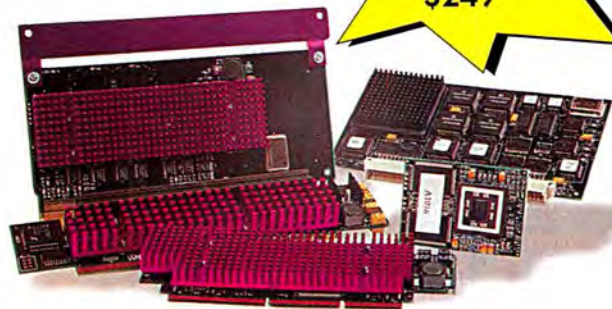

Sonnet™ Technologies manufactures the finest Macintosh processor upgrade cards for a wide range of computers including 68040, NuBus, PCI, and G3 Power Macs.

- Match or beat the CPU performance of a new G3 system.
- 100% software compatible.
- Plug-and-play installation.
- No switches or control panels to set.
- Backed by a three-year warranty.

If you have a 7100 or 8100 with a video card in the PDS slot just install one of our 7100 or 8100 Adapter Kits. Or install a Sonata Pro 24 for comparable or superior performance to the Apple PDS AV and High Performance Video Cards.

Other PCI Power Macs (upgrade-challenged) can now be upgraded through the Level 2 (L2) cache slot.

Got a Quadra or Centris? You can now run Mac OS 8.6 and realize all the performance of PowerPC native applications.

CRESCENDO G3 CARDS FOR NUBUS MACS (FITS IN PDS SLOT)

Power Mac 6100/7100/8100/8115 • Wrkgrp Srvr 6150/8150/9150
Performa 6110/6112/6115/6116/6117/6118 • Power 100/120 • Radius 81/110

Crescendo G3/NuBus 266 MHz/133 MHz/512K Cache	\$299 ⁹⁵
Crescendo G3/NuBus 266 MHz/133 MHz/1MB Cache	\$349 ⁹⁵
Crescendo G3/NuBus 300 MHz/150 MHz/1MB Cache (80, 110 & 120 MHz machines only)	\$449 ⁹⁵
Crescendo G3/NuBus 400 MHz/200 MHz/1MB Cache (80 & 120 MHz machines only)	\$699 ⁹⁵

Video Options

7100 PDS AV/HPV Video Adapter Kit for Crescendo G3	\$99 ⁹⁵
8100 PDS AV/HPV Video Adapter Kit for Crescendo G3	\$99 ⁹⁵
7100/8100 Sonata Pro 24 NuBus Video Card	\$199 ⁹⁵

CRESCENDO G3 CARDS FOR PCI MACS (FITS IN PROCESSOR SLOT)

Power Mac 7300/7500/7600/8500/8515/8600/9500/9515/9600
Wrkgrp Srvr 7350/8550/9650 • DayStar Genesis • PowerCenter
PowerCenter Pro • PowerCurve • Power Tower • Power Tower Pro
PowerWave • UMAX J700/S900

Crescendo G3/PCI 250 MHz/125 MHz/512K Cache	\$249 ⁹⁵
Crescendo G3/PCI 300 MHz/150 MHz/512K Cache	\$299 ⁹⁵
Crescendo G3/PCI 300 MHz/150 MHz/1MB Cache	\$399 ⁹⁵
Crescendo G3/PCI 333 MHz/166 MHz/1MB Cache	\$449 ⁹⁵
Crescendo G3/PCI 400 MHz/200 MHz/1MB Cache	\$599 ⁹⁵
Crescendo G3/PCI 466 MHz/233 MHz/1MB Cache	\$899 ⁹⁵

CRESCENDO G3 UPGRADES FOR "UPGRADE-CHALLENGED" PCI POWER MACS (FITS IN L2 CACHE SLOT)

POWER MAC 55/6500 • PERFORMA 6360/64XX • 20TH ANNIV. MAC • POWERBASE DESKTOP
Power Mac 4400 • StarMax 3000/4000

Crescendo G3/L2 250/125 MHz/512K Cache	\$249 ⁹⁵
Crescendo G3/L2 300/150 MHz/512K Cache	\$299 ⁹⁵
Crescendo G3/L2 300/150 MHz/1MB Cache	\$399 ⁹⁵
Crescendo G3/L2 400/200 MHz/1MB Cache (55/6500, TAM only)	\$599 ⁹⁵
Crescendo G3/L2 250/125 MHz/512K Cache	\$249 ⁹⁵
Crescendo G3/L2 300/150 MHz/512K Cache	\$299 ⁹⁵
Crescendo G3/L2 300/150 MHz/1MB Cache	\$399 ⁹⁵

ENCORE G3 CARDS FOR G3 POWER MACS (FITS IN ZIF SOCKET)

Power Mac G3 All-in-one/Blue & White/Desktop/Tower/Server
Encore G3 466/233 MHz/1 MB Cache

Encore G3 466/233 MHz/1 MB Cache	\$699 ⁹⁵
----------------------------------	---------------------

PRESTO PPC UPGRADES FOR QUADRA & CENTRIS (FITS IN PDS SLOT)

Quadra 700/800/900/950 • Quadra/Centris 610/650
(610 Requires Adapter)

Presto PPC 100 MHz/1MB Cache	\$299 ⁹⁵
Quadra/Centris 610 Adapter	\$49 ⁹⁵

G3 Speeds Up to 900% as Fast for Your PCI Power Mac!

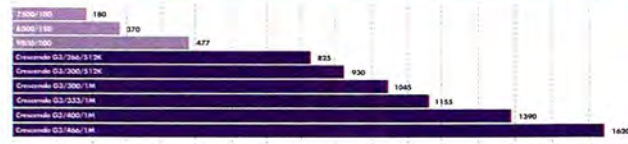

Performance results based on MacBench 4.0 processor scores

Run Your NuBus Power Mac at G3 Speeds Up to 1400% as Fast!



Performance results based on MacBench 4.0 processor scores

Sonnet Technologies, Inc.

18004 Sky Park Circle, Irvine, CA 92614-6428
Tel: 949-261-2800 Fax: 949-261-2461
E-mail: sales@sonnettech.com



800-786-6260
<http://www.sonnettech.com>

Visa, MasterCard and American Express no surcharge. Government, corporate and education P.O.s welcome. Sonnet products are covered by a three-year limited warranty. Prices are subject to change without notice. Returns require an authorization and are subject to a restocking fee. Sonnet, the Sonnet logotype, Crescendo, Encore, Presto, and the Simply Fast logotype are trademarks of Sonnet Technologies, Inc. ©1999 Sonnet Technologies, Inc.

Open Monday-Friday: 9am-8pm & Saturday: 10am-5pm CST E-Mail Us at: owc@macsales.com

other world computing

Serving the Mac Universe Since 1988



800-275-4576



Competitive Prices, Quality Products and NEVER a Surcharge for Credit Cards!

www.macsales.com
has Easy, Fast,
Secure Internet
Ordering Now.



It's a Snap to add G3 Power to your PowerMac!

NUBUS

PCI

GO G3
Get Your Mac Up To Speed

**FAST!
EASY!
SECURE!**



**G3 Upgrades for PowerMac 6100/7100/8100/
8150/9150/ Radius; Performa 611X Series**

**G3 Upgrades for PowerMac 7300/7500/7600/
8500/8600/9500/9600s; WGS 7350/8550/8650/
9650; PowerCenter/PowerWave/PowerTower;
UMax S900/J700**

**G3 Upgrades for PowerMac 4400/5500/
6360/6400/6500/ 20th Anniversary Mac;
PowerBase; Umax C500/600 StarMax 3000/
4000/5000 Series; Most Motorola Clones**

SONNET Cresendo Nubus Series from \$295
G3/240-266mhz 512k - \$295
G3/240-266mhz 1mb - \$345
G3/293-300mhz 1mb - \$439
NEW! G3/400mhz 1024k - \$679

SONNET Cresendo PCI Series from \$245
G3/250mhz 512k - \$245
G3/300mhz 512k - \$289
G3/300mhz 1024k - \$385
G3/400mhz 1024k - \$575

SONNET Banker G3 Series from \$245
G3/250mhz 512k - \$245
G3/300mhz 512k - \$295
G3/300mhz 1024k - \$385
G3/400mhz 1024k - \$585

DaughterCard Gives Your PCI Mac ZIF Upgradeability!

Interex XLR8 ZIF Carrier PCI DaughterCards
XLR8 G3ZIF Carrier w/o Processor \$159
XLR8 G3ZIF Carrier w/Mercury 333mhz 1mb 2:1 \$339
XLR8 G3ZIF Carrier w/Mercury 350mhz 1mb 2:1 \$375
XLR8 G3ZIF Carrier w/Mercury 400mhz 1mb 2:1 \$449
XLR8 G3ZIF Carrier w/10x 450mhz 1mb 2:1 \$799

Go G3 Now and Easily Upgrade to the New G4 ZIF Processors In The Future!

Quantum Viking 4.5gb
7200rpm 8ms 512k w/3yr
SAVE @OWC \$195 int. \$249 ext.

MacOS 8.5 WITH Norton Utilities 4.0 AND AfterLife (game) AND FullThrottle (game) ONLY \$49.95
OWC SUPER DEAL

SCSI Hard Drives int. ext.
Quantum
9.1gb Atlas IV 2048k Cache 7.5ms 5yr: \$345 \$399
18.2gb AtlasIII 1024k Cache 7.5ms 5yr: \$545 \$599
Seagate
9.1gb Barracuda I8LP 7.1ms 5yr: \$349 \$399
18.2gb Barracuda I8LP 7.1ms 5yr: \$579 \$639
IBM
4.3gb IBM Apple Rom 8.5ms 1yr: \$175 \$229
9.1gb UltraStar I8ES 7.5ms 5yr: \$335 \$389
18.2gb UltraStar I8ES 7.5ms 5yr: \$625 \$679

ixMicro Ultimate Rez I28 PCI
Video Card SPECIAL! \$75
With 8mb of V-Ram
NEW WITH 5 YEAR WARRANTY

IDE Hard Drives
SAVE BIG! 4.3gb Quantum Only: \$99
IBM
15.2 - \$169
25.0 - \$315
37.5 - \$480
Seagate
4.3gb - \$99
13.0gb - \$165
28.0gb - \$315
Maxtor
8.4gb - \$129
13.6gb - \$175
20.4gb - \$255

Removable SCSI Drives
Bare Internal External
omega Zip 100 SCSI \$79 \$99 \$99
omega Zip 250 Plus \$179 \$175
omega Zip 250 for B&W G3s \$179
omega Jaz 2gb SCSI \$319 \$329 \$329

IDE PowerBook Hard Drives
for PowerBook150: 190/1400/5300/3400; G3 PowerBooks:
Duo 2300 and 2400 Series. 4200rpm with 3 year warranty
2.1gb IBM Travelstor non-slim 4900 rpm \$109
6.4gb Toshiba Slim \$229
6.4gb IBM Travelstor Slim \$255
8.1gb IBM Travelstor Slim \$319
10.1gb Toshiba Slim \$339
14.4gb IBM Travelstor non-slim 4900 rpm \$489

Zip 100mb Carts - \$11 each / \$95 for 10
Jaz 1gb Carts - \$89 Jaz 2gb Carts - \$95
Yamaha CDRW 6x4x16 \$299 \$349 \$399
Teac CDR 6x24x \$269 \$299 \$349
CDR & CDRW Internal and External Drives Include Toast Software and Media.
CDR 74 Minute Silver Media w/Jewel Case - 10 for \$15 / 50 for \$69.95 / 100 for \$129

POWERLOGIX New PowerLogix Spartan G3 G3/250mhz with 512k Cache
SAVE @OWC \$169
Only
Call for other Speeds.

www.fastermacs.com
• More Stuff to Make your Mac a FasterMac!
• Upgrades for Older Macs too!

www.macsales.com
• More Mac products and information
• FREE DELIVERY* when you place your order online!

Mac Memory
SDRAMs Apple Spec PC100
Memory for ALL Beige G3 Desktops,
Minitowers, All-In Ones, & New
Blue & White G3 Computers (work with PC's too)
32mb - \$39 64mb - \$75 128mb - \$145
256mb (66mhz for Beige) \$299
256mb (100mhz for Blue & White) \$335

G3 PowerBook (WallStreet & Lombard) / iMac (All Speeds)
NEW! iBook
32mb - \$39
64mb - \$71
128mb - \$139
256mb* - \$335
*not suitable for iBook.

168 Pin MacDimms 5V 5V Edo 3.3V Edo
16mb \$35 \$39 \$49
32mb \$64 \$64 \$95
64mb \$119 \$119 \$189
128mb \$229 \$259 N/A

72 Pin Simms
16mb- \$31 32mb- \$63 64mb*- \$119
*for 6171/8100 and compatibles only.
Call or visit www.macsales.com for V-Ram and Video Card upgrades.

MEMORY

WE'LL BEAT ANY PRICE!

Special Web Site Pricing
available only at www.mac solutions.com

ABSOLUTELY, POSITIVELY,
THE BEST PRICES!

Plus, Lifetime Warranty on all RAM!

YOSEMITE - PC 100		iMAC RAM		G3 SDRAM - In Stock!!	
32 mb	\$ 34	32 mb	\$ 36	32 mb	\$ 36
64 mb	66	64 mb	64	64 mb	64
128 mb	136	128 mb	125	128 mb	129
256 mb	325	256 mb	335	256 mb	265
PowerBook G3 (98-99)		168 Pin DIMMs		SIMMs 72 & 30 pin	
32 mb	\$ 36	16 mb	\$ 28	4 mb 30 pin	\$ 7
64 mb	64	32 mb	58	16 mb 30 pin	19
128 mb	125	64 mb	105	16 mb 72 pin	26
256 mb	335	128 mb	192	32 mb 72 pin	51

CACHE • VRAM • PRINTER, DIGITAL CAMERA & PC-CLONE MEMORY AVAILABLE

www.mac solutions.com



PRE-OWNED MACS

CALL
for Used G3 Desktop, MiniTower
& PowerBook pricing & availability

GREAT DEALS ON USED MACHINES

9600/200 MP	64/4gb/24x/Zip	\$ 2,100
9500/120	16/1gb/4x	800
7300/180	32/2gb/8x	800
8500/120	16/1gb/4x	650
7500/100	16/1gb/4x	550
7200/90	16/500/4x	450
PwrBook G3/300	64/8gb/56k/DVD	2,300
PwrBook 1400c/117	16/1gb/6x	1,100
PwrBook 1400cs/117	16/750/6x	990
PwrBook 5300c/100	8/500	650
PwrBook 5300cs/100	8/500	600

SPECIALS

Microsoft Office 4.2.1 CD only	\$ 75
Apple Mac™ OS 8.1 CD only	25
Mac™ OS 8.6 upgrade with Free 8.5 CD	68
Apple Final Cut Pro	999
Norton Utilities 4.0	69
Iomega Zip Disks 10 -pak	90
Iomega Jaz Cartridges 3-pak 1gb/2gb	230/250
Canon all-in-one Printer/Fax/Scanner	369
Keyspan USB to Serial port adapter	79



HARD DRIVES



IBM 1 gb SCSI	\$ 79
Quantum 1.2 gb SCSI	105
Quantum 2.2 gb Viking SCSI	130
Seagate 4.5 gb Medalist Pro SCSI	189
Seagate 9.1 gb Medalist Pro SCSI	315
Quantum 9.1 gb ATLAS IV UltraWide SCSI	330
Seagate 9.1 gb Barracuda UltraWide SCSI	355
Seagate 9.1 gb Cheetah UltraWide SCSI	530
Quantum 18.1 gb ATLAS IV UltraWide SCSI	595
Seagate 18.1 gb Barracuda UltraWide SCSI	595
Seagate 18.1 gb Cheetah UltraWide SCSI	865
Quantum 4.3 gb IDE	99
Quantum 6.4 gb IDE	119
Quantum 9.1 gb Katana IDE	145
Quantum 18.2 gb Katana IDE	239
Toshiba 10 gb for 98/99 PowerBook G3	325
IDE to USB External Case use those drives!	80

Pre-owned machines subject to prior sale. Inventory changes daily, call for availability. New Apple product available in-store only.

ADAPTEC • ASANTE • EPSON • GLOBAL VILLAGE • IBM • IMATION • IOMEGA • NEWER • QUANTUM • SEAGATE • SONY • UMAX • VST

Apple Authorized Dealer Apple Specialist Apple Authorized Service Provider

(800) 873-3RAM

MacSolutions, Inc. Fax: (310) 966-4433
11933 Wilshire Blvd, West Los Angeles, CA 90025
University & School P.O.'s Welcome.

Secure Online Ordering at

www.mac solutions.com



MAC Solutions

All prices are subject to change. Merchandise subject to prior sale. Please call for up-to-the-minute info and availability. Not responsible for typographic errors. Limited to stock on hand. Ad Code #819

Digital Imaging

Slides & Negatives \$3.75
 4x5 Transparencies/Negs \$30
 Large Posters & Displays \$45
 Scanning: Hi & Lo Res
 Kodak Photo-CD Scans
 Short Run Color Printing

Show & Tell 39 W 38th St., NY, NY 10018
www.show-tell.net
 212 840-2912 212-840-7953 (fax)
 showtel@ibm.net • shotel@aol.com

205 on card or www.macworld.com/getinfo

BIG POSTERS & HUGE DISCOUNTS FROM YOUR COMPUTER FILES

HIGHEST QUALITY PRINTS AT THE BEST VALUE. AIRBORNE • STATE OF THE ART EQUIPMENT • UP TO 600dpi

24" x 36" Full color print on 7 mil high or low gloss paper \$25 NO MINIMUMS VOLUME DISCOUNTS	36" x 48" Full color print on 7 mil high or low gloss paper \$50 NO MINIMUMS VOLUME DISCOUNTS	48" x 72" Full color print on 7 mil high or low gloss paper \$125 NO MINIMUMS VOLUME DISCOUNTS
---	---	--

FOR MORE INFO & PRICING VISIT OUR WEBSITE
www.BIGPOSTERS.com
 CREATIVE JUICES PRINTING & GRAPHICS INC.
(In New York) Tel: 516-520-4533 Fax: 516-520-4534 • 24 Walnut Pl., Levittown, NY 11756

1-888-880-HUGE

207 on card or www.macworld.com/getinfo

WHOLESALE WATERLESS COLOR PRINTING FROM YOUR COMPUTER FILES

1000 FULL COLOR BUSINESS CARDS FOR \$100 Sug. retail price \$179
1000 FULL COLOR POSTCARDS FOR \$149 Sug. retail price \$249

Printed waterless at 300 line screen from your computer files on Super Premium 10pt. Kromekote with our FREE scratch-resistant aqueous coating.

SPORTARREDO

World-Class Tanning Equipment and Service

KERRY ROADES

TOLL FREE 888.776.8266
 LOCAL 636.305.8222
 FAX 636.305.9444
 E-MAIL: teamtan.com
 www.teamtan.com

575 RUDDER RD., SUITE 102 FENTON, MO 63026

Try Our Fast 4/C Print Quotes!

- BUSINESS CARDS
- POSTCARDS
- CD INSERTS
- CD TRAY LINERS
- BROCHURES
- BOOKLETS
- NEWSLETTERS
- POSTERS & MORE

ROBERT LANG
 OWNER
 MAUI: 808.572.8118

TROPICAL GIFTS:
 CHIMES, SARRISSE, MAGNETS,
 MOBILES, LETTER OPENERS,
 STATUES, FRAMES & BOXES

TOLL FREE: 800.962.6254
 WEB PAGE: MANALI.COM
 E-MAIL: MANALI@MANALI.NET
 FAX: 808.572.4988

P.O. Box 1139, MAUNAWA, MAUI HAWAII 96768

FEATURING 300 LINE SCREEN WATERLESS OFFSET PRINTING

Rates for Brochures, Booklets and Flat Sheets are also available.

4-COLOR WATERLESS SPECIAL

1,000 PRESENTATION FOLDERS \$1499

9" x 12" 4-Color Folders with 4" pockets and BC slits printed 4/0 from your files at 300 line screen on 10 pt. Kromekote with FREE aqueous coating.
Get 2,000 Folders for only \$2,199

SUGGESTED RETAIL \$2,299



QUARK
 Authorized Service Bureau

Factory Authorized
COREL
 Service Bureau

Se Habla Español

GRAPHIC ARTS AVAILABLE

4413 82nd Street • Lubbock, TX 79424 • FAX: 806.798.8190

Email your requests for printing quotes to request@copycraft.com

1.800.794.5594

CALL TODAY FOR A FREE COPY OF OUR NEW 32-PAGE FULL COLOR CATALOG

Visit www.copycraft.com for more Specials...in English or Spanish!

208 on card or www.macworld.com/getinfo

Data Recovery in hours.

- Over 10 years of experience with clients worldwide including Apple, NASA, HP, and FedEx.
- We've recovered more than half-a-million megabytes of Mac Data alone.
- You only pay when there's a recovery.
- Express One-Day Service is available.
- Call 24 hours a day.

415-495-5556 • FAX 415-495-5553 • RESTRICTIONS MAY APPLY
 381 Clementina Street • San Francisco, California 94103



LAZARUS

DATA RECOVERY

Working at the speed of business.

800-341-DATA

206 on card or www.macworld.com/getinfo



877-4MY-DATA
 WHATEVER IT TAKES.™

Total Recall™

The Data Recovery Company™

www.totalrecall.com

2462 Waynoka Rd. Colorado Springs, CO 80915

(719) 380-1616 • 380-7022 fax

204 on card or www.macworld.com/getinfo



Colorprints
.com

Virtual home of the
39¢
digital color print



visit our website at www.colorprints.com for the lowest prices on digital color prints

213 on card or www.macworld.com/getinfo

CD-ROM PRODUCTION

1000 Retail-Ready Stamped CDs

Includes two color discs, four color glossy insert & tray cards, jewel case, and poly wrap. Complete turnkey — just send a CD-R and art files! Call for details.



Business Card CDs! New! 18Mb of data or audio on a business card shaped disc. It really plays! See our web site for details.



CATALOGIC

Your CD-ROM Production Source™
<http://www.catalogic.com>

We Also Offer:

- CD-R silk-screening service
- Short run CD-R duplication
- Standalone CD-R dupers

Call today: (800) 255-4020

990 Richard Ave Ste 103 • Santa Clara, CA 95050
Telephone: 408-486-0800 Fax: 408-486-0809



214 on card or www.macworld.com/getinfo

DATA RECOVERY: 800-440-1904

"Thanks for saving my butt!"

— Guy Kawasaki, *The Macintosh Way*

7 good reasons to choose DriveSavers:



Since 1989
INTL: 415-382-2000

1. We are the fastest, most trusted, and most successful data recovery professionals.
2. Retrieve recovered data instantly with DATAEXPRESS™ over secured Internet lines.
3. Recommended and certified by all drive companies to maintain your warranty.
4. 24-hour, onsite, and weekend service available.
5. Advanced, proprietary recovery techniques.
6. Featured by CNN, BBC, Forbes, and others.
7. Federal and State Contracts (GSA, CMAS.)

Reseller & Service Companies: Call about DriveSavers' Referral Program.

www.drivesavers.com

215 on card or www.macworld.com/getinfo

DISASTER PROOF YOUR COMPUTER!



Safeware's comprehensive computer insurance protects your Apple desktop or notebook system against:

- Accidental Damage
- Flood
- Theft
- Fire
- Power Surge
- Lightning
- Vandalism
- Other Natural Disasters

Call 1-800-800-1492™ for information and enrollment.



Safeware,™ The Insurance Agency Inc.
6500 Busch Blvd., Suite 233, Columbus, OH 43229-1785
(614) 781-1492 • Toll-free: 1-800-800-1492

Visit our website at www.safeware.com • E-Mail: safeware@safeware.com

UT845982-0799
ahbr

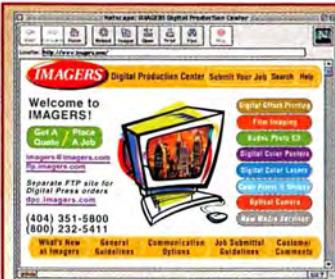

www.imagers.com

Free Shipping/Call for details

Send PC/Mac files by FTP or Priority Air Express to Image output services, your finished work is in your hands the ve

- Digital Short-Run Printing
- Photo CD Film Scanning
- Digital Posters & Banners
- Fuji Digital Photo Prints
- Slides & Overheads
- New Media Services
- Prepress Support Team!



We guarantee our work!

1575 Northside Dr. Ste. 490 Atlanta 30318

800.672.7029/404.351.1

216 on card or www.macworld.com/getinfo

800-WE-FIX-MACS

Free Diagnostics • Best Prices • Best Warranties • Huge Inventory

7100 Logic Board...from \$129	6100 8/0..... from \$99	Apple 24x CD Rom \$99
6400 Logic Board...from \$299	7100 8/0.....from \$199	
6500 Logic Board...from \$299	8100 8/500..... from \$399	Apple 4GB SCSI HD \$179
7500 Logic Board...from \$199	20th Anniversary Base & Unit..... \$1499	
8500 Logic Board...from \$199		Apple 1GB SCSI HD \$99
8600 Logic Board...from \$299		
9500 Logic Board...from \$299		
9600 Logic Board...from \$299		

G3/iMac Parts In Stock!

PowerComputing Specialists

2202 N. First Street San Jose, CA 95131 • 800 933-4962 • www.allmac.com

data recovery

www.mcrecovery.com



When you absolutely, positively have to get your data back...

- 24hr. Emergency Data Recovery
- Worldwide Services

MICROCOM
20802 Plummer St. Chatsworth, CA 91311 • 818 718-1200
800 469-2549

**LOOK
HERE FOR ALL
YOUR
MACINTOSH
SERVICE
NEEDS!**

Macworld
SHOPPER

DELUXE COLOR PRINTING!



Our ultra thick, deluxe high gloss cards stand out from the rest!
FREE SAMPLES
Call Now!



- Super thick card • Ready in 5-7 days!
- Glossy UV coating • NO Film Charge!

1-800-957-5787

www.postcardpress.com
Preferred by over 5,000 professionals!

For COLOR PHOTO BUSINESS CARDS

YOU DO THE MATH!

1000 Full Bleed Business Cards
200 Linescreen - Photo Quality
4 Color Process - Heidelberg
10 Point Coated Cardstock
+ 5-7 Day Turnaround
\$59.95 (plus \$15 initial setup fee)
- Resale Prices Available!

SEND BY MEDIA:
CD Rom • Zip 100

SEND BY INTERNET:
ftp Site • eMail Attachment

APPLICATIONS:
QuarkXpress • Photoshop • Illustrator

1-800-772-9993

www.daicolocard.com



DDAICOLO CORPORATION
21203A Hawthorne Boulevard, Torrance, CA 90503

217 on card or www.macworld.com/getInfo

the compression factory

Professional QuickTime Streaming Services

We offer 24/7 encoding and hosting for QuickTime 4 streaming media for video-on-demand & live events. Our state of the art automated compression facility provides clients such as Apple Computer, HBO, Fox Sports, Warner Bros., VH1, and Reprise Records with the highest possible quality RTSP and HTTP video and audio. Visit our QuickTime microsite for more info and online streaming samples:
<http://www.compressionfactory.com>

24/7 QuickTime digitizing & encoding
Beta SP, DV & other sources accepted
Same-day service available via FTP
Live event planning, hosting & broadcasting
MacOSX QuickTime Streaming Server hosting
Encoding, hosting and systems consultancy

Call **415 884 2155** today
Discover the future of broadband communication

The Compression Factory is a trademark of 21st Century Media™ LLC.

219 on card or www.macworld.com/getInfo

MAC REPAIR & UPGRADE

24 HOUR SERVICE TURNAROUND • LONGER WARRANTY
FREE DIAGNOSTIC • COMPETITIVE PRICE



- * Specialize in component repairs:
• Power Mac • Power Book • Logic boards
- * Advance Exchanges

**DT & T
MACINTOSH
SERVICES, INC.**

800-622-7977

3095 Osgood Court, Fremont, CA 94539 • Tel: 510-661-0999 • Fax: 510-661-6788
<http://www.dtservice.com>

218 on card or www.macworld.com/getInfo

DATA RECOVERY

ALSO IN CALIFORNIA For MAC - (Hard Drives, Opticals, Removables)

By Nick Majors' DATA RECOVERY LABS
"The Best Data Recovery Service available - Anywhere - at any Price!"

Dedicated in-house MAC specialists are available to work on your emergency data recovery. Complete facility with clean rooms and full MAC capabilities.

Free evaluations. All recoveries are 100% satisfaction guaranteed. Complicated / top priority projects are our specialty.

1-800-563-1167
www.datarec.com

USA • Canada • Japan

The Repeal of Moore's Law

THE CHIPS ARE FAST ENOUGH. WHEN WILL THE REST OF THE MAC CATCH UP?

IN A 1965 SPEECH, COMPUTER scientist Gordon Moore, who shortly thereafter became a founder of Intel, predicted that personal-computer speeds would double every year. That impressive observation, soon dubbed Moore's Law, surprised millions of people, prepared the PC-buying world for the "whatever you buy today will be obsolete next year" syndrome that dogs us to this day, and became a favorite of journalists everywhere. Writers trot it out to justify whatever argument they happen to be making, from "Buy the stuff reviewed in our magazine" to "Apple is dead."

Get It Right

But believe it or not, Moore's Law is malarkey. First of all, we didn't even get the quote right. Moore wasn't talking about computer *speed* doubling at all; he was talking about the *number of transistors* on a typical chip, which isn't necessarily related. (For that matter, he didn't actually say that the doubling would take place every year; he really said "every 18 to 24 months.") Second, even if we had understood it right, Moore's Law wouldn't be accurate anyway. The first Mac, in 1984, ran at 8MHz; if that speed had doubled every 18 months, we would now be scooting along on 8,192MHz PowerPC chips that would melt right through our desks and straight on down to China.

Instead, the state of the Macintosh art today is a 400MHz PowerPC G3 chip. Now, the following may shock you, so I hope you're sitting down: I think that today's chips are fast enough. I'm not one of these people who scans the Mac rumor Web sites every week looking for news of the G4, G12, or G28 chip; my Mac scrolls, displays graphics, and totals spreadsheets instantaneously. I can't imagine why anyone would want to pay more for a faster chip.

I'm not saying that I think *Macs* are

fast enough—I'm saying that the *chips* are fast enough. There's a big difference. For example, ten years ago, today's Macs would have been considered unimaginably quick. (Remember the Mac IIx, ten times slower than today's Power Macs? This very magazine called it "wicked fast.") And yet, consider how many times every day you wind up just sitting there waiting for something to happen: every time you launch a program, turn file sharing on, switch your AppleTalk connection, dial the Internet, wake up your com-

Doubler (shareware) memorize your extensions, shaving 30 seconds or more off every start-up. The iBook's new Save And Shut Down command is equally brilliant: according to Apple's prerelease documents, it memorizes the current status of all your open programs. When you turn on the iBook again later, you're taken directly back to whatever you were doing, bypassing the entire start-up and document-opening sequences. Any program (such as Intuit's Quicken and Palm Desktop) that attempts to autocomplete your typing is also a godsend.

Also doing remarkable work in SpeedSmart Software is, of all companies, Microsoft. Because the company's gigantic applications may never actually run quickly, they compensate by saving us time in other ways. Classic example: a single click on the glorious AutoFill icon on the Internet Explorer tool bar tells the application to fill your name, address, phone number, and other repetitive information into the blanks on any Web page. Similarly, when you save a document, Word proposes naming the

file after the first line of the document ("November Meeting Agenda," for example) instead of "Untitled." You save ten seconds each time it guesses right.

Only if such not-so-artificial intelligence blossoms in our everyday software (and in the Mac OS) will we ever catch up to the speed gains promised by Moore's So-Called Law. Otherwise, we'll continue to suffer from the effect described by *Pogue's Law*: any extra speed introduced by faster chips is soon offset by increasingly bloated software. **m**



puter from sleep, or—this is the big one—start up the computer. These and many other bottlenecks make a mockery of our hopes that faster processors will help us get our work done sooner.

Bright Ideas

Fortunately, as the computer industry heads into the year 2000, a few bright minds have begun to discover that software can compensate for such bottlenecks. These clever programmers are making it clear that to get faster Macs, we don't have to wait, like sitting ducks, for the next generation of PowerPC chips.

For example, programs like Speed-Startup (Casady & Greene) and Startup-

DAVID POGUE (www.davidpogue.com) is the author of the upcoming *The iBook for Dummies* (IDG Books Worldwide, 1999).



Sometimes Newer Is Better Than New.



Faster! Faster! Faster!



Play games on your beige or blue Mac the way they were meant to be played. Just plug in a MAXpower™ G3 upgrade card from Newer Technology. Topping out at a blistering 466MHz, these patent-pending cards give you the smooth, flawless game play you want, at a price you can't beat. And right now, you can get a free copy of Tomb Raider II* with every Newer upgrade card you purchase. Newer is the largest G3 upgrade provider and leads the industry in compatibility. So check our web site for a complete list of supported systems, then get the most out of your Mac gaming experience.

To get your FREE* copy of Tomb Raider II, check out our web site at www.newertech.com or call 316-943-0222 ext. 290.



To learn how to get the most from your Mac, visit us at www.newertech.com.

Newer is a registered trademark and MAXpower is a trademark of Newer Technology, Inc. TOMB RAIDER is a registered trademark of Core Design Ltd. TOMB RAIDER and LARA CROFT and LARA'S IMAGE are trademarks of Core Design Ltd. EIDOS and EIDOS INTERACTIVE are trademarks of Eidos Interactive, Inc. Copyright 1997/1999 Eidos and Core. All other product names are trademarks or registered trademarks of their respective holders. No part of this document may be reproduced mechanically, electronically or by any other means without the express written permission of Newer Technology, Inc. All rights reserved. *This offer is valid through November 30, 1999. Additional rules apply. See web site or call for details.

Choose 55 at www.macworld.com/getinfo

Part Professor. Part Ginger.



MouseWorks® and TurboBall's smart, customizable buttons help you be more productive, while their sculpted shapes are designed to keep your hand in a more natural position. Smarts that help you work better and good looks designed for comfort... who said brains and beauty don't belong together? For more info visit www.kensington.com/shape.

KENSINGTON

Smart design at work.

Kensington and MouseWorks are registered trademarks and TurboBall is a trademark of ACCO World Corporation. All other registered and unregistered trademarks are the property of their respective owners. ©1999 Kensington Technology Group, a division of ACCO World Corporation.