

Reference:

ITB16-015a

Date: COPYRIGHT© NISSAN NORTH AMERICA, INC.

July 15, 2016

## **VOLUNTARY SERVICE CAMPAIGN 2011 – 2013 QX56 AND M56; TIMING CHAIN**

This bulletin has been amended. The CLAIMS INFORMATION section has been revised.  
No other changes have been made. Please discard previous versions of this bulletin.

**CAMPAIGN ID #:** P6305  
**APPLIED VEHICLES:** 2011-2013 QX56 (Z62)  
2011-2013 M56 (Y51)

**Check Service Comm to confirm campaign eligibility**

### **INTRODUCTION**

Infiniti is conducting a Voluntary Service Campaign on certain 2011-2013 QX56 and 2011-2013 M56 vehicles to replace the "Timing Chain". This service will be performed at no cost to the customer for parts or labor.

### **IDENTIFICATION NUMBER**

Infiniti has assigned identification number P6305 to this campaign. This number must appear on all communications and documentation of any nature dealing with this campaign.

### **DEALER RESPONSIBILITY**

Dealers are to correct each vehicle falling within the range of this campaign that enters the service department. This includes vehicles purchased from private parties or presented by transient (tourist) owners and vehicles in a dealer's inventory.

Infiniti Bulletins are intended for use by qualified technicians, not 'do-it-yourselfers'. Qualified technicians are properly trained individuals who have the equipment, tools, safety instruction, and know-how to do a job properly and safely. NOTE: If you believe that a described condition may apply to a particular vehicle, DO NOT assume that it does. See your Infiniti retailer to determine if this applies to your vehicle.

## SERVICE PROCEDURE

NOTE: Go to page 4 for M56

### 2011-2013 QX56

**IMPORTANT:** The following service procedure for 2011-2013 QX56 is an abbreviated version of the Electronic Service Manual (ESM) procedure to replace the timing chains and related components. The Claims Information is based on this abbreviated procedure.

1. Turn ignition ON and write down the customer preferred setting for the Automatic Air Conditioning System.
  - If needed, refer to System Settings in the HAC section of the ESM.
2. Turn the ignition OFF.
3. Disconnect the vehicle 12 volt battery.
  - Refer to the ESM, section **PG – Power Supply, Ground & Circuit Elements** for the procedure to disconnect the 12 volt battery.
4. Remove the timing chains.
  - Refer to the ESM, section **EM – Engine Mechanical** for the procedure to replace the Timing Chains.

**During the repair the following parts will not be removed:**

- Oil strainer (Oil pan pick-up). ESM step 17.
- Thermostat housing. ESM step 24.
- Intake timing control solenoid valves for bank 1 and 2. ESM step 26.
- Water pump. ESM step 31.  
NOTE: Water pump pulley must be removed before removing the front cover.
- Exhaust camshaft sprocket. ESM step 48.
- Rocker covers. ESM step 50.
- Intake camshaft sprocket. ESM step 51.

**IMPORTANT:** After disassembly of the timing chains from the engine, inspect the bank 1 and bank 2 chain oil jets. If the chain oil jets are found to be damaged, replace them.

- Refer to the Oil Jet Replacement on page 5 for procedure, and then proceed to step 5 below.
5. Install new timing chains, chain guides, and crank sprocket.

6. Connect the vehicle 12 volt battery.
  
7. Reset the customer preferred settings for the Automatic Air Conditioning System.
  - If needed, refer to System Settings in the HAC section of the ESM.
  
8. Reinitialize and check the Anti-Pinch Function for all Auto-UP power windows:
  
9. Reinitialize "Automatic Drive Positioner" (ADP).
  
10. Reset/reinitialize systems as needed.
  - Refer to the Electronic Service Manual (ESM), section **PG – Power Supply, Ground & Circuit Elements**, for a listing of systems that require reset/initialization after reconnecting the battery.
  - Look in the PG section index for ADDITIONAL SERVICE WHEN REMOVING BATTERY NEGATIVE TERMINAL.
  - This list often includes items such as radio, power windows, clock, sunroof, etc.
  - Inform the customer that:
    - Some memory settings in the navigation system may need to be reset.
    - Settings for ADP seat and mirror may need to be reset.

## 2011-2013 M56

**IMPORTANT:** The following service procedure for 2011-2013 M56 is NOT abbreviated. Follow the complete Electronic Service Manual (ESM) procedure to replace the timing chains and related components.

1. Disconnect the vehicle 12 volt battery.
  - Refer to the ESM, section **PG – Power Supply, Ground & Circuit Elements** for the procedure to disconnect the 12 volt battery.
2. Remove the timing chains.
  - Refer to the ESM, section **EM – Engine Mechanical** for the procedure to replace the Timing Chains.

**IMPORTANT:** After disassembly of the timing chains from the engine, inspect the bank 1 and bank 2 chain oil jets. If the chain oil jets are found to be damaged, replace them.

- Refer to the Oil Jet Replacement on page 5 for procedure, and then proceed to step 3 below.
3. Install new timing chains, chain guides, and crank sprocket.
  4. Reconnect the vehicle 12 volt battery.
  5. Reset/reinitialize systems as needed.
    - Refer to the Electronic Service Manual (ESM), section **PG – Power Supply, Ground & Circuit Elements**, for a listing of systems that require reset/initialization after reconnecting the battery.
    - Look in the PG section index for ADDITIONAL SERVICE WHEN REMOVING BATTERY NEGATIVE TERMINAL.
    - This list often includes items such as radio, power windows, clock, sunroof, etc.
    - Inform the customer that:
      - Some memory settings in the navigation system may need to be reset.
      - Settings for ADP seat and mirror may need to be reset.

## Oil Jet Replacement (as needed)

1. Remove the B2 oil jet using Remover Tool J-51269-1 (see Figure 1).
  - a. Install the remover tool onto the oil jet and flush against the engine block (see cutaway, Figure 1).
    - Align the hex bolts to contact the oil jet's flat and worn sides.
    - Slide the threaded shaft all the way in the outer housing.
  - b. Hand tighten both hex bolts with an Allen wrench.
    - Tighten enough to keep the remover tool from slipping, but no more.

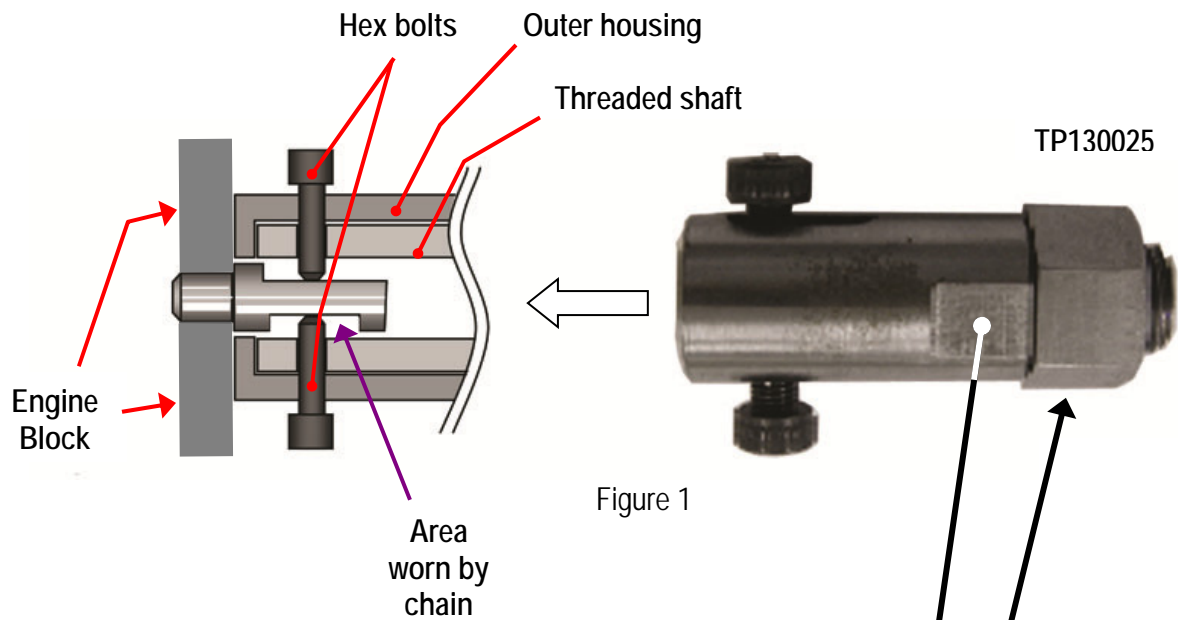

- c. Hold the remover tool's outer housing with a wrench while turning the nut clockwise.
      - This procedure will extract the oil jet from the block.
      - If the oil jet is not extracted on the first attempt, steps 1a - 1c will need to be performed a second time.

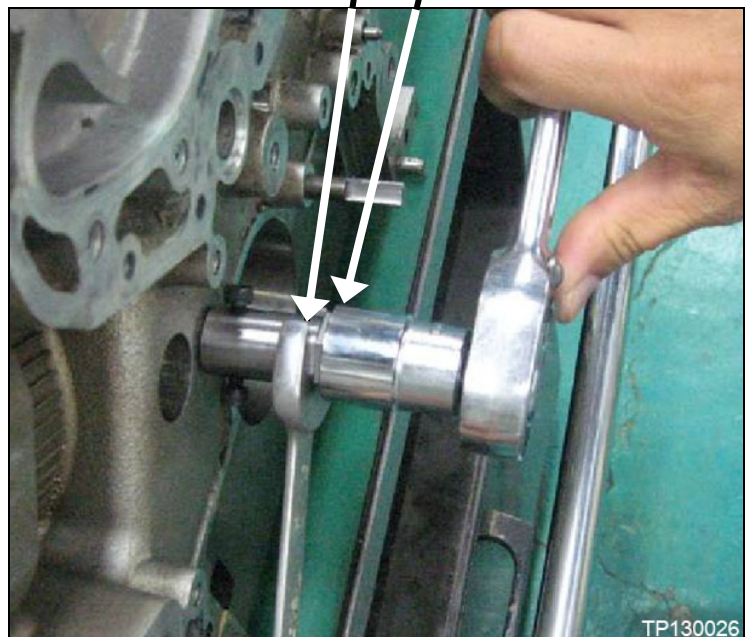

- d. Determine if oil jet replacement is possible by inserting the gauge pin into the block's hole:

**NOTE:** The gauge pin comes with essential tool J-51269 Oil jet Remover/Installer Kit.

- If the gauge pin cannot be inserted into the hole more than 3 mm, oil jet replacement can be completed. Go to **Install Oil Jet** below.
- If the pin can be inserted into the hole more than 3 mm, this repair cannot be performed replace long engine.

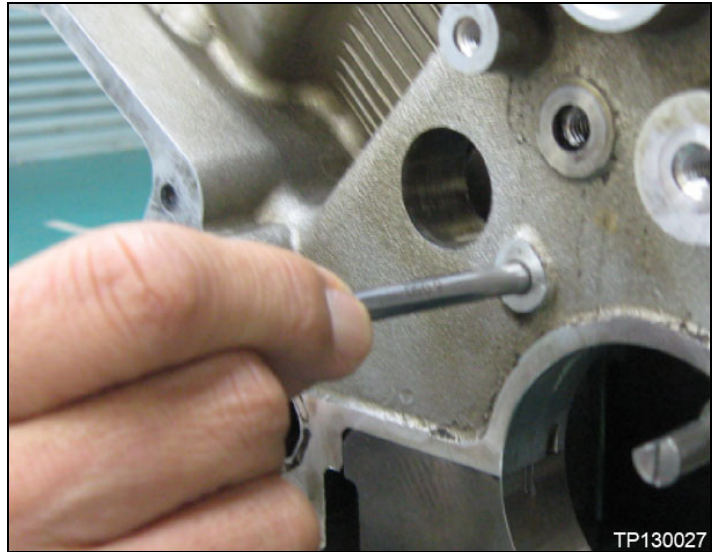

Figure 3

**IMPORTANT:** Powertrain Call Center must be called for preauthorization first before replacing a long engine (long block). Please see details starting on page 14.

### Install Oil Jet

1. Insert the new oil jet into the installer tool.
  - For QX56, use tool J-51269-2.
  - For M56, use tool J- 51316.

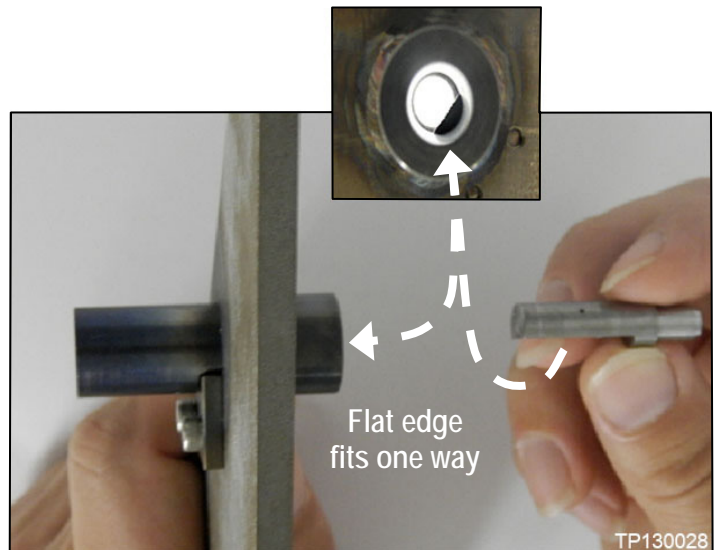

Figure 4

2. Mount the installer tool to the block.

- With the oil jet inserted in the installer tool, position the other end of the oil jet in the block's hole, and then align and finger tighten the three bolts.
- Finger tighten the bolts enough to position the installer tool flush with the block.

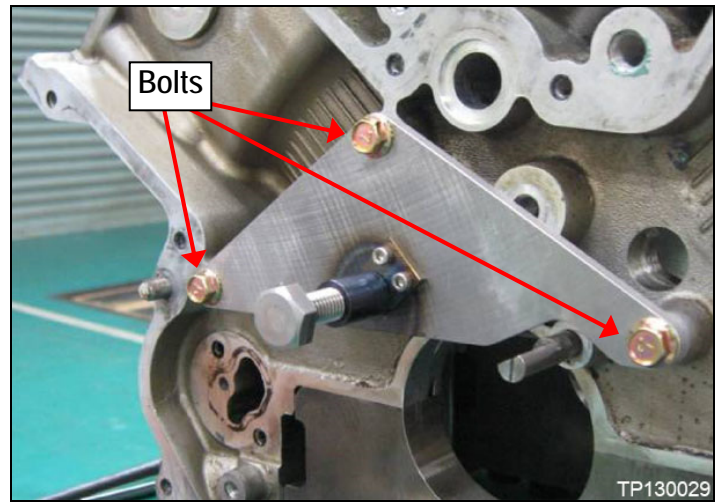

Figure 5: QX56

- **For M56:** Before tool installation, make sure old sealant has been removed from the mounting surface on the block.

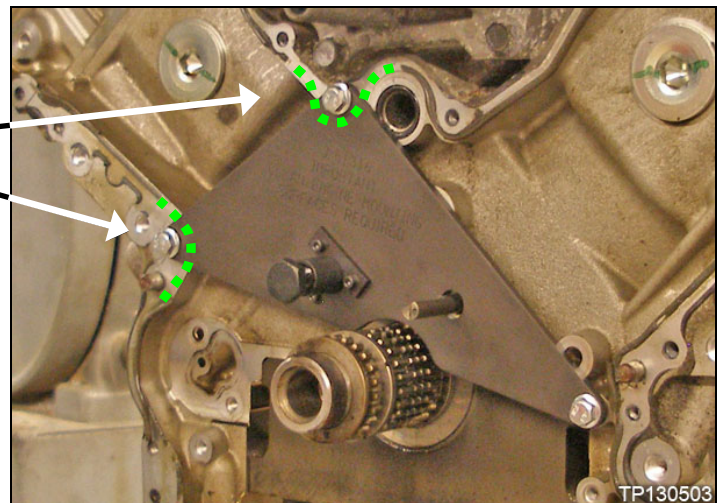

Figure 6: M56

3. Install the press bolt with your fingers until it bottoms out on top of the oil jet.
4. Next, tighten the press bolt two (2) full turns.
5. With a suitable tool, hand tighten, but not over-tighten, the three bolts.
  - Bolts should only be tight enough to seat the installer tool to the block.

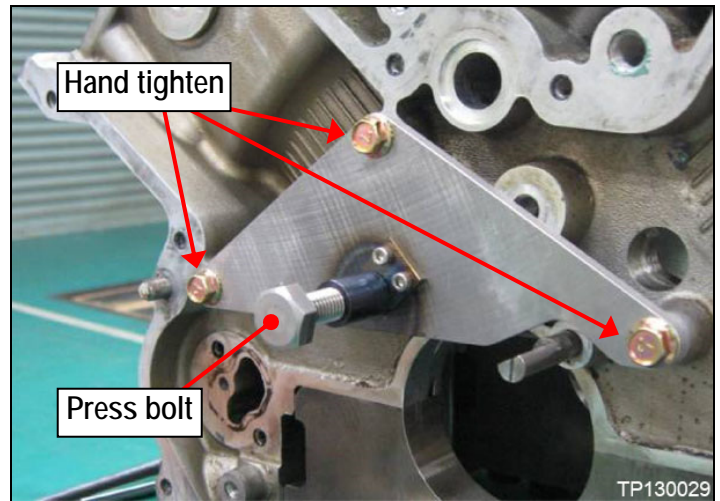

Figure 7

6. Tighten the press bolt until the oil jet bottoms out on the block.

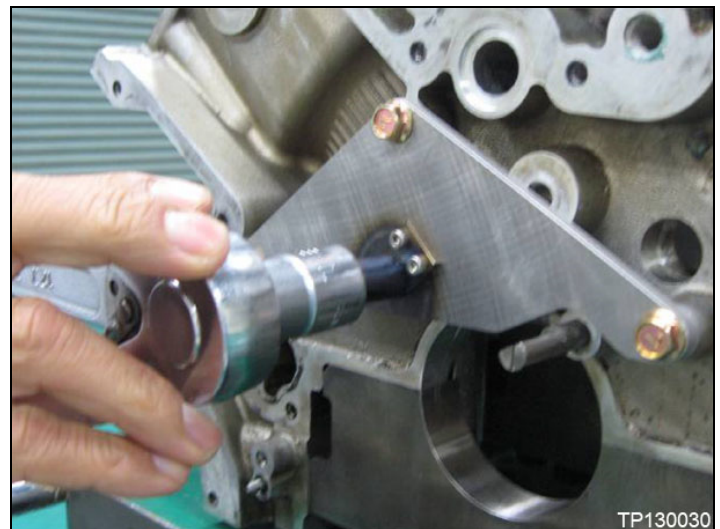
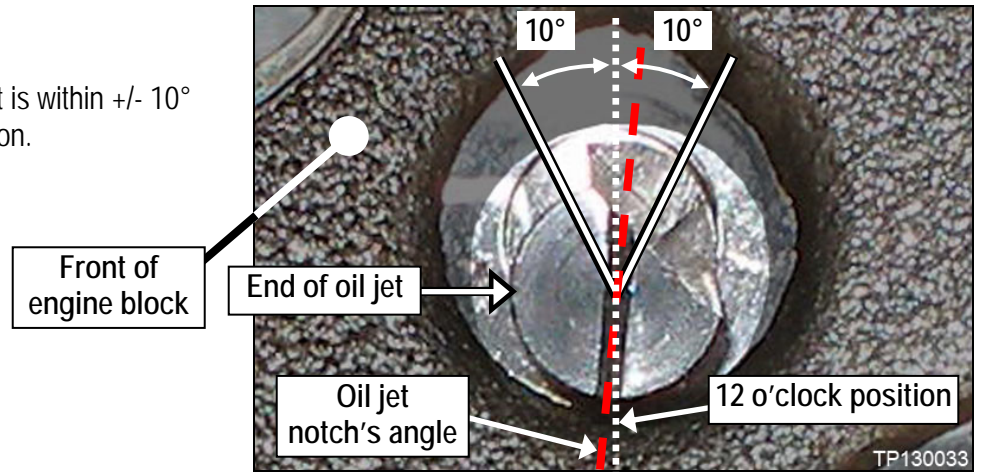

Figure 8



7. Confirm the following:

- a. The notch on the oil jet is within  $\pm 10^\circ$  of the 12 o'clock position.



- b. Confirm the oil jet is flush with the block.

- If the oil jet is not properly installed on the first attempt, steps 2 - 7 will need to be performed a second time.

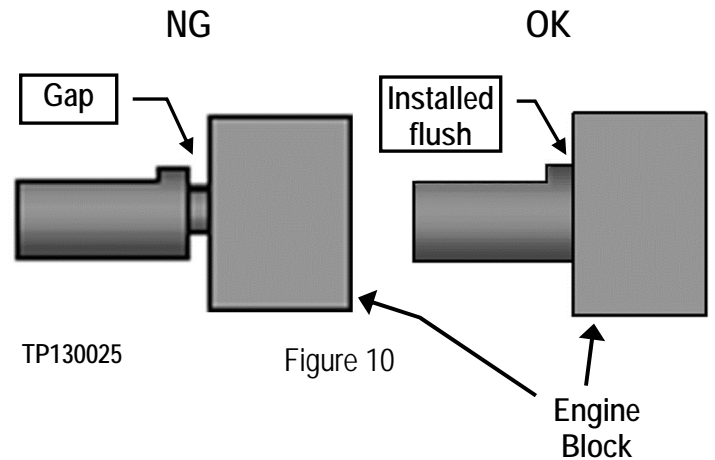

8. Once proper oil jet installation is confirmed, reassemble the engine with new Bank 1 and Bank 2 timing chains and guides.

PARTS INFORMATION

M56 Parts List

Parts Name	Part Number	Quantity	
		2WD	4WD
GASKET EXHAUST	20691-0P600	2	2
GASKET EXHAUST	20691-30P00	2	2
GASKET EXHAUST	20692-65J00	N/A	1
GASKET EXHAUST	20692-8H30A	N/A	1
GASKET INTAKE MANIFOLD	A4035-1MC0A	1	1
GASKET - INTAKE ADAPTER	16175-1CA0A	2	2
SEAL, CAMSHAFT	13042-3HD0A	12	12
SEAL - O-RING	22131-EN205	4	4
SEAL - O-RING	16618-1LA0D	1	1
TIMING CHAIN CAMSHAFT kit (bank 1)	A3028-1LA4A	1	1
TIMING CHAIN CAMSHAFT kit (bank 2)	A3028-1CA4A	1	1
OIL FILTER	15208-9E01A	1	1
TUBE ASSY - FUEL (pump side)	17520-1LA0B	1	1
TUBE ASSY - FUEL (bank side)	17520-EZ30A	1	1
WASHER - DRAIN-PLUG	11026-JA00A	1	1
SEAL - O-RING	15066-ZL80A	3	3
WASHER - COPPER	49726-Y0100	6	6
WASHER - LOCK	37121-JK20A	N/A	4
PACKING - WATER DRAIN	21481-18000	1	1
SEAL - O-RING	92470-HC050	8	8
SEAL - O-RING	92472-N8210	4	4
SEAL - O-RING	92474-N8210	2	2
LIFTER VALVE	13231-1MC5E	1	1
WASHER SEAL	21626-32U00	N/A	4
SEAL-OIL, CRANKSHAFT FRONT	13510-1LA0A	1	1
GASKET OIL STRAINER	15053-31U00	1	1
SEAL - O-RING	15066-1CA0A	4	4
SEAL - O-RING	15066-ZL80C	1	1
SEAL - O-RING	15066-3RC6B	4	4
SEAL-OIL LEVEL GAUGE GUIDE	15066-4W000	1	1
SEAL - O-RING	15066-6N204	2	2
SEAL - O-RING	15066-AR010	2	2
SEAL - O-RING	15066-AR020	1	1
SEAL - O-RING	37170-05U00	2	2
GASKET	46237-1LA0A	1	1
WASHER-COPPER	49726-50W00	6	6
GASKET WATER OUTLET	11062-1CA1A	1	1
BOLT-FIX, PROPELLER SHAFT	37120-AH00A	N/A	4
BOLT-FIX, PROPELLER SHAFT	37120-AL60A	N/A	4
BOLT-FIX, PROPELLER SHAFT	37120-CG10A	N/A	4
NUT FIX, EXHAUST TUBE	20602-41G00	8	8
NUT-FIX, PROPELLER SHAFT	37171-AL60A	N/A	4
PIN COTTER (AWD Only)	08921-3252A	N/A	2

M56 Parts List (continued)

Parts Name	Part Number	Quantity	
		2WD	4WD
PIN COTTER (AWD Only)	40073-0L700	N/A	4
NUT (AWD Only)	54588-2Y00A	N/A	2
NUT (AWD Only)	54588-JK00A	N/A	2
SPROCKET CRANKSHAFT	13021-1CA0A	1	1
SPROCKET CRANKSHAFT	13021-1LA1A	1	1
OIL COOLER ASSY	21305-1CA3B	1	1
COCK-WATER DRAIN	21441-5V000	1	1
SEAL-O-RING	15066-2Y510	3	3
NISSAN LIQUID GASKET (1)	999MP-1217HP	1	1
GENUINE INFINITI 5W-30 (1)	999PK-005W30Q	7	7
GENUINE INFINITI 5W-30 (Bulk) (1)	999BK-05W30QW	7	7
NISSAN LONG LIFE ANTIFREEZE (1)	999MP-L25500P	4	4
FRONT DIFFERENTIAL GEAR LUBE 80W-90 (1)	999MP-1XGPP0P	N/A	4
POWER STEERING FLUID (1)	999MP-AG000P	N/A	2
AUTOMATIC TRANSMISSION FLUID (1)	999MP-MTS00P	N/A	9

(1) Order via the Maintenance Advantage website. The website can be accessed through [www.nnanet.com](http://www.nnanet.com) (NNANET.COM, Parts & Service, Maintenance Advantage-Tire/Wiper/Battery/Chemical). Or call through the Infiniti Maintenance Advantage program: Phone: 877-INF-IMA1 (877-463-4621).

QX56 Parts List

Parts Name	Parts Number	Quantity	
		2WD	4WD
SEAL, CAMSHAFT	13042-3HD0A	6	6
SEAL - O-RING	22131-EN205	2	2
SEAL - O-RING	16618-1LA0D	1	1
TIMING CHAIN CAMSHAFT kit (bank 1)	A3028-1LA4A	1	1
TIMING CHAIN CAMSHAFT kit (bank 2)	A3028-1CA4A	1	1
TUBE ASSY-FUEL (pump side)	17520-1LA0B	1	1
WASHER - DRAIN-PLUG	11026-JA00A	1	1
GASKET INTAKE MANIFOLD	14035-1LA0A	8	8
SEAL-O-RING	15066-ZL80A	1	1
GASKET - INTAKE ADAPTER	16175-1LA0A	1	1
SEAL-O RING	15066-1LA0B	2	2
OIL FILTER	15208-9E01A	1	1
LIFTER VALVE	13231-1MC5E	1	1
GASKET CYLINDER BLOCK	11026-EA20A	1	1
SEAL - OIL, CRANKSHAFT FRONT	13510-1LA0A	1	1
SEAL - O-RING	15066-1LA0A	1	1
SEAL - O-RING	15066-6N204	2	2
SEAL - OIL LEVEL	15066-7S010	1	1
SEAL - OIL LEVEL GAUGE GUIDE	15066-7S020	1	1
SEAL - O-RING	15066-AR010	2	2
SEAL - O-RING	15066-AR020	3	3
GASKET	46237-1LA0A	1	1
NUT STANDARD HARDWARE	08918-6461A	3	3
BOLT FIX, PROPELLER SHAFT	37120-5X05A	N/A	8
PIN COTTER (AWD Only)	08921-3252A	N/A	2
PIN COTTER (AWD Only)	40073-0L700	N/A	2
NUT-FIX, PROPELLER SHAFT	37171-AL60A	N/A	8
SPROCKET CRANKSHAFT	13021-1CA0A	1	1
SPROCKET CRANKSHAFT	13021-1LA1A	1	1
COCK-WATER DRAIN	21440-1LA0A	1	1
NISSAN LIQUID GASKET (1)	999MP1217HP	1	1
GENUINE INFINITI 5W-30 (1)	999PK-005W30Q	7	7
GENUINE INFINITI 5W-30 (Bulk) (1)	999BK-05W30QW	7	7
NISSAN LONG LIFE ANTIFREEZE (1)	999MP-L25500P	4	4
FRONT DIFFERENTIAL GEAR LUBE 80W-90 (1)	999MP-1XGPP0P	2	2
POWER STEERING FLUID (1)	999MP-AG000P	2	2

(1) Order via the Maintenance Advantage website. The website can be accessed through [www.nnanet.com](http://www.nnanet.com) (NNANET.COM, Parts & Service, Maintenance Advantage-Tire/Wiper/Battery/Chemical). Or call through the Infiniti Maintenance Advantage program:  
Phone: 877-INF-IMA1 (877-463-4621).

## CLAIMS INFORMATION

**Submit a Campaign (CM) line claim using the following claims coding:**

CAMPAIGN ("CM") ID	VEHICLE	DESCRIPTION	OP CODE	FRT
P6305	QX56 with 2WD	Replacement of timing-chain, chain-guides, and crank sprocket with countermeasure parts	P63050	11.0 hrs.
		Replacement of timing-chain, chain-guides, and crank sprocket with countermeasure parts <u>and</u> repair oil jet	P6305A	11.2 hrs.
	QX56 with 4WD	Replacement of timing-chain, chain-guides, and crank sprocket with countermeasure parts	P63051	12.0 hrs.
		Replacement of timing-chain, chain-guides, and crank sprocket with countermeasure parts <u>and</u> repair oil jet	P6305B	12.2 hrs.
	M56 with 2WD	Replacement of timing-chain, chain-guides, and crank sprocket with countermeasure parts	P63052	13.1 hrs.
		Replacement of timing-chain, chain-guides, and crank sprocket with countermeasure parts <u>and</u> repair oil jet	P6305C	13.3 hrs.
	M56 with AWD	Replacement of timing-chain, chain-guides, and crank sprocket with countermeasure parts	P63053	13.8 hrs.
		Replacement of timing-chain, chain-guides, and crank sprocket with countermeasure parts <u>and</u> repair oil jet	P6305D	14.0 hrs.

**NOTE:** Powertrain Call Center must be called for preauthorization first before replacing a long engine (long block). The PCC will provide claims information for long engine replacement.

### Long Engine Replacement Approval Procedures

If a **new** oil jet pin can be inserted into the hole more than 3 mm and indicates **long engine replacement** is required.

1. Complete the PCC Preauthorization Form in ASIST.

2. Attach the required video (15 seconds or less) of oil jet pin test and vehicle VIN to the Preauthorization Form.
  - Failure to submit a continuous video showing evidence of loose oil jet hole and the VIN will cause immediate denial of request for long engine replacement.
3. Call the PCC for authorization at **800-973-9992 (opt 1)**.

**IMPORTANT:** Make sure the video has a clear image of the VIN on the F.M.V.S.S.

