

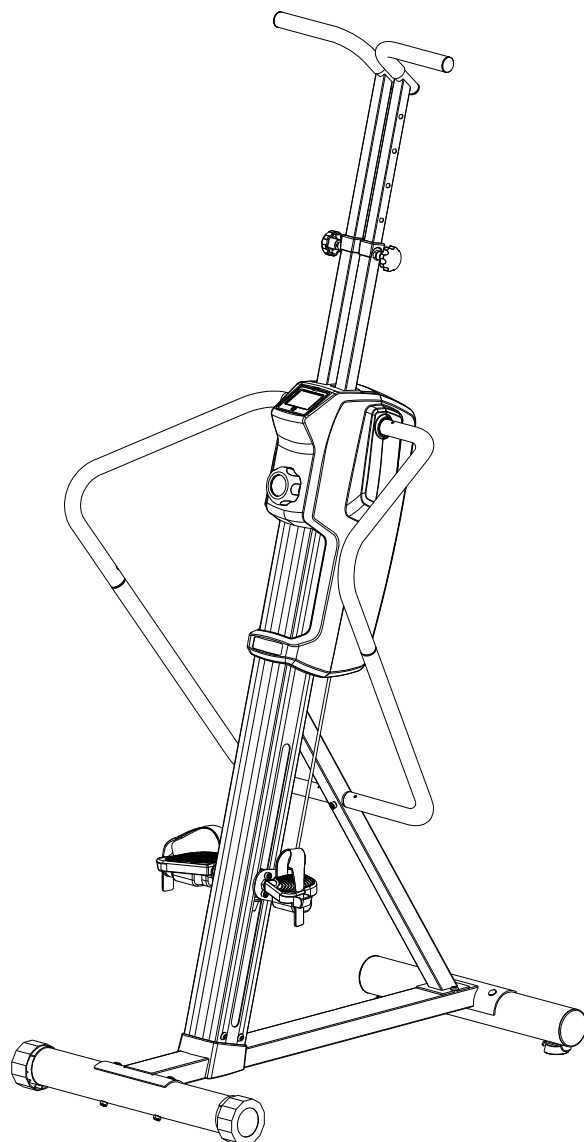

USER MANUAL – EN
IN 21964 Verticon inSPORTline Home



CONTENTS

- SAFETY INSTRUCTIONS 3
- PRODUCT DESCRIPTION 4
- ASSEMBLY 5
 - STEP 1 6
 - STEP 2 7
 - STEP 3 8
 - STEP 4 9
 - STEP 5 10
 - STEP 6 10
 - STEP 7 11
 - STEP 8 12
 - STEP 9 13
- MOVING 14
- PLACEMENT 15
- CONSOLE 16
 - BUTTONS 17
 - FUNCTION..... 17
- USE 18
- MAINTENANCE 18
- GENERAL TRAINING RECOMMENDATIONS 18
- EXERCISE INSTRUCTIONS 19
 - THE WARM UP PHASE 19
 - THE COOL DOWN PHASE 20
- DIAGRAM 21
- PARTS LIST 23
- ENVIRONMENT PROTECTION 24
- TERMS AND CONDITIONS OF WARRANTY, WARRANTY CLAIMS 24

SAFETY INSTRUCTIONS

- Read the manual carefully before first use and assembly and keep it for future reference.
- Only assemble the device on a flat and clean surface so as not to affect its functionality.
- Clean the device regularly. Metal parts can easily rust.
- Talk to your doctor about your medical condition before using the device. This is especially important if you suffer from health problems or limitations.
- Exercise carefully and do not overextend yourself. Exercise must match your physical capabilities. If you feel pain or you are fainting, stop exercising immediately.
- Before each exercise, make sure that all bolts and nuts are tight (properly tightened). Replace damaged or worn parts immediately. If sharp edges appear on the device, do not use it. Also, do not exercise if the device makes atypical sounds.
- Do not use the device outdoors.
- No adjustable part should protrude so as not to restrict the user's movement.
- Keep children and pets away from the device. Do not leave children unattended close or near the device.
- Do not put your hands, feet, or hair near moving parts. Only place your hands on the designated places.
- Exercise sensibly and prevent injuries.
- Use the device only in accordance with the manual. Do not use the device unless it is completely assembled. If you are unsure, contact a professional service.
- Place the device on a flat and clean surface. For greater safety, keep a distance of min. 0.6 m from other room equipment.
- Wear suitable sportswear for exercise. Do not wear too loose clothes that get easily caught. Always wear closed shoes. Tighten the laces firmly.
- The device is not suitable for people who suffer from diseases or health complications. The device should not be used by people with reduced susceptibility, delayed reactions, or other limitations. People with insufficient exercise experience should also avoid using the device.
- The device is not suitable for pregnant women.
- The device may only be used by one person at a time.
- Do not place sharp objects on or near the device. Do not pinch or injure your hands during installation. If you hear abnormal sounds or the device is not working correctly, stop using the device immediately until the device is repaired.
- If the device is not working properly or is damaged contact your supplier.
- Use only original spare parts for repairs.

Weight limit: 136 kg

Category: HC – suitable for home use

WARNING! The heart rate monitoring system may not be accurate. Overextending during training can cause serious injury or death. If you feel nauseous, stop the exercise immediately!



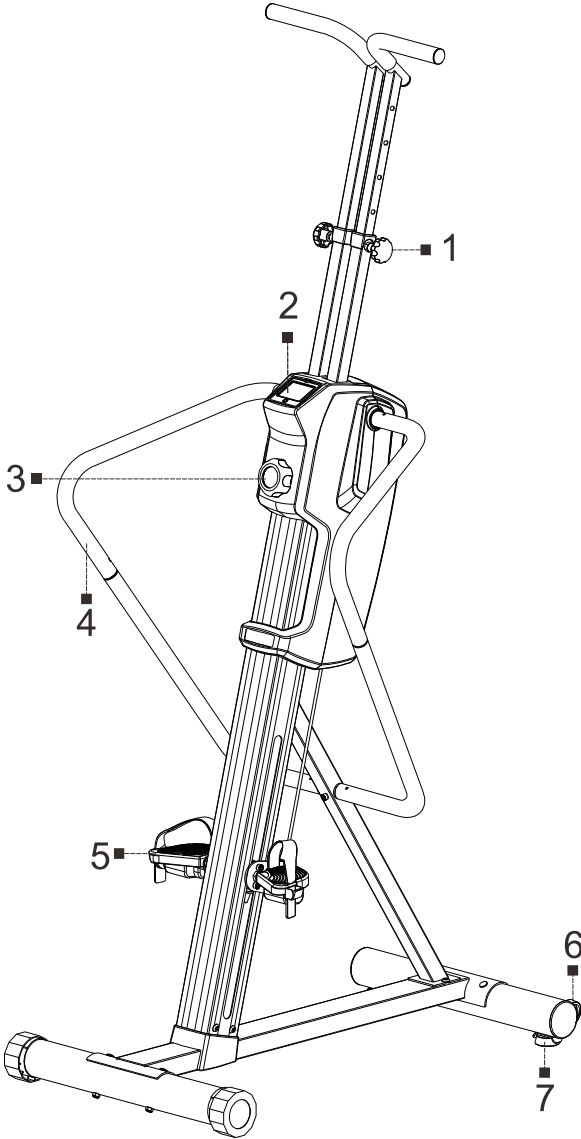





PRODUCT DESCRIPTION





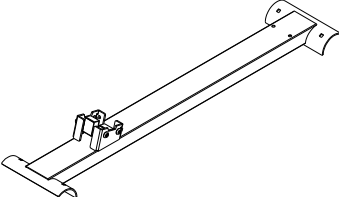

- | | |
|----|-----------------------|
| 1. | Height adjusting knob |
| 2. | Console |
| 3. | Resistance knob |
| 4. | Handle |
| 5. | Pedal |
| 6. | Transport wheel |
| 7. | Level feet |

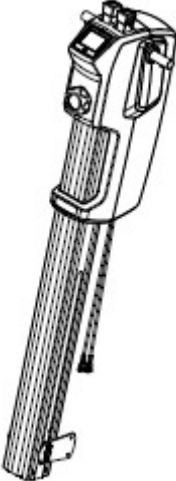
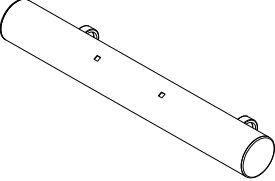
ASSEMBLY

Unpack all parts to clean area. Check that all parts are present. Do not dispose the packing material before the assembly is completed. Tools and hardware are included.

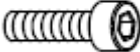
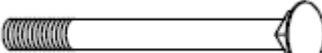
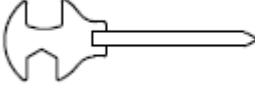

Handlebar (25, 26)	Upper handlebars (39, 40)	Rear handlebars (41, 42)
		
Leveling feet (62)	Adjusting knobs (28)	Pedals (35, 36)
		
Rear stabilizer (58)	Base frame (60)	Base cover (54)
		
Support tube (55)	Main frame (53)	Front stabilizer (59)
		

Hardware

32		Spacer (8 x 12 x 5mm)	2 pcs
66		Washer (8 x 25 x 3.0t)	4 pcs
71		Nut (M8x p1.25)	6 pcs
81		Allen bolt (M8 x p1.25 x 25 mm)	2 pcs
96		Carriage bolt (M8 x p1.25 x 85 mm)	4 pcs
		Multi wrench tool with screwdriver	
		Allen key	

Some parts can be pre-assembled.

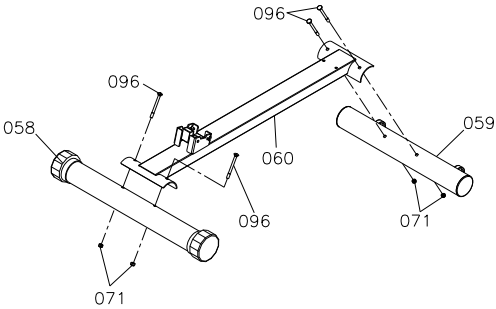
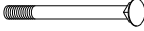
STEP 1

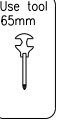
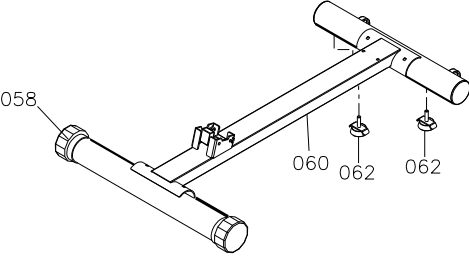
	<p>Attach the rear stabilizer (58) and front stabilizer (59) to the base (60) as shown and secure with 4x bolts (96) and 4x nuts (71)</p> <div style="display: flex; align-items: center; justify-content: center;"> <div style="text-align: center; margin-right: 20px;"> <p>96</p>  <p>x4</p> </div> <div style="text-align: center; margin-right: 20px;"> <p>71</p>  <p>x4</p> </div> <div style="border: 1px solid black; padding: 5px; text-align: center;"> <p>Use tool 65mm</p>  </div> </div>
	<p>Using the drawing, attach the 2x leveling feet (62) under the base (60). Then use the feet to level the machine so that it is stable.</p> <p>Note: To move, the transport wheels (63) must be higher than the leveling feet (62).</p>

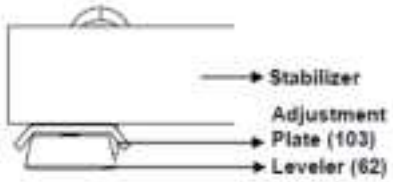
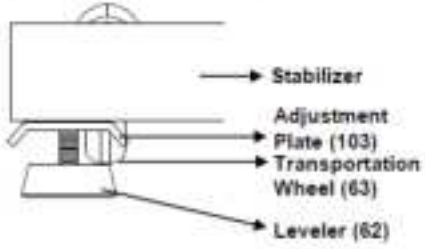
<p><u>Detailed Lever- drawing 1</u></p>  <p><u>Detailed Lever- drawing 2</u></p> 	<p>After placing in the required place, check the stability of the machine. If the machine is not level, proceed as follows:</p> <p>Loosen the foot (62), the plate will release.</p> <p>Adjust the height of the leveling foot (62) with one hand.</p> <p>Once the machine is level, secure the foot with the other hand using the plate (103) to a stable position.</p> <p>Note: To move, the transport wheels (63) must be higher than the leveling feet (62).</p>
---	--

STEP 2

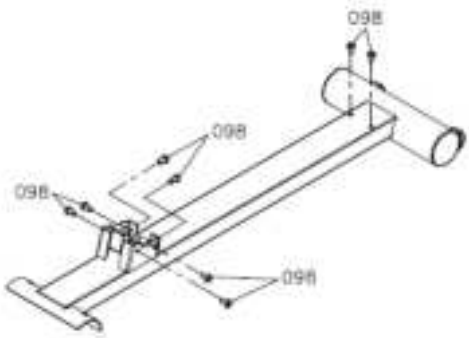
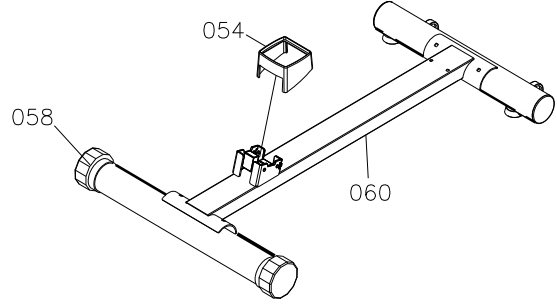
	<p>The bolts (98) have already been pre-assembled. Unscrew the screws (98) before proceeding.</p>
	<p>Attach the main frame cover (54) to the base (60).</p> <p>Make sure that the cover (54) is attached in the same direction as shown.</p>

STEP 3

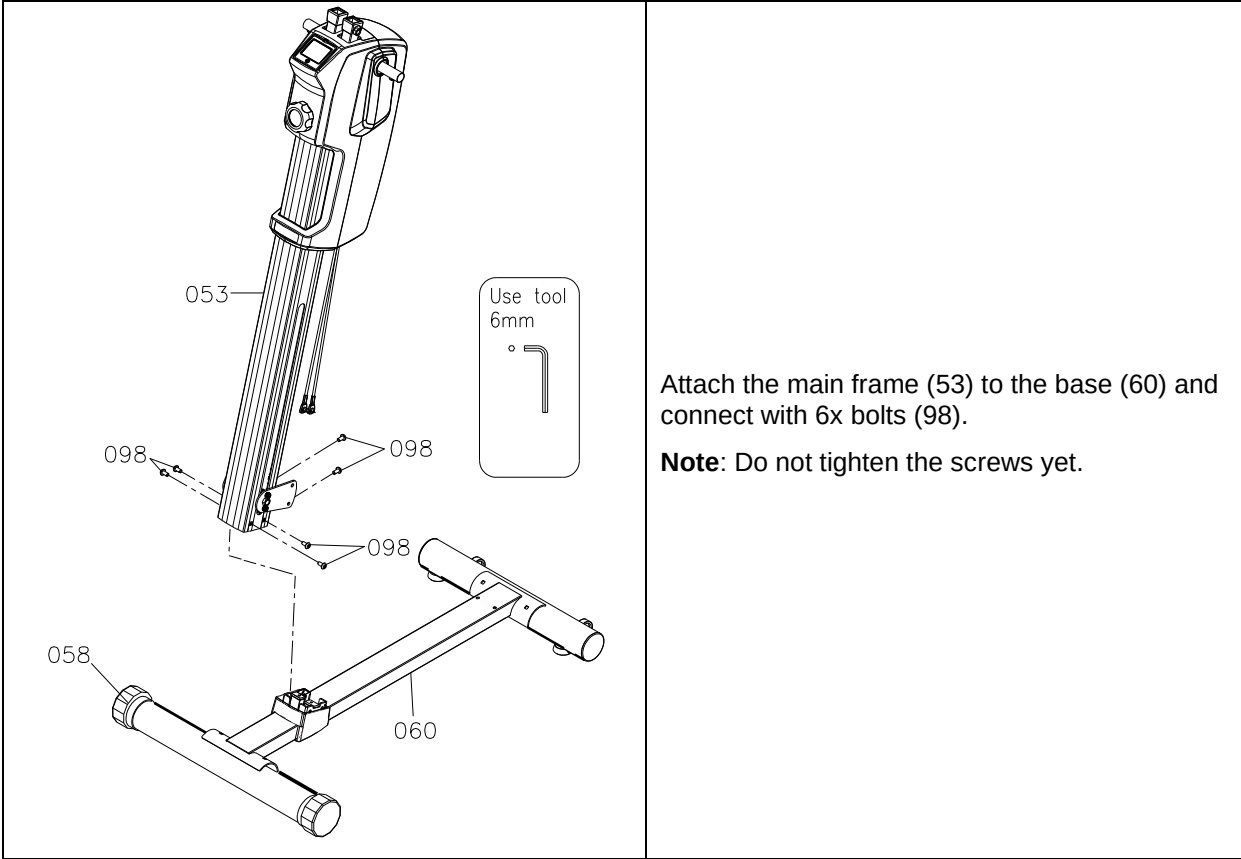

STEP 4

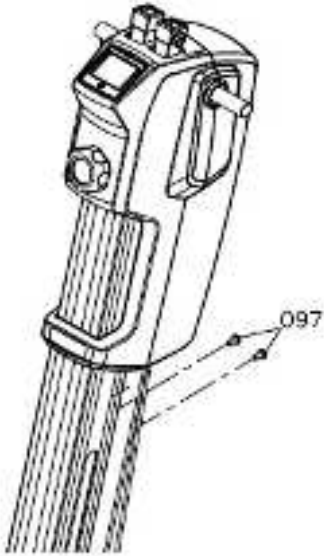

The bolts (97) are pre-mounted on the main frame (53).

Unscrew the bolts for the next procedure.

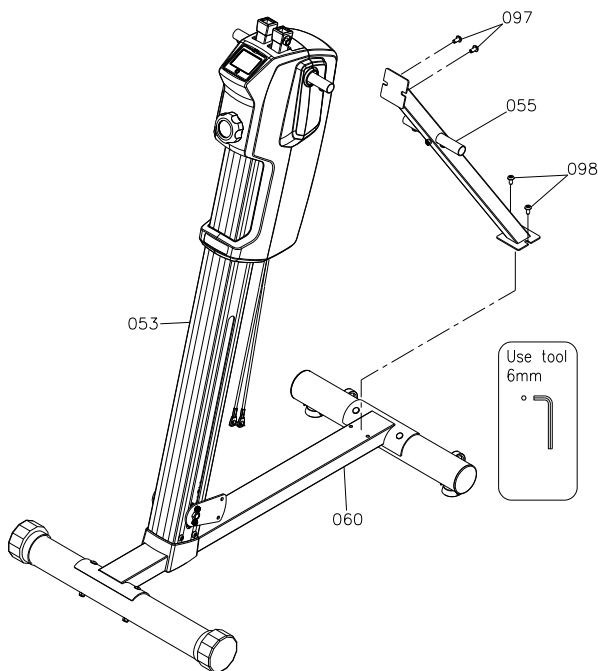

Attach the support tube (55) to the base (60) and main frame (53) with 2x bolts (97 and 98).

Make sure that the bolts are tightened.

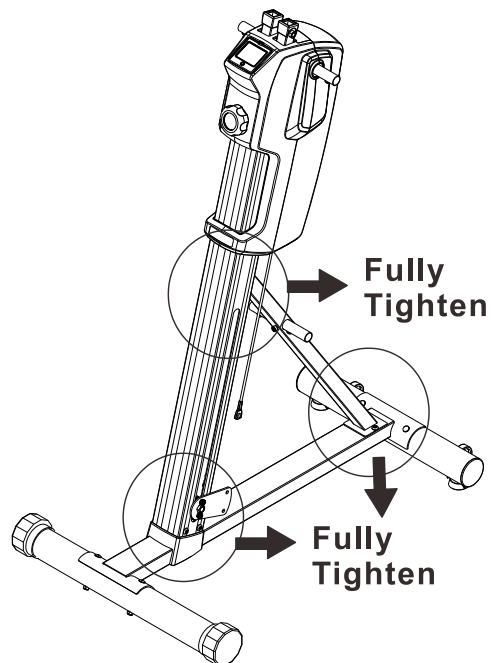

STEP 5

The machine is designed so that there are 2 types of pedal heights (406 mm and 508 mm) according to the user's needs. The figure below shows the mounting options and type for each option.

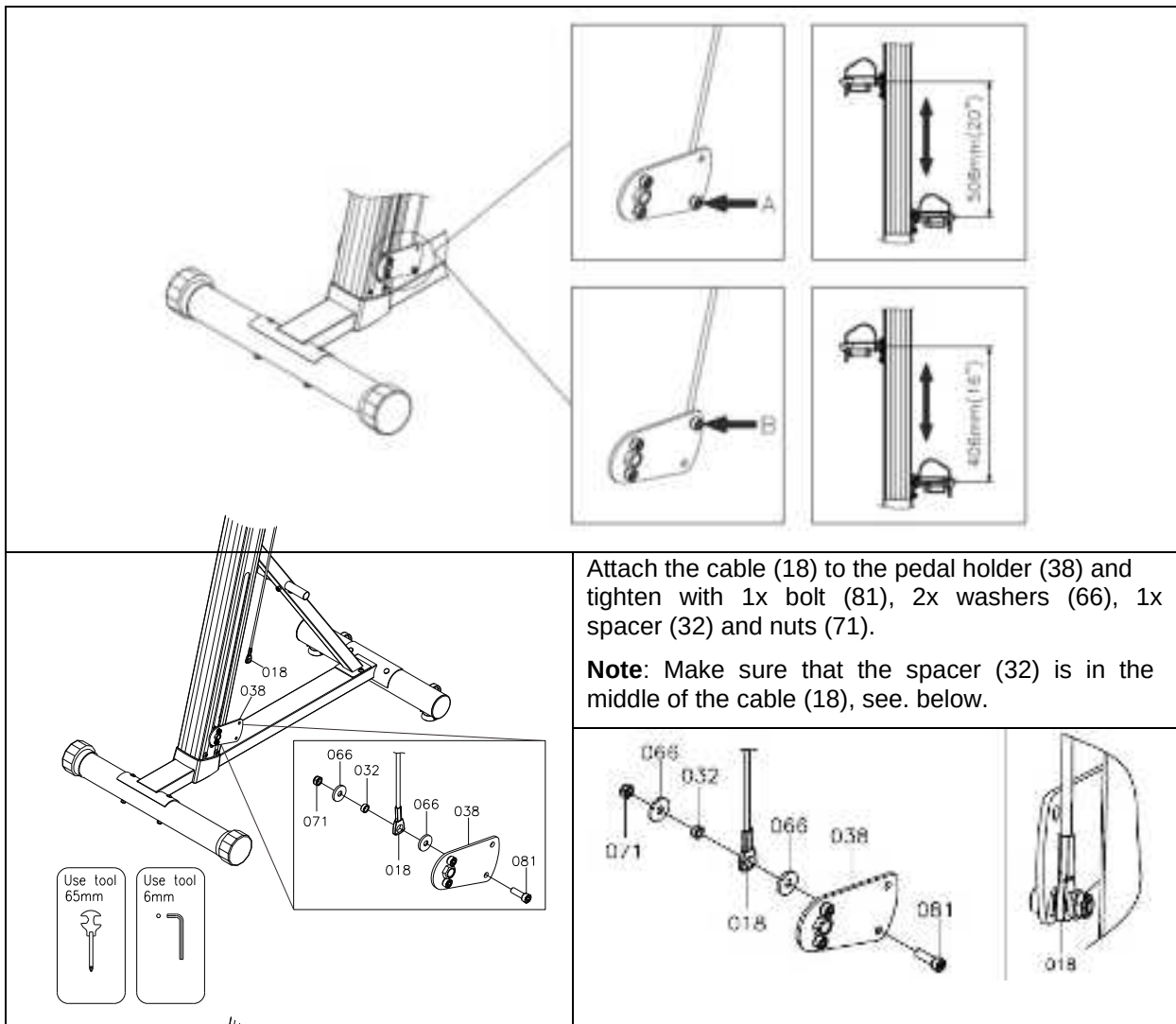

Attach the cable (18) to the pedal holder (38) and tighten with 1x bolt (81), 2x washers (66), 1x spacer (32) and nuts (71).

Note: Make sure that the spacer (32) is in the middle of the cable (18), see. below.

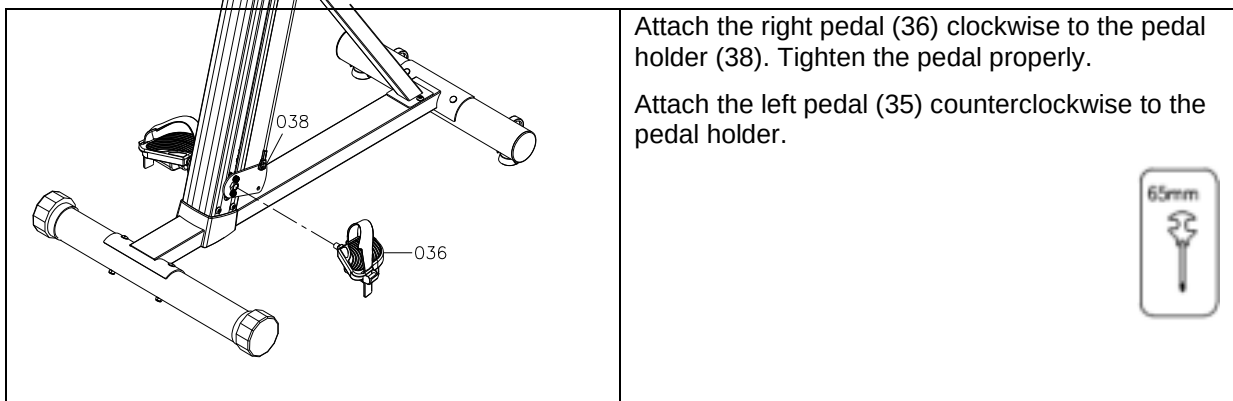

STEP 6



Attach the right pedal (36) clockwise to the pedal holder (38). Tighten the pedal properly.

Attach the left pedal (35) counterclockwise to the pedal holder.

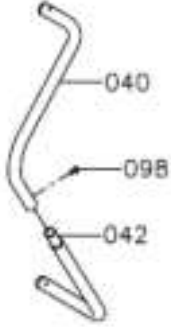
STEP 7

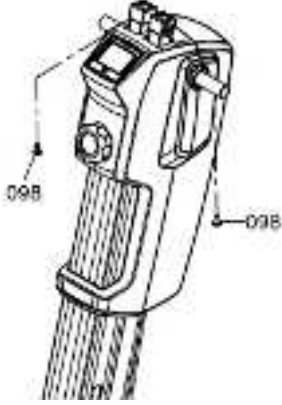
	<p>Bolts (98) are screwed in front of the handles (42).</p> <p>You must unscrew the bolts for the next steps.</p>
 <p>6mm</p>	<p>Connect the right handles (40 and 42) with 1x bolts (98). Do not tighten the screws.</p> <p>Repeat for the left side.</p>
	<p>Remove the 2x bolts (98) from the support rod (55) for the next step.</p>
	<p>Remove the 2x bolts (98) from the main frame (53) for the next step.</p>

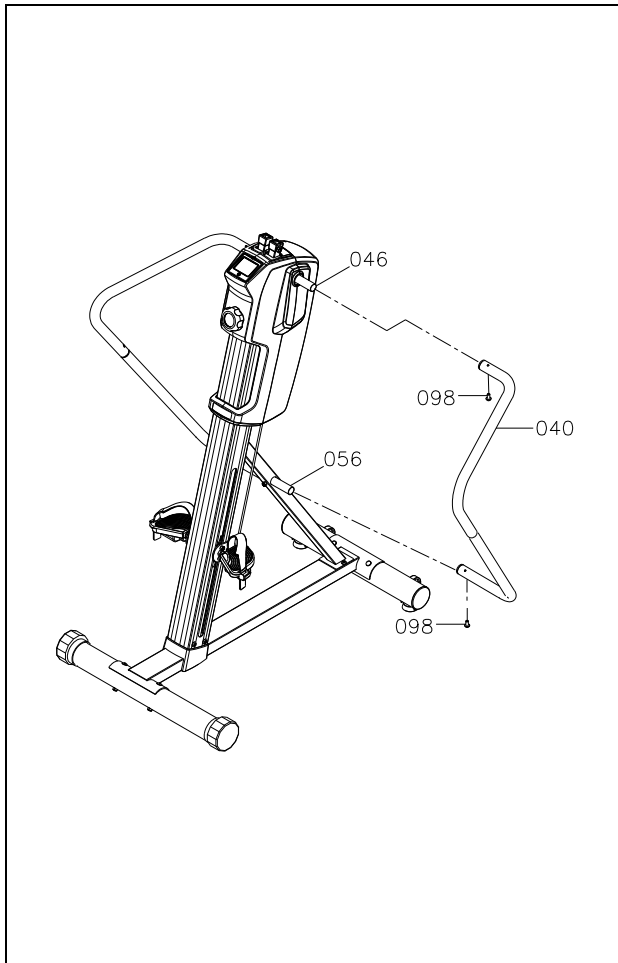

Attach the handles (40) to the handle holders (46, 56) with 2x bolts (98).



Make sure that the handles are properly fastened.

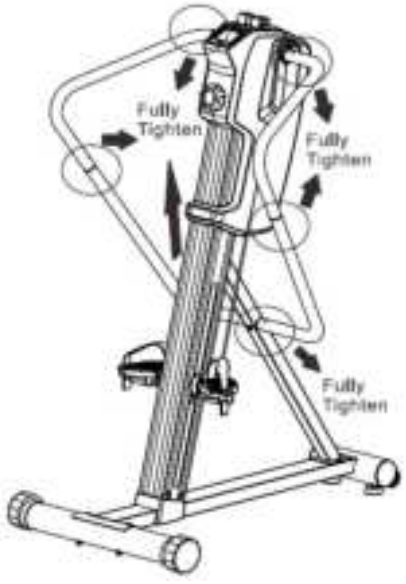

Repeat on the other side.

STEP 8

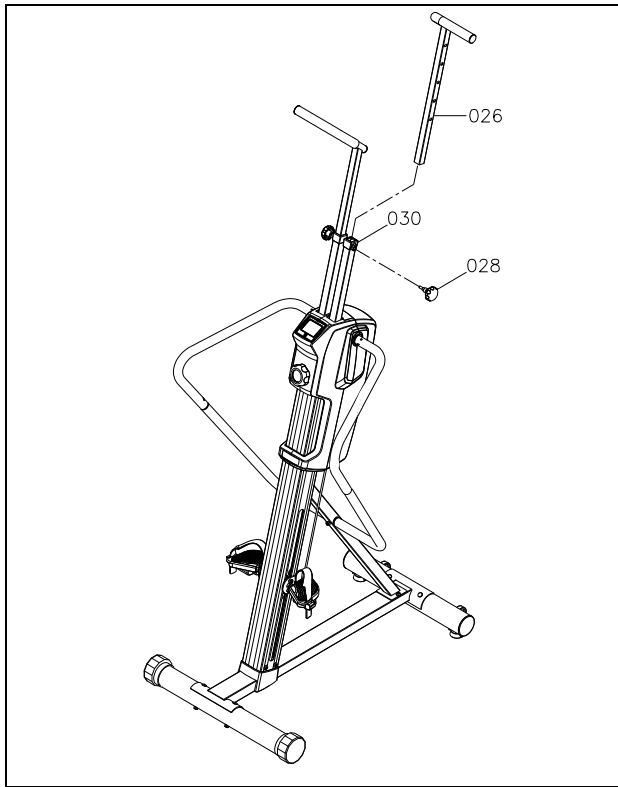

Attach the right handle (26) to the bracket (30).
 Select the appropriate height (5 positions to choose from) and tighten the hand screw.
 Repeat on the left.
 Make sure all bolts are properly tightened.

Load adjustment:

To increase the resistance, turn the knob clockwise. To reduce the resistance, turn the knob counterclockwise.

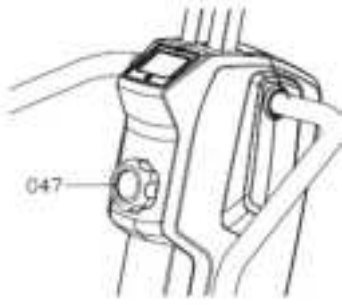

STEP 9

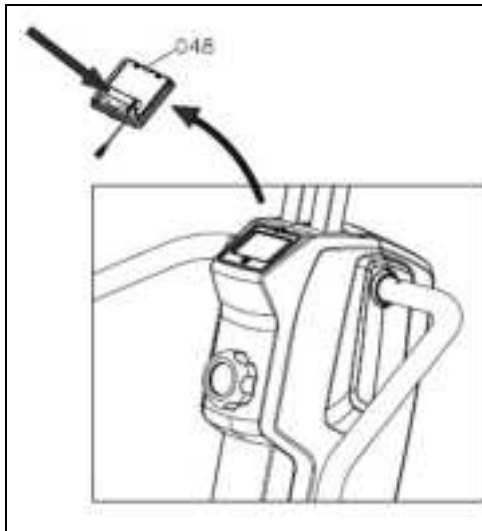

Release the clip on the console (38) and disconnect the cables.

The console (38) is powered by two AAA batteries.

Attach the console (38) back to the frame.

Note:

- Do not damage the cables.
- Do not mix new and old batteries.
- Do not combine battery types.
- Rechargeable batteries are not recommended.

MOVING

- You must screw up the leveling feet to move.
- Hold the rear stabilizer (58) with two hands and move it with the transport wheels.
- The floor must be leveled.

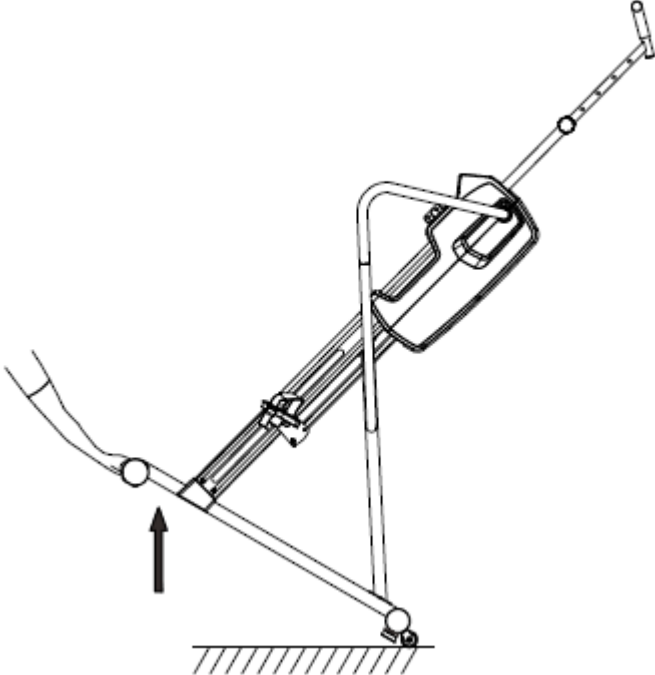

PLACEMENT

Place the machine on an area of at least 1300 x 1000 x 2500 mm (l x w x h). Make sure that there is enough space around the machine for free movement.

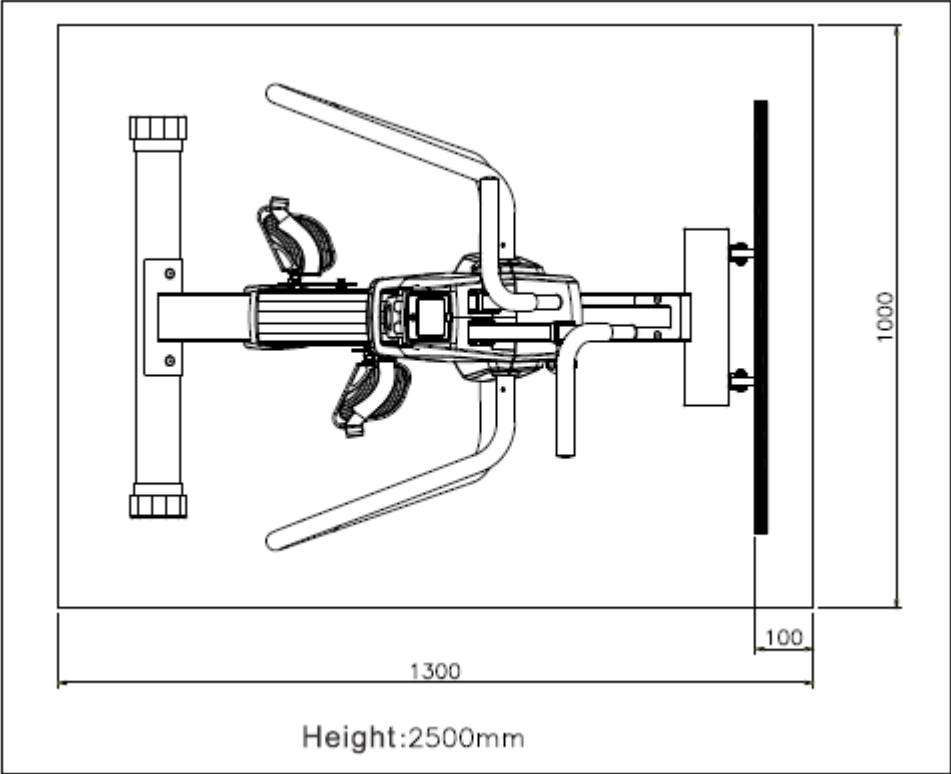

CONSOLE

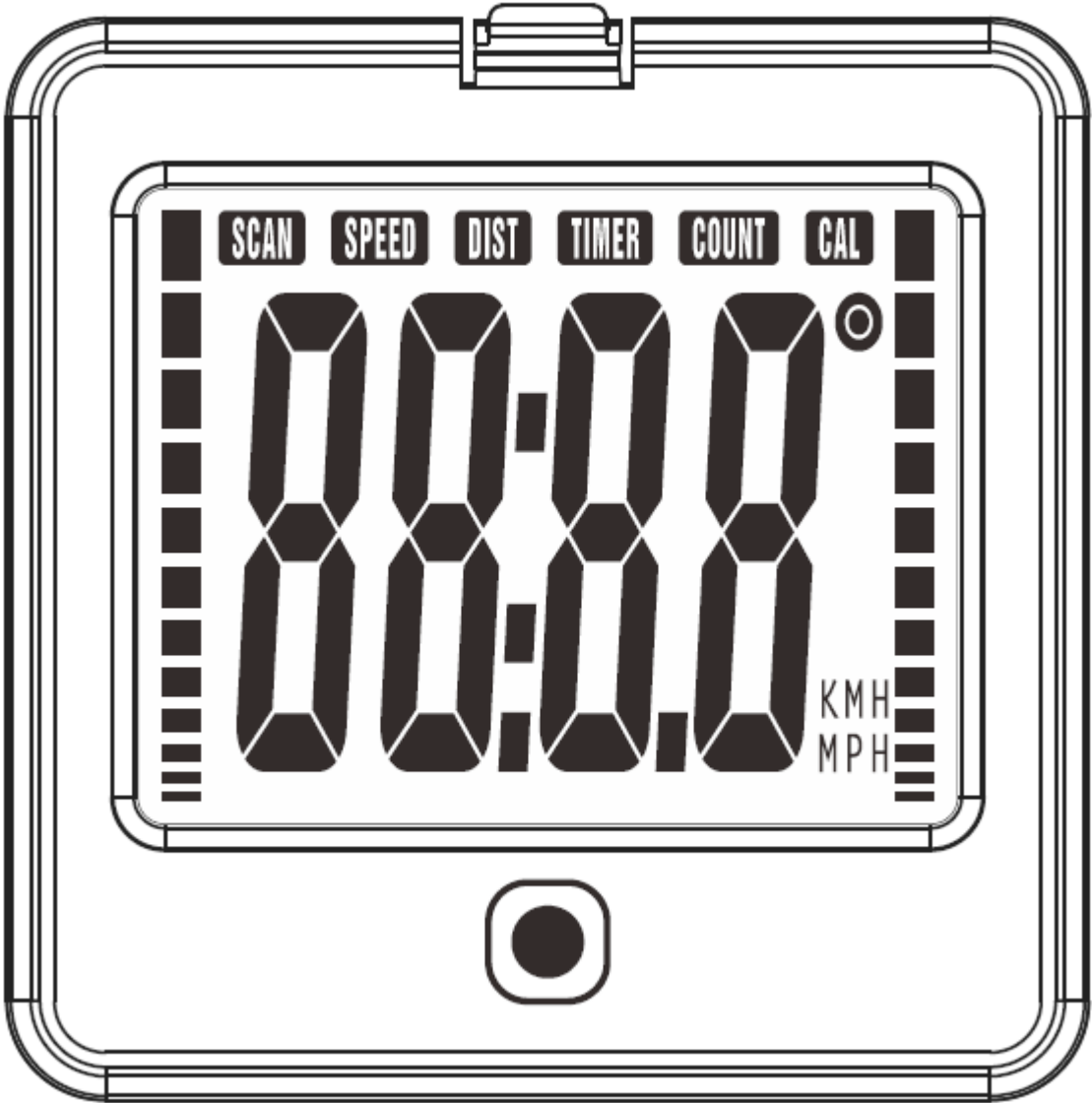

Turning on

Any movement or pressing of the button turns on the console. Make sure the batteries are inserted.

Turning off

The console automatically shuts off after 4 minutes of inactivity. All values are reset.

BUTTONS



Press the MODE button to change the displayed data: SPEED, DISTANCE, TIMER, COUNT, CALORIES.

Holding down the MODE button resets the values.

FUNCTION

SCAN	<p>SCAN</p> <p>Automatically displays SPEED, DISTANCE, TIMER, COUNT and CALORIES data, the displayed data changes every 5 seconds. To start the function, select the SCAN with MODE button.</p>
SPEED	<p>SPEED</p> <p>Displays speed from 0 to 99.9 km / h or mph</p>
DIST	<p>DISTANCE</p> <p>Displays the distance from 0 to 999 KM / mil</p>
TIMER	<p>TIME</p> <p>Displays the time from 0:00 to 99:59 minutes</p>
COUNT	<p>COUNT</p> <p>Displays the number of repetitions from 0 to 9999</p>
CAL	<p>CALORIES</p> <p>Displays burned calories from 0 to 9999 Kcal. Calories are for comparison purposes only, not for medical purposes.</p>

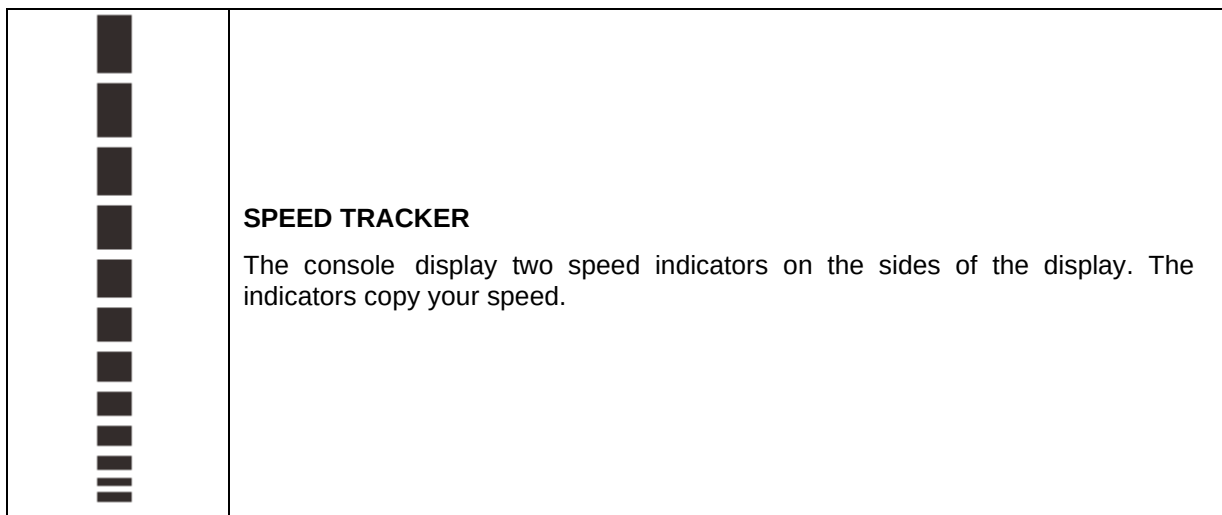

USE

The device is designed to copy the same movement as when climbing. You will exercise the upper and lower parts of your body, improve your metabolism, and burn more calories. Your body weight provides enough resistance for exercise.

Keep your feet on the pedals so that you feel the muscles in your buttocks and thighs engage during exercise. If you want to train your calf muscles, stand on the pedals closer to your toes. Grasp the adjustable handles and let your arms, shoulders, chest and back engage in your workout. If your shoulders hurt while exercising, place your hands on the firm handles. Make sure you keep your head straight and look ahead and avoid straining your neck while exercising. If you want to increase the intensity of the exercise, lift your legs higher or increase the frequency.

MAINTENANCE

- When assembling, tighten all screws properly and set the device to a horizontal position.
- Check for proper tightening after 10 hours of use.
- Wipe sweat after exercise. Clean the device with a cloth and mild detergent. Do not use solvents or aggressive cleaning agents on plastic parts.
- In case of increased noise, it is necessary to check the correct tightening of all connections.
- Place the product in a clean, ventilated, and dry room.
- Do not expose the device to direct sunlight.

GENERAL TRAINING RECOMMENDATIONS

Be careful when starting your exercise program, exercise should not take too long, and you should not exercise more than once every two days. Extend the duration of exercise each week. Do not set unreachable goals. In addition to running on the treadmill, do other sports activities, such as swimming, dancing or cycling.

Always warm up before training. Stretch or perform gymnastic exercises to warm up for at least 5 minutes to reduce muscle tension and prevent pain.

During the exercise, breathe regularly and calmly.

Drink regularly during exercise. Remember that the recommended daily dose of fluids is 2-3 liters and this increases with physical activity. The fluids you drink should have room temperature.

Always wear comfortable and lightweight clothing as well as sports shoes while exercising on the device. Do not use too loose clothes that could get caught in the moving parts of the device during exercise.



Regularly measure your heart rate. If your device is not equipped with a heart rate monitor, talk to your doctor about how you can measure the heart rate yourself. Determine the interval in which your heart rate will move, so training will be more effective. Consider your age and physical condition. The following table is used to determine the optimal heart rate interval:



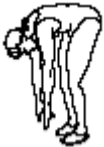

Age	Heart rate frequency 50-75% (from maximum heart rate) – optimal pulse	Maximum heart rate 100%
20 age	100 – 150	200
25 age	98 – 146	195
30 age	95 – 142	190
35 age	93 – 138	185
40 age	90 – 135	180
45 age	88 – 131	175
50 age	85 – 127	170
55 age	83 – 123	165
60 age	80 – 120	160
65 age	78 – 116	155
70 age	75 – 113	150

EXERCISE INSTRUCTIONS

THE WARM UP PHASE

This stage helps get the blood flowing around the body and the muscles working properly. It will also reduce the risk of cramp and muscle injury. It is advisable to do a few stretching exercises as shown below. Each stretch should be held for approximately 30 seconds, do not force or jerk your muscles into a stretch. If it hurts, STOP.

	<p>Touching your toes</p> <p>Slowly bend your back from hips. Keep your back and arms relaxed while stretching downwards to your toes. Do it as far as you are able and hold the position for 15 seconds. Bend your knees slightly.</p>
	<p>Shoulder lifts</p> <p>Raise your right shoulder up towards your ear and hold for 2 seconds. Then repeat for your left shoulder while lowering the right.</p>

	<p>Hamstring stretched</p> <p>Sit and outstretch your right leg. Rest the sole of your left foot against the inside of your right thigh. Stretch out your right arm along your right leg as far as you can. Hold for 15 seconds and relax. Repeat all with your left leg and left arm.</p>
	<p>Side stretches</p> <p>Raise your arms above your head. Stretch your right arm towards the ceiling as far as possible. Stretch your upper body towards the right side. Then repeat the exercise for the left side.</p>
	<p>Calves and Achilles tendon</p> <p>Lean against a wall with your left leg in front of the right one and your arms forward. Stretch out your right leg and keep your left foot on the floor. Bend your left leg and lean forwards by moving your right hip in the direction of the wall. Hold for 15 seconds. Keep your leg stretched and repeat exercising with other leg.</p>
	<p>Head rolls</p> <p>Slowly tilt your head to the right, stretching out the left side of your neck. Hold for 20 seconds. Then tilt it back again to the left and continue until the right side of your neck is stretched out. Hold for 20 seconds. Slowly tilt your head forwards and stick out your neck. Don't rotate your head all the way round. Repeat it several times.</p>

THE COOL DOWN PHASE

This stage is to let your Cardio-vascular System and muscles wind down. This is a repeat of the warm up exercise e.g. reduce your tempo, continue for approximately 5 minutes. The stretching exercises should now be repeated. Again, remember not to force or jerk your muscles into the stretch.

As you get fitter, you may need to train longer and harder. It is advisable to train at least three times a week, and if possible, space your workouts evenly throughout the week.

DIAGRAM

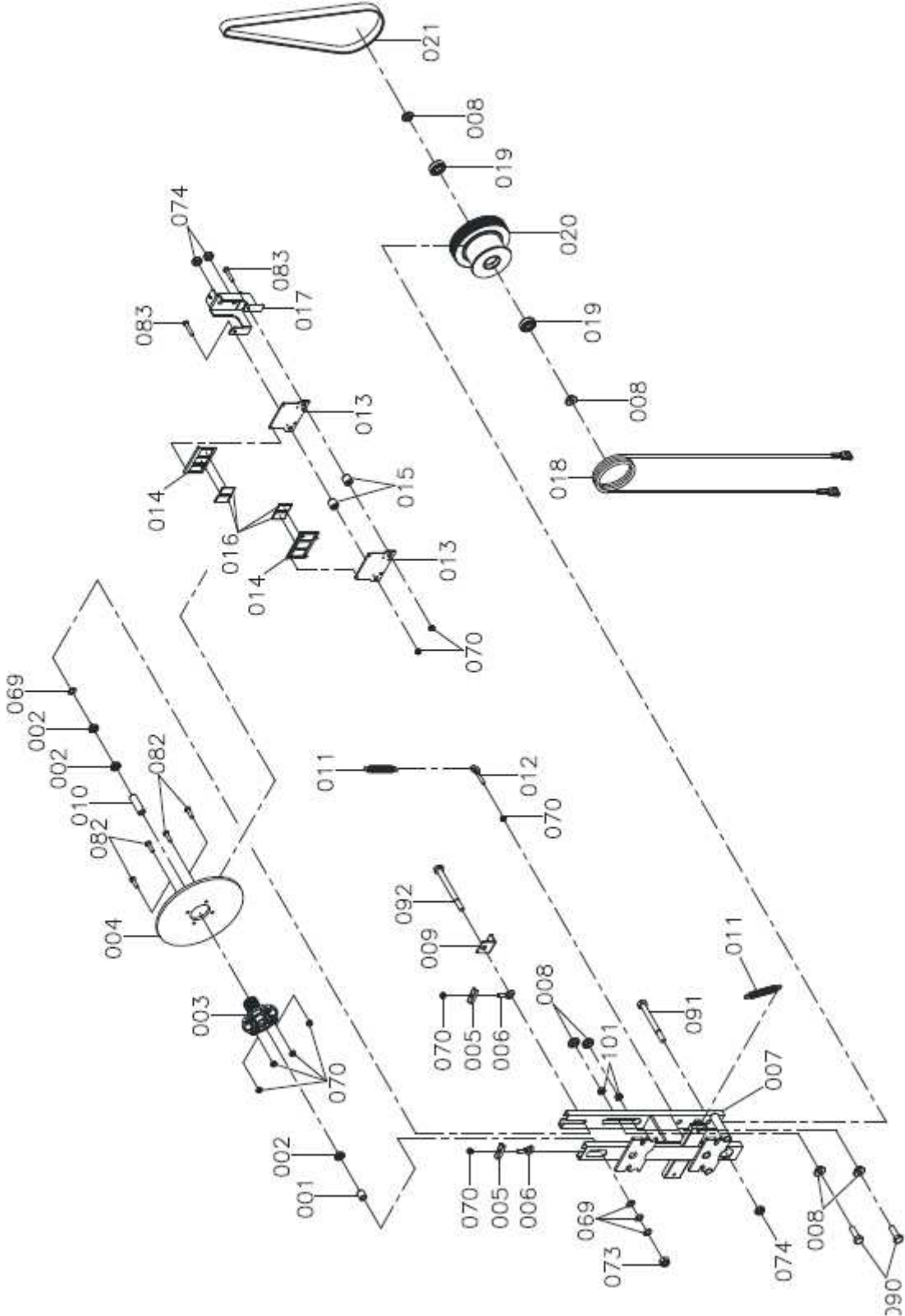

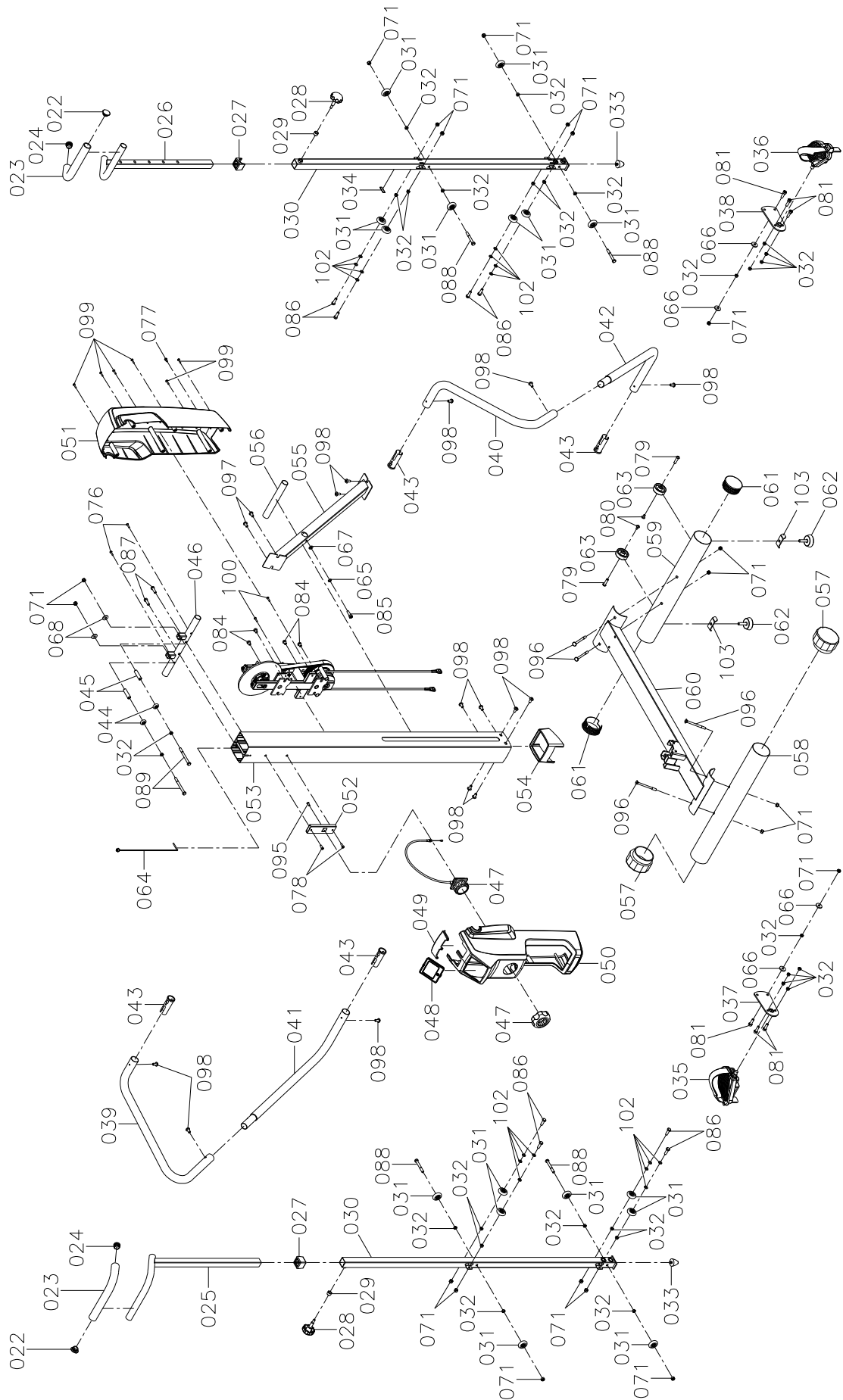

PARTS LIST

No.	Name	Qty.	No.	Name	Qty.
1	Spacer (10x14x15 mm)	1	36	Right pedal	1
2	Bearing (6800)	3	37	Left pedal bracket	1
3	Pulley	1	38	Right pedal bracket	1
4	Flywheel	1	39	Left upper support handle	1
5	Tension bracket	2	40	Right upper support handle	1
6	Eye Bolt (67 mm)	2	41	Left bottom support handle	1
7	Resistance bracket	1	42	Right bottom support handle	1
8	Bearing adapter	6	43	Handlebar bush	4
9	Fixed cable plate	1	44	Guide Wheel (24x8 mm)	2
10	Spacer (10x14x45 mm)	1	45	Spacer (8x12x45 mm)	2
11	Tension spring	2	46	Upper handle fixed tube	1
12	Eye Bolt (57 mm)	1	47	Resistance knob	1
13	Magnetic shield plate	2	48	Console	1
14	Magnetic bracket	2	49	Upper decoration cover	1
15	Plate spacer	2	50	Front cover	1
16	Magnet	4	51	Back cover	1
17	Slider bracket	1	52	Fixed bracket for knob	1
18	Cable	1	53	Main frame	1
19	Bearing (6002)	2	54	Base cover	1
20	Pulley for cable	1	55	Support tube	1
21	Belt (864J8)	1	56	Bottom handlebar fixed tube	1
22	Round plug (25.4)	2	57	Endcap	2
23	Foam grip	2	58	Rear stabilizer	1
24	Tube plug	2	59	Front stabilizer	1
25	Left handlebar	1	60	Base frame	1
26	Right handlebar	1	61	Round Plug (76 mm)	2
27	Spacer for Fixed Tube	2	62	Leveler	2
28	Adjusting knob	2	63	Transportation wheel	2
29	Cushion foam	2	64	Sensor wire	1
30	Fixed tube	2	65	Lock washer (m8)	1
31	Rail roller	16	66	Washer (8x25x3.0t)	4
32	Spacer (8x12x5mm)	28	67	Washer (8x16x2.0t)	1
33	Endcap(35mm)	2	68	Washer (8x23x2.0t)	2
34	Magnet	1	69	Washer (10x16x1.0t)	4
35	Left pedal	1	70	Nylon Nut (M6xp1.0)	9

Hardware					
71	Nylon nut (M8×p1.25)	20	89	Bolt (M8×p1.25×85 mm)	2
73	Nylon nut (M10×p1.5)	1	90	Bolt (M10×p1.5×30 mm)	2
74	Thin nylon nut (M10×p1.5)	3	91	Bolt (M10×p1.5×100 mm)	1
76	Screw (M4×32 mm)	2	92	Bolt (M10×p1.5×110 mm)	1
77	Screw (M5×18 mm)	1	93	Bolt (M8×p1.25×20 mm)	2
78	Screw (M5×p0.8×20 mm)	2	94	Bolt (M5×p0.8×10 mm)	2
79	Bolt (L=30mm)	2	95	Bolt (M5×p0.8×15 mm)	1
80	Bolt (M6×p1.0×12 mm)	2	96	Bolt (M8×p1.25×85 mm)	4
81	Bolt (M8×p1.25×25 mm)	6	97	Bolt (M8×p1.25×12 mm)	2
82	Bolt (M6×p1.0×20 mm)	4	98	Bolt (M8×p1.25×16 mm)	14
83	Bolt (M6×p1.0×30 mm)	2	99	Screw (M4×20 mm)	6
84	Bolt (M8×p1.25×10 mm)	4	100	Bolt (M4x25 mm)	2
85	Bolt (M8×p1.25×16 mm)	1	101	Spacer (10x14x5 mm)	2
86	Bolt (M8×p1.25×25 mm)	8	102	Washer (8x14x1.0t)	16
87	Bolt (M8×p1.25×30 mm)	2	103	Adjustment Plate	2
88	Bolt (M8×p1.25×62 mm)	4			

ENVIRONMENT PROTECTION

After the product lifespan expired or if the possible repairing is uneconomic, dispose it according to the local laws and environmentally friendly in the nearest scrapyard.

By proper disposal you will protect the environment and natural sources. Moreover, you can help protect human health. If you are not sure in correct disposing, ask local authorities to avoid law violation or sanctions.

Don't put the batteries among house waste but hand them in to the recycling place.

TERMS AND CONDITIONS OF WARRANTY, WARRANTY CLAIMS

General Conditions of Warranty and Definition of Terms

All Warranty Conditions stated here under determine Warranty Coverage and Warranty Claim Procedure. Conditions of Warranty and Warranty Claims are governed by Act No. 89/2012 Coll. Civil Code, and Act No. 634/1992 Coll., Consumer Protection, as amended, also in cases that are not specified by these Warranty rules.

The seller is SEVEN SPORT s.r.o. with its registered office in Strakonická street 1151/2c, Prague 150 00, Company Registration Number: 26847264, registered in the Trade Register at Regional Court in Prague, Section C, Insert No. 116888.

According to valid legal regulations it depends whether the Buyer is the End Customer or not.

“The Buyer who is the End Customer” or simply the “End Customer” is the legal entity that does not conclude and execute the Contract in order to run or promote his own trade or business activities.

“The Buyer who is not the End Customer” is a Businessman that buys Goods or uses services for the purpose of using the Goods or services for his own business activities. The Buyer conforms to the General Purchase Agreement and business conditions.

These Conditions of Warranty and Warranty Claims are an integral part of every Purchase Agreement made between the Seller and the Buyer. All Warranty Conditions are valid and binding, unless

otherwise specified in the Purchase Agreement, in the Amendment to this Contract or in another written agreement.

Warranty Conditions

Warranty Period

The Seller provides the Buyer a 24 months Warranty for Goods Quality, unless otherwise specified in the Certificate of Warranty, Invoice, Bill of Delivery or other documents related to the Goods. The legal warranty period provided to the Consumer is not affected.

By the Warranty for Goods Quality, the Seller guarantees that the delivered Goods shall be, for a certain period of time, suitable for regular or contracted use, and that the Goods shall maintain its regular or contracted features.

The Warranty does not cover defects resulting from (if applicable):

- User's fault, i.e. product damage caused by unqualified repair work, improper assembly, insufficient insertion of seat post into frame, insufficient tightening of pedals and cranks
- Improper maintenance
- Mechanical damages
- Regular use (e.g. wearing out of rubber and plastic parts, moving mechanisms, joints, wear of brake pads/blocks, chain, tires, cassette/multi wheel etc.)
- Unavoidable event, natural disaster
- Adjustments made by unqualified person
- Improper maintenance, improper placement, damages caused by low or high temperature, water, inappropriate pressure, shocks, intentional changes in design or construction etc.

Warranty Claim Procedure

The Buyer is obliged to check the Goods delivered by the Seller immediately after taking the responsibility for the Goods and its damages, i.e. immediately after its delivery. The Buyer must check the Goods so that he discovers all the defects that can be discovered by such check.

When making a Warranty Claim the Buyer is obliged, on request of the Seller, to prove the purchase and validity of the claim by the Invoice or Bill of Delivery that includes the product's serial number, or eventually by the documents without the serial number. If the Buyer does not prove the validity of the Warranty Claim by these documents, the Seller has the right to reject the Warranty Claim.

If the Buyer gives notice of a defect that is not covered by the Warranty (e.g. in the case that the Warranty Conditions were not fulfilled or in the case of reporting the defect by mistake etc.), the Seller is eligible to require a compensation for all the costs arising from the repair. The cost shall be calculated according to the valid price list of services and transport costs.

If the Seller finds out (by testing) that the product is not damaged, the Warranty Claim is not accepted. The Seller reserves the right to claim a compensation for costs arising from the false Warranty Claim.

In case the Buyer makes a claim about the Goods that is legally covered by the Warranty provided by the Seller, the Seller shall fix the reported defects by means of repair or by the exchange of the damaged part or product for a new one. Based on the agreement of the Buyer, the Seller has the right to exchange the defected Goods for a fully compatible Goods of the same or better technical characteristics. The Seller is entitled to choose the form of the Warranty Claim Procedures described in this paragraph.

The Seller shall settle the Warranty Claim within 30 days after the delivery of the defective Goods, unless a longer period has been agreed upon. The day when the repaired or exchanged Goods is handed over to the Buyer is considered to be the day of the Warranty Claim settlement. When the Seller is not able to settle the Warranty Claim within the agreed period due to the specific nature of the Goods defect, he and the Buyer shall make an agreement about an alternative solution. In case such agreement is not made, the Seller is obliged to provide the Buyer with a financial compensation in the form of a refund.

CZ
SEVEN SPORT s.r.o.

Registered Office: Strakonická 1151/2c, Praha 5, 150 00, ČR
Headquarters: Dělnická 957, Vítkov, 749 01
Warranty & Service: Čermenská 486, Vítkov 749 01

CRN: 26847264
VAT ID: CZ26847264

Phone: +420 556 300 970
E-mail: eshop@insportline.cz
reklamace@insportline.cz
servis@insportline.cz

Web: www.inSPORTline.cz

SK
inSPORTline s.r.o.

Headquarters, warranty & service center: Električná 6471, Trenčín 911 01, SK

CRN: 36311723
VAT ID: SK2020177082

Phone: +421(0)326 526 701
E-mail: objednavky@insportline.sk
reklamacie@insportline.sk
servis@insportline.sk

Web: www.inSPORTline.sk